

ANC



POPULAR MECHANICS

MAGAZINE

WRITTEN SO YOU CAN UNDERSTAND IT

REG'D. TRADE MARK, GREAT BRITAIN, NO. 410426

REG. U.S. PAT. OFF.



FLY INTO THE HEART OF A TYPHOON

—Read this terrific story of a B-29 crew—Page 133

NEW PLYMOUTH



packed with value and ready to prove it!

Here's the sensational new standard for excellence in the low-priced car field—the brilliant new, value-packed Plymouth!

No other car at the price gives you anything like the new Plymouth's great engineering advantages. The speed and ease of Ignition Key starting . . . the thrilling performance of the 7.0 to 1 high compression en-

gine . . . the swift, smooth stops of big Safe-Guard Hydraulic Brakes . . . the positive blowout protection of Safety-Rim Wheels.

The new Plymouth rides like a heavy, high-priced limousine yet handles with amazing ease! No wonder this fine car of great value is now—more than ever—the car that likes to be compared! No wonder this

new American Beauty is now—more than ever—the low-priced car most like high-priced cars!

Plan to visit your nearby Plymouth dealer now. He'll gladly arrange for a demonstration drive. Then you can test this car and see for yourself that the new Plymouth is the most car value you can possibly buy at Plymouth's low price!



NOW—more than ever—the car that likes to be compared

PLYMOUTH Division of CHRYSLER CORPORATION, Detroit 31, Michigan

A NEW STAR RISES



PATENTED **CORALOX** INSULATOR

CORALOX is rising swiftly in public preference, because it eliminates the principal causes of spark plug trouble.

Fouling at low engine speeds—misfiring under heavy loads—failure due to heat shock—accumulation of oxide coating—these are primarily *insulator* troubles.

CORALOX is AC's patented Insulator. It has 4 times greater heat conductivity—10 times greater electrical resistance at high temperatures—than the best ceramic insulator material in use before **CORALOX**. It is 3 times as strong. It is basic in chemical composition.

For better and more economical performance in your car, truck or tractor, use AC Spark Plugs with patented **CORALOX** Insulator. There's a size and type for *your* engine.



AC SPARK PLUG DIVISION • GENERAL MOTORS CORPORATION

MARCH 1950

This One



1

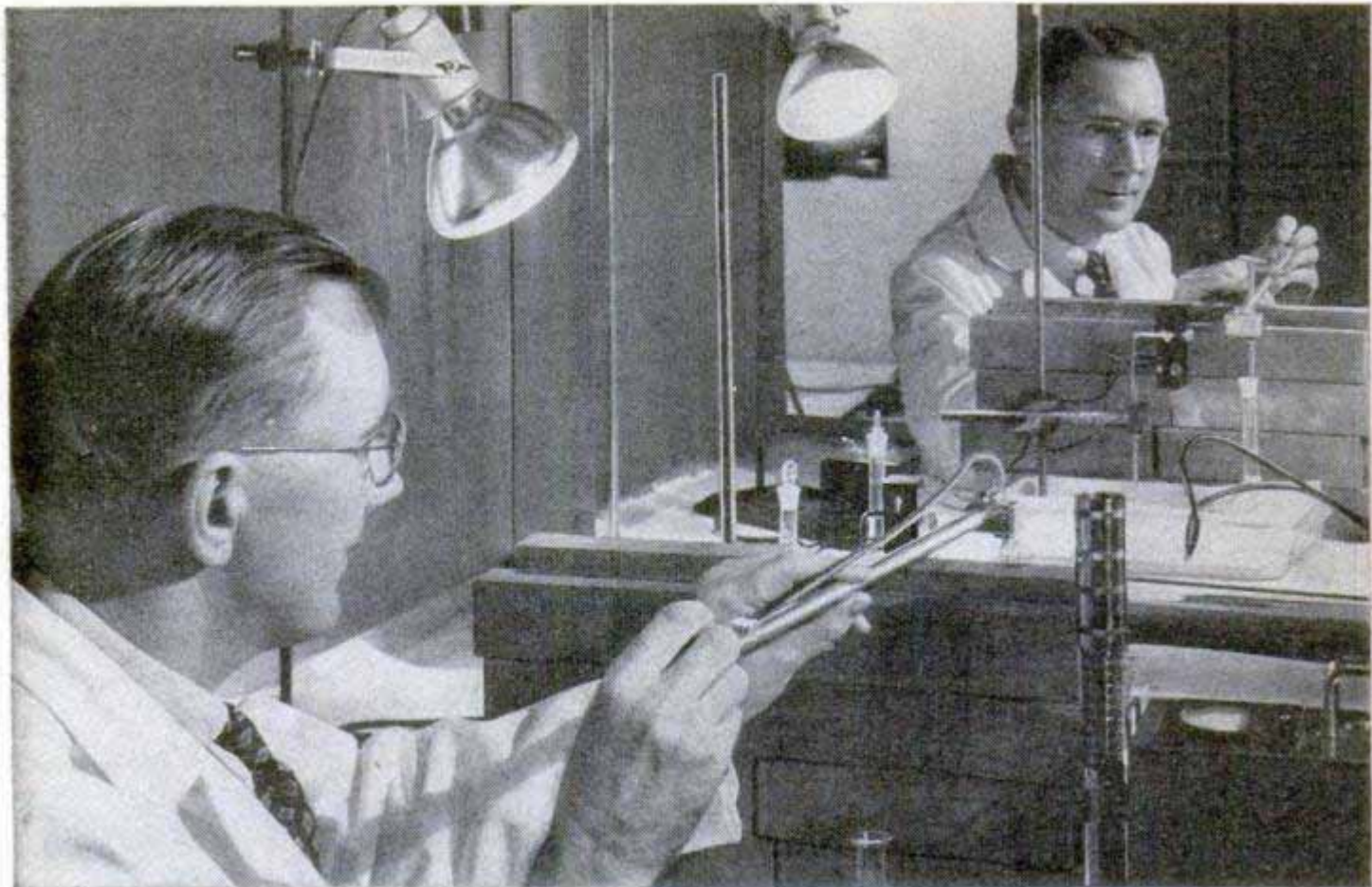

IT'S **DONE WITH MIRRORS!**

Protected by a wall of lead bricks and using a mirror to guide his instruments, this Bell Laboratories scientist is preparing a solution of a radioactive isotope, for use as a tracer to study materials for your telephone system.

Bombardment by neutrons turns some atoms of many chemical elements into their "radioactive isotopes"; these are unstable and give off radiation which can be detected by a Geiger counter. Chemically a "radioactive isotope" behaves exactly like the original element. Mix the two in a solution or an alloy and they will stay together; when the Geiger counter shows up an isotope, its inactive brother will be there too. Minute amounts beyond the reach of ordinary chemical methods can be detected—often as little as one part in a billion.

The method is used to study the effect of composition on the performance of newly developed germanium transistors—tiny amplifiers which may one day perform many functions which now require vacuum tubes.

It enables scientists at Bell Telephone Laboratories to observe the behavior of microscopic impurities which affect the emission of electrons from vacuum tube cathodes. It is of great help in observing wear on relay contacts. And it may develop into a useful tool for measuring the distribution and penetration of preservatives in wood.

Thus, one of science's newest techniques is adopted by Bell Laboratories to make your telephone serve you better today and better still tomorrow.



BELL TELEPHONE LABORATORIES

EXPLORING AND INVENTING, DEVISING AND PERFECTING,
FOR CONTINUED IMPROVEMENTS AND ECONOMIES IN TELEPHONE SERVICE

Popular Mechanics Magazine

Registered in U. S. Patent Office and Canada

H. H. WINDSOR, Founder

H. H. WINDSOR, JR., Editor and Publisher

Volume 93 MARCH 1950 Number 3

Managing Editor.....Roderick M. Grant
 Assistant Managing Editor.....Wayne Whittaker
 Shop Notes and Crafts Editor.....James R. Ward
 Radio-Television, Electronics Editor.....Frank L. Brittin
 Associate Editor, Aviation.....Aubrey O. Cookman, Jr.
 Associate Editor.....Clifford B. Hicks
 Art Director.....Frank Beatty
 Director, Bureau of Information.....Allan Carpenter

Assistant Editors

Donald R. Brooks Dorothy E. Hoffmann Arthur R. Railton
 Assistant Editors, Shop Notes and Crafts

W. Clyde Lammey Wayne C. Leckey Frank N. Stephany A. E. Youngquist
 Eastern Editor.....Richard F. Dempewolf
 Empire State Bldg., Room 2906, New York 1, N. Y.

Western Editor.....Thomas E. Stimson, Jr.
 3872 Franklin Ave., Los Angeles 27, Calif.

Representative in Great Britain.....Douglas W. Wedderspoon
 77 Baker St., London W. 1, England



this month's cover

SLAMMED AND WRENCHED by the mighty muscles of Nature, that B-29 on our cover is skywriting history. She is a tough old bird, the only plane ever to circle at low level through the eye of a typhoon and come out alive. She barely limped back to base, flaps twisted, rivets popped from her skin, great gaps in her wings and her fin askew. Her opponent was Beverly, as vicious a lady as ever roared out of the tropics to threaten the islands of the Pacific. Beverly started as a wisp of a cloud, then wrapped herself in a swirling wind and sped northeast, spinning like a destructive top. She toyed playfully with the big B-29, then roared on to the Arctic where a mass of polar air tore her heart out. "Look a Typhoon in the Eye" on page 133 is as exciting a story as we've ever presented, a story of weather research that reads like fiction. Artist Roswell Brown depicted the eerie battle on our cover

Published monthly by Popular Mechanics Company, 200 E. Ontario St., Chicago 11, Ill. H. H. Windsor, Jr., president; William Harrison Petridge, vice president; D. F. Windsor, vice president and secretary-treasurer; Clover L. Perkins, advertising manager; Alan M. Doyce, circulation manager. Single copy in the United States and Canada, 35 cents; subscription rates in United States and possessions, Canada, Philippines and countries of the Pan-American Postal Union, 1 year, \$3.50; 2 years, \$6.00; 3 years \$8.00. To all other countries add \$1.00 a year over United States prices for overseas postage. If you plan to move, notify us at least 30 days in advance so you will not miss an issue. Give both old and new addresses. Entered as Second Class Matter, September 15, 1903, at the Post Office at Chicago, Illinois, under Act of March 3, 1879. Entered as Second Class Matter at Post Office Dept., Canada. Copyright 1950 by Popular Mechanics Company. Copyright under International Copyright Union. Copyright in France. All rights reserved under Pan-American Copyright Union. Printed in the United States of America.

IN THIS ISSUE

Inventor in a Carriage House	- - - - -	81
Forest Killers Are on the Run	- - - - -	92
Masterpieces in Miniature	- - - - -	97
Sea-Going Eggbeaters	- - - - -	102
Broncos With Rubber Tires	- - - - -	106
Suicide Simon	- - - - -	114
Manhattan's Aluminum Venus	- - - - -	118
What's New for Your Home	- - - - -	128
Look a Typhoon in the Eye	- - - - -	133
They've Conquered a Cantankerous Crop	- - - - -	144
Boom in Tongue-Twisting Metals	- - - - -	150
When Oil Wells Run Dry	- - - - -	156
FBI Road Show	- - - - -	166

For the Craftsman

Kiddie Roller Coaster	- - - - -	174
Inexpensive Windows for Your Lake Cottage	- - - - -	184
Lay Your Own Linoleum—Part II	- - - - -	188
Motorizing an Old Reed Organ	- - - - -	201
Make Your Own Transformer—Part II	- - - - -	213
Combine Cutter Bar Operated Electrically	- - - - -	218
Bandsawed Castings	- - - - -	223
Radio-Television, Electronics	- - - - -	229
Clinic for Homemakers	- - - - -	240

Other items, and manufacturers of available products described, are listed on pages 10, 12 and 14

It's FORD for '50

**ITS NEW
SUPER-QUIET
100 h.p. V-8
WHISPERS QUALITY!**

New cast camshaft with special quieting ramp on cam lobes gives "hushed" valve operation.

New "super-fitted" pistons have steel struts in cam-ground skirts to control expansion, permit closer clearances. Result—longer life, extra quiet.

Perma-quiet valve assembly with straight-stem valve, one-piece valve guide and shot-peened valve spring requires no adjustment.



New 3-blade fan gives greater air flow with minimum noise.

New extra-narrow V-belts drive accessories quietly, efficiently.

New laminated composition timing gear meshes with metal gear on crankshaft for practically noiseless operation.

There's a *Ford* in your future
...with a future built in!

50

WAYS NEW



New rotary door latch, with nylon-plastic shock absorber in striker plate—doors close silently and securely.



Style Note—The rich, new Ford medallion on hood and rear deck marks America's "Fashion Car."



Ford's "Lifeguard" Body—now 13 ways stronger—additional heavier sealer in 41 areas for better sound and weather conditioning.



New automatic courtesy light goes on when either front door is opened—for comfort, convenience, safety.



New double-walled glove compartment door has piano-type hinge. Looks and works better.

Dozens of other new advancements—AND 35% easier acting King-Size Brakes . . . "Hydra-Coil" and "Para-Flex" Springs... "Mid Ship" Ride . . . "Deep Deck" Luggage Locker.



The one and only car with "Fashion Car" Styling—the one FINE car in the low-price field.

Take a **GOOD** look—Take a **GOOD** ride!
AT YOUR FORD DEALER'S

TO EVERY SPARK PLUG USER!

CAPT. EDDIE RICKENBACKER VOLUNTEERS THIS AMAZING STORY ABOUT **CHAMPIONS!**

President and General Manager of Eastern Air Lines
Credits **SAME SET OF DEPENDABLE CHAMPIONS** with
240,000 Miles of Air Travel!

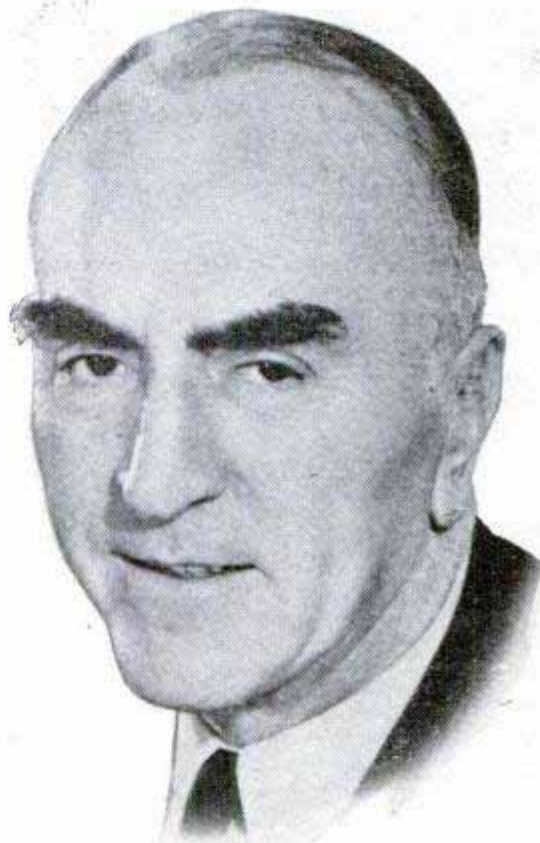

← **"THIS SPARK PLUG** is one of the set of thirty-six (36) which operated in the #4 engine #75737 in Eastern Air Lines' new type Lockheed Constellation #115A for 811 consecutive hours of trouble-free operation. This amount of operating time, which is most unusual, based on an average cruising speed of 300 MPH, is equal to approximately 243,000 miles. During this period the spark plug fired approximately sixty million times. This type of service from a spark plug is remarkable even when compared to the type of operation as recent as a year ago. During its life it was one of the spark plugs (none of which were changed) that helped carry myself and party on our Latin American Tour during August of 1949."

Eddie Rickenbacker

FOLLOW THE EXPERTS

Demand



All Champion Spark Plugs, regardless of type or purpose, are products of the same unequalled research engineering and manufacturing facilities. As a result, the same qualities of outstanding performance and dependability, so dramatically demonstrated above, are inherent in every Champion for every engine!

CHAMPION SPARK PLUG COMPANY, TOLEDO 1, OHIO

Listen to the CHAMPION ROLL CALL . . . Harry Wismer's fast sportscast every Friday night, over the ABC network

Protect your car

ROUND THE CLOCK

with PYROIL

● Every time you add Pyroil to your car, you're improving lubrication. No matter what kind of gas or oil you use, Pyroil gives oil the added property of clinging to cylinder walls and piston rings, protecting these vital parts against exposure to condensation, and metal-to-metal friction. Pyroil prevents clogging due to gummy deposits. Pyroil prevents damaging dry starts—because that constant clinging film of oil is a round-the-clock protector whether your car is rolling along or parked for the night.

Ask your gas station attendant to "add Pyroil"—and add miles of carefree driving.

Pyroil for Aircraft Engines

Use Aircraft Pyroil B for lubricating oil, Aircraft Pyroil A for gasoline.

GIVEN! An attractive Pyroil metal savings bank—takes coins up to 50c pieces. **MOTORISTS, it's yours for the asking—sent postage paid.**

Manufactured and Guaranteed by Pyroil Company, 101 Pyroil Bldg., La Crosse, Wisconsin

Canadian Distributors: Central Purchasing Agencies, Ltd., Toronto, Ontario



PYROIL COMPANY

101 Pyroil Bldg., La Crosse, Wisconsin

I want my car to last and run properly. Please tell me more about Pyroil and how it can accomplish this for me.

Name _____

Address _____

City or Town _____ State _____



in this corner.....

THE EDITORS



World's Largest "Pineapple"

WHEN the Hawaiian Pineapple Company announced plans for a huge water tank, the City Fathers cried out against any "eyesore" on the lovely Hawaiian sky line. The result, writes Dick Botts, author of the story on the mechanizing of the pineapple plantations (page 144) is shown here—the world's largest "pineapple."



* * *

Letter to the Editor

It has taken us just 32 years to learn that we played the part of Cupid, unwittingly, in a World War I romance of 1917. The story began at—well, let William E. Rohrer tell it himself, in the letter he wrote to the Editor:

November 1, 1949

"This is a letter I have been wanting to write to *Popular Mechanics Magazine* for the past 25 years. While serving in the U.S. Army at Camp McClellan, Anniston, Ala., in the summer of 1917, I visited the camp library and became interested in an issue of *Popular Mechanics*. While reading same I noticed the name of a girl in Jersey City, N. J. Also her address. The name was Frances Gude, 254 Sherman Ave., Jersey City. I felt the urge to write to her at the time just for the sake of correspondence. You know how it is in Army camps.

"I was 18 at the time and I later found out that she was 16. I continued writing to her during the period which I served overseas. When I returned from overseas our friendship became stronger, though I will admit I had some competition. It was not long before I had the situation well in hand.

"So on November 19, 1924, we were married.

"I want to take this opportunity to thank a wonderful magazine for introducing me to a wonderful girl who has been a wonderful wife for the past 25 years, along with three daughters. My wife has all of my

(Continued to page 8)

5 reasons why ACCOUNTANCY

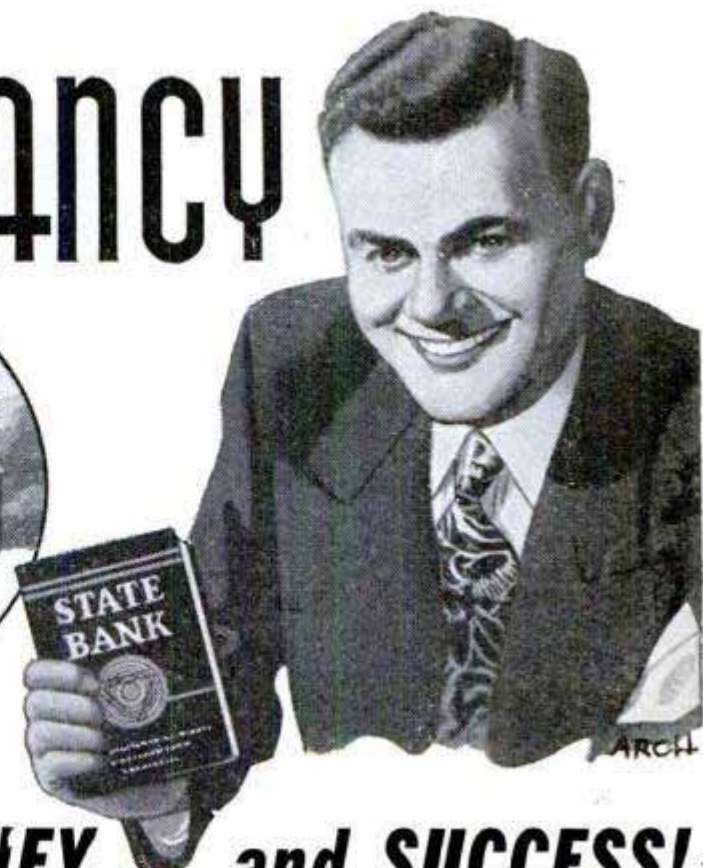
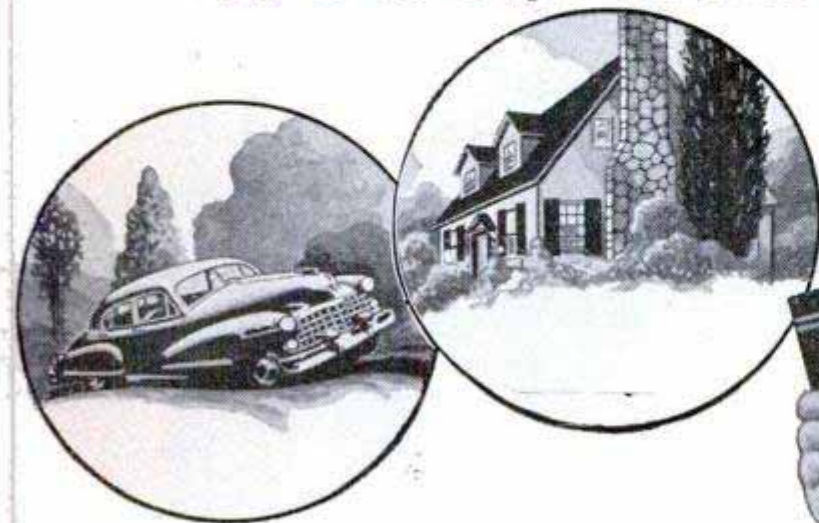

offers you MORE MONEY... and SUCCESS!

REASON #1. If you were an expert accountant right now, chances are you would find yourself among the highest-paid of all professional men and women. Even back in "depression years," surveys showed that accountants earned more on the average than men in other major professions.

REASON #2. The demand for accountants is great—everywhere. All businesses must have trained accountants to cope with ever-growing requirements. It's a profession offering wide opportunity—always—to the man who knows.

REASON #3. You can fit into any business, anywhere in the country—because accounting principles are universal. Think what this means in terms of security and independence!

REASON #4. Accountancy is open to all. Any man or woman of good intelligence, who enjoys figure work and is willing to follow LaSalle's systematic "problem method" plan, can rapidly qualify for a highly profitable, enjoyable

lifetime career... and he doesn't have to finish his training before beginning to "cash in."

REASON #5. Without losing a day from your present work, you can prepare in spare hours at home, at low cost, under LaSalle's step-by-step "Problem Method" of "learning by doing." This famous plan accounts for LaSalle's remarkable record of having trained nearly 10 per cent of all Certified Public Accountants in the U. S. . . . and of having put many thousands of others into high-paying careers.

Send today for LaSalle's interesting booklets, "Accountancy, the Profession That Pays," and "Success Reports." Learn about the five great fields of opportunity... and LaSalle's time-tested plan for helping men and women to rapid advancement, higher income, greater prestige and professional standing. The coupon below will bring these fact-filled booklets to you—without cost or obligation. Mail the coupon NOW.

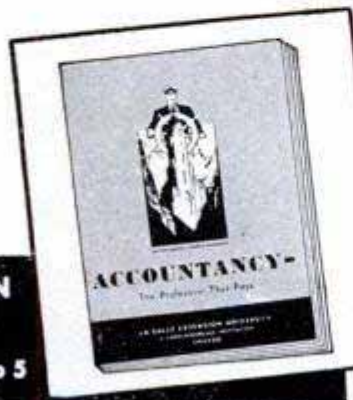

LaSalle Extension University A Correspondence Institution

Dept. 364-H, 417 S. Dearborn St., Chicago 5, Ill.

Please send me, free of all cost or obligation, your 48-page illustrated book "Accountancy, the Profession That Pays," and the booklet "Success Reports"—send also "Ten Years' Promotion in One"—a book which has helped many men.

Name.....Age.....
Address.....
City, Zone, State.....

**LASALLE EXTENSION
UNIVERSITY**
417 S. Dearborn St., Chicago 5

NEW LOW PRICE!

Get Giant Tube
Regularly 49¢

NOW ONLY

43¢

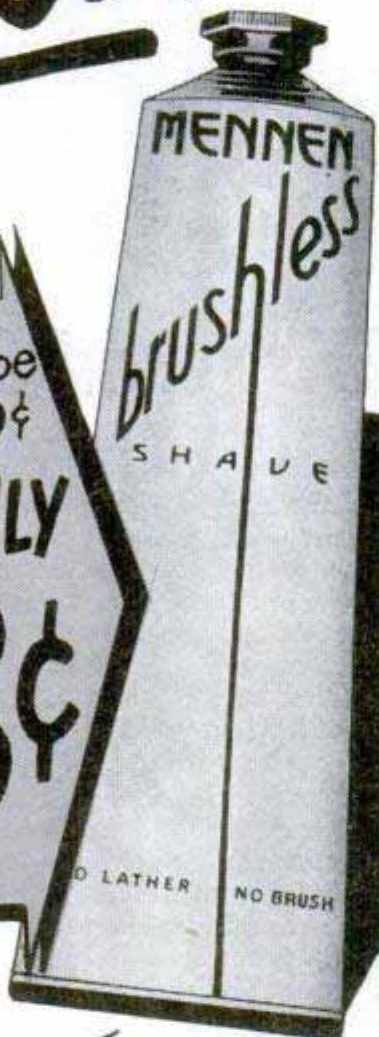

**MORE
DOCTORS**

Who Specialize in Care of The Skin

USE MENNEN BRUSHLESS

Than All Other Brands Combined

HELPS MAKE BEARDS UP TO 47% SOFTER!

(Continued from page 6)

letters to her; her letters to me at the time we met by mail were lost when a transport was sunk in the Atlantic.

"Wishing you many successful years . . . I remain ever thankful to you.

"William E. Rohrer
254 Sherman Ave.
Jersey City, N. J."

* * *

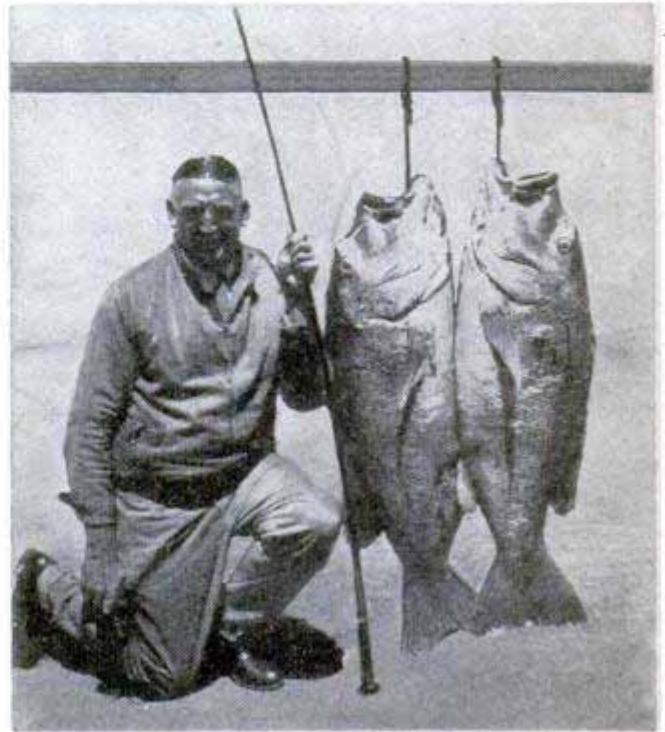

Letter to the Editor

Your recent articles on fishing lures (April, May, June 1949) were very interesting. I am an ardent fisherman and we do really get some big stuff here. I enjoy the "hints and tips" given in your magazine . . . may I give you one or two?

When fishing with bait which is liable to be nibbled off by small fish, try criss-crossing an elastic band around the bait when on the hook so the small fish cannot get it off.

Iron or steel exposed to sea water . . . rusts away quickly. The following is a mixture I put on some exposed iron work 36 years ago. It is still unblemished. The proportion is as follows: Coal tar, one gallon; paraffin oil, one pint; cement, one pound; mix well, heat and keep stirring; apply hot and your troubles are over.

I enclose a shot of two red steenbras caught by me on light tackle within 25 minutes of each other from a pier at Simons-town. One was 73 pounds, the other 70 pounds. In case you get mixed, I am the person holding the rod.

Col. W. McI. Robinson,
The Firs,
Simonstown, South Africa.

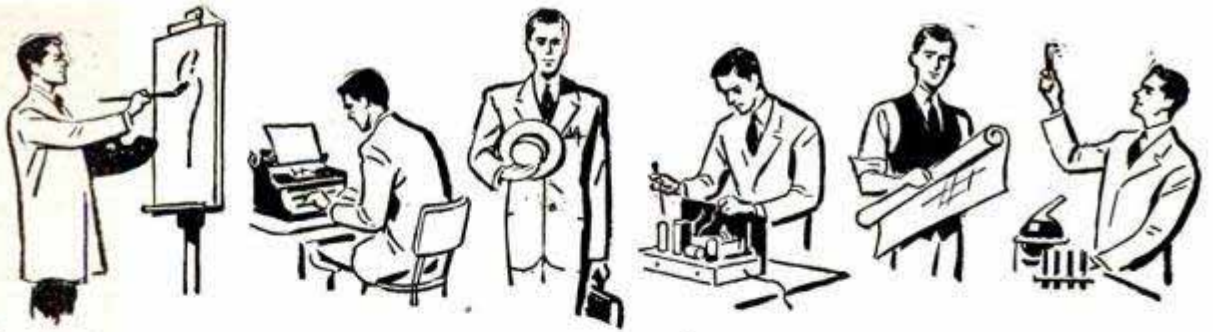

CASH IN on your HIDDEN TALENTS

Locked in your mind may be the germ of a valuable idea . . . an undeveloped aptitude . . . a hidden talent. And the key that can help unlock those capabilities of yours is *training*—sound, practical, down-to-earth training!

Helping men and women bring out the best that's in them has been the job of I. C. S. for more than 57 years. In every field of industry, you'll find leaders whose skills were developed through study with I. C. S.

They are the ones who sensed a latent ability within themselves—and who proceeded to do something about it. While others (equally gifted, perhaps) plodded along in routine jobs, they mastered I. C. S. Courses . . . qualified themselves for rich rewards.

You can develop your hidden talents the same way they did. Start *today* and be ready for tomorrow's opportunities. Here's the coupon to mail:

INTERNATIONAL CORRESPONDENCE SCHOOLS



BOX 5671-K, SCRANTON 9, PENNA.

Without cost or obligation, please send me full particulars about the course BEFORE which I have marked X:

- | | | | |
|---|---|--|---|
| <p>Air Conditioning and Plumbing Courses</p> <p><input type="checkbox"/> Air Conditioning
<input type="checkbox"/> Heating
<input type="checkbox"/> Refrigeration
<input type="checkbox"/> Plumbing
<input type="checkbox"/> Steam Fitting</p> <p>Chemical Courses</p> <p><input type="checkbox"/> Chemical Engineering
<input type="checkbox"/> Chemistry, Analytical
<input type="checkbox"/> Chemistry, Industrial
<input type="checkbox"/> Chemistry, Mfg. Iron & Steel
<input type="checkbox"/> Petroleum Refining
<input type="checkbox"/> Plastics
<input type="checkbox"/> Pulp and Paper Making</p> <p>Civil Engineering, Architectural and Mining Courses</p> <p><input type="checkbox"/> Architecture
<input type="checkbox"/> Architectural Drafting
<input type="checkbox"/> Bridge and Building Foreman
<input type="checkbox"/> Building Estimating
<input type="checkbox"/> Civil Engineering
<input type="checkbox"/> Coal Mining
<input type="checkbox"/> Contracting and Building
<input type="checkbox"/> Highway Engineering
<input type="checkbox"/> Lumber Dealer
<input type="checkbox"/> Reading Structural Blueprints
<input type="checkbox"/> Sanitary Engineering
<input type="checkbox"/> Structural Drafting</p> | <p><input type="checkbox"/> Structural Engineering
<input type="checkbox"/> Surveying and Mapping</p> <p>Communications Courses</p> <p><input type="checkbox"/> Electronics
<input type="checkbox"/> Practical Telephony
<input type="checkbox"/> Radio, General
<input type="checkbox"/> Radio Operating
<input type="checkbox"/> Radio Servicing
<input type="checkbox"/> Television
<input type="checkbox"/> Telegraph Engineering</p> <p>Electrical Courses</p> <p><input type="checkbox"/> Electrical Drafting
<input type="checkbox"/> Electrical Engineering
<input type="checkbox"/> Electric Light and Power
<input type="checkbox"/> Lighting Technician
<input type="checkbox"/> Practical Electrician</p> <p>Internal Combustion Engines Courses</p> <p><input type="checkbox"/> Auto Technician
<input type="checkbox"/> Diesel-Electric
<input type="checkbox"/> Diesel Engines
<input type="checkbox"/> Aviation
<input type="checkbox"/> Gas Engines</p> <p>Mechanical Courses</p> <p><input type="checkbox"/> Aeronautical Engineer's, Jr.
<input type="checkbox"/> Aircraft Drafting
<input type="checkbox"/> Forging
<input type="checkbox"/> Foundry Work
<input type="checkbox"/> Heat Treatment of Metals
<input type="checkbox"/> Industrial Engineering
<input type="checkbox"/> Industrial Instrumentation</p> | <p><input type="checkbox"/> Industrial Metallurgy
<input type="checkbox"/> Machine Shop
<input type="checkbox"/> Mechanical Engineering
<input type="checkbox"/> Mold-Loft Work
<input type="checkbox"/> Patternmaking—Wood, Metal
<input type="checkbox"/> Reading Shop Blueprints
<input type="checkbox"/> Sheet-Metal Drafting
<input type="checkbox"/> Sheet-Metal Worker
<input type="checkbox"/> Ship Drafting
<input type="checkbox"/> Tool Designing
<input type="checkbox"/> Toolmaking
<input type="checkbox"/> Welding Engineering
<input type="checkbox"/> Welding—Gas and Electric</p> <p>Railroad Courses</p> <p><input type="checkbox"/> Air Brake
<input type="checkbox"/> Diesel Locomotive
<input type="checkbox"/> Locomotive Engineer
<input type="checkbox"/> Locomotive Fireman
<input type="checkbox"/> Locomotive Machinist
<input type="checkbox"/> Railroad Section Foreman
<input type="checkbox"/> Steam-Diesel Loco. Eng.</p> <p>Stationary Eng'g Courses</p> <p><input type="checkbox"/> Boilermaking
<input type="checkbox"/> Combustion Engineering
<input type="checkbox"/> Engine Running
<input type="checkbox"/> Marine Engineering
<input type="checkbox"/> Power Plant Eng'g
<input type="checkbox"/> Mech. Drafting
<input type="checkbox"/> Ship Fitting
<input type="checkbox"/> Toolmaking
<input type="checkbox"/> Car Inspector
<input type="checkbox"/> Steam Engr.</p> | <p>Textile Courses</p> <p><input type="checkbox"/> Cotton Manufacturing
<input type="checkbox"/> Loom Fixing
<input type="checkbox"/> Textile Designing
<input type="checkbox"/> Rayon Weaving
<input type="checkbox"/> Woolen Manufacturing</p> <p>Business and Academic Courses</p> <p><input type="checkbox"/> Accounting
<input type="checkbox"/> App. Psychology
<input type="checkbox"/> Business Administration
<input type="checkbox"/> Bus. Correspondence
<input type="checkbox"/> Certified Public Accounting
<input type="checkbox"/> Commercial
<input type="checkbox"/> Cost Accounting
<input type="checkbox"/> Federal Tax
<input type="checkbox"/> Foremanship
<input type="checkbox"/> Good English
<input type="checkbox"/> Higher Mathematics
<input type="checkbox"/> Industrial Supervision
<input type="checkbox"/> Motor Traffic
<input type="checkbox"/> Retailing
<input type="checkbox"/> Salesmanship
<input type="checkbox"/> Sign Lettering
<input type="checkbox"/> Spanish
<input type="checkbox"/> Advertising
<input type="checkbox"/> Bookkeeping
<input type="checkbox"/> Bus. Law
<input type="checkbox"/> Commercial Art
<input type="checkbox"/> Commercial Art
<input type="checkbox"/> First Year College
<input type="checkbox"/> French
<input type="checkbox"/> High School
<input type="checkbox"/> Illustration
<input type="checkbox"/> Postal Civil Service
<input type="checkbox"/> Retail Bus. Management
<input type="checkbox"/> Secretarial
<input type="checkbox"/> Stenography
<input type="checkbox"/> Traffic Management</p> |
|---|---|--|---|

Name _____ Age _____ Home Address _____

City _____ State _____ Working Hours _____ A.M. to _____ P.M.

Present Position _____ Employed by _____

Length of Service in World War II _____ Enrollment under G.I. Bill approved for World War II Veterans. Special tuition rates to members of the Armed Forces. Canadian residents send coupon to International Correspondence Schools Canadian, Ltd., Montreal, Canada.

One Step AHEAD!



with
EMBRY-RIDDLE
Training

AIRCRAFT & ENGINE MECHANICS

An urgent need exists for properly trained A & E Mechanics throughout commercial aviation. Our C.A.A. approved school with a quarter-century of experience assures your quickest advancement. Embry-Riddle students learn fast with modern equipment...working on live aircraft in airline-size hangars.

ENGINEERING

Embry-Riddle's Design Engineering and Maintenance Course offers you A & E certification eligibility plus basic engineering knowledge necessary to fill such positions as Field Service, Project or Maintenance Engineer.

A & E COMBINED * WITH COMMERCIAL

Airmen with dual pilot-engineering ability are needed by aviation companies and operators. Embry-Riddle combination training offers you the most in your aviation career.

*Not available to veterans, but combined courses may be taken consecutively with proper justification.

COMMERCIAL PILOT

Embry-Riddle trained pilots benefit from our years of experience with 30,000 students...the best instructors, up-to-date aircraft, superb year-round flying weather... qualifications unexcelled anywhere. Instrument and instructor's ratings also available.

Never has there been such opportunity for properly trained men in commercial aviation. Put yourself one step ahead of the crowd. Start your career now at Embry-Riddle -- dormitories directly on the airport. For full information fill in the coupon below and mail today!



Embry-Riddle
International
SCHOOL OF AVIATION
MIAMI 30, FLORIDA

Dean of Enrollments - Dept. 99
Embry-Riddle School of Aviation
Miami 30, Florida

Please Print

NAME _____

ADDRESS _____

City _____

State _____ Age _____

I am interested in...

- A.&E. Mechanic
- Commercial Pilot
- Engineering
- A.&E. Combined with Commercial Pilot *
- Flying Mechanic *
- Drafting & Design

Check One Veteran Non-Veteran

TRAIN IN MIAMI--AIR CAPITAL OF THE WORLD

WHERE-TO-BUY-IT INDEX

Source of supply appears after items commercially available

AUTOMOTIVE

- Japan electrifies the gas buggy..... 88
- Rear-view mirror aids safe driving (Am-Ben Corp., 4140 W. Belmont, Chicago 41)..... 104
- Water vapor from radiator increases gasoline mileage (Humphries Vaporizer Corp., 1470 Chester Ave., Cleveland 14, Ohio)..... 105
- Fender skirt swings out on hinges (Rolls-Royce, Ltd., Derby, England)..... 141
- Carburetor jig (Keller Research Corp., 12727 Stout Ave., Detroit, Mich.)..... 141
- Trailer coupler applies brakes (Stromberg Hydraulic Brake & Coupling Co., Room 1424, 105 W. Adams St., Chicago)..... 160
- "Economy" car stops the show (Fiat Co., Turin, Italy)..... 161
- Hydraulic lifter speeds auto repairs (Weaver Mfg. Co., Springfield, Ill.)..... 164

HOUSE AND HOME

- Cold-drink dispenser fits any refrigerator (Trylyn Mfg. Co., 57 Post St., San Francisco 4, Calif.)..... 128
- Quart of cherries pitted in a minute (Smith Hoover Industries, 2340 Westledge Ave., Kalamazoo 35, Mich.)..... 128
- Space saver holds six garments on one hook (A. J. Burger Co., 236 W. 10th St., New York City 14)..... 128
- All-purpose ladder (Lincoln Mfg. Co., Inc., New Windsor, Md.)..... 128
- Fire guard emits whistle (Syracuse Fyr-Larm Co., Syracuse, N. Y.)..... 129
- Electric dishwasher (Applied Products, 324 N. La Brea Ave., Los Angeles 36, Calif.)..... 129
- Safety hook has spring-loaded guard (Vincent J. Lawler Co., 5518 Media Drive, Los Angeles 42, Calif.)..... 129
- De luxe opener (Pretorius Approved Products, 1115 S. Glendale Ave., Box 229, Glendale, Calif.)..... 129
- Vertical blinds made of translucent fabric (Sun Vertical Blind Co., 3313 Main St., Kansas City 2, Mo.)..... 129
- Invisible wallpaper coating (Manson Chemical Co., 8106 Merion Ave., Highland Park, Upper Darby, Pa.)..... 130
- Bottle sterilizer (Ekco Products Co., 1949 N. Cicero Ave., Chicago)..... 130
- Steel fireplace can be suspended from wall (Acorn Houses, Inc., 57 Brattle St., Cambridge 38, Mass.)..... 130
- Needle threader for any size needle (Cary Products Co., 934 N. Lancaster, Dallas 8, Tex.)..... 131
- Sink divider (Duo Sink, Box 206, Station F, Milwaukee 9, Wis.)..... 131
- Two-way slicer for vegetables (S. A. Products, 1891 1/2 Greenfield Ave., Los Angeles 25, Calif.)..... 131
- Splatter stopper fits around the skillet (Ruth N. Meyer, Box 1176, Beverly Hills, Calif.)..... 131
- Magnetic rack has bobby-pin opener (Howard Industries, Inc., 15 Roetzer St., Buffalo 11, N. Y.)..... 131
- Tray clamps to arm of chair (Alomar Molded Products, Inc., 1163 E. Hyde Park Blvd., Inglewood, Calif.)..... 131
- One-wheel garden tractor (George Tractor Division, Community Industries Association, Sullivan, Ill.)..... 142
- Weed cutter uses razor blades (Lowe Engineering Co., Lincoln Park, N. J.)..... 142
- Heat circulator can be inserted in fireplace (Fireplace Insert Circulator Co., 625 Williams St., Lansing, Mich.)..... 170

INDUSTRY

- Rubber "bath" toughens leather..... 87
- Bath polishes metal (The Globe Chemical Co., Inc., Murray Road and Big 4 Railroad, Cincinnati 17, Ohio)..... 91
- Plastic piping drains salt water from oil deposits..... 101
- Wire stone saw cuts granite wafer thin (L. M. Gilbert Co., 430 Chestnut St., Philadelphia 6, Pa.)..... 112
- Wax from waste bark..... 117
- Model of river helps build dam..... 122
- Push-button icer for trains..... 126
- Typewriter keyboard on type-setting machine (Kellogg Switchboard & Supply Co., 6650 S. Cicero Ave., Chicago)..... 140
- Vacuum "churn" for oils may improve quality..... 142
- Folding hand truck will carry 700-pound load (Business Equipment Specialists, 19 W. 44th St., New York City 18)..... 143
- No-contact printing system (W. C. Huebner Laboratories, 102 Mamaroneck Ave., Mamaroneck, N. Y.)..... 143
- Mine-trolley phone system (Farmers Engineering & Mfg. Co., 549 Brushston Ave., Pittsburgh 21, Pa.)..... 161
- Vibrating meat cutter..... 171
- The packers also sell meat..... 172

NOVELTIES

- Discarded nylon hose make artificial flowers..... 86
- Bottle-cap vases..... 149
- Danish electric motor as small as a match head..... 164

OUTDOOR RECREATION

- Pocket gauge checks golf-ball size (Golf-Aid Products, Newton, Bucks County, Pa.)..... 111
- Canine caddy..... 113
- Knapsack bike..... 117
- Cartridge carrier (Moore-Warden Products, 2222 Mesita Drive, Wichita, Kans.)..... 122
- "Boathouse on wheels" built beneath trailer..... 123
- Back-yard beach..... 132

PHOTOGRAPHY

- "Paintbrush" photo kit (Brush-A-Photo Co., Metropolitan Life Bldg., Minneapolis, Minn.)..... 90
- Camera wagon for photographer..... 91
- Artificial sapphire lens for movie camera resists scratches..... 123
- Gear-driven tripod (Mr. Ashley P. Hartman, 7515 Clinton St., Los Angeles 36, Calif.)..... 127

(Continued to page 12)

WHAT Every AUTO MECHANIC Wants to Know

A motor vehicle is a machine of many parts, each part designed and constructed for its own special function. All good mechanics, like good doctors, should know the working theory and operation of each part and understand what causes trouble and how to remedy it.

LET AUDELS AUTO GUIDE SOLVE YOUR PROBLEMS

Every auto mechanic, helper, serviceman and operator can use AUDELS AUTO GUIDE. The information it gives saves time, money and worry. Highly endorsed by all users. It presents the whole subject of auto mechanics from A to Z in plain language and simple terms.

This Big Practical Book gives full information with working diagrams covering the principles, construction, ignition, service and repair of modern cars, trucks and buses.

A complete Guide of 1800 pages, with over 1500 illustrations showing inside views of the working parts, with instructions for service jobs. Diesel engines, Fluid and Hydra-matic drives fully explained.

IT PAYS TO KNOW HOW TO

How to fit pistons—How to locate engine knocks—How to fit connecting rod bearings—How to service main bearings—How to re-condition valves—How to time valves—How to adjust fan belts—How to adjust carburetors & chokes—How to rebuild a clutch—How to service automatic transmissions—How to service brakes—How to adjust steering gear—How to cope with ignition troubles—How to service distributors—How to time ignition—How to "tune up" an engine.

INFORMATION IN A HANDY FORM

73 INTERESTING CHAPTERS—Read this partial list of subjects on which practical information is fully given for quick reference under the headings as shown below. Ready Reference Index.

All Parts of an Automobile—Automotive Physics—The Gas Engine—Gas Engine Principles—Multi-Cylinder Engines—Horse Power—Automobile Engines—Stationary Parts—Moving Parts—Pistons—Piston Rings—Connecting Rods—Crank Shafts—Valves—Valve Gear—Cams and Cam Action—Valve Timing—Cooling Systems—Fuel Feed Systems—Dual Fuel Feed—Mixture—Carburetors—Carburetor Service—Automatic Choke—Super-Chargers—Transmissions—Special Transmissions—Fluid and Hydra-matic Drives—Clutches—Universals and Propeller Shafts

A Ready Reference

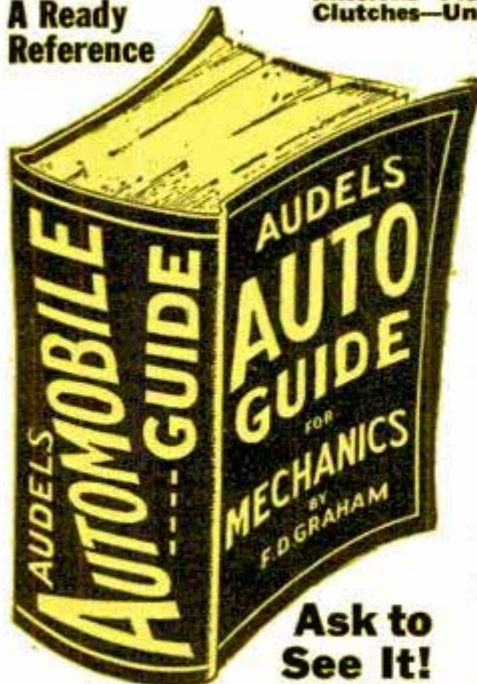

Ask to See It!

—The Differential—Rear Axles—Rear and Front Suspension—Running Gear—Brakes—Wheel Alignment—Knee Action—Steering Gear—Tires—Lubricants and Lubrication—Automotive Electricity—Ignition Systems—Magneto Ignition—Spark Plugs—Ignition Coils—Distributors—Automatic Spark Control—Ignition Timing—Generators—Starters—Generator and Starter Testing—Lighting Systems—Storage Batteries—Charging and Testing—Diesel Engines and Trouble Shooting.

7 DAYS' FREE TRIAL
TO GET THIS ASSISTANCE FOR YOURSELF SIMPLY FILL IN AND MAIL COUPON TODAY.

\$4 COMPLETE PAY \$1 A ONLY 1 MO.



Sent on 7 Days Approval

Step up your own skill with the facts and figures of your trade. Audels Mechanics Guides contain Practical Inside Trade Information in a handy form. Fully illustrated and Easy to Understand. Highly Endorsed. Check the book you want for 7 DAYS FREE EXAMINATION. Send No Money. Nothing to pay postman.

---CUT HERE--- MAIL ORDER

AUDEL, Publishers, 49 W. 23 St., NEW YORK 10, N. Y.

Please send me postpaid for FREE EXAMINATION books marked X below. If I decide to keep them I agree to mail \$1 in 7 Days on each book or set ordered and further mail \$1 monthly on each book or set until I have paid price, otherwise I will return them.

- AUTO GUIDE**, 1800 Pages . . . \$4
- DIESEL ENGINE MANUAL, 400 Pages . . . 2
- WELDERS GUIDE, 400 Pages . . . 1
- MACHINISTS Handy Book, 1600 Pages . . . 4
- POWER PLANT ENGINEERS Guide, 1500 Pages. 4
- ENGINEERS & FIREMANS EXAMS, 528 Pages. 1
- PUMPS, Hydraulics & Air Compressors, 1658 Pgs. 4
- MARINE ENGINEERS Handy Book, 1280 Pages 4
- ENGINEERS & Mechanics Guides (8 Book Set). 12
- Answers on Practical ENGINEERING, 254 Pages 1
- ELECTRIC WIRING DIAGRAMS, 210 Pages . . 1
- ELECTRICIANS EXAMINATIONS, 250 Pages. 1
- ELECTRICAL DICTIONARY, 9000 Terms . . . 2
- ELECTRIC MOTOR GUIDE, 1000 Pages . . . 4
- HANDY BOOK OF ELECTRICITY, 1440 Pages 4
- ELECTRICAL POWER CALCULATIONS, 425 Pgs. 2
- RADIOMANS GUIDE, 914 Pages 4
- ELECTRONIC DEVICES, 216 Pages 2
- ELECTRIC LIBRARY, 7000 Pages (12 Book Set). 18
- Vols. I, II, III, IV, V, VI, VII, VIII, IX, X, XI, XII \$1.50 Ea. 1
- OIL BURNER GUIDE, 384 Pages 4
- HOUSE HEATING GUIDE, 1000 Pages 4
- CARPENTERS & Builders Guides (4 Book Set). 6
- PLUMBERS & Steamfitters Guides (4 Book Set). 6
- MASONS & Builders Guides (4 Book Set) . . 6
- BLUE PRINT READING, 416 Pages 2
- PAINTERS & DECORATORS MANUAL, 450 Pgs. 2
- GARDENERS & GROWERS Guides (4 Book Set). 6
- REFRIGERATION & Air Conditioning, 1280 Pgs. 4
- SHEET METAL WORKERS Handy Book, 388 Pgs. 1
- SHEET METAL PATTERN LAYOUTS, 1100 Pgs. 4
- AIRCRAFT WORKER, 240 Pages 1
- MECHANICAL DRAWING GUIDE, 160 Pages. 1
- MECHANICAL DRAWING & DESIGN, 480 Pgs. 2
- MATHEMATICS & CALCULATIONS, 700 Pgs.. 2
- MECHANICAL Dictionary, 968 Pages 4
- MILLWRIGHTS & Mechanics Guide, 1200 Pgs. 4

Name _____
Address _____
Occupation _____
Employed by _____

AUDEL, Publishers, 49 W. 23 St., New York 10, N. Y.

EXTRA!

a different name for your old friends:

PROTO TOOLS

-formerly-

PLOMB TOOLS

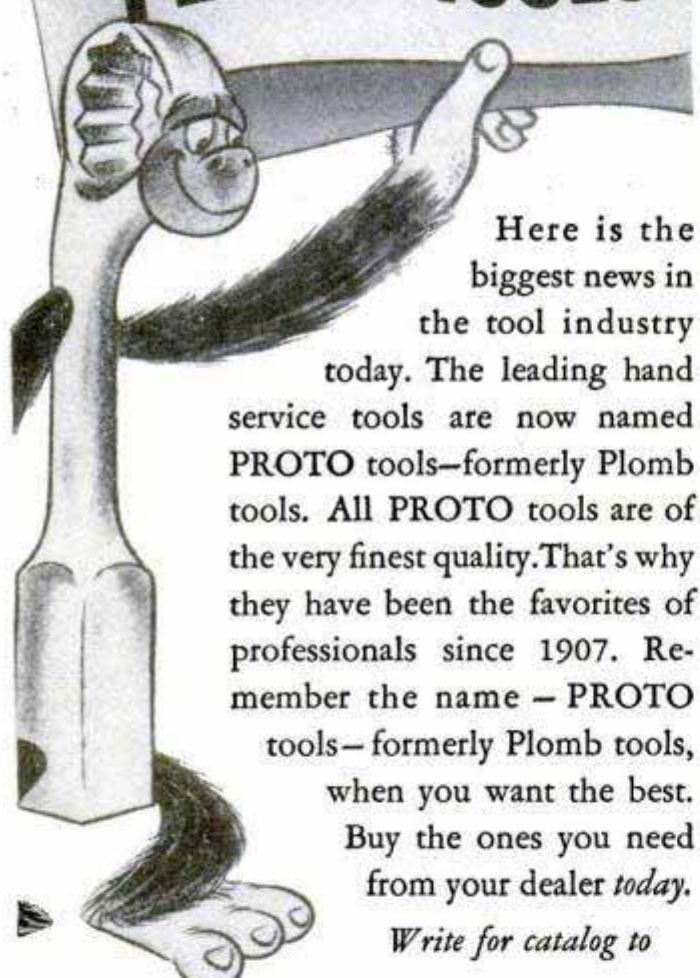

Here is the biggest news in the tool industry today. The leading hand service tools are now named PROTO tools—formerly Plomb tools. All PROTO tools are of the very finest quality. That's why they have been the favorites of professionals since 1907. Remember the name — PROTO tools—formerly Plomb tools, when you want the best. Buy the ones you need from your dealer today.

Write for catalog to

PLOMB TOOL COMPANY
2255M Santa Fe Ave., Los Angeles 54, Calif.

4985

PROTO
Professional Quality
TOOLS
LOS ANGELES

(Continued from page 10)

Twist of the wrist loads and cocks camera (Burke & James, Inc., 321 S. Wabash Ave., Chicago).....141
Meter tests photoflash batteries (Sterling Mfg. Co., 9205 Detroit Ave., Cleveland, Ohio).....141
Photo meter converts for color (Harrison & Harrison, 6363 Santa Monica Blvd., Los Angeles 38, Calif.).....164
Automatic slide changer (Three Dimension Co., 4555 W. Addison St., Chicago).....165
Camera photographs temperature of objects.....170

TOOLS

Super scissors (Super Manufacturing Corp., 4538 W. Fillmore, Chicago).....86
Nailing machine speeds building (Azor Products Co., 683 Santa Fe Ave., Los Angeles 21, Calif.).....96
Saw cuts its own starting hole (The Forsberg Mfg. Co. Seaview Ave., Bridgeport, Conn.).....96
File handle makes pressure easy (Riverview Foundry Co., 1148 Devol St., Fall River, Mass.).....111
Steel folding rule takes punishment (Durall Tool Corp., 117 Woodworth Ave., Yonkers 2, N. Y.).....127
Bricklaying jig (Hodgson-Sommers, Inc., 732 Monroe St., Montgomery, Ala.).....127
Jack-of-all-trades (Coffing Hoist Co., Danville, Ill.).....132
Pneumatic pruning tool (Miller-Robinson Co., 7007 Avalon Blvd., Los Angeles, Calif.).....143
Hydraulic jack has separate pump (The Duff-Norton Mfg. Co., Pittsburgh 30, Pa.).....149
Electric drive for small lathe has stepless speed control (General Electric Co., Schenectady 5, N. Y.).....155
Mechanical pencil "yardstick" (Roller Rule Sales Co., 5601 Valley Blvd., Los Angeles 32, Calif.).....155
Gun welds aluminum four times faster (Air Reduction Sales Co., 60 E. 42nd St., New York City 17).....155
Machine drives nails like stapler (The Heller Co., 2135 Superior Ave., N.E., Cleveland 14, Ohio).....161
Six-purpose tool (Laster Export-Import Co., 7 E. 42nd St., New York City).....165
Center-raising attachment increases lathe capacity (The Production Machine Tool Co., 629 E. Pearl St., Cincinnati, Ohio).....278

TRAFFIC AND TRANSPORTATION

Japanese cycle truck.....86
Tough plastic disks for street markers (Beaman Plastic Products Co., 2315 W. First, Portland, Ore.).....90
"Juke box" caller announces trains (Clifford Herring Sound Equipment Co., Fort Worth, Tex.).....104
Traffic through tunnel controls ventilation blowers.....112
Non-jump highway divider.....140

MISCELLANEOUS

One-shot capsules fill lighters (The Tyesules Corp., 1044 Madison Ave., New York City).....87
Adjustable stand focuses light for many uses (Bretford Mfg., Inc., 9351 Chestnut St., Franklin Park, Ill.).....87
Elevator on wheels loads bus luggage.....90
Private cable car.....96
"Three speed" X-ray unit gives varied treatments.....101
Sea-going eggbeaters.....102
Acrobatic bomber (English Electric Co., Ltd., Queen's ho., Kingsway, London W.C. 2, England).....105
Odorless paint.....113
Cyclist propels 24-foot balloon through sky.....113
Mapping a molecule.....124
Portable respirator works by bellows.....149
Two-language cards help students learn foreign tongue (Visual Education Association, Inc., 230 W. 5th St., Dayton 2, Ohio).....160
Counting machine is "sleuth" (Pitney-Bowes, Inc., Stamford, Conn.).....160
Jewels from mastodon tusks.....162
Chemical kills brush (The Dow Chemical Co., Midland, Mich.).....165
Sectional masts of lightweight plywood tubing (Special Purpose Products Co., 155 Perry St., New York City 14).....171
Blind musicians' helper.....171
Chemical reduces danger of lethal radiations.....278

Craftsman and Shop Notes Index

FARM

Down pipe on cesspool drain eliminates clogging.....182
Chemical "ferret" for deep holes.....182
Rotating tether prevents tangling.....187
Paper cup aids transplanting.....187
Special watering-trough brooms facilitate cleaning.....216
Spring-cushioned drawbar.....222
Mole trap weighted with spikes.....222
Creosote dispenser for cornfield.....222
Wire guard excludes predators from poultry runs.....228
Stair-step stile for farm fence.....228

HOUSE AND HOME

Window boxes detached quickly if hung with shelf brackets.....182
Woolens stored in sandwich bag.....182
Improvised door bumper.....182
Handy condiment compartment installed in sink cabinet.....187
Lightweight cupboard tongs of duralumin reach high shelves in cabinet kitchen.....194
Saplings supported with posts.....196
Folding tablecloth for storage.....196
Flowerpot saucers made from aluminum foil.....198
Cellulose tape removes lint from clothing.....198
Chilling helps popcorn to pop.....198
Cellulose tape reinforces shelf paper.....199
Cleaning grit from teeth of fingernail file.....199
Hanger crimped for sleeveless dresses.....199

(Continued to page 14)

You Practice COMMUNICATIONS

I Send You Parts To Build This Equipment

As part of my new Communications Course I send you parts to build your own transmitter. Conduct actual procedure demanded of Broadcast Station Operators, make experiments, learn how to put a transmitter on the air.

NEW



You Practice Radio SERVICING

On This Modern Radio You Build With Parts I Send

As part of my Servicing Course, I send you the speaker, tubes, chassis, transformer, loop antenna. EVERYTHING you need to build this modern Radio Receiver that brings in local and distant stations. You use it to conduct many tests and experiments.



BE A RADIO-TELEVISION TECHNICIAN

Learn Servicing or Communications by Practicing in Spare Time with MANY KITS OF PARTS I Send

YOU BUILD this tester as part of my Servicing Course. It soon helps you earn \$5, \$10 and more a week EXTRA MONEY fixing neighbors' Radios in spare time while learning.



YOU BUILD this Power Pack as part of my new Communications Course. Use it to conduct fascinating experiments with frequency amplifiers, multipliers, buffer stages, etc.



YOU BUILD this Superheterodyne Receiver Circuit and conduct Frequency Modulation experiments and many other tests as part of my Servicing Course.



J. E. SMITH, Pres. National Radio Institute

Do you want a good-pay job in the fast growing RADIO-TELEVISION Industry? Or do you want to have your own money-making Radio-Television Shop? Here is your opportunity. I've trained hundreds of men to be successful Technicians . . . MEN WITH NO PREVIOUS EXPERIENCE. My tested and proved train-at-home method makes learning easy. You learn Radio-Television principles from my illustrated lessons. You get practical experience building, testing and experimenting with parts I send. All equipment yours to keep.

Make Extra Money In Spare Time

The day you enroll, I start sending you SPECIAL BOOKLETS that show you how to make \$5, \$10 a week or more EXTRA MONEY fixing neighbors' Radios in spare time while learning. From here, it's a short step to your own shop or a good-pay Radio-Television servicing job. Or be a licensed Radio-Television Operator or Technician. In 1945, there were 943 Radio Stations. Today about 2700 are on the air! RESULT—THOUSANDS OF QUALIFIED MEN STEPPED INTO GOOD JOBS. Another example—only 19 Television stations were on the air in 1947. Today, more than fifty. Within a few months, 150, say the experts—and 1000 within three years. Then add developments in FM, Two Way Radio, Police, Marine, Aviation, Microwave Relay Radio. Think what this means! New jobs, more jobs for qualified men.

Mail Coupon For Books Free

Act now! Send for my FREE DOUBLE OFFER. Coupon entitles you to actual lesson, "GETTING ACQUAINTED WITH RECEIVER SERVICING." It shows how many pictures and diagrams are used to make learning at home easier, practical. You also get my 64-page book, "HOW TO BE A SUCCESS IN RADIO-TELEVISION." It tells more about YOUR opportunities . . . details of my Course . . . what my graduates are doing and earning . . . how quickly you can be on your way to good pay, success, a bright future. Send coupon in envelope or paste on penny postal. J. E. SMITH, President, Dept. OCP, National Radio Institute, Pioneer Home Study Radio School, Washington 9, D. C.

YOU BUILD this Signal Generator as part of my Servicing Course for more valuable experience. It provides amplitude-modulated signals for many interesting tests and experiments.



VETERANS

GET THIS TRAINING WITHOUT COST UNDER G. I. BILL MAIL COUPON

YOU BUILD this Wavemeter as part of my new Communications Course. Use it with Oscillator you also build that furnishes basic power to transmitter and determines transmitter frequency.



I TRAINED THESE MEN AT HOME

"My first job was operator with KDLR, obtained for me by your Graduate Service Dept. Am now Chief Engineer, WQOX." —T. S. Norton, Hamilton, O.

"N. R. I. has been my stepping stone from a few hundred dollars to over \$4,000 a year as a Radio Engineer." —A. E. Michaels, Trenton, Georgia.

"I received my 2nd Class Radiotelegraph License and worked on ships. Now with Station WEAN as control operator." —R. Arnold, Rumford, R. I.

"Two months after starting, took a part-time job. Now working full time. Make \$200 a month plus commission on servicing." —L. McNeil, Rockdale, Texas.

"Today I am considered an expert Radio-Television Technician. Have 4 employees. Radiorepair business has doubled." —F. G. Miller, Toledo, Ohio.

"While learning, made \$5, \$10 a week in spare time. Now have spare-time shop at home and earn up to \$25 a week." —Leander Arnold, Pontiac, Michigan.

MAIL COUPON! FIND OUT ABOUT THIS TESTED WAY TO BETTER PAY

Good for Both—FREE

MR. J. E. SMITH, President, Dept. OCP National Radio Institute, Washington 9, D. C.

Mail me Sample Lesson and 64-page Book about How to Win Success in Radio-Television —both FREE. (No Salesman will call. Please write plainly.)

Name.....Age.....

Address.....

City.....Zone.....State.....

Check if Veteran Approved for training under G. I. Bill



PLS!

HERE IT IS:

YOUR BOOK

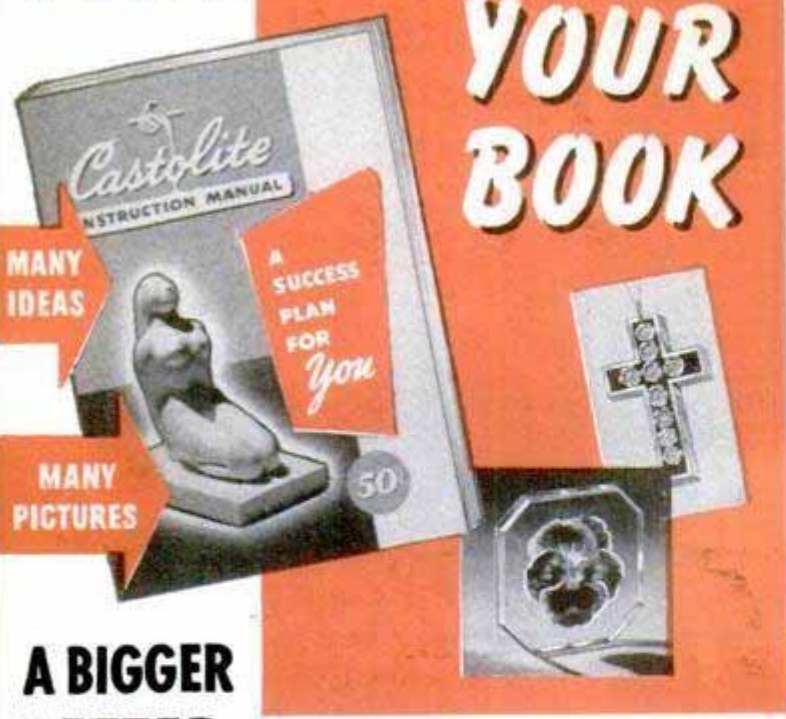

A BIGGER BETTER PLASTIC MANUAL

Combined with NEW SUCCESS PLAN!

Great news at last for people who want to make all kinds of fine things with Plastic! Now, just released, is a great new Plastic Book—bigger, better, more complete than anything ever before published in this field. This Book not only tells you how to make valuable articles at home, but also gives proved Success Methods for having a business of your own. Positively new—startling—different—100% Practical—for those who want to make things—and make money, besides.

GREAT NEW MONEY-MAKING IDEAS



New, Modern developments are explained. Think of producing gorgeous baby shoe mementoes with the very latest "plastizing" process, instead of old, slow, costly electroplating methods. Just treat shoes with Castolite, new, magic liquid plastic, and get any desired color-finish. Also make your own handsome mountings, any shape, any color. Or create striking plastic profile silhouette wall plaques of children, family, friends. Have the time of your life, also get the extra money you've been wanting.

NEW LIQUID PLASTIC

With new Liquid Castolite it's easy to make swell things like costume jewelry, fancy buttons, lamp bases, candle holders, coasters, wall plaques, desk sets, clock cases, other valuable articles.

EASY TO START

Begin making things very first day. But first get this handsome book giving complete instructions and Success Secrets. Tells what you can do; what others are doing in this fascinating field. Send 25c today for your copy of "A Success Plan for You".

(Continued from page 12)

- Electric-mixer beaters washed quickly.....199
- Garbage containers hidden on inside of sink doors.....199
- Handle of toothbrush used for threading drawstring top.....199
- Salt removes fresh ink stains.....200
- Umbrella rack for baseboard.....203
- Retractable clothesline for low basement stored against ceiling joists.....205

NOVELTIES

- Lamp costumer for children.....197
- Novelties lettered with noodles.....200
- Chinese-modern "fire screen".....204
- Novel night light with convenient handle is switched on automatically when lifted.....205
- Candid recordings.....206

OFFICE, SHOP AND STORE

- Concrete service-entrance ramp poured on hollow-tile fill....216
- Pins in hinged edge of door insure against intruders.....216
- Cleaning rubber stamps.....222
- Inserting hectograph ribbon without soiling hands.....228

PAINTS AND BRUSHES

- Sample checks matching paint.....187
- Brush container of clear plastic permits even drying.....203
- Slits in sponge-rubber strip hold artists' brushes.....228

PHOTOGRAPHY

- On-the-spot darkroom.....209
- Removing lint from matte prints.....210
- Curled prints pressed flat with household iron.....210
- Baking soda neutralizes hypo in developing tank.....210
- Paper clips furnish hangers for drying negatives.....210
- Wax paper seals developer bottle.....210
- Shadowless reflector.....211
- Auxiliary right-angle viewer makes candid shots easy.....212
- Template aids trimming photos.....212
- Testing condition of hypo solution.....212
- Agitation improves negatives.....212
- Ferrotypes tins cleaned thoroughly with soapless detergent.....212

SEWING

- Several needles previously strung on thread save time when sewing.....194
- Adhesive tape facilitates sewing straight seam.....198
- Thimble aids threading needle.....200

TOOLS

- Bench jig aids sanding end grain.....196
- Cutting glass jars and bottles.....196
- Poultry wire forms tool rack.....208
- Screwdriver made from knife.....208
- Clamping jig for butt welding provided by horseshoe.....216
- Addition of special anvil adapts micrometer for measuring tapered parts.....217
- Bending thin-walled conduit.....222
- Jig aids machining flats on taper.....228

WOODWORKING

- Carved wall vase.....183
- Twin-ball letter holder.....193
- Lead screw draws special expansive bit through cross-grained wood.....194
- Curio cabinet.....195

MISCELLANEOUS

- Combination noted on tape label when storing unused padlock.....187
- Repairing worn shock arms.....196
- Teaspoon forms perfect mold for casting fishing sinkers.....200
- Striped luggage identified quickly.....200
- Coloring Easter eggs facilitated by ring-type dipper.....208
- Lengthening rivets for reuse.....208
- Ribbon sewed to handbag holds door keys.....208
- Connecting rubber tubing.....216
- Relay automatically turns on fog lights when fuse blows in headlight circuit.....217

Radio-Television, Electronics

- Helpful hints for 1950 (Screen enlarges TV picture, Plastics Division of Willson Camera Co., Philadelphia, Pa.; high-fidelity amplifier, Allied Radio Corp., 822 W. Jackson Blvd., Chicago; combination hearing aid and radio receiver, John Bell & Croyden, Acoustic Works, Oxford, England).....229
- 1950 "Little Giant" is a complete FM receiver.....230
- Power units for phone transmitter.....232

IMPORTANT NOTICE—It is the intention of this magazine to provide its readers with information regarding the latest developments in the mechanical arts. We take no responsibility as to whether the disclosures contained in our articles are covered by patents and advise readers to investigate this subject before making, using, or selling any of the products, machines, or processes described in order to avoid possible liability for patent infringements.

DEALERS

Financially responsible dealers have excellent opportunity handling Castolite products. Send for this new Manual and complete

The CASTOLITE Co.
Dept. C-1
WOODSTOCK, ILL.

INVENTORS

Learn how to protect your invention. The U. S. Patent Laws provide that any new and useful art, machine, article of manufacture, or composition of matter, or any new and useful improvement thereof, may be patented if the act of invention is involved. Therefore, every inventor with a valuable invention should take advantage of the Patent Laws and proceed for patent protection in order to safeguard his rights.

A patent gives the inventor the exclusive right to prevent others from making, using, or selling the invention claimed in the patent for a period of seventeen years.

The Patent Laws were enacted for the benefit of the inventor to give him protection for the features of his invention which are patentable. These features must be properly and concisely set forth and claimed in a formal application for patent, in order to comply with the requirements of the Patent Laws. For that reason, unless the inventor is familiar with patent matters, he should engage a competent registered patent attorney or agent to represent him. We are registered to practice before the U. S. Patent Office and are prepared to serve you in the handling of your patent matters.

A specially prepared booklet entitled "Patent Guide for the Inventor", containing detailed information with respect to patent protection and procedure, together with a "Record of Invention" form will be promptly forwarded to you without obligation upon request.

CLARENCE A. O'BRIEN & HARVEY JACOBSON

Registered Patent Attorneys

O 1 - C DISTRICT NATIONAL BUILDING • WASHINGTON 5, D. C.

Patents • • • Trademarks • • • Copyrights

YOU Need My PRACTICAL Training to Make Money in

TELEVISION- RADIO and ELECTRONICS!



I'll Send You
8 BIG KITS of
Radio Parts and Equipment

Learn at
HOME
IN YOUR
SPARE TIME

Now is the Time to Get Into This Fast
Growing Industry—Prepare for a Fine
Paying Job or Your Own Business!

I have trained hundreds of men to become technicians—and I'm ready to do the same for you. Whether your goal is a fine paying job in one of Radio's many branches—or a successful Radio and Television business of your own—you need the kind of training I offer! My training is practical and down to earth. YOU NEED NO PREVIOUS EXPERIENCE. I start you with basic fundamentals and give you plenty of practical shop-bench training with many kits of parts I send you. This is the training that sticks with you and makes money for you on the job!

GET PAID FOR SPARE TIME WHILE LEARNING

Soon after you start training I send you my famous BUSINESS BUILDERS that show you how to make money in spare time doing interesting Radio jobs. I send you 8 big kits of Radio parts and equipment and help you build step-by-step a powerful 6-tube superhet radio, a 16-range test meter, plus other mighty useful equipment for Radio and Television servicing. You will perform over 175 fascinating experiments while training. You will learn about Television—so that you will be qualified to step into this fast growing, profitable field. I also send you many valuable service manuals, diagrams, and my book telling exactly how to set up your own Television and Radio shop. Clip and mail the coupon below for my two big FREE Radio books. I employ no salesmen—and nobody will call on you

HAVE A BUSINESS OF YOUR OWN

A profitable Radio and Television Service Shop may be started with little capital. I will show you how to get started. At left is pictured one of my graduates, Mr. Merrit C. Sperry, Fairmont, Minn. in his own shop.

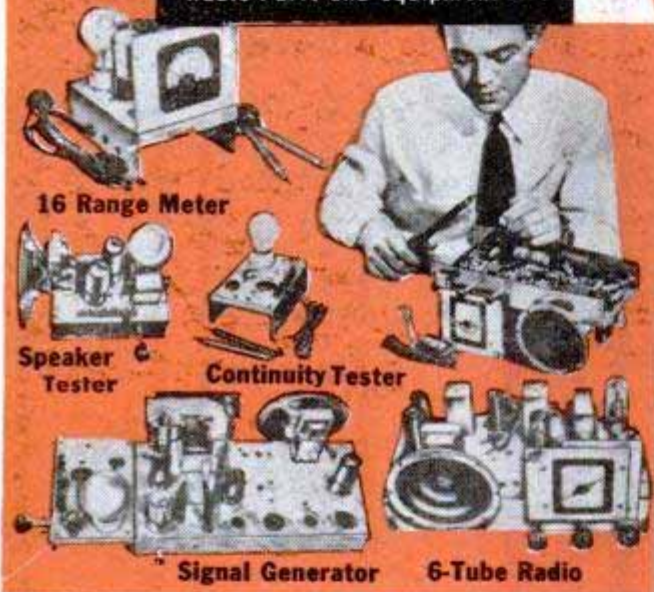

All Kits Are YOURS TO KEEP

Each of the hundreds of Radio parts and other items I send my students is theirs "for keeps." You may use this equipment in your Radio and Television service work and save many dollars by not having to buy expensive "ready-made" test equipment.



CALVIN SKINNER of New Orleans, La. tells us he makes \$5 to \$10 in spare time repairing radios. He is now also working with a Television set.



LOREN D. SAUCIER of Coloma, Mich. reports that my training has made it possible for him to repair large numbers of Radio and Television sets.

Radio and Television Industry Booming

You couldn't pick a better time to get into Radio-Television and Electronics. New Television stations are going off the air to serve every major city—hundreds of new AM and FM Radio broadcasting stations are also on the air. All this creates new and bigger opportunities for the trained man who knows Radio-Television and Electronics

VETERANS

THIS
TRAINING
AVAILABLE TO
YOU UNDER
THE G.I. BILL

RUSH COUPON Today!

SPRAYBERRY ACADEMY of RADIO, Dept. 10-G
111 North Canal Street,
Chicago 6, Illinois

Please rush my FREE copies of "How To Make Money In Radio-Television and Electronics" and "How To Read Radio Diagrams and Symbols."

Name.....Age.....

Address.....

City.....State.....

() Check here if you are a Veteran

My Training
Includes ...
**Television,
FM (Frequency
Modulation),
Public
Address
and High
Frequency
Applications**



These Two Big FREE!
Radio Books

Just mail coupon for a FREE sample Sprayberry Lesson and my big FREE book, "How To Make Money In Radio-Television and Electronics." Learn why my really practical training is best of all for you. Discover what's ahead for you in Radio-Television and Electronics. No obligation. Don't delay! Mail the coupon now—and count on me for fast action.

SPRAYBERRY ACADEMY OF RADIO
111 N. CANAL, DEPT. 10-G, CHICAGO 6, ILL.

INVENTORS

If you believe that you have an invention, you should find out how to protect it. The first step is to have a search made of the prior pertinent U. S. patents. If a report on this search indicates that the invention appears patentable you can apply for a patent, and the specifications and claims should be prepared.

The firm of McMorrow, Berman & Davidson, with offices in Washington, D. C., is qualified to take the necessary steps for you. We can make a preliminary search on your invention, advise you whether we think it can be patented, and prepare your application for patent.

Unless you are fully familiar with the U. S. Patent Laws, we recommend that you engage the services of a Registered Patent Attorney to protect your interests. The patent laws are *your* laws. A patent gives you the right to prevent others from making, using or selling the invention claimed in your patent for a period of 17 years.

Use these patent laws for your protection. Investigate whether your invention can be patented. If you have what you believe to be an invention, we suggest that you have this firm make a search for you.

Send for a copy of our Patent Booklet entitled "How To Protect Your Invention," containing information about patent protection and patent procedure. Along with this we will also send you an "Invention Record" form, for your use in writing down and sketching details of your invention. We will mail them promptly. No obligation. They are yours for the asking.

McMORROW, BERMAN & DAVIDSON

Registered Patent Attorneys

PATENTS • TRADE MARKS • COPYRIGHTS

135-A VICTOR BUILDING, WASHINGTON 1, D. C.

Lend Me 15 Minutes A Day



..and I'll prove
I can make you
a **NEW MAN**

I'M trading in old bodies for new! I'm taking men who know that the condition of their arms, shoulders, chests and legs—their strength, "wind," and endurance — is not 100%. And I'm making **NEW MEN** of them!

If you can simply raise your arm and flex it, I can add **SOLID MUSCLE** to your biceps—yes, on each arm—in double-quick time! I can broaden your shoulders, strengthen your back, develop your whole muscular system **INSIDE and OUTSIDE!**

What Only 15 Minutes a Day Can Do

I can add inches to your chest, give you a vise-like grip, make those legs of yours lithe and powerful. I can shoot new strength into your old backbone, exercise those inner organs, help you cram your body so full of pep, vigor and red-blooded vitality that you won't feel there's even "standing room" left for weakness and that lazy feeling! Before I get through with you I'll have your whole frame "measured" to a nice, new, beautiful suit of muscle!

I Was a 97-lb. Weakling

All the world knows I was **ONCE** a skinny, scrawny 97-pound weakling. And **NOW** it knows that I won the title, "The World's Most Perfectly Developed Man." Against all comers! How did I do it? How do I work miracles in the bodies of other men in only 15 minutes a day? The answer is "Dynamic Tension," the amazing method I discovered and which changed me from a 97-pound weakling into the champion you see here!

My Illustrated Book Is Yours —Not for \$1.00 or 10c—But FREE

Send **NOW** for my famous book, "Everlasting Health and Strength," 48 pages, packed from cover to cover with actual photographs and valuable advice. Shows what "Dynamic Tension" can do, answers vital questions. Page by page it shows what I can do for YOU.

This book is a real prize for any fellow who wants a better build. Yet I'll send you a copy absolutely FREE. Just glancing through it may mean the turning point in your whole life! So don't put it off—send the coupon to me personally: **Charles Atlas, Dept. 83, 115 East 23rd St., New York 10, N. Y.**

Charles Atlas

Actual photo of the man who holds the title, "The World's Most Perfectly Developed Man."



**CHARLES ATLAS, Dept. 83,
115 East 23rd St., New York 10, N. Y.**

Send me—absolutely FREE—a copy of your famous book, "Everlasting Health and Strength"—48 pages, crammed with actual photographs, answers to vital health questions, and valuable advice to every man who wants a better build. I understand this book is mine to keep, and sending for it does not obligate me in any way.

Name _____ Age _____
(Please Print or Write Plainly)
Address _____
City _____ State _____

LAW FREE BOOK



Write today for **FREE** book, "THE LAW-TRAINED MAN," which shows how to learn law for business and the bar easily in spare time at home through the famous Blackstone professional law course compiled by 60 expert law authorities including law college deans, professors, lawyers and Supreme Court judges. We furnish all necessary instruction material including big 18-volume Modern American Law library cited by the courts of last resort as "M.A.L." Many successful attorneys among our graduates, LL.B. degree conferred, Moderate tuition; low monthly terms. Money-back Agreement. Write today.

BLACKSTONE COLLEGE OF LAW
225 N. Michigan Ave., Dept. 53, Chicago 1, Ill.
A Correspondence Institution Founded in 1890



LEARN MEAT CUTTING At Home—In Spare Time

Get into the vital meat industry. Concise, practical Home Training based on 25 years proven instruction methods used at National's famous resident school. Prepares you for bigger pay as Meat Cutter, Supervisor, market manager or more money in your own store. Go as rapidly as your spare time permits. Diploma. Start NOW to turn your spare hours into money. Send for **FREE** bulletin today. No obligation.

NATIONAL SCHOOL OF MEAT CUTTING, INC., Div. U-114, Toledo 4, Ohio

LEARN WATCH REPAIRING



AT HOME. By our modern and original system of instruction you can learn every part of the **WATCH REPAIRING TRADE AT HOME.** Prepare yourself for a well-paying position or start in business after completing our course of instruction. Good watch repairers are in demand and generally earn very good salaries. For particulars apply to the **WISCONSIN SCHOOL OF WATCH REPAIRING** 759 North Milwaukee St., Milwaukee 2, Wis.

TRI-STATE COLLEGE

**B. S.
DEGREE IN
27 MONTHS**

Founded 1884
World-Wide
Enrollment

Civil, Elect., Mech., Chem., Aero., Radio and Telev., Engineering; Bus. Adm., Acct. Visit Campus, see well equipped labs. Low cost. Prep. courses. Personalized instruction. Grads. successful. Enter March, June, Sept., Jan. Catalog. 430 College Ave., Angola, Ind.



MAKE MONEY!

**RAISE CHIN-CHIN
CHINCHILLA RABBITS**

Pedigreed! Valuable Breeders!
PROFITABLE! EASY! PLEASANT!
Free Illustrated Booklet—WRITE TODAY!
SELLERSVILLE 36, PA.

ROCK HILL RANCH

LEARN POULTRY AT HOME

Poultry provides a good full—or part-time income—for thousands of men and women. Thorough training and "Know-How" can mean the difference between success and failure. That's why thousands have obtained their poultry education from N.P.I. home-study courses during past 29 years. Courses are easily understood, interesting, practical—bring students the hard-earned experience of experts in every phase of this \$3½ billion industry. If you have chickens, or wish to enter the poultry business, you should get our free catalog describing courses, methods, service, opportunities. Write today to Charles N. Burmaster, Mgr., Dept. 50.



Write for
**Free
CATALOG**



NATIONAL POULTRY INSTITUTE Adams Center, N.Y.

IF THERE ever was a "Stairway to Success" the training you get from I. C. S. is *it!* Many of the leaders of industry are I. C. S. graduates. And tens of thousands of "average" people have won promotions and pay increases that they attribute to I. C. S. training.

It's only natural. The International Correspondence Schools have been training men for 58 years. They know how to do it. I. C. S. courses are written by the experts in their fields. You'll find texts practical, thorough, easy to grasp.

You learn at home—in your spare time. You move ahead just as quickly as your ambition and energy permit. Start now to step *up!* Check the course you want—and mail the coupon *today!*

This way up!

Clerk

Supervisor

Foreman

Superintendent

General
Manager



**INTERNATIONAL
CORRESPONDENCE
SCHOOLS**

BOX 5672-K, SCRANTON 9, PENNA.

Without cost or obligation, please send me full particulars about the course BEFORE which I have marked X:

- | | | | |
|--|--|--|--|
| <p>Air Conditioning and Plumbing Courses</p> <ul style="list-style-type: none"> <input type="checkbox"/> Air Conditioning <input type="checkbox"/> Heating <input type="checkbox"/> Refrigeration <input type="checkbox"/> Chemical Engineering <input type="checkbox"/> Chemistry, Analytical <input type="checkbox"/> Chemistry, Industrial <input type="checkbox"/> Chemistry, Mfg. Iron & Steel <input type="checkbox"/> Petroleum Refining <input type="checkbox"/> Pulp and Paper Making <input type="checkbox"/> Civil Engineering, Architectural and Mining Courses <input type="checkbox"/> Architecture <input type="checkbox"/> Architectural Drafting <input type="checkbox"/> Bridge and Building Foreman <input type="checkbox"/> Building Estimating <input type="checkbox"/> Civil Engineering <input type="checkbox"/> Coal Mining <input type="checkbox"/> Contracting and Building <input type="checkbox"/> Highway Engineering <input type="checkbox"/> Lumber Dealer <input type="checkbox"/> Reading Structural Blueprints <input type="checkbox"/> Sanitary Engineering <input type="checkbox"/> Structural Drafting | <p><input type="checkbox"/> Structural Engineering</p> <p><input type="checkbox"/> Surveying and Mapping</p> <p>Communications Courses</p> <ul style="list-style-type: none"> <input type="checkbox"/> Electronics <input type="checkbox"/> Practical Telephony <input type="checkbox"/> Radio, General <input type="checkbox"/> Radio Servicing <input type="checkbox"/> Telegraph Engineering <input type="checkbox"/> Electrical Drafting <input type="checkbox"/> Electrical Engineering <input type="checkbox"/> Electric Light and Power <input type="checkbox"/> Lighting Technician <input type="checkbox"/> Practical Electrician Internal Combustion Engines Courses <input type="checkbox"/> Auto Technician <input type="checkbox"/> Diesel-Electric <input type="checkbox"/> Diesel Engines <input type="checkbox"/> Aeronautical Engineer's, Jr. <input type="checkbox"/> Aircraft Drafting <input type="checkbox"/> Forging <input type="checkbox"/> Heat Treatment of Metals <input type="checkbox"/> Industrial Engineering <input type="checkbox"/> Industrial Instrumentation | <p><input type="checkbox"/> Industrial Metallurgy</p> <p><input type="checkbox"/> Machine Shop</p> <p><input type="checkbox"/> Mechanical Engineering</p> <p><input type="checkbox"/> Mold-Loft Work</p> <p><input type="checkbox"/> Patternmaking—Wood, Metal</p> <p><input type="checkbox"/> Reading Shop Blueprints</p> <p><input type="checkbox"/> Sheet-Metal Drafting</p> <p><input type="checkbox"/> Sheet-Metal Worker</p> <p><input type="checkbox"/> Ship Drafting</p> <p><input type="checkbox"/> Tool Designing</p> <p><input type="checkbox"/> Welding Engineering</p> <p><input type="checkbox"/> Welding—Gas and Electric</p> <p>Railroad Courses</p> <ul style="list-style-type: none"> <input type="checkbox"/> Air Brake <input type="checkbox"/> Diesel Locomotive <input type="checkbox"/> Locomotive Engineer <input type="checkbox"/> Locomotive Fireman <input type="checkbox"/> Locomotive Machinist <input type="checkbox"/> Railroad Section Foreman <input type="checkbox"/> Steam-Diesel Loco. Eng. Stationary Eng'r's Courses <input type="checkbox"/> Boilermaking <input type="checkbox"/> Combustion Engineering <input type="checkbox"/> Engine Running <input type="checkbox"/> Marine Engineering <input type="checkbox"/> Power Plant Eng'r's | <p><input type="checkbox"/> Mech. Drafting</p> <p><input type="checkbox"/> Rayon Weaving</p> <p><input type="checkbox"/> Textile Designing</p> <p><input type="checkbox"/> Woolen Manufacturing</p> <p>Business and Academic Courses</p> <ul style="list-style-type: none"> <input type="checkbox"/> Accounting <input type="checkbox"/> App. Psychology <input type="checkbox"/> Business Administration <input type="checkbox"/> Bus. Correspondence <input type="checkbox"/> Certified Public Accounting <input type="checkbox"/> Commercial <input type="checkbox"/> Cost Accounting <input type="checkbox"/> Federal Tax <input type="checkbox"/> Foremanship <input type="checkbox"/> Good English <input type="checkbox"/> Higher Mathematics <input type="checkbox"/> Industrial Supervision <input type="checkbox"/> Motor Traffic <input type="checkbox"/> Retailing <input type="checkbox"/> Salesmanship <input type="checkbox"/> Sign Lettering <input type="checkbox"/> Spanish <input type="checkbox"/> Traffic Management |
|--|--|--|--|

Name _____ Age _____ Home Address _____

City _____ State _____ Working Hours _____ A.M. to _____ P.M.

Present Position _____ Employed by _____

Length of Service in World War II _____ Enrollment under G.I. Bill approved for World War II Veterans. Special tuition rates to members of the Armed Forces. Canadian residents send coupon to International Correspondence Schools Canadian, Ltd., Montreal, Canada.

INVENTORS

If you consider your invention to be something of importance—if you have invented any new and useful art, machine, manufacture or composition of matter or improvement thereof—you are advised to protect your invention by applying for a U. S. patent.

A patent is a valuable right. It grants you a monopoly—the right to exclude others from making, using or selling your invention as claimed for a term of seventeen years.

The specification and claims of a patent, particularly if the invention be at all complicated, constitute one of the most difficult legal instruments to draw with accuracy. Therefore, unless you are thoroughly familiar with such matters, you are advised to employ a competent registered patent attorney or agent.

This firm is registered to practice before the U. S. Patent Office and is available to assist in the preparation and prosecution of your patent application.

The "Evidence of Invention" form mentioned below is offered as a convenience to you in making your disclosure to us for search purposes.

You should date and sign your disclosure and have it witnessed by two or more persons who are capable of understanding your invention.

Your disclosure should be mailed to us together with a letter authorizing us to conduct a preliminary

search among previously granted U. S. patents for similar types of invention.

We then make this search and prepare a report of the probable patentability of your invention. If such report is favorable, we recommend the further course for you to take.

The "Evidence of Invention" form and booklet are suggested as conveniences to you and us in starting action on your invention.

VICTOR J. EVANS & Co. *Merlin M. Evans*
REGISTERED PATENT ATTORNEY
530-C MERLIN BUILDING, WASHINGTON 6, D. C.

We shall be glad to send you promptly and without obligation, an instructive booklet, "Patent Protection for Inventors", which was prepared to give inventors detailed information and steps to take toward patent protection—also our convenient "Evidence of Invention" form. Use address Victor J. Evans & Co., 530-C Merlin Building, Washington 6, D. C.

PATENTS COPYRIGHTS TRADEMARKS

Command Bigger Money! STUDY LAW

STUDY AT HOME for BUSINESS SUCCESS and LARGER PERSONAL EARNINGS. 40 years expert instruction — over 114,000 students enrolled. LL.B. Degree awarded. All text material furnished. Easy payment plan. Send now for FREE BOOK — "Law and Executive Guidance." It explains the course — how you may enroll and the many ways you can profit from Law Study. Write TODAY to:

AMERICAN EXTENSION SCHOOL OF LAW
Dept. 24-PM, 646 N. Michigan Ave., Chicago 11, Ill.

AMAZING SECRETS REVEALED TO EVERY POULTRY RAISER



ABSOLUTELY FREE BOOK. My new Picture Tour Book telling all about one of America's largest and best Poultry Breeding Farms and Hatchery organizations. I know you'll enjoy it, and profit in your poultry work by reading it. Tells latest methods of profitable chicken raising, feeding and especially about pure-breds, cross-breds and hybrids. If you want to know about better and more profitable chickens, be sure to write me TODAY for your FREE copy. Just a postcard will bring it.

MRS. HARRY HAM, Route 56, Atchison, Kansas



BOYS! Make Your OWN RADIO!

Learn Interesting Details

You may start a successful career in RADIO. Send 25c

Fun, interest and education in making your own simple, tubeless, batteryless crystal radio. Send 25c for a genuine Melomite crystal with complete illustrated instructions for making your own set. Compete with others for long distance reception. Crystal sent postpaid with instructions and our own publication "The Magic Crystal" which is full of news, diagrams, questions and answers of interest. Send 25c TODAY.

ALLEN RADIO, Dept. 137, Clinton, Mo.

RADIO ENGINEERING. Broadcasting, Television, FM, Servicing, Electronics, Aviation, Marine & Police Radio taught thoroughly. Engineering course equivalent to 3 years' college radio work. Approved Veteran Training. Catalog free.
VALPARAISO TECHNICAL INSTITUTE, Dept. D, Valparaiso, Ind.

YOU CAN SUCCEED BY KLOK TRAINING

There is no other practical training in the wood industry whereby you can succeed so quickly as through our training. You can study either at home by correspondence or come to Grand Rapids and study with us here. The KLOK Course teaches you Sketching—Drafting—Rod Making—Time Study—Cost and Production Scheduling. The training will enable you to run your own shop more successfully or enable you to get a top position in the furniture and woodworking industry. Write NOW for free booklet, "Stepping Stones to Top Positions in the Woodworking Industry." State preference—Home Study or Resident Training—Age, and if you are a Veteran.

FREE G.I. TRAINING



KLOK INSTITUTE

Louis St., N. W., Grand Rapids, Michigan

Prepare in our
Big Training
Shops for these

GREAT OPPORTUNITY FIELDS!

ELECTRICITY OR **RADIO AND TELEVISION**



This big fire-proof building is occupied entirely by Coyne.

FIVE BIG FLOORS PACKED WITH MASSIVE EQUIPMENT

Thousands of men and young men have come to our big training shops where we have floor upon floor packed with massive equipment to train with, to prepare for good jobs and real futures in the opportunity fields of Electricity and Radio-Television. For many years, these fields have offered great opportunities to trained men. With new developments, including Electronics and Television, they will continue to grow and offer even greater opportunities. Why be satisfied with a "no future" job? Many "one operation" jobs that exist today will not last. Prepare for a good job with a real future for steady pay and advancement by training NOW in the great training shops of COYNE in Chicago.

NOT "HOME-STUDY" COURSES

Our famous Radio-Television Practical-Technical method gives you practical experience on a massive outlay of equipment. Not by correspondence, but actual shop work plus necessary technical training. You are trained right here in the great Coyne shops that have been training men and young men for over 50 years.

ELECTRICITY RADIO-TELEVISION

INCLUDING INDUSTRIAL ELECTRONICS

Big future in Power Plant Work, Motors, Armature Winding, Home and Factory Wiring, Appliances, Refrigeration, Maintenance, Illumination, etc. Electricians are in demand everywhere—lifetime job service to Coyne graduates. Send for BIG FREE BOOK.

A great field now, even greater growth ahead. Here at COYNE you're trained for Construction, Testing, Trouble-Shooting on Radio, Public Address, Sound Units. Training includes FM, Television Servicing, etc. Many Coyne trained men in good jobs or own well paying Radio-Television businesses of their own.

ELECTRIC REFRIGERATION

This valuable training now included with either course means added opportunities.

G. I. APPROVED

NON-VETERANS who are short of cash can finance most of their tuition and pay in easy monthly payments after graduation. Many earn while learning.

B. W. COOKE, President

COYNE ELECTRICAL AND RADIO-TELEVISION SCHOOL

500 So. Paulina St., Dept. 30-72H, Chicago 12, ILL.

LARGEST, OLDEST, BEST EQUIPPED SCHOOL OF ITS KIND IN THE U.S.

Mail Coupon for
Big FREE Book!



Whether you prefer Electricity, or Radio-Television, train on actual equipment at Coyne. We have a big, fully illustrated book on each course, and we'll send you the one you want, or both if you want to consider both fields, without obligation. Mail coupon—TODAY.

B. W. Cooke, President
COYNE ELECTRICAL AND RADIO-TELEVISION SCHOOL 500 S. Paulina St., Dept. 30-72H, Chicago 12, Ill.

Send me the book, checked below and details of your training offer. This does not obligate me and no salesman will call.

ELECTRICITY RADIO-TELEVISION

NAME.....

ADDRESS.....

CITY..... STATE.....

DOES YOUR FUTURE NEED A "TUNE-UP" JOB?

Take the "knocks" out of your career — Learn a good trade through famous C. T. I. !

If you don't like your present job—if your income is low—or if you feel you're not getting ahead fast enough . . . *it's time you learned a trade!* Opportunities for success may never again be as great as they are today. Good jobs are waiting for trained men. *You can acquire technical skill through C.T.I. within months.* You can learn either at home in your spare time or, in our resident school.

So, "step on the starter". *Fill out and mail coupon below. Do this today!*

THESE C.T.I. MEN ARE GETTING SET FOR SUCCESS

Technical skill makes a *big* difference in whether or not you will succeed. Many C.T.I. graduates discovered this fact, as they tell you in their own words: "Your training has been of great assistance in helping me get ahead. Since beginning your course *I have more than doubled my earnings.*" . . . "I own my own shop now, and if I don't get ahead, I can truthfully say it will be my own fault." . . . "Since I finished my training through C.T.I., I've made enough money to buy tools, and now have a small business started." . . . "I am on my own. It came sooner than I anticipated, and with the training I've received from C.T.I., I'm sure I'll go places, but fast!"

Each of these graduates—as well as many others—at one time did *just what you're going to do right now:* They mailed a coupon to C.T.I.! (See below)



- C.T.I. OFFERS PRACTICAL TRAINING IN**
- AUTOMOTIVE MECHANICS
 - BODY & FENDER REBUILDING
 - DIESEL MECHANICS
 - REFRIGERATION & AIR CONDITIONING
 - ELECTRICITY & ELECTRONICS
 - RADIO & TELEVISION
 - BUILDING CONSTRUCTION
 - MECHANICAL DRAFTING

FILL OUT - CUT OUT - MAIL TODAY

Mr. R. C. Anderson, President
COMMERCIAL TRADES INSTITUTE, Dept. E2-3 Veteran
 1400 Greenleaf Ave., Chicago 26 Non-Veteran

Send free illustrated Brochures and other information about the field I have checked below:

- | | |
|---|--|
| <input type="checkbox"/> Automotive Mechanics | <input type="checkbox"/> Electricity & Electronics |
| <input type="checkbox"/> Body & Fender Rebuilding | <input type="checkbox"/> Radio & Television |
| <input type="checkbox"/> Diesel Mechanics | <input type="checkbox"/> Building Construction |
| <input type="checkbox"/> Refrigeration & Air Conditioning | <input type="checkbox"/> Mechanical Drafting |

Name _____ Age _____

Address _____

City _____ State _____

C.T.I. TRAINING IS G.I. APPROVED

All C.T.I. courses, both residential and home study, are fully approved by the Veterans Administration—which means that eligible veterans will have their tuition paid by the government.



R. C. Anderson
President

**COMMERCIAL TRADES
INSTITUTE, Dept. E2-3**

1400 Greenleaf - Chicago 26



GET INTO

DIESEL-AUTO MECHANICS

Master All Phases

JOB LIKE THESE ARE AVAILABLE TO TRAINED MECHANICS. CHOOSE THE FIELD YOU LIKE BEST

Get Complete Training

- Diesel Fuel Injection
- Automotive Motor Tune-up
- Diesel Engine Rebuilding
- General Garage Mechanic
- Agricultural Implements
- Auto Engine Rebuilding
- Auto Elec. Service
- Public Utilities
- Parts Dealers
- Bus & Truck Lines
- Industrial Maintenance
- Contracting & Excavating
- Business of Your Own
- AND MANY other similar openings.

As a National Schools graduate, you are trained for ALL opportunities in the Diesel & Auto Industries

EARN WHILE YOU LEARN

With our practical Master Shop-Method Home Training, you study at home in your spare time. You receive Spare Time Work Lessons, which show you how to earn while you Learn . . . for extra money and experience. You Learn by DOING.

TOOLS AND EQUIPMENT

To make your training complete, we give you selected mechanic's tools and equipment, illustrated below, including all-metal toolbox—as a regular part of your instruction.

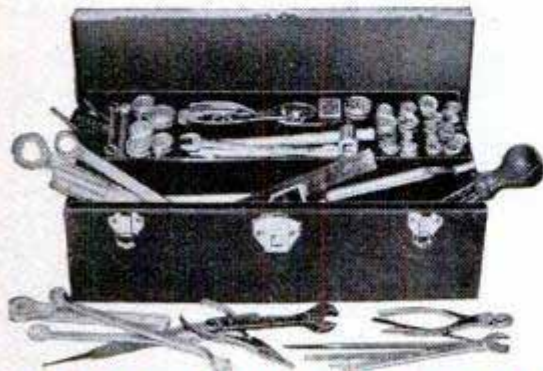

WE GIVE YOU TOOLS OF YOUR TRADE



Shop-Method Home Training by an Established Resident School Prepares you for Many Good Jobs

Opportunity is everywhere for the trained Diesel-Auto Mechanic. Highways throng with cars, busses, trucks, tractors. Garages and Service Stations are kept busy. Factories, ships, farms, railroads, general industry, are dependent upon engine power. Here's a dynamic, fast-growing field that needs trained men who know ALL phases: installation, operation, maintenance and repair. Now—National Schools offers you a practical, all-embracing Diesel-Auto Mechanic's Course, including all of these advantages:

Complete training, covering—Diesels, High Speed and Heavy Duty; Semi-Diesels, Gasoline and Special Fuel Engines AND Allied Mechanics.

- Basic Lesson Texts
- Diesel Installation
- Operation - Maintenance
- Diesel Chart Manual
- Spare Time Lessons
- Engine Service Manuals
- Engine Repair
- Drive Systems
- Diesel Electric Power
- Thermodynamics

TOOLS AND EQUIPMENT

INVESTIGATE

Secure Full Information

NEW, ILLUSTRATED BOOK & SAMPLE LESSON SHOW HOW WE TRAIN YOU . . . SEND FOR THEM TODAY!



NO COST NO OBLIGATION

APPROVED FOR VETERANS

Check coupon below

NATIONAL SCHOOLS

LOS ANGELES 37, CALIF. • EST. 1905



FIND OUT NOW... MAIL COUPON TODAY

NATIONAL SCHOOLS, DEPT. PMD-3
4000 South Figueroa Street
Los Angeles 37, California

(Mail in envelope or paste on penny postcard)

Mail me FREE the book, YOUR FUTURE IN DIESEL-AUTO MECHANICS, together with the Sample Lesson. I understand I may keep and use the information with no obligation.

Name _____ Age _____

Address _____

City _____ Zone _____ State _____

Check here if Veteran of World War II

Thoughts . . . THAT MOVE MOUNTAINS



. . . IS MIND POWER REAL?

HAVE YOU READ volumes on the power of thought? Perhaps you have listened to lengthy theoretical addresses on the forces of mind. You may have wondered if these same writers and lecturers on mind power know how to use it. How many mountains of personal obstacles—everyday trials and tribulations—have *they* moved? What are these subtle principles whereby man can skillfully remove the barriers that impede his progress? How can *you* displace the obstructions and hindrances to *your* goal... the mountains in *your* life? Can practical information about inner power be reduced to mere words... words for public dissemination? Or, is there a secret method especially and uniquely preserved for the worthy seeker... practicable only under ideal circumstances? If so, who has the secret method? Where can it be found?

The

ROSICRUCIANS (AMORC) San Jose, California

Investigate the Rosicrucians (NOT a religion), the oldest *practical* philosophical fraternity on earth. See if they cannot show you a method for attainment such as you may not have dreamed possible. Thousands of men and women today are enjoying mental mastery... realization of ideals... the attainment of their objectives. They *know* the secret methods for converting mountains of personal problems into green valleys of achievement.

ACCEPT THIS OFFER

A FREE book, *The Mastery of Life*, is yours for the asking. It explains how easily you may enter upon the path of attainment. Fill in and send coupon *today!*

SCRIBE Q.M.K.
THE ROSICRUCIANS (AMORC)
San Jose, California

Please send me the book, *The Mastery of Life*, which explains how I may learn to use my faculties and powers of mind.

Name _____

Address _____

City _____

Zone Number _____ State _____

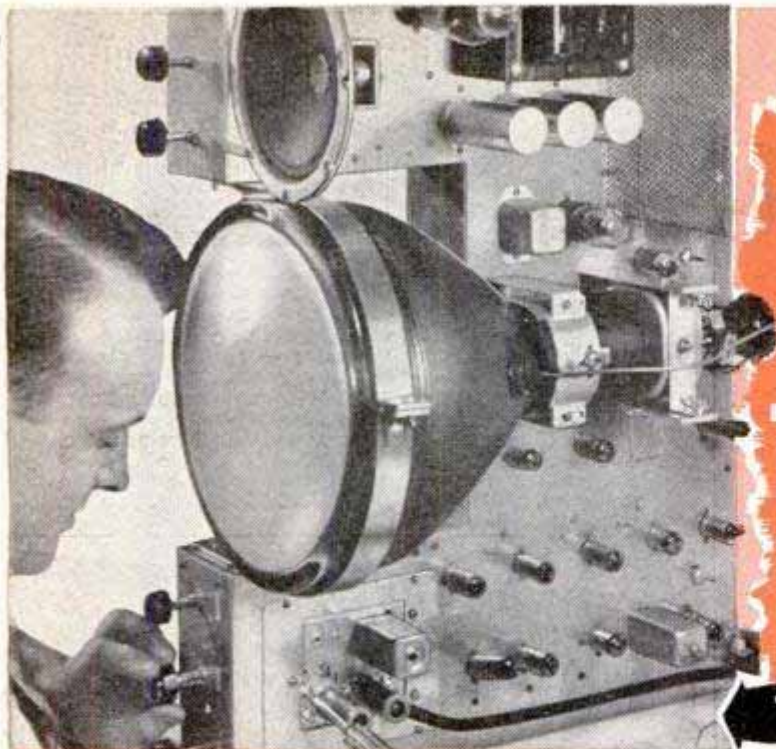

Only D.T.I.
offers you the
"BIG 5"
TELEVISION
RADIO-ELECTRONICS
Laboratory Type
HOME TRAINING

Build and Keep 10, 12½ or 16 inch Picture Tube Quality TELEVISION RECEIVER as you prepare for a Profitable Future



Here is everything you need to prepare you at home for FASCINATING WORK, GOOD MONEY and a THRILLING FUTURE in one of America's most promising fields.

This includes the opportunity to build and keep the top quality Television Receiver shown above—with choice of a 10, 12½ or 16 inch picture tube that gives big, bright, sharp, steady pictures. This is an optional feature—available when you complete your training described below. Get the complete facts. See how D.T.I.'s wonderfully practical "BIG 5" method meets industry's needs: No previous experience needed. Mail coupon today!

16 Big Shipments of Parts — Plus Lessons

Work over 300 electronic experiments and projects from 16 big shipments of parts. This includes building and keeping all test equipment and radio set shown at left side of page. Modern easy-to-read lessons with handy fold-out diagrams simplifies your entire training.

You Also Use Home Movies

D.T.I., alone, includes the modern, visual training aid . . . MOVIES to help you learn faster, easier at home. See electrons on the march and other fascinating "hidden action"—a remarkable home training advantage that speeds your progress.

EMPLOYMENT SERVICE

When you complete your training, our effective Employment Service helps you get started toward a real future in Television-Radio-Electronics.

Modern Laboratories

If you prefer, you can get ALL your preparation in our new, Chicago training laboratories . . .

6 Tube
Radio
Receiver

one of the finest of its kind. Ample instructors . . . modern equipment. Write for details!

DeFOREST'S TRAINING, INC.

Chicago 14, Illinois
A DeVry Institution

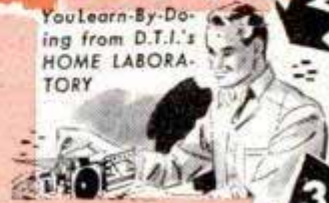

You Learn-by-Reading from D.T.I.'s MODERN LESSONS



MAIL THIS COUPON TODAY!

DeFOREST'S TRAINING, INC. PM-G-3
2533 North Ashland Avenue,
Chicago 14, Illinois.

Without obligation, give me complete facts showing how I may make my start in Television-Radio-Electronics.

Name _____ Age _____
Street _____ Apt. _____
City _____ Zone _____ State _____



\$250,000 FOR THIS!

2100 Other Inventions Badly Needed—Big Cash Waiting for Your Little Ideas

IT'S OFTEN the *simplest* ideas that make the *most* money! The Kiddie Kar brought its inventor a cool MILLION dollars. A 70-year-old grandmother made \$350,000 on an improved overall buckle. The paper clip, the hair-pin, the rubber pencil tip all made fortunes for the people who "dreamed" them up.

You can cash in, too — if you concentrate on the inventions that are really needed!

The EASY Way to Get Started

Don't waste time and brain-work on something nobody wants! Find out WHAT to invent. A valuable book by Raymond F. Yates, noted science editor and inventor, lists and describes over 2100 PRACTICAL, money-making ideas that are crying aloud to be invented!

These 2100 ideas are the things most needed and surest to make money. They are listed under 34 different headings for quick reference: Electrical Radio, Automotive, Agricultural, Building, Household, Clothing, Toys, Time-savers, etc.

This book ALSO tells how to think inventively; how to PROTECT your ideas; how to develop an invention STEP-BY-STEP, etc.

FREE EXAMINATION OFFER SEND NO MONEY

Wouldn't you like a slice of the \$280,000,000 that American inventors get each year in royalties? Get started now! You don't risk a penny. Simply mail coupon below WITHOUT MONEY — and get "2100 Needed Inventions," by Raymond F. Yates, for 5 days' FREE TRIAL. If, even in that short time, you are not convinced that this book can help you make money — just return it and owe nothing. Otherwise, send only \$2.50 plus few cents postage, as payment in full.

Any one of the 2100 ideas in this book can bring somebody a fortune. Maybe it can be YOU! Mail coupon at once! Wilfred Funk, Inc., Dept. T493, 227 East 44th Street, New York 17, N. Y.



FREE 5-DAY EXAMINATION

WILFRED FUNK, Inc.
Publishers, Dept. T493
227 East 44 Street, New York 17, N. Y.

Please send me 2100 NEEDED INVENTIONS, for FREE EXAMINATION. If I keep the book I will send you \$2.50 plus few cents postage. Otherwise I will return it within 5 days, without further obligation.

Name _____

Address _____

City _____ Zone No. _____ State _____
(if any)

Check here if enclosing \$2.50 WITH this coupon, and we will pay all postage charges. Same 5-day return privilege, for full refund, applies. Canadian Orders—25c extra for carrying charges. (Only U.S. funds accepted.)

Enjoy a hobby that's fun!



Get this picture-packed book on Model Railroad-ing now!

• It's simple — this book will tell you how you can have your own railroad in your basement, attic, or even a corner. It's inexpensive — surprisingly little money is needed. It's constructive — hobbyists from 17 to 70 spend absorbing hours with the world's fastest-growing hobby.

Fully illustrated — this book explains how you, too, can start. Send 10c today for your copy of "Model Railroad for You," written by a well-known authority. MODEL RAILROADER MAGAZINE, DEPT. 1539, Milwaukee 3, Wis.



Play GUITAR in 10 DAYS

INSTRUMENTS SUPPLIED on cash or credit, ask for Price List and Credit Plan.

OR GET YOUR MONEY BACK! Let Ed Sale, top radio guitarist, teach you to play with his famous diagram-photo system. Book contains 53 photos, 43 diagrams showing exactly how to place your fingers. Gives you 110 popular songs, words and music—along with complete, easy to learn instructions. Imagine your joy when you find after only two weeks you are playing beautiful music! Amaze your friends! Be the life of the party!

PAY POSTMAN \$1.95 PLUS C.O.D. OR SAVE C.O.D. SEND \$1.95 NOW! \$1.95 ED SALE, Dept. 68, Point Pleasant, New Jersey



RAISE HAMSTERS

The new wonder animals from Syria. Often called Toy Bears. Delightful pets. Everyone wants them. Laboratories need thousands. Clean, odorless. Raise anywhere. A profitable and interesting hobby or business. We furnish breeding stock with manual of instructions.

Write today for free illustrated literature. GULF HAMSTERY, 1536 BASIL, MOBILE, ALA.

Learn PHOTOGRAPHY

There's big money in PHOTOGRAPHY — and an action-packed career for you. Our HOME STUDY COURSE—famous throughout the world — is your spare-time SHORT CUT TO SUCCESS! Or if you wish . . . PERSONAL ATTENDANCE TRAINING at our famous New York Studios is available with subsistence under the G. I. BILL. Our 40th year. Write immediately!

NEW YORK INSTITUTE OF PHOTOGRAPHY

Dept. "49", 10 W. 33 St., New York 1, N. Y.

ELECTRICIANS' SCHOOL

HOUSE AND COMMERCIAL WIRING • MOTOR REPAIR AND REWINDING • ELECTRIC REFRIGERATION

Approved for Veterans Training

PENNSYLVANIA INSTITUTE SCHOOL OF ELECTRICITY

42nd and SPRUCE STS.

PHILADELPHIA 4, PENNA.

Learn WATCH REPAIRING

Earn while AT HOME you Learn

Learn this fascinating and profitable trade in your spare time at Home through our Correspondence Department. Each individual student receives individual attention! Post-Graduate course at resident school optional for correspondence students.

OUR MOTTO: Not how quickly, OR how thoroughly we can train you.

AT OUR RESIDENT SCHOOL

APPROVED FOR G. I. TRAINING
Our school is set up on an individual basis where every student receives individual attention from our competent instructors in a home-like and cheerful atmosphere.
Write TODAY FOR FREE INFORMATION: JOHN VAN PUFFELEN, Director
American Institute of Specialized Watch Repair
270-276 East Blvd., Grand Rapids 6, Michigan

NOW! BRAND-NEW, UP-TO-THE-MINUTE Edition of Famous Manual
MAKES Any AUTO REPAIR JOB

Your "Meat!"

ENLARGED!

95 MORE Pages!
 795 BIG Pages in All!
 More Chapters! More Facts!

REVISED!

418 NEW Pictures—
 2100 in All! 141 NEW
 Pictures on Hydramatic Drive!

NEW!

Now You Can Repair
**ALL 1949 MODELS—As Well
 As Any Car Built Since 1935!**

TRY BOOK FOR A WHOLE WEEK—FREE

Return and Pay Nothing if Not Satisfied!

HERE it is!—the brand-new, revised, enlarged edition of MoToR's Auto Repair Manual! Now you can "lick" any auto repair job on any car built since 1935—including all 1949 models! Just look up make, model, and job in quick index—and go to it.

EVERYTHING YOU NEED TO KNOW TO REPAIR ANY CAR!

795 BIG pages; 2100 "how-to-do-it" pictures; 200 "quick-check" specifications, charts, and tables; over 200,000 facts make every operation a "snap"! Beginners will find in this giant book the most helpful guidance on every kind of service and repair job imaginable. Experts will be amazed by the shortcuts they'll discover.

Win Prestige! Earn More Money!

Factory engineers from every auto plant in America worked out these time-saving procedures. Now you get all this wealth of "know-how" from over 150 *Official Shop Manuals*, "boiled down" into clear terms in one handy book! Now you can tackle jobs you wouldn't think of trying before. And you'll

win more prestige, more money!

Right at your fingertips you have every "How-to-do-it" fact you want. Over 35,000 essential dimensions on 697 car models! Whether you want to make a simple carburetor adjustment or completely rebuild a transmission, step-by-step instructions show exactly **WHAT** to do, **HOW** to do it. Used by U. S. Army, technical schools, thousands of auto service men.

Used by
 U. S. ARMY
 and NAVY

**COVERS ANY
 CAR BUILT
 SINCE 1935!**

- | | |
|--------------|------------|
| Auburn | Cord |
| Austin | Crosley |
| Buick | De Soto |
| Cadillac | Dodge |
| Chevrolet | Ford |
| Chrysler | Frazier |
| Graham | Hudson |
| Hupmobile | Kaiser |
| Lafayette | La Salle |
| Lincoln | Mercury |
| Nash | Nash |
| Oldsmobile | Packard |
| Pierce Arrow | Plymouth |
| Pontiac | Reo |
| Studebaker | Terraplane |
| Willlys | |

SEND NO MONEY

Send no money. Enjoy this brand-new book—at our risk—for a full week, **FREE!** Test it right in your own garage or shop. If book doesn't more than pay for itself in 7 days, simply return it and pay nothing. Mail coupon NOW to MoToR Book Dept. Desk 1C, 250 West 55th St., New York 19, N. Y.

MoToR

Published
 by MoToR,
 The Leading
 Automotive
 Business
 Magazine



**Same FREE Offer on
 MoToR's TRUCK MANUAL**



Covers EVERY job on EVERY truck made from 1936 thru 1946! 1400 pictures, 952 pages, 300,000 facts. All types Gasoline Engines, Truck Diesels, Hesselmanns, Fuel Systems, Governors, Lubrication, Ignition, Starters, Clutches, Axles, Brakes, etc., etc.

ALSO covers many buses, tractors, contractor and road building equipment, stationary power machinery. Check box in coupon.

MAIL COUPON NOW FOR 7-DAY FREE TRIAL

MoToR BOOK DEPT.
 Desk 1C, 250 West 55th St., New York 19, N. Y.

Rush to me at once (check box opposite book you want):
 MoToR's **AUTO REPAIR MANUAL**. If O.K., I will remit \$1 in 7 days (plus 35c delivery charges), \$2 monthly for 2 months and a final payment of 95c one month after that. Otherwise I will return the book postpaid in 7 days. (Foreign price, remit \$8 cash with order.)
 MoToR's **TRUCK REPAIR MANUAL**. (Described at left.) If O.K., I will remit \$2 in 7 days, and \$2 monthly for 3 months, plus 35c delivery charges with final payment. Otherwise I will return book postpaid in 7 days. (Foreign price, remit \$10 cash with order.)

Print Name.....Age.....

Print Address.....

City..... State.....

Check box and save 35c delivery charge by enclosing WITH coupon entire payment of \$3.95 for Auto Repair Manual (or \$8 for Truck Repair Manual). Same 7-day return refund privilege applies.

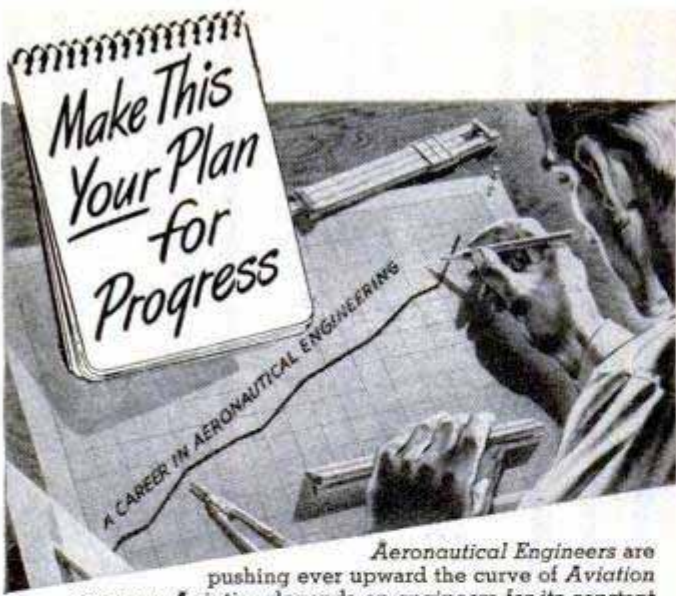

Aeronautical Engineers are pushing ever upward the curve of Aviation progress. Aviation depends on engineers for its constant and amazing achievements and growth. A career in this key division of Aviation can be YOUR personal plan for progress.

Here is a career with security and a lifetime of opportunity—for YOU. Besides fascinating work, you enjoy these rich rewards—good pay from the start, wide-open opportunity for advancement, the security of a big, growing industry. Whether you are creative or practical, there is a place for YOUR talents and ability.

Start the upward "curve" of YOUR plan for progress—with Northrop training. You are already IN Aviation when you train at Northrop. You get actual experience in every-day engineering duties—like the students shown here testing a nose wheel installation for braking effect. In the other photograph you see three pulse-jet engines designed and built as a typical practical project in studying the latest types of aircraft power plants.

Northrop training gives you big advantages... advantages that have won choice jobs for graduates with ALL leading aircraft manufacturers and airlines. Get the whole story, in the big illustrated Institute catalog. Classes start every 8 weeks—you can start YOUR training soon.



Send Coupon for this Catalog NOW

APPROVED FOR VETERANS



Northrop Aeronautical Institute
 Division of Northrop Aircraft, Inc.
 1527 EAST BROADWAY, HAWTHORNE,
 LOS ANGELES COUNTY, CALIFORNIA

NORTHROP AERONAUTICAL INSTITUTE
 1527 East Broadway, Hawthorne, Los Angeles County, Calif.
 Please send information on opportunities in Aeronautical Engineering, your catalog, and starting dates of classes. I am interested in:

Aeronautical Engineering • Aircraft & Engine Mechanics

Name _____ Age _____

Address _____

City _____ Zone _____ State _____

Check one: Veteran Non-Veteran

Be an INVESTIGATOR

JAMES S. BOLAN, FORMER POLICE COMMISSIONER OF NEW YORK CITY offers MEN & WOMEN an attractive opportunity to prepare for a future in *Investigation & Criminology* by comprehensive Home Study Course. Free placement service assists graduates to obtain jobs. APPROVED UNDER G. I. BILL OF RIGHTS. Write for Free Booklet PM.

THE BOLAN ACADEMY, INC.
 EMPIRE STATE BLDG., NEW YORK 1, N. Y.

WOULD \$400 PER MONTH INTEREST YOU?



It is easily possible to earn \$400 to \$500 a month raising ANGORA RABBITS. No experience required. Wool brings top price. Plenty markets. WRITE TODAY for FREE INFORMATION, PRICES and WHERE TO SELL.

WHITE'S RABBITRY
 NEWARK 10, OHIO

How to Make Money with Simple Cartoons



A book everyone who likes to draw should have. It is free; no obligation. Simply address

FREE BOOK

CARTOONISTS' EXCHANGE
 Dept. 93-D Pleasant Hill, Ohio

BE A LOCKSMITH



LEARN LOCKSMITHING and KEYMAKING from EXPERTS in YOUR SPARE TIME at HOME! Locksmiths in big demand! No layoffs, no slow seasons! Age or physical handicap no disadvantage. Year-round, steady income in this permanent, respected field. Full or part time. Practical, illustrated lessons show you how to make money even while learning! All materials and special tools supplied. Send for FREE BOOKLET.

INSTITUTE OF LOCKSMITHING, Dept. P-5
 55 Park Ave., Rutherford, N. J.

FREE BERRY'S NEW POULTRY BOOK



BABY CHICKS or STARTED. Champion-Mated, Licensed-Inspected, B.W.D. TESTED. 52 BREEDS, 7 CROSSES. Sexed or straight. Mature Iowa. Hatching Eggs and Remedies. LOW PRICES. The ORIGINAL Berry's Farm—over 50 years' service. LARGE BEAUTIFUL BOOK FREE. Stamps appreciated. **BERRY POULTRY FARM, Bx. 29, CLARINDA, IOWA**

WHY DON'T YOU WRITE?

Writing short stories, articles on business, politics, sports, shop crafts, local and club activities, etc., will enable you to earn extra money. In your own home, on your own time, the New York Copy Desk Method teaches you how to write the way newspaper men learn—by writing. Our unique "Writing Aptitude Test" tells whether you possess the fundamental qualities essential to successful writing. You'll enjoy this test. Write for it, without cost or obligation.

Veterans: This course approved for Veterans' Training
NEWSPAPER INSTITUTE OF AMERICA
 SUITE 5590-C, ONE PARK AVENUE, NEW YORK 16, N. Y.

REAL ESTATE BE A BROKER

PAYS BIG! SEND FOR FREE, BIG, ILLUSTRATED CATALOG NOW! No obligation. Graduates report making substantial incomes. Start and run your own business quickly. Men, women of all ages, learn easily. Course covers Sales, Property Management, Appraising, Loans, Mortgages, and related subjects. **STUDY AT HOME** or in our classrooms in big cities. Diploma awarded. G.I. approved. Nationally known.

WEAVER SCHOOL OF REAL ESTATE (Est. 1936)
 15 E. Pershing Road Dept. PM Kansas City, Mo.



Learn BAKING At Home

Baking is one of America's high industries in wages. Nearly depression-proof. Thorough basic home course lays sound foundation. If you have aptitude, write for FREE BOOKLET, "Opportunities in Commercial Baking."



National Baking School, 1315 Mich. Ave., Dept. 1353, Chicago 5

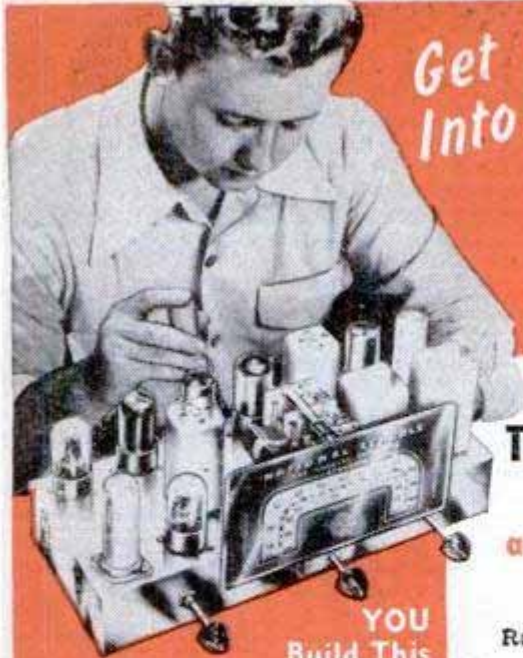

Get
Into

RADIO, TELEVISION and ELECTRONICS Master ALL Phases

**Get Complete Training. You Receive and Keep All
Tubes, Equipment, Parts and Lessons. No Extra Charges.**

**YOU
Build This
Superheterodyne**

You receive complete standard equipment, including latest type High-Mu Tubes, for building various experimental and test units. You progress step by step until you build a complete Superheterodyne Receiver. It is yours to use and keep.



**YOU RECEIVE THIS
PROFESSIONAL MULTITESTER!**

You will use this professional instrument to locate trouble or make delicate adjustments—at home—on service calls. You will be proud to own this valuable equipment. Complete with test leads.



**SIGNAL
GENERATOR**

You construct the Transifron Signal Generator shown here, demonstrating Transifron Principles in both R.F. and A.F. stages. You study negative type oscillators at firsthand.

AUDIO OSCILLATOR:

An electronic device, which produces audio-frequency signals for modulating R.F. (radio frequency) carrier waves, testing A.F. (audio frequency) amplifiers, speakers, etc.



**T.R.F.
RECEIVER**

You build several T.R.F. Receivers, one of which, a 4-tube set, is shown here. You learn construction, alignment, make receiver tests, and do trouble shooting.

**GOOD PAY
and Unlimited Opportunities
in JOBS LIKE THESE:**

Business of Your Own
Radio Manufacturing, Sales, Service
Broadcasting Telecasting
Television Manufacturing,
Sales, Service
Laboratories: Installation, Maintenance of Electronic Equipment, Electrolysis, Call Systems
Garages: Auto Radio Sales, Service
Sound Systems and Telephone Companies; Oil Well and Drilling Companies; Engineering Firms
Theatre Sound Systems Police Radio
**And scores of other good jobs
in many related fields**

**YOU CONDUCT MANY
EXPERIMENTS LIKE THESE!**

Checking action of condensers
Experiments with AF and RF amplifiers.
Experiments with resonance
Producing beat frequencies
Calibrating oscillators
Experiments with diode, grid-bias, grid-leak and infinite impedance detectors
Practical experience in receiver trouble shooting
Application of visual tester in checking parts and circuits
Experiments with audio oscillators
Advanced trouble-shooting
and many, many others

**Complete Training by Practical
Resident Trade School, Est. 1905**

The same highly trained faculty, instruction materials and methods used here in our large, modern resident school, are adapted to your training in your own home. Shop Method Home Training has been proved by hundreds of successful graduates.

**Both Resident and Home Study
Courses Offered**

**YOU
LEARN BY
DOING**

You receive special laboratory experiment lessons to show you how to build with your own hands various experimental units such as those shown at left, and how to conduct many tests.

You will find all lessons easy to understand because they are illustrated throughout with clear diagrams and step-by-step examples that you work out yourself. Every piece of the equipment and complete lesson material we send you is yours to keep and enjoy, including the multimeter, experimental equipment, all parts of the Superheterodyne, tube manual, radio dictionary, and complete, modern Television texts. All parts are standard equipment.

**Shop Method Home Training . . .
Earn While You Learn**

With our practical resident Shop Method Home Training, you study in your spare time. You receive Spare Time Work Lessons, which show you how to earn while you learn. Service neighbors' radios and TV receivers, appliances, etc., for extra money and experience. Many National students pay all or part of their training with spare time earnings!

**DON'T DELAY! The Radio-Television
Industry needs trained men NOW!**

**APPROVED
FOR
VETERANS!**

Check coupon below!

For quick action,
mail coupon
today and we'll
rush you full information.

Free!

**NEW, ILLUSTRATED
OPPORTUNITY
BOOK AND SAMPLE
LESSON SHOW YOU
HOW WE TRAIN
YOU . . . SEND FOR
THEM TODAY! NO
COST. NO
OBLIGATION.**



NATIONAL SCHOOLS

LOS ANGELES 37, CALIF. • EST. 1905



FIND OUT NOW . . . MAIL COUPON TODAY

National Schools, Dept. PM-3
4000 South Figueroa Street
Los Angeles 37, California

Send me your FREE book "Your Future in Radio" and the sample lesson of your course. I understand no salesman will call on me.

NAME _____ AGE _____

ADDRESS _____

CITY _____ ZONE _____ STATE _____

Check here if Veteran of World War II

Mail in envelope
or paste on
penny postal.

Owners are making BIG MONEY



WITH A
VERY SMALL
INVESTMENT

operating this FRANCHISED ROADSIDE STAND

One of the greatest opportunities in America! A business you can start with very little capital . . . and make thousands of dollars if you follow our *proved* methods of stand building and operating. A 28-page folder shows plans, testimonials from owners . . . gives hundreds of other essential facts. Send for your *free* copy!

GO IN
BUSINESS
FOR
YOURSELF!
FREE
FOLDER
TELLS
HOW

RICHARDSON Corp.,
Dept. PM-3
Rochester 3, N. Y.
Please send me
FREE folder on RICHARDSON stand.

Name _____
Address _____
Place _____
Phone _____



PLUMBERS & STEAM FITTERS



AUDELS PLUMBERS & STEAM FITTERS GUIDES. This valuable set explains in practical concise language the principles, advances and shortcuts of the trade—based on good practice. Includes careful detailed instructions on how to figure & calculate various jobs. A quick reference; saving time & money. A complete Trade course.

Over 1,670 Pages—
3,642 Trade Illustrations

PRACTICAL TRADE INFORMATION ON:

Soldering, tinning. Joint wiping, bending, beating. Pipe—iron—steel, threading. Mathematics, tables, physics. Materials—iron, steel, copper, brass, lead, tin, antimony, etc. Sheet metal—galvanized—plate. Sanitation, syphonage, tanks. Drainage, sewage, purification. Fixtures—bath—kitchen. Pipe fittings, soil pipe, tools. Laying out work. Roughing. Screwed fittings, flanges, joints. Pipe bending, examples. Elbows. Heating, ventilation, air conditioning, refrigeration. Water supply, mains, wells, tanks. Gas-fittings. Sheet metal work, problems, methods. Brazing, heating, lead burning. Welding, various welds, methods. Blacksmithing, forges, tools. Copper Tubing. Marine Pipe Fitting & Oil Burners. **HIGHLY ENDORSED—ASK TO SEE THEM. TO GET THIS ASSISTANCE FOR YOURSELF, FILL IN AND**

MAIL ORDER

AUDEL, Publishers, 49 W. 23rd St., New York 10, N. Y. Mail Audels Plumbers' Guides, 4 vols. on 7 days' free trial. If O. K. I will remit \$1 in 7 days and \$1 monthly until \$6 is paid. Otherwise I will return them. No obligation unless I am satisfied.

4 \$6
VOLS. 6
COMPLETE
PAY ONLY \$1 A MO.
Name _____
Address _____
Occupation _____
Employed by _____ PM

PROFITABLE HOBBIES



Let us show you how extremely easy it is to make beautiful and useful things out of LIQUID PLASTICS, LIQUID MARBLE, LIQUID IVORY, LIQUID GLASS, CERAMICS, ETC. . . as easy as pouring water out of a glass! Make novelties, jewelry, gifts, artware, toys, tools, dies, gadgets, ceramics . . . a million useful things! We supply everything—MATERIALS, INSTRUCTIONS and BUYERS! Send only 25c for 1. Big catalog of 300 casting materials, molds and accessories. 2. A beautiful CAMEO free (to show you what you can do), and 3. Actual INSTRUCTIONS on how to cast and start in the CASTING BUSINESS! Send 25c today—this may be the lucky coin that will start the most fascinating and profitable phase of your life! (Catalog only—10c)

PLASTICAST COMPANY (DEPT. C)
4637 N. Kedzie Ave. (Write to Chicago 25, Ill. nearest address)
P. O. Box 987
Polo Alto, Calif.
CANADIAN CUSTOMERS, please order directly from: CANADIAN INDUSTRIAL PLASTICS, LTD., 1076 1/2 Pender West, Vancouver, B. C.

"LEARN-BY-DOING" ELECTRICITY

NATION'S LARGEST EXCLUSIVE ELECTRICAL SCHOOL
G.I. APPROVED
Practical Electricity; Housewiring, Motors, Const., Maintenance, etc. Living arrangements. Part-time jobs, etc. A post card brings the story.
MICHIGAN TECHNICAL INSTITUTE, Dept. PM-3
2281 W. Fort St., Detroit 16, Michigan



LABORATORY TECHNICIAN

BE A LABORATORY SPECIALIST; complete course. Big demand from hospitals, doctors, clinics. We teach all branches of medical laboratory work, including Medical and Dental X-Ray. Approved by American College of Medical Technologists
Co-educational Free Placement Bureau
Free Catalog
Accredited for "veteran" training
CHICAGO COLLEGE OF LABORATORY TECHNIQUE
Dept. P.M., 431 S. Wabash Ave. Chicago 5, Illinois



STURDY 7 JEWEL WATCH \$5.75

Excellent timekeeper. Accurate Swiss Movement. Heavily plated in Chrome. Thin Model that looks so grand on a man's wrist.
• Written Guarantee • Radium painted numerals and hands • Easy to read—non reflecting dial • Sweep Second hand • Unbreakable Crystal • Double Chrome plated.
An excellent value for \$5.75 plus 10% tax (\$6.33). Mail your order NOW. Send Check or Money order. C.O.D. orders plus postage.
DELUXE MODEL: with Metal Stretch Band (\$7.57 including Tax).
CHARM SALES CO.
125 East 46th St., Dept. 1707-C, New York 17, N.Y.

STAMMERER?
New booklet, "Stammering, and How to Stop It," sent free to any stammerer upon request. Write today. BENJAMIN N. BOGUE, Dept. 504, Circle Tower, Indianapolis 4, Ind. GET THIS FREE BOOK!



FREE!
SAMPLE!
That GLOWS IN THE DARK!
An Easy Way To MAKE BIG MONEY
Be the first to sell sensational luminous house numbers, light switch plates, wall protectors, cord pulls, novelties, etc. Also luminous pictures, ash trays, keyholders, statues, decals, religious, nursery objects, etc. **THAT GLOW IN THE DARK. SELL ON SIGHT. Get into this new and growing industry. ENORMOUS DEMAND . . . NO COMPETITION . . . BIG PROFITS.** Represent a large manufacturer, established over 35 years. **Write at once for liberal MONEY-MAKING offer and FREE samples to show you HOW THEY GLOW IN THE DARK.**
Madison Mills, 303 Fourth Avenue
DEPT. G-4 NEW YORK 10, N. Y.



What's the matter...
**NOT SATISFIED WITH
 YOUR PAY CHECK?**

Home study training, in spare time, can increase your earnings!

For 52 years we've been training men for BETTER JOBS AT BIGGER PAY

The successes of thousands of today's money-makers started in a coupon similar to the one below, which they checked, signed and mailed to AMERICAN SCHOOL. The information they received opened doors of real opportunity, and steps upward

which brought promotions and better living through bigger pay checks.

● Who earns promotions — more money — security? It's the ambitious man with know-how and the self-confidence that comes from training. It's the man who looks far beyond the next pay day and sets his goal. He is determined to merit responsibility and its rewards, and is willing to devote some of his spare time to acquiring the knowledge that will give him the power to climb. For over half a century American School has provided specialized training for commercial and technical advancement. It has enabled men to *earn* more while they *learned* more and win promotions. In almost every business field you'll find highly paid leaders whose success began with American School training.

IT COSTS SO LITTLE — PROVIDES SO MUCH

At a cost you can afford and in hours you might otherwise waste you can prepare to climb in the field of work you prefer. American School, an educational institution *not for profit*, offers you a wide choice of training opportunities. Give serious thought to the list in the coupon, then check one or more subjects, add your name and address and mail it. You will receive full information, without obligation of any kind. Do it now. You'll be glad you did.

PRACTICAL, EFFECTIVE HOME

STUDY TRAINING SINCE 1897

Take This First Easy Step

CHECK, CLIP AND MAIL COUPON NOW

AMERICAN SCHOOL, Dept. G-345, Drexel at 58th, Chicago 37, Ill.

Without obligation, please send me FREE information on training course checked below.

- | | | |
|---|--|---|
| <input type="checkbox"/> Accounting | <input type="checkbox"/> Business Management | <input type="checkbox"/> Plastics Engineering |
| <input type="checkbox"/> Air Conditioning | <input type="checkbox"/> Contracting | <input type="checkbox"/> Plumbing—Practical |
| <input type="checkbox"/> Architecture & Building | <input type="checkbox"/> Diesel Engineering | <input type="checkbox"/> Private Secretary |
| <input type="checkbox"/> Automotive Engineering | <input type="checkbox"/> Drafting & Design | <input type="checkbox"/> Radio Operating & Servicing |
| <input type="checkbox"/> Aviation—Practical | <input type="checkbox"/> Electrical Engineering | <input type="checkbox"/> Railway Training |
| <input type="checkbox"/> Aviation Drafting & Design | <input type="checkbox"/> Electricity—Practical | <input type="checkbox"/> Refrigeration |
| <input type="checkbox"/> Better Foremanship | <input type="checkbox"/> Electronics, Industrial | <input type="checkbox"/> Sheet Metal Pattern Drafting |
| <input type="checkbox"/> Bookkeeping | <input type="checkbox"/> High School Courses | <input type="checkbox"/> Shop Management |
| | <input type="checkbox"/> Machine Shop Operations | <input type="checkbox"/> Tool Making |
| | <input type="checkbox"/> Mechanical Engineering | |

Name _____ Occupation _____

Address _____ Age _____

City & Zone _____ State _____

AMERICAN SCHOOL
 Dept. G-345, Drexel at 58th Street, Chicago 37



**YOU
can
acquire**

LAW NIGHTS AT HOME! L. B. DEGREE

LaSalle's famous Law Library—used as reference in many Law libraries and Law offices—has enabled thousands to master Law surprisingly fast, in spare hours at home, for business and professional advancement.

These 14 remarkable volumes, compiled by leading professors and lawyers, cover the whole basic field of Law in condensed, orderly, simplified manner.

You advance rapidly with this great library, plus special lectures furnished. We guide you step-by-step with personalized Problem Method of instruction . . . you *learn by doing*—handling legal problems—not by memorizing rules.

Send for two FREE 48-page booklets, "Law Training for Leadership," and "Evidence," answering questions about Law and its value to you, and telling how LaSalle Law graduates are winning rapid advancement in business and public life. Mail coupon below. No obligation.

LA SALLE EXTENSION UNIVERSITY A Correspondence Institution

417 S. Dearborn St., Dept. 364-L, Chicago 5, Ill.

Send me your two FREE booklets described above; without obligation.

Name..... Age.....

Street.....

City, Zone & State.....

BIG PAY JOBS for men who qualify in DIESEL



ASSURE YOUR FUTURE. Steady, high-pay jobs await men qualified in Diesel, Tractor, and Heavy Equipment. Are you qualified for job and advancement opportunities in this fast-growing field? You can qualify!

COMPLETE DIESEL COURSE NOW AVAILABLE. If you are ambitious and want to get ahead in this big money field, you'll want to know about the complete Diesel home training course now offered by Interstate Training Service. Covers all phases of operation, repair, service. Easy to master in spare time. No interference with present job. Up-to-the-minute. Regularly revised to cover new developments. We invite comparison of material offered. Free placement advisory service.



YOU OWE IT TO YOURSELF to investigate Interstate Training Service Diesel Training. Thousands agree it has helped them to better jobs... better pay. It can do the same for you!

SEND FOR FREE BOOK TODAY!

INTERSTATE TRAINING SERVICE, Portland 13, Ore.
Please see that I receive FREE 24-page book,
"Getting Ahead in Diesel." (K-3)

NAME..... AGE.....
ADDRESS.....
CITY..... ZONE..... STATE.....

PRINT YOUR OWN POST CARDS

**COMPLETE
OUTFIT
only
\$7.50**



Amazing results in sales, inquiries and contacts . . . saves time and money . . . very easy to use GEM STENCIL DUPLICATOR is ideal for Advertising, Announcements, Notices, Labels, Forms, Price Lists—hundreds of uses for every type of business and organization. Comes complete with all supplies, instructions and 60-page Book of Ideas.

FREE TRIAL OFFER: Try it before you buy it! Write and a GEM OUTFIT will be sent you postpaid. After 10 days, send only \$7.50 or return the GEM, no questions asked. The GEM must sell itself; you be the judge.

**BOND EQUIPMENT CO. • Dept. 135
6633 Enright • St. Louis 5, Mo.**

SEND NO MONEY • FREE TRIAL OFFER

STOP AUTO ACCIDENTS



with new STOP LIGHT FLASHER!

MAKES YOUR STOP LIGHT FLASH 115 TIMES A MIN.

FREE OFFER TO YOU! The "Stop-It" warns cars behind—makes your stop light flash on & off, on & off! Completely automatic, acts instantly when you step on foot brake . . . attaches in 5 minutes to any car or truck. Approved by safety engineers, used by Police & Fire depts. Non-rusting, dust, oil, vapor, waterproof. Write NOW for free introductory offer—no obligation. Get this amazing "Stop-It" for your car at no cost to you! Dealers, salesmen wanted.

MACCHI & CO., Dept. MC, 927 Larkin St., San Francisco 9, Calif.

EASY TO LEARN CODE

Learn or increase speed with an Instructograph—the Radio-Telegraph Code Teacher that takes the place of an operator-instructor and enables anyone to master code without further assistance. Available tapes from beginners' alphabet to typical messages on all subjects. Speed range 5 to 40 WPM. Always ready—no QRM. Thousands have "acquired the code" with the Instructograph System. Write today for convenient rental and purchase plans.

INSTRUCTOGRAPH COMPANY

4701-V Sheridan Road, Chicago 40, Illinois



LIFE AFTER DEATH

"Heaven and Its Wonders, and Hell"

by **EMANUEL SWEDENBERG**, with a brief biography of this famed theologian, philosopher and scientist. 632 page book, treating fully of life hereafter, will be sent for **5¢**



List of publications free.
The SWEDENBERG FOUNDATION
Room 161B, 51 E. 42nd St., New York 17, N.Y.

NEED MORE? MONEY?

Thousands already earn big, steady profits selling famous Bostonian shirts, rainwear, hosiery, underwear and other everyday needs for men, women and children. Also new line of Hamilton shoes. No selling experience needed—if you're keen and really want to assure yourself of a steady income, Bostonian will back you and set you up in business. You get big profits, immediate cash and big selling kit. Our Company has tripled its business in the last year. Write now—big Spring season ahead. Bostonian Mfg. Co., Dept. 339, 89 Bickford Street, Boston 30, Mass.

Write for
**FREE
Selling
Kit**

AMAZING NEW OFFER!

LEARN HOW TO MAKE REAL MONEY IN

TELEVISION

RADIO & ELECTRONICS

YOURS TO KEEP AND ENJOY

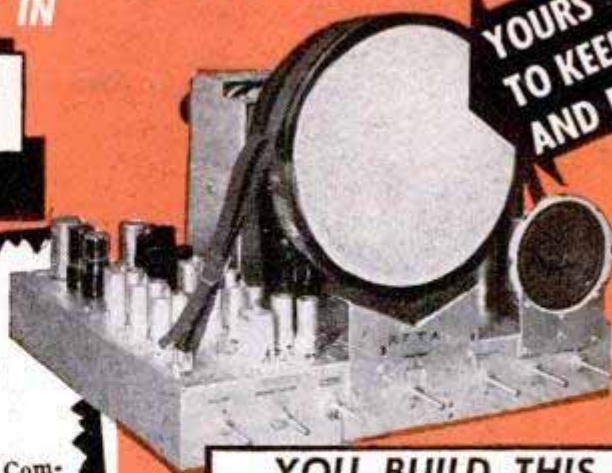

YOU BUILD THIS
LARGE SCREEN
TELEVISION RECEIVER

YOUR CHOICE OF 10, 12½ OR 16 INCH
PICTURE TELEVISION TUBE

CAN BE CONVERTED
FOR COLOR TELEVISION



R.F. SIGNAL GENERATOR

YOU
KEEP ALL
EQUIPMENT

YOU GET
15 BIG
TELEVISION-
RADIO KITS
AT NO EXTRA COST.
YOU BUILD THESE
ILLUSTRATED
UNITS



MULTITESTER



AUDIO OSCILLATOR

STUDY
AT HOME
IN YOUR
SPARE
TIME

AT NO EXTRA COST! YOU GET A ROUND TRIP TO NEW YORK CITY

After you have completed the home study section of your course, your transportation to *New York City*—both ways—from any point in the United States or Canada will be paid by RTTA. At our affiliated training shops in *New York City* you'll get 2 solid weeks—50 hours of intensive laboratory work—on the most modern and scientific equipment. You'll live in *New York City*, the heart of the television industry, where the headquarters of the National Broadcasting Company.

American Broadcasting Company, Columbia Broadcasting System, Mutual Broadcasting System and many large television and radio companies are located.

FREE EMPLOYMENT HELP

Upon completing your laboratory resident course, you will personally be recommended for a position by our placement director, who will help you get started toward a money-making future in television, radio and electronics.

IN DOUBLE QUICK TIME EARN BIG PAY,

OWN YOUR OWN BUSINESS

Now—you can qualify for a money-making career, through RTTA's sensational plan. In addition to becoming a CERTIFIED TELEVISION TECHNICIAN, you build yourself a complete large screen television set of the finest commercial quality, for your own use. You get 15 BIG KITS to enable you to get practical experience, build the equipment illustrated, plus a 6 TUBE STANDARD SUPERHETERODYNE radio set, and many other testing units.

No matter where you live, no matter what you do, RTTA's effective methods can help you toward a FAT PAY CHECK OF YOUR OWN BUSINESS. Previous experience is unnecessary.

ALL EQUIPMENT FURNISHED

The kits you will receive contain all the necessary TUBES and BATTERIES... a complete set of tubes for your TELEVISION RECEIVER including the PICTURE TUBE. In addition, you'll receive everything needed to build a complete TV set, and many more testing units.

EARN WHILE YOU LEARN

You will learn how to earn money in your spare time, without interfering with the work you are now doing. From the very beginning, the RADIO TELEVISION TRAINING ASSOCIATION's plan is a practical MONEY-MAKING COURSE. We will show you how to cash in on your new knowledge, even while you are learning. Act now by clipping the coupon to find out how you can become a CERTIFIED TELEVISION TECHNICIAN and earn extra money.

YOU GET YOUR FCC LICENSE

RTTA prepares you to qualify for your FCC license. Pay is higher for the FCC license holder because only a comparative few of the thousands of men in radio-television today hold FCC tickets.

FREE!

Get the new career book "HOW TO MAKE MONEY IN TELEVISION", and sample lesson to show you how easily you can train for a money-making job. Send for them today. Absolutely no cost, no obligation. RADIO TELEVISION TRAINING ASSOCIATION, Newark, N. J.

RADIO TELEVISION TRAINING ASSOCIATION
972 BROAD STREET
NEWARK 2, NEW JERSEY

MAIL COUPON NOW!

RADIO-TELEVISION TRAINING ASSOCIATION, DEPT. S-KM
972 Broad Street, Newark, N. J.

Send me, absolutely free, your book, "HOW TO MAKE MONEY IN TELEVISION" and the sample lesson of your course. I understand no salesman will call on me.

NAME _____ AGE _____
ST. & No. _____
CITY _____
STATE _____ ZONE _____



YOU CAN HAVE THIS KIND OF BUSINESS..

A big business where there is a constantly growing demand . . . all of the time. **ELECTRICAL APPLIANCE SERVICING!** Millions of new appliances are sold annually. All will eventually need repair.

•• IF YOU ARE AMBITIOUS

Want Financial Security . . . want Independence . . . a profitable business of your own, full or part time . . . or just extra spare time earnings. Learn **ELECTRICAL APPLIANCE SERVICING**. Age is no barrier.

•• IF YOU ARE WILLING TO DEVOTE SPARE TIME

Our New Shop Method Home Training Program will bring practical and technical Electrical training right into your home! You learn by working with your hands . . . Building, Testing, Repairing.

•• IF YOU ARE MECHANICALLY INCLINED

Like to "tinker" with tools . . . CTS will send you their big **FREE Illustrated Book**, "Electrical Appliance Servicing" and special form for getting their Electronic Kit, special training kits, etc., on a "Pay from earnings while learning" plan.

•• IF YOU MAIL THIS COUPON TODAY!

CHRISTY TRADES SCHOOL, Dept. D-7903
4432 N. Kedzie Ave., Chicago 25

Please rush me **FREE BOOK**, Facts about **ELECTRONIC KIT**, Special form for paying from "Earnings While Learning".

Name _____ Age _____

Address _____

City _____ Zone _____ State _____

BOOK WORTH \$3,500

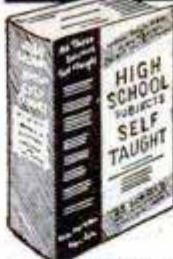

FREE!
READING OFFER

A YEAR TO YOU!

Big Pay Jobs Waiting for HIGH SCHOOL GRADUATES

Big 1250 page book shows you how to qualify quickly in only 15 minutes a day spare time reading! Records prove High School Graduates average \$3500. a year more than untrained men and women. "High School Subjects Self Taught" makes it easy to learn more and earn more. No tedious study, but fascinating reading. No class room examinations. You "Pass" yourself! Write now! Get Book that can mean a small fortune to you.

SEND NO MONEY. Pay postman \$9.95 plus postage, or send money, order or check and book will be sent postpaid. Read book for 5 days. Show friends, High School Teachers, Students. If you don't agree this Book is best investment you ever made, return for full refund by next mail.

Mail order today and we'll include **FREE 150-page book** of study material to help you take and pass test for a **HIGH SCHOOL EQUIVALENCY DIPLOMA** (legally equivalent of diploma issued upon graduation after four years high school, now possible without high school attendance, in practically every State. Don't delay. Send order now to: **NATIONAL SELF-STUDY INSTITUTE, INC.**, 90-61 Sutphin Boulevard, Jamaica 2, N. Y.

FREE "HOW TO ANSWER ADS"



Never before have you seen anything like this. Tells you in simple language the correct way to answer ads. Gets you quicker replies—better results, and greater satisfaction. Will save you time and money and it's **ABSOLUTELY FREE**. No obligation whatever. Every reader of advertising should have this booklet. Send a postcard for your copy **NOW**. Advertising Department, Popular Mechanics Magazine, 200 East Ontario Street, Chicago 11, Ill.

AJAX LIGHT BRAHMAS

Wonderlay Strain Egg-show winners. Gigantic size. Quick growing. Heavy layers. Exceptional big capons. U. S. Approved-Pullorum Controlled. Thousands hatching weekly. Low farm prices. Catalog **FREE**. Write **TODAY**.
AJAX HATCHERY, Box 916, QUINCY, ILLINOIS

make MONEY CASTING AT HOME

Make your own rubber molds quickly, cheaply with **X.L. RUBBER**. Cast thousands of perfect figurines, book ends, plaques, ornaments, ash trays, etc. **GREAT PROFITS!**
Write for **NEW Catalog**.
X.L. Rubber, Pts. \$2.00; Qts. \$3.50; Gallons \$8.95; Models and enough rubber for 3 molds \$1.30 postpaid.
PLASTIC ARTS STUDIO Dept. 2, 3403 S. MADISON ST., Muncie Ind.

BIG MONEY SIGN PAINTING

Learn in Spare Time

Quickly become an expert. Tremendous demand everywhere for trained men. We teach you quickly—at home in spare time. No previous experience or artistic talent needed. Simple, illustrated Course quickly qualifies you to start a Big-Pay Business of your own.

FREE! Don't send a penny—just your name and address on postcard and we will send you—absolutely free—complete information and valuable money-making facts on how you can quickly land a Big-Pay Job, or get started in a Business of Your Own. No cost—or obligation. Rush name and address today to Farrell School of Commercial Sign Lettering, 734 Long Ave., Chicago 44.

Tells How You Can Learn to MOUNT BIRDS!

FREE BOOK

Learn At Home
Men, Boys, Hunters, Fishermen, mount and save your lovely wild-game trophies. Be a Taxidermist. Mount Birds, Animals, Heads, Fish, Tan skins. YOU learn easily, quickly in spare time. Have a grand home-museum. The finest and the greatest hobby known, for sportsmen. Fun, real profits.

FREE BOOK
Yes, **FREE**. Beautiful strange, valuable **Book**, telling all about Taxidermy. Contains over 100 beautiful game-pictures. And it's yours **FREE**, if you rush your request. You can mount all kinds of wild-game, and common specimens too. We can positively **TEACH YOU**. So **GRASP** this opportunity. **RUSH** letter or postal for this amazing **FREE BOOK**. Don't delay. State your **AGE**.
N. W. SCHOOL OF TAXIDERMY, 2503 Elwood Bldg., Omaha 2, Neb.

Get into the World's Fastest Growing Industry

I Can Train You at Home For a Fascinating Money Making Career in RADIO and TELEVISION



Not in two decades has such an opportunity been available as is now presented to the ambitious, forward looking man to get into a giant new industry of the future, at the start of its growth.

Television, the hand-maiden of radio, has just started to grow. Now is the time to get the training that can equip you for a bright, successful career in this world's fastest growing industry. Such an opportunity may not come again in your life-time. My 2-way method of training, lesson instruction PLUS actual practice has been planned to train you FASTER, MORE THOROUGHLY, right in your home.

My 2-way method gives you actual practice



You construct scores of circuits like those shown below

I SEND YOU 10 Big Kits of parts with your training with which you make HUNDREDS of tests, build SCORES of circuits, to help you learn MORE THOROUGHLY, FASTER.

You Keep All Kits

After performing hundreds of tests and experiments, you then construct the 6-tube, 4-band super-heterodyne receiver, and Multi-purpose Shop Test Panel shown here, with the parts I send you. Thus, you have TWO valuable pieces of equipment.



APPROVED FOR VETERANS

Check Coupon

If a veteran of World War II

HOLLYWOOD RADIO & TELEVISION INSTITUTE
810 West 6th St., Los Angeles 14, California, U.S.A.



Thousands of new Television Receivers are being sold each day—more Television Stations are coming on the air each month. It is predicted that Radio-Television will be one of the world's top ten industries in the next 5 years.

MAKE YOUR MOVE NOW!

Now is the time to get the training that will help prepare you for success in Radio-Television. But be sure that you get the best training available, for your future success may well be measured by the quality of the training you get.

FREE!

Sample TV Lesson and 56-page Book which explains my 2-way method of training, actual practice PLUS lesson instruction.

Sending for this book has marked the turning point in the lives of many men. You owe it to yourself to find out about H.R.T.I. training. Mail below coupon TODAY!

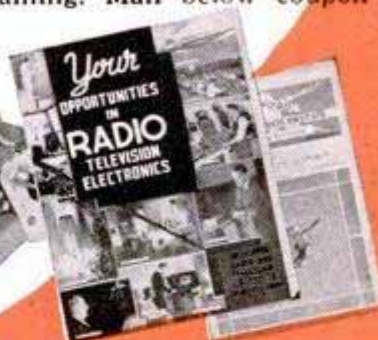

C. H. MANSFIELD, Pres., Dept. A-19 (Established 1929)
Hollywood Radio and Television Institute
810 West Sixth St., Los Angeles 14, California, U.S.A.

Send me your FREE book, "Your Opportunities in Radio, Television and Electronics," which explains your 2-way home study training method. Also the FREE Sample Television Lesson.
No Salesman Will Call

Name _____
Please print or write plainly your name and address

Address _____

City _____ Country _____

If a veteran of World War II, check here

Learn CLOCK Repairing in THREE *Easy* LESSONS AT HOME

There is big money to be made in this fascinating field—

And you need no previous experience to become expert in clock repairing.

We teach you in three easy lessons how you can overhaul and repair an alarm clock—mantel clocks—and even chime and grandfather clocks. Our course consists of three simple, comprehensive lessons, explained in understandable, non-technical language that even a boy can understand.

There is nothing mysterious about clock repairing—almost any one can become proficient in a very short time, and start making extra money quickly. Our course has been prepared by experts in this field, and you can learn as fast as you choose.

WE GIVE YOU EVERYTHING YOU NEED TO START

Included as part of the course for you to keep are 2 pliers, clock tweezers, 7 screwdrivers, hand puller, 2 hammers, pinvise, eye loupe, hand drill, 8 drill bits, bench keys, 2 files, bench vise, set of closing punches, bench block, 4 brushes, cleaner, rinse, clock oil, oil cup, level, hand chuck, bundle of pegwood, 2 broaches, assorted pithwood. AND—a spring balance clock movement and an 8-day pendulum clock movement.

So learn clock repairing—send the coupon today for FREE information how you can get into this money-making, fascinating field quickly.

Course prepared by the Illinois School of Watch Repairing, the largest correspondence school of its kind in the world.

If more interested in watch repairing or jewelry repairing, check coupon below and mail.

MAIL COUPON TODAY.

Mr. E. KING
Illinois School of Watch Repairing, Dept. PM-3
2870 Elston Avenue, Chicago 18, Ill.

Send me at once without obligation FREE literature on

CLOCK REPAIRING
 WATCH REPAIRING JEWELRY REPAIRING

Name.....

Address.....

City, Zone & State.....

BE AN AUTO MACHINIST



Draw Top Pay • No Job Worries

Earn more money in auto mechanics—Specialize! New FREE booklet tells how to prepare for good jobs with high pay and job security. Our modern equipment and practical instructions make it easy to learn—get experience in

ENGINE REBUILDING or
GENERAL AUTO MECHANICS

Job Placement Service FREE

Practical Shop Training
Learn to operate the very latest shop machinery. Friendly instructors take a real interest in preparing you for a good job.

VETERANS
American is a G.I. approved school.

WRITE TODAY FOR
FREE BOOKLET

AMERICAN TRADE SCHOOL
2411 McGee Kansas City, Mo.

PLANNING YOUR FUTURE IN AUTO MECHANICS



FREE TO HOME PLANNERS

"Little Red Booklet" of 29 popular plans sent FREE to acquaint you with our MONEY SAVING home planning service which includes 1200 Tested Designs; beautifully illustrated plan books; working drawings; material lists; specifications—all at LOW COST. Write today for FREE RED BOOKLET and complete information. America's pioneer residential plan service.

YOUR NEW HOME PLANS.....50c
Modern homes for 1950
BLUE RIBBON HOMES.....50c
Chosen most popular in sales
ALL AMERICAN HOMES.....50c
More than 150 styles, all types
RANCH AND SUBURBAN.....50c
151 designs, town and country
YOUR HOME IN BRICK.....\$1.00
Excellent selections, all brick

NEW POPULAR BOOKS
SHOWING ALL TYPES
OF HOME DESIGNS
All 5 Books for \$2.50
Postpaid
Many designs in color

L. F. GARLINGHOUSE CO., INC., Box PM-6 TOPEKA, KANSAS

RUPTURED?

Get Relief This Proven Way

Why try to worry along with trusses that gouge your flesh—press heavily on hips and spine—enlarge opening—fail to hold rupture? You need the Cluthe. No leg-straps or cutting belts. Automatic adjustable pad holds at real opening—follows every body movement with instant increased support in case of strain. Cannot slip whether at work or play. Light. Waterproof. Can be worn in bath. Send for amazing FREE book, "Advice To Ruptured," and details of liberal truthful 60-day trial offer. Also endorsements from grateful users in your neighborhood. Write:

CLUTHE SONS, Dept. 31, Bloomfield, New Jersey

LEARN MONEY-MAKING CARTOONING

IN SPARE TIME — by Easy Picture Chart Method

Same Simplified Method that has helped train creators of "Terry & Pirates," "Freckles," "Out Our Way," "Winnie Winkle," "Regular Fellers," "Strange As It Seems," "The Neighbors," and many others. Earn while learning. Send 10c for Picture Chart (to test your ability), and full details. (State age.)



THE LANDON SCHOOL, 5003 Cleve. Transit Bldg., Cleveland, O.

Learn CARPENTRY BRICK LAYING

Big money in the Building Trades. Learn now while opportunities are greatest. Train in our completely equipped shops under expert instructors, or by Home Study. Veterans attending school entitled to G.I. Benefits. Write for FREE catalog.

MIDWEST SCHOOL OF BUILDING TRADES, Dept. PM-3
411 N. Center St. Bloomington, Ill.



Thrilling Work COLORING PHOTOS

Fascinating vocation learned at home by those with aptitude. Thrilling pastime. National method brings out life-like colors. Free booklet.

NATIONAL PHOTO COLORING SCHOOL
1315 S. Michigan, Dept. 1353, Chicago 5

**YOU BUILD THIS
23-TUBE
TELEVISION
RECEIVER**

NOW!

FOR THE FIRST TIME YOU CAN GET
Real Practical HOME TRAINING In

TELEVISION

RADIO AND ELECTRONICS

RTS LEADS THE WAY

WE GIVE YOU

**11 BIG
TELEVISION
AND RADIO KITS
AT NO EXTRA COST**

**YOU WORK AND LEARN
WITH REAL TELEVISION
AND RADIO EQUIPMENT**

RADIO-TELEVISION TRAINING SCHOOL'S master Technicians guide you. Located in the very heart of America's Television, Broadcasting, Radio and Sound Industries, RTS is right "on-the-spot" where new technical improvements are first introduced; is in the best possible position to bring students ACTUAL METHODS and practices developed by the RADIO-TELEVISION industry, leading to real money making opportunities. The 11 BIG KITS RTS gives you enable you to do many practical jobs, build the equipment illustrated; perform more than 100 other fascinating, valuable experiments. These jobs you do give you ACTUAL SHOP experience so vitally necessary to your future success. Thus RTS methods assure you BALANCED TRAINING—Theory PLUS Real Experience.

**OPPORTUNITIES NOW
WIDE OPEN FOR
Properly Trained Men**

Latest reports estimate 400 MILLION new television and radio sets will be built in the next 10 years . . . more than 72 million dollars is being spent RIGHT NOW just for radio repairs ALONE! When you are thoroughly trained by RTS Experts—who have their fingers on the pulse of the Radio-Television industry—a field of unlimited opportunities will open up for you in Your Own Radio-Television Sales & Service Business, F.M., Equipment Manufacturing, Communications and allied fields.

**EARN EXTRA MONEY
while learning at HOME**

Under the RTS amazingly easy, practical home-training plan there is no need for you to quit your present job. You study in SPARE TIME ONLY! RTS Experts show you how

to earn WELCOME EXTRA CASH, even BEFORE FINISHING YOUR TRAINING! In fact, when friends and neighbors know you are studying Radio-Television of you may—like many RTS students—actually get MORE REPAIR WORK THAN YOU CAN HANDLE.

**27 YEAR
SUCCESS RECORD**

Backed by over a quarter-century of experience in home training, RTS (formerly Radio Training Association of America) offers practical "Learn-by-doing" methods, assuring you quick step-by-step progress. Begin preparing for your future in Radio-Television now while the time is ripe. If you are at all mechanically inclined—and have a grammar school education, RTS can teach you how to MAKE GOOD in Radio-Television.

GET THE FACTS

Send for FREE BOOK which tells you all about the RTS "time-tested" home-training plan, developed by technicians in the heart of the Radio-Television field. Fill out the coupon now—TODAY! and your FREE BOOK entitled "How To Make Good in Radio-Television" will go out to you AT ONCE. No Obligation. No salesman will call. ACT NOW!

**YOU BUILD THIS
6-TUBE STANDARD
RADIO SET with
SHORT WAVE
CONVERTER**

**★
SEND
FOR THIS
30-PAGE
FREE
BOOK
★**

**YOU
KEEP ALL
EQUIPMENT
—it's Yours!**

RADIO-TELEVISION TRAINING SCHOOL
5100 SO. VERMONT AVE., LOS ANGELES 37, CALIF., U.S.A.
ESTABLISHED 1922 — 27 YEARS AGO

RADIO-TELEVISION TRAINING SCHOOL, DEPT. PM-3
5100 South Vermont Avenue, Los Angeles 37, Calif., U.S.A.

Send FREE Illustrated Book showing how I can make good in TELEVISION and Radio through training under the guidance of expert RTS Technicians. No obligation. (No Salesman will call).

NAME _____ AGE _____
ST. & No. _____
CITY _____ ZONE _____
STATE _____

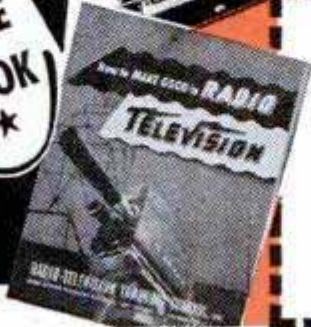

AUDELS Carpenters and Builders Guides 4 vols. \$6

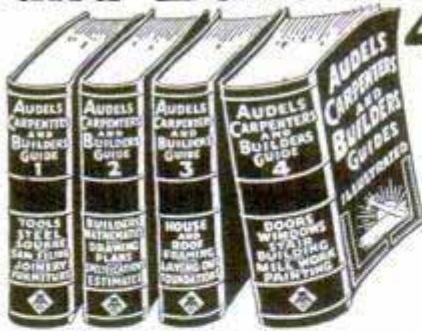

Inside Trade Information for Carpenters, Builders, Joiners, Building Mechanics and all Woodworkers. These Guides give you the short-cut instructions that you want—including new methods, ideas, solutions, plans, systems and money saving suggestions. An easy progressive course for the apprentice and student. A practical daily helper and Quick Reference for the master worker. Carpenters everywhere are using these Guides as a Helping Hand to Easier Work, Better Work and Better Pay. To get this assistance for yourself, simply fill in and mail the FREE COUPON below.

Inside Trade Information On:

How to use the steel square—How to file and set saws—How to build furniture—How to use a mitre box—How to use the chalk line—How to use rules and scales—How to make joints—Carpenters arithmetic—Solving mensuration problems—Estimating strength of timbers—How to set girders and sills—How to frame houses and roofs—How to estimate costs—How to build houses, barns, garages, bungalows, etc.—How to read and draw plans—Drawing up specifications—How to excavate—How to use settings 12, 13 and 17 on the steel square—How to build hoists and scaffolds—skylights—How to build stairs—How to put on interior trim—How to hang doors—How to lath—lay floors—How to paint



AUDEL, Publishers, 49 W. 23rd St., New York 10, N. Y.
Mail Audels Carpenters and Builders Guides, 4 vols., on 7 days free trial. If OK I will remit \$1 in 7 days and \$1 monthly until \$6 is paid. Otherwise I will return them. No obligation unless I am satisfied.

Name _____
Address _____
Occupation _____
Employed by _____ PM

Learn A Trade NOW! PRACTICAL SHOP TRAINING!

In Our Chicago Shops

- | | |
|---|--|
| <input type="checkbox"/> AUTO MECHANICS | <input type="checkbox"/> WELDING—ARC and GAS |
| <input type="checkbox"/> DIESEL MECHANICS | <input type="checkbox"/> MACHINIST |
| <input type="checkbox"/> REFRIGERATION | <input type="checkbox"/> PIANO TUNING |
| <input type="checkbox"/> BODY-FENDER | |

Above Approved For G. I.'s and Civilians
One of America's Leading Practical Schools
7 Floors of Fully Equipped Shops
Over 48,000 Successful Graduates
Expert Individual Instruction
Learn by Doing—Low Living Expense
Established 1902—Day and Evening Classes

Also the following Home Study Courses

- | | | |
|----------------------------------|--|---------------------------------|
| <input type="checkbox"/> PLASTIC | <input type="checkbox"/> REFRIGERATION | <input type="checkbox"/> DIESEL |
|----------------------------------|--|---------------------------------|

—CALL IN PERSON OR MAIL THIS AD TO—

GREER SHOP TRAINING

(Desk 16) 460 South State St., Chicago 5, Ill.

Please send without obligation free information regarding trade checked above. (Specify whether you are a Veteran or Civilian)

Name _____ Age _____
Address _____
City _____ State _____

SPEED AND POWER Handbook



50 CHAPTER LIBRARY EDITION
Build Fast Stock Cars! California Roadsters! 160 MPH Rods! Covers Crosleys to Cadillacs—all makes. Breathtaking Methods. Authentic—Direct from California!

SAVE MANY DOLLARS

Build your own Dual Manifolds! Superchargers! Hot Cams! Water Injectors! Hi-Compression Heads! Mileage Devices! Get up to ten more miles per gallon! Get racing speed, lightning acceleration, dynamic power increases from any make passenger automobile! Get construction drawings! Tuning techniques! Speed tricks! Economy secrets! Ingenious formulas! Covers "Racing Frames"—"Reciprocating Masses"—"Jet Engines"—"Braking Characteristics"—"Dynamometers"—"Dual Pipes, Gears, Fuels, Manifolds, Porting, Relieving, Lowering! Balancing, Including 1950 Racing Equipment Catalogue!"



Includes "CALIFORNIA AUTOMOBILE CUSTOMIZING"—Drawings! Photographs! Diagrams! Newest Ideas! Conversions! CarsonTops! Restyling all makes! Streamlining! Chopping! Channeling! Complete—\$1.98 Postpaid.
NEWHOUSE AUTOMOTIVE INDUSTRIES
5805 EAST BEVERLY BLVD. DEPT. B4
LOS ANGELES 22, CALIF.

New MIRACLE WALL CLEANER

Saves Costly Redecorating!
AMAZING INVENTION. Banishes old-style housecleaning mess and fuss. No tags—no sticky "dough"—no red, swollen hands. No more dangerous stepladders. Literally erases dirt like magic from walls, ceilings, window shades, upholstery, furniture, etc. Endadurocery! SAVES REDECORATING!
SAMPLES FOR AGENTS Sample offer sent immediately to all who send name at once. A penny postal will do. SEND NO MONEY—just your name, KRISTEE CO., 696 Bar Street, AKRON, OHIO.

LEARN TO WRITE a Good Hand!

FOR BUSINESS AND SOCIAL SUCCESS!
Easy to improve your handwriting at home quickly with my new instruction books just off the press. Master all the secrets of better penmanship. Simple and easy, fully illustrated, highly endorsed. Begin today. Write for: New Free Book, "How to Become a Good Penman," or check books wanted, \$1.00 each. Business Writing Artistic Writing Card Writing Engraving Alphabets Bird and Design Flourishing Complete Set \$4.50 Enclose 10c for your name beautifully written and special postpoint for shaded writing.
S. A. Ziller, President, TAMBLYN SCHOOL OF PENMANSHIP
441 Ridge Bldg. In Business Over 52 Years Kansas City, Mo., U.S.A.

NEW! LOW COST! RESPIRATOR

Wear when sanding, grinding, paint spraying, sweeping, dusting, furnace cleaning, etc. Handy as a pair of glasses. Just keep mouth closed and breathe through nose is all you do to operate. Protects against nuisance dusts, lint, coal, cement, grain dust, hay fever pollen. Has 9 sq. in. filter. For EYE protection against paint spray, dusts, soot, fumes, smoke, order our Fog-Proof Rubber GOGGLES \$1.65p.p. (All prices postpaid in U.S.A.)
JERRY BRYANT, Dept. PM
919 N. Michigan Ave. Chicago 11, Ill.

HIGH SCHOOL AT HOME — IN SHORTEST POSSIBLE TIME

Course prepares you for College entrance, professional schools, and personal advancement. Diploma awarded. Why be handicapped all your life when you can become a High School graduate with so little effort? Write for free prospectus. See what High School training did for so many of our graduates—what it can do for YOU. Residence course approved for veterans.

ACADEMY FOR ADULTS, Dept. 23
30 W. Washington, Chicago 2, Illinois

Say You Saw It in Popular Mechanics

FALSE TEETH

KLUTCH holds them tighter

KLUTCH forms a comfort cushion; holds dental plates so much firmer and snugger that one can eat and talk with greater comfort and security; in many cases almost as well as with natural teeth. Klutch lessens the constant fear of a dropping, rocking, chafing plate. 25c and 50c at druggists... If your druggist hasn't it, don't waste money on substitutes, but send us 10c and we will mail you a generous trial box. © I. P. INC.

KLUTCH CO. Box 5093-C ELMIRA, N. Y.

**\$200 GROSS IN MY
FIRST WEEK!**



**Some Make More, Some
Less . . . Start This Busi-
ness for YOUR OWN**

Would YOU like to own a permanent, year-round business in which it is possible to take in as much as \$200 gross the first week, as did L. A. Eagles? R. E. Traynor says, "I made \$62 gross in one day." R. R. Newlin reports, "I have averaged \$173 gross per week." Others report gross from \$100 per week to \$12,000 per year.

Surely YOU will want to investigate a golden opportunity like that. You need not have any special skill or experience, but if you are ambitious, honest and courteous, we will help you to start and succeed in YOUR OWN money-making business where net profits are high.

No Shop Necessary

Our Electric Rug Washer cleans rugs and carpets like new right on the customer's floor. This quick, thorough and highly efficient method removes dirt and grime, thus restoring the natural, fresh beauty of floor coverings. Anyone can run it. Rugs and carpets are not harmed.

There are hundreds of possible customers in YOUR vicinity. Most of them have several rugs needing regular cleaning. To get a quick start,

FREE BOOK! MAIL COUPON

**VON SCHRADER MFG. CO.
310 PL, Racine, Wis.**

Send at once (no obligation) your FREE booklet containing information about your Electric Rug Washer and how I can own my own permanent, profitable business.

Name _____

Address _____

City _____ (Zone) _____ State _____

shampoo a few rugs or carpets. These customers tell their friends and soon you should have an independent, prosperous business, and you should be able to keep it growing. Send the coupon RIGHT NOW for booklet that explains everything.

**Every Machine Guaranteed
and Easy to Own**

You take no risk. These wonderful, fully guaranteed machines have been used and endorsed by largest hotels, railroads—also used by U. S. Government. Many individuals have built up successful businesses that made big profits. Mail the coupon TODAY and we will send complete information, including how to start and succeed in YOUR business without a large investment. Don't delay your BIG opportunity. Send the coupon AT ONCE.



MAIL COUPON TO

VON SCHRADER MFG. CO., 310 PL, RACINE, WIS.

BE A PHOTO-ENGRAVER



We furnish complete equipment and supplies. Learn at home or in our modern, friendly APPROVED school in MISSOURI. Get into this big demand, high profit, high wage field. You can start your own profitable, full time or part time PHOTO-ENGRAVING business right in your own home.

Be independent, be your own boss or pave the way to a high pay job with experience gained in your own shop.

TASOPÉ TRAINING and TASOPÉ EQUIPMENT has enjoyed world wide recognition since 1931. Write for descriptive literature today. No obligation.

THE AURORA SCHOOL OF PHOTO-ENGRAVING, DEPT. 9PM., TASOPÉ BLDG., AURORA, MO.

BLISS Electrical Training

BLISS Intensive 32 weeks' residence course in fundamentals of industrial electrical engineering, including radio and electronics. Extensive laboratory, shop work, drafting. Prepares for electrical technician and engineering aides

in communications, power, manufacturing, business machines, sales, service. G.I. approved. 57th year. Enter March 6, Sept. 5. Catalog. 7628 TAKOMA AVENUE, WASHINGTON 12, D. C.



Watchmakers MAKE MONEY!

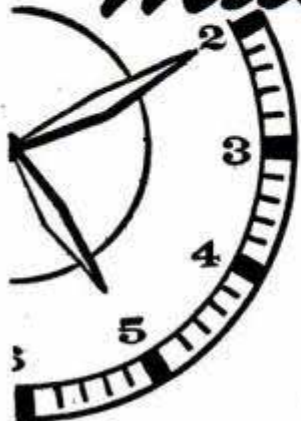

Large earnings with no dull seasons, professional dignity, a steady secure future are yours as a Master Watchmaker! You can

choose a fine job or go into your own business. The famous Sweazey System teaches you . . . expertly, quickly, successfully.

**SEND FOR FREE
BOOK NOW →**

Since 1908, Chicago School of Watchmaking graduates have been in constant demand. Write today for your free copy of our new illustrated book about the big opportunities in watch repairing, gem setting and engraving.

CHICAGO SCHOOL OF WATCHMAKING, 1608 Milwaukee Avenue, Chicago 47, Illinois, Dept. 130

Please send your new book, "Master Watchmakers Wanted" without cost or obligation.

- I am interested in attending residence school.
- I am interested in home study.
- I am a veteran. I am a non-veteran.

NAME _____

ADDRESS _____

CITY _____ ZONE _____ STATE _____

INVENTORS

Before you make any effort to market your invention, you should take the first steps toward proceeding for patent protection.

The usual first step is to have a search of the U. S. patent records conducted, so that I can report to you on the question of patentability.

I shall be pleased to furnish you with information relative to patent procedure and also on the matter of trade-mark registration, upon request from you, and this will be without any obligation on your part.

PATRICK D. BEAVERS

(Formerly RANDOLPH & BEAVERS)

Registered Patent Attorney

934 Columbian Building Washington 1, D. C.

INVENTORS

IF YOU WISH TO PROTECT YOUR INVENTION, You should take steps to protect it by a U. S. Patent. Write me for "Record of Invention" form.

CARL MILLER

REGISTERED PATENT ATTORNEY

WOOLWORTH BLDG., 35th FLOOR, 30A,
NEW YORK CITY

BE AN INVESTIGATOR

WORK HOME or TRAVEL. Experience unnecessary.

INVESTIGATOR Particulars FREE. Write to
GEO. M. P. WAGNER, 125 W. 86th St., N. Y.



LEARN MOVIE PROJECTION THEATRE MANAGEMENT

The Motion Picture Theatre Business offers big opportunities for trained men. Get into a fascinating field with a promising future. Train at home in spare time. Free Catalog. Established 20 years.

THEATRE SCHOOL, 370 Washington St., Elmira, New York

INVENTORS

Whether an invention is patentable can be substantially determined by a search of the U.S. Patent records. Without obligation, write for information explaining the steps you should take to secure a patent.

JOHN N. RANDOLPH

Registered Patent Attorney

201 Columbian Building, Washington 1, D. C.

INVENTING

-FOR PROFIT! If you have an inventive turn of mind, write for free 28-page booklet explaining how the Institute of American Inventors is helping inventors pre-test the profit possibilities of proposed devices to fill today's unprecedented demand for useful new inventions.

INSTITUTE of AMERICAN INVENTORS

Dept. 4, 631-E St., N.W., Washington 4, D. C.

PATENTS

AND TRADE MARKS

C. A. SNOW & CO.

REGISTERED PATENT ATTORNEYS

WRITE FOR INFORMATION TO

428 SNOW BUILDING, WASHINGTON 1, D. C.

PATENTS PATENT LAWYER

TRADE MARKS
GUSTAVE MILLER
30-PM WARNER BLDG.
WASHINGTON 4, D. C.

ASSOCIATE EXAMINER
U. S. PATENT OFFICE 1922-1929
Patent Attorney and Advisor
U. S. NAVY DEPT. 1930-1947
REGISTERED PATENT ATTORNEY
Send for PATENT INFORMATION
book and "INVENTOR'S RECORD"
without obligation

TRADE MARKS •
COPYRIGHTS •

PATENTS

The Time to Contact
a Patent Attorney is Promptly
After You Have Finished Your Invention

Write for FREE "INVENTOR'S GUIDE" & "Record of Invention"

FRANK LEDERMANN Registered Patent Attorney
154 Nassau St. • 20th Floor • New York 7, N. Y.

SAY YOU SAW IT IN POPULAR MECHANICS

BE A NOTARY PUBLIC

Old legal-supply house, 22 cities, helps you get appointment by governor if you qualify, equips you fully. Pay after appointment (2 payments \$12.50 each). Respected public office. You certify legal papers, use official seal made with your name, collect your fees. Easy, Inquire—
STATIONERS EXCHANGE HELOTES, TEXAS

HIGHEST ROYALTIES and CASH

FOR YOUR INVENTIONS

Write for FREE booklet without obligation

UNIVERSAL MARKETING CO.

354 S. SPRING ST. (Suite M)

LOS ANGELES 13, CALIF.

How to Build—at a Price that will Make You GASP!

50,000 Now Letting This Book Build for Them—You, Too, Can Find Out FREE How to Plan, Buy, or Build! Get Top Quality—Save HUNDREDS!

Free 7 DAY TRIAL

Just Mail Coupon

When a Texas man who never built before, writes this "building instructor" helped him to "build his own . . ." when an experienced architect writes "the best book on building for the average man . . ." When hundreds of schools, colleges, universities rapidly replace old-time textbooks with this amazing volume. . . . Then you, too, ought to have this book at your elbow! We have proof—a cabinet full of letters from people who are beating high costs, getting first class construction—their money's worth NOW, today. Let "How to Build a Better Home" prove without risk, that it can tackle any building or remodeling job. Let it work with you on the job. Let it solve problems as they come up. Best of all, let it do all this, without risking a cent!

Some of the Things This Book Explains:

Here at Your Fingertips, the Secrets that Produce Fine Small Homes — Completely Revealed in this Great-Easy-Reference Book! How to Get Started; Deciding Upon Home Ownership; How to Select Professional Service; How to Finance Your Home; How to Select a Building Lot; How to Plan the Home; Where to Get Stock Plans; Taxes, Insurance, Interest, Maintenance, Assessments; How to Choose a Bank, Real Estate Dealer, Contractor; Locating House on Lot, Tax Searches, Comparative Costs, Designs; Prefabricated Houses; How to Fill Out Contract Documents; How to Obtain Good Construction; How to Prevent Termites; How to Prevent Decay; How to Prevent Corrosion; How to Lay Out Building, Excavate, Grade; Monolithic Concrete Construction; Masonry Construction; Footings for Foundation Walls, Chimneys, Piers; How to Build Piers, Foundation Walls; Basement Construction; How to Waterproof Basements and Foundation Walls; How to Build Chimneys and Fireplaces; How to Select the Proper Species and Grades of Wood; House Framing Methods and Details; Finish Carpentry and Millwork; How to Insulate; Sheet-Metal Work; Roofing, Stucco, Lath and Plaster; How to Paint and Finish; Tile Work, Electrical Work, Plumbing, Heating; List of Over 100 Free Publications for the Home Builder; Bungalows, List of Usual Mistakes; Architectural "Don'ts" and over 300 additional paragraphs of important information.

QUICK REFERENCE INDEX TO SPECIAL PAGE-SIZE PLATES (HUNDREDS OF ILLUSTRATIONS)

Footings — foundation walls — basements; Garage floor, footings, etc. — septic tank — grease trap — area for basement window; Concrete porches, steps, automobile runways and driveways and walks; Brick steps, walks and terraces; Brick, tile and stone wall details — Balcony and stepping stone walks; Masonry dwellings — brick veneer walls; Chimney and fireplace details; Balloon framing details (minimum-shrinkage type); Balloon framing details (box sill type); Roof framing details; Basement columns and girders — framing of openings — bridging; Miscellaneous framing details; Watertables — exterior sidewalls of siding or shingles — cornices — porch columns; Double-hung wood window details; Door frame details — points for millwork — stock doors and windows — sash details; Paneling — stairwork — baseboard details; Termite shields — miscellaneous flashings; Flashing details; Gutters and leaders (downspouts); Roofing details.

Nothing Like It Before! One Simple Fact May Repay you a HUNDRED Times its Small Cost. A Book You Will Refer to for Years to Come!

Read What Great Building Authorities Say About This Amazing Book (names on request)

Excerpts from typical letters of praise:
 ". . . the best book on the subject that has been published to date." "was thrilled." ". . . valuable information for the new home-builder."
 ". . . an excellent piece of work" ". . . helped us decide our building plans" ". . . well worth price."
 ". . . very much impressed. . . an excellent reference book."
 ". . . the writing is clear and compact . . . complete and unbiased information."
 ". . . most interesting and complete." "You are to be congratulated. Contains more information than any volume seen . . . Everything you said."
 ". . . One of the best works of its kind I have ever seen. Send me 10 more for presents."

And from an amateur:

"From this book, I did the plans myself! Had never done anything like it before. . . . A neighboring architect said I was an up-and-coming designer and he found not one fault with my plans. . . . The building is now finished and everyone says it's beautiful! . . . I saved \$1900!"

Let "How to Build a Better Home" prove without risk, that it can tackle any building or remodeling job. Let it work with you on the job. Let it solve problems as they come up. Best of all, let it do all this, without risking a cent!

Honest-to-God Practical Guide Book

We will pay you QUADRUPLE if you can beat it. If Undecided Whether To Build or Buy—if Leery of 'Cheap' Building, Shoddy Work, Poor Design—if Fed-Up With DREAMING About Your New House and Want To Get Started—Then This Will Prove a GOD-SEND to YOU.

Here is the answer to how to build. The WORKS—how to plan, construct, supervise—simply, clearly explained step-by-step. Jam-packed with everything you need to build your own, or have a contractor build it. Hundreds of clear-cut, COMPLETE diagrams. Amaze everyone! Read it FREE AT OUR RISK!

EVERYTHING YOU NEED TO KNOW to GET STARTED

All the facts. Whether you spend \$2,000 or \$20,000—whether you employ an architect or use stock plans—or are going to buy instead of build, this book will help you. Before you build know the difference between good and bad. Now—save hundreds of dollars. Get a thrill out of being "in the know," "wise" to the game. Talk building language. Be respected, admired, get better workmanship, a feeling of pride as your friends admire the home being built.

Where to Begin

No matter what your problem, you will find the answer in this amazing volume. No truth is kept from you. You are told disadvantages as well as advantages. You are told of precautions to safeguard your investment, how to select a lending institution, lawyer, real estate dealer, architect, contractor. Discusses methods of buying fully. Glance at the partial table of contents on this page for some of thousands of FACTS on building which this volume contains. Those who have bought a copy write they have never seen so thorough a work on this subject for ANY PRICE, ANYWHERE!

Hundreds of Construction Details

Explains "mysteries" of permits, contracts, construction, How to build the right kind of home. Avoid cracker-box construction, get house suitably located, beautiful, priced right.

How To Build—from Plans to Paint Not one important step missing. See for yourself.

SEND NO MONEY Let It Build for You, Too, 7 Days FREE!

Don't risk a cent to examine "How to Build a Better Home." Just mail coupon. Study it for a week, FREE! See how easy it is to supervise or build, YOURSELF—even if you know nothing about construction NOW! Then, if THRILLED, send only \$3.98 (plus postage). If not thrilled, return book and pay nothing! This is your chance to build not just a house, but a BETTER HOME! Mail FREE EXAMINATION COUPON NOW to Westport Publishing Company, Dept. MP-3, Westport, Conn.

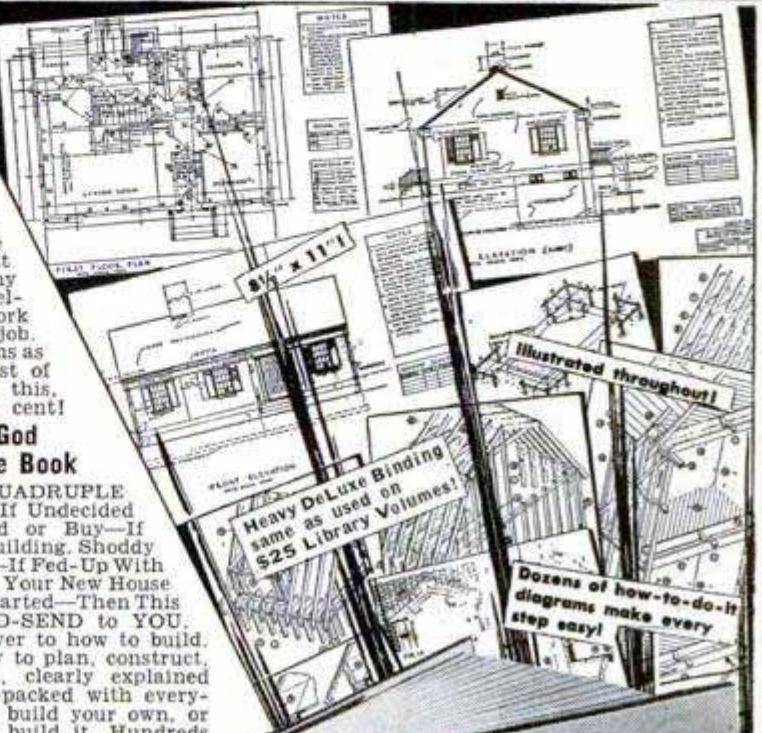

Heavy DeLuxe Binding same as used on \$25 Library Volumes!

Illustrated throughout! Dozens of how-to-do-it diagrams make every step easy!

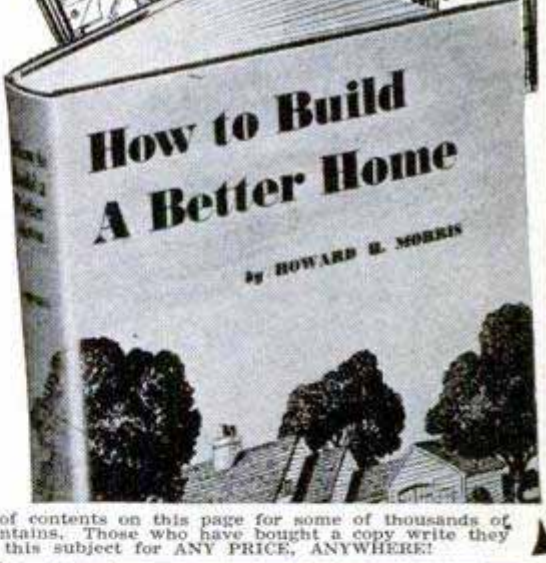

How to Build A Better Home

By HOWARD B. MORRIS

FREE Examination Coupon—Mail Now

The Westport Publishing Company, "Books of Merit," Dept. MP-3, Westport, Conn. Please send me, for one week's FREE EXAMINATION, a new de-luxe edition copy of "How to Build a Better Home." After 7 days I will either return this book and owe nothing, or I will keep it and send you \$3.98 (plus shipping charges). (In two monthly payments, if I wish.)

Name _____ Age _____
(please print)

Address _____

City & Zone _____ State _____

Save postage. Check here if you enclose full payment of \$3.98 (check or money order) WITH coupon. WE then pay shipping. If not thrilled return and we will refund your money by AIR MAIL! Foreign Orders \$4.50 Cash with order.

FREE

get it now—

ALLIED'S 1950 TV & RADIO CATALOG!

196 PAGES OF BIG VALUES

EVERYTHING IN RADIO AT LOWEST PRICES



Send for Radio's Leading Buying Guide

Save money on every radio need! Get the new 196-page 1950 ALLIED Catalog, preferred and used by everyone in radio. See the world's largest stocks of top-quality equipment, all at low, money-saving prices! Latest TV releases, home radios and radio-phonos, Amateur equipment, PA systems and High-Fidelity Sound, recorders, test instruments, builders' kits—plus thousands of parts, tubes, tools, books and diagrams. Have all the advantages of quick delivery, complete selections, big savings and expert personal help from the World's Largest Radio Supply House. Send today for your FREE copy of the 1950 ALLIED Radio Buying Guide!



TELEVISION AND HOME RADIOS



SERVICE SUPPLIES BUILDERS' SUPPLIES



AMATEUR GEAR



AMPLIFIERS, P.A. SYSTEMS, RECORDERS

ALLIED RADIO

ALLIED RADIO CORP.
833 W. Jackson Blvd., Dept. 5-CC-0
Chicago 7, Illinois

Rush FREE 1950 ALLIED Catalog

Name

Address

City.....Zone.....State.....



CORTINAPHONE Makes it EASY To: Speak FRENCH-SPANISH GERMAN-ITALIAN



Count Cortina

BIG OPPORTUNITIES await Americans who speak languages. Learn as a child learns—"by listening" to these CORTINA recordings. The CORTINAPHONE METHOD, famous for 68 years, teaches you right at home to speak FRENCH, SPANISH, GERMAN, or ITALIAN as a NATIVE speaks!



Listen to this Record!

VETS

FRENCH or SPANISH course available under G.I. Bill State if Veteran

Sent on 5 Days' Approval

Write today for free book which describes the amazing "Cortina Short-Cut" Method. State Language interested in.

FREE BOOK

CORTINA ACADEMY

Dept. 643, 105 W. 40 Street, N.Y.C.

Save Your Feet

Thousands relieved from pain walk freely with HEEFNER ARCH SUPPORTS



Write for Free Booklet

"FOOT FACTS"

HEEFNER ARCH SUPPORT CO., 673 Logan Bldg., Salem, Virginia



Bar Bells

Buy Direct From Factory

Write for free booklet and price list

\$8.95 up

INDEPENDENT IRON WORKS

2416 East 23rd Street, Dept. B
Los Angeles 11, Calif.

BRAND NEW! 7 JEWELS!

3 Year SERVICE GUARANTEE

• Sweep Second Hand \$5.95

• Radiant Dial P.Paid

• Chrome Case Add

• Leather Band 50c Tax

• Shock, Water Resist

Special! Order today! Money Back if not satisfied Sorry, no C.O.D.'s.

ELCO PRODUCTS CO., 3805 Broadway, K.C.2 Mo



it's fun to earn

RAISING HAMSTERS

Cash in on the growing demand for SYRIAN GOLDEN HAMSTERS recently introduced into the U. S. Ideal pets . . . big laboratory demand. Hardy, clean, odorless. Easily and profitably raised anywhere.

AKOPIAN HAMSTERY

the largest in the West

7358 H VARNA AVE. • NORTH HOLLYWOOD, CALIF.



write for FREE booklet

GET THIS SUIT AS A BONUS!

YOU PAY 1/2 • WE PAY 1/2

Sell popular Smith tailored-to-measure suits. Make up to \$10-\$15 daily, taking orders from friends. As an extra bonus, get your own suit at HALF wholesale cost. No experience needed. Send for FREE selling kit and sample line. Send no money. Write fully, state age, etc.

W. D. SMITH & CO., Dept. D
833 W. Jackson Blvd., Chicago 7, Ill.



Learn PHOTOGRAPHY at Home

Splendid opportunities. Prepare in spare time. Practical basic training. Long-established school. Send for free book, "Opportunities in Photography." No obligation.

AMERICAN SCHOOL OF PHOTOGRAPHY
1315 S. Michigan Ave. Dept. 1353 Chicago 5, Ill.

SALESMEN!

SALES GOING CRAZY!

Work hard for 7 months
...then LOAF the rest of the year!

AMAZING *Underground* SPRINKLER SYSTEM -

Retails for ONLY... **\$49⁵⁰**

...SWEEPING SALESMEN INTO THE BIGGEST MONEY OF THEIR LIVES! "GOLD MINE" FOR DISTRIBUTORS!

Last year, EVERSPRAY created a nationwide sensation — poured spectacular profits into the laps of salesmen everywhere.

This year, the NEW, Improved EVERSPRAY is going to make last year's earnings look like small change! Because *this year*, we offer Salesmen TWO spectacular order getters until now unheard of in the history of Direct Selling.

1. A COMPLETE DEMONSTRATOR you carry right in your pocket.
2. An Everspray SYSTEM complete in every detail that you can

spread out on a prospect's lawn and have in full operation IN LESS THAN 10 MINUTES!

This year—right before a prospect's very eyes—you can show him exactly how his Everspray Underground Sprinkler System is going to work *when it's installed in his lawn!*

With either one of these two amazing demonstrations you clinch a sale 9 times out of 10. Every home owner who takes a speck of pride in his lawn will want to install an Everspray as quick as it can be delivered to his door!



Everspray installed at North Acres Gardens, Anderson, Indiana

"People Tell Me I Have the Finest Lawn They've Seen in Years"

L. G. Johnson

"When my Everspray is in operation, people actually stop their cars to watch it and to admire the smooth, velvety green texture of my lawn. I never saw anything like Everspray in all my life."

And R. C. Freeman, Chicago, says: "It's amazing how EVERSPRAY keeps our lawn in tip-top condition all season long. Best of all, I don't have to waste hours of time sprinkling with a garden hose."

CUSTOMER INSTALLS IN FEW HOURS without damage to lawn!

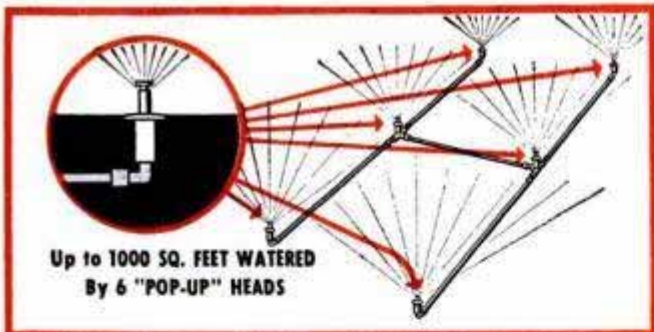

Now, for the first time in history, any home owner—anywhere—can get an Underground Sprinkler System at a price he can afford. Now his lawn can be sprinkled like a million-dollar estate. And look! Everspray is all solid brass and copper. Nothing to rust or wear out. No pipe fitting to do. No plumber's bills to pay. No repairs. No inspection. No maintenance. No freezing

because Everspray *drains itself*—automatically—every time it's shut off. No wonder home owners by the thousands are rushing to buy Everspray!

No wonder Ray J. Eckenrode says: "EVERSPRAY works like a charm. On the strength of this installation, a neighbor asked me to purchase the same layout for him."

DON'T CALL YOURSELF A SALESMAN IF YOU CAN'T MAKE

\$60⁰⁰ A DAY!

In the NEW Improved EVERSPRAY you've got your hands on the biggest summer seller ever invented. When most lines are dead or dying, *Everspray is just coming to life!* Our sure-fire "Jack-Pot" Pyramid Sales Plan turns your first sale into TEN or more. Then EXTRA orders start pouring into your hands *automatically—without a bit of effort on your part!*

FREE! SEND NAME

This very minute, send your name on the coupon or penny postcard for beautiful Illustrated Folder that shows pictures of actual Everspray installations, Demonstrator Offer and Details of sure-fire "Jack-Pot" Pyramid Sales Plan. Everything is FREE. No charge now or ever. Time is precious. Send name today.

CARRY COMPLETE DEMONSTRATOR RIGHT IN YOUR POCKET!

You can't believe it until you see it. We show you how to use this amazing "POP-UP" Sprinkler Head to make a Demonstration, right before your prospect's very eyes! Special Demonstrator Offer sent FREE. Just mail postcard or handy coupon.



John Oakman, Sales Mgr.
EVERHOT PRODUCTS CO., (Everspray Division) Dept. 2-C
2001 Carroll Ave., Chicago 12, Ill.

Rush Illustrated Folder, Demonstrator Offer and details of your "Jack-Pot" Pyramid Sales Plan that offers me an opportunity to make \$59.40 a day on only 3 sales. Everything is FREE and costs nothing now or any other time.

I am not a salesman. I am interested in Everspray for my own use. Send details of User-Agent Plan.

Name.....

Address.....

City..... Zone..... State.....

EVERHOT PRODUCTS CO.
(Everspray Division)

2001 Carroll Avenue, Dept. 2-C, Chicago 12, Illinois

PLASTICS EVERYTHING YOU NEED UNDER ONE ROOF



CLARO-CAST A clear liquid casting plastic for imbedding insects, flowers, coins, etc. Taps for casting novelties. Price 1 pt. \$1.95; 1 qt. \$3.75; 1 gal. \$16.00. Instruction book — \$.20.

DYE—Deep, rich colors blend beautifully. dropper cap. Red, Old Rose, Fuchsia, Yellow, Green, Blue, Orchid, Black, Brown, Fluorescent Red. Price—1 oz. \$.30; 4 oz. \$1.00; 1 pt. \$2.75.



METALLIC ACETATE

Newest thing in plastics craft material. Make costume jewelry, flowers, book covers, etc. Colors—Aquamarine, orchid, pink, copper, chartreuse, black, purple, ice blue, gold, silver, red, blue, green, fuchsia, lime, iris, rose pink, white, multi-color. Sheets 10"x25"—Price \$.85. 20"x50"—Price \$3.00.

PRACTICE BLOCKS—Plexiglas and Lucite. Special price—\$1.00 lb., 5 lb.—\$4.75, 10 lb.—\$9.00.

DRILLS—Special precision, machine made, tapered drills ground to perfect points, sharp cutting edges.

DIAMETER	EACH	DOZEN
1/16"	\$.95	\$10.45
3/32"	.95	10.45
1/8"	1.00	11.00

"INTERNAL CARVING IN PLASTICS" A COMPLETE course of instructions by an expert, H. A. Zosack. Price—Only \$1.50.

PL-1 Plexiglas-Lucite Cement Apply with brush, eye dropper or hypodermic needle. 30-second action. Permanent bond, no discoloration. Price—4 oz. \$.60; 1 pt. \$1.50.

PLASTIC JEWEL BOX Size 3 1/2" x 3 3/4" x 1 1/4". Modern style jewelry boxes add richness, charm to any merchandise. Price—Each \$.15; Dozen \$1.50.

TO ORDER—Send check or money order. Add 15% of order to cover postage. (Any postage overpayment will be refunded.) Send 25% deposit with C.O.D. orders.

CRYST-L-CRAZE Newest decorative coating. Easily applied by brush. Gives beautiful crystallized pattern—White or colors—to plastics, glass, copper and ceramics. Colors—Red, Blue, Green, Black, Violet, Orange, Yellow, Clear and Fluorescent Pink. Price—4 oz. \$.75; 1 pt. \$1.75; 1 qt. \$3.10.



FOR PLASTICS "KNOW-HOW"—Latest book by Cherry. Recommended for all-around "how-to-do-it." Price \$1.50.

COMPLETE CATALOG — FREE! A catalog of plastics supplies for the hobbyist. Everything in plastics under one roof—at prices you can afford. GET YOURS NOW!



FRY PLASTICS CO. — Dept. 73
7604 So. Vermont—Los Angeles 44, Calif.

SAY YOU SAW IT IN POPULAR MECHANICS

Do you want

- .. to go to College?
- .. or to enter a Profession?
- .. or get an Office Position?

(Such as Accounting, Architecture, Nursing, Dentistry, Teaching, Social Work, Osteopathy, Beauty Culture, Optometry, Embalming, Chiropody, Law, Medicine, etc.)

To get anywhere, you practically MUST finish High School FIRST. You can complete our simplified High School Course in SPARE time at home, as FAST as your time and abilities permit. Equivalent to resident school work—prepares you for college, pre-professional examinations, business, industry. Standard texts furnished. Diploma. Credit for H.S. subjects already completed. Single subjects if desired. Low tuition, easy terms. American School, Chicago, est. 1897—endorsed by educators. Finish your high school education NOW. Write TODAY!

High School Course at Home

Many Finish in 2 Years

American School, Dept. H345, Drexel Ave. at 58th St., Chicago 37, Ill.

Gentlemen: Send me FREE information covering special training in subjects checked below. No obligation on my part.

- | | |
|--|--|
| <input type="checkbox"/> High School Course | <input type="checkbox"/> Diesel Engineering |
| <input type="checkbox"/> Architecture and Building | <input type="checkbox"/> Drafting and Design for Men & Women |
| <input type="checkbox"/> Automotive Engineering | <input type="checkbox"/> Plastics |
| <input type="checkbox"/> Business Management | <input type="checkbox"/> Private Secretary |
| <input type="checkbox"/> Electrical Engineering | <input type="checkbox"/> Mechanical Engineering |
| <input type="checkbox"/> Elec. and Gas Refrigeration | <input type="checkbox"/> Aviation |
| <input type="checkbox"/> Air Conditioning | <input type="checkbox"/> Salesmanship |
| <input type="checkbox"/> Railway Training | <input type="checkbox"/> Radio |
| <input type="checkbox"/> Electronics, Industrial | |

Name.....

Address.....

LIGHT or HEAVY INDUSTRIAL

WHEELS

Pressed Steel • Rubber Tires
ALL BALL-BEARING
If you are building portable equipment that uses pneumatic wheels, here's a standard high-quality line at attractive prices. All are made for standard axles (1/2" or 3/4") and finished with infra-red baked enamel.



Money Back Guarantee

LOW PRICES—CASH WITH ORDER			
6 x 1.50	\$1.25	10 x 2.00	\$2.30
10 x 1.75	1.95	10 x 2.75	3.35
10 x 2.50	3.30	6 x 2.00	3.15
8 x 1.75	1.60	8 x 2.50	3.80
10 x 2.75	\$5.25	Fully Pneumatic	
4 x 8.00 (4-ply tire) with tube			\$10.75 (1/4 or 1/2" bore)

Please Specify Bore Desired!

NEFF EQUIP. CO. 400 PETROLEUM BLDG. WICHITA, KANSAS

FOR YOUR BETTER FUTURE

Learn AIRCRAFT-PRECISION Instruments, be a specialist in a great industry. Trained men in demand now. Short, intensive training appvd. for Vets, non-vets. Employment and housing assistance. Visit school or write for free information.

WEST COAST UNIVERSITY, School of Aircraft Instruments
5145 W. SAN FERNANDO RD. LOS ANGELES 39, CALIF.

HOMESITES \$300 LOW TERMS

In California's loveliest Garden Spot, on scenic shores of beautiful Morro Bay. Enjoy future independence with excellent soil, soft water, wonderful fishing, hunting, boating, bathing, etc. Grow fruits, vegetables, poultry. Perfect temperate climate. Congenial community. Finest investment. Free literature.

RICHARD S. OTTO

DEPT. M SAN LUIS OBISPO, CALIFORNIA

FREE Bargain Book

Packed with hundreds of sensational bargains—new and used—in still and movie photo equipment and accessories. Write for your free copy today to
Central Camera Co.
Dept. BC, 230 S. Wabash, Chicago 4, Ill.

Photographic Headquarters Since 1899

WAR SURPLUS BARGAIN! LUFKIN ENGINEERING TAPES



SPECIAL PRICE \$1.00 Ea. Ppd.

New, 10 ft. Divided in tenths and hundreds of a ft. All steel. Compact. Durable. Rolls up smoothly. Ideal for tying in points. Indispensable to architects, engineers, surveyors, etc. Please send cash or check.

E. G. HOWARD CO.
52 Friend St., Boston 8, Mass.

171 MPH—Ford V8

INCREASE SPEED • INCREASE POWER



This V8 powered Streamliner using a Howard Cam was clocked at 171 M.P.H.

20% or more in your stock car with HOWARD GROUND CAMS
Write for prices and literature
Dealers Invited

Ford V8 exchange
\$25.00
Other Cars Comparatively Low

Howard's Cams

10122 S. Main Street
Los Angeles 3
California

POPULAR MECHANICS



**I MADE
\$14 PER DAY**
While still learning!

T. E. H.—WEST VIRGINIA



**I MADE
\$800 IN 3 MONTHS**
While taking your course!

F. V.—NEW YORK

Get into the

ELECTRIC APPLIANCE REPAIR & SERVICE BUSINESS

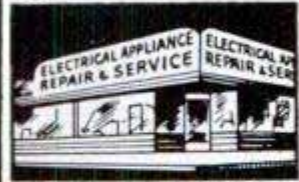

OPEN YOUR OWN SHOP

As soon as you enroll, I send you my New Book "How to Open Your Own Business" at no extra cost. PTS training is more than a home study course in electric appliance repair and service. It gives you the "know how" on the operation of your shop from a business standpoint: What to charge, how to get customers. Everything possible is done to start you on the road to success.

WE TEACH YOU:

Electric motors, house wiring, refrigerator, auto ignition, automatic washers, garbage disposals, fluorescent lights, irons, cleaners, etc., at home.
FULL OR SPARE TIME

SPARE OR FULL TIME

You can actually increase your income while still learning—spare or full time
ACT NOW

Want a good-paying business—a job in a fast-growing industry? Send now for your **BIG FREE BOOK**—"My Plan for your Success." Get started **NOW**

EASY TO LEARN

Men of all ages, yes, even the man of 69 can get into this expanding field. A **REAL OPPORTUNITY** for the practical man who wants the **BETTER THINGS IN LIFE**. The easy PTS Home Study Plan prepares you for greater earnings **NOW!**

**I SEND
YOU A**

**BIG
KIT of
TOOLS
at No
Extra
Cost**

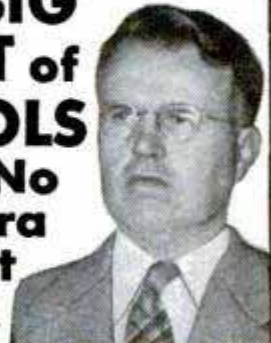

H. T. ARMSTRONG

**SEND
FOR
THIS
FREE
BOOK**



MAIL THIS COUPON TODAY

PACIFIC TRAINING SCHOOL H. T. ARMSTRONG
7219 So. Broadway, Dept. P-503, Los Angeles 3, Calif.
Please send me, without obligation, your free booklet and details.

Name _____
Address _____
City _____ Zone _____ State _____



Put Your Future in Your Own Hands Be an ARTIST

**HERE'S THE AMAZING WAY WE TEACH YOU
STEP BY STEP TO DRAW AT HOME IN SPARE TIME**

**LEARN TO DRAW
FOR MONEY**

TWO BIG ART OUTFITS GIVEN

As soon as you enroll, we send you the first of the **TWO** complete Artists' Outfits, including all the material you need to start the course. Later in the course you receive the second, advanced outfit . . . all at no extra cost.

Read What These Graduates Say:
TRAINING PAYS OFF—Fred B. Chott of Cicero, Illinois, says "I have turned your teaching into profit very quickly." (1-49)

STAFF ARTIST AND CARTOONIST—G. W. Thomas, Los Angeles newspaper artist says: "W.S.A. is Number One school in U. S. A." (1-48)

WRITE FOR FREE BOOK

"**ART FOR PLEASURE & PROFIT**" Tells about our course of instruction and commercial opportunities for you . . . also about W.S.A. students, reproductions of their art work, and results enjoyed by our graduates.

Approved for Veterans Est. 1914



Prepare yourself for a pleasant, profitable Art career. **COMMERCIAL ART, DESIGNING, CARTOONING**—all in one richly illustrated, modern home study course. Good art positions available in this great field. You can become your own boss—work at home on your own time. Many students earn extra money while learning by designing posters, rendering simple artwork, lettering, etc. W.S.A. is now in its 36th successful year of training men and women. No previous Art experience necessary, we teach you from the beginning for professional art jobs in advertising, television, newspaper and magazine publishing, department stores, printing, art studios, etc. Get the facts now. Low cost—only \$5 monthly.

FREE BOOK gives details

WASHINGTON SCHOOL OF ART, Studio 123W
1115—15th St., N. W., Washington 5, D. C.

Please send me full information and your Free Book, "Art for Pleasure and Profit." (Please print)

Name _____ Age _____
Street _____
City _____ Zone _____ State _____
 I am entitled to training under the G.I. Bill.



WASHINGTON SCHOOL OF ART

Train for these growing fields

AIR CONDITIONING HEATING REFRIGERATION

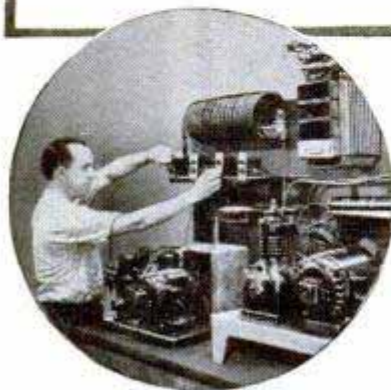

**Prepare for
a substantial
opportunity
in industry
or a business
of your own**

In 6 to 24 months you can be equipped for a career in these fascinating fields. This 47-year-old, nonprofit technical school offers world-famous training programs. Experts from industry cooperate with faculty of specialists to keep courses geared to latest developments. Laboratories and shops are well-equipped. Specialized technical training is coupled with solid education in basic sciences and related arts. You pass step-by-step to certificates of "Refrigeration Serviceman" in 6 months—"Refrigeration-Heating Serviceman" 6 months later—and "Refrigeration, Heating-Air Conditioning Technician" in 12 added months.

Military, Academic or Practical Training is evaluated for advanced credit. Preparatory courses available.



Faculty of 85 specialists. 1555 currently enrolled from 48 states and 23 foreign countries. Over 35,000 alumni. Terms open April, July, Oct., Jan.

MILWAUKEE SCHOOL of ENGINEERING

Founded 1903 by Oscar Werwath

Write for free 110-page catalog and 48-page pictorial booklet, "Your Career".



Milwaukee School of Engineering
Dept. PM-350

1020 N. Broadway, Milwaukee, Wis.
Without obligation, send me the 110-page catalog and 48-page "Your Career" booklet.

(Check 6 to 36 month courses which interest you)

- | | |
|---|---|
| <input type="checkbox"/> Air Conditioning | <input type="checkbox"/> Electricity |
| <input type="checkbox"/> Refrigeration | <input type="checkbox"/> Radio-Television |
| <input type="checkbox"/> Heating | <input type="checkbox"/> Welding |

Electrical Engineering—B.S. Degree:
 Power Electronics

Name _____ Age _____

Address _____

City _____ Zone _____ State _____

Check if World War II Veteran

SAY YOU SAW IT IN POPULAR MECHANICS

WANTED MAN WITH CAR



**No Time Like
Now to Get In
McNessBusiness**

It's no trick to make good money when you use your car as a McNess "Store on Wheels." Farmers buy everything they can from McNess Men because McNess Products are tops in quality, represent extra values. Attractive business-getting prizes and premiums; also money-saving deals to customers make selling McNess daily necessities a snap.

We Supply Capital—Start Now!

There's no better work anywhere. Pays well, permanent, need no experience to start, and we supply capital to help you get started quick. You begin making money first day. Write at once for McNess Dealer Book. It's FREE. Tells all—no obligation. (1)

THE McNESS CO., 883 Adams St., Freeport, Ill.

**Use Your
CAR
to Raise
Your
PAY**

SADDLES

GENUINE
McCLELLAN

12.95
COMPLETE

Express collect.

Normally worth \$75 to \$90—these wonderful Army Surplus Saddles of finest first-quality top-grain select cowhide. Complete with braided horsehair cinch, metal stirrups, russet saddle leather. Send check or money order.



200 SMITHFIELD ST., DEPT. PM
PITTSBURGH 22, PA.

NATIONAL STORES



Learn to Write at Home in spare time

You can easily improve your writing or become an Expert Penman by my Simplified Method at home in spare moments, for your Social and Business Advancement. Without obligation, write for Details and my FREE BOOK, "How to Become an Expert Penman," which contains specimens and tells what others learned. Send 10c for Special Penpoint and your name with a flourished bird elegantly written on a card.

W. M. Davis
WRITE TODAY

Box 25K, CHILLICOTHE, MO.

**NEW! BIG
FIELD**

FOR PROFIT AND PLEASURE COPPER TOOLING & ETCHING



EARN BIG MONEY—SPARE OR FULL TIME

No experience needed—start at once. BIG MONEY waiting in COPPER ART field. Plaques, Bowls, Trays, Gifts, Souvenirs of all kinds. Start on the road to success NOW! Here is an opportunity to get started in your own Big Paying Business—FREE DETAILS don't wait—WRITE NOW!

Hollywood Copper Art Studios
4257 Beverly Blvd., Dept. PM-3, Los Angeles 4, Calif.

BUILD SOLID MODELS for display



Wingspread, 8-1/4"
length, 6-1/2"

Planes—trains—ships!
Accurate scale models to decorate home or office, display on mantel, desk, or in collector's groups. All parts ready-shaped for easy assembly. Wide range of subjects, including newest ships, planes, and historic trains.

Also solid model cars for HO layouts. See them at your Hobby Dealer.

StromBecker

Send for free circular describing all models
STROMBECK-BECKER MFG. CO., Dept. PM-3, Moline, Illinois

New! PRINT YOUR OWN ADVERTISING POST CARDS

New, easy, low-cost way to greatly increase sales for any business! Amazing, new **ROTO-PRINT DUPLICATOR** prints and illustrates your Advertising messages on 1c Government Post Cards, or larger cards. Thousands surprised at great amount of extra business such low-cost advertising brings—and great amount of money it saves on printing. Also prints Announcements, Notices, Price Lists, Labels, Forms, Order Blanks, etc., on cards or paper. Dozens of uses for business concerns, churches, clubs, any organization. Should pay for itself on first job. Many make big profits printing for others. Not a toy—but a strong, speedy, professional machine. Easy to use. Cylinder and Handle of finest steel. Hard, smooth Base has Card Guide—to assure even, uniform printing. Prints several colors. **GUARANTEED FOR LIFE-TIME**. Comes complete with necessary supplies and instructions.



Low
Factory
To-You
Price

**16-DAY
TRIAL OFFER**

FREE! Write for full Information about **ROTO-PRINT AGENTS** and big, **FREE** Book of Money-Making Ideas — **WANTED!** **16-DAY TRIAL OFFER**—and **Low Factory-to-You Price!** **ROTO-PRINT CO., 211 North 7th St., Dept. B-1, St. Louis 1, Mo.**

3-Pc PAINT STRIPE SET *Only \$1.00*



3 SEPARATE TOOLS—Each makes different width

Stripe perfect lines—straight, curved, with any paint, lacquer, enamel, easy as drawing lines with ruler! Beautify furniture, toys, autos; make signs and imitation tile. Simple instructions included.

SEND NO MONEY. Mail order. Pay postman only \$1.00 plus postage. If not delighted return in 5 days for money back. Order Now.

STRADER MFG. CO.

259 Strader Ave. Dept. M-351
Cincinnati 26, Ohio

Utilities Engineering Institute

Founded 1927

Diesel • Auto Body & Fender REFRIGERATION • AIR CONDITIONING

Practical training in these big pay trades covers overhauling, trouble-shooting, installation, maintenance techniques. Proved, easy-to-follow method prepares you at home in spare time, follows with actual shop practice. Also G.I. approved resident courses.

Full information **FREE!** Write today
2525 Sheffield Ave., Dept. C-3, Chicago 14, Ill.

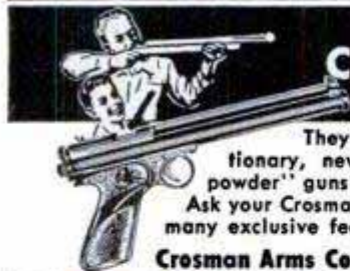

Seen the NEW Crosman CO₂ PISTOL & RIFLE?

They're sensational... a revolutionary, new idea in "power without powder" guns that is sweeping the country. Ask your Crosman dealer to demonstrate their many exclusive features. Write for literature.

Crosman Arms Co., Inc. • Rochester 7. N. Y.

KEEP COLLAR POINTS DOWN

SMART NEW PLASTIC-IZED Adhesive STAYS

Re-usable, can't harm, fray, or tear fabric. Won't "show." No slots or pins. Use again and again!



Just stick 'em under your collar **32 Pairs \$1** Postpaid Year's Supply

P-R-E-S-S-T-A-Y

SEND \$1.00 TODAY TO:
WES-KO DISTRIBUTORS
2619 S. SANTA FE AVE. LOS ANGELES 11, CALIF.

Get into BUSINESS for Yourself!

METALIZING BABY SHOES AT HOME IN SPARE TIME



Get facts about amazing money-making **Warner Success Plan** that shows you every easy step in completely charted path to personal independence—with your home as your headquarters... This proved and tested Plan is working like magic. It's backed by an old, reliable company... And we send it to you on a **No-Risk Trial Money Back Guarantee**.

QUICK CASH WAITING

Demand for **METALIZED Baby Shoes** and other keepsakes is growing bigger daily. Our Tested Plan Shows How to Do the Work, How to Bring in the Business, How to Make as much as \$5 an Hour. Spare or full time, big steady profits are waiting for you. Send penny postcard or mail coupon for **FREE** Facts. Act! Time is precious.

FREE
offer of
**COMPLETE
MONEY
MAKING
PLAN**
•
**SEND NO
MONEY
Just Mail
COUPON**

Ray Brandell, Mgr., Warner Electric Co.,
1512 JARVIS AVE., DEPT 3-C, CHICAGO 26, ILL.

Please rush complete details about your **No-Risk Trial Money Back Plan** for Metalizing Baby Shoes. Everything you send is **FREE** and costs me nothing—now or ever.

NAME _____

ADDRESS _____

CITY _____ ZONE _____ STATE _____



AUTO BOOKS ON APPROVAL

SEND NO MONEY. Just mail the coupon for a complete set of 4 Big, Thick Auto Books. 20th Edition. Over 2700 Pages! Whether you are a mechanic or helper, expert or apprentice, auto owner or driver, take immediate advantage of this **FREE EXAMINATION OFFER**.

MAKE GOOD MONEY NOW HOLD A PERMANENT JOB

America wants its automobiles kept in good repair. Men with "know how" are in demand, at big pay. These books will help you get and hold an important job, or give you a chance to go into business for yourself now or later. Any man who half tries to improve himself can learn auto servicing and repairing by this quick reference method. Use the **JIFFY INDEX** to find easily understood answer to any auto problem. These wonder books prepared by eleven of America's great automobile engineers. Many hundreds of valuable illustrations. Send the coupon **TODAY**.

A year's consulting privileges with our engineers now given with these books without extra charge.

Publishers Since 1898

AMERICAN TECHNICAL SOCIETY, Dept. A319
Drexel Ave. at 58th St., Chicago 37, Ill.

I would like to examine your 4-Volume Set of Auto Books. I will pay the delivery charges only, but if I choose I may return them express collect. If after 10 days' use I prefer to keep them, I will send you \$2 and pay the balance at the rate of only \$3 a month until \$24.80 has been paid. Include consulting service as offered above.

Name _____

Address _____

City _____ State _____

Please attach letter stating age, occupation, employer's name and address and name and address of at least one business man as reference. Men in service, also please give home address.

EARN MORE IN DRAFTING



Steady Employment
•
More Opportunities for Promotion

"Here I am at work making good money as a draftsman. I'm glad I sent the coupon to Chicago Tech for that Free Trial Lesson and found out how easy it is to learn Drafting in spare time at home. Today I feel secure in my job because the draftsman's work comes first on any new project. And, in addition, draftsmen can't be replaced with machines. What's more, I feel I'm slated for promotion and more pay, because I see so many draftsmen advancing to high-pay jobs."

LEARN IN SPARE TIME—AT HOME! (or at the College in Chicago)

A few hours of pleasant home study every week—that's all. No interference with your present job. All the tools you need; drawing outfit included. With Chicago Tech's help, you train yourself step by step. This tested method—developed over 45 years of C.T.C. progress—prepares men quickly for good positions in industry.



FREE INFORMATION—SEND COUPON

To prove to you how easy it is to learn Drafting at home by the Chicago Tech method, we will send you this FREE TRIAL LESSON. No charge for this lesson, now or later. Fill out and mail coupon, or send post card today.

CHICAGO TECHNICAL COLLEGE

C-213 Tech Bldg., 2000 S. Michigan Ave., Chicago 16, Illinois
Mail me FREE Lesson with information about big opportunities in DRAFTING.

Name _____ Age _____
Address _____
City _____ Zone _____ State _____

SANDEE

Mufflers—All Ford, Chev., Ply... \$4.45

All Buick, Pont., Olds., Chrys.,
Dodge, Hudson, K.F., Pack., etc... \$5.45

V-8 and Merc. Duals
(32-49 incl.)

\$15.95



SPORTONE
(Reg. U. S. Pat. Off.)
MUFFLERS

DURABILITY

1 TONE
DEALERS WANTED

Beautiful
SANDEE
Fender Skirts
\$9.95

A SANDEE Sportone will outlast two ordinary mufflers and give More Power! More Speed! More Mileage!—plus a tone quality unsurpassed.

Please ship (item): _____ Price _____
Car and Year _____ Name _____
Address _____

SANDEE MUFFLER CO. 5643 Corryne Pl. Culver City, Calif.

"WOVEN-Gards"

BETTER

Hand Protection at Amazing Low Cost

"Woven-Gards" are hand protectors, mitts, pads and sleeves made out of a wholly new safety material to provide flexibility, comfort, resistance to abrasion and cutting far beyond that of anything used before. They are extremely oil-absorbent for excellent handling of oily, slippery sheets and slabs. The porous weave makes them the best "hot" handlers ever offered. Thousands of enthusiastic users say they have never seen values like "Woven-Gards," best protection at lowest cost. Send now for descriptive folder and prices.

INDUSTRIAL GLOVES CO.
1405 Garfield St., Danville, Ill.
(In Canada: Safety Supply Co., Toronto)



INDUSTRIAL
Safety Apparel

LEARN EXPORT



Buy and sell world-wide without capital. Travel abroad if desired. Export men and women in demand. Your own business — profits unlimited. Salaried jobs in many branches of Export-Import. Practical, low cost WORLD TRADE COURSE teaches you quickly at home in spare time. No previous special experience or schooling needed. World Trade Certificate awarded. Write today for FREE BOOKLET. No obligation. State if veteran. Air-mail reaches us overnight. **THE MELLINGER CO.,** Exporters-Importers, 1418-BH Westwood, Los Angeles 24, Calif.

WHAM-O SPORTSMAN

\$1.00 postpaid

HITS LIKE A .22 RIFLE — KILLS RABBITS, SQUIRRELS. For Hunting, Target, Routing Pests.



HUNTING SLINGSHOT

Powerful, silent, accurate. Complete with 40 pellets and extra rubber straps. Send \$1.00 today to—

Wham-O Mfg. Co., Box 2P, South Pasadena, Calif. PROFESSIONAL MODEL OF THE NAT'L SLINGSHOT ASSN.

Dealers Write

HEAVY DUTY STOCK

STUDY AT HOME

WITH AN EDUCATIONAL INSTITUTION

Courses in ENGINEERING: Electrical, Civil, Mechanical, Drafting, Architectural, Automotive, Steam, Diesel, Aeronautical, Radio, Structural, Mining, Industrial, Petroleum, Marine, Refrigeration, Air Conditioning, Chemical.

Courses in ARTS AND SCIENCES: Philosophy; Education; Letters; Public Health; Medical Jurisprudence; Psychology; Sociology; Physics; Chemistry; Geology; Pol. Science; Theology; Law; Business and Commerce; Accounting; Mathematics; Statistics; Agriculture.

McKinley-Roosevelt Incorporated, 4610-K3, Sheridan Rd., Chicago 40, Illinois

SPEED & MILEAGE MANUAL

140 Illustrations



Easily Get Super Speed, Acceleration, Mileage—Top Racing Performance From Any Automobile!

Famous New Book shows simplified Soap-up Methods—Speed Tuning—Economy Secrets—Customizing Plans—Latest Track Proven Methods for all cars! Tells how to build your own SPEED

EQUIPMENT! FAST SPORT CARS! "CALIFORNIA HOT RODS"! 200 H.P. ROAD & TRACK CONVERSIONS! Complete instructions on building inexpensive Superchargers! Dual Manifolds! "Water Injectors"! High Compression Heads! Twin Mufflers! Economizers! All about—Fast Engines, Gas Saving, Restyling, "Cam Secrets," Multiple Carburetion, Fuels, Porting, Ratios, Frames, "Offys"! **BRAND NEW METHODS, Plans, Formulas, "Racing Tricks"!**—"STOCK CAR SPEED SECRETS"! *Reveals 100 ways to save gas!* Shows latest "HOLLYWOOD CUSTOM STYLING"! Streamlining! Sport Changes! Lowering! Speed Conversions! Including—California Roadster Plans! Racer Diagrams! Working Drawings! Performance Charts! Graphs! Beautiful Photographs! Etc. Large manual (plus) "California Equipment Catalog" and Racing Handbook.

ALL THREE \$1.98 Post-paid

ALMQUIST AUTOMOTIVE ENGINEERING, Milford 83, Pa.

Prepare Now for Big-Pay TV Job—Or Your Own Service Business

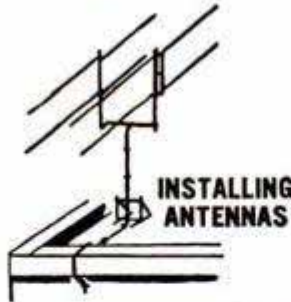

"TAKING THE TUBE APART"



AT LAST!

The ABC's of TELEVISION

all in one big book!

Complete Self-Teaching Course in TELEVISION Prepared by Famous RCA Institutes Instructor — Starts From Scratch, Takes You Step-by-Step From Elements of Set Design To Advanced Problems and Color Television

NOW, you can do ANY TV installation, service, or repair job like an expert; operate field testing equipment; understand problems of TV broadcasting.

Bernard Grob, instructor at the famous RCA Institutes has taught hundreds of men just like you to become TV experts. He knows the questions that come up in a student's mind . . . and how to answer these questions *simply and clearly!* Now, he gives you everything you want to know about TV theory, broadcasting, repairs, installations . . . a complete TV course in one GIANT manual—so that you can become a TV "whiz" at home . . . in your spare time!

and expertly. At-a-glance trouble-shooting charts identify the symptoms, tell step-by-step how to "clear the picture."

Prepares You For The Future

This book will pay for itself the first time you use it on a job. Contains more than enough material to qualify you for FCC's added FM and TV requirements for 1st Class License Test. Qualifies beginner for big-pay jobs — or own service business! Gives experienced technician more confidence, shows him new tricks!

At-A-Glance Charts Trace Trouble In A Jiffy, Show How To Fix It



How to "cure" poor pictures. Over 50 common troubles fixed step-by-step.

TRY BOOK Free FOR 10 DAYS!

Get ready now for a prosperous career in America's fastest growing industry. Be the TV expert of your neighborhood.

SEND NO MONEY! Mail coupon below to try "Basic Television" FREE for 10 days. No obligation whatsoever. Mail it NOW.

Offer applies in U. S. A. only.



Qualifies You for FCC's New FM, TV 1st Class License Test!

"A 'must' for the video service technician."
—RADIO NEWS
"Exceptionally thorough explanation of TV and FM. Makes every detail perfectly clear."
—RADIOFILE
"As a comprehensive self-study course in television receiver servicing, this book can help anyone interested in knowing more about Television."
—PRODUCT ENGINEERING

PARTIAL CONTENTS

Installation Made Easy • Repair of Circuit Troubles • Testing Equipment • Making the Switch To Color TV • Control Adjustments • Portable Field Equipment • Short Cuts to Proper Tuning • Trouble Shooting Transmissions • Amplifier Installation, Repair • Receiver Alignment • Tube Troubles and Their Cure • How To Get Rid of "Shadows," "Clouds," "Snow," "Bars," "Sound Signals," and "Hums" • Televising Motion Picture Film • Solving Scanning Troubles • Synchronizing Sight and Sound • Brightness Control and D-C Reinsertion • The Video Signal from Camera Pickup to Image Reproduction • Techniques of Camera Pickup • Projection TV • AND MUCH, MUCH MORE!

Almost 600 Pages—400 Pictures

In 592 big pages, 401 pictures, diagrams, 14 tables, charts—he shows you how to install and service TV receivers expertly . . . how the video AM and audio FM signals originate . . . how each is transmitted . . . how each is received. Full directions for servicing each circuit block of receiver. How to read oscilloscope patterns in voltage, amplitude, frequency.

No matter what the repair problem is—this book shows you how to "lick" it quickly

Same 10-Day FREE TRIAL OFFER on "Elements of RADIO SERVICING"

A basic book on the principles and practice of radio servicing. Covers the super-heterodyne A-M receiver, phonograph combination problems, push-button equipment, the auto radio, designs for your radio workshop. 475 pages, almost 400 illustrations. Only \$4.50 on easy terms. But examine it first without cost or obligation!



CHECK PROPER BOX IN COUPON

McGraw-Hill Book Co., Inc., Dept. PME-3, 327 West 41st St., New York 18, N. Y.

Please send me for 10 days' FREE EXAMINATION:

"Basic Television". If not satisfied, I will return it, pay nothing. Otherwise I will keep it and send only \$2 then (plus postage) and \$2.25 monthly for 2 months.

"Elements of Radio Servicing". If not satisfied, I will return it, pay nothing. Otherwise, I will keep it and send \$1.50 then (plus postage) and \$1.50 monthly for 2 months.

Name

Address

City..... State.....

WE'LL PAY POSTAGE if you enclose full payment WITH coupon. "Basic Television", \$6.50. "Elements of Radio Servicing", \$4.50. Same 10-Day Return Privilege, for full refund.

Secure YOUR FUTURE 3 TRADES IN 1 CAREER



WATCHMAKING • JEWELRY- ENGRAVING • STONE SETTING •

Each trade can be a full-time job; together they assure numerous high paying opportunities, or a business of your own. Profit by the *Nationally Recognized Training Methods of the Kansas City School of Watchmaking.*

ENROLLMENTS NOW AVAILABLE

Clip and Mail this Coupon Today

KANSAS CITY SCHOOL OF WATCHMAKING
1218 Admiral Blvd.
Kansas City 6, Missouri

Please send me, without obligation, complete information on training in the above courses.

Name _____

Street _____

City _____ State _____

Check if Veteran G. I. Approved

NEW PHOTO PROCESS

enables you to print any photograph on cloth, leather, wood, paper



No photographic experience or equipment necessary. Easy to use. Just follow simple directions. You can reproduce any snapshot negative you have on ties, handkerchiefs, scarfs, greeting cards, stationary. Permanent—won't wash off. Won't harm fabric or negative. Kit contains complete instructions and enough solution to make over 200 prints. Only \$1.49, prepaid.

\$1.49

PREPAID

BURKE CO. 8052 MUSKEGAN AVE. CHICAGO 17, ILLINOIS

PING PONG TABLE

- SAVE UP TO \$30 ON THIS STURDY REGULATION SIZE PING PONG TABLE
- S-O E-A-S-Y TO ASSEMBLE. ALL YOU NEED IS A SCREW DRIVER. COMPLETE INSTRUCTIONS AND HARDWARE INCLUDED
- FOLDS FLAT... EASY TO STORE...



SEND NO MONEY! WE SHIP C.O.D. COLLECT
KAY-BILT MFG. CO., 189 RICHARD ST., BROOKLYN, N. Y.

Stop Dust and Pollen Irritation... New FLEX-a-FOAM Masks



Unbelievable relief with new feather-weight Flex-a-Foam Filter Masks! Stops particles as small as 1/25000 of an inch! A-1 protection for indoor and outdoor jobs. Comfortable snug fit—unequaled breathing freedom. Attractive, easy to clean... With three extra washable pure latex filters \$2.00 p. p. — Order Now!



GOOGLE PARTS CO. — Dept. PM — Cleveland 13, Ohio

NEW ELECTRIC LIBRARY

\$ 1.50 A VOLUME

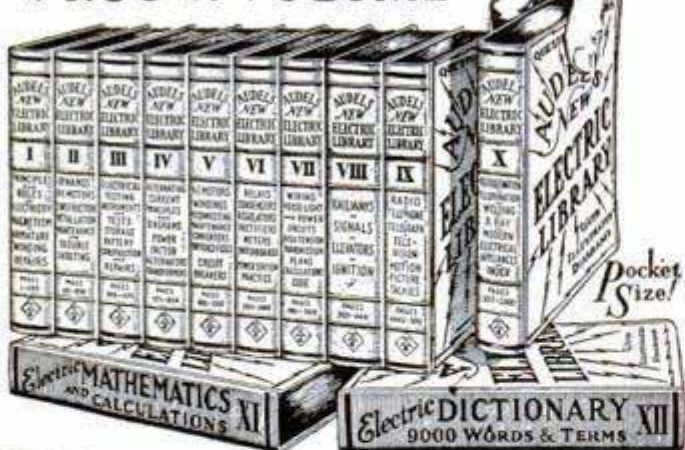

WHAT EVERY ELECTRICIAN WANTS TO KNOW!

is easily found in AUDEL'S NEW ELECTRIC LIBRARY. Electricity made simple as ABC. Up-to-date, trade dope for the expert and ALL electrical workers. Questions, answers, diagrams, calculations, underwriter's codes, design, construction, operation and maintenance of modern electrical machines and appliances FULLY COVERED.

All available at small cost, easy terms. BOOK-A-MONTH service puts this NEW information in your hands for 6¢ a day. You can start your subscription with any volume. Write TODAY for electric Folder and FREE TRIAL offer.

THEO. AUDEL & CO., 49 W. 23rd St., New York City

Mail Vol. I, Electric Library on 7 days' free trial. If O. K. I will remit \$1.50, otherwise I will return it. I also request you to mail one book each month on same terms. No obligation unless I am satisfied.

Name.....

Address.....

Occupation.....PM

FOREIGN EMPLOYMENT

IN ALASKA, LATIN AMERICA, FAR EAST, AFRICA and many other countries. Big pay for executives, technicians, office help, mechanics and skilled or semi-skilled workers. Wide choice of jobs. For comprehensive latest bulletin of firms now working and hiring, and valuable tips, advice and suggestions send \$1.00 to

RICO, INC.
P. O. BOX 388,
MIAMI, FLORIDA

MAKE MONEY IN LANDSCAPING

Thorough training by Internationally known Landscape Architect to start your own business, improve your home or advance in this well paid field. Many Opportunities. Approved for Veterans. Send for FREE BOOK.



NATIONAL LANDSCAPE INSTITUTE
Dept. P-3, 310 So. Robertson Los Angeles 48, Calif.

RUNNING WATER SYSTEM

For Shallow Well, Cistern, Lake or Stream
Or as Replacement or Booster-Pump

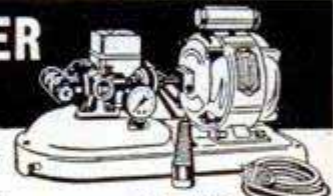

\$59.50

Simply connect to water source (22' depth or less)—plug in cord—turn on faucet—have all the sparkling water you want, instantly! Up to 300 gal. per hour! Newest improved pump principle. Motor starts when any faucet opened. Built-in pressure tank insures continuous flow. Pressure gauge. Automatic switch. 110-V. A-C. Amazingly compact. Complete. Anyone can install. Fully Guar. Only \$59.50 prepaid. Order from ad or write for details and for gigantic mail-sale bargain catalog.



BURDEN SALES COMPANY
805 "O" ST., LINCOLN, NEBR.

Embed Real Flowers In New MAGIC PLASTIC

Now create lovely things like the unusual pansy coaster shown—made by embedding real pansies in Castolite, the "Magic" liquid casting plastic. Comes crystal clear or may be colored. Produce gorgeous effects. Make jewelry, book ends, candle holders, picture frames, figurines. Embed real flowers, butterflies, coins, photos, for novel plaques, paper weights, tiles, other objects. Use only home tools.

New Book SHOWS HOW

Big, new book explains simple methods to get started. Also gives proved Success Plan for making extra money. Hundreds succeeding. Send 25c today for "A Way to Success." The Castolite Co., Dept. TC-1, Woodstock, Ill.



SALESMEN!

WRITE
THREE
WORDS
COLLECT
\$9⁹⁵

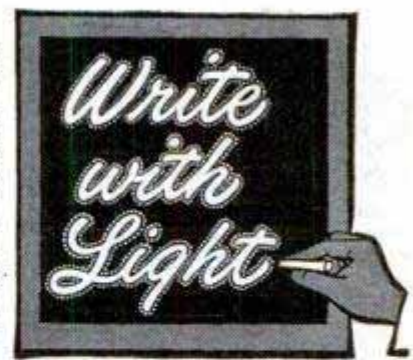

SENSATIONAL NEW ADVERTISING SIGN

YES, MAKE \$9.95 on 10-second demonstration to merchants. Write on glass with amazing magic crayon and presto—a 5-color advertising message takes fire and glows like a brilliant neon sign! Three sales a day and \$29.85 profit is for "lazy" men. Workers can double to triple that amount. FREE SALES KIT. Don't wait. Rush your name and address on a penny postcard for full details and complete sales kit—ALL FREE.

**MAXILUME CO., 125 W. Hubbard
DEPT. L-83 CHICAGO 10, ILLINOIS**

MASTER MIND!



Learn Short-Cut Mathematics

Juggle figures, do baffling number tricks. Make people gasp at your marvelous lightning-quick mind. Multiply 4 figures by 4 figures without using old-fashioned multiplication! Big cloth-bound volume; fully illustrated course. Includes worked-out problems, answers, etc. Sensational bargain, only \$1.49, postpaid — or COD plus postage. Satisfaction guaranteed or refund. Order this amazing "Short-Cut Mathematics" today!

**NELSON-HALL CO., 1139 S. Wabash Ave. \$1.49
Dept. 2C-2 Chicago 5, Ill. Complete**

RUPTURE!

An amazing Air-Cushion Invention allows body freedom at work or play. Light, neat, cool, sanitary. Durable, cheap. Day and night protection helps Nature support weakened muscles gently but surely. No risk. Sent on Trial! Write NOW for free Booklet and Proof of Results. All correspondence confidential. Brooks Company, 161-G State St., Marshall, Mich.



FREE UPHOLSTERING LESSON

With your Order for Upholstering Supplies

Tools, foam rubber, furniture frames, imitation leather, springs, webbing, etc. Everything for repairing or making furniture. Send for Free Price List.

THE TYCON COMPANY, Dept. 3M, CHALFONT, PA.

BIG-MONEY PROFESSION FOR YOU EARN IN FULL OR SPARE TIME LEARN AT HOME



Large incomes in Scientific Swedish Massage, working for doctors, hospitals, sanitariums, clubs or in your own private practice. Hydrotherapy and Electrotherapy included in easy-to-learn course. Prepare for Diploma and Security in this interesting and profitable field. Write for facts and Success Book—FREE.

**THE COLLEGE OF SWEDISH MASSAGE
Dept. 064C, 41 E. Pearson, Chicago 11**

SAVE ALMOST HALF!

PRECISION MAUSER-TYPE VERNIER CALIPER

World famous precision, style, workmanship of former Mauser organization of Germany. Made to exacting standards. One-hand operation with positive-action release. Chrome steel throughout, a perfect tool for shop and home. Measures accurately to 1/1000 of an inch and 1/20 mm. Mechanics, tool makers, inspectors, technicians, hobbyists need this excellent instrument. Precise measurements quickly and easily: outside and length, inside, thread, depth measurements. Now, because full scale production is again under way, this beautiful Mauser-type caliper is yours at a price almost half of any comparable tool! Order yours today!



Prepaid with your check or money order.
10 day money back guarantee

ONLY \$15⁰⁰

In protective leatherette case. Dealer inquiries invited.
GLOGAU & CO., INC.
1906 Birchwood Avenue,
Chicago 26, Illinois

F.O.B. Chicago, C.O.D.



START AS HIGH AS \$3,450.00 YEAR

Many early Examinations Expected. Prepare NOW! Veterans Get Special Preference! 40-Page Civil Service Book FREE

**Franklin Institute
Dept. B84
Rochester 4, N. Y.**
(Not Gov't Controlled)

Gentlemen: Rush to me FREE of charge, list of U. S. government big pay jobs. Send FREE 40-page book describing salaries, vacations, hours, work, etc. Tell me how to qualify for one of these jobs.

Mail Coupon Today SURE

Name _____

Address _____ Vet? _____

SHOP by MAIL - SAVE at KLEIN'S - Buy Direct from ad!

GLASS ROD & REEL



Only Klein's offers the new "Southwester" 4 1/2 or 5 ft. Solid Glass Fiber Rod with Pistol Grip offset handle and hardened steel guides, plus the Klein's DeLuxe \$11.00 Value Level-wind Reel. Anti-backlash, both for only \$9.95. An actual \$18.95 Value!

\$30 Spinning Outfit \$19.95



Balanced! Save 33 1/3%! Fresh 1950 Stock! Complete outfit contains: Airex "Spinner" Bache Brown Reel, Montague 6 1/2 ft. two-piece Split Bamboo Rod, 100 yds. Nylon Spinning Line, 4 Bache Brown Spinning Lures, Instruction Booklet, Worth \$30.00, all for only \$19.95.

HEDDON "PAL" ROD & MARHOFF REEL \$24.95



Save \$12.55! New 1950 Model Shakespeare famous "Marhoff" level wind reel, plus the Heddon "De Luxe Pal" tubular steel casting rod—5 ft. 3" (discontinued length—fresh new stock). Rod is \$22.50 Value. Reel alone is \$13.20. Both Rod and Reel, only \$24.95.



BALANCED ROD & REEL \$25.20 Value, Both \$9.95

AMAZING BARGAIN! "GEP", \$14.20 Solid Steel rod with famous "pistol grip." Choice of 4 1/2, 5 or 5 1/2 ft. (discontinued model). PLUS \$11.00 "De Luxe" level-wind and anti-backlash Reel. Both are Top Quality! An Unusual Value!

H & R "922" TARGET REVOLVER—NEW!

Double Action 9 shot, 22 caliber, newly redesigned. The "922" is recognized as the country's leading revolver for value and performance. Shoots all 22 cartridges, regular or high speed. State choice of 6", 4" or 2 1/2" barrel length. Blued Finish. (Add \$2.00 if Chrome Finish is wanted.) Weight 24 oz. Amazing Value, only \$24.75. Also available: The new Iver Johnson Sealed Eight 22 Revolver—8 shot—6 inch barrel \$20.40.

SALE! NEW MERCHANDISE

- 20 Power Spotting Scope & Stand... \$ 9.95
- \$19.95 Rochester 22 cal. Air Rifle... 9.95
- 24.95 Crosman 22 or 177 Air Rifle... 14.95
- 22.60 Crosman 22-20 Shot Rptr... 14.95
- 42.95 Stevens 22 Hornet or 30/30... 34.95
- Tiny Czech "Duo" 25 Auto Pistol... 39.50
- \$22.50 Webley 177 cal. Air Pistol... 9.95
- 42.00 Webley 22 cal. Air Pistol... 19.95
- 5.00 Army Jungle Boots, 7 1/2 to 11... 1.99
- Bullet Trap, 18 lbs., for all 22 ctgs... 9.45
- \$19.80 Crosman 22 Air Rifle... 11.95

KLEIN'S SPORTING GOODS, INC., Dept. 21
227 W. Washington, Chicago 6, Ill.
(Send 25c for Special Catalog Offer or Free with any order from this Ad.)
Please rush me.....

Satisfaction Guaranteed or Your Money Back
Enclosed is \$..... In full Payment.
 20% C.O.D. deposit. 20% Time Payment deposit—balance to be paid in four monthly payments.
Firearms Purchasers Sign: "I am not an alien, and I have never been convicted of a crime of violence, nor am I under indictment or a fugitive from justice."

Signed.....
Occupation..... Age.....
(Write your Address on Separate Sheet)
No Guns Sold to Minors
OUR GUNSHOP DOES FINEST GUN REPAIRS,
STOCK WORK, POLY CHOKE, ETC.

PFLUEGER REEL & GLASS ROD

\$19.95



\$30.00 Value! Both the De Luxe clear solid glass-fiber rod and the great Pflueger "Summit" Reel for only \$19.95. State choice of 4 1/2, 5, or 5 1/2 ft. Rod, made specially for Klein's by a famous Rod Maker—top quality with special curved grip and stainless steel guides. Rod will never rust, rot, or take a set! Summit reel only \$12.75.

"Supreme" Reel & Heddon Rod

\$44.70



Save \$12.80 on these two great new items! The balanced combination of the Heddon "De Luxe Pal" Rod and Pflueger "Supreme" Reel cannot be equaled! The Rod is 5 ft. 3 or 4 inch length—discontinued length—fresh stock—finest tubular steel—stainless steel guides—checkered walnut forward grip. Supreme Reel alone is \$32.95.

"AKRON" REEL & "GEP" ROD

\$13.39



Balanced! Another Klein's exclusive! The famous pistol grip "Gep" Actionized solid steel casting Rod, choice of 4 1/2, 5 or 5 1/2 ft. length, discontinued Model 555, \$9.45 value, plus the new 1950 Model Pflueger "Akron" level wind and anti-backlash Reel both for only \$13.39. (Akron Reel alone is \$8.50.)

"NOBBY" REEL & TRUE TEMPER ROD

\$16.95



True Temper "Challenger" Model 500 tubular steel 4 1/2, 5 or 5 1/2 ft. casting rod, plus the great new 1950 Pflueger "Nobby" level wind and anti-backlash reel. Both for \$16.95. (Reel alone is \$9.75.)

"WONDEREEL" & TRUE TEMPER ROD

\$19.88



Save \$8.12. For only \$19.88 you get both the Shakespeare Model 1921 Light Wonderel, plus the True Temper Custom Grade "Champion" 4 1/2 or 5 ft. Solid Steel Casting Rod with the famous "Speedlock" reel fastener. (Reel alone is \$9.60.)

MARKSMAN AIR PISTOLS \$4.95



Looks and Feels like U.S. Army NEW 45 Auto. Ac-MODEL! curate and Powerful. Shoots 177 caliber pellets, darts, and BB's. Generous supply included. Specially Priced... \$4.95

FREE CATALOG

Klein's Big Bargain Sports Catalog FREE WITH ANY ORDER FROM THIS AD, or send 25c for catalog only. Gift Included!

RUGER 22 AUTO



\$37.50

For the shooter who must have the best! 10 shot, 22 Long Rifle, 4 3/4" Barrel, blued. Weight 36 oz. American Made by Sturm Ruger & Co., of finest materials and workmanship. Complete price new is \$37.50.

NEW SHOTGUNS



- Browning Belgian Auto. 12 or 16 Ga. \$108.80
- Browning Belgian Auto. Light Wgt. 124.50
- Browning Over-Under, Rib, 12 or 20 Ga. 219.00
- Browning Over-Under, Vent. Rib. 244.00
- Marlin M. 90 Over-Under, all Ga. 82.45
- Stevens 22/410 Over-Under... 32.25
- Remington Streamlined Automatic, all Ga. 99.95
- Remington Auto., Ventilated Rib. 119.95
- Rem. 1 or Winch. 12 Pump, all ga. 84.95
- Remington new model 870 pump. 69.95
- Ithaca 37 Pump 12, 16, 20 Ga. 78.93
- Ithaca 37R Pump Raised Rib... 94.64
- Winchester 42-410-3" Shell Pump 73.95
- Winchester 25-12 Ga. Pump... 72.85
- Stevens 820 Pump, 12 Gauge... 53.90
- Winchester 24 Double, all Ga. 68.95
- Stevens 311 Double, all Ga. 52.95
- L. C. Smith Double, all Ga. 98.95
- Fox Model "B" Double, all Ga. 62.50
- Mossberg 185D-20 Ga. Repeater... 22.95
- Mossberg 183D-410 Repeater... 20.55
- Kessler 12 Ga.—3-shot Repeater... 18.95
- H&R 12 Ga.—3-shot Repeater... 29.95

NEW HANDGUNS



- Smith & Wesson K22, K32 or K38... \$65.00
- S&W M&P 38 Spl. 2, 4, 5 or 6" 56.50
- S&W 32 Hand Ejector 2 or 3-1/4" 51.25
- S&W 38/44 Heavy Duty 4 or 5" 64.00
- Coit 22 or 38 O. M. Target Special. 75.00
- Coit Official Police 38 or 22 cal. 65.00
- Coit Woodman 4 1/2"—\$60.00; 6"—\$70.00; M.T. 85.00
- H&R 922 Target Revolver, 22 cal. 24.75
- Iver Johnson 22 Target Revolver... 20.40
- H&R "Sportsman" Revolver, 22 cal. 44.95
- Iver Johnson 22 Super Shot... 37.75
- Hi Standard 22 Auto., Model HB... 42.15
- Model GB—\$54.00; GD—\$67.00; GE 75.00
- Coit 22/45 or 22/38 Conversion... 40.00
- Coit 38 Super or 45 Auto. 65.00

NEW RIFLES

- Marlin 39A Lever action 22... \$ 52.30
- Winchester 63 Automatic 22... 63.50
- Remington 241 Automatic 22... 63.50
- Remington 550 Automatic 22... 34.95
- Winchester 74 Automatic 22... 33.95
- Marlin 30/30 Model 336SC... 61.45
- Marlin 30/30 Model 336A... 72.55
- Winchester 94, 30/30, 32 Special, 25/35 62.45
- Winchester 43, 22 Hornet, 25/20, 32/20 54.95
- Winchester 70—All calibers... 109.50
- Remington 721-30/06 or 270... 79.95
- Remington 722-300 or 25... 74.95
- Remington 141A-35 cal.—\$104.95; 81A 129.95
- Savage 99EG 250/3000 or 300... 96.45

STEVENS 22 RIFLE



NEW! \$8.95

Below wholesale price! Famous Stevens Model 15-Bolt action single shot rifle, 22" Barrel for all 22 ctgs. Weight 4 lbs. Sporting sights. Limited Quantity! \$8.95. Also available: New Savage & Marlin 22 Repeaters. Samples @ \$19.95.

Dealers: Write for Quantity Prices
If you don't see what you want, write us!

KLEIN'S PAY ONLY 20% DOWN

CHICAGO 6, ILLINOIS

Order Today - Satisfaction Guaranteed!



CLASSIFIED Advertisements



Advertisements in this section 75 cents per word, each insertion, minimum 10 words, payable in advance
To be inserted under proper classification, copy must be in our office the 22nd of the
second month preceding date of issue

F. W. Johnson, Manager, Classified Advertising
Popular Mechanics Magazine, 200 East Ontario Street, Chicago 11, Illinois

1207 CLASSIFIED 1207 OPPORTUNITIES ADVERTISEMENTS FOR YOU

AUTOMOBILES, MIDGET CARS

GENUINE Crosley parts, accessories. New "1950" demonstrators less 500 miles. Sedans \$799. Station wagons \$849 complete. Write Walraven Motors, "King of the Crosleys," Marion, Ohio.

CALIFORNIA Custom accessory headquarters. Buy direct from original designers and save. Solid hood sides, grille panels, lowering kits, fender skirts, dual pipes, chrome motor accessories, speed equipment, push button door conversions, chrome dash panels. Revised catalog, 34 illustrated pages. 25c. Eastern Auto Supply, 3319-A South Grand, Los Angeles 7, Calif.

STREAMLINED Midget roadsters, 2 passenger plans, ideas. \$1.00. Mathison's, Highland and Billups, Clarkston, Wash.

SEE Our ad under Motorscooters for midget car bargains. Midget Motors Directory, Athens, Ohio.

SPEED & Mileage Manual—New edition! 140 illustrations, drawings, charts, photographs! Guaranteed finest, most authoritative book! Easy, inexpensive ways to build speed equipment! California hot rods! Beautiful custom cars! 200 h.p. road track conversions! Superchargers! Dual manifolds! Racing heads! Twin mufflers! Water injectors! Economizers! Get super speed, mileage, acceleration, top racing performance from any car! Complete instructions with working diagrams on fast engines, speed tuning, restyling, customizing, gas saving, racing tricks, cams, fuels, balancing, porting, ratios, frames, Offys! Learn 100 ways to save gas! Reveals stock car speed secrets! California speed shop methods! Custom styling information! Streamlining! Lowering! Sport changes! Hollywood roadster plans! Speed conversions! Covers all cars. Large manual plus equipment catalog plus racing handbook, all three only \$1.98. Almqvist Engineering, Milford 62, Pennsylvania.

FORD Owners and mechanics, we supply several simple replacement parts making Ford and Mercury brakes free floating, super powerful with soft pedal; eliminating squeal, chatter and groan—\$4.25-\$6.90. All models, 1928-1948. Easily installed by yourself. Write for details. Super Brake-Floater Company, 4022 West Lake Street, Chicago 24, Illinois.

JUNIOR Midget racing. America's newest and most exciting sport. Kits and complete cars now available. Also 2 passenger midget highway cars. 6 h.p. engines. All steel precision-built cars. We manufacture the lowest priced, finest constructed, and most complete line of midget cars in the world. Sold direct at low factory prices. Send 25c for illustrated literature. National Manufacturing & Supply Co., 215 24th Street, Sacramento 16, California.

RACING Camshafts, Ford, Mercury, Chevrolet, and others. Increases speed and power. Send 10c for catalogue giving speed hints, information, prices, and valve timing for maximum output. Dealerships open. Eddy Iskenderian, 5000 West Jefferson, Los Angeles 16, California.

NEW Big catalog! Over 500 racing, hot rod, speed equipment, auto parts and Hollywood accessories! Pictures! Speed data! Customizing tips! Lowest prices! Illustrated catalog 25c. Almqvist Engineering & Mfg., Milford 83, Pennsylvania.

BIG Bargains! Fender skirts for most cars \$10.95 pair. 6 volt electric siren with push button \$10.95. Send deposit. Send 25c for new illustrated catalog. J. C. Whitney & Co., 1919da Archer, Chicago 16.

DIRECT From California. Dual manifolds for Willys Jeeps to Oldsmobile Rockets. Finned heads, three carburetor manifolds, over 150 different makes and models. Speed and dress-up equipment for passenger automobiles. Magneto ignitions, aluminum flywheels, racing camshafts, water injectors, crash helmets, exhaust headers. New 1950 illustrated speed catalogue, 25c. (Dealers, request wholesale catalogue). Newhouse Automotive Industries, 5805-B7 East Beverly, Los Angeles 22.

SPEED Catalog 25c. Pictures, novelties, publications, emblems, model racing, books. Frank Smith, 17 Watson, Paterson 2, New Jersey.

"**SPEED** Equipment" bargains—California. mufflers \$4.50, V-8 duals \$15.90, chrome carburetor stacks 98c, dual manifolds \$9.95, chrome echo cans \$1.65, racing camshafts \$29.95 exchange, water injectors \$12.95, hi-compression heads \$19.75. All popular brands! Big illustrated catalog 25c. Dealers wanted. Almqvist Engineering & Mfg., Milford 82, Pennsylvania.

JUST Published! Clymer's No. 6 Motor Scrapbook. Latest and best. Heretofore unlisted antique cars, motorcycles. \$2.00. History Motorized Vehicles, data on early gasoline, steam, electric cars, steam engines and motorcycles, \$2.00. Clymer, Dept. 3A, 1268 S. Alvarado, Los Angeles 6, Calif.

AUTOMOBILE Nuts—New national all-hobby automobile club mobilizing forces for amateur mechanics, collectors and talk-auto enthusiasts, offers automobile dealer materials, books, data books, motor magazines, dope on old and new cars, engineering manuals. Read about other car crazes. Write Auto Maniacs, Inc., Stockbridge, Mich., to get name on free mailing list.

LATEST Chevrolet Speed Manual! 90 pages of accurate information on how to increase speed and acceleration of any 1937 thru 1949 Chevrolet. How to install late engines in pre-1937 chassis. Full data on cams, high compression, multiple carburetion, supercharging, ignition, etc. Guaranteed the finest manual of its type! Proves that your Chevrolet can have superior power and speed! Sent postpaid only \$2.00. California Bill, Box PMC-3, Eaglerock, Los Angeles 41.

NEW Clymer books. National Air Race Sketch and History Book, 190 sketches, charts, drawings. Information all national air races 1930-1949 inclusive. \$2.00—Pictorial Grand Prix Racing with 48 action photos \$1.00—Catalog of 1949 automobiles, 120 photos every American car with complete specifications compares all cars in one book, \$2.00—Catalogs '49-'50 all British cars, \$2.00—'49 Chevrolet Test Report and Survey \$1.50.—Ford Owner's Handbook gives complete servicing information all Fords 1932 to 1950, \$1.50—Complete Service Manual Model "A" Ford \$1.00. Model "T" \$1.50.—Life of Ted Horn, three-time American Automobile Racing Champion, \$2.00—Complete Outboard Service Manual covers all makes, \$3.50—Revised Hot Rod Book 1946, 1947, 1948 records, \$1.50—Steam Traction Engine Album, 160 pages, describes, illustrates 105 historical steam vehicles, \$2.50—How to Build Racing Automobile, \$2.00. All postpaid. Specify books wanted. Clymer Motorbooks, Dept. 3A, 1268 S. Alvarado, Los Angeles 6, Calif.

HOT Rod—The only monthly magazine about building roadsters, streamliners, etc. Sample copy 25c. \$3.00 yearly. Hot Rod, 548 S. San Vicente, Los Angeles 48, Calif. Dept. PM.

LATEST Ford speed manual. 128 pages full of cutaway construction drawings, photos, and understandable technical data. Includes complete data on installing V-8 motor in Model A chassis, hydraulic brakes for any Ford, roadster and fast car info. How to rework these engines for speed: V-8, Merc., Ford 6, Zephyr, Model A. Guaranteed finest manual of its type published. Sent postpaid for \$2.00. California Bill, Box PMC-3, Eaglerock, Los Angeles 41.

HORSELESS Carriage caravan book. Information Harrah's Club Reno 1949 tour with 50 antique cars through historical mining districts of Nevada. Descriptions every entrant. Photos participating cars. Interesting, educational. \$2.00 postpaid. Clymer, Dept. 3A, 1268 S. Alvarado, Los Angeles 6, Calif.

SPEED & Power Handbook—50 chapter library edition! Diagrams! Breathing methods, authentic, direct from California. Covers Crosleys to Cadillacs, all makes. Build your own dual manifolds. Superchargers. Hot cams. Water injectors. Hi-compression heads. Mileage devices. Save many dollars! Get racing speed, lightning acceleration, dynamic power increases from any make passenger automobile! Build fast stock cars. California roadsters. 160 m.p.h. rods! Get construction drawings! Tuning techniques! Speed tricks! Economy secrets! Ingenious formulas! Covers Racing Frames, Reciprocating Masses, Jet Engines, Braking Characteristics, Dynamometers. Also dual pipes, gears, fuels, porting, relieving, lowering, balancing! Includes 1950 speed equipment catalogues! Also California Automobile Customizing, photographs. Drawings. Newest ideas. "Conversions. Carson tops. Re-styling all makes. Streamlining. Chopping. Channeling. Complete \$1.98 postpaid. Newhouse Automotive Industries, 5805-B2 East Beverly, Los Angeles 22. (See page 38, Display Advertisement.)

FROM Speedway to roadway! Track-proved hi-speed heads and manifolds now available for your passenger car! No special tools needed! Increase horsepower 25%! Astounding getaway! Free illustrated catalog. Speedsport, 6215P Diversey, Chicago 39.

AUTOMOBILE Racing book, fifth edition, well-illustrated. Building bodies, frames, engines, Ford conversions. Plans. Roadsters. Indianapolis cars. \$1.00 postpaid. Popular Mechanics Press, 200 E. Ontario St., Chicago 11, Ill.

"**WATER** Injection." Also speed, power, economy methods! Free descriptive, illustrated, information. Neher Industries, La Verne, California.

RACING Car equipment for all cars, engines, racing heads, manifolds, carburetors, mufflers, etc. Speed instructions and literature \$1.00—refunded first order. Lee Motorcraft Co., 1412-D Great Northern Bldg., Chicago 4, Ill.

AUTOMOBILE Racing, sixth edition, 100 illustrations. Drawings, building instructions Ford-60 midget, California roadster, Offenhausser racer. World's record 158.5 m.p.h. car. \$2.00 postpaid; \$2.40 c.o.d. Popular Mechanics Press, 200 E. Ontario St., Chicago 11, Ill.

NEW Sensational seat cover. Mono, 6545 Santa Monica Blvd., Hollywood, California.

WE sell direct to customer speed parts manufactured by us. Ford, Studebaker, Chevrolet and Willys, complete engines for race cars and boats. \$1.00 for illustrated literature and price sheet. R. & R. Mfg. Co., Robert M. Roof, Box 546, Anderson, Indiana.

AUTO SUPPLIES AND EQUIPMENT

EMERGENCY Brakes save lives. Frozen rusted cables, result in costly replacements of linings, drums and cables. Install \$1.50 set of oilers in a jiffy, and have good brakes. (Agents wanted.) Williams Brake Cable Oilers, 1404 East 19th Ave., Columbus 11, Ohio.

AUTO Parts—New, used, rebuilt. We sell for less! Nationally known lines at dealer prices. Used parts at 50% of list, or less. Prompt replies. Kerwood Auto Parts, 511 E. North St., Decatur, Ill.

PICKUP Truck operators. New self-locking end gate fastener. Braces box, easily opened, all steel, fits any truck. Write: Engalo, McPherson 3, Kansas. Welder dealers wanted.

AMERICAN Bantam, Austin and Flat 500 parts. 1435 North 35th, Fort Smith, Ark.

MARCH Winds, April showers are as welcome as May flowers to Doubleseal; insulates under overhead doors, stops wind, rain, rain damage. Edwards Industries, Dept. 103, 4268 Shenandoah Ave., St. Louis 10, Mo.

SPEEDOMETERS. We rebuild any make, \$4.95. Western Speedometer Rebuilders, 10452 Magnolia, No. Hollywood, Calif.

AUTOWELD Training pays. G. I. approved school. Free catalog. Hobart Welding School, Box M-303, Troy, Ohio.

BUICK Parts—Enjoy new-car pep and power in your old Buick. Same day service from world's largest stock of new (not rebuilt) Buick parts and engines. Ship anywhere. Dime brings catalog. Write today. Robertson Buick Co., 1001 S. Wabash Ave., Chicago 5, Ill.

ECONOMETER For autos, trucks, boats. Meters gasoline at carburetor, indicates gallons per hour on electric dash gage. \$22.50. Ringelstetter Co., Plain, Wis.

ARC Welding frames, bodies, fenders. Pays with Hobart welders. Easy terms. Catalog free. Box M-302, Troy, Ohio.

SPOTOIL, The oil that "lubricates" lubricating oil. Nongumming blend of dehydrated nonviscous oils. No additives, no detergents. For gasoline, diesel, refrigeration, air compressors, firearms, etc. Eliminates sticky valves and rings. Money back guarantee. Handy 3½ oz. can 75c, quarts \$1.50, gallons \$5.50. Spotoil, Dept. 22, 133-S.E. Madison, Portland 14, Oregon.

AXLES, Bearings, chains, gaskets, gears, piston pins, rims for old cars. E. Clayton Smith, Box 775, Babylon, N. Y.

DIM-LITE Signs for cars as seen in Aug. Pop. Mech. \$1.00. Collins Dim-Lite Co., 4329 Lovers Lane, Dallas, Texas.

JEEP Parts for military and civilian Jeeps. Fast, efficient service. Phone and wire orders given immediate attention. Retail Supply Co., Box 906, Dept. 1B, Steubenville, Ohio. Phone 4-0854.

MOTORISTS Save gasoline by Vacuumating overrich mixtures. Fits all cars. For free particulars write Vacuumatic, Dept. 1567, Wauwatosa, Wis.

100% PROFIT Handling patented car washer. Fast seller at \$1.98. Write for details. McCallum Industries, 506 Ellen Street, Fenton, Michigan.

GET Racing speed—performance. Engine manual 50c. Carpenter, 3051 Salina, Wichita, Kansas.

NEW Accessory for cars with overdrive! Free details. Signalite, 3908-G Bertheau, Chicago.

LACHAPELLES Motor and motor fuel treatment (patented U. S. and foreign), stops ping, gives more miles per gallon, more miles per motor. 100,000 miles treatment. \$3.00 postpaid. Ferns Products, 8120 Walnut Dr., Los Angeles 1, Calif. (Data sheet on request.)

EXCLUSIVE Information—Auto efficiency, "soup-up" methods! Avoid costly mistakes! Enjoy super performance, inexpensively! \$2.00 manual, only \$1.20 p.p. Limited time. Special offer! Safeguard your engine against wear with famous "Lube-Plate" oil concentrate! Guaranteed. Only \$3.98, full year's supply! D. W. Hartman, Box 128, Batavia, N. Y.

MAKE Yourself super device. Saves 45% gasoline guaranteed, purifies oil. Plans \$1.00. Mike Brodie, Vilna, Alberta.

RADIATORS! Save 30%. New 36-48 Chevrolet \$29.95, 36-48 Ford, Mercury \$39.95. All makes. Guaranteed. Bares & Associates, 1121 E. 185, Cleveland, Ohio.

"AIRFLOW Needles." Save gasoline! Free trial! If satisfactory, \$1.50. Specify car, carburetor. Neher Industries, La Verne, California.

AUTOMOTIVE Surplus tool specials! Pullers, wrenches, socket sets, reamers. Other bargains. Nationally advertised merchandise. Send dime for catalogue. Glenco Supply, 7521 Myrtle Avenue, Glendale 27, N. Y.

AUTO And truck parts. New and used. Lowest prices. Complete stock. Prompt replies. Babbitt Auto Parts, 2833 Chicago Ave., Chicago 22, Ill.

NEW And used guaranteed parts for civilian and army cars and trucks. Largest stock in America. Mail orders. Pioneer Auto Wrecking Co., 734 W. 13th Ave., Denver, Colorado.

CHEVROLET Parts. Scarce motor, body, sheet metal parts. Grossman Chevrolet, Minneapolis, Minnesota.

BRUSH Plating outfits connect to a battery. No tanks or shop required. Free particulars. Gunmetal Co., Avenue J, Decatur, Illinois.

GOVERNMENT Surplus. Low voltage circuit tester in steel box. Cost \$202.00. Our price \$27.50. Will test batteries, starters, generators, voltage regulators, grounds, short circuits. Wilt Electrical Company, 7829 S. Racine Ave., Chicago 20, Ill.

AUTO TRAILERS

BUILD Folding camp trailer. Plans \$1.00, parts and kits available. Literature free. Trail Hut, 800A Sixteenth Street, Oakland 12, California.

WHOLESALE! Trailer running gears—all capacities. Bumper hitches for all new cars! State your needs. Austins, 31742 Sheridan, Garden City 2, Michigan.

"TORSION Axle" trailers can't sway. Safer, smoother ride. Simple, use any axle. Inexpensive. Practicable instructive guide, \$1.00. Roberts, 1204 Bill Holt, Great Falls, Montana.

BUILD Your own trailer! Save money! Have every feature you want! Plans for house, sport, camp and utility trailers. Catalog describing 9 models 10c. 15c in Canada and overseas. Jim Dandy, Box 125-A, Wausau, Wisconsin.

TRAILER Coaches. Save money. Buying? Building? Sound engineering construction, chassis, bodies, furnishings. Travel, dwelling, trailer plans. \$1.50 postpaid. Popular Mechanics Press, 200 E. Ontario St., Chicago 11, Ill.

MOTORCYCLES, BICYCLES, MOTORSCOOTERS AND SUPPLIES

DOODLEBUG Motorscooter \$5, three wheeled motorscooter \$15, midget racer \$30, less engine; Whizzer motorbike \$25, Servicycle \$30, motorscooter \$30, complete and serviceable. Engines \$3 up. Outboards \$5 up. Midget car kit \$25. Four balloon tires \$3. Plenty new motor scooters, midget cars, homebuilders parts, plans, transmissions, clutches, engines, sprockets, etc. at factory prices. Mailorder only. Send 25c for illustrated catalogue Number 34 just out listing these and hundreds of other bargains, new and used. (35c by first class mail.) Midget Motors Directory, Athens, Ohio.

KNEEACTION Motorbike \$15; midget car (steel frame) \$25; Moto-Scoot \$15; Whizzer motorbike with all attachments \$25; Indian motorbike \$30. Other motorscooters \$8 up, motors \$3 up. Send 25c for new catalog #944 listing many other sensational bargains in used motors, motorscooters, motorcycles, parts, etc. Associated, Box 1764-CS, Toledo, Ohio.

INDIAN And Harley, new and used parts catalog, 15c. Cylinder reboring, motor rebuilding, batteries, accessories. Everything for the motorcycle. Bootz, 1700 East University, Des Moines 16, Iowa.

MOTORCYCLE Magazine—Worldwide coverage. Yearly subscription \$1.00. Sample 15c. Motorcycle News, 5424-A Sawyer, Chicago 25.

BICYCLE Supplies. Wholesale, retail list, 10c. Universal, 4713 Virginia, St. Louis, Missouri.

HARLEY-Davidson parts, accessories, repair manuals on all models, 24 hour service. Authorized factory dealer. Philadelphia Harley-Davidson Company, 857 North Broad Street, Philadelphia 23, Penna.

WHIZZERS \$20 Each; Cushman motor-scooter \$15; Shaw bicycle motor \$15; midget car \$15; 1946 motorscooter \$22.50 (needs painting); complete motorbike \$30. Rush 25c for new spring catalog #16 listing many other amazing bargains in wheels, motors, motorscooters, midget cars, motor-wheels, monocytes, motorettes, etc. Gail, 538 Erie, Toledo, Ohio.

WORLD'S First jet turbine bicycle engine. Fits any bike. Smooth, economical, \$150.00. Dealers wanted. Literature 25c. Jet Engine Co., St. Augustine, Fla.

MOTORCYCLE Pistons and parts, new, used. Harley, Indian, Henderson, Super-X. List 10c. Ballak, 811 N. 9th, St. Louis 1, Missouri.

HARLEY-Davidsons—Used, guaranteed. Genuine Harley-Davidson parts, accessories, obsolete model parts, expert service. Send 25c for motorcycle and accessory bulletins. \$2.25 for 45" Army Motorcycle Manual. Knuth's, 2491 Fondulac, Milwaukee, Wis.

MOTORCYCLE Cams ground and special carburetion. Schaller Cams, Turlock, California.

RECONDITIONED Motorcycles and motors. Chromium accessories. Complete stock Indian parts. Expert rebuilding. Fast service. Indian Motorcycle Sales, Kansas City 1, Mo.

TIRES And industrial wheels, suitable for scooters, wheelbarrows, farm equipment, etc. All sizes. Bicycles and accessories. Send dime for list. Cycle Transport Company, 1241 So. Michigan Ave., Chicago 5, Illinois.

AVIATION

RAM Jets—Be a contributor to our nation's ram jet know-how. Send post card for free information. Decker Engine Works, Dept. PM-1, Plasterco, Va.

PROPELLERS—Designed for sleds, boats. Literature. Standard Aero Craft, Box 387, Ft. Worth, Texas.

PROPELLERS, Plans, skis and engines for snow sleighs, air boats. Literature 20c. Banks-Maxwell, Box 3301E, Ft. Worth, Texas.

JET Engine \$3.00; plans \$1.00; literature 10c. M.E.W., 387 University, St. Paul, Minn.

BATTERIES, GENERATORS

AIRCRAFT Generator, welder heat adjustment rheostat, dial adjustment 0-300 amps. With nichrome coil low amperage tap. On mounting panel with instructions. \$13.50 postpaid. New p-2 200 amp. fan cooled generators. Haddican Mfg. Co., Satanta, Kansas.

GENUINE Edison batteries, Fifteen year life. Unconditionally guaranteed. Free literature. See-Jay Company, 3522 Webster Avenue, New York 66, N. Y.

EDISON Nickel batteries, 37 to 600 ampere. Also kits with Edison plates; make your own. Interesting literature. The Valley Smith Co., Croton Falls 1, New York.

ELECTRICAL SUPPLIES

LAMP Parts—Extra money modernizing, converting, repairing lamps at home. 3c stamp for illustrated folder. Lamp Shop, 1348 Richmond, Des Moines, Iowa.

MAGNET Wire, insulation, transformer lamination. Morton Electrical Service, Maywood 8, Illinois.

32 VOLT Appliances—World's largest line. Catalog free. Haines Corporation, Dept. N, Minneapolis, Minn.

"FLUORESCENT Service Manual" with diagrams, prepaid \$1.00. Fleetway Company, 3208 W. Valley, Alhambra, Calif.

ELECTRIC Pencil: Engraves all metals, \$1.00. Guaranteed. Reiss, 3017-K Ocean Parkway, Brooklyn 24, N. Y.

BUY Lamp parts wholesale—Parts you need for building, repairing, or assembling. Save money on large or small orders. New catalog for 10c. Gearon Company, Dept. 300-B3, 27 South Desplaines, Chicago 6, Ill.

ELECTRIC Pencil—Engraves all metals. \$2.95. Reb Industries, Elmhurst, Illinois.

24 SMALL Motor brushes, assorted sizes, \$1.00 p.p. No c.o.d.'s. Box 263, Cedar Rapids, Iowa.

HEATING Made automatic. Catalog 25c. Refunded. Summit Sales, 3270 Waterbury Ave., New York City 61.

RECTIFIER Selenium—Complete 5A-0-7 volts d.c. 110 a.c. full wave rectification with regulator, meter, switch, terminals. Literature on request for this or larger units. Rapid Electric, 6682 Crane, Detroit 13, Mich.

ELECTRIC Appliance parts catalog and complete repair handbook. Letterhead for wholesale list. Send \$1.00 (refunded on \$5.00 order) to C-US Supply, 2512 Prevost, Fort Worth 7, Texas.

LAMPS—How to build lamps from vases, pitchers, etc. Chart for top and bottom lighting, alternately or together. How to wire oil lamps, all in 56 page illustrated catalog of all lamp parts, 25c. Gyro Lamps, 5402P Clark, Chicago 40.

FREE Catalog—Motors, generators, welders from aircraft generators, water softeners, many other electrical bargains. LeJay Company, Minneapolis, Minnesota.

ELECTRIC Pencil: Engraves all metals \$1.25. Beyer Mfg., 10511-H Springfield, Chicago 43.

ELECTRIC Motors, free bargain list. Plenge, 9 Stuyvesant Oval, New York 9, N. Y.

LEARN Electrical appliance repair. House wiring, motors, washers, cleaners, refrigerators, lamps, auto ignition, etc., complete illustrated course. Tools furnished. Free booklet. Pacific School, 7219 South Broadway, Los Angeles 3.

WELDING, SOLDERING, PLATING

BIG Profits in welding business with a Hobart "Build-Your-Own" portable. Catalog free. Hobart Brothers Company, Box M-304, Troy, Ohio.

ACETYLENE Welding outfits, new \$45.00, used \$25.00; arcwelders \$46.50. Eagle Welding, Dept. PM, 5085 Broadway, Chicago 40, Ill.

NEW—Electrolytic tank chrome plating unit. Hard or decorative. Guaranteed, \$8.00 complete. Manteno Mfg. Co., Box 247, Manteno, Ill.

BUILD D.C. arcwelder without rewinding armature. Plans \$1.00 each. 25 to 600 amperes from automotive d.c. motors, light plant generators, automobile starter-generators. Welders Club, AB-3432, Chicago 54. Also 100, 200, 300 ampere a.c. welder plans \$1.00 each.

110V. PORTABLE Transformer welders, \$29.50. Morris, 1850A State, Schenectady 4, N. Y.

200 AMPERE Welding generators. Free literature. Lewis Short, Burrton, Kansas.

RECTIFIERS 0-4 V.D.C. \$9.50, 0-8 V.D.C. \$12.50, 0-12 V.D.C. \$18.50. All 0-100 amps. Starkweather, Ottawa, Kansas.

RADIATOR Repairing books, supplies, equipment, gasoline torch. Write, Curfman Co., Maryville, Mo.

BUY Direct from factory. Welding and cutting equipment. All makes of equipment repaired. Established 1913. Box 331, Hamilton, Ohio.

ELECTROPLATING Salts and rectifiers. Mirror resilvering and chipped glass nameplate supplies. John Sprinkle, V55, Marion, Indiana.

MACHINERY, TOOLS, SUPPLIES

ELECTRIC Sump pumps. (Cellar drainers). Wholesale. Also mercury tubes and close-out bargains. Heydt, 827 E. 233 Street, New York City 66.

LOWEST Prices on a.c.-welders, power mowers, parts. Holgerson's Service, Canton, Kans.

BURGESS Vibra-Spray for paints, insecticides. Regularly \$12.95; special \$9.70 postpaid. Malisales, Box 1207, Paterson, New Jersey.

SURPLUS Circular saw blades—8" diameter, 3/8" hole. \$2.00 each. Satisfaction guaranteed. Van Dick, Little Falls, N. J.

POWER Tools. Big savings when you build your own with Lewis castings. 23 wood and metalworking tools with blueprints. Most can be completed with lathe and drillpress. Commercial quality. Ideal for home shops, schools, small manufacturing. Catalog 10c. Lewis Machine Tool Co., 3217 Union Pacific Ave., Dept. M, Los Angeles.

POWER Tools, equipment wholesale prices. Free bulletin. Homecrafters Cooperative, Grand Rapids 6, Michigan.

BALL Bearings 1/4 list price. Free list. Burgess, Box 168, Ferguson, Mo.

SAW Blades—Factory prices. Free catalog on all types. Tubergen Saw Co., 1912 Jerome Ave., Grand Rapids 7, Mich.

WHILE They last. 2" Universal precision lathe chuck, \$14 value only \$2.95. Also precision ball bearings 1" o.d. x 1/2" i.d. Package of 10 bearings, \$11 value only \$2.95. Check or money order. Har-Mur, 2349 Devon, Chicago 45, Ill.

POWER Tools, equipment wholesale prices. Free bulletin. Homecrafters Cooperative, Grand Rapids 6, Michigan.

AMAZING! "New" powerful 7 1/2" self-locking slip joint plier! No adjusting. Speedy! Convenient! Unequaled! Send \$1.98. Sarvie Tool Co., Alexandria, Minn.

POLISHING And buffing compounds and wheels. Write for free circular. Burns Manufacturing Corp., 42 Withers Street, Brooklyn 11, N. Y.

SURPLUS—Electric drills, 1/4" \$16.95; 1/2" \$29.95. (Jacobs geared chucks.) 6" electric portable hand saws with case \$56.00. Send check or M.O. Money back guarantee. Send 10c for illustrated folder. Byron Tool Company, 1609 Unionport Road, New York 60, New York.

HYDRAULIC Cylinder double acting, 2 1/2" bore, 16 1/2" travel, 1-3/16" shaft, brand new \$11.00. Discount ten or more. Spencer Aircraft, 8410 Dallas, Seattle, Wash.

CONCRETE Block machines. Standard sizes. \$39.50. Average 400 daily. Free catalog. Concrete Machine Company, 5129 South Compton, St. Louis 11, Mo.

FLOOR Sanders; rebuilt; \$50.00 up. Mutual, Box 202, Kansas City, Mo.

CHUCKS, Independent, universal; threaded 1 1/2"-8, 1"-8, 1"-10, 1"-12, or with adapter recess. Other chucks to 16" diameter. Write for quotation and free literature. No obligation. Westcott Chuck Co., 3600 Walnut, Oneida, N. Y.

HOME Lathe owners—Build your own attachments. Send for picture, sample of work and list of blueprints. Cut gears, ratchets, etc. Make neat screws easy way. The Home Shop, 415 Raymond Ave., Glendale 1, Calif.

BOATS, OUTBOARD MOTORS

WOOD Hulls can be permanently water-proofed with our Fiberglass-Plastic treatment. Eliminates leaking, caulking, splitting, painting. Easily applied, complete instructions. Cost only \$4.75 square yard hull or deck. Save time and maintenance costs. Enjoy a dry boat this summer. Industrial Plastics, 3807 Harrison, Oakland, California.

BUY Our conversion parts to change your auto engine into a high-grade marine engine. Marine manifolds, transmissions changed to high speed reverse. Marine bronze pumps, propellers, shafts, couplings, stuffing boxes, struts, rudders, etc. Buy direct from the factory and keep the dealers profit for yourself. Money back guarantee. Conversion Parts Co., 278 Adams St., Boston 22, Mass., U.S.A.

KNOCK-DOWN Boat kits. Outboards, inboards, sails, hydroplanes. Easy to assemble. Minimum cost. Catalog with specifications, prices, 25c. Brooks Boat Company, Carrollton, PM, Michigan.

BUILD Your own—Three point racing hydroplanes, others. Informative literature 25c. Champion Boats, P.O. Box 7132, Long Beach 7, California.

BUILD Your boat from our accurate paper patterns or materials, thirty designs. Forty years designing and construction. Descriptive literature 25c. Illustrated book, small boat construction \$1.50 postpaid. Germain Boat Company, W. Saginaw, Michigan.

FULL Size, cut to shape boat patterns, blueprints, 7 1/2-38 feet. Illustrated "Build a Boat" catalog, 25c (coin). "How to Build Boats" book, \$1.00. PolyWog houseboat plans \$10. Marine catalog \$1.00. Marine Specialty Mfg. Co., 3107 Detroit Ave., Cleveland 13, Ohio.

CONVERT Fords and Jeep to 100% marine engines with Osco's world famous Convo-Kits. Deluxe catalogue 25c (coin). Oscomotors, 2020B Orleans, Philadelphia 34, Penna.

FREE! World's most complete catalog listing. Boat kits, plans, patterns, marine engines, conversions, boat building lumber, plywood, marine hardware, trailer parts. Marine Mart, Buffalo 7-B, New York.

REBUILT Outboard motors—Late models. We specialize in new-used parts. Write for price quotations giving us description of parts needed. Money back guarantee. Standard and oversize outboard motor pistons. Outboard Motor Mart, 309B Atlantic Avenue, Boston 10, Mass.

STEERING Wheels, windshield brackets, from \$6.95. Modern fittings at lowest prices. Complete pre-cut plywood boats. Bargains galore. Folder 10c. Marine, Box 681, Mendota, Minnesota.

TWENTY Plywood boat plans \$1.00. Catalog of boatbuilding plans 10c. The Rudder, 15 Murray Street, New York 7.

SAVE 2/3 Cost. Build your own boat with our ready cut parts by the Welch system. No experience necessary. Rowboats to cruisers. Illustrated catalog 25c. Midwest Boat Company, Menomonee Falls, Wisconsin.

OUTBOARD Motors—Used bargains, \$45 up, free list. Used parts, most models, save money! Boat and motor equipment and accessories. Big catalog, send dime. Crandall-Hicks, 911 Commonwealth, Boston, Mass.

NEW, Used, rebuilt marine motors. Marine conversions, fittings. Free catalog. Stokes Marine Supply, Dept. 24, Coldwater, Michigan.

MARINE Conversions for Ford and Jeep engines. Catalog 10c. Lehman Manufacturing Company, Department D, Newark 2, New Jersey.

ENGINES, MOTORS, DYNAMOS

CLOSE-OUT Sale new 1 h.p. gasoline engines. Never unpacked. Motorize lawn mower, saw, pump, sprayer. Check, c.o.d. \$27.50. Jedway Corporation, Acton, Indiana.

BARGAINS. Welders. Alternating or direct current, gas or electric drive, portable or stationary. Advise us your needs. William Harrison Company, Box M-305, Troy, Ohio.

WELDING Generator, 150 ampere \$47.50. Motors, 1/2 horse \$15. 1 horse \$30. Water pumps \$12.50. Butler, 1885 Milwaukee, Chicago 47.

MOTORS, Repulsion, induction: 1/2 h.p. 1750 r.p.m., \$15.00; 1/3 h.p. \$10.50. 1/2 h.p. grinder complete \$32.50. Roberts, 7232 Madison, Forest Park 9, Illinois.

ELECTRIC Motors, 1/2 h.p. \$14. Standard makes. No c.o.d. Columbia P, Silver Creek, N. Y.

WATER Motors—All sizes; for any purpose. (Rotary and semi-rotary.) Adapted to air or steam. Duplex Motors, Burlington, Iowa.

MOTOR Winders, free testing and winding equipment bulletins. Motor Industries, Quincy, Illinois.

WINDING Data, listing 225 motors, single and three phase, \$1.00. Motor Data Co., Box 7631, Kansas City 3, Mo.

ATHLETIC EQUIPMENT, BODY BUILDING COURSES

MUSCLE Courses \$2.00. (Pictures, etc. 10c.) Sid's System, PM14, Southgate, Calif.

ACROBATS! Strength. Health. Free booklet. Write! Knoff, A350, Pewaukee, Wisconsin.

FREE Illustrated catalogue—10c for postage and handling appreciated. Dr. Frank Thompson, Dept. 10, 919 Fourth, Manhattan, Kans. World's leading dealer.

BARBELLS, 95 Pound set, \$11.50. Develop your body. Jackson Barbells, Springfield 4, N. J.

GREAT Strength easily obtained. See page 75, December issue 1949.

BARBELLS—Finest quality, \$7.98 up. Free catalog. Lurie Barbell Co., 1729-M1 Rockaway Parkway, Brooklyn, New York.

DEADLY Judo—Fiercest fighting technique. Trick knockouts. (Over 200 illustrated pictures.) Expert instructions; three volumes. Complete \$2.25. Variety House, Box 46-B Wall Station, New York 5.

BARBELLS, Exercise equipment. Courses. Free booklet. Good Barbell Co., Reading, Penna.

SPORTING GOODS, GUNS, FISHING TACKLE, ARCHERY, TRAPPING

FREE Guidebook, "Top Tips For Fishermen." Send now for this fascinating, new, free, Richardson 32-page booklet containing 357 fishing tips, compiled by the expert fishermen who make Richardson rods—the fishing rods that are tagged with the "Sign of the Fish!" For your copy, sent without cost or obligation, print your name and address on a penny post card and mail to Richardson Rod & Reel Co., 3166 N. Sawyer Ave., Chicago 18, Ill.

TENTS, All types and sizes, vast selection, camping equipment; war surplus. Lowest prices. Free catalogue. Morsan, 10-19E 56th Ave., Long Island City 1, N. Y.

FISH Line, 1500 ft. Dupont 2 ply nylon 25 lb. test, \$1.98 postpaid. Allender & Co., Chicago 16, Ill.

FISHERMEN—Make your own sinkers with our molds. Free illustrated booklet. Reading Instrument Co., Box 78, Reading, Penna.

GUNS—Bought, sold, swapped. Barlow's, 5565 South Howell Ave., Milwaukee 7, Wisconsin.

LEARN Gunsmithing! Details, copy "Guns and Gunsmithing" 25c. Gunsmith, Palatine, Illinois.

SEND 10c for list 100 used guns. Frayseth's, Willmar, Minn.

FELLOWS! Fishin's just around the corner. Catch 'em with this new bait. 25c. Specialty House, Box 542, Danville, Ill.

FREE 50 Page catalog—Fly-tying, lures, spinners, rod making materials, hooks, fishing supplies. Scully Tackle Co., 3436 W. 5th Ave., Chicago 24, Ill.

GUN Replacement parts, state your needs. Jos. Claudio, 67 West 101 Street, New York.

BETTER Fishing bobber. Cast easier, less backlash. 49c. W. F. Schulz, Lakefield, Minn.

BOGAN'S Merchandise lists again available, 20c. Bogan Company, Dahlgren, Illinois.

MOLDS For fisherman's sinkers, jigs, squids and lures, completely machined and fully guaranteed. Write for free catalogue to E. L. Sweet & Son, Dept. 8, Tonawanda, New York.

AMMUNITION, Foreign-American; firearms. List 25c. Frank Parish, Vicksburg, Miss.

190 PROFUSELY illustrated pages antique and modern pistol, sword, etc. values. 50c. Robert Abels, A860 Lexington Ave., New York 21.

SHOTGUNS, Rifles, revolvers, over 500 modern, obsolete. Also cartridges, list 10c coin. Ed Howe, 52 Main, Coopers Mills, Maine.

5000 BARGAINS, Firearms, binoculars, war relics. Catalog 40c. Smith Firearms, Runnemed, New Jersey.

TAXIDERMISTRY

"**MODERN Taxidermist Magazine**," Greenfield Center, N. Y. Devoted exclusively to taxidermy. Two sample copies 25c.

BINOCULARS, TELESCOPES, MICROSCOPES, MAGNIFIERS

TELESCOPES, 30 Power, extends 36"; precision lenses. Satisfaction guaranteed or money refunded. \$2.95 postpaid. Criterion, Dept. PMC 4, 438 Asylum, Hartford 3, Conn.

SAVE 50% On new binoculars! Free catalog. Free book, "How to Select Binoculars." Write today! Bushnell Importers, 43-M3 East Green, Pasadena 1, California.

ASTRONOMICAL Telescopes, binoculars, microscopes; bought, sold, repaired. Books. Lists 10c. Rasmussen-Reece, Amsterdam, N. Y.

WAR Surplus bargains, binoculars, telescopes, sextants, millions of lenses, prisms, reticles, eyepieces, objectives, etc. Request free "Catalog CH." Send \$1.00 for Stock CH—10-piece lens kit and big instruction booklet. Edmund Salvage Co., Barrington, N. J.

GIANT Astronomical telescope with 6 ft. tripod \$15.00, f.o.b. factory. 100 power. (10,000 area magnification). Clear vision, full power guaranteed. Ready for use. Suffolk Science Service, Dept. BT, Riverhead, N. Y.

BINOCULARS, Telescopes, watches, guns. Buy, sell, trade. Schweer's, Donnellson, Iowa.

REFLECTING Telescopes, 60X, completely assembled \$25.00. Guaranteed observatory clearness. Free information. Skyscope, 475 Fifth Avenue, New York 17.

TELESCOPES, Binoculars, microscopes, big bargain catalog free. Brownscope Company, 24 West 45th Street, New York.

POWERFUL Astronomical telescopes easily made. Perfect lenses and instructions; 100X \$3.00; 100X and 200X \$4.00; 100X, 200X and 400X \$6.00. Full power, clear vision guaranteed. Instructions alone 10c. Suffolk Science Service, Riverhead, N. Y.

PETS—DOGS, BIRDS, RABBITS, HAMSTERS, ETC.

RABBIT Hutch and housing. New, revolutionary patented features, automatic, economical enabling two persons care for 1000 does. Plans, photographs \$5.00 postpaid. Reliable Industries, Montebello, Calif.

RAISE Guinea pigs. Make extra cash. Booklet free. Taylor, Box 426A, Hapeville, Georgia.

MAKE Money raising Angoras. Circular free. Vaughn's Rabbitry, Otley, Iowa.

CAPONIZE Chemically, no surgery, tenderizes, flavorizes four to eight weeks all age roosters. Free simple instructions. Golden Valley Hatchery, Dept. 14, Parkville, Missouri.

HAMSTERS: No finer breeder or pet stock at any price. \$2.50 pair, \$3.75 trio. Free folio. Valley Hamstery, 734 North Milam, San Benito, Texas.

ZOOLOGICAL And pet animals for sale. Illustrated catalogue, literature, 25c. Trails End Zoo-5, St. Stephen, S. C.

I BUY Hamsters, rabbits, guinea pigs, rats, mice, other small animals. List animals you raise, send 25c (coin) for shipping information, prices, additional particulars. Stanley Tears, Jr., 221 Rosalind Ave., Gloucester City 1, N. J.

RABBITS: New Zealand whites. Ringland Rabbitry, 1726—30th, Des Moines 3, Iowa.

GOLDEN Hamsters. Vigorous stock. Breeding age males \$1.25, females \$1.50. 5 weeks old 25c less. Best cage made \$1.45. Large breeding cage \$2.45. Satisfaction guaranteed. Fullers Hamstery, 16745 Sierra Hiway, Saugus, Calif.

HAMSTERS: Pair \$3.00. Supplies, literature, quantity discounts. Harold Frank, Box 633, Stamford, Connecticut.

RAISE Hamsters for pleasure and profit. Breed in 16 days. Illustrated literature. Pat's Hamster Farm, Waterford 3, N. J.

GOLDEN Syrian hamsters, selected breeders and pets. Free information on how to raise these clean, inexpensive to raise, animals for pets and profit. The E. K. Farm, Route 1, Box 56A, Arlington Heights, Illinois.

SEE Gulf Hamstery ad on page 26. Shows picture of Hamster.

\$300 MONTHLY Raising Angoras for our market. Particulars free. Wilson, Stanton 17, Calif.

RAISE Chinchilla rabbits! Real profits from breeders, meat, furs, laboratories. Markets supplied! Write today! Rockhill Ranch, Sellersville 15, Penna.

BREED Mink—Booklet, pen plans free. Lake Ontario Mink Ranch, Gravel Road, Webster, N. Y.

RAISE Rabbits. Four pound fryers in eight weeks. Ready market for meat, fur, wool. Illustrated book, describing leading breeds, housing, breeding, feeding, marketing. By America's largest rabbit association 10c. American Association, 12 AR&CBA Building, Pittsburgh 17, Penna.

\$1.00 FOR Booklet "Canary, Its Care, Breeding and Training," and three copies cage-bird magazine. American Canary, 2839PM N. Halsted, Chicago 14, Ill.

MINK Raising information free. Complete. Lake Superior Mink Farm, Superior, Eel, Wisconsin.

\$400 MONTHLY Raising Angora rabbits. No experience required. Details free. White's Rabbitry, Newark, Ohio.

GRINSTEAD'S Famous Angoras! Giant Chinchillas! World's most profitable rabbits. Finest pedigree, heavy-producing, prize-winners. Literature free. Grinsteads, Edwardsville, Illinois.

\$3000 YEARLY Raising Angora rabbits. We buy your output. Contract particulars free. Kise's Enterprises, St. Paul 8, Minn.

INCREASE Your income by raising domestic rabbits. Small space needed. Ready market for delicious meat, fur and wool. Largest magazine in the industry tells you how. \$1.50 per year. Sample 15 cents. No stamps. Small Stock Magazine, Lamoni 20, Iowa.

PLANTS, SEEDS, NURSERY AND GARDEN SUPPLIES

GINSENG, Goldenseal. Hundred seeds \$1.50; thousand \$5. Dozen plants \$1.50; hundred \$9. Growing-selling instructions included. F. M. Collins, Viola, Iowa.

CACTI, Succulents; colorful, thornless. Ideal house plants. 7 for \$1.00, 17 for \$2.00 prepaid. All different. Munsil's Gardens, Vista, Calif.

MULTIPLY Garden yield, build simple device, plans 50c. S&K Specialty, 2847 N.W. 22, Oklahoma City 7.

GLADIOLUS, List, 100 varieties, new, rare, novelties. Robinsons, Sebastopol, California.

RAISE Your own trees and shrubs from seed for shade, windbreak, erosion control, etc. Write for free planting guide and price list. Woodlot Seed Co., Norway 4, Michigan.

FARMS, FARM LANDS, REAL ESTATE

\$3.75 PER Acre Missouri-Oklahoma land, total price. Warranty title. Large, small tracts; cash, terms. Free list, maps. Frederick Calvert, (Owner), Winter Haven, Florida.

HOMESITES \$300—Convenient payments. California's finest garden section. On Morro Bay's scenic shores. Wonderful fishing, hunting, boating, bathing. Fertile soil, softest water, temperate climate, congenial community. Free literature. Richard Otto, Department M, San Luis Obispo, California.

\$5.00 MONTHLY Buys 40 acres near town; price \$200. Free list. Box 425-P, Carthage, Mo.

STROUT'S Golden anniversary farm catalog. Over 2800 outstanding bargains. Coast-to-coast, 32 states. Mailed free. Strout Realty, 7 So. Dearborn St., Chicago 3, Ill.

NEW Free spring catalog, farm bargains, many equipped, illustrated, several states! United Farm Agency, 1408-PM Consumers Bldg., 220 South State St., Chicago 4, Ill.

FREE List farms, ranches, central Arkansas. Owen Farm Agency, Conway, Ark.

FLORIDA Facts. Jobs, wages, rents, weather, living costs. Questions answered. Russell, 504 Melville, Tampa, Fla.

RAYBURN'S Ozark guide. Eureka Springs, Arkansas. Homeseekers; tourists magazine. Year, \$1.50.

GOVERNMENT Lands \$2.00 acre up. Information all states twenty-five cents. National Tax Service, 901-A Majestic Bldg., Detroit.

CANADIAN Tax sale lands for two dollars an acre and up. Small monthly payments. Farms, timber, hunting and fishing camps, minerals. Limited number of properties. Write at once for free catalogue. Tax Sale Service, Room 105, 120 Bloor St. W., Toronto 5, Canada.

ALASKA Farms free—160 acre homesteads. Farming, dairying, ranching. Unlimited opportunities. Details \$1.00. Edward Wade, 6215 University, Chicago 37, Illinois.

FARM Manual shows you how to make extra profits from your farm. 284 pages of farming lore. \$3.00. Popular Mechanics Press, 200 E. Ontario, Chicago 11, Ill.

SOLD For taxes, Calif., Oregon, Washington timber, grazing, ranch and mining lands. 25c to \$3 acre min. bid. 10c (coin) brings circulars, photos, maps. Pacific Lands, Box 2350-PM, Hollywood, Calif.

FLORIDA Campsites—\$95.00 at \$5.00 monthly buys nice, high dry lot in Lake County (world's best bass fishing, wonderful hunting) near Ocala National Forest, St. Johns River, beautiful lakes, pavement. Folder free. Howard Vernor, DeLand, Florida.

GOOD Farms—Ranches. Washington, Minnesota, Montana, Idaho, Oregon, North Dakota. Dependable crops, favorable climate. Write for literature, lists describing typical farm opportunities. Specify which state. J. W. Haw, 119 Northern Pacific Ry., St. Paul 1, Minn.

FARMS, Ranches, lodges, resorts. Big selection, Milwaukee Road territory, Washington, Idaho, Montana, Dakotas, Minnesota, Iowa, Missouri, Michigan, Wisconsin, Illinois, Indiana. Free colorful descriptive folders, price lists. L. H. Robbins, 738J Union Station, Chicago 6, Ill.

FARM MACHINERY AND SUPPLIES

FOR Sale—Recker push off wagon unloader. Will unload chopped hay, ensilage, and all other farm crops in 3 to 8 minutes and return endgate to front in 6 seconds. Write for free lit. F. B. Recker Co., Hopkinton, Iowa.

POULTRY, FARM SUPPLIES

EARN \$4 to \$12 hourly. Chick sexing, turkey sexing, culling and caponizing. G. I. approved. Pilch's School, Box S-10, Thompsonville, Connecticut.

BABY Chicks, champion mated. 52 varieties, 7 crosses, licensed inspected, bloodtested. Rush postal, large colored book free, low prices. Berry's Farm, Route 12, Clarinda, Iowa.

RAISE Fryers new easy way. One man home plan earns \$3000 yearly. Circular free. Poultryman's Institute, 1046 So. Olive, Los Angeles 15, Calif.

RAISE Turkeys the new way. Write for free information explaining how to make up to \$3000 in your own backyard. Address—National Turkey Institute, Dept. 3, Columbus, Kansas.

KNOW How to raise poultry for profit. Read Northeastern Poultryman. Every issue packed with helpful hints and practical suggestions. Latest articles on breeding, feeding and management. Subscribe now. 1 year 65c. 2 years one dollar, foreign subscriptions \$1.00 a year. Northeastern Poultryman, Dept. P.M., 376 Boylston St., Boston 16, Mass.

PROFITABLE OCCUPATIONS

BE An invisible re-weaver—Learn profitable trade, earn over \$20 daily, full or part time; repair cuts, tears, burns in clothing or any fabric so damage cannot be seen. Big demand, big profit, uncrowded field. Complete low-cost home-study course includes lifetime equipment. Easy-to-learn, pay-as-you-earn; can mean lifetime income. Details free. Fabricon, Dept. N-2, 8342 S. Prairie Ave., Chicago 19, Ill.

HAVE Fun! Make money! "Working With Leather"—64-page booklet tells how. Send 25c for copy. Free catalog and valuable information included. Wilder-Craft, 1039 Crosby, Chicago 10.

LEARN Reweaving! Free details. Frank Harris, 2502 St. Thomas, New Orleans, La.

SOAP From kitchen fats. Profitable swap with housewives. Circular free. Cater, 638 West Colfax, Denver 4, Colorado.

\$250 WEEK Reported! Free booklet "505 Odd, Successful Enterprises." Work home! Expect something odd! Pacific-A, Ocean-side, California.

MUSHROOMS Grown boxes. Barrels. Instructions 50c. Spawn \$1.00. Manureless process. \$2.00. Gordons, 553 William, Winnipeg, Manitoba.

LOCKSMITHING Secrets! Key fitting, lock repairing, opening; prices, sources. Illustrated book \$1.00. Wechsler, 7 West 36, New York City.

POSTCARDS Bring orders galore; 75c to \$1.50 profits. New, dignified, no stock to buy. Data and 62 page book, "How to go into business for yourself." 25c—Refundable. Jack Rabbit Mailing Service, P.O. Box 15-P, Eutawville, South Carolina.

"FROG Raising!" New book tells how! Illustrated literature free. Marlboro-A, Box 7002, New Orleans 19, Louisiana.

MAKE Flexible molds! Cast plaques, novelties, bookends! Free sample! H. Tooker, Hamilton 9, Ohio.

BIG Money—Learn watch-clock repairing at home. Inquire Modern Technical Supply, 55-PM West 42nd Street, New York 18.

GET Big money for old phonograph records. Listings free. C. Carr & Co., Dept. R, Beverly, New Jersey.

DOMESTICATED Earthworms. World's best garden and fertilizer builders. Booklet 10c. Avery's Earthworms, Wichita 12, Kansas.

START With small capital right from your own home. No office needed. No personal contact. Location no obstacle. Sell by mail thru ads, postcards, circulars. This magazine tells you about it. Send for free copy now. N. Willis, 1401 White-lock St., Baltimore 17, Md.

MAKE Money at home—Casting fast-selling plastex novelties and metallizing baby shoes. Tremendous possibilities—full spare time. No experience needed. Full instructions given. Write: Leonard Moese, 161-A Madison Ave., New York 16, N. Y.

FREE Book "How to Make Money With Home Workshop" describes amazing methods used by hundreds of successful craftsmen. Tells what to make, how to sell workshop output spare time. Write at once for details. Remember it's free! Craftsman, 115A2 Worth St., New York City.

FOREIGN Employment! Overseas directory of oil and construction companies, exporters, airlines, etc., \$1.00. R. Carmody, 1605 New Hampshire N.W., Washington, D. C.

BE The Popular Mechanics representative in your neighborhood and earn big profits in your spare time. Write Popular Mechanics Magazine, Room 408M, 200 E. Ontario St., Chicago, Ill.

FREE Plans; raising earthworms. Suggestive ideas, stamp. Stoners, Chattanooga 4, Tenn.

\$5,000 YEARLY By working 365 "hours." Small initial investment. 25c for details. Iulucci, Waterford 20, N. J.

CONSTRUCTION Men — Construction Register tells you where the new jobs are and who's building them. Send one dollar only for current bulletin. M. E. Ober, Box 786-R, New York 8, N. Y.

MEN—Women. "Everybody likes candy." Learn to make professionally at home. Details free. (Our 40th year.) Ragsdale Candies, D6, East Orange, New Jersey.

ALASKA—The great American frontier, offers unlimited opportunities. \$1.00 brings 1950 copyrighted report and government map. Business directory listing big construction projects; fishing; mining; aviation; hunting-fishing-game rules, fur-farming, lumber; agriculture; live stock raising; transportation; homestead and highway information. Hot list of firms hiring. Alaska Opportunist, P.O. Box 883-P, Hollywood 28, Calif.

INTERESTED In Latin American and foreign employment? \$1.00 brings 1950 copyrighted "Foreign Service Directory" with new complete listings in U. S. and Canadian construction companies; worldwide oil firms, mining, aviation, steamship, transportation; manufacturers; importers and exporters; domestic and foreign listings. Special daily listing of firms hiring. Tells how-when-where to apply, application form. Global Reports, P.O. Box 883-P, Hollywood 28, Calif.

\$400 MONTHLY Raising Angora rabbits. No experience required. Details free. White's Rabbitry, Newark, Ohio.

\$46 FROM Square foot plywood; jigsaw necessary. Write, Woodarts, P-38, Bridge-water, Mass.

OWN And operate mirror shop! Supplies for resilvering mirrors, making chipped glass nameplates and electroplating. John Sprinkle, V50, Marion, Indiana.

RAISE Fishworms. Easy, profitable. Send 25c in coin for complete instructions. Huffman Worm Ranch, Rives Junction, Mich.

TYPISTS, Profitable business at home. Complete copyrighted information 50c. Rosdahl Industries, 72-A W. Washington St., Chicago 2, Ill.

\$40.00 WEEKLY Made growing mushrooms, fresh, dried. Dominion patent 331583. Free spawn. North American, 169P Yonge, Toronto, Canada.

BOOKS, PERIODICALS, PICTURES, POSTCARDS

ENTERTAINMENT Package, 3 wonderful books: Puzzle Paradise, Self-Entertainment, Coronet Quiz Book, \$3.75 value, all yours for just \$1.00. Supply limited. Rush order. Book Readers' Circle, Box M, 80 East 11th Street, New York 3.

POSTCARDS—Roberts Kodachrome process. Beautiful, historical. U. S., Alaska, Hawaii. 25—\$1.00; 80—\$3.00. Satisfaction guaranteed. Ernest Hall, Box 3660, San Francisco 19.

FREE Catalogue. Special interesting books. Melvin Powers, 1324 Wilshire, Hollywood, California.

BIG Cartoon booklet, fifty comic cards, \$1. Harris, Box 550, Palm Springs, Calif.

SELF-EXPLAINING Bible: Illustrated circular free. Box 446-P, Minneapolis, Minn.

BOOKS! Many subjects. Catalogue, 3c stamp. Mesa, Box 55-B, New York 19.

BACK Issues magazines, reasonable. Reedmore, 240 East 9th, New York, N. Y.

SEARCH Light on Bible and x-ray by organic super natural and artificial science. Sidney Moore, P.O. Box 547, Portsmouth, Virginia.

MOTOR Trend Magazine—Custom, foreign, domestic, sports cars. Road testing, racing, auto shows, etc. Sample copy 25c. Full year \$3.00. Motor Trend, 548 S. San Vicente, Los Angeles 48, Calif., Dept. PM.

HOW-To-do-it books on every subject. Written in Popular Mechanics' famous easy-to-understand style and profusely illustrated. Subjects include workshop planning and practices, projects, hobbies, household repairs, motoring, outdoor sports, photography, home building and many others. Also booklets on specific topics. Write for free illustrated catalogue. Popular Mechanics Press, 200 E. Ontario, Chicago 11, Ill.

BOOKHUNTERS! All subjects. Send wants! Jaher Book Service, 620-P East 178 Street, New York 57.

BOOKFINDERS! (Scarce, out-of-print, unusual books). Quickly supplied. Send wants. Clifton, Box 1377-PM, Beverly Hills, Calif.

NATIONAL Geographic Magazines 1888-1949. Any issue. Box 327-PM, Periodical Service, Swarthmore, Penna.

TEXAS Books, on Texana and Southwest, catalog, 10c postpaid. Old Fort Davis, Fort Davis, Texas.

GAMES, TOYS, NOVELTIES

2550 ADDRESSES—Toy and novelty dealers \$5.00. Kapaon, 75 Bridge Street, Salem, Mass.

INDIAN Squaw with papoose or Indian chief dolls—14" high, only \$3.50 each postpaid. Full chief headdress \$2.50. Satisfaction guaranteed. Seneca Lodge, Watkins Glen, N. Y.

MAGIC TRICKS, PUZZLES, JOKER NOVELTIES

AMAZING New book "100 Puzzles" shows how to solve, make puzzles—straight line peg, circle peg, checker board, string, glass topped box, six piece burr, scores others. Astonish friends. Be life of party. Order now. \$1.25. Refundable. A. S. Barnes, 101A Fifth, New York City 3.

JOKER'S Headquarters! Imitation bed bugs, dribbling water glasses, "poo poo" cushions, many others. Illustrated catalogue 25c (refunded first order). J. C. Fink Specialty Co., B-1618, 9th and Market Sts., Philadelphia 5, Penna.

SEND 10c For latest joker trick and catalog. Yakity yak talking teeth \$1.00. Laramie Sales, 4800 S. Laramie Ave., Chicago, Ill.

EARN \$1.00 Per minute entertaining with magic. Introductory assortment \$1.00. Free book of card tricks included. Konjurors Kabin, Dept. M, 8871 18th Ave., Brooklyn 14, N. Y.

500 TRICKS Catalog and book "84 Card Tricks," both only 50c. Robbins Co., 131-P West 42nd St., New York.

WILD Porcupine Aiggs and Mexican Thunder-Burds. Mail friends these goofy gags. Both 50c postpaid. Hal Empe, Duncan, Arizona.

279 MAGIC Tricks book 20c. Card to matchbox 10c. Diminishing card 5c. All 25c. Garvey, 44-2 Bates Road, Brockton 58, Mass.

VANISHING Coin and magic catalog 50c. Larry's Magic, 324 First, Milford, Mich.

VENTRILOQUIST Dummies. Catalogue 10c. Be a ventriloquist. Free literature. State age. Maher, Box 36-M350, Kensington Station, Detroit 24, Michigan.

DIRECTIONS For performing 275 tricks. 10c. Aim Magic Company, 143 Verona Avenue, Newark 4, New Jersey.

SEND For free list of joker novelties and magic tricks. Smilin Jim, 125 N. Gallatin Ave., Uniontown 3, Penna.

16 CARD Tricks and catalog 25c. Sterling Magic, Royal Oak, Mich.

500 NEW Howls for magicians, comics, etc. \$1.00. Send 25 cents in stamps for latest price list. Laughs Unlimited, 276 W. 43rd St., New York, N. Y.

GIGANTIC Magic-joker catalog, samples—10c. Mammoth fun kit 25c. Funland, 6419 San Vicente, Los Angeles 48-A, California.

MISS Television. Sensational new novelty \$1.00. Tupler, 216 W. Jackson, Chicago.

"SPECIAL Magic offer." Tricks, novelties. "Marean" Magic Shop, Hopewell, Virginia.

500 TRICKS. Douglas famous catalog 27 now only 10c. Unequaled service to magicians for 30 years. Send 10c today. Douglas Magicland, Dept. 1, Dallas, Texas.

INTRICATE Wooden puzzles. Sample 25c; 5, \$1.00; 12, \$2.00. House of Kraft, 75 Bridge St., Salem, Mass.

LATEST And best tricks described in our new large catalog. Send 25c to Jeffries Magic Company, 17 North Hudson Street, Oklahoma City, Okla.

500 TRICKS Catalog and book "84 Card Tricks," both only 50c. Robbins Co., 131-P W. 42nd Street, New York.

200 ELECTRIC Stunts, 110 volts, \$1. Kutting Sons, Los Altos, Calif.

400-PAGE Catalogue of 2000 tricks, pocket, parlor, stage. World's finest magic. Send \$1.00 for catalogue (refunded first \$5.00 order). Kanter's, M-1311 Walnut, Philadelphia 7.

MAGIC Tricks, puzzles, books, cards, punch boards. Catalog 10c. Specialty, Box 671, St. Louis 1, Mo.

WORLD'S Largest professional magic shop, keeps you in touch with latest tricks. To receive mailings, send 50c for new catalog. Holden's, M220 West 42nd St., New York.

BE A magician. Large professional magic catalog of latest tricks, 35c. Ireland, C-109 North Dearborn, Chicago 2.

PROFESSIONAL Catalog. 124 pages, 25c. Williams, 900 Plymouth, Ellwood City, Penna.

VENTRILOQUISM Taught. 3c stamp bring particulars. Smith, 801 Bigelow, Peoria 5, Ill.

FREE Watermark detector, perforation gauge with U. S. approvals. Manning, 3259 Decatur Ave., New York 67, N. Y.

50 DIFFERENT Countries. Abyssinia-Zanzibar 3c, to approval applicants. Mohawk, Box 141P, West Springfield, Mass.

500 JAPAN Stamps 10c! Kenmore, Arlington 74-J4, Mass.

"HOW to Recognize Rare Stamps." Free book, illustrated! Kenmore, Arlington 74-H8, Mass.

OLD Scarce U. S. seconds on approval. Slightly defective. Bargain prices. Hernefield, Clintonhill Station, Newark 8, N. J.

FREE Zeppelin, Columbian, Roosevelt, air-mail. Illustrated lists. Approvals included. Third Co., 101 3rd Ave., Newark 4, New Jersey.

200 BRITISH Empire stamps plus valuable publications only 3c. Kenmore Stamps, Arlington 74-B17, Mass.

ARMENIA. Ten bicolor stamps, value 75c, free to approval applicants. Apex Stamps, Box 2188, Miami 13, Florida.

FREE! Scarce triangle-diamond packet to approval applicants! Send 3c postage. Thrifty Stamps, Silver Spring, Maryland.

ATOMIC Bomb airmail and 100 different from war-torn China. 10c to approval applicants. Star Stamp Company, Jamestown, New York.

FREE Gigantic, beautiful, bi-colored mint, U. S. George Rogers Clark commemorative stamp to approval applicants. Mohawk, Box 524, Albany, N. Y.

RARE Bargain. Six mint German sets. 50c value. Only 10c to approval applicants. Stamp Mart, 1412 Great Northern Bldg., Chicago.

FREE. Scott's International album, valuable colorful collection, hinges, other big premiums. Full particulars with approvals. Raymax, 123-Z William St., New York 7.

FREE Catalog! Illustrated. Forty pages. United States, Foreign. Albums. Supplies. "How to Collect," etc. Harrisco, 202 Transit Bldg., Boston 17, Mass.

TOPS! Our book "How to Collect Stamps." Send for your free copy today! Littleton Stamp Co., Littleton 37, N. H.

25 DIFFERENT Ecuador, including 70 Centavo air mail 5c. Approvals included. Ranson, 721 West Maple, Compton 4, Calif.

750 FRANCE And colonies stamps 10c. Littleton Stamp Co., Littleton 25, N. H.

1000 WORLD Wide 67c. Pacific, P.O. Box 5704, Los Angeles, Calif.

GRAND Value packet with five foreign sets, free. Stoll Stamp Service, 2632 Burnett, Louisville 10, Kentucky.

FREE—Cuba Roosevelt issue and illustrated catalog. Maynard, Littleton 12, N. H.

EXCHANGE! Send 25 U. S. commemorative duplicates. Receive 200 different world. Sundman, Littleton 6, N. H.

POSITIVELY Greatest free offer—Latest Scott's international \$6.00 stamp album, covering entire world, contains 36,000 illustrated descriptive spaces, Scott's New Standard \$7.00 catalogues "Philately's Encyclopedia"—absolutely free to applicants for foreign approvals becoming customers. Plymouth Specialty Co., Dept. A-9, Box 510, Bell, California.

STAMP Magazine! Copy free! "Stamp Post." S. Catalina, Pasadena 1, Calif.

10,000 DIFFERENT 1c Each! Gordon Davison, Box 1019S, Manchester, N. Hamp.

U. S., Canada, Newfoundland, Mexico: "Gold Nugget approvals." Nothing like them! Write today. 312 mixed U. S. only 10c. Kessel's, Folsom, California.

GIFT—Tokelau Is. complete mint to approval applicants. Deane Stamps, Box 87, Miami 35, Florida.

110 DIFFERENT Hitlers, Roosevelt, Liberia, Vatican, etc. 10c. Buckley, 208 Ludlow Bldg., Dayton 2, Ohio.

WORLD—500 Diff. 50c, 1000-\$1.00, 75 Canada 25c. Approvals, lists. Victoria Stamp Company, London 4, Canada.

\$1-\$2-\$5 UNITED States, commemoratives, airmail, high values in large collection United States stamps only 5c to applicants United States approvals. Metropolitan, 140B Nassau, New York 7.

UNITED States stamps nearly 100 years old, Roosevelt set, others, 40c value—only 5c to applicants United States approvals. Wakonda, 140G Nassau, New York 7.

FLAG Stamp free, if you request my U. S. approvals. Wenigman, 1933 Patterson, Chicago.

MAGNIFIER, Big stamp magazine; first U. S. commemorative; plus unused \$5000 Foreign Legion, diamond, giant, and other worthwhile stamps. Everything free to approval buyers. Capital Stamp Company, Little Rock 2, Arkansas.

300 DIFFERENT Given free with approvals. Postage 3c. Windsor Stamps, 1435 East 6th Place, Chicago 37.

FREE—Illustrated catalog! Kenmore Stamps, Arlington 74-C7, Mass.

FREE! Powerful magnifying glass—To approval applicants; also big bargain lists. Jamestown Stamp Co., Dept. 207, Jamestown, New York.

200 DIFFERENT Stamps 10c with approvals. 500 mixed United States 25c. Carlton's, Tujunga, Calif.

DEALERS—Wholesale list. Postage 3c. Frank, 5031 Queensberry, Baltimore 15, Md.

1c EACH And less! Thousands of bargains! Cole, 43-A Rinewalt, Buffalo 21, New York.

ZOWIE-E! A barrel of fun for only a dime. 500 United States stamps—absolutely unpicked and unsorted—just as received from church missions. Many varieties, including large commemoratives, airmails, high denominations up to \$5.00! Stampdom's biggest package of fun—and you might find something really valuable! Price only 10c to serious approval service applicants. Money back if not delighted. Illustrated bargain lists with each order. Mystic Stamp Company, Dept. 80, Camden, New York.

50 DIFFERENT U. S. 10c. No approvals. Pricelist free. Seidenberg, Cassopolis, Mich.

WOW! \$10.00 Worth of fun 10c! What a treasure hunt! Big package 500 foreign stamps, including airmails, pictorials and others from the world over; stamps worth up to 25c each. This offer sent for 10c to approval applicants only. Jamestown Stamp Co., Dept. 22, Jamestown, New York.

U. S. Price list. Send postage. State Stamp Service, 1225 Park Building, Pittsburgh 22, Penna.

FREE U. S. price list, postage 3c. Mark Hanna, 335 5th Ave., Pittsburgh 22, Penna.

WORLD'S Largest stamp (7½x14 inches). A real curiosity! Retail for 50c, only 3c to approval applicants. Tatham Stamp Co., Springfield 30, Mass.

STAMP Collections wanted. Complete collections, duplicate lots, surplus stock, mint and used. Prefer trade for printing or other items, buy outright if priced right. What have you, what's wanted? Vanroy Shirk, Lebanon, Penna.

FREE! 100 Worldwide different stamps to approval buyers. Big U.S. and illustrated bargain lists sent with approvals. Bookman, Maplewood, N. J.

ANTIQUES, RELICS, INDIAN GOODS, CURIOS

GENUINE Relics: Indian arrowhead, 3 square pioneer nails, 1 ancient rifle ball, piece crystal quartz. Postpaid \$1.00. Old Fort Davis, Box 771, Fort Davis, Texas.

ANCIENT Indian relics and artifacts, old long and hand guns. Send 10c, postpaid catalog. Old Fort Davis, Fort Davis, Texas.

PRECIOUS STONES, MINERALS

GEMS—Save money, buy direct. Zircons and other semi-precious stones. List 10c. J. Lavinger, P.O. Box 1034, Redwood City, California.

MINERAL—Treasure locators — Geiger counters. Can be purchased on monthly payment plan. Free literature. Fisher Research Lab., Inc., Palo Alto, Calif.

GEM Hobbyists supplies, materials, tools. Lowest prices. Gemco, Elkhart Lake, Wisconsin.

AGATES, Gems and mountings. Free list. North West Gems, Box 305, Tacoma 1, Wash.

GEMSTONES, Mineral specimens. Every variety. Lowest prices. Postcard brings free booklet. Plummer's, 2183C Bacon, San Diego 7, California.

GEMS, Precious and semi-precious, all genuine, from world wide sources. Deal direct, no overhead, save money. Catalog 10c. Hill Co., Route 7, Salem, Oregon.

METAL Detectors. The very latest circuit. Send 25c for literature. Hedden Metal Detectors, 3329 Liberty Ave., Pittsburgh 1, Penna.

HOBBIES AND COLLECTIONS

OVER 100 Sources of handicraft supplies. List 25c. Shamrock, 179-M Edgewood Ave. Atlanta, Georgia.

BRONZE Horses, 10x11½ \$4.95. Free picture. Box 2225, Portland 14, Oregon.

POSTCARDS Your hobby? Samples, lists, 25c. Wilkins, 417 Hill, London 13, Canada.

DRESDENCRAFT Course! Figurines, copies of expensive china, supplies. Add-A-Craft, 2082 Wellesley, St. Paul 5, Minnesota.

PENNANT Collecting is fun! Impress friends, be popular! Free list! Komar Company, M-3, LaPorte, Indiana.

GOURDCRAFT—Fascinating, easy, profitable. Seed, details, 30c. Sigler, Fullerton, Louisiana.

PETRIFIED Wood—Living wood turned to stone. For a beautiful specimen send 50c in coin to: Petrified Woods, Box N, Calistoga, Calif.

COLLECT, Mount war medals. Large foreign, U. S. lists 20c. Batson, 1024 Dupont Circle Bldg., Washington 6, D. C.

UNPAINTED Plaster ornaments. Loxite for moulds. Free literature. Midwest Novelty, Box 788-A, Anaconda, Montana.

UNUSED Matchbook covers—100 different \$1.00. Catalog 10c. Charles Edelman, 1311C East 84, Cleveland 3, Ohio.

INVENTING Can be an interesting and profitable hobby. Write for complete particulars. Institute of American Inventors, Dept. 40-E, 1926-Eye St. N. W., Washington 6, D. C.

CAMERAS, PHOTO SUPPLIES

NEW Dark room timer, no setting, no alarm, no dial; ticks audible seconds which you count while your eyes and hands are on your work. Operates on 110 volts 60 a.c. Price \$7.75. Money back guarantee. P. Franz Mfg. Co., New Haven 11, Conn.

FREE Album and 5x7 enlargement with every 8 exposure roll, developed and over-size printed, 35c. Caron Photo Service, Box 6399, Chicago 80, Illinois.

ROLL Film adapters, graphic type, 4x5 \$12.51. Also many other sizes. California Photo Supply, Dept. P, Box 211, Altadena, Calif.

FREE Catalog—Terrific surplus buys. Write today. Freestyle Sales Co., 1431 N. Western Ave., Hollywood 27, Calif.

ENLARGERS, All sizes, lowest prices. Booklet "A" free. J. B. Photo, 41-09 19th Ave., Long Island City, N. Y.

SNOOPERSCOPE Tube. Permits nighttime vision. Tube and complete instructions \$14.95. Limited quantities. Infrared filters 15c. Precise, 942 Kings Highway, Brooklyn 23, New York.

FREE Camera bargain list. Write Alfred Bass, 585 Market Street, San Francisco.

SAVE On cameras, projectors, etc. Send name and address on postcard for list. (No exports.) Photo Sales Co., P.O. Box 21, St. Louis 19, Mo.

FREE Photographic bargain book packed with hundreds of sensational values in still and movie cameras, lenses and latest accessories. Super savings for you in new and used equipment. Liberal trade-in allowances, too, on your equipment. Write now for your free copy to Central Camera Company, Dept. 9B, 230 S. Wabash Ave., Chicago 4. (Photographic headquarters since 1899.)

PHOTOMURALS. Giant transparencies, photos on canvas. Your negatives, photos, or ours. We satisfy nation's leading photographers. 1950 catalogue, 25c refunded on orders. Photomammoth Murals, 12048 Vanowen St., North Hollywood, Calif.

PHOTOGRAPHY For pleasure or profit. Learn at home. Practical basic training. Long established school. Write for free booklet. American School of Photography, 1315 Michigan, Dept. 3432, Chicago 5.

PHOTOCOPY Anything, papers, books. No darkroom, 8½" x 11" complete, \$6.95. Fotoflek, 4801 Yarmouth, Cincinnati 29, Ohio.

BASS Says: Bargaingram 257 ready and waiting for you. The book which tells all. The finest in new and used camera equipment, a veritable encyclopedia. Write, phone or call the sign of the old "Horse Trader." 39th year of satisfaction or your money back dealing. Bass buys, sells and trades. Bass Camera Company, Dept. AG, 179 W. Madison St., Chicago 2.

PHOTO FINISHING

8 HOUR Service. Your 8 exposure roll printed jumbo or regular size 30c; 12 exposures 35c; 16 exposures 50c; 20 exposures 75c; 36 exposures \$1.00. Reprints 3c. Fine grain developing. Send for mailers. Quality Photo Service, Box 468A, San Francisco 1, Calif.

NO Negative? Send picture and \$1.00 for negative and enlargement. Robert Patterson, 4509 Queens, Dayton 6, Ohio.

AMATEUR Art developed and printed. All sizes. Free mailers. Universal, Box 124, Station "P," Brooklyn 12, N. Y.

PRIVATE Laboratory. Amateur art. Black-white and color. 35mm. specialists. GK Laboratories, Box 127, Catskill, N. Y.

PERSONALIZED Finishing. Roll developed and 8 prints 50c. Lakeside Photos, Box 591, Burlington, Vermont.

25 WALLET Size prints from your negative \$2.00. Satisfaction guaranteed. Wagric Photos, Box 791, Peoria, Illinois.

THE Photo Mill. Immediate service! No delay! Eight exposure roll developed and printed for thirty cents, plus valuable coupon for eight reprints, four jumbos or two 5x7 enlargements for a slight additional charge. Film developed and eight jumbo prints 35c. Thousands of satisfied customers send us their work year after year. The Photo Mill, Dept. K, 1511 Hennepin, Minneapolis, Minnesota.

FIVE Quality 8x10 enlargements \$1; 40 reprints \$1. Surgals, 3300 Beach, Chicago 51.

STAMP Size photos. Sheet of 100 gummed perforated stamp photos from any size picture or negative \$1.25 original returned. Bay Photo Service, Box 210, Oakland 12, Calif.

16 CONTACT Prints from 8 exposure roll 35c. Reprints 3c each; 40, \$1.00. Double size prints in album book. 8 exposure roll, 35c; 12, 50c; 16, 65c. Reprints 4c each. Apex Photo Service, Box 197, Bronx 51, N. Y.

OIL Coloring photographs can be a fascinating hobby or profitable sideline for those with artistic talent. Learn at home. Easy simplified method. Send for free booklet. National Photo Coloring School, 1315 Michigan, Dept. 3432, Chicago 5, Ill.

BONDED Double size photos. 8 exp. rolls. 30c. 12-45c. 16-60c. Honest quality photo finishing. Satisfaction, or money back. Try Bonded Photo Service, Box 29, Inglewood, California.

FREE Price list on quality developing, printing, enlarging. Write for it today. Bryan's Photo Shop, Dept. M, Panama City, Florida.

NEW Negative and two 5x7 enlargements from your photo. \$1.00. Complete service list free. Photo-Lab, 1204 Sutter, San Francisco 9, Calif.

AUTOMATIC Photo-electric finishing. 8-25c; 12-40c; 16-55c. Oversize, add 10c. Mississippi Finishing, 2212 East 12th, Davenport 4, Iowa.

35MM Rolls developed. Enlarged 3 1/2 x 5 prints, 36 exposures \$1.00, 20 exposures 65c. 8 exposure rolls developed, printed oversize 30c. 12 exposures 45c, 16 exposures 55c. MacDonald's Photos, Box 30-J, Wheaton, Illinois.

FREE 5 x 7 Enlargement with each roll developed and printed. 6 or 8 picture roll 35c. 12 or 16 picture roll 55c. Send coin with roll. No c.o.d. If you fail to get pictures on your roll of film, we will mail a new roll to you at no additional cost. Overnight service. Mailers sent free on request. Deluxe Film Service, Box 1268, Shreveport, Louisiana.

8 BEAUTIFUL Double size pictures and roll developed 30c. 8 hour service. Free mailers. Pacific Photo Service, Box 666, San Francisco, Calif.

2 BEAUTIFUL Hi-Gloss prints each good negative and enlarging coupon with each 8 exposure roll developed 28c. Free mailers. Owlphoto Co., Weatherford, Oklahoma.

MOTION PICTURES AND SOUND EQUIPMENT

MISCELLANEOUS 16MM. sound movies. Rush \$2.00 for 300 foot, postpaid. Complete shorts \$5.00 reel. Pastime, 122 Hackensack Street, Wood-Ridge, New Jersey.

BIGGEST 16MM. sound film bargain! Twelve good used 100' "soundies" musicals, \$9.95 plus postage. Hundreds of titles available at \$1.49 each. Write for our big list. Blackhawk Films, Davenport, Iowa.

16MM. Sound features \$25.00. Shorts \$5.00. Bedner, 5300 So. Talman, Chicago.

"JUDO Girl"—Rough, tough, fast, slam-bang action bout movie. 8mm. \$2, 16mm. \$4. For free list just drop a card. Peerless Sales, Box 171-A, Canal St. Sta., New York City 13.

WORLD'S Wonder movie screen paint. Free literature. 126 1/2 West Main, Danville, Illinois.

GUARANTEED Fresh anti-halo outdoor movie film! Weston 16! Daylight loading! Processing free! Three spools double 8 mm. \$4.50! Six single 8 mm. for Univex, \$4.60! Postpaid! Catalog. Eso-S, 47th Holly, Kansas City 2, Missouri.

FILM—Free processing 100 ft. 16mm. Weston 12 \$3.25. Weston 24 \$4.90. Weston 64 \$4.95, 25 ft. double 8mm. Weston 12 \$1.50. Weston 24 \$1.89. Weston 64 \$1.99. Free circulars. Fromader Genera, Davenport, Iowa.

BETTER 8mm. and 16mm. movie camera film. Free equipment catalog. Better Films, 742 New Lots, Brooklyn 7, N. Y.

"BEARS!" 8MM. 50' film produced in Rockies by famed Eberhart organization. Send \$1.75. Receive "Bears!" plus free wild game films list. Wild Life Films, Dept. 3-PM, 6063 Sunset Blvd., Hollywood, California.

CLEARANCE 16MM. sound projectors \$95.00 up, sound films. Write promptly for free listing. Harris, 303 West 42nd Street, New York 18.

FREE. Movie catalog, sample films; bargains now. Goodwill Company, Jackson, Tennessee.

SENSATIONAL Bargains! Comedies, cartoons, everything! Mammoth 8-16mm. catalog, samples 10c. Fabulous Films, 6411 Hollywood Blvd., Hollywood 28-A, Calif.

MOVIE Film—Equipment. Sacrifice prices. 16mm. sound features \$22.50, shorts \$3.95, projectors \$97.50, silent features \$15.00, shorts \$1.00, projectors \$22.50 and up. All types film, equipment sold, bought, traded. Lists free. Mogull's, 112 W. 48, New York.

SOUND Rentals 16mm. Free catalog. National Cinema, 69 Dey St., New York City 7.

MOTION Picture films, projectors, cameras, recorders, 16, 35, 8mm. professional, studio, lab. equipment, new, used, sold, traded, purchased. Lists free. Mogull's, 112 W. 48 St., New York.

MOVIES—Black and white, color, sound or silent: \$1.00 up. Large selection includes famous Disney cartoons. Write laboratory for free catalog. (State 8 mm., 16 mm. or sound.) Hollywood Films, 6060-K Sunset Blvd., Hollywood 28, Calif.

"SAMSON And Delilah" and large selection religious films now available on 16mm. s.o.f. Lists free. Dealer inquiries solicited. Mogull's, 112 W. 48 St., New York 19, N. Y.

PROCESS Your own movie film. Easy instructions, formulae, 25c. Superior Bulk Film Co., 105G S. Wells St., Chicago 6, Ill.

BARGAINS—1600' Reels \$1.35; storage cans for two 1600' reels 95c; reel, can sets, 400', 39c, 800', 99c; three reel fibre shipping cases, 1600', \$1.90, 1200', 85c; 300 watt, pref. lamps \$1.48. Trades accepted. Lists free. Mogull's, 112 W. 48 St., New York.

FILMS And equipment exchanged or bought for cash. Sound, silent. Bargains. Lists free. Frank Lane, Little Bldg., Boston, Mass.

RENT 16MM. sound films, 50c reel. Large selection; free catalog. Film Service, 128 Chestnut St., Roselle Park, N. J.

"THE World's Greatest Passion Play." 8mm., 16mm. and 35mm. Specify silent or sound. Rent or purchase. Hemenway Film Co., 33-F Melrose St., Boston 16, Mass.

FREE Movies. Thousands of subjects. Interesting. Entertaining. Fascinating. New directory—only 50c. International Cine Society, 126 Lexington Ave., Dept. M, New York 16, N. Y.

8-16MM. Silent-sound films. Complete rental library. All latest subjects. Free catalogue. (sample film 10c). Garden Film, 317 West 50th, New York 19.

MOTION Picture technique at home. Big money. Special registration for veterans. Free catalog. Motion Picture Institute, Birmingham 4, Mich.

BASS Says: 39 years of leadership guarantees satisfaction. Finest cine equipment. 8mm., 16mm., and 35mm., silent and sound. Write the old "Horse Trader." Satisfaction or your money back always! Bass Camera Company, Dept. A, 179 W. Madison St., Chicago 2.

LEARN Movie projection, management. Free catalog. Theatre Institute, Elmira, N. Y.

MUSIC AND MUSICAL INSTRUMENTS

SONGWRITERS! Outstanding, ethical offer. Hibbeler, C5, 2157 N. Avers, Chicago 47.

SONGWRITERS—Honest, outstanding music writing offer. Len-Tex Studios, Leonard, Texas.

POEMS Wanted, Melodies, arrangements furnished. Terry Tune Master, 709 1/2 PM North Broadway, Oklahoma City 2.

POEMS Wanted for musical setting. Send poems for free examination. Five Star Music Masters, 630 Beacon Bldg., Boston, Mass.

SONGWRITERS! Send poems, songs. Music Service, 243 West 72nd St., PM, New York 23.

PHONOGRAPH Records 15c. Catalogue. Paramount, TA-313 East Market, Wilkes-Barre, Penna.

\$1.00 RECORDS Your song! Send music. Urab-D, 245 West 34th, New York 1.

RECORDS Guaranteed new. Hillbilly, popular, spirituals. 4 for \$1.00. Free record with first order. Free catalog. Mallore, Dept. 65, 570 N. Gay St., Baltimore 2, Md.

1950 ACCORDIONS—Wholesale. Free catalog. American Accordion Center, 5329 Belmont, Chicago.

POEMS Wanted to be set to music. Free examination. Send poems. McNeil, Master of Music, 510-PM S. Alexandria, Los Angeles, California.

MUSIC Arranged, songs printed. Frank Wildt, Music Publisher, Lancaster, Penna.

WRITE Songs. Big money and reputation. Write for information. J. Gordon Pub. Co., 201 N. Hoyne Ave., Chicago.

RADIO AND TELEVISION

FREE—Money saving bargain catalogs in radio and television sets, record changers, tubes, parts, amplifiers, speakers, etc. Write today. Radionic Equip't Corp., Dept. 2003, 170 Nassau St., New York 7, N. Y.

RADIO Tubes, surplus radio equipment, bargains. Ask for list. Kay Electronics, Box 25, Hollis, New York.

"LOUDEST" Crystal, radio plans, cat-whisker, catalog: 25c. Amorose, Route Four, Richmond, Virginia.

MAKE A crystal radio. Simple, economical. We supply x-tra long distance crystal and instructions, 25c. D-X150, Box 201, Marshall, Mo.

FIX Any radio. Amazing new instrument locates radio troubles double quick. Simple instructions show you how. Thousands now in use. Free. Write today for 32-page illustrated technical manual. "The Inside Story." Feiler Engineering Co., Dept. 3PM5, 1601 S. Federal St., Chicago 16, Ill.

TELEVISION Sets 10", \$135. 12", \$160. Confidential list 3c. Sunshine, Berkshire Heights, Penna.

FREE Radio parts dictionary, telegraph code instructions and catalog of kits priced from 90c. Build your own receivers, transmitters, test equipment with our easy-to-assemble Pict-O-Graph instructions. Write today! Electronic Kit Co., 326A Park Row Bldg., New York 7.

MAKE Simple, tubeless, batteryless, distance-getting crystal radios. Crystal and illustrated instructions 25c postpaid. Allen, 427-P, Clinton, Mo.

SEND For our bargain bulletins on radio and electronic components. Never under-sold. Buyers Syndicate, 30 E. Taylor St., Springfield 3, Mass.

BUSINESS OPPORTUNITIES

ELECTRICALLY Inclined? Make \$100-\$250 weekly installing, maintaining fluorescent lighting. Make beautiful lights for 50c each. Exclusive, inexpensive, illustrated instructions enables you to cash in on this fast growing industry. Request impressive evidence on this proven business opportunity. Wilber Distin "Fluorescent," 712-A, State Tower Bldg., Syracuse 2, N. Y.

A STAR Popcorn machine for your store is big business. Central Popcorn Supply Company, 44 Arch Street, New Britain, Conn.

FIX Typewriters, full or part time. Inexpensive copyrighted home study course quickly trains you for high earnings. Factory methods cover all phases with drawings and illustrations. No curiosity seekers. Typewriter Repair, 3915 Corbet, Tarentum, Pennsylvania.

MAKE Big money making quick pictures with the new, complete EZ Portable Studio. Glossick Mfg. Co., 544 Monson St., Dept. K, East Peoria 8, Ill.

TRADE Magazines help you get ahead. Latest copies. More than 1150 covering every trade, business or interest available through our easy-to-get-acquainted service. Full particulars and price-list free. Commercial Engraving Publishing Co., 34C North Ritter, Indianapolis 19, Indiana.

START Home manufacturing business making cleaning compounds, soaps, insecticides, cosmetics, polishes, food flavors. No machinery. Literature free. Kemix, Park Ridge, Ill.

SELL Catalog describing plans for home, farm devices and equipment. Long profits. Handbook, details, 25c. (Refundable.) Kimo, Box 307JJ, New York 19.

COLOR Concrete with chemicals. Glazed cement pottery. Garden ornaments. Stucco-rock walls. Dime brings sample, pictures. Hollywood Cementcraft, 8527-R Wonderland, Hollywood 46, California.

LIKE To make extra income at home? Proven mailorder plans show how. Free details. Perry Publications, Wenatchee 1, Washington.

BRONZED Baby shoe mountings; metals, onyx, plastics, hardening solution. Wholesale, Box 2095, Wichita, Kansas.

YOU Successfully sell our business cards by mail. Successful "beginner's" plan gets lifetime repeat orders mailed you. Free details. Lynn, 5710-M Bankfield, Culver City, California.

RESURFACE Butchers' chopping blocks with easy, fast working, portable electric machine. Unique service in wide demand with little competition. Large steady profits from full or part time work. Hill Machine Company, Box 677B, Rockford, Ill.

LEARN Piano tuning, repairing—at home in 30 days. Unlimited income. Phonograph recordings, tools and instructions furnished. Write Capitol City Tuning Co., Department C-334, 129 East Michigan, Lansing 16, Michigan.

TIN Cans. Turn them into cash. Nine methods. Instructions 50c. Charles, 12-AWF, Norwood, Ohio.

\$250 WEEK Reported! Free booklet "505 Odd Successful Enterprises." Work home! Expect something odd! Pacific-A, Ocean-side, California.

EARN Money by mail with my plan. Free details. Satterfield, Box 345-C, Mansfield, Ark.

DESIGN And mold new fast sellers from plastics, plasters, compositions. Amazing profits. Quick cash. Free literature. Plastics Digest, 2925-B4, Kansas City 3, Mo.

SAWDUST. Turn it into cash. Six methods. Instructions 25c. Charles, 12-AWF, Norwood, Ohio.

WHY Job worry? Start electroplating, metal finishing business. Free booklet, trade secrets. M. Hyde, 327 West 120th Street, Los Angeles 61, California.

WHY Spend money for equipment? We "electroplate" baby shoes wholesale! Foster's, 1520 Ardmore, Chicago 26.

MAIL Order offers amazing opportunities. Write Benson Barrett, 1151 Taylor, Detroit 2, Mich.

MAKE Tough, durable plastic—1c pound. Makes attractive floors, walls, built-ins, roofs. Build good homes, \$150.00 room. Bays Laboratory, Oklahoma City 9.

THREE Million new prospects yearly for our personalized baby record books and readi-cut, wool baby shoes. Mail dealers use same successful literature we do; yours practically at cost. Get going big, fast with proved sellers. No-Co-Ro, Oakland 6, California.

BRONZING Baby shoes is big business. Start your own business for \$5.95 includes materials and instructions. No equipment required. Particulars free. Metaloids, Box 2095, Wichita, Kansas.

"HOW To start a successful mail order business." The guide to sound, profitable mail merchandising. 25c. Manhattan House, 126-B Lexington, New York 16.

START Home plaster novelty business. Amazing course tells how. Literature free. Kemo-Courses, 3745 N. Odell, Chicago 34, Illinois.

A FACTORY in your home, garage! Mfg. and sales rights, mechanics' waterless hand cleaner, glass cleaner, and amazing "Lazybones" auto cleaner-polish, \$500-\$800 monthly. No special equipment necessary. All formulas free. Western Aircraft Mfg., Dept. D, Los Angeles 6, Calif.

LEARN Printing at home. Complete simplified course by long experienced craftsmen. Send stamp for complete details. Director, Printing Courses, Box 941, Meriden 2, Conn.

BIG MONEY! Spare or full time in your home. No selling! Spray new miracle finishes, plush and suede, on signs, radios, automobiles, figurines, lamps, toys, etc. Our business is booming. Help us fill huge demand. New easy Flok-Kraft methods. Material costs few pennies. You get dollars. Free samples, complete powerful money-making plan free. Write now! Coast, 1002D S. Los Angeles St., Los Angeles 15, Calif.

BRONZED Baby shoe mountings, equipment and supplies. We manufacture world's largest assortment of all metal mountings. Wholesale only. Ramyr selenium platers \$49.50. Complete baby shoe plating assemblies low as \$59.50. Write for free copy of electroplating instructions. Tech. Dept., Hollywood Bronze Supply, 1766-70 N. Vermont Ave., Hollywood 27, Calif.

YOUR Own plastic business at home. Produce costume jewelry, novelties, statuettes. Liquid plastic, liquid marble. Flexible molds. Write for free book. American Trades, Box 1473-A, Cincinnati 1, Ohio.

START Own profitable mailorder business. "Natural" money-makers revealed! E. Lay, 3819 Kenmore, Chicago 13.

MILLION Articles wholesale. Supply source directory 10c. Publisher's, Box 1302, Detroit 31.

NEW Way. Earn \$50 weekly at home. Free literature. "Dollar-a-Month Plan," 5236-P, Philadelphia 26, Penna.

PIANO Tuning taught by mail. Write Piano Technician, 708 Rawlings, Carbon-dale, Illinois.

MORE Money—Easier! Revolutionary methods make public bookkeeping easy, interesting, profitable. Earn to \$5.00 hourly within short time! Simple, complete instructions. Full-spare time. Success-revealing information free. Auditax Systems, 10775 W. Tabor, Los Angeles 34.

START Your own business on credit. Always your own boss. 1554 dealers, sold \$5,000 to \$26,500 in 1948; their average \$6,742. We supply stocks, equipment on credit. 200 home necessities. Sales experience not needed to start. Wonderful opportunity to own pleasant, profitable business backed by world-wide industry. Write Rawleigh Co., Dept. C-U-PPM, Freeport, Ill.

BE Independent, be secure, have your own profitable business—earn \$10.00 and more a day making beautiful, fast-selling lamps at home. No equipment needed. Illustrated course teaches you quickly. Course, parts catalog, wholesale price list, only \$2.00. Gearon Company, Dept. 200-B-3, 27 South Desplaines, Chicago 6, Ill.

ELECTROPLATING Know-how includes baby shoe metallizing; other lucrative fields. Learn easily. Free illustrated booklet. Joseph B. Kushner, Electroplating Engineer, Stroudsburg, 72M, Penna.

CLEVER. Resultful mail order circulars, ads, letters. Reasonable. O'Malley Advertising, 309 Rittenhouse NW, Washington, D. C.

BUY 800,000 Items wholesale. Includes nationally advertised merchandise, factory prices, unusual offers. Literature free. Olsen, 1231-A East Third St., Duluth 5, Minn.

EARN Money cleaning automobile upholstery. Free information. Write Lambert, 5531 Plover, St. Louis 20, Missouri.

BRONZE Baby shoes. 2000% profit. New, easy method assures success. Literature free. Metallizing Industries, Box 263, Hagerstown, Maryland.

ELECTRIC Pencil—Engraves all metals. \$2.95. Reb Industries, Elmhurst, Illinois.

MAKE Perfume. Men, women write Carey Laboratories, 1914 Chouteau PM3, St. Louis 3, Missouri.

MAIL Selling opportunities galore! Free! Wehner, Box 142-A4, Roxbury 19, Mass.

NEW. Proved methods get money by mail. Amazing, eye-opening. Details free. Lexington Mail, 5538-A Lexington, Chicago 44.

MAKE Flexible molds! Cast plaques, novelties, bookends! Free sample! H. Tooker, Hamilton 4, Ohio.

SUCCESSFUL Advertising, only \$2.00, postpaid. Satisfaction guaranteed. William Bennett, 114-35L 116th Street, Ozone Park 16, New York.

MAKE Money by mail! Write! Peterson, Box 598, Minneapolis 1, Minn.

START Home mailorder business. Details. Gedgard, Box 798-O, New York 1, N. Y.

BIG MONEY! New home business. Amazing liquid plastic. Make hundreds clear or colored items. 25c brings finished sample and information. Complete kit for \$3, \$4, or \$6. Kemnitz Corp., 1021 N. Water, Milwaukee, Wisconsin.

TOW-CHAIN (Spring). Prevents jerking. Autoists buy on sight. Amazing profits. Literature free. Samples \$4.85. Barnorarl Industry, 19338 Griggs, Detroit 21, Mich.

GET Your copy of the new 1950 edition of the Official Concessionaires Guidebook. 76 pages, jam-packed with money making formulas, m.o. ideas, games and equipment for concessions, roadside stands, carnivals, etc. Send \$1.00 to: Concessionaires Guidebook, Station H, Zone 13B, Toledo 6, Ohio.

DISPLAY An Amidon scaffold tower and it will put you in business, \$92.40 delivered. Satisfaction guaranteed. Amidon Engineering Co., Elyria 4, Ohio.

CLINTON Powered mowers—\$99.95. Delivered. World's cheapest. Rotacut, R-2003, Excelsior Springs, Missouri.

INCORPORATE Your business. Delaware laws. Free details. Tax Research Bureau, Inc., Box 710, Wilmington, Del.

YOUR Own profitable home business. Preserve live flowers to last forever. New simple discovery. Enormous demand all year 'round. Tremendous profits! Light fascinating work. Send \$2.00 for working equipment, instructions, and valuable sales plans. Satisfaction guaranteed or money promptly refunded. Alfred Hermansen, 210 Fifth Ave., Suite 1102A, New York 10, N. Y.

CASH Low? Get "101 Ideas For a Home Business" and build it up. Only 25c. Charles Hansen, 7603-60th Place, Argo, Illinois.

START Your own business in home or office. Tested business plans. Full particulars free. Ideal Mail Service, 617 Belmont Ave., Newark 8, N. J.

METAL Book ends for mounting bronze baby shoes, \$2.50 pair. Urban's, 2806 Holiday, Wichita Falls, Texas.

RUBACREAM! Natural latex cream! Makes molds quicker! Thicker! Free sample convinces! Castcraft Studios, 2027-P Fulton St., Brooklyn 33, N. Y.

BOOKKEEPERS Earn \$100.00 week operating your "bookkeeping service." Simplified plan. Information free. Bookkeeping Service, Box 664-M, Springfield, Missouri.

ANNOUNCING: Complete simplified shoe repair course, big demand, in depression proof trade, \$4.95 complete, information free. Shoe Service System, Conway, New Hampshire.

LIBERAL Commission selling weatherstrip. Metal inexpensive. Illustration from E-Z-On, 1009 Harvard, Evanston 29, Ill.

BABY Shoe metallizing. Amazing offer. Send card. Schoettie, Friendship, Ohio.

INVENT For profit. Read my ad under "For Inventors." Cunningham.

OPERATE Mail order business. Free literature. Joseph Boyle, Box 61, McAdoo, Penna.

\$1 BRINGS Complete working method for entering a profitable mail order field. Put into understandable language from years of experience. Surveys. A. K. Thompson, 35-12 92 St., Jackson Heights, New York.

DOLLARS Made—Full or part time by selling automatically controlled rotary foglite that turns with the wheels for 1949-1950 Ford V-8. \$9.25 retail. Send \$6.00 (plus state sales tax), f.o.b. Mescos, Box 26, Detroit, Michigan for sample and information.

PROFIT At home! Complete mail order instructions. Free literature. Progress, Box 214, Detroit 31.

WANTED. Men interested in electrical trouble-shooting, all year repair work, and (big profits) from electrical junk. Sensational (new) opportunity free. Write, Manhattan, Box 6, New York 35, New York, Dept. PM.

PROFITABLE Business making and building with easy-laying interlocking building blocks. Rex Products, Dept. 10, Piqua, Ohio.

START Salted nut business. Amazing moneymaker. Easily learned. Work at home. I'll teach you all. 15 years experience. Low cost will surprise you. Free details. Reed, Box 823, Louisville, Ky.

COAST Lodge enjoying club license, overlooking ocean, \$40,000.00. Kingwell Agency, 1820 N.E. 66th, Portland, Oregon.

YOUR Home as headquarters make a product to clean dirty mechanic hands in 30 to 50 seconds without water. Big profit. Postcard gets free folder. Harbin, Box 4624, Atlanta 2, Ga.

NEW Patented screw-holding drivers! Remove, insert screws inaccessible places; factories, garages, stores buy quantities; big profits, exclusive distributor. Toolco, 408 Summit, Brookline, Mass.

EARN Money at home with your typewriter! Spare time. Details free! Edwards, Publisher, 3915-P, 12th, Des Moines 13, Iowa.

SENSATIONAL Nylons guaranteed against runs. Nationally advertised. Not sold in stores. No experience or money needed. Also lingerie, robes, men's hosiery. Outfit, sample, etc. free. Wonderful opportunity earn big money spare or full time. See our full page advertisement on page 71. Kendex Co., Babylon 546, New York.

"HOW To Win Success in the Mail Order Business." New book revealing how and what to sell. \$2 postpaid. Lordlee Company, 220 Fifth Ave., New York 1.

EARN Money at home; full, part time. Listman, Box 2160, Seattle 11, Wash.

COAST Motel overlooking ocean \$58-800.00. Kingwell Agency, 1820 N.E. 66th, Portland, Oregon.

MAKE Your fortune with food specialties. Others have. People have to eat. Enter \$100,000,000 industry without experience or capital. Gaynor, 4406 Cottage, St. Louis 13, Missouri.

ESTABLISHED Mail order business for sale. Musical composition; thousands sold during past seven years. Owner retiring. Box # 707, Hutchinson, Kansas.

REACH Spanish-speaking mail-order buyers. Great new market for your merchandise. Your classified ad in the Spanish Edition of Popular Mechanics will bring you some nice business from this new field. Rate only 25c per word. Circulation 100,000 copies. Mail a trial ad right now. Popular Mechanics Magazine (Spanish Dept.), 200 E. Ontario Street, Chicago 11, Ill.

CHILDREN'S Ready-to-wear \$12,000. Kingwell Agency, 1820 N.E. 66th, Portland, Oregon.

HOME Business making statuettes, plaques, artificial marble, rubber molds. Metallizing baby shoes. Silvering mirrors. Formulas. Folder free. Creative, 236-L, Winnetka, Illinois.

WANT A mailorder business? Avoid mistakes by reading "Mailorder Pitfalls." Send for free circular. Better Sales Co., 2139 Clifton Ave., Cincinnati, Ohio.

MANUFACTURE Camera at home. Experience unnecessary. Taylor's Laboratories, 4015 Oketo, Chicago 34.

MEN—Women. "Everybody likes candy." Learn to make professionally at home. Details free. (Our 40th year.) Ragsdale Candies, D5, East Orange, New Jersey.

OPERATE Profitable mail order business. Lachman, 1636-M Shatto, Los Angeles 14, Calif.

PLAN Your mail order business profitably. Free literature on five famous books. Mail Marketing Services, Rt. 1, Box 522, Dayton 5, Ohio.

EARN At home casting novelties. Free instructions using latex molds. Major Chemical Co., 164 Portland St., Cambridge 39, Mass.

"WATERLESS (Lanolin) Hand Cleaner." (Oil base.) Make, sell. No machinery. Build profitable business. Complete formula \$1.00. Ideal Service, Park Ridge 1, Ill.

CO-PUBLISH And advertise in The Central Mail Advertiser. Sample copy 10c. Low rates. Large circulation. Bagby Printing Co., Georgetown, Ohio.

OPERATE Mail order book shop at home, spare time. Easy! Fascinating! Profitable! Details free. Kraft, Aurora 31, Missouri.

BUY Direct. We furnish sources of any manufactured item you need for business, hobby. 10 current sources, your item—\$1.00. Business Information Center, Chesterland, Ohio.

WORK At home. Sell by mail. Details free. J. Hogan, 922 North Lewis Ave., Waukegan, Ill.

DECORATE Discarded furniture and tinware for home or profit. Free details. The Stewarts, X-3, Bridgewater, Mass.

\$25 WEEKLY Working two hours daily. No canvassing. No manufacturing. Lycke, Box 2471-A, Cleveland 12, Ohio.

LOCATE Opportunity in U.S.A. \$1.00. Research, 407 Washington, Shreveport, Louisiana.

EARTHWORM Breeding. Valuable bulletins on successful methods mailed free. Earthmaster Publications, Dept. 14, Sun Valley, Calif.

SPIN Angora wool into beautiful yarn at home. Easy, enjoyable work. House of Angora, PM, Springfield, Illinois.

BUSINESS Opportunities galore, hundreds successful! Interesting details free. Stout, 1110A Caesar, Pasadena 10, Calif.

MAKE Money spare or full time, casting metal toys and novelties. Big wholesale and chain store demand for cast metal autos, soldiers, ashtrays, banks, etc. keeps manufacturers busy. Production moulds furnished for up to 100 and more castings per hour. No experience or special place necessary. Write for full information and illustrations of patterns needed. Metal Cast Products Co., Dept. A, 1696 Boston Road, New York 60, N. Y.

POPCORN And potato chip equipment. Long Eakins Company, 5060 High, Springfield 99, Ohio.

PEARL Finishing—New, amazing. Huge profits. Start making big money first day. Free facts show easy way to \$25 to \$50 per day at home. Absolutely no experience. Be first; scoop the market. Write Pearl-Kote, Dept. R, 2111 W. Manchester, Los Angeles 47, Calif.

SEWING Machine business tops. Big money—not crowded. Spare time home set-up. Repair course, new machines, motors, etc., wholesale. Hurry. Taylor Service, PM, Hamilton, Ohio.

LEARN The letter shop and addressing business. Complete copyrighted information; \$2.00. Rosdahl Industries, 72 W. Washington St., Chicago 2, Illinois.

PROFITABLE Mail order plan. Details free. Stanley Skinner, Star Route, Nicholson, Penna.

PIANO Tuning learned at home. Free information. Empire School, Champaign, Illinois. (Est. 1935.)

QUICK Money! "Repairing car batteries!" At home! Easy too! Batteryman, Grand Junction, Colorado.

HOW And where to obtain capital. Small and large loans. Free particulars. Star Service, Wapakoneta, Ohio.

DRESDEN Craft figurine molds and many others, natural liquid rubber, statuary plasters, flock finishes, etc. Illustrated catalog and "Plastercraft" manual free. Blue Rapids Supply, Blue Rapids, Kansas.

WANTED Unused U. S. postage stamps, small discount. Advance Stamp Co., 24 East 23rd St., New York.

LIQUID Marble—Colorful, glossy! Molded, brushed, sprayed! Cast novelties, statuary, colored tiles. Flexible molds. Composition floors. Particulars free. Marbleizing Service, Edwardsville, Illinois.

EXTRA Money. No selling; operate vendors. Amazing profits, details free. Silver King, Suite B, 622 Diversey, Chicago 14.

UNPAINTED Bookends, plaques, statues, figurines. List. Haverly Products, 1219 8th Ave., Altoona, Penna.

RICHS In your own business. Let me show you how. Addison, Box 1153, Hot Springs, Ark.

RESILVER Mirrors at home. Formula 25c. Ideal Service, Park Ridge 8, Illinois.

UNPAINTED Figurines—Wholesale, retail. Illustrated list free! Oman, 642L Broadway, St. Paul 1, Minnesota.

HOW To set up and run a mirror shop! Resilver mirrors. Make chipped glass nameplates. Electroplating salts and rectifiers. John Sprinkle, V60, Marion, Indiana.

MAKE Rubber stamps, metalize baby shoes, repair dolls, silver mirrors, make plaster novelties. Catalogue of "30 ideas" free! Universal, Box 1076-A, Peoria, Ill.

CASH For your idea, 280 manufacturers need inventions, patented or unpatented. List free. Invention Bureau, 208M Clinton, Oak Park, Illinois.

MAKE Money making new greaseless doughnuts at home on electric machine. Wholesale to grocers, drug stores, cafes, hamburger shops. Send for free recipes and plans. M. Ray Company, 3605 South 15 Ave., Minneapolis 7, Minnesota.

RECAST Old batteries into new. Latest achievements. Battery Laboratories, Minneapolis.

ENVELOPES Addressed accurately, reasonably. Fast service. We have capable addressers in your city. Glenway System, 5713-Y Euclid, Cleveland 3, Ohio.

I MAKE Big money in the mail-order business. You can do the same at home with copyrighted system. Write me. I'll tell you how. F. Little, R.D. #1, Glenshaw, Penna.

BIG Money regraining, refinishing automobile dashboards, garnish mouldings. Write Outman Service, 4323 So. 38th, St. Louis 16.

LIQUID Rubber. Make flexible molds. Free sample. Chaney, 1130 E. 16th St., Jacksonville 6, Fla.

NATURAL Molding Latex. Extra thick. Free sample. W. Wooley, 115-A Donald, Peoria, Ill.

MOLDING Rubber for hobbyists, industry, classroom projects! Flexible molds easily made from the best quick-drying white liquid rubber! (Gallon, \$7.95; quart, \$2.95; sample half-pint \$1.00) prepaid parcel post! Plastercraft Supply Co., 3051 St. Clair Ave., Cleveland 14, Ohio.

LEARN Electrical appliance repair. House wiring, motors, washers, cleaners, refrigerators, lamps, auto ignition, etc., complete illustrated course. Tools furnished. Free booklet. Pacific School, 7219 South Broadway, Los Angeles 3.

SELL By mail. Good deal with nice profits. Home City Services, Box 1062-PM, Springfield, Mass.

OWN A printing business. Good profit printing cards, stationery, etc., in spare time. Easy rules furnished. Have home shop. Write for details. Kelsey Corp., Meriden 24, Conn.

WHERE To buy 500,000 articles wholesale. Details free. Krueger, 3418A Wolcott, Chicago 13.

MANUFACTURERS Getting rich with new post-war products, all lines. You can easily make them at big profit from guaranteed, chemist-developed formulas and analyses. Literature free! Miller, Analytical Chemist, Tampa 6, Florida.

FREE! Illuminating folder "A Business Gold Mine." Real dividends for your spare time in lucrative business. No personal selling. Kabel, 1413 W. Tioga St., Philadelphia 40, Penna.

GROW—Sell potted flowers, vegetable plants. Details free. Shiffer Associates, Box 129, Millersburg, Penna.

PROFITABLE Home business. Start on small capital with latest tested formulas. Interesting booklet free. Pont, Box 635-XM, Terre Haute, Indiana.

SPECIAL Rubber for making molds. Literature and sample free. Universal, Box 1076-A, Peoria, Ill.

MAKE Money at home decorating greeting cards. We supply instructions. Powell, 5713-C Euclid, Cleveland 3, Ohio.

VENDING Machines earn big money! An investment as low as \$10.50 will start you in this fascinating, profitable business that can lead you to the road of success and independence. Routes can be established and operated in either full or spare time with no experience needed. Write for full details and our free catalog illustrating our nut, candy, gum and stamp vendors; also pin ball machines, music boxes, etc. Write immediately to Parkway Machine Corporation, Dept. 7, 623 W. North Avenue, Baltimore 17, Maryland.

READ "Advance"—The voice of mail order. Offers money-making opportunities, sources of supply, personal guidance, etc. Issued monthly. Sample copy 25c. Yearly subscription \$2.00. Advance Publishing Company, 313 East 21st Street, Suite 450, New York 10, N. Y.

A BUSINESS In your own home! Our chemicals, plus free water and cheap "grocery store" materials can bring you over \$500 monthly earnings. Plans and formulas free. Chemica Division, 1269 S. Norton, Los Angeles 6.

START Mailorder bookshop—Everything furnished, 25c brings booklet, samples, exciting ideas. General Publications, Ossining, N. Y.

OPERATE Profitable mail order business. Write Walter Service, 4159-A East 112th, Cleveland 5, Ohio.

COLORGLAZED Concrete pottery made without molds. Patented method. Cemetery products, novelties, tiles. Basement leak-sealing. Money-making projects. Booklet, details free. Men only. National Potteries Company, Grand Rapids, Minnesota.

137 WAYS To make money, in home or office, business of your own. Full particulars free. Elite Co., 220 Grand St., New York 13.

COPUBLISH Leading m.o. paper. Latest copy Mail Sale Advertiser and proposition, dime. Vanroy W. Shirk, Lebanon, Penna.

BRUSH Plating outfits connect to a battery. No tanks necessary. Good paying business at home plating autoparts, bathroom fixtures, bicycles, reflectors, silvering mirrors. No shop or experience required. Outfits furnished. Free booklet. Gunmetal Co., Ave. H, Decatur, Ill.

MAILING Postcards selling repeat merchandise is profitable. Everything supplied. Details free. Gordon Publishers, Box 23, Pawtucket, R. I.

BIG Time mail business propositions built-to-order. Professional preparation-production. Personal guidance. Descriptive bulletin free. National, Box 88-Z, Dorchester 22, Mass.

MONEYMAKING OPPORTUNITIES

SHARPEN And gum saws for others. Build machine yourself. For crosscuts, woodlot circulars, bucks and bow saws. Saves hand labor. Illustrations, instructions \$1.00. Satisfaction guaranteed. C. Lashley, Wellington, Ohio.

IT'S Smart to have two incomes. Start a coin machine business. Spare time. Big proven, profitable field. Few dollars starts you. Folder free. Kenneth Fleck, Columbia City 2, Indiana.

BIG Money, easy work, spare time. Meixell, Box 261, Boothwyn, Penna.

CHURCHES. Organizations, clubs, \$130.00 free plus 24 card tables. Unique Gift Club Plan, Pine Hill, New Jersey.

\$250 WEEK Reported! Free booklet "505 Odd Successful Enterprises." Work home! Expect something odd! Pacific-A, Ocean-side, California.

MONEY-MAKING Hobbies earn extra income. Free literature. Benson Barrett, 1151 Taylor, Detroit 2, Mich.

FREE Particulars many spare time "home business projects." Cottage Industries, 2804-E Hanover, Omaha 12, Nebr.

"DEPRESSION Insurance!" Own money-making business. Information free! "Pru-A-Ex," Kingsport, Tennessee.

TIRE regrooving bible! The only copyrighted, illustrated regrooving information sold anywhere! \$2.95. Moro Regrooving Institute, Box 2169, Station H, Cleveland 8, Ohio.

CO-PUBLISH Opportunities preferred, many sources of profit. Details free. Sample copy 25c. Rinehart, 235 Baltimore St., Hanover, Penna.

MAKE Money to live as you dream to. Send 3c stamp for proof. Hollywood Upholstery Studio, P.O. Box 1544, Oakland, Calif.

WIN Cash, cars in prize contests! Write for copy filled with current contests, winning hints and tips. Send only 25c. Wright Contest Digest, Dept. 17-C, P.O. Box 2266, St. Louis 9, Missouri.

MASONIC Book ends. Manufacture by ornamental casting in garage or basement. Easily learned, fascinating, splendid profits, large market. Many other fast selling art novelties. Small investment. Plastercraft, 395-9th St., San Francisco 3.

NEW! Small-capital plans. Home business. Booklet 25c. Grant Lovell, 2166 South Shore, Erie 15, Penna.

RAISE Tadpoles and frogs for pleasure, profit. Free booklet. Specialties, Whiting 3, Indiana.

LEARN Professional candy making, also marketing system. Details 10c. Pate, Kissimmee, Florida.

ELECTRICIANS Make big money. Earn while you learn. Students supplied with materials at wholesale prices. For complete information, send fifty cents for one of our dollar bantam flashlights. Credit allowed on course. McCarty Electric Corporation, Kalamazoo, Michigan.

MAKE More money in 1950. Over 1000 money-making tips. Details free. L. & M. Service, Box 377, Sharon, Penna.

HOME Book shop opportunity—Get orders by mail. New! Different plan! Big profits. Everything furnished. National, Box 88-K, Dorchester, Mass.

FREE Facts! How you can make big money in new, different, exciting home mail business! Smith, Box 2592-A, Hines, Illinois.

MADE \$24.50 Using money making plans from Scherer Magazine, Box 775M, Alliance, Ohio. Year \$2.00. Sample 20c.

EARN Money evenings, copying and duplicating comic cartoons for advertisers. Adservice, Argyle 1, Wisconsin.

CANDLEMAKING Is profitable! Detailed instruction manual, \$1.00. Particulars free. Robins, 77 Sylvan Lake, Mundelein, Illinois.

PRIZE Contests! How and where to win your share! 25c coin (refundable). National Contest Bulletin, Box 2685-P, Miami 16, Florida.

MONTHLY Contests. Cash prizes. Magazine subscription \$1.00. Fezler, Patchogue, N. Y.

5 GUARANTEED Plans! Enjoy building up national mail order business. Information sheets, free. Vargo Company, 9080-M Lyon Street, Detroit 17, Michigan.

EARN Money by mail, like I do! Free details. House of Friendship, Bowen Court, Douglas, Mass.

EARN Money at home! Amazing lesson tells how. Sample 25c. Write Income Builders, Hollywood 508, Calif.

COLD Cash at home! No selling, investment, experience. \$5-\$15 hourly! Proof: Aichner, 267-A Maple, New Wilmington, Penna.

\$82.00 FROM Scrap wood, spare time, first month I used this method. Plans, instructions \$1.00. E. Bunnell, Tarpon Springs, Florida.

HUGE Profits using easy to apply luminescent products. Catalog, liberal samples 25c. Glowelico, 475-B Fifth Ave., New York 17, N. Y.

OPERATE Concessions at carnivals, fairs, shows. Surprising details. Stampico, Detroit 4, Mich.

URANIUM — Prospecting, information free. Write Sharpe, Prospector, Box 142, North Battleford, Canada.

"OPPORTUNITIES Preferred Magazine" tells how. Sample, 25c. Glen, Howel 3, Kentucky.

"WESTERN Advertiser" offers many worthwhile money-making opportunities. Sample copy 3c. H. Edlund, 577 Kensington, Los Angeles 26, California.

EASY Ways to earn extra income are described in Money-Making Hobbies. 132 projects you can make at home and sell anywhere. 160 pages, \$2.00. Popular Mechanics Press, 200-MH East Ontario, Chicago 11, Ill.

RAISE Ginseng. Roots bring fortunes. Circular free. Fezler Seed Co., Patchogue, N. Y.

MAKE Flexible arch supports. Profitable business. Tunis System, 1341 Kwis, Puente, Calif.

WANT Notary Public appointment? Official in usually 10 days. Stationers Exchange, Boerne 50, Texas.

UNPAINTED Figurines. Free list. Progress Company, 4033-P Chowen, Minneapolis 10, Minn.

DOLLARFUL Ideas for you every month in advance—"Voice of Mail Order." Leads the field in exclusive supply sources. Plans for mail order operation; new products, etc. Details free. Advance Publishing Company, Suite 350, 313 East 21st Street, New York 10.

WIN Contest money. General Contest Bulletin gives hundreds of tips. Lists current contests and rules. Sample 25c. General Contests, 1609½ East 5th, Duluth, Minn.

PUBLISH Your own magazine. Handsome 52 page format, well edited, illustrated. Cost low as \$1.00 month. Brings you prestige, profits. 25c brings sample, details. National, Ord, Nebr.

EARN Money at home! Thousands do! "Home Worker Magazine" tells how. Sample, 25c. Sizemore, Box 7, 4917 Kostner, Chicago 30, Ill.

THOUSANDS Articles wholesale. "Supply Source Directory" 10c. Ideal Service, Park Ridge 30, Illinois.

READ Progressive Mailtrade, the magazine that tells how to make money by mail. Dime brings sample and special offer. Progressive Mailtrade, Box 357, Sheboygan, Wisconsin.

FORMULAS, PLANS, ETC.

MILLER'S Modern post-war formulas make products that get the business. Fifty years supplying the best. Literature free! Miller, Manufacturer's Chemist, Tampa 6, Florida.

FREE Formulas for making 3 types of waterless hand cleaner. Also glass cleaner and amazing "lazybones" auto cleaner-polish. Organic Chemicals, 1269 S. Norton Ave., Los Angeles 6.

10,000 FORMULAS And trade secrets. Free literature. Stillman, 555 Kingston Ave., Brooklyn 3, N. Y.

MAKE—Sell cleaners, soaps, polishes, flavors, cosmetics. No machinery. Formula literature free. Kemico, Park Ridge 16, Illinois.

FORMULAS For nearly everything. Catalog free. Write Creative, Winnetka, Ill.

TESTED Formulas. Interesting descriptive booklet free. Pont, Box 635-PM, Terre Haute, Indiana.

REAL Manufacturing formulas. Lists free. Cummings, Chemist, Gordon Ave., Syracuse 4, N. Y.

PLASTICS

PLASTIC: Sheets, cut pieces, and scrap in clear and colors. Rod, tubing, acetate, dies, jewelry findings. Send \$1.00 for 4 pound scrap assortment and fabricating manual. Regal Plastic Supply, 720 Main, Kansas City, Missouri.

ADHESIVES For thermoplastic materials. Lucite, polystyrene, celluloses. Half pint \$1.00. Craft Chemical Lab, 453½ East Exchange St., Akron 4, Ohio.

INTERNAL Carved roses, orchids, swans, goldfish, butterflies, etc. Jewelry and gifts. Crystal Floral Novelty Co., Bound Brook, New Jersey.

INTERNAL Carvers—Guaranteed fast cutting, high speed, tapered drills with sharp points that make carving easier. 1/16", 3/32"-80c; 1/8"-\$1.00 each postpaid. Send for literature. Bay Sales, Dept. B, 101 Fifth Ave., New York 3, N. Y.

EMBED Real flowers, butterflies, shells, photos, to make unusual coasters, plaques, tiles, jewelry, buttons, other objects with new liquid plastic. Crystal clear or colors. Saw, carve, turn, drill. Use only home tools. Big, picture-packed manual shows how to make things very first day. Book also explains proved 6-point success plan for starting your own profitable plastics business. Send 35c for "A Success Plan for You." Castolite, Dept. C-101, Woodstock, Illinois.

SPECIAL Prime masked 6" x 12" Plexiglas sheets 3 for \$1.25 postpaid. Carving drills 1/16" 75c; 1/8" 85c each postpaid. Free catalogue. Craft Plastics, Somerville, New Jersey.

AMAZING Liquid plastic kit \$3.25. Embed photographs, keepsakes, coins. Makes solid objects, clear, colors. Beautiful results in half hour. Easily tooled. Inexpensive hobby. Send 15 cents for catalogue. Kristalon Plastics, Dept. Z-30, Box 29, Wilmette, Illinois.

PLASTIC Engineer and consultant, 65 East Rich Street, Columbus 15, Ohio.

EARN Money with plastics. New book, "Money-Making Hobbies," shows you how. 160 pages, \$2.00. Popular Mechanics Press, 200 E. Ontario, Chicago 11, Ill.

LUCITE, Plexiglas. Any size sheets, masked. Square foot (12 x 12) cost, 1/16", 96c; 1/8", \$1.25; 3/16", \$1.52; 1/4", \$1.80. Colors add 10%. Include 10% postage. Almac Plastics, 230 Fifth Ave., New York 1, N. Y.

PLASTIC, Sheets, rods, tubes, etc. Free list. Plastic Supply Co., 2901 N. Grand Blvd., St. Louis 7, Mo.

WHOLESALE Plastics supply catalog, 10c. Lucite, clear, colored. Metallic acetate, 15 colors. Thick lucite cutoffs, polished blanks for carving. Metal findings, tools, ideas, bargains galore. Quantity prices on casting plastic. Gem-O-Lite, Box 686S, North Hollywood, Calif.

CHEMISTRY

USEFUL Laboratory item, catalog of chemicals, laboratory apparatus, 10c. Rex Laboratories, 2849A Birchwood, Chicago 45, Illinois.

NEW, Used catalog 10c, refundable. Atlantic Laboratory Supply, 21 Wenham, Boston JP, Mass.

NEW Idea chemical and apparatus outfits for home experimenting. Photo-scales, microscopes, chemicals, biological and laboratory supplies in small quantities. Catalog 15c. Established 1931. John H. Winn, 124A West 23rd Street, New York, N. Y.

ILLUSTRATED Catalog: Chemistry, mineralogy, biology, 10c. Tracey Laboratories, Evanston, Illinois.

CHEMICALS And apparatus for industrial, analytical, and private laboratories. Catalog 15c. Dept. M-50, Biological Supply Co., 1176 Mt. Hope Ave., Rochester, 20, N. Y.

SNOOPERSCOPE Tube. Permits nighttime vision. Tube and complete instructions \$14.95. Limited quantities. Infrared filters 15c. Precise, 942 Kings Highway, Brooklyn 23, New York.

TUBULAR Ultra-violet light units for laboratory or hobby, \$4.50. Write for details. C. Warner, 82-60 116 St., Kew Gardens 15, New York.

NEW Laboratory supply catalog of chemicals and apparatus. Contains many thousands of items with illustrations. Send 25c. Standard Science Supply Company, 1232 N. Paulina St., Chicago 22, Ill.

HELP WANTED

VENETIAN Blind salesmen. Full-part time. Liberal commissions. Kraft, 309-68 St., Brooklyn 20, N. Y.

WANTED. One boy in every town to work during spare time advertising our Cleo safety razor blades. Write for information. Cleo Razor Blade Co., Easley, S. C.

AGENTS WANTED

MAKE 1950 Your biggest year. Sell improved Shopwell shopping bag. Every housewife prospect. Quick turnover. Over \$1.00 profit. Bonus plan. No investment. Sample \$1.50. Request free catalog fast selling items. Johnson Brothers, 730 Illinois, Morris, Illinois.

TRIPLE Your investment—Sell brushes, waxes, deodorants, household necessities. Send for catalogue. Frank-Lin Brush Co., 91 Allyn St., Hartford 3, Conn.

COLLECT Easy profits to 100%. Sell biggest line greeting cards. Plastic everyday, comics, gift wrappings, scented floral stationery, hankie gifties, plastic tablecloths, novelties bring money galore. Bonus. Write today for deluxe all-occasion, little pearls assortments on approval and special offer. Tom-Wat Studios, Dept. PM, Bridgeport, Conn.

CANVASSERS! Crew managers! A penny post card brings you full details on how you can become a direct factory dealer in your area without any risks, with our beautiful, popular priced, fast selling stainless tableware. Guaranteed for lifetime! Enormous profits! Dept. PM, John Hull Cutlery Corp., 1239 Broadway, New York City, N. Y.

EARNINGS Of \$25 to \$100 weekly possible selling established family shoe line direct to consumer. 70 styles. Amazing comfort features. Samples to producers. Experience unnecessary. Mench Shoes, MH-27, Brockton, Mass.

"SUCTION" Auto washer. New invention. Mirror finish. Banishes autowashing drudgery. Lightning seller. Samples sent on trial. Kristee 145, Akron, Ohio.

MONEY In your pocket! Profits to 100% yours selling sensational greeting card values. Everyday, religious, birthday, children's, little pearls, gift wrap assortments, gifts. Experience unnecessary. Special offers. Request samples personal imprinted stationery and deluxe all-occasion assortment on approval. Holiday Card Co., 463 Congress, Dept. E, Portland, Maine.

FREE Samples personalized stationery. Napkins, coasters, matches bring you extra money! Customers buy on sight. Profits to 100% selling sensational new plastic greeting cards, gift wrappings, children's books. Big demand. Experience unnecessary. Write today. Senrab Co., 129 North Warren St., Syracuse, N. Y.

GREETING Card moneymakers. Birthday, Easter, mothersday. Catalog free. Greenport Art Company, Brooklyn 15, New York.

BRAND New! Amazingly different and smart everyday cards. Magic window designs. 2 in 1 metallics. Take easy orders. Pays up to 100% cash profit. Big line of everyday assts. retail 60c up. Personal stationery, coasters, napkins. Free imprint samples. Assortment on approval. Write today. North Star. 31 Glenwood, Dept. G-18, Minneapolis, Minn.

BOYS! Earn big money easy, spare time selling brass name plates for neighbor's doors. Write Hubstamp, 359-C Congress, Boston, Mass.

\$85.00 WEEKLY Selling 4 pair shoes daily direct. Free outfit. Samples. No investment. Experience unnecessary. Advance commissions, bonus. Paragon Shoes, 739 Columbus, Boston, Mass.

EASY Dollars even for beginners! Sell friends plastic greeting cards, scented stationery. Profits to 100%. Bonus. Glamorous metal foil, little pearls, hankie gift greetings. Irresistible novelties. Free samples imprinted, decorated stationery. Deluxe all-occasion samples on approval. Special offers. Write Pilgrim Greetings, 111 Summer, Dept. AN-3, Boston, Mass.

MAKE \$50 Selling America's leading all-occasion greeting card assortments. Samples on approval. Complete line fast money makers. Free samples imprinted and monogrammed stationery, napkins and guest towels. Write Lorain Art Studios, Dept. AO-1, Vermilion, Ohio.

REAL Cash income! Sell exclusive cushion shoes insulated against summer heat. Advance commissions. Bonuses. Free new selling outfit. Concordian Shoes, G-2 West Concord, Mass.

EVERYDAY Cards. Earn \$5.00 with every ten \$1.00 boxes of everyday cards you sell. Also new plastic cards, note paper and wrappings. Send for samples today. Howard P. Ellis, Dept. PM-3, Pitman, N. J.

AMAZING Offer—\$40 is yours for selling only 50 boxes. Also entirely different, new deluxe all-occasion assortment with television card, Little pearls, hankie gift greetings, other surprise items. Feature boxes on approval. Free samples imprinted stationery and rose scented notes. Write today. It costs nothing to try. Cheerful Card Co., 1226, White Plains, N. Y.

EXTRA Money! Sell new, different greeting cards. Complete line includes regal plastic assortment, metallics, "stand-up" and "double" cards. Free samples exclusive imprinted and engraved stationery. Sales kit on approval. Regal Greetings, Dept. PM-13, Hazel Park, Mich.

TIE Salesmen—Sell the finest quality and fastest sellers in \$1.00 and \$1.50 neckwear direct. Write: Wolfmark, 931 W. Roosevelt, Chicago, Ill.

FEATHER Bird pictures. Sample 25c. A. Staff, 7975 Lakeshore, Rt. 1, Port Huron, Mich.

300% PROFIT Selling razors. Send 25c for sample. 4-S-Razor, Hutchinson, Kans.

SPARE Time, \$50 up, selling top line everyday greeting, personalized stationery, napkins, coasters. Victory Studios, Mt. Vernon, N. Y.

SELL Stainless steel, burglarproof window guards. Free details. Sample: 25c. Artware, 11110 Ventura, North Hollywood, California.

MEXICAN Feather pictures. Big profits! No investment! Free details. Sample 10c stamps. Silvia-P. Apartado 9036, Mexico City.

AT Last! Something new and sensational in everyday cards. Make extra money fast! Show gorgeous satin velour metallic cards. Get orders easy. Scented stationery, charmettes, napkins, kiddie cards. 25 other assts. retail 60c to \$1.25. Samples on approval. Puro Co., 2801 Locust, Dept. O40-C, St. Louis 3, Mo.

SELLS Fast to housewives. Book of 760 household hints. Sample with prices—\$1. King Sales Service, 55-P Oleander, West Springfield, Mass.

STRANGE "Dry" window cleaner. Sells like wild. Replaces messy rags, liquids. Simply glide over glass. Samples sent on trial. Kristee 146, Akron, Ohio.

BUY Nylons direct from mill. Make good profits on fast selling nylons. Quick delivery on any quantity. Write for confidential wholesale price list. Joy Hosiery Mills, Delaware 13, New Jersey.

AGENTS Wanted. Amazing repeat profits. New medical discovery—Saf-Te-Gard Vaporizer. Kills 85% germs, viruses. Send for details. Sample \$1.75. Sells \$2.50. Hunssinger Sales Co., 8526 So. Ada St., Chicago 20.

SOAPSAVER—New, magic, automatic measuring device for all granulated substances. Eliminates waste. Distributors wanted. Price \$1.20 dozen, retails 25c. Soap saver, 3410 Glenway, Cincinnati 5, Ohio.

"GLINT" Amazing new cleaner concentrate. Simply mix with water. Cleans windows, dishes, woodwork like magic. Whirlwind seller—great repeater. Excellent profits. Carhoff, 9321 Buckeye, Cleveland, Ohio.

SPARETIME Profits operating your own magazine subscription agency from home. Also handle all type greeting cards, stationery. Big confidential catalog and supplies free! It costs you nothing to try! Cassell Service, Westfield 3, N. J.

AGENTS—Sell finest food products direct to homes. Successfully sold for 25 years. Big profits. Powerful combination sales plans make sales easy. Permanent repeat business. Powerful premiums and free door openers for easier sales. Samples furnished. Live territories open to distributors. Mother Hubbard Products Co., 4139 Grand, Dept. M-3, Chicago.

STARTLING New product—No competition. Tremendous field. Good profit. Free sample. Ford Prod. Co., 7143 S. Claremont, Chicago 36.

THEY Smiled when I went out to sell! "My family humored me—thought me too old to work. I earned \$50.00 my first week." Free selling outfit. Consolidated Shoe System, Dept. S-541, Chippewa Falls, Wis.

CASH In now! Sell Forcolcar Canasta cards, Pixie cameras, Woody Woodpicker toothpick dispensers, novelty weather forecasters, greeting cards, stationery, and other items. Samples c.o.d. on request. Details free. Sunshine Sales, Dept. W-P2, Loudonville, Ohio.

EXTRA Money! full or part time selling "Sunshine Line" religious cards. New all-occasion greeting cards and Christian correspondence notes. Special new gift wraps with religious motifs is a winner. Write Triumphant Art Publishers, N9, San Jose, Calif.

OUR Agents are making big money, reaping tremendous profits. Write today for agents' proposition. You can now obtain pure silver in liquid form under our trade mark Liquid Silver. Nothing like it on the market. When applied with cloth it will immediately deposit a new layer of pure silver on copper, brass, bronze, rusty or tarnished auto bumpers, etc. L & D Mfg. Co., 270 Delancey St., New York 2, N. Y.

SENSATIONAL Nylons guaranteed against runs. Nationally advertised. Not sold in stores. No experience or money needed. Also lingerie, robes, men's hosiery. Outfit, sample, etc. free. Wonderful opportunity earn big money spare or full time. See our full page advertisement on page 71. Kendex Co., Babylon 546, New York.

AMAZING Opportunity. Big money. Demonstrating roll of honor Bible. We instruct. No invest. Col. Smith, 1211 Chestnut, Room 603-D, Philadelphia 7, Penna.

JOIN Manufacturers "Products of the Month Association" and get California's hottest selling lines. Sponsored by manufacturers. Dollar bill brings membership, and, Hollywood's newest \$1.95 automotive accessory. Director, Box 2470, Hollywood, California.

FAST Seller—Big profit. Sell our book "Be a Photographer's Model in 10 Days." Copy 50 cents. Money back guarantee. Schick Publishing Co., 631 Third Ave., New York City.

MAKE Big money with fast selling item every automobile operator will buy for \$1.00. Send \$1.00 for two introductory samples or \$5.00 for one dozen samples, postage prepaid. Peggio, 117 Arch Street, Philadelphia 6, Penna.

BUY Thousands of nationally advertised products direct from manufacturers and distributors. Write for "buy direct and save." Service Publishing, 218-A Investment Bldg., Pittsburgh 22, Penna.

SAMPLE Power mowers \$74.50; garden tractors \$77.00. Seasonal selling is most profitable. Ohio Power Equipment Service, Wakeman, Ohio.

LOOK Here! Wanted—Men to start in business on credit. Sell some 200 farm-home products. Thousands our dealers now make quick sales, big profits. For particulars write Rawleigh's, Dept. C-192-PPM, Freeport, Ill.

BIG Money in decals—Entirely new line of name plates. Tremendous demand. Also terrific new monogram display set ups for retail stores. Sells on sight. Constant repeats. Excellent side line printing and advertising salesmen. Free samples. Enco, 817 W. Cumberland, Philadelphia 33, Penna.

NYLON Uniforms. Immediate delivery, immediate profits. Sell to doctors, dentists, nurses, waitresses, beauticians, housewives. Free sales kit. Superior Fabrics, Dept. P3, 3936 Market, Philadelphia 4, Penna.

START Your own business on credit. Always your own boss. 1554 dealers, sold \$5,000 to \$26,500 in 1948; their average \$6,742. We supply stocks, equipment on credit. 200 home necessities. Sales experience not needed to start. Wonderful opportunity to own pleasant profitable business backed by world-wide industry. Write Rawleigh Co., Dept. C-U-PPM, Freeport, Ill.

ABSOLUTELY Free! Big package actual sample fabrics and style presentation of dresses, lingerie, hosiery, etc. Take orders. Commissions big. Send no money. Melville Co., Dept. 5277, Cincinnati 3, Ohio.

FREE Samples, and amazing plan, giving you gorgeous dress without penny cost. Rush name today, with dress size. Harford, Dept. B-435, Cincinnati 25, Ohio.

AMAZING New discovery makes hats, shoes, garments, etc. rainproof at home. Big profits. Amhar Industries, Plant 5E, Huntington, New York.

MAKE Money calling on friends. Show nationally advertised greeting card assortments. 16-card all occasion assortment only \$1.00. Also birthday, gift wrapping, plastics, imported English napkins, floral stationery, children's books, many more! Up to 50c profit on each assortment. Experience unnecessary. Samples on approval. Write Wallace Brown, 225 Fifth Avenue, Dept. J-4, New York 10.

HOUSE Paint—Your name on label. Agents wanted. Experience unnecessary. Free sample. Certified Products, Louisville, Ky.

STEADY Profits—No investment. Earn \$50-\$75 weekly spare time. \$100-\$250 full time. Plastic aprons, tablecloths, etc. Free catalog. Halliday Co., Dept. M-3, 347 Broadway, Passaic, New Jersey.

FREE Literature—Thousands wholesale supply sources. Money-making business ideas. Wilkin Company, Hillsboro 2, Ohio.

\$1 STARTS You in business. Sell top quality \$1.00 ties. Now only \$7.20 dozen, your profit \$4.80 dozen. Regular \$1.50 up values. Send \$1.00 for introductory offer two ties. Catalog complete line free. Philip's Neckwear, 20 West 22nd St., Dept. K-41, New York 10.

HOT Special! Power mowers \$59.50. Delivered. World's cheapest. Modern, 7401-AC, North Kansas City, Mo.

\$18 An Evening for you! Spend just two hours showing housewives exclusive D-Frost-O-Matic refrigerator control. Saves time, food, money. Sure-fire sales plan. Write today. No obligation. D-Frost-O-Matic, 6 N. Michigan Ave., Chicago 2.

NEW! Birthday party pack. Be first! Sell this sensational new assortment. Contains everything but the food. The invitations, table cover, napkins, nut baskets, place cards, snapper hats, cups, plates, game booklet and six different games; a complete party for eight. Sample \$1.25. Also America's leading greeting card line featuring personalized stationery, napkins, book matches and exclusive new wedding invitations. Free samples. Elmcraft Chicago, 5930 S. Western, Chicago 36, Illinois.

EASY Sales! Guaranteed button hole maker \$1. Fits any sewing machine. Large profits. Particulars free. Telford Sales Company, Telford 1, Penna.

SELL New clothing. Lowest prices. Operate from home, auto, store. Enormous profits. Big catalog free. National Mail Order, 1219-F South Jefferson, Chicago.

SELL Balloons! Combs! Novelties! Excellent sideline. Carleton House, Texas City, Texas.

DRESSES. 18c; Coats \$1.00, blouses 35c. Free catalog. Crown, 164-P Monroe Street, New York 2.

WHERE To buy 800,000 articles and nationally advertised merchandise direct from manufacturers and jobbers. Sent free. "Buy direct and make bigger profits." Glass Pub. Co., Ellwood City 7, Penna.

\$100.00 FAST—Easy. New office necessity does it. Hudson, 934 Lakeside, Chicago 40.

BE Renewal headquarters for all magazines. Handle everything at home. Big profits. No experience—no capital needed. Free catalog tells how. Write: McGregor Magazine Agency, Dept. 500A, Mount Morris, Ill.

DOUBLE Your income—Sell wool and cotton uniforms, badges, initial buckles, belts, etc. Write Hook-Fast, Box 480PM, Roanoke, Va.

FREE Samples. Big profits showing amazing glow-in-the-dark specialties. House numbers, pictures, plastic novelties, ashtrays, keyholders, religious and nursery objects, etc. Madison Plastics, 303 Fourth Ave., New York 10, N. Y.

JEWELRY Factory desires salesmen. Distributors, jobbers. Pickcraft, 19 Bank Street, Attleboro, Mass.

BIG Bargains for big profits. Over 100 sensational values. Men's used suits \$2, pants 35c, topcoats \$1.25, overcoats \$2, shoes 20c. Experience unnecessary. Free wholesale catalog. Superior, 1250-A Jefferson, Chicago 7.

NEWEST Money-making sensation, miniature authentic replicas, police and firemen's badges also pocket pieces, key chains. Write for descriptive folder. Hook-Fast Specialties, Dept. 20, Box 1425, Providence, R. I.

SCHOOL Seniors! Your postal will bring our wonder. Kwick-Sell cardalog of popular graduation name cards. Biggest profits! Only firm giving free souvenir chest and card case. Don't miss out! Hurry that postal! Craftcards, Box 235 (L), Pittsburgh 30, Pennsylvania.

AGENTS—Stamping names on key protectors. Sample 25c. Stamping outfits, checks, social security and name plates. Hart Mfg. Co., 303 Degraw St., Brooklyn, N. Y.

SELL Big money-maker to men and women. Easy handwork makes fast-selling useful articles. Sunmade Company, Brockton 64, Mass.

SCHOOL Seniors—Earn 40% commission selling classmates America's most beautiful graduation name cards. Largest selection. Outsells all others. Free sample kit. Printcraft, Dept. M, 1425 E. Elm St., Scranton 5, Penna.

LOOK! Make money all year round selling personal initialed individualized belts, buckles, cap badges, tie holders, complete line police and firemen's badges. 2000 emblems to choose. Big profits, whole or part time. Please write today special outfit offer. Hook-Fast Specialties, Box 1425, Dept. 6, Providence, R. I. Established 1926.

SEWING Machine electrification kit. Nationally advertised. Has Good Housekeeping Guaranty Seal. Can be demonstrated and sold in 5 minutes. Make at least \$5 per sale. For complete details write today to Brownell Distributors, Inc., Dept. PM, 308 Canal St., New York 13, N. Y.

FREE Water and our concentrates, make flavors, lotions, shampoos, 125 products, labels, bottles supplied. Quaioco, E20030 Russell, Detroit.

MAGIC Cleaner—Laundry soap deal. Hotter than a firecracker. Big profits. Sample free. Bestco, 4642 No. Central, Chicago.

GOLD Lacquered window sign letters. Large sizes penny each. New foils. Absolutely beautiful. Free samples. Atlas, 544 W. 79th, Chicago 20.

EXCELLENT Sideline for printing and advertising salesmen. Decalomania name plates in small quantities. Great demand. Also, make money with our line of automobile initials and sign letters. Free samples. "Ralco" XL-Roxbury, Boston 19, Mass.

PHOTO-Salesmen-agents. Sell beautiful hand-colored plastic enlargements. Collect deposit, we deliver. Profitable sideline. Send card, for free sample kit. Novel Portrait Co., 3343 North Ave., Chicago, Ill.

AGENTS—300% Profit selling genuine gold window letters: stores and offices. Free samples. Metallic Letter Co., 438-B North Clark, Chicago.

CLEAN Up with plastic rayon towels. Powerful quick demonstration. Ink, grease rinse right out. Every home, every business a prospect. Package 6 towels sells \$1.00. Gross \$54.00. Send \$1.00 sample package. Sunbeam Products, 701 Third St. So., St. Petersburg, Florida.

HIGH-GRADE SALESMEN

50% COMMISSION, Steady repeat orders. Lifetime income, free outfit. Nichols Company, Purvis, Miss.

SALESMEN. Earn \$50 weekly, selling only three pairs shoes daily. Commission and bonus. Wide variety for men, women, children. No investment. Experience unnecessary. Free catalog. Tanners Shoes, 559, Boston, Mass.

SALESMEN—Sideline. Earn \$3,000 next 5 months selling calendars, advertising specialties. Buyers everywhere. Big commission advanced. Samples free. Continental Calendar, 542-A South Dearborn, Chicago.

INDUSTRIAL Maintenance, write for free prospectus. Own your own business. Pioneer Chemical Manufacturing Co., 1828 Columbus, Cleveland 13, Ohio.

SELL Ultra-blue stock signs to stores. 1000 slogans, comedy, general, religious. "7x11" cost 6c, sells 35c. Make money. 15 samples ultra-blue signs "7x11" \$1.00 postpaid. Lowy, 8 West Broadway, Dept. 525, New York City 7.

SELL New automatic floor waxer. Trigger on handle. Hands never touch floors or wax. Retail \$2.95. Profit 125%. Write Smith, Inc., Greenfield 29, Mass.

MAKE \$15.00-\$30.00 Daily selling full size shopping bag that folds into purse size. Firestone plastic; looks, wears like leather. Every housewife wants one. Details free. Vinyl Industries, 839-P N. Western, Chicago 22.

ADVERTISING Book matches—Cash in on big demand; sell union label matches. Cuts for all businesses and political parties. Free powerhouse selling kit, low prices, protection guaranteed on repeat orders. Cash commissions. Superior Match Co., Dept. M-350, 7530 Greenwood, Chicago.

SENIORS Electric air deodorizer. Minute demonstration sells 9 out of 10. Long profit. Free introductory offer. Melco Products, Inc., 24 East Hennepin, Minneapolis 1, Minnesota.

CALENDARS And advertising novelties. Full time or side line. Every business wants them. Few calendar salesmen are on the road now which means more sales for you. Fleming Calendar Co., 6539 Cottage Grove, Chicago 37, Ill.

OVER 50% Profits—New concealed automatic fire control. Quality closes sales. Red Ball Inc., Box 1552, Salt Lake City, Utah.

EARN Big money fast! Sell finest-quality advertising work uniform to garages, factories, filling stations, etc. Free selling kit. Topps, Dept. A-30, Rochester, Ind.

BIG Money selling tooth powder. J. Walker, 633 Plymouth Ct., Dept. 1, Chicago 5, Ill.

SALESMAN Wanted. Make over \$100.00 a week. Each sale you make \$10.00. Selling on instalment watches: Bulova, Longines, Elgin, Benrus at \$2.00 weekly easy to sell. We supply samples. Car necessary. For new open territories. Furnish references. Ergim Co., Inc. (Wholesalers), 992 Columbus Avenue, New York City.

BIG Cash profits for men and women introducing Flexiclogs, sensational new flexible footwear. Experience unnecessary. Nationally advertised styles for women, children, men. Excellent sideline, no investment. Easy to average hundreds of dollars weekly. Free sales helps and sample offer. Get details now! Flexiclogs, Dept. L-3, New Holstein, Wisconsin.

SENSATIONAL Nylons guaranteed against runs. Nationally advertised. Not sold in stores. No experience or money needed. Also lingerie, robes, men's hosiery. Outfit, sample, etc. free. Wonderful opportunity earn big money spare or full time. See our full page advertisement on page 71. Kendex Co., Babylon 546, N. Y.

JOIN. Salesman's Club. Education, social. Fraternal. Application. Professor Martin, Bonners Ferry, Idaho.

NEW Jobs open in selling! Send name, address for five free issues of Opportunity Magazine's money-making guide, listing hundreds of companies who'll pay you well, full or part-time. No experience needed. Opportunity, 28 E. Jackson, Dept. 17, Chicago 4, Ill.

BIG Money taking orders. Shirts, ties, Sox, pants, jackets, sweaters, shoes, uniforms, etc. Sales equipment free. Experience unnecessary. Nimrod, 4922-AN Lincoln, Chicago.

EDUCATIONAL AND INSTRUCTION

LEARN The collection agency business. Highly profitable. Easily mastered. Free folder. Cole Associates, Syracuse 2, N. Y.

NEW Profession—Pedemetry (foot correction). Learn at home. Write: American Foot Health Institute, 514 S. Sacramento Blvd., Chicago 12, Ill.

WANT \$66.34 a week? U. S. civil service jobs. Men, women. You can qualify now for secure positions. Many openings expected soon. Write today for free 40-page book showing jobs, salaries, sample tests. Franklin Institute, Dept. C-24, Rochester, N. Y.

LEARN Auto or diesel mechanics for higher pay. Actual shop training in our up to date Chicago shops. Approved for veterans and civilians. Established 1902. For free information write to Greer Shop Training, Dept. 210C, 460 South State Street, Chicago 5, Illinois.

PRINTING Correspondence course with type. Work for others or in business for yourself. Printing S. Institute, 4328 Lincoln, Chicago 18, Ill.

STUDY To be a doctor of psychology or metaphysics. Obtain Ps.D., Ms.D., D.D. or Ph.D. degree. Chartered by state. Write for free book telling how. The Neotarian Fellowship, Dwight Building, Kansas City 6, Missouri.

LOCATE Missing persons, hidden assets. Be a credit investigator or skip tracer. Free details. Continental School, 492 44th Street, Oakland, California.

INVESTIGATOR—Criminology courses. Free literature. Allied Schools, 14 No. East, Indianapolis.

BECOME A Doctor of Psychology or Metaphysics. Teach secret of contentment, happiness. Win degree of Ps.D. or Ms.D. Solve mental worries. Free book. College of Universal Truth, 5153-C North Clark, Chicago.

EXPORT-Import! Big money and world-travel opportunities. Represent buyers, sellers. International mail order without capital. Practical inexpensive course teaches you quickly at home in spare time. Free book Mellinger, 103W, Los Angeles 24, Calif.

MAKE Up to \$35-845 week as a trained practical nurse! Learn quickly at home. Booklet free. Chicago School of Nursing, Dept. M-3, Chicago.

"HOW To Break and Train Horses"—A book every farmer and horseman should have. It is free; no obligation. Simply address Beery School of Horsemanship, Dept. 1103, Pleasant Hill, Ohio.

USED Correspondence courses and educational books bought, sold, rented. Catalog free. Educational Exchange, Summer-ville, Ga.

INCREASE Your earnings—Learn watch repairing at home. Ten easy lessons. We furnish free watches and all tools. A licensed school. Large percentage of students make up to \$40 a week in spare time while learning. Write today for free information. Illinois School of Watch Repairing, Dept. CPM-3, 2870 Elston Ave., Chicago 18, Illinois.

NON-Resident courses: High school, college. Earn Triplespeed selfstudy short-hand. Capital City College, Washington 5, D. C.

FREE—Bookkeeping lesson, particulars. Buchalter, 1280 Ocean Avenue, Brooklyn 30, N. Y.

PHOTOGRAPHIC Mind with Super-memory. Write Thor Books, M-3, Box 1210, Chicago.

BECOME Mail order specialist. Operate own profitable business or assist others. New course reveals successful methods of the experts. Free information. Mail Business Associates, Inc., 919 State Tower, Syracuse 2, N. Y.

BE A real estate broker through home study or classroom instruction. Write for free book. Approved for veterans. Weaver School of Real Estate, 15 E. Pershing Rd., Box CP-3, Kansas City 8, Missouri.

MIND Asleep? Try "Thinking-Alphabet." Write Frank Tibolt, 17M, Philadelphia 20.

VOICE! Priceless secrets! Free information! Studio, 14356B Jersey Avenue, Norwalk, California.

READ With speed! New amazing method. Save time. Learn more. Earn more. Send for free home test and details. Brownson, 9111 Hoyne, Chicago 20.

LINGUAPHONE Makes languages easy. At home learn to speak Spanish, Portuguese, Italian, French, German, Russian, by quick, easy Linguaphone Conversational Method. Save time, work, money. Send for free book. Linguaphone Institute, 83 RCA Bldg., New York 20, N. Y.

HOME Bible course. Simple, helpful, instructive. Total cost \$4.00 includes textbooks, stationery, examinations, certificate. \$1.00 starts you, or simply request prospectus. The Bible Study School, 378 Van Houten Street, Paterson 1, N. J.

HOME Study course, drugless therapy. Free literature. Institute of Drugless Therapy, Tama, Iowa.

ELECTRIC Appliance service handbook with catalog C-50, \$1.00 (refunded on \$5.00 order). C-US Supply, 2512 Prevost, Fort Worth 7, Texas.

YOU For president of your own credit-collection business. Many who answered our ads now have their names on office doors. Franklin Credit, Roanoke 7, Va.

INVESTIGATOR Training. Phillips Secret Service System, 1917-B North Ken-neth, Chicago 39.

HOW To get a job the scientific way. Take your pick of the jobs you should have. Secure your future. Send for details. Bushnell, 25 Union Park, Boston, Mass.

USED Correspondence courses. Bought, sold, rented. Free literature. Baker, 5509-B Winthrop, Chicago 40.

INVESTIGATORS Needed in every town. National, 3911 Tacon, Tampa 9, Florida.

USED Correspondence courses and books bought, sold, rented and exchanged. Catalog free. Lee Mountain, Pisgah, Alabama.

BOOKKEEPERS! Increase your earnings! Operate your own simplified "dollar-a-week" bookkeeping and tax service. Full or spare time. Details free. No obligation. Ellis, Box 200, Cedar Grove, N. C.

PIANO Tuning pays. Learn this profitable profession at home. Our Tunometer and mechanical aids make learning easy. No knowledge music necessary. Diploma granted. Largest and oldest school—52nd year. G.I. approved. Write for booklet. Niles Bryant School, 78 Bryant Bldg., Washington 16, D. C.

WRITE For pay and pleasure! You can make extra money, have fun, when you take our "earn while you learn" writing courses. We back up our statement with 31,000 satisfied students. Send penny postal today for free details. Comfort Writer's Service, 200 S. 7th St., Dept. PM150, St. Louis 2, Mo.

SHORTHAND In one week. Easy long-hand system. \$1.48. Self-instructor. Free literature. Zinman, 215F West 91, New York 24, New York.

SECRET Investigation. Experience unnecessary. Investigators particulars free. George Wagner, M 125 West 86th, New York.

MEDICAL Laboratory Technicians in great demand. We train you in your own home. Catalogue free. Imperial Technical Institute, Box 973-J, Austin, Texas.

PLAYS, STORIES, MANUSCRIPTS

WRITE For pay. Proven-easiest way! Receive checks for \$3 to \$100—offered daily, for re-writing ideas in newspapers, magazines, books. C.C., Mich. writes: "Received check for \$27." Mrs. R.C.B., Mass., writes: "I made \$20." No previous experience necessary. Write for free details and how to get free Writer's Market Guide! Comfort Writer's Service, Dept. 1-L, 200 South 7th St., St. Louis, Mo.

I WANT New writers to cash checks of \$1 to \$100 offered daily. The easiest way to write for pay. No previous experience necessary. Free details. Saunders M. Cummings, 468-11 Independence Bldg., Colorado Springs, Colo.

BUSINESS SERVICE

LET Me re-mail your letters from Boston, The Bake Bean City, 20c. William Cuppello, 24 Mayberry Ave., Medford 55, Mass.

MIAMI Postmark! Letters 25c each; \$3.00 monthly. McDowell, 504 Pacific Building, Miami 32, Florida.

SPECIAL SERVICES

CUBA—Letters remailed, 25c each. R. Morejon, Box 1291, Havana.

ATTENTION Manufacturers, home shop operators, hobbyist, salesmen. Let us show you where you can buy everything you want, have parts made, sources of supplies, tools, machinery, etc. This is not a mailing list. We choose reliable manufacturers, suppliers, importers that can furnish exactly what you want. Save time and money by buying direct. List of five for only \$1.00, additional 15c each. Minimum order \$1.00. Guaranteed prompt service. Tell us what you want. We'll furnish names and addresses of reliable sources or refund your money. John Allis, Box 214, Mount Clemens, Michigan.

MAKE Our Chicago address yours for profit and prestige. Business or personal mail. Low rates. Free details. Schultz House, 3116 Seminary, Chicago 13.

INVESTIGATION And cash liquidation—Old or recent stock certificates, bonds, bank books, promissory notes, deeds, wills, financial documents of every description. Send us your list for appraisal. National Evaluators, P.O. Box 5852, Cleveland 1, Ohio.

DRAFTING, Mechanical design, detailing. Send sketch and particulars for estimate. Robert Worsham, 5635 Cottage Grove, Chicago 37, Ill.

"CUSTOM Die cutting." cork, rubber, paper, metal, to any shape. Medco, 416 S. 6th Street, St. Louis 2.

CARTOONING, COMMERCIAL ART, SHOWCARD WRITING, SIGN PAINTING

LEARN Professional lettering. Easy, experience unnecessary. Amazing mechanical process. Complete instructions, 75 alphabets, 250 designs \$1.00. Major-Art System, 3510-B Palmer, Chicago 47.

CARTOON Your way to success! Internationally known instructor. Raye Burns, will personally teach you to create salable, original cartoons at home. Course of 26 lessons only \$2.85. Send remittance with order or write for free details and addresses of successful students. Raye Burns School, Box 3583-M, Cleveland 18, Ohio.

130 ALPHABETS, Many numerals. New \$1.50 book for sign men, students. Special \$1.00. Gray Associates, 3852 North Oakley, Chicago 18.

EDITORIAL Cartooning—Tells how and where to get ideas, \$2.75. ISCM Press, Ames, Iowa.

CARTOONISTS! 150 Basic stick-figure drawings by "Zin," nationally famous cartoonist. Makes cartooning easy; only 25c! Latest free lance market guide. Lists 150 magazines paying \$3-\$40 per cartoon, \$1.00. Zin, Box 10215, Tampa, Fla.

SHOWCARD Writing pays big! Learn rapid, artistic lettering quickly, easily. Our low-cost course shows how. Details free. Sherwood Publishing Co., Irvington 7, N. J.

"HOW To Make Money With Simple Cartoons"—A book everyone who likes to draw should have. It is free; no obligation. Simply address Cartoonists' Exchange, Dept. 93-C, Pleasant Hill, Ohio.

EARN Money evenings, copying and duplicating comic cartoons for advertisers. Advertise. Argyle 2-B, Wisconsin.

BARGAIN, Quick landscape painting, poster art—lettering, art lessons, catalog 10c. Art Book Shop, Arnold 8-D, Missouri.

TALENT Test, information. Give age. Art, Box 8066, Dallas 8, Texas.

SIGN Painting taught at home. Test lesson free. Ben Kerns, Box 812-T, Greenville, S. C.

CHALK Talks. Laugh producing program, \$1.00. Catalog 10c. Balda The Cartoonist, Oshkosh, Wisconsin.

ADVERTISING AGENCIES, LETTER WRITERS, FOR ADVERTISERS

BETTER Sales letters—Stronger ads. Complete advertising service any size budget. Write fully. Monroe, Box 1002, Chicago 90.

TRADEMARKS Designed complete with cut, \$10.00. Rough sketch, \$1.00. Catalog free. Burke, 3208 McKinney, Dallas.

MAILING Lists: \$5.00-1000 up. Write Dixie Service, King, N. C.

FREE! 1949 Advertisers Rate and Data Directory, 52 pages! E. H. Brown Advertising Agency, 20 N. Wacker, Chicago 6.

ADVERTISERS! Reach nearly 18,000,000 readers. 23 Sunday national key newspapers, 18 words, \$51.50. "Terrific pullers." 20 popular newspapers, \$10.00. "Free booklet." Special—One inch display 2-821,198 circulation, \$48.30. Newmark's Advertising Agency, (Established 1893), 317-7th Ave., New York 11.

ADVERTISE! 24 Words, 40 newspapers \$3.50. Lists free. Advertising Bureau, 10511-C Springfield, Chicago 43.

AVOID Costly advertising mistakes. Get enlightening Ad-Guide and Ratebook leading newspapers, magazines, mailing lists, 10c. Chicago Advertising Agency, (Established 1900), Chicago 4.

24 WORDS In 50 weeklies, \$4.96. J. Darnell, 730 Hays, Jackson, Tennessee.

REACH Spanish-speaking mail-order buyers. Great new market for your merchandise. Your classified ad in the Spanish Edition of Popular Mechanics will bring you some nice business from this new field. Rate only 25c per word. Circulation 100,000 copies. Mail a trial ad right now. Popular Mechanics Magazine (Spanish Dept.), 200 E. Ontario Street, Chicago 11, Ill.

ADS Placed in out of town newspapers and magazines. Low rates. Catalogue free. Ideas that pay. Baker Advertising Agency, Successors Ankrum Agency, 189 W. Madison, Chicago 2.

TYPEWRITERS, DUPLICATORS, OFFICE DEVICES

FAST Figuring secrets in "How to Use the Chinese Abacus." \$1.00. Low-cost fast adding-calculators available. Free circulars. W. D. Loy, 1317 R.I. Ave., N.E., Washington 18, D.C.

ADDING Machine, Desk model portable \$12.95. Business Taxtimer, \$7.00. Details one stamp. Johnson, 2611 Harriet, Minneapolis 8, Minnesota.

PHOTOGRAPHIC Stencils for your duplicator. Free information. Smith Co., Halfwaytree—21, Jamaica, B. W. I.

RECONDITIONED Typewriters, printing devices. Write Dixie Service, King, N. C.

NEW, Selffeeding mimeograph prints postcard to full letter size. Only \$27.50. Factory discount to distributors. Dansen Company, Hopkins, Minnesota.

ADVERTISE. Increase business. "Printomatic" selffeeding "mimeograph" post card duplicator prints, reproduces, thousands anything typewritten, handwritten, \$13.50. Literature. Pittsburgh Typewriter Company, 336-3 Fourth Avenue, Pittsburgh 22, Penna.

RUBBER STAMPS AND OFFICE SUPPLIES

MIMEOGRAPH Paper, 68c ream, samples. Brookman, 56-A West 24th, New York 10.

RUBBER Stamps. Send for catalog. Excello, Box 500, Shreveport, Louisiana.

PRINTING, MULTIGRAPHING, MIMEOGRAPHING, GUMMED LABELS

BUSINESS Cards—Blue or black raised lettering. 1000 guaranteed \$3.40. C-U's Supply, 2512 Prevost, Fort Worth 7, Texas.

EMBOSSED Cards, envelopes, letterheads. Samples. Spada Enterprises, 4 Eastview, Rocky Hill, Conn.

YEAR'S Supply personalized printed memos, (2000) with beautiful bakelite desk holder, packaged for each month, only \$3. Indispensable. Print name clearly. Memos. Bovey, Minn.

BUSINESS Cards—Raised printing. Blue or black. 1000 \$3.50 postpaid. Samples. Arthur Mitchell, 220 Arguello, San Francisco, Calif.

100 EACH Noteheads, envelopes, printed name, address, \$1.15. Gooch, 202PM, Hernando, Miss.

1000—6 $\frac{3}{4}$ WHITE Wove envelopes \$3.75 f.o.b. Ideal Printing Company, 225 State, Hudson 7, New York.

100 8 $\frac{1}{2}$ x 11 **HAMMERMILL** Letterheads and 100 envelopes, \$1.85. Herbert Hudson, Centredale, R.I.

PRINTING. Lowest prices. Free samples. Belanger's, 51-X Talcott Ave., Rockville, Conn.

500 2x3 **TWO** Color shipping labels \$2.25. General printing. Myers Company, 1228-C Adams, Owosso, Michigan.

ECONOMICAL Printing; state requirements. Odum Supply, Box 9345, Tampa, Florida.

250 **ENVELOPES** And 8 $\frac{1}{2}$ x 11 bond letterheads \$3.00. Webpress, Farmland, Indiana.

1000 **BEAUTIFULLY** Embossed business cards \$2.75. Avery, 112-M Elizabeth, Wichita 12, Kansas.

MIMEOGRAPHING. Modern vari-typed, 500 for \$3.50. Samples free! Creamer, Box 737, Lowell, Massachusetts.

ENCLOSE Stamp for lower prices. Crane, Box 7625-D, Kansas City 3, Mo.

100 8 $\frac{1}{2}$ x11 **HAMMERMILL** Letterheads and envelopes printed—4 lines \$1.75. Samples. Rex, 446 East 87th Place, Chicago 19.

QUALITY — 150 Business cards or 60 noteheads and envelopes, \$1. Free price list. Johnson, A-24, 140 Spring, Rochester, N. Y.

QUALITY Printing. Lowest prices. Anything in any quantity. Free price list. Albert Wilcox, Nichols, Georgia.

2000 **FEATHERWEIGHT** Business cards only \$3.00. Free samples. Havos, Dept. P.M., 1133 Broadway, New York 10, N. Y.

PHOTO Offset printing. No cuts needed. Lowest prices. Literature free. Ramshaw Co., 180 West Washington, Chicago.

GUMMED Labels, stationery. List free. Reed, Box PM-135, Spiro, Okla.

QUALITY Printing. We specialize in publications, newspapers, tabloids. Send copy for estimate. Bagby Printing Co., Georgetown, Ohio.

1000 **BUSINESS** Cards \$2.50. 2000 \$4.50 prepaid. Murrell, 715 Cedarcroft Road, Baltimore 12, Md.

5000 6 $\frac{3}{4}$ **ENVELOPES** Printed \$2.75 per thousand, price list free. Michel, Box 76F, New York 16.

SEND 10c Now, for our 48 page 1950 price list—refunded first order. McCall Press, 1326 South 27th, Omaha, Nebraska.

1000 **BUSINESS** Cards \$2.50 prepaid. Samples free. Reliable Print Shop, 905 East Jefferson, Louisville 6, Ky.

QUALITY Printing! Free price list. Nationwide Printing Company, Dept. PM, 2337 Bath Avenue, Brooklyn 14, N. Y.

500 3 $\frac{1}{2}$ x2 $\frac{1}{4}$ **FOUR** Line gummed stickers 35c; red border 50c. Moritz Printery, Saginaw, Mich.

MIMEOGRAPHING—Letters, pricelists, formulas, instructions. Lowest prices. Lem's Letter Shop, 5710 Stanton, Detroit 8.

PRINTING OFFSETS AND SUPPLIES

PRESSES, Type, cabinets, supplies. List for stamp. Lincoln Press Company, 220H Hartwell, Fall River, Mass.

PRESSES, Type, supplies. Catalog 10c. Printers Supply, 211, Springfield, Missouri.

HOBBY Printers' new press; productive, inexpensive; details free. Roberts, Box 184, Walpole, Mass.

MAKE Your own rubber printing cuts. Self molding process. Plexirubber, Argyle 1, Wisconsin.

PRINTING Presses, type, supplies. Lists 3c. Turnbaugh Service, Loysville, Penna.

PATENT ATTORNEYS

PATENT Protection—Unless you are thoroughly familiar with such matters, you are advised to employ a competent, registered patent attorney because the value of a patent depends largely upon the skillful preparation of the specification and claims. Send for booklet, "Patent Protection for Inventors," outlining preliminary steps to take to obtain patent protection. Victor J. Evans & Co., 531-C Merlin Building, Washington 6, D.C.

PATENTS. "Proof of Invention" folder mailed without obligation. E. E. Vrooman, Registered Patent Attorney, 507 McKim Building, Washington 5, D.C.

INVENTORS—If you believe you have an invention, you should find out how to protect it. The firm of McMorrow, Berman & Davidson with offices in Washington, D.C., is qualified to take the necessary steps for you. Send for copy of our patent booklet "How to Protect Your Invention." We will also send you an "Invention Record" form. No obligation. They are yours for the asking. McMorrow, Berman & Davidson, Registered Patent Attorneys, 134-X Victor Building, Washington 1, D.C.

HERMAN Lewis Gordon, Registered Patent Attorney. Patent investigations and opinions. Warner Building, Washington, D.C.

PATENTS—Trade marks. Gustave Miller, Registered Patent Attorney, 10-A Warner Building, Washington 4, D. C. Patent Lawyer.

REGISTERED Patent attorney offers services. Sanders, 6430 Evans, Chicago 37, Ill.

CANADA—Ramsay Company Registered, 273 Bank Street, Ottawa, Canada.

PETER Fries, Jr., Registered Patent Attorney. Patents, trademarks, novelty searches, copyrights. 110 East 42nd Street, New York City.

PATENTS—Trade marks. Irving L. McCathran, 315 McLachlen Bldg., Washington 1, D.C. Registered Patent Attorney.

INVENTORS: When you are satisfied that you have invented something of value write me, without obligation, for information as to what steps you should take to secure a patent. Write Patrick D. Beavers (Formerly Randolph & Beavers) Registered Patent Atty., 935 Columbian Bldg., Washington 1, D. C.

C. A. SNOW & Co.—M-427, Snow Building, Washington 1, D. C. Registered Patent Attorneys. Write for information.

"INVENTOR'S Guide" free on request. Frank Ledermann, Registered Patent Attorney, 154 Nassau St., New York 7, N. Y.

INVENTORS: Learn how to protect your invention. Unless the inventor is familiar with patent matters, he should engage a competent registered patent attorney or agent to represent him. We are registered to practise before the U.S. Patent Office and prepared to serve you in handling your patent matters. "Patent Guide for the Inventor" containing detailed information concerning patent protection and procedure with "Record of Invention" form will be forwarded to you upon request—without obligation. Clarence A. O'Brien & Harvey Jacobson, Registered Patent Attorneys, 01B-A District National Building, Washington, D. C.

INVENTORS: Without obligation, write for information explaining the steps you should take to secure a patent. John N. Randolph, Registered Patent Attorney, 203 Columbian Bldg., Washington 1, D. C.

INVENTORS: Write for free brochure "Evidence of Invention." Labiner, World Building, New York 7.

PATENT Practice before U. S. Patent Office. Validity and infringement investigations and opinions. Booklet and form "Evidence of Conception" forwarded upon request. Lancaster, Allwine & Rommel, Registered Patent Attorneys, Suite 411, 815-15th Street, N.W., Washington 5, D. C.

INVENTORS. For "Record of Invention" form, contact Carl Miller, Registered Patent Attorney, Woolworth Building, New York.

FOR INVENTORS

PATENT Searches \$5.00. Reports airmailed within 4 days. Invention protection forms free. Write Miss Ann Hastings, Patent Searcher, P.O. Box 176, Washington 4, D. C.

INVENTORS—This firm is registered to practice before the United States Patent Office and is available to assist you in the preparation and prosecution of your patent application. "Patent Protection for Inventors" booklet containing detailed information and steps to take toward patent protection will be sent upon request. No obligation. Victor J. Evans & Co., 532-C Merlin Building, Washington 6, D. C.

PATENT Searches \$5.00, includes patent copies. Same reliable search as conducted for attorneys. 48 hour service. Free protection forms. Patent Service Institute, 945-A Pennsylvania Avenue, Washington 4, D. C.

PATENT Searches \$5.00. Reports airmailed within 4 days. Invention protection forms free. Write Raymond L. Smith, Patent Searcher, 410 Bond Building, Washington 5, D. C.

INVENTORS—If you believe you have an invention, you should find out how to protect it. The firm of McMorrow, Berman & Davidson with offices in Washington, D.C., is qualified to take the necessary steps for you. Send for copy of our patent booklet "How to Protect Your Invention." We will also send you an "Invention Record" form. No obligation. They are yours for the asking. McMorrow, Berman & Davidson, Registered Patent Attorneys, 134-W Victor Building, Washington 1, D. C.

1001 **NEEDED** Inventions. A new bulletin listing 1001 needed inventions with sound commercial value. Put your talent to work on the right problem. Inventors' Idea Guide. Send \$1.00. Satisfaction guaranteed or return in 5 days for refund. C. J. Specialties, Box 5007, Dept. 12, St. Paul, Minnesota.

PATENT Searches \$5.00. Includes nearest patent copies. 48-hour service. Free protection forms. Patent Research Engineering, 318 Evans Building, Washington 5, D. C.

DRAFTING—Engineering service. Drawings illustrating inventions—\$8.00 per sheet. Three full size prints furnished. Herman Lewis Gordon, Warner Building, Washington, D. C.

INVENTORS! Save time, money and patience. Deal direct with prospective manufacturers. Details free. Willard Industries, 544 Russ Bldg., San Francisco 4, Calif.

INVENTORS: \$5.00 Analyze your ideas regarding practicability, engineering soundness. Ernst Eger, Consulting Engineer, 410 North Rossmore, Los Angeles 4, Calif.

INVENT For profit. What to invent. How to do it. Sell or manufacture. Ten lessons \$5.00, including club membership. Free information—C30. Cunningham, Box 1132, Chicago 90, Ill.

I.F.I. Creative co-operation includes: Superscope patent searches; commercial prospects analysis; pre-patent priority protection; invention-improving; finding backers; invention-styling for sales-leadership, plus the promoting, marketing, and selling of inventions for maximum cash and royalties. Write today for free information. Inventors-for-Industry, Inc., Dept. PM3, 501, 1947 Broadway, New York 23.

INVENTORS: Learn how to protect your invention. Unless the inventor is familiar with patent matters, he should engage a competent registered patent attorney or agent to represent him. We are registered to practise before the U.S. Patent Office and prepared to serve you in handling your patent matters. "Patent Guide for the Inventor" containing detailed information concerning patent protection and procedure with "Record of Invention" form will be forwarded to you upon request—without obligation. Clarence A. O'Brien & Harvey Jacobson, Registered Patent Attorneys, 01A-A District National Building, Washington, D. C.

COMPLETE Services for inventors. Patent searches including analysis, patent copies. Inventions, patents marketed. Protection forms free. Industrial Patent Reports, Box 1081, Massachusetts Avenue and North Capitol, Washington 13, D. C.

INVENTORS: If you have an invention for sale, patented or unpatented, write Institute of American Inventors, Dept. 40A, 1926 Eye St. N.W., Washington 6, D. C.

INVENTIONS Wanted. Prominent manufacturers and national distributors look to us for new products. You can also benefit by having us assist you with your invention from the idea stage through to the developed product, fully protected. Ask for Booklet "M." Elo Development Co., Chatham Phenix Bldg., Long Island City 1, New York.

PATENT Owner Representative. Years of experience. Can I help you? Charles A. Scott 773PM Garson Avenue, Rochester 9, N. Y.

INVENTORS: Without obligation, write for information explaining the steps you should take to secure a patent on your invention. John N. Randolph, Registered Patent Attorney, 202 Columbian Bldg., Washington 1, D. C.

CASH For your idea. 280 manufacturers need inventions, patented or unpatented. List free. Invention Bureau, 208M Clinton, Oak Park, Illinois.

"INVENTOR'S Guide" free on request. Frank Ledermann, Registered Patent Attorney, 154 Nassau St., New York 7, N. Y.

INVENTORS. For "Record of Invention" form, contact Carl Miller, Registered Patent Attorney, Woolworth Building, New York.

INVENTORS: The usual first step is to have a search of the U. S. Patents conducted, so I can report on patentability. Write, without obligation, Patrick D. Beavers (Formerly Randolph & Beavers), Registered Patent Atty., 936 Columbian Bldg., Washington 1, D. C.

INVENTORS—Subscribe to "The Visioneer," a monthly publication giving you leads and information to help you sell your invention. Sample copy 25c. Write Visionering, Inc., Security Bldg., West Bend, Wis.

INVENTIONS WANTED

INVENTIONS, Gadgets, patented, unpatented. Free offer. Grayland, 5312B Grace, Chicago 41.

INVENTIONS Wanted. Patented or patent pending only. American Invention Sales Co., 21 Palm St., Nashua, N. H.

THE U. S. patent system does not compel inventors into rash "patent spending." The intent of the patent law is to give you the chance of making a pre-patent test of the worth of your ideas. And high-character priority protection for this purpose can be obtained through: Inventors-for-Industry, Inc., Dept. PM3, 501, 1947 Broadway, New York 23.

CASH—Royalty. We manufacture, internationally distribute. C. W. Burbridge, Pres., Automotive-Household Products Co., Oklahoma City, Okla.

INVENTIONS Promoted. Patented or unpatented. Write Adam Fisher Company, 61 Enright, St. Louis, Mo.

INVENTORS—What have you, patented, patent pending to offer manufacturers? Booklet, information free. Market Contacts, 11106-A2 Longwood, Chicago 43.

HIGHEST Royalties—Cash. Request free Booklet "M." Universal Marketing Co., 354 South Spring St., Los Angeles 13, Calif.

INVENTORS: Hundreds of manufacturers have requested our assistance in locating marketable new products. Complete information, free. Institute of American Inventors, Dept. 40-D, 1926-Eye St. N.W., Washington 6, D. C.

CASH For your idea. 280 manufacturers need inventions, patented or unpatented. List free. Invention Bureau, 208M Clinton, Oak Park, Illinois.

INVENTIONS Wanted. Patented or pending only. Inventors' Exchange-B, Hartford 1, Conn.

PATENTS FOR SALE

PLAYGROUND Equipment manufacturers! Patent # 2,448,325! Sensational "Scenicwing!" Poorman, Sch. Haven, Penna.

PENDING Two inventions. Combination Phillips and regular screwdriver handle performs leverage and ratchet action. Combination utility trailer and boat. Baker, 1610 Dewey St., Parkersburg, W. Va.

PATENT Pend. triple cake and dough cutter. Cuts uniform pieces. Sell to bakeries, restaurants and households. Josephine Henrikson, Climax, Minn.

REVOLUTIONARY: New patented tubular safety chassis frame automotive utility trailers. Outright or royalty. Charles Nelson, 2908 Washington Ave., Santa Monica, California.

INVENTORS: Test the commercial value of your patented or unpatented inventions, quickly and inexpensively. Write for free information. Institute of American Inventors, Dept. 40-B, 1926-Eye St. N.W., Washington 6, D. C.

MANUFACTURING

MODELS, Tools, dies. Experimental work. Small manufacturing. Domm Machine Works, 1700 77th Street, North Bergen, N. J.

YOU Name it. We'll make it. Wood-work in lots. Clifford Meinert, 523 17th Ave., Monroe, Wisconsin.

DEPENDABLE Source for manufacturing tools, dies, stampings. Porsberg, Northfield, Ohio.

ENGRAVING—Nameplates, plastic or metal. Complete service. Christian, Box 39, Stratford, Conn.

WANT Something made? We'll make it. Consultation free. Write Jayemm Company, Burlington, Kentucky.

MODELS—Small lot manufacturing. Metals, plastics, etc. Milburn, Burlington, Kentucky.

MODELS, MODEL SUPPLIES

MINIATURE Engines, castings and drawings. Catalog world's largest selection 25c. Miniature Engine Laboratories, 200-A Cement Ave., Sandusky, Ohio.

BUILD Historic ship models, complete kits 39c to \$9.00. Catalog 10c. Ideal Models, 19 West 18th, New York 11, N. Y.

SHIP And yacht model fittings; blueprints. Send 25c for illustrated catalog No. 25—listing hundreds of items. A. J. Fisher, 1002-1 Etowah Ave., Royal Oak, Mich.

READY! Our 1950 catalog of ship model kits and fittings; sail, steam, diesel. Send 25c for catalog. Model Shipways Folio, 60, 476 Main St., Fort Lee, N. J.

BRASS Gears and model supplies for the inventors. Send 10c for catalog. Pierce Model Works, Tinley Park, Ill.

RAILROADERS—50c Gets new Catalog Reference Manual. State O or HO gauge. Walthers, 247 Erie, Milwaukee 2, Wis.

STEAM Locomotives, 1 1/2", 3/4", 1/2", 1/4" scales. Castings, parts, rail, steam fittings! Thorough drawings with instructions. Catalog 35c. Little Engines, Lomita, Calif.

LIONEL Trains catalog 10c. 36 pages illustrated. Hobby Shop, 72 West Washington, Chicago 2, Illinois.

SHIP Models and yacht supplies complete. Large 64 page catalogue 30c. Bill Wild's, 510 East 11 St., New York City 9.

HOME CRAFTSMEN

LEATHERCRAFT Supplies, leather and tools, low prices. Send 10c for catalog. Jonas Handicraft Co., (Dept. M3), 32 Frankfort St., New York 7.

SWISS Music movements, finest make, assorted tunes, \$1.90. Direct imports. Helaxe Company, 233 West 72 Street, New York.

LEATHERCRAFT Tools, supplies. Free catalog. Harte's Craft Shop, Holyoke, Colorado.

90 ALL New, full size lawn ornament and novelty patterns, up to 20" high, \$1.00. 68 popular plans with necessary full size patterns of toys, novelties, furniture, lawn chairs, garden figures, etc., \$1.00. 16 new lawn chairs, 22 picnic tables, benches, trellises, etc. All 38 plans, with necessary full size patterns, \$1.00. Mastercraft 34M, 7041 Olcott, Chicago 31, Ill.

HANDICRAFTERS! World's finest designs, patterns—For pleasure, profit! Exclusive monogram-alphabets for leathercraft, woodcrafts, metalcrafts, textiles. Five monogram sizes, easily traced. Veteran, fraternal, scout organization emblems. \$1.00 complete! Leathercraft designs; 55 projects (belts, billfolds, purses, desk accessories, more!) \$1.00 complete! 45 Leathercraft designs for men, smart personal, desk and den items, only \$1.00! Copper tooling, large, magnificent picture designs plus instructions, \$1.00 complete! All postpaid. Specify items wanted. Savage and Savage, 8844 Sunset, Los Angeles 46, California.

JIGSAW Owners attention! Start earning money at home cutting out wooden novelties and souvenirs. Write H. Cook, 4407 S. Normal Ave., Chicago 9, Ill.

WORKING Model spinning wheel kit, 12 inches high. Wood parts ready for turning. Complete kit, plans, and instructions \$3.50 or plans and instructions \$1.00. Williams Woodcraft, 6408 31st Ave., Kenosha, Wisconsin.

ILLUSTRATED Catalog of burs, cutters, stones, polishing supplies, equipment for working metal, wood or carving plastic 50c, credited first order. Any accessory for handgrinders or flexible shaft. Brass sheet, rod, nickel silver, phosphor bronze, for model makers. Gold, silver, amateur jewelers supplies. Catalog and 48 assorted recut dental drills \$2.00, gross \$4.50 postpaid. Schrader Instrument Company, Independence 1, Iowa.

CACTUS Wood, lamp size sample, 60c postpaid. 214 East Yavapai, Tucson, Arizona.

LUMBER For home craftsmen. Cut to order. Write Forest Products Company, Box 341, Binghamton, New York.

CEDAR, Tennessee, aromatic, dry, dressed 2 sides, 3/4", 15c per bd. ft. Craftsman Cedar Works, Fayetteville, Tennessee.

TUBING, 5" O.D. x 1/4" wall laminated plastic. Up to 9' lengths at 50c linear foot. Textole, Forestdale, Mass.

WALNUT Lumber—Send your requirements. Dry, rough or dressed. Prehn, Bethalto, Illinois.

LEATHER Carving. Fascinating, highly-paid art; age-old secrets now taught for first time in home study course. For hobby, profession or profitable business, write: Baird School of Leather Carving, Box 1367-J, Manitou Springs, Colo.

MAKE Original jewelry — Earring, pin, other findings shipped promptly. Free list. Lambert Sales, Dept. M, 153 E. 26th St., New York 10.

TURN Your workshop into cash. Send dime (refunded first order) for catalog describing hundreds of things to make for fun or profit. Craftplans, 1321-E South Michigan, Chicago 5.

WEATHER-VANE—Sailboat design. Satin, black finished lifetime titanite metal. Swings freely. Adds distinction. Postpaid, \$4.45. Catalog, 25c. Midwest Supply, 1913 W. Vliet, Milwaukee 5, Wis.

REVOLVING Work bench rack — For screws, brads, nails, spacers, buttons, etc. Mounts on bench or wall. Glass containers swing on natural finished wood rack. Ready to assemble. 12 containers, \$2.25; 16, \$2.55; 20, \$2.85, postpaid. Catalog, 25c. Midwest Supply, 1913 W. Vliet, Milwaukee 5, Wis.

CHESS, Checker board kits. Beautiful rare woods, die cut veneer squares, solid moldings. Easy to assemble. Complete instructions. \$4.95 ppd. Industrial Models, 3210 N. Lee St., Philadelphia 34, Penna.

SEA Shells, cut shells, oil colored shells at lowest prices. Free illustrated catalogue showing many new jewelry designs with instructions. Southern Shellcraft Supply, Clearwater, Florida.

FREE Catalog! Unpainted or painted figurines, lamp bases. B. Katon, 7807—21st Ave., Brooklyn 14, N. Y.

CRAFT Catalog free. "Artercraft's Little Giant." 6500 items covering several crafts. "Tops in our field." Artercraft Leather, Dept. PM, 271 12th St., Oakland 7, Calif.

LAWN Ornaments. Ready cut patterns, full size. 20 assorted \$1.00 postpaid. Lincoln Craft Studio, Farmington, Conn.

8 BEAUTIFUL Full-size whatnot patterns 25c. Joannes, P.O. Box 141-M, Omaha 7, Nebr.

80 FULL Sized patterns. Lawn ornaments, toys, novelties \$1.00. Modern Woodcraft, Saginaw, Mich.

BANDSAW, Jigsaw owners, let your machine bring extra profits, fun. Free details. Nu-Art, Dept. B, Box 2235, Boston, Mass.

LEATHERCRAFT—Two link belt, billfold project, instructions. \$2.29 postpaid, craft catalog. Kale Crafts, 2250 Milwaukee, Chicago 47.

LEATHERCRAFT, Copper tooling, textile painting. Materials, tools, supplies. Free illustrated catalog. Kit Kraft, 7377 Melrose, Los Angeles 46, California.

SHELLS, Plastics, findings. Low prices. Free catalog. Frances Jones, Box 251, Sarasota, Fla.

MAKE Gifts from rare and beautiful Oregon myrtlewood, free price list. Myrtlecraft Studio, Grants Pass, Ore.

WHOLESALE Shellcraft Book 15c. Large shellcraft kit \$1.69 postpaid. Shell-Art Novelty, Dept. PM, 5th and Moore, Philadelphia 48, Penna.

SHELLCRAFT—Free catalogue and instructions. Complete line shells. Smooth beautiful colors. Findings. Rice's Shellcraft, Dept. B, 114 S. Court, Orlando, Fla.

Figurines. Send for free list. S. T. Fari-nella, 706 L'Orant, St. Paul, Minnesota.

LEATHER. Retail, mail orders, catalog, tools, lacing, supplies. National Handi-craft Co., 30 Frankfort St., New York City 7.

LEATHERCRAFTERS: Belt kits, pro-jects, leather, supplies. Free catalog. Art Leather, 411 Joseph Ave., Rochester 5, N.Y.

SPECIAL Offer: 80 full size toy, novelty, and lawn ornament patterns only \$1.00 postpaid. Lynds, Box 193D, Medway, Mass.

546 FROM Square foot plywood. Jigsaw necessary. Write, Woodarts, C-38, Bridge-water, Mass.

KNOCKDOWN Cedar chests. Lumber and veneers. Free price list. Giles & Ken-dall Company, Huntsville, Ala.

PROFIT With Larson Leathercraft. Belts, purses, 100 other ideas. Largest sup-ply in U. S. Catalog 10c. Larson, Dept. C, 824 S. Tripp, Chicago 24.

JEWELRY Findings, rhinestones, pearls, sequins, cameos, J & M Novelties, Box 464F, Griffith, Ind.

MAKE IT YOURSELF

\$1.00 WILL Save you \$5.00. "Skotty" shaving lotion concentrate makes a full quart of finest shaving lotion at cost of about \$1.50. Easy directions on bottle. Satis-faction guaranteed. Postpaid, \$1.00. Skotty Products, Box 144 Station C, At-lanta 5, Ga.

STREAMLINED Kitchen plans 50c. Ply-wood Cabinets, 4617 Johnson Avenue, Western Springs, Illinois.

BUILD A guitar player. Leaves both hands free. Information free. Plans \$1.00. Electric, Box K-103, Salmon, Idaho.

BUILD Your own "tractor." Plans, in-structions, Walking, riding, Farming-gar-dening books. Send postcard. Free informa-tion. Ellsworth Tractor Co., D-1, Campton-ville, California.

SAVE 50%-75% Building your Zeolite home water softener. Details 10c. Carson Products Company, Room 202, Minneapolis 18, Minn.

FREE Handbook, build sawmills, block machines, freezers, tractors, scooters, 250 shop, farm, home machines. Nichols Co., Dept. C-501, Purvis, Miss.

WORKBENCH: Rugged, portable, heavy duty, inexpensive. Six, nine and twelve foot or longer. Satisfaction a must. Plans \$1.00. Chester Snuyr, Box 102, Romulus, Michigan.

JUST Off the press—8-page folder illus-trating 6 beautiful, popular lamps you can make; for yourself, for Xmas gifts, or to sell others. It's fun, highly profitable; as hobby, or part or full time basis, 8-page folder, 32-page parts catalog, wholesale price list only 25c; refundable first order. Gearon Company, Dept. 400-B3, 27 South Des-pla, nes, Chicago 6, Ill.

MELT Cast iron with old automobile crankcase oil. Make castings and iron molds for your shop and for profit. Send for free illustrated pamphlet. Ursutz Burner, Box 92-A, Globe, Arizona.

STEAM Cleaner, build your own from our plans. Low cost, easy to build. Steam pressure in 90 seconds. Plans and in-structions only \$1.50. Connery Mfg. Co., Adrian, N. Dakota.

MAKE Perfume from your own house and garden flowers. Complete directions plus bottle of "Parfum Extraordinaire," \$5. J. Gerald Haag, Route One, Punxsu-tawney, Penna.

GRANDFATHER Clock easily built. Big savings. See ad on page 251.

STREAMLINED. Built-in kitchen cabi-nets to fit any kitchen. Illustrated manual describes designing and construction. All for \$1.00. Thombert Company, Newton 10, Iowa.

BUILD Your own concrete blockmaker. Easy. Inexpensive. Motor or hand. Make block per minute. Write, C. Lee, Mountain View, Okla.

SOLAR Water heater systems efficient any locality. Standard materials, low cost. Free facts. Solar Water Company, Box 175, Coral Gables, Florida.

"CONCRETE Block Homes." 32 page booklet on how to build. \$1.00. H. C. Lightfoot, Civil Engineer, Richboro 1, Penna.

PLANS AND BLUEPRINTS

MAKE Own home, farm devices and equipment. Booklet describing plans 25c. Kimo, Box 307J, New York 19.

BEAUTIFUL Genuine zircon rings. Wes-ton, 1414 West 14, Sioux City, Iowa.

ANY Watch cleaned, oiled, repaired in-cluding parts, \$5.00. Satisfaction guaran-teed. Mail watch to Watchrepair, 1211 Commonwealth, Allston, Massachusetts.

WATCHMAKERS. Jewelers, modelmak-ers tools, supplies. Veterans 16 school. Cat-alog free. Stewart's, 727 Market, St. Louis, 1, Mo.

AMERICA'S Only bonded gold buyers will pay you highest prices for old jewel-ry, gold teeth, coins, watches, rings, diamonds, spectacles, silverware, etc. Satis-faction guaranteed. Mail items or write for free shipping container. Lewis Co., Dept. 225, Locust Bldg., St. Louis, Mo.

WATCHMAKERS! Tools, materials, sold, bought. Catalogue! Bengal Company, Cul-ver City, California.

WATCHES Cleaned, repaired. Maximum charge \$4.00. Year guarantee. National Watch Repair, Box 2414R, Cleveland 12, Ohio.

EXPERT Watch repairing. Estimate furn-ished. Established 25 years. Interna-tional Watch, Box 229, Grand Central Sta-tion, New York.

DIAMOND Like zircons; Alexandrites; rubies; others. Fiery sample zircon \$2.00; c.o.d.'s accepted, \$1.00 deposit. Free price list. Imhufex, Box 232, Dept. PM, White Plains, N. Y.

SENSATIONAL Values! Double head electric shavers with \$22.50 price tag af-fixed. Simulated pig skin pouch, \$2.85 each in dozen lots, sample \$4.00. Foun-tain pens \$35.00 gross, sample assortment \$2.00. Rings: men's, ladies' sterling, 14 kt. gold filled, plated, finished, \$1.90 per dozen, up; sample assortment \$5.00. Beau-tiful chronograph wrist watches, expensive looking, \$4.65 each; sample \$5.00. On quantities, send 25¢ with order. Hurry! C & O Sales, P.O. Box 2311, Dallas, Tex.

HIGHEST Prices paid for old gold, sil-ber, platinum, diamonds, watches, gold teeth, spectacles. Cash immediately. Goods returned if offer unsatisfactory. Govern-ment licensed. United Smelting Works. (The Old Reliable), 39-B South State, Chicago 3.

GOLD \$35.00 Ounce—Mail old gold teeth, jewelry, watches, diamonds—receive cash by return mail. Satisfaction guar-anteed. Free information. Dr. Weisberg's Gold Refining Company, 1500-Q Henne-pin, Minneapolis, Minn.

HIGHEST Cash paid for old, broken jewelry, gold teeth, watches, silverware, diamonds, spectacles, platinum. Free in-formation. Satisfaction guaranteed. Govern-ment licensed. Rose Smelting Company, 29-A East Madison, Chicago.

WATCHMAKERS' Journal contains helpful hints on watch repairing. Sample copy 20c. Dean Co., 116-K Nassau St., New York 7, N. Y.

TOBACCO, SMOKERS' SUPPLIES

MAKE Pipes. It's fun, it's profitable. Card brings details. Buildapipe, Dept. PM, Ivoryton, Conn.

FREE Literature. Pipes and pipemakers' supplies. Carvapipe, 2829-A Dixie, Ham-ilton, Ohio.

CIGARETTE Smokers get wise! Save over half. Parker-15, Hoboken, New Jersey.

RAZORS, BLADES, SHARPENING

TO Convince you—20 chrome steel blades, 10c plus stamped envelope. Groote, 159 East 34th, New York 16.

FREE! Ball point pen with 100 super double edge blades at \$1.00. Smoother shaves guaranteed. Peerless Company, 1285 Medford, Topeka, Kansas.

ELECTRIC Shaver repair. Prompt, guaranteed. \$5.00 trade-in allowance also. Electric Shaver Shop, Box 426, Culpeper, Va.

FOR THE HOME

OPENER For cans containing evaporated milk or other liquids. Required for every home. 25c. C & C, P.O. Box 17, W. Lynn, Mass.

NEW Type filter that fits into hot-air register. Easily installed. Keeps atmos-phere dust-free. Ends dirt halo accumulat-ing around registers. Free literature. Mod-ern Metal Products, 169 Clinton St., War-ren, Ohio.

HOW To do your own paperhanging—120 illustrations actually shows how. Send \$1.50. Gilton Books, Box 4638, Philadel-phia 27, Penna.

tricity. Illustrated literature free. Rob-ert Poarch, 1034-A N.E. Russet St., Port-land 11, Oregon.

OF INTEREST TO WOMEN

OUTDOOR Toilets, cesspools, septic tanks cleaned, deodorized with amazing new product. Just mix dry powder with water; pour into toilet. Safe, no poisons. Save digging and pumping costs. Postcard brings free details. Burson Laboratories, Dept. P-44, 955 Willard Ct., Chicago 22, Ill.

SELL Dress fabrics to friends, neigh-bors. Stylish, beautiful materials. Year round profits. No experience needed. Free details. National, 640 Broadway, Dept. M, New York 12.

1000 WAYS To save time, money, labor. Amazing new book "Short-Cuts to Bet-ter Housekeeping." 160 pages packed with ideas every housewife will appreciate. Well illustrated. Only 60c postpaid. Popular Mechanics Press, Dept. SC, 200 E. Ontario St., Chicago 11, Illinois.

FOR SALE—MISCELLANEOUS

EARN More with closeouts. Pricelist free. Metro, 60 South Street, Boston 11, Mass.

WHOLESALE Hosiery. Nylons, rayons, cottons, 8c pair. Complete stock list 25c. Sibert Mills, Chattanooga 4, Tenn.

BARGAINS In Aero-Seal hose clamps. Worm drive for positive clamping. 1/4", 3/8", 1/2", 3/4", 1" sizes, 10c each; 8c in lots of 100 or more. AMC Supply Company, P.O. Box 1440B, Port Worth 1, Texas.

FREE Catalog! Save money. Surplus clothing bargains. N. Y. Clothing Co., New York 29.

DRESSES 18c; Coats \$1.00; blouses 35c. Free catalog. Crown, 164-PA Monroe Street, New York 2.

WAR Surplus, aircraft items. Shop equipment, machinery and a million other items. Send 10c for 64 page catalog. Atlas Equipment, 229 Southwest Blvd., Kansas City 8, Mo.

WANTED—MISCELLANEOUS

WANTED—Scrap mercury (quicksilver), tantalum, bismuth, tungsten. Metallurgi-cal Products Co., Established 1909, 35th and Moore Sts., Phila. 45, Penna.

PERSONAL

BORROW By mail. Loans \$50 to \$300 to employed men and women. Easy, quick. Completely confidential. No endorsers. Re-pay in convenient monthly payments. De-tails free in plain envelope. Give occupa-tion. State Finance Co., 210 State Finance Bldg., Dept. F-14, Des Moines 8, Iowa.

N. Y. Postmark. Letters 25c each. S. Douglas, 175 Mapes Ave., Newark, N. J.

STOP Forgetting! Win friends! Win pro-motion! Write Harrison Books, 726E North Fifteenth, Waco, Texas.

MEXICAN Mailing service. Your letters remailed, received 20c. Mystify friends. Photographic postcards 10c. Tillotson. Apartado 1405, Guadalajara, Jalisco, Mex.

HAPPY At work? Learn tested job-get-ting technique. Details free. Excelsior Service, 1330 January, St. Louis 10, Mo.

REVOLUTIONARY Hearing device. No battery, no wires. Just a simple ear plug that carries sound to the ear drum. Beaudry, 4337-H 30th Avenue South, Min-neapolis 6, Minn.

"DUSFIL," Washable home hot air fil-ter, helps safeguard health, winter, sum-mer. Less housework, too! \$1.00 postpaid. Satisfaction guaranteed or money back! (Descriptive literature free.) Micamp, 8629 Crispin, Philadelphia 36, Penna.

HAIR Today, gone tomorrow, \$10.00 worth hair raising facts for only 25c to Hair Foundation, Glen Ellyn, Illinois.

LOANS By mail, \$50 to \$300. Quick, easy, confidential to employed men and women. No endorsers. Easy monthly pay-ments. Write for free information sent in plain envelope. Postal Finance Co., Dept. 45, Sioux City, Iowa.

MEXICAN Law. General Practice At-torney. 1203 Arizona Street, El Paso, Tex.

"HOW Can I find out?" You can! In-formation discreetly developed. Any mat-ter, person, problem, anywhere. World-wide. Officially licensed, bonded service. Established 1922. Reasonable. Confidential. William Herman, 170 Broadway, New York.

PENMANSHIP Corrector! Improves your penmanship in 3 hours. Proof free. Ozment 9, St. Louis, Mo.

MISCELLANEOUS

"WATERLESS (Lanolin) Hand Cleaner." (Oil base.) Make, sell. No machinery. Build profitable business. Complete formula \$1.00. Ideal Service, Park Ridge 3, Ill.

STOP Forgetting! Win Friends! Win promotion! Write Harrison Books, 726E North Fifteenth, Waco, Texas.

ELECTRIC Shavers repaired. One day service. Trade-in allowance. Accessories. Shoppers Shaver Service, 425 State, Madison 3, Wisconsin.

SAVE—Make money, buy everything wholesale. Free information. Orysten, 1147 Sunkist, Waukesha, Wisconsin.

SMALL Mailing cartons, shipping labels, postal scales. List. Fountainhead, 1049 Bluff Street, Beloit, Wisconsin.

ALASKA Highway offers thousands jobs-opportunities. Complete information 15,000 fact-packed words. Postpaid \$1.00 cash. Guide, Box 142, North Battleford, Canada.

"INTERESTING Mails" — 25c keeps name on mailing list three months. Bentz, Jr., Desk-A/97, Chatawa, Miss.

NEW—Four color pencil. Writes four different colors red, green, blue, black. Finger tip control switches any one of its colors into writing position instantly. Handy and makes writing a pleasure. Order yours today, \$2.95 postpaid. Dowling Company, Ozark, Alabama.

100 MARKETS for handicrafts. Leather, wood, metal, crochet, novelties, etc. Big buyer's bulletin \$1.00. Research, 2409 12th Ave., Los Angeles 16, Calif.

MILLION Articles wholesale. Supply source directory 10c. Publisher's, Box 1302, Detroit 31.

SENSATIONAL New line of Geiger counters for uranium detection. All types, all prices. No finer selection. Also new gold, silver and mineral detector available. Complete information free. Detectron Co., 5637 Cahuenga, Dept. B-3, North Hollywood, California.

ELECTRIC Pencil—Engraves all metals. \$2.95. Reb Industries, Elmhurst, Illinois.

YOUR Leather jacket renovated by our craftsmen expertly, reasonably. Request free descriptive circular No. 8. Berlew Mfg. Co., Freeport, N. Y.

MEN! Large size shoes, large size socks! We specialize in large sizes 10 to 16, widths AAA-EEE. Dress, sport, work shoes. Guaranteed. Write for free catalog. King-Size, 321, Brockton, Mass.

NAME Plates, 40 Engrem. Rutland, Vermont. Brass, chrome, plastic. List.

BARGAINS In foam rubber, flat or cored stock. We have special prices on U.S. Koylon foam rubber in bulk. Re-upholster seats, furniture and automobiles. AMC Supply Company, P.O. Box 1440B, Fort Worth 1, Texas.

BUY Wholesale and save! Plumbing, heating, roofing, building supplies, tools, paints, etc. Rush 25c for price lists, catalogs, samples, other details. Dept. E. "Handy Man Wholesale Buying Plan," 1009 E. Cheltenham Avenue, Philadelphia 44, Penna.

SAVE Money on paint brushes. Buy direct. Postcard brings descriptions and prices. Kenmore Brushes, P.O. Box 53, Kenmore, N. Y.

ROC-WOOD Handsome hardwood flooring laid with trowel! Sand, varnish. Fire-waterproof. Home, basement, garage, shop. Inexpensive. Roc-Wood, 333 North Michigan Ave., Chicago 1, Illinois.

\$600 BUILDS Cozy home, 4 room concrete block. Step-by-step instructions and blueprint, \$1.00. L. H. Farrow, G83, Box 645, Columbus 16, Ohio.

CARD Players—3 decks with name or initials \$2.00. Edro Card Co., 2850 Tuckahoe Road, Camden 4, New Jersey.

IMPROVED Hybrid popcorn, 4 lbs. \$1.00 p.p. Lee Fell, Riverton, Iowa.

FREE—Amazing new book, "How to Answer Ads." Never before have you seen anything like this. Tells you in simple language the correct way to answer ads. Gets you quicker replies—better results, and greater satisfaction. Will save you time and money and it's absolutely free. No obligation whatever. Every reader of advertising should have this booklet. Send a postcard for your copy now. F. W. Johnson, (Room 600), 200 East Ontario Street, Chicago 11, Ill.

TRADE Neckties. Mail 6 neckties you are tired of for 6 different handsomely cleaned ties like new. Pay postman \$1.00. Tietown, Box 5463-M, Chicago 80.

SENSATIONAL! Become a mental superman overnight! Floor everybody! Order "Memoprop!" \$1.00. Bijou, Box 1727, Hollywood 28, California.

INSTRUCTIONS For building Radio Treasure Finder, \$1.00. Wyss, 104 1/2 Francis, St. Joseph, Mo.

PANNING Gold—Beginners booklet 36 pages; catalogue, supplies, mining books, maps "where to go." 25c. Old Prospector, B-305 Dutch Flat, Calif.

IF You want to earn \$200 month, inventing toys, games, gadgets, write, Hendrickson, Argyle 1-A, Wisconsin.

SPANISH Souvenirs, magazines, postcards. Catalog free. Cicerone, Hortaleza 27, Madrid, Spain.

URANIUM Prospecting equipment. New, improved Geiger counters, \$48.50 to \$125. Scintilliscopes \$5.95. Mineralights from \$12.50. Complete with accessories and radioactive specimens. Prepaid. Improved metal detectors for gold and silver, from \$128.50. Western Radiation Laboratory, 1107 West 24th Street, Los Angeles 7, Calif.

YOUR Own sign. Weatherproof, 3 inch letters, two lines, maximum fifteen letters each, \$2.95. Print copy. Darby, West Pittston, Pennsylvania.

TREASURE-Mineral locators — Geiger counters M-scope type for arctic-tropic use. Unsurpassed in efficiency. Factory guarantee. Lowest prices. Can be purchased on monthly payment plan. Free literature. Fisher Research Lab., Inc., Palo Alto, Calif.

SQUARE Dance instructions. Calls, 25 sets, \$1.00. Rayburne, Eureka Springs, Arkansas.

PERSONAL Stationery, 50 double sheets of paper, 50 envelopes, name and address neatly printed in beautiful plastic relief \$1.00 postpaid, money refunded if not satisfactory. Craftway Press, Box 149-M, Chicago 90.

DUCTS, Pipes, fittings for installing your own heating system. Catalog. Metal Products, Antioch, Illinois.

LUMINOUS Reflective paints glow day and night in technicolor! New angle money-maker. Assorted color samples 25c. Research, 1842-PM Byron, Chicago 13.

BEAUTIFUL Colored granite memorials. Delivered. Guaranteed. Direct from factory. Agents wanted. Box 191, St. Cloud, Minnesota.

GEIGER Counter plans plus prospecting manual \$1.00. Satisfaction or refund. Box 486, Detroit 31, Michigan.

TREASURE, Mineral locators. Goldak now offers treasure locators for \$75.00. Geiger counters reduced to \$95.00. Write the Goldak Co., 1542 West Glenoaks Blvd., Glendale 1, Calif.

VERMONT Maple syrup and sugar, 100% pure, list. H. Marshall, Poultney, Vt.

SQUARE Dance instructions, 40 dances, \$1.00. Wesley Rader, 1922 Grant, Denver, Colorado.

"RECEIVE Mail," Moneymaking offers, opportunities, catalogs. Name listed 10c. Ideal Service, Park Ridge 10, Ill.

70 BIBLE Lessons, 25c. Bulletin, Box 87, Cathedral Station, New York 25.

TATTOOING Outfits, supplies. Illustrated list free. Zeis, 728 Lesley, Rockford, Illinois.

TATTOOING Machines, outfits. Free catalogue. Jensen, 120 West 83rd Street, Los Angeles 3.

ENGINEERING DEGREE IN 27 MONTHS

Big Demand for Graduates
Aeronautical, Chemical, Civil, Electrical, Mechanical and Radio Engineering (including Television)

Hundreds of young men are earning engineering degrees in this recognized institution each year—continuous operation. New terms start quarterly. Many students earn a major part of their college expenses in this large industrial center.

Low tuition. Competent instruction. Thorough intense practical program. Modern laboratory facilities including new physics lab. and modernized wind tunnel. Individualized instruction emphasized.

Approved for Veterans. Engineering preparatory courses. Students from 48 states and 21 foreign countries. Enter March, June, September or December. Send coupon for free catalog and full information. Enroll now.

— SEND COUPON TODAY —

INDIANA TECHNICAL COLLEGE
530 E. Washington Boulevard
Fort Wayne 2, Indiana

Please send me free information on B.S. Engineering Degree in 27 months as checked.

Aeronautical, Chemical, Civil, Electrical,
 Mechanical, Radio-Television.

Name _____

Address _____

SAY YOU SAW IT IN POPULAR MECHANICS

Freeland METAL BOATS

Rugged, low up-keep boats that feature electronic seam weld; spray rails, styrofoam safety floats; removable flooring. 12 and 14 ft. lengths.

Models from \$65.00. Write Dept. 73 for folder, prices.

GALVANIZED STAINLESS STEEL

FREELAND SONS CO. Sturgis, Mich.

BARBELLS

Save Money—Buy the finest barbell equipment direct from our foundry—No other company can match our low price or value!

Send to-day for our FREE Barbell Catalog

BUR BARBELL CO.
Lyndhurst 15, New Jersey

GEIGER COUNTERS

FOR LOCATING URANIUM

and all radioactive ores. OSSCO Geiger counters are in use throughout United States, Canada, Alaska and other countries. Use an OSSCO Geiger counter on your next field trip. Write Dept. Y for details and prices.

OMAHA SCIENTIFIC SUPPLY CO.
3601 N. 24TH ST. - OMAHA 10, NEBR.

YOU CAN'T LOSE!

HAVE A PROFIT MAKING BUSINESS OF YOUR OWN

NATIONALLY ADVERTISED PRODUCTS

NO EXPERIENCE NECESSARY

NO MONEY TO INVEST

FREE SAMPLE OUTFITS

FULL OR PART TIME

A LIFETIME FUTURE

Man or woman—young or old, YOU can earn a steady income in full or spare time as an independent Kendex dealer. Amazing and almost "impossible" earnings can become a reality for you. Herbert Armstrong of Tenn. earned \$202 in 9 days. C. O. Watkins of Oregon sent 92 orders in one day. You have the same opportunity to duplicate these exceptional earnings. Over one million dollars will be earned in 1950 by Kendex dealers—why not let us establish you in your own business and get a share of these wonderful earnings?

KENDEX NYLONS REPLACED FREE . . .

if they run or snag within guarantee period up to three months! Impossible? It's true! No matter what the cause—hard use or deliberate abuse—whether it is fault of the hose or the wearer—Kendex nylons are replaced FREE if they run, snag or become unfit for wear within the guarantee period. How could any woman resist a positive guarantee of satisfaction when she can obtain it without paying any more than other standard advertised brands? Kendex nylons are NOT sold in stores, so you have no competition. Complete line includes everything from heavy 70 denier service weight to gossamer luxurious ultra sheer 15 denier 60 gauge. Proportioned sizes and lengths. Latest colors plus white.

LINGERIE - ROBES - HOUSECOATS - MEN'S HOSE

In addition to the sensational Kendex nylons, you will have a complete line of glamorous lingerie, beautiful robes and housecoats plus a complete line of Kencraft mens' hosiery guaranteed for one full year. Any pair or pairs of men's hose that does not give satisfactory wear within one year of purchase will be replaced FREE!

NATIONALLY ADVERTISED

Kendex will spend over \$350,000.00 in 1950 to tell millions of readers of the advantages in buying from you. Almost every issue of Good Housekeeping, Saturday Evening Post, McCall's, Women's Home Companion and Ladies' Home Journal carry our advertising in addition to many others. Kendex has advertised in Life, Look, Collier's, etc. Awarded Good Housekeeping Seal. Thousands of orders are shipped daily, from coast to coast.

EVERYTHING GIVEN FREE

Risk nothing! Mail coupon and we will send you, free and prepaid, complete money-making outfits including sample nylon stocking, samples of lingerie, robes, housecoats and men's hose fabrics and everything you need to immediately start making money. Complete outfits become your property even if you don't send any business. Simply write orders, we deliver and collect. Advance cash plus huge bonus. No money or experience needed. Mailing the coupon is all you need to start on the road to a 52-weeks-of-the-year high paying business of your own. You have everything to gain and nothing to lose.

FREE NYLON STOCKING

KENDEX COMPANY, BABYLON, 546, N.Y.



FOUR MONEY-MAKING LINES

- WOMEN'S NYLON HOSIERY
- GLAMOROUS LINGERIE
- HOUSECOATS - ROBES
- MEN'S HOSIERY

MAIL TODAY

NOTHING TO PAY

NO OBLIGATION

KENDEX COMPANY
BABYLON 546, N.Y.

Date _____ 1950

Send me, free and prepaid, everything I need to make money as a Kendex dealer, including sample stocking etc. There is nothing for me to pay now or later and I am under no obligation in accepting your money-making outfits.

Name _____

Address _____

City _____ State _____

BE A CLERK all my life? NOT ME!!



Of course you say you won't. But you may be unless you do something about it.

Hoping and wishing won't get you a better job and more money.

You must prepare for that step ahead—be ready to make promotion come.

We have helped thousands of ambitious men and women get ahead in the business world—perhaps we can help you.

At least you should investigate. It may be the turning point in your life to a better job and more money. So send the coupon without delay. Check the field of your choice and we'll send you without obligation the requirements and opportunities in that field—plus "Ten Years' Promotion in One"—a book which has helped many men.

LASALLE Extension University A Correspondence Institution

417 S. Dearborn St., Dept. 364-R, Chicago 5, Ill.

I want to know whether you can help me get ahead in the field I have checked below. Send free 48-page booklet and full information about your home-study training—plus "Ten Years' Promotion in One."

- | | |
|--|---|
| <input type="checkbox"/> Higher Accountancy | <input type="checkbox"/> Salesmanship |
| <input type="checkbox"/> C.P.A. Coaching | <input type="checkbox"/> Traffic Management |
| <input type="checkbox"/> Bookkeeping | <input type="checkbox"/> Foremanship |
| <input type="checkbox"/> Law: LL.B. Degree | <input type="checkbox"/> Industrial Management |
| <input type="checkbox"/> Business Management | <input type="checkbox"/> Stenotypy
(Machine Shorthand) |

Name..... Age.....
Address.....
City..... Zone..... State.....

New Advertising Machine

Prints & Illustrates 1¢ Post Cards

FREE Learn how thousands of business men, in every line, are boosting sales in spite of conditions—with 1¢ messages—printed and illustrated in a few minutes on gov't post cards—with amazing new patented **CARDMASTER**. Your "today's" ideas, read by your prospects next morning. Not a toy, but a sturdy advertising machine, built to last for years. Low price, sold direct. Guaranteed for five years. Send name today.

SEND NAME We'll send **FREE** illustrated book of money-making **IDEAS** for your business and complete, unique advertising plans. **RUSH YOUR NAME TODAY.**

CARDMASTER COMPANY
1920 SUNNYSIDE, Dept. 133, CHICAGO 40, ILL.

\$169 in 1 Week!

P. Zuccaro earned it showing amazing new pocket-sized fire extinguisher. You can make good money too!



Zuccaro is just one of many men "cleaning up" with amazing new kind of fire extinguisher. "Presto" is about the size of a flashlight! Yet does job of bulky extinguishers that cost 4 times as much, are 8 times as heavy. Contains new war-discovered chemical 1.5 to 6 times more effective. **Guaranteed for 20 years!** Sells for only \$3.98. Can earn you good money too. Just show it to people who have homes, cars, boats, etc. Write for **FREE DETAILS**. No obligation.

Science's New Midget "Miracle" "PRESTO"
MERLITE INDUSTRIES, Dept. 53,
201 East 16th St., New York 3
(If you want demonstration sample too send \$2.50. Money back if you wish.)

Is Your Life Crowned With Success?

LEXIPOWER



WE THINK IN WORDS. THOUGHT IS POWER. Let this New Science show you how to win with **WORDS**—financially, socially, culturally. Develop a **MASTERFUL VOCABULARY**. Influence others. Improve your personality, manifest your latent ability. You are judged and rated by every sentence you utter. Start using the **POWER of LEXIPOWER** after the first Lesson. Write **NOW** for **FREE** details about **LEXIPOWER**. Dime-a-Day **LESSON CLUB**.

LEXIPOWER LESSON CLUB
517-M W. Deming Place Chicago 14, Illinois



ITALIAN ACCORDIONS

Hand Made. Very Best. Buy Direct from Factory Representative at lowest wholesale prices and Save Money. Send Name and Address for **FREE** catalog.

ITALIAN ACCORDION MFG. CO.
7600 Cottage Grove Ave., Dept. PM-3, Chicago 19, Ill.

AMAZING NEW CHEMICAL MAKES

OLD BUMPERS LIKE NEW!

Not a Paint! Not a Polish! Looks like expensive chrome plating! Wonderful new chemical puts chrome-like finish on car bumpers, door handles, trim, etc. No electricity—no plating tanks—no acids needed. Just smooth it on and watch it gleam! Takes a brilliant polish **JUST LIKE CHROME**—so simple a child can do it. **REFINISH BUMPER IN 10 MINUTES!** WORKS LIKE MAGIC—finish lasts for years. Increases resale value of your car and adds NEW beauty to other chrome plated or metal items. **TRY AT OUR RISK! SEND NO MONEY!** Just send name and address. Pay postman amazing low price of \$1.00 plus few cents postage for each kit ordered, or send cash and we pay postage. Try kit 10 days. If not delighted return for instant refund! **BUMPER RE-NU, Rm. 2, Box 147, Hamtramck, Mich.**

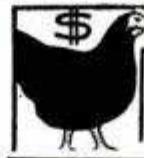

AJAX AUSTRALORPS

SENSATIONAL WORLD CHAMPION LAYERS
Mature fast. Excellent roasters-capons. Massive size. U.S. Approved-Pullorum Controlled. Low farm prices. **PROFIT SHARING PLAN.** Catalog **FREE.** Write today.
AJAX HATCHERY, Box 914, QUINCY, ILLINOIS

NEW HOT ROD CATALOG!!

Get Yours Now!! A Complete Catalog of **SPEED EQUIPMENT & SPECIAL PARTS** by such leading manufacturers as Offenhauser, Edelbrock, Winfield, Stewart-Warner & many others.
DON'T MISS THIS MONEY SAVER! — Only 25¢
DOUGLASS MUFFLER MFG. CO., DEPT. M-3
1916 WEST VALLEY BLVD. ALHAMBRA, CALIF.

BUILD YOUR FUTURE IN WATCHMAKING and JEWELRY

Avoid dime-a-dozen trades—learn Watchmaking, today's top mechanical profession, at the world's largest and best equipped school of its kind. Work for established jewelers or build your own business. Veteran-training approved courses are offered in watch, clock, chronograph and jewelry repair and engraving. Enroll any time, day or evening classes. Send now for free 116-page illustrated information packet.



**WESTERN PENNSYLVANIA
HOROLOGICAL INSTITUTE**
DESK 40, 706 SMITHFIELD ST., PITTSBURGH 22, PA.
World's Largest Watchmaking School

ARGYLE Scooter Cub

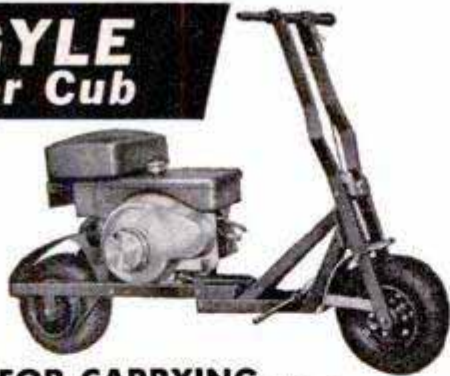

**FOLDS FOR CARRYING . . .
UNFOLDS FOR RIDING . . . in 15 seconds!**

Carry it anywhere — in your car, boat, plane or trailer. Amazingly compact — 15" x 18½" x 24". Weighs only 50 lbs.

400 LB. CAPACITY! Will carry 2 heavy people. Sturdy steel frame . . . ruggedly built throughout.

100 MILES PER GAL. for highest transportation economy. Speed up to 30 mph. Powerful 2 cycle Power Products engine.

AUTOMATIC CLUTCH . . . positive brake . . . comfortable 3" sponge rubber seat.

WRITE FOR LOW PRICE. Dealer inquiries invited.

ARGYLE MANUFACTURING CO. COLCHESTER, ILLINOIS

LEARN TO MOUNT BIRDS



ANIMALS, FISH, PETS

Be a Taxidermist. Save your hunting TROPHIES. Have a fine home-museum. Hunters, save and MOUNT your beautiful DUCKS, QUAIL, DEER, TAN skins, FURS, Great Fun. Spare-time PROFITS. **FREE BOOK** Tells ALL about it. 100 fine wild-game pictures, 48 pages. SEND TODAY, don't delay. Get this WONDERFUL FREE BOOK, MEN AND BOYS. Learn Taxidermy. Double your hunting pleasure. Rush letter or POSTAL today. STATE YOUR AGE. N. W. SCHOOL OF TAXIDERMISTRY, Dept. 2563, Omaha, Neb.

REAL ESTATE BE A BROKER

PAYS BIG! SEND FOR FREE, BIG, ILLUSTRATED CATALOG NOW! No obligation. Graduates report making substantial incomes. Start and run your own business quickly. Men, women of all ages, learn easily. Course covers Sales, Property Management, Appraising, Loans, Mortgages, and related subjects. **STUDY AT HOME** or in our classrooms in big cities. Diploma awarded. G. I. approved. Nationally known.

WEAVER SCHOOL OF REAL ESTATE (Est. 1936)
15 E. Pershing Road, Dept. PMB, Kansas City, Mo.

**GUARANTEED
USED-REBUILT**

HARLEY-DAVIDSONS

ALL MODELS - LOW PRICES

Parts, accessories, oil, tires, service by experts.

Parts for obsolete models.

Send 25c for Accessory & Motorcycle Bulletin.

KNUTH'S 2491 W. FOND DU LAC AVE.
MILWAUKEE 6, WIS.



BIG FREE CATALOG

of WAR SURPLUS

OPTICAL BARGAINS

Build Your Own RIFLESCOPE, BINOCULARS, TELESCOPES, ETC.

We Furnish Optics and Instructions

• LENSES, PRISMS & RETICLES

Send \$1.00 for Stock #2-H
10-Piece Lens Kit and Big
Instruction Booklet.

• EYEPIECES and OBJECTIVES

We Have Numerous Types of Assembled Optical Instruments Including BINOCULARS and RIFLESCOPES.

CHECK OUR BARGAINS . . . Request CATALOG H

EDMUND SALVAGE COMPANY

BARRINGTON, NEW JERSEY

FACTORY-TO-YOU MIDWEST RADIO and TELEVISION



**EASY
TERMS**

30 DAYS TRIAL

**NEW
GIANT
16"
PICTURE
TUBE**

**MIDWEST Model CX-26
A Complete 16-Inch
TELEVISION Chassis**

Here is Television at its best! . . . brought to you by Midwest, the world's oldest and largest Exclusive Factory-To-You radio and television manufacturer. For 1950 Midwest offers a complete line of Television Consoles and complete, ready-to-operate chassis (not kits) featuring the new giant 16-inch tube, clear, steady pictures, synchronized sound and pictures that a child can tune perfectly. Buy your Television direct from Midwest at Low Factory Prices, on Long EASY TERMS and 30 DAYS TRIAL. Send coupon for FREE 32-page, 4-color catalog TODAY.



... Also a Complete New 1950 Line of
**MIDWEST
RADIOS**
with new long distance
FM Circuit and new
3-Speed Phonograph.

Write for FREE 32-Page, 4-Color Catalog
or Paste This Coupon on 1c Post Card

Midwest Radio & Television Corp.
Dept. X258, 909 Broadway, Cincinnati 2, Ohio
Please send me your new FREE 1950 Midwest Catalog

Name _____
Address _____
City _____ Zone _____ State _____

Learn A Trade NOW! PRACTICAL SHOP TRAINING!

In Our Chicago Shops

- | | |
|---|--|
| <input type="checkbox"/> AUTO MECHANICS | <input type="checkbox"/> WELDING—ARC and GAS |
| <input type="checkbox"/> DIESEL MECHANICS | <input type="checkbox"/> MACHINIST |
| <input type="checkbox"/> REFRIGERATION | <input type="checkbox"/> PIANO TUNING |
| <input type="checkbox"/> BODY-FENDER | |

Above Approved For G. I.'s and Civilians
One of America's Leading Practical Schools
7 Floors of Fully Equipped Shops
Over 48,000 Successful Graduates
Expert Individual Instruction
Learn by Doing—Low Living Expense
Established 1902—Day and Evening Classes

Also the following Home Study Courses

- | | | |
|----------------------------------|--|---------------------------------|
| <input type="checkbox"/> PLASTIC | <input type="checkbox"/> REFRIGERATION | <input type="checkbox"/> DIESEL |
|----------------------------------|--|---------------------------------|

— CALL IN PERSON OR MAIL THIS AD TO —

GREER SHOP TRAINING

(Desk 10) 460 South State St., Chicago 5, Ill.

Please send without obligation free information regarding trade checked above. (Specify whether you are a Veteran or Civilian)

Name _____ Age _____
Address _____
City _____ State _____

Say You Saw It in Popular Mechanics

Can a Man MY Age Become a

HOTEL EXECUTIVE

Even Though He Has No Previous Hotel Experience?

Would you like to step into a well-paid position as Hotel, Club, Restaurant or Inn Manager, Purchasing Agent, Social Director or Assistant Manager? Would you like to look forward happily to the future? The success of Lewis graduates from 18 to 50 PROVES you can — though you have no experience in hotel work.



**Clyde B. Corley, Veteran,
Without Hotel Experience,
Wins Ass't Manager's Position.**
"After my release from the Air Force, I enrolled for Lewis Training. Now Assistant Manager of this Club, my position is fascinating as well as lucrative. The people with whom I am associated are of the finest calibre. My salary is more than \$400. a month, and I've been in this work less than a year! All thanks to Lewis Training."

Step Into a Well-Paid Hotel Position FREE Book Gives Fascinating Facts

Our FREE Book, "Your Big Opportunity," explains how you can qualify for a well-paid position at home, in leisure time; tells how you are registered FREE of extra cost in the Lewis National Placement Service. Most important, it shows how you can be a Lewis Certified Employee—certified to "make good" when placed in a position. Mail the coupon NOW!

Course Approved for Veterans' Training

LEWIS HOTEL TRAINING SCHOOL
Room SC-324, Washington 7, D. C.

34th SUCCESSFUL
YEAR

Send me the Free Book, "Your Big Opportunity," without obligation. I wish to know how to qualify for a well-paid position at home, in my leisure time.

Name _____

Address _____

City _____ Zone _____ State _____

Check here if eligible under G.I. Bill of Rights.

**World's Greatest
BINOCULAR
VALUES**

- BRAND NEW.
- GERMAN ENGINEERED.
- IMPROVED POST WAR MODELS.

Each instrument precision built to rigid military specifications. Buy direct at lowest unheard of prices! Example: Model 7x35 - \$155.00 Value, Fully Guaranteed. Importer-to-you Only \$49.50!

Send for FREE CATALOG and
Free Book "How To Select Binoculars"

BUSHNELL IMPORTERS Dept.-M3, 43 E. Green, Pasadena 1, Calif.

Learn ACCOUNTING BOOKKEEPING

This nationally renowned school has demand for graduates in good salary positions thru National-wide recognition and placement service. Write Department PMJ today for Big 32 **FREE** page Success Book to be sent to you

**Hills BUSINESS UNIVERSITY AND
EXTENSION SCHOOL**
619 W. MAIN ST. OKLAHOMA CITY 2, OKLAHOMA



How Many Men Will Wear this SAMPLE SUIT

and Make up to \$15.00 in a Day?
Amazing plan! Wear sample suit and take orders for handsome made-to-measure tailoring from friends, neighbors. Just take a few orders—earn big cash profits and get your own suits **Without 1c Extra Cost!** Send no money; pay no money. Write for free outfit containing actual samples, styles, full instructions. Write now! J. C. FIELD & SON, INC., Dept. C-1716 Harrison & Throop Sts., CHICAGO 7, ILL.

MAKE BIG MONEY

Become An Artist!

CASH IN ON BIG ART MARKET!
LEARN Cartooning, Commercial Art, Lettering, Showcard Writing, Photo Coloring, etc., QUICKLY with our NEW, EASY METHODS.

Interesting Catalog **FREE**
NATIONAL ARTISTS BUREAU
Dept. A Box 4248 Dallas 8, Texas



AUTO WASHER

Your car sparkling clean—in a jiffy—magic "sponge" cleaning-cloth. Simply glide over car. PRESTO! Dust, grease, dirt, and grime disappear in a jiffy. Leaves finish clear, lustrous. Autos gleam like a mirror.

SAMPLES for AGENTS

Sample offer sent immediately to all who send name at once. Penny postal will do. Send no money—JUST YOUR NAME.
KRISTEE CO., 695 Bar St., Akron, Ohio

SHOE REPAIR OFFERS BIG INCOME LEARN IN 12 WEEKS TIME



You can own your own shop or earn big income as skilled shoe repairman. Growing demand everywhere at top wages for men who know how. We teach you quickly by actually working on shoes and modern machines. School open to all from 18 to 60 years of age. FREE BIG 20 PAGE BOOK explains everything. Send for your copy today. Chicago & Los Angeles schools only approved for Vets.

MODERN SHOE REBUILDING SCHOOL
Established 1927
2937 Belmont Ave., Chicago. 361-12th St., Oakland, Calif.
806 So. Figueroa St., Los Angeles 14, Calif.

STOPS THIEVES AMAZING WAY



FOR CARS
•
HOMES
•
FARM
BUILDINGS



A South Dakota manufacturer has discovered an easy way to protect cars, homes, farm buildings from Burglars, sneak and chicken thieves. The manufacturer is so sold on his sensational DEVIL DOG Burglar Alarm that he is willing to let you try it for ten days and will offer you \$1.00 for testing it. New sales plan promises big money to hustlers. Be first to get your DEVIL DOG Burglar Alarm for introducing in your territory. CASH-IN on the tremendous demand this device will create. Shipped prepaid from factory on ten year guarantee. Rush name and address for details to

NORTHWEST ELECTRIC CO., Dept. 110 C, Pukwana, S. Dak.

Now CHEAP OIL BURNER FOR HEATING AND COOKING STOVES • FURNACES

HEAT YOUR HOME, COOK YOUR MEALS
WITH CHEAP FURNACE OIL

NO MORE SHOVELING COAL OR ASHES. Sensational Fuelizer Starter Vaporizing System turns Cheap No. 1 Furnace Oil, also Range, Heater, Tractor Distillate, Kerosene and like oils into oil heat—one of the quickest, hottest fires known. LIFETIME GUARANTEE. \$1.00 Bonus Offer for Testing. We will let you try it in your own stove or furnace for one month. Get yours for introducing. Big profits QUICK. Be first. Send in your name today for details and cash in on the tremendous demand for this Amazing Invention.

NORTHWEST MFG. CO., 730-C, Mitchell, S. Dak.

REMEMBER, IT'S DANGEROUS

to pay less if you want safe, balanced matched tires. WE REPEAT—Consider your family's safety, not just PRICE. You see our adv. every month. Positively not recaps. We serve ambulances, fire trucks, school buses, trucks and cars. "Out-of-town folks" buy now and take 10% discount.

GOOD YEAR **Firestone**
Goodrich **U. S. ROYAL**

and others. Original good tread. Slightly worn. Extra fine traction

FREE TUBE WITH EACH TIRE	20 MONTHS GOLDEN RULE GUARANTEE BOND			
	These are genuine "Many Purpose" "AAA" Tires Read that top line again! You'll save MORE than \$.			
600-16 \$5.35	650-16 \$5.45	700-15 \$5.55	475-19 \$5.95	
600-16(6) 6.50	700-17 9.99	650-15 5.45	525-18 5.95	
700-16 6.85	750-16 7.95	550-17 6.90	550-16 5.85	
America's great Lo-Price Value 10 MONTHS GUAR. Limited Supply				
600-16 \$3.65	650-16 \$3.85	700-16 \$5.50	650-15 \$3.95	
	700-15 3.95	750-16 6.50	550-17 5.85	
LO-PRICE TRUCK TIRES 10 MONTHS GUARANTEE				
32x6(8) \$8.95	750-20(10) \$9.25	1100-20 \$13.95	900-20 11.95	
32x6(10) 10.95	825-20 11.25	700-20 9.25	1000-20 12.95	
SUPERCUSHION TIRES (24 lb. air) to fit your present wheels				
670-15(650-15) \$6.25	760-15(650-15) \$7.45	670-16(600-16) \$6.66		
710-15(650-15) 6.85	820-15(700-15) 6.25	760-16(650-16) 7.50		

WE ARE TRUCK-TIRE EXPERTS Matched Tires, the world over, depend on us to keep their trucks rolling ON TIME. A few ¢ more means 1000's of extra miles. 6-8-10-12-14-16 ply. "Many Purpose" "AAAA" Grade

GOLDEN RULE 20 MONTHS REPLACEMENT GUARANTEE BOND			
600-20 \$9.95	32x6(8) \$10.70	900-20 \$15.55	1000-22 \$17.25
650-20 9.59	32x6(10) 13.33	1000-20 16.65	1100-22 18.45
700-20 10.85	34x7 12.75	1100-20 17.77	1100-24 19.99
750-20 10.50	825-20 15.95	750-15 11.45	700-17 13.00

MILITARY "AAAA" Guar. 20 Mos. (Supers 10 Mos.)	
900-16 SUPER QUALITY . . . \$8.60	750-20 SUPER QUALITY . . . \$8.95
900-16 AAAA 10.90	750-20 AAAA . . . \$12.95
Fits 750-16 Wheels also Fits 650-20, 700-20, 32-6, 34-7	
750-20 Military Rugged Deluxe Guar. 30 Months \$16	

BLATT GIRARD & LANCASTER AVES., Dept. PM
BLATT BLDG., PHILADELPHIA 31, PA.
Send ck. or money order and this ad. for rush shipment. We won't ship a tire we wouldn't use ourselves. Instant shipment down South, far West and the world over. The name to trust in rubber.



Week-End Painting is Fun!

NEW, QUICK, EASY WAY TO ENJOY
AMERICA'S FAST-GROWING HOBBY

People Who Never Dreamed
They Had Any Talent Are
Now Painting Good Pictures
—Thanks to This New Guide



NEW guide to OIL PAINTING makes it easy to paint landscapes, trees, shadows, sunlight, reflections on water, etc. Amaze your friends with your artistic ability. Create lovely gifts. Decorate your home with your own paintings. Thousands of readers of the new book, "Week-End Painter" are doing it already—business men, professional people, office workers, craftsmen, technicians, etc. Many of them even make extra money from their new hobby, by letting local stores display and sell their work.

No Previous Training Needed
"Week-End Painter" was written by a businessman who took up painting as a hobby years ago, Laurence V. Burton. The author has questioned many famous artists about their secret methods. He has experimented with hundreds of different brushes, paints, canvases, easels—painted hundreds of landscapes. His book is packed with all his accumulated wisdom. It's written especially for people "starting from scratch." No previous training of any kind necessary.

Mr. Burton takes you to the art supply store, helps you choose materials wisely, economically. Then he gives you complete set of simple painting directions, from first brush stroke to framing finished paintings. Tells how to save money on materials. How to use wet and dry paints; mix and use colors, thinners, driers; create moods in pictures; draw compositions before painting; choose subjects; "capture" sunlight, shadows; produce special effects. Shows you so many ingenious short cuts, you'll be amazed at how quickly you learn to paint a good landscape friends will marvel at.

SEND NO MONEY
Examine Book Free 10 Days
Painting is a wonderful hobby. It develops your artistic ability. It provides a wonderful "escape" from nagging worries and frustrations. You'll be the envy of your friends and neighbors. But find out for yourself. Examine "Week-End Painter" FREE for 10 days. Simply mail coupon to: **McGRAW-HILL BOOK CO., INC., Dept. PMF-3, 327 West 41st St., New York 18, N. Y.**

THIS BOOK TELLS YOU:
The Things You'll Need. How to choose brushes, easel, Colors.
A-B-C of Color. How to "get" any color you see.
Practical Tips. Paintbrush magic with different whites, blacks, grays, reds, yellows, blues, greens, browns.
Brushes. Kinds. How to use, care for.
What to Paint. How to "spot" easy landscapes.
Working Methods. Sketching tips. Composition. Putting on the paint. 12 steps.
Special Tricks. Capturing sunlight. Painting realistic trees, grass, Secret of "clean color." Cezanne's secret of painting clouds. Hundreds of other hints.

Same FREE EXAMINATION Offer on "Water-Color Painting is Fun," by Frank A. Staples
18 different water color landscapes, how to paint them. Chart of 132 color mixtures, when to use them. How to choose materials, create feeling of distance, etc. 100 illustrations. \$3.50 on easy terms.

McGRAW-HILL BOOK CO., INC., Dept. PMF-3
327 West 41st St., New York 18, N. Y.

Please send me for 10 days' FREE EXAMINATION:

"Week-End Painter" If not satisfied, I will return it —pay nothing. Otherwise I will keep it and send only \$1.95 (plus postage) and \$2 one month later.

"Water-Color Painting is Fun" If not satisfied, I will return it—pay nothing. Otherwise I will keep it and send only \$1.50 plus postage and \$2 one month later.

Name

Address

Zone No. State

City

WE'LL PAY POSTAGE if you enclose full payment WITH coupon. "Week-End Painter," \$3.95. "Water-Color Painting is Fun," \$3.50. Same 10-Day Return Privilege, for full refund.

EARN MORE MONEY IN ELECTRICITY!

with **APPLIED PRACTICAL ELECTRICITY**



JUST OFF PRESS

Coyne's new set helps men get ahead in Electricity. This great Set gives you complete, A to Z know-how. It's all explained in easy-to-follow language, hundreds of charts, examples, pictures. Covers practically all branches of electricity including appliance repairing; AC and DC equipment; electrical refrigeration; industrial electronics and much more. Brings you 10,500 electrical facts; 3,400 subjects; hundreds of wiring diagrams, tables, formulae, shortcut methods. Written and proved in the Coyne shops — backed by 50 years experience in electrical training that has put hundreds of electricians on the road to top earnings. **APPLIED PRACTICAL ELECTRICITY IS THE MOST COMPLETE ELECTRICAL SET IN AMERICA.**

Sent on **FREE TRIAL**

USE SET FREE FOR 7 DAYS!

You have to SEE these books to know how much they'll help you. See them FREE! Just fill out coupon below and mail it in. **SEND NO MONEY.** Examine the set for 7 days AT OUR RISK!

150 SHOP PRINTS BOOK FREE—FOR PROMPT ACTION



Act promptly and we will include FREE, our valuable new book "150 Shop Prints and How to Read Them". If you return the set at our expense in 7 days, you owe nothing. To keep Set, send either \$23.75 in cash or \$3.00 after 7 days and \$3.00 per month until \$25.50 is paid. Either way, you keep the 150 Shop Prints Book. It's yours FREE! Coupon below is just a request to see APPLIED ELECTRICITY Set and to get FREE Shop Prints Book for doing so. Mail coupon AT ONCE!

FREE TRIAL COUPON—MAIL NOW!

Educational Book Publishing Division
COYNE ELECTRICAL & RADIO SCHOOL,
500 S. Paulina St., Dept. 30-R6, Chicago 12, Ill.

YES! Send Coyne's new 8 volume Set, "Applied Practical Electricity" to me, postpaid, for 7 days FREE TRIAL per your offer. Include, FREE of charge, your 150 Shop Prints Book.

Name _____ Age _____
Address _____
Town _____ Zone _____ State _____

AUDELS BLUEPRINT READING

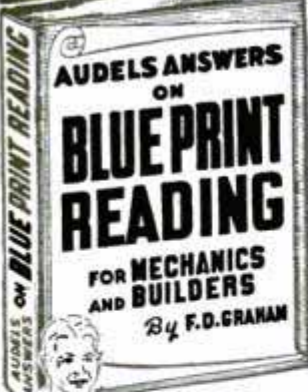

JUST OUT—FOR THE MAN WHO WORKS FROM BLUE PRINTS

"The Blue Print of Today is the Machine of Tomorrow." **AUDELS ANSWERS ON BLUE PRINT READING** covers All Types of plan reading including AIRCRAFT & SHIP BUILDING—tells How to Easily Understand Working Drawings.

What to look for first. Tells what each Line and each Symbol Means. The relation of one part to another. How to Understand Scales & Specifications. How to Make a Sketch. How to Make Blue Prints. A Key Book for Every Mechanic, Builder & Draughtsman—352 pages—It's New, Comprehensive. Fully Illustrated. Gives Short Cuts, Helps, Hints, Suggestions. Questions and Answers.

ASK TO SEE IT!
To get this assistance for yourself, simply fill in and mail coupon today. **\$2**

AUDEL, Publishers, 49 West 23rd St., New York
Please mail AUDELS BLUE PRINT READING (Price \$2). If satisfactory, I will remit \$2 on its safe arrival, otherwise I will return the book.

Name _____
Address _____
Occupation _____
Company _____

NOTICE! You Can't Buy Better Quality at any price. We sell just **GOOD TIRES** — No fancy promises. **ONE Quality — ONE Price — Why take less?** Our Tires used on Buses & Trucks for every purpose — **One Trial Will Convince You.**



WRITTEN GUARANTEE
Sent with every Tire You Buy
TUBE GIVEN WITH EACH TIRE
10% Discount May Be Taken on 1 or more tires if you **SEND THIS AD**

Be Wise — Read this Before You Buy!
OUR EXPERIENCE ASSURES YOU THE BEST BUY IN GOOD ORIGINAL TREAD USED TIRES —
Needless to pay more — risky to pay less.
BUY IN CONFIDENCE POPULAR BRANDS
Positively Not Re-Caps or Re-Molds

5.50-17 ... \$5.02	6.70-15 ... \$6.75	7.50-16 ... \$7.62
6.00-16 ... 5.02	6.70-16 ... 6.75	7.60-15 ... 7.62
6.50-15 ... 5.02	7.00-15 ... 5.30	7.60-16 ... 7.62
6.50-16 ... 5.02	7.00-16 ... 6.30	8.20-15 ... 8.62

GOOD TREAD—NO RE-CAPS. THESE TIRES WILL CARRY YOU TWICE AS FAR!

6.50-20(6) \$9.22	8.25-20(10) \$15.52	11.00-20(12) \$16.42
7.00-20(8) 10.52	9.00-20(10) 15.52	11.00-22(12) 18.42
7.50-20(8) 10.52	10.00-20(12) 16.22	32x6 (8) 10.02

750-20 MILITARY 8 PLY REGULAR \$9.62—SUPER \$12.92
900-16 MILITARY 8 PLY REGULAR \$8.72—SUPER \$10.72

Thousands of Tires Shipped to Satisfied Customers Throughout United States and Many Distant Points. Send This Ad with Check or Money Order. Dept 2.

STANDARD 834 N. Broad St., Philadelphia 30, Pa.



LEARN MEAT CUTTING

through actual practice. Profitable Meat Cutting and Self Service Meats taught easily, quickly. **LEARN BY DOING** at Toledo in just eight short weeks under actual market conditions. For beginners or men with experience. All subjects taught thoroughly and completely. Diploma. Job help. Get store of own. People must eat. School in operation over 25 years. Approved for GI training. Send today for FREE illustrated catalog. No obligation.

NATIONAL SCHOOL OF MEAT CUTTING, Dept. 50-C, Toledo 4, Ohio

ANGORAS FOR QUICK MONEY

Angoras cheaply and easily raised. Thousands needed for breeders in new industry furnishing wool for textile mills. Free illustrated booklet shows sales opportunities, success stories, markets. Write: **WILSONS STANTON 17, CALIFORNIA**



BARBELLS

FINEST QUALITY.....\$8.98 up
FREE CATALOG

Send today for big new 4 color fully illustrated free catalog of **BARBELLS, Dumbbells and Health equipment.** Free—world famous \$15.00 Dan Lurie Barbell and Dumbbell training courses with every purchase.

DAN LURIE BARBELL CO.
DEPT. 159C, 1729-M3 ROCKAWAY PARKWAY
BROOKLYN 12, N. Y.



CARTOONING

HAVE FUN! MAKE MONEY! Cash in on your sense of humor AT HOME—BY MAIL. No experience needed to start. Write today for FREE TRIAL LESSON and full particulars. **MOON Gag Cartoon School, Dept. D, Fall Creek, Wis.**

E-Z CAR WASHER

Soaps & Washes in One Operation
No Special Soap Required

Easily used—insert teaspoonful of any household soap powder or detergent in built-in soap pouch. 40-inch aluminum handle. Replaceable mop. Washes cars easily without getting yourself wet. Send \$3.50 check or money order. We deliver post paid. **MONEY BACK IF NOT SATISFIED**

Simply attach to garden hose.



E-Z CAR WASHER

401 W. 48th St., Dept. PM10, New York 19, N. Y.

\$3.50
POSTPAID

FAMOUS BAND LEADER LEARNED MUSIC THIS EASY A-B-C WAY!

You, too, can learn to play by this simple, short-cut method.

Read what Lawrence Welk says about it . . .

"I got my start in music with a U. S. School Course. And was I ever surprised when I began my lessons and found out how easy it is to learn to read notes and play an instrument this "teach yourself" way! Everything is so clear and easy to understand. In fact, this school did so much for me that I've enrolled my two

daughters . . . one for the Piano Course and one for the Violin. I strongly urge anyone who is interested in learning music quickly and reasonably to take advantage of the U. S. School courses."

Thousands have learned music by this money-saving, no-teacher method!



LAWRENCE WELK,
Popular Orchestra Leader



Imagine learning music by playing from real notes the very first lesson. Simple melodies to start with, then more advanced pieces. Soon you should be able to play almost any popular number right off. It's easy as A-B-C to learn this fascinating Print and Picture way. No tedious exercises . . . no trick number systems. And it costs only a few cents a day. Decide now to learn your favorite instrument. Mail the coupon for Free 36-Page Illustrated booklet and Print and Picture Sample. They give full details. U. S. School of Music, 73 Brunswick Bldg., New York 10, N. Y.

FREE PRINT AND PICTURE SAMPLE

U. S. SCHOOL OF MUSIC
73 Brunswick Bldg., New York 10, N. Y.
Please send me free booklet and Print and Picture Sample. I would like to play instrument checked below.

Piano	Reed Organ
Guitar	Tenor Banjo
Violin	Modern Elementary
Piano Accordion	Harmony
Saxophone	Clarinet
Trumpet, Cornet	Other Instrument

Name _____
(PLEASE PRINT)
Street _____
City _____ State _____

New Easy Way
TO MAKE

Write Now

BIG MONEY!

AT HOME

Costs You Only 5¢ - You Get \$5.00

Now is the time to cash in on this big-paying, easy-to-operate year 'round business, and you need no experience! Metallize Baby Shoes in real GOLD, SILVER, BRONZE, and PEARL. Everything furnished so YOU can start earning money at once—up to \$1,000 per month full time, or \$50 to \$75 per week spare time—at \$5 per hour. They will last FOREVER, and there are 10 million eager customers every year waiting to buy. FREE DETAILS—send no money—a postcard with your name will bring all the facts. Don't pass up this opportunity to start your own business on a shoestring—so ACT NOW. Write at once to:

KIKTAVI COMPANY, Dept. PM-3
2111 W. MANCHESTER BLVD., LOS ANGELES 44, CALIFORNIA

FULL OR SPARE TIME

FREE! INSPECTION
3 way profit plan yours to inspect at my risk for 7 days. Includes two actual metallized baby shoes—or a pair of your own metallized at no extra cost.

- Big Income
- Huge Demand
- Sales Plans
- Future Security
- Your Own Boss
- Money Back Guarantee
- Most Successful Name in Metallizing

HOLLYWOOD MUFFLER

THE TONE YOU LOVE TO HEAR

All Ford, Chevrolet, Plymouth . . . \$6.00
All other cars . . . \$8.00

Duals, Ford & Merc. \$24.50. Send check or M.O. We pay postage.

Dealers Write **WILKINSON MUFFLER CO.** 811 WILT STREET FT. WAYNE, IND.

New 1950 Plastics Supplies Catalog

Just off press. Get details on Plexiglas, Lucite, rods, sheets, tubes, Acetates, cements, dyes, buffs, molding sets, tools, carving kits, everything in plastics. Lowest prices. Price 10c, stamps or coin, with ad for catalog.

Plastics Mfg. & Supply Corp., Dept. PM-3, 4707 Euclid Ave., Cleveland, Ohio

SHIP MODELS for Everyone!

AUTHENTIC KITS FOR BOTH NOVICE AND EXPERIENCED BUILDERS

New "Clipper-Bilt" Kits at only \$3.95 each have carved balsa hulls, die-cut wood parts, tapered masts, finished fittings and simple plans. Send for your kit today. Select Schooner, Clipper, Barque or all 3. \$3.95 ea.

Big catalog describes over 30 beautiful ship models, 600 fittings and several authentic, fascinating gun models. Only 35c. Send for yours at once. **MARINE MODEL CO., Dept. G, Halesite, Long Island, N.Y.**

Learn REFRIGERATION and AIR CONDITIONING

Prepare yourself for a fine paying job. Get practical training at home—plus 4-full weeks in the ITI Shops. Job placement help. FREE book—write

INDUSTRIAL TRAINING INSTITUTE Dept. G-1, 2130 Lawrence Ave., Chicago 25, Ill.

TRAIN NOW FOR AN AVIATION CAREER

IN SUNNY SOUTHERN CALIFORNIA

MAXIMUM TRAINING IN MINIMUM TIME
Specializing in AERONAUTICAL ENGINEERING and MASTER AVIATION MECHANICS since 1929 America's Finest Aeronautical Institute 7000 successful graduates. MAKE MORE MONEY MAIL COUPON TODAY APPROVED FOR VETERANS. Board and Room now available.

Without obligation, send free catalogue with full information.

NAME _____ AGE _____
ADDRESS _____
CITY _____ ZONE _____ STATE _____

CAL-AERO TECHNICAL INSTITUTE
GRAND CENTRAL AIR TERMINAL • GLENDALE 1, CALIFORNIA

9 BIG BUILDING BOOKS

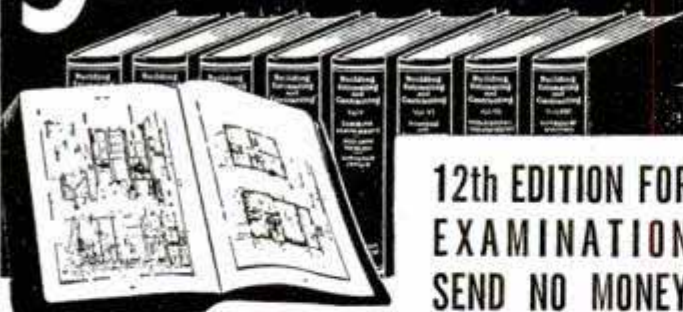

12th EDITION FOR EXAMINATION SEND NO MONEY

Learn to draw plans, estimate, be a live-wire builder, do remodeling, contracting. These 9 practical, profusely illustrated books cover subjects that will help you to get more work and make more money. Masonry, concrete forms, carpentry, steel square, roof framing, construction, plumbing, heating, painting, decorating and many other subjects. More than 4000 pages — 2750 illustrations.

BETTER JOBS — BETTER PAY

A nationwide building boom is in full swing and trained men are needed. Big opportunities are always for **MEN WHO KNOW HOW**. These books supply quick, easily understood training and handy, permanent reference information that helps solve building problems.

UP-TO-DATE EDITION

These books are the most up-to-date and complete we have ever published on these many subjects.

Coupon Brings Nine Big Books for Examination

AMERICAN TECHNICAL SOCIETY—Publishers since 1898
Dept. G319 Drexel at 58th Street Chicago 37, Ill.

You may ship me the Up-to-Date edition of your nine big books, "Building, Estimating and Contracting," without any obligation to buy. I will pay the delivery charges only, and if fully satisfied in ten days, I will send you \$2.00, and after that only \$3.00 a month, until the total price of only \$34.80 is paid. I am not obligated in any way unless I keep the books.

Name _____

Address _____

City _____ State _____

Please attach a letter stating your age, occupation, employer's name and address, and name and address of at least one business man as a reference. Men in service, also please give home address.

DIESEL MECHANICS NEEDED BIG PAY . . . GOOD FUTURE



If you have no trade or profession that assures you steady employment and top pay through good times or bad, and regardless of whether you want to be a mechanic, technician, salesman, executive — or have

your own profitable shop—you should investigate NOW this opportunity to enter world-famous Bailey Diesel Schools. Prepare yourself, this proven way, for an important place in the fast growing field of Diesel.

Why Gamble With Your Future!

Your future success depends largely on the reputation of the school you attend. Don't take chances! Train at Bailey's—America's foremost school of diesel training. Approved by Missouri State Board of Education. Approved, also, for G. I. Training. Full details FREE. Return coupon below NOW.

MAIL TODAY FOR FREE CATALOG

BAILEY DIESEL SCHOOLS
1656 So. Grand Blvd., St. Louis, Mo.
Please Send Me Your FREE Catalog.

Name _____

Address _____

Town _____ State _____

Veteran Non-Veteran

Resident Training Home Study

NEW FALSE TEETH IN ONE DAY



ONLY \$17.00 PER SET

Remake Old, Loose, Cracked or Chipped Plates Into Perfect Fitting Natural Beauty-Pink Dupont PLASTIC PLATES

NEW METHOD—NO IMPRESSION NEEDED

No more loose plate discomfort or danger to health thru improperly chewed food. No more germ-breeding cracks and crevices. Your teeth will be like new — perfect fitting \$100. Dupont beauty-pink plastic plates for only \$17.00. All work is guaranteed. Order direct—save over 50%.

SEND NO MONEY—WRITE FOR DETAILS TODAY

BEST DENTAL CO. Dept. M
475 5th AVENUE NEW YORK 16, N. Y.

500 Pages, 7000 Novelties



10c

Send 10c for mammoth, amazing catalog of 7000 novelties. 1-inch thick, roto picture section, 6-color cover. Carnival, circus, world's fair & science exhibit rolled into one! Includes live animals & pets, scientific supplies, hobbies, funmakers, planes & boats, looms, magic tricks, joke articles, unusual seeds, gadget timesavers, cameras, optical goods, projectors, movies, lucky jewelry, religious novelties, telegraph sets, disguises, musical instruments, stamps, coins, puzzles, fortune tellers, radios, experimental sets, auto & bike accessories, Western wear, telescopes, magnifiers, compasses, banks, smokers' gadgets, artists' supplies, printing sets, engines, motors, shockers, knives, billfolds, fireworks, guns, rifles, sports, money makers, swimming helps, 1000 fascinating books, games, locks, live chameleons, rings, exercisers, curious plants, etc., etc., etc. (DeLuxe Hard Bound Library Edition 25c Postpaid.) Regular paper covered edition 10c. (Stamps accepted.) Sent Air Mail, \$1.00. **JOHNSON SMITH & COMPANY, Dept. 222, DETROIT 7, MICHIGAN**

NOW! EASY PICTURE MAKING

from your own negatives, in ordinary room light!



You can make permanent, professional looking prints in less than one minute with BRUSH-A-PHOTO. Complete home hobby kit contains special print paper, developing and fixing liquids, two brushes, print frame, cartoon negative and instructions. At your dealer or send \$1.49 to BRUSH-A-PHOTO, Dept. PM, Paper 12 sheets 35c Metropolitan Life Building, Minneapolis, Minn.

REFILL Print
Paper 12 sheets 35c

TOOTHACHE?



Ask your Druggist for

DENT'S

TOOTH GUM
TOOTH DROPS
POULTICE

New ARMY MINE DETECTOR

An/PRS-1 is a portable device for detecting metallic and non metallic objects. Metals, Buried Cables and sewer Tile.

Our Special Price **\$26.40**
with battery
\$17.50 without battery

By lengthening dipole rods operator will be able to increase the depth sensitivity. This unit comes complete with spare tubes, antenna dipole and reflector, and instructions manual, in wooden chest 9 1/2" height x 28 1/4" length x 15 1/2" depth. Weight in operation is only 22 lbs. LESS Batteries. Power supply: Three 45 volt and one 6 volt batteries. Uses standard batteries. Original COST \$364.00. Shipping weight appr. 80 lbs. F.O.B. New York. No C.O.D.'s. Send Order to:



COLUMBO TRADING CO., INC.

304 CANAL ST. DEPT. P.M. NEW YORK, 13, N.Y.

POPULAR MECHANICS

LOWEST PRICE EVER

FOUR COLOR MECHANICAL PENCIL



ONLY
\$2.98

THIS TYPE
OF PENCIL
USUALLY
SELLS FOR
\$4.50-
\$6.98

Never before at this low price—the repel-propel mechanical pencil that lets you write in red, blue, green or black! A flick of the thumb instantly changes the color of the lead. Light weight, beautiful chrome finish, fully adjustable—visible color indicator—non slip clip . . . special lead holder prevents lead breakage . . . comes with soft eraser and extra standard red, blue, black and green leads. Ideal for executives . . . engineers, architects, artists, draftsmen, editors, accountants, advertising people, students.

FULLY GUARANTEED . . . SATISFACTION OR YOUR MONEY BACK. SEND NO MONEY. PAY POSTMAN \$2.98 plus postage. If you send \$2.98 on our unconditional money back guarantee, we pay the postage.

STUDWELL PRODUCTS COMPANY, Dept. 250
70 East 45th St. New York 17, N. Y.



WELDING SHOP TRAINING

G. I. APPROVED—GAS AND ARC

Classes start on Monday each week. Payment Plan for Non-Vets. Welders needed in practically every industry—train for a field where you have greater assurance of Steady Work, Good Pay. Write for Free Information.

A & S VOCATIONAL WELDING SCHOOL
1212 E. 63rd Street, Dpt. PM-3, Chicago, Illinois

BIG MONEY

at HOME Weaving



NO SEWING

EARN at Rate of **\$7.50** an Hour

STRIP SEQUINN

LAPEL PINS EAR-RINGS and SCATTER PINS

Easy to weave the "WEAVER BIRD" and other fast-selling designs with Fashion's newest discovery—Strip Sequinn—in sparkling Gold, Silver, Black . . . AND MANY BRILLIANT COLORS.

Easy to Make! No Sewing. Do everything with your fingers! Start making money with my SPECIAL INTRODUCTORY KIT that includes one Completely Assembled Weaver Bird (Gold Color), plus simple, easy directions and all the material you need to make 3 more that you may sell for \$2 each. Total resale value \$8.00! **SEND NO MONEY.** Complete Introductory Kit costs only \$2.00 postage paid. Or send name on penny postcard and I'll send Kit and Instructions C. O. D. for \$2.00 plus postage and C. O. D. fee. Your \$2.00 back by next mail if you are not delighted. **ORDER TODAY . . . write now.**

MARTHA GREEN HOBBIES, Dept. 73, EVANSTON, ILLINOIS



GENUINE

BUELL

AIR HORNS

\$39.50

postpaid

COMPLETE KIT

Your Preventive Accident Insurance

Buell Air Horn power reaches out and warns when other horns can't be heard. One accident avoided pays for horns many times. Easily installed under hood or on fender. Kit includes chromed horns 5" dia. x 18" long, Foot Control Valve, air tank, etc. Compressor can be added. Same horns as heard on Greyhounds. See dealer or send \$39.50 check, M.O., or C.O.D. while offer lasts.

Money-Back Guarantee:

You must be absolutely satisfied with your purchase of Buell Air Horns or your money will be immediately refunded.

BUELL MANUFACTURING COMPANY • PLANT 2
919 West 49th Place • Chicago 9, Illinois

Don't Envy The PLUMBER—Be One



Make \$15 to \$50 a Day
(and work every day)

Every skilled workman will tell you Plumbers have the best of it. WINTER and SUMMER the Plumber is busy at top wages. No skilled Plumber is ever out of a job . . . compare his opportunities with any trade, and decide where your opportunity is.

Own Your Own PLUMBING BUSINESS

No other business offers you the opportunity of starting in your own business, and making good profits, with little other investment than Universal's training and a kit of tools.

JOURNEYMAN PLUMBER

Gets Good Salary

Master Plumbers own their own shop. A Journeyman works for a Master. With Universal's training a journeyman can depend on high wages from the start.

FREE

DETAILS SHOW YOU HOW TO START

You can start now to success as a plumber by simply filling out the coupon and mailing it . . . or just write Universal Plumbing School, 877 Holmes, Kansas City, Mo. FREE details showing how will be sent by return mail.

Plumbing, to the man with know how, means profit. Investigate Universal's unique "Shop Method" system . . . This system, developed over a quarter century ago by a master plumber, offers you the opportunity to quickly get into the plumbing business. This is not a "war born school" . . . but a plumbing school developed and operated by plumbers since 1923.

BE A PLUMBER

In Just 32 Weeks

Now, just 32 weeks of intensive training equips you to be a plumber. No need ever serve an apprenticeship. Don't envy the plumber's big profits . . . enjoy them.

System Shows How With Tools . . . Not Books

Universal's highly developed method makes plumbers by a special developed system showing how to use plumbing tools . . . not books. Every instructor is a Licensed Master Plumber capable of showing every trick of the trade . . . Lead Work . . . Blueprint for plan reading, etc. This offers a wonderful opportunity for the man who likes to work with tools.

Over 7,000 Successful Plumbers Recommend This School

This system has made more than 7,000 plumbers. Each will testify it was the Universal Plumbing School that started him on the road to profits. Investigate our past performance . . . then decide. Universal is the largest and only school in America devoted exclusively to plumbing. It was established in 1923 under a system developed by a plumber and is owned and operated by licensed plumbers.

Don't waste your time looking over "war horn schools" . . . investigate this system . . . then get into the profitable plumbing business.

JUST MAIL COUPON

Send me FREE details about the plumbing business and tell me how to make profits as a plumber . . . I understand there is no obligation.

Name _____

Address _____

City _____ State _____

G. I. Approved. Established 1923

UNIVERSAL PLUMBING SCHOOL

877 HOLMES KANSAS CITY, MO.

Say You Saw It in Popular Mechanics



HIGH PAY • SECURITY
When You
LEARN A TRADE

Get ready for a well-paid, lifetime job or a business of your own in one of these **FIVE ESSENTIAL TRADES**. Complete training under expert instructors with practical experience prepares you to step into a good paying job with a future and security.

ELECTRICITY: Basic electricity, Residential and Industrial Wiring and Appliance Repair

PLUMBING: Every phase - pipe cutting and threading to complete installations, blue print reading.

AUTOMOTIVE & TRACTOR: Engine overhaul, Transmissions, Carburetion, Generator-Ignition Systems, Tune Up.

DRAFTING: College level training in general Machine and Architectural Drafting

SHOE REPAIRING: Complete practical training includes reconditioning and rebuilding.

Approved For Veteran's Training

NATIONAL TRADE SCHOOL
2610 Grand • Kansas City 8, Mo.

Without obligation to me please send full information on the course checked

.....Automotive and Tractor Technician .. Drafting
.....PlumbingElectricityShoe Repairing

Name..... Age.....
Address.....
City..... State.....
Veteran?.....

Here's How CREI Prepares You for a Professional Career with Industry-Recognized Training in a Minimum of Time

**TELEVISION
RADIO-ELECTRONICS ENGINEERING**

GRADUATES of CREI residence school are preferred by industry because of their *training and ability*. This recognition is the reason that CREI men quickly find good jobs. With 23 years of practical teaching experience in these highly technical fields, CREI offers an outstanding faculty, modern and complete laboratories, shops and equipment. New students are accepted twice monthly and each may advance as rapidly as he is capable. The basic course with one specialized course requires an average of 20 months to complete.

CREI is recognized as one of the country's leading technical institutes. Its work is of college level. It prepares the young man for a good job in industry in a minimum of time.



G. I. Approved

CAPITOL RADIO ENGINEERING INSTITUTE
An Accredited Technical Institute Founded in 1927
Mail coupon for Free Catalog

Capitol Radio Engineering Institute, Dept. 173B
16th & Park Road, N.W., Washington 10, D. C.
Please send me your residence school catalog and complete details. (If interested in Home Study check below.)

Name.....
Age..... If in school, what term?.....
Street.....
City..... Zone..... State.....
 I am entitled to training under G.I. Bill. Send information on Home Study Courses.

WAR SURPLUS BARGAINS

STARK'S

WAR SURPLUS BARGAINS

\$500,000.00 INVENTORY for QUICK LIQUIDATION

Surplus items—hundreds of them for home, shop, factory, farm and outdoor use. New items, used items, reconditioned items—all at tremendous savings—all priced for quick sale.

Page After Page of Values

This big catalog shows page after page of amazing money saving values. Write for your copy today. Send 10c to cover postage, mailing, etc. Write today!

SEND TODAY FOR YOUR COPY

10c

STARK'S Dept. 509 So. STATE STREET CHICAGO 5, ILLINOIS

MAGIC

AMAZING NEW MAGIC CATALOG

350 pages of mystifying, easy-to-do tricks and illusions. 600 illustrations. Send \$1.00 now for catalog, credited on your first \$5.00 purchase.

NATIONAL MAGIC CO.
119 S. State St. Dept. M-3 Chicago 3, Ill.

ANALYZE HANDWRITING

NEW, uncrowded, fascinating field. Gratifying earnings reported by graduates in Employment, Credit, Social Service, Police and Entertainment fields. Others have developed profitable private practice, full or spare time, as Personal and vocational Counselors. Send for 3,000-word TEST LESSON and PROOF book FREE. Write today!

Free

I.G.A.S., Inc., 303 Wilhoit Bldg., Springfield 4, Mo.

SAY YOU SAW IT IN POPULAR MECHANICS

TRADE MAGAZINES HELP YOU GET AHEAD

Latest single copies. More than 1150 different periodicals covering every trade, business or interest available through our easy-to-get acquainted service. Write now for full particulars and price-list.

COMMERCIAL ENGRAVING PUB. CO., 34B No. Ritter, Indianapolis 19, Ind.

AMAZING NEW FLYIN'-SAUCER

Scientific gyroscopic airfoil. Zooms to 50 feet or more. Flies, banks, loops, returns. Fascinating game of skill for all ages. Harmless. Flexible, durable plastic, 9 1/2 inch dia. In stores everywhere or send one dollar to manufacturer. Satisfaction guaranteed.

B & N SALES, Dept. M Dealers, Jobbers, write.
4579 York Blvd • Los Angeles 41, Calif.

Learn **REFRIGERATION**

MOTION PICTURE and GAS REFRIGERATION

ALTHOUGH... THROUGH

Make Top Profits Service Sealed Units and Home Freezers

Ambitious refrigerator service men with experience will find this book is just what they need to specialize in servicing Sealed Units and Home Freezers. Beginners will find it the best means of getting started on pleasant, profitable career. Non-technical. Covers theory, practical application of refrigeration in all branches. Diagrams in eight colors. 928 pages, 408 illus. Clip this ad. and mail with \$5.00 bill or check today. Money back if not satisfied.

GOODHEART-WILCOX CO., Dept. 115
1321 S. MICHIGAN AVE., CHICAGO 5

GOLD BOND



WHOLESALE GUARANTEED EXCEPTIONALLY GOOD USED TIRES DIRECT TO YOU

10% discount on 2 or more tires if you send this ad with order

TUBE DELIVERED WITH TIRE AT NO EXTRA COST FOR 15" AND 16" PASSENGER TIRES

Safe — Our tires used on school buses and ambulances

EXCEPTIONALLY GOOD TREAD — NO RECAPS

GUARANTEED FOR 24 MONTHS

600-16—6 ply Military—Mud and Snow Tire.....\$6.37

600-16	\$5.49	700-16	\$6.79	525-18	\$6.69	750-20(10)	\$15.98
600-16 (6 ply)	6.49	650-15	5.79	600-20	9.89	825-20	16.98
650-16	5.49	700-15	5.79	650-20	9.98	900-20	17.79
650-16 (6 ply)	6.79	550-17	7.79	750-16	12.50	1000-20	18.29

ALL GOOD TIRES GUARANTEED FOR 12 MONTHS

600-16	\$3.59	550-17	\$5.69	700-20(8)	\$9.29	825-15(14)	\$14.98
650-16	3.89	750-16	8.40	700-20(10)	12.48	825-20	11.19
650-15	3.89	600-20	7.98	750-20(8)	11.79	900-20	11.89
700-15	3.98	650-20	7.99	750-15(10)	11.97	1000-20	12.89

GOLD BOND SPECIAL — 750-20 MILITARY TIRES

Will fit 650 x 20 700 x 20 (8 & 10 ply) 34 x 7 (8 & 10 ply)

Special	\$10.49	Guaranteed 12 months	
Superior Quality	12.98	Guaranteed 18 months	
Gold Bond Finest	14.98	Guaranteed 24 months	
900 x 16 Special	9.03	900 x 16 extra	11.19

Send check or money order with this ad

GOLD BOND TIRE CO., Dept. PM 24

512 NORTH 1ST ST., RICHMOND, VA.

"A gold bond written guarantee with every tire"

New! SPEEDMASTER

ELECTRIC GRILLE GUARD



Protect your cars in parking lots at the curb in traffic. Your horn sounds the warning on contact with another bumper. Fits all cars. Handsome chrome finish. Easily installed with only a screwdriver and wrench. Order yours today. Cash with order postpaid

2.95

COD orders add postage.

SPEEDMASTER

900 Doolittle Drive • San Leandro, California

SIX MILLION



mufflers are torn out yearly. Original SIMPLEX Repair Guards will save you tearing out yours, saving time, money, labor, inconvenience. Do not confuse with former cheap, flimsy affairs. Easily and quickly installed. Fits all diameters both oval and round. Protects, reinforces; stops noise instantly. Heavy gauge, cold-rolled steel, treated against rust; asbestos lined. Stays put; lasts indefinitely. Order yours now. Send \$1.50 plus 15c postage. We ship by return mail. Good deals still available for qualified specialty men. Write today.

PARKER LABORATORIES Sta. H CLEVELAND 8, OHIO

FLASH Your Turns



ELIMINATE HAND SIGNALLING

ENJOY SAFE — COMFORTABLE WINTER DRIVING WITH THE SIMPLEX DIRECTIONAL SWITCH

Here is a safe and comfortable way of signalling your intention to make a left or right turn. Flashes from 60 to 80 times per minute.

Kits furnished with all necessary material for perfect installation. No outside mounting of any kind. Uses your present parking and tail lights. Either of our two models fit most cars from 1942 to 1949.

A PRACTICAL GIFT FOR MOTORISTS!

Specify year and make of car. Money back guarantee. Tested and Approved to meet SAE requirements.

DEALERS INQUIRIES INVITED

\$8.95 Send check or money order. Postage extra on C.O.D.'s

SIMPLEX SALES COMPANY 1303 W. Jackson Blvd. Dept. A-4, Chicago 7, Illinois

BUILD YOURSELF A HANDY HIDEAWAY



IT'S easy to turn unused attic space into your own private "office" with new Gold Bond Insulation Board. It comes in big ivory coated panels and in tiles and random width planks finished in ivory and harmonizing variegated blends. No further decoration is needed. Just nail the board in place and the job is done. You will not only have an attractive room, but one that's insulated ... warmer in winter, cooler in summer. For further details on new Gold Bond Insulation Board write Div. X, Dept. PM-3a.

Available at your local Gold Bond Lumber and Building Materials Dealer!

NATIONAL GYPSUM COMPANY

BUFFALO 2, N. Y.

SAY YOU SAW IT IN POPULAR MECHANICS

WORK FOR THE



RAILWAY POSTAL CLERKS **CLERKS** **CITY CARRIERS**

GOVERNMENT START AS HIGH AS \$3,450.00 YEAR

Veterans Get Special Preference

MEN — WOMEN

Railway Mail Clerks
Postoffice Clerks, Carriers
Liquor Inspectors
Stenographers-Typists
Meat Inspectors
Many Other Jobs

PREPARE IMMEDIATELY FOR NEXT EXAMS

Common Education Often Sufficient

Franklin Institute
Dept. B83
ROCHESTER 4, N. Y.
(Not Government Controlled)

Gentlemen: Rush to me, FREE of charge, list of U. S. Government big pay jobs. Send FREE 40-page book describing salaries, vacations, hours, work. Tell me how to qualify for one of these jobs.

COUPON

Name _____

Address _____ Vet? _____

★ Mail Coupon TODAY

Sensational NEW... **ELECTRO-MATIC** SPRAYER

NO MOTOR...NO COMPRESSOR NEEDED



ONLY
\$9.95

Postpaid in U.S.
Postage extra on C.O.D.'s

HERE'S A SPRAYER THAT REALLY WORKS!

Just fill this amazingly simple sprayer with enamel, lacquer, varnish, stain, light oil, insecticide, moth or fly spray, plug it in to 110-125 volt AC 60 cycle current, and you are ready to do a professional job of painting furniture, automobiles, shop equipment, farm machinery, bicycles, screens, woodwork, etc. Use it for disinfecting, mothproofing, fly sprays, livestock sprays, rust proofing, too. Precision engineered for long service, fully guaranteed. Replaceable mason jar. Weight 2½ lb.

The LESTER Co. 1743 MILWAUKEE AVENUE
BOX M-3E, CHICAGO 47, ILL.

USE EASTER SEALS

World's Leading AUTO BOOK

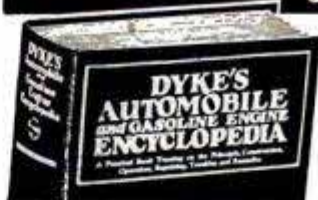

Indispensable Help for Mechanics, Beginners, Car Owners, Classrooms

Dyke's is more than a book on automobiles. It is a complete course in Auto Mechanics with

special emphasis on trouble shooting, testing, adjusting and repairing. Tells HOW to do things as well as WHY. 1481 pages, 4600 illus. Clip this ad. and mail with \$7.50 check or money order today. Money back if not satisfied.

GOODHEART-WILLCOX CO., Dept. 113
1321 S. Michigan Ave., Chicago 5

LOCKSMITHING & Key Making

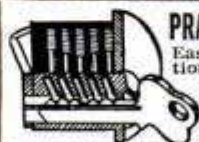

PRACTICAL UP-TO-DATE COURSE—ONLY \$3.95

Easy-to-learn modern information for self-instruction. How to work on locks, jet-code, make master-keys, repair, install, service, etc. For every handyman, home owner, carpenter, mechanic, service station operator, fix-it shop, hardware dealer, gunsmith. 53 plain illustrated lessons. **FULL PRICE ONLY \$3.95. SEND NO MONEY.**

Just pay postman plus C.O.D. postage. Or send \$3.95 with order, we'll ship postpaid. Satisfaction guaranteed or refund.
NELSON-HALL CO., 1139 S. Wabash Ave., Dept. C-2, Chicago 5, Ill.

"BIG SHOT" SLINGSHOT

NOT a toy. Kills crows, squirrels, rabbits, etc. No noise. Get extra shots at game. Get high scores on your target.

Packed with pellets and spare bands. Start your fun today. See your dealer, or send \$1 now to:

BOND PRODUCTS CO., Dept. M3
13139 Hamilton Ave., Detroit 3, Mich.



SEND ONLY
\$1

\$10,000 REWARD

Earn the government bonus by locating Radio-Active Ores with a



P.R.I. GEIGER COUNTER

The most sensitive portable Geiger counters made. Weight only 2 lbs. Battery lasts a year. Prospecting book included free. Priced from \$49.50 complete.

PRECISION RADIATION INSTRUMENTS, INC.
5478-P Wilshire Blvd. Los Angeles 36, Calif.

DEALER INQUIRIES INVITED

WAR SURPLUS BARGAINS

Substantial Savings on WAR SURPLUS and other MERCHANDISE **OVER 200 TIMELY ITEMS**

FREE CIRCULAR **SIoux FALLS SURPLUS STORE**
SIoux FALLS S.D.

FISHERMEN! DRIVERS! BOY SCOUTS!

Send For Your HANDI-LITE

Amazing all-purpose flashlight! Two-directional beams. Clip it to shirt pocket, or inside tackle box, for handling tackle at night. Clips to back-view mirror for night map reading. Clips to belt as guiding light. A hundred uses where you need both hands free. Only 3x1½". Uses standard bulb and batteries. Fluorescent case glows in dark. Mirror on back. Ideal as gifts. Send \$1. postpaid. No c.o.d. Agents write for attractive offer.



ALLIED MFG. CO. 743 N. 4th ST., P1, MILWAUKEE 3, WIS.

Your BLUEPRINT FOR PROFIT

NELS IRWIN
Will help you start your own successful, lifetime business.

AMAZING NEW Miracle Finish
MEANS \$\$\$ TO YOU

BIG PROFITS
Rich profits are waiting to be tapped in this new field. New MIRACLE finish gives a velvety, luxurious surface to radios, lamps, toys, signs, store displays, figurines, auto dashboards, and hundreds of other items. Make old objects beautiful and salable—make new things worth much more with this soft, rich covering that can be applied to any surface, even if old and worn.

START RIGHT AWAY
Yes you can learn in a few days to start MAKING MONEY! Everything you need is furnished including fully detailed, illustrated instructions that are complete and easy to understand. Every point is explained. To show you how to start on the road to big money, full or spare time, right in your own home.

EVERYTHING COMPLETE
In addition to full instructions you get a complete set of materials that enables you to start at once. A few cents worth of materials can mean many dollars in return to you—you can earn up to \$5 per hour and more spare or full time. Add to your income from your present job or start a profitable business of your own. Our Business is Booming. Help us fill HUGE DEMAND.

ACT NOW
Grasp this opportunity TODAY—Start your own business. It's too good to miss! SEND NO MONEY—fill out the coupon and stick it on a post card or in an envelope and mail today for full details. FREE samples of FLOK-KRAFT covered material, and hundreds of useful and profitable IDEAS. Do it NOW—be first!

COVERS WOOD, FABRIC, METAL, GLASS, PLASTER, PLASTIC OR ANY SURFACE

USE COUPON FOR FREE SAMPLE
COAST INDUSTRIES Dept. 23
1004 S. Los Angeles St., Los Angeles 15, Calif.
Gentlemen: Please rush me all the details.

FLOK-KRAFT

NAME _____
STREET _____
CITY _____ STATE _____

FAMOUS MAKE, PRECISION **CALENDAR WATCH**



TELLS AT A GLANCE DATE, HOUR, MINUTE and SECOND!

WITH AUTOMATIC CALENDAR

ONLY \$12.95

Postpaid Fed. Tax Included

(Regular price . . . \$21.25)

In Rolled Gold Case **\$14.95** Waterproof, Screw Back **\$15.95**
(Regular price \$25.00) (Regular price \$27.50)

- ★ Ruby jewels for all principal bearings
- ★ Mainspring power for 40 hours running
- ★ All parts of non-magnetic alloys
- ★ Shatterproof, non-discoloring crystal
- ★ Patented shock absorber device
- ★ Luminous hands and numerals
- ★ Non-tarnishing, steel back case
- ★ Handsome, genuine leather strap

3 YEAR SERVICE GUARANTEE! 10 DAY RETURN PRIVILEGE!

Mail orders carefully and promptly filled; enclose remittance for CALENDAR WATCH of your choice, or we ship C.O.D. plus postage. **SATISFACTION GUARANTEED!**

IMPEXTRA 551 Fifth Ave. (Dept. PM-4), New York 17, N. Y.

TWIN-USE **LOWEST PRICE EVER at \$9.95**

POCKET WATCH & ALARM CLOCK



Dependable time keeper & **APPOINTMENT REMINDER** for pocket, table & office use. Loud ring; Luminous hands, numerals & second indicator. Chromed case. Back opens as stand. Easy to set. Regular \$17.50. **Only \$9.95.** We pay tax & del. chges., or sent C.O.D. **10 DAY RETURN PRIVILEGE. IMPEXTRA, (PM-5), 551 Fifth Av., N.Y. 17.**

AJAX WHITE GIANTS



FAMOUS MEAT-EGG PRODUCERS
Extra big profit breed. Contest-show winners. Massive capons, quick maturing. U. S. Approved-Pullorum Controlled. Low farm prices. **PROFIT SHARING PLAN.** Colored catalog **FREE.** Write **TODAY.**
AJAX HATCHERY, Box 915, QUINCY, ILLINOIS



WORK SHIRT BARGAIN

SURPLUS STOCK FROM MID-WEST SUPPLY FIRM!

69¢
3 for \$1.79

What a buy! These sturdy, serviceable work shirts, though used, have been washed, sterilized and put in perfect condition. Every shirt is cut from durable wash materials, choice of blue or tan. Well made with reinforced stitching at strain points. Order today at our risk! Money-back guarantee!

SEND NO MONEY! Just send name, address, neck size and color choice. Pay postman plus postage or send cash and we ship prepaid. Inspect 10 days. Return for refund if not delighted!

WORK PANTS TO MATCH 99c
Send waist measure and leg length
COVERALLS \$1.49
Send chest measurement

MILCO SALES, Dept. P-263, 9350 Roselawn, Detroit 4, Mich.

THE NEW WAY TO ELECTRIFY TREADLE SEWING MACHINES



1 YEAR GUARANTEE

Terrific! Amazing! Changes any treadle sewing machine, regardless of age, into a modern electric! A child can do it in 5 minutes! Kit comes complete with Universal motor, foot control, belt, pulley, brackets. Completely wired — just clamp on and plug it in!

MAKE BIG MONEY!

FREE! \$2.95 Sewlight with each Kit.

Start now! Make \$5.20 on every kit you sell. Millions of women who can't afford new electric machines are waiting for it! Easy to sell over 10 per day! And Brant's back you with a complete line,

from needles to new machines — for BIG profits without any investment! Sell from our catalog and collect commissions in advance! Send for your kit and free literature, today!

RETAILS FOR \$16.95 YOU PAY \$11.75

BRANT SEWING MACHINE CO.

Department DM-2, Cincinnati 10, Ohio

- Rush motor kit C.O.D. I'll pay \$11.75 plus postage.
- I enclose \$11.75 — Ship postpaid.
- I want to be an agent! Send complete sales plan. My machine is a

Hand wheel turns toward me. away from me.

Name
Address
City Zone State

ROCKET

HYDRAULIC BRAKE BOOSTER



NOW... You can have power brakes on your car like the big trucks and buses—stop twice as fast with half the effort—with this amazing new invention.

SAVE... Owners report double the brake lining life after installing a ROCKET BOOSTER.

EASY TO INSTALL... No special tools required—easily installed in about 30 minutes—connects directly to your master cylinder. Each kit contains all necessary line and fittings, with complete instructions.

SPECIAL PRICE TO READERS OF POPULAR MECHANICS **\$9.95**
postpaid, including tax . . .

ORDER TODAY

Car and Year Name

Address

ROCKET SALES - DEPT. D2
363 W. CLAREMONT ST., PASADENA 3, CALIFORNIA

PROFIT from PEARL FINISHING

BIG MONEY RIGHT AT HOME

AMAZING NEW PEARL FINISH

Simple method starts you on the road to success in your own lifetime business—new, BIG PROFIT field. Beautiful PEARL finish applied to ANY article—leather, wood, plastic, plaster, paper, glass, metal, etc. Beautify baby shoes, statuettes, figurines, picture frames, book ends, jewel boxes, radio cabinets. Goes on new objects or renews and beautifies old, worn objects. Make unusual costume jewelry. Make things for sale in quantity to stores. All this at big profits for you.

BABY SHOES

Big—New—Terrific Demand. Baby Shoes are so much more precious when finished with Pearl Kote in baby's own colors: Baby Pink, Baby Blue and Ivory.

HELP FILL HUGE DEMAND!

Start small and grow big. Spare or full time. NO COURSE OF INSTRUCTIONS TO BUY. Complete, step-by-step instructions included with materials. NO EXTRA COST! BIG demand—help us fill it.

FREE DETAILS

Fantastic profits waiting if you act NOW—it pays to BE FIRST... It costs you nothing to get the free facts. Scoop the market with this quick, easy way to big money overnight. Mail coupon today.

PEARL-KOTE COMPANY, Dept. PM-3,
2111 W. Manchester Blvd.,
Los Angeles 47, California.



LAMPS



BOOK ENDS



PICTURE FRAMES



COSTUME JEWELRY



JEWEL CASES



BABY SHOES

PEARL-KOTE CO. Dept. PM-3,
2111 W. Manchester Ave., Los Angeles 47, Calif.

Okay! RUSH me FREE FACTS at once. I understand there is NO INSTRUCTION COURSE TO BUY!

Name _____

Address _____

City _____

Zone _____

State _____

"ROCKET PERFORMANCE" FOR ANY CAR

The revolutionary new VAPOJET is designed on the war developed principle of WATER INJECTION. It offers an ideal, INEXPENSIVE way to gain superior performance from any car. For the owners of new cars with HIGH COMPRESSION engines, VAPOJET gives extra power with low octane gas. Thousands of VAPOJETs are now in use and users report better pick-up, smoother running power and BIG mileage increases on regular gas. Complete, easily installed kit fits all cars, boats and stationary engines and is backed with a 30 day money back GUARANTEE.

- Designed to Give
- More Speed
 - More Mileage
 - More Power

Eliminates carbon & "ping."
Reduces wear.

Order Today

Only **\$9.75**

post paid.

Send check or money order and save postage. \$1 deposit on C.O.D. List car, year, and no. of cylinders.



Patent No. 2,188,175

VAPOJET MFG. CO.

11424 Biona Dr. Dept. PMC-3
Los Angeles 34, California
AGENTS WANTED

Learn CRIME Detection!

Learn Scientific Criminology AT HOME. Opportunities in Investigation and Detective work—Identification—Finger Printing—Homicide Investigation—Infrared Photography—Photo-micrography for law enforcement. Send for FREE Book.

Institute of Scientific Criminology
310 So. Robertson Blvd., Los Angeles 48, Calif., Dept. PM-3

Name _____

Age _____

Address _____

NEW IMPROVED...AMERICANIZED JUDO



TWO BIG BOOKS FULLY ILLUSTRATED
1220 SHOW-HOW PHOTOS. 71 LESSONS
MANY NEW HOLDS

Protect yourself and others. Size and strength mean nothing. Knowledge and skill enable you to master any situation even against biggest bullies or armed thugs. Written and illustrated by one of the world's great Judo experts. Volume 1, basic and advanced holds. Volume 2, very advanced. . . each volume \$1.50.

Big Combination Offer!
SAVE...

BOTH BOOKS \$2.50 POSTPAID
OR C.O.D. PLUS POSTAGE
5-day Money Back Offer. ACT NOW!

DEPT. PM-3

IMPROVED JUDO, INC. P. O. Box 7355, Sta. L, Los Angeles, Calif.

APTITUDE TESTS

discover the kind of work or studies best for your success! You get a personal report—a guide for life—more happiness—more prosperity. For men, women, boys and girls. Write for complete facts.

VOCATIONAL COUNSELING INSTITUTE
956 Maccabees Bldg., Detroit 2, Michigan

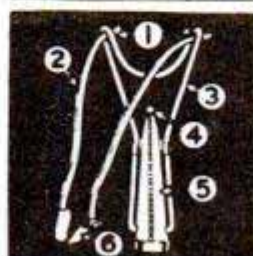

Repeating Slingshot

AMAZING NEW repeating slingshot. Shoots 150 B.B. shot. Loads from handle. Just the thing for hunters and trappers, young and old. Shoots thru ordinary 100 page magazine. More powerful than an air rifle. Send 75c in coin, money order or stamps (coins and money order preferred) for one of these REPEATERS. No C.O.D.'s.

THE SLINGO COMPANY
DEPT. B-3 ALEXANDRIA, VA.

STRENGTHEN Your VOICE!

YES—you can now build yourself a powerful speaking and singing voice with this amazing new scientifically sound tested method. Self-training . . . no music or piano required. Results GUARANTEED. Just send your name for the sensational details. FREE chart of your vocal mechanism included! Please state your age.

PERFECT VOICE INSTITUTE, Studio C-2, 1141 S. Wabash Ave., Chicago 5, Ill.



This NEW TYPE ACCORDION

is much easier to play

You can even learn to play it by yourself. For free information write to:

HUNIBEL ACCORDIONS
5154 N. Clark St., Chicago 40, Ill.

RE-STRING RACKETS AT HOME—EARN MONEY

EASY — PLEASANT — PROFITABLE
FREE Write for 1949 Catalog and Instruction Sheet NOW.
W. A. BICKEL & CO., 803 S. Boulevard, Dept. F-53, Oak Park, Ill.



HERE'S EVERYTHING YOU NEED TO LEARN THE MATCHLESS ART OF LEATHER CARVING—AT HOME

Now carve your own beautiful bags, bill-folds, belts, moccasins, key cases—anything from leather—at one-tenth the cost. We supply everything: patterns, tools, leathers, fittings, instruction books for craftsmen. Turn hobby into a business. Send \$1 for big set patterns, or

Send Only 25c for New Catalog #102

BURTONS LTD. 1755 1/2 GLENDALE BLVD. LOS ANGELES 26, CALIF., DEPT. E3

PLASTICIZE YOUR CAR with PLASTIC-SHINE

CLEANS, GLAZES AND PROTECTS IN ONE EASY APPLICATION

- ✓ Luster lasts up to one year
- ✓ Showroom finish in 40 Minutes
- ✓ Won't fingermark or smear
- ✓ Send today for this miracle plastic car polish ONLY 98c

DEALERS
Exclusive Territories
NOW OPEN
Write for details

PLASTIC SHINE

LARGE SIZED CAN ONLY

98¢
Money Refunded If Not Completely Satisfied.



P. O. BOX 1306 CHICAGO, ILL.
MFG. BY PLASTIC-SHINE LABORATORIES

HIGH POWER TELESCOPE

60 POWER - ALUMINUM TUBES - OPENS TO 33"

Variable Power Eyepiece Adjustable to 15X, 30X and 60X.

\$4.50 Leather Case Included

5 Sections. 4 Ground & Polished Lenses. Also used as 50X Microscope. Ready to use, only \$4.50 POSTPAID.
BROWSCOPE CO. Dept. 3M, 24 W. 45th St. NEW YORK 19, N. Y.

DON'T DRIVE BLIND
Be SAFE with PANA-VUE
THE CURVED REAR VIEW MIRROR WITH MAXIMUM VISION

• Eliminate blind spots—Pana-Vue lets you see out quarter panel as well as rear window. Letter A in drawing shows limited vision with old style mirror. Letter B shows increased scope with Pana-Vue. • Pana-Vue is made of non-distorting fire tempered glass mounted in protective rubber rimmed frame. • Easy to install—universal clamps fit over old mirror. **MONEY BACK GUARANTEE!** Send check or M. O. plus 15c postage today!
Moto Products Sales Co., 5410 Stone Ave., Cleveland 2, Ohio



\$1.85 In Ohio add 6c sales tax

OIL FILTER ELEMENTS... 7c

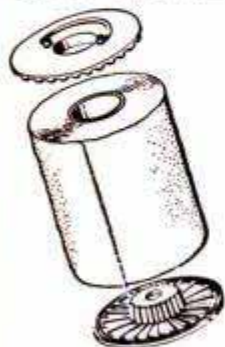

Here's News! Ordinary toilet paper makes an ideal oil filter. Laboratory tests prove it cleans oil faster and better than popular makes of filter elements. All you need is a simple set of Retlif Adapter Plates . . . and you can start using toilet paper rolls (costing about 7 cents) in your present oil filter. For proof and descriptive literature, send name and address to:

RETLIF OIL FILTER CORPORATION
1237 No. Highland, Dept. PM3, Los Angeles, Calif.

5 YEAR WRITTEN GUARANTEE 17 JEWEL CHRONOGRAPH

2 PUSH BUTTON
ORIGINALLY \$71.50

- Post-War Surplus
- WRISTWATCH
- STOPWATCH
- TELEMETER
- TACHOMETER

Our Price Now Only

\$21.95 Plus \$2.20 Tax



Precision 4 in 1 Timepiece. Incabloc shock resistant feature. Sweep Second hand. Anti-magnetic. Radium Dial. Stainless steel back. Perfect for physicians, scientists, technicians, engineers, aviators, photographers, broadcasters, navigators, sportsmen, servicemen, etc. Thousands sold at \$71.50. Order now while they last at this record breaking low price.

5 YEAR WRITTEN GUARANTEE \$16.95 PLUS \$1.70 TAX

ORIGINAL PRICE \$59

SHOCK INCABLOC—PROTECTED WATER REPELLENT . . .

Sacrificed Because They're POST-War Surplus Luminous dial . . . sweep second hand . . . Super Accurate . . . Imported Swiss precision movement and case. You get these Men's New 5 Year Guaranteed Watches now for a small fraction of the original price. Don't delay! Order now . . . while they last.

TRIAL OFFER! Wear at our risk! Money back in 5 days if not delighted. Pay balance to postman on arrival plus postage. Or we pay postage if you include full payment plus tax with your order.

FREE! Handsome Expansion Band Included. ORDER NOW!
MARYLAND DISTRIBUTORS, Dept. 29
501 EAST BALTIMORE STREET BALTIMORE 2, MD.



NOW! CLEAN—CLEAR WATER Right from YOUR FAUCET



SCIENTIFIC TESTS PROVE—
THE AQUA-MITE FILTER REMOVES
RUST, SILT, DIRT, ALGAE,
Chlorine Tastes, Disagreeable Odors

Get sparkling clear, spring fresh tasting water from kitchen or bathroom faucet. Rid drinking water of obnoxious tastes and odors. The mighty AQUA-MITE, an amazing scientific discovery, actually performs miracles . . . yet costs so little. Order an AQUA-MITE filter today! Taste the difference . . . see the difference in your drinking water! AQUA-MITE is precision-built, guaranteed by Del-Mar Services of Chicago, Illinois.

AQUA-MITE is duo-action (chemical & mechanical), filters hot and cold water. 20 vari-mesh monel screens, inside casing, are rust and corrosion proof. Approved chemicals do not need replacement. No messy cleaning, simply reverse and flush.

COSTS ONLY \$6.95 LASTS FOR YEARS

ORDER NOW!
ENJOY CLEAN, PURE, TASTY, HEALTHFUL WATER

See your local dealer or send check or money order—AQUA-MITE will be mailed prepaid.

DEL-MAR SERVICES
3937 Milwaukee Ave., Chicago 41, Ill.

Please send AQUA-MITE filters.
. check money order enclosed.

Name
Address
City State

Every Mason Will Want This
MASONIC QUIZ BOOK

OR

"Ask Me Another, Brother"

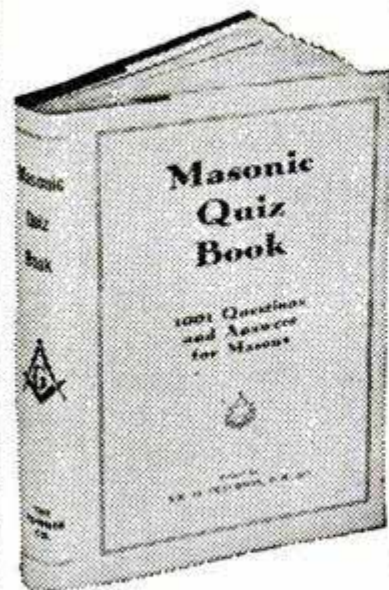

A real help to every Lodge Officer, Master Mason or Masonic Student for advancement in Masonry. Does not disclose any Secret Work, but gives a vast amount of authoritative information on Masonic history, ritual. Includes such interesting questions as:

- What did Masons have to do with the Boston Tea Party?
- What reference is made to the Catholic Church in Masonic teachings?
- Has every President of the United States been a Mason?

284 pages, 5 1/2 x 8", bound in cloth, and a distinct addition to the library of any man, even though he is not a Mason.

\$3.00 Postpaid

A Gift that every Mason and prospective Mason will appreciate

or C.O.D. plus postal charges

ORDER YOUR COPY TODAY

THE CHARLES T. POWNER CO., 407 S. DEARBORN ST. PM3, CHICAGO 5, ILL.

"YOU ARE UNDER ARREST!"



There's a Thrill in Bringing a Crook to Justice Through Scientific CRIME DETECTION

I have taught thousands of men and women this exciting, profitable, pleasant profession. Let me teach you, too, in your own home. Prepare yourself in your leisure time to fill a responsible, steady, well-paid position in a very short time and at very small cost. What others have done, you too, can do.

53% of All American Identification Bureaus

Be A FINGER PRINT Expert

Employ students or graduates of I.A.S. This fascinating work is easy to learn and the training is inexpensive. You, too, can fit yourself to fill a responsible crime detection job with good pay and steady employment. But don't delay—get the details now. Let me show you how easily and completely I can prepare you for this fascinating work, during spare time, in your own home. You may pay as you learn. Write today for free Crime Book.

FREE! "THE BLUE BOOK OF CRIME"

It's a thriller. Tells about some of the most interesting crimes ever perpetrated and how they were solved through the very methods taught by I.A.S. Send now—be sure to state age.

INSTITUTE OF APPLIED SCIENCE
 Dept. 1353, 1920 Sunnyside Ave., Chicago 40, Illinois

New DIRECTION SIGNAL

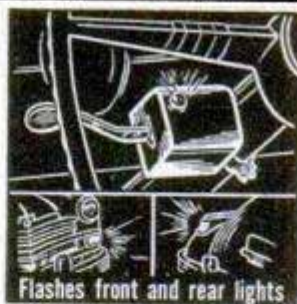

Flashes Your Turns Electrically

No more winter window cranking for arm signals. The new AUTO-TURN DIRECTION SIGNAL fits any car, flashes parking and tail lights 60-80 times a minute. No interference with regular lights, no extra lights to mount for most late cars. Smoothly operating, featherlight control lever. Works similar to factory installed models. All parts furnished—install it yourself. SPECIFY MAKE AND YEAR. For cars earlier than 1942, write for price.

Flashes front and rear lights
 Durable, attractive brown or chromium case. Specify finish.
\$10.95 Postpaid in U.S.
 Send check or money order. Postage extra on C.O.D.'s.

MONEY BACK GUARANTEE

The LESTER Company Box M-3, 1743 North Milwaukee Ave. Chicago 47, Illinois

Appliance Repairing Made Easy!

Here's a new and SIMPLIFIED METHOD of repairing appliances. Can be LEARNED QUICKLY—begin repairing immediately! A COMPLETE APPLIANCE TESTER INCLUDED! Fix any appliance with this tester. Prepare for a GOOD INCOME NOW. Send for the Simplified Course TODAY and get the famous Model 40 Appliance Tester—BOTH FOR ONLY \$9.95 postpaid, or plus c.o.d. charges. SATISFACTION GUARANTEED. Free Circular.

B. T. S. CO. 4317-A, SOUTH VERMONT AVE. LOS ANGELES 37, CALIF.

WHEELS - WHEELS

- 5" Disc Wheel 5/8" Tire 5/16" or 3/8" Sleeve.....30c ea.
- 6" Disc Wheel 5/8" Tire 5/16" or 3/8" sleeve.....35c ea.
- 7" Disc Wheel 3/4" Tire 3/8" sleeve.....45c ea.
- 8" Disc Wheel 1 1/4" Tire 1/2" sleeve.....70c ea.
- 7" Disc Wheel 1" Tire 1/2" ball bearing.....80c ea.
- 8" Disc Wheel 1 1/8" Tire 1/2" ball bearing.....\$1.00 ea.
- 8" Disc Wheel 2" semi-pneum. T. 1/2" B.B.....\$1.35 ea.
- 10" Disc Wheel 1.75 semi-pneum. T. 1/2" B.B.....\$1.50 ea.

Above wheel prices include hub cap.
 10" Aluminum Wheel 2 3/4" semi-pneum. T. 1/2" B.B.....4.50 ea.
 Plus Postage, 20% - C.O.D.'s accepted.

UNITED WHEEL STAMPING CO., PM-3
 2756 W. 115th STREET CHICAGO 43, ILLINOIS

YOU CAN BE AN All Around HE-MAN All 5 famous courses by George F. Jowett, world's greatest body builder in 1 complete muscle building volume (valued at \$5 each) now only 10c. Packed with How-to-Do-it pictures. 1. How to Mold a Mighty Arm. 2. Mighty Chest. 3. Mighty Back. 4. Mighty Grip. 5. Mighty Legs. Free strong men photo book. Quick results or money back! Send the name, address, age. JOWETT INSTITUTE, Dept. PM-03, 230 Fifth Avenue, New York City

TAKE 3-DIMENSIONAL PICTURES WITH YOUR OWN 35 MM CAMERA

NEW REDUCED PRICE (Outfit No. 101, was \$22.50)

STEREO-TACH \$17.70

Plus \$2.09 Fed. Tax and 3-D Slide Viewer complete. Make marvelous stereo color slides. Get Stereo-Tach from your dealer or direct. Money back guarantee. Dept. PM3.



ADVERTISING DISPLAYS, INC. Covington, Ky.

Use Easter Seals

Learn AUTO BODY-FENDER REPAIR



Specialize—Draw Top Pay

Here is a book covering every phase of auto body and fender repair work that will put you right into this profitable business. Covers use of tools, latest approved procedure, shows how to do a professional job. Also how to operate a shop successfully. Clip this ad. and mail with \$3.50 today. Money back if not satisfied.

GOODHEART-WILLCOX CO., Dept. 119
 1321 S. Michigan Ave., Chicago 5

No Shop
Needed

Operate YOUR OWN Business



Clean and Mothproof Rugs and Upholstery

See our column "ad" in April House & Garden
Can you qualify? . . . If you are dependable, honest and willing to work, send for FREE Booklet explaining how you can become "your own boss" in a growing business of your own. You'll use proven successful methods of established DURACLEAN Dealers. Service rendered "in the home," offices and public buildings. Easy to learn. No experience necessary.

DURACLEAN cleans by absorption! No scrubbing. No soaking or shrinkage. Fabrics dry in just a few hours. Dirt, grease and many unsightly spots vanish as if by magic . . . colors revive. Upholstery and floor coverings last longer.

DURAPROOF kills moths and carpet beetles. Makes material resistant to both! Another year 'round service. **DURAPROOF**, to our knowledge, is the only moth proof service backed by a National Money Back, 4 YEAR WARRANTY. Also rendered on location "In the Home," at your customer's convenience.

These services are Nationally Advertised! Leading furniture and department stores recommend **DURACLEAN** Dealer's service. Almost every building in your territory houses a potential customer. Even auto dealers buy your service to revive upholstery in used cars. You get many voluntary and repeat orders.

Some dealers establish a shop or an office after business has grown. Others continue to operate from their own home. Profits up to \$15 and \$20 for a day's service on EACH of your service men.

Territories are limited! Write now for FREE Booklet explaining details of these Nationally Advertised services.

Duraclean Co., 0-163 Duraclean Bldg., Deerfield, Illinois

GARDEN TRACTORS

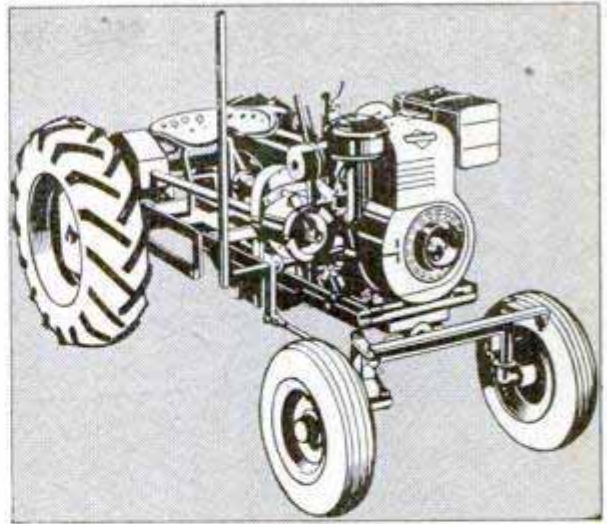

LOOK--SPEEDEX AGAIN PAVES THE WAY TO LOWER PRICES IN GARDEN TRACTORS

FOUR-- MODELS 1.9 H. P., 3 H. P., 5 H. P. and our famous 8 H. P. four wheel riding type.

Prices start at only \$119.50 to \$350.00 for the powerful 8 H. P. Rider

ALL-- Speedex Garden Tractors are built with enclosed gears running in oil, powered with popular-make engines and equipped with the latest type rubber tires.

JUST-- for the asking we will mail you absolutely FREE a circular illustrating and describing these tractors.

WHY-- not write today. Please use a penny post card.

SPEEDEX GARDEN TRACTOR CO.
BOX 216-D1 Ravenna, Ohio
P-1149-34

ARTISTS MAKE MONEY

Do you like to draw? Send name, address, age and occupation for FREE ART TEST, to find out your ability.

ART INSTRUCTION, Inc.

3130 ART INSTRUCTION BLDG., MINNEAPOLIS 15, MINN.

YOU CAN HELP CRIPPLED CHILDREN—USE EASTER SEALS

BUILD AND RUN A MODEL RAILROAD A HOBBY FOR REAL CRAFTSMEN

JOIN 300,000 MODEL RAILROAD FANS

If you appreciate fine authentic detail in models you'll get hours of fun, pleasure and satisfaction building a true to scale railroad that operates by electricity. Not toys, but precision made masterpieces that are easy to construct. HO GAUGE keeps cost down and allows big layouts in small spaces. Start with a single car kit or a full train kit, but start.

Authentic Gondola Car Kit \$2.95

Switch Engine Kit
Complete with electric motor \$15.00

Complete Train Kit (save the price of one car)—
Switch Engine, Tender, 2 Flat cars, Gondola and
Caboose only \$27.50

Model Railroad Manual, 66 pages \$.50

Send 10c for Railroad booklet and catalogs today. We pay Postage. Money Back Guarantee. Shipped postpaid on receipt of check or Money Order. On C.O.D. send \$1.00 deposit.

TRAIN DEPT. Mail Order Supply Co.
3511 CONNER ST., N. Y. C. 66, N. Y.



ELECTRIFY your SEWING MACHINE



NEW LOW PRICE!
\$11.50 1 YR.
GUARANTEE

Buy direct from manufacturer and save! Kit comes fully wired, installed in a jiffy. Fits all machines! You get these all-new parts:

- Motor & Bracket
- AC-DC 115v 60c
- Steel pulley & belt
- Carbon-type foot control
- Cord set & block
- Easy instructions

FREE . . . reg. \$2.95 chrome SEWLITE given with every kit.

10 DAY FREE TRIAL—ORDER NOW!

Send no money, pay C.O.D. or send money order and we'll pay postage. Please state whether wheel on your machine turns toward you or away from you. Shipping wt. 6 lbs.

Dealer Inquiries Invited

CONTINENTAL SALES CO.

83 GRAHAM AVENUE Dept. PM7 BROOKLYN 6, N. Y.

BE A HIGH-PAID MAN IN YOUR COMMUNITY WITH THIS LONG NEEDED INVENTION



Earn up to \$10,000 or more per year!
Nothing to invest! Be your own boss!

U.S. Pat.
D 133853
D 133854

A worldwide product needed by every home, business and farm . . . priced to sell quickly! Automatic Red Comet goes into action as soon as fire starts, smothers fire without human aid. It's a sales "natural"!

FREE SALES KIT

Demonstrator units, sales literature, etc., furnished you FREE. Handsome leather-type kit. Tried and proved, it will make you an independent businessman. ACT NOW! Someone in your community will be appointed soon. Write for details, today!

RED COMET, INC.

586 R. C. Bldg. Littleton, Colorado





Perfect Circle

'THE MOST HONORED NAME IN PISTON RINGS

Honored by Doctors of Motors, America's expert mechanics, who actively express their piston ring preference by installing millions of Perfect Circles every year.

Honored by America's foremost automotive engineers, who recently acclaimed Perfect Circle Piston Rings as best engineered—4 to 1.*

Honored by motor-wise car owners all over America, who in survey after survey have invariably named Perfect Circle their first choice by a wide margin.

Look for this sign (*right*). It identifies a place where your car will receive expert attention. Your local Doctor of Motors knows your car, knows the value of honest workmanship and reliable parts. He will install a set of Perfect Circle Piston Rings *Custom Made* for your car to restore power, save gas, stop oil pumping.

Perfect Circle Corporation. Offices: Hagerstown, Indiana and Toronto, Canada. Plants: Hagerstown, Richmond, New Castle, and Tipton, Indiana, and Toronto.

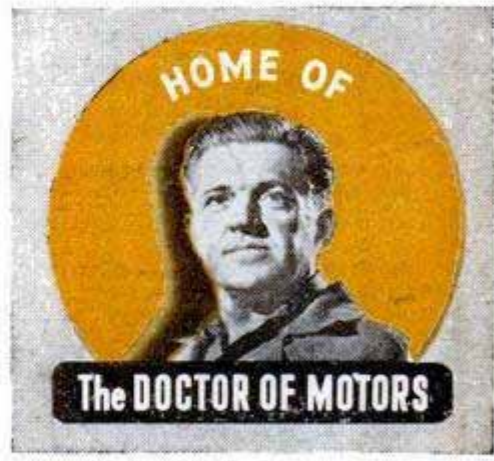

**In an independent survey among automotive engineers—maintenance men, fleet operators and designers of new equipment—Perfect Circle was first choice as the best engineered piston ring—first by more than 4 to 1—and received more votes than ALL other brands combined!*

Illustrated— WS-85 Oil Ring, one of 62 types of Perfect Circle Piston Rings for Custom Made Sets

POPULAR MARCH 1950 MECHANICS

WRITTEN SO YOU CAN UNDERSTAND IT
VOL. 93 NO. 3

Inventor in a Carriage House

By
Walter E. Burton

James H. Rand, III, sold a washing-machine invention for \$500,000, plus royalties. From his Ohio workshop come also such items as metal fabric, a heart massager for surgeons — and a diaper

NOW IF YOU will hold out your hand . . ." the man suggested.

I extended one hand, palm upward, and he spread over it a four-inch square of thin, metallic-looking cloth. After perhaps 10 seconds, he said, "Now tell me what you feel?"

"It's getting warm!"

He nodded. "Your hand feels warmer, but it isn't receiving any heat from the outside or from the cloth. What you feel is the accumulation of heat radiated by your skin, heat that normally would be lost. The cloth keeps it from escaping."

Rand, shown at one of his milling machines, established a busy center for inventive research in an old carriage house

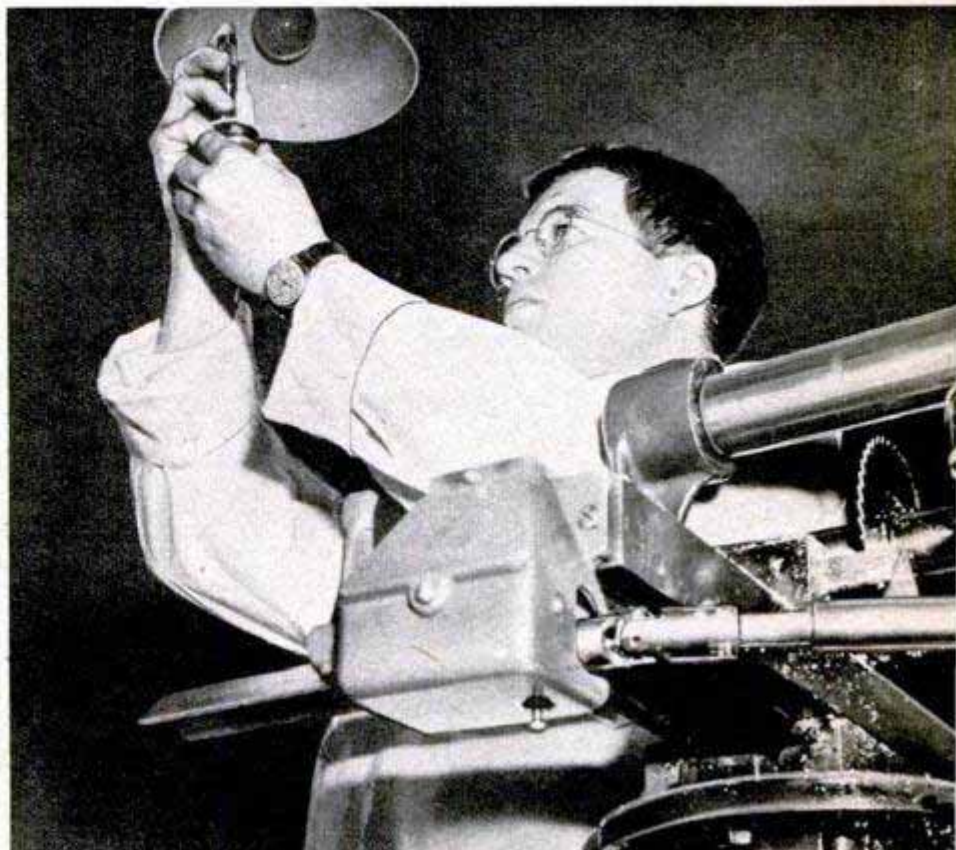



Staff members test a sleeveless jacket made of metallized cloth which stores up the heat radiated from the body. Below, wheel chair at left is operated by one finger, that at right by tongue in the mouthpiece



This new kind of cloth, by enabling us to get along with lightweight gold, silver or aluminum-lined clothing in the severest weather, may change our centuries-old ideas of how to keep warm.

The demonstrator was James H. Rand, III, who operates a unique research and invention center in Bratenahl, a suburb of Cleveland, Ohio. I had gone to his workshop, which formerly was a carriage house, mainly to learn how he had developed a washing-machine idea he sold for \$500,000 plus royalties. I discovered that this ex-barn is a humming laboratory in which are brewing dozens of ideas for making living easier and cheaper, and even for saving life itself.

Rand, a 36-year-old son of the president of Remington Rand, Inc., is considered one of the country's most energetic inventors. Among other accomplishments, he designed the Remington Rand electric shaver. Since 1936 he has been operating his own research establishment and has surrounded himself with a staff of scientists and mechanical specialists. His chief engineer, W. M. Nichols, has been with him for 15 years.

The inventor has set up the Rand Foundation for Medical Research, which builds special medical equipment—for free. Of all the money Rand's laboratory earns from development work and the sale of patents, 25 percent goes into the medical foundation. Three shop projects out of four pertain to medical problems.

Among Rand's newest inventions is a "robot watchman" that calls the fire department if a house catches on fire when the family is not at home. It is a telephone attachment that is set off by a thermostat when heat reaches 160 degrees. The machine dials the fire department and when a fireman answers a phonograph record starts

and a voice reports the blaze. If the wrong number is accidentally dialed by the attachment, the "robot" tells whoever answers of the fire and asks them please to call the fire department. The attachment, nearing production, will sell for between \$25 and \$50.

Naturally, Rand frequently is approached by inventors who are seeking help in perfecting or marketing their ideas. He tells them that he is not a promoter. Being an inventor himself, he is really one of their competitors.

As an example of Rand's strikingly original thinking, take a look at his flexible washing machine. He sold the patent rights for \$500,000 plus royalties that may bring him several times that amount. Surprisingly simple in operation, the washer has a tub made of a flexible material. Extending upward in the tub center is a plastic agitator which produces an undertow action in the water. After a period of agitation, a suction pump extracts air from the top of the tub through the hollow agitator. Atmospheric pressure pushes the tub wall inward, squeezing the clothes toward the agitator. Lighter-than-water impurities are floated to the top and disappear down the agitator spindle, while sand and other heavy materials pass out through a bottom drain. At the end of the washing cycle, rinsed clothes are subjected to the vacuum and squeezing action until they are damp-dry and ready for the line.

A laboratory flask planted the idea for the novel washer in Rand's mind. He had observed many times that water can be made to boil in a partly filled flask by pumping air from the space above it. Water alone will boil for a time, but eventually the action stops. But if the water contains a trace of soap, bubbling will continue until the flask has boiled dry.

It occurred to the inventor that this action might be applied to washing clothes. He tried various methods before

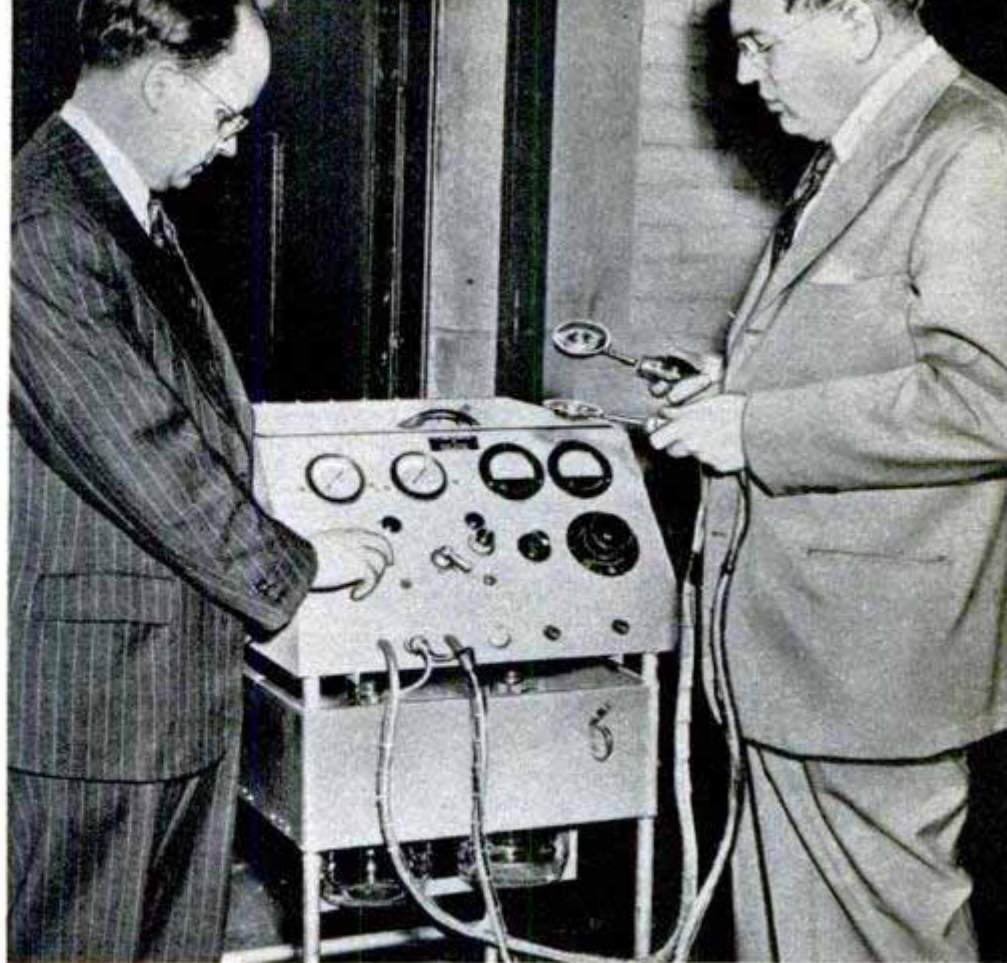

In Rand's hands are two vacuum pumps he invented for surgical use. They massage heart to revive action if it stops during an operation

he hit upon the idea of a flexible tub. Lowering of the atmospheric pressure in the covered tub duplicates the action in the evacuated flask.

The National Association of Washing Machine and Ironer Manufacturers has set up, as a target for all makers of washers, a "standard washing machine" that has an

Rand's plastic air mattress prevents bed sores. Divided into compartments, it is inflated and deflated to change its shape automatically

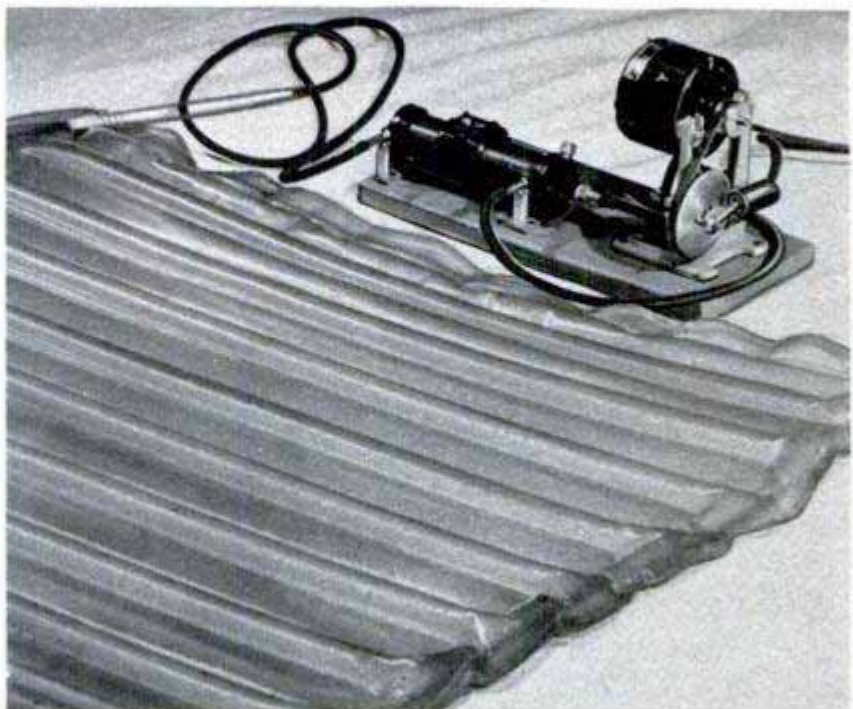

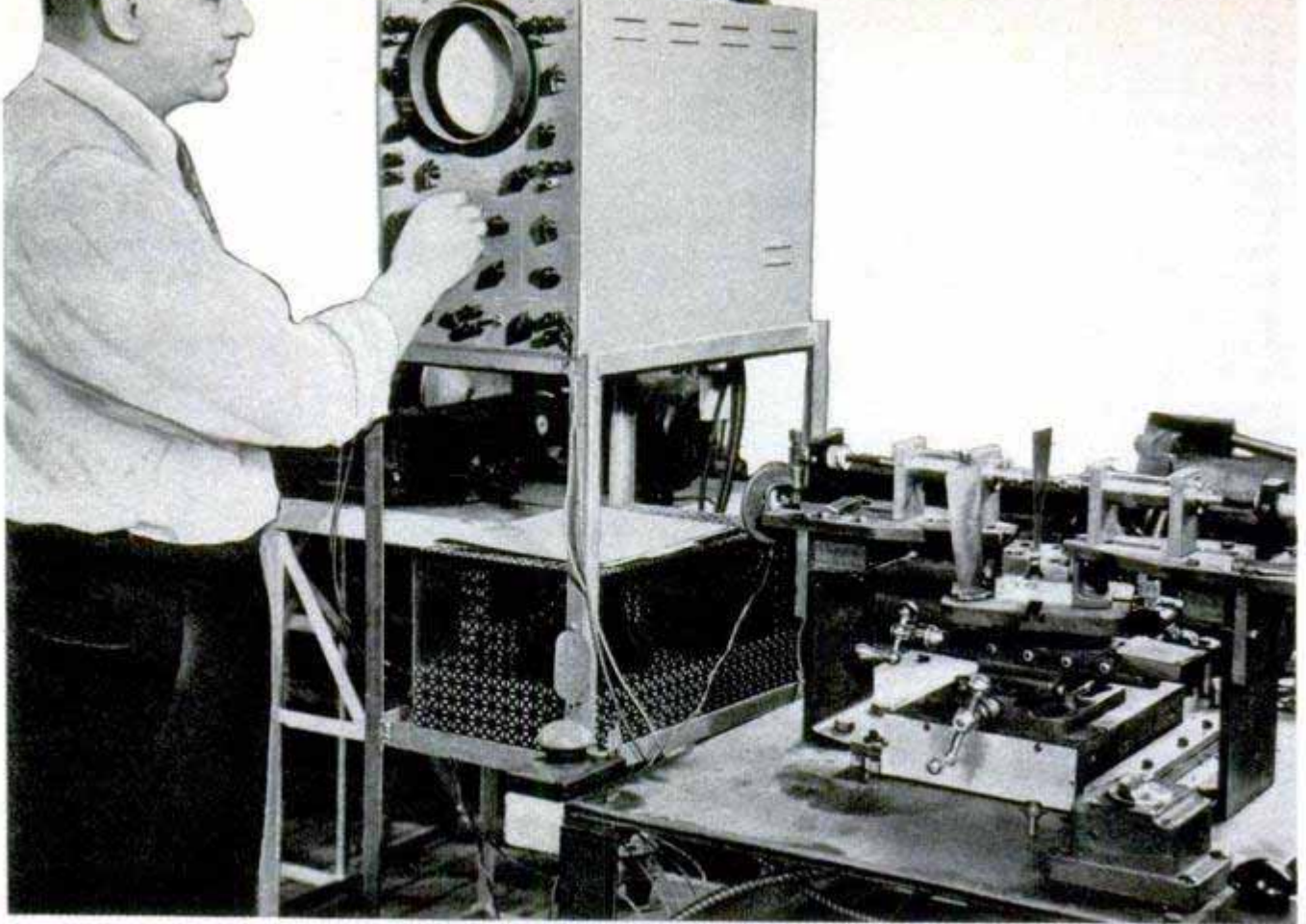

Tracing instrument analyzes the complicated contours of jet-engine rotor blades on an oscilloscope screen

arbitrary cleaning efficiency of 100 percent. When Rand's squeeze-tub machine was tested against the standard, its efficiency was reported at 188 to 120 percent.

Some day your winter shirt may be a lightweight rayon affair coated with gold, and your overcoat a featherweight topper having a silver or aluminum lining—if Rand's metal-treated fabrics are generally adopted.

Rand explains that the body loses heat in four ways: by convection, conduction, evaporation and radiation. For centuries,

people have been trying to regulate this heat loss by controlling, largely with wool and cotton clothing, the first two factors and, to some extent, the third. But almost no effort has been made to regulate the fourth and usually the most important—radiation.

When the temperature is around 70 degrees Fahrenheit, as much as 70 percent of the body heat may be radiated. At lower temperatures, the loss is still higher.

Wool fibers are constructed of smooth-surface, overlapping plates, making wool a

Rand's seatless water faucet will last indefinitely, cleans itself and can be operated with one finger

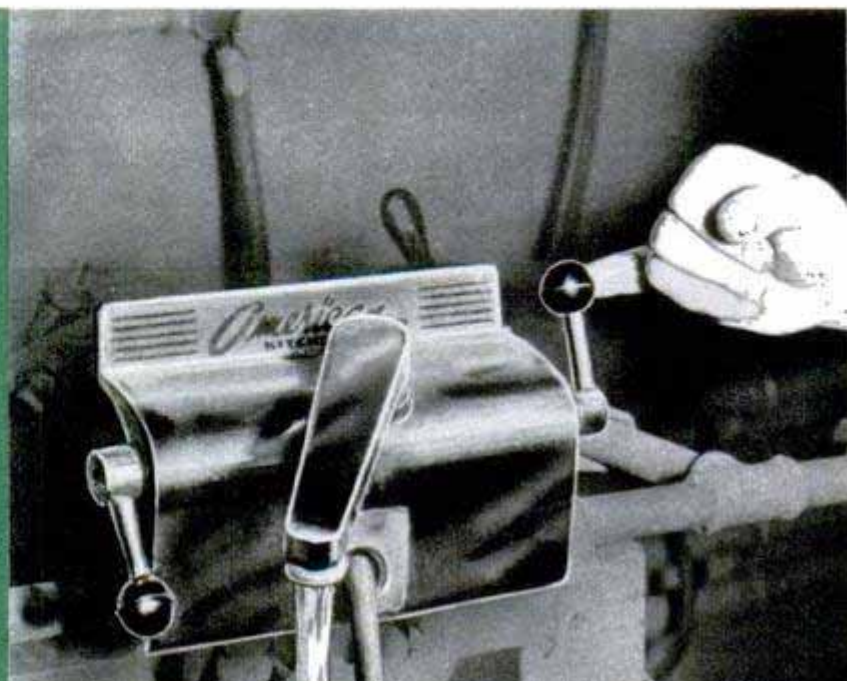
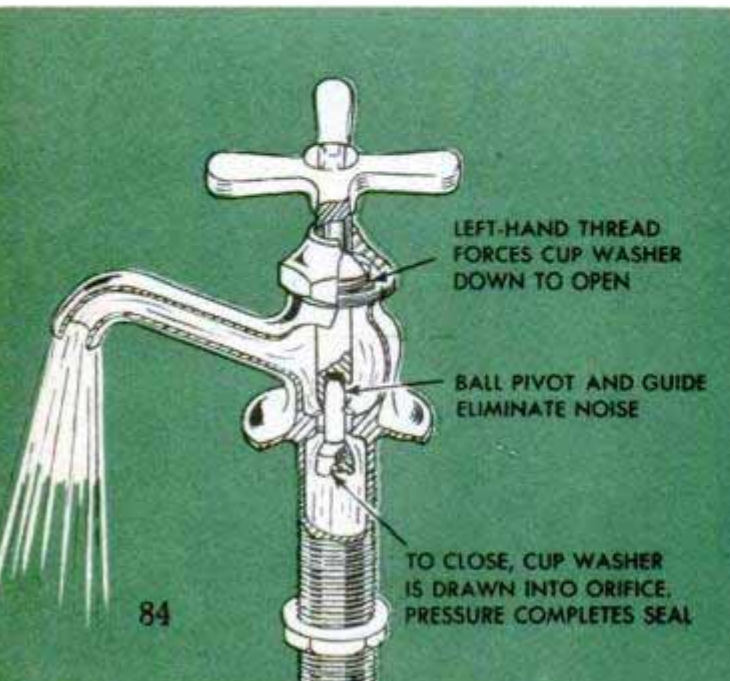

fairly good natural reflector of heat. But Rand has shown that there can be better materials for conserving body heat.

By metallizing rayon cloth .008 inch thick, he can make it warmer than unmetallized wool .033 inch thick. The metal, whether gold, aluminum or something else, is in the form of very thin overlapping flakes. Because of its thinness, even gold can be used economically, just as gold leaf is used for decorating book covers.

Rand explains that the fabric won't become uncomfortably hot, for it is porous and permits hot air and moisture to escape through it.

Another Rand invention is a seatless valve that apparently will last untold years. A test water faucet has been turned on and off, twice a second, for months, has worn out one automatic counter and is still going strong after 32,000,000 on-off operations.

Conventional valves, the inventor explains, try to compress rubber, which is essentially an incompressible material. Rubber flows under pressure. If the flow is extensive enough it will undergo permanent set. So Rand designed his simple valve so that the rubber in it is distorted only slightly—enough to make a tight seal but not to cause permanent set. When the valve is open the rubber plunger moves against the pressure, which tends to close it. At each movement the plunger wipes the seat clean. Rand demonstrates the valve's dirt-handling ability by dumping a spoonful of sand into a disassembled model, reassembling it and then cleaning out the sand in two or three open-shut operations. The faucet works so easily that it can be opened and closed with the little finger.

Rand's ideas wander into strange fields. One of his inventions, now on the market, is a baby diaper that eliminates the flood hazard. A waterproof-plastic envelope carries a replaceable pad that absorbs moisture, drawing it away from baby's skin.

(Continued to page 258)



Inventor's respirator automatically breathes for the patient during an operation, administers anesthesia at definite rate. Below, washing machine with flexible tub earned him \$500,000 and royalties



Washer's agitator moves clothes through suds to start the action

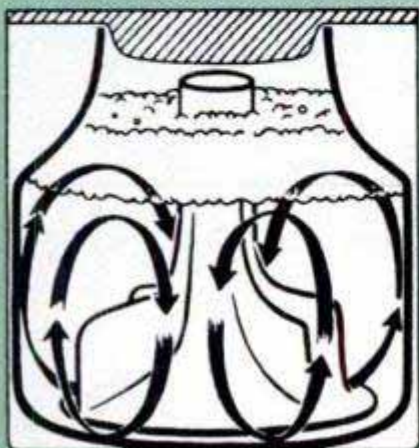

Vacuum folds in sides, squeezing dirt through washer's two drains

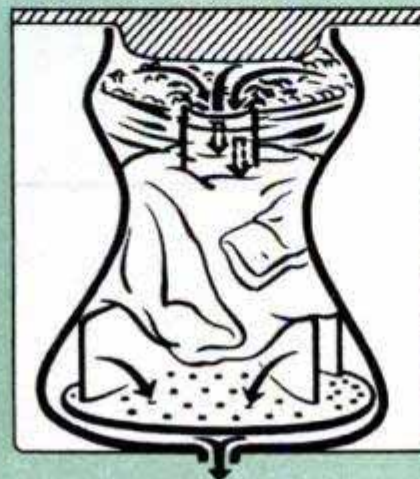

In the final step the sides firmly squeeze most of water from clothes

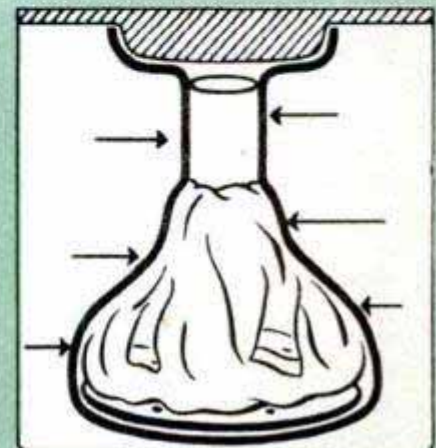

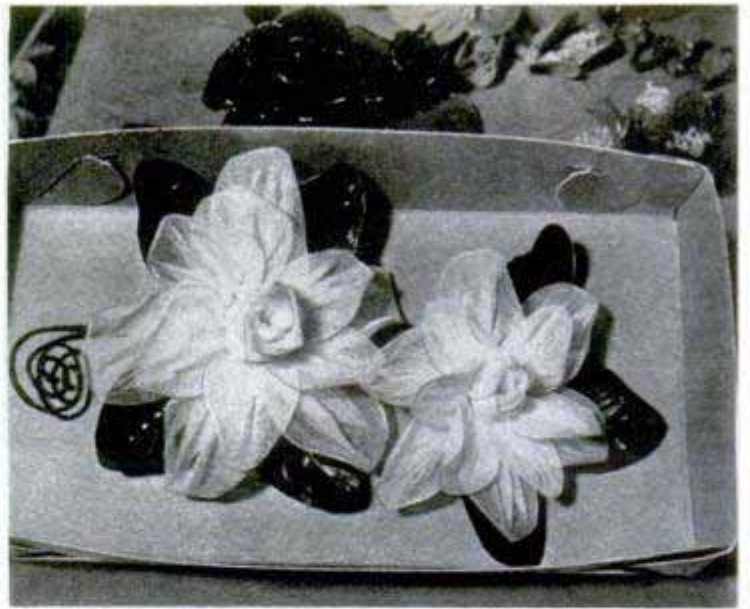

Discarded Nylon Hose Make Artificial Flowers

Discarded nylon hose, some fine copper wire and an artistic talent are all that Mrs. Vivian Keller of Long Beach, Calif., needs to create beautiful artificial flowers. She bleaches the nylon and tints it to the de-

sired shades. The copper wire is formed to the shape of the petal or leaf and the nylon folded over it and fastened with adhesive. Commercial stamens complete the attractive floral displays.

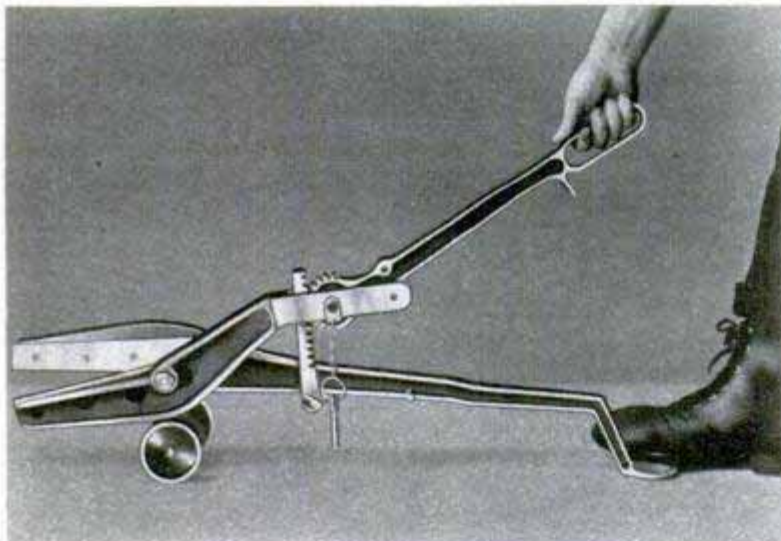

Super Scissors

Giant scissors employing compound leverage will cut metal stock in sheets, rods or bars up to $\frac{1}{8}$ inch thick. Added leverage for the shears comes from a rack and gear mechanism. Only 60 pounds of pressure are needed to cut stock that requires 145 pounds of pressure with ordinary shears. One of the handles ends in a foot pedal which can be held stationary while both hands are used to apply leverage. The tool is 36 inches long, has 9-inch blades and weighs 27 pounds.

Japanese Cycle Truck

Powered by a liquid-cooled motor, a three-wheel cargo cycle is used in Japan where narrow streets and congested traffic make the small truck excellent for delivery purposes. The cooling system, which uses two radiators, one on each side of the motor, prevents the motor from overheating at the slow speeds necessary in city streets. A combination chain-and-shaft drive transmits the power to the rear wheels.

Aluminum, one of the most versatile metals, already has more than 4000 applications.

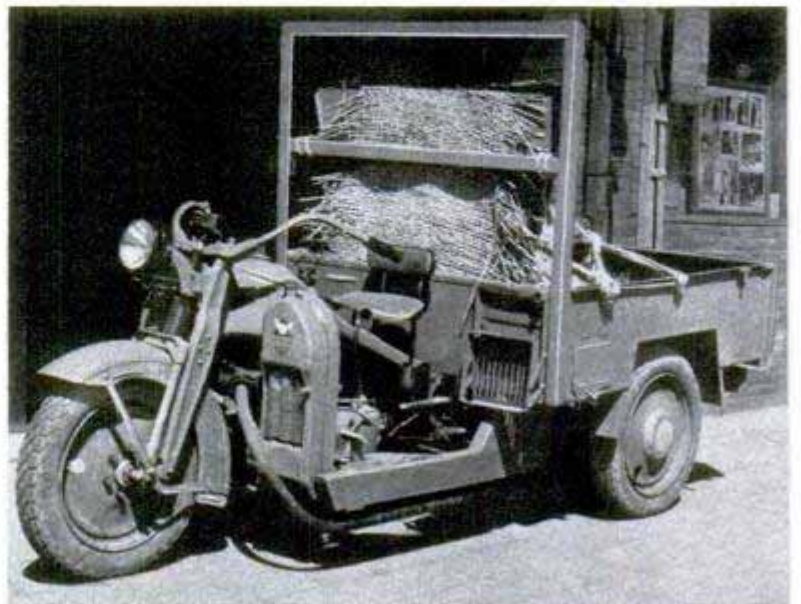

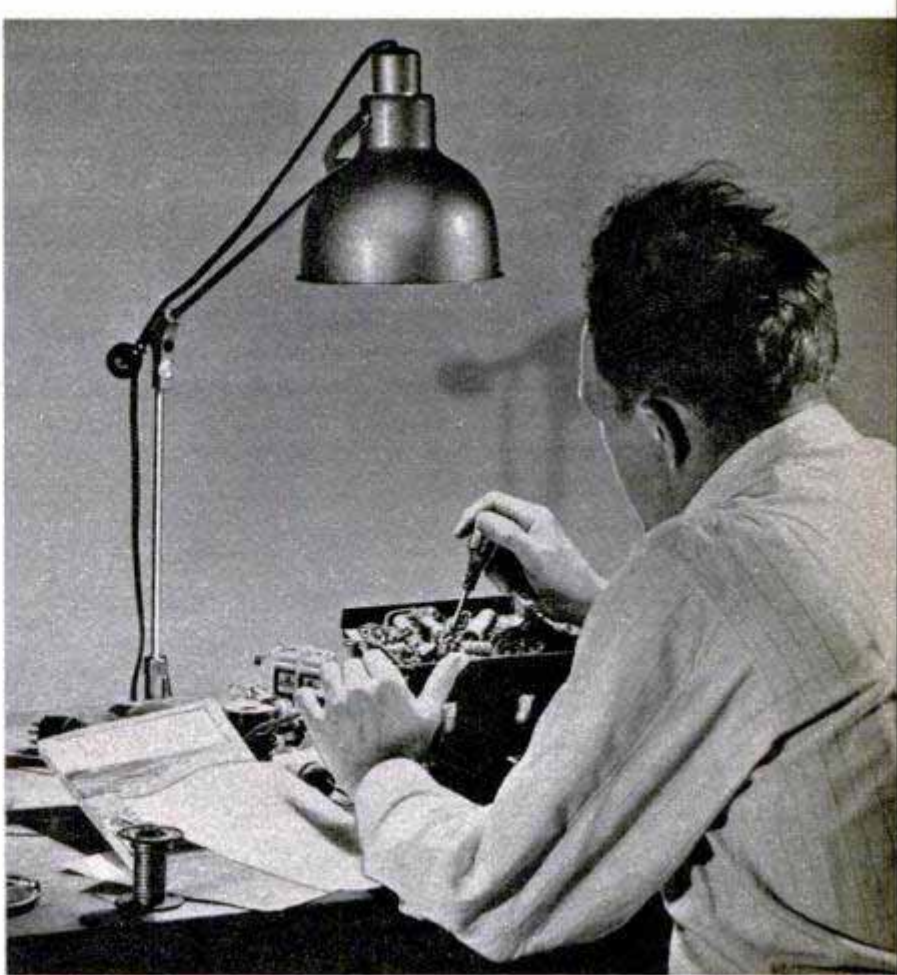

Adjustable Stand Focuses Light for Many Uses

With an adjustable stand and metal reflector the homeowner can direct a concentrated pool of light anywhere from the top of his head to the tip of his toes. An ordinary light bulb, a sun lamp, an infrared lamp or a photoflood bulb can be used with the stand. With the proper bulb, the light

stand can be used as a hair drier, reading lamp, nail polish and glue drier and radiant heater. When the stand is to be readjusted, a lever is depressed and the extension rod pushed into the new position. The slight pressure required prevents the stand from collapsing during the change.

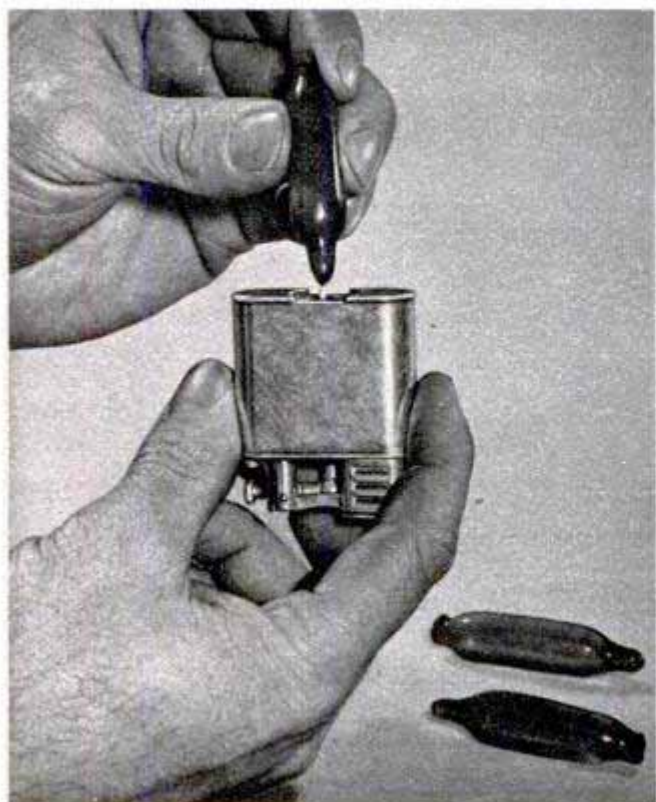

One-Shot Capsules Fill Lighters

You can carry lighter fluid in your pocket or suitcase without danger of leakage, thanks to an unbreakable capsule that holds enough fluid to fill a standard cigarette lighter. Imported from England, the gelatin capsules are sealed to prevent evaporation. Pricking the capsule with a pin allows the fluid to be squeezed out. The capsules are also handy for emergency removal of stains from clothing.

Rubber "Bath" Toughens Leather

Soaking leather in a solution of natural rubber increases its durability, according to three National Bureau of Standards scientists who developed the new treating process. Abrasion and water resistance are increased sufficiently to allow even substandard leather to be used commercially. Rubber stock for the solution is first cold-milled to make it less viscous and better able to penetrate the leather.

JAPAN ELECTRIFIES THE GAS BUGGY

Detroit auto builders would gasp with unbelief if they visited the Japanese plant that makes 35 Tama cars each month by hand. The model changes are a cinch

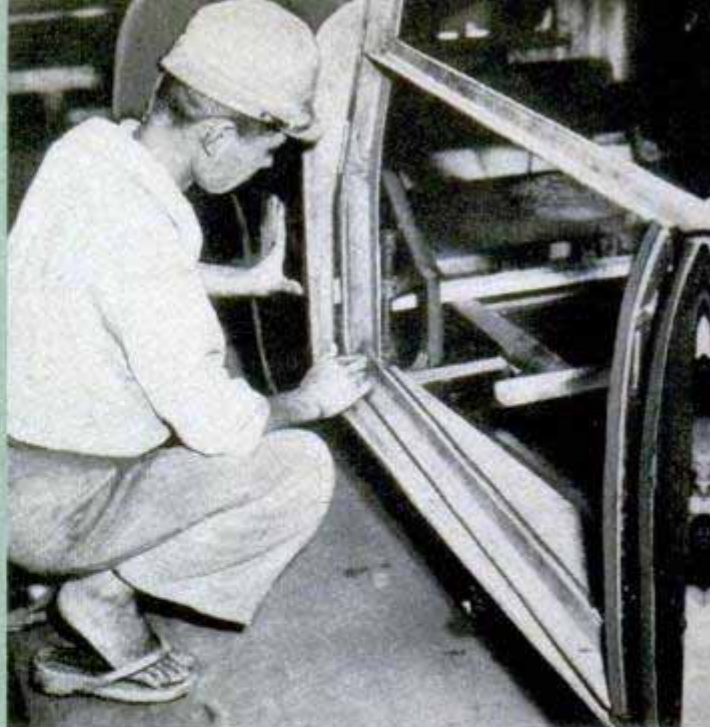

U. S. Air Force photos

In Tama plant nothing fits until it's made to fit. Worker is adjusting part of a body on a wooden jig

PAPA SAN has fired his jinrikisha man. Nowadays, when he leaves for the chopstick factory in Tokyo, he buzzes off in a shiny new Tama, Japan's postwar menace to the pedestrian. It has a top speed of 33 miles per hour, can be operated for a fraction of a cent per mile and passes up all the gas stations. Every time the speedometer begins to show another 200 kilometers (about 125 miles) Papa San merely gets out his long extension cord and looks for the nearest wall plug. The Tama is powered by a battery-driven electric motor, and the batteries can be recharged anywhere.

The Tokyo Electric Automobile Compa-

ny, which builds the cars, is a source of amazement to visiting Yanks from the near-by Tachikawa Air Force Base. The plant is manned by "monkey wrench" mechanics and has no overhead cranes, no hydraulic presses or no heavy machine tools. Hundreds of hours of handwork go into each car. The wooden frame is held together by screws and is carried by hand to a body shop where sheet-metal panels are cut to size, hammered and rolled into shape, and hand-fitted to it. From this point on,

Front view of car (left) shows battery installation and at right worker is grinding pigment to paint a car

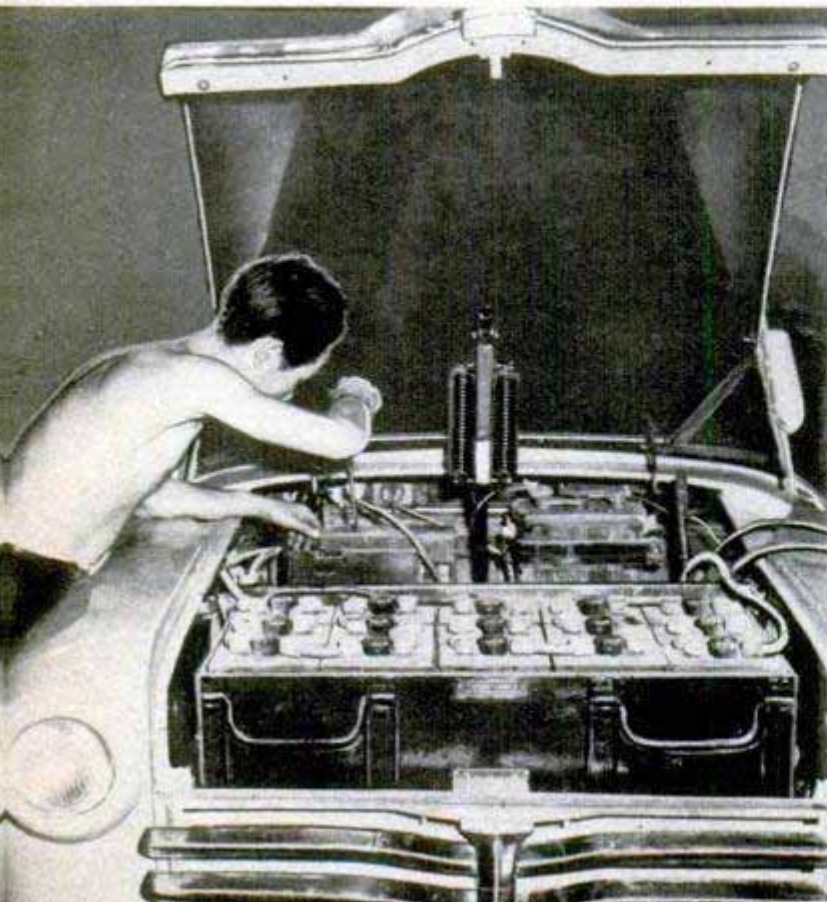



the body is pushed around on wooden dollies rolling on boards. Each part is installed by the worker who made it. Only the motor and wheels are received from outside sources.

After the car is given a primer coat of paint, it is pushed out in the open air to dry and when the final color is decided on, a worker makes the paint by hand. Upholstery is put in by an outside contractor.

Model changes are a simple matter; with no expensive re-tooling to worry about, each worker is merely instructed how to cut or hammer his own part into a new shape.

The Tama is manufactured in two five-passenger models. Tama Senior has an over-all length of 165.3 inches and is priced at 900,000 yen, which adds up to a little over \$2300. Tama Junior sells for about \$1388.

American Jeep is considered a big car in Japan. Here one is posed alongside the electric Tama Senior, the larger of the two Tamas now being manufactured by hand in unique factory near Tachikawa Air Force Base

A sheet-metal panel is rolled by hand into shape in factory where mass production and high-speed assembly lines are unknown. Model changes are made with ease—each worker cuts his part to a different design

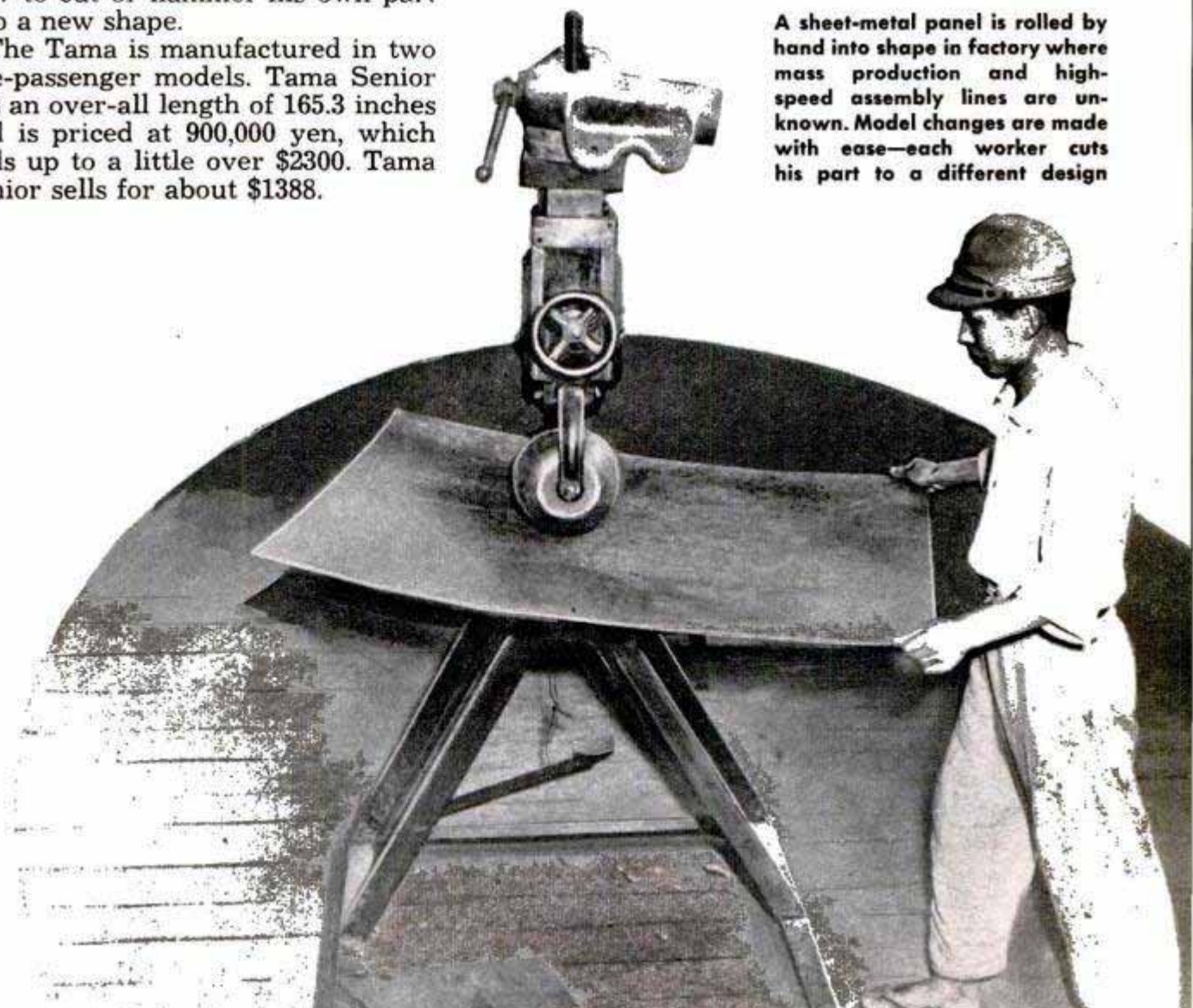



Tough Plastic Disks For Street Markers

Longer-lasting plastic street markers are replacing painted lines in Portland, Ore. The tough 4½-inch disks will last from four to six years, compared with the painted lines that have to be redone about twice yearly. On asphalt they are laid on a hot mastic adhesive and secured by driving a two-inch pin through the center. On concrete the installation is identical, except that a hole is drilled through the marker and into the concrete for the smaller one-inch securing pin.

"Paintbrush" Photo Kit

Even an inexperienced child can make permanent prints with an unusual photographic kit that is used in ordinary room light and requires no trays or mixing of chemicals. The special printing paper is placed in a frame with the negative and exposed to the light from a 100-watt bulb. When developing and stabilizing liquids are applied to the paper with a small brush, the permanent image results.



Elevator on Wheels Loads Bus Luggage

Luggage is loaded aboard the top of busses at an airport in France by a mobile elevator. Mounted on a tiny truck, the elevator is wheeled up to a bus waiting to be loaded and the baggage is placed on the machine's endless belt. The truck's engine drives a generator which supplies electric current to rotate the belt. The luggage moves to the top of the bus where an attendant fastens it in place.



Bath Polishes Metals

Metal products are polished to a mirror-like luster simply by dipping them in a chemical bath that does not deposit anything on the metal, but merely shines it. No buffing is required and the shiny surface will serve as a base for plating or, if desired, can be left as the finished surface.

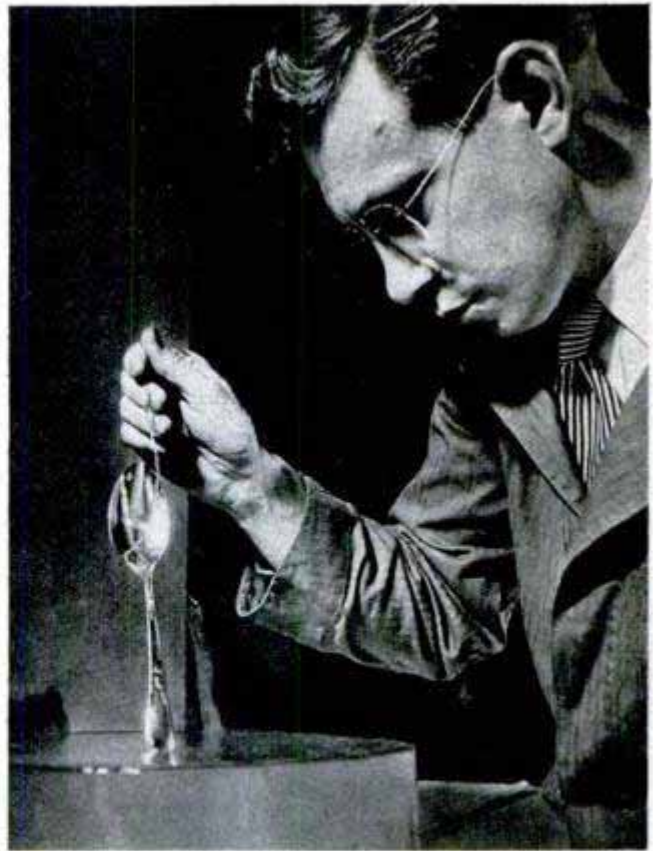

Metals that can be chemically polished include brass, copper, nickel, Monel and aluminum. No electricity is used, the polishing baths being simply a mixture of acids. Immersion periods vary from 10 seconds to 10 minutes and are followed by a rinse bath. It is expected that the process, developed by Battelle Institute, will result in savings in the manufacture of metal products.



Photographer's Camera Wagon

When Langston McEachern, Louisiana news photographer, drives off on an assignment, he doesn't worry about leaving any of his equipment behind. His car, a Jeepster, is designed to carry all his photo equipment and, in addition, it serves as a platform from which he shoots over



crowds. In place of the rear seat, McEachern installed a cabinet with drawers and compartments for film, maps, cameras, tripods and other accessories. There is even space for extra clothing. The cabinet has a hinged lid, strong enough for him to stand on with a tripod. Lights inside the cabinet and under the dashboard enable McEachern to locate his equipment at night.



C-47 showers death along a strip of woodland in Pennsylvania in the successful battle against gypsy moth

Forest Killers Are on the Run

Cameraman photographs a droplet released by plane. Such experiments lead to the most effective sprays
USDA photo



IF, AS THE scientists say, the insects one day will be in charge, it's fairly certain that the gypsy moth will not be among the bugs running the earth. Nor will the tussock moth, the hemlock looper, spruce budworm or a host of other little monsters that have been chewing through some 500,000,000 board feet of timber each year.

A new offensive on a dozen buggy war fronts, spearheaded by the U.S. Department of Agriculture's "air force," is resulting in the first real wipe-out operations in history. Last spring the anti-insect fleet of about a hundred government and private aircraft, equipped with DDT spray booms under the wings, roared up to shower a mist of death over more than a million acres of infected forest from coast to coast. In Idaho, the DDT fleet routed huge infestations of the tussock moth, whose ugly little larvae were busily chewing the needles off a half-million acres of virgin firs. More than 800 billion tussock-moth caterpillars bit the dust under the 390,000-gallon DDT storm. Not a single moth has been seen in the area since.

In the Northwest, the hemlock looper has taken a 300,000-acre shellacking and

will get another, bigger jolt this spring. The spruce budworm won't be back to gnaw new shoots off a quarter-million acres of Maine and Oregon spruce forests that were sprinkled last year. The gypsy moth is on its way to complete extermination — the first such annihilation of a forest insect pest ever achieved.

The gypsy is a harmless-looking miller about the size of a quarter. But towering forests of dead, gray snags are a grim monument to the destructive prowess of the midget.

Today, the gypsy is losing ground under a fantastic DDT bombardment. In 1948, six spray planes zoomed over upper New York on wipe-out operations. Last year Pennsylvania saw the end of huge infestations, and 664 square miles throughout New England were swept clean. But there's a lot of infested forest still left.

Gypsy-moth slaughter begins in spring. The first warm days bring out little green caterpillars with appetites out of all proportion to their one-inch

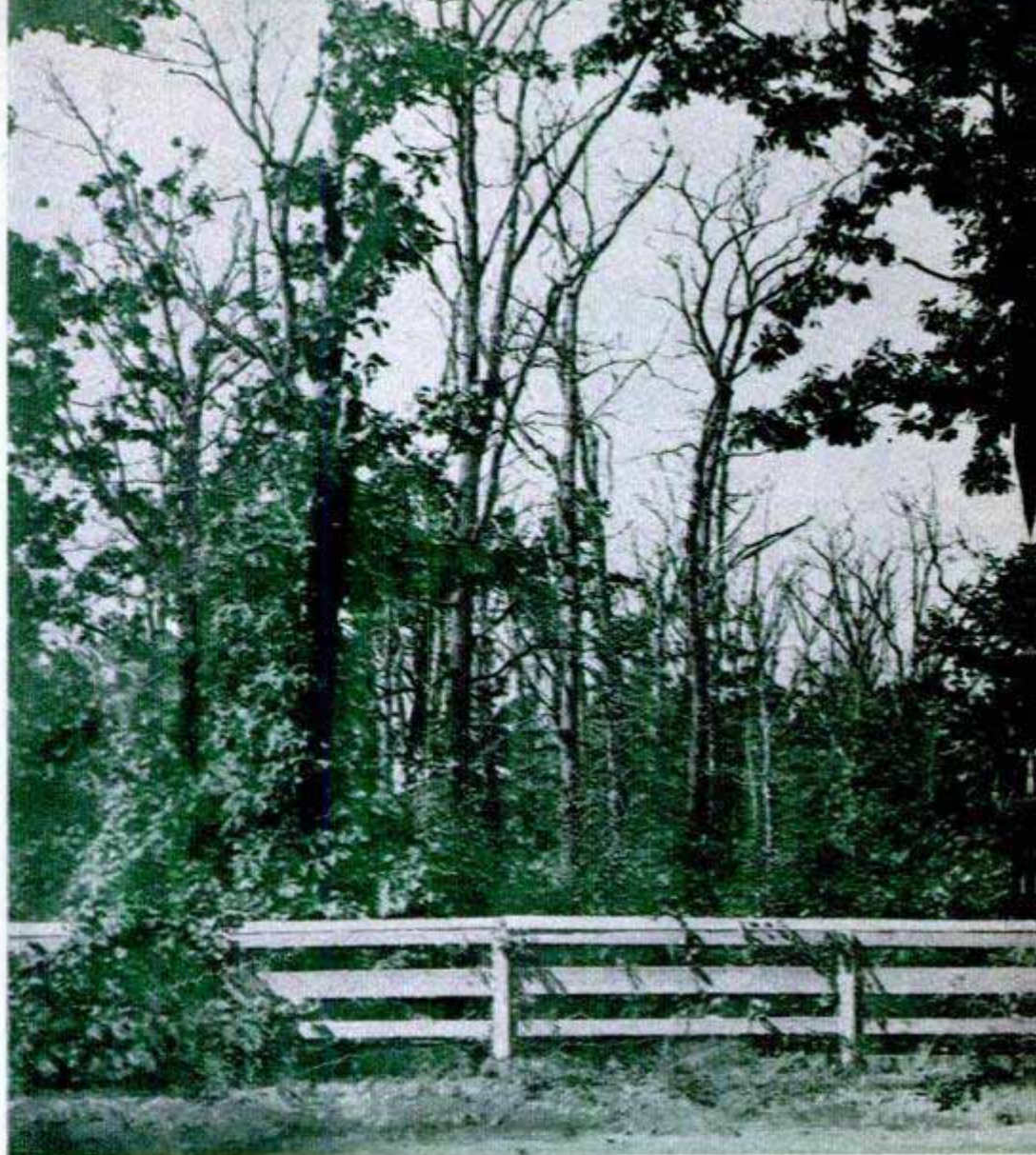

Trees stripped of foliage show the tremendous damage caused by gypsy moths each year. Below, left, first warm days of spring bring out little green caterpillars that eat through the forests. Below, female moth's scent in paper cone attracts males who stick to substance daubed on tree

USDA photos

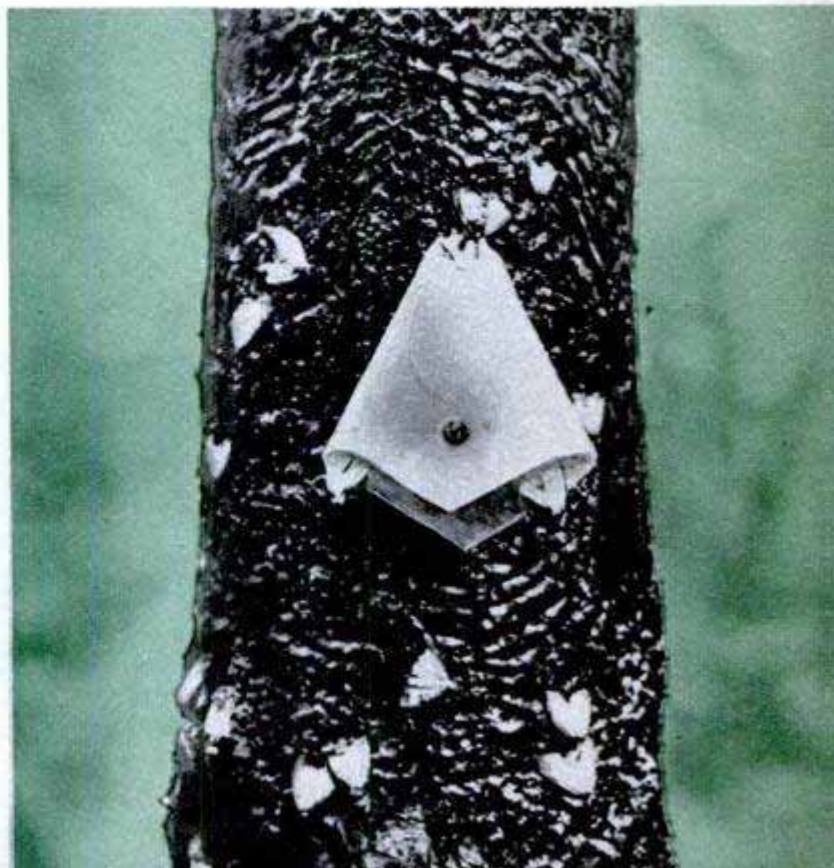

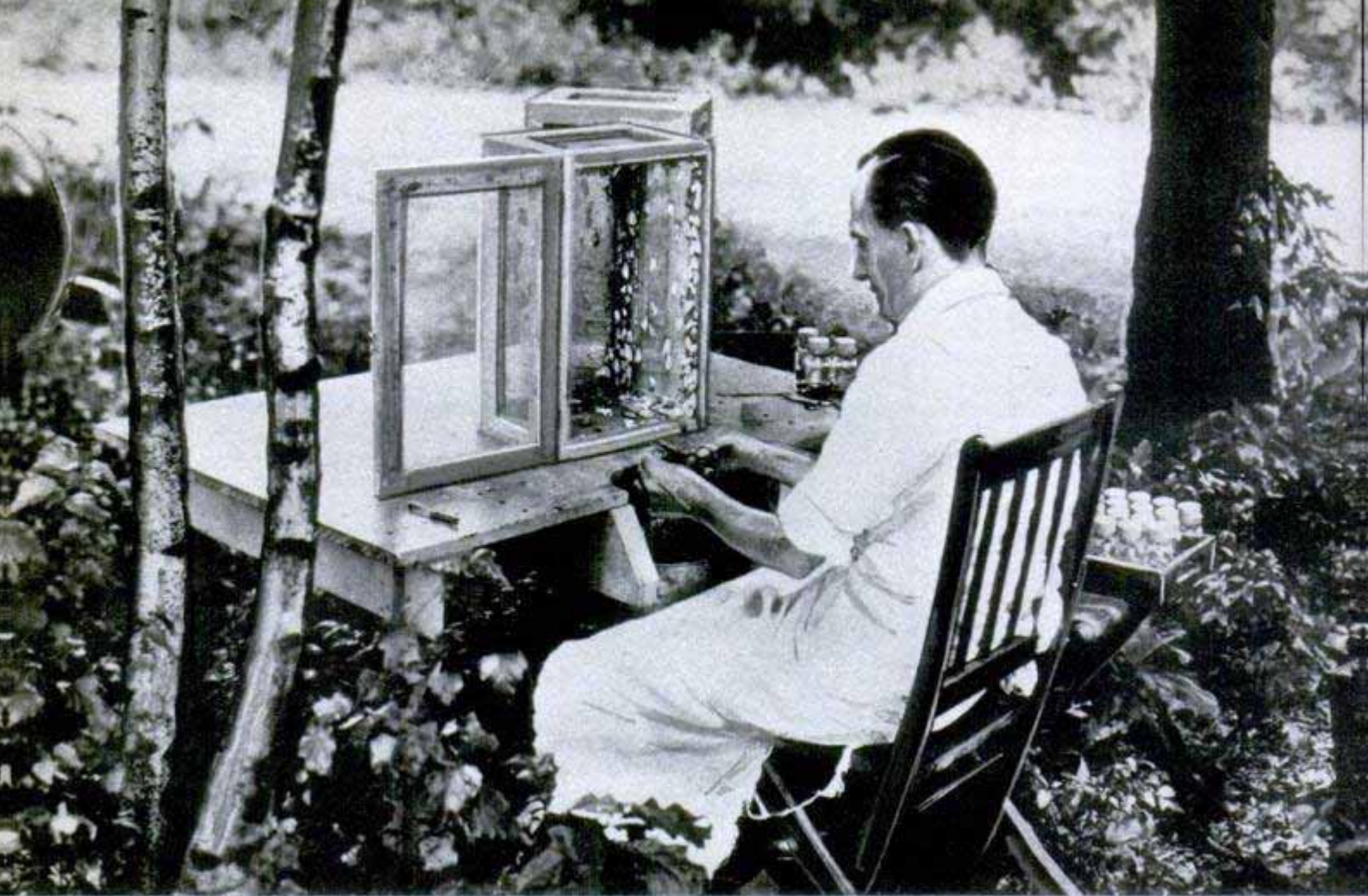

Scent of females is made stronger in "aging cage." Then their tail segments are clipped and odor extracted

wheel bases. After stripping the trees, caterpillars "pupate" and finally emerge as grown adult moths. Along toward mid-summer, lady moths lay their egg clusters on tree trunks—or anything else handy.

Armies of entomologists used to scout the woods each summer to count those

clusters, thereby getting advance information on where to spray.

Today, under Jack M. Corliss who heads up the Gypsy and Brown Tail Moths Control Headquarters in Greenfield, Mass., the boys have developed a neat system for making the moths count themselves.

Young lady moths, it seems, are especially endowed with perfume in the last two segments of their tails, which attracts male moths like mad. So, every June, some 75 men from the Greenfield station prowl the New England forests plucking moths from the trees. Last year they got 2,000,000—enough to bait 25,000,000 acres of forest. These are kept in wire-screen trays in the Freetown, Mass., insectary until they hatch. Then males are destroyed. Females go in "aging cages." This aging, explains Corliss, increases the intensity of the attractant. Then the clippers go to work, snipping the tail segments and

Shaped like a bomb, new 25-gallon dispensing tank can be installed on any plane within five minutes. DDT sprays out the propeller blades



dropping them in a chemical solvent. The liquid solvent, loaded now with "attractant," is dropped on paper wicks in special traps. Some traps consist of tin cylinders with screen baffles on each end. More common is a simple affair made of a sheet of tangle-foot paper, in the center of which is placed an inverted paper cone containing the bait.

Thousands of these contraptions are tacked to tree trunks in suspect areas. Nature does the rest. As little as three milliliters of the attractant draws eager male moths from a quarter of a mile around. Simply by counting the males thus trapped, entomologists get an accurate estimate of the number of moths in that whole area—thus determining the need for spray the following spring.

The toughest problem in gypsy-moth control has been to keep the demon from getting out of the New England area and starting new colonies. The lightweight fuzzy caterpillars, spinning from treetops on their silken strands, have been known to carry 20 miles on a stiff breeze.

Worse, lady gypsy moths aren't fussy about where they lay their eggs. Christmas trees, railroad ties, telephone poles, lumber, furniture, rugs — everything shipped from infested areas must be inspected by eagle-eyed quarantine officials.

The big weapon in the new offensive is, of course, the new insecticides. DDT and other high-powered bug killers are easy to handle, spread easily and cost one fourth as much as the older types to spray. They are spread from planes equipped with spinner-disk sprayers, designed to break up the solution into extremely fine mist over a 110-foot swath. Nowadays, a good pilot like Don Whittam can cover 80 acres of infested forest in three minutes.

It's the most hazardous kind of precision flying a few feet above the trees. In hilly country the pilot must fly on the contour around slopes for most effective placements of spray. There must be no overlap or "misses." Whittam knows how to keep throttled to 80 or 85 miles an hour—and to manage mushy controls at that near-stalling speed while skimming the leaves.

The only monkey wrench in the whole high-powered insecticide air program is people—some just ignorant, others frightened. No sooner was word of the tremendous success against the gypsy and tussock moths rumored about, than Department of Agriculture mailbags were stuffed with squawks from sportsmen, claiming that DDT was killing hordes of fish; bird lovers, who fumed that it killed birds and destroyed their food; nature lovers, who said it upset the balance of nature. A bird watcher in Scranton saw the planes fly over

spreading mist and knew what it was. She promptly called the Secretary of Agriculture himself and complained bitterly. The Secretary asked if she had seen any dead birds. "Well, no," replied the bird lover, "but there's a bumblebee in my back yard in terrible shape."

What about the beneficial insects, birds and balance of nature? Down at the Department of Agriculture's big farm in Beltsville, Md., there's an experimental biplane with a 60-gallon tank. Every calm morning it roars into the sky to test different spray concentrations and droplet sizes, over carefully controlled areas. Dr. C. H. Hoffmann usually is on hand. It's his job to find out just what the poison will do to insects important as natural control agents and as food for game and wildlife.

Before the battle of DDT started in earnest, Hoffmann marked off a square-mile area of forest and also a trout stream for test work. Fish were netted, counted and put back in the stream. Weirs were set up at the downstream end of the area to catch fish that might die of DDT. A hive of bees was borrowed and placed in the center of the square mile.

Finally, on a mild spring morning, the N3N zoomed aloft, carrying its poison cargo, to be sprayed in murderous concentration—five pounds to the acre.

While the pilot was dumping his mist, Hoffmann and a team of scientists went in under it. "Within 10 minutes bugs fell from trees like rain," he recalls. "Birds quit singing and disappeared."

The men found seven dying birds. In the weirs, by the week's end, were about 1.3 percent of the total native brook-trout population.

It sounds bad, but don't forget it was five times the normal dose. What about the balance of nature in that forest? How long would it take for uncontaminated insect food for birds and fish to build up again, and where would it come from? Hoffmann and his men found out. With a special digging tool, they cut a square foot of soil three inches deep from the forest floor and carefully screened it. In that tiny chunk they discovered more than 10,000 crawling insects of all kinds and sizes.

Ask the bug men about insecticides upsetting the "balance of nature" and you'll get a mighty short answer. "Bugs do more unbalancing than any bug killer," they point out. "When all the trees in a big forest are killed by insects, birds must go elsewhere, food disappears, watersheds are ruined, waters become silted and won't sustain many types of native fish, the recreational value is lost. No insecticide known at the present time does that much damage—even temporarily."



Saw Cuts Its Own Starting Hole

There's no need to drill a starting hole for internal sawing when you use a light-weight, portable power saw that will start cutting anywhere. The blade quickly drills its way through the material and cuts any intricate shape in wood up to an inch thick, making $\frac{1}{4}$ -inch turns without binding. It can also be used as a table saw for band or jigsaw work by clamping it in a table that is sold as an accessory.



Nailing Machine Speeds Building

Subfloors and sheathing are nailed securely and speedily by a pneumatic machine that drives the nails at a rate of 40 to 50 nails a minute. Weighing about 32 pounds, the machine has a capacity of 400 to 600 nails. The operator steps on a foot-rest to steady the machine during use. Operated by air pressure, the tool handles 7, 8 and 10-penny nails, driving them below the surface, if desired.

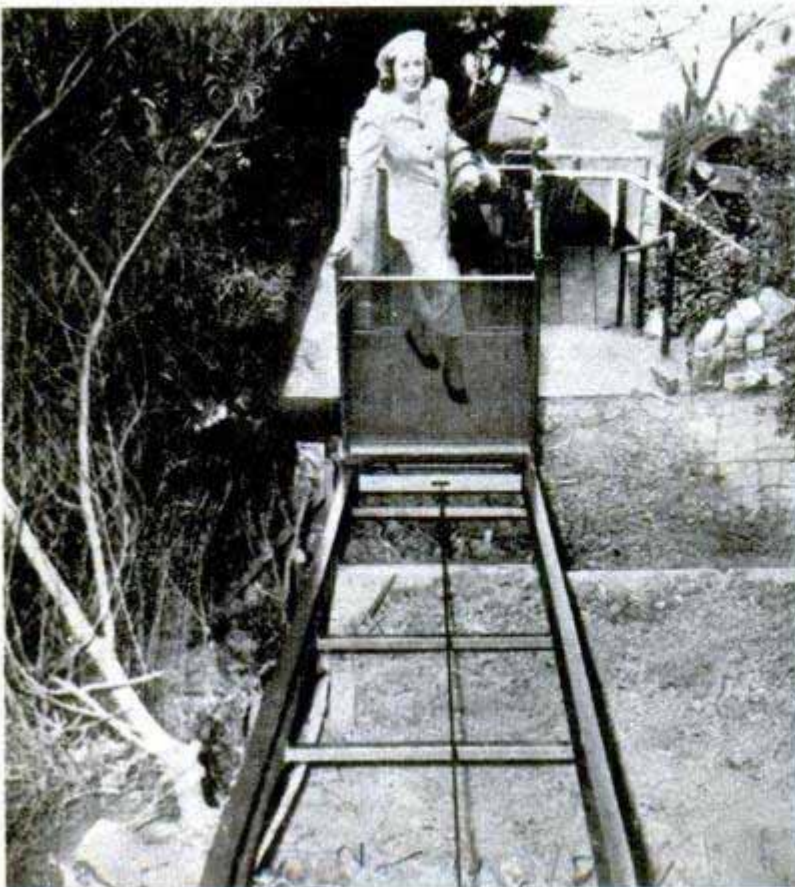

Private Cable Car

Tired of climbing the 62 steps to his home, James M. Hammil of San Francisco had a personal-type cable car installed to run from street level to the door. Powered by a $\frac{3}{4}$ -horsepower motor, it makes a 60-foot steep ascent over an 80-foot track. The car automatically stops at each end of the line and will also halt if the cage gate is opened during the run. Over 100 similar cars are being installed in the city.

Popular Mechanics provides two sources of further information pertaining to articles published in each issue: the **WHERE-TO-BUY-IT INDEX**, which appears on pages 10, 12 and 14, and the **WHERE-TO-FIND-IT INDEX**, available to readers without charge. To obtain a copy of the latter index, just send a postcard to Bureau of Information, Popular Mechanics Magazine, 200 East Ontario Street, Chicago 11, Illinois



Masterpieces in Miniature

By Richard F. Dempewolff

ALL RIGHT from a distance, but terribly crude." If the builder of the intricately rigged model sailing vessel in a steamship line's Chicago show window had heard August Crabtree's comment, he'd probably have had a convulsion. But Crabtree, tall, gaunt and quiet, meant what he said. His criticism was based on his own 15-ship fleet over which he has toiled 12 to 15 hours a day for the past 22 years.

The models, built $\frac{1}{4}$ inch to the foot, literally are jewels of microscopic perfection. Sails can be raised or lowered by hauling threadlike lines through blocks smaller than apple seeds. Even the smallest— $\frac{1}{16}$ inch in diameter—have movable sheaves, so tiny they are made under a microscope. "Drop one on the floor, and it will slip into the nap of the rug and get lost," says

To carve intricate decorations on his seven-inch gondola, Crabtree uses this chisel which has a $\frac{1}{2000}$ -inch blade

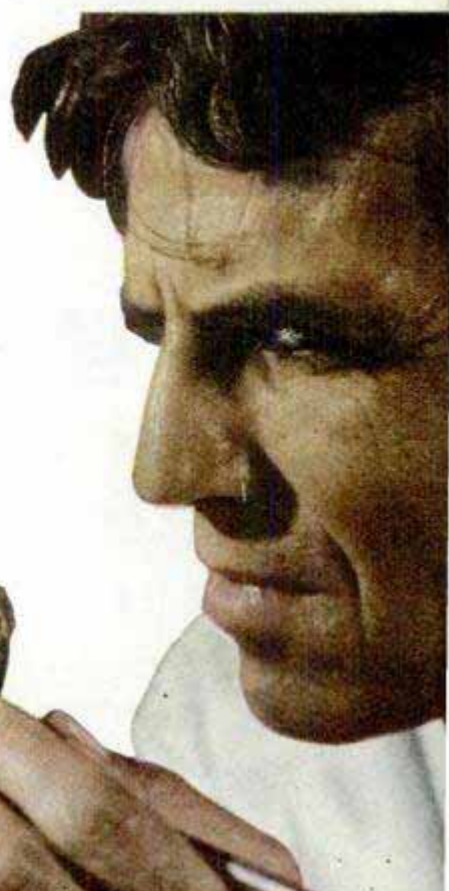

MARCH 1950

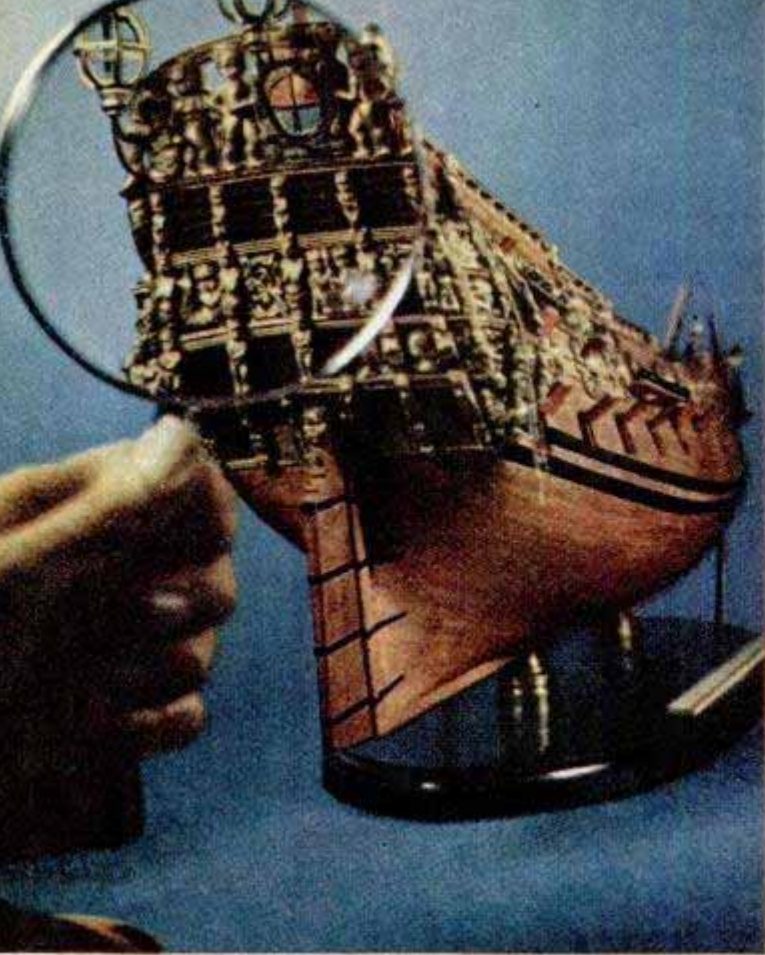

Opposite page, intricate carvings on sterns of these three vessels follow the originals exactly. At left is the French galley. Center is the Royal Yacht of Charles II, with its beautifully carved portholes. Smaller model at right is the Dutch Admiralty yacht →

their builder, speaking from experience.

No single detail of construction is faked on any Crabtree ship. Each is built up plank by plank, fixture by fixture. Quarter-inch gun ports open and close on infinitesimal hinges. Belaying pins, $\frac{1}{4}$ inch long, slip into racks along the carved balusters. Ring bolts no bigger than this "o" are hand-forged to scale. Other fittings, the size of pinheads, must be placed with a magnifying glass. One-inch grille hatch covers—usually punched or carved from a wood block by model builders—are made up of painstakingly scaled "lumber," notched, fitted and framed, just as they were on the real ships.

Each detail of hull construction conforms to big-ship plans, even to the size of timbers that are pegged or nailed with scale replicas of the pegs or spikes specified by the original shipwrights. The foot-long deck spikes used by old builders show up as $\frac{1}{4}$ -inch brass nails on Crabtree's models. Some he made himself, others were specially made for him in England. Commercial supplies rarely satisfy him. To get proper texture and scale, he weaves his own line of fine linen thread and forges his own minute chain.

Even the six-inch lifeboats on Crabtree's



Top, model of the "St. Albans" has 270 carvings, some of which are shown under reading glass. Left, stern lamp of Dutch Admiralty yacht has all the details of the original. Below, left, primitive vessels of the Crabtree fleet are a Stone Age raft and hollow log. Below, unplanked side of British East Indiaman shows rib design. Portions of the deck are unplanked also







Above, that's the first known seagoing vessel at the left. Other sailer is William the Conqueror's "Mora"

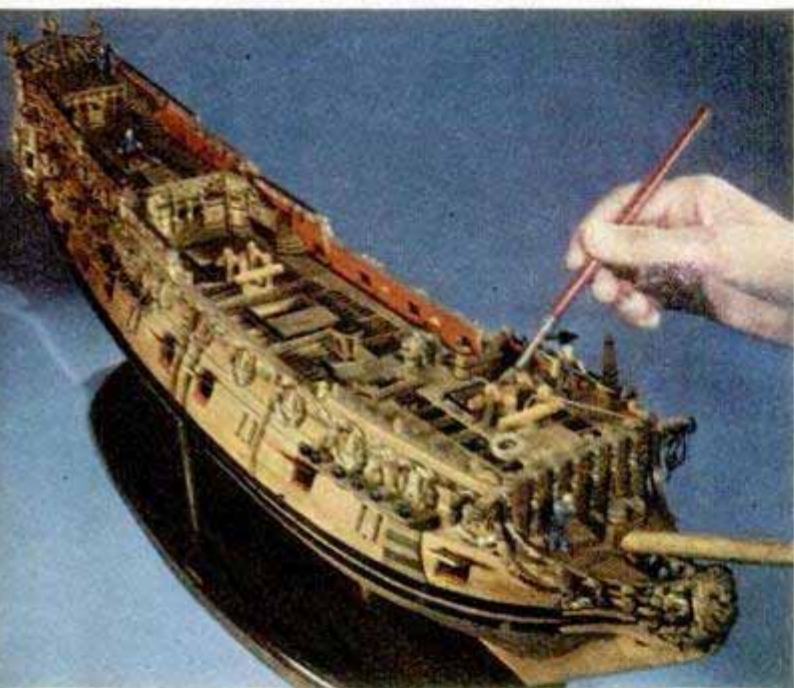

Above, dusting intricate models is done with a small oily brush, being used here on "St. Albans." Below, Mrs. Crabtree touches up paint on Venetian galleass



ships are not carved from blocks, but are built up in lap-strake fashion. To remain faithful to scale in these lifeboats, the builder shaved shiplap so fine that the eggshell hulls are often transparent.

"Building them accurately and faithfully," Crabtree explains, "is harder than building a real ship. You work with unusually small bits of wood and very small tools. On a big ship, if you make a mistake on hull construction, you can always go below later and change it. But you can't go below on a model. It must be right the first time."

Though the Crabtree fleet ranges from a beautifully sculptured, inch-high Stone-Age man poling a raft to a six-foot model of the Cunard Line's first sidewheeled steamer launched in 1840, most are models of the ornately carved vessels that rode the seas centuries ago. This often means months of poring through rare books, crumbling shipwrights' plans and charts just to get the proper detail for a single item—like the profile of a figurehead, or the contour of a tiny baluster.

Crabtree never knows where he'll find the necessary data. The best working description for his model of the old Roman grain ship in which St. Paul took his last voyage, came from the Bible. Similarly, his model of William the Conqueror's "Mora," a Viking-type ship of lap-strake construction with shields along the side and a dragon figurehead, was pieced together largely from a picture of it which he discovered quite accidentally on the famous old Bayeaux tapestry in Normandy, France. Tiny covers over the sweep tholes on this model are so thin you can see light through them, but they open and close just as they did on the real ship.

The model with the most far-flung and romantic research background is that of the first seagoing ship known—an Egyptian vessel built about 1500 B.C.

General contours of the ship came from bas-reliefs carved in the Temple of Dier el Bahari and from hieroglyphics discovered by V. O. Lawson, British archeologist, who opened King Tut's tomb. Ancient books and parchments revealed that Egypt had no tall timber, nor did she import any in those days. Hence, Crabtree knew that side planking for the old bark would be short. The King Tut and temple drawings showed him how the short timbers were butted and dovetailed and also showed a long, heavy rope stretched from bow to stern over supports, giving the weakly constructed vessel support to prevent it from "hogging," or breaking in the middle in a heavy sea. This was known as a "hog truss."

Working with Lawson, Crabtree was able to duplicate the old ship in scale. He wove

(Continued to page 238)

"Three Speed" X-Ray Unit Gives Varied Treatments

Producing radiation of phenomenal intensity and in a wider range than any of the single X-ray treatment units, the Maxitron 250 makes possible three types of treatment. Capable of delivering X-rays at voltages ranging from 100,000 to 250,000, the unit can be throttled down to produce non-penetrating "soft" rays effective in the treatment of skin diseases. The machine produces rays that penetrate sufficiently to reach lesions of medium depth in the body, and at its full voltage, can be used to treat deep-seated malignancy. The intensity of radiation is a result of a beryllium window located in a special tube and an amount of amperage double that usually used in therapy units. Differing radically in design from therapy machines, the Maxitron employs an end-grounded, multisection tube which allows the anode end of the tube to be brought closer to the part that is being treated. The design of the head makes possible 360-degree rotation and permits the beam to be aimed in any direction. Another new feature of the Maxitron is the use of a spe-

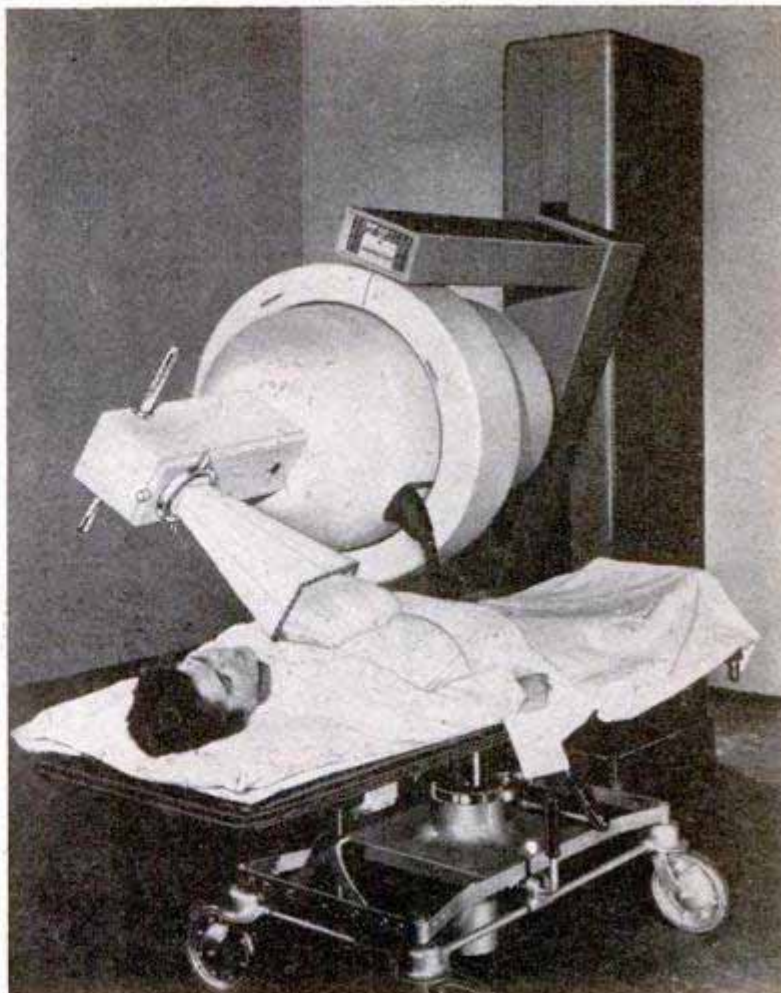

cial gas instead of oil as insulation in the cylindrical tank containing the tube and transformer.

Plastic Piping Drains Salt Water From Oil Deposits

Weighing less than one pound per foot, a noncorroding plastic piping, made of Tenite, is being used by oil producers to draw off salt water from crude deposits. Being plastic, the pipe is not corroded by

the salt water and requires no cement lining as does the steel pipe normally used. In addition, the tubing is flexible enough to follow the contours of the earth, making backfill requirements much less exacting.

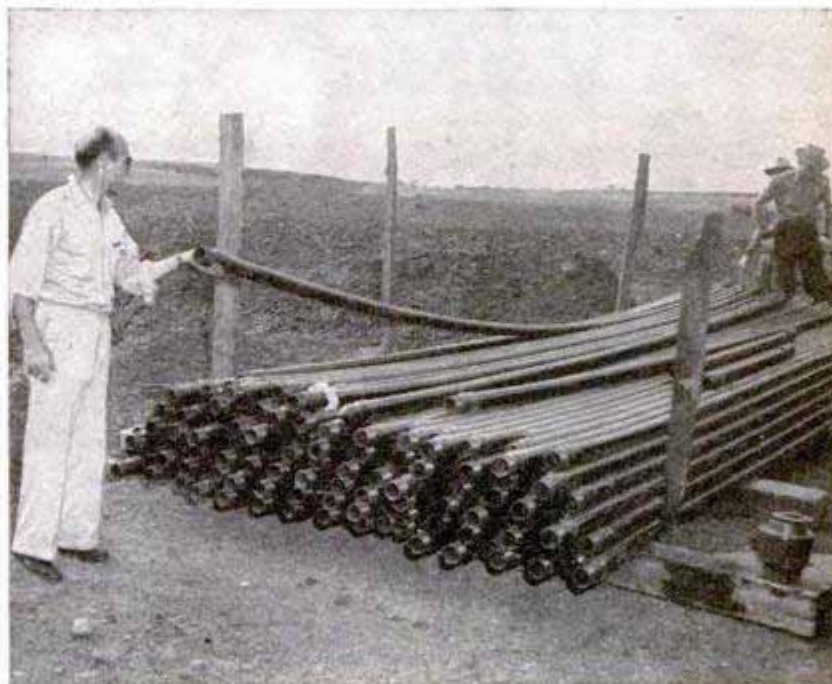



U. S. Army photos

Mine planter equipped with whirling blades makes a neat about-face, reversing course within its own length

SEA-GOING EGGBEATERS

A BIG TANKER, with trawler in tow, hove-to in Charleston Harbor recently, while all hands lined the rails to watch a Navy mine planter that seemed to be wallowing and in need of help.

Suddenly, eyes popped as the mine planter spurted forward with incredible speed, spun like a top in a space no greater than its own length and headed for a pier. It didn't coast in to a landing. It roared up parallel with the dock, about 50 feet offshore and, as though by magic, stopped on a dime. Then, like some crazy waterbug, it crabbed sideways into the pier and tied up.

Astounded watchers on board the tanker had reason to gape. They were looking at the results of the greatest advance in marine propellers since invention of the helical screw. The secret of the mine-planter's antics was "cycloidal propulsion," a method of locomotion developed in this country by Prof. F. A. Kirsten of the University of Wisconsin.

First tested on a harbor tugboat some three or four years ago, the Voith-Schnei-

der or "eggbeater" propeller is made up of a disklike blade wheel, flush with the bottom of the ship. Sticking downward from the bottom of the blade wheel are anywhere from four to eight blades, similar to airplane propellers chopped in half. As the blade wheel whirls, the blades rotate, too, so that in ordinary forward movement they knife the water on the forward sweep, and present a paddle surface on the backward sweep. Through hydraulic controls on the bridge the pilot can adjust or even reverse the angle of the blades. The ship will respond by going faster, slower, turning, sidling broadside, backing up or spinning as though hung on a pivot. Since all movement is controlled by the propellers, the ship has no rudder.

Because of advantages in maneuverability, cycloidal propellers are considered ideal for military craft, towboats, mine planters and tugs. The propellers have tremendous drive, giving a speed about 30 percent faster than is possible with the conventional screw.

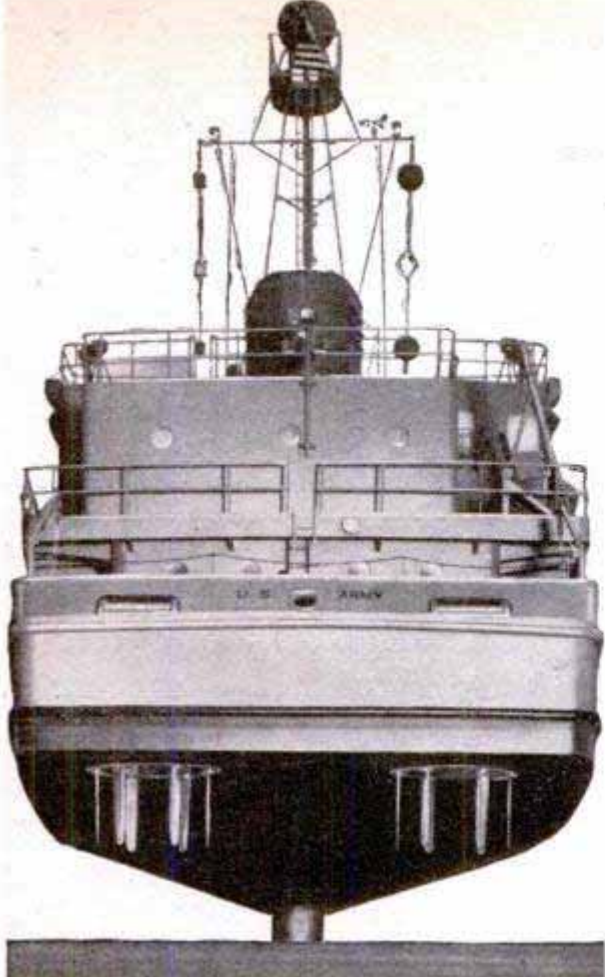

↑ Twelve blades knife downward from the two blade wheels on a model of the mine planter. Below, cycloidal propeller also was installed on a towboat. Though this unit has eight blades, number can vary

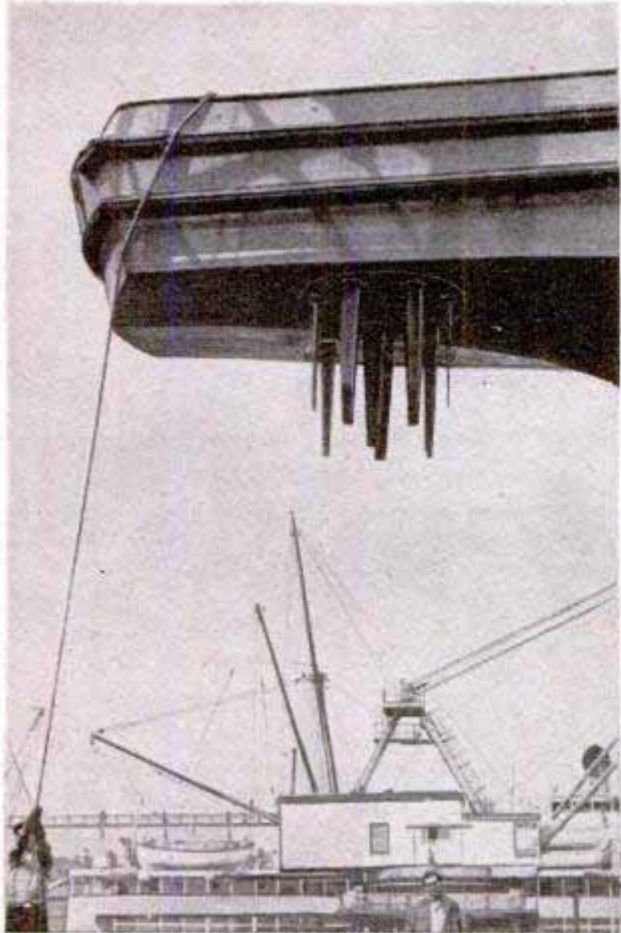

↑ Simple controls on the bridge permit pilot to spin the ship like a waterbug. Three diagrams below show how angle of blades changes direction of craft. Arrows in groups show thrust of the blades to maneuver ship in direction indicated by single arrows

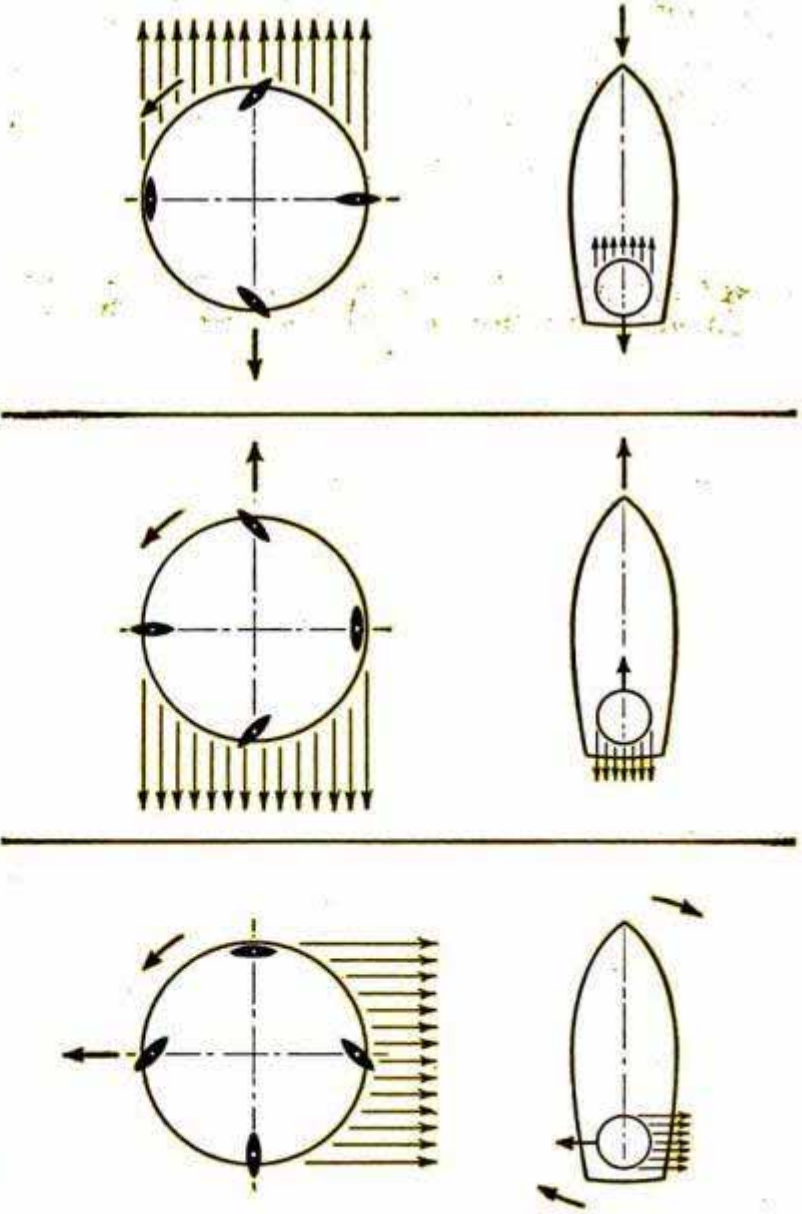



Wide-View Mirror Aids Safe Driving

Motorists can see in a 160-degree arc to the rear with a five-section rear-vision mirror that attaches to the upper molding of the windshield. With the mirror, motorists can see both sides of the road as well as directly to the rear, eliminating the need for glancing over the shoulder in traffic. The mirrors are set in a metal frame at various angles to provide the continuous view rearward. The inventor, Charles L. Bennett of Chicago, adapted the 70-square-inch mirror from a wartime model he produced for aircraft.

"Juke Box" Caller Announces Trains

Once the chore of a leather-lunged man in uniform who sometimes sounded as though his mouth was full of pebbles, train calling is now being done in distinct and well-modulated tones by an adaptation of the modern juke box. Built for the new Texas & Pacific station at Fort Worth, the electronic caller uses a series of professional recordings that gives the calls of all trains arriving and departing from the station. Two automatic selectors, of the type used in restaurant juke boxes, are mounted behind the ticket counter in the waiting room. All a clerk has to do is dial the name of the desired call and the announcement goes out clearly over a public-address system. Professional radio talent was used to make the recordings to assure proper enunciation.

Top, selecting the proper train call is as simple as dialing a tune on a juke box. Right, this changer automatically plays any of 38 recorded announcements

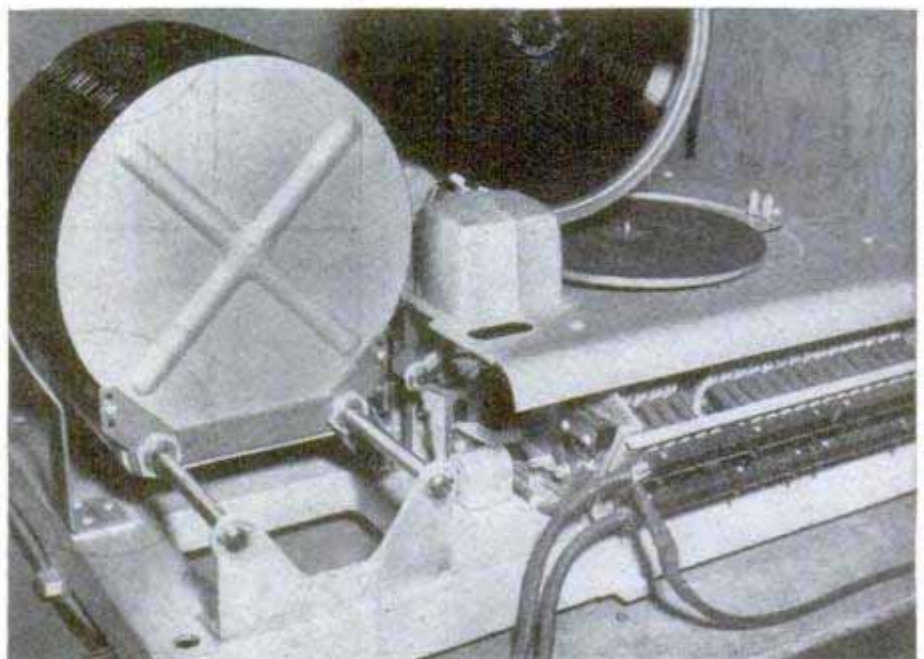
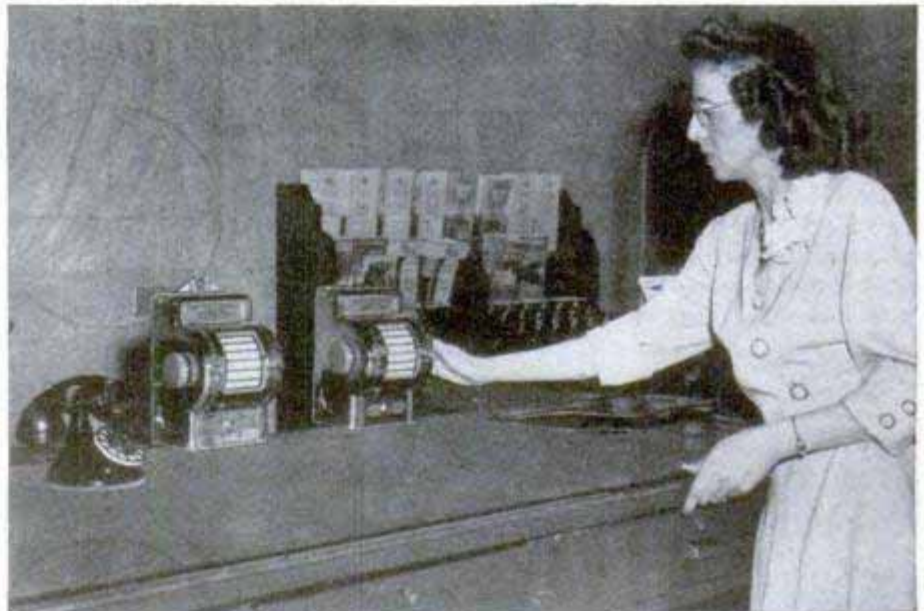

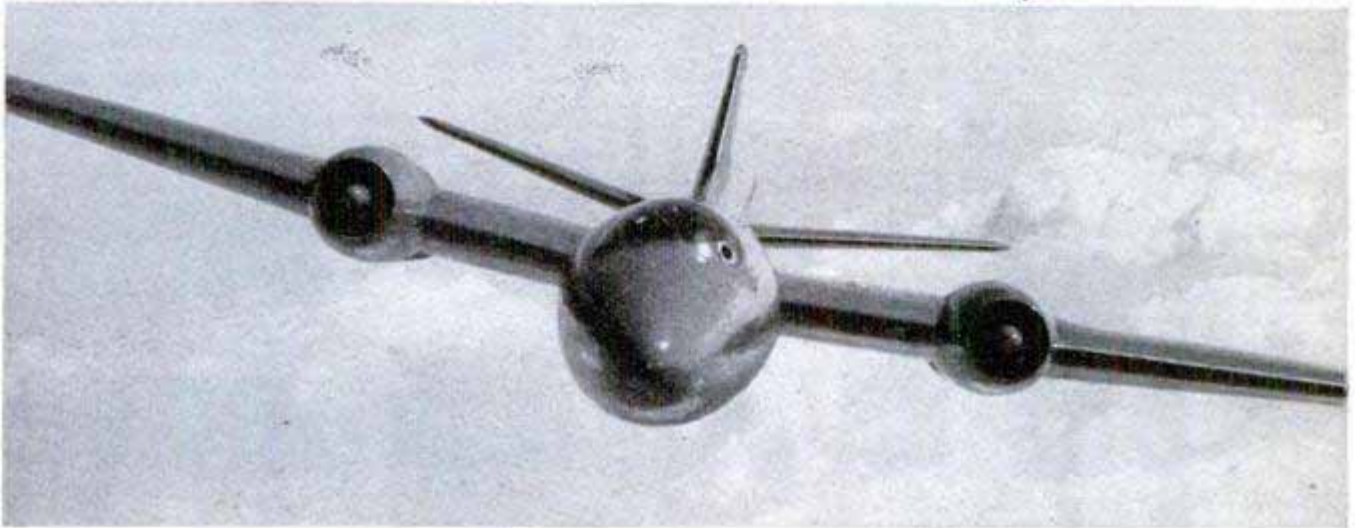
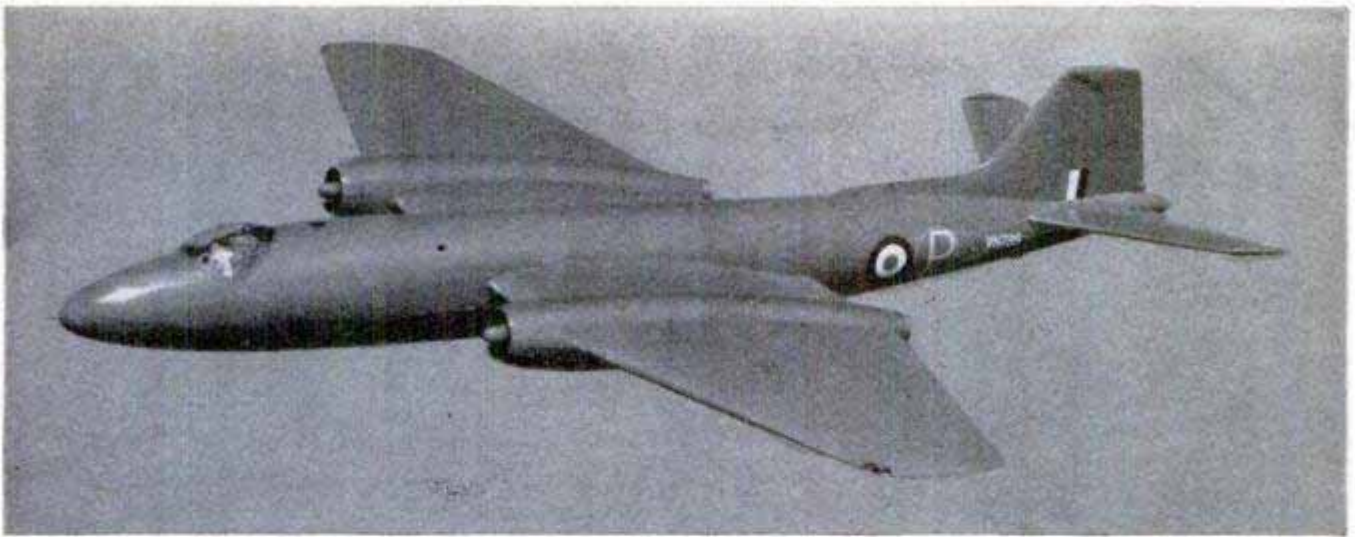

Acrobatic Bomber

One of the most unusual new warplanes is Britain's twin-jet Canberra, a bomber that does slow rolls, high-speed turns and sharp climbs like a fighter. It has a speed range of from less than 100 to more than

500 miles an hour. Classed as a light bomber, carrying a 10,000-pound bomb load, the Canberra has a crew of two, pilot and radar operator. Twelve are being built by the English Electric Company for Royal Air Force service testing. It is Britain's first jet bomber.

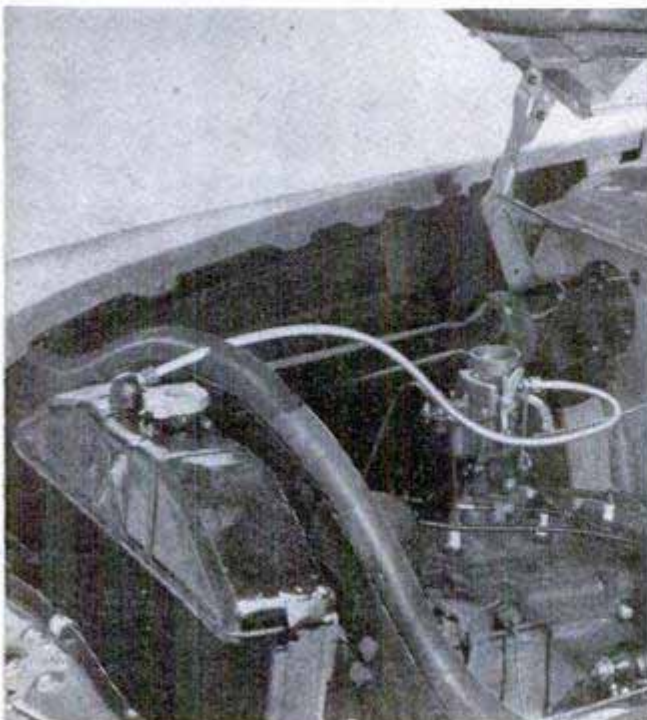

Water Vapor From Radiator Increases Gasoline Mileage

By transferring water vapor from the radiator to the carburetor, a vaporizer is said to make automobile-engine operation smoother and more economical. From a thermal dome, soldered to the radiator, a length of aluminum tubing carries the moisture-laden air to the carburetor to act as an antidetonant, producing more even combustion. According to the manufacturer, the vaporizer, which provides the same moist air that makes your car run better on rainy days, increases gas mileage, reduces carbon and gives longer oil life. Antifreeze, either permanent or alcohol-base, does not lessen the effect; in fact, alcohol vapors increase the benefits.

☐ Airline travel throughout the world averaged 70,000 passengers a day during the past year.

Top drivers for 1949, left to right: Johnny Castner, double-bottom king; Ben Winterberger, semitrailer, and Steve Moon, straight truck



If you've cussed 'em on the highway, prepare to take it all back. They're the world's safest drivers, these cowboys who ride

BRONCOS WITH RUBBER

Expert drivers whip around the "roadeo" course, almost perfectly, in 3 minutes

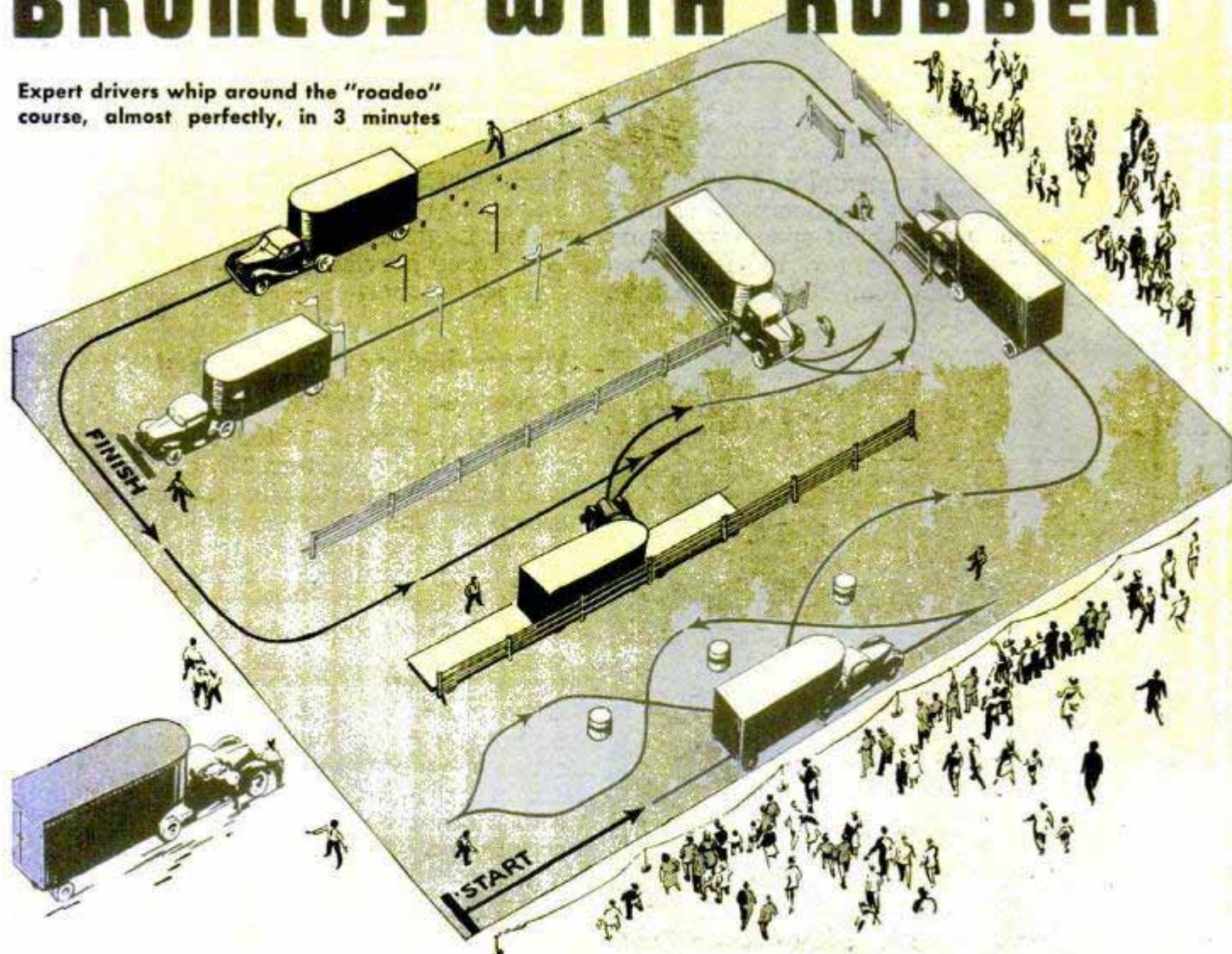

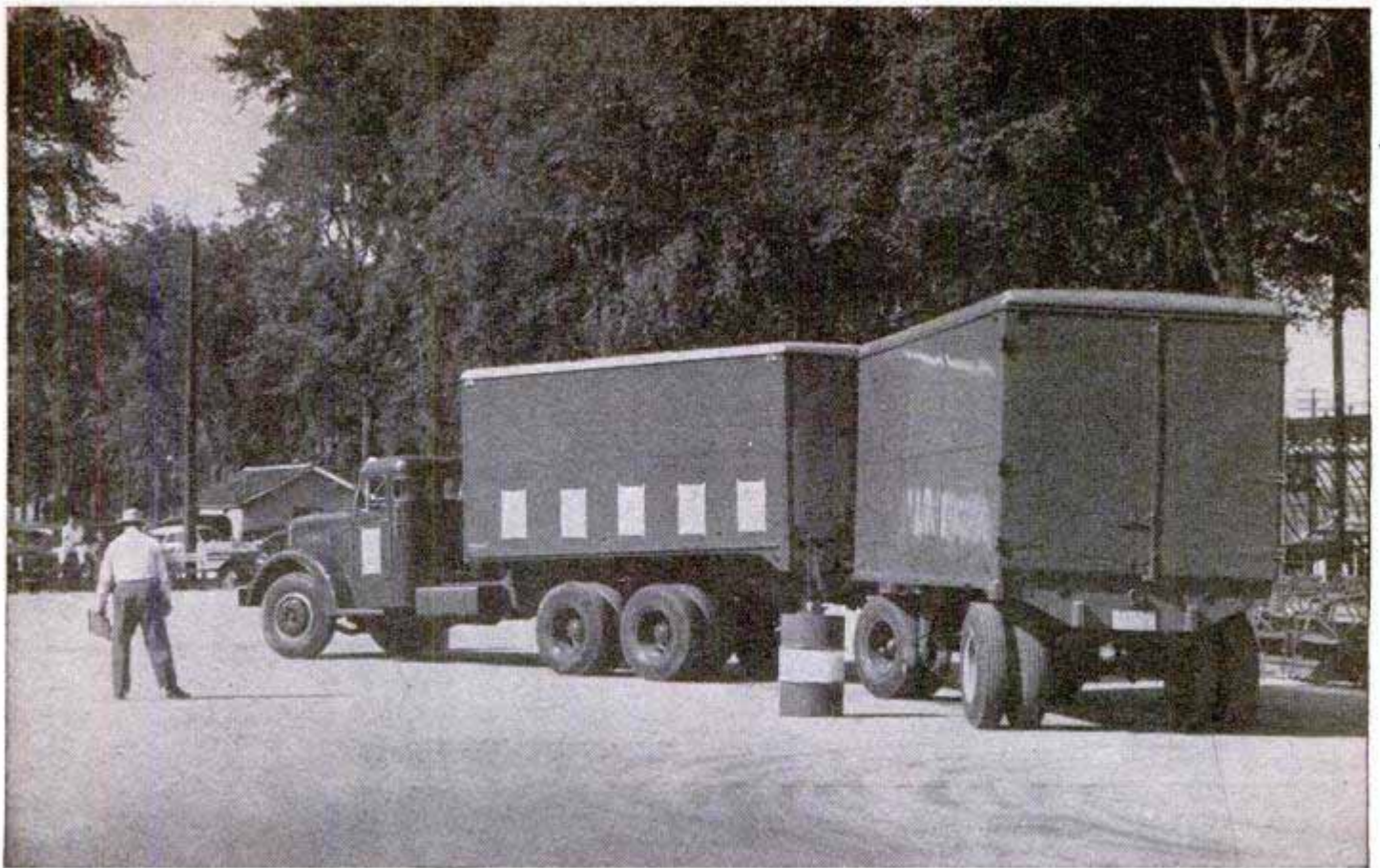

TIRES

It takes precise wheel-handling to roll this 18-wheel double-bottom truck forward and backward through the serpentine without hitting a single barrel

Champion Johnny Castner shows a former B-29 pilot, Leverett Richards, how to do the two-handed shift

The Portland Oregonian



By

Richard F. Dempewolf

RODEOS once were affairs in which bandy-legged cowboys rode kidney-busting broncos and Brahma bulls, rope-tied calves and "yahooed" all over the corral.

Now, like everything else, rodeos have gone 20th century. The steeds are there, all right, but they "augerate" on bolognas (rubber tires to you) instead of iron shoes. And instead of snorting, they roar oil or gas-fumed defiance. Instead of the comfortable creak of saddle leather, there's a clashing of gears and a rumble of 20-ton trailers being whipped through narrow alleys, snaked around barrels and backed into docks that are invisible from the driver's seat.

Even the spelling of the game has been changed to conform with progress. It's a "roadeo." The only familiar item in the whole show is dust, which swirls from the spinning dual wheels of the mighty transport trucks more abundantly than it ever did from under the shoes of an ornery bronc.

The National Truck Roadeo is a natural outgrowth of a fast-growing industry. In 20 years, trucking has grown from almost nothing to a point where now some 7,500,000 thundering vehicles carry 80,000,000,000 ton-miles of freight each year across the country's supply lanes. That's more than half of all the freight in the nation. Eight billion

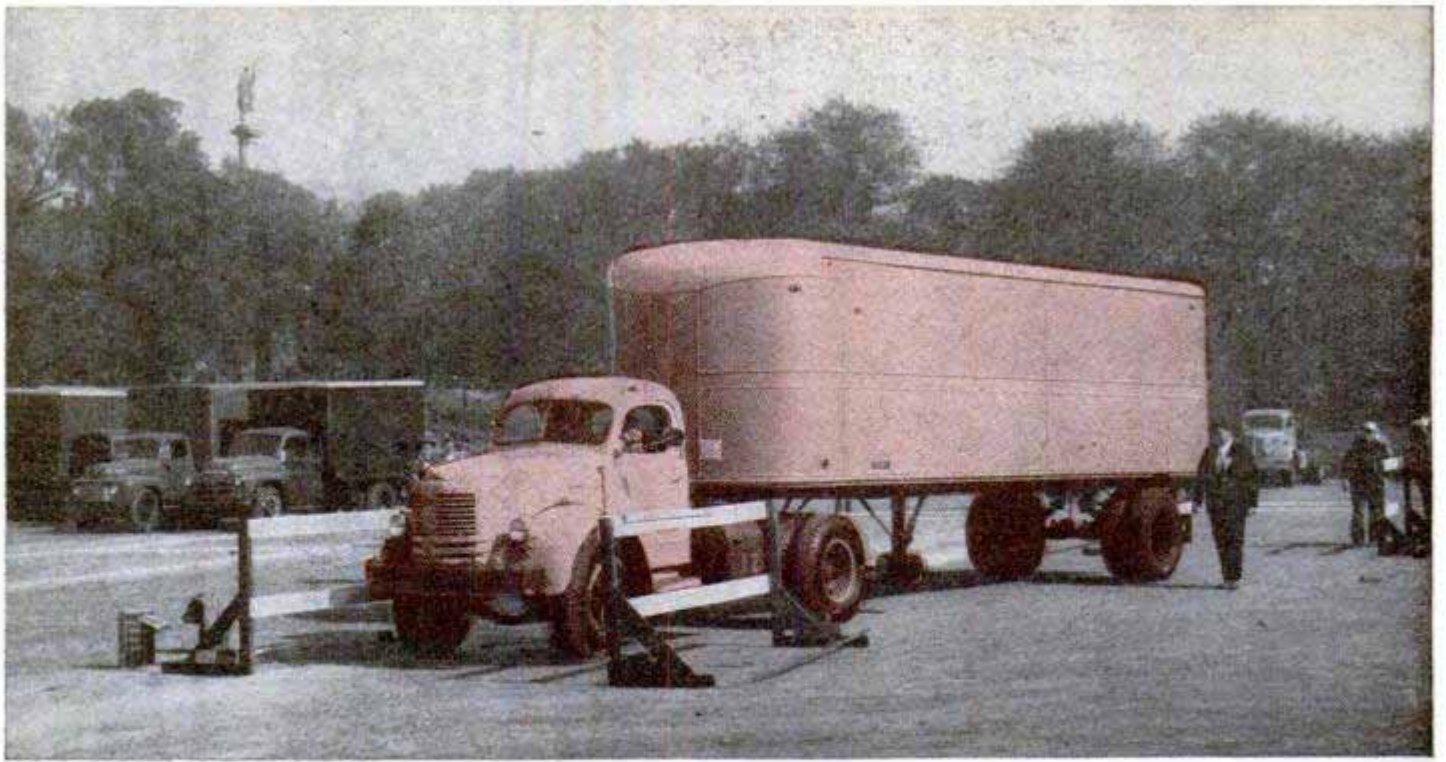

After leaving the serpentine, the truck has to maneuver through this offset alley with only inches to spare

gallons of gas each year go into the hungry maws of those transports. If all that gas were put in gallon cans, you'd have enough to make five stacks to the moon.

The men who weave these gas or diesel monsters through today's traffic are a tight-knit group of swell guys, not too different from airline pilots. They are primarily interested in engines and horsepower and they're wizards behind a wheel.

It was to show the public the incredible degree of safety, courtesy and driving judgment these men have achieved that the American trucking associations held

their first roдео in 1937. It was such a whopping success that, except for a war-time intermission, it has been held every year since.

The 1949 winners of preliminaries in 34 state rodeos roared around Boston Common in their cumbersome rigs to determine who were the best truck drivers in three classes: truck and full trailer; tractor and semitrailer, and straight truck.

Biggest are the "double bottoms." These 14 to 20-wheel, 36-ton rubber-tire "freight trains," measuring some 60 feet from end to end, consist of a full-size truck with a

This hydraulic control, between cab and trailer body, is said to stop jackknifing. Pressure in cylinders retards whip action on turns and, if desired, disks can be locked in center to make vehicle a rigid unit

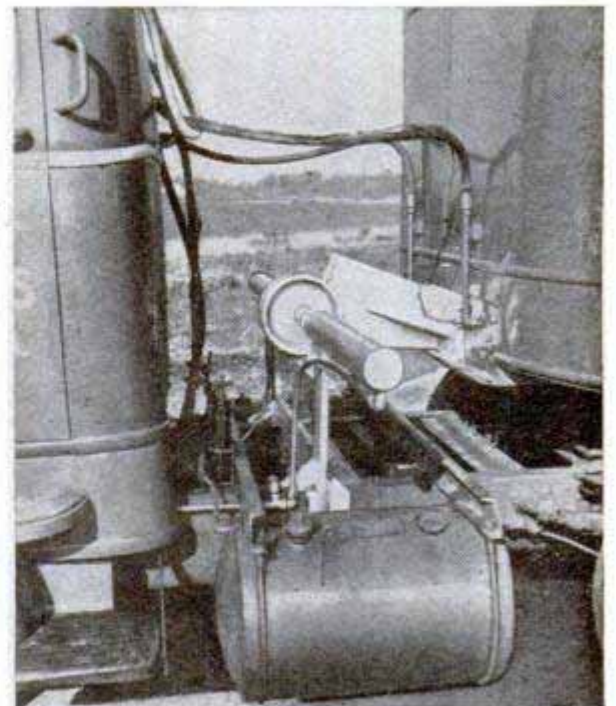
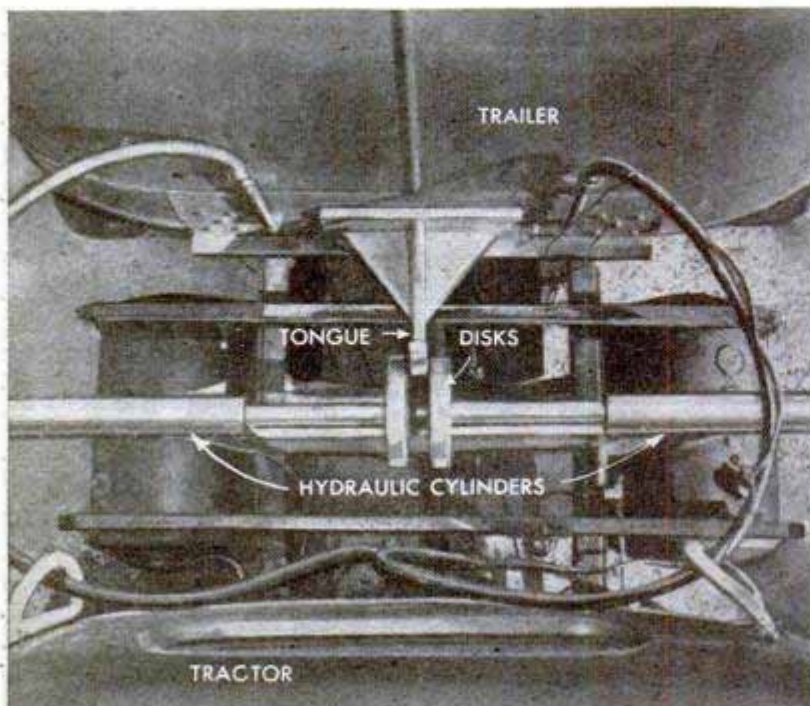

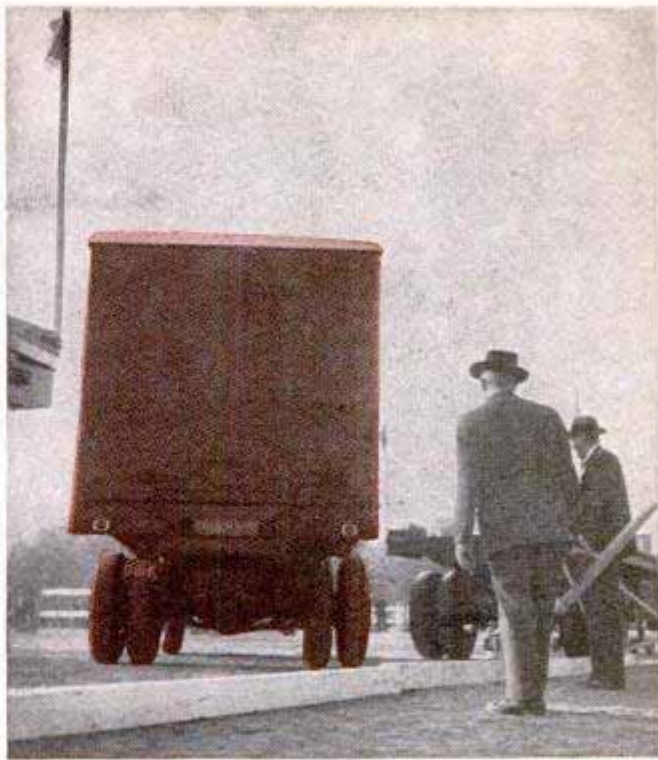
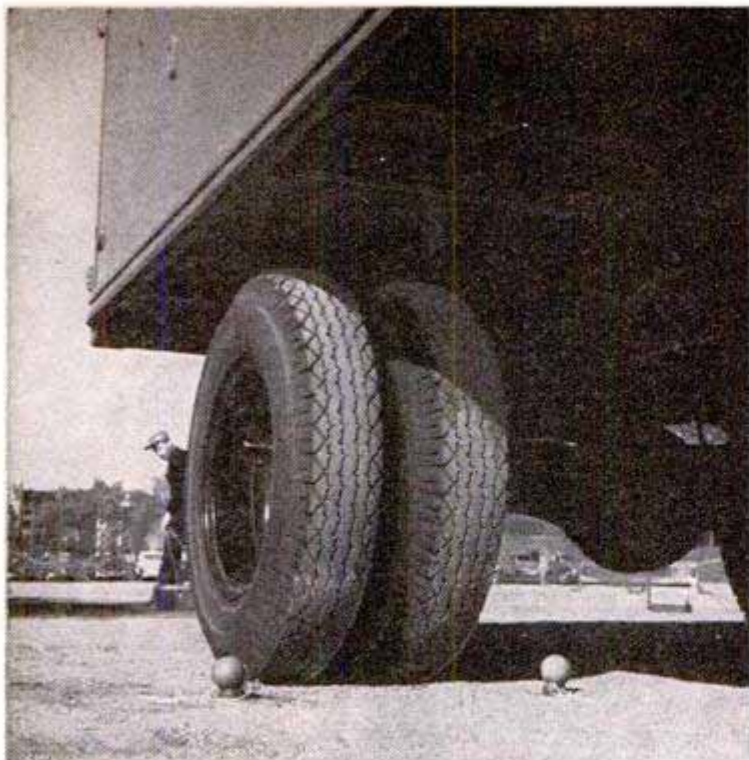

Left, on straightaway, wheels are driven between these markers. Right, backing into a tight parking space

full trailer. They haul freight across the Rockies. Besides the usual collection of multiple gearshift levers and a maze of instruments including tachometer (since diesels are shifted according to engine speed instead of road speed), they carry flares, shovels, sand (for trouble), and a "suicide box" or sleeping compartment behind the driver's seat. The boys call these rigs "pajama wagons."

Since most double-bottoms are out West, their roдео finals were run off in Phoenix last year. Only the familiar tractor-trailer and straight trucks competed in Boston.

Before a driver can qualify for the

roдео, he must not have had a single accident during the previous year—even one that wasn't his fault. Then he must pass an examination on ICC regulations, first aid, fire fighting and general trucking-industry questions, as well as a personal-appearance test. If he weathers all this, he's already logged up a possible 100 points against the roдео maximum of 400.

At Boston Common, where the semi-finals were run off last October, the park was a beehive of motorized activity. Conversation among the snappily uniformed contestants was spattered with truck jargon. Riding a tractor without trailer is a

Semitrailer being backed into alley dock must stop within six inches of the end and no fair touching sides

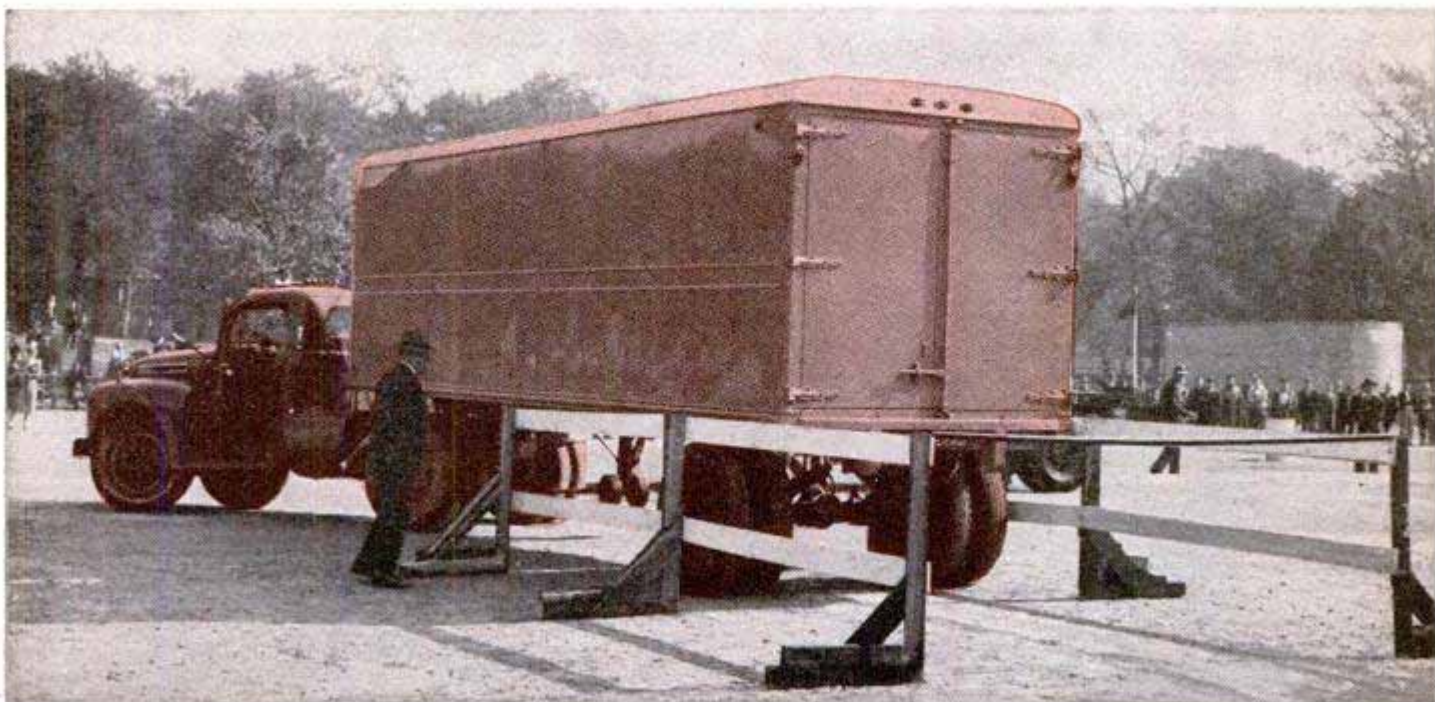



Backing a semitrailer can be hazardous. Because the fifth wheel doesn't turn, this sharp tilt results



To prevent the tilt, shown at top of page, this new fifth wheel turns with the trailer. Below, the same truck in the same maneuver, but this time there is no tilt because the tractor has the new fifth wheel

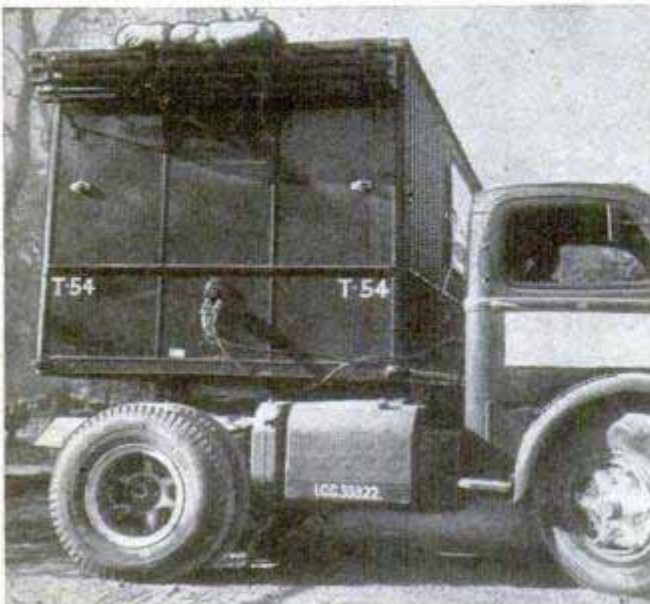

"bareback" ride. An explosive truck is a "broom wagon," a poultry truck a "cackle crate." You don't have noisy brakes; you have "cop callers." A beat-up jalopy has "friendly fenders" that wave at you. A cab without windows is a "pneumonia sedan," and you never haul an empty truck—you "haul postholes."

Truck drivers must know every inch of their vehicles, check them over thoroughly before each run. So, each roadeo contestant must check a truck he has never seen before—and into which the judges have introduced eight "bugs;" a loose lug nut, a headlight that conks out on high bright, a loose wiper and so on. The driver is graded on the number of defects he finds and his method of inspection. Now he's ready to climb behind the wheel.

First, the roadeo driver backs his rig in and out through the "serpentine"—a row of three barrels, spaced 34 feet apart. If any are left standing, he weaves forward through them.

Now he moves to the "offset alley"—a pair of alleys about 24 inches wider than the truck. They are 10 feet apart. The second alley jogs a full 10 feet to the right of the first, so the driver must "S-turn" his long rig through both without so much as brushing a "wall."

If he's still in the fight, the jockey then does a parallel-parking job between two trucks. Straight trucks get a six-foot clearance. Trailers only get four, since they can jackknife into place. Everybody gets two cracks at it and must wind up no more than six inches from the curb without having touched either parked vehicle. Otherwise, he loses points. He loses points for hitting the curb, too.

Next comes the "alley dock," into which the driver backs, without being able to see where he's going. In spite of this, he's got to wind up with his tailgate within six inches of the loading dock at the end. One reporter at the double-bottom roadeo in Phoenix looked at it and announced: "It's impossible, that's all. Impossible." Nevertheless, Johnny Castner, last year's winner in the double-bottoms, managed the alley dock in 30 seconds—maneuvering his 60-foot rig like a tricycle.

Generally, Johnny and all the other boys manage their backing feats by use of rear-vision mirrors alone. But that's not always enough. One fellow in a previous roadeo, after three bad tries, finally ground his gears down to the "bottom hole," shut the throttle to $\frac{1}{16}$, then got out and walked the rig into place, steering with one hand from the ground. This trick was banned in the 1949 roadeo; the drivers now are allowed to be only far enough out the door to put one foot on the running board.

Once out of the dock, the driver "walks the plank"—running his right-hand dual wheels through a double row of rubber balls on tees. He's got two-inch clearance on each side of his big tires and loses points for every ball he tees off. If he makes it, he swings into the "diminishing alley"—a row of six-foot poles which get closer and closer as the driver approaches the finish line. When he stops between the last two poles, each stick will be exactly one inch from the side of the truck—provided the vehicle has stayed "on course."

"An extra layer of paint on the truck and we can't make it," one contestant observed.

All these shenanigans must be executed at a "cruise" pace—no jiggles, jumps or hesitations. And the man who winds up with the most points and shortest time for the course is the winner.

It pays to win, too. First place in the double-bottoms was copped by Johnny Castner, driver for Pierce Auto Freight Lines in Oregon, who piled up 344 points out of a possible 350. Semitrailer winner was Ben Winterberger of the Dohrn Transfer Co., in St. Louis, with 368 of a possible 400 points. Steve Moon of the Georgia Highway Express took the straight trucks with 385 of a possible 400 points. Besides big trophies, these lads will all get \$50 a month for one year from the A.T.A. Second and third-place winners get \$30 and \$20, respectively.

Roadeo obstacles are not so far removed from the conditions which the average truck driver meets in his daily rounds.

"That alley dock," says Kermit Kruschka, semitrailer champ from Wisconsin, "doesn't hold a candle to one of my daily Green Bay stops. Every day I back my 40-foot rig half a block down an alley that is exactly two inches wider than the truck—and it's not bad until I hit the bend. I've got it down to 15 minutes now, with only two pull-ups to straighten out. This roadeo thing—if you don't make it, you don't make it. But that Green Bay loading dock . . . ! If I don't roll the cargo in, I carry it in."

Tommy Bennane, three-time Michigan straight-truck champ and last year's national winner, claims that practically all city delivery alleys are offset. "I've got one with fire escapes that come so close, if I stuck my head out the window I'd wear it right down to my neck," he says. Steve Moon, present national straight-truck champ, delivers to an Atlanta radio shop at the end of an alley with a two-inch clearance and an S-curve to boot. He has to pull in his mirrors and sneak back by instinct.

Even so, if you think it's easy to wham a big rig through its roadeo paces, think again. Out in Portland, Ore., Lev Richards,

(Continued to page 272)



File Handle Makes Pressure Easy

Pressure is distributed evenly along a file by a new handle which gives the tool a planing motion. The handle has a tapered groove into which the shank of the file is slipped. It describes an arc above the file, thus exerting pressure along the tool instead of at one end only. Quickly installed or removed, the handle fits all sizes of flat or half-round files from 8 to 16 inches in length. The handle also can be used with carpenters' rasps.

Pocket Gauge Checks Golf-Ball Size

Golfers can be sure the ball they are using is perfectly round, thus eliminating one cause of bad shots, with a pocket gauge that is accurate to $\frac{3}{1000}$ inch. The gauge is made of aluminum and is precision bored to match Professional Golf Association standards for ball diameter.

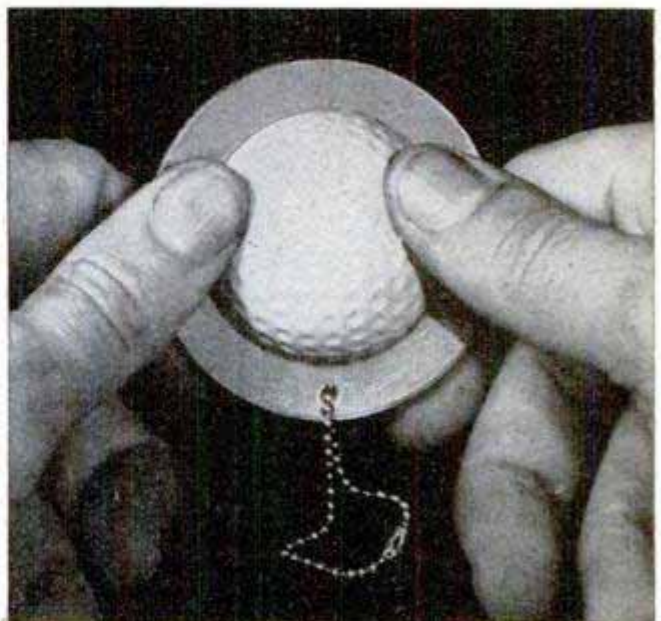

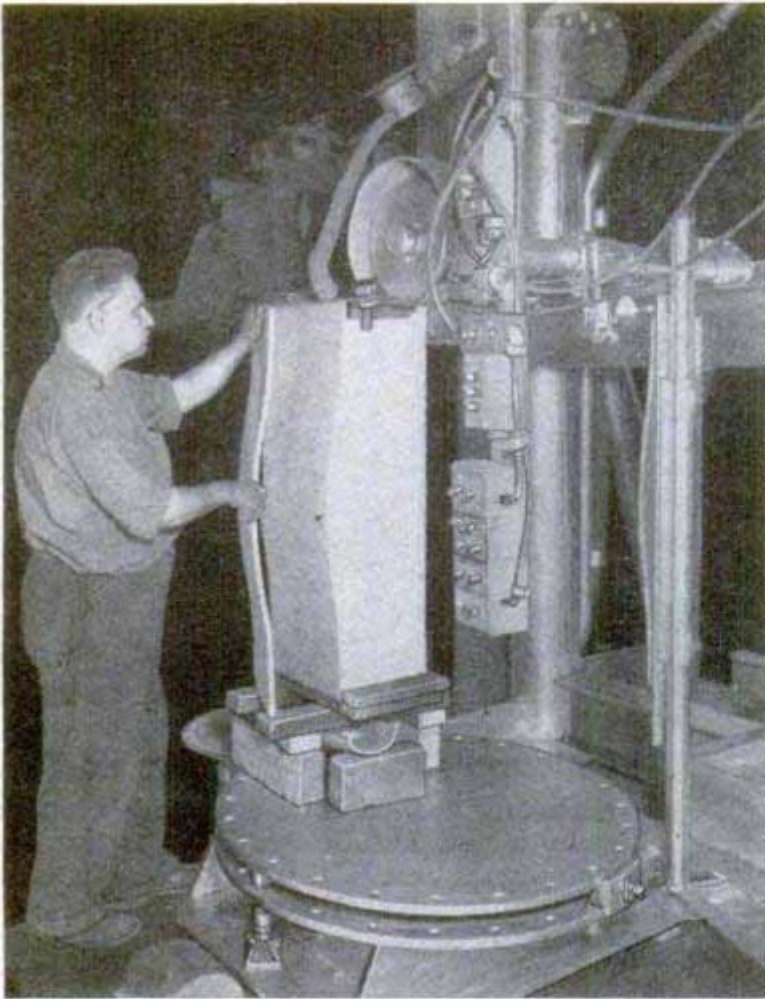

Wire Stone Saw Cuts Granite Wafer Thin

Originally developed to cut granite—in addition to marble, sandstone, limestone and other rocks—a wire stone saw may have an important bearing on a variety of stonework. A basic part of this electro-pneumatic machine is a three-strand steel rope which, when used with an abrasive, cuts the densest of stone much as a big knife would slice cheese. Granite may be cut to such waferlike thinness that it is translucent. It may be cut into blocks, slabs, veneers or other shapes requiring straight, vertical, horizontal, radius or internal cutting. Granite veneers obtained by using this machine lend themselves to at-

tractive and original designs for the exteriors of stores and office buildings, and the interiors of theaters, office buildings, and even homes. The natural beauty of rock can be utilized without the depth and weight of solid blocks. The saw cuts granite at speeds ranging from 12 to 36 inches per hour. This machine, developed by the L. M. Gilbert Company, Philadelphia, is 13 feet 5 inches high, 18 feet wide and 18 feet 11 inches long. The three-strand steel-wire blade rotates in a horizontal plane around two large wheels which are automatically lowered as the cut progresses. The outfit is powered by a $5\frac{1}{2}$ -horsepower motor.

Traffic Through Tunnel Controls Ventilation Blowers

What is believed to be the first tunnel to have automatic ventilation control is now being built near Houston, Tex., under the ship channel connecting that port to the Gulf of Mexico. The speed of the blower fans providing fresh air for the new Washburn Tunnel will be governed automatically by the number of cars in the tube and the amount of poisonous carbon monoxide in the air. Photoelectric cells at the entrance and exit of each side of the tunnel will count traffic in both directions. They will transmit their count to a mechanical

computer, which will keep a running total of the traffic. Traffic increases will speed up the blowers. At two points in the tunnel an automatic air-analysis machine, connected to the fan governor, keeps a constant carbon-monoxide count. Whichever unit—car counter or air analysis—calls for the most fresh air actually controls the blowers' speed at any particular time.

ⓄTransportation costs for all goods and people in the U. S. during 1949 added up to a total of over 38 billion dollars.

Canine Caddy

Capitalizing on the dog's sport of chasing a ball, Dominic Colucci of Chicago converted his Great Dane, King, into a caddy by means of a harness and two-wheel cart. During the wartime caddy shortage, Colucci began using the dog to pull his caddy cart and now he wouldn't think of beginning a round of golf without him. Lost balls are infrequent because King gallops after the ball as soon as it has been hit.

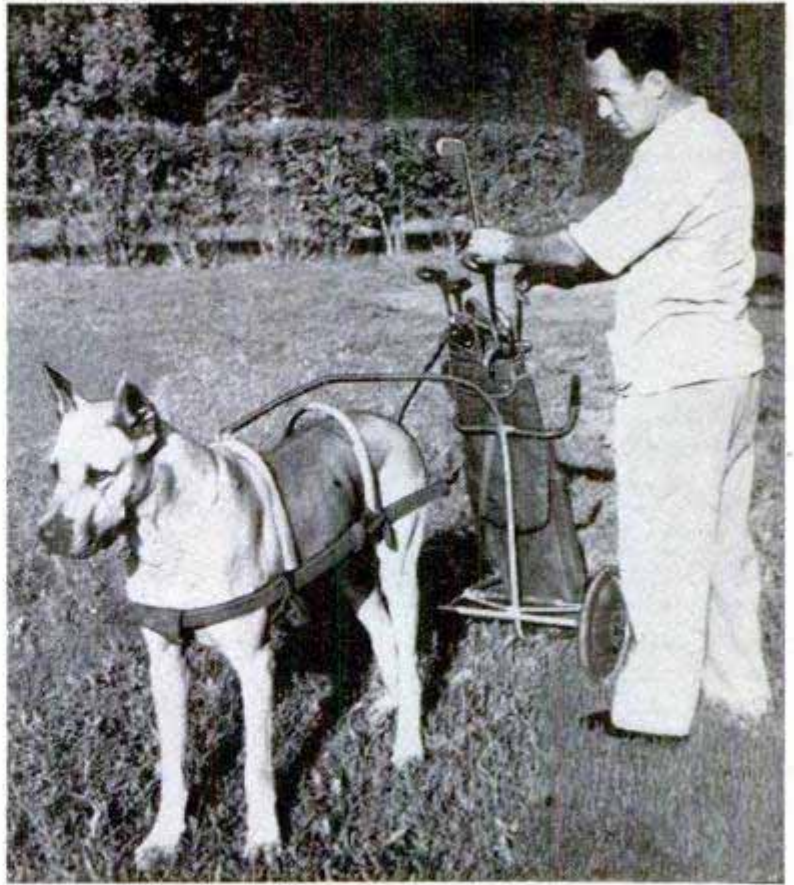

Odorless Paint

Millions of submicroscopic balls of rubber, whipped up in water to form an odorless rubbery film, may be used to coat the interiors and exteriors of houses of the future. It is washable. The new paint, made by the Dow Chemical Company, Midland, Mich., dries by the evaporation of the water component, leaving a thin sheet of rubber which adheres firmly to the wall but allows dirt to be washed off. Ordinary water-base paints now in use do not always wash satis-

factorily. Pigments can be added to the new paint, but there are no turpentine, solvents or oils to cause odors.

Cyclist Propels 24-Foot Balloon Through Sky

Leg power alone runs a unique pedal-copter built by Charles Paul, a Lakehurst, N. J., attorney. He sits in a bicycle frame

suspended below a 24-foot balloon and pedals a bicycle device to turn the helicopter blades operating the craft.

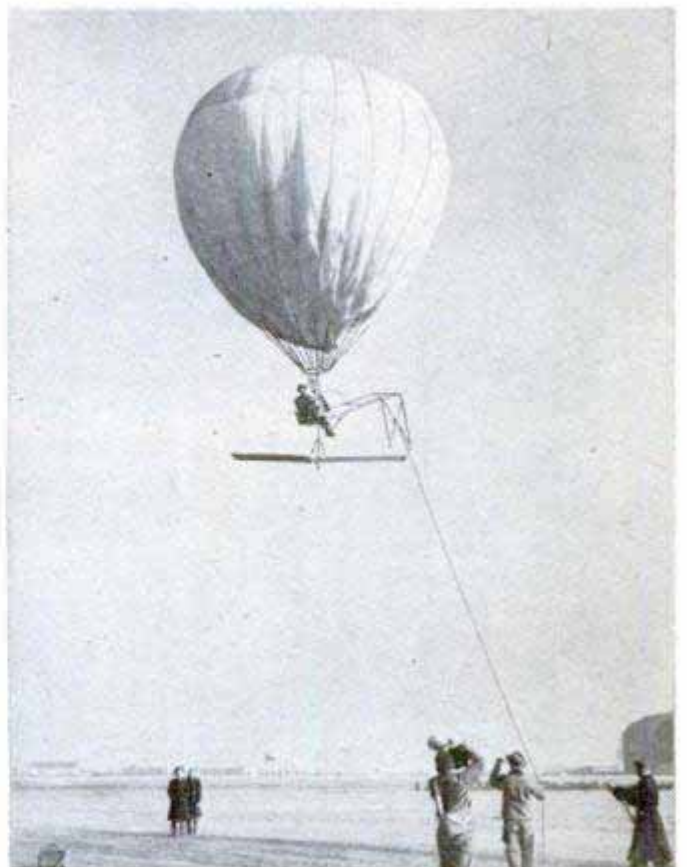

NIGHTLY, on the circus lot, a stocky 44-year-old Texan eases his 212 pounds into a cardboard carton, puts his head inches away from a stick and a half of dynamite and blows himself up! And all he gets is an occasional headache. How Leopold Simon does it puzzles the thousands who watch the act from behind a wire fence a safe distance away.

But it is no puzzle to Suicide Simon. He has worked out his chances of coming out alive down to a science. "My head," he says, "is only six inches from the dynamite when it goes off. I'm in the center of a vacuum. That's why I'm safe. If I were three feet away, the explosion would kill me."

The box in which he and the dynamite get together is made of wooden slats and corrugated cardboard. It is five feet long, two feet wide and two feet high. Half of the top piece is stapled to the sides of the box, the other half being left unfastened so Simon can get in. A piece of nylon string is used to tie the box down to the platform. The dynamite, together with a

There are many ways of earning a living. Blowing himself up nightly with dynamite is the chosen profession of a Texan called

Suicide Simon

By Edward Pinkowski

Below, here's how Simon doubles himself up inside the box. When the dynamite goes off, he wears protective clothing, including "Buck Rogers" helmet, above

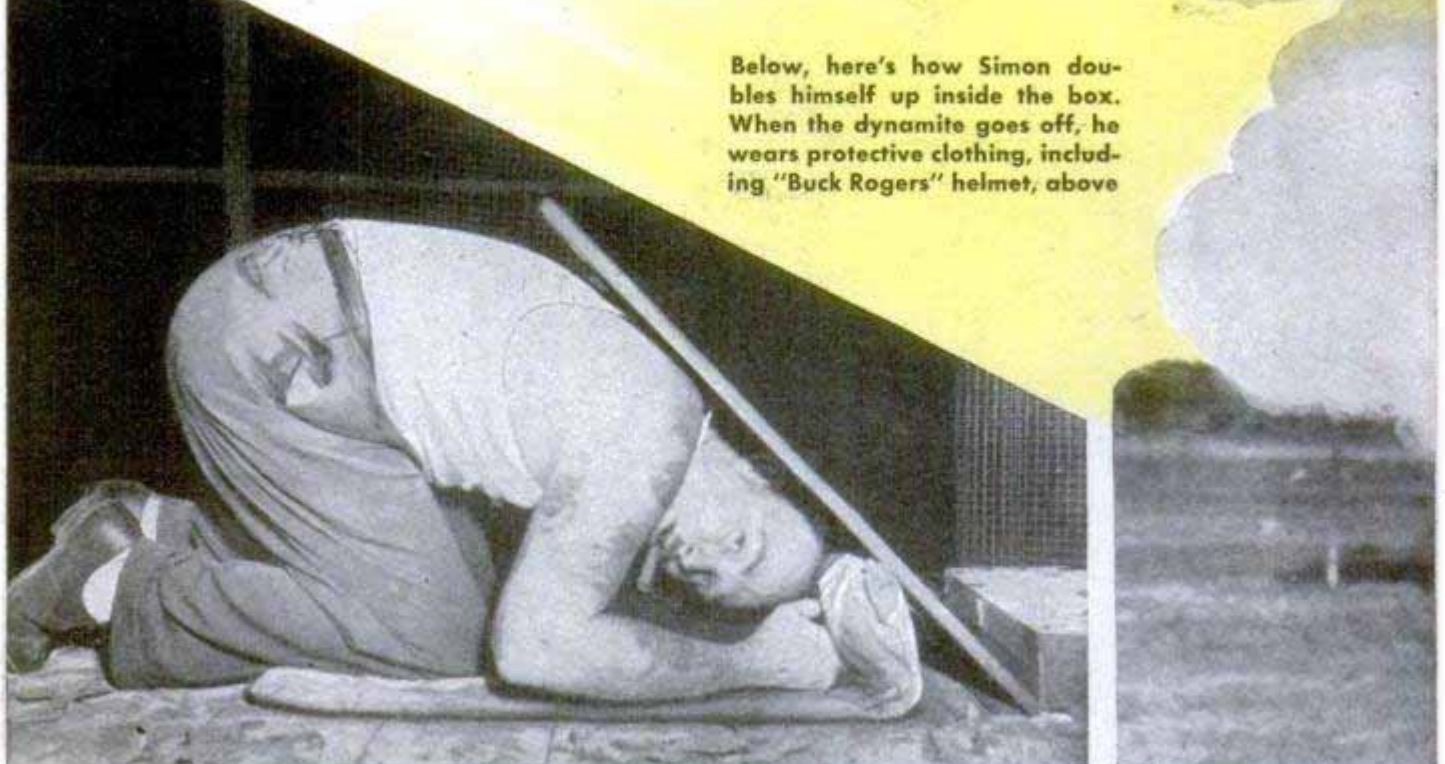

bag of black powder and two pounds of talcum powder (to make the smoke), lies on a three-inch armor plate in the front end of the box.

When show time arrives, Suicide Simon dons a padded jacket to protect his neck, which has been broken three times, but not by dynamite blasts. Although hard of hearing, he stuffs his ears with cotton and adjusts a "Buck Rogers" contraption over his head. It is nothing more than an Army helmet put over a football helmet and a steel rod bent over the top to hold rubber earpieces with water-faucet handles.

When he crawls into the box, he pulls the lid down over him. Inside, Simon crouches on his hands and knees and bends his head under a 5/8-inch

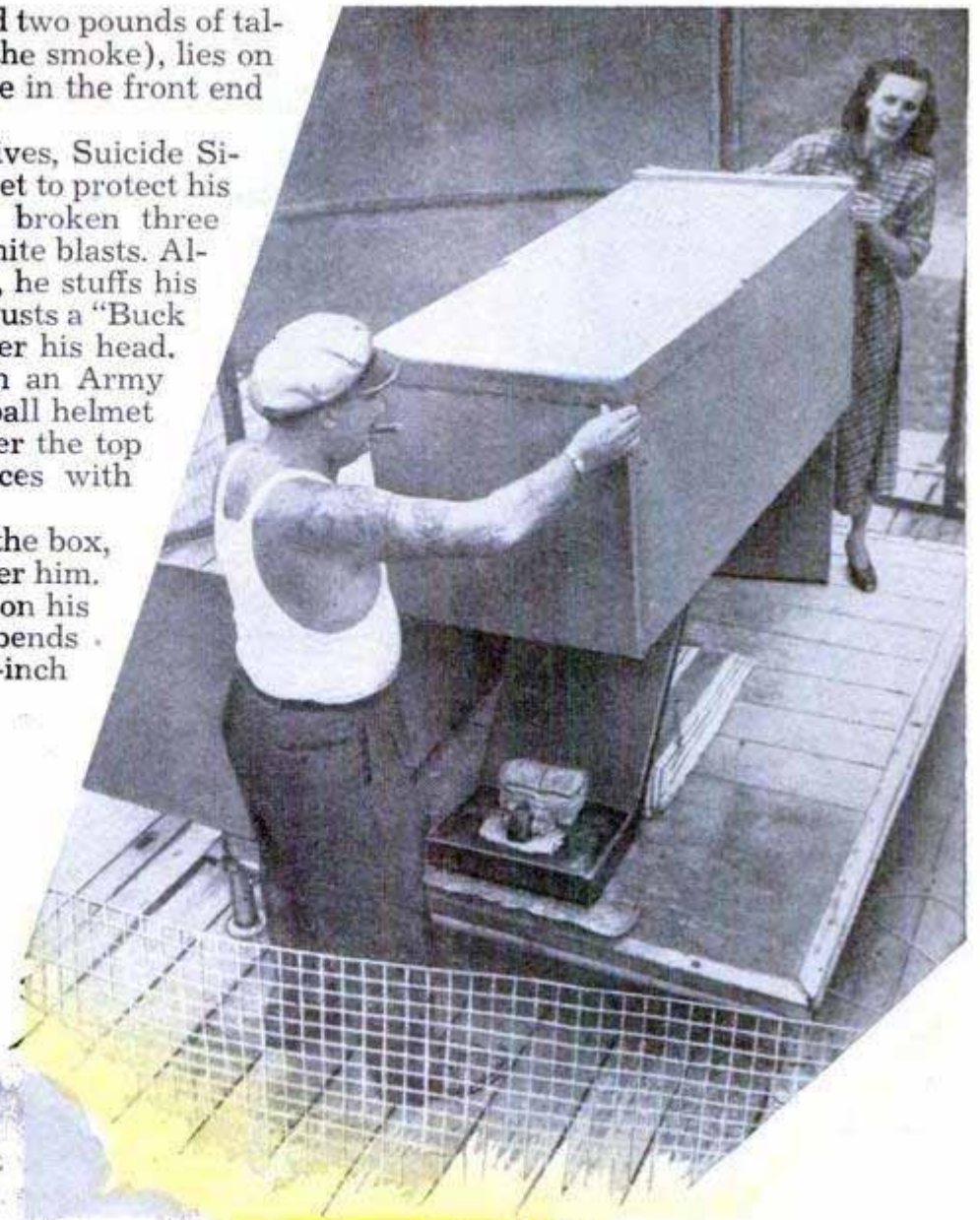

Dynamite and powder are seen in front of the steel slab as the two Simons lower the box into place. Below, protected by the slab, Simon lives through another "suicide" act

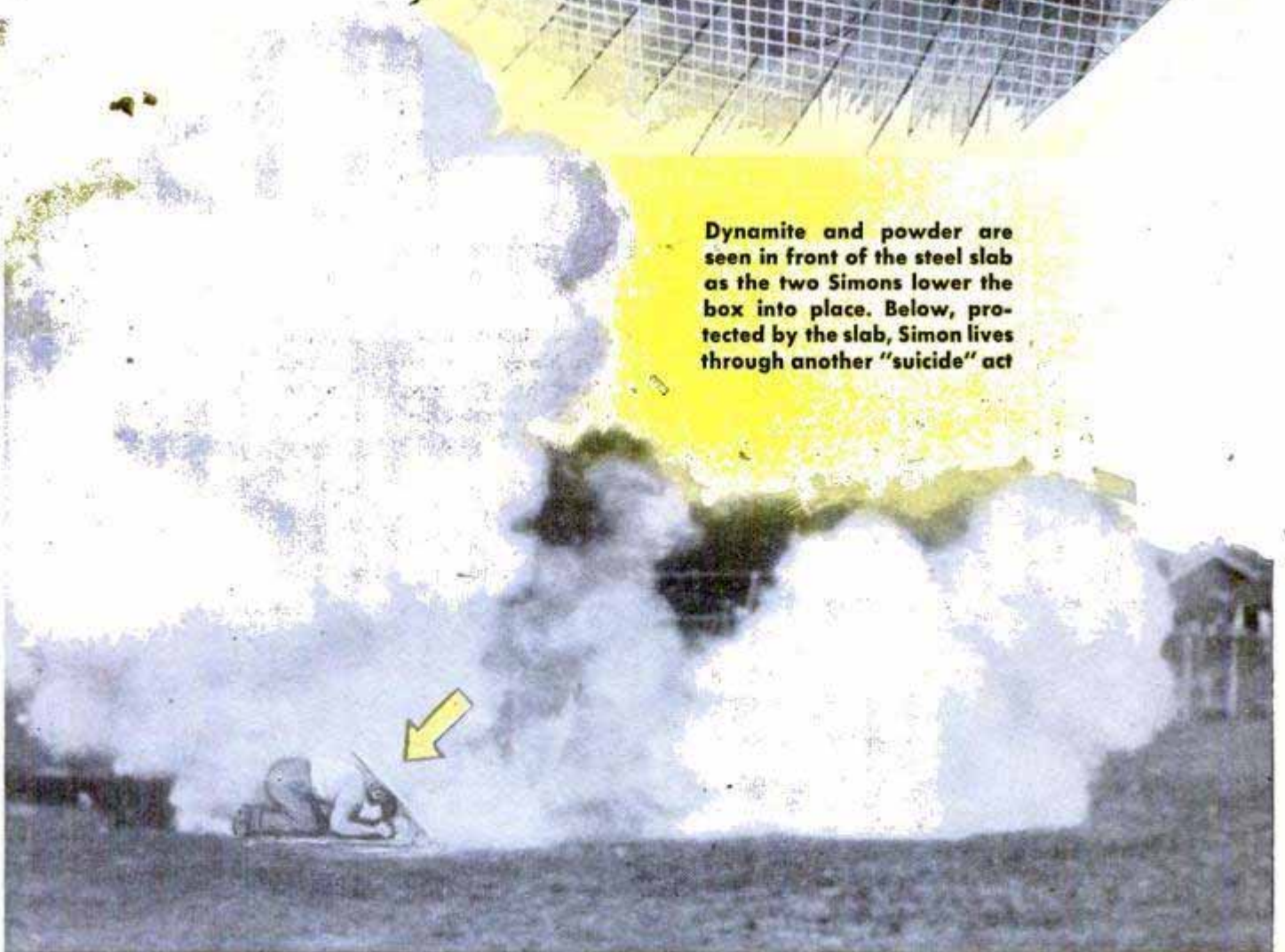

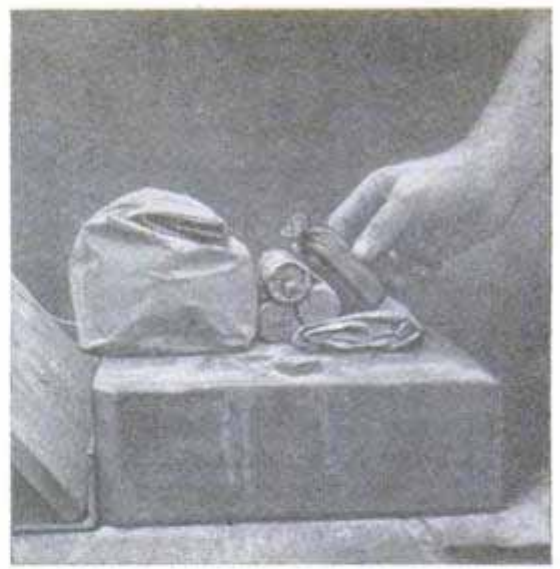
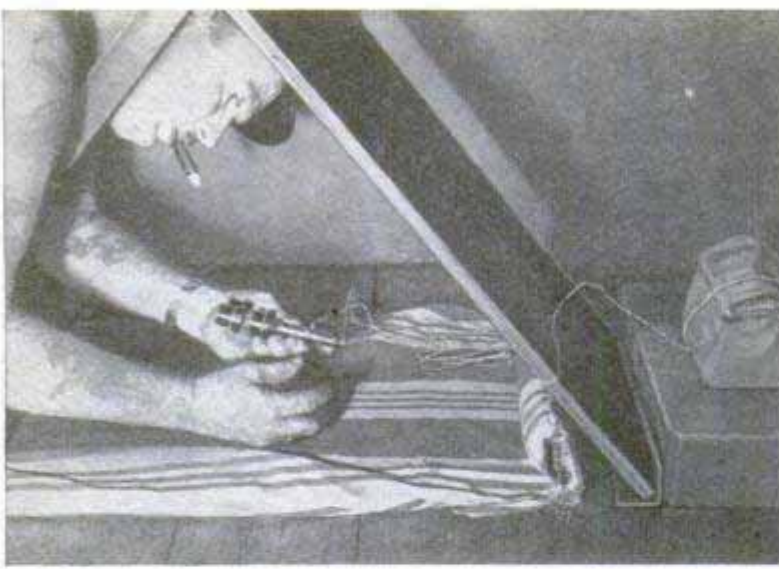

Left, Simon checks the switch before the show. Right, he places a bag of black powder next to the dynamite

plate. With the plate supported by his shoulders, he reaches for an improvised pencil flashlight that he uses to fire the dynamite. The spectators wait tensely.

Suddenly there is a deafening roar, a towering cloud of smoke and millions of pieces of box flying in the air. Somewhere in the debris is the dynamite demon. Sometimes he hits the screen with the force of a cannonball and bounces back in the center of the stage. Or, he might jack-knife above the spot where the dynamite went off.

Some months ago, in Jacksonville, Fla., the plate on which the dynamite rests broke in two, but he didn't get a scratch. He doubled the thickness next time. Feeling a little cocky after his narrow escape from death, he added a little more dynamite to his act. But when he set it off, he

landed on his back and, instead of jumping up to bow to the crowd, he lay still. His wife, Donna, who helps him put on the show, rushed into the cage and found him unconscious. She summoned an ambulance.

A short distance from a hospital, he regained consciousness. "Where am I?" he asked. "You're going to a hospital," Donna replied. "Turn around," he said, "I'm all right." The following night, Suicide Simon was jarring himself again with 50 percent nitroglycerine lollipops.

The hardest part of the performance, Simon admits, is the timing. He has to exhale the air out of his lungs, place his tongue in the right spot and still keep his mouth open. He moves the plate up and down until he coordinates all his movements and as the plate is moving down he

(Continued to page 276)

A trailer opens out to form a platform. The box is inside the wire netting that protects the spectators

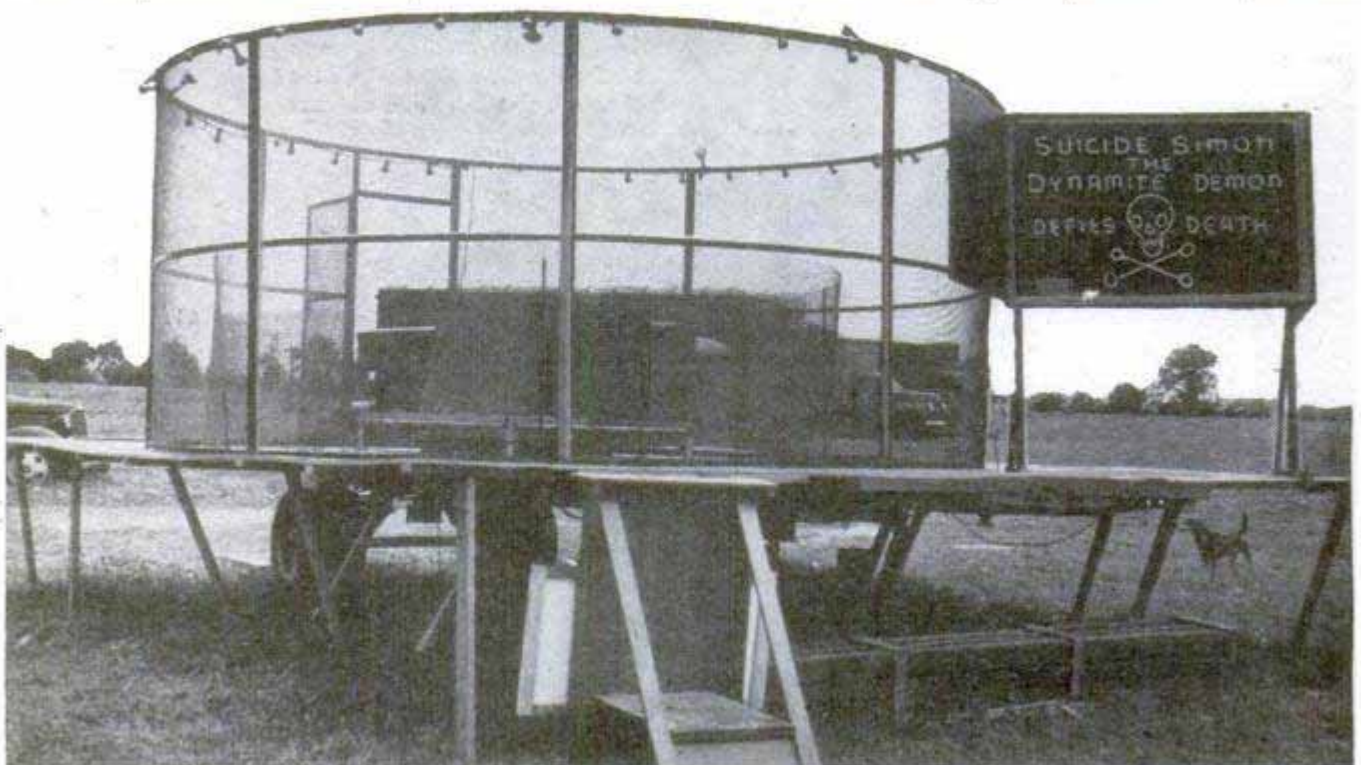

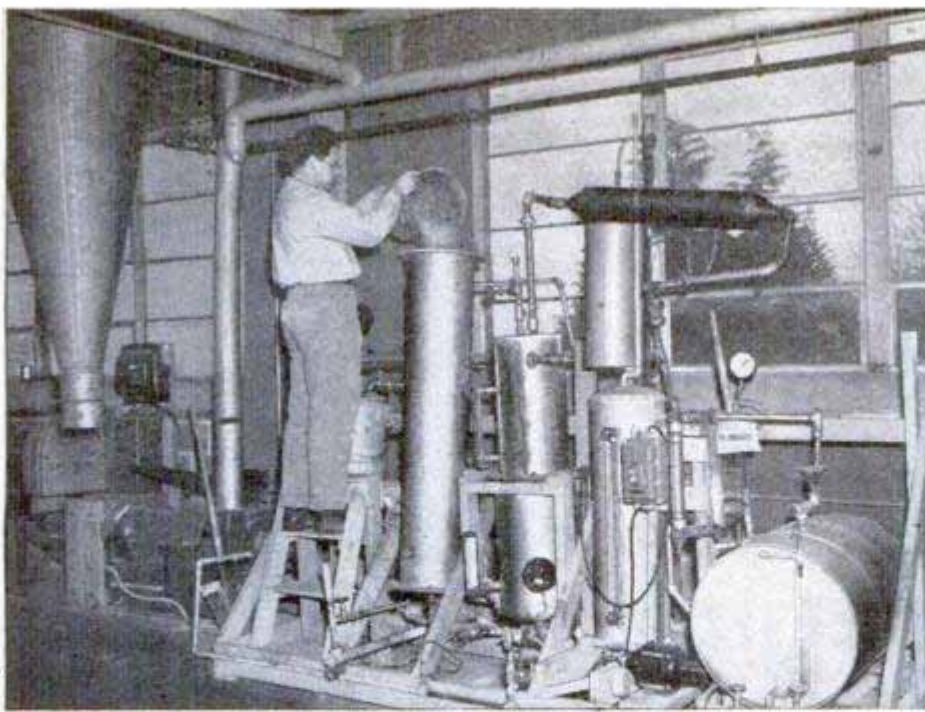

Left, extractor removes wax held by the girl at right. Shredded bark is shown falling from her left hand

Wax From Waste Bark

Douglas-fir bark, at present a waste product that piles up around lumber mills in Oregon, may soon be converted into highest wax which will make this country independent of foreign supplies. Developed at the Oregon State College, an extraction process produces 54 pounds of wax from the bark of 1000 board feet of logs. At 40

cents a pound for best-quality wax, this would mean the waste bark would be worth \$20, enough to make the lumber operators anxious to perfect the process for commercial application. At present, the scientists are working out methods to reduce the cost and complexity of the process. Another by-product of the extraction process is tannin, an important item that is used by the leather-tanning industry.



Knapsack Bike

Instead of a bike carrying man, man now can carry a bike if he uses a type invented by Johann Kaiser of Munich, Germany.

The purpose, of course, is to make the bike easily portable when you don't want to ride it. With one bolt removed, the frame can be folded up and stored in a zipper bag along with the wheels.

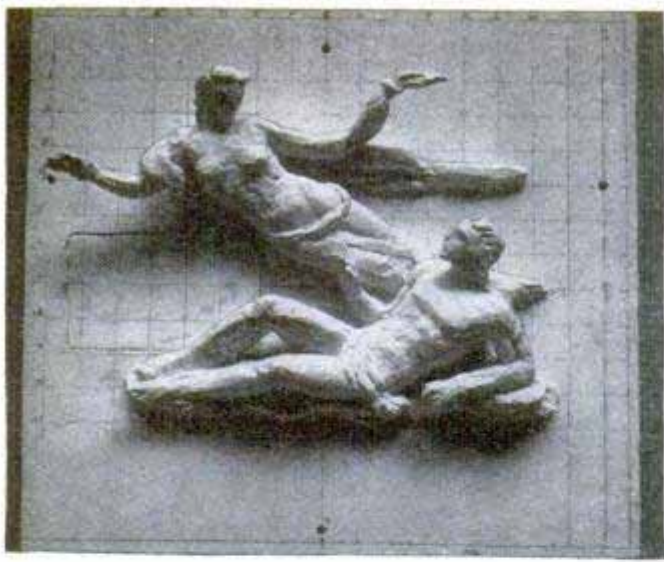

← First step in casting the gleaming aluminum statue was to make this "sketch model" in clay. Model then was cast in plaster and served as guide for statue

MANHATTAN'S ALUMINUM VENUS

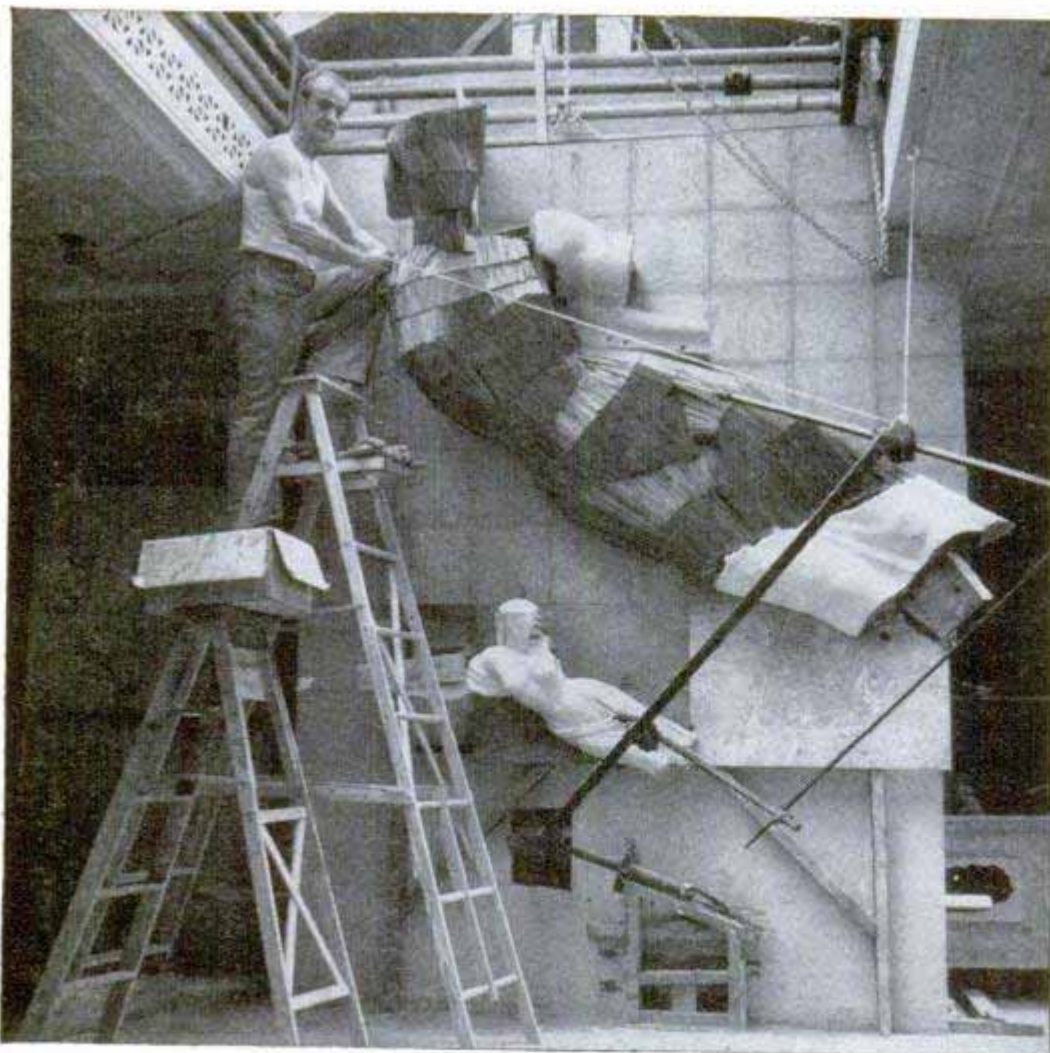

Sculptor Williams uses a pantograph to transfer proportions from the "sketch model" to the armature made of wood. Space between clay nubbins is filled to make the finished clay model

Armature—the base—was also made by using a pantograph to trace dimensions in the air. The wood lath is covered with clay

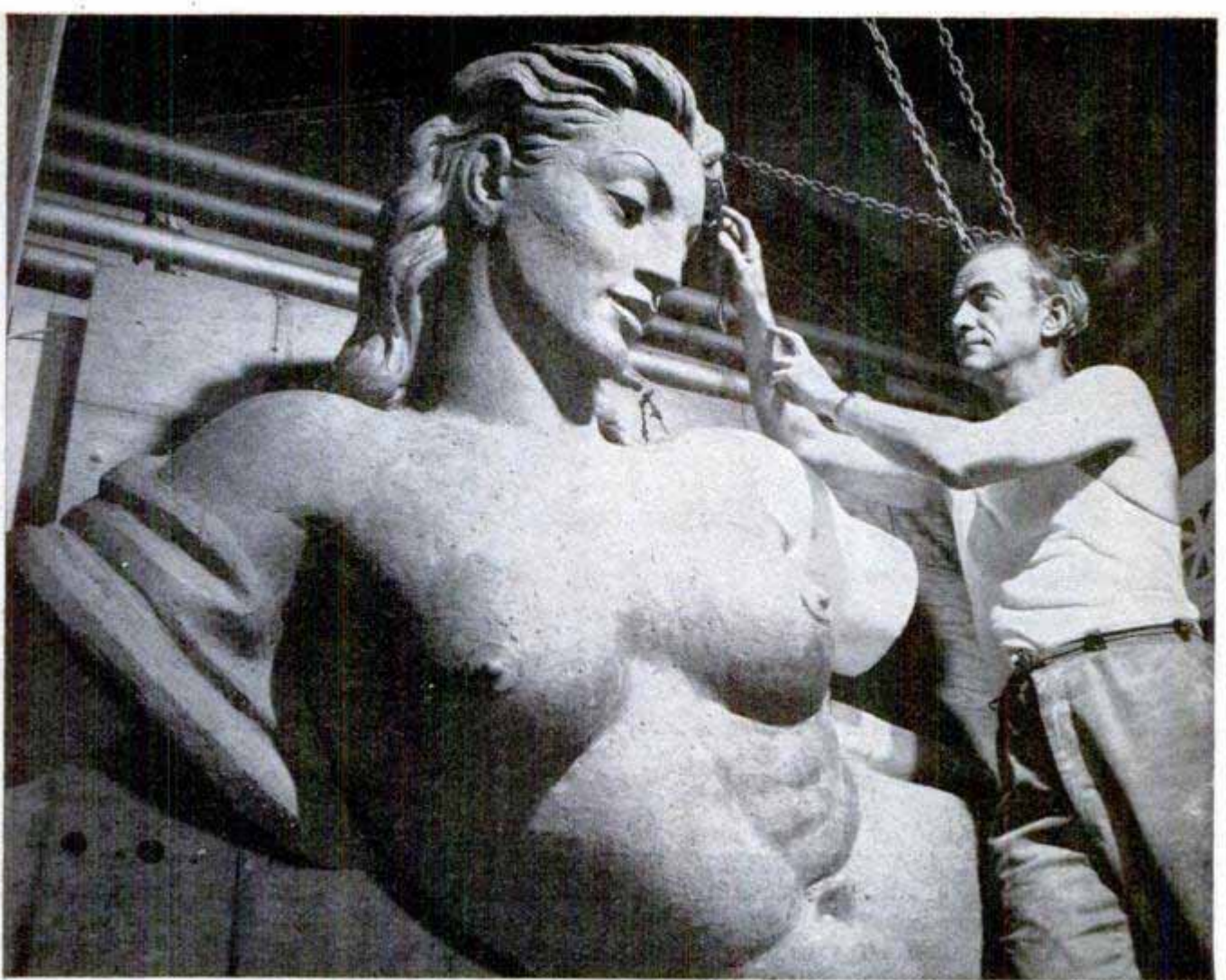

Hal Phylfe photo

With a layer of clay covering the armature, Williams does the final delicate sculpture on one of the figures

MAKE US a cast-aluminum statue in full round relief, colossal proportions, to throw interesting shadows across the entry of the new Parke-Bernet galleries. We need it in nine months."

That was the substance of the order Sculptor Wheeler Williams got from the New York City Investing Company a year ago. Not much to it. "Like asking for an atom-powered jet plane to be delivered day before yesterday," says Williams, who is among the nation's top 10 sculptors.

Today the statue, "Venus and Manhattan," gleams like old silver over the entrance to the new gallery—a monument to the incredible achievement of Williams.

Many people think of sculptors as dreamy folk. "Nothing," Williams points out, "could be further from the truth. Every sculptor worth his salt has to be a first-rate carpenter, carver, solid geometrist, anatomist, plasterer, draftsman, rigger, acrobat, businessman with bank connections, metallurgist with complete knowledge of foundry work and salesman. But," he adds, "all this is useless unless he is an artist as well."

Any statue starts with a pencil sketch. From this, a "sketch model" is roughed out in Plasteline or Italian clay. Williams'

sketch was one inch to the foot. This is covered with plaster to make a mold. From the mold a plaster cast is made.

Next, working from this sketch model, the sculptor models a bigger clay reproduction. In this case, it was one third the size of the finished statue. This, too, is molded and cast in plaster—only now it's done in sections just as it will be in the final scale.

All of these sections later are locked together in the finished statue by what sculptors know as "Roman joints"—pyramidlike projections on one piece that fit into identically shaped sockets of the other. Thus the parts become rigidly joined and are bolted on the inside.

Having completed his accurate one-third scale model, Williams went to work on identical sections of the full-size colossus. By now, he had a staff of men in the shop.

Together, they helped build the "armature," or wooden frame on which the Plasteline would be laid. No big sculpture is ever solid Plasteline or clay. Its own weight would break it apart.

To get the armature just the right size, the men used a three-dimensional pantograph. This is a simple rig, with two pointers coming off a pole which is hinged at the

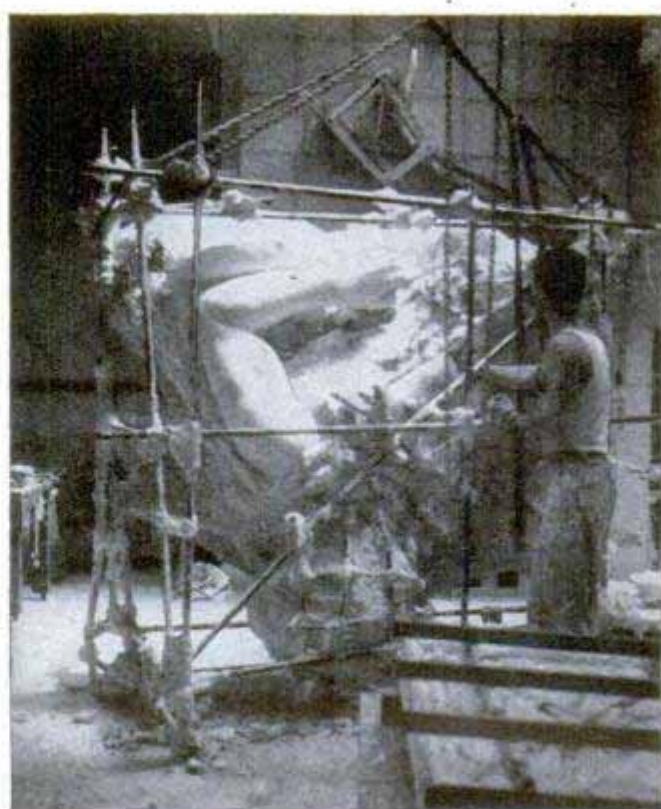

Figure is divided so sections can be lifted off. Right, original mold is chipped away from plaster mold

base on a universal joint. By adjusting the distance between the pointers and the length of the pointers themselves, any object touched by the bottom pointer will be increased to the desired size by the top pointer. In this case, the bottom pointer took "points" on the scale model. The top pointer jabbed the air above. The men knew that anything built out to it would

be exactly three times the size of the little statue. In making their armature, they allowed an inch or two for the thickness of the Plasteline.

First, two-by-four framework went down. Then "contour boards" or shelves were set up to give the frame fullness. To these were nailed shinglelike slabs of lathing. In a short time, the thing taking shape

Beautiful statue adorns building entrance. Diagram shows how an arm was cast by the "lost wax" method

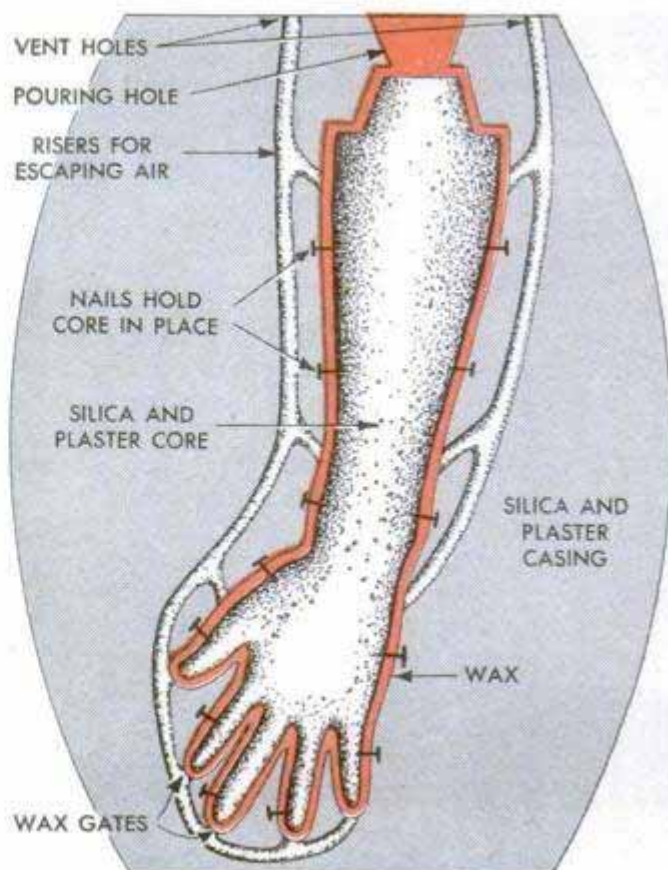



Hal Phylfe photo

Molten wax is poured into the mold, flushed out, and the process repeated until ¼-inch layer is built up

on the wall began to resemble some Frankensteinian robot.

Using the pantograph again, Williams then took accurate "points," which he marked with nubbins of Plasteline. Later, the spaces between the nubbin points were filled in and the statue section was modeled to perfection.

As sections of the big Plasteline model

came down, the plaster casters went to work on the big molds and casts. Molds are made by coating the Plasteline statue sections with plaster. When the mold has attained a desired thickness, it is reinforced with a cage of iron pipes held together by ties of burlap dipped in plaster. To divide the mold so it can be removed, the men

(Continued to page 268)

Imperfections are removed by metalworkers and sections bolted together to complete "Venus and Manhattan"

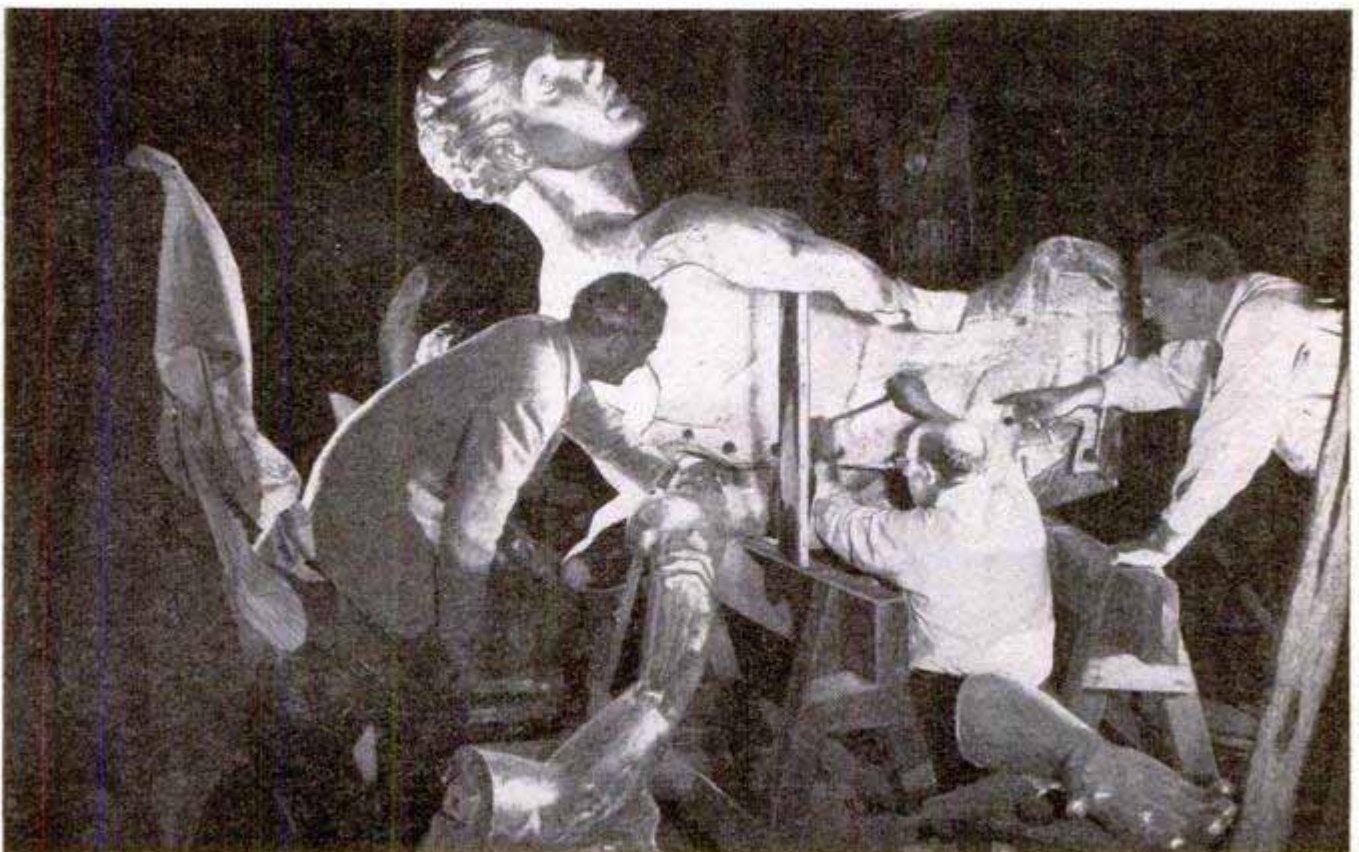



Drawing shows huge dam to be built in India. Below, river model shows points where erosion can be expected

Model of River Helps Build Dam

Hydraulic engineers at the University of Minnesota are conducting experiments in river control that eventually will aid in building one of the world's largest dams. To be constructed halfway around the world from the Minnesota campus, the Ramapadasagar dam and power site will harness the Godavari River in southeastern India. Built of concrete, it will impound a reservoir 100 miles long which will supply irrigation for 2,000,000 acres of land. The dam will be 428 feet high and 1½ miles in length. Engineers have built a model of the river with an ad-



justable flow. When the water is cut off, the sandy bed shows points of erosion. The information will be used in building cofferdams for the river while the dam is built.



Cartridge Carrier

Large enough to hold a box of .22 cartridges, a carrying case dispenses cartridges one at a time at the touch of a finger. The case is molded of plastic and accommodates .22 short, long, and long-rifle cartridges. With the case clipped to his belt in a convenient position, the rifleman can load his gun with one hand.

☐ About 300,000 passengers flew across the North Atlantic on 11,000 scheduled flights made in 1949.



Carrying a boat beneath his house trailer, Coultas is always ready to go fishing. He just pulls the boat out like a drawer, below left, hooks on a tail wheel, below right, and hauls it away behind his car, above

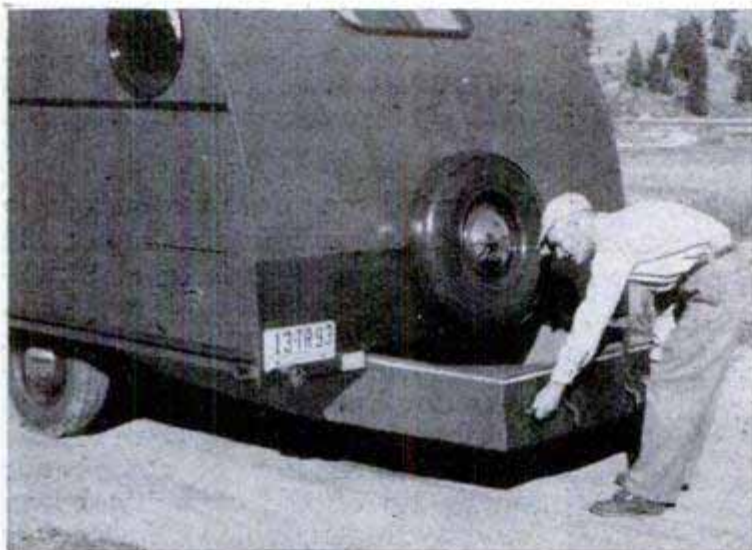

"Boathouse on Wheels" Built Beneath Trailer

When Jack Coultas of Conner, Mont., takes his house trailer to the lake or river, he doesn't have to worry about renting a boat because he carries one with him under the trailer floor. The 13-foot boat slides on tracks beneath the trailer body, closing dust-tight like a desk drawer. A forked tail wheel can be snapped into lugs on the bow for easy wheeling to the water's edge or, if

the distance is long, the boat is hitched to the car and towed like a trailer. The out-board motor is stored in a locker at the rear of the trailer, which was designed by Coultas and contains a toilet, shower bath, photographic darkroom, air-conditioning unit, refrigeration and sleeping facilities for four persons. A small power plant supplies electricity for the appliances.

Artificial Sapphire Lens for Movie Camera Resists Scratches

Motion-picture camera lenses made of artificial sapphire have been developed at the University of Rochester. The lenses have several advantages over those made of glass. Artificial sapphire, made by crystallizing oxygen and aluminum oxide in a high temperature, is much harder than optical glass. Lenses made of the material can be cleaned by scouring them with sand without injury. The sapphire lens also has a high refractive index and low dispersion,

which improves the sharpness of the images produced. As artificial sapphire is relatively inexpensive, the principal handicap to making lenses of the material is its extreme hardness, which makes it more expensive to polish than glass.

☐Sunflower-seed hulls formerly thrown away by a Canadian vegetable-oil company are being pressed into fuel "logs" three times as dense as wood.



Above, a G.E. scientist studies photographic film spotted by X-rays deflected from their path by the internal structure of a decaborane crystal. The film was in cylinder form during test. Below, Dr. John Kasper holds model of a decaborane crystal

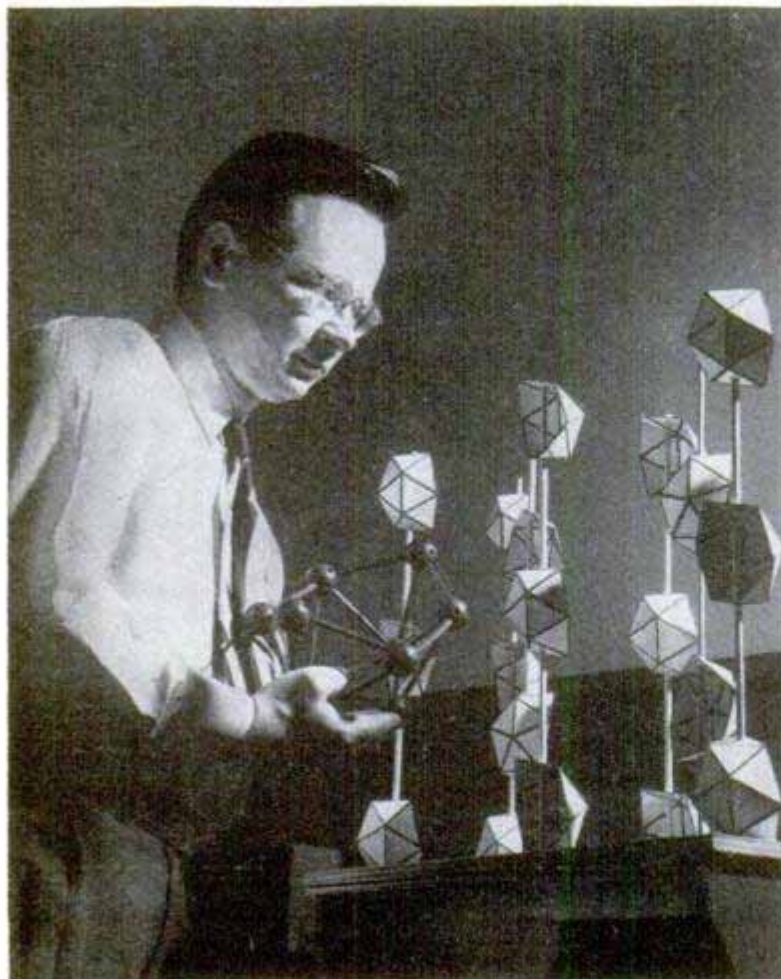

MAPPING

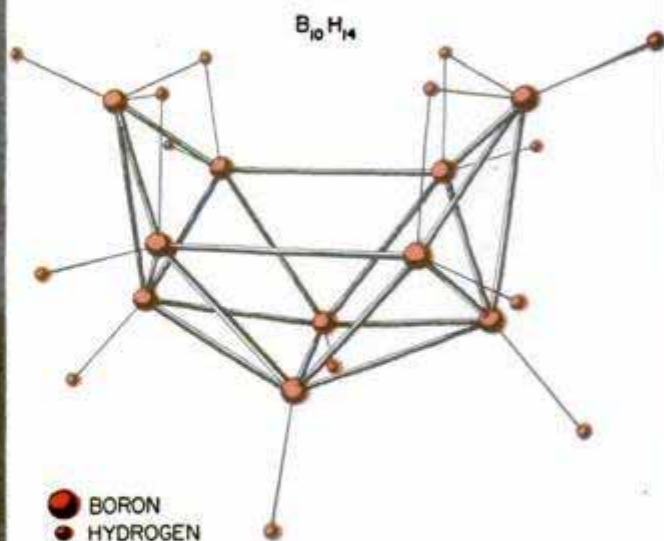

Diagram of a decaborane molecule, showing relative location and linkage of 10 boron and 14 hydrogen atoms that comprise it

THREE men have just spent two years exploring a region 30 billionths of an inch long, 16 billionths wide and 10 billionths high. The area they "mapped" was a molecule whose structure is unlike any known before.

Chemists have long been baffled by the behavior of compounds made up of the elements boron and hydrogen, which didn't act as they should under the laws of chemistry. To find out why, Drs. David Harker, C. M. Lucht and John S. Kasper set about mapping the molecule of a boron and hydrogen compound called decaborane. For their exploration, the three General Electric Company crystallographers used the X-ray-diffraction technique.

Two years of data gathering, rechecking and almost constant use of calculating machines were needed to fix the relative location of each of decaborane's 10 boron and 14 hydrogen atoms. In revealing decaborane to be a new exception to one of the laws of chemistry, the mapping showed why chemists have been at a loss to explain the molecule's behavior.

Any given element, depending on its make-up, is supposed to have only a fixed number of links with adjacent atoms. Decaborane's boron atoms, supposedly capable

A MOLECULE . . .

of only three links, are bonded to six adjacent atoms. Four of the hydrogen atoms, theoretically limited to single links, have somehow formed two apiece.

The mapping was accomplished by passing an X-ray beam through a needlelike crystal of the substance, which was surrounded by a cylinder of photographic film. When the beam struck planes in which the atoms were arranged, it broke up and scattered at different angles. The deflected X-rays made spots on the film.

From the position of the spots, it was possible to determine the direction of the planes in the crystal. The intensities of the reflected beams, gauged by the darkness of the spots, revealed the positions of the boron and hydrogen atoms.

Based on the results of their experiment, Harker, Kasper and Lucht believe X-ray-diffraction techniques and advances in mathematics will eventually permit exploration of the structures of such materials as hormones and viruses.

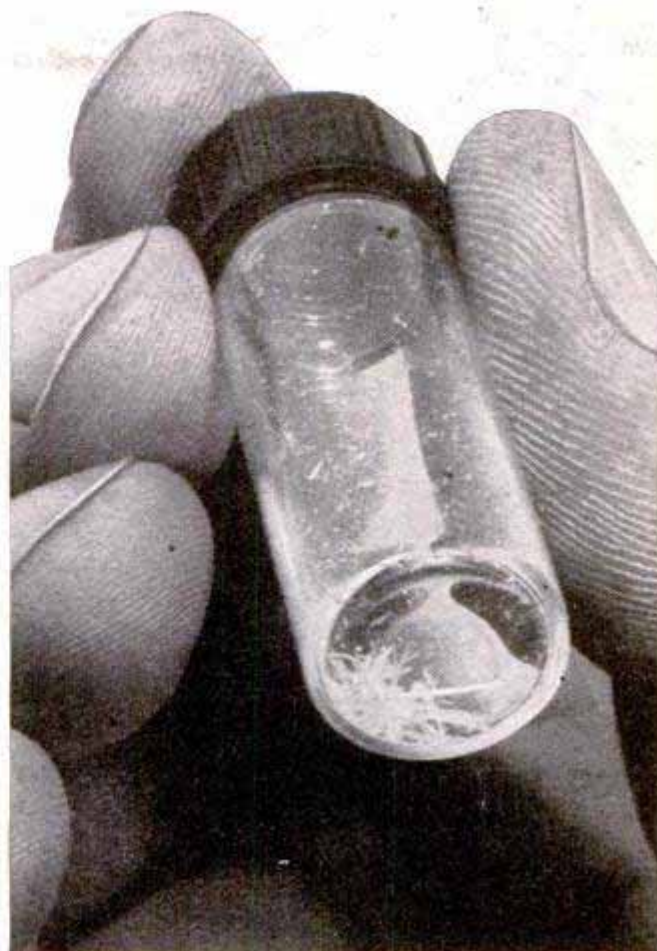

Right, white crystals in the bottle are decaborane crystals. Below, "map" of a molecule. The concentric circles indicate areas of different electron densities, the highest of which are the nuclei of atoms

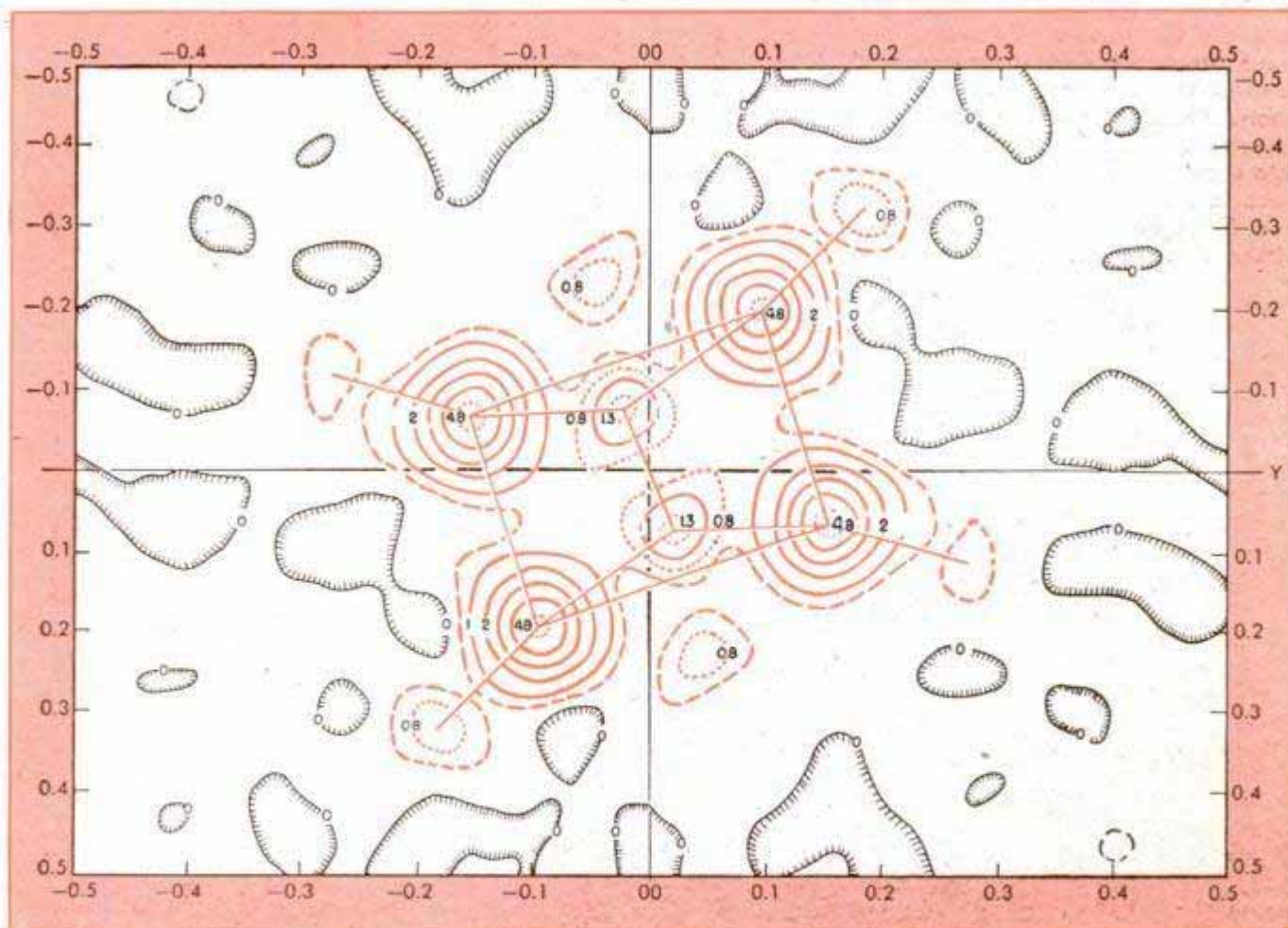

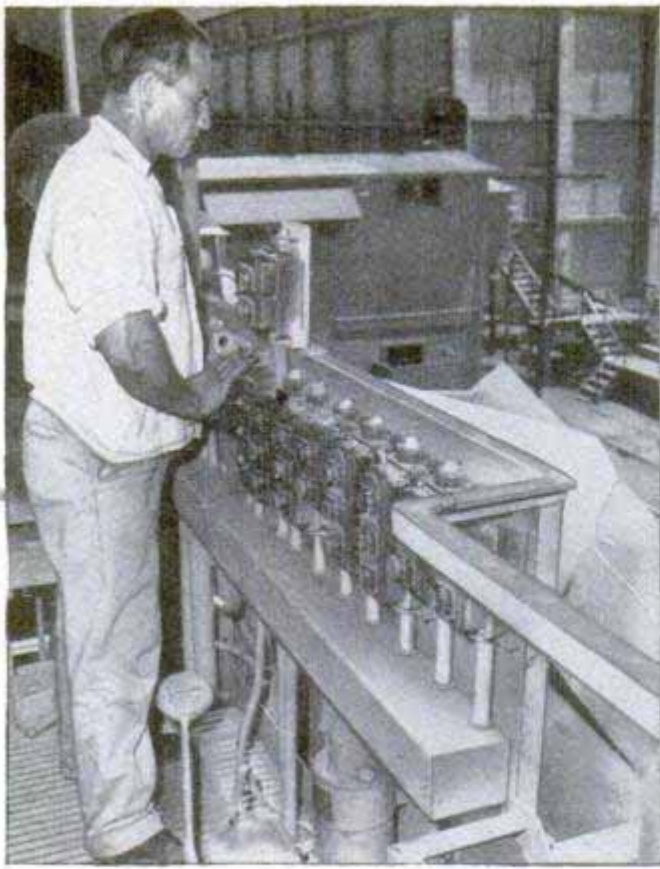

PUSH-BUTTON ICER FOR TRAINS

Five tons of ice are crushed and delivered into the bunkers of a refrigerator car within 90 seconds by a mobile machine. Operated by the Santa Fe Railway, the crusher rides along railroad tracks on a dock at car-top level. A chain conveyor scoops up forty 300-pound blocks of ice a minute and carries them to crusher rolls which smash them into coarse or fine pieces. The ice then goes into either one of two hoppers and flows down chutes into cars on either side of the huge icing dock.

Above, left, operator has a battery of push buttons to control movement of ice. Above, ice pours into "reefers" from chutes on either side of the dock. Below, conveyor scoops up blocks of ice and delivers them to crusher. Machine moves along railroad tracks

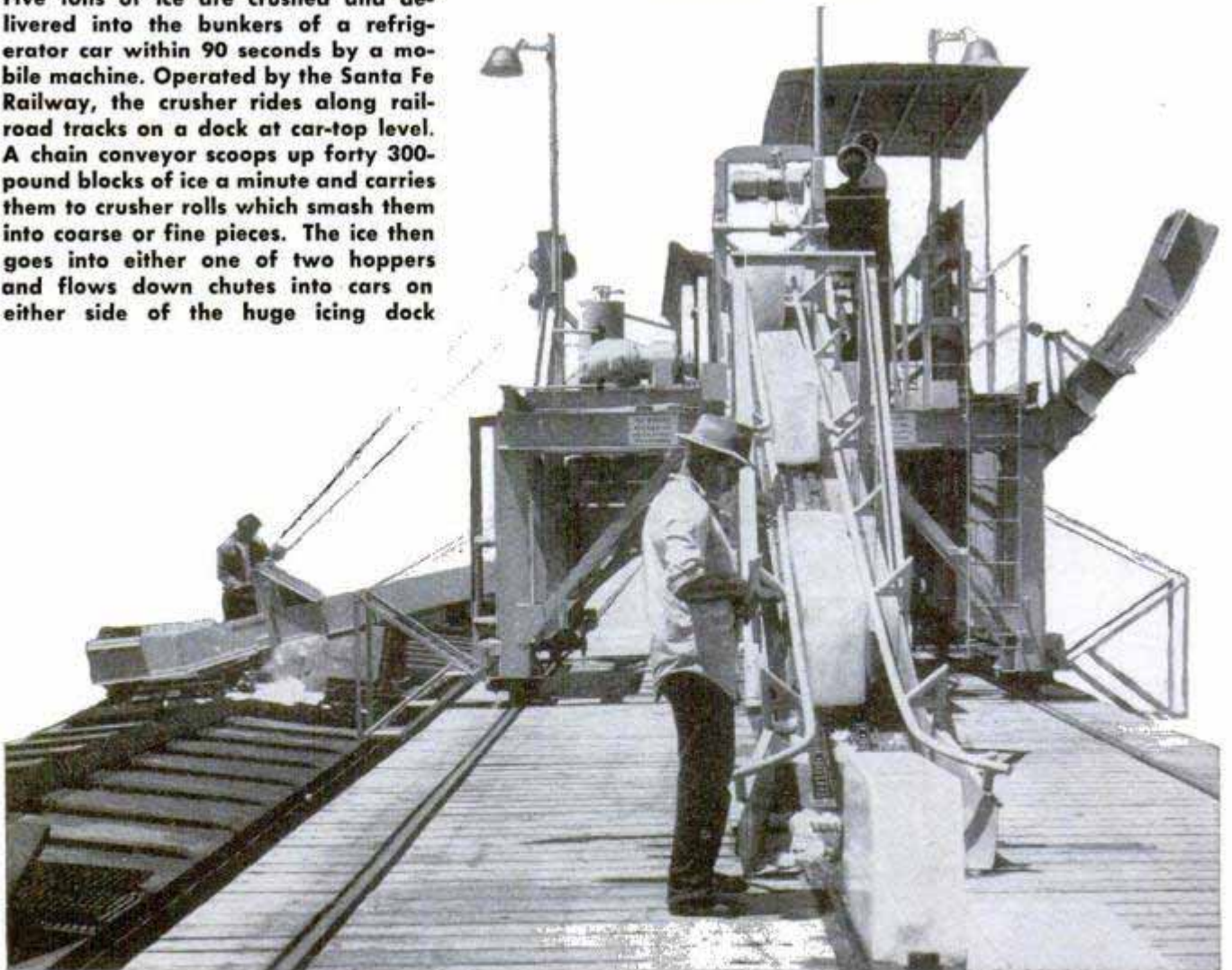

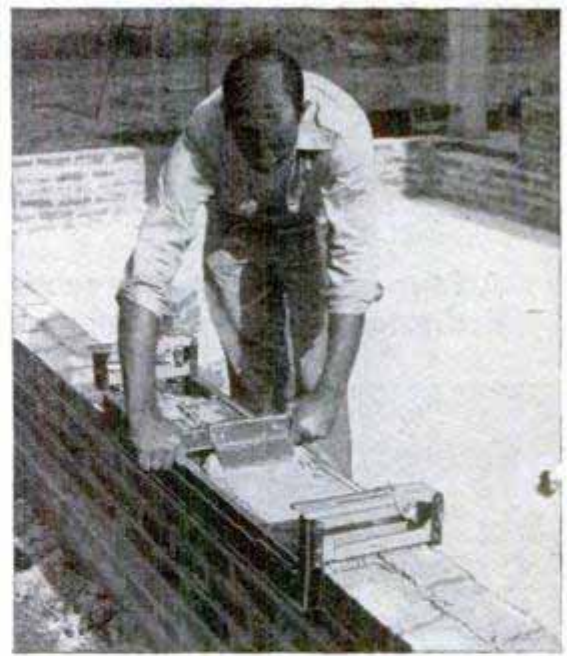
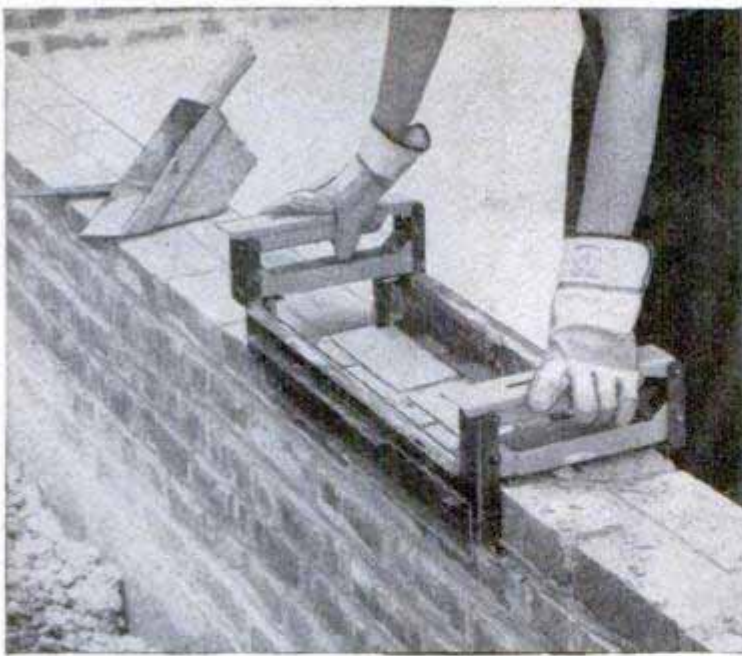

Bricklaying Jig

Bricks are laid three or four times faster with a portable jig that enables the workman to lay up to 12 bricks at a time. A giant scoop spreads sufficient mortar to bed the 12 bricks and spirit levels on the jig assure

accurate placement. With the bricks in place, a second scoopful of mortar and a single troweling complete the operation. The jig is then lifted and placed in an adjacent position for the next operation. According to the manufacturer, a novice can learn to lay bricks quickly with the jig.



Gear-Driven Tripod

Vertical or horizontal panoramic shots are made as "smooth as oil" with a gear-driven tripod head designed for home-movie fans. There are no lock knobs or keys to tighten or loosen when you need the camera most. You just crank one of the handles for vertical movement, the other for horizontal movement. There is also a clutch to disengage the gear mechanism entirely.

Steel Folding Rule → Takes Punishment

Combining the features of a steel tape with those of a wooden folding rule, a tempered-steel zigzag rule is so flexible it can be twisted like a pretzel without damage. It can be wrapped around cylindrical objects to measure circumference, yet it has the rigidity of a standard rule, enabling it to be used as a straightedge for drawing lines. Lighter than the average wooden rule, it does not have to be folded after each use because it

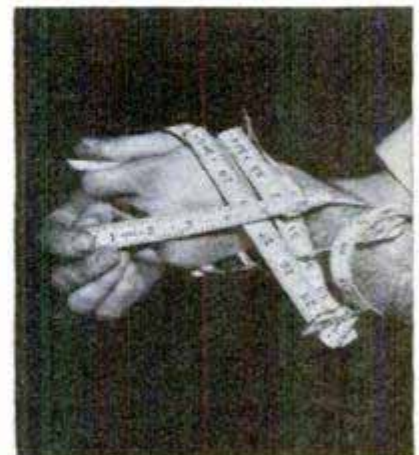
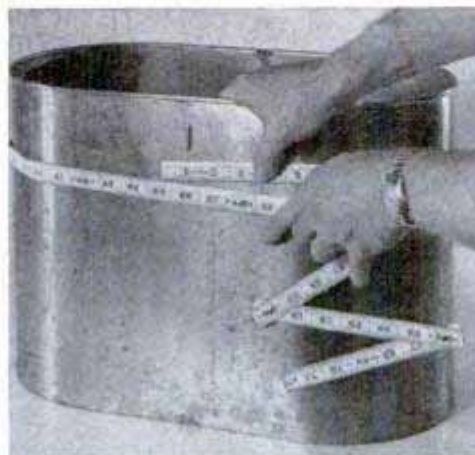

is virtually indestructible. You can even step on the steel rule while it is open or closed without damage.

WHAT'S NEW *For Your Home*

A four-page "shopping section"
dedicated to modern homemakers

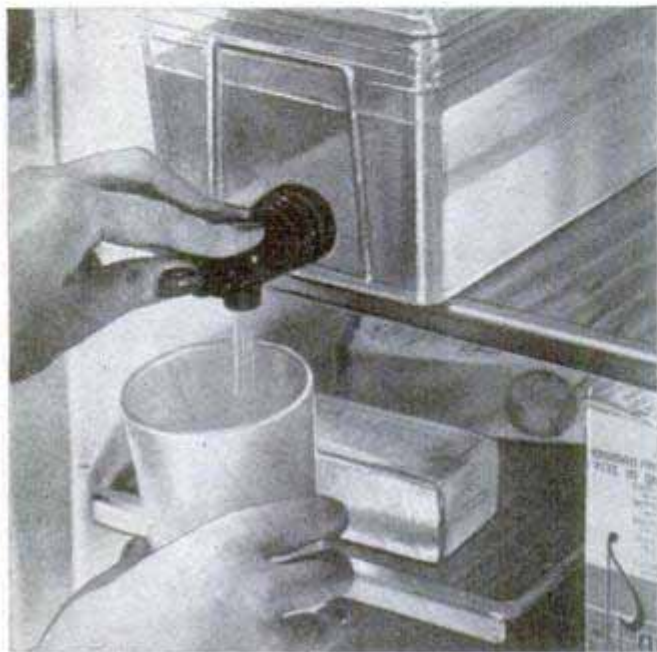

COLD DRINKS serve themselves from a dispenser that fits any refrigerator shelf. You just press a push-type faucet and you've poured yourself a drink



CHERRY PITTER removes the stones from a quart of cherries a minute! Crank-driven, the pitter feeds by gravity, discharging pits and cherries separately

SPACE SAVER for closets holds as many as six garments on one hook. Made of plastic with a metal hook, the hanger comes in two models, one for dresses, the other for slacks

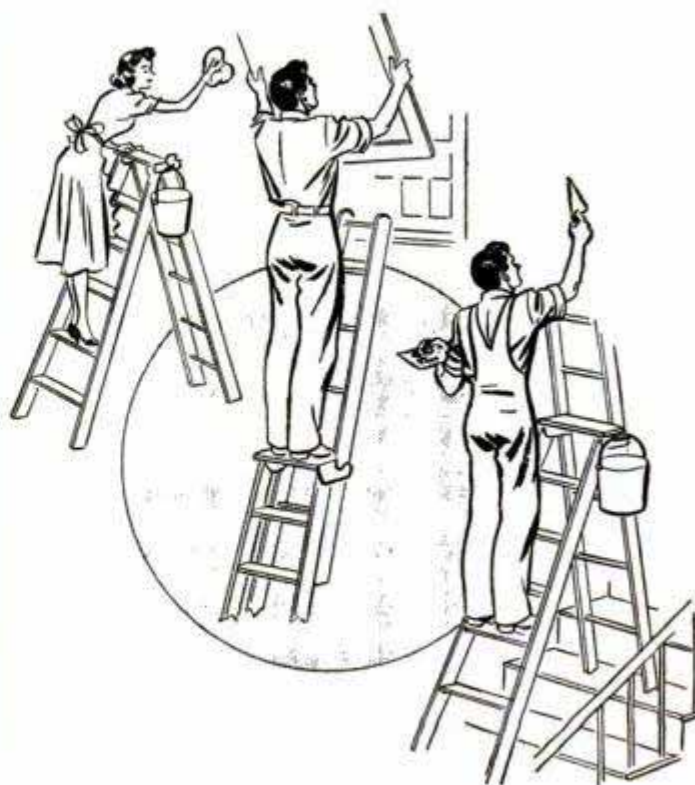

ALL-PURPOSE LADDER is used as a step-ladder, extension ladder or stairway ladder, as well as two individual ladders, if desired



FIRE GUARD, top left, is on duty 24 hours a day to warn you of fires. When a fire starts, the guard lets out a shrill whistle that is audible for $\frac{1}{4}$ mile

ELECTRIC DISHWASHER, top right, washes and rinses a dinner service for four in 10 minutes. It weighs 25 pounds and takes up little storage space

SAFETY HOOK, right, protects youngsters from accidents and discourages prowlers. To unlatch the screen or door, you push back a spring-loaded guard

OPENER DE LUXE, below left, is a whole kitchen workshop in one item. With it, you can open any can, bottle or jar, remove corks and even screw-on lids

VERTICAL BLINDS, below right, are decorative and practical. Made of translucent fabric, they are colorful, can be washed and put back in 20 minutes

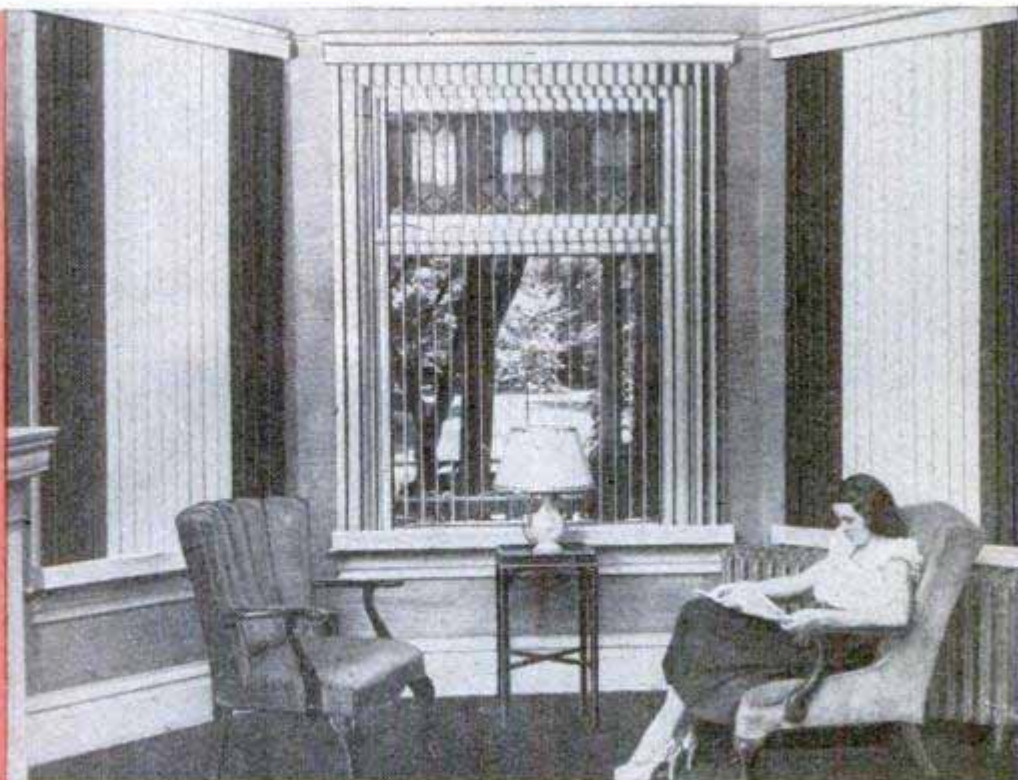
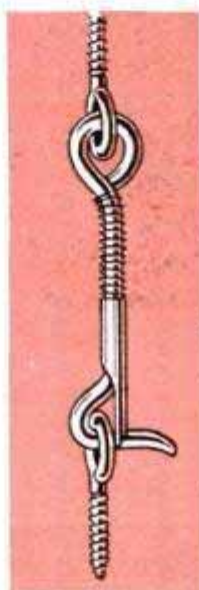

WHAT'S NEW *For Your Home*

Continued from preceding page

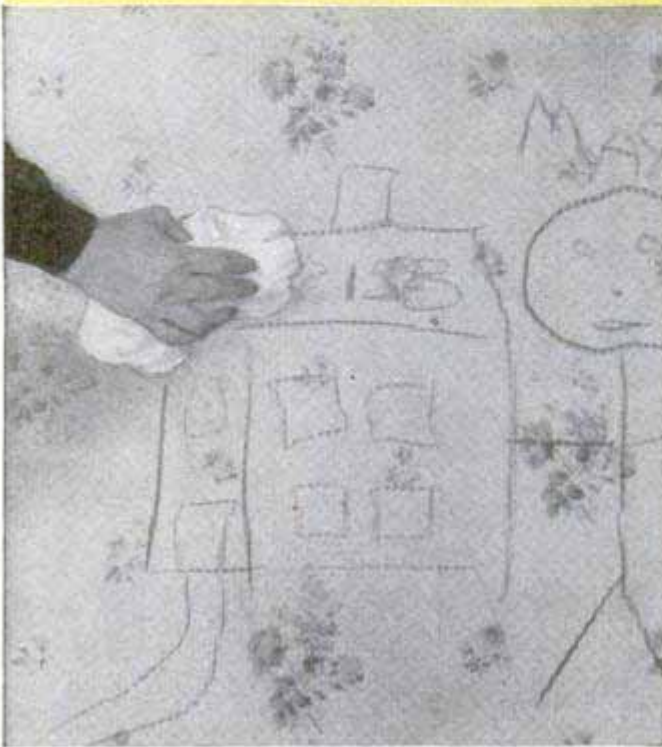

WALLPAPER COATING is invisible, but it protects the paper so you can wash off marks with a soapy cloth.



BOTTLE STERILIZER works under pressure and it lets you sterilize the bottles with formula in them.

STEEL FIREPLACE can be installed wherever a flue is available. It can even be suspended from the wall.



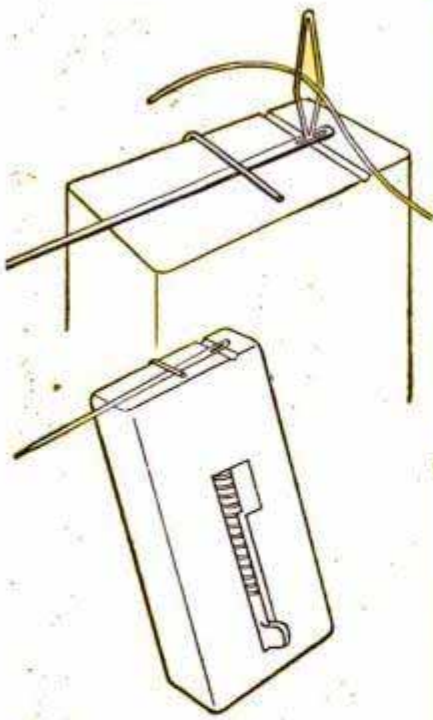

NEEDLE THREADER works with any size needle. A spring on a wire loop pulls thread through the eye



SINK DIVIDER makes a regular sink into a double-compartment model. A rubber channel strip is held against the sink by suction cups, forming a watertight seal on any sink. An aluminum sheet is the partition

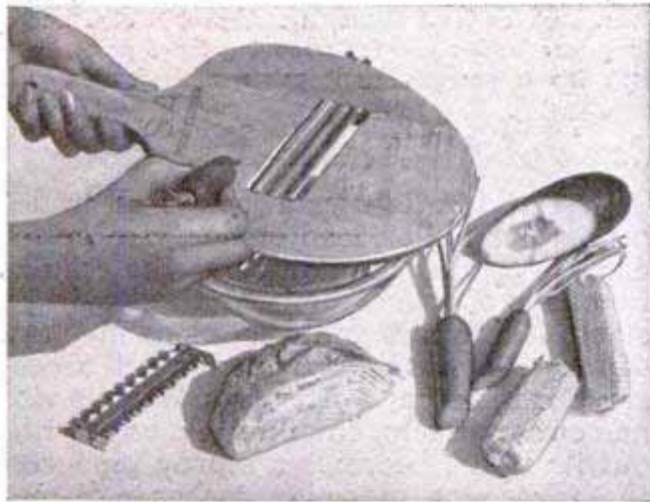

TWO-WAY SLICER has a double blade so you cut the vegetable in both directions, speeding the job

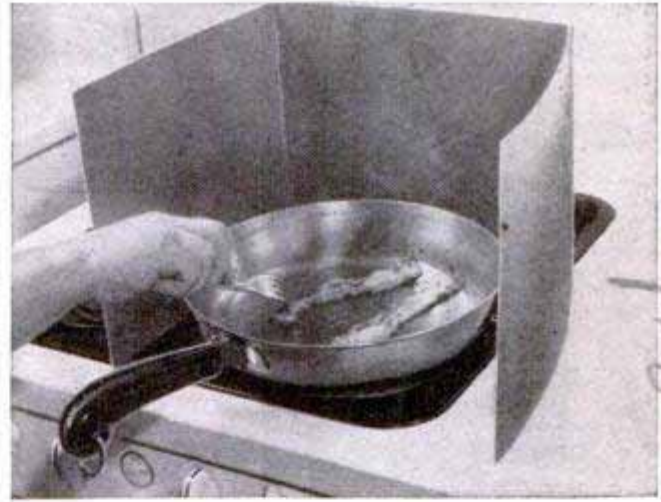

SPLATTER STOPPER fits around the skillet to prevent grease from flying all over the stove and the wall

MAGNETIC RACK, below, holds small metal items upright by magnetism. The top has bobby-pin opener

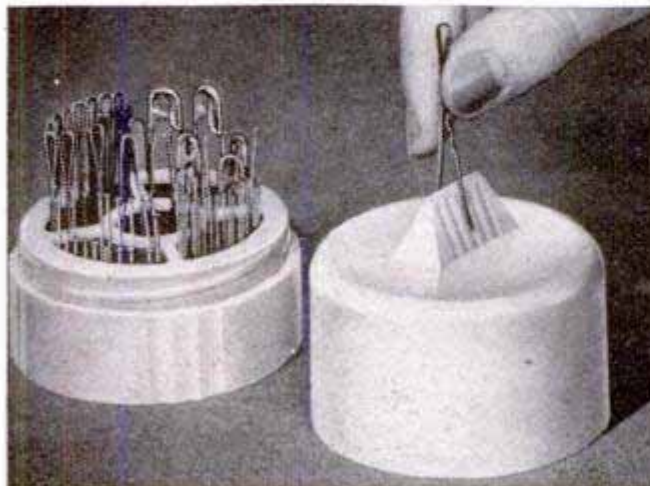

GRIP TRAY, below, clamps firmly to the arm of a chair, providing a safe place for a cup or a glass

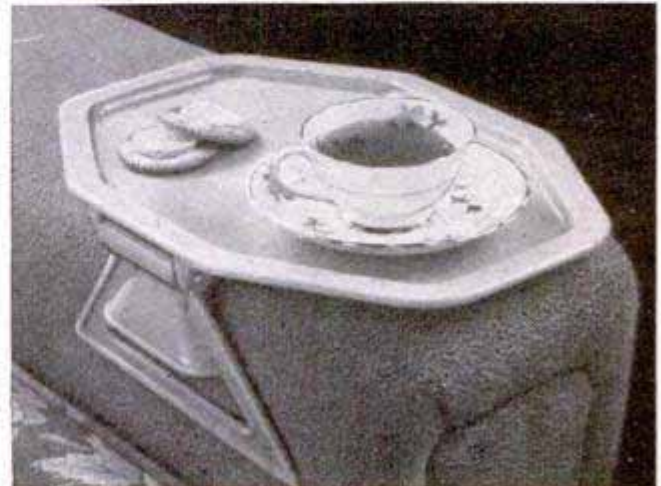

*Patent Cases -
Manufacturer - MRS. LETHA O.W. CORDREY, 4071 KANSAS ST., SAN DIEGO 4, CA*

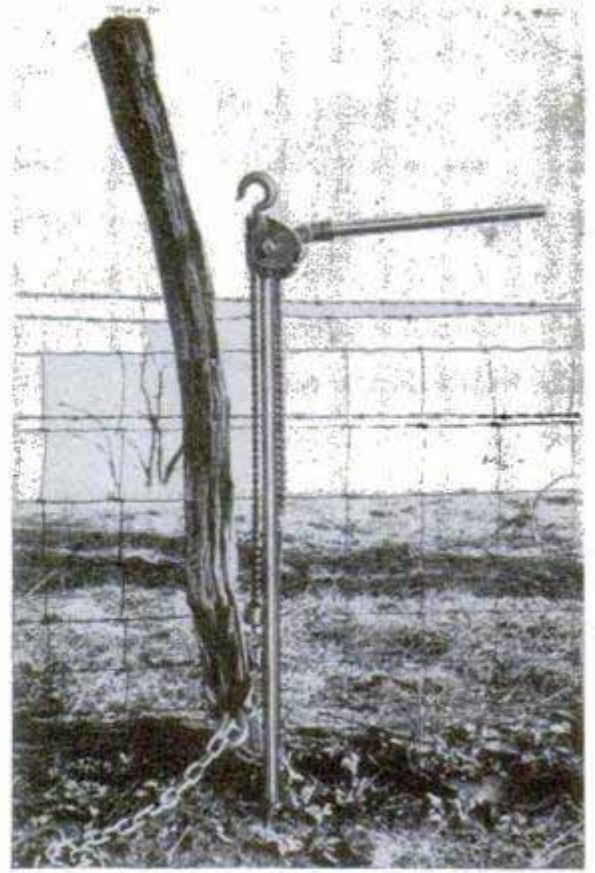

Above, left, this jack can be used for many pulling jobs, such as load tightening. Above, it also has a long, continuous pull for removing fence posts, and, left, it's a powerful bolt cutter and vise as well

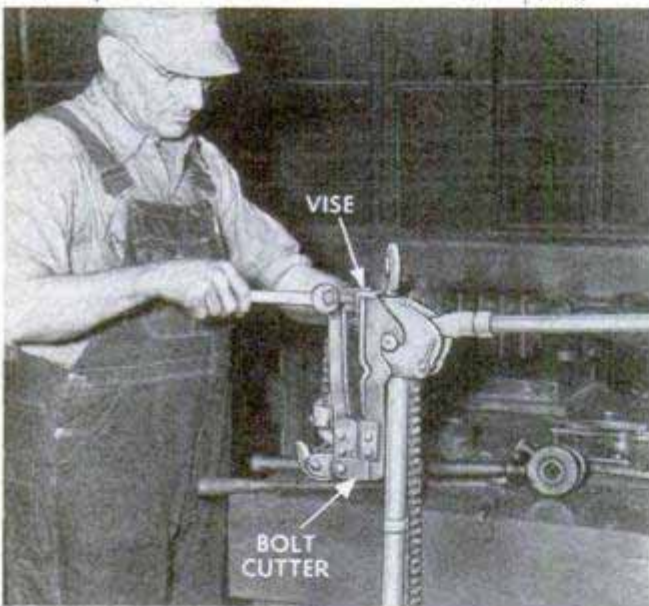

Jack-of-All-Trades

Versatile in its uses a jack-of-all-trades serves as a puller, load binder, vise, cutter and post puller in addition to the regular functions of a bumper jack. Used with its stand, it lifts cars and tractors as much as 44 inches. It has the continuous pull necessary for removing fence posts. With its vise and cutter attachment, the jack, used without its stand, becomes a sturdy pipe vise that takes pipe up to eight inches in diameter. It also serves as a bolt cutter with a capacity of $\frac{3}{8}$ inch.

Back-Yard Beach

Larry Nelson of Burbank, Calif., converted a war-surplus rubber pontoon into a family-size back-yard swimming pool. Thirty feet long, seven feet wide and three feet deep, the pontoon is the type Army engineers used in building temporary bridges. It can be inflated in 15 minutes with a tank-type vacuum cleaner and quickly deflated by opening valves. Nelson's total cost was less than \$70.

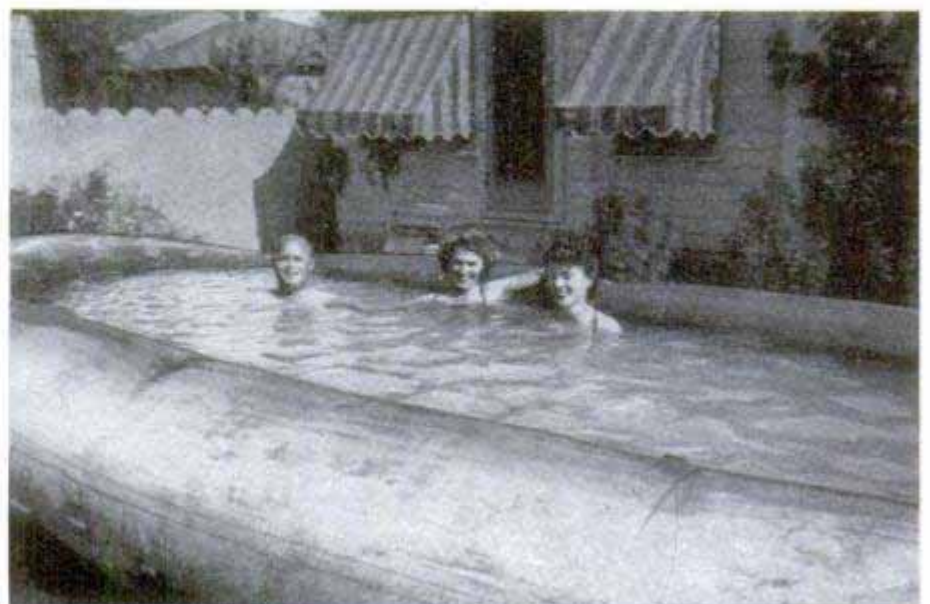



U. S. A. F. photos

Heroic in peace as in war, B-29 crews roam the wide Pacific exploring the turbulent hearts of typhoons

Look a Typhoon in the Eye

By
George Scullin

Beverly was a typhoon. When Lt. Lykins' B-29 flew into its heart, it was like hitting Niagara. This is the heroic story of one of the missions of our typhoon trackers over the Pacific

HER NAME was Beverly, and when she was born she was just another puff of cloud on the northern edge of the doldrums. Millions like her had been born that day, and they lay in the warm sun above the equatorial current like a blanket of cotton bolls all the way from Borneo to the coast of the Americas. All day they floated in the hot, moist air, their shadows barely moving on the dead, blue water below, and that night in the coolness they slowly sank and vanished. All except Beverly.

Sometime during that December

Lt. Lykins makes a careful instrument check before take-off on perilous flight into storm



MARCH 1950

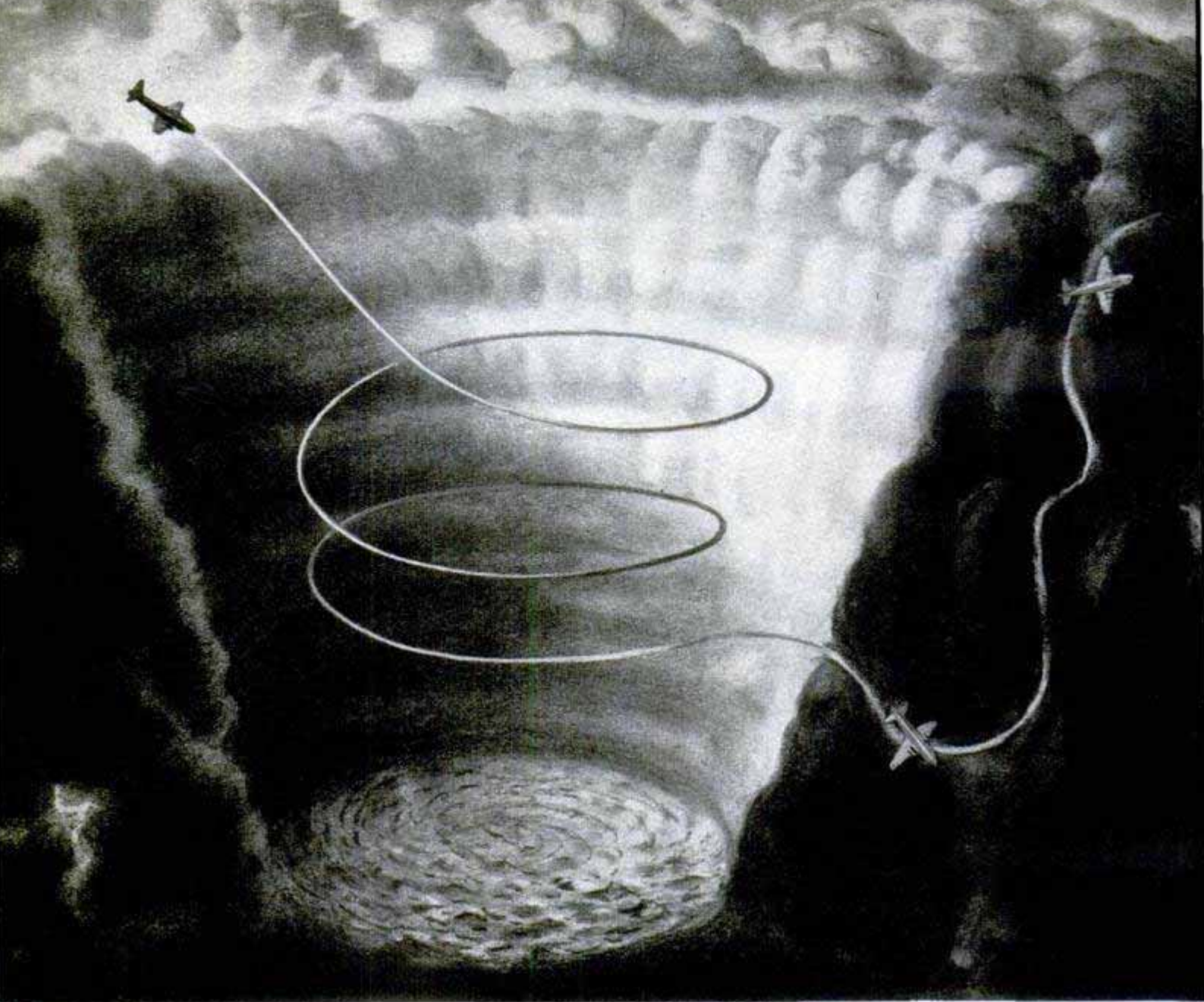

Harrowing flight into the typhoon eye and out again is depicted by Leydenfrost, noted illustrator. Lykins' plane came out of the eye at 1500 feet and was tossed up and down at rate of 1000 feet a minute on way out

afternoon the stagnant air held within the strange walls of the doldrums had spilled over, and Beverly was carried north on the overflow. That night there was no warm air beneath her in which to sink into oblivion. Instead, a refreshing cool stream from an air mass to the north slid below, and she found herself being hurried up its slope. Around her in the darkness were other vague shapes and, as she rose higher, they fell in behind her and began joining their forces to hers. Before dawn, swollen into a vast, towering mass, she expressed her resentment of her uncomfortable condition by releasing bolt after bolt of lightning into the cold air that had caused it all.

The next day did nothing to improve her temper. She found herself squeezed into a narrow valley between two domes of cool air, and while it was easy to drift down the valley, every hour carried her farther and farther away from the quiet doldrums. It

was getting colder. The left side of the valley was steep and rough; the right side sloping and smooth, and the obstructions kept dragging at her left side, holding her back. As she flowed north at 15 miles an hour, she encountered a new annoyance. Down around the equator the pull of the spinning earth had been constant, almost as straight as gravity itself, but up around latitude 15, North, its pull was weaker on her north side than on the south. Twisted by the pull of the earth and snagged by the obstructions on her left, she began to turn like a chip in a swirling stream. So Beverly drifted north and east, fuming and spluttering and drawing to her assistance all the warm, moist air from a hundred miles around. Occasionally, her rage overflowed and she would drench the ocean with lakes of water, or she would lash at an island with venomous fury, tearing out giant palms like dandelion tufts.



D. Leydenfrost

On her third day, grown now to a hundred miles in diameter and still circling sluggishly while awaiting reinforcements, she made a trial test of her strength. While an alarmed skipper saw the bottom fall out of his barometer, she hit his freighter a quartering blow with a 60-knot gust that drove the starboard rail into the water. She hit him again before the ship could right itself, but she had neglected to pile up enough of a sea to smash him down for keeps. The ship lurched out of the danger area, but with no radio left to notify the world of its experience. Beverly lashed on, pounding the seas with such violence that the bottom three miles below shook.

On the island of Guam, a thousand miles to the east, the ultrasensitive seismograph of the U. S. Navy's weather station picked up the vibrations of the ocean bottom. A few minutes later the seismographs at Okinawa and Manila were taking bearings on Beverly's outburst, and within an hour her position had been pegged. She was, the Navy announced, a big storm that had am-

bitions to become a dangerous typhoon.

The boys at the U. S. Air Force weather station on Guam had not been caught napping. They had noticed an hour earlier an almost imperceptible drop in the barometer. On this island, where the weather is always perfect, a change of any kind can be only for the worse, and a pressure change so light as to be ignored elsewhere is here regarded with deep suspicion. The radio, too, was bringing in the repercussions of Beverly's electronic indigestion.

The next morning there was no need for seismographs or barometers to warn of Beverly's approach. A roller longer than the whole island heaved out of nothing and smashed upon the coral. A long pause, as though the sea were taking a deep breath, and another roller foamed up the beach. After that you could see them, a quarter of a mile from one round crest to another, each roller firmly rounded in front and then gently sloping back in a long smooth fetch to the base of the next. In the west the blue of the sky was cloudless, but the



U. S. Navy photo

An aircraft carrier rides out a typhoon in South China Sea. Despite the extreme roll and apparent danger, at least one crewman grins with confidence



Light cruiser is tossed around like a rowboat in heavy typhoon sea. Below, destroyer looks half submerged but is only caught in trough of giant waves

milky whiteness that usually lay low upon the horizon now extended well up into the heavens, and it was no longer friendly.

The time had come to do some flying.

The big B-29, peregrinating weather laboratory of the 514th Reconnaissance Squadron of the 2143rd Air Weather Wing, is gassed for very long range, and the ground crew again goes over her sun-bleached, rain-scarred skin, looking for ripples in the aluminum fairing and for loose rivets. She is a tough old bird.

In the weather shack of the U. S. Air Force Weather Central at Harmon Field, the weather forecasters and analysts of the Typhoon Warning Network were going over their charts with Lt. David W. Lykins, in command of the flight, his two copilots, his weather observer and his navigator. The charts showed Beverly had tightened up considerably during the night, and although her top was spread like an umbrella over 200 miles of sky, she was winding up around a central core of less than 50 miles in diameter. Wind velocities on the northeast side were pounding at the 100-knot mark, while those in the southwest quadrant were hitting 70 and 80 knots in gusts.

"She seems fairly well behaved," says the chief observer. "Not as bad as Ione or Karen or Libby. We'd like to have you hit her at about 10,000 feet and penetrate to the eye."

"Any special instructions?"

The chief hesitates. "Well, yes," he admits. "When you get inside the eye, you might buzz around a bit, then drop down to 1500 feet and break through her wall at that level. We're getting a good picture of typhoons at high level, and we know from ships what they do at sea level. Now we would like a cross section at low level."

Bedlam in the cockpit is portrayed on opposite page → as the B-29 worked its way out of the typhoon eye. The crew said it was like "hitting Niagara Falls"







Before take-off on weather-reconnaissance flight from Guam, the crewmen check over emergency equipment

The three pilots exchange glances. The navigator gulps. The weather observer looks eager. "Yes, sir," he says.

No plane, or at least none ever seen again, had tackled a typhoon at low level before.

At 3 p.m. the B-29 leaves Harmon Field and heads due west. On board, in addition to the men listed above, are a radar operator, a radio man, a flight engineer and two scanners, one for each side of the plane, to watch for damage during those moments of extreme turbulence when not even the loss of an engine would be felt by the pilot. Flight lunches and all gear are carefully stowed. Safety belts and shoulder straps are checked again for the 20th time.

Two hours out the first feathers of a high fan of cirrus clouds reach their tips over the plane, and the weather observer, seated in the nose between and slightly below the pilots, estimates their altitude at 30,000 feet and their length at 100 miles. Lykins is holding the plane at the 700-millibar level, and the radar altimeter by the navigator shows a true altitude of 10,000 feet. Under normal weather conditions the barometric altimeter scaled in millibars drops 34 millibars for each thousand feet of climb from a standard of 1013 millibars at sea level, and a quick comparison of the two altimeters shows that Beverly's presence has caused little drop in barometric pressure.

Ahead the swells on the sea are growing closer together and higher. They are like the spreading ripples of a stone dropped into a millpond, closest together near the scene of the disturbance, but now, even from 10,000 feet, the sea is no millpond.

Whitecaps appear on the swells, and then the whitecaps are blown to a froth that whips away at right angles to the direction in which the waves are moving. The navigator estimates the swells rolling east at 26 knots, the wind swirling north at 50 knots. A high-reaching gust flows beneath the plane and gives it a playful toss the height of a five-story building, and then drops it ten. The radar operator, tuning in on the eye, has his hand wrenched from the knob by the toss, and has to begin over.

And then Beverly looms before them.

Radar operator on weather plane found weak spot in typhoon wall through which Lykins' plane "escaped"



Low at first, only her crown of innocent puffs gleaming white beneath the late sun. To north and south the rolls of clouds lie, almost in a straight line, and the B-29, much smaller now, moves toward them as if drawn by some superior power. Minute by minute the clouds seem to grow higher. The sun is swallowed, leaving a blazing halo on the topmost puffs, while the solid wall beneath turns from gray to black. Lightning flashes inside the blackness like the opening and closing of doors in a blast furnace. A deck of strato-cumulus clouds slides beneath the plane, looking amazingly smooth and calm after roiled waves, lashing out in all directions.

The radar operator has the eye of the storm on his screen, high and to the right. Lykins swings the plane 25 degrees to the right, and stretches against the shoulder straps that are pressing him into his seat until his backbone seems permanently curved. The picture of the eye is clear, like an X-ray in green of the bow of a man's rib. Occasionally, lightning flames across the screen, but the eye always returns.

The navigator makes his final notations as Beverly towers above him, her 40,000-foot summit suddenly wiped out in a blast of rain. His pencil bites deep into the paper on an updraft. "Surface winds, 70 knots from 180 degrees." A downdraft lifts him hard against his shoulder straps but his trained pencil, barely touching the paper, records, "Temperature still 10 degrees Centigrade at 7:56Z."

The weather observer had quit making notations on paper, and is now talking into a voice recorder. "Moderate rain. Ex-ooh-treme turbulence."

The radio operator has locked his mike in a bracket and is now pounding his key at a steady 20 words a minute as the navigator hands him position reports and the ob-

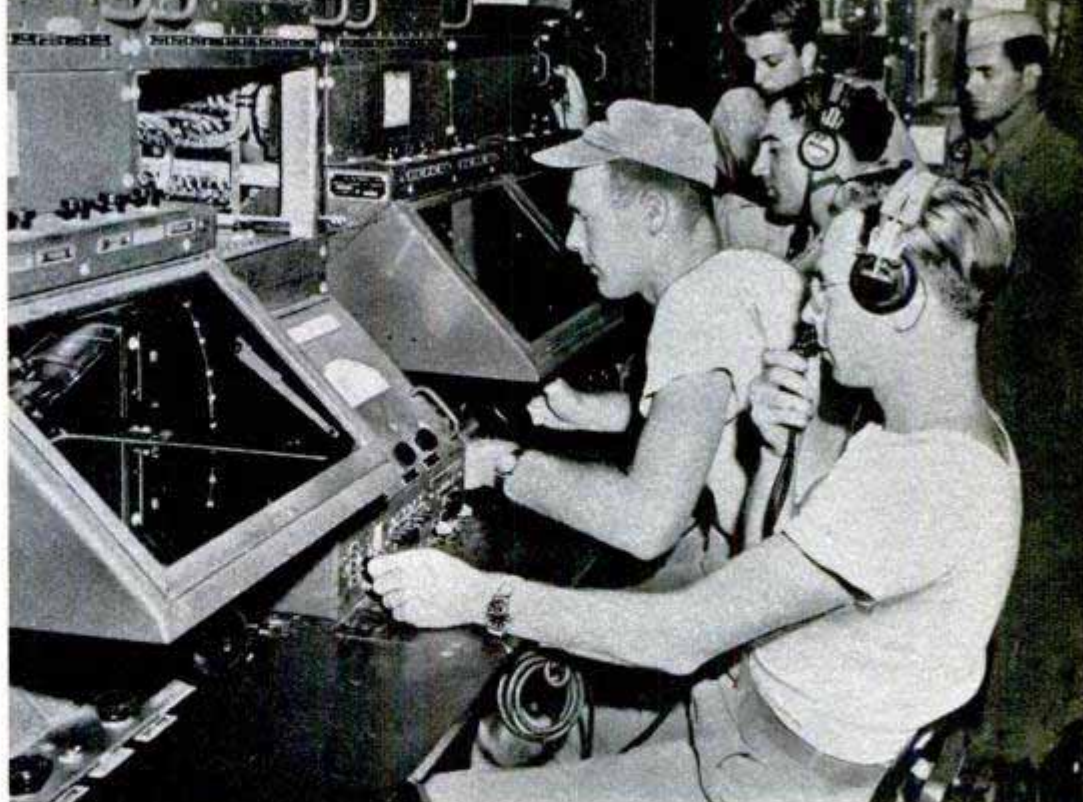

Zippo, high-precision radar device at Guam field, lands planes in fog

server feeds him the last written notations. The third pilot, clinging grimly to any handhold, acts to relay the messages from man to man.

From Lykins report we get the following: "At 09:06Z we broke into the most beautiful and well-defined eye that I have ever seen. It was a perfect circle, about 30 miles in diameter, and perfectly clear overhead. The sides sloped gently inward toward the bottom from 25,000 feet, and appeared to be formed of a solid stratus layer down to

(Continued to page 248)

Wartime typhoon caught USS Hornet and twisted her deck like a hat brim

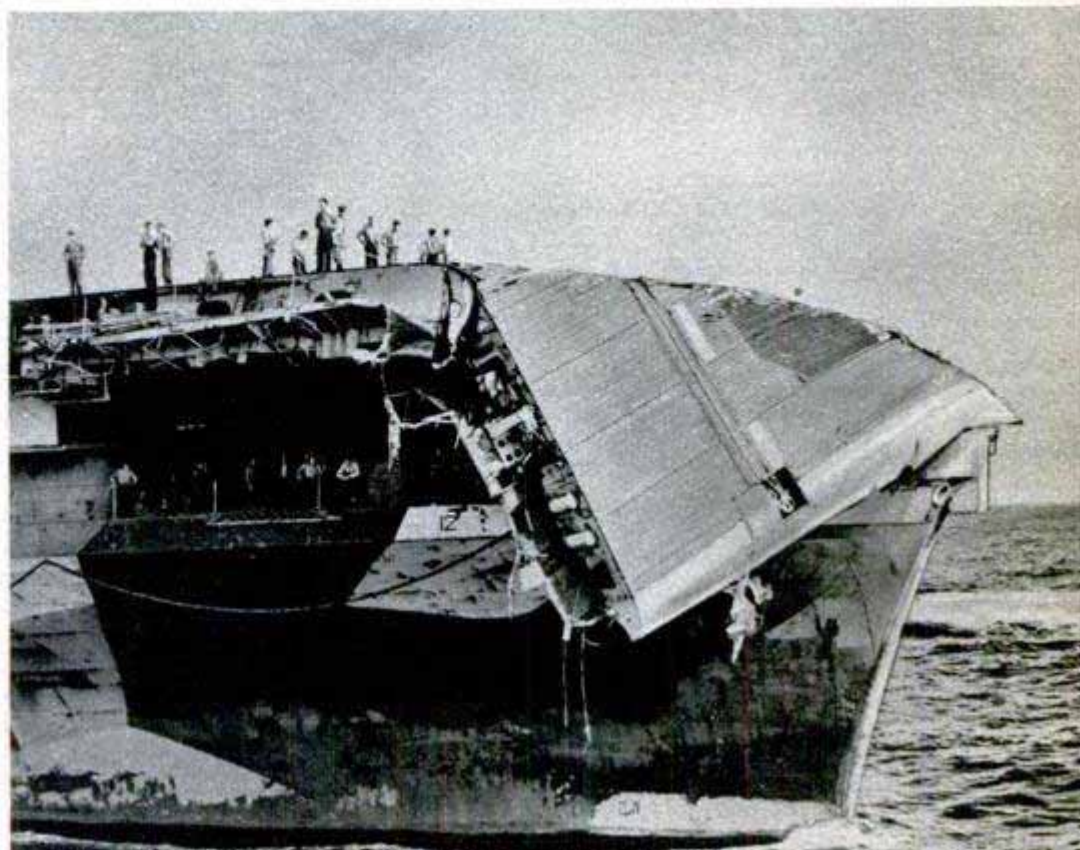



Above, concrete divider in background is replacing wood-steel type on California roads. Right, close-up of the new divider

Non-Jump Highway Divider In 10-Foot Sections

Neither speeding autos nor heavily loaded trucks can "jump" a new-style highway divider being installed in California. It consists of 10-foot-long slabs of reinforced concrete, curved inward on the sides and bolted to the road. The state says the divider, costing \$7.50 per foot to build, will pay for itself in a little over two years, since maintenance on the wood-steel barrier that is now in use averages \$3.50 per foot yearly.

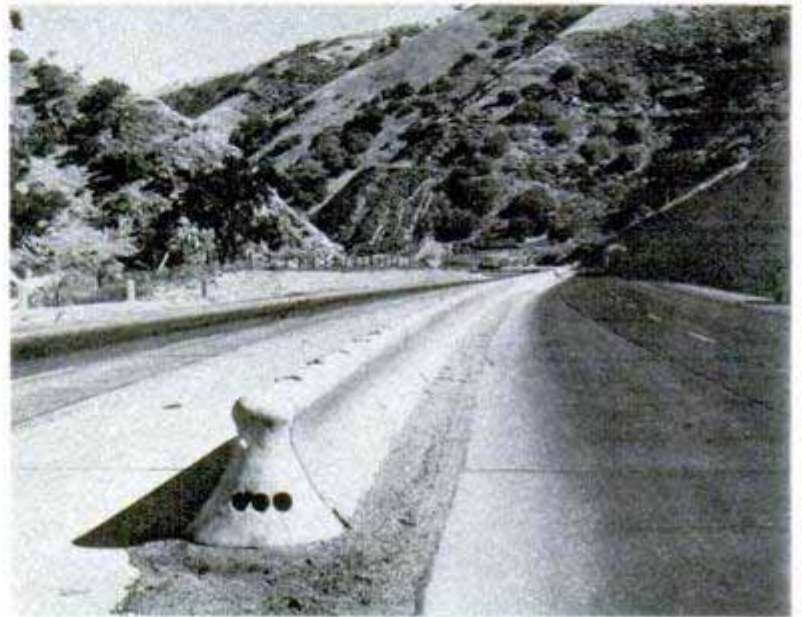

Typewriter Keyboard On Typesetting Machine

Typists can now set type on Linotype and Intertype composing machines through the development of a keyboard that has the standard keys of a typewriter. Forty-four keys, electrically operated, fit over the 90 keys of a standard composing machine. The keyboard can be moved from one composing machine to another as there is no installation. The new keyboard is simply placed over the top of the existing keyboard and the unit is ready for use when it is plugged into an electrical outlet. The complete outfit weighs only 25½ pounds.

Information not listed on articles in the index, starting on page 10, frequently is listed in the WHERE-TO-FIND-IT INDEX, which is available without charge from Bureau of Information, Popular Mechanics Magazine, 200 East Ontario Street, Chicago 11, Illinois

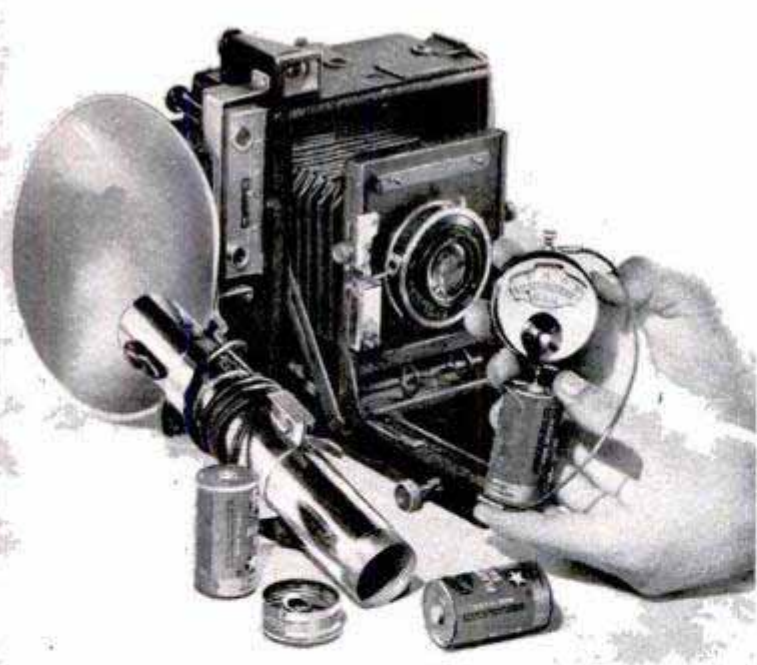

Meter Checks "Juice" in Batteries To Insure Firing of Photo Bulbs

With a new meter, photographers can check the "juice" in photoflash batteries before they make that all-important shot. A spur on the meter is touched to the positive end of the battery and a flexible cord is pressed against the bottom of the battery. The available power then is read in amperes on the meter. The little meter is scaled from 0 to 23 amperes and gives positive evidence as to whether the batteries are strong enough to fire the bulbs.

CARBURETOR JIG, at right, gives the mechanic an extra "hand." Holding a Ford V-8 carburetor firmly, it lets him work with both hands. The jig, made of aluminum, can be clamped in a vise or bolted down

FENDER SKIRT swings out on hinges to provide easy access to the wheel. This innovation was shown at the International Motor Show in London and was demonstrated on a Rolls Royce. It's a low-cost item

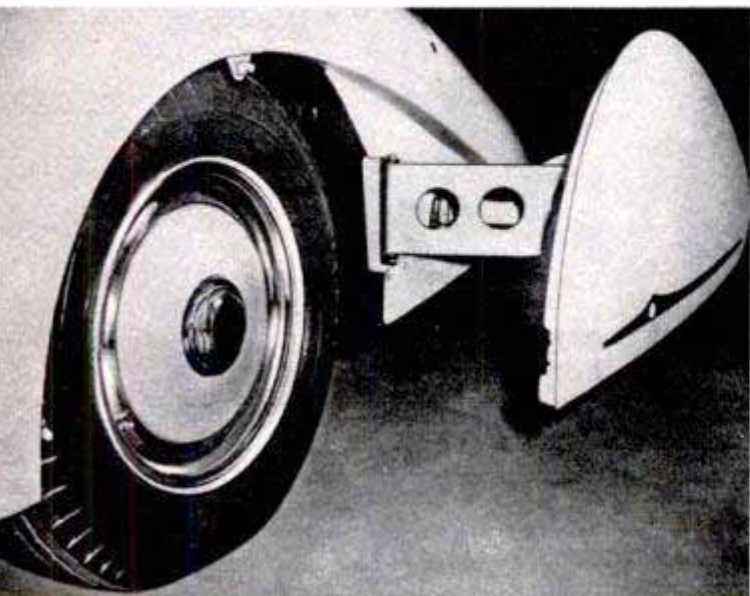

Twist of the Wrist Loads and Cocks Camera

Sequence shots of rapid action are taken by a fast-operating camera designed for sports and spot-news photographers. A twist of the left wrist cocks the shutter and automatically advances the film. The lens aperture is adjusted without looking at the scale by counting audible clicks that mark each stop. The focal-plane shutter has speeds from $\frac{1}{100}$ to $\frac{1}{500}$ second. The camera comes with an f:4 lens and uses 80-mm. perforated film.

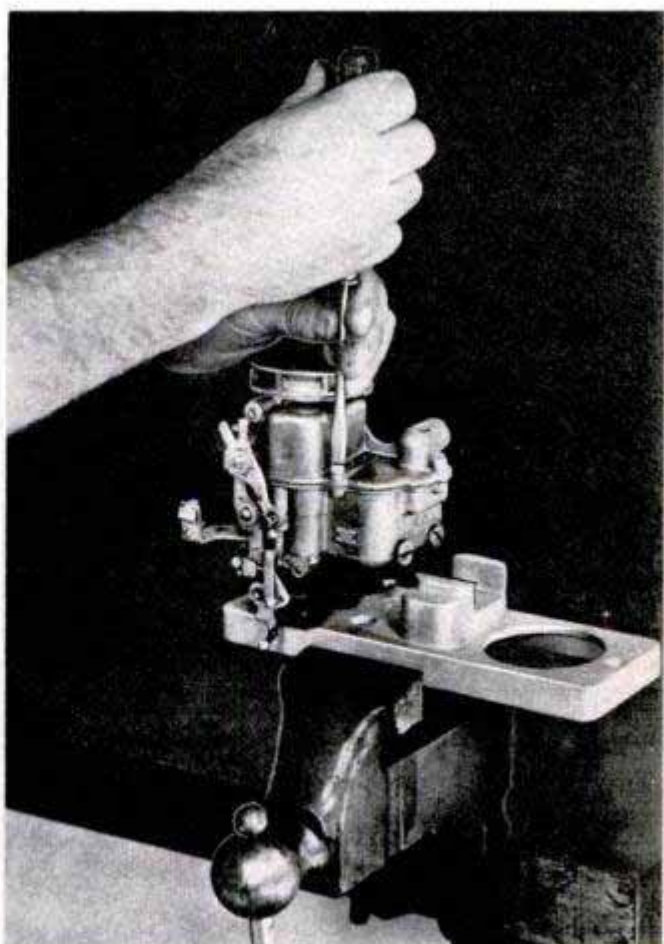

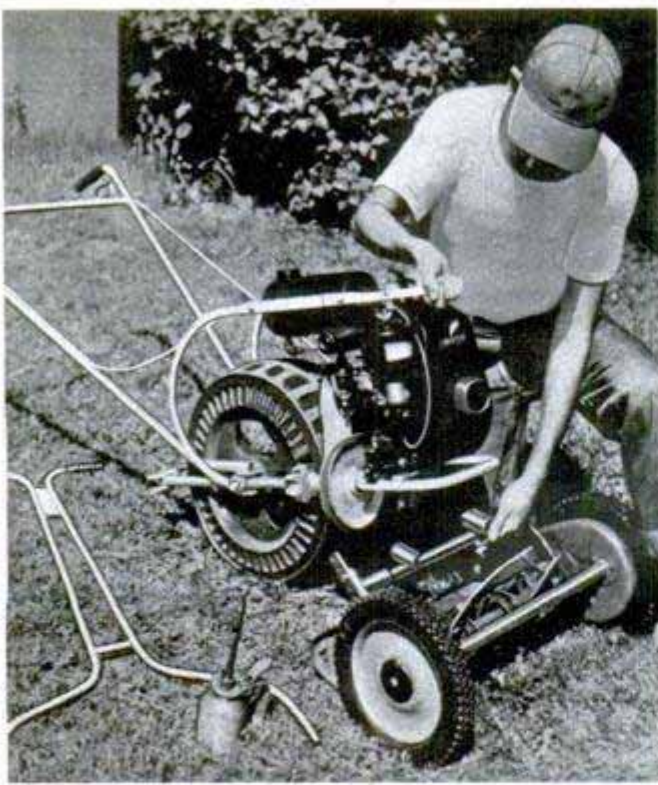

One-Wheel Garden Tractor

Weighing only 87 pounds, a new lawn and garden tractor has only one wheel that not only supports the tractor, but also has, as part of the casting, a ring gear which drives the implement. The wheel has a six-inch tread for good traction and load distribution. A regular lawn mower, with handle detached, can be hooked to the tractor to convert it into a power mower.



Weed Cutter Uses Razor Blades

Old razor blades are put to good use in a grass cutter that takes four single or double-edge blades. A slide, which fits into the cutting arm of the tool, holds the blades firmly for good cutting action. Designed for use in trimming grass around flower beds and trees, the cutter can also be used to remove weeds by cutting below the ground surface and for light pruning.

Vacuum "Churn" for Oils May Improve Quality

Better lubricants may result from a new research technique, known as molecular distillation, that reduces changes in the molecular structure of oil to a minimum. Key to the process is an apparatus consisting of a shallow steel cone, spun at 1725 revolutions a minute inside a glass vacuum chamber. The oil is fed to the center of the cone through a tube and centrifugal force spreads it over the radiantly heated metal surface in less than $\frac{1}{10}$ second. The more volatile or lighter portions of the oil are distilled off and collected, while the less volatile portions are thrown off the edge and collected as residue. Because the liquid spreads over the cone in a layer only 3000 molecules thick, it is distilled in a fraction of a second, thus keeping hydrocarbon decomposition at a minimum.

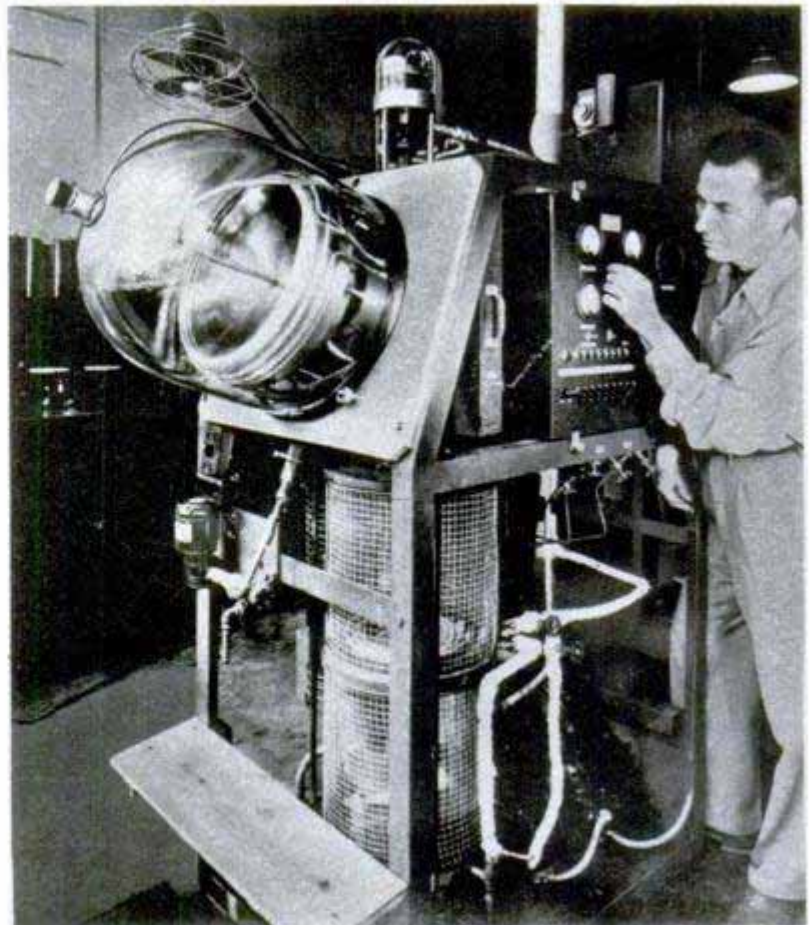

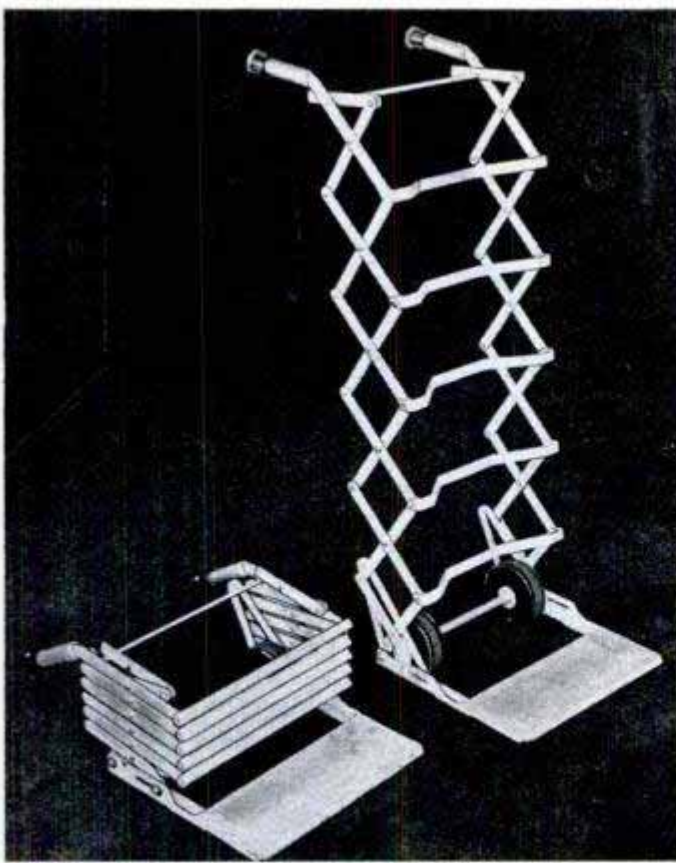

Folding Hand Truck Will Carry 700-Pound Load

Folding like an accordion, a lightweight hand truck — weighing only 25 pounds — can carry up to 700 pounds. It folds into a compact heap, only nine inches high; when folded, 10 of these trucks can be stored in a space ordinarily occupied by two rigid-

type trucks. When fully opened, the truck reaches a height of 42 inches. A glider bar on the truck makes it easy to take loads up and down stairs. The wheels are mounted inside the frame to prevent them from catching on passing objects.

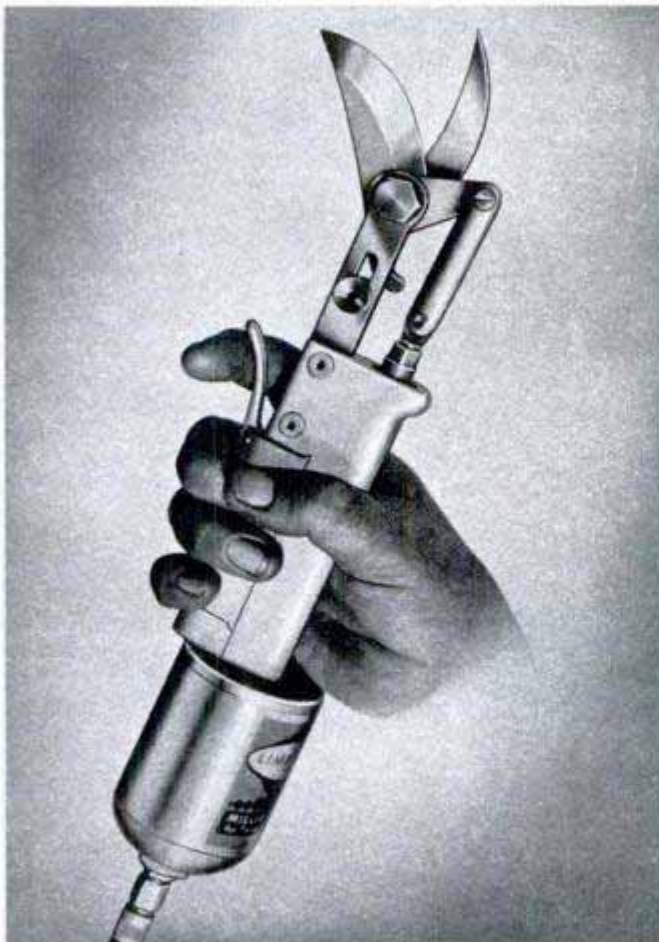

Pneumatic Pruning Tool

Only the touch of a trigger is required to lop off limbs with a new air-operated pruning tool. The pruner handles limbs ranging up to $\frac{3}{4}$ inch in diameter, and larger cuts can be made if the operator rotates the tool slightly between pulls of the trigger. Action is rapid because air pressure opens as well as closes the cutters of the $1\frac{3}{4}$ -pound tool. The cutter opening can be adjusted from wide to narrow range by a slide stop to increase efficiency in cutting small vines and branches.

No-Contact Printing System

Onset printing, a revolutionary system in which no contact or pressure is used, transfers ink to paper by what is called an electronographic press. Positive and negative electrical forces work to attract the ink to the paper from the inked image. The paper is separated from the image by .001 inch. The inventor of the process, W. C. Huebner of Mamaroneck, N. Y., claims it can be used with any of 32 different printing processes and will print one or both sides of the paper in one to six colors.



Worker inserts steel trowel through mulch paper spread over the ground and plants a pineapple slip. Twenty months later the ripe pineapple (below) is ready for harvesting. A second crop ("ratoon") ripens a year later

STRANGE INVENTIONS of the past have nothing on the Hawaiian pineapple industry which for sheer survival has had to create some pretty queer machinery over the years. Today, after many decades of designing odd contraptions, the highly mechanized, multimillion-dollar industry hums along like a well-oiled machine producing golden sun-ripened pineapples by the millions.

Yet, the early producers who first grew pineapples commercially about 50 years ago found the going anything but smooth and must have frequently cursed the Spaniard, Don Francisco de Paula y Marin, for introducing such a cantankerous fruit to the islands in 1813.

Strangely enough, it was the very cantankerous nature of this West Indian fruit which started the trend toward mechanizing the infant industry around the turn of the century. For instance, the industrial pioneers found peeling and coring the pineapple by hand costly and time consuming. Gathering the crop solely by hand was slow and dangerous, for the fruit grows tough, razor-sharp and needle-pointed leaves which liked nothing better than poking out a worker's eye or slicing his legs as he hauled his bag of pines through the field. And, to top everything, the pineapple ripens suddenly and spoils unless picked, transported and canned within 48 hours.

Thus, the industry from the start was forced, by the temperament of the fruit, into mechanization until today pineapple

THEY CONQUERED

By **Richard M. Botts**

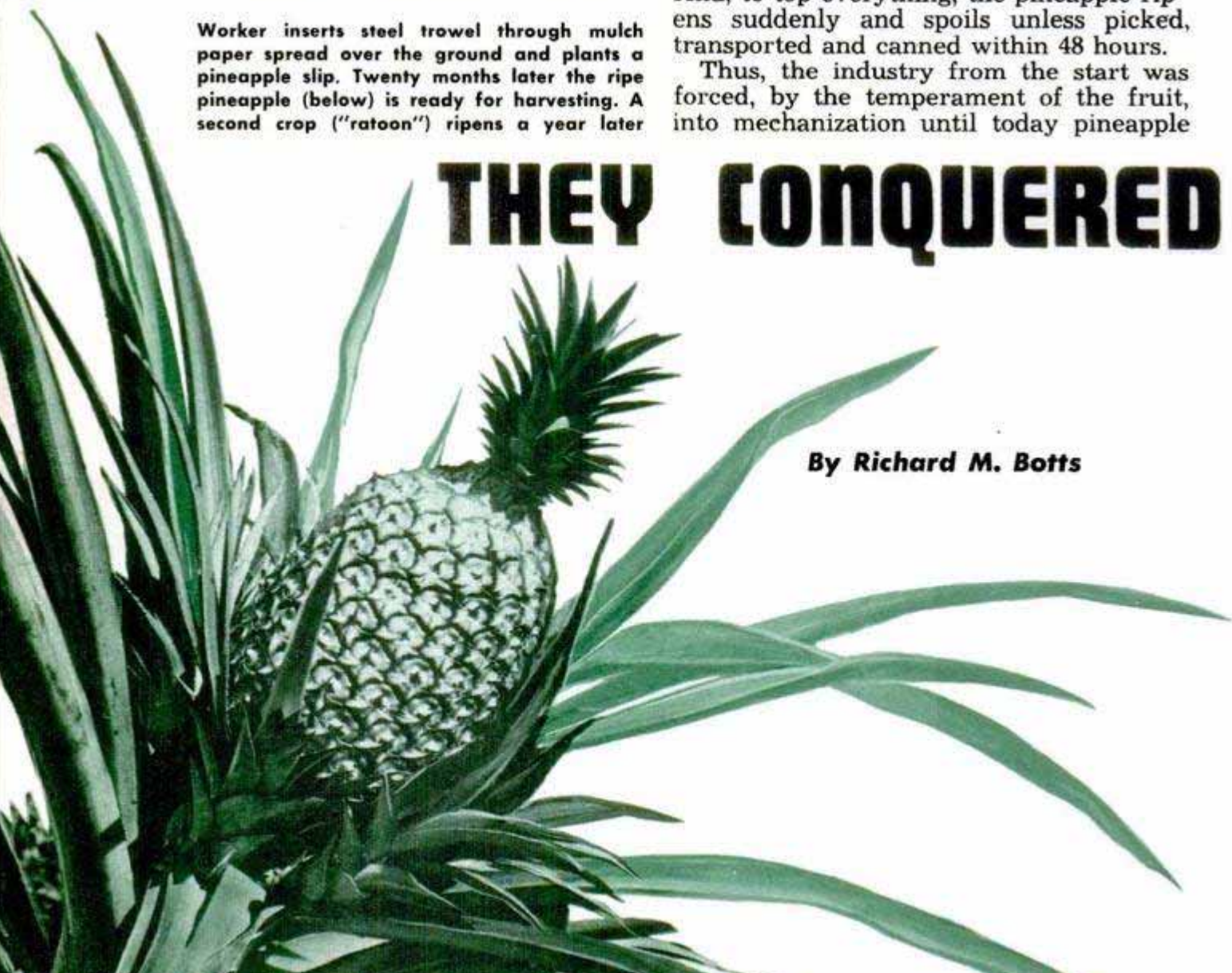



Aerial view of huge pineapple field in Hawaii shows contour planting which guards against soil erosion

A CANTANKEROUS CROP

is handled almost entirely by mechanical work horses from planting to final canning.

The mechanical robots begin in the virgin field from six to eight months before the pineapple is ready for planting. The land is prepared by powerful tractors, which plow about 12 inches into the soil. This is followed by multiple disk harrows which are drawn back and forth across the field. Between plowings the soil is left to rest and soak in rainfall.

Besides plowing, subsoiling is frequently practiced. The subsoilers are tractors which trail specially built steel booms behind them. On the booms are large disks which break up the soil to a depth of 20 inches. At the tail end of the boom is a long roller that smooths out the soil after the disks have torn it up.

Finally, when the field is ready for planting, the mulch-laying machine unrolls strips of 30-inch mulch on the soil. This tar-paper-looking substance is used to dis-

courage weed growth and hold moisture and heat within the soil. As the machine unrolls the mulch, disks on either side toss soil on the edge of the paper to hold it down. Workers, following the machine, plunge steel trowels through spots marked on the mulch and insert the pineapple slips.

While it takes about 20 months for these slips to bear, mechanical aids to the pineapple's health are continually applied until the fruit is ready for picking. For instance, it was found that while Hawaiian soils contain iron it is, oddly, in a "fixed" state and cannot be taken up by the plant's roots. And iron plant food is necessary for good, healthy pineapples. To add the required iron, growers simply dissolved scrap iron in sulphuric acid, thus creating iron sulphate.

When spraying is contemplated, these green iron-sulphate crystals are dissolved in water and sprayed from derrick booms on the back of trucks. The spray is shot over the fields from the booms so as much



Disks on subsoiling tractor break up the ground to depth of 20 inches; roller on end of boom smooths earth

iron as possible will fall on the leaves which in turn absorb the iron into the plant.

Another spray machine invented by the industry is a truck mounted with a long, right-angled pipe boom. This is used for killing the mealy bug which at one time almost wiped out the pineapple industry. The bug feeds on the plant, sucking the juice and eventually killing the plant. An effective spray was finally found and is now used to completely saturate the plant and kill the bug. From the truck, the spray is forced under heavy pressure out through the many small holes in the pipe boom and onto the plants. A great number of plants are sprayed at one time by this method.

When the pineapples have ripened, a mechanical harvester enters the field. The harvester resembles a "carry all" lumber

vehicle. There are four hydraulically operated wheelless metal "legs" which support the harvester about 20 feet off the ground. A truck coming in for a load of pines drives between these spindly legs. The "legs" are then hydraulically drawn up so the harvester actually rides on the back of the truck. The harvester then lowers its conveyor-belt boom over the field and rides piggyback on the rear of the truck, which slowly moves ahead with the pineapple pickers.

The field worker picks the pineapple, strikes off the crown with a sharp knife and dumps the pine on the conveyor-belt boom. The conveyor belt carries the pineapple along the boom to a revolving "stepladder," which transports the fruit to the top of the harvester and then down into the wooden

Strips of mulch paper 30 inches wide are placed on plowed earth just before planting to discourage weeds

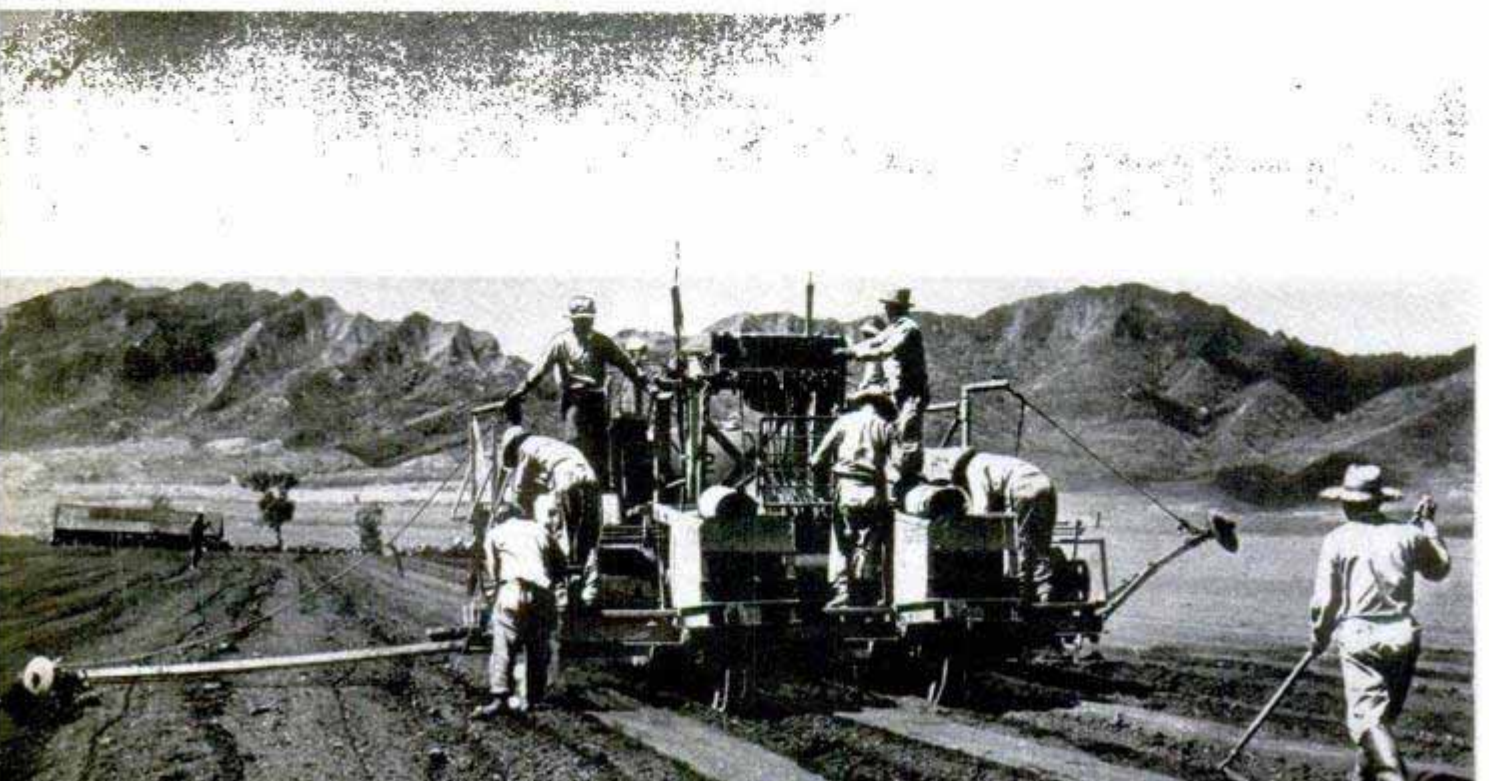



Pineapple plants must have their iron so this spray machine dispenses barrels of iron sulphate over them

bin on the truck. When the bin is filled, the mechanical harvester lowers its legs and lifts its body off the back of the truck. The truck then pulls away and proceeds to the cannery while another truck takes its place.

At the cannery the wooden bin is lifted from the truck's back by tall straddle trucks known as Ross carriers. The bin is then placed on a hydraulic dumping unit which tilts one end of the bin, sending the fruit rolling out onto spiral graders.

The spiral graders have conveyor belts 48 inches wide and 250 feet long and can handle up to 100,000 pineapples an hour. The graders automatically separate the large and small pineapples and carry them on different conveyor belts into the can-

nery. All along the route, the pineapples are washed by high-pressure water sprayers which remove the field dirt.

At the end of the conveyor belt the pineapples are ready for the first step in the canning process—the Ginaca machine.

Invented by Henry Ginaca, in 1913, this machine is the key to mass pineapple production. The pineapples go head first into the machine and in split seconds are shelled, center cores punched out, and the naked cylinders of fruit are sent sliding through tubes to the trimming table. The machine may be adjusted to shell fruit to any size can and easily processes 100 pineapples a minute. With 30 Ginaca machines operating at full capacity, a cannery can

Besides their "iron diet" young plants must be adequately nourished with commercial fertilizers carried by special tractors. They have high wheels and the fertilizer boxes on either side of the tractor. Mechanical "hands" elevate the hoses for the correct height



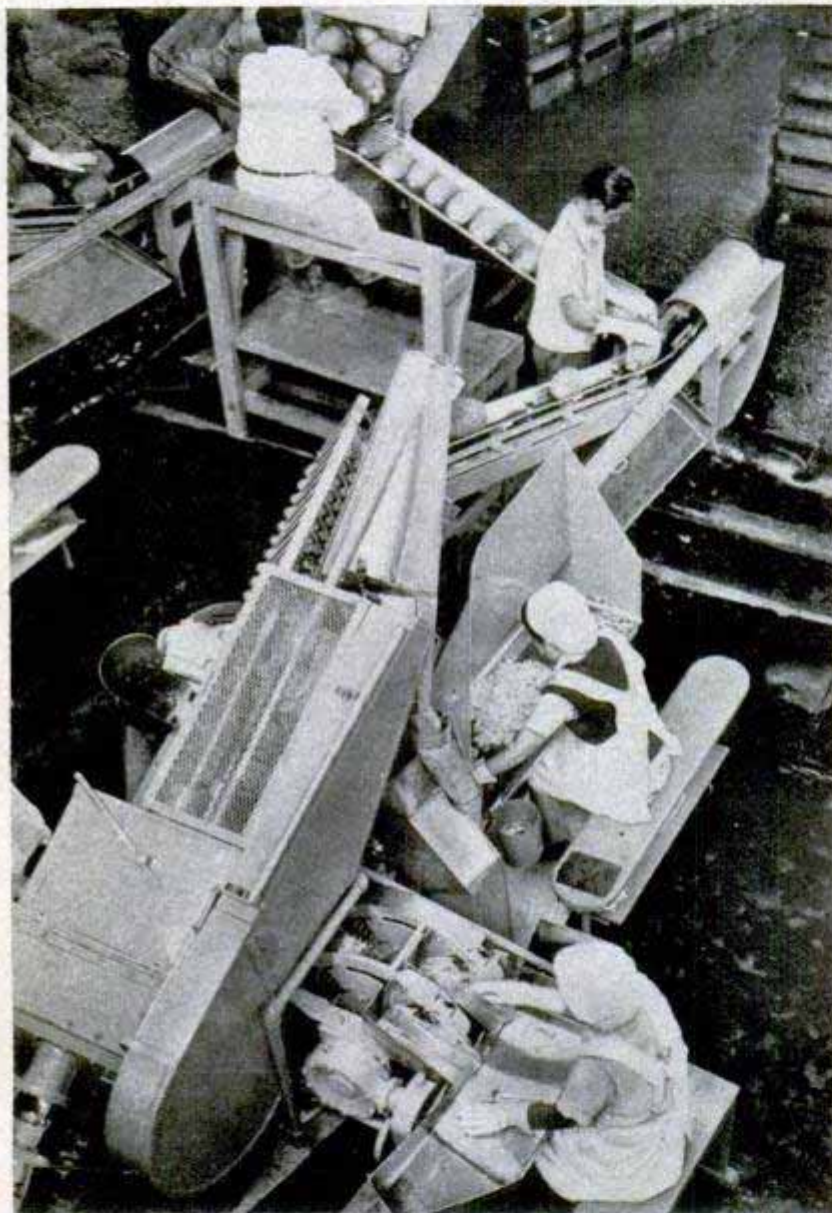

handle 180,000 pineapples an hour.

At the trimming table highly trained girls quickly inspect the fruit and do whatever final trimming the Ginaca machine missed. From the trimming table the cylinders of fruit pass onto a moving chain where they go through a cold-water spray and then into the slicing machine, which automatically cuts the pineapple cylinders into uniform slices.

From the slicing machine the pineapples move on a belt to the packing table. This is one operation that hasn't been mechanized and the sorting of pineapple slices into grades and packing into cans is done by trained workers. The workers fill the cans which are then stacked and sent to the syruping machines.

After receiving their syrup the cans of pineapple slices are run through the sealing machine which completes the vacuuming process. From here the hermetically sealed cans go to the pasteurizers where they are heated for 5 to 15 minutes so as to sterilize completely the canned product.

Cold-water sprays then cool the sterilized cans. When down to normal temperature, the cans are sent on their final assignment—to the labeling machine which can label over 1400 cans a minute.

Then, from Hawaii the mechanized pineapple goes by the millions to the far corners of the world—an example of American ingenuity and high mechanization.

Left, a close-up of the Ginaca machine for processing pineapples. Pineapple moves side-wise down chute and is spaced as it enters machine. Cored pineapple shoots through tube on far left. The girls in the picture keep pulp moving into separate chute. Below, harvester moving through field. When truck on left was full, harvester raised up to permit it to pass through. A second truck (empty) waits its turn at the harvester



Hydraulic Jack Has Separate Pump

Designed for work in close quarters, a new hydraulic jack comes in two sections. The pump is in one section and the jack in another, the two parts being connected by a rubber tube, permitting the pump to be placed some distance from the work. Because the oil is completely sealed inside the mechanism, the jack can be used in any position, horizontal or vertical. The low-lying jack is designed for railroad and industrial uses.



Portable Respirator Works by Bellows

Firemen and police officers may be able to save more lives with a compact resuscitator that requires little storage space. Developed by Dr. Joseph Kreiselman of Washington, D. C., the portable artificial respirator consists of a facepiece connected to a small bellows. The mask is held across the victim's nose and mouth with one hand while the other pumps the bellows to force air in and out of his lungs.

Bottle-Cap Vases

Discarded bottle caps provide the raw material for yard vases made by an Illinois hobbyist. The caps are center-punched and strung on stovepipe wire to form rings of varying sizes. These rings are then used to build up the vase. When completed, the vases are lacquered to prevent rusting. One large vase contains almost 6000 caps.

☞ Sounding like the whistle of a steam locomotive, a six-tone diesel horn has been invented by a Canadian railway worker.



By Georg Mann



Here are samples of the tongue-twisters with scores of uses from camera lens to cigarette-lighter flint

Boom in Tongue-Twisting Metals

TUCKED AWAY in a corner of the periodic table of the elements—that chart which every year baffles a new generation of high-school chemistry students—is a group of chemical elements that nobody pays much attention to. They are called the “rare earths” and properly speaking are the “rare earth metals.” If there is time, the teacher may point out that there are 15 of these rare earths, that their atomic numbers range from 57 to 71, and there is one of these elements that even scientists are not absolutely sure exists.

Nobody minds snubbing the rare earths. Even their names are forbidding and include such tongue-twisters as praseodymium, gadolinium, ytterbium and dysprosium. Chemists are a little inclined to blush because they mar the regular pattern of the periodic table itself.

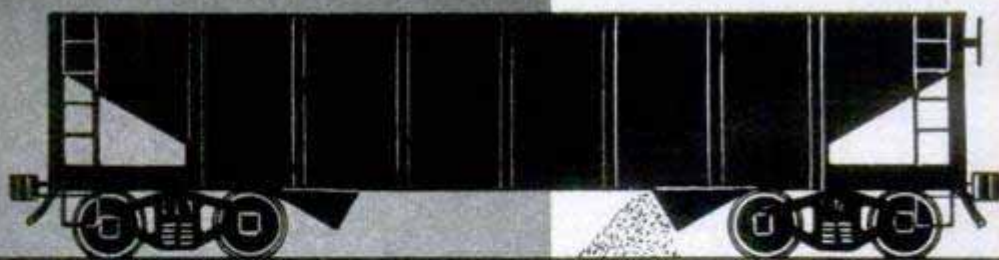

One 50-ton carload of monazite sand yields the following “rare earth metals”: A—32,500 lbs. of mixed rare-earth oxides, B—16,300 lbs. of cerium oxide, C—6000 lbs. of lanthanum oxide, D—4750 lbs. of neodymium oxide (95 percent pure), E—400 lbs. of samarium oxide. Among the important uses for these oxides is making cores for arc-light carbons which burn brilliant white

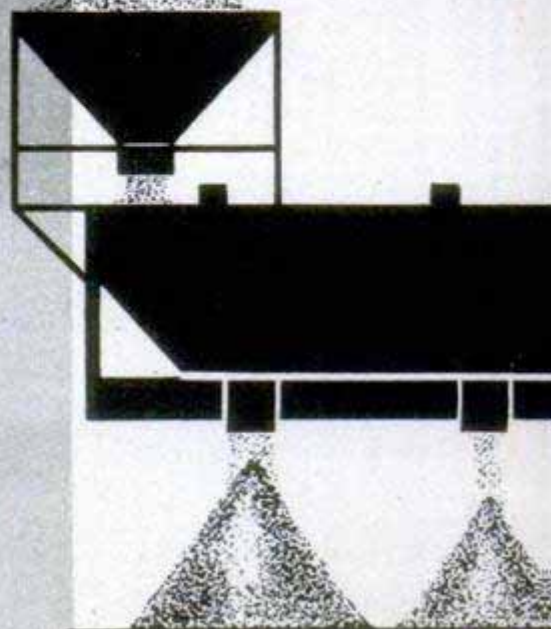

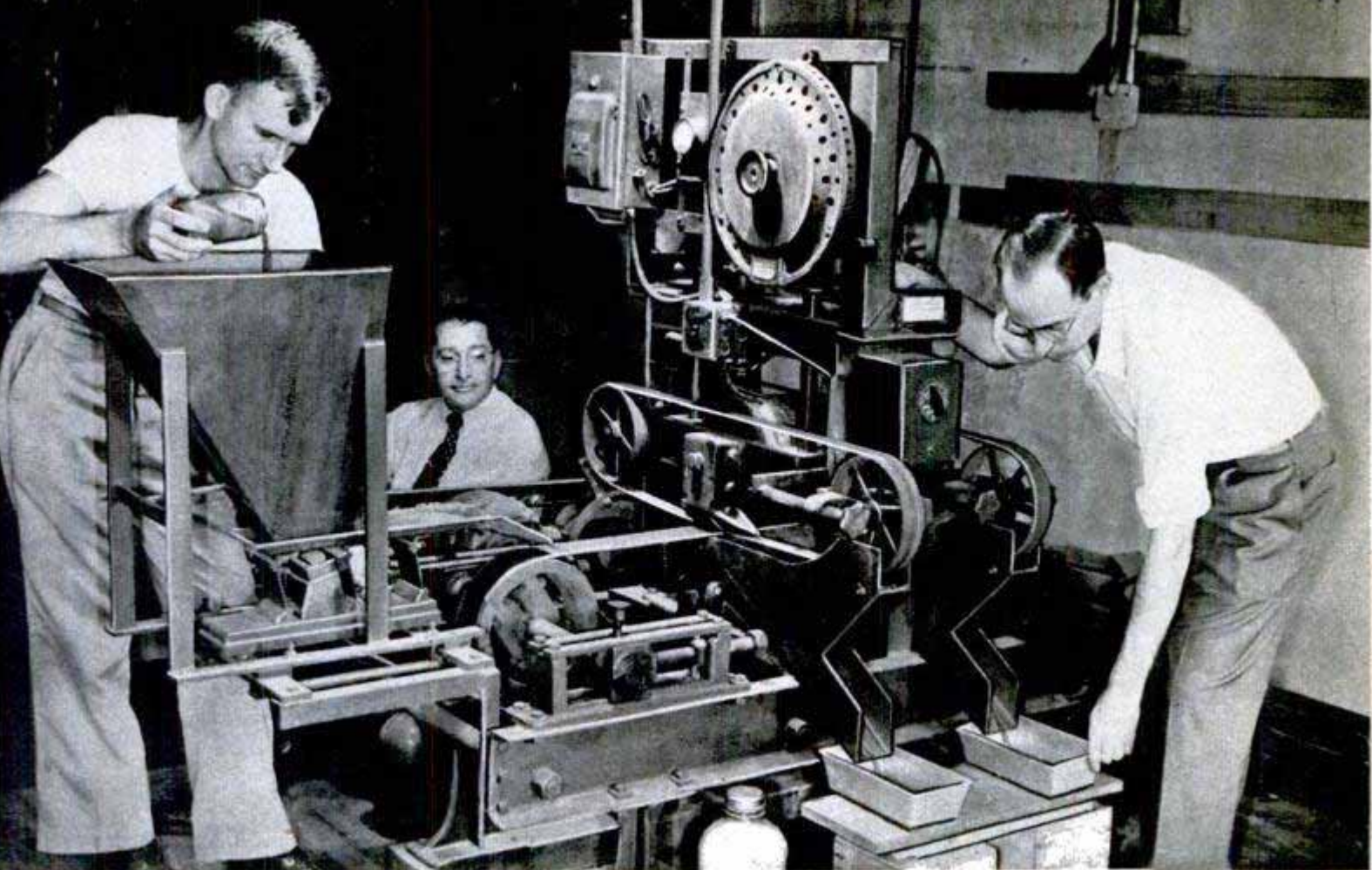

Magnetized belts leading from hopper separate rare-earth ores into monazite and iron ore in laboratory

But without fanfare, a few industrial chemists have been making useful, hard-working citizens out of these orphan children of the periodic table. Chances are the sparks that fly when you flick your cigarette lighter come from a flint that contains some of the rare earths. The mantle hooked up to a gas jet or used to make gasoline or kerosene flames burn more brightly owes its efficiency to a healthy trace of one of the rare earths in its make-up. That expensive raspberry-colored goblet you admired on a trip through the department store probably owed its unique color to another of the rare earths. And better lenses for cameras, eyes that see farther for the Air Force, have come from putting the rare earths into overalls.

The story is a long one. It jumps from

Sweden to laboratories in Paris, Heidelberg and the University of Illinois. At one time or another, a Swedish army surgeon, a Finnish professor, a Czech chemist and an Austrian baron enter into the story. It all began more than 160 years ago when a strange-looking black rock turned up near the little Swedish town of Ytterby. Slowly, step by step, the Swede, the Finn, the Czech and the Austrian—plus others—found first one, then another unique chemical element in this strange-looking mineral. The search for the rare earths resembles nothing so much as the listings for a golf or tennis tournament seen wrong end to. In such a tournament, a group of players start; from every pairing one victor emerges, until one final champion is crowned. In the case of the rare earths, the chemists first found two elements in the black rock from Ytterby, then in successive steps broke these down into new substances until they arrived at a final result of 15.

Two of the 15—rare earths called praseodymium and neodymium—were discovered by Karl Auer, an Austrian chemist who first put the rare earths to work. Auer was a pupil of Robert Bunsen, the chemist who invented the Bunsen burner. Auer was dissatisfied with the flickering gas flames that provided light during the 1880s. He had a hunch that if some mineral were put into the flame, it would glow and give a brilliant,

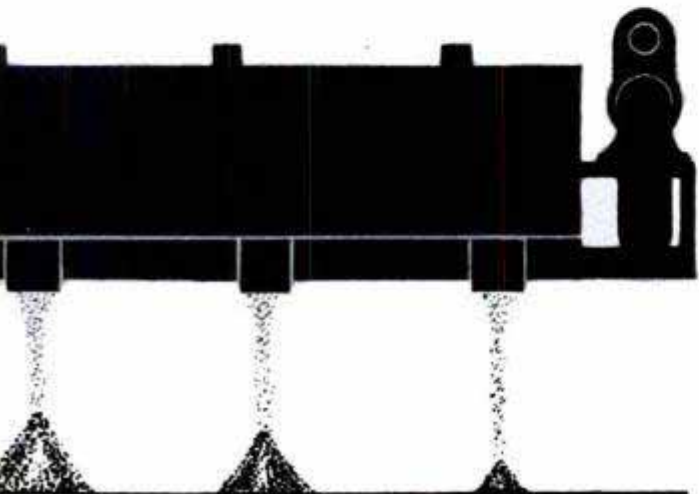

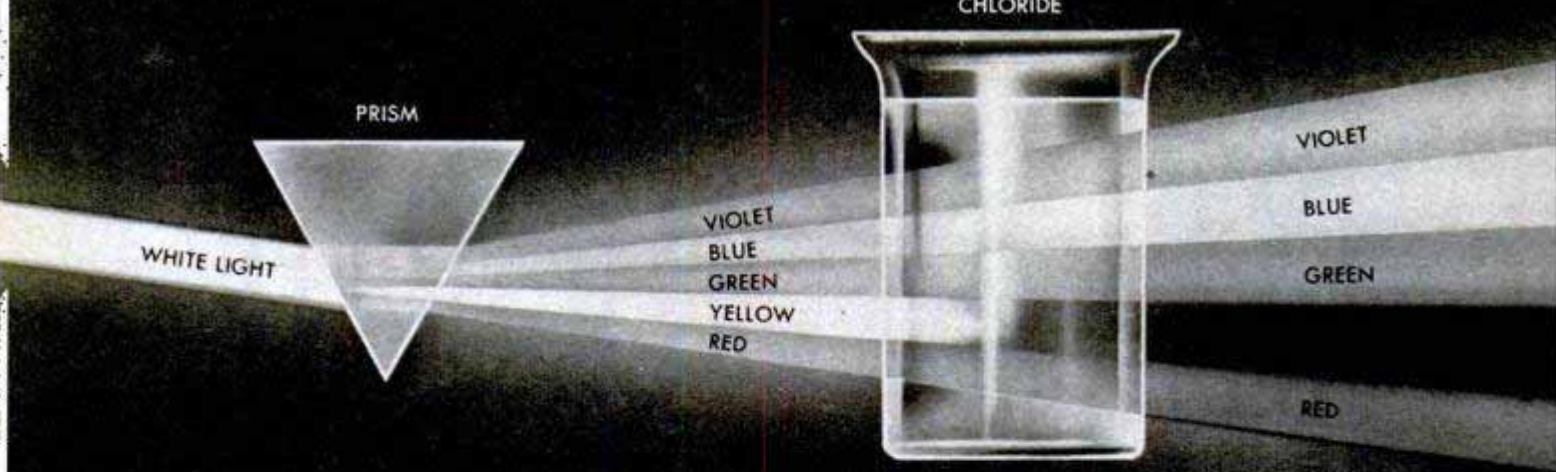

This demonstration with a prism and beaker containing a weak solution of didymium chloride shows the white light entering prism and being separated into all the colors of the spectrum. The didymium solution stops the yellow light—a boon to glass workers hampered by the brilliant yellow glare given off by sodium

steady light. Thorium, a radioactive chemical but not one of the rare earths, looked like the best bet. But Auer's thorium gas mantles didn't work properly. Not until he mixed a thorium compound with one percent of a compound of cerium—still the most useful of the rare earths—did he produce a mantle that satisfied the customers.

That was in 1885. Cerium helped make Auer a millionaire, bought him an impressive castle, and eventually led the Emperor Franz Joseph to turn plain Karl Auer into Karl, Baron Auer von Welsbach. More than

40,000 workers all over the world made and sold his gas mantles. And there are few Americans over 50 who haven't touched a match to a Welsbach mantle.

Fame and a more modest degree of fortune came even more slowly to the other rare earths. Auer made use of a mixture of the rare earths and iron that gave off sparks when it was struck in an automatic gas lighter. The flint in your cigarette lighter is a lineal descendant of Auer's device. But for years the firms that made gas mantles regarded the rare earths as a good deal of

TABLE OF THE RARE EARTHS AND THEIR USES

Rare earth	Symbol	Atomic number	Use
Lanthanum	La	57	better camera lenses
Cerium	Ce	58	gas mantles, optical polishing, coloring glass, alloys
Praseodymium	Pr	59	rare-earth mixtures used—arc-light carbon cores
Neodymium	Nd	60	coloring glassware, filter for ultraviolet in sunglasses
Illinium		61	discovery disputed
Samarium	Sa	62	infrared phosphors
Europium	Eu	63	infrared phosphors
Gadolinium	Gd	64	minor
Terbium	Tb	65	minor
Dysprosium	Dy	66	occurs in rare-earth mixtures
Holmium	Ho	67	used in mixtures
Erbium	Er	68	used in mixtures
Thulium	Tm	69	used in mixtures
Ytterbium	Yb	70	used in mixtures
Lutecium	Lu	71	used in mixtures

} none of these have important separate uses



Didymium lenses used by glass blower block out 90 percent of brilliant glare from yellow sodium flame. Top photo at right shows how bright flame obscures details of the work while just below it work is shown through lens. Below, separator sorts the rare earths in accordance with their magnetic strengths

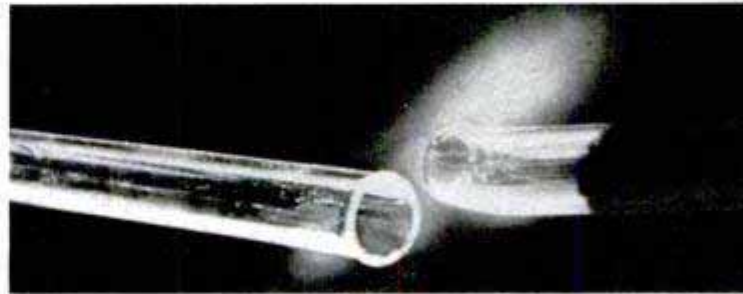
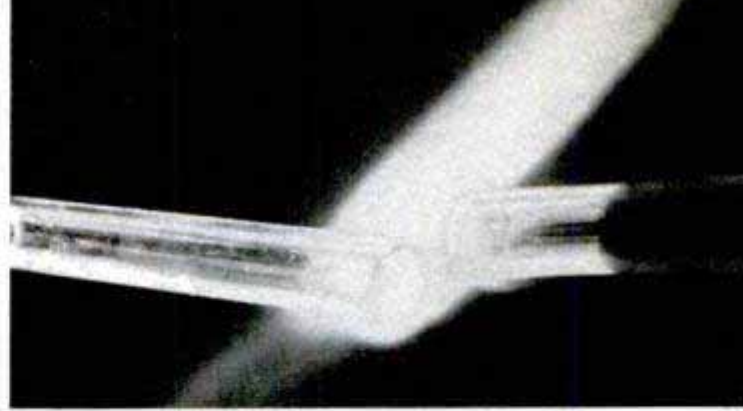

a nuisance in the ore they refined. At most, they were saved in small amounts for what, in the language of industrial chemistry, was strictly a "drugstore business."

The growth in the importance of the rare earths can be seen in the history of the Lindsay Light and Chemical Company of West Chicago, the largest U. S. producer of these neglected elements. This firm, first known as the Lindsay Light Company, was founded by Charles Lindsay, Jr., back in

1902. Lindsay was interested in the sale of gas mantles. Eventually, he became interested in refining the raw materials for the mantles, manufacturing them directly for the market. By 1916, Lindsay Light was refining monazite sand, the principal commercial ore of thorium and the rare earths.

During the first World War, the gas-mantle business boomed. But inevitably, the market for gas mantles began to contract as electricity dominated the lighting field. There was still a market for mantles but the future didn't look rosy. In the meantime, Lindsay's chemists were finding a mounting pile of rare earths on their hands from the monazite sand they were refining.

The situation called for some action. As Mark Eichelberger, Lindsay's vice-president explains it, monazite sand from Brazil contains six to eight percent thorium compounds. But nearly 60 percent is made up of the rare earths, and cerium makes up nearly half of these rare earths. So the chemists got busy. They worked with the rare earths, analyzed properties, tried to fit them into current methods of industrial production. They sent samples of rare-earth compounds to firms they thought would have a use for them. The missionary work paid off. Sales of the rare earth began to mount. In fact, shortly before World War II broke out, the thorium in the monazite was a drug on the market, the rare earths were the salable returns.

The atomic research of World War II brought thorium back with a bomblike bang, however, when researchers discovered that thorium could be the starting point for atomic fission. Thorium from being a temporary stepchild, became a stand-in for uranium and plutonium in the atomic-energy program.



Lanthanum lens in this camera assures photographer clearer, faster pictures with much less distortion

Processing of monazite sand has stepped up enormously. Before the war, Lindsay Light and Chemical processed about 700 tons of monazite a year. Now they are extracting rare earths and thorium from 2500 tons a year. Most of the monazite comes from Brazil, although smaller amounts are shipped in from Idaho and Florida. India is another major source. And because of its thorium content, prospectors in a great many atom-ambitious countries are on the hunt for the ore. Dr. Howard E. Kremers, Lindsay's research director, averages two

or three inquiries a week from people interested in the cinnamon-brown heavy sand. And he replies with a quick, "Sure," when asked whether it's worth-while prospecting for. Current delivered prices for the monazite average around \$145 a ton, more than twice what the ore sold for in 1945.

In spite of the beginning boom, not all of the 15 rare earths are important commercially. Some of them are simply too hard to get in any reasonably pure form. Others have no immediate uses. Currently, cerium, lanthanum and neodymium are among the leaders. Cerium, in a pure form soft as lead, turned up more than a century ago in the researches of the great Swedish chemist, Jons Jacob Berzelius. Nobody ever saw pure cerium, however, until 1911. That year, after three years of intensive laboratory work, Dr. Alcan Hirsch of the University of Wisconsin prepared cerium in a pure form, that is 98 percent pure. In the form of compounds, however, cerium is turning into a minor industrial jack-of-all-trades. Every one of the 15 million gas mantles made every year contains cerium nitrate. Compounds of cerium and oxygen are highly recommended for polishing glass, particularly precision lenses. Other cerium compounds are mixed into the glass itself to get rid of unwanted colors that sometimes turn up. Such compounds also ward off the color-changing effects of the sun on glass. Mixed with the metal titanium, other cerium compounds give glass a fine yellow tint. And yet other cerium compounds are being tested in metal alloys. So far, they've been found to give new and better properties to cast iron. And cerium has also turned up in therapeutic lamps and powders for flashlight photography.

Lanthanum was first discovered by the

(Continued to page 262)

Carbon arc lights made of rare-earth oxides give this motion-picture set a natural "daylight" illumination



Gun Welds Aluminum Four Times Faster

Aluminum is welded four times faster by a pistol-shaped tool which feeds the filler metal in wire form at controlled speeds. The metal carries the welding current. A sheath of argon or helium gas surrounds the arc between the wire and the aluminum, preventing air from contacting and oxidizing the molten metal. A trigger regulates the gas flow and wire feed. Drive rollers move wire to the gun at speeds ranging from 100 to 350 inches per minute.

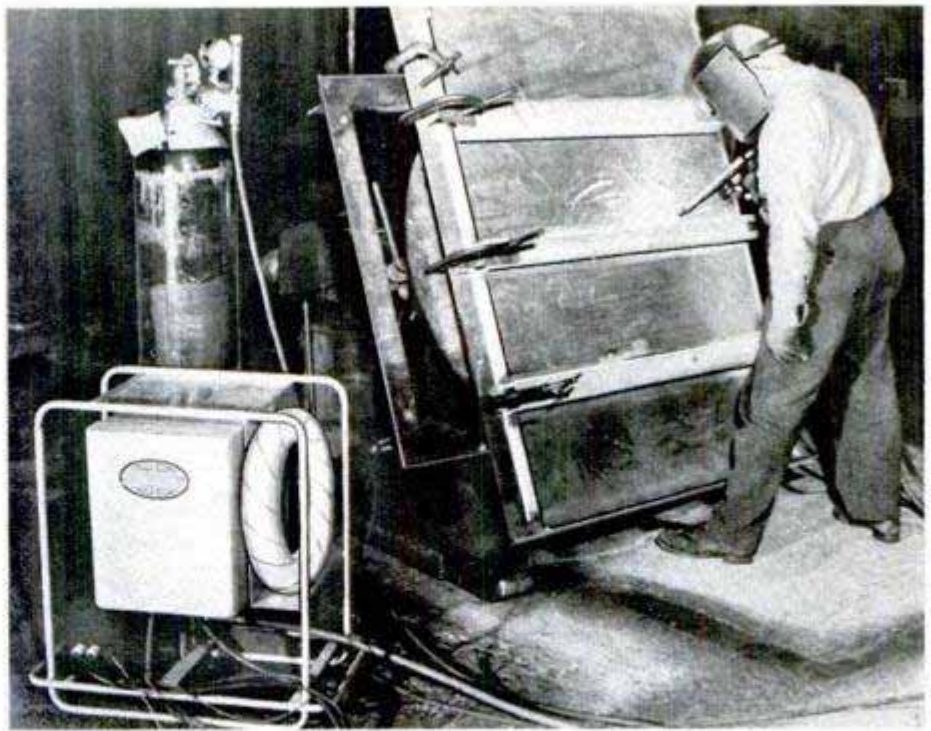

Mechanical Pencil "Yardstick"

Here's a mechanical pencil with a built-in "yardstick" that enables the user to measure any distance, from a fraction of an inch upward, simply by rolling the head along the line of measurement. The head is mounted on a shaft that rotates, moving a pointer along a longitudinal slot in the side of the pencil. It has a "range" of 36 inches in one direction; for greater distances, the pencil can be reversed every 36 inches so the pointer moves the other way. The pencil can also be used as a calculator for adding and subtracting.

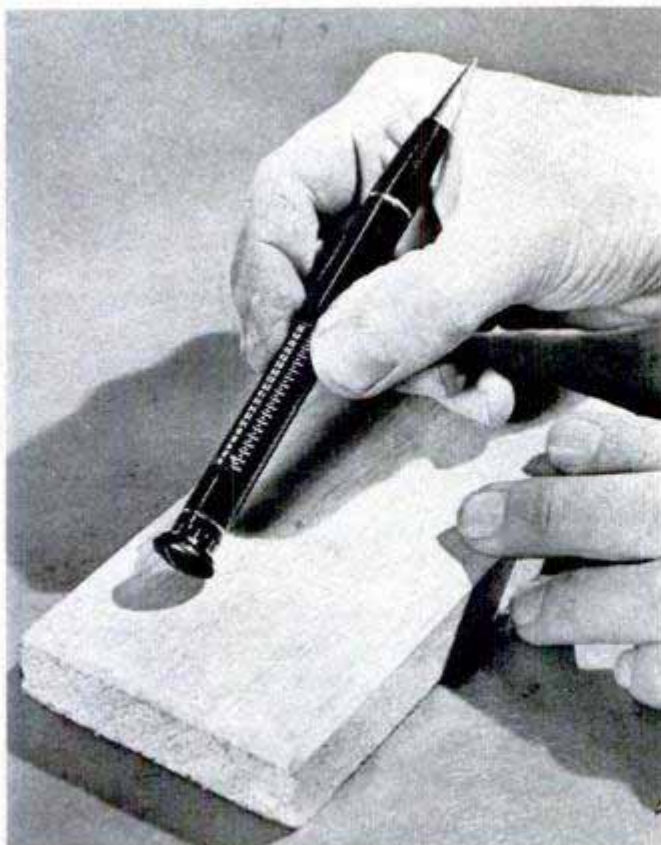

Electric Drive for Small Lathe Has Stepless Speed Control

Smooth and stepless speed control for a small lathe is now available by turning a single knob. The equipment does away with mechanical adjustments of gears and belts while providing greater speed range and smooth transition. Speeds may be preset or varied during operation. Developed by General Electric and called the Thy-motrol drive, the unit is easy to wire because the terminals are located at the front of an electronic panel and separated from the tubes by a protective cover. The simple control station has stop and start buttons and the knob for adjusting speed. The drive operates from 220-volt alternating current.





U. S. Bureau of Mines photos

Spent shale at the Bureau of Mines experimental plant at Rifle, Colo., is pushed into a ravine by a bulldozer

By Thomas E. Stimson, Jr.

When Oil Wells Run Dry....

there's gasoline for hundreds of years in our mountains of shale, already being refined in a pilot plant in Colorado

MECHANIZED mining and improved processing is cutting the price of shale oil to where it can compete with petroleum for the motorist's gasoline dollar.

W. C. Schroeder, chief of the Office of Synthetic Fuels of the U. S. Bureau of Mines, estimates that gasoline can be produced from oil shale for as little as 8.4 cents per gallon. This is based on trials at the bureau's experimental plant near Rifle, Colo., where the shale is mined and trucked to a huge retort, to have its waxy oil extracted

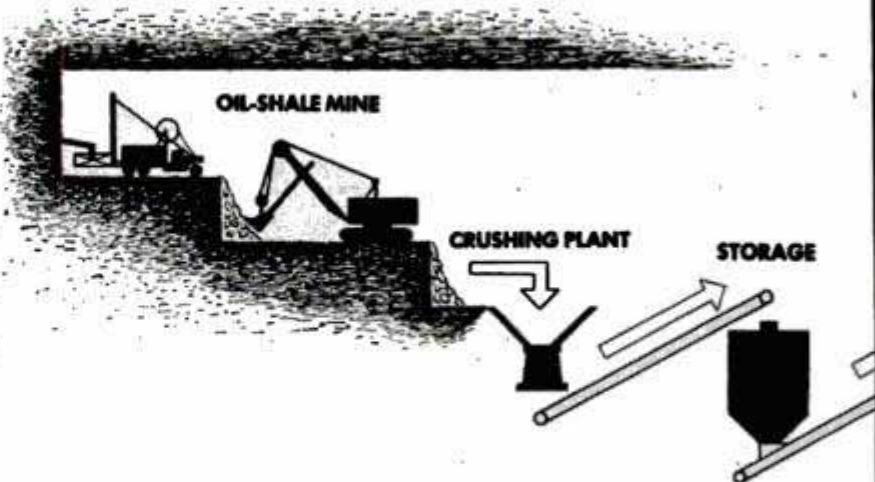

Left, in the Green River shale formation beneath Utah, Wyoming and Colorado—once thought to be valueless—there is potentially enough oil to assure the U.S. an adequate supply for at least several centuries. It covers 1100 square miles. Above and right, steps in the production of liquid fuels from shale. Conversion of the shale is more expensive than refining of most crude petroleum

and refined into gasoline. Fuel oils and other typical products can also be produced.

Ordinary overhead, transportation to market, profits and taxes would raise the base cost of shale gasoline considerably. Delivered to the consumer, shale-oil derivatives could be expected to sell in the same price range of petroleum products.

This doesn't mean that the market is going to be flooded with shale oils and gasolines. For one thing, the United States and the world in general are enjoying a temporary overproduction of crude oil. For the next several years, at least, there is all the crude oil we need, even though the United States alone is consuming six million barrels a day.

Too, oilmen say that a complete shale-oil plant, producing 100,000 barrels a day, would cost a fabulous \$400,000,000. No oil company can afford such a huge investment as long as it has adequate amounts of crude petroleum to feed to expensive refineries it already owns. Smaller shale-oil refining units would not permit the savings that are possible with large production.

Instead of starting a price war, the Rifle plant is confirming the comfortable thought that this country will not run out of liquid fuels for at least several centuries. Concern about our dwindling petroleum reserves (which is quite true) has lost its sting. The Green River oil-shale formation in Colorado, Utah and Wyoming, covering 1100 square miles, has an estimated minimum of 300 billion barrels of recoverable oil.

Boyd Guthrie, engineer-in-charge at Rifle, has the job of determining the cheapest way to mine the rock, the easiest way of extracting its oil and the most efficient method of refining it into useful products. Original ideas by his staff, techniques from



Gasoline for all the autos and trucks used at the pilot plant is now being made from the shale mined near by

abroad and suggestions by the oil industry at large are all evaluated.

At Rifle the rich 73-foot-thick Mahogany Ledge that assays 100 million barrels per square mile is used for testing mining methods. Entrance to the mine is high on the face of a cliff and the mine itself is actually an underground quarry. During a recent test period, when an average of 1491 tons of shale were broken out and moved per day, the direct mining cost was estimated to be 32.9 cents per ton. This is about half of what earlier estimates indicated.

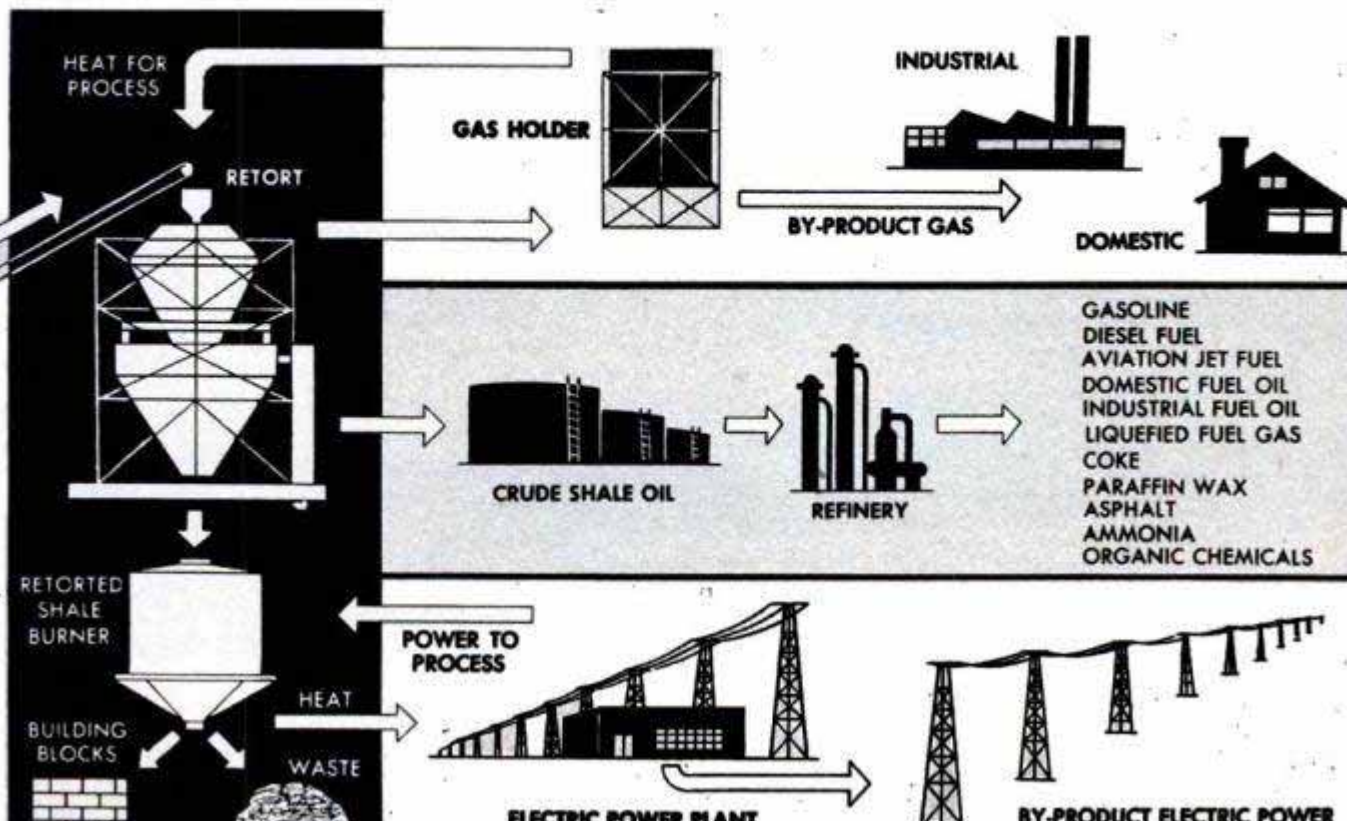

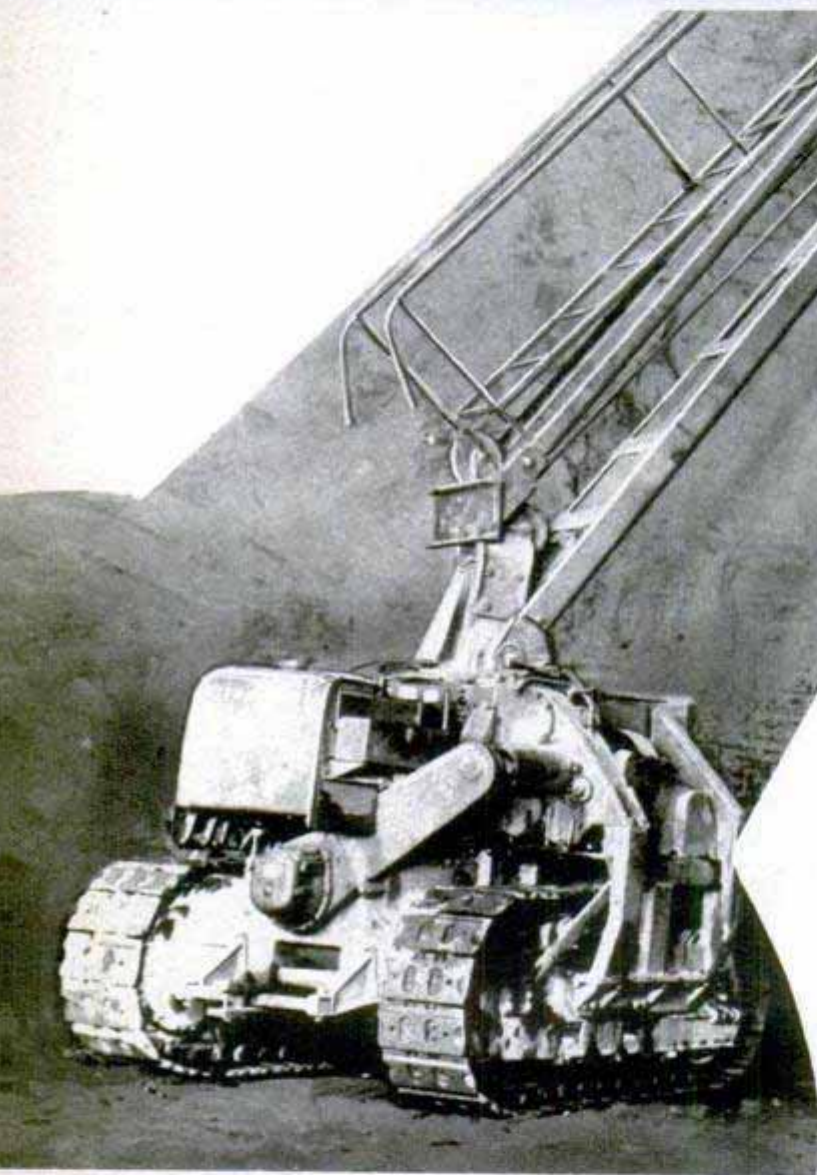
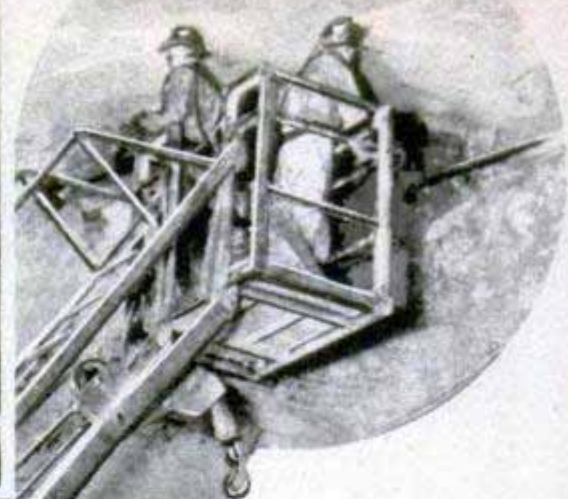
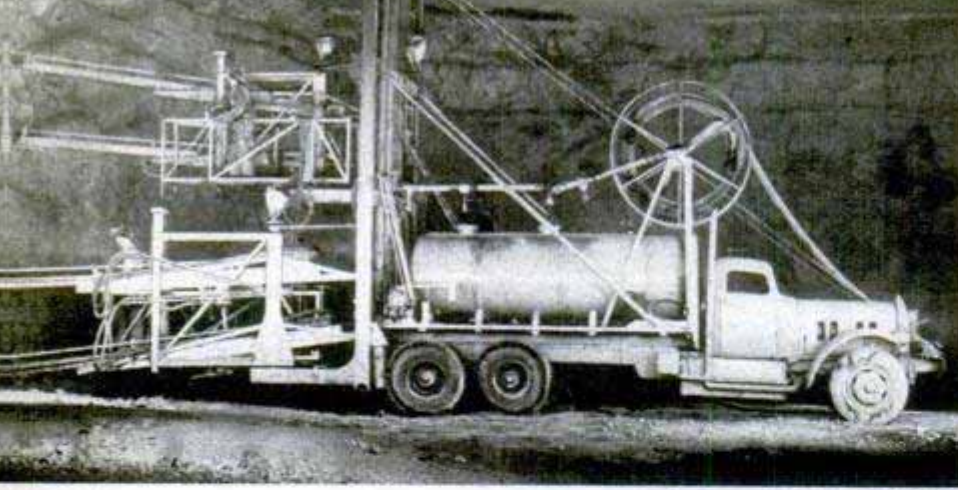

Upper left, new multiple carriage developed by Mines Bureau drills 72 fifteen-foot shot holes in six hours. Left, a scaling rig helps men reach loose rock clinging to the walls. Lower left, "steps" in the Rifle mine are spacious enough for large, open-cut type equipment. Below, cracking unit where diesel oil and gasoline are both produced



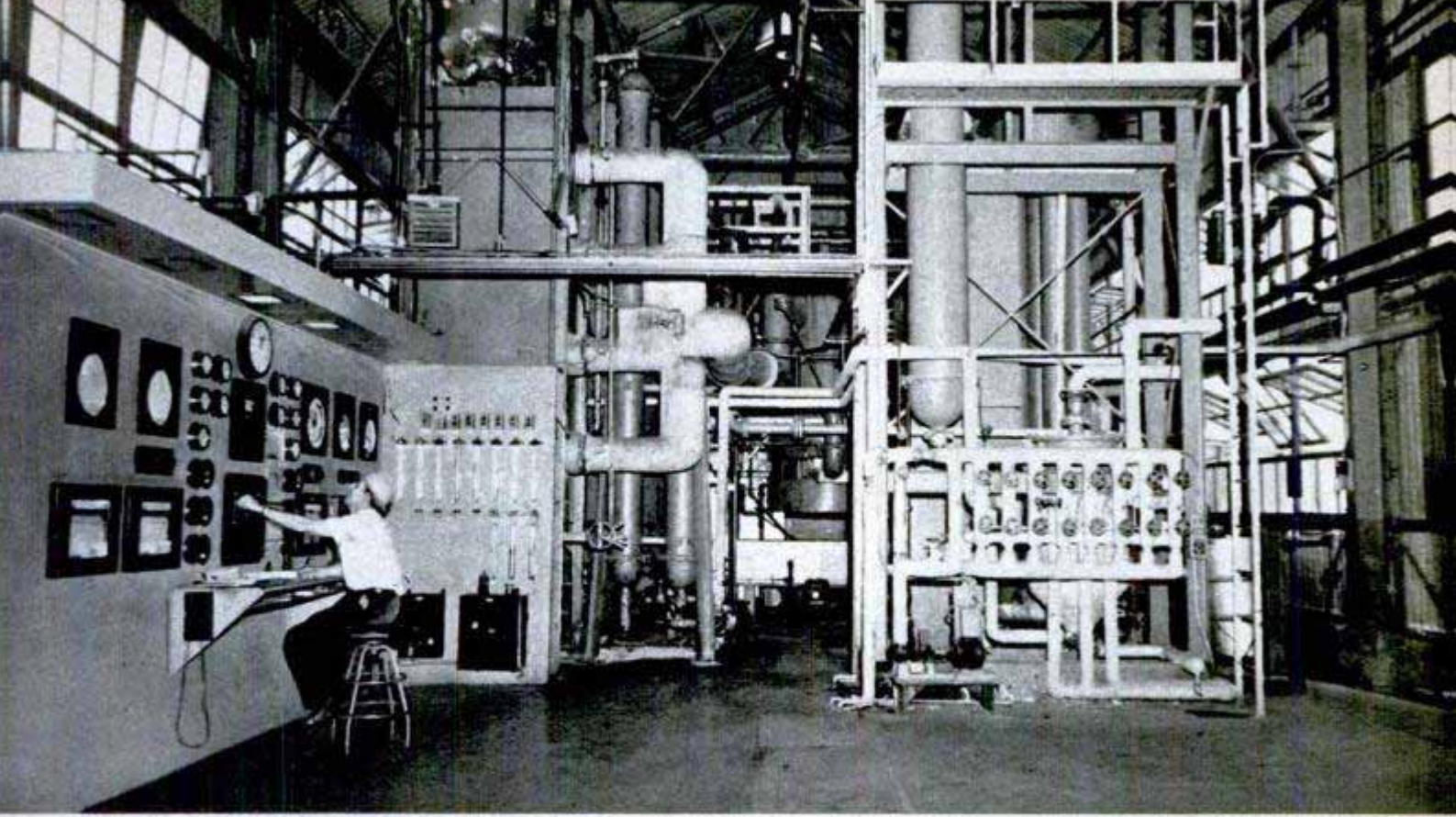

To get the costs down that low, power shovels are used in place of hand shovels and 15-ton diesel trucks replace ordinary mine cars. The trucks drive right into the mine and haul their loads direct to the retorting plant.

The mine is a huge cavern of the room-and-pillar type, with 60-foot square pillars of shale left 60 feet apart supporting the roof. Mining is done on three levels and in cross section the mine appears in the form of three giant steps. The top step is 27 feet from floor to roof. Behind it is a 23-foot-deep bench, and below and behind it is a second bench.

Fifteen-foot shot holes are drilled into the top step with a special multiple-drill jumbo that enables two men to drill 72 holes in six hours. Then the face is blasted out with dynamite. The lower benches are advanced by similar blasting operations.

At the preparation and retorting plant, the shale is crushed to particles one to four inches in size and moved by conveyor belt to the retort. There, oil is extracted by heat.

The present Rifle retort is of the batch type. Various oil companies have developed continuous-flow types of retorts and some of these are to be tested at Rifle.

(Continued to page 260)

Above, continuous-flow retort now used at Rifle. In it the residual oils and carbons in spent shale are burned to supply hot gas that in turn heats raw shale and drives off its oil

Below, smoke, fire and dust billow forth as 35 tons of spent shale is dumped out a trap door beneath one of the retorts

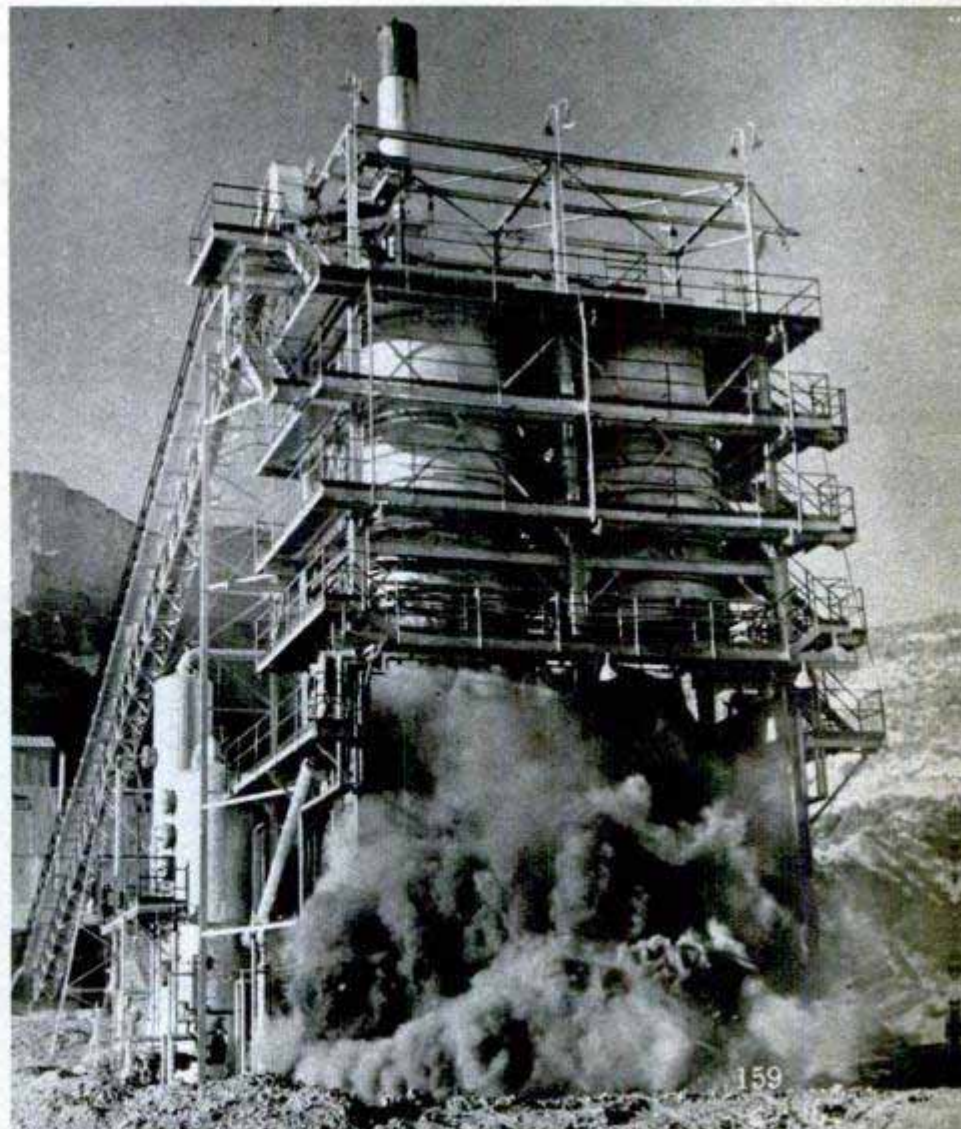

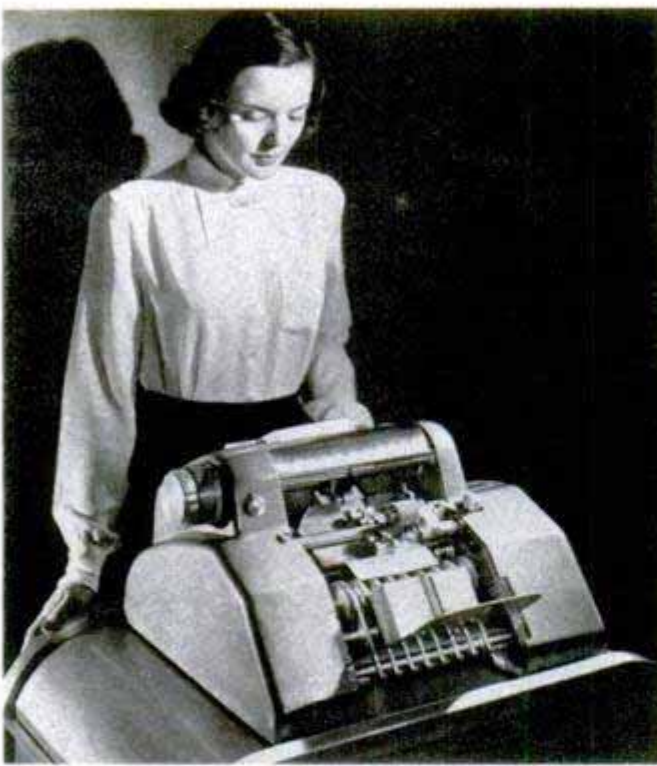

Counting Machine is "Sleuth"

Anything from dollar bills to world-series tickets is counted accurately at speeds up to 1000 a minute by a new machine that feeds and stacks automatically. An optional imprinting device permits dating, coding, endorsing or canceling during the counting operation. Its trip mechanism is said to be so sensitive that it once picked out a counterfeit bill from a stack of currency, rejecting it and stopping the machine because the bill was too thick.



Trailer Coupler Applies Brakes

When the trailer and automobile are coupled with a new type of hitch, the two braking systems act as one, making it unnecessary for the driver to operate two separate controls. When he applies the brakes on his car, the coupler actuates those on the trailer. Built into the hitch is a delay mechanism which applies the trailer brakes slightly before the car brakes. Should the trailer uncouple accidentally, the brakes are locked automatically.

Two-Language Cards Help Students

Vocabulary cards aid in learning the words of a foreign language. The cards have a foreign word on one side and the English meaning on the other. Several cards are placed on the table and then put

Learn Foreign Tongue

aside one by one as the meanings are memorized. A complete set includes 1000 foreign words and their meanings, plus a set of blank cards upon which the student may write other words.

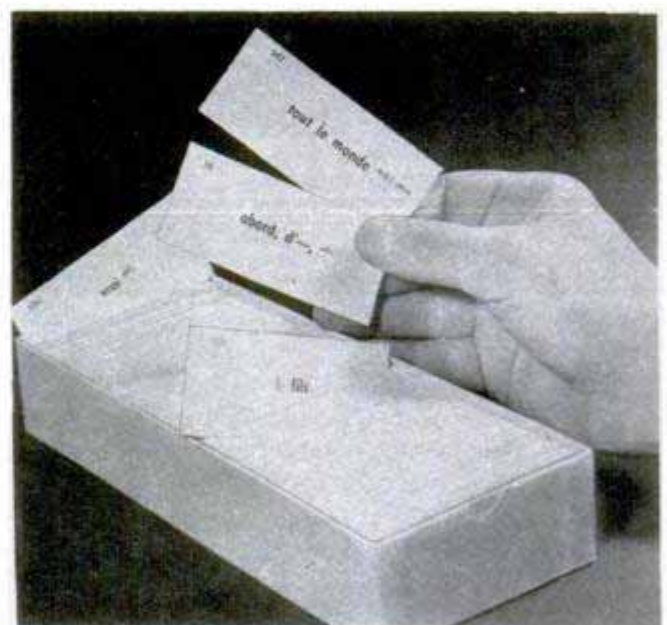
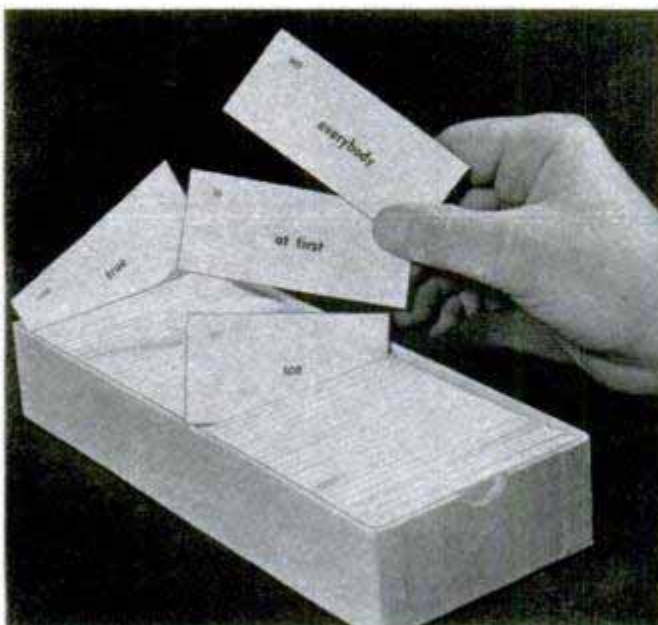

Mine-Trolley Phone System

Collision hazards of electric trolleys in coal mines have been reduced to a minimum by a carrier-wave telephone system. With the communications system, which puts out a high-frequency signal over the power wire, motormen can talk to each other and to the dispatcher simply by pressing a button on the microphone. A loudspeaker on the car is always turned on, broadcasting all messages sent over the system. The set is shock-mounted to protect it from vibration.

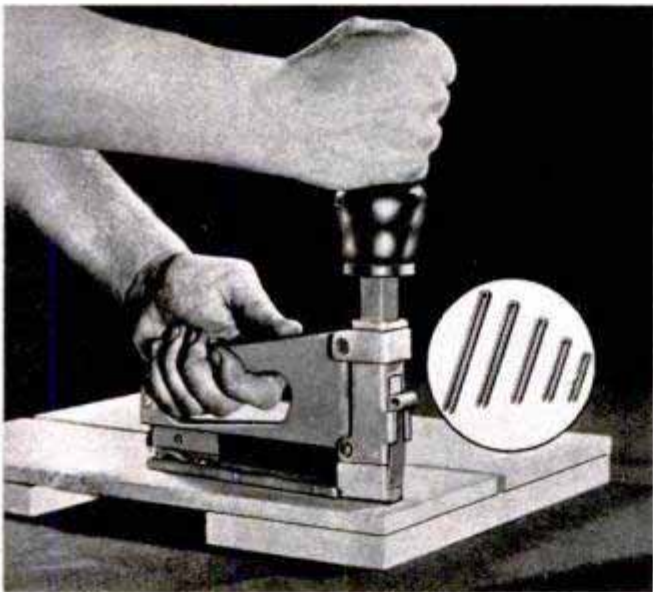

Machine Drives Nails Like Hand Stapler

Four times faster than hand nailing, this portable nailing device operates like a stapler. One blow drives and countersinks the U-shaped nail that locks into the wood. Holding 100 nails in strip form for easier loading, the device feeds the nails automatically. The nailer can be used with hard or soft wood, composition and light metals. The U-shaped nail possesses greater holding strength and will not split wood. Available in several sizes from $\frac{7}{16}$ to $1\frac{1}{8}$ inches long, the nails are galvanized, copper, bronze or electroplated. The machine enables factory workers with little skill or experience to do the precision work.

"Economy" Car

One of the most popular new small cars at the recent International Automobile Show in Paris was the Italian "economy" car. It contains a basic Fiat engine and is said to burn a minimum of gasoline. The car has a top speed of 77 m.p.h.

☐ At any given moment, there are approximately 1800 thunderstorms in progress all around the earth, the number needed to recharge the earth's electrical field and keep it healthfully "negative."



On a square of ivory cut from a tusk of a prehistoric mastodon, Yukon craftsman Jack Elliott is sketching the flower design that he uses for one pin. Also shown are several samples of jewelry in various stages of production

By
Lyn Harrington



Jewels From Mastodon Tusks

Elliott slices through a mastodon tusk with his bandsaw. Originally, this tusk was 14 feet long

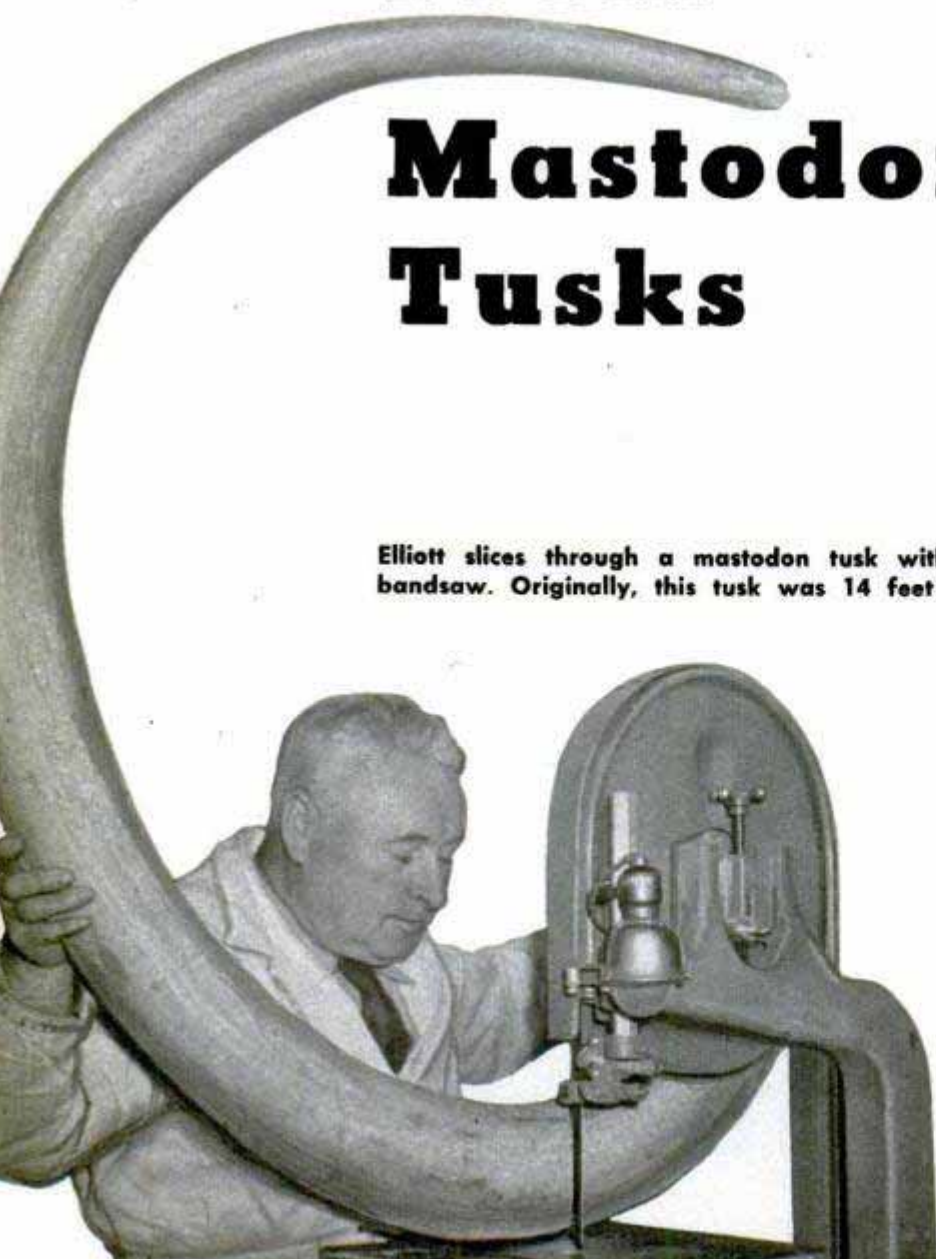

PROBABLY the last place you'd expect to find a jewelry craftsman is far north in the Yukon, where men are rough and tough and winters are long and cold. Yet, Jack Elliott of Whitehorse, Yukon, has been turning fossilized mastodon tusks into fine costume jewelry for years and it all began because of the long, cold winters.

Elliott went to the Yukon in 1916 on his way to China, but that's as far as he got and he still has no desire to leave. He took an engineer's job on a stern-wheeler plying the Yukon River. The long, cold winter, however, turns the river into solid ice and that meant no work for Elliott, and no pay. Spotting some fossilized mastodon tusks that gold miners often uncover, he thought he saw a way to pay his winter grocery bills. Since then, he has been carving the ivory into earrings, pendants and other novelties which are eagerly bought by tourists who ride his river boat in the summer.

Mastodons roamed North America in the Pleistocene Era, about 20,000 years ago. Their bones have been covered during the centuries by layers of

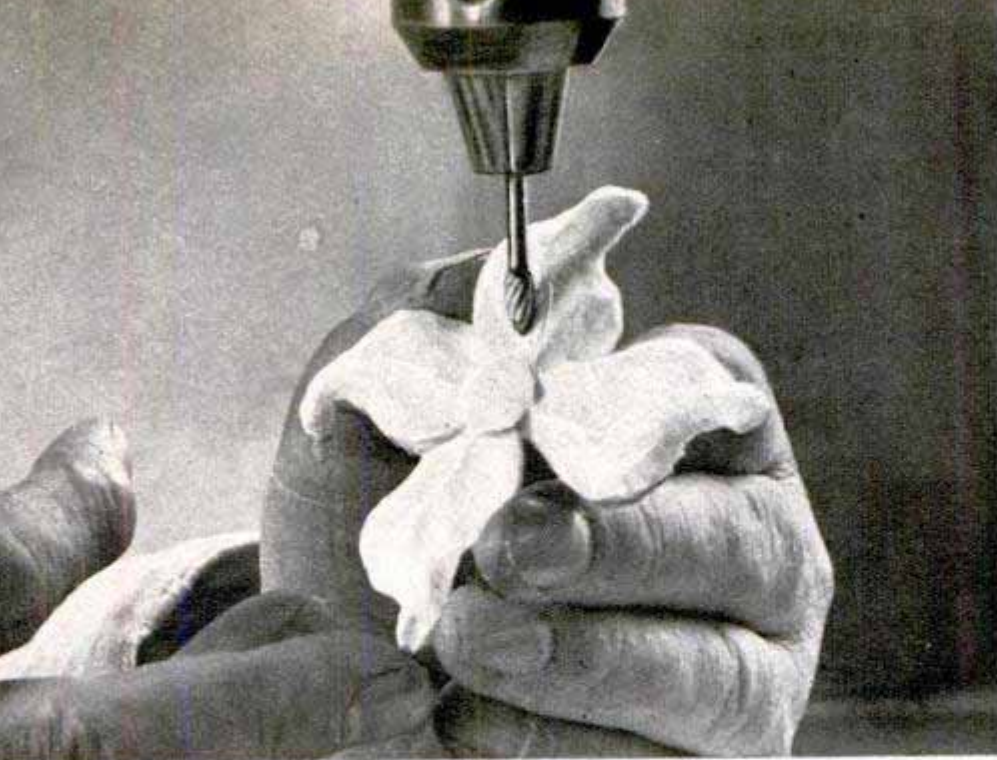

When he first started creating costume jewelry, Elliott used simple hand tools. Today, this power drill with a variety of heads enables him to do the job faster and much more skillfully

Photos by

Richard Harrington

earth, now permanently frozen. Today, hydraulic dredges that mine the gold of the North uncover these bones, providing Elliott and other craftsmen with jewel materials.

Carving fossilized mastodon tusks is no job for a blunt jackknife. At first, Elliott used files and scrapers to shape his unusual jewels. Now, he uses a power drill with 60 different heads. With a band-saw, he slices the tusk to the correct thickness. Then he sketches the design on the flat surface and, with the drill heads, carves back and forth to form the ornament. A buffing operation brings out a high luster. Most of his jewels also have a small gold nugget, an appropriate souvenir of the Yukon. The nugget and a strong clasp are attached by gold screws, securely tightened in the ivory.

To the tourist, anxious to take home a gift or souvenir that has the flavor of the Yukon, mastodon-ivory jewelry is perfect. Fashioned in these pins and trinkets are centuries upon centuries of Nature's work plus the skill and individual touch of a true craftsman of the Yukon.

Earrings, pendant, pin and dinner ring worn by this girl are all part of Elliott's handiwork. Each has a polished nugget set in the center





Hydraulic Lifter Speeds Auto Repairs

For fast and efficient transmission repairs, a hydraulically operated lift permits one man to remove transmission units from all makes of passenger cars and trucks. After the transmission is removed, the lift can be used to transport the unit to any part of the shop. Because of its great flexibility—the lift tilts backward, forward, to the right and left of center—the lifter can be used to replace the transmission unit. It can be fully rotated and permits quick alignment of locating pins with bolt holes. The hydraulic unit can also be used for other lifting tasks such as handling of drive shafts, gasoline tanks, power take-offs and truck springs. It has a lifting table 15½ inches in width. With a capacity of 800 pounds, the lifter cannot be harmed by the accidental letting down of the car as a safety relief valve protects both the car and the lifter. Maximum lift height is 70 inches.

Danish Electric Motor As Small As a Match Head

Powered by a one-volt battery, a midget electric motor built by a Danish electrician, Joergen Joergensen, is no larger than the head of a wooden match. The motor is mounted inside a glass tube to protect it from damage. A small propeller, attached to the shaft of the motor, spins rapidly when the current is turned on.

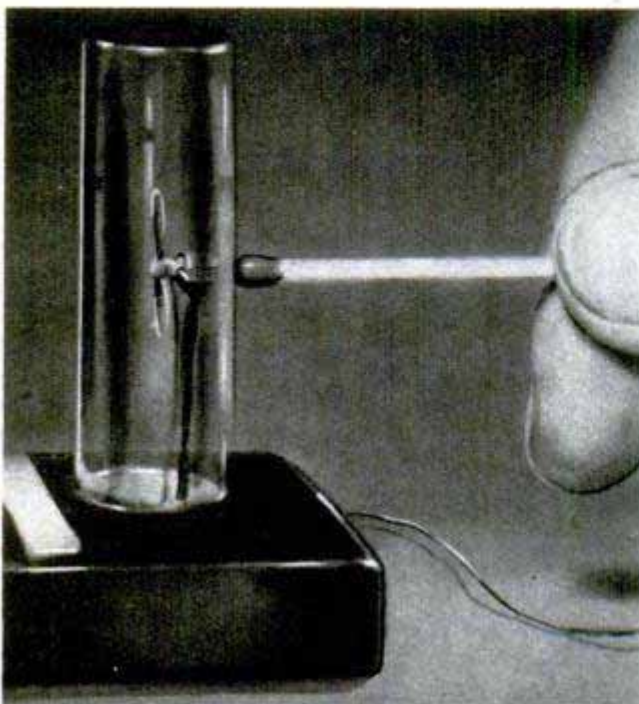

Photo Meter Converts for Color

By attaching a converter to his General Electric exposure meter, the photographer can measure the color temperature of the light and select the proper correction filter. The instrument has a range from 2800 to 30,000 degrees Kelvin, sufficient for use with any light. It also can be used for measuring incident light, thus being useful for either black-and-white or color film.



Automatic Slide Changer

You never have to handle your color slides once you file them in a plastic tray that serves as a magazine for an automatic slide changer. The slides fit in conveniently numbered slots in the tray which can be labeled for quick reference. When you want to show slides on a certain subject, you select the proper tray, insert it in the slide changer, mounted on the projector, and you are ready to put on a show! A half-turn on the changer crank moves the slide into projecting position. The second half-turn of the crank returns the slide to its original position in the tray. Additional turns move the other slides in and out of the tray for projection. When the 30 slides have been shown, you slip the tray from the changer and return it to its storage place, the slides back in original order and still untouched by hand. You can reverse the crank motion to repeat any slide

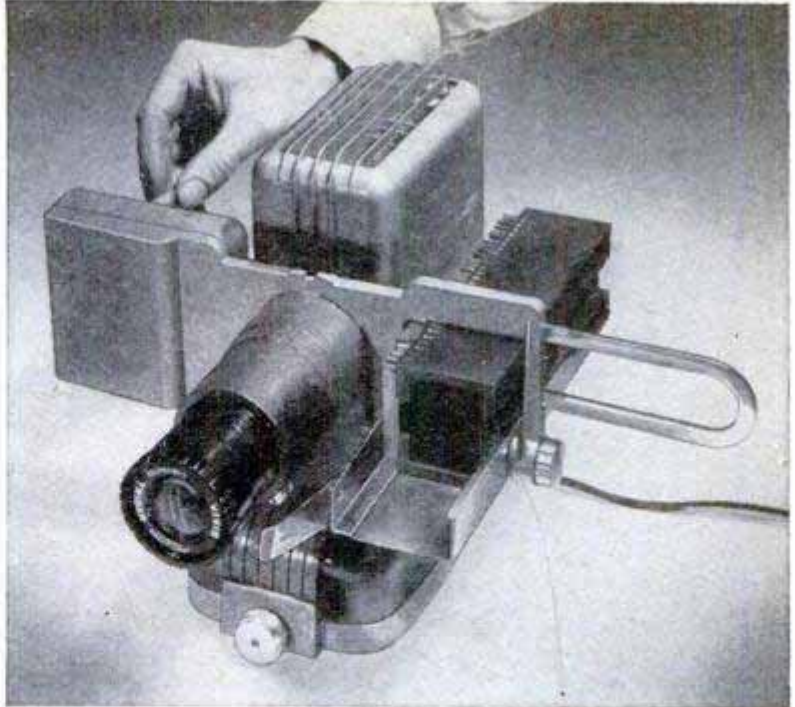

or, if you wish, you can skip any number of slides. The automatic changer is designed for use with any TDC Vivid projector and works with any type of 2 by 2-inch slide.

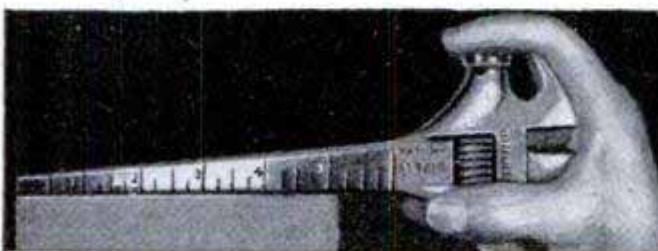
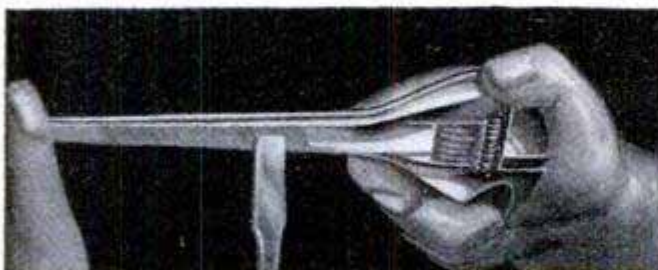
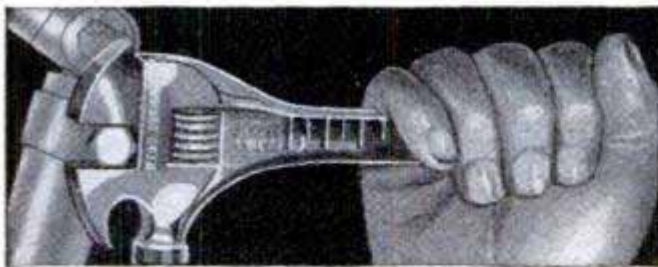

← Six-Purpose Tool

For the home handyman there is a new British-built utility tool that serves six different purposes. Made of forge-hardened steel, it is a hammer, has a claw for removing nails and has a spanner end that will turn nuts and bolts up to $\frac{3}{4}$ inch in width. One side of the tool handle is a file, the other is a six-inch rule and the tapered tip acts as a screwdriver.

Chemical Kills Brush

Brush and stumps can be prevented from resprouting by spraying them with weed killer during the cold dormant season, according to the Dow Chemical Company. In one test, brush sprayed during the winter with the weed-killing 2,4,5-T failed to produce leaves in the spring. Freshly cut stumps sprayed with 2,4-D and 2,4,5-T in kerosene or fuel oil during winter did not resprout.

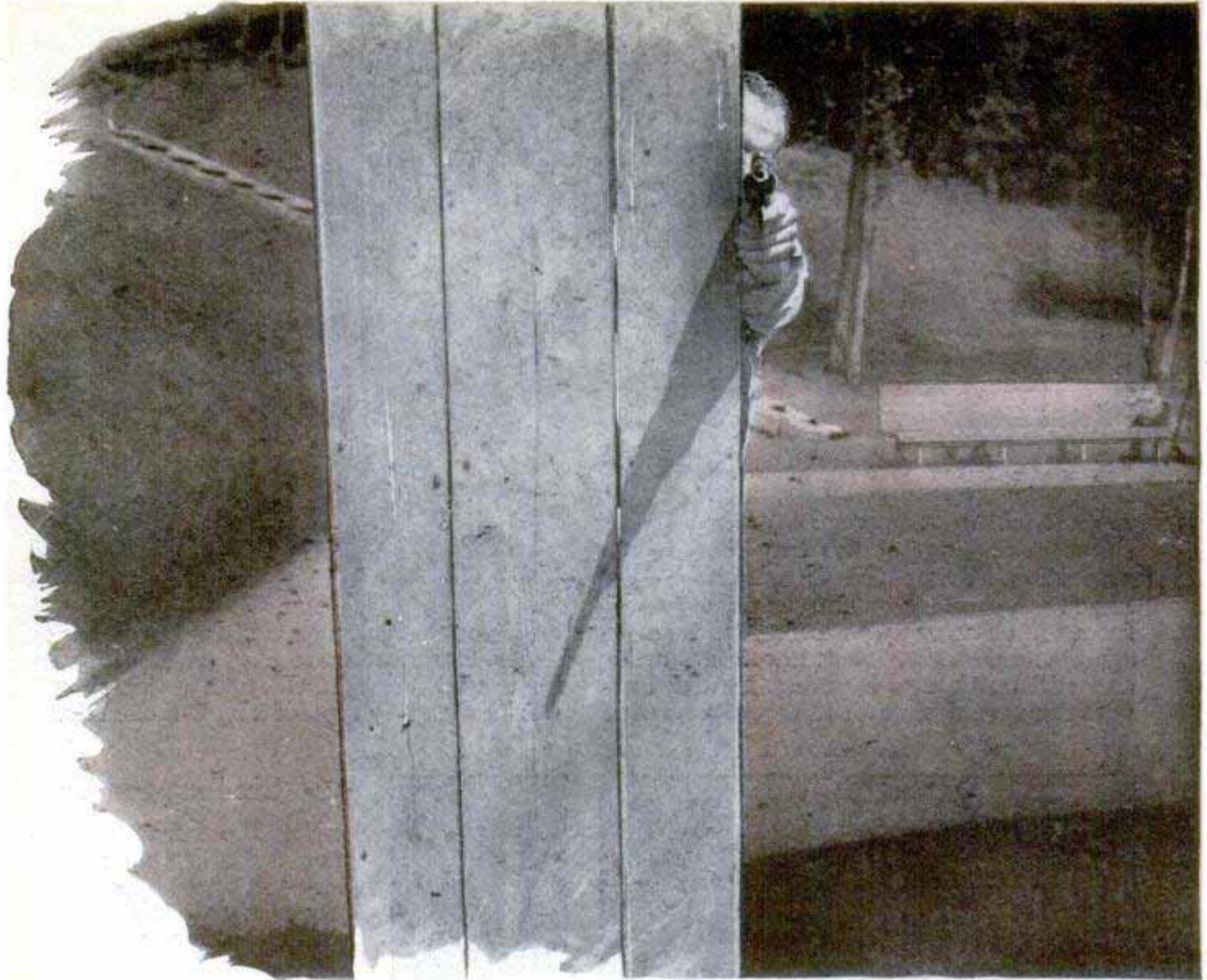

Police learn to shoot without exposing themselves. Less than five percent of the officer is visible here

FBI ROAD SHOW

By Rafe Gibbs

AN FBI AGENT and five policemen were sitting in the agent's car parked beside the police station in a little Western town. They were talking shop and spotting the darkness with glowing cigarettes.

Suddenly, a new sedan with out-of-state license plates squealed around the corner, sped on down the street.

"This is for us," said the FBI man and spun the motor of his car into action.

The racing sedan cut off on a deserted road leading to the country and the police-loaded car reeled after it. As the gap closed, the siren sounded. The sedan slowed reluctantly, pulled to a stop at the side of the road. The FBI agent cut in behind it, quickly stepped out and walked over to the sedan, his hand on the gun at his hip.

"All right, you can—"

The driver of the sedan, holding a lev-

eled pistol, pulled the trigger. The FBI agent slumped to the road—then got up quickly and dusted himself off.

"See what I mean?" he asked the policemen. "I'm dead—or would be if that gun was loaded and the man who pulled the trigger wasn't another agent. Now I'll do it right."

The agent got back in the car and this time, before stepping out, he swung a spotlight on the driver of the sedan. Then he eased out of the car, taking care to stand behind the protective glare of the spotlight.

"Now, you in the sedan, step out."

The roadside drama was just part of the "classwork" in one of the world's most unusual traveling schools conducted for policemen by the FBI. In these schools, the book is not "thrown at the students." It is thrown away. There are lectures, of course,



This dummy has been "murdered" hundreds of times to help the FBI teach proper methods of handling clues

but they are kept to an absolute minimum.

Practical demonstrations are stressed, with emphasis on the word "practical." Checking up on a suspicious car, for instance, is one of the most dangerous assignments a policeman has to perform. The number of officers now dead from bullets fired inside a car attest to this fact and the FBI is stressing the wary approach.

As one agent told a class, "It's sometimes an officer's own fault when he gets killed."

It is significant to note that you rarely read of an FBI agent being killed by a criminal. The answer is his training, which is now being brought directly to the nation's local police stations. This police-school program, with a curriculum covering such varied subjects as safe-cracking, bank robbery and murder, is the most intensified and widespread this country has ever known.

Between June 30, 1945, and Nov. 30, 1949, enrollment in

training schools put on by the FBI totaled 316,150. During the current year that training is expected to continue at an even higher rate. Many officers represented in these enrollment figures attend more than one school, but, since World War II, it is estimated that more than 150,000 different officers have had an opportunity to familiarize themselves with the latest FBI techniques.

The need for such widespread training is pressing. Our crime rate went up rapidly

during and following the war and has maintained a high level. In the first six months of 1949, crime increased 2.7 percent in the cities and 7.6 percent in rural areas, compared with the same period in 1948. Burglaries rose 4.4 percent in cities and 13.1 percent in the country, and larcenies went up 3.3 and 8.8 percent, respectively, in cities and rural areas. Robberies remained about the same in urban areas but increased 8 percent in rural districts.



On a large table-top city at the FBI Academy in Washington, search and arrest techniques are worked out before being taught to police in your home town

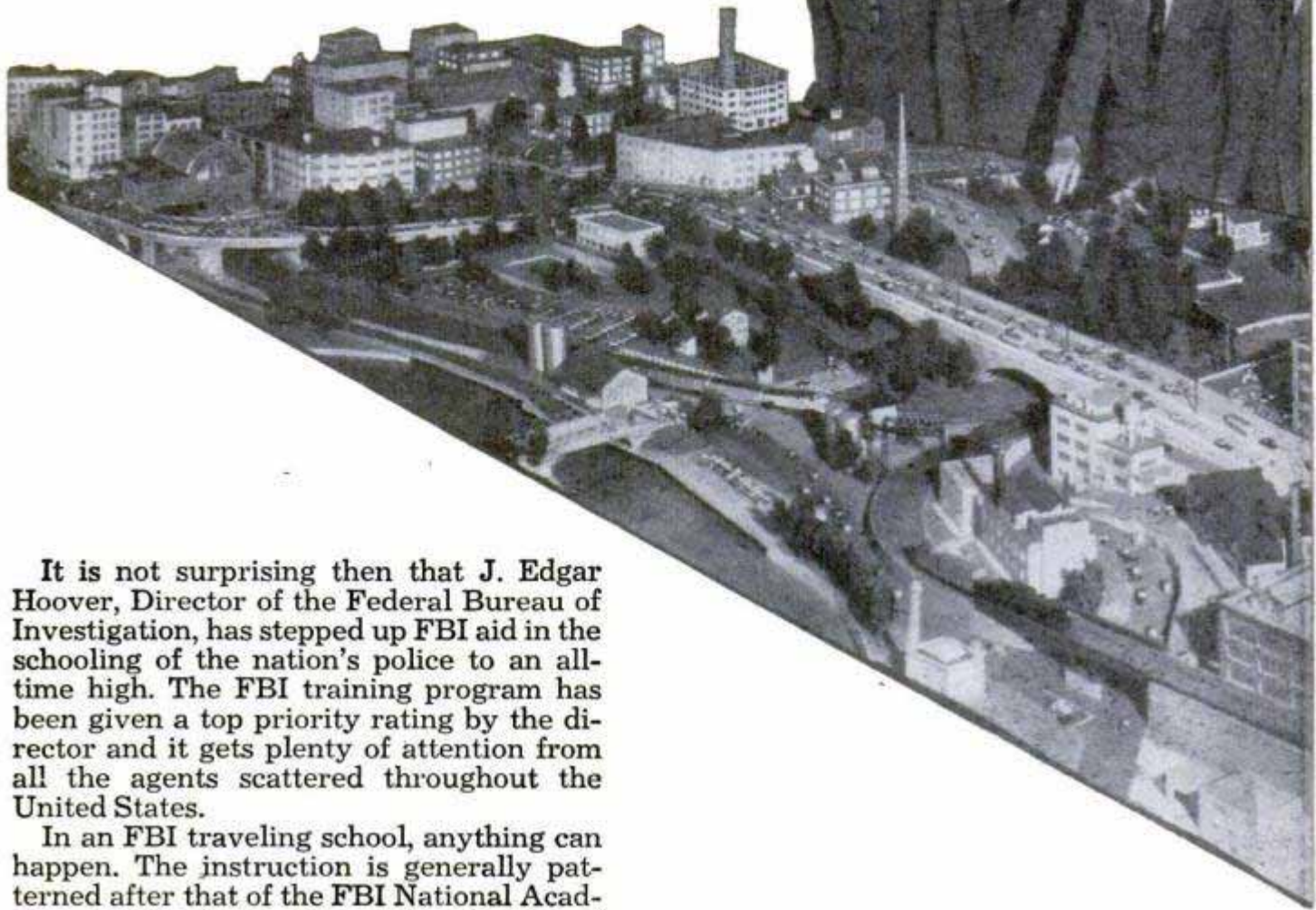

It is not surprising then that J. Edgar Hoover, Director of the Federal Bureau of Investigation, has stepped up FBI aid in the schooling of the nation's police to an all-time high. The FBI training program has been given a top priority rating by the director and it gets plenty of attention from all the agents scattered throughout the United States.

In an FBI traveling school, anything can happen. The instruction is generally patterned after that of the FBI National Academy, but the ingenuity and imagination of the individual agents leave their mark on the various schools.

While one school was in progress, a safe was cracked in the town's biggest warehouse and the policemen students were put to work on the case. The best clue was the peculiar tread mark of a tire so the students spent hours between classes checking tires

in town. Finally, one patrolman, who was willing to suspect anybody, found the right tire—on the local chief's car parked daily in front of the school. The safe-cracking job was a cooperative one between the chief and the FBI for instructional purposes.

One of the most dramatic traveling-

Policemen learn judo also. This is the wrist throw

This disarming maneuver has to be done fast or else!

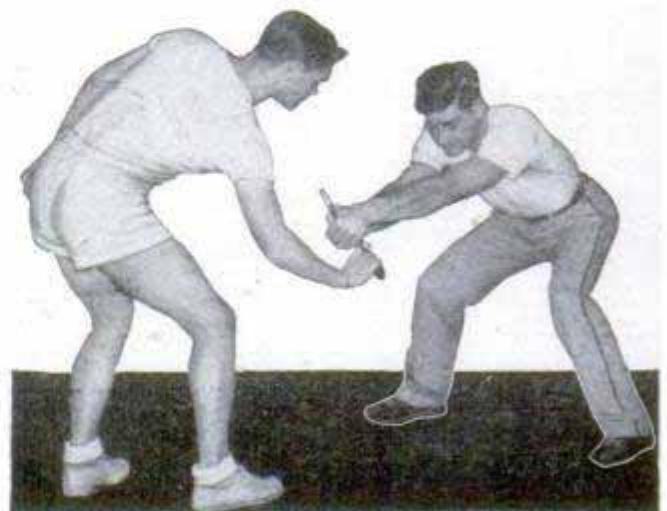
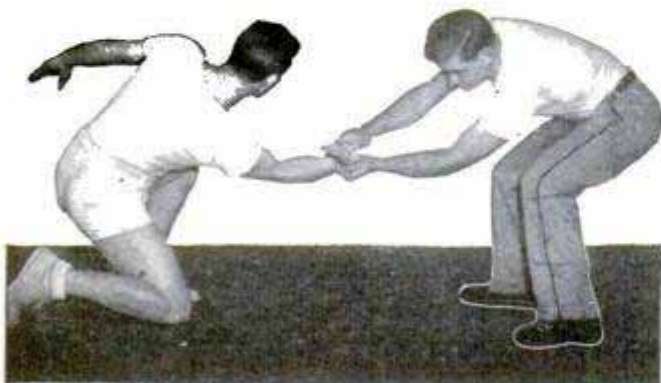

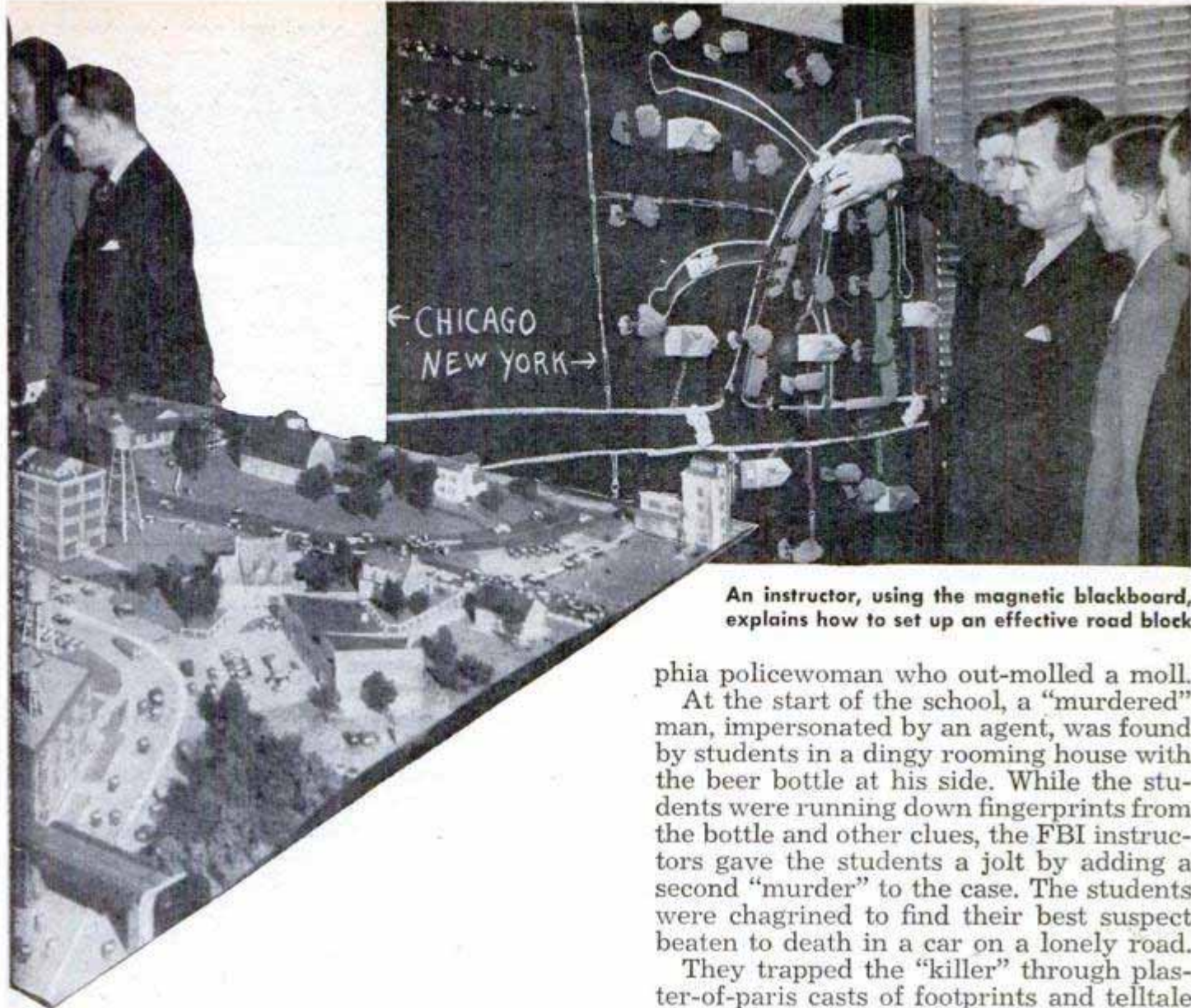

An instructor, using the magnetic blackboard, explains how to set up an effective road block

school crimes was the "Case of the Bloodstained Beer Bottle," staged by agents of the Philadelphia office in a Pennsylvania town. In addition to FBI agents, the actors included a local judge, prosecuting attorney, chief of police, some of the businessmen, a college law professor and a Philadel-

phia policewoman who out-molled a moll. At the start of the school, a "murdered" man, impersonated by an agent, was found by students in a dingy rooming house with the beer bottle at his side. While the students were running down fingerprints from the bottle and other clues, the FBI instructors gave the students a jolt by adding a second "murder" to the case. The students were chagrined to find their best suspect beaten to death in a car on a lonely road.

They trapped the "killer" through plaster-of-paris casts of footprints and telltale arm scratches, but when he was tried in a moot court, the jury acquitted him. The students had failed to follow up on a couple of vital pieces of evidence, which would probably have knotted the rope around the "killer's" neck. One consisted of fibers of cloth caught in the molding at the scene of

(Continued to page 266)

Caught in a bar hammer lock, the pupil is helpless



The hip throw is used to counter a right-hand punch

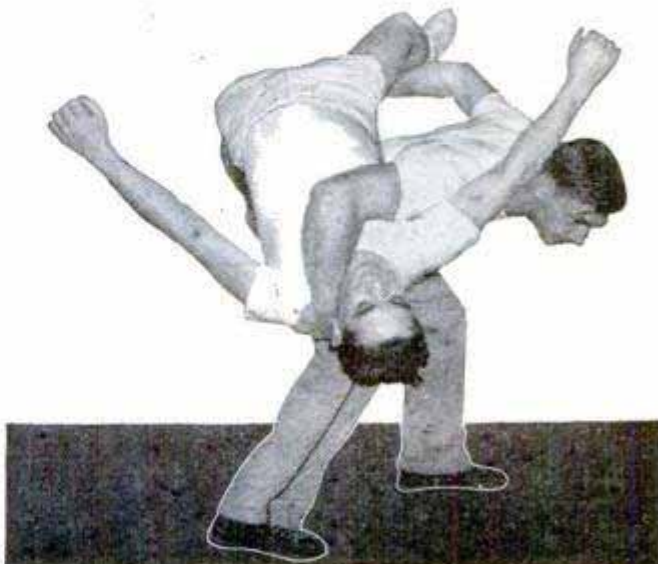



SETUP FOR THERMORADIOGRAPHY

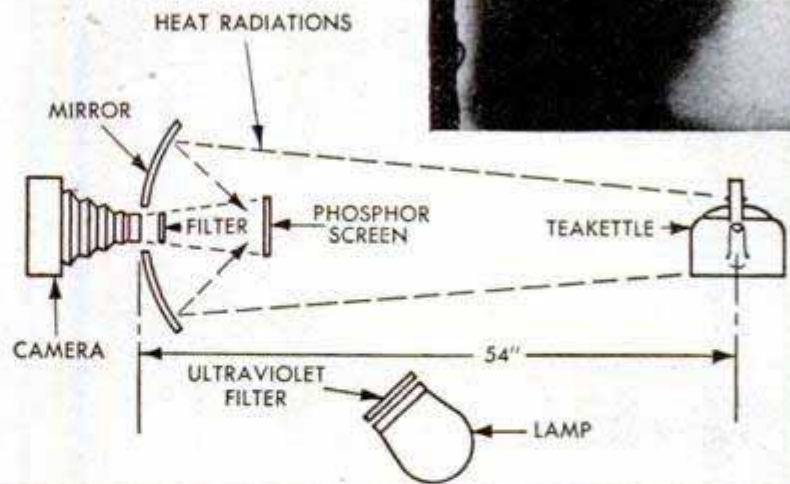

Small white screen in front of the camera lens is the phosphor screen where the object appears under ultraviolet light. The drawing shows the setup for photographing the heat of a teakettle through the screen

Camera Photographs Temperature of Objects

Sensitive chemicals known as phosphors, which absorb heat waves and give off a glow, are used to "take" the temperatures of objects by photography. With the technique, it is possible to record temperatures of many parts of an object simultaneously. A small screen, coated with phosphors, is placed between the object and a large curved mirror which focuses the heat radiations of the object on the screen. When ultraviolet light is flashed on the screen, an image of the object, varying in bright-

ness as its temperature varies, can be photographed through a hole in the mirror. Because the phosphors show a 20-percent change in brightness with each Centigrade-degree change in temperature, accurate temperature readings can be computed from the varying tones in the photograph. This is the first time such a comprehensive picture of heat distribution has been available, according to scientists at Eastman Kodak, where the temperature-recording technique was developed.



Left, heat circulator in fireplace opening and, right, partially inserted, showing smoke and gas outlets

Heat Circulator Can Be Inserted In Fireplace

No rebuilding is required for a new heat circulator that can be inserted in the opening of a conventional fireplace. It eliminates loss of heat through the chimney, uneven

heating of the room and formation of drafts within the room. The circulator, which can be controlled by hand or thermostat, is custom-made in aluminum, copper or brass.

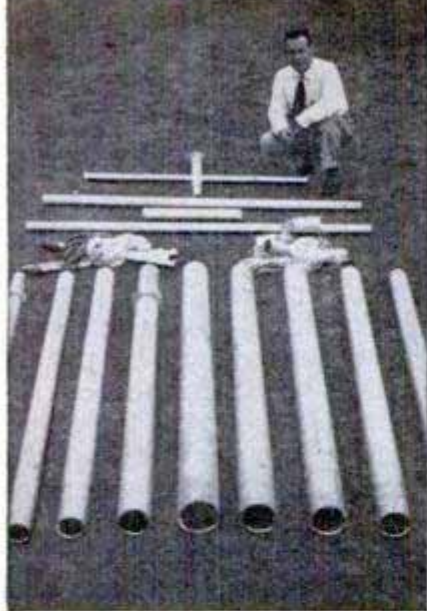

Sectional Masts of Lightweight Plywood Tubing

Weighing less than 1½ pounds per foot, a strong mast of plywood tubing provides a long-lasting support for television antennas. Sold in kit form for masts of various heights, the tubing comes in handy six-foot sections which nest together, forming firm, unyielding joints. One person can erect a flagpole or unguyed antenna mast unaided

and it takes only two persons to put up a 90-foot guyed mast with an erection boom furnished with the kit. The mast won't rust and doesn't conduct electricity. The lead-in wire is strung through the tubing where it is protected from the weather. Also available are lampposts, flagpoles and roof-peak antenna masts.

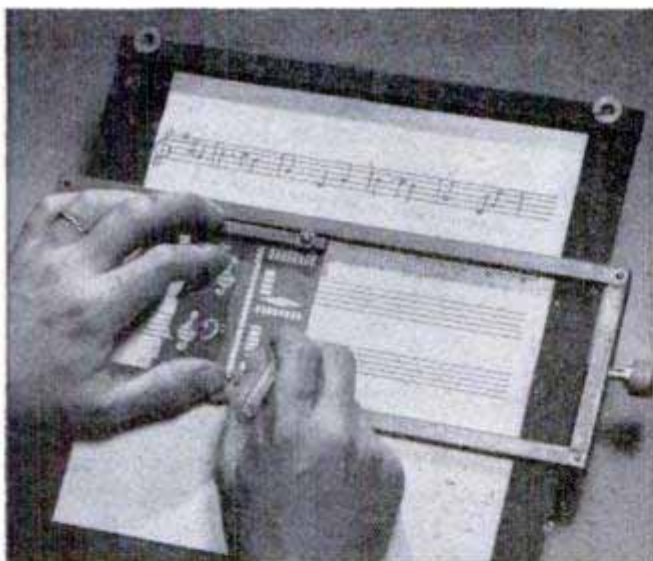

Blind Musicians' Helper

Blind composers and arrangers can write anything from be-bop to counterpoint with a special music writer. It consists of a stencil—with all the musical signs and notations—that travels within a guide mounted on an inclined board. The inventor, a blind Belgian organist named August Liessens, has allowed just enough space within the guide so that notes drawn with the stencil against the bottom are on the line, while those notes drawn with the stencil against the top are in the spaces. Liessens' invention has been put into production by the American Foundation for the Blind.



Vibrating Meat Cutter

Using a short, vibratory stroke similar to a jigsaw, a cutting machine, developed in Switzerland, slices meat to any thickness. Instead of a cutting wheel, the machine uses an oscillating arm on which the blade is mounted. The blade, which can be changed in a few seconds, vibrates as it cuts.

☞ Chemical 2,4-D, sprayed from airplanes over an area in Oklahoma, killed 90 percent of the sagebrush at a cost of \$2.25 per acre.

The Packers Also Sell Meat . . .

LESS THAN a hundred years ago the meat packers of this country were engaged in the simple business of selling meat. They paid hard money to teamsters who would haul away any part of the carcasses not fit for your dinner table.

Today not much is left to haul away. The packers are still in the business of selling steaks and chops, but even at today's fancy prices for beef and bacon the "waste" of packingtown earns a substantial percentage of the industry's profits. Hide and hair, hoofs and glands go down the production line into an amazing variety of goods.

One of the newest and most publicized end-products of the hog market is the drug ACTH, certainly one of the essential ingredients of De Soto's fountain of youth if its benefits prove out the promises of its first tests.

The hormone is extracted from a tiny fraction of the pea-sized pituitary gland of the hog. One 61-year-old businessman who had suffered crippling arthritis for 10 years was a "guinea pig" for the ACTH arthritis treatment. Within 48 hours after he received the first injection of the hormone, he tossed away his cane. A few days later all swelling had gone from his arthritic joints.

The effects were dramatic. The doctors and the packers are tempering their enthusiasm, however, with hard facts. One fact is that a handful of experimental "cures" does not prove the over-all value of the drug; it apparently relieves the symptoms of arthritis so long as ACTH is continued, but does not cure; and there may be less pleasant effects.

Fact No. 2 is that it takes 400,000 hogs to supply enough pituitary glands to pile up one pound of ACTH. It will be a long time before a sufficient supply is available for adequate research, let alone the treatment of the more than 6,000,000 Americans suffering from arthritis.

The new hormone is just one example of the results of scientific research applied to the packing-industry products. Considerable research has been conducted of late into the fatty acids derived from animal wastes, and both Armour and Swift have built new plants to isolate commercial chemicals from these fats and oils. The process is roughly similar to the fractionation of petroleum. The fatty acids serve as starting materials, and further synthesis produces new chemicals with such unusual properties that even the scientists are seeking industry's help in exploring all the uses of them.

Certain of these chemicals combine with

metals, metallic oxides or metallic hydroxides to form salts and soaps. Detergents now popular in hard-water areas come from these fatty acids and don't precipitate scum in hard water.

Another chemical, stirred in small amounts into printing inks, "pulls them together" to decrease spread on the paper. Asphalt compounded with another chemical is more fluid when hot and tack-free when cool. Surfaces wiped with still another actually repel dust because static electricity is eliminated. Added to paint, one of them prevents a skin from forming inside the can. Still other chemicals are powerful germicides and disinfectants. Some are excellent softening and finishing agents for textiles. Another, mixed into garden sprays, "sticks" the chemicals to the plant.

A new wax, compounded with the chemicals, is resistant to both acids and alkalis, and won't melt even when boiling water is poured across the surface.

Several of the chemicals have an odd ability to cause some water-attracting surfaces to become water-repelling and oil-attracting. A small amount stirred into a mixture of asphalt will cause it to coat sand and gravel even after a heavy rain—a fact which may bring large savings in the upkeep of the nation's highways. Ordinarily, asphalt can't be mixed unless the aggregate is dry, and keeping it dry often entails considerable expense and delay.

Still another new product from animal waste is a novel upholstery material. There are objections to the two materials most frequently used at present in upholstery and mattresses. Curled animal hair, used in furniture upholstery for hundreds of years, has a tendency to pack down and may mildew. The more modern foam rubber is uncomfortably warm for the human body in some applications because there is restricted air circulation through it. The new material combines the advantages and eliminates the disadvantages of each. Millions of tiny hair curls are covered and interlaced with a thin coating of rubber which binds them together, making a pad that is cool and resilient, will not lump or shift. You can sew it, nail it or tuft it. It is water, moth and vermin resistant. You'll find it in some of the latest automobiles.

Not much of the animal carcass is considered waste, now that industry and medicine have found uses for these by-products. Even the animal's gallstones bring income to the packer—for centuries peoples of the Orient have considered them good-luck charms!

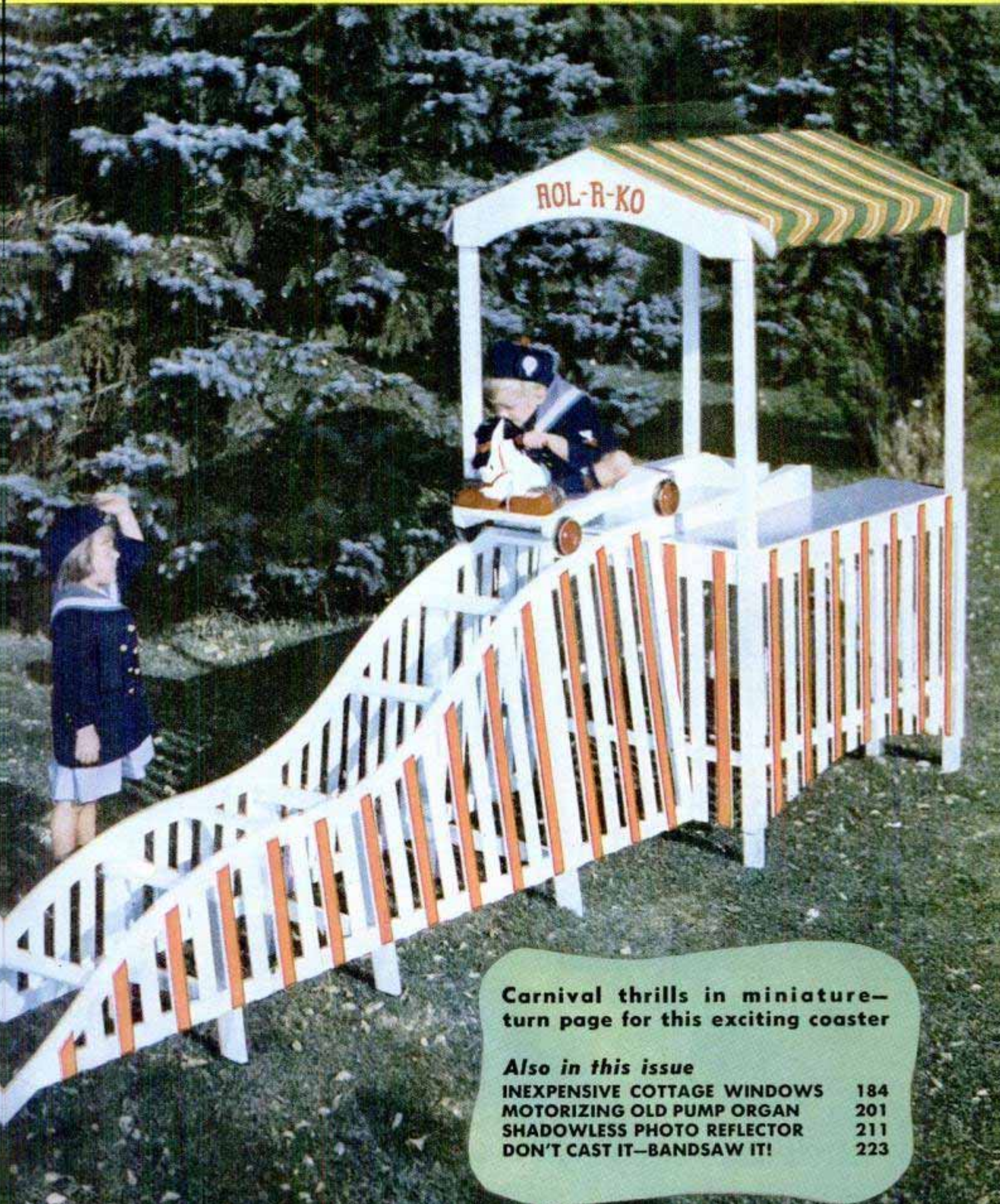
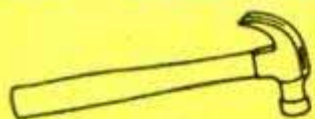

**Carnival thrills in miniature—
turn page for this exciting coaster**

Also in this issue

INEXPENSIVE COTTAGE WINDOWS	184
MOTORIZING OLD PUMP ORGAN	201
SHADOWLESS PHOTO REFLECTOR	211
DON'T CAST IT—BANDSAW IT!	223

Toys you can make
KIDDIE ROLLER COASTER

Designed by WAYNE C. LECKEY

ROL-R-KO is a toy that will make your back-yard playground complete. You can build it from common lumber and standard iron wheels, and it comes apart in seven easy-to-handle sections for winter storage





ROLLICKING good times are ahead for Billy and his pals when dad sets up this thrilling back-yard roller coaster. The rider mounts the platform by steps at the rear and climbs aboard a four-wheel car. Depressing a trip lever starts the car on its way, sending it down the dips and up an inclined section of track. In climbing the incline, the car gradually loses speed and strikes a spring bumper at the end of the track. From there it rolls backward and finally comes to a stop at ground level. The car is returned to the starting platform by pushing it back up the track. Having a platform only 3 ft. high, and deep-flanged wheels which hold the car on the track, Rol-R-Ko is perfectly safe for three-year-old youngsters. The toy is complete as originally built and pictured here, but if you have a large yard, the track can be extended to provide a much longer and more thrilling ride. This can be done either by adding additional dips down the line or merely letting the track run off on level ground, using flat, straight sections. The track sections are staked to the ground to assure a solid roadbed for the car. This, together with the flared structure



which supports the elevated sections, eliminates any likelihood of the toy tipping over or the track giving way under the weight of the rider. There's no problem in putting Rol-R-Ko up for the winter as it is designed for easy dismantling in sections of a size convenient to handle and store overhead in a garage. For example, the canopy lifts off, both sides of the platform pull away and the steps slide out as a unit, leaving the floor and rear posts of the platform in one piece. The track itself is detachable from the platform by removing four screws and, in turn, comes apart in two separate sections. Being of knockdown construction, Rol-R-Ko can be built easily in the basement workshop which permits you to get an early start and have the toy ready to set

up outdoors when warm weather arrives.

The complete toy is constructed from common lumberyard material, No. 2 grade being good enough. The posts for the canopy are 2 x 2s, the platform framework is of 1 x 4s, the slats are common 1 $\frac{3}{4}$ -in. lattice stock and the majority of the track and bracing is of 1 x 2s. The flanged cast-iron wheels for the car are standard items which can be purchased for $\frac{1}{2}$ -in. axles. Colorful waterproof awning material is selected for the canopy.

A simplified and less-expensive version of Rol-R-Ko is suggested on page 179. Here, the toy is stripped to the minimum, a straight length of track being substituted for the dipped section which is merely extended off onto the ground with whatever

1 ASSEMBLY OF STARTING PLATFORM

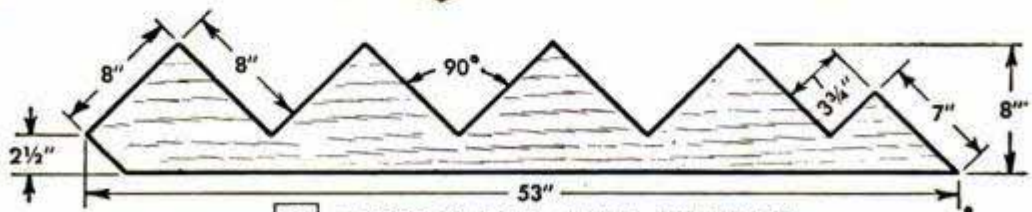
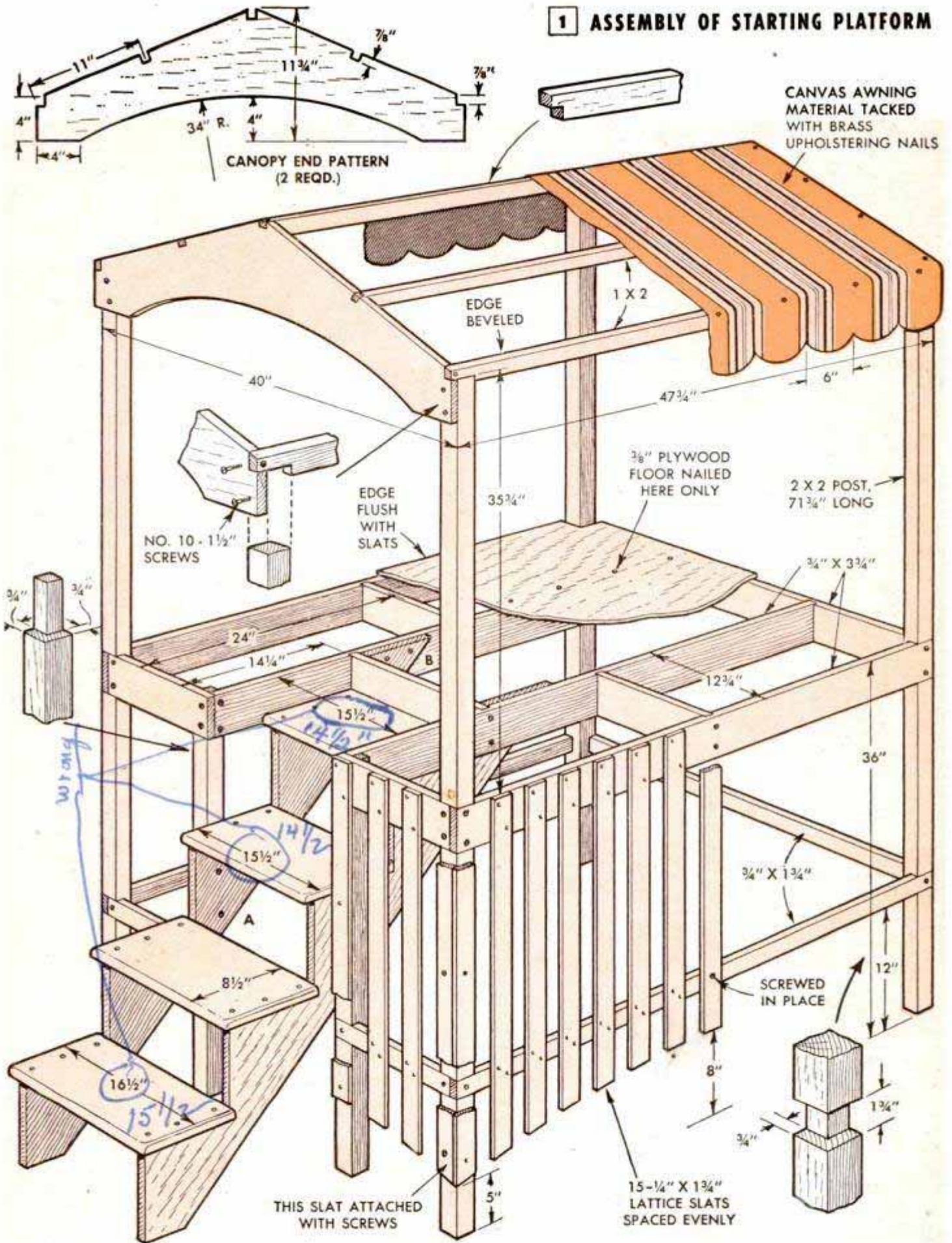

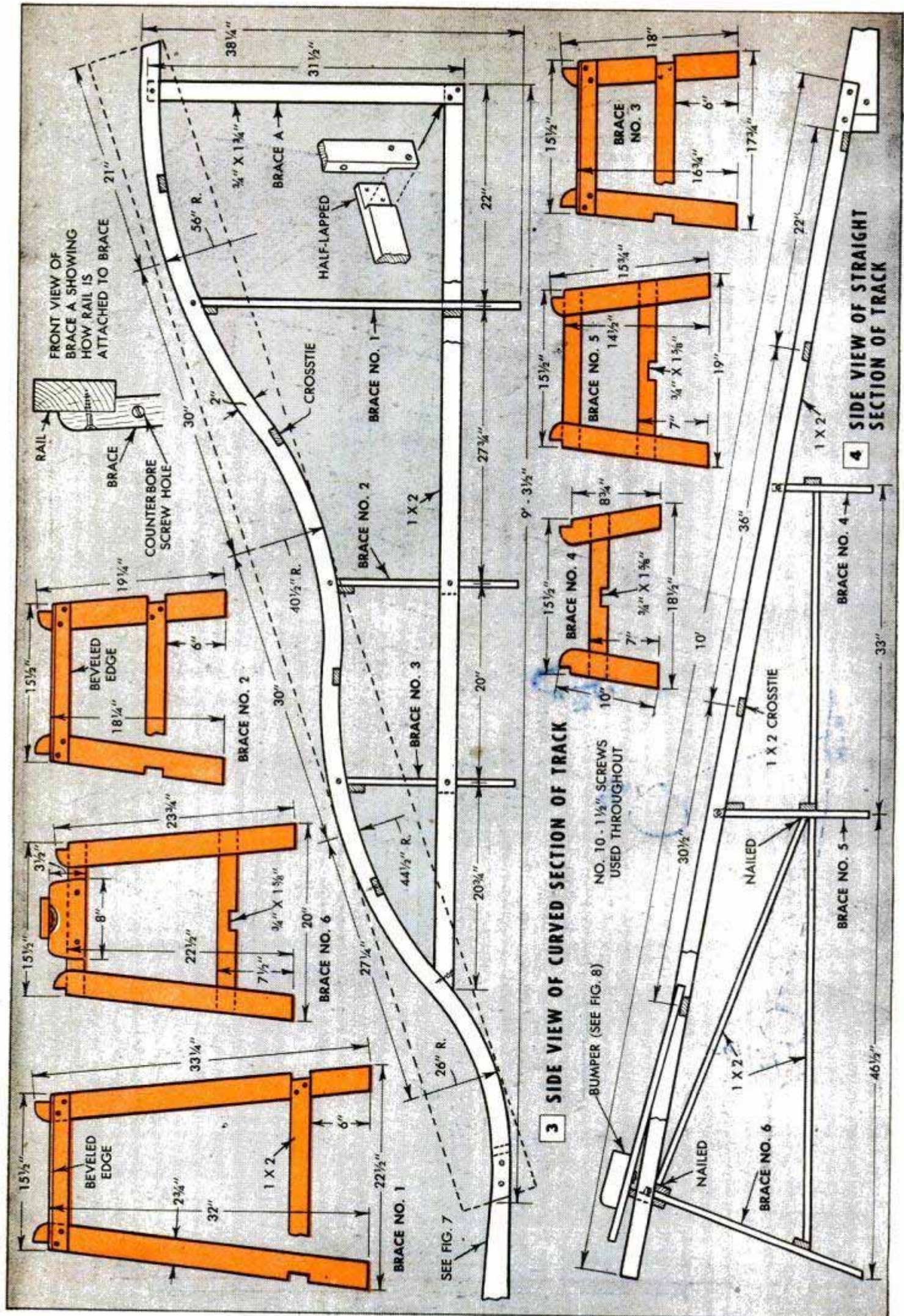

Here's a suggested way of building Rol-R-Ko in its most simplified form which will still give youngsters an exciting ride. Basic construction of track and platform differs very little, straight rails being substituted for band-sawed ones. As pictured, the inclined track merely runs off onto flat sections on ground

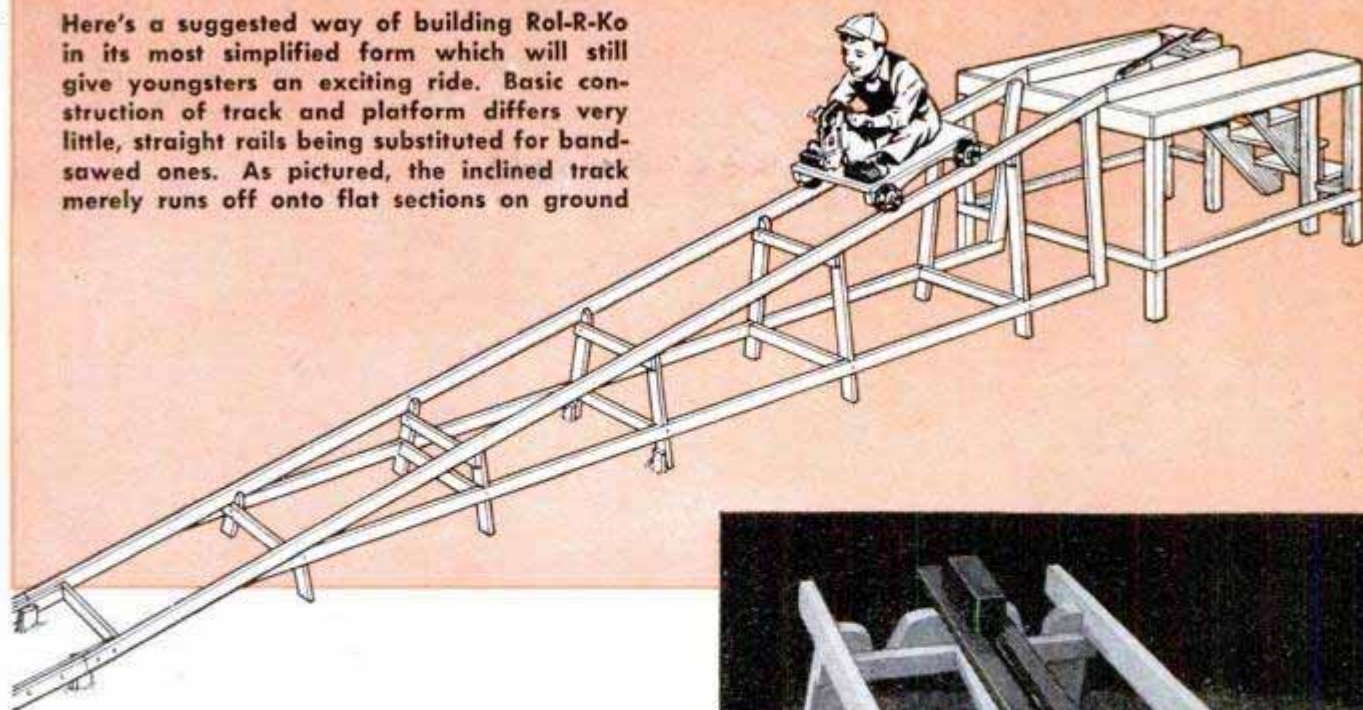

number of straight sections of track you have room for. In either case, the basic construction of the platform is the same. The cutaway drawing in Fig. 1 details the assembly, with No. 10, 1½-in. screws being used throughout. Two 12-ft. lengths of 2 x 2 will make the four posts with waste allowed for cutting. As shown in the lower detail, Fig. 1, the posts are notched on two adjacent faces to receive the 1 x 4 platform framing and the 1 x 2 bracing at the bottom. Mortising the ends of the cross members of the framing in dado cuts makes for rigid construction, although plain butt joints can be used. The steps, Fig. 2, are assembled as a separate unit and are fastened in place with eight screws at points A and B on both sides. A 4 x 4-ft. sheet of plywood is used to floor the platform. Note that this is notched at the corners to fit around the posts and is cut out for the steps. The plywood is nailed to the ends and all cross members of the platform, *but not along the sides*, as otherwise the sides of the structure cannot be removed. The slats around the sides of the platform are optional, although when painted alternately red and white they add considerably to the colorful carnival appearance of the toy. All of the slats are nailed in place except those that are indicated; namely, the end ones, Fig. 9, those at each corner and the center one on each side. These must be attached with screws so that the slats can be taken off to get at the screws that are removed in dismantling the toy. Two screws at each corner of the canopy are used to fasten it to the upper ends of the posts. Each end of the canopy framework is cut from a 1 x 12-in. board and then notched along the top edges for joining both together with 1 x 2

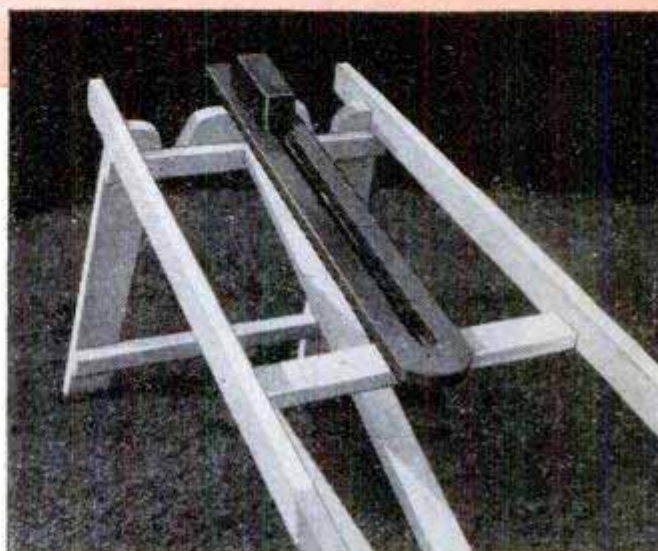

Spring-loaded bumper absorbs the impact when the car strikes it and the car rolls back down the track

LUMBER LIST

(Sizes are stock sizes—not actual)

- 1 pc. pine, 2 x 2 x 6 ft.—Stair posts
 - 2 pcs. pine, 2 x 2 x 12 ft.—Corner posts
 - 1 pc. pine, 1 x 10 x 10 ft.—Stair stringers
 - 1 pc. pine, 1 x 10 x 6 ft.—Stair treads
 - 1 pc. plywood, ¼" or ⅜" x 4 ft. sq.—Floor
 - 1 pc. pine, 1 x 12 x 8 ft.—Canopy ends
 - 5 pcs. pine, 1 x 2 x 4 ft.—Canopy stretchers
 - 2 pcs. pine, 1 x 4 x 8 ft.—Platform framing
 - 1 pc. pine, 1 x 4 x 10 ft.—Platform framing
 - 1 pc. pine, 1 x 2 x 10 ft.—Platform stretchers
 - 11 pcs. lattice, 1¾ x 10 ft.—Platform slats
 - 1 pc. pine, 1 x 4 x 6 ft.—Platform track
 - 2 pcs. pine, 1 x 8 x 10 ft.—Bandsawed rails
 - 2 pcs. pine, 1 x 2 x 10 ft.—Straight rails
 - 2 pcs. pine, 1 x 2 x 8 ft.—Track side rails
 - 1 pc. pine, 1 x 2 x 12 ft.—Track cross ties
 - 8 pcs. lattice, 1¾ x 10 ft.—Track slats
 - 1 pc. pine, 1 x 2 x 6 ft.—Braces (A)
 - 1 pc. pine, 1 x 3 x 10 ft.—Brace legs Nos. 1 and 6
 - 1 pc. pine, 1 x 3 x 12 ft.—Rest of brace legs
 - 1 pc. pine, 1 x 2 x 10 ft.—Brace cross cleats
 - 1 pc. pine, 1 x 2 x 12 ft.—Track bracing
 - 1 pc. pine, 1 x 4 x 3 ft.—Bumper
 - 1 pc. pine, 1½" x 10" x 14"—For horse head
 - 1 pc. pine, 1" x 13" x 26"—Base for car
 - 1 pc. pine, 1" x 4" x 26"—Sides for car
 - 1 pc. pine, 2 x 4 x 2 ft.—For bumper, etc.
- (Waste from rails will make track coupling)

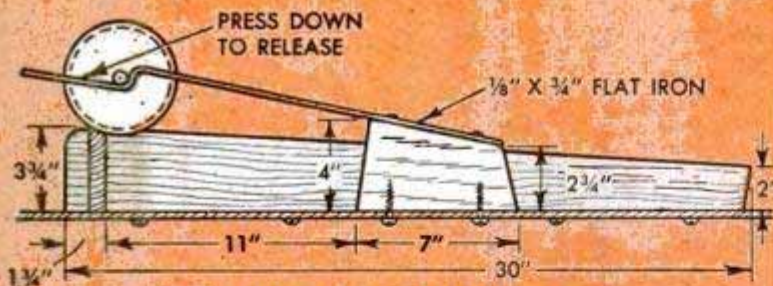

5 SIDE VIEW OF TRIP LEVER

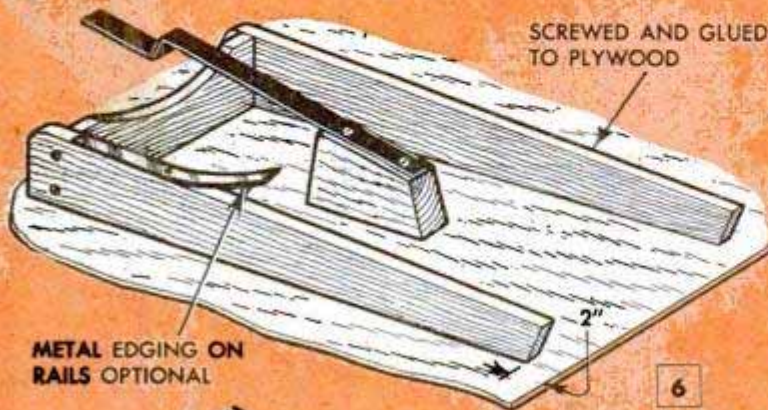

6 STARTING RAMP

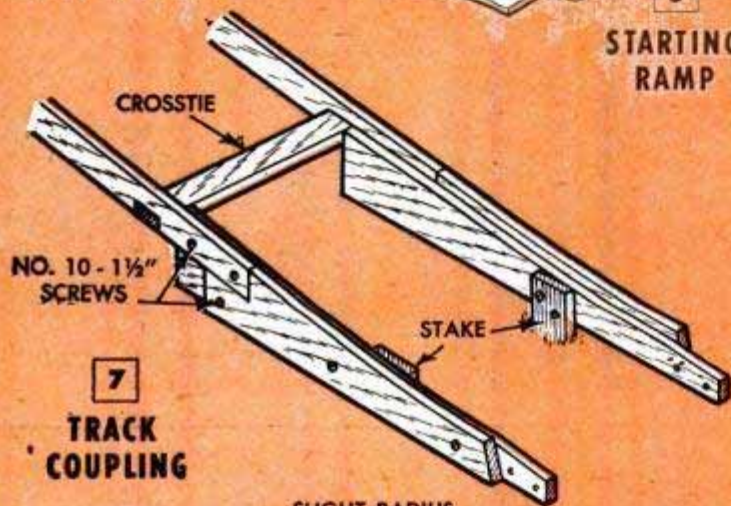

7 TRACK COUPLING

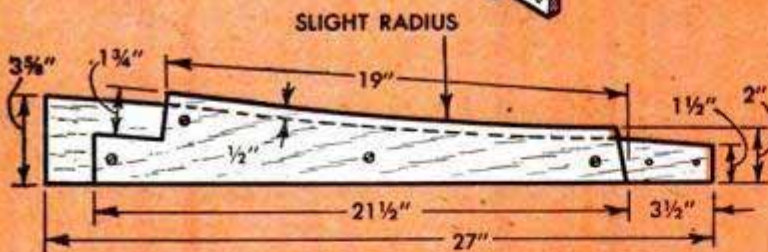

8 SIDE VIEW OF TRACK COUPLING

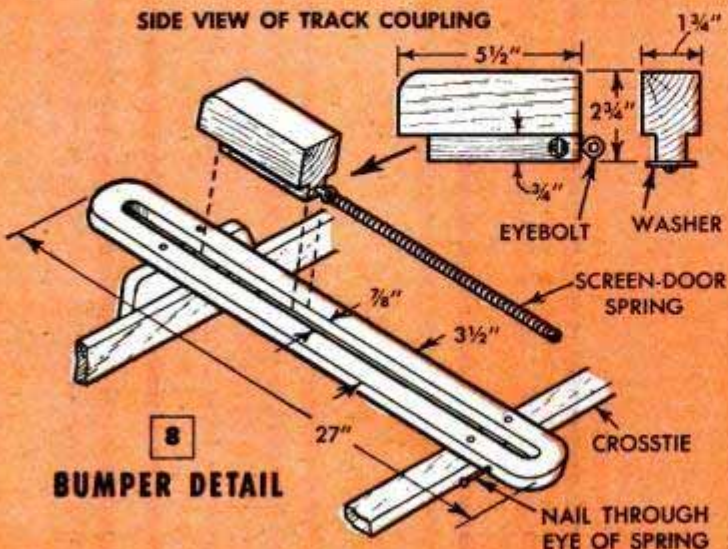

9 BUMPER DETAIL

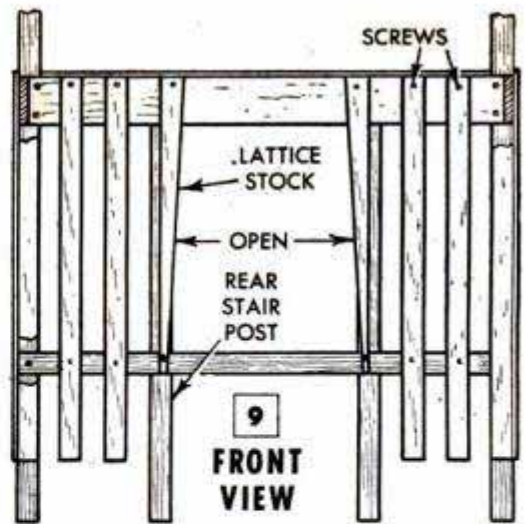

9 FRONT VIEW

stretchers. Unless you can buy 48 or 54-in. awning material, two separate pieces will have to be stitched together to cover the top. Eight scallops are cut along each edge and small copper nails are used to fasten the canvas in place.

The rails for the curved-track section, Fig. 3, are bandsawed 2 in. wide from two 1 x 8 x 10-ft. pieces. Starting from the upper end, each board is marked off lengthwise according to the drawing and the various radii indicated are swung at these points, using a long flat stick for a compass. With help, both rails can be cut at one time and notched on the bottom edges for four crossties, 15 1/2 in. long. A fifth crosstie at the lower end of the track is notched 1/2 in. deep at each end for wheel clearance and merely butted between the inner faces of the rails. The curved track is supported at the points indicated by braces, Nos. 1, 2 and 3. Brace No. 2 measures 19 1/2 in. across the bottom. The legs of each one are cut from 1 x 3 stock and the crosspieces are 1 x 2s. Notches are cut on the outside of each leg for 1 x 2 side rails, 7 ft. 6 1/2 in. long. The ends of these rails are half-lapped into braces A which, in turn, are drilled and counterbored for screws that are used to attach the section to the platform.

The straight inclined section of track, Fig. 4, is made similarly. Here, the rails are 10-ft. lengths of 1 x 2, crosstied together as before and supported by braces Nos. 4, 5 and 6. Both sections of track are coupled together as shown in Fig. 7, the outside pieces being notched to take the 1 x 2 ends of the inclined track. The coupling becomes a permanent part of the

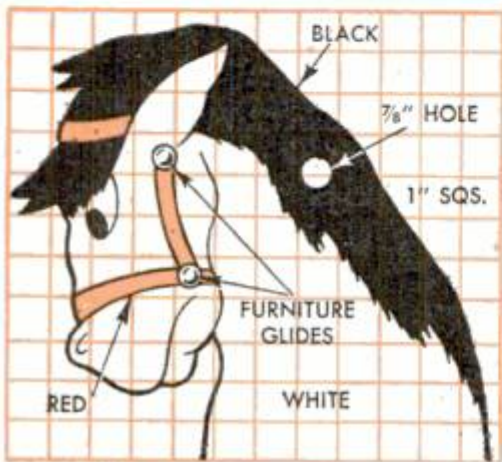
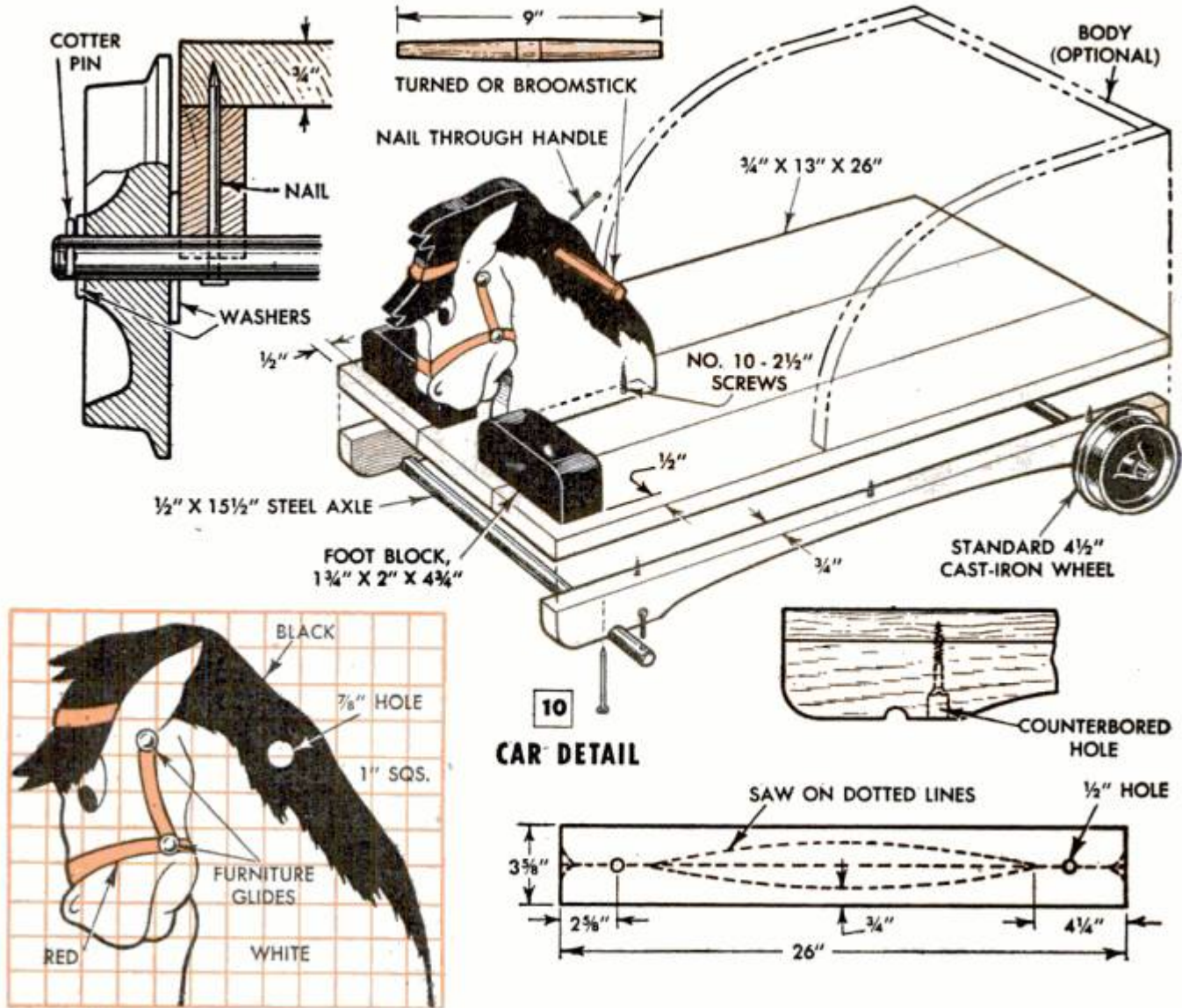

CAR DETAIL

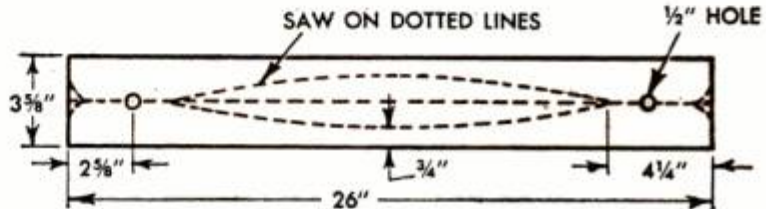

inclined section. The short section of track on the starting platform, Figs. 5 and 6, is screwed to the plywood from the underside and is positioned to align with the abutting track. The manner in which the trip lever engages the rear axle of the car is shown in Fig. 5. The lever should extend far enough behind the car to permit the rider to reach around and release it. The bumper, Fig. 8, makes use of a screen-door spring to ease the shock when the front axle of the car strikes it. It's apparent from the drawing just how it works. The bumper itself is rabbeted along each side to fit in a 7/8-in. slot cut in a piece of 1 x 4. A nail driven through from the side of the slot engages the eye of the spring, while a screw and large washer retains the bumper in the slot and yet allows it to slide freely. One end of the slotted member is fastened to a crossie and the other end to a block screwed to brace No. 6, Fig. 3. The top edges of the rails can be faced with a metal strip, if desired, although the wood will withstand considerable wear. Regular linoleum seam molding makes a neat facing.

The car is assembled as detailed in Fig. 10. If you are unable to obtain a piece of wood 13 in. wide for the base of the car, it

can be built-up by doweling and edge-gluing together several narrow pieces. Both side rails of the car are cut from a single piece of 1 x 4 in the manner shown in the detail below Fig. 10. First, holes for the axles are drilled at each end and the piece is ripped in half through the center of the holes. Then each strip is bandsawed on the dotted lines. These pieces are screwed securely to the underside of the base flush with the side edges. The axles for the wheels are placed in the half-round notches, drilled for an 8d nail and pinned as shown in the sectional detail, Fig. 10. Drill a pilot hole for the nail so that it does not split the wood. A standard 1/2-in. washer placed on each axle between the wheel and the car will provide the correct tread. A paper pattern for the horse head is drawn full size from the squared outline given, then traced and cut from a piece of 1 1/8-in.-thick wood. The head is drilled at the point indicated for a cross handle turned in a lathe or improvised from a broomstick. The handle is locked in position by driving a nail through it from the edge. The horse head is fastened securely to the base, 2 in. from the edge, with three long screws and finally the foot blocks are screwed in place.

Window Boxes Detached Quickly If Hung With Shelf Brackets



Small flower boxes on garage windows are easy to remove for painting or refilling if they are hung with metal shelf brackets. Two brackets are used for each box. These are inverted and screwed to the top edges of the box ends, and the holes in the upright arms are slipped over heavy screw hooks turned into the siding. To be sure the brackets will clear the window sill allowing the box to hang straight, the box should be longer than the window frame.

G. E. Hendrickson, Argyle, Wis.

Down Pipe on Cesspool Drain Eliminates Clogging

When a cesspool is drained directly from the surface of the water, the draintile is likely to become clogged with muck, causing the cesspool to back up and overflow. To remedy this condition, install a down pipe on the end of the drain so that the open end of the pipe is at least 6 in. from the bottom of the cesspool. In this way, only

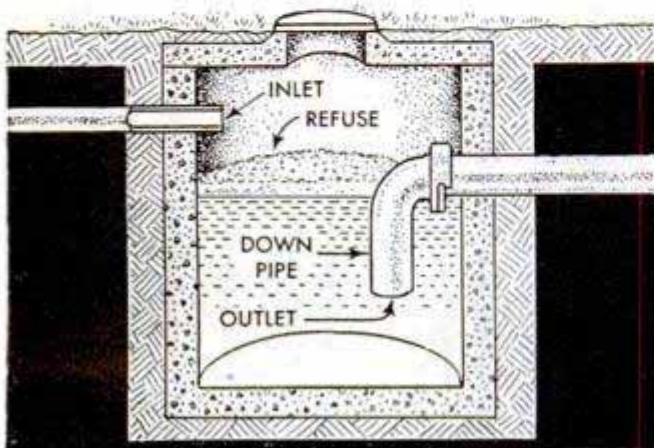

clear water is drained off, the solid matter floating to the top of the water where it decomposes. Be sure that the horizontal run of tile is below frost level.

Septic Bend Co., Rockland, Mass.

Woolens Stored in Sandwich Bag

Mothproof storage of woolen yarn, gloves and other small items is attained by placing the material together with several moth balls in a wax-paper sandwich bag. The open end of the bag is sealed with cloth or cellulose tape. Not only are the contents of the bag protected in this way, but they are prevented from becoming breeding places for moths which are likely to infest larger garments.

Helen Lemberger, Chicago.

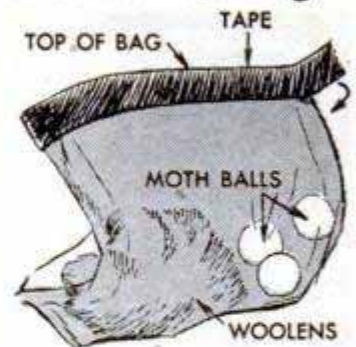

Chemical "Ferret" for Deep Holes

Animals can be routed from the deepest den in a few minutes without digging or drowning if this chemical ferret is burned in the hole. To make the ferret, saturate 6 x 6-in. squares of Canton flannel with a solution of potassium nitrate (saltpeter), 1 part, and water, 2 parts. After the squares have dried thoroughly, sprinkle the rough side of the flannel with a finely ground mixture of cayenne pepper, 1 part, dry mustard, 1 part, and sulphur, 3 parts. Roll the pieces of cloth, similarly to rolling a cigarette, and cement the loose edges in place with waterglass. To use, ignite one end of the roll and push it as far down into the hole as possible. The fumes given off by the burning mixture will quickly ferret the animal from its den.

R. A. Jenkins, St. Louis, Mo.

Improved Door Bumper

If a door bumper is broken, the wall can be protected by this improved bumper until a new one can be obtained.

Cut one of the flanged ends from a thread spool and fasten it to the baseboard with a long wood screw. Then, simply press a crutch tip, if available, or a short piece of hose, over the end of the spool. Using the crutch tip and painting the exposed portion of the spool provides a suitable bumper that will give long service in proportion to its extremely small cost.

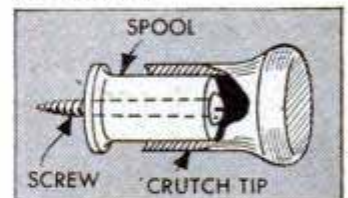

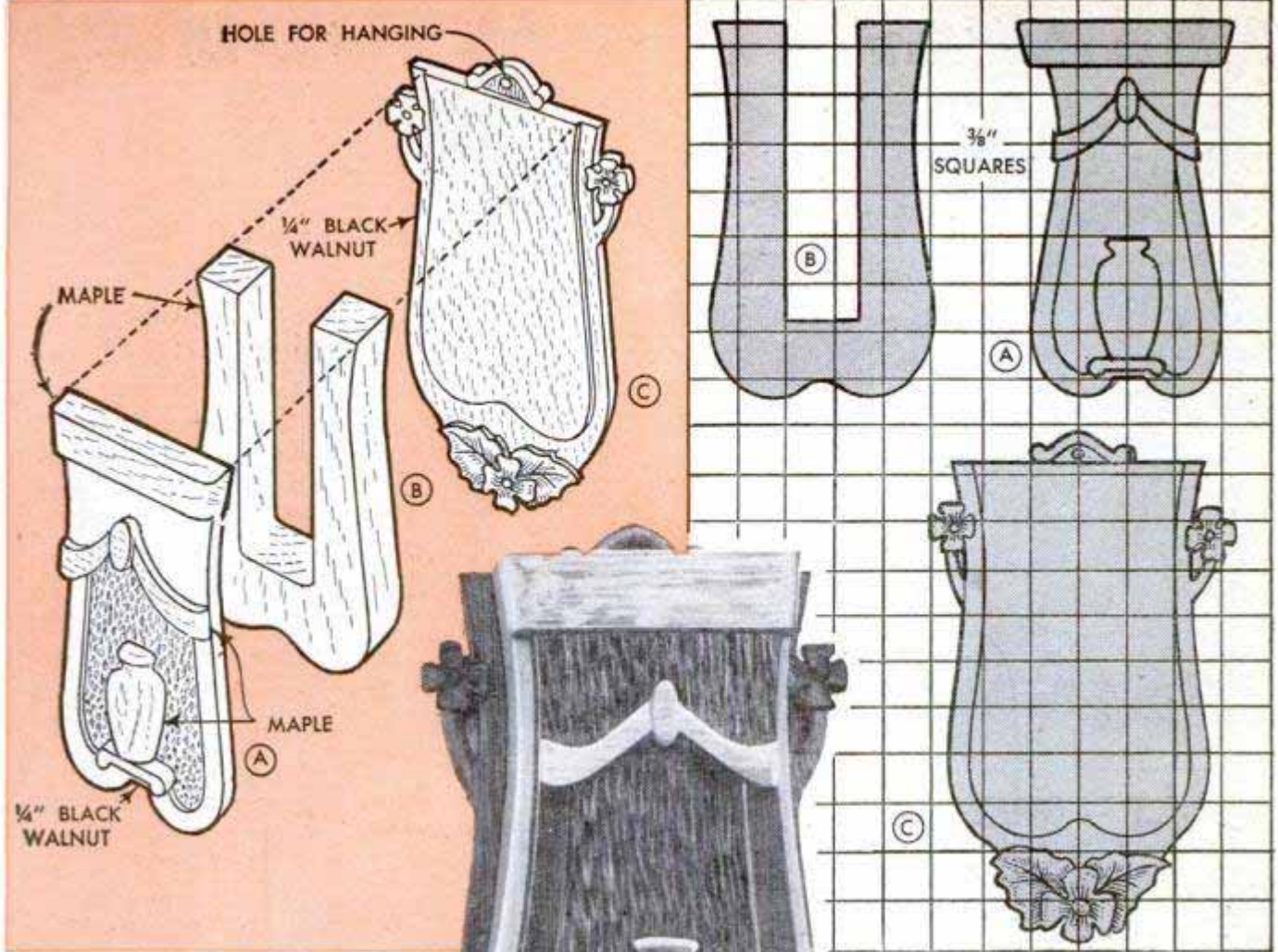

Carved WALL VASE

By Dick Hutchinson

IF YOU'D like to try your hand at elementary wood carving, a pair of these unique wall vases provides a simple project for beginners. Some jigsawing also is required as well as practice in making a split turning. The vase is built up of three pieces (A, B and C) from black walnut and maple. First, a pattern of each cutout is made full size. Piece B, which forms the pocket in the vase, is cut from $\frac{3}{4}$ -in. stock, while the others are cut from $\frac{1}{4}$ -in. material. After piece B has been cut and sanded, its outside profile is traced directly on piece C. This establishes a guide line to follow in carving the outer edge in low relief, about $\frac{1}{8}$ in. deep. Score the petals and leaves of the design with the point of a sharp knife and carve in bas-relief. Piece A is similarly carved, the inside area being

marked off according to the pattern and given a tree-bark texture by taking small gouging cuts with a narrow gouge.

Now, the three pieces are glued together, centering and gluing piece B to piece C first. When in proper position, all three are glued and clamped together. Watch to see that they do not shift, and wipe off any excess glue. With piece A being smaller than piece B, a border of maple extends beyond the edge of piece A. The maple overlay pieces are added last. The piece at the top comes flush with the sides of piece B and the jigsawed cutout below it is merely surface-glued to piece A. The urn overlay is a split turning made by gluing two blocks of wood together with a thin cardboard inserted between them. This permits the turning to be parted in half with a knife.

INEXPENSIVE WINDOWS

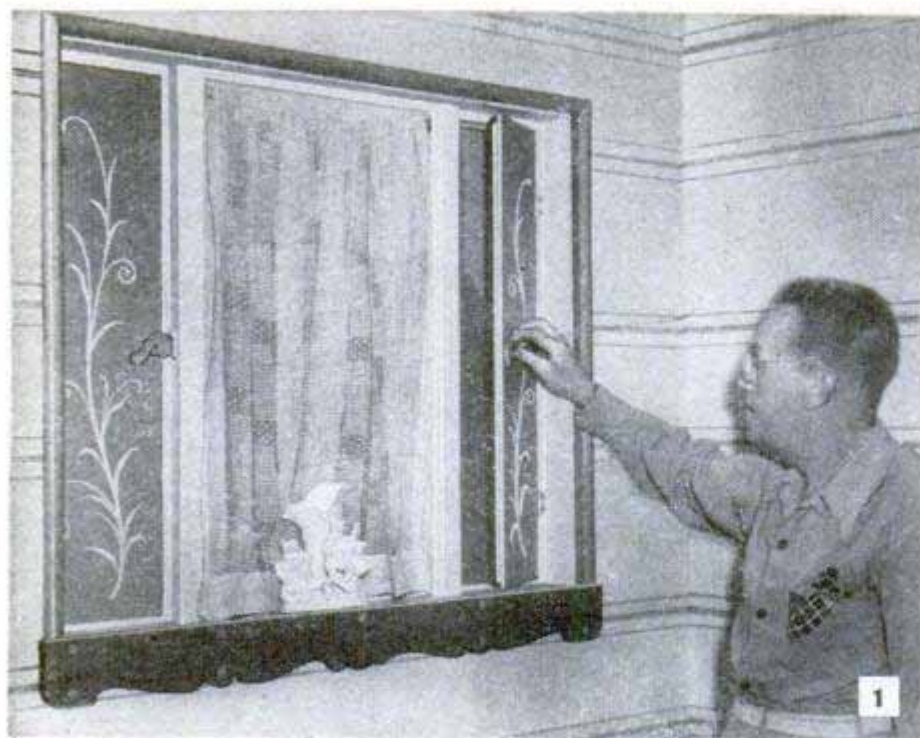

By
Carl R. Berg

Although designed primarily for summer cottages, these windows are suitable for installation in small ranch-type homes, particularly those with board-and-batten construction. From the outside, the louvered inserts appear to be ordinary window shutters.

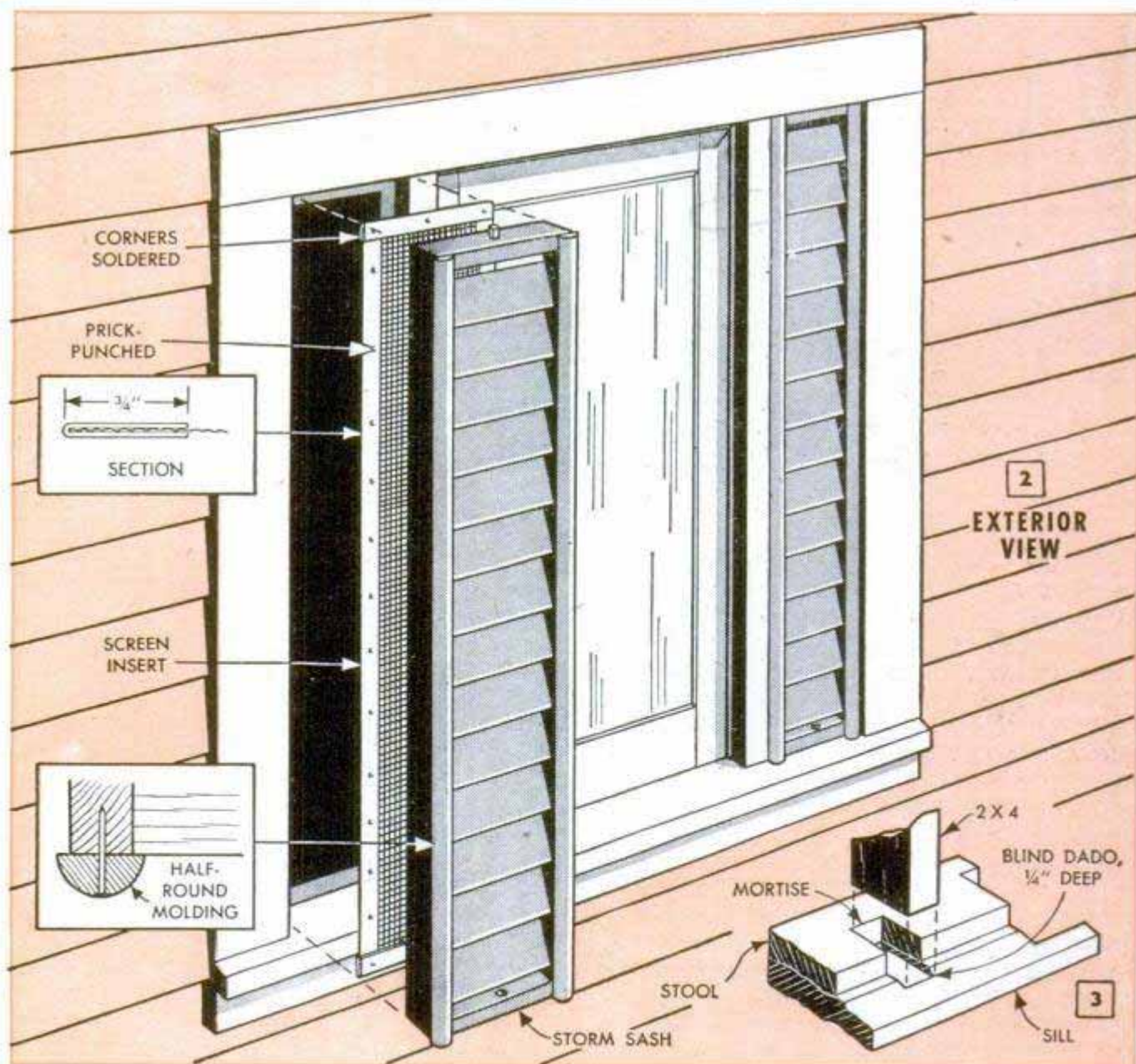

for your LAKE COTTAGE

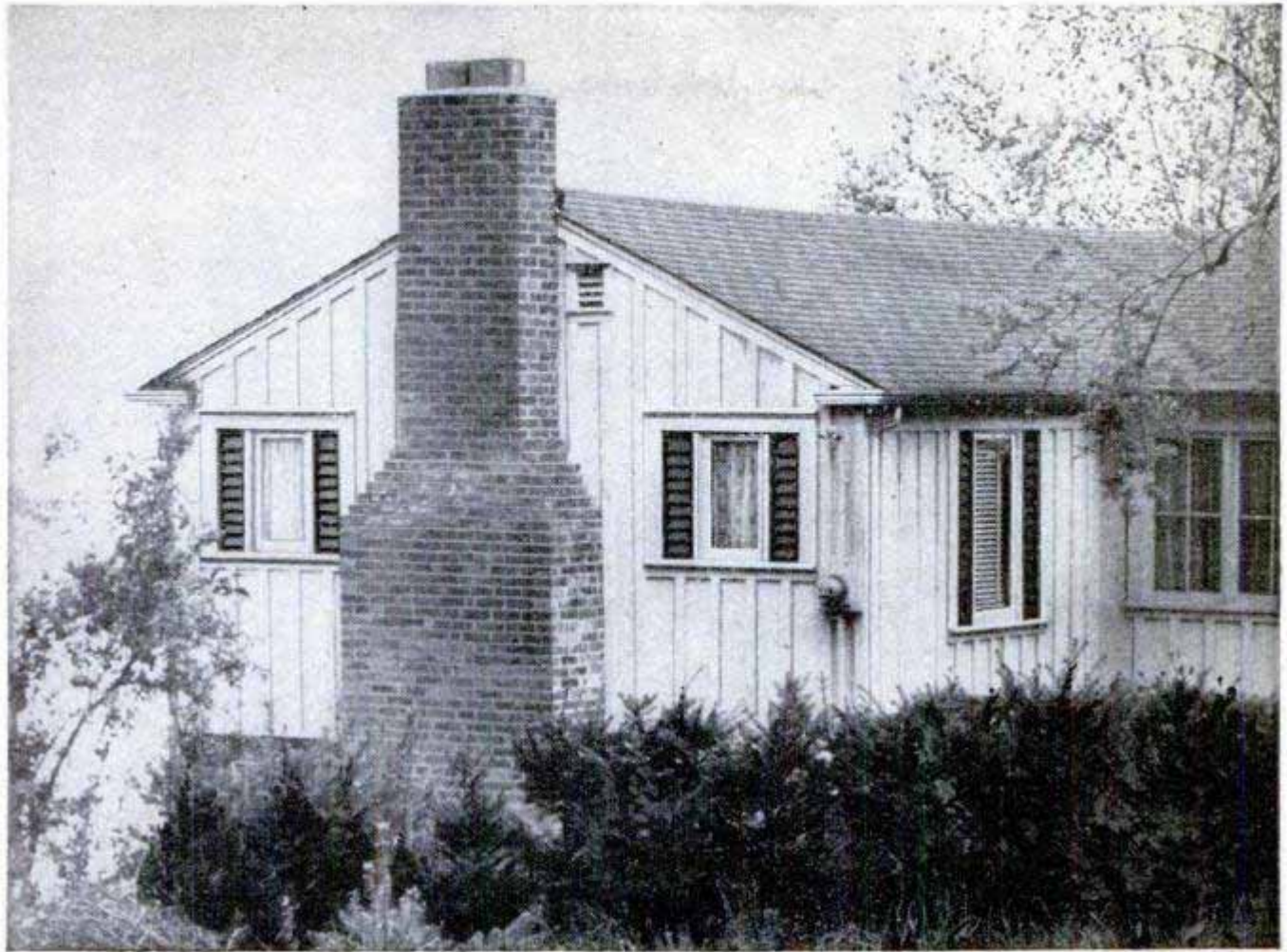

THE REMOVABLE louvers of these novel windows not only add to the architectural lines by giving the effect of shuttered sash, but they also provide ample air circulation in summer and serve the purpose of storm sash in winter. As detailed, the frame is fitted with solid, hinged shutters with a painted decoration on the inside, Figs. 1 and 4, while the openings are closed on the outside by removable louvers made as in Figs. 2, 3 and 7. The frame must be large enough to accommodate both the window sash and the louvers, which fit into openings $6\frac{1}{2}$ in. wide. Vertical members, or muntins, within the frame are dadoed into the sill and the stool is notched around them as in Fig. 3. The upper ends of the center members are simply toenailed to the upper rail of the frame. The single-pane fixed sash, Fig. 6, is fitted between the center frame members and is held in place with quarter-round molding as in section A-A. On the outside, the molding should be coped at the corners and attached with screws so that it is easily removed without damage. On the inside, the joints can be mitered and the molding nailed in place.

Note from sections A-A and B-B in Fig. 6 that the apron overlaps the stool, while the sill is nailed flat on the header, not tilted

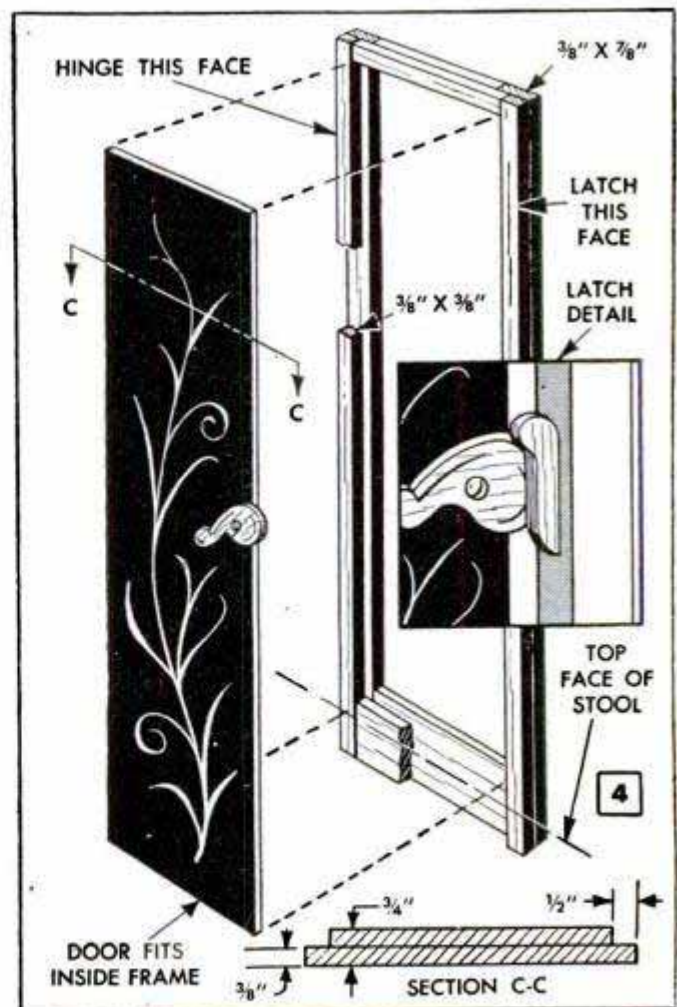

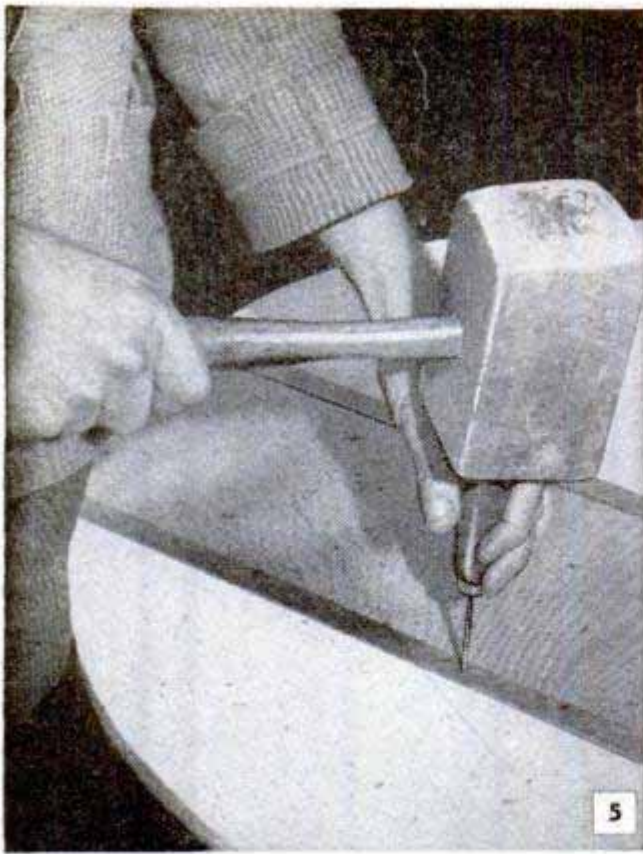

Screen inserts are made by folding strips of metal in half lengthwise and placing over edges of screen wire. Prick-punching the metal holds wire in place

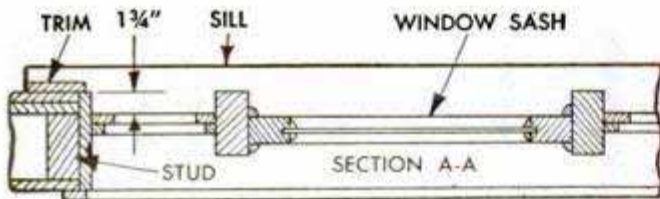

at an angle. There are two ways of installing the frame: Assemble the frame first, and then fit it into the wall opening, or simply build it into the opening piece by piece. If the latter method is used, set the sill and the headpiece first. Then fit the side members and also the center members in place.

The inside panels, Figs. 1 and 4, are hinged at the outer edge and swing into built-up frames as in Fig. 4. The frames are made by nailing and gluing together strips of two different widths, making a frame rabbeted on all four inside edges. Likewise, two plywood panels are fastened together to form a matching rabbet, section C-C, Fig. 4. Tight closure of the panel is made by means of a two-part hardwood latch in scrolled design. Construction of the louvers is detailed in Fig. 7. Grooves to take the louver slats are laid out on the uprights, or stiles, as in the detail. The slats are of 1/4-in. stock and the lower edges are beveled so that they are flush with the outer edges of the stiles when assembled. After assembly of the unit, the edges of the stiles are finished with half-round molding as in Fig. 2. Note that the molding is placed so that it overhangs the edges slightly. For summer use, screens are placed behind the louvers as in Figs. 2 and 5. In winter, the space can be closed by panels made by gluing together several thicknesses of felt paper. The louver unit is installed in the frame by placing the top end so that the short dowel enters the hole drilled in the frame. The bottom end is held securely in place by a single wood screw.

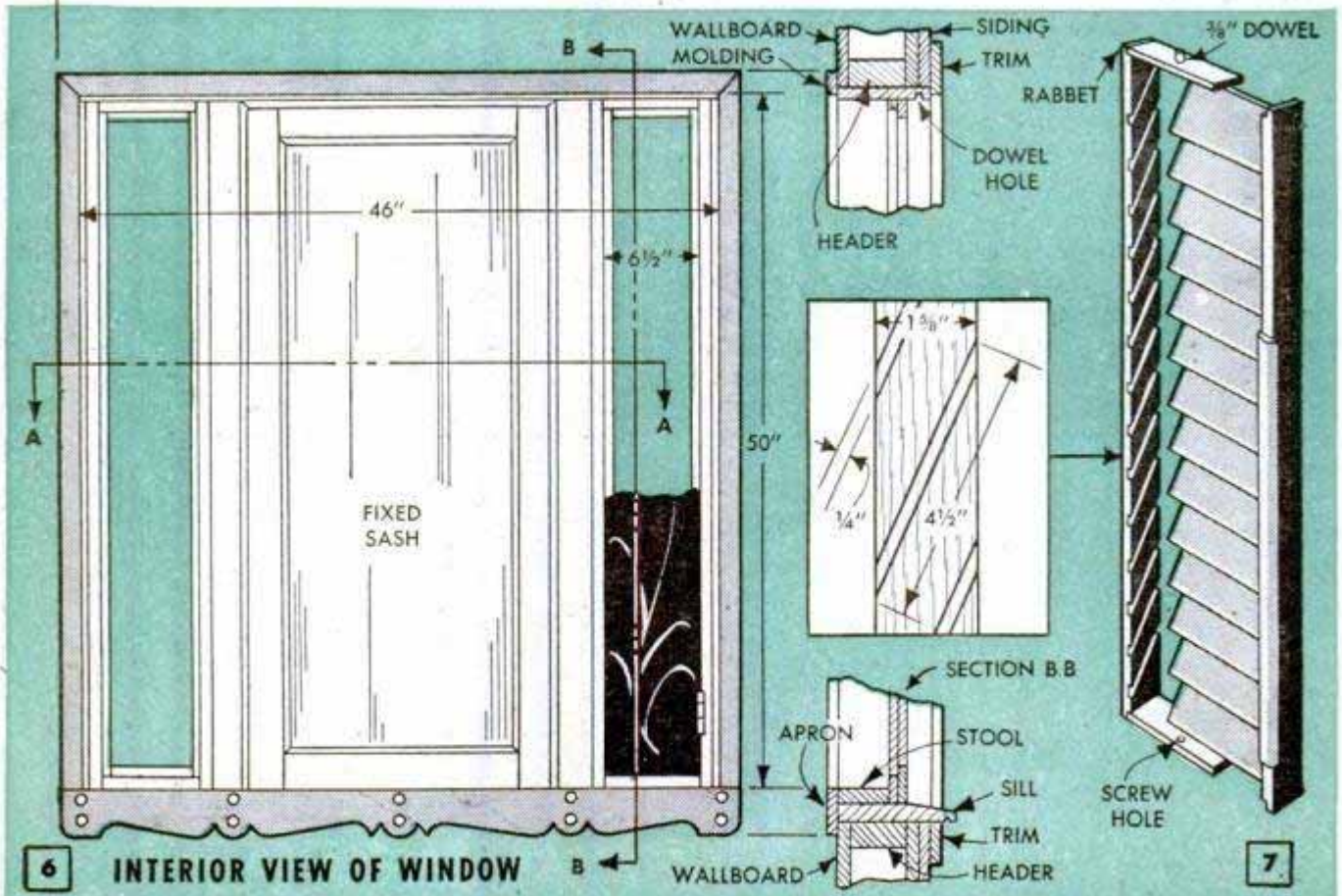

Combination Noted on Tape Label When Storing Unused Padlock



After a combination-type padlock is stored for a considerable length of time, the combination is likely to be forgotten or mislaid. One of the easiest ways of keeping the combination with the lock and prevent its being lost is to print it on a strip

of adhesive tape and stick the tape to the lock. When the lock is in use, the tape can be removed and placed in some inconspicuous spot for future reference.

Rotating Tether Prevents Tangling

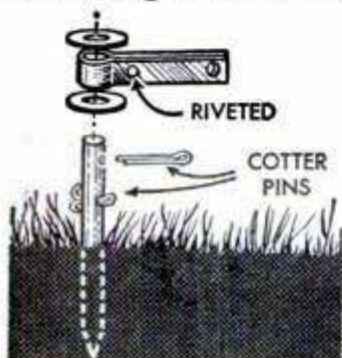

Winding of a tether line around the stake often reduces the area of the yard capable of being covered by a watchdog or the grazing radius of a farm animal. This will be prevented and the animal allowed the

full length of the rope if a rotating tether is used. The stake is simply a length of pipe or pointed rod which is drilled transversely near the upper end for two cotter pins. Washers and a rotating arm are slipped over the stake between the cotter pins as shown. The arm is bent from a piece of flat iron to fit loosely over the pipe. Two holes are drilled through the arm, one to permit riveting the two ends of the flat iron together and the other to allow fastening the rope to the free end of the arm.

Paper Cup Aids Transplanting



Starting small plants, such as tomato and cabbage, in wax-paper drinking cups facilitates transplanting, as the plants can be left right in the cup. Before setting the plant in the ground, the bottom of the cup is removed.



Handy Condiment Compartment Installed in Sink Cabinet

Owing to the construction of many wooden cabinet sinks, it is a simple matter to utilize the waste space in front of the sink basin as a convenient storage compartment for spices, salt and pepper. On this type of cabinet there usually is a panel directly in front of the sink and above the doors which is fastened from the inside and can be removed easily. All that is necessary to install the condiment shelf is to measure carefully the space between the sink basin and the front of the cabinet and then build the compartment to fit. Nail a backing of 1/4-in. plywood or hardboard to two side members of solid stock, nailing the latter to the cabinet posts. Then screw the shelf to the lower edges of the side members. Use the front panel to provide a door, mounting it on standard cabinet hinges and fitting it with a catch. A length of chain should be fastened at each end of the door to support it in the horizontal position. It will be necessary to bevel the edge of the rabbet at the top of the panel so it will not bind when closed.

John Dalen, Morton Grove, Ill.

Sample Checks Matching Paint

When mixing paint to match a color already applied, eliminate guesswork by drying a swatch of the mixed paint and comparing it with the color to be matched. Paint the sample swatch on a tin can or scrap of sheet metal and place it on a radiator or in the oven to speed drying.

100 W. P.



Courtesy Douglas Fir Plywood Association

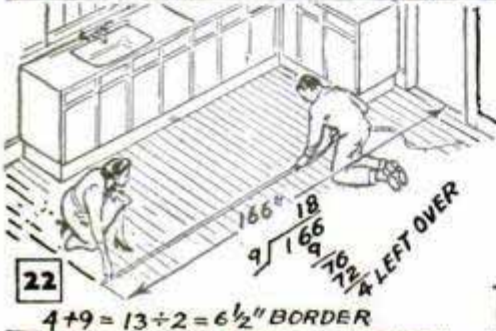

LAY YOUR OWN

PART II

By Sam Brown

LAYING LINOLEUM on floors from wall to wall, and the procedures for laying the border and the border-and-feature-strip designs were covered in Part I last month. But that was only the beginning. Linoleum is supplied as either floor or wall tile to be applied in various sizes and pattern combinations and it's also used for wainscoting, all-over wall coverings and counter tops. Such applications require somewhat different procedures.

Floor tiles: Linoleum tiles are easy to install over wood floors and, in some cases, over concrete floors that are dry at all times. The most common tile sizes are 9 in. square and 9 x 18 in. rectangular. The squares can be laid in one color only or in various patterns such as shown in Figs. 23 to 26 inclusive. Tiles are obtainable in a variety of plain and marbled colors in standard linoleum

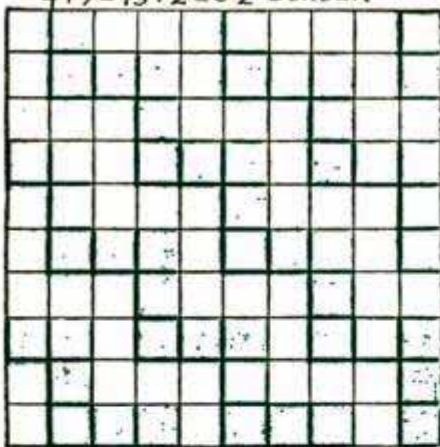

23 ZIGZAG

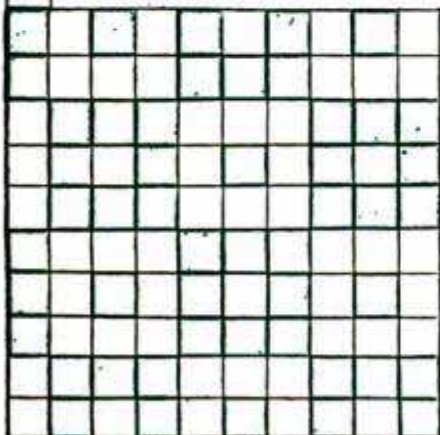

24 ENCLOSED SQUARE

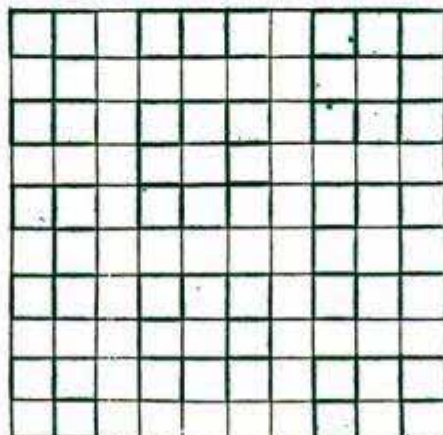

25 SQUARE WITH RUNNER

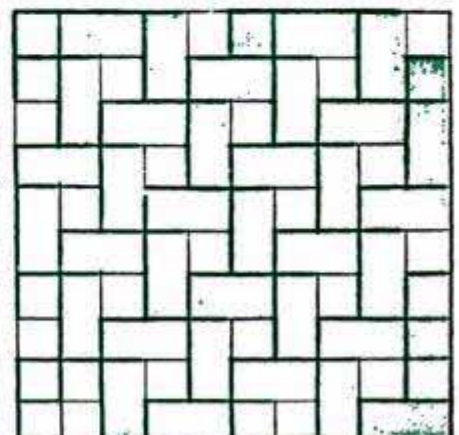

26 PINWHEEL (9" X 18" TILES)

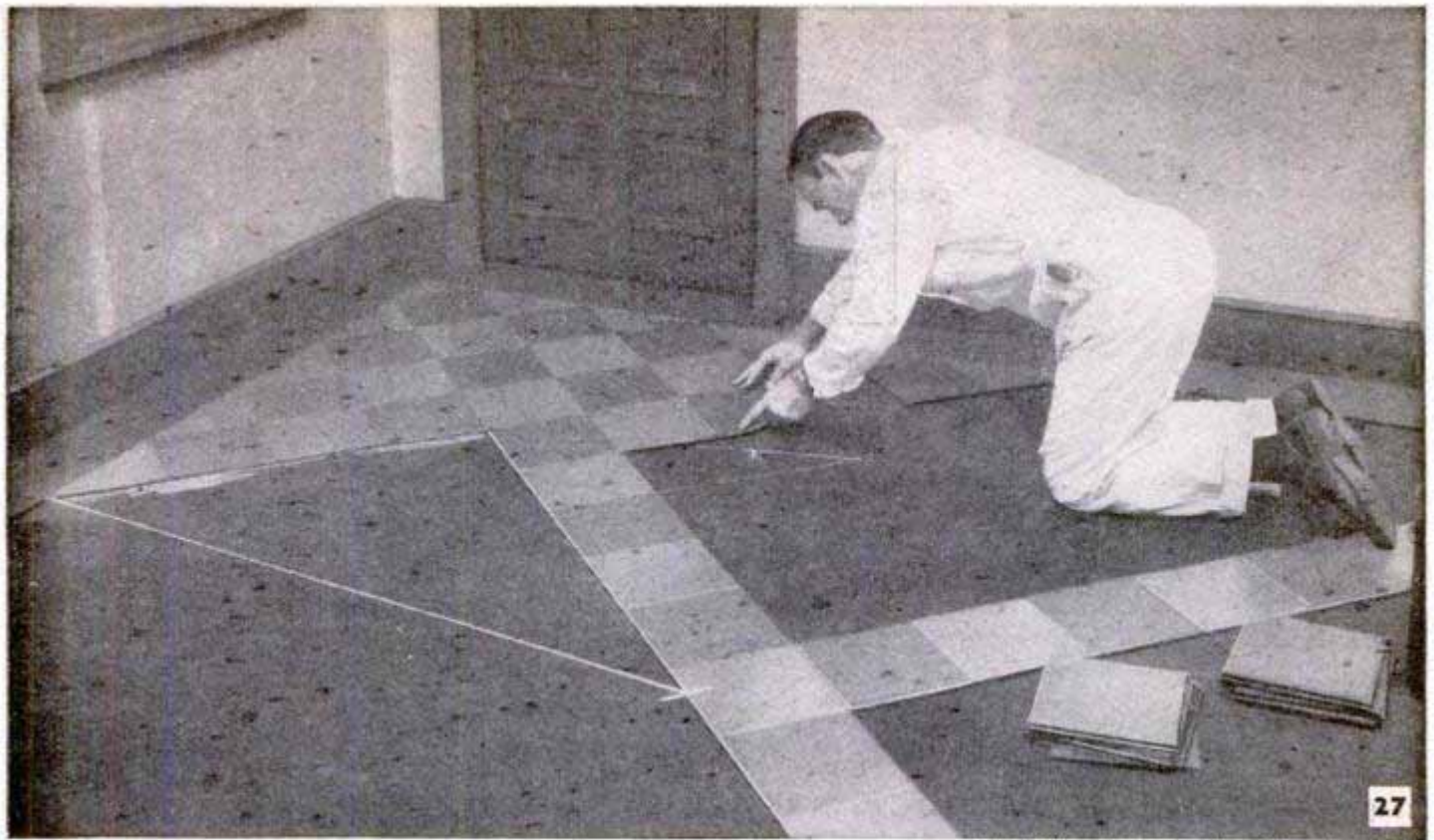

Installation photos courtesy Congoleum-Nairn

LINOLEUM

and also in a special asphalt-base product. The latter floor covering is intended for use over concrete floors below grade, Fig. 21. The ordinary linoleum tile should not be laid on damp basement floors. On wooden floors, the tile is regularly applied over a felt liner which has been previously cemented to the floor. On concrete floors below grade no liner is used. Instead, the tiles are applied directly to the concrete, using a special cement which is proof against dampness. It is important that the floor over which the tiles are to be laid be made smooth and level.

Application of tile: Tiles usually are applied in a field-and-border design and the border width for any room is determined by using the simple calculation given in Fig. 22. After determining the border width required, the first border piece is laid out and cut, but is not cemented down. Then the second piece is left overwidth and is fitted to the second wall. The width of this piece is then marked at the point A, Fig. 28, and it is then squared by using the 3-4-5-ft. method, A, B, C, Fig. 28, or any other means which will assure a square corner. Never depend on the room being square. The second border piece is then cut and both the first and second pieces are cemented down. Now, start putting the tiles in place. Apply the cement with a toothed trowel over an area about equal to that covered by 8 to 10 tiles. Position each tile individually and press firmly in place. If

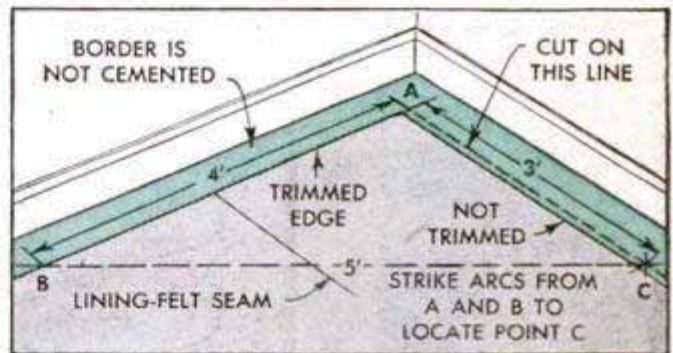

28 SQUARING THE BORDER IS FIRST OPERATION



29 DIAGONAL CHECKERBOARD STARTS WITH QUARTER TILE

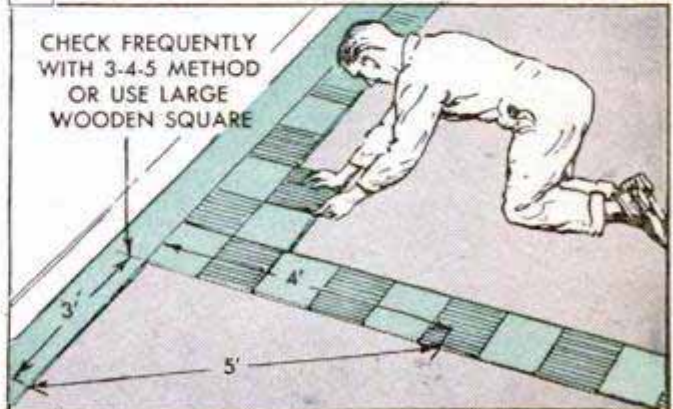

30 BREAK LARGE FIELDS INTO SMALLER AREAS



Standard wall linoleum comes 4 ft. 6 in. wide and is cemented directly to the wall, keeping it running level with a guide line marked on the wall. Detail shows how corner molding fits



Top of linoleum is finished with cap mold

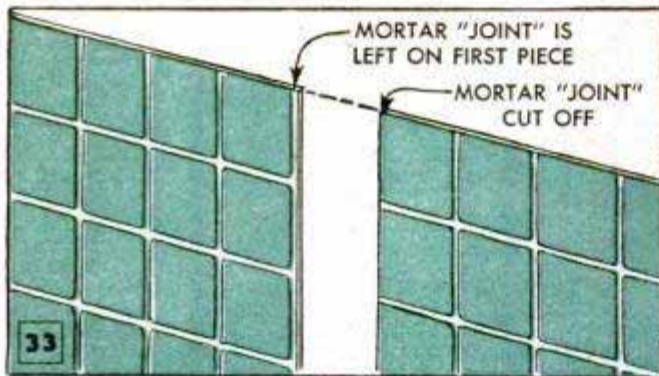

the field (room) is large, take a little extra time to square up smaller areas and then fill in these areas by working from outside to center as in Figs. 29 and 30. Wipe off all surplus cement with a damp cloth, and roll the tiles lightly as they are laid, using an ordinary rolling pin. Check carefully as each row of tiles is laid so that straight lines are maintained in both directions, Fig. 27. This precaution will assure that you finish with a straight line of tiles at the opposite walls. When the field is completed, scribe and fit the remaining border pieces. If you use a diagonal checkerboard pattern, the start in the corner is made with a quarter tile, Fig. 29. Of course, the edges will be finished with half tiles. Asphalt tiles will break cleanly along a scored line, but linoleum tiles must be cut through with a sharp knife. It will save time to make a simple wooden frame to serve as a template, or cutting jig, for this special purpose.

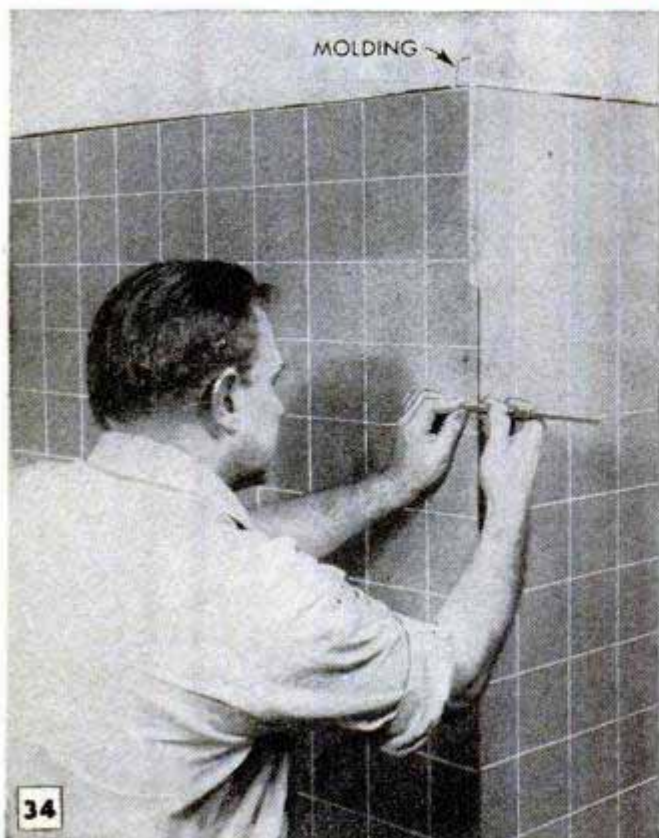

Wall installations: The standard material for wall application is linoleum sheets ruled into 4½-in. squares. Usually the sheets are 4½ ft., or 54 in. wide. If the baseboard is level, the job is simple. Always check the room and the baseboards with the level first. If the baseboard is not level all around then it will be necessary to scribe a leveled line around the room a little less than 4½ ft., or the width of the linoleum sheet, above the top of the baseboard. The top edge of the linoleum is fitted to the line, Fig. 32, and the bottom edge is

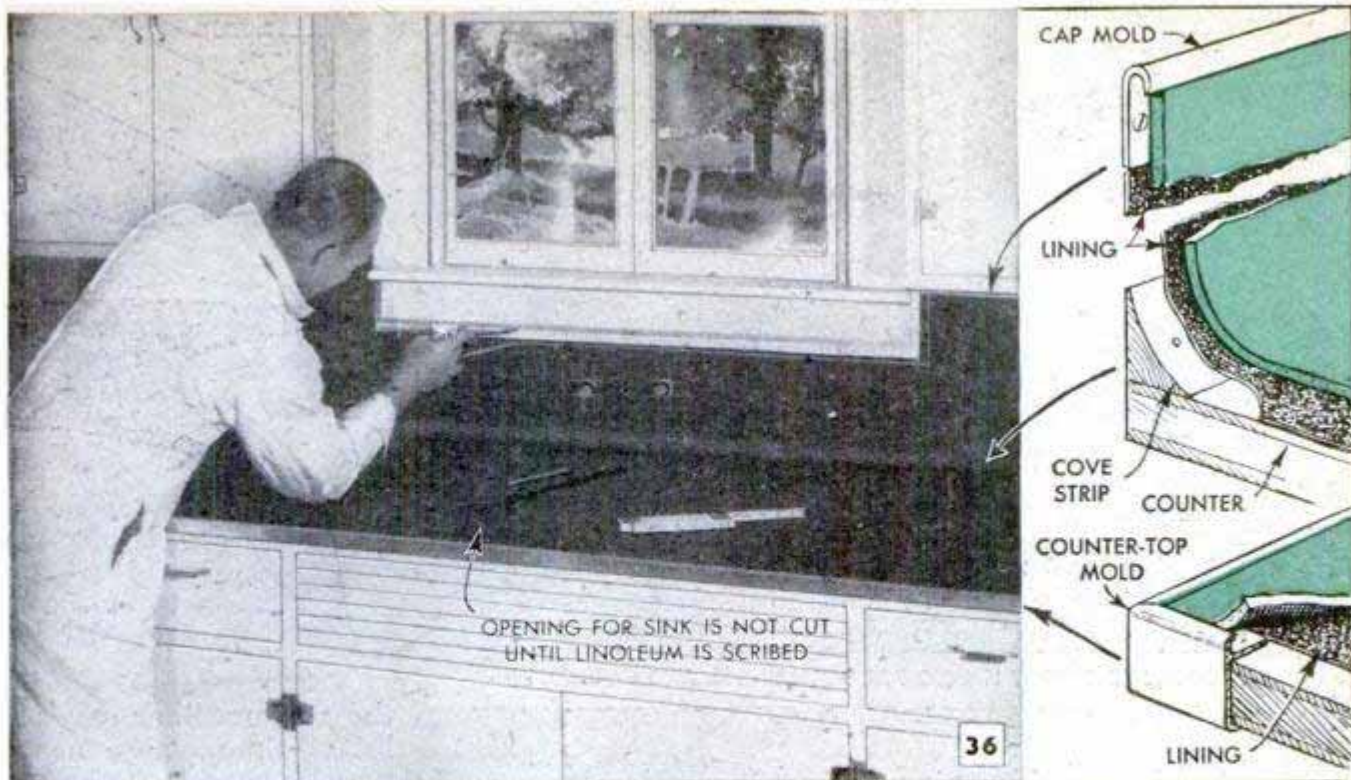

Above, counter installation is made over a duplex felt lining. After the lining is fitted, it is used as a pattern for marking and cutting linoleum as at right

scribed to fit the baseboard. Joints should be butted, Fig. 33, and if there is an outside corner, Fig. 31, it is fitted with a metal or plastic molding after one of the walls has been finished. The adjacent wall is then fitted and the edge is under-scribed to fit the molding, Fig. 34. Inside corners can be butted, although special metal moldings available for this purpose make a neater job. After the linoleum has been applied to all the walls, the job generally is finished with a metal cap strip as in Fig. 35. Wooden strips and matching linoleum strips sometimes are used. If the baseboard is fitted with a top molding, this should always be removed before fitting the linoleum. In this case, rough fitting at the bottom edge is satisfactory as the edge will be covered when the molding is replaced. If the original baseboard is badly scratched it may be replaced with a new matching baseboard of rubber or plastic. These baseboards usually are applied with special cement.

Counter tops: Counter-top jobs call for the best-quality linoleum and careful workmanship. It's common practice to lay

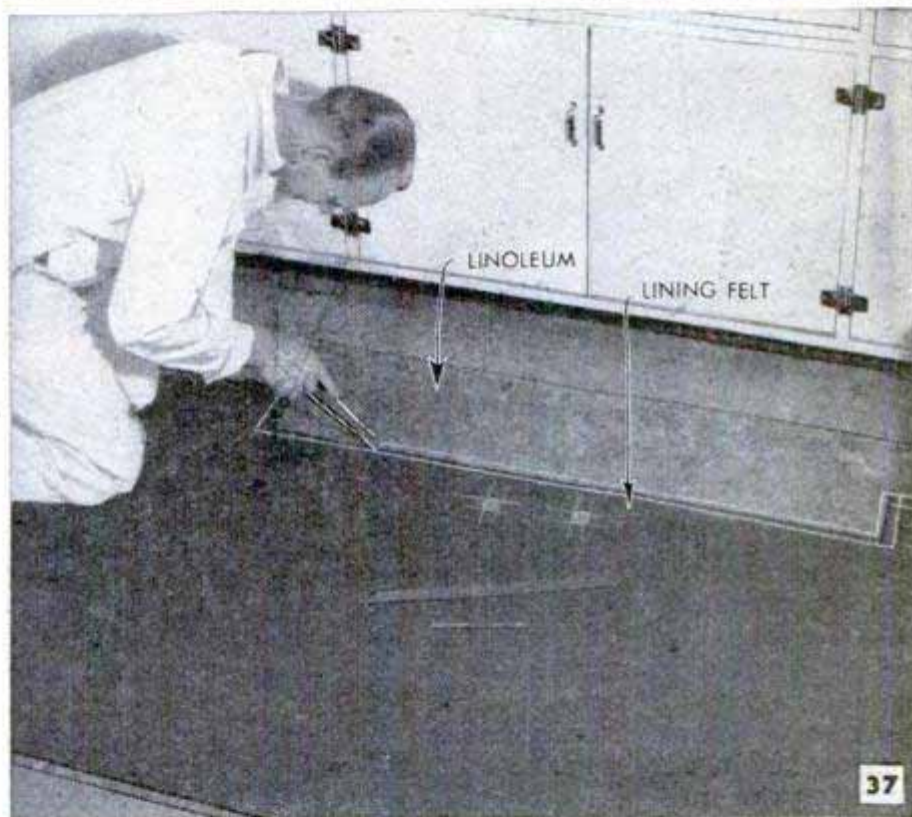

the linoleum top over a felt liner, which provides not only a good cementing base but also a template for cutting the linoleum accurately. Start the job by installing all metal trim, Fig. 36. Then, if the linoleum is to extend up the wall to provide a splash back, apply a flexible plastic cove strip in the corner between the counter top and the wall. Next, fit a length of liner felt $\frac{1}{2}$ in. short at the corners, edges and metal trim. Do not cut out for the sink well; this will be taken care of later. After rough-cutting the felt, fasten it securely with thumbtacks so that it will not move during the scribing operation which is to follow. Be sure that



38

DAMPPROOF CEMENT IS USED FOR BOTH LINING AND LINOLEUM

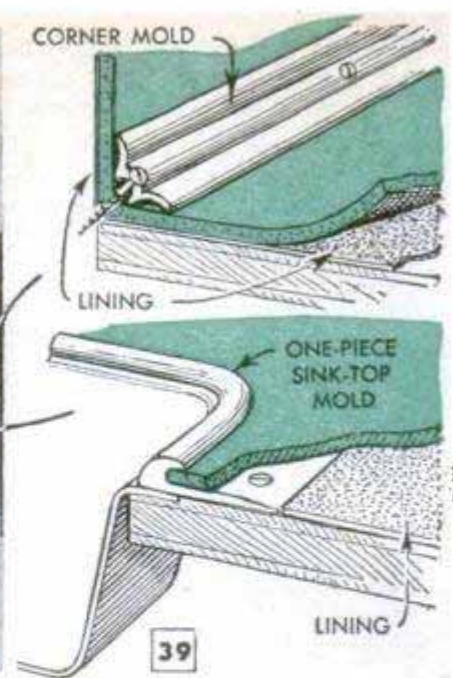

39

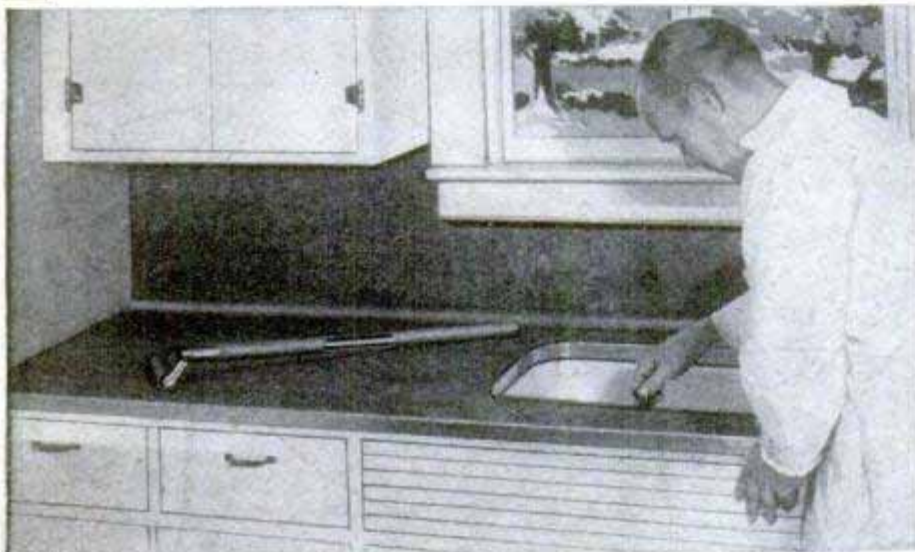

40

THE LINOLEUM IS UNDERSCRIBED TO FIT THE SINK MOLDING

the felt is pushed tightly against the cove strip. Set the scribe (dividers) to approximately a 1-in. opening and scribe up to all edges except the sink well and the front edge, Fig. 36. Now, remove the felt and spread it over the linoleum. Tape it in place to prevent movement. Then, with the same divider setting, retrace the scribed lines to transfer the outline to the linoleum as in Fig. 37. Next, place the felt back on the counter top and fit it carefully to the flanged metal trim. Then cement in place, using a moistureproof cement. Cut the linoleum to the scribed lines, spread moistureproof cement over the felt, Fig. 38, and roll the linoleum in place. Make certain of a good contact over the cove strip in the corner. Go over the entire linoleum surface with a rolling pin to assure perfect contact. Underscribe the overhanging front edge and roll it down last. Cut out the sink well with a sharp knife about 1 in. oversize. Then underscribe to a neat fit in the sink-top molding as in the lower detail, Fig. 39, and also in Fig. 40. For this particular work

the underscriber saves a lot of time where neatness is so essential. The upper detail in Fig. 39 shows an alternate back-corner treatment which is somewhat easier to work out than using the continuous top and splash back over a corner cove. In this, the top and back are applied separately, the back being butted to the top in a right-angle butt joint. A corner mold of plastic or metal finishes the joint. Finish all counter tops with paste wax rubbed to a high polish.

Patching: Very often existing linoleum installations on floors, walls and counter tops can be made to give much longer service by patching the worn areas. Greatest wear comes in narrow traffic lanes through doors, in front of the kitchen stove and sink, and also on the counter top at both sides of the sink. Since most linoleum patterns are stock items, it generally is possible to purchase the amount necessary to make the repair. If the linoleum is figured, be sure to allow material for matching the pattern. Cut out the worn area, following the pattern lines wherever possible. Then match the new piece over the opening. Fasten with thumbtacks or tape and rough-cut to about 1 in. oversize. Then use the underscriber to obtain a perfect cutting line. Spread cement in the open area and press the patch firmly in place, rolling it down until it makes full contact. Clean up all excess cement and, finally, rub lightly with fine steel wool to dull the surface so that it will match the old as closely as possible.

THE END

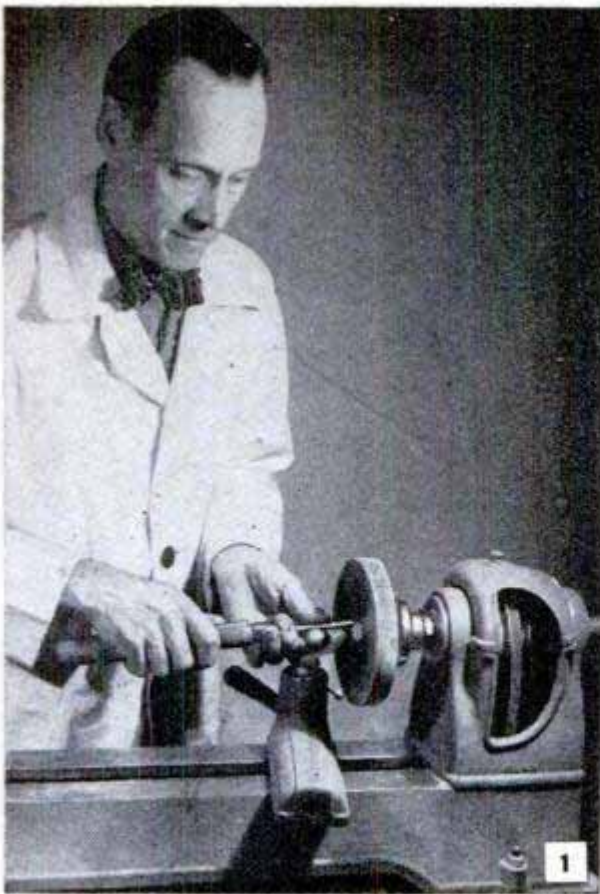

Twin-Ball LETTER HOLDER

HERE'S something decidedly different in a letter holder for your desk. Two wooden balls of equal size resting in a dished base, Figs. 2 and 5, automatically expand to accommodate one or more letters. Resting on a concave surface, the balls provide a constant inward pressure to grip the envelopes firmly. The sectional drawing in Fig. 3 shows the contour to follow in dishing the base. The work is mounted on a lathe faceplate, Fig. 1, by first gluing it to a scrap block. A piece of paper or thin cardboard inserted between the work and the block will permit separating the two easily with a knife blade after the turning is completed. The balls should be turned as near to a perfect sphere as possible, using a cardboard template as a guide. The balls are first rough-turned between centers, Fig. 4. Using a four-jaw chuck to hold the work permits backing away the tail center and turning the outer end. To finish off the chucked end, a wooden chuck is made by turning out a soft block to a radius slightly less than the diameter of the ball and pressing the ball firmly in place.

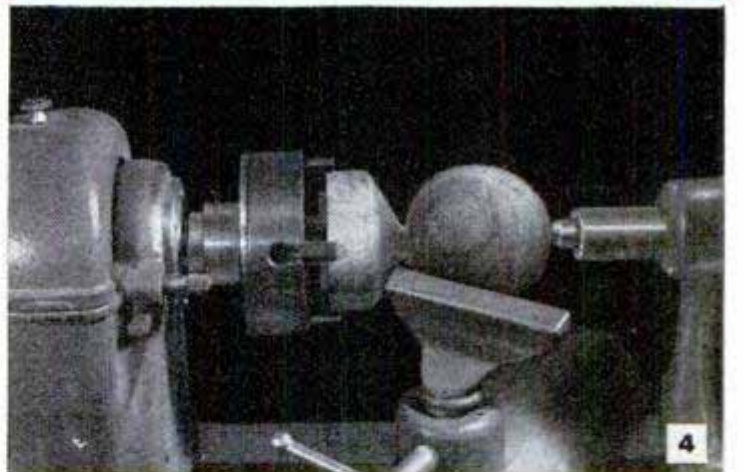
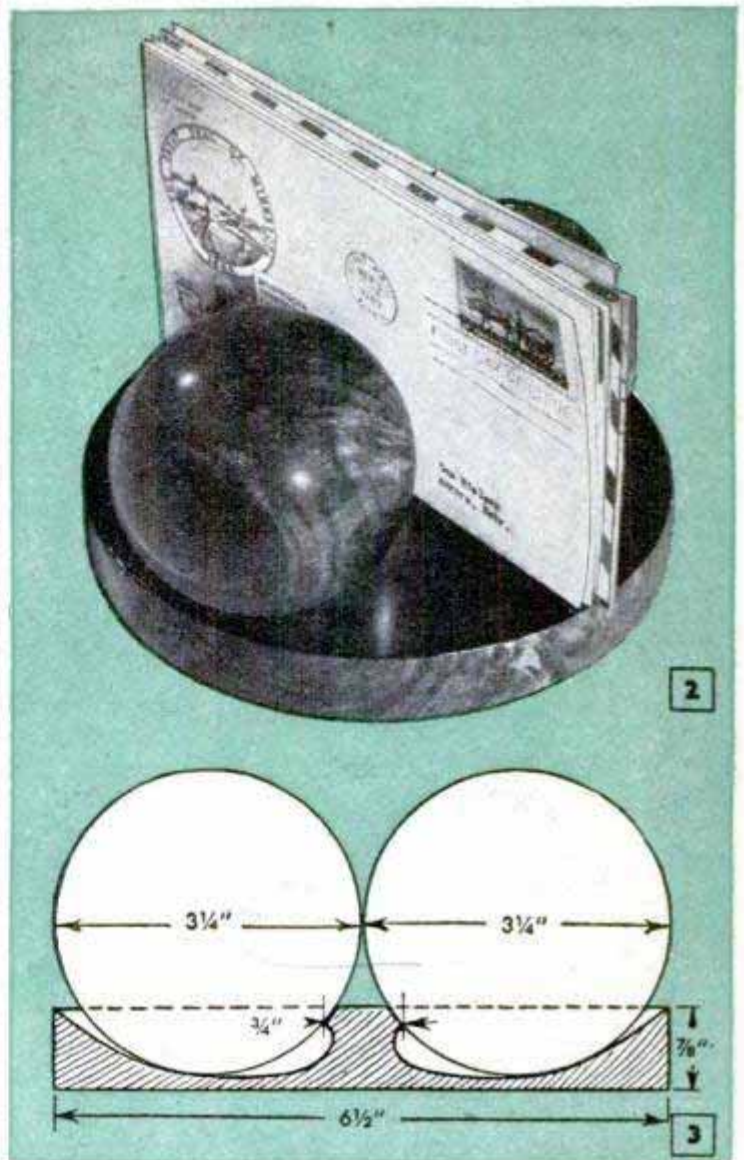

Lightweight Cupboard Tongs of Duralumin Reach High Shelves in Cabinet Kitchen

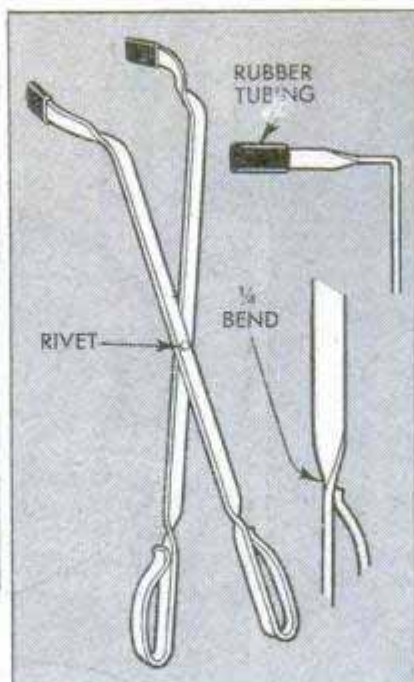

You don't have to climb a ladder or stand on a chair to take canned goods off high cabinet or pantry shelves. Just use a pair of these easy-to-handle tongs which can be made quickly from lightweight duralumin. The metal is bent as shown in the detail and the two parts are riveted at the center, a washer being inserted between them for smooth operation. In this way, a positive gripping action is attained, causing the arms to grasp the can firmly when the handles are held closed. Note that the arms of the tongs are curved slightly and that a piece of rubber tubing is pressed over the ends.

Several Needles Previously Strung on Thread Save Time When Sewing

Sometime when you have a few minutes to spare, why not thread five or six needles on each spool of thread that you use frequently. Then, when you're in a hurry to finish a particular job of sewing, you won't have to bother threading needles. Just use the first one threaded on the spool, slipping

the others down the thread and using them in succession as needed. If your vision is such that it is difficult to thread a needle, it is helpful to have someone else thread a number of them so you will have a supply of threaded needles on hand.

Mrs. Nancy Smith, Camden, N. J.

Lead Screw Draws Special Expansive Bit Through Cross-Grained Wood

When drilling large-diameter holes through floor joists, one plumber found that the lead screw on the ordinary expansive bit lacked sufficient "bite" to draw the bit through, especially when drilling in cross-grained wood. To remedy this trouble, he made a special bit having a

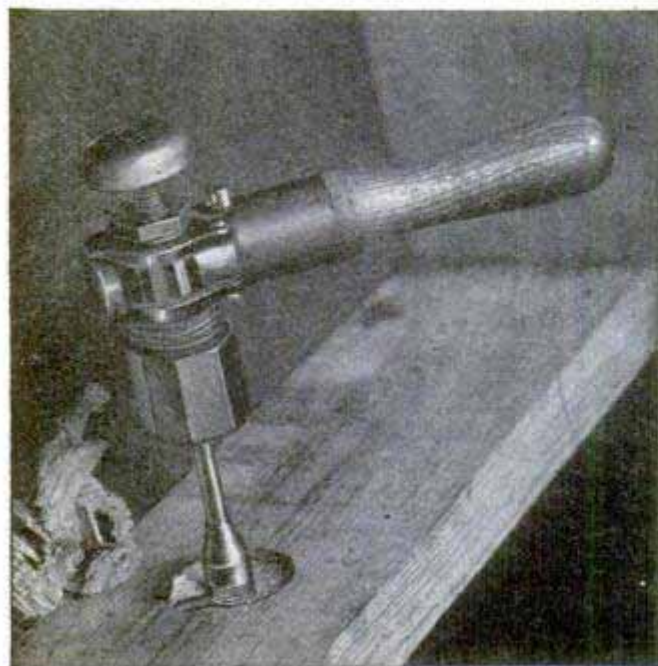

wing-type cutter with the same general clearance and cutting-edge characteristics as the one furnished with the regular bit, but having a lead screw turned on the body of the bit so that it would follow a pilot hole of the same diameter as the body. The body and shank of the bit are turned from tool steel and the body is shouldered and threaded for about half its length, the thread running back from the outer end to the shoulder. Next, the body is drilled transversely to provide an opening for insertion of the wing cutter, which is ground and filed to shape from tool steel. A second hole is drilled into the first one at right angles and tapped for a headless setscrew to hold the wing cutter in place. To use the bit, first drill a pilot hole clear through the wood, the pilot hole being of the same diameter as the body of the bit measured at the bottom of the thread. Then insert the threaded end of the bit in the hole and turn the brace slowly until the threads "take" in the wood. While an auger-bit brace will serve for ordinary work, the short-handled ratchet illustrated is best in places where movement is restricted.

E. K. Walrath, West Springfield, Mass.

CURIO CABINET

Colonial both in design and finish, this little curio cabinet provides an appropriate setting for displaying your treasured bits of bric-a-brac. Typical cabinet joinery is used, a right and left-hand side member being cut first from maple or birch and rabbeted along the rear edges for a 1/4-in. plywood panel. Except for the shelf above the door, all others, including the top and bottom of the cabinet, are cut the same size. The scrolled valance, which frames the open shelves, is built-up from four separate pieces, the side strips being bandsawed from stock 2 in. wide. The side pieces are joined to the top and bottom scrolled pieces with mortise-and-tenon joints and then nailed to the face of the cabinet flush with the sides. Finally, the top is finished off with a cove molding, and the bottom is fitted with a raised-panel door, being built-up as detailed and hung with wrought-type hinges. A bullet friction catch holds the door shut. A bullet friction catch holds the door shut.
 Norbert Engels, South Bend, Ind.



Furniture you can build p 139

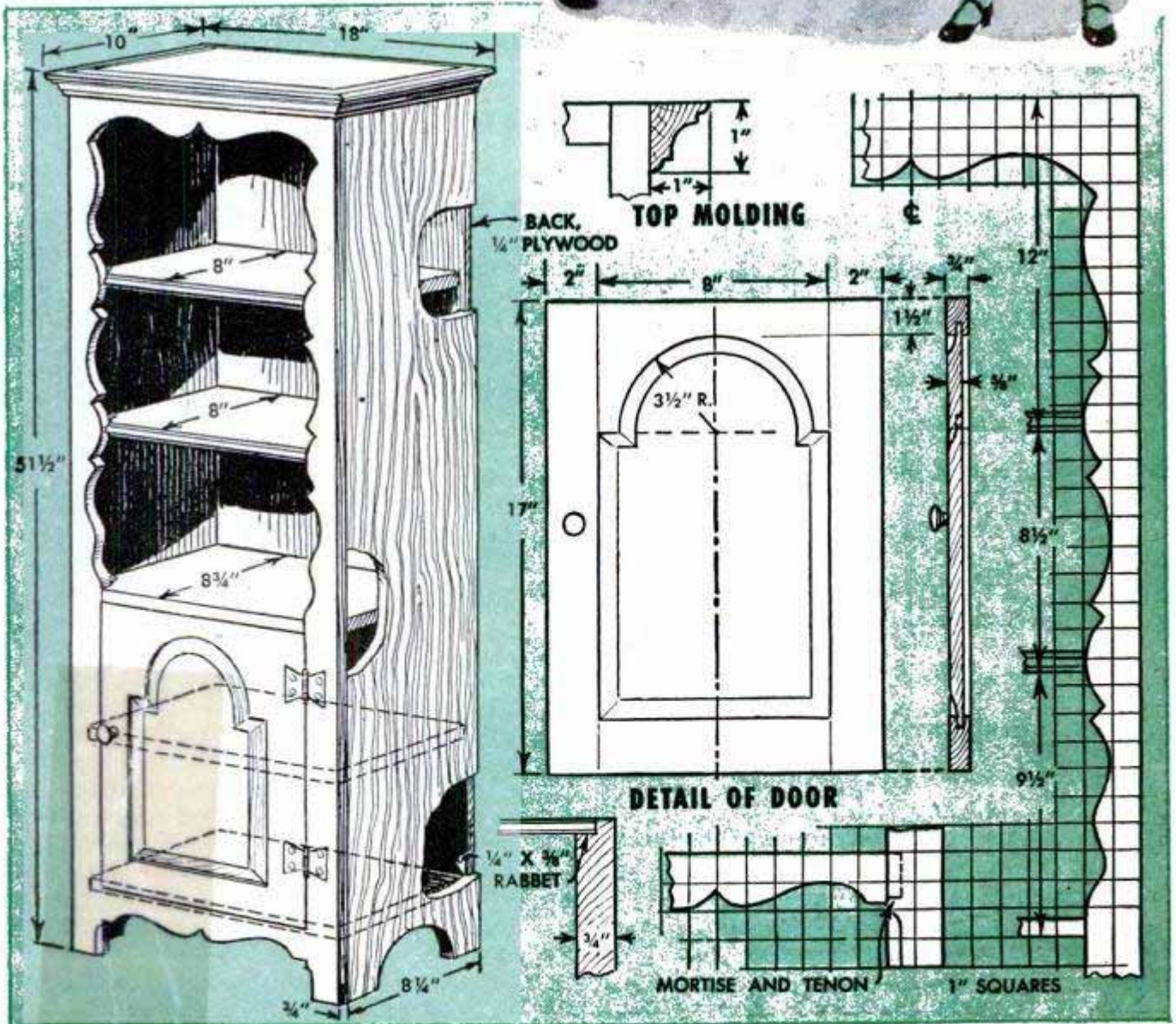

Bench Jig Aids Sanding End Grain

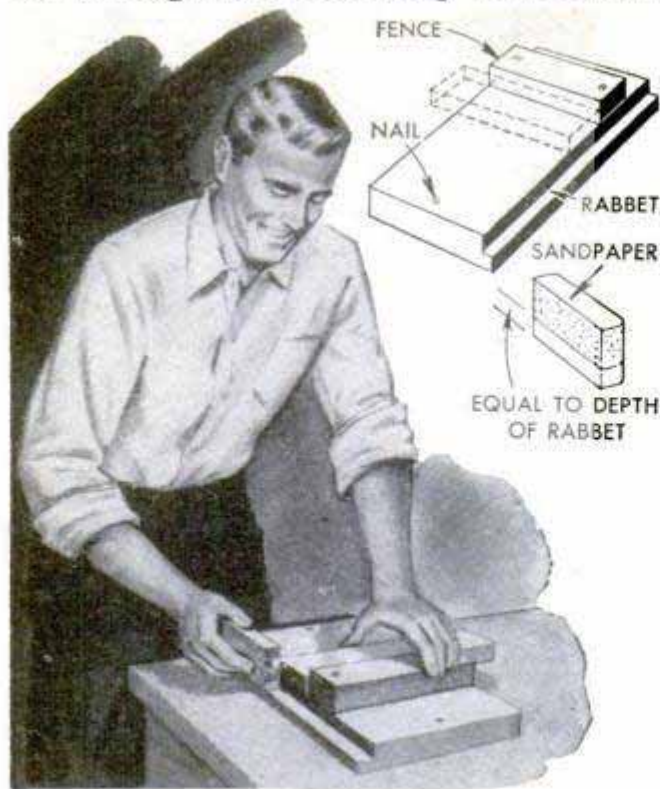

In order to facilitate holding work on the bench top while sanding the end grain, one craftsman made this sanding jig simply by nailing a cleat to a rabbeted board. The cleat provides a fence against which the work is held and a sanding block is moved back and forth along the rabbet. A nail, dropped through a hole in each end of the jig so that it engages a hole drilled in the bench top, holds the unit stationary while the work is being sanded. The sanding block is made by wrapping a strip of sandpaper around a block of hardwood and tacking it at the back. Note, however, that the lower portion of the block is not covered with sandpaper.

Lorenzo Daniel, Ciego de Avila, Cuba.

Saplings Supported With Posts

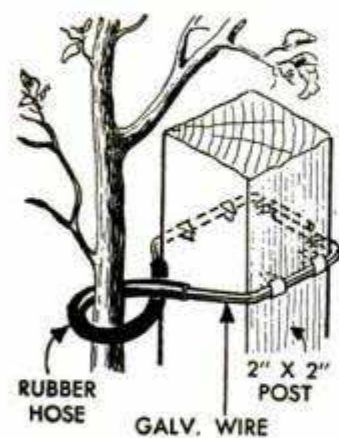

Supporting young saplings with guy wires until they are old enough to stand alone forms a hazardous obstacle and detracts from the appearance of the yard. To eliminate the possibility of children tripping over the wires while playing and also to provide an

inconspicuous support for the trees, use a 2 x 2 post embedded in the ground near the base of each tree. Wrap two lengths of galvanized wire around the trunk and sta-

ple them to the post, as shown, placing one about 3 ft. from the ground and the other near the top of the tree. Sections of rubber hose slipped over the portion of the wire which comes in contact with the trunk will protect the tree. The brackets will not only hold the tree upright but will also keep it away from the post.

D. H. Anderson, Long Beach, Calif.

Cutting Glass Jars and Bottles

To do a fast and neat job of cutting the top from a glass jar or bottle, try using oil and a heated steel rod. Fill the jar with oil to the point at which it is to be cut. Then, holding a length of steel rod with a pair of pliers, heat the rod to a cherry red, and immediately quench it in the oil.



In most cases, the glass will break at the level of the oil.

Paul H. Will, Chicago.

Folding Tablecloth for Storage

After washing a tablecloth that is used only on rare occasions, fold it wrong-side-out for storage. Then, if the creases become soiled, the spots will be on the underside of the cloth when it is placed on the table.—Pat Fey, New York City.

Repairing Worn Shock Arms

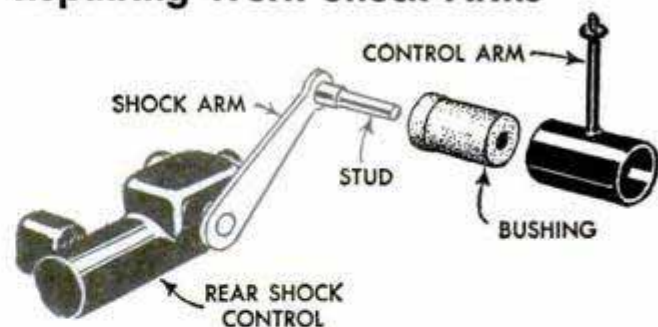

Unable to purchase new control arms for the rear shocks on my 1939 Oldsmobile, I repaired the old ones with rubber bushings of the type found in the rear-spring shackles of late-model Chryslers. I forced the bushing over the stud and pressed the control arm over the bushing. Lubricating the bushing with vegetable-oil soap or graphite aids in slipping the control arm over it.—Coolidge T. Braley, Oswego, N. Y.

Woodenware should not be placed near the fire to dry, as it is likely to crack.

LAMP COSTUMER

For Children

LITTLE folks soon learn to keep play-rooms in order when they have this novel lamp costumer which not only provides four hangers for child-sized garments but serves as an attractive floor lamp as well. Four elephant cutouts stand patiently on the base with heads bracing the lamp column. Note that the column is made from two strips, each grooved lengthwise to take $\frac{1}{8}$ -in. pipe which holds the assembly together and houses the wire, the strips being glued together to form one piece. Join the parts of the base as shown in the pull-apart detail. Round or chamfer all exposed corners and assemble and wire the lamp as indicated. Bandsaw the elephant cutouts and join them to the base and column with dowels and glue. Paint or stain to suit.

I. M. Fenn, Chicago.

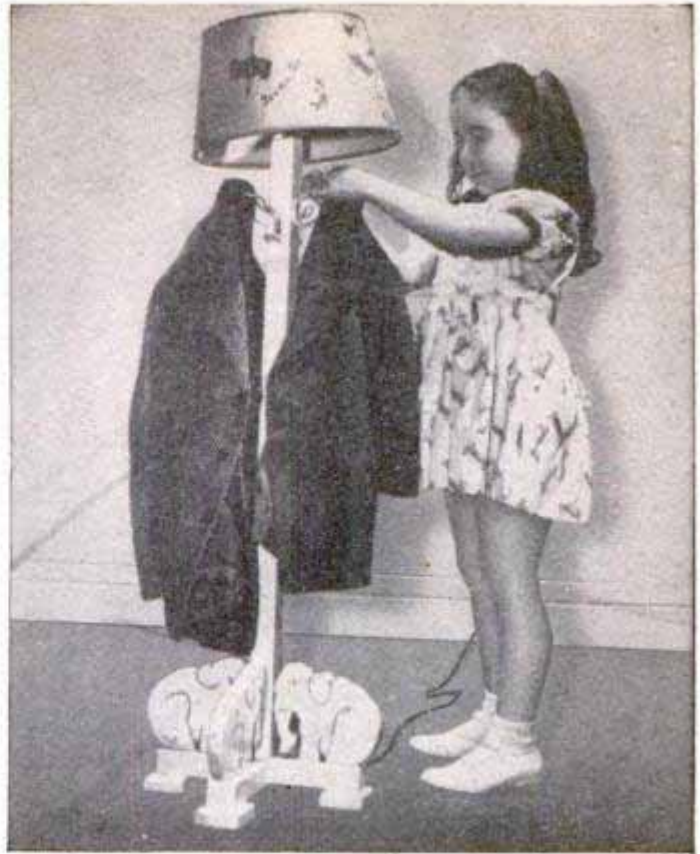

Furniture you can build p 143

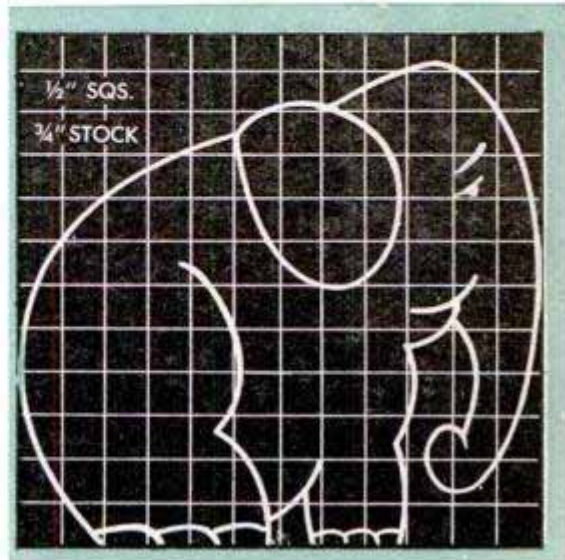
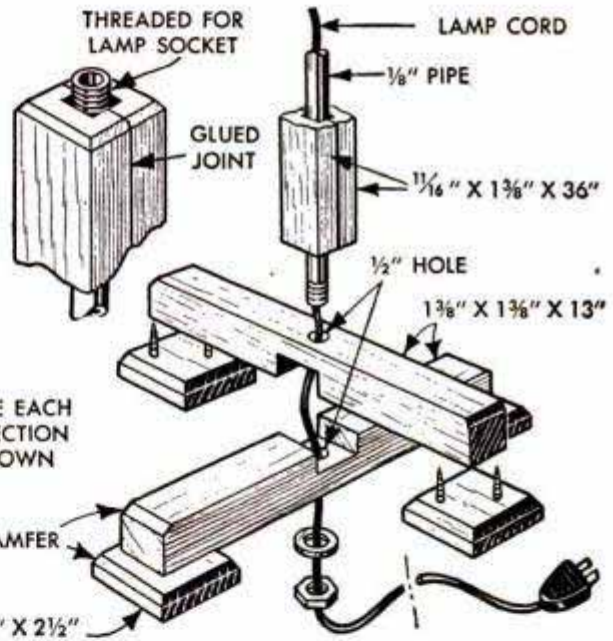
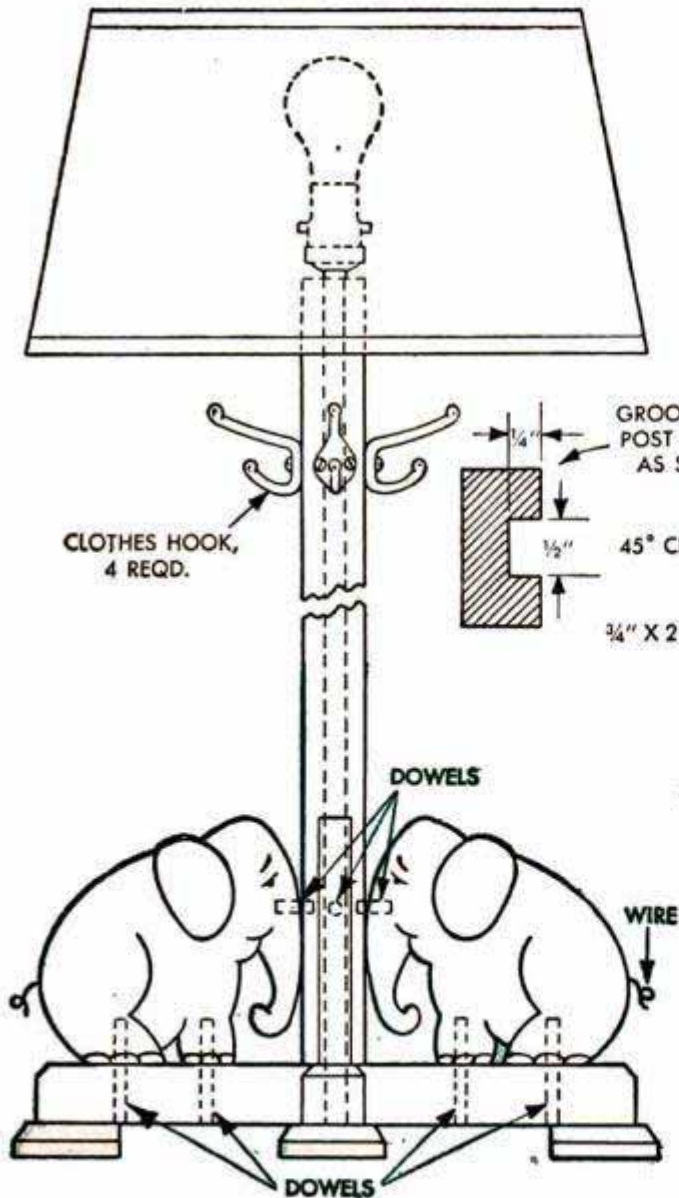



FLOWERPOT SAUCERS that are both attractive and waterproof can be made quickly from disks of aluminum foil. Disk is cut slightly larger than base of the pot and formed between two jar lids, crimping the edge

Solving HOME PROBLEMS

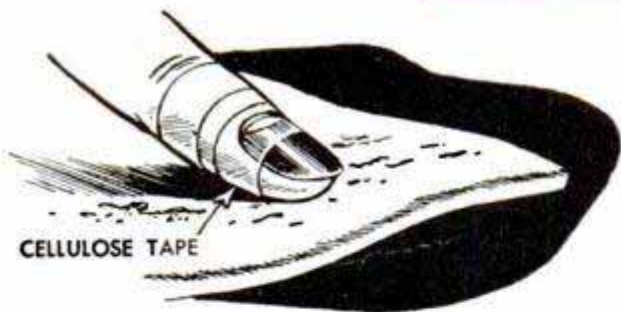

REMOVING LINT FROM CLOTHING is done in a jiffy with cellulose tape. Wrap the tape, sticky side out, around the finger and then stroke the fabric lightly

TO INSURE THOROUGH POPPING of popcorn, pour the kernels in a glass jar, cap tightly and chill in the refrigerator for at least an hour before popping

STRAIGHT SEAMS ARE EASY TO SEW if a strip of adhesive tape is used as a guide. Stick the tape to bed of machine and guide seam along edge of tape

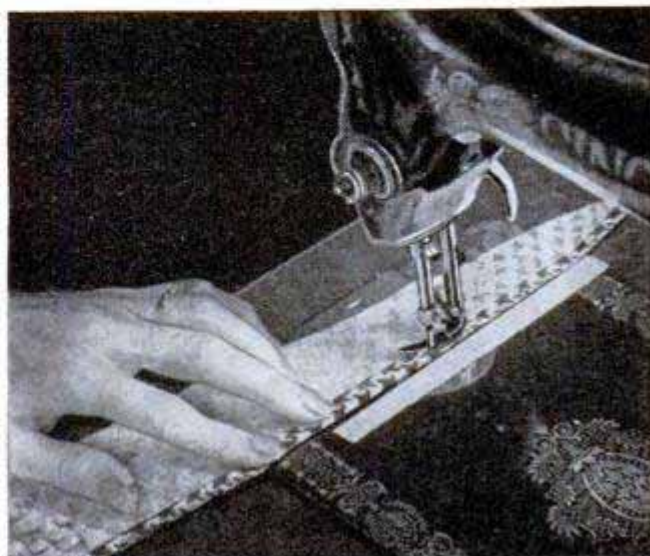

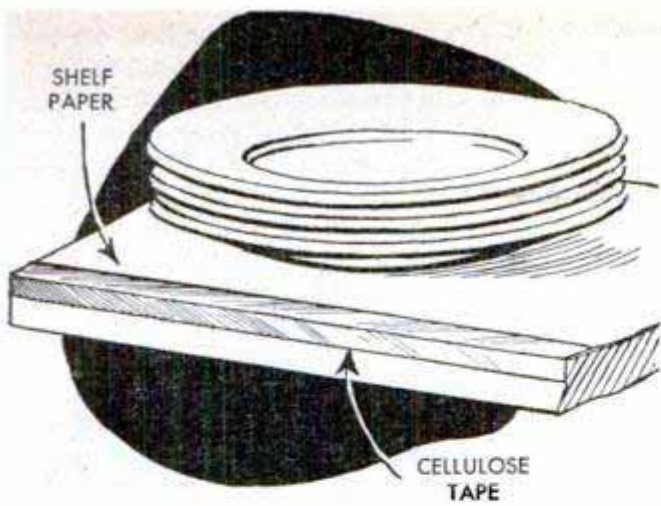

EDGE OF SHELF PAPER REINFORCED with cellulose tape gives longer service without becoming curled or frayed. Tape also minimizes chances of tearing

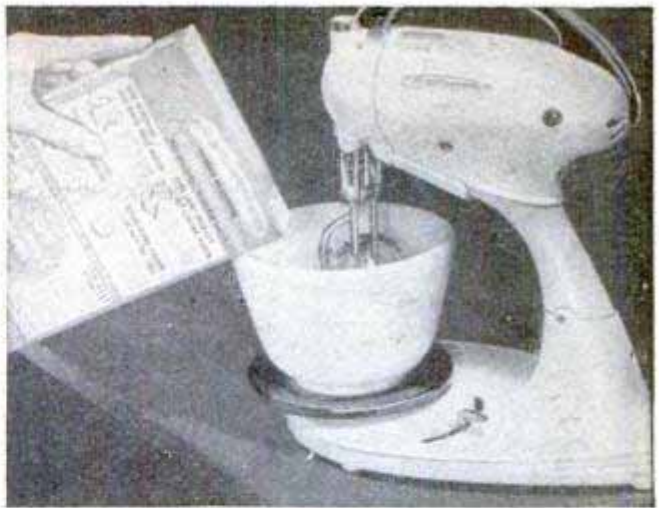

BEATERS CAN BE WASHED right in the bowl of an electric mixer by adding soap-and-water solution to bowl. Run the mixer at low speed

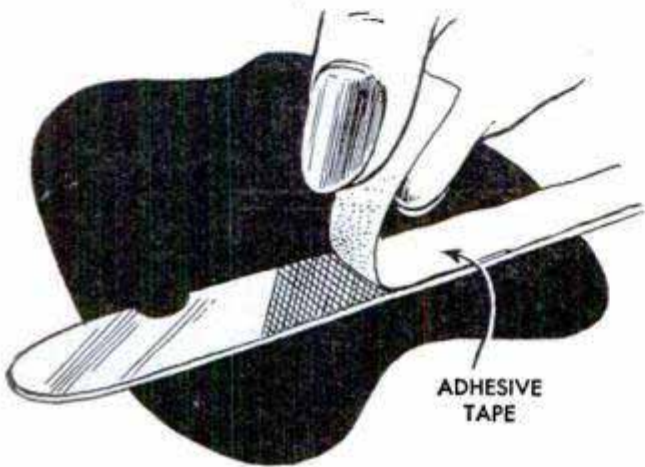

ADHESIVE TAPE CLEANS GRIT from the teeth of a fingernail file. Tape is pressed over the teeth of the file and pulled loose, repeating if necessary



HIDDEN GARBAGE CONTAINERS held with metal brackets on inside of sink doors are out of sight and yet always conveniently at hand

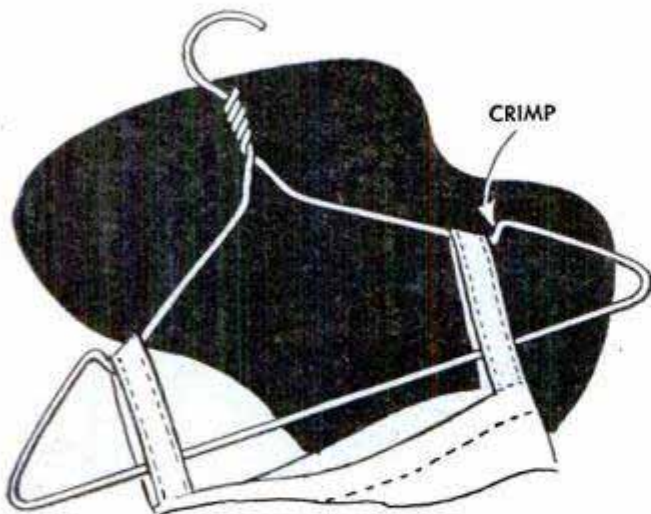

FOR HANGING SLEEVELESS DRESSES, crimp the arms of a wire coat hanger so the straps will not slip off. Wire is crimped easily with a pair of pliers

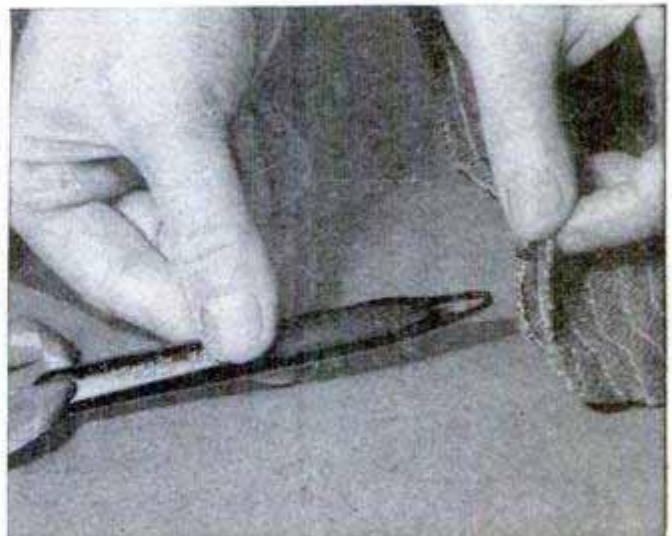

HANDLE OF DISCARDED TOOTHBRUSH forms excellent tool for threading ribbon through drawstring top. Handle is cut off and rounded

Novelties Lettered With Noodles



Teen-agers in many parts of the country are going overboard for these clever initialed noodle pins. A pin can be made in a few minutes by cementing alphabet noodles to a wooden or colored cardboard backing, the wood being stained or the noodles colored to gain a variety of attractive combinations. Sections cut from ice-cream sticks or small tree branches form excellent backings, or they can be made by gluing together pieces of toothpick cut to the proper length. After the front portion of the pin has been completed, it is cemented to a scrap of wood or plastic. The latter is grooved on the underside and fitted with a safety pin for attaching to the garment.

Frank W. Dresser, Philadelphia, Pa.

Thimble Aids Threading Needle

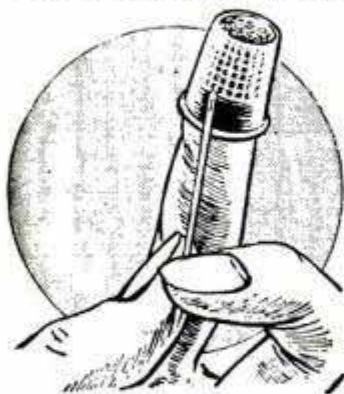

Holding the eye of a needle against a yellow or white thimble makes the opening easier to see for threading. The light-colored background will be sharply visible against the metal surrounding the needle eye.

Salt Removes Fresh Ink Stains

It's a good idea to keep a container of table salt in one of the drawers of your writing desk, as the salt can be used to remove ink stains providing it is applied im-

mediately. As soon as ink is spilled on the rug, sprinkle the spot liberally with salt. After the salt has soaked up a considerable amount of the ink it is swept up and fresh salt applied to the spot. The second application of salt is removed and then foamy rug cleaner is applied to the remaining spot. Even stains from permanent-type inks can be removed if this treatment is applied before the ink has had a chance to dry.

Teaspoon Forms Perfect Mold For Casting Fishing Sinkers

Filling an old aluminum or steel teaspoon with molten lead is a quick way of making snagproof sinkers. First drill a hole near the tip of the spoon and press a nail through the hole from the underside. The nail should be a snug fit in the hole. Pour the lead into the spoon and, after it hardens, pull out the nail with pliers. Then tap the lead from the spoon and you will have an oval-shaped sinker with a hole for the line near one end. If still larger sinkers are desired, use a tablespoon for the mold.

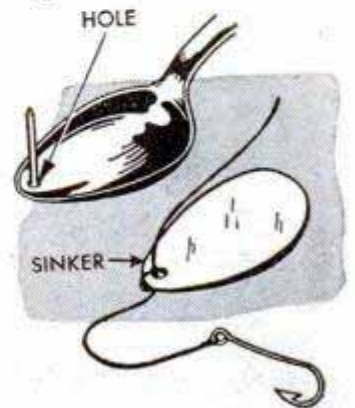

Striped Luggage Identified Quickly

To save time and confusion when retrieving your luggage at an airport or railroad station, mark both ends of each bag with a clearly visible stripe. If the stripes are located the same distance from the bottom on all pieces, the group of luggage is extremely easy to spot, as shown in the photo. Use white or colored cloth-tape or aluminum paint and make the stripes wide enough to be unmistakably identified from a considerable distance.

Robert Hertzberg, Jackson Heights, N. Y.



Motorizing An Old REED ORGAN

WHY PERMIT that heirloom organ to gather dust in the storeroom or basement when you can easily motorize the foot-operated bellows mechanism and enjoy reed-organ music at its best? On most old organs of the foot-operated type very few changes are necessary to adapt the instrument to a motor-driven bellows. You'll need a vacuum-cleaner motor of the type having the fan housing attached directly to the motor housing, as shown in Figs. 1 and 4. It's a good idea to have this unit on hand before you begin work. Then turn out the screws that hold the back of the organ cabinet in place and remove the back entirely so that you can get at the works from both the front and back of the cabinet. Nearly all old organs are fitted with two bellows, a large and small one, mounted separately. Remove these carefully to avoid damaging any other parts. Usually, the reed-and-valve

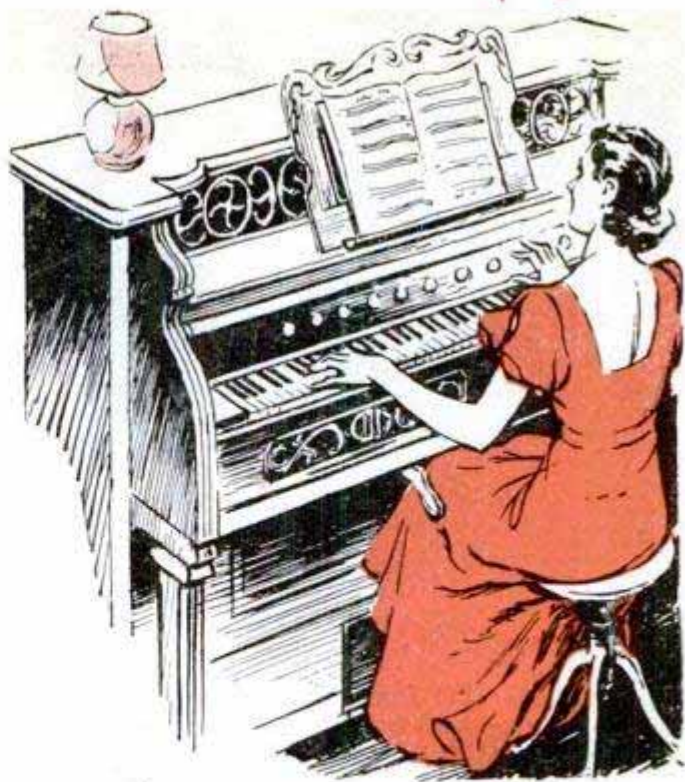

On old organs of the type shown below, air was supplied to the reeds by pumping the treadles. Very few basic changes are necessary to install a motor-driven exhaust blower, thus relieving the organist of the labor of operating the bellows by foot power alone

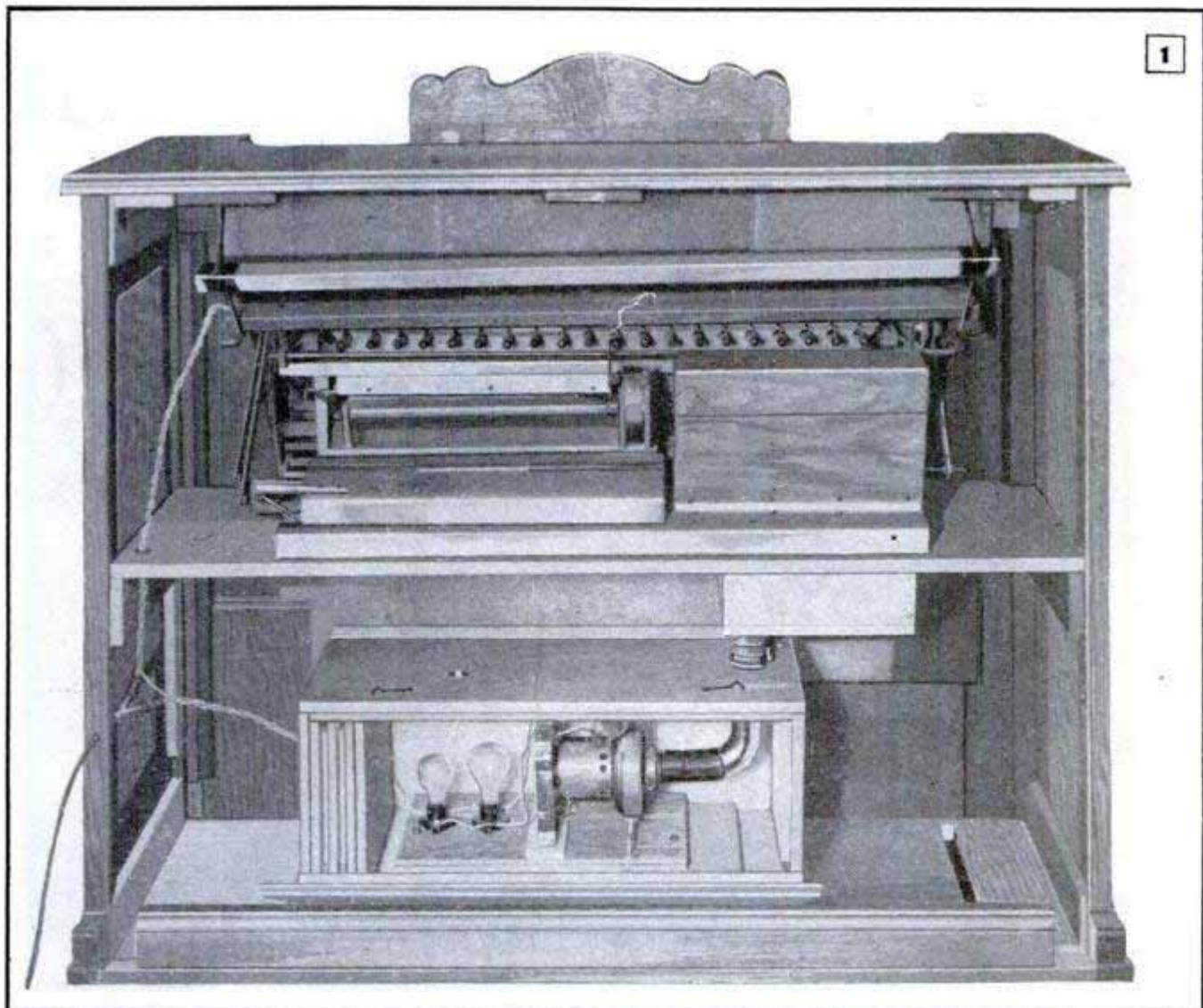



2

The opening in the front of the organ where the pedals were removed is filled in with wood finished to match the rest of the cabinet as closely as possible

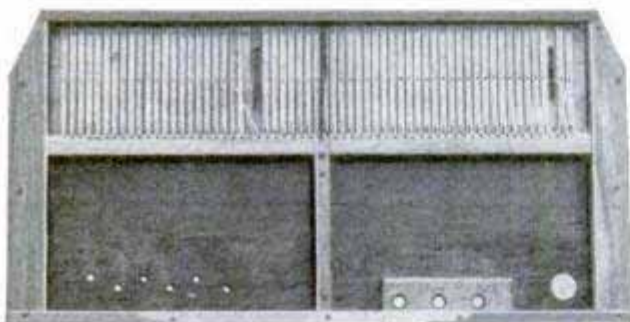

3

Above, the underside of the valve-and-reed shelf must be covered with a plywood panel to replace old bellows assembly. Below, blower unit is shown

assembly and also the air duct, Fig. 3, are supported by the bellows frame. This must be covered on the underside with a 1/4-in.-plywood panel. When removing the bellows it may be necessary to prop or brace the reed assembly and the air duct temporarily in place. The air duct originally provided for passage of air from the reeds and it is essential to retain this unit intact. Be especially careful not to damage it during removal.

In the conversion to motorized operation, both the air duct and the reed assembly are supported on a plywood shelf installed in the cabinet as in Fig. 1. The shelf is supported on cleats screwed to the ends of the cabinet. An opening is cut through the shelf to permit air to pass from the air duct to the air box, or wind box, from which it is withdrawn by the vacuum-cleaner unit and exhausted through a labyrinth as in Fig. 4. A new air box must be made as in the upper detail in Fig. 4. It must be of airtight construction and the opening should be dimensioned according to the requirements of the particular organ you have. Bore a

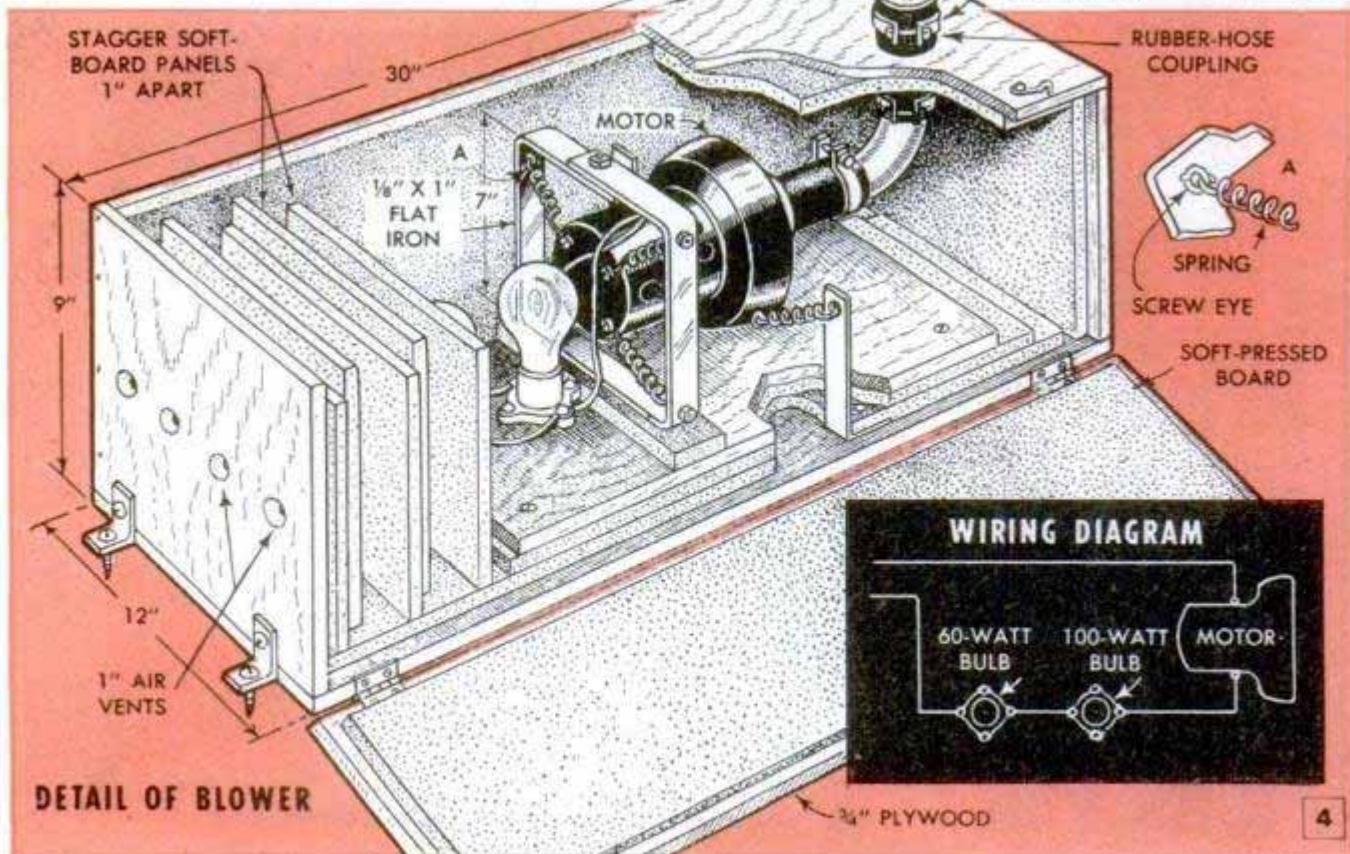
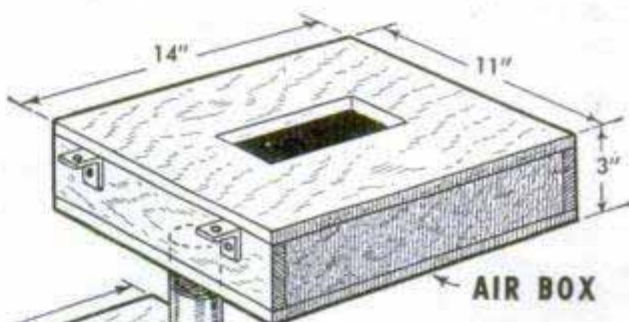

DETAIL OF BLOWER

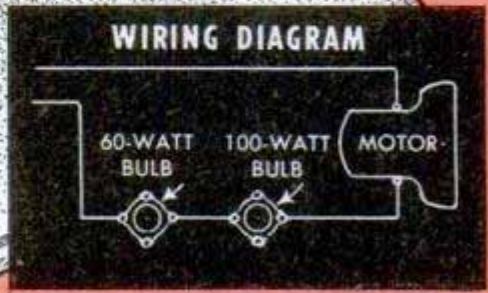

4

hole in the bottom of the air box near one end and force-fit a short length of 2-in. thin-wall brass tubing in the hole. Then glue and screw the box to the bottom of the shelf as in Fig. 1. Just how the air duct and reed assembly are attached to the shelf will depend on the construction of these units. If possible, attach the parts to the shelf with screws and glue. In any case, the joint must be made airtight; if no other method can be used, apply adhesive tape to close open joints.

Fig. 4 details the construction of the blower unit. First, build a plywood box of approximately the dimensions given (these may have to be altered somewhat to suit the space available) and line it, top, bottom, ends and sides, with softboard as shown. The motor unit is spring-mounted in flat-iron brackets attached to the auxiliary plywood bottom of the box. In attaching the coil springs to the motor, it may be necessary to drill and tap the end housing for small screws. Detail A shows how the springs are attached in the four corners of the rectangular bracket. The fan housing is supported on two coil springs attached by means of short screws inserted through the spring eyes and turned into holes drilled and tapped in the bottom of the housing. Build the labyrinth in one end of the box as shown and drill four 1-in. air vents in the end of the box. Then wire the motor as in the wiring diagram. The 60 and 100-watt lamp bulbs are wired in the circuit to serve as resistors and reduce the speed of the motor. The motor is controlled by a toggle switch mounted on a panel near the keyboard within easy reach of the organist. Locate the blower unit in the bottom of the cabinet and anchor it firmly with screws driven through angle brackets. Connect the air box to the blower with light rubber hose and an elbow as shown in Fig. 4. Then replace the back panel.

The treadle opening in the front of the organ cabinet should be closed with a single panel cut from wood that can be finished to match the cabinet, Fig. 2. As a rule, the organ cabinet will require refinishing and generally one will be well repaid for the extra work as the cabinets of the better-grade instruments were made from fine cabinet woods with elaborately carved and scrolled parts. In refinishing, remove front panels, the music rack, keyboard cover and other parts readily removable and finish these separately. Usually, refinishing is simply a matter of softening the old finish with a suitable varnish remover and then scraping, sanding, staining and varnishing the parts to restore the original grain and color of the wood. Of course, if the wood is open-grained, such as oak or walnut, it may also be necessary to apply a wood filler.

Brush Container of Clear Plastic Permits Even Drying



This handy container of clear plastic stores artist's brushes horizontally so they will dry without paint seepage into the ferrule. The box is ventilated to speed drying and, being transparent, allows the contents to be seen at a glance. The box is made from sheet plastic bent around two endpieces and cemented in place. The plastic lid slides in grooves cut lengthwise in the sides of the container just above the endpieces. The grooves are cut before bending the plastic. Note that ventholes are drilled in one end of the lid and a small block of plastic is cemented near the other end to provide a handle to facilitate opening the lid.

Umbrella Rack for Baseboard

A neat-appearing and convenient umbrella rack is had in a jiffy by nailing a length of board to the baseboard of the front hall or closet. The board is band-sawed as shown and drilled between the scallops to receive the umbrella tips. The bottom edge of the rack can be shaped to fit over the shoe mold or the latter can be cut away so the rack fits flush with the flooring. After installation, the rack is painted to match the baseboard. Be sure that the umbrellas are completely dry before standing them in this rack.

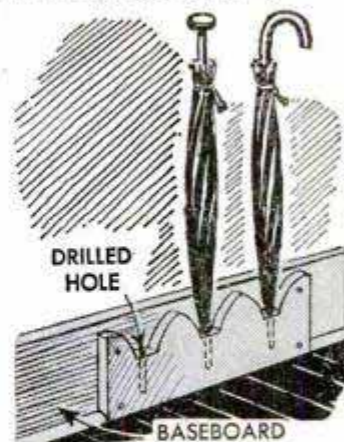

Chinese-Modern "FIRE SCREEN"

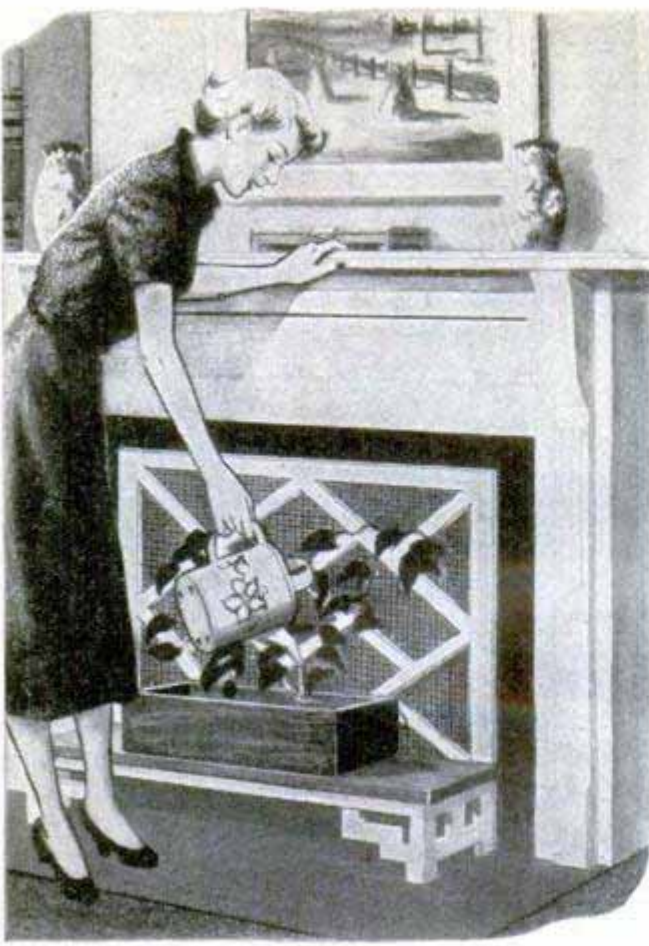

FROM a decorative standpoint, the blackened interior of an unused fireplace is an eyesore, especially during spring and summer months when color is necessary to give a new lift to old surroundings. That's when you need this attractive trellis "fire screen" to camouflage the opening. Chinese in motif both in color and design, the screen, when augmented with a growing or artificial vine, provides a smart summer treatment for an uninviting fireplace. The outer framework of the trellis is mortised at the corners. Then the diamond shape in the center is fastened with long screws and the remaining parts with corrugated fasteners. The back of the trellis is covered with hardware cloth which is painted black to contrast with a Chinese-red framework. The base and shelf of the screen are cut from plywood, and the wooden flower box, mitered and splined at the corners, is fitted with a copper lining. The flower box and shelf are painted black to set off the red.

Furniture You Can Build p. 23

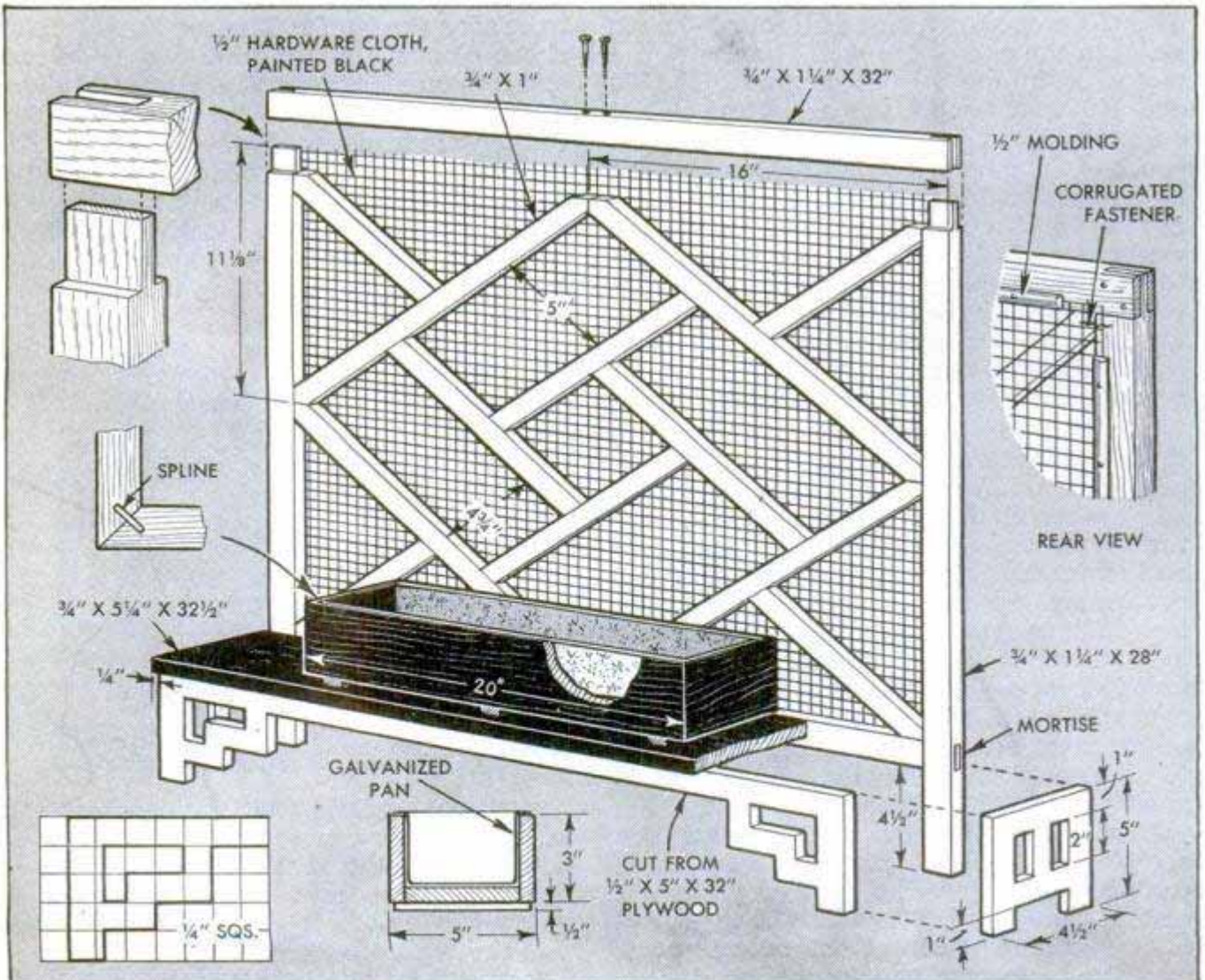

Kept within easy reach on a bedside table, this handy little night light turns on as soon as it is lifted. Two plungers fitted in the base raise the battery away from the contacts when the light is resting on the table. When it is picked up, the plungers drop and lower the battery, allowing the terminals to make contact. No dimensions for the lamp are given, as these are determined by the size of the battery used. Note, however, that there must be no side play for the battery so the terminals will not slip off the brass-screw contacts. Also, the height of the battery case must be sufficient to permit the battery terminals to clear the contacts completely. On this type of battery, one terminal usually will extend across

Novel Night Light With Convenient Handle Is Switched on Automatically When Lifted

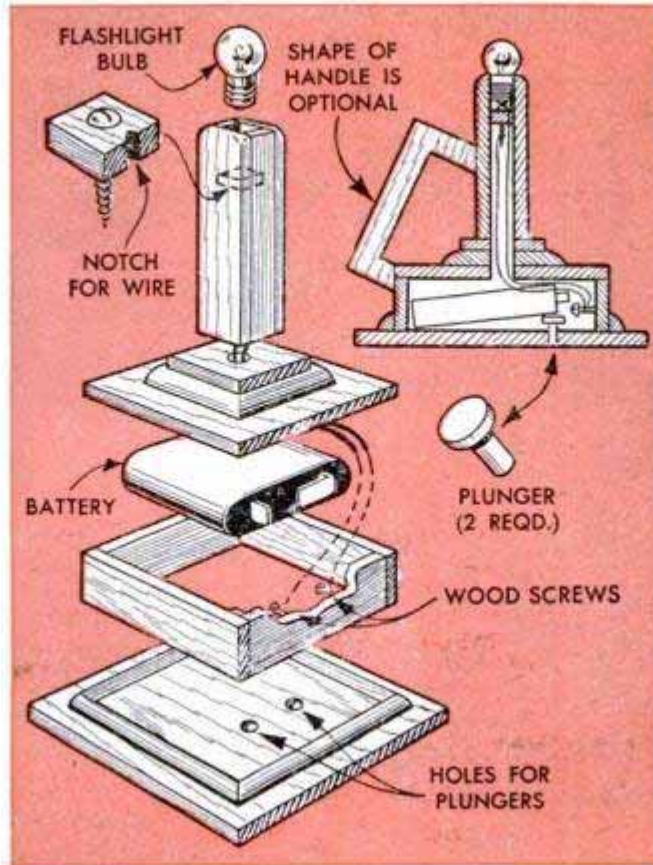

the face to the second terminal, and the long one should be cut off as shown. The contact for the base of the flashlight bulb is a brass wood screw driven through a square piece of wood which is glued inside the lamp upright. The wood is notched for a wire which makes contact with the threaded portion of the bulb. The entire

unit is of simple box-type construction and can be made of plywood or scraps of solid stock, using quarter-round beading to enhance the design. The plungers can be turned from wood or metal or made by gluing a disk cut from a 1/2-in. dowel to a length of 3/16-in. dowel.

Peter Adamidis, Cairo, Egypt.

Retractable Clothesline for Low Basement Stored Against Ceiling Joists

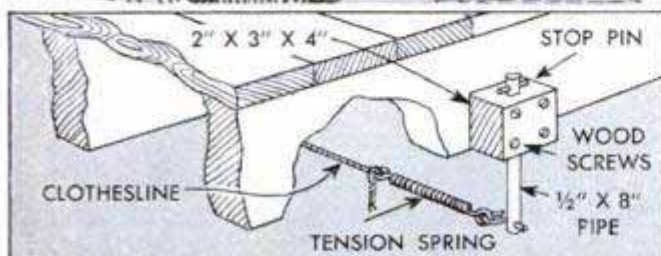
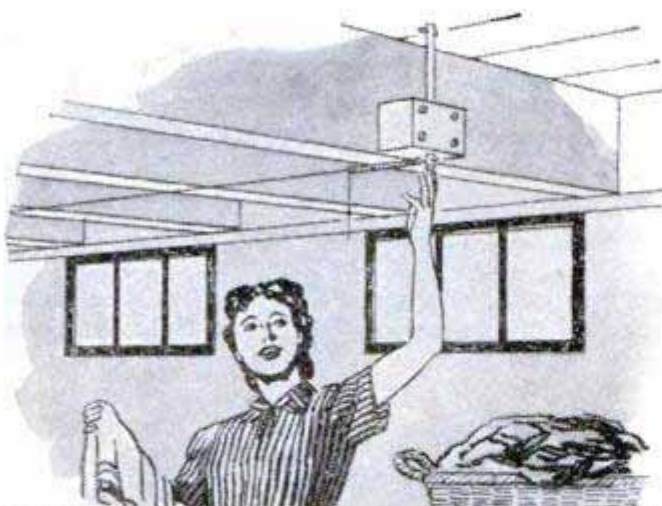

If there is not room in the basement for a separate area used exclusively for hanging wash, it usually means that the clothesline must be taken down after every washing. To save time, one homeowner installed this retractable clothesline which is a permanent installation and is merely pushed up against the ceiling joists and out of the way after the wash is taken down. Each end of the line is fastened to a length of pipe which slides up and down in a wooden hanger. The latter is a piece of 2 x 4 drilled for the pipe and mounted on the side of a joist with wood screws. A stop pin keeps the pipe from being pulled out of the hanger. Note that a tension spring is installed at one end between the line and the pipe to hold the line taut.

Joseph L. Jehlicka, Chicago.

☐ The interior of a refrigerator can be deodorized by washing it with soapy water containing a teaspoonful of dry mustard.

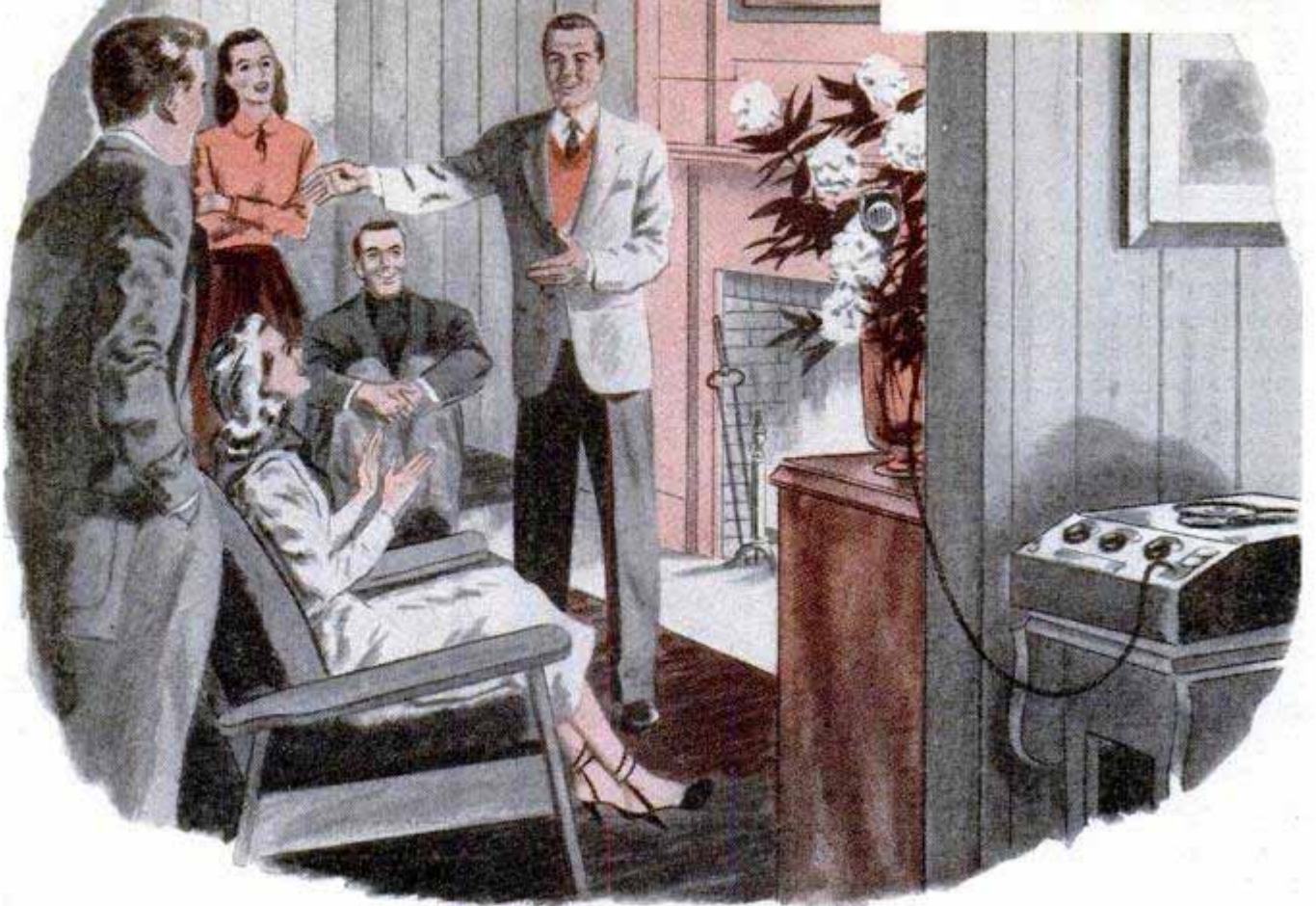

By M. G. Winterton

AS A SURPRISING climax to your next informal party, play back a candid recording of the evening's conversation. Without a doubt the playback will provide some lively entertainment, especially if you have carefully planned the recording beforehand. Of course, in making candid recordings the trick is to carry out the whole procedure undetected by your guests. With a small group this is easy to do, but recording large groups requires a planned program. Acting as host, you also can fill in as master of ceremonies, directing the conversation to hold the attention of all and keep them grouped together before the concealed microphone. Usually the recorder can be located in an adjoining room where it is not likely to be discovered, but concealing the mike in the average home calls for some ingenuity. Sometimes a small radio set will solve the problem. Just remove the back of the cabinet, fold the radio cord inside, place the mike in the cabinet and there you are. Floor-length draperies and draw curtains offer good hiding places for both mike and cord. The cord is not likely to attract attention if carefully placed along the baseboard, around a doorjamb or run from the wall outlet to the radio set in

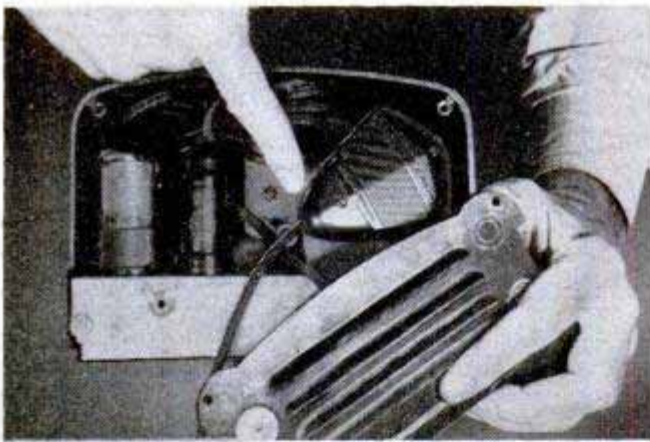

Above, often a small radio set can be used to conceal the microphone. The radio power cord is folded and placed in the cabinet and the mike cord takes its place. Below, draperies hide the mike effectively

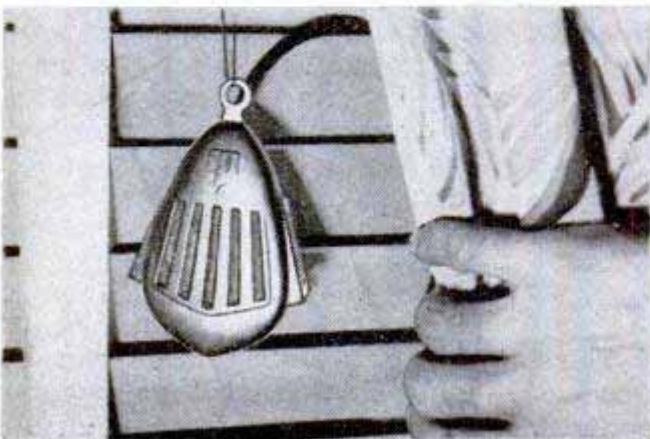

RECORDINGS

which the mike is hidden. If any of the guests attempts to turn on the radio you can always explain blandly that the set is temporarily out of order.

Ordinarily, a lamp offers the best place for concealing the microphone, particularly if it is a small lamp of the novelty type. It can be placed anywhere in the room, and, even if unlighted, it is the least likely of any of the common household objects to attract the attention of the guest who may suspect that you are up to something unusual. Methods of concealing the microphone will depend on the construction of both the lamp and the microphone, but the photos at the right suggest two practical ways of doing it. In one instance, a dummy "lamp" is made from the mike stand by covering the base of the stand with the bottom cut from a tin can. The column of the stand is covered with a decorated paper tube and the setup is finished off with a small cloth lamp shade. The open top of the shade is covered with matching cloth. Another method makes use of a novelty lamp with a tubular shade. Fold the lamp cord into the base and attach a wire bracket to the base in such a way that it will provide a support to which the mike can be fastened with a rubber band. On some occasions it is possible to conceal the mike in your shirt pocket. This works especially well when recording conversation of the players and comment of the kibitzers at a lively card game and for picking up idle, off-the-record chatter around the basement playroom. Here, you either must be seated or standing behind a table or counter in order that the mike cord can be concealed in the clothing.

Although the microphone, which comes with the recorder as standard equipment, generally can be used for candid recording, the nondirectional mike is more versatile, as it will pick up sound from all directions. Of course, distance and background noise must be considered in planning the setup. The flat, semidirectional mike, shown in several of the photos, also is satisfactory where the sound comes from one general direction over a wide angle, as from a large group. In handling larger groups, try to locate the concealed mike so that everyone present can be induced to cut his share of the record at relatively close range. At large gatherings it seldom is practical to record everything being said at any one time. Although not essential for good recording, a preamplifier, shown in one of the photos, will increase the range of the recording set.

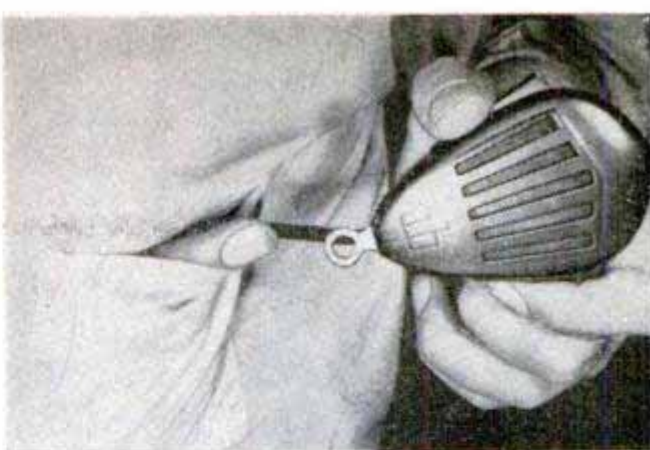

A small mike can be concealed in your shirt pocket. Cut a small slit inside the pocket for the mike cord



For candid recordings of small groups, mikes mounted on stands usually are disguised as occasional lamps



Above, a novelty lamp is just the thing for concealing the mike. Hide the lamp cord in the base as shown

Below, sometimes a preamplifier can be used to good advantage to increase the range of the microphone



Poultry Wire Forms Tool Rack

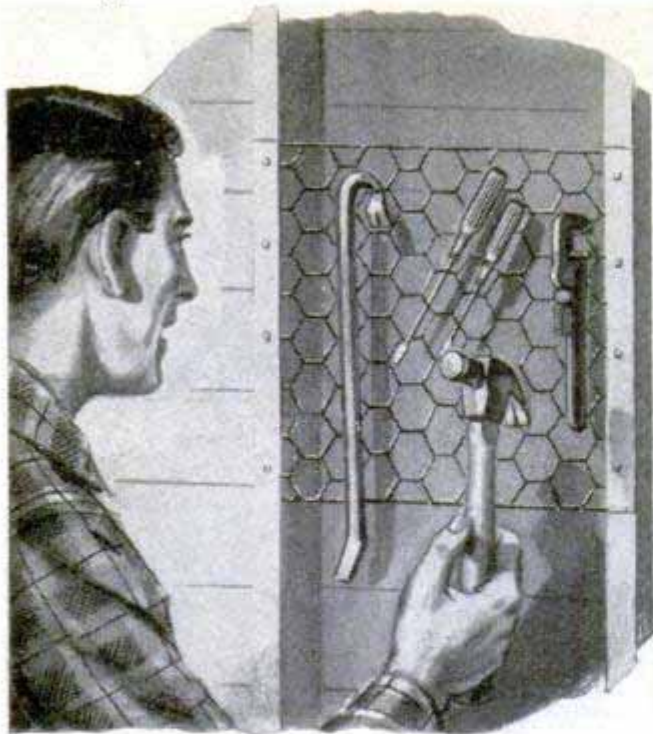

Fastened to the studs of a garage wall, a piece of poultry wire provides a handy rack for hammers, wrenches and other hand tools. Even screwdrivers and chisels can be hung on the rack by threading their blades between the sections of the wire. The wire is held in place by thin wooden strips nailed to the edges of the studs so that the nails engage the wire mesh.

Coloring Easter Eggs Facilitated By Ring-Type Dipper



You can do a better job when coloring Easter eggs by dipping them with a simple rack bent from stiff wire. Most of the excess dye will drain from the egg when it is removed from the solution, minimizing the dark rings that

otherwise form when the egg is placed on a paper or cloth to dry. Using scraps of wire or sections cut from wire coat hangers, form one rack for each color of dye to be used.—R. F. Donovan, Jersey City, N.J.

Lengthening Rivets for Reuse

When repairing a camera tripod, I discovered that new rivets of the proper size could not be purchased. As the old rivets were removed by filing off their heads, each one was shortened by approximately the diameter of the shank. I was able to reuse

them by laying each rivet on a small anvil and using a light machinist's hammer to lengthen it by hammering the center portion of the shank. No hammering was done near either end of the rivet, so the only reduction in diameter was near the center. This method, of course, can be used only on rivets that are long enough to make hammering practicable.—Ed Packer, Chicago.

Screwdriver Made From Knife

Instead of throwing away a broken or worn out kitchen knife, use it to provide an extra screwdriver for the shop. Cut the knife blade to the desired length and grind the remaining portion to shape, making the tip of the blade the required size.

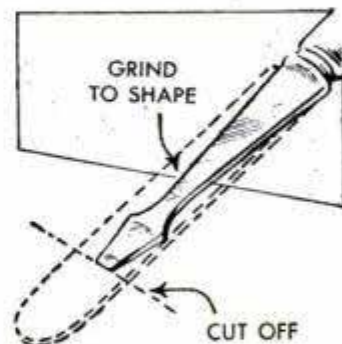

S. S. Palestrant, Bronx, N.Y.

Ribbon Sewed to Handbag Holds Door Keys

To eliminate rummaging through your handbag for the house-door keys, tie them to a ribbon so they can be pulled from the bag in a moment. Select a ribbon that matches the handbag and loop one end around the handle, sewing it tightly in place. Then thread the keys on the ribbon or lace them to the free end. The ribbon should be long enough to permit inserting the key in the lock without difficulty.

Michael Ligocki, Gary, Ind.



On-the-Spot DARKROOM

WHEN it is important that you come back with a picture and the chance of retaking the same shot later is out of the question, an on-the-spot darkroom will enable you to see the results right away. This portable one doubles as a carrying case for all the processing equipment needed, with room to spare for the camera. The details below show how the two-part case is built from $\frac{1}{4}$ -in. plywood and made light-tight by covering the outside with balloon cloth. Elastic in the hem around the handholes makes the trap lightproof and allows the film to be loaded into the tank without the slightest danger of fogging it.

Austin H. Phelps, Omaha, Neb.



In any photographic work requiring the developing of exposed film on the spot, a portable darkroom unit of camera-case size is an essential part of the photographer's equipment. This one provides both developing facilities and space for camera and film

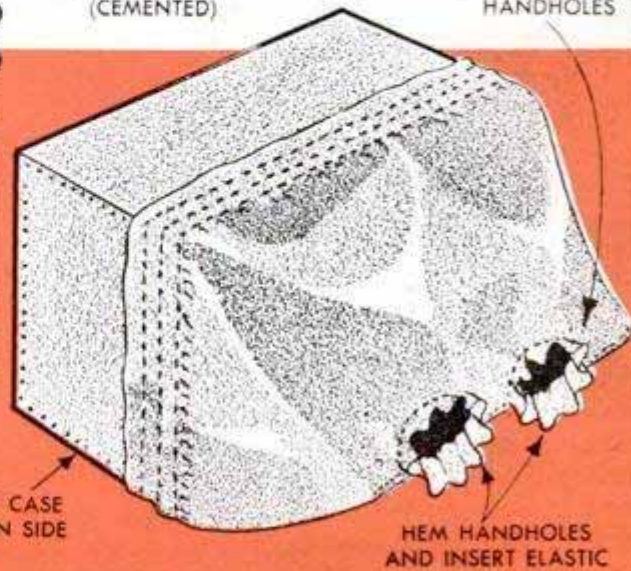
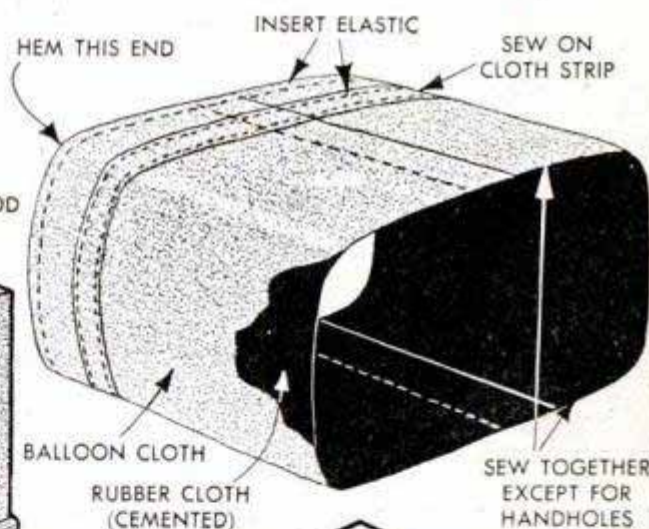
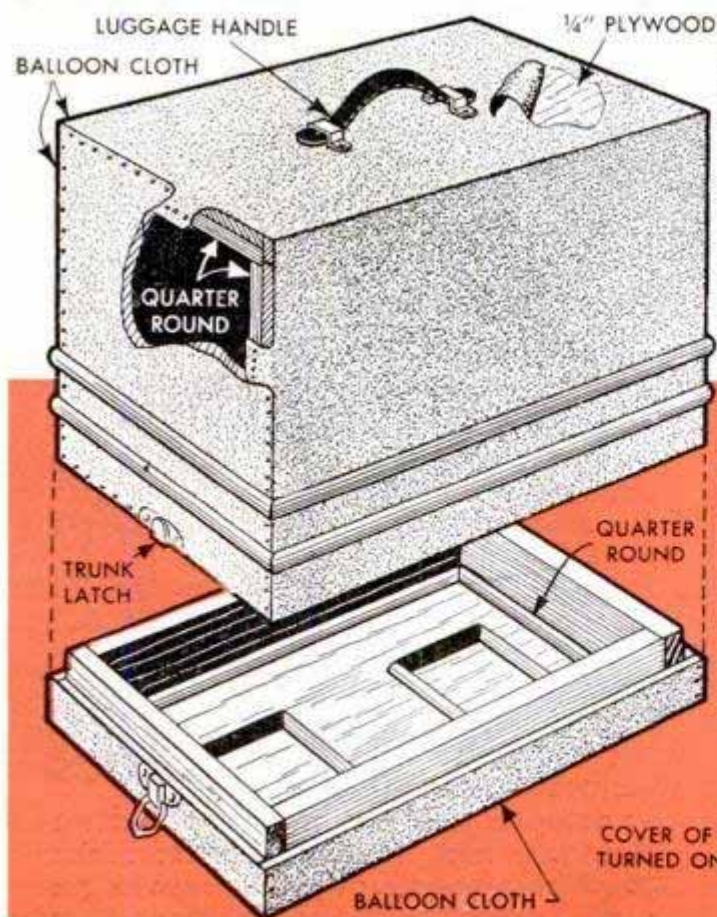

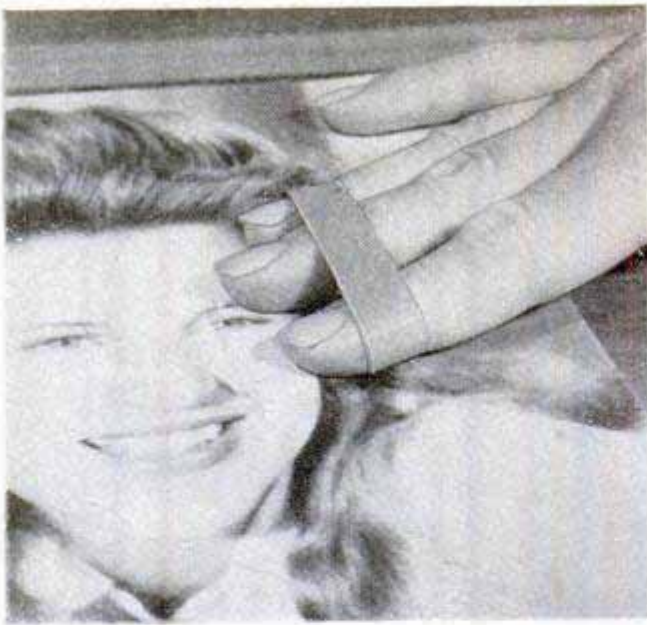

Removing Lint From Matte Prints

Lint from drying blotters sometimes sticks so tightly to the surface of matte prints that it is almost impossible to brush off. A quick way to remove these stubborn particles of lint is to tap the surface of the print gently with the sticky side of a strip of cellulose tape. The tape can be handled easily if wrapped around the fingers as shown in the photo.

Virginia Hanson, Santa Monica, Calif.

Curled Prints Pressed Flat With Household Iron

If your darkroom equipment for processing photos at home does not include an electric print drier, the household iron can be put to work to press the curl out of blotter-dried prints. Simply place the print face down on the ironing board and press the back with a medium-warm iron. If a steam-type iron is used, the result will be a print as flat as starched clothing.

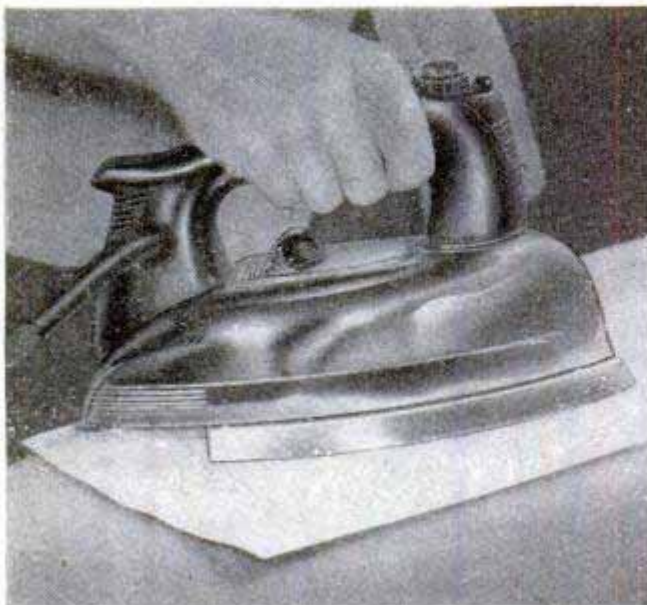

Baking Soda Neutralizes Hypo In Developing Tank

To make sure that any traces of hypo left in a roll-film tank will not contaminate the developer the next time the tank is used, I always rinse the tank with baking soda before putting it away. To do this, place a pinch of common baking soda in the tank, fill it with water and place the reel in the tank. Let it stand for a few moments and then wash the tank and reel in running water. Washing will usually remove all traces of soda, but even if some remains, the soda will not contaminate the developer as will the acid from hypo.

Richard Hanscom, Elmhurst, Ill.



Paper Clips Furnish Hangers For Drying Negatives

When drying a number of cut-film negatives, use paper clips to suspend them from a length of cord. These clips are inexpensive, and are easily slipped over the cord and clamped to the negative. Also, they make a smaller hole in the corner of the film than standard hangers.—Jeanne Stasack, Chicago.

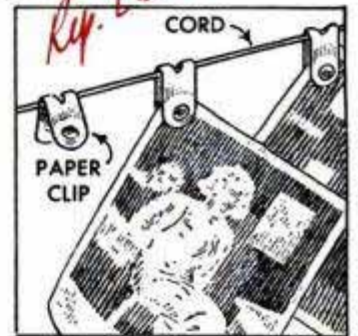

Wax Paper Seals Developer Bottle To Prevent Rapid Deterioration

Few persons realize how rapidly stock developer deteriorates when the bottle in which it is stored is not capped tightly. Contamination from the metal cap itself, caused by corrosive action of the chemical, also contributes to early deterioration. A simple way to assure a tight seal and protect against corrosion is to place a couple of pieces of wax paper over the mouth of the bottle before capping.



SHADOWLESS REFLECTOR

There are no harsh shadows in your pictures when you shoot them through this "cake pan" photo reflector. Encircling the lens, the reflector floods the subject evenly from all angles. The original was designed to hang right on the tilting front of a view camera, Fig. 2, by means of brackets A and B, Fig. 1. However, a floor stand of $\frac{1}{8}$ -in. pipe and fittings can be made to support the reflector in front of the camera. In either case, bracket B is bolted to the rear side of the reflector as shown in Fig. 1. Ten auto taillight sockets are installed in the bottom of the reflector. Holes are made for these in the metal and also in an insulating ring of sheet asbestos which is pressed in the bottom of the reflector before the sockets are soldered in place. Note how the sockets are wired in series, using regular asbestos heater cord. Each socket is fitted with a 100 or 300-watt projection lamp.—Del Naylor, Chicago.

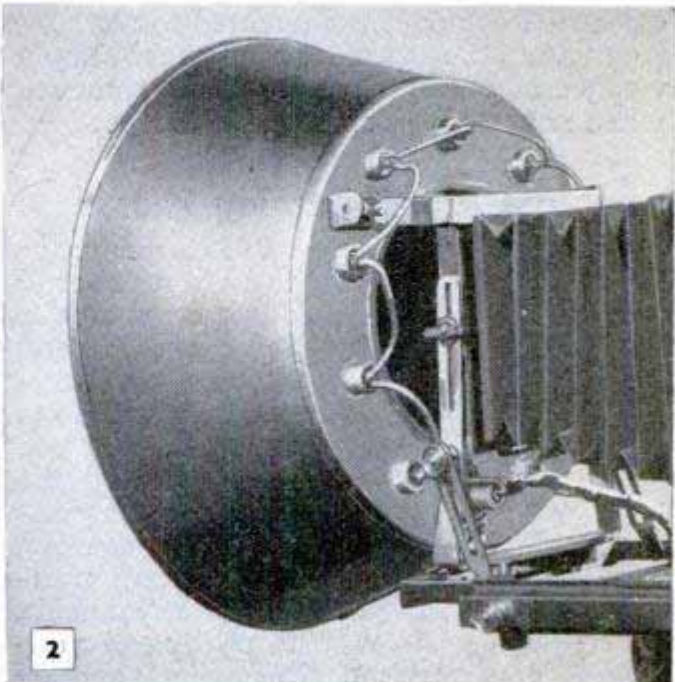
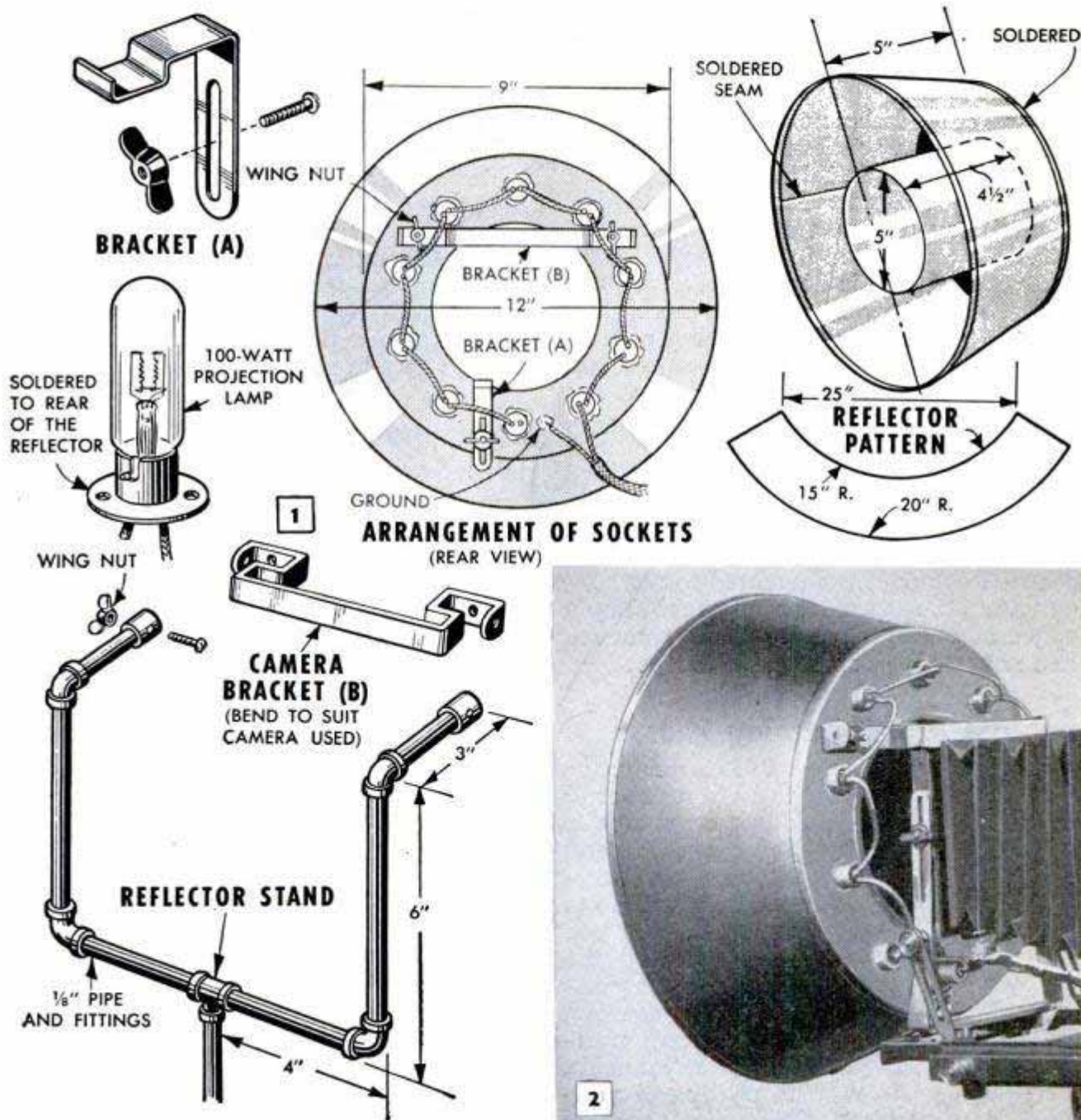

Auxiliary Right-Angle Viewer Makes Candid Shots Easy

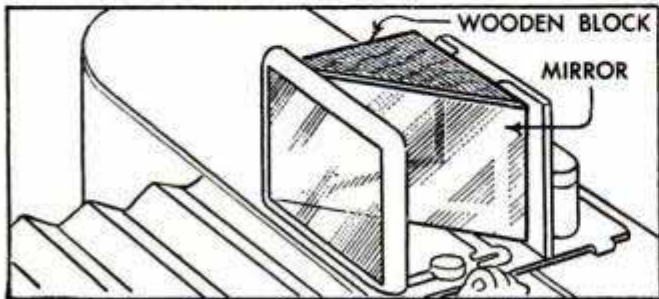

Taking candid shots of camera-shy children and adults without their knowledge is a lot of fun with this little right-angle viewer. Inserted in the regular view finder, the auxiliary one permits the camera to be focused and aimed in the normal manner, except that it is done from a side position. To the unwary subject, this makes it appear that the camera is being pointed in another direction. Thus, the subjects are completely at ease, their expressions are natural and their antics sometimes are surprisingly funny. The viewer consists of a small triangular-shaped block of wood which is cut to fit the camera view finder. One face is cut at a 45-deg. angle and a small piece of mirror taken from a woman's discarded compact is cemented to the surface. As the auxiliary viewer simply wedges in place, it can be easily removed when not used.—Bob Hurst, Chicago.

Template Aids Trimming Photos



If it is necessary to cut a number of different photos to the same size and shape, use a sheet-plastic template to speed the job and save marking the print. As the plastic is transparent, it is easily positioned on the print. A coating of rubber cement applied

around the edges of the template will keep it from slipping out of place while the photo is being trimmed.

Testing Condition of Hypo Solution

When in doubt as to the condition of a hypo bath, you can test it quickly with a 20-percent solution of potassium iodide. Using a medicine dropper, place a drop or two of the solution in the hypo bath. If a white precipitate forms, the hypo should be discarded—if not, the quality of the hypo is still satisfactory.

Agitation Improves Negatives

For consistently good results when processing negatives, it is important to agitate the film during development. One of the best methods of agitation is to lift the film entirely out of the developer and allow it to drain for a few seconds. This should be done once every minute during the period of development, as it insures that the film comes in contact with fresh developer after each draining. If draining the film is adopted as a standard procedure, the results will always be the same.

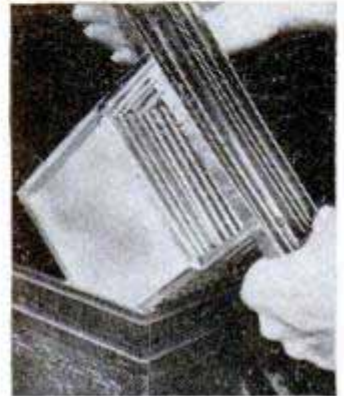

Ferrotypes Tins Cleaned Thoroughly With Soapless Detergent

Ferrotypes tins may be cleaned thoroughly without leaving an oily soap film if they are sponged with one of the soapless detergents now in general use. Work some of the detergent into a water-soaked sponge to make a rich lather and then rub the lather over the tin. Rinse the tin with clear water when finished.



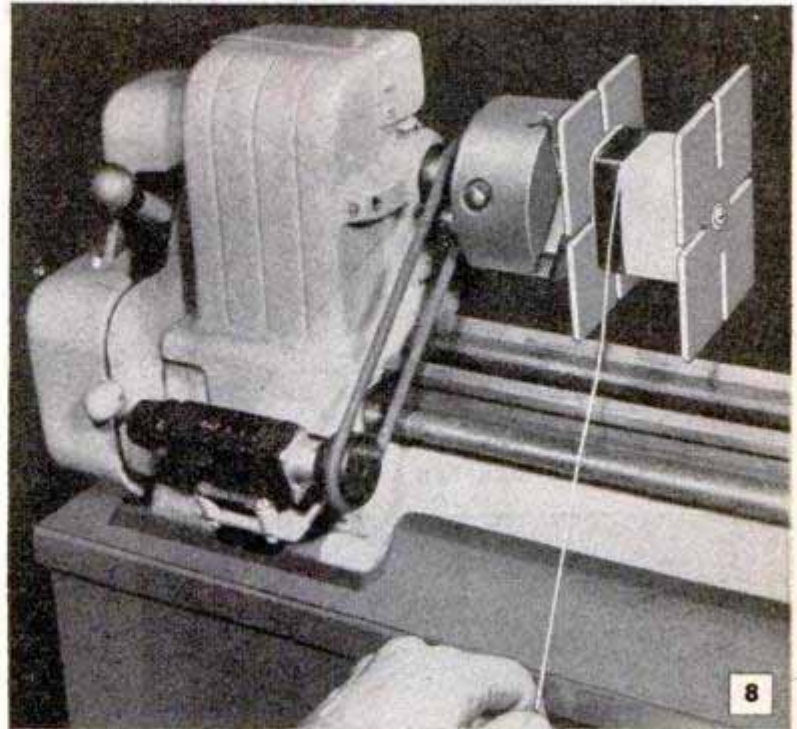
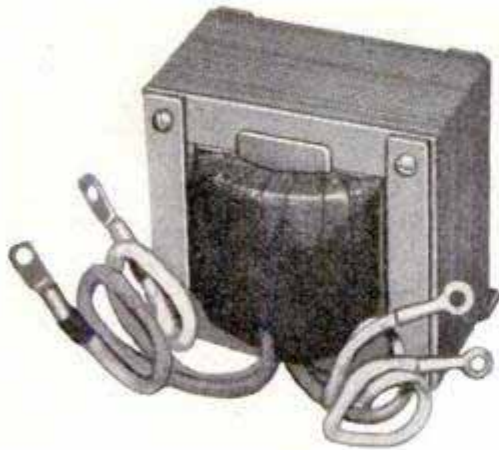

Make your own TRANSFORMER

By Harold P. Strand

PART II—BUILDING

AFTER careful study of basic transformer design given last month in Part I of this story, you are ready to take up the actual building of a transformer. Although the information can be applied to the design of many other sizes and types of transformers, the calculations given will be used as an example.

The first step in building a transformer is the selection or making of the laminated iron core. Standard E-shaped pieces of iron for this purpose may be purchased or the iron from a burned out transformer may be used. The core can also be made of sheet-metal strips. In either case, the estimated size of the finished coil must be known, so the window openings of the core can be checked for sufficient clearance. The coil will consist of primary and secondary windings of wire, several layers of insulating paper and a wrapping of white cotton tape applied around the completed coil.

To calculate the cross-sectional area of the wire coils, refer to the table, Fig. 7 of Part I. The No. 19 wire to be used for the primary is listed as having 665 turns per sq. in. Dividing the 300 turns needed by 665 gives .451 sq. in. The No. 23 wire is listed as having 1600 turns per sq. in. Dividing 636 by 1600 gives .397 sq. in.

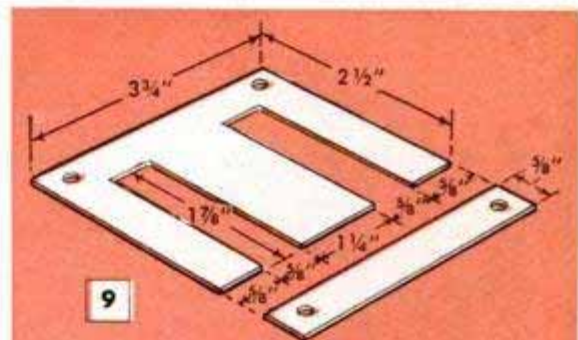

9
E-SHAPED LAMINATIONS SALVAGED FROM OLD TRANSFORMER

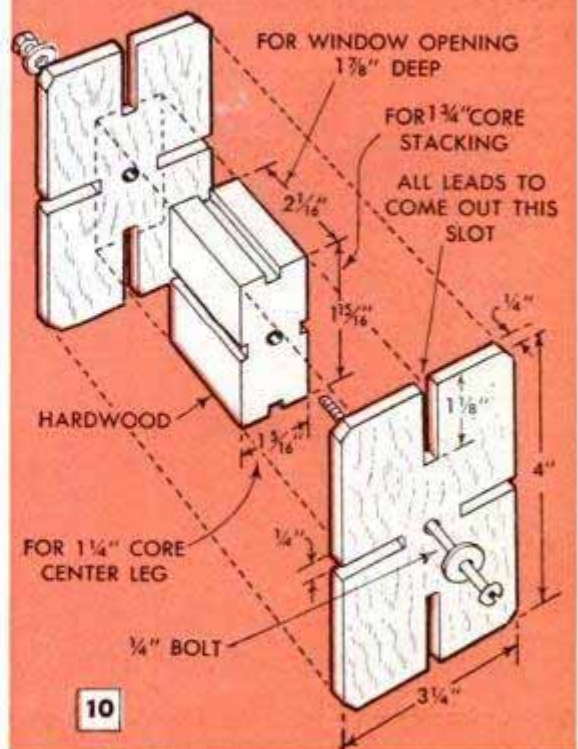

10

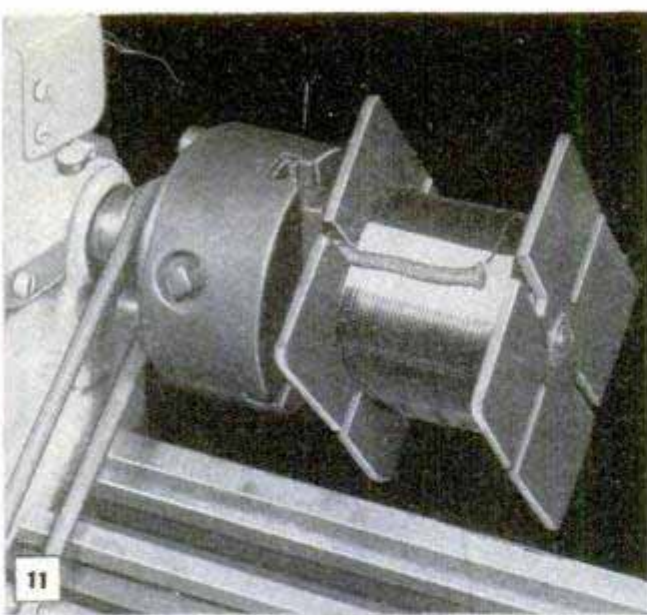

11
Finish end of primary-coil wire is laid over a piece of tape for added insulation where it crosses coil

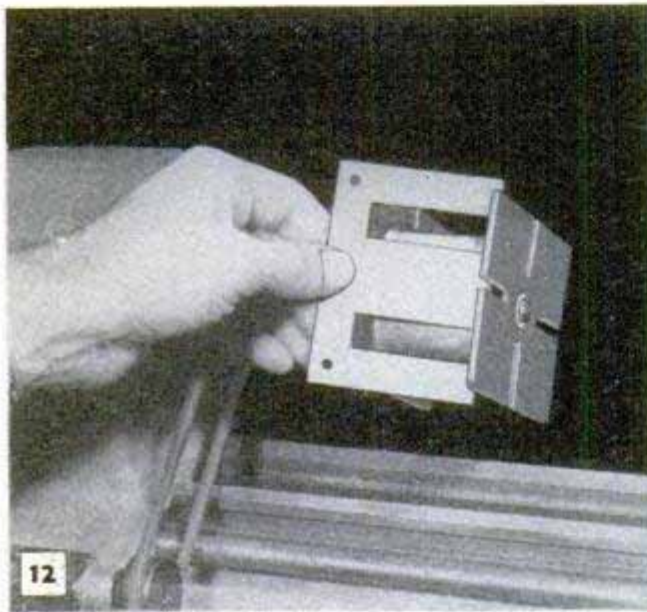

12
For a quick check to determine how much room is left for secondary coil, hold a lamination against coil

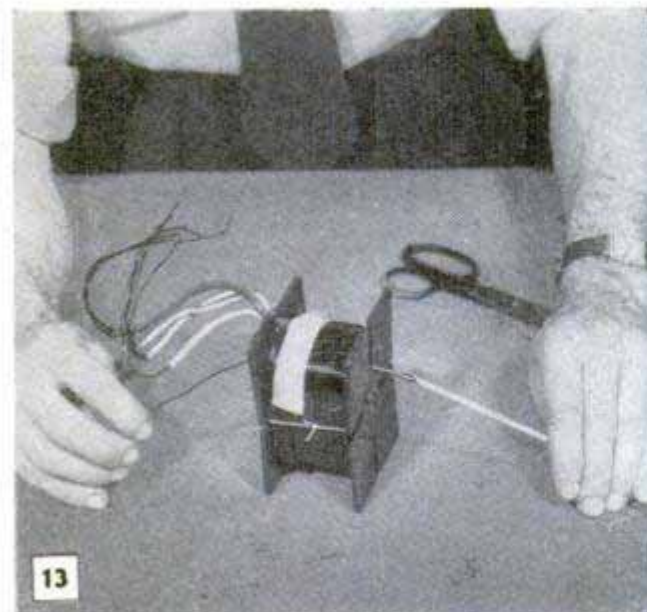

13
Use a piece of wire with small hook bent on one end to draw coil-tying string through slots in form

Adding these two figures makes a total of .848 sq. in. required for the wire coils. An additional 25 percent of the area needed for the wires (in this case, .212 sq. in.) will take care of the space required for insulating material. This will give a grand total of 1.06 sq. in. of window space needed for the completed coil. Since the window openings of the core iron selected for this transformer, Fig. 9, are $\frac{5}{8} \times 1\frac{7}{8}$ in. or 1.17 sq. in., the coil should just fit, provided the turns of wire are wrapped tightly and are close together.

To wind the coil, a form as shown in Fig. 10 will be needed. The dimensions of the form should be carefully figured in relation to the size of the laminations. The dimensions given are suitable for the laminations shown in Fig. 9. The coil can be wound by hand or with a hand drill clamped in a vise. However, considerable time can be saved if the form is mounted in a lathe equipped with a turn counter. The counter, shown mounted on the lathe bed, Fig. 8, is driven by a tight-fitting rubber vacuum-cleaner belt which fits over a 1-in.-dia. wooden pulley on the counter shaft and a groove turned in the hub of the lathe chuck. Both pulley diameters must be the same size to assure an accurate turn count. The center block of the form is first wrapped with one turn of flexible armature paper of .010 in. to .015 in. thickness. The start end of the wire coil, which should be about 6 in. long, is fitted with a sleeve of cotton insulating material.

After winding on the 300 turns of the primary coil, snip off the wire, allowing about 6 in. for a lead. Cover this with cotton sleeving and run it out from the coil through a slot in the narrow side of the form as indicated in Fig. 10. A piece of tape is then placed across the top layer of wire and under the lead wire, Fig. 11, for added insulation. A quick check can be made at this time by holding one of the E-shaped laminations against the coil as in Fig. 12, noting the diameter of the coil in relation to the window openings of the core. Next, place one turn of insulating paper around the primary windings, and over this the 636 turns of the No. 23 wire for the secondary coil. A piece of cotton sleeving should be used around both leads of the secondary coil and carried out through the slot in the narrow side of the form. Some transformer designs call for a fairly heavy wire with only a few turns involved. If the wire is too heavy to wind easily, two wires having a cross-sectional area equal to that of the single wire may be paralleled or wound side by side for easier winding. A neater and more uniform winding will result if a hammer and a

block of wood are used to tap the turns in place after winding each layer. Another block of wood placed under the form and resting on the lathe bed will offer a support while tapping the turns of wire.

After both coils are wound, the form and coils are removed from the lathe and four lengths of string drawn through the four slots and grooves of the form with a wire as shown in Fig. 13. The coils are then tied tightly together and the form separated. Care must be taken when knocking out the center block to avoid disrupting the shape of the coils. After this, the coils are wrapped with $\frac{3}{4}$ -in. white, cotton coil tape as in Fig. 14. Cut and remove the strings one at a time as the strings are approached with the tape and secure the end of the tape with a needle and thread. Dipping the coils in insulating varnish is the next step. Use air-dry varnish and allow the coil to remain submerged for about five minutes so that it is thoroughly impregnated. Then hang it up to dry for several days in a hot, dry place. If the coil, after drying, is too large to fit the window openings of the laminations, reinsert the center block of the winding form and compress the coil in a vise between two pieces of wood, as in Fig. 15. Before assembling the core laminations, place thin pieces of fiber on the sides and edges of the coil that will be covered by the core.

The laminations are stacked around the coil in alternate positions. This is done by placing the center portion of an E-shaped lamination in the core opening, as in Fig. 16. A straight lamination is then butted against the edges of the E-shaped lamination on the opposite side of the coil. Then, the center portion of the second lamination is inserted in the core opening on the opposite side from which the previous E-shaped lamination was placed. Thus, the sets of laminations are assembled alternately until the full height is reached.

Next, four angle brackets are made from $\frac{3}{16}$ -in. flat iron. Two holes are drilled in each bracket to correspond with those in the laminations. Bolt the angle brackets to the core so the bent portion of the brackets will serve as feet on which to stand the transformer. To prevent a hum in the transformer due to loose laminations, cut two pieces of hard fiber the width of the lamination center legs, and force them down between the latter and the coil at both sides. Terminal lugs soldered to the ends of the four lead wires complete the transformer. When properly designed and built, a transformer should operate with moderate temperature rise and draw but little current from the line at no load.

THE END

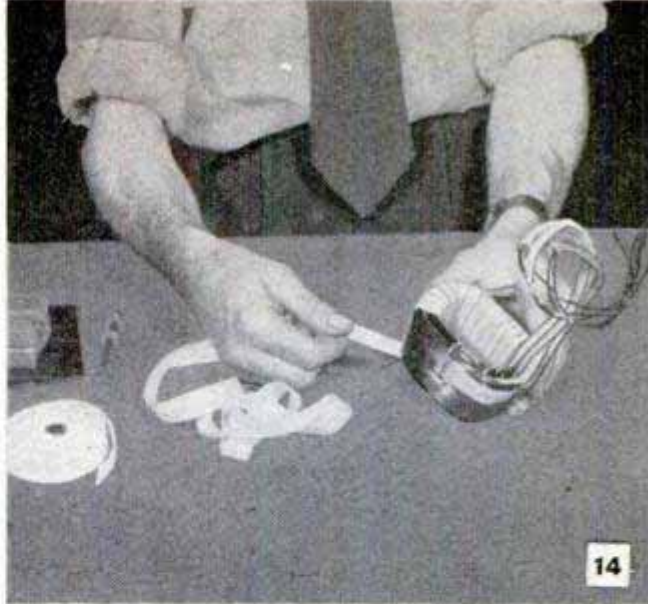

Completed coils are taped together with white cotton tape. Remove the tie strings as tape approaches them

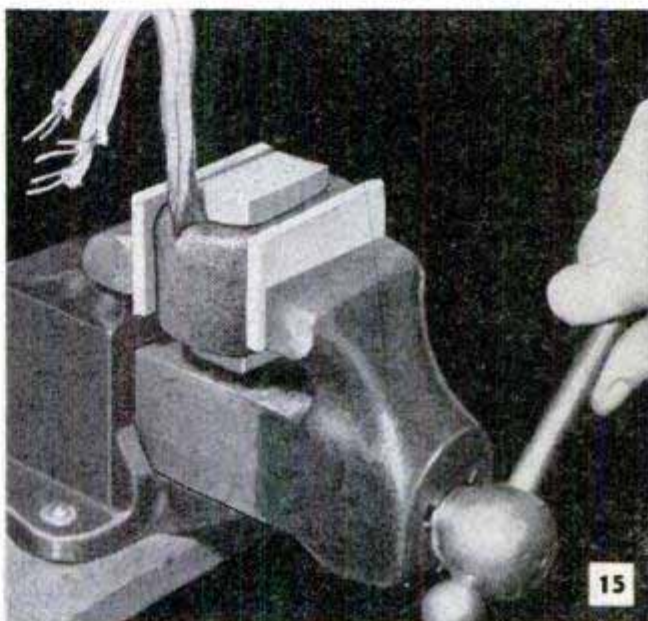

If outside of coil is too large to fit window openings of laminations, compress between jaws of a vise

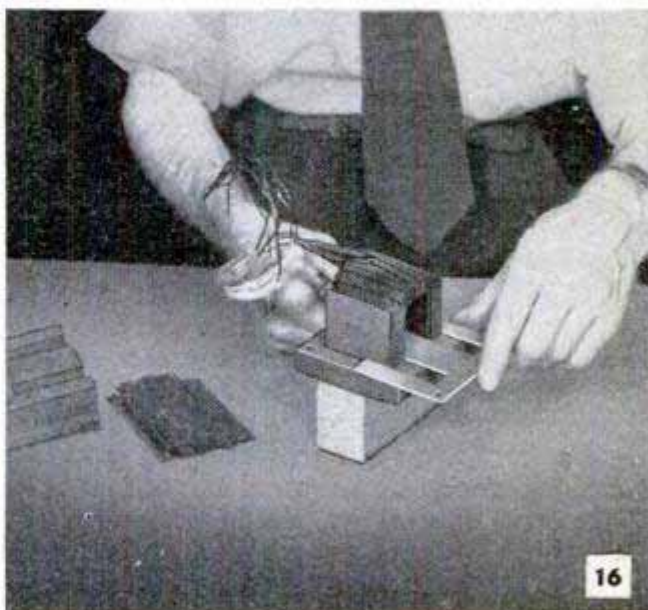

In assembling core and coil, alternate positions of the straight and E-shaped laminations from side to side

Concrete Service-Entrance Ramp Poured on Hollow-Tile Fill



Needing a low, all-weather ramp leading to the service door of his small store, one merchant saved both time and material costs by pouring a concrete slab over a fill made from discarded hollow tile. To retain the loose fill while the concrete slab is poured, hollow tile are laid up in mortar to form two sloping walls, using broken sections of tile on the second course and also at the lower end of the walls to give the required slope. Although the width of the ramp can be made to individual requirements, the original was made sufficiently wide to accommodate a medium-sized hand truck. Gauge the width of the fill accordingly. After the mortar has set, the fill is completed with pieces of broken tile, brick and small stones packed tightly together in the space between the retaining walls. Then a form is made and fitted over the top of the fill to retain the concrete, which is troweled smooth after it has partially set.

A. M. Wettach, Mt. Pleasant, Iowa.

Pins in Hinged Edge of Door Insure Against Intruders



A locked door that opens outward will do little to bar the entrance of an intruder, as it is a simple matter to remove the door if it is hung with loose-pin

hinges. When a door of this type leads to the back room of a store, an office or a storeroom, it can be made considerably more burglarproof by pinning the hinged edge of the door to the jamb. Drill two small holes in the edge of the door, one near the top and the other near the bottom. Then drive a steel pin or large nail in each hole,

cutting the heads from the nails if the latter are used. Finally, drill corresponding holes in the jamb to receive the ends of the pins, which should extend far enough to engage the holes when the door is closed tightly.—Dr. Bernard Matzen, Napa, Calif.

Special Watering-Trough Brooms Facilitate Cleaning

To facilitate sweeping litter from watering troughs, one poultryman made several small whisk brooms from the straws of a worn-out broom. He bundled the straws together and wrapped one end of the bundles with wire to form

a handle about 1½ in. in diameter. Wire unwound from the old broom can be salvaged and reused to bind the new ones.

Hi Sibley, Nuevo, Calif.

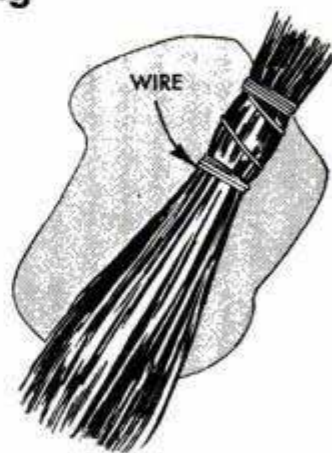

Connecting Rubber Tubing

Tight-fitting hose or rubber tubing is easier to slip over faucets or glass-tubing connections if the inner surface is lubricated with glycerin. Apply the latter to about the first ½ in. of the tubing.

Clamping Jig for Butt Welding Provided by Horseshoe

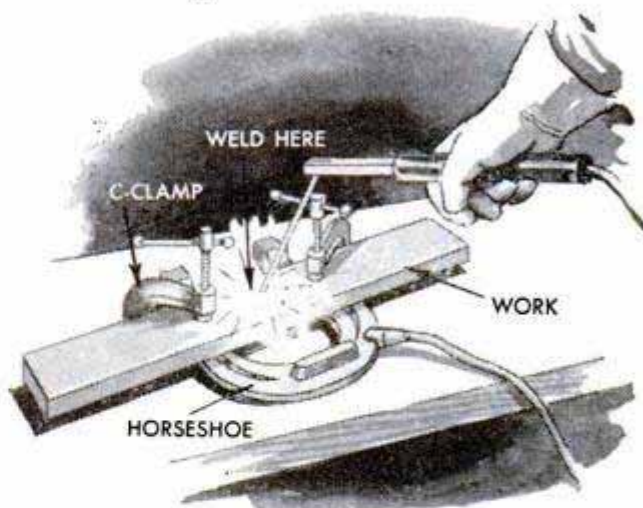

Two small C-clamps and a horseshoe form a jig for holding small pieces that are to be butt-welded. Simply assemble the jig as in the sketch, checking with a straight-edge to make sure that the workpieces are in line, with the ends butted squarely together before tightening the clamps.

Herbert E. Fey, New Braunfels, Tex.

blackness. To prepare for just such a situation, one driver used a modified relay to turn on the fog lights automatically if the headlights fail. The fixed contact arm of the relay is lengthened and the points changed as shown. With current flowing through the headlight circuit, the relay coil is energized, holding the arm down and the points open. The instant current stops flowing in the headlight circuit, the relay arm is released, moving upward to close the fog-light circuit.—A. J. Seymour, Jr., Salmon Falls, N. H.

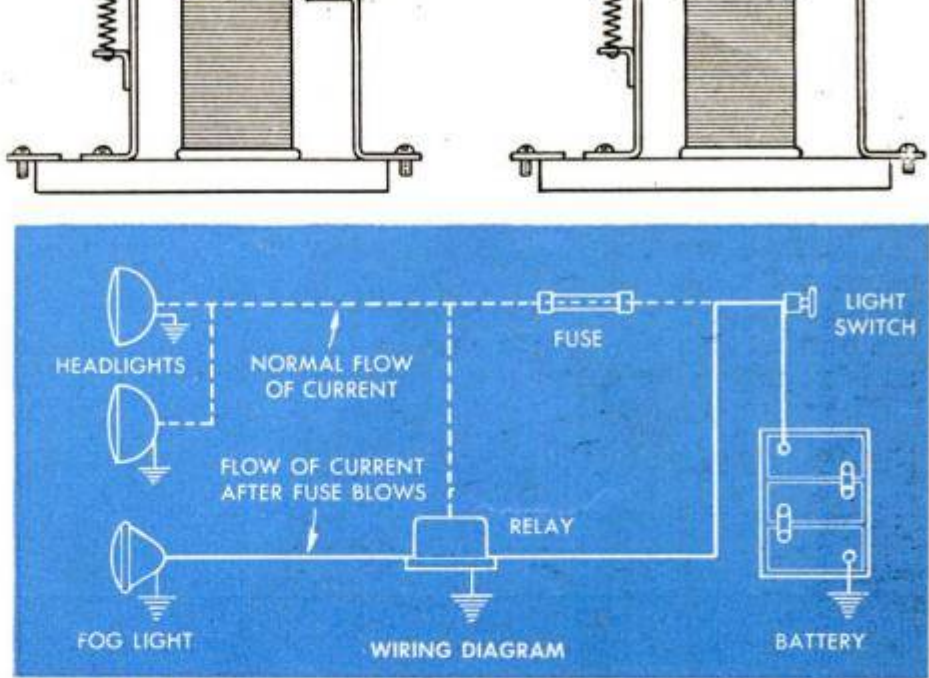

Addition of Special Anvil Adapts Micrometer for Measuring Tapered Parts

Job machine shops confronted with the problem of checking measurements on small lots of tapered parts, such as gibs, often find the solution through a simple adaptation of an ordinary micrometer. Usually, blueprints and specifications of such parts require that the finish dimension be checked at the small end of the taper, and adaptation of the mike to this work re-

quires only the substitution of a special tapered anvil in place of the regular anvil. The substitute anvil is made from tool steel and the frame of the mike is altered by first removing the regular anvil and grinding a shouldered flat, E-F, on the frame to serve as a seat for the tapered anvil. Next, a groove is milled lengthwise in the underside of the anvil piece, the dimension A on the milled groove being equal to the thickness of the mike frame. Then the piece is slotted to form surface G and milled to form surface C. The slotting cut should be deep enough to form a chip clearance between surfaces C and G as shown in the left-hand detail. Now, the partly finished anvil is seated on the mike frame and holes are drilled through the anvil and frame and reamed for taper pins. At this stage the anvil is hardened. After the anvil is pinned in place on the frame of the mike, the milled flat, B, is surface-ground to 90 deg. with the micrometer spindle and the angle flat, C, is finish-ground to the degree of taper required. Surface G is ground to bring its center line exactly on the axis line of the micrometer spindle. Then distance D is measured and an amount equal to this distance is removed from the end of the micrometer spindle by grinding. To assure accuracy in the altered micrometer, the finish grinds on measuring surfaces must be held to close limits.

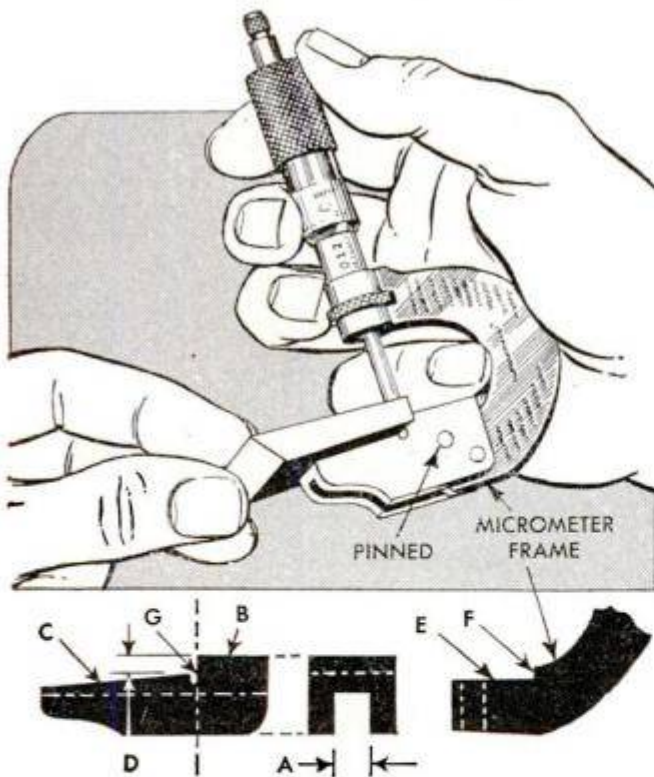

D. E. McDonald, Ansonia, Conn.

THE HARDEST WORK of operating a tractor-towed grain combine—twisting and straining repeatedly to raise or lower the cutter bar—is eliminated with this simple electric control unit, which is operated by the flick of a switch. The unit consists of an old car-starting motor belted to a threaded shaft, which moves one end of the unit horizontally to actuate the raising-and-lowering mechanism of the cutter bar.

The method of mounting the unit on the combine will be determined by your particular machine. Any method can be used if you keep in mind the fact that the movable end of the unit must be attached to

the raising mechanism in a manner similar to that of the lever for manual operation, which is disconnected. In some cases, it may be possible to connect the shaft to the arm of the mechanism where the lever linkage was removed. In the original installation, it was necessary to weld another arm to the mechanism as in Fig. 10.

A careful study of the top, side and front views in Figs. 1 and 8, the cutaway view, Fig. 9, and the perspective view, Fig. 10, will give you a good idea of the assembly. Figs. 2 to 6 inclusive give other views of the unit mounted on the combine. The blue portion of Fig. 10 shows the new parts that

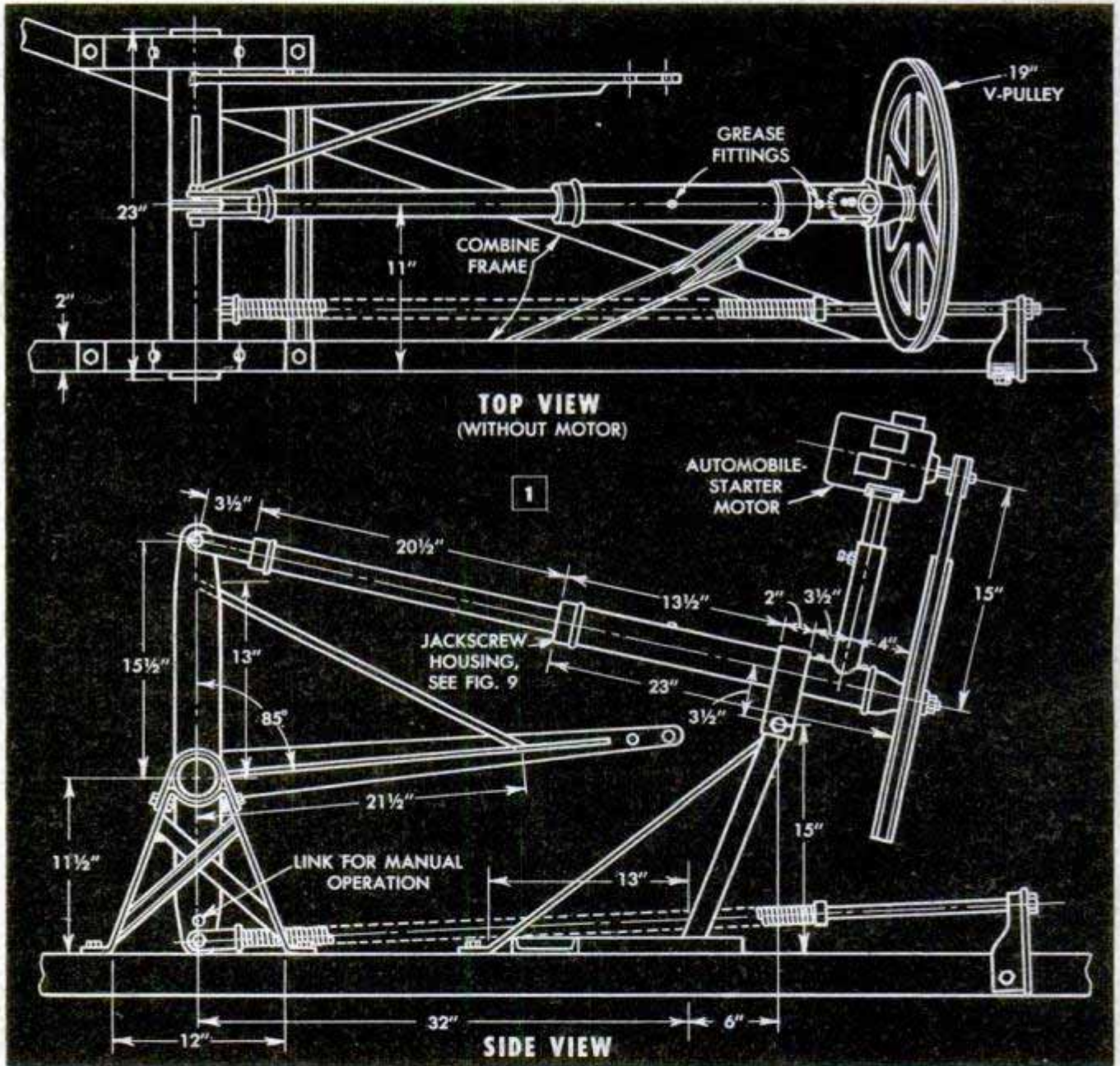

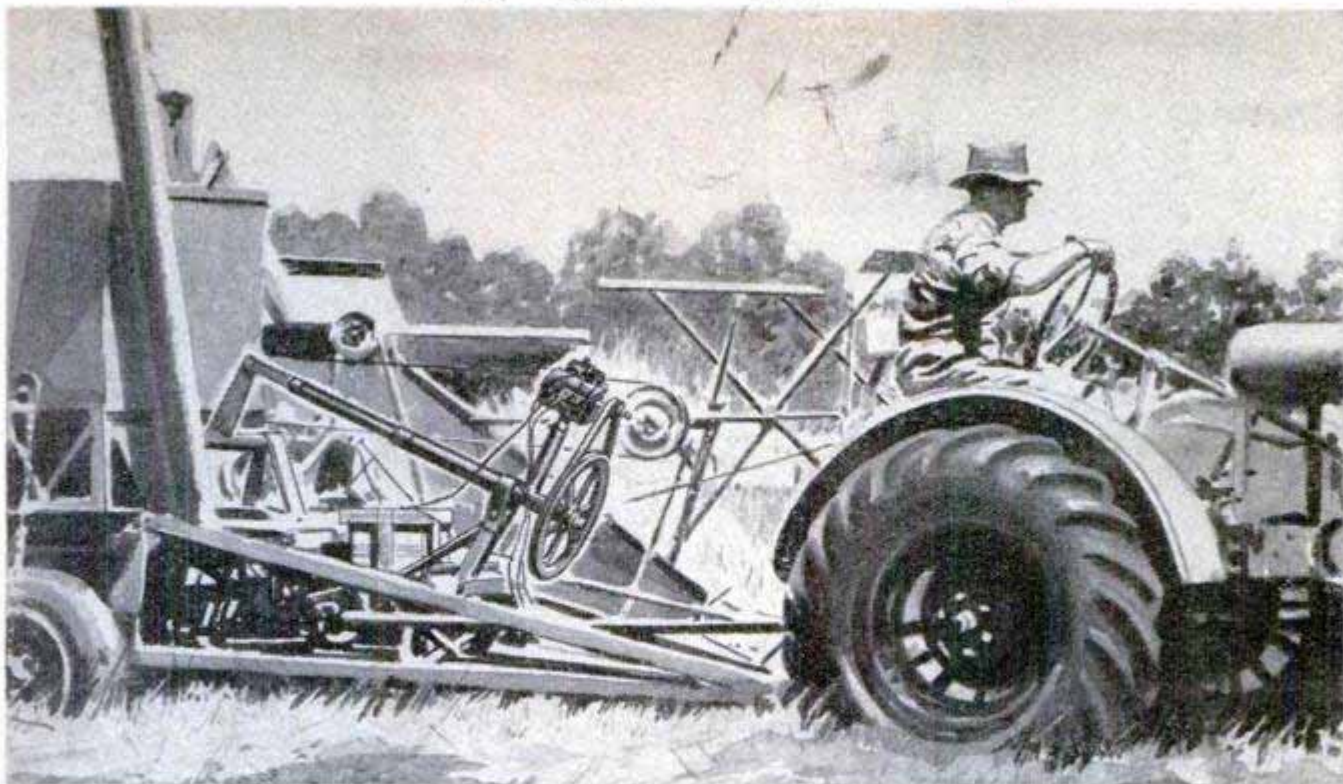

There is no twisting or straining to raise or lower the cutter bar when this electric control unit is used

were added to the original installation, and Fig. 9 details the screw portion of the assembly. When rotated by the starter motor, a threaded shaft inside the assembly moves a length of pipe in or out, depending on the direction of rotation, to actuate the raising-and-lowering mechanism of the cutter bar.

The outer housing of the assembly is a length of 2-in. pipe with a cap at one end and a reducing fitting at the other. The cap is bored in the center to take a length of 1 $\frac{1}{4}$ -in. pipe as a sliding fit, and the reducer is fitted with a bronze bushing made to screw into it. A length of 1-in. shafting to provide a jackscrew is turned to a diameter of $\frac{7}{8}$ in. at one end to form a spindle, which fits into the bushing, the length of the spindle being determined by the length of the bushing plus the thickness of a large pulley hub. The latter fits on the end of the spindle where it is keyed in place and belted to a smaller pulley on the motor shaft. The other end of the shaft is threaded for a distance of 5 in. to take a "nut" of similar length, which is made of bronze. The nut floats with a $\frac{1}{16}$ -in. clearance inside the smaller pipe where it is held by a pin and a pipe cap, the latter being bored for the shaft. The opposite end of this smaller pipe, which is a sliding fit inside the larger one, also is capped and a clevis or linkage welded to it for attaching to the arm of the fulcrum or lifting mechanism. The starter motor is mounted on this unit by means of a telescoping support, which is made of pipe as shown in the lower right-hand detail of Fig. 10, and then welded in place.

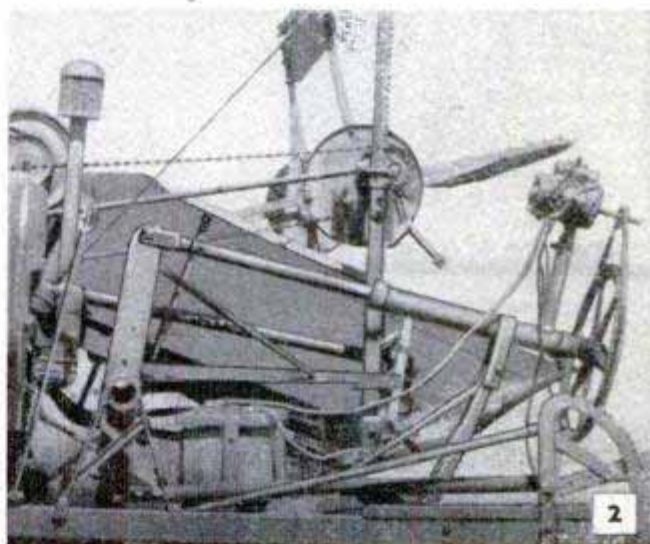
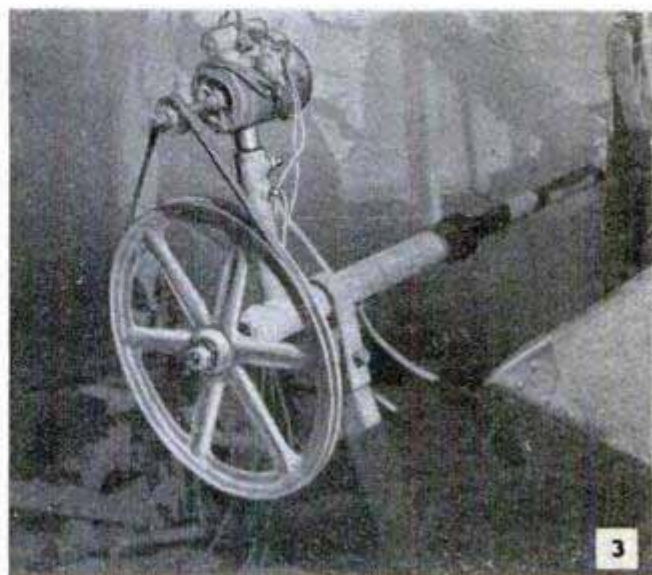
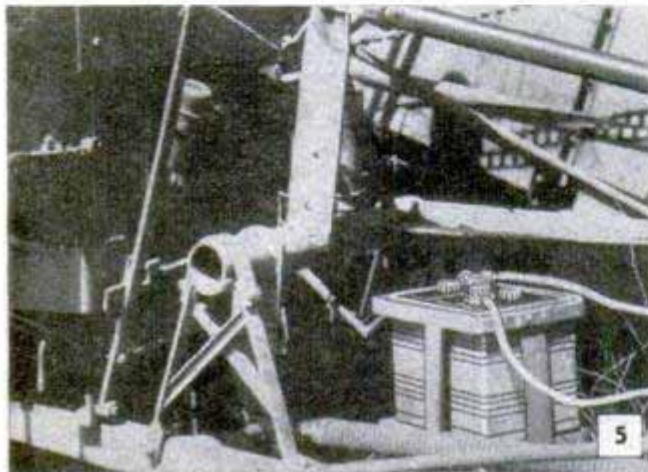

Photo above shows side view of control unit mounted on tongue and frame of combine. Photo below shows close-up view of motor and pulley on control unit





The photo gives a good idea of how the control unit appears from the front, and the photo below shows the location of the auxiliary battery



Below, good view of the motor and pulleys used to operate the control unit. The size of the large pulley determines speed at which the unit will operate

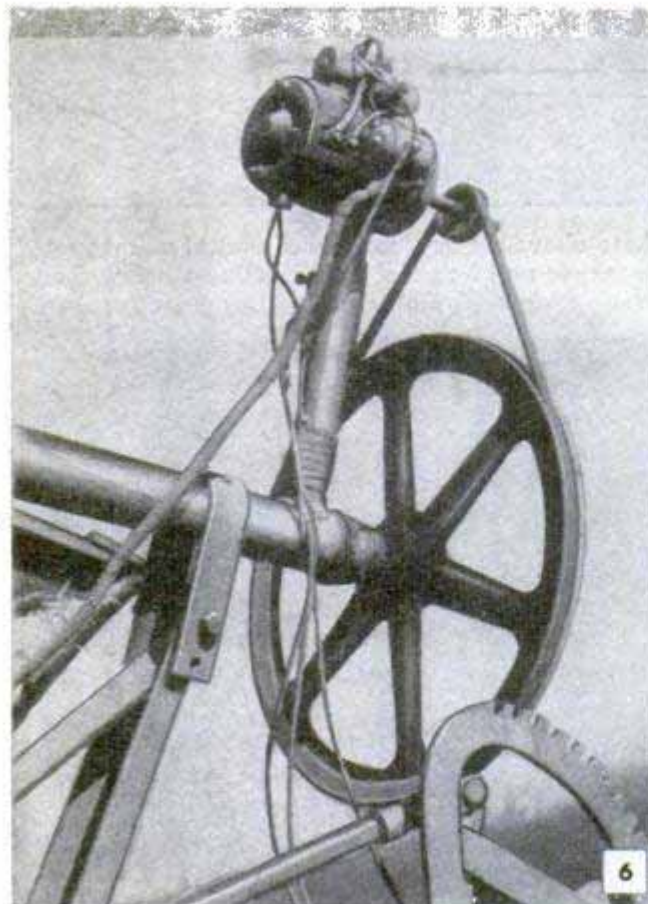

7
WIRING
DIAGRAM

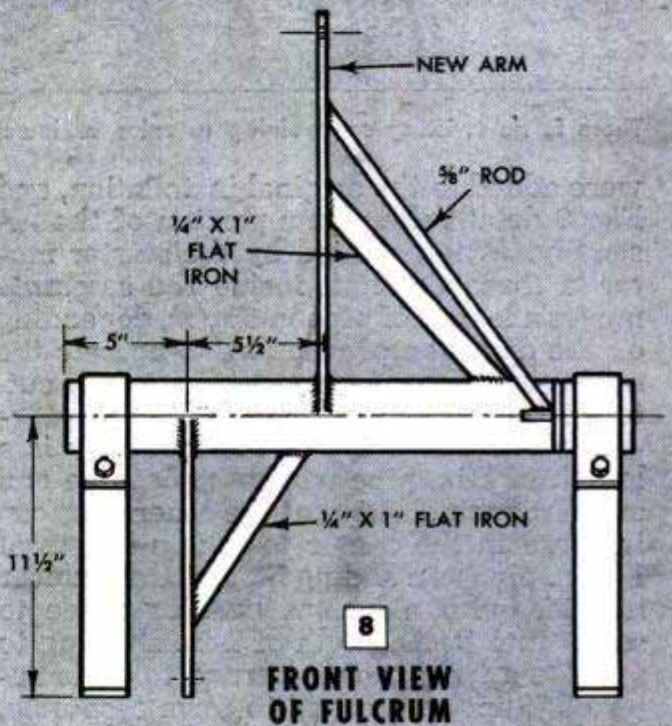
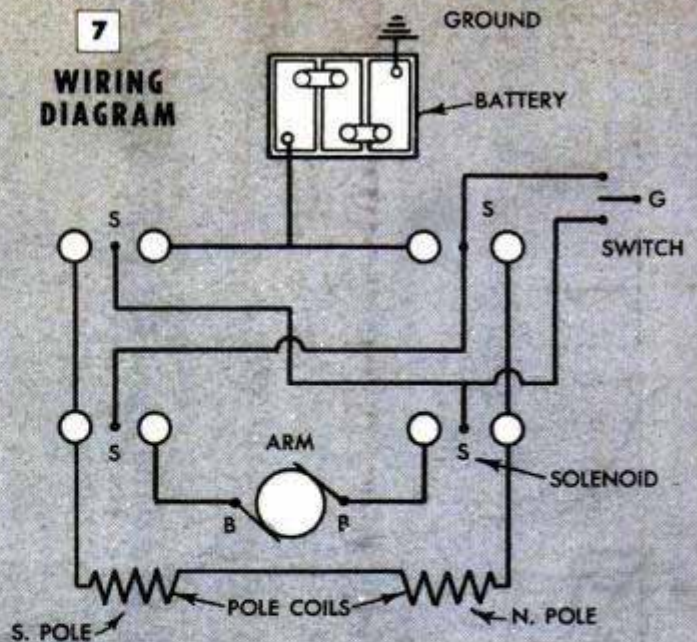

This type of support permits adjustment of the motor height to maintain correct tension on the belt.

Electricity to operate the starter motor is provided by a 6-volt storage battery, which is mounted on the combine frame, as pictured in Fig. 5, and charged by the tractor generator. The tractor battery could be used, provided it were heavy enough to take care of the extra load, but this would necessitate running two heavy starter cables from the tractor battery to the starter motor. Since these cables are quite expensive, it is better to use a separate battery.

The starter motor used must be of the type that can be reversed. The one used in the original installation was taken from a model-A Ford car. The wiring diagram for reversing the motor is shown in Fig. 7. If

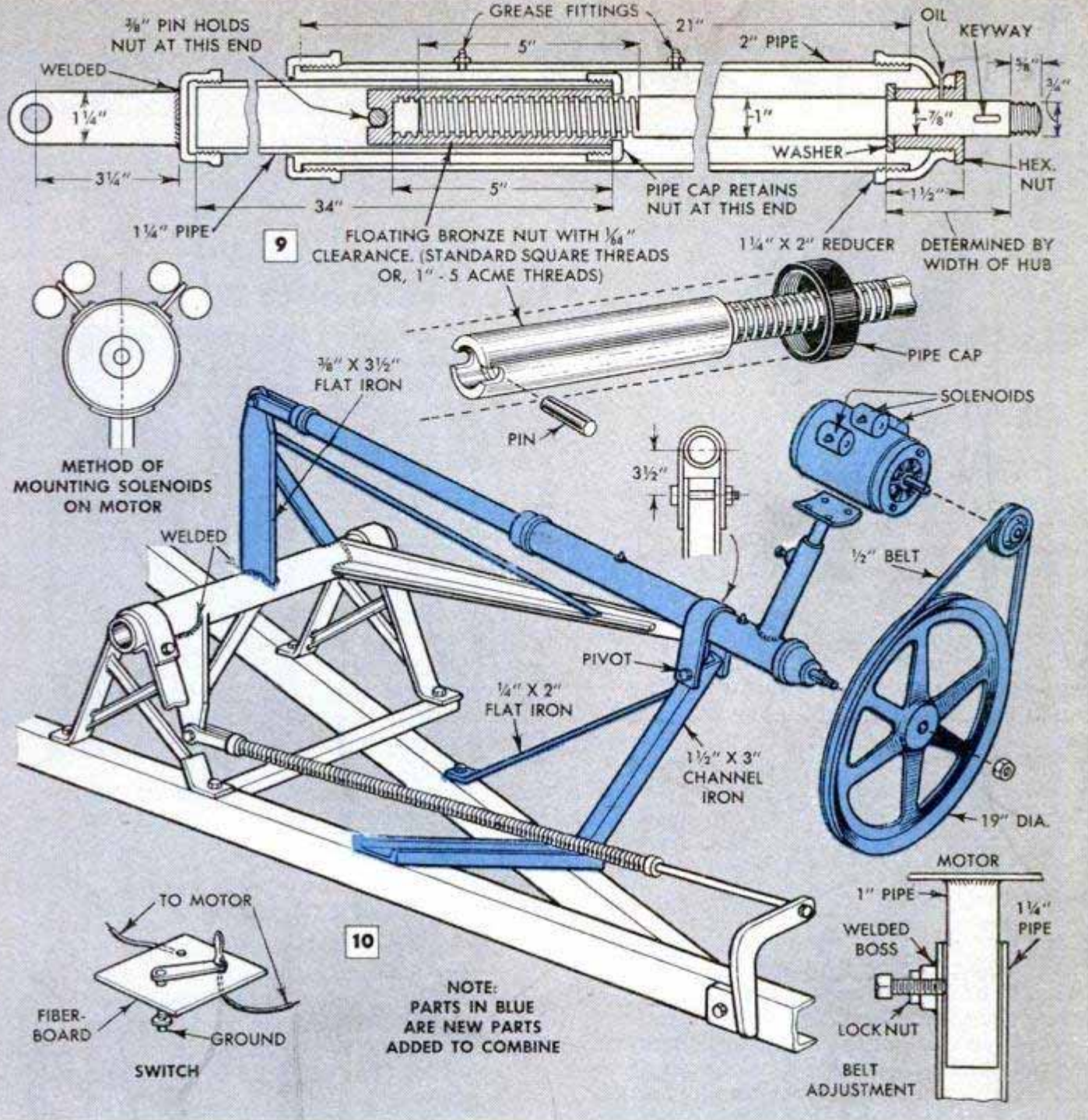

you do not feel capable of doing this job yourself, your local garage mechanic or electrician should be able to do it. Notice in the diagram that four solenoid switches are used instead of manually operated switches, the solenoids being mounted on the motor housing. This is done to avoid running a number of wires to a reversing switch mounted within convenient reach of the tractor driver. With this hookup, it is only necessary to run two wires to the reversing switch on the tractor. This switch is made as shown in the lower left-hand detail of Fig. 10. It is nothing more than a piece of fiberboard fitted with two brass-screw contacts and a brass lever, the latter being grounded to complete the circuit.

In this way, only three wires are required from the tractor to the combine, two to the

switch and starter motor and one from the tractor generator to the battery on the combine. However, it will be necessary to use a heavy insulated wire to ground the frames of the tractor and combine together to complete the battery-charging circuit. When connecting the battery on the combine, ground the same side of the battery to the combine frame as is grounded on the tractor battery. With a hookup like this, you have two separate electrical circuits handled by one generator, hence the reason for grounding the frames of the combine and the tractor together.

If the control unit does not operate the cutter bar rapidly enough to suit you, use a smaller pulley on the jackscrew. A pulley 19 in. in diameter was found suitable on the original installation.

Bending Thin-Walled Conduit

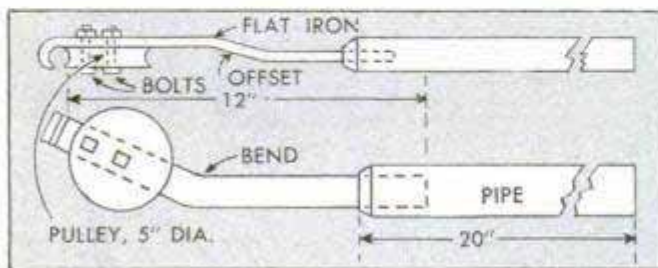

An electrician designed this bender especially for making short-radius bends in thin-walled conduit without crushing or folding it. The shank of the bender is made from a length of flat iron. One end is forced into a 20-in. length of pipe and welded to form a suitable handle. The other end of the shank is heated and bent around a rod of the same radius as the conduit. Next, the shank is bent edgewise and offset bends are put in as indicated. Then a grooved pulley, or better, a rope sheave having a round-bottom groove of the same radius as the conduit, is attached to the shank with two bolts. In use, the bender is slipped over the end of the conduit and the handle is pressed downward to start the bend. By "inching" the bender along the conduit and applying the necessary bending pressure at regular intervals, uniform bends of almost any required radius are made easily.

Adolph Sprenzel, Chicago.

Spring-Cushioned Drawbar

When operating certain types of tractor-drawn farm equipment over rough ground or in terraced fields, a spring-cushioned drawbar snubs the violent forward and backward thrust on a loose-pinned hitch and also eases the tractor into the load



without a sudden jerk when starting. It is especially useful on tractor trailers hitched either singly or in tandem. As pictured, two heavy L-brackets are bolted to the drawbar. The ends are drilled to take the rod which carries the coil springs and an eye or clevis-type yoke at the outer end. The springs bear against the brackets and also against stops on the rod to give both forward and backward snubbing action.

Mole Trap Weighted With Spikes

One farmer wired two spikes from an old spike-tooth harrow to his mole trap and thus considerably increased the effectiveness of the trap. Because of the recoil of the lighter trap, the animals often were able to wriggle free of the prongs. However, with the addition of the spikes, which weigh approximately two pounds each, much of the recoil is overcome, giving the trap a fast, positive action.—A. E. Holden, Angola, Ind.

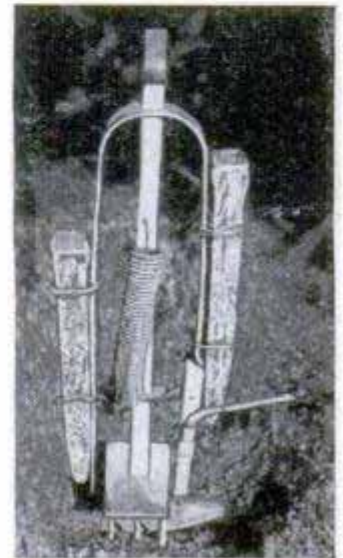

Cleaning Rubber Stamps

Rubber-stamp lettering that becomes clogged and blurred can be cleaned quickly by stamping it a few times on the sticky side of a piece of cellulose tape. Stamp pads can be cleaned by pressing tape against them.—A. E. Howell, San Diego, Calif.

Creosote Dispenser for Cornfield

To keep chinch bugs out of a cornfield, use this handy dispenser for quickly applying creosote to a tar-paper "fence." The dispenser is made by soldering two lengths of copper tubing to the sides of a gallon motor-oil can near the bottom. These are bent to direct a stream of creosote to each side of the fence simultaneously. The cover of the can is punctured to permit the entrance of air and allow the creosote to flow freely.

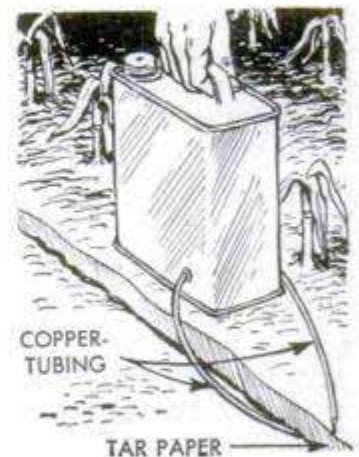

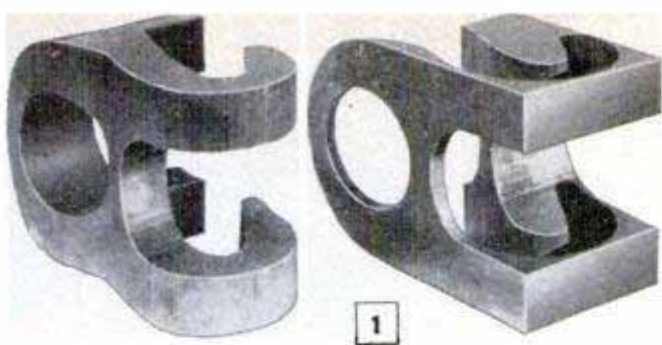

1

BANDSAWED "CASTINGS"

By Alexander Maxwell

MANY PARTS that normally would be cast or forged can be produced quickly in the small machine shop, and even in the home workshop, simply by cutting them out with a bandsaw. Bandsawing is especially helpful where only a single part or, at most, only a few identical parts must be made from steel and nonferrous metals. The speed with which the average job can be done cuts production costs to the minimum. Intricate work involving short-radius compound cuts can be done on any small bandsaw by using the proper blade and reducing the wheel speed in accordance with recommendations which have been worked out by manufacturers of metal-cutting blades.

Typical examples of bandsawed metal parts are pictured in Figs. 1, 3, 8, 10 and 13. Note the intricate compound cuts, the neatly turned fillets and the precise short-radius cuts which have been produced in forming these parts by bandsawing. In some cases, the work will not even require filing or grinding unless, of course, it is necessary to ream bore sizes, break (round) corners or finish-grind a flat to serve as a working surface for succeeding operations. In most cases, sawing is done



2

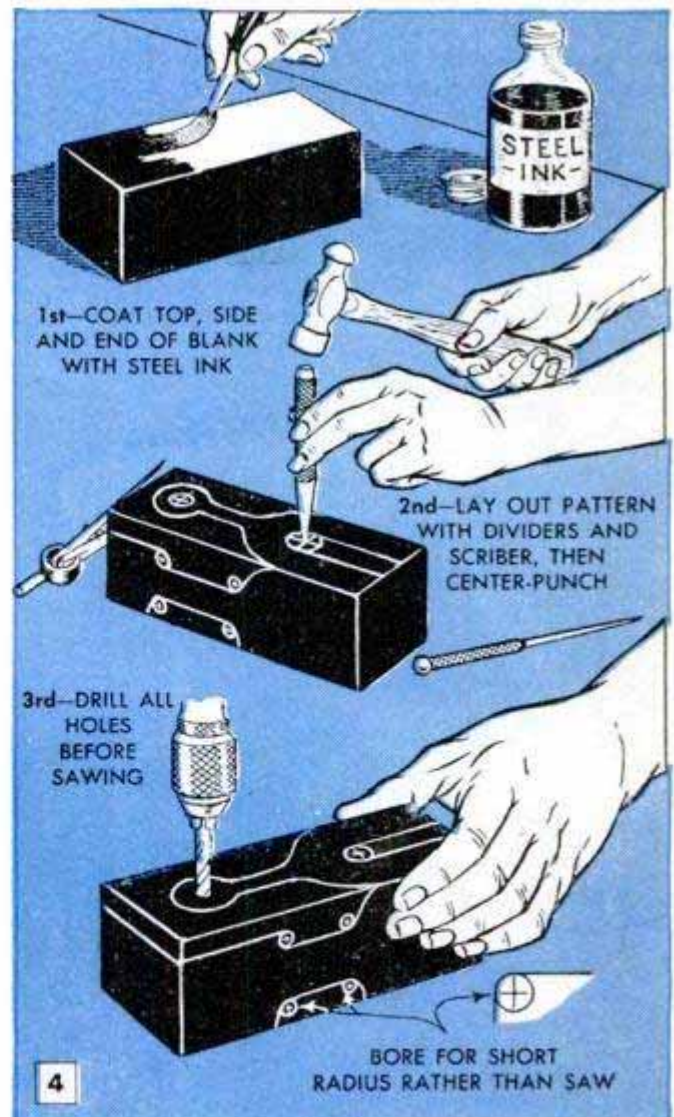

4

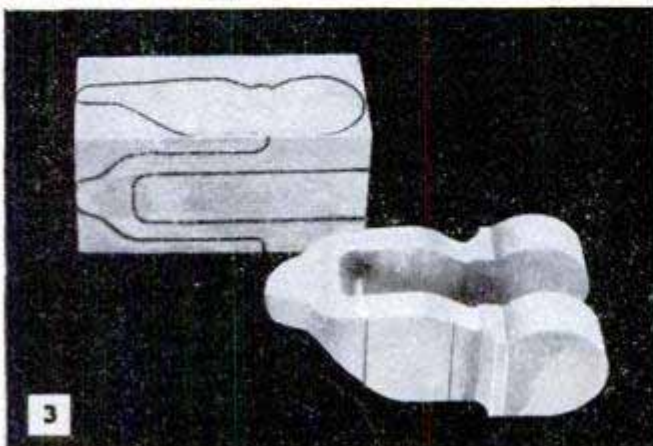

3

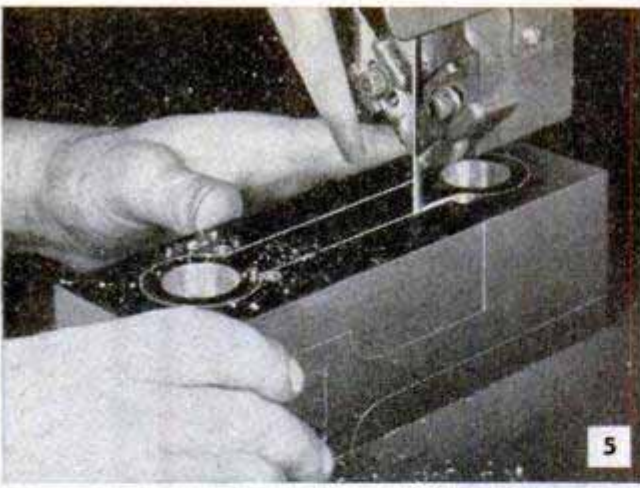

5

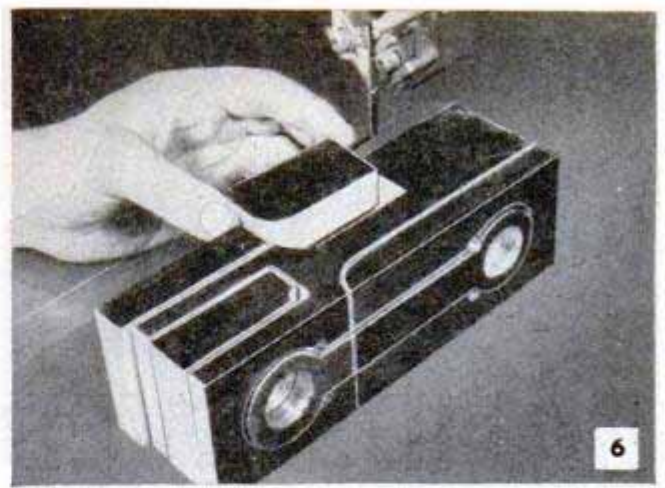

6

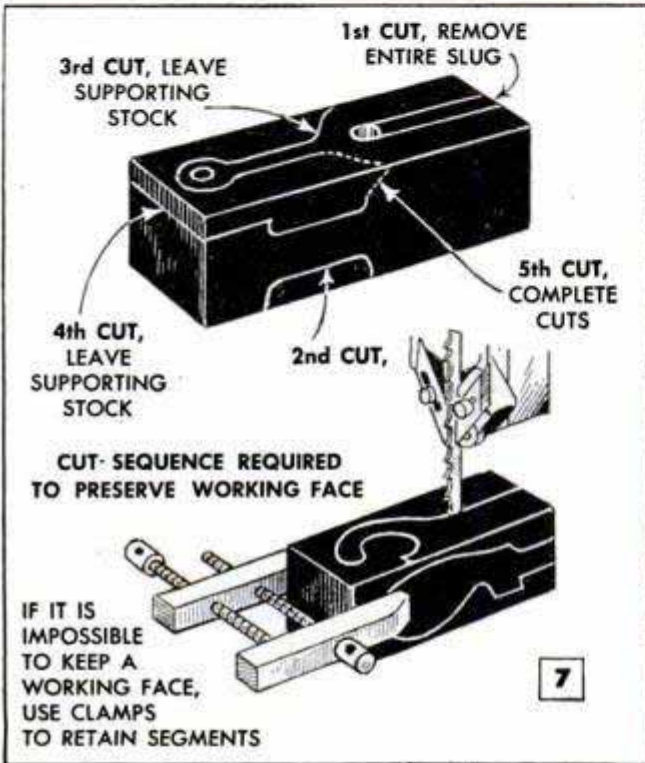

7

freehand as in Fig. 2, but on some types of work, particularly larger parts where involved short-radius cuts are necessary, special jigs and fixtures must be used to assure uniformity, Fig. 13. In freehand operations the sawing technique is simple but rather tiring for the operator, as the trick in producing clean cuts is in maintaining a constant and uniform pressure on the work. The importance of uniform pressure is shown in the left-hand detail in Fig. 2. Each saw tooth performs exactly like any edged metal-cutting tool when cutting thick stock. As each tooth engages the work it lifts a chip, curls it and carries it all the way through. If the pressure is uniform, the chips will be uniform in size and the edges of the work will be smooth but, if the pressure varies, or if the work is stopped momentarily, the blade will vibrate sidewise, causing a ridge to form on the side of the saw cut. Maintaining con-

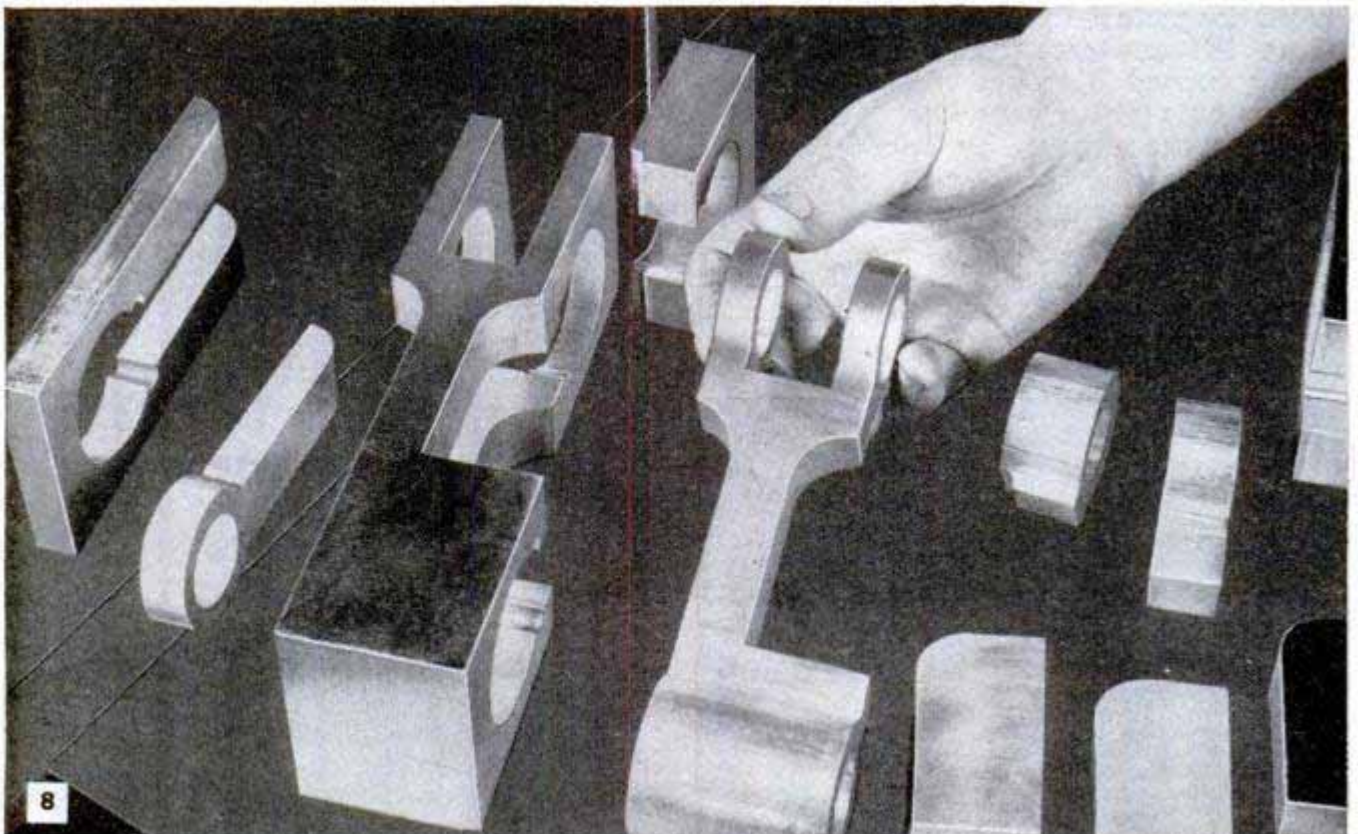

8

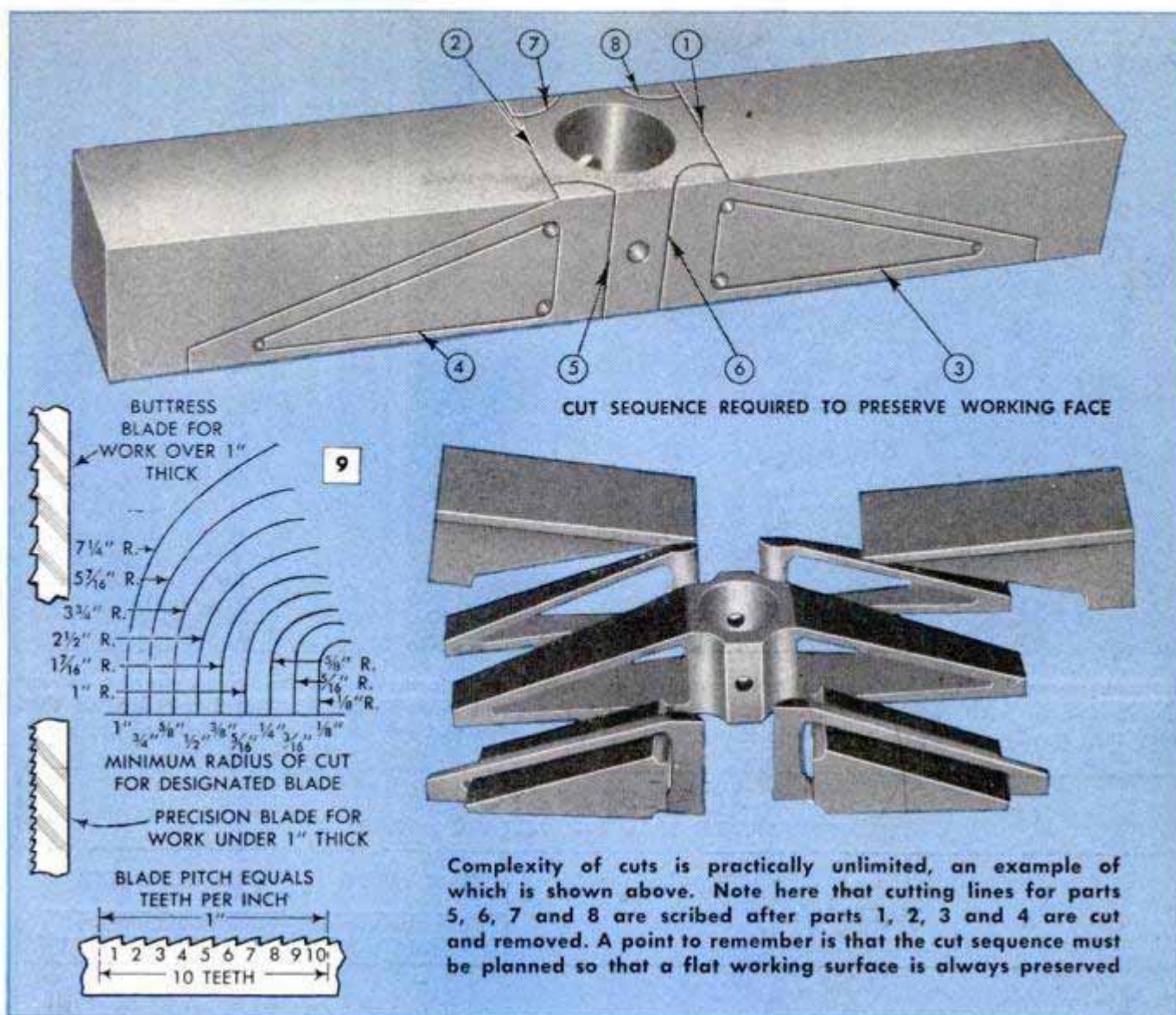

stant cutting pressure is especially important when making cuts on a radius, as the blade is then subjected to lateral thrust and tangential stress not encountered in the straight-line cut.

On some types of work the complete layout can be made on the blank before any cuts are made. On other jobs, only a part of the layout can be made before cutting. Figs. 4 and 7 detail typical layout procedure. In the first step, Fig. 4, the metal blank is coated with a preparation known to the trade as "steel ink," a quick-drying purple lacquer through which the layout lines are scribed with a sharp-pointed scriber or dividers. The contrast between the dark-purple ground and the brilliance of the scribed line on the metal makes the layout line easy to follow. Radii less than the minimum turning radius of the band-saw blade are formed by center-punching and drilling before sawing. The minimum turning radius for blades ranging from 1/8 to 1 in. wide is given in Fig. 9. In making cuts which must pass successively through the work in two directions, it is necessary to plan the procedure so that there will always be a flat working surface in contact

with the table, Figs. 5, 6 and 7. Otherwise, there is danger of the work twisting or rocking on the table and kinking the blade. In most cases, pieces removed by sawing are clamped back into place as in the lower detail, Fig. 7, thus preserving the original bearing surface of the blank until all separate cuts have been completed. In Fig. 9, the cuts are numbered in the order in which they must be made to preserve a working face. Inside cuts, that is, those which cannot be started from an outside edge, are made by breaking or cutting the blade, passing one end through a turning hole and then rewelding. After the cut is finished, the blade is again broken, withdrawn from the work and rewelded. Production machines are provided with built-in welders designed especially for this purpose. Separate blade welders are available for shops not equipped with machines having built-in welders.

The left-hand details in Fig. 9 show two types of metal-cutting blades in common use. The buttress, or skip-tooth blade, in the narrow widths is used for work over 1 in. in thickness, while the regular blade, with the standard tooth spacing, is used on

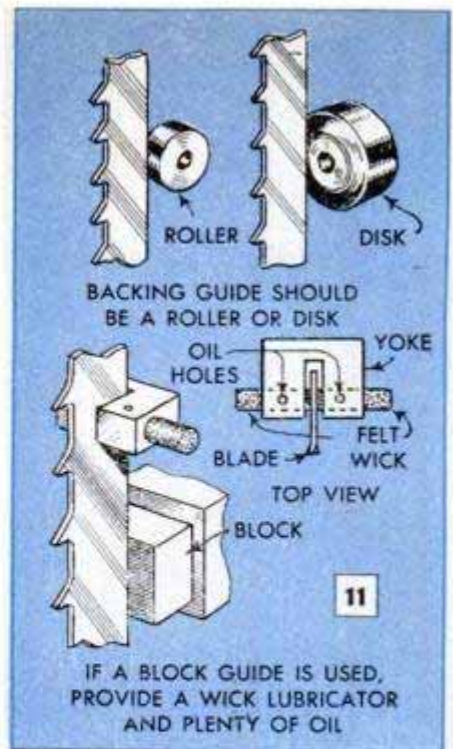
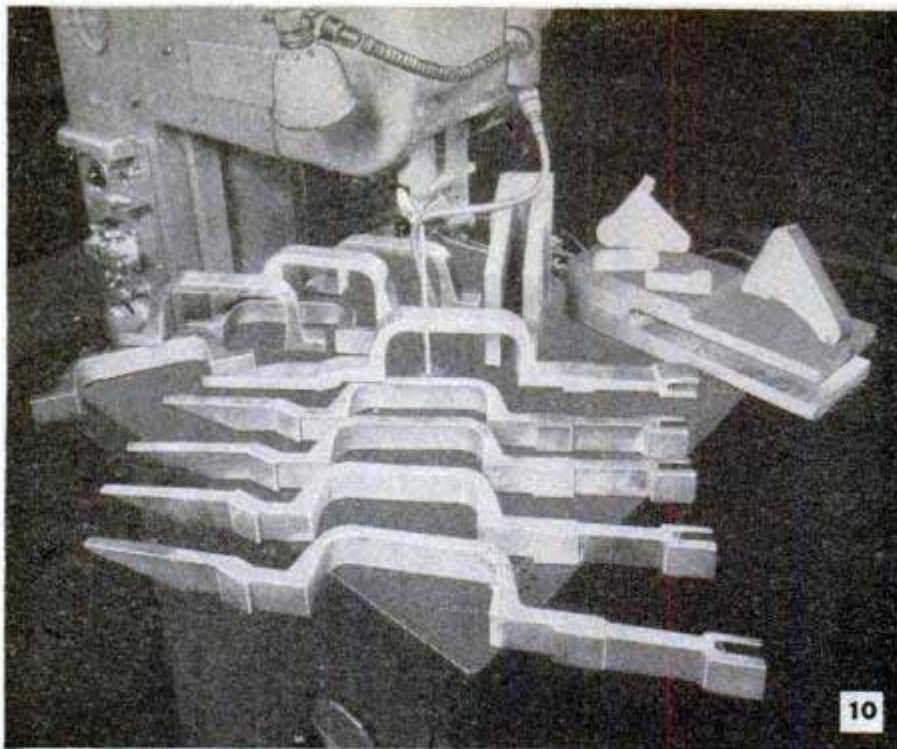

Intricate work having short-radius turns requires a careful setting of the blade guides. Before setting the guides, be sure the blade is correctly tracked on the band wheels. Set the backing rollers so that they turn slowly when the machine is idling. Set the guide pins to bear on full body width of the blade

CHART I

JOB SELECTOR
SAW SPEEDS, 50 TO 1500 FEET PER MINUTE

MATERIALS	SAW PITCH				SAW VELOCITY			
	Work Thickness				Work Thickness			
	1/16"	1/4"	1"	3"	1/16"	1/4"	1"	3"
STEELS—S.A.E.								
Carbon Steels #1010-#1095.....	24	14	10	6	250	200	175	150
Manganese Steels #T1330-#T1350.....	18	14	12	8	200	150	125	100
Free Machining #X1112-#X1340.....	18	14	10	6	250	200	175	150
Nickel Steels #2015-#2515.....	18	14	12	8	175	125	100	75
Nickel Chromium #3115-#3415.....	18	14	12	8	125	100	75	50
Molybdenum Steels #4023-#4820.....	18	14	12	6	150	125	100	75
Chromium Steels #5120-#5150.....	18	14	12	6	150	125	100	75
Chromium Steels #51210-#52100.....	24	14	10	6	100	75	50	50
Chromium Vanadium #6115-#6195.....	18	14	12	8	175	100	75	50
Tungsten Steels #7260-#71360.....	13	14	12	8	150	100	75	50
N. E. Steels #8024-#8949.....	18	12	8	6	175	175	150	150
Silicon Manganese #9255-#9260.....	18	14	10	6	175	125	100	50
CASTINGS								
Gray Cast Iron.....	18	14	10	6	200	150	100	75
Malleable Cast Iron.....	18	12	8	6	200	175	150	125
Meehanite.....	18	10	8	6	150	100	75	50
Nickel Iron, Cast.....	18	12	10	6	200	150	100	50
Steel, Cast.....	18	14	12	8	225	200	150	75
Swedish Cast Iron.....	18	12	10	6	200	150	100	75
ALUMINUM AND ALUMINUM BASE ALLOYS								
Aluminum (Pure, Rolled or Forged).....	18	10	6*	6*	1500	1500	1100	750
Duralumin 14ST.....	18	10	8*	6*	1500	1500	1200	750
Duralumin 17ST.....	18	10	6*	6*	1500	1500	1500	1500
Duralumin 24ST.....	18	10	6*	6*	1500	1500	1500	1500
Aluminum (Cast).....	18	10	6*	6*	1500	1500	1200	750
OTHER METALS AND ALLOYS								
Babbitt—Lead.....	14	8	6	6	1500	1500	1500	1500
Brass (Soft).....	18	14	8*	6*	1500	750	350	300
Bronze—Aluminum.....	18	12	10	6	500	300	225	150
Bronze—Ampco.....	18	12	10	6	200	150	100	75
Bronze—Manganese.....	18	12	8	6	300	250	225	150
Bronze—Phosphorus.....	18	14	10	6	500	300	200	150
Bronze (Tobin, Naval Brass).....	18	12	10	6	300	250	225	200
Beryllium Copper.....	18	12	8	6	400	300	250	150
Copper (Med. Hard).....	18	10	6*	6*	1100	700	500	200
Magnesium.....	14	10	6*	4*	1500	1500	1500	1500
Gunite Castings.....	24	18	12	8	300	175	125	100

* Use buttress Nos. 2 and 3 pitch only on aluminum as indicated by asterisk. Use No. 3 buttress on brass, copper and magnesium as indicated.

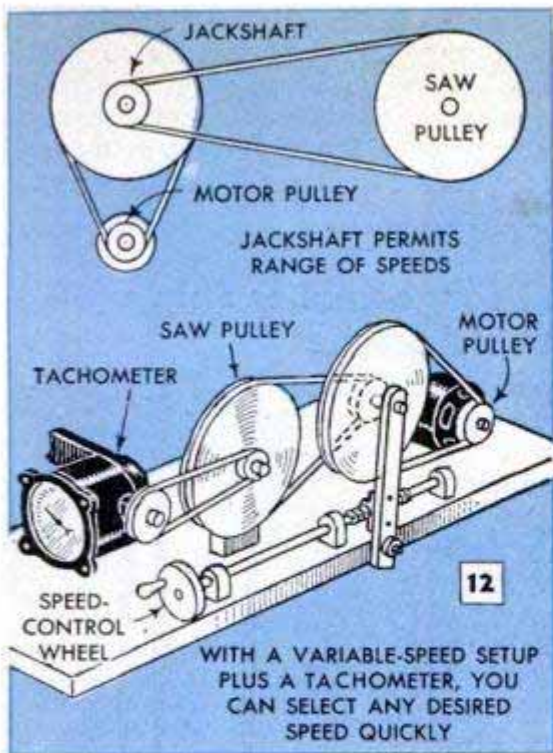

work less than 1 in. in thickness. Note also in Fig. 9 that the blade pitch is designated as the number of teeth per inch. Chart I gives general data on blade pitch and blade velocities required to handle a wide range of metals available in stock sizes. This chart is not intended to supplant manufacturer's specifications which may vary from it, but is included merely to give a general idea of the requirements.

On small bandsaws designed primarily for woodworking, it is necessary to make a careful adjustment of the blade guides before cutting metal. Nearly all small machines are fitted with roller guides above and below the table. On some of these, the back of the blade runs on the periphery of the roller while on others the back of the blade bears against the side of the roller. The upper details in Fig. 11 show the two types. On some older machines the back of the blade bears on a fixed pin. In this case it will be necessary to provide wick lubricators as in the lower details, Fig. 11. It also is important to track the blade and adjust the roller so that the stationary guide pins, which bear against the blade from both sides, give full support to prevent the blade from twisting or "running out." Adjust the roller in or out to bring the full body width of the blade between the guide pins, allowing only the set points of the teeth to clear the corners of the pins.

CHART II—BANDSAW BLADE SPEEDS

REVOLUTIONS PER MINUTE (APPROX.)	SIZE OF BANDSAW WHEELS			FEET PER MINUTE
	10"	12"	14"	
				50
				75
				100
50				125
		50		150
			50	175
				200
				225
100				250
		100		300
150			100	400
		150		500
			150	600
				700
300	250		200	750
450	350		300	1100
500	400			1200
550	500		400	1500

FIGURES CORRECT WITHIN 10 PERCENT + OR - WHICH IS CLOSE ENOUGH

Chart II outlines the average speed-reduction requirements and Fig. 12 suggests methods of reducing the band-wheel speed. The lower detail shows a multiple-pulley speed reducer utilizing an expansible pulley for speed variation. The unit is belted to a tachometer which indicates the speed of the bandsaw pulley.

Wire Guard Excludes Predators From Poultry Runs

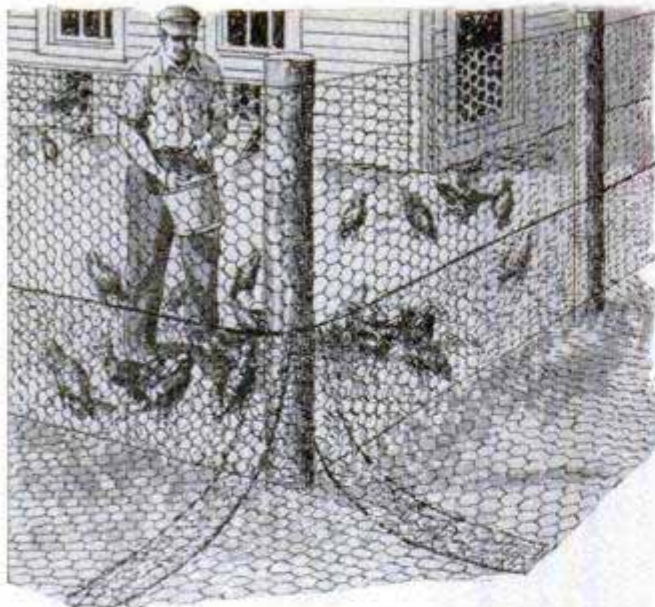

To prevent foxes, weasels and other predators from gaining entrance to his poultry runs by digging under the fence, one poultryman attached mats of woven wire to the outside of the fences with staples and lengths of smooth wire. Arranged in the manner pictured, the mats effectively prevent small animals from digging under the fence and also keep them from getting near it, as no solid foothold is obtainable on the slanting portion of the wire mats.—John Krill, North Lima, Ohio.

Stair-Step Stile for Farm Fence

Climbing over a high wire fence is made easy by this stair-step stile. As you can see from the photo, it's built just like an open stair unit, the treads being cut from 2 x 8-in. stock and spiked to 2 x 10-in. runner planks. Lower treads are passed through the wire mesh while the upper ones go through the

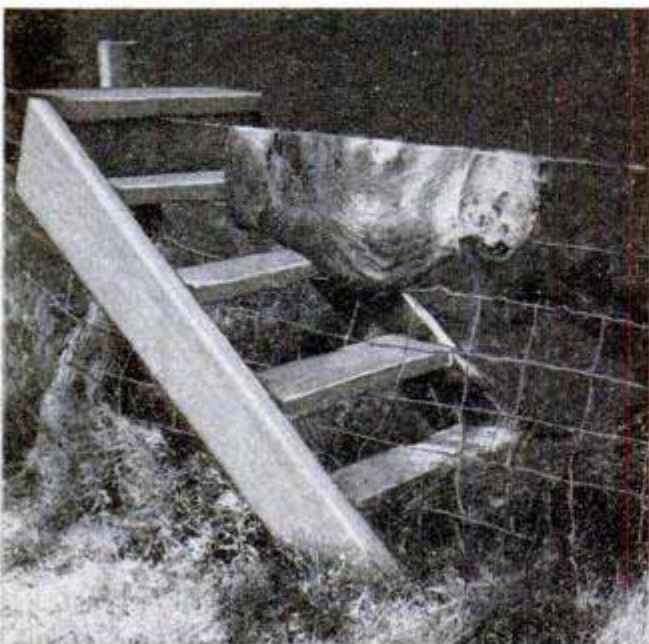

spaces between the individual strands, the top tread being nailed to the fence post. The treads are spaced equally on each side of the wire and the top barbed-wire strand is covered with a piece of canvas or a burlap sack to protect the user from the sharp-pointed barbs.

Slits in Sponge-Rubber Strip Hold Artists' Brushes

A strip of sponge rubber glued to a taboret or drawing board provides a convenient holder for artists' brushes. A slit is cut partially through the thickness of the rubber for each brush which is simply pressed into the

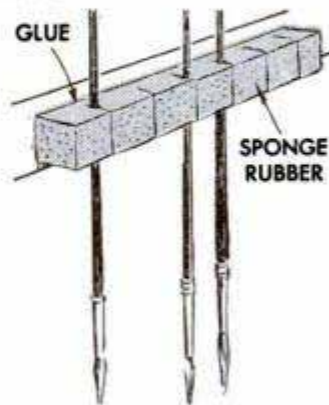

slit when not in use. With this holder the brushes can be stored in a bristle-down position, thus keeping water from softening the glue in the heel of the brush and prolonging its life.—Fred Linn, Chicago.

Inserting Hectograph Ribbon Without Soiling Hands

It is not necessary to soil the hands when inserting a hectograph ribbon in the typewriter. Just fasten a leader of ordinary ribbon to the end of the hectograph ribbon using cellulose tape, and thread the leader in the machine.

Jig Aids Machining Flats on Taper

When Morse tapers are turned in a shop that does not have a milling machine, this useful jig permits a shaper to be used to machine the tongue at the end of the taper. The jig is made to the dimensions given in the detail and carefully bored and reamed to fit the Morse taper. When machining the flats on the taper, both sides of the jig are chalked to prevent metal accidentally being removed from the jig. The setscrew keeps the taper from turning in the jig while it is being machined and any marks left by the screw are removed before using the taper.—Earl R. Goddard, Denver, Colo.

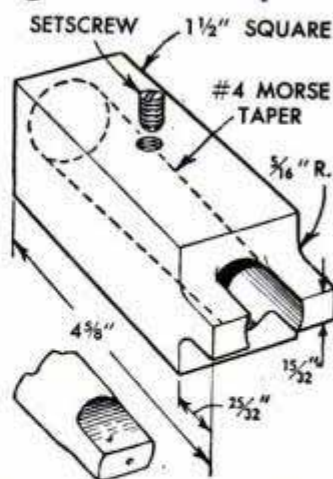

HELPFUL HINTS FOR 1950

A—Producing large-size images from TV screens of nominal dimensions, this glareless, flat and extremely thin lightweight screen utilizes the Fresnel principle of magnification. Advantages are claimed to include good optical quality and freedom from edge distortion. The magnifying element of the screen is a thin sheet of Plexiglas into which hundreds of tiny circular grooves are pressed. It includes a glare filter and enlarges the image from a 10-in. TV tube up to the size received on a 16-in. tube.

B and C—High-fidelity amplifier, specially designed for those critical experimenters who assemble their own combination phono-radio sets. With the increased number of FM stations now on the air, and the wider use of microgroove records, a high-fidelity audio amplifier of the type shown in the photos is desirable. No technical knowledge is necessary to make interconnections. Photo B shows the simple controls, and photo C is a rear view with the top cover removed. Output impedances permit connection to any type of speaker, and to magnetic cutting heads of disk recorders. Push-pull 6L6 tubes give high output at low distortion.

D—Tiny hearing aid, demonstrated recently at Radiolympia in London, also includes a radio receiver for receiving one broadcast program.

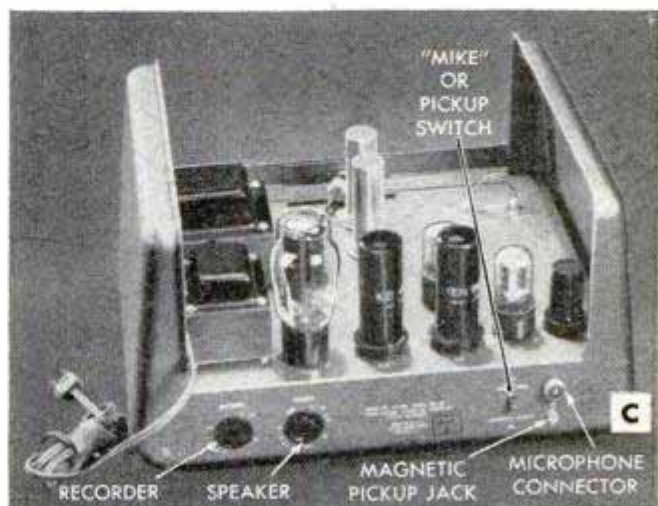

1950 "LITTLE GIANT"

By L. M. Dezettel

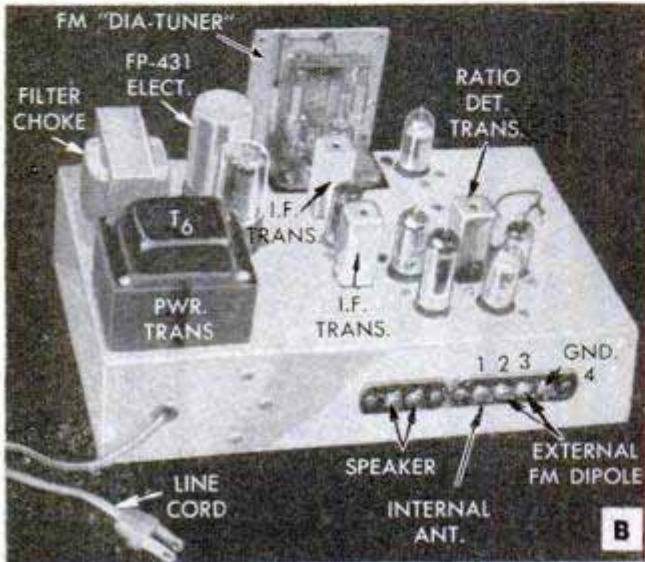
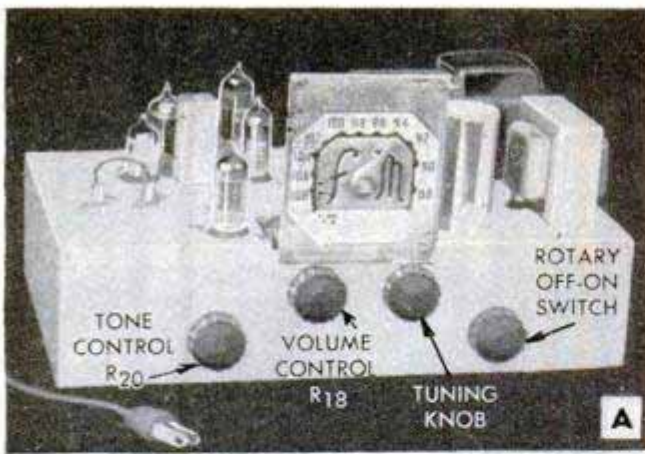

RESISTORS

R1 — 470 ohms, 1/2-watt carbon	R15 — 6800 ohms, 1/2-watt carbon
R2 — 2200 ohms, 1/2-watt carbon	R16 — 6800 ohms, 1/2-watt carbon
R3 — 4700 ohms, 1-watt carbon	R17 — 1 megohm, 1/2-watt carbon
R4 — 4700 ohms, 1-watt carbon	R18 — 500,000-ohm volume control, audio taper 1/4" (Molly U-48)
R5 — 4700 ohms, 1-watt carbon	R19 — 470,000 ohms, 1/2-watt carbon
R6 — 100,000 ohms, 1/2-watt carbon	R20 — 200,000-ohm tone control
R7 — 68 ohms, 1/2-watt carbon	R21 — 270,000 ohms, 1/2-watt carbon
R8 — 4700 ohms, 1/2-watt carbon	R22 — 470,000 ohms, 1/2-watt carbon
R9 — 470,000 ohms, 1/2-watt carbon	R23 — 330 ohms, 2-watt wire-wound
R10 — 68 ohms, 1/2-watt carbon	R24 — 3000 ohms, 10-watt, wire-wound
R11 — 4700 ohms, 1/2-watt carbon	R25 — 700 ohms, 10-watt, wire-wound
R12 — 220 ohms, 1/2-watt carbon	R26 — 3900 ohms, 1/2-watt carbon
R13 — 3.9 ohms, 1/2-watt wire-wound	
R14 — 22,000 ohms, 1/2-watt carbon	

DEFINITELY the most popular construction article for the radio student and experimenter is the one describing the "Little Giant" model that always appears in the March issue of Popular Mechanics Magazine. It is designed to include new features of special interest to advancing students and experimenters. Although this model is not intended for beginners, it is simple to build. The receiver to be described tunes the entire FM band from 88 mc. to 108 mc. While it does not include AM broadcast reception, figures show that FM broadcasts now cover a greater area of the United States than AM. The band from 88 mc. to 100 mc. is for worldwide broadcasting use; therefore, this complete FM student receiver may be used in any country where FM broadcast programs are available. Nearly all programs carried on AM are duplicated on FM.

This complete FM receiver may be housed in a table-type cabinet or it may be incorporated into a combination console. The outstanding feature that makes it comparatively easy to build is the availability of the completely prewired and aligned front-end FM tuner. This FM "diatuner" is a permeability-tuned unit made by the Aermotive Company and is available from all radio supply houses. It comprises all of the parts and wiring shown in the white block in circuit diagram Fig. 3. As only four connections are necessary to incorporate it in the circuit, it greatly simplifies construction. The antenna coupler coil and R.F. choke coil No. 1 are made by the same manufactur-

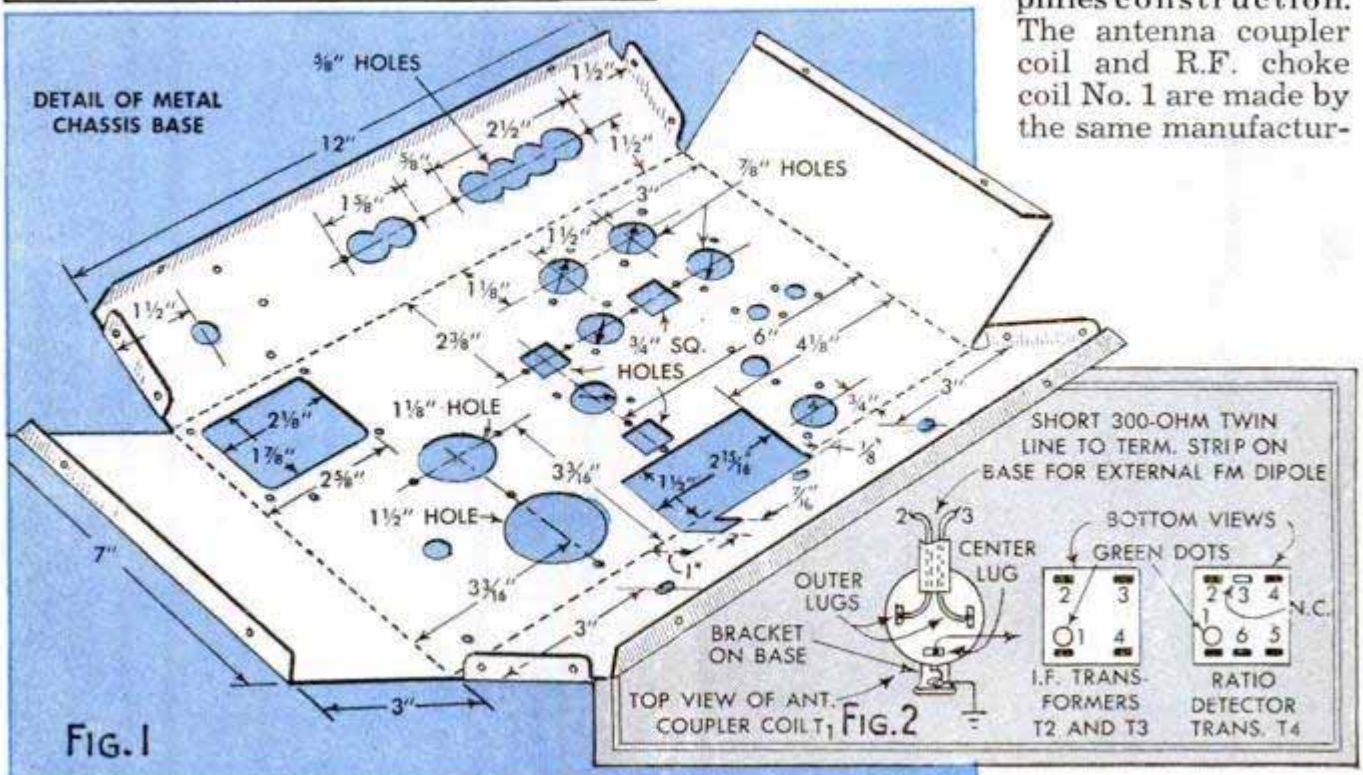

IS A COMPLETE FM RECEIVER

er. The Stanwyck midget-type transformers, T2, T3 and T4 shown in Figs. 2 and 3, are available from all parts houses. Additional features include choice of built-in antenna or a standard outdoor FM dipole. Of special interest is the recently available disk-type ceramic condensers which are used in place of the older and larger tubular paper-type condensers. They are flat and about the diameter of a dime. Their small size saves space and permits the use of the shortest possible leads, which is important in the high-frequency FM circuit. Some very small tubular ceramic condensers are also used.

When mounting the tube sockets on the metal chassis base, detailed in Fig. 1, arrange them so that they are keyed in the positions indicated by the arrows. Follow the parts layout just as identified in photos A, B and D. Assemble the dia-tuner last so as to reduce the possibility of damage to it. Chassis cutouts for the dia-tuner and power transformer can be made with a coping

(Continued to page 234)

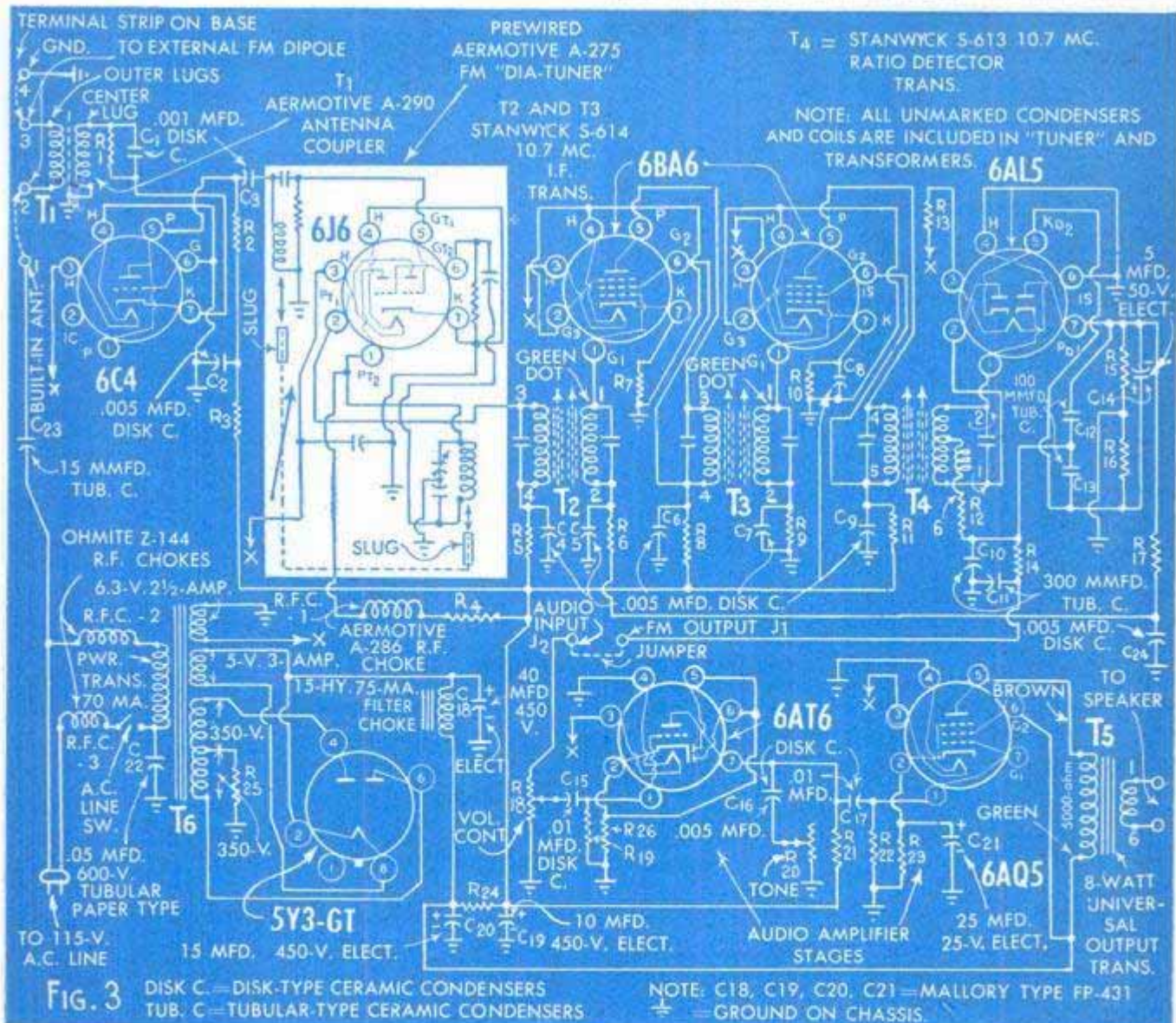
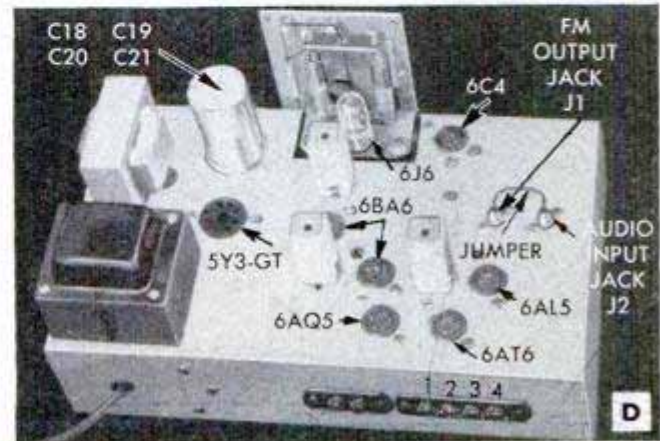

Power Units for Phone Transmitter

PART II

ALTHOUGH it is quite possible that many amateurs have suitable power-supply units to operate the 160-meter phone transmitter described in the February issue, others may not. The units illustrated in photos A and B are employed in the original rig. Photo C is an underside view of the large transmitter power-supply unit. The sheet-metal chassis base of this unit is 3 x 7 x 17 in. and the base for the separate modulator power-supply unit is 2 x 7 x 11 in. Both of these bases are standard sizes and are available from radio-parts houses. These units supply plate voltage for the modulator, and both plate and heater voltage for the R.F. section of the transmitter. Dual electrolytic condensers C4, C5, and C6, C7 are directly back of T5 in photo A.

(Continued to page 236)

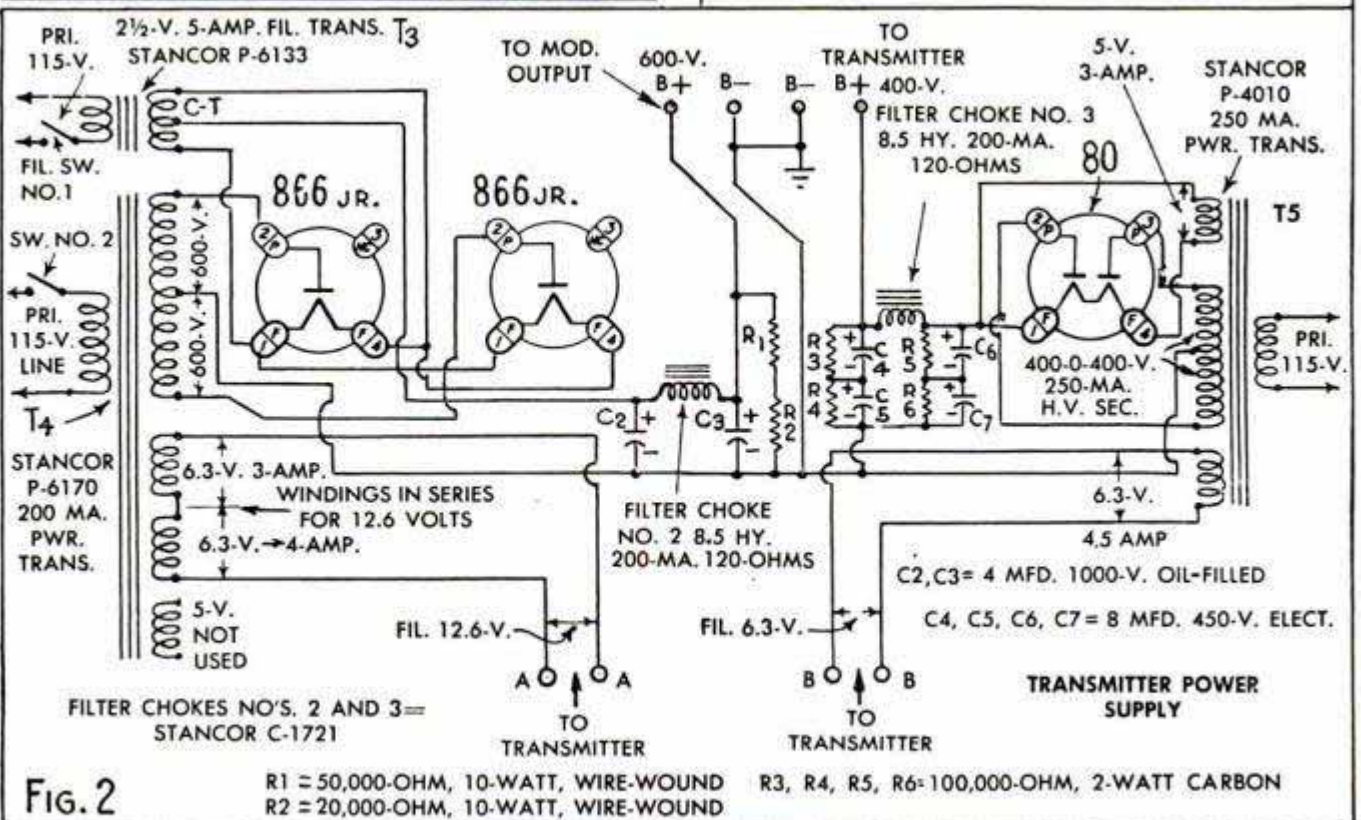
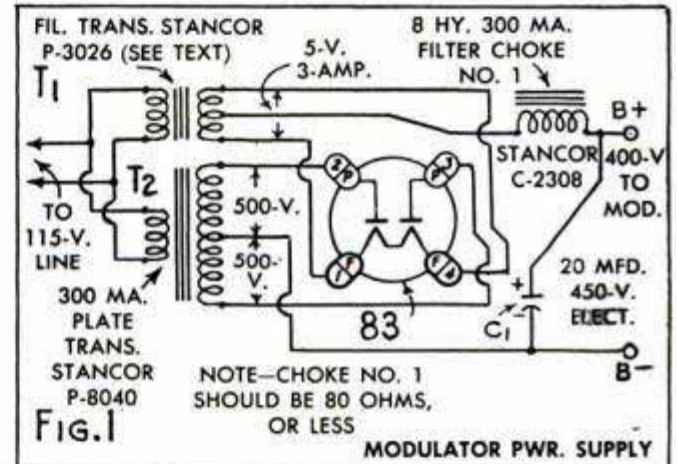
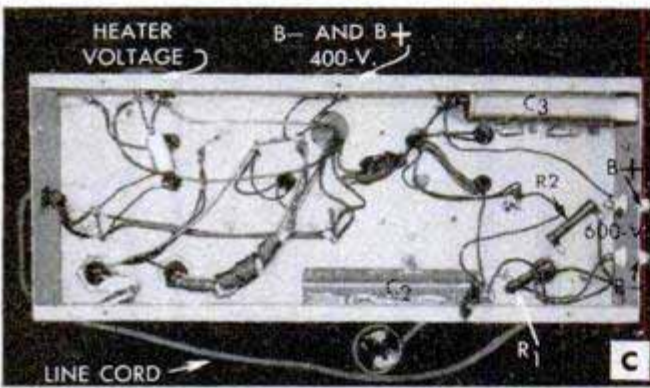
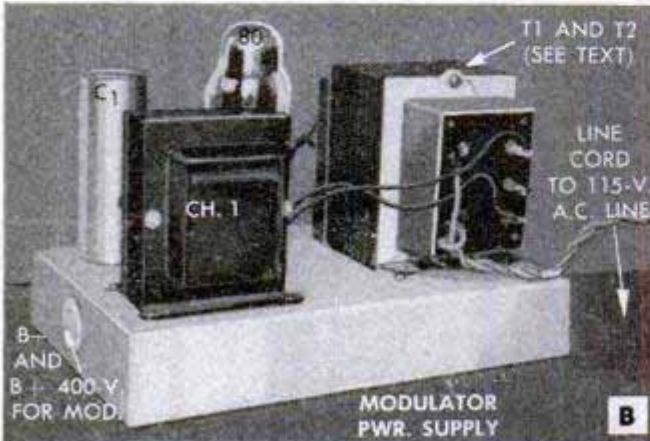
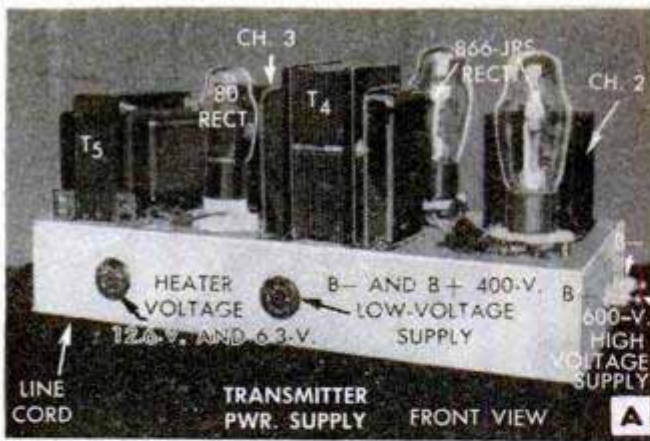

R1 = 50,000-OHM, 10-WATT, WIRE-WOUND R3, R4, R5, R6-100,000-OHM, 2-WATT CARBON
R2 = 20,000-OHM, 10-WATT, WIRE-WOUND

TAILOR-MADE FOR YOU— in performance...in price

See these fine 2x2 slide projectors
at your Kodak dealer's

Images 7 feet wide—

What a "throw"—what a color show! For all-round brilliant performance, look at the Model 2A. Two fine *Lumenized* lenses available, the Kodak Projection Ektanon 5-inch *f*/3.5 and the Kodak Projection Ektanon 7½-inch *f*/4. Heat-absorbing glass protects slides. Turn of knob tilts projector. Price, \$47.50. Accessory Kodaslide Changer, \$17.50.



**KODASLIDE
PROJECTOR,
MODEL 2A**

**KODASLIDE
PROJECTOR,
MODEL 1A**



Most for your money—

Kodak's "economy model," but with "big-time" performance. *Lumenized* optical system steps up screen brilliance 50%.

Cooling by convection. *Lumenized* Kodak Projection Ektanon Lens 4-inch *f*/3.5, 150-watt lamp, slide carrier, and 12-foot cord included in price, \$27.50.

Brightest of them all—

Projects your transparencies with new beauty, new brilliance and realism—at home or in an auditorium. 1000-watt lamp delivers more light to the screen than any other 2x2 projector. Turbine fan cools slides on both sides. Choice of 5 superb Kodak Ektar and Kodak Ektanon Lenses. Carrying case included. \$181 to \$295, depending on lens choice.



**KODASLIDE
PROJECTOR,
MASTER MODEL**

**EASTMAN KODAK COMPANY
ROCHESTER 4, N. Y.**

Kodak
TRADE-MARK



Care and Feeding of Engines

BY S. P. CORP

HOW OFTEN TO CHANGE OIL?

Within the past year there have been many conflicting recommendations on how often to change oil. One magazine article suggested that every 4000 miles is often enough under normal conditions. The point most often missed is that the average car owner does most of his driving between home and work. The engine does not have time to warm up enough. Sludge forms.

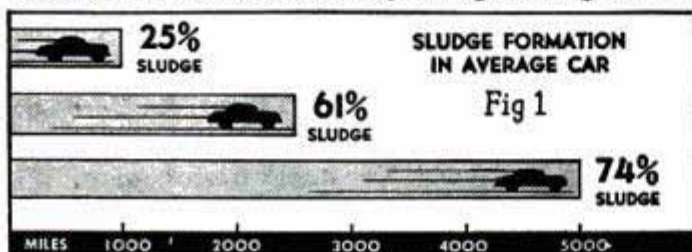

This sludge is potentially dangerous to your engine, no matter how efficient your oil filter. The best insurance against such danger is to change oil every 1000 miles.

WHAT ABOUT TIRE PRESSURE?

Many drivers are confused by conflicting advice on the new low-pressure tires. If you were told to keep this pressure at 24 pounds, remember that that means 24 pounds in a cold tire. A tire with a cold pressure of 24 pounds may have 29 pounds when hot. If you have tires checked while hot, and have the 29 pounds pressure reduced to 24, you will be running on under-inflated tires, and will notice rapid tire wear or uneven wear. If you have your low-pressure tires inflated while hot, inflate them to 29 pounds. They will have only 24 pounds when they cool off.

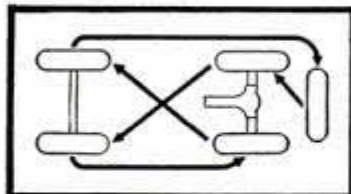

FIG. 2

WATCH FOR EXHAUST SMOKE

If you buy a used car, or if your new car has gone more than 20,000 miles, watch for exhaust smoke—an indication that you need new Sealed Power Piston Rings. There is a set of Sealed Power Rings specifically engineered to do the best possible job in your engine, whatever the make, model, or engine condition. No other ring equals the Sealed Power MD-50 Steel Oil Ring for oil control, even in badly tapered and out-of-round cylinders. To save oil, save gas, and restore engine power, get new Sealed Power Piston Rings when your exhaust smokes!

SWITCH TIRES FREQUENTLY

Due to different kind of wear on front and rear, it is important to switch low-pressure tires frequently, following the method indicated in Fig. 2.

1950 "Little Giant"

(Continued from page 231)

saw. The square cutouts for the R.F. transformers and ratio detector are easily made by means of the now available square punches that work by tightening a screw. Tube-socket holes can be made with similar round punches. Photo E shows the arrangement of the parts and wiring under the chassis base. If your power transformer has a filament center-tap lead in the form of two twisted wires, solder the ends together, then tape and coil this unused lead.

Alignment is best done with a high-resistance voltmeter or a vacuum-tube voltmeter. Connect the negative lead of the voltmeter to the negative side of the 5 mfd. 50-volt electrolytic condenser C14, and the positive lead to the chassis. Adjust the two

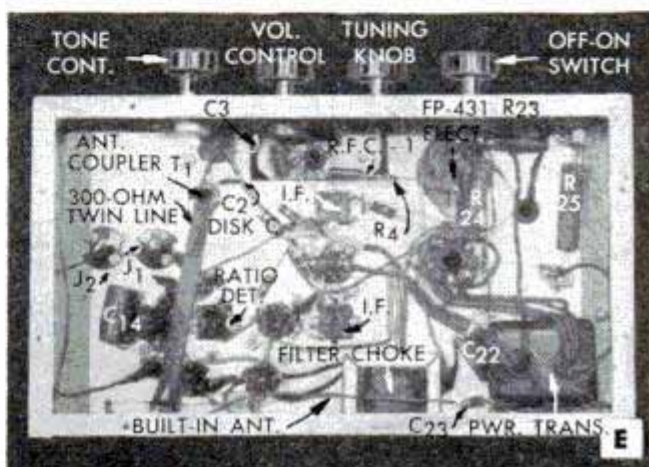

I.F. transformers for maximum reading on the voltmeter. These transformers are "slug-tuned" and require the use of a small insulated screwdriver. The trimmer slugs are reached through the top and bottom of each can. The bottom slug only of the ratio detector transformer should be adjusted for maximum voltmeter reading. These adjustments are, of course, made with a signal tuned in at the loudest point, or at maximum reading on the voltmeter. At the same time, adjust the small compression trimmer condenser on the top of the dia-tuner for maximum signal. The negative terminal of the voltmeter is connected to the junction of the 22,000-ohm resistor R14, the 220-ohm resistor R12 and the 300-mmfd. condenser C10. The positive terminal of the voltmeter remains on the chassis. Trim the top slug in the ratio detector transformer T4 counterclockwise as far as it will go without coming completely out. Now slowly turn the slug clockwise until the voltmeter begins to deflect. Deflection may be either above or below the zero reading. If it is below, reverse the polarity of the voltmeter. Continue to turn the slug until you

(Continued to page 236)

Take the Thrill-road to Good times!

RIDE A NEW 1950

HARLEY-DAVIDSON

HYDRA-GLIDE



RIDE THE "CHAMP"!

You've got a *new* thrill coming! A touch of the throttle and you're off like a comet! Hills melt away like magic! Rough roads fly beneath you with hardly a quiver of the handlebars. Steering is feather light. Braking is smooth and sure. Day-long riding leaves you fresh and ready for more fun as you take in exciting races, hillclimbs, delightful gypsy tours and club events. Easy payment terms bring you this finest Harley-Davidson of all time. See your Harley-Davidson dealer today. Mail the coupon now!

HARLEY-DAVIDSON MOTOR CO., Dept. P, Milwaukee 1, Wisconsin

Send for *free* copy of ENTHUSIAST Magazine filled with motorcycle action pictures and stories; also literature on new 1950 models.

Name.....

Address.....

City..... State.....

DEALERS: Valuable franchises available for the full line of famous Big Twins and 125 Model. Your opportunity to line up with the greatest name in motorcycles. Write or wire today.

obtain a maximum reading and it starts down again to zero. Optimum tuning is this zero point. When the proper adjustment is made, you should be able to tune through a station and hear a feeble station as you enter into peak tuning, then some distortion and next the maximum volume of the station. Then you pass through a path of distortion again and another feeble signal from the same station. After this, it goes out altogether. The center signal, or the loudest and clearest signal, is the proper one for listening in any FM set.

When using the built-in antenna, connect jumper wires from 1 to 2 and from 3 to 4; be sure to remove these jumpers, which are shown in Fig. 3, when you are using a standard outdoor FM dipole antenna. The jacks J1 and J2 are ordinary RCA-type phono plugs and jacks with a jumper wire connected to the plugs. This arrangement permits the builder to use a separate high-fidelity audio amplifier instead of the two built-in audio stages if desired. The built-in two-stage audio amplifier can also be used as an amplifier for a record player or an AM tuner if required. The PM speaker can be any size from 8 to 15 in. depending upon baffle and cabinet facilities. Photo C shows the set in operation on top of a Jensen bass-reflex speaker cabinet in which a 12-in. PM speaker is installed. Detailed student mate-

rial list R-387 is available from Popular Mechanics Radio and Electronics department upon receipt of ordinary letter postage.

Power Units for Phone Transmitter

(Continued from page 232)

The modulator unit has its own built-in power supply (which furnishes both screen voltage for the modulator tubes and plate and screen voltage for the speech amplifier tubes). The modulator plate supply can be simple as shown in diagram Fig. 1. A combination plate and filament supply transformer is shown in photo B but the separate Stancor transformers specified as T1 and T2 in Fig. 1 are advised as they are easier to obtain. A ceramic four-prong socket is mounted in the end of the chassis base to carry the power-output terminals to a standard four-prong cable plug. The large power-supply unit for the R.F. section is really two power units in one as will be noted in diagram Fig. 2. A separate filament transformer T3 is used for the 866-Jr. rectifier tubes. Filament switch No. 1 should be turned on to heat up these tubes before throwing the transmitting plate switch No. 2. All other filaments and plates can go on with switch No. 2. Detailed student material list R-386 covers the complete four-unit transmitter.



"But I always carry Weldwood Glue; it's wonderful for emergencies."



Remember Weldwood Glue when you need dependable wood-to-wood bonds. Quick and easy to mix with cold water . . . tremendously strong . . . stain-free . . . rot-proof . . . and *permanent*. At paint, hardware, variety stores and lumber yards. 15¢, 35¢, 65¢, 95¢ and larger sizes.

WELDWOOD PLASTIC RESIN GLUE

United States Plywood Corporation, New York 18, N. Y.

ALSO HANDY FOR WOOD HOBBYISTS!



Firzite

— to give you smooth finishes on fir plywood and other soft woods.

A pre-finishing material that seals the wood pores . . . tames the wild grain . . . virtually eliminates checking and grain raising. An excellent base for stain, paint or enamel. White or clear. White Firzite provides an easy, low-cost way to achieve "blond," "bleached" or "wiped" finishes.



Satinlac

— to preserve the beauty of all woods.

An inexpensive coating for the proper finishing of Weldwood Hardwood Plywood and similar woods. Clear. No brush marks. Brings out all the natural beauty of wood. Does not yellow or darken with age.

FIRZITE and SATINLAC are available from paint, hardware and lumber dealers. Write for leaflet No. 3 on finishing plywood.

NEW *Fastwin by Evinrude*



The
Gearshift Motor
with the
"All-Day" Tank



ABC
*O.S.C.
certified
brake H.P.
at 4000
R.P.M.

● Here's the happy combination for boating fun!

A great new Evinrude packed with eager performance! 14 horsepower* for thrilling speed! With *Gearshift Control*... you start in *Neutral*... back away from docks... maneuver with finger-tip ease. Separate *Cruis-a-Day Tank* provides fuel for an average day's running without re-fueling. Plug fuel hose into motor—stow tank anywhere! *Quik-Chek Fuel Gauge* tells you supply at a glance!

SEE YOUR EVINRUDE DEALER—and see the complete 1950 line of 6 advanced models... the right motor for every boat! New **FLEETWIN** with *Duo-Clutch*, 7.5 horsepower*, gives you *Neutral* for starting and idling, *Safti-Grip Propeller Drive* for trouble-free operation in shoal water. Two famed light models with revolutionary **FISHERMAN DRIVE**. Look for your dealer's name under "Outboard Motors" in the yellow pages of your phone directory. **CATALOG FREE**—write for it today! **EVINRUDE MOTORS**, 4462 N. 27th Street, Milwaukee 9, Wis.
In Canada: Evinrude Motors, Peterboro, Ontario



NEW
Fleetwin
with
DUO-CLUTCH

EVINRUDE FIRST IN OUTBOARDS
... FORTY-FIRST YEAR

Starrett

makes more than 3000 fine precision measuring tools designed to help you do better work with greater confidence and accuracy. Ask your Distributor to show you the right Starrett Tools for your job.



from 0.0001" ... to 100'

... USE **Starrett**[®]
PRECISION MEASURING TOOLS



Quick Reading Steel Tape No. 530.
25, 50, 75 and 100 foot lengths.

"Satin Chrome" Micrometer
No. 230. 1" capacity, tapered
frame, sycamore case.



Dial Indicator Gage No. 1010.
Vest pocket size — red plastic case.

Flexible Steel Rule No. 327. 6" length,
graduated two sides, in case.



Kit of Tools No. 902 for apprentices — the
same fine tools used by skilled mechanics.

GET THIS MECHANIC'S HAT — ONLY 15¢

Wear an official Starrett hat — the badge of a precision craftsman — on the job, in your home shop, working around the car, etc. Send 15¢ in coin to cover handling and mailing. Please specify head size. Address Dept. AP.



THE L. S. STARRETT CO. • ATHOL, MASS., U. S. A.

TRADE MARK
Starrett
REG. U. S. PAT. OFF.

Since 1880... Standard of Precision

MECHANICS' HAND MEASURING TOOLS AND PRECISION
INSTRUMENTS • DIAL INDICATORS • STEEL TAPES • HACKSAWS
BAND SAWS AND BAND KNIVES • PRECISION GROUND FLAT STOCK

Buy Through Your Distributor

Masterpieces in Miniature

(Continued from page 100)

the tiny hog truss himself, spliced it and secured it in genuine Egyptian fashion.

While these ships are old and interesting, Crabtree considers them "easy." Some of his more elaborate models would give a watchmaker nightmares.

The "St. Albans," a British ship launched in 1686 and bearing the extreme ornamentation of the era, has 270 minute carved figures set in the hull. A hundred cherubs, about 1/4 inch high, flit along stern and quarter galleries alone. Crabtree chipped, chiseled, carved and shaved away for three years, putting in thousands of hours before the last piece was in place. Under the cupids and the British coat of arms on the stern, are rows of windows of real glass set in tiny metal frames. Intricate gilt wreaths circle each gun port.

Even more elaborate is the Venetian galleass, a ship dating back to 1660, which combines the features of a sweep-driven slave galley and sailing ship. Decorating the hull of this gem are 359 sculptured figures in bas-relief. Babies' heads, no more than 1/16 inch in diameter, adorn the stanchions. The galleass has scuppers 1/16 inch in diameter. On the original, these scuppers were lead lined. So Crabtree lead lined his, too. He even wove eye-splices on the thread-thin shrouds, because that's what appeared on the real ship.

Crabtree's passion for accuracy knows no bounds. On his 42-inch French galley, containing 162 carvings, the 1/4-inch-high balusters were crowned with babies' heads back to back. This meant carving two sets of features on each tiny head! There are dozens of such balusters on the ship. Even the 40-odd sweeps for propelling the ship are adorned with carving. Under the scarcely discernible overhang on the ladder steps, he incorporated a molding, so fine it cannot be seen with the naked eye.

The ultimate in the realism department, however, is the fur and skin used on the models. Crabtree needed the fur to dress his little stone-age man, the skin for a drum on which the coxswain beat rhythm for the French-galley slaves. No purchasable leather or fur was fine-textured enough to suit Crabtree and he refused to use substitute material. So he killed a mouse, skinned it and tanned the hide.

Some may feel that's carrying things pretty far, but it's just such details that make Crabtree's ships so superior.

On several of his models, the planking has been left off one side of the hull to show accuracy of construction below decks.

(Continued to page 244)

WHEN YOUR PAINTING TURNS
OUT LIKE THIS...IT'S TIME
FOR A NEW BRUSH...

and

IF YOUR CAR FEELS LIKE THIS
...IT'S TIME FOR MARFAK
CHASSIS LUBRICATION

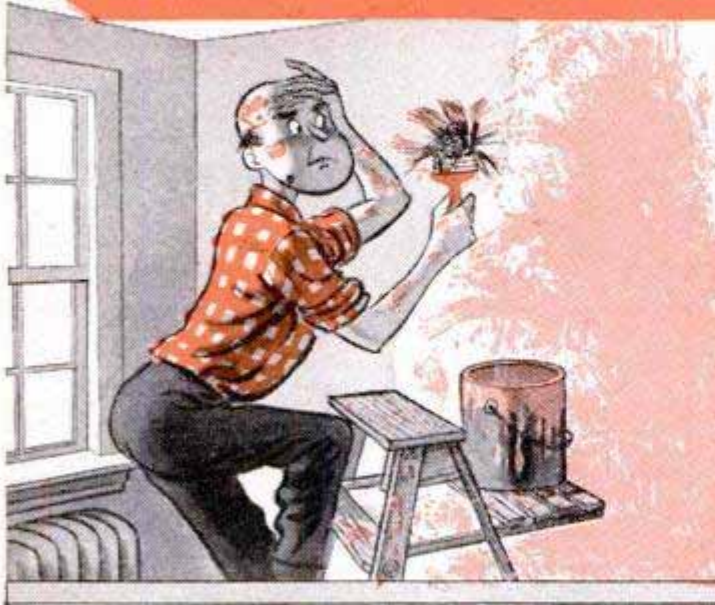

THAT CUSHIONY FEELING LASTS LONGER WITH MARFAK!

You enjoy *smooth* riding when *Marfak* lubrication protects the chassis. This tough, stretchy lubricant guards bearings and wear points for 1,000 miles and *more*. Longer-lasting *Marfak* is specially compounded to resist road pounding and wash-out—in spite of slushy going. That's why that wonderful "cushiony" feeling *lasts and lasts!* Get *Marfak* lubrication today from your Texaco Dealer, *the best friend your car ever had.*



THE TEXAS COMPANY
TEXACO DEALERS IN ALL 48 STATES

Texaco Products are also distributed in Canada and in Latin America

TUNE IN . . . TEXACO STAR THEATER presents MILTON BERLE on television every Tuesday night. METROPOLITAN OPERA radio broadcasts every Saturday afternoon. See newspaper for time and station.

NOW! this FULL WEIGHT Blade in Handy Dispenser

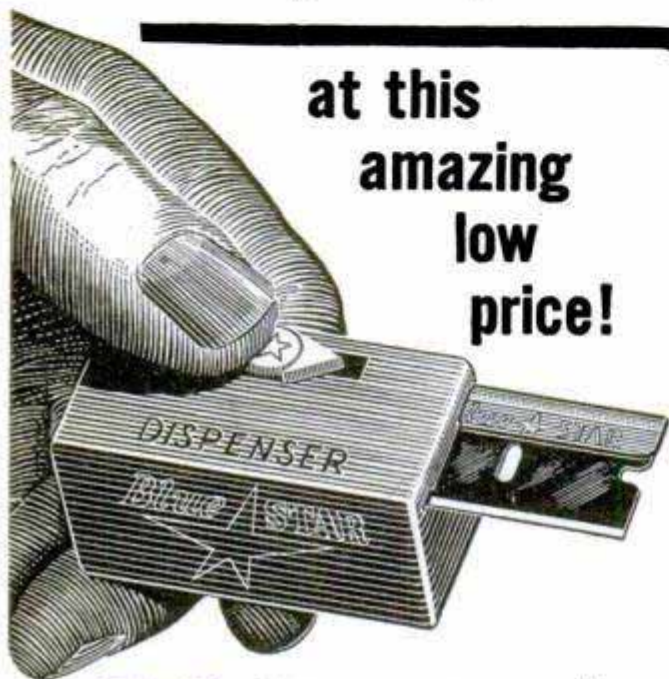

at this
amazing
low
price!

10 BLADES IN DISPENSER **25¢**
REGULAR PACK 3 for 10¢

Try this sturdy, full-weight Blue Star on those tough, hard-to-shave spots. If *any* blue steel blade, at any price, gives you better shaves than Blue Star, we'll give you double your money back.

Blue STAR

SINGLE EDGE

DOUBLE EDGE

PRECISION  PRODUCTS

AMERICAN SAFETY RAZOR CORP. BROOKLYN 1, N. Y.

Clinic



for Homemakers

As a service to our readers in solving the hundreds of problems pertaining to a home—inside or out—the editors of *Popular Mechanics* invite you to present your problems to The Clinic Editor for help and advice. Address your questions to The Clinic Editor, *Popular Mechanics Magazine*, 200 East Ontario Street, Chicago 11, Ill.



Sweating Window

Q—We have a large picture window in the living room of our new home. The sash frame is of metal. In cold weather the window sweats and water runs onto the floor making it necessary to use a mop frequently. Several floor tiles have been loosened as a result of constant dampness. What causes this, and what can we do about it? — W. M., Jefferson City, Mo.

A—Briefly, moisture will condense on any surface that is colder than the air in contact with it. For this reason, moisture from the air in the room condenses on the glass panes of your picture window because the glass is much colder than the warm air in the house. Installing a storm sash usually will cure this trouble, or at least will minimize condensation to the point where it is no longer a problem. When installing the storm sash, seal the edges with felt strips about $\frac{3}{4}$ in. wide and use turn buttons as fasteners. In some cases it will help to direct the blast from a small electric fan against the window. Place the fan directly in front of the window and about 4 to 6 ft. from it.

Spots on Papered Walls

Q—My home is newly papered throughout except ceilings in the kitchen and living-dining room. In all but one room light-brownish discolorations with irregular edges show on the walls in several places. I've thought that this possibly was due to moisture but a local paper hanger says the spots are caused by too much alkali in the plaster mixture and that there is no way to remedy the trouble without repapering. Who is right? Is there any way to correct this tendency?

D.F., Columbus, Ohio.

A—We think you are both right, at least partially. As a rule, there is no practical way to remove the discolorations that you describe without damaging the wallpaper. Probably the best thing to do is remove the paper. After removing the damaged paper, coat the bare walls with a zinc-sulphate solution, about 1 lb. to each gal. of water, and allow to dry at least 48 hours. Some paper hangers

(Continued to page 242)

CRAFTSMAN Circular Saws and Dado Sets

*NOW at the lowest
prices we know of
for such top quality!*

Circular Saws: 6, 7, 8,
10, 12-in. sizes



Crosscut
(Cut-off) Saws
\$195
8-in.

Rip Saws
\$195
8-in.

Flat-ground
Combination
Saws
\$195
8-in.

Hollow-ground
Combination
Saws
\$369
8-in.



6-inch
Dado Set
\$95

1/2 or 5/8-in.
hole

FREE!

SEARS new 1950 Power
Tool and Mechanics' Tool
Catalogs . . . free! Get
yours NOW, at the Hard-
ware Dept. of your near-
est SEARS Retail Store!



CRAFTSMAN Heavy Duty 8-in. Electric Hand Saw

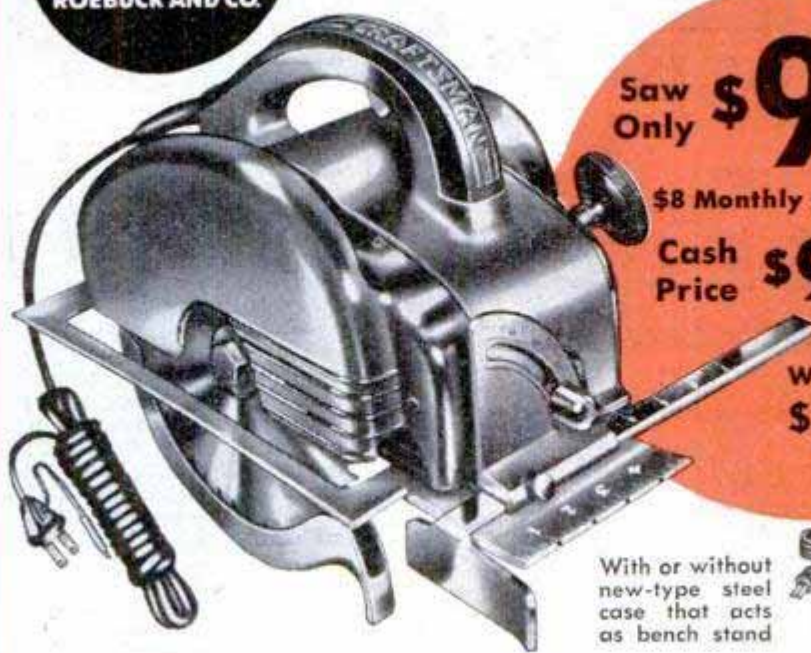

Saw
Only **\$950**
Down
\$8 Monthly on Easy Terms
Cash
Price **\$9250**
With Case
\$500
Extra



With or without
new-type steel
case that acts
as bench stand

**Tops in Quality and Performance...
yet DOLLARS LOWER than any other similar saw!**

Compact! Safe! 10 times faster on dozens of jobs!



Makes perfect fit-
ting straight and
miter cuts quickly;
right on the job!



0 to 2 7/8-in. depth of
cut. Cuts several
pieces at one time;
speeds up the job!



Will cut concrete,
tile, granite, met-
als, etc., with cut-
off wheel (below).



Easy to notch and
cut rafters, siding,
flooring, large ply-
wood panels; fast!

**We know of NO other com-
plete contractor-type 8-in.
electric hand saw at any-
where NEAR this low price!**

A terrific time and work saver! Don't confuse it with similarly-priced, light-duty saws! It's precision-built for professional extra-heavy duty; perfectly balanced for easy handling! Blade on right side for safety. SKF precision ball bearings. Helical-cut gears. Telescoping guard; saw-dust blower. Strong die-cast frame; enclosed trigger switch. Ripping guide. Underwriters' Labs. approved. Heavy-duty universal G.E. motor (110-120-volt, 25 to 60-cycle, AC-DC). Rated at 1-H.P.; will develop 1 1/2-H.P. Free blade speed 5300 R.P.M. 15 1/2-in. long. 8-in. combination blade. With 10 ft., 3-wire cord; plug.

**These Accessories
will make your
saw more useful!**

CUT-OFF WHEEL **\$139**
8-in. Cuts tile,
concrete, gran-
ite, metals. 1/2-
in. arbor hole

NAIL-CUTTING
SAW. 8-in. For
rough work with
hand saw above,
and 1/2-in. arbor-
hole bench saws



\$450

**See this CRAFTSMAN Saw at your nearest SEARS Retail Store TODAY!
Buy it NOW! Pay for it on SEARS convenient Easy Terms AS YOU USE IT!**

CRAFTSMAN Hand and Power Tools by **SEARS, ROEBUCK and CO.**

Famous for fine quality . . . precision performance . . . low price!

Save Fuel - Be Cool in Summer

**INSULATE YOUR
ATTIC FOR ONLY
\$29.90***

**SAVE \$75 to \$100
with ALFOL**
ALUMINUM FOIL
BUILDING BLANKET



You can insulate your attic, garage, porch or any other room with unfinished walls with ALFOL reflective insulation in an evening, using an ordinary hammer to nail it to studs, beams or rafters.

Alfol's scientific design creates a series of air spaces sealed with pure aluminum foil and forms a perfect moisture barrier. Keeps heat out in summer—in during the cold months.

ALFOL IS COMPACT - LIGHTWEIGHT - EFFICIENT

Each roll of ALFOL aluminum foil reflective insulation weighs only 20 lbs., yet does the work of 250 lbs. of bulk material. ALFOL reflects 95% of all radiant heat—the greatest factor in heat loss. ALFOL is clean and safe to use. No dust, no dirt, no splinters. Used by builders, the U. S. Navy and in the dome of the 200-inch telescope at Mt. Palomar Observatory.

ORDER ALFOL NOW!

ALFOL comes in rolls 250 sq. ft. each, in widths for 12", 16", or 24" centers. You just unroll ALFOL, expand and tack it in place. Price \$14.95 per roll, Postage Pre-paid. Two rolls will do the average attic—but measure your requirements to make sure. Check or money order. Sorry, no C.O.D.'s—Money-back guarantee backs ALFOL's claims!

BOOKLET TELLS YOU HOW

With each order, we'll send our illustrated book, explaining the scientific principle of ALFOL reflective insulation and containing full instructions for installing ALFOL. Booklet will be sent without order on receipt of 15 cents in coin.

*This buys 500 sq. feet of ALFOL—enough for the average attic.

REFLECTAL CORPORATION

COMMERCE BUILDING

NEW YORK 17, N. Y.

**NOW
A 5 ROOM HOME ANYONE
CAN BUILD COMPLETELY for only**

\$2895.

F.O.B. Marlette,
Michigan

Complete
Information
FREE
Send Us
A Post Card



The "Scotchman" is the result of over 40 years of lumber and building experience. Available in 2 and 3 bedroom models.

We have proven its value and the great savings possible with our system time and again near our plant. See for yourself how we can give you a complete house for so little. Write today. You'll be amazed—you'll be pleased. It's your chance to get your own home NOW.

L. H. RIEDEL LUMBER CO.
DEPT. A1 • MARLETTE, MICH.

recommend as an added precaution that the walls be coated with aluminum paint and then sized before repapering.

Warped Table Leaf

Q—I have a drop-leaf table I would like to refinish. This table is very old, the finish is checked and grimy and one leaf is warped, or cupped, badly. I tried to straighten it with a heavy weight but without success; in fact, the piece began to split at the center, due, I suppose, to the application of the weight. Is there a way this can be done to restore the leaf?

F.G., Raleigh, N.C.



A—Although you did not say, we are assuming that, because the table is described as old, it is built of solid wood and that the large surfaces are not veneered or built up by lamination. If this assumption is correct then probably the best and surest procedure is to remove the warped leaf and rip it lengthwise into strips about 2 in. wide. If the leaf has a curved, molded edge, keep the strips in order. Measure the width of the saw cut, or kerf, and keep track of the number of saw cuts made, as a matching strip must be fitted when the leaf is reassembled. The width of the new strip must be equal to the combined width of the saw cuts plus whatever planing is necessary in squaring the edges. Now, joint (plane) the edges of each strip square with the face. Assemble the original strips in order and from this determine the required width of the filler strip. Cut this slightly longer than required and see that the filler strip matches the original as nearly as possible in color and graining. Glue the pieces together edge to edge with waterproof glue and clamp until dry. When dry, sand the surface smooth on both sides. True the molded edge with sandpaper and a wood rasp until the curve is true and the mold is of the original shape. Then refinish the leaf with whatever color and type of finish is desired.

Loosening Tight Sash

Q—I want to paint my house this coming summer and I must do all the preparatory work and painting myself. How does one loosen upper sash that stick so tightly they cannot be pried loose without danger of breakage? I've tried all the methods I know without success. I don't want to paint the frames without lowering the sash. — J.F., Toronto, Ont., Can.



A—As a rule, this is quite easy to do with a putty knife. Force the blade of the knife between the sash frame and the stop and draw it along both the stiles and the top rail. Do this inside and outside to break the paint film that has hardened between the frame and the stop. Usually the sash will loosen and slide quite easily after this treatment. Sometimes the sticking is due either to swelling of the wood or settling of the building, which warps the window frame slightly. In this case it may be necessary to pry out the outside stops in order to loosen the sash without damaging the wood or breaking the pane. If removal of the stops is necessary it's a good idea to replace them with new ones as the film built up by repeated applications of paint will have increased the sectional size of the stop considerably. Before replacing the sash, determine what has caused it to bind and if possible remove the cause by planing or other alteration to prevent further trouble.



TIME-SAVING TOOLS for SHOP and HOME

The Most Versatile Tool a Man Can Own

MOTO-TOOL

Approx. 25,000 RPM

GRINDS, ROUTS, DRILLS, POLISHES, ETC. Moto-Tools, Kits and Accessories should not be confused with "bargain offers." Compare Dremel Products, feature for feature, with other similar equipment. If ours are not superior in quality, design and performance, we don't want you to buy.

LOOK AT THESE MOTO-TOOL FEATURES

Dynamically balanced armature eliminates vibration • Oilless (oil-sealed) bearings • Patented automatic chuck lock pin • Snap-type sliding switch • Cord protector • Shockproof bakelite housing • Dust-filtered air-cooling system • Weighs 13 oz. • Plugs into any 110-120 V. AC outlet. Backed by over 13 years' use in plants of General Electric • Ford • Remington Arms • Nash-Kelvinator • Westinghouse • Douglas Aircraft, etc. . . . plus a money-back Guarantee if not delighted after 5 days' trial.



PRE-WAR PRICES STILL PREVAIL

MOTO-TOOL KIT No. 2, with 23 accessories including high-speed steel cutters and Model 2 Moto-Tool in natural finish hardwood case. . . . **\$23.50**
MOTO-TOOL No. 2 with one emery wheel point. . . . **\$16.50**



Portable DRILL PRESS



This 12" high, precision drill press is ideal for model making, wood carving, routing, etc. Utilizes No. 2 Moto-Tool.

Only **\$9.95** (Less Moto-Tool)

USE COUPON TO ORDER—If your dealer cannot supply you.

DREMEL MFG. CO., Dept. 110-C, Racine, Wis.

FUN FOR BOYS FROM 8 TO 80

DREMEL Electric COPING SAW

CUTS SCROLLS LIKE MAGIC—SANDS AS IT SAWS



BLADE FACES 4 WAYS

SAFE! AS A HANDSAW

JUST GUIDE IT!

Only **\$5.85** with 3 saw blades



Plans for making six useful, decorative projects packed with each Dremel Electric Coping Saw.

For men who harbor a hobby or do their own repair work . . . for boys who like to make things . . . no other tool will give so much pleasure and satisfaction in the home or workshop for the small amount of money invested as a Dremel Electric Coping Saw. It works in any direction . . . delivers 7,200 strokes per minute . . . so easily, there is no effort . . . so smoothly, work needs no sanding. Saws through 3/4" medium-hard wood at a foot-a-minute speed. Touch-of-the-trigger, foolproof action. Only two moving parts, never needs oiling. Operates on 110-120 v. AC. Thousands and thousands of satisfied users.

MONEY BACK GUARANTEE—If your dealer cannot supply you, use coupon to order direct from factory for five day trial.

DREMEL MFG. CO., Dept. 110-C, RACINE, WIS.

3

TOOLS IN ONE



Only **\$14.85** POSTPAID

PATENTED

Dremel Electric SANDER POLISHER-MASSAGER



Works Easily in Awkward Places



Sands Flat Surfaces Evenly



Makes Play of Wax Polishing



Soothes Tired Muscles

Say goodbye to hand sanding and polishing! This miracle machine is so easy to handle, a child can use it. Craftsmen and housewives find (1) As a sander, it takes the effort out of sanding walls, woodwork, furniture, workshop projects, etc. Its straight-line, (non-rotary) action will not burn or scratch surfaces. (2) As a polisher, it does a professional job on waxed surfaces of cars, furniture, etc. (3) As a massager, it's ideal for tired or sore muscles.

LOOK AT THESE DREMEL FEATURES

Dremel Sander delivers 14,400 strokes per min., weighs only 2 1/2 lbs. It's foolproof (has only two moving parts . . . never needs oiling). Dremel Sander operates on 110-120 Volt AC. Thousands and thousands of satisfied users prove its value.

SATISFACTION GUARANTEED

Dremel Sander comes complete with 6 sheets assorted grade Garnet Paper for sanding, plus felt pad and sheepskin for polishing. If your dealer cannot supply you, use coupon to order direct from factory. Money back if not delighted after 5 days' trial.

Dremel Mfg. Co., Dept. 110-C, Racine, Wis.

If Your Dealer Cannot Supply You USE THIS HANDY ORDER FORM

DREMEL MFG. CO., Dept. 110-C, Racine, Wisconsin

- Enclosed find \$_____ (check or money order) in full payment for items checked below.
- Enclosed find \$2. Ship items checked below C. O. D. I'll pay postman balance plus postage and fee.
- Dremel Sander **\$14.85**
- Dremel Coping Saw **\$5.85**
- Moto-Tool No. 2
- Moto-Tool, **\$16.50**
- Kit No. 2, **\$23.50**
- Drill Press **\$9.95**
- Send FREE Catalog on Moto-Tool Dremel Sander Dremel Coping Saw

Name _____

Address _____

City _____ Zone _____ State _____

His model of "Catherine," royal yacht of Charles II, is that way to show the 17th century framing with single timbers. Double frames didn't appear until 100 years later. Such details are vital to Crabtree.

This particular ship, incidentally, has extremely fancy carving. It took Crabtree nine months to do the stern carvings alone. Thirty-five figures decorate the British coat of arms, plus the usual cherubs flapping around in trailing draperies. Some of the detail work on these carvings is so fine that a soiled finger rubbed over them would fill in the grooves.

The delicate work of such carving entails plenty of nervous strain. On the real fine finishing work, which he often does under magnification, Crabtree can only spend about 35 minutes at a time.

The builder does not wear glasses, nor does he use a magnifying glass until the final touches are being applied. "If you used a glass on the features and outlines," he explains, "your carvings would be all out of proportion."

Fine carving also calls for special tools. Crabtree has an elaborate shop in his home at Kissimmee, Fla., but most of his vital implements he carries with him in a cigar box. These are tools devised and made by himself, since commercial knives are much too crude. Most of his knives and chisels

have been made from dentists' picks and hair-bladed surgeons' scalpels. For his microscopic finishing work on super-delicate carvings, he uses a chisel made from a dental tool. This implement has a blade measuring $\frac{1}{2000}$ inch across the broad side. Even Crabtree, with his eagle eye, needs a bright light and a magnifying glass to determine which is the broad side.

A jeweler's drill and lathe are part of his shop equipment. Painting of the carvings, done by Mrs. Crabtree (who also is sailmaker for the Crabtree shipyards), is accomplished with a camel's-hair brush boasting a total of three hairs.

It's typical of Crabtree that he wouldn't be satisfied with the kind of wood you can buy. "The commercial variety is no good," he declares. "It's not seasoned properly, and usually is too brittle, lifeless and coarse-grained for fine work." The master builder spent years experimenting with 140 different kinds of wood for various uses on his ships before he found what he wanted.

Apple wood, he decided, was best for hull planking, because it is close-grained, bends true and won't split. Fire thorn heartwood, cut in the forests of Oregon, is Crabtree's favorite carving medium. It's extremely dense and won't chip while being worked. Elm is used for sharp curves,

(Continued from page 246)

**LOWEST-PRICED
COMPLETE
POWERCYCLE**

198

DELIVERED

Fully Equipped

Freight and U.S. Tax Paid

**3-SPEED TRANSMISSION
KICK STARTER**

**100 MILES
PER GALLON**



Other Models, \$248 to \$280. See your local Servi-Cycle Dealer.

If there is no dealer, write for Servi-Cycle Rider-Dealer Plan; or, if you are established in business, use your letterhead to write for our Dealer Plan.

SIMPLEX MANUFACTURING CORPORATION

540 N. CARROLLTON AVE.
NEW ORLEANS 19, U.S.A.

Repair Electrical Appliances and Utilities with the aid of
THE NEW MODEL 50

UTILITY TESTER



Compact—Measures 3 1/8" x 5 7/8" x 2 1/4"

A NEW KIND OF INSTRUMENT FOR TESTING ALL ELECTRICAL CIRCUITS AND APPLIANCES SUCH AS—

- RANGES
 - VACUUM CLEANERS
 - SHAVERS
 - AIR CONDITIONERS
 - HEATERS
 - REFRIGERATORS
 - IRONERS
 - SUN LAMPS
 - WASHERS
 - TOASTERS
 - FANS
 - WASHING MACHINES
- and MOTORS

[ALL MOTORS—single phase, multi-phase, universal, squirrel cage, induction, in fact every type of motor from fractional H.P. to 2 H.P.]

THE MODEL 50 UTILITY TESTER:

- Will test condensers for both opens and shorts.
- Will accurately check and locate the exact cause of failure in 3 way heat control switches.
- Will check field coils for opens and shorts.
- Will indicate when one side of an appliance or motor connected to the line under test is "grounded".
- Will measure the actual current consumption of any appliance or utility either A.C. or D.C. and will measure it while the unit is in operation. The reading will be direct in amperes. The appliance or utility may be plugged directly into the front panel receptacle. A special pair of insulated clip-end leads is included for motors, etc.
- Will measure the actual voltage and indicate whether the current is A.C. or D.C. and if the frequency is 25 cycles or 60 cycles.
- Incorporates a sensitive direct-reading resistance range which will accurately measure all resistances commonly used in electrical appliances, motors, etc. This range will enable continuity checks and tests for shorts and opens.
- Will indicate excessive leakage between a motor and a line up to 10 Megohms.
- Will indicate when a three phase motor is running erratically due to a "blown" fuse.
- Will test Thermostats under actual working conditions.
- Is the ideal trouble-shooter as it will instantly locate opens, shorts and grounds.
- Will test all bulbs, radio tube filaments, pilot light lamps, all fuses including cartridge, screw, etc., fluorescent bulbs, etc.

SHIPPED ON APPROVAL NO MONEY WITH ORDER—NO C.O.D.

TRY BEFORE YOU BUY! Yes, you need send no money with order or pay anything on delivery. Simply fill out this order form and mail it today. Try the Model 50 for 10 days. If completely satisfied, remit \$13.90. If not, return the instrument—no explanation necessary.

The Model 50 Utility Tester comes housed in a round cornered molded bakelite case. Complete with all test leads and operating instructions—only ...

\$13⁹⁰

GENERAL ELECTRONIC DISTRIBUTING CO.
98 PARK PLACE, NEW YORK 7, N. Y.

PM3

Please rush one Model 50 Utility Tester. I will either remit \$13.90 after a 10-day trial or return the instrument via Parcel Post.

Name _____

Address _____

City _____ State _____

FREE PREMIUM!!

Check here if you include \$13.90 payment with order. In return for saving due to bookkeeping, we will include a set of 6 assorted key chains with your Model 50. If the Model 50 does not meet with your wholehearted approval after a 10-day trial, return it for full immediate refund of \$13.90—keep the premium for your trouble.

SAVE MONEY— use EASI-BILD* Full Size Patterns

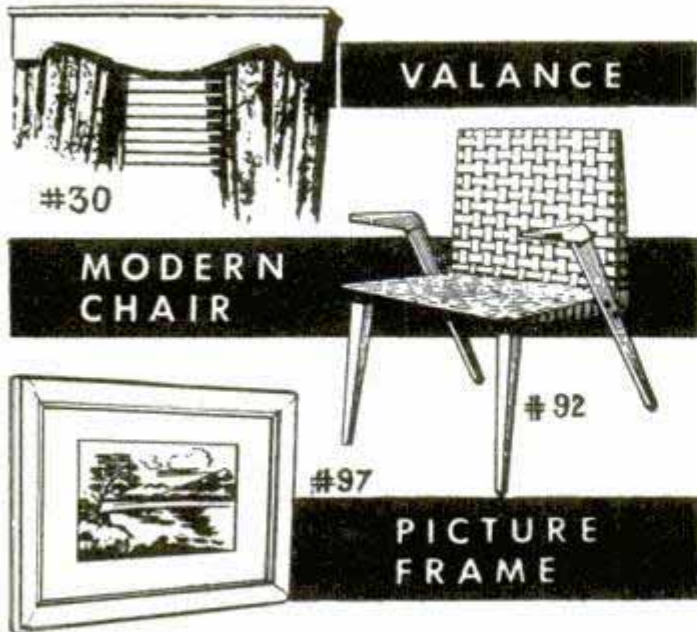

Simplify building everything your home needs. With Easi-Bild FULL-SIZE Patterns, it's easy, quick, and economical. No special tools or skill required—you just trace pattern on wood, saw, and assemble with one of the CASCO Glues described below.

Send for these patterns and colorful 32-page Pattern Book. Mail coupon today. *Coop. 1949. East-Bild Pattern Co.

How to choose a glue!



CASCOPHEN—waterproof glue for outdoor projects
CASCO—for heavy-duty joints, rough surfaces
CASCAMITE—for stain-free veneering, cabinets
CASCOREZ—fast-set, ready-mix glue for home jobs

SEND COUPON FOR PATTERNS AND BOOK TO:

Casco Pattern Dept. PM-30
 P. O. Box 215, Pleasantville, N.Y.

Enclosed is \$... for material checked below:

Valance, Pattern No. 30—25¢
 Modern Chair, Pattern No. 92—25¢
 Picture Frame, No. 97—25¢
 32-page Pattern Book illustrating 94 pattern projects—20¢

Name _____
 Address _____
 City _____ Zone _____ State _____

THE BORDEN CO. • CHEMICAL DIVISION
 Makers of Casco Glues

and cascara he uses sometimes for deck beams. Laurel, English and French walnut and lime wood from the West Indies also find their way into Crabtree's ships.

All of these woods, of course, Crabtree cures himself so he'll know they're right. First he water-cures the wood in a creek for two or three weeks to remove all acids. Then it is dried out in a cool place with a little ventilation. After drying, the builder cuts his logs into miniature lumber and puts it away for about three years until the wood is seasoned to perfection.

The business of earning sufficient money to support a wife and an expensive hobby might have thrown anyone with less determination than Crabtree. He never let it bother him. Whenever he had to have cash, he found his services much in demand. Hollywood needs models for miniature sets and Crabtree has made many of them. "It's a nice vacation to do that junk," he says, "but it's crude set stuff, lacks important detail and would ruin a man for good work if he kept at it."

After working so many years on old ships, Crabtree has become an authority on antique vessels. He has hired out as technical advisor for such movies as "Mutiny on the Bounty," "Captains Courageous," "Captain Caution," "Reap the Wild Wind" and others. During the war he was a naval architect in the Kaiser shipyards. By adapting principles used by the ancients, he patterned and lofted the big doors on landing craft—a problem that had stumped the experts for months.

Today, however, it's no longer necessary for Crabtree to fret about prostituting his art for money. The fleet is enough of an eye-stopper so that big-city department stores pay huge sums to rent it for display. The Crabtrees have had a special truck built to accommodate their precious cargo as they tote it around the country on tour. This year they hope to set up a private museum in Florida and charge admission for a look at the handiwork.

Carting the delicate ships around the country is not Crabtree's idea of fun. It's risky and uses up time that he would rather spend building new models. The fleet is insured for \$100,000, which, the owner points out, wouldn't begin to replace the labor that went into them. Crabtree feels that all the money in the world couldn't pay for them, anyway—which is one reason none has ever been for sale. When a big merchant line offered to pay him a fabulous sum to make some old ship models, he agreed to do it if they'd let him retain ownership.

"It's this way," he says, "would you sell your own child?"

A DOUBLE-BARRELED OPPORTUNITY TO

MAKE MONEY!



NEW HOMES



OLD HOMES

**No Schooling —
Steady Work**

Be Your Own Boss!

Another booming year is ahead in the building industry—and here's a double-barreled way for *you* to CASH IN!

Start your own business as a floor surfacing contractor with American Machines—and you will find hundreds of new and old homes are year 'round prospects for your services! No special schooling needed. No long waiting to get going in a business of your own. You can start sanding floors and make money as your own boss *the very first day* your machines arrive! Earnings of \$25 and more a day are not uncommon among men like yourself who have become floormen.

You'll be proud to be a floor surfacing contractor and take your place alongside the plumber, the electrician, the painter and other building craftsmen as an important cog in the construction industry. In new construction you work as a sub-contractor and when resurfacing older homes you will usually operate as a separate businessman.

The investment in floor sanding equipment is small. The overhead is low and you need no elaborate offices, workshop, storeroom or heavy trucking equipment. Many men operate from their own homes and use a regular passenger car to transport their equipment from job to job. Pleasant indoor work... steady the year 'round... prospects everywhere... and *you are your own boss*... a real opportunity for a man with ambition to get ahead and **MAKE MONEY!**

Send for "money-making" booklet entitled "Opportunities in Floor Surfacing"—use coupon and enclose 25c in coin or stamps to cover handling.

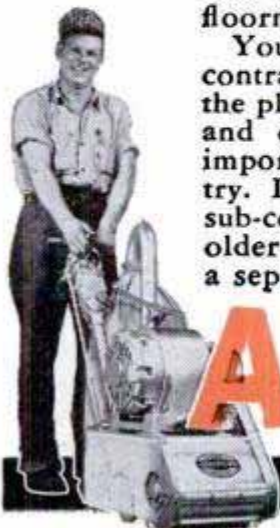

AMERICAN

FLOOR MACHINES

SEND COUPON TODAY!

The American Floor Surfacing Machine Co., 535 So. St. Clair St., Toledo, Ohio,



Enclosed find 25c in stamps or coin for booklet "Opportunities in Floor Surfacing" telling me how I can start my own floor sanding business.

Name _____

Street _____

City _____ State _____

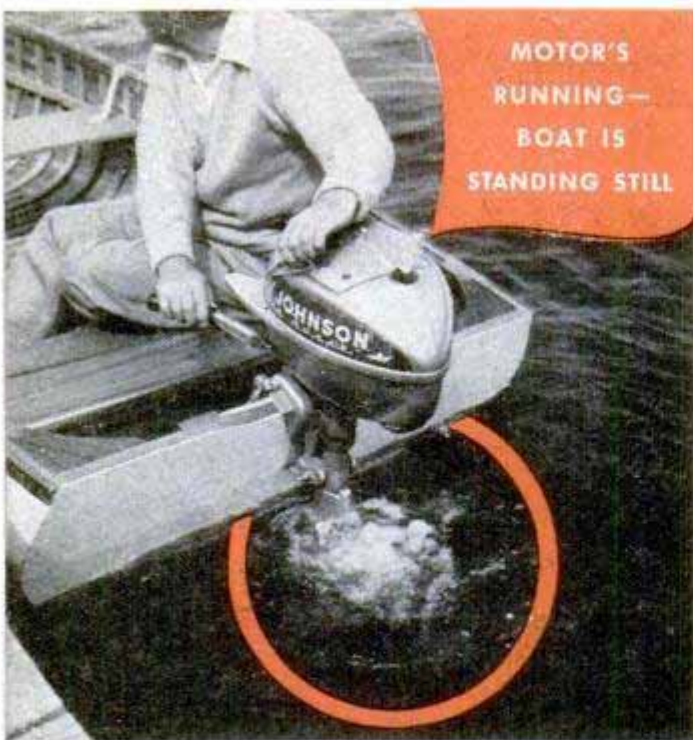

JOHNSON Neutral Clutch

Man, here's a fishin' friend—the new 5 h.p.* Johnson outboard motor with Neutral Clutch and 31 other great features!

Start in neutral. Flip the lever, and GO! Idle, anywhere. Maneuver like an expert.

Go through shallows without a care—with sure-fire Shock Absorber Drive. Ride wide open or at a crawl—your motor runs *smooth* and *cool*. Relax—it's a Johnson, it's **DEPENDable!**

See your Johnson dealer. Look for his name under "Outboard Motors" in your classified telephone directory. *1950 Johnson prices are lower!*

FREE! HANDY CHART

Complete description of all five 1950 models including the sensational Model QD with Gear Shift Control and Mile-Master Fuel Tank. Sent free. Write!

JOHNSON MOTORS

400 Pershing Road, Waukegan, Illinois
Johnson Motors of Canada, Peterboro, Canada



JOHNSON

SEA HORSES

for *DEPENDability*

NEW MODEL TN. Johnson Neutral Clutch and Full Pivot Reverse. Alternate Firing. Dual Carburetion. Sure-fire Shock Absorber Drive. Vari-Volume Pump. Synchro-Control. Ready-Pull Starter. S-l-o-w Trolling—24 other features. *And no increase in weight or price!*



*OBC Certified Brake H. P. at 4000 r. p. m.

Look a Typhoon in the Eye

(Continued from page 139)

approximately 5000 feet. From 1000 feet to 5000 feet were tiers of circular cumulus clouds giving the effect of seats in a huge stadium.

"The wind was estimated at about 35 knots in the center. No calm water was seen because of the undercast.

"After the navigator had taken a loran fix and the weather observer had taken his observation, a sounding descent was begun to 1500 feet, using the eye as the let-down area."

Up to now Beverly has been behaving like a lady. But now she is a lady who has been trifled with, and as the B-29 swings in smooth circles within the solidity of her internal walls, she is preparing to vent her wrath with all the howling furies she can summon from hundreds of miles around.

The barometric altimeter reads 4100 feet. Over the intercom comes the sharp voice of the weather observer, "True altitude 1500 feet."

The radar operator cuts in, "Weak spot in the wall at 305 degrees."

Lykins banks sharply in the tight circle at the foot of the cone. As the gyrocompass reaches 330 degrees he rolls out of his bank heading 305 and level. "Hold on," he says grimly.

It is like hitting Niagara Falls. The plane sags under a wall of water. But Beverly is no puny Niagara with forces moving only in one way. The powers in the twisting crosscurrents and the vicious updrafts are each in their own right so staggering as to reduce by comparison the potency of Niagara to a finger leak in a dyke. Lykins is hurled into his shoulder straps so viciously his feet cannot find the rudder. A wrenched second later he is slammed into his seat, his hand nearly torn from the control column. A bolt of lightning sears past their eyes, blinding them to the weak blue of their fluorescent instruments. The copilot reaches a weighted hand to turn up the lights, and another crushing blow smashes against the nose from below. The copilot's hand, still on the knob, is snatched downward, and not until later does he see he has torn the rheostat from the instrument panel.

Lykins is trying to hold the speed of the plane to within safety limits. At times she seems racing to destruction. At other moments the wings shake with an approaching stall. She is flipped on her side and then wrenched in the opposite direction. Beverly is playing now, and both pilots have not time enough to man the throttles.

(Continued to page 250)



Only **ATKINS**
 makes "Silver Steel"
SAWS



That's an important fact to remember when selecting saws—for any purpose... because "Silver Steel" Saws—developed, perfected and manufactured only by Atkins—are made of the finest, toughest, longest-lasting steel ever alloyed for sawing operations. They are backed by 93 years of continuous research and scientific advancement! Tell your hardware dealer you want Atkins "Silver Steel" Saws.



E. C. ATKINS AND COMPANY
 402 S. Illinois St., Indianapolis 9, Indiana

... OF ALL FINE SAWS—THE FINEST ARE "SILVER STEEL" SAWS

GET THE FACTS—
 the all-new **IDEAL LAWNMOWER SHARPENER**



A Complete Lawnmower Shop in One Machine!

Here it is, after four years of research and development, the **COMPLETELY NEW IDEAL LAWNMOWER SHARPENER**. Designed and built to sharpen post-war and pre-war hand and power lawnmowers with precision and speed, the **NEW IDEAL SHARPENER** includes a tapered-cup grinding wheel for sharpening bed knives and a "lapping-in" reconditioner as standard equipment. *Power mowers need not be dis-assembled, engines and handles remain in place during sharpening.* Chain hoists or ropes are not needed to support heavy mowers, the **IDEAL** supports the entire weight of the mower within its rugged cast-iron frame. The **IDEAL SHARPENER** is a complete lawnmower shop all in one machine. Send for the **IDEAL CATALOG** describing the new **Model 300 IDEAL LAWNMOWER SHARPENER** and the other machines we manufacture for the lawnmower serviceman.

Model 300 — the result of 48 years experience
 — Catalog free!

THE FATE-ROOT-HEATH CO. DEPT. G-3 PLYMOUTH, OHIO



FLOODLIGHT LANTERN

*Prices as low as \$9.95 in U. S. A.



"My Coleman Lantern adds more hours of fun, with plenty of good light in camp at night," says **ANDY DEVINE**, sportsman and picture star, and owner of Sportsmen's Tavern, Big Bear Lake.



"I wouldn't be without my Coleman. You need it for a brighter camp light and longer outings," says **JOE GODFREY**, founder of the Sportsman's Club.



"You need adequate light when you haul big ones aboard—that's why I use Coleman," says **JOHN HIGHTOWER**, noted outdoorsman.

Floodlights 100-ft. area—20 times as bright as wick-type lantern. Storm-proof. Safe. Ask your dealer.

GOOD EATS Quick...Anywhere

Cooks like a city gas range. Lights instantly. Folds up; carries like a suitcase. Safe. Prices as low as \$9.95 in U. S. A.



Folding Camp Stove

The Coleman Company, Inc., Wichita 1, Kansas

The Coleman Company, Inc., Dept. 208-PM, Wichita 1, Kans. Please send me FREE booklet, about Coleman Lanterns and Camp Stoves.

NAME.....

ADDRESS.....

CITY..... STATE.....

The third pilot unbelted himself from his observer's seat and lurches forward. An updraft crushes him to his knees, and a forward pitch tosses his head into the aluminum tubing of the captain's seat. Another twisting dive slams his ribs against the copilot's seat, but he gets a death grip on a cross brace. One big hand closes over the four throttles and the speed is brought under control.

But Beverly is not through. She shakes the B-29 until the rivets pop out of the flight deck. The aerial camera is torn from its rack, dashed against the ceiling and hurled to the floor. The radio operator's earphones are torn from his head and then thrown back into his face. The navigator's kit is emptied of maps, and they float in the air, obeying no laws of gravity.

Back in the cabin the two scanners, battered by flight lunches, Thermos bottles and life rafts, watch in consternation as sheets of aluminum torn from the wing fairings go flashing by in the brilliant glare of the Aldis lamps they have directed over the wings.

Says Lykins in his report:

"It is impossible for me to describe accurately or to exaggerate the severity of the turbulence we encountered. To some it may sound utterly fantastic, but to me it was a flight for life. I have flown many weather missions in my 30 months with the 514th Reconnaissance Squadron. I have flown night combat missions in rough winter weather out of England, and I have instructed instrument flying in the States, but never have I dreamed of such turbulence as we encountered in typhoon Beverly. It is amazing to me the ship held together as it did."

Suddenly it is all over. Beverly has lost her plaything. When turbulence has been reduced to ordinary cyclonic intensity, the crew has time to take stock of what has happened. The period of extreme violence has lasted six minutes. Present altitude, 6000 feet, a climb of a thousand feet a minute while trying to fly level, and in spite of downdrafts, some of which exceeded a thousand feet. The inside of the plane looks as though Beverly had blown through it instead of around it. The navigator crawls around on the floor, retrieving his gear. Green grass flickers across his loran screen, and then the signals come marching in, straight and true. He takes a fix and gives the heading for Clark Field, north of Manila. At 11:35Z the B-29 is on the ground again, staggering slightly as she rolls to a stop on the long runway.

The B-29 lived through that one by a narrow margin. Hundreds of rivets had

(Continued to page 252)

5 YEAR WRITTEN GUARANTEE BULOVA 15 JEWEL

ORIGINALLY
SOLD AS HIGH
AS
\$59.50



ONLY
\$14.95
Plus \$1.50
Tax

Also Choice Of
● BENRUS
● LONGINES
● WALTHAM
● or ELGIN
WATCHES

Choice
\$14.95

Genuine Bulova, Benrus, Longines, Waltham, Elgin and other famous wrist watches in latest style Yellow Gold Cases. You get these undecimated 5 year guaranteed lifetime quality famous make watches now at truly enormous savings because we bought out SURPLUS STOCKS of leading New York and Maryland Jewelers. Order now, while they last. State make preferred. Order men's or Ladies'.

TRIAL OFFER! WEAR AT OUR RISK!
Money Back in 5 Days If Not Delighted!
SEND ONLY \$1 down payment with order. Pay balance to postman on arrival, plus postage. Or we pay postage if you enclose \$14.95, plus \$1.50 tax.

HANDSOME EXPANSION BAND INCLUDED WITH PREPAID ORDERS. Order now.
MARYLAND DISTRIBUTORS, Dept. 27
501 E. Baltimore St. Baltimore 2, Md.
FREE FOLDER: America's best Watch and Diamond Ring Values. Wholesale prices to user direct.

**15 or 17 JEWEL
Wrist Watch**
Waterproof,
Shockproof . . .
with Swiss
Precision
Movement.
Originally
\$30;
**OUR PRICE
NOW \$9.95,**
plus \$1. tax

STANDARD GARDEN AND TRACTORS



RIDE-OR-WALK Powerful Gas Tractors for Small Farms, Gardeners, Florists, Suburbanites, Fruit and Poultrymen.
1 & 2 Cylinders
Rubber or Steel Tires.
**Plow
Seed
Cultivate
Mow Haul.
Belt Work**

STANDARD ENGINE COMPANY
MINNEAPOLIS, MINN. NEW YORK, N. Y.
3221 Como Avenue 617 West 26th Street

HAUCK FLAME GUN KILLS WEEDS



KILL WEEDS, crab grass, Canada thistle—stalks, seeds and roots. Destroy brush, caterpillar nests, diseased trees, grasshoppers, chinch bugs, etc. Clear irrigation ditches, split rocks, burn tree stumps. Sterilize poultry houses, kennels, barns. Use as portable home forge. Melt ice, thaw pipes. Safe, inexpensive. Burns only 6% kerosene, 94% air! Thousands satisfied users. 7 models. Write for FREE CATALOG.

HAUCK MFG. CO., 75 Tenth St., Brooklyn 15, N.Y.

BUILD FINE GRANDFATHER CLOCK NOW



The simple sensible Red-i-Kut way as thousands have—SAVE HALF. SHOP TESTED PLANS "SPIRIT OF THE CENTURY" Narrow waist 83" tall or stately "SPIRIT OF AMERICA" straight side model. EASY-TO-FOLLOW photo-pack PLANS tell all—plus BROCHURE of heavy brass weight Westminster, tube chime, movements, dial's 3 1/2" solid mahogany case kits. Send \$1.00 today—Both Plans \$1.50 NOW.

KUEMPEL CHIME CLOCK CO., #7 Kuempel Bldg., Minneapolis 16, Minn.

BURKS WATER SYSTEMS Last Longer



You'll want a BURKS Dual Purpose Super Turbine Water System because of its LIFE-LOK feature. It'll outlast any other water system by many years—give you more water—at lowest cost.

For deep or shallow wells
BURKS Dual System gives you completely automatic service from deep or shallow wells. New folder explains this, also LIFE-LOK feature. Shows why BURKS is best buy. Self Priming—One Moving Part—Dependable Service. Write for literature—prices.

DECATUR PUMP CO., 61 Elk St., DECATUR 70, ILL.

Make 100% to 150% Profit!

MANUFACTURE BUILDING BLOCKS In Your Own Back Yard



AMAZING GENERAL
BLOCK MACHINE
CAPACITY 1000 BLOCKS PER DAY
Only **\$199** LESS MOTOR
F.O.B. PLANT

SHIPPING WEIGHT 400 Lb.

Here is an outstanding opportunity for men of vision and small capital. Cinder and concrete blocks are in great demand. Millions used for homes, factories, public buildings. Sell all you produce at 100% to 150% mark-up.

PEAK BUILDING DEMAND!

The General Block Machine is amazingly practical, foolproof. Simple to operate indoors or outdoors. Rugged all steel construction. Vibrator mounted in sealed ball bearings. Produces up to 1,000 blocks per day. Superior 3 Core Type that meets all building code requirements. Can produce 4 x 8 x 16, 8 x 8 x 16, 12 x 8 x 16 blocks. All materials obtainable anywhere. All operating instructions and mixing formulas supplied. Full details FREE without obligation.

HOW TO
BUILD
YOUR OWN
CONCRETE
BLOCK
HOME
Only 1 Prepaid

Wonderful
Book Written
& Illustrated
by Experts

GENERAL ENGINES CO.

DEPT. P6 • 307 HUNTER ST. • GLOUCESTER, N. J.

Includes floor plans for 6 beautiful, easy to build concrete block bungalows. Shows ways to save money. How to lay blocks, lay out building lines, mix concrete, build steps, porches and concrete floors. Mail coupon at once with \$1.

Name.....
Address.....
City.....Zone...State.....

Snap-on * PRY BAR

FORGED FROM FINEST ALLOY STEEL!
HANDLES A DOZEN DIFFERENT JOBS

Use the point for lining up work
... use the rolling head when
you want to exert great
pressure or leverage
for prying.

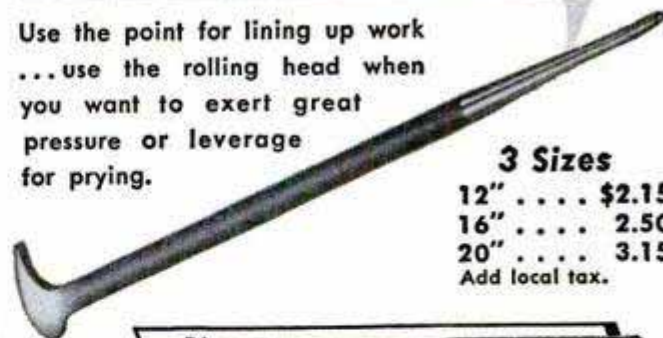

3 Sizes

12" \$2.15
16" 2.50
20" 3.15
Add local tax.

SCREW STARTERS make jobs easy!

End of tool chucks tightly into Set of 3 screw slot. Provides 8 lb. grip. **\$3.50**
Releases automatically. 3 sizes.

*T. M. REG.
U. S. PAT. OFF.

Add local tax

SNAP-ON TOOLS

CORPORATION
8062-C
28th Ave.
Kenosha,
Wisconsin

I enclose Check Money Order for the following:

Pry Bar 12", 16", 20"
Set of 3 Screw Starters

Name.....
Address.....
City.....State.....

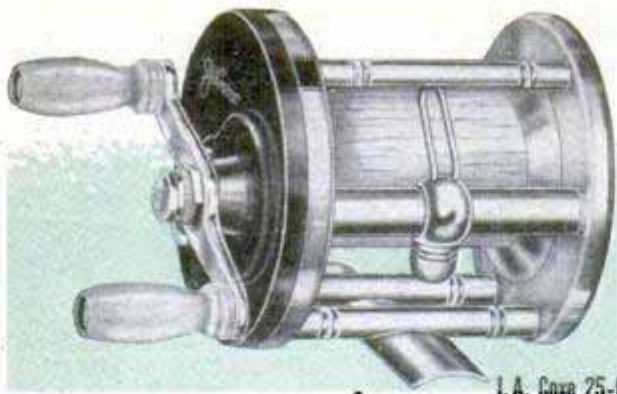

J. A. Coxo 25-C

\$33.00

*The finest reel
money can buy*

● It's the only reel of its kind—the J. A. Coxo automatic free spool reel. Precision built to the smallest detail, yet you can take it apart—without tools—in less than ten seconds! Exclusive Coxo cross-bolt design assures perfect spool alignment and extra years of casting accuracy. Phosphor bronze bearings, rust-proof nickel-silver frame.

*no finer reel
for the money*

● A tackle value you never thought you'd find! Green anodized aluminum head cap and tail plate—the rest completely chrome-plated. Adjustable drag—new lightweight spool with snap-on plastic arbor—famous Bronson Duo-Pawl. Swift and sturdy and light as its name, you'll want the *Green Hornet* for every one of your fishing family!

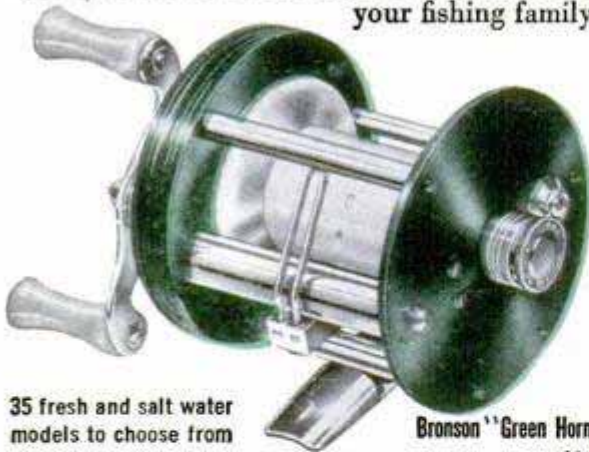

35 fresh and salt water models to choose from

Bronson "Green Hornet"
\$4.95

Bronson made

J. A. Coxo
FISHING REELS

Bronson

BRONSON REEL COMPANY • BRONSON, MICHIGAN
World's Largest Makers of Fine Fishing Reels

been popped from her skin. The flaps were twisted. Great gaps showed in her fairing, and the R.F. unit in the center section of the bomb bay had been torn from its moorings. The fuselage was twisted. Whether she will ever fly again still remains to be seen after a survey of her internal structure is completed.

Beverly roared on out to sea, obeying no laws of meteorology. A nice trough developed into which she could drift northwest into China as do most of her sisters, but she broke through it. A steering wind at the 600-millibar level was guiding her north when suddenly she turned on it and ripped it to bits. Then when it looked like no power on earth could stop her, and the poor Aleutians were going to lose some more breakwaters, a great mass of polar air tore the heat out of her in great gouts of rain. When last seen on the weather map, she was just a mild speck in a cold winter.

The lakes of water carried by Beverly and the billions of tons of sea water she displaced were all wasted on the open sea. But it was only her own strange whims that kept her from assaulting the land with the same vicious force that destroyed 20,000 boats and killed a quarter of a million people in Bengal. A twist to the west, and she could have duplicated the typhoon that washed over Honshu in 1934, killing 4000, or she might have equalled the damage of her predecessor who hit India in 1942 and killed 40,000.

Modern structures and even great battle-ships mean nothing to typhoons like Beverly. In 1944 one caught the U. S. fleet off Japan, damaging 28 ships and rolling over and sinking three destroyers. More than 800 officers and men were lost in that blow. A few months later the heavy cruiser, Pittsburgh, had her bow cut off as though hit with a giant ax. Two other heavy cruisers were knocked out of commission, the great aircraft carriers Hornet and Bennington had their flight decks smashed to kindling wood, and 28 other ships of the fleet were too battered to continue the mission.

Only the warnings of the typhoon trackers prevented greater loss when the worst typhoon in 20 years struck Okinawa in October 1945, killing 43 Americans and leaving 50,000 homeless. All that was loose was blown away, and then the ropes and anchor chains were torn from everything thought secure. Almost all food was lost, and 130 vessels of all kinds were sunk, crashed into the beach, or swept far inland.

Sometimes not even taking refuge in storm cellars will help. The typhoon that hit the Philippines in 1911 dropped 46 inches of rain in 24 hours (approximately

(Continued to page 254)

GARAGEMEN, SERVICE STATION OPERATORS, CAR OWNERS!

SAVE UP TO 50% ON THESE NATIONALLY-KNOWN AUTOMOTIVE SERVICE ITEMS



\$39.

KRW SIX AMPERE SLOW CHARGER

Headles 1 to 12 3-Cell Batteries or Equivalent. Complete ready to use. This heavy-duty battery charger is ideal for safe charging of all types of car, truck and aircraft batteries. It incorporates all the latest design and construction features. Comes complete with bulb, wiring and connectors, ready to plug in and operate. Case is 11" x 13" x 6". Operation is simple and fool-proof. Plug and Jack arrangement, like a telephone switch-board. You merely plug in to the jack corresponding to number of batteries on the line. Thousands now in use. Operates on 110 Volt, 60 Cycle.

For better than 30 years, the KRW Direct-to-User Policy has SAVED MILLIONS for THOUSANDS of Garage and Service Station Operators and Car Dealers. KRW manufactures hundreds of specialized tools and equipment which have been factory-approved by Ford and other car manufacturers. KRW Tools are used the world over. See our rating in Dun & Bradstreet. It's tops.

\$130.

KRW FASTCHARGER

FULLY AUTOMATIC. OPERATES ON 110 VOLTS A. C.

Simplest and most efficient on the market. Only one knob to turn, one dial to watch. New electric timer is foolproof in operation... it automatically discharges, fast charges, slow charges and shuts off. Customer can be shown exact condition of battery on the easily understood full-color dial. You can do this under proper load without danger of buckling plates. Use it also for "cycling" batteries that are badly sulphated. Equipped with 8" fan and heavy-duty motor. Lowest priced dependable unit on market. Money back if not satisfied after 30 days.



KRW GARAGE JACK



3 TON CAPACITY

Lowest Price only **\$87.**

This outstanding Jack value meets every requirement of strength, fast lifting, quick spotting and dependability. Lifting capacity 3-tons. Weight 195 lbs. Length overall including handle 88". Length of chassis 53". Floor to top of rest pad 4" minimum. Raises to 24" maximum. Equipped with Self-cleaning Release Valve, Tamper Proof Safety Valve. Crowned, Roller Bearing Front Wheels and Ball Bearing Swivel Rear Wheels. Finger-tip Control Button.

SOLD WITH 30-DAY MONEY-BACK GUARANTEE

KRW AIR COMPRESSORS. TWO STAGE

Highest Quality. 4 Models—9.75 to 38.3 cu. ft. Displacement.

Why pay \$200 to \$300 Premium. For 35 years, KRW has passed these savings on to users. Every feature which can contribute to maximum efficiency and long life has been "built in". Cylinders are nickel-chrome alloy iron. Crankshafts drop-forged with integral counterweights. Timken Roller Bearings. Lynite Connecting Rods. Semi-steel Pistons with 3 compression and one oil ring. Constant level oiling system. Plate-type Valves. Automatic Air Breather. Combination Filter and Air Cleaner. Pressure Unloader for Easy Starting. Pressure Control Switch and Thermal Relay protects motor against overloading and undervoltage. 200 lbs. pressure ASME Tanks. PRICES FOLLOW:
2 H.P. 9.75 c.f.m., 80 gal. tank **\$375.00** 7½ H.P. 28.4 c.f.m., 80 gal. tank **\$654.00**
5 H.P. 20 c.f.m., 80 gal. tank **\$440.00** 10 H.P. 38.3 c.f.m., 80 gal. tank **\$685.00**

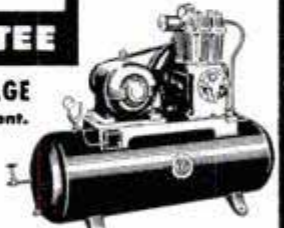

WRITE FOR LITERATURE WITH DETAILED SPECIFICATIONS

TERMS: Cash with order. If C.O.D., 25% must accompany order. Concerns with established credit sold on open account. All PRICES F. O. B. Factory. (Subject to change without notice.)

SATISFACTION OR MONEY BACK GUARANTEE All Tools or Equipment

described in this advertisement are sold subject to your trial for 30-days after receipt. If you are then not thoroughly satisfied, return the goods to us and your money will be immediately REFUNDED.

SERVICE AVAILABLE IN ALL PRINCIPAL CITIES

K·R·WILSON 213 MAIN ST. BUFFALO 3, N.Y.

WORLD'S LARGEST MANUFACTURER OF GARAGE TOOLS AND EQUIPMENT

CUT-TO-FIT HOMES CUT BUILDING COSTS

ORDER NOW SAVE UP TO **1/3**

Build your own home and save the builders' profit—plus savings in lumber and labor with Sterling Ready-Cut-Homes. Anyone can assemble with simple, easy to follow plans furnished. Every house complete with all lumber, roofing, nails, glass, hardware, paint, doors and windows marked ready to erect. Freight paid. Complete building plans ready for filing at low cost. Sold separately if desired. Write today!

CHOICE OF 57 DESIGNS



PRICED FROM **\$1885 UP**

INTERNATIONAL MILL AND TIMBER CO. DEPT. P.M.-350, BAY CITY, MICHIGAN

Send **25c** for NEW COLOR CATALOG

Your Car STARTS INSTANTLY

WITH A Stewart-Warner *Electric Fuel Pump*



Save Your Battery with instant starts—every time! Stewart-Warner's Electric Fuel Pump fits any car or truck. Feeds a steady, even flow of fuel into your engine as soon as you switch on the ignition. Thousands now in use!

Easy to Install. Complete fittings supplied. Do it yourself or see your local Carburetor Shop or Service Garage.

FREE—Illustrated Booklet on request Stewart-Warner Corp., Dept. K30 1840 Diversey Pkwy., Chicago 14, Ill. Please send FREE Illustrated Booklet on the dependable new Stewart-Warner Electric Fuel Pumps.

Name _____

Address _____

City _____ Zone _____ State _____

For Cars For Trucks

"MOTO-MOWER"

Best known name in power lawn mowers for thirty one years!



24" Lawn Keeper

22" Scout

for every size
LAWN

20" Moto-Boy

18" Ace

*17½" Power Cut

other models
up to 71"

There's one to
fit every
pocketbook

\$79.95*
POWER CUT
f.o.b. factory



- and anyone in the family can use it!

Write for catalog and name of nearest dealer

The MOTO-MOWER Company

4615 Woodward

Detroit 1, Mich.

HUNDREDS OF ITEMS AND IDEAS FOR THE WOODWORKER

A board or carload—Top grade kiln dried Mahogany—Walnut—Wh. Hd. Maple—Cherry—Poplar—Aromatic Red Cedar—Red, White and English Brown Oak—Sapeli—Andiroba—Balsa Wood. **NEW LOW PRICES.**

HARD TO FIND LUMBER

**BIG NEW NO. 17
CATALOG FOR
WOODWORKERS.
144 PAGES
OF HARD-TO-FIND
SUPPLY ITEMS.**

The finest catalog we ever published. Full of unequalled bargains and useful information.

Greatest Selection of Fine Domestic and Imported Woods

Catalog shows in natural color 32 rare and fancy woods. 43 matched veneer designs, multi-colored bandings, inlays, overlays. 275 scroll patterns to choose from, labor-saving machinery and a section for beginner's instruction.

OVER 100 NEW ITEMS

My stocks are gigantic—bigger than ever before. Really FAST SERVICE on your orders. My new catalog includes a "gold mine" of hard-to-find hardware items. Whatever Wood Craftsmen need—I HAVE IT.

MAIL COUPON TODAY for
GIANT NEW CATALOG #17

Only 15c Refunded on
first order.

Harold F. Hunt, President
CRAFTSMAN WOOD SERVICE CO.
2729 S. Mary St., Dept. A-3, Chicago 8, Ill.

I enclose 15c, to be refunded on my first order. Please send me your big new Catalog No. 17.

NAME _____

ADDRESS _____

TOWN _____

ZONE _____

STATE _____

New York's annual rainfall) and then backed up to drop four feet more in the next three days. An eight-foot lake covered all level ground.

Last year, with the seismograph boys bringing their new science of storm detection through earth tremors to perfection, and the typhoon trackers riding hard on all storms, the damage was greatly reduced. But that only applies to ships and aircraft that can be moved out of harm's way. In January 1948, Karen nearly washed away the island of Yap, the only food left being the taro roots deeply embedded in the ground. Libby moved in on Okinawa again, doing \$10,000,000 in damage, but this time no lives were lost. Ione slammed into Tokyo with a heavy toll of life and damage.

All told, the 514th has flown more than a hundred typhoon-tracking missions in a single year with eight storms developing into full-fledged typhoons. The average is 25 a year. There is no such thing as a typhoon season; it's just that they get a little worse in August and September. Nor is there such a thing as a typhoon belt. In general, typhoons seem to show a tendency to drift northwest, dissipating over North China, but any one of them is just as apt to take off for the Aleutians or North America, or to turn around and go back where it came from. Some just can't make up their minds, like the one that blasted Okinawa in 1945. It went by, backed up for a second crack, and then just lay there in indecision, its trailing cone of intense wind flicking back and forth over the island like the tail of a stalking cat.

The typhoon, from the Chinese *t'ai fung* (great wind) or the Arabic *tufan* (tempest) does not qualify as such until its velocity reaches 75 miles. Some have been known to reach 175 miles per hour.

Technically, there is no difference between a Pacific typhoon, an Atlantic hurricane, an Australian willy-willy, or an Indian Ocean cyclone. All are born of the warm, moist air girdling the earth at the equator, a stagnant belt known as the doldrums. If they move north, they pick up the spin of the earth at about 15 degrees latitude and begin to twist in a counter-clockwise direction. If they move south, the spin is reversed to a clockwise direction. Some hold that the Pacific typhoon is more violent than the Atlantic and Caribbean hurricane, but if this is so, it is only because typhoons have vaster areas to get up momentum before encountering obstructions. The hurricane that wiped out Galveston, killing 6000 in 1900, or the one that roared over Florida in 1928, blowing

(Continued to page 256)

Removing Paint is no problem now!



Yes, it's easy to remove any type of finish the professional WONDER-PASTE way. There's no arm-tiring work with a torch; no messy sanding needed afterward.

Simply apply WONDER-PASTE directly over the old finish with a paint brush . . . Allow time for complete penetration—then remove with a putty knife. The butter-soft sludge peels off easily, quickly, cleanly! Won't injure wood, metal, fabrics, or your hands.

At paint and hardware stores everywhere.

Write for Leaflet

WONDER-PASTE

Wilson-Imperial Company, 119 Chestnut Street, Newark 5, N. J.

MONEY MEN ALL FREE

DATA

THE PLASTEX Industry needs manufacturers on small scale and for big production of Lamp and Clock Stands, Art Goods and Novelties in Plastex and Marble imitation. Experience unnecessary. 1/2¢ material makes regular 10¢ store sellers. Rubber moulds furnished for speed production. Small investment brings good returns. Big chain store orders now being placed. Ambitious men have chance for real prosperity. Our Free booklet will interest and benefit you.

PLASTEX INDUSTRIES, Dept. A
3400 Third Ave. New York 56, N. Y.



Gerstner TOOL CHESTS

Machinists and toolmakers prefer a GERSTNER Chest for systematic care of good tools. Free catalog.

GERSTNER TOOL CHESTS
450 Columbia St. Dayton 7, Ohio

Pioneers

Leaders

AIR RIFLES

BENJAMIN

WITH SAFETY LOCK

AIR PISTOLS

SEND FOR FREE FOLDER OF LATEST MODELS TODAY

If you want a REAL GUN for PRACTICAL USE inside or outdoors, get a SAFE—CLEAN—ECONOMICAL—BENJAMIN with Adjustable Power and Amazing Accuracy. Use BENJAMIN H-C PELLETS for BEST RESULTS in all rifled models. WRITE AT ONCE.

BENJAMIN AIR RIFLE CO., 812 MARION ST., ST. LOUIS 4, MO.

Hobbyist Catalog



64 pages

WE PAY POSTAGE!

SHIP MODELS . . . TRAINS . . . PLANES
Cars . . . Art Supplies . . . Tools . . .
Projects . . . Games.
U.S.A. and Canada Orders Only.

10¢

write **Braun-Craft**

1232 ETOWAH, DEPT. PM-7, Royal Oak, Mich.

HYDRAULIC Power Transmission

WITH Infinitely VARIABLE SPEEDS, Clutch and INSTANT REVERSE—OUTPUT TORQUE ADJUSTMENT UP TO 180 inch POUNDS

This positive displacement Hydraulic Torque Converter is the ideal fluid drive with thousands of uses . . . Output Speeds Infinite .0 to 550 R.P.M. . . . In either direction . . . Change Speeds WHILE RUNNING . . . Control and Transmit your power this SMOOTH OH-Way . . . Will handle 1/4 H.P. to 1 1/2 H.P. Motor, Industrial or Home & Farm Use . . . Cost Government \$300. High Quality Precision Workmanship. Buy this unit to get the most for your money. Case measures 7 1/2" long 7" high 6 1/2" wide. Input & Output Shafts 5/8" dia. Beautiful Red Crackle Finish Case.

FINGER TIP CONTROL

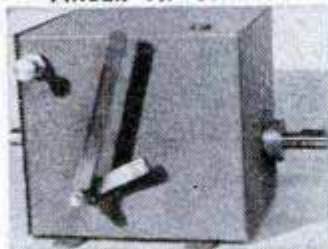

Shipping Wght. 25 pounds

Only \$54.50

If C.O.D. is requested a 10% Deposit must accompany order and we ship F.O.B. Chicago.

1 1/2"-8 thread Lathe Chuck Adapter, \$3 extra

PREPAID 2 quarts oil included FREE

DIRZIUS MACHINE SHOP "T" 1423-25 So. 52nd Ave., Cicero 50, Ill.

ASK YOUR DEALER

Using too much oil?

SWITCH to PENNZOIL

SOUND YOUR

Z

If you suspect you've been using too much oil, why not find out? Switch to Pennzoil, the 100% Pennsylvania oil with *staying power*.

Over 60,000 better dealers, coast to coast, recommend Pennzoil. It's worth looking for, easy to find at the yellow oval sign. Just sound your Z—get the genuine.



Member Penn. Grade Crude Oil Assn., Permit No. 2

PENNZOIL® MOTOR OIL AND LUBRICANTS AT BETTER DEALERS... COAST TO COAST

Make \$3.00 AN HOUR AND MORE
IN FULL OR SPARE TIME!
SHARPENING LAWN MOWERS
IN YOUR GARAGE or BASEMENT!

READ WHAT THIS CUSTOMER SAYS:

"I am buying a home and my Universal is going to be a tremendous help paying for it." Another Universal owner says, "I have taken in last season **more than \$3500.00.**" Another "During this year I sharpened 602 mowers." Spare time or full time, **you, too,** can make big money in your own business and be your own boss. No other lawn mower sharpener has the advantages that Universal offers. That's why owners tell glowing success stories in this profitable business. Write today for full details of our proved success plan.



ONLY ON THE UNIVERSAL LAWN MOWER GRINDER

can the inside face and edge of the stationary blade, and all reel blades, be ground to proper clearance

ALL IN ONE SET-UP

WITHOUT REMOVING ANY BLADE FROM THE MOWER

Men with 20 and 30 years of experience have tried them all and acclaim the UNIVERSAL Grinder best.

OUR PLAN GIVES ALL THE PROVED SHORT-CUTS TO SUCCESS

SHOWS YOU HOW STEP BY STEP
 From the successful experience of hundreds of our customers, we have evolved a basic plan, simple and easy to follow, which leads you to quick success in either spare or full time.

ROGERS MFG. CO.
 DEPT. M-30, LINDSEY, OHIO

SEND THIS COUPON NOW

ROGERS MFG. CO., Dept. M-30 Lindsey, Ohio
 Please send me full details about the profit possibilities of Lawn Mower Sharpening.

NAME _____

ADDRESS _____

CITY _____

STATE _____

the water right out of Lake Okeechobee and drowning 2000 persons, can hold their own in any typhoon league.

Only in the last five years has man had the means and the courage to study typhoons inside out and from top to bottom. The airplane, radar and the seismograph are revealing a lot of their mysteries, but so far nothing is known why they behave as they do, and go where they go. The seismograph is the latest instrument to be brought into play in tracking the typhoons. The Rev. J. E. Ramirez, while at work at St. Louis University, was first to notice that heavy storms produced enough earth tremors to be picked up by a sensitive seismograph, and in 1943 the Navy began experimental work along his suggested lines. Today, microseisms reveal the presence of small storms as far as 300 miles away, and the giant typhoons can be detected more than 2000 miles away. With several seismographs taking bearings on the disturbance, its path can be followed minute by minute with an accuracy of 20 miles.

In the meantime, the typhoon trackers and the hurricane hunters continue to slice through the tempests in their study of typhoon anatomy. It is doubtful that ever again will any existing planes make a low-level assault such as Lykins' attack upon Beverly, but much still remains to be learned at the upper levels. Maybe somewhere between 10,000 feet and 50,000 feet will be found the secret of where the storm is going next.

Thanks to their work, the death toll has been reduced from 80 lives per \$10,000,000 damage to four lives. It is true that this picture is not entirely accurate, property values having increased tremendously, billions of dollars in crops and industries having been developed in the Pacific within the last 20 years, and more billions along our Gulf Coast. But by the same token there has been a huge increase in population density. And, thanks to the warnings, property damage has been greatly reduced by proper precautions, and the heavy loss in shipping has been nearly eliminated by getting ships and airplanes out of the threatened area.

Whether or not ways can be found to prevent typhoons remains to be seen. Since the typhoon's power is based on its latent heat, it may be vulnerable to attacks by Dry Ice, but one dry comment to this is that there isn't that much Dry Ice in the world.

Until some way is found to stop them, the Navy has prepared detailed instructions on how to sail through a typhoon, the instructions applying to all craft up to battle wagons. In full they read: **STAY WELL OUT!**

PAINTERS' STRIPING TOOL

A TOOL... NOT A BRUSH

NEW, IMPROVED

Modern—streamlined—fits the hand like a fountain pen! Easy to use as a pencil. Draws parallel lines—straight, curve or circular. Does expert job on autos, furniture, toys, bikes, model planes, signs, bulletins, linoleum. (Makes wall board look like tile.) Every painter and craftsman needs one! Type "M" MASTER Painters' Striping Tool complete with tip for 1/16" stripe, \$1.00. Other tools complete with following tips: 1/64", 1/32", 3/64", 5/64", 3/32", 1/8"; \$1.50 ea. Extra tips 75c ea. Entire kit with tool and 7 tips—\$5.00. (COD's postage collect.) Paint dealers, write!

\$1.00 POST PAID

EASY AS USING A PENCIL!



WENDELL MFG. CO.

4234-B Lincoln Ave., Chicago 18, Illinois

NOW... FOR 1/10th THE COST

CONVERT ANY DRILL PRESS INTO A PLANER • SHAPER • JOINTER POWER SANDER • ROUTER

This FREE Book Tells You How

BARRON TOOL COMPANY, INC.
969 Architects Bldg., Detroit 1, Mich.



Find HIDDEN TREASURES

GEIGER COUNTERS for uranium ore detection. TREASURE DETECTORS for Gold, Silver, other metals and minerals. Light weight, highly sensitive. None finer at ANY PRICE.

Detector co. Dept. 3-B
5637 Cahuenga, No. Hollywood, Calif.

PISTONS



ALUMINUM ALLOY. For Every Make Engine. Any Year, Odd or Foreign! For auto, "hot rod", racing, truck, tractor, motorcycle, scooter, bike, outboard, marine, compressor, industrial. Send sample or specifications.

JUDSON MFG. CO., 1709 Gillingham, Phila. 24, Pa.

THRILLING NEW SPORT BOAT!

as featured in
Aug. 15 LIFE
pages 52-54

Sailfish

Trade Mark
SPORTABOUT

Now the fast, brilliant "Sailfish" comes knocked down for easy home assembly at a big saving! Safe-T-Plane hull can't sink or swamp. Carries conveniently on car top. Precision pre-cut and pre-formed parts of high quality materials go together quickly. All hardware included. HULL KIT, \$69.75. SAIL KIT, with centerboard, rudder, spars, rigging and finished sail, \$49.75. ASSEMBLED BOAT, factory finished and complete with sail, \$189. All prices are f.o.b. Waterbury, Conn. Illustrated literature on request.

Dept. S., ALCORT, INC., Waterbury, Conn.

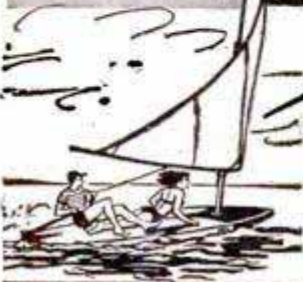

I'M VERY DEAF BUT I HEAR

Everything with My New

ZENITH "MINIATURE" HEARING AID

Don't let deafness kill the joys of living. Let a Zenith home trial prove you, too, can even hear a whisper. Here's Zenith's amazing guarantee—if any \$200.00 hearing aid outperforms Zenith's newest, tiny, 6¾ oz. single-unit "Miniature" Ration Hearing Aid in efficiency or economy, your money back—under our 10-Day Return Privilege. Only \$75.00 complete, ready to wear. For authorized Zenith Hearing Aid Dealer in your locality, consult your classified telephone book; or write us for complete coast-to-coast dealer list. Free descriptive literature on request. Address—

Zenith Radio Corporation, Hearing Aid Division
Dept. 391, 5801 W. Dickens Ave., Chicago 39, Ill.

Makers of World Famous Zenith Radio,
FM and Television Sets

PRESSURE PRINCESS

Makes every job EASIER

YOU have never seen a single cylinder portable air compressor that packs so much power as this one. Built by the makers of the famous 4 cylinder Pressure Queen, the Princess will do any job, from inflating tires to painting buildings. Compact, simple and rugged, it will last your lifetime and pay for itself over and over again.

Powered by electric motor or gas engine.

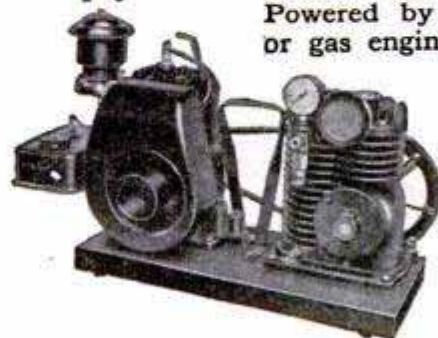

Write for Literature and Prices

THE CAMPBELL-HAUSFELD CO.

1046 Railroad Avenue

Harrison, Ohio



Radio and TV Sets—Parts—Tools—Hi-Fi—Public Address—Kits—Test Equipment—Ham Gear—Record Changers—Recorders, etc.

164 pages packed with all new, latest-model, famous-make radio and TV equipment at money-saving prices.

Invest a penny postcard and send for this great new 1950 Lafayette Catalog. Then sit down with pencil and paper and make a price comparison test. Check model for model, and see if Lafayette doesn't save you anywhere from a few pennies to a few dollars on most every item.

If you're a service man, experimenter, ham, hi-fi bug, engineer, set-builder, or serious amateur—send for your 1950 Lafayette Catalog now. It's one of the biggest things in America you can get "for free"!



SALE!

Lafayette

**famous FM-AM
HIGH-FIDELITY CHASSIS
with built-in
PHONO PRE-AMPLIFIER
INCLUDING WIDE RANGE
12" PM SPEAKER**

\$59.50

**PRICED
AT ONLY**

Look at these \$300 set features: Latest 11-tube circuit plus rectifier. 10 watts undistorted power output. Phono pre-amplifier permits direct connection of variable reluctance pick-ups. High and low impedance phono input. Tone control. Slide rule dial. Supplied with loop and folded dipole cabinet antenna. 12" PM speaker with Alnico V magnet. 105-125 volts, 60 cycles, AC only. Chassis dimensions: 13x9x9½. Shipping weight: 25 lbs. Complete with tubes \$59.50. **30-day Money-Back Guarantee!** If not fully satisfied, return to us within 30 days, and you'll receive full refund, less transportation charges.

NEW YORK:
100 Sixth Avenue and
542 E. Fordham Road
(Bronx)
CHICAGO:
901 W. Jackson Blvd.
ATLANTA:
265 Peachtree Street
BOSTON:
110 Federal Street
NEWARK:
24 Central Avenue

Lafayette
RADIO
OUR 29th YEAR

RUSH COUPON NOW FOR FREE CATALOG

LAFAYETTE RADIO, Dept. LC-50
901 W. Jackson Blvd., Chicago 7, Ill.
or 100 Sixth Avenue, New York 13, N. Y.

Rush me your FREE 1950 164-page Catalog.

Name _____

Address _____

City _____ Zone _____ State _____

PASTE ON PENNY POSTCARD

Inventor in a Carriage House

(Continued from page 85)

It's a far jump from inventing a diaper to analyzing a jet engine, but Rand has made it. One of his instruments records the complicated contours of jet rotor blades and other irregular objects. Tracer points analyze the blades, and this information then is fed to an oscilloscope where it is reproduced as an image on the screen.

For a Cleveland surgeon Rand developed a respirator that he says "breathes for a patient during an operation better than the patient can breathe for himself." The machine alternately squeezes and releases an anesthetic bag, and can be regulated to meet the needs of any case.

Another product of the medical-research program is a mechanical heart that maintains the patient's normal circulation while an operation is being performed on the regular heart—actually a mechanical heart that "beats" outside the body.

A third remarkable surgery aid is a heart massager that does a better job than a surgeon's hand. Occasionally, during an operation a patient's heart will stop, and the surgeon will attempt to start it by massaging with his hand through an incision. While a surgeon can forcibly cause the heart to contract by squeezing it, he has had to depend on the heart's willingness to expand to get the blood back into it. Rand's device consists of two vacuum cups, each at the end of a long handle. The surgeon presses a cup against each side of the heart, squeezes it to expel blood, then moves the cups apart so their suction can dilate the heart walls.

Built into one cup is an electrode controlled by a switch in the handle. When the heart appears to be capable of working on its own, the surgeon presses the switch and the heart receives a stimulating electrical shock that may stir it to normal action. In one experiment, this massager was used to maintain circulation in a dog whose heart had been stopped for five hours. The heart was shocked into operating normally.

Still another aid from the laboratory is a plastic-film mattress which prevents bed sores. It is divided into compartments which can be inflated and deflated independently. An automatic pumping device controls this action, changing the mattress pressure on each part of the patient's body at three-minute intervals.

Rand has developed an electrical power unit for a wheel chair. The control system permits the patient to start, steer and stop the chair by moving only a finger tip or even only his tongue.

There's no need for a night watchman

(Continued to page 260)

Home Workshop Tools

**PRICED TO
EVERY FAMILY PURSE**



12" Band Saw
\$68.95*

10" Band Saw
\$39.95*



Saber Saw \$15.75*



10" Wood Turning Lathe \$42.50*



12" Drill Press
\$44.95*

12" Floor Model
Drill Press
\$54.00*



7" Tilting Arbor
Bench Saw \$39.95*



8" Tilting Arbor Bench Saw \$67.50*



8" Tilting Table Bench Saw \$52.50*



6" Jointer \$71.50*

4" Jointer \$39.95*



Spindle Shaper
\$44.50*



Belt and Disc Sander

\$49.95*



15" Jig Saw \$24.95*



10" Floor
Model
Tilting
Arbor Saw
\$97.50*

*Zone 2, less motor.

**She'll enjoy your shop and
the money you'll save with
SHOPMASTER
woodworking tools**

You can start your home workshop with a Shopmaster Saber Saw, like the one pictured above. The cost is less than \$16.00. With it you can cross cut, rip, and do many other complicated sawing operations.

You can add to your shop at any time. All Shopmaster Tools are independent and designed to do specific work. Independent tools are always ready, and require little adjusting. Just flip the switch and you are ready to go. These uniform precision-built tools can be mounted together and powered with one motor if you wish, or can be independently powered.

There is a size of tool for every shop, so make yours a Shopmaster shop.



SHOPMASTER, INC.

1214 Third St. S., Minneapolis, Minn.

Send me your new full color catalog giving full details on the complete line of SHOPMASTER "Uniform Precision" Tools, and shop layout sheet.

Name _____

Address _____

City & State _____

get the world's greatest RADIO & TELEVISION CATALOG! **FREE**

ALLIED'S
196-PAGE GUIDE
TO EVERYTHING
IN RADIO & TV AT
LOWEST PRICES



TELEVISION AND
HOME RADIOS



SERVICE SUPPLIES
BUILDERS' SUPPLIES



AMATEUR GEAR



AMPLIFIERS, P.A.
SYSTEMS, RECORDERS

**Everything for Experimenters,
Builders, Amateurs, Service-
men, Engineers, Soundmen**

Save money on every radio need! Get the 196-page 1950 ALLIED Catalog featuring the world's largest stocks of top-quality equipment, at low, money-saving prices! Latest TV releases, home radios and radio-phonos, Amateur equipment, PA systems and High-Fidelity Sound, recorders, test instruments, builders' kits—plus thousands of parts, tubes, tools, books and diagrams. Get more for your money from the World's Largest Radio Supply House. Send today for your **FREE** copy of the 1950 ALLIED Radio Buying Guide!

when the Rand robot watchman is on duty against fire and burglars. If a sensing element such as a thermostat or a photoelectric cell closes the circuit, a battery throws current into the robot. The robot then closes the telephone circuit, waits for a dial tone and dials a number by means of a cam. It then waits for an answer. If it gets a busy signal, it hangs up and dials again. After having made contact with the police or fire department, it speaks a message which has been previously recorded on a wire recorder. After the fire or police department has received the message, the robot must be called back or it will continue to make the call every three minutes. The robot does just about everything except draw a revolver on a burglar or throw a bucket of water on a fire.

To the outsider, Rand's carriage-house laboratory seems a tinkerer's paradise. Machinery, electronic equipment and all sorts of instruments are everywhere, yet there's no hurry or confusion. There's an old saying around the laboratory that people who work there work themselves straight out of one job and into another. But there are always new projects brewing in Rand's mind, ideas that will become inventions in the old carriage house.

When Oil Wells Run Dry

(Continued from page 159)

The principle common to all the retorts is to burn the residual oils and carbons in the spent shale to provide the heat or hot gas that in turn heats the raw shale and drives off its oil.

This crude oil is then pumped to a small flexible refinery unit for thermal cracking operations. Here the diesel oil used by the mining equipment is produced, as well as the gasoline for the plant's automobiles, burner fuels, coke and intermediate stocks.

Shale oil has excessive amounts of sulphur, nitrogen and oxygen compounds and its conversion into high-quality products is more expensive than is the refining of most crude petroleum. This, however, is balanced by cheaper production costs. It's cheaper to mine and retort the shale than explore for petroleum and dig wells.

The Bureau of Mines is also studying the production of liquid fuels from agricultural residues such as corncobs, seeking ways of extracting additional petroleum from exhausted oil fields, and testing methods of converting the hydrocarbons in coal into liquid fuels. Started as an emergency measure during the war, the whole program has brought assurance to the United States that this country won't run out of liquid fuels for perhaps 1000 years to come.

ALLIED RADIO ★

ALLIED RADIO CORP.
833 W. Jackson Blvd., Dept. 5-C-0
Chicago 7, Illinois

Rush FREE 196-Page Catalog

Name.....

Address.....

City.....Zone...State.....



NOW 1950 MODEL **HANDEE**
of the famous...
at new **LOW PRICE**
TOOL OF 1001 USES

It's here—biggest buy of all. First tool of this type and today's finest. The "Cadillac" of small power tools—choice of mechanics and home-crafters everywhere. Make costume jewelry, train and plane models, puppets, tool leather, initial tumblers, internally carve plastics, etc.



A Whole Tool-shop in one hand. Grinds Drills Engraves Polishes Cuts, Routs Saws, Sands

NEW LOW PRICE
\$24.95

A FINE GIFT

Handee with 51 accessories in new steel case.....

Handee with 7 accessories **\$19.95**

Here's smooth, controlled power at your fingertips. Handee has 7-bar armature and is perfectly balanced. 25,000 r.p.m. AC or DC. Wt. 12 oz. Order today postpaid on money-back guarantee or write for catalog. Chicago Wheel & Mfg. Co. 1101 W. Monroe St., Dept. PM, Chicago 7, Ill.

POWER MOWERS & KITS **FREE PLANS**



LOW FACTORY PRICES DIRECT TO YOU

on America's finest Lawn Mowers and Easy-To-Assemble Kits and Parts. TRIANGLE Mowers are quality-built and powered high for easy cutting and long wear.

SAVE MONEY 3 WAYS

1. Buy complete assembled mowers in 3 or 4 wheel models. 18" and 20" sizes.
2. You assemble complete mower from our precision built Kits and Parts.
3. Build your own from our FREE PLANS using Triangle Kits, Parts, Engines, Wheels, Etc.

WRITE TODAY for full facts, Free Plans, Parts List, and LOW, Factory Prices.

TRIANGLE MFG. CO.
Dept. M-B, Box 185
Fort Scott, Kansas

POWER HACKSAW \$47.25

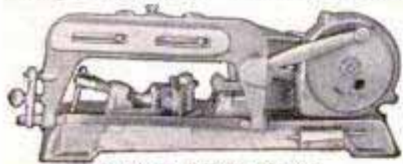

LESS MOTOR
F. O. B. Benton Harbor

● Rugged cast iron construction. Wt. 56 lbs. bronze bearings. Draw cut. Auto. return lift. Auto. shut-off. Vise swivels 45°. Cap. 4"x4".

Send for full details and name of nearest dealer.

EXCEL MACHINE TOOLS Dept. PM-30 BENTON HARBOR, MICHIGAN

make your own Gems **29.50**
F.O.B.

All necessary lapidary equipment is furnished, including a super-charged diamond blade for sawing, and all wheels for grinding, shaping and polishing; also complete instructions. The complete equipment as shown, less motor and belt, for only \$29.50, f.o.b., Burlington, Wisconsin. Write today for information and literature.



B&I MANUFACTURING CO.
Dept. S Burlington, Wis.

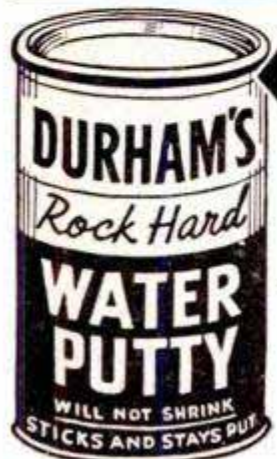

The Modern PLASTIC for lasting Home Repairs

PERMANENTLY mends cracks or holes in wood, tile, stone or plaster. Sticks and stays put—Does not chip, shrink or fall out. Easy to use. Economical. Mold it, chisel it, polish or paint it. If unobtainable from your lumber, paint or hardware dealer, the big 4-lb. can will be sent you postpaid (in U.S.) for only \$1. Full money-back guarantee, order now.

DONALD DURHAM CO.
Box 804-O, Des Moines, Iowa

EXTRA BEDROOM IN YOUR ATTIC!

FINISH off an extra attic bedroom quickly and inexpensively with Gold Bond Insulation Board. This new material gives you 3 big benefits for one low price. It decorates, insulates and hushes noise. It comes in tiles and random width planks finished in ivory and harmonizing variegated blends. Also in big ivory-coated panels. No further decoration is needed. Ideal for game rooms, dens or for remodeling living or dining rooms. For further details write Div. X, Dept. PM-3.

Available at your local Gold Bond Lumber and Building Materials Dealer

NATIONAL GYPSUM COMPANY
BUFFALO 2, N. Y.



FAST—Old Town Lapstrake Boat

SMOOTH lines of this lapstrake out-board boat help you start in a hurry—and get there fast! She's roomy, too, with wide cross seats (folding backs) and long seats on both sides at the stern. Handles easily, with deep bow to fight stormy waves! Built of handsome woods for strength and service. Upkeep is easy.

FREE CATALOG shows just the model you need. Write for one today! Also rowboats, sailing dinghies, sailboats, canoes.

OLD TOWN BOATS

643 Elm Street, Old Town, Maine
PLEASE SEND ME FREE CATALOG

Name _____
Address _____
City _____ State _____

"DAY OR NIGHT THE BIG ONES HIT JITTERBUG"

23-lb. Musky and 21-lb. Northern Pike taken at Penetang, Georgian Bay, Canada, on a Black Jitterbug by Leonard Kline of Cleveland, Ohio, and Clarence Mulhorn of Vandergrift, Penna. "Following day we took 5 Large-mouth Bass & another Northern Pike on a Red and White Jitterbug."



NOISY SURFACE BAIT

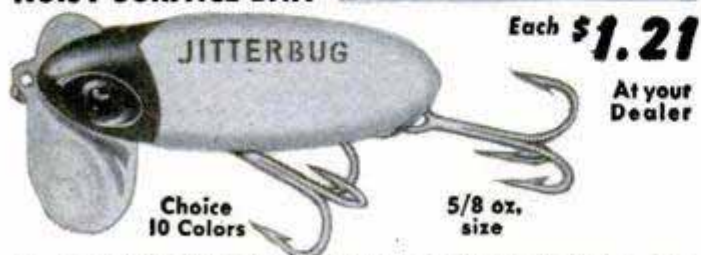

Each **\$1.21**

At your Dealer

Also in 3 FIREPLUG® FLUORESCENT FINISHES \$1.45 each.
MUSKY JITTERBUG (1-1/4 oz.) gets the biggest. \$2.00 each.
PEANUT JITTERBUG (3/8 oz.) for light tackle and spinning outfits \$1.21 each.

► WRITE FOR FREE FULL-COLOR BAIT CATALOG ◀

FRED ARBOGAST & CO., INC.
1623 WEST NORTH STREET • AKRON 3, OHIO



AT WAREHOUSE-TO-YOU PRICES

Now ... from **one** convenient and economical source you can get these high quality metals for your needs, pre-cut to your specifications.

ALUMINUM, BRASS, COPPER, STAINLESS STEEL in RECTANGULAR SHEETS

Easy to work, adaptable to hundreds of uses such as lamp shades, serving trays, wall brackets, etc. Ideal for modern silhouette cut-outs.

CIRCLES of ALUMINUM and COPPER
Perfect for shaping and forming into useful items, and for perforated design work.

Write for price lists and complete information

FREE BOOKLETS tell how YOU can use these metals—easily and quickly. Write for your free copies today.



METAL GOODS CORPORATION

Dept. P M 5239 Brown Ave. St. Louis 15, Mo.

Boom in Tongue-Twisting Metals

(Continued from page 154)

Swedish army surgeon, Karl Mosander, back in 1839. Like most of the rare earths, lanthanum is seldom seen pure, is commonly used in the form of colorless salts. During the 1930s, chemists found that using lanthanum in camera lenses made for clearer, sharper photographs. During World War II, lanthanum went into the aerial cameras used in photographing enemy installations from high in the sky. Now lanthanum lenses are appearing in the better cameras sold to amateur photographers.

Neodymium, one of the elements discovered by Karl Auer when he was still an earnest student, began his researches with only enough of the rare earth containing minerals to fill a child's hand. Now it can be produced in varying grades of purity for industry. It serves as a brilliant coloring material for expensive glassware. The raspberry and amethyst colors it creates cannot be duplicated anywhere. It's expensive though, the neodymium alone in one colored goblet could cost anywhere from \$5 to \$15. In smaller amounts, neodymium cuts out unwanted yellow colors in glass. And a good pair of sunglasses may contain some small amounts of this rare earth. It has a great ability to filter out ultraviolet rays from the sun which are hard on the eyes.

Various mixtures of the rare earths also have important industrial uses. One mixture, called didymium, is what is left when cerium is taken out of the rare earths in monazite sand. Industrially, didymium is used to make glass colorless, in nonglare lenses, and—like neodymium which it contains—to cut down on the ultraviolet rays which pass through sunglasses. Other mixtures include most of the heavier rare earths found in monazite, as well as cerium. The chloride salts of this mixture can be applied to textiles to make them waterproof. Furthermore, they are also valuable in killing mildew that might settle on the textiles. The fluorides and oxides of this mixture go into the cores of the carbon rods used to produce arc lights. They help make the light that results when electricity jumps between the rods a brilliant white. Pound for pound, this use of the fluorides and oxides in the cores of arc-light carbons is probably the most important single use of the rare earths.

One mixture of rare earths, called cerium oxalate, is used in medicine. It helps prevent nausea.

There are a good many production headaches in getting the rare earths out of the monazite sand. For one thing, they all tend

(Continued to page 264)

U-CAN-DO-IT

WOODWORKING PLANS



You don't have to be an expert to make your own furniture! These simplified instructions will show you how to make your own end tables, shelves, scrap hampers, etc.

You also get a full size bottle of our famous "Gorilla Grip" Glue. Rogers has a ton of strength in every drop. It's great for making and repairing furniture.

Send 10c Now to Rogers Isinglass and Glue Co., Gloucester, Mass.



ROGERS

the best LIQUID FISH GLUE
GLOUCESTER, MASS.

Sand Casting—Forging—Heat Treating—Case Hardening BRONZE FOUNDRY



In your own workshop allows you to design and build your own GASOLINE ENGINES, STEAM ENGINES, STATUARY, ART OBJECTS, SPECIAL TOOLS, NEW INVENTIONS, ETC. You can also make forgings and case harden steel. Your shop is not complete without a FOUNDRYETTE. Three sizes are available capable of making bronze castings of 1 1/2, 3 and 6 pounds weight, aluminum, copper, brass, etc., \$22.50, \$29.50, \$42.00 f.o.b. Kansas City. Domestic gas supply and 110 volt AC or DC energy required for operation. Write for circular.

KANSAS CITY SPECIALTIES CO.

Box 6022, Dept. P-2

Kansas City, Mo.

JET POWER YOUR CAR!

Merrick's Multi-jet fuel atomizer gives your car worlds of added power... quicker starting and take-off... smoother, quieter performance... plus more miles per gallon of gas. Install it yourself in a few moments in manifold. Try it for ten days and if you are not delighted with results, return it. Will gladly refund money. When ordering give make and year of car. Prepaid any place—\$7.75

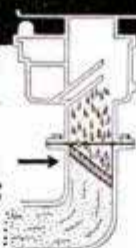

MERRICK ENGINEERING CO.

6700 IMPERIAL AVE. SAN DIEGO, CALIF.

OTTAWA Buzz Master

7 MODELS—\$99.00 up

Greatest offer made in our 46 years of manufacturing. A model to fit your needs and your pocketbook. Free details.

OTTAWA MFG. CO., 2-027 Brush St., Ottawa, Kans.



No Other Like It!

MODERN LAWN MOWER SHARPENER

FOR LAWN MOWER SHOPS
FIX-IT SHOPS

GOLF COURSES • PARKS
101 OTHER JOBS

Sharpens All Reel Type Mowers • Hand, Power or Gang • 10 to 20 Minutes • No Dismantling • No Extra Attachments Needed.

All reel type mowers, from 5-inch edgers to 36-inch power mowers, are quickly sharpened to extreme ends of both left and right twist blades.

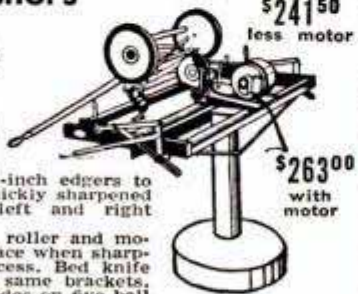

PRICE \$241.50 less motor

\$263.00 with motor

Handle, wheels, roller and motor remain in place when sharpening is in process. Bed knife is sharpened in same brackets. Grinding head rides on five ball bearing races. Easy to operate. Also sharpens chisels, joiner knives, planer blades. Big profit maker. Own your own business. Send Today for FREE Illustrated Bulletin No. 10-C

ORDER NOW
Immediate Delivery

MODERN MFG. CO. 160 N. FAIR OAKS AVE. PASADENA, CALIFORNIA

Use this →

PARAGON SPRAYER

FOR 10 DAYS

WRITE FOR SPECIAL OFFER

Spray your own fruit trees, and growing plants. Kill lice and parasites on poultry and stock. Disinfect and whitewash pens, barns and out-buildings. Destroy weeds. Easy-working. Self-straining, non-clogging. Paragon Sprayer stands steady on uneven ground.

Income from renting or spraying for others will bring you extra profits year after year.

No. 3; 12-gallon capacity with pipes, hose, nozzles and truck \$29.95.

To take advantage of early spraying write, phone, or wire today for our special proposition.

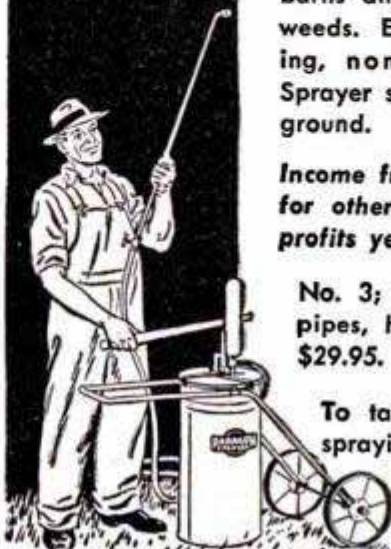

THE CAMPBELL-HAUSFELD CO.

45 State Ave., HARRISON, OHIO

here's the

VERSA-VISE

the versatile vise for every woodworking need

- * Stands Up
- * Lies Flat
- * Turns to the most Convenient Position



cast semi-steel construction - weighs 16 lbs.

Only \$8.95, f. o. b. Orrville, Ohio. Buy it from your dealer, or send check or money order direct to us for \$8.95 (Ohio customers remit 3% sales tax) and pay the small shipping costs upon delivery. Satisfaction guaranteed or your money back.

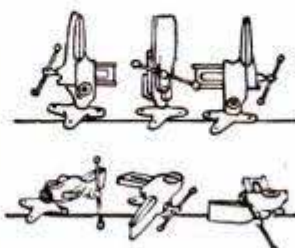

The Will-Burt Co. ORRVILLE, OHIO
Department P

THOUSANDS BUILD AT 1/2 THE PRICE

20 MODELS

U-MAK-IT BOAT KITS

EASY TO BUILD

ROWBOATS
8 TO 14 FT.
Special Models For Fishermen

PRAMS

OUTBOARDS
Fast Round or V Bottoms
12 TO 16 FT. Newest Assembly Methods

INBOARDS & CABIN CRUISERS
For Fishing, Racing or Cruising 16 TO 23 FT.

BUILD THE BEST
U-MAK-IT
KITS

SEND 25c (coin) ORDER YOUR CATALOG TODAY

U-MAK-IT PRODUCTS 703P-WHITTIER ST. New York 59, N. Y.



"SAVE IT AND FIX IT"

REPAIRS

**CHINA, TOYS, FURNITURE
BOOKS AND LUGGAGE**

It's transparent, waterproof,
flexible and durable.

Get a tube
today.



DUCO CEMENT

REG. U. S. PAT. OFF.

to behave alike, although Doctor Kremers says that under certain conditions, cerium, samarium and ytterbium can be made to act like chemical individualists. This helps speed separation. And, in the meantime, he isn't talking too much about just how the earths are pulled out from the mixture in the monazite.

The rare earths, incidentally, are hip-deep in the atomic-energy program. The 1947-1948 report of the Atomic Energy Commission, issued recently, cites the progress in preparing purified forms of the rare earths. So far, purified forms of lanthanum, cerium, praseodymium, neodymium, samarium, gadolinium and ytterbium have been prepared. The AEC reports that the demand for these substances from other laboratories is greater than the supply. Furthermore, it says, "It now appears that they (the rare-earth metals) may have a bright commercial future as alloy metals in the manufacture of high-temperature structural materials and other specialized products."

And a scientific controversy on a now-you-see-it, now-you-don't basis is still raging around one of the rare earths. This element is number 61 in the periodic table. In recent years it has operated under three different aliases, illinium, florentium and promethium. Illinium was the name given it by Prof. B. Smith Hopkins of the University of Illinois, who discovered it through the hotly debated magneto-optic effect, which many scientists distrust. Florentium was the name given it by Prof. Luigi Rolla of Florence, and his discovery has been doubted. Promethium is the name proposed by the team of atomic scientists who created radioactive isotopes of the element in the laboratory. So far, it doesn't seem to have turned up in nature. They obtained their samples of the element by bombarding neodymium with the atomic particles called neutrons. The form they discovered doesn't last long, has a radioactive half-life estimated at 3.7 years.

In spite of this argument, however, and the technical difficulties in extracting the rare earths, one thing is certain. Future generations of chemistry students are going to have a much better acquaintance with this family of elements than their fathers ever had. What was once a brief detour in high-school chemistry classes may become a broad paved highway for chemical engineering.

☐ An air strip has been built on the Kansas State Fair grounds at Hutchinson, Kans., so that farmers, who once drove their horses many miles to see an airplane at the fair, now can fly there in their private planes—to see the horses.

3-purpose hair tonic

DESIGNED TO DO ALL THREE THINGS A HAIR TONIC SHOULD DO!

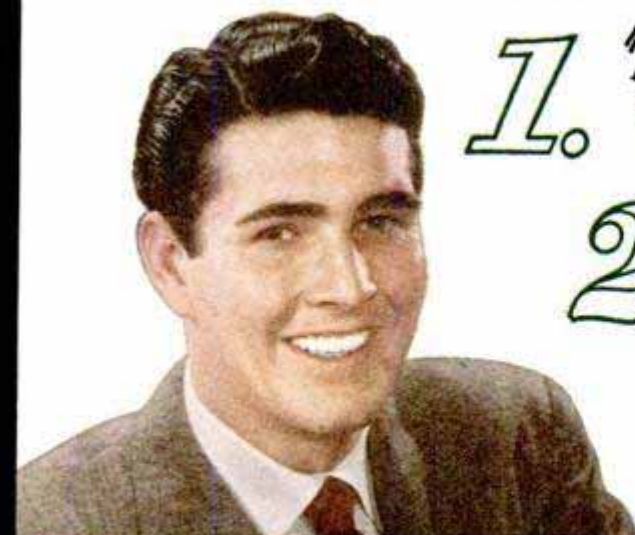

1. "Wakes Up" Scalp Yes... Lucky Tiger relieves itching quickly, cleans scalp of loose dandruff scales, gives scalp a keen, zesty tingle. Scalp feels better—you feel better!

2. Kills Dandruff Germs* Lucky Tiger gets at a common cause of infectious dandruff—actually kills the germ *pityrosporum ovale** on contact—so you can make progress against dandruff!

3. Grooms Hair Perfectly! Lucky Tiger adds lustre, makes hair easy to comb and keep in place—without that slicked-down, greasy look. You don't look "sharp"—just naturally well groomed!



Get This Pin-Up FREE!

To get a beautiful, four-color, 8½ x 11 glossy stock reproduction of the Lucky Tiger Pin-Up Girl ABSOLUTELY FREE and postpaid—simply send coupon below or write the Lucky Tiger Mfg. Co., Dept. PM 10, 544 Delaware St., Kansas City 6, Mo.

3-WAY LAIR TONIC!

- 1. WAKES UP** dull, drab, uninteresting rooms—gives life a keen, zesty tingle!
- 2. KILLS** the Monday, Tuesday, Wednesday, Thursday, Friday, Saturday and Sunday off-hour Blues—Lucky Boy you!
- 3. GROOMS** the mind . . . perfect dream material—Lair Tonic cures what ails you!

SEND TODAY! Act at once if you want a beautiful, four color, 8½ x 11 reproduction on glossy stock of the Lucky Tiger Pin-Up girl. Only a limited amount available—make sure you get yours by ordering NOW!

Lucky Tiger
HAIR TONIC

PHOTO BY HURREL

LUCKY TIGER MANUFACTURING CO.
Dept. PM 10, 544 Delaware St.,
Kansas City 6, Mo.

Gentlemen: Please send me, postpaid, a beautiful four color, 8½ x 11, glossy stock reproduction of the Lucky Tiger Pin-Up girl, absolutely FREE!

Name _____

Address _____

City _____ State _____

She's yours for the asking!



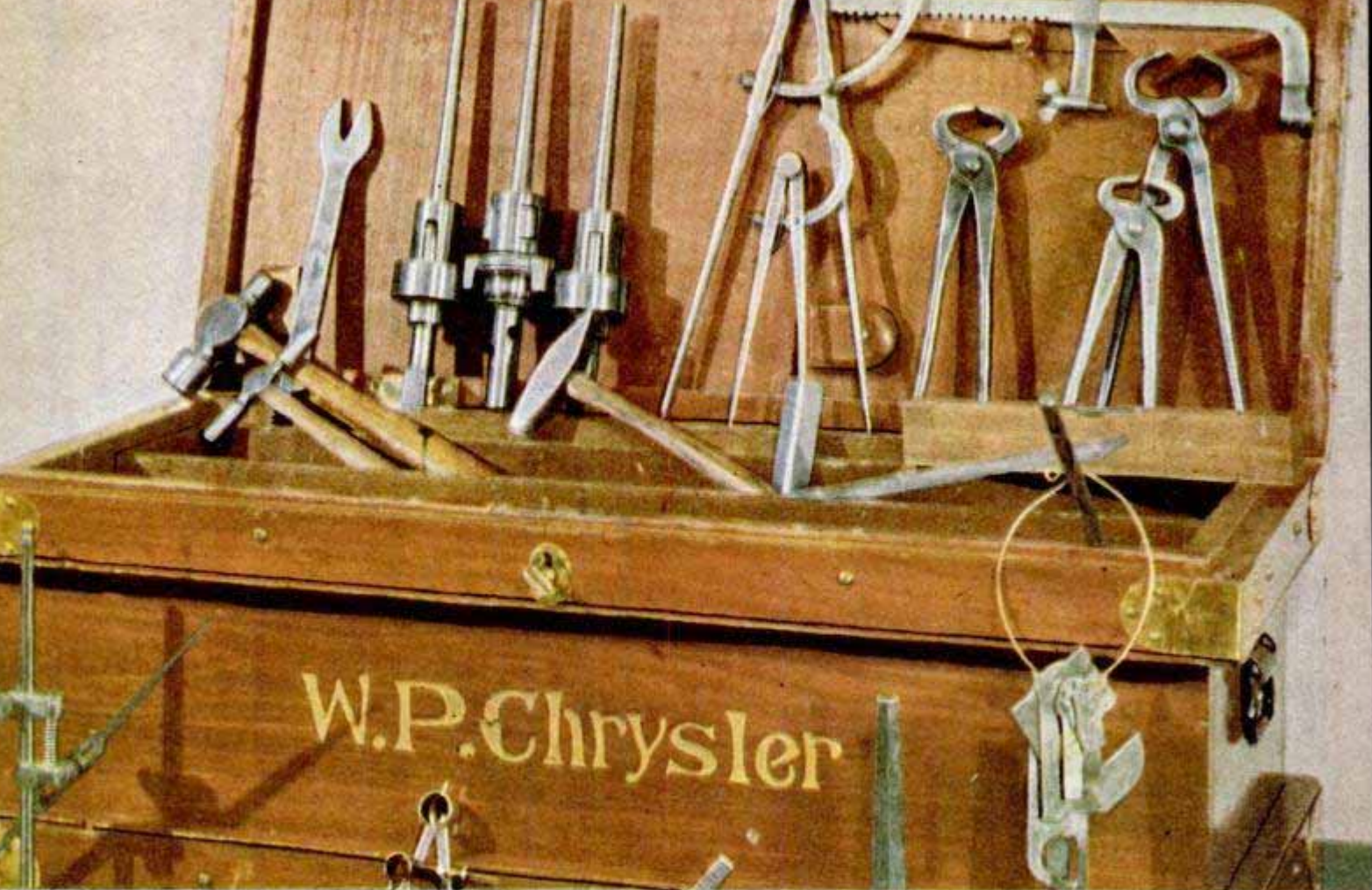

Walter Chrysler's original tool chest—on display in the Chrysler Automobile Salon, New York

The tools that money couldn't buy

Walter Chrysler made them himself. He was 17, working in a railroad roundhouse. His mechanic's fingers itched for a kit of tools of his own. So young Walter took steel and made his own.

As he shaped them, he shaped a dream as well. It was a special American kind of dream—free-ranging imagination anchored to solid things like common sense, working a little harder, making things a little better. And asking no odds.

It led Walter Chrysler to success in railroading when he was young. It led him to study the automobiles of the day. Why couldn't a man build *better* cars than any known—nimble, safer, more comfortable, handsomer?

So, 25 years ago, Walter Chrysler introduced the first Chrysler car. What he did changed the whole pattern of American motoring. He changed it with high-compression engines, 4-wheel hydraulic brakes, all-steel bodies, new ways of distributing weight for better riding . . . many originations the entire automobile industry eventually followed.

As Mr. Chrysler's birthday, April 2nd, approaches and as Chrysler Corporation this year observes its own 25th anniversary, it is fitting to pay this tribute to Walter Chrysler and his genius.

And the tools of his earlier mechanic's days? I remember when he found them in his mother's house. It was long after he had asked me to work with him. He brought the tools back from Kansas. A few of them needed fixing and he asked me to fix them. It was a compliment I have never forgotten.

The qualities Mr. Chrysler put into his own tools still mark the great organization he founded. He built not merely material things; he inspired men with a zeal to carry on his splendid ideals.

Chrysler Corporation is still young enough to feel his inspiration. He wished this company always to be a producer of fine automobiles of great value.

And those of us who were privileged to work with him believe that the new Plymouth, Dodge, De Soto and Chrysler automobiles live up to his tradition.

It is a tradition uniquely American—to live and work with the idea of finding better ways to make what people want.

W. K. Kellogg
President

Fine Automobiles of Great Value
PLYMOUTH DODGE DE SOTO CHRYSLER

CHRYSLER CORPORATION

Airtemp • Chrysler Marine & Industrial Engines • Dodge Job-Rated Trucks • Oilite • Mopar • Cycleweld

KING MIDGET

HOME ASSEMBLED AUTO



WORLD'S LOWEST PRICED AUTOMOBILE!

80-90 MI. PER GAL.—45-50 MI. PER HR.

Drive for as low as 50c per week. Precision built parts direct from factory with beautiful all steel body. Get the facts on this amazing small auto—send 25c for detailed circular with large picture, 3 view drawings and price of all parts, or send \$1 (refunded first order) for this plus actual assembly book with 42 photos, drawings; blueprints of snow, ice conversions, information on mini-midget racing, etc.

King Midget is ideal for errands, sports use, to work, short business or pleasure trips; or second-car utility for the whole family. Also tops for mini-midget racing. Room for six footer.

MIDGET MOTORS MFG. CO., ATHENS 1, OHIO

BUILD YOUR OWN 5-ROOM HOUSE

\$2500



showing 21 MODERN HOMES—38 FLOOR PLANS with estimates for pre-cut or custom-assembled materials.

Price includes lumber, millwork, doors, windows, glass, hardware, roofing, etc. Immediate shipment. Build it yourself and save up to \$3000 or more. Simple step-by-step building instructions furnished. SEND 50c TODAY for Plan Book 149

SUPERIOR HOMES, INC.

220 GALE BLDG.

JACKSON, MISS.

Order by Mail!

NEW!

Sportsman Jr.
4-WAY
AIR PISTOL

Shoots BB's, slugs, darts & corks

\$3.95

Complete with ammunition

Looks like a Luger, accurate to 25-35 feet Muzzle adapter for different ammunition. Indoor, outdoor use, target practice, small game Fully guaranteed.



No C.O.D.'s Please

At dealers, or order direct.
SPORTSMAN, JR.
Dept. C.
6411 Hollywood Blvd.
Hollywood 28, Calif.

Print Your Own

Cards, stationery, circulars, tags, labels, photo and movie titles, advertising, etc. Save money. **Print for Others, Good Profit!** easy rules sent. Raised Printing like Engraving, too. Sold direct from factory only. Write for free catalog of outfits and all details. **KELSEY PRESSES, M-37, Meriden, Conn.**

Always write your name and full address clearly when answering advertisements

10 SHELF PLANS

NEW FULL SIZE

New, full size, easily built, beautiful wall shelf plans ready to trace on lumber, cut out and assemble. Corner and wall racks with 1 to 3 shelves. Stores charge about \$75.00 for these shelves. Make money selling them. Finest selection available. **PLUS BONUS** of 48 other novel cut-outs, Dutch Boys, Girls, Toys, etc., etc. **PLUS FREE** latest Handicraft Catalog. Send only \$1 to



\$1



JACKSON, Dept. 16

3933 N. 28th St.
Milwaukee 10, Wis.

MARCH 1950

BUILD YOUR OWN POWER MOWER!



EASY TO ASSEMBLE!

SAVE MONEY!

MAKE GRASS AND WEED CUTTING EASY, QUICKER

We supply everything needed: Parts, engines, wheels, etc. to build all types of power mowers.

Complete mower parts kit for either gasoline or electric power. You can easily assemble this highly efficient mower in a few hours. We furnish instructions. Cut your lawn or field quickly at small cost. Does the work of far more expensive mowers. Factory appearance. From the world's largest manufacturer of rotary power mowers.

WRITE TODAY! FREE INFORMATION!

J. G. DOYLE ENGINEERING CO.

526 CHERRY ST. DEPT. A KANSAS CITY, MISSOURI



HANDY CALCULATOR FOR WOODWORKERS.. ONLY 10c

Just set dial, quickly solves countless problems. Converts linear to board feet, compares workability of various woods, shows bit sizes, nail specifications. Also tool sharpening tips, etc. 6" diameter heavily varnished cardboard. Send 10c to Greenlee Tool Co. 2103 Columbia Av., Rockford, Ill.

A WORKSHOP WONDER at a wonderful LOW PRICE



25 piece set only \$14.95

LIFE-TIME PLASTIC CHEST

Improved **CASCO**

ELECTR-O-TOOL KIT
DRILLS • SAWS • ETCHES • POLISHES

Casco's ELECTR-O-TOOL kit is the most complete, practical power-workshop any craftsman or hobbyist can own. Has ALL the accessories you need to drill, cut, etch, carve, grind, buff, polish, sand, engrave, saw, clean and sharpen — metal, wood, glass, leather, plastic and fibre. 1001 year-round money-saving uses. Operates on AC and DC current. Fully GUARANTEED.

Now on sale at Department Appliance, Hardware, Auto Accessory and Jewelry stores.

CASCO Products Corp. Bridgeport 2, Conn.

WHY WASTE

TIME *with*

"Temporary polishes?"

Simoniz gives twice the shine and it lasts!

Simonizing really protects and preserves the finish . . . keeps colors from fading . . . saves time and effort because it lasts 10 times longer than "here-today-gone-tomorrow" polishes. Try this Deluxe Beauty Treatment, today!



Newer cars need only Simoniz to clean and beautify the finish in a single, simple operation.

On older cars, first use Simoniz Kleener (Liquid or Paste) to clean the finish. Then Simoniz for lasting beauty. . . THE SIMONIZ COMPANY, CHICAGO 16, ILL.

Motorists Wise **SIMONIZ.**

Gives cars lasting beauty

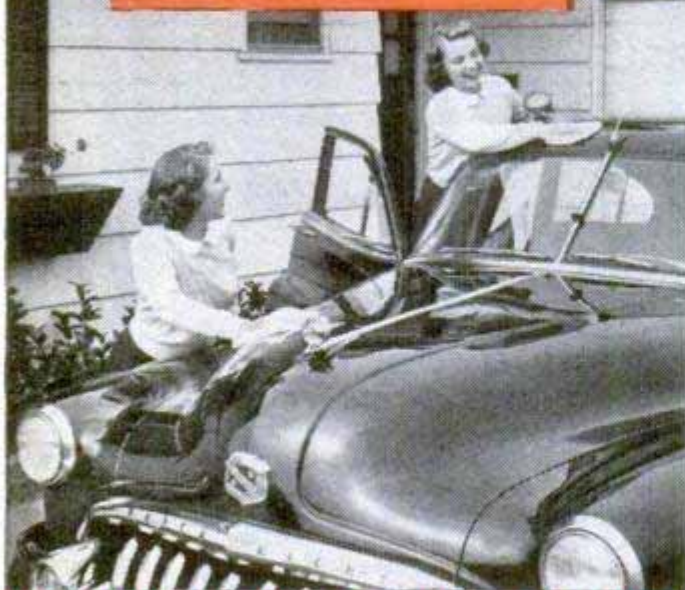

The sooner you Simoniz your car the better!

FBI Road Show

(Continued from page 169)

the first "murder." Scientific analysis would have shown they came from the "killer's" coat. The other important evidence which the students failed to exploit was a pocket comb, containing hair. This could also have been used scientifically to strengthen the case. The lesson was well taken by the otherwise alert students, who blamed lack of coordination and cooperation among themselves for the slip-ups.

Generally, the sample crimes staged at the traveling schools are of the type that the particular area has been experiencing most frequently. For instance, when California had a plague of bank robberies, many of the schools held in that state staged holdups to demonstrate action to be taken when an alarm is sounded.

Demonstrations are conducted on the raiding of a place known to harbor criminals or the trapping of criminals as they emerge. One example, which has for its moral the value of patience, depicts a city street scene in front of a theater.

The police have a tip that a wanted man will attend the movie that night and officers are strategically placed at all exits to the theater, with the entrance, where the action is most likely to occur, covered from all angles. The criminal shows up at the theater and buys his ticket, but not an officer makes a move. Why?

Simply because it is better to trap a man coming out of a theater than going in. A man leaving a theater ordinarily is still thinking about the movie, is a bit turned around in directions and is partly blinded by the abrupt contrast in lighting.

So the police just stand and wait until their man steps out of the theater. A signal is given by the officer in charge and the police move in.

In this case, the criminal spots the closing jaws of the trap and instinctively reaches for his gun. The police have the jump on him, physically and psychologically, and cut loose with their guns. The criminal falls dead on the pavement.

This is not something out of a movie scenario, but a page from real life—the capture and killing by FBI agents of John Dillinger on July 22, 1934, in front of the Biograph Theater in Chicago.

The police are also taught how to handle a clue when they find it. They learn how to pick up a sample of dried blood from a concrete floor. (It's really simple. The blood is scraped up with a knife and put into a pill-box, or a wet piece of filter paper—a white, moistened blotter will do—is applied.)

(Continued to page 268)

Repower your
FORD Car or Truck
with an

Authorized

Reconditioned
Ford Engine

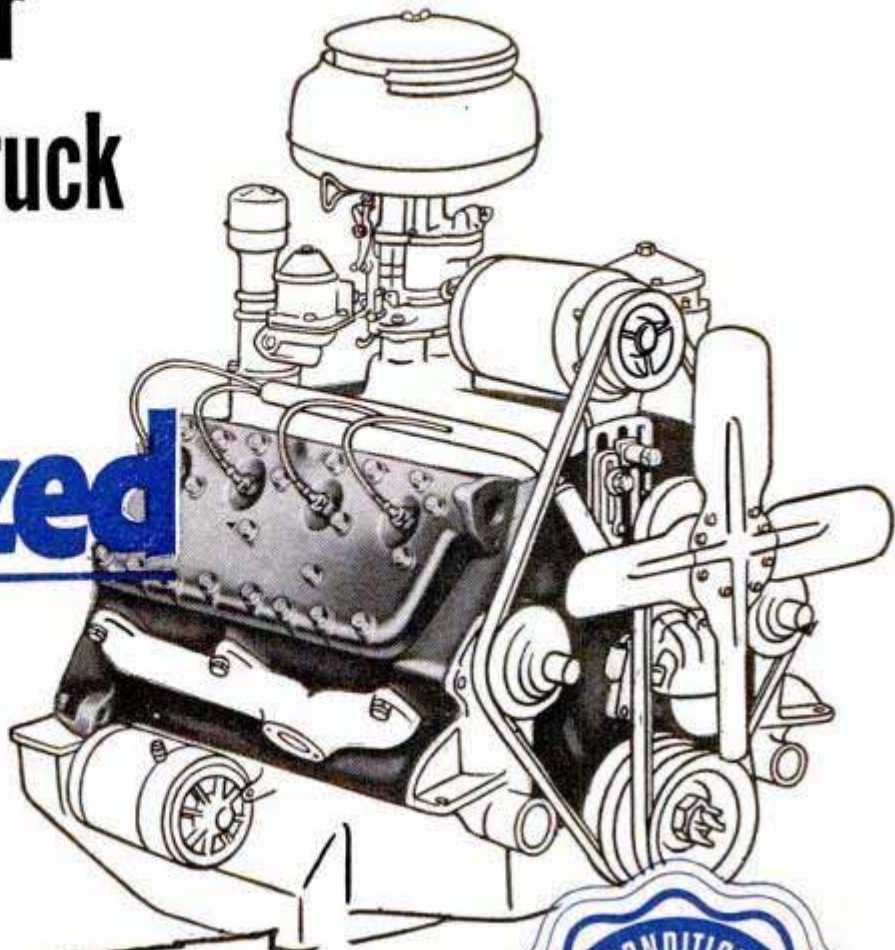

ONLY AN Authorized
RECONDITIONED FORD ENGINE
GIVES YOU ALL THIS:

- ★ One-day installation.
- ★ Genuine Ford Parts—new or completely reconditioned.
- ★ Built and tested to Ford-factory standards in Ford-authorized, Ford-inspected plants.
- ★ Material and workmanship fully guaranteed by authorized reconditioner.
- ★ Costs only a few dollars more than a ring and re-bore job.

Look for
this emblem



For complete information see
your friendly Ford dealer or
independent garage displaying
the **Authorized**
emblem and selling AUTHORIZED
Reconditioned Ford Engine
and Engine Accessories.

WILLIAMS SUPERSOCKETS

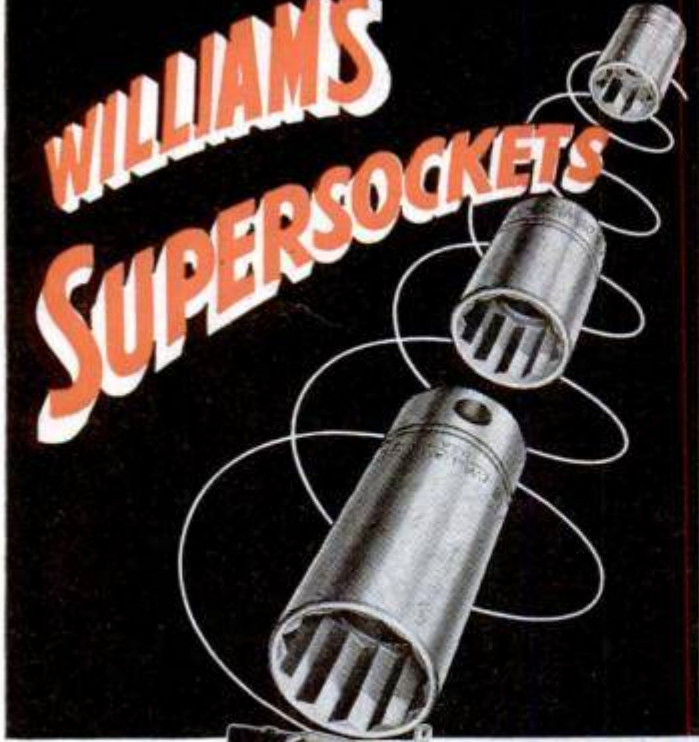

Set No. S-10
21 Sockets
and 15 Attach-
ments.



WORLD'S MOST FLEXIBLE WRENCH SYSTEM

The engineered flexibility of Williams "Supersockets" permits the combining of sockets, handles and accessories to create special wrenches for special jobs. Available in five different patterns, with drives ranging from $\frac{1}{4}$ " to 1" square, and with socket openings from $\frac{3}{16}$ " to $\frac{3}{8}$ ". Sold by Hardware Dealers, Automotive and Industrial Distributors. Write for "Supersocket" Catalog A-50.



J. H. WILLIAMS & CO., Dept. M, BUFFALO, N. Y.

Major stress is placed on fingerprint work and many of the schools run by the FBI are devoted exclusively to it. From every section of the nation, during the first six months of 1949, a total of 400,089 fingerprint-arrest records were received by the Identification Division of the FBI, and 59.4 percent represented persons who already had fingerprint-arrest cards on file in Washington. These figures pertain to fingerprint-arrest records only, and in no way relate to civil identification files at the FBI.

The police also learn jujitsu. That's the easy method of sending a 200-pound tough spinning on his ear. The FBI has not only adopted the ancient Japanese tricks, but has added a few of its own—especially for disarming a criminal.

And highly significant is the fact that this training program is not a one-way street.

"I learn something from every school I conduct," was the typical comment of W. G. Banister, agent in charge of the FBI office at Butte, Mont. "We encourage the exchange of ideas and experiences, and this is one of the most valuable features of the traveling schools."

Manhattan's Aluminum Venus

(Continued from page 121)

stick rows of little brass "shims" into the Plasteline along the desired dividing lines before applying plaster. Then the mold is removed in sections.

Flaws inside the mold are carved out by the sculptor. The inside of the mold is then shellacked and coated with green soap as a separator so the cast won't stick to it. Then the pieces are bound together, and liquid plaster is applied.

When the cast has set, the mold is chopped away with mallet and chisel.

"All this represents lots of time and work," Williams points out, "but we still had no statue—only a lot of plaster casts."

In the gloomy confines of a Long Island foundry, however, men stripped to the waist were even then sweating out the tedious process of converting a plaster statue into one of hollow aluminum. There are two common methods of casting a metal statue; sand casting, or the "lost wax process" in which molten metal replaces a wax replica of the image embedded in a silica-plaster mix. Williams chose the latter for his statue. Here's how it works:

The plaster cast is covered with clay an inch or so thick. Over this goes another layer of plaster, divided by shims so it can be removed in two or more pieces. Holes are left in each section here and there. When hard, this outer shell is removed.

(Continued to page 270)

Only wide-gap Auto-Lite Resistor Spark Plugs give you

SMOOTHER PERFORMANCE DOUBLE LIFE and GREATER GAS SAVINGS

Cut-away view shows the 10,000 ohm Resistor which permits wider initial gap settings and makes these advantages possible. Double life under equal conditions as compared with regular type spark plugs.

MILLIONS of car owners from coast to coast are switching from narrow-gap spark plugs to the sensational new wide-gap Auto-Lite Resistor Spark Plug. They want smoother performance—money-saving gas economy—improved starting in extreme cold weather. They want the *Built-in Resistor* that doubles spark plug life and reduces interference with radio and television reception.



To get these remarkable benefits for your car, see your Auto-Lite Spark Plug Dealer today. You're always right . . . with Auto-Lite.

Tune in "Suspense!"... CBS Radio Thursdays... CBS Television Tuesdays

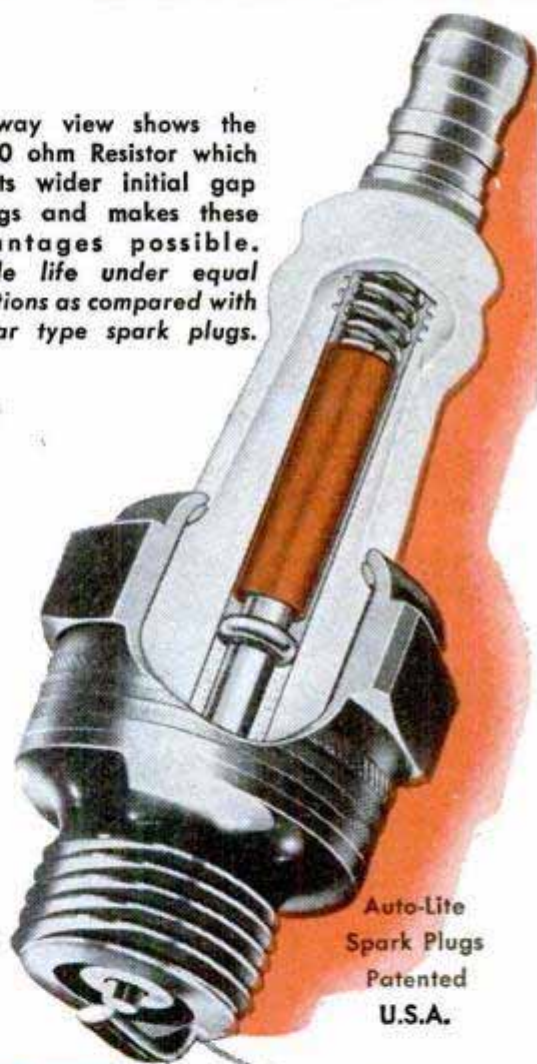

Auto-Lite
Spark Plugs
Patented
U.S.A.

AUTO-LITE *Resistor* SPARK PLUGS

RESISTOR, REGULAR AND TRANSPORT TYPES



Speediest member of the animal kingdom is the Cheetah. In India it is used for the hardest kind of hunting. The Cheetah is turned loose from a moving car to overtake fast game like antelopes.

SPEEDIER

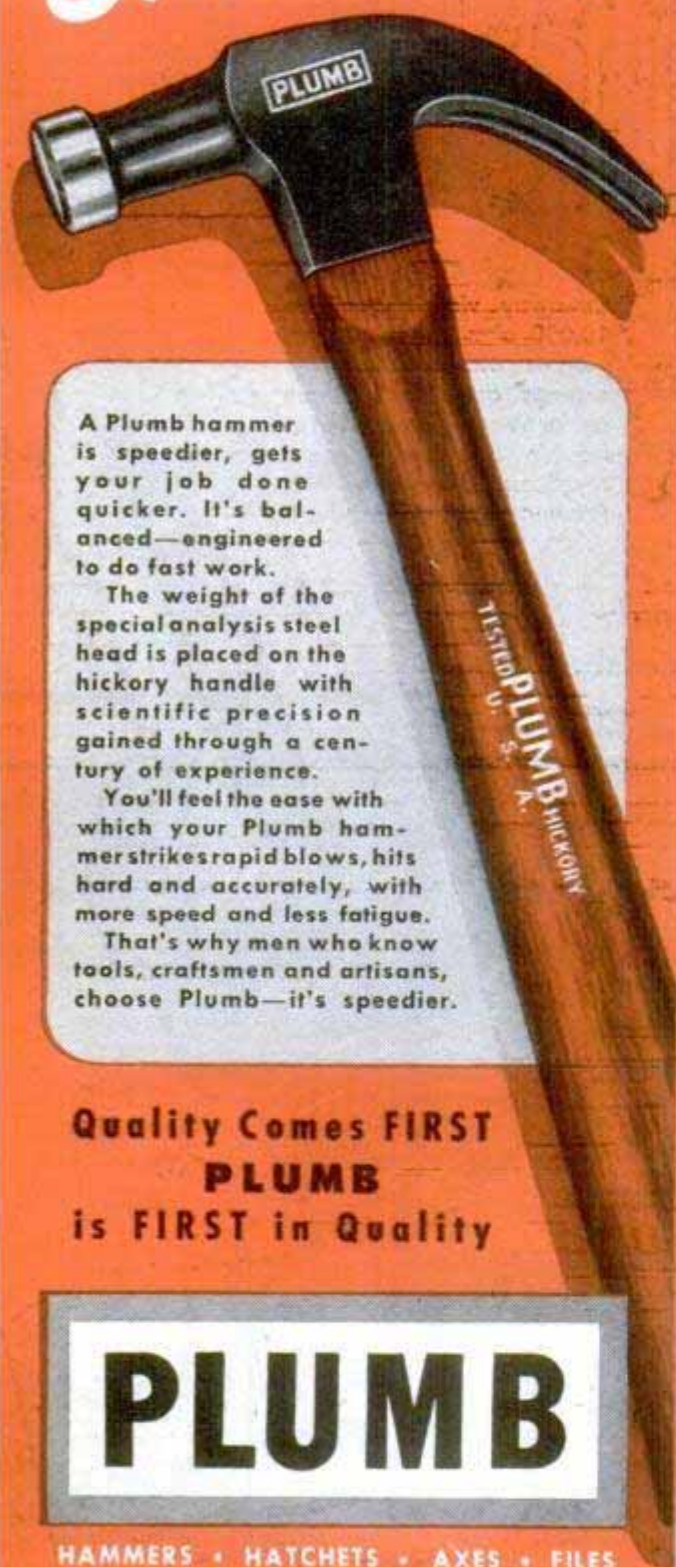

A Plumb hammer is speedier, gets your job done quicker. It's balanced—engineered to do fast work.

The weight of the special analysis steel head is placed on the hickory handle with scientific precision gained through a century of experience.

You'll feel the ease with which your Plumb hammer strikes rapid blows, hits hard and accurately, with more speed and less fatigue.

That's why men who know tools, craftsmen and artisans, choose Plumb—it's speedier.

Quality Comes **FIRST**
PLUMB
is **FIRST** in Quality

PLUMB

HAMMERS • HATCHETS • AXES • FILES

The clay is lifted off the cast carefully, and the outer casing is put back in position, covering the original plaster cast like a tent. This time there's space between its inner surface and the surface of the cast—where the clay used to be. Through a pouring hole that was provided for in the outer casing, the men pour liquid glue to make the "glue mold." When this coagulates, it looks and feels just like rubber.

Now the outer casing is removed again, and the glue mold is stripped off the plaster cast. Unsupported, it collapses like a wobbly, boneless rubber man. But not for long. The outer casing goes back on it, holding it in proper shape, like a corset. Its inner surface, of course, is a perfect impression of the statue part that has been removed. Over this interior the men now brush melted beeswax in all the nooks and crannies, until it is $\frac{1}{16}$ inch thick. Then melted wax is poured in and swished around, until the wax layer is built up to $\frac{1}{4}$ inch thick.

The hollow interior is now packed with a mixture of silica—a sort of fine, powdery sand—and plaster in a semiliquid solution. When it dries it hardens.

The outer plaster shell is pulled off and tossed away—like everything else in this odd business. So is the glue mold. All that's left now is a fine, $\frac{1}{4}$ -inch-thick replica of the statue piece in pure delicate wax, surrounding a hard core of plaster.

Next step involves covering the whole outside of the piece with a heavy layer of the plaster-silica mix. But before this outer shell goes on, rows of nails are driven through the wax and embedded in the hard core. Their heads are left sticking out, like pins in a cushion. This is so that when the wax is melted out, the outer shell will be rigidly attached to the core.

Now a brick kiln is built around the case, and a fire started under it. The wax melts and runs out through holes, or "gates," which are channeled to a principal opening.

Those gates serve another purpose, too. When thoroughly cooked, the case is removed from the furnace, uprighted, packed in sand and molten aluminum is poured through the principal opening into the space vacated by the wax. The metal, too, runs through all the gates. If the gates weren't there, air wouldn't escape from the mold spaces.

No such disasters occurred on "Venus and Manhattan." As fast as completed aluminum casts came from molds, they were bolted together, all the seams flattened. On November 2, "Venus and Manhattan" emerged in full splendor over the doorway of the new Parke-Bernet Galleries. Williams heaved a deep sigh and went up to his country home to collapse for awhile.

When you use pliers . . .

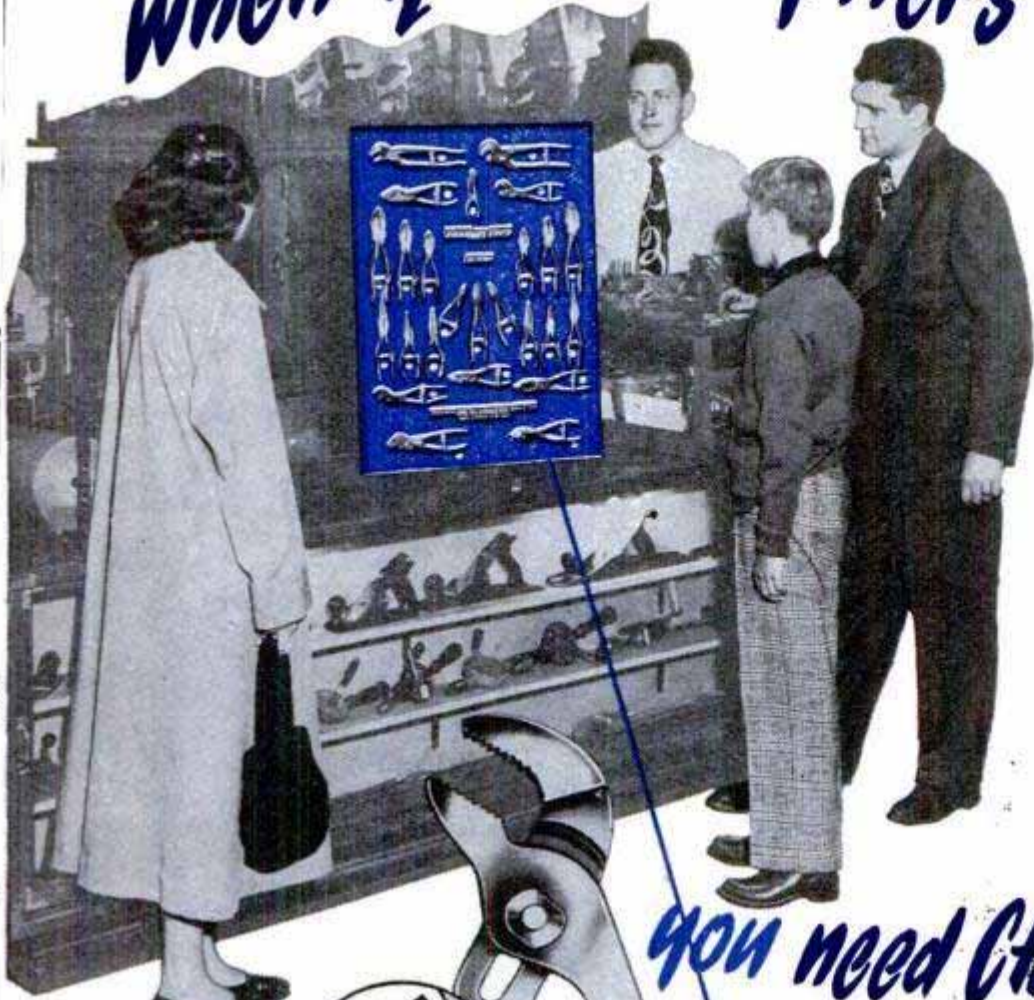

you need CHANNELLOCK

Channellock's patented tongue and groove joint gives you these "plus" features:
 Greater Strength, Longer Wearing, Self-Cleaning, Closely-spaced Adjustments, Visible Adjustment, No Wear on Joint Bolt.

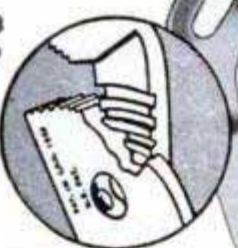

There are lots of "fussy fix-it" jobs around the house that Dad, Mom or the kids can easily do when Channellock pliers are handy. No matter what—electrical, automotive, plumbing, battery, or anything mechanical—you need Channellock pliers. Look for the Blue Channellock Display Board the next time you're shopping for tools. Step up and select the plier you need from the complete Channellock line. If you use pliers . . . you need Channellock.

CHAMPION DEARMENT TOOL CO.
 MEADVILLE, PA.

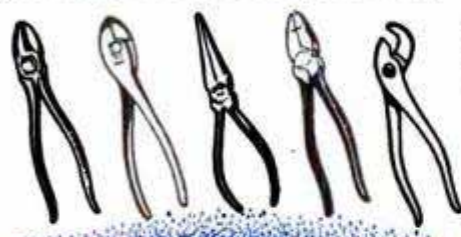

Send for Catalog C-14 today.



Only CHAMPION DEARMENT MAKES . . .

CHAN NEL LOCK

Outboard News

About the new Scott-Atwater **SHIFT** motors



What's WRONG here?

PLENTY! He shouldn't be struggling with that oar. With a new Scott-Atwater Shift outboard, he could make safe landings under power! You just ease up in Forward, Shift to Reverse to brake speed, then Shift to Neutral.

Get a **COMPLETE Shift**—with Neutral, Forward, Full Control Reverse. You back up by *Shifting* to Reverse, not by swinging the whole motor around. All controls are always facing you. You have complete maneuverability—full control of steering, speed, and Shift. That's the *complete Shift*—the kind you'll find on all 4 Scott-Atwater Shift models.

Biggest Improvement

“Sure think the Shift is the biggest improvement since the outboard was invented. I own a 1-16.”—Louis Vandervest, Green Bay, Wis.

FOUR SHIFT MODELS!



1-30 SHIFT
16 HP TWIN
(TO BE CERTIFIED)
1 to 30 MPH
\$349.50!

NO OTHER OUTBOARD LIKE THE 1-30! 1 to 30 m.p.h. Separate “stow-away” gas tank—automobile-type fuel pump. Steering-handle control of throttle and spark. And all four Shift models have the complete Shift, plus single knob control, push-button carburetor drain.

1-14 SHIFT 4 hp* twin
1 to 14 m.p.h. \$149.50!

1-16 SHIFT 5 hp* twin
1 to 16 m.p.h. \$179.50!

1-20 SHIFT 7½ hp* twin
1 to 20 m.p.h. \$199.50!

1-12 Non-Shift 3.6 hp single**
1 to 12 m.p.h. \$79.50!

!West Coast price slightly higher

SEE FOR YOURSELF...SHIFT FOR YOURSELF...

Dept. 57,
Scott-Atwater
Mfg. Co., Inc.
Minneapolis 13,
Minn.

SHIFT

FREE BOOK!
64 pages showing “How to get the most out of an Outboard.” Write today!

to Scott-Atwater

*OBC Certified @ 4200RPM **OBC Certified @ 4000 RPM

Broncos With Rubber Tires

(Continued from page 111)

aviation editor of the Portland Oregonian, was wheeled into driving one of the double-bottoms. Johnny Castner, the new champ, had heard that Lev was a B-29 pilot during the war. “If you can handle a 50-ton plane with four 2200-horsepower engines,” he told the reporter, “what’s a 35-tonner with only 200 horses?”

Richards was game. He donned a parachute for effect, climbed aboard and gaped. Besides a nightmare of instruments, he found himself confronted by two gearshift levers, which give the big baby 12 speeds forward and three in reverse.

He found it takes two hands to shift. Veteran drivers stick one arm through the wheel while shifting and steer with an elbow. Richards said he did it with his teeth. “There’s really nothing to it,” he maintains, “— if you’re part octopus.” On the diminishing alley, he noted that after he made his “bomb run,” he’d mowed down enough poles “to build teepees for the whole Pendleton Roundup.”

It took Richards 15 minutes to do the course. Castner has made it in less than three. “But,” says Lev, “you must remember, he missed every target.”

Any driver will tell you, though, that the everyday feats he performs with his lumbering charge far exceed anything he’ll ever have to do in a rodeo. This is especially true of the semitrailers and double-bottoms. Handling 35,000 to 74,000 pounds of rolling freight on wet or icy mountain highways takes the best drivers in the world—and these are the boys. Jackknifing is always a threat on icy roads.

“Going up an icy hill with no traction,” explains a tractor-trailer man, “can spell trouble. You can feel her grind slower and slower until she starts back. Then she ‘jacks’ and you do one of two things: get out or ride her down and try to ditch her.”

Oddly, it’s safer coming down a slick hill than going up, if the road is clear. Experienced drivers can usually feel the trailer behind them start to sway if it’s getting ready to jackknife. Icy or not, the remedy is simple but hair-raising. “Just pour on the water,” explains a veteran, “and pull the tractor out ahead.”

The tippability of trailers has been lessened recently by the invention of a new “fifth wheel,” or swivel coupling on the tractor which slides under the “box” and hooks onto a coupling pin. The fifth wheel is hung on a “rocking shaft” to permit the coupling to rock fore and aft so the tractor and trailer will snake over bumps and

(Continued to page 274)

New Star of the Lightweights

★
WHIZZER
Sportsman
 A completely new
 Motor Bike

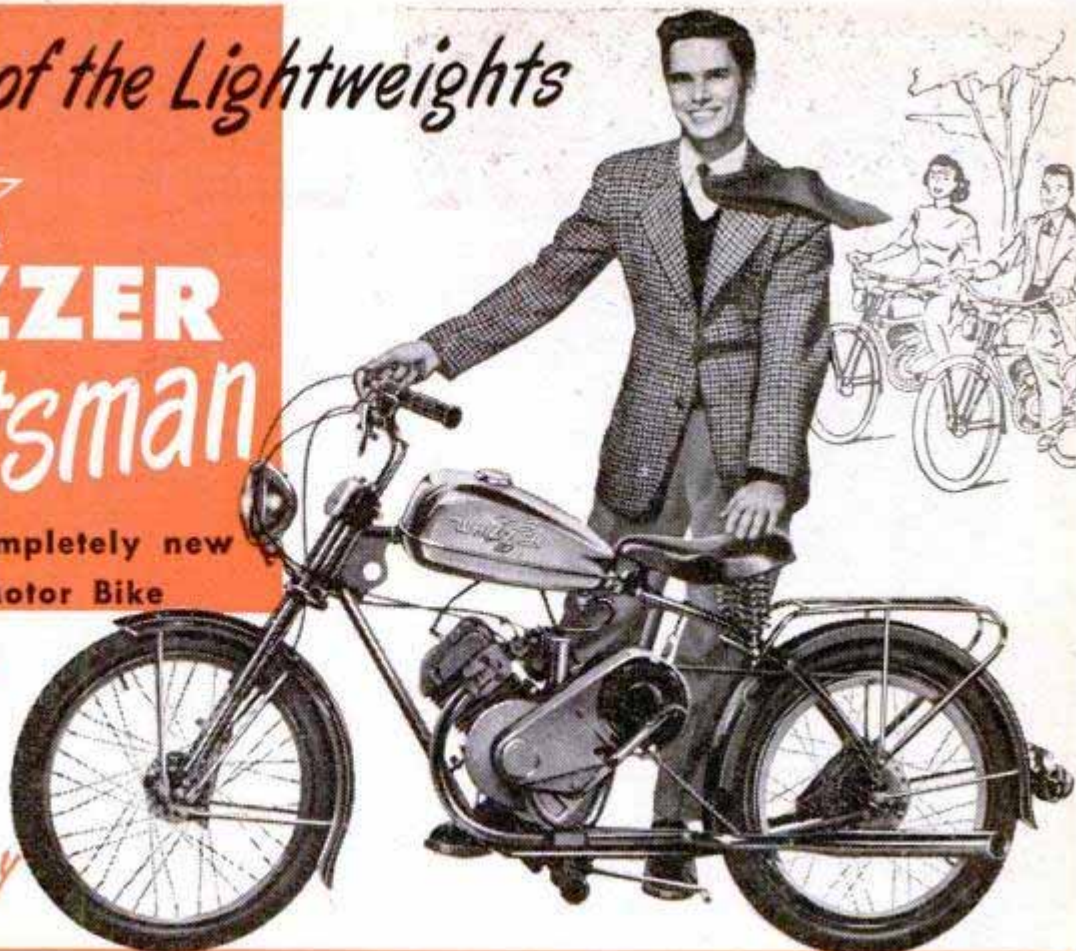

NEW beauty
NEW power
NEW economy

- ★ Big new 3 horsepower motor, 138 c.c.
- ★ Kick starter
- ★ Extra-large drum brakes, front and rear
- ★ 2-speed transmission; automatic shifting
- ★ 5 to 40 m.p.h.; over 100 miles per gallon of gas
- ★ Built-in generator, Sealed Beam headlight

RIDE ONE and you'll BUY ONE!

Pleasure's *built into* Whizzer's new Sportsman! Powered by rugged, 3-horsepower, 138 c.c. motor, 4-cycle, precision-built. Automatic 2-speed transmission has low gear to conquer hills, give quick starts. Low center of gravity with full-size frame

on 20" heavy-duty wheels. Long wheel-base. Extra-large front and rear drum-type expander brakes, rear brake pedal-controlled. Folding footrests, chrome echo-tube exhaust. For work, low-cost travel and pleasure-riding, **\$239⁵⁰** you'll want Whizzer SPORTSMAN!

complete, plus Fed. tax
 F. O. B. Pontiac, Mich.

Power Package
 FOR YOUR BIKE!

Famous WHIZZER, America's Finest Bike Motor

Now 3 Big Horsepower!

4-cycle, 138 c.c. 5 to 40 m.p.h. on your bike! For low-cost travel, fun! Motor, complete **\$109⁹⁷** with attachments. F.O.B. Pontiac, Mich.

SEE YOUR WHIZZER DEALER TODAY!

WHIZZER MOTOR CO., 300 S. Sanford, Pontiac 15, Mich.
 Please send me, by return mail, *free* illustrated catalog on Whizzer motor bikes.

Name _____
 Address _____
 City _____ State _____

Speed every job from
barn to bird house

SKIL Home Shop DRILLS



1/4" SKIL Home Shop Drill

If you do home repairs, remodeling or hobby work get 1/4 in. SKIL Home Shop Drill. Fast, easy-to-handle on all drilling up to 1/4 in. in steel . . . 1/2 in. in hard wood. With accessories it's a workshop in itself to help you grind, wire brush, polish . . . save time and work on a hundred jobs. See SKIL Home Shop Drill today!

\$21.45 geared chuck
\$18.95 hex key chuck

1/2" SKIL Home Shop Drill

A sturdy, easy-handling drill for heavy jobs. Weighs only 7 1/2 lbs; only 12 1/2 inches long. Drills 1/2 in. in steel; 1 in. in hard wood. Ask to see 1/2 in. SKIL Home Shop Drill at your dealer's.



\$38.95 geared chuck

\$35.95 hex key chuck



SKIL Home Shop Drill and Kit

Do and enjoy 1,000 jobs with this well-planned kit. Includes 1/4 inch drill and everything needed for drilling, scouring, burnishing, grinding and sharpening, for buffing and surfacing on wood, metal, plastics. See it at your dealer's now. **\$39.95**

See these other SKIL Home Shop Tools!

- SKIL Home Shop Bench Stands
- SKIL Home Shop Saw
- SKIL Home Shop Saw Table
- SKIL Home Shop Belt Sander
- SKIL Home Shop Sander-Polisher
- SKIL Trimmer—the electric hedge clipper

SKIL Home Shop Tools made only by

SKIL home shop Tools

SKILSAW, INC.
5033 Elston Avenue
Chicago 30, Illinois

SKILSAW, INC.
Home Shop Division, Dept. C-3
5033 Elston Ave. Chicago 30, Ill.

Please send me full information on SKIL Home Shop Tools and the name of my nearest dealer.

Name

Address

City.....Zone.....State.....

SEND
COUPON
TODAY
FOR FULL
INFORMATION

gullies instead of riding rigid. On a tight turn, though, the shaft on older types didn't turn with the trailer and the trailer rocked sideways. The new fifth wheel turns with the trailer, so that the rocking shaft is always parallel with the trailer axle.

Another fifth-wheel problem was that when a driver unhooked for repairs en route and left his trailer on the roadside, highjackers could come along with a standard tractor, hook on and ride away with the trailer full of booty. Today, there is a "pin lock" that caps the trailer pin like an inverted mushroom to foil thieves.

Pleasure drivers, probably to excuse their own carelessness behind a wheel, have a bad habit of blaming trucks for accidents. Actually, trucks are responsible for less than 16 percent of all the accidents on the road. Few drivers in the world are safer, more courteous or clearheaded than the men in the big rigs. Once in a great while, a big trailer may "get away" on a hill. When this happens, the driver does not "clip telephone poles" or plow into traffic. If there's a clear road ahead, he may try to ride it out. Some men, by weaving the front end, have set the big box swaying until finally it whipped over, snapped loose and crashed into the woods. Then they ditched the front end. Dozens of drivers have deliberately crashed their entire rigs to avoid hitting foolish pleasure drivers and have gone to the hospital or cemetery for their pains.

Every "gear grinder" at the Boston Rodeo can remember a buddy who wound up dead because of a careless motorist. "People don't realize," they'll tell you, "that it takes a full 90 feet to stop a loaded rig going 40 miles an hour after the brakes are applied. We allow 500 feet between us and the next car. Motorists cut in too soon."

Truck drivers would like to have people who are overtaking them dim their lights. "Their brights are blinding us from three different mirrors," they point out.

"Truck drivers," one fellow put it, "are conservative drivers." When you see them wheel their 20 to 65-foot rigs around a rodeo arena as though they were handling scooters, you begin to thank your lucky stars that they are. They can gauge the power of their engines down to the last horse and their judgment of distance is better than a cat's whiskers. They'll tell you within a layer of paint whether or not they can get through a hole. And if they say "yes," you know they can do it.

So, if you're one who figures the truck driver for a grizzled, lantern-jawed bulldozer pusher—trot around to the rodeo in your state this year and watch your mind change.



New scintillation counter, using electron tube developed at RCA Laboratories, gives faster, more accurate measurements of atomic radiations.

What can you hear through an ear of grain?

When agriculturists want to learn what nourishment a plant is getting, they inject radioactive materials into the soil and trace their absorption with sensitive instruments. Industry and medicine also use this ingenious technique.

Until recently, scientists *heard* what was happening, followed the passage of atomic materials with a clicking Geiger counter. Now a more sensitive instrument—a new scintillation counter made

possible by a development of RCA Laboratories—can do the job more efficiently.

Heart of this counter is a new multiplier phototube so sensitive that it can react to the light of a firefly 250 feet away! In the scintillation counter, tiny flashes, set off by the impact of atomic particles on a fluorescent crystal, are converted into pulses of electrical current and multiplied as much as a million times by this tube.

See the newest advances in radio, television, and electronic science at RCA Exhibition Hall, 36 West 49th Street, New York. Admission is free. Radio Corporation of America, Radio City, N. Y.



The principle of RCA's multiplier phototube is also used in the supersensitive RCA Image Orthicon television camera, to give you sharp, clear television pictures in dim light.



RADIO CORPORATION of AMERICA

World Leader in Radio — First in Television

Your house stays **BRIGHT**



with **LUMITE**
saran screening!

because it's . . .

*** RUSTPROOF** Guaranteed never to rust, rot or mildew . . . unaffected by salt air or smoke, rain or snow or industrial fumes! It's the ideal screening for every exterior use.

*** STAINPROOF** Lumite is guaranteed stainproof because it's rustproof. It never needs protective painting. It cleans easily.

*** LASTS AND LASTS** Lumite offers long range economy . . . costs only 11½ to 12¢ a square foot . . . gives years of trouble-free screen protection! Sold by hardware, lumber, and building supply dealers.

LUMITE
SARAN SCREENING

*Registered Trade-mark

SEND FOR FREE SAMPLE TODAY

LUMITE DIVISION,

Chicopee Manufacturing Corp. of Ga.
47 Worth Street, New York 13, N. Y.

Please send me information and FREE sample of Lumite Screening.

Name

Address

City.....Zone.....State.....

PM-3

Suicide Simon

(Continued from page 116)

presses the button. Ordinarily, it takes only 10 seconds to do this. Once it took him as long as two minutes.

The dynamite-laden box is no place for a sissy. Simon has a physique that looks as if it were hewn from granite. When you shake hands with him, you feel that you are shaking the hand of a marble statue. He hardened his body in 17 years of high diving. He used to saturate his clothing with gasoline, set it afire and jump 100 feet into a tank of water. But he broke his neck and other bones so many times that he decided to try something less hazardous.

Three years ago, he saw Captain Frakes, ex-Hollywood stunt man, blow himself up with dynamite. The dynamite bug hit him right away. Frakes, however, wouldn't tell him how he did it. "If Frakes can do it," Simon told himself, "I can do it."

He bought some dynamite and detonator caps and took them to his winter quarters in El Jobean, Fla. That winter he experimented, first with five steel plates, then three and two, until the dynamite worked the way he wanted it.

After wasting almost a box of explosives, he used a milk bottle to test the pressure inside the plates. When it did not break, he crawled into a wooden box himself and set off the dynamite. The blast sent him spinning like a whirligig for over 20 feet. If he had not known how to roll and tumble, the blast might have killed him. As it was, his bones ached for weeks. He made changes and found that a quarter stick of dynamite did not make enough vacuum. It hurt him more than a full stick did. Now he uses a stick and a half.

His first public appearance was in a Jacksonville park. He has appeared in many other places since then. Recently, he decided to take out some insurance. Lloyds of London charged him \$40 per thousand a month for high diving, but did not show any interest to insure him in his dynamite stunt. Another company offered to insure him for 10 percent of his salary, but Simon refused the offer.

Suicide Simon works at blowing himself up only three months a year. The rest of the time he likes to go alligator hunting in the Everglades, fish for snook and jewfish in the lazy Miakka River and entertain the guests in his 28-room hotel at El Jobean.

This year, he is trying out another idea to make people think he is crazy. He is building a jet-propelled rocket to carry him about 1500 feet in the air and drop him off with a parachute. Sounds suicidal? Well, at least he'll come down by parachute.

ASSEMBLE YOUR OWN MOWER
 . . . We Furnish All Parts,
 Completely Finished and Painted,
 Including NEW CLINTON 1.8-2 H.P.
 VERTICAL ENGINE
SAVE 40% **\$69.60**
 F.O.B. FACTORY



Here's your opportunity to save some real money on a high-class quality product.

CAST ALUMINUM BASE
 This is a modernized streamlined and nicely finished product. Two-tone baked enamel. Full 20" cut, hardened steel, one-piece cutting blade with safety clutch. Ball bearing, rubber tired wheels.

CUTS TALL GRASS
 Will mow to carpet smoothness tall rough, grass. Cuts close to fence. Three cutting heights. Can be assembled in 30 minutes. Easy to operate. Guaranteed satisfaction or money back. Clinton engine alone retails for \$60.00. Price mower complete . . . \$69.50 f. o. b. factory.

No C. O. D.'s. Cash or money order must accompany order. Order today!
 Reference: Fourth National Bank

NEFF EQUIP. CO. . . . 400 Petroleum Bldg. . . . Wichita, Kansas

**TWO Lights-
 ONE Lantern**

\$4.65 less battery



800-ft. spotlight — and brilliant floodlight. Safe. Convenient. Sturdy. Uses standard 6-volt dry battery. At hardware, sport, or electric stores.
 DELTA ELECTRIC COMPANY, MARION, IND.

Delta POWERlite 2-LITE ELECTRIC LANTERN

2 BUYS FOR YOUR WORKSHOP



FAMOUS "MALLDRILL"
SPEED and POWER for any material! Use it with attachments for drilling metal, wood, masonry, plastics, sawing with portable saw attachment (below), etc. A terrific value!
 As illustrated . . . **\$15.00** only
 (with Jacobs Gear Chuck) . . . **\$18.00**



PORTABLE SAW ATTACHMENT
 Converts any 1/4" drill into a portable saw with 1 1/8" cutting capacity!
 A welcome addition to any tool shop!
 Now you can have a real portable saw for only **\$9.95**

ALL SHIPPED F.O.B. NEW YORK CITY — add 50c for postage and handling per item—ENCLOSE CHECK OR MONEY ORDER. NO C.O.D. 10 DAY MONEY-BACK GUARANTEE.

HERMAN MACHINE & TOOL CO. 714 Third Ave. N. Y. 17, N. Y.

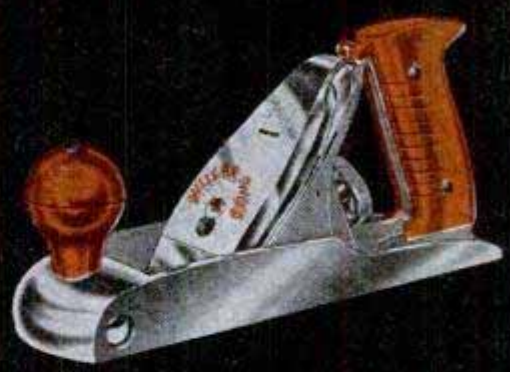

*The Finest Planes
 in the World*

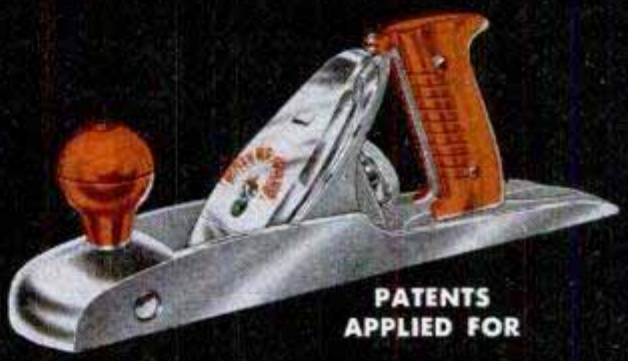

PATENTS APPLIED FOR

If you want the very last word in performance, you'll get it in these two new streamlined beauties. They are loaded with new features never before available in a bench plane — better balance . . . more positive clamping . . . easier adjustments . . . unbreakable handles . . . roomier, surer grip . . . finer performance in every way. See them, try them, buy them at your hardware dealer's today.



MILLERS FALLS COMPANY

GREENFIELD MASS.

SAY YOU SAW IT IN POPULAR MECHANICS

Make \$20 to
\$30 a Week
**EXTRA
MONEY**



MACHINE SAW FILING PAYS UP to \$2 or \$3 an HOUR

Turn your spare time into CASH—sharpening saws with a Foley Automatic Saw Filer pays up to \$2 or \$3 an hour. You will find you can make \$20 to \$30 a week in your spare time as a starter.

You can work in your basement or garage—no experience necessary. "The first saw I sharpened with my Foley Filer came out 100%"—writes Clarence E. Parsons. No canvassing—"I advertised in our local paper and got in 93 saws"—says M. L. Thompson. The Foley is the only machine with which you can file all hand saws, also band saws and cross-cut circular saws.

SEND FOR FREE BOOK "INDEPENDENCE AFTER 40!"

Shows how you can get business from home owners, farmers, carpenters, schools, factories, etc. With a small investment, no overhead, no stock of goods to carry, you can get right into a cash business—and possibly later on develop into a full-time repair shop. Send coupon today for Free Book. No salesman will call.

"Each saw I filed got me six more and business has been picking up that way since a year ago. If it keeps up I will have to buy another Foley Saw Filer." — William C. Baldwin

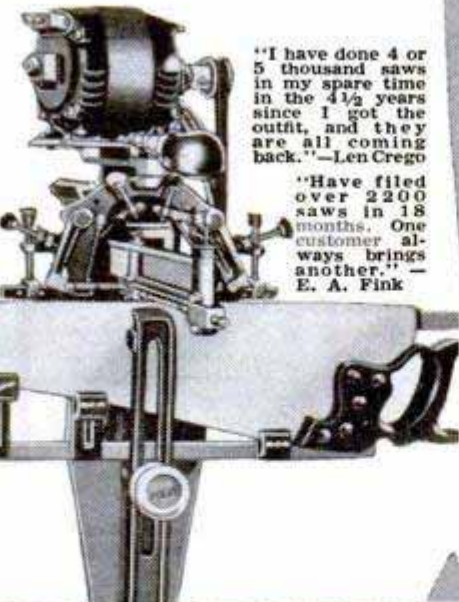

"I have done 4 or 5 thousand saws in my spare time in the 4 1/2 years since I got the outfit, and they are all coming back."—Len Crego

"Have filed over 2200 saws in 18 months. One customer always brings another." — E. A. Fink



SEND COUPON FOR FREE BOOK

FOLEY MFG. CO.

316-O Foley Bldg., Minneapolis 18, Minnesota

Send FREE BOOK—"Independence After 40."

Name _____

Address _____

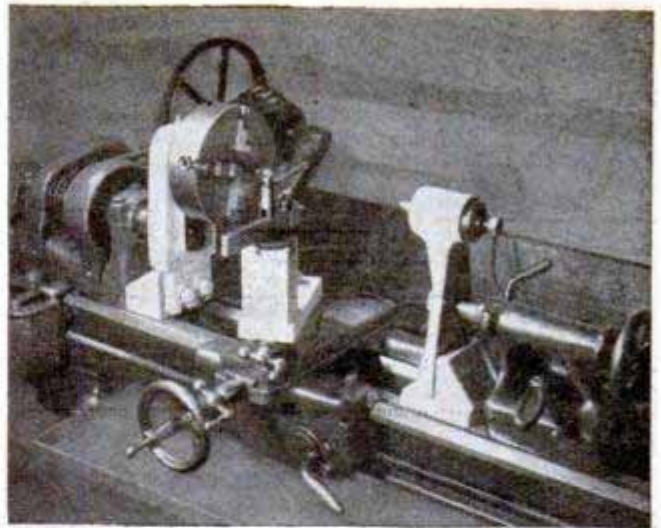

Center-Raising Attachment Increases Lathe Capacity

Small lathes, with from 9 to 12-inch capacities, can be converted to take work from 17 to 20 inches in diameter with a center-raising device. There are three gears in the headstock end and the gear ratio is unchanged by the converter. The tailstock and tool post are also raised so that feed mechanisms operate normally.

Chemical Reduces Danger Of Lethal Radiations

Atomic scientists at the Argonne National Laboratory have developed a method of protecting animals against death from normally lethal X-rays. The chemical used in the protective treatment is cysteine and is given orally or intravenously in a single dose within an hour before exposure. Since its administration immediately after exposure is not effective, it is believed that the cysteine, in some unknown manner, prevents cell constituents from destruction by the X-rays. Experiments show that 70 to 80 percent of the animals treated with cysteine survive an irradiation which kills about 80 percent of the untreated animals.

CHAMPION V-GLOW PLUGS

for model engines only

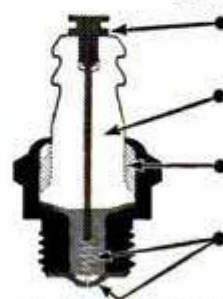

CHAMPION TERMINAL—assures better center electrode seal and provides sturdier electrical connection.

CHAMPION-CERAMIC INSULATORS—proved dependable in millions of Champion Spark Plugs.

CHAMPION SILLMENT SEAL—prevents excessive compression leakage between insulator and shell.

CHAMPION "THERM-O-FLEX" CONSTRUCTION—longer element life, more dependable performance.

Follow recommendations of plug types and fuels approved by engine manufacturer.

CHAMPION SPARK PLUG COMPANY, TOLEDO 1, O.

DELTA MILWAUKEE

®

Delta-Milwaukee 14" Band Saws can be found in shops of all kinds — wherever accurate cutting must be done easily and economically.



Hobbyists who want the best in power tools equip with a Delta-Milwaukee 14" Band Saw.

\$115⁸⁵*

without motor or switch

Double table-supports help you get greater accuracy—even on big, heavy work... with a DELTA-MILWAUKEE® 14" Wood-cutting Band Saw

Cuts wood, felt, corrugated board, paper, other materials

Two trunnions — widely spaced — one on either side of the blade — support the table of the Delta-Milwaukee 14" Band Saw. This gives you a steadier surface to work on. The table stays rigid, at any angle. You're able to saw more accurately.

That's only one reason why this Delta-Milwaukee machine is first choice of those who know fine tools. There are many other quality construction features:

- Ball bearings are used, giving trouble-free performance — and they are lubricated for life.
- The table is big — 14" x 14". It has a 3/8" x 3/4" miter-gage groove. Tilts 45° right and 10° left.
- Blade guide controls can be adjusted safely at the front of the table.
- Aluminum wheels are carefully balanced, so that the blade is true-running.
- Upper and lower wheels are completely guarded, to protect you. Guard covers saw blade at rear; sliding guard covers all but working surface of blade in front.
- Rip gage is available for ripping.

Have your nearby Delta distributor tell you more about these features for safety, accuracy, economy, and convenience. Inspect the Delta-Milwaukee 14" Band Saw there now — and see his complete Delta-Milwaukee line.

Look for the name of your Delta distributor under "Tools" in the classified section of your telephone directory.



One of the 2 trunnions that are spaced 9 inches apart to support table.

Widely used wherever folks insist upon high-quality tools:

- Cabinet Shops
- Carpenter Shops
- Display Shops
- Furniture Factories
- Home Workshops
- Hotels
- Pattern Shops
- Sign Shops
- Theatres
- Upholsterers
- and other places!

Upper wheel has blade-tension adjustment. Index shows correct tension for various widths of blades.

You can independently adjust blade guides and blade supports with micrometer accuracy.

\$235⁷⁵*

without motor or switch rod

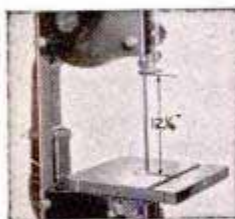

Simple attachment increases capacity from 6 1/4" under the guide to 12 1/4". Can be added any time.

Two machines mounted together — to save space, time, and money DELTA-MILWAUKEE SAW-JOINTER COMBINATION

Circular saw and jointer mounted on one steel stand and driven by same motor. Both may be operated singly or together. 10" circular saw cuts 3 1/4" stock. Rips to center of 50" panel. Jointer surfaces boards 6" wide; cuts rabbets 1/2" deep. Both tools have lubricated-for-life ball bearings. See this dual-purpose machine at your Delta distributor.

*Prices subject to change without notice

TEAR OUT COUPON AND MA'IL TODAY!

DELTA MANUFACTURING DIVISION
Rockwell Manufacturing Company
802C E. Vienna Ave., Milwaukee 1, Wis.

Send me free copy of Delta-Milwaukee Catalog B-48.

Name.....

Title.....

Company.....

Address.....

City..... (.....) State.....

HM-65



Send for free catalog!

NATIONAL HARDWARE WEEK SPECIAL

69¢
to
\$1.25

VISIT YOUR HARDWARE STORE
APRIL 28 TO MAY 6. YOUR DEALER
WILL HAVE A SPECIAL ASSORTMENT OF
EAGLE RULES



AN ASSORTMENT FOR *Every* PURSE
AND *Every* MEMBER OF *Every* FAMILY

Only 'Royal Eagle' Rules, 'All-American' Eagle Rules, and 'Columbia' Eagle Rules have RIVETED STRIKE-PLATE JOINTS . . . strike plates that prevent wear on markings . . . riveted to prevent slipping or stretching or twisting apart. Made of best, selected, hard maple, of course.

DON'T JUST ASK FOR A RULE . . . ASK FOR AN EAGLE RULE

EAGLE RULE MFG. CORP.
NEW YORK 59, N.Y.

THESE CHORES
A
PROBLEM?

BETTER BUY

Bready!

- Gardening
- Lawn Mowing
- Lawn Rolling
- Trimming Woods
- Shoveling Snow



From Only
\$14950
F.O.B.
Factory

1½ H.P. and 2½ H.P. Models

BREADY GARDEN TRACTOR—time, work and dollar saver for home and farm. Powerful, easy-guiding, economical. Gardening implements, plus lawn mower, cutter bar, lawn roller, snow plow, other attachments • Let Bready Do The Work!

Write today for free folder & name of dealer
THE BREADY TRACTOR & IMPLEMENT CO. Box 230, Solon, O.

TOMORROW'S TOOLS . . . TODAY!

At your dealer or order direct

2. DRILL PRESS WOOD-SHAPER MODEL #60. Heavy-duty shaper. Exclusive pilot bearing eliminates side thrust, chatter, vibration—assures smooth cutting action. Complete, as pictured, with **\$12.95** 6 pair blades.



WOODSHAPER #60

6. ALADDIN LATHEMASTER. Fool-proof factory method of woodturning, adapted and priced for the home workshop for the first time! Even beginners can't go wrong because Lathemaster measures as it cuts. Now one woodturning tool does everything—comes with standard chisel blades as well as new form cutters. Hardwood handle, chrome-plated shank, interchangeable blades of shaper steel. Complete, as pictured, mounted on attractive wood tool rack **\$9.95**



ALADDIN LATHEMASTER

3. CIRCLE SAW WOOD-SHAPER, MODEL #SA-10. Solid steel. Absolutely safe—blades locked in position with screws all the way through. In ordering, state diameter of your circle saw shaft. Complete, as pictured, with 6 pair blades and tool rack . . . **\$14.95**

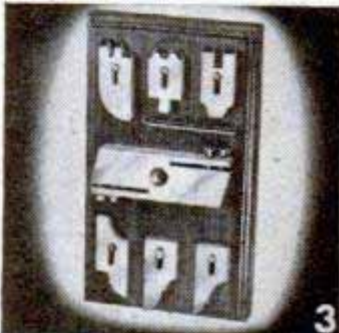

WOODSHAPER #SA-10

5. THREE-IN-ONE DRUM SANDER. 1", 2", and 3" drum sander all in one! "Telescoping" diameters easy to change. Pilot bearing eliminates side thrust, chatter, vibration. Complete with sandpaper sleeve for each diameter **\$6.95**

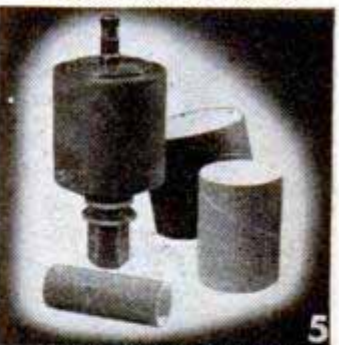

3-in-1 DRUM SANDER

11. ALADDIN WOOD-SHAPING BLADES. Specially-selected shaper steel brought to correct hardness to hold keen edges indefinitely. Exclusive money-saving feature: Aladdin blades are double-ground so you can make two standard cuts with each blade. Note that woodshaping tools #60, SA-10 and Lathemaster come only with blades pictured with each tool; when ordering extra blades, order by blade number. All blades shown below, **\$1.00** each. (\$2.00 per pair)—except B-5 (\$.75 ea.), ready-hardened blank blade you can grind to shape desired.

ALL ALADDIN TOOLS ARE GUARANTEED

At your dealer or send cash, check, or money order for prepaid shipment to

Aladdin E. Manufacturing Co., Inc.

3121 MAIN STREET KANSAS CITY, MO.
Dealers—Write for new 1950 catalog

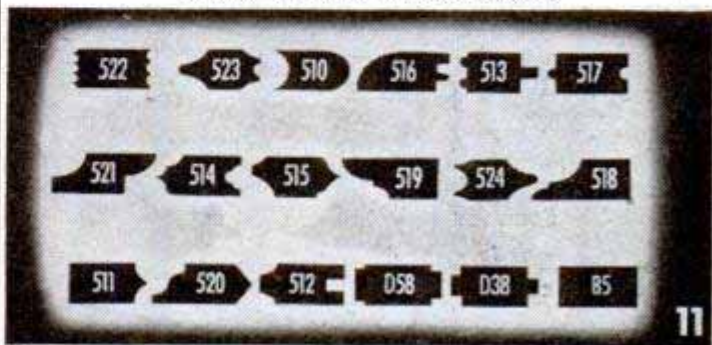

SAY YOU SAW IT IN POPULAR MECHANICS

POPULAR MECHANICS

We've promised you Tomorrow's Tools today—now
MEET THE NEW BULL SAW!

Convert your electric drill into a powerful, portable saw for only **\$9.95**



BELT SANDER

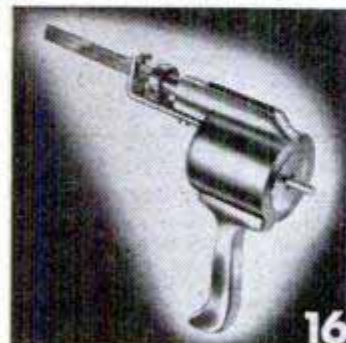

BULL HACK SAW

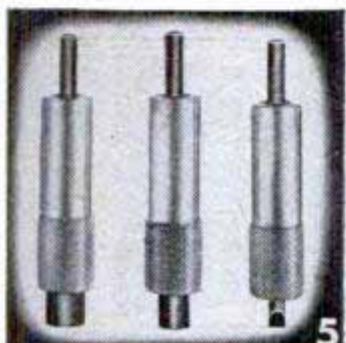

BULL DRIVER



BULL HOLE SAW

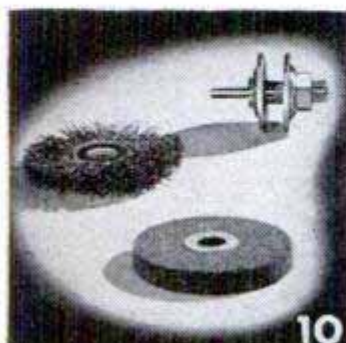

UTILITY ACCESSORIES



Your electric drill becomes a portable saw with power to spare when you attach the new Bull Saw! It's sturdy, rigid—yet light enough for *one-hand* operation. New visual guide lets you see where you're going; new extra wide shoe plate keeps saw blade on the straight-and-narrow. Blade of high-carbon steel . . . one-piece safety guard of polished aluminum . . . double bearings for long life. Fits rigidly on any 1/4" electric drill. Depth of cut: 1 1/8". **OUR GUARANTEE:** *This tool is as outstanding in design and performance as the Bull Buffer.* Complete, ready to use **\$9.95** as pictured

(When ordering, ask for model BS-C)

IF YOU ALREADY OWN A BULL BUFFER,

you can make your own Bull Saw for only \$7.50! Here's how: Order the saw housing (photo 13) and attach it to the angle-head of your Bull Buffer, following the simple directions we send you. That's all—it only takes a minute to change your Bull Buffer into a powerful, portable saw! The housing you need comes complete, only **\$7.50**

(When ordering, ask for model BS-H)

POLISH-SAND-'N-SAW KIT, ONLY \$14.95!

Includes (a) Bull Buffer (photo 2), the famous right-angle polisher-sander, complete with rubber pad, sheepskin bonnet, and 2 sanding discs, and (b) Saw Housing (photo 13) that fits on Bull Buffer angle-head to give you a powerful Bull Saw. \$19.90 value—but it's yours for only **\$14.95**

(When ordering, ask for model BS-K)



Who wouldn't be a "handy guy" with these NEW BULL TOOLS!

8. SHOPCHIEF BELT SANDER. Convert your electric drill into a portable belt sander! Handles like a plane. Interchangeable pressure plates and sanding belts do all the work from roughing to finishing. Big, rugged—almost 19 sq. inches of sanding surface! Complete, with 3 pressure pads and 2 sanding belts, **\$19.95**

16. BULL HACK SAW. A handy tool for home craftsmen—a "must" for every carpenter, electrician, plumber and repairman! Cuts through wood, plastic, nails, sheet metal—gets into "tight" spots with power. Ideal for making repairs on walls or floors. Small, light and sturdy, easy to carry from job to job. All working parts of hardened steel. Complete **\$16.95**

5. BULL DRIVER. Drives screws home in wood or metal in seconds with any electric drill, drill press or flexible shaft! Automatically centers on screw groove; automatic release. (left) Model A—for screws up to

#14, (center) Model B—for small machine screws, (right) Model C—hand-centering model with long blade for countersunk jobs. All models available in standard or Phillips head. Specify model when ordering. Any model..... **\$4.95**

4. BULL HOLE SAW. Cut 1", 1 1/2", 2", 2 1/2" holes—with one hole saw! Fits any electric drill or drill press. Cuts cleanly through any 3/4" stock—wood, metal or plastic. Complete, with arbor and 4 blades..... **\$4.95**

10. UTILITY ACCESSORIES. Make your drill more useful with these handy accessories—3/8" arbor for 1/4" electric drill, \$4.9 ea. . . steel wire brush that removes paint, rust, and scale, \$.95 ea. . . 3" grindstone, \$.95 ea. Complete kit as pictured **\$1.95**

2. THE BULL BUFFER. Famous polisher-sander with gear reduction. Comes complete with rubber pad, sheepskin bonnet and 2 sanding discs.... **\$9.95**

BERTRAM E. ENGINEERING CO.

Dealers—Write today for new 1950 catalog.

3121 MAIN STREET

KANSAS CITY, MO.



**AT LAST! THE
BEST OF EVERYTHING IN
ONE GREAT MOWER—**

**THE NEW 1950
Worcester
21-INCH SHEAR MASTER**

Only
\$109.50
f.o.b.
factory



Think of it!
In this one fine
mower you get:

1. Quick-starting Briggs & Stratton 4-cycle, 1½ h.p. engine.
2. Famous, long-wearing Timken bearings.
3. Grass guards to prevent clogging of reel.
4. Heavy-duty, tractor-tread, non-skid tires.
5. Clutch and speed controls on handle.
6. Free-floating, shock-reducing handle. Stands upright for small space parking.

Yes... you get all these great features, and many more.

See Your Dealer—

or Write Dept. C-12 for Illustrated Literature

WORCESTER LAWN MOWER COMPANY
Div. Savage Arms Corporation, Chicopee Falls, Mass.

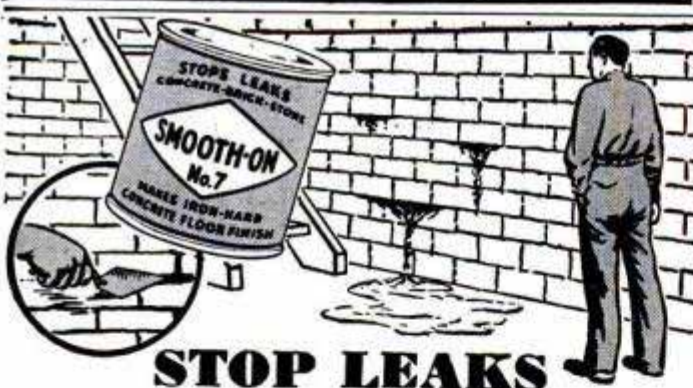

STOP LEAKS IN CELLAR WALLS

Do it with Smooth-On No. 7 Cement! Apply with trowel or stiff brush to leaky cracks, holes, porous spots, seams or other leaks in concrete, brick or stone walls and floors. The leaking will stop and Smooth-On will "stay put", for it expands slightly as it hardens. May be applied to wet or dry surfaces, indoors or outside. Use Smooth-On No. 7, too, to seal openings around pipes passing through walls. Buy Smooth-On No. 7 by name and number in 1-, 5-, 25- or 100-lb. size. If your hardware store hasn't it, write us.

FREE Leaflet and Handbook

We'll send you leaflet showing No. 7 uses, also the famous 40-page Smooth-On Repair Handbook describing other Smooth-On Cements and showing many helpful home repairs. 170 illustrations. Write today.

SMOOTH-ON MFG. CO., Dept. 37C
570 Communipaw Ave., Jersey City 4, N. J.



Do it with
SMOOTH-ON
NO. 7 CEMENT

**Thompson
BEATS
the World
on BOATS**



**Better Built
Lower Prices**



**Safe Boats With
Full Length Spray Rails**

Keep passengers perfectly dry—even at high speeds. Catalog also shows two new models of "Take-Along" Boats. Two big factories—save you freight.

CATALOG FREE
Write for your copy. State kind of boat in which you are interested.

THOMPSON BROS. BOAT MFG. CO. (151)
213 Ann St. (Write to either place)
PESHIGO, WIS. 113 Elm St.
CORTLAND, N.Y.

Light Boat for Auto

NU-WAY HEAVY DUTY CUTTING UNIT
with Timken Roller Bearings

**PRICE
\$16.50**
WHY PAY MORE



Build your own rotary type lawn or weed cutter. Take the hard work out of weed cutting. Build yourself an up-to-date weed and lawn mower with the Nu-Way heavy duty unit.

Write for Free Circular—We Supply Cutting Unit Complete
TRACTOR-LITE MFG. CO., Spirit Lake, Iowa

Save Money—Make Money
with **LARSON Leathercraft**

For gifts or for sale—make easy-to-assemble leather items. Complete stock leathers, tools, accessories.

Send ten cents for new catalog of 101 money-making ideas.

J. C. LARSON CO. 824 S. Tripp Ave.
Chicago 24, Illinois

CIRCLE SHOOTING ACCURACY
PAT. SPOTSHOT PEND.

Bead sight, Die Cut one piece rubber sling. The sportsman's choice for hunting and target shooting. Model #2—Shoots 5/16 steel Pellets 3 3/8 circle—Postpaid \$1.69. Shipped complete with sling and pellets. Send check or money order today. Dealers inquiries invited.

WEST MANUFACTURING COMPANY, LONDON, OHIO
ESTABLISHED 1899



AUTOMATIC CENTER PUNCH
TOOL OF 1000 CRAFT USES! ONE-HAND PRESSURE releases internal spring-hammer. The professional tool for EASE, SPEED, ACCURACY in punch-marking, staking of metals, plastics, etc. These tools are gov. surplus, at under dealer cost. Fixed pressure unit, \$1.00. Adjustable pressure unit, \$1.75. Postpaid. 10 Day Money-back Guarantee. No C.O.D. **ASBURY TOOL SALES CO., Dept. P-1, Asbury Park, N. J.**



**ONAN Portable
ELECTRIC PLANTS**

**FOR CABINS, TRAILERS,
CONTRACTORS, BOATS**

Light weight, compact, air-cooled engine-driven. Furnish regular city-type A.C. electricity for lights, appliances, radios, etc. Can be carried by hand. Fit trunk of car. Plug-in receptacles on plant. Larger models for farms, homes, businesses beyond highlines. Catalog shows over hundred models. 350 to 55,000 watts.



Gasoline or Diesel Powered

WRITE FOR CATALOG
D. W. ONAN & SONS INC.
5831 Royalston Ave., Minneapolis 5, Minn.



FINE TOOLS NEED FINE OIL!



- Lubricates
- Prevents Rust
- Cleans • Polishes

SOLD EVERYWHERE

3-IN-ONE Oil



WAR SURPLUS WINCH

Pulls Over 3,000 Lbs.

12"x14", 9" high. 80-to-1 ratio power. Used by leading truck lines for unloading. Ideal for farmers, contractors, etc. Excellent for any hoist, boat dock, wagon unloader, etc. Drive with small A-C motor, power take-off, fan pulley, etc. Mount on dock, tractor, truck or jeep. Finest steel and bronze gears. Guar. Cost Gov't. over \$100.

\$24.95

Order from ad or write for Bargain Catalog!

BURDEN SALES COMPANY

805 '07' ST., LINCOLN, NEBR.

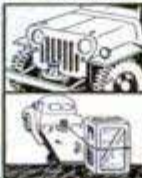

GENIE Home-Hobby Tools... THE GEM OF ALL HAND TOOLS

Precision engineered for particular home-hobby craftsmen. GENIE 22-in-1 Tool performs 9 different types of operations: It notches, saws, cuts V-shapes, drills, cuts razor thin, chisels, cuts holes, carves on all kinds of materials.

Send Check or M. O. Add Tax on Orders in Calif.

19 pc Set \$6.50 - 24 pc Set \$9.95 - Free Catalog on Request

DEALERS INQUIRIES INVITED
Tool Craft Co.
629 South Hill Street
Los Angeles 14, Calif.

IT SAWS - IT NOTCHES - IT CHISELS - CUTS HOLES

The New
**WISE-GRIP
WRENCH**
Does Jobs
No Other Tool
Can Do!

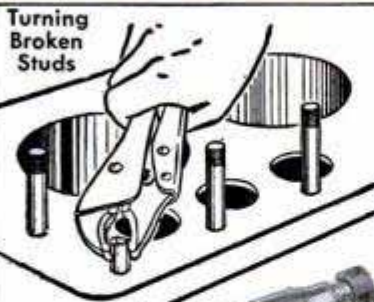

Does toughest jobs Easier and Faster! Jaws LOCK to work with more than Ton-Grip, leaves hands free. New In-volute Jaw Curve holds all shapes—nuts, rounds, irregular shapes with ease. Kurlied Jaw Tips grip to the very tip. Has Thin Nose and Super Wire-Cutter. WITH CUTTER—No. 7W, 7", \$2.25; No. 10W, 10", \$2.50. WITHOUT CUTTER—No. 7C, 7", \$1.85; No. 10C, 10", \$2.25. If not at your dealers, order direct.



Low as
\$1.85

PETERSEN MFG. CO., Dept. P3, DeWitt, Nebr.

Motors made for BETTER SERVICE Motors made for LONGER LIFE

Hoover Electric Motors perform like champions and last for years because they're built like motors costing far, far more. Stator cores are laminated electrical silicon steel, with coils dipped in high-grade varnish and baked under infrared lamps. Such processing is typical of workmanship that has made Hoover Cleaners famous for forty years. It's one reason folks say, "Whatever your workshop requirements, hitch up a Hoover and hitch up the best!"

A typical Hoover capacitor-start motor for hard-starting, continuous-duty applications. Split-phase and polyphase motors are also available.



Check these features
of the Hoover line

- Capacitor-start, split-phase and polyphase types
- Ratings from ¼ to 1½ H.P., some with double-end shafts
- Single or dual voltage, 1725 or 3450 R.P.M.
- Ball or sleeve bearings
- Rigid or resilient mounts that meet NEMA specifications
- Service and parts available from authorized agencies and dealers

HOOVER MOTORS



THE HOOVER COMPANY
North Canton, Ohio
Kingston-Conley Division
North Plainfield, N. J.

SAY YOU SAW IT IN POPULAR MECHANICS

ELECTRIC "SAFETY" PAINT-STRIPPER

Instantly softens and strips off old paint, varnish, putty, from wood, without fire-hazard. Eliminates need of heavy sanding or filling. Operating cost 2¢ to 3¢ per hour. Wt. 1½ lbs.

"SAFETY" IS AN ALL PURPOSE TOOL

Used by professional and lay painters for stripping houses, interior trim, wooden boats, canvas canoes, antique furniture, etc. Also in lifting or laying composition tile on floors, linoleum, patches on roofs or boats. Removes painted or unpainted wall paper.

RUGGEDLY BUILT

for years of active service, "Safety" has finest quality heating unit. Ceramic embedded nickel-chrome wire, with nickel lead-ins through porcelain insulators. Four sharp stripping edges. Idle-rest built in. Use "Safety" as you might a torch. You'll like it! Safe, fast, silent, clean, economical and convenient, "Safety" is the result of 10 years' work. Guaranteed against original defects. Detailed instructions with each tool. Order from your dealer, or direct.



115 VOLT
STANDARD MODEL
"B"

LIST \$17.95

FOB Rochester

A Patented Product of

HEATING EQUIPMENT CO.
P. O. BOX 318 • ROCHESTER 1, N. Y.

Better, Easier, Quicker GROOVE CUTTING or CABINET-MAKING

with *Warren* DADO SAWING WASHERS

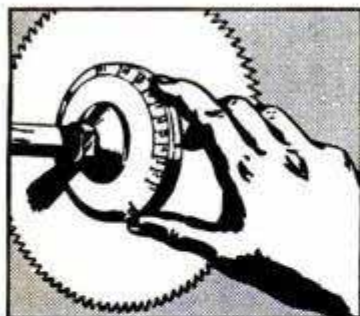

Just dial
DESIRED CUT

Cut accurate, parallel grooves—any width, any angle. Just dial desired width with Micromatic adjustment. Cuts smooth and clean—no burning or chewing to mar fine wood. Just four simple washers. Available in 5 sizes—½", ¾", 5/8", 1", 1 1/8". Free booklet on request. See your dealer or write direct. Absolutely guaranteed! In Canada, send money order for \$4.95 (duty and sales tax extra).

\$4.95
A SET

Dealers, Jobbers, Write for Information!

WARREN DADO SAWING WASHERS CO.
70 Medbury, Dept. 23, Detroit 2, Michigan

POWER MOWERS

Only \$74.63
DEALER'S PRICE

Powerful—Streamlined

Complete with Maytag, Power Products or Briggs-Stratton Engine—18" rotary tool-steel, fully guarded blades—cast aluminum body. Cuts grass and weeds, wet or dry—does all trimming—chops grass into fine mulch, eliminating raking. Send check with order, or specify C.O.D. Write Dept. M-3 for literature.

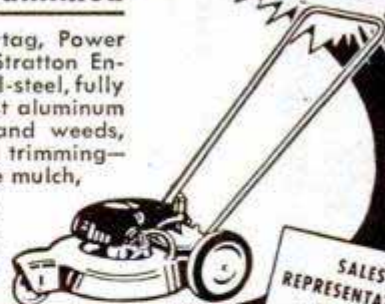

SALES REPRESENTATIVES WANTED

HARTMAN Corp.

1100 SOUTH KIRKWOOD ROAD • ST. LOUIS COUNTY 22, MO.

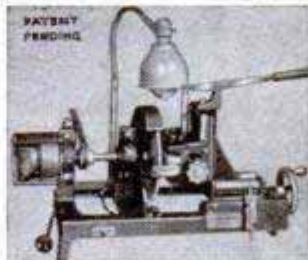

Start a NEW BUSINESS!

or Add to your present Repair Business

SHARPEN DULL PIPE WRENCHES

PIPE TAPS & DIES
"GUM" CIRCULAR SAWS
Write for Information

J. C. MOORE INDUSTRIES
BOX M 276 FREDONIA, PA.

MAKE! FOLDING TABLES - BENCHES - HORSES - IN A JIFFY

FOLD-A-WAY CHANNEL STEEL LEGS

Shipped complete, ready to fasten to your top in a minute. Rubber tipped. Used on the job, in homes, workshops, ping pong tables, trailers, camps, boats, churches, lodges, banquet halls. Send for free circular.



\$4.98 Pr.
24" Legs
\$5.98 Pr.
30" Legs
Postpaid in U.S.A.

THE DIAMOND MFG. COMPANY

1180 ALTAHONY AVENUE SCHENECTADY 7, N. Y.

Dept. PM

Rupture Troubles Ended

Advanced method has healed thousands. No leg straps, no elastic, no plasters. No pressure on hips or spine. Flexo-pad. Entirely different. Endorsed by doctors, mechanics, clerks. Very light. **INEXPENSIVE. GUARANTEED.** Write for information and trial.

SMITH MANUFACTURING COMPANY

EST'D 1893 DEPT. PM PRESTON, ONTARIO

BOAT BLUEPRINTS & FULL SIZE PATTERNS

and specifications. Designed by Naval Architect. Cruisers, runabouts, sloops, outboards, sailing canoe, etc. Low prices. Send 25c (coin) for illustrated catalog. SPECIAL: Send \$1.00 for "HOW TO BUILD BOATS" book, postpaid. PolyWog Houseboat Plans, \$10. Marine Catalog \$1. Cleveland Boat Blueprint Co., Dept. 666, Cleveland 13, Ohio

Ball-Bearing SPEED WHEELS



JUVENILE WHEELS (No bearing, solid tires)
4" 40c 6" 65c
5" 45c 8" 75c
(Semi-pneumatic tire, ball bearing)
8 x 1.25 1.85 10 x 1.25 2.20
8 x 1.75 1.95 10 x 1.75 2.30
8 x 2.00 2.20 10 x 2.00 2.65
12 x 1.75 3.45

INDUSTRIAL WHEELS

Lug Base, Semi-Pneumatic tire
5 x 1.75 3.65 10 x 2.00 6.10
6 x 2 SW 3.45 10 x 2.75 5.15
6 x 2.00 4.00 12 x 2.00 6.90
8 x 2.00 5.20 12 x 3.00 9.20
8 x 2.50 5.40 16 x 4.00 15.15
Smooth Base, Pneumatic tire and tube
8 x 3.00 11.00 12 x 4.00 12.10
10 x 2.75 6.80 4.00 x 8 13.10
10 x 3.50 10.55 14 x 4.50 13.40

Dealers, Jobbers, and Manufacturers! Our new prices will interest you.

Available Now—CASTERS
Write for circulars on all wheels.

No c.o.d. orders. Prices F.O.B. our plant.

JIM BROWN TOY COMPANY
1093 HOME AVENUE AKRON 10, OHIO

LIGHT PLANT GENERATOR



115 Volts
60 Cycle A.C.
(ITEM #267) **IDEAL FOR:** Home Lighting, Hunting Lodges, Stand-by Electricity, Running All AC Electrical Appliances including: Fans, Motors, Electric Razors, Refrigerators, Incubators, etc. 750 Watts at 1800 RPM using 1 1/2 HP gasoline engine.

O-150 Voltmeter with Regulator; 1" diameter shaft with keyway for direct or belt drive, carried in two bearings, one bronze and one ball-thrust bearing. Protection for emergencies to operate oil burner, stoker, freezer, water pump, and lights. These units, built to exacting Signal Corps specifications, are the answer to your lighting needs. Shipping wt. 60 lbs.

59.50
F.O.B. Chicago

AN OUTSTANDING VALUE

PNEUMATIC AIR DRILLS

Made by Chicago Pneumatic Tool Co. Light, powerful, compact, pistol grip, trigger control. Ideal for shop use where air pressure is available.



ITEM #80. Equipped with 1/4" Jacobs key chuck. Overall dim. 6 1/2" long, 5" high, 1 1/2" thick. Wt. 3 lbs. F.O.B. Chicago. **14.95**

ITEM #81. Larger size, equipped with 1/2" Jacobs key chuck. Overall dim. 7 1/2" long, 5" high, 2" thick. Wt. 4 lbs. F.O.B. Chicago. **19.95**

NOW . . . It's Easy to Weld with this handy **ARC WELDER**



250 AMP. MODEL 252
Designed for many years of trouble-free service. Handles anything from light gauge sheet metal to 1/2" plate (ITEM #65)

FOR ANY WELDING JOB, LIGHT OR HEAVY
This precision-engineered direct current ELECTRIC ARC WELDER is offered at but a fraction of its original value. It can be mounted permanently or easily transported for portable use. Does the job instantly, where and when you need it.

The War Surplus generators for these Arc Welders were built by General Electric, Westinghouse, and Delco-Remy at a cost of over \$300.00. They are light in weight; have oversized lifetime grease-sealed ball bearings; air-cooled commutator; dial type rheostat for easy pinpoint control; high-low range switch; reactor coil for even arc; handles 1/16" to 1/4" rods. Run welder at 2500 R.P.M. from drive pulley or power take-off of tractor, a 7 1/2 H.P. electric motor or a 10 H.P. gas engine. Use two V-belts, or flat belt (on pulley). Continuous welding rating—200 amps.; intermittent rating—250 amps.; 0-30 volts. Now . . . AT A FRACTION OF ITS VALUE. Price includes double V or flat belt pulley and instruction book. Ship. wt. 107 lbs. Only one or two jobs will pay for entire welder. F.O.B. Chicago **99.50**

ACCESSORY KIT including welding helmet, electrode holder, two 10 ft. cables with clamp, and 5 lbs. of assorted welding rods. (ITEM #66) F.O.B. Chicago **10.50**

FREE: 1950, 44-PAGE CATALOG
Write For Yours Today—It's Waiting For You.

PUROLATOR OIL FILTER



PERMANENT TYPE
The perfect oil filter to keep your motor oil or hydraulic fluid clean at all times. Protect your pump or engine with this unit. Just turn the handle and the element is clean. Standard 3/4" inlet and outlet ports to accommodate 12 gallons per minute. Shipping weight 4 lbs. A \$13.00 Value.

(Item #70)
4.95

WATEROUS PUMP



Rated 500 gallons per minute at 120 P. S. I. This high efficiency pump is designed for front end mounting on General Motors, Dodge, Studebaker and Ford trucks and comes complete with gear box and power take-off for easy mounting and attachment to crank shaft. Net weight of pump 500 lbs. Shipping weight 1200 lbs. F.O.B. Chicago. EACH

149.50

GEAR TYPE—ALL MANGANESE BRONZE INSECTICIDE PUMP



For Spraying D. D. T., 2,4-D, Sulphur Compounds, etc. BRAND NEW. Pressures up to 200 lbs. and 14 gallons per minute—at 1200 R.P.M. Will not rust, pit, foul or freeze up. Use rubber hose inlet, 3/4" pipe outlet. Equipped with double mounting bracket. Weight 24 lbs. Dimen. 8"x7"x10". Standard 1" manganese bronze shaft with keyway. U. S. Govt. Acquisition Cost \$62.00. NOW **15.00** F.O.B. Chicago

(ITEM #250)
15.00
F.O.B. Chicago

and performance data with each pump.

NEW AIRCRAFT QUALITY

HYDRAULIC EQUIPMENT

UNCONDITIONALLY GUARANTEED



LOGAN HEAVY DUTY HYDRAULIC CONTROL VALVE

Has built-in adjustable relief valve, will operate one double-acting hydraulic cylinder or two cylinders as one or a reversible hydraulic motor. Valve handle latches in neutral position. Made of rugged cast aluminum alloy. Open center unloads the pump in neutral position. Throttling control allows operator to regulate the speed of movement of the hydraulic cylinder or motor. Has removable mounting brackets with 4 bolt holes. 3/4" pipe thread connections. Overall dimen.: 12 1/2" H x 8 1/2" D x 8" W. Ship. wt. 17 lbs. Govt. Acq. Cost \$100.00. An Excellent Buy. F.O.B. Chicago. **21.95**

(ITEM #37)

ITEM #16—Double acting cylinder, 1 1/2" bore, 27" stroke. (Will lift 1760 lbs. in 2 seconds with Logan Pump.) Wt. 8 lbs. A \$53.00 hydraulic cylinder value for only **12.95** postpaid

ITEM #17—Double acting cylinder, 2 3/8" bore, 8" stroke. (Will lift 4400 lbs. in one second with Logan Pump.) Will withstand 1500 P.S.I. against wall. Wt. 7 lbs. A \$65.00 value **14.50** postpaid

ITEM #15—Double acting cylinder, 3" bore, 8 1/2" stroke. All steel hydraulic cylinder, (will lift up to 7000 lbs. in 3 seconds with Logan Pump). Wt. 12 lbs. A \$78.00 value **19.50** postpaid



VICKERS MF9 HYDRAULIC PUMP or MOTOR

COMPLETE WITH MOUNTING KIT READY TO INSTALL **19.90** \$75.00 value
Pump is compact, powerful, rated 1,000 P.S.I., 507 cu. in. per revolution, 8 gal. per min. at 3750 RPM. Change rotation by reversing flow. Delivers up to 6 H.P. Requires 1 1/2 to 6 H.P. to drive directly or by pulley. **BRAND NEW.** Mounting kit has been especially designed to provide maximum utility and ease of mounting MF series Vickers Pumps. Brackets are constructed of heavy steel plate; shaft is made of 1/2" steel with one end splined to fit pump; other end of shaft has machined flat for mounting a standard pulley with 1 1/2" hole. Shaft runs in oilite bronze bearings. **14.95** postpaid

MOUNTING KIT ONLY (ITEM #18) \$ 4.95 postpaid
BOTH AS COMPLETE UNIT (ITEM #39) \$19.90 postpaid

Large supply of new labor-saving, economical hydraulic equipment in many types and sizes . . . including actuating cylinders, control valves, tanks, pumps, fittings, hose, and data on hydraulic applications. Use these positive, highly efficient, smooth pressure hydraulics on presses, arbors, lifts, brakes, plastic dies, auto frame alignment, etc., etc.



(ITEM #42)

LOGAN HEAVY DUTY HYDRAULIC PUMP

BRAND NEW . . . for operating hydraulic cylinders and hydraulic motors on tractors, bulldozers, construction machinery, lift trucks, industrial applications, etc. Delivers 8 GPM at 1200 RPM at 1000 P.S.I. using 5 H.P. Has 1 1/2" pipe thread inlet, 3/4" pipe thread outlet. 3/4" shaft with flat and keyway for direct or pulley drive. Has flange with 4 bolt holes for convenient mounting. Ship. wt. 22 lbs. Overall dimen.: 7" L x 5 1/2" H x 5 1/2" W. A \$105.00 value. **FOR ONLY 22.50** F.O.B. Chicago



(ITEM #29)

ITEM #31—Double acting cylinder, 3 1/2" bore, 11" stroke. (Will lift 9600 lbs. in 2 seconds using Logan Pump.) Wt. 15 lbs. A \$92.00 value. **22.50** postpaid

ITEM #61—Double acting Hanna air cylinder, 5" bore, 26 1/2" stroke, 40 1/2" overall length closed. With 100 lbs. input will lift 1900 lbs. Net wt. 89 1/2 lbs. Gov't. acq. cost \$101.85 **39.50** F.O.B. Chicago

ITEM #83—Hand hydraulic pump with built-in 4-way control valve. **12.95** POSTPAID

ITEM #42—Double action hydraulic cylinder, 4" bore, 18" stroke. Rated lift capacity with 1000 P.S.I. input is 12,560 lbs. using Logan Pump. Ship. wt. 30 lbs. **AN EXCELLENT VALUE for F.O.B. Chicago 32.50**

HI-PRESSURE FITTINGS for cylinders and valves available at 35c ea. for 3/8" pipe and 50c ea. for 1/2" pipe.

HYDRAULIC CONTROL VALVES

ITEM #24. Four-way control valve with built-in relief valve, for use with one double action hydraulic cylinder, may be used with 1500 P.S.I. hydraulic system to open and close hydraulic cylinders. Brand new. Ship. wt. 8 lbs. A \$38.00 value. **7.95** Postpaid

ITEM #26. Four-way control valve for use with two hydraulic double-action cylinders. Each cylinder may be operated independently of the other or in conjunction with the other. Oil may be locked in any of the cylinders to hold the piston at any required position. Brand new. Ship. wt. 6 lbs. A \$60 value **postpaid 10.95**

ITEM #28. A two cylinder double action valve with a unique arrangement, allowing the operator to raise both cylinders simultaneously, to lower them simultaneously or to raise one and lower the other at any predetermined rate and speed. Brand new. Ship. wt. 8 lbs. A \$75.00 value, **postpaid 14.95**



ORDER DIRECT FROM AD. SEND PAYMENT CHECK OR PURCHASE ORDER TODAY

GROBAN SUPPLY CO. 1507 SOUTH MICHIGAN AVE. Chicago 5, Ill. Dept. PM - 3

"I'll take the **WHITE** one every time!"



WYTEFACE Steel Tapes, with their jet black markings on a white background, are easier to read in any light. They are rust-resisting, hard to kink and easy to clean.

Protected by U. S. Patent 2,089,209

WYTEFACE

TRADE MARK

STEEL TAPES

KEUFFEL & ESSER CO.

SAVE TIME • EFFORT
• MONEY —
with **MOW-MASTER**
POWER MOWER



MOWS EVERYTHING

Triple Duty

1. Trims lawns velvety smooth.
2. Cuts tall weeds and grass.
3. Pulverizes leaves—abolishes raking, hauling and burning.

It's great fun to trim the lawn with the New Mow-Master. It is lighter than ever, handles like a dream and mows everything. All metal rugged construction, built for the toughest mowing jobs. Amazing New Grind-a-Leaf attachment pulverizes leaves. Surplus of smooth flowing power from improved 2 H.P. POWER-PAK Engine. See it at your dealers.

FREE booklet "POINTERS ON MAKING GOOD LAWNS" and our MOW-MASTER literature sent upon request.

PROPULSION ENGINE CORP. Dept. PM-3
7th St. and Sunshine Rd. Kansas City 15, Kans.

HOLD-E-ZEE

The Original
**AUTOMATIC GRIP
SCREWDRIVERS**

Hold, start and set up screws in unhandy places. Gripper instantly released by **SPRING ACTION**, sliding up out of way when not in use. Highest quality throughout.

New Models FOR RECESSED HEAD SCREWS



UPSON BROS., INC., ROCHESTER 4, N. Y.

At Leading Dealers Everywhere



TODAY'S BIGGEST PREFAB BOAT BUY

Build a better boat than you can buy. Save up to 55%. See OZARKA'S new 1950 line of trim, top-quality 12- and 14-footers with laminated rib construction, all-oak frame and other exclusive features, for motors up to 25 H. P. Send 25c for complete Boat & Accessory Catalog, to be refunded on first purchase. OZARKA, Inc., 630 Borden Lane, Woodstock, Illinois.

**\$39.50
AND UP**

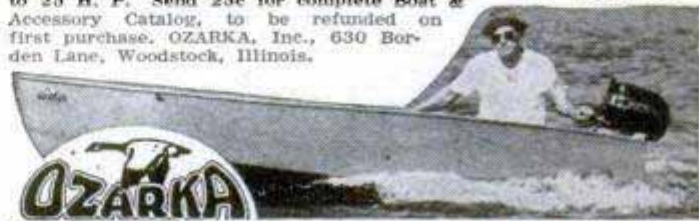

UTILITY TOOL CASE

specially designed for home-and-farm owners, craftsmen, radio and TV repairmen, fishermen, hunters, campers. Adopted by large utility companies for service men. Resists rust. Made of hard vulcanized fibre with reinforced corners, with removable tray and space for electric or large tools. Strong, durable, light! Solid, comfortable plastic handle. Full 8 inches wide; 9 inches high; two sizes:



- 17 inch (6 compartments) \$6.25 postpaid.
- 21 inch (8 compartments) \$6.50 postpaid.

NO C.O.D. Moneyback guarantee if returned within 10 days in good condition.

WILLHOUR COMPANY
277 N.J.R.R. Ave., Newark 5, N. J.

Only \$498



**OTTAWA
Mule Team Tractor**

Finest low-cost tractor. Costs too little to do without. Engines burn gasoline or kerosene. Starter and lights available. Other larger Models to choose from. Over 4,000 in world-wide use. Time-proved and tested. At low cost they easily mow, plow, disc, harrow, plant, cultivate, etc. Sold only direct to user. Write for **FREE** details.

OTTAWA MFG. CO., 2-027 Garden St., Ottawa, Kansas

ARC WELDING
FOR PROFIT OR PLEASURE

60 LBS. OF READY MADE PARTS

Only \$24.95

**BUILD YOUR OWN
HEAVY DUTY WELDER**

SAVE
Buy Only NECESSARY PARTS

All parts Ready-Made and easy to assemble. You can do all around welding on steel, cast iron and other metals after only a few hours practice. Illustrated instruction manual included. Sold on 30-Day Money-Back Guarantee!

FREE: Write today for fully illustrated Pamphlet P-3

ATOMIC ARC WELDER CO.
1037 So. 19th St. OMAHA, NEBR.

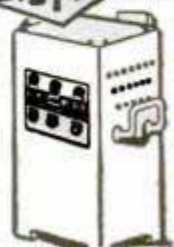

Gives 100% penetration. Welds are stronger than original metal. Operates on 110 or 220 AC.

NEW POWER KING 8" Tilt/Arbor Ball Bearing Saw

A New Standard of Value for you
Made by *Atlas*

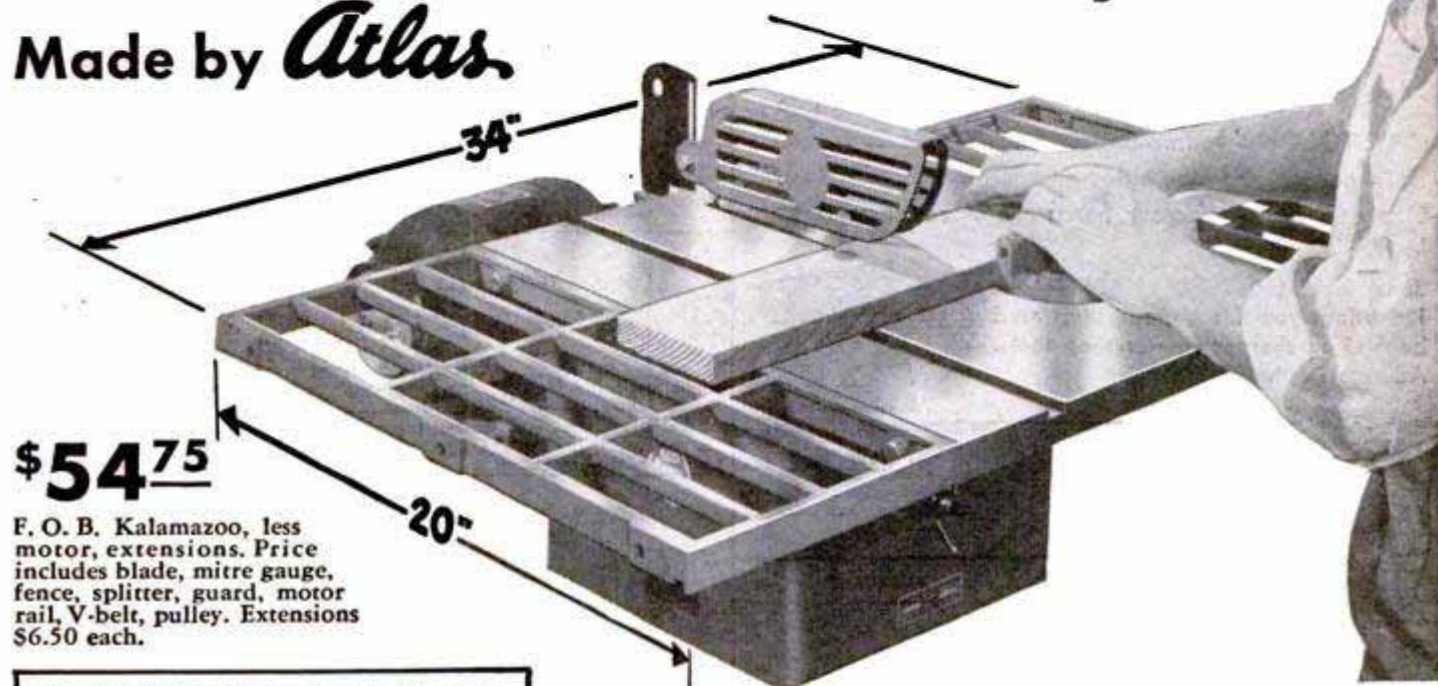

\$54⁷⁵

F. O. B. Kalamazoo, less motor, extensions. Price includes blade, mitre gauge, fence, splitter, guard, motor rail, V-belt, pulley. Extensions \$6.50 each.

- Some of the Outstanding Features**
- ★ Tilt/Arbor, Ball Bearing Construction! Controls At Front!
 - ★ 2 $\frac{5}{8}$ " Depth of Cut — Greatest in its class.
 - ★ 11 $\frac{1}{2}$ " Table Surface Ahead of Blade on 1" Cut!
 - ★ Big Precision-Ground 16" x 20" Grey Iron Table! 34" x 20" with two extensions.
 - ★ Quick Positioning Rip Fence—Locks At Both Ends!

The Big Capacity and Quality You've Wanted

Here — at low cost — is a saw that gives you the capacity you need for any type of construction for your home, the accuracy you need for fine model and furniture projects, and the quality manufacture that assures a lifetime of useful service.

You'll value the big grey-iron table of this new Power King — its solid support for long or wide boards and big panels. You'll value its *permanently* smooth, easy-sliding, *precision-ground* surface — the quick-adjusting, *full-length* rip fence, the convenient *front controls* for blade height and angles, and the tilting arbor, with sealed ball bearings. Only in saws costing much more do you find *all* the quality features that Atlas engineers have put into this new Power King No. 3102.

See it at your nearest Power King dealers at your first opportunity. And for a catalog with many useful woodworking hints, send a postcard today.



NEW! FREE CATALOG SHOWS ALL 8 POWER KING TOOLS

Send a Postcard



ATLAS PRESS Company
335 N. Pitcher St., Kalamazoo, Mich.



MATCHED PRECISION TOOLS FOR WOODWORKING AND METALWORKING

Just a few strokes does it
with a

NORTON
abrasives®
STONE

Sharpening is quick, easy and efficient with a CRYSTOLON® combination bench stone. It has both coarse and fine sides and is already oil-filled. Get one today at your hardware store. Priced as low as \$1.10.

Send for "HOW TO SHARPEN" — 10¢ brings you this 48-page illustrated booklet on sharpening workshop tools. Address Dept. PM 3.



BEHR-MANNING
TROY, N. Y.
Also Mfrs. of Abrasive Paper and Cloth



HAGERTY ONLY
SEA SHELL \$35

MAKE every week end a real vacation! Take along your HAGERTY SEA SHELL! Handy and light (65 lbs.) for easy carrying, easy rowing. Rugged for years of service. Takes a small outboard. Kit easily assembled in a few pleasant evenings! Holds 3 adults in safety. Ideal for all-around use. Over 15,000 in service. Fully guaranteed.

THIS 8-FOOTER SAVES YOU MONEY

Put the SEA SHELL together and save half the cost of a ready-made rowboat. It's fun! Only ordinary hand tools needed. Kit includes pre-cut waterproof plywood and wood parts, screws, oarlocks, seam compound, full instructions. Beam 4 ft., depth 16 ins. Sailboat conversion kit available.

HAGERTY, 113 Front St., Cohasset, Mass.

- Please send me FREE booklet, name of nearest dealer.
- Please send SEA SHELL kit, freight collect. Enclosed is \$35.

Name _____
Address _____
City _____ State _____

Make-ur-Own Rotary
POWER MOWER

ATLAS KEEN-MOWER
SHIPPED ASSEMBLED AS SHOWN

Model 50M. Just add electric motor or gas engine. Concealed blade for safety. 3 cutting heights, 1½", 2½", 3½". 18" blade. Cuts to within ½" of sidewalk. Ball-bearing rubber tired wheels. Wt. 43 lbs.

Order Now

America's Greatest Power Mower Value
FOB K. C. Send Check or M.O.

ATLAS EQUIPMENT CO.

229 S. W. Blvd. Dept. PM3 Kansas City, Mo.



Wear Sample Suit
NOT 1¢ TO PAY!



Here's an amazing plan! Write me today and I'll show you how to get a fine, all-wool made-to-measure suit for yourself—to wear and show to friends. Just take a few orders, that's all! Here's an easy way to get your own suit without paying 1¢, and also make fine cash profit on every order you take. You send no money, now or ever. Just rush name and address for Sample Woolens and Valuable Sample Suit Coupon. Act now.

W. Z. GIBSON, 500 S. Throop Street
Dept. C-516, Chicago 7, Illinois



5 big-capacity
power tools in

1 rugged, precision-
built unit

Write for free, 20-page, profusely illustrated book. SHOPSMTIH, Dept. 109-B, 12819 Coit Rd., Cleveland 8, O.



Baseball Uniforms

Buy direct—Save nearly 1/2

\$11.95 Uniforms \$6.95

Lettering at no extra cost

Order direct, save on big-league-cut, tough cricket cloth uniforms. 10 sewn letters at no extra cost! Write for free illustrated catalog with swatches. Big savings on all baseball equipment.

BACHARACH RASIN CO.

Dept. R, 14 North Howard Street, Baltimore 1, Maryland

ONLY
\$2.00
POSTPAID



Professional Woodworking Clamps only \$2.00

Now for the first time these clamps are available to the home craftsman. Holds work securely in all positions. Better than "C" clamps. Won't mar your work. Packed in kits, complete less jaws. Make the jaws yourself in one hour, with easy to follow instructions. Screws accurately machined from high tensile steel. Clamps open 9" to do all types of work. Jaws 10" long. Note: Most gluing jobs require 4 clamps. Order yours today. \$2.00 each, postpaid.

Minneapolis Hardware Mfg. Co.
4524 18th Ave. S., Minneapolis 7, Minn.

How To Get MULTIPLE UTILITY When You Buy a SMALL GRINDER

BUY THE FOREDOM MODEL 100 FLEXIBLE SHAFT MACHINE

the choice of tens of thousands because:—Pencil-size handpiece provides positive, sensitive, finger-tip control, works in hard-to-reach places. Your work always well in view. Precision construction and silencer-equipped flexible shaft assures smooth-running per-

formance. Motor not dwarfed to fit the hand, hence more power, longer motor life. Price only \$16.95. Foot rheostat \$4.85 extra.

USE IT TO GRIND, POLISH, DRILL, SAW, SAND, CARVE, MILL, CLEAN, ETCH, ENGRAVE, etc. on all metals, wood, plastics, glass, leather, linoleum, etc.

35"
FLEXIBLE
SHAFT
\$16.95
COMPLETE
WITH
MOTOR



Model
100

PRESTO-
FLEX
\$5.95

BUT THAT'S NOT ALL—

For \$4.95 extra get Foredom's new **DRILL PRESS ATTACHMENT**. Magically and quickly converts machine into a power drill press.

AND FOR ONLY \$3.50 EXTRA there's Foredom's new **B-R-S ATTACH-**

And here's another Amazing

Foredom Product Now turn your old motor, drill press or electric drill into a Flexible Shaft Tool with FOREDOM PRESTO-FLEX with PENCIL SIZE handpiece. Attached or removed in a jiffy! Gets into tight places. Handy 35" overall length. And—only \$5.95 complete! Precision made. For use on motor, specify motor shaft diameter and add 50c for coupling. (Available for 1/4, 5/16, 3/8, and 1/2" shafts.) No. 50 Accessory set \$1.50 extra.

MENT. Makes machine serve 3 EXTRA FUNCTIONS—Bench Grinder with angular adjustment, Router with detachable guide for borders, and SHAPER. Budget your purchase or buy FOREDOM MULTI-PURPOSE THREESOME comprising Model 100 Machine, Drill Press Attachment and B-R-S Attachment \$24.95.



NEW ACCESSO-RAK Mount on wall or back of bench and hang up machine. Comes with 40 highly useful accessories, all at your finger tips. Sensational value, only \$4.95.

ORDER TODAY. Send check or money order for items above or sent C.O.D. plus postage. Sold on 10 day money back TRIAL.

Write Today for FREE CATALOG No. 1127-E

FOREDOM ELECTRIC CO., Dept. 1127-E, 27 PARK PLACE, NEW YORK 7, N. Y.

FOREDOM — Used by INDUSTRY — Preferred by HOBBYISTS!



Dealer Inquiries Invited

SET THE PACE WITH THE

- Cruises at 45 MPH—with faster pickup than car
- 39" high, 71" long overall, wt., 190 lbs.
- 8 HP motorcycle engine
- 50 miles to the gallon
- Automatic clutch
- Internal expanding brakes — handle-grip throttle controls

POWELL MANUFACTURING COMPANY

DEPT. PM350 ● COMPTON, CALIF.

ONLY
\$247³⁴
AT COMPTON, CALIF.
EXCISE TAX
INC.

P-81!

Write for FREE folder and name of nearest dealer

FEELS RIGHT...WORKS RIGHT!

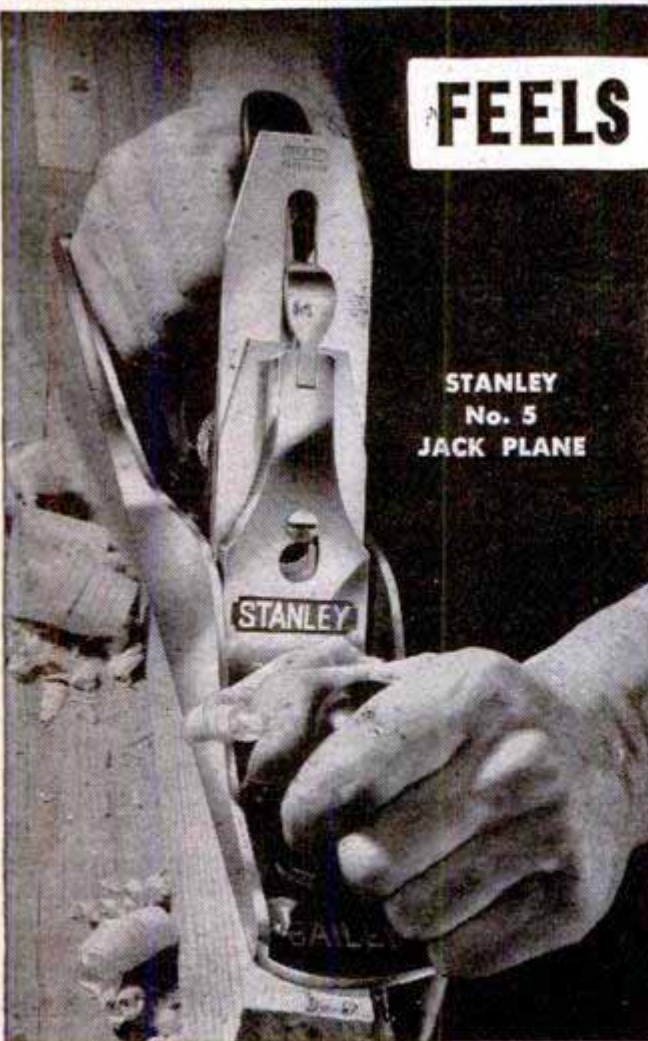

STANLEY
No. 5
JACK PLANE

The minute you grasp a Stanley Plane and ease the cutter into the wood, you feel the fitness of a fine tool . . . the skill of your hand and eye going right down to the face of the work. It's responsive! It's beautifully balanced! It's right in every detail, from the bevel of the cutter to the way the knob and handle fit into your hands. A lot more than good steel goes into a tool like that . . . the best ideas of generations of the best tool users. You can't get more than that in any tool: you always get a full measure of it in Stanley Tools.

Let this coupon bring you these two books

THE TOOL BOX OF THE WORLD

STANLEY

Reg. U.S. Pat. Off.

HARDWARE • TOOLS • ELECTRIC TOOLS • STEEL STRAPPING • STEEL

Stanley Tools, 130 Elm St., New Britain, Conn.
Please send by return mail:

FREE booklet: "The Joy of Accomplishment". 188-page book: "How to Work with Tools and Wood". \$1.00 enclosed.
(In Canada: Send order to Stanley Tool Co. of Canada, Ltd., 112 Stanley St., Roxton Pond, Quebec.)

Name.....

Address.....

City..... State.....

Peels
Off
Paint

New!

NO WASH!

Non-Inflammable!

Now you can "strip off" any finish safely, easily, without mess.

Old-fashioned, inflammable solvents work by "dissolving," leaving a sticky, waxy surface that must be carefully washed, or "neutralized." But Klean-Strip penetrates all layers of old paint and actually "breaks" the bond between the bottom layer and the surface to be stripped.

Klean-Strip changes any finish into a wrinkled film that is easily peeled off with brush or putty knife. Leaves surface smooth, clean and dry.

Buy Klean-Strip whenever you buy paint. At better paint, hardware and department stores.

KLEAN-STRIP REMOVER

Product of W. M. BARR & CO.
2350 S. Lauderdale, Memphis, Tenn.

START A BUSINESS this quick way

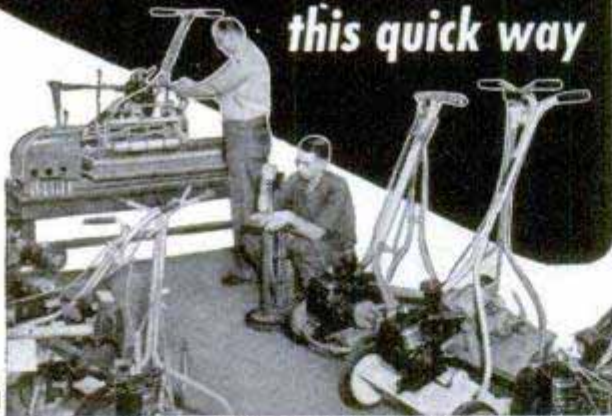

with

FOLEY LAWN MOWER SHARPENER

"I have taken in 100 mowers in 5 weeks since I got my Foley, —with no advertising," says George C. Wise. "In two months I have sharpened 155 hand mowers, 6 power mowers and 1 trimmer. My machine has paid for itself and everything I take in now is all profit!" —from Otis Zacharia.

Here's a business you can start in spare time, and begin to make a CASH PROFIT right away. The Foley handles up to 3 or 4 mowers per hour, and prices run \$1.50 to \$3.00 for hand mowers, \$5.00 to \$8.00 for power mowers.

FREE BOOK "HOW TO SHARPEN POWER MOWERS" shows just how to sharpen any make of power lawn mower with the Foley. Low prices, only \$98.50 to \$139.50—easy payments. Mail coupon today — we'll also send FREE PLAN telling how to start your own business without previous experience. No salesman will call.

FOLEY MFG. CO. 307-O Foley Bldg., Minneapolis 18, Minn.
Send FREE BOOK "How to Sharpen Power Mowers", and FREE PLAN on lawn mower business.

NAME _____

ADDRESS _____

SORE MUSCLES?



When muscles are stiff and sore from unusual exercise or strain, use HEET®, the liniment that's strong yet does not burn the skin. Wonderful relief from muscular soreness comes as comforting HEET quickly starts to penetrate. Just brush it on with the applicator. HEET starts at once to ease muscular pain and keeps on working for hours, warms and soothes the painful area.

SHARPEN CIRCULAR SAWS LIKE AN EXPERT



\$6.95

No experience needed. Two simple adjustments. Gets hollow-ground, cross-cut or combination saw blades true and sharp. Fits 6" to 12" blades with 1/2" to 13/16" centers. Includes file and complete instructions. \$6.95 postpaid. (Check or money order) C.O.D.s postage extra. Guaranteed—Money back if not satisfied after 10 day trial. A money maker for fix-it shops. Soon pays for itself. Order today. Free folder. **SURE SHARP MFG. CO., Dept. M-30** P. O. Box 24 Santa Ana, Calif.

FURNACES FOR HOME AND SHOP



COAL—LP—GAS—OIL. Fittings, pipes and registers. Water heaters, Ranges and floor furnaces. BLOWERS with motors. Get the parts you need and modernize your own heating system. Wholesale & Retail. Lowest prices.

FREE BOOKLET

PEERLESS SALES & SUPPLY
4318 Sheridan Lincoln 6, Nebr.

DO MORE PLANING JOBS WITH LOW-COST BELSAW \$195.



AMAZING 12 1/2-IN. PLANER Does All Ordinary Planing Mill Jobs. Provides attachments for Jointing, Rabbeting, Tongue, Groove, Matching. 12 1/2 x 6-in. capacity, 3-knife solid round all-steel cutterhead. Power feeds at 24 feet per minute, 42 cuts per inch. Provides for full line of accessory attachments—Grind and Joint Knives IN THE CUTTERHEAD WITHOUT REMOVING.

FREE BOOK

BELSAW MACHINERY CO.
81011 Field Bldg., 315 Westport Rd., Kansas City 2, Mo.

KINKADE GARDEN TRACTOR and Power Lawnmower

A Practical Power Plow and Cultivator for Suburbanites, Gardeners, Florists, Estates, Fruit, Nursery & Poultrymen.

Easy Terms - Write Today

American Farm Machine Co.
1058 33rd Ave. S. E. Minneapolis, Minn.



Catalog Free

NEW PACKAGED BOATS 1950 KITS



17 New models. Improved design, skiffs, outboards, inboards, sail boats. Tredonic racers, cruisers. 8 to 16 ft., exclusive features. Preamsembled frames, Tri-Keel construction, Tredonic bottom, full length spray rails, widest beam, simplified construction, easy to build. World's best boat buy! Send 25c for new 1950 literature, or send \$1.00 for literature, plus booklet "Plywood Boats."

BOAT PATTERNS-BLUE-PRINTS

1950 Catalog—over 100 modern designs by famous naval architects. Racing classes, cruisers, inboard, outboard, sail, 6 to 35 ft. Plywood—Steel—Plank. Construction plans, full-size patterns. Send 35c for catalog or \$1.00 for catalog and helpful booklet on "Boat Building."

MARINE MART-DEPT. 24-BUFFALO 7, N. Y.

Make Garden Masonry for Spare-Time Profits

Millions of homes can use these Ornamental products — urns, vases, flower boxes, bird baths, lawn seats, flagstones, etc. Easily made of sand and cement. Permanently glazed in a range of smart colors. Distinctive — attractive — quick selling.

Eye-Appeal Makes for Cash- and-Carry Sales



Selling prices allow 200% to 300% mark-up on basic costs.

Only a small investment needed for supply of molds. Easily set up in shed or garage. Write immediately for catalogue OM and price list.

COLORCRETE INDUSTRIES, INC.
710 Ottawa Ave., Holland, Mich.



Sprunger

precision built

POWER TOOLS

pay for themselves

on just a few jobs. Make your own furniture, home repairs, etc. with these rugged, precision tools.

See them at your dealer's.

WRITE
DEPT. PM-35

for latest literature. (Prices subject to change without notice.)



8" TILT ARBOR
SAWS. BL—\$74.95
—"C"—\$49.95



18" JIG SAW
\$34.95



14" BAND SAW
\$84.95



6" JOINTER-PLANER
\$79.95



10" GAP-BED LATHE
\$49.95

SPRUNGER BROS. INC. TOPEKA, IND.

\$SAVE! \$SAVE! \$SAVE!

UNSURPASSED VALUES IN USED AUTO PARTS

Never before in our 30 years history have we had such a tremendous stock of good used guaranteed auto parts for practically all makes and models.

'49 Ply. Sed.	'41 Buick Spec. Sed.
'47 Kaiser Sed.	'47 Lincoln Cpe.
'47 Dodge Sed.	'42 Linc. Cont. Cpe.
'47 Hudson Sed.	'46 Chev. Sed.
'47 Hudson Coach	'42 Chev. Sed.
'47 Olds. "98" Sed.	'41 Chev. Sed.
'48 Stude. Champ. Cpe.	'41 Dodge Sed.
'48 DeSoto Cpe.	'41 Ford Sed.
'42 Buick Super Sed'tte	'41 Ford Coach
'47 Buick Rd.Mster. Sed.	'47 Nash Sed.

Now Dismantling These and Hundreds More.
We Specialize in Competent, Courteous Service

SPECIAL—SPECIAL—SPECIAL

Good Used 15" and 16" Tires

All Sizes — Popular Brands — \$3.50 each

Free Tube With Each Tire Purchased

LARGEST STOCK — IMMEDIATELY AVAILABLE EXCEPTIONAL VALUES IN GUARANTEED USED PARTS

Year	Make	Motors	Trans.	Rear Ends
'37-'38	Chev	\$45.00	\$18.75	\$18.75
'40-'41	Chev	56.25	22.50	18.75
'37-'38	Ply	37.50	20.80	15.00
'40-'41	Ply	63.75	22.50	18.75
'37-'38	Ford	56.25	18.75	18.75
'40-'41	Ford	75.00	26.25	26.25

Above prices are NET WHOLESALE to POPULAR MECHANICS readers. Other models at comparable low prices

WE SHIP ANYWHERE PROMPTLY AND PROPERLY

All merchandise fully guaranteed as represented. Order direct from this ad and receive commercial discount. Prices F.O.B. San Bernardino, California. Pay by Postal money order or check. 50% deposit on C.O.D.'s. California orders add 3% retail sales tax.

SAN BERNARDINO AUTO WRECKING

239 ARROWHEAD AVE. SAN BERNARDINO, CALIF.
Telephones 411-72 and 523-51

SAY YOU SAW IT IN POPULAR MECHANICS

FREE!

NEW
BOOK ON
FISHING!

You need new "Fishing—What Tackle and When"—nearly 100 pages of helpful fishing tips, casting instructions, fish pictures, tackle, etc. Write for it today. FREE!

SOUTH BEND GLASS CASTING ROD
New! Hundreds of thousands of glass fibers scientifically bonded for perfect action — strength — durability. Won't "set," rot or corrode. \$15.75
No. 2800. 3 lengths — 5, 5-1/2 or 6 ft.

South Bend Bait Co., 891 High St., South Bend 23, Ind.

SOUTH BEND

A NAME
FAMOUS IN
FISHING

CROSLEY

LOWERS ALL PRICES!

Now the Crosley, made in America with U. S. skill and precision, cuts prices up to \$105. And 1950 Crosley cars have hundreds of improvements including Hydradisc (air-plane type hydraulic) Brakes and Crosley engine with rugged cast iron block and 8-to-1 compression ratio. Save with a new Crosley when you buy it, while you drive it—up to 50 miles on a gallon of regular gasoline.

STATION WAGON:
Price reduced \$105. Seats 4, or 2 with 1/4 ton load. All steel.



SEDAN DELUXE:
Price reduced \$101. Speedline styling. Rich fabric upholstery. Seats 4, plus luggage.

CONVERTIBLE:
Price reduced \$101. Four passenger. Easy-to-handle top. Big luggage space.



HOTSHOT:
Price reduced \$51. A new thrill in motoring. America's own sports car. Two passenger.

Just out! New Super Sports—a deluxe sports roadster at about \$50 more than the Hotshot.

Crosley Trucks, both Panel Delivery and Pick-up have also been reduced—\$83 on each model! Dealers and driver agents wanted!

CROSLEY
a FINE car

"You see them everywhere!"

IT'S FREE! IT'S NEW!
The 1950 CROSLEY CATALOG. Write Crosley Motors, Inc., 2530-HP Spring Grove Avenue, Cincinnati 14, Ohio.

Big 6 HORSEPOWER ROTARY TILLER

\$299

No Extras to Buy

The Mulsifier Rotary Soil Tiller! Unsurpassed for tilling and cultivating. Makes it easy to work 1 to 20 acres. Prepares the soil in one operation. Nothing to do but guide it. High-powered—adequate for all soils. Unbreakable tines. Gives you more horsepower per dollar than any other garden tractor. Attachments available. Money-Back Guarantee. Send postcard for circular.



MULSIFIER IMPLEMENT CO.
7758 HAMILTON, DETROIT 2, MICH.

*Trade Mark Reg. U. S. Pat. Off.

Free CIRCULAR

Mulsifier
ROTARY SOIL TILLER

BURR HAND SAW FILER

Makes More PROFITS

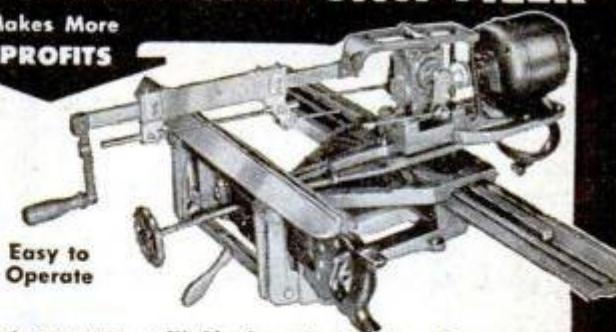

Easy to Operate

Fast, accurate, will file from both sides. Operator controls file arm. No saw carrier or adjusting screws to fuss with. A money-maker in any shop.

BURR MFG. CO.
8933 VENICE BOULEVARD
LOS ANGELES 34, CALIF.

WRITE TODAY!

LAWN ORNAMENT-NOVELTY PATTERNS

28 Lawn Ornament Patterns, 25c. Other patterns; 15-20" high; Dutch Girl, Dutch Boy, Pirate, Bull Terrier, Mexican Girl, Mexican Boy, Dwarf, Penguin, Flower Girl, 10c each. 25 Novelty Patterns, 30c. All 62 Full Size Patterns, \$1.00 Postpaid. Strother Pattern Service, Dept. 80-8, Box 128, Belington, W. Va.



750' 2-PLY NYLON 25 lb. T
150' 3-PLY NYLON 85 lb. T
250' 3-PLY NYLON 45 lb. T
300' SILK LINE 30 lb. T
500' 3-PLY Nylon 35 lb. T
500' Linen Line 24 lb. T

BRAIDED NYLON LINE

200' 15 or 20 lb. Test
175' 35 lb. Test
150' 50 lb. Test
125' 75 lb. Test
100' 100 lb. Test
50' 200 lb. Test

110 ft. Nylon Drop Line, 100 lb. Test—50c
Pachner & Koller Liteweight Fly Reel \$1.00
All lines available in longer lengths. Send Check, Money Order. We pay Postage.

MAC-MILLS, Dept. K-3, Pleasant Valley, New York, N.Y.

AGENTS 300% Profit SIGN LETTERS

For Store Fronts and Office Windows. Anyone can put them on. Free Samples. Liberal Offer to General Agents.

METALLIC LETTER CO., 430 N. Clark, Chicago 10

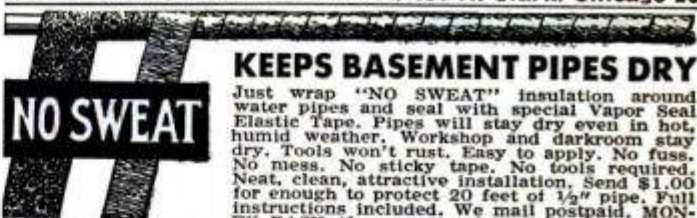

KEEPS BASEMENT PIPES DRY

Just wrap "NO SWEAT" insulation around water pipes and seal with special Vapor Seal Elastic Tape. Pipes will stay dry even in hot, humid weather. Workshop and darkroom stay dry. Tools won't rust. Easy to apply. No fuss. No mess. No sticky tape. No tools required. Neat, clean, attractive installation. Send \$1.00 for enough to protect 20 feet of 1/2" pipe. Full instructions included. We mail postpaid. MONEY BACK if you are not completely satisfied.

ASSOCIATED SPECIALTIES, 10658 Gratiot, Detroit 13, Mich.

JOIN \$2 MERCHANDISE CLUB

Factory Close-Outs, etc. Amazing Value! Money back guarantee! Be surprised! Send \$2 today!
DRUM & DRUM, Irvington 11, N.J.

NO SPARKS • NO ASHES • NO BURNS
WHILE DRIVING SPILLED ON RUG TO CLOTHING

Seal-ETT

HOLDER HAS BUILT-IN ASH TRAY



ELIMINATES FIRE HAZARDS: You even can smoke in bed safely, with a featherlight "SEAL-ETT" holder! Fine mesh tube holds ashes until emptied. Holder does not alter natural cigarette flavor; you hold cigarette itself in mouth. Starts talk wherever shown, be first to have one! Greatest smoking safety aid since safety match. Not sold in stores; order by mail, today! 60¢ each, cash or money order. Car dash attachment 15¢ extra; get 1 for pocket, 1 for car! Money-back guarantee. Postpaid. **2 for \$1.00.**

R. J. Turner, Box 211-B, Montebello, Calif.

NEW POWER FOR YOUR CAR ENGINE !

BY CONSTANT BALANCE OF LUBRICATING OIL SUPPLY

*Give Your Car this Tonic —
Add Power, Pep and Performance*

MARVEL INVERSE OILER



Here's the famous, low cost, auxiliary lubricating system that meters MARVEL MYSTERY OIL to critical upper cylinder engine parts, precisely in accordance with engine load. The compact INVERSE OILER functions inversely to manifold vacuum, retarding feed *visibly* when throttle is closed or at engine idle, an exclusive MARVEL feature! You can keep ring, piston and valve wear down and performance way UP with the sensational MARVEL INVERSE OILER.

Learn about MARVEL MYSTERY OIL too—the famous oil improving Additive for YOUR motor oil that produces a slow idle, faster engine pick-up and an even, power pull. Thousands of car owners are using it in increased volume for engine protection. MARVEL lowers oil drag resistance, reducing frictional wear and increasing effective power. Add it to your motor oil!



MODEL TU
2 QUART

WRITE FOR THE FACTS NOW!

The MARVEL INVERSE OILER Is Easily Installed on Most Engines

EMEROL MANUFACTURING COMPANY, INC.
242 West 69th Street (Dept. P. M.), New York 23, N. Y.

MONEY SAVER

BRIGHTEN YOUR BASEMENT

... at surprisingly low cost

Want an easy, inexpensive way to give your basement walls and ceiling a fresh, clean look? FREE BOOK TELLS HOW. Send for your copy of "Paint It Bright"—the 24-page book full of helpful painting hints. And remember, there is a difference in aluminum paints. Basement walls, for example, call for Aluminum Metal & Masonry Paint. It's available from the dealer who displays the Alcoa symbol of quality on the brand he sells.



Look for  this shield on aluminum paints made by many paint manufacturers using **ALCOA PIGMENTS**

MAIL THIS COUPON

Paint Service Bureau, ALUMINUM COMPANY OF AMERICA,
1718C Gulf Building, Pittsburgh 19, Pa.

Please send me free copy of "Paint It Bright".

Name (please print) _____

Address or RFD No. _____

City _____ State _____

I want to paint the following: _____



Experts tell in "Paint It Bright" how to obtain best painting results with aluminum paints. For free copy, mail coupon.



W. R. BROWN CORPORATION
CHICAGO 39, ILL.
Specialists in Portable Sprayers for Over 20 Years!

Speedy Sprayer

Here's a real "professional" spray outfit that paints anything from a house to a toy! In addition, Speedy Sprayer handles any material—enamel, varnish, lacquer, calcimine, insecticide, etc. Speedy Sprayer saves time and money, too. Does any job in *minutes* instead of hours... makes paint go further. It's the favorite sprayer whose dependability is proven by 20 years of usage. At hardware, paint, lumber or auto supply dealers.

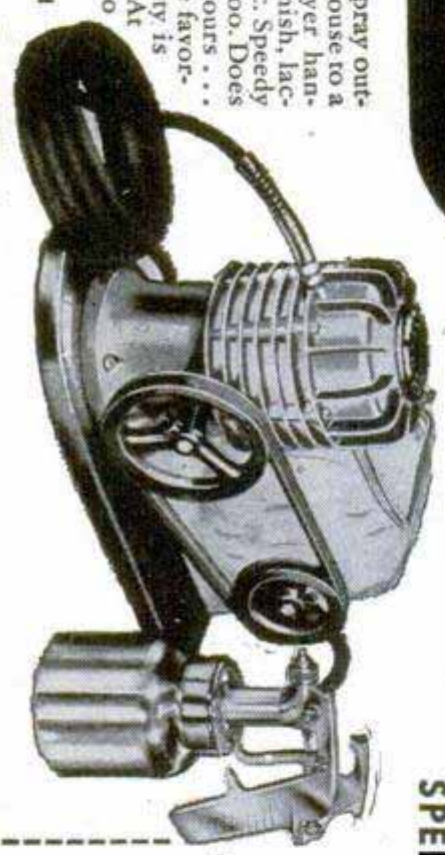

Heavy duty all-purpose paint sprayer for
Hobbyists, Mechanics, Home Owners who
demand superior performance and results!

SPEEDY SPRAYER 890

Delivers 2 cu. ft. per minute, clean, oil-free air at 30-40 lbs. pressure. Operated by any 1/4 h.p. motor. Never needs oiling. Complete outfit—gun, valves, nozzles, air hose, less motor.

\$26.50

Free

W. R. Brown Corporation
5717 Armitage Ave., Chicago 39, Ill.
Free Booklet "How to Spray". Also Speedy Sprayer literature.

Name _____
Address _____
City _____ State _____

GRINDING WHEEL KITS

HUNDREDS OF ASSORTED ITEMS—WORTH OVER \$50!

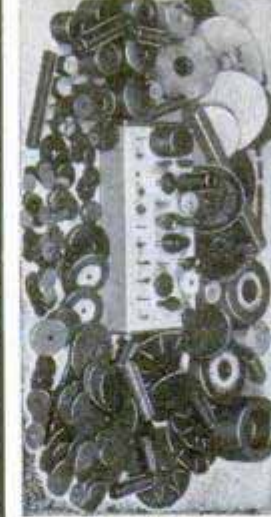

FOR GRINDING, CUTTING, POLISHING AND SHAPING—METAL, PLASTIC OR WOOD. WHILE THEY LAST—COMPLETE KIT ONLY. **\$7.95** f.o.b. Chicago

- KIT INCLUDES OVER 300 ITEMS**
- 25 Grinding and Cut-off Wheels, sizes 1" to 5", 1/8" to 1" arbor holes. 10 Mounted stones 3/32", 1/8", 1/4" shank.
 - 3 Steel Cutters 1/8" shank. 5 Steel Cutters 3/32" shank. 1 Circular saw 1" dia. mounted on 1/8" mandrel. 1 Drum sander 3/4" mounted on 1/4" mandrel. 6 Abrasive bands for Drum sander. 6 Cut-off Wheels and 1/4" mandrel. 1 Buffing Wheel 1" on 1/8" mandrel. 1 High Speed rotary file 1/4" shank. 1 Abrasive belt
 - 2 Leather bobs 1 Tampico Wheel
 - 2 Sharpening stones 100 Paper sanding discs 3/4"
 - 3 Honing stones 50 Cloth abrasive discs and buffers 1" to 7" dia.
 - 2 Felt polishing cylinders
 - 15 Abrasive rolls 2 Muslin buffs 3" and 8"
 - 5 Felt wheels 1 Wire wheel 4" 1" dia.
 - 5 Rubber wheels 1 Wire wheel 1" dia.
 - 1 Wire wheel 1" dia.

ORDER TODAY! Send check or money order. All orders shipped by Ry. Exp. Illustrated Bargain Catalog—10c
SCHUPACK SUPPLY CO. 7331 Cottage Grove Avenue Dept. M-3, Chicago 19, Ill.

OTTAWA Tiller & Mower

Patented Powerful 2 H-P Red Seal Continental Motor. Attachments for mowing, tilling, power take-off, cultivating and spraying. Lowest prices in history. Two speeds and free wheeling. Thousands in use. Rotary mower only \$89. Made by men with know-how. Now in our 47th year. Free details.
OTTAWA MFG. CO., 5-027 Lawn Ave., Ottawa, Kans.

World's Biggest Power Tool Bargain

65 lbs. of REAL machinery. With Emrick 5-in-1 Shop you can turn, drill, saw, grind and sand. Handles BIG work. Complete only \$39.95 cash, or on Easy Time Payments. 10-Day FREE Trial. Write for FREE literature. **EMRICK, INC., 1502, Clinton Avenue, Kalamazoo, Mich.**



Get largest auto accessory & parts catalog in world. Over 15,000 items, including Hollywood accessories, hi-speed equipment, rebuilt engines; all parts & accessories for all cars, trucks. New, used, rebuilt! We have that hard-to-get part! Completely illustrated, jam-packed with bargains! Send 25c.
J. C. WHITNEY & CO., 1917 ARCHER AVE., CHICAGO 16



USE YOUR BEACH SAW
With Our six in. tool steel cutters. Make mouldings, casings, drop-leaf tables, grooves beading & jointing 1" wide \$1.75, 1 1/2" \$2.25. Postpaid. State size hole, List & folder free.
John A. Sandstrom, Rt. 2-D, Clearwater, Fla.

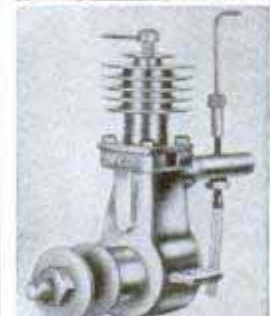

★ ★ ★ ★ ★ ★ ★ ★ ★ ★
OUR 244th ADVERTISEMENT
REAL DIESEL ENGINE!
\$2.95
You can't beat this price!
Ideal for planes, boats, midget cars
Actually runs at 7500 RPM, produces 1/7 HP
Precision machined for smooth operation
Comes to you completely assembled, ready for operation
MAYBE WE'RE CRAZY, giving away a precision diesel engine, complete with cylinder and piston, carburetor, crankshaft, connecting rod, etc. for **ONLY \$2.95**. But we're selling thousands of DEEZILS all over the world, and that keeps our production costs down. DEEZIL is streamlined, compact, rugged. Starts quickly, easy to install, runs for years! Fast delivery if you **ORDER DEEZIL TODAY!**
Send **\$2.95 plus 25c postage**
GOTHAM HOBBY CORP., Dept. P, 107 E. 126th St., New York 35, N. Y.

Lay Your Own Beautiful Kentile Floor .. Save Money!

Easy as ABC!

AS LOW AS
\$21⁷⁵
 FOR A 9' x 10' KITCHEN FLOOR
 (PRICES VARY WITH SIZE OF ROOM
 AND THE COLORS YOU CHOOSE)



**LAY KENTILE IN YOUR SPARETIME HOURS!
 ENJOY ITS BEAUTY FOR MANY, MANY YEARS!**

Your Kentile floor goes down so quickly...you lay it easily, tile by tile in any design or color combination you like! You can do a section of a room at a time and you can walk on Kentile as soon as it's down!

Your Own Designs! Now you can have the most beautiful floors...alive with color, and custom-designed by you alone! Yes, you can create your own floor design with Kentile...lay it quickly, easily, tile by tile!

Wears for Years! Each tile is pure tough flooring all the way through... no felt or other backing. Colors go all the way through, too...can't wear off!

Easy to Keep Clean! Kentile floors resist stains, soil. Stay clean longer. Need only occasional no-rub waxings to keep them beautiful.

Imagine the Money You Save! You can't buy a finer longer-lasting floor than Kentile for any money...and it costs so little when you lay Kentile yourself.

At Your Dealer's Now! Look under FLOORING in your classified phone book for the name and address of your nearest Kentile dealer.

FREE! COMPLETE INSTRUCTIONS AND COLOR CHART!
 Send for easy-to-follow self-installation instruction folder and complete color chart showing all Kentile's 23 lovely tile colors. Start planning your floor now! Write to David E. Kennedy, Inc., 58 2nd Ave., Brooklyn 15, N. Y.

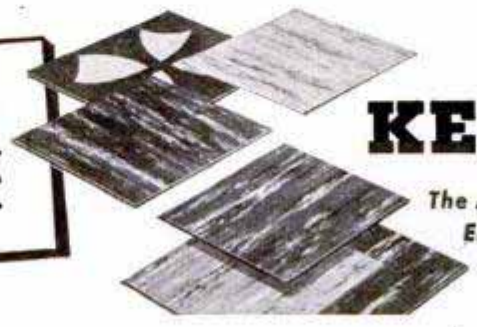

KENTILE®
 The Asphalt Tile Of Enduring Beauty 

HOME CRAFTSMEN AND HOBBYISTS!

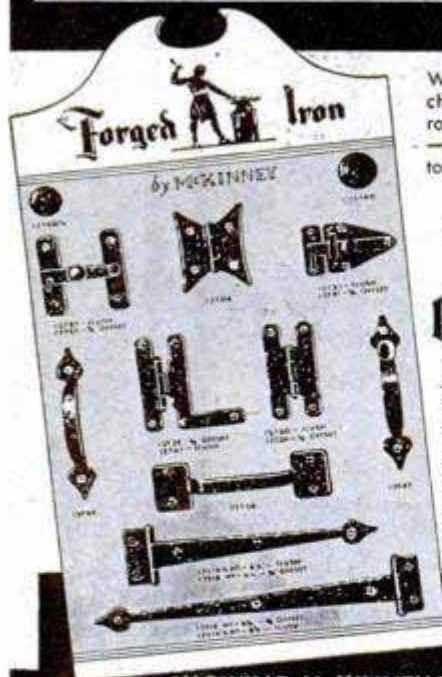

When you build cabinets, chests, furniture, remodel rooms, redecorate your home—add the distinctive finishing touch by using

McKINNEY

Forged Iron Cabinet hardware

Attractive authentic Heart pattern strap hinges, H and L hinges, latches, drawer pulls and knobs, etc. in dull black or Swedish iron finish. Buy them at your local hardware, lumber or paint dealer. Look for the McKinney display.

SEND FOR FREE FOLDER

SHOWING McKINNEY PERIOD PATTERNS AND SUGGESTED USES.

McKinney Manufacturing Company
1400 Metropolitan Street, Pittsburgh 12, Pa.

Please send free folder on McKinney Forged Iron Hardware to:

NAME _____

ADDRESS _____

CITY _____

STATE _____

PM _____

DO YOUR OWN
Calking
WITH Nu-CALK
SPEED LOAD
AND THIS NEW SPEED LOADER

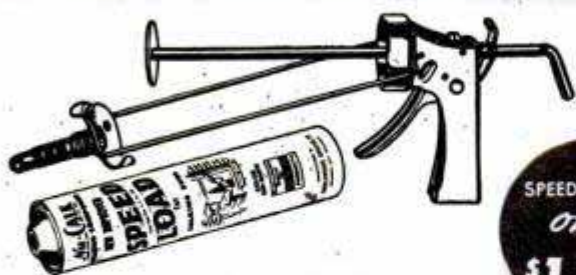

SPEED LOADER
only
\$1.95

Every home should be calked and here's the combination that enables you to do the job yourself. Just snap a Nu-Calk SPEED LOAD into the SPEED LOADER Calking Gun and you're ready to calk. You have an easy, fast, economical way to apply the world's finest calking compound.

Macklanburg-Duncan Co., Oklahoma City 1, Okla.



NO MAIL ORDERS
SOLD ONLY THROUGH LEADING
HARDWARE STORES, LUMBER YARDS
AND BUILDING SUPPLY DEALERS

WOOD FASTENERS



Don't split wood—Use amazing new "CHEVRONS"—A new type hardened steel fastener for wood joining—(miter joints). Scientifically designed to draw wood together eliminating doweling, mortising, nailing. Just drive in with ordinary hammer—"Presto"—A firm joint! No wobble, no distortion. Narrow surface outline of fastener lends artistic appearance. Can easily be countersunk and concealed with wood fillers. Permits planing of wood on all sides. Can be used in hard wood where others fail. Handy, easy-to-use for mill workers, artisans and HOME CRAFTSMEN for making and repairing screens, doors, sash, frames, cabinets, chests, furniture, moulding, etc. Hurry—Order now from your dealer or send Only 25c (no stamps) for box of 30, 3/8" depth, suitable for thickness of wood up to 1 1/4 inch, or send \$1.00 for our GIANT-Size box. NOW! Money back if not delighted.

E. B. PACKARD CO., Inc., Dept. PM3
139 CEDAR ST. NEW YORK 6, N. Y.
Dealers—Send for our folder "A."



CAPE COD CHAIRS TRELLISES • ARBORS DUTCH WINDMILLS

Chairs style B-C-A
PLANS 50c Ea., all 3
only \$1.00. 12 differ-

ent trellis designs PLAN of all 12 only 50c. Authentic 40" high Dutch Windmill Detailed PLAN only 75c. Unique 40" high Light-house having copper lantern, ideal for garden or on lake shore of summer home. Large detailed PLAN 75c.

SPECIAL ALL PLANS ABOVE \$3.00 VALUE ONLY \$2.50

SEND 10c for catalogue of many fine projects.

Dept. P14

CRAFTSMAN'S MODEL CO. DELAFIELD, WISCONSIN

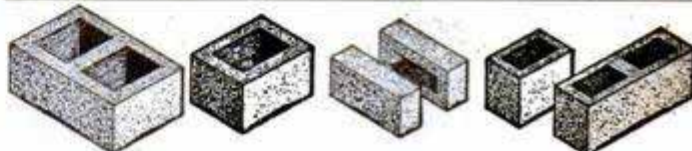

Make Concrete Blocks and Bricks

New superior method makes square, true, easy-to-lay units which will pass any building code. Small investment, high production, big profits. One \$30.00 machine will make four 5"x8"x12" blocks per minute—1000 per day. Pays for itself in a few days. Sell blocks or save 2/3 building cost by making and laying your own.

POST CARD BRINGS FREE FOLDER

Economy Manufacturing Company
Dept. P Stone Mountain, Georgia

CARBURETOR TOO RICH MAKES MOTORIST TOO POOR



Car owners who are wasting money and not getting proper gas mileage due to over-rich mixtures will be pleased to learn how to save gasoline by VACU-MATING over-rich mixtures. VACU-MATIC fits all cars, trucks and tractors. It is automatic and operates on the supercharge principle. Easily installed in a few minutes.

SALESMEN WANTED! Big Profits!

Send name, address on penny postcard for free particulars and how to get yours for introducing.

VACU-MATIC CO., 7617-1566 W. State St., Wauwatosa, Wis.

BUILD YOUR OWN REVERSE CYCLE SYSTEM

Heat and Cool Without Fuel

Complete blueprints for building your own residential Reverse Cycle heating and cooling system are now available. One unit both heats and cools. Send for free information.

Blueprints, **\$10.00** ppd.

WEST COAST TRADES INSTITUTE

745 N. RUSSELL ST.

PORTLAND, OREGON

WAR SURPLUS AND OTHER BARGAINS



HYDRAULIC UNIT! VICKERS PF9 & 2 1/2 HP EMERSON PUMP & MOTOR

Small powerful pump rated 1500 P.S.I., 3750 R.P.M., Rotation changed by reversing flow. Pump capacity: .208 cu. in. per rev. Type D50EZ-218 Emerson Motor 24 V., D.C., 4000 R.P.M. Govt. Cost, complete unit, about \$285, pump \$85. Our price, while they last—Complete Unit, Motor and Pump, New . . . **\$29.75**
Hydraulic Pump only, New **\$13.95**

MICROMETERS Chrome plated, precision engineered and carefully tool to give long life. All new
0-1" cap. each **\$2.25**
1-2" capacity each **3.50**
2-3" capacity each **5.50**
3-4" capacity each **6.50**

HIGH SPEED DRILLS
All New. Fractional & numbered. Orig. Val. \$15. Nationally known brand. Ast. sizes. Set 30, **\$3.50**



ELECTRIC BELLS—Vibrating type, high pitch. 115 V., 60 Cycle. Ideal for use indoors or outdoors—on ranches, for schools, plant installations, as signal systems, burglar alarm systems, etc. Nationally known Mfr. ALL NEW in orig. Pkgs. Solid brass clapper & 8 1/2" gong. Wt. 8 lbs. Govt. cost about \$67.50. **Close out at . . . \$7.95**
Send check, money order or cash. 25% deposit required on C.O.D. orders. All prices F.O.B. Culver City, Calif.
Send 25c for illustrated Catalog.

AIRBORNE SALES CO., INC. DEPT. PM 3-0
CULVER CITY, CALIF.



Start Quickly BIG MONEY ROLLING WITH LIFE CHARGE

MAKE PLEASANT, DIGNIFIED CONTACTS
The MIRACLE Chemical that helps Batteries stay AUTOMATICALLY charged. Adds Months of useful service. Eliminates freezing, overheating and cable corrosion. Revives old Batteries. Saves time and money for user. **EAGER BUYERS EVERYWHERE!** Fleet owners, garages, service stations and individuals all buy. **FOUR EASY SALES A DAY NETS YOU \$144.00 WEEKLY!** Advertising and Promotional Material free. Sold on satisfaction guaranteed or money back plan. Send \$1.00 for special sample offer enough for two batteries, or write for free details. **GET IN THE BIG MONEY FIELD! DO IT NOW. DON'T DELAY...WRITE TODAY!**

BATTERY CHARGE PRODUCTS COMPANY
728 W. Peachtree Street, Dept. M Atlanta, Georgia

HEAVY CAST ALUMINUM BLOWER, NOW ONLY \$9.75

SINGLE EXHAUST BLOWER, DELIVERS APP. 100 CFM. For workshops, labs, kitchens, refrigeration, air conditioning. Ready to install yourself with any household tools. 110V AC 50-60 cycles cont. duty motor.
DOUBLE EXHAUST BLOWER—with 2 housings on extended shaft motor. Now only \$15.
Also **LARGE 275CFM BLOWERS.**
DUST-O-VAC—Picks up & backs shavings and dust from all machines, for home workshops & industry, only **\$19.95.**
FREE Literature. Send check, M.O. All shipments F.O.B. Yonkers, N. Y. Pay postman delivery charges.
UNIVERSAL YONKERS CORP., (M3) 137 Alexander St., Yonkers 2, N. Y.



MAKE YOUR OWN!



Griffin READCUT LEATHER PROJECTS

Over 100 KITS in every kind of Tooling and Carving Leather, accurately cut, all parts included Only Top Grade Leathers used You do the choosing You do the tooling, carving, stamping, the punching and assembling

SEND FOR COMPLETE CATALOG
Please send 10c to cover mailing.

EVERYTHING FOR THE LEATHER WORKER

Largest, most complete stock of Leathercraft Tools and Accessories in U.S.A.
HIDES AND SKINS of Craft Leathers of every kind if you prefer to cut your own.

SINCE 1924
OUT OF THE WEST, THE HOME OF LEATHER CARVING
Griffin Craft Supplies
5626-A TELEGRAPH AVE.
OAKLAND 9, CALIFORNIA

Do Nearly Every Round-the-House Job...



**FASTER..
EASIER...
BETTER...**
with this amazing



DRILLS



POLISHES



GRINDS

\$44⁵⁰
for real quality

You can't find a more useful tool for jobs about the house, shop and garage than this sensational Guild Combo-Tool. By simply changing attachments on this light, vibrationless tool you can do the widest variety of jobs imaginable. You can grind, sand, sharpen, drill — even through steel. You can remove rust, cut stone, polish everything from your car to the brass candlesticks. You can remove paint — or mix it — and do every job quickly, easily, professionally. Makes your wife's tasks easier, too — takes the drudgery out of scouring, polishing floors and furniture. Mounted on a bench stand (see picture below) the Guild Combo-Tool makes a perfect wheel grinder and buff.



These are only a fraction of the countless jobs made easy by this power-packed little tool. You can do almost a week's work in a day with it. No gadget this — but a heavy-duty, production tool that will give you years and years of service because it's precision made. Try one today at your hardware or tool supply dealer. May be purchased separately or in your choice of three versatile kits full of attachments.

Attached to a Guild Bench Stand (\$1.50) the Guild Combo-Tool becomes the handy **WHEEL GRINDER.**

Other Guaranteed Guild Electric Tools



Saw



Belt Sander



Hedge Shear



Bench Belt Grinder

Send me literature on Combo-Tool and other Guild tools for home shop. Also, name of my nearest dealer.

Name.....

Address.....

City.....State.....

PORTER-CABLE MACHINE COMPANY
2283 N. Salina St. Syracuse 8, N. Y.

SURPLUS AIRCRAFT—HYDRAULIC BARGAINS

UTILITY ITEMS FOR FARM—SHOP—INDUSTRIAL



1. **PUMP**, hydraulic, Genuine Vickers, constant displacement; 1000 psi, self priming, 400 gph at 3750 rpm. Precision piston design; has 5/8 inch ports. Original cost over \$100. Shipping weight 8#; now priced at only **\$9.95**
 2. **MOTOR**, hydraulic, Genuine Vickers; 1000 psi, 3750 rpm. Both left and right rotation; operated by Vickers pump illustrated above. Has flat 7/16" shaft. Shipping weight 8#. **\$12.95**
- (Both items, pump & motor for only \$19.95)
3. **PUMP**, hydraulic, Pesco, gear type, 1000 psi, app. 2000 rpm. Shipping weight, 7#. Has flat 1/2" shaft, now only **\$9.95**
 4. **PUMP**, hydraulic, hand operated, 1000 psi, built-in check valve, good used condition. Shipping weight, 8#. **\$8.95**
 5. **PUMP**, fuel, Chandler-Hill marine; fits Hall-Scott engines. Flat 1/2" shaft. Unused, part #312843, ship. wt. 5#. **\$4.95**
 6. **PUMP**, oil, for Marine Hall-Scott engines (actually 2 pumps in one). Has 2 outlets, 2 inlets, 1 shaft. Pt. #321279, Shipping wt. 15#. **\$9.95**

FOUR WAY CONTROL VALVES For Operating Two-Way Cylinders

7. **VALVE**, #580, 1000 psi, positive lever type actuation. App. 2 1/2"x4"x2 1/4" size, center position neutral, 1/4" pipe ports, shipping weight 3#. Now only **\$12.50**
8. **VALVE**, #101, 1000 psi, rotary shaft actuation, app. 2 1/2"x2 1/2"x2 1/2" size, 1/4" ports, shipping weight, 2#. **\$9.50**
9. **VALVE**, dual, 4 way for operating two 2-way cylinders, #986, double rotary shaft actuation; app. 3 1/2"x2 1/2"x4" size, shipping weight 6#. **\$19.50**
10. **VALVE**, 2-way, plunger type, operates by push button; normally closed, standard tube fittings, Shipping weight 2#. now only **\$2.50**
11. **ACCUMULATOR**, hydraulic, app. 6" diameter, good used, shipping weight 8#. Now **\$8.95**
12. **FILTER**, oil, Cuno, self cleaning by turning handle **\$3.95**
- FILTER**, oil, Purolator, self cleaning by turning handle, used **\$2.95**
- FILTER**, oil, Cuno, large size, 4"x8" size **\$8.95**
13. **VALVE**, relief, Hydraulic; range 500 to 800 PSI (set at 700) range 1250 to 1500 PSI (set at 1250). Your choice either, only **\$2.95**
14. **CYLINDER**, #403, OD diameter 1 3/4", stroke 3 1/4" overall length open 13", ship. wt., 5#. now **\$5.95**
15. **CYLINDER**, #915, OD diameter 1 3/4", stroke 2", overall length open 16", ship. wt., 5#. now **\$6.95**
16. **CYLINDER**, #115, OD diameter 2", stroke 4 1/2", overall length open 18", ship. wt., 7#. now **\$9.95**
17. **CYLINDER**, #104, OD diameter 1 5/8", stroke 9 1/4", overall length open 24 1/2", ship. wt., 7#. now **\$12.95**
18. **CYLINDER**, #580, OD diameter 2 1/2", stroke 7 1/2", overall length open 28", ship. wt., 11#. now **\$15.95**
19. **CYLINDER**, #401, OD diameter 1 3/4", stroke 2 5/8", overall length open 6", ship. wt., 13#. now **\$17.95**
20. **CYLINDER**, #402, OD diameter 4", stroke 18", overall length open 46", ship. wt., 45#. now **\$29.95**
21. **BOMB HOISTS**, 2000 pound capacity, drum type, 20 to 1 ratio, app. 20 foot 1/4" aircraft cable, good used condition, shipping weight 22#. without mounting bracket. **\$20.00**
- shipping weight app. 35#. **\$22.50**

ALL ITEMS FOB: SEND CHECK OR MONEY ORDER.
25% DEPOSIT ON CODs.

SOUTHWEST AERO SUPPLY, 8102 Lockheed Houston 17, Texas

★ ROTADRILL

The new rotating twist-drill stand that keeps your bits where they should be—RIGHT ON THE DRILL PRESS. Perched in the top of the column, your bits are always at finger tips, never misplaced. Stand rotates for quick selection and can be lifted off for use at the workbench. Fits any popular home workshop drill press having a 1 1/2" or 2 3/8" in. inside-dia. column. Cast in aluminum, stand comes drilled to hold a complete set of 29 drills, 1/16 to 1/2 in. Only **\$3.00**, plus 20c postage.



STANDARD PARTS CO., P. O. BOX 6211, CHICAGO, ILL.

ACE TOOLS



Be permanently tool-ed-up for every operation on your Metal Cutting Lathe.

No. 8-A Ace Tool Set for 9" and 10" Swing Lathes—fits shank size 3/8" x 3/4" Includes Turning, Cutting-off, Boring, Knurling and Threading Tools with high speed cutters, blades and wrenches. 8 complete tools in fitted steel case—nothing else to buy. See your local dealer or order direct.

ARMSTRONG BROS. TOOL CO.
5268 W. Armstrong Ave., Chicago 30, Ill.

\$24.25

MAGNETS OF ALL TYPES—10c UP

AMAZINGLY POWERFUL!!

8 oz. Alnico Magnet, lifts 10 lbs. \$1.00. Our Leader, 15 oz. Magnet, lifts 40 lbs. \$2.50. New alloy—will not weaken! Useful for lifting valuables from tanks, lakes, or rivers easily! 7 small magnets \$1.10 with list of many shop and home uses. Satisfaction guaranteed.

R. EYRICH, 2566 N. 49TH ST., MILWAUKEE 10, WIS.

BUILD 3 Rm. HOUSE FOR \$500



Long lasting, good looking, insulating. Garages and barns built for as low as \$50.00 with our methods. 100 illustrations and 100 ways to save money and labor. Get this book before you start to build. Guaranteed, \$1.00.

SHEET METAL COTTAGES and other buildings. Several new methods. Illustrated instructions, 50c.

FURNITURE OF COMPOSITION. Cement, sawdust, asbestos, etc., scrap wood, metal, etc. Illus., 50c.

SHOP MACHINES FROM OLD AUTO PARTS: Over 60 described, 50c.

HOME MFG. ENTERPRISE. 50 home shop projects. Illus., 50c.

Special: All five booklets described above, \$2.00 postpaid.

HOME INDUSTRIES, 1116 So. 27th St., Dept. P3, Omaha 5, Nebr.

SAY YOU SAW IT IN POPULAR MECHANICS

BUILD AN ARC WELDER FROM OLD GENERATOR

For Light or Heavy Work. 75-200 amps. No previous experience needed. Complete PLANS and valuable Catalog 35c.

LEJAY MANUFACTURING CO.
1347 LeJay Bldg., Minneapolis 8, Minn.



CONVERT HAND MOWERS TO POWER MOWERS

Takes less than 3 hours

The Handy-Dandy Lawn Mower Kit fits any hand mower from the 16 to the 20 inch size. Complete with all necessary parts. Kits can be purchased separately, complete with engines or complete with Pennsylvania mower.



Also manufacturers of a complete power mower and garden cultivator attachments.

DEALERS WANTED

LE CLAIRE MFG. CO., Le Claire, Iowa, Dept. PM

AMERICA'S MOST-WANTED SMALL TRACTOR!



SEE THE POWERFUL S-H.P. GRAVELLY—

the world's finest, yet most moderately priced Garden Tractor. Complete line of exclusively designed power tools for every Garden, Lawn and Field job.

GRAVELLY TRACTOR

FIELD-TESTED FOR 27 YEARS

MAIL NOW! FOR NEW FREE BOOKLET!

GRAVELLY MOTOR PLOW & CULTIVATOR CO
BOX 363 DUNBAR, W. VA.

NAME _____

ADDRESS _____

TOWN _____ STATE _____

SOLVING YOUR LAWN & GARDEN PROBLEMS



NOW *Martin* MASTER MOTOR
CRAFTSMEN GIVE YOU YOUR CHOICE OF 4
**"Best Outboards
Ever Built!"**

MARTIN "100"
10 H.P. Twin

MARTIN "60"
7.2 H.P. Twin

MARTIN "40"
4½ H.P. Twin

MARTIN "20"
2½ H.P. Single

MARTIN MOTORS
are priced from
\$99.50
F.O.B. Factory

BEST FOR SPEED . . .

BEST FOR TROLLING . . .

Best because every MARTIN MOTOR is "Performance Tested" to assure *perfect performance* at all speeds! Among the many exclusive MARTIN MOTOR features are: ✓ Improved mechanically-controlled poppet valves ✓ "Aquamatic Control" ✓ Full 360 degree steering ✓ Vertical stern adjustment ✓ "Depend-A-Pull" starter ✓ Centralized, streamlined controls ✓ Matched, diamond-bored connecting rods ✓ Improved carburetion and cooling systems and many others . . . exclusive features that have made MARTIN MOTORS "The New Standard of Performance."

FREE! Beautifully illustrated booklet packed with complete news about the 4 NEW "Best Outboards Ever Built" and the name of your nearest MARTIN MOTOR dealer. Write: MARTIN MOTORS, Dept. 507, Eau Claire, Wis., today!



MARTIN MOTORS, Division of National Pressure Cooker Company, Eau Claire, Wis.
Canadian Sales by: MARTIN MOTORS, Division of National Pressure Cooker Co. (Canada) Ltd., Wallaceburg, Ontario.

**ZIP through
hobby projects,
home repairs**

**. . . with this low cost Duro
8" Ball Bearing Table Saw**

This precision saw may easily double your woodworking skill and enjoyment. You'll be able to cut mitres, simple and compound angles, do ripping and cross-cutting and many other operations with "professional" ease and accuracy. Its many features and advantages include: rugged cast iron table and base; spindle mounted on New Departure ball bearings; super size 20¼" x 25" work table; maximum cut of 2¼" at 90°; dual lock safety rip fence; exclusive rubber cushioned anti-kickback; mitre gauge with adjustable cut-off rods; safety blade guard—plus many other features you'd expect to find only on high priced saws!

Duro's thirty years of building precision tools makes possible "today's greatest power tool values."



**H3012-8" Ball
Bearing Table Saw
with extension**

Write for **FREE** illustrated catalog of new 1950 Duro precision-engineered, *economy-priced* power tools. Shows complete Duro line—saws, drill presses, jointers, lathes, sanders and accessory tools.

Duro Metal Products Co.
2676 N. Kildare Ave.
Chicago 39, Ill.

Duro Metal Products Co.
2676 N. Kildare Avenue
Chicago 39, Illinois

Gentlemen: Please send me details on your new 8" table saw . . . also the complete new Duro Power Tool Catalog.

Name _____

Address _____

City _____ Zone _____ State _____

PALMGREN



No. 000 ANGLE VISE
For MILLING—DRILLING—GRINDING
FITTING—FILING
Solve Difficult Angle Jobs

Quick, accurate set-ups at any angle. End make-shift methods—time loss—rejections. Ideal for tool rooms or home workshop. Accurately machined and graduated. Once set it stays locked. Jaws of steel—2 1/2" wide, plain or grooved. PRICE \$12.05 complete with Swivel Base—Vise only \$8.75. Write for other styles and sizes.

DRILL PRESS VISES

For tool room, machine shop, school shop, home shop or repair shop. Accurately machined. Best semi-steel castings. Adjusting screw of hardened steel with fine pitch thread and long bearing. Jaws of steel, grooved or plain. Sizes 1 1/2" — 2 1/2" — 4" Jaws.



No. 6
1 1/2" GROOVED STEEL
JAW. \$3.30.

No. 83 ROTARY TABLE with . . . DUAL CROSS FEED and ROTARY FEED



Has 8" Circular Table with full 360° movement and 4" crossfeed travel. Free moving adjusting wheels and dials graduated in degrees. Crossfeed adjusting screws have Acme threads with adjustable dials graduated in thousands. Four slots in base, and key slots for bolting to table.
No. 83 Rotary 8" Table . . . \$49.50
No. 82 Dual crossfeed—with-out rotary . . . \$39.75

IMMEDIATE DELIVERY Write for Circular No. 12 — Order from dealer or direct postpaid if he can't supply.

CHICAGO TOOL AND ENGINEERING CO.
8365 South Chicago Avenue Chicago 17, Illinois
Telephone — Saginaw 1-9675

PAGE Garden Tractor

Catalog sent free. **WRITE TODAY FOR YOURS!**

PAGE DOES IT FASTER — EASIER!

WITH WALKING AND RIDING MODELS
New 1950 line with extra features, for spring plowing and dozens of other uses the year 'round! Riding and walking models, 2 to 6 HP. Complete gear drive with reverse, no cheap belts or chains. Large tires — easy to handle — power turn. New reduced factory prices, \$188 to \$440, with cultivator. Get benefits of our 25 years' experience!

FREE CATALOG SHOWS ALL ATTACHMENTS

PAGE DAIRY and FARM EQUIPMENT

1904 S. 81st Street • Milwaukee 14, Wis.

7x50 PRISM BINOCULARS
PRECISION OPTICS—BRAND NEW
\$36*

6x50 ACHROMATIC FIELD GLASSES \$16*

*20% Federal Tax
Send for Free Catalog of Binoculars, Telescopes and Microscopes

BROWNSCOPE CO.
Dept. 3M, 24 W. 45th St. New York 19, N. Y.

7x50 \$36 Illustrated

INTERLOX.. THE TELESCOPIC WOOD RULE!

\$2.00

An accurate measuring tool with all the sturdiness and utility of a folding rule . . . plus the convenience of split-second direct reading inside measure. Exceptionally smooth, fast action for all measurements saves time every time.

Each stick slides easily and securely with overlapping telescopic action at the touch of a finger . . . locks automatically into measuring position. INTERLOX is made entirely of the finest straight grain maple finished with glass hard lacquer for permanent legibility. Fittings are of solid brass.

INTERLOX is the aristocrat of wood rules. See it at your local dealer . . . or use the coupon to order by return mail.

MASTER

REG. U.S. PAT. OFF.

WOOD AND STEEL TAPE RULES

MASTER RULE MFG. CO. INC. PH 5
201 Main Street, White Plains, N. Y.

Please send by return mail (How Many)
INTERLOX Rules at \$2.00 each. I enclose \$

NAME

ADDRESS

CITY STATE

CASH IN YOUR SPARE TIME

MAKE BIG MONEY IN OWN BUSINESS
EXPERT SAW GRINDERS Earn BIG MONEY. Easy to learn. No experience required. All instructions furnished. Sharpen circular saws for woodworkers, lumber yards, farmers, others. New BELSAW Powered Saw Gumming Machine does fast, precision work on all saws 6 to 48-in. diameter with 1-2 to 2-in. arbor holes. Quickly pays for itself, lasts a lifetime. Send postcard for FREE Catalog.

BELSAW MACHINERY CO
G370 Field Bldg., 315 Westport Road, Kansas City, Mo.

BATTERIES! — START

—a factory at home and re-cast junk batteries into new; latest achievement. We supply complete instructions and everything needed. Big Profits!

BATTERY LABORATORIES, Dept. PM, Minneapolis 4, Minn.

SAVE \$55.00 ON THE PRICE OF THIS VERSATILE HEAVY DUTY TOOL!

1/4 H. P.
115 v. AC-DC motor
4200 R. P. M.

ONLY \$42.50 Direct from mfr.

Get this bargain now! Limited offer from surplus stock. No "catch." Brand new A-1 Spinner. Send check or M.O. today. (No C.O.D.) Money refunded within 10 days if not satisfied.

CALIFORNIANS ADD 3% STATE SALES TAX

HOLT MFG. CO., 272 BADGER AVE., 651 20th STREET,
NEWARK 8, N. J. OAKLAND 12, CALIF.

In a
tight spot?
"YANKEE"

Offset Screw Driver
Drives . . . draws screws
in close quarters!

Get 'em out or drive 'em easily in tight places with a "Yankee" Offset Ratchet Screw Driver! Lever action gives more power than a regular 8" screw driver. No. 3400 illustrated has $\frac{1}{4}$ " and $\frac{3}{8}$ " blades for slotted screws; other models for Phillips Recessed Head Screws. At your Stanley dealer's. Write for free "Yankee" Tool Book.

"YANKEE" TOOLS
NOW PART OF

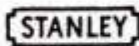

THE TOOL BOX
OF THE WORLD

NORTH BROS. MFG. CO., Philadelphia 33, Pa.

BUILD YOUR OWN POWER LAWN MOWER

WHY BREAK YOUR BACK
MOWING FIELD OR LAWN?

WRITE
FOR
FREE
Building
Instructions
The Rite-Way
Mower
Attachment
Ball Bearing

SAVE MONEY
SAVE TIME

Now anyone can save time and effort mowing field or lawn by building their own whirl type power mower. Build according to your own ideas and needs at small cost. Cut close to fences, walks, buildings, etc. Build in short time with parts and instructions we furnish. Save hours of time and back breaking labor.

IT'S FUN TO BUILD

WRITE TODAY FOR FREE INFORMATION

T & H MFG. CO., Dept. MPB-3
811 E. 31, Kan. City 3, Mo.



\$4.95 REAL ENGINE VALUE

A miniature gas engine that really operates. Thousands of Buzz "B" gasoline engines have been sold at twice the price. Now is your chance to buy a real 1/6 H.P. gas engine for only \$4.95. Turns up over 8,000 r.p.m. For boats, planes, midget cars, etc. Guaranteed and ready to run. Includes Champion spark plug and tank. Send only \$1.00, engine shipped collect for balance, same day.

WRITE FOR FREE CATALOG OR
SEND 10c FOR NEW MAMMOTH ILLUSTRATED
CATALOG OF THOUSANDS OF HOBBY ITEMS.

America's Hobby Center, Inc., Dept. B-30, 156 West 22nd St., N. Y. 11



**2
DRILLS
IN 1**

This attachment gives you two drills in one. It converts any $\frac{1}{4}$ inch electric drill to $\frac{1}{2}$ inch capacity. Reduction gears reduce the drill speed 5 to 1, the average speed of a $\frac{1}{2}$ inch drill, and thereby increases the power. Absolutely indispensable for all shop work and home craftsmen. Satisfaction guaranteed. Order yours now.

Send check or Money Order with order.
Jobbers write for special information.

\$11.95
post paid

G. M. CO. MANUFACTURING, INC.
1308 43rd AVE. LONG ISLAND CITY 1, NEW YORK



Earn
\$150 to \$300 extra
profit monthly with
Hobart Simplified
Arc Welding

Own Your Own Business on
"Pay Out of Earnings Terms"

With good, up to date, ample capacity welding equipment, you can get the big pay jobs that saves customers costly replacement parts and expensive delays.

The new Hobart Arc Welders make you independent of any electric company or power supply. Gasoline engine driven, electric self-starting and auxiliary power, if you wish, for making your own current for lights, tools, motors, etc.

You can quickly get into big paying welding service with practically no outlay on your part. There is a size and model suitable for all welding requirements in AC Transformer or DC Generator equipment—or you can save \$300 to \$500 by building your own arc welder, using the Hobart Generator Only and belt or coupling to a used gas engine. Free catalog and data. Write today.

Easy "Pay out of Profits" terms

Helps you get started now with minimum cash outlay

REPAIRS . . . auto-
motive, farm tools,
machines, anything
metal.

CONSTRUCT . . . scaf-
folding, benches, etc.

CONTRACT WORK . . .
Be busy year 'round on
good paying jobs.



Free
Booklet gives all
details. Write for
yours today!

HOBART Brothers Co., Box M-30
Troy, Ohio—
"One of the world's largest builders of arc welders"



Motor Oil Changes

ENTIRELY UNNECESSARY
after attaching

RECLAMO The World Famous
HEATED Oil-Filter
(Cast Aluminum) and Re-Refiner!!

Makes short work of solids and liquid impurities—after 150 miles you won't believe it's the same oil! REMEMBER—"Oil does not wear out mechanically", states U. S. Bureau of Standards. Convince yourself—just read our "Oil Facts", 32 pages, FREE on request.

RECLAMO MFG. CO.
5083 Elston Ave., Dept. 25, Chicago 30, Ill.
Dealers Wanted

Vapor Outlet
Oil Return (to crankcase)
Heat Inlet (from manifold)
Heat Outlet
Oil Inlet

Experienced Craftsmen Say:
"YOU CAN'T FINISH WITH A DISC SANDER!"

The disc sander is excellent for roughing, hogging off, removing paint, and for other coarse sanding. But any experienced craftsman will tell you that these same characteristics prohibit its use for finishing, because of swirling, scorching, gouging and other blemishes caused by the disc sander's high speed.

OSCILLATING MOTION IS THE *only* MOTION FOR A PERFECT FINISH!

THE DU-FAST* SANDER AND POLISHER produces quick, easy, perfect finishes at low cost. It requires no special skill or knack. You get an industrial type finish on wood, metal, plastics, plaster and composition materials the first time and every time you use DU-FAST! USE DU-FAST TO REMOVE DISC SWIRLS.

Model BDHU 1 attaches in seconds to either the Home Utility 1/4" Electric Drill or the Home Utility 5" Disc Sander-Polisher. (Products of Black & Decker Mfg. Co.) Model SK*1 fits the Skil Home Shop 1/4" Electric Drill manufactured by Skilsaw, Inc.



ONLY
\$14⁹⁵

(Attachment)
 (Either Model)

*Not Applicable

DU-FAST SANDERS ARE AVAILABLE
 AT ALL BETTER HARDWARE DEALERS

Manufactured by
DU-FAST, INC.
 32 EAST FOURTH STREET, NEW YORK 3, N. Y.

WE FURNISH ALL MACHINED METAL PARTS, EVERY SCREW,
 NUT, BOLT, WASHER, AND COMPLETE PLANS FOR THIS...

BIG 10" POWER SAW

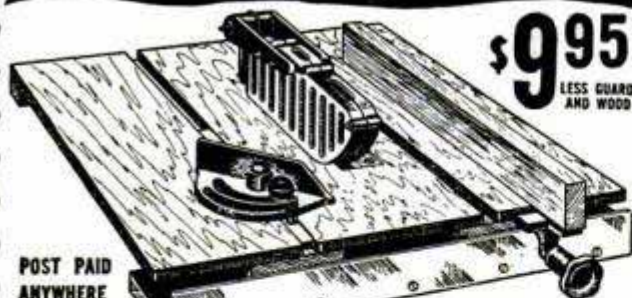

\$9⁹⁵
 LESS GUARD
 AND WOOD

POST PAID
 ANYWHERE
 IN U.S.A.

FULL \$9.95
 REFUND IF
 NOT SATISFIED
 WITHIN 10 DAYS

ASSEMBLE IT YOURSELF WITH
 SIMPLE HOUSEHOLD TOOLS!

TABLE 24" x 20" • TILTS TO 45°
 CUTS 0" TO 3/4" DEEP • TAKES 10" BLADE

COMPLETE PLANS (WITHOUT PARTS) 10c

MARCUS • POLLAK DEPT. 44
 ROYERSFORD, PA.

PRESTO! ANYONE CAN MASTER GLAZE



LEAVES HARD GLASS-LIKE FINISH
 EASY TO APPLY
 PROTECTS THE SURFACE
 NO SMEAR OR STREAKS AS WITH WAX
 LASTS SIX MONTHS TO A YEAR
 SEALS THE PORES OF THE SURFACE
 WILL NOT FINGER-MARK
 NO OILY FILM AS WITH POLISH
 EASY TO KEEP CLEAN

SAVED YOU MONEY

Car Owners! Meet Master Glaze—the sensationally different luster for new and used cars! Not a wax—not an oil polish—not a paint!—nothing that “smears” over the surface.

MASTER GLAZE is a unique discovery—a creamy liquid—quick and easy to apply! Gives a hard, glass-like surface. Even gasoline cannot dull it! Lasts six months to a year! Amazing luster—beautiful, sparkling clean and brilliant! Doesn't finger-mark—doesn't smear! A match box full glazes an entire car. Seals the pores—protects! NOTHING LIKE IT!

FREE SAMPLE

Just send your name and address to
MASTER GLAZE CO., 7720-682 W. Harwood Ave., Milwaukee, Wis.

GET HIGH COMPRESSION!

IN YOUR 1939-48 FORD V-8 or MERCURY

with **ROCKET** Cylinder Heads

CAST IRON



7.5 and 8.5 to 1 compression ratio. Increase horsepower and gas mileage 20%. Dodge and Plymouth 1935-48—7.5 to 1 compression ratio, \$39.50 ea. Write for details.

\$39.50
 PER PAIR

WESTERN SALES & MFG. CO.
 2229 So. Maple Ave., Los Angeles 11, Calif.

HULL AUTOMOBILE COMPASS

Best Friend in the World
 WHEN YOU NEED IT

Beaconlite illuminated \$5.95 Streamline standard \$3.95

At your dealer's. Write for literature.

HULL MFG. CO., P. O. Box 246-D3, Warren, Ohio



DRAINS CELLARS, WASH TRAYS CIRCULATES OIL



Pumps 1800 GPH 300 gal. 30' high, use 1/8 to 1/2 HP motor. Will not clog. **\$6⁵⁰**

Postpaid if cash with order. (Add 50c for west of the Mississippi.)

Thousands in use since 1936

LABAWCO PUMPS, BELLE MEAD 7, N. J.

Take the **work** out of

Gardening—

WITH THE *Little Farmer* POWERED CULTIVATOR

COSTS LESS THAN \$100.00

At last, an effective powered cultivator in the low-price field. LITTLE FARMER is ideal for city or farm garden use. Compact design and fine balance make it easy to operate. Just right for narrow rows where large equipment may damage plants. Write NOW for complete information. Dealer inquiries also invited.



The Will-Burt Co. ORRVILLE, OHIO
 Department P

BRICKRETE

Local Manufacturing of this Modern Masonry Has High Earning Power

Several hundred territories are being opened up for local Brikcrete manufacture by men of vision and aggressiveness. Brikcrete ties in with today's huge building program. Makes possible better construction at lower cost. Truly better than brick; actually cheaper than lumber. Combines strength, safety, insulation value, colorful beauty that fits today's styling.

Brikcrete is made in locally owned plants, using local materials and local labor. That's why high quality and low price still permit a 100% to 150% mark-up. We supply complete equipment; easy terms if required. Generous co-operation. Exclusive manufacturing privileges in protected territory. Write for information.
Brikcrete Associates, Inc.
4679 Division Ave. S
Grand Rapids 8, Mich.



**SERRATED JAWS FOR
POSITIVE GRIP**



**Only
Locking Plier
with All These Features**

A plier, wrench, clamp; 1000's of uses in garage and home. Heavy pressed steel body, rugged tool steel, replaceable jaws. 7" size, \$1.75; 10", \$2.25 (10% higher, Denver & West). At dealers everywhere.

SEYMOUR SMITH & SON, Inc.
900M Main St., Oakville, Conn.
Quality Tools Since 1850

**SEYMOUR SMITH
"Snap-Lock"
PLIER-WRENCH**

**ALL-NICKEL
FINISH**

**CAPACITY
INDICATOR**

**INSTANT
LOCK
RELEASE**

More Fish! More Fun!

WITH *Shakespeare*

WONDEREEL



**Long Casts
No
Backlash**

**NO THUMBING →
3-WAY SPIN CONTROL
is the Reason!**

This Shakespeare Wonder reel exclusive feature prevents backlash, gives you long, perfect casts without even thumbing. The reasons are:

1. Oversize tail end bearing 2. Adjustable head end spool cap 3. Lightweight spool for easy starting, quick stopping.

This means spool starts easy, stops fast, line doesn't outrun bait. No backlash "birds nests" to untangle. You cast more times, have more fun, catch more fish. In three models:

No. 1920—\$10.00 No. 1921—\$11.00 No. 1922—\$13.50



BOTH FREE—1950 Tackle Book and Fishing Calendar—Show best days to fish, best ways to fish, best rods, reels, lines, bait. Mail coupon!

Shakespeare

RODS, REELS, LINES, BAIT

Shakespeare Company, Dept. PM-3
Kalamazoo 2, Michigan
Send me your free 1950 Tackle Book and
Pocket Fishing Calendar.

Name.....
Address.....

HONOR BUILT SINCE 1897

M-SCOPE TREASURE -MINERAL LOCATORS

WRITE FOR FREE, ILLUSTRATED 16-PAGE BOOKLET

M-Scope Treasure-Mineral Locators, Geiger Counters. New Low Prices, unsurpassed in efficiency. Full factory guarantee. Immediate shipment.

YOU CAN PURCHASE THESE INSTRUMENTS ON A MONTHLY PAYMENT PLAN



URANIUM

FISHER RESEARCH LAB., INC., PALO ALTO, CALIF.

GOLD



BUY the BEST — Buy

Darra-James POWER TOOLS



SEND FOR FREE BROCHURE NOW

TOOLKRAFT CORP., SPRINGFIELD, MASS.

DEPT. M5: Rush Darra-James Brochure!

NAME

ADDRESS

CITY STATE



Ride
Anywhere
for LESS!

75 MILES
PER
GALLON

No wonder you see so many Cushman's, everywhere! Thousands ride 'em because they're so Amazingly Economical! Think of getting 75 miles to the gallon! Cheaper than shoe leather! Far less than bus fare and no long waits.

Even more impressive is Cushman's advantage in traffic—its ease of handling, fast get-away, its ability to slip in and out of narrow places. You get there quicker and easier—then, you park anywhere! Wonderful for getting to work, school, market, doing errands, making deliveries. Dependable, safe, comfortable. Powered by famous long-life Cushman "Husky" engine. Powerful quick-acting brakes.

FREE See your Cushman dealer for demonstration of new 1950 models. Or, mail card to Dept. M3

DEALER
INQUIRIES
INVITED

CUSHMAN MOTOR WORKS, Inc
LINCOLN, NEBRASKA U.S.A.



Cushman
MOTOR SCOOTER

An Amazing Tool!

**THE APEX
PUTTY PLOW**

- For faster, easier removal of putty
- Cleans all 4 sides and corners
- Pierces hardest of putty without splitting sash or endangering glass
- Allows you to remove window glass without removing sash
- Eliminates expensive heating tools
- Also handy for driving glaziers points

Made from high grade tool steel with 45° angle cutting blade. Sturdy hardwood handle.

Send check or money order

\$150

Postpaid
Anywhere
In U.S.A.

Write to **APEX MFG. CO.**
33 Franklin St. Buffalo 2, N. Y.

For the:
Painter
Glazier
Carpenter
Mechanic
Farmer
Layman

Dealers
Inquiries
Invited



HANG IT UP
OR STAND
IT AT
ANY
ANGLE



**MAGNETIX
DROP LITE**
STIX WHERE YOU FIX

LIGHT ON THE JOB!

Fastens by magnet to any iron or steel surface or hang it up. Gives you close lighting at any angle. Magnetix is ruggedly constructed . . . built to take punishment and give years of service . . . features a lifetime powerful alnico magnet that grips thru paint, enamel, grease, etc. No mechanic or shop can afford to be without it. Indispensable in the repair shop, garage, home, factory. Save time, save labor, make the job easier—GET **MAGNETIX**, the strongest most convenient service light ever made.

**POWERFUL
ALNICO**

Lifetime Magnet lifts up to 15 lb. — or 20 times its own weight.

No. 825 Magnetix (25 foot cord) \$4.50 ea. postpaid
No. 850 Magnetix (50 foot cord) \$5.50 ea. postpaid

Order by mail. Send check or money order. We pay postage anywhere in U.S.A. C.O.D. orders plus C.O.D. fee. Your money back if you are not satisfied.

MAGNETIX, INC., 101 S. VAN BRUNT ST., ENGLEWOOD, N. J.

PLYWOOD BOAT KITS

\$87.50

(Freight Included)



Build this 12-ft. sport runabout from ready-cut parts. Kits include all hardware, paint, etc., to complete the boat shown. Send for free folders of all models as low as \$29.95 freight included.

TAFT MARINE WOODCRAFT

Dept. L, 636 39th Ave., N. E., Minneapolis 21, Minn.

ELECTRIC SHEAR SHARPENER

Over 65,000 Sold—It Must Be Good!



Genuine Carborundum wheel ideal for shop or home use. Send remittance with order and shipment will be made at once, prepaid to your door, complete with electrical goods catalogue.

Motor driven

\$9.75

complete with vise

WILLIAM MARVY COMPANY
477 St. Peter Street St. Paul 2, Minn.

ECONOMY TRACTOR



**POWERFUL!
LIGHTWEIGHT!**
Adjustable Tread, High Clearance, 8 H.P. Air Cooled Engine. Automotive Clutch, Differential and Transmission. 15 Attachments.

Write for Catalogue

ENGINEERING PRODUCTS CO., 915-E3, Niagara Ct., Waukesha, Wis.

WAR SURPLUS

Below are just a few of the many items we have in stock at seasonally low prices.

Pumps
Grinders
Air compressors
Air tanks
Spray outfits

Extension cords
V pulleys
All size light plants
Generators
Fire pumps

Gear head motors
Electric hand saws
Electric chain saws
Saw tables
Winches

A TERRIFIC BUY!

GAS ENGINES

Briggs & Stratton NEW in original crates. Model AP 1 3/4 to 2 1/2 HP. List Price \$102. Your Price . . . \$49.50
Model ZZ, with pulley, 5 to 7 HP. List Price \$141. Your Price . . . \$79.50



"MERCURY" CLUTCH

For motor-scooters, motorbikes, lawn mowers, etc. Can be used with electric motor or any gas engine. "A" belt pulley. List Price \$28.00. YOUR price 3/4" bore \$8.95.

Write TODAY for our free catalog listing thousands of MONEY SAVING bargains.

WRITE FOR CATALOG

C & H ELECTRIC Co.

434 W. JUNEAU AVE.
MILWAUKEE 3, WISCONSIN

EASY WAY to BUILD a TRAILER

Save Money!

with complete FAYETTE Undercarriage Assembly



Puts your trailer
on the road

Save money, buy direct from America's leading builder of trailer undercarriages. Units designed for simplest installation. Fayette precision built tubular type axles eliminate up to 40% needless dead weight. Heat treated alloy steel spindles, precision ground, provide smooth, long wearing bearing surfaces. Rubber mountings contribute to Fayette's famous Glide-Ride. You'd pay much more if you bought parts separately without getting Fayette's engineered performance.

Complete assembly includes axle, springs, shackles, hangers, wheels and hubs; electric brakes if required.

FOR UTILITY AND BOAT TRAILERS OR PORTABLE EQUIPMENT... \$49 and up.

SPECIFICATION DRAWINGS and DATA

Send for engineering drawings, state size, use, type and approximate weight of trailer you wish to assemble. Send 10c for postage and handling.

FAYETTE MFG. CO. 600 FRONT ST., FAYETTE, OHIO

POWERFUL CAMPUS "BEE" ENGINE

RUNS Like Magic on CO₂, which is Sold at All Drug and Hardware Stores!

3/16" bore & stroke, 8000 RPM, weighs 5/8 oz. Complete piston-type engine, ready to run. For model planes, boats, race cars, etc. Charging unit included. Safe, economical, precision engineered.



ACTUAL SIZE

4.95
Postpaid
GUARANTEED

Send Check or Money-Order

CAMPUS INDUSTRIES • 1100 Adams Ave., Phila. 24, Pa.
Manufacturers of World's Smallest Engine

DELTA HOME-CRAFT[®] MILWAUKEE



Only \$9.95

Miter gage, motor and belt extra



New! Low-cost Delta[®] Homecraft 8 1/2" Disk Sander

Helps you get a smooth finish easily and quickly. Sand any surface — on wood, plastics, ivory, and non-ferrous metals. Extra-value features include tilting table. Quality-made by Delta. Have your dealer demonstrate this new Delta Homecraft Disk Sander today!

POWER TOOL DIVISION



Rockwell
Manufacturing Company

8025 E. Vienna Ave., Milwaukee 1, Wis.



FREE BOOK!

"How to Start Your Home Workshop." Write for your copy today.

SAY YOU SAW IT IN POPULAR MECHANICS

**THE BIGGEST
VALUE
ON THE MARKET
DIRECT FACTORY TO YOU**

DYNAMIC ARC-WELDER Super Charged

DOES WELDING, BRAZING, SOLDERING, CUTTING

This is one of the finest scientifically designed and precision-built genuine heavy duty transformer-welders on the market today! Made by an old established firm. High efficiency, heavy-duty output does work you'd expect from costlier machines. It's EASY TO OPERATE. Do expert work in a jiffy by following the simplified instructions furnished. Works on iron, steel, brass, bronze, aluminum or other metals. OPERATES from any convenient properly wired 110 VOLT A. C. line. **SAVE TIME AND MONEY**... build or repair your own auto, home, farm, or shop equipment and appliances, etc. Make big money doing work for others in spare or full time. **OVER 50,000 SATISFIED USERS** all over the country, hobbyists, maintenance and repair men, farmers, tinsmiths, engineers, home and auto owners. Order today on 10-day trial or send coupon for full details.

GIFT WORTH \$680 INCLUDED



For Prompt Action
AT NO EXTRA COST

SEND TODAY FOR FREE DETAILS

Please send complete descriptive Dynamic Welder literature and details on 10 day Money back trial and gift offer.

Name.....
Address.....
City..... State.....

DYNAMIC WELDER CO., Dept. D2-CA4, 15 E. 23rd St., Chicago 16, Ill.

WELDING MADE EASY!

With
LEJAY'S
Powerful

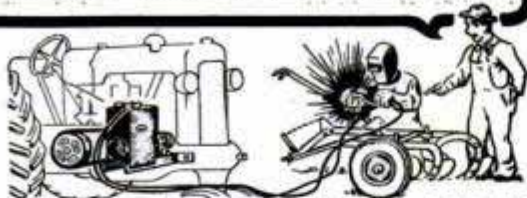

NEW D.C. ARC WELDER

This amazing machine delivers 200 amperes continuous duty and up to 250-300 amps. intermittent duty. The SUPER smooth operation is accomplished by a dial-type control. It easily mounts on your tractor or elsewhere.

NO JOB TOO HARD

for this super duty LEJAY Welder and one or two welding repair jobs could easily more than pay for it. Even handles 1/4" rods.

Money Back 10-Day FREE Trial

is our liberal offer—in addition the welder is guaranteed for 1 year. Over \$300 value at less than 1/3. Free literature. ORDER YOUR WELDER FROM THIS AD.

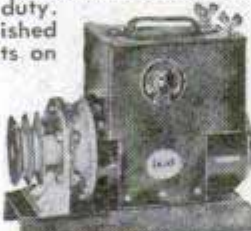

ONLY
\$97.50

OR, Send 35c for PLAN "Build your own Arc Welder from Aircraft Generator", we'll include the literature.

LEJAY MFG., 847 LeJay Bldg., Minneapolis 8, Minn.

Fine Power Tools Only \$8.00 Each

Do turning, drilling, sawing, grinding and sanding on ONE machine, using ONE motor. Complete, only \$39.95 cash, or on Easy Time Payments, 65 lbs. of REAL machinery. Handles Big Work. 10-Day FREE Trial. Money-Back Guarantee. Write for FREE literature.
EMRICK, INC., 1501, Clinton Avenue, Kalamazoo, Michigan

The JIFFY metal CABINET

**YOUR ANSWER TO
SMALL ITEMS STORAGE**
at home, office, and shop
(IDEAL GIFT, TOO)

So handy to keep nuts, bolts, screws, nails, parts, washers, stamps, hobbyists' needs, etc., at your fingertips.



THIS 32 DRAWER UNIT ONLY \$5.95 POSTPAID

Stop searching, get a 32 or 64 drawer Jiffy to keep those small items that usually get mislaid. Spot welded steel, gray enamel finish, metal drawer guides. Dividers included with aluminum drawers make possible three compartments per drawer. Looks good anywhere. Send check or money order, please—no C. O. D.'s. Prices below. Your money refunded if not satisfied. Dealers write for quantity discount.

SPECIFICATIONS	WITH ALUMINUM DRAWERS	WITH CARDBOARD DRAWERS
32 Drawer Unit 6" Deep 12 3/4" Wide 15 1/4" High	Dividers and Index Cards Included	Suitable for most home uses. Heavy board kraft covered. Metal drawer pulls.
64 Drawer Unit 6" Deep 25 1/2" Wide 15 1/4" High	One piece rustproof aluminum drawers for heavy service—good for work bench and industry use.	
Drawer Size 1 1/4" Deep 2 3/4" Wide 6" Long	32 drawer - \$8.95 64 drawer - \$15.95	32 drawer \$5.95 64 drawer \$9.95
	OHIO ORDERS ADD 3% SALES TAX Marproof Rubber Feet included with all cabinets.	
	POSTAGE PAID	POSTAGE PAID

KAYTEE PRODUCTS, Dept. M, Box 588, Canton, O.

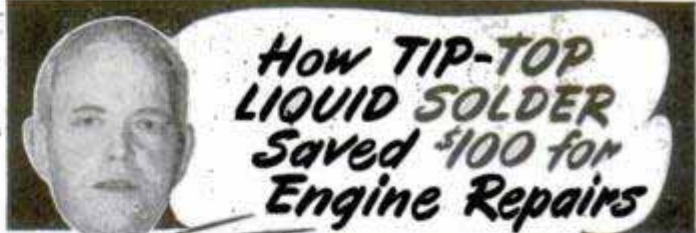

**How TIP-TOP
LIQUID SOLDER
Saved \$100 for
Engine Repairs**

"My engine overheated dangerously on a mountain trip last Summer. I found the thermostat housing gasket was leaking badly. Tip-Top Liquid Solder stopped the leak almost instantly. I refilled the radiator from a nearby stream and went on till I could have gasket replaced. I'm sure it would have cost \$100 or more for repairs if the motor had continued to overheat."

—G.E.R., Nebr.

Tip-Top Liquid Solder is perfect for hundreds of emergency repairs. Forms perfect joint in metals, woods, glass, and fabrics. Water and gasoline-proof . . . sticks where others fail. Keep Tip-Top handy at home—in the shop. If your dealer doesn't have Tip-Top, mail us 25c for a tube along with your dealer's name today.

Tip-Top Products Co.
Omaha, Nebraska



WAR SURPLUS Power Plants

110-V, 60-C, 3,000-W. Remote switch electric self-starter. Easily made full automatic. Army's finest plants. Full instructions. Ideal for farmers, sportsmen, contractors. New condition. Fully guaranteed. Order from ad or rush card for gigantic mail-sale Bargain Catalog.

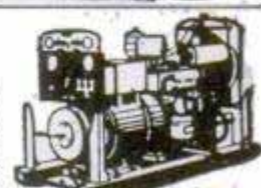

Cost Gov't \$756

Sale **\$345**

Fr't. Prepaid

BURDEN SALES COMPANY
805 "O" ST., LINCOLN, NEBR.

DOUBLE ACTION HYDRAULIC ACTUATING CYLINDER

Also pneumatic. Raise, lower, push, pull machinery, garage doors, dump trucks, bulldozer blades, shovels, other uses. Brand new; war surplus; Has attached high pressure swivel connector. Genuine Bendix Aviation part #402885; 4" bore, 1 1/2" stroke, 31" long solid impeller shaft, 1 1/2" diam.; mounting holes, 3/4" I.D. 100-2000 p.s.i.; fittings 1/4"-16 thread. Gov. cost \$200; a top value; powerful, economical. Only \$24.50 Chicago area. Send check or money order, 25% w. C.O.D.'s. Sh. Wgt. 40 lbs. Satisfaction guaranteed. Order today. Quantity buyers, write for spec. discount.



Only \$24.50

STAHLER DISTRIBUTORS, PM-3, 810 Michigan, Evanston, Ill.

MARCOT KEY MACHINE

Immediate Delivery



MARCOT No. 8 KEY MACHINE, mounted on Cabinet, less motor \$ 95.00
Auto Code Book and Depth Keys . . . 12.50
100 Dz. Popular Key Blanks . . . 60.00
Set—Key File, Follow-Through Rods, Lock Picks, Bit Key Gauge, Thumbie, Pins, Springs . . . 10.50
"Locksmith Trade Books" . . . 6.75
How to Open Locks without Keys or Picks; Secret of Locksmithing! How to Make Keys by the Impression Method; Master Key Systems.
TOTAL COST . . . \$184.75

A. J. MARCOTTE CO., 1200 N. Kedzie Ave., Dept. PM, Chicago 51, Ill.



WHITTLE CIRCULAR SAW

Chucks into Any
ELECTRIC DRILL

Only **\$8.95**
Postpaid

Makes up to 1 3/4" cut. Will cut dressed 2 x 4. Has adjustable depth gauge. No oiling necessary. Handle fits hand and fingers. As powerful as the drill behind it. Includes 5" combination cross cut and rip saw blade made of high quality chrome-nickel saw steel. Extra blades \$2.50 ea.

ORDER THROUGH LOCAL DEALER OR DIRECT FROM

J. D. WHITTLE CO.

Dept. M-3 1056 Wellington Ave. Chicago 3, Ill.

increased "gas" mileage?



GANE

"Air-Flow" NEEDLES

NEW air-bleed idling jet. Replaces present SOLID IDLING ADJUSTMENT SCREW in your carburetor. (8 cyl. cars use 2.) The objective is to lessen the vacuum and thus try to INCREASE YOUR GAS MILEAGE. About 1/2 MILLION NOW IN USE!

Most users who write swear by them and report up to **25% MORE MILEAGE**

and many comment on: **SMOOTHER MOTOR; EASIER STARTING; FASTER PICKUP; BETTER IDLING.** But FRANKLY, some swear at them and curl our hair with "NO improvement"... and fire them back AT OUR EXPENSE — proving Ganes CAN sometimes FAIL. Therefore, we invite YOU to TRY the

"LITTLE STINKERS"

WITHOUT COST to see what they will do for you. Send NO money. Pay postman NOTHING.

Try Before You Buy — 10 Day Free Trial Offer
Just send us your Name, Address, Make of Your Car, No. of Cyls., and Make of Carburetor by post-card or note. Ganes with literature will be promptly sent you postage paid. ANYONE can install them in ONLY 5 MINUTES.

USE GANES 10 DAYS

Check for INCREASED "GAS" MILEAGE, which must average 2, OR MORE, EXTRA MILES PER GALLON, or else NEEDLES are NOT worth buying. End of 10 days, send us only \$1.50 per Gane Needle; or you, too, can fire the Little Stinkers back home AT OUR EXPENSE—AND YOU'LL OWE NOTHING—AND WE'LL ASK NO QUESTIONS.

SEND FOR GANES TODAY

National Automotive Research Co.

350 W. Washington Blvd., Dept. J-3, Venice, California

TWO CYLINDER BRAND NEW AIR COMPRESSORS

Fully Guaranteed, Backed By 44 Yrs. Air Equipment Experience

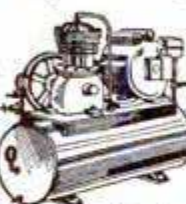

FULLY AUTOMATIC—BEST BUY IN YEARS!

TWIN CYLINDER for double power, faster compression, smoother operation. Displacement 3.5 C.F.M.

TWIN CAPACITORS for stronger starting power against pressure. 1 1/2 H.P. Holtzer-Cabot Motor. Single phase A.C. 60 cycle. **TWIN VOLTAGE** can be operated on 110 or 220 Volts.

TWIN "V" BELTS for maximum power drive.

TWIN GAUGES. 1 reserve tank gauge and 1 gauge with adjustable pressure regulator.

REGULATOR for pressure adjustment from 0 to 100 lbs. Safety valve, drain valve and 12"x30" horizontal tank with 1/4" hose conn.

FULLY AUTOMATIC. It's a husky, sturdy unit, complete with motor, ready for use. Built for industrial use in shops, factories, garages for spraying paint, cleaning, blowing, tire inflation and many other compressed air uses. Attractively finished in metallic blue.

1/2 HP—12"x24" TANK. One cyl. 2.86 CFM Displ. **\$63** COMPRESSOR



BIG VALUE! 2 WAY VENTILATOR-BLOWERS

250 CFM 4 3/4" dia. in-take, 3 1/4"x5 3/8" discharge. 110V-AC. motor. **\$13.95**

100 CFM 3 3/4" dia. in-take, 2" discharge. 110 V-AC. motor. **\$7.95**

F.O.B. WAREHOUSE—SEND CHECK OR MONEY ORDER. Write for Bargain List

ELECTRIC TRADING CO., 313 A CANAL ST., NEW YORK, N.Y.

10 TIMES FASTER THAN HAND SAWING!

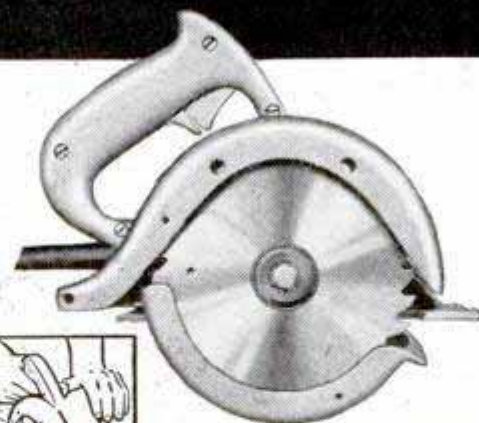

Crosscutting



Cutting Tile, Transite, Slate



Ripping



Angle Cutting

HOME-UTILITY 6" Electric SAW

(Cuts to 2" Depth)

NOW Reduced to **\$54.50**

HOME-UTILITY 6" Electric

Saws are a better buy than ever! At their new low price, they save days and dollars, beat hand sawing 10-to-1, in general carpentry, home construction and alterations, farm building and maintenance! Saw stair stringers; trim stock size mill-work to fit; cut out plywood and wallboard panels; saw lumber to construction length; do hundreds of other jobs!

Built by Black & Decker, world's largest maker of quality electric tools, this perfectly-balanced, close-coupled Saw has many features you wouldn't expect to find at such a low price. Powerful universal (AC-DC) motor operates on standard power line. Easy to handle, easy to follow, safe to use!

See it, try it, at your hardware, electrical or implement dealer.

ELECTRIC HOME-UTILITY TOOLS



Products of The BLACK & DECKER Mfg. Co. Dept. H3M Towson 4, Maryland

SAVE UP TO 25% ON QUALITY BALL-BEARING WHEELS!

Bilt-Rite wheels roll smoothly and easily, are semi-pneumatic, ball-bearing, painted red; guaranteed top quality—and you save up to 25%! Compare Bilt-Rite's quality and price—then get your order in today! Dealer inquiries invited.



BILT-RITE BARGAINS on BALL-BEARING WHEELS

(For 1/2-inch Axles)	
6 x 1.00.....	\$1.30
10 x 1.25.....	\$1.95
8 x 1.25.....	1.65
10 x 1.75.....	2.15
8 x 1.75.....	1.80
10 x 2.00.....	2.45
6 x 1.50.....	\$1.50
(For 5/8-inch axle)	
6 x 2.00.....	\$3.95
8 x 2.50.....	\$4.45
10 x 2.75.....	Only \$4.65!

Bilt-Rite Guarantee
No better wheels are made regardless of price; 10 day return privilege.

If size you need isn't listed, write for Folio A ORDER TODAY—Send cash, check, or M.O.—Pay postage on arrival.

BILT-RITE WHEEL COMPANY
520 EAST MISSOURI AVE. KANSAS CITY 6, MISSOURI

BUILD YOUR OWN TILTING ARBOR SAW!

Exclusive GIL-BILT Build-It-Yourself Features

- No machining—build easily with hand tools only
- No blueprint reading—step-by-step pictorial plans, full scale patterns, actual photographs
- Sturdy wood, aluminum, and steel construction
- Capacity and performance of commercial saws selling for \$60 and up

SAVE \$50 OR MORE

GIL-BILT 10-INCH TILTING ARBOR SAW



- 27x28 in. table, 13 1/2 in. capacity in front of blade
 - 10 in. blade cuts 3 1/4 in. deep, tilts full 45 degrees
 - Floor model 34" high, table always stays level
 - New Departure ball bearing arbor, 3/4" precision shaft turned down for 5/8" bore blades, alum. housing, shipped ready to run
 - Jackscrew and 4 1/2 in. dia. handwheel lowers and raises blade
 - Cast aluminum miter gauge and self-aligning rip fence guide
- GIL-BILT Metal Parts Kit includes Plans, ball bearing arbor, miter gauge and bar, rip fence guide, dado insert, lock knobs, jack screw mechanism and handwheel, and all other metal parts (less blade).....\$20.95
Same Kit with 10" Combination Blade \$24.90
Same Kit with 8" Combination Blade \$23.90

GIL-BILT 8-INCH TILTING TABLE SAW

- 21x27 in. table tilts full 45 degrees, 13 in. capacity in front of blade
- 8 in. blade cuts from 0 to 2 1/2 inches
- New Departure ball bearing arbor, 5/8" precision shaft turned down for 1/2" bore blades, alum. housing, ready to run
- Cast aluminum miter gauge and self-aligning rip fence guide (same as above)



GIL-BILT Metal Parts Kit includes Plans, Ball Bearing Arbor, Miter Gauge and Bar, Rip Fence Guide, Machined Lock Knobs, Tilt Support Segments and All Other Metal Parts (less blade).....\$15.95
Same Kit with 8" Combination Blade.....\$18.95

GIL-BILT 12-INCH BAND SAW

- Cuts to center of 24 inch circle
 - Handles stock up to 6 inch thick
 - 18x18 inch table tilts 45 degrees
 - Lower wheel and drive pulley runs on sealed New Departure Ball Bearings; Upper wheel runs on two 5/8" bore Oilite Bronze bearings.
 - Upper wheel tension and tilt mechanism of cast aluminum, completely assembled.
 - Upper and lower blade guides. Each has ball thrust bearing, self-lub bronze jaws
 - Rubber tired wheels. Choice of cast aluminum or make-your-own wood wheels on metal hubs.
 - Uses standard 78 inch blades up to 3/8 in. wide.
 - Fully enclosed mechanism for utmost safety.
- GIL-BILT Metal Parts Kit includes Plans, rubber tires, 3/4 inch blade, hubs for wood wheels, ball bearing spindle, tilt mechanism, guides, table tilt segments and all other metal parts.....\$16.95
Same Kit with two machined ready-to-install 12" cast aluminum wheels.....\$20.95

NO DEALERS—ONE LOW FACTORY PRICE! Return in 10 days for full refund if not satisfied. Prices include postage within 600 miles. Over 600 miles add 5%. Send cash, check, or money order for parts kit, or send \$1.00 for Step-by-Step Plans and order kit later less cost of Plans. Plans sent postpaid anywhere in the world.

GILLIOM POWER TOOLS

P. O. Box 1-PC, Lambert Field, St. Louis 21, Missouri

COMPLETE PLANS only \$1.00 EACH

Make all your tools more useful with a DESMOND-SIMPLEX VISE

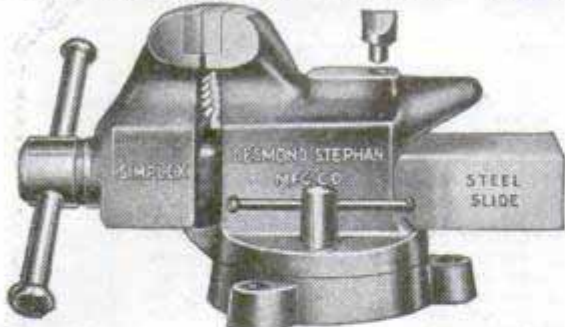

Enclosed Screw . . . Steel Channel Slide

Here's your best vise value by far. And at a surprisingly low price. Steel slide encloses screw; prevents damage from falling chips. Swivel base for maximum convenience. Non-pinching type handle. Pipe jaws part of vise. Replaceable hardened steel jaw inserts fit snugly on heavy shoulder, withstand heaviest blows from any angle. Hardened steel cut-off tool on anvil. Get a Desmond-Simplex Vise from your hardware store. Write us direct for valuable folder on your basic shop tool.

The Desmond-Stephan Mfg. Co.
Walnut Street, Urbana, Ohio

SAFE JIG SAW READY!

At last—a revolutionary, new electric jig saw small children may use, yet powerful enough to be the basic tool in Dad's workshop. Make "Standing Photo Silhouettes" of favorite snapshots . . . fancy what-nots, toys, for fun and profit! Just plug in! No motor to buy—no oiling. Thousands sold. Use in livingroom, apartments, etc. Patented. Nothing else like it. Mail postal NOW for illustrated. Free Circular, low price! Dealers Write! **SYNGRO CORPORATION**, Dept. H-35, Rochester, Mich.



Make Personalized HOUSE, LAWN MARKERS Or Profit



17 new silhouette cutouts (3 shown plus 14 other novel designs) complete alphabet and numbers, ready to trace onto wood. Sawing is easy. Marker with name or address is distinctive personalized gift or addition to your own home. Make markers for fun and to sell. Set of 17 full-size, ready-to-use patterns, alphabet numbers, only \$1.00, postpaid. Money Back Guarantee.

Clip This Ad and Mail With **CRAFTPLANS** Dept. P-158, Chicago 5, Ill.
Dollar Bill or Check TODAY 1321 S. Michigan Ave.

AUTO ACCESSORIES WANTED

from manufacturers for direct-mail campaign. Send full details, prices, terms, discount—all facts to **POWER SALES CO.** WHITING, IND.

SCREWMIX—BEARINGS

Mixed screws & metal screws—30c Lb.	Bore	O.D.	Type	Price
Mixed wood screws—Mixed washers—Mixed cotter pins—30c Lb.	5/32"	5/8"	Ball	15c
Mixed nuts—Mixed aluminum rivets—50c Lb. Mixed steel rivets—20c Lb.	3/16"	1/2"	Needle	15c
BARGAIN OFFER (\$2.40 value) one lb. each of above 7 mixtures—\$1.95	1/4"	3/8"	Ball	22c
POSTAGE Screw Mix, Add 5c per lb.	5/16"	1/2"	Needle	15c
POSTAGE Bearings, Add 10c per order.	3/8"	7/8"	Ball	35c
Minimum order \$1.00	1/2"	1 1/4"	Ball	40c
	5/8"	1 1/4"	Ball	30c
	3/4"	1 3/4"	Ball	40c
	1"	1 3/4"	Needle	28c

JAY-CEE SALES CO., 4519 Grand River Ave., Detroit 8, Michigan

G. I. COVER CLOTH

Plasticated, lightweight, pliable. Use for dust cover, storage wrapping, painter's drop cloth and 1001 other uses. Send \$1.49 for 8 ft. x 8 ft. cloth or \$2.79 for 9 ft. x 15 ft. size. C.O.D.'s accepted. Quantity discounts.
SAX-ON, Dpt. KK-1, 3840 FULLERTON AVE., CHICAGO 47



BULL DOG Hitches, Parking Jacks and Axles for all types of trailers!

TRAILER PARTS

Write for **FREE Catalog**
Hammer Blow Tool Company
Wausau 13, Wisconsin

1950 Shop Notes Now Ready!



Popular Mechanics **SHOP NOTES** is always sought after and this year it is better than ever. 240 interest-packed pages for electrician, carpenter, mechanic, painter, auto-worker, welder, farmer, plumber and home craftsman. The 1950 issue contains data on drilling, fenders, batteries, clamps, milling, gauge block, making arc welder, making bandsaw, belt sander, etc. **Hundreds of articles—Hundreds of ideas.** See your newsdealer or order direct from

POPULAR MECHANICS PRESS — \$1.00
200 East Ontario Street — Chicago 11, Illinois

Use Easter Seals



AMAZING OIL FILTER - SAVES \$\$\$

LIFETIME POROUS METAL CARTRIDGE —
Saves replacement costs. Gives positive oil cleansing action. Non-absorbent . . . save a full quart of oil in every oil change. **Fits all cars. \$8.50** post paid.
Easy installation • Free literature.
MONEY-BACK GUARANTEE
Filterall Co., Inc., 4408 San Fernando Road • Glendale 4 • California

**Here's the Handgrinder you've always wanted...
for HOBBYWORK...HOME USE...PROFITS**

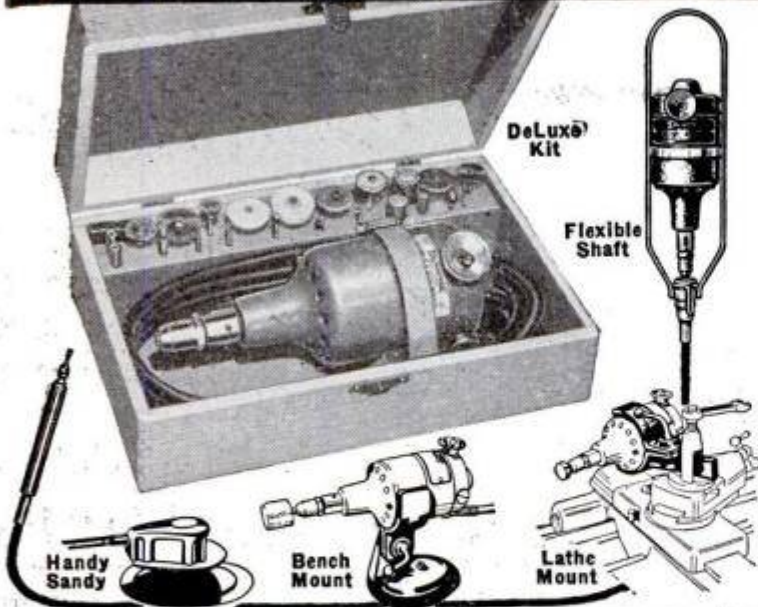

**More power, capacity, versatility
than any other handgrinder**

With the Dumore Duplex you get an all-around tool for your workshop... not just a one-purpose tool. 1/14 h.p. gives you extra power for heavy jobs... extra chuck capacity lets you handle all standard 1/4", 1/8", 3/32" shank tools... 8 low cost attachments (extra) quickly convert to flex-shaft, bench or lathe use, permit budget purchase of this 1-kit tool shop.

DRILLS GRINDS SAWS **BUFFS POLISHES BURRS** **CHAMFERS SANDS SHARPENS** **CARVES ROUTS ETC.**

Perfect for your shop, for odd-jobs, as a gift, the Duplex is the best buy in handgrinders. See it today at your hardware dealer, or send in coupon below.

The DUMORE COMPANY

Dept. C-51 Racine, Wisconsin

- Please send New Dumore Hobby Catalog.
- Send me DeLuxe Duplex Kit with 51 accessories (as illustrated): \$29.75 enclosed.
- Send me Standard Duplex Kit (9 accessories): \$21.50 enclosed. (Send check or money order — we'll pay postage. Send 10% and we'll ship C.O.D. plus postage.)

NAME
ADDRESS
CITY ZONE STATE DD-1

SEND FOR NEW HOBBY CATALOG

SPECTACULAR SALE OF WAR SURPLUS Prices Cut to the Bone!

Save \$\$\$ on Current Needs, and for Months Ahead! All Items BRAND NEW... Never Used!

WRIGHT HI-SPEED, 3-TON

SPUR Chain Hoist GEAR
Hook-type, ideal for garages, shops, and industry. Operates with maximum mechanical efficiency. Holds load at any point, will not self-lower. Equipped with 40 ft. of chain. Lifts 20 ft. Original cost \$215.00. **OUR LOW PRICE... \$85.00**

Speed Reduction Box
Has 1 1/2" dia. take-off shaft with clutch. Cast aluminum housing, three mounting ports. Handle may be removed for motor drive. Ratio 75 to 1. Gear box is equipped with 8 B.B., permanent grease supply. **OUR LOW PRICE... \$3.75**

110V/220V TRANSFORMERS

Originally built for Hartman Quick Battery Chargers. Input 110V/220V AC. Output 18V, 100 amps. Perfect for building your own electric welders, quick battery chargers, etc. Primary leads 26" long, secondary leads 18". Size 7 3/4 x 5 1/2 x 6 in. Mounting brackets, Wt. 40 lbs. Original cost \$32.50. **OUR LOW PRICE... \$11.75**

RECTIFIERS—Full wave, 1 amp. Converts 11V AC input to 7V DC output. **OUR LOW PRICE... \$1.25**

Stewart-Warner TACHOMETERS

Checks speeds up to 2500 RPM. Runs clockwise. Size 3 1/2" dia. x 4 1/2" long. Luminous dial. Has cup tip for flexible shaft. Mounting bracket. **OUR LOW PRICE... \$3.75**

TRADE WIND MARINE BLOWERS

Single exhaust. Ideal for heating, ventilating, air conditioning, drying, exhaust fan on boats, dust collectors, 4" sq. mounting flange; 4" dia. intake; 2 1/2" sq. discharge. Squirrel cage blower wheel powered by direct-connected 12V 6.5 amp. DC Redmond motor. Size, less flange, 8" wide, 7 1/2" high, 6 1/2" deep. Sturdily built. **OUR LOW PRICE... \$8.75**

GEAR HEAD MOTORS

—24V DC, 20 amps. Originally designed for ammunition boosters on bombers. Has double shaft gear reduction box. Perfect for models and displays. Size 5" x 3". Wt. 3 1/4 lb. **OUR LOW PRICE... \$3.95**

24-hr. EMERGENCY LIGHTS

Dent blister on bottom to light flare. Burns continuously. Ideal for truckers, tourists, campers. Non-deteriorating. **3 for \$1**

ORDER BY MAIL FROM THIS AD! Send bank draft, cash, or money order. All merchandise guaranteed to be as represented. These prices F.O.B. St. Louis, Mo. Quantities limited.

MAIN SURPLUS & Supply Co., 11 So. 3rd St., St. Louis 2, Mo.

Handy Flexible SHAFT

Converts any motor, drill press, electric drill, electric fan (10 inch or larger) into a handy rotary tool

Attach ROTA-SHAFT in a jiffy. Use for grinding, polishing, sharpening, cleaning, engraving, making tools, carving on metal, plastic, wood, glass. Convenient handpiece for easy handling... with 1/8 inch Adjustable Chuck. 40-inch overall length. Complete with buff and sanding disc ready to use in a drill press chuck. Order today!

ONLY \$2.95

SEND NO MONEY! Mail your order. Pay postman only \$2.95 plus postage on delivery. Try 10 days—if not delighted, return for money-back. For use on motor, add 35c for Special Coupling and state shaft diameter.

STRADER PRODUCTS CO.
DEPT. P-101
259 Strader Ave. Cincinnati 26, Ohio

OLD FAN MOTOR
VACUUM CLEANER MOTOR

INSTANT FLAME with PREPO TORCH

Only **\$9.75** COMPLETE WITH FUEL

EXTRA CAN OF PREPO FUEL
Single lots .95 each
Lots of Six .85 each

**NO PUMPING * NO PRIMING
NO POURING**

PREPO TORCH FEATURES:

- No refill problems—Discard empty PREPO container and slip in new one.
- Instant blue flame—just open the valve and light. Hot flame—2200 F.
- Long life—8500 B.T.U. in single container. Under ordinary use one container lasts over four hours.
- Versatile—change of burners (two are furnished—regular, throws pointed flame; heavy duty, throws bushy flame) makes PREPO Torch adaptable to all jobs, indoors or out.
- May be used in any position. Especially handy for soldering, loosening nuts, soldering joints, burning paint.
- Positively safe—Time tested and approved. No old fashioned torch hazards.
- Satisfaction guaranteed.

Send your check or money order to—
**J. N. TOOL SALES, P. O. Box 3511
CHICAGO 54, ILLINOIS**
F.O.B. Chicago — Shipments Express Collect

**ATTENTION!
ALL MEN!**

AMAZING
VALUE!

UNBELIEVABLE
BUT TRUE!



**BRAND NEW, GENUINE
ARMY AIR FORCE
FLYING JACKET and TROUSERS**
Both FOR ONLY **\$4.98**

A PRIZE "FIND" FOR HUNTERS,
FISHERMEN, FARMERS, TRUCKERS,
MECHANICS—EVERYONE!

Unbelievable, but true. These brand new, genuine government surplus Army Air Force Flying Jackets and Trousers just obtained by us. Actually cost government many times this price. Individually packed in original boxes—never opened. Full zipper front jacket and knit cuff, coverall type trousers. Of genuine olive green NYLON with satin sheen finish. Extremely wind and weather resistant. Maximum warmth with free body movement. Made for real rugged wear. A value that cannot be duplicated anywhere. Supply limited. When they're gone, there will be no more. These NYLON Jackets and Trousers made for government as electrically heated flying suits. A few wires attached but can be removed. Hurry. Both jacket and trousers complete for only \$4.98 plus postage and C.O.D. fee or \$4.98 plus 40c postage if money sent with order. State size (34-44).
ALYN & CO., DEPT. PM, 271 VANCE, MEMPHIS, TENN.

**SUPPLY
LIMITED!
HURRY!**

MILLER ROTARY
Hi-Speed (OPE-SAW) DRILL-BIT
IT SAWS & CUTS DREAMS

Amazing high speed combination bit and saw fits any electric drill or drill press; takes place of up to 550 in tools. Drills own starting hole to cut, saw and ream an opening in the center of light metal, wood, plastic, etc. Easy to operate. Ideal for mechanics, electricians, plumbers, hobby workers, many others.

DRILL PRESS SAW-CUTTING

SAWING, CUTTING AND REAMING SECTION

DRILL PRESS HANDY CUTTER

Send cash, check or M.O.

Order Now

PRICE **\$3.95**

International Twist Drill Corp. PM-1
7th & Wyandotte • Kansas City, Mo.

**ELECTRO
MAGNET**

110 volts AC or DC. Will separate ferrous from non-ferrous metal. Will lift 30 to 40 lb. load flat surface. Will also magnetize screw driver, hammer or other tools. Made of highest quality Government surplus parts. Satisfaction guaranteed or money refunded if returned within 1 week. Send check or money order. Postpaid **\$3.95**
MACKLEY, 25H PARK PLACE, NEW YORK 7, N. Y.

NEW QUICK-CLAMP 30" BRAKE

Forms angles, flanges, seams. Bends 26 gauge steel. Heavier copper and aluminum. Cam locking. Portable, can be clamped to edge of truck. All steel. Wt. 42 lbs. Express Collect... **\$24.50**
36" size **\$29.00**

12" BRAKE. Fits in vise to form difficult compound bends, up to 20 gage steel... **\$12.50 PP.**

CUTTER. Cuts 18 gage steel any length and width, **\$12.50 PP.**

SHEET METAL PLIERS. 2 1/2" wide, **\$2.00; 3", \$3.00.**

IRON BENDER. Forms hooks, braces, eyelets, Bends 1/4x2, **\$10.00**

Immediate delivery. Order direct, cash or C.O.D., or send for folder.

WISE BRAKE MFG. CO., P1116 So. 27th St., Omaha 5, Nebr.

**FURNITURE MAKING
and CABINET WORK**

By **B. W. PELTON**

Complete Step-by-Step Directions for making Every Type of Furniture
—Including Built-in Conveniences and Home-remodeling Jobs

Here, in a great new handbook is everything you want to know about furniture making; cabinet work, repair jobs, and remodeling projects. Accurate drawings and practical instructions show you all the tricks of the trade and the real professional methods of repairing, refinishing and reupholstering worn or broken pieces. And there are complete directions for every type of home-remodeling project. Every job is explained in careful detail by a master craftsman who gives you authentic instructions on exactly how to carry out each step in the work—from obtaining the materials to the final finishing operations; staining, varnishing, waxing, etc.

MAIL THIS COUPON

D. VAN NOSTRAND COMPANY, INC. Examine This **FREE!**
350 Fourth Avenue, New York 3, N. Y. Great New Book

Please send me a copy of "Furniture Making and Cabinet Work." Within 10 days I will either return the book, or send you \$2.95, plus postage, as a down payment, and \$2.00 a month for two months until the total price of \$6.95, plus postage, is paid. (If you send entire amount of \$6.95 with this coupon, we will pay postage. Same return privilege and refund guarantee if not completely satisfied.)

SEND NO MONEY

NAME _____
ADDRESS _____
CITY _____ ZONE _____ STATE _____
Pop. Mechanics—3-50

GARDEN TRACTOR

2-3-4H
5 1/2 H.P.
and NEW
4 1/2 H.P.
Riding Model
Guaranteed

- 30 ATTACHMENTS
- NO BELTS
- NO CHAINS
- POWER TURNING
- GEAR DRIVEN

Plows deep furrows. Change attachments in seconds. FREE Instruction Booklet.

Buy Direct • Special Discount
Send Postcard for Big Free 22-page Catalog

RED-E TRACTOR CO.
52 FOND DU LAC RD., RICHFIELD, WISCONSIN

METALS FOR HOME WORKSHOPS

Aluminum, Brass, Copper, Monel, Steel and Cast Iron. In Bars, Angles, Channels, Sheets and Tubes. Sold in Small Quantities. Write for Free Price List.

CASHMETALS CO.
2720 CALIFORNIA AVE. PITTSBURGH 12, PA.

SOLDERING MADE EASY!

**REAL SOLDER
LARGE TUBE**

\$1

POSTPAID ANYWHERE IN U. S.

Real Solder, the amazing new All Purpose Solder in paste form does a complete job in one operation. No cleaning, no tinning, no flux. NOT A CEMENT, but a real, heat solder. Simple, just apply paste and heat. Any heat will do, even a match for small jobs. Requires no skill to get a strong, permanent bond. One of the famous micro-film alloys, Real Solder solders anything except aluminum. Does many jobs impossible with ordinary solder. Full Money Back Guarantee. Send cash, money order or check—today.

HOWARD PRODUCTS, Box B-3, Chardon, Ohio

World's strongest patented pliers NOW at your dealers

Not to be confused with ordinary pliers, the WELLOCT specially patented plier is scientifically heat-treated from drop forged chrome steel, triple polished. A jewel in your workshop. 120 years of tool making experience assures you of perfection in every tool. Light pressure on handles gives amazing vice grip. Because of shark teeth and patented lock, up to 40% extra gripping power is assured.

WELLOCT pliers are hand-made.
WELLOCT pliers will stand pressure over 900 lbs. and every plier is pretested.
WELLOCT pliers requires a 32 man operation to produce one plier.
WELLOCT makes a plier for every purpose.



This is the first consumer announcement on WELLOCT'S famous hand-made tools. We invite your inquiries into Carpenter, Plumbing, Automotive and Electrical Tools.

Palmer **WELLOCT** Tools

MEADVILLE, PENNSYLVANIA

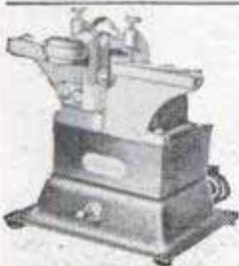

MAKE and REPAIR YOUR OWN
BAND SAW BLADES with the
ERWOOD Electro Band Saw Brazer

No more slowdowns . . . it takes less than TWO MINUTES to repair a blade with the Erwood Brazer. Save money too . . . do inside contour sawing easier and faster. And make your own band saws from coil stock. 110 or 220 volt.

The ERWOOD Company
209 Woodstock, Crystal Lake, Illinois

WAR SURPLUS - U.S. SIGNAL CORPS

Genuine EE 8 Portable Telephones
Telephone Wire - Equipment

Big Annual
Money-Saving SALE

Amazingly simple to install your own private telephone system with portable telephones and wire. All you do is string wire, attach phones to each end and you are ready to ring and talk up to 17 miles! Add up to 6 phones on main line for dependable 2-way communication around HOME, FARM, SHOP, CONSTRUCTION PROJECTS, FACTORIES, etc. Powered by standard flashlight batteries. Phones checked for perfect operation. Fully guaranteed.

BRAND NEW EE8 Phones (Formerly \$21.50) NOW.....\$17.50 ea.

LIKE NEW. Each phone thoroughly reconditioned like new. Ea. phone \$12.95—SPECIAL: 2 for.....\$24.50 USED. Reconditioned. Excellent. Ea. \$9.95—SPECIAL: 2 for \$18.50

BRAND NEW EE99A TELEPHONE REPEATERS EA. \$14.50

TELEPHONE WIRE. Prices slashed to near wholesale cost.

W110B Grade I unused, new, stored in open. Weatherproof, durable, 2-conductor, twisted telephone wire, insulated. Many extra uses for this handy item.

ONE MILE REELS, formerly \$27.50 mile. SPECIAL \$21.00

1/2 MILE REELS, formerly \$14.25 ea. SPECIAL \$11.00

500 FOOT COILS, formerly \$3.95 SPECIAL \$ 3.00

1,000 FOOT COILS, formerly \$7.25 SPECIAL \$ 5.75

W110B Grade II, unused, outer layer wire stained, weathered, but when removed inside layers perfect. Good for years of service.

ONE MILE REELS, formerly \$27.50 mile. SPECIAL \$17.50

1/2 MILE REELS, formerly \$14.25 ea. SPECIAL \$ 9.00

BRAND NEW W-130 Lightweight, 2 conductor, 1/2 MILE REELS. Wt. 16 lbs. Formerly \$15. SPECIAL \$12.95

1/4 MILE REELS slightly weathered, unused NEW. \$ 4.95

Write for Free Folder. Sale on Field Telephone parts. Other specials!

All prices F.O.B. Sacramento. No C.O.D. California residents add 3% for sales tax. Small orders sent postage collect plus small handling charge.

SEND CHECK OR
MONEY ORDER

LORIS SALES

P. O. BOX 1896-B-3

SACRAMENTO, CALIFORNIA

IT'S GREAT TO BE REGULAR



ALL-VEGETABLE
Makes the Difference

Thousands of modern men and women in all parts of America have turned to Nature's Remedy, NR Tablets for dependable, yet gentle relief, when a laxative is needed. They know that the all-vegetable idea is so right. They find an NR at night produces thorough morning regularity with no perturbing effects. It's so kind to the system.

Try NR at our expense. 25 tablets only 25c. Buy a box at any drug store. Try them. If not completely satisfied, return box with unused tablets to us. We will refund your money plus postage.

NR

Nature's Remedy
NR-TABLETS-NR

Easter Seals Help Crippled Children



Scientists say "SUCCESS depends on HEALTH and KNOWLEDGE"

Comfor-Reader
is the key!

- Enables easier, faster, longer reading.
- Gives complete comfort, better concentration, doubled efficiency.

Write for
Catalog



Pat. No.
2354998



Collapsed

All prices
FOB-N.Y.C.
Money Back
Guarantee

- Adjusts in 8 directions, to any angle, height.
- Stops eye strain, "study slump," poor breathing.

—MODELS—

"Standard"—maple, aluminum joints\$16.95

"Super"—walnut, aluminum poles & joints...\$24.95

"THRIFT SET"—Introductory Offer:
You assemble-finish wood parts.
Aluminum parts finished.

"Standard" \$6.95

"Super" \$9.95

SWING LAMP ATTACHMENT
SOLD SEPARATELY

Sell—Make \$10 on
each set you finish

COMFOR-READER, INC. 5 BEEKMAN ST., N.Y.C. 7

Compare Our Prices!

All Items Brand New

LOGAN HYDRAULIC CONTROL VALVE

has built in adjustable relief valve, will operate double action cylinders or hydraulic motors at various speeds. Comes with removable mounting bracket. Equipped with Trigger type control which locks in neutral position \$6.45 Shipping wt. 18 lbs.—Enclose Postage



HYDRAULIC CONTROL VALVE

4 Way control valve with built in relief valve. Can be used with 1000 to 1500 P.S.I. Hydraulic Systems. Will operate cylinders in both directions. Brand new in original cartons. Part No. 62026B-F \$4.25 Shipping wt. 6 lbs.—Enclose Postage



HYDRAULIC CYLINDERS

\$6.75

A sensational surplus buy. Two-way hydraulic cylinder, will stand up to 1500 lbs. pressure. Overall length 31" with a 2" bore and 18" stroke. The piston rod is 1 1/4" in diameter and has a bearing type rod end with 5/8" diameter hole. These cylinders have a swivel type mount, and are equipped with neoprene seals so that they will operate on any mineral base oil. (Shipped Express—Charges Collect)

Extra Special only \$6.50

2 Way Hydraulic Cylinder with approximately 29 inch stroke, over all length 37 inches by 1 1/2 inch bore. Equipped with a swivel pad mounting on the base and a cast mounting bracket at the top. Has a one inch hardened steel hollow shaft with a 5/8" inch I.D. Shipped Express or Motor Freight, charges, ONLY collect. Shipping weight 35 lbs. MICHIGAN RESIDENTS ADD 3% SALES TAX

N. SILVERSTINE CO.
6532 E. McNichols DETROIT 12, MICH.

World's Largest Stocks of Jeep Parts

Write For Your Special Requirements—We can Fill Any Order!

The King of Jeeps



GUARANTEED REBUILT JEEP MOTOR BLOCKS

COMPLETE WITH PAN (Less Head)

This motor is completely rebuilt with all new parts. Guaranteed for 90 days or 4000 miles against defective parts or workmanship. You must prepay freight when shipping old block to us. Add to \$2.50 for crating to above prices.

\$88.50
EXCHANGE

\$107.50
OUTRIGHT



New RADIATOR ASSEMBLY



Complete with Shroud. Interchangeable with Civilian jeeps.

\$24.95

MUFFLERS

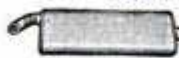

A6118
Oval Type
\$2.75

EXHAUST PIPES

Complete from manifold to muffler. A10199 **\$3.50**

CRANKSHAFT BEARINGS
A6798 Std. \$3.10
A6746 .010 3.90
A6747 .020 4.10
A6728 .030 4.10

Connecting Rod Bearings
All sizes. **45c** each.



MASTER CYLINDER
Complete A556
GPW2140 **\$5.95**

BUMPER SNOW PLOW



Easy to install. Brand new. All steel. F.O.B. Buffalo, N. Y. **\$69.50**

BIG, FREE CATALOG
Write For Your Copy Today

Thousands of other parts and accessories available. SHOP BY MAIL—Order direct from this ad today.

BERG TRUCK & PARTS CO., INC.
1601 SO. WABASH AVENUE, Dept. M-3, CHICAGO 16, ILL.
Cable Address... JEEP KING

AIR COMPRESSORS

Lowest-Ever Closeout Price!

WESTINGHOUSE

Reg. \$60.50

1850
FOR PCH

Model T-1 Complete

Brand New Surplus Special at an amazing low price. Westinghouse Double-piston type, 6.54 CFM volume. Mounts on truck or car engine—or operate with 1/2 HP motor. For farm, home, industry, pointers. Instructions and spare parts kit included. Send check or money order. Weight 25 lbs. We carry a complete line of spare parts.

AIR HOSE—to fit, 25-ft. length with fittings & chuck—\$2

NATIONAL STORES 300 SMITHFIELD ST., DEPT. 36 PITTSBURGH 22, PA.

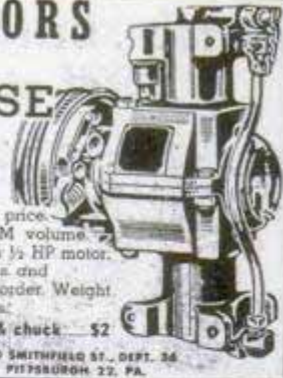

ALL 5 Only \$39.95

WORLD'S LOWEST PRICES

- 1 30" LATHE
- 2 DRILL PRESS
- 3 SAW-8" CAP.
- 4 GRINDER
- 5 SANDER

EMRICK WORKSHOP gives you everything listed at right—65 lbs. of REAL machinery. Five Big Capacity power tools using ONE motor. Many new 1950 features. 10-Day Free Trial. MONEY-BACK Guarantee. Only \$39.95 cash, or on Easy Time Payments. Get FREE literature today showing how to save up to \$200 on fine power tools you'll be proud to own. EMRICK, INC., 1946, Clinton, Kalamazoo, Michigan.

AMERICA'S BIGGEST KAYAK VALUES!

BUILD Your Own

LIGHT • STRONG • SAFE • SPEEDY

Complete easy-to-assemble kit with instructions, pre-cut parts, canvas, dope, trim & hardware. Nothing else to buy. No steaming or bending. Ideal: Father & Son project—fun hunting and fishing. Models catalog as low as \$16.75—today! Sent. P.M.-1

DEDHAM KAYAKS DEDHAM, MASSACHUSETTS

LIQUID MARBLE

COMPOSITION FLOORS FLEXIBLE MOLDS MOLD novelties, Stationery, Art Goods in Flexible Plastic Molds; material makes \$1 seller. Make Marbleized floors, Tile Walls. Colorful, glossy, amazing! Easily learned! start in garage or basement. Particulars free.

Mold, Brush, Trowel, Spray!!! MARBLEIZING SERVICE, Dept. 10-F, Edwardsville, Ill.



\$2.95
EACH

NOW! FILE YOUR OWN SAWS

Do expert saw filing at home. Precision filing easy without experience. Two simple adjustments. Keeps any hand saw extra sharp and true-cutting. Complete with file. Money back guarantee. Cash with order, prepaid. (COD postage extra.) Order today. \$2.95.

ANOTHER SPEEDCOR TOOL
THE SPEED CORP. PM-3
512 N.E. 73 Ave., Portland 16, Oregon

BURIED TREASURE, MINERALS

AMAZING NEW GOLDAK LOCATORS

SENSATIONAL NEW MODEL!

ONLY 11 pounds weight! One hand operation! Money-Back Guarantee of Superiority. Write for full details.

THE GOLDAK CO.
1542 WEST GLENOAKS BLVD.
GLENDALE 1, CALIFORNIA

World's largest maker of fine locators



TORQUE WRENCHES

(At Real Bargain Prices)



KENT MOORE \$1.85

New Torque Wrenches at a fraction of the usual price. All are guaranteed new and unused. Surplus stock... must be sold. Take Advantage Of These Low Prices.

KENT MOORE: 3/4 inch drive, 25 pound. Used largely by Chevrolet Service Departments. Real Bargain. **\$1.85**

STURTEVANT: 3/8 inch drive. Floating handle, 25 pound. Recommended for Chrysler Service. Value \$15.00. **\$2.45**

STURTEVANT: 1/2 inch drive, 100 pound. Floating Handle 19 1/2 inches overall. **\$6.50**

DURO: 1/2 inch drive, 100 pound. No. 80991 1/2. Yellow shockproof plastic handle. Complete unit in green enameled metal box. Only **\$5.85**

TERMS: Cash with order or \$1.00 deposit balance C.O.D.

Main Supply Store, Dept. 2, 523 Main St., Kans. City, Mo.

YOUR CHEAPEST INSURANCE AGAINST A DAMAGED MOTOR



"OIL-SPY"

YOUR "PRIVATE EYE" ON YOUR OIL SUPPLY

Measures Oil Level Accurately & Automatically

Amber Light—1 qt. low
Red Light—2 qts. low

Your car needs one. OIL-SPY, the only inside-the-car-on-the-dash automatic oil level checker, ends for all time the bothersome, time-consuming chore of checking your oil level with a dip-stick. You know when your oil level goes down too low. The OIL-SPY never lets you down. An amber light flashes when oil is 1 qt. low and a warning red light when oil falls 2 qts. low. A factory approved accessory, OIL-SPY was thoroughly tested on the proving grounds of five leading automobile manufacturers.

Most Valuable Car Accessory Since Automatic Transmissions

FOUR EASY STEPS FOR INSTALLATION

1. Replace original crankcase drain plug with OIL-SPY plug unit.
2. Install OIL-SPY light unit in instrument panel.
3. Connect lead line to ignition switch.
4. Thread cable through fire wall and connect to OIL-SPY plug unit.

\$9.95

Order Now! Fits All Cars State Make, Model, Year of Car

We pay postage when check, cash, or money order is sent with order. Send cash by registered mail only. When ordering C.O.D. send \$2.50 with order. Pay postman balance on arrival. Shipped complete with full directions for installation.

YOU MUST BE SATISFIED AFTER 10 DAYS TRIAL OR YOUR MONEY BACK

GARBISCH-EDGINGTON

465-M-3 Hippodrome Annex Cleveland 14, Ohio

B-M POWER MOWERS

FOR MODERN LAWN CARE

Choose from three models of our fine rotary mowers for your special cutting needs. The D-3 (pictured here), the self-propelled PD models, or our light VD mower with vertical shaft engine and direct blade drive. Dependable 4-cycle engines, lifetime construction. Prices, complete with engine, \$89.00 and up.

- Prompt Shipment
- Low Factory Prices
- Fully Guaranteed
- Model D-3

Write for free literature.

B-M MOWER CO., Box 66-PM, Blue Mound, Kansas

CRESCENT TOOLS

Give Wings to Work

ASK YOUR HARDWARE DEALER

WORKSHOP MOTOR BARGAIN



• 1/4 H. P. ONLY \$6.50 •
Leland, Delco, Westinghouse, Sunbeam, and others. Induction type motors. Alternating current, 110 Volt, 60 cycle single phase, 1725 R.P.M. Like New. Fully Guaranteed, some shop worn, many brand new. Every one a whale of a bargain. F.O.B.

THE VAPORITE Automatic HUMIDIFIER for Warm Air Furnaces

Thermostatically controlled water supply puts more moisture in the air. Easily installed in bonnet of air furnace. Complete with THERMO-STAT Water Control Valve, Tubing and parts for complete installation. GIVES HEALTHIER AIR.

Value \$15. Value ONLY \$7.50



We have large stock of Standard & Special Motors; all sizes. Write for BARGAIN MOTOR CIRCULAR and SAVE MONEY.

C. MARSHALL SALES RUSH ORDER
3546 W. Fullerton Ave., Dept. P-3, CHICAGO 47, ILL.

AUTOMATIC BLINKER LANTERN
RED FLASHER
New Amazing HANDILITE

SPECTACULAR MONEY MAKER ON 1 SECOND DEMONSTRATION

FAST CASH FOR AGENTS AND SALESMEN
Revolutionary new invention. Sensational seller. HANDILITE lantern ends danger of night-time accidents when car is parked for tire change or emergency repair. Warns off traffic. 3-WAY ACTION. Red flasher light only (visible a mile away)—or both flasher and 1,000-foot white beam—or white light only at a turn of the switch. Indispensable to car, truck owners. Unequaled as utility or spot light, boat light, for fishing, hunting, vacationing.

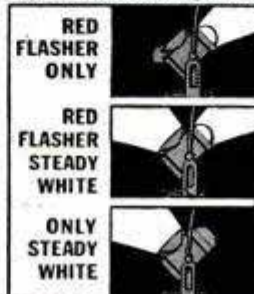

A "GOLDMINE" FOR SALESMEN - DISTRIBUTORS
Millions need it now. Nothing like it. Sells on sight. Just turn switch—HANDILITE STARTS FLASHING. Makes its own demonstration. So spectacular, prospects take it away from you. Huge profit opportunity. Sensational Summer Seller. Get details and Sample Offer. Don't delay. Send name today for free facts.

THE HANDILITE CO.
Dept. 43, Sturgeon Bay, Wis.

Snap-on* MAGNETIC PICK-UP TOOLS

- Powerful Lift
- Small Size
- Hinged Handles

Perfect for retrieving iron and steel objects, such as bolts, nuts, washers, cotter pins, etc., that fall into small places.

9" Size \$1.00
Lifts 8 oz.

16" Size \$1.95
Extends to 27" Lifts 24 oz.



DIRECT THRUST HACKSAW

One-piece steel tube back is fitted into a precision-machined cast-aluminum handle. With 10" blade . . . \$3.95



* T.M. REG. U. S. PAT. OFF.

SNAP-ON TOOLS

CORPORATION
8062-C
28th Ave.
Kenosha,
Wisconsin

I enclose Check Money Order for the following tools:

Pick-up Tool 9", 16"
Hacksaw Frame, blade

Add Local Sales Tax

Name.....

Address.....

City.....State.....



**Finished Photos
in 2 Minutes!**
**Greatest
QUICK-PHOTO
INVENTION
in History!**
**PDQ CHAMPION
PHOTOMASTER**
**Takes and finishes 30
to 40 photos an hour**

Beautiful, everlasting photos—black and white or sepia, size 2 1/2 x 3 1/2 in. Guaranteed not to fade. No dark room needed. Photos are taken DIRECT on "SUPER SPEED" direct positive paper. Loads enough paper for 50 shots in half a minute—in broad daylight.

No experience required. Simple instructions tell how to operate the Champion Photomaster. This portable photo studio weighs only 6 lbs. Size 4 1/2" x 5" x 10".



**Be a PDQ
Photographer**
Work at home or travel—make expenses plus extra profits. Most amazing money-maker ever invented.

YOUR PROFIT OVER 700%

Pictures cost you only 2c. Sell for 15c to 25c. Folks just grab for 'em. They are amazed to see their own photos come to life in broad daylight. Photomaster "shoots" any subject—individuals or groups—buildings and scenes. This new and fascinating business offers unheard-of money-making opportunities everywhere—every day throughout the year. **DETAILS FREE! WRITE**

P D Q CAMERA CO.

1161 N. Cleveland Ave., Dept. PM3, Chicago 10, Ill.

PARTS FOR MILITARY TRUCKS

**4 or 6 Wheel Drive at a SAVINGS—
1/4 ton to 20 ton.**

Parts List Available on Most Makes
Military Trucks and Jeep Models
Write stating model of Truck



**Brand New — Weatherizing Kits
JEEP TOPS and CURTAINS**

Fits all military jeeps, also adaptable to civilian jeeps. Complete top with back curtain and side curtains with doors, and 5 windows. Waterproof O.D. color. Shipping wt. 40 lbs. Less Steel Bows.

Our low price for complete set only..... **\$49.50**
Also available Tops only with back curtains attached **\$29.50**
Side curtains to match with doors and windows, only **\$20.00**

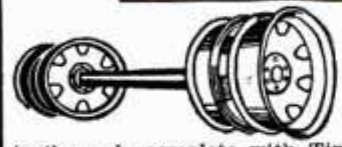

TRAILER AXLE

Heavy duty trailer axle suitable for many types of trailer construction. Also excellent for building of heavy farm trailers and wagons. It is a 12,000 lb. capacity square type straight

trailer axle complete with Timken roller bearings, hubs, and 6 hole 750 x 20 Budd Wheels. Without brakes. Axle is 2 inches square and 69 inches between wheel mounting flanges. Std. width.

With Single Wheels. **\$59.50** With Dual Wheels. **\$69.50**

GAS TANK Utility, 6 qts.—New Surplus. Cylindrical 5 1/2" x 15 1/2", complete. **\$2.10**

Brand New **HYDRAULIC JACKS** Walker, 3 ton. Complete, limited supply, ea. **\$9.95**

WINCH CABLE, 1/2", 250 ft. **\$30.00**

Hundreds of Other Truck & Jeep Parts and Supplies
All prices quoted good 30 days FOB, Kansas City, 25% Deposit Required on All Orders.

American AUTO PARTS CO.
1830 LOCUST — DEPT. PM
KANSAS CITY, MISSOURI



ALL-PURPOSE SMALL MOTORS



D-2 Converts to 110 V AC in ten minutes, diagram included, contains integral gear box having four 1/4" drive shafts turning simultaneously at the following speeds:
4000 RPM — Grinders, buffers, flexible shaft tools, etc.
150 RPM — Wrapping fishing rods, slow speed tools.
25 RPM — Dev. tray rocker for photo darkroom.
5 RPM — Turning barbecue spits.
Adv. Disp. Beams, A Thousand Other Uses Around the Work Shop, ONLY **\$5.95**
Converted to 110 volts AC..... **\$7.95**

D-1 Converts to 110 V AC in ten minutes, diagram included, reducer with 2 shafts and pulleys at the other end. **1001 uses. Only \$4.95**
A real beauty, removed from aircraft.

6-V. MOTOR Type used for auto fan. Many uses. Ea. **98c**

RM-29 PORTABLE FIELD TELEPHONE

An ideal portable field telephone. Complete in a rugged steel case for years of wear. Ringer circuit and handset. 5" x 6" x 9". Simple two wire operation. 15 miles distance and upwards. Can be used for television installation, intercom system, construction companies, outside and inside work, etc. **13 lbs. \$9.95 2 for \$18.95**
All prices F.O.B. Chicago. 20% deposit required on all C.O.D. Orders. Write for free catalog.



NESCOP ELECTRONICS Dept. PM-3, 2635 W. Grand Ave. Chicago 12, Ill.

110 AC-DC ARC WELDER



A sturdy, compact metal Arc Welding Outfit for light welding. For home workshops, mechanics, farmers, etc. Repairs toys, fenders and other steel items 16 to 22 gauge. Everything you need—Welder, Helmet, Rods, Attachments, Instructions. Only **\$5.95** post-paid, or C.O.D. plus few cents postage. Ten-day Trial Offer. Money back guarantee if not satisfied.

COMPLETE **\$5.95**

MINEX 44 DEBOLT ST. NEWTOWN, OHIO

BRUSH PLATING OUTFITS

for re-plating articles in the home and shop. No tanks necessary. Free particulars.

GUNMETAL CO., AVE. M, DECATUR, ILLINOIS

Take steps to help those who can't—use Easter Seals

SPECIAL OFFER to Hobbyists

ONLY **4.95**

Hard Angle Jobs Set-up in 5 Seconds

Save TIME! MONEY! Drill, mill, grind, etc., round, square, irregular pieces at any angle—Quickly—Easily—Accurately with **PALMGREN "HOBB-E" ANGLE VISE**
Accurately machined and graduated. 1 1/4" Jaws, 1-Plain, 1-Grooved. Order NOW! Only **\$4.95**.



Write for "HOBB-E-HELPS" Circular. **CHICAGO TOOL & ENGINEERING CO.**
8365 South Chicago Ave., Chicago 17, Ill.

CASITE GUARANTEES BETTER AND SMOOTHER MOTOR PERFORMANCE

New BELT SANDER ONLY **\$10.95**



Stationary and Portable

Ideal all-purpose sander for home or shop! Stop-Fence Unit adjusts to 4 positions — tilts to 45°. Sturdy aluminum construction. May be powered by electric motor, drill, lathe, etc.

Send for free circular NOW!

JOHNSON Mfg. Co., Dept. 1C, Lincoln Park 7, R. L.



**WORLD'S LOWEST PRICED
ADDING MACHINE**

IDEAL FOR BUSINESS AND PERSONAL USE — GUARANTEED ACCURATE. Not a toy. Operates with only a finger flick. Adds, subtracts, multiplies, divides. Counts up to one billion. Pays for itself over and over. Ideal Gift — for Business, Income Tax and School use. **\$2.95**

MONEY BACK GUARANTEE. Send name and address. Pay postman only \$2.95 plus postage. (Send full cash if outside U.S.) Beautiful rich-looking Leatherette Case included at no extra cost. Money back in 10 days if not delighted. AGENTS WANTED.
CALCULATOR MACHINE CO., (Mfrs.)
Dept. 224, P. O. Box 248 Glenview, Illinois

PESCO ELECTRIC PUMP



FOR FARM, HOME AND SHOP

Brand New Complete self contained, Explosion proof electric pump with 1/4 H.P. electric motor. Ideal for pumping Gasoline, oils, water and liquids. Equipped with mounting flange 5 1/2" dia. with 12 holes 3/4" on a 4 7/8" dia. circle. The discharge is a 3/4" hose connection. Cap. 2 G.P.M. 24 Volt A.C. or D.C. Can be converted to other voltage. For farms, Cottages, basements, Laboratories, boats and trucks. Greatest value in pumps. \$85.00 value; (Stock #659). Only **\$8.95**

WEAVERS HYDRAULIC HAND PUMP



Brand new. For hydraulic Jacks, presses, hoists, etc. For operating hydraulic cylinders to pump oil or hydraulic fluid under pressure. Has built in check valve and is capable of delivering 1000 lbs. pressure; wt. 10 1/2 lbs. A \$50.00 value. Instructions incl. (Stock #53). Postpaid **\$8.50**

TREMENDOUS Gear Bargain

Bearing Angle Gear unit. This is a heavy angle gear Equipped with ball bearings on all shafts. There are 3 shaft connections. The Angle shafts are 60 degree to right and left. Gear ratio 1:1. This drive will transmit 10 H.P. Ideal for double swinging door closer, and driving various attachments to Farm, tractor, and other machinery. (Stock #75). Price Only **\$7.50**

SPEED REDUCER

10-1 or 5-1 ratio. 90 degree angle Shaft Driven. 1 1/2" spline shaft with 3 mounting holes 5/16" Gears held in forged and machined aluminum housing with two needle bearings, one bronze bearing and three high speed shielded bearings. Sealed self lubricating chamber. (Stock #70). Postpaid **\$3.95**

AMPLIDYNE MOTOR GENERATOR

#5AN31N318A - Use as 24/32 Volt D.C. motor, pulls 1/2 H.P. or 0/60 V. D.C. Generator Belt driven will deliver 30/40 amps. Can be adapted to 110 V. A.C./D.C. 10,000 R.P.M. 1/2 H.P. by simple changes in connections. Unused instructions incl. (Stock #790). Gov't. Cost \$140.00. Only **\$5.50**

SENSATIONAL FASCINATING MYSTERIOUS SELSYN

Two or more connected together can be adapted for 110 V. A.C. For weather vanes, rotating directional antennas or controlling distance operations. Diagram and instructions incl. Price per pair **\$3.95** postpaid



A TREMENDOUS BARGAIN. Thompson BOOSTER PUMP

This is an exceptionally well built pump with direct connected motor. Runs on 24 Volt A.C. or D.C. 5.2 amps. The motor is Explosion proof constructed, making it suitable for pumping gasoline, fuel transfer, Hot water heating, circulator. As coolant pump, fuel booster, and as oil pump. Discharge connection is for 1" hose, rated Cap. is 5 G.P.M. (Stock #1200). Only **\$7.50**

New Purolator GASOLINE FILTER

aircraft type. Today's advanced gasoline Re-refining filter for all cars, trucks, tractors and motor boats, cleans and re-refines gasoline as you drive. Removes soline, water and prevents sludge formation. Install at home in a few minutes. STOP GASOLINE WASTE AND EXPENSE. Permanent. Needs no replacements. Instructions incl. **\$4.95** postpaid



CUNO OIL FILTER



BRAND NEW. Aircraft type. Filter oil without cartridge replacements. Just turn handle and the element is clean. Standard 3/8" inlet and outlet ports. Install at home in a few minutes. STOP CHANGING OIL. Instructions incl. (Stock #507). Now only **\$4.95** postpaid

ELECTRIC MOTOR 1/4 H.P. 27 V. D.C. R.P.M. 4000. No. 750. For intermittent or Continuous duty. 5/8" Shaft. VARIABLE SPEED MOTOR. CAN BE ADAPTED TO 110 V. A.C. or R.E. A. line by simple arranging armature brush leads. UNUSED. Instructions **\$5.50**

ELECTRIC MOTOR 1/4 H.P. 24 Volt D.C. R.P.M. 2500. Amp. 22. #HCA24. Gov't. cost **\$3.50** \$75.00. Brand new

ELECTRIC MOTOR 1/4 H.P. 28 Volt D.C. R.P.M. 4000 by Bendix #451350-0-2. Gov't. Cost \$82.84. Brand new **\$3.50** (With instructions to convert to 28-32 volt A.C.)

ELECTRIC MOTOR 1/5 H.P. 27 V. D.C. 3800 R.P.M. Unused **\$2.50**

ECLIPSE MOTOR & GEAR UNIT

Brand new. This is a 24 V. D.C. motor with built-in planetary and bevel gear reduction. Has 1 Horizontal and 1 vertical take-off shaft. Overall gear ratio to motor is 40-1. can be adapted for 2-1 or 20-1 ratio. Unit can be operated from 32 V. D.C. Farm light plant. Ideal as OVERHEAD GARAGE DOOR OPERATOR. DRIVE FOR SMALL HOIST. WELL PUMP JACK. LAWN MOWER DRIVE. DRIVE FOR POST DRILL, etc. Wt. 23 lbs. Gov't. cost \$221.00. Instructions incl. Only **\$12.50**

D. C. GENERATOR

Brand new. For farm—Home—Ranch. Delivers 430 Volts D.C. at 3450 R.P.M. Ball bearing supported. Fan cooled armature. Self lubricating bearing. Drive it off farm tractor gas engine, etc. #211220-A. **\$5.50** Wt. 21-lbs. Now only



BRAND NEW WONDERFUL ROTATOR MOTOR

For rotating Ham FM Antennas, Turntables, Telescopes, etc. Operates directly on 110 V. A.C. 60 cycles (requires only 12 MFD condenser) 3/4 R.P.M. For operating Ventilating Louvers such as used with Attic Fans, Furnace Dampers or check drafts. Instructions incl. (Plus 35 cents postage). Ea. **\$3.95**

BENDIX ELECTRIC HYDRAULIC PRESSURE SWITCH

BRAND NEW. Acts as an electric shutoff—turn on. This is a hydraulic operated pressure switch, with extra heavy contacts which are arranged so that with no pressure the contacts are closed making this switch suitable for automatically starting and stopping the motor used to drive hydraulic pumps. The switch may be removed leaving a small cylinder with a 5/16" Dia. shaft extending 5/8" for operating locks and stops. GREAT SAVING AT THIS LOW **\$7.95** postpaid

SELF-PRIMING ADEL ELECTRIC PUMP

Compact—Brand New. Applications: For pumping light oil, aquariums, fluid metering fuel pump, tool post grinder, coolant pump, pressure lubricating pump, general industrial use. Double ball bearing series wound motor, continuous duty. Rated 12,000 R.P.M. Can be operated, 24 Volt A.C. or D.C. Pump rated 1.25-30 G.P.H. Overall length 6 3/4" Dia. 2 1/2". The pump body may be detached from the motor which exposes a 1/4" dia. shaft to which other attachments may be made. A \$50.00 value. **\$7.95** (Stock #J-40-24). Postpaid

All items Guaranteed as represented. Send check or Money Order. Prices f.o.b. K. C. except when marked postpaid.

GENERAL SALVAGE CO.
2922 E. 27 ST. DEPT. 17
KANSAS CITY, MO.

STRATOPOWER HEAVY DUTY HYDRAULIC PUMP



BRAND NEW. For operating hydraulic cylinders and hydraulic motors on tractors, bulldozers, construction machinery, lift trucks, fuel or oil transfer, coolant pump, industrial applications, etc. Delivers 2 GPM at 1500 R.P.M. at 1400 P.S.I. Has 3/4" inlet and outlet. Can be used as hydraulic motor. Has flange with 4 bolt holes for convenient mounting. With built-in relief at head. Wt. 8 lbs. overall dimen.: 5 1/2" x 4". (Stock #37). An \$85.00 value FOR ONLY **\$12.50**

Hydraulic Cylinders

AIR OR OIL Use Hydraulic cylinders for the following applications: For arbor presses, hydraulic presses, hay lifts, manure loaders, lift trucks, push or pull, tilt or turn, press or squeeze, open or close, lift and lower, etc. Use with either air, or oil. Finest quality and workmanship.

Stock No. 10
Double action, 1" Bore, 3" Stroke, 3/8" Shaft Clevis mounting. Overall length 9". Capacity 700 lbs. with 1000 P.S.I. input. Has a capacity of 1050 lbs. with Stratopower pump. Is perfect for applications such as door openers, positioners, small loaders, control units, etc. A REAL TERRIFIC VALUE. Postpaid **\$4.50**

Stock No. 11
Double action, 1 1/2" Bore, 6" Stroke, 3/8" Dia. Shaft Clevis mounting base and shaft end. Cap. 1160 lbs. with 1000 P.S.I. input. Has a Capacity of 1740 lbs. with STRATOPOWER PUMP. A \$50.00 value. Postpaid **\$9.50**

Stock No. 32
This is a double action hydraulic cylinder 2" Bore—3 1/2" stroke, 3/8" Shaft Clevis mounting on both base and shaft ends. Capacity 3100 lbs. with 1000 lbs. pressure. Has a capacity of 4650 lb. with the Stratopower pump. **\$12.50** postpaid Only

Stock No. 9
Double Action Hydraulic cylinder, 3 1/2" Bore, 1 1/2" Stroke, 1-5/16" Dia. shaft Clevis mounting Base & Shaft end. Capacity 9625 lb. with 1000 P.S.I. Has a capacity of 14437 lb. with Stratopower Pump. Value **\$19.50** postpaid \$100.00. Now, only

Stock No. 12
Cylinder Double action, 4" BORE, 8 3/4" STROKE, 1-5/16" shaft, Clevis mounting base and shaft end. Capacity 12560 lbs. with 1000 P.S.I. Has a Capacity of 18840 lb. with the STRATOPOWER PUMP. EXCELLENT VALUE. **\$27.50** Postpaid

HYDRAULIC VALVES

BRAND NEW HYDRAULIC CONTROL VALVES

Four way control for use with two hydraulic double action cylinders. Each cylinder may be operated, independently of the other or in conjunction with the other. Oil may be locked in any of the cylinders to hold the piston on any required position. Brand New \$60.00 value. (Stock #620). Only **\$8.95** postpaid

BRAND NEW HYDRAULIC CONTROL VALVE

This is a TWO CYLINDER DOUBLE ACTION VALVE with unique arrangement allowing the operator to raise both cylinders simultaneously, to lower them simultaneously or to raise one and lower the other at any predetermined rate and speed. A \$75.00 value. Postpaid **\$8.95** (Stock #137)

ADEL PRECISION VALVE — BRAND NEW

This is for a double end cylinder control or for two single cylinders that are to work in opposition to each other. When pressure is applied on one line, it will open opposite check valve so that pressure in that line can be **\$5.50** postpaid relieved. No. 10335. Now only

VICKERS CONSTANT DISPLACEMENT HIGH PRESSURE PUMP. Use it for any type liquid pumping job 375 gal. per hr. at 3750 K.P.M.: 1000 pounds pressure per sq. in. Can be used as hydraulic motor O. Acq. \$100.00. Brand new directions incl. **\$8.95** postpaid Wt. 7 lbs.

HYDRAULIC CHECK & RELIEF VALVE

VICKERS UNLOADING VALVE. Brand New—by passes full amount output of the pump while the cylinder is not in operation. Takes starting load off of electric motor driving the pump. Price **\$4.95** postpaid

PARACHUTE, 24 foot, white nylon, with harness, nylon strings, etc. App. 60 s. yds. material for drapes, clothing, etc. Used, clean, only **\$15.00**

AVIATION TYPE SUN GLASSES

Lens: 4 base ground, polished recessed green glass. Frame: gold plated, cable temples & sweat bar & nose pads. Carrying case with belt loop. Sizes: large or medium. Guaranteed against breakage: postpaid. **\$1.95**



AIRPLANE WIRE ROPE
EXTRA FLEXIBLE, CORROSIVE RESISTANT

Size	Strands	App. break lbs.	Per foot
3/32"	7/7	920	.04c
1/8"	7/19	2000	.06c
5/32"	7/19	2800	.08c
3/16"	7/19	4200	.10c
1/4"	7/19	7000	.13c

No. CODs. Postage prepaid. Min. order \$2.00. Discount 10% 100 ft. or more.

AIRPLANE GENERATOR, P-1 type, 200 amps, 24V; use for welding, lighting, etc. Good used condition, FOB. Ship. weight, app. 60#. reduced to **\$15.**

CO2 FIRE EXTINGUISHER

Hand type, filled with CO2 and reconditioned. Shipped Express only, shipping wt. 15#. only **\$9.95**

FAIRCHILD A10 SEXTANT, \$5.95

AAF War Surplus, included is the A10 Sextant, wood carrying case and battery case. These are used condition, no operational warranty given; they are just as received. We do guarantee a good bubble assembly. **\$5.95**

FAIRCHILD A10-A SEXTANT, w/case, as above, \$7.95
Sextants prepaid for 75c additional.

\$4.95 BOX CAMERA, \$1.50

Built to sell for \$4.95; metal box camera. Takes 12 pictures per standard #620 or 120 load, picture size 2 1/4 x 2 1/4". All new. Postpaid. **\$1.50**
Leatherette carrying case with strap, 50c extra



AIRCRAFT CONTROLLER (DC MOTOR)

24V DC, .01 hp, rpm 7000, torque 200 psi, reversible, stroke .45 seconds; by Barber-Colman, #2066, size 3 1/2" x 8". Reconditioned. Shipping wt. 5#. **\$2.95**

FLAP ACTUATOR W/DC MOTOR

24V, 11,000 rpm, Lear #108, low speed take-off. Reconditioned. Shipping wt. 5#. **\$3.95**

All F.O.B. Houston. Send Check, cash, Money order

AERO PARTS SUPPLY, Dept. PM-2

8102 LOCKHEED ST. HOUSTON 17, TEXAS

PISTON TYPE COMPRESSOR



EASY PROFIT IN PAINT SPRAYING

Paints walls, ceilings, screens, furniture and machinery faster, better. All complete as shown less motor. Carry anywhere. Fully guaranteed. Could be used with 1/2 H.P. motor or less. Price \$35.00 less motor F.O.B. Chicago. \$5.00 deposit balance C.O.D. or see your dealer. With motor \$55.00.

IDEAL AUTOMATIC PUMP CO., Dept. P.M. 8
801 W. Washington Blvd. Chicago 7, Ill.

WAR EQUIPMENT MAIL SALE!

Buy Direct By Mail—SAVE!

SAVE 50% to 75% on gigantic close-out sale of 100s of guaranteed items. All shipping charges prepaid.

- A. Utility Clutch, up to 6.5 h.p. **\$13.95**
- B. Magneto Rural Telephones... **12.40**
- C. Burglar Alarm System... **6.95**
- D. Fire Alarm System... **9.95**
- E. 2000-watt 110-volt Elements... **.99**
- F. City Wall or Desk Phones... **4.99**
- G. Rotary Gear Pumps... **3.95**
- H. Briggs 1.5 h.p. Engine... **44.90**
- I. Multi-Speed 110-V, 60-C Motor **8.75**

Order direct from ad. Satisfaction guaranteed. Or, rush card for sensational mail-sale bargain catalog!

BURDEN SALES COMPANY

805 "O" ST., LINCOLN, NEBR.

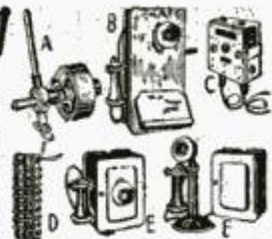

Dozens Bargains in electronic, hydraulic, mechanical items. Electrical drills, saws, etc.

SEND FOR CATALOG!

SAVE MONEY

Build this 18 ft. House Trailer yourself \$286.00.

Blueprints, Building instructions and 1950 parts catalog 50c. Don't Delay, Write Today

NATIONAL TRAILER EQUIPMENT COMPANY

Dept. PM-3, 1007 N. WATER STREET, MILWAUKEE, WISCONSIN



Build your own JET ENGINE!



Order these plans today

1. JET PROPELLED BICYCLE, Assemble your own. Photo and instructions \$1.00.
2. HOW TO MAKE EXPERIMENTAL JET ENGINES, Seven sheets drawings with information and instructions \$2.95.
3. BOTH OF ABOVE in one order \$3.75. SEND NO MONEY. Order both at once \$3.75 C.O.D. in USA plus c.o.d. postage. Send check or Money Order and we pay postage. Get other information too. Rush Order.

J. HOUSTON MAUPIN, Dept. 55, Tipp City, Ohio

BAKE YOUR OWN FINISHES IN YOUR SHOP

Real Industrial baked finishes now possible for small consumers and home workshops. Quality paints at factory prices. Write for free color charts, information and prices TODAY. M & S INDUSTRIAL PAINT CO., 549 W. Washington Street, Chicago 6, Ill.

It costs money to help crippled children. Use Easter Seals

AMAZING NEW WOOD-TURNING TOOLS

SHARPEN ONCE IN 12-YEARS! (UNDER NORMAL USE)

These remarkable tools tipped with TUNGSTEN CARBIDE will astound you with their performance. They work FREE HAND equally well in wood, plastic or soft metals—and at the same time hold their razor-like edge almost indefinitely. Tests show that they will turn wood or plastic for days and days CONTINUOUSLY without showing any signs of dulling. They are the finest tools available at any price. Beautifully finished 5" blade—flush ground, polished tip—flame brass tube ferrule—9" hardwood handle—over all length 14"—25 tools to choose from: round & square nose from 1/8" to 1/2"; 1/4" and 3/16" cut off; 1/2" x 30° skew, spear, r. & l. skew, turning and parting. Amazingly Low Prices! Write at once for free literature.

JOHNS MFG. CO., DUNELLEN 8, N. J.

\$\$ EXTRA PROFITS! \$\$ Flocks & Sandblasts

Dual Purpose Spray Gun! Uses only 25 lbs. Air Pressure

● Thousands of uses in Home, Shop, Industry: Makes Auto Interiors Clean & New, Lines drawers, Marproofs lamp bases, Refinishes any object. All in colorful Flock, Etch & Frost windows, glassware, etc. Removes Paint & Rust from Autos, Tools. Guaranteed! Send \$19.75 or write for free information. Flocking supplies!

BLASTO SPRAY GUN MFG.
Dept. PM-3, 7007 Haas Avenue, Los Angeles 47, Calif.

NONE BETTER! SUPER DRILL GRINDER

Sharpens round shank drills from 3/32" to 1/2" in diameter, up to 6" long. Grinds old drills like new in 4 different point angles, using hand or power grinding wheels. Money-back guarantee.

Price only **\$2.95**
At Dealers or Postpaid

CRANDALL MFG. CO. 1512 W. Slauson, Dept. FA-47, Los Angeles 44, Calif.

INCREASE SAW SHARPENING PROFITS!

REYNOLDS CIRCULAR SAW GRINDER

Produces top quality results in fraction of time usually necessary for resharpening, jointing, gumming and tooth forming. Any hook or pitch of tooth and depth of cut is quickly adjusted. Both hands are free to control position of saw while grinding. Write now for free circular!

PROVIDENCE SAW & KNIFE COMPANY
305 Eddy St. Providence 3, R. I.

WELD BRAZE, SOLDER, CUT quickly... easily

The FOUR-WAY PORTABLE ARC-WELDER

COMPLETE ONLY \$9.95 F.O.B. 10 DAY TRIAL

MAKE OR REPAIR HOME & FARM APPLIANCES FENDERS BICYCLES METAL FURNITURE & 1001 ITEMS

YOU'LL BE AMAZED by the work you can do on your first job! Plugs into any convenient properly wired 110 volt A.C. or D.C. line. Follow simple directions. Work on iron, steel, bronze, brass, aluminum and other metals. Save money doing own repairs. Make money repairing for others. Thousands of users among maintenance and repair men, farmers, tinmiths, engineers, home and auto owners, etc. Pays for itself over and over. Order on ten-day trial or send for details.

FREE! FOUR-WAY WELDER CO., Dept. F2-CA, 2326 So. Michigan Avenue • Chicago 16, Illinois

Full Details SEND TODAY

FOUR-WAY WELDER CO., 2326 So. Michigan Ave., Chicago 16, Dept. F2-CA. Please send as checked below.

Four-Way Welder on 10-day trial. I enclose \$9.95, or I enclose \$_____ as a deposit. Ship C.O.D. for balance.

Illustrated and described details on Four-Way Welder.

NAME _____

ADDRESS _____

CITY _____ STATE _____

"Wellworth" Sensational Offer! Reg. \$60.50 WESTINGHOUSE AIR COMPRESSOR

Compressor, pressure tank, air gauge, air chuck, 20-ft. hose, pop valve, copper tubing with 4 brass flared fittings for connecting compressor to tank, 4-way cross and 3 nipples. COMPLETE OUTFIT, wt. 52 lbs.

Equipment less Compressor, \$12.50. Compressor separately, \$21.50
Compressor has 2" bore, 1 1/2" stroke, ball bearing, 3.27 CFM at 600 R.P.M. Capacity up to 6.54 CFM. Size 9"x11 3/4"x6 3/4". Wt. 26 lbs. Ideal for spraying paints, insecticides, etc., inflating tires, operating air tools, and other uses. All new equipment. U.S. government surplus. Replacement parts available. Amazing buy. Don't miss it.

Model T-1 Brand New - 2 CYLINDER PISTON TYPE. Operates with 1/2 H.P. Motor or equivalent gas engine.

\$32.50

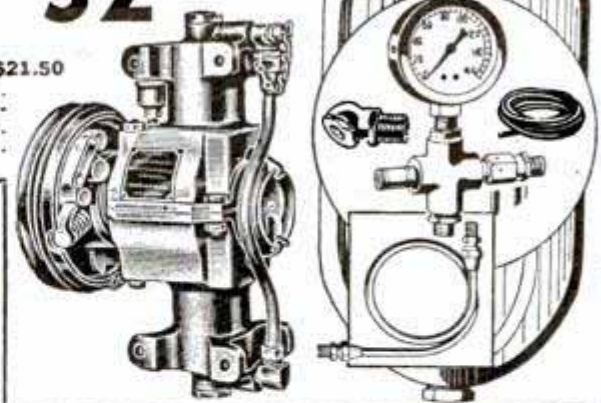

PORTABLE SPRAY OUTFIT

1/4 H. P. HEAVY DUTY MOTOR
EXTERNAL ATOMIZING GUN

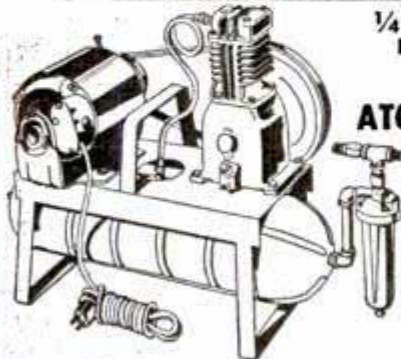

Paint Sprayer mounted on 6 x 24 inch tank, 1/4 H.P. 110 V. 60 cy. Heavy duty motor with overload relay, 10 ft. cord and plug, V belt drive. Piston type Compressor with 2 Compression rings, 1 oil ring, 2 inch Bore, 1 3/4 inch stroke, displacement 2.86 C.F.M. at 60 lbs. pressure. Safety Valve. Gun external atomizing. Flat and round spray, quart cup; maintains 35 to 40 lbs. working pressure. Oil and water extractor, 1 air gauge, 20 ft. heavy duty 2-braid air hose carrying handle.

with leak proof fittings, complete with Net weight 54 lbs., ship. wt. 60 lbs.

\$57.50

COMPLETE OUTFIT

Outfit less motor, Wt. 30 lbs. \$47.50
Compressor only, Wt. 14 lbs. 17.50
Spray gun and 20 ft. hose, Wt. 7 lbs. 12.95

Portable Automatic Paint Spray Unit

Spray paint your home, car, garage, etc.



Complete outfit Including Spray Gun. \$150.00 Value.

\$89.50

Same unit, stationary, \$79.50

Use also for spraying insecticides on plants and flowers. 1/2 H.P. heavy duty capacitor motor. AC 110/220 volt, 60 cycle, 2 x 1 3/4 inch piston type compressor, splash feed lubrication, 12 1/2 x 24 inch tank, automatic pressure switch, CFM 2.8 at 100 lbs. pressure, or 150 lbs. pressure for intermittent duty. Check valve, safety valve, air regulator with gauge and filter, spray gun with 20 ft. air hose and air chuck for inflating tires, V belt drive, mounted on 2 wheels, ball bearing, with 29 x 10" pneumatic tires. Portable, with handle. Shipping wt. 90 lbs. Regular \$150.00 value. ONE YEAR GUARANTEE. Only \$89.50 complete.

PARTS SOLD SEPARATELY

Compressor	17.50	wt. 16 lbs.
Automatic pressure switch	7.50	wt. 3 lbs.
Regulator, gauge and filter	8.50	wt. 5 lbs.
Spray gun	9.95	wt. 4 lbs.
Tank, wheels and base	17.50	wt. 32 lbs.
20 ft. hose	2.95	wt. 6 lbs.
1/2 H.P. Cap. motor	22.50	wt. 28 lbs.
Air gauge	1.75	Adjustable pop valve
1 1/4" check valve	2.75	wt. 2 lbs.

"Wellworth" BLOWER at a Bargain Price

Quiet operating. Double wheel inlet, double width blower. For heating, ventilating, cooling, drying, air washing, exhausting and forced draft. DIMENSIONS: 10" wheel; outlet 13 1/2" x 11 3/4"; inlet 8 3/4". Height 19". Width 18". Depth 14 1/2". C.F.M. 1 1/4" S.P. 1600; outlet vel. 1575; motor 1/4 H.P. with overload relay; cord & plug, 110 v. 60 cy. AC. Ship. Wt. 67 lbs. Special price. \$39.50

140 CFM "WELLWORTH" BLOWER

Single-inlet blower that gives top performance on heating, ventilating, exhausting, cooling, drying and similar applications. 3 1/4 x 4" mounting flange with 2 1/2" square discharge. 3 1/2" dia. blower wheel powered by direct-connected 1/15 H.P., 110 V., 60C., A.C. motor with cond. box and 20' leads. 7 1/2" wide less flange by 7 1/4" fl. x 6 3/4" D. Suited for hundreds of new and replacement uses. Shpg. wt. 6 lbs. \$14.20

50 CFM Blower 2 1/2" discharge \$6.95

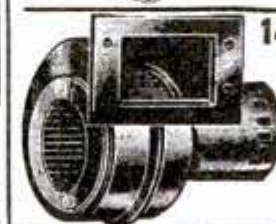
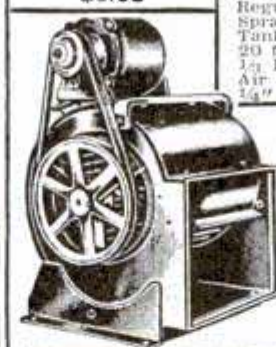

PNEUMATIC AIR TOOLS

USED, GUARANTEED LIKE NEW.

Chicago Pneumatic Lever Type AIR DRILL

With 1/4" Jacob Chuck. Wt. 2 lbs. List price \$55.00. Only \$14.95

Ingersoll Rand AIR DRILL
With 1/4" Jacob Chuck. Wt. 2 lbs. List price \$55.00. Only \$14.95

68 PAGE BOOK!
Motor guide, air compressors, home and factory workshop tool catalog. Send 10c to cover postage and handling.

CHICAGO PNEUMATIC RIVETER & CHIPPING HAMMER
CP4X Pistol grip handle. Takes up to 3/16" rivet. Weight 6 lbs. List price \$73.00.
Ideal for work on fenders and auto bodies
SPECIAL PRICE \$10.95
Same as above, brand new \$22.50

AIR TANK and ACCESSORIES

Air receiver, stainless steel, 12 1/2" x 24", 400 lb. test. Ideal for carrying on trucks, autos and wherever compressed air is needed. Equipped with 500 lb. air gauge, tire chuck, 3 ft. highest air hose, air inflation valve with core for retaining pressure in tank, and fittings.
Complete outfit \$6.95
Shipping wt. 20 lbs.
Tank only \$4.95

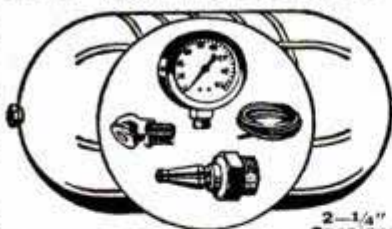

2-1/4" Openings

6 FT. STOW FLEXIBLE SHAFT
Heavy Duty, 3/8" Core. Best piano wire. Ball bearing handle and arbor, rubber covered housing; for 1/2" motor shaft; for 1/2" bore wheels. Operates on 1/4 H.P. Motor at 1725 or 3450 R.P.M. \$29.00 Value, \$14.50. Wt. 8 lbs.

All items advertised on this page are guaranteed BRAND NEW

300 GAL. COOLANT PUMP A Heavy-Duty Pump at 40% Less

You pay less and get a larger, higher pressure, higher capacity, heavy duty coolant-type, recirculating pump. Also extensively used on evaporator coolers. Will deliver 60 gal. per hr. at 8 ft. head and 300 GPH at no head. Heavy duty 1/30 H.P. totally enclosed, 110V., 60C. motor with long life oiling. Noncorrosive shaft and pump. 10 1/2" high, 3/8" I.P.T. Ship. wt. 12 lbs. \$15.95



SUMP PUMPS. ALL SIZES. BARGAINS. SEE CATALOG

Prices f.o.b. Chicago. Immediate delivery. All items sold on money back guarantee. Send check or money order today.

WELLWORTH TRADING CO.

1831 S. STATE ST. DEPT. D-3 CHICAGO 16, ILL.

BARRON Drill Press TOOLS

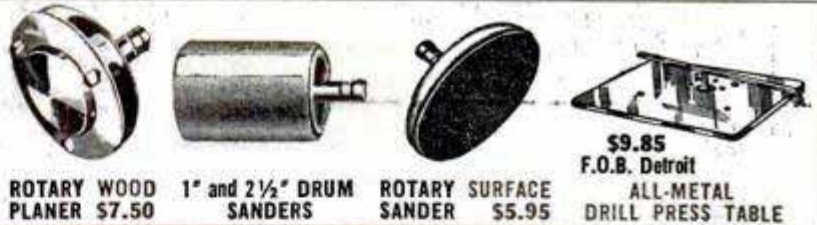

ROTARY WOOD PLANER \$7.50 1" and 1/2" DRUM SANDERS ROTARY SURFACE SANDER \$5.95 \$9.85 F.O.B. Detroit ALL-METAL DRILL PRESS TABLE

ALL-METAL SHAPER FENCE \$8.25 F.O.B. Detroit



ROUTER & MORTISING BITS \$9.50 per set of six

SHAPER CUTTERS \$9.00 including 3 sets Blades

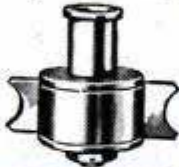

15 ESSENTIAL WORKSHOP OPERATIONS . . .

You can convert any standard make drill press into your most versatile, useful, low cost workshop tool. Barron Precision Tools now enable you to perform 15 indispensable shop operations—surface—plane woods and plastics—rabbet—tenon—panel—bead—groove—bevel—mortise—route—cut dovetail—sand surfaces and contours—shape—cut moldings—grind and buff. Over 200,000 Barron Tool users. Every tool sold on full 10 day money back guarantee.

See Your Dealer . . . Or Write Direct

BARRON TOOL COMPANY, INC.
869 Architects Bldg., Detroit 1, Mich.

FREE Workshop Guide & Catalog



SENSATIONAL BARRON SPEED-VISE!

PERMANENT—PORTABLE
Slickest, handiest, most useful all-metal work bench vise. A workshop "must" for—
PLANING • SAWING • DRILLING • SANDING • FILING • ETC.

Only \$175
Include 20c for shipping

Won't mar, mark or dent woods, plastics, metals. No piece too small or too large. 10 Day Money Back Guarantee. BARRON TOOL CO. Dept. MP DETROIT 1, MICH.

RETAIL PRICE \$125.00
FACTORY TO YOU \$59.95

SUPERSHOP includes precision-built 8" tilting table saw, vertical and horizontal drill press, 30" lathe, sander, grinder. 100% BALL BEARING. Write for FREE catalog, full details, trial plan.



POWER TOOLS, INC.

109 YATES AVENUE
BELOIT, WIS.

SPECIAL OFFER!

LOCK-STITCH SEWING AWL

\$1.

Postpaid

Famous, patented lock-stitch sewing awl complete with needles, waxed thread and direction folder. Hundred uses—sewing, repairing leather goods, canvas, belting, harness, saddles, gun cases, awnings, golf bags. Extra needles and thread available. Satisfaction guaranteed or money back. Send currency, check or money order. Yates Mfg. Co., 611-H Main St., Lake Geneva, Wisconsin



Ask Your Hardware Store for
FULLER'S
Unbreakable Amber Handle
SCREW DRIVERS



America's most popular line of moderately-priced screw drivers! Wide range of sizes. FULLER TOOL COMPANY, Inc. 911 Fuller St. New York 59
World's largest makers of Amber-Handle Tools

FREE AMAZING NEW BOOK "HOW TO ANSWER ADS"



Never before have you seen anything like this. Tells you in simple language the correct way to answer ads. Gets you quicker replies—better results, and greater satisfaction. Will save you time and money and it's ABSOLUTELY FREE. No obligation whatever. Every reader of advertising should have this booklet. Send a postcard for your copy NOW. Advertising Department, Popular Mechanics Magazine, 202 East Ontario Street, Chicago 11, Ill.

SURPLUS CUTTING TOOLS

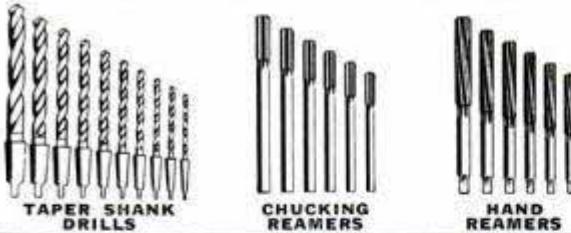

Set	Description	Price
Set 1.	8 different size High Speed Morse Taper Shank Drills up to 1/2" with No. 1 and 2 Tapers. \$25 value. New and slightly used surplus. Sharpened. Priced at only	\$3.85
Set 2.	10 different size High Speed Morse Taper Shank Drills from 1/2" to 1 1/4". \$50 value. New and slightly used surplus. Sharpened. Priced at only	\$7.85
Set 3.	10 different size High Speed Hand Taps up to 3/8". Priced at only	\$2.00
Set 4.	10 different size Straight Shank Drills from 3/8" to 1". Extra long drills. New and slightly used surplus. Priced at only	\$4.75
Set 5.	10 different size Taper Shank High Speed Reamers up to 1". New and slightly used surplus. Priced at only	\$4.50
Set 6.	6 different size Straight Shank High Speed Chucking Reamers. Up to 1/2". Priced at only	\$3.50
Set 7.	6 different size Straight Shank High Speed Chucking Reamers from 1/2" to 1". Priced at only	\$4.95
Set 8.	6 different size Hand Reamers up to 1/2". Priced at only	\$3.10
Set 9.	8 different size Hand Reamers 1/2" to 1 1/4". Priced at only	\$5.50
Set 10.	10 different size High Speed Morse Taper Shank Drills 1" to 2". \$180.00 value for only	\$39.95
Set 11.	10 different size Carbon Steel Morse Taper Shank Drills 1" to 2". \$80 value to \$100.00 value for only	\$22.50

All merchandise is sold with money back guarantee and is shipped POSTPAID.

T & T TOOL 101 WEST ARCHER
TULSA, OKLAHOMA

FLASH FLOOD FLUX

Hard soldering and welding problems solved immediately with this new, improved flux. Guaranteed to work on all metals including Stainless Steel, only exception aluminum and pot metal, or your money refunded. Send \$1.50 today for your Flash Flood Flux or write for free circular.

LARRY GUTHMAN WHOLESALERS LAKE WORTH, FLORIDA

SAY YOU SAW IT IN POPULAR MECHANICS

LAWN MOWER SHARPENER



lawn mower sharpening at low cost!
\$47.50
less motor.

turn spare time into dollars
Order direct from
QUAD CITY PRODUCTS
Company, Inc.
Box 42, Rock Island, Ill.

SAVE UP TO 85%

IN WAR SURPLUS from "GADGETS FROM HEAVEN"

92 PAGE CATALOG
War Surplus - Tools, Machinery, Raw Materials, Clothing, etc. Illustrated with valuable info., tables, charts & data. Send 25¢ to cover handling & postage.



PALLEY FAMOUS MIXES! Prepared especially for the HOME CRAFTSMAN, HOBBYIST, INVENTOR, GADGETTEER or SHOP MECHANIC.

GADGET MIX - Rivets, Spacers, Bolts, Screws, Gears, Wheel bearings, Springs and C.lamps.
No. 106, 5 lbs. **1.19**

BEARING MIX, No. 170A. Approx. 20 needle, Ball & Roller Bearings, New & Used. Sizes: 1/2" to 4". Some of these cost Gov't \$10 a piece. Never such a value!
5 lbs. **ONLY** **1.59**

HINGE MIX, No. 170H. 12 pairs of Strap and butt hinges, Hasps, 1" x 1" to 7/8" x 10" in length and 8" strap, 2 lbs. **1.09**

ABRASIVE AND GRINDING WHEEL MIX - 50 pieces including honing stone, pencil rolls, wheels, etc. A sharp value. No.170AG **99c**

SPRING MIX, No. 206 - Torsion, Compression & Tension Springs. Astd. sizes. A treasure trove for emergencies.
2 lbs. for **ONLY** **89c**

COMBO-MIX - Comb. of all above in one pkg. Special deal. CB-2 **4.95**

FILE MIX - Ten assorted Files, 4" to 12", includes 3 Vixens, half rounds bastards, mills, etc., in seconds and used but in good condition. 1:1. Value alone worth our price for entire mix. F-1 **99c**

PULLEY MIX, No. PM-1 - You'll want this one around. 10 micarta & metal pulleys ranging from 1" to 5" with ball and one piece bearings. These are aircraft pulleys, the best made with 100's of uses. A WONDERFUL BUY!!! **2.95**

COUNTERSINK MIX, No. 168. Wide assortment. Excellent condition. High speed steel. Assortment of ten 100° and 110° with pilot sizes ranging from 3/32" to 3/16" No. CM-1 **2.69**

SCREW MIX - 5 lbs. incl. 2 1/2 lbs. wood screws & 2 1/2 lbs. machine screws. All sizes. Save dollars and always have plenty of screws on hand. **1.39**

NUT MIX, NM-1 - 3 lbs. approx. 500 nuts. Anchor, Lock, Castle, Hex, Elastic Stop Nuts, etc. You'll always have plenty of Nuts in the shop. NM-1 **1.39**

SUPER COMBO MIX - No. SC2. Here's a real bargain. All ten of above mixes for **ONLY** **12.95**

REAMER MIX - No. 168. Reamer assortment: Special Taper line finish Reamers. High Speed Steel. Slightly used but in excellent condition. Ten assorted sizes ranging from .168x.165 & .244x.215 to .425x.385 & .432x.403. One alone worth our selling price of ten.
For set of ten Reamers ... **4.49**

PLASTIC Mallet CLEAR PLASTIC with 2" dia. x 4" head & 12" handle. For soft metal or plastic work where non-marking or light tapping is desired. **79c**

15" MONKEY WRENCH Adjustable Jaw - Opens to 4" Drop Forged. Auto Type. Cadmium Plated **89c** Black **79c**

PIANO HINGE Overall Width Length Price Ea. 1 1/2" (5/8" side) 72" alum. \$1.00 2" (1" side) 9" alum. **\$1.75**

PALLEY SUPPLY COMPANY
6321 SAN FERNANDO RD.
DEPT. PM3 GLENDALE 1, CALIF

No 100 WINCH HOIST
A sturdy, dependable hoist, originally used as bomb hoist in B-29's. Capacity 2500 lbs. with 24 to 1 gear ratio. Has bronze worm gear and drum has 19 ft. of 1/4" flex. steel cable with hook on end, and two speed handle. Ideal for shops, garages, tow-trucks, boats. **\$21.99**

New Westinghouse AIR COMPRESSOR
Thousands now in use for spraying, inflating, industrial use, trucks, tractors - air tools, laboratory, garage, etc. Lightweight but powerful, can be run by H.P. Motor or Gas Engine. Operates in either direction of operation. Gives approx. 3.27 CFM at 600 RPM, 6.54 CFM displacement at 1200 RPM. Has 2 inch bore, 1 1/2" stroke. Suggested pressure 75 P.S.I. Size: 9" x 12" x 16 1/2". W. approx. 23 lbs. **AT THIS NEW LOW PRICE 23.95** Motors, Tanks, Fittings to adapt this unit also available **AT GREAT SAVINGS TO YOU!!**

NEW PRESSURE TANKS
Stainless Steel, Shatterproof & Rustless. Ideal for painting, cooking, spraying, ocean buoys, underwater fishing, or diving.
G-1-12 1/2 x 24 inches. 2100 Cu. In. capacity **NEW 4.75**
F-1-10 x 18 inches. 1000 Cu. In. capacity **USED 4.19**
F-2-6 x 45 inches. 1000 Cu. In. capacity **NEW 3.95**
D-2-6 1/2 x 24 inches. 500 Cu. In. capacity. Stainless Steel Construction **USED 3.49**
D-2A-Corrosion resistant steel. Same as D-2. **NEW 2.49**
A-6-5 1/2 x 15 inches. 280 Cu. In. capacity **USED 2.25**
A-4-5 x 8 inches. 104 Cu. In. capacity **NEW 1.35**
NOTE: All tanks listed are used and guaranteed serviceable and free from leaks or dents.

FIRE EXTINGUISHER
Kiddie Lux CO2 Type. Built to Gov't spec. Shatter-proof, heavy case. Fully re-charged, with horn. No. 601C - 2 lb. wheel control **11.75**
No. 602A - 7 1/2 lb. \$35 Value. **19.25**
No. 603 - 10 lb. A. \$65 Value. **25.75**
No. 605-A - 15 lb. New. Break disc Type. A. \$75 Value. **29.75**
No. 605-B - 15 lb. Wheel Control Type **32.95**
No. 605-C - 15 lb. New. Squeeze Grip Type. \$85 Value. **39.95**

AIRCRAFT CABLE
Rust resistant alloyed steel, extra flexible, preformed - 7 x 19 strand on reels.
1/16" 3c ft. 1/4" 8c ft.
3/32" 4c ft. 9/32" 9c ft.
1/8" 4 1/2c ft. 3/8" 12c ft.
5/32" 5c ft. 1/2" 15c ft.
3/16" 6c ft. 1/4" Bronze 14c ft.
1/8" Stainless Steel, per. foot. 12c
Aircraft control cable 18 ft. long, 3/16 in. diam. with turnbuckle ends. **99c ea.**

OXFORD BRG & TOOL SCRAPERS
Complete set of 8 Tools packed in Grained Wood Case
Contains 1 ea. 8", 10", 12", 14" half round scraper, 1-6" Three square Scrap. er. 1-12" Double end Scraper. Made of Finest Tool Steel. SET Forged, Tempered, and Hollow Ground. An Unheard of Price! **\$2.49**

New CLAMP
Carpenters, Cabinet makers, Wood workers you need this one! Opens to 8" with 2 3/4" thumb screw. All Steel sturdy and dependable. Handy for gluing, etc. **ONLY \$1.59**

METAL SNIPS-Hard steel blades. Compound action. Expansion spring & lock device. Right and Left hand types. **\$2.59**

TWO HEAT SOLDERING IRON
World's Hottest Iron Value!
Two soldering irons in one with button heat control. Push the button-Select 150 or 300 Watt heat for light or heavy work. Complete with tip, bench holder, 5' asbestos cord, 110V AC. **\$3.95**

HANDY REPAIR KIT
Here's one for every purpose! 6 useful tools... a steel trimming knife-pair of genuine WISS Heavy Duty scissors - a sealing roller for cementing fabrics, 2-1/2" half round files & a burnishing brush. Ideal for wallpaper, insulation, etc. Comes in compact cloth roll. A 9.95 Value For. **3.29**

U.S. NAVY BATTLE LANTERN
A powerful lamp complete with 2 1 1/2 volt dry cell batteries. Size: 7" x 7" x 4" **32.9**

Sperry Aircraft Directional GYRO COMPASS
Dial is 360° swing calibrated 1/10° (6 min). Panel Mount 4 1/2" square with 3" luminous dial. Can be used in autos, planes, or boats by attaching one tube to intake manifold for required vacuum. Complete with reset caging knob. Gov't. overhauled - **ONLY \$4.99**

D. C. GENERATORS
Suitable for adaption to home welding units, portable and rural lighting. Use as power plant on boats, etc.
TYPE AMPS VOLTS PRICE
P1 200 27 1/2 **17.95**
R1 300 30 **29.75**
E5A 50 12 **14.95**
Used but Guaranteed Condition

D. C. METERS
AMMETERS VOLTMETERS
0-30 0-30 0-120 0-30 **\$3.95**
-60 -0-60 -0-240
-120 -0-120 -0-300
Your choice 3.95 ea.
COMBINATION VOLTMETER - AMMETER
30V - 30 AMP **\$4.95**
30V - 60 AMP
All meters 2" face except 0-300 which is 3 1/2" face.
SHEETS - Required for use with D.C. Ammeters 30-60-120-240 **\$1.00**
SOLD ONLY WITH METERS.

NEW ELECTRIC MOTORS
No. 500 - New 1/2 HP - 27 Volt DC-AC. This motor can be readily adapted to deliver up to 1/2 HP on 110 Volts AC by the simple method of rearranging armature brush leads. Free diagram with each order. A sensational Value. **\$5.95**
No. 500-A - Converted to 110 Volts-AC Equipped with plug and 3 1/2 ft. Heavy Duty Cord **\$8.49** ..
No. 502 - 2 HP-24V. DC Motor Used **8.95**

OXYGEN & ACETYLENE REGULATORS
OXYGEN REGULATOR -- Bottle Press. Gauge - 0-3000 PSI. Regulating Press. Gauge - 0-400 PSI
ACETYLENE REGULATOR - Bottle Press. Gauge - 0-500 PSI. Regulating Pressure Gauge - 0-50 PSI.
AIRCO & Other Popular Makes to fit ALL Standard Bottles -- ALL NEW!! **\$12.95**
A Real Buy at **\$25.00**
or Both for

PNEUMATIC AND AIR TOOLS
10,000 in various popular makes, sizes, types, Cleco, Aro, Ingersol Rand, Chicago, Pneumatic, Buckeye, etc.

RIVET GUNS
#180 Pistol & Gooseneck Type #115
VALVE **\$8.95** Pistol
SPECIAL
Aro PISTOL **\$17.95**
Air Drill or Air Motor with 1/4" Jacobs chuck.
Send for Catalog and List of Other Sizes, Types of Pneumatic Tools.

NEW HYDRAULIC CYLINDER SPECIAL
Gives 20,000 lb. thrust (push pull) using 1500 PSI line pressure as obtained from our hyd. pumps. Or will produce 40,000 lb. thrust with 3,000 lb. line pressure. CAN ALSO BE OPERATED ON LOW PRESSURE AIR SYSTEMS. 4" Bore, 1 1/2" dia. piston shaft, 18" stroke, length 30 1/2". Equipped with ball bearing loaded clevis type mounting and swivel type high pressure steel pipe bracket for easy use. Ideal for road, farm & shop machinery, presses, etc. Cost Gov't \$390.00 **22.50**

We carry the World's Largest Supply of New Hydraulic Equipment featuring over 20,000 Cylinders in 61 Sizes & Types. Can also supply all accessories such as Pumps, Fittings, Valves, Tanks, Hose Fittings. Let us solve your hydraulic problems. Write for information.

BENDIX HYDRAULIC HAND PUMP
Provides an instantaneous source of tremendous power for almost any heavy work. Double action stroke. Delivers .30 cu. in. per cycle at 3000 PSI. Max. press. 5000 PSI. Built-in Reservoir cap. 2 1/2 qts. 3/8" pipe outlets. Has Pressure Release Valve. 7 1/2" dia. by 23 3/16" overall ht. Weight 15.2 lbs. A \$40.00 Value for... **\$15.95**
Used - In Good Condition... **11.95**

Vickers Hydraulic Transmission
Self contained, 2 H.P. constant torque at all speeds with variable volume reversible, piston pump (controlled by outside lever) supplying piston hydraulic motor. Automatic pressure, dash pot for smooth control. Power output R.P.M. - 0 to 1/3 input R.P.M. in both directions. Input R.P.M. 1800 continuous 4000 intermittent. Dash pot can be removed for greater R.P.M. Ideal for Lathes, Duplicator Setup on Mills, Conveyors, Small Cars, Drives, Gearing, etc. Includes 2-4" Spline Shafts for input & power take-off - Cost Gov't approx. \$400. **\$27.50**

GEAR BOXES VTG-1 - 90°
Bevel gear 1 1/2 to 1 reduction, size 7" x 6". A Life-time Value. **\$3.95**
VTG-2 - Inline spur gear 16 to 1 reduction, thru 4 gears. Final take-off 4 1/2" dia. 26 tooth. 3/4" Alum. spur gear. **\$6.49**
(Both above gear boxes have lever control for engaging & disengaging positive clutch. Dust proof housing. Lubricated bearings. Both can be adapted to Vickers Transmission.

VALUABLE GEAR BARGAINS!
8 to 1 ratio, spindle drive #110 **\$2.98**
6 to 1 with screw shaft #111 **\$4.98**
85 to 1 (can be used for radio, antennae, etc.) #112 .. **\$3.95**
#G-11 - 10-1 gear ratio **\$3.95**

ELECTRONIC TRANSMISSION GEAR TRAIN
GT-1 Containing approx. 50 Bronze Spur & Pinion Gears - ranging from 3/8" to 4" dia., 5 sets of 7 cluster gears, 2 complete worm & worm gear drive sets, 40 N.D. ball bearings from 1/2" to 1 1/2" dia. watch springs, bushings, posts, face plates, housings - Micro Switches, 2 miniature, controlled clutches, etc. 19 lbs Of Pleasure and profit. A Tremendous Gadget Mine. **ONLY \$8.49**
Gears in above train are all in multiple size & sequence with identical tooth ratio giving 100's of ideal gear reduction comb.

Order from this Ad. All sales final. All Prices F.O.B. Los Angeles. Pay by M.O. or Check. P.O.'s Acprpd. from D & B. firms. 1/4 deposit with C.O.D.'s.

THE LARGEST FIRM OF ITS TYPE IN THE WORLD



**Hoot
Mon!**

**Look what \$47.35*
puts in your shop!**

*9" x 3' Model C Bench Lathe; 6-speed drive; 1/4 h.p., 115 v., motor and switch. Cash price— **\$187.35**

Payment terms: \$47.35 with order, \$12.36 for 12 months.
Usual carrying charges included—All prices f.o.b. factory.

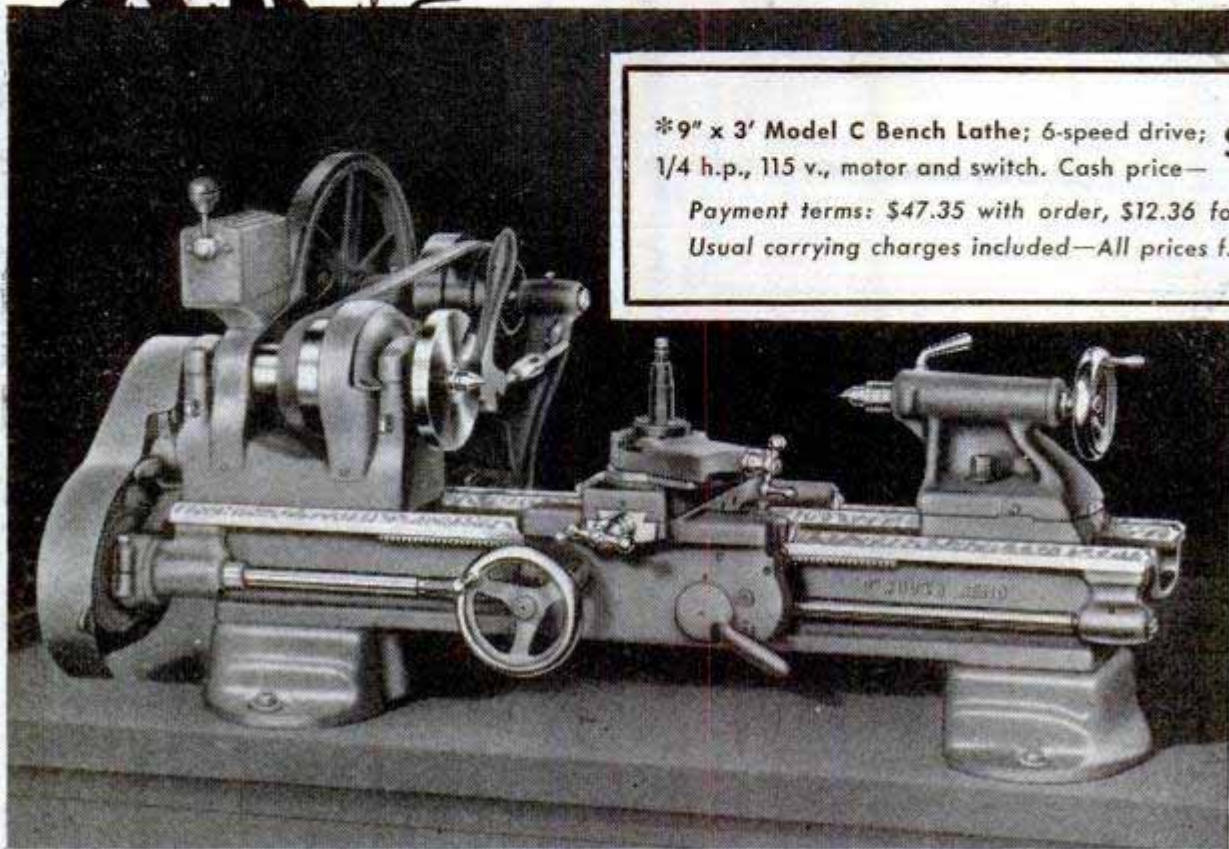

Install this fine lathe in your shop now and let it help pay for itself. Capable of a wide variety of operations, this lathe is ideal for general machine work in the small shop and for machining small parts in the large shop. A complete line of practical attachments and accessories simplify the tooling of this lathe for many special classes of work.

All sizes of South Bend Lathes, 14" Drill Presses, and 7" Bench Shapers are available on comparable time payment terms: 25% down, 12 monthly payments. Reasonable finance charges.

Building Better Tools Since 1906

SOUTH BEND LATHE
SOUTH BEND, INDIANA

Send for Information:

- 9" BENCH LATHES
- LATHE TOOLS AND ATTACHMENTS
- TIME PAYMENT PLAN

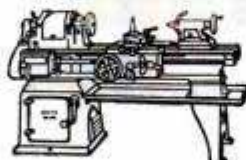

10" TO 16" FLOOR LATHES

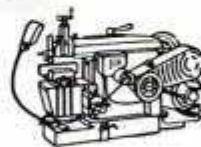

7" BENCH SHAPER



14" DRILL PRESSES

1/2" and 1" Collet TURRET LATHES



Name _____

Street _____

City _____ Zone _____ State _____

Printed by Popular Mechanics Company, Chicago, Ill., U. S. A.

Score on Hard Jobs the Quick, Easy Way
COST Less TO BUY--COST Less TO OPERATE

Famous SHAW

DU-ALL and PEPPY-PAL TRACTORS



RIDING MODELS--5 to 12 H.P.

Just the Tractors for Gardens, Nurseries, Estates, Poultry Farms, Golf Courses and Cemeteries

EASY TO OPERATE

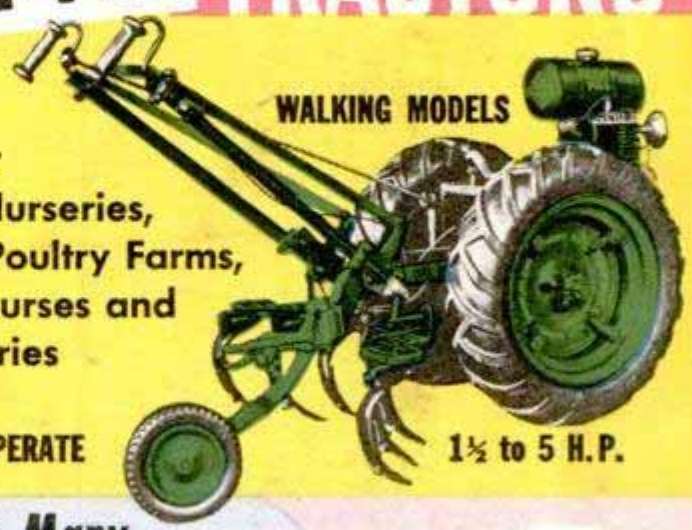

WALKING MODELS

1½ to 5 H.P.

In Use Throughout the Nation and in Many Foreign Lands... Saving **TIME, MONEY** and **WORK!**

Right now is the time to plan ahead... plan to do your work easier, in less time and at less cost this year. Plan to get a famous SHAW Tractor... the machine that does scores of hard jobs the quick, easy, better way! No other investment will pay you better dividends year after year.

TRIED AND PROVED RIGHT! For nearly a half-century SHAW Tractors have proved their value throughout the Nation and in foreign countries. They are built right... to do the job right... with quality materials and expert engineering. Equipped with high-grade air-cooled gasoline or oil engines. You get a full year guarantee against any defect in material or workmanship. They serve faithfully for many years.

LOW-COST DEPENDABLE WORKERS—SHAW Tractors have proved dependable, versatile, low-cost helpers on scores of jobs... ideal workers on small farms, in gardens, truck farms, nurseries, orchards, cemeteries, golf courses, poultry farms and estates. Great for plowing, cultivating, discing, seeding, harvesting, spraying, mowing; operate cutter bars and lawn mowers. Riding tractors with bulldozer also used in foundries and by building contractors for moving sand, dirt, etc. For power on belt jobs... sawing wood, pumping water, grinding feed and running belt machinery. First cost is low and low operating cost will surprise and please you.

EASY TO OPERATE—You'll find a SHAW "Peppy Pal" or "Du-All" Tractor just fitted to your needs... 1½ to 12 H.P. And you'll find that a SHAW will do things a big tractor can't. Easy to operate by elderly persons, boys and girls. Easy to change from one piece of equipment to another. We can supply many attachments at low prices.

GET FULL DETAILS—Get all the facts and you'll get a SHAW! Plan now to do your hard jobs the easy way. Have a SHAW Tractor to do a better job... easier and quicker. It will serve you well... it will give you years of satisfactory, trouble-free, willing service... at amazingly low cost. Many dealers throughout the U. S. sell SHAW Tractors. See them... see their many great, exclusive features. In the meantime, fill out and mail coupon for FREE folders, prices, etc. Get all the SHAW Facts now!



PLOW

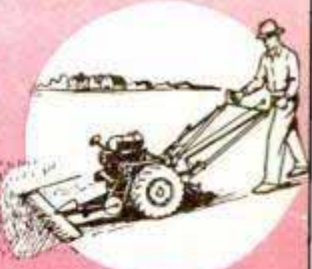

MOW



CULTIVATE

FILL OUT, CLIP and MAIL COUPON

FREE FOLDERS and PRICES

SHAW MANUFACTURING CO.
 4501 Front St., Galesburg, Kans., or 6686 N. 4th St., Columbus, O.
 Send me Free Folders and Prices on SHAW Tractors.

NAME _____

ADDRESS _____

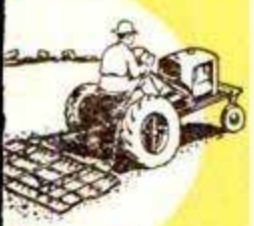

HARROW

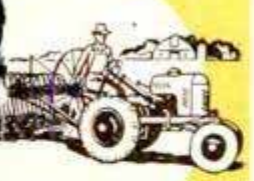

RAKE



BULLDOZE and BLOW SNOW

SHAW Saws Wood, Grinds Feed and Does any Belt Jobs

NOTED THROAT SPECIALISTS REPORT ON 30-DAY TEST OF CAMEL SMOKERS...

Not one single case of throat irritation due to smoking **CAMELS!**

YES, THESE WERE THE FINDINGS OF NOTED THROAT SPECIALISTS AFTER A TOTAL OF 2,470 WEEKLY EXAMINATIONS OF THE THROATS OF HUNDREDS OF MEN AND WOMEN WHO SMOKED CAMELS—AND ONLY CAMELS—FOR 30 CONSECUTIVE DAYS!



COLLEGE STUDENT Anne Hogan: "My doctor's report after my 30-day test proved what my own throat told me from the start—Camels are wonderfully *mild!*"



MR. AND MRS. RICHARD COLE of Fresh Meadows, N. Y., made the test under observation of a throat specialist. Both agree, "Camels are the mildest cigarette!"



PERSONNEL DIRECTOR Robert R. Lamkie: "Camel mildness agreed with my throat from the start. I like everything about Camels—my cigarette!"



CONNIE SCHWOGLEGLER

Twice winner of National Individual Match Game Championship and 1949 "Bowling of the Year"

R. J. Reynolds Tobacco Company, Winston-Salem, N. C.



Start your own 30-Day Camel MILDNESS Test Today!

Smoke Camels—and only Camels—for 30 days. Compare them in your "T-Zone" (T for taste, T for throat). Let your own throat tell you about Camel's cool, cool mildness. Let your own taste tell you about Camel's wonderful flavor.