

ANC



# POPULAR MECHANICS

## MAGAZINE

WRITTEN SO YOU CAN UNDERSTAND IT

REG'D. TRADE MARK, GREAT BRITAIN, NO. 410520



*In this issue*  
**MIRACLES YOU'LL SEE  
IN NEXT FIFTY YEARS**  
by Waldemar Kaempffert  
*— Also —*  
**COLOR CAN MAKE  
YOUR HOME HAPPIER**

Dave Mink

See page 148

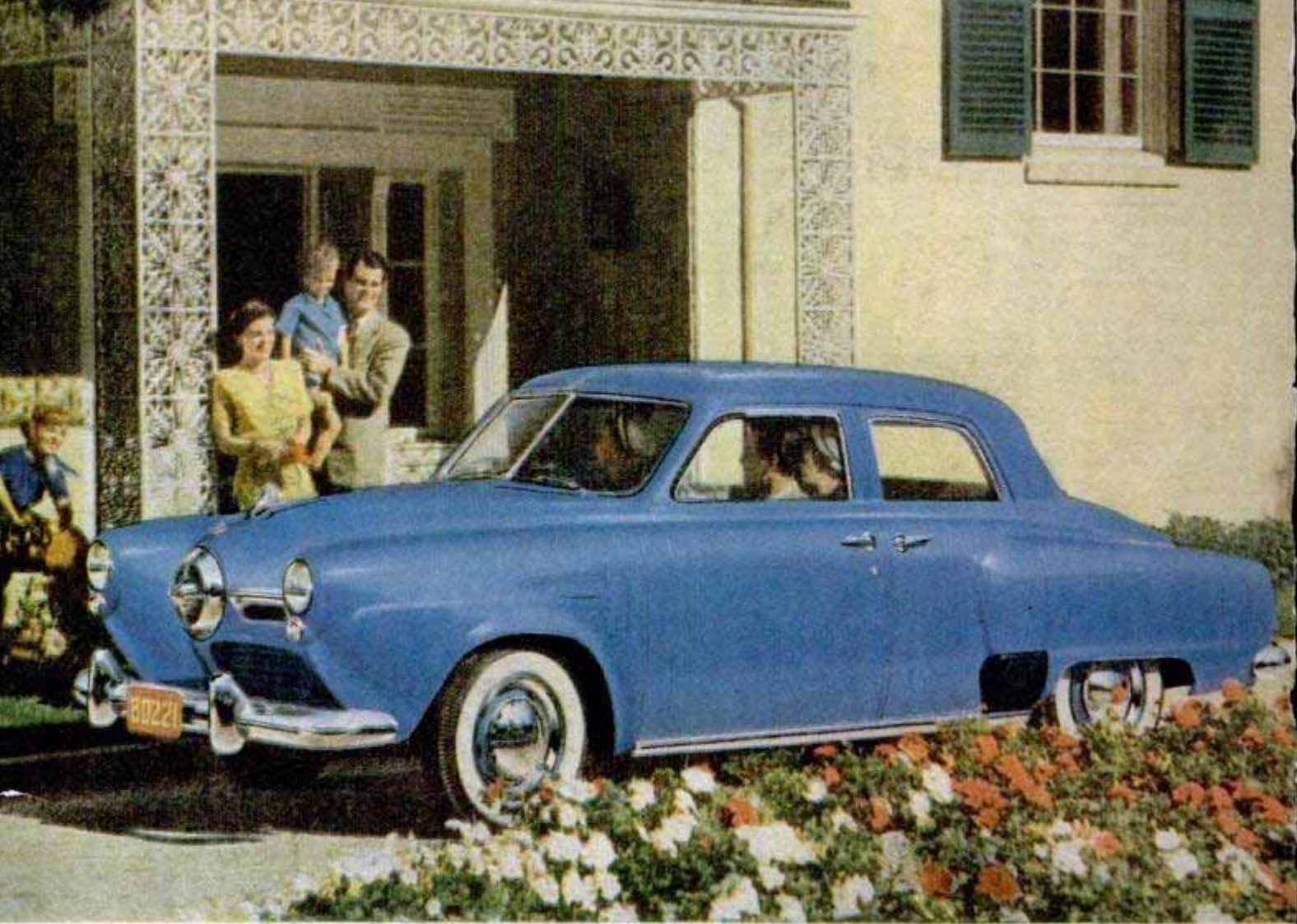

Studebaker Champion 4-door sedan

## Smart 1950 buy—this Studebaker's thrift and value!

JUST a look at the low, long, alluring new 1950 Studebaker tells you that it's a car with the right build for real money saving.

You see no bulging excess bulk that would hitch a ride at your expense—no surplus poundage to squander your gasoline needlessly.

You get welcome protection against unexpected repair bills, too.

The whole structure of this refreshingly different new car has the solid durability of top-quality materials and wear-resisting craftsmanship.

Take the logical next step in getting the most for your new-car money.

Try out the amazing "next ride" of this distinctive "next look" Studebaker.

Stop in at a nearby Studebaker dealer's showroom and go out for a convincing drive in a low-price Champion—a value-packed Commander—a special extra-long-wheelbase Land Cruiser.

## NEW 1950 STUDEBAKER

*Styled ahead and engineered ahead!*

White sidewall tires and wheel trim rings optional at extra cost



You ride in deep-bedded comfort—New balance of design and a brand new kind of coil spring front-end suspension!



You're money ahead on gas with a 1950 Studebaker because it has trim, sleek, aerodynamic lines—and the whole



You don't roll back on up-grades—Automatic hill holder is standard on Commanders and Land Cruisers—extra



You get trustworthy craftsmanship that's the pride of numerous Studebaker father and son teams. It's your as-

**“That hammer?  
You’re kidding!”**



It's a fact, Bill. I've been using this same hammer for 29 years. It helped to build the house you were born in.

Well, I don't know how you do it. I hardly ever *use* a hammer, and yet I've broken two of them in the last year or so.

That so? What kind of hammers were they? What brand, I mean.

Gosh, I don't know. Guess they didn't have any brand names. But they were good bargains.

That's where the trouble is, Bill. Look . . . see the name on this hammer? Whenever you see that brand name, you

*know* it's a good hammer. Stick to the well-known, advertised brands when you buy tools, and in the long run you'll save a lot of money.

That makes sense, Fred. I'll remember it.

And do your buying at the hardware store, where they don't try to sell you anything but quality tools. That way you'll always get your money's worth.



**POPULAR MECHANICS**

The one  
fine car  
 in the  
 low-price  
 field

'50  
 FORD

50

WAYS NEW

Take a GOOD look—  
 Take a GOOD ride

AT YOUR  
 FORD DEALER'S



**NEW** box-type frame rails have steel of greater thickness for increased rigidity. Five rugged cross members give torsional strength.

**NEW** shields on front brakes plus labyrinth seals between backing plate and drum on all wheels protect brakes from dirt and water.



**NEW** gas filler tube and cover... new non-spill vent tube that allows air to escape freely. Closed cover blends into body.

**NEW** one-piece torsional stabilizer, rubber mounted on lower control arms, and improved front suspension add to Ford's famous roadability.



**NEW** front end styling... new parking lights... new smart medallion... new "Air Foil" grille... new stronger bumper guards and bumper support arms.



ENGINEERING ADVANCEMENTS MAKE  
**FORD'S 100 h.p. V-8**  
 QUIET AS A WHISPER!



**NEW** permanent-type lubricant on hand brake shaft assures continued easy operation. Smart new hardware—inside and out—adds new beauty.

**NEW** "Magic Air" heater control is clearly marked, compact, easy to operate and lighted for after-dark use. ("Magic Air" heater optional at extra cost.)



**NEW** defroster openings are 44% wider and air flow is 25% greater for wider vision in bad weather... new interior light switch mounted on instrument panel saves groping in the dark.

★ **Dozens of other BIG features!**

There's a *Ford* in your future...  
 with a future built in!

# Popular Mechanics Magazine

Registered in U. S. Patent Office and Canada

H. H. WINDSOR, Founder

H. H. WINDSOR, JR., Editor and Publisher



## this month's cover

DAVE MINK, one of the country's leading illustrators and cover artists, is never baffled by the locale of a cover scene. Last September (remember the big twin-hulled airplane?) he presented an enemy beach and the aqua-blue water found in the tropics. This month's chilling cover takes you to an ice field in Alaska. The explosion in the distance shows what happens when curious scientists set off a charge of dynamite on the crust of a glacier. Seismic recording equipment in the foreground picks up echoes of the explosion. The time that elapses between the original explosion and reception of the reflected wave is used to figure the depth of the glacier. In this case, it was close to 2000 feet. Thomas E. Stimson's article, which appears on page 148, tells why the Office of Naval Research is promoting expeditions for "Probing the Secrets of the Glaciers"

Published monthly by Popular Mechanics Company, 200 E. Ontario St., Chicago 11, Ill. H. H. Windsor, Jr., president; William Harrison Petridge, vice president; D. F. Windsor, vice president and secretary-treasurer; Clover L. Perkins, advertising manager; Alan M. Deyoe, circulation manager. Single copy in the United States and Canada, 35 cents; subscription rates in United States and possessions, Canada, Philippines and countries of the Pan-American Postal Union, 1 year, \$3.50; 2 years, \$6.00; 3 years \$8.00. To all other countries add \$1.00 a year over United States prices for overseas postage. If you plan to move, notify us at least 30 days in advance so you will not miss an issue. Give both old and new addresses. Entered as Second Class Matter, September 15, 1903, at the Post Office at Chicago, Illinois, under Act of March 3, 1879. Entered as Second Class Matter at Post Office Dept., Canada. Copyright 1950 by Popular Mechanics Company. Copyright under International Copyright Union, Copyright in France. All rights reserved under Pan-American Copyright Union. Printed in the United States of America.

Volume 93 FEBRUARY 1950 Number 2

Managing Editor.....Roderick M. Grant  
 Assistant Managing Editor.....Wayne Whittaker  
 Shop Notes and Crafts Editor.....James R. Ward  
 Radio-Television, Electronics Editor.....Frank L. Brittin  
 Associate Editor, Aviation.....Aubrey O. Cookman, Jr.  
 Associate Editor.....Clifford B. Hicks  
 Art Director.....Frank Beatty  
 Director, Bureau of Information.....Allan Carpenter

### Assistant Editors

Donald R. Brooks      Dorothy E. Hoffmann      Arthur R. Railton  
 Assistant Editors, Shop Notes and Crafts  
 W. Clyde Lammey      Wayne C. Leckey      Frank N. Stephany      A. E. Youngquist  
 Eastern Editor.....Richard F. Dempewolf  
 Empire State Bldg., Room 2906, New York 1, N. Y.  
 Western Editor.....Thomas E. Stimson, Jr.  
 3872 Franklin Ave., Los Angeles 27, Calif.  
 Representative in Great Britain.....Douglas W. Wedderspoon  
 77 Baker St., London W. 1, England

## IN THIS ISSUE

Five Roads to Doomsday - - - - -	81
We Built the PM House for Our Minister - - -	92
Your Color Type and How to Live With It - - -	97
Count Off, Americans - - - - -	106
Miracles You'll See in the Next 50 Years - - -	112
Bone Detective - - - - -	122
What's New for Your Home - - - - -	128
New Discoveries of the Diamond Cutters - - -	132
The Old Sugar House Goes Modern - - - - -	137
Probing the Secrets of the Glaciers - - - - -	148
The Battle of the Great Lakes - - - - -	159
Focus on the Crash! - - - - -	164
17-Acre Bargain Counter - - - - -	170

## For the Craftsman

Frosted Candy Plate and Jewel Box - - - - -	178
Lay Your Own Linoleum—Part I - - - - -	194
Rubbing to a Final Finish - - - - -	202
Make Your Own Transformer—Part I - - - - -	213
Bale Loader - - - - -	217
Drilling Holes in Glass - - - - -	224
Radio-Television, Electronics - - - - -	229
Clinic for Homemakers - - - - -	240

Other items, and manufacturers of available products described, are listed on pages 10, 14 and 18

# UNSUSPECTED POWER



## The Mysterious Influence In The Air You Breathe!

THE SOUL OF THE UNIVERSE is in the air you breathe. Deposited in your blood—with each inhalation you take—is *the intelligence* that directs the course of the planets through the misty reaches of space, and the strange phenomenon of life itself.

What is it that causes your heart to beat, your lungs to expand and contract? What mind directs *the cells* of your being, each in their purpose—some to create bone, others tissue and hair? What *consciousness* pervades these vibratory *globules of life* and gives them awareness of their Cosmic function?

Are you one of the millions who have looked *beyond yourself* for some external Divine Power or agency? Have you searched in vain for some outer sign or word of Divine assurance when in doubt or in need? Now learn of the *unsuspected power* that exists in every simple breath—and that becomes *part of you*. The ancient Egyptians believed that the essence of life was borne on the wings of the air. The Bible pro-

claims that with the first breath man becomes not just an animated being—but a "*living soul*." Try this experiment, and prove a Vital Life Force exists in the air. When you are in pain or despondent take a deep breath. Hold it as long as comfortable—then notice the momentary relief.

### This Amazing Free Book

Would you seriously like to know how to draw upon this Intelligence of the Cosmic, with which the air is permeated? You can use it to awaken the creative powers of your mind, and for making life an experience of *achievement*. Use the coupon below for a free copy of the book, "The Mastery of Life." It tells how in the privacy of your home *you may learn* to use these simple, useful, *natural laws*.

#### -----USE THIS GIFT COUPON-----

Scribe Q. C. F. The Rosicrucians (AMORC)  
Rosicrucian Park, San Jose, California

I am sincerely interested in learning how to use the mysterious influences of the universe in the betterment of my life. Please send me a free copy of the book, "The Mastery of Life."

NAME \_\_\_\_\_

ADDRESS \_\_\_\_\_

*Rosicrucians are NOT a religious organization*

**THE ROSICRUCIANS (AMORC) SAN JOSE, CALIFORNIA, U. S. A.**

**CRESTOLOY LINEMEN'S  
SIDE-CUTTING PLIERS.**  
No. 1950, in 6, 7 and  
8" sizes.

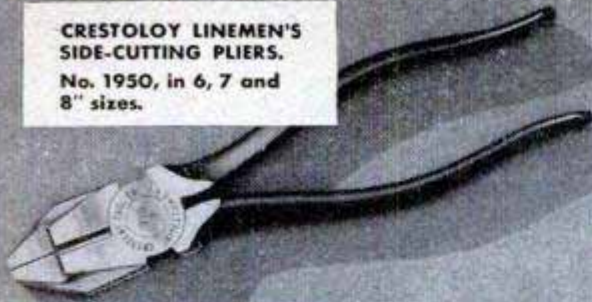

**CRESTOLOY END  
CUTTING NIPPERS.**  
No. 72, in 6 & 7" sizes.

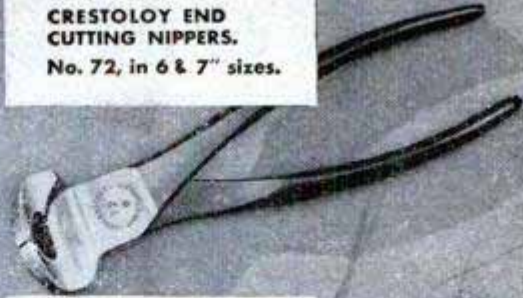

**CRESTOLOY DIAGONAL  
CUTTING PLIERS.**  
No. 942, in 4, 5, 5 1/2  
and 6" sizes.

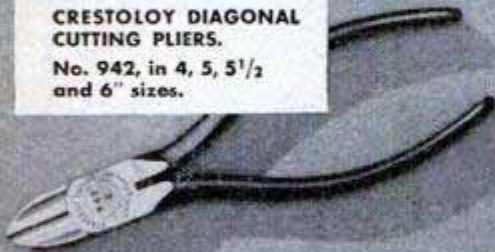

**CRESTOLOY LONG  
NOSE PLIERS.**  
No. 1033, in 6 & 7" sizes.  
Also No. 654, same  
except with side cutter.

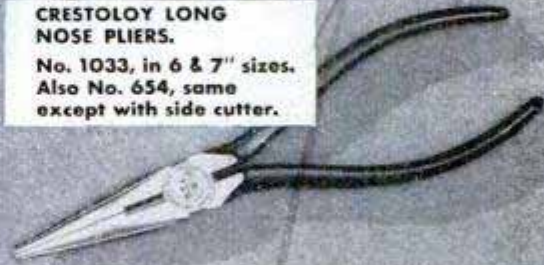

**CRESTOLOY HEAVY  
DIAGONAL CUTTING PLIERS.**  
No. 542, in 7" size only.



**CRESTOLOY LONG FLAT  
NOSE, SIDE-CUTTING PLIERS.**  
No. 650, in 7" size only.

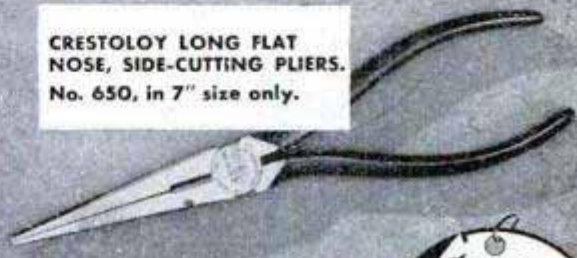

## CRESTOLOY PLIERS

*are individually tested!*

Crestoloy Pliers take all the guesswork out of plier buying, because Crescent has taken all the guesswork out of plier making. Rigid specifications establish the material, design, workmanship, tests and inspection of these better tools. Strict adherence to these specifications is maintained by continuous tests and relentless inspection of the *individual* tools. Every plier carries the Crestoloy tag certifying that it has been individually tested.

**YOUR FINGERS  
OF STEEL**

Ask your hardware dealer or write us for your copy of this little folder which illustrates 21 popular patterns of Crescent and Crestoloy Pliers.



"Crescent" is our trade-mark, registered in the United States and abroad, for wrenches and other tools. Sold by leading distributors and retailers everywhere and made only by  
**CRESCENT TOOL COMPANY, JAMESTOWN, NEW YORK**

# more power to you... with PYROIL

Wintertime is no time to risk the smooth, dependable running power of your car. When you add Pyroil, you prevent "dry starts" and battery drain—the hazards of winter driving with low viscosity oils.

Pyroil, with its special property of clinging to piston and cylinder surfaces, maintains the constant lubrication protection your car needs more than ever for low temperature driving.

Add Pyroil . . . add more powerful miles to your car.

### Pyroil for Aircraft Engines

Use Aircraft Pyroil B for lubricating oil, Aircraft Pyroil A for gasoline.

**GIVEN!** An attractive Pyroil metal savings bank—takes coins up to 50c pieces. **MOTORISTS,** it's yours for the asking—sent postage paid.

Manufactured and Guaranteed by Pyroil Company, 100 Pyroil Bldg., La Crosse, Wisconsin

Canadian Distributors: Central Purchasing Agencies, Ltd., Toronto, Ontario



### PYROIL COMPANY

100 Pyroil Bldg., La Crosse, Wisconsin

I want my car to last and run properly. Please tell me more about Pyroil and how it can accomplish this for me.

Name \_\_\_\_\_

Address \_\_\_\_\_

City or Town \_\_\_\_\_ State \_\_\_\_\_



in this corner.....

## THE EDITORS

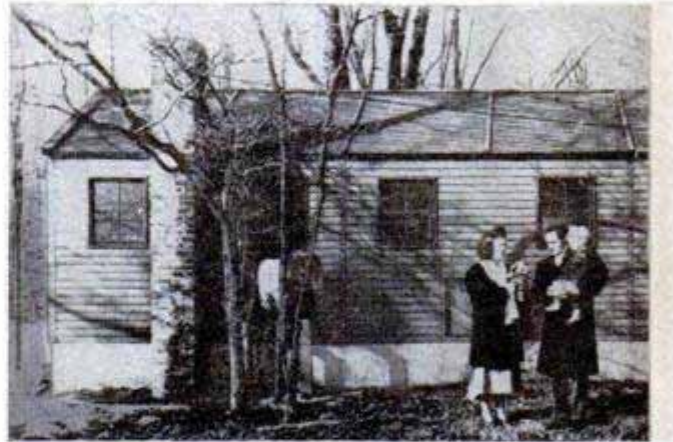

Not much of a home for their minister—so the congregation built a house from Popular Mechanics' plans

WE MIGHT have titled the story on page 92, "The Minister Moved Out of the Doghouse," for that's what happened. There was no place for Rev. Clinton Rutherford to live in his new parish except an oversized kennel until the congregation got together and built him a home from *Popular Mechanics'* plans. Alden Stahr, the author, tells us, "I still shiver when I look at that high-pitched roof—it fell to my



Stanley Scholefield, Homewood, Ill., scanned hundreds of plans, then built this PM home for his bride

lot to put up the cornice alone and on the top of a long extension ladder in a high wind. Guess I'm allergic to such places ever since I walked over the edge of a roof while looking in the ground glass of my camera, a very foolish practice. Enclosed is a photo of the Rutherfords in front of our doghouse, where they lived before starting their *Popular Mechanics* house."

The minister's new home is only one of hundreds of homes built from the plans

(Continued to page 8)



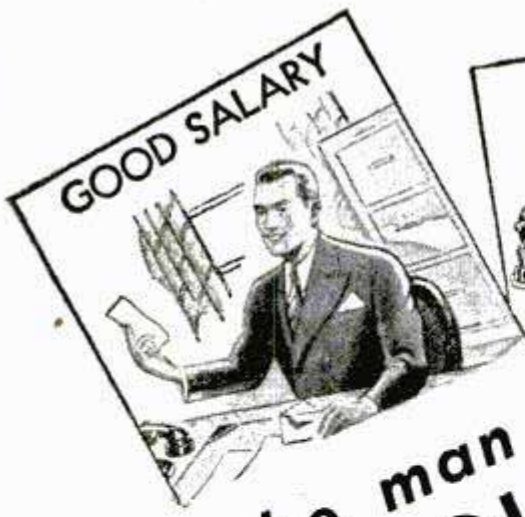

To the man who wants to enjoy  
**an ACCOUNTANT'S CAREER**

**IF** you're that man, here's something that will interest you.

Not a magic formula—not a get-rich-quick scheme—but something more substantial, more practical.

Of course, you need something more than just the desire to be an accountant. You've got to pay the price—be willing to study earnestly, thoroughly.

Still, wouldn't it be worth your while to sacrifice some of your leisure in favor of interesting home study—over a comparatively brief period? Always provided that the rewards were good—a salary of \$3,000 to \$10,000?

An accountant's duties are interesting, varied and of real worth to his employers. He has *standing!*

Do you feel that such things aren't for you? Well, don't be too sure. Very possibly they *can* be!

Why not, like so many before you, investigate LaSalle's modern Problem Method of training for an accountancy position?

Just suppose you were permitted to work in a large accounting house under the personal supervision of an expert accountant. Suppose, with his aid, you studied accounting principles and solved problems day by day—easy ones at first—then more difficult ones. If you could do this—and could turn to him for advice as the problems became complex—soon you'd master them all.

That's the training you follow in principle under the LaSalle Problem Method.

You cover accountancy from the basic Principles right up through Accountancy Systems and Income Tax Procedure. Then you add C. P. A. Training and prepare for the C. P. A. examinations.

As you go along, you absorb the principles of Auditing, Cost Accounting, Business Law, Statistical Control, Organization, Management and Finance.

Your progress is as speedy as you care to make it—depending on your own eagerness to learn and the time you spend in study.

Will recognition come? The only answer, as you know, is that success *does* come to the man who is really *trained*. It's possible your employers will notice your improvement in a very few weeks or months. Indeed, many LaSalle graduates have paid for their training—with increased earnings—before they have completed it! For accountants, who are trained in organization and management, are the executives of the future.

**Write For This Free Book**

For your own good, don't put off investigation of *all* the facts. Write for our free 48-page book, "Accountancy, The Profession That Pays." It'll prove that accountancy offers brilliant futures to those who aren't afraid of serious home study. We'll also include "Ten Years' Promotion in One"—a book which has helped many men. Send us the coupon *now*.

Over 2800 Certified  
 Public Accountants among  
 LaSalle alumni

**LASALLE EXTENSION  
 CHICAGO 5, ILL.**

- Other LaSalle Opportunities**
- Higher Accountancy
  - C.P.A. Coaching
  - Bookkeeping
  - Law: LL.B. Degree
  - Business Management
  - Salesmanship
  - Traffic Management
  - Foremanship
  - Industr'l Management
  - Stenotypy  
 (Machine Shorthand)

**LASALLE EXTENSION UNIVERSITY  
 A CORRESPONDENCE INSTITUTION**

417 S. Dearborn St. Dept. 264-HR Chicago 5, Ill.

I want to be an accountant. Send me without obligation, "Accountancy, The Profession That Pays"—also "Ten Years Promotion in One."

Name.....Age.....

Address.....

City, Zone & State.....



This One



# One Step AHEAD!



with  
**EMBRY-RIDDLE**  
Training

## AIRCRAFT & ENGINE MECHANICS

An urgent need exists for properly trained A & E Mechanics throughout commercial aviation. Our C. A. A. approved school with a quarter-century of experience assures your quickest advancement. Embry-Riddle students learn fast with modern equipment...working on live aircraft in airline-size hangars.

## ENGINEERING

Embry-Riddle's Design Engineering and Maintenance Course offers you A & E certification eligibility plus basic engineering knowledge necessary to fill such positions as Field Service, Project or Maintenance Engineer.

## A & E COMBINED \* WITH COMMERCIAL

Airmen with dual pilot-engineering ability are needed by aviation companies and operators. Embry-Riddle combination training offers you the most in your aviation career.

\*Not available to veterans, but combined courses may be taken consecutively with proper justification.

## COMMERCIAL PILOT

Embry-Riddle trained pilots benefit from our years of experience with 30,000 students...the best instructors, up-to-date aircraft, superb year-'round flying weather...qualifications unexcelled anywhere. Instrument and instructor's ratings also available.

Never has there been such opportunity for properly trained men in commercial aviation. Put yourself one step ahead of the crowd. Start your career now at Embry-Riddle -- dormitories directly on the airport. For full information fill in the coupon below and mail today!



**Embry Riddle**  
International  
SCHOOL OF AVIATION  
MIAMI 30, FLORIDA

Dean of Enrollments - Dept. 99  
Embry-Riddle School of Aviation  
Miami 30, Florida

Please Print

NAME \_\_\_\_\_

ADDRESS \_\_\_\_\_

City \_\_\_\_\_

State \_\_\_\_\_ Age \_\_\_\_\_

I am interested in...

- A.&E. Mechanic
- Commercial Pilot
- Engineering
- A.&E. Combined with Commercial Pilot \*
- Flying Mechanic \*
- Drafting & Design

Check One  Veteran  Non-Veteran

**TRAIN IN MIAMI--AIR CAPITAL OF THE WORLD**

(Continued from page 6)



Albert Cassier, Stillwater, N. Y., erected this home from our plans, then two friends borrowed his book and built others. Below, John Yates, Detroit, followed how-to-build advice and built this house



and "How-to-Build" house book published following our story (April-May-June, 1947) of the young GI who built the house for his bride. One Palatine, Ill., man towed an abandoned frame schoolhouse five miles to his lot and used it as the basis for a P.M. house. Some of the others of which we've heard are pictured here.

\* \* \*

### Letter to the Editor

Dear Sir:

I have a collection of 1000 sketches of aircraft designs and inventions, most of which, I am sure, are patentable. I want to dispose of this collection and wonder if any of your readers would be interested in having them... free, of course!

Rene Charette,  
213 Besserer St.,  
Ottawa, Ont., Can.

First come, first served.

\* \* \*

☞ Sniff the packages around some food products and you'll find that they have pleasing aromas similar to their contents, reports Monsanto Chemical Company, which predicts that many more cardboards soon will be chemically treated with agreeable odors.

# FILL THE GAPS IN YOUR TRAINING



No one goes into a job perfectly prepared. Sooner or later the "weak spots" are bound to show up. And when they do, the successful man is quick to recognize them, *quick to fill the gaps.* International Correspondence Schools can help you get whatever training *you* may need. You have some 400 famous, spare-time I.C.S. Courses to choose from. Or, if you wish, brief "refresher" courses, advanced lessons, or special instruction combining one or more specific business or technical subjects can be *tailored* to fit your needs. The coupon below brings full information without obligation. Mark and mail it today!

## INTERNATIONAL CORRESPONDENCE SCHOOLS

APPROVED  
under the  
G.I. BILL

BOX 5669-K, SCRANTON 9, PENNA.

Without cost or obligation, please send me full particulars about the course BEFORE which I have marked X:

- |   |  |  |  |
|---|--|--|--|
| <p><b>Business and Academic Courses</b></p> <ul style="list-style-type: none"> <li><input type="checkbox"/> Accounting</li> <li><input type="checkbox"/> App. Psychology</li> <li><input type="checkbox"/> Business Administration</li> <li><input type="checkbox"/> Bus. Correspondence</li> <li><input type="checkbox"/> Certified Public Accounting</li> <li><input type="checkbox"/> Commercial</li> <li><input type="checkbox"/> Commercial Art</li> <li><input type="checkbox"/> Cost Accounting</li> <li><input type="checkbox"/> Federal Tax</li> <li><input type="checkbox"/> First Year College</li> <li><input type="checkbox"/> Foremanship</li> <li><input type="checkbox"/> Good English</li> <li><input type="checkbox"/> Higher Mathematics</li> <li><input type="checkbox"/> Industrial Supervision</li> <li><input type="checkbox"/> Motor Traffic</li> <li><input type="checkbox"/> Retailing</li> <li><input type="checkbox"/> Salesmanship</li> <li><input type="checkbox"/> Sign Lettering</li> <li><input type="checkbox"/> Spanish</li> <li><input type="checkbox"/> Air Conditioning and Plumbing Courses</li> <li><input type="checkbox"/> Heating</li> <li><input type="checkbox"/> Refrigeration</li> </ul> | <p><b>Chemical Courses</b></p> <ul style="list-style-type: none"> <li><input type="checkbox"/> Chemical Engineering</li> <li><input type="checkbox"/> Chemistry, Analytical</li> <li><input type="checkbox"/> Chemistry, Industrial</li> <li><input type="checkbox"/> Chemistry, Mfg. Iron &amp; Steel</li> <li><input type="checkbox"/> Petroleum Refining</li> <li><input type="checkbox"/> Pulp and Paper Making</li> <li><input type="checkbox"/> Civil Engineering, Architectural and Mining Courses</li> <li><input type="checkbox"/> Architecture</li> <li><input type="checkbox"/> Building Estimating</li> <li><input type="checkbox"/> Civil Engineering</li> <li><input type="checkbox"/> Contracting and Building</li> <li><input type="checkbox"/> Highway Engineering</li> <li><input type="checkbox"/> Lumber Dealer</li> <li><input type="checkbox"/> Reading Structural Blueprints</li> <li><input type="checkbox"/> Sanitary Engineering</li> <li><input type="checkbox"/> Structural Drafting</li> <li><input type="checkbox"/> Structural Engineering</li> <li><input type="checkbox"/> Surveying and Mapping</li> <li><input type="checkbox"/> Communications Courses</li> <li><input type="checkbox"/> Electronics</li> <li><input type="checkbox"/> Prac. FM and Television</li> <li><input type="checkbox"/> Prac. Telephony</li> <li><input type="checkbox"/> Radio, General</li> <li><input type="checkbox"/> Telegraph Engineering</li> </ul> | <p><b>Electrical Courses</b></p> <ul style="list-style-type: none"> <li><input type="checkbox"/> Electrical Drafting</li> <li><input type="checkbox"/> Electrical Engineering</li> <li><input type="checkbox"/> Electric Light and Power</li> <li><input type="checkbox"/> Lighting Technician</li> <li><input type="checkbox"/> Practical Electrician</li> <li><input type="checkbox"/> Power House Electric</li> <li><input type="checkbox"/> Ship Electrician</li> <li><input type="checkbox"/> Internal Combustion Engines Courses</li> <li><input type="checkbox"/> Auto Technician</li> <li><input type="checkbox"/> Diesel-Electric</li> <li><input type="checkbox"/> Diesel Engines</li> <li><input type="checkbox"/> Aeronautical Engineer's, Jr.</li> <li><input type="checkbox"/> Aircraft Drafting</li> <li><input type="checkbox"/> Forging</li> <li><input type="checkbox"/> Heat Treatment of Metals</li> <li><input type="checkbox"/> Industrial Engineering</li> <li><input type="checkbox"/> Industrial Instrumentation</li> <li><input type="checkbox"/> Industrial Metallurgy</li> <li><input type="checkbox"/> Machine Shop</li> <li><input type="checkbox"/> Machine Shop Inspection</li> <li><input type="checkbox"/> Mechanical Drafting</li> <li><input type="checkbox"/> Mechanical Engineering</li> </ul> | <p><b>Mold-Loft Work</b></p> <ul style="list-style-type: none"> <li><input type="checkbox"/> Patternmaking—Wood, Metal</li> <li><input type="checkbox"/> Reading Shop Blueprints</li> <li><input type="checkbox"/> Sheet-Metal Drafting</li> <li><input type="checkbox"/> Sheet-Metal Worker</li> <li><input type="checkbox"/> Ship Drafting</li> <li><input type="checkbox"/> Ship Fitting</li> <li><input type="checkbox"/> Tool Designing</li> <li><input type="checkbox"/> Toolmaking</li> <li><input type="checkbox"/> Welding Engineering</li> <li><input type="checkbox"/> Welding—Gas and Electric</li> <li><input type="checkbox"/> Railroad Courses</li> <li><input type="checkbox"/> Air Brake</li> <li><input type="checkbox"/> Diesel Locomotive</li> <li><input type="checkbox"/> Locomotive Engineer</li> <li><input type="checkbox"/> Locomotive Fireman</li> <li><input type="checkbox"/> Locomotive Machinist</li> <li><input type="checkbox"/> Railroad Section Foreman</li> <li><input type="checkbox"/> Steam and Diesel Loco. Eng.</li> <li><input type="checkbox"/> Stationary Engineering Courses</li> <li><input type="checkbox"/> Boilermaking</li> <li><input type="checkbox"/> Combust. Engrg.</li> <li><input type="checkbox"/> Myrine Engineering</li> <li><input type="checkbox"/> Power Plant Engr.</li> <li><input type="checkbox"/> Cotton Manufacturing</li> <li><input type="checkbox"/> Rayon Weaving</li> <li><input type="checkbox"/> Woolen Manufacturing</li> </ul> |
|---|--|--|--|

Name \_\_\_\_\_ Age \_\_\_\_\_ Home Address \_\_\_\_\_

City \_\_\_\_\_ State \_\_\_\_\_ Working Hours \_\_\_\_\_ A.M. to \_\_\_\_\_ P.M.

Present Position \_\_\_\_\_ Employed by \_\_\_\_\_

Length of Service in World War II \_\_\_\_\_ Enrollment under G.I. Bill approved for World War II Veterans. Special tuition rates to members of the Armed Forces. Canadian residents send coupon to International Correspondence Schools Canadian, Ltd., Montreal, Canada.

**Big News!**

**a different name for your old friends**  
 You will find **PROTO** tools — formerly **Plomb** tools — everywhere! Over 10,000 better class dealers display them. Since 1907, high quality, superior design and long life have made them the favorites of professionals. Remember, the new name — **PROTO** tools. Buy them from your dealer today.



4986

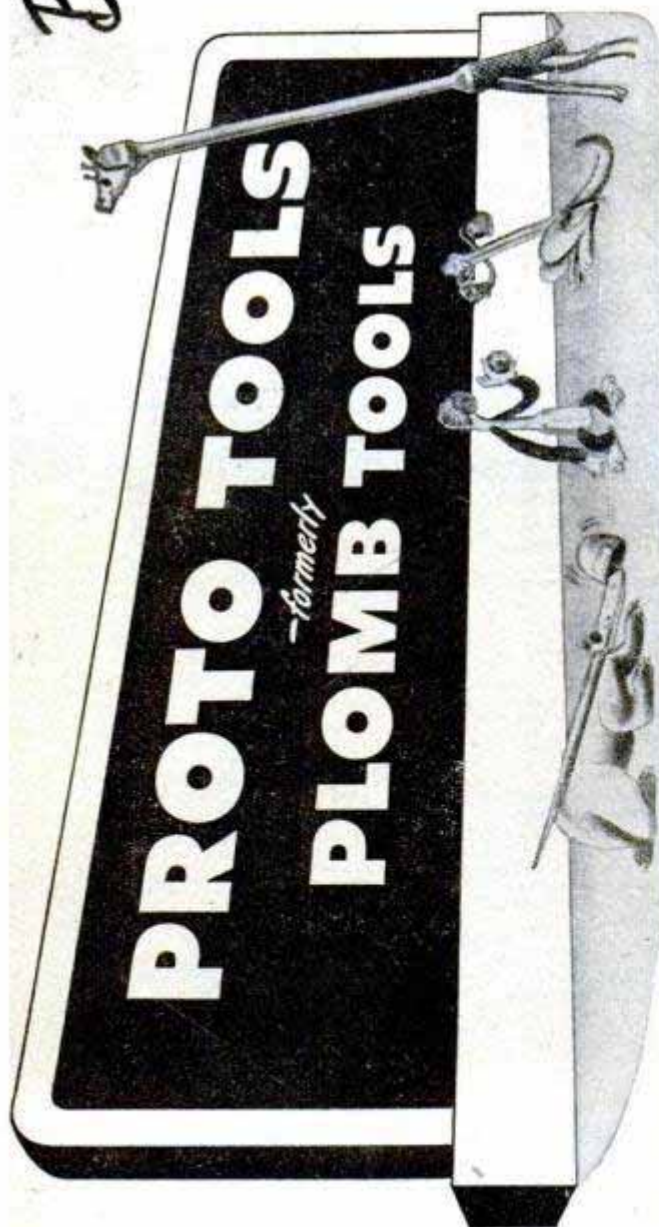

Write for catalog to **PLOMB TOOL COMPANY** 2255N Santa Fe Ave., Los Angeles 54, Calif.

**WHERE-TO-BUY-IT INDEX**

Source of supply appears after items commercially available

**AUTOMOTIVE**

De-icing fluid clears windshield (Birma Mfg. Co., Inc., Buffalo 14, N. Y.).....126  
 Homemade convertible will go 100 m.p.h.....157  
 Probing tool removes pebbles from tire cuts (K-D Manufacturing Co., 526 N. Plum St., Lancaster, Pa.).....162  
 Calking for cars (Minnesota Mining & Mfg. Co., St. Paul 6, Minn.).....168  
 Converted tire chains go on wheels quickly (Time Saver Corporation of America, 161 E. Erie St., Chicago 11).....174

**AVIATION**

Tall tails.....88  
 "Litter blisters".....105  
 Jeep and elevator fly with Liftmaster.....111  
 Low-pressure tunnel to test rockets.....111  
 World's largest airplane service dock at Miami.....120  
 Skis for Navy's arctic plane.....121  
 Fuel tanks lengthen range of Boeing bomber.....126  
 Air-to-air missile for U. S. Air Force.....127  
 Nose doors 12 feet high in Globemaster.....136  
 Jet sailplane.....146  
 Assault transport (Chase Aircraft Co., Inc., West Trenton, N. J.).....146  
 Airplane pilots spin wheel to get navigational data.....146  
 Sky spear.....153  
 Truck keeps plane "alive" on ground (D. W. Onan & Sons, Inc., Minneapolis 5, Minn.).....156  
 "Baby" jet unit boosts light plane into air.....163

**BOATS AND MOTORCYCLES**

Inboard-outboard runabout (Seamaster Boat Co., Box 161, Avon, Mass.).....90  
 Motorcycle skis.....119  
 Bike for six.....127  
 Either power or pedal drives "Bombo" boat.....163

**ELECTRICAL**

Pop-up lighter for table plugs into electric outlet (Electrolunch Co., Inc., 9300 Stone Road, Algonac, Mich.).....156  
 Hymns in color.....168  
 Fluorescent street lights.....175

**FARM**

Big vacuum cleaner harvests grass seed.....91  
 Tractor-tire remover (Coats, Loaders & Stackers, Inc., Fort Dodge, Iowa).....125  
 Prune picker.....153  
 Huge "vacuum cleaner" for land of cotton (Allied Engineering, Inc., 1547 Texar, Memphis, Tenn.).....174

**FISH AND FISHING**

Fly tier (Reelon Corp., 100 S. Linden Ave., South San Francisco, Calif.).....86  
 Flip-flop bait box fools the worms (Kruse Hardware & Sporting Goods, Inc., 1108-10 Maumee Ave., Fort Wayne 4, Ind.).....91  
 Partition gives submarine effect.....96  
 "Grass skirt" for fishing plugs (Fred Arbogast Co., Inc., Akron, Ohio).....121  
 Flexible refrigerator bag carries fisherman's catch (Flexible Products Co., 2708 Wright Ave., Racine, Wis.).....121  
 Eel trap.....158

**HOUSE AND HOME**

Triple duty dinette (Doehler Metal Furniture Co., Inc., 192 Lexington Ave., New York City 16).....128  
 "Frost" paint for windows (Sapolin Paints, Inc., 229 E. 42nd St., New York City).....128  
 Steamer on wheels (Osborn Brothers, 223 W. Jackson Blvd., Chicago 6).....128  
 Double-blade spatula (Buckly Culinary Products, Inc., 315 N. Aberdeen St., Chicago 7).....128  
 Aluminum foil eliminates soiled pots and pans (Reish Products, Inc., South Bend, Ind.).....128  
 Pocket tool kit (Baves Manufacturing Co., Inc., 30 Irving Place, New York City 3).....129  
 Wrinkle chopper for vegetables and meats (Lawton Lines, 1610 Stevens Ave., Minneapolis 4, Minn.).....129  
 Vacuum cup holds on any smooth surface (Van Dusen Engineering Co., Escondido, Calif.).....129  
 Hook-on bar is tie or towel rack (B-W Manufacturers, Inc., 721 N. Webster St., Kokomo, Ind.).....129  
 Portable dishwasher (Wilshire Engineering Corp., 6181 Barrows Drive, Los Angeles, Calif.).....129  
 Cedar paint for closets (AHMCO Products, 678 Massachusetts Ave., Cambridge, Mass.).....131  
 Homes of china clay.....144  
 Pneumatic Quonset.....153

**INDUSTRY**

Giant footprints.....130  
 Controller supplies electricity with unwavering voltage.....131  
 Fast French locomotive.....147  
 Giant circuit breaker.....162  
 Straw chopper stops road erosion (Papec Machine Co., 30 W. Main St., Shortsville, N. Y.).....168  
 Deepest hole ever drilled.....169  
 Largest supersonic wind tunnel.....176

(Continued to page 14)

# WHAT Every AUTO MECHANIC Wants to Know

A motor vehicle is a machine of many parts, each part designed and constructed for its own special function. All good mechanics, like good doctors, should know the working theory and operation of each part and understand what causes trouble and how to remedy it.

## LET AUDELS AUTO GUIDE SOLVE YOUR PROBLEMS

Every auto mechanic, helper, serviceman and operator can use AUDELS AUTO GUIDE. The information it gives saves time, money and worry. Highly endorsed by all users. It presents the whole subject of auto mechanics from A to Z in plain language and simple terms.

This Big Practical Book gives full information with working diagrams covering the principles, construction, ignition, service and repair of modern cars, trucks and buses.

A complete Guide of 1800 pages, with over 1500 illustrations showing inside views of the working parts, with instructions for service jobs. Diesel engines, Fluid and Hydra-matic drives fully explained.

## IT PAYS TO KNOW HOW TO

How to fit pistons—How to locate engine knocks—How to fit connecting rod bearings—How to service main bearings—How to recondition valves—How to time valves—How to adjust fan belts—How to adjust carburetors & chokes—How to rebuild a clutch—How to service automatic transmissions—How to service brakes—How to adjust steering gear—How to cope with ignition troubles—How to service distributors—How to time ignition—How to "tune up" an engine.

## INFORMATION IN A HANDY FORM

73 INTERESTING CHAPTERS—Read this partial list of subjects on which practical information is fully given for quick reference under the headings as shown below. Ready Reference Index.

All Parts of an Automobile—Automotive Physics—The Gas Engine—Gas Engine Principles—Multi-Cylinder Engines—Horse Power—Automobile Engines—Stationary Parts—Moving Parts—Pistons—Piston Rings—Connecting Rods—Crank Shafts—Valves—Valve Gear—Cams and Cam Action—Valve Timing—Cooling Systems—Fuel Feed Systems—Dual Fuel Feed—Mixture—Carburetors—Carburetor Service—Automatic Choke—Super-Chargers—Transmissions—Special Transmissions—Fluid and Hydra-matic Drives—Clutches—Universals and Propeller Shafts

A Ready Reference

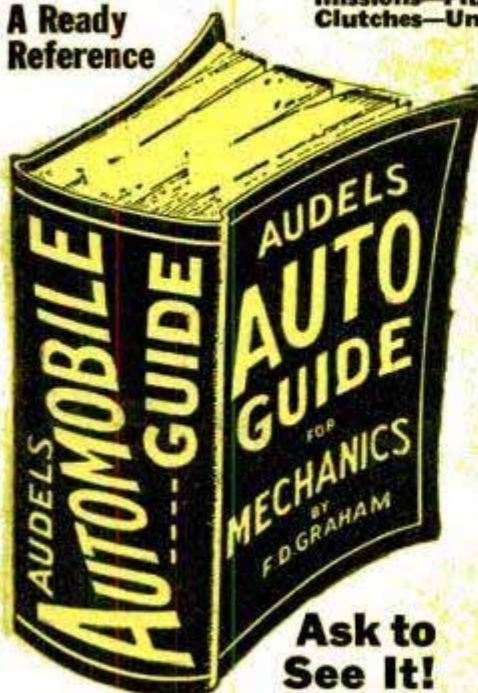

—The Differential—Rear Axles—Rear and Front Suspension—Running Gear—Brakes—Wheel Alignment—Knee Action—Steering Gear—Tires—Lubricants and Lubrication—Automotive Electricity—Ignition Systems—Magneto Ignition—Spark Plugs—Ignition Coils—Distributors—Automatic Spark Control—Ignition Timing—Generators—Starters—Generator and Starter Testing—Lighting Systems—Storage Batteries—Charging and Testing—Diesel Engines and Trouble Shooting.

**7 DAYS' FREE TRIAL**  
TO GET THIS ASSISTANCE FOR YOURSELF SIMPLY FILL IN AND MAIL COUPON TODAY.

**\$4 COMPLETE PAY \$1 A ONLY 1 MO.**



## Sent on 7 Days Approval

Step up your own skill with the facts and figures of your trade. Audels Mechanics Guides contain Practical Inside Trade Information in a handy form. Fully illustrated and Easy to Understand. Highly Endorsed. Check the book you want for 7 DAYS FREE EXAMINATION. Send No Money. Nothing to pay postman.

## CUT HERE MAIL ORDER

AUDEL, Publishers, 49 W. 23 St., NEW YORK 10, N. Y.

Please send me postpaid for FREE EXAMINATION books marked (X) below. If I decide to keep them I agree to mail \$1 in 7 Days on each book or set ordered and further mail \$1 monthly on each book or set until I have paid price, otherwise I will return them.

- AUTO GUIDE, 1800 Pages . . . \$4**
- DIESEL ENGINE MANUAL, 400 Pages . . . 2
- WELDERS GUIDE, 400 Pages . . . 1
- MACHINISTS Handy Book, 1600 Pages . . . 4
- POWER PLANT ENGINEERS Guide, 1500 Pages. 4
- ENGINEERS & FIREMANS EXAMS, 528 Pages. 1
- PUMPS, Hydraulics & Air Compressors, 1658 Pgs. 4
- MARINE ENGINEERS Handy Book, 1280 Pages 4
- ENGINEERS & Mechanics Guides (8 Book Set). 12
- Answers on Practical ENGINEERING, 254 Pages. 1
- ELECTRIC WIRING DIAGRAMS, 210 Pages . . . 1
- ELECTRICIANS EXAMINATIONS, 250 Pages. 1
- ELECTRICAL DICTIONARY, 9000 Terms . . . 2
- ELECTRIC MOTOR GUIDE, 1000 Pages . . . 4
- HANDY BOOK OF ELECTRICITY, 1440 Pages 4
- ELECTRICAL POWER CALCULATIONS, 425 Pgs. 2
- RADIOMANS GUIDE, 914 Pages . . . 4
- ELECTRONIC DEVICES, 216 Pages . . . 2
- ELECTRIC LIBRARY, 7000 Pages (12 Book Set). 18
- Vols. I, II, III, IV, V, VI, VII, VIII, IX, X, XI, XII \$1.50 Ea.
- OIL BURNER GUIDE, 384 Pages . . . 1
- HOUSE HEATING GUIDE, 1000 Pages . . . 4
- CARPENTERS & Builders Guides (4 Book Set). 6
- PLUMBERS & Steamfitters Guides (4 Book Set). 6
- MASONS & Builders Guides (4 Book Set) . . . 6
- BLUE PRINT READING, 416 Pages . . . 2
- PAINTERS & DECORATORS MANUAL, 450 Pgs. 2
- GARDENERS & GROWERS Guides (4 Book Set). 6
- REFRIGERATION & Air Conditioning, 1280 Pgs. 4
- SHEET METAL WORKERS Handy Book, 388 Pgs. 1
- SHEET METAL PATTERN LAYOUTS, 1100 Pgs. 4
- AIRCRAFT WORKER, 240 Pages . . . 1
- MECHANICAL DRAWING GUIDE, 160 Pages. 1
- MECHANICAL DRAWING & DESIGN, 480 Pgs. 2
- MATHEMATICS & CALCULATIONS, 700 Pgs.. 2
- MECHANICAL Dictionary, 968 Pages . . . 4
- MILLWRIGHTS & Mechanics Guide, 1200 Pgs. 4

Name \_\_\_\_\_  
Address \_\_\_\_\_  
Occupation \_\_\_\_\_  
Employed by \_\_\_\_\_

AUDEL, Publishers, 49 W. 23 St., New York 10, N.Y.



Makes \$10

Has Radio Television Servicing Store



Spare Time Service Pays Well



Calls N.R.I. His "Stepping Stone"

...considered Radio and Television. I have been working for my business — Paul G. Toledo, Ohio.

"Work only spare time at Radio and average about \$40 a month. Knew nothing about Radio before enrolling with N.R.I." — Samuel T. DeWald, St. Clair, Pennsylvania.

"N.R.I. has been my stepping stone from a few hundred dollars to over \$4,000 a year as a Radio Engineer. Make extra money servicing Radios." — Alton B. Michaels, Trenton, Ga.

# BE A SUCCESS IN RADIO-

## Learn by Practicing

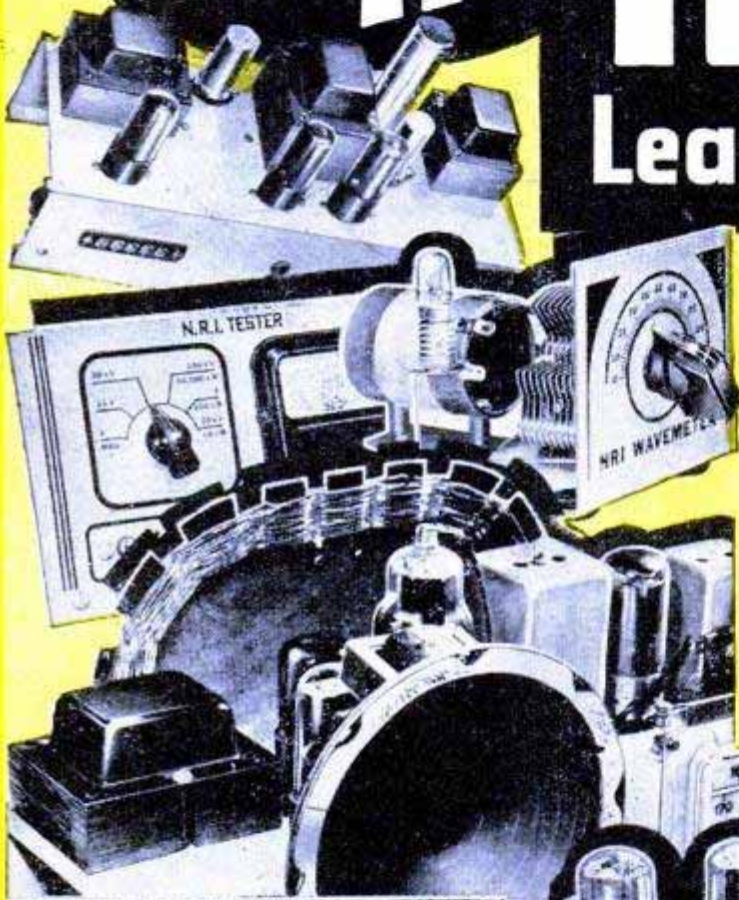

### You Build Equipment Like This With Kits I Send

I give you PRACTICAL EXPERIENCE with many Valuable Kits I send that "bring to life" my illustrated texts. In my Servicing Course, you build a modern Radio, Set Tester, AM Signal Generator, etc. In my Communications Course, you assemble a low-power Broadcasting Transmitter, Wavemeter, Electronic Multitester, etc. Some equipment from both the courses is shown on this page. All of the equipment that you build is yours to keep.



### MAKE EXTRA MONEY WHILE LEARNING

I show you how to earn \$5, \$10 a week, or more, in spare time fixing Radios. I send you parts to build the SET TESTER you use to do it. Frank Lhotsky, Cicero, Ill., above, one of my many students who earned while training, writes, "when I enrolled, I didn't know the difference between a power transformer and a condenser. Your outstanding course made a new, prosperous man of me."

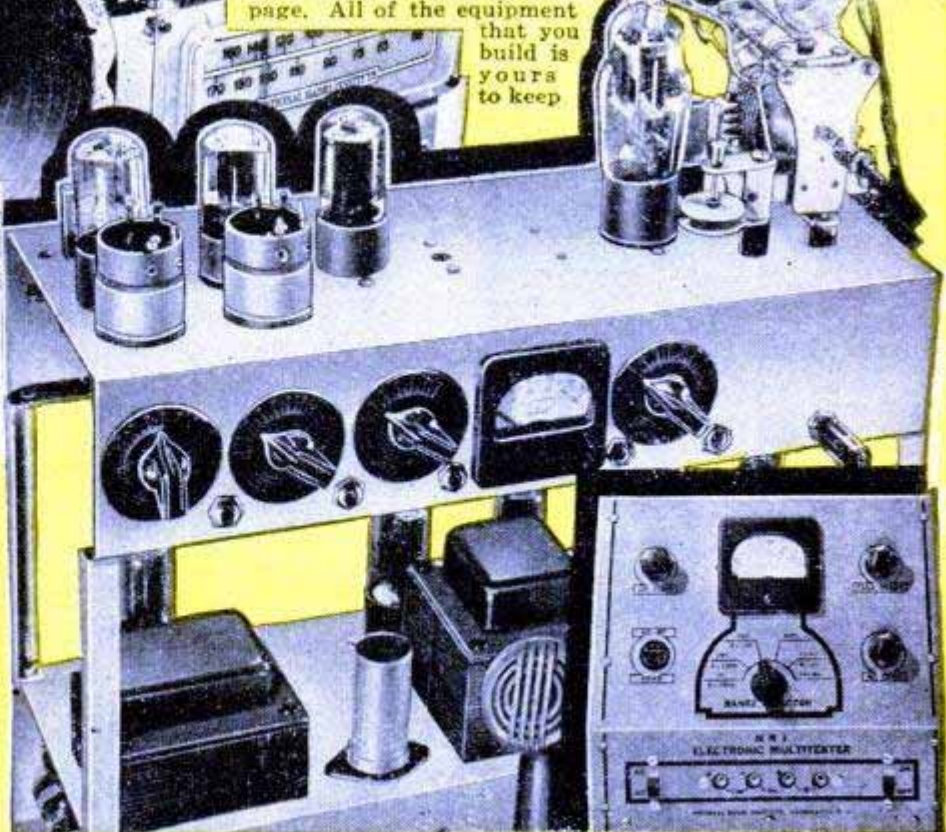



**Sees Profit In Radio-Television**

"I am operating a Radio Sales and Service business. With FM (Frequency Modulation) and Television in the offing, we have a very profitable future."—Albert Patrick, Tampa, Fla.



**Radio Mechanic For Air Line**

"N.R.I. helped qualify me for position as Radio Mechanic with United Airlines. Have my Radiotelephone 2nd Class License."—L. M. Hauger, San Bruno, California.



**Gets First Job Through N.R.I.**

"My first job was operator with KDLE, obtained for me by your Graduate Service Dept. Am now Chief Engineer Police Radio Station WQOX."—T. S. Norton, Hamilton, Ohio.

**I TRAINED THESE MEN**



# TELEVISION

## at Home in Spare Time

**Get a Good Job--Have a Bright Future in America's Fast Growing Industry**

Do you want a good pay job in the fast growing RADIO-TELEVISION Industry? Or do you want your own money-making Radio-Television Shop? Here is your opportunity. I've trained hundreds of men to be successful Technicians . . . **MEN WITH NO PREVIOUS EXPERIENCE.** My tested and proved train-at-home method makes learning easy. You learn Radio-Television principles from my illustrated lessons. You get practical experience building, testing and experimenting with **MANY KITS OF PARTS** I send. All equipment I send is yours to keep.

### MAKE EXTRA MONEY IN SPARE TIME

The day you enroll, I start sending you **SPECIAL BOOKLETS** that show you how to make \$5, \$10 a week or more **EXTRA MONEY** fixing neighbors' Radios in spare time while learning. From here, it's a short step to your own shop or a good pay Radio-



### HAVE A BUSINESS OF YOUR OWN

Let me show you how to have a good, steady income from your own Radio-Television shop. Many N.R.I.-trained men each year start without capital, like Robert Dohmen, New Prague, Minn., above. He writes, "Am now tied in with two television outfits."

## VETERANS

**Get This Training Without Cost Under G. I. Bill**

Television servicing job. Or be a licensed Television Operator or Technician.

### TELEVISION OFFERS BRIGHT FUTURE

In 1945, there were 943 Radio Stations. Today, about 2700 are on the air! **RESULT—THOUSANDS OF QUALIFIED MEN STEPPED INTO GOOD JOBS.** Another example—only 19 Television stations were on the air in 1947. Today, more than fifty. Within a few months, 150, say the experts—and 1000 within three years. Then add developments in FM (Frequency Modulation), Two Way Radio, Police, Marine, Aviation, Microwave Relay Radio. Think what this means! New jobs, more jobs for qualified men. The man who prepares **NOW** can reap rich rewards in this changing, developing, fast growing field!



**FREE**

### ACTUAL LESSON AND 64 PAGE BOOK

Act now! Send for my **FREE DOUBLE OFFER.** Coupon entitles you to actual lesson, "GETTING ACQUAINTED WITH RECEIVER SERVICING." It shows how many pictures and diagrams are used to make learning at home easier, practical. You also get my 64-page book, "HOW TO BE A SUCCESS IN RADIO-TELEVISION." It tells more about **YOUR** opportunities . . . details of my Course . . . what my graduates are doing and earning . . . how quickly you can be on your way to good pay, success, a bright future. Send coupon in envelope or paste on penny postal. **J. E. SMITH, Pres., Dept. OBP, National Radio Institute, Pioneer Home Study Radio School, Washington 9, D.C.**

**MAIL THIS NOW**

### Good For 2 Books FREE

**MR. J. E. SMITH, President, Dept. OBP National Radio Institute, Washington 9, D. C.**

Mail me Sample Lesson and 64-page book on winning success in Radio-Television—both **FREE.** (No salesman will call. Please write plainly.)

NAME..... AGE.....

ADDRESS.....

CITY..... ZONE..... STATE.....

Check if Veteran. Approved Under G. I. Bill.

# YOUR PROFIT \$28.50

## on 3 Easy-to-Make Items

with **NEW LIQUID PLASTIC**



**WE SHOW YOU HOW**

**YES**, now it is possible to make the items shown, right at home, to sell at a profit of \$28.50. Such profit is possible because of high eye-appeal and low materials-cost. Think of making gorgeous, glamorous, IN-DEMAND articles at a profit of over 1000% above cost! That's being done with the new liquid Plastic known as Castolite. The articles on this page are only a few of the many valuable things you can make. Amateurs get professional results. We tell you how to make these things and many more besides.

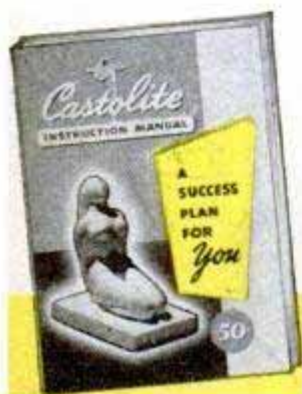

### BIG NEW BOOK Gets You Started

To get started, send for this new book of step-by-step instructions and a modern, tested 6-Point Success Plan for having a profitable plastics business of your own. Do like John Zack of Chatham, N. J., a former salesman, who writes: "I sold the things I made at a handsome profit. Therefore I have gone into manufacturing on my own." Or succeed like Gladys Smith of Steveston, B. C. She wrote: "I made buttons, brooches and wall plaques and took them to our leading department store. The manager was enthusiastic and asked me to make up more articles to sell to their trade. I never made anything to sell before in my life."

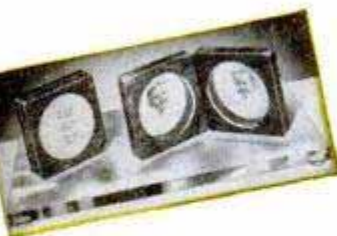

### NEW SUCCESS PLAN

With the Castolite Success Plan you quickly learn how to make the things that sell fast; how to make your business self-advertising; how to get stores, novelty shops, even commercial photo studios to handle your line. New methods and what-to-make-suggestions are explained in this big, interesting fact-ful plastics book. Worlds of fun, big extra profits are within reach. To get off to a quick, sure start, send 25c today for your copy of "A Way to Success."



**DEALERS!**

Many recognized Dealers are now handling Castolite products. There may be an opportunity in your

**The CASTOLITE CO.**

(Continued from page 10)

#### OUTDOOR RECREATION

Trigger lock (H. M. Sheer Co., Quincy, Ill.).....	86
Reducing suits.....	105
Telescoping walking stick (N. Sakata, 12 Fujimicho, 2-Chome, Chiyodaku, Tokyo, Japan).....	142

#### TOOLS

Internal wrenches (L. C. Domack, 1149 Milwaukee, Chicago 22) 90	90
Portable saw guide (Packard Mfg. Corp., Noble at Market, Indianapolis 2, Ind.).....	96
Stick of screws (American Screw Co., Providence 1, R. I.).....	111
Saw setter and filer (Sure-Sharp Manufacturing Co., Box 24, Santa Ana, Calif.).....	126
Portable machine for shape cutting (Air Reduction Sales Co., 60 E. 42nd St., New York City 17).....	147
Miniature bandsaw complete in case (H & S. Machine Co., 866 Riverside Drive, Methuen, Mass.).....	169
Gasket cutter (Zimmerman Packing Company, Cincinnati 12, Ohio).....	175

#### TOYS AND NOVELTIES

Vest-pocket ash tray.....	125
Weather-vane man.....	154
Youngsters' personal car is battery-powered.....	157

#### MISCELLANEOUS

Long-distance storm spotter.....	18
Arithmetic jigsaw.....	86
Revolving rubber heel.....	86
"Liquid stone" table tops.....	87
Radioactive atoms aid study of mice and plants.....	90
Stars "on the air" 24 hours a day.....	91
Mechanical cow.....	119
Plastic shelter for traffic cop.....	119
Sign sticks to glass without adhesive (Flexon Products Co., 239 W. 34th St., New York City 1).....	127
Japanese taxi.....	131
Camp or kitchen griddle (H. & S. Metal Polishing, Inc., 4023 Fulton Court, Cleveland 13, Ohio).....	131
Suit protects firemen at 2000 degrees.....	136
Lead-glass gowns.....	142
Huge Rotterdam building covers two blocks.....	142
Cloud analyzer.....	143
Rockets get atmosphere samples at 230,000 feet.....	143
Poison gases make blood transfusions safer.....	157
Fire-fighting gun shoots foam 190 feet.....	169
Car "crashes" wall 24 hours a day.....	176

### Craftsman and Shop Notes Index

#### ELECTRICAL

Metal loop on receptacle, plate snubs appliance cord.....	188
Toolbox handle serves as reel for winding extension cord.....	192
Cord of drill press concealed by passing through column.....	193
Labeling transformer leads.....	216

#### FARM

Repairing rotted fence posts by reinforcing with pipe.....	184
Simple decoy for crow hunters easily shaped from a wire coat hanger.....	189
Farm gate offset from highway affords safe parking area.....	216
Continuous-flowing poultry fountain is supplied by elevated water tank.....	222
Stool utilizes cultivator disk.....	222
Silage truck with flanged wheels rolls on elevated track.....	226
Board tied to neck tames buck.....	226
Audible brooder warning system signals temperature drop.....	228

#### HOUSE AND HOME

Removing candle drippings.....	180
Towel rack holds iced doughnuts.....	180
Fireplace hood.....	181
Toothbrush simplifies cleaning kitchen range.....	182
Guard aids chopping nut meats.....	182
Restoring aroma to old cedar chest.....	182
Crayon line prevents unraveling of fabric.....	182
Leveling sagging drapery cranes.....	182
Paintbrush cleaner removes old polish from shoebrush.....	183
Muffin tin forms serving tray.....	183
Keeping sectional-sofa units in place.....	183
Handy bedside storage pockets.....	183
Darning egg for finger tips of gloves.....	183
Squeezing pulp-free lemon juice.....	184
Repairing holes in linoleum.....	184
Vertical shoe rack conserves closet space when mounted in convenient spot on wall.....	192
Horseshoe provides ceiling hanger.....	200
Dress snap holds fabric samples.....	200
Vacuum cleaner plugged into dead outlet facilitates replacing fuse.....	201
Tape holds beads on string.....	208

#### NOVELTIES

Buttons improvised from beads.....	180
Hands up! to hold your books.....	185
Colorful window-shade pulls utilize spools and beads.....	188

(Continued to page 18)

**IMPORTANT NOTICE**—It is the intention of this magazine to provide its readers with information regarding the latest developments in the mechanical arts. We take no responsibility as to whether the disclosures contained in our articles are covered by patents and advise readers to investigate this subject before making, using, or selling any of the products, machines, or processes described in order to avoid possible liability for patent infringements.



# INVENTORS

Learn how to protect your invention. The U. S. Patent Laws provide that any new and useful art, machine, article of manufacture, or composition of matter, or any new and useful improvement thereof, may be patented if the act of invention is involved. Therefore, every inventor with a valuable invention should take advantage of the Patent Laws and proceed for patent protection in order to safeguard his rights.

A patent gives the inventor the exclusive right to prevent others from making, using, or selling the invention claimed in the patent for a period of seventeen years.

The Patent Laws were enacted for the benefit of the inventor to give him protection for the features of his invention which are patentable. These features must be properly and concisely set forth and claimed in a formal application for patent, in order to comply with the requirements of the Patent Laws. For that reason, unless the inventor is familiar with patent matters, he should engage a competent registered patent attorney or agent to represent him. We are registered to practice before the U. S. Patent Office and are prepared to serve you in the handling of your patent matters.

A specially prepared booklet entitled "Patent Guide for the Inventor", containing detailed information with respect to patent protection and procedure, together with a "Record of Invention" form will be promptly forwarded to you without obligation upon request.

## CLARENCE A. O'BRIEN & HARVEY JACOBSON

*Registered Patent Attorneys*

01-B DISTRICT NATIONAL BUILDING • WASHINGTON 5, D. C.

*Patents • Trademarks • Copyrights*

**YOU** Need My PRACTICAL Training to Make Money in

# TELEVISION

## RADIO and ELECTRONICS!



I'll Send You  
**8 BIG KITS** of  
Radio Parts and Equipment

Learn at  
**HOME**  
IN YOUR  
SPARE TIME

Now is the Time to Get Into This Fast  
Growing Industry—Prepare for a Fine  
Paying Job or Your Own Business!

I have trained hundreds of men to become technicians—and I'm ready to do the same for you. Whether your goal is a fine paying job in one of Radio's many branches—or a successful Radio and Television business of your own—you need the kind of training I offer! My training is practical and down to earth. **YOU NEED NO PREVIOUS EXPERIENCE.** I start you with basic fundamentals and give you plenty of practical shop-bench training with many kits of parts I send you. This is the training that sticks with you and makes money for you on the job!

### GET PAID FOR SPARE TIME WHILE LEARNING

Soon after you start training I send you my famous **BUSINESS BUILDERS** that show you how to make money in spare time doing interesting Radio jobs. I send you 8 big kits of Radio parts and equipment and help you build step-by-step a powerful 6-tube superhet radio, a 16-range test meter, plus other mighty useful equipment for Radio and Television servicing. You will perform over 175 fascinating experiments while training! You will learn about Television—so that you will be qualified to step in this fast growing, profitable field. I also send you many valuable service manuals, diagrams, and my book telling exactly how to set up your own Television and Radio shop. Clip and mail the coupon below for my two big **FREE** Radio books. I employ no salesmen—and nobody will call on you.



### HAVE A BUSINESS OF YOUR OWN

A profitable Radio and Television Service Shop may be started with little capital. I will show you how to get started. At left is pictured one of my graduates, Mr. Merrit C. Sperry, Fairmont, Minn. in his own shop.

### Radio and Television Industry Booming

You couldn't pick a better time to get into Radio-Television and Electronics. New Television stations are going on the air to serve every major city—hundreds of new AM and FM Radio broadcasting stations are also on the air. All this creates new and bigger opportunities for the trained man who knows Radio-Television and Electronics.

### VETERANS

THIS  
TRAINING  
AVAILABLE TO  
YOU UNDER  
THE G.I. BILL

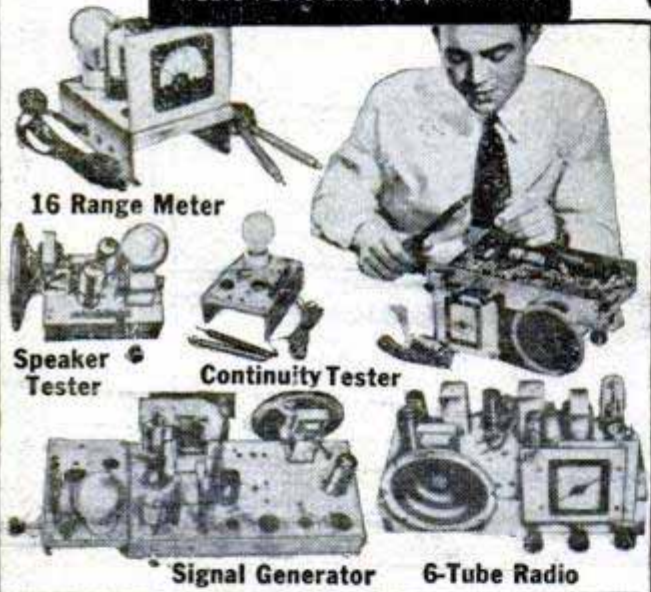

All Kits Are **YOURS TO KEEP**

Each of the hundreds of Radio parts and other items I send my students is theirs "for keeps." You may use this equipment in your Radio and Television service work and save many dollars by not having to buy expensive "ready-made" test equipment.



**CALVIN SKINNER** of New Orleans, La. tells us he makes \$5 to \$10 in spare time repairing radios. He is now also working with a Television set.



**LOREN D. SAUCIER** of Coloma, Mich. reports that my training has made it possible for him to repair large numbers of Radio and Television sets.

## RUSH COUPON Today!

**SPRAYBERRY ACADEMY of RADIO, Dept. 10-F**  
111 North Canal Street,  
Chicago 6, Illinois

Please rush my **FREE** copies of "How To Make Money In Radio-Television and Electronics" and "How To Read Radio Diagrams and Symbols."

Name.....Age.....

Address.....

City..... State.....

( ) Check here if you are a Veteran

My Training  
Includes...  
**Television,  
FM (Frequency  
Modulation),  
Public  
Address  
and High  
Frequency  
Applications**



### These Two Big **FREE!** Radio Books

Just mail coupon for a **FREE** sample Sprayberry Lesson and my big **FREE** book, "How To Make Money In Radio-Television and Electronics." Learn why my really practical training is best of all for you. Discover what's ahead for you in Radio-Television and Electronics. No obligation. Don't delay! Mail the coupon now—and count on me for fast action.

**SPRAYBERRY ACADEMY OF RADIO**  
111 N. CANAL, DEPT. 10-F CHICAGO 6, ILL.

# INVENTORS

If you believe that you have an invention, you should find out how to protect it. The first step is to have a search made of the prior pertinent U. S. patents. If a report on this search indicates that the invention appears patentable you can apply for a patent, and the specifications and claims should be prepared.

The firm of McMorrow, Berman & Davidson, with offices in Washington, D. C., is qualified to take the necessary steps for you. We can make a preliminary search on your invention, advise you whether we think it can be patented, and prepare your application for patent.

Unless you are fully familiar with the U. S. Patent Laws, we recommend that you engage the services of a Registered Patent Attorney to protect your interests. The patent laws are *your* laws. A patent gives you the right to prevent others from making, using or selling the invention claimed in your patent for a period of 17 years.

Use these patent laws for your protection. Investigate whether your invention can be patented. If you have what you believe to be an invention, we suggest that you have this firm make a search for you.

*Send for a copy of our Patent Booklet entitled "How To Protect Your Invention," containing information about patent protection and patent procedure. Along with this we will also send you an "Invention Record" form, for your use in writing down and sketching details of your invention. We will mail them promptly. No obligation. They are yours for the asking.*

**McMORROW, BERMAN & DAVIDSON**

*Registered Patent Attorneys*

**PATENTS • TRADE MARKS • COPYRIGHTS**

**1359 VICTOR BUILDING, WASHINGTON 1, D. C.**

# ARE YOU *NATURALLY* **INVENTIVE?**

"Cash In" On Your Natural Talent  
By Learning **WHAT** To Invent—

## 2100 Inventions Needed Now!

**T**URN your talents into CASH! Invent the *simple* things that people need and want!

The Kiddie Kar brought its inventor a cool MILLION dollars. A 70-year old grandmother made \$350,000 on an overall buckle. Others became independently wealthy by "dreaming up" the rubber pencil tip, the ordinary paper clip, the hair-pin, etc. YOU can cash in, too—if you concentrate your talent on the inventions that are really NEEDED!

### The EASY Way to Get Started



\$250,000



\$135,000

Don't waste time and brain-work on something nobody wants! Find out **WHAT** to invent. A valuable book by Raymond F. Yates, noted science editor and inventor, lists and describes over 2100 PRACTICAL, money-making ideas that are crying aloud to be invented!

These 2100 ideas are the things *most needed* and *surest to make money*. They are listed under 34 different headings for quick reference: Electrical, Radio, Automotive, Agricultural, Building, Household, Clothing, Toys, Time-Savers, etc.

This book **ALSO** tells how to think inventively; how to **PROTECT** your ideas; how to develop an invention **STEP-BY-STEP**, etc.



\$100,000



\$1,000,000

## SEND NO MONEY

### FREE 5-DAY EXAMINATION

Would YOU like a slice of the \$280,000,000 that American inventors get *each year* in royalties? Get started *now!* Just mail the coupon and get "2100 Needed Inventions," by Raymond F. Yates, for 5 days' FREE trial. If, even in that short time, you are not convinced this book can help you make money—just return it and owe nothing. Otherwise, send only \$2.50, plus few cents postage, as payment in full.



Any one of the 2100 ideas in this book can bring *somebody* a fortune. Maybe it can be YOU! Mail the coupon and get this book on **FREE TRIAL** at once! **Wilfred Funk, Inc., Dept. T492, 227 East 44th Street, New York 17, N. Y.**

**WILFRED FUNK, Inc., Publishers, Dept. T492, 227 East 44 Street, New York 17, N. Y.**

Please send me 2100 NEEDED INVENTIONS for FREE EXAMINATION. If I keep the book I will send you \$2.50 plus few cents actual postage. Otherwise I will return it within 5 days, without further obligation.

Name \_\_\_\_\_

Address \_\_\_\_\_

City \_\_\_\_\_ Zone No. \_\_\_\_\_ State \_\_\_\_\_  
(If any)

Check here if enclosing \$2.50 WITH this coupon, and we will pay all postage charges. Same 5-day return privilege, for full refund, applies. (Canadian Orders—25c extra for carrying charges. Only U. S. currency accepted.)

(Continued from page 14)

Decorative candleholder has clear plastic base surmounted by polished-aluminum leaf design.....	189
Funny faces .....	190
Wall-bracket ivy holder made of aluminum.....	201
Novel metal piggy bank assembled from flush-tank float and oilcan .....	205
Direction of propeller controlled by rubbing notched stick.....	208

### PHOTOGRAPHY

Auxiliary flash adapter.....	209
Jiffy kitchen darkroom.....	210
Refrigeration of stock print developer results in brilliant negatives .....	211
Safelight mounted on gooseneck permits using brighter lamp.....	212
Solution bottles washed after use to prevent chemical dust.....	212
Photos marked with credit line by using flashlight printer.....	212
Timer made from alarm clock.....	212

### TOOLS

Metal shingle-nail dispenser hooks on trouser belt.....	180
Inexpensive gluing clamps made from turnbuckles.....	184
Pulley holds dowel upright to facilitate drilling end.....	184
Floating jackshaft for wood lathe facilitates shifting V-belts.....	188
Foot switch operates saw.....	192
Board fastened to bench-saw miter gauge serves as guide fence for cutting spirals.....	193
Turning dowels on disk sander.....	200
Wooden turn button on tool-chest lid supports doors for planing .....	205
Locking pliers form bench vise.....	208
Drilling true burr-free holes in thin sheet metal.....	216
Floor-model drill press improvised from hand drill and pipe fittings .....	222
Spring holder for threading tool results in mirror-bright finish .....	223
Large fruit-juice cans provide electrode carrier.....	223
Portable welding torch cuts tie wires to speed removing wall forms .....	223
Index plate for wood lathe.....	226
Power-tool stands .....	227

### MISCELLANEOUS

Pen modified for drawing ink.....	180
Block aids fastening tire chains.....	180
Neckties carried in suitcase protected by magazine.....	188
Sawdust sprinkled evenly over wet varnish provides nonslip boat deck .....	192
Washer facilitates scroll layout.....	193
Keeping fingernails clean.....	200
Sag removed from folding cot by straps at rail hinges.....	200
Ink-bottle stand includes handy utility tray which forms nontip base .....	201
Polishing plastics quickly.....	205
Pan-fishing through ice.....	206
Paper aids drying wet shoes.....	208
Handle for vacuum bottle.....	208
Nail perforates heavy directory to permit hanging on wall.....	216
Filing corners of square bolt head adapts it for hex socket wrench .....	216
Funnel prevents spilling powder when filling bottles.....	226
Estimating number of wall studs.....	228
Bottoming short bolt in acorn nut.....	228
Trick faucet is interesting display.....	228

### Radio-Television, Electronics

TV pictures projected on home movie screen (North American Philips, Inc., 100 E. 42nd St., New York City 17).....	229
Phone transmitter for 160-meter amateur band.....	230
Radio and television today (Rectangular TV picture bulb, Owens-Illinois Glass Co., Toledo 1, Ohio; television juke box, General Electric Co., Schenectady 5, N. Y.; private radio for personalized listening, Satchell-Carlson, Inc., New Brighton, Minn.; twin-lead lightning arrester, JFD Manufacturing Co., Inc., 6101 Sixteenth Ave., Brooklyn 4, N. Y.; twin-stylus variable-reluctance cartridge, General Electric Co., Syracuse, N. Y.; Voiceraser, Gray Manufacturing Co., Hartford, Conn.; portable uranium prospecting unit, The S. C. Baer Co., 1600 Times-Star Tower, Cincinnati, Ohio).....	232

### Long-Distance Storm Spotter

Radar that detects storms as far as six to eight hours away is operating atop a 100-foot tower at the Army Signal Corps' Fort Monmouth, N. J., laboratories. It can warn of bad weather anywhere within a 200-mile radius. Radar signals "paint" electronically on oscilloscopes pictures similar to a relief map of the area or give a vertical cross section of the storm. The equipment introduces its own "scale of miles" on the map so the operator can estimate the storm's location.

# How do you rate?

## LENGTH OF SERVICE IN WORLD WAR II

- 3 MONTHS
- 6 MONTHS
- 9 MONTHS
- 12 MONTHS
- 15 MONTHS
- 18 MONTHS  
(or more)

## EDUCATION BENEFITS UNDER THE G.I. BILL

- 15 MONTHS
- 18 MONTHS
- 21 MONTHS
- 24 MONTHS
- 27 MONTHS
- 30 MONTHS (plus  
one month for each  
additional month of  
service)

## I. C. S. TRAINING TO WHICH YOU'RE ENTITLED

- 60 MONTHS
- 72 MONTHS
- 84 MONTHS
- 96 MONTHS
- 108 MONTHS  
(Training benefits  
expire at the end  
of nine years)

**Y**OUR veteran training benefits may be worth more to you than you think. Figure it out for yourself. If you are a qualified veteran with three months' service, you are entitled to 15 months' education in an approved resident school—or five years of approved correspondence training. If you have used up most of your entitlement and have only three months remaining, you can still study with I.C.S. for a full year.

I. C. S. Courses do not interfere

with your job. You study in your spare time. Furthermore, you progress as rapidly as you wish with no limit to the amount of material you cover during your period of entitlement. And you have 400 practical, success-proved courses from which to choose.

**IMPORTANT:** You must enroll within four years after your discharge or before July 25, 1951—whichever is later. The time for action is *now!* Mark and mail the coupon TODAY!

## INTERNATIONAL CORRESPONDENCE SCHOOLS

**APPROVED**  
under the  
**G.I. BILL**

BOX 5670-K, SCRANTON 9, PENNA.

Without cost or obligation, please send me full particulars about the course BEFORE which I have marked X:

- |   |  |  |  |
|---|--|--|--|
| <p><b>Air Conditioning and Plumbing Courses</b></p> <ul style="list-style-type: none"> <li><input type="checkbox"/> Air Conditioning</li> <li><input type="checkbox"/> Heating</li> <li><input type="checkbox"/> Refrigeration</li> </ul> <p><b>Chemical Courses</b></p> <ul style="list-style-type: none"> <li><input type="checkbox"/> Chemical Engineering</li> <li><input type="checkbox"/> Chemistry, Analytical</li> <li><input type="checkbox"/> Chemistry, Industrial</li> <li><input type="checkbox"/> Chemistry, Mfg. Iron &amp; Steel</li> <li><input type="checkbox"/> Petroleum Refining</li> <li><input type="checkbox"/> Pulp and Paper Making</li> </ul> <p><b>Civil Engineering, Architectural and Mining Courses</b></p> <ul style="list-style-type: none"> <li><input type="checkbox"/> Architecture</li> <li><input type="checkbox"/> Architectural Drafting</li> <li><input type="checkbox"/> Bridge and Building Foreman</li> <li><input type="checkbox"/> Building Estimating</li> <li><input type="checkbox"/> Civil Engineering</li> <li><input type="checkbox"/> Coal Mining</li> <li><input type="checkbox"/> Contracting and Building</li> <li><input type="checkbox"/> Highway Engineering</li> <li><input type="checkbox"/> Lumber Dealer</li> <li><input type="checkbox"/> Reading Structural Blueprints</li> <li><input type="checkbox"/> Sanitary Engineering</li> <li><input type="checkbox"/> Structural Drafting</li> </ul> | <ul style="list-style-type: none"> <li><input type="checkbox"/> Structural Engineering</li> <li><input type="checkbox"/> Surveying and Mapping</li> </ul> <p><b>Communications Courses</b></p> <ul style="list-style-type: none"> <li><input type="checkbox"/> Electronics</li> <li><input type="checkbox"/> Practical Telephony</li> <li><input type="checkbox"/> Radio, General</li> <li><input type="checkbox"/> Radio Operating</li> <li><input type="checkbox"/> Radio Servicing</li> <li><input type="checkbox"/> Telegraph Engineering</li> </ul> <p><b>Electrical Courses</b></p> <ul style="list-style-type: none"> <li><input type="checkbox"/> Electrical Drafting</li> <li><input type="checkbox"/> Electrical Engineering</li> <li><input type="checkbox"/> Electric Light and Power</li> <li><input type="checkbox"/> Lighting Technician</li> <li><input type="checkbox"/> Practical Electrician</li> </ul> <p><b>Internal Combustion Engines Courses</b></p> <ul style="list-style-type: none"> <li><input type="checkbox"/> Auto Technician</li> <li><input type="checkbox"/> Diesel-Electric</li> <li><input type="checkbox"/> Diesel Engines</li> </ul> <p><b>Mechanical Courses</b></p> <ul style="list-style-type: none"> <li><input type="checkbox"/> Aeronautical Engineer's, Jr.</li> <li><input type="checkbox"/> Aircraft Drafting</li> <li><input type="checkbox"/> Forging</li> <li><input type="checkbox"/> Heat Treatment of Metals</li> <li><input type="checkbox"/> Industrial Engineering</li> <li><input type="checkbox"/> Industrial Instrumentation</li> </ul> | <ul style="list-style-type: none"> <li><input type="checkbox"/> Industrial Metallurgy</li> <li><input type="checkbox"/> Machine Shop</li> <li><input type="checkbox"/> Mechanical Engineering</li> <li><input type="checkbox"/> Mold-Loft Work</li> <li><input type="checkbox"/> Patternmaking—Wood, Metal</li> <li><input type="checkbox"/> Reading Shop Blueprints</li> <li><input type="checkbox"/> Sheet-Metal Drafting</li> <li><input type="checkbox"/> Sheet-Metal Worker</li> <li><input type="checkbox"/> Ship Drafting</li> <li><input type="checkbox"/> Tool Designing</li> <li><input type="checkbox"/> Welding Engineering</li> <li><input type="checkbox"/> Welding—Gas and Electric</li> </ul> <p><b>Railroad Courses</b></p> <ul style="list-style-type: none"> <li><input type="checkbox"/> Air Brake</li> <li><input type="checkbox"/> Diesel Locomotive</li> <li><input type="checkbox"/> Locomotive Engineer</li> <li><input type="checkbox"/> Locomotive Fireman</li> <li><input type="checkbox"/> Locomotive Machinist</li> <li><input type="checkbox"/> Railroad Section Foreman</li> <li><input type="checkbox"/> Steam-Diesel Loco. Eng.</li> </ul> <p><b>Stationary Eng'r'g Courses</b></p> <ul style="list-style-type: none"> <li><input type="checkbox"/> Boilermaking</li> <li><input type="checkbox"/> Combustion Engineering</li> <li><input type="checkbox"/> Engine Running</li> <li><input type="checkbox"/> Marine Engineering</li> <li><input type="checkbox"/> Power Plant Eng'r'g</li> </ul> | <ul style="list-style-type: none"> <li><input type="checkbox"/> Mech. Drafting</li> <li><input type="checkbox"/> Ship Fitting</li> <li><input type="checkbox"/> Toolmaking</li> <li><input type="checkbox"/> Car Inspector</li> <li><input type="checkbox"/> Steam Engr.</li> </ul> <p><b>Textile Courses</b></p> <ul style="list-style-type: none"> <li><input type="checkbox"/> Cotton Manufacturing</li> <li><input type="checkbox"/> Loom Fixing</li> <li><input type="checkbox"/> Textile Designing</li> <li><input type="checkbox"/> Woolen Manufacturing</li> </ul> <p><b>Business and Academic Courses</b></p> <ul style="list-style-type: none"> <li><input type="checkbox"/> Advertising</li> <li><input type="checkbox"/> App. Psychology</li> <li><input type="checkbox"/> Business Administration</li> <li><input type="checkbox"/> Bus. Correspondence</li> <li><input type="checkbox"/> Certified Public Accounting</li> <li><input type="checkbox"/> Commercial</li> <li><input type="checkbox"/> Cost Accounting</li> <li><input type="checkbox"/> Federal Tax</li> <li><input type="checkbox"/> Foremanship</li> <li><input type="checkbox"/> Good English</li> <li><input type="checkbox"/> Higher Mathematics</li> <li><input type="checkbox"/> Industrial Supervision</li> <li><input type="checkbox"/> Motor Traffic</li> <li><input type="checkbox"/> Retailing</li> <li><input type="checkbox"/> Salesmanship</li> <li><input type="checkbox"/> Sign Lettering</li> <li><input type="checkbox"/> Spanish</li> <li><input type="checkbox"/> Traffic Management</li> </ul> |
|---|--|--|--|

Name \_\_\_\_\_ Age \_\_\_\_\_ Home Address \_\_\_\_\_

City \_\_\_\_\_ State \_\_\_\_\_ Working Hours \_\_\_\_\_ A.M. to \_\_\_\_\_ P.M.

Present Position \_\_\_\_\_ Employed by \_\_\_\_\_

Length of Service in World War II \_\_\_\_\_ Enrollment under G.I. Bill approved for World War II Veterans. Special tuition rates to members of the Armed Forces. Canadian residents send coupon to International Correspondence Schools Canadian, Ltd., Montreal, Canada.

# INVENTORS

If you consider your invention to be something of importance—if you have invented any new and useful art, machine, manufacture or composition of matter or improvement thereof—you are advised to protect your invention by applying for a U. S. patent.

A patent is a valuable right. It grants you a monopoly—the right to exclude others from making, using or selling your invention as claimed for a term of seventeen years.

The specification and claims of a patent, particularly if the invention be at all complicated, constitute one of the most difficult legal instruments to draw with accuracy. Therefore, unless you are thoroughly familiar with such matters, you are advised to employ a competent registered patent attorney or agent.

This firm is registered to practice before the U. S. Patent Office and is available to assist in the preparation and prosecution of your patent application.

The "Evidence of Invention" form mentioned below is offered as a convenience to you in making your disclosure to us for search purposes.

You should date and sign your disclosure and have it witnessed by two or more persons who are capable of understanding your invention.

Your disclosure should be mailed to us together with a letter authorizing us to conduct a preliminary

search among previously granted U. S. patents for similar types of invention.

We then make this search and prepare a report of the probable patentability of your invention. If such report is favorable, we recommend the further course for you to take.

The "Evidence of Invention" form and booklet are suggested as conveniences to you and us in starting action on your invention.

**VICTOR J. EVANS & Co.** *Merlin M. Evans*  
REGISTERED PATENT ATTORNEY  
530-B MERLIN BUILDING, WASHINGTON 6, D. C.

We shall be glad to send you promptly and without obligation, an instructive booklet, "Patent Protection for Inventors", which was prepared to give inventors detailed information and steps to take toward patent protection—also our convenient "Evidence of Invention" form. Use address Victor J. Evans & Co., 530-B Merlin Building, Washington 6, D. C.

PATENTS      COPYRIGHTS      TRADEMARKS

## PRINT YOUR OWN POST CARDS

COMPLETE OUTFIT  
only

**\$7.50**

Amazing results in sales, inquiries and contacts... saves time and money... very easy to use GEM STENCIL DUPLICATOR is ideal for Advertising, Announcements, Notices, Labels, Forms, Price Lists—hundreds of uses for every type of business and organization. Comes complete with all supplies, instructions and 60-page Book of Ideas.

**FREE TRIAL OFFER:** Try it before you buy it! Write and a GEM OUTFIT will be sent you postpaid. After 10 days, send only \$7.50 or return the GEM, no questions asked. The GEM must sell itself; you be the judge.

**BOND EQUIPMENT CO. • Dept. 135**  
6633 Enright • St. Louis 5, Mo.

SEND NO MONEY • FREE TRIAL OFFER

## LEARN TO WRITE

*a Good Hand!*

FOR BUSINESS AND SOCIAL SUCCESS!

Easy to improve your handwriting at home quickly with my new instruction books just off the press. Master all the secrets of better penmanship. Simple and easy, fully illustrated, highly endorsed. Begin today. Write for:  New Free Book, "How to Become a Good Penman," or check books wanted, \$1.00 each.  Business Writing  Artistic Writing  Card Writing  Engrossing Alphabets  Bird and Design Flourishing  Complete Set \$4.50  Enclose 10c for your name beautifully written and special penpoint for shaded writing.

S. A. Ziller, President, TAMBLYN SCHOOL OF PENMANSHIP  
441 Ridge Bldg. In Business Over 52 Years Kansas City, Mo., U.S.A.

**WOULD \$400 PER MONTH**



**INTEREST YOU?**

It is easily possible to earn \$400 to \$500 a month raising ANGORA RABBITS. No experience required. Wool brings top price. Plenty markets. WRITE TODAY for FREE INFORMATION, PRICES and WHERE to SELL.

**WHITE'S RABBITRY**  
NEWARK 10, OHIO



## Bar Bells

Buy Direct From Factory

Write for free booklet and price list

**\$8.95**  
up

**INDEPENDENT IRON WORKS**

2416 East 23rd Street,  
Los Angeles 11, Calif.

Dept. B

## YOU CAN SUCCEED BY KLOK TRAINING

There is no other practical training in the wood industry whereby you can succeed so quickly as through our training. You can study either at home by correspondence or come to Grand Rapids and study with us here. The KLOK Course teaches you Sketching—Drafting—Rod Making—Time Study—Cost and Production Scheduling. The training will enable you to run your own shop more successfully or enable you to get a top position in the furniture and woodworking industry. Write NOW for free booklet, "Stepping Stones to Top Positions in the Woodworking Industry." State preference—Home Study or Resident Training—Age, and if you are a Veteran.

**FREE G.I. TRAINING**



**KLOK INSTITUTE**

Louis St., N. W., Grand Rapids, Michigan

These Men are Learning

# ELECTRICITY

ON REAL EQUIPMENT

in the GREAT SHOPS of COYNE



**Why Spend Years Preparing for a Good Job?  
Train Quickly at COYNE—Be Making Real  
Money While Others are Still Puttering Along!**

**PREPARE FOR PERMANENT  
JOBS LIKE THESE**

- Light and Power Wiring
  - Power Plant Work
  - Armature Winding
  - Substation Operator
  - Maintenance Electrician
  - Electrical Testing
  - Signal Maintenance
  - Industrial Electronics
  - Electric Refrigeration
  - and many others
- Our Employment Bureau for graduates gives **FREE** Lifetime Job Service.



**B. W. COOKE**

Yes, you can get ready for Good Pay—a Big Future in **ELECTRICITY**—by coming to **COYNE** in Chicago to train on actual equipment! Here you work on real motors, armatures, switchboards—do actual wiring and trouble-shooting—get the "all-around" training you need.

**Not a "Home-Study" Course**

We do not teach by mail. All training is given in our Great Shops, plus necessary theory. Expert instructors guide you. No advanced education or previous experience needed.

**EARN WHILE LEARNING**

If you need part-time work to help out with living expenses while at Coyne, we'll help you get it. Don't be held back by lack of money.

**Electrical Refrigeration Included**

Added training now included in great new field of Electric Refrigeration—Industrial Electronics also included. Both mean added opportunities.

**GI Approved—Finance Plan for Non-Vets**

COYNE courses are fully approved for G.I. training. Non-veterans may enroll now, pay most of tuition after graduation. Coupon brings details.

**GET THE FACTS!**

**BIG FREE BOOK** tells all about your future in Electricity and how you can get ready quickly at COYNE. Dozens of pictures. Rush coupon today!

**FREE BOOK**



**COYNE ELECTRICAL AND RADIO SCHOOL**

500 S. Paulina St., Dept. 20-72, Chicago 12

**B. W. COOKE, Pres.**

This modern fireproof building is occupied entirely by COYNE. Located in Chicago, the Electrical Center of the World,

**FOUNDED 1899**



**51st ANNIVERSARY YEAR**

**MAIL NOW**

**B. W. COOKE, Pres.  
COYNE ELECTRICAL  
AND RADIO SCHOOL, Dept. 20-72  
500 S. Paulina St., Chicago, 12, Ill.**

Send me your big **FREE BOOK** on **ELECTRICITY**. This does not obligate me in any way and no salesman will call on me.

NAME.....

ADDRESS.....

CITY..... STATE.....

**HERE'S YOUR CHANCE TO EARN MORE BY LEARNING MORE!**

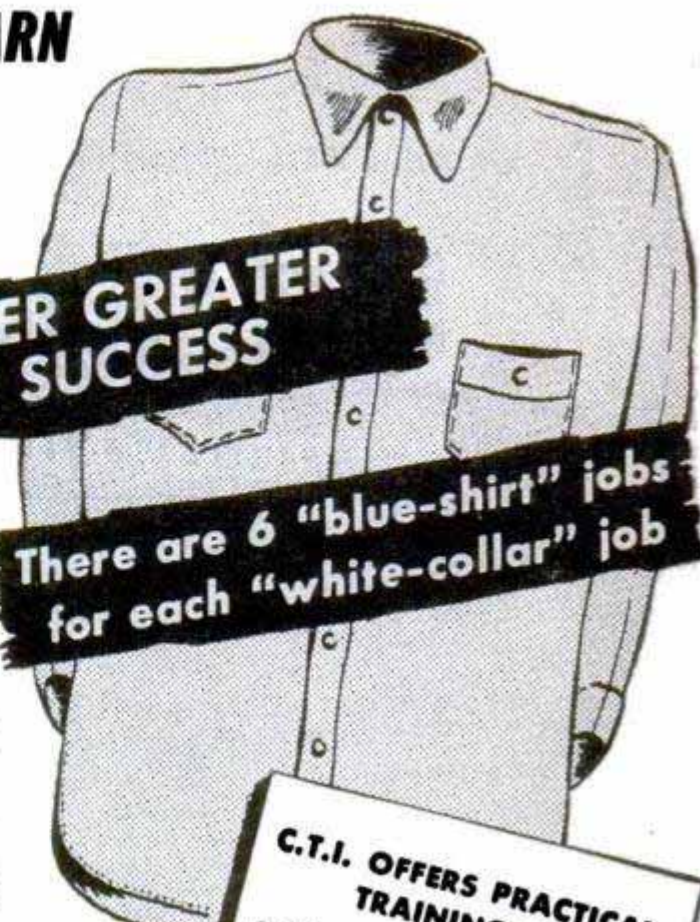

**"BLUE-SHIRT" JOBS OFFER GREATER OPPORTUNITIES FOR SUCCESS**

There are 6 "blue-shirt" jobs for each "white-collar" job

**LEARN A TRADE AT C.T.I.**

**Train in Our Modern Shops or thru C.T.I. Home Study...**



R. C. Anderson  
President

If you'd like to earn greater income and security as a mechanic or a technician—*be proud!* Leading educators and business men now point out that opportunities for success are greater today in *industry*—and that chances for advancement are best in the "blue shirt" classification. They add that there is lesser hope for progress among "white collar" job groups.

However, to wear a blue shirt isn't enough—you *still need training!* You can acquire this vital training through C.T.I. in a matter of *months*. Thousands of C.T.I. graduates have done it—you *can, too!* Read what a few of them tell us:

"As a result of my training at C.T.I., I am now in full charge of the shop where I am employed. I expect to own my own shop shortly" "Since I graduated, I have built a garage, bought the most important equipment, and have a waiting list of customers." . . . "I have a shop on the north side and have four men working for me." . . . "Since beginning your course I have more than doubled my earnings." . . . "Your course was very satisfactory. I own my own shop now!" . . . "Through the efforts of C.T.I., I received a job that I like very much." . . .

- C.T.I. OFFERS PRACTICAL TRAINING IN**
- AUTOMOTIVE MECHANICS
  - BODY & FENDER REBUILDING
  - DIESEL MECHANICS
  - REFRIGERATION & AIR CONDITIONING
  - ELECTRICITY & ELECTRONICS
  - RADIO & TELEVISION
  - BUILDING CONSTRUCTION
  - MECHANICAL DRAFTING

**DON'T DELAY - ACT TODAY!**

Yes, to advance in industry—or to prepare for owning a business of your own—it *certainly pays to train through C.T.I.!* So, choose the field you like best (see above list of opportunities) . . . *then fill out and mail coupon to C.T.I. today.* Remember—it's important to *act at once!*

**G.I. APPROVED**—All C.T.I. courses, both residential and home study, are fully approved by the Veterans Administration—which means that eligible veterans will have their tuition paid by the government. Remember, there's a time limit on when training must begin—so, act now!

**FILL OUT - CUT OUT - MAIL TODAY**

Mr. R. C. Anderson, President  
**COMMERCIAL TRADES INSTITUTE, Dept. E2-2**  
 1400 Greenleaf Ave., Chicago 26

Veteran  
 Non-Veteran

Send free illustrated Brochures and other information about the field I have checked below:

<input type="checkbox"/> Automotive Mechanics	<input type="checkbox"/> Electricity & Electronics
<input type="checkbox"/> Body & Fender Rebuilding	<input type="checkbox"/> Radio & Television
<input type="checkbox"/> Diesel Mechanics	<input type="checkbox"/> Building Construction
<input type="checkbox"/> Refrigeration & Air Conditioning	<input type="checkbox"/> Mechanical Drafting

Name \_\_\_\_\_ Age \_\_\_\_\_  
 Address \_\_\_\_\_  
 City \_\_\_\_\_ State \_\_\_\_\_

**COMMERCIAL TRADES INSTITUTE, Dept. E2-2**

1400 Greenleaf - Chicago 26





GET INTO

# DIESEL-AUTO MECHANICS

Master All Phases

**JOBS LIKE THESE ARE AVAILABLE TO TRAINED MECHANICS. CHOOSE THE FIELD YOU LIKE BEST**

### Get Complete Training

- Diesel Fuel Injection
- Automotive Motor Tune-up
- Diesel Engine Rebuilding
- General Garage Mechanic
- Agricultural Implements
- Auto Engine Rebuilding
- Auto Elec. Service
- Public Utilities
- Parts Dealers
- Bus & Truck Lines
- Industrial Maintenance
- Contracting & Excavating
- Business of Your Own
- AND MANY other similar openings.

As a National Schools graduate, you are trained for ALL opportunities in the Diesel & Auto Industries

### EARN WHILE YOU LEARN

With our practical Master Shop-Method Home Training, you study at home in your spare time. You receive Spare Time Work Lessons, which show you how to earn while you Learn . . . for extra money and experience. You Learn by DOING.

### TOOLS AND EQUIPMENT

To make your training complete, we give you selected mechanic's tools and equipment, illustrated below, including all-metal toolbox — as a regular part of your instruction.

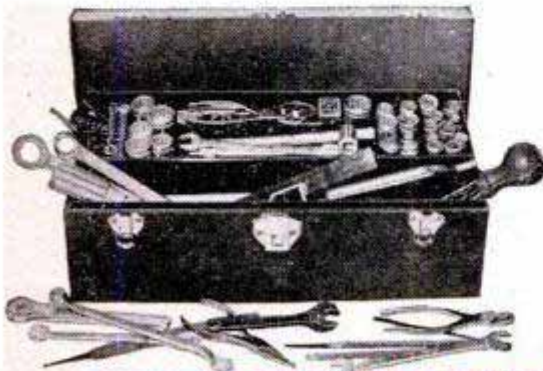

**WE GIVE YOU TOOLS OF YOUR TRADE**



### Shop-Method Home Training by an Established Resident School Prepares you for Many Good Jobs

Opportunity is everywhere for the trained Diesel-Auto Mechanic. Highways throng with cars, busses, trucks, tractors. Garages and Service Stations are kept busy. Factories, ships, farms, railroads, general industry, are dependent upon engine power. Here's a dynamic, fast-growing field that needs trained men who know ALL phases: installation, operation, maintenance and repair. Now—National Schools offers you a practical, all-embracing Diesel-Auto Mechanic's Course, including all of these advantages:

### Complete training, covering—Diesels, High Speed and Heavy Duty; Semi-Diesels, Gasoline and Special Fuel Engines AND Allied Mechanics.

- Basic Lesson Texts
- Diesel Installation
- Operation - Maintenance
- Diesel Chart Manual
- Spare Time Lessons
- Engine Service Manuals
- Engine Repair
- Drive Systems
- Diesel Electric Power
- Thermodynamics

### TOOLS AND EQUIPMENT

#### INVESTIGATE

Secure Full Information

**NEW, ILLUSTRATED BOOK & SAMPLE LESSON SHOW HOW WE TRAIN YOU . . . SEND FOR THEM TODAY!**



NO COST

NO OBLIGATION

**APPROVED FOR VETERANS**

Check coupon below

## NATIONAL SCHOOLS

LOS ANGELES 37, CALIF. • EST. 1905



### FIND OUT NOW... MAIL COUPON TODAY

NATIONAL SCHOOLS, DEPT. PMD-2  
4000 South Figueroa Street  
Los Angeles 37, California

(Mail in envelope or paste on penny postcard)

Mail me FREE the book, YOUR FUTURE IN DIESEL-AUTO MECHANICS, together with the Sample Lesson. I understand I may keep and use the information with no obligation.

Name \_\_\_\_\_ Age \_\_\_\_\_

Address \_\_\_\_\_

City \_\_\_\_\_ Zone \_\_\_\_\_ State \_\_\_\_\_

Check here if Veteran of World War II

**FREE**  
7-DAY TRIAL

JUST MAIL COUPON

# HOW TO BUILD A BETTER HOME

If You Are Undecided Whether You Should Build or Buy—  
If You Are Leery of 'Cheap' Building, Shoddy Work or Poor Design—  
If You Are Fed-Up With DREAMING About Your New House and  
Want to Get STARTED—Then This Will Prove a GOD-SEND to YOU!

HERE is the answer to how to build your own home. Here is the WORKS—how to plan, how to construct, how to supervise—simply, clearly explained step-by-step. Jam-packed with everything you need to know about building your own home yourself, or having a contractor build it for you. Hundreds of clear-cut, complete diagrams. You will be able to build a home that will amaze everyone!

Everything You Need to Know to Get Started

**Some of the Things This Book Explains:**

Here at Your Fingertips, the Secrets that Produce Fine Small Homes—Completely Revealed in this Great-Easy-Reference Book!  
How to Get Started; Deciding Upon Home Ownership; How to Select Professional Service; How to Finance Your Home; How to Select a Building Lot; How to Plan the Home; Where to Get Stock Plans; Taxes, Insurance, Interest, Maintenance, Assessments; How to Choose a Bank, Real Estate Dealer, Contractor; Locating House on Lot, Tax Searches, Comparative Costs, Designs; Prefabricated Houses; How to Fill Out Contract Documents; How to Obtain Good Construction; How to Prevent Termites; How to Prevent Decay; How to Prevent Corrosion; How to Lay Out Building, Excavate, Grade; Monolithic Concrete Construction; Masonry Construction; Footings for Foundation Walls, Chimneys, Piers; How to Build Piers, Foundation Walls; Basement Construction; How to Waterproof Basements and Foundation Walls; How to Build Chimneys and Fireplaces; How to Select the Proper Species and Grades of Wood; House Framing Methods and Details; Finish Carpentry and Mill-work; How to Insulate; Sheet-Metal Work; Roofing; Stucco, Lath and Plaster; How to Paint and Finish; Tile Work; Electrical Work; Plumbing; Heating; List of Over 100 Free Publications for the Home Builder; Bungalows, List of Usual Mistakes; Architectural "Don'ts" and over 300 additional paragraphs of important information.  
**QUICK REFERENCE INDEX to SPECIAL PAGE-SIZE PLATES (HUNDREDS OF ILLUSTRATIONS)**

Footings—foundation walls—basements; Garage floor, footings, etc.—septic tank—grease trap—area for basement window; Concrete porches, steps, automobile runways and driveways and walks; Brick steps, walks and terraces; Brick, tile and stone wall details—flagstone and stepping stone walks; Masonry dwellings—brick veneer walls; Chimney and fireplace details; Balloon framing details (minimum-shrinkage type); Balloon framing details (box sill type); Roof framing details; Basement columns and girders—framing of openings—bridging; Miscellaneous framing details; Water-tables—exterior sidewalls of siding or shingles—cornices—porch columns; Double-hung wood window details; Door frame details—points for mill-work—stock doors and windows—sash details; Paneling—stairwork—baseboard details; Termite shields—miscellaneous flashings; Flashing details; Gutters and leaders (downspouts); Roofing details.

Nothing Like It Before! One Simple Fact May Repay you a HUNDRED Times its Small Cost. A Book You Will Refer to for Years to Come!

**Read What Great Building Authorities Say About This Amazing Book (names on request)**

Excerpts from typical letters of praise:  
"... the best book on the subject that has been published to date." "was thrilled" "... valuable information for the new home-builder."  
"... an excellent piece of work" "... helped us decide our building plans" "... well worth price."  
"... very much impressed... an excellent reference book."  
"... the writing is clear and compact... complete and unbiased information."  
"... most interesting and complete." "You are to be congratulated. Contains more information than any volume seen... Everything you said."  
"... One of the best works of its kind I have ever seen. Send me 10 more for presents."  
**And from an amateur:**  
"From this book, I did the plans myself! Had never done anything like it before... A neighboring architect said I was an up-and-coming designer and he found not one fault with my plans... The building is now finished and everyone says it's beautiful!... I saved \$1900!"

Provides you with all the facts Whether you are going to spend \$2,000 or \$20,000 for your home—whether you are going to employ an architect or use stock plans—or whether you are going to buy a house instead of building, this book will help you. Before you build you should know the difference between good and bad construction. Now—in these days of shortages—just one of the hundreds of diagrams can save you thousands of dollars. You will get a thrill out of being "in the know," being "wise" to the game, being able to talk to building people in their own language. You'll be respected, admired and get better workmanship on your home. You'll get a feeling of pride as your friends admire the home being built. Here, in one clear-cut volume is all the basic information you will need!

**Where to Begin**  
No matter what your building problem may be, you will find the answer in this amazing volume. No truth is kept from you. You are told the disadvantages of home ownership as well as the advantages. You are told of the precautions you will need to safeguard your investment. You are shown how to select a lending institution, a lawyer, a real estate dealer, an architect, a contractor. Your questions on methods of buying are fully answered. Just a quick glance at the partial table of contents on this page will show you some of the thousands of facts on building which this complete volume contains. Those who have bought a copy write that they have never seen so thorough a work on this subject for any price, anywhere!

**Hundreds of Construction Details**  
Explains all the "mysteries" of permits, contract forms, and construction. Tells you how to build the right kind of home, how to avoid "cheap," cracker-box construction, how to get a house that is suitably located, beautiful to look at and priced within your means—a house you will be proud to call your home.

**How to Build—from Plans to Paint**  
Not one important step is missing from this volume. See for yourself. Every conceivable thing you would want to know about building will be found in this wonderful new book!  
**SEND NO MONEY**  
**Examine It for 7 Days**  
**FREE!**

You don't even risk a cent to examine "How to Build a Better Home." Just mail coupon. Study book for a week, FREE! See how easy it is to supervise or build a better home, YOURSELF—even if you know nothing about construction NOW! Then, if you are THRILLED with this amazing volume, send only \$3.98 (plus postage) (split it into two monthly payments if you wish.) If you are not thrilled, return book and pay nothing! This is your chance to build not just a house, but a BETTER HOME! Mail FREE EXAMINATION COUPON NOW, to The Westport Publishing Company, Dept. MP-2, Westport, Conn.

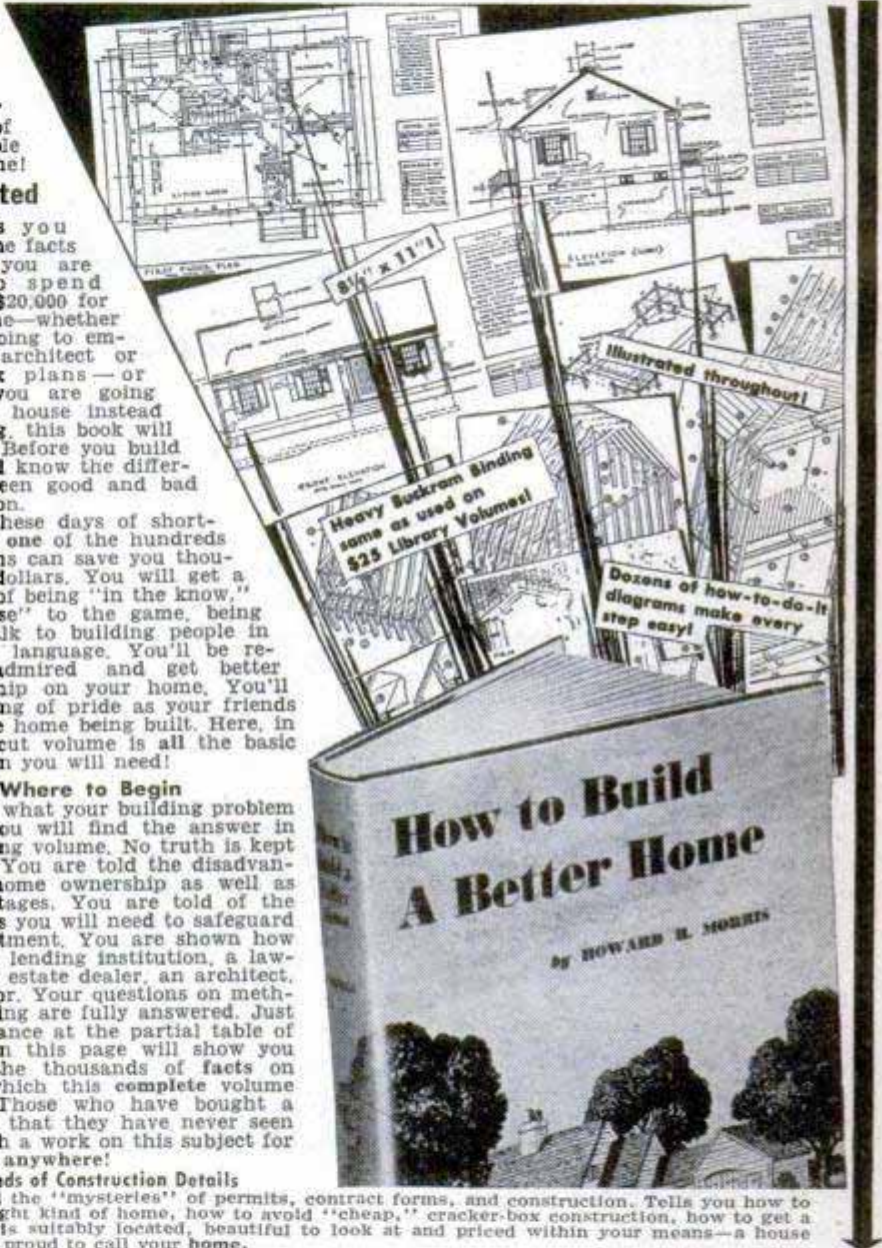

**How to Build A Better Home**  
By HOWARD B. MORRIS

**FREE Examination Coupon—Mail Now**

The Westport Publishing Company, "Books of Merit," Dept. MP-2, Westport, Conn. Please send me, for one week's FREE EXAMINATION, a new de-luxe edition copy of "How to Build a Better Home." After 7 days I will either return this book and owe nothing, or I will keep it and send you \$3.98 (plus shipping charges). (In two monthly payments, if I wish.)

Name..... Age.....  
(please print)

Address.....

City & Zone..... State.....

Save postage. Check here if you enclose full payment of \$3.98 (check or money order) WITH coupon. WE then pay shipping. If not thrilled return and we will refund your money by AIR MAIL! Foreign Orders \$4.50 Cash with order.

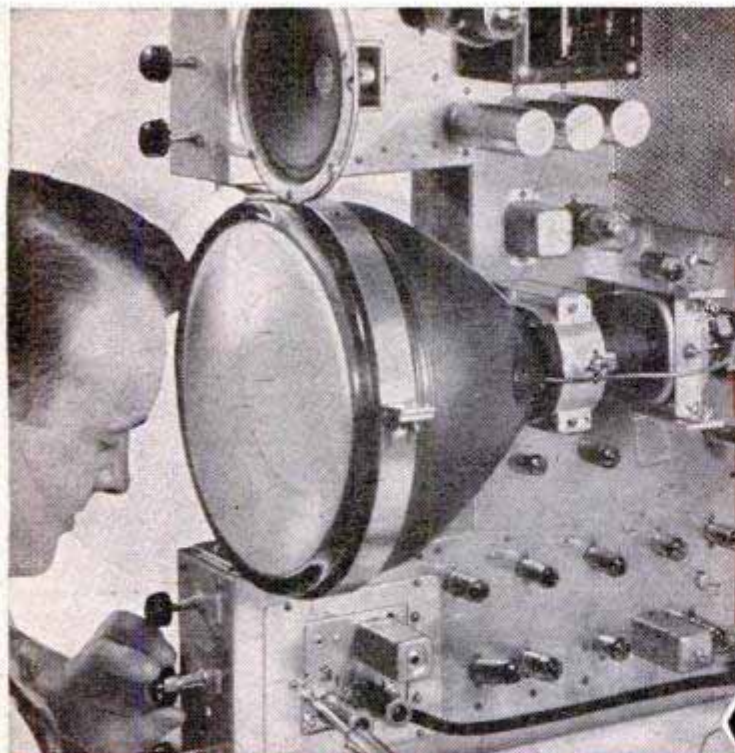

Only D.T.I.  
offers you the  
**"BIG 5"**  
**TELEVISION**  
RADIO-ELECTRONICS  
Laboratory Type  
**HOME TRAINING**

Build and Keep 10, 12½ or 16 inch Picture Tube Quality TELEVISION RECEIVER as you prepare for a Profitable Future

Here is everything you need to prepare you at home for FASCINATING WORK, GOOD MONEY and a THRILLING FUTURE in one of America's most promising fields.

This includes the opportunity to build and keep the top quality Television Receiver shown above—with choice of a 10, 12½ or 16 inch picture tube that gives big, bright, sharp, steady pictures. This is an optional feature—available when you complete your training described below. Get the complete facts. See how D.T.I.'s wonderfully practical "BIG 5" method meets industry's needs; No previous experience needed. Mail coupon today!

**16 Big Shipments of Parts — Plus Lessons**

Work over 300 electronic experiments and projects from 16 big shipments of parts. This includes building and keeping all test equipment and radio set shown at left side of page. Modern easy-to-read lessons with handy fold-out diagrams simplifies your entire training.

**You Also Use Home Movies**

D.T.I., alone, includes the modern, visual training aid . . . MOVIES to help you learn faster, easier at home. See electrons on the march and other fascinating "hidden action"—a remarkable home training advantage that speeds your progress.

**EMPLOYMENT SERVICE**

When you complete your training, our effective Employment Service helps you get started toward a real future in Television-Radio-Electronics.

**Modern Laboratories**

If you prefer, you can get All your preparation in our new, Chicago training laboratories . . . one of the finest of its kind. Ample instructors . . . modern equipment. Write for details!

6 Tube  
Radio  
Receiver

You Learn-By-Doing from D.T.I.'s HOME LABORATORY

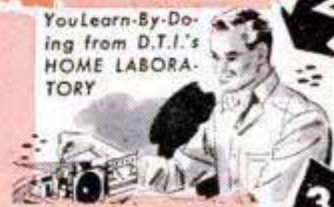

You Learn-by-Reading from D.T.I.'s MODERN LESSONS



You Learn-by-Seeing from D.T.I.'s HOME MOVIES

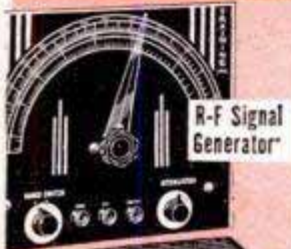

R-F Signal Generator

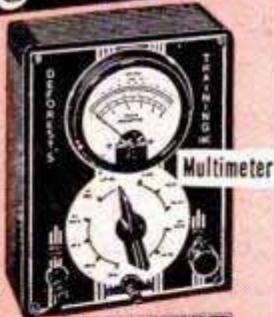

Multimeter



Oscilloscope



**DeFOREST'S TRAINING, INC.**

Chicago 14, Illinois  
A DeVry Institution

**MAIL THIS COUPON TODAY!**

DeFOREST'S TRAINING, INC. PM-G-2  
2533 North Ashland Avenue,  
Chicago 14, Illinois.

Without obligation, give me complete facts showing how I may make my start in Television-Radio-Electronics.

Name \_\_\_\_\_ Age \_\_\_\_\_  
Street \_\_\_\_\_ Apt. \_\_\_\_\_  
City \_\_\_\_\_ Zone \_\_\_\_\_ State \_\_\_\_\_

# DRAW ME!



COPY THIS GIRL AND TRY FOR

## \$1200.00 in Prizes

**5 PRIZES IN THIS NEW CONTEST! 5 Complete \$240 Art Courses, including Drawing Outfits!**

Here's your big chance, if you want to become a commercial artist, designer, or illustrator! An easy-to-try way to win FREE art training!

Whether you win or not our instructors

send you their comments on your work, if your drawing shows promise! Trained illustrators and artists now making big money. Find out now if YOU have profitable art talent. You've nothing to lose—*everything to gain*. Start your drawing now. Mail it today.

**ART INSTRUCTION, INC., DEPT. 2130**  
500 S. 4th St., Minneapolis 15, Minn.  
Please enter my attached drawing in your  
March drawing contest. (PLEASE PRINT)

Name \_\_\_\_\_ Age \_\_\_\_\_  
Address \_\_\_\_\_ Phone \_\_\_\_\_  
City \_\_\_\_\_ Zone \_\_\_\_\_ County \_\_\_\_\_  
State \_\_\_\_\_ Occupation \_\_\_\_\_

**RULES:** You must be amateur. Our students not eligible. Make copy of girl 5 ins. high. Pencil or pen only. Omit lettering. All drawings must be received by March 31, '50. None returned. Winners notified. If desired, send stamped, self-addressed envelope for list of winners.



Member  
National Home  
Study Council

*Art Instruction, Inc.*

MINNEAPOLIS • NEW YORK  
CHICAGO • LOS ANGELES

# NOW YOU CAN "Breeze Through" ANY AUTO REPAIR JOB!



Yes—EVERY Auto Repair Job is a "Snap"—with This Big, BRAND-NEW, Time-Saving, Money-Saving Manual. Shows You How to Service and Repair ANY Part of ANY Standard Car, Including 1949 Models!

DON'T waste time and patience trying to "dope out" difficult car repairs! Just look up make, model, and job in MoToR's AUTO REPAIR MANUAL—and you can "whiz" through ANY job in almost no time. Clear, illustrated instructions lead you step by step all the way.

**WORTH BIG MONEY TO:** Mechanics, Handymen, Garage-men, Farmers, Repair Men, Service Station Operators, Taxi Owners.

### See How Much You Get!

This BIG, brand-new 795-page book combines information from over 150 official Factory Shop Manuals. OVER 200,000 service, repair, tune-up facts—35,000 essential dimensions—on all makes and models, 1935 thru 1949! More than 2100 cut-away photos, diagrams show you exactly WHAT to do and HOW to do it. Used by the U. S. Army, tech schools; thousands of auto servicemen.

### Win Prestige! Earn More Money!

MoToR's Manual makes every operation so easy that you'll find yourself tackling jobs you wouldn't think of doing before. And you'll win added prestige and more money in the bargain.

Beginners will find usable helpful guidance on every kind of repair and service job imaginable. Experts will be amazed by the time and labor-saving short cuts they'll discover.

### SEND NO MONEY

Without risk, see for yourself how easily, clearly this book covers every job on every car! Just mail coupon — without money—for FREE 7-Day Trial. Unless you're convinced it's worth many times its cost, return book in 7 days and pay nothing! MoToR Book Dept., Desk 1B, 250 W. 55th Street, New York 19, N. Y.

Published by MoToR, The Leading Automotive Business Magazine.



Used by U. S. Army and Navy

### COVERS ANY CAR BUILT SINCE 1935!

- Auburn
- Austin
- Buick
- Cadillac
- Chevrolet
- Chrysler
- Cord
- Crosley
- De Soto
- Dodge
- Ford
- Frazer
- Graham
- Hudson
- Hupmobile
- Kaiser
- Lafayette
- La Salle
- Lincoln
- Mercury
- Nash
- Oldsmobile
- Packard
- Pierce
- Arrow
- Plymouth
- Pontiac
- Reo
- Studebaker
- Terraplane
- Willlys

**FREE**  
7-DAY TRIAL

**MOTOR'S**  
**AUTO**  
**REPAIR**  
**MANUAL**

**NEW!**

## Same FREE Offer on MoToR's TRUCK MANUAL



Covers EVERY job on EVERY truck made from 1936 thru 1946! 1400 pictures, 952 pages, 300,000 facts. All types Gasoline Engines, Truck Diesels, Hesselmanns, Fuel Systems, Governors, Lubrication, Ignition, Starters, Clutches, Axles, Brakes, etc., etc.

ALSO covers many buses, tractors, contractor and road building equipment, stationary power machinery. Check box in coupon.



### Just 2 of the Many Letters of Praise

"MoToR's Manual paid for itself on the first 2 jobs, and saved me valuable time eliminating guess-work."—W. SCHROP, Ohio



"Instructions so clear have no trouble learning anything about any car. Now working as mechanic in big plant."—SAM ORDÓÑEZ, Cal.

### MAIL COUPON NOW FOR 7-DAY FREE TRIAL

#### MoToR BOOK DEPT.

Desk 1B, 250 W. 55th St., New York 19, N. Y.

Rush to me at once (check box opposite book you want):

MoToR's New AUTO REPAIR MANUAL. If O.K., I will remit \$1 in 7 days (plus 35c delivery charges), \$2 monthly for 2 months and a final payment of 95c one month after that. Otherwise I will return the book postpaid in 7 days. (Foreign price, remit \$8 cash with order.)

MoToR's TRUCK REPAIR MANUAL. (Described at left.) If O.K., I will remit \$2 in 7 days, and \$2 monthly for 3 months, plus 35c delivery charges with final payment. Otherwise I will return book postpaid in 7 days. (Foreign price, remit \$10 cash with order.)

Print Name..... Age.....

Print Address.....

City..... State.....

Check box and save 35c delivery charge by enclosing WITH coupon entire payment of \$5.95 for Auto Repair Manual (or \$8 for Truck Repair Manual). Same 7-day return-refund privilege applies.



**Start As High As \$3,450 a Year**  
**Get Ready Now for 1950 Examinations**  
**In Your Locality**  
**Veterans Get Preference**

**City Mail Carriers, Post Office Clerks**

Clerks and Carriers now get \$2,870.00 the first year on regularly and automatically increase \$100 a year to \$3,670.00. Open to men, women 18 to 50.

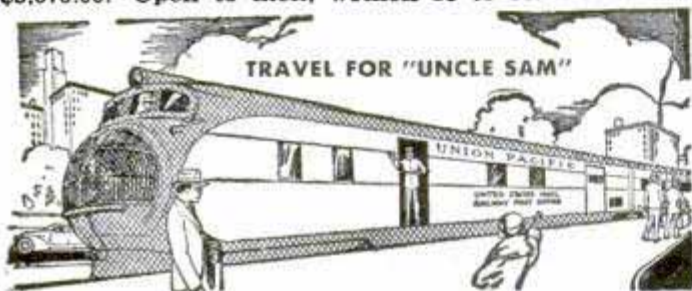

**Railway Postal Clerks**

Railway Postal Clerks get \$3,170.00 the first year regular, being paid on the first and fifteenth of each month. (\$132.08 each pay day.) Their pay is automatically increased yearly to \$3,970.00. Advance may be had to Chief Clerk at \$5,970.00 a year. (\$248.75 each pay day.) Male veterans only.

**3 Days On—3 Days Off—Full Pay**

Railway Postal Clerks on long runs usually work 3 days and have 3 days off duty or in the same proportion. During this off duty their pay continues just as though they were working. They travel on a pass when on business. When they grow old, they are retired with a pension.



**Many Other Positions**

Many other positions are obtainable. Rural Carriers—Stenographers—Typists—Assistant Statistical Clerks—Customs Inspectors—Liquor Inspectors—etc. Those wishing these positions should qualify at once.

**Get Free List of Positions**

Fill out the following coupon. Tear it off and mail it today—NOW, at once.

Although not government sponsored this investment can result in your getting a big paid government job.

**FRANKLIN INSTITUTE**, Dept. A-84, Rochester 4, N. Y.  
 Rush to me, entirely free of charge (1) a full description of U. S. Government Jobs; (2) Free copy of illustrated 40-page book, "How To Get A U. S. Government Job"; (3) List of U. S. Government Jobs; (4) Tell me what to do to qualify for one of these jobs.

Name \_\_\_\_\_

Address \_\_\_\_\_ City \_\_\_\_\_ State \_\_\_\_\_ Zip \_\_\_\_\_

Use This Coupon Before You Mislaid It. Write or Print Plainly.

**MAKE MONEY WITH YOUR CAR**

**EARN A SWELL LIVING THE EASY McNESS WAY**

Use your car as a McNess Store On Wheels. Sell things farmers need and consume. Serve same families year after year. Everything guaranteed. Big demand already exists, as farmers know only best quality products carry McNess name. You start right in making money the first day. No selling experience necessary. Advertising—premiums—offers—sales know-how supplied.



**USE OUR CAPITAL**—Get started at once. Write today for FREE Book that explains all. Tell what county and state you wish to serve. No obligation.  
**THE McNESS CO., 882 Adams St., Freeport, Ill.**

**"How to Make Money with Simple Cartoons"**



A book everyone who likes to draw should have. It is free; no obligation. Simply address

**FREE BOOK**

**CARTOONISTS' EXCHANGE**  
 Dept. 92-D Pleasant Hill, Ohio



**HEAD LETTUCE**  
*will head in any climate*

**GREAT LAKES-ICEBERG TYPE**  
**ALL AMERICA WINNER, TRY IT**

Resistant to heat and sun. Medium size. Solid crisp heads. Send only 5c for big packet and New Seed & Nursery Catalog. **FREE**  
**R. H. SHUMWAY SEEDSMAN, Box 687 Rockford, ILL.**

**EARN EXTRA MONEY**  
**SELL GREETING CARDS, STATIONERY & NOVELTIES**

to friends, neighbors and others. The country's outstanding line. Write for samples. Prompt service.  
**LIBERTY BELL STUDIOS—Dept. 15, 1013 Filbert St., Phila. 7, Pa.**

**SAY YOU SAW IT IN POPULAR MECHANICS**

**Command Bigger Money!**  
**STUDY LAW**

**STUDY AT HOME** for BUSINESS SUCCESS and LARGER PERSONAL EARNINGS. 40 years expert instruction — over 114,000 students enrolled. LL.B. Degree awarded. All text material furnished. Easy payment plan. Send now for FREE BOOK — "Law and Executive Guidance." It explains the course — how you may enroll and the many ways you can profit from Law Study. Write TODAY to:

**AMERICAN EXTENSION SCHOOL OF LAW**  
 Dept. 23-PM, 646 N. Michigan Ave., Chicago 11, Ill.



Get  
Into

# RADIO, TELEVISION and ELECTRONICS

## Master ALL Phases

**Get Complete Training. You Receive and Keep All Tubes, Equipment, Parts and Lessons. No Extra Charges.**

**YOU  
Build This  
Superheterodyne**

You receive complete standard equipment, including latest type High-Mu Tubes, for building various experimental and test units. You progress step by step until you build a complete Superheterodyne Receiver. It is yours to use and keep.



**YOU RECEIVE THIS  
PROFESSIONAL MULTITESTER!**

You will use this professional instrument to locate trouble or make delicate adjustments—at home—on service calls. You will be proud to own this valuable equipment. Complete with test leads.



**SIGNAL  
GENERATOR**

You construct the Transatron Signal Generator shown here, demonstrating Transatron Principles in both R.F. and A.F. stages. You study negative type oscillators at firsthand.

**AUDIO OSCILLATOR:**

An electronic device, which produces audio-frequency signals for modulating R.F. (radio frequency) carrier waves, testing A.F. (audio frequency) amplifiers, speakers, etc.



**T.R.F.  
RECEIVER**

You build several T.R.F. Receivers, one of which, a 4-tube set, is shown here. You learn construction, alignment, make receiver tests, and do trouble shooting.



**GOOD PAY  
and Unlimited Opportunities  
in JOBS LIKE THESE:**

Business of Your Own  
Radio Manufacturing, Sales, Service  
Broadcasting Telecasting  
Television Manufacturing,  
Sales, Service  
Laboratories: Installation, Maintenance of Electronic Equipment, Electrolysis, Call Systems  
Garages: Auto Radio Sales, Service  
Sound Systems and Telephone Companies; Oil Well and Drilling Companies; Engineering Firms  
Theatre Sound Systems Police Radio  
And scores of other good jobs  
in many related fields

**YOU CONDUCT MANY  
EXPERIMENTS LIKE THESE!**

Checking action of condensers  
Experiments with AF and RF amplifiers.  
Experiments with resonance  
Producing beat frequencies  
Calibrating oscillators  
Experiments with diode, grid-bias, grid-leak and infinite impedance detectors  
Practical experience in receiver trouble shooting  
Application of visual tester in checking parts and circuits  
Experiments with audio oscillators  
Advanced trouble-shooting  
... and many, many others

**Complete Training by Practical  
Resident Trade School, Est. 1905**

The same highly trained faculty, instruction materials and methods used here in our large, modern resident school, are adapted to your training in your own home. Shop Method Home Training has been proved by hundreds of successful graduates.

**Both Resident and Home Study  
Courses Offered**

**YOU  
LEARN BY  
DOING**

You receive special laboratory experiment lessons to show you how to build with your own hands various experimental units such as those shown at left, and how to conduct many tests.

You will find all lessons easy to understand because they are illustrated throughout with clear diagrams and step-by-step examples that you work out yourself. Every piece of the equipment and complete lesson material we send you is yours to keep and enjoy, including the multitester, experimental equipment, all parts of the Superheterodyne, tube manual, radio dictionary, and complete, modern Television texts. All parts are standard equipment.

**Shop Method Home Training ...  
Earn While You Learn**

With our practical resident Shop Method Home Training, you study in your spare time. You receive Spare Time Work Lessons, which show you how to earn while you learn. Service neighbors' radios and TV receivers, appliances, etc., for extra money and experience. Many National students pay all or part of their training with spare time earnings!

**DON'T DELAY! The Radio-Television  
Industry needs trained men NOW!**

**APPROVED  
FOR  
VETERANS!**  
Check coupon below!

For quick action,  
mail coupon  
today and we'll  
rush you full information.

**Free!**

**NEW, ILLUSTRATED  
OPPORTUNITY  
BOOK AND SAMPLE  
LESSON SHOW YOU  
HOW WE TRAIN  
YOU ... SEND FOR  
THEM TODAY! NO  
COST. NO  
OBLIGATION.**



**NATIONAL SCHOOLS**

LOS ANGELES 37, CALIF. • EST. 1905

**FIND OUT NOW ... MAIL COUPON TODAY**

National Schools, Dept. PM-2  
4000 South Figueroa Street  
Los Angeles 37, California

Send me your FREE book "Your Future in Radio" and the sample lesson of your course. I understand no salesman will call on me.

NAME.....AGE.....

ADDRESS.....

CITY.....ZONE.....STATE.....

Check here if Veteran of World War II

Mail in envelope  
or paste on  
penny postal.

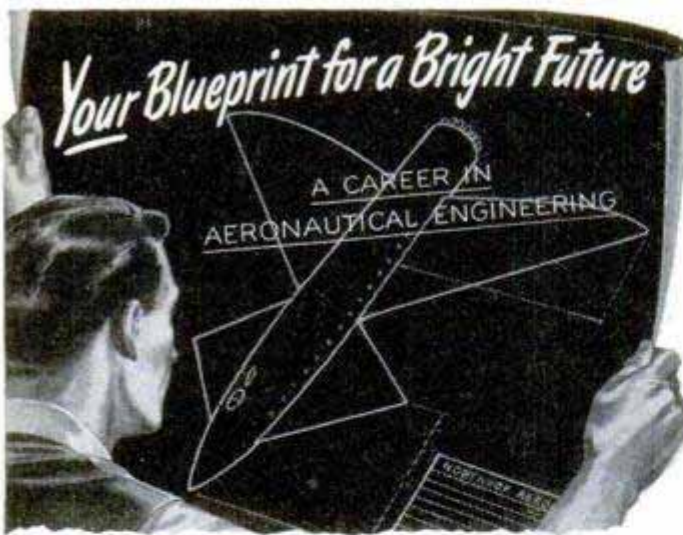

Blueprints guide the great aerial parade of spectacular new planes and aircraft power plants. Back of those blueprints is the *Aeronautical Engineer*. His original ideas, creative talents, technical knowledge, and professional skill produce the improved designs and new aircraft that give wings to the great *Air Age*. A career in the fascinating profession of *Aeronautical Engineering* can be *YOUR blueprint for a bright future*.

**Lifelong Adventure—and Rich Rewards**

Besides fascinating duties, you enjoy these practical rewards—good pay from the start... wide-open opportunity for quick advancement... the satisfaction of putting your own original ideas into action... the security of a field already huge, and still growing. *Northrop* graduates are enjoying these rich rewards, throughout *Aviation*. Hundreds hold good jobs with ALL leading aircraft manufacturers and airlines.

You are already *IN Aviation* when you train at *Northrop*. You enjoy many important practical advantages, such as illustrated by the training scenes at left and below... with many "live" aircraft giving *Northrop* students first-hand knowledge of aircraft construction and power-plant installation... and with actual aircraft

design projects providing *advance* experience in engineering duties. Get full details in the big, profusely illustrated *Institute* catalog. Classes start every 8 weeks—you can start *YOUR* training soon.



Send Coupon for this Catalog NOW

Catalog NOW

APPROVED FOR VETERANS

**Northrop**  
*Aeronautical Institute*

Division of Northrop Aircraft, Inc.  
1527 EAST BROADWAY, HAWTHORNE,  
LOS ANGELES COUNTY, CALIFORNIA

**NORTHROP AERONAUTICAL INSTITUTE**

1527 East Broadway, Hawthorne, Los Angeles County, Calif.

Please send information on opportunities in Aeronautical Engineering, your catalog, and starting dates of classes. I am interested in:

Aeronautical Engineering     Aircraft & Engine Mechanics

Name \_\_\_\_\_ Age \_\_\_\_\_

Address \_\_\_\_\_

City \_\_\_\_\_ Zone \_\_\_\_\_ State \_\_\_\_\_

Check one:  Veteran     Non-Veteran

**LEARN POULTRY AT HOME**

Poultry provides a good full—or part-time income—for thousands of men and women. Thorough training and "Know-How" can mean the difference between success and failure. That's why thousands have obtained their poultry education from N.P.I. home-study courses during past 29 years. Courses are easily understood, interesting, practical—bring students the hard-earned experience of experts in every phase of this \$3½ billion industry. If you have chickens, or wish to enter the poultry business, you should get our free catalog describing courses, methods, service, opportunities. Write today to Charles N. Burmaster, Mgr., Dept. 50.



Write for Free CATALOG



**NATIONAL POULTRY INSTITUTE** Adams Center, N.Y.

**Learn WATCH REPAIRING**  
*Earn while AT HOME you Learn*

Learn this fascinating and profitable trade in your spare time at Home through our Correspondence Department. Each individual student receives individual attention! Post-Graduate course at resident school optional for correspondence students.

OUR MOTTO: Not how quickly, **FOR** but how thoroughly we can train you.

**AT OUR RESIDENT SCHOOL**

APPROVED FOR G. I. TRAINING  
Our school is set up on an individual basis where every student receives individual attention from our competent instructors in a home-like and cheerful atmosphere.  
**Write TODAY FOR FREE INFORMATION:** JOHN VAN PUFFELEN, Director  
American Institute of Specialized Watch Repair  
270-276 East Bldg., Grand Rapids 6, Michigan

**MAKE MONEY!**  
**RAISE CHIN-CHIN CHINCILLA RABBITS**  
Pedigreed! Valuable Breeders!  
PROFITABLE! EASY! PLEASANT!  
Free illustrated Booklet—WRITE TODAY!  
ROCK HILL RANCH    SELLERSVILLE 36, PA.

**NEW! LOW COST! RESPIRATOR**

Wear when sanding, grinding, paint spraying, sweeping, dusting, furnace cleaning, etc. Handy as a pair of glasses. Just keep mouth closed and breathe through nose is all you do to operate. Protects against nuisance dusts, lint, coal, cement, grain dust, hay fever pollen. Has 9 sq. in. filter. For EYE protection against paint spray, dusts, gases, fumes, smoke, order our Fog-Proof Rubber GOGGLES \$1.65 p.p. (All prices postpaid in U.S.A.)

JERRY BRYANT, Dept. PM  
919 N. Michigan Ave.    Chicago 11, Ill.

Order Today \$1.00 POST PAID

**STAMMERER?**  
New booklet, "Stammering, and How to Stop It," sent free to any stammerer upon request. Write today. **BENJAMIN N. BOGUE**, Dept. 504, Circle Tower, Indianapolis 4, Ind.

GET THIS FREE BOOK!

**Is this real or a model?**

Get the answer in this picture-packed book on Model Railroading . . . . . only 10c

● Learn about the greatest of all hobbies. Model railroading is the hobby that fascinates hundreds of thousands of men all over the world.

This exciting book tells you that model railroading is simple, is inexpensive, and is constructive. Fully illustrated. Send 10c today for your copy of "Model Railroading for You," written by a well-known authority. The MODEL RAILROADER, DEPT. 1538, Milwaukee 3, Wis.



# WHICH OF THESE *Opportunities* INTERESTS *You* MOST?

Accounting  
Air Conditioning  
Architecture & Building  
Automotive Engineering  
Aviation—Practical  
Aviation Drafting & Design  
Better Foremanship  
Bookkeeping  
Business Management

Contracting  
Diesel Engineering  
Drafting & Design  
Electrical Engineering  
Electricity—Practical  
Electronics, Industrial  
High School Courses  
Machine Shop Operations  
Mechanical Engineering

Plastics Engineering  
Plumbing—Practical  
Private Secretary  
Radio Operating & Servicing  
Railway Training  
Refrigeration  
Sheet Metal Pattern Drafting  
Shop Management  
Tool Making

... In Job Competition  
Where Do You Stand?  
**Specialized Training Will Help You to  
GET AHEAD and STAY AHEAD!**

● Have you noticed that more and more the important, good-pay jobs are held by those who have had specialized training? Have you realized that Uncle Sam has turned out technically trained men by the thousands? Do you know that competition for jobs and promotions is strong now and will continue to grow stronger? Where do you stand now? *Where will you stand two, three, five years from now?* Can you keep up with job and promotion competition?

For more than 50 years we have trained men, in spare time at home, for better jobs . . . higher pay . . . brighter futures. We can do the same for you. Right now choose the job you want and prepare for it. Or if you are in work you like best, start training for quicker promotion. Then check that subject on coupon, add your name and address and mail it at once and we will send full details on our training plan.

PRACTICAL, EFFECTIVE HOME - STUDY TRAINING SINCE 1897

Take This First Easy Step  
**CHECK, CLIP AND MAIL COUPON NOW**

- AMERICAN SCHOOL, Dept. G-245, Drexel at 58th, Chicago 37, Ill.  
*Without obligation. Please send FREE and postpaid, bulletin and details of the Subject checked.*
- |  |   |  |
|--|---|--|
| <input type="checkbox"/> PLASTICS ENG'R            | <input type="checkbox"/> Railway Training             | <input type="checkbox"/> Drafting and Design for Men and Women |
| <input type="checkbox"/> Refrigeration             | <input type="checkbox"/> Accounting                   | <input type="checkbox"/> Radio                                 |
| <input type="checkbox"/> Architecture and Building | <input type="checkbox"/> Electrical Engr.             | <input type="checkbox"/> High School                           |
| <input type="checkbox"/> Contracting               | <input type="checkbox"/> Electricity-Pract.           | <input type="checkbox"/> Air Conditioning                      |
| <input type="checkbox"/> Practical Plumbing        | <input type="checkbox"/> Electronics, Industr.        | <input type="checkbox"/> Mechanical Eng.                       |
| <input type="checkbox"/> Automotive Engineering    | <input type="checkbox"/> Bookkeeping                  | <input type="checkbox"/> Shop Management                       |
| <input type="checkbox"/> Aviation Drafting         | <input type="checkbox"/> Private Secretary            | <input type="checkbox"/> Tool Making                           |
| <input type="checkbox"/> Aviation                  | <input type="checkbox"/> Diesel Engineering           | <input type="checkbox"/> Better Foremanship                    |
| <input type="checkbox"/> Business Mngment          | <input type="checkbox"/> Sheet Metal Pattern Drafting | <input type="checkbox"/> Machine Shop Operations               |

**AMERICAN SCHOOL**  
Dept. G-245, Drexel at 58th Street, Chicago 37

Name \_\_\_\_\_ Occupation \_\_\_\_\_  
Address \_\_\_\_\_ Age \_\_\_\_\_  
City \_\_\_\_\_ State \_\_\_\_\_

Which of these 2 one time WEAKLINGS PAID only a Few Cents to become an All-Around HE-MAN at Home?



Which One Paid Hundreds of Dollars to Train at My Side? REX FERRIS, was a skinny weakling, paid a few cents to start building into a Champion All Around He Man! LARRY CAMPBELL paid me hundreds of dollars to train at my side years ago. Start to become an All Around He Man at home with these same secrets for only a few cents—like Rex Ferris did!

Amazing get-acquainted offer—YOURS for only **10c** Instead of \$1 For all 5 Courses plus FREE Photo Book!

Be A Winner at Anything YOU Tackle with Progressive Power—SPORTS! JOB! SCHOOL! FRIENDS!

Let's Go, Pal! I'll prove I can make YOU an

**"ALL-AROUND" HE-MAN**

FAST—OR NO COST! says George F. Jowett World's Greatest Body Builder

Enjoy My "Progressive Power" Strength Secrets! Give Me 10 Easy Minutes a Day—Without Strain! I'll teach you the "Progressive Power Method" through which I rebuilt myself from a physical wreck the doctors condemned to die at 15, to the holder of more strength records than any other living athlete or teacher! "Progressive Power" has proven its ability to build the strongest, handsomest men in the world. And I stand ready to show you on a money back basis—that no matter how flabby or puny you are I can do the same for you right in your own home. Let me prove I can add inches to your arms, broaden your shoulders, give you a man-sized chest, powerful legs and a Rock-like back—in fact, power pack your whole body so quickly it will amaze you! Yes, I'll jam you with power and confidence to master any situation—to win popularity—and to get ahead on the job! Through my proven secrets I bring to life new power in you inside and out, until YOU are fully satisfied you are the man you want to be.

**PROVE IT TO YOURSELF IN ONE NIGHT**  
Send only 10c for my 5 easy-to-follow, picture-packed courses now in 1 complete volume "How to Become a Muscular He-Man." Try it for one night! Experience the thrilling strength that surges through your muscles. **10 DAY TRIAL!** Think of it—all 5 famous courses in one picture-packed, muscle-building volume only 10c. You must actually FEEL results in ONE WEEK, or your money will be promptly refunded!



Whom experts call **George F. Jowett** "Champion of Champions," World's wrestling and weight lifting champ at 17 and 19. World's Strongest Arms 4 times World's Perfect Body—plus other records.

**FREE!**

PHOTO BOOK of Famous Strong Men!

HOW TO MOLD MIGHTY LEGS

HOW TO MOLD A MIGHTY BACK

HOW TO MOLD A MIGHTY ARM

HOW TO MOLD A MIGHTY CHEST

HOW TO MOLD A MIGHTY GRIIP

How to BECOME A MUSCULAR HE-MAN

I want thousands of new friends—regardless of cost! Get all 5 (valued at \$5.00 each) Muscle Building Courses, for only 10c. Packed with How-To-Do-It Pictures! Start to build a body you will be proud of.

**FREE GIFT COUPON!**

Jowett Institute of Physical Culture DEPT. PM-02  
230 Fifth Avenue, New York 1, N.Y.

Dear George:—Please send by return mail, prepaid, FREE Jowett's Photo Book of Strong Men, along with all 5 Muscle Building Courses, 1. Molding a Mighty Chest, 2. Molding a Mighty Arm, 3. Molding a Mighty Grip, 4. Molding a Mighty Back, 5. Molding a Mighty Legs—Now all in One Volume "How to Become a Muscular He-Man." Enclosed find 10c for postage and handling. No C.O.D.'S.

NAME \_\_\_\_\_ AGE \_\_\_\_\_  
ADDRESS \_\_\_\_\_

# STUDY AT HOME

With An Educational Institution

Men with specialized training win higher positions, insure larger earnings, and are bigger successes in business and public life. Opportunities NOW greater than ever before. Send for our Catalog.

## ARTS and SCIENCES

Courses in Philosophy; Education; Letters; Public Health; Medical Jurisprudence; Psychology; Sociology; Physics; Chemistry; Geology; Political Science; Theology; Business and Commerce; Accounting; Mathematics; Statistics; Agriculture.

## ENGINEERING

Courses in Electrical, Civil Mechanical, Drafting, Architectural, Steam, Aeronautical, Radio, Structural, Mining, Industrial, Petroleum, Marine, Chemical, Diesel, Automobile, Refrigeration, and Air Conditioning Engineering.

## LAW

Complete Professional Law Course includes 18 Hornbook Series college grade textbooks. Courses also in Commercial Law, Patent Law and Medical Jurisprudence.  
McKinley-Roosevelt Incorporated, 4610-K, Sheridan Rd., Chicago 40, Ill.

**NATION'S LARGEST EXCLUSIVE ELECTRICAL SCHOOL**

**"LEARN-BY-DOING" ELECTRICITY**

**PRACTICAL TRAINING NOT "HOME STUDY"**

**G.I. APPROVED** Get actual experience in great shops of M.T.I. Learn all phases Practical Electricity; Housewiring, Motors, Const., Maintenance, etc. Living arrangements, Part-time jobs, etc. A post card brings the story.  
MICHIGAN TECHNICAL INSTITUTE, Dept. PM-2  
2281 W. Fort St., Detroit 16, Michigan

# FREE BARGAIN CATALOG of BOOKS

25,000 books of all publishers listed in our 55th Annual Bargain Catalog of 256 pages. Old-time favorites—latest "best sellers." Reference, Fiction, Juvenile, History, Scientific, etc. Supplying schools, colleges, libraries and thousands of individual customers. Send postcard today for our new 1950 catalog, "Bargains in Books."

**THE BOOK SUPPLY COMPANY, DEPT. 132**  
564-566 West Monroe St. Chicago 6, Ill.

**MAKE MONEY IN LANDSCAPING**

Thorough training by Internationally known Landscape Architect to start your own business, improve your home or advance in this well paid field. Many Opportunities. Approved for Veterans. Send for FREE BOOK.

**NATIONAL LANDSCAPE INSTITUTE**  
Dept. P-2, 310 So. Robertson Los Angeles 48, Calif.

# IS YOUR JOB DEPRESSION PROOF?

Can you lose employment because of depression, business failure or old age? Learn watchmaking, the mechanical profession called "depression-proof for trained men" by impartial national authorities. Old age brings increased respect rather than insecurity. Study veteran training approved courses in watch and clock repair, jewelry engraving, chronograph repair at the world's largest, best-equipped watchmaking school.

SEND FOR FREE 116-PAGE INFORMATION PACKET

**WESTERN PENNSYLVANIA HOROLOGICAL INSTITUTE**  
WORLD'S LARGEST WATCHMAKING SCHOOL

Desk 40, Chamber of Commerce Bldg., Pittsburgh, Pa.

# AMAZING NEW OFFER!

LEARN HOW TO MAKE REAL MONEY IN

# TELEVISION

RADIO & ELECTRONICS



**YOURS TO KEEP AND ENJOY**

## AT NO EXTRA COST! YOU GET A ROUND TRIP TO NEW YORK CITY

After you have completed the home study section of your course, your transportation to New York City—both ways—from any point in the United States or Canada will be paid by RTTA. At our affiliated training shops in New York City you'll get 2 solid weeks—50 hours of intensive laboratory work—on the most modern and scientific equipment. You'll live in New York City, the heart of the television industry, where the headquarters of the National Broadcasting Company,

American Broadcasting Company, Columbia Broadcasting System, Mutual Broadcasting System and many large television and radio companies are located.

### FREE EMPLOYMENT HELP

Upon completing your laboratory resident course, you will personally be recommended for a position by our placement director, who will help you get started toward a money-making future in television, radio and electronics.

**YOU BUILD THIS  
LARGE SCREEN  
TELEVISION RECEIVER**

**YOUR CHOICE** OF 10, 12½ OR 16 INCH PICTURE TELEVISION TUBE

**CAN BE CONVERTED  
FOR COLOR TELEVISION**

### IN DOUBLE QUICK TIME EARN BIG PAY; OWN YOUR OWN BUSINESS

NOW—you can qualify for a money-making career, through RTTA's sensational plan. In addition to becoming a CERTIFIED TELEVISION TECHNICIAN, you build yourself a complete large screen television set of the finest commercial quality, for your own use. You get 15 BIG KITS to enable you to get practical experience, build the equipment illustrated, plus a 6 TUBE STANDARD SUPER-HETERODYNE radio set, and many other testing units.

No matter where you live, no matter what you do, RTTA's effective methods can help you toward a FAT PAY CHECK or YOUR OWN BUSINESS. Previous experience is unnecessary. If you have a grammar school education or its equivalent, the Radio Television Training Association's "LEARN BY DOING" method can prepare you for a money-making career in television, radio and electronics. Clip and mail coupon to learn how you can get your part of over \$7,000,000,000—yes, 7 billion dollars—being spent in these booming industries today.

### EARN WHILE YOU LEARN

You will learn how to earn money in your spare time, without interfering with the work you are now doing. From the very beginning, the RADIO TELEVISION TRAINING ASSOCIATION's plan is a practical MONEY-MAKING COURSE. We will show you how to cash in on your new knowledge, even while you are learning. Act now by clipping the coupon to find out how you can become a CERTIFIED TELEVISION TECHNICIAN and earn extra money.

### YOU GET YOUR FCC LICENSE

RTTA prepares you to qualify for your FCC license. Pay is higher for the FCC license holder because only a comparative few of the thousands of men in radio-television today hold FCC tickets.

### FREE!

Get the new career book "HOW TO MAKE MONEY IN TELEVISION", and sample lesson to show you how easily you can train for a money-making job. Send for them today. Absolutely no cost, no obligation. RADIO TELEVISION TRAINING ASSOCIATION, Newark, N. J.

**YOU GET  
15 BIG  
TELEVISION-  
RADIO KITS  
AT NO EXTRA COST.  
YOU BUILD THESE  
ILLUSTRATED  
UNITS**



R.F. SIGNAL GENERATOR

**YOU  
KEEP ALL  
EQUIPMENT**

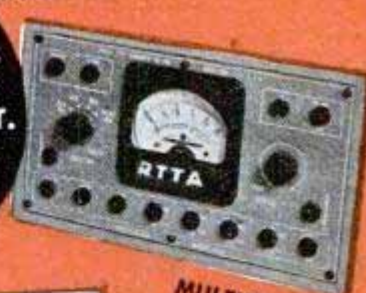

MULTITESTER

**STUDY  
AT HOME  
IN YOUR  
SPARE  
TIME**



AUDIO OSCILLATOR

## MAIL COUPON NOW!

RADIO-TELEVISION TRAINING ASSOCIATION, DEPT. 3-FM  
972 Broad Street, Newark, N. J.  
Send me, absolutely free, your book, "HOW TO MAKE MONEY IN TELEVISION" and the sample lesson of your course. I understand no salesman will call on me.  
NAME \_\_\_\_\_ AGE \_\_\_\_\_  
St. & No. \_\_\_\_\_ CITY \_\_\_\_\_  
STATE \_\_\_\_\_ ZONE \_\_\_\_\_

**RADIO TELEVISION TRAINING ASSOCIATION  
972 BROAD STREET  
NEWARK 2, NEW JERSEY**

# Home-Study COURSES

Offered under the Faculty Graded System of Training Available to Non-Veterans, and also Veterans in All States

under Public Law 16 and 346

- Practical Business Administration
- Fundamentals of Sales and Advertising
- Production Management
- Bookkeeping and Accounting
- Building, Estimating and Contracting
- Automobile Maintenance and Repair
- Diesel Locomotive Operation
- Diesel Locomotive Maintenance and Repair
- Steam Locomotive and Repair
- Railway Locomotive Maintenance and Repair
- Railway Electrical Maintenance
- Railway-Car Shop Maintenance
- Electrical Courses
- Machine and Allied Courses

For Further Information and Catalog Check, Without Obligation, Course Interested in and Mail to F. G. S. Training Division

## AMERICAN TECHNICAL SOCIETY

Desk PM, 850 East 58th Street  
Chicago 37, Illinois

# Secure YOUR FUTURE 3 TRADES IN 1 CAREER



## WATCHMAKING • JEWELRY- ENGRAVING • STONE SETTING •

Each trade can be a full-time job; together they assure numerous high paying opportunities, or a business of your own. Profit by the **Nationally Recognized Training Methods** of the **Kansas City School of Watchmaking**.

ENROLLMENTS NOW AVAILABLE

Clip and Mail this Coupon Today

**KANSAS CITY SCHOOL OF WATCHMAKING**  
1218 Admiral Blvd.  
Kansas City 6, Missouri

Please send me, without obligation, complete information on training in the above courses.

Name \_\_\_\_\_  
Street \_\_\_\_\_  
City \_\_\_\_\_ State \_\_\_\_\_  
 Check if Veteran G. I. Approved

## WHAM-O SPORTSMAN

HITS LIKE A .22 RIFLE —  
KILLS RABBITS, SQUIRRELS.  
For Hunting, Target,  
Routing Pests.

\$1.00  
postpaid



### HUNTING SLINGSHOT

Powerful, silent, accurate. Complete with 40 pellets and extra rubber straps. Send \$1.00 today to—  
Wham-O Mfg. Co., Box 2P, South Pasadena, Calif.  
PROFESSIONAL MODEL OF THE NAT'L SLINGSHOT ASSN.

Dealers Write

HEAVY DUTY STOCK



MAKE BIG MONEY

## Become An Artist!

**CASH IN ON BIG ART MARKET!**  
LEARN Cartooning, Commercial Art, Lettering, Showcard Writing, Photo Coloring, etc., QUICKLY with our NEW, EASY METHODS.

Interesting Catalog FREE

NATIONAL ARTISTS BUREAU  
Dept. A, P.O. Box 4248, Dallas 8, Texas



## LABORATORY TECHNICIAN

BE A LABORATORY SPECIALIST; complete course. Big demand from hospitals, doctors, clinics. We teach all branches of medical laboratory work, including Medical and Dental X-Ray.

Approved by American College of Medical Technologists

Co-educational Free Placement Bureau

Free Catalog

Accredited for "veteran" training

CHICAGO COLLEGE OF LABORATORY TECHNIQUE  
Dept. P.M., 431 S. Wabash Ave. Chicago 5, Illinois



## ITALIAN ACCORDIONS

Hand Made. Very Best. Buy Direct from Factory Representative at lowest wholesale prices and Save Money. Send Name and Address for FREE catalog.

ITALIAN ACCORDION MFG. CO.

7600 Cottage Grove Ave., Dept. PM-2, Chicago 19, Ill.



## LEARN MEAT CUTTING

through actual practice. Profitable Meat Cutting and Self Service Meats taught easily, quickly. LEARN BY DOING at Toledo in just eight short weeks under actual market conditions. For beginners or men with experience. All subjects taught thoroughly and completely. Diploma. Job help. Get store of own. People must eat. School in operation over 25 years. Approved for GI training. Send today for FREE illustrated catalog. No obligation. NATIONAL SCHOOL OF MEAT CUTTING, Dept. 50-B, Toledo 4, Ohio

# Rupture Troubles Ended

Advanced method has healed thousands. No leg straps, no elastic, no plasters. No pressure on hips or spine. Flexo-pad. Entirely different. Endorsed by doctors, mechanics, clerks. Very light. **INEXPENSIVE. GUARANTEED.** Write for information and trial.

SMITH MANUFACTURING COMPANY  
EST'D 1893 DEPT. PM PRESTON, ONTARIO

## HELPFUL BOOKS

Send post card asking for FREE catalog  
Popular Mechanics Press, 200 E. Ontario, Dept. 601, Chicago 11

it's fun to earn

## RAISING HAMSTERS

Cash in on the growing demand for SYRIAN GOLDEN HAMSTERS recently introduced into the U. S. Ideal pets . . . big laboratory demand. Hardy, clean, odorless. Easily and profitably raised anywhere.

AKOPIAN HAMSTERY

the largest in the West  
7358 H VARNA AVE. • NORTH HOLLYWOOD, CALIF.



write for FREE booklet

## Thrilling Work COLORING PHOTOS

Fascinating vocation learned at home by those with aptitude. Thrilling pastime. National method brings out life-like colors. Free booklet.

NATIONAL PHOTO COLORING SCHOOL  
1315 S. Michigan, Dept. 1352, Chicago 5

# START YOUR OWN BUSINESS!



## ELECTRICAL APPLIANCE REPAIRING

**SECURITY-INDEPENDENCE  
WORK SHORT HOURS**

There are millions of electrical equipment units in daily use . . . in factories, homes, office buildings and on farms. Skilled electrical technicians are needed to keep this equipment in good running condition.

You can now BE TRAINED to fill this BIG NEED. . . a need that grows day by day because of new electrical inventions for home and factory.

If you are mechanically inclined, can hold and use tools, we can give you the training and time-saving kits that will enable you to . . . Command More Money At Work . . . A Better Paying Job Elsewhere . . . Or A Business Of Your Own!

The ELECTRONIC KIT, a multi-purpose trouble detector, and other valuable Shop Method Training Kits are sent to you! All instruction material is written in simple, easy-to-understand language, chock full of hundreds of detailed photos and drawings.

We show you how to quickly locate the trouble, how to fix it and what to charge. ALSO, how to solicit business and keep business coming to you.

Get Full Facts on how you can get this training at home in your spare time and pay for it out of your earnings while learning!

**IN YOUR OWN  
KITCHEN,  
BASEMENT,  
OR GARAGE**

You don't need elaborate fixtures or expensive equipment to be a successful repairman. Work as many hours as you wish. The Electrical Appliance Technician is his own boss!

**\$5.00-\$6.00  
HOUR**

often charged for making ordinary repairs. We show you how to repair refrigerators, vacuum cleaners, washing machines, motors, etc., etc.

**AGE IS NO  
BARRIER**

Nor is a minor physical handicap. Work is light, pleasant and PROFITABLE.

**EARN WHILE YOU LEARN!**



Only had your course a few short weeks and have already made \$800.00. Going to quit my job paying \$250.00 straight salary to operate my own business. — J.D.S., St. Louis, Mo.

I work day times at the shipyard and after 4:00 P.M. I operate from my cellar and garage. I average \$10.00 to \$15.00 clear every day. — Walter Hanly, Brockton, Mass.



**SEND COUPON TODAY**



**FREE BOOK**

**CHRISTY TRADES SCHOOL, DEPT. D-7803  
4432 N. Kedzie Ave., Chicago 25, Ill.**

Gentlemen:  
Please rush me FREE ILLUSTRATED BOOK and full facts about America's fastest growing industry—ELECTRICAL EQUIPMENT SERVICING.

Name \_\_\_\_\_ Age \_\_\_\_\_  
Address \_\_\_\_\_  
City \_\_\_\_\_ Zone \_\_\_\_\_ State \_\_\_\_\_

# BIG PAY JOBS for men who qualify in DIESEL



**ASSURE YOUR FUTURE.** Steady, high-pay jobs await men qualified in Diesel, Tractor, and Heavy Equipment. Are you qualified for job and advancement opportunities in this fast-growing field? You can qualify!

**COMPLETE DIESEL COURSE NOW AVAILABLE.** If you are ambitious and want to get ahead in this big money field, you'll want to know about the complete Diesel home training course now offered by Interstate Training Service. Covers all phases of operation, repair, service. Easy to master in spare time. No interference with present job. Up-to-the-minute. Regularly revised to cover new developments. We invite comparison of material offered. Free placement advisory service.



**YOU OWE IT TO YOURSELF** to investigate Interstate Training Service Diesel Training. Thousands agree it has helped them to better jobs... better pay. It can do the same for you!

**SEND FOR FREE BOOK TODAY!**

INTERSTATE TRAINING SERVICE, Portland 13, Ore.  
Please see that I receive FREE 24-page book,  
"Getting Ahead In Diesel." (K-3)

NAME \_\_\_\_\_ AGE \_\_\_\_\_  
ADDRESS \_\_\_\_\_  
CITY \_\_\_\_\_ ZONE \_\_\_\_\_ STATE \_\_\_\_\_

# PEARL FINISHING OFFERS YOU BIG MONEY RIGHT AT HOME

AMAZING NEW PEARL FINISH can be instantly applied to any article—leather—wood—plastic—glass—metal, etc.

BABY SHOES preserved for life in beautiful Baby Pink, Blue, and Ivory thrill mothers and bring immediate sales.

Nothing else like it! Costume jewelry, buttons, earrings, treasured mementos, etc., etc. take on new splendor and beauty at once.

**TREMENDOUS DEMAND**—Help us fill it—Fantastic profits await those who act NOW. Be First! Scoop the market. Never before has such an opportunity been offered. Never before such Big Profits made so quickly—**SPARE OR FULL TIME.**

## NO INSTRUCTION COURSE TO BUY!

Complete Step-by-Step Instructions included at **NO EXTRA COST!** First time in History that such an offer has been made! Send **COUPON TODAY** for **FREE FACTS** on this **NEW BIG PROFIT BUSINESS.**

**DON'T PASS THIS UP**—It costs Absolutely Nothing to get the **FREE FACTS** that show you the **EASY WAY** to **QUICK, BIG MONEY** overnight! Mail Coupon **TODAY!**

PEARL-KOTE CO., Dept. 24  
2111 W. Manchester Ave., Los Angeles 47, Calif.  
Okay! **RUSH** me **FREE FACTS** at once. I understand there is **NO INSTRUCTION COURSE TO BUY!**

Name \_\_\_\_\_  
Address \_\_\_\_\_  
City \_\_\_\_\_ Zone \_\_\_\_\_ State \_\_\_\_\_

# RUPTURED?

## Get Relief This Proven Way

Why try to worry along with trusses that gouge your flesh—press heavily on hips and spine—enlarge opening—fail to hold rupture? You need the Cluthe. No leg-straps or cutting belts. Automatic adjustable pad holds at real opening—follows every body movement with instant increased support in case of strain. Cannot slip whether at work or play. Light. Waterproof. Can be worn in bath. Send for amazing **FREE** book, "Advice To Ruptured," and details of liberal truthful 60-day trial offer. Also endorsements from grateful users in your neighborhood. Write:

**CLUTHE SONS, Dept. 31, Bloomfield, New Jersey**

# REAL ESTATE BE A BROKER

**PAYS BIG! SEND FOR FREE, BIG, ILLUSTRATED CATALOG NOW!** No obligation. Graduates report making substantial incomes. Start and run your own business quickly. Men, women of all ages, learn easily. Course covers Sales, Property Management, Appraising, Loans, Mortgages, and related subjects. **STUDY AT HOME** or in our classrooms in big cities. Diploma awarded. G.I. approved. Nationally known.

**WEAVER SCHOOL OF REAL ESTATE (Est. 1936)**  
15 E. Pershing Road Dept. PM Kansas City, Mo.

FREE  
BOOK  
TELLS  
HOW

# LEARN TO PLAY CHECKERS

By subscribing to the "American Checkerist." Published monthly \$4.75 per year, \$9.00 - 2 years, \$12.75 - 3 years.

Send money order or check to:

**AMERICAN CHECKERIST CORP.**

345A Payne Avenue

North Tonawanda, N. Y.



*Learn to Write at Home in Spare Time*

You can easily improve your writing or become an Expert Penman by my Simplified Method at home in spare moments, for your Social and Business Advancement. Without obligation, write for Details and my **FREE BOOK**, "How to Become an Expert Penman," which contains specimens and tells what others learned. Send 10c for Special Penpoint and your name with a flourished bird elegantly written on a card.

*Write Today*

Box 25R, CHILLICOTHE, Mo.



# LEARN LANDSCAPING

Profitable career—absorbing hobby for men and women! Thorough home-study course in landscaping, garden design. 45 lessons beautifully printed and illustrated. Learn in spare time 8-12 months. Hundreds of successful graduates all over the world. 34th year. Write for **Free Catalog.**

**AMERICAN LANDSCAPE SCHOOL**  
6571 Grand Ave., Des Moines 12, Ia.

# BE AN AUTO MACHINIST



## Draw Top Pay • No Job Worries

Earn more money in auto mechanics—Specialize! New **FREE** booklet tells how to prepare for good jobs with high pay and job security. Our modern equipment and practical instructions make it easy to learn—get experience in

**ENGINE REBUILDING or GENERAL AUTO MECHANICS**

**VETERANS**  
American is a G.I. approved school.

Job  
Placement  
Service  
FREE

**Practical Shop Training**  
Learn to operate the very latest shop machinery. Friendly instructors take a real interest in preparing you for a good job.

**WRITE TODAY FOR  
FREE BOOKLET**

**AMERICAN TRADE SCHOOL**  
2411 McGee Kansas City, Mo.

PLANNING  
YOUR FUTURE IN  
AUTO MECHANICS



**YOU BUILD THIS  
23-TUBE  
TELEVISION  
RECEIVER**

**NOW!**

FOR THE FIRST TIME YOU CAN GET  
Real Practical HOME TRAINING In

# TELEVISION

## RADIO AND ELECTRONICS

**RTS LEADS THE WAY**

WE GIVE YOU

**11 BIG  
TELEVISION  
AND RADIO KITS  
AT NO EXTRA COST**

**YOU WORK AND LEARN  
WITH REAL TELEVISION  
AND RADIO EQUIPMENT**

RADIO-TELEVISION TRAINING SCHOOL'S master Technicians guide you. Located in the very heart of America's Television, Broadcasting, Radio and Sound Industries, RTS is right "on-the-spot" where new technical improvements are first introduced; is in the best possible position to bring students ACTUAL METHODS and practices developed by the RADIO-TELEVISION industry, leading to real money making opportunities. The 11 BIG KITS RTS gives you enable you to do many practical jobs, build the equipment illustrated; perform more than 100 other fascinating, valuable experiments. These jobs you do give you ACTUAL SHOP experience so vitally necessary to your future success. Thus RTS methods assure you BALANCED TRAINING—Theory PLUS Real Experience.

**OPPORTUNITIES NOW  
WIDE OPEN FOR  
Properly Trained Men**

Latest reports estimate 400 MILLION new television and radio sets will be built in the next 10 years . . . more than 72 million dollars is being spent RIGHT NOW just for radio repairs ALONE! When you are thoroughly trained by RTS Experts—who have their fingers on the pulse of the Radio-Television industry—a field of unlimited opportunities will open up for you in Your Own Radio-Television Sales & Service Business, F.M., Equipment Manufacturing, Communications and allied fields.

**EARN EXTRA MONEY  
while learning at HOME**

Under the RTS amazingly easy, practical home-training plan there is no need for you to quit your present job. You study in SPARE TIME ONLY! RTS Experts show you how

to earn WELCOME EXTRA CASH, even BEFORE FINISHING YOUR TRAINING! In fact, when friends and neighbors know you are studying Radio-Television you may—like many RTS students—actually get MORE REPAIR WORK THAN YOU CAN HANDLE.

**27 YEAR  
SUCCESS RECORD**

Backed by over a quarter-century of experience in home training, RTS (formerly Radio Training Association of America) offers practical "Learn-by-doing" methods, assuring you quick step-by-step progress. Begin preparing for your future in Radio-Television now while the time is ripe. If you are at all mechanically inclined—and have a grammar school education, RTS can teach you how to MAKE GOOD in Radio-Television.

**GET THE FACTS**

Send for FREE BOOK which tells you all about the RTS "time-tested" home-training plan, developed by technicians in the heart of the Radio-Television field. Fill out the coupon now—TODAY! and your FREE BOOK entitled "How To Make Good in Radio-Television" will go out to you AT ONCE. No Obligation. No salesman will call. Act now!

**YOU BUILD THIS  
6-TUBE STANDARD  
SUPER HETERODYNE  
RADIO SET with  
SHORT WAVE  
CONVERTER**

**★  
SEND  
FOR THIS  
30-PAGE  
FREE  
BOOK  
★**

**YOU  
KEEP ALL  
EQUIPMENT  
—it's Yours!**

**RADIO-TELEVISION TRAINING SCHOOL, DEPT. PM-2  
5100 South Vermont Avenue, Los Angeles 37, Calif., U.S.A.**

Send FREE Illustrated Book showing how I can make good in TELEVISION and Radio through training under the guidance of expert RTS Technicians. No obligation. (No Salesman will call).

NAME \_\_\_\_\_ AGE \_\_\_\_\_  
 ST. & No. \_\_\_\_\_  
 CITY \_\_\_\_\_ ZONE \_\_\_\_\_  
 STATE \_\_\_\_\_

**RADIO-TELEVISION TRAINING SCHOOL**  
 5100 SO. VERMONT AVE., LOS ANGELES 37, CALIF., U.S.A.  
 ESTABLISHED 1922 — 27 YEARS AGO

# INVENTORS

Before you make any effort to market your invention, you should take the first steps toward proceeding for patent protection.

The usual first step is to have a search of the U. S. patent records conducted, so that I can report to you on the question of patentability.

I shall be pleased to furnish you with information relative to patent procedure and also on the matter of trade-mark registration, upon request from you, and this will be without any obligation on your part.

## PATRICK D. BEAVERS

(Formerly RANDOLPH & BEAVERS)  
Registered Patent Attorney

934 Columbian Building Washington 1, D. C.

# INVENTORS

IF YOU WISH TO PROTECT YOUR INVENTION, You should take steps to protect it by a U. S. Patent. Write me for "Record of Invention" form.

## CARL MILLER REGISTERED PATENT ATTORNEY

Woolworth Bldg., 35th Floor, Dept. 20A,  
New York City

# BE AN INVESTIGATOR

WORK HOME or TRAVEL. Experience unnecessary.  
INVESTIGATOR Particulars FREE. Write to  
GEO. M. P. WAGNER, 125 W. 86th St., N. Y.



## LEARN MOVIE PROJECTION THEATRE MANAGEMENT

The Motion Picture Theatre Business offers big opportunities for trained men. Get into a fascinating field with a promising future. Train at home in spare time. Free Catalog. Established 20 years.

THEATRE SCHOOL, 370 Washington St., Elmira, New York

# INVENTING

**-FOR PROFIT!**

If you have an inventive turn of mind, write for free 28-page booklet explaining how the Institute of American Inventors is helping inventors pre-test the profit possibilities of proposed devices to fill today's unprecedented demand for useful new inventions.

## INSTITUTE of AMERICAN INVENTORS

Dept. 4, 1926 Eye St., NW, Washington 6, D. C.



# PATENTS

## AND TRADE MARKS

### C. A. SNOW & CO.

REGISTERED PATENT ATTORNEYS

WRITE FOR INFORMATION TO

428 SNOW BUILDING, WASHINGTON 1, D. C.



# PATENTS PATENT LAWYER

TRADE MARKS  
GUSTAVE MILLER  
20-PM WARNER BLDG.  
WASHINGTON 4, D. C.

ASSOCIATE EXAMINER  
U. S. PATENT OFFICE 1922-1929  
Patent Attorney and Advisor  
U. S. NAVY DEPT. 1930-1947  
REGISTERED PATENT ATTORNEY  
Send for PATENT INFORMATION  
book and "INVENTOR'S RECORD"  
without obligation

TRADE MARKS •  
COPYRIGHTS •

# PATENTS

The Time to Contact  
a Patent Attorney is Promptly  
After You Have Finished Your Invention

Write for FREE "INVENTOR'S GUIDE" & "Record of Invention"  
FRANK LEDERMANN Registered Patent Attorney  
154 Nassau St. • 20th Floor • New York 7, N. Y.

# INVENTORS

Whether an invention is patentable can be substantially determined by a search of the U.S. Patent records. Without obligation, write for information explaining the steps you should take to secure a patent.

## JOHN N. RANDOLPH

Registered Patent Attorney

201 Columbian Building, Washington 1, D. C.

# BE A NOTARY PUBLIC

Old legal-supply house, 22 cities, helps you get appointment by governor if you qualify, equips you fully. Pay after appointment (2 payments \$12.50 each). Respected public office. You certify legal papers, use official seal made with your name, collect your fees. Easy. Inquire—  
STATIONERS EXCHANGE BOERNE 52, TEXAS

# HIGHEST ROYALTIES and CASH

## FOR YOUR INVENTIONS

Write for FREE booklet without obligation

## UNIVERSAL MARKETING CO.

354 S. SPRING ST. (Suite M)

LOS ANGELES 13, CALIF.





# BUNK!

NOBODY IS JUST "Naturally"

# SKINNY!

Give Me 15 Minutes A Day And I'll Give YOU A NEW BODY

WOULD you believe it? I was once a skinny 97-pound weakling. People used to laugh at my spindly build. I was ashamed to strip for sports or for a swim. Girls snickered at me behind my back. Folks said I was just "naturally-born skinny!"

Then I discovered my marvelous new muscle-building system—"Dynamic Tension." And it turned me into such a complete specimen of MANHOOD that today I hold the title, "THE WORLD'S MOST PERFECTLY DEVELOPED MAN."

### ARE YOU

- Skinny and run down?
  - Always tired?
  - Nervous?
  - Lacking in confidence?
  - Constipated?
  - Suffering from bad breath?
  - Do you want to gain weight?
- WHAT TO DO ABOUT IT is told on this page!**

"Dynamic Tension" is the easy, NATURAL method that you can practice in the privacy of your own room—JUST 15 MINUTES EACH DAY—while your scrawny chest and shoulder muscles begin to swell . . . those spindly arms and legs of yours bulge . . . and your whole body starts to feel full of zip, ambition, self-confidence, and new energy!

### "Dynamic Tension" Builds You NATURALLY

Thousands of other fellows are becoming marvelous physical specimens—my way. I give you no gadgets or contraptions to fool with. You simply utilize the dormant muscle-power in your own body. In a very short time, you'll watch it grow and multiply into real, solid, rippling, LIVE MUSCLE.

*Charles Atlas*

Awarded the title of "The World's Most Perfectly Developed Man" in an international contest.

### WHAT'S MY SECRET?

When you look in the mirror and see a healthy, husky, strapping fellow smiling back at you—then you'll be astonished at how fast "Dynamic Tension" GETS RESULTS!

**FREE BOOK** Mail coupon now. I'll send my illustrated book, "Everlasting Health and Strength." Tells about my "Dynamic Tension" method. Shows photos of men I've made into Atlas Champions. It's a valuable book! And it's FREE. Mail coupon to me personally. CHARLES ATLAS, Dept. 82, 115 East 23rd Street, New York 10, N. Y.



**CHARLES ATLAS, Dept. 82, 115 East 23rd Street, New York 10, N. Y.**

I want the proof that your system of "Dynamic Tension" will help make a New Man of me—give me a healthy, husky body and big muscular development. Send me your free book, "Everlasting Health and Strength."

Name..... Age.....  
(Please print or write plainly)

Address .....

City..... State.....



# AUTO BOOKS ON APPROVAL

**SEND NO MONEY.** Just mail the coupon for a complete set of 4 Big, Thick Auto Books. 20th Edition. Over 2700 Pages! Whether you are a mechanic or helper, expert or apprentice, auto owner or driver, take immediate advantage of this **FREE EXAMINATION OFFER.**

## MAKE GOOD MONEY NOW HOLD A PERMANENT JOB

America wants its automobiles kept in good repair. Men with "know how" are in demand, at big pay. These books will help you get and hold an important job, or give you a chance to go into business for yourself now or later. Any man who half tries to improve himself can learn auto servicing and repairing by this quick reference method. Use the **JIFFY INDEX** to find easily understood answer to any auto problem. These wonder books prepared by eleven of America's great automobile engineers. Many hundreds of valuable illustrations. Send the coupon **TODAY.**

A year's consulting privileges with our engineers now given with these books without extra charge.

Publishers Since 1898



### CAN YOU FIX IT?

These wonder books tell step by step **HOW** to make difficult repairs and adjustments, how to keep a car at maximum efficiency, including latest improvements in car design and operation. Engine troubles and how to correct them well covered.

**4 BIG, THICK VOLUMES** Over 2700 pages, 2000 illustrations, wiring diagrams, etc. Be a useful modernistic, washable cloth binding.

### AMERICAN TECHNICAL SOCIETY, Dept. A219

Drexel Ave. at 58th St., Chicago 37, Ill. I would like to examine your 4-Volume Set of Auto Books. I will pay the delivery charges only, but if I choose I may return them express collect. If after 10 days' use I prefer to keep them, I will send you \$2 and pay the balance at the rate of only \$3 a month until \$24.80 has been paid. Include consulting service as offered above.

Name \_\_\_\_\_

Address \_\_\_\_\_

City \_\_\_\_\_ State \_\_\_\_\_

Please attach letter stating age, occupation, employer's name and address and name and address of at least one business man as reference. Men in service, also please give home address.

# PLUMBERS & STEAM FITTERS



**AUDELS PLUMBERS & STEAM FITTERS GUIDES.** This valuable set explains in practical concise language the principles, advances and shortcuts of the trade—based on good practice. Includes careful detailed instructions on how to figure & calculate various jobs.

A quick reference; saving time & money. A complete Trade course.

Over 1,670 Pages—  
3,642 Trade Illustrations

### PRACTICAL TRADE INFORMATION ON:

Soldering, tinning, Joint wiping, bending, beating. Pipe—iron—steel, threading. Mathematics, tables, physics. Materials—iron, steel, copper, brass, lead, tin, antimony, etc. Sheet metal—galvanized—plate. Sanitation, syphonage, tanks, Drainage, sewage, purification. Fixtures—bath—kitchen. Pipe fittings, soil pipe, tools. Laying out work. Roughing. Screwed fittings, flanges, joints. Pipe bending, examples. Elbows. Heating, ventilation, air conditioning, refrigeration. Water supply, mains, wells, tanks. Gas-fittings. Sheet metal work, problems, methods. Brazing, heating, lead burning. Welding, various welds, methods. Blacksmithing, forges, tools. Copper Tubing. Marine Pipe Fitting & Oil Burners. **HIGHLY ENDORSED—ASK TO SEE THEM. TO GET THIS ASSISTANCE FOR YOURSELF, FILL IN AND**

### MAIL ORDER

**AUDEL, Publishers, 49 W. 23rd St., New York 10, N. Y.** Mail Audels Plumbers' Guides, 4 vols. on 7 days' free trial. If O. K. I will remit \$1 in 7 days and \$1 monthly until \$6 is paid. Otherwise I will return them. No obligation unless I am satisfied.



**4 \$6**  
**VOLS. COMPLETE**  
**PAY ONLY \$1 A MO.**

Name \_\_\_\_\_  
Address \_\_\_\_\_  
Occupation \_\_\_\_\_  
Employed by \_\_\_\_\_ PM

# LEARN WATCH REPAIRING



**AT HOME.** By our modern and original system of instruction you can learn every part of the **WATCH REPAIRING TRADE AT HOME.** Prepare yourself for a well-paying position or start in business after completing our course of instruction. Good watch repairers are in demand and generally earn very good salaries. For particulars apply to the **Wisconsin School of Watch Repairing** 759 North Milwaukee St., Milwaukee 2, Wis.

## APTITUDE TESTS

discover the kind of work or studies best for your success! You get a personal report—a guide for life—more happiness—more prosperity. For men, women, boys and girls. Write for complete facts.

**VOCATIONAL COUNSELING INSTITUTE**  
956 Maccabees Bldg., Detroit 2, Michigan

# WHY DON'T YOU WRITE?

Writing short stories, articles on business, sports, homemaking, travel, shop crafts, local and club activities, etc., will enable you to earn extra money. In your own home, on your own time, the **New York Copy Desk Method** teaches you how to write the way newspaper men learn—by writing. Our unique "Writing Aptitude Test" tells whether you possess the fundamental qualities essential to successful writing. You'll enjoy this test. Write for it, without cost or obligation.

**Veterans: This course approved for Veterans' Training.**

**NEWSPAPER INSTITUTE OF AMERICA**  
SUITE 5590-B, ONE PARK AVENUE, NEW YORK 16, N. Y.

## CHICKS on NO-RISK



**30-DAY TRIAL GUARANTEE.** Money refunded on any chicks not true to breed. No need to take chances. 30 days to make sure chicks are as represented. Pullets or males. Low prices. All varieties. Easy buying plan. Chick Manual Free. **MISSOURI STATE HATCHERY, Box 289, Butler, Mo.**

## GET THIS FINE SUIT NO MONEY TO PAY!



### BIG CASH EARNINGS, TOO!

Big News! This fine tailored suit yours without paying one cent—and big cash earnings, too! It's easy! Just take a few orders. Earn up to \$10 in a day and get your own suit as extra bonus. Over 100 rich new fabrics, superbly tailored in latest styles, at low prices produce orders on sight. Money-back guarantee.

**FREE SAMPLES!** Write today giving name, address, age, etc. for big complete outfit of actual samples and details of amazing new Bonus Suit and money-making plan. —All Sent Free! No experience. **SEND NO MONEY!**

W. Z. GIBSON, Inc., 500 S. Throop St., Dept. B-516, Chicago 7, Ill.

### MAGIC TRICKS

**IT'S FUN TO DO MAGIC!**

BE POPULAR! AMAZE—MYSTIFY—ENTERTAIN!  
FOR 30 YEARS DOUGLAS HAS SATISFIED CUSTOMERS ALL OVER THE WORLD. NOW YOU CAN ENJOY THIS FASCINATING HOBBY, ONLY 25¢ BRINGS OUR CATALOG. 500 TRICKS—CONTAINING BRAND NEW TRICKS FOR POCKET, PARLOR, STAGE.

**JOIN IN THE FUN... SEND 25¢ TODAY**

**DOUGLAS MAGICLAND, DEPT. K, DALLAS, TEXAS**

# RADIO ENGINEERING, Broadcasting, Television, FM, Servicing, Electronics, Aviation, Marine & Police Radio taught thoroughly.

Engineering course equivalent to 3 years' college radio work. Approved Veteran Training. Catalog free. **VALPARAISO TECHNICAL INSTITUTE, Dept. D, Valparaiso, Ind.**

SAY YOU SAW IT IN POPULAR MECHANICS

## TRAIN NOW FOR AN AVIATION CAREER IN SUNNY SOUTHERN CALIFORNIA

### MAXIMUM TRAINING IN MINIMUM TIME

Specializing in **AERONAUTICAL ENGINEERING** and **MASTER AVIATION MECHANICS** since 1929. America's Finest Aeronautical Institute. 7000 successful graduates. **MAKE MORE MONEY MAIL COUPON TODAY APPROVED FOR VETERANS.** Board and Room now available.

Without obligation, send free catalogue with full information

NAME \_\_\_\_\_ AGE \_\_\_\_\_ PM-2  
ADDRESS \_\_\_\_\_  
CITY \_\_\_\_\_ ZONE \_\_\_\_\_ STATE \_\_\_\_\_

**CAL-AERO TECHNICAL INSTITUTE**  
GRAND CENTRAL AIR TERMINAL • GLENDALE 1, CALIFORNIA

**FREE-10 DAY TRIAL**

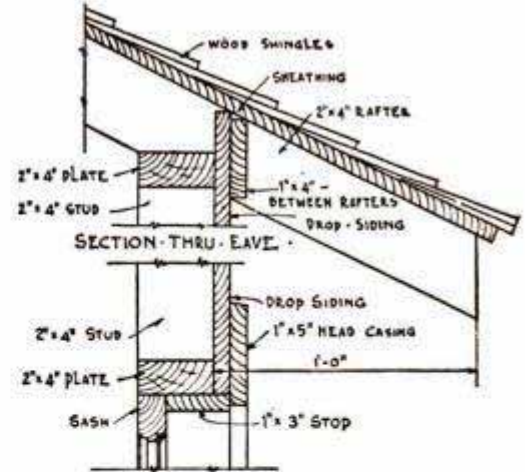
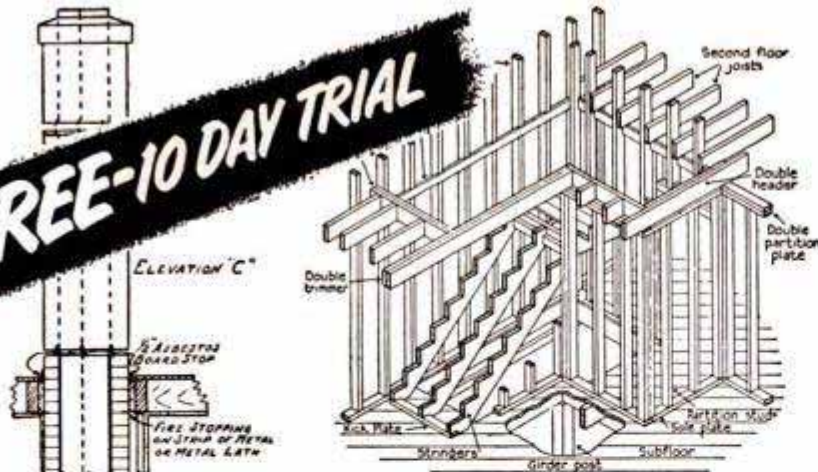

**NOW—Get the INSIDE TRADE FACTS on  
HOUSE CONSTRUCTION DETAILS**

**Save Money and Time — Get Better Construction —  
with these Professional Methods**

Here, at last, is an exact working guide on every detail of house construction from foundation to finish. Tells you dimensions, materials, processes, step-by-step working methods. Hundreds of scale drawings and photographs make every step easy to follow. Can be used for alterations in a set of stock plans, for making additions or changes in a building, or for complete con-

struction of a dwelling. Conforms with modern practice and building regulations in all parts of the country. A book you will refer to for years! The professional guidance you get on even a single house construction detail can *repay you a hundred times the small cost* of this wonderful volume! Send for free-examination copy today. Mail coupon below.

**Every Step in House Construction  
Explained and Illustrated:**

- Excavations • Footings and drainage • Foundation forms • Sills • Girders • Joists • Sub-flooring • Exterior wall framing • Interior wall framing • Ceiling joists • Gable roof • Hip roof • Gambrel roof • Dormers • Siding and shingling • Cornices • Porches • Exterior walls of wood • Exterior walls of brick • Interior walls finished in plaster, in plywood • Wall panels • Mouldings for interior trim • Stair construction • Windows • Sash details • Window framing details • Doors and door trim • Hardware used in dwellings • Closets, shelves, built-in equipment • Breakfast alcove • Sewing room • Flooring • Chimneys and fireplaces • Mantels and seats • Outdoor fireplaces • Scaffolds • Garages • Electric wiring • Insulation • Arches and gates • Lattice porch, lattice trellis • Garden benches, tables • Swings and other garden furniture • Picket fences • Log cabins, camps, cottages • Barns • Feeders and nests • Rabbit hutch • Septic tank • Painting and finishing • Heating systems • Air conditioning systems • Prefabricated houses • Useful information for home builders including architectural styles and data on modern building materials.

**313 PAGES, SIZE 8½ x 11. FULLY INDEXED. 1500 ILLUSTRATIONS**

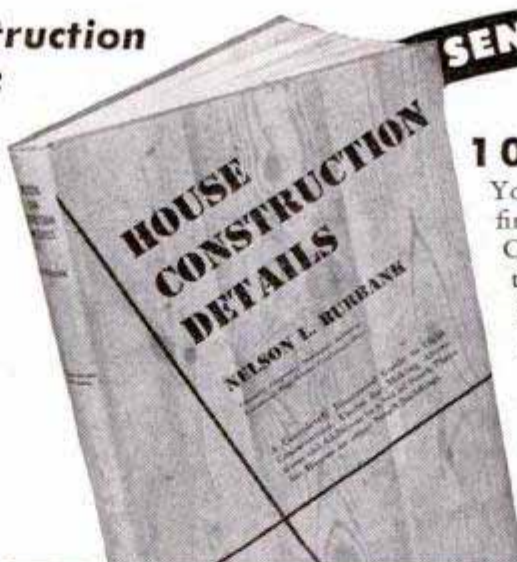

**SEND NO MONEY!**

**Examine  
10 DAYS FREE**

You don't risk a penny to find out how valuable "House Construction Details" can be to you. Just mail coupon. See for yourself how you get clear, professional guidance on every building detail. Then either send only \$4.50 (plus postage) in full payment, or return the book and owe nothing. Mail free-examination coupon NOW.

**MAIL THIS COUPON**

**Simmons-Boardman Publishing Corp.** Pop. Mech. 250  
**30 Church Street, New York 7, N. Y.**

Send me for 10 DAYS' FREE EXAMINATION, "House Construction Details." I will either return it in 10 days and owe nothing, or send only \$4.50 (plus shipping charges) in full payment.

Name.....  
 Address.....  
 City & State.....

**SAVE!** Send \$4.50 with this coupon and we will pay postage. Same return and refund privilege.

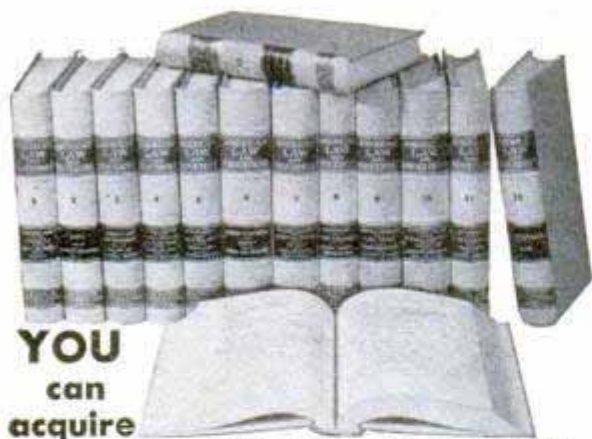

YOU  
can  
acquire

## LAW NIGHTS AT HOME! L. B. DEGREE

LaSalle's famous Law Library—used as reference in many Law libraries and Law offices—has enabled thousands to master Law surprisingly fast, in spare hours at home, for business and professional advancement.

These 14 remarkable volumes, compiled by leading professors and lawyers, cover the whole basic field of Law in condensed, orderly, simplified manner.

You advance rapidly with this great library, plus special lectures furnished. We guide you step-by-step with personalized Problem Method of instruction . . . you learn by doing—handling legal problems—not by memorizing rules.

Send for two FREE 48-page booklets, "Law Training for Leadership," and "Evidence," answering questions about Law and its value to you, and telling how LaSalle Law graduates are winning rapid advancement in business and public life. Mail coupon below. No obligation.

### LA SALLE EXTENSION UNIVERSITY A Correspondence Institution

417 S. Dearborn St., Dept. 264-L, Chicago 5, Ill.

Send me your two FREE booklets described above, without obligation.

Name \_\_\_\_\_ Age \_\_\_\_\_

Street \_\_\_\_\_

City, Zone & State \_\_\_\_\_

## Ugly BLACKHEADS OUT IN SECONDS



Keep your complexion free of Blackheads this new way — look attractive instantly!



### Try VACUTEX

#### Blackhead-Remover

The amazingly effective Vacutex extracts Blackheads automatically — WITHOUT squeezing the skin or injuring tissues. Easy to use with three fingers. It reaches Blackheads anywhere. Try it 10 days and if not delighted, return VACUTEX and your money will be refunded.

\$7.00



AT YOUR DEALER OR USE COUPON

### 10 DAY TRIAL COUPON

BALLCO PRODUCTS CO., Dept. A-3202  
19 West 44th St., New York 18, N. Y.

- Enclosed find \$1. Send postpaid.  
 Send C.O.D. I will pay postman \$1 plus postage;  
\$1 refund if not delighted.

SORRY. NO C. O. D.'s OUTSIDE U. S. A.

## Yours For An EXTRA INCOME

the Year 'Round

Lovely Greeting Cards for all events bring you easy dollars! 15 All-Occasion Folders sell for \$1. Just show Sample Box to friends, others. Pocket up to 100% CASH PROFIT. Also show Gift Wraps, Plastic, Metallic Cards, Imprinted Notes, Napkins, Stationery, other easy sellers. FREE Imprint Samples, Assortments ON APPROVAL. WRITE NOW!  
**FRIENDSHIP STUDIOS, INC.**  
62 ADAMS ST. - ELMIRA, N. Y.

**FRIENDSHIP  
Everyday  
Cards**



## AUTO WASHER

Your car sparkling clean—in a jiffy—Amazing "Suction" Auto Washer. Simply glide over car. PRESTO! Dust, grease, dirt, and grime disappear like magic. Leaves finish clear, lustrous. Auto gleams like a mirror.

### SAMPLES for AGENTS

Sample offer sent immediately to all who send name at once. Hurry, postal will do. **SEND NO MONEY—Just your name.**  
KRISTEE CO., 694 Bar St., Akron, Ohio

## HOMESITES \$300 LOW TERMS

In California's loveliest Garden Spot, on scenic shores of beautiful Morro Bay. Enjoy future independence with excellent soil, soft water, wonderful fishing, hunting, boating, bathing, etc. Grow fruits, vegetables, poultry. Perfect temperate climate. Congenial community. Finest investment. Free literature.

**RICHARD S. OTTO**

DEPT. M

SAN LUIS OBISPO, CALIFORNIA

## Learn ACCOUNTING BOOKKEEPING

This nationally renowned school has demand for graduates in good salary positions thru Nationwide recognition and placement service. Write Department PMI today for Big 32 page Success Book to be sent to you **FREE**



**Hills BUSINESS UNIVERSITY AND  
EXTENSION SCHOOL**  
619 W. MAIN ST. OKLAHOMA CITY 2, OKLAHOMA



## AJAX LIGHT BRAHMAS

Wonderlay Strain Egg-show winners. Gigantic size. Quick growing. Heavy layers. Exceptional big canons. U. S. Approved-Pullorum Controlled. Thousands hatching weekly. Low farm prices. Catalog **FREE**. Write **TODAY**.

AJAX HATCHERY, Box 916, QUINCY, ILLINOIS

## EASY TO LEARN CODE

Learn or increase speed with an Instructograph—the Radio-Telegraph Code Teacher that takes the place of an operator-instructor and enables anyone to master code without further assistance. Available tapes from beginners alphabet to typical messages on all subjects. Speed range 5 to 40 WPM. Always ready—no QRM. Thousands have "acquired the code" with the Instructograph System. Write today for convenient rental and purchase plans.



**INSTRUCTOGRAPH COMPANY**

4701-V Sheridan Road, Chicago 40, Illinois

## RUPTURE-EASER

FOR MEN, WOMEN AND CHILDREN

A strong, form fitting, washable support. Back lacing adjustable. Snaps up in front. Adjustable leg strap. Soft, flat groin pad. No steel or leather bands. Unexcelled for comfort. Also used as after-operation support. Give measure around the lowest part of the abdomen. Specify right or left side or double. We pay postage except on COD's. **PIPER BRACE CO.**  
308 East 12th Dent. PM-25

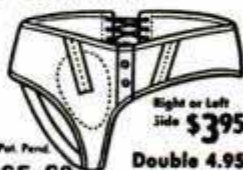

Right or Left side \$3.95

Double 4.95

Kansas City 6, Mo.

SAY YOU SAW IT IN POPULAR MECHANICS

## Learn BAKING At Home

Baking is one of America's high industries in wages. Nearly depression-proof. Thorough basic home course lays sound foundation. If you have aptitude, write for **FREE BOOKLET**. "Opportunities in Commercial Baking." National Baking School, 1315 Mich. Ave., Dept. 1352, Chicago 5



Enter a dynamic profession! Become an  
**ELECTRICAL ENGINEER**



- MAJOR IN POWER OR ELECTRONICS
- B. S. DEGREE IN 36 MONTHS

**L**OOK at the powerful trends which influence your future in these fields.

Men specializing in *Power* become equipped to serve the electrical power industry, which must face an 80% expansion of its generating capacity by 1960.

Men specializing in *Electronics* enter a science of tremendous, growing value—in communications, radio, television, broadcasting, high-frequency heating, power system control, printing and other fields.

This 47-year-old Technical Institute and College offers important advantages to the young man preparing for these opportunities. You are invited to get the full facts on what they mean to your career.

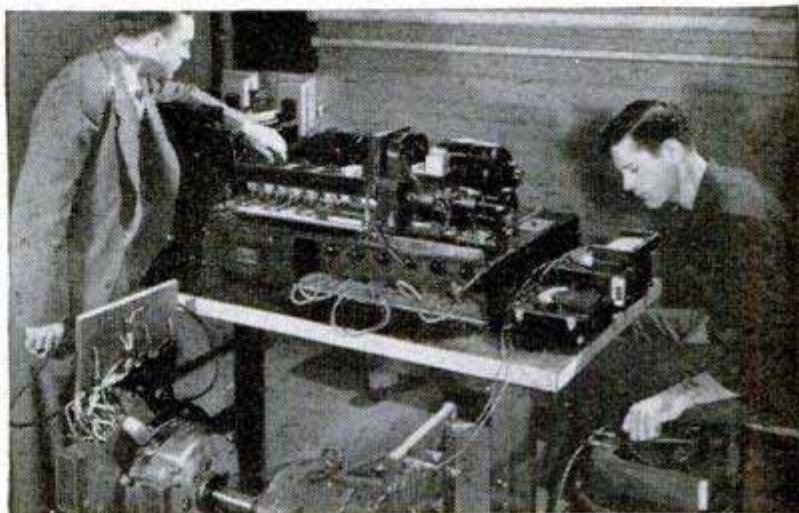

The World-famous Course in Power covers 24 technical specialty subjects in Electrical Power, including 8 in Electrical Design. Students in the College of Electrical Engineering receive practical technical laboratory experience on modern equipment. This is integrated, in each successive term, with fundamental education in engineering and the humanities.

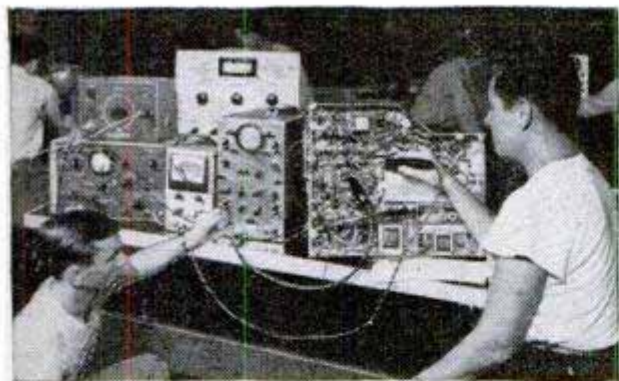

The Electronics Course covers 19 technical specialty subjects in Electronics Engineering, including 4 in Electronic Design.

**MILWAUKEE SCHOOL of ENGINEERING**

Founded 1903 by Oscar Werwath

Over 35,000 alumni and 1,555 students. Faculty of 85 specialists.

Practical, military or academic training evaluated for advanced credit. Preparatory programs also available.

TERMS OPEN APRIL, JULY, OCTOBER, JANUARY



**WRITE TODAY** for this free, helpful guidance literature. See how these 6 to 36-month courses can lead to a worthwhile career.



**MILWAUKEE SCHOOL OF ENGINEERING**  
 Dept. PM-250—N. Broadway,  
 Milwaukee, Wis.

Without obligation, send:

- 110-page Catalog
- 48-page Pictorial bulletin "Your Career"

I am interested in: ELECTRICAL ENGINEERING —  
 Power     Electronics

- Radio-Television     Electricity     Welding
- Air Conditioning     Heating     Refrigeration

Name..... Age.....

Address.....

City.....Zone.....State.....

Check if World War II Veteran

# Do you want

- ..to go to College?
- ..or to enter a Profession?

(Such as Accounting, Architecture, Nursing, Dentistry, Teaching, Social Work, Osteopathy, Beauty Culture, Optometry, Embalming, Chiropody, Law, Medicine, etc.)

- ..or get an Office Position?

To get anywhere, you practically MUST finish High School FIRST. You can complete our simplified High School Course in SPARE time at home, as FAST as your time and abilities permit. Equivalent to resident school work—prepares you for college, pre-professional examinations, business, industry. Standard texts furnished. Diploma. Credit for H.S. subjects already completed. Single subjects if desired. Low tuition, easy terms. American School, Chicago, est. 1897—endorsed by educators. Finish your high school education NOW, Write TODAY!

## High School Course at Home

Many Finish in 2 Years

American School, Dept. H245, Drexel Ave. at 58th St., Chicago 37, Ill.

Gentlemen: Send me FREE information covering special training in subjects checked below. No obligation on my part.

- |  |  |
|--|--|
| <input type="checkbox"/> High School Course          | <input type="checkbox"/> Diesel Engineering                  |
| <input type="checkbox"/> Architecture and Building   | <input type="checkbox"/> Drafting and Design for Men & Women |
| <input type="checkbox"/> Automotive Engineering      | <input type="checkbox"/> Plastics                            |
| <input type="checkbox"/> Business Management         | <input type="checkbox"/> Private Secretary                   |
| <input type="checkbox"/> Electrical Engineering      | <input type="checkbox"/> Mechanical Engineering              |
| <input type="checkbox"/> Elec. and Gas Refrigeration | <input type="checkbox"/> Aviation                            |
| <input type="checkbox"/> Air Conditioning            | <input type="checkbox"/> Salesmanship                        |
| <input type="checkbox"/> Railway Training            | <input type="checkbox"/> Radio                               |
| <input type="checkbox"/> Electronics, Industrial     |  |

Name.....

Address.....

# LAW FREE BOOK



Write today for FREE book, "THE LAW-TRAINED MAN," which shows how to learn law for business and the bar easily in spare time at home through the famous Blackstone professional law course compiled by 60 expert law authorities including law college deans, professors, lawyers and Supreme Court judges. We furnish all necessary instruction material including big 18-volume Modern American Law library cited by the courts of last resort as "M.A.L." Many successful attorneys among our graduates. LL.B. degree conferred. Moderate tuition; low monthly terms. Money-back Agreement. Write today.

**BLACKSTONE COLLEGE OF LAW**  
225 N. Michigan Ave., Dept. 52, Chicago 1, Ill.  
A Correspondence Institution Founded in 1890

## WATCHMAKING

★ Watch Repairing ★ Jewelry Engraving ★ Jewelry Repairing

Combination men earn top pay. Learn in school fully accredited by Horological Institute of America c/o U.S. Bureau of Standards, Washington, D. C. and United Horological Association of America. Approved for veterans. Receive tools, tuition and subsistence while learning.

Established 1935. Write for FREE booklet



**The Baronian School, Inc.**

2116 WALNUT ST. (DEPT. C) PHILA. 3, PA.



Free Book

## RAISE HAMSTERS

The new wonder animals from Syria. Often called Toy Bears. Delightful pets. Everyone wants them. Laboratories need thousands. Clean, odorless. Raise anywhere. A profitable and interesting hobby or business. We furnish breeding stock with manual of instructions.

Write today for free illustrated literature.  
GULF HAMSTERY, 1536 BASIL, MOBILE, ALA.

# NEW ELECTRIC LIBRARY

\$ 1.50 A VOLUME

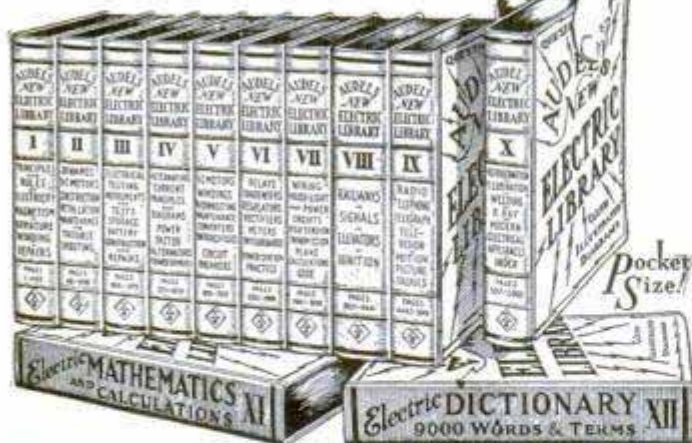

## WHAT EVERY ELECTRICIAN WANTS TO KNOW!

Is easily found in AUCAL'S NEW ELECTRIC LIBRARY. Electricity made simple as ABC. Up-to-date, trade dope for the expert and ALL electrical workers.

Questions, answers, diagrams, calculations, underwriter's code; design, construction, operation and maintenance of modern electrical machines and appliances FULLY COVERED.

All available at small cost, easy terms. BOOK-A-MONTH service puts this NEW information in your hands for 6c a day. You can start your subscription with any volume. Write TODAY for electric Folder and FREE TRIAL offer.

**THEO. AUDEL & CO., 49 W. 23rd St., New York City**

Mail Vol. I, Electric Library on 7 days' free trial. If O. K. I will remit \$1.50, otherwise I will return it. I also request you to mail one book each month on same terms. No obligation unless I am satisfied.

Name.....

Address.....

Occupation..... PM

## Free Catalog

Ready February 2

Fully illustrated, 92 pages, showing special fishing tackle, footwear, clothing and forty-eight other leather and canvas specialties of our own manufacture.

**L. L. Bean, Inc.**

62 Main St.

Freeport, Maine  
Mfrs. Fishing and Camping Specialties



## SPEED AND POWER Handbook

50 CHAPTER LIBRARY EDITION

Build Fast Stock Cars! California Roadsters! 160 MPH Rods! Covers Crosleys to Cadillacs—all makes. Breath-taking Methods—Authentic—Direct from Californian!

Photos Drawings

SAVE MANY DOLLARS

Build your own Dual Manifolds! Superchargers! Hot Cams! Water Injectors! Hi-Compression Heads! Mileage Devices! Get up to ten more miles per gallon! Get racing speed, lightning acceleration, dynamic power increases from any make passenger automobile! Get construction drawings! Tuning techniques! Speed Tricks! Economy secrets! Ingenious formulas! Covers "Racing Frames"—"Reciprocating Masses"—"Jet Engines"—"Braking Characteristics"—"Dynamometers"—"Dual Pipes, Gears, Fuels, Manifolds, Porting, Relieving, Lowering! Balancing, Including 1950 Racing Equipment Catalogues!



SPEED SHOP METHODS

Includes "CALIFORNIA AUTOMOBILE CUSTOMIZING"—Drawings! Photographs! Diagrams! Newest Ideas! Conversions! CarsonTops! Restyling! all makes! Streamlining! Chopping! Channeling! Complete—\$1.00 Postpaid.  
**NEWHOUSE AUTOMOTIVE INDUSTRIES**  
5805 EAST BEVERLY BLVD. DEPT. B4  
LOS ANGELES 22, CALIF.

# \$200 GROSS IN MY FIRST WEEK!



Some Make More, Some Less... Start This Business for YOUR OWN

Would YOU like to own a permanent, year-round business in which it is possible to take in as much as \$200 gross the first week, as did L. A. Eagles? R. E. Traynor says, "I made \$62 gross in one day." R. R. Newlin reports, "I have averaged \$173 gross per week." Others report gross from \$100 per week to \$12,000 per year.

Surely YOU will want to investigate a golden opportunity like that. You need not have any special skill or experience, but if you are ambitious, honest and courteous, we will help you to start and succeed in YOUR OWN money-making business where net profits are high.

### No Shop Necessary

Our Electric Rug Washer cleans rugs and carpets like new right on the customer's floor. This quick, thorough and highly efficient method removes dirt and grime, thus restoring the natural, fresh beauty of floor coverings. Anyone can run it. Rugs and carpets are not harmed.

There are hundreds of possible customers in YOUR vicinity. Most of them have several rugs needing regular cleaning. To get a quick start,

## FREE BOOK! MAIL COUPON

VON SCHRADER MFG. CO.  
210 Pl, Racine, Wis.

Send at once (no obligation) your FREE booklet containing information about your Electric Rug Washer and how I can own my own permanent, profitable business.

Name \_\_\_\_\_

Address \_\_\_\_\_

City \_\_\_\_\_ (Zone) \_\_\_\_\_ State \_\_\_\_\_

shampoo a few rugs or carpets. These customers tell their friends and soon you should have an independent, prosperous business, and you should be able to keep it growing. Send the coupon RIGHT NOW for booklet that explains everything.

### Every Machine Guaranteed and Easy to Own

You take no risk. These wonderful, fully guaranteed machines have been used and endorsed by largest hotels, railroads—also used by U. S. Government. Many individuals have built up successful businesses that made big profits. Mail the coupon TODAY and we will send complete information, including how to start and succeed in YOUR business without a large investment. Don't delay your BIG opportunity. Send the coupon AT ONCE.



MAIL COUPON TO

VON SCHRADER MFG. CO., 210 PL, RACINE, WIS.

# Put Your Future in Your Own Hands Be an ARTIST

HERE'S THE AMAZING WAY WE TEACH YOU  
STEP BY STEP TO DRAW AT HOME IN SPARE TIME

LEARN TO DRAW  
FOR MONEY

### TWO BIG ART OUTFITS GIVEN

As soon as you enroll, we send you the first of the TWO complete Artists' Outfits. Later in the course you receive the second, advanced outfit . . . all at no extra cost.

### Read What These Graduates Say:

**FREE LANCE ARTIST**—Gloria Bailey of Grants, New Mexico, sold around 150 paintings ranging from \$5 to \$50. (10/49)

**STAFF ARTIST AND CARTOONIST**—G.W. Thomas, Los Angeles newspaper artist says: "W.S.A. is Number One School in U.S.A." (1/48)

### WRITE FOR FREE BOOK

"ART FOR PLEASURE & PROFIT" Tells about our method of instruction and commercial opportunities for you . . . also about W.S.A. students, what our graduates say, and shows reproductions of their artwork.

Approved for Veterans Est. 1914



Enroll now for a pleasant, profitable Art career. COMMERCIAL ART, DESIGNING, CARTOONING—all in one complete modern home study course. Good-paying art positions available for qualified artists. You can become your own boss. Many students earn extra money while learning by designing posters, signs, lettering, etc. W.S.A. is now in its 36th successful year of training ambitious men and women. No previous art experience necessary, our practical, easy method prepares you for professional art jobs in advertising, television, newspaper and magazine publishing, department stores, printing, engraving, etc. Get the facts now. LOW COST—ONLY \$5 MONTHLY.

### FREE BOOK gives details

WASHINGTON SCHOOL OF ART, Studio 122W  
1115—15th St., N. W., Washington 5, D. C.

Please send me full information and your Free Book, "Art for Pleasure and Profit." (Please print)

Name \_\_\_\_\_ Age \_\_\_\_\_

Street \_\_\_\_\_

City \_\_\_\_\_ Zone \_\_\_\_\_ State \_\_\_\_\_

I am entitled to training under the G.I. Bill.

WASHINGTON SCHOOL OF ART

# EARN MORE IN DRAFTING



Steady Employment  
•  
More Opportunities for Promotion  
•

"Here I am at work making good money as a draftsman. I'm glad I sent the coupon to Chicago Tech for that Free Trial Lesson and found out how easy it is to learn Drafting in spare time at home. Today I feel secure in my job because the draftsman's work comes first on any new project. And, in addition, draftsmen can't be replaced with machines. What's more, I feel I'm slated for promotion and more pay, because I see so many draftsmen advancing to high-pay jobs."

## LEARN IN SPARE TIME—AT HOME! (or at the College in Chicago)

A few hours of pleasant home study every week—that's all. No interference with your present job. All the tools you need; drawing outfit included. With Chicago Tech's help, you train yourself step by step. This tested method—developed over 45 years of C.T.C. progress—prepares men quickly for good positions in industry.



### FREE INFORMATION—SEND COUPON

To prove to you how easy it is to learn Drafting at home by the Chicago Tech method, we will send you this FREE TRIAL LESSON. No charge for this lesson, now or later. Fill out and mail coupon, or send post card today.

## CHICAGO TECHNICAL COLLEGE

B-213 Tech Bldg., 2000 S. Michigan Ave., Chicago 16, Illinois  
Mail me FREE Lesson with information about big opportunities in DRAFTING.

Name \_\_\_\_\_ Age \_\_\_\_\_  
Address \_\_\_\_\_  
City \_\_\_\_\_ Zone \_\_\_\_\_ State \_\_\_\_\_

## ENGINEERING DEGREE IN 27 MONTHS

### Big Demand for Graduates

Aeronautical, Chemical, Civil, Electrical, Mechanical and Radio Engineering (including Television)

Hundreds of young men are earning engineering degrees in this recognized institution each year—continuous operation. New terms start quarterly. Many students earn a major part of their college expenses in this large industrial center.

Low tuition. Competent instruction. Thorough intense practical program. Modern laboratory facilities including new physics lab. and modernized wind tunnel. Individualized instruction emphasized.

Approved for Veterans. Engineering preparatory courses. Students from 48 states and 21 foreign countries. Enter March, June, September or December. Send coupon for free catalog and full information. Enroll now.

SEND COUPON TODAY

## INDIANA TECHNICAL COLLEGE

520 E. Washington Boulevard  
Fort Wayne 2, Indiana

Please send me free information on B.S. Engineering Degree in 27 months as checked.

Aeronautical,  Chemical,  Civil,  Electrical,  
 Mechanical,  Radio-Television.

Name \_\_\_\_\_  
Address \_\_\_\_\_

## AMAZING SECRETS REVEALED TO EVERY POULTRY RAISER



ABSOLUTELY FREE BOOK. My new Picture Tour Book telling all about one of America's largest and best Poultry Breeding Farms and Hatchery organizations. I know you'll enjoy it, and profit in your poultry work by reading it. Tells latest methods of profitable chicken raising, feeding and especially about pure-breds, cross-breds and hybrids. If you want to know about better and more profitable chickens, be sure to write me TODAY for your FREE copy. Just a postcard will bring it.

MRS. HARRY HAM, Route 56, Atchison, Kansas

## SHORTHAND in 6 Weeks at Home

Famous Speedwriting system. No signs; no symbols; no machines; uses ABC's. Easy to learn; easy to write and transcribe. Low cost, 100,000 taught by mail. For business and Civil Service. Also typing, 27th year. Write for free booklet to:

**Speedwriting**  
Dept. 1502-A, 55 W. 42 St., New York 18



MAKE THIS

### MASSIVE STERLING SILVER INITIAL RING WITH YOUR OWN INITIALS

No special skills or training needed. With our Ring Kit containing unfinished Sterling Silver ring and 2 or 3 initials, all materials needed and illustrated instructions, you can, in a few hours, make this beautiful heavy Sterling Silver ring for yourself, as a gift to someone special or for sale.

Send check or M.O. today with finger size and initials, or send 3c stamp for finger gauge.

COMPLETE PRICE inc. Fed. Tax  
**\$4.50**

AMERICAN JEWELRY MODELS, 62 W. 47th St., New York 17

## Save Your Feet

Thousands relieved from pain walk freely with HEEFNER ARCH SUPPORTS



Write for Free Booklet

"FOOT FACTS"

HEEFNER ARCH SUPPORT CO., 672 Logan Bldg., Salem, Virginia



## Play GUITAR in 10 DAYS

### OR GET YOUR MONEY BACK!

Let Ed Sale teach you to play with his famous diagram-photo system. Book contains 53 photos, 43 diagrams showing exactly how to place your fingers. Gives you 110 popular songs, words and music—along with complete, easy to learn instructions. Imagine your joy when you find after only two weeks you are playing beautiful music! Amaze your friends! Be the life of the party!

INSTRUMENTS SUPPLIED on cash or credit, ask for Price List and Credit Plan.

SEND NO MONEY. Pay postman \$1.95 Plus Postage ED SALE, Dept. 6A, Point Pleasant, New Jersey

## Be an INVESTIGATOR

JAMES S. BOLAN, FORMER POLICE COMMISSIONER OF NEW YORK CITY offers MEN & WOMEN an attractive opportunity to prepare for a future in Investigation & Criminology by comprehensive Home Study Course. Free placement service assists graduates to obtain jobs. APPROVED UNDER G. I. BILL OF RIGHTS. Write for Free Booklet PM.

THE BOLAN ACADEMY, INC.  
EMPIRE STATE BLDG., NEW YORK 1, N. Y.



# IMAGINE THEIR JOY

## WHEN THEY FOUND THEY COULD PLAY This easy as A.B.C. way!



### LEARNED QUICKLY AT HOME

"I didn't dream I could actually learn to play without a teacher. Now, when I play for people they hardly believe that I learned to play so well in so short a time."  
\*H. C. S., Calif.

### INVESTMENT PAID BACK A THOUSAND FOLD

"Anyone with musical ability should make good with your course. My little investment paid back a thousand fold. I have been playing for 4 years now. Today I play in one of our top bands."  
\*J. M., San Juan, P. R.



### PLAYS AT DANCES

"I have completed your course and your lessons have been most satisfactory. I can play all of the popular songs. I have also earned money playing at dances."  
\*E. N. J., New York.

### PLAYS ON RADIO

"As a proud student I can't keep from telling you that as a result of my course I have a good position playing from KTHS, Hot Springs, Ark., every morning."  
\*J. S., Okla.



### INVITED TO PARTIES

"I enjoyed taking this course and I get a lot of pleasure out of it. I have made much progress and have many invitations to play at parties. I owe you much for making this possible."  
\*K. U., N. Y.

## Thousands Have Learned to Play Quickly, Easily at Home

WHAT instrument would you like to play? We'll show you how you can learn to play it—quickly, easily, in spare time at home for only a FEW CENTS A DAY! Never mind if you don't know one note of music from another—don't worry about "special talent." The truth of the matter is that thousands now play who never thought they could! Yes, men and women everywhere are enjoying the thrilling satisfaction of playing the piano, violin, guitar, saxophone or other favorite instrument. Some of them are playing in orchestras and over the radio; others are teaching music, making money in spare or full time. And thousands are playing for their own enjoyment

and the entertainment of their friends.

It all came about when they wrote to the U. S. School of Music for the Free Booklet that shows you how EASY it is to learn music at home this modern way. No tedious scales, no tiresome exercises. You learn to play by playing—start right in almost at once with the melody of a simple tune! It takes only a few minutes a day and the cost is trifling; you save the expense of a private teacher. Does it sound too good to be true? Mail the coupon and get the FREE PROOF! (Our fifty-second year—Est. 1898.) U. S. School of Music, 72 Brunswick Bldg., New York 10, N. Y.

### NOTICE

Please don't confuse our method with any systems claiming to teach "without music" or "by ear." We teach you easily and quickly to play real music, any music, by standard notes . . . not by any trick or number system.

### SEND TODAY ➔

### FOR COMPLETE DETAILS

• You'll open your eyes when you find how quickly and easily you can learn to play your favorite instrument. Don't doubt; don't hesitate. Send for the fascinating illustrated booklet that answers all your questions: let the free Print and Picture Sample show you how this method actually works. If interested, mail the coupon NOW.

\*Actual pupils' names on request. Pictures by professional models.

### FREE! Print and Picture Sample

#### U. S. SCHOOL OF MUSIC

72 Brunswick Bldg., New York 10, N. Y.

I am interested in music study, particularly in the instrument checked below. Please send me your free illustrated booklet, "How to Learn Music at Home."

Piano	Saxophone	Modern Elementary
Guitar	Trumpet, Cornet	Harmony
Hawaiian Guitar	Reed Organ	Clarinet
Violin	Tenor Banjo	Practical Finger
Piano Accordion	Mandolin	Control
		Other Instrument

Have you instrument? \_\_\_\_\_

Mr. \_\_\_\_\_  
Miss \_\_\_\_\_  
Mrs. \_\_\_\_\_ Please Print

Address \_\_\_\_\_

City \_\_\_\_\_ State \_\_\_\_\_

NOTE: If you are under 16 years parent must sign coupon.

Save 2c—Stick coupon on penny postcard.

# ELECTRICAL BOOKS

shipped for  
**EXAMINATION**



**8  
BIG BOOKS**

**SEND NO MONEY  
APPLIED  
ELECTRICITY  
INCLUDING RADIO  
AND REFRIGERATION**

Here's great news for anyone interested in Electricity. NEW, up-to-date 19th Edition of Applied Electricity with new subjects fully covered, including blueprint reading, electronics, F. M. radio, fluorescent lighting, 8 Big Books sent for examination!

**NEW Edition for  
Beginners and  
Experts**

Over 3700 pages, 2700 illustrations and 134 tables in most complete electrical work we have published. Dynamos, motors, diesel plants, power stations, transmission—everything explained for easy understanding.

**BIG FIELD! Big Demand!  
Big Pay!**

Men who understand electricity are needed now in all kinds of industries. Practically every business depends on electrical knowledge, and men who know this subject make big money. Learn easily with these new, interesting books. Send coupon for a set of books on approval. See how they will help you to get ahead faster.

**SEND  
NOW**

[A year's consulting privileges with our engineers now given to all buyers of this famous Cyclopaedia of Electricity.]

**AMERICAN TECHNICAL SOCIETY**  
Vocational Publishers Since 1898

American Technical Society, Dept. E219, Drexel at 58th St., Chicago 37  
Send for 10 days' free use, 8 volume set of New 19th Edition, Applied Electricity, including a certificate entitling me to consulting privileges for one year. I will pay the delivery charges only on the books. If I wish I may return them in 10 days and owe you nothing, but if I keep them, I will send \$2.00 after 10 days, then \$3.00 a month until the total price of only \$34.80 is paid.

NAME \_\_\_\_\_

ADDRESS \_\_\_\_\_

CITY \_\_\_\_\_ STATE \_\_\_\_\_

Please attach letter stating age, occupation, employer's name and address, and name and address of at least one business man as reference. Men in service, also please give home address.

# AUDELS Carpenters and Builders Guides 4 vols. \$6



**Inside Trade Information** for Carpenters, Builders, Joiners, Building Mechanics and all Woodworkers. These Guides give you the short-cut instructions that you want—including new methods, ideas, solutions, plans, systems and money saving suggestions. An easy progressive course for the apprentice and student. A practical daily helper and Quick Reference for the master worker. Carpenters everywhere are using these Guides as a Helping Hand to Easier Work, Better Work and Better Pay. To get this assistance for yourself, simply fill in and mail the FREE COUPON below.

**How to use the steel square—How to file and set saws—How to build furniture—How to use a mitre box—How to use the chalk line—How to use rules and scales—How to make joints—Carpenters arithmetic—Solving mensuration problems—Estimating strength of timbers—How to set girders and sills—How to frame houses and roofs—How to estimate costs—How to build houses, barns, garages, bungalows, etc.—How to read and draw plans—Drawing up specifications—How to excavate—How to use settings 12, 13 and 17 on the steel square—How to build hoists and scaffolds—skylights—How to build stairs—How to put on interior trim—How to hang doors—How to lath—lay floors—How to paint**



**AUDEL, Publishers, 49 W. 23rd St., New York 10, N. Y.**

Mail Audels Carpenters and Builders Guides, 4 vols., on 7 days free trial. If OK I will remit \$1 in 7 days and \$1 monthly until \$6 is paid. Otherwise I will return them. No obligation unless I am satisfied.

Name \_\_\_\_\_

Address \_\_\_\_\_

Occupation \_\_\_\_\_

Employed by \_\_\_\_\_ PM

**Now CHEAP OIL BURNER**  
FOR HEATING AND COOKING. OILS • FURNACES  
HEAT YOUR HOME, COOK YOUR MEALS  
WITH CHEAP FURNACE OIL

**NO MORE SHOVELING COAL OR ASHES.** Sensational Fuelizer Starter Vaporizing System turns Cheap No. 1 Furnace Oil, also Range, Heater, Tractor Distillate, Kerosene and like oils into oil heat—one of the quickest, hottest fires known. **LIFETIME GUARANTEE. \$1.00 Bonus Offer for Testing.** We will let you try it in your own stove or furnace for one month. Get yours for introducing. Big profits QUICK. Be first. Send in your name today for details and cash in on the tremendous demand for this Amazing Invention.

**NORTHWEST MFG. CO., 730-B, Mitchell, S. Dak.**

**REWARD** comes to those who prepare themselves with skill and knowledge of new developments in their trade. The toughest soldering problems can be licked by "Conduction Soldering," the newest technique in this old art. Any man who now is or may in the future be responsible for soldering or brazing in production, repair or experimental work should write us for complete information.

**WASSERLEIN MFG. CO., INC.**

7400 3rd AVE. NO. ST. PETERSBURG 6, FLA.

# RUPTURE!

An amazing Air-Cushion Invention allows body freedom at work or play. Light, neat, cool, sanitary.



Durable, cheap. Day and night protection helps Nature support weakened muscles gently but surely. No risk. **Send on Trial!** Write NOW for free Booklet and **Proof of Results.** All correspondence confidential.

**Brooks Company, 161-G State St., Marshall, Mich.**

**Practical Economical Winter Travel**

Call Air SnowCar, plans, engine and propeller — \$495.00. Complete 125 h.p. 4 place factory built jobs — \$1950.00.

**CALLAIR, Afton, Wyoming**

**AJAX AUSTRALORPS**

**SENSATIONAL WORLD CHAMPION LAYERS**  
Mature fast. Excellent roasters-capons. Massive size. U.S. Approved-Pullorum Controlled. Low farm prices. **PROFIT SHARING PLAN.** Catalog FREE. Write today.  
**AJAX HATCHERY, Box 914, QUINCY, ILLINOIS**

**BE A LOCKSMITH**

**Learn Locksmithing and Keymaking from Experts in Your Spare Time at Home!**  
Locksmiths in big demand! No layoffs, no slow seasons! Age or physical handicap no disadvantage. Year-round, steady income in this permanent, respected field. Full or part time. Practical, illustrated lessons show you how to make money even while learning! All materials and special tools supplied. Send for **FREE BOOKLET.** **LOCKSMITHING INSTITUTE, Dept. P4, 55 Park Ave., Rutherford, N. J.**

**MUCH MORE SPEED FOR OUTBOARDS!**

of all makes from 7½ to 50 HP on racing runabouts is provided with the famous Michigan "AQUA-JET" propellers. No rebuilding of lower unit is necessary. Each propeller is specifically engineered for the motor on which it is to be used. Other propellers for superior performance for practically every outboard in every application. Write for 1950 catalog, the "Outboarder's Bible," FREE. Michigan Wheel Co., Dept. 1-2 Grand Rapids 3, Michigan.

**\$350** IN ONE WEEK **GROSS**

IN MY OWN BUSINESS

Some Make More, Some Less...  
Start This Business for **YOUR OWN**

George Held earned \$350 in one week with

**ELECTRIC UPHOLSTERY CLEANER**

Here's YOUR chance to start a money-making, year-round business of your own and make the success you've dreamed about. R. O. Donnley took in \$40 in seven hours. O. W. Ware landed a \$750 hotel job and made a fine profit. J. S. Corbit grossed \$279.50 his first month. P. D. Ash cleaned 23 auto seats at \$5 each in one week. And so it goes. Homes, hotels, offices, clubs, all places where furniture is used, offer you big profit possibilities. Auto seats and interiors, also.

**NO SHOP OR OFFICE NECESSARY**

You clean furniture on customers' premises. No hauling costs. No high rents. Supplies are in-

**FREE BOOK! MAIL COUPON**

VON SCHRADER MFG. CO.  
41B Pl., Racine, Wisconsin

Send at once (no obligation) your FREE booklet containing information about your Electric Upholstery Cleaner and how I can own my own permanent, profitable business.

Name \_\_\_\_\_

Address \_\_\_\_\_

City \_\_\_\_\_ Zone \_\_\_\_\_ State \_\_\_\_\_

expensive and you operate, at low cost, from your home. What you take in is mostly profit. Surely YOU will want to investigate an opportunity like that—right away. Own your own business. Be your own boss. If you are ambitious, honest and courteous, we will help you to start and succeed.

**FULL INFORMATION FREE  
MAIL COUPON TODAY**

Send the coupon or write for Furniture Cleaner Booklet. It tells all about this electric cleaner—how to start YOUR business—how to make a profitable success. Don't delay. It's your BIG opportunity.



MAIL COUPON TO

VON SCHRADER MFG. CO., 41B Pl., RACINE, WIS.



I MADE  
**\$14 PER DAY**  
While still learning!

T. E. H.—WEST VIRGINIA



I MADE  
**\$800 IN 3 MONTHS**  
While taking your course!

F. V.—NEW YORK

Get into the

**ELECTRIC APPLIANCE  
REPAIR & SERVICE BUSINESS**

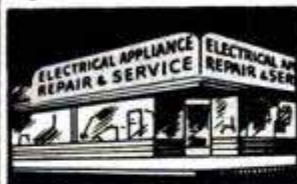

**OPEN YOUR OWN SHOP**

As soon as you enroll, I send you my New Book "How to Open Your Own

Business" at no extra cost. PTS training is more than a home study course in electric appliance repair and service. It gives you the "know how" on the operation of your shop from a business standpoint: What to charge, how to get customers. Everything possible is done to start you on the road to success.

**WE TEACH YOU:**

Electric motors, house wiring, refrigerator, auto ignition, automatic washers, garbage disposals, fluorescent lights, irons, cleaners, etc., at home.

**FULL OR SPARE TIME**

**SPARE OR FULL TIME**

You can actually increase your income while still learning—spare or full time

**ACT NOW**

Want a good-paying business—a job in a fast-growing industry? Send now for your BIG FREE BOOK—"My Plan for your Success." Get started NOW

**EASY TO LEARN**

Men of all ages, yes, even the man of 69 can get into this expanding field. A REAL OPPORTUNITY for the practical man who wants the BETTER THINGS IN LIFE. The easy PTS Home Study Plan prepares you for greater earnings NOW!

I SEND YOU A

**BIG KIT of TOOLS at No Extra Cost**

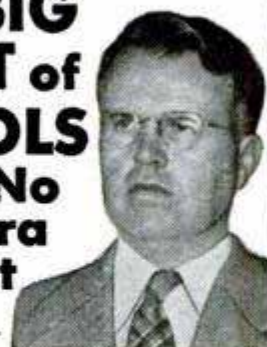

H. T. ARMSTRONG

SEND FOR THIS FREE BOOK



**MAIL THIS COUPON TODAY**

PACIFIC TRAINING SCHOOL H. T. ARMSTRONG  
7219 So. Broadway, Dept. P-502, Los Angeles 3, Calif.  
Please send me, without obligation, your free booklet and details.

Name \_\_\_\_\_

Address \_\_\_\_\_

City \_\_\_\_\_ Zone \_\_\_\_\_ State \_\_\_\_\_

# Lots of DIESEL

IN THE PACIFIC NORTHWEST



Yes, DIESEL is BIG business in Oregon, Washington, and adjoining states where industries and populations are growing so incredibly fast.

**DIESEL IS THE KING OF POWER** . . . on our railroads, highways, waterways and in our industries.



L. L. ADCOX, President

I PRODUCE DIESEL MEN IN 3 SHORT MONTHS

**MEN WHO ARE** equipped with the thorough training they get at the ADCOX SCHOOL, are prepared for a splendid future in the great Northwest. A fine place to live and enjoy life.

**NEWEST FACILITIES AND EQUIPMENT,** Advanced Instruction Methods by highly paid, Expert Instructors, combined with my 40 YEARS of trade school experience, enable me to turn out **REAL DIESEL ENGINE TROUBLE SHOOTERS.** When you receive your Adcox Diploma you are ready to begin your career in Diesel.

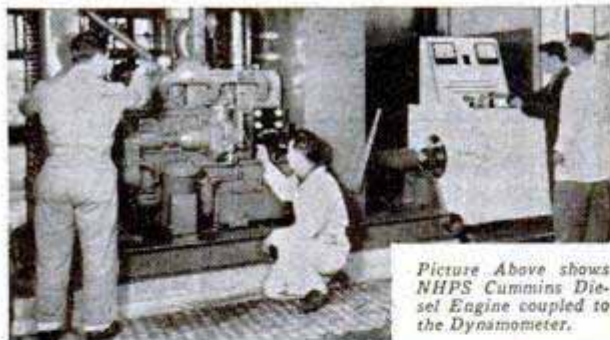

Picture Above shows NHPS Cummins Diesel Engine coupled to the Dynamometer.

**YOU LEARN ENGINE CONSTRUCTION FROM THE GROUND UP.** Special laboratory for Injection, Fuel Pumps, Nozzles and Governors. Trouble Shooting under full Dynamometer Load (as shown in picture).

This kind of training puts ADCOX out in front!

**CLASSES LIMITED.** — Latest type equipment (no obsolete engines), Skilled Instructors — combine to insure best possible training. You learn Diesel **RIGHT**, and you learn it **FAST** . . . in this Nationally Famous School!

**DIESEL SCHOOL CATALOG** APPROVED FOR VETERANS **FREE**

L. L. ADCOX, President  
**ADCOX SCHOOL**  
237 N. E. Broadway, Portland 12, Oregon  
Without obligation, send **FREE** Catalog No. PM.

Name \_\_\_\_\_  
Address \_\_\_\_\_  
Town \_\_\_\_\_ State \_\_\_\_\_  
If World War II Veteran, Check Here



Always write your name and full address clearly when answering advertisements

# WATCH REPAIRING

**Be A Master Watchmaker**

Large earnings with no dull seasons and a steady secure future are yours as a Master Watchmaker! The famous Swezey System teaches you how . . . expertly, quickly, successfully . . . at home or in our modern school.

**FREE BOOK**

Write today for your free copy of "Master Watchmakers Wanted." Tells about big opportunities in Watch Repairing, Gem Setting and Engraving.

**CHICAGO SCHOOL OF WATCHMAKING**

Famous Since 1908

DEPT. 120 — 1608 N. MILWAUKEE AVE., CHICAGO 47

# Learn CARPENTRY BRICK LAYING

Big money in the Building Trades. Learn now while opportunities are greatest. Train in our completely equipped shops under expert instructors, or by Home Study. Vets attending school entitled to G.I. Benefits. Write for **FREE** catalog.

**MIDWEST SCHOOL OF BUILDING TRADES,** Dept. PM-2  
411 N. Center St. Bloomington, Ill.

# LIFE AFTER DEATH

"Heaven and Its Wonders, and Hell"

by **EMANUEL SWEDENBERG**, with a brief biography of this famed theologian, philosopher and scientist. 632 page book, treating fully of life hereafter, will be sent for . . . . .



**5c**  
The **SWEDENBERG FOUNDATION**  
Room 1618, 51 E. 42nd St., New York 17, N. Y.

# BIG MONEY SIGN PAINTING

Learn in Spare Time

Quickly become an expert. Tremendous demand everywhere for trained men. We teach you quickly—at home in spare time. No previous experience or artistic talent needed. Simple, illustrated Course quickly qualifies you to start a Big-Pay Business of your own.

**FREE!** Don't send a penny—just your name and address on postcard and we will send you—absolutely free—complete information and valuable money-making facts on how you can quickly land a Big-Pay Job, or get started in a Business of Your Own. No cost—or obligation. Rush name and address today to Farrell School of Commercial Sign Lettering, 734 Long Ave., Chicago 44.

# TRI-STATE COLLEGE

**B. S. DEGREE IN 27 MONTHS**

Founded 1884

World-Wide Enrollment

Civil, Elect., Mech., Chem., Aero., Radio and Telev., Engineering; Bus. Adm., Acct. Visit Campus, see well equipped labs. Low cost. Prep. courses. Personalized instruction. Grads. successful. Enter March, June, Sept., Jan. Catalog. 420 College Ave., Angola, Ind.

# Photography

for

**PLEASURE or PROFIT**



Learn at home. Spare time. Practical basic training. Long-established school. Many have earned while learning. Send coupon below for free booklet, "Opportunities in Modern Photography" and full particulars.

**AMERICAN SCHOOL OF PHOTOGRAPHY**

1315 Michigan Avenue Dept. 1352 Chicago 5, Illinois  
Send booklet, "Opportunities in Modern Photography," full particulars and requirements. No salesman will call.

Name \_\_\_\_\_ Age \_\_\_\_\_  
Address \_\_\_\_\_  
City \_\_\_\_\_ Zone \_\_\_\_\_ State \_\_\_\_\_

POPULAR MECHANICS

## WE CAN TEACH YOU TO MOUNT BIRDS

GEE, BILL, THIS SQUIRREL ACTUALLY LOOKS ALIVE. ALL THE FELLOWS THINK YOUR DEN IS GREAT.

IT'S EASY, FRED, ONCE YOU GET THE HANG OF IT. I LEARNED BY MAIL IN MY SPARE TIME. TAXIDERMISTRY IS THE GRANDEST HOBBY IN THE WORLD — AND PROFITABLE, TOO. IN FACT, THIS OWL BOOK-END IS FOR A CUSTOMER. FRED, WHY DON'T YOU WRITE TO THE NORTHWESTERN SCHOOL FOR THEIR FREE BOOK?

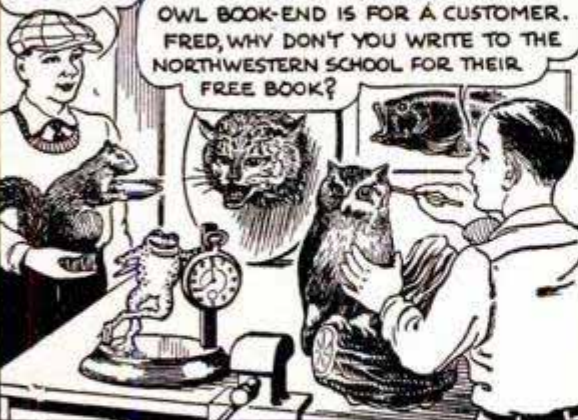

Send for Free Book Now!

### FUN - FASCINATION - PROFIT

Be a Taxidermist. New Profitable business. Learn quickly at home, to MOUNT life-like Birds, Animals, Game-Heads, Fish. Save your valuable trophies. Decorate your home and den. Learn genuine Chrome Tanning for harness and sole leather, buckskin and fine furs. Mount Common specimens, squirrels, rabbits, owls, even frogs, into marvelous craft-work groups, both useful and humorous. Wild-game not necessary. Send Today for Free Book!

**BIG PROFITS** Turn your spare time to cash. Have a side-line profitable business. Mount game trophies for sportsmen; sell your own mounts: save money and Make Money with expert tanning. Learn by mail from old reliable school, with 400,000 graduates. Investigate Today.

**FREE BOOK** 48 pages very interesting, 100 beautiful GAME PICTURES. Tells how YOU can become a taxidermist. Absolutely FREE if you send at once. Write for YOUR copy TODAY — THIS MINUTE. State your AGE.

N.W. School of Taxidermy, 2502 Elwood Bldg., Omaha, Neb.

**GREAT PROFITS**

MAKE YOUR OWN RUBBER MOLDS

**X.L. RUBBER MOLDS**  
will realize your great profits quickly!  
**WRITE FOR NEW FREE CATALOG**

YOU can EASILY learn to cast thousands of perfect plaques, book ends, figurines, ash trays, etc. IT'S EASY, FUN, PROFITABLE! X.L. Rubber, Pts. \$2.00; Qts. \$3.50; Gallons \$8.95; Models and enough rubber for 3 molds \$1.30 postpaid.

Address Dept. 2  
3403 S. Madison St., Muncie, Ind.

SEND FOR FREE FACTS

## How to Write Short Stories, Mysteries, Articles



Keith Monroe

**For Part-Time or Full-Time Income, Learn at Home. Free Lesson Shows How**

**H**AVE you ever had an urge to write? Have you or your friends had interesting experiences or ideas about people, places, hobbies, sports, business or social activities, that might make interesting stories or articles for general magazines, trade and technical journals, fraternal publications, etc.?

Editors agree: the demand for new writers is greater than ever, and you don't have to be a genius to make money. Many Palmer beginners earn while learning, receiving small but welcome checks for material that may be turned out quickly once you acquire the technique. And now it's easier to learn than you may imagine, through Palmer's unique method of training—for not just one field of writing, but for all: Fiction, Article, Radio. Endorsed by famous authors—including Rupert Hughes, Gertrude Atherton, Katharine Newlin Burt, A. E. Van Vogt, and by hundreds of successful graduates.

### Now Sells to Big Magazines

"Since studying the Palmer course, I've been able to sell to The Post, Life, American, Esquire, Reader's Digest, and other top magazines. It's the finest course anywhere."—Keith Monroe, Santa Monica, Calif.

You get practical writing assignments to do at home, saving time, effort and money. Your work is individually handled by professional writers.

**FREE** sample lesson and free book, "The Art of Writing Salable Stories" shows how you may earn extra income or make writing a full-time career. Be independent—work where, when, how you please. Send today! Palmer Institute of Authorship, Since 1917, Desk T-20, 1680 N. Sycamore, Hollywood 28, Calif.

APPROVED FOR VETERANS

### FREE LESSON Palmer Institute of Authorship, Desk T-20 1680 N. Sycamore Hollywood 28, Calif.

Please send me free sample lesson and illustrated book explaining how your home-study training helps new writers get started. This is confidential. No salesman will call.

Mr. \_\_\_\_\_  
Mrs. \_\_\_\_\_  
Miss \_\_\_\_\_

Address \_\_\_\_\_

City \_\_\_\_\_ Zone \_\_\_\_\_ State \_\_\_\_\_

Please print clearly. Veterans:  Check here

SAY YOU SAW IT IN POPULAR MECHANICS

*Always write your name and full address clearly when answering advertisements*

## LEARN MEAT CUTTING EASILY - QUICKLY At Home - In Spare Time



The steady, dependable trade of Meat Cutting taught easily, quickly by improved HOME METHOD. National School, established over 25 years, has organized its famous "Learn By Doing" Classroom, Cutting room and Retail Market training system into sound, practical HOME STUDY form.

Now, by the miracle of this EXTENSION TRAINING you can prepare in Your Spare Time At Home, for a better job, bigger responsibilities or success and security in a store of your own. Remember, PEOPLE MUST EAT!

Buying, cutting, percentage, pricing, advertising, selling—a complete meat education. For beginner or men with ex-

perience. Thousands of successful graduates. Send coupon for FREE Bulletin NOW!

### MAIL THIS COUPON TODAY FOR FREE BULLETIN

**National School of Meat Cutting Div. U-113, Toledo 4, Ohio**  
Send me your FREE Bulletin on Meat Cutting and Meat Merchandising. No obligation. No salesman will call.

Name \_\_\_\_\_

Street \_\_\_\_\_

City \_\_\_\_\_ State \_\_\_\_\_

# Learn A Trade NOW! PRACTICAL SHOP TRAINING!

## In Our Chicago Shops

- |   |  |
|---|--|
| <input type="checkbox"/> AUTO MECHANICS   | <input type="checkbox"/> WELDING—ARC and GAS |
| <input type="checkbox"/> DIESEL MECHANICS | <input type="checkbox"/> MACHINIST           |
| <input type="checkbox"/> REFRIGERATION    | <input type="checkbox"/> PIANO TUNING        |
| <input type="checkbox"/> BODY-FENDER      |  |

Above Approved For G. I.'s and Civilians  
One of America's Leading Practical Schools  
7 Floors of Fully Equipped Shops  
Over 48,000 Successful Graduates  
Expert Individual Instruction  
Learn by Doing—Low Living Expense  
Established 1902—Day and Evening Classes

## Also the following Home Study Courses

- |                                  |  |                                 |
|----------------------------------|--|---------------------------------|
| <input type="checkbox"/> PLASTIC | <input type="checkbox"/> REFRIGERATION | <input type="checkbox"/> DIESEL |
|----------------------------------|--|---------------------------------|

—CALL IN PERSON OR MAIL THIS AD TO—

## GREER SHOP TRAINING

(Desk 16) 460 South State St., Chicago 5, Ill.

Please send without obligation free information regarding trade checked above. (Specify whether you are a Veteran  or Civilian )

Name \_\_\_\_\_ Age \_\_\_\_\_  
Address \_\_\_\_\_  
City \_\_\_\_\_ State \_\_\_\_\_

# AUDELS BLUEPRINT READING

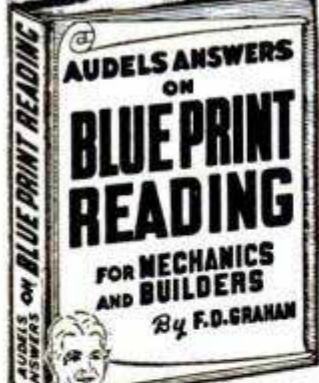

JUST OUT—FOR THE MAN WHO WORKS FROM BLUE PRINTS

"The Blue Print of Today is the Machine of Tomorrow." AUDELS ANSWERS ON BLUE PRINT READING covers All Types of plan reading including AIRCRAFT & SHIP BUILDING—tells How to Easily Understand Working Drawings.

What to look for first. Tells what each Line and each Symbol Means. The relation of one part to another. How to Understand Scales & Specifications. How to Make a Sketch. How to Make Blue Prints. A Key Book for Every Mechanic, Builder & Draughtsman—352 pages—It's New, Comprehensive. Fully Illustrated. Gives Short Cuts, Helps, Hints, Suggestions. Questions and Answers.

ASK TO SEE IT!  
To get this assistance for yourself, simply fill in and mail coupon today. **\$2**

AUDEL, Publishers, 49 West 23rd St., New York  
Please mail AUDELS BLUE PRINT READING (Price \$2). If satisfactory, I will remit \$2 on its safe arrival, otherwise I will return the book.

Name \_\_\_\_\_  
Address \_\_\_\_\_  
Occupation \_\_\_\_\_  
Company \_\_\_\_\_ PM

## SHOE REPAIR OFFERS BIG INCOME LEARN IN 12 WEEKS TIME



You can own your own shop or earn big income as skilled shoe repairman. Growing demand everywhere at top wages for men who know how. We teach you quickly by actually working on shoes and modern machines. School open to all from 18 to 60 years of age. FREE BIG 20 PAGE BOOK explains everything. Send for your copy today. Chicago & Los Angeles schools only approved for Vets.

MODERN SHOE REBUILDING SCHOOL  
Established 1927  
2937 Belmont Ave., Chicago. Dept. PM  
361-12th St., Oakland, Calif.  
806 So. Figueroa St., Los Angeles 14, Calif.

## TODAY'S BIGGEST PREFAB BOAT BUY

Build a better boat than you can buy! Save up to 55%. See OZARKA's Model 12-A—a trim, top-quality 12-footer with laminated rib construction, all oak frame for years of boating pleasure with motors up to 16 HP. Send 25¢ for complete Boat & Accessory Catalog, to be refunded on first purchase. OZARKA, Inc., 620 Borden Lane, Woodstock, Illinois. **\$39.50 AND UP**



## FREE AMAZING NEW BOOK "HOW TO ANSWER ADS"



Never before have you seen anything like this. Tells you in simple language the correct way to answer ads. Gets you quicker replies—better results, and greater satisfaction. Will save you time and money and it's ABSOLUTELY FREE. No obligation whatever. Every reader of advertising should have this booklet. Send a postcard for your copy NOW. Advertising Department, Popular Mechanics Magazine, 200 East Ontario Street, Chicago 11, Ill.



## Start Quickly BIG MONEY ROLLING WITH LIFE CHARGE

MAKE PLEASANT, DIGNIFIED CONTACTS  
The MIRACLE Chemical that helps Batteries stay AUTOMATICALLY charged. Adds Months of useful service. Eliminates freezing, overheating and cable corrosion; Revives old Batteries. Saves time and money for user. EAGER BUYERS EVERYWHERE! Fleet owners, garages, service stations and individuals all buy. FOUR EASY SALES A DAY NETS YOU \$144.00 WEEKLY! Advertising and Promotional Material free. Sold on satisfaction guaranteed or money back plan. Send \$1.00 for special sample older enough for two batteries, or write for free details. GET IN THE BIG MONEY FIELD! DO IT NOW. DON'T DELAY...WRITE TODAY!

BATTERY CHARGE PRODUCTS COMPANY  
728 W. Peachtree Street, Dept. M Atlanta, Georgia



TIES  
SCARFS  
BLOUSES  
DRAPERIES  
LAMP SHADES  
UPHOLSTERY



LEATHER



COPPER

HERE'S EVERYTHING YOU NEED TO LEARN THE NEW ART OF TEXTILE PAINTING AT HOME — FOR FUN OR FOR PROFIT

Now paint in beautiful, fast colors with Formulabs Transparent Lacquer. No setting or pressing. Goes on easily with brush, spray or stencil. Leaves fabric smooth and pliable. No mixing required. We show you how to have fun—or turn hobby into a business. No experience needed. Send only \$3.95 for BIG starting kit containing everything you need including complete instructions and FREE Patterns.

FORMULABS 36 W. GREEN ST., DEPT. PM PASADENA 1, CALIF.

# PLASTICAST

THE GREATEST THING IN PLASTICS!



## A NEW HOME INDUSTRY AND HOBBY!

The following materials are just a few of the hundreds of items for **CASTING, MOLD MAKING, manufacturing**, etc. that you will find in our new Catalog No. 10. **CASTING** is as easy as pouring water out of a glass! No tools or machinery required. Everything is supplied.

**PLASTICAST** . . . a transparent liquid plastic; clearer than glass, hard as steel. Ideal for imbedding flowers, butterflies, insects, photos, souvenirs, cigarette lighters, pen sets, jewelry, etc. See 4th and 6th illust. above. **PLASTICAST OUTFIT**, 1 lb. plastic, hardener, 3 molds, dye, imbed. materials, complete with accessories and **INSTRUCTION MANUAL POSTPAID, \$3.50**

**ONE POUND PLASTICAST, hardener and 1 MOLD POSTPAID** . . . . . 2.25

**LIQUID IVORY** . . . anything can easily be cast out of this beautiful material. Very strong. Ideal for novelties, jewelry, toys, tools, dies, forms, handles, statues, knobs, etc. See 1st & 3rd illust. above.

**LIQUID IVORY OUTFIT**, 1 lb. plastic, hardener, 8 molds, dye, jewelry accessories and **INSTRUCTION MANUAL, complete POSTPAID** . . . . . \$4.95

**ONE POUND IVORY PLASTIC, hardener and 1 MOLD POSTPAID** . . . . . 2.25

**LIQUID MARBLE** makes very beautiful things. See 2nd illust. above. Make lamps, bookends, vases, statues and countless similar items. As hard and as beautiful as real marble!

**LIQUID MARBLE OUTFIT**, 1 lb. material, hardener, 3 molds, pigments, complete with instructions . . . . . **POSTPAID, \$3.95**

**ONE POUND LIQUID MARBLE, hardener and 1 MOLD POSTPAID** . . . . . 1.75

**CASTEX** . . . a remarkable plastic that makes hollow but very strong practically unbreakable castings! Possesses soft skin-like surface. Ideal for **DOLLS and TOYS**. See 5th illust. above.

**CASTEX**, one pound . . . . . **POSTPAID \$1.75**  
**CASTEX**, one pound and **1 MOLD** . . . . . **POSTPAID 3.50**

**MULTIPLY** . . . THE IDEAL MOLD MATERIAL. Flexible, takes deep undercuts easily. Any material may be cast in this mold; gives faithful reproductions of original model. Can be re-melted and used over endlessly.

**MULTIPLY**, one pound . . . . . **POSTPAID \$2.25**  
**Quart, POSTPAID** . . . . . \$4.00

**HUNDREDS OF OTHER ITEMS AND ACCESSORIES FOR CASTING AND MOLD MAKING IN OUR BIG CATALOG.** See Below.

**TERMS:** We pay the postage (U.S.A. only) if full cash accompanies order. C.O.D. accepted (U.S.A. only) if \$1.00 deposit included for each item ordered.

**DEALERS: WRITE FOR CATALOG, DISCOUNTS & PROMOTIONAL MATERIAL**

## FREE!

Let us show you how extremely easy it is to make beautiful and useful things out of **LIQUID PLASTICS, LIQUID MARBLE, LIQUID IVORY, LIQUID GLASS, CERAMICS, ETC.** . . . as easy as pouring water out of a glass! Make novelties, jewelry, gifts, artware, gadgets, toys, ceramics . . . a million useful things! We supply everything—**MATERIALS, INSTRUCTIONS AND BUYERS!** Send only 25c for 1. Big catalog of 300 casting materials, molds, and accessories, 2. A beautiful **CAMEO** free (to show you what you can do), and 3. Actual **INSTRUCTIONS** on how to cast and start in the **CASTING BUSINESS!** Send 25c today—this may be the lucky coin that will start the most fascinating and profitable phase of your life! (Catalog only—10c)



**PLASTICAST COMPANY (DEPT. C)**  
 4637 N. Kedzie Ave. Chicago 25, Ill. (Write to nearest address)  
 P. O. Box 987 Palo Alto, Calif.  
**CANADIAN CUSTOMERS, please order directly from: CANADIAN INDUSTRIAL PLASTICS, LTD., 1056 1/2 Pender West, Vancouver, B. C.**

# BIG FREE CATALOG of WAR SURPLUS OPTICAL BARGAINS

Build Your Own RIFLESCOPE, BINOCULARS, TELESCOPES, ETC. We Furnish Optics and Instructions

- LENSES, PRISMS & RETICLES
- EYEPIECES and OBJECTIVES

Send \$1.00 for Stock #2-H 10-Piece Lens Kit and Big Instruction Booklet.

We Have Numerous Types of Assembled Optical Instruments Including BINOCULARS and RIFLESCOPES. CHECK OUR BARGAINS . . . Request CATALOG H

**EDMUND SALVAGE COMPANY**  
 BARRINGTON, NEW JERSEY

# These Men are Getting PRACTICAL TRAINING



# IN RADIO-TELEVISION

On Real TELEVISION SETS RADIO and F.M. RECEIVERS

# IN THE GREAT SHOPS OF COYNE

Big opportunities are waiting for men who know the practical and technical end of Radio and Television. That's what you get at COYNE—besides practical Shop Training in F.M., Electronics and other branches of this giant field. Remember, Television is the fastest growing opportunity field today, and Radio is one of the biggest.

## NOT "HOME STUDY" COURSES

All Coyne Training is given in our mammoth Chicago training shops. We do not teach by mail. You train on actual equipment, under friendly instructors. Previous experience unnecessary. Hundreds of firms employ Coyne trained men.

## OLDEST, LARGEST, BEST EQUIPPED SCHOOL OF ITS KIND IN AMERICA

Come to the Great Shops of Coyne in Chicago. Established 1899—now in our 51st Year. Fully approved for G.I. training. Finance plan for non-veterans.

## MAIL COUPON FOR FREE BOOK

Send today for big new book packed with large pictures taken in Coyne Shops. No obligation. No salesman will call. Get the facts now!



**COYNE** B. W. Cooke, President  
**ELECTRICAL, RADIO & TELEVISION SCHOOL**  
 500 S. Paulina St., Dept. 20-3H  
 Chicago 12, Illinois

B. W. COOKE, Pres.  
 COYNE Electrical, Radio & Television School,  
 500 S. Paulina Street, Dept. 20-3H, Chicago 12, Ill.

Send FREE BOOK and full details on Radio-Television Course.

NAME.....

ADDRESS.....

CITY.....STATE.....

SAY YOU SAW IT IN POPULAR MECHANICS

# We'll establish you in Your Own Business and help finance you!

Ever said to yourself, "I don't like the idea of working for others. Someday I'd like to have my own business, and be my own boss." . . . Here, then, is an opportunity made-to-order for you. We are NOW enlarging this **20 YEAR OLD**, Nationwide chain of individually-owned *Certified Service* business. If you are dependable, honest and willing to work, we invite you to mail coupon below for details on how to become financially independent in a profitable, lifetime

*business of your own.* We will establish you in your own business and arrange finance terms to help get you started. You use the proven successful methods of long established **DURACLEAN** Dealers. Here is truly a sound, steady, lifetime business. Dealerships grow from **REPEAT** and **VOLUNTARY** orders. Your gross profits (above materials and labor) are up to \$20 for a day's service on **EACH** of your service men. It's easy to learn . . . quickly established.



Foamovator becomes carrying case

## You Become an Expert in cleaning and protecting Rugs and Upholstery!

**DURACLEAN** cleans by *absorption*. An aerated foam, created by the patented electric Foamovator, restores the natural lubrication of wool and other animal fibers in rugs and upholstery. Dirt, grease and many unsightly spots vanish as if by magic. Fabrics and floor coverings are cleaned with a *new consideration for their life and beauty*.

Cleaning is done *right in the home!* Fabrics dry in just a few hours. No inconvenience for customers. Rug pile again stands erect and even. Furnishings are left clean, fresh and enlivened.

**DURAPROOF** is another year 'round service rendered right in the home, office or institution — *without removing furnishings*. It protects carpets, upholstery, furs, clothing, piano felts and auto interiors against damage by moths, carpet beetles or mildew. The U. S. Government says, "Moths are present in practically every household... No section of the country seems free from such infestations." **DURAPROOF** not only kills moths and carpet beetles . . . it makes materials non-eatable to both.

To our knowledge, **DURAPROOF** is the only mothproof service backed by a National **MONEY BACK, 4 YEAR WARRANTY**.



Fabrics *last longer* because this modern, safe cleaning process avoids the use of strong soaps and harmful solvents that so often damage dyes or fabrics. . . . No machine scrubbing! This eliminates unnecessary wear on pile and the breaking of fibers.

## Easy To Learn • No Overhead Expense

### Start Full or Part Time

No experience necessary! Some dealers establish shops or an office . . . others operate from their own homes. At the start you may want to render service yourself. Service may be rendered in homes, offices, hotels, theaters or institutions. Auto dealers buy your **DURACLEAN** Service to revive upholstery in used cars. Foamovator converts to easy carrying case. Almost every building in your territory houses a potential customer needing one or both services.

### Repeat and Voluntary Orders

Demonstrations win new customers. Men with **DURACLEAN** Dealerships find **REPEAT** and **VOLUNTARY** orders become a major source of income. Customers are not merely satisfied — many are enthused with results and tell their friends and neighbors. Furniture and department stores and interior decorators turn over rug and upholstery cleaning and mothproofing to **DURACLEAN** Dealers. We show you **21** ways to get *new* customers.

### Two-Way Profit

You enjoy big profits on both materials and labor — after paying service men and salesmen. These are year 'round services for which there is always a constant need. You have National prestige and the cooperation of a National **20 YEAR OLD** organization interested in your services. The rapidly growing need for **Certified Service** makes **TODAY** the ideal time to become the owner of a **DURACLEAN** Certified Service business.

## FREE Booklet

Our first letter and 16 page illustrated booklet will explain everything — the two modern, urgently needed services, waiting market, how business grows, your large profit, easy terms and **PROTECTED** territory.

Send Coupon **TODAY!**

## "OWN a Business" Coupon

### Duraclean Co.

Division of HOME SERVICE CO.  
0-162 Duraclean Bldg., Deerfield, Illinois

With no obligation to me, send booklet and letter giving full details. Tell me how I may **OWN** a growing business of my own built upon satisfied customers.

Name \_\_\_\_\_ Age \_\_\_\_\_

Address \_\_\_\_\_

City \_\_\_\_\_ State \_\_\_\_\_

## Dealer Comments:

R. Kimbrough: "Finished First White House of Confederacy and am to **DURACLEAN** Governor's Mansion."

O. D. Hefflebower: "People who have seen the work have expressed amazement."

E. Schalehlin: "Have on hand 5 orders totaling over \$500.00 . . . obtained from recommendations of customers."

## EASY TERMS!

A moderate payment establishes your own business. Easy terms permit you to pay balance from your sales. We furnish electric machines, folders, store cards, introduction slips, sales portfolio, demonstrators and enough material to return your **TOTAL** investment. You can have your business operating in a very few days. **Mail coupon today!** No obligation.

Copyright 1947 by

**DURACLEAN CO.** 0-162  
Duraclean Bldg.  
Deerfield, Ill.



**WORLD'S  
BEST  
WANT AD  
MEDIUM**

# CLASSIFIED Advertisements



Advertisements in this section 75 cents per word, each insertion, minimum 10 words, payable in advance  
To be inserted under proper classification, copy must be in our office the 22nd of the  
second month preceding date of issue

F. W. Johnson, Manager, Classified Advertising  
Popular Mechanics Magazine, 200 East Ontario Street, Chicago 11, Illinois

## 1030 CLASSIFIED ADVERTISEMENTS 1030 OPPORTUNITIES FOR YOU

### AUTOMOBILES. MIDGET CARS

**FROM** Speedway to roadway! Track-proved hi-speed heads and manifolds now available for your passenger car! No special tools needed! Increase horsepower 25%! Astounding getaway! Free illustrated catalog. Speedsport, 6215P Diversey, Chicago 39.

**ROLLS** Royce sedan, like new, \$1200.00. Indianapolis 2 man race car, perfect, \$1200.00. Many others. Bud, 4th Maryland, Gary, Indiana.

**WANTED** Automobile magazines, catalogs, photos. Armida, Box 2650, Mexico City.

**DIRECT** From California—The very latest in speed equipment for all makes of passenger automobiles! All of the nation's leading racing accessory manufacturers represented in one catalogue! See and compare brands, specifications, costs! We ship all over the world. Wholesale, retail. Illustrated catalogues, speed, power, mileage information 50c complete. Newhouse Automotive Industries, 5805-B7 East Beverly, Los Angeles 22.

**SPEED & Mileage Manual**—New edition! 140 illustrations, drawings, charts, photographs! Guaranteed finest, most authoritative book! Easy, inexpensive ways to build speed equipment! California hot rods! Beautiful custom cars! 200 h.p. road, track conversions! Superchargers! Dual manifolds! Racing heads! Twin mufflers! Water injectors! Economizers! Get super speed, mileage, acceleration, top racing performance from any car! Complete instructions with working diagrams on fast engines, speed tuning, restyling, customizing, gas saving, racing tricks, cams, fuels, balancing, porting, ratios, frames, "Offys!" Learn 100 ways to save gas! Reveals stock car speed secrets! California speed shop methods! Custom styling information! Streamlining! Lowering! Sport changes! Hollywood roadster plans! Speed conversions! (Covers all cars). Large manual plus equipment catalog plus racing handbook, all three only \$1.98. Alquist Engineering, Milford 72, Pennsylvania.

**GENUINE** Crosley parts. Cast iron block kits \$48.85. Hydra disk brake kits \$75.00. Hot water heater and defroster \$19.95. Radio with aerial \$49.95. Send 25¢ deposit. Balance c.o.d. Walraven Motors, "Crosley" Distributors, Marion, Ohio.

**HOT Rod**—The only monthly magazine about building roadsters, streamliners, etc. Sample copy 25c. \$3.00 yearly. Hot Rod, 548 S. San Vicente, Los Angeles 48, Calif. Dept. PM.

**CALIFORNIA** Custom accessory headquarters. Buy direct from original designers and save. Solid hood sides, grille panels, lowering kits, fender skirts, dual pipes, chrome motor accessories, speed equipment, push button door conversions. Revised catalog, 34 illustrated pages, new low prices 25c. Eastern Auto Supply, 3319-A South Grand, Los Angeles 7, Calif.

**"SPEED Equipment"** bargains—California mufflers \$4.50. V-8 duals \$15.90. chrome carburetor stacks 98c. dual manifolds \$9.95. chrome echo cans \$1.65. racing camshafts \$29.95 exchange. hi-compression heads \$19.75. All popular brands! Big illustrated catalog 25c. (Dealers wanted). Alquist Engineering & Mfg., Milford 72, Pennsylvania.

**RACING** Books. Grand Prix Story 50c. Book of Race Cars \$1.00; Road and Track Magazine \$3.50 per year. Many others, list 10c. Enthusiasts Publications, Box 409-F, North Hollywood, California.

**"SPEED & Power"** Handbook—50 chapter library edition! Photographs! Breathing methods, authentic, direct from California. Covers Crosleys to Cadillacs, all makes! Build your own dual manifolds. Superchargers. Hot cams. Water injectors. Hi-compression heads. Mileage devices. Save many dollars! Get racing speed, lightning acceleration, dynamic power increases from any make passenger automobile! Build fast stock cars. California roadsters. 160 m.p.h. rods! Get construction drawings! Tuning techniques! Speed tricks! Economy secrets! Ingenious formulas! Covers "Racing Frames," "Reciprocating Masses," "Jet Engines," "Braking Characteristics," "Dynamometers." Also dual pipes, gears, fuels, porting, relieving, lowering, balancing! Includes 1950 speed equipment catalogues! Also "California Automobile Customizing," photographs. Diagrams. Newest ideas! Conversions. Carson tops. Re-styling all makes. Streamlining. Chopping. Channeling. Complete \$1.98 postpaid. Newhouse Automotive Industries, 5805-B2 East Beverly, Los Angeles 22.

**NEW Ford Speed Manual**, 128 pages full of cutaway construction drawings, photos, and understandable technical data. Includes complete data on installing V-8 motor in Model A chassis, hydraulic brakes for any Ford, roadster and fast car info. How to rework these engines for speed; V-8, Merc., Ford 6, Zephyr, Model A. Guaranteed finest manual of its type published. Sent postpaid for \$2.00. California Bill, Box PMC-2, Eaglerock, Los Angeles 41.

**HOLLYWOOD** Deeptone mufflers—Straight-thru design increases efficiency, speed, acceleration, mileage! Singles. All cars \$4.85. Finest V-8 duals \$15.90. (Satisfaction guaranteed). Speed equipment catalog 25c. Alquist Engineering, Milford 72, Pennsylvania.

**SAVE Gasoline!** Sensational Gane needles. Free trial. See page 285.

**NEW Chevrolet Speed Manual!** 90 pages of accurate information on how to increase speed and acceleration of any 1937 thru 1949 Chevrolet. How to install late engines in pre-1937 chassis. Full data on cams, high compression, multiple carburetion, supercharging, ignition, etc. Guaranteed the finest manual of its type! Proves that your Chevrolet can have superior power and speed! Sent postpaid only \$2.00. California Bill, Box PMC-2, Eaglerock, Los Angeles 41.

**NEW Catalog**—Over 400 racing, hot rod, speed equipment, custom items! Pictures! Speed data! Customizing tips! Bargains galore! Big catalog 25c. Alquist Engineering & Mfg., Milford 72, Pennsylvania.

**USE Toilet paper** for oil filter cartridges. See ad on page 298.

**JUST Out!** Get the largest auto accessory and parts catalog in the world. Over fifteen thousand items, including Hollywood accessories, hi-speed equipment, rebuilt engines; all parts and accessories for all cars and trucks. New, used and rebuilt! We have that hard-to-get-part! Completely illustrated, jam-packed with bargains. Send 25c. J. C. Whitney & Co., 1919 Archer Ave., Chicago 16, Ill.

**"SPEED & Power"** Amazing new invention—Ox-o-Jet. Plans and instructions, postpaid \$1.50. Henry Albert, Cambria, Virginia.

**"WATER Injection."** Also speed, power, economy methods! Free descriptive, illustrated, information. Neher Industries, La Verne, California.

**SEE** Our ad under Motorscooters for midget car bargains. Midget Motors Directory, Athens, Ohio.

**RACING** Car equipment for all cars. engines, racing heads, manifolds, carburetors, mufflers, etc. Speed instructions and literature \$1.00—refunded first order. Lee Motorcraft Co., 1412-D Great Northern Bldg., Chicago 4, Ill.

**NEW Sensational** seat cover. Mono, 6545 Santa Monica Blvd., Hollywood, California.

**AUTOMOBILE** Racing book, fifth edition, well-illustrated. Building bodies, frames, engines, Ford conversions. Plans. Roadsters. Indianapolis cars. \$1.00 postpaid. Popular Mechanics Press, 200 E. Ontario St., Chicago 11, Ill.

**WE Sell** direct to customer, speed parts manufactured by us. Fords, Studebaker Champion, Chevrolet and Willys, complete engines for race cars and boats. \$1.00 for illustrated literature and price sheet. R. & R. Mfg. Co., Robert M. Roof, Box 546, Anderson, Indiana.

**AUTOMOBILE** Racing, sixth edition, 100 illustrations. Drawings, building instructions Ford-60 midget, California roadster, Offenhauser racer. World's record 158.5 m.p.h. car. \$2.00 postpaid; \$2.40 c.o.d. Popular Mechanics Press, 200 E. Ontario St., Chicago 11, Ill.

### AUTO SUPPLIES AND EQUIPMENT

**LACHAPELLES** Motor and motor fuel treatment (patented U. S. and foreign), stops ping, gives more miles per gallon, more miles per motor. 100,000 miles treatment. \$3.00 postpaid. Ferns Products, 8120 Walnut Dr., Los Angeles 1, Calif. (Data sheet on request.)

**"SMITHY'S Mufflers."** Send for list. Buck's Auto Parts, 1296H, Merced 15, Calif.

**INFRARED** Auto engine warmer. Automatic, new! Literature free! Engineering Development, Box 37M Station "C," Lincoln, Nebraska.

**AUTO Thief alarm!** Prevents car theft, looting. Avoid loss, trouble! Low cost. Details free. Write! Grand, 2506M—52nd, Kenosha, Wisconsin.

**1950 SUPERIGNITIONITER.** Starting, pep, mileage. \$5.50. Special \$4.50. EG Mfg., Elmsford, N. Y.

**RENEW** The beauty of your car upholstery. Material and instructions \$1.75 post paid. John Farrell, 1030 N. W. 103rd, Miami, Fla.

**MAKE Yourself** super device, saves 45% gasoline guaranteed, purifies oil. Plans \$1.00. Mike Brodie, Vilna, Alberta.

**MOTORISTS** Save gasoline by Vacuumating overrich mixtures. Fits all cars. For free particulars write Vacuumatic, Dept. 1561, Wauwatosa, Wis.

**MOTORISTS, Truckers,** get miracle auto accessory, most needed aid to safe driving since invention of the automobile. 55% more vision. No state, local ordinance prohibiting its use. Save your car, save a life. Sent c.o.d. \$1.00. Send cash, save c.o.d. charges. Spiers Sales Co., Dept. M—Rm. 1610, 608 So. Dearborn St., Chicago 5, Ill.

**AUTOMATIC** Ignition booster—For faster starting, longer battery life. Easily installed. Specify car. Free details. Southwest Enterprises, P.O. Box 5033, Phoenix, Arizona.

FORD, Mercury owners attention: Buy direct from factory and save. No dealers, please. Complete dual muffler sets for all V-8 Fords and Mercury 1932-50. Specify year and model. Chrome exhaust tips 98c, single mufflers \$3.75, long shackles Fords 1932 to 1948 and Mercury 1939-48, \$1.00, lowering blocks for Ford and Mercury 1949-50 \$3.00, specify Ford or Merc. Fender skirts \$8.95, specify year and model. Speed & Power Manuals \$1.75. Send cash with order or 50% deposit. The Edco Co., Box 68, Bell Gardens, Calif.

AMERICAN Bantam and Austin parts. 1435 North 35th, Fort Smith, Ark.

AUTOISTS! At your finger tips hold pencil, pad, drivers license, maps, etc., on visor above steering wheel, with this patented visor clip. Start 2 your way by mailing printed address and \$1.00 today to R.E.K. Manufacturing, 8530 Woodward, Detroit 2, Mich.

RADIATORS! Save 30%. New 36-48 Chevrolet \$29.95, 36-48 Ford, Mercury \$39.95. All makes. Guaranteed. Bares & Associates, 1121 E. 185, Cleveland, Ohio.

SPEED And custom equipment at new low prices. Hollywood powertone mufflers, large chrome echo cans, high compression heads, dual manifolds, cams, fender skirts and other equipment at rock bottom prices. Send 25c for literature and deduct it from your first order. Jack Hubbard, Dept. PM3, 9440 MacKenzie Rd., St. Louis 23, Mo.

NIGHT Drivers—Forget about glaring headlights on long trips at night. The O. W. Glare Eliminator positively blocks the glare without blocking your safe view ahead. Widely used by businessmen, truckers, salesmen, others. Easily installed. Money back guarantee, \$9.75. O. W. Automotive Devices Co., 4413 Underwood St., Hyattsville, Md.

BARGAINS, Pistons, rings, valves, for cars, trucks, tractors, 1920-1949. Zrubeks, Pratt, Kansas.

ARC Welding frames, bodies, fenders. Pays with Hobart Welders. Easy terms. Catalog free. Box M-202, Troy, Ohio.

DOUBLESEAL Your overhead doors. Stop drafts. Edwards Industries, Dept. 102, 4268 Shenandoah Ave., St. Louis 10, Mo.

SAVE Gasoline! Sensational Game Needles. Free trial. See page 285.

ECONOMETER, Watches your gas mileage. Actually measures the gas as used. See January ad. Only \$22.50. Ringelstetter Co., Plain, Wis.

AUTOWELD Training pays. G.I. approved school. Free catalog. Hobart Welding School, Box M-203, Troy, Ohio.

HYAMP Helps weak batteries! Guaranteed. \$1.00. Electronic Industries, Cleveland 11, Ohio.

"AIRFLOW Needles." Save gasoline! Free trial! If satisfactory, \$1.50. Specify car, carburetor. Neher Industries, La Verne, California.

"LEKTRON" Coil booster saves gas! Quick winter starting for cars, trucks, tractors. Easily installed. \$2.00. Guaranteed. Electronic Industries, Cleveland 11, Ohio.

AUTOMOTIVE Surplus tool specials! Pullers, wrenches, socket sets, reamers. Other bargains. Nationally advertised merchandise. Send dime for catalogue. Glenco Supply, 7521 Myrtle Avenue, Glendale 27, N. Y.

AUTO And truck parts. New and used. Lowest prices. Complete stock. Prompt replies. Babbitt Auto Parts, 2833 Chicago Ave., Chicago 22, Ill.

NEW And used guaranteed parts for civilian and army cars and trucks. Largest stock in America. Mail orders. Pioneer Auto Wrecking Co., 734 W. 13th Ave., Denver, Colorado.

BUICK Parts—Enjoy new-car pep and power in your old Buick. Same day service from world's largest stock of new (not rebuilt) Buick parts and engines. Ship anywhere. Write today. Robertson Buick Co., 1001 S. Wabash Ave., Chicago 5, Ill.

CHEVROLET Parts. Scarce motor, body, sheet metal parts. Grossman Chevrolet, Minneapolis, Minnesota.

BRUSH Plating outfits connect to a battery. No tanks or shop required. Free particulars. Gunmetal Co., Avenue J, Decatur, Illinois.

GOVERNMENT Surplus. Low voltage circuit tester in steel box. Cost \$202.00. Our price \$27.50. Will test batteries, starters, generators, voltage regulators, grounds, short circuits. Wilt Electrical Company, 7829 S. Racine Ave., Chicago 20, Ill.

## AUTO TRAILERS

TRAIL Hut folding camp trailer sleeps four. Plans \$1.00, guaranteed. Information free. Trail Hut, 600 Sixteenth Street, Oakland 12, California.

TRAILER Plans—House, utility, boat, etc. Axles, chassis, hitches, windows, etc. Catalog with booklet. "Trailer Hints," \$1.00. Catalog only, 50c. Marine Mart, Buffalo 7-B, New York.

TRAILER Coaches. Save money. Buying? Building? Sound engineering construction, chassis, bodies, furnishings. Travel, dwelling, trailer plans, \$1.50 postpaid. Popular Mechanics Press, 200 E. Ontario St., Chicago 11, Ill.

BUILD Your own trailer! Save money! Have every feature you want! Plans for house, sport, camp and utility trailers. Catalog describing 9 models 10c. 15c in Canada and overseas. Jim Dandy, Box 125-A, Wausau, Wisconsin.

## MOTORCYCLES, BICYCLES, MOTORSCOOTERS AND SUPPLIES

MOTORCYCLE Pistons and parts, new, used. Harley, Indian, Henderson, Super-X. List 10c. Ballak, 811 N. 9th, St. Louis 1, Missouri.

INDIAN And Harley, new and used parts catalog, 15c. Cylinder reboring, motor rebuilding; batteries, chrome accessories. Everything for the motorcycle. Bootz, 1700 East University, Des Moines 16, Iowa.

INDIAN Motorcycle engines complete clutch, transmission, ignition, model 741 V type 2 cylinder, new unused war surplus, new cost \$475. Our price \$200 f.o.b. Milwaukee, Wis. H. R. Douglas, 1133-N 25th St., Milwaukee, Wis.

HARLEY-Davidsons—Used, guaranteed. Genuine Harley-Davidson parts, accessories, obsolete model parts, expert service. Send 25c for motorcycle and accessory bulletins. \$2.25 for 45" Army Motorcycle Manual. Knuth's, 2491 Fondulac, Milwaukee, Wis.

BICYCLE Supplies. Wholesale, retail list 10c. Universal, 4713 Virginia, St. Louis, Missouri.

MOTORCYCLE Cams ground and special carburetion. Schaller Cams, Turlock, California.

SALISBURY Motorscooter \$25, shop built motorscooter \$15, midjet racer less motor and wheels \$10; Whizzer motorbike complete \$35; Indian motorcycle \$25; Bantam panel truck \$40; Briggs Stratton engine \$3.50. Plenty new motorscooters, midjet cars, homebuilders parts, plans, automatic clutches, transmissions, engines, tires, etc., at factory prices. Special sale, four balloon tires for \$3. Over 5000 tires in stock. Mailorder only. Send 25c for big new war-bargain catalogue Number Thirty-Three just out, listing these and hundreds of other bargains. (35c by first class mail.) Midjet Motors Directory, Athens, Ohio.

WHIZZER Bike-motor \$25; Cushman motorscooter \$15; midjet racer \$40; Shaw bicycle motor \$15; Harley-Davidson motorcycle \$15; Smith motor-wheel \$25; Good motorscooter (twist grip) \$22.50. Rush 25c for new catalog #15 listing many other amazing bargains in motorscooters, used motors, midjet cars, parts, wheels, etc. Gail, 538 Erie, Toledo, Ohio.

KNEE-ACTION Motorbike \$15; midjet car (steel frame) \$25; Moto-Scoot \$15; Whizzer motorbike with all attachments \$25; Indian motorcycle \$30. Other motorscooters \$8 up, motors \$3 up. Send 25c for new catalog #944 listing many other sensational bargains in used motors, motorscooters, motorcycles, parts, etc. Associated, Box 1764-CS, Toledo, Ohio.

RECONDITIONED Motorcycles and motors. Chromium accessories. Complete stock Indian parts. Expert rebuilding. Fast service. Indian Motorcycle Sales, Kansas City 1, Mo.

MOTORCYCLE Journal—Worldwide coverage. Illustrated. Year's subscription \$1.00. Sample 15c. Motorcycle News, 5424-A Sawyer, Chicago 25.

TIRES And industrial wheels, suitable for scooters, wheelbarrows, farm equipment, etc. All sizes. Bicycles and accessories. Send dime for list. Cycle Transport Company, 1241 So. Michigan Ave., Chicago 5, Illinois.

## AVIATION

JET Engine \$3.00; plans \$1.00; literature 10c. M.E.W., 387 University, St. Paul, Minn.

SNOW Sleighs and air boats—Build your own for \$350. Propellers, plans, skis, engines, complete sleighs. Literature 20c. Propeller clocks \$12.50. Banks-Maxwell, Box 3301E, Ft. Worth, Tex.

## BATTERIES, GENERATORS

GENUINE Edison batteries, Fifteen year life. Unconditionally guaranteed. Free literature. See-Jay Company, 3522 Webster Avenue, New York 66, N. Y.

EDISON Nickel batteries, 37 to 600 ampere. Also kits with Edison plates; make your own. Interesting literature. Hawley Smith Co., Croton Falls 1, New York.

## ELECTRICAL SUPPLIES

ELECTRIC Appliance parts catalog and complete repair handbook. Letterhead for wholesale list. Send \$1.00 (refunded on \$5.00 order) to C-US Supply, 2512 Prevost, Fort Worth 7, Texas.

BUY Lamp parts wholesale—Parts you need for building, repairing, or assembling. Save money on large or small orders. New catalog for 10c. Gearon Company, Dept. 300-B2, 27 South Desplaines, Chicago 6, Ill.

ELECTRIC Pencil: Engraves all metals, \$1.00 postpaid. Guaranteed. Reiss, 3017-G Ocean Parkway, Brooklyn 24, N. Y.

ELECTRIC Pencil—Writes, engraves all metals. 110 volt model \$2.95; 6 volt model \$1.25. Reb Industries, 265-DY, Elmhurst, Illinois.

MAGNET Wire, insulation, transformer lamination. Morton Electrical Service, Maywood 1, Ill.

LAMPS—How to build lamps from vases, pitchers, etc. Chart for top and bottom lighting, alternately or together. How to vary oil lamps, all in 56 page illustrated catalog of all lamp parts, 25c. Gyro Lamps, 5402P Clark, Chicago 40.

LAMP Parts—Extra money modernizing, converting, repairing lamps at home. 3c stamp for illustrated folder. Lamp Shop, 1348 Richmond, Des Moines, Iowa.

FREE Catalog—Motors, generators, welders from aircraft generators, water softeners, many other electrical bargains. LeJay Company, Minneapolis, Minnesota.

ELECTRIC Pencil: Engraves all metals \$1.25. Beyer Mfg., 10511-H Springfield, Chicago 43.

ELECTRIC Motors, free bargain list. Plenge, 9 Stuyvesant Oval, New York 9, N. Y.

LEARN Electrical appliance repair. House wiring, motors, washers, cleaners, refrigerators, lamps, auto ignition, etc., complete illustrated course. Tools furnished. Free booklet. Pacific School, 7219 South Broadway, Los Angeles 3.

## WELDING, SOLDERING, PLATING

ACETYLENE Welding outfits, new \$45.00, used \$25.00; arcwelders \$46.50. Eagle Welding, Dept. PM, 5085 Broadway, Chicago 40, Ill.

110V. PORTABLE Transformer welders, \$29.50. Morris, 1850A State, Schenectady 4, N. Y.

WELDER! New portable Champion Special transformer welder; 110/120 volts a.c. develops to 75 amps.; 9 heat stages. Welds, brazes, solders, cuts all metals. Easy to use. Simple instructions. Special flame weld torch free. Splendid for shop, farm, home repairs. Saves hundreds of dollars yearly. Only \$27.50. Also heavier models. 10 day free trial. Magic Welder Co., 239 MP Canal St., New York, N. Y.

BIG Profits in welding business with a Hobart "Build-Your-Own" Portable. Catalog free. Hobart Brothers Company, Box M-204, Troy, Ohio.

OXY-ACETYLENE Torches with 12 tips, used, heavy duty \$14.00 cash f.o.b. Air and oxy-acetylene hose, pumps, drills, etc. Send for list. Acme Tool Co., 229-78th St., Brooklyn, New York.

LOWEST Prices on new a.c. welders. Holgerson's Service, Canton, Kans.

200 AMPERE Welding generators. Free literature. Lewis Short, Burrton, Kansas.

RECTIFIERS 0-4 V.D.C. \$9.50, 0-8 V.D.C. \$12.50, 0-12 V.D.C. \$18.50. All 0-100 amps. Starkweather, Ottawa, Kansas.

RADIATOR Repairing books, supplies, equipment, gasoline torch. Write, Curfman Co., Maryville, Mo.

BUY Direct from factory. Welding and cutting equipment. All makes of equipment repaired. Established 1913. Box 331, Hamilton, Ohio.

ELECTROPLATING Salts and rectifiers. Mirror resilvering and chipped glass nameplate supplies. John Sprinkle, V55, Marion, Indiana.

RADIATOR Repairing, cleaning, recoring. How to equip small shop at low cost. Supply sources, trade secrets, instructions. Now only \$3.50 postpaid. Radiator Service, McBain, Mich.

## MACHINERY, TOOLS, SUPPLIES

**SURPLUS**—Electric drills,  $\frac{1}{4}$ " \$16.95;  $\frac{1}{2}$ " \$29.95. (Jacobs geared chucks.) 6" electric portable hand saws with case \$56.00. Send check or M.O. Money back guarantee. Send 10c for illustrated folder. Byron Tool Company, 1609 Unionport Road, New York 60, New York.

**FREE Handbook**, build sawmills, block machines, freezers, tractors, scooters, 250 shop, farm, home machines. Nichols Co., Dept. C-401, Purvis, Miss.

**WAR Surplus** in small tools for machine shop. Send 15c for bulletin. Travers Tool Co., Dept. P, 5 Court Square, Long Island City 1, N. Y.

**$\frac{3}{16}$ " METAL Shaper**. Blueprints \$3.00. Blueprints of small engines, pumps, boilers, etc. Scott Nicoll, 1433 1st Ave., York, Penna.

**SHEAR**—Moderate duty power driven bench type, for light sheet metals. Literature and information. Write Besco Mfg. Co., Box 1163, Cincinnati 1, Ohio. Dealers and jobbers invited.

**MORTISER**, hollow chisel, bench type with electric drill, \$61.90. Chisels with bits  $\frac{1}{4}$ ",  $5/16$ " or  $3/8$ " per set \$5.97;  $\frac{1}{2}$ " \$6.87 per set. Woodworkers' Tool Works, Jefferson and Quincy Sts., Chicago 6, Illinois.

**THE Improved Simplex saw jointer** will please you. 50c without file. Simplex Manufacturing Co., R. 7, Palestine, Texas.

**SURPLUS Circular saw blades**: 8" diameter.  $\frac{3}{8}$ " hole. \$2.00 each. Satisfaction guaranteed. Van Dick, Little Falls, New Jersey.

**DRILL Grinder** for twist drills, \$2.95. See ad on page 274.

**LAWN Mower** repairmen. Free price list blades, rollers, supplies. Vernon Goeller, Mountain Lakes 2, New Jersey.

**HYDRAULIC Cylinder** double acting,  $2\frac{1}{2}$ " bore,  $16\frac{1}{2}$ " travel, 1-3/16" shaft, brand new \$11.00. Discount ten or more. Spencer Aircraft, 8410 Dallas, Seattle, Wash.

**CONCRETE Block machines**. Standard sizes. \$39.50. Average 400 daily. Free catalog. Concrete Machine Company, 5129 South Compton, St. Louis 11, Mo.

**FLOOR Sanders**; rebuilt; \$50.00 up. Mutual, Box 202, Kansas City, Mo.

**CHUCKS**, independent, universal; threaded  $1\frac{1}{2}$ "-8, 1"-8, 1"-10, 1"-12, or with adapter recess. Other chucks to 16" diameter. Write for quotation and free literature. No obligation. Westcott Chuck Co., 3600 Walnut, Oneida, N. Y.

**HOME Lathe owners**—Build your own attachments. Send for picture, sample of work and list of blueprints. Cut gears, ratchets, etc. Make neat screws easy way. The Home Shop, 415 Raymond Ave., Glendale 1, Calif.

## BOATS, OUTBOARD MOTORS

**FREE!** World's most complete catalog listing. Boat kits, plans, patterns, marine engines, conversions, boat building lumber, plywood, marine hardware, trailer parts. Marine Mart, Buffalo 7-B, New York.

**GET Our big 224 page low-price marine hardware and boat equipment catalog for 1950!** Send \$1.00 to cover packing and mailing; refunded with first order. Garland Frasher Marine Sales, Dept. F, 540-31st St., Huntington, West Virginia.

**FREE Circular**, small boat hardware. H. & H. Marine, 98 Green, Kingston, N. Y.

**HOW To build small boats**. Amazing new book shows 16 complete small boat designs—rowboats, sailboats, hydroplane, runabout. Clear, practical explanations of all details. Order now! Only \$5.00. (Money back guarantee). Scribner's, Dept. BPM, 597 5th Avenue, New York City 17.

**KNOCK-DOWN Boat kits**. Outboards, inboards, sails, hydroplanes. Easy to assemble. Minimum cost. Catalog with specifications, prices, 25c. Brooks Boat Company, Carrollton P-A12, Michigan.

**REBUILT Outboard motors**—Late models. We specialize in new-used parts. Write for price quotations giving us description of parts needed. Money back guarantee. Standard and oversize outboard motor pistons. Outboard Motor Mart, 309B Atlantic Avenue, Boston 10, Mass.

**SAVE 50%**—Assemble your own boat. Famous Schneider speedsters, rowboats, sailboats, hunting skiffs, in easy to assemble kits. Also boat plans and templates. Illustrated literature 25c. Schneider Boats, 1913 W. Vliet, Milwaukee 5, Wis.

**STEERING Wheels**, windshield brackets, from \$6.95. Modern fittings at lowest prices. Complete pre-cut plywood boats. Bargains galore. Folder 10c. Marine, Box 681, Mendota, Minnesota.

**TWENTY Plywood boat plans \$1.00**. Catalog of boatbuilding plans 10c. The Rudder, 15 Murray Street, New York 7.

**SAVE  $\frac{2}{3}$  Cost**. Build your own boat with our ready cut parts by the Welch system. No experience necessary. Rowboats to cruisers. Illustrated catalog 25c. Midwest Boat Company, Menomonee Falls, Wisconsin.

**OUTBOARD Motors**—Used bargains, \$45 up, free list. Used parts, most models, save money! Boat and motor equipment and accessories. Big catalog, send dime. Crandall-Hicks, 911 Commonwealth, Boston, Mass.

**NEW**, Used, rebuilt marine motors. Marine conversions, fittings. Free catalog. Stokes Marine Supply, Dept. 24, Coldwater, Michigan.

**MARINE Conversions** for Ford and Jeep engines. Catalog 10c. Lehman Manufacturing Company, Department D, Newark 2, New Jersey.

## ENGINES, MOTORS, DYNAMOS

**WELDING Generator**, 150 ampere, \$47.50. Motors,  $\frac{1}{2}$  horse, \$15. 1 horse \$30. Water pumps \$12.50. Butler, 1885 Milwaukee, Chicago 47.

**BARGAINS**. Welders. Alternating or direct current, gas or electric drive, portable or stationary. Advise us your needs. William Harrison Company, Box M-205, Troy, Ohio.

**MOTOR Winders**, free testing and winding equipment bulletins. Motor Industries, Quincy, Illinois.

**WINDING Data**, listing 225 motors, single and three phase. \$1.00. Motor Data Co., Box 7631, Kansas City 3, Mo.

**MAKE Your own 5 h.p. gas engine**. Machine your own castings. Prints and instructions. Free literature. Keenest Motors, Antioch, Illinois.

## ATHLETIC EQUIPMENT, BODY BUILDING COURSES

**ACROBATS!** Strength. Health. Free booklet. Write! Knoff, 249A, Pewaukee, Wisconsin.

**BARBELLS**—Finest quality, \$7.98 up. Free catalog. Lurie Barbell Co., 1729-M1 Rockaway Parkway, Brooklyn, New York.

**DEADLY Judo**—Fiercest fighting technique. Trick knockouts. (Over 200 illustrated pictures.) Expert instructions; three volumes. Complete \$2.25. Variety House, Box 46-B Wall Station, New York 5.

**BARBELLS**, Exercise equipment. Courses. Free booklet. Good Barbell Co., Reading, Penna.

## SPORTING GOODS, GUNS, FISHING TACKLE, ARCHERY, TRAPPING

**MOLDS** For fisherman's sinkers, jigs, squids and lures, completely machined and fully guaranteed. Write for free catalogue to E. L. Sweet & Son, Dept. 8, Tonawanda, New York.

**TENTS**, Canvas and nylon. All styles and sizes. Camping equipment. Catalogue. Morsan, 10-19E 50th Ave., Long Island City 1, N. Y.

**DUCK Hunters**. Get them next year with decoys from tested plans. Easily made, inexpensive. \$1.00. Ducks, 2051 Waldeck, Columbus 1, Ohio.

**FISHWORMS** Raised simple, easy. Postcard brings details. Tennessee Worm Hatchery, Box 265-B9, Nashville 2, Tenn.

**AMMUNITION**, Foreign-American; firearms. List 25c. Frank Parish, Vicksburg, Miss.

**SPORTING Goods** at great savings. Buy direct. Exclusive distributor Berlee line used by champs. Free catalogue. Priart, Inc., 140-P Liberty St., New York 6.

**TWELVE Utility boxes**, assorted sizes, sturdy crystal plastic. \$1.00. Tackle catalog included. Woodslore, Bradley Beach, N. J.

**SNOOPERSCOPE Tube**. Permits nighttime vision. Tube and complete instructions \$14.95. Limited quantities. Infrared filters 15c. Precise, 942 Kings Highway, Brooklyn 23, New York.

**FISHERMEN**—Make your own sinkers with our molds. Free illustrated booklet. Reading Instrument Co., Box 78, Reading, Penna.

**190 PROFUSELY Illustrated** pages antique and modern pistol, sword, etc. values. 50c. Robert Abels, A860 Lexington Ave., New York 21.

**SHOTGUNS**, Rifles, revolvers, over 500 modern, obsolete. Also cartridges, list 10c coin. Ed Howe, 52 Main, Coopers Mills, Maine.

**5000 BARGAINS**. Firearms, binoculars, war relics. Catalog 40c. Smith Firearms, Runnemede, New Jersey.

## TAXIDERMY

"**MODERN Taxidermist Magazine**," Greenfield Center, N. Y. Devoted exclusively to taxidermy. Two sample copies 25c.

## BINOCULARS, TELESCOPES, MICROSCOPES, MAGNIFIERS

**16X MAGNIFIER**: Exceptional power, beautifully mounted. Factory closeout \$1.00. Optical Assembly Co., Celina, Ohio.

**DOLLAR Brings** four expertly mounted and stained microscopic slides. Two bacteriological and two histological. K-Guard Labs, 607 Market Street, San Francisco 5, California.

**TELESCOPIC Discoveries**, "Mars," "Saturn." Free illustrated circular. Don Cyr, 1412 Palm Terrace, Pasadena 6, Calif.

**SAVE 50%** On new binoculars! Free catalog. Free book, "How to Select Binoculars." Write today! Bushnell Importers, 43-M2 East Green, Pasadena 1, California.

**WAR Surplus bargains**, binoculars, telescopes, sextants, millions of lenses, prisms, reticles, eyepieces, objectives, etc. Request free "Catalog CH." Send \$1.00 for Stock CH—10-piece lens kit and big instruction booklet. Edmund Salvage Co., Barrington, N. J.

**GIANT Astronomical telescope** with 6 ft. tripod \$15.00, f.o.b. factory. 100 power. (10,000 area magnification). Clear vision, full power guaranteed. Ready for use. Suffolk Science Service, Dept. BT, Riverhead, N. Y.

**BINOCULARS**, Telescopes, watches, guns. Buy, sell, trade. Schweer's, Donnellson, Iowa.

**REFLECTING Telescopes**, 60X, completely assembled \$25.00. Guaranteed observatory clearness. Free information. Skyscope, 475 Fifth Avenue, New York 17.

**TELESCOPES**, Binoculars, microscopes, big bargain catalog free. Brownscope Company, 24 West 45th Street, New York.

**POWERFUL Astronomical telescopes** easily made. Perfect lenses and instructions; 100X \$3.00; 100X and 200X \$4.00; 100X, 200X and 400X \$6.00. Full power, clear vision guaranteed. Instructions alone 10c. Suffolk Science Service, Riverhead, N. Y.

## PETS—DOGS, BIRDS, RABBITS, HAMSTERS, ETC.

**RAISE Guinea pigs**. Make extra cash. Booklet free. Taylor, Box 426A, Hapeville, Georgia.

**BABY Skunks**, raccoons, minks. Breed females. Catalog 25c. Shady Fur Farm, Springfield, Minnesota.

**\$300 MONTHLY Raising Angoras** for our market. Particulars free. Wilson, Stanton 17, Calif.

**RAISE Chinchilla rabbits!** Real profits from breeders, meat, furs, laboratories. Markets supplied! Write today! Rockhill Ranch, Sellersville 15, Penna.

**HAMSTERS, Pets**—Select breeders. Low as \$1.50. Literature free. Wisconsin Hamstery, Pewaukee, Wisconsin.

**GOLDEN Syrian hamsters**, selected breeders and pets. Free information on how to raise these clean, inexpensive to raise, animals for pets and profit. The E. K. Farm, Route 1, Box 56A, Arlington Heights, Illinois.

**SEE Gulf Hamstery ad on page 44**. Shows picture of Hamster.

**RABBITS**: New Zealands. Ringland Rabbitry, 1726-30th, Des Moines 3, Iowa.

**BREED Mink**—Booklet, pen plans free. Lake Ontario Mink Ranch, Gravel Road, Webster, N. Y.

**HAMSTERS**—Finest pedigreed stock. Reasonably priced. Free illustrated literature. Mount Clemens Hamstery, 94 Church, Mount Clemens, Mich.

**RAISE Rabbits**. Four pound fryers in eight weeks. Ready market for meat, fur, wool. Illustrated book, describing leading breeds, housing, breeding, feeding, marketing. By America's largest rabbit association 10c. American Association, 12 AR& CBA Building, Pittsburgh 17, Penna.

**\$1.00 FOR Booklet** "Canary, Its Care, Breeding and Training," and three copies cage-bird magazine. American Canary, 2839PM N. Halsted, Chicago 14, Ill.

MINK Raising information free. Complete. Lake Superior Mink Farm, Superior, Eel, Wisconsin.

\$400 MONTHLY Raising Angora rabbits. No experience required. Details free. White's Rabbitry, Newark, Ohio.

GRINSTEAD'S Famous Angoras! Giant Chinchillas! World's most profitable rabbits. Finest pedigree, heavy-producing, prize-winners. Literature free. Grinsteads, Edwardsville, Illinois.

MAKE Money! Raise Chinchilla rabbits. Experience unnecessary. Valuable breeders. Extra profit from laboratories, furs, delicious meat. Pleasant hobby. Write today! Rockhill Ranch, Sellersville 15, Penna.

\$3000. YEARLY Raising Angora rabbits. We buy your output. Contract particulars free. Kise's Enterprises, St. Paul 8, Minn.

MAKE Extra cash. Raise Giant Chinchilla rabbits. Waters Rabbit Farm, Glennville, Ga.

INCREASE Your income by raising domestic rabbits. Small space needed. Ready market for delicious meat, fur and wool. Largest magazine in the industry tells you how. \$1.50 per year. Sample 15 cents. No stamps. Small Stock Magazine, Lamont 20, Iowa.

### PLANTS, SEEDS, NURSERY AND GARDEN SUPPLIES

GLADIOLUS, List, 100 varieties, new, rare, novelties. Robinsons, Sebastopol, California.

RAISE Your own trees and shrubs from seed for shade, windbreak, erosion control, etc. Write for free planting guide and price list. Woodlot Seed Co., Norway 4, Michigan.

WE Sell on the installment plan. Best varieties peach and apple trees, low as 12c; grapevines 4c; shrubs 13c; evergreens 15c. Berries and plants. Catalog free. Benton County Nursery, Box 542, Rogers, Arkansas.

### FARMS, FARM LANDS, REAL ESTATE

HOMESITES \$300—Convenient payments. California's finest garden section. On Morro Bay's scenic shores. Wonderful fishing, hunting, boating, bathing. Fertile soil, softest water, temperate climate, congenial community. Free literature. Richard Otto, Department M, San Luis Obispo, California.

RAYBURN'S Ozark guide, Eureka Springs, Arkansas. Homeseekers; tourists magazine. Year, \$1.50.

NEW Free spring catalog! Farm and country real estate bargains, good pictures, many states, easy terms, many equipped, crops included. For special service, state requirements, desired location. United Farm Agency, 1408-PM Consumers Bldg., Chicago 4, Ill.

STROUT'S Golden anniversary farm catalog. Over 2800 outstanding bargains. Coast-to-coast, 32 states. Mailed free. Strout Realty, 7 So. Dearborn St., Chicago 3, Ill.

GOVERNMENT Lands \$2.00 acre up. Information all states twenty-five cents. National Tax Service, 901-A Majestic Bldg., Detroit.

CANADIAN Tax sale lands for two dollars an acre and up. Small monthly payments. Farms, timber, hunting and fishing camps, minerals. Limited number of properties. Write at once for free catalogue. Tax Sale Service, Room 105, 120 Bloor St. W., Toronto 5, Canada.

ALASKA Farms free—160 acre homesteads. Farming, dairying, ranching. Unlimited opportunities. Details \$1.00. Edward Wade, 6215 University, Chicago 37, Illinois.

FARM Manual shows you how to make extra profits from your farm. 284 pages of farming lore. \$3.00. Popular Mechanics Press, 200 E. Ontario, Chicago 11, Ill.

5 ACRES, So. Missouri—\$275.00. Field, 6126 So. Michigan, Chicago, Ill.

SOLD For taxes. Calif., Oregon, Washington timber, grazing, ranch and mining lands. 25c to \$3 acre min. bid. 10c (coin) brings circulars, photos, maps. Pacific Lands, Box 2350-PM, Hollywood, Calif.

\$5.00 MONTHLY Buys 40 acres near town; price \$200.00. Free list. Box 425-P, Carthage, Mo.

FLORIDA Campsites—\$95.00 at \$5.00 monthly buys nice, high dry lot in Lake County (world's best bass fishing, wonderful hunting) near Ocala National Forest, St. Johns River, beautiful lakes, pavement. Folder free. Howard Vernor, DeLand, Florida.

GOOD Farms—Ranches. Washington, Minnesota, Montana, Idaho, Oregon, North Dakota. Dependable crops, favorable climate. Write for literature, lists describing typical farm opportunities. Specify which state. J. W. Haw, 119 Northern Pacific Ry., St. Paul 1, Minn.

FARMS, Ranches, lodges, resorts. Big selection, Milwaukee Road territory, Washington, Idaho, Montana, Dakotas, Minnesota, Iowa, Missouri, Michigan, Wisconsin, Illinois, Indiana. Free colorful descriptive folders, price lists. L. H. Robbins, 738J Union Station, Chicago 6, Ill.

### POULTRY, FARM SUPPLIES

BABY Chicks, champion mated, 52 varieties, 7 crosses, licensed inspected, bloodtested. Rush postal, large colored book free, low prices. Berry's Farm, Route 12, Clarinda, Iowa.

RAISE Fryers new easy way. One man home plan earns \$3000 yearly. Circular free. Poultryman's Institute, 1046 So. Olive, Los Angeles 15, Calif.

KNOW How to raise poultry for profit. Read Northeastern Poultryman. Every issue packed with helpful hints and practical suggestions. Latest articles on breeding, feeding and management. Subscribe now. 1 year 65c. 2 years one dollar, foreign subscriptions \$1.00 a year. Northeastern Poultryman, Dept. P.M., 376 Boylston St., Boston 16, Mass.

RAISE Turkeys the new way. Write for free information explaining how to make up to \$3000 in your own backyard. Address—National Turkey Institute, Dept. 3, Columbus, Kansas.

### PROFITABLE OCCUPATIONS

HAVE Fun! Make money! "Working with Leather"—64-page booklet tells how. Send 25c for copy. Free catalog and valuable information included. Wilder-Craft, 1039 Crosby, Chicago 10.

MEN—Women. "Everybody likes candy." Learn to make professionally at home. Details free. (Our 40th year.) Ragsdale Candies, D6, East Orange, New Jersey.

FOREIGN Employment. Construction men, building trades mechanics, helpers, office men. Good workers needed for oil projects, mining, pipe lines, dams, power plants, roadways, shipping, etc. Transportation and quarters furnished; high wages. Listings of firms actively working and hiring on projects in South America, Arabia, Asia, Africa, Alaska, Central America, etc. Send \$1.00 for foreign construction compendium and application forms. Foreign Service Bureau, Dept. PM-2 (Employment), P.O. Box 295, Metuchen, New Jersey.

INTERESTED In Australia? 5000 word illustrated booklet answers most frequently asked questions concerning Australia. Specific questions answered by Australian. Booklet \$1.00. Free details. Southwest Enterprises, P.O. Box 5033, Phoenix, Ariz.

BREEDERS Of world famous domesticated earthworms (red hybrids) offer you detailed propagation methods, 10c. Midwest Earthworm Farms, Box 999E, Wichita 1, Kansas.

LEARN Watch-clock repairing at home, our easy way! Free information. Modern Technical Supply, 55-PM West 42nd Street, New York 18.

MUSHROOMS Grown boxes, barrels. Instructions 50c. Spawn \$1.00. Manureless process. \$2.00. Gordons, 553 William, Winnipeg, Manitoba.

PLATING Technicians make money! Learn easily. Details free. Joseph Kushner, Electroplating Engineer, Stroudsburg 16m, Penna.

ALASKA—The great American frontier, offers unlimited opportunities. \$1.00 brings 1950 copyrighted report and government map. Business directory listing big construction projects; fishing; mining; aviation; hunting-fishing-game rules, fur-farming, lumber; agriculture; live stock raising; transportation; homestead and highway information. Hot list of firms hiring. Alaska Opportunist, P.O. Box 883-P, Hollywood 28, Calif.

EXTRA Money at home selling by mail. Complete instruction sheets \$1. George Millan, Box 29, New York 34, N. Y.

LEARN Professional candy making. Profitable home occupation. Details 10c. Pate, Kissimmee, Florida.

INTERESTED In Latin American and foreign employment? \$1.00 brings 1950 copyrighted "Foreign Service Directory" with new complete listings in U. S. and Canadian construction companies; worldwide oil firms, mining, aviation, steamship, transportation; manufacturers; importers and exporters; domestic and foreign listings. Special daily listing of firms hiring. Tells how-when-where to apply, application form. Global Reports, P.O. Box 883-P, Hollywood 28, Calif.

LOCATE Missing persons. Be a skip tracer. Interesting. Profitable. Job opportunities, instructions, \$1. R. Mac Callum, 492-44th Street, Oakland, California.

WOULD You pay 3¢—First \$350 made? Book "505 Odd, Successful Enterprises" free! Work home. Expect something odd! Pacific, Oceanside, Calif.

\$400 MONTHLY Raising Angora rabbits. No experience required. Details free. White's Rabbitry, Newark, Ohio.

\$46 FROM Square foot plywood; jigsaw necessary. Write, Woodarts, P-38, Bridgewater, Mass.

OWN And operate mirror shop! Supplies for resilvering mirrors, making chipped glass nameplates and electroplating. John Sprinkle, V50, Marion, Indiana.

RAISE Fishworms. Easy, profitable. Send 25c in coin for complete instructions. Huffman Worm Ranch, Rives Junction, Mich.

TYPISTS, Profitable business at home. Complete copyrighted information 50c. Rosdahl Industries, 72-A W. Washington St., Chicago 2, Ill.

BE The Popular Mechanics representative in your neighborhood and earn big profits in your spare time. Write Popular Mechanics Magazine, Room 408M, 200 E. Ontario St., Chicago, Ill.

\$40.00 WEEKLY Made growing mushrooms, fresh, dried. Dominion patent 331583. Free spawn. North American, 169P Yonge, Toronto, Canada.

### GAMES, TOYS, NOVELTIES

ROLL-O-KITE! Giant spool type kite. Spins as it flies. Amazing performance. 50c. Roll-O-Kite, 737 So. Westlake, Los Angeles 5, Calif.

CHESKERS. A game of skill, livelier than checkers. Designed for checker and skill game enthusiasts. For box, checker board, instructions and checkers \$2.00. Guerin Games, 212 Maple Ave., Irvington 11, N. J. Dept. A.

### BOOKS, PERIODICALS, PICTURES, POSTCARDS

QUICK Profits taking magazine subscriptions, handling greeting cards. Cassell Publishers Service, Westfield, N. J.

BOOKS! Many subjects. General list 3c. Mesa, Box 55-B, New York 19.

BOOKS. Out-of-print. Hard-to-find. Any book. Any subject. Banker Book Co., Dept. 16, Sherman Oaks, Calif.

MOTOR Trend Magazine—Custom, foreign, domestic, sports cars. Road testing, racing, auto shows, etc. Sample copy 25c. Full year \$3.00. Motor Trend, 548 S. San Vicente, Los Angeles 48, Calif., Dept. PM.

HOMEWORKSMEN Everywhere subscribe for leading British technical monthly, Practical Mechanics. Packed with unusual ideas, latest British-European inventions; home workshop and model-making sections. Send only \$1.50 made payable to our authorized agent Jeremy North, Bookseller (PM22), "Friendship House," Jamestown, Rhode Island, for 12 consecutive issues sent direct to your address from London. Two years \$2.75.

BOOK Bargains. Books—used, new, library surplus, publishers' overstock, 25c up. Novels, mysteries, love, general. Free catalog. Bookland PM, CollegePoint, N. Y.

BOOKS On gems, gem cutting, jewelry making, watch repairing. Catalog. McMillen, 328 E. 11th St., New York City.

FREE Catalogue. Special interesting books. Powers, 1324 Wilshire, Hollywood 14, California.

HOW-To-do-it books on every subject. Written in Popular Mechanics' famous easy-to-understand style and profusely illustrated. Subjects include workshop planning and practices, projects, hobbies, household repairs, motoring, outdoor sports, photography, home building and many others. Also booklets on specific topics. Write for free illustrated catalogue. Popular Mechanics Press, 200 E. Ontario, Chicago 11, Ill.

BOOKHUNTERS! All subjects. Send wants! Jaher Book Service, 620-P East 178 Street, New York 57.

**BOOKFINDERS!** (Scarce, out-of-print, unusual books). Quickly supplied. Send wants. Clifton, Box 1377-PM, Beverly Hills, Calif.

**NATIONAL Geographic Magazines 1888-1949.** Any issue, Box 327-PM, Periodical Service, Swarthmore, Penna.

### MAGIC TRICKS, PUZZLES, JOKER NOVELTIES

**JOKER'S Headquarters!** Snake nut cans, imitation bed bugs, squirt rings, many others. Illustrated catalogue 25c (refunded first order). J. C. Fink Specialty Co., B-1618, 9th and Market Sts., Philadelphia 5, Penna.

**GAGS, Acts, scripts!** Catalog, 10c. Kleinman 5146-B Stroh, North Hollywood, Calif.

**AMAZE Everybody!** Year's outstanding mystifier! Worth dollars! Send only 25c. P.O.B. 43, Portland 7, Ore.

**LEARN Fire eating, novelty acts.** 200 S. Ave. 56, Los Angeles 42.

**VENTRILOQUIST Dummies.** Catalogue 10c. Be a ventriloquist. Free literature. State age. Maher, Box 36-M150, Kensington Station, Detroit 24, Michigan.

**500 TRICKS** You can do! Send 25c for Douglas' famous catalog, best in magic at lowest prices. Unequaled service to magicians for 30 years. Douglas Magicland, Dept. 1, Dallas, Texas.

**LATEST** And best tricks described in our new large catalog. Send 25c to Jeffries Magic Company, 17 North Hudson Street, Oklahoma City, Okla.

**500 TRICKS** Catalog and book "84 Card Tricks," both only 50c. Robbins Co., 131-P W. 42nd Street, New York.

**200 ELECTRIC Stunts,** 110 volts, \$1. Kutting Sons, Los Altos, Calif.

**400-PAGE** Catalogue of 2000 tricks, pocket, parlor, stage. World's finest magic. Send \$1.00 for catalogue (refunded first \$5.00 order). Kanter's, M-1311 Walnut, Philadelphia 7.

**MAGIC Tricks, puzzles, books, cards, punch boards.** Catalog 10c. Specialty, Box 671, St. Louis 1, Mo.

**LEARN Magic, ventriloquism, mind-reading.** Write for particulars. Quackenbus, Big Flats, N. Y.

**WORLD'S Largest professional magic shop,** keeps you in touch with latest tricks. To receive mailings, send 50c for new catalog. Holden's, M220 West 42nd St., New York.

**BE A magician.** Large professional magic catalog of latest tricks, 35c. Ireland, C-109 North Dearborn, Chicago 2.

**PROFESSIONAL Catalog.** 124 pages, 25c. Williams, 900 Plymouth, Ellwood City, Penna.

**VENTRILOQUISM Taught.** 3c stamp bring particulars. Smith, 801 Bigelow, Peoria 5, Ill.

### COINS, TOKENS, CURRENCY

**OLD Money** wanted. Do you know that coin collectors pay up to \$100.00 for certain U. S. cents? And high premiums for all rare coins? We buy all kinds. Send 4c for large coin folder. May mean much profit to you. Numismatic Co., Dept. 20, Fort Worth, Texas.

**COIN Bargains,** 25c each, large cent, Flying Eagle cent, white Indian, two cent, three cent, half dime. Hollinbeck, R. U. L. Bldg., Des Moines, Iowa.

**4 WHITMAN** Coin albums \$1.00; 125 page handbook 75c. 100 different foreign coins \$3.95; 20 different \$1.00. Giant bargain list 10c. Olson, 5800 Lake, Chicago 44.

**60 COINS** And bills, \$1.00. 100 bills, \$1.00. Oddehon, Box 482, St. Louis, Mo.

**FOREIGN Bills,** 10 different 15c; foreign coins, 10 different 25c. Lists. O. Arnold, Macon, Mo.

**WE Buy** and sell coins. Send 25c today for bargain list and Indian cent. Dept. PM3, Guarantee Coin Co., Box 6370A, Chicago 80.

**KNOW** True value rare coins. Will sell ancient Roman coin over 1500 years old \$1.00. Will pay \$5.00-\$150.00 1901-S quarter, 1894-S dime \$500.00. 1913 Liberty head nickel \$1000.00. Hundreds of others. Our complete catalogue with samples of conditions \$1.00. Catalogue alone 25c. Worthycoin Corporation, 294 Washington (D-503), Boston, Mass.

**\$1,116.66** FACE Value, Jap-U.S. Invasion money, \$2. Approvals. Tatham Coin Company, Springfield 30, Mass.

**20 DIFF.** Coins 50c, free lists, approvals upon application. Bishop, Box 2201, Kansas City, Mo.

**FREE!** Foreign coin, banknote and coin collectors illustrated catalog to approval service applicants. Send 3c postage. Tatham Coin Co., Springfield 30, Mass.

**GET Profit** and pleasure in collecting old coins. Send 10c for 56 page illustrated coin catalog. You'll be delighted with it. Send for it now. B. Max Mehl, 370 Mehl Bldg., Fort Worth, Texas. Largest rare coin establishment in U. S. Established 50 years.

**16 PAGE** Coin bargain list and Mexican 10 peso bill, all for dime. Coin Shop, 31 North Clark, Chicago 2, Illinois.

**COINS** Wanted, will pay up to \$2000 for certain coins, send 25c for catalogue. Burton's, 111 So. Third, Columbus, Ohio.

**COMMEMORATIVE** 3/2. Oregon, Texas, Kentucky, Cleveland, Long Island, \$2.00 each. Illustrated catalogue 25c. Norman Shultz, Salt Lake 9, Utah.

### STAMP COLLECTING

**UNITED States** bargain. It sounds unbelievable, but it's true! 50 different United States ranging in age as far back as over 60 years and in face value as high as one dollar. Only postage, commemorative, and air mails included. Nothing else. Extra 2 Jap Occupation of Philippines, all for only 10c to approval applicants. Please state whether approvals shall consist of U. S. or foreign stamps or both. Globus Stamp Company, 268 Fourth Avenue, New York 10, N. Y., Dept. 211.

**FREE**-Famous Americans set, Flag set, National Parks set, and Presidential set to \$5.00. A total of 90 stamps free to customers for our unsurpassed U.S. and foreign selections. Send 3c for 15 of the above stamps and full particulars. Triboro Stamp Co., 145 Nassau St., Dept. 102, New York.

**SENSATIONAL!** Set each Honduras, Martinique, Guadeloupe, Guiana, also \$2,000,000.00 stamp, Brunei, over 100 different others. Everything 10c with approvals. Whitehead, 315F So. 5th Ave., Canton, Ill.

**FREE!** Stamps from Abyssinia to Zanzibar. Includes airs, odd shapes, bicolors, etc. Catalog value well over \$1.00. Free with approvals. A. Moulblow, 740 Hegney, Bronx 56, New York.

**ZANZIBAR, Pitcairn Islands, Turks, Caicos, Gilbert, Ellice, Solomon, Lee-ward, Gambia, Tanganyika and others.** Complete collection free. Send 5c for postage. Gray Stamp Company, Dept. PM, Toronto 5, Canada.

**FINE Approvals,** fast, personal service. What countries do you prefer? I'll send their stamps. Skinner, 438 Locust, Long Beach 12, Calif.

**STAMP** Packets. Every country. Amazing values. List free. Francis Stretton, 25 Salem Place, Malden 48, Mass.

**FREE!** 25 Different Switzerland, with swell approvals. Kardell, 209 Bower, Santa Fe, New Mexico.

**PENNY** Approval bargains! Write Department PM, 1267 Tutwiler, Memphis 7, Tennessee.

**FREE!** Indo-China's and Spanish Morocco's colorful pictorial airmail sets. Approvals. "PG," 195 Park, Lewiston, Maine.

**U. S. Stamp mixture** 70c pound. Nichols, 746 River, Mattapan 26, Mass.

**FREE**-A different United States price list. McKinney, Elsie, Mich.

**THICK** Packet stamps 10c, with approvals. Hough, 3751 Aniston, Cincinnati 27, Ohio.

**WHOLESALE** Lists to dealers. 3c postage. Grossman, 100 West 42nd, New York 18.

**TASMANIA!** Included! Stamps from forty countries 10c. No approvals. Elsea, Bowling Green, Ohio.

**TRIANGLE-Diamond** packet! Free! Approvals. Colonial, Box 326A, Passaic, N. J.

**1000 DIFFERENT** Worldwide 80c. Martin Band, 4143E 39th Place, Sunnyside, New York.

**SOUTHERN Rhodesia "Falls" set,** 5c, approvals. Howard Laquerre, Camden 2, New York.

**MADAGASCAR** Set, free. Approvals. Nass, 439 W. Palmer, Detroit 2, Mich.

**50 DIFFERENT** Countries. Abyssinia-Zanzibar 3c, to approval applicants. Mohawk, Box 141P, West Springfield, Mass.

**BE Thrifty** in 1950—Send for free money saving catalog. Stamps, albums, packets, supplies. Ewing-Stamps, 109 N. Dearborn, Chicago 2.

**500 STAMPS** Free with our 1000 all different world wide collection, \$1.00. Dimond Co. 3152 Cuthbert, Oakland 3, Calif.

**25 DIFFERENT** French colonies large pictorial 10c with penny approvals. Roscoe Stamp, 1321 Roscoe, Chicago 13.

**500 JAPAN** Stamps 10c! Kenmore, Arlington 74-J4, Mass.

**200 DIFFERENT** 25c, Satisfaction guaranteed. Penniston, 9137 Moritz, Brentwood, Mo.

**FREE**-25 Diff. Japan with approvals. Karl Scheerer, Box 301, Pottsville, Penna.

**BUILD** Your collection. Fine U. S., foreign approvals. Harry Peterson, 284, Ponca, Neb.

"**HOW** To Recognize Rare Stamps." Free book, illustrated! Kenmore, Arlington 74-H8, Mass.

**ALL Stamps** at 1c each. Collection of 10,000 different, divided in 20 \$5 lots each containing 500 stamps. You just buy one lot at a time as often as you like. Each lot delivered as soon as paid for. No contract. No obligation. Real savings. N. V. Robillard, 812 West Vantrees Street, Washington, Indiana.

**21 DIFFERENT Famous** Americans 25c. Dicranian, 1006 44th, Brooklyn 19, N. Y.

**WORTHWHILE** Approvals at economy prices. None over 2c. Flinn, 208 Dilworth St., Pittsburgh 11, Penna.

**100 DIFFERENT** U. S. commemoratives, one dollar. Request approvals. Harold Holub, 18 East 198 Street, New York 58, N. Y.

**OLD** Scarce U. S. seconds on approval. Slightly defective. Bargain prices. Hernefield, Clintonhill Station, Newark 8, N. J.

**FREE** Zeppelin, Columbian, Roosevelt, air-mail. Illustrated lists. Approvals included. Third Co., 101 3rd Ave., Newark 4, New Jersey.

**LATIN America**-U. S. Total 25 with approvals 6c. Burgett Stamps, Lima, Ohio.

**500 COMMEMORATIVES.** Air-mails, etc. 25c. Approvals. Perkins, Hamilton Square, N. J.

**200 BRITISH** Empire stamps plus valuable publications only 3c. Kenmore Stamps, Arlington 74-B17, Mass.

**307 ALL** Different free. Commemoratives, triangles, bicolored beauties, high values. Strange countries. Free to approval buyers. Garcelon, Box 500, Calais, Maine.

**FREE Mixtures.** 1500 U. S. Approval buyers only. Superior Stamps, 6908 Zoeter, Cleveland 3, Ohio.

**FALKLAND** Centenary showing ram for 15c with approvals. L. W. Hudson, Box 229, Whittier, Calif.

**ARMENIA,** Ten bicolored stamps, value 75c, free to approval applicants. Apex Stamps, Box 2188, Miami 13, Florida.

**AROUND** The globe, 40 pictorials from 40 diff. countries 10c with approvals. Fields, 1939 E. 85, Cleveland 6, Ohio.

**50 U. S. Airmails,** commemoratives, 25c. Norwood Exchange, 4005 Ivanhoe, Norwood, Ohio.

**LIBERIAN** Triangulars, 10c with approvals. Vargo Stamps, 6044 South Fairfield, Chicago 29, Illinois.

**BAHAWALAPUR.** Oriental scenes in gorgeous bicolors. Complete set free. Garcelon, Calais, 111, Maine.

**UNITED States** commemoratives—25 different, 10c. Approvals. Stearns, 26970-B Princeton, Inkster, Michigan.

**199 DIFFERENT**—33 Countries, including 38 19th century; diamonds, airmails, jubilees, 10c. Approvals. Brooks, 2352B East 23rd Street, Brooklyn 29, New York.

**SPECIAL,** 1c Approvals. Gene, 1806 First Ave., Yuma, Arizona.

**FREE!** Scarce triangle-diamond packet to approval applicants! Send 3c postage. Thrifty Stamps, Silver Spring, Maryland.

**FREE** U. S. Virginia Dare to approval applicants. Litten, 318 North Fifth Avenue, Maywood, Illinois.

**FREE** Philatelic supply list. Penny approvals on request. Reed Company, Box 980E, Chicago 90, Illinois.

**200 WORLDWIDE** Different, 13c. Approvals. Charlie Seifert, Box 1672, Reading, Penna.

**ATOMIC** Bomb airmail and 100 different from war-torn China. 10c to approval applicants. Star Stamp Company, James-town, New York.

"**GOYA Nude**" set (catalogs 55c) 15c. Approvals. Royal Stamp Company, Tamqua, Penna.

**100 DIFFERENT** World-wide, 5c. Approvals. Stearns, 26970-B Princeton, Inkster, Michigan.

**GERMANY** "War issue," planes, tanks, Hitlers; (18) free to sincere approval applicants. William Deems, Ravenswood, West Virginia.

**FREE** "StampFinder." Tells instantly country to which any stamp belongs. 36 pages profusely illustrated. Garcelon, Calais, 17, Maine.

**FREE** Gigantic, beautiful, bi-colored mint, U. S. George Rogers Clark commemorative stamp to approval applicants. Mohawk, Box 524, Albany, N. Y.

**FREE!** Liberia triangle airmail set, package hinges, approvals. Greenwood, 441 Washington, Miami Beach, Fla.

**RARE Bargain.** Six mint German sets. 50c value. Only 10c to approval applicants. Stamp Mart, 1412 Great Northern Bldg., Chicago.

**FREE.** Scott's International album, valuable colorful collection, hinges, other big premiums. Full particulars with approvals. Raymax, 123-Z William St., New York 7.

**FREE** Catalog! Illustrated. Forty pages. United States. Foreign. Albums. Supplies. "How to Collect," etc. Harrisco, 202 Transit Bldg., Boston 17, Mass.

**FREE!** Collection over 100 stamps of world—odd stamps, planes, camels, cavalry charge, leprosy stamp, new Leipzig Fair set, many others all to approval buyers; plus Scott International Albums, stamp catalogs. Bell Stamp Service, Dept. S, 4248 Elizabeth St., Bell, Calif.

**TOPS!** Our book "How To Collect Stamps." Send for your free copy today! Littleton Stamp Co., Littleton 37, N. H.

25 DIFFERENT Vatican 10c; quality approvals. Chase, 1026 Walker Ave., Oakland 10, California.

25 DIFFERENT Ecuador, including 70 Centavo air mail 5c. Approvals included. Ranson, 721 West Maple, Compton 4, Calif.

750 FRANCE And colonies stamps 10c. Littleton Stamp Co., Littleton 25, N. H.

**ILLUSTRATED** Price lists free. Herget, 92 Arden, Buffalo 15, New York.

1000 **WORLD** Wide 67c. Pacific, P.O. Box 5704, Los Angeles, Calif.

**ALBUM,** 100 Stamps, premiums—20c. Northeast, Box 6618, Kansas City, Mo.

**CANADA** Peace set 10c with attractive approvals. Rheume, 8949 Routhier, Montreal 12, Canada.

**STAMP** Magazine! Copy free! "Stamp Post," S. Catalina, Pasadena 1, Calif.

**WORLDWIDE** Stamps. All different. 200, 25c; 500, 50c; 1000, \$1.00; 2000 \$2.75; 5000, \$13.50. Beacon Sales, Northboro 2, Mass.

**FREE!** Volcano pictorial! Madagascari! Burmese! Nigeria! Approvals. Keating, 637-P Bergen, Jersey City, New Jersey.

**GRAND** Value packet with five foreign sets, free. Stoll Stamp Service, 2632 Burnett, Louisville 10, Kentucky.

**THOUSANDS** Of beautiful stamps 1c each. Why pay more when you can get the best for less. Write today for trial selection. Thrifty Stamp Service, P.O. Box 1610, Long Beach, California.

**FREE**—Cuba Roosevelt issue and illustrated catalog. Maynard, Littleton 12, N. H.

**EXCHANGE!** Send 25 U. S. commemorative duplicates. Receive 200 different world. Sundman, Littleton 6, N. H.

**POSITIVELY** Greatest free offer—Latest Scott's international \$6.00 stamp album, covering entire world, contains 36,000 illustrated descriptive spaces, Scott's New Standard \$7.00 catalogues "Philately's Encyclopedia"—absolutely free to applicants for foreign approvals becoming customers. Plymouth Specialty Co., Dept. A-9, Box 510, Bell, California.

10,000 DIFFERENT 1c Each! Gordon Davison, Box 1019S, Manchester, N. Hamp.

U. S., Canada, Newfoundland, Mexico: "Gold Nugget approvals." Nothing like them! Write today. 312 mixed U. S. only 10c. Kessel's, Folsom, California.

10 ASSORTED U. S. Commemorative 15c. Five U. S. Air Mail 15c. 10 Famous Americans 25c. All for 50c. Ideal Stamp, Box 179-K, Park Ridge, Illinois.

**GIFT**—Tokelau Is. complete mint to approval applicants. Deane Stamps, Box 87, Miami 35, Florida.

110 DIFFERENT Hitlers, Roosevelt, Liberia, Vatican, etc. 10c. Buckley, 208 Ludlow Bldg., Dayton 2, Ohio.

**WORLD**—500 Diff. 50c. 1000-\$1.00, 75 Canada 25c. Approvals, lists. Victoria Stamp Company, London 4, Canada.

**FREE \$25.00** Outfit. Latest large Scott album, valuable collection of 1050 all different beautiful stamps, airmails, triangles, diamonds, high values, etc. Plus watermark detector, tongs, "stamp finder" magnifying glass, perforation gauge, hinges—actual value over \$25.00—but all absolutely free when you become a customer. Write for our foreign stamps on approval now. America's Stamp Service, Redlands, California.

**\$1-\$2-\$5 UNITED STATES**, commemoratives, airmail, high values in large collection United States stamps only 5c to applicants United States approvals. Metropolitan, 140B Nassau, New York 7.

**UNITED STATES** stamps nearly 100 years old, Roosevelt set, others, 40c value—only 5c to applicants United States approvals. Wakonda, 140G Nassau, New York 7.

**FLAG** Stamp free, if you request my U. S. approvals. Wenigman, 1933 Patterson, Chicago.

**EXOTIC** Collection—Fezzan Ghadames, Togoland, Camerouns, Andorra, Reunion, Miquelon, Algeria, Somalis, Guadeloupe, Guiana. Natives, maps, ships, idols, snakes, rhinoceros, others 5c. Imperial Stamps, Tampa, Florida.

**MAGNIFIER**, Big stamp magazine; first U. S. commemorative; plus unused \$5000 Foreign Legion, diamond, giant, and other worthwhile stamps. Everything free to approval buyers. Capital Stamp Company, Little Rock 2, Arkansas.

300 DIFFERENT Given free with approvals. Postage 3c. Windsor Stamps, 1435 East 67th Place, Chicago 37.

**FREE**—Illustrated catalog! Kenmore Stamps, Arlington 74-C7, Mass.

**FREE!** Powerful magnifying glass—To approval applicants; also big bargain lists. Jamestown Stamp Co., Dept. 207, Jamestown, New York.

200 DIFFERENT Stamps 10c with approvals. 500 mixed United States 25c. Carlton's, Tujunga, Calif.

**TRAINS!** Trains! Trains! 12 train stamps and packet of 100 different stamps for 10c with approvals. Reich Stamp Company, 4647 Kenmore, Dept. M20, Chicago 40, Illinois.

**DEALERS**—Wholesale list. Postage 3c. Frank, 5031 Queensberry, Baltimore 15, Md.

1c EACH And less! Thousands of bargains! Cole, 43-A Rinewalt, Buffalo 21, New York.

**ZOWIE-E!** A barrel of fun for only a dime. 500 United States stamps—absolutely unpicked and unsorted—just as received from church missions. Many varieties, including large commemoratives, airmails, high denominations up to \$5.00! Stampdom's biggest package of fun—and you might find something really valuable! Price only 10c to serious approval service applicants. Money back if not delighted. Illustrated bargain lists with each order. Mystic Stamp Company, Dept. 80, Camden, New York.

**FREE!** United States commemorative price list. Historical Stamp Co., 1280 Ocean Ave., Brooklyn 30, N. Y.

50 DIFFERENT U. S. 10c. No approvals. Pricelist free. Seidenberg, Cassopolis, Mich.

**WOW!** \$10.00 Worth of fun 10c! What a treasure hunt! Big package 500 foreign stamps, including airmails, pictorials and others from the world over; stamps worth up to 25c each. This offer sent for 10c to approval applicants only. Jamestown Stamp Co., Dept. 22, Jamestown, New York.

U. S. Price list. Send postage. State Stamp Service, 1225 Park Building, Pittsburgh 22, Penna.

**FREE** U. S. price list, postage 3c. Mark Hanna, 335 5th Ave., Pittsburgh 22, Penna.

**WORLD'S** Largest stamp (7 1/2 x 1 1/4 inches). A real curiosity! Retail for 50c, only 3c to approval applicants. Tatham Stamp Co., Springfield 30, Mass.

**STAMP** Collections wanted. Complete collections, duplicate lots, surplus stock, mint and used. Prefer trade for printing or other items, buy outright if priced right. What have you, what's wanted? Vanroy Shirk, Lebanon, Penna.

**FREE!** 100 Worldwide different stamps to approval buyers. Big U.S. and illustrated bargain lists sent with approvals. Bookman, Maplewood, N. J.

**ANTIQUES, RELICS, INDIAN GOODS, CURIOS**

3 ANCIENT Arrowheads and 3 genuine pioneer square wrought nails. \$1.00. Old Fort Davis, Fort Davis, Texas.

## PRECIOUS STONES, MINERALS

**"GENUINE"** Deep red Arizona rubies (garnets). Send quarter for packet. Bitners, Box 2651, Phoenix, Arizona.

**MINERAL**—Treasure locators — Geiger counters. Can be purchased on monthly payment plan. Free literature. Fisher Research Lab., Inc., Palo Alto, Calif.

**GEM** Hobbyists supplies, materials, tools. Lowest prices. Gemco, Elkhart Lake, Wisconsin.

**GENUINE** "Deep-mined" anthracite coal souvenirs. Send 50c. Box 441, Wilkes-Barre, Penna.

**CASSITERITE** 25c. Bixbyite 50c. Helvite 50c. Fool's Gold 25c. Free lists. Prospector, Winston, N. Mex.

**AGATES**, Gems and mountings. Free list. North West Gems, Box 305, Tacoma 1, Wash.

**GEMSTONES**, Mineral specimens. Every variety. Lowest prices. Postcard brings free booklet. Plummer's, 2183C Bacon, San Diego 7, California.

**GEMS**, Precious and semi-precious, all genuine, from world wide sources. Deal direct, no overhead, save money. Catalog 10c. Hill Co., Route 7, Salem, Oregon.

**METAL** Detectors. The very latest circuit. Send 25c for literature. Hedden Metal Detectors, 3329 Liberty Ave., Pittsburgh 1, Penna.

## HOBBIES AND COLLECTIONS

50 DIFFERENT Army embroidered patches \$1. Other bargains. Insignia Mart, 703A Broadway, New York 3, N. Y.

**PETRIFIED** Wood—Living wood turned to stone. For a beautiful specimen send 50c in coin to: Petrified Woods, Box N, Calistoga, Calif.

**COLLECT**, Mount war medals. Large foreign, U. S. lists 20c. Batson, 1024 Dupont Circle Bldg., Washington 6, D. C.

**SHIP** Photographs. Lists 10c. Scozzafava, 1648 59th Street, Brooklyn 4, N. Y.

**PENNANT** Collecting is a thrilling hobby! Send for free list! Komar Company, M-2, LaPorte, Indiana.

**KLONDIKE** Novelty and jewelry findings. For jewelry makers! Novelty jewelry findings swept from manufacturers' tables. Parts for bracelets, pins, earrings, finished and unfinished chains, rings, stones, clips, beads, many others. Sample pound assortment \$2.00, 5-pound lots, \$7.50. Also, unset stones, for rings, jewelry; all colors, sizes, designs, 1000 assortment \$5.00, sample 100 assortment \$1.50. Also, beads, assorted colors, sizes, 5-pound lots \$4.00, sample pound \$1.00. Prepaid only. Merchandise Distributing Co., 19 East 16th Street, Dept. 2PM, New York 3.

**UNPAINTED** Figures and novelties, new original designs. Illustrated folder free. Creekturn Pottery, Hainesport, N. J.

**EMBROIDERED** American and foreign emblems, 30 for 50c including pricelist. Hobbyguild, 57B Sumner, Brooklyn, N. Y.

**UNPAINTED** Plaster ornaments. Loxite for moulds. Free literature. Midwest Novelty, Box 788-A, Anaconda, Montana.

**UNUSED** Matchbook covers—100 different \$1.00. Catalog 10c. Charles Edelman, 1311C East 84, Cleveland 3, Ohio.

**INVENTING** Can be an interesting and profitable hobby. Write for complete particulars. Institute of American Inventors, Dept. 40-E, 1926-Eye St. N. W., Washington 6, D. C.

## CAMERAS, PHOTO SUPPLIES

**FREE** Photographic bargain book packed with hundreds of sensational values in still and movie cameras, lenses and latest accessories. Super savings for you in new and used equipment. Liberal trade-in allowances, too, on your equipment. Write now for your free copy to Central Camera Company, Dept. 9B, 230 S. Wabash Ave., Chicago 4. (Photographic headquarters since 1899.)

**SAVE** On cameras, projectors, etc. Send self addressed stamped envelope for list. (No exports.) Photo Sales Co., P.O. Box 21, St. Louis 19, Mo.

**MAKE** Color stereo (3-dimensional) slides with your own 35mm camera and Stereo-Tach. Now only \$19.79 complete with viewer, tax included. Was \$24.59. Ask your dealer or write for illustrated literature. Dept. 71, Advertising Displays, Inc., Covington, Ky., U.S.A.

**ENLARGING** Or projecting: F2:8 lens system, mounted, 2" F. L. Iris diaphragm, ready to use. Actual cost \$24. Closeout \$10.00. Optical Assembly Co., Celina, Ohio.

**PHOTOMURALS.** Giant transparencies, photos on canvas. Your negatives, photos, or ours. We satisfy nation's leading photographers. 1950 catalogue, 25c refunded on orders. Photomammoth Murals, 12048 Anowen St., North Hollywood, Calif.

**MODELS' Publication** exposes rackets, traps, foul play of photographers and agents. \$1.00. Hold-It, 41 W. 52nd St., New York City.

**PICTORIALAMP**—The perfect way to display color transparencies. Free literature. C-P-C-S, 5017-P 22nd, Cicero 50, Illinois.

**PHOTO Handbook** tells you how to take, develop and print your own pictures, build your own enlarger, etc. For the amateur and professional photographer. 160 pages, \$2.00. Popular Mechanics Press, 200-PP East Ontario, Chicago 11, Illinois.

**PHOTOGRAPHY** For pleasure or profit. Learn at home. Practical basic training. Long established school. Write for free booklet. American School of Photography, 1315 Michigan, Dept. 3432, Chicago 5.

**YOUR Name on every photo.** Send one dollar for Kodalith plate to fit your printer or easel. Made to your specifications. Money back guarantee. Ben Parker Co., 510 W. 6th St., Los Angeles 14, Calif.

**WILL You risk 25c for mammoth photographic catalog?** Deductible from first \$2.50 order. Bloom's Camera Center, 1657-PM Main, Springfield, Mass.

**PHOTOCOPY** Anything, papers, books. No darkroom, 8½" x 11" complete, \$6.95. Fotoflek, 4801 Yarmouth, Cincinnati 29, Ohio.

**BUY Photographic supplies wholesale.** Free catalog. Expert camera repairing. Capitol Photo Supplies, 2428 Guadalupe, Austin, Texas.

**BASS Says: Bargaingram 257 ready** and waiting for you. The book which tells all. The finest in new and used camera equipment, a veritable encyclopedia. Write, phone or call the sign of the old "Horse Trader." 39th year of satisfaction or your money back dealing. Bass buys, sells and trades. Bass Camera Company, Dept. AG, 179 W. Madison St., Chicago 2.

### PHOTO FINISHING

**16 CONTACT Prints** from 8 exposure roll 35c. Reprints 3c each; 40, \$1.00. Double size prints in album book. 8 exposure roll, 35c; 12, 50c; 16, 65c. Reprints 4c each. Apex Photo Service, Box 197, Bronx 51, N. Y.

**OIL Coloring photographs** can be a fascinating hobby or profitable sideline for those with artistic talent. Learn at home. Easy simplified method. Send for free booklet. National Photo Coloring School, 1315 Michigan, Dept. 3432, Chicago 5, Ill.

**PRIVATE Laboratory.** Amateur art. Specialists 35mm-828-127 split. Black-white and color. GK Laboratories, Box 127, Catskill, N. Y.

**BONDED Double size photos.** 8 exp. rolls, 30c. 12-45c. 16-60c. Honest quality photo finishing. Satisfaction, or money back. Try Bonded Photo Service, Box 29, Inglewood, California.

**FREE Price list on quality developing,** printing, enlarging. Write for it today. Bryan's Photo Shop, Dept. M, Panama City, Florida.

**NEW Negative and two 5x7 enlargements** from your photo, \$1.00. Complete service list free. Photo-Lab, 1204 Sutter, San Francisco 9, Calif.

**AUTOMATIC Photo-electric finishing.** 8-25c; 12-40c; 16-55c. Oversize, add 10c. Mississippi Finishing, 2212 East 12th, Davenport 4, Iowa.

**35MM Rolls developed.** Enlarged 3½x5 prints, 36 exposures \$1.00, 20 exposures 65c. 8 exposure rolls developed, printed oversize 30c. 12 exposures 45c, 16 exposures 55c. MacDonald's Photos, Box 30-J, Wheaton, Illinois.

**FREE 5 x 7 Enlargement** with each roll developed and printed, 6 or 8 picture roll 35c. 12 or 16 picture roll 55c. Send coin with roll. No c.o.d. If you fail to get pictures on your roll of film, we will mail a new roll to you at no additional cost. Overnight service. Malters sent free on request. Deluxe Film Service, Box 1268, Shreveport, Louisiana.

**8 BEAUTIFUL Double size pictures** and roll developed 30c. 8 hour service. Free mailers. Pacific Photo Service, Box 666, San Francisco, Calif.

**2 BEAUTIFUL Hi-Gloss prints** each good negative and enlarging coupon with each 8 exposure roll developed 28c. Free mailers. Owphoto Co., Weatherford, Oklahoma.

### MOTION PICTURES AND SOUND EQUIPMENT

**BIGGEST 16 MM. sound film bargain!** Twelve good used 100' "soundies" musicals, \$9.95 plus postage. Hundreds of titles available at \$1.49 each. Write for our big list. Blackhawk Films, Davenport, Iowa.

**BETTER 8MM. and 16mm. movie camera film.** Free equipment catalog. Better Films, 742 New Lots, Brooklyn 7, N. Y.

**FILMS** And equipment exchanged or bought for cash. Sound, silent. Bargains. Lists free. Frank Lane, Little Bldg., Boston, Mass.

**RENT 16MM. sound films, 50c reel.** Large selection; free catalog. Film Service, 128 Chestnut St., Roselle Park, N. J.

**UNUSUAL 8 And 16mm. films,** used by many art students. Write for free catalogue. Friart, 140-A-Liberty Street, New York 6.

**"THE World's Greatest Passion Play."** 8mm., 16mm. and 35mm. Specify silent or sound. Rent or purchase. Hemenway Film Co., 33-F Melrose St., Boston 16, Mass.

**LOOK—400 Foot sound \$4.00** at Jack Smiling, P.O. Box 1332, Ventura, Calif.

**HOT Out of the camera.** 1950 productions just completed. \$2.50 8mm., \$6.00 silent 16mm., \$7.50 16mm. sound. 40 all new numbers. Free list. Comet Productions, 11651 Riverside Drive, North Hollywood, Calif., Dept. K.

**WORLD'S Wonder movie screen paint.** Free literature. 126½ West Main, Danville, Illinois.

**FREE Movies.** Thousands of subjects. Interesting. Entertaining. Fascinating. New directory—only 50c. International Cine Society, 126 Lexington Ave., Dept. M, New York 16, N. Y.

**RARE Medicals, oldtimers.** Free catalogue. International, 2120 Strauss, Brooklyn, New York.

**GUARANTEED Fresh anti-halo outdoor movie film!** Weston 16! Daylight loading! Processing free! Three spools double 8 mm. \$4.50! Six single 8 mm. for Univex, \$4.60! Postpaid! Catalog. Filmcraft, 47th Holly, Kansas City 2, Missouri.

**8-16MM. Silent-sound films.** Complete rental library. All latest subjects. Free catalogue, (sample film 10c). Garden Film, 317 West 50th, New York 19.

**MOTION Picture technique** at home. Big money. Special registration for veterans. Free catalog. Motion Picture Institute, Birmingham 4, Mich.

**BASS Says: 39 years of leadership** guarantees satisfaction. Finest cine equipment, 8mm., 16mm., and 35mm., silent and sound. Write the old "Horse Trader." Satisfaction or your money back always! Bass Camera Company, Dept. A, 179 W. Madison St., Chicago 2.

**LEARN Movie projection, management.** Free catalog. Theatre Institute, Elmira, N. Y.

**I BUY, Exchange, swap movies.** What have you? What do you want? Lowest exchange rates in world. Catalogue \$1.00. Refundable. Harvey Iris, Box 539, Brockton, Mass.

### MUSIC AND MUSICAL INSTRUMENTS

**1950 ACCORDIONS — Wholesale.** Free catalog. American Accordion Center, 5329 Belmont, Chicago.

**POEMS Wanted** for musical setting. Send poems for free examination. Five Star Music Masters, 630 Beacon Bldg., Boston, Mass.

**DRUM** By this simple, self-taught method. Complete instructions and beautiful hand-turned, hardwood drumsticks; all for \$1.00 plus 10c postage. An exceptional value. Rudiment Drum School, Box 81, Weymouth 88, Mass.

**SONG-Poems set to music.** Send your poem for our proposition and useful Rhyming Dictionary. Richard Brothers, 24 Woods Building, Chicago.

**POEMS Wanted.** Melodies, arrangements furnished. Terry Tune Master, 709½ PM North Broadway, Oklahoma City 2.

**SONGWRITERS.** Sample magazine, 20c. Songmakers Magazine, Box 309-M, Oregon City, Ore.

**POEMS Wanted.** Splendid offer. Rush! Radio Composers, WPMMD, Clinton, N. C.

**SONGWRITERS!** Outstanding, ethical offer. Hibbeler, C5, 2157 N. Avers, Chicago 47.

**POEMS Wanted** to be set to music. Free examination. Send poems. McNeil, Master of Music, 510-PM S. Alexandria, Los Angeles, California.

**MUSIC** Arranged, songs printed. Frank Wildt, Music Publisher, Lancaster, Penna.

**WRITE Songs.** Big money and reputation. Write for information. J. Gordon Pub. Co., 201 N. Hoyne Ave., Chicago.

### RADIO AND TELEVISION

**GET Complete service information** for your own postwar TV, FM or AM receiver. Also for any record changer. Accurate, easy to use laboratory-analyzed data. Includes special schematics, photographs, circuit analysis, alignment data, replacement parts list, dial restringing, disassembly instructions, valuable servicing hints. Any postwar TV set \$1.00. AM or FM set 50c. Any record changer 75c. State make, model number. Money back if not satisfied. Merritt, 4440 Marcy Lane, Indianapolis, Indiana.

**FIX Any radio.** Amazing new instrument locates radio troubles double quick. Simple instructions show you how. Thousands now in use. Free. Write today for 32-page illustrated technical manual. "The Inside Story." Feiler Engineering Co., Dept. 2PM5, 1601 S. Federal St., Chicago 16, Ill.

**FREE — Money saving bargain catalogs** in radio and television sets, record changers, tubes, parts, amplifiers, speakers, etc. Write today. Radionic Equip't Corp., Dept. 2002, 170 Nassau St., New York 7, N. Y.

**TELEVISION Towers** wholesale prices direct from the factory. Write The Youngstown Steel Towers, 1316M Wilson Ave., Youngstown 8, Ohio.

**MAKE A crystal radio.** Simple, economical. We supply x-tra long distance crystal and instructions. 25c. D-X150, Box 201, Marshall, Mo.

**\$1.00 GETS This kit** of parts. 40 .01 mfd. 400 volt condensers; 5 20 mfd. 350 volt filter condensers; 100 ½ inch rubber grommets; 25 ft. hook-up wire. Add postage. E. Weibert, 127 Ash, Buffalo 4, N. Y.

**5c MAKES Clear, loud mike.** Plays through radio-phonograph. Plans 25c. Mondo Enterprises, 289 Grandview Avenue, Buffalo 14, New York.

**24 PAGE Plans "18 Long Distance Crystal Sets,"** catalog and "Radiobuilder"—25c. Laboratories, 578-C, San Carlos, California.

**MAKE Simple, tubeless, batteryless,** distance-getting crystal radios. Crystal and illustrated instructions 25c postpaid. Allen, 427-P, Clinton, Mo.

**SEND For our bargain bulletins** on radio and electronic components. Never undersold. Buyers Syndicate, 30 E. Taylor St., Springfield 3, Mass.

**150 ASSORTED Radio parts.** Satisfaction guaranteed. \$2.00 postpaid U.S.A. Buyers Syndicate, 30 Taylor St., Springfield 3, Mass.

### BUSINESS OPPORTUNITIES

**HOME Business** making statuettes, plaques, artificial marble, rubber molds. Metallizing baby shoes. Silvering mirrors. Formulas. Folder free. Creative, 236-L, Winnetka, Illinois.

**WANT A mailorder business?** Avoid mistakes by reading "Mailorder Pitfalls." Send for free circular. Better Sales Co., 2139 Clifton Ave., Cincinnati, Ohio.

**MANUFACTURE Camera** at home. Experience unnecessary. Taylor's Laboratories, 4015 Oketo, Chicago 34.

**"HOW To build your own mail order business."** 10,000-word handbook; starts you right. Sent postpaid 25c. Satisfaction guaranteed. Excelsior Service, 1330 January, St. Louis 10, Mo.

**MEN—Women.** "Everybody likes candy." Learn to make professionally at home. Details free. (Our 40th year.) Ragsdale Candies, D5, East Orange, New Jersey.

**LEARN Piano tuning, repairing**—at home in 30 days. Unlimited income. Phonograph recordings, tools and instructions furnished. Write Capitol City Tuning Co., Department C-234, 129 East Michigan, Lansing 16, Michigan.

**TRADE Magazines** help you get ahead. Latest copies. More than 1150 covering every trade, business or interest available through our easy-to-get-acquainted service. Full particulars and price-list free. Commercial Engraving Publishing Co., 34C North Ritter, Indianapolis 19, Indiana.

**START Home mailorder business.** Details. Gedgard, Box 798-N, New York 1, N. Y.

**OPERATE Profitable mail order business.** Lachman, 1636-M Shatto, Los Angeles 14, Calif.

**START** Home manufacturing business making cleaning compounds, soaps, insecticides, cosmetics, polishes, food flavors. No machinery. Literature free. Kemix, Park Ridge, Ill.

**ASSEMBLE** And sell electric bed warmers for \$5. Costs \$1. Franchise \$5. Details free. Aitooze Co., 7811 Guthrie, Cleveland 2, Ohio.

**START** Your own business on credit. Always your own boss. 1554 dealers, sold \$5,000 to \$26,500 in 1948; their average \$6,742. We supply stocks, equipment on credit. 200 home necessities. Sales experience not needed to start. Wonderful opportunity to own pleasant, profitable business backed by world-wide industry. Write Rawleigh Co., Dept. B-U-P/M, Freeport, Ill.

**BE** Independent, be secure, have your own profitable business—earn \$10.00 and more a day making beautiful, fast-selling lamps at home. No equipment needed. Illustrated course teaches you quickly. Course, parts catalog, wholesale price list, only \$2.00. Gearon Company, Dept. 200-B2, 27 South Desplaines, Chicago 6, Ill.

**BE** Independent—Operate America's lowest price penny vending machine. Big profits. Immediate shipments. Write for bulletin and prices. Fielding Mfg. Co., Desk 20, Jackson, Mich.

**PLAN** Your mail order business profitably. Free literature on five famous books. Mail Marketing Services, Rt. 1, Box 522, Dayton 5, Ohio.

**"FROG Raising!"** New book tells how! Illustrated literature free. Marlboro-A, Box 7002, New Orleans 19, Louisiana.

**EARN** At home casting novelties. Free instructions using latex molds. Major Chemical Co., 164 Portland St., Cambridge 39, Mass.

**"WATERLESS (Lanolin) Hand Cleaner."** (Oil base.) Make, sell. No machinery. Build profitable business. Complete formula \$1.00. Ideal Service, Park Ridge 1, Ill.

**CO-PUBLISH** And advertise in The Central Mail Advertiser. Sample copy 10c. Low rates. Large circulation. Bagby Printing Co., Georgetown, Ohio.

**BUILD** Mail order business of your own—Anywhere! Free, illustrated, "Modern Mail Merchandising." Write Mail Enterprises, 315 Fox Building, Detroit 1, Mich.

**OPERATE** Mail order book shop at home, spare time. Easy! Fascinating! Profitable! Details free. Kraft, Aurora 31, Missouri.

**BUY** Direct. We furnish sources of any manufactured item you need for business, hobby. 10 current sources, your item—\$1.00. Business Information Center, Chesterland, Ohio.

**START** Your own business in home or office. Tested successful business plans. Full particulars free. Ideal Mail Service, 617 Belmont Ave., Newark 8, N. J.

**WORK** At home. Sell by mail. Details free. J. Hogan, 922 North Lewis Ave., Waukegan, Ill.

**AUTOMOBILE** Gadget. Manufacture, wholesale, 1000 daily, 700% profit. Sample, dime. Ralph Kelley, Box 583, Clearwater, Fla.

**DELIGHTFUL** Plans! Australia. South America. Free book "372 Unusual World-wide Businesses." \$800 month reported! Work home (U.S.A.)! Get surprise! Publishers, Carlsbad, Calif.

**EARN** Extra money at home free. Chadwick's Service, Tacoma 7, Wash.

**BETTER** Business. First ad brought 200 orders. Folio 25c. New imprint, if requested. Grant Lovell, 2166 South Shore, Erie 15F, Penna.

**100% PROFIT.** Lovely, fast selling personalized jewelry. Free literature. Delite Corp., 4324-P Church Ave., Brooklyn, N. Y.

**DECORATE** Discarded furniture and tinware for home or profit. Free details. The Stewarts, X-3, Bridgewater, Mass.

**DOLLARS** In personalized baby record books. Sell by mail. Use same literature we do. No-Co-Ro, Oakland 6, California.

**ELECTRICALLY** Inclined? Make \$100-\$250 weekly installing, maintaining fluorescent lighting. Make beautiful lights for 50c each. Exclusive, inexpensive, illustrated instructions enables you to cash in on this fast growing industry. Request impressive evidence on this proven business opportunity. Wilber Distin "Fluorescent," 400 Foote Bldg., Syracuse 2, N. Y.

**\$25 WEEKLY** Working two hours daily. No canvassing. No manufacturing. Lycke, Box 2471-A, Cleveland 12, Ohio.

**YOUR Own** plastic business at home. Produce costume jewelry, novelties, statuettes. Liquid plastic, liquid marble. Flexible molds. Write for free book. American Trades, Box 1473-A, Cincinnati 1, Ohio.

**FREE** Details—Mail business. Ed Medved, Dept. M, Yukon, Penna.

**DRAFTSMEN** Investigate, worthwhile opportunity. Kendall Associates, 23 Nichols St., Gardner, Mass.

**WANT** A business of your own? Make \$20 to \$30 a week extra money at home! Thousands do! Interesting service cleaning upholstery and rugs. Big demand. No selling. Free illustrated folder tells how. Americane Company, Inc., Dept. G-26, 211 North 7th Street, St. Louis, Missouri.

**SAWDUST.** Turn it into cash. Six methods. Instructions 25c. Charles, 12-AWB, Norwood, Ohio.

**START** With small capital right from your own home. No office needed. No personal contact. Location no obstacle. Sell by mail thru ads, postcards, circulars. This magazine tells you about it. Send for free copy now. Willis Book Shop, 1401-A Whitelock St., Baltimore 17, Md.

**MAIL** Order business—Complete copyrighted information furnished for only 25c. Wonderful opportunity for very small investment. Most practical. Continental Products Company, Box 2526, San Diego, California.

**SUCCEED**—Over 850 pages, scientific formulas, trade secrets, hobbies, etc. \$3.00. Rite Monroe, Box 142, Pacific Palisades, Calif.

**MAIL** Selling opportunities galore! Free. Wehner, Box 142-A-3, Roxbury 19, Massachusetts.

**EARN** Money by mail with my plan. Free details. Satterfield, Box 345-C, Mansfield, Ark.

**WITHOUT** Capital operate general merchandise store. Detailed plan, 25c. Box 328, Paragould, Arkansas.

**ALUMINUM** Ladders, disappearing attic stairways, rope fire escapes, contractor's equipment. Wholesale; retail. Distributors wanted. American, 429 Palisade, Jersey City 8, N. J.

**WHY** Spend money for equipment? We "electroplate" baby shoes wholesale! Foster's, 1520 Ardmore, Chicago 26.

**MORE** Money—Easier! Revolutionary methods make public bookkeeping easy, interesting, profitable. Earn to \$5.00 hourly within short time! Simple, complete instructions. Full-spare time. Success-revealing information free. Auditax Systems, 10775 R Tabor, Los Angeles 34.

**LOCATE** Anything made in U.S.A. \$1.00. Research, 407 Washington, Shreveport, Louisiana.

**KITCHEN** Odor killer made with 95% water for 12c pint assures unlimited profits. Big demand repeat item. Twenty-two fragrances. Two manufacturing formulas with source of supply \$1. Mike Saulin, 3521 Juniper Street, Freeland, Penna.

**BABY** Shoe metallizing. Instructions, supplies. Custom plating. Schoettle, Friendship, Ohio.

**FIX** Typewriters, full or part time. Inexpensive copyrighted home study course quickly trains you for high earnings. Factory methods cover all phases with drawings and illustrations. No curiosity seekers. Typewriter Repair, 2915 Corbet, Tarentum, Pennsylvania.

**NEW.** Proved methods get money by mail. Amazing, eye-opening. Details free. Lexington Mail, 5538-A Lexington, Chicago 44.

**MAKE** Men's and ladies' plastic wallets. Earn sparetime profits. Details free. Lakeshore Supply, Dept. PM2, 534 Surf St., Chicago 14, Ill.

**START** Your own business selling new specialty hand cleaner. Experience unnecessary. Send for free details today. Tuxis Chemical Co., Academy Street, Madison, Conn.

**EARTHWORM** Breeding. Valuable bulletins on successful methods mailed free. Earthmaster Publications, Dept. 14, Sun Valley, Calif.

**MAKE** Perfume at home. Write Carey Laboratories, 1914 Chouteau, PM2, St. Louis 3, Missouri.

**PROSPER** With plating! Growing field! Easily learned! Send postcard. New particulars free. Joseph Kushner, Electroplating Engineer, Stroudsburg 17m, Penna.

**MAKE** Money selling all-occasion and plastic cards, stationery, wrappings, shopping bags, children books and phone book covers. \$1.00 for samples starts you in business. Pascale Greeting Cards, PMJ, Irvington 11, New Jersey.

**BUY** It wholesale. Manufacturers, distributors offer 850,000 items. Literature free. Olsen, 1231-A East Third St., Duluth 5, Minn.

**MILLION** Articles wholesale. Supply source directory 10c. Publisher's, Box 1302, Detroit 31.

**DESIGN,** Model, mold new fast sellers from plastics, plasters, compositions. Amazing profits. Quick returns. Free literature. Plastics Digest, 2925-B3 Michigan, Kansas City 3, Mo.

**TIN** Cans. Turn them into cash. Nine methods. Instructions 50c. Charles, 12-AWC, Norwood, Ohio.

**UNPAINTED** Figurines. Free list. Arbo Products, P44 W. Cook, St. Paul 3, Minn.

**SPIN** Angora wool into beautiful yarn at home. Easy, enjoyable work. House of Angora, PM, Springfield, Illinois.

**FREE!** Adventure in selling by mail, plus 3 m.o. plans. Enclose stamp. Supply limited. B. Service, 385 8th Ave., New York 1, N. Y.

**BIG** Money in new home business. Amazing liquid plastic. Cast hundreds clear or colored items. 25c brings finished sample and information. Kemnitz Corp., 1021 N. Water, Milwaukee, Wisc.

**"FROG Raising!"** New book tells how! Illustrated literature free. Marlboro-A, Box 7002, New Orleans 19, Louisiana.

**BUSINESS** Opportunities galore, hundreds successful! Interesting details free. Stout, 1110A Caesar, Pasadena 10, Calif.

**MAKE** Money spare or full time, casting metal toys and novelties. Big wholesale and chain store demand for cast metal autos, soldiers, ashtrays, banks, etc. keeps manufacturers busy. Production moulds furnished for up to 100 and more castings per hour. No experience or special place necessary. Write for full information and illustrations of patterns needed. Metal Cast Products Co., Dept. A, 1696 Boston Road, New York 60, N. Y.

**POPCORN** And potato chip equipment. Long Eakins Company, 5060 High, Springfield 99, Ohio.

**PEARL** Finishing—New, amazing. Huge profits. Start making big money first day. Free facts show easy way to \$25 to \$50 per day at home. Absolutely no experience. Be first; scoop the market. Write Pearl-Kote, Dept. R, 2111 W. Manchester, Los Angeles 47, Calif.

**SEWING** Machine business tops. Big money—not crowded. Spare time home set-up. Repair course, new machines, motors, etc., wholesale. Hurry. Taylor Service, PM, Hamilton, Ohio.

**EXCELLENT** Opportunities in profitable mail order business. Details free. Burnett's Mail Service, P.O. Box 2231, Greensboro, N. C.

**LEARN** The letter shop and addressing business. Complete copyrighted information; \$2.00. Rosdahl Industries, 72 W. Washington St., Chicago 2, Illinois.

**PROFITABLE** Mail order plan. Details free. Stanley Skinner, Star Route, Nicholson, Penna.

**PIANO** Tuning learned at home. Free information. Empire School, Champaign, Illinois. (Est. 1935.)

**QUICK** Money! "Repairing car batteries!" At home! Easy too! Batteryman, Grand Junction, Colorado.

**SELL** Publications by mail. Small capital, five way profits. Free advertising. Complete plan 10c. With samples 25c. Shaw, 660 N.E. 8th St., Hialeah, Fla.

**BIG** Money. Spare or full time in your home. No selling! Spray new miracle finishes, plush and suede, on signs, radios, automobiles, figurines, lamps, toys, etc. Our business is booming. Help us fill huge demand. New easy Flok-Kraft methods. Material costs few pennies. You get dollars. Free samples, complete powerful money making plan free. Write now! Coast, 1010 S. Los Angeles St., Los Angeles 15.

**HOW** And where to obtain capital. Small and large loans. Free particulars. Star Service, Wapakoneta, Ohio.

**DRESDEN** Craft figurine molds and many others, natural liquid rubber, statuary plasters, flock finishes, etc. Illustrated catalog and "Plastercraft" manual free. Blue Rapids Supply, Blue Rapids, Kansas.

**WANTED** Unused U. S. postage stamps, small discount. Advance Stamp Co., 24 East 23rd St., New York.

**LIQUID** Marble—Colorful, glossy! Molded, brushed, sprayed! Cast novelties, statuary, colored tiles. Flexible molds. Composition floors. Particulars free. Marbleizing Service, Edwardsville, Illinois.



**EXTRA Money.** No selling; operate vendors. Amazing profits, details free. Silver King, Suite B, 622 Diversey, Chicago 14.

**UNPAINTED Bookends, plaques, statues, figurines.** List. Haverty Products, 1219 8th Ave., Altoona, Penna.

**RICHES** in your own business. Let me show you how. Addison, Box 1153, Hot Springs, Ark.

**BRONZED** Baby shoe mountings, equipment and supplies. We manufacture world's largest assortment of all metal mountings Wholesale only. Ramyr selenium platers \$39.95. Gold and silver plating assemblies low as \$97.50. Write for free copy of electroplating instructions. Tech. Dept., Hollywood Bronze Supply, 1770 N. Vermont Ave., Hollywood 27, California.

**RESILVER** Mirrors at home. Formula 25c. Ideal Service, Park Ridge 8, Illinois.

**UNPAINTED Figurines—Wholesale, retail.** Illustrated list free! Oman, 642L Broadway, St. Paul 1, Minnesota.

**HOW** To set up and run a mirror shop! Resilver mirrors. Make chipped glass nameplates. Electroplating salts and rectifiers. John Sprinkle, V60, Marion, Indiana.

**MAKE** Rubber stamps, metalize baby shoes, repair dolls, silver mirrors, make plaster novelties. Catalogue of "30 ideas" free! Universal, Box 1076-A, Peoria, Ill.

**CASH** For your idea, 280 manufacturers need inventions, patented or unpatented. List free. Invention Bureau, 208M Clinton, Oak Park, Illinois.

**MAKE** Money making new greaseless doughnuts at home on electric machine. Wholesale to grocers, drug stores, cafes, hamburger shops. Send for free recipes and plans. M. Ray Company, 3605 South 15 Ave., Minneapolis 7, Minnesota.

**"SPECIALTY Manufacturing."** Big money business. Start on small capital with dependable formulas. Send for free interesting booklet. Howard Robinson, Ph. G., 1300-A South Ohio Street, Sedalia, Mo.

**RECAST** Old batteries into new. Latest achievements. Battery Laboratories, Minneapolis.

**ENVELOPES** Addressed accurately, reasonably. Fast service. We have capable addressers in your city. Glenway System, 5427 Euclid, Cleveland 3, Ohio.

**I MAKE** Big money in the mail-order business. You can do the same at home with copyrighted system. Write me. I'll tell you how. F. Little, R.D. #1, Glenshaw, Penna.

**METALLIZE** Baby shoes. Excellent profits. New system assures success. Free details. Treasures Forever, 38-B Michigan Ave., Lynn, Mass.

**"HOW** To start a successful mail order business." The guide to sound, profitable mail merchandising, 25c. Manhattan House, 126-B Lexington, New York 16.

**BIG** Money regaining, refinishing automobile dashboards, garnish mouldings. Write Outman Service, 4323 So. 38th, St. Louis 16.

**MAKE** Tough, durable plastic—1c pound. Makes attractive floors, walls, built-ins, roofs. Build good homes, \$150.00 room. Bays Laboratory, Oklahoma City 9.

**LIQUID** Rubber. Make flexible molds. Free sample. Chaney, 1130 E. 16th St., Jacksonville 6, Fla.

**NATURAL** Molding Latex. Extra thick. Free sample. W. Wooley, 115-A Donald, Peoria, Ill.

**MOLDING** Rubber for hobbyists, industry, classroom projects! Flexible molds easily made from the best quick-drying white liquid rubber! (Gallon, \$7.95; quart, \$2.95; sample half-pint \$1.00) prepaid parcel post! Plastercraft Supply Co., 3051 St. Clair Ave., Cleveland 14, Ohio.

**LEARN** Electrical appliance repair. House wiring, motors, washers, cleaners, refrigerators, lamps, auto ignition, etc., complete illustrated course. Tools furnished. Free booklet. Pacific School, 7219 South Broadway, Los Angeles 3.

**SELL** By mail. Good deal with nice profits. Home City Services, Box 1062-PM, Springfield, Mass.

**WOULD** You pay 3%—first \$350 made? Book "505 Odd, Successful Enterprises" free! Work home. Expect something odd! Pacific, Oceanside, Calif.

**OWN** A printing business. Good profit printing cards, stationery, etc., in spare time. Easy rules furnished. Have home shop. Write for details. Kelsey Corp., Meriden 24, Conn.

**WHERE** To buy 500,000 articles wholesale. Details free. Krueger, 3418A Wolcott, Chicago 13.

**MANUFACTURERS** Getting rich with new post-war products, all lines. You can easily make them at big profit from guaranteed, chemist-developed formulas and analyses. Literature free! Miller, Analytical Chemist, Tampa 6, Florida.

**FREE!** Illuminating folder "A Business Gold Mine." Real dividends for your spare time in lucrative business. No personal selling. Kabel, 1413 W. Tioga St., Philadelphia 40, Penna.

**GROW—**Sell potted flowers, vegetable plants. Details free. Shiffer Associates, Box 129, Millersburg, Penna.

**FIGURINES** And all supplies for Dresden painting. Gift ornaments. Unpainted, many to choose from. Start a profitable business; hobby. Send 25c for catalog. Will refund on first order. Suiter Art Industries, 314 Westport, Kansas City, Mo.

**PROFITABLE** Home business. Start on small capital with latest tested formulas. Interesting booklet free. Pont, Box 635-XM, Terre Haute, Indiana.

**START** Home plaster novelty business. Amazing course tells how. Literature free. Kemo-Courses, 4862 Catalpa, Chicago 30, Illinois.

**SPECIAL** Rubber for making molds. Literature and sample free. Universal, Box 1076-A, Peoria, Ill.

**MAKE** Money at home decorating greeting cards. We supply instructions. Powell, 5713-C Euclid, Cleveland 3, Ohio.

**VENDING** Machines earn big money! An investment as low as \$10.50 will start you in this fascinating, profitable business that can lead you to the road of success and independence. Routes can be established and operated in either full or spare time with no experience needed. Write for full details and our free catalog illustrating our nut, candy, gum and stamp vendors; also pin ball machines, music boxes, etc. Write immediately to Parkway Machine Corporation, Dept. 7, 623 W. North Avenue, Baltimore 17, Maryland.

**READ "Advance"**—The voice of mail order. Offers money-making opportunities, sources of supply, personal guidance, etc. Issued monthly. Sample copy 25c. Yearly subscription \$2.00. Advance Publishing Company, 313 East 21st Street, Suite 450, New York 10, N. Y.

**A BUSINESS** in your own home! Our chemicals, plus free water and cheap "grocery store" materials can bring you over \$500 monthly earnings. Plans and formulas free. Chemica Division, 1269 S. Norton, Los Angeles 6.

**A FACTORY** in your home garage! Mfg. and sales rights, mechanics' waterless hand cleaner, \$500-\$800 monthly. No special equipment necessary. Formula free. Western Aircraft Mfg., Dept. D, Los Angeles 6, Calif.

**START** Mailorder bookshop—Everything furnished. 25c brings booklet, samples, exciting ideas. General Publications, Ossining, N. Y.

**OPERATE** Profitable mail order business. Write Walter Service, 4159-A East 112th, Cleveland 5, Ohio.

**COLORGLAZED** Concrete pottery made without molds. Patented method. Cemetery products, novelties, tiles. Basement leak-sealing. Money-making projects. Booklet, details free. Men only. National Potteries Company, Grand Rapids, Minnesota.

**137 WAYS** To make money, in home or office, business of your own. Full particulars free. Elite Co., 220 Grand St., New York 13.

**BRUSH** Plating outfits connect to a battery. No tanks necessary. Good paying business at home plating autotparts, bathroom fixtures, bicycles, reflectors, silvering mirrors. No shop or experience required. Outfits furnished. Free booklet. Gunmetal Co., Ave. H, Decatur, Ill.

**COPUBLISH** Leading m.o. paper. Latest copy Mail Sale Advertiser and proposition, dime. Vanroy W. Shirk, Lebanon, Penna.

**MAILING** Postcards selling repeat merchandise is profitable. Everything supplied. Details free. Gordan Publishers, Box 23, Pawtucket, R. I.

#### **MONEYMAKING OPPORTUNITIES**

**HUGE** Profits using easy to apply luminescent products. Catalog, liberal samples 25c. Glowelco, 475-B Fifth Ave., New York 17, N. Y.

**SELL** Books, folios by mail. Big profits. Everything furnished. Send dime for samples, complete set-up. Quackenbus, Big Flats, N. Y.

**VEND** Razor blades, 6c profit on 10c sale. Write Wyandotte Sales, 1464-21 Street, Wyandotte, Mich.

**BOOKKEEPERS** Earn \$100.00 week operating your "bookkeeping service." Simplified plan. Information free. Bookkeeping Service, Box 664-M, Springfield, Missouri.

**OPERATE** Concessions at carnivals, fairs, shows. Surprising details. Stampico, Detroit 4, Mich.

**GROW** Bean sprouts in dark room. Pays well. Free information. D. Nickell, Route 3, Box 94, Bend, Oregon.

**NEW** Way. Earn \$50 weekly working at home. We show you how. Ability in simple arithmetic essential. Write for free details. Dollar-a-Month Plan, Box 5236-P, Philadelphia 26, Penna.

**URANIUM**—Prospecting, information free. Write Sharpe, Prospector, Box 142, North Battleford, Canada.

**HOME** Workers, salesmen supplies. Circulars, lists free. Lincoln, Box 449, Irwin 4, Penna.

**WIN** Cash, cars in prize contests! Write for copy filled with current contests, winning hints and tips. Send only 25c. Wright Contest Digest, Dept. 17-B, P.O. Box 2266, St. Louis 9, Missouri.

**EARN** Money at home—Robert Colliers lesson tells how! Sample 25c. Income Builders, Hollywood 28, California.

**EARN** Money evenings, copying and duplicating comic cartoons for advertisers. Adservice, Argyle 1, Wisconsin.

**DELIGHTFUL** Plans! Australia, South America. Free book "372 Unusual Worldwide Businesses." \$800 month reported! Work home (U.S.A.)! Get surprise! Publishers, Carlsbad, Calif.

**"OPPORTUNITIES Preferred Magazine"** tells how. Sample, 25c. Glen, Howel 3, Kentucky.

**QUICK** Money in small town promotions! Write, 204-6 Danfill Building, Paragould 2, Arkansas.

**TRANSPARENT** Mirror. Look through the wall without being seen! If you've ever wished you could see without being seen then this is for you. Perhaps you've heard of the new mirror that can be seen through from the back side but you probably haven't seen one because the manufacturing process has been a guarded secret. Now you can make transparent mirrors in your own kitchen by merely applying two solutions to common window glass. Ingredients obtainable anywhere. Your cost? About 15c per mirror. Your complete set of instructions will be mailed upon receipt of \$1.00. Don't miss out on this! Make a transparent mirror and watch the fun begin. Sell them at huge profit. Average person has never seen one. Trigoon, Box 3053, Beaumont, Texas.

**"WESTERN Advertiser"** offers many worthwhile money-making opportunities. Sample copy 3c. H. Edlund, 577 Kensington, Los Angeles 26, California.

**INCOME** And independence from a small, part-time business of your own! Rush \$2.00 for "Home Business Digest." Brevitt, Box 851, GPO, New York 1, N. Y.

**GET** Inside news about new products before they hit the market. Surplus goods. Sellouts. Buyers bulletin makes, saves you money. Monthly. Sample 25c. National, 2014 Broadway, Indianapolis 2, Ind.

**FAST** Seller—100% profit. Sell our book "Be a Photographer's Model in 10 Days." Sample 50 cents. Schick Publishing Co., 631 Third Ave., New York City.

**EASY** Ways to earn extra income are described in Money-Making Hobbies. 132 projects you can make at home and sell anywhere. 160 pages, \$2.00. Popular Mechanics Press, 200-MH East Ontario, Chicago 11, Ill.

**GET** Into pleasant home operated profitable business, working by mail. Everything furnished! Tremendous possibilities! Get exciting details. National, Box 88-M, Dorchester 22, Mass.

**RAISE** Ginseng. Roots bring fortunes. Circular free. Fezler Seed Co., Patchogue, N. Y.

**MAKE** Flexible arch supports. Profitable business. Tunis System, 1341 Kwis, Puente, Calif.

**WANT** Notary Public appointment? Official in usually 10 days. Stationers Exchange, Boerne 50, Texas.

**UNPAINTED** Figurines. Free list. Progress Company, 4033-P Chowen, Minneapolis 10, Minn.

**WOULD** You pay 3%—first \$350 made? Book "505 Odd Successful Enterprises" free! Work home. Expect something odd! Pacific, Oceanside, Calif.

**CHURCHES.** Organizations. Clubs. \$130.00 free plus 12-card tables. Unique Gift Club Plan, Pine Hill, New Jersey.

**EARN Money** at home. Little or no capital needed. Free particulars. G. Huthnance, 201 Holbrook, Flint, Mich.

**MAILORDER** Know-how. Free literature. Bruce, Box 341-AD, Palo Alto, Calif.

**DOLLARFUL** Ideas for you every month in advance—"Voice of Mail Order." Leads the field in exclusive supply sources. Plans for mail order operation; new products, etc. Details free. Advance Publishing Company, Suite 350, 313 East 21st Street, New York 10.

**WIN Contest money.** General Contest Bulletin gives hundreds of tips. Lists current contests and rules. Sample 25c. General Contests, 1609½ East 5th, Duluth, Minn.

**PUBLISH** Your own magazine. Handmade 52 page format, well edited, illustrated. Cost low as \$1.00 month. Brings you prestige, profits. 25c brings sample, details. National, Ord, Nebr.

**PRIZE Contest bulletin** gives various contests now operating, and valuable hints. 3c stamp. National Contest Bulletin, Box 2685P, Miami, Florida.

**EARN Money** at home! Thousands do! "Home Worker Magazine" tells how. Sample, 25c. Sizemore, Box 7, 4917 Kostner, Chicago 30, Ill.

**THOUSANDS** Articles wholesale. "Supply Source Directory" 10c. Ideal Service, Park Ridge 30, Illinois.

**READ** Progressive Mailtrade, the magazine that tells how to make money by mail. Dime brings sample and special offer. Progressive Mailtrade, Box 357, Sheboygan, Wisconsin.

#### FORMULAS, PLANS, ETC.

"**WATERLESS** (Lanolin) Hand Cleaner." (Oil base.) Make, sell. No machinery. Build profitable business. Complete formula \$1.00. Ideal Service, Park Ridge 3, Ill.

10,000 **FORMULAS** And trade secrets. Free literature. Stillman, 555 Kingston Ave., Brooklyn 3, N. Y.

**FORMULA:** Embalm telephone, telegraph, power pole butts. Improved high efficiency. Inexpensive. Bramel, 22NEG, Portland, Oregon.

**FREE Formula catalog.** Anything analyzed \$20.00. Western Chemical, Salem, Oregon

**HOT Tamale.** Making for profit. Particulars, Box 384, Altus, Okla.

**MILLER'S** Modern post-war formulas make products that get the business. Fifty years supplying the best. Literature free! Miller, Manufacturer's Chemist, Tampa 6, Florida.

**MAKE—Sell** cleaners, soaps, polishes, flavors, cosmetics. No machinery. Formula literature free. Kemico, Park Ridge 16, Illinois.

**FORMULAS** For nearly everything. Catalog free. Write Creative, Winnetka, Ill.

**TESTED** Formulas. Interesting descriptive booklet free. Pont, Box 635-PM, Terre Haute, Indiana.

**REAL Manufacturing formulas.** Lists free. Cummings, Chemist, Gordon Ave., Syracuse 4, N. Y.

#### PLASTICS

**PLASTIC Engineer** and consultant. 65 East Rich Street, Columbus 15, Ohio.

**NEW Liquid plastic.** Clear, colors. Cast without heat. Embed flowers, insects, coins. Saw, drill, carve. Send 35c for exciting new home project manual showing how to get started. Castolite, Dept. B101, Woodstock, Illinois.

**AMAZING Liquid Plastic kit** \$3.25. Embed photographs, keepsakes, coins. Make solid objects. Clear, colors. Beautiful results in half hour. Inexpensive hobby. Send 15 cents for catalogue. Kristalon Plastics, Dept. Z-20, Box 29, Wilmette, Ill.

**FLEXIBLE Mold makers handbook** makes you an expert. Only \$1.00 postpaid. Boruski, 505-D Fifth Ave., New York 17.

**SPECIAL Prime** masked 6" x 12" Plexiglas sheets 1/16". 3 for \$1.45 postpaid. 1/8" 3 for \$1.75 postpaid. Free catalogue. Craft Plastics, Somerville, New Jersey.

**INTERNAL Carvers—Guaranteed** fast cutting, high speed, tapered drills with sharp points that make carving easier. 1/16", 3/32"-80c; 1/8"—\$1.00 each postpaid. Send for literature. Bay Sales, 101 Fifth Ave., New York 3, N. Y.

**PLASTICS Supplies.** Free catalog. Terrell's Plastics, 3562 4th Ave., Sacramento, Calif.

**EARN Money** with plastics. New book, "Money-Making Hobbies," shows you how. 160 pages, \$2.00. Popular Mechanics Press, 200 E. Ontario, Chicago 11, Ill.

**LUCITE, Plexiglas.** Any size sheets, masked. Square foot (12 x 12) cost, 1/16", 96c; 1/8", \$1.25; 3/16", \$1.92; 1/4", \$1.80. Colors add 10%. Include 10% postage. Almac Plastics, 230 Fifth Ave., New York 1, N. Y.

**PLASTIC, Sheets, rods, tubes, etc.** Free list. Plastic Supply Co., 2901 N. Grand Blvd., St. Louis 7, Mo.

**WHOLESALE** Plastics supply catalog. 10c. Lucite, clear, colored. Metallic acetate, 15 colors. Thick lucite cutoffs, polished blanks for carving. Metal findings, tools, ideas, bargains galore. Quantity prices on casting plastic. Gem-O-Lite, Box 686S, North Hollywood, Calif.

#### CHEMISTRY

**TUBULAR** Ultra-violet light units for laboratory or hobby, \$4.50. Write for details. C. Warner, 82-60 116 St., Kew Gardens 15, New York.

**USEFUL** Laboratory item, catalog of chemicals, laboratory apparatus, 10c. Rex Laboratories, 2649-A Birchwood, Chicago 45, Illinois.

**SNOOPERSCOPE** Tube. Permits nighttime vision. Tube and complete instructions \$14.95. Limited quantities. Infrared filters 15c. Precise, 942 Kings Highway, Brooklyn 23, New York.

**NEW Laboratory supply catalog** of chemicals and apparatus. Contains many thousands of items with illustrations. Send 25c. Standard Science Supply Company, 1232 N. Paulina St., Chicago 22, Ill.

**NEW, Used catalog** 10c, refundable. Atlantic Laboratory Supply, 21 Wenham, Boston JP, Mass.

**NEW Catalog: Chemistry, mineralogy,** biology. 10c. Tracey Laboratories, Evanston, Illinois.

**NEW Idea chemical and apparatus** outfits for home experimenting. Photo-scales, microscopes, chemicals, biological and laboratory supplies in small quantities. Catalog 15c. Established 1931. John H. Winn, 124A West 23rd Street, New York, N. Y.

**CHEMICALS** And apparatus for industrial, analytical, and private laboratories. Catalog 15c. Dept. M-50, Biological Supply Co., 1176 Mt. Hope Ave., Rochester, 7, N. Y.

#### HELP WANTED

**TAKE Orders** at home. Spill coffee or ink on 275 sq. inches free fabrics, demonstrating sensational tablecloth invention. Not ordinary plastic. Withstands 16 years cleanings. Styleco, Dept. 73, Cincinnati 10, Ohio.

#### AGENTS WANTED

**AGENTS.** Sell finest food products direct to homes. Successfully sold for 25 years. Big profits. Powerful combination sale plans make sales easy. Permanent repeat business. Powerful premiums and free door openers for easier sales. Samples furnished. Live territories open to distributors. Mother Hubbard Products Co., 4139 Grand, Dept. M-2, Chicago.

**NEW! Birthday party pack.** Be first! Sell this sensational new assortment. Contains everything but the food. The invitations, table cover, napkins, nut baskets, place cards, snapper hats, cups, plates, game booklet and six different games; a complete party for eight. Sample \$1.25. Also America's leading greeting card line featuring personalized stationery, napkins, book matches and exclusive new wedding invitations. Free samples. Elmcraft Chicago, 5930 S. Western, Chicago 36, Illinois.

**EXTRA Money!** Sell new, different greeting cards. Complete line includes Regal plastic assortment, metallics, "stand-up" and "double" cards. Free samples exclusive imprinted and engraved stationery. Sales kit on approval. Regal Greetings, Dept. PM-12, Hazel Park, Mich.

**STRANGE "Dry"** window cleaner. Sells like wild. Replaces messy rags, liquids. Simply glide over glass. Samples sent on trial. Kristee 144, Akron, Ohio.

**NYLON Uniforms.** Immediate delivery, immediate profits. Sell to doctors, dentists, nurses, waitresses, beauticians, housewives. Free sales kit. Superior Fabrics, Dept. P2, 3936 Market, Philadelphia 4, Penna.

**MAKE Money** calling on friends. Show nationally advertised greeting card assortments. 16-card all occasion assortment only \$1.00. Also birthday, gift wrapping, plastics, imported English napkins, floral stationery, children's books, many more! Up to 50c profit on each assortment. Experience unnecessary. Samples on approval. Write Wallace Brown, 225 Fifth Avenue, Dept. H-4, New York 10.

**START** Your own business on credit. Always your own boss. 1554 dealers, sold \$5,000 to \$26,500 in 1948; their average \$6,742. We supply stocks, equipment on credit. 200 home necessities. Sales experience not needed to start. Wonderful opportunity to own pleasant profitable business backed by world-wide industry. Write Rawleigh Co., Dept. B-U-PPM, Freeport, Ill.

**MAKE Money** fast. Sell gorgeous, new metal and \$1 plastic greeting card assortments. 100 other sell-on-sight items. 21 all-occasion cards for \$1.00, birthday, Easter, relative cards. Wrappings, scented stationery, gifts. Amazing profits. Bargain offers. Write for samples on approval. Hedenkamp, Dept. PM-4, 361 Broadway, New York.

**BETTER** Way to extra money! Sell outstanding new plastic, metallic greeting cards. Gift wrappings, scented stationery. Profits to 100%. Bonus. Request free samples exclusive name imprinted and floral stationery, free catalog and feature all-occasion samples on approval. Special offers. New England Art Publishers, North Abington 203, Mass.

**MAKE Money** every day. Sell newest air cushion shoes. Big advance commissions, bonuses. Complete line lightning sellers. Special shoe offers. Premiums. Experience unnecessary. Free outfit. Merritt Shoes, I-50, Brockton, Mass.

**AMAZING Offer—\$40** is yours for selling only 50 boxes. Also entirely different, new deluxe all-occasion assortment with television card. Little pearls, hankie gift greetings, other surprise items. Feature boxes on approval. Free samples imprinted stationery and rose scented notes. Write today. It costs nothing to try. Cheerful Card Co., 1154, White Plains, N. Y.

**MAKE \$25.00** Quickly showing Write-well greeting cards, stationery, name labels. "How to make money" booklet free. Samples on approval. Writewell, 500 Transit Building, Boston.

**SELL** DuPont nylon uniforms. Complete line famous exclusive Hoover styled nylon uniforms for beauty shops, nurses, doctors, waitresses, others. Best quality, splendid values. Exceptional income. Real future. Equipment free. Write fully. Hoover, Dept. C-100, New York 11, N. Y.

**ABSOLUTELY Free!** Big package actual sample fabrics and style presentation of dresses, lingerie, hosiery, etc. Take orders. Commissions big. Send no money. Melville Co., Dept. 5276, Cincinnati 3, Ohio.

**AT Last!** Something new and sensational in everyday cards. Make extra money fast! Show gorgeous satin velour metallic cards. Get orders easy. Scented stationery, charmettes, napkins, kiddie cards. 25 other assts. retail 60c to \$1.25. Samples on approval. Puro Co., 2801 Locust, Dept. O40-B, St. Louis 3, Mo.

**MORE Money,** selling Sunshine's everyday greetings. Little Dutch garden 21, millinery fashion notes, value-packed 48 Sunshine notes, beautiful pastelle suede plus birthdays, sympathy, plastics, children's, gift wrap, imprinted stationery and napkins. Outstanding values, profits. Write today, samples on approval The Sunshine Art Studios, 115 Fulton St., Dept. PM-2, New York 8, N. Y.

**REAL Cash income!** Sell exclusive cushion shoes insulated against summer heat. Advance commissions. Bonuses. Free new selling outfit. Concordian Shoes, G-1 West Concord, Mass.

**BRAND New!** Amazingly different and smart everyday cards. Magic window designs. 2 in 1 metallics. Take easy orders. Pays up to 100% cash profit. Big line of everyday assts. retail 60c up. Personal stationery, coasters, napkins. Free imprint samples. Assortment on approval. Write today. North Star, 31 Glenwood, Dept. F-18, Minneapolis, Minn.

**YOU** Positively sell our business cards by mail. Successful "beginner's" plan gets lifetime repeat orders mailed you. Free details. Lynn, 5710-A Bankfield, Culver City, California.

**NOW** We are positive! Pro-Check-Tor—the \$3.95 check protector designed for everyone will be the sensation of 1950. You can make thousands. 23,000,000 waiting prospects. Don't pass up this opportunity. Federal Pro-Check-Tor Co., 627-C Grove, Evanston, Ill.

**MORE Money**—So easy! Sell distinctive new greeting cards, stationery. Fast selling plastic, metallic, 3-dimension, 21-card \$1.00 all-occasion assortments. Profits to 100%. Exclusive gift wraps. Novel "double" cards. Animated books, gifts. Bonus. Special offers. Write for free samples exclusive name imprinted decorated stationery and feature all-occasion samples on approval. Elmira Greeting Card Co., 2209, Elmira, New York.

**EXCLUSIVE Agency.** Power mowers—\$49.50. Delivered. Modern, 7401-BM, North Kansas City, Mo.

**FREE Samples**, and amazing plan, giving you gorgeous dress without penny cost. Rush name today, with dress size. Hartford, Dept. B-335, Cincinnati 25, Ohio.

**ENJOY Earning \$85.00 weekly** selling shoes direct. Experience unnecessary. No investment. Advance commissions. Bonus. Free outfit. Samples. Paragon Shoes, 739 Columbus, Boston, Mass.

**NEW "Sponge" wall cleaner.** Erases dirt like magic. Wallpaper, painted walls, ceilings. Saves redecorating. Lightning seller. Samples sent on trial. Kristee 143, Akron, Ohio.

**GUARANTEED Battery restorer.** 400% profit. Steady. Box 7-F, Ingiewood, Calif.

**CASH In** on tremendous demand for new low priced burglar alarm for cars, homes and farm buildings. Nothing like it. Everybody wants one. 286% profit. Unique sample offer. Northwest Electric Co., Dept. B10, Pukwana, S. Dak.

**MAKE \$50 Selling America's leading** all-occasion greeting card assortments. Samples on approval. Complete line fast money makers. Free samples imprinted and monogrammed stationery, napkins and guest towels. Write Lorain Art Studios, Dept. AO, Vermillion, Ohio.

**BLUE Display stock signs** for stores and bars, \$6 per hundred, 15 trial signs \$1. Hudak, 125 Sullivan St., New York 12, N. Y.

**MAKE 1950 Pay big.** Sell improved Shopwel shopping bag. Every housewife prospect. Quick turnover. Over \$1.00 profit. Bonus plan. No investment. Sample \$1.50. Request details. Johnson Brothers, 730 Illinois, Morris, Illinois.

**EASY Sales!** Guaranteed button hole maker \$1. Fits any sewing machine. Large profits. Particulars free. Telford Sales Company, Telford 1, Penna.

**\$1 STARTS You in business.** Sell top quality \$1.00 ties. Now only \$7.20 dozen, your profit \$4.80 dozen. Regular \$1.50 up values. Send \$1.00 for introductory offer two ties. Catalog complete line free. Phillip's Neckwear, 20 West 22nd St., Dept. K-40, New York 10.

**SELLS Fast to housewives.** Book of 760 household hints. Sample with prices—\$1. King Sales Service, 55-P Oleander, West Springfield, Mass.

**STA-DRI Water repellent rainproofs** hats, shoes, garments, etc. Big profits. Amhar Industries, Plant 5-C, Huntington, N. Y.

**CASH In** on tremendous demand for new cheap oil burner that fits in cooking-heating stoves and furnaces. Burns all kinds of oil including crankcase. Lifetime guarantee. Big profits. Be first. Write quick to Northwest Mfg. Co., 1093 Main, Mitchell, S. Dak.

**MAKE Big money** with fast selling item every automobile operator will buy for \$1.00. Send \$1.00 for two introductory samples or \$5.00 for one dozen samples, postage prepaid. Pepsco, 117 Arch Street, Philadelphia 6, Penna.

**PROFITS On repeat sales.** Be a distributor! Supply guaranteed tonics, shampoos, etc. to barber and beauty shops, wagon jobbers, stores. Metheny's Supply House, Paragould 5, Arkansas.

**SELL New clothing.** Lowest prices. Operate from home, auto, store. Enormous profits. Big catalog free. National Mail Order, 1219-F South Jefferson, Chicago.

**BIG Profits—Amazing Safe-Lock** (for cars with center opening doors) locks rear doors; children can't fall out. Dollar item sells on sight! Send 50c for sample and details. Safe-Lock, Box 1071-M (PM2), Pasadena, Calif.

**TALKING Tape,** pull thru box, actually speaks! 500% profit. Loud demonstrator 25c. Box 1530-G, San Francisco.

**SELL Balloons! Combs! Novelties!** Excellent sideline. Carleton House, Texas City, Texas.

**BUY Thousands** of nationally advertised products direct from manufacturers and distributors. Write for "Buy Direct and Save." Service Publishing, 218-A Investment Bldg. Pittsburgh 22, Penna.

**FREE Nylons** given if Kendex hosiery runs or snags! World's only women's hosiery sold with written guarantee amazing everybody. Mere words could not express unbelievable money-making opportunity. Fantastic earnings become reality. Armstrong earned \$202 in 9 days. Watkins sent 92 orders in one day. Imagine replacing hosiery free regardless of cause—whether use or abuse! Truly sales dynamite for terrific profits. Even if you never sold before, three magic words: "Guaranteed Against Everything" will open doors for you—make women listen and pour money in your pocket. Nationally advertised in Life, Ladies Home Journal, Saturday Evening Post, McCall's and Woman's Home Companion. Awarded Seal of Approval by Good Housekeeping. 75 million readers will see Kendex advertising to help you make quick sales and big money. Complete line from sheerest 15 denier 51 gauge to heavy 70 denier service. Sizes 8½ to 11½; lengths 28 to 35 inches; latest fashion colors plus white; full fashioned seamed and seamless. No competition because Kendex nylons are not sold in stores. Also complete line men's hosiery actually guaranteed for one full year or replaced free. Nothing like this anywhere. Includes rayon, nylon, lisle, wool, cotton, mixtures etc. All styles, patterns, colors, prices to please everybody. 200,000 pairs constantly in stock for fast delivery. Thousands shipped daily. Over 30 years in business. You need no money or experience. Nothing to pay now or later. Just show free outfits. Write orders. We deliver and collect. Big advance cash plus huge bonus. Earn money spare or full time—exclusively or as side line. No restrictions. Become manager—appoint others to sell for you—earn steady income on their sales. Man of woman, young or old, experienced or beginner, you can make money and friends writing orders. Everything you need is furnished free, including sales books in color, samples of hosiery materials etc. Simply write your name and address on postcard and make money next week with money-making outfits sent free and prepaid. No obligation. Kendex Company, Babylon 53, N. Y.

**MEXICAN Feather pictures.** Big profits! No investment! Details, sample, 10c stamps. Sylviap, Apartado 9036, Mexico City.

**AGENTS And distributors** wanted. Big profits. Amhar Industries, Plant 5-D, Huntington, New York.

**DRESSES, 18c; Coats \$1.00, blouses 35c.** Free catalog. Crown, 164-P Monroe Street, New York 2.

**WHERE To buy 800,000 articles** and nationally advertised merchandise direct from manufacturers and jobbers. Sent free. "Buy direct and make bigger profits." Glass Pub. Co., Ellwood City 7, Penna.

**\$100.00 FAST—Easy.** New office necessity does it. Hudson, 934 Lakeside, Chicago 40.

**NEW! Stainless steel, burglar-proof** window guard! Sells itself! Millions of eager prospects! Literature, samples: \$1. Artware Corporation, 11110 Ventura Blvd., North Hollywood, California.

**BE Renewal headquarters** for all magazines. Handle everything at home. Big profits. No experience—no capital needed. Free catalog tells how. Write: McGregor Magazine Agency, Dept. 500A, Mount Morris, Ill.

**DOUBLE Your income—Sell wool** and cotton uniforms, badges, initial buckles, belts, etc. Write Hook-Fast, Box 480PM, Roanoke, Va.

**FREE Samples.** Big profits showing amazing glow-in-the-dark specialties. House numbers, pictures, plastic novelties, ashtrays, keyholders, religious and nursery objects, etc. Madison Plastics, 303 Fourth Ave., New York 10, N. Y.

**BIG Money taking orders.** Shirts, ties, Sox, pants, jackets, sweaters, shoes, uniforms, etc. Sales equipment free. Experience unnecessary. Nimrod, 4922-BG Lincoln, Chicago.

**AGENTS! 100 Brand new products.** Confidential bulletin monthly. Publishers, Gardenville 8, N. Y.

**JEWELRY Factory** desires salesmen, distributors, jobbers. Pickcraft, 19 Bank Street, Attleboro, Mass.

**BIG Bargains** for big profits. Over 100 sensational values. Men's used suits \$2, pants 35c, topcoats \$1.25, overcoats \$2, shoes 20c. Experience unnecessary. Free wholesale catalog Superior, 1250-A Jefferson, Chicago 7.

**AGENTS: Stamping names** on key protectors. Sample 25c. Stamping outfits, checks, social security and name plates. Hart Mfg. Co., 303 Degraw St., Brooklyn, N. Y.

**AMAZING Ketchup dispenser!** Pumps ketchup out of bottle. Sells fast to housewives, restaurants, stores. King, 55-P Oleander, West Springfield, Mass.

**NEWEST Money-making sensation,** miniature authentic replicas, police and firemen's badges also pocket pieces, key chains. Write for descriptive folder, Hook-Fast Specialties, Dept. 20, Box 1425, Providence, R. I.

**SELL Big money-maker** to men and women. Easy handwork makes fast-selling useful articles. Sunmade Company, Brockton 64, Mass.

**SCHOOL Seniors—Earn 40% commission** selling classmates America's most beautiful graduation name cards. Largest selection. Outsells all others. Free sample kit. Printercraft, Dept. M, 1425 E. Elm St., Scranton 5, Penna.

**SCHOOL Seniors!** Your postal will bring our wonder, Kwick-Sell cardalog of popular graduation name cards. Biggest profits! Only firm giving free souvenir chest and card case. Don't miss out! Hurry that postal! Craftcards, Box 235 (L), Pittsburgh 30, Pennsylvania.

**LOOK! Make money** all year round selling personal initialed individualized belts, buckles, cap badges, tie holders, complete line police and firemen's badges, 2000 emblems to choose. Big profits, whole or part time. Please write today special outfit offer. Hook-Fast Specialties, Box 1425, Dept. 6, Providence, R. I. Established 1926.

**SEWING Machine electrification kit.** Nationally advertised. Has Good Housekeeping Guaranty Seal. Can be demonstrated and sold in 5 minutes. Make at least \$5 per sale. For complete details write today to Brownell Distributors, Inc., Dept. PM, 308 Canal St., New York 13, N. Y.

**FREE Water** and our concentrates, make flavors, lotions, shampoos, 125 products, labels, bottles supplied. Qualco, E20030 Russell, Detroit.

**MAGIC Cleaner—Laundry soap deal.** Hotter than a firecracker. Big profits. Sample free. Bestco, 4642 No. Central, Chicago.

**GOLD Lacquered window sign letters.** Large sizes penny each. New foils. Absolutely beautiful. Free samples. Atlas, 544 W. 79th, Chicago 20.

**EXCELLENT Sideline** for printing and advertising salesmen. Decalomania name plates in small quantities. Great demand. Also, make money with our line of automobile initials and sign letters. Free samples. "Ralco" XL-Roxbury, Boston 19, Mass.

**PHOTO-Salesmen-agents.** Sell beautiful hand-colored plastic enlargements. Collect deposit, we deliver. Profitable sideline. Send card, for free sample kit. Novel Portrait Co., 3343 North Ave., Chicago, Ill.

**AGENTS—300% Profit** selling genuine gold window letters: stores and offices. Free samples. Metallic Letter Co., 438-B North Clark, Chicago.

**CLEAN Up** with plastic rayon towels. Powerful quick demonstration. Ink, grease rinse right out. Every home, every business a prospect. Package 6 towels sells \$1.00. Gross \$54.00. Send \$1.00 sample package. Sunbeam Products, 701 Third St. So., St. Petersburg, Florida.

## HIGH-GRADE SALESMEN

**SALESMEN.** Earn \$50.00 weekly, selling only three pairs shoes daily. Commission and bonus. Wide variety for men, women, children. No investment. Experience unnecessary. Free catalog. Tanners Shoes, 559 Boston, Mass.

**SELL Ultra-blue stock signs** to stores. 1000 slogans, comedy, general, religious. "7x11" cost 6c, sells 35c. Make money. 15 samples \$1.00 postpaid. Lowy, 8 West Broadway, Dept. 512, New York 7.

**ADVERTISING Book matches—Cash in** on big demand; sell union label matches. Cuts for all businesses and political parties. Free powerhouse selling kit, low prices, protection guaranteed on repeat orders. Cash commissions. Superior Match Co., Dept. M-250, 7530 Greenwood, Chicago.

**SALESMEN—Absolutely make \$50.00 a day.** New sensational utility item for every food, beverage outlet, etc. Samples furnished. Johnson-Hill, 53-A West Jackson, Chicago.

**CALENDAR Cards—10 beautiful** assorted subjects with customers advertisement. Samples, particulars 25c. Paramount, 1187 Broadway, New York 1.

**SALESMEN**—Sell America's finest, biggest line of adv. specialties. Sensational sellers to all types of business. Big commissions advanced. Sensational sales plans nets you top earnings. Free outfit. Charms & Cain, 407B South Dearborn, Chicago 5.

**OVER 50% Profits.** Complete fire control line. Every sales help. Red Ball Inc., Box 1552, Salt Lake City, Utah.

**RAT-SNAP 35c; 60c; \$1.00 Size.** Ferto-Pots; lawn seeded soil. Allen Company, Pittstown, N. J.

**WHY Not try selling?** Men have succeeded selling shoes who believed they could not sell. Free selling outfit puts you in secure business. Consolidated Shoe System, Dept. S-540, Chippewa Falls, Wis.

**EARN Big money fast!** Sell finest-quality advertising work uniform to garages, factories, filling stations, etc. Free selling kit. Topps, Dept. A-20, Rochester, Ind.

**HARDWARE**—Manufacturers agent calling on hardware outlets to handle nationally advertised homeworkshop. Liberal commissions paid weekly. We carry accounts. Send resume. Eastport Corp., Box 364, New Britain, Conn.

**NEW Jobs open in selling!** Send name, address for five free issues of Opportunity Magazine's money-making guide, listing hundreds of companies who'll pay you well, full or part-time. No experience needed. Opportunity, 28 E. Jackson, Dept. 17, Chicago 4, Ill.

**BIG Money taking orders.** Shirts, ties, Sox, pants, jackets, sweaters, shoes, uniforms, etc. Sales equipment free. Experience unnecessary. Nimrod, 4922-AN Lincoln, Chicago.

### EDUCATIONAL AND INSTRUCTION

**LINGUAPHONE** Makes languages easy. At home learn to speak Spanish, Portuguese, Italian, French, German, Russian, by quick, easy Linguaphone Conversational Method. Save time, work, money. Send for free book. Linguaphone Institute, 83 RCA Bldg., New York 20, N. Y.

**MUSIC Lessons.** Be your own teacher. Learn at home. Simple as A-B-C—everything in print and pictures. Real notes, no numbers or trick music. Lessons consist of catchy tunes, no tiresome exercises. In a few months you'll amaze your friends! Costs few cents a day. Over 850,000 students. Send for free book and print and picture sample. Mention favorite instrument. U. S. School of Music, 72A Brunswick Bldg., New York 10, N. Y.

**HOME Bible course.** Simple, helpful, instructive. Total cost \$4.00 includes textbooks, stationery, examinations, certificate. \$1.00 starts you, or simply request prospectus. The Bible Study School, 378 Van Houten Street, Paterson 1, N. J.

**"HOW To Break and Train Horses"**—A book every farmer and horseman should have. It is free; no obligation. Simply address Beery School of Horsemanship, Dept. 1102, Pleasant Hill, Ohio.

**MAKE Up to \$35-\$45 week** as a trained practical nurse! Learn quickly at home. Booklet free. Chicago School of Nursing, Dept. M-2, Chicago.

**BE A real estate broker** through home study or classroom instruction. Write for free book. Approved for veterans. Weaver School of Real Estate, 15 E. Pershing Rd., Box CP-2, Kansas City 8, Missouri.

**EXPORT!** Learn at home from established world trader. Big paying positions. Your own profitable world-wide business by mail order without capital; or travel abroad. Experience unnecessary. Free booklet. Mellinger, 102W, Los Angeles 24, California.

**HOME Study course, drugless therapy.** Free literature. Institute of Drugless Therapy, Tama, Iowa.

**LEARN The collection agency business.** Highly profitable. Easily mastered. Free folder. Cole Associates, Syracuse 2, N. Y.

**ELECTRIC Appliance service handbook** with catalog C-50, \$1.00 (refunded on \$5.00 order). C-US Supply, 2512 Prevost, Fort Worth 7, Texas.

**YOU For president of your own credit-collection business.** Many who answered our ads now have their names on office doors. Franklin Credit, Roanoke 7, Va.

**INVESTIGATOR Training.** Phillips Secret Service System, 1917-B North Kenneth, Chicago 39.

**3800 LATEST Used correspondence courses.** Catalog 50c. EG, Elmsford, N. Y.

**WANT U. S. government job?** Start high as \$66.35 week. Men—women. Qualify now for secure positions. Many openings expected. Experience usually unnecessary. Write for free 40-page book showing jobs, salaries, sample tests. Franklin Institute, Dept. B-24, Rochester, N. Y.

**MATHEMATICS,** Masterkey to well-paying fields. Individualized instruction courses as low as \$6. Pay-as-you-study. NCS, Box 27, St. Johns, Brooklyn 13, New York.

**BOOKKEEPER,** Male or female. Study practical credit management with an experienced credit man. J. Cooke, 116 St. Stephen St., Boston, Massachusetts.

**USED Correspondence courses** and educational books bought, sold, rented. Catalog free. Educational Exchange, Summerville, Ga.

**PHOTOGRAPHIC Mind** with Super-memory. Write Thor Books, P-2, Box 1210, Chicago.

**VIS-ED Vocabulary flash cards** makes language easy. Learn to read or speak French, German, Latin, Spanish. 1000 printed vocabulary cards. Box \$2.00 prepaid. Visual Education Association, 230 West Fifth Street, Dayton 2, Ohio.

**HOW To get a job** the scientific way. Take your pick of the jobs you should have. Secure your future. Send for details. Bushnell, 25 Union Park, Boston, Mass.

**READ With speed!** 60% faster with new easy three lesson course. Save time. Learn more. Earn more. Lesson one 50c. Brownson, 9111 Hoyne, Chicago 20.

**BIBLE Course free.** Write. Victory Service, Dept. 250PM, Emmaus, Penna.

**FREE Booklet** "How to make working contact with the bigger man within you," with full details about our home-study "behavior-control" plan. Let us send yours without obligation. School of Personal Psychology, Tenth Floor, Washington Bldg., Louisville 2, Ky.

**USED Correspondence courses.** Bought. Sold. Rented. Free literature. Baker, 5509-B Winthrop, Chicago 40.

**INVESTIGATORS** Needed in every town. National, 3911 Tacon, Tampa 9, Florida.

**FREE "Check-Chart."** Income "booster" plan. Professor Martin, Bonners Ferry, Idaho. Mention occupation, plans.

**"BETTER Memory"** will help you win friends and influence people. Write Thomas D. Harrison, 726 N. 15th, Waco, Texas.

**USED Correspondence courses** and books bought, sold, rented and exchanged. Catalog free. Lee Mountain, Pisgah, Alabama.

**BE A disc jockey.** Pays big. Easy to learn. Free details. Jockey Jack, Box 5751, Chicago 80m, Illinois.

**PIANO Tuning pays.** Learn this profitable profession at home. Our Tonometer and mechanical aids make learning easy. No knowledge music necessary. Diploma granted. Largest and oldest school—52nd year. G.I. approved. Write for booklet. Niles Bryant School, 78 Bryant Bldg., Washington 16, D. C.

**BOOKKEEPERS!** Increase your earnings! Operate your own simplified "dollar-a-week" bookkeeping and tax service. Full or spare time. Details free. No obligation. Ellis, Box 200, Cedar Grove, N. C.

**WRITE For pay and pleasure!** You can make extra money, have fun, when you take our "earn while you learn" writing courses. We back up our statement with 31,000 satisfied students. Send penny postal today for free details. Comfort Writer's Service, 200 S. 7th St., Dept. PM150, St. Louis 2, Mo.

**SHORTHAND** In one week. Easy long-hand system. Excellent for secretaries, students. \$1.48. Zinman, 215J West 91, New York 24, New York.

**STUTTER? Stammer?** Literature sent free. Teurfs Studio, 25 E. Jackson, Chicago 4, Ill.

**SECRET Investigation.** Experience unnecessary. Investigators particulars free. George Wagner, M 125 West 86th, New York.

**MEDICAL Laboratory Technicians** in great demand. We train you in your own home. Catalogue free. Imperial Technical Institute, Box 973-J, Austin, Texas.

### PLAYS, STORIES, MANUSCRIPTS

**I WANT New writers** to cash checks of \$1 to \$100 offered daily. The easiest way to write for pay. No previous experience necessary. Free details. Saunders M. Cummings, 468-11 Independence Bldg., Colorado Springs, Colo.

### BUSINESS SERVICE

**BOOKKEEPERS!** Salesmen! Keep books for small businesses with, or sell our amazingly simplified, double entry system and money comes easily. Complete system, with operating instructions, retails for \$10.00. Introductory system is yours for \$7.50. Order yours now. Master Accounting, 4315 Faculty Avenue, Long Beach 8, Calif.

**NEW Products,** Bulletin 35c. George Chaffee, Researcher, 1611 Chicago Ave., Evanston, Ill.

**HOT Prospects—100, \$1.00; 1000, \$4.00.** Zenith, Box 95, South Orange, N. J.

**MIAMI Postmark!** Letters 25c each. McDowell, 504 Pacific Building, Miami 32, Florida.

### SPECIAL SERVICES

**DRUG Products consultant** advises about formulas, federal regulations, labels, advertising. Write Halm, Box 1052, Glendale 5, California.

**CANADIAN Mailing.** Kelowna, B. C. postmark. Letters received, forwarded, 25c each. Ritchie, Box 686, Kelowna, B. C., Canada.

**MECHANICAL Design and drafting.** Engines, tools, models, machines. Patent drawings. Registered mechanical engineer. Scott Nicoll, 1433 1st Ave., York, Penna.

**DRAFTING,** Mechanical design, detailing. Send sketch and particulars for estimate. Robert Worsham, 5635 Cottage Grove, Chicago 37, Ill.

**MAKE Our Chicago address yours,** for profit and prestige. Business or personal mail. Low rates. Write for free details. Schultz House, 3116 Seminary, Chicago, Ill.

**IF You sincerely desire to improve your position** in life write us. No charge whatsoever. Self Development System, Box 6370A, Chicago 80.

### CARTOONING, COMMERCIAL ART, SHOWCARD WRITING, SIGN PAINTING

**SHOWCARD Writing pays big!** Learn rapid, artistic lettering quickly, easily. Our low-cost course shows how. Details free. Sherwood Publishing Co., Irvington 6, N. J.

**CARTOON Your way to success!** Internationally known instructor. Raye Burns, will personally teach you to create salable, original cartoons at home. Course of 26 lessons only \$2.85. Send remittance with order or write for free details and addresses of successful students. Raye Burns School, Box 3583-M, Cleveland 18, Ohio.

**"HOW To Make Money With Simple Cartoons"**—A book everyone who likes to draw should have. It is free; no obligation. Simply address Cartoonists' Exchange, Dept. 92-C, Pleasant Hill, Ohio.

**LEARN Sho-card writing.** Hollywood Sho-Card School, Box 710, Alhambra, Calif.

**FREE Lance cartoon markets.** Complete list \$1.00. National Cartoons, Box 10215, Tampa, Fla.

**BARGAIN, Quick landscape painting,** poster art—lettering, art lessons, catalog 10c. Art Book Shop, Arnold 8-D, Missouri.

**TALENT Test, information.** Give age. Art. Box 8066, Dallas 8, Texas

**SIGN Painting taught at home.** Test lesson free. Ben Kerns, Box 812-T, Greenville, S. C.

**9 ALPHABET 3 Numeral pattern sets** and catalog, \$1.00. Sign Letter Distributors, P.O. Box 101, Mineola, N. Y.

**CHALK Talks.** Laugh producing program, \$1.00. Catalog 10c. Balda The Cartoonist, Oshkosh, Wisconsin.

### ADVERTISING AGENCIES, LETTER WRITERS, FOR ADVERTISERS

**MAILING Lists; \$5.00-1000 up.** Write Dixie Service, King, N. C.

**SUCCESSFUL Advertising,** only \$2.00, postpaid. Satisfaction guaranteed. William Bennett, 114-35K 116th Street, Ozone Park 16, New York.

**FREE! 1949 Advertisers Rate and Data Directory.** 52 pages! E. H. Brown Advertising Agency, 20 N. Wacker, Chicago 6.

**ADVERTISERS! Reach nearly 18,000,000 readers.** 25 Sunday national key newspapers, 18 words, \$51.50. "Terrific pullers." 20 popular newspapers, \$10.00. "Free booklet." Special—One inch display 2,-821,198 circulation, \$48.30. Newmark's Advertising Agency, (Established 1893), 217-7th Ave., New York 11.

ADVERTISE: 24 Words, 40 newspapers \$3.50. Lists free. Advertising Bureau, 10511-C Springfield, Chicago 43.

AVOID Costly advertising mistakes. Get enlightening Ad-Guide and Ratebook leading newspapers, magazines, mailing lists, 10c. Chicago Advertising Agency, (Established 1900), Chicago 4.

24 WORDS in 50 weeklies, \$4.96. J. Darrell, 730 Hays, Jackson, Tennessee.

REACH Spanish-speaking mail-order buyers. Great new market for your merchandise. Your classified ad in the Spanish Edition of Popular Mechanics will bring you some nice business from this new field. Rate only 25c per word. Circulation 100,000 copies. Mail a trial ad right now. Popular Mechanics Magazine (Spanish Dept.), 200 E. Ontario Street, Chicago 11, Ill.

ADS Placed in out of town newspapers and magazines. Low rates. Catalogue free. Ideas that pay. Baker Advertising Agency, Successors Ankrum Agency, 189 W. Madison, Chicago 2.

### TYPEWRITERS, DUPLICATORS, OFFICE DEVICES

ADDING Machine. Desk model portable. Adds, subtracts, divides, multiplies. \$12.95 postpaid. Johnson, 2611 Harriet, Minneapolis 8, Minnesota.

RECONDITIONED Typewriters, printing devices. Write Dixie Service, King, N. C.

ABACUS, Loy's. Does work of adding machine and slide rule. \$6.50. Details free. Loy's, 1317 Rhode Island Ave., N.E., Washington 18, D. C.

NEW. Selffeeding mimeograph prints postcard to full letter size. Only \$27.50. Factory discount to distributors. Dansen Company, Hopkins, Minnesota.

ADVERTISE. Increase business. "Printomatic" selffeeding "mimeograph" post card duplicator prints, reproduces, thousands anything typewritten, handwritten, \$13.50. Literature. Pittsburgh Typewriter Company, 336-3 Fourth Avenue, Pittsburgh 22, Penna.

### RUBBER STAMPS AND OFFICE SUPPLIES

MIMEOGRAPH Paper, 68c ream, samples. Brookman, 56-A West 24th, New York 10.

RUBBER Stamps. Send for catalog. Excelsior, Box 500, Shreveport, Louisiana.

### PRINTING, MULTIGRAPHING, MIMEOGRAPHING, GUMMED LABELS

PHOTO Offset printing. No cuts needed. Lowest prices. Literature free. Ramshaw Co., 180 West Washington, Chicago.

MIMEOGRAPHING—100 8½ x 11 \$1.00, additional hundreds 50c. Mimeographing, Madison, Tenn.

GUMMED Labels, stationery. List free. Reed, Box PM-135, Spiro, Okla.

QUALITY Printing. We specialize in publications, newspapers, tabloids. Send copy for estimate. Bagby Printing Co., Georgetown, Ohio.

ENVELOPES: Hammermill letterheads: 100—\$1.00. Odum, Box 9345, Tampa, Florida.

1000 BUSINESS Cards \$1.85 prepaid. CPR Sales, 914 East 217 Street, New York 67.

1000 EMBOSSED Business cards \$2.75. Samples. Avery Printery, 112-Z Elizabeth, Wichita 12, Kansas.

ENVELOPES, Paper, tags. Lowest prices. Jeka, 326 First St., Jersey City 2, N. J.

BUSINESS, Personal stationery, reasonable. Cook, 730 West Gift, Peoria 5, Ill.

MIMEOGRAPHING—Reasonable. Any copy. Mailers Service, Box 606-B, Chicago 90, Ill.

1000 BUSINESS Cards \$2.50. 2000 \$4.50 prepaid. Murrell, 715 Cedarcroft Road, Baltimore 12, Md.

BUY Your printing wholesale. Sell to others. Lowest prices in America. Louis Enterprises, Box 5, Hazel Park, Mich.

100 8½ x 11 HAMMERMILL Letterheads and 100 envelopes \$1.85. Herbert Hudson, Centredale, R. I.

5000 6¼ ENVELOPES Printed \$2.75 per thousand, price list free. Michel, Box 76F, New York 16.

200 SINGLE Sheets or 100 folded and 100 envelopes printed, Hammermill bond, \$1.50. John T. Robinson, Printer, Ansonia, Conn.

SEND 10c Now, for our 48 page 1950 price list—refunded first order. McCall Press, 1326 South 27th, Omaha, Nebraska.

1,000 EMBOSSED Business cards \$4.00. Geo. Siman, 3538 W. Melrose St., Chicago 18, Ill.

1000 BUSINESS Cards \$2.50 prepaid. Samples free. Reliable Print Shop, 905 East Jefferson, Louisville 6, Ky.

BETTER Grade printing reasonable. Estimates on anything. Economic Press, Leonia, N. J.

MIMEOGRAPHING—Any copy; bargain prices! Topical Emprise, 1527 Highland, Box 42-P, Louisville 4, Ky.

QUALITY Printing! Free price list. Nationwide Printing Company, Dept. PM, 2337 Bath Avenue, Brooklyn 14, N. Y.

500 ¾x2¼ FOUR Line gummed stickers 35c; red border 50c. Moritz Printery, Saginaw, Mich.

MIMEOGRAPHING—Letters, pricelists, formulas, instructions. Lowest prices. Lem's Letter Shop, 5710 Stanton, Detroit 8.

### PRINTING OUTFITS AND SUPPLIES

PRINT Your own cards, stationery, circulars, advertising. Save money. Simple rules. Print for others, nice profit. Raised printing like engraving too. Have home shop. Details free. Kelsey Presses, L-11, Meriden, Conn.

MAKE Your own rubber printing cuts. Self molding process. Plexirubber, Argyle 1, Wisconsin.

BARGAINS—Presses, type. Lists 5c. Garza, 98 Pleasant, Cambridge 39, Mass.

PRESSES, Type, cabinets, supplies. List for stamp. Lincoln Press Company, 220G Hartwell, Fall River, Mass.

PRINTING Presses, type, supplies. Lists 3c. Turnbaugh Service, Loysville, Penna.

### PATENT ATTORNEYS

PATENTS—If you have a valuable invention, you are advised to authorize a preliminary search through appropriate classes of United States patents. This firm is registered to practice before the patent office, and is available to make such search and report to you concerning the probable patentability of your invention. Instructive booklet with "Evidence of Invention" form sent upon request. Victor J. Evans & Co., 531-B Merlin Building, Washington 6, D. C.

INVENTORS—Patent laws encourage the development of inventions. The Rules of Practice of the U. S. Patent Office advises—unless an inventor is familiar with such matters; that he employ a competent registered attorney or registered agent, as the value of patents depends largely upon the skilful preparation of the specifications and claims. Write for further particulars as to patent protection and procedure and "Invention Record" form at once. No obligation. McMorro, Berman & Davidson, Registered Patent Attorneys, 134-V Victor Building, Washington 1, D. C.

PATENTS, Trademarks, Mexico, Latin America. Particulars free. International Patent Bureau, Mexico, Apartado 10727.

PATENTS—Trade marks. Gustave Miller, Registered Patent Attorney, 10-A Warner Building, Washington 4, D. C. Patent Lawyer.

REGISTERED Patent attorney offers services. Sanders, 6430 Evans, Chicago 37, Ill.

HERMAN Lewis Gordon, registered patent attorney. Patent investigations and opinions. Warner Building, Washington, D. C.

PETER Fries, Jr., Registered Patent Attorney. Patents, trademarks, novelty searches, copyrights. 110 East 42nd Street, New York City.

CANADA—Ramsay Company Registered, 273 Bank Street, Ottawa, Canada.

PATENTS—Trade marks. Irving L. McCathran, 315 McLachlen Bldg., Washington 1, D. C. Registered Patent Attorney.

INVENTORS: When you are satisfied that you have invented something of value write me, without obligation, for information as to what steps you should take to secure a patent. Write Patrick D. Beavers (Formerly Randolph & Beavers) Registered Patent Atty., 935 Columbian Bldg., Washington 1, D. C.

C. A. SNOW & Co.—M-427, Snow Building, Washington 1, D. C. Registered Patent Attorneys. Write for information.

"INVENTOR'S Guide" free on request. Frank Ledermann, Registered Patent Attorney, 154 Nassau St., New York 7, N. Y.

INVENTORS: Learn how to protect your invention. Unless the inventor is familiar with patent matters, he should engage a competent registered patent attorney or agent to represent him. We are registered to practise before the U.S. Patent Office and prepared to serve you in handling your patent matters. "Patent Guide for the Inventor" containing detailed information concerning patent protection and procedure with "Record of Invention" form will be forwarded to you upon request—without obligation. Clarence A. O'Brien & Harvey Jacobson, Registered Patent Attorneys, 01B-A District National Building, Washington, D. C.

INVENTORS: Without obligation, write for information explaining the steps you should take to secure a patent. John N. Randolph, Registered Patent Attorney, 203 Columbian Bldg., Washington 1, D. C.

INVENTORS: Write for free brochure "Evidence of Invention." Labiner, World Building, New York 7.

PATENT Practice before U. S. Patent Office. Validity and infringement investigations and opinions. Booklet and form "Evidence of Conception" forwarded upon request. Lancaster, Allwine & Rommel, Registered Patent Attorneys, Suite 411, 815-15th Street, N.W., Washington 5, D. C.

INVENTORS. For "Record of Invention" form, contact Carl Miller, Registered Patent Attorney, Woolworth Building, New York.

### FOR INVENTORS

INVENTORS—Patent laws encourage the development of inventions. The Rules of Practice of the U. S. Patent Office advises—unless an inventor is familiar with such matters; that he employ a competent registered attorney or registered agent, as the value of patents depends largely upon the skilful preparation of the specifications and claims. Write for further particulars as to patent protection and procedure and "Invention Record" form at once. No obligation. McMorro, Berman & Davidson, Registered Patent Attorneys, 134-T Victor Building, Washington 1, D. C.

INVENTORS—If you consider your invention to be something of importance, you may take steps to protect it with a U. S. Patent which gives you the right to exclude others from making, using and selling your invention as claimed. "Patent Protection for Inventors" booklet outlining steps to take to secure patent protection will be mailed promptly without obligation. Victor J. Evans & Co., Merlin M. Evans, Registered Patent Attorneys, 532-B Merlin Building, Washington 6, D. C.

SEARCHES \$5.00. Including patent copies. Same reliable search that we conduct for patent attorneys. Free protection forms, 48 hour service. Patent Service Institute, 945-A Pennsylvania Avenue, Washington 4, D. C.

PATENT Search \$5.00. Confidential. Reliable. Individual service. Prompt report. P. Davis-Carrington, Box 7530, Washington 4, D. C.

MAKE Your good inventions produce profits! 57 financing, selling and other service organizations want to help. Authorized descriptions. Five day return privilege for full refund. \$2 brings you book "Directory of Inventor Aids," Drawer 1289-K, Clearwater, Fla.

INVENTORS: Learn how to protect your invention. Unless the inventor is familiar with patent matters, he should engage a competent registered patent attorney or agent to represent him. We are registered to practise before the U.S. Patent Office and prepared to serve you in handling your patent matters. "Patent Guide for the Inventor" containing detailed information concerning patent protection and procedure with "Record of Invention" form will be forwarded to you upon request—without obligation. Clarence A. O'Brien & Harvey Jacobson, Registered Patent Attorneys, 01A-A District National Building, Washington, D. C.

1001 NEEDED Inventions. A new bulletin listing 1001 needed inventions with sound commercial value. Put your talent to work on the right problem. Inventors' Idea Guide. Send \$1.00. Satisfaction guaranteed or return in 5 days for refund. C. J. Specialties, Box 5007, Dept. 12, St. Paul, Minnesota.

INVENTORS: If you have an invention for sale, patented or unpatented, write Institute of American Inventors, Dept. 40A, 1926 Eye St. N.W., Washington 6, D. C.

**PATENTED**, Unpatented inventions promoted. M. Joyce Humphries, 1424 Land-tite, Philadelphia 10, Penna.

**DEDICATED** To more worthwhile inventions; fewer worthless patents. Inquire to-day. Dept. 324, Inventors-For-Industry Inc., 501, 1947 Broadway, New York 23.

**INVENTORS-For-Industry**, Scientific programme for successful inventing improves quality and quantity of ideas and demonstrates modern sales-ways. Dept. 324, Inventors-For-Industry Inc. 501, 1947 Broadway, New York 23.

**INVENTIONS** Wanted. Prominent manufacturers and national distributors look to us for new products. You can also benefit by having us assist you with your invention from the idea stage through to the developed product, fully protected. Ask for Booklet "M." Elo Development Co., Chatham Phenix Bldg., Long Island City 1, New York.

**COMPLETE** Services for inventors. Patent searches including analysis, patent copies. Inventions, patents marketed. Protection forms free. Industrial Patent Reports, Box 1081, Massachusetts Avenue and North Capitol, Washington 13, D. C.

**PATENT** Owner Representative. Years of experience. Can I help you? Charles A. Scott 773PM Garson Avenue, Rochester 9, N. Y.

**INVENTORS:** Without obligation, write for information explaining the steps you should take to secure a patent on your invention. John N. Randolph, Registered Patent Attorney, 202 Columbian Bldg., Washington 1, D. C.

**CASH** For your idea. 280 manufacturers need inventions, patented or unpatented. List free. Invention Bureau, 308M Clinton, Oak Park, Illinois.

**"INVENTOR'S Guide"** free on request. Frank Ledermann, Registered Patent Attorney, 154 Nassau St., New York 7, N. Y.

**INVENTORS.** For "Record of Invention" form, contact Carl Miller, Registered Patent Attorney, Woolworth Building, New York.

**INVENTORS:** The usual first step is to have a search of the U. S. Patents conducted, so I can report on patentability. Write, without obligation, Patrick D. Beavers (Formerly Randolph & Beavers), Registered Patent Atty., 936 Columbian Bldg., Washington 1, D. C.

### INVENTIONS WANTED

**NEW** Inventions wanted. Patented or pending only. Wish to buy outright or manufacture on royalty. Products to be of interest to motorist, housewives, farmers or sportsmen. Write John D. Stransky, Secy., Northwest Mfg. Co., Western Bldg., Mitchell, S. Dak.

**CASH—Royalty.** We manufacture, internationally distribute. C. W. Burbridge, Pres., Automotive-Household Products Co., Oklahoma City, Okla.

**GOOD** Inventions, practical ideas wanted for promotion. Write Jenisch, Burlington, Kentucky.

**EARN** Up to \$2000 year, inventing simple gadgets. Special cash markets. Hendrickson, Argyle 1, Wisconsin.

**LEVEL-Headed** inventors are invited to discuss their plans with Dept. 324, Inventors-For-Industry Inc., 501, 1947 Broadway, New York 23, after obtaining free booklet.

**INVENTIONS** Promoted. Patented or unpatented. Write Adam Fisher Company, 61 Enright, St. Louis, Mo.

**IMAGINEERING:** A new name for successful inventing in the world today. If you are inventive-minded, learn more about it. Dept. 324, Inventors-For-Industry Inc., 501, 1947 Broadway, New York 23.

**INVENTORS—**What have you, patented, patent pending to offer manufacturers? Booklet, information free. Market Contacts, 11106-A2 Longwood, Chicago 43.

**HIGHEST** Royalties—Cash. Request free Booklet "M." Universal Marketing Co., 354 South Spring St., Los Angeles 13, Calif.

**INVENTORS:** Hundreds of manufacturers have requested our assistance in locating marketable new products. Complete information, free. Institute of American Inventors, Dept. 40-D, 1926-Eye St. N.W., Washington 6, D. C.

**CASH** For your idea. 280 manufacturers need inventions, patented or unpatented. List free. Invention Bureau, 208M Clinton, Oak Park, Illinois.

**INVENTIONS** Wanted. Patented or pending only. Inventors' Exchange-B, Hartford 1, Conn.

### PATENTS FOR SALE

**JUST** Invented. New way shaving brush. Only responsible manufacturers considered. Walter Lockhart, 2504 15th St., Denver 11, Colo.

**JUST** Invented. Combination adjustable hair trimmer and razor. Only responsible manufacturers considered. Walter Lockhart, 2504 15th St., Denver 11, Colo.

**BRUSH** For cleaning type. Hyman Jacobs, 90 Brainerd Rd., Allston, Mass.

**INVENTORS:** Test the commercial value of your patented or unpatented inventions, quickly and inexpensively. Write for free information. Institute of American Inventors, Dept. 40-B, 1926-Eye St. N.W., Washington 6, D. C.

### MANUFACTURING

**MANUFACTURING** For particular people. Tool, dies, stampings. Porsberg, Northfield, Ohio.

**FREE** Estimates: Models, small lot manufacture, design, metal, plastics, etc. Petty Manufacturing, 5033 Exposition, Los Angeles 16, Calif.

**WANT** Something made? We'll make it. Consultation free. Write Jayemm Company, Burlington, Kentucky.

**MODELS** — Small lot manufacturing. Metals, plastics, etc. Milburn, Burlington, Kentucky.

### MODELS, MODEL SUPPLIES

**SHIP** Modelers—Are you looking for authentic, precision-made kits? Send 35c for richly illustrated catalog describing more than 30 models retailing from \$3.95—Clipper ships to modern cruisers—also decorative authentic naval and field gun kits from \$4. Address Marine Model Co., Dept. B, Halesite, Long Island, N. Y.

**READY!** Our 1950 catalog of ship model kits and fittings: sail, steam, diesel. Send 25c for catalog. Model Shipways Folio, 60, 476 Main St., Fort Lee, N. J.

**TINY** Power miniature steam engines, locomotives, boilers, fittings, steam tractors. Catalog 25c coin. Chas. Arnold, Plant City, Florida.

**BRASS** Gears and model supplies for the inventors. Send 10c for catalog. Pierce Model Works, Tinley Park, Ill.

**RAILROADERS—**50c Gets new Catalog Reference Manual, State O or HO gauge. Walthers, 247 Erie, Milwaukee 2, Wis.

**BUILD** Historic ship models, complete kits, 39c to \$9. Catalog 10c. Ideal Models, 19 West 18th, New York 11, N. Y.

**STEAM** Locomotives, 1 1/2", 3/4", 1/2", 1/4" scales. Castings, parts, rail, steam fittings! Thorough drawings with instructions. Catalog 35c. Little Engines, Lomita, Calif.

**LIONEL** Trains catalog 10c. 36 pages illustrated. Hobby Shop, 72 West Washington, Chicago 2, Illinois.

**SHIP** And yacht model fittings; blueprints. Send 25c for illustrated catalog No. 24—listing hundreds of items. A. J. Fisher, 1002-1 Etowah Ave., Royal Oak, Mich.

**SHIP** Models and yacht supplies complete. Large 64 page catalogue 30c. Bill Wild's, 510 East 11 St., New York City 9.

### HOME CRAFTSMEN

**ILLUSTRATED** Catalog of burs, cutters, stones, polishing supplies, equipment for working metal, wood or carving plastic 50c, credited first order. Any accessory for handgrinders or flexible shaft. Brass sheet, rod, nickel silver, phosphor bronze, for model makers. Gold, silver, amateur jewelers supplies. Catalog and 48 assorted recut dental drills \$2.00, gross \$4.50 postpaid. Schrader Instrument Company, Independence, Iowa.

**TOYS.** Novelties, furniture, garden figures, lawn chairs, etc. 68 popular plans with full size patterns, \$1.00. Mastercraft 21M, 7041 Olcott, Chicago 31, Illinois.

**LEATHERCRAFT** Supplies, leather and tools, low prices. Send 10c for catalog. Jonas Handicraft Co., (Dept. M-2), Frankfort St., New York 7.

**16 NEW** Lawn chairs, 22 picnic tables, benches, trellises, etc. All 38 plans, with necessary full size patterns, \$1.00. Mastercraft 23M, 7041 Olcott, Chicago 31, Illinois.

**USE** Magnetic jigsaw; cut any size quarter inch, plywood projects. Illustrated instructions. 25c. Raymond West, 2701 Missouri Ave., St. Louis 18, Mo.

**SEA** Shells, cut shells, oil colored shells at lowest prices. Free illustrated catalogue showing many new jewelry designs with instructions. Southern Shellcraft Supply Clearwater Florida.

**LEATHERCRAFT** Tools and supplies. Free catalog. Harte's Craft Shop, Holyoke, Colorado.

**90 ALL** New, full size lawn ornament and novelty patterns, up to 20" high. Only \$1.00. Mastercraft 22M, 7041 Olcott, Chicago 31, Illinois.

**DUPLICATE** Any picture with a simple pantograph, make patterns, etc. Up to 6 times size of original. Detailed plans for constructing yourself, 25 cents. Everson, 6 Franklin, West Orange, New Jersey.

**FREE** Catalog! Unpainted or painted figurines, lamp bases. B. Katon, 7807—21st Ave., Brooklyn 14, N. Y.

**DON'T** Be a drip, use a Brushmaster Wiping Bar. It helps you get professional painting results, stops mess, saves paint, time and money. Fits quarts, and gallon cans. 25 cents postpaid. Ralph Rasmussen Co., Pontiac, Illinois.

**CRAFT** Catalog free. "Arctcraft's Little Giant." 6500 items covering several crafts. "Tops in our field." Arctcraft Leather, Dept. PM, 271 12th St., Oakland 7, Calif.

**MAKE** Money printing emblems, ads on hankies, signs, T-shirts, pennants for merchants, lodges, other organizations. 3c stamp brings catalogue with details for screen printing. Artisan House, 230 W. 4th St., Cincinnati 2, Ohio.

**SHELLCRAFT.** Make jewelry at home for pleasure and profit. Instructions free. \$2 brings shells and material to make 6-pair brooches and earrings. Shell Company, 302 Chamber Commerce Bldg., Miami 32, Florida.

**HOBBYISTS!** Draw patterns easily, quickly. Handy drawing sheets, 17"x22", 1/2-inch ruled squares, 12 for \$1.00 ppd. G-E-M Enterprises, PM1, Box 375, Freeport, New York.

**BIG,** New, practical, fact-ful plastics book shows how to make swell things at home with new liquid plastic. Embed real flowers, butterflies, shells, photos, to make handsome wall plaques, coasters, paper weights, trays, etc. Cast unusual book ends, candle holders, desk sets, lamp bases. Plastize baby shoes or make profile silhouette plaques of children, dear ones. Also explains proved 6-point success plan for starting your own profitable plastics business. Hundreds successful. Send 35c for "A Success Plan for You." Castolite, Dept. TB101, Woodstock, Ill.

**SHELLCRAFT!** Make seashell jewelry, novelties. Income or hobby. Supplies, instructions. Buy direct. Pace's, Box 279PM, Bradenton, Florida.

**TURN** Your workshop into cash. Send dime (refunded first order) for catalog describing hundreds modern, saleable items. Craftplans, 1321-A South Michigan, Chicago 5.

**SPAYDCRAFT** Wood finish—Simple, easy to apply. Brings out life, natural beauty without oils, stains, fillers, shellacs, varnishes. Penetrates; seals against abrasions, scratches, dirt, moisture, alcohol, acids. Saves hours on every job. Natural, \$1.00; mahogany, walnut, dark oak \$1.20, postpaid. Spaydcraft, 131 Huffman St., Bellevue, Ohio.

**PLYWOOD** Money-maker! Sells itself. Plan 25c. Box 56-A, Braintree 84, Mass.

**LAWN** Ornaments. Ready cut patterns, full size, 20 assorted \$1.00 postpaid. Lincoln Craft Studio, Farmington, Conn.

**8 BEAUTIFUL** Full-size whatnot patterns 25c. Joannes, P.O. Box 141-M, Omaha 7, Nebr.

**SELL** Flying duck windmills. Send \$1.50 for sample. B. Reitz, 13820 Wentworth Ave., Chicago 27, Ill.

**80 FULL** Sized patterns. Lawn ornaments, toys, novelties \$1.00. Modern Woodcraft, Saginaw, Mich.

**50 FULL** Size, new 1950 novelty and lawn ornament patterns, up to 20" high, only \$1.00. Pattern Service, Medway 7, Mass.

**OLD** Watch movements, \$1.00 each, six assorted \$5.00. Field Bros., 39-B South State Street, Chicago 3.

**BANDSAW,** Jigsaw owners, let your machine bring extra profits, fun. Free details. Nu-Art, Dept. B, Box 2235, Boston, Mass.

**LEATHERCRAFT—**Two link belt, bill-fold project, instructions, \$2.29 postpaid, craft catalog. Kale Crafts, 2250 Milwaukee, Chicago 47.

**LEATHERCRAFT.** Copper tooling, textile painting. Materials, tools, supplies. Free illustrated catalog. Kit Kraft, 7377 Melrose, Los Angeles 46, California.

**CATALOG.** Patterns: Plywood novelty furniture, lawn ornaments, silhouettes, weathervanes, letters, numerals. Decals, books, booklets. Hundreds illustrations, 10c. Wo-Met, Ashburn, Georgia.

**SHELLS, Plastics, findings. Low prices. Free catalog. Frances Jones, Box 251, Sarasota, Fla.**

**MAKE Gifts from rare and beautiful Oregon myrtlewood, free price list. Myrtlecraft Studio, Grants Pass, Ore.**

**WHOLESALE Shellcraft Book 15c. Large shellcraft kit \$1.69 postpaid. Shell-Art Novelty, Dept. PM, 5th and Moore, Philadelphia 48, Penna.**

**DRESDEN CRAFT Supplies, unpainted figurines. Send for free list. S. T. Farinella, 706 L'Orient, St. Paul, Minnesota.**

**SHELLCRAFT—Free catalogue and instructions. Complete line shells. Smooth beautiful colors. Findings. Rice's Shellcraft, Dept. B, 114 S. Court, Orlando, Fla.**

**LEATHER, Retail, mail orders, catalog, tools, lacing, supplies. National Handicraft Co., 30 Frankfort St., New York City 7.**

**LEATHERCRAFTERS: Belt kits, projects, leather, supplies. Free catalog. Art Leather, 411 Joseph Ave., Rochester 5, N.Y.**

**LEATHERCRAFT. Quality leather, lacing, tools and accessories at bargain prices. Free catalog. Frisco Krafts, Dept. A, Box 3016, Rincon Annex, San Francisco 5, California.**

**SPECIAL Offer: 80 full size toy, novelty, and lawn ornament patterns only \$1.00 postpaid. Lynds, Box 193D, Medway, Mass.**

**46 FROM Square foot plywood. Jigsaw necessary. Write, Woodarts, C-38, Bridgewater, Mass.**

**KNOCKDOWN Cedar chests. Lumber and veneers. Free price list. Giles & Kendall Company, Huntsville, Ala.**

**PROFIT With Larson Leathercraft. Belts, purses, 100 other ideas. Largest supply in U. S. Catalog 10c. Larson, Dept. C, 824 S. Tripp, Chicago 24.**

**JEWELRY Findings, rhinestones, pearls, sequins, cameos. J & M Novelties, Box 464P, Griffith, Ind.**

### MAKE IT YOURSELF

**BARBEQUE Pit, unusual idea, new, different. Plans \$1.00. General Sales, 301 Bank Building, Hollywood, Florida.**

**JUST Off the press—8-page folder illustrating 6 beautiful, popular lamps you can make; for yourself, for Xmas gifts, or to sell others. It's fun, highly profitable; as hobby, or part or full time basis, 8-page folder, 32-page parts catalog, wholesale price list only 25c; refundable first order. Gearon Company, Dept. 400-B2, 27 South Desplaines, Chicago 6, Ill.**

**BUILD Your own work bench, picnic table, using electrically welded steel legs. So simple, just apply lumber and it's complete. Literature free. East Moline Metal Products, Department M, East Moline, Ill.**

**MAKE Your own 20 watt fluorescent lights for \$1.00. Guaranteed plans \$1.00 cash or money order. Checks \$1.15. Specialty Sales, Box 1086, Muncie, Ind.**

**WREN House free with 3 other patterns. Lumber 15c. Sell \$1.50 each. Guaranteed. All postpaid dollar, 4 dimes. Guy Kuns, Greenville, O.**

**GRANDFATHER Clock easily built. Big savings. See ad on page 276.**

**STREAMLINED. Built-in kitchen cabinets to fit any kitchen. Illustrated manual describes designing and construction. All for \$1.00. Thombert Company, Newton 10, Iowa.**

**SAVE 50%-75% Building our Zeolite home water softener. Complete engineered plans \$1.00. Carson Products Company, Room 201, Minneapolis 18, Minn.**

**BUILD Big two foot balsa glider. Will soar hundreds of feet. Complete parts and plans \$1.00. Grosser, 2854 Fairfield Ave., Bridgeport, Conn.**

**BUILD Your own concrete blockmaker. Easy. Inexpensive. Motor or hand. Make block per minute. Write, C. Lee, Mountain View, Okla.**

**BUILD Your own "tractor." Plans, instructions. Walking. Riding. Send postcard. Free information. Ellsworth Tractor Co., D-1, Camptonville, California.**

**SOLAR Water heater systems efficient any locality. Standard materials, low cost. Free facts. Solar Water Company, Box 175, Coral Gables, Florida.**

**"CONCRETE Block Homes." 32 page booklet on how to build. \$1.00. H. C. Lightfoot, Civil Engineer, Richboro 1, Penna.**

### PLANS AND BLUEPRINTS

**BUILD Own farm, home equipment, 180 plans. Catalogue 25c. Dealers wanted. Kimo, Box 307J, New York 19.**

### WATCHES, OLD GOLD, JEWELRY

**GOLD \$35.00 Ounce—Mail old gold teeth, jewelry, watches, diamonds—receive cash by return mail. Satisfaction guaranteed. Free information. Dr. Weisberg's Gold Refining Company, 1500-Q Hennepin, Minneapolis, Minn.**

**SAVE Money—Watches cleaned, repaired. Maximum charge \$4.00. Year guarantee. National Watch Repair, Box 2414W, Cleveland 12, Ohio.**

**WATCHMAKER'S Catalogue 20c, deductible. Tinker kit, instructions, catalogue, \$4.00. Bengal Company, Culver City, California.**

**COSTUME Jewelry manufacturers: illustrated parts list 10c. Conner, Box 188, National Park, N. J.**

**GOLD Plated jewelry supplies—Rhinestones, pearls. Illustrated catalog 10c. Barry's, 47-A Branford Place, Newark 2, N. J.**

**HIGHEST Prices paid for old gold, silver, platinum, diamonds, watches, gold teeth, spectacles. Cash immediately. Goods returned if offer unsatisfactory. Government licensed. United Smelting Works. (The Old Reliable), 39-B South State, Chicago 3.**

**HIGHEST Cash prices paid for old gold, diamonds, coins, gold teeth, rings and watches. Satisfaction guaranteed. Argee, Dept. PM1, 2824 S. Cloverdale Ave., Los Angeles, Cal.**

**HIGHEST Cash paid for old, broken jewelry, gold teeth, watches, silverware, diamonds, spectacles, platinum. Free information. Satisfaction guaranteed. Government licensed. Rose Smelting Company, 29-A East Madison, Chicago.**

**WATCHMAKERS' Journal contains helpful hints on watch repairing. Sample copy 20c. Dean Co., 116-K Nassau St., New York 7, N. Y.**

### SURVEYING INSTRUMENTS

**GUARANTEED Factory rebuilt transits and levels, sale or rent, with purchase option. We will repair, trade or buy old instruments. Write for list M-49. Warren-Knight Co. (Manufacturers of Surveying Instruments), 136 North 12th St., Philadelphia 7, Penna.**

### TOBACCO, SMOKERS' SUPPLIES

**FREE Literature. Pipes and pipemakers' supplies. Carvapipe, 2829-A Dixie, Hamilton, Ohio.**

**CIGARETTE Smokers get wise! Save over half. Parker-15, Hoboken, New Jersey.**

### RAZORS, BLADES, SHARPENING

**FREE! Ball point pen with 100 super double edge blades at \$1.00. Smoother shaves guaranteed. Peerless Company, 1285 Medford, Topeka, Kansas.**

**ELECTRIC Shaver repair. Prompt, guaranteed. \$5.00 trade-in allowance also. Electric Shaver Shop, Box 426, Culpeper, Va.**

### FOR THE HOME

**VENETIAN Blind tape and cord, any color, any size tape 35c yard; cord 7c yard. Willinger Bryer Company, 1411 Devon Ave., Chicago 26, Illinois.**

**GREATEST Home invention since electricity. Illustrated literature free. Robert Poarche, 1034-A N.E. Russet St., Portland 11, Oregon.**

### OF INTEREST TO WOMEN

**SELL Dress fabrics to friends, neighbors. Stylish, beautiful materials. Year round profits. No experience needed. Free details. National, 640 Broadway, Dept. M, New York 12.**

**1000 WAYS To save time, money, labor. Amazing new book "Short-Cuts to Better Housekeeping." 160 pages packed with ideas every housewife will appreciate. Well illustrated. Only 60c postpaid. Popular Mechanics Press, Dept. SC, 200 E. Ontario St., Chicago 11, Illinois.**

### FOR SALE—MISCELLANEOUS

**BRONZE Horses, beautiful. Free picture. Write: Box 2225, Portland 14, Ore.**

**STEEL Tool boxes any size 5c lb. N. Y. Salvage, 196 Chambers St., New York.**

**FREE Catalog! War surplus clothing bargains. N. Y. Clothing Co., New York 29.**

**DRESSES 18c; Coats \$1.00; blouses 35c. Free catalog. Crown, 164-PA Monroe Street, New York 2.**

**WAR Surplus, aircraft items. Shop equipment, machinery and a million other items. Send 10c for 64 page catalog. Atlas Equipment, 229 Southwest Blvd., Kansas City 8, Mo.**

### WANTED—MISCELLANEOUS

**OLD Records wanted. We pay high prices for certain old phonograph records. We buy many and currently pay up to \$300. Send 10 cents (to cover handling) for our late listings. May mean many dollars to you. C. Carr & Co., Dept. R, Beverly, New Jersey.**

**WANTED—Scrap mercury (quicksilver), tantalum, bismuth, tungsten. Metallurgical Products Co., Established 1909, 35th and Moore Sts., Phila. 45, Penna.**

### PERSONAL

**BORROW By mail. Loans \$50.00 to \$300.00 to employed men and women. Easy, quick. Completely private, confidential. No endorsers. Repay in convenient monthly payments. Details free in plain envelope. Write State Finance Co., 210 State Finance Bldg., Dept. E-14K, Des Moines 9, Iowa.**

**WIN Friends and influence people. Write for "Better Memory." Harrison Books, 726 N. 15th, Waco, Texas.**

**LOANS By mail. \$50 to \$300. Quick, easy, confidential to employed men and women. No endorsers. Easy monthly payments. Write for free information sent in plain envelope. Postal Finance Co., Dept. 45, Sioux City, Iowa.**

**"INTERESTING Mails" — 25c keeps name on mailing lists three months. Bentz, Jr., Desk A/83, Chatawa, Mississippi.**

**MEXICAN Mailing service. Your letters remailed, received 20c. Mystify friends. Photographic postcards 10c. Tiltotson, Apartado 1405, Guadalajara, Jalisco, Mexico.**

**GLOBAL Viewcard selection; worldwide remailing service. Free particulars. Travelpost, Box 5453, Tucson, Arizona.**

**MEXICAN Law. General Practice Attorney, 1203 Arizona Street, El Paso, Tex.**

**"DUSFIL," Washable home hot air filter, helps safeguard health, winter, summer. Less housework, too! \$1.00 postpaid. Satisfaction guaranteed or money back! (Descriptive literature free.) Micamp, 8629 Crispin, Philadelphia 36, Penna.**

**PENMANSHIP Corrector! Improves your penmanship in 3 hours. Proof free. Ozment 9, St. Louis, Mo.**

**"HOW Can I find out?" You can! Information discreetly developed. Any matter, person, problem, anywhere. Worldwide. Officially licensed, bonded service. Established 1922. Reasonable. Confidential. William Herman, 170 Broadway, New York.**

### MISCELLANEOUS

**"MINIATURE Golf." Complete plans, specifications, \$25.00. Reference. Eastern Golf Co., Fred Salonen, 61 Berdan St., Rochelle Park, N. J.**

**NEW Postwar merchant marine, exciting opportunities. Men, women, high pay. Overseas travel experience unnecessary. Write today. American Seamen's Guide, 545 Fifth Avenue, New York.**

**ATTENTION Salesmen: For practical household advertising specialties, side line or full time job. Well-known line by a long established manufacturer. Write for details on open protected territories. Patent Novelty Co., Dept. PM, Fulton, Illinois.**

**ITALIAN Spaghetti (genuine). Easily prepared. Delicious. Complete formula 25c. Settini and Gordon, Box 577 P.S.C., Davenport, Iowa.**

**PRIMITIVE Eskimo sealskin charm mailed with polar-bear stamp. Send \$1.00 to Sigreid, Ivigtut, Greenland.**

**TREASURE-Mineral locators — Geiger counters M-scope type for arctic-tropic use. Unsurpassed in efficiency. Factory guarantee. Lowest prices. Can be purchased on monthly payment plan. Free literature. Fisher Research Lab., Inc., Palo Alto, Calif.**

**ENTERTAIN Your friends. Be life of the party. For information write: Novel-art, Laurens, S. C.**

**SQUARE Dance instructions. Calls. 25 sets. \$1.00. Rayburne, Eureka Springs, Arkansas.**

**PANNING Gold—Beginners booklet, 36 pages, catalogue, supplies, mining books, maps—"Where To Go." 25c. Old Prospector, B-304, Dutch Flat, Calif.**

**BULLETIN** Boards for home, office or hobby "pin-ups." G. M. Carlson, 1629 W. Decatur St., Decatur, Ill.

**SELL**, Buy, trade anything. Write "Trading Post" Magazine, Z-525 Dewey, Jackson, Michigan.

**PERSONAL** Stationery, 50 double sheets of paper, 50 envelopes, name and address neatly printed in beautiful plastic relief \$1.00 postpaid, money refunded if not satisfactory. Craftway Press, Box 149-M, Chicago 90.

**TROPICAL** Fishes and home aquaria. Amazing, new complete reference, guide book covers every phase of aquaria, assembling, feeding, breeding, sicknesses and treatment. Illustrations, photographs and essential information on every type of fish. Only \$3.50. Order now! Money back guarantee. Charles Scribner's Sons, Dept. FPM, 597 5th Avenue, New York City 17.

**HANDSOME** Western wallets. Genuine calf. All around zipper. Braided edges. Secret pocket. Individually boxed. \$3 each. Order two for \$5. Free descriptive circular on wallets and other merchandise. Western Enterprise, 3519 Camden, Tucson, Arizona.

**"JITTERBUGGING** Is Easy." Popular new illustrated course teaches everything. Readable, understandable, guaranteed. Only \$1.00. Sorry, no C.O.D.'s. The Peters Co., Dept. TP, 328 Adams St. N.E., Washington 2, D. C.

**SAVE** Money—Buy everything wholesale. Free information. Orysen, 1147 Sunkist, Waukesha, Wis.

**MILLION** Articles wholesale. Supply source directory 10c. Publisher's, Box 1302, Detroit 31.

**FRUIT** — Tree ripened grapefruit, oranges. Guaranteed, \$2.50 bushel, you pay express. Fruit Basket, Route 1, Box 170, Bradenton, Florida.

**INTERESTING** Mails! \$1.00 keeps your mail box full one year. 25c three months. Also receive free gift. James Willingham, 637-B Princeton Ave., Birmingham, Ala.

**GEIGER** Counters for locating uranium; metal detectors for gold, silver and minerals. Lightweight, low cost, ultra-sensitive. None finer at any price. Free information. Detlectron Company, 5637 Cahuena, Dept. B-2, North Hollywood, Calif.

**BEAUTIFUL** Colored granite memorials. Delivered. Guaranteed. Direct from factory. Agents wanted. Box 191, St. Cloud, Minnesota.

**\$600 BUILDS** Cozy home. 4 room concrete block. Step-by-step instructions and blueprint. \$1.00. L. H. Farrow, G83, Box 645, Columbus 16, Ohio.

**TURKISH** Bath, inexpensive, collapsible. Simple operation. Comfortable home treatment. Free literature. Gordon Brothers, 337-T East 139 St., New York 51, N. Y.

**DUCTS**, Pipes, fittings for installing your own heating system. Catalog. Metal Products, Antioch, Illinois.

**LUMINOUS** Reflective paints glow day and night in technicolor! New angle money-maker. Assorted color samples 25c. Research, 1842-PM Byron, Chicago 13.

**URANIUM** Prospecting equipment: Geiger counters \$48.50 to \$70.00. New improved mineralights from \$12.50. Scintilliscopes \$5.95. Prepaid. Guaranteed. Test-specimens free. Western Radiation Laboratory, 1107 West 24th Street, Los Angeles 7, Calif.

**GEIGER** Counter plans plus prospecting manual \$1.00. Satisfaction or refund. Box 486, Detroit 31, Michigan.

**TREASURE**, Mineral locators. Goldak now offers treasure locators for \$75.00. Geiger counters reduced to \$95.00. Write the Goldak Co., 1542 West Glenoaks Blvd., Glendale 1, Calif.

**VERMONT** Maple syrup and sugar. 100% pure, list. H. Marshall, Poultney, Vt.

**SQUARE** Dance instructions. 40 dances, \$1.00. Wesley Rader, 1922 Grant, Denver, Colorado.

**"RECEIVE** Mail." Moneymaking offers, opportunities, catalogs. Name listed 10c. Ideal Service, Park Ridge 10, Ill.

**WOODWORKING** Power tools — Make them yourself from old auto parts, pipe fittings, scraps. Sanders, drill presses, lathes, saws, etc. Complete details on 40 tools in 96-page book \$1.50. Popular Mechanics Press, (C-43), 200 E. Ontario, Chicago.

**70 BIBLE** Lessons, 25c. Bulletin, Box 87, Cathedral Station, New York 25.

**TATTOOING** Outfits, supplies. Illustrated list free. Zeis, 728 Lesley, Rockford, Illinois.

**TATTOOING** Machines, outfits. Free catalogue. Jensen, 120 West 83rd Street, Los Angeles 3.

**SOAP** Box Racer; Fun to make. Build an exact duplicate of 1946 winner. Clear, easy-to-read blueprints. Simple construction. Order prints #1101. 25c. Popular Mechanics Press, 200 E. Ontario St., Chicago 11, Ill.

**ME—in  
a rut?  
Could be!**



YES—you may be in a rut—just getting by—and not fully realizing it.

Every day you stay in that rut you "dig deeper"—make it harder and harder to get out.

So today while you think of it, take stock of yourself—are you getting ahead as fast as you should—are you satisfied to go along in a small job at small pay the rest of your life?

Hundreds of thousands of our students have won promotion and more money—and the prestige and happiness that success brings—perhaps we can help you.

Better investigate—the coupon below is for your convenience. Just check the field of your choice and we'll send you without obligation full information on that field—the requirements and opportunities—plus "Ten Years' Promotion in One"—a book which has helped many men.

Take the first step to get out of that rut—make more money—get a better job.

**LASALLE** Extension University  
A Correspondence Institution

417 S. Dearborn St., Dept. 264-R, Chicago 5 Ill.

If I am in a rut, I don't want to stay in it. Please send me your free 48-page booklet on the field I have marked below and full information about your spare-time training.

- |   |  |
|---|--|
| <input type="checkbox"/> Higher Accountancy | <input type="checkbox"/> Business Management   |
| <input type="checkbox"/> C. P. A. Coaching  | <input type="checkbox"/> Traffic Management    |
| <input type="checkbox"/> Bookkeeping        | <input type="checkbox"/> Foremanship           |
| <input type="checkbox"/> Law: LL.B. Degree  | <input type="checkbox"/> Industrial Management |
| <input type="checkbox"/> Salesmanship       | <input type="checkbox"/> Stenotypy             |
|   | (Machine Shorthand)                            |

Name..... Age.....

Address.....

City..... Zone..... State.....

# CARPENTRY BRICKLAYING

APPROVED FOR VETERAN TRAINING • FREE CATALOG

**PENNSYLVANIA INSTITUTE SCHOOL OF TRADES**  
30th & MARKET STS. PHILA. 4, PENNA.

## Can a Man MY Age Become a HOTEL EXECUTIVE

Even Though He Has No Previous Hotel Experience?

Would you like to step into a well-paid position as Hotel, Club, Restaurant or Inn Manager, Purchasing Agent, Social Director or Assistant Manager? Would you like to look forward happily to the future? The success of Lewis graduates from 18 to 50 PROVES you can — though you have no experience in hotel work.



**Nelson Davis, Newspaper Route Man,  
Now Assistant Manager, Knew  
Nothing About Hotel Work.**

"I had nothing to look forward to but hard, monotonous work, long hours, poor pay. Then I answered a Lewis advertisement and shortly afterwards enrolled. Soon after graduation, the Lewis School placed me in a fine Pennsylvania hotel. Later the manager asked me to go to Miami to take a similar position. Now Assistant Manager. Lewis Training did it all."

### Step Into a Well-Paid Hotel Position FREE Book Gives Fascinating Facts

Our FREE Book, "Your Big Opportunity," explains how you can qualify for a well-paid position at home, in leisure time; tells how you are registered FREE of extra cost in the Lewis National Placement Service. Most important, it shows how you can be a Lewis Certified Employee—certified to "make good" when placed in a position. Mail the coupon NOW!

Course Approved for Veterans' Training

**LEWIS HOTEL TRAINING SCHOOL**  
Room SB-324, Washington 7, D. C.

**34<sup>th</sup>** SUCCESSFUL  
YEAR

Send me the Free Book, "Your Big Opportunity," without obligation. I wish to know how to qualify for a well-paid position at home, in my leisure time.

Name.....

Address.....

City..... Zone..... State.....

Check here if eligible under G.I. Bill of Rights.



# YOU CAN'T LOSE!

## HAVE A PROFIT MAKING BUSINESS OF YOUR OWN

NATIONALLY ADVERTISED PRODUCTS

NO EXPERIENCE NECESSARY

NO MONEY TO INVEST

FREE SAMPLE OUTFITS

FULL OR PART TIME

### A LIFETIME FUTURE

Man or woman—young or old, YOU can earn a steady income in full or spare time as an independent Kendex dealer. Amazing and almost "impossible" earnings can become a reality for you. Herbert Armstrong of Tenn. earned \$202 in 9 days. C. O. Watkins of Oregon sent 92 orders in one day. You have the same opportunity to duplicate these exceptional earnings. Over one million dollars will be earned in 1950 by Kendex dealers—why not let us establish you in your own business and get a share of these wonderful earnings?

### KENDEX NYLONS REPLACED FREE . . .

if they run or snag within guarantee period up to three months! Impossible? It's true! No matter what the cause—hard use or deliberate abuse—whether it is fault of the hose or the wearer—Kendex nylons are replaced FREE if they run, snag or become unfit for wear within the guarantee period. How could any woman resist a positive guarantee of satisfaction when she can obtain it without paying any more than other standard advertised brands? Kendex nylons are NOT sold in stores, so you have no competition. Complete line includes everything from heavy 70 denier service weight to gossamer luxurious ultra sheer 15 denier 60 gauge. Proportioned sizes and lengths. Latest colors plus white.

### LINGERIE - ROBES - HOUSECOATS - MEN'S HOSE

In addition to the sensational Kendex nylons, you will have a complete line of glamorous lingerie, beautiful robes and housecoats plus a complete line of Kentcraft mens' hosiery guaranteed for one full year. Any pair or pairs of men's hose that does not give satisfactory wear within one year of purchase will be replaced FREE!

### NATIONALLY ADVERTISED

Kendex will spend over \$350,000.00 in 1950 to tell millions of readers of the advantages in buying from you. Almost every issue of Good Housekeeping, Saturday Evening Post, McCall's, Women's Home Companion and Ladies' Home Journal carry our advertising in addition to many others. Kendex has advertised in Life, Look, Collier's, etc. Awarded Good Housekeeping Seal. Thousands of orders are shipped daily from coast to coast.

### EVERYTHING GIVEN FREE

Risk nothing! Mail coupon and we will send you, free and prepaid, complete money-making outfits including sample nylon stocking, samples of lingerie, robes, housecoats and men's hose fabrics and everything you need to immediately start making money. Complete outfits become your property even if you don't send any business. Simply write orders, we deliver and collect. Advance cash plus huge bonus. No money or experience needed. Mailing the coupon is all you need to start on the road to a 52-weeks-of-the-year high paying business of your own. You have everything to gain and nothing to lose.

# FREE NYLON STOCKING

## KENDEX COMPANY, BABYLON, 446, N. Y.



### FOUR MONEY-MAKING LINES

- WOMEN'S NYLON HOSIERY
- GLAMOROUS LINGERIE
- HOUSECOATS - ROBES
- MEN'S HOSIERY

MAIL TODAY

NOTHING TO PAY

NO OBLIGATION

KENDEX COMPANY  
BABYLON 446, N.Y.

Date \_\_\_\_\_ 1950

Send me, free and prepaid, everything I need to make money as a Kendex dealer, including sample stocking etc. There is nothing for me to pay now or later and I am under no obligation in accepting your money-making outfits.

Name \_\_\_\_\_

Address \_\_\_\_\_

City \_\_\_\_\_ State \_\_\_\_\_

Here's How CREI Prepares You for a Professional Career with Industry-Recognized Training in a Minimum of Time

# TELEVISION RADIO-ELECTRONICS ENGINEERING

**G**RADUATES of CREI residence school are preferred by industry because of their *training and ability*. This recognition is the reason that CREI men quickly find good jobs. With 23 years of practical teaching experience in these highly technical fields, CREI offers an outstanding faculty, modern and complete laboratories, shops and equipment.

New students are accepted twice monthly and each may advance as rapidly as he is capable. The basic course with one specialized course requires an average of 20 months to complete.

CREI is recognized as one of the country's leading technical institutes. Its work is of college level. It prepares the young man for a good job in industry in a minimum of time.



G. I. Approved

## CAPITOL RADIO ENGINEERING INSTITUTE

An Accredited Technical Institute Founded in 1927

Mail coupon for Free Catalog

Capitol Radio Engineering Institute, Dept. 172 B  
16th & Park Road, N.W., Washington 10, D. C.

Please send me your residence school catalog and complete details. (If interested in Home Study check below.)

Name \_\_\_\_\_

Age \_\_\_\_\_ If in school, what term? \_\_\_\_\_

Street \_\_\_\_\_

City \_\_\_\_\_ Zone \_\_\_\_\_ State \_\_\_\_\_

I am entitled to training under G.I. Bill.  Send information on Home Study Courses.

# EARN MORE

\$\$\$



FREE  
118 PAGES

### SEND FOR THIS FREE BOOK NOW!

● Increase your earning power. Become *thoroughly* trained in a well-paid profession. Without obligation, find out about the opportunities in Electrical, Mechanical, Plastics, Civil, Mining and other engineering fields. Our *free* 118-page handbook, lists details of home study courses, compiled by world authorities. See for yourself how you can soon earn more dollars. Write today, to: Canadian Institute of Science and Technology, Ltd., 494 Century Building, 412, 5th Street, N.W., Washington, D. C.

Special discounts for Servicemen

MAIL THIS COUPON NOW

Canadian Institute of Science & Technology, Ltd.,  
494 Century Building, 412, 5th Street, N.W.  
Washington, D. C.

Please forward free of cost or obligation of any kind your 118-page handbook "Engineering Opportunities."

Name \_\_\_\_\_ Age \_\_\_\_\_

Address \_\_\_\_\_

CANADIAN ENQUIRIES: 263 Adelaide St. W, Toronto

# CHEMISTRY

**LEARN AT HOME...**Chemical knowledge is essential for thousands of good jobs in industry, business, science. IPC enables you to master practical chemistry. It's the **ONLY** home study chemistry course which enables you to learn by performing actual experiments—using chemicals and apparatus supplied with the course—in addition to your IPC textbook studies. Compares with recognized college courses in General Chemistry. Write today for free descriptive booklet.

**INSTITUTE OF PRACTICAL CHEMISTRY**  
3 PROSPECT AVENUE, HAGERSTOWN, MD.

## Learn REFRIGERATION and AIR CONDITIONING

Prepare yourself for a fine paying job. Get practical training at home—plus 4-full weeks in the ITI Shops. Job placement help. **FREE** book—write  
**INDUSTRIAL TRAINING INSTITUTE** Dept. F-1, 2130 Lawrence Ave., Chicago 25, Ill.



## FOR PROFIT AND PLEASURE COPPER TOOLING & ETCHING

EARN BIG MONEY — SPARE OR FULL TIME

No experience needed—start at once. **BIG MONEY** waiting in **COPPER ART** field. Plaques, Bowls, Trays, Gifts, Souvenirs of all kinds.

Start on the road to success **NOW!** Here is an opportunity to get started in your own Big Paying Business—**FREE** DETAILS don't wait—**WRITE NOW!**

Hollywood Copper Art Studios

4257 Beverly Blvd., Dept. PM-2, Los Angeles 4, Calif.



## AJAX WHITE GIANTS

FAMOUS MEAT-EGG PRODUCERS

Extra big profit breed. Contest-show winners. Massive capons, quick maturing. U. S. Approved-Pullorum Controlled. Low farm prices. **PROFIT SHARING PLAN.** Colored catalog **FREE.** Write **TODAY.**

AJAX HATCHERY, Box 915, QUINCY, ILLINOIS



## GROW YOUR OWN . . .

vegetables, flowers, house plants by hydroponics (without soil). It's easy to get **big returns** in a small space, indoors or outdoors. A clean pleasant way to grow any plant for fun or profit. Send for **FREE** 24 page booklet.

GILBERT & COMPANY, 846X West Ivy, San Diego, California

## PAY RAISING

Get the specialized help you need to qualify for top pay on present job, a better job, or business of your own—from these practical books:

- AUTOMOTIVE SERVICE MANAGEMENT**  
This new book shows you exactly how to start and run an auto service business profitably. Tells what to do, when; how to make money as shop owner or manager. 470 pages, 223 illus. \$5.00
- MODERN ELECTRIC & GAS REFRIGERATION**  
Covers repairs, adjustments, overhauling of every type of domestic, commercial and industrial equipment. Non-technical. 928 pages, 408 pictures, 17 working diagrams in colors. \$5.00
- DYKE'S AUTO ENCYCLOPEDIA** (World's greatest auto book)  
Complete course in auto mechanics, with special emphasis on trouble shooting, testing, adjusting and repairing. New 21st ed., 1483 pages, 4600 illus. \$7.50
- DYKE'S SELF-STARTER**  
Provides complete self-instruction course for Dyke's Auto Encyclopedia. \$1.00
- AUTO BODY & FENDER REPAIRS**  
Shows you how to get good job or start business of your own. Gives approved methods for doing professional jobs. 325 pages, 232 pictures. \$3.50
- HOUSE WIRING**  
New 6th ed. — a working manual for student and electrician alike. Covers every phase of house wiring. 350 pages, 600 illus. \$3.00
- AIR CONDITIONING**  
Makes you familiar with dif-

# BOOKS

- ferent types of equipment. Tells how to figure requirements, make installations, etc. \$4.00
- A. C. POWER WIRING**  
466 pages, 600 illustrations. \$4.00
- D. C. POWER WIRING**  
497 pages, 533 illustrations. \$4.00
- DYKE'S CARBURETOR BOOK**  
Testing, adjusting, diagnosing troubles, repairing \$3.50
- MODERN WELDING PRACTICE**  
Information on every known welding procedure. \$4.00
- PLUMBING & PIPE-FITTING**  
Be the one who lays out jobs for others. \$2.50
- BAILEY'S HANDBOOK**  
Operating, maintaining steam plants. \$2.00
- VOCATIONAL MATHEMATICS** (Shop Arithmetic)  
Learn mathematics without drudgery. \$1.25
- VOCATIONAL MATHEMATICS** (Geometry, Algebra, Trigonometry) \$1.50
- MECHANICAL DRAWING**  
Effective way to learn fundamentals. \$1.50
- SHEET METAL DIE DESIGN**  
\$2.25
- ELECTRICAL TROUBLE SHOOTING ON THE MOTOCAR**  
\$5.00
- DIESEL HANDBOOK** \$5.00
- ELECTRONIC TELEVISION** \$2.50
- AIRPLANE DRAWING** (Design & Construction) \$1.50
- AIRCRAFT FLIGHT INSTRUCTOR** \$2.50
- AIRCRAFT SHEET METAL WORKERS' MANUAL** \$2.50

Check the books you want, clip this ad and mail with check, money order, or U.S. currency, carefully wrapped. Money Back if not satisfied.

**GOODHEART-WILCOX CO.**

Dept. 111 1321 S. Michigan Ave. Chicago 5, Ill.

# CUT HEAT BILLS WAY DOWN!



**Y**ES, you'll save a lot of money in fuel bills by insulating with new fireproof Gold Bond Rock Wool Batts or Sealed Blankets. Keeps you warmer in winter, cooler in summer. Light, easy-to-handle batts in 2 and 4 ft. lengths, and 8 ft. blankets. Both come in standard widths that slide right in between rafters or attic floor joists. Be sure they're Gold Bond and "full-thick" for maximum heat savings and fire protection. For free booklet on insulation, write Division Y, Dept. PM-2a.

*Available at your local Gold Bond Lumber and Building Supply Dealer!*

**NATIONAL GYPSUM COMPANY  
BUFFALO 2, N. Y.**

## DIESEL MECHANICS NEEDED BIG PAY . . . GOOD FUTURE



If you have no trade or profession that assures you steady employment and top pay through good times or bad, and regardless of whether you want to be a mechanic, technician, salesman, executive — or have your own profitable shop—you should investigate **NOW** this opportunity to enter world-famous Bailey Diesel Schools. Prepare yourself, this proven way, for an important place in the fast growing field of Diesel.

### Why Gamble With Your Future!

Your future success depends largely on the reputation of the school you attend. Don't take chances! Train at Bailey's—America's foremost school of diesel training. Approved by Missouri State Board of Education. Approved, also, for G. I. Training. Full details **FREE**. Return coupon below **NOW**.

### MAIL TODAY FOR FREE CATALOG

**BAILEY DIESEL SCHOOLS**  
1656 So. Grand Blvd., St. Louis, Mo.  
Please Send Me Your **FREE** Catalog.

Name .....

Address .....

Town ..... State .....

Veteran     Non-Veteran

Resident Training     Home Study

## THE NEW WAY TO ELECTRIFY TREADLE SEWING MACHINES



**Terrific! Amazing!** Changes any treadle sewing machine, regardless of age, into a modern electric! A child can do it in 5 minutes! Kit comes complete with Universal motor, foot control, belt, pulley, brackets. Completely wired — just clamp on and plug it in!

**1 YEAR GUARANTEE**

### MAKE BIG MONEY!

Start now! Make \$5.20 on every kit you sell. Millions of women who can't afford new electric machines are waiting for it! Easy to sell over 10 per day! And Brant's back you with a complete line,

from needles to new machines — for **BIG** profits without any investment! Sell from our catalog and collect commissions in advance! Send for your kit and free literature, today!

**FREE!**  
\$2.95 Sewlight with each Kit.

RETAILS FOR  
\$16.95  
YOU PAY  
**\$11.75**

### BRANT SEWING MACHINE CO.

Department DM-1, Cincinnati 10, Ohio

Rush motor kit C.O.D. I'll pay \$11.75 plus postage.

I enclose \$11.75 — Ship postpaid.

I want to be an agent! Send complete sales plan.

My machine is a.....

Hand wheel turns  toward me.  away from me.

Name.....

Address.....

City.....Zone.....State.....

# SALESMEN!

**WRITE  
THREE  
WORDS  
COLLECT  
\$9.95**

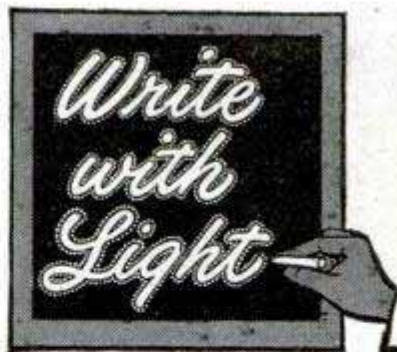

## SENSATIONAL NEW ADVERTISING SIGN

**YES, MAKE \$9.95** on 10-second demonstration to merchants. Write on glass with amazing magic crayon and presto—a 5-color advertising message takes fire and glows like a brilliant neon sign! Three sales a day and \$29.85 profit is for "lazy" men. Workers can double to triple that amount. **FREE SALES KIT**. Don't wait. Rush your name and address on a penny postcard for full details and complete sales kit—**ALL FREE**. Write Today!

**MAXILUME CO., 125 W. Hubbard St.  
DEPT. L-81 CHICAGO 10, ILLINOIS**

# NEON SIGN SCHOOL

G. I. APPROVED

Learn Neon. Interesting, clean work, BIG PAY—\$1.50 to \$2.00 an hour to start. Our 12½ week Job-Practice Course gives you practical training in Glass Blowing, Neon Tube Bending, Color Gassing, other branches. No home study. No text books. No mathematics. FREE FOLDER explains. Write today.

ACME NEON INSTITUTE, Dept. B-3  
330 South Paulina St. Chicago 12, Ill.

LEARN  
IN 12½  
WEEKS

# BLISS Electrical Training

ELECTRICAL SCHOOL

Intensive 32 weeks' residence course in fundamentals of industrial electrical engineering, including radio and electronics. Extensive laboratory, shop work, drafting. Prepares for electrical technician and engineering aides

in communications, power, manufacturing, business machines, sales, service. G.I. approved. 57th year. Enter March 6, Sept. 5. Catalog. 7626 TAKOMA AVENUE, WASHINGTON 12, D. C.



## BE A PHOTO-ENGRAVER

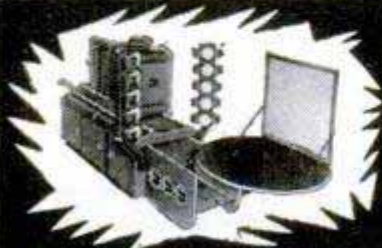

We furnish complete equipment and supplies. Learn at home or in our modern, friendly APPROVED school in MISSOURI. Get into this big demand, high profit, high wage field. You can start your own profitable, full time or part time PHOTO-ENGRAVING business right in your own home.

Be independent, be your own boss or pave the way to a high pay job with experience gained in your own shop.

TASOPÉ TRAINING and TASOPÉ EQUIPMENT has enjoyed world wide recognition since 1931. Write for descriptive literature today. No obligation.

THE AURORA SCHOOL OF PHOTO-ENGRAVING, DEPT. 9PM., TASOPÉ BLDG., AURORA, MO.

Is Your Life Crowned With Success?



## LEXIPOWER

WE THINK IN WORDS. THOUGHT IS POWER. Let this New Science show you how to WIN WITH WORDS—financially, socially, culturally. Develop a MASTERFUL VOCABULARY. Influence others, improve your personality, manifest your latent ability. You are judged and rated by every sentence you utter. Start using the POWER of LEXIPOWER after the first Lesson. Write NOW for FREE details about LEXIPOWER. Dime-a-Day LESSON CLUB.

LEXIPOWER LESSON CLUB

517-L W. Deming Place Chicago 14, Illinois

## Safeguard Your Health.. FLEX-a-FOAM Dust Masks



New Featherweight Flex-a-Foam Dust Mask filters dusts and pollen as small as 1/25000 of an inch! Comfortable snug fit—unequaled breathing freedom. Ideal for woodworking, cleaning, furnace tending, etc. Attractive design - easy to clean. With three extra washable pure latex filters \$2.00 pp. - order now!

Order NOW \$2.00 Post Paid

BOGGLE PARTS CO. — Dept. PM — Cleveland 13, Ohio

## Learn this Profitable Profession



IN 90 DAYS AT HOME

## Money-Making Career Open to Men and Women, 18 to 50

Hundreds of men and women between 18 and 50 make \$10 to \$20 in a single day giving scientific Swedish Massage and Hydro-Therapy treatments. There is big demand from doctors, hospitals, sanatoriums and clubs. Graduates earn large full time incomes from these or in private practice in their own offices. Others make good money from home treatments given in spare time. Learn this interesting, money-making profession in your own home, through our home study course. Same instructors as in our nationally known resident school. You can win independence and prepare for future security by qualifying for your Diploma. Course can be completed in 3 to 4 months. Many earn while they learn. Begin your training at once.



## Anatomy Charts & Booklet FREE

Enroll now and we will include, at no extra cost, many needed supplies. Fit yourself to help meet growing demand for Scientific Swedish Massage. Send the coupon at once for complete details. Anatomy Charts and 32-Page Illustrated Booklet, FREE, postpaid.

THE COLLEGE OF SWEDISH MASSAGE  
Dept. 064B, 41 E. Pearson, Chicago 11, Illinois

Please send me FREE and postpaid, Anatomy Charts, 32-page Booklet and complete details on Home Training.

Name \_\_\_\_\_ Age \_\_\_\_\_

Address \_\_\_\_\_

City \_\_\_\_\_ State \_\_\_\_\_

## Learn A Trade NOW! PRACTICAL SHOP TRAINING!

### In Our Chicago Shops

- AUTO MECHANICS
- DIESEL MECHANICS
- REFRIGERATION
- BODY-FENDER
- WELDING—ARC and GAS
- MACHINIST
- PIANO TUNING

Above Approved For G. I.'s and Civilians  
One of America's Leading Practical Schools  
7 Floors of Fully Equipped Shops  
Over 48,000 Successful Graduates  
Expert Individual Instruction  
Learn by Doing—Low Living Expense  
Established 1902—Day and Evening Classes

### Also the following Home Study Courses

- PLASTIC
- REFRIGERATION
- DIESEL

—CALL IN PERSON OR MAIL THIS AD TO—

## GREER SHOP TRAINING

(Desk 10) 460 South State St., Chicago 5, Ill.

Please send without obligation free information regarding trade checked above. (Specify whether you are a Veteran  or Civilian )

Name \_\_\_\_\_ Age \_\_\_\_\_

Address \_\_\_\_\_

City \_\_\_\_\_ State \_\_\_\_\_

**NEW for  
1950**

# MIDWEST

Celebrates its 30th YEAR of FACTORY-TO-YOU  
Selling with a Sensationally NEW 1950 LINE of

# TELEVISION

CONSOLES *and* Complete CHASSIS

**New  
GIANT 16"  
PICTURE  
TUBE**

Here is Television at its finest! ... brought to you by Midwest, for 30 years a leader in the field of radio and electronics. Immense 151-square-inch screen on new 16" metal-glass tube ... clear, steady, bright pictures ... Synchronized sound and picture that a child can tune in perfectly ... Highest quality FM sound ... Big 12" Electro-Dynamic Panasonic Speaker. Available in beautiful Consoles or in complete chassis as illustrated (not a kit, but a complete Television receiver ready to plug in and play) to place in your own cabinet. And you can buy Midwest Television at Low Factory Prices, with Low Down Payment and Long Easy Terms — and on 30 Days Trial!

**NEW  
LOW  
Down Payment  
Long EASY  
TERMS**



**LOW  
FACTORY-  
TO-YOU PRICE**

**30 DAYS TRIAL**

Not a KIT... This is  
a Completely  
assembled Receiver

... also a Magnificent Line of NEW 1950  
**MIDWEST RADIOS**  
featuring the latest Improved FM Circuit  
and the New 3-SPEED RECORD PLAYER

Powerful new 1950  
Series 16 and Series  
12 AM-FM Radio  
in complete chassis.  
Also beautiful new  
Console models including the magnificent Symphony  
Grand Radio-Phonograph with latest  
FM circuit and new  
3-Speed Automatic  
Record Player.

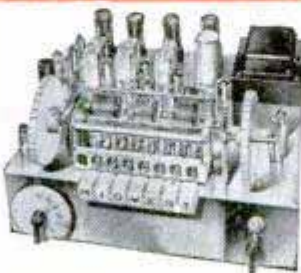

**BUY DIRECT FROM  
THE MIDWEST FACTORY and SAVE!**

**MIDWEST RADIO & TELEVISION CORP.**

Dept. X257, 909 Broadway, Cincinnati 2, Ohio

SEND  
FOR  
**FREE**  
32-Page  
Full Color  
CATALOG



Write in Name and Address (Please  
Print) on Coupon or 1c Postcard.

MIDWEST RADIO & TELEVISION CORP.  
Dept. X257, 909 Broadway, Cincinnati 2, Ohio  
Please send me your new FREE 1950 Catalog.

NAME \_\_\_\_\_

ADDRESS \_\_\_\_\_

CITY \_\_\_\_\_ ZONE \_\_\_\_\_ STATE \_\_\_\_\_

**Your BLUEPRINT FOR PROFIT**



**NEL IRWIN**  
Will help you start your own successful, lifetime business.

**AMAZING NEW Miracle Finish**  
MEANS \$\$\$ TO YOU

**BIG PROFITS**  
Rich profits are waiting to be tapped in this new field. New MIRACLE finish gives a velvety, luxurious surface to radios, lamps, toys, signs, store displays, figurines, auto dashboards, and hundreds of other items. Make old objects beautiful and salable—make new things worth much more with this soft, rich covering that can be applied to any surface, even if old and worn.

**FREE! A PLAN FOR YOUR SUCCESS**

**START RIGHT AWAY**  
Yes, you can learn in a few days to start MAKING MONEY! Everything you need is furnished, including fully detailed, illustrated instructions that are complete and easy to understand. Every point is explained, to show you how to start on the road to big money, full or spare time, right in your own home.

**EVERYTHING COMPLETE**  
In addition to full instructions you get a complete set of materials that enables you to start at once. A few cents worth of materials can mean many dollars in return to you—you can earn up to \$5 per hour and more spare or full time. Add to your income from your present job or start a profitable business of your own. Our Business is Booming. Help us fill HUGE DEMAND.

**ACT NOW**  
Grasp this opportunity TODAY—Start your own business. It's too good to miss! SEND NO MONEY—fill out the coupon and stick it on a post card or in an envelope and mail today for full details. FREE samples of FLOK-KRAFT covered material, and hundreds of useful and profitable IDEAS Do it NOW—be first!

**COVERS WOOD, FABRIC, METAL, GLASS, PLASTER, PLASTIC OR ANY SURFACE**

**USE COUPON FOR FREE SAMPLE**  
**COAST INDUSTRIES Dept. 22**  
1004 S. Los Angeles St., Los Angeles 15, Calif.  
Gentlemen: Please rush me all the details.

NAME \_\_\_\_\_  
STREET \_\_\_\_\_  
CITY \_\_\_\_\_ STATE \_\_\_\_\_

**EXPORT PAYS BIG**

World Trade firm offers men and women plan for big pay positions or unlimited-profit businesses of their own in Export-Import. Mail orders World-wide without capital, from home, or travel abroad. Write today for Free Book. State if veteran Airmail reaches us over night. **The Mellinger Co 1418-A5 Westwood, Los Angeles 24, Calif**

**FREE BOOK**

**MAKE MONEY**

**RAISE Pedigreed RABBITS FOR US!**  
Grinstead's Famous ANGORAS,  
GIANT CHINCHILLAS and NEW ZEALANDS  
(World's Most Profitable Rabbits)  
We buy ALL you raise — ALL the time!  
Write today for FREE INSTRUCTIONS, Illustrated Literature, and Prices.  
**GRINSTEAD FARMS, Dept. 70, Edwardsville, Ill.**

**BARBELLS**

Save Money—Buy the finest barbell equipment direct from our foundry—No other company can match our low price or value!  
Send to-day for our FREE Barbell Catalog  
**BUR BARBELL CO.**  
Lyndhurst 14, New Jersey

95 lb. SET \$10.80  
Extra plates 10c lb.

**Become a Doctor of PSYCHOLOGY**

Win the degree of Ps.D. Teach the secret of contentment, happiness. Solve mental worries. Experience the revelation of truth. Chartered college. Individual help. Write for FREE book. **COLLEGE OF UNIVERSAL TRUTH, 5153-B North Clark St., Chicago.**

**Utilities Engineering Institute**

Founded 1927

**Diesel • Auto Body & Fender REFRIGERATION • AIR CONDITIONING**

Practical training in these big pay trades covers overhauling, troubleshooting, installation, maintenance techniques. Proved, easy-to-follow method prepares you at home in spare time, follows with actual shop practice. Also G. I. approved resident courses.  
Full information FREE! Write today  
2525 Sheffield Ave., Dept. C-2, Chicago 14, Ill.

**Say You Saw It in Popular Mechanics**

**In California LEARN WATCHMAKING and REPAIRING**

Have as your goal a **STORE OF YOUR OWN**

In California—intensive, practical training unsurpassed anywhere. Award of Graduation, West Coast University, School of Watchmaking. Accredited by United Horological Association of America. Approved for Veterans and Non-veterans. Part-time employment and housing assistance. Our catalog will interest you. Sent upon request. No obligation.

**MAIL COUPON BELOW TODAY!**

West Coast University, School of Watchmaking  
5145 W. San Fernando Rd., Dept. PM-20  
Los Angeles 26, California

Gentlemen: Please send me complete information about your training program.

NAME \_\_\_\_\_ Age \_\_\_\_\_  
STREET \_\_\_\_\_ Zone \_\_\_\_\_  
CITY \_\_\_\_\_ State \_\_\_\_\_  
Veteran \_\_\_\_\_ Non-veteran \_\_\_\_\_

**21st EDITION • Auto Library in ONE Book Leader for 38 Years**

**WORLD'S GREATEST AUTO BOOK**

**New Material on Transmissions, Trucks, Tractors, Diesels, Aircraft and Auto Engines**

Now, with millions of cars needing repairs and thousands of men needed to do the work, you need the famous DYKE Auto Book more than ever before. 21st Edition covers all principles, construction, repair, adjustments, testing, troubles and remedies. Over a half million copies of 20 editions of Dyke's have been sold. Gives specifications of old and many newer cars. World's biggest book value, \$7.50.

This big book, a complete auto library in one volume, has 1483 pages—4600 illustrations and diagrams—weighs 8 lbs.—equal to all books shown above.

**MAIL COUPON**

Goodheart-Willcox Co., Dept. 110, 1321 S. Michigan Ave., Chicago

Send Dyke's Auto Book at once.  C.O.D.  \$7.50 Enclosed. Payment refunded in 5 days if not pleased.

Name \_\_\_\_\_  
Address \_\_\_\_\_  
City \_\_\_\_\_ State \_\_\_\_\_

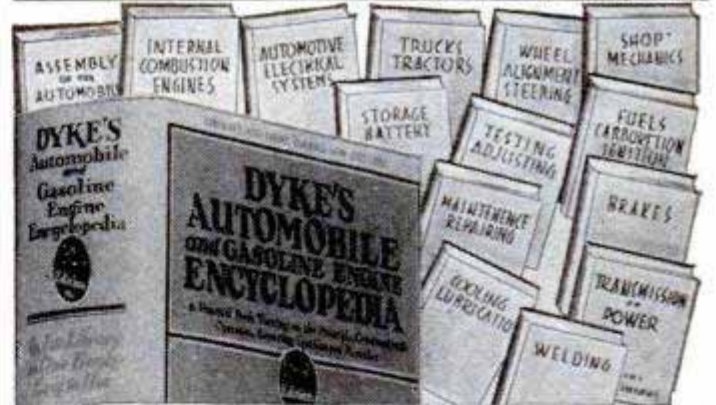

**21st EDITION • Auto Library in ONE Book Leader for 38 Years**

**WORLD'S GREATEST AUTO BOOK**

**New Material on Transmissions, Trucks, Tractors, Diesels, Aircraft and Auto Engines**

Now, with millions of cars needing repairs and thousands of men needed to do the work, you need the famous DYKE Auto Book more than ever before. 21st Edition covers all principles, construction, repair, adjustments, testing, troubles and remedies. Over a half million copies of 20 editions of Dyke's have been sold. Gives specifications of old and many newer cars. World's biggest book value, \$7.50.

This big book, a complete auto library in one volume, has 1483 pages—4600 illustrations and diagrams—weighs 8 lbs.—equal to all books shown above.

**MAIL COUPON**

Goodheart-Willcox Co., Dept. 110, 1321 S. Michigan Ave., Chicago

Send Dyke's Auto Book at once.  C.O.D.  \$7.50 Enclosed. Payment refunded in 5 days if not pleased.

Name \_\_\_\_\_  
Address \_\_\_\_\_  
City \_\_\_\_\_ State \_\_\_\_\_

# Don't Envy The PLUMBER·Be One

## Make \$15 to \$50 a Day

Every skilled workman will tell you Plumbers have the best of it. WINTER and SUMMER the Plumber is busy at top wages. No skilled Plumber is ever out of a job. Compare his opportunities with any trade. To the man with know how, Plumbing means profit. Investigate Universal Plumbing School. Not a "war born School," but a plumbing school developed and operated by plumbers since 1923.



### Own Your Own BUSINESS

Have your own business and big profits with little other than training and a kit of tools.

### JOURNEYMAN Gets Good Salary

Master Plumbers own their own shop. A Journeyman works for a Master. With this training journey-men can depend on high wages.

G. I. Approved. Established 1923

## UNIVERSAL PLUMBING SCHOOL

877 Holmes Street

Kansas City, Mo.

### BE A PLUMBER IN JUST 32 WEEKS Learn With Tools—Not Books

No need ever serve an apprenticeship. Don't envy the plumbers big profits—enjoy them. Learn every trick of the trade—Leadwork—Blueprint for plan reading, etc. under Licensed Master Plumbers.

### Over 7,000 Successful Plumbers Recommend This School

This system has made more than 7,000 plumbers. Investigate our past performance. If you like to work with tools this is your opportunity. Become a Plumber in America's largest and only school devoted exclusively to plumbing. Write today for FREE information.

G. I. Approved. Established 1923

## UNIVERSAL PLUMBING SCHOOL

877 Holmes Street

Kansas City, Mo.

**BIG  
PAY  
TRADE**

## AIR-CONDITIONING REFRIGERATION

*Mastered by Mail*

### HOME STUDY COURSE

Teaches Air Conditioning and Refrigeration . . . the field of the future with a future. Get in now on the ground floor. Restaurants, taverns, stores, theaters, etc., all need and are installing air conditioning. Maintenance men will be needed for Big Pay Jobs. Learn at Home in your spare time. Four week practical training period in our great modern shops in Baltimore included in course.

For Full Details—

### MAIL COUPON TODAY!

**AIR CONDITIONING & REFRIGERATION INST.**  
110-114 Alpaca St., Dept. PM-2, Baltimore, Md.

Please send without obligation free information regarding Air Conditioning and Refrigeration Home Study Courses.

NAME \_\_\_\_\_ AGE \_\_\_\_\_

ADDRESS \_\_\_\_\_

CITY \_\_\_\_\_ ZONE \_\_\_\_\_ STATE \_\_\_\_\_

## CORTINAPHONE makes it FUN to Learn

# French-Spanish GERMAN - ITALIAN

**BIG OPPORTUNITIES and  
JOBS** await Americans who can speak a foreign language. Millions being spent by gov't and industry in Europe, Latin America. Travel booming.



**Only 15 Minutes a Day Listen to  
this Record!**

Speak FRENCH, SPANISH, German or Italian like a native! CORTINAPHONE METHOD, famous for 67 years, teaches you—BY LISTENING, to CORTINA RECORDINGS. Right in your own home, relaxed and at ease.

### Sent on 5 Days Approval

THOUSANDS have learned a second language this quick, easy way for PLEASURE and BUSINESS! FREE 32-page book describes this famous method; tells how you can try it at home for 5 days. NO COST IF NOT DELIGHTED. Send for free book NOW!



Count Cortina

## VETS! FRENCH OR SPANISH COURSE AVAILABLE UNDER G. I. BILL

CORTINA ACADEMY (Language Specialists for 68 Years)  
Dept. 642, 105 W. 40th St., New York 18, N. Y.

Please send me—without obligation—your free book. I am interested in (check language interested in)

French  Spanish  German  Italian

Name.....

Address.....

Check here if you are a VETERAN

# TRAVEL for ★"UNCLE SAM"



START  
as high as  
**\$3,450 Year**

Prepare NOW for  
1950 Examinations

**VETERANS GET  
SPECIAL PREFERENCE**  
Many examinations  
expected soon  
City Mail Carriers  
City Postoffice Clerks  
Stenographers-Typists  
Messengers,  
Liquor Inspectors—  
and many others.  
**40-Page Book  
on Civil Service  
FREE**

Mail Coupon  
today—  
**SURE**

15,000 appointments each month

## FRANKLIN INSTITUTE

(Not Government Controlled)

Dept. A-85  
Rochester 4, N. Y.

Rush to me, entirely free of charge, 40-page book with:  
(1) A full description of U. S. Government jobs; (2) A list of U. S. Government jobs; (3) Tell me how to qualify for a job.

Name \_\_\_\_\_

Address \_\_\_\_\_

Vet? \_\_\_\_\_

# 9 BIG BUILDING BOOKS

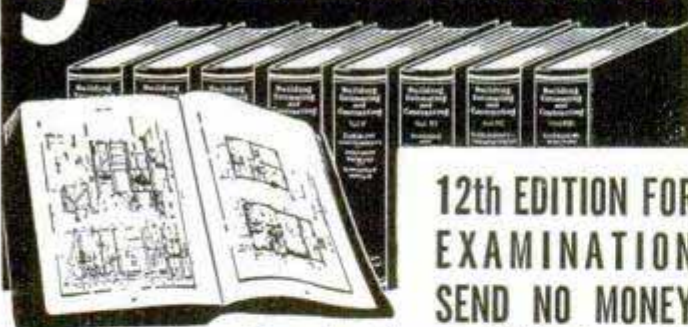

12th EDITION FOR  
EXAMINATION  
SEND NO MONEY

Learn to draw plans, estimate, be a live-wire builder, do remodeling, contracting. These 9 practical, profusely illustrated books cover subjects that will help you to get more work and make more money. Masonry, concrete forms, carpentry, steel square, roof framing, construction, plumbing, heating, painting, decorating and many other subjects. More than 4000 pages — 2750 illustrations.

## BETTER JOBS — BETTER PAY UP-TO-DATE EDITION

A nationwide building boom is in full swing and trained men are needed. Big opportunities are always for MEN WHO KNOW HOW. These books supply quick, easily understood training and handy, permanent reference information that helps solve building problems.

These books are the most up-to-date and complete we have ever published on these many subjects.

## Coupon Brings Nine Big Books for Examination

AMERICAN TECHNICAL SOCIETY—Publishers since 1898  
Dept. G219 Drexel at 58th Street Chicago 37, Ill.

You may ship me the Up-to-Date edition of your nine big books, "Building, Estimating and Contracting," without any obligation to buy. I will pay the delivery charges only, and if fully satisfied in ten days, I will send you \$2.00, and after that only \$3.00 a month, until the total price of only \$34.80 is paid. I am not obligated in any way unless I keep the books.

Name \_\_\_\_\_

Address \_\_\_\_\_

City \_\_\_\_\_ State \_\_\_\_\_

Please attach a letter stating your age, occupation, employer's name and address, and name and address of at least one business man as a reference. Men in service, also please give home address.

## The Steady Pay Profession Good Times or Bad!

### SCIENTIFIC CRIME DETECTION

FOLLOW  
THIS MAN

Operator  
No. 38



### It Is Easy to Learn!

I will teach you this fascinating science during your spare time at home. It pays to be an expert in Finger Printing, Firearms Identification, Police Photography and Criminal Investigation. I have trained hundreds of men and women now successfully serving in identification bureaus throughout America. You, too, may quickly prepare yourself to become a well-paid valued officer of the law, often sharing in the generous rewards offered for wanted criminals.

**FREE! OVER 800**

### "BLUE BOOK OF CRIME"

This book is full of exciting information on scientific crime detection. It will show how you can get started in a grand career. Now, at amazingly low cost. Clip coupon now... Mail it today.

of all Identification Bureaus in the U. S. employ students and graduates of I. A. S. A majority of these men are heads of Bureaus. Many of them knew nothing about crime detection before training with me. Now they have steady jobs, good salaries and a fine future. Write today for full particulars and free book. Give age.

**INSTITUTE OF APPLIED SCIENCE**  
1920 Sunnyside Ave., Dept. 1352, Chicago 40, Ill.

**INSTITUTE OF APPLIED SCIENCE**  
1920 Sunnyside Ave., Dept. 1352, Chicago 40  
Gentlemen: Without any obligation on my part, send me the "Blue Book of Crime," and complete list of Identification Bureaus employing your students or graduates, together with your low prices and Easy Terms Offer. (Literature will be sent ONLY to persons stating their age.)

Name..... Age.....

Address.....

RFD or Zone..... State.....

## AUTOMOTIVE MANUFACTURER SEEKS INVENTOR WITH PRACTICAL IDEA FOR NEW PRODUCT IN AUTO FIELD

Offers opportunity to  
convert that "good  
idea" into cash

Chicago, Jan. 15—One of America's pioneer producers of nationally advertised automotive products, with a background of 30 years in this profitable field, is looking for new product ideas among the mechanical-minded readers of this magazine.

"Here is a real opportunity," an official of the firm points out, "for the man who's keeping a good idea in the back of his head to turn that idea into cash royalties and help himself to future security."

Popular Mechanics readers with plans or ideas, patented or unpatented, for new products in the automotive line are asked to submit them by mail not later than March 31, 1950. All correspondence will be acknowledged promptly and will be treated in absolute confidence. In case two or more persons submit an identical unpatented idea, only the first letter received will be considered. All plans and ideas will be fairly and impartially judged in complete secrecy, and those not used will remain the private property of the senders.

Send your plan or idea to Department W, Room 1313, 307 North Michigan Ave., Chicago 1, Ill.

## ANALYZE HANDWRITING

NEW, uncrowded, fascinating field. Gratifying earnings reported by graduates in Employment, Credit, Social Service, Police and Entertainment fields. Others have developed profitable private practice, full or spare time, as Personal and vocational Counselors. Send for 3,000-word TEST LESSON and PROOF book FREE. Write today!



I.G.A.S., Inc., 303 Wilhoit Bldg., Springfield 4, Mo.

## LOCKSMITHING & Key Making

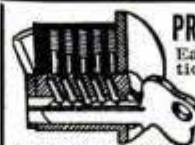

### PRACTICAL UP-TO-DATE COURSE—ONLY \$3.95

Easy-to-learn modern information for self-instruction. How to work on locks, de-code, make master-keys, repair, install, service, etc. For every handyman, home owner, carpenter, mechanic, service station operator, fix-it shop, hardware dealer, gunsmith. 53 plain illustrated lessons. FULL PRICE ONLY \$3.95. SEND NO MONEY.

Just pay postman plus C.O.D. postage. Or send \$3.95 with order, we'll ship postpaid. Satisfaction guaranteed or refund. NELSON-HALL CO., 1139 S. Wabash Ave., Dept. B-2, Chicago 5, Ill.

## New DIRECTION SIGNAL



Flashes front and rear lights

### Flashes Your Turns Electrically

No more winter window cranking for arm signals. The new AUTO-TURN DIRECTION SIGNAL fits any car, flashes parking and tail lights 60-80 times a minute. No interference with regular lights, no extra lights to mount for most late cars. Smoothly operating, featherlight control lever. Works similar to factory installed models. All parts furnished — install it yourself. SPECIFY MAKE AND YEAR. For cars earlier than 1942, write for price. MONEY BACK GUARANTEE.

Durable, attractive brown or chromium case. Specify finish. \$10.95, postpaid in U. S. Send check or money order. Postage extra on COD's.

### The LESTER Company

Box M-2, 1743 North Milwaukee Avenue, Chicago 47, Illinois



# New Advertising Machine



## PRINTS and ILLUSTRATES

1¢ Post Cards

**FREE** Learn how thousands of business men, in every line, are boosting sales in spite of conditions—with 1¢ messages—printed and illustrated in a few minutes on gov't post cards—with amazing new patented **CARDMASTER**. Your "today's" ideas, read by your prospects next morning. Not a toy, but a sturdy advertising machine, built to last for years. Low price, sold direct. Guaranteed for five years. Send name today.

**SEND NAME** We'll send **FREE** illustrated book of money-making **IDEAS** for your business and complete, unique advertising plans. **RUSH YOUR NAME TODAY.**

**CARDMASTER COMPANY**  
1920 SUNNYSIDE, Dept. 132, CHICAGO 40, ILL.

## Learn CARTOONING

HAVE FUN! MAKE MONEY! Cash in on your sense of humor at HOME—BY MAIL. No experience needed to start. Write today for **FREE TRIAL LESSON** and full particulars.

**MOON Gag Cartoon School, Dept. E, Fall Creek, Wis.**



## Learn PHOTOGRAPHY

There's big money in **PHOTOGRAPHY**—and an action-packed career for you. Our **HOME STUDY COURSE**—famous throughout the world—is your spare-time **SHORT CUT TO SUCCESS!** Or if you wish . . . **PERSONAL ATTENDANCE TRAINING** at our famous New York Studios is available with *subsistence* under the G. I. BILL. Our 40th year. Write immediately!

**NEW YORK INSTITUTE OF PHOTOGRAPHY**

Dept. "49", 10 W. 33 St. New York 1, N. Y.

## STRENGTHEN Your VOICE!

**YES**—you can now build yourself a powerful speaking and singing voice with this amazing new scientifically sound tested method. Self-training . . . no music or piano required. Results **GUARANTEED**. Just send your name for the sensational details. **FREE** chart of your vocal mechanism included! Please state your age.

**PERFECT VOICE INSTITUTE, Studio B-2, 1141 S. Wabash Ave., Chicago 5, Ill.**



## Easy Way to Practice Radio Code

**NEW** amazing Telegraph Code Practice Set. Light touch of **DUPLEX PRACTICODE** telegraph key produces **LOUD PROFESSIONAL "BEEP"** thru its large 4-inch Permanent Magnet Speaker. Works 6 months on *only one 1 1/2 volt cell*—No parts to burn out! Safe! **COMPLETE WITH REAL PROFESSIONAL TELEGRAPH KEY AND BATTERY**—Nothing else needed!

As many as 6 sets can operate on one line! Colorful Wood Cabinet, 3 1/2 x 5 x 10 1/2", in red, green, yellow or blue pastels. One-year factory guarantee. **\$8.95** complete

Send M. O. or Check, we ship Postpaid. Write for Catalog M  
**MARTIN MFG. CO., Dept. PM, 194 Gelston Ave., Brooklyn 9, N. Y.**

# EIGHT SPARE TIME BUSINESSES YOU CAN START AT HOME

With an investment as low as \$4.45

Send for your free copy of the fascinating book that tells of eight different businesses you can run from your home—every one of them fun—every one of them profitable. No courses to buy or study. No special experience needed. All directions given free, together with lists of equipment needed costing as little as \$4.45. Here are "thumb-nail" descriptions of the businesses that are fully explained in the Free book.



**How to Make Money with Felt Flocking.** The popular new finish. Apply soft, suede-like felt flocking to book ends, picture frames, radios, lamps, and a score of other projects. A few pennies in materials brings dollars in profits.

**How to turn Plaster Paris into Cash.** Five cents a pound buys the material—yet the figures, plaques, statues, and art objects you cast from rubber molds you make yourself brings you as high as Five Dollars a pound.

**How to "Personalize" for Profit.** Put gold initials or entire names on wallets, billfolds, key cases, book covers and all leather, cloth, or flexible materials. Everyone wants his possessions "personalized." Small material cost brings big prices.

**How to Cash in on Laminating Plastic.** Scores of needs for Plastic Laminating to protect cards, photos, stamps, autographs, souvenirs, etc. Stores are your agents. Do work at home on a press weighing only two pounds.

**How to Make and Sell Advertising Signs.** A simple and wonderful outfit that enables any novice to make "letter-perfect" advertising signs for merchants, resorts, factories, and many others. Get high prices for paper and ink.

**How to Draw Anything You Can See.** Yes, and make the figures or objects as lifelike as the work of skilled artists. Many uses for profit, and lots of fun as a hobby.

**How to Carve Wood for Profit.** Copy any carving in wood or plastic faithfully and accurately with an amazing carving machine. Many profit possibilities. Many uses in home and shop. Method and equipment completely described.

**Make Money with Monograms.** Genuine metal letters that can be attached permanently to cars, leather, marble, metal, fabrics, or wood. 30c brings \$1.50.

Send for it—it's **FREE!** 44 pages of pictures, descriptions, instructions, and listings of equipment. Eight businesses you can start "on a shoestring" and run from your home—full or spare time. **FREE.** No charge, now or at any other time. Just send your name on a penny postcard, or use the coupon. You may find just what you've wanted in the way of spare time cash. Just ask for the "Book of Home Businesses."

**Warner Electric Co., 1512 Jarvis, Dept. K-42, Chicago 26, Ill.**

**WARNER ELECTRIC COMPANY, Dept. K-42**  
 **1512 Jarvis Ave., Chicago 26, Illinois**  
 Please send free of charge and without any obligation whatever a copy of your "Book of Home Businesses" showing how I can start a profitable business at home for as little as \$4.45. No charge, now or ever.  
 Name.....  
 Address.....  
 City..... Zone... State.....

SAY YOU SAW IT IN POPULAR MECHANICS



**DELTA  
MILWAUKEE**  
®

Model No. 37-595

**\$23575**

Motor and switch rod extra  
**Easy time payments!**

Price subject to  
change without notice

# Cuts costs, boosts output!

For pattern makers . . .



. . . For builders



For cabinet makers . . .



. . . For furniture makers

For sign shops . . .



. . . For hobbyists



For *everybody* who cuts wood!

## Delta<sup>®</sup>-Milwaukee Saw-Jointer Combination

A big-capacity, precision-built unit that's portable! Move it anywhere in your shop — take it right to an outside job. You can easily load it on your truck.

Saves space, both 10" tilting-table saw and 6" jointer mounted on one steel stand and driven by the same motor. Saves the cost of an additional motor. Saves on power costs, too.

Use the machines singly or together — there's no interference between them. Cut 3¼" stock. Rip to center of 50" panel. Surface boards 6" wide. Rabbet ½" deep. Both tools have lubricated-for-life ball bearings. Saw table tilts 45° to right. Jointer fence tilts 45° to right or left.

See at first hand how you save space, time, and money with a Delta-Milwaukee Saw-Jointer Combination. Have your Delta dealer demonstrate it today.

Look for the name of your Delta dealer under "Tools" in the classified section of your telephone directory.



POWER TOOL DIVISION



**Rockwell**

Manufacturing Company

680B East Vienna Avenue N

MILWAUKEE 1, WISCONSIN

HM-77

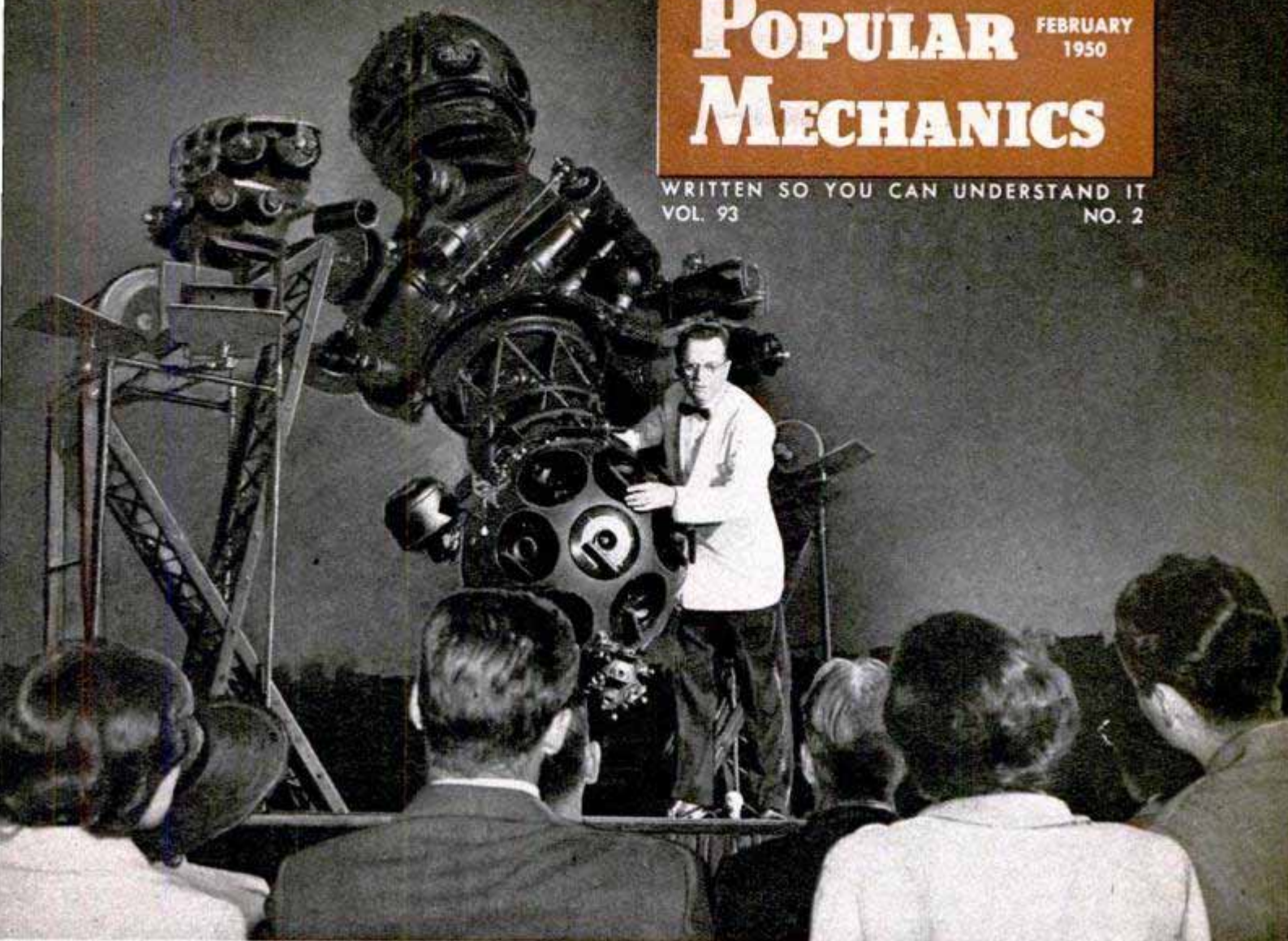

Hayden Planetarium photo

Zeiss star projector unfolds the awesome story of the universe on the dome-shaped ceiling of the planetarium

## Five Roads to Doomsday

By Richard F. Dempewolff

UNDER a star-studded dome of blue sky, people gazed upward uneasily. Something was wrong with the solar system. The friendly, familiar moon had ceased to be friendly. Slowly, it was moving closer and closer to earth until, finally, an unfamiliar moon, huge and terrible, filled half the sky.

There was no beauty in the awesome spectacle. With the moon's advance, ocean tides grew into mountains of water, spilling over continents, obliterating cities. Molten matter from deep under the earth's crust, spewed from every crater and crevasse. Oceans atomized with hissing roars. Cities crumbled and were engulfed in a sea of liquid fire.

At last, with an astronomical crash, the moon itself exploded, unable to stand the tremendous gravitational pull. Roar after

roar filled a reddened sky as thousands of moon fragments broke into thousands more. Captured by the earth's gravitational sphere, these moon bits circled the dying planet like a halo—a weirdly beautiful ring of moonlets.

Scare fiction? Not at all. For years astronomers have believed that some day, billions of years hence, the moon will be pulled back to the earth. When it is, the end of the world will be assured—provided we have not met with some other major calamity in the meantime.

At the Hayden Planetarium in New York recently, thousands of visitors gasped as they watched the big Zeiss star projector portray the five astronomical catastrophes that sky scientists now think may befall us. High on the vast blue planetarium sky-dome our own particular star—the sun—

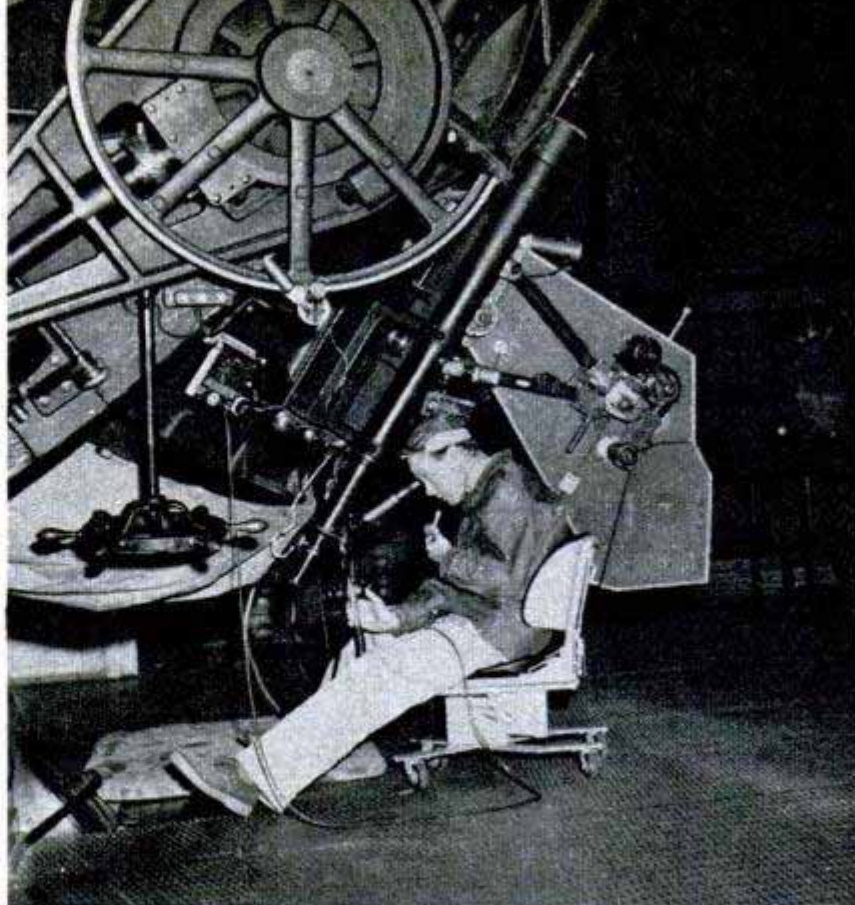

Mount Wilson Observatory photo

Our earth is hurtling straight toward this star cluster at  $12\frac{1}{2}$  miles per second. There's plenty of room for us to pass through, though. Right, spectrograph attached to telescope analyzes star composition and movement

suddenly did what more than 30 stars in the firmament do each year. It "blew up," releasing incredible amounts of heat and energy, under which the earth shriveled in sudden, hot death.

Spectators shivered under the second possibility as they watched a dying sun go into a long period of cooling until Arctic chill gripped an unfamiliar earth. Ice began a death march down the mountains to erase all vestiges of life on a planet whose eventual chill achieved the sublime fridity of absolute zero, or about minus 459.4 degrees F.

The third great disaster from the thousand-eyed projector involved a hit-and-run star from space colliding with our own sun, resulting in a superatomic explosion that destroyed our entire solar system.

Similar was the approach of a wandering comet toward the earth. Across the celestial stage it came, fiery tail growing bigger and bigger, catapulting under terrific speed until—*whooooom!* It collided with terrific impact against a shuddering world.

The fifth calamity, of course, was the return of the moon.

Of all these five roads to doomsday, planetarium astronomers have found that people fear most a collision of the earth or sun with another star.

The planetesimal theory, explaining the formation of our solar system, is based on the idea that our sun, once much bigger than it is now, collided with or came too

close to another star billions of years ago, and that we and our neighbor planets are the result.

Actually, such a collision is the most remote of all the probable ends of the world. Why? Astronomers merely point to the roominess of our universe.

The universe is made up of billions of wispy saucer-shaped spirals known as galaxies. There's quite a bit of vacuum between them—hundreds of thousands of light-years, in fact. It takes the light from the nearest one 750,000 years to reach us. If it disappeared from the sky 749,999 years ago we wouldn't know it until next year.

Each of those wispy galaxies is made up of billions of stars. We live in such a galaxy somewhere off the center of the saucer. What we call the Milky Way is the edge of our saucer, made up of stars some of which would put our own sun to shame. There's one called Antares that's so big we could put our sun in the center of it, include all our planets *in their orbits* around it, and Mars still would stay inside the rim of Antares. That star is almost  $2\frac{1}{2}$  billion miles in diameter.

So, you can readily see that the stars in our galaxy—and any other galaxy—have plenty of space to operate without colliding. The star nearest our sun is Proxima Centauri—about  $4\frac{1}{2}$  light-years away, or 25 trillion miles. If you still think there's a remote possibility of collision then you still have no idea of the immensity of space.

Imagine a couple of ping-pong balls 500 miles apart crashing into each other. That's about the proper scale to use for the sun and Proxima.

So the remoteness of our sun or earth sideswiping another star is very remote indeed. Besides, there'd be plenty of warning.

With great modern telescopes trained on the heavens, astronomers keep pretty fair track of what's in the road. We'd have quite a few thousand years to get busy colonizing another solar system.

Old-time astronomers had to use crude triangulation to tell star distances and movements. Today's professional stargazers use the spectrograph, a prismatic instrument through which the light of a heavenly body is passed. Chemical elements of the star cause the light to break down into specific colors. The color lines shift depending on whether the star is coming or going. With this neat gadget, astronomers have discovered that most galaxies are going away from us at a good clip. The spectrograph informs our astronomers that right now our sun—taking us with it—is moving toward the star cluster Hercules at a rate of about  $12\frac{1}{2}$  miles per second. If the sun should pile into one of these big stars (a few billion years from now at that snail's pace) we'd never know what happened. Hot pieces of both suns would fly off in all directions. Earth and all the planets would vaporize under the tremendous heat energy released, or else the sun would lose its gravitational grip on us and we'd go flying off into space.

What are the chances of cracking into a Hercules star? Very poor.

Dr. Lloyd Motz, of Columbia University, points

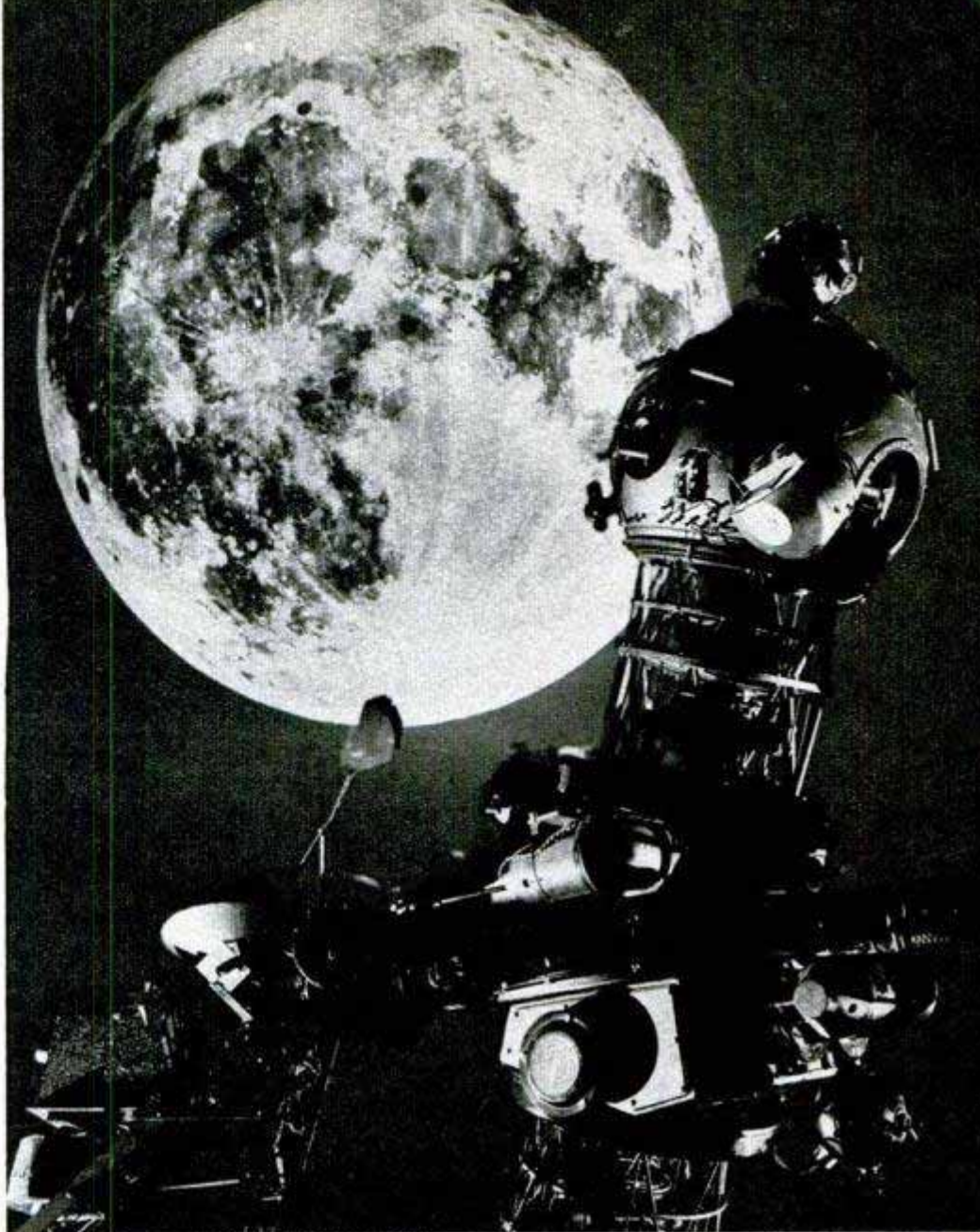

New York Museum of Natural History photo

Moon grows monstrous and terrifying as it approaches the earth on the sky-dome of the planetarium, where astronomers preview the possible roads to doomsday with grim realism. Below, Gordon Atwater, left, chairman and curator of the planetarium, points out details of famous Wilamette Meteorite found in 1902, the largest ever found in this country

Hayden Planetarium photo

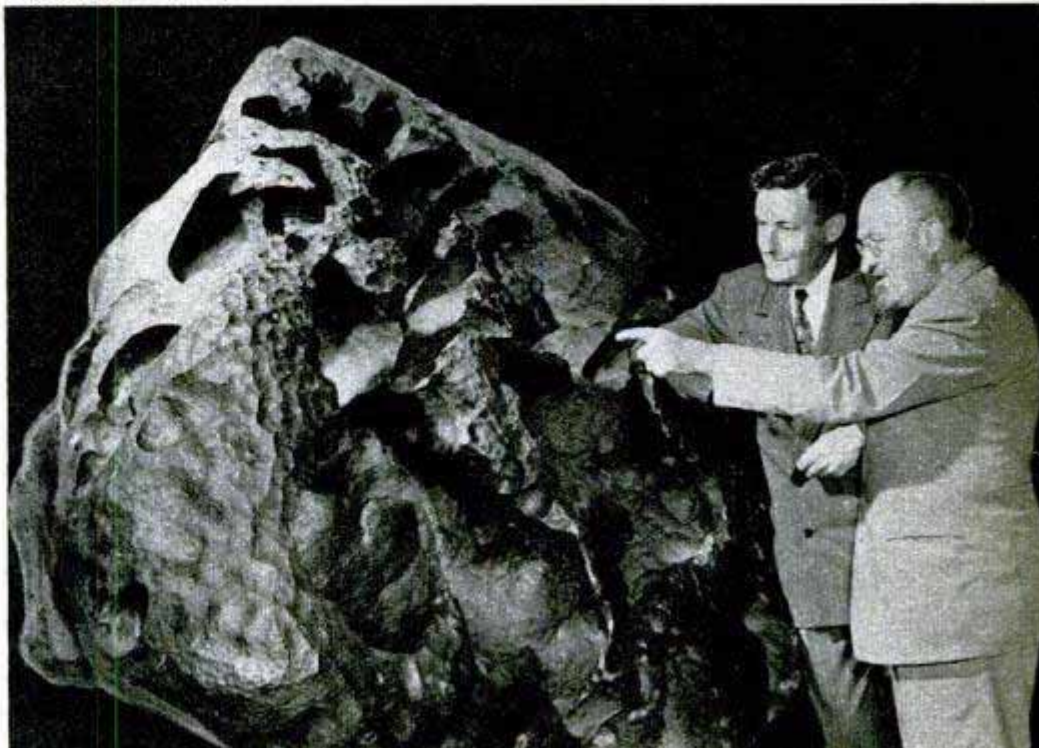



Artist depicts possible ways earth may die. Above, moon, pulled back to earth, drowns continents in tidal waves. Below, death of sun brings perpetual snows. Below, right, sudden flare of sun burns earth to crisp

out that if our whole solar system suddenly scooted off through space it might even travel through whole galaxies of stars without getting appreciably close to a collision course. But, it *could* happen. Maybe.

What about the comet collision? From time immemorial people who have seen these mysterious bearded wanderers from space sweep in toward the earth have wondered what could prevent them from becoming trapped in the earth's gravitational field, and being pulled in to wreak terrible destruction. "A head-on collision between the earth and a comet is possible, though not probable," says Gordon A. Atwater, chairman and curator of the planetarium. "Comets have been known to pass within 100,000 miles of the sun, so they naturally had to pass a point where the earth might have been at the time."

If a runaway comet *should* hit the earth, it would be the least disastrous of the possible calamities. Though the head of a comet may be as big as the earth, it's not as dense. There'd be a crash all right and, as one planetarium astronomer succinctly put it, "It would be moving day for a lot of people." But star experts know that such a collision would create only local destruction. The concussion would be terrific. The earth would shudder in a worldwide earthquake. Surface heat of the comet's head, caused by friction as the body zipped



through earth's atmosphere, might start huge fires. Cities in the vicinity would be wiped out, but a lot of the world would be left.

Less remote roads to doomsday than those requiring celestial collisions may be paved by the antics of the sun and moon, according to the planetarium experts. The business of the sun becoming a nova would purely finish us off. What is a nova?

Old-time astronomers often noticed bright stars suddenly appear in the heavens. Now with super telescopes like the ones at Palomar and Wilson, astronomers may watch an average of about 30 a year. They're not new stars. They are stars that suddenly for no accountable reason, blow up—release tremendous amounts of heat and energy, then simmer down again to a normal glitter. Sometimes, a supernova will blow up completely and disappear. That is what the astronomers say *might* happen to our own sun some day. By complicated mathematical formulas they have been able to calculate the normal surface temperature of the sun at something like 11,000 degrees F. Inside, it's estimated at around 70,000,000 degrees. If the sun became a nova, that inside heat is what we'd get. People on the day-side of the earth would fry to an instantaneous crisp. Those on the night-side would never know what happened, for within 8½ minutes the entire world—and all our other planets with it—would be turned into nothing but a thin gaseous vapor.

Many astronomers laugh at this possibility, however. "Nobody needs to worry about the sun becoming a nova," says Dr. Motz of Columbia, "for the only novae recorded have been limited to blue-white, or exceedingly hot

(Continued to page 238)

Adapted from drawings by  
New York Museum of Natural History

**Meteorites bombard earth. Astronomers say damage would be mostly local but cities could be destroyed**

FEBRUARY 1950





### Revolving Rubber Heel

An ingenious Long Beach, Calif., inventor has come up with a revolving rubber heel. A large circular section can be separated from the rest of the heel. In the center of the circle is a hard-rubber button which fits into a socket in the base structure, forming a suction and pivot, allowing the heel to revolve.

### Trigger Lock

Guns are locked to prevent accidental discharge or unauthorized use by a cover that slips over the gun's trigger guard. The push lock works like the one on the glove compartment of your car and can be locked with a key or simply latched in place to prevent accidental discharge. Made of aluminum, it is lightweight and provides a sure method of preventing accidents when guns are carried through underbrush or over rough country.

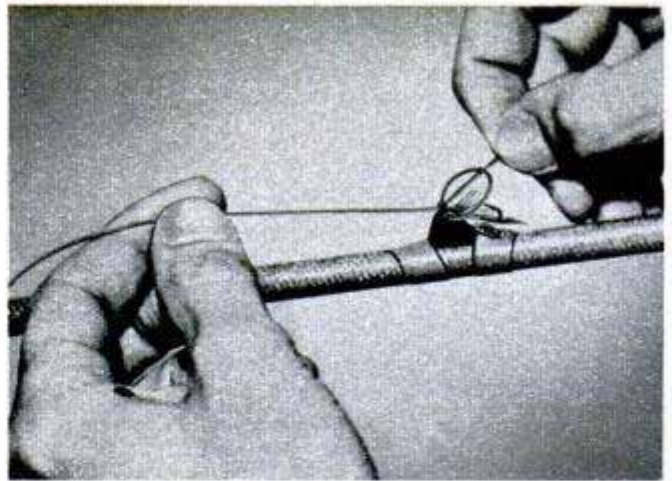

### Fly Tier

Fishermen are given a "third hand" in tying a leader to a fly by a holder that fastens to the rod like a guide. When a new fly is to be fastened to the leader, the hook is inserted into the holder. The leader then can be knotted properly without fumbling.

### Arithmetic Jigsaw

Mathematics may now seem more a pleasure than a problem to the students of Arvil Davis, Wichita Falls, Tex., school-teacher. Davis has devised a puzzle method for teaching arithmetic to elementary-school pupils which works on the theory of an ordinary jigsaw puzzle, but uses numerals instead of pictures. The pieces are shuffled and the students are required to put the puzzle back into form. If the addition board is used, the piece of cardboard bearing the numerals 10 plus 7 will fit only beside the piece marked 17. The same method is used with multiplication, division and subtraction.

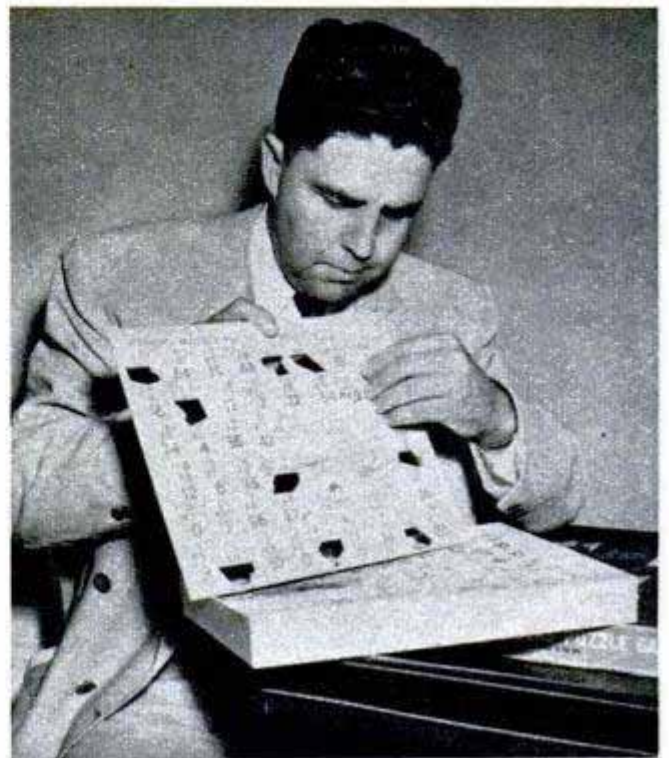



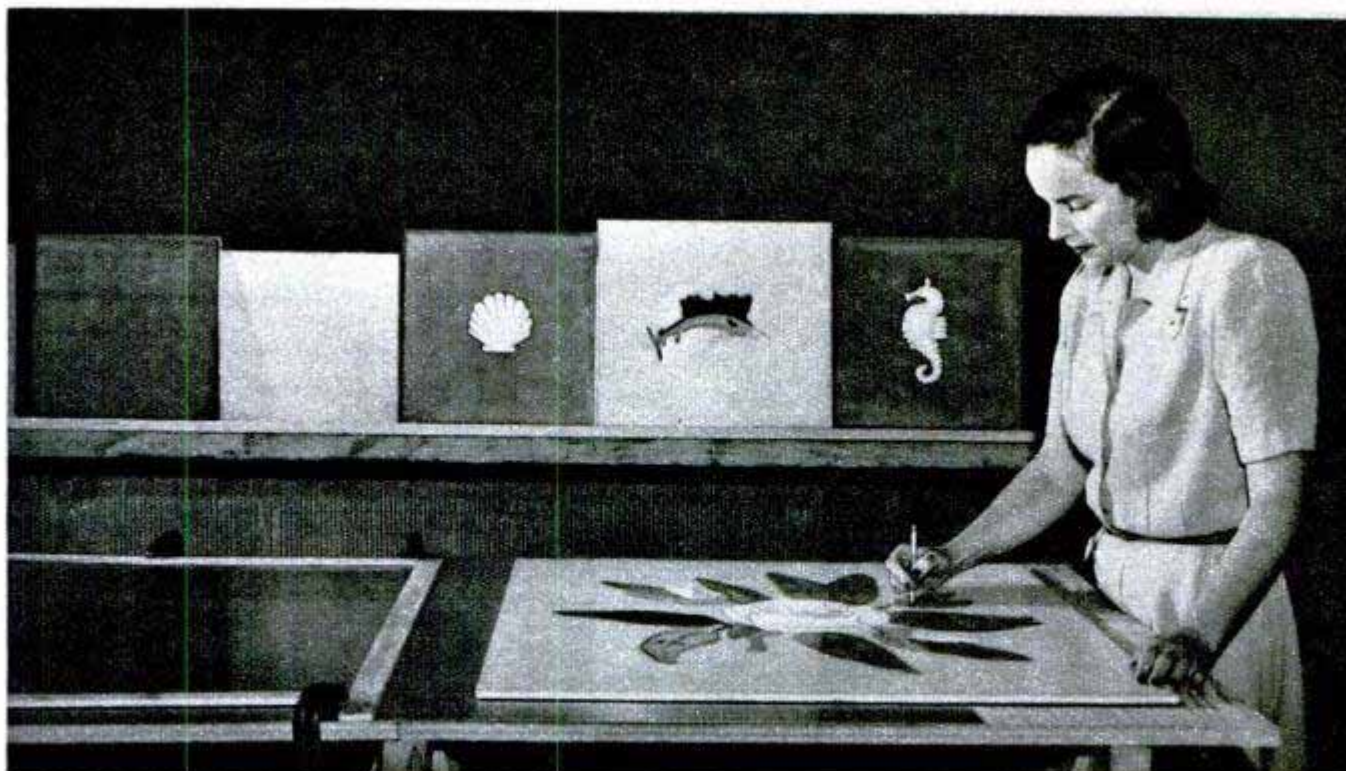

Using her own unique process, Mrs. White embeds and touches up a colorful design in a partially set top

## "Liquid Stone" Table Tops

Ornamental table tops, hard as stone and smooth as satin, are made in a home in Southern Pines, Ga. Mr. and Mrs. Bill White fashion the table tops and trays from a formula they developed themselves. Water is added to dry ingredients, includ-

ing a base of oxychloride cement, to produce a "liquid stone" which is poured into molds. When the cement is partially set, Mrs. White "paints" a design with a putty knife and colors. The decorating substance is a powerfully adhesive viscose material. Later the design is sealed in with a lacquer which is impervious to sun and water.

White blends the ingredients with a baker's mixer. Then Mrs. White stirs design material with kitchen mixer

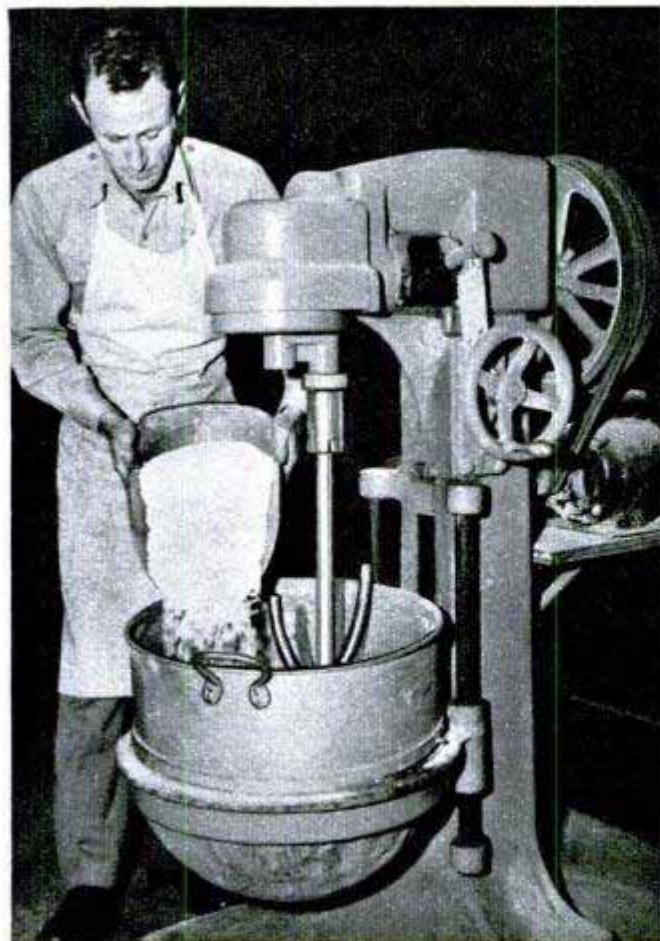

# TALL TAILS

These are the shapes of tomorrow, weird products of the new gas jet era. They are tail-end views of eight of America's jet airplanes



Above, fish or fowl? Neither, but instead a rear look at the U. S. Air Force's first three-jet bomber, the Martin XB-51. Two of its engines are below the wing and forward, while the third power unit is in the tail

Below, acclaimed as the "world's most powerful bomber" when it first flew, Northrop's YB-49 jet flying wing has the equivalent of 32,000 horsepower. The 100-ton sky dreadnought spans 172 feet between the wing tips



Below, airmen blink when this emerges in mid-air from the bomb bay of a B-36. The McDonnell XF-85 "parasite" fighter, only 15 feet long and 21 feet across, is moved in and out of its aerial hangar on a "trapeze"

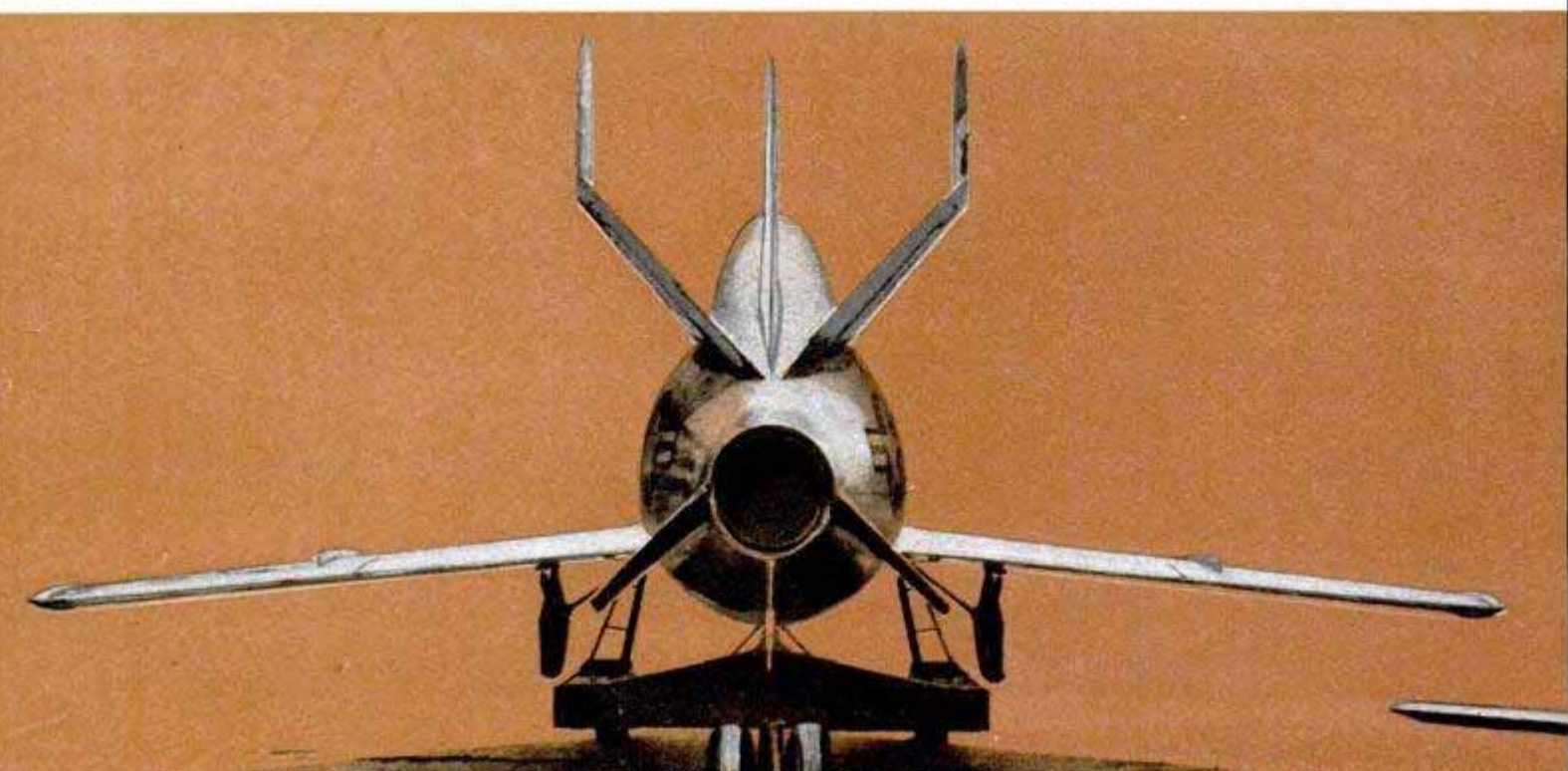

Right, a new look in aquatic shapes is offered by the Convair XP5Y-1 flying boat. Four turboprop units give it a top speed near 400 m.p.h.



Below, folding wings add to the Phantom's odd rear-end appearance. They also cut the plane's "width" down from 40 to 16 feet for more compact stowage aboard carriers. The McDonnell-built craft tops 500 m.p.h.

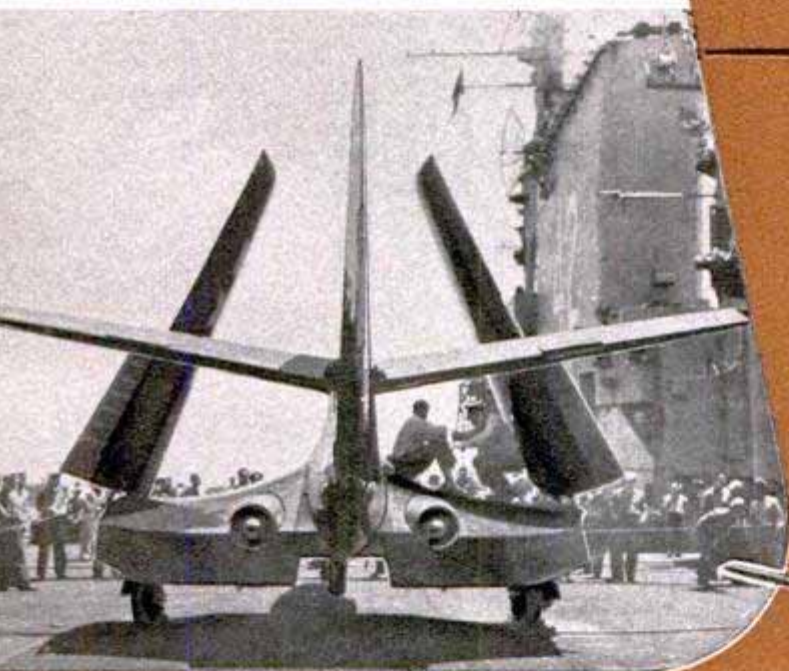

Below, despite its trim, fighter-like lines, the North American B-45 is a heavy bomber by World War II standards. For ease of maintenance the four jet power plants are ahead of the leading edge of the wing, paired off in single nacelles



Left, this is a view most flyers get as they trail in the wake of North American's F-86, holder of the world speed mark. Below, Northrop built the X-4 to help research behavior of tailless, sweptwing aircraft designs in the extremely high-speed zones

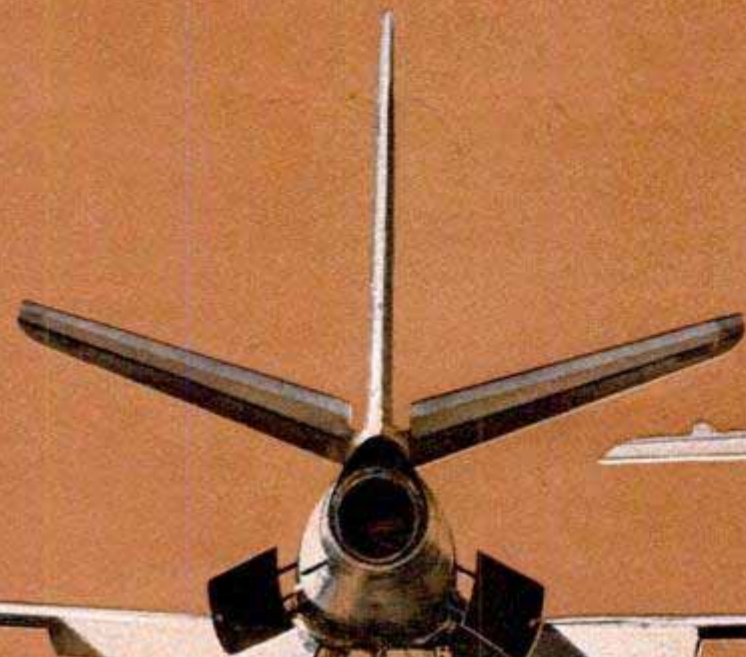

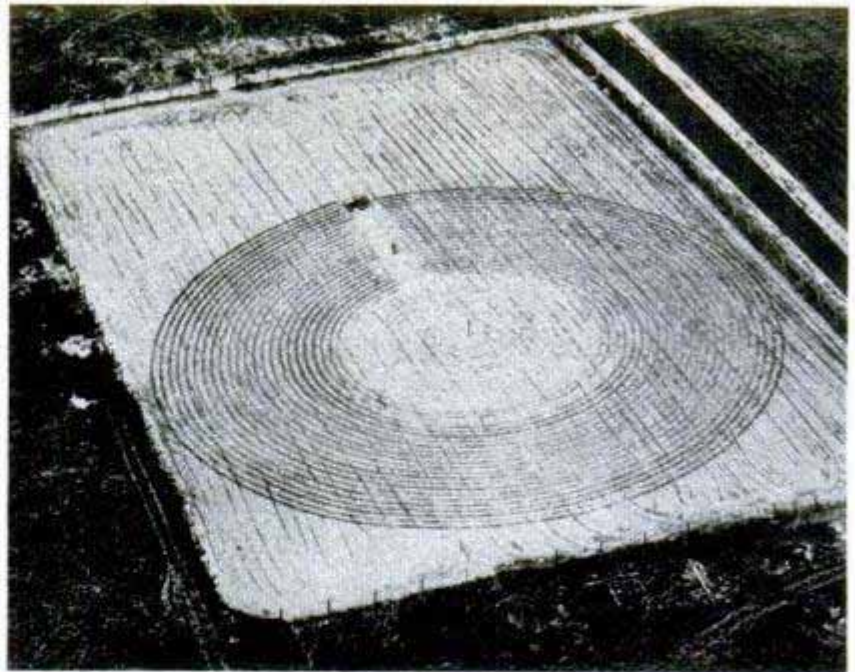
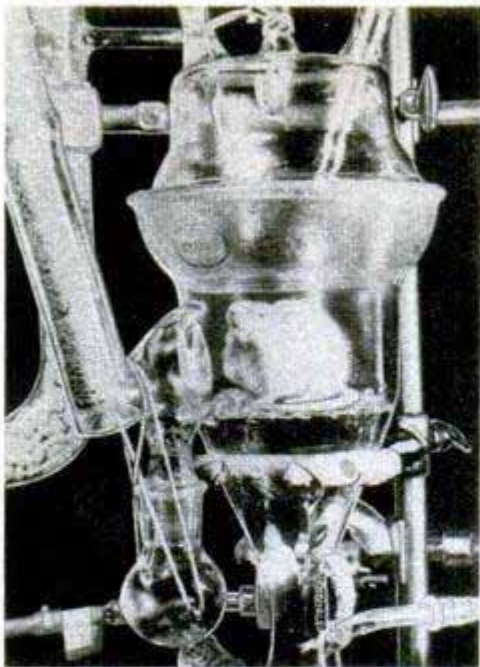

## Radioactive Atoms Aid Study of Mice and Plants

Atomic scientists, using the atom as a tool to increase our knowledge of plants and animals, are experimenting with "bull's-eye" farming and mice that live in glass houses. In the plant experiment, crops are laid out in rings around a bull's-eye where radio-cobalt, a source of radiation, is placed. The radioactivity of the plants is measured after harvest and the

scientists learn how far radioactivity extends and what happens to plants as the amount of radiation decreases. The mouse, with less privacy than a goldfish, is sealed in an all-glass cage and is fed food "tagged" with radioactive carbon. The metabolism cage collects exhaled air and other body excretions so that scientists can learn new facts about body functions.

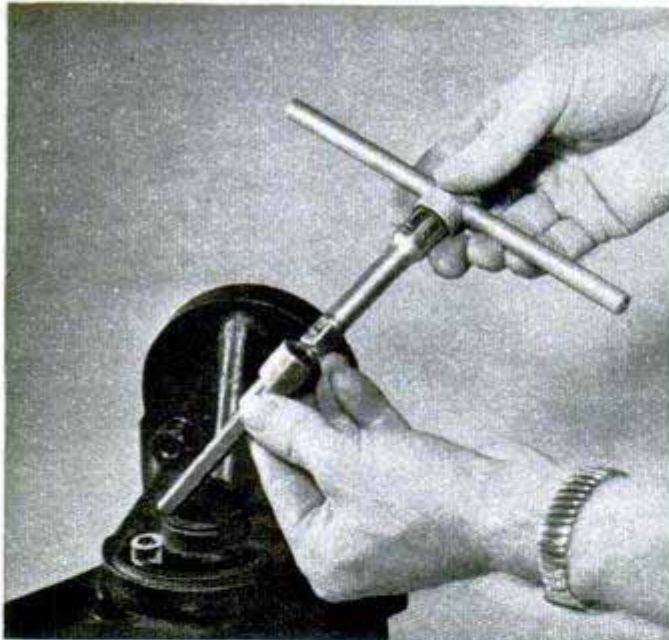

## Internal Wrenches

Socket-head screws are tightened and loosened quicker and with less effort when you have an internal wrench which can be used with standard socket-wrench drivers. Hard-to-reach screws are easy to get at because of the long shaft of the wrench. The handle-type base of the wrench is knurled to provide a sure grip even with oily fingers. The wrenches come in sets of five of varying sizes.



## *see post card* Inboard-Outboard Runabout

Rough water won't bother an outboard runabout that has a motor well in the stern, allowing greater freeboard at high speeds. The propeller unit of the motor projects through a notch in the bottom. This notch is carried up into the outer transom to allow the motor to tilt normally when beaching. Air chambers on each side of the motor well provide enough buoyancy to support the weight of the outboard should the boat ever be swamped. Designed for use on large lakes and ocean bays, the boat is sold complete or in kit form.

## Big Vacuum Cleaner Harvests Grass Seed

Grass seed now is harvested by a huge vacuum cleaner which sucks the kernels off the fields. The machine, built by Otto Bohnert of Central Point, Ore., is mounted on two trailers. One carries the motor and blower and the second acts as a receiving hopper for the straw and seed. A revolving brush loosens the straw, which then is picked up by the four individual nozzles of the vacuum cleaner. About two acres can be vacuum cleaned in an hour with the equipment. A treated field is free of any straw, and seed recovery is 90 to 95 percent complete, according to Bohnert.

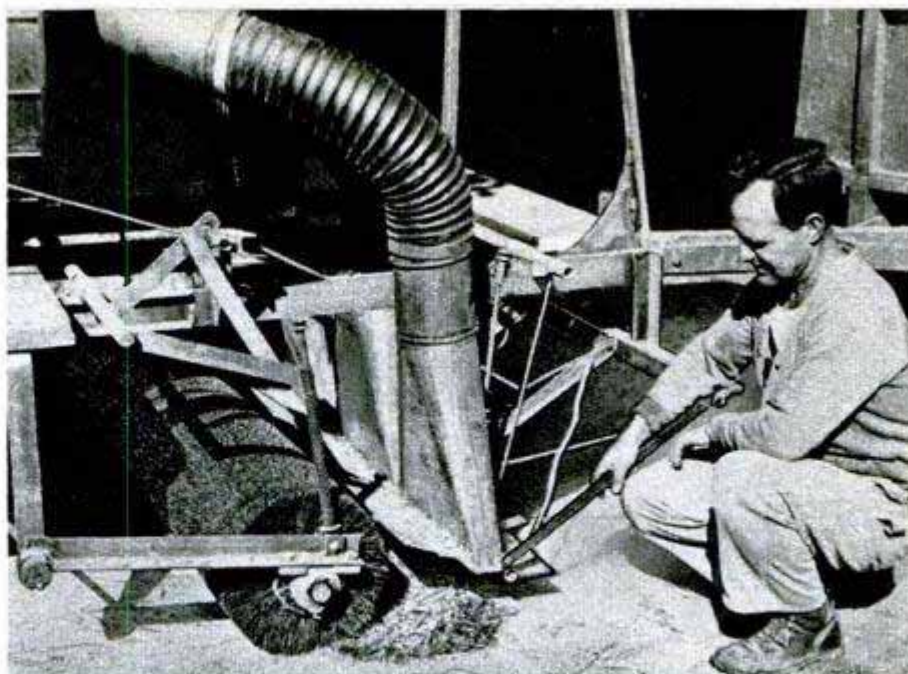

## Stars "On the Air" 24 Hours a Day

There are stars broadcasting on the radio waves 24 hours a day, day in and day out, but you've probably never heard of them. They're real stars, too, stars high in the heavens which broadcast short-wave radio noises that are picked up with special antennas. British scientists, who have been listening to these stars broadcasting, believe they are dim stars, too faint to be seen by the naked eye, although they are about as large as most visible stars. Two major sources of the radio signals and 23 smaller

ones have been discovered by the radio astronomers. Electrons in the signal-producing stars have a motion corresponding to at least 10-billion electron volts, suggesting the possibility that cosmic rays originate in them.

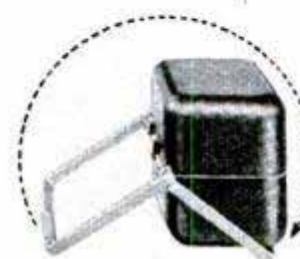
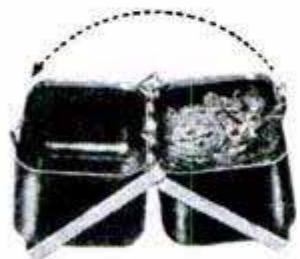

## Flip-Flop Bait Box Fools the Worms

When fish worms are carried in a new bait box, they can't hide from the angler. The two parts of the box are hinged on one side and fasten with a snap catch on the other. When the box has stood open for some time, the worms crawl to the bottom. The box is closed and flipped over. When it is reopened, the worms are on top.

When the minister arrived with his bride there was no home for them—so the congregation and community had a house-building bee

By Alden Stahr  
Photos by the author

Rev. Clinton Rutherford carefully studies Popular Mechanics' "how to build" house book with his wife



## We Built the Popular Mechanics

"Plenty of room for the baby," was verdict of the Rutherfords as they went over plans for two-bedroom house

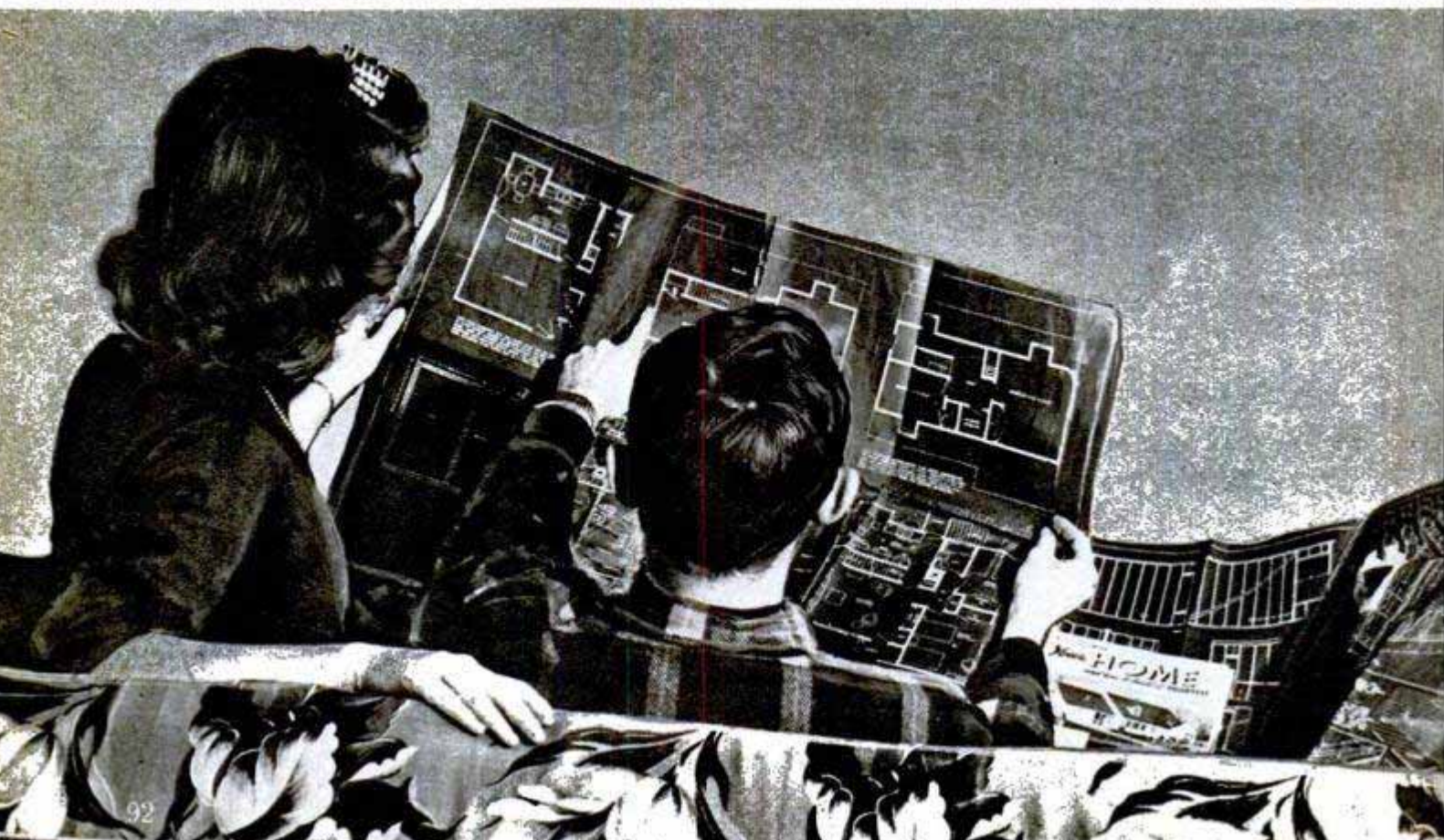

**W**HEN Clinton Rutherford, our young minister, got married, he was worried about finding a place to house his bride. Since he came from Kentucky and his wife from Kansas there was no moving in with the folks—both places are a long way from New Jersey.

One day, when we were talking about the difficulty of finding a place to live I said jokingly, "If the worst comes to worse you might move into our kennel house!"

"It has come to that already," he said. "I've looked everywhere and can't find a thing to rent and I haven't money to buy."

Our dog house at Basking Ridge, N. J., isn't quite as bad as it sounds. It's a 10 by 30-foot prefabricated building which my wife's folks had used for dachshunds. It had a coal range, hot and cold water, and we had put in a small bathroom. Soon the men and boys of the Wildwood Church had scrubbed, Sheetrocked, painted and trimmed the inside, and the ladies put up curtains and painted, too. Since we had stored surplus beds and bureaus in the building, furniture was no problem.

The arrival of little David a year later made the kennel house inadequate because babies have a way of taking up more space than their eight pounds might indicate. Clinton (everyone, young and old, calls him by his first name) thought long and hard

about his new housing problem. His church is a tiny nondenominational chapel which holds only 75 persons and it had no manse nor the means to build one.

The solution to the problem was simply a projection of the work which had been done on the kennel house. If the men and women of the congregation could do that job so well, perhaps they could build a house. Everyone was willing to try so the project was begun last summer, following a set of *Popular Mechanics* plans.

The excavating was begun late in July on land at Mendham, N. J., given by a church member, and the foundation was put up by a local contractor because it was felt that this basic operation should be done professionally. Actually, this was the slowest part of the whole operation for it took a month before the foundation was ready. Then late in August a crew of amateurs assembled one Saturday morning to try to make a house out of the great piles of lumber which was trucked up from Kentucky at a saving of 25 percent.

That first day most of the first floor beams were set in place and many a blister and sore muscle reminded the men and women and children how unaccustomed they were to this kind of work. An electric saw saved a lot of pushing, but carrying beams and driving nails are still good hard labor. From

## House for Our Minister

With a little professional help the congregation finished the house just before Christmas and the Rutherfords moved in. There are two unfinished rooms in the attic

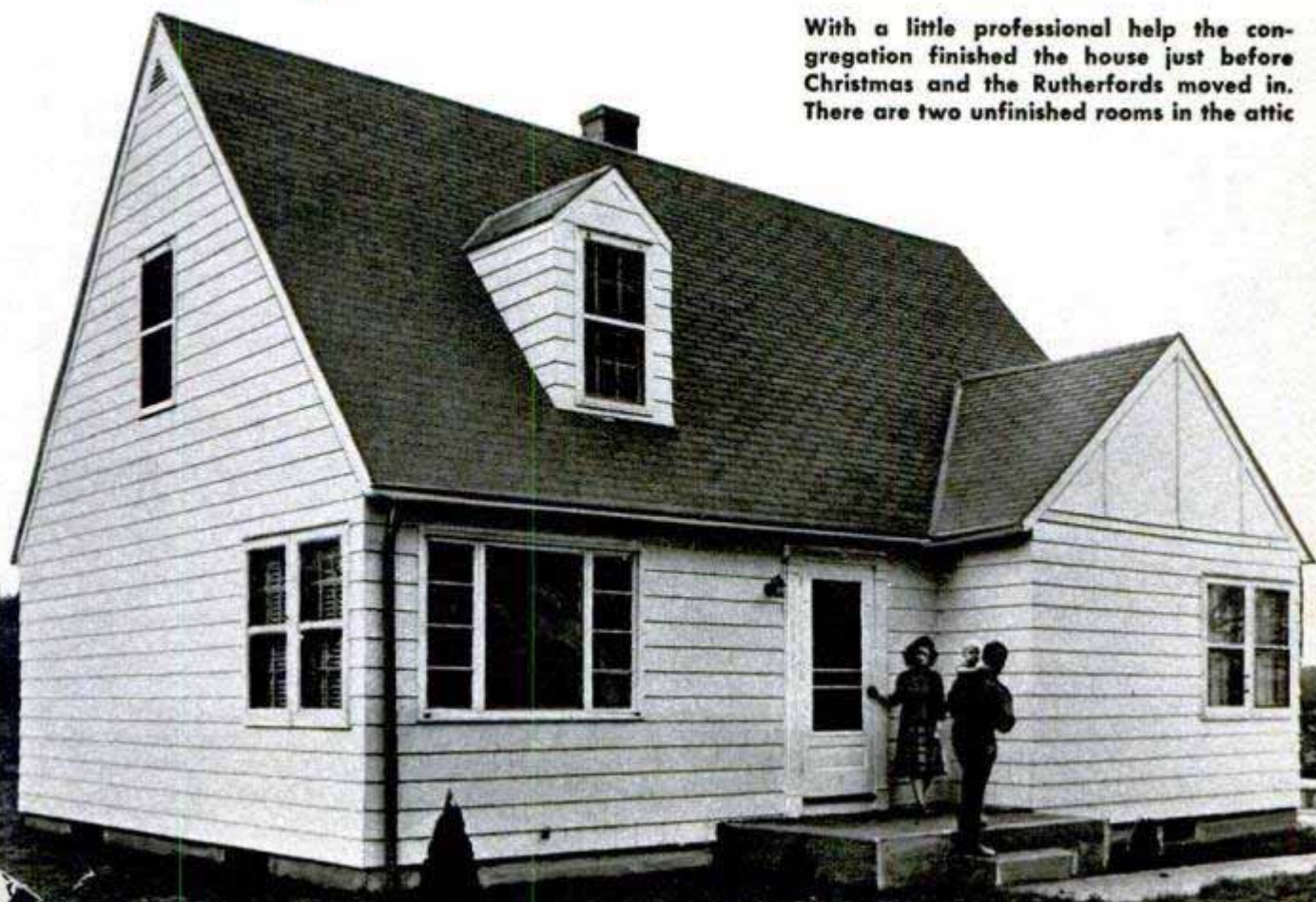



After the third Saturday's work, the Rutherford's house was framed up and ready for the second-floor beams

this time on almost all the work was done on Saturdays, the only time most of the congregation had free, and as many as 20 persons would be swarming over the building at one time. During the week, however, several of the ladies would show up to drive nails and carry lumber for Clinton, who worked on the house from early morning till bedtime when his other duties would permit. His wife, Bonnie, came down almost every day with little David, who lent urgency to the work.

It was a problem at times to find jobs for so many inexperienced hands. Several of the men had worked on their own homes so each of these would have a crew. At one

time, for example, three boys were digging a water trench, girls were carrying rough floor boards, several women and a couple of men were nailing these down upstairs, three groups were working on the cedar side shingles and two groups were up on the roof putting on shingles. It was bedlam but everybody was happy and such activity is recommended to any congregation.

When the roof was on and winter approaching, a retired contractor in the neighborhood came to our rescue. He hired a plumber and an electrician and a man to finish the shingling. Clinton and an equally unskilled helper had built the chimney up to the roof in two days and our contractor friend got a mason to top off the chimney. He said he was doing this as a memorial to his wife.

Help came from other unexpected sources, too. The young people of the congregation voted to devote the Wednesday evening recreational program to helping with the house so they reported en masse week after week and worked with the aid of electric lights. The Church of Christ in New York City learned of the project and on many a Saturday five or six helpers from the city showed up for this labor of love. And members of a nearby Methodist church, too, volunteered to help.

Here five helpers are at work shingling the roof and working on the rear wall. More or less experienced men headed up the congregation's crews

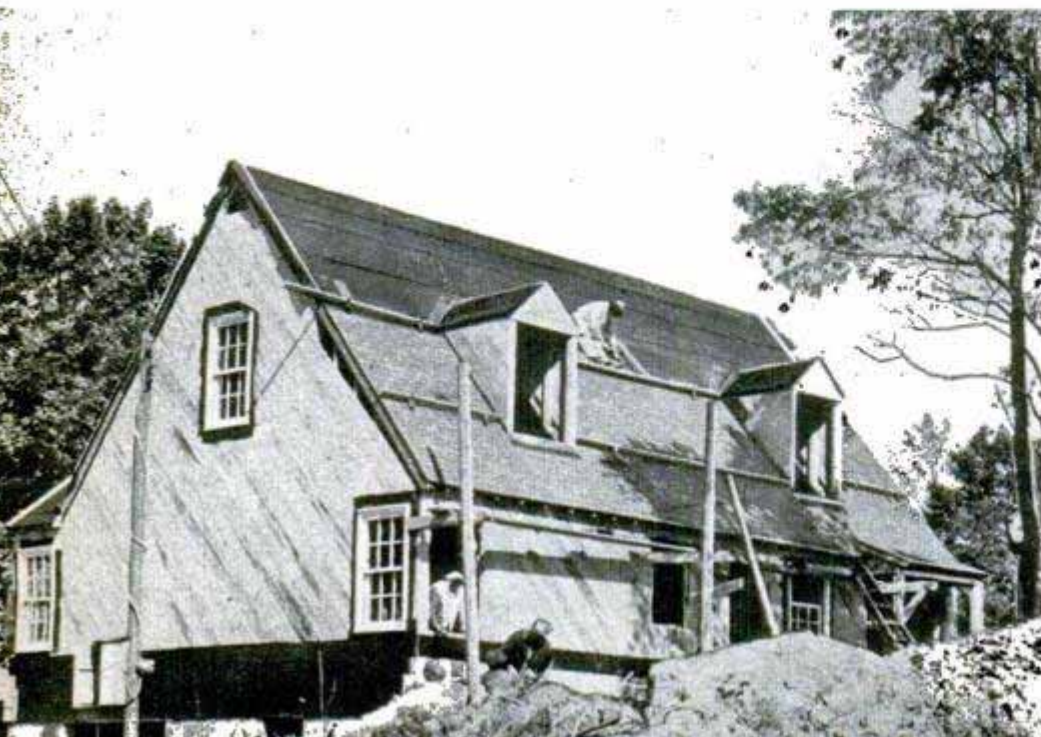



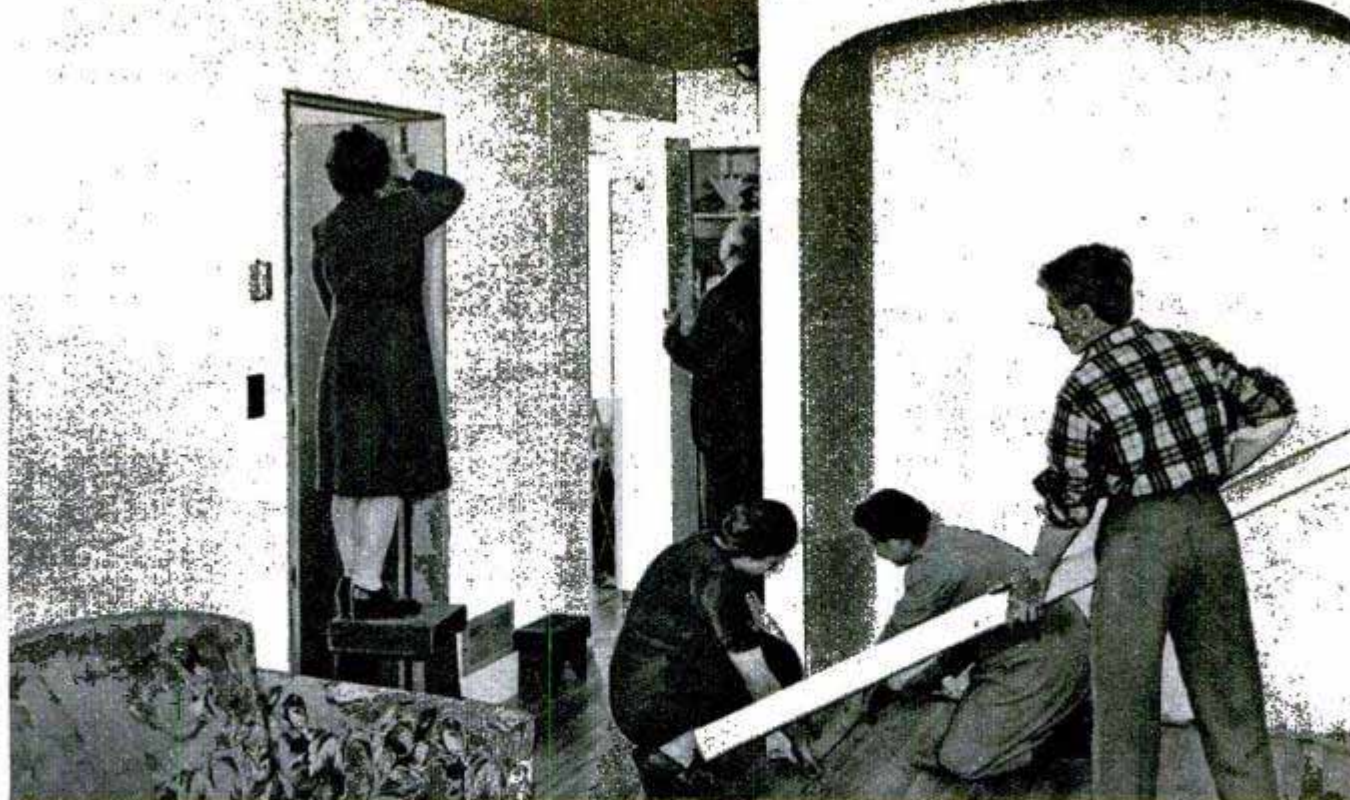

Work went right along on the interior after Rutherfords moved in. Young David is peeking through the gate

All these helpers made short work of putting up inside partitions and fitting and nailing up the lath, but we were deprived of the fun of dabbling in wet plaster. A real mason was hired to do the exacting job of plastering but he did it, sympathetically, for a reasonable fee.

The Rutherfords moved in just before Christmas and they and the helpers carried on with laying finished floor and hanging doors and putting on trim. The painting was done by the same amateurs and the first outside coat of white paint was applied with the permission of an unusually mild fall. The house is handsome and people have come for miles to admire its neat design and the "expert" craftsmanship with which it was put together. We were lucky to get it up with few mistakes and no accidents.

It's a light, capacious house with two bedrooms, bath, kitchen and living room on the first floor and expansion space for two more bedrooms upstairs. The big basement houses the car, heating system and plenty of room for workshop and laundry.

The Rutherford's house is a heartening example of what cooperation and the spirit of giving can accomplish and, as usual in such cases, those who gave, received as much in

satisfaction and good fellowship as they contributed in time and labor. Clinton and Bonnie Rutherford, on their own behalf and for the church, have already thanked everyone concerned, both privately and publicly, but they asked me to express in this article, too, how grateful they are to all who helped.

The economic results were gratifying to everyone who had a part in the project. Several contractors have said that the \$8000 cost is just half of what such a house would cost to build today by contract, and mortgages were obtained for the entire cost of construction and materials. Anybody got a house to build?

Almost finished. The big window arrived a little late so the last few shingles are being put on. This window is in dining nook off kitchen

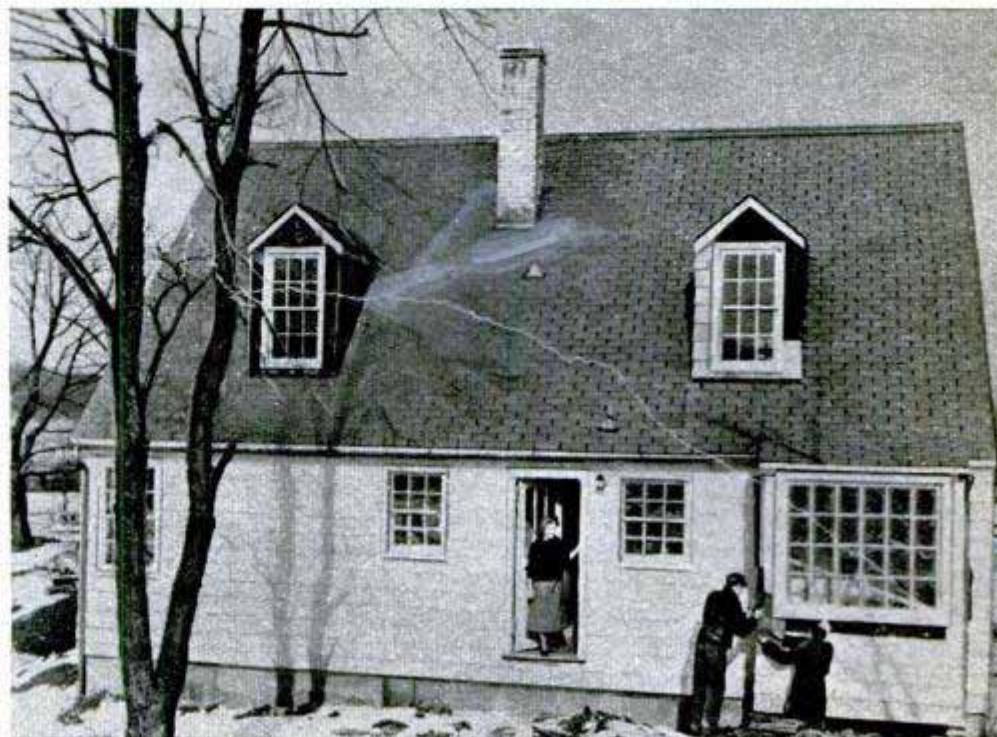



Bark partition above, left, hides wiring and plumbing of fish tanks and swings aside for access to tanks, right

## Partition Gives Submarine Effect

Spectators receive the illusion of looking directly into a group of small, beautiful submarine gardens when they view the collection of rare tropical fish owned by Fred Joerger, Hollywood motion-picture artist. All the glass tanks that hold the fish are concealed behind a partition of shaggy

redwood bark and are viewed through irregular ports cut through the bark. The partition completely hides the wiring and plumbing required for maintaining the fish. Each tank is separately lighted from above. Hinged at one end, the partition may be swung out of the way to feed the fish, clean the tanks, and adjust water and air supplies.

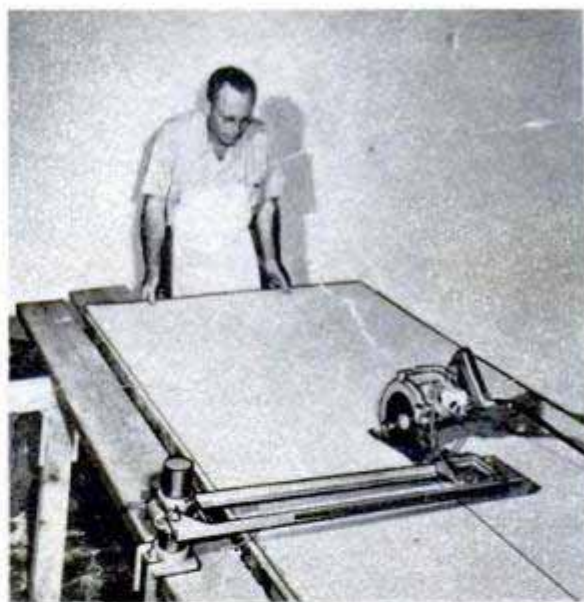
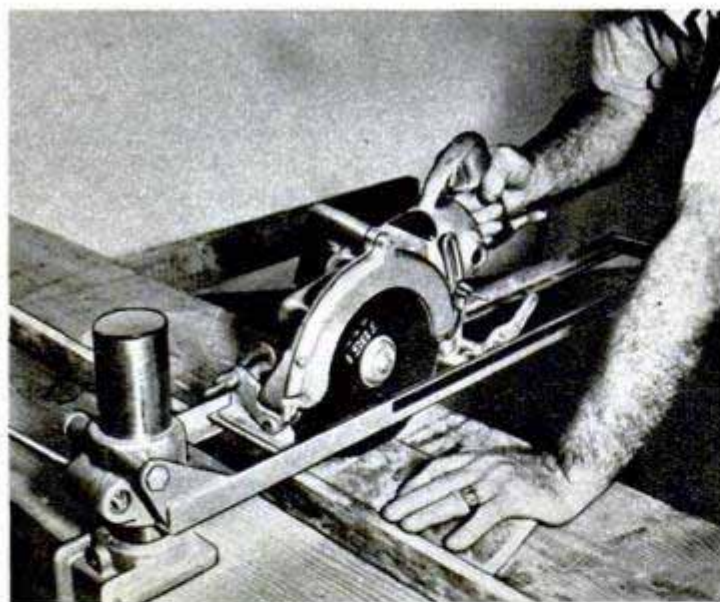

## Portable Saw Guide

Precision work can be turned out in less time and maximum safety with a new radial-arm saw guide. The guide is completely portable, making possible quicker job changes, and it is easily put into operation in less than five minutes. Among many other capacities, it crosscuts, bevel-crosscuts, miters, bevel-miters, rips, bevel-rips and notches. Using a saw with an abrasive disk, the guide will cut ceramics, marble or tile

to all shapes and sizes without breakage. The maximum travel of the guide is 21 inches. It will cut any angle up to 180 degrees vertically and angles up to 60 degrees horizontally. The guide weighs 26 pounds without a saw and is available in many sizes.

☐ Dirt and snow are kept out of the engine room of Electro-Motive's latest diesel-electric locomotives by a system of forced filtered air that keeps the room under slight pressure.

# and how to live with it



Step right up, folks, and select a color to fit your personality. The correct hue will make you sparkle, says Louis Cheskin, top color expert, who offers tips on redecorating your home

**By Clifford B. Hicks**

**I**F YOU ARE emotionally normal, your favorite color likely is a particular shade of blue and your wife feels a strong attraction for magenta-red.

Your small children — given a choice — select bright-red toys. If you are a farmer, you prefer a great many colors other than grass green, but if you work in a steel mill, grass green likely is one of your favorites.

You may not realize it, but you probably find a strong-blue room depressing, a vivid-yellow room head-splitting, a bright-red room nerve-wracking and a leaf-green room boring.

These are just a few of the facts turned up by a recent spurt in color research. Surprisingly, the theory that colors have a profound influence on human beings hasn't been given broad recognition until the past few years. Now psychologists, probing colors and their relation to people, have discovered some facts that can make anyone's life happier and more useful.

Among the foremost of these pioneering authorities on color is Louis Cheskin, technical director of the Color Research Institute of America. He has tested the reac-

tions of thousands of persons to thousands of colors. He's a plain-speaking young man who can tell your wife exactly what color her dress should be to flatter her figure. More important, he can tell you what colors to paint or paper your walls in order to tune them to your particular way of life.

Cheskin's research has demonstrated that each color has an individual personality. He feels it's extremely important that the personalities of colors in the home match the personality of the homeowner. Otherwise, a home can become a place to escape from instead of a haven of relaxation. Emotional stability depends mostly on environment, of which color is one of the most important elements.

The spectrum specialist points out that cool colors of the green-blue families are sedatives—they provide excellent relaxation for nervous persons. On the other hand, the warm colors of the red-yellow families provide stimulation for persons who tend to be melancholy and morose.

Once Cheskin painted two adjoining walls of a living room a cool green-blue. The two walls that formed the opposite

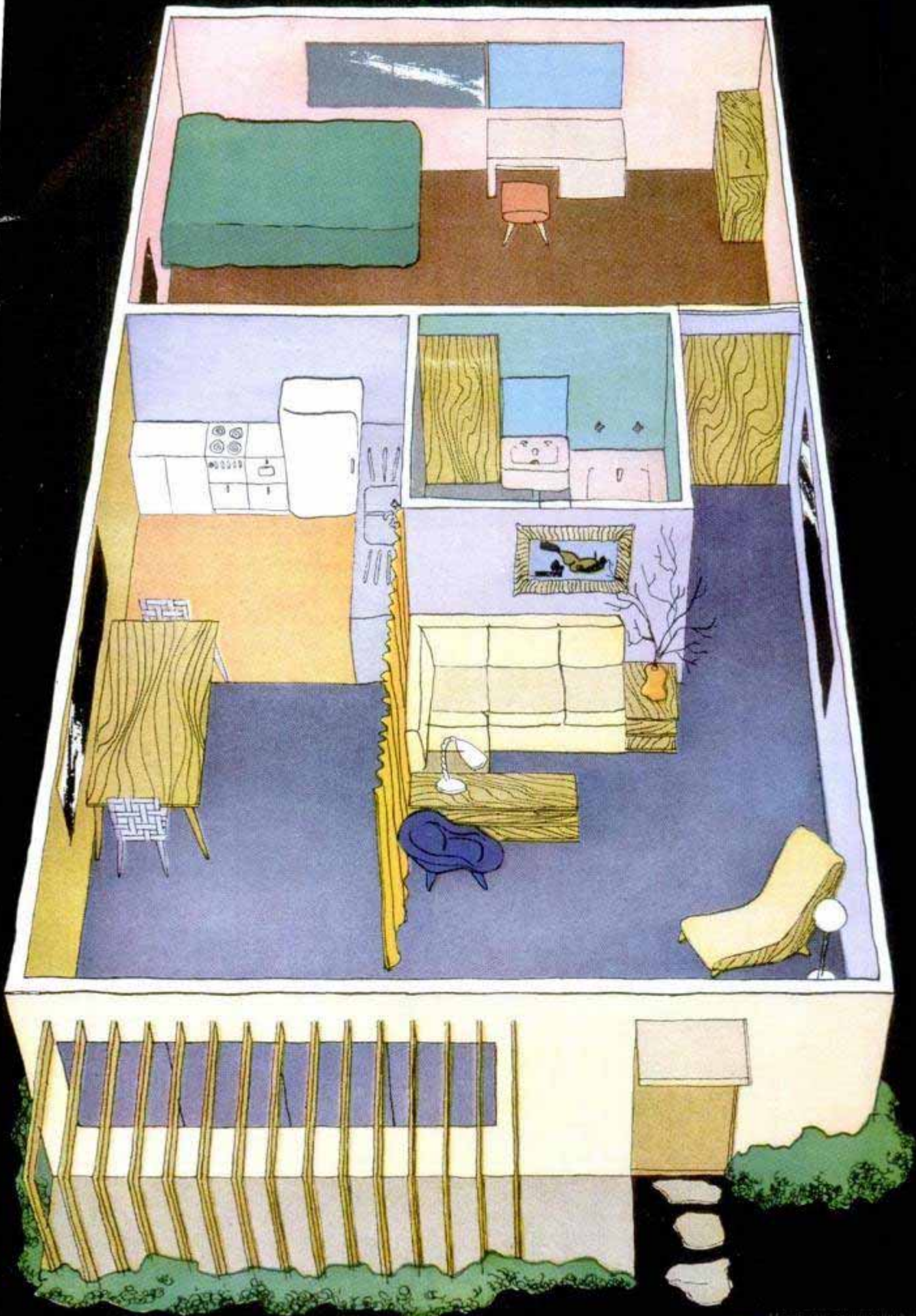

← Only two main colors—complementaries—plus their tints, tones and shades are used in decorating each room of this small home. Color plan would fit high-spirited young couple. Below are drawings of same room decorated to fit three different couples

corner he painted a warm peach. Except for color, he furnished each of the two corners with identical furniture. When preparations were completed, he invited a married couple to visit. The husband disliked social life and tended to withdraw into himself. The wife, on the other hand, was lively and full of fun.

When the husband and wife entered the test room, they walked about for a minute or two. Then like well-directed robots they walked to opposite corners and sat down, the husband in the corner decorated with warm colors and the wife in the shadow of the cool blue-green.

"See?" says Cheskin. "They subconsciously chose the colors that were good for them—colors that complemented their personalities."

In a series of tests in the room, nervous people inevitably chose the cool corner and quiet persons the warm corner.

Cheskin has made a science of determining color preferences. He uses a Holland graphometer, similar to a lie detector, to determine the reaction of an individual to a particular color. Flash a hue that the person dislikes in front of him and the pen on the graphometer will wave like a pendulum. One surprising fact that Cheskin has learned is that frequently people will think they like a certain color, whereas they actually may detest it subconsciously.

He once ran a preference test with 85 women. Cheskin showed them six different kerchiefs and asked them which color they preferred. A great majority—68 women—chose the same color. Later Cheskin diverted their minds from the kerchiefs, then at the end of the test told the 68 women to take home a kerchief as a reward. When the women had cleared out, a tally showed that only 9 of the 68 actually had

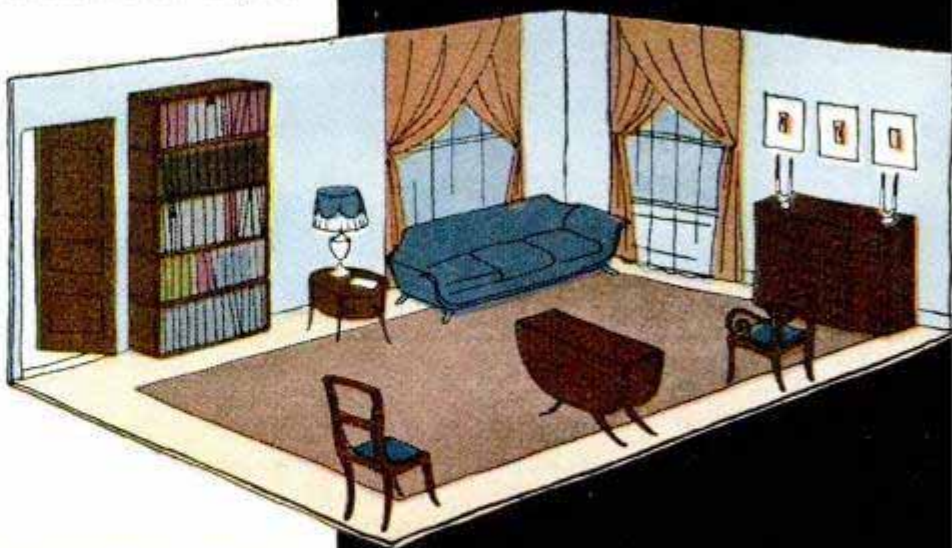

These colors and furnishings are tailored to a middle-aged couple. Cool walls give them relaxation in evening. Circled colors are the hues used plus one tone. Family of complementaries always pleases

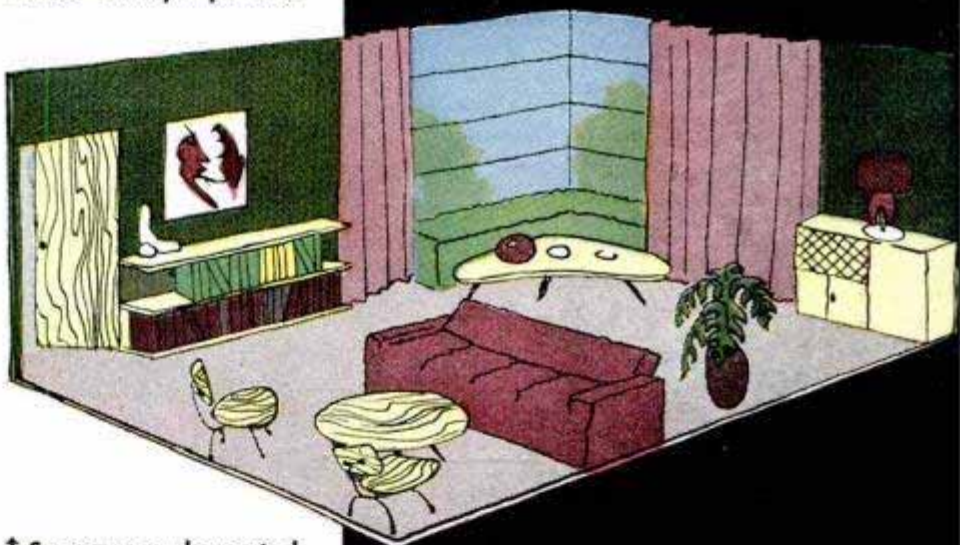

↑ Same room decorated and furnished this way would fit young people who do much entertaining. Red rug, draperies provide stimulation. Below, restful color scheme with cool blues fits an older couple

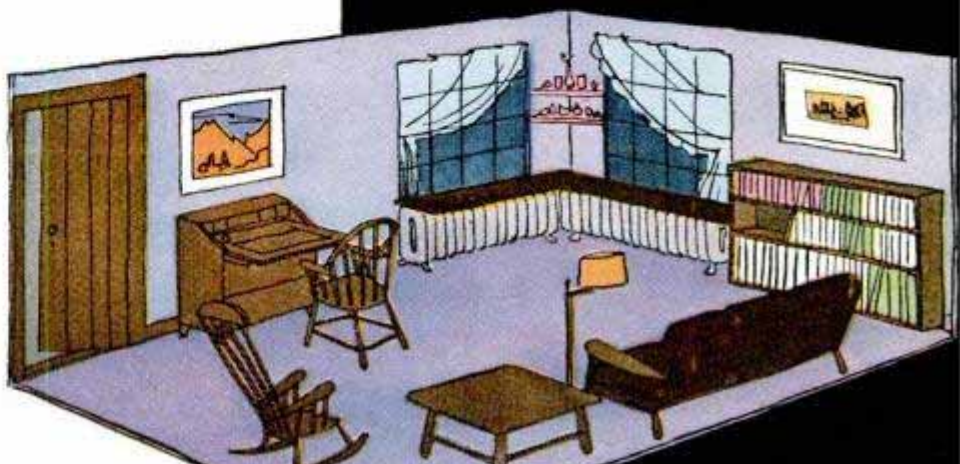



chosen the color for which they had voted.

The color expert will come right down to earth in discussing colors for the home. He points out that colors take up no room, and correct colors are no more expensive than inharmonious colors.

Before he'll make any recommendations, he insists that everyone should know the meaning of certain confusing color phrases. Here are the basic definitions:

*Primary colors* of paint pigments are green-blue, magenta-red and yellow.

*Hues* are the primary colors and their mixtures.

*Tints* are hues plus white.

*Shades* are hues plus black.

*Tones* are hues plus both black and white.

Combining primaries in varying proportions, therefore, produces an infinite number of hues. Adding black, white or both to any hue produces an infinite number of shades, tints or tones. Cheskin has developed a popular color system which has 4800 colors based entirely on the three primaries plus white and black. Gradations finer than that number of colors, he says, can't be differentiated by the human eye.

Anyone who learns the fundamentals will be able to decorate his home in colors that will be as pleasing as punch, according to Cheskin. His major rule is this: Use only two complementary colors in decorating a room.

He quickly points out that a room in which only two colors appear might become tiresome. But books, pictures and other furnishings will provide countless spots of color. Cheskin's idea is that only two colors should predominate. For example, paint or paper your walls the complementary hue of the rug. Then use draperies, lamp shades, vases and other small items that are the hue of the rug, but lighter or darker.

Each hue, of course, not only has its mate

### COLOR-TUNE YOUR LIVING ROOM

Answer the following questions. Then turn to page 102 for instructions on finding the proper colors.

1. What color is your rug or most valuable piece of furniture? \_\_\_\_\_
2. Name your favorite color. \_\_\_\_\_
3. Does any member of your family strongly dislike any color? Yes \_\_\_\_\_ No \_\_\_\_\_
4. Does anyone in your family frequently become depressed? Yes \_\_\_\_\_ No \_\_\_\_\_
5. Is anyone in your family nervous and high-strung? Yes \_\_\_\_\_ No \_\_\_\_\_
6. What kind of natural light do you have in your living room? North \_\_\_\_\_ East \_\_\_\_\_ South \_\_\_\_\_ West \_\_\_\_\_
7. Is the living room small or large? \_\_\_\_\_  
(Complementaries below will be used later.)



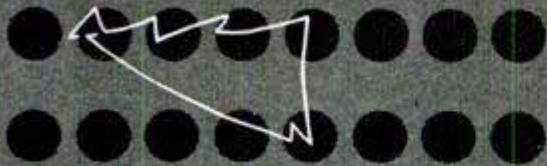

Study the color chart at left. Then note diagram above made with eye movement camera. This is a typical pattern with such colors. Yellow stands out, catching eye first. Eye moves to right, down to the red, then back to yellow

— the complementary — but it fathers an entire family. Every tint (the hue plus white), every shade (the hue plus black) and every tone (the hue plus black and white) will fit into this color scheme. If your rug is a shade of yellow (brown, tan or beige), make the walls blue; if the rug is a shade of red, make the walls green. But instead of putting brilliant colors on the walls, use a delicate tint, tone or shade.

"The ideal combination," says Cheskin, "is a deep tone with a complementary light tone or tint—or a shade with a complementary light tone or tint."

There's a sound scientific reason why it is as natural for humans to like complementaries as it is for them to walk upright. Any color absorbs part of the white light

striking it and reflects the rest. It is this reflected light which determines the color we see. The complementary color reflects the remainder of the spectrum. The total effect is a complete reflection of white light in the room but not from one source. And because the eye is accustomed to see in white light, the result is pleasing.

Now Cheskin sounds one warning. Complementaries provide the most vivid possible contrast, and in their purest tones will vibrate. Therefore, Cheskin recommends that the woodwork in the room be painted a white or off-white, which will provide a separation between the two. Complementaries work as highly-efficient partners as long as there is a third, neutral person in the vicinity.

Providing some concrete suggestions, Cheskin recommends that the home dweller who is about to redecorate a room determine what is his most important and valuable furnishing—the one item he can't afford to change or doesn't want to change. Often this will be the rug. Color the walls in a complementary tone of that furnishing. Duplicate the color of that valuable piece, only in purer tones, in the upholstery, draperies and lamp shades. Such things as pictures and vases, in the purest tones, can provide bright spots of color.

Ceilings, he says, should be pure white to reflect the greatest amount of light.

Cheskin realizes it usually is too expensive to wipe the color slate clean by changing or eliminating many expensive furnishings. So he recommends that a family design a balanced diet of color for the entire home, and then gradually work toward

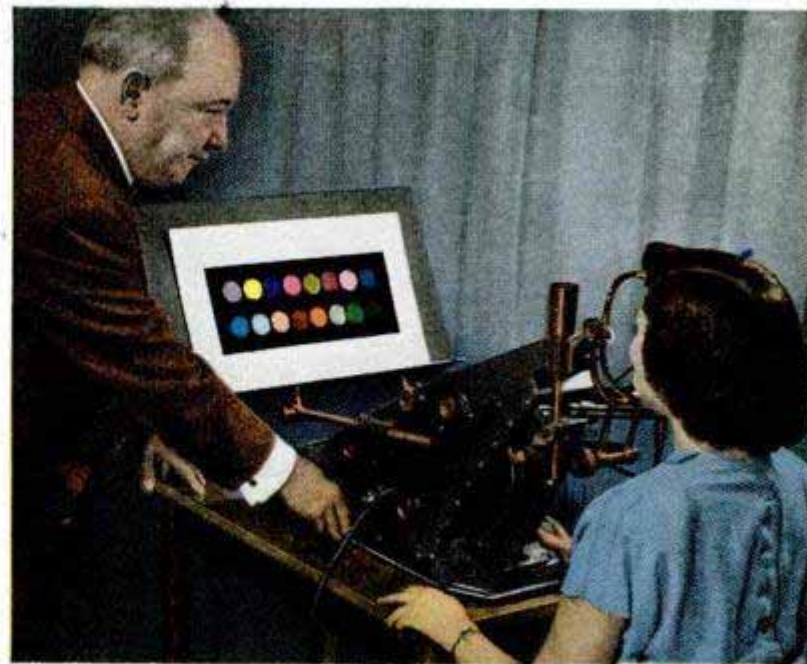
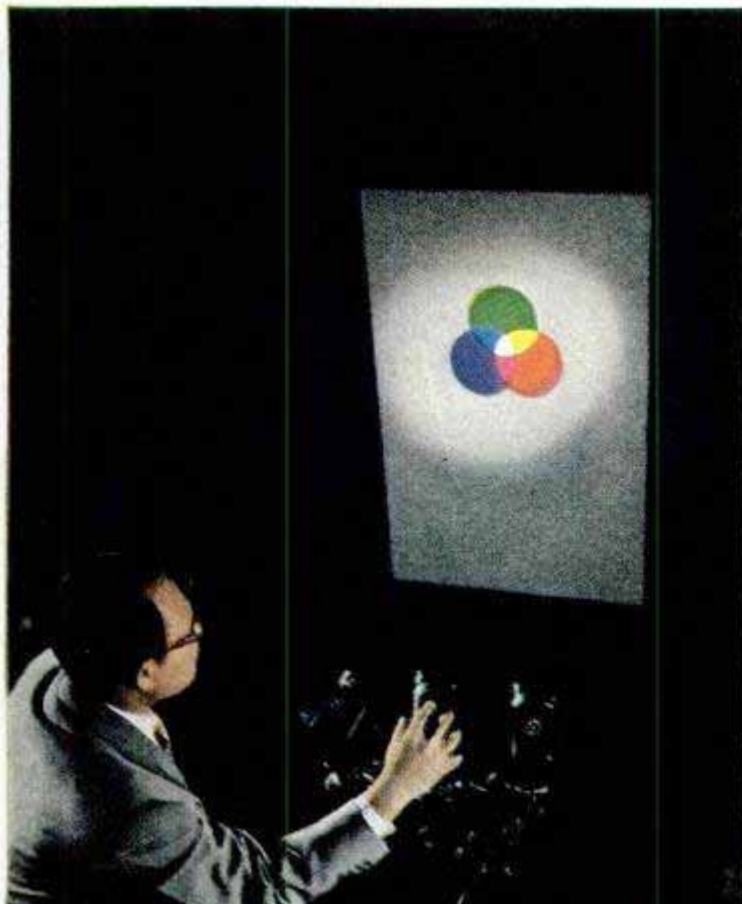

Subject, seated at eye-movement camera, is tested with color chart on opposite page. Camera records where her eyes stop and how long they linger. Left, color mixer shows white made from primaries

## COLOR-TUNE YOUR LIVING ROOM

The 14 colors just beneath the questionnaire on page 100 are arranged in complementary pairs. Most of them are shades, tints or tones of pure hues.

1. Choose the color which is closest to the hue of your rug. Then start with its complementary, which is just above or below.
2. If your favorite color is the same as the rug, drop the complementary and use a tint, tone or shade of the rug. Make other furnishings complementary. But if the hue of the rug is not your favorite color, then retain the complementary for a moment.
3. If this complementary hue is disliked strongly, drop it and return to the hue of the rug. Otherwise retain it.
4. If any member of the family becomes easily depressed, take another look at the color you now have in mind. If it is a shade of green, blue or violet, then switch to its complementary to pep you up. Otherwise retain the same color.
5. If the color you have in mind is a shade of red, orange or yellow, and if any member of your family is exceptionally nervous, then switch to the complementary to provide relaxation. Otherwise retain the same color.
6. You now have determined a color that will look well on your walls. Use a tint, tone or shade of this hue. If your light is north, use a tint. If it's south, use a shade. If east or west you can go either way.
7. If your room is small, add white to the final color. If it's large, add a little black.

Chart shows colors which most men and women prefer. For example, more men will accept color at top left in their surroundings than any other color

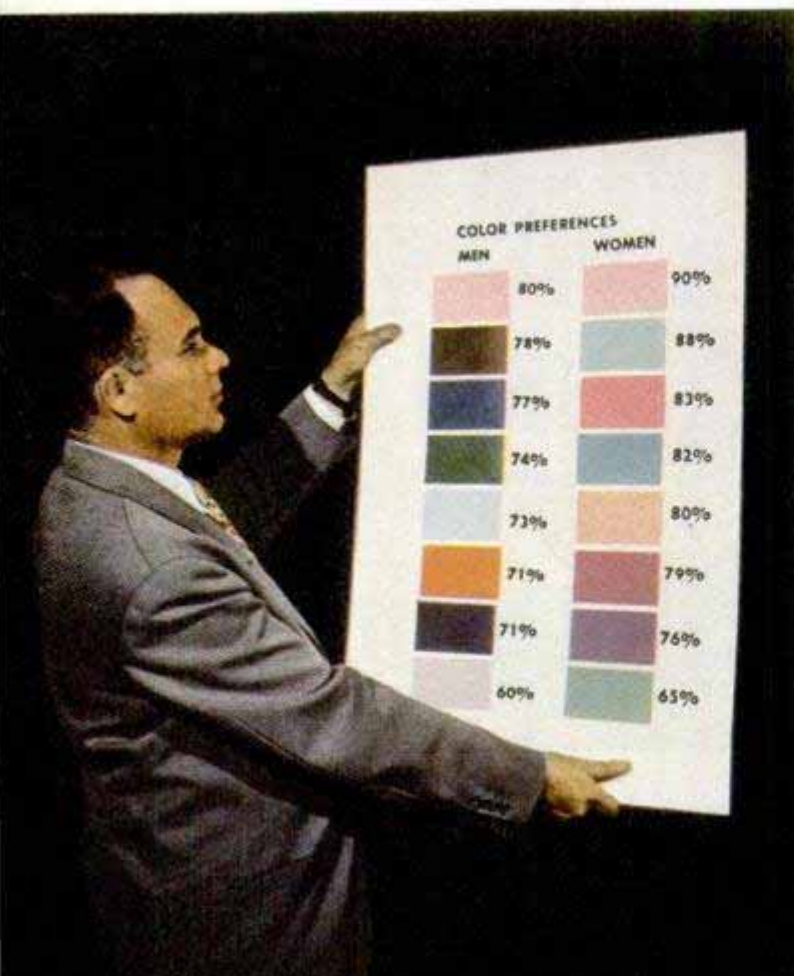

that master plan as a goal. New furnishings then can be bought with an eye toward the ideal color scheme.

At this point the personalities of the family members and the use for each room should be analyzed.

Consider the living room first. It should provide relaxation for the entire family, but at the same time should stimulate discussion and play. If your family is inclined to be quiet, to entertain little, Cheskin recommends a warm color to pep you up. Therefore, the walls of your living room could be a shade of any of the warm red-yellow colors such as peach or rose.

If, on the other hand, your family is creative even in its hours of relaxation, if some of the members are nervous and high-strung, Cheskin recommends any of the sedative colors of the green-blue family. Or, you can use the warmer colors but in very delicate tints or tones that won't be overstimulating.

As the bedroom is a place of rest, it should be decorated in cool, serene colors that will not hinder the occupants' desire for relaxation. Shades and tones of green, turquoise and blue are ideal, although shades of red may be satisfactory for younger people.

Kitchens, on the other hand, are designed for work and should stimulate the housewife. Cheskin guarantees any husband more cakes and pies if he'll redecorate his kitchen in bright peach, yellow-orange, red, or any color with red in it. In the kitchen, of course, it is the linoleum, dishes, clocks and flowerpots that can provide the complementary color.

Tots aren't impressed a bit by baby blues and delicate pinks. The child recognizes pure, bright hues first, and it is these colors that appeal most to him. As a possible color combination for the nursery, Cheskin suggests a deep peach for the large walls, a blue-green for the narrow walls, a peach, gray and blue-green rug, natural furniture and a toy chest in bright red.

North light (light which is not direct sunlight, such as that which comes in a north window) and fluorescent light will increase the depth of any color and make it appear slightly more blue. Direct sunlight, which contains much more orange and red, makes walls appear brighter and warmer. An incandescent bulb has a maximum of red and can change the color of the wall greatly.

Deep, warm tones always give the impression of nearness; light, cool tones seem distant. Therefore a long, narrow room can be made to appear shorter and wider by using a warm color on the narrow, distant walls and a cool tone on the side walls. For the same reason, a red-tinted room





**Cheskin uses graphometer—similar to lie detector—to check subject's reaction to hues flashed on a screen**

appears smaller than a blue-tinted room. Tints, in general, lend spaciousness. And you'll definitely feel cooler in a blue room, warmer in a red room.

A light rug with dark furniture or a deep-colored rug with light wood produces a dramatic effect which is pleasing.

He suggests that the family of average means depend on small, inexpensive objects to accomplish color harmony by providing a complementary hue. Low-cost yard goods, a new lamp shade, a vase in a prominent place can do wonders.

Cheskin has worked with a paint manufacturer to develop an entirely new paint system. It is based on Cheskin's development of three primary pigments, each of which reflects exactly two thirds of white light. Mix the three pigments in equal amounts and you'll get black.

Today, if you walk into this type of paint store, you will find only these three colors plus a large supply of white paint and some black on the shelves. You'll look over the color chart and choose the particular color you want. Then, the dealer will give you

**Graph shows reactions of three people to six colors. Note strong reaction of normal person to yellow. Melancholic person has no violent reaction to any color. Nervous person is affected most by reds and yellows**

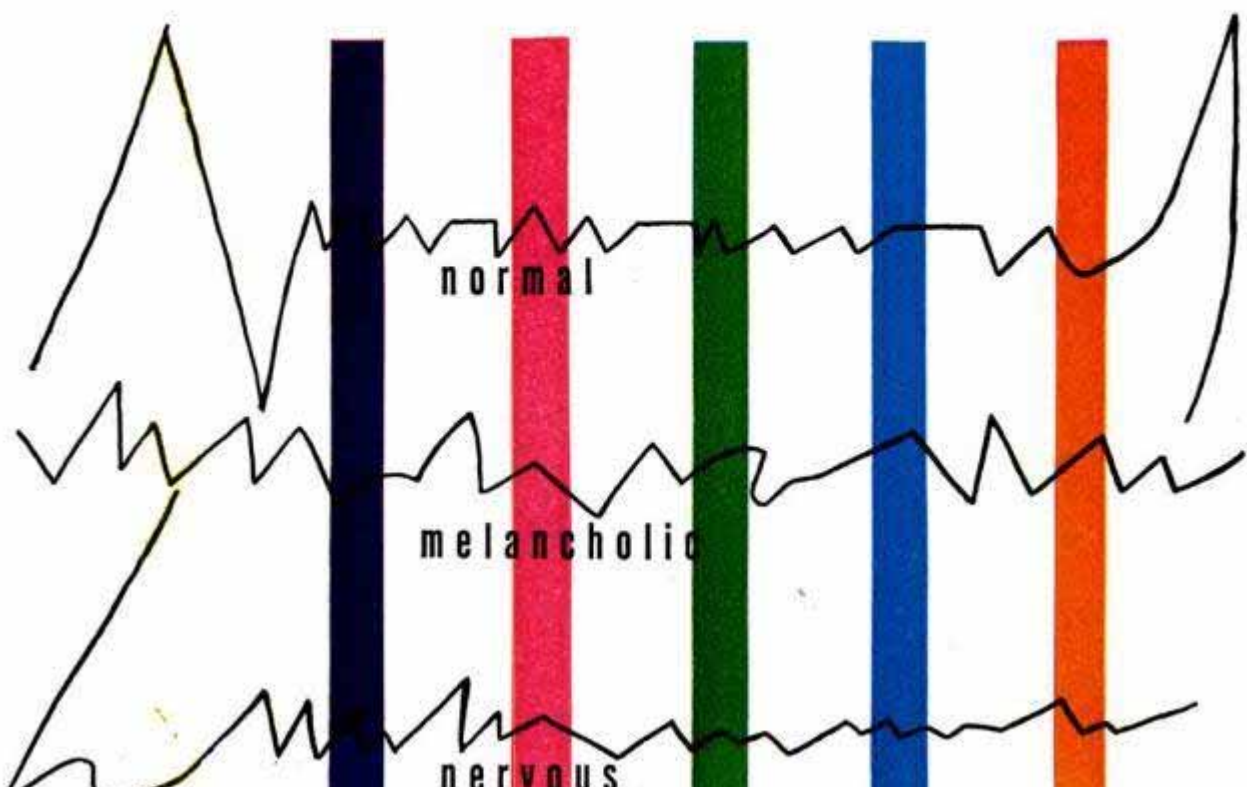



Cheskin's system permits anyone to mix paint to match a color chip. Just follow the recipe, adding measured amounts of pigments to white-paint base

white paint plus one or more of the primaries. He'll also provide you with a recipe.

You take the paint home and read the recipe. It says to add a four-ounce can of yellow pigment and a four-ounce can of red pigment to a gallon of white paint. As six teaspoons equal one ounce, you easily can measure out any specific amount. Mix it well and you'll come up with exactly the same color of peach as the paint chip. Even a color-blind person can do it.

Now suppose six months later you want to paint a new bookcase the identical color of the walls. If you had mixed the paint by the old system of "adding pigment until it looks good," you'd never be able to duplicate the color exactly. Under the Cheskin system, all you do is take your color specification back to the paint store. The dealer again will provide the necessary ingredients. Stir up another batch and you'll find that you have produced a perfect twin for the color on the wall.

Cheskin sounds one last warning to the family planning to redecorate. Don't use any color which is disliked by any member of the family. Once a man came to Cheskin who had a violent dislike for deep blue and became almost speechless whenever he was near a man wearing a deep-blue suit.

A psychologist as well as a color expert, Cheskin asked the man a good many questions. Among them—"Were you ever in serious trouble as a child?"

"Well," said the patient, "the only time I ever caused any trouble was when a pal and I swiped some apples and were caught by a cop."

"What was the reaction of your family?" asked Cheskin.

"They were mortified. So embarrassed my father even considered leaving town."

"What did the policeman do to you?"

"Put us in jail for several hours." As the man recalled his experience, he became so nervous that he had difficulty speaking.

"Do you remember the color of the officer's uniform?"

"Deep blue," said the man. As soon as he spoke, he realized why deep blue made him so uncomfortable. Once he had discovered the reason for his aversion, he no longer felt uncomfortable in the presence of the color.

That, says Cheskin, is pretty good proof why anyone should follow his color recommendations only to a certain point.

Here's proper decoration for walls and furnishings to match temperament. Normal person can lean either way

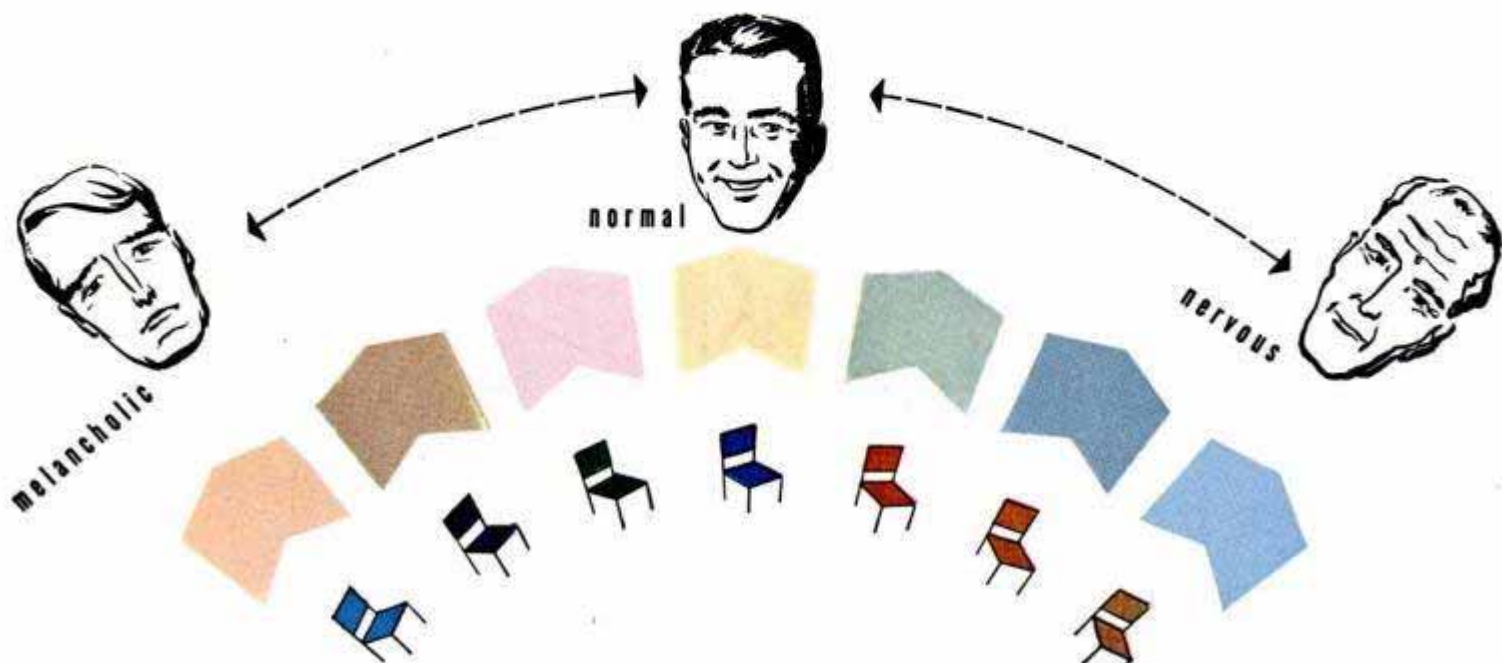

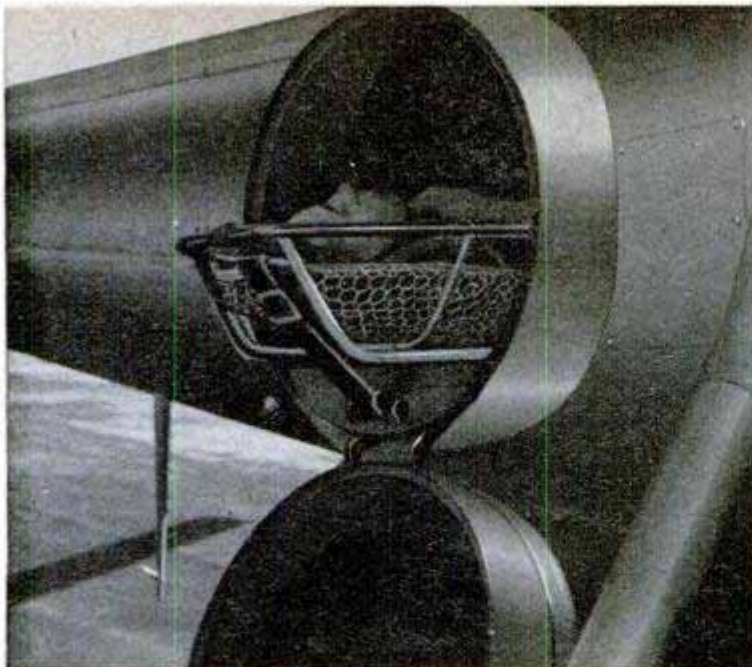

Above, left, head end of litter extending out from rear "blister" hatch of rescue helicopter. Above, right, airman closing hatch preparatory to take-off. Below, pontoons and wheels fit craft for either land or water rescues

U. S. Air Force photos



### "Litter Blisters"

Two patients are accommodated fore and one aft in "litter blisters" in a new Sikorsky helicopter used by Air Force rescue squadrons. The litters are placed crosswise in the pontoon-equipped aircraft, after loading through side hatches either by hand or by winch power. Only the two patients forward are accessible to the medical attendant, the only crewman aboard the craft other than the pilot.

### Reducing Suits

Horses, as well as overweight humans, can trim off pounds by sunning in a plastic "silhouette" suit. Jockeys say it helps them reduce as much as five pounds in an hour.

Sources of available products described in this issue are listed on pages 10, 14 and 18. Sources of further information on other articles are listed in the WHERE-TO-FIND-IT INDEX, which is available without charge from Bureau of Information, Popular Mechanics, 200 East Ontario Street, Chicago 11

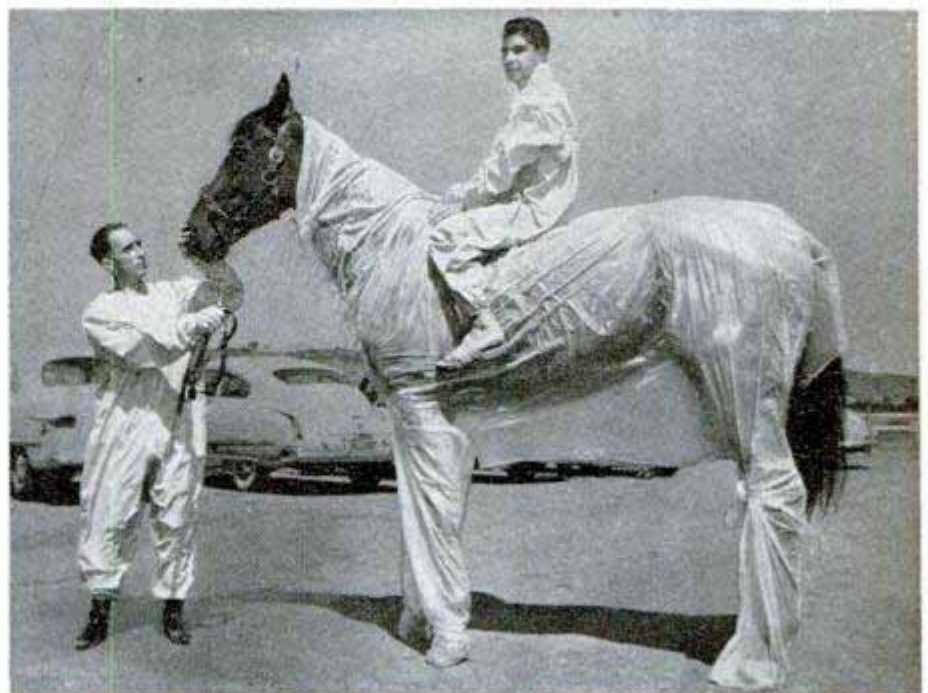



# COUNT OFF, AMERICANS...



**By Richard F. Dempewolff**

These five scenes show census takers on the job of counting some 150,000,000 noses. On opposite page (top) trailer families seldom hold still for counting; farmer (center) only pauses for interview and the Navajo family below needs an interpreter. Just above, the census taker has found the family of a railroad section hand in a boxcar. At top is Bill Arends who travels North Alaska to count Eskimos

**F**OR A house-to-house canvass that will make all the brush salesmen in the world look like an army of pikers, wait until you see the one that gets under way April first. Yup, it's time for the 1950 decennial census, Uncle Sam's national inventory of noses—the biggest quiz show, most mammoth tabulating phenomenon and most accurate poll in history.

It's a job that has taxed the ingenuity of a harried Census Bureau every zero year since 1790. At that time 17 U. S. marshals and 600 assistants knocked on colonial doors, asked five questions of whoever answered, then tacked their lists on the walls of local taverns, so that people who'd been skipped could add their names or Xs when they dropped by for a flagon of ale. Results were mailed to the President.

The job has grown a little more complicated since 1790. This year, 140,000 hurried but polite "enumerators" will scour the country armed with pencils and paper forms measuring about two by three feet. They must ring some 45,000,000 doorbells, ask 60 or 70 questions and tally data on an estimated 150,000,000 people; all in two weeks.

To accomplish the staggering job, the Census Bureau has divided the country into 14 regions. Each region is divided and subdivided into about 14,000 "enumerating districts." Census supervisors will man about 450 field offices. It's going to take 90 mail cars to haul supplies to those offices, and when the quiz is over, completed schedules will go to Washington in 60,000 boxes.

This year, census takers will have some new tools to help them with their great American man hunt. For years, Air Force and Department of Agriculture planes have been zooming across the country taking vertical aerial photographs of every nook and cranny of the U.S.A. Already these maps have helped farmers with their contour plowing and reclamation work. Now they're going to help the census taker. For the first time in history, the roving statistician will have a real picture of his territory, showing every road, stream, shack and shanty in the area.

All last year, up in the darkroom of the census map division, geographers were busy preparing about a million of these and other diagrammatic maps for the field workers. Many of the aerial shots have been used to make diagrammatic maps of obscure places. Census geographers project the aerials through a monster machine to scale. An operator traces the projection,

A	V	V	V	Sheet	Line	4	5	6	7	No	Dist	11	12	13	14	15	No	17	V	V	V	H	24	25	26	V	V	V	V	28	29	30	31	32			
X	X	X	X																																		
•	•	•	•	•	•	•	•	•	•	•	•	•	•	•	•	•	•	•	•	•	•	•	•	•	•	•	•	•	•	•	•	•	•	•	•	•	•
1	1	1	1	1	1	1	1	1	1	1	1	1	1	1	1	1	1	1	1	1	1	1	1	1	1	1	1	1	1	1	1	1	1	1	1	1	1
2	2	2	2	2	2	2	2	2	2	2	2	2	2	2	2	2	2	2	2	2	2	2	2	2	2	2	2	2	2	2	2	2	2	2	2	2	2
3	3	3	3	3	3	3	3	3	3	3	3	3	3	3	3	3	3	3	3	3	3	3	3	3	3	3	3	3	3	3	3	3	3	3	3	3	3
4	4	4	4	4	4	4	4	4	4	4	4	4	4	4	4	4	4	4	4	4	4	4	4	4	4	4	4	4	4	4	4	4	4	4	4	4	4
5	5	5	5	5	5	5	5	5	5	5	5	5	5	5	5	5	5	5	5	5	5	5	5	5	5	5	5	5	5	5	5	5	5	5	5	5	5
6	6	6	6	6	6	6	6	6	6	6	6	6	6	6	6	6	6	6	6	6	6	6	6	6	6	6	6	6	6	6	6	6	6	6	6	6	6
7	7	7	7	7	7	7	7	7	7	7	7	7	7	7	7	7	7	7	7	7	7	7	7	7	7	7	7	7	7	7	7	7	7	7	7	7	7
8	8	8	8	8	8	8	8	8	8	8	8	8	8	8	8	8	8	8	8	8	8	8	8	8	8	8	8	8	8	8	8	8	8	8	8	8	8
9	9	9	9	9	9	9	9	9	9	9	9	9	9	9	9	9	9	9	9	9	9	9	9	9	9	9	9	9	9	9	9	9	9	9	9	9	9
E	D	Sheet	Line	Op	Folio	Vol	Rest	Relief	Col	Age	HS	Sch	Grade	E	Pl	Co	W	Time	Occ	Ind	C	W	Wage	Day	W	W	W	W	W	W	W	W	W				
2	2	4	5	5	5	7	3	3	3	3	3	3	3	3	3	3	3	3	3	3	3	3	3	3	3	3	3	3	3	3	3	3	3	3	3		

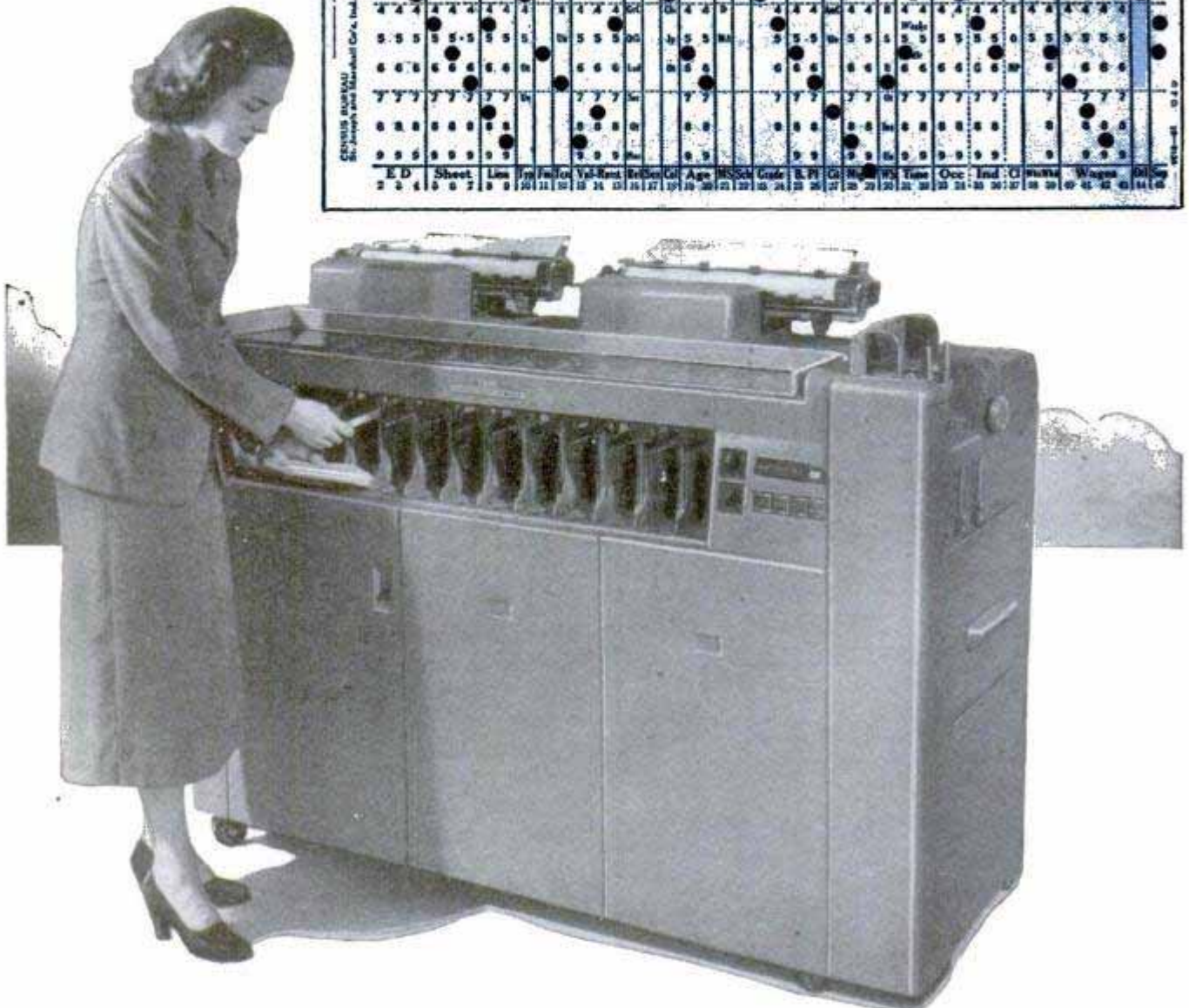

It would take the lifetime of 500 persons to do the job this machine will accomplish during the census. It counts, classifies and edits

detailing dwellings, roads, waterways, bridges and boundaries. Out goes the finished sketch to blueprint machines, or an Ozelid printer that reels off duplicates at a rate of about 20 a minute.

The Ozelid's four-foot-wide ribbon of paper takes two maps across. For a while, men stood at the end of the machine with great shears, snipping the endless sheet up the middle, and across, as each pair of maps came out. They tore a lot of maps with their double-barreled snipping. Then one smart opera-



Sample of new census card is shown at top. Below is a sketch of census taker riding across chasm on cable to reach the men working in mines

tor rigged a crossbar over the drums. In the center, he hung a razor blade on an arm. Now the boys just snip the sheet across; the razor slits it down the middle between the maps, as it reels off the drums.

Importance of maps to an enumerator cannot be underestimated. Boundaries change from year to year. Rivers change course each year—especially the Mississippi, which continually builds new islands and inundates old ones. Suddenly an island belongs to the state on

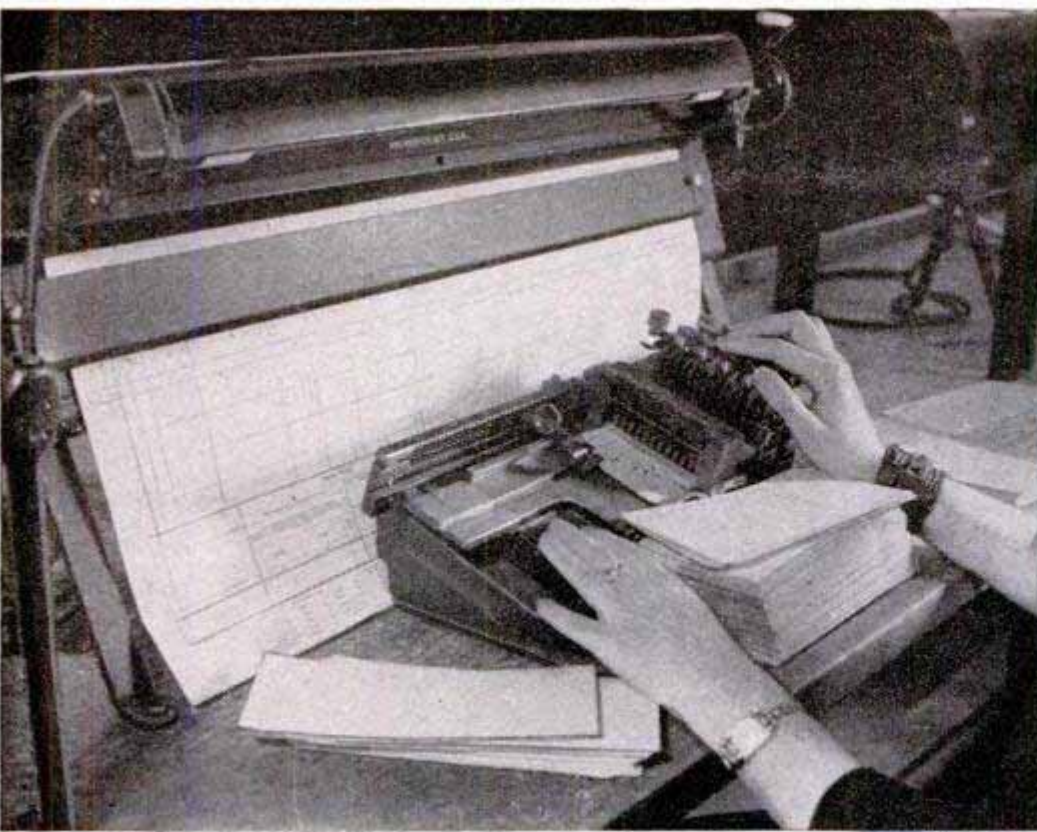

Information from the census-taker's sheet is transcribed to an arrangement of holes punched in cards which later are sorted by machine according to location of the holes

Sketch shows how one lady census taker had to climb a 70-foot chimney to contact a steeplejack who refused to come down

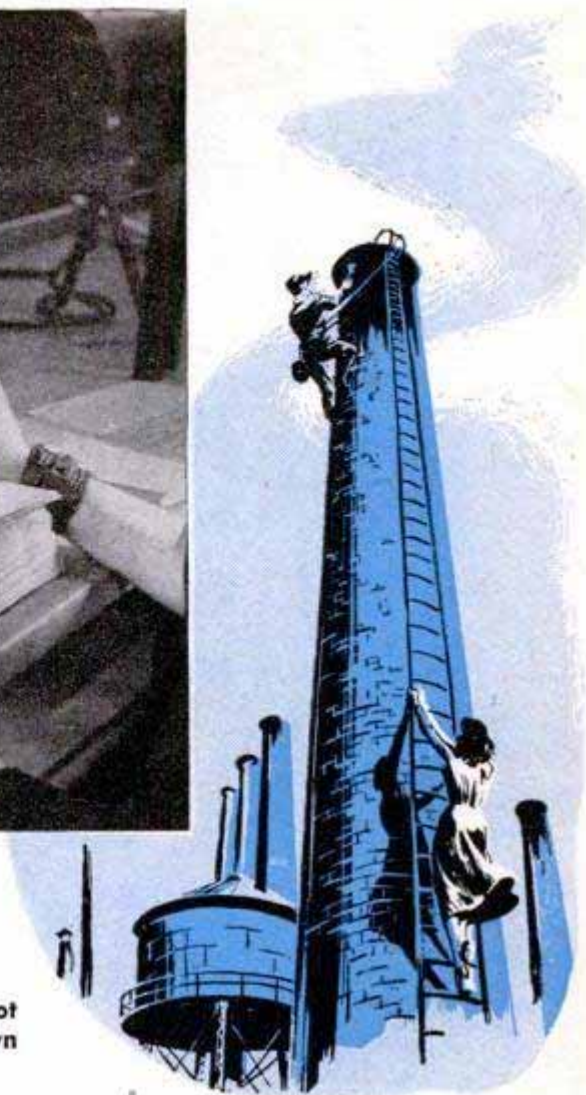

the other side of the river; both states claim it, or perhaps neither. If people live on it, the census takers never know what state they belong to, or which enumerator's responsibility they are.

So, this year, each census taker will have a diagram map or aerial photo of his exact district. There will be no overlaps or misses. He may find some new houses and roads, but the hunt will be lots easier.

Even with good maps, the census-taker's job is no dream. Temporary trailer cities spring up and disappear overnight. There's a tremendous population of gypsy-minded Americans living in tin and box-board "jungles" who are here today and gone tomorrow. Grizzled prospectors in the desert won't hold still for counting. Nor will the shepherds on the wind-chilled plateaus of the Rockies, hermits living in wilderness caves, or the hoboes on boxcars in remote sidings. Yet, the enumerators must get them all, and they will.

Ex-schoolteachers, retired businessmen, widows are the people who do the nose-counting. Whatever their civilian calling, they all must have a spirit of adventure. Ten years ago, months before the counting was to begin in the states, Bill Arends, assistant to the Alaska supervisor, set out across the frozen tundra by dog sled to count Eskimo noses in the bleak regions

above the Arctic Circle. His job was completed by the time the 1940 census got under way in the U. S. proper. His counterpart for the 1950 census is already on his way and will have his job done by the time you read this.

Down in the Florida swamps and the Mississippi Delta country, enumerators will have to ferret out Indian villages and wandering muskrat trappers, deep in the jungle bogs. They'll pole their way through tangled cypress roots in long, thin pirogues which, says one government pollster, "are just stable enough so that if you hold your cigarette square in the middle of your mouth, you may not tip over."

Their tired cars will climb to the heart of wilderness mountains at 10,000 feet elevation, and steam across the parched floor of Death Valley, 200 feet below sea level. They'll be battered by hurricanes, whipped by blizzards. They'll bog down in swamps and blow tires miles from civilization. They'll meet high adventure at every turn, like the fellow tabulating lumber camps in the Northwest. He was caught in a raging forest fire and had to sit neck deep in a creek for a whole day while searing flames swept over his head. Every time a good blast of flame came through, he'd duck his



**Holding clothes and papers aloft in one hand, census taker swam icy stream to reach old prospector**

head under, and keep it there for a spell.

Census takers have done some incredible things in the line of duty. To get across an impassable gorge and tabulate workers in an ore mine, one enumerator rode over to the tippie in a glorified breeches buoy, dangling from cables 1000 feet in the air. Another swam an icy river with one hand, holding his clothes and papers aloft in the other, to quiz an old prospector who was too busy panning gold to quit for a moment and row across in his boat. Then, there was a lady census taker who climbed a 70-foot chimney to question a steeplejack who whimsically refused to come down.

In the course of their rounds, some roving compilers will find themselves as did enumerators in 1940, serving as midwives in delivering babies. Others will stagger home in tatters from encounters with dogs, billy goats, angry bulls, bears and peculiar people who, in spite of this enlightened age, still think the census taker is something akin to a member of the OGPU, out to grab all their belongings for the "State."

A tough job? You haven't heard half of it. When the field reports are complete by April 15, the real work starts. In the big white Census Bureau building in Suitland, Md., thousands of people will spend two full years checking, editing, coding and tabulating data on the 150 million people in the United States. By December 31, 1952, the job will be finished and printed in more volumes than an encyclopedia. No one knows how many books will be filled by the 1950 census, but the last one came to 80 volumes, filling three five-foot bookshelves.

To help them, census employees have the fanciest collection of complicated machinery the mind of man has been able to devise. The mechanization started in 1890,

(Continued to page 260)

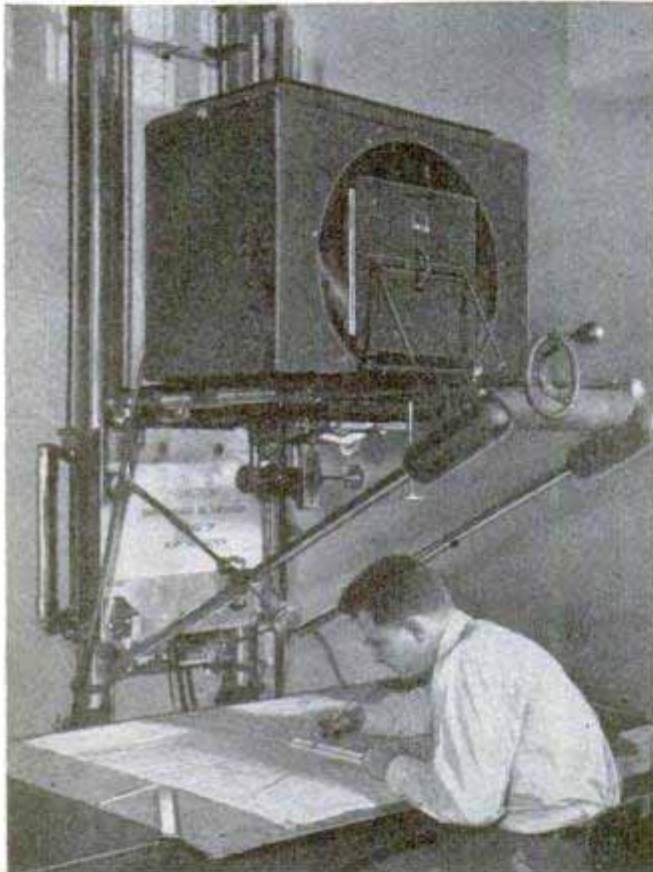

Real photo

**Aerial maps are used to help census taker with his work. Maps are projected by this machine to scale**

**Scaled aerial maps roll off duplicating machine in pairs. Razor blade on center arm slices the paper**

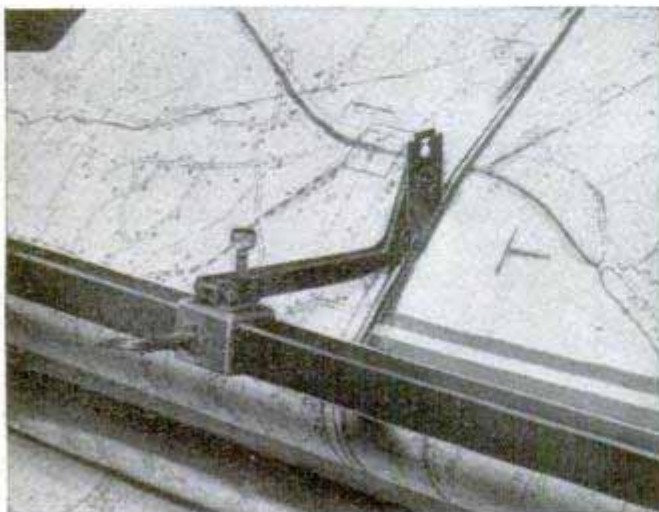

**Below, census taker poling his way through tangled cypress roots to find trappers in a swampy region**





## Low-Pressure Tunnel To Test Rockets

High-altitude flight conditions are simulated in a new faster-than-sound, low-pressure wind tunnel developed at the University of Michigan. The "ionic wind tunnel" will be used for experiments with high-speed rockets and other high-altitude apparatus. It produces a flow up to 10 times faster than sound by means of an electric arc generated between a copper cylinder and a surrounding copper ring.



## Jeep and Elevator Fly With Liftmaster

Part of the standard equipment of the Douglas Liftmaster, a new commercial cargo transport, is a Jeep and an elevator. The 4000-pound-capacity power lift easily handles the 2175-pound vehicle and its driver. A special adapter enables the Jeep to be driven aboard the truck-bed level of the elevator. With a top flying weight of 100,000 pounds and a cruising speed over 300 miles an hour, the Liftmaster was developed from the DC-6 airliner.

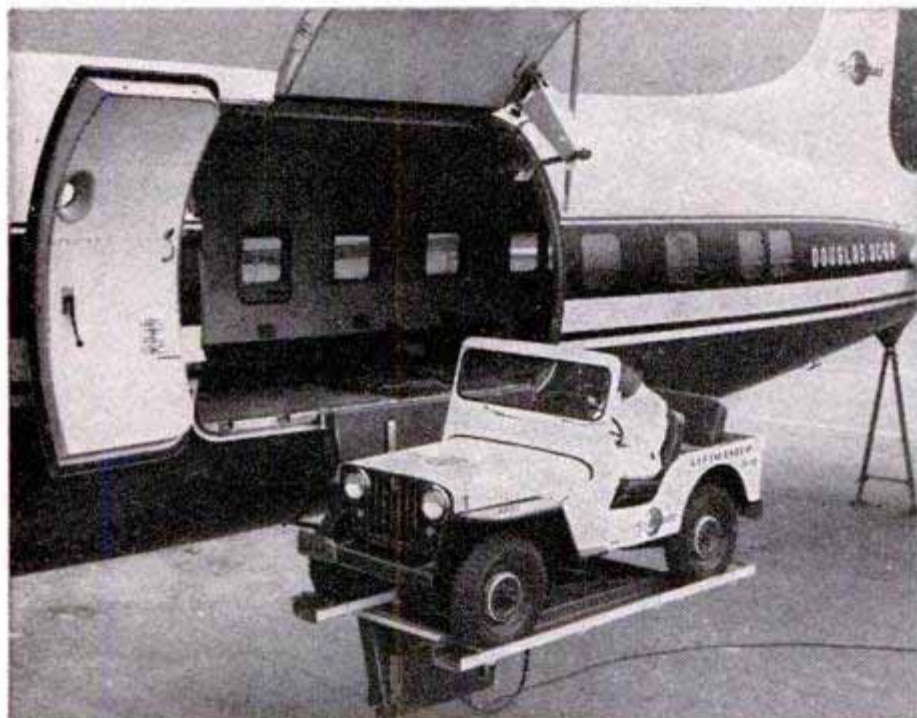

## Stick of Screws

Screws made in one-piece "sticks" can be installed as fast as the operator can aim the driver. The head end of each screw is joined to the thread end of the following screw, making a stick which is inserted in a pneumatic driver. As each screw is driven home, the joining neck breaks and the next screw is automatically advanced. The head of the driven screw is burnished by the next one to be driven. The screws are uniformly tightened because the size of each neck is the same. The screwsticks, available in various sizes, can also be used in electric, spiral or hand ratchet drivers.





# MIRACLES YOU'LL SEE

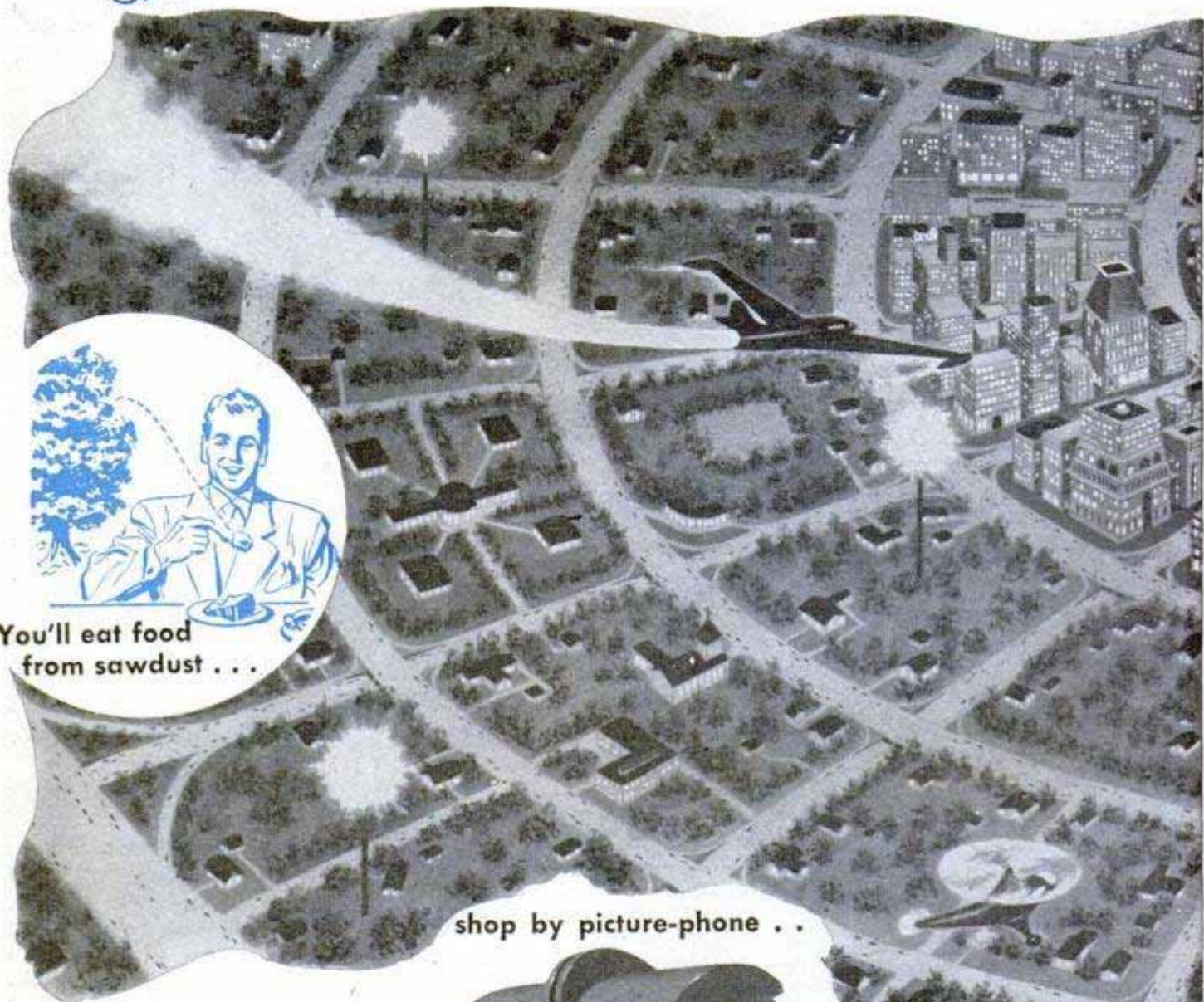

You'll eat food  
from sawdust . . .

shop by picture-phone . .



Drop in by rocket plane on Totten-ville, the sootless garden city where you'll live in scientific comfort in A.D. 2000. You'll cook by solar heat, shop by television in the world just around the corner

# IN THE NEXT FIFTY YEARS

By **Waldemar Kaempffert**  
Science Editor, *The New York Times*

**W**HAT WILL the world be like in A.D. 2000? You can read the answer in your home, in the streets, in the trains and cars that carry you to your work, in the bargain basement of every department store. You don't realize what is happening because it is a piecemeal process. The jet-propelled plane is one piece, the latest insect killer is another. Thousands of such pieces are automatically dropping into their places to form the pattern of tomorrow's world.

The only obstacles to accurate prophecy are the vested interests, which may retard progress for economic reasons, tradition, conservatism, labor-union policies and legislation. If we confine ourselves to processes and inventions that are now being hatched in the laboratory, we shall not wander too far from reality.

The best way of visualizing the new world of A.D. 2000 is to introduce you to the Dobsons, who live in Tottenville, a hypothetical metropolitan suburb of 100,000. There are parks and playgrounds and green open spaces not only around detached houses but also around apartment houses. The heart of the town is the airport. Surrounding it are business houses, factories and hotels. In concentric circles beyond these lie the residential districts.

Tottenville is as clean as a whistle and quiet. It is a crime to burn raw coal and pollute air with smoke and soot. In the homes electricity is used to warm walls and to cook. Factories all burn gas, which is generated in sealed mines. The tars are removed and sold to the chemical industry for their values, and the gas thus laundered is piped to a thousand communities.

The highways that radiate from Tottenville are much like those of today, except that they are broader with hardly any curves. In some of the older cities, difficult to change because of the immense investment in real estate and buildings, the highways are double-decked. The upper deck is for fast nonstop traffic; the lower deck is much like our avenues, with brightly illuminated shops. Beneath the lower deck is the level reserved entirely for business vehicles.

Tottenville is illuminated by electric "suns" suspended from arms on steel towers 200 feet high. There are also lamps which are just as bright and varicolored as those that now dazzle us on every Main

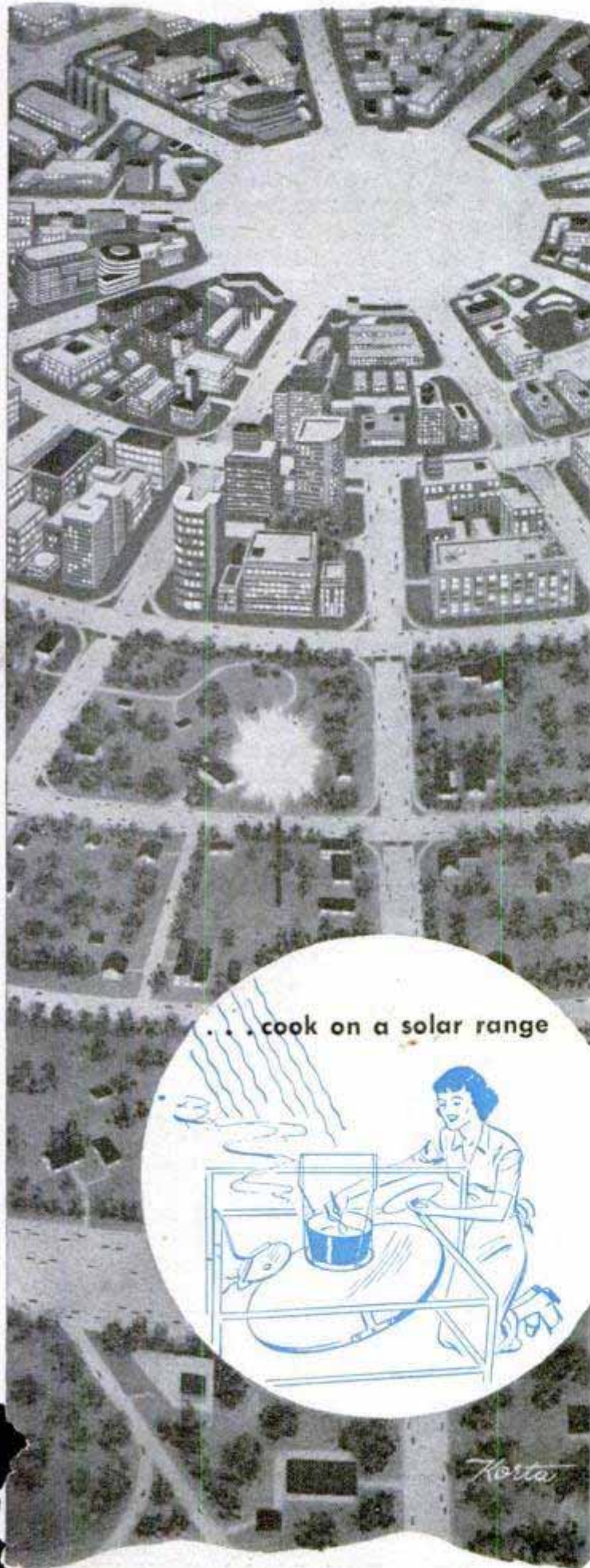

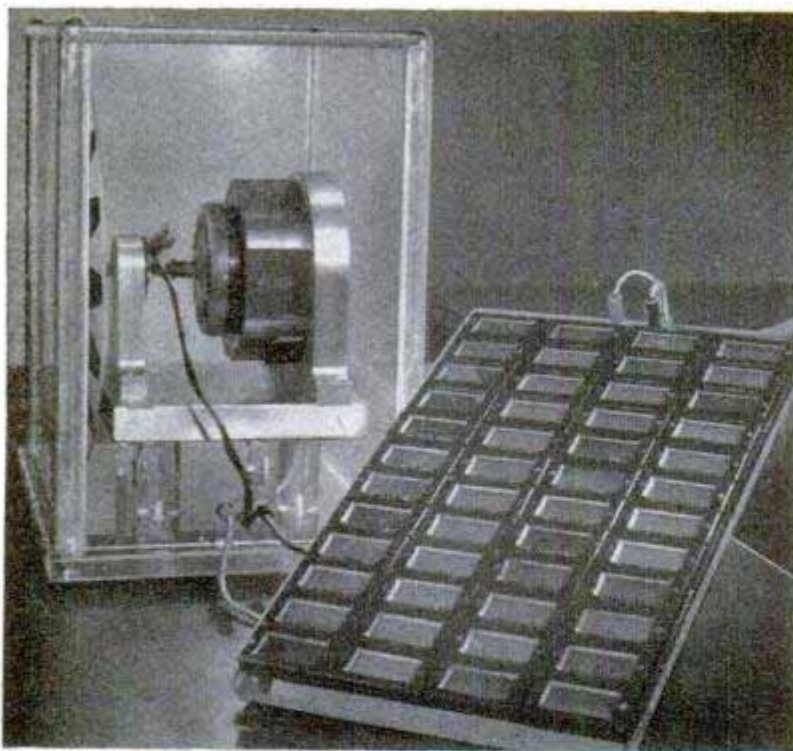

General Electric photo

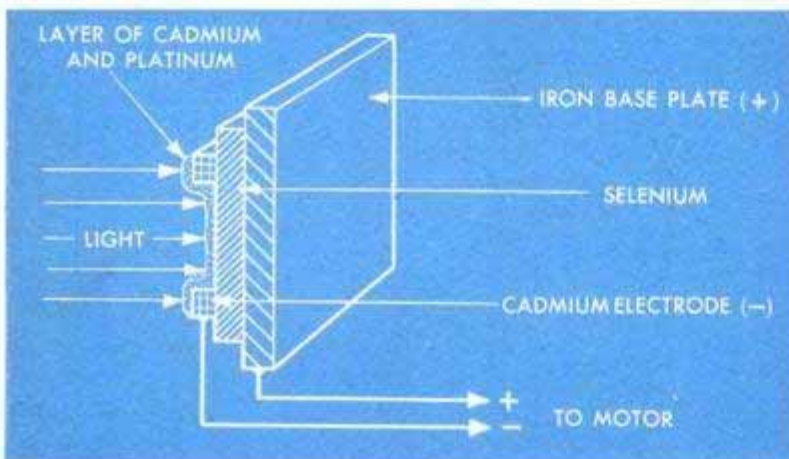

Top, Old Sol turns this electric motor. Drawing shows one of the motor's cells. Sunlight liberates electrons in selenium, which pass into cadmium-platinum plate to charge it negatively. Below, in another solar power plant the heat turns the motor

Smithsonian Institution photo

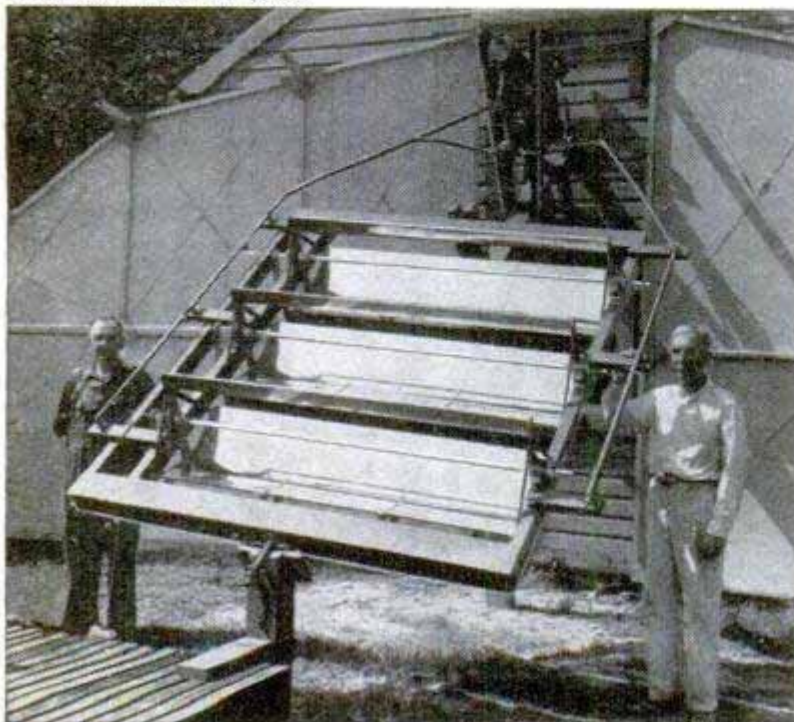

Street. But the process of generating the light is more like that which occurs in the sun. Atoms are bombarded by electrons and other minute projectiles, electrically excited in this way and made to glow.

Power plants are not driven by atomic power as you might suppose. It was known as early as 1950 that an atomic power plant would have to be larger and much more expensive than a fuel-burning plant to be efficient. Atomic power proves its worth in Canada, South America and the Far East, but in tropical countries it cannot compete with solar power. It is as hopeless in 2000 as it was in 1950 to drive machinery directly by atomic energy. Engineers can do no more than utilize the heat generated by converting uranium into plutonium. The heat is used to drive engines, and the engines in turn drive electric generators. A good deal of thorium is used because uranium 235 is scarce.

Because of the heavy investment that has to be made in a uranium or thorium power plant, the United States government began seriously to consider the possibilities of solar radiation in 1949. Theoretically, 5000 horsepower in terms of solar heat fall on an acre of the earth's surface every day.

Because they sprawl over large surfaces, solar engines are profitable in 2000 only where land is cheap. They are found in deserts that can be made to bloom again, and in tropical lands where there is usually no coal or oil. Many farmhouses in the United States are heated by solar rays and some cooking is done by solar heat.

The first successful atomically driven liners began to run in 1970 after the U. S. Navy had carried on many expensive, large-scale secret experiments. Outwardly the liners are not much different from the Queen Mary and Queen Elizabeth, but they have much more cargo and passenger space because it is no longer necessary to carry about 12,000 tons of fuel.

The metallurgical research that makes the gas turbines in the power plants and in the trans-Atlantic liners possible has influenced both civil engineering and architecture. Steel is used only

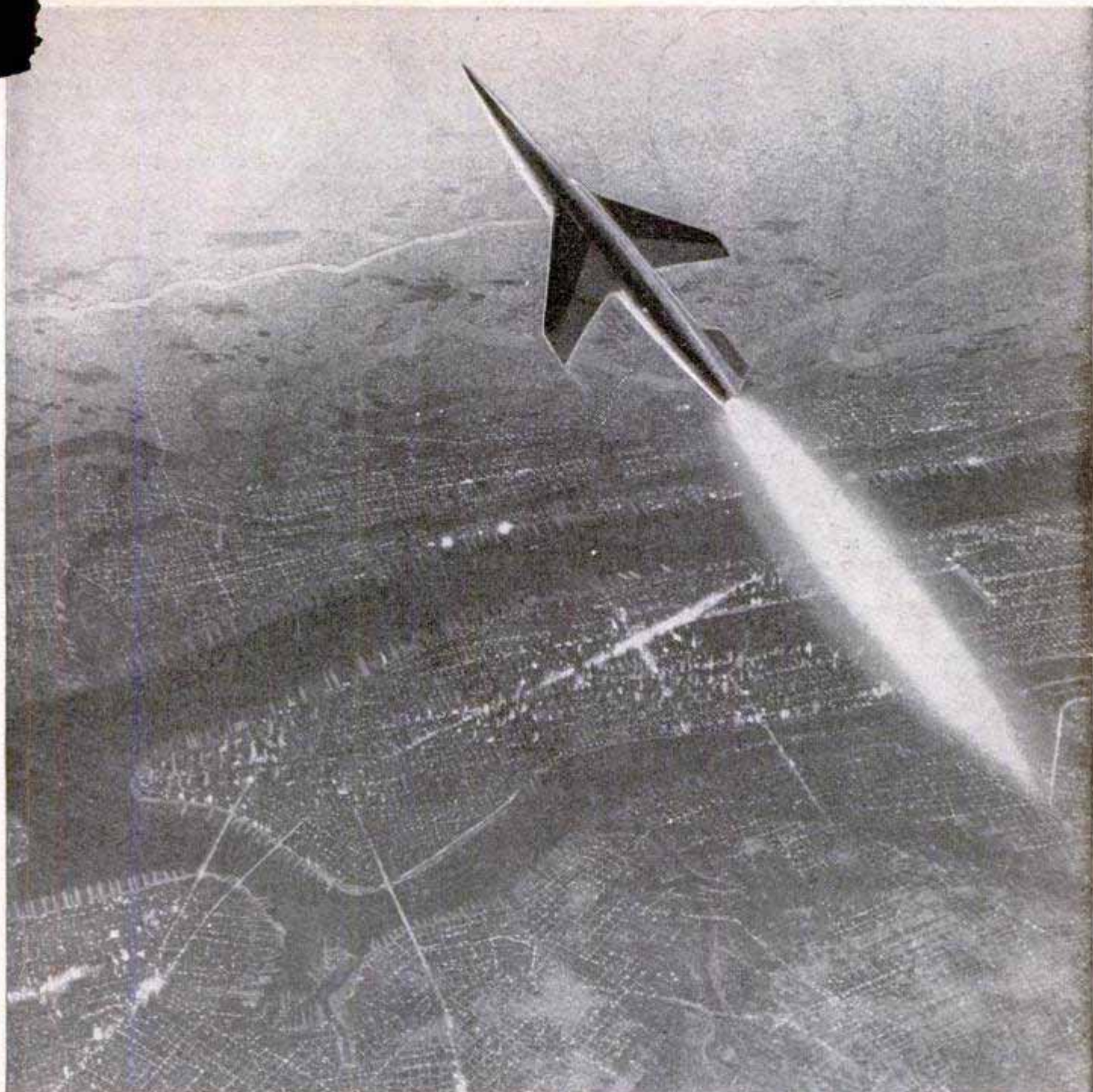

Copyright 1947, Chesley Bonestell from "The Conquest of Space"

**In 2000, rocket passengers may arch through space from New York to San Francisco in less than two hours**

for cutting tools and for massive machinery. The light metals have largely displaced it. Ways have been found to change the granular structure so that a metal is ultrastrong in a desired direction and weaker in other directions. As a result, the framework of an industrial or office building or apartment house is an almost lace-like lattice.

Thanks to these alloys, to plastics and to other artificial materials, houses differ from those of our own time. The Dobson house has light-metal walls only four inches thick. There is a sheet of insulating material an inch or two thick with a casing of sheet metal on both sides.

This Dobson air-conditioned house is not a prefabricated structure, though all its parts are mass-produced. Metal, sheets of

plastic and aerated clay (clay filled with bubbles so that it resembles petrified sponge) are cut to size on the spot. In the center of this eight-room house is a unit that contains all the utilities—air-conditioning apparatus, plumbing, bathrooms, showers, electric range, electric outlets. Around this central unit the house has been pieced together. Some of it is poured plastic—the floors, for instance. By 2000, wood, brick and stone are ruled out because they are too expensive.

It is a cheap house. With all its furnishings, Joe Dobson paid only \$5000 for it. Though it is galeproof and weatherproof, it is built to last only about 25 years. Nobody in 2000 sees any sense in building a house that will last a century.

Everything about the Dobson house is



**No more bouts with the razor for man of tomorrow. He'll whisk away whiskers with a chemical solution**

synthetic in the best chemical sense of the term. When Joe Dobson awakens in the morning he uses a depilatory. No soap or safety razor for him. It takes him no longer than a minute to apply the chemical, wipe it off with the bristles and wash his face in plain water.

This Dobson house is not as highly mechanized as you may suppose, chiefly because of the progress made by the synthetic chemists. There are no dish-washing machines, for example, because dishes are thrown away after they have been used once, or rather put into a sink where they are dissolved by superheated water. Two dozen soluble plastic plates cost a dollar. They dissolve at about 250 degrees Fahrenheit, so that boiling-hot soup and stews can be served in them without inviting a catastrophe. The plastics are derived from such inexpensive raw materials as cottonseed hulls, oat hulls, Jerusalem artichokes, fruit pits, soy beans, bagasse, straw and wood pulp.

When Jane Dobson cleans house she simply turns the hose on everything. Why not? Furniture (upholstery included), rugs, draperies, unscratchable floors—all are made of synthetic fabric or waterproof plastic. After the water has run down a drain in the middle of the floor (later concealed by a rug of synthetic fiber) Jane turns on a blast of hot air and dries everything. A detergent in the water dissolves any resistant dirt. Tablecloths and napkins are made of woven paper yarn so fine that the untutored eye mistakes it for linen. Jane Dobson throws soiled "linen" into the incinerator. Bed sheets are of more substantial stuff, but Jane Dobson has only to hang them up and wash them down with a

hose when she puts the bedroom in order.

Cooking as an art is only a memory in the minds of old people. A few die-hards still broil a chicken or roast a leg of lamb, but the experts have developed ways of deep-freezing partially baked cuts of meat. Even soup and milk are delivered in the form of frozen bricks.

This expansion of the frozen-food industry and the changing gastronomic habits of the nation have made it necessary to install in every home the electronic industrial stove which came out of World War II. Jane Dobson has one of these electronic stoves. In eight seconds a half-grilled frozen steak is thawed; in two minutes more it is ready to serve. It never takes Jane Dobson more than half an hour to prepare what Tottenville considers an elaborate meal of several courses.

Some of the food that Jane Dobson buys is what we miscall "synthetic." In the middle of the 20th century statisticians were predicting that the world would starve to death because the population was increasing more rapidly than the food supply. By 2000, a vast amount of research has been conducted to exploit principles that were embryonic in the first quarter of the 20th century. Thus sawdust and wood pulp are converted into sugary foods. Discarded paper table "linen" and rayon underwear

**Already available is electronic stove which can prepare meal in 75 seconds. It may replace present ranges**

General Electric photo



are bought by chemical factories to be converted into candy.

Of course the Dobsons have a television set. But it is connected with the telephones as well as with the radio receiver, so that when Joe Dobson and a friend in a distant city talk over the telephone they also see each other. Businessmen have television conferences. Each man is surrounded by half a dozen television screens on which he sees those taking part in the discussion. Documents are held up for examination; samples of goods are displayed. In fact, Jane Dobson does much of her shopping by television. Department stores obligingly hold up for her inspection bolts of fabric or show her new styles of clothing.

Automatic electronic inventions that seem to have something like intelligence integrate industrial production so that all the machines in a factory work as units in what is actually a single, colossal organism. In the Orwell Helicopter Corporation's plant only a few trouble shooters are visible, and these respond to lights that flare up on a board whenever a vacuum tube burns out or there is a short circuit. By holes punched in a roll of paper, every operation necessary to produce a helicopter is indicated. The punched roll is fed into a machine that virtually gives orders to all the other machines in the plant. The holes in the paper indicate exactly how long a



Housewives in 50 years may wash dirty dishes—right down the drain! Cheap plastic would melt in hot water

reamer is to smooth the inside of a cylinder, just when a stamping machine is to pass a sheet of aluminum along to its neighbor with orders to punch 22 holes in indicated places. There are mechanical wrenches that obediently turn nuts on bolts and stop all by themselves when the bolts are in place, shears that know exactly where to cut a sheet of metal for a perfect fit. Every

Inches-deep lake on roof already cools Southern homes and may become important air-conditioning method

Pomerance & Breines drawing

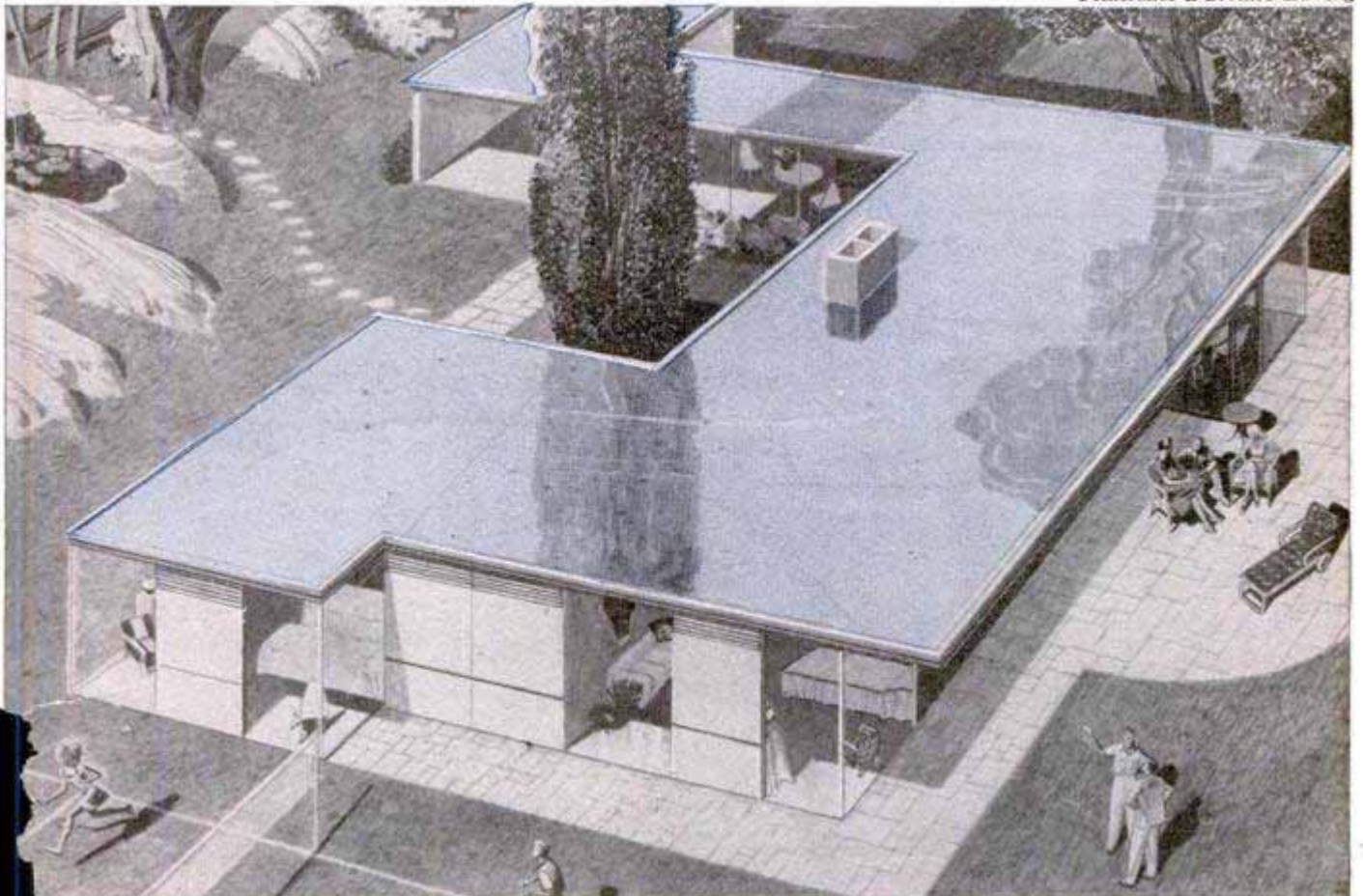



**Because everything in her home is waterproof, the housewife of 2000 can do her daily cleaning with a hose**

operation in the plant is electronically and automatically controlled.

One of the more remarkable electronic machines of 2000 is a development of one on which hundreds of thousands of dollars had been spent in the middle years of the 20th century by Dr. Vladimir Zworykin and Dr. John von Neumann. The purpose of this improved Zworykin-Von Neumann automaton is to predict the weather with an accuracy unattainable before 1980. It is a combination of calculating machine and forecaster. The calculator solves thousands of separate equations in a minute;

the automatic forecaster carries out the computer's instructions and predicts the weather from hour to hour. In 1950, meteorologists had no time to deal with the 50-odd variables that should have been mathematically handled to predict the weather 24 hours in advance.

Following suggestions made by Zworykin and Von Neumann storms are more or less under control. It is easy enough to spot a budding hurricane in the doldrums off the coast of Africa. Before it has a chance to gather much strength and speed as it

(Continued to page 264)

**Forecast of home of tomorrow? This house was built in few days by pouring concrete into standard forms**

Revere Copper & Brass photo

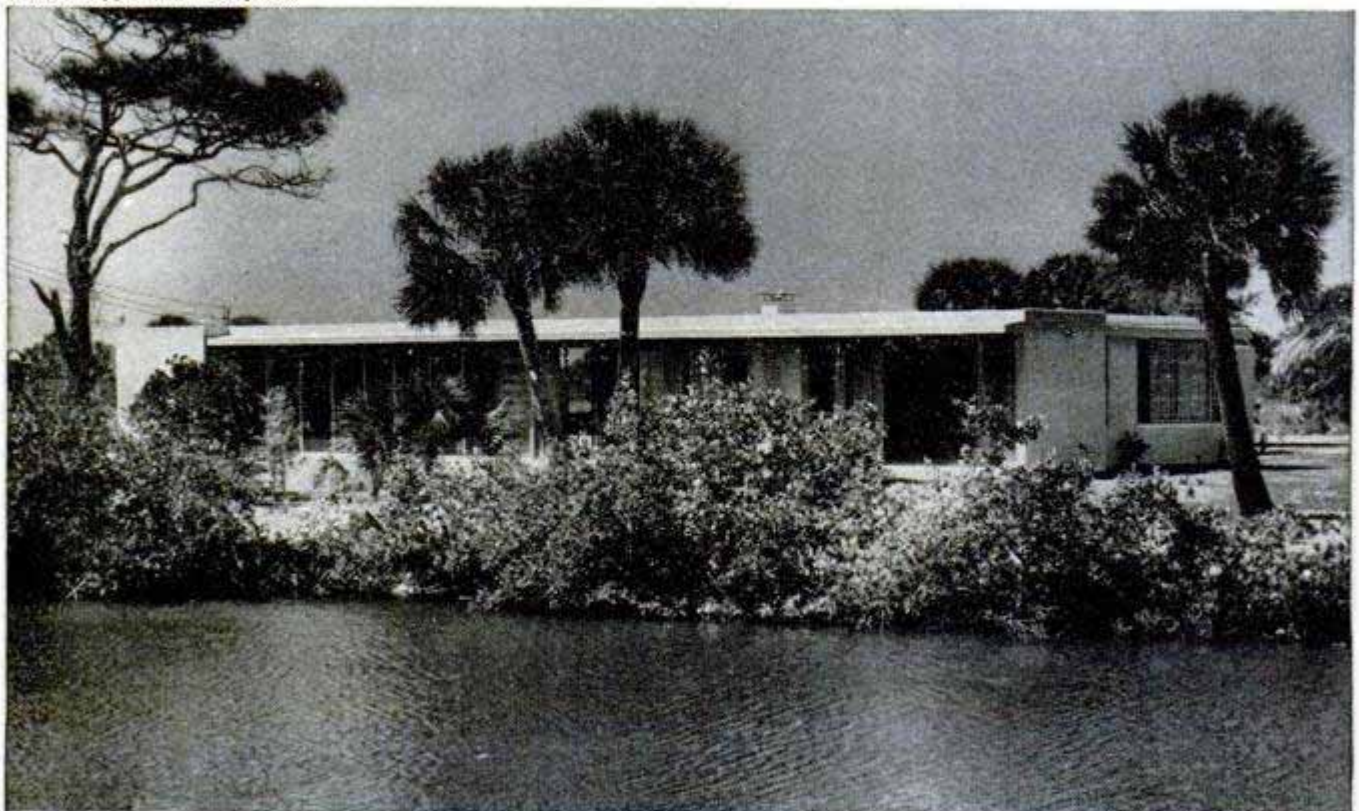





### Plastic Umbrella For Traffic Cop

Traffic officers in Rome, Italy, don't worry about rainstorms. They are equipped with a rainproof pedestal that is rolled out into the street intersection. A plastic umbrella keeps them dry on wet days and a shield, also plastic, around the base of the pedestal protects them from splash.



### Motorcycle Skis

Motorcyclists now have a new sport—"ski cycling" over ice and snow. A broad, short ski fastens to each side of the motorcycle frame. It is held at the correct level by springs which absorb the shock as the ski runs over the snow surface. As the wheels are slightly lower than the skis, they still provide traction.

### Mechanical Cow

Up in Whitehorse, the largest settlement in the Yukon Territory, children get their milk from a mechanical cow. Actually, the machinery works in reverse—it churns milk stock, pure water and butter back into rich milk. The water is heated to 100 degrees Fahrenheit and the milk stock added. Then the mixture is brought to a boil and butter mixed in at a temperature of 145 degrees. Electric heaters churn the mixture for a half hour, when it is homogenized and passed over the corrugations of the cooler where the temperature is dropped to 30 degrees. The result is a smooth and creamy milk. The mechanical cow produces milk at 30 cents a quart, compared to the former cost of 75 cents a quart for milk shipped to Whitehorse.

World production of commercial fertilizer has reached an all-time record high with 11,500,000 tons.

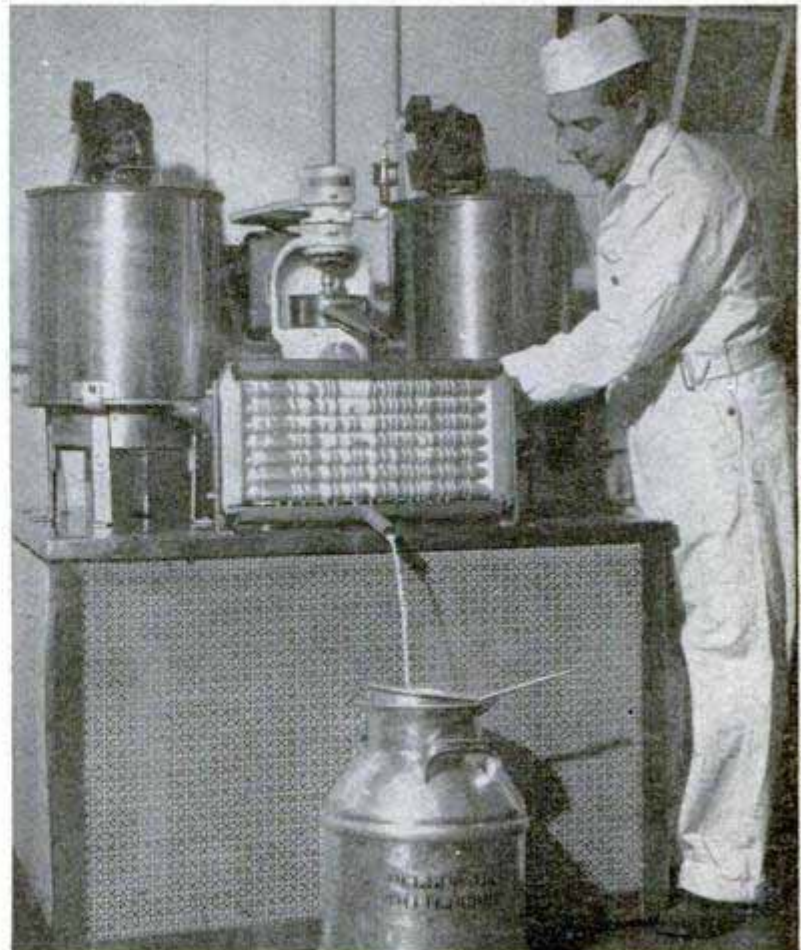

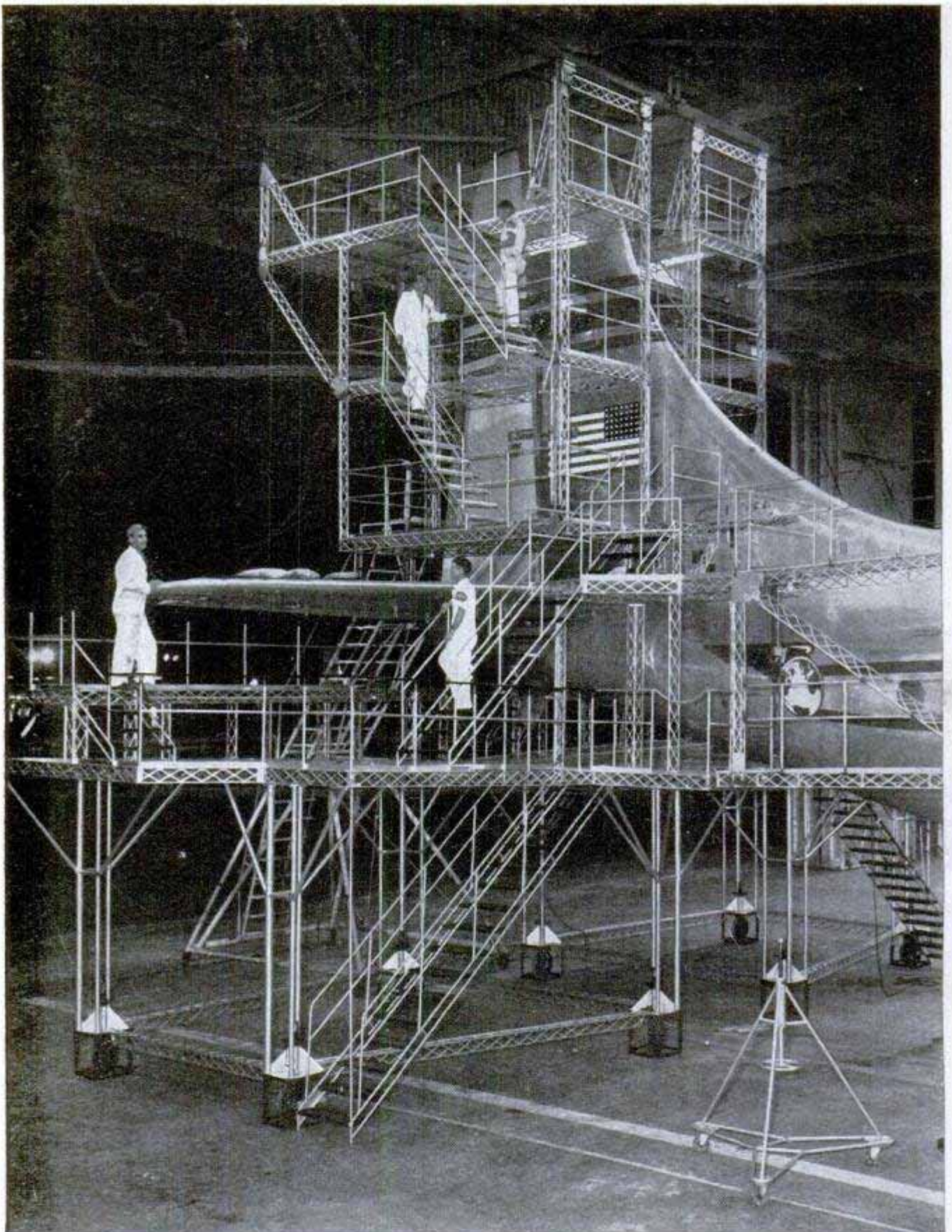

## World's Largest Airplane Service Dock at Miami

Quick, easy access to every inch of the biggest transports is afforded by the world's largest airplane service dock, now in use at Pan-American World Airways' Miami overhaul base. Fabricated in five major sections, the 75-ton dock is rolled into position around the plane after it has been towed into the hangar. The under-wing

ramps, engine stands and lower parts of the four-story tail stair are mounted on retractable wheels. The upper sections and the catwalks fitting against either side of the fuselage are suspended by a monorail system in the roof girders. A nine-station "intercom" permits the foreman to contact workers at other levels and positions.



Lockheed Aircraft Co. photo

## Skis for Navy's Arctic Plane

Aluminum skis, 16 feet long, are the newest additions to Navy P2V Neptunes, largest combat aircraft fully equipped for arctic operation. They fit over the wheels of the

regular tricycle landing gear. Retractable in flight, the skis are tucked inside a fairing beneath the engines and at the nose to reduce in-flight drag. The plane also has special radio and radar for use near the magnetic poles.



## Flexible Refrigerator Bag Carries Fisherman's Catch

Anglers can bring home their catch in good condition inside a flexible refrigerator bag which requires a minimum of storage space. When not in use, the bag folds small enough to fit into the glove compartment of a car. Made of waterproof fabric, it has a zipper opening for inserting ice and fish. A rubber tube leading from a drain in the bottom of the bag carries off water, keeping the contents as cold as possible at all times. The bag also can be used to carry beverages and foods for campers. It has a capacity of more than 2¼ cubic feet.

## "Grass Skirt" for Fishing Plugs

More action from any treble-hook fishing lure is assured by a "hula skirt" that can be clipped instantly in place. The skirt has been permanently attached to several baits for years, but now is available as an accessory for other lures. Made of rubber, it has 20 individual tails and is manufactured in 11 colors.

☐ According to scientific theory, the planet Jupiter consists of a core of metal and rock about 37,000 miles in diameter, surrounded by a layer of ice 17,000 miles deep.

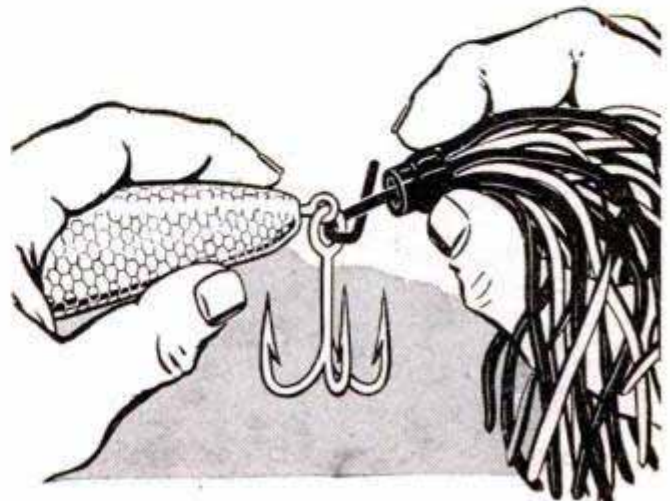

# BONE DETECTIVE

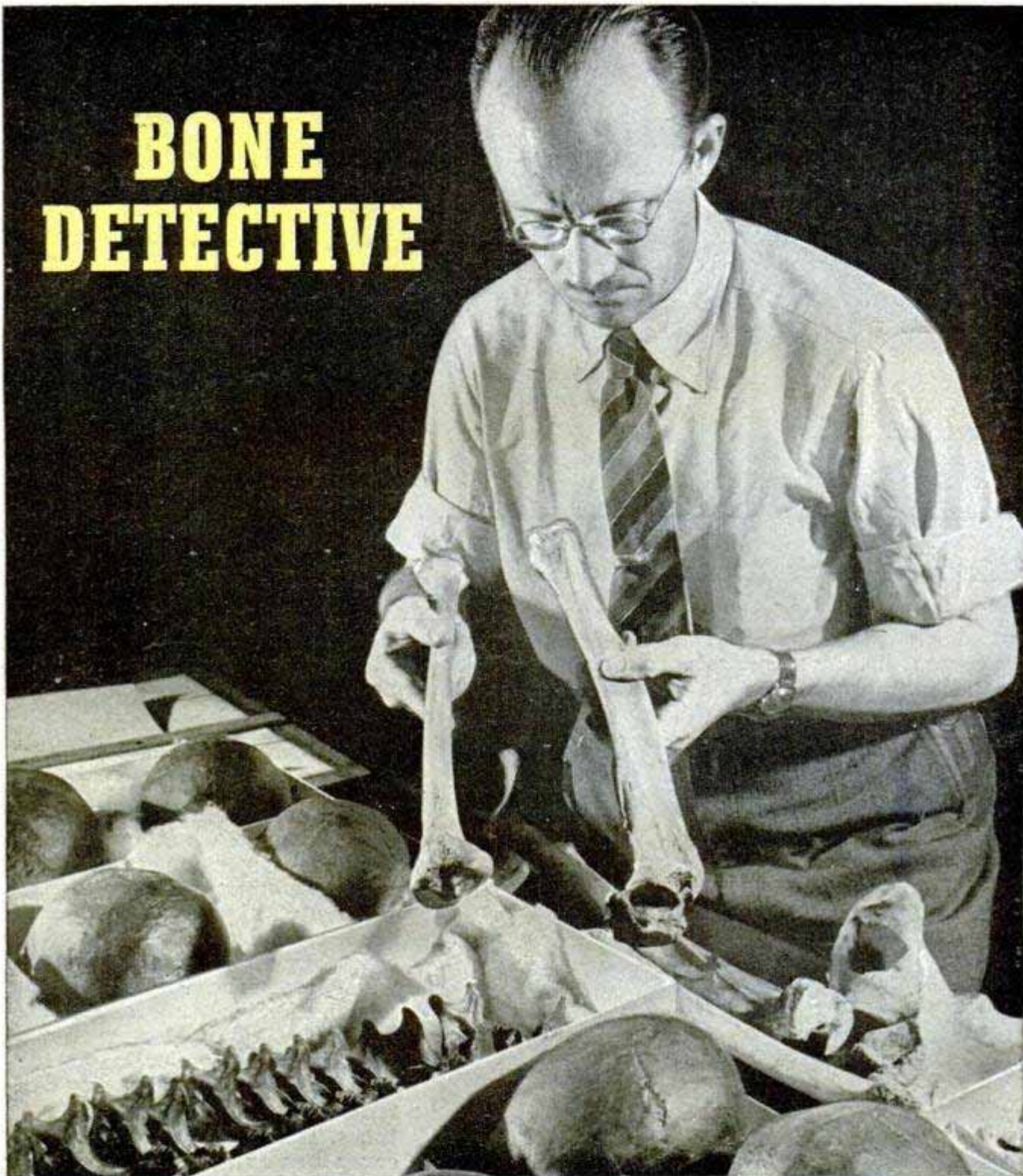

Ex-steer or ex-taxpayer? If Dr. T. Dale Stewart deduces latter from bones FBI brings him, a killer may hang

By Alfred Eris

**A**N EGYPTIAN!" The FBI agent drew back, startled. "But, Doctor Stewart," he protested, "This hand was found in Oklahoma!" He waited for the slim, bespectacled Smithsonian scientist to switch his diagnosis.

Doctor Stewart just looked at him, quietly. "I know. Still, it's Egyptian!"

The Federal man stared hard at the shriveled hand partially wrapped in moldy fabric, then sighed. "Do you mind if we quote you?"

The scientist nodded assent.

The result was precisely what the FBI man anticipated. Midwestern newspapers had a field day gibing at the Smithsonian "expert" who confused the hand of an honest Oklahoman with the mitt of an ancient Egyptian. Eventually, the furore and hilarity came to the ears of a rural citizen who promptly claimed the mysterious hand, and silenced the merriment by announcing that it was, without question, Egyptian. Furthermore, there was more than just a hand; there was all of the rest of a mummified Middle-Eastern gentleman brought home by a family globe-trotter. Some playful children or household pets

had probably dragged the appendage from an attic into the open, where it was brought to the attention of startled local sleuths, who hurriedly called in the FBI.

Episodes like this explain why FBI men call about once a month on Dr. T. Dale Stewart in his office at the near-by Smithsonian Institution. Formally known as curator of physical anthropology, Doctor Stewart is surrounded by more skeletons than any other man in America. Exactly how many, no one knows; the counting stopped when files bulged with over 20,000 separate specimens.

Day after day bones pour in from all over the nation, in paper bags or cardboard boxes, from the pit dug by a murderer or from Indian burial graves centuries old. Each bone is carefully lettered and neatly filed away in its appropriate group. Every bit of space in the offices of the physical anthropology section is so crammed that new arrivals now are stored in filing drawers stacked up some 10 feet high in the corridor.

From years of study of all these bones, Doctor Stewart has garnered a knowledge of our skeletal make-up rivaled by few. Given a few bones, he will quickly paint an astonishingly accurate portrait of the body that once surrounded them. Such data is invaluable to law-enforcement officers.

A few years ago, the federal men brought to Doctor Stewart some bones found in an abandoned well in Quantico, Va., by trembling workmen. After careful scrutiny, Doctor Stewart quietly announced that the body was that of a young, white man, 26 to 28 years old, five feet eight inches in height and of medium build. Then, he added casually that the victim had been suffering from pyorrhea and had been left-handed.

Investigators hurriedly went to work. Soon, in checking Marine Corps records at the giant Quantico base, they found that John Bradford Ellison, a left-handed Marine, had disappeared in 1928. Later, enough circumstantial evidence was gathered to convict Raymond "Scissors" Saunders for a murder committed 17 years previous to his arrest! Doctor Stewart, though, was far from elated; he was off a full ½ inch in his estimation

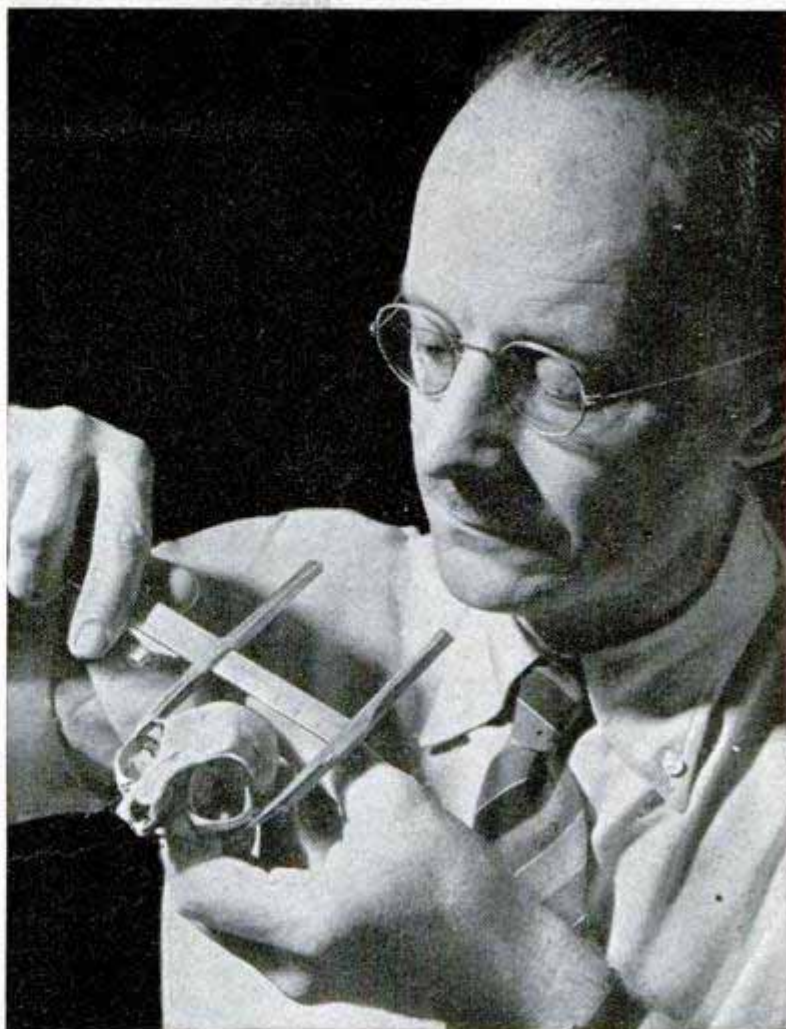

Amateur sleuths turn up Indian remains, think they've got a murder victim. Doctor Stewart sets them straight. Here, with calipers, he measures cat skull found in an Indian tomb. Below, with stereograph, he traces outline of an Indian skull

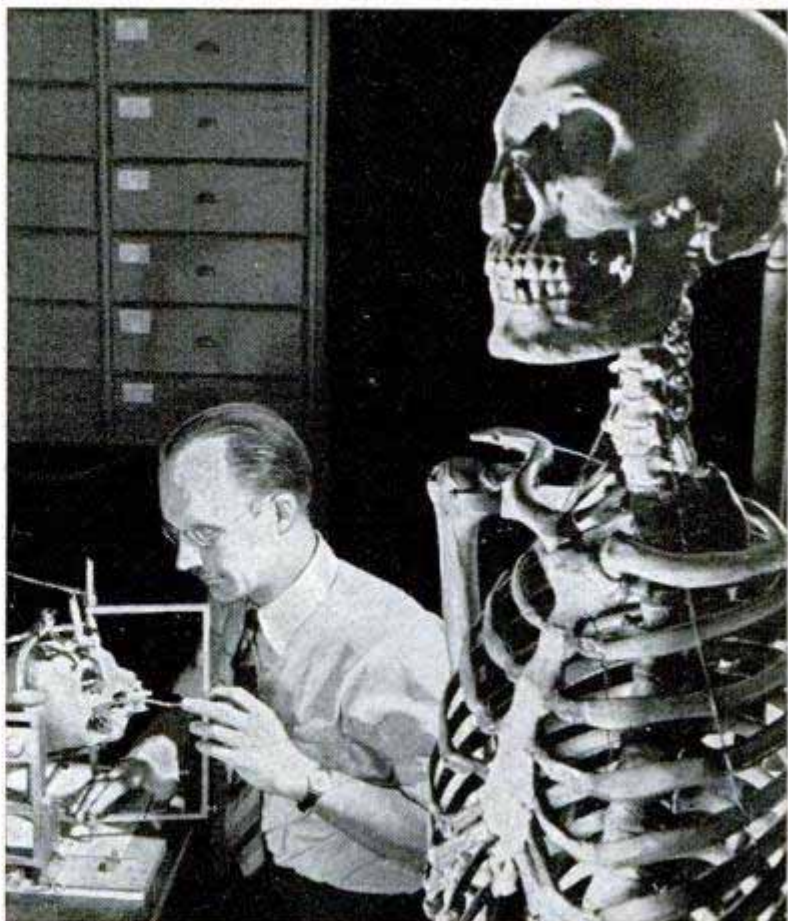

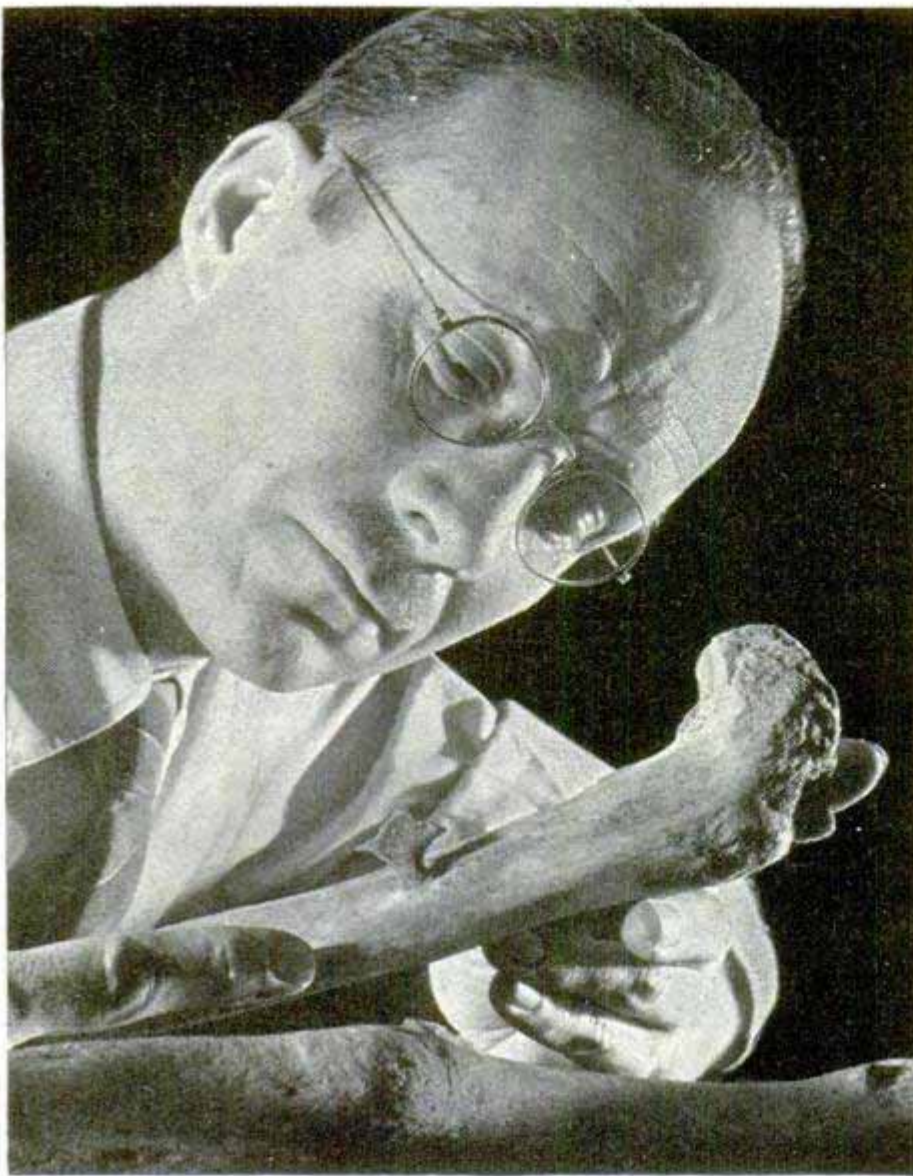

Centuries-old Indian leg bone gives evidence of a brawl. Stewart thinks odd growth is embedded arrowhead; thickness at end swelling from blow

Stacks of skeleton files, containing human and animal bones, line the walls of Doctor Stewart's Smithsonian laboratory. Those are Indian busts



of the Marine's height, and Ellison had been 29 instead of 26 to 28.

In appearance, Dr. T. Dale Stewart is a typical scientist, quiet-mannered, high-browed and with a slightly preoccupied air. It seems a bit farfetched to connect this mustached, soft-spoken, unassuming man with unsolved murders, grisly crimes and such. But the federal men have come to regard him as an important, if unsung, "aide." Time after time he has clinched cases for the state with his testimony.

One morning, in 1946, federal men drove over from Pennsylvania Avenue to the Smithsonian, carrying eight small fragments of charred bone found in Arkansas. If they were human, a murderer would hang. Several minutes after the bundle was deposited on Doctor Stewart's desk, the scientist looked up and nodded—"Yes, they're human."

"How can you tell?" the FBI agent asked.

"You see this tiny bit of charred tissue clinging to this bit of bone?" Doctor Stewart pointed out. "Undeniably human." He indicated a suture of the joints on a bit of human skull. "These joints don't grow together until a person is over 35," he explained. "The victim was at least that age!" Incredible is the word for the lengths to which a murderer will go to conceal his crime. In this instance, Leon Merrow had, after killing his wife, put her body on a fire and stoked it for three days and three nights.

At the trial, the conviction hinged on Doctor Stewart's testimony as to whether or not the few bones found were those of an Indian, cremated decades ago, or those of the accused's wife. Stewart,

himself, had admitted that the bones resembled those he had seen taken from Indian funeral pyres. The courtroom was tense as the defense attorney tried to get the expert to testify that they were Indian. Doctor Stewart shook his head and pointed out that a small piece of tissue was still attached to one of the pieces of bone. The tissue was leathery and had obviously been subjected to great heat, but it would have disintegrated in time—and could not possibly have come from an old Indian grave. The defense collapsed.

This confusion of Indian remains with the victims of mayhem is a very frequent source of bother to Doctor Stewart. Only recently, a skull, complete with barnacles, was dredged from the mouth of the Mississippi by fishermen who were certain that here was genuine proof of a very foul deed on a dark night. Doctor Stewart took one look at the skull which he instantly recognized as that of a good Indian brave who went to the happy hunting grounds many years ago, and counseled—"Forget it."

Law-enforcement men have inquiring minds and Doctor Stewart marvels at the amount of chicken and duck bone they unearth and offer for his inspection. He must scrutinize said bones carefully, however, and decide on the few scraps available, whether the remains are those of a cow, sheep or a taxpayer.

At times, the relentless concentration of the police on human remains infects Doctor Stewart. When they brought in a few bones believed to be those from a human hand, the expert announced firmly that the hand could not be human. He suggested a chimpanzee or near-relation. Federal men went to the mammalogists, where they soon learned that their "hand" was really the tailbone of a horse!

As a scientist, Stewart welcomes police calls as another field for exploration. But, as a law-abiding citizen, he is shocked by the number of remains which never do seem to become finally identified. His reaction to modern crime is compounded of surprise and mild bewilderment. "There seem to be lots of bodies around," he says.

The young Mr. Stewart really didn't mean to stay very long when he first arrived at the Smithsonian in 1927 from York County, in Pennsylvania. He "substituted" for a sick friend who died. Now, after 20 years, it looks like a lifetime job.

Criminals and their doings take up only part of Doctor Stewart's time. Most of his mysteries are more complex. Among his most fascinating riddles: "Why do American Indians diminish in size according to their geographical location?" Anthropologists have found that an Illinois Indian

(Continued to page 256)



### Tractor-Tire Remover

Stubborn tractor tires can be quickly removed from their wheels with a new leverage tool. The lever "breaks" the bead of the tire without injuring tire or tube. Attachments with the tool adapt it for use with wheels that have flat-base rims, disk wheels or drop-center rims. Tires can be removed when the wheel is either on or off the tractor.

### Vest-Pocket Ash Tray

What can you do with cigarette ashes when there's no ash tray around? Dr. John H. Findlay, Westinghouse engineer, often was looking for a place to deposit ashes so his colleagues came up with an answer—a vest-pocket ash tray. They made it from part of an electronic tube and fastened on a clip that holds it to the user's pocket.





## Fuel Tanks Lengthen Range of Boeing Bomber

Two droppable 700-gallon wing fuel tanks have stretched the new Boeing B-50's range to more than 6000 miles. The tank fittings, when not needed for extreme range, each may be used to carry a 4000-

pound bomb, giving the airplane a total bomb capacity of 28,000 pounds. An earlier model of the bomber, Lucky Lady II, made the first nonstop flight around the world with the aid of midair refueling.

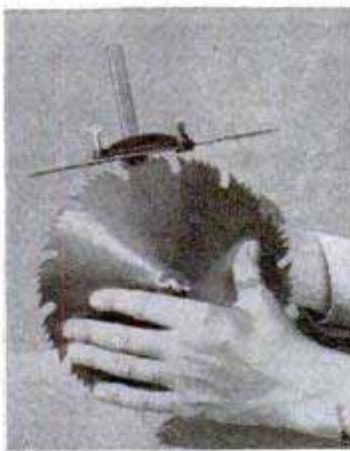
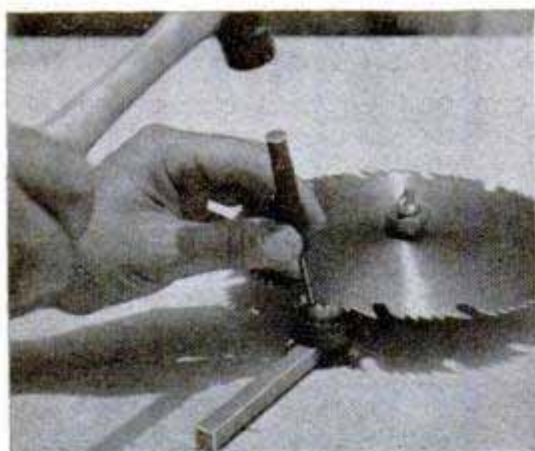

## Saw Setter and Filer

Teeth on a circular-saw blade are set and filed to correct height by a combination tool that assures a fast-cutting and absolutely round blade. Adjustable, the tool will firmly hold blades with diameters from 6 to 12 inches. Changing from jointer to saw set takes only a few seconds.

## De-icing Fluid Clears Windshield

Sprayed over an ice-covered windshield, a de-icing fluid turns the ice into slush which is quickly cleared away by the wiper blades. The fluid is packaged in a flexible Bakelite container that acts as an atomizer when squeezed, spraying the fluid over the ice. The "bottle" is unbreakable and can be carried in the glove compartment.

☐ Per capita aircraft ownership is highest in the sparsely populated states of Nevada, North Dakota, Montana and Wyoming.

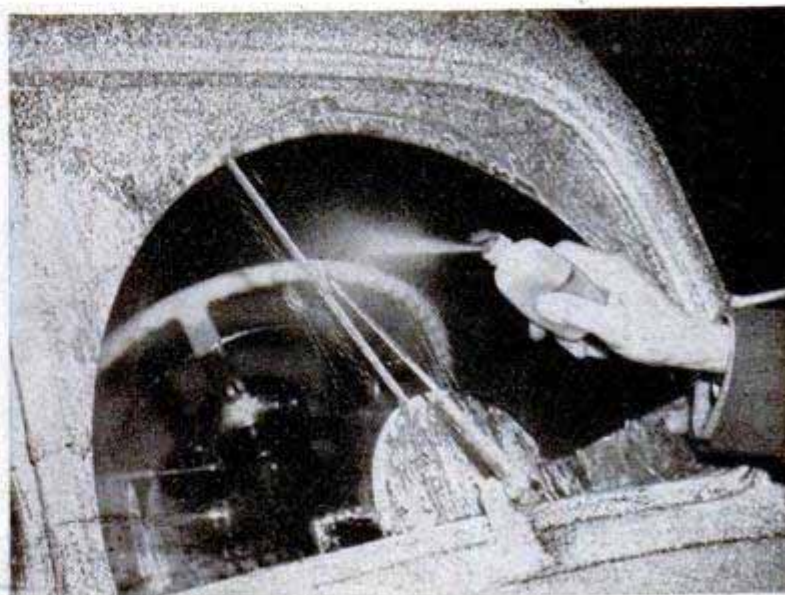



## Air-to-Air Missile For U. S. Planes

First Air Force air-to-air guided missile is the 10-foot-long Ryan "Fire-bird," which can head off and destroy its objective in a matter of seconds. It is fired from a "mother" plane in single or multiple launchings. A booster rocket propels the missile until maximum speed is reached, then it is jettisoned by explosive charge and rockets in the remaining section carry on to the target. A self-contained radar navigation system guides the "bird." The warhead, preset to explode close to the objective, automatically detonates if the target is missed.

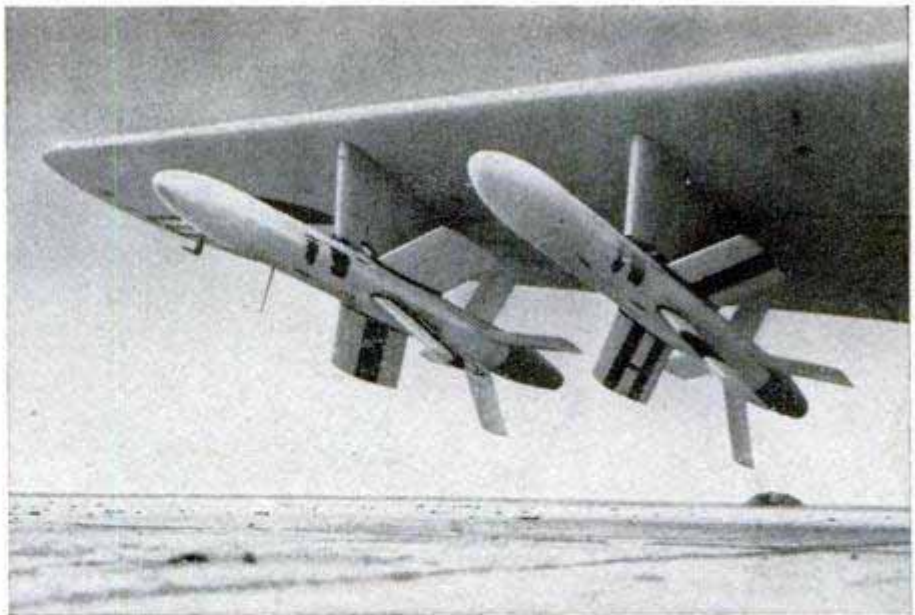

## Sign Sticks to Glass Without Adhesive

Simply by pressing it in place, you can mount a new material on glass or other polished surface. As smooth as the glass to which it sticks, the material won't adhere to the fingers or to any surface except one that is highly polished. Advertising signs or other legends can be printed on the material in any desired colors. Ideal

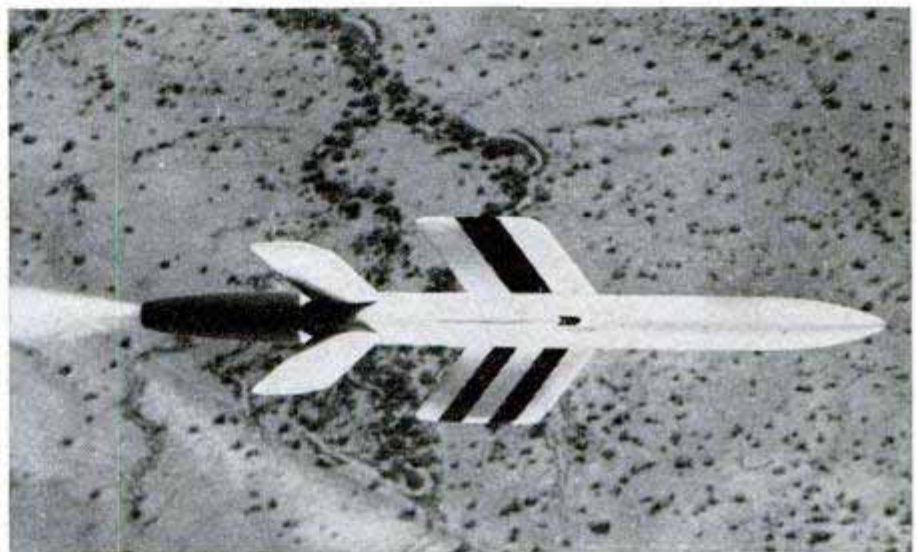

for showroom labels on automobiles or electrical appliances, the material is instantly removable and leaves no mark.

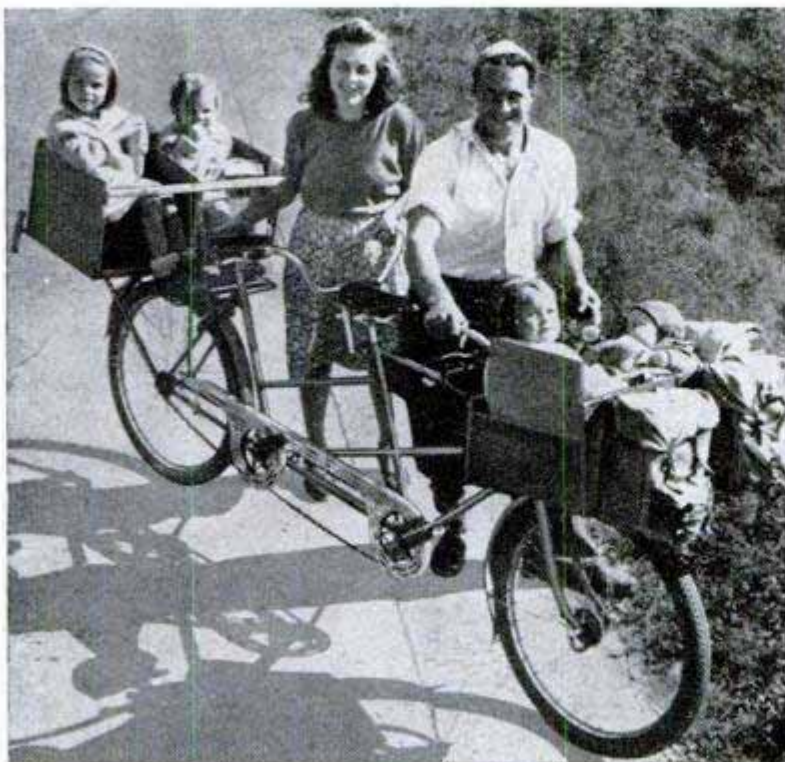

## Bike With Extra Seats Carries Family of Six

How to provide inexpensive vacation transportation for a family of six is the problem solved by Lars Georg Swerin, a Swedish farm worker. The enterprising young man built two front seats and two back seats on a tandem bicycle. Then he and his wife pedaled down the highway while their four small children enjoyed the changing scenery from the extra seats.

Information not listed on articles in the index, starting on page 10, frequently is listed in the WHERE-TO-FIND-IT INDEX, which is available without charge from Bureau of Information, Popular Mechanics Magazine, 200 East Ontario Street, Chicago 11, Illinois

# WHAT'S NEW *For Your Home*



**TRIPLE-DUTY DINETTE**, consisting of two benches and a table, also serves as a laundry aid and storage cabinet. One bench contains a built-in ironing board, the other holds linens or cutlery

**"FROST" PAINT** for windows gives the same effect as ground glass. It can be sprayed or brushed on the pane

**STEAMER ON WHEELS** rolls anywhere to direct a jet of steam on clothing, removing wrinkles and creases, softening shoes and refreshing felt nap

**DOUBLE-BLADE SPATULA** firmly grasps food and prevents splashing of grease. Bottom, **ALUMINUM FOIL** slips into oven to eliminate soiled pots and pans

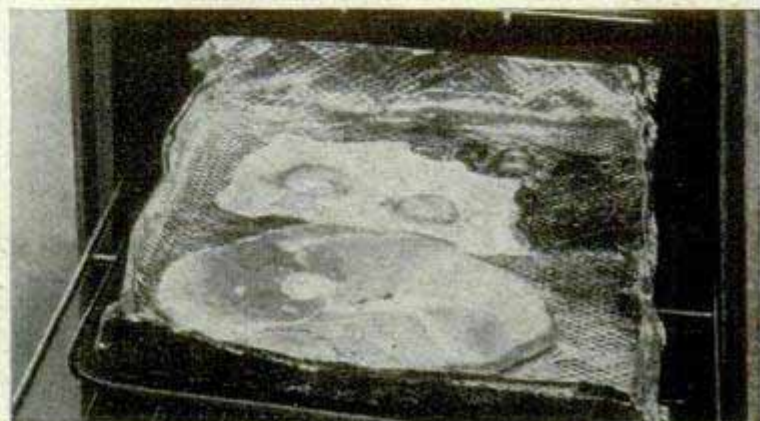
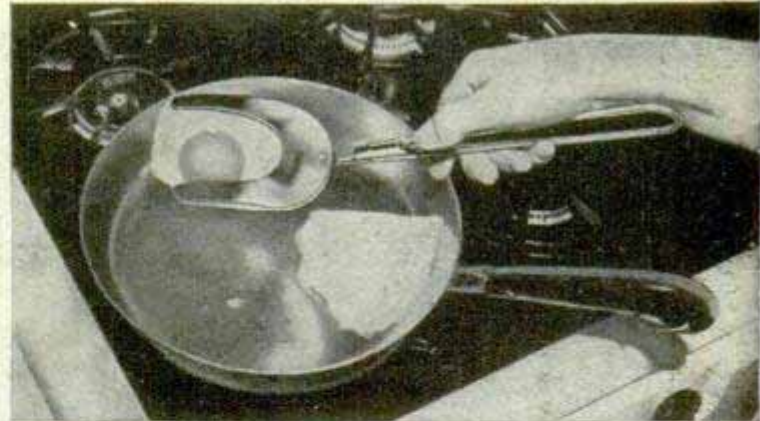

**PORTABLE DISHWASHER**, right, folds down into a unit only 10 inches high when not in use. Tiny electric motor swishes 79 jets of water across dishes. The little washer cleans, rinses and dries full service for a family of four



↑ **POCKET TOOL KIT** has nine implements pivoted inside steel frame which serves as a handle. Tools include can opener, knife, awl, hammer, auger, saw

↓ **BIG VACUUM CUP** holds fixtures to any smooth surface including side of the refrigerator. The vacuum is created by turning a screw in middle of cup



↓ **WRINKLE CHOPPER** cuts vegetables with wiggly edges. Potatoes cut this way can be French fried faster. Six-inch blade also will tenderize meat

↓ **HOOK-ON BAR**, bottom, clamps over the edges of most home doors to provide tie or towel rack. The bar itself is tightly coiled, rustproof spring

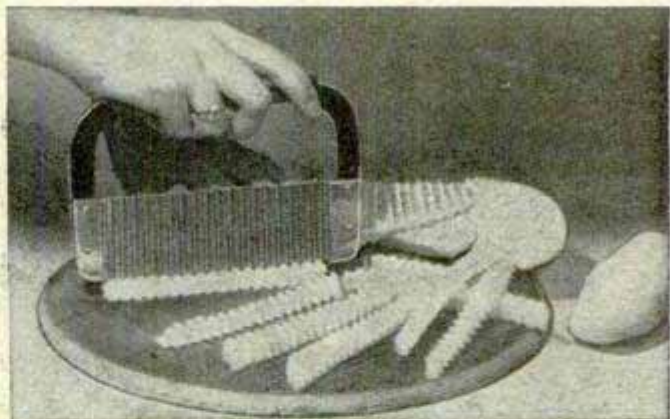
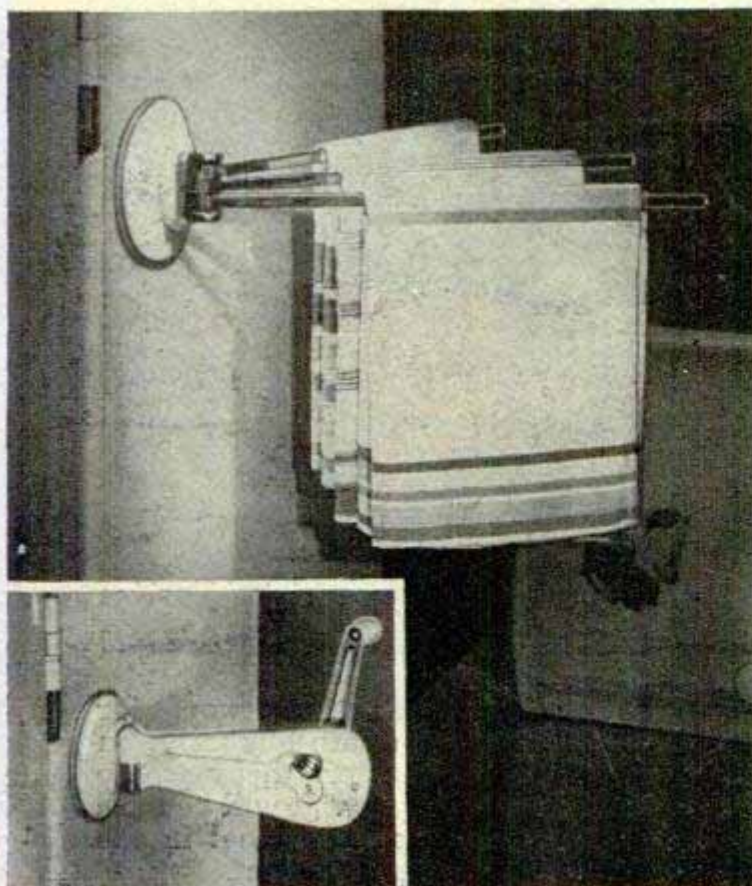

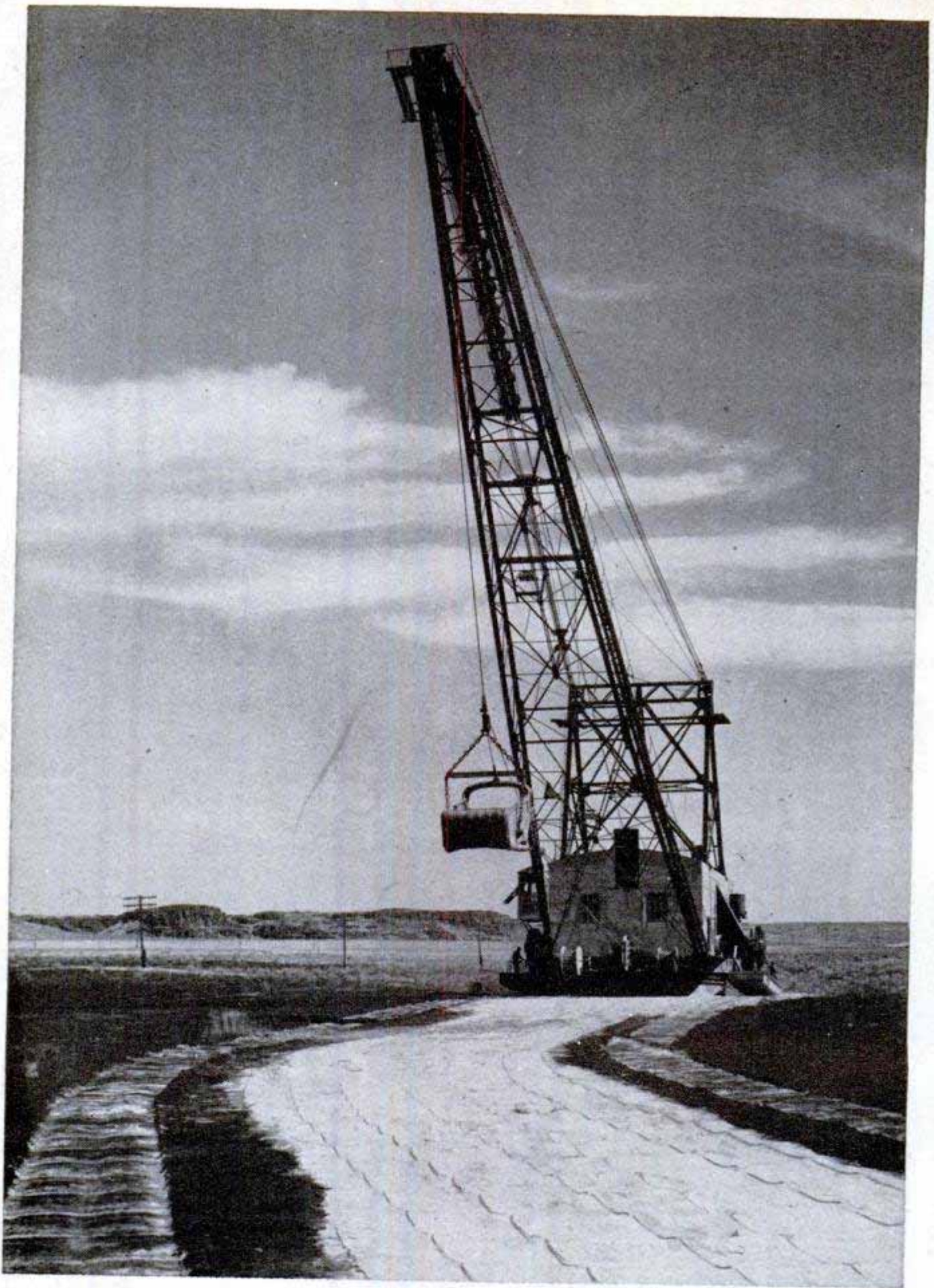

## GIANT FOOTPRINTS

Like a prehistoric dinosaur, a huge dragline left an interesting pattern of "footprints" as it "walked" across eastern Washington on its way to a new excavation job.

The giant machine, walking backwards for 30 miles, left a broad swath of ripples on the ground. No speedster, the machine moves only one mile a day. It will be used in the excavation of a new canal in the Columbia Basin irrigation project.

## Camp or Kitchen Griddle →

Campfire cooking is easy with a griddle that also can be used in the kitchen. Made of lightweight metal, the griddle measures 10¼ by 16 inches—large enough to cover two burners of a stove when used by the housewife. Two wire standards are pushed into the ground to support the griddle for use outdoors. A detachable aluminum handle slips into either end of the griddle, eliminating the need for pot holders. The housewife also can use the griddle inside the oven for baking biscuits and cookies.

## Controller Supplies Power With Unwavering Voltage

Electrical measurements requiring a virtually unwavering power supply now are possible through a controller used by the National Bureau of Standards. The wide-range instrument is believed to be the most accurate of its kind ever built, maintaining electric power that varies no more than .05 percent, according to General Electric engineers. The voltage on an ordinary power supply may vary as much as 10 per-



cent and therefore cannot be used in delicate measurements. The controller provides power from 500 to 50,000 volts.



## ← Japanese Taxi

Built by a former general of the Japanese Air Force who is now in the taxi business in Tokyo, a two-seater taxicab is powered by a motorcycle. The cab driver rides behind the passengers on a standard motorbike frame. Two wheels support the cab and balance the cycle;

## Cedar Paint for Closets

Cedar coating for closets and trunks now can be applied with a paintbrush. A new moth preventive in powder form is mixed with water to form a heavy paste, then brushed on closet walls to about the thickness of a penny. The product is made from wood grain and cedar oil mixed with a powdered plastic binder. It can be spread on wood, plaster, wallpaper and most other wall-covering materials. The resulting surface, which dries in 24 hours, gives off the odor of cedar wood, prevents moths and is fireproof. Nails will not crack the surface.

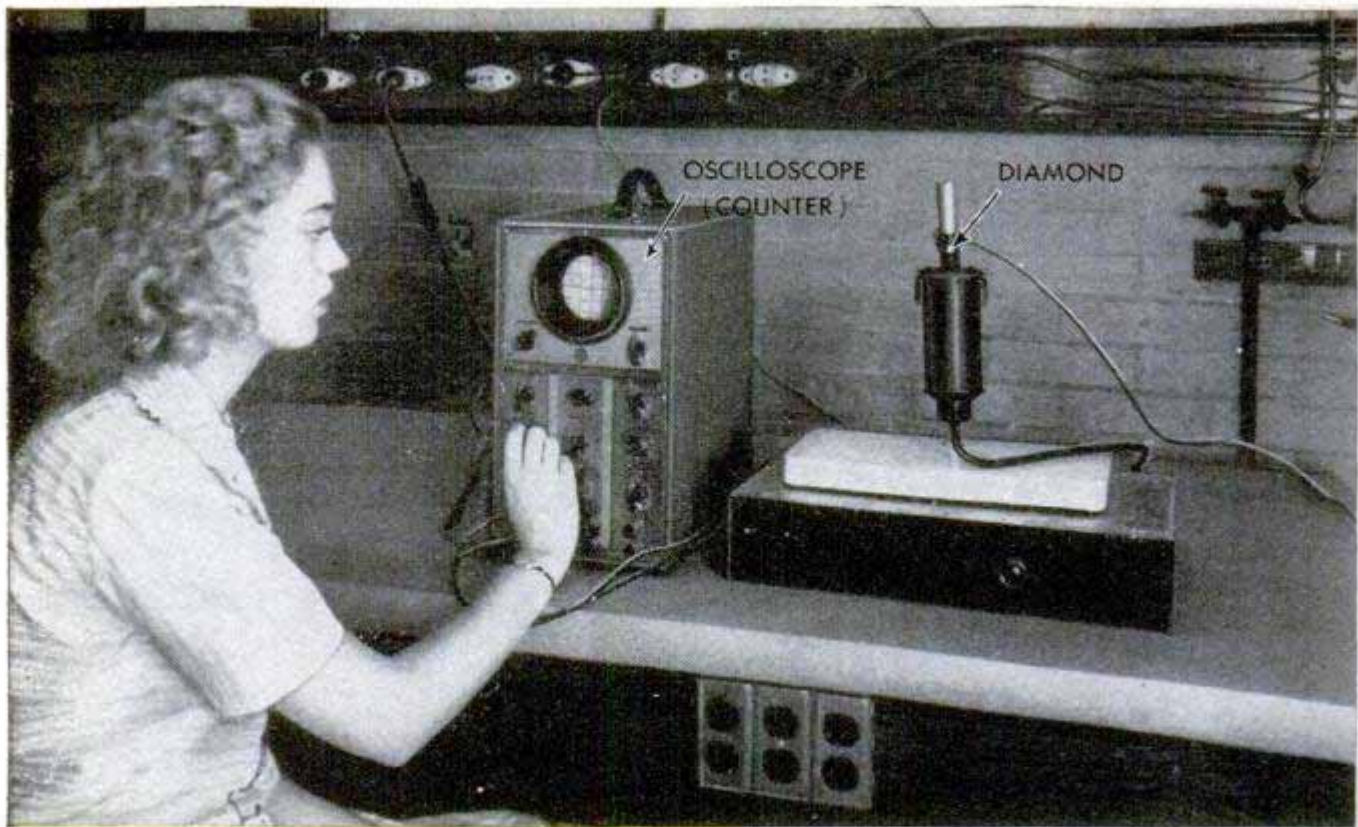

National Bureau of Standards photos

Radiation detective: diamond, clamped between two electrodes, counts gamma rays in vicinity. Screen of the oscilloscope shows the results

## NEW DISCOVERIES OF THE DIAMOND CUTTERS

By John L. Kent

**D**IAMONDS — prize gems throughout man's history—now are pitching in to help him probe the secrets of radioactivity. Scientists at the National Bureau of Standards laboratories in Washington have come up with some modern methods of handling diamonds and sparking new uses for these million-year-old pebbles.

First, they found that modern science could improve the age-old, time-consuming method of cutting the diamonds. Then they found that they could harness the inherent quality of diamonds to modern laboratory use of radioactivity.

Radioactivity studies at the bureau have shown that diamonds are highly sensitive to gamma rays and may be used to detect this radiation in the same way as a Geiger-Muller counter. Gamma rays, of short wave length, are used in medicine for treatment of disease and in industry for radiographic examination of metals.

To use a diamond as a counter, it is clamped between two small brass electrodes maintained at a difference in potential of about 1000 volts. When a

Industrial diamond inside the window absorbs the gamma radiation. Strange property gives it more accuracy, longer life than Geiger counter

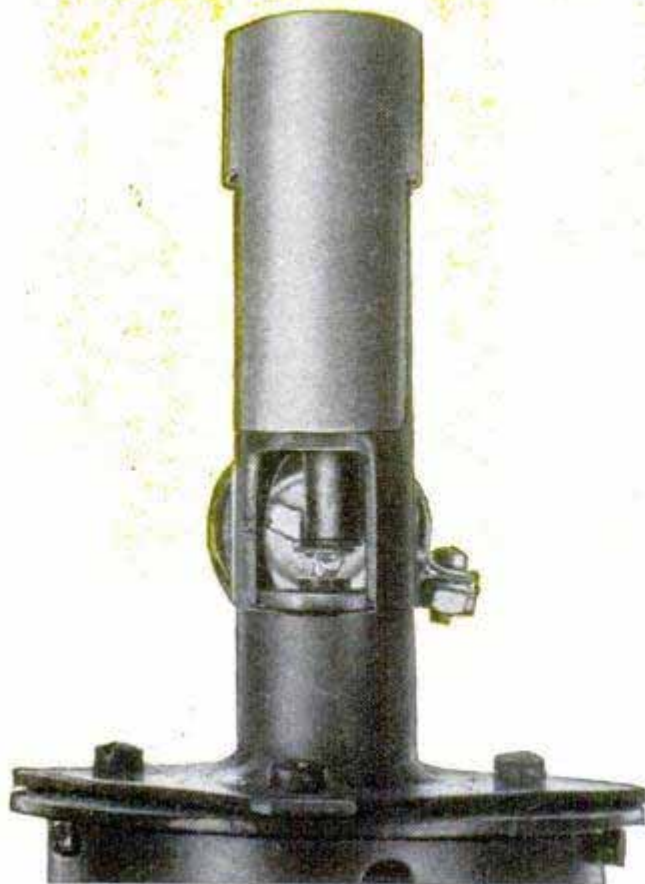

source of gamma radiation is brought within range of the diamond, pulses of current occur across the electrodes which can be amplified and counted by such indicating devices as an oscilloscope, a current meter or even a loudspeaker.

The pulse-producing property of the diamond is believed to be a result of its highly symmetric crystalline structure. Because of the nature of its "oscillations," the diamond is a very "fast" counter, capable of indicating a much greater number of pulses per minute than is possible with the Geiger-Muller counter.

The diamond counter is longer-lasting, being almost indestructible, while the Geiger-Muller counter lasts only three months to two years.

The diamond-cutting improvement is of value in preparing diamonds which will be used as milady's precious gems.

Diamonds have always been stable currency in an unstable world. Because of their great value in relation to their small size, diamonds have figured prominently in history.

The Piggott diamond was a factor in the death of a sovereign. The big Koh-I-Noor — which carries a legend of hard luck to all male owners—is now in the crown of the Queen of England. The "jinxed" blue Hope diamond, owned by the late Evalyn Walsh McLean, is linked with several disasters.

During World War II the U. S. Army found itself in possession of many diamonds and gems belonging to royal families. The temptation of the glittering stones was too much for a few men. The postwar court-martial of Colonel Durant, for example, revolved around the Hesse jewels stolen from a German castle.

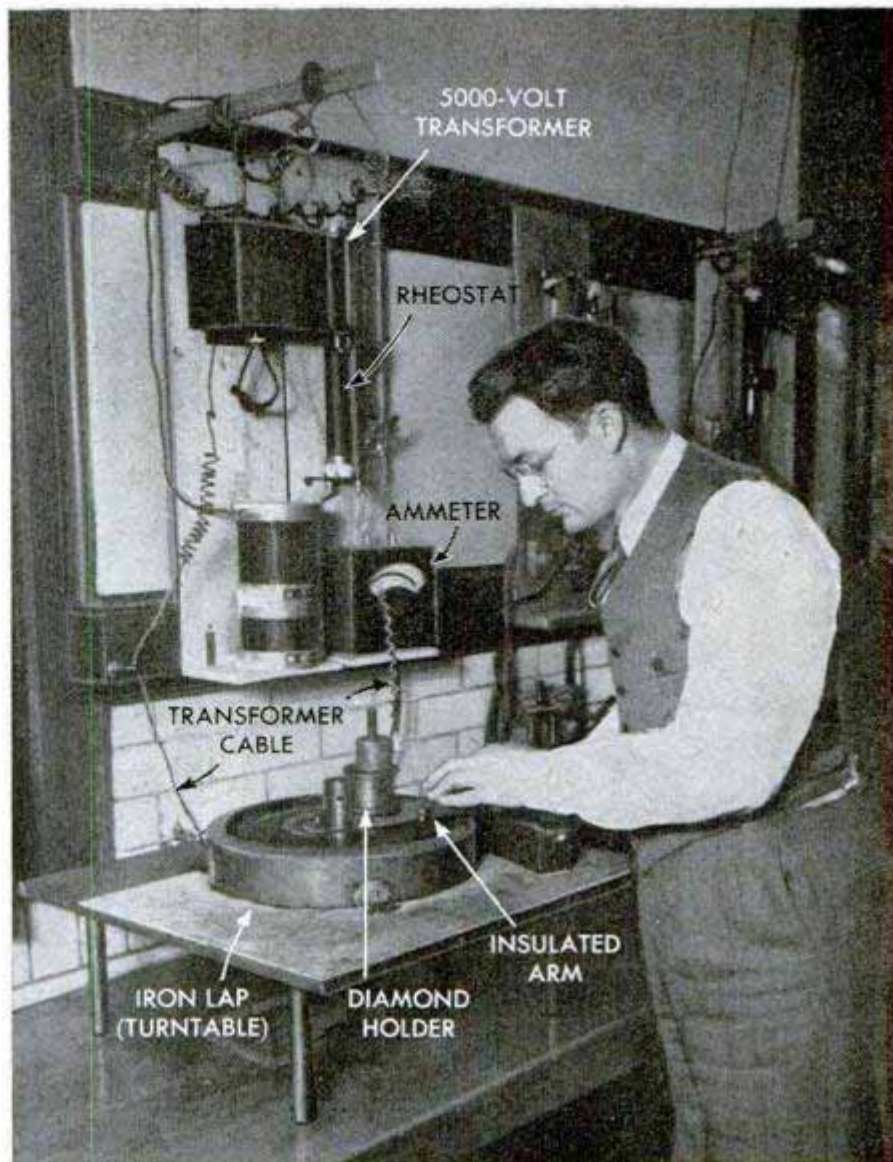

New technique speeds the cutting of diamonds. A high-voltage current connected to the diamond "softens" it during the cutting process. Below, rotating wheel gives high polish to each of 58 facets in its turn

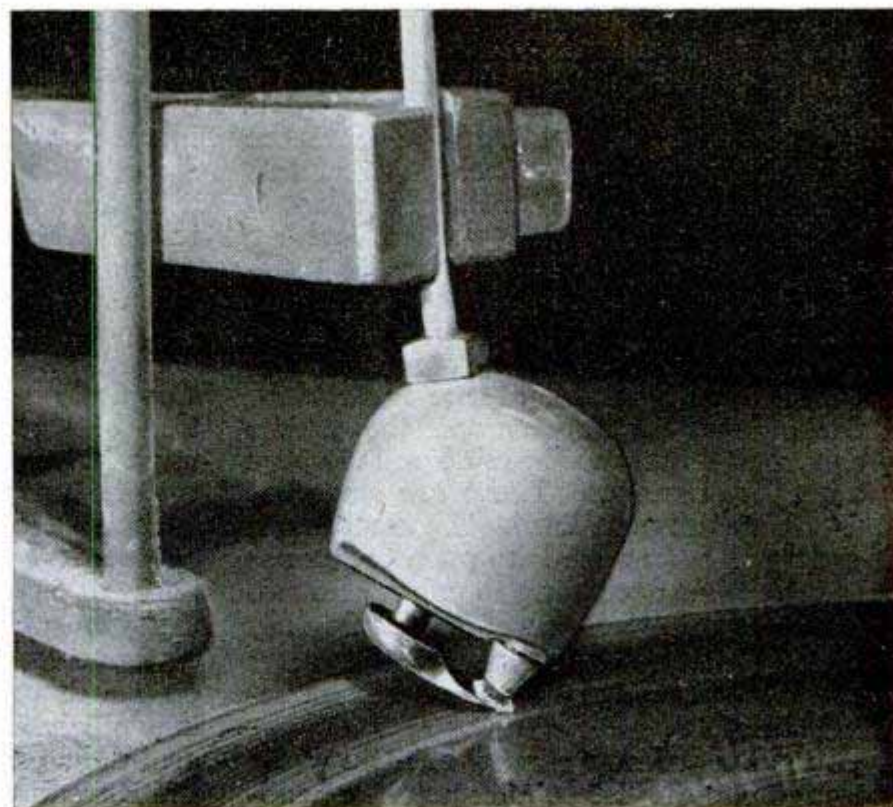

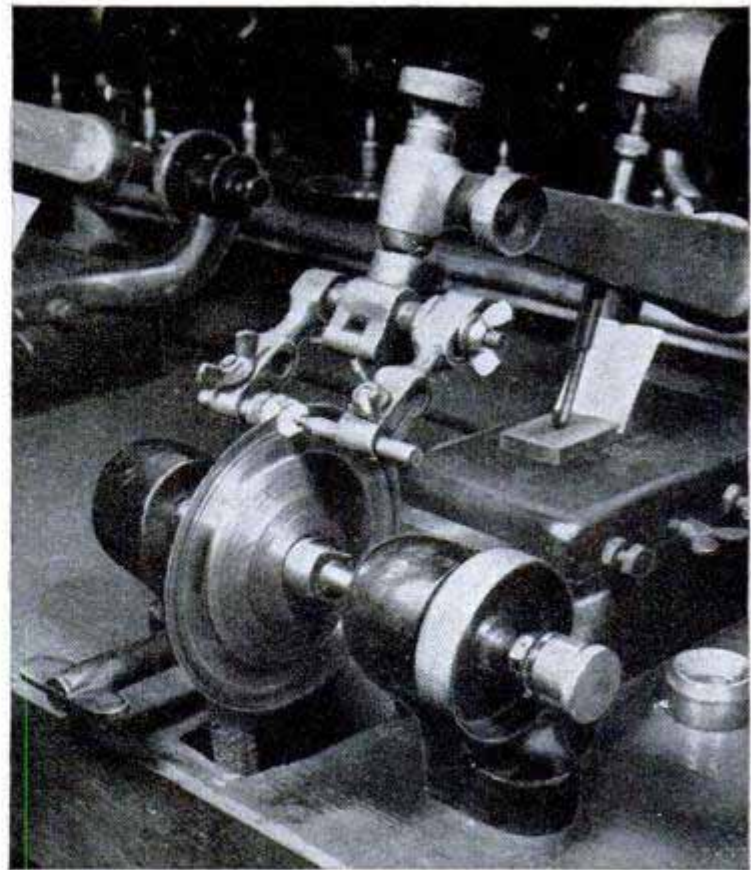
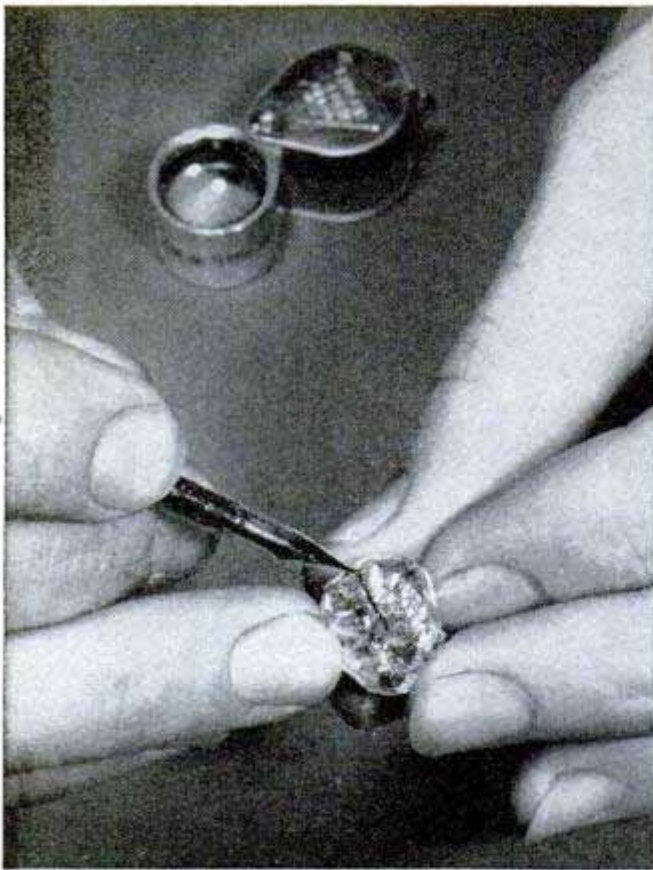

After long study a valuable diamond is marked with India ink for sawing. A mistake in judgment could ruin the entire stone. Right, the gem, clamped in holder, then is thrust down on saw blade which makes the cut

Almost every well-known diamond has a tragic history of robbery, treachery or violent death. Yet, the diamond was once such a dull little pebble that you wouldn't even stoop to pick it up.

Diamonds are found in deep, rootlike veins called blue ground, some of which extend more than two thirds of a mile straight down. The hard ground is blasted by dynamite, loaded into little cars and wheeled to the mine head. The "ore" is crushed, sieved and washed.

About 99 percent of the material is discarded. The one percent remaining is called the concentrate. At one time the diamond crystals were picked out of this concentrate by trained hands. Today, a vibrating table, the surface spread with a ¼-inch layer of petroleum jelly, is used. A group of the natives mixes the concentrate with water and flushes it over the tables. The diamonds stick fast to the grease while the other material flows away.

Other workers now scrape the grease tables, melt down the Vaseline and retrieve the actual diamonds. These are sorted at long tables in north light. The sorters use tweezers or even pencils to push the stones into little piles according to color, size and clarity. Out of 4½ carats of diamonds, only one carat is fine enough to use in jewelry; the balance goes into tools and other industrial channels.

The gems are now placed in little white diamond papers. These look just like head-

ache-powder envelopes but their fold is a little more intricate. The diamond slides into a groove at the bottom of the paper and cannot pop out when it is opened.

At the cutting plant, the first step in changing the rough diamond into a brilliant gem is study. The expert examines the stone through a little magnifying glass called a loupe. He must decide which way the grain runs, how the stone should be divided so as to eliminate flaws and still save the greatest possible amount of the precious material from loss in the process of cutting. He then marks the stone with India ink to show where it should be cleaved or sawed.

If the stone is to be cleaved, it is first set in a shellac mixture at the end of a holder. A small notch is then cut into the stone by means of another diamond which has been sharpened and set similarly in another holder. The notch must be cut in such a way that it guides the knife along the direction of the cleavage plane. The cleaver must know the structure of the stone, else the one blow may shatter it to chips!

When the rough diamond is a natural octahedron (like two pyramids base to base) it is usually sawed. The saw is a thin phosphor-bronze blade treated with diamond dust mixed with oil—because only a diamond will cut a diamond. This is a mechanical process taking up to several days on a large stone. It is here that the Bureau of Standards scientists stepped



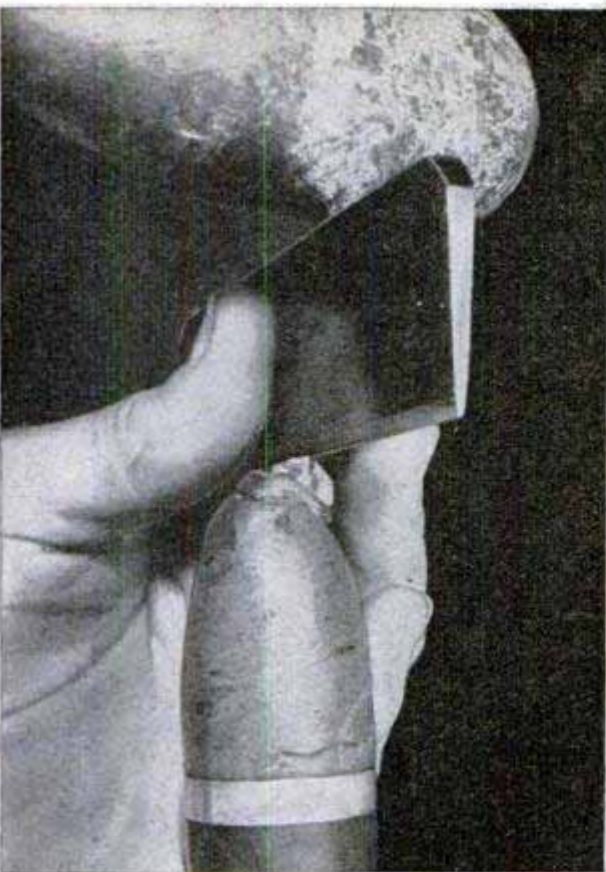

## HOW A DIAMOND IS CUT



NORMAL SHAPE IS AN OCTAHEDRON

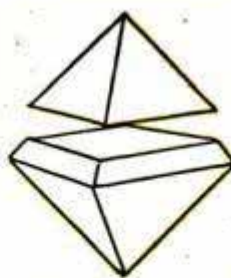

STONE IS SAWED INTO TWO PARTS

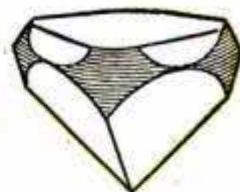

CORNERS ARE GROUND TO "ROUND" STONE

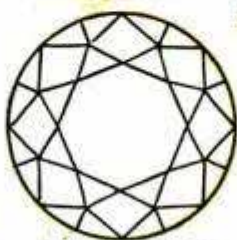

TOP—33 FACETS

STANDARD BRILLIANT CUT



SIDE VIEW

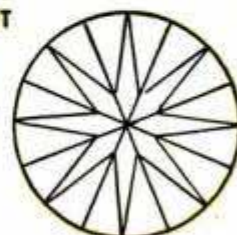

BOTTOM—25 FACETS

When the stone is to be cleaved instead of sawed, a notch is cut in exactly the right place. Then a light tap of mallet splits gem along natural cleavage plane. Right, drawings show how standard 58-facet stone is cut

in and found a short cut. They hooked the saw and the diamond together in a 5000-volt electric circuit. The high voltage had the effect of "softening" the hard diamond so that it could be sawed through in a matter of hours.

The octahedral stone has a deep slice taken off the top, leaving a piece somewhat larger than an exact pyramid. The corners are then removed from this in a process called rounding. One diamond is rubbed against another and the diamond dust resulting is saved and used in the next step—facet cutting. Grinding facets on the surface of the diamond at precise intervals allows light rays to enter to make the stone sparkle.

This is the most highly skilled and highly paid work. The cutting wheel for faceting is flat, like a phonograph record, made of porous iron coated with a mixture of diamond dust and oil. The disk whirls at high speed and the diamond is held in a "dop" (holder) against it. The angle must be changed for each facet of the stone.

The latest improvement is the adoption of the high-voltage cutting technique for the faceting operation. It speeds up this difficult job so that only a few hours instead of weeks or even months are required.

The most popular form of cutting is the "brilliant" which produces a round gem with 58 little facets or sides.

A few years ago three New York jewelry firms came out with their own patented

ways of making diamonds with more than the standard 58 facets. One of these known as "King-Cut" provides 86 facets above and below the "girdle" or widest part. The upper part of the King-Cut has 12 instead of 8 facets. Another cut known as "Multi-Facet Cut," has 98 facets. The extra 40 facets are cut into the edge of the girdle. Even this wasn't enough, and the creators of "Magna-Cut" designed a cut with a total of 102 facets.

During the cutting, half the weight of the diamond is lost but its value is greatly increased. It begins to sparkle with the polishing of the first facets. When it has been finished and cleaned in acid, your eye catches the "fire" that never burns out even if you hold the gem under water.

It has been months now since the diamond was mined, and many weeks have gone into the cutting, but it still is a loose stone which nobody could wear. So the next step is the creation of a metal mounting to transform the gem into jewelry.

This may take from one to six months. In the case of an elaborate piece where large fancy-cut stones must be matched—perhaps in the diamond markets of Europe as well as in New York—a full year may be required. But the finished work-of-art is timeless.

The diamond itself is probably millions of years old when man discovers it. A few more centuries as a family heirloom are but a few days in its fabulous history.



## 18-Layer Suit Protects Firemen at 2000 Degrees

Aircraft crash firemen in a newly developed suit stay at a comparatively cool 130 degrees while working in a flaming inferno of gasoline and oil registering a sizzling 2000 degrees. Though only about  $\frac{1}{2}$  inch thick, the suit is made up of 18 layers of

various kinds of glass fiber, cloth, aluminum and silver foil and nylon. A blanket of the same material shields victims being brought out through the flames. Developed by the Air Materiel Command, the suit's total weight is 29 pounds.

## Nose Doors 12 Feet High In Globemaster

Clamshell doors almost 12 feet high allow wheeled vehicles to enter through the nose of the Air Force's new C-124 Globemasters. Weighing 175,000 pounds, they will be the largest production transports in mili-

tary service. As a troop carrier, the C-124's interior can be double-decked for 200 men and their field equipment. As an airborne hospital, it can accommodate 136 stretcher patients and 52 attendants.

Douglas Aircraft Co. photo

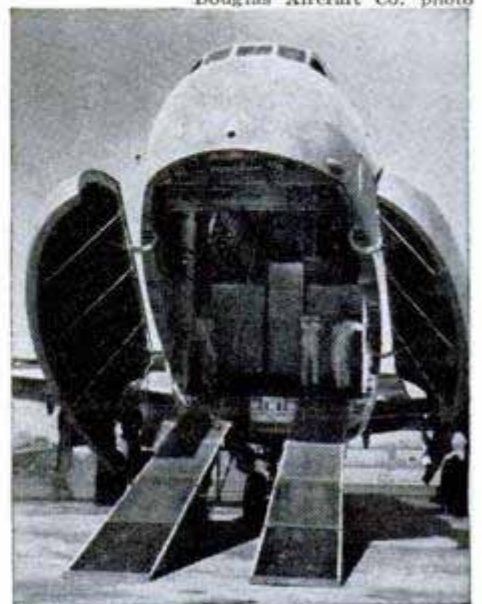
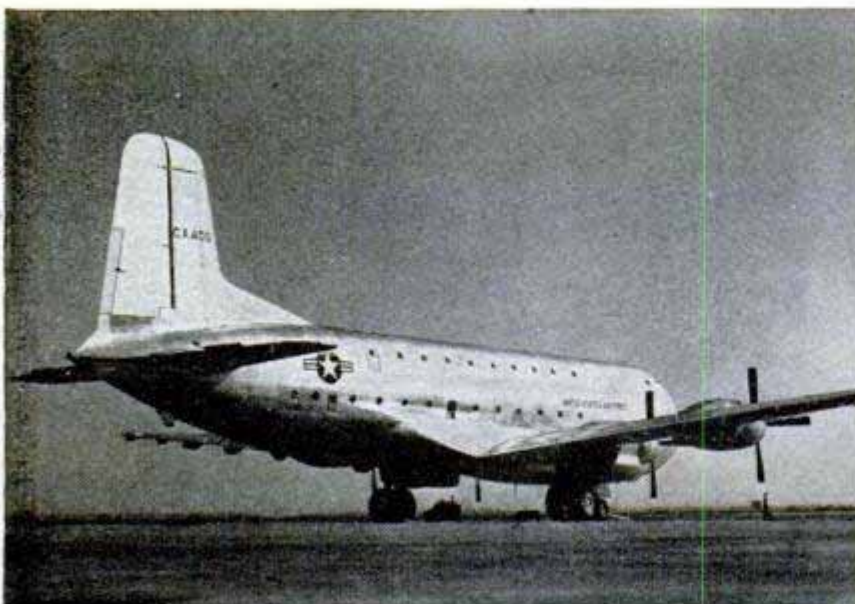

# The Old Sugar House Goes Modern



**By William Gilman**

*Photos by Eleanor Gilman*

Maple syrup and hot cakes! Food for a king! The 10 jars in the background contain sap right from the tree. It takes that much sap to produce the amount of syrup shown here. Below, Vermont youth "taps out" a maple the modern way

**D**OWN ON THE FARM the Yankee trick of making maple syrup "ain't what she used to be." The maple tree itself is still a mystery, challenging scientists who don't know why its sap is so sweet and flows so temperamentally. But sugaring has gone modern, using mechanized equipment and pipe lines to convert the maple's juice into fancy-priced nectar.

In its fundamentals, this odd type of farming remains unchanged. From a hard-maple tree, between 30 and 45 drops of sap produce one drop of syrup for the great American pancake. If you have the tree, all you need is a tap-hole, a spout, a can, fruit jar or pail for collecting sap, and a pan for boiling it until a few drops on a spoon will "sheet" like jelly. That's finished syrup.

Anybody with maples in his yard has the makings of a worth-while springtime hobby. A dozen trees should net five gallons of syrup for pancakes, cake icings and candy, plus a few quarts to spare at Christmas.





Pouring the sap downhill is a lot easier than the old method of hauling it with oxen. There are six miles of pipe on this sugar farm. Each main line is numbered and the markers are set high so snow won't hide them

Below, this is the end of the pipe line and the end of the sap, too, because here it is boiled down to syrup. There two sap houses produce 1000 gallons of syrup a year. Even the tree in the foreground has been tapped

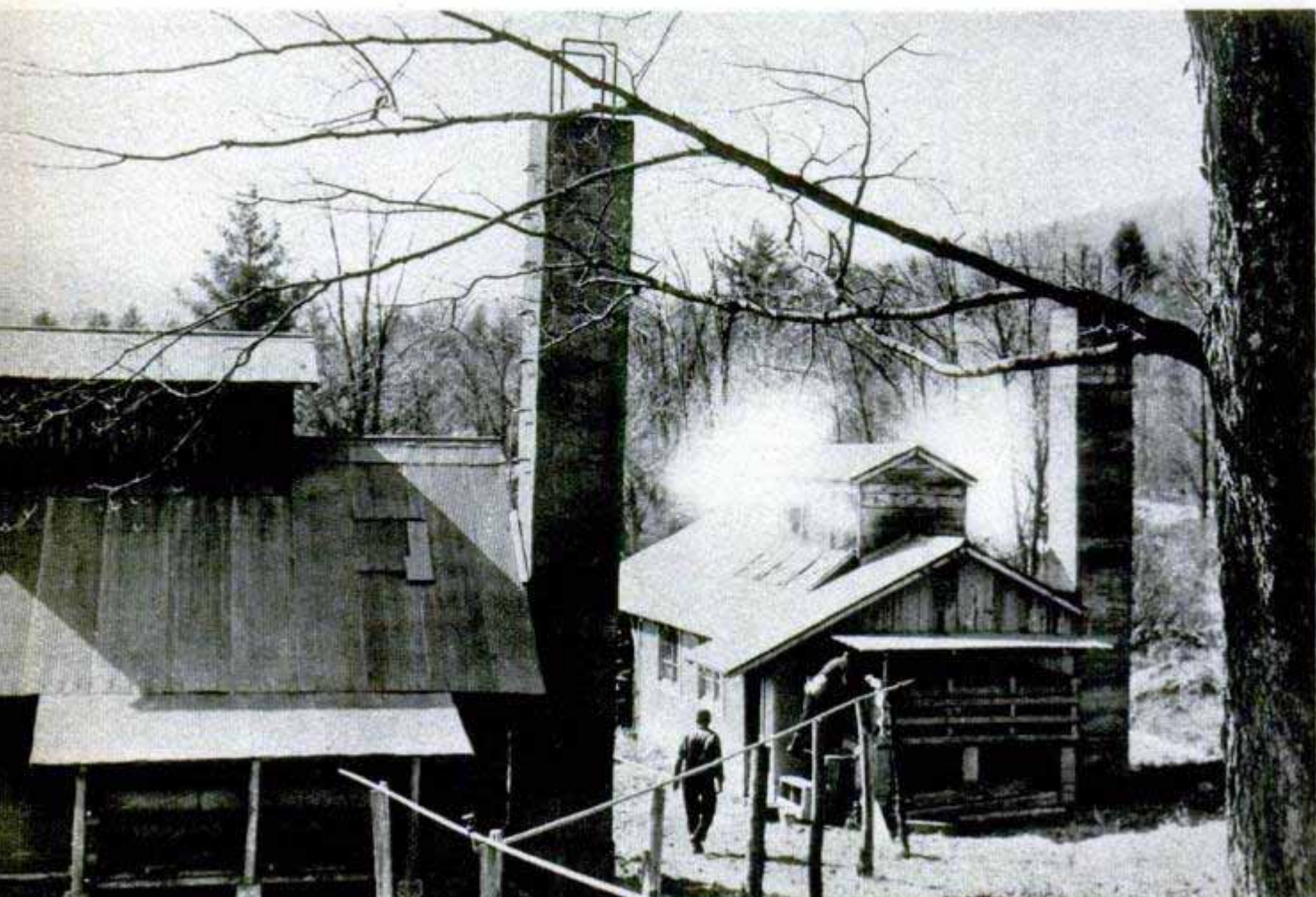



Large bucket screws to pipe to serve as a funnel. Perforated pail, left, slips inside to strain sap

But to the commercial syrup maker, the drip-drip-drip of sap into metal buckets hung on thousands of maples is sweet music to the ears and dollars in the pocket. He hangs at least 4000 buckets and aims to get 1000 gallons of syrup worth \$5000. It's all done in a hurry. Compared to other crops, syrup piles all the work into six weeks of hectic harvesting — there's no plowing, seeding or weeding necessary.

It takes a million drops of sap to make a gallon of syrup and that's why labor saving pays. A new device is the power tapper, replacing the breast drill and old-fashioned brace and bit for boring tapholes.

It's a portable gasoline motor equipped with shaft-driven bit that drills holes  $\frac{3}{8}$  inch in diameter and  $1\frac{1}{2}$  inches deep. Most are homemade. Some, mounted on war-surplus rucksack frames, are packed on the back. Others are held over the chest by shoulder straps.

When Wilson Clark of Wells, Vt., built one for his father's farm, he used a motor from a washing machine and handle bars from an old sled. He made aluminum castings for the chuck and pulley. With the rig he can "tap out" for 800 sap buckets in six hours. It takes two men, driving spouts and hanging buckets, to keep up with him.

That's only the first step. Most of the

work is in visiting a few thousand trees through snow and mud to empty the buckets daily during a sap run—then bring the "liquid sunshine" to the evaporator.

One canny farmer, Jay Gould of Middle Granville, N. Y., uses a tractor to pull the trailer carrying his collection tanks. He sticks to highway maples, usually higher in sugar content than woodland ones, over a route of several miles. For every dozen trees "rented," he returns a gallon of syrup to their owner and nets himself about eight gallons.

Most efficient method of horseless sugaring is the pipe line. Some operators have tried linking the sap hole right to the pipe by means of a gooseneck connection, but it hasn't worked as well as pouring sap into the line and letting gravity do the rest of the work. At Scott Nearing's mountain farm near Jamaica, Vt., six miles of pipe line—a fanning system of four main lines and their spurs—bring 35,000 gallons of sap down during a season.

Spaced 100 feet apart through the woods are standpipe Ts into which Nearing's men pour sap gathered from near-by trees. Buckets on the Ts serve as funnels.

Downhill, sap is boiled in two fireproof sugaring houses, each with a modern evaporator. A valve sends sap into either or both, when a big sap run is on.

Like other modern producers, Nearing doesn't allow sap to accumulate—that causes fermentation. Old-timers blamed bad sap on a swelling of the maple tree's buds. They called it "buddy sap." Scientists say it should really be called "buggy sap." The bacteria are not harmful to health, but cause a change in the sap's sugar composition, resulting in syrup that is too strong, and black instead of amber.

Holding late-afternoon sap for the next day's run caused much of this. Now, big operators have electrified sugar houses and they keep up their boiling into the night.

In a modern sugar house, much of the space is occupied by the evaporator—large ones are 5 by 16 feet. Sugaring has come a long way since the pioneers learned the art from the Iroquois Indians, who simply gashed a tree, caught sap in a hollow log and evaporated by throwing hot stones into the liquid.

The modern tin evaporator is a refined version of a shallow pan. It rests on a long, narrow furnace, called an "arch." In the firebox, a hungry fire devours cords of wood and it's a knack to know how hot the fire should be.

Unlike the mountain moonshiner who cooks corn mash and wants the alcohol in the vapor, the mountain syrup maker lets steam go up through a roof vent and catches in on the residual liquid. Sap enters one



The old, and still reliable, way to tell when syrup has boiled enough is to see if it "sheets" when drained from this scoop. Below, Mrs. Helen Nearing helps out by running the evaporator

end, flows around several partitions of the pan, losing water as it moves.

A special hydrometer and thermometer record the finish point. Standard syrup weighs 11 pounds per gallon and boils seven degrees above water's boiling point. Many producers, however, admit they like to double-check by using the old sheeting method, too. Syrup is then strained through felt to remove mineral grit before it is graded according to color and stored in tins or barrels.

There is still room for improvements in the process and a fortune awaits the man who can figure out how to get rid of the water in the sap more quickly. Vacuum distillation has been tried. It boiled the sap quicker and at lower temperatures, but the resulting syrup had lost its famed maple flavor.

One improvement scientists are promising is a sweeter maple tree. Richer sap will mean less boiling to produce more syrup.

The tree most commonly tapped because of its superior sugar content is known as the sugar or hard maple. Its sap averages three percent sugar. Since pioneer days,

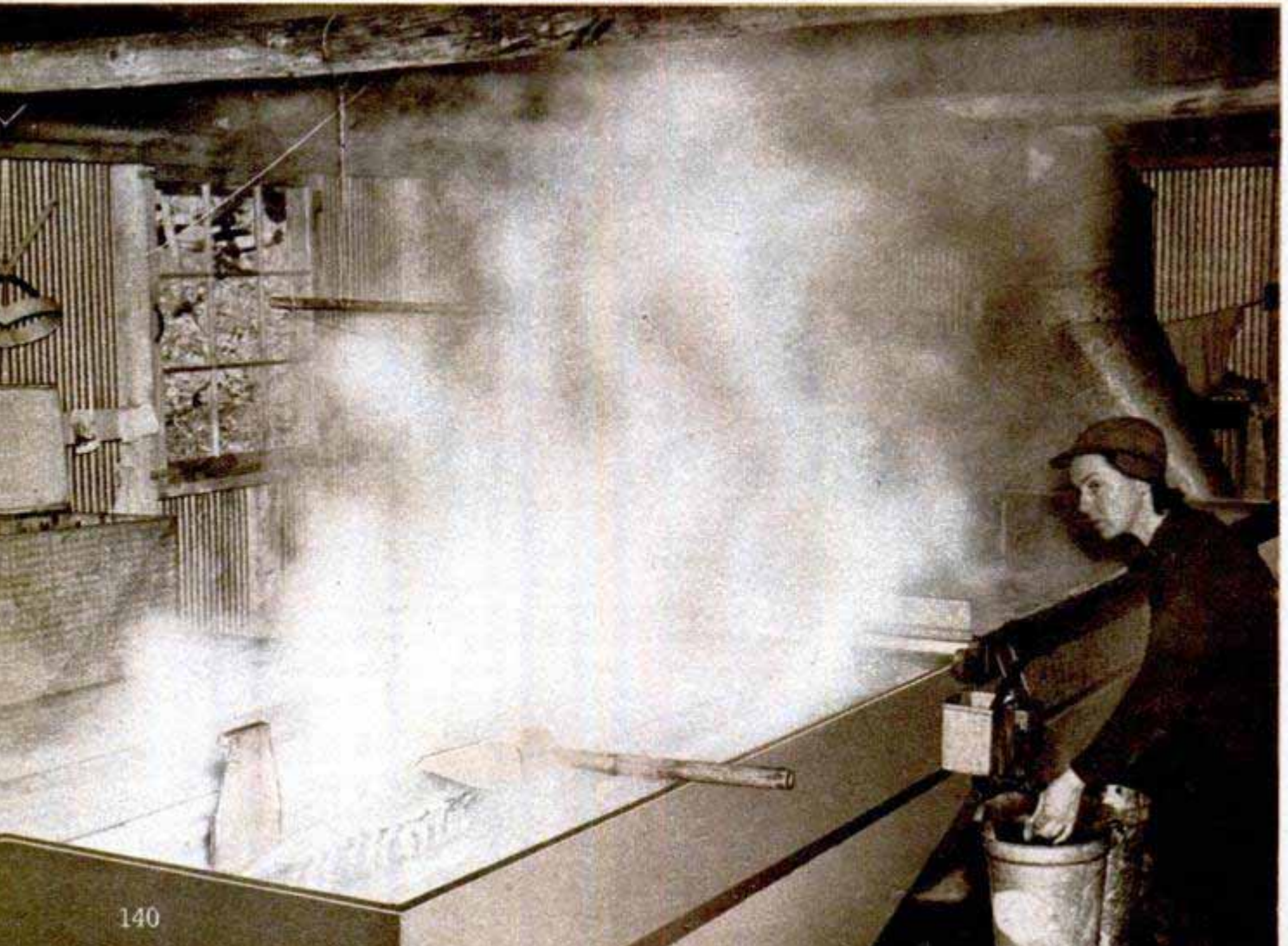



Roadside trees are rich in sugar content. This farmer drives his tractor on the highway, picking up his crop

it has been a wild tree. But the University of New Hampshire has begun a program to grow better ones. After a long hunt for outstanding specimens, UNH men found one just off their campus and promptly named her Sweet Sue. Her sap contains nine percent sugar — three times average. They are now rooting cuttings from that tree under fluorescent light. Their goal is to populate farm lands with lots of Sweet Sues which will be set out in orchards the way pedigreed fruit trees are planted.

Meanwhile, although the maple is one of the best known of trees, scientists still don't know just what goes on inside the tree itself. They want to know why one sap season is good and another bad and why sap flows well only on a sunshiny spring day after a freezing night.

There are many oddities in the picture. It's ordinary belief that sap flows up a tree. But during tapping season, twice as much comes down as goes up

One experimenter, using an ordinary steam gauge mounted at a taphole, found it registering 25 pounds of sap pressure per square inch inside the tree at noon. That's as much pressure as you carry in your automobile tires. At night, the sap pressure turns into suction.

Even the log of a freshly cut

maple tree will work like a sap pump. UNH experimenters got sap from branches, logs, posts and trees standing upside down in tubs of water. Every night, the "dead" wood sucked in water and every day it gave forth sap through the taphole.

Researchers at the University of Vermont have gone even further. They cut limbs from a maple tree in March and store them in refrigerators.

In July or November, they take out a branch. It wakes up and starts right in flowing with March sap.

Dr. Stuart Dunn, botanist at the University of New Hampshire, is raising maple trees with three times as much sugar as the average

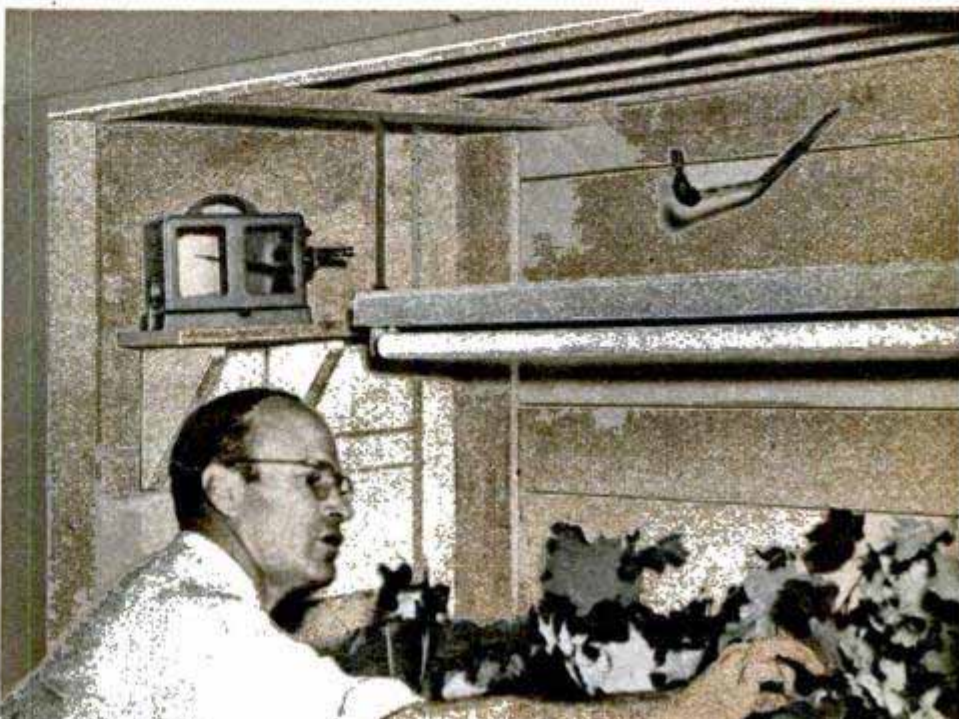

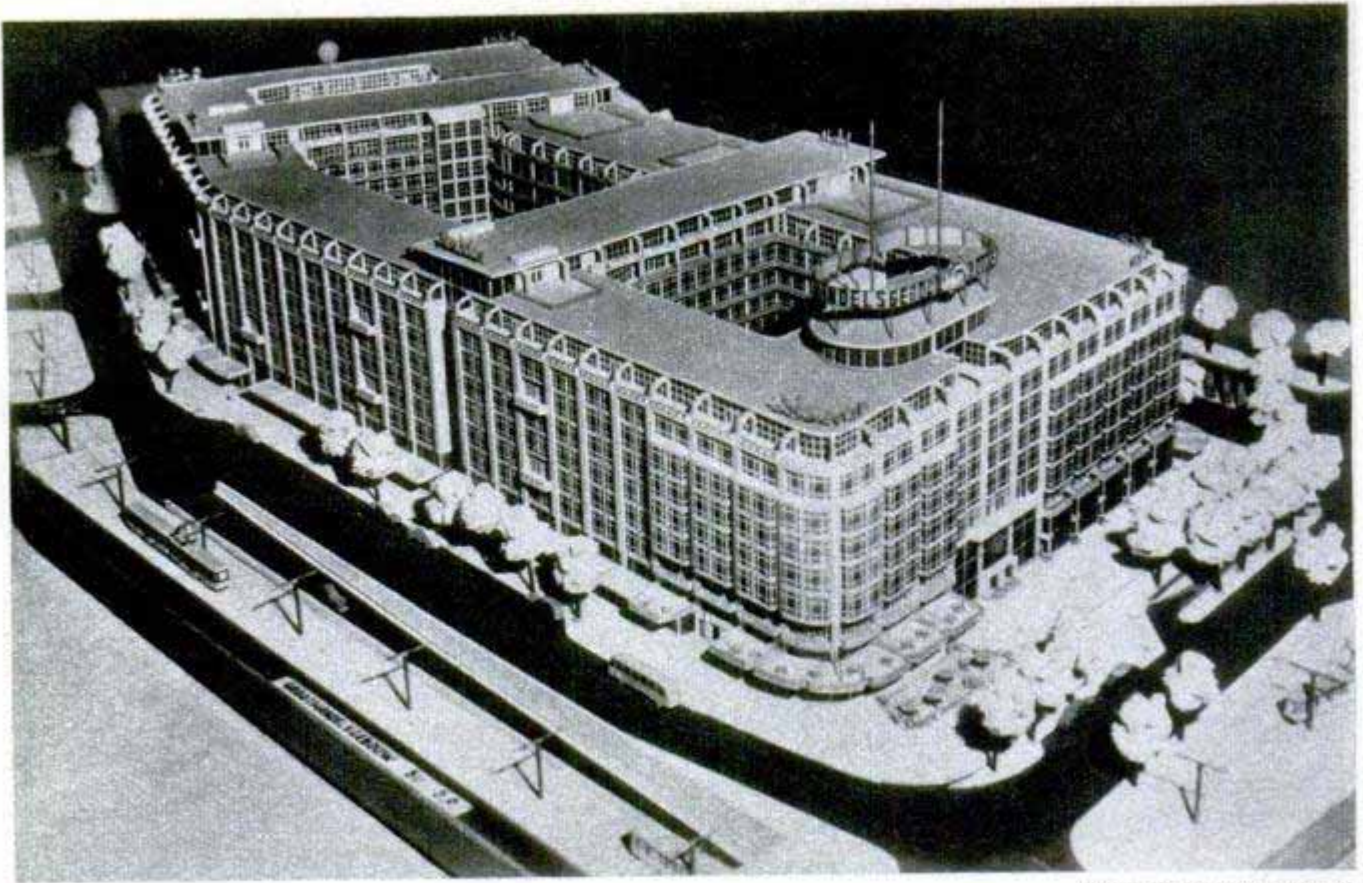

Photo by Hamilton Wright

## Huge Rotterdam Building Covers Two Blocks

Two blocks long and covering about twice the ground area of the R.C.A. Building in New York City, a Rotterdam building now under construction is said to be the largest in Europe. Located in the center of the city, the building, known as the Rotterdam Trade Center, will house 150 trade organizations which lost their offices

and warehouses under German bombardment. Passageways and elevators are designed to permit trucks to go as high as the third floor of the seven-story building. In the building will be offices, warehouse space, garages, showrooms, stores, a bank, post office, restaurant and medical center. The construction was started in April 1948.



### ← Telescope Walking Stick

Hikers can spot faraway objects as they tramp with a walking stick which has a built-in telescope. Made in Japan, the telescope can be fitted to any stick to form the handle. It is pivoted across the top of the stick and easily adjusted to see through.

### Lead-Glass Gowns

Gowns made of a lead-glass fabric are protecting doctors and their assistants from injury by X-rays and the beta rays of atomic fission. The gowns were developed by Dr. Vincent W. Archer of the University of Virginia. They replace gowns made of lead and rubber, which have less flexibility and cover a smaller portion of the body.

Information not listed on articles in the index, starting on page 10, frequently is listed in the WHERE-TO-FIND-IT INDEX, available without charge from Bureau of Information, Popular Mechanics Magazine, 200 East Ontario St., Chicago 11



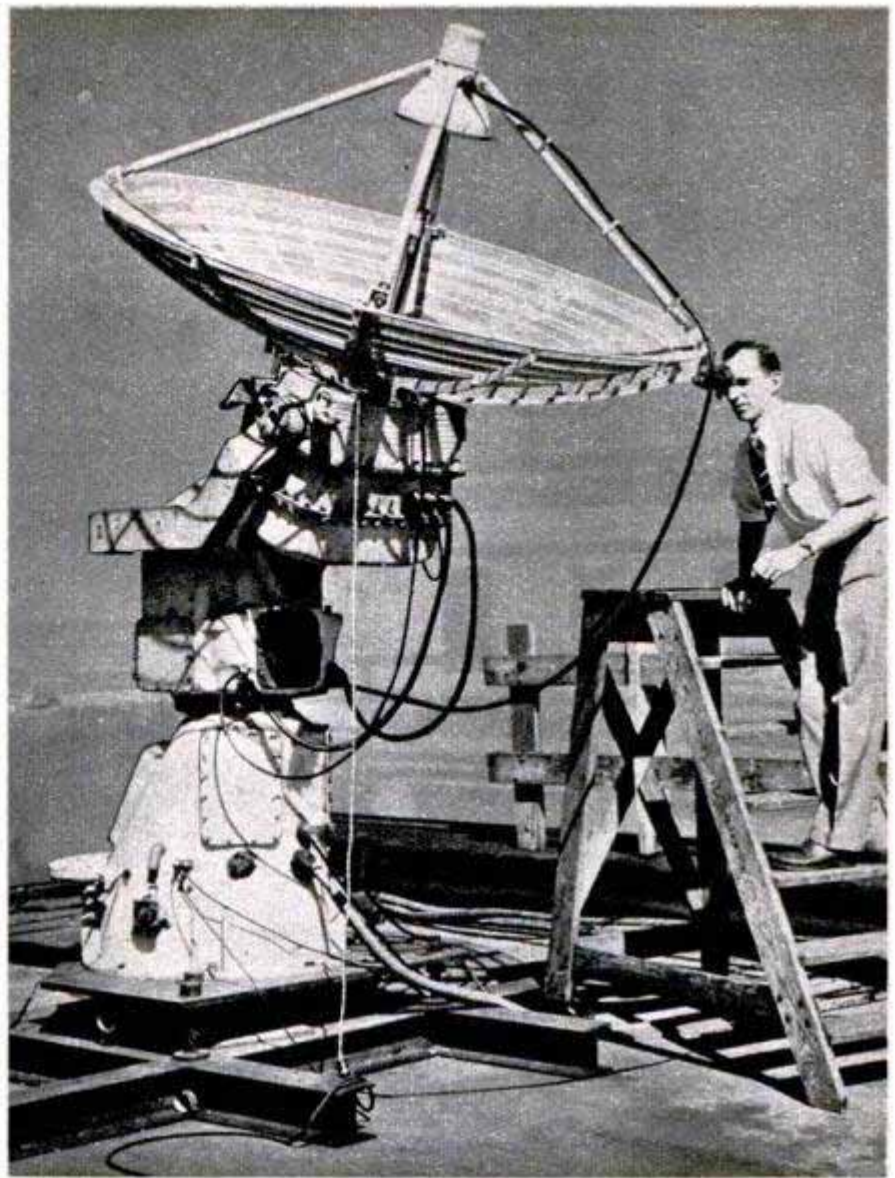
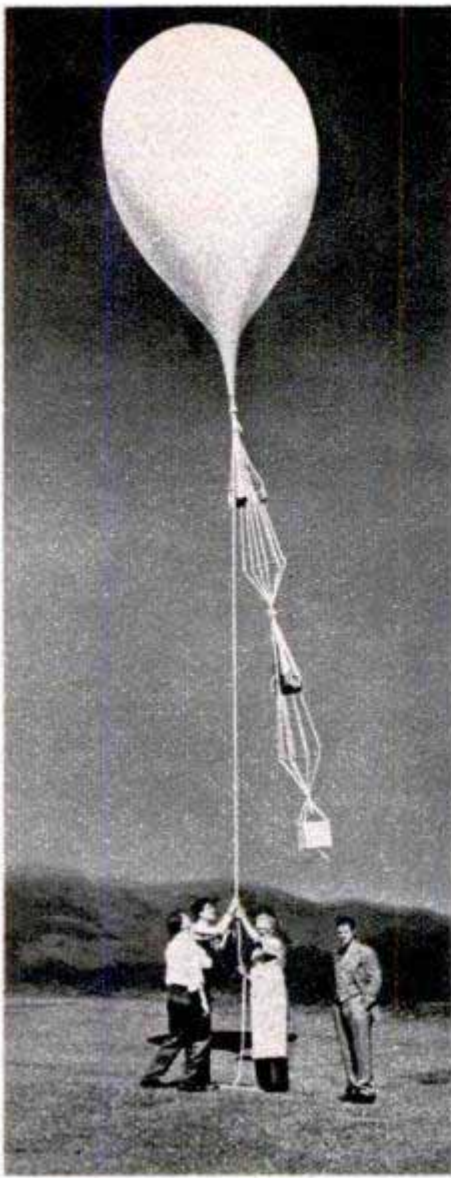

Left, launching the analyzer. Right, antenna automatically tracks balloon, receiving reports from analyzer

## Cloud Analyzer

Clouds withhold no secrets from an electronic analyzer that is carried aloft by a weather balloon so it can transmit a running description by radio to a ground station as it passes through cloud formations. The balloon carries the analyzer upward at 1200 feet a minute until it reaches 75,000 feet where it bursts, allowing the equipment to descend by parachute. Should the analyzer be lost or damaged in the fall, the reports are not affected because they are

automatically recorded by the ground station throughout the flight. Among the data transmitted are the height of the cloud at its base and summit, its density, temperature, air pressure and relative humidity. The airborne transmitter sends this data 120 times a minute during the flight. A piece of string, saturated with a salt solution through which an electric current is passed, forms the heart of the analyzer. As moisture in the air increases, the conductivity of the string increases in measurable amounts.

## Rockets Get Atmosphere Samples at 230,000 Feet

Using rockets, University of Michigan scientists have obtained samples of the earth's atmosphere at 230,000 feet. It was the first collection ever made above 100,000 feet. Thin-walled steel bottles, like the breathing-oxygen type used by airplane crews, are sent aloft with rockets at the government's White Sands, N. Mex., rocket-testing range. On each is a mechanism that opens the evacuated sealed bottle after 80 seconds elapse, when the rocket is about

40 miles high. Then the bottle's intake tube is closed by a "mousetrap," an electrically operated double-headed hammer that smashes the tube together. At the same time, a small charge of powder in the hammer head is ignited, providing heat that melts the solder covering the inside of the tube. Fusing of the solder seals the bottle and prevents escape of the atmospheric sample. The bottles are recovered after the rocket crashes to earth.

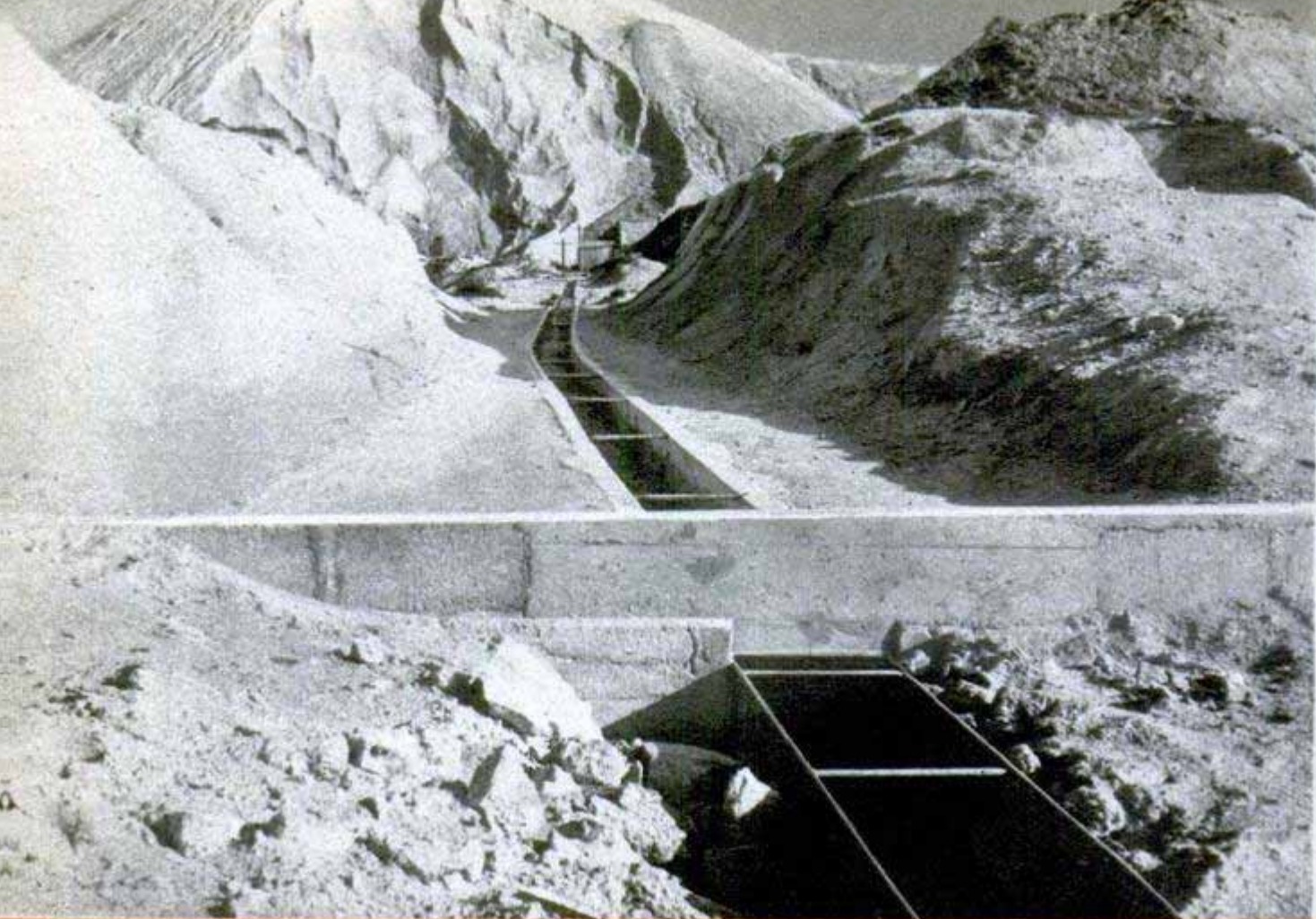

Above, material from piles of china-clay residue in the background is washed down stream in foreground to factory for processing and molding

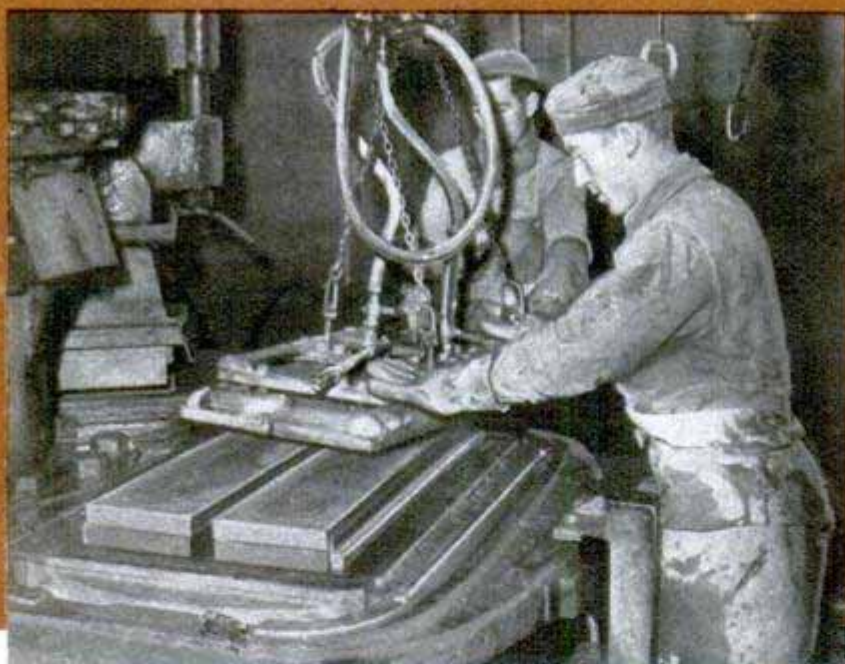

Above, after cement is mixed with clay waste it is deposited in steel molds and pressed into shape. The complete blocks are lifted from the molds by suction

Right, before they can be used blocks have to be stacked outdoors for a three-week drying period. The finished blocks are then trucked to construction sites



# HOMES of CHINA CLAY



**WASTE** from the Cornish china-clay industry, long heaped in great piles that have become a regular feature of the landscape near St. Austell, is helping to solve Britain's housing shortage. The residue is mixed with cement, molded into blocks, dried for three weeks and used to form double-walled unit homes. The various-sized blocks, easily fitted together by semiskilled workers, are strong and permanently waterproof. Their edges are placed in grooves along the sides of upright posts, erected securely at intervals on a substantial plinth. Four-man teams, two masons and two laborers, build the homes. Originally intended to meet a serious housing shortage for Cornwall workers, they are now used all over Britain.

Above, the blocks forming the walls of these trim homes for Cornwall workers were made from residue once heaped in mounds like those in the background

Below, left, workmen fitting blocks into the grooves on the sides of upright posts. The Cornish factory makes enough blocks each day to build six houses

Below, right, unit-constructed part of a house nears completion. Two layers of blocks, with an air cavity between for extra insulation, provide a sturdy wall

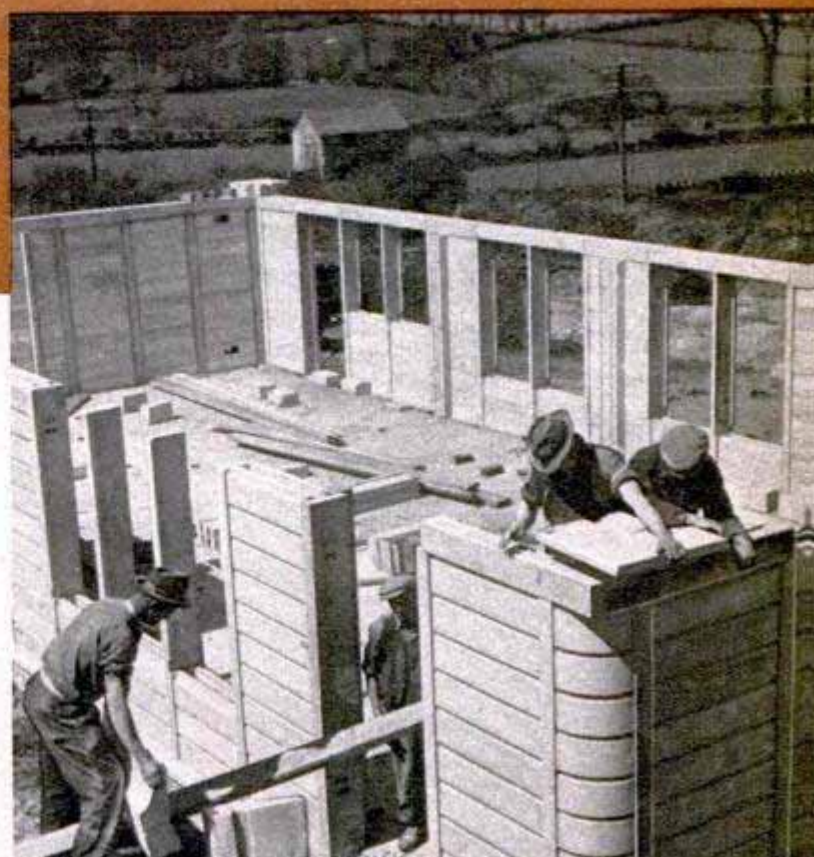



## Assault Transport

Combat troops and supplies are carried into front-line, unprepared fields and then supported by a new assault transport, the Chase XC-123. The plane is powered

by two 2400-horsepower Pratt & Whitney engines mounted in special nacelles which can be quickly removed from the wings for engine change. Wingspan of the transport is 110 feet and it is 77 feet long. The cargo hold is about 36 feet long.

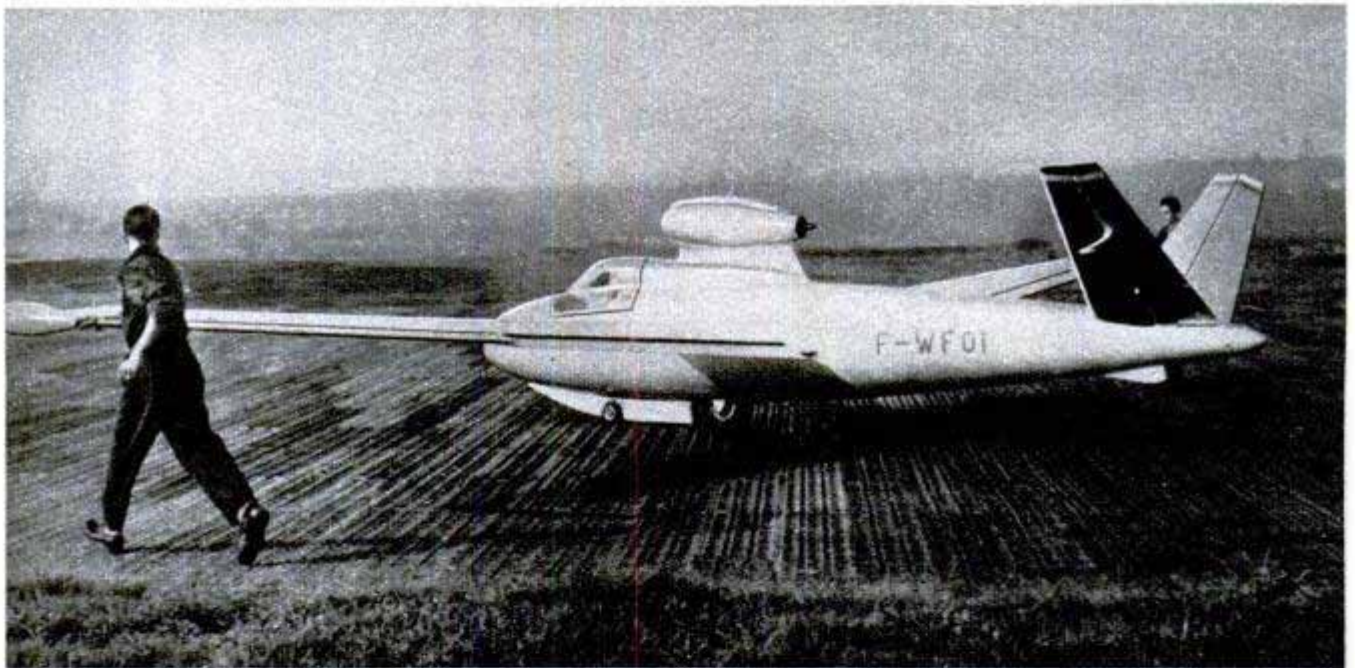

## Jet Sailplane

French sailplanes equipped with 190-pound jet engines enable a pilot to get home if he runs out of thermal currents. The engine is capable of propelling a plane

at speeds up to 160 miles per hour. Not only a boon to the sailplane pilot, the engine also enables the ground crew to relax and watch the flying instead of dragging equipment over the countryside to find the house from which the pilot phoned after landing.

## Airplane Pilots Spin Wheel to Get Navigational Data

Pilots who want navigational data for flights from Medford, Ore., to other airports in the West get it quickly from a drum-type chart developed by CAA employees. Simply by spinning the drum to

the desired destination, the pilot reads through a slot in the housing the following information: distance, magnetic course, field elevation, runway length and type, and terrain characteristics en route.

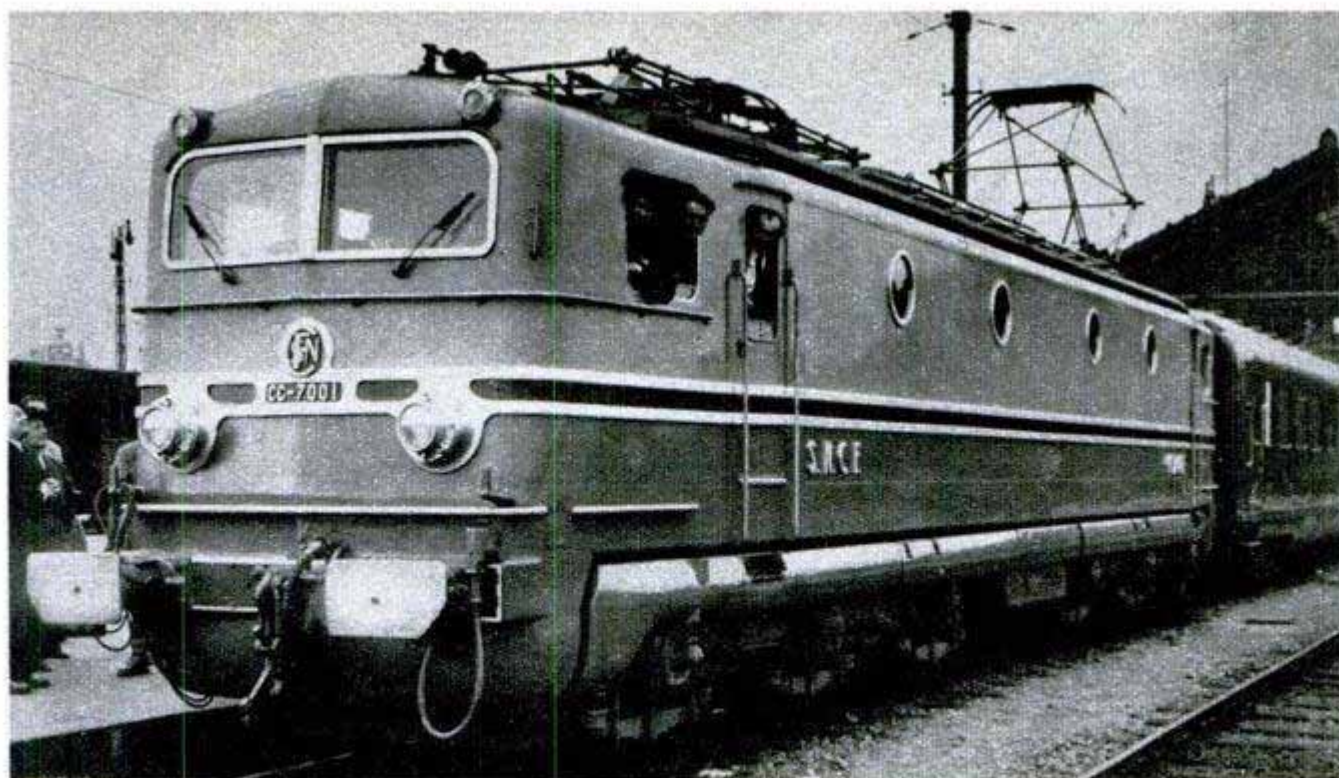

Above, featuring a clean-cut, streamlined design, this electric locomotive of the French National Railways has a top speed of 100 miles an hour. Left, the engineer has unrestricted visibility from the cab

### Fast French Locomotive

With a top speed of 100 miles an hour, a new French electric locomotive was recently put into service between Paris and Tours. Establishing a record for the 362-mile run between the two cities, the locomotive made the trip with an average speed of 71.3 miles an hour. It is said to be the fastest electric locomotive in Europe.

### Portable Machine For Shape-Cutting

Light enough to be carried around the shop by two men, a portable oxy-acetylene shape-cutting machine cuts steel up to 8 inches thick at speeds from 3 to 30 inches a minute. Any shape can be cut within a 32 by 54-inch area. The machine also handles straight-line, circle and bevel cutting with a high degree of accuracy. The complete unit packs in a carrying case that can be stored in a small space and its total weight is only 110 pounds.

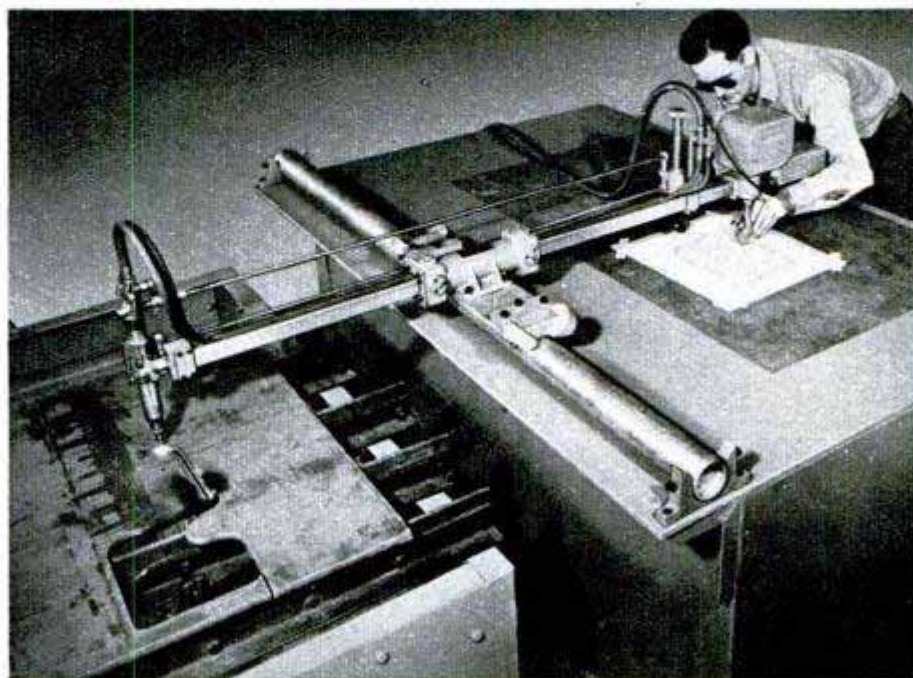



**That favorite whopper of Alaskan sourdoughs—glacier worms—is absolutely true. It's also true that glaciers have built-in plumbing and talk constantly to themselves, say scientists who are peeking inside these mountains of ice**

**Flow lines, formed by gravel and dirt at the convergence of separate ice streams, draw a striking pattern on Barnard Glacier**

**Seismic recording equipment, hauled across the ice on a sled, is set up to measure the depth of firn and ice of the glacier**



# PROBING THE SECRETS OF THE GLACIERS

By Thomas E. Stimson, Jr.

**T**WO EXPEDITIONS to Alaska last summer literally dusted off a few of that territory's glaciers and then settled down to study these creeping mountains of ice.

The scientists probed 200 feet beneath the surface with a gigantic hot needle. They penetrated a 50-foot layer of fresh snow to lay bare the real skin of the glacier. They exploded black powder charges in and above the snow, listened with seismographs and shot radar beams hundreds of feet through the ancient ice. They toted in supplies and carried out notebooks crammed with facts on the lives of these glaciers.

Their purpose? Little has been known about what goes on inside glaciers. Yet they dot the earth to form one of the few living clues to the history of the world's weather during the last century. When the growth of a glacier can be compared to its rate of dissipation, it may be possible to forecast a glacier's future. A mass of such information from all parts of the world may explain how glaciers were born and make it

possible to forecast the general trend of the world's climate for a century or more. Sort of a worldwide weather prediction for our great-grandchildren.

In addition, the armed services are vitally interested in all kinds of arctic conditions. The Office of Naval Research supported both these expeditions to Alaska as part of a vast program of research. Cold facts learned now could save servicemen's lives in the future.

The scientists turned up some interesting lore on glaciers. For example, an easy way to get lots of water from some of them is merely to dig a well. The zone where a glacier gets its moisture is called its generation area. In such an area, the glacier contains a great deal of water. You may have to pump it out mighty fast in winter time to prevent its freezing before it reaches the surface, but it's there.

That favorite fiction of Alaska sourdoughs—glacier worms—is not a whopper after all. Thousands of living black worms

Right, snow forms a natural bridge which hides a portion of the crevasse. Studies of the crevasse walls yield much information on the annual snow deposit

Dynamite blasts the surface of Seward ice field. Sound wave of the explosion will bounce back from bottom of glacier, recording depth of river of ice

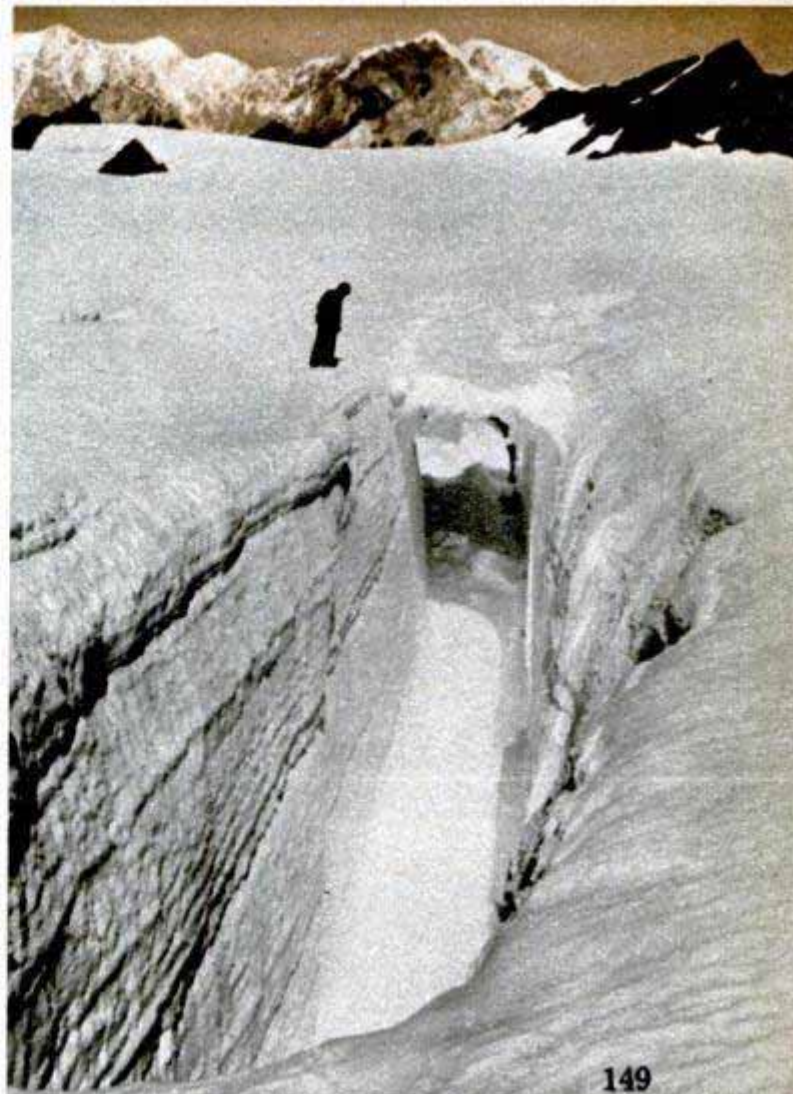
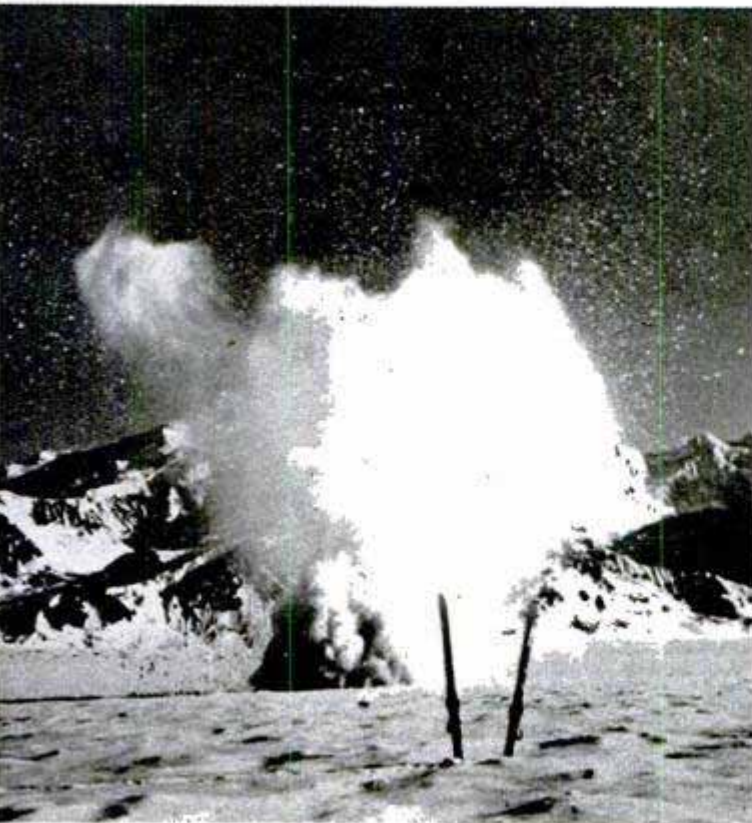



Scientist plods across skin of glacier with vital equipment, a portable battery charger, on his back

Electric thermometers buried deep in glacier show that its ice and snow are just about at the melting point

about an inch long have been found on glacier ice and snow, presumably feeding on pink algae that also live there.

Glaciers have annual rings comparable to tree rings and by measuring these layers and their densities scientists can calculate the annual precipitation for as many as 10 years back. This phenomenon occurs in the generation area where each year's deposit of fresh snow rests on a film of dust that was blown across the old crust during the summer.

Glaciers are "talking" all the time though not always loud enough for their voices to be heard by human ears. Sensitive geophones that are buried 10 or 20 feet in the new snow at a glacier's upper end often pick up an occasional sound similar to the drip of a leaky faucet. Embedded in the wall of an ice grotto the geophones reveal occasional creakings much like those made by a rusty door hinge. When placed at greater depths, the instruments pick up a steady sizzling noise punctuated by pops or bursts of louder crackling. All these sounds are caused by the gradual settlement of new snow, called firn, during its change into ice.

Most glaciers are shrinking because of the warm climate but at least one of them is advancing at about two feet per day. Some of them, with huge upper ice fields that must squeeze through narrow mountain passes before spreading out again, flow at speeds of approximately 100 feet





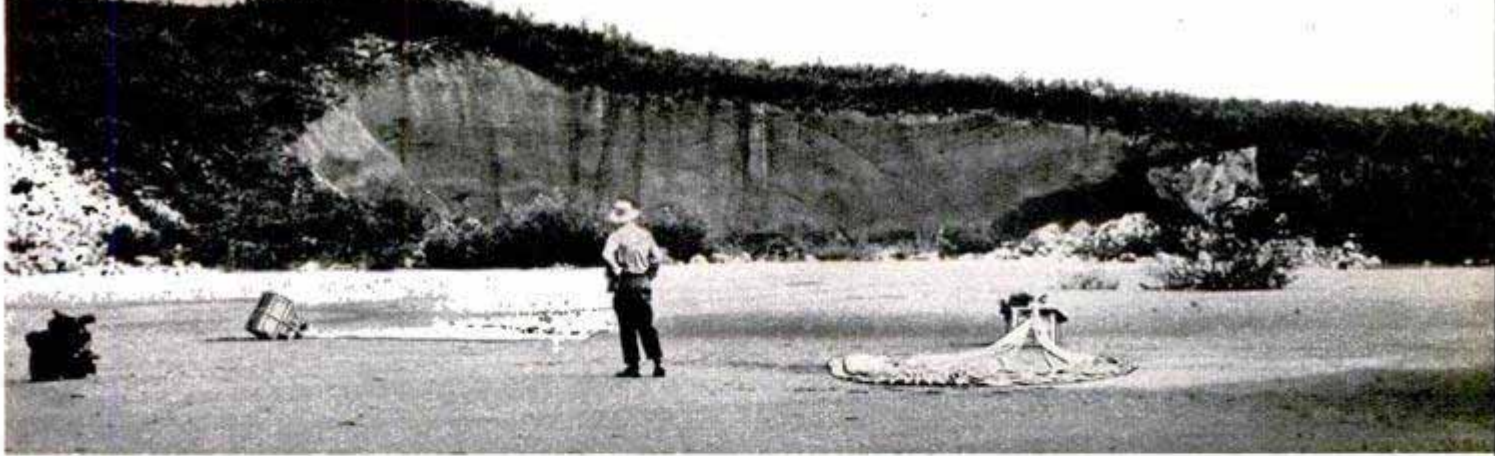

Trees and brush grow in dirt that covers part of the Malaspina Glacier. The cliff in background is solid ice

per day through the constricting "funnels."

Each of the two groups of scientists is to return to the North to continue its studies this summer. Among other things, the glaciologists are learning a great deal about the depths of glaciers, how they are formed and how they maintain themselves.

Contrary to general belief, no more than 30,000 square miles of continental North America are covered with permanent ice. All the continent's icy regions added together are smaller than the state of Maine. Two thirds of these ice-covered lands are found in southern Alaska, mostly in the vicinity of the Gulf of Alaska. The rest of the northland gets bitter cold, to be sure, but especially in the interior the climate is too arid to permit formation of glacial ice.

Thus, when scientists want to study glaciers they usually make their headquarters at Juneau or some near-by spot. The expe-

dition of the American Geographical Society made its base at Juneau and studied the Juneau ice field, in particular the 25-mile-long Taku Glacier.

During the same months a group sponsored by the Arctic Institute of North America and headed by Walter A. Wood operated out of Yakutat, about 200 miles northwest. The expedition probed the huge Seward ice field that consists of a generation area about 35 miles long and 10 to 20 miles wide, the outflowing 20-mile-long Seward Glacier and the vast Malaspina Glacier, 25 by 40 miles in area, that is fed by the Seward Glacier.

Included in the Arctic Institute's group were Dr. Henri Bader of the University of Minnesota, formerly of the Swiss Snow and Avalanche Commission, and a team from the California Institute of Technology.

Each expedition was flown to a smooth

Photo of advancing Taku Glacier was made 20 years ago. Today its terminus is at lower margin of picture

3 1/4 MILES OVER 1100 FEET DEEP      2 1/2 MILES UP TO 800 FEET DEEP      3 1/4 MILES UP TO 1500 FEET DEEP

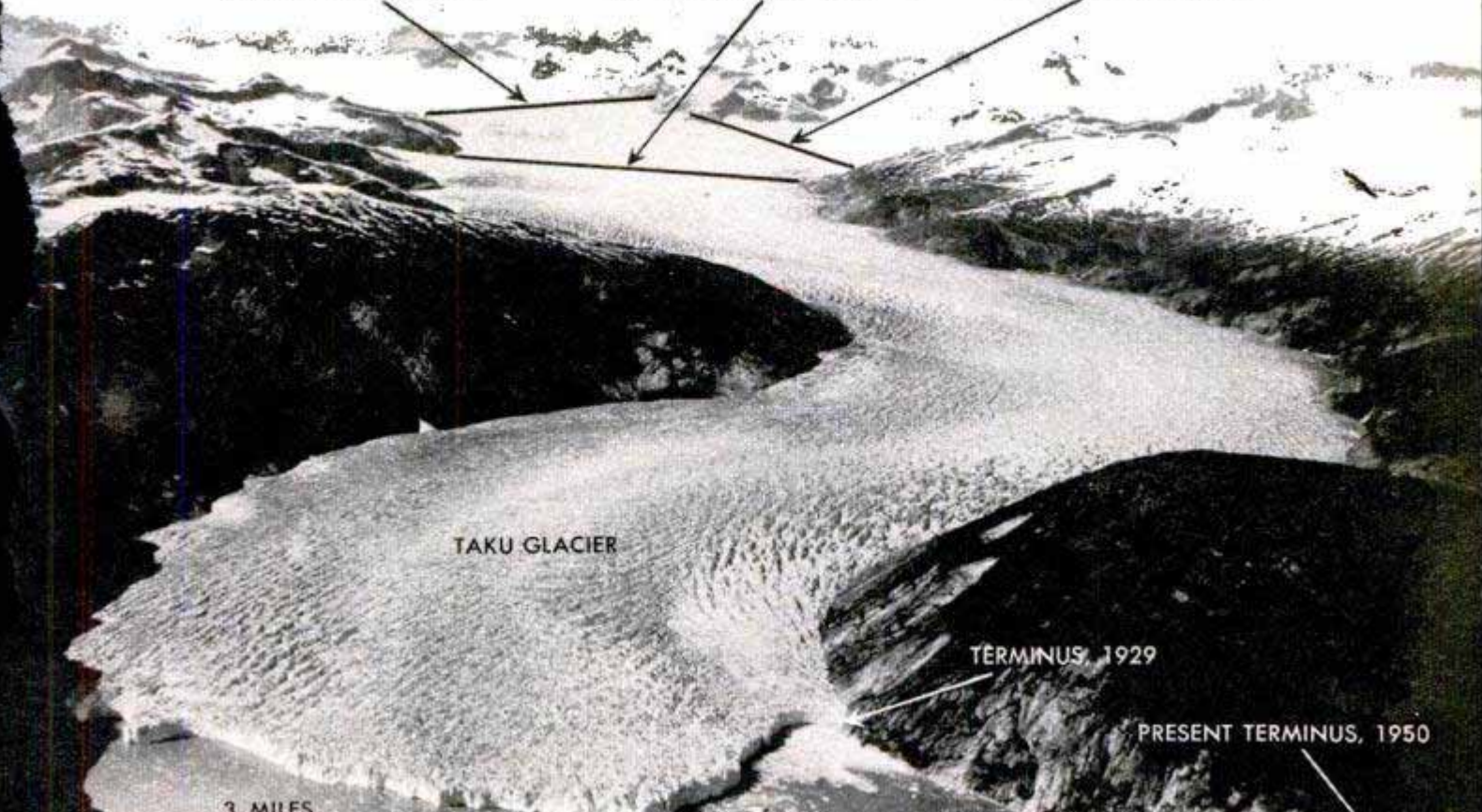

TAKU GLACIER

TERMINUS, 1929

PRESENT TERMINUS, 1950

3 MILES

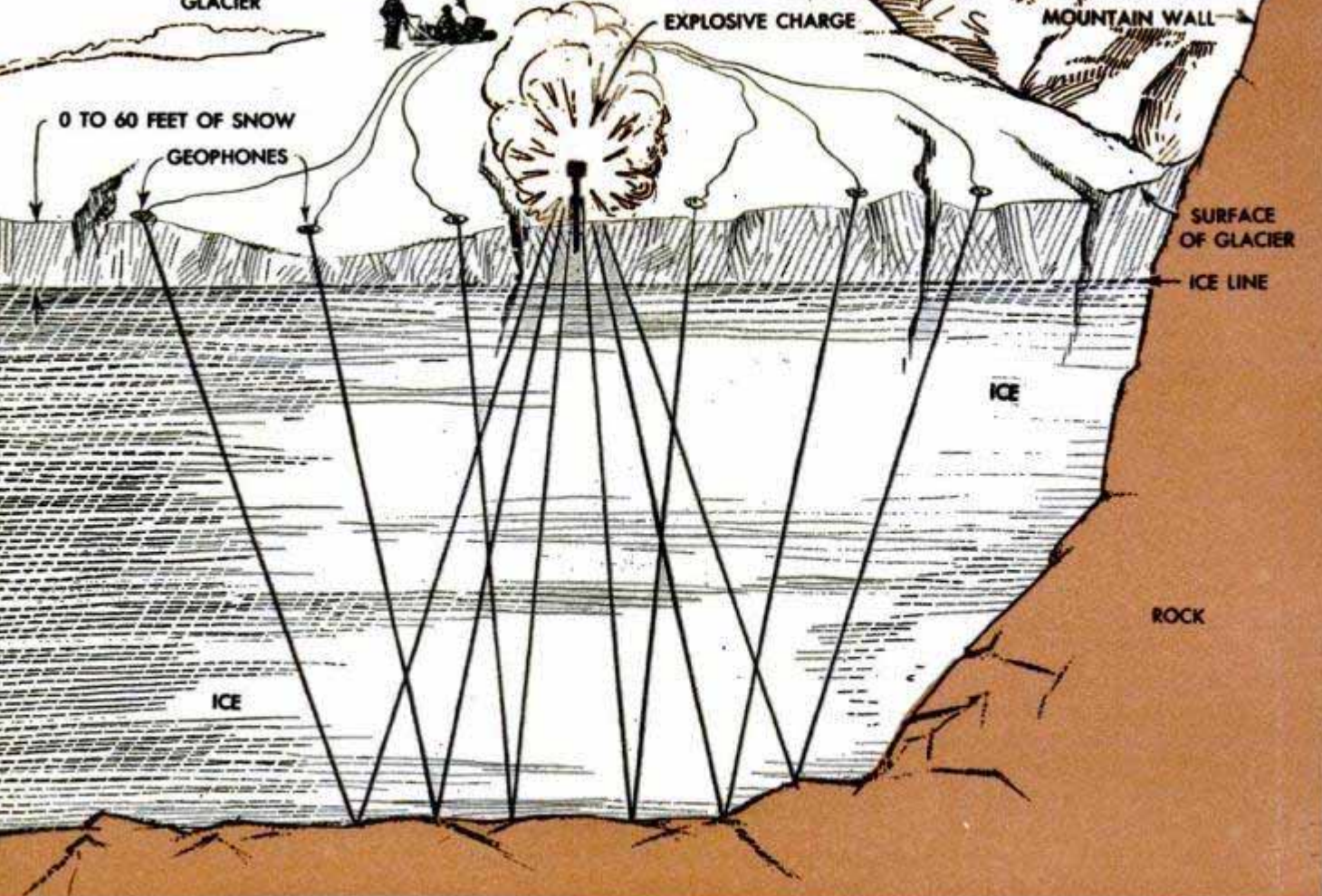

In Poulter system, charges explode above glacier. Geophones pick up reflected wave to record glacier's depth

landing area on the upper end of its chosen ice field. From there the members hauled their equipment and supplies to the selected site on sleds and on their backs. They marked sled trails through the tumbled snow and ice on the Juneau ice field by chopping and cleaning arrow designs into the veneer of summer dust that lay on the surface. The cleaned ice melted less rapidly than did the surrounding dust-covered ice. In a few days the "carved" arrows were raised and gleaming, an inch or so above their surroundings.

Similarly, the ice and snow under the tents melted less rapidly under the summer sun. Within several weeks the tents stood on well-drained pedestals 20 inches high.

A typical glacier has its beginnings in a high mountain snow field and flows downhill until it melts or reaches the ocean. It is literally a river of plastic ice

(Continued to page 252)

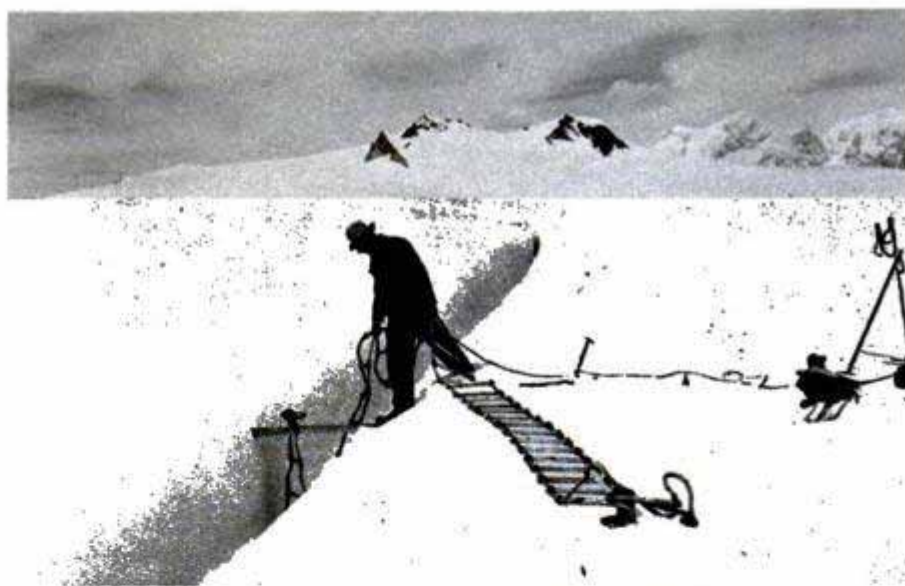

Glaciologist drives a peg into snow across crevasse and lowers a rope ladder. He'll study the annual "growth rings" beneath glacier's surface. Scientists tried radar in measuring depth of the glaciers. Experiments were inconclusive, but radar may become valuable research tool



## Sky Spear

Mounted on the nose of high-speed research aircraft, a slender, needle-nosed spear probes the atmosphere ahead of the plane as it zooms through the skies at supersonic speeds. Crowded into the restricted space of the tube are instruments which give instant readings of air speed, yaw, angle of attack and temperature. An altitude indicator also can be installed. The spear is said to be the first all-electric instrument mast for high-speed research planes.

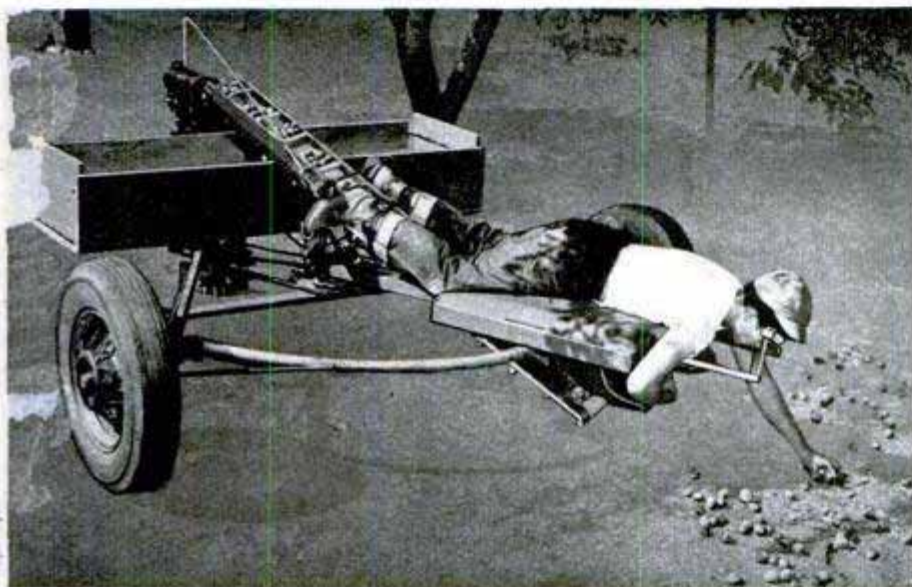

## Prune Picker

Powered by the operator's feet, a new machine rolls along the ground to speed the harvesting of prunes and other ground crops. A platform supports the operator in a prone position above his work. He flips the prunes off the ground into a hopper. A conveyor then carries them to a receiving box. When he wants to move the machine, he shoves two pedals with his feet. The inventor estimates one picker on the machine can do the work of three to five using ordinary methods.

## Pneumatic Quonset

Something new in Arctic housing—an inflatable Quonset-type hut—has been developed by the Air Materiel Command and the U. S. Rubber Company. The hut, which can be inflated in three minutes with hand pumps, is designed as an emergency home for airmen stranded in cold zones. Four feet high, seven feet wide and nine feet long, the little building will comfortably house four men. It is made of inch-thick, two-layer cotton fabric coated with a synthetic rubber that will withstand severe cold. The air space between the two layers provides excellent insulation. A 10-foot-long air duct



attached to a sidewall is snaked along the ground outside the hut to provide good ventilation without drafts.

# WEATHER-

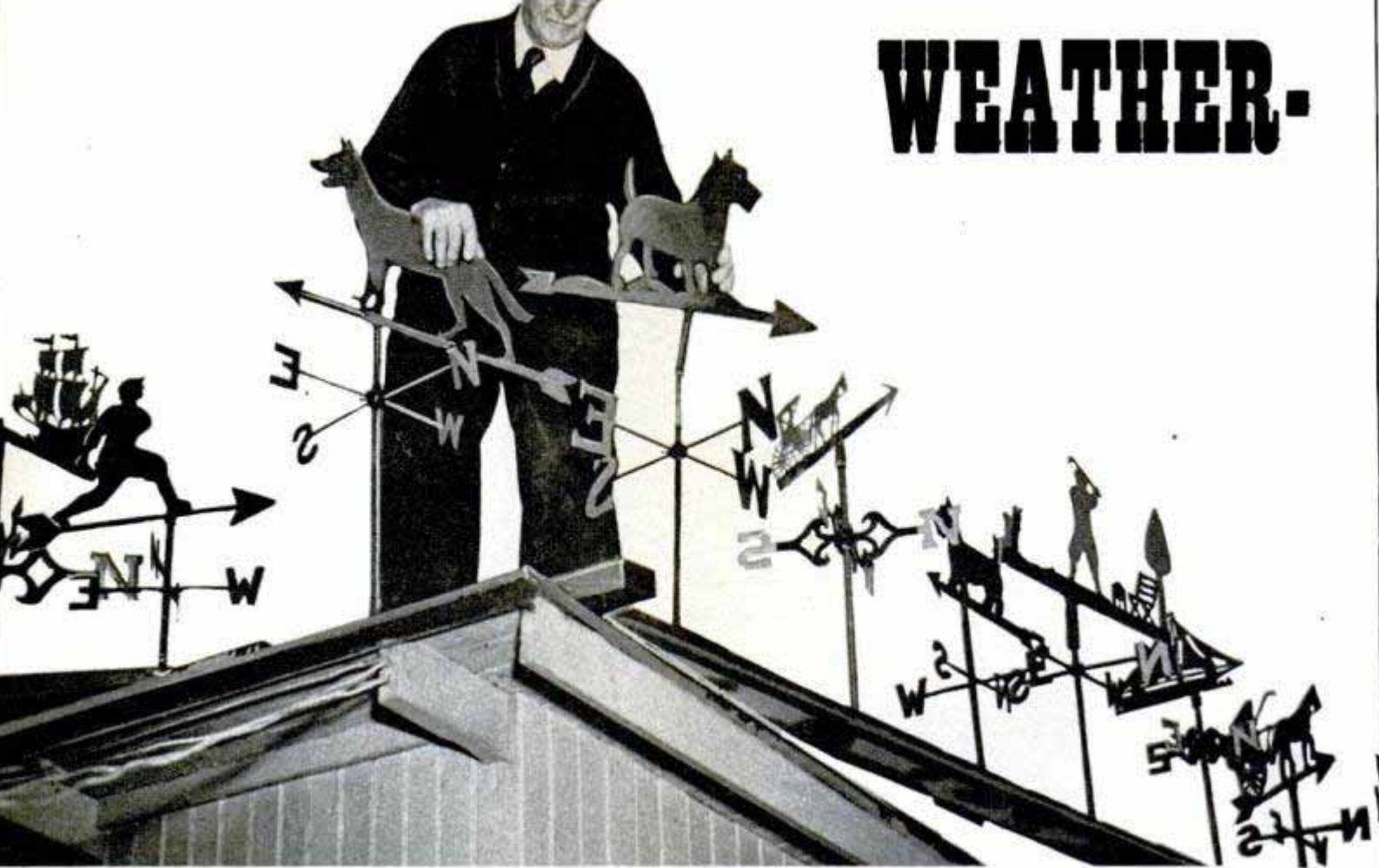

Elmer Lever's workshop roof is studded with unusual weather vanes, each handmade by the 86-year-old craftsman who has been working with metal for 70 years and still loves his work

Below, the country doctor in his buggy is Lever's favorite design. Here, he uses gold paint to satisfy a customer, although he prefers black which shows up best against the sky

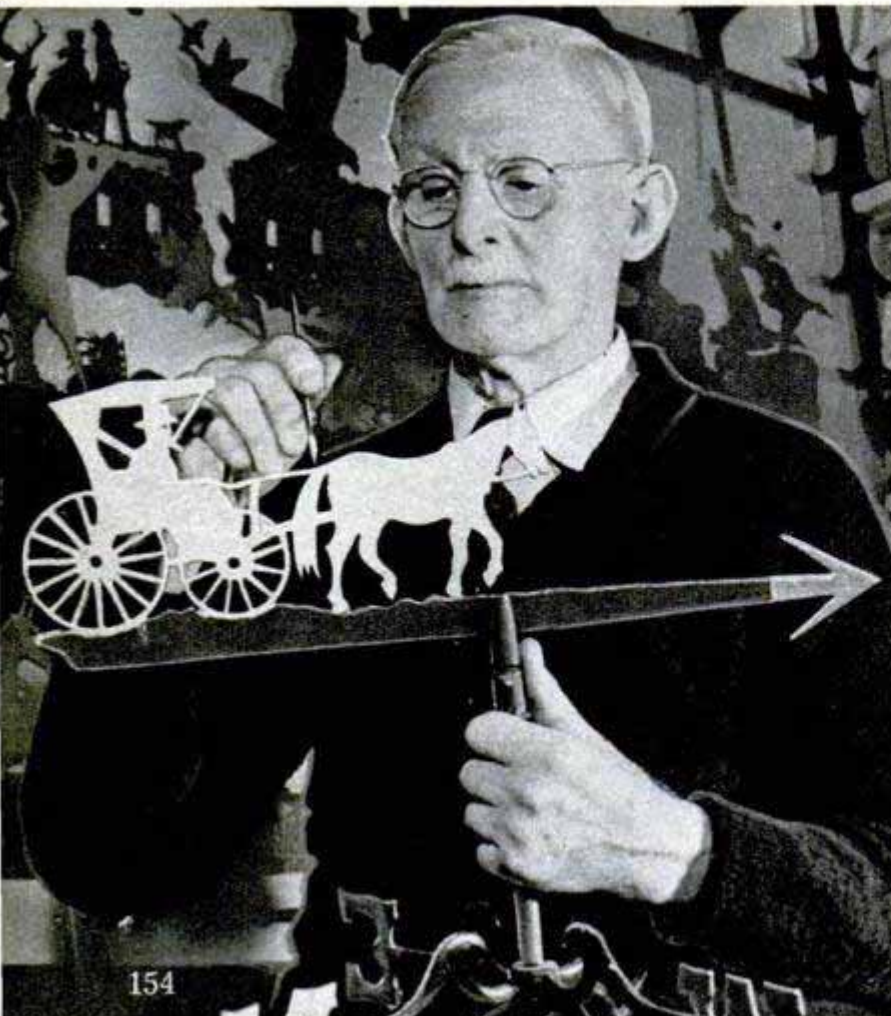

By H. W. Kellick

**M**OTORISTS passing through Red Bank, N. J., stop to gape at a workshop roof top thickly populated with dogs and horses, sailing ships and golfers—each with an arrow pointing into the wind.

The roof top is the advertising billboard of Elmer Lever, the weather-vane man. Eighty-six years old, he has been fashioning weather vanes for 70 years.

Lever began as an apprentice ornamental iron worker in Philadelphia in 1880, but only in recent years devoted full time to creating copper and brass vanes for customers around the country, most of his designs following drawings or photographs furnished by the customer.

Transferring the design to the metal by means of carbon paper, Lever cuts out the figure with a circular hand shear. Compass-point letters, in gothic type, are snipped out with a tinsmith's shear as are the arrow point and feather. Arms and supports are made of copper tubing and the vane rotates on a steel ball bearing. This bearing is the only part of the vane that is not either copper or brass.

The vanes are always painted a

# VANE MAN

dull black, a finish which provides the best visibility against the sky. Some customers ask for colors, but Lever usually persuades them that black is the best.

Weather vanes are not his only product. He also creates decorative figures and picturesque signs for homes and estates, usually duplicating drawings or photographs provided by the customer.

Recently a Kentuckian, attracted by the roof-top display, asked him if he could make a sign that would be representative of his business, horse breeding. He showed Lever a photograph of a thoroughbred and several colts grazing in a wooded pasture. That was all the craftsman needed. He had the small photo enlarged to the size he planned to make the sign and traced the outlines on a copper sheet. With a circular shear, he cut out the horses, foliage and other features. In tight spots, he used chisels and punches. Two name plates, about four inches high, were chiseled out and a sheet of white enamel sandwiched between them so the name could be read from either side. A brass strip formed a frame around the completed sign, which was a sheet-metal version of the photograph. Total cost of the materials was \$10. Lever sold the sign for \$150, realizing a good profit for his work.

Lever, being a man whose work and hobby are the same, can't turn down any metalwork that calls for imagination and skill. He makes copper window boxes, flower boxes, brackets and decorative figures for walls and doors. He has even made metal grave markers, one of them being a lifesize image of a pet cocker spaniel, hammered from lead.

The octogenarian loves his work and he likes to talk about it to strangers. But you have to talk to him while he is working, he's too busy to stop for a long chat. In fact, although his roof is covered with weather vanes, most of the time he's too busy to step outside to find out which way the wind is blowing!

FEBRUARY 1950



Above, working from this crude sketch, Lever cuts out another buggy design, this one with the horse galloping. He is filing the rough cuts made with the circular hand shear

Right, the weather-vane man also makes signs and this nautical design is one of his best. To give the effect of a clouded sky, he mounted the sign on a white-enamel sheet



Below, the tools that he uses are simple: shears, hammer, chisels, punches and files. With them, he turns out such beautiful work that he has trouble keeping ahead of orders

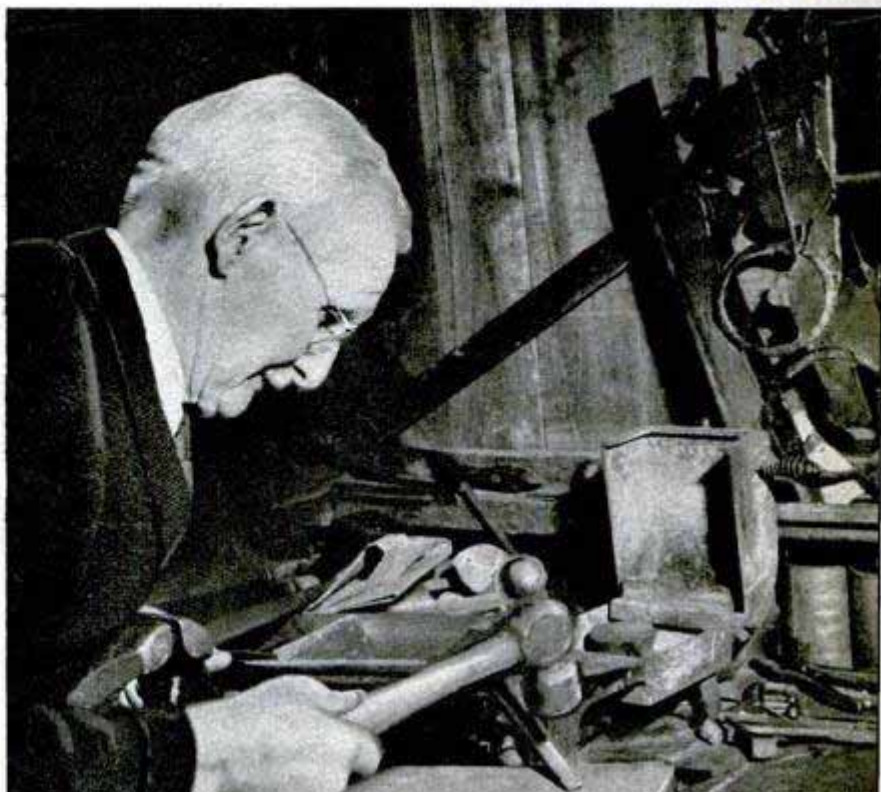

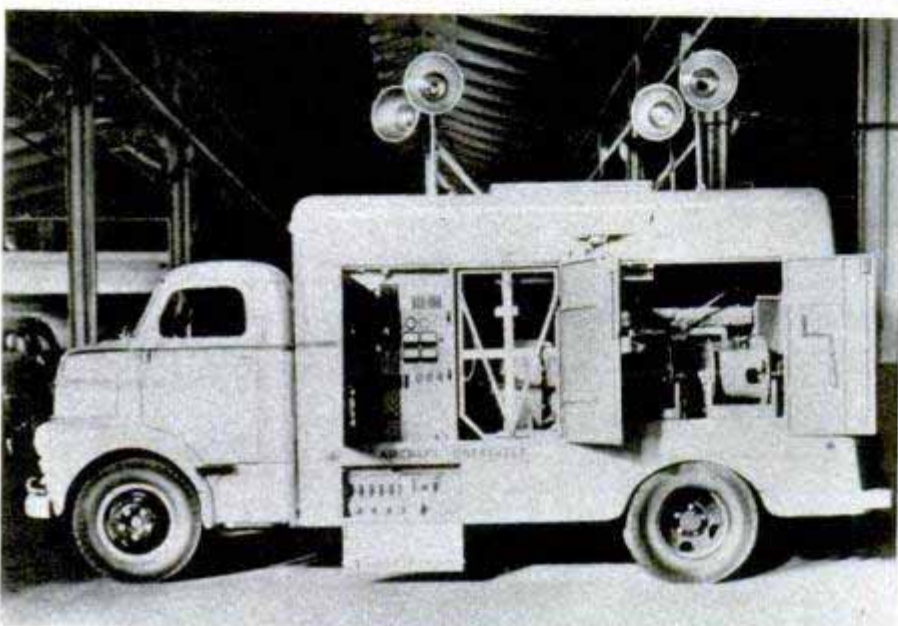

## Truck Keeps Plane "Alive" on Ground

When a giant airliner comes down to earth and cuts its engines, it is dependent on an earth-bound power truck for electricity to run its many accessories and, when ready to leave, to start its powerful engines. Such accessories as the scores of instruments, air-conditioning system, galley, heaters, interior and exterior lights and the radar and communications equipment are all dependent upon electricity. In flight, the giant motors drive generators which provide the necessary current, but when the plane comes down it has to call upon a mobile power unit. A new unit, designed for such planes as the Stratocruiser, has its own 140-horsepower gasoline engine that drives two generators, one 50-kilowatt, d.c., the other 15-kilowatt, a.c. In addition, the truck contains floodlights and emergency fire-fighting equipment.

## Pop-Up Lighter for Table Plugs Into Electric Outlet

Push down on a new table cigarette lighter and a moment later it will pop back up ready for use. The electric lighter operates on the same principle as most car lighters. It can be plugged into any 110-volt outlet and has the advantage of requiring no flints or fuel. The anodized-aluminum finish is available in several color combinations.

Lighter operates from any 110-volt outlet, pops up when ready for use. The base serves as an attractive desk accessory.

Information that is not listed on articles in the index, starting on page 10, frequently is listed in the WHERE-TO-FIND-IT INDEX, which may be obtained without charge by writing to the Bureau of Information, Popular Mechanics, 200 East Ontario Street, Chicago 11



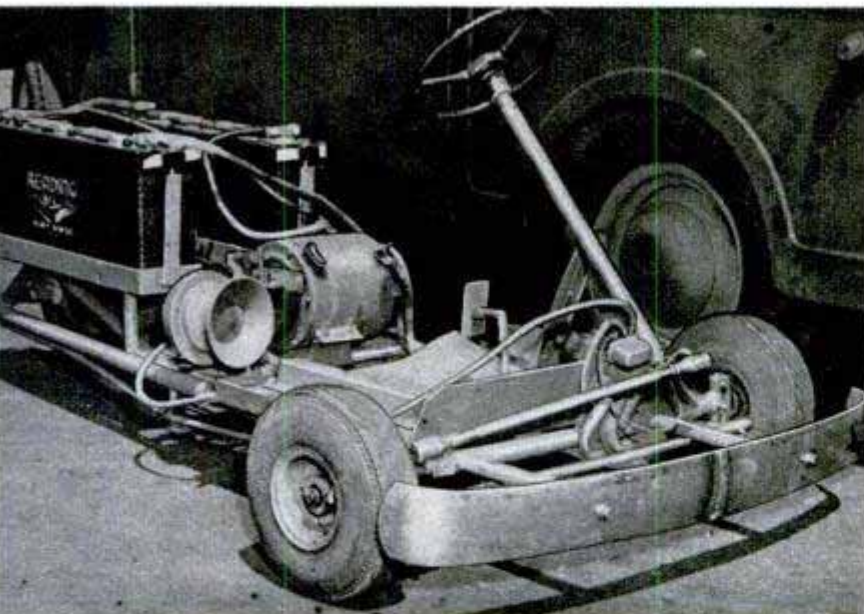

## Youngsters' Personal Car Is Battery-Powered

There may be prouder youngsters in the world than the two MacFarland boys of Atlantic City, but that is hard to believe once you've seen them driving around in their personal car! The tiny vehicle, built by their father, is powered by an old 12-volt Dodge generator and two storage bat-

teries. With its full load of two youngsters, the car travels at a top speed of five miles an hour. The single rear wheel is chain-driven and the tires are pneumatic. Recharged every three days, the two batteries have been found to last more than 18 months even though used daily.

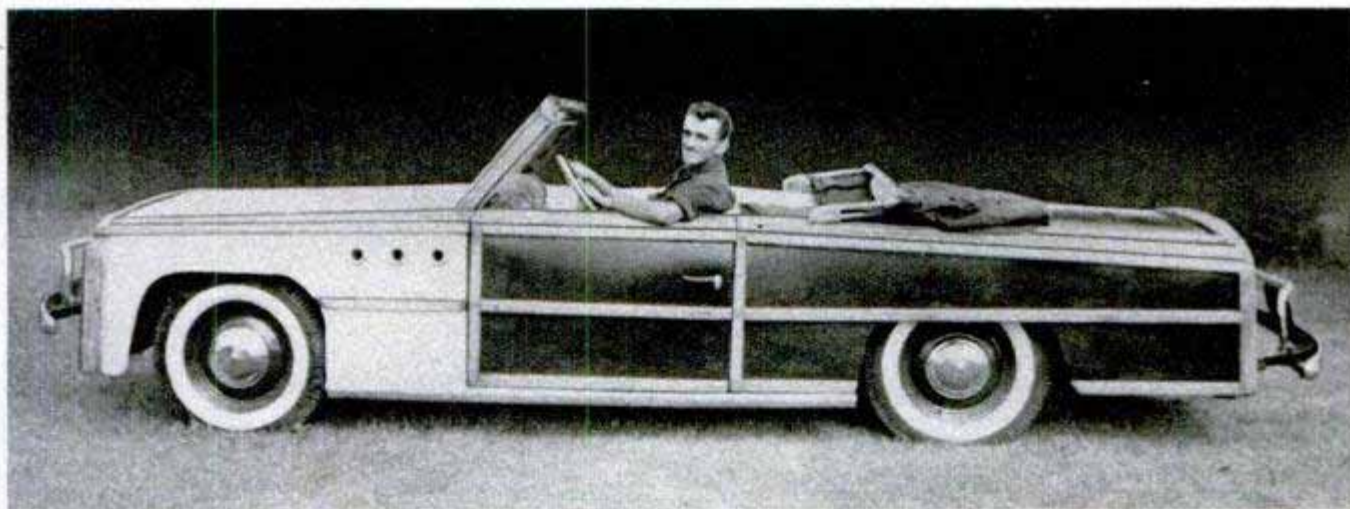

## Homemade Convertible Will Go 100 M. P. H.

Discouraged by the high price of convertibles, Russell Kmiecik of Peshtigo, Wis., built his own for \$300. The 55-horsepower engine was made from Ford parts ranging in age from 1914 to 1949. The sleek body was formed from white ash and tempered hardboard. Kmiecik's innovations

include placing of central wiring and all vital parts directly under the hood, a heavily padded crash panel in front of driver and passengers, a back-to-back twin radiator and power-controlled brakes. There are two Model-T fenders, a Model-T front axle and a 1934 V-8 rear axle.

## Poison Gases Make Blood Transfusions Safer

Nitrogen-mustard war gases, designed to kill enemy soldiers, soon may be used to make blood-plasma transfusions safer. The gases have the power to destroy the virus which causes jaundice. Pooled plasma, which comes from the blood of many donors, sometimes is contaminated with jaun-

dice virus by a donor who did not know his blood contained the virus. From four to ten out of every 100 persons who receive pooled plasma are attacked by jaundice. Scientists at Henry Ford Hospital in Detroit discovered that nitrogen mustard could be used to sterilize the plasma.

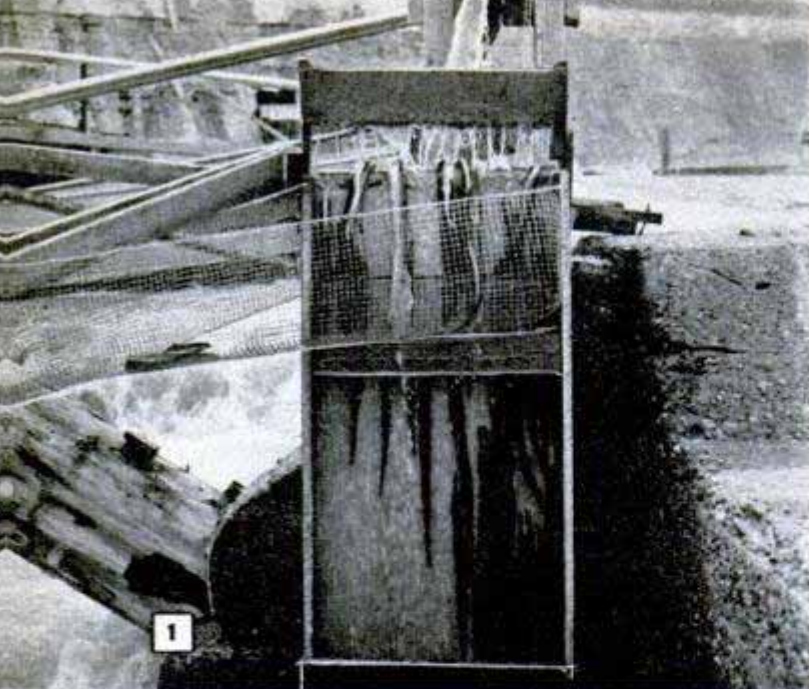

1

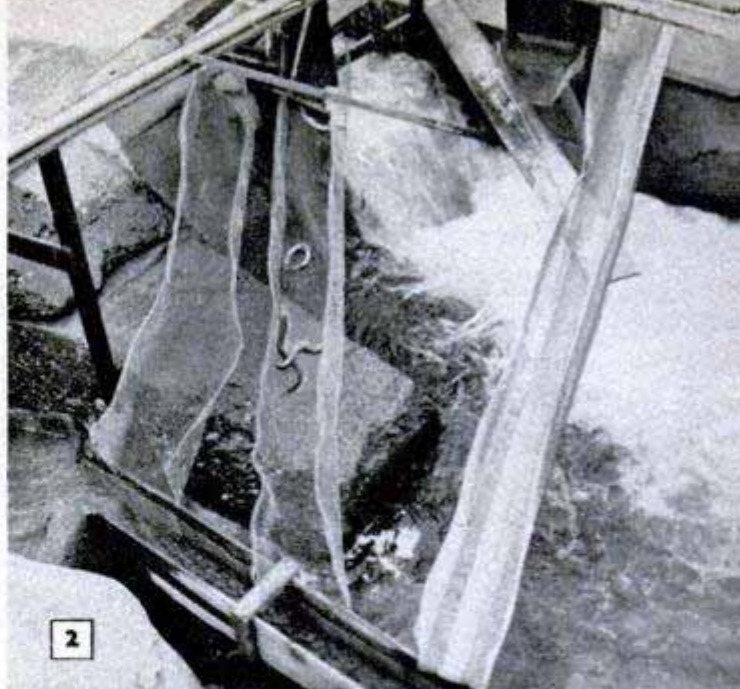

2



3

## EEL TRAP

**1**—Here you see eels climbing to the top of a plywood board trap. Finding no place to go from there, they flop into the netting on either side of the board

**2**—Once in the netting the eels have no way of securing a suction so they wiggle snakelike down the netting into a flume filled with fast-running water

**3**—The fast-water flume carries the befuddled eels into a scow where they are loaded into barrels to be hauled away. It takes 500 eels to fill a barrel

**4**—This is a close-up of the end of the flume and shows eels dropping into the scow. In one season, traps like this netted 110 tons of eels for market

**5**—Hardest job is dipping eels into barrels. This trap was perfected by Lee Critchlow of Oregon City, Ore. Many like it are used in the Willamette River

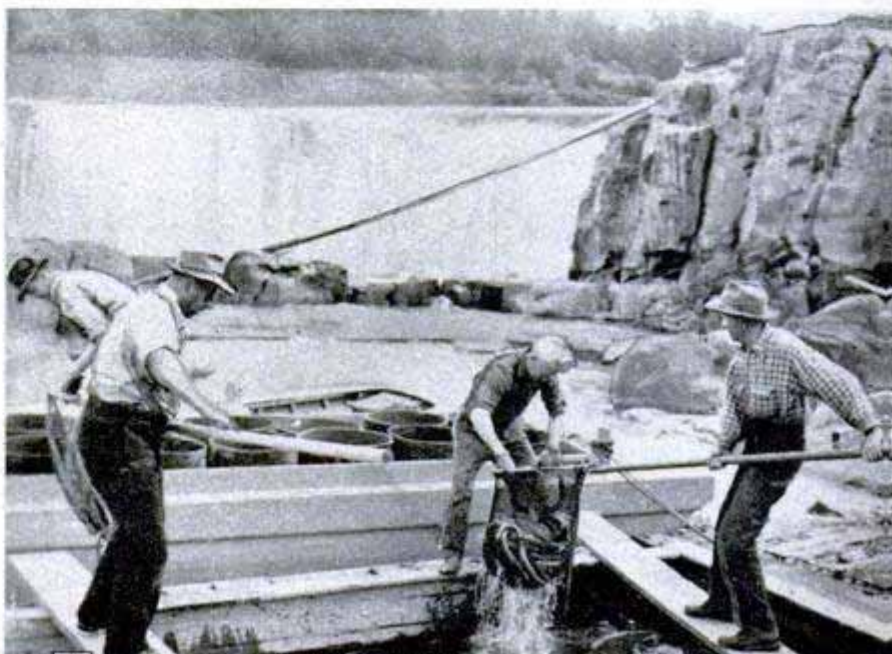
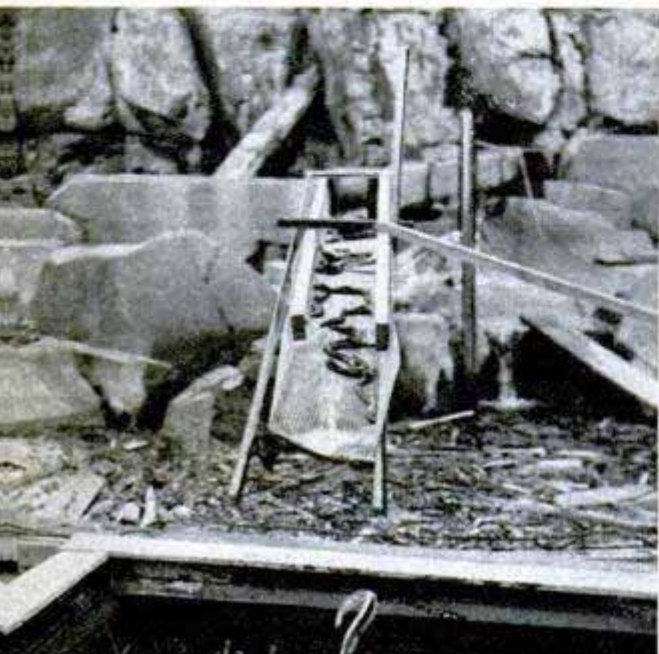



# The Battle of the Great Lakes



Michigan Department of Conservation photo

**A killer from the sea is slaughtering our lake trout and whitefish at an enormous rate. U. S. and Canadian wildlife scientists have joined forces in a war on this new enemy—the lamprey**

**By Cleland van Dresser**

**A**N UNDERWATER BATTLE is now raging in the Great Lakes that may mean life or death to the nation's greatest fresh-water fish resources. Allied on one side are the scientists and technicians of the United States Fish and Wildlife Service and the conservation departments of the eight lake states and Canada. They are pitted against the sea lamprey, an eel-like killer from the Atlantic Ocean, which is slaughtering the fish population of the Great Lakes at a rate never before experienced in history. On the outcome of this life-and-death struggle depends the future of the game and commercial fish of the Great Lakes.

At present, sea lampreys are killing lake trout at an appalling rate. Trout, the principal catch of Lake Huron up to a few years ago, is practically nonexistent today in that

Trap for sea lamprey near a spawning bed. Below, dead lamprey attached to sucker

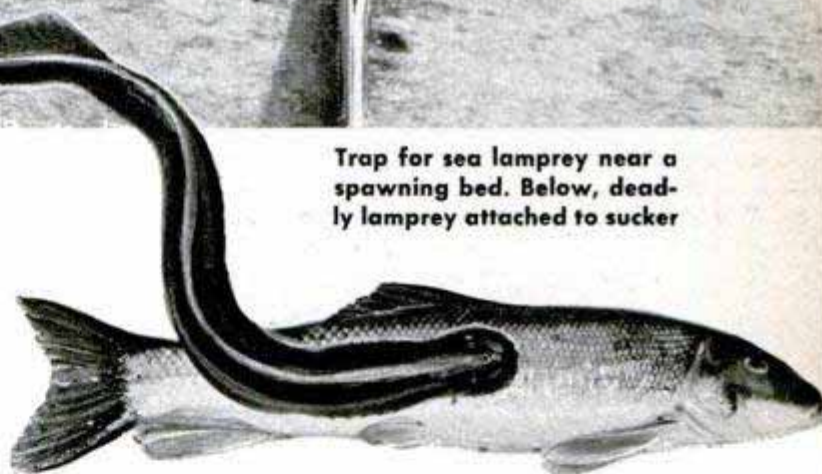

body of water. The annual catch on that lake has dropped from almost 2,000,000 pounds to about 5000 pounds. The situation in Lake Michigan is almost as bad—23,000 pounds caught last May, as contrasted to 350,000 pounds during the corresponding month of 1948. Other species of fish—the famed whitefish, pike, sucker, chub—all are beginning to show declines from depredations of the sea lamprey and all are threatened with potential extinction.

As far as the contestants in this war of survival are concerned, the conflict has just started. The sea lamprey has the edge at present for it has recently sneaked in and got a foothold in the Great Lakes where science never dreamed it could establish itself on a permanent basis.

Seemingly going against all natural laws, the sea lamprey, a hideous creature from

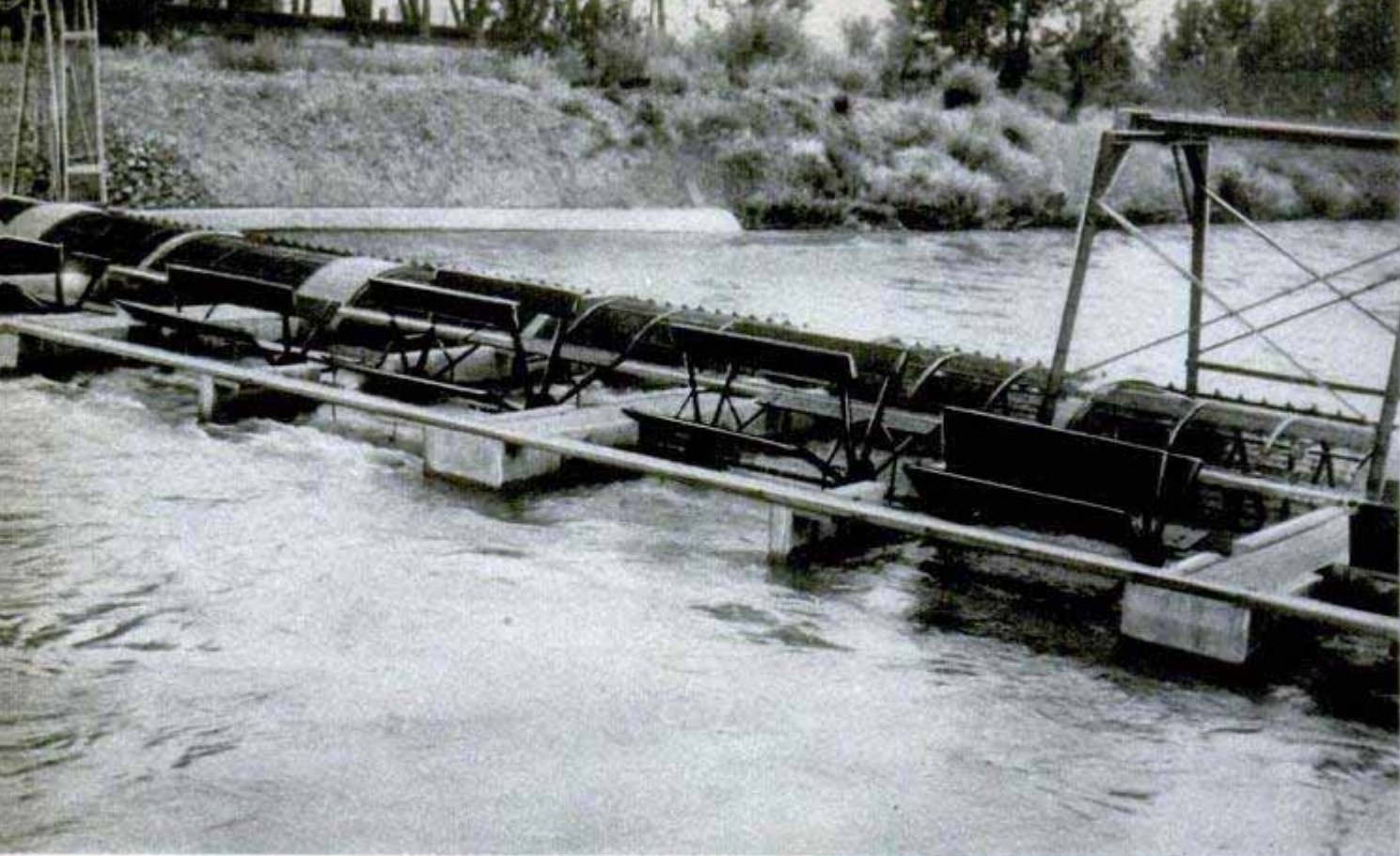

Rotary fish screen keeps young salmon from entering irrigation canals. It will be used against sea lamprey

the salt waters of the ocean, has decided to live out its life span in the Great Lakes and dine sumptuously on the fish therein.

Heretofore, this marine denizen had spawned in tributary waters of Lake Ontario, and after the eggs had hatched and the resultant larvae had emerged into the young adult stage, they migrated back to the ocean via the St. Lawrence to live out most of their lives in salt water.

Until recently, the lampreys pursued this migratory life cycle: the adults spawning and dying in water of the Lake Ontario area; the larvae existing up to five years in mud bottoms of streams and rivers; the young adults, after emerging from the larval stage, migrating to the Atlantic to live

for three more years; and finally returning again up the St. Lawrence to fresh water to spawn and die. This entire process of minor evolution took approximately eight years. At no time during that period did sea lampreys in any form prey noticeably on fresh-water fish.

During the last few years, and for no reason as yet discovered by science, the sea lamprey is changing its habits and is living its entire life span in the Great Lakes, the last three years of which is devoted to devouring fish, mostly lake trout. It has traveled westward through the Welland and Sault Ste. Marie canals until it is now spread throughout all of the Great Lakes. Even Lake Superior fishermen, who never

Left, removing sea lamprey attached to body of a sucker. Right, mouth and side of head of vicious killer

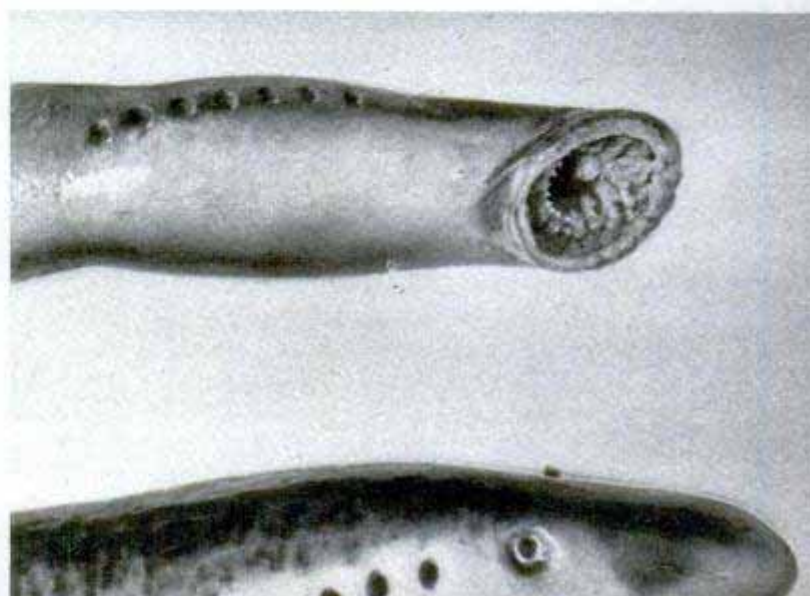
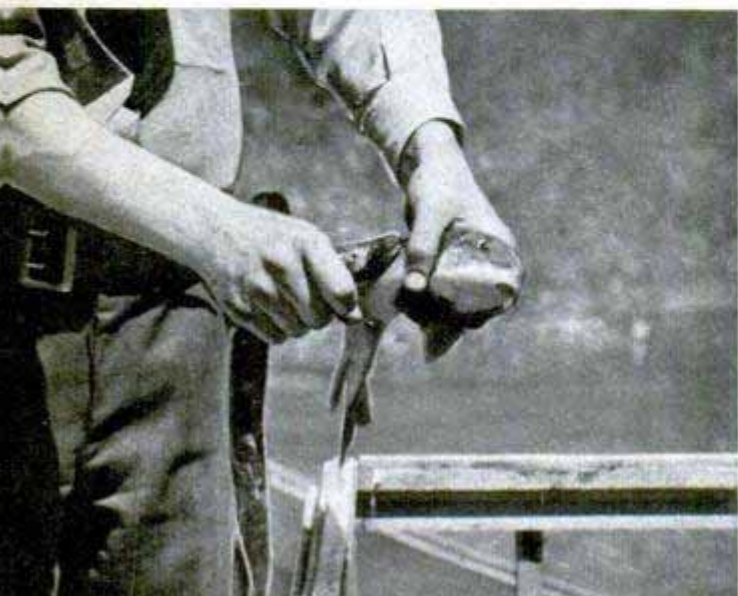



Death grip—or suction—on this fish by the lamprey shows fate awaiting millions of Great Lakes fish

before have seen sea lampreys in that body of water, now report that last year the killers put in an appearance there.

The effect on the fishing industry of the lake states and Canada is one of the gravest apprehension, and immediate steps are being taken to exterminate the underwater murderer before it exterminates the fish.

In appearance, the sea lamprey resembles an eel with a suction disk, a head equipped with sharp teeth and rasplike tongue. It attaches itself to the body of a fish, cuts through its scales and feeds on the blood and juices of its victim. Such an attack lasts from several hours to upward of a week, usually resulting in the death of the fish. Apparently, few trout escape attack. Even with the drastically reduced catches today, the vast majority of the fish caught bear scars from lamprey attacks.

The lamprey attains an average full adult length of slightly under two feet, but specimens of 40 inches have been caught. The female lays up to more than 100,000 eggs at a spawning in streams and rivers that empty into the Great Lakes, and if conditions were entirely favorable, its rate of increase would be astronomical.

With a request for federal funds to equip and man a floating laboratory, the U. S. Fish and Wildlife Service plans to make a thorough survey of the Great Lakes and its tributary streams and rivers in a grim effort to find some means, biological, chemical or mechanical, to wipe out this scourge. Joining forces with the service is the technical personnel of the Great Lakes Sea

Lamprey Committee, comprised of the conservation departments of Minnesota, Michigan, Wisconsin, Illinois, Indiana, Ohio, Pennsylvania, New York and the Province of Ontario. The committee has headquarters at Ann Arbor, Mich., and is headed by Dr. John Van Oosten. The campaign is being conducted by W. F. Carbine, who is Chief of the Inland Fisheries Division, Washington, D. C.

One phase of the sea-lamprey's life cycle is in favor of the conservation scientists. They have learned that if lampreys cannot find suitable spawning beds in rivers and streams, they will die before laying their eggs. Already the Fish and Wildlife Service has located and charted several such spawning beds and is trapping and destroying the underwater killers as they approach them. One trap on the Ocqueoc River in Michigan has yielded some 9000 adult lampreys so far this year. Two more have just been erected by the Michigan Department of Conservation, and additional structures planned as new spawning beds are located throughout the Great Lakes area.

The use of "electric screens" will also come into play. This mechanical device emits a shock that is sufficient to deter any aquatic animal from entering a stream or river across which it is erected. The idea is to locate these screens across the mouths of streams which harbor known lamprey spawning beds.

The main trouble with this system is that the screens will also prevent all fish

(Continued to page 244)

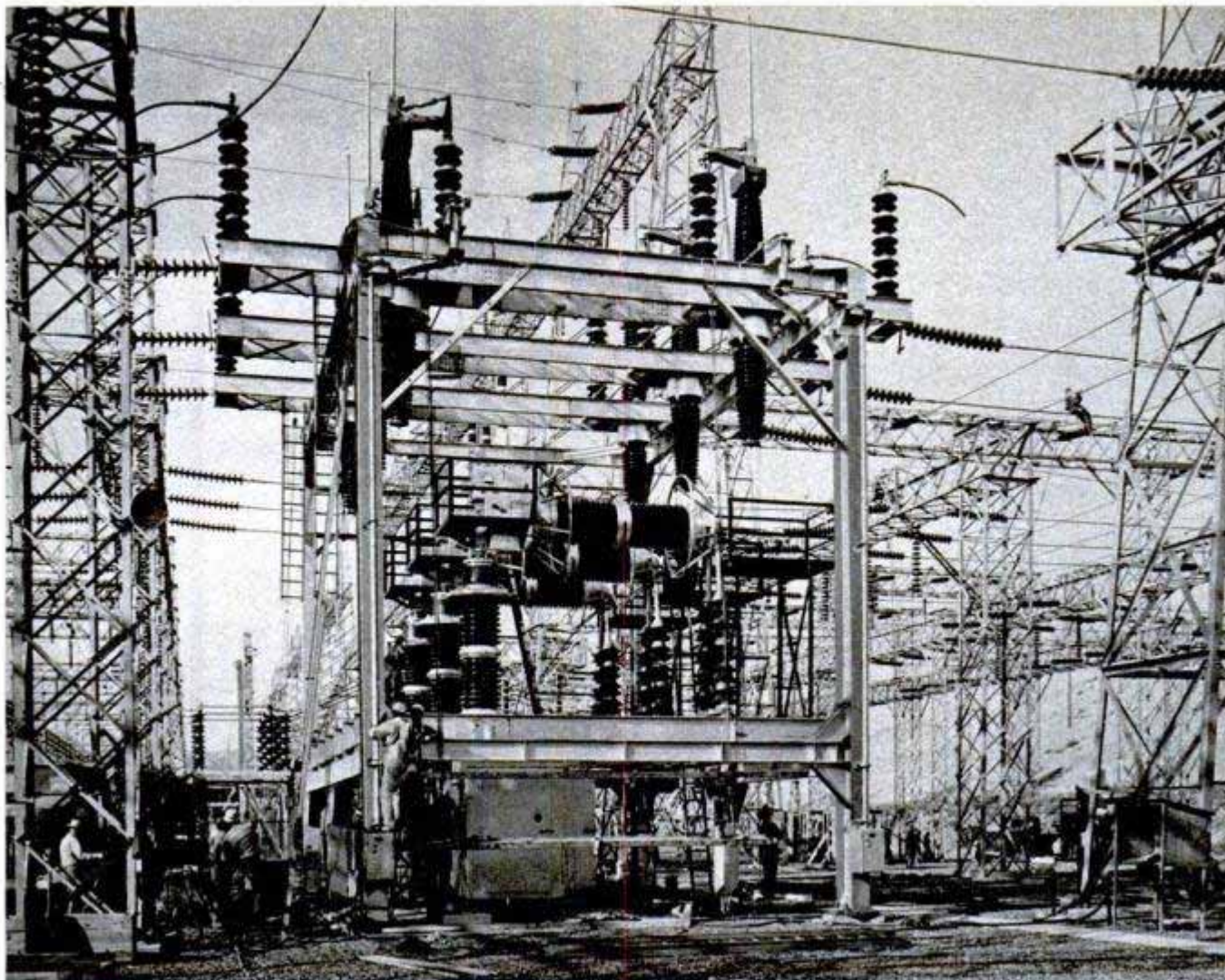

## Giant Circuit Breaker

Protecting the power line from Grand Coulee Dam is a gigantic circuit breaker, said to be the world's largest, that can interrupt an electrical fault of 10-million kilovolt-amperes. Exceedingly fast despite its

massiveness, the breaker can clear transmission-line trouble in  $\frac{1}{20}$  second. It automatically re-establishes the flow of power in  $\frac{1}{3}$  second. The disconnect switches are motor-operated. Twelve similar breakers will be installed in the new east switch yard of the Grand Coulee Dam.

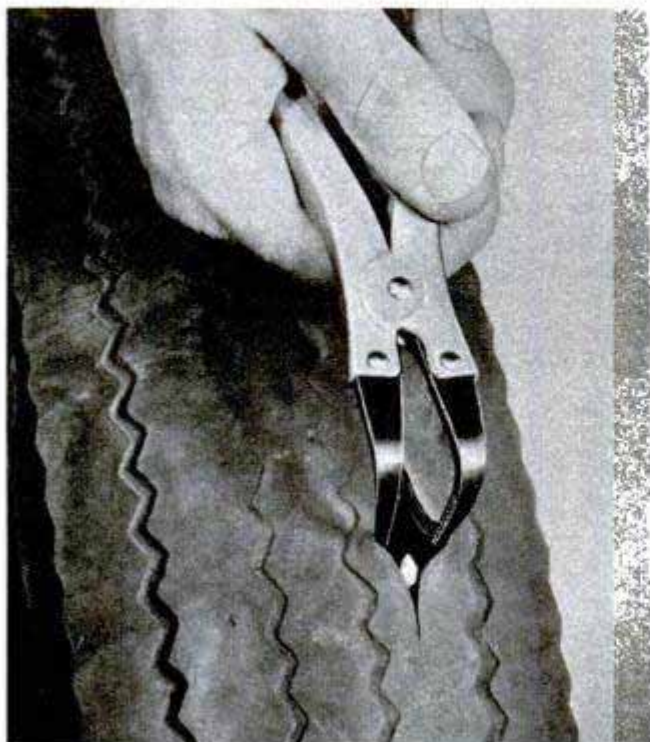

## Probing Tool Removes Pebbles From Tire Cuts

Pebbles and other foreign objects embedded in tire cuts can be quickly and easily removed with a probing tool. After the probes are inserted in the cut, pressure on the handles spreads the jaws apart to expose the embedded object. The pebble then can be picked out with a pointed instrument or gripped with the serrated jaws of the probing tool and lifted out. With this tool, it is unnecessary to remove the tire or wheel as long as the car is jacked up. The tool is six inches long and is made of steel with a rustproof finish.

Even at a standstill, the Westinghouse jet engine on the Navy's Banshee fighter "breathes" 100 tons of air an hour, sucking air in the front end at 250 miles an hour and spitting it out the jet nozzle at the rear at 1200 miles an hour.



## "Baby" Jet Unit Boosts Light Plane Into Air

Slightly larger than a picnic jug, the Jato Junior rocket engine develops 250 pounds of thrust for 12 seconds to assist pilots on steep take-offs from small high-altitude fields surrounded by obstacles. Developed by the Aerojet Engineering Corporation, the motor was mounted beneath the cabin of a Ryan Navion for the tests. Assisted

by the Jato engine, this plane was able to clear a 50-foot obstacle in only 300 feet, whereas it normally required 875 feet to climb over the obstacle. The engine was designed and developed for the commercial market, but as yet is not available because of restrictions by the U. S. Navy Bureau of Aeronautics.

## Either Power or Pedal Drives "Bombo" Boat

Made from a salvaged B-29 drop tank, the first of a series of "Bombo" boats that can be propelled either by power or pedal has been completed by a Californian. A 1½-horsepower engine, operating on a V-belt drive, moves the craft along at a seven-knot speed. The boat has a 10-inch, three-blade propeller. Emergency power is provided by a bicycle pedal drive, with a simple gear ar-

angement for either forward or reverse directions. A scissor jack used to tighten the V-belt also serves as clutch for instant transfer of power from engine to pedal, or vice versa. Two 32-inch inner-tube "pontoon" are attached to the sides of the boat near the center as an added safety factor, though the craft's low center of gravity makes it difficult to capsize.

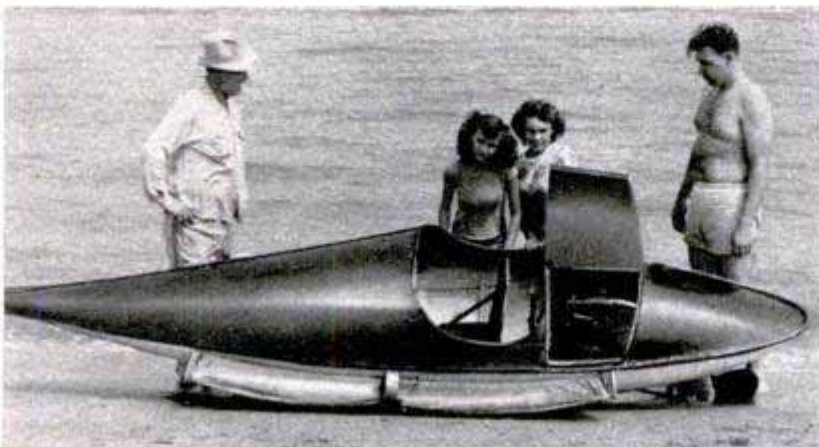

**F**ROM A BLOCK AWAY you hear that sickening sound of tires braked hard against pavement, then an explosive crash. Ahead of you, automobiles pull to the side of the street. You, too, swing over and park. You see men running, a crowd already forming. Then you hear sirens.

Surely—you say to yourself—whatever help you could give won't be needed now. There are plenty of hands, and the police are here.

But in your car, you have a camera.

You can help—if you will—by taking pictures.

Pictures taken at the scene of a traffic accident are evidence of what happened. In court they can be used to bring punishment upon a law-breaking, negligent driv-

er, or to protect an accused driver from unjust punishment. They can help to bring fair settlement of damage claims.

Good photographs can be the best evidence obtained at the scene to show what really happened, so that judge or jury can reach a fair decision. And you will not be expected to donate your pictures; law-enforcement agencies, insurance companies and attorneys will pay reasonable prices for pictures that "tell the story."

What kind of pictures should you take? What should they show?

In almost every traffic accident, there has been a violation of right-of-way or a turn from a wrong lane of traffic. One party, or the other, or both, violated one or more rules for safe driving. The court problem in either criminal or civil trial is to determine what happened.

To tell what happened, your pictures must show many things—more things than a hurry-up snapshot will show. If you know what those are, your work will be more effective.

Your pictures must define the location.

By **Richard W. Emery**

Photos by the Author

# **FOCUS ON THE**

Excellent accident shot shows witnesses who may be found later if case comes to court



They must show the general layout of the scene, revealing whether there were traffic signals, road stripes or marks and other signs. They should make clear the nature of the area, whether business district or residential.

Your pictures should indicate weather conditions and their effect on road surface and visibility, and in at least a general way should show about what time the accident happened.

They should show the presence or absence of any marks indicating the paths traversed by vehicles just before the collision occurred.

They should show what damage was done to each vehicle.

They should show license numbers, makes of vehicles, names of streets involved and permanent landmarks on either side of the accident scene.

They should show the face of at least one person who can be identified and located long afterward—perhaps a year or two later—to identify the pictures in court.

All those requirements sound like a big



Photo records exact place of accident by showing railroad signal, edge of pavement, telephone pole

One driver was killed in this accident. Photo shows that one of the automobiles was struck broadside

# **CRASH!**



order. But those are the things which help to show who was at fault and who wasn't, and may determine who pays the bills.

If there are injured persons still present when you arrive with your camera, you should first make a picture showing them and the vehicles involved. This picture times your arrival.

That first picture, the close-up of injured, is the typical news photo. In court its value is limited because the picture shows only a very small area and probably does not locate the scene in relation to permanent landmarks.

In making that first photo, take care not to impede urgent work being done by police and ambulance men. Experienced traffic officers know that photographic evidence may be needed later; they probably will let you move about the scene to take pictures if you don't get in the way. Ask them if there is any picture they want you to shoot.

Many big cities equip their traffic investigators with cameras. "On the scene" photos are excellent evidence for prosecution in accidents involving hit-and-run, drunken driving and other serious offenses. A picture showing a driver at the scene of a wreck has been used in court to help prove that it was he who was driving, not someone else using his driver's license.

Your next photos should be made from farther back, to show relative positions of the vehicles involved. Set your camera carefully for enough exposure to show skid or abrasion marks on the pavement. Get far enough back to include landmarks in foreground and background—such immovable things as buildings, poles, curbs, trees and fire plugs.

If you can climb to a high spot overlook-



Skid marks on the pavement may indicate the paths traveled by vehicles. Center line serves as landmark

ing the scene, you can make a panoramic view. Perhaps you can stand atop an automobile, or on a porch or fire escape. A high shot reveals respective distances better than a street-level picture.

For additional photos, get long shots indicating the view each driver had of the road ahead, some 200 feet before the crash. These pictures may show whether his vision was obstructed, and whether signals were present.

Keep in mind that your pictures may be used to prove that something was not there. Absence of skid marks may indicate one driver was inattentive or asleep.

Absence of traffic signs, road marks, wigwags or other warning signals at the time of the accident may be an important point

**Panoramic photos of this type may be bought by insurance companies to help prove their case during trial**







↑ Long shot taken from a second-story porch shows that this corner has no traffic signals or road stripes

↓ Two occupants of building were hurt when car crashed through wall. Officers can identify photo later

in court. Your long shots may be used to prove that the big billboard on the corner lot was not there when the accident happened—it was erected several days later.

Close-ups of damage to vehicles may help experts to determine what happened in the split second before the crash. Dents made by a pair of headlights in the side of a second car have been used as court evidence to show that a driver did not swerve his car, an indication he was either asleep or otherwise inattentive. In shooting such pictures, stay far enough back to show license plates or other identification marks.

Close-ups of windshield damage may help to determine that a passenger was pitched headfirst into the glass. Dents or

(Continued to page 246)



Here one car was in the wrong lane. The location of the center line on highway makes this photo valuable



## Straw Chopper Stops Road Erosion

Highway builders have found a new use for a farm implement. A chopping machine, used on farms for chopping hay, straw and silage corn, now is distributing straw evenly over the dirt shoulders of new highways to prevent erosion while grass seedings are getting a start. Ordinarily, men scatter the straw with pitchforks. Now two men feed the chopper baled straw while two others aim the long flexible tube to scatter the straw across the dirt.



## Calking for Cars

Calking material of a putty type which can be rolled in the hands to any shape is useful as an auto-body sealer. It is packaged in a solid bar 10 inches long and 2½ inches in diameter and is wrapped in an oil-resistant paper inside a foil-lined sleeve. The sealer is designed for use on seams between roof and side panels, between floor and side panels, over dust holes, under clip moldings and other areas which are not in contact with occupants or materials carried in the car. It requires no application equipment and will not shrink or harden.

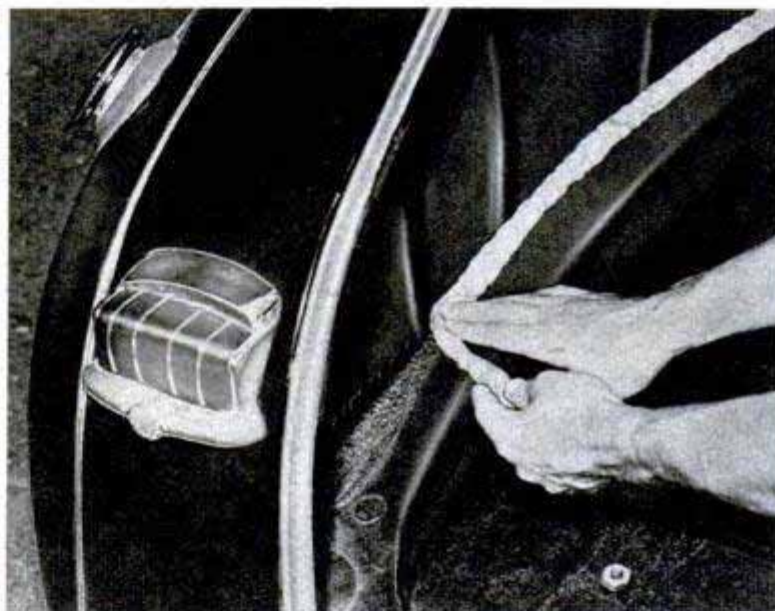

## Hymns in Color

Using fluorescent chalk and black light, N. R. Swartwout of Evanston, Ill., draws two pictures on the same board and, with an ingenious lighting system, fades one picture out as the other is faded in. Swartwout developed the lighting system to illustrate hymns during church talks.

British doctors have successfully replaced an eight-inch section of a diseased thighbone in the leg of a 10-year-old boy with a substitute "bone" which was carved from polyethylene plastic.



## Fire-Fighting Gun Shoots Foam 190 Feet

Fire-extinguishing foam is squirted 190 feet through the air by a gun invented by M/Sgt. Valton Allen, Jr., of the Air Force. Sergeant Allen is fire chief of the Air Force base at Furstenfeldbruck, Germany, and his gun is used on every large base in Europe. Three jets feed a mixture of water and foam into the gun, where air pressure swirls it into the smothering agent found to be the most effective for fighting gas and oil fires. A high-pressure pump forces the foam through the long nozzle. Properly mounted, the gun discharges 500 gallons of the foam in 3 minutes and 22 seconds.



Air Force photos

## Deepest Hole Ever Drilled

Drilling at ever increasing depths into the earth for oil, one company recently set a new record of 20,251 feet—nearly four miles. This operation, which turned out to be a dry hole, was in Sublette County, Wyo., and is reputed to have cost the Superior Oil Company around three million dollars. The temperature at the bottom of the hole exceeded 300 degrees Fahrenheit. Drill pipe used to reach the 20,000-foot depth weighed 300,000 pounds and it had to be withdrawn every time the bit was



changed. Deep drilling has increased rapidly over the last 15 years. In 1934 the depth of 10,000 feet was reached for the first time. The 15,000-foot mark was passed in 1938 and early this year a well was abandoned in California as a dry hole at 18,734 feet.



## Miniature Bandsaw Complete in Case

Weighing only 30 pounds, a midget bandsaw can be carried from job to job. The bandsaw case holds the belt, pulleys and motor. Blade tension is adjusted by turning a knob on the top of the saw frame. The little saw also can be used as a shaper. Rotary files in the base cut sharp contours. A double pulley permits speed changes.

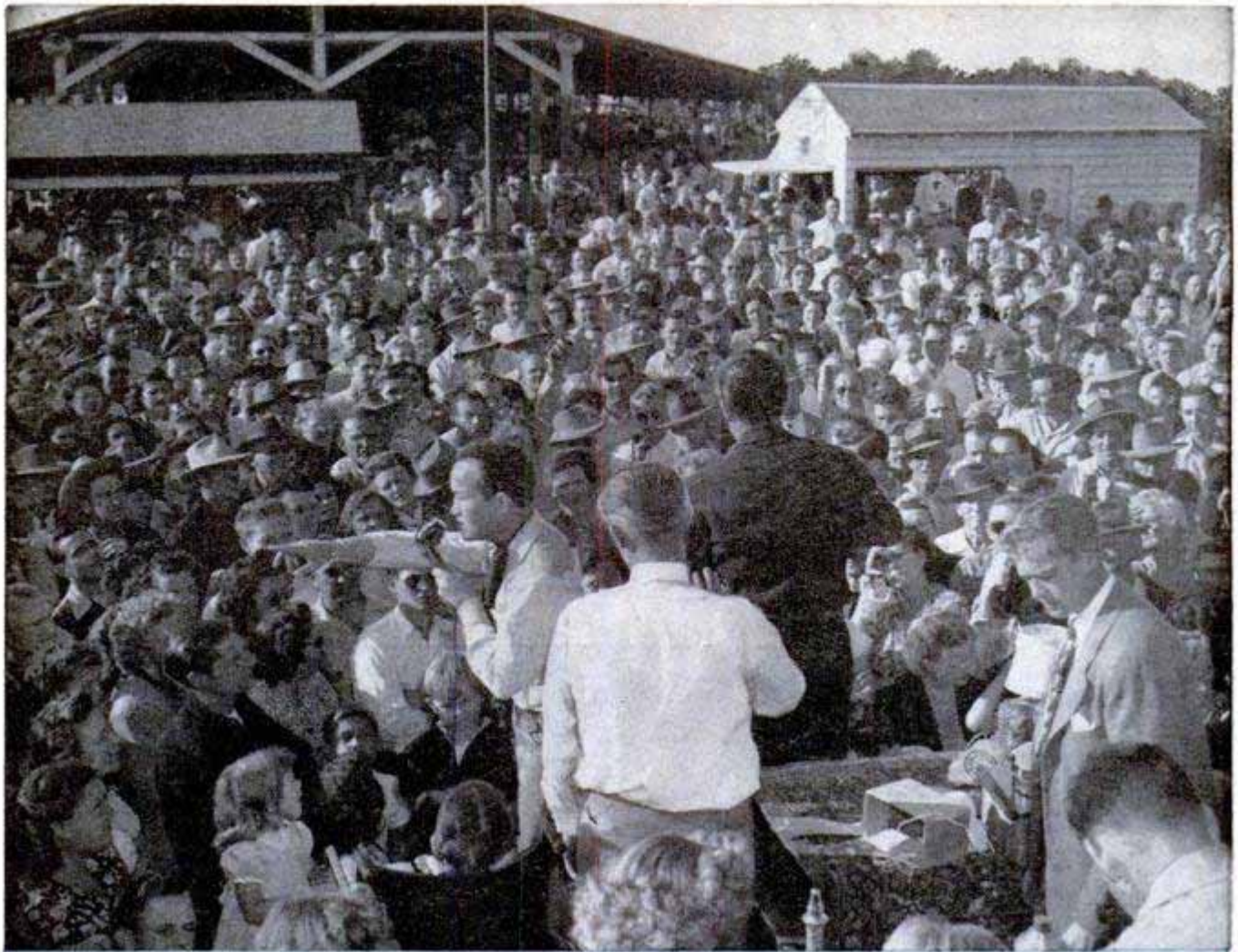

Auctioneer harangues inquisitive crowd. It's as much fun as a county fair.

## 17-ACRE BARGAIN COUNTER

**Wanna buy a duck, a 1914-model coffee grinder or a slightly used swimming pool? Everything's for sale at the Auction City dreamed up by three U. S. Army officers while on European duty**

**By Weldon D. Woodson**

**W**HOO EVER HEARD of an auction sale that went broke?" asked young Albert G. Jeffries. He was speaking to two Army buddies in Europe, Charles W. Harris and Ernest Kleiner. The three officers were figuring angles for their careers after the war was over.

Harris and Kleiner thought about auctions for a moment. Then Harris said, "Might work."

"But we'd have to enlarge and improve upon auctions," commented Kleiner.

By the time the three turned in they had worked out a basic idea for a novel postwar business enterprise.

Two weeks before the European phase of

World War II ended, however, Jeffries got shot up. For 2½ years he was confined to a hospital. When Harris was released from the Army, he became an insurance salesman. Kleiner waited for a while, hoping that the three would get together, then enlisted in the Army for a three-year hitch. When his enlistment was up he planned to join his partners.

Finally Jeffries was dismissed from the hospital. He and Harris still were convinced that a gigantic auction, week in and week out, was their chosen occupation. To attract attention, they realized, the auction must be gigantic. Their home, the southern part of California, is accustomed to large enterprises. Therefore, they would create in California a super-auction, the biggest

in the world, an "Auction City" where anything could be bought or sold.

They searched for a place to establish it. Not all communities permit auctions, so when looking over an area they first learned whether it was legal. They decided upon 17 acres of level land 1½ miles east of the small town of Downey, or approximately 15 miles southeast of downtown Los Angeles. It fronts Firestone Boulevard, over which an incessant stream of traffic flows. Tens of thousands each day would see the "city." They in turn would tell others. Newspaper, magazine and radio advertising helps, but a locality adjacent to a busy highway is a necessity for an auction sale gone "big time."

To buy the land, erect the buildings and promote it would require money. When in Europe, the three began to save a portion of their officer's pay each month. In all, they managed to pool about \$3000. Not much, but enough to carry out their idea.

"In fact," confides Harris, "we even had 17 cents left over when we were ready to hang up our sign."



Going! Going! Gone! And sold to the highest bidder was this 1914-vintage coffee grinder. That's Jeffries himself swinging the gavel and no one asks a buyer what he'll do with the stuff. Below, typical western zoo appeals to visiting kids and most of their parents, too



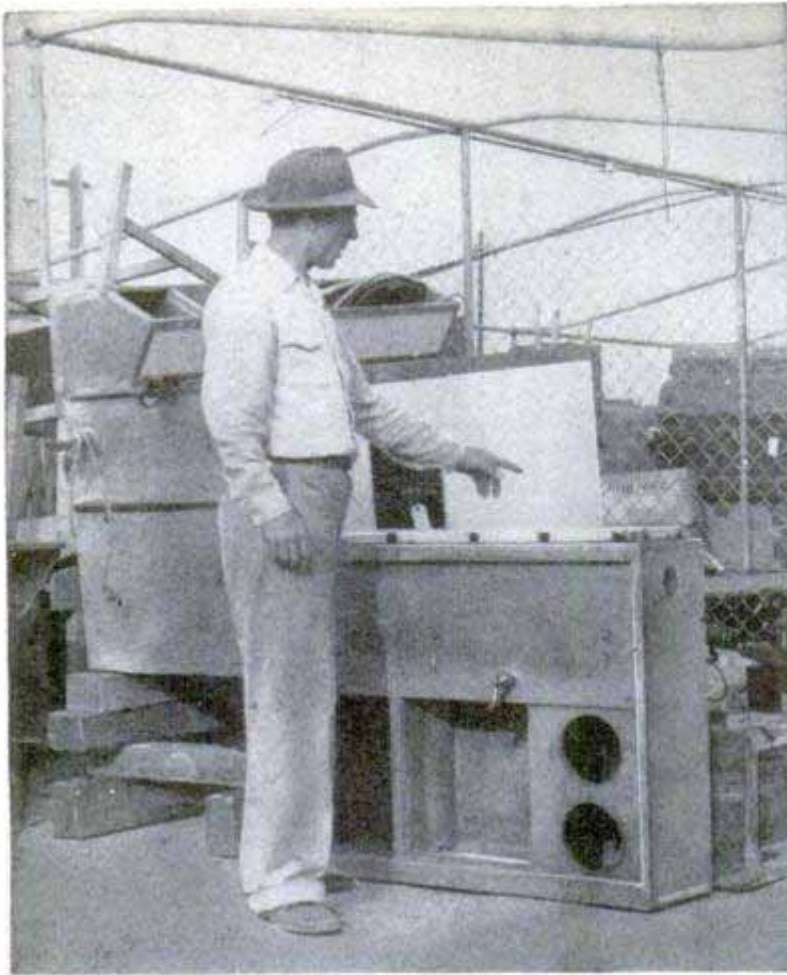

At Auction City you'll find everything from old bed springs to a baby coyote for sale. Someday a buyer will turn up for the dishwasher above. Below, a curious visitor examines a pinball machine. Will she buy? Probably not, but someone will



Already, a lawyer friend had advised them to form a corporation. They had to obtain an option on the 17 acres; plan the buildings to the minutest details; draw up a program of public relations. Moreover, they determined the exact nature of their contemplated business. They not only were well versed in the good points of their dream, but could—without the least hesitation—offer sound answers to any possible objections. Too many persons, they believe, launch an enterprise without thinking it through and appraising it from every angle. Under Auction City, Inc., and with Jeffries as President, Harris, Secretary-Treasurer, they placed the stock on the market. It all was purchased the first day.

On July 25, 1948, they held their first auction—or auctions, for actually as many as 14 may be going at once. So large is the main building that the sign "Auction City," painted across the entire length of the roof, can be seen from the air. That initial day, more than 75,000 persons milled from one auction gallery to another. Three and a half acres had been marked off for parking, but this was not sufficient. As far as the eye could see, cars were parked on both sides of Firestone Boulevard.

There was only one flaw during the day—30 children lost their parents, or their parents lost them, depending upon whether you look at it from the child's or the adult's standpoint. At any rate, by closing time the stray children had been matched with the stray parents and everybody—including Jeffries and Harris as they totaled their day's receipts—called the opening a tremendous success.

Since then, they never have worried about crowds. The weekly attendance averages over 50,000 persons. Sunday (morning, afternoon and evening) is their best day, but Wednesday and Friday evenings—the other auction days—see a great turnout. So far, the opening day holds the record, but another approached it. They held a charity auction for the benefit of the Los Angeles Orthopedic Foundation, a hospital for crippled children. It brought in \$2000 for the hospital.

The coffers of Auction City, Inc.,

are enriched in many ways. Of the 14 auction galleries, the corporation reserves only one for itself. It employs an auctioneer to handle it. Some of the remaining 13 are rented outright for various periods of time; others leased on a commission basis. Each operates independently.

In addition, Jeffries and Harris will auction off, for a percentage, anything you bring to them, from last year's Easter bonnet to — as happened in one case — a baby coyote. Throughout the Los Angeles area folks periodically ransack their own homes to see what, if anything, can be disposed of at "The City," as it is referred to. If there are no bidders, your material will be returned to you without charge.

Especially do mechanically minded persons come here to buy every gadget imaginable. Ready buyers were found for two auto tires on wheels, a set of fog lights and a rubberized electric cord with wire guard around the globe. Also without effort, they sold air horns used on large trucks and transcontinental busses. The new owners rigged them up on family jalopies. Easily disposed of are

(Continued to page 244)



Need a hair drier? You'll find them at "The City" right next to the old gas stoves. Below, miniature roller coaster keeps the kids occupied while the parents make their bids. The young businessmen have found it pays to cater to the whole family

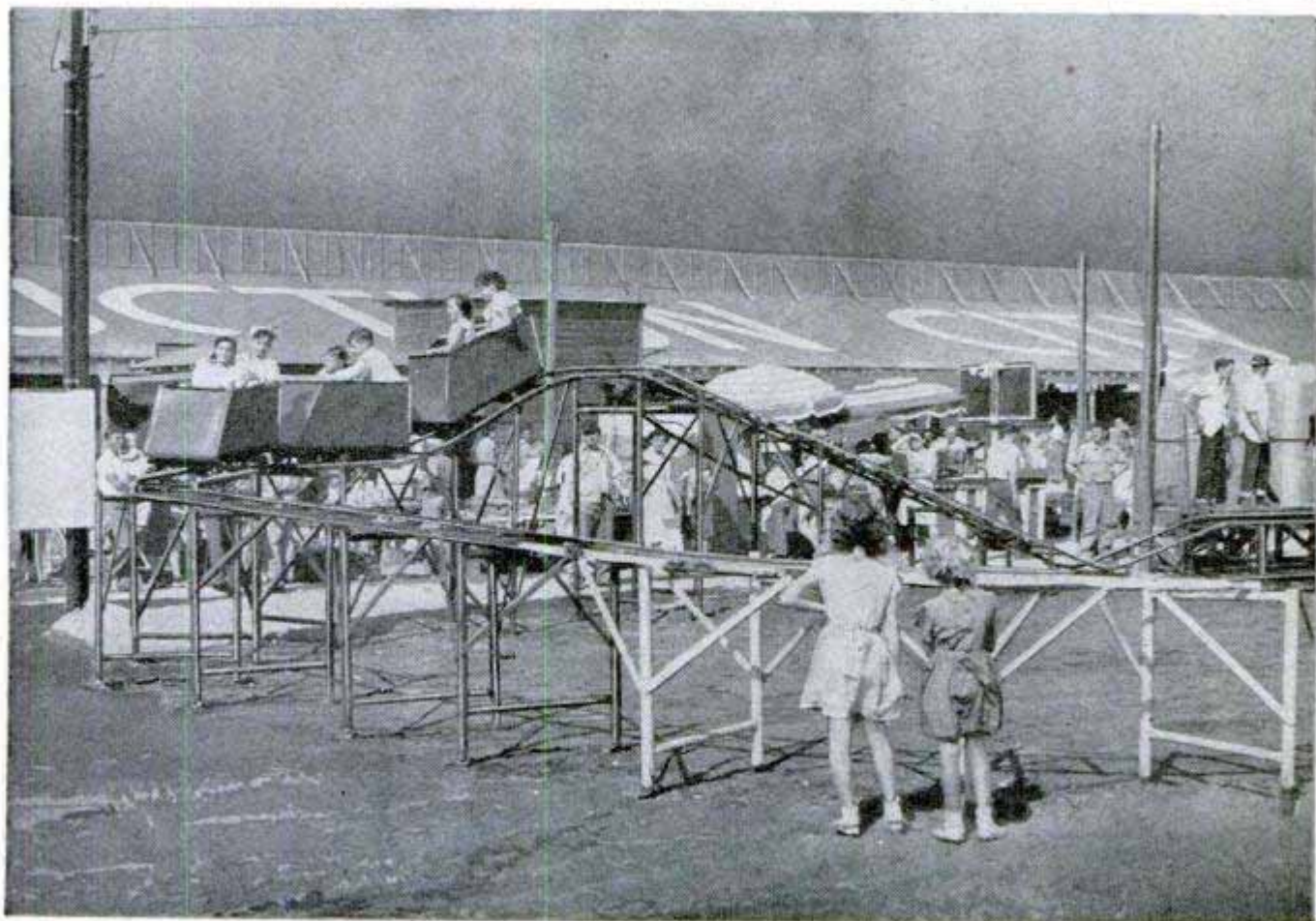

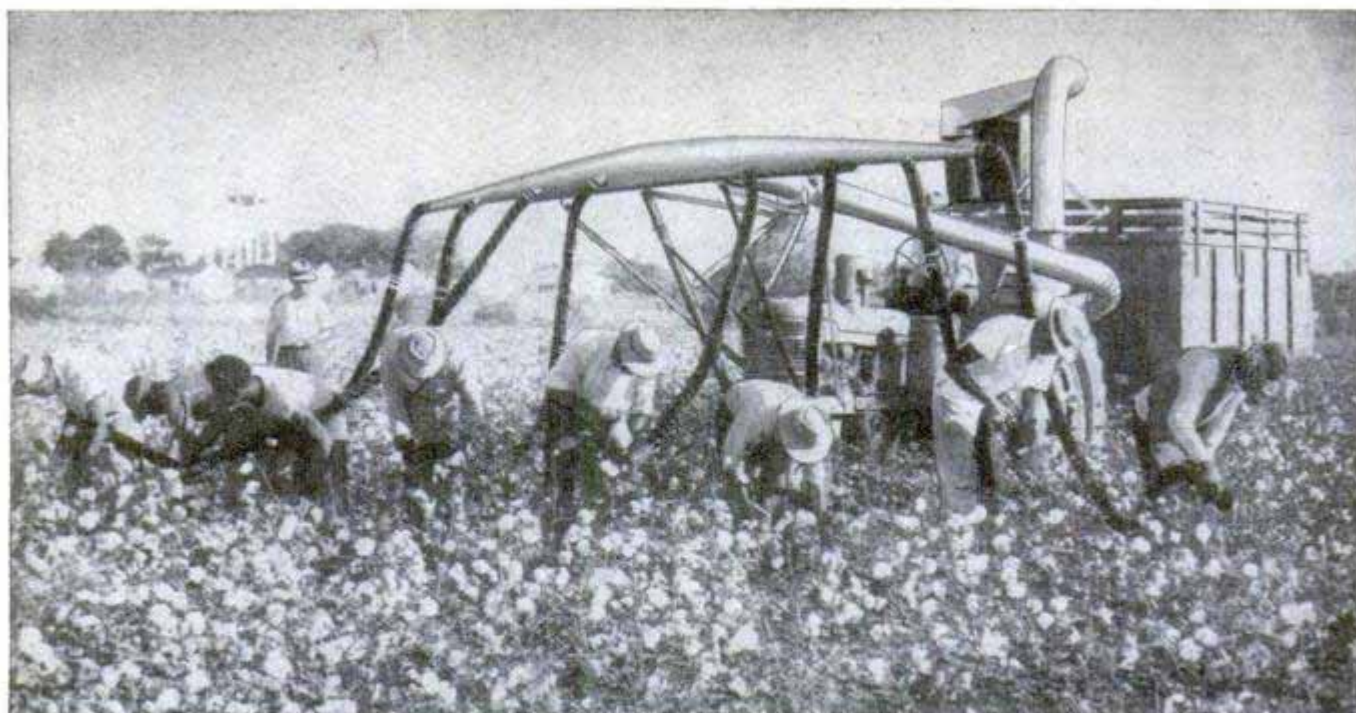

## Huge "Vacuum Cleaner" For Land of Cotton

Like a gigantic vacuum cleaner, a new semimechanical cotton picker sucks the cotton bolls from the plants, speeding the harvesting of the Dixie crop. Mounted on a

tractor, the picker has eight suction tubes and will harvest up to 3200 pounds of the fluffy fiber each day. It was demonstrated on a cotton field near West Memphis, Ark.

## Converted Tire Chains Go on Wheels Quickly

You don't have to jack up your car, move it or even crawl around behind the wheel to put on a set of tire chains that are equipped with a new hook-up device. The device, which can be installed on any set of chains, even makes it possible to mount the chains while the car is bogged down on a steep hill. It consists of an extension of one end section of the chain so that it is long enough to be pulled behind the wheel, then crossed over the tread to serve as a

cross chain and finally locked on the shorter end section on the outside of the wheel. To mount the chains, you merely drape them over the tire and toss the end-section extension behind the wheel so that you can reach it from the rear. Then by pulling it across the tread, through a pair of bottle links, you are ready to hook it to the other end section. Two clamps on the extension hold the chain in place should a cross-chain link break during use.

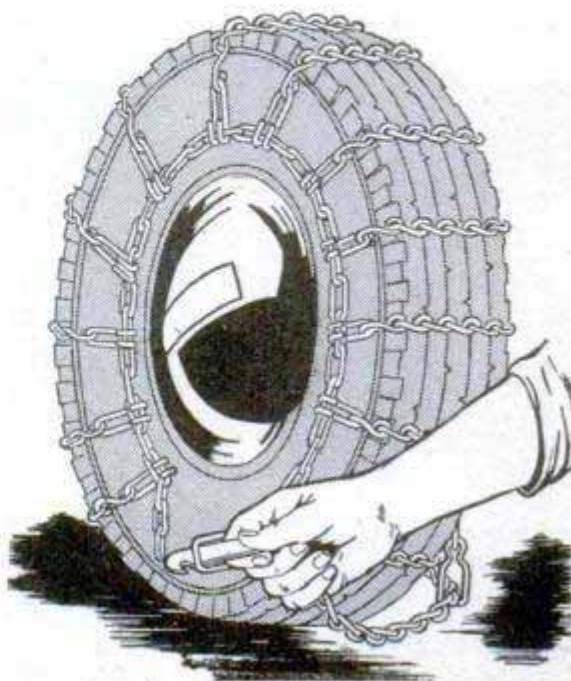



## Fluorescent Street Lights

Fluorescent street lights, developed by General Electric, provide glareless illumination which means better visibility, especially when pavements are wet. The new light consists of a long, slender aluminum tube in which two pairs of eight-foot fluorescent lamps are mounted. Two reflectors, mounted back to back, direct the light downward through plastic windows. Well suited for tunnels, the lights may be used eventually on open roadways.

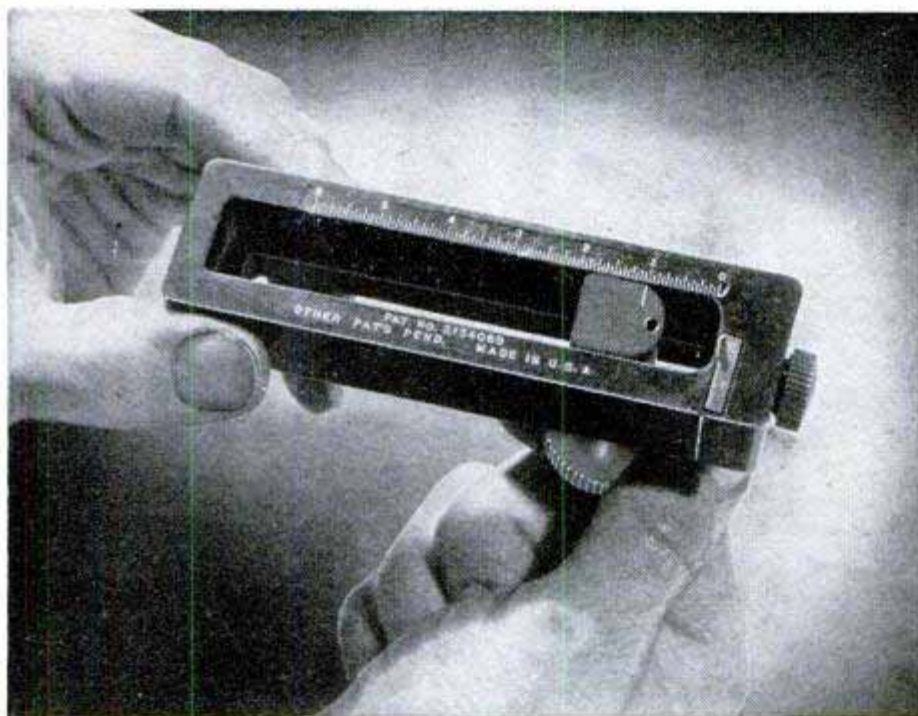
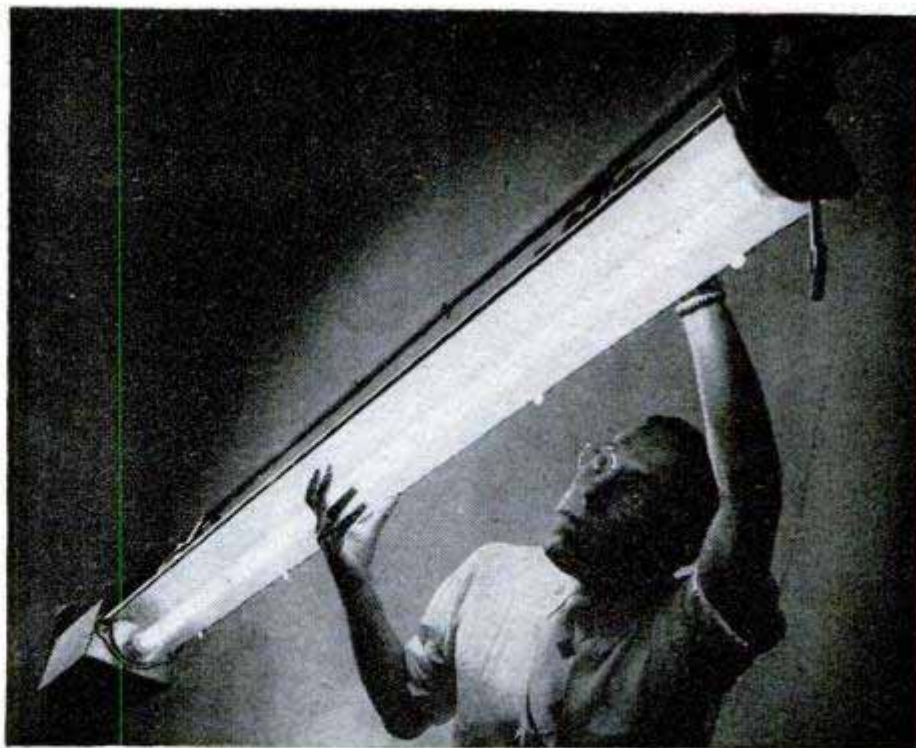

## Gasket Cutter

Cutting all types of gasket materials, a new cutter not only cuts circular gaskets quickly and accurately, but also can be used for freehand cutting of irregular shapes. The cutter, made of plastic, has a slot in one end for the blade, which can be adjusted for depth of cut. An adjustable center post, locked in position by a knob, serves as a pivot when cutting circles. The scale on the pivot post permits quick setting of the desired radius. For cutting straight lines or irregular shapes, the center post is removed and the cutter guided by hand. The cutter, which comes with four blades, works equally well on aluminum foil, asbestos, canvas, cork, leather and other gasket materials. It can also be used for cutting designs in linoleum, rubber tile and wallboard.

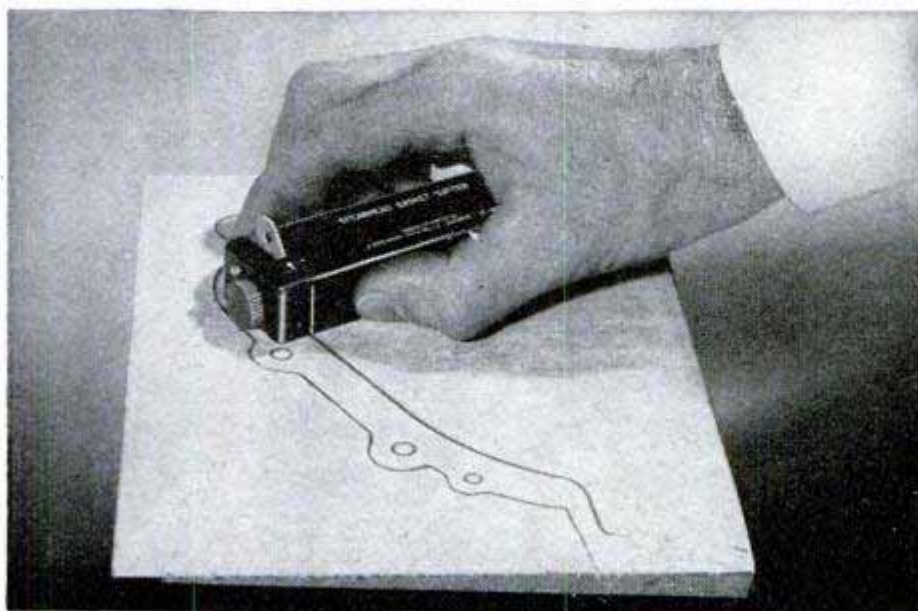

☞ Coast Guard photographic airplanes "counted" 40,232 icebergs during the 1949 iceberg census conducted over the Baffin Bay region near Greenland.

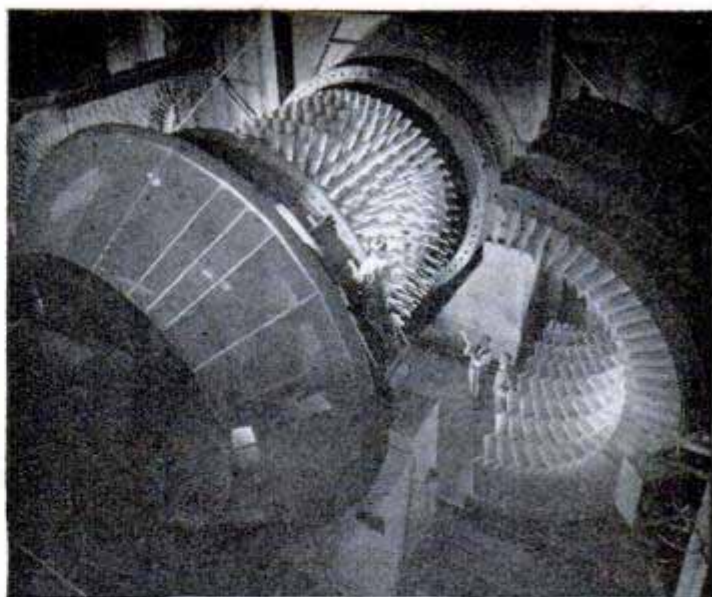

National Advisory Committee for Aeronautics photos



Top, left, engineers installing a test shape in world's largest supersonic wind tunnel. Top, right, motors with 87,000 hp. turn rotor blade on huge compressor shaft. Above and left, models used in assessing comparative speed, altitude and power performance data

In the world's largest supersonic wind tunnel, at Cleveland, engineers are getting their first opportunity to study turbo and ram jet engines operating at speeds twice that of sound. Equipment in the six by eight-foot test section is run under temperature and pressure conditions similar to that at 35,000 feet. At maximum speed, as much as two million cubic feet of air per minute—weighing almost 75 tons—

## Largest Supersonic Wind Tunnel

are drawn into the tunnel. The process, used to keep the air dry, to prevent condensation and velocity disturbances, removes as much as a ton of water a minute on a hot day. The test area's size is controlled by flexing its stainless-steel side plates, 35 feet long and 8 feet high, with 14 hydraulically operated screw jacks. The tunnel is part of the Lewis Flight Propulsion Laboratory.



## Car "Crashes" Wall 24 Hours a Day

Motorists driving on Route 78 near Escondido, Calif., are startled momentarily by the sight of a car "crashing" into a restaurant. A closer look reassures them, however, since the car is really only half a car and the "crash" is painted on. The restaurant is located on a sharp curve, thus heightening the effect.

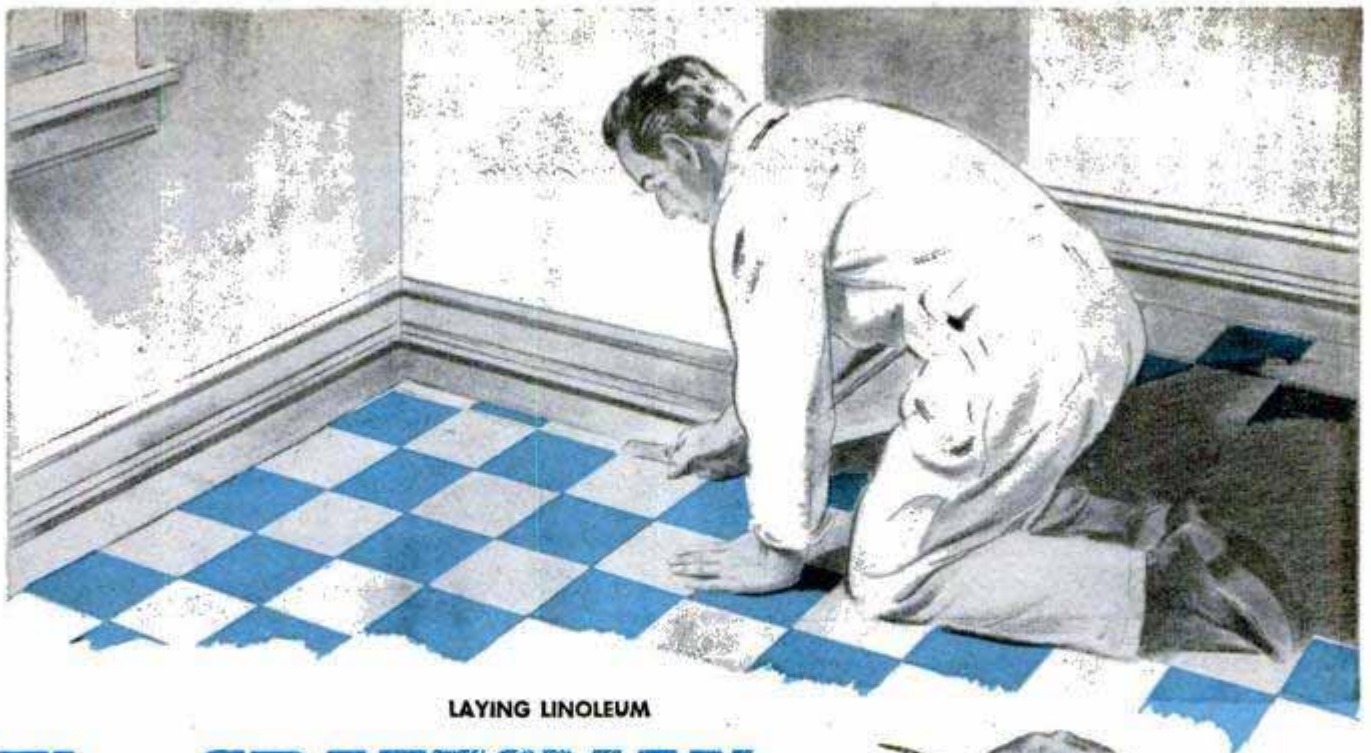

LAYING LINOLEUM

## The CRAFTSMAN

★ No special skill or practice is required to lay linoleum. It's so simple to do that you can expect a good floor the first time you try if you carefully follow a few easy-to-understand directions. A story on page 194 pictures and describes the procedure in detail.

★ If you're a home craftsman, sooner or later you'll be called on to drill holes in glass. It's easy when you use special drill bits made from old files. Just turn to page 224 for full instructions.

★ Nowadays farmers can ease the back-breaking job of loading baled hay onto a truck or trailer by building a bale loader which handles the job automatically. The construction details are outlined on page 217.

★ Readers have asked, "How do finishers produce that satin-smooth finish I see on fine furniture?" On page 202 one of the experts lets us in on a few tricks of his trade.

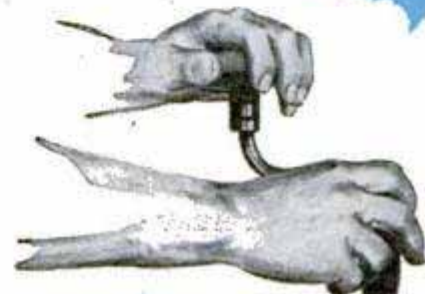

DRILLING HOLES IN GLASS

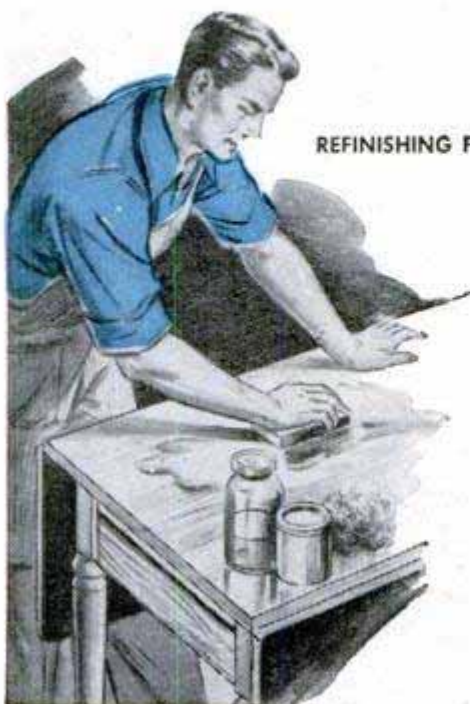

REFINISHING FURNITURE



BALED-HAY LOADER

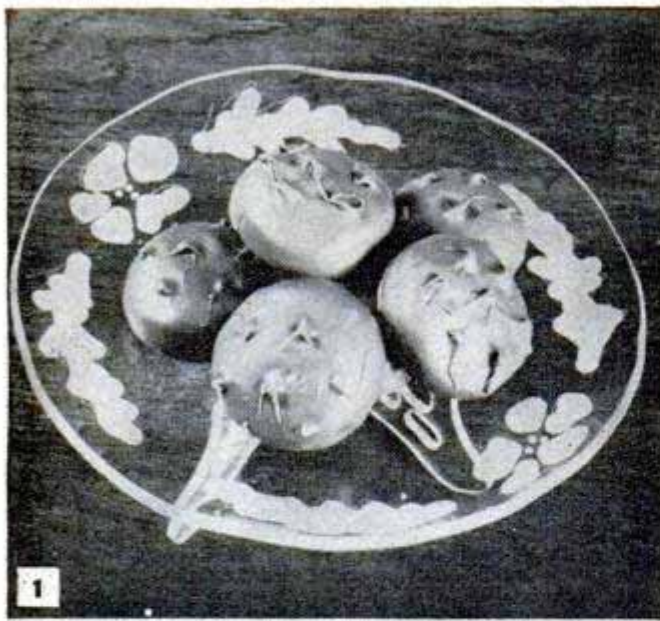

1 Frosted design enhances appearance of candy plate

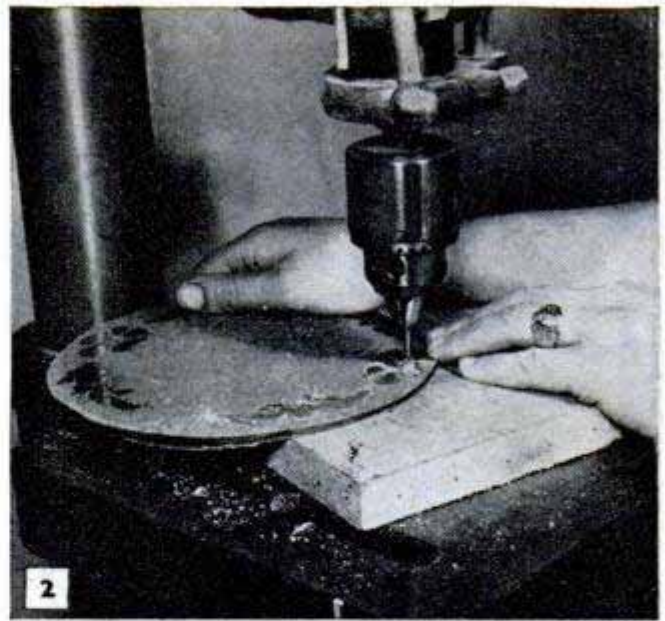

2 Routing plastic with small burr gives frosted effect

## FROSTED CANDY PLATE AND JEWEL BOX

HERE ARE TWO quickie projects that utilize transparent plastic to the best advantage. The circular candy plate, Fig. 1, is entirely of plastic and features an unusual frosted design, while the jewel box, Fig. 6, is an attractive combination of clear plastic and pieces of select hardwood.

To make the candy plate, cut a 7-in. disk from  $\frac{1}{8}$ -in. plastic, leaving the protective paper covering intact. Lay out the design on the paper covering according to the squared pattern, Fig. 3, and cut through the paper around the outline of the design with the point of a knife. Peel off the paper

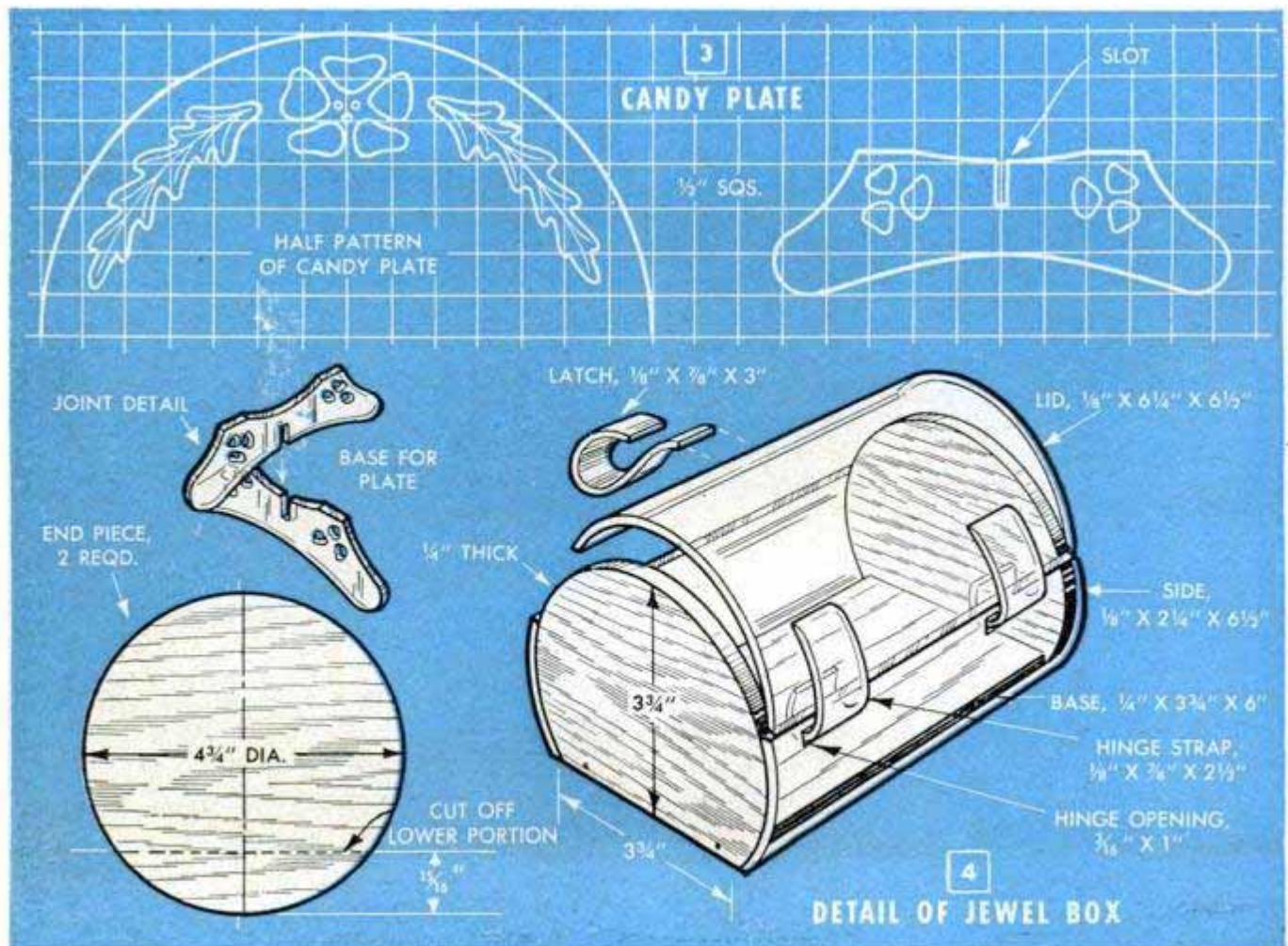

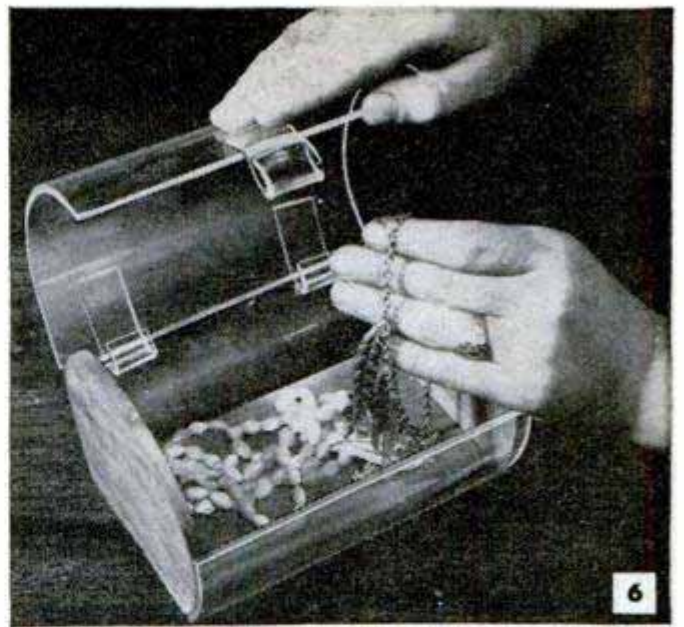
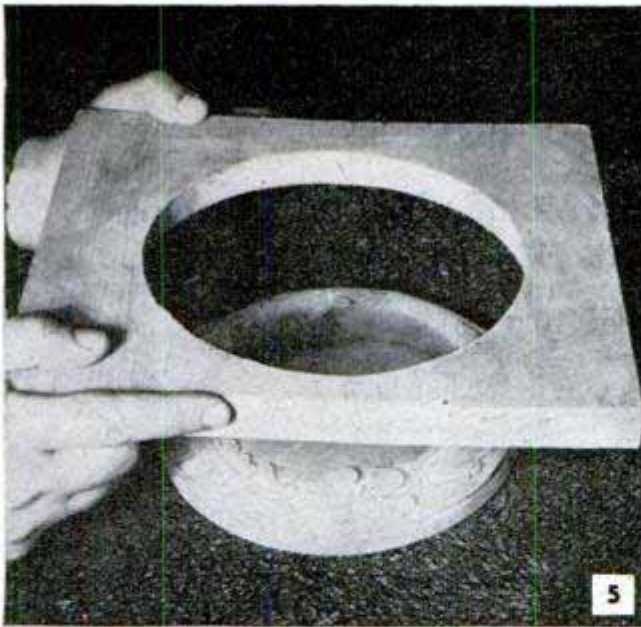

Left, plate curved by pressing plastic over wood form. Right, jewel-box lid is held closed with friction latch

By  
*Elma Waltner*

to expose the areas to be frosted. Use a small flat-bottomed burr to frost the design, Fig. 2, and after frosting, vein the leaves with a fine grinding tool or a dentist's drill. The plastic is dished with the aid of a two-piece wooden form as in Fig. 5. The bottom of the form consists of a 6½-in. disk, one face of which has been rounded in the lathe. The top makes use of the waste stock from which the disk was jigsawed and is used to press the edges of the plastic over the form. To soften the plastic, remove the protective paper and heat the disk until pliable in an oven set at 250 deg. F. The two leg units are cut out as shown in Fig. 3. Be sure that the radius along the top edge of the legs matches the curvature of the plate. The legs are half-lapped and cemented to the underside of the plate.

Begin making the jewel box by cutting the ends and bottom from ¼-in. hardwood. The ends are disks with the lower portion cut off as in the left-hand detail, Fig. 4. The sides and the lid of the box are cut from ⅛-in. plastic and the lower edges of the sides are beveled so they are flush with the bottom of the box. One side of the box is slotted for plastic hinges. The parts are heated and shaped by bending around the box ends, Fig. 7. It is best to protect the hands with cotton gloves or cloth when doing this. After the sides have been cemented to the ends and bottom, the hinges are bent to fit through the slots, Fig. 8, and cemented to the lid. With the lid in the closed position, the latch is formed so it serves as a friction catch against the front side of the box, and it is then cemented to the center of the lid, the lower portion overhanging the front edge as in Fig. 6.

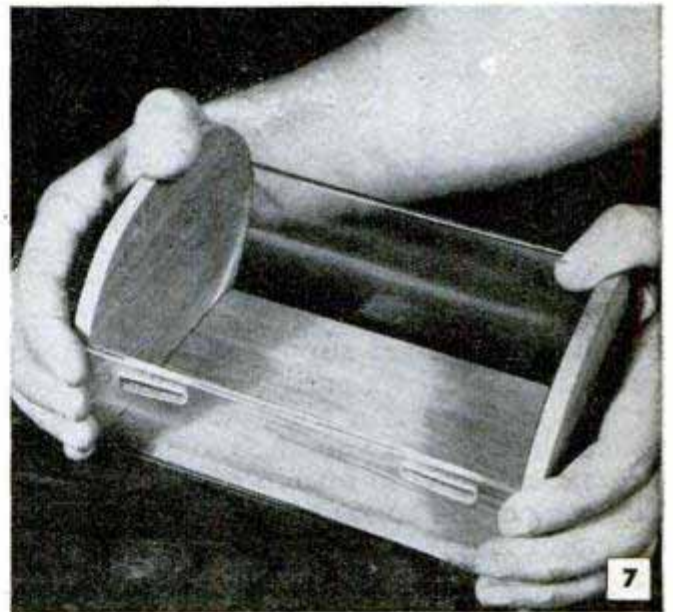

Above, plastic sides are heated, formed around ends of the jewel box and cemented to the edges of the wooden parts. Below, hinges are bent to engage slots cut in rear side of box and then cemented to lid

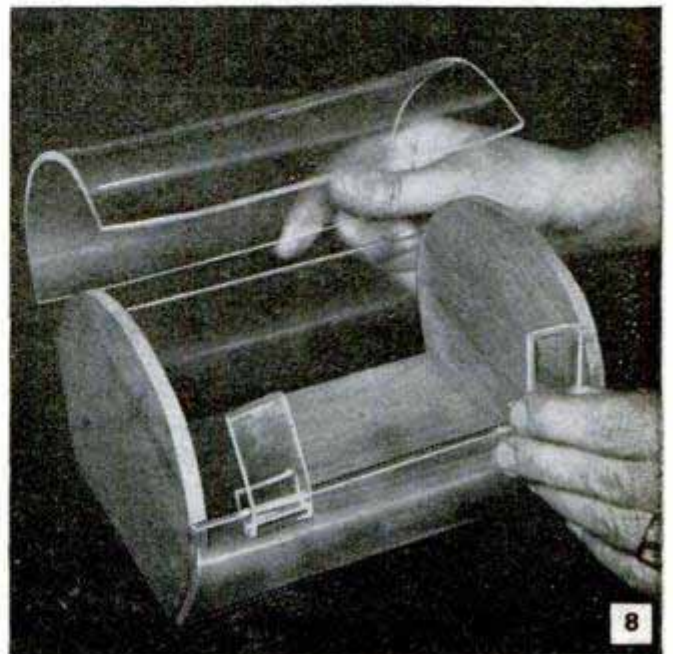

## Metal Shingle-Nail Dispenser Hooks on Trouser Belt



When shingling a roof there is nothing like having a good supply of nails where you can reach them easily, and the answer to this problem is a sheet-metal nail dispenser hung from your belt. The metal is cut and soldered to form a four-sided box. The back of the box is T-shaped and is bent over and riveted to form a belt loop. The nails drop into a slot which runs the full length of the bottom of the box. These are pulled through a notch in the end of the box one or more at a time, as desired. A piece of spring steel screwed to the box covers the notch to keep the nails from sliding out when the box is tilted.

## Buttons Improvised From Beads

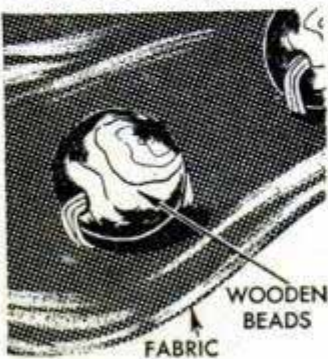

If buttons of the desired color are not available, use wooden or glass beads as a substitute. These are obtainable in a variety of colors and sizes and are sewed to the fabric as shown.

## Removing Candle Drippings

To remove unsightly candle drippings from a tablecloth or scarf, place several layers of blotting paper both over and un-

der the spotted portions of the cloth. Then heat the blotting paper with an iron so that the wax will be melted and absorbed by the paper.—Helen Lemberger, Chicago.

## Pen Modified for Drawing Ink

Should you have occasion to use drawing ink to make sketches or special place cards for a party, there is no need to buy a special pen for the purpose. The ink capacity of an ordinary writing pen can be increased sufficiently by pressing a straight pin into the lower end of the penholder. The head of the pin should rest against the inner surface of the pen.

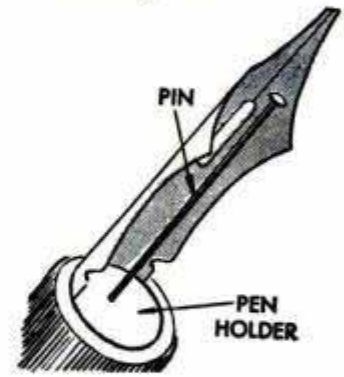

Edward A. Lakso, Glendale, Calif.

## Towel Rack Holds Iced Doughnuts

After icing doughnuts on both sides, it is often a problem to find a spot to set them while the icing hardens. Next time, try slipping the doughnuts over the arms of a folding towel rack. This allows the icing to dry uniformly on both sides of the doughnuts.—Benj. Nielsen, Aurora, Neb.

## Block Aids Fastening Tire Chains

Attaching a tire chain is done faster and with less effort if the wheel of the car is raised with a small block of wood. Cut the block from a 2 x 4 or use half of a brick. Lay the chain flat on the ground and place the block in one of the sections of the chain. Then, just back up the car until the wheel rests on the block, pull the ends of the chain up around the tire and fasten them. By using two blocks both wheels can be raised simultaneously. As the blocks require little storage space, they can be carried in the trunk along with the chains.

Charles Herbst, Dallastown, Pa.

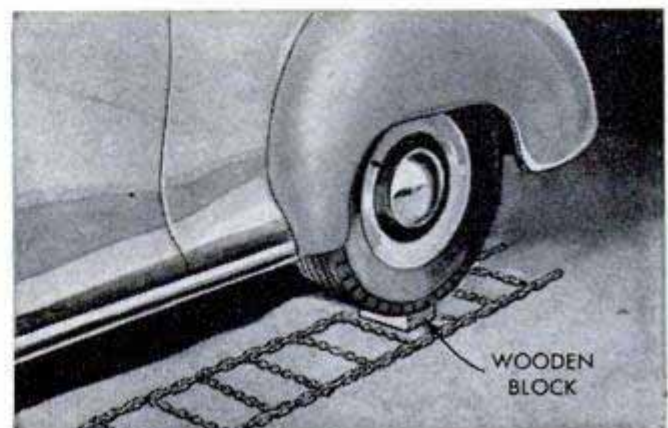

# FIREPLACE HOOD

**M**ADE of gleaming burnished copper, this attractive hood adds a Western touch to the front of a plain brick fireplace. Installation of the hood makes the opening appear lower and therefore wider, resulting in a more pleasing over-all appearance. Sheet copper is cut to the dimensions given in the detail. Note, however, that the length of the hood is not listed, as this must be determined by adding 16 in. to the width of the fireplace opening. The sheet is drilled for rivets and lag screws and then bent along the dotted lines. The top edge is rounded at the corners by brazing pieces of scrap copper to fill the notches opposite the bends, and then a  $\frac{1}{8}$  x 1-in. brass strip is riveted to the bottom edge. The completed unit is mounted on the fireplace by driving lag screws into lead shields inserted in the mortar joints as in the center detail. If desired, copper pilasters may be attached to the corners of the fireplace opening.

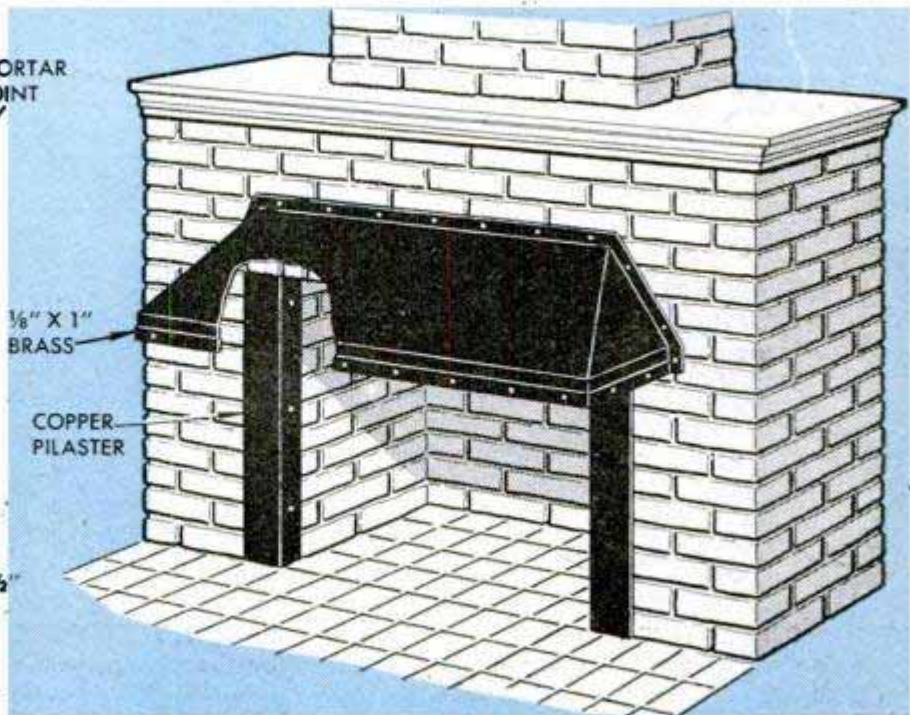
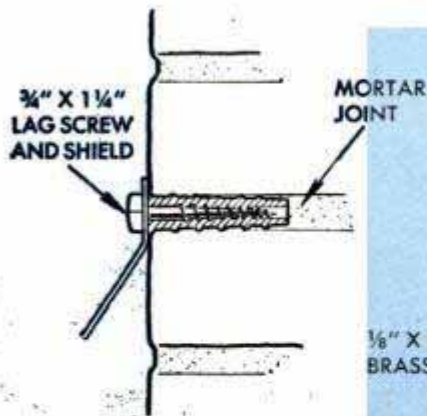
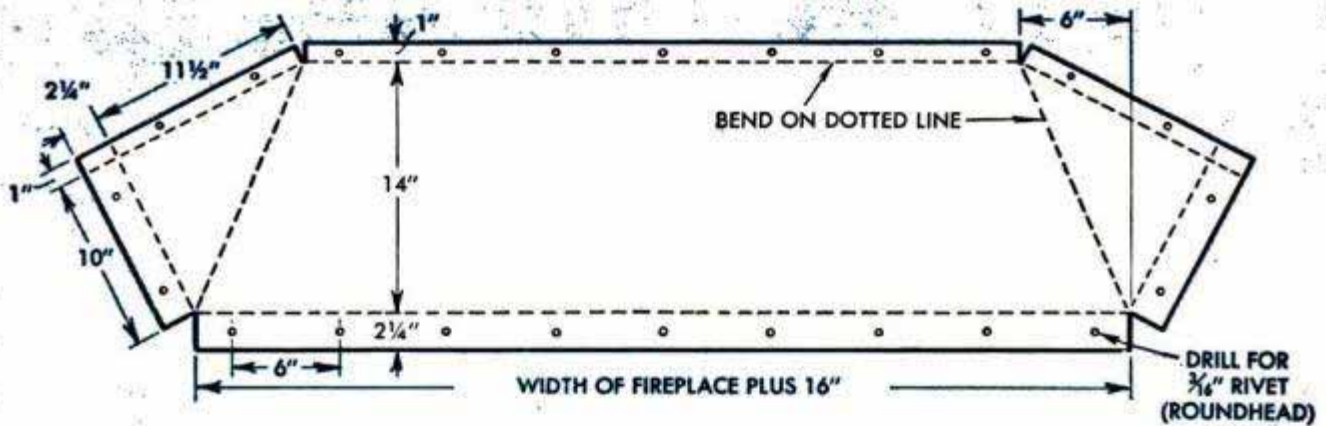

# SOLVING HOME PROBLEMS



**CLEANING A KITCHEN RANGE** is simplified by using a toothbrush to get into the cracks and crevices around handles, burners and vents. Dip the toothbrush first in warm water and then in a cleanser

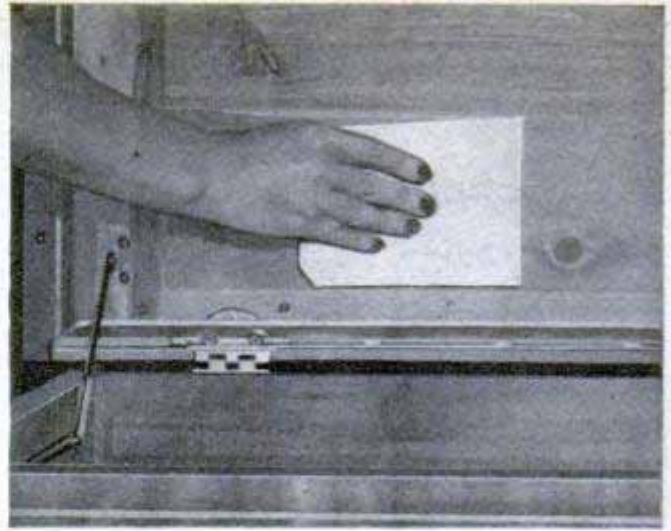

**IF THE AROMA OF THE WOOD** in an old cedar chest has lessened noticeably because of age, gently rub the interior of the chest with very fine sandpaper to restore the odor to its original intensity

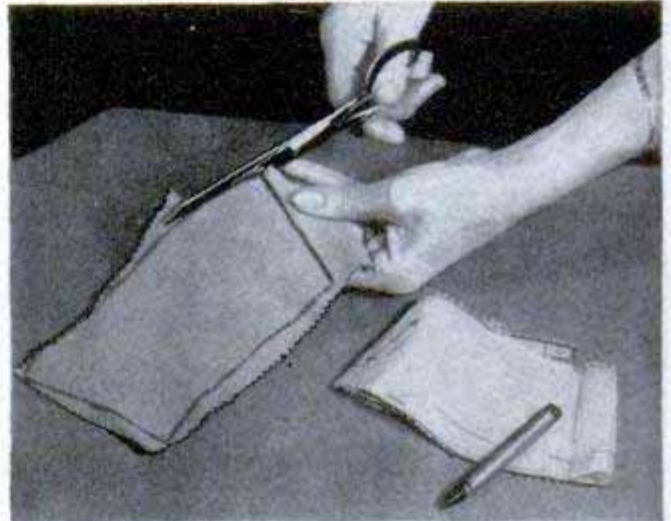

**TO PREVENT UNRAVELING** of fabric when cutting out patterns, trace around the edge of the paper pattern with a wax crayon and cut along the line made by the crayon. The cut edges will not fray

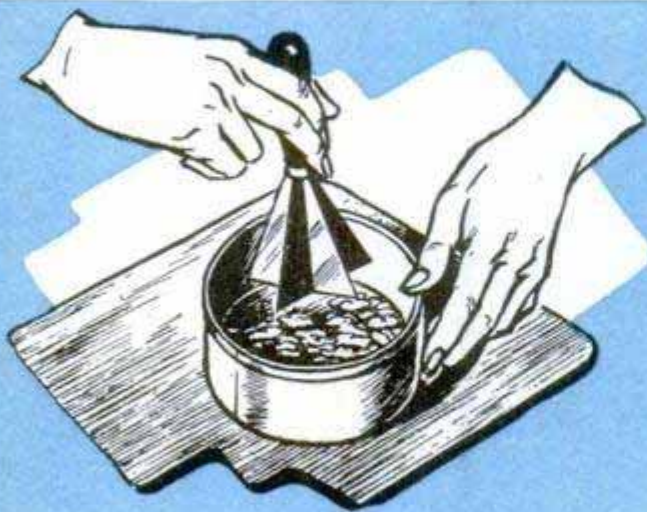

**WHEN CHOPPING NUT MEATS**, keep the pieces from flying all around by using a guard made from a coffee can. Cut the bottom from the can and place the metal cylinder around nut meats

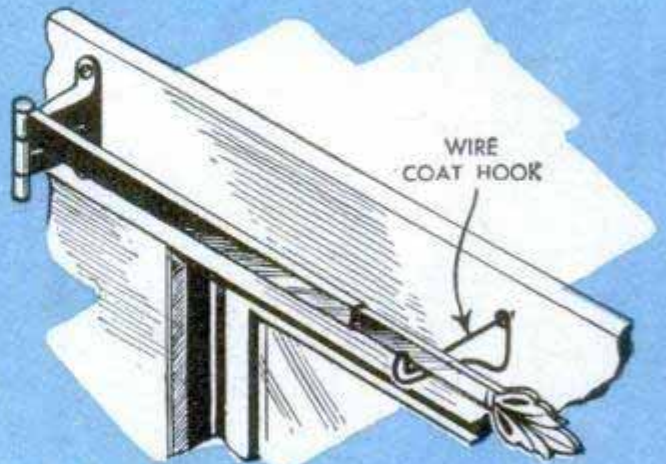

**SAGGING DRAPERY CRANES** can be leveled by supporting them with wire coat hooks turned into the window casing near the outer ends of the cranes. The draperies will conceal the hooks





**POLISH IS REMOVED** from a shoebrush by soaking the bristles in a solution of paintbrush cleaner and washing soda. Suspend the brush as shown and soak overnight. Then rinse in water and allow to dry

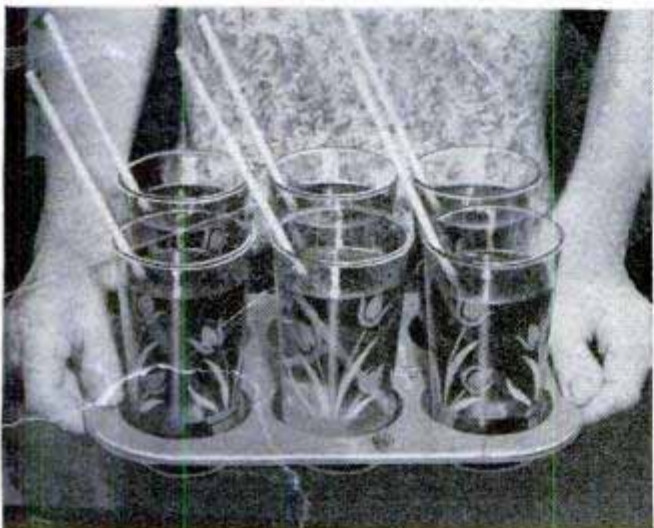

**A MUFFIN TIN** forms an excellent serving tray for cold beverages. If the glasses are a close fit in the depressions of the tray, there is no danger of their sliding while the tray is being carried

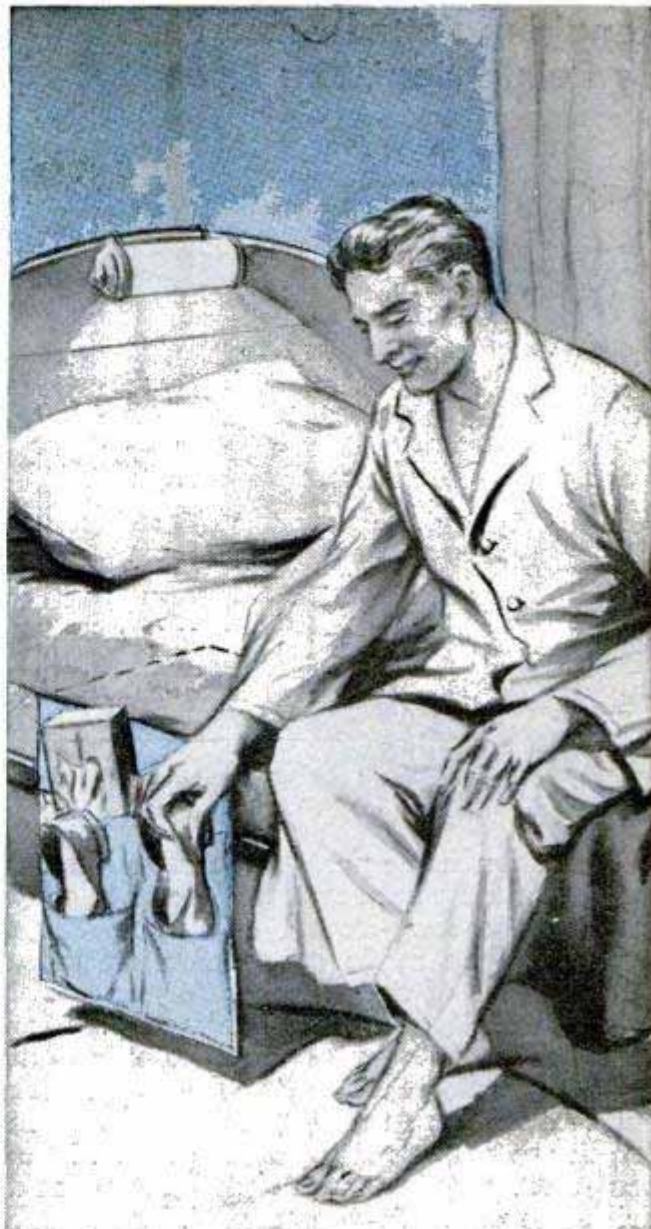

**BEDSIDE POCKETS** for slippers, tissues and other items are had by inserting one end of an 8 or 12-pocket shoe bag between the mattress and spring of the bed. Allow several pockets to hang over the side

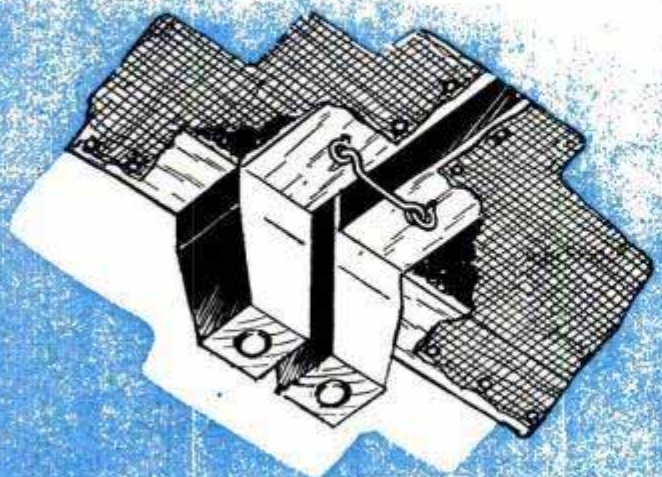

**SECTIONAL-SOFA UNITS** won't separate if they are coupled with screen-door hooks attached to underside of the frame. Combinations can be varied if hooks are located similarly on each unit

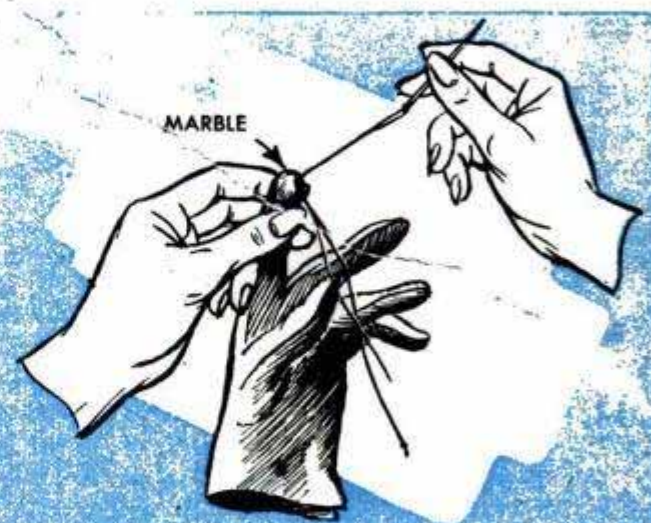

**DARNING THE FINGER TIPS** of woolen gloves is facilitated by using an ordinary glass marble to provide a miniature darning egg. Just drop the marble into the glove finger in need of repair

## Repairing Rotted Fence Posts By Reinforcing With Pipe

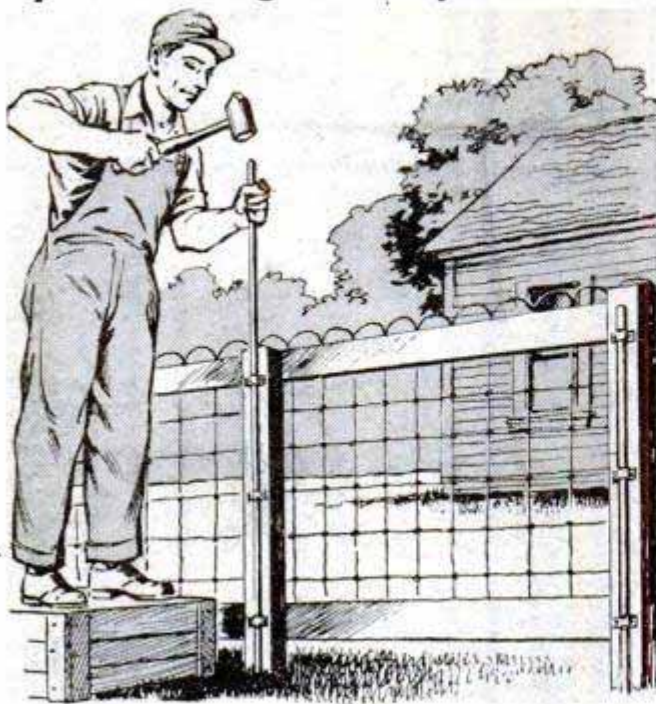

If wooden fence posts have rotted below ground and the upper portion is still in good condition, a long-lasting and inexpensive repair can be made by reinforcing them with lengths of discarded water pipe. Cut a length of  $\frac{3}{4}$  or 1-in. galvanized pipe for each post so it is long enough to extend at least 3 ft. into the ground when its upper end is even with the top of the post. Then fasten the pipe loosely to one side of the post with three or more pipe straps and drive the pipe into the ground. The straps serve as guides for driving the pipe and are tightened after the pipe has been driven.

Charles Doescher, Waterbury, Conn.

## Inexpensive Gluing Clamps Made From Turnbuckles

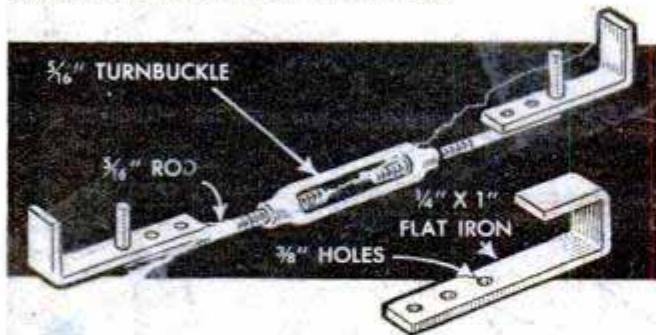

Enough gluing clamps to handle all your projects from comparatively small novelties to large pieces of furniture can be had at little cost by making them from turnbuckles, rod and flat iron. The original eyebolts of the turnbuckle can be pried open to form the linkage between the turnbuckle and the flat-iron hooks, or L-shaped links can be made by bending and threading lengths of rod. The hooks are bent from flat

iron and a series of holes is drilled in each one to permit attaching to the linkage. The capacity of the clamps is determined by the length of the rods or hooks and by the number of holes drilled in the hooks. When gluing flat work, the hooks are inverted from the position shown.

W. W. Cary, St. Paul, Minn.

## Pulley Holds Dowel Upright To Facilitate Drilling End

It's considerably easier to drill accurate holes in the ends of short lengths of dowel if a jig is used to hold the work upright on the drill-press table. An extra pulley is just the thing to provide a steady base to aid in centering the work under the



bit. Insert the opposite end of the dowel in the hub of the pulley and tighten the set-screws to lock the dowel in place.

Roland Cueva, Heyburn, Idaho.

## Squeezing Pulp-Free Lemon Juice

By squeezing lemon juice through small slits cut in the rind, pulp-free juice can be had even though a strainer is not available. Make two slits through the rind, one on each side of the navel and parallel to the other.



The juice will flow from the slits while the pulp and seeds are retained inside the lemon. Do not apply pressure to the lemon too suddenly, as it may result in breaking the rind and releasing the pulp.

## Repairing Holes in Linoleum

A long-lasting repair for small holes in linoleum is had by filling the holes with a paste consisting of finely chopped cork and shellac. Allow the paste to harden in the hole, smooth carefully with sandpaper and then touch up with paint to match the surrounding area.

R. F. Donovan, Jersey City, N. J.

☐ Melted ski wax provides an excellent waterproofer for leather footwear.

100 W.P.

# Hands Up!

## to hold your books

Cash in on personalized book ends. Cast in a flexible mold from a master pattern of a human hand and finished in bronze, they bring a handsome spare-time profit

By Thomas A. Dickinson

LIKE THE BRONZING of baby shoes, here's an idea that can be turned into a profitable spare-time business—casting book ends from human hands. But whether it's done for profit or just for fun, it costs little and your friends are sure to be intrigued by a life-size reproduction of their own hands, supporting their favorite books.

Producing a pair of these personalized book ends consists of making a "splash" plaster mold directly from the person's hand. To do this, the hand is first coated with Vaseline, Fig. 1, which prevents the plaster from sticking. Then the hand is rested palm down on wax paper on a flat surface and covered to the wrist with a mixture of casting plaster, Fig. 2. This splash coating should be at least  $\frac{1}{2}$  in. thick all over. After allowing the plaster to harden for about 30 minutes, the hand is turned over and worked free by gently wiggling the fingers, Fig. 3. This usually can be done without damaging the mold, but any small chips or flaws that might occur can be easily corrected later in the master pattern.

Next, the hand impression in the splash mold is coated with two or more applications of lacquer, Fig. 4, to seal the pores in the plaster and to produce a glossy finish. This is followed with a coat of paste wax to prevent the master pattern from sticking. The master pattern is made by merely filling the splash mold with plaster, the open end of the cavity being blocked off as in Fig. 5. As the splash mold is no longer needed, the

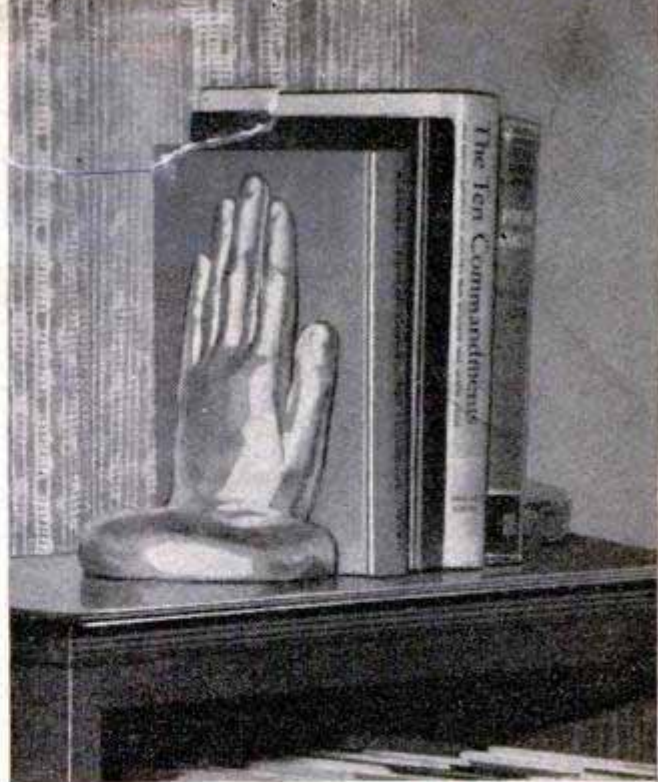

First step, coat both sides of hand with Vaseline

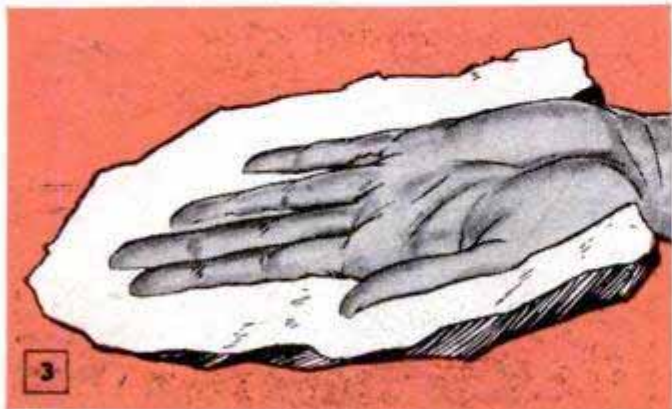

Hand is freed from plaster mold by wiggling fingers

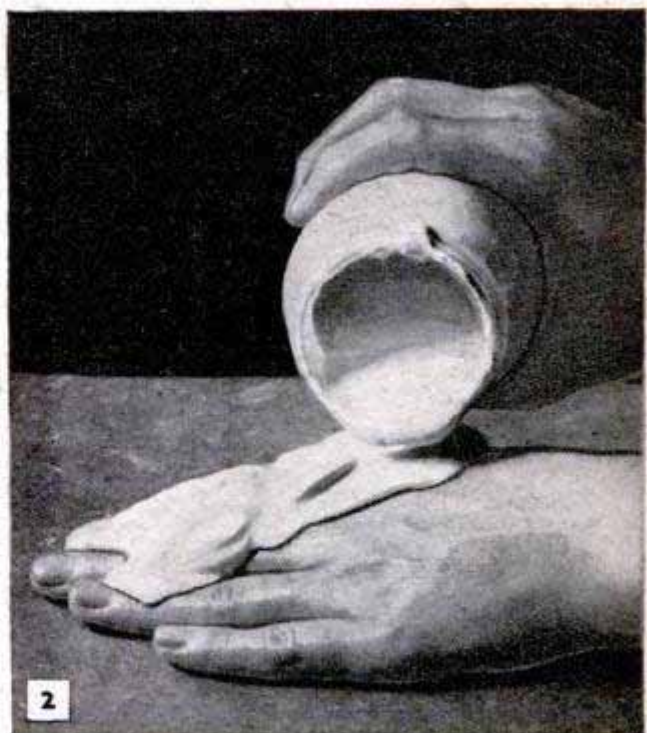

Next, rest hand on wax paper and cover with plaster

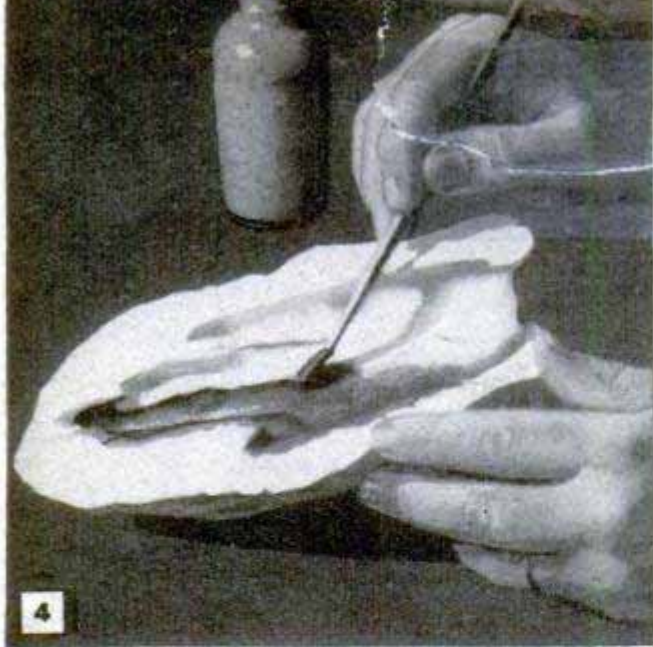

Cavity of mold is painted with two coats of lacquer

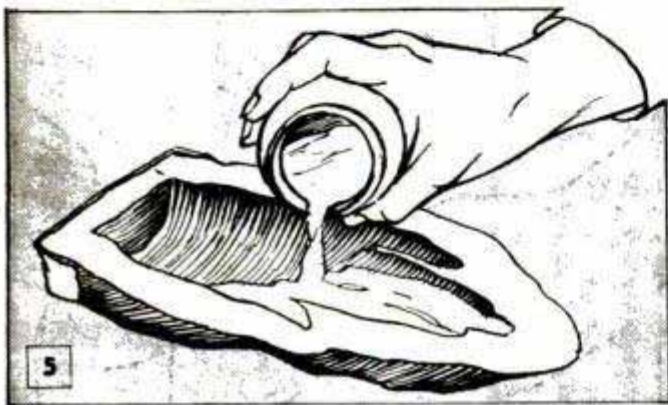

Master pattern is made by filling mold with plaster



Mold is carefully chipped from master with pliers

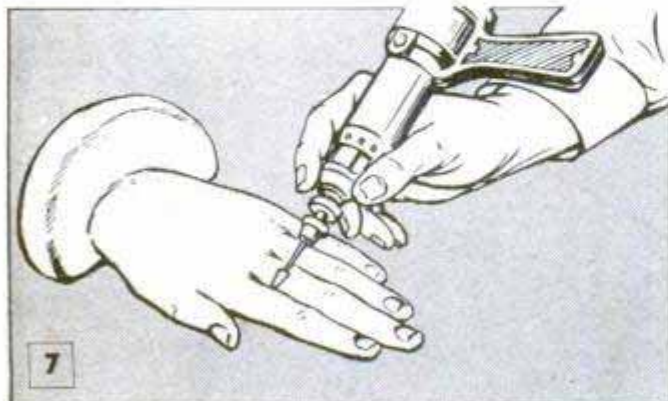

Completed master is cleaned up by sanding the flaws

breaking away small pieces of the mold with a pair of pliers, Fig. 6.

When this is done, a base is added to the hand. Using a tin can as a form, plaster is poured into the can to a depth of 1 in., and while the plaster is still wet the master pattern is placed upright in the can and embedded in the soft plaster, Fig. 8. Small holes due to air bubbles and other irregularities in the master casting can be corrected by sanding and patching where necessary. A handy tool for cleaning up the pattern is a small hand grinder, Fig. 7. The portion of the base projecting on the flat side of the hand is carefully sawed off flush with the surface. Next, the master pattern is coated with lacquer, followed, when dry, with linseed-oil soap, consisting of equal parts of linseed oil, water and laundry soap. This is applied to keep the pattern from sticking to the flexible mold.

Material for the flexible mold is compounded by mixing together 4½ lbs. of flake gelatin, 4½ pts. of water, 9 lbs. of glycerin, 1 lb. of glucose and 1 oz. of denatured alcohol in the following order: Add the water to the gelatin and cover the container with a damp cloth to prevent evaporation. Stir the water-and-gelatin mixture every 10 min., replacing the cloth each time until the gelatin is thoroughly softened. Drain off any surplus water in the mixture and then place the gelatin in a double boiler, Fig. 9. Next, warm the glycerin and add it to the melted gelatin,

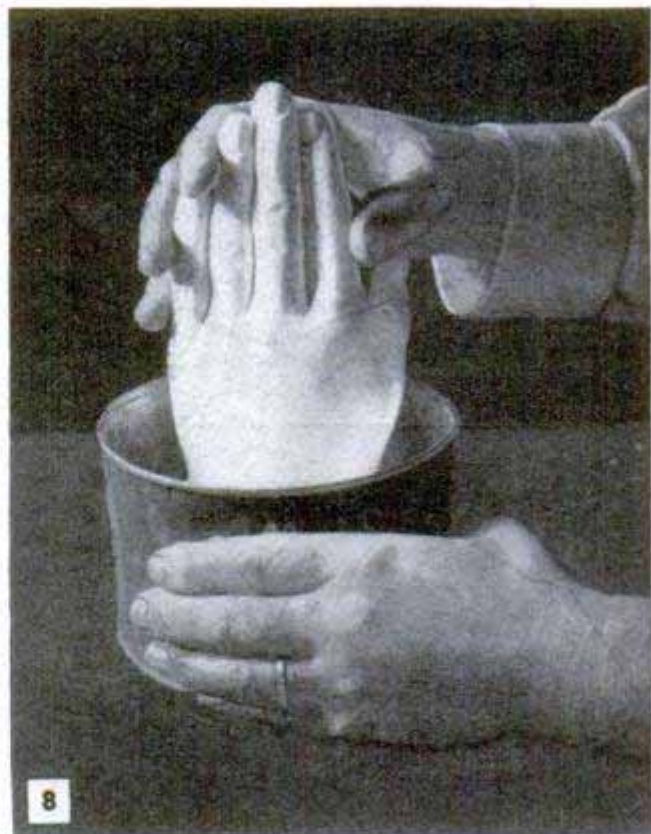

Base is added to master by standing in wet plaster



Ingredients for the flexible mold are cooked in a double boiler and then alcohol is added to the mixture



Master and subsequent castings are extracted from mold by stretching it. Open-end can provides mold form

and then warm and add the glucose. When thoroughly "cooked," remove the mixture from the double boiler and stir in the alcohol, Fig. 10. The mixture is now ready to be poured over the master pattern. A mold for the pattern can be made by removing both ends from a large can or by wrapping cardboard into a tube, Fig. 12. The form should clear the pattern at least 1 in. all around. After pouring, the flexible mold is allowed to stand for about 12 hrs. before separating it from the pattern.

Preparatory to making the finished casting, the flexible mold is dusted on the inside with talcum powder and left for an hour to allow any moisture in the mold to evaporate. If the casting material used requires a melting point of more than 100 deg. F., the mold cavity should be treated with a strong solution of alum, which is made by heating 1 lb. of alum in 1 qt. of water. This is applied cold to the mold and allowed to dry. If any alum residue remains in the mold, remove it by tapping.

Low-melting materials that may be used

to make finished castings include a metal called Cerrolow, thermo-setting plastics, regular casting plaster and other compounds which do not require heating the mold beyond 150 deg. F. Before each casting is made, the mold cavity should be brushed with a mixture of 7 parts of kerosene and 5 parts of stearic acid. In addition to cleaning the mold surface, this mixture serves as a parting agent. In filling the mold, care should be used to pour the liquid down the side of the mold so that the lowest parts of the mold will be filled first, forcing any air bubbles to the top. Pouring should be done steadily without splashing. When the flexible mold has served its purpose, it can be melted and the material used again.

Finishing the book ends can be done with pastel enamels or bronzing powders. A glaze-like finish in shiny black makes an attractive pottery-type job. If plain plaster is used to cast the hand, it should be sized with shellac before painting to seal the porous surfaces. Apply several coats of paint to build up a smooth heavy finish.

## Colorful Window-Shade Pulls Utilize Spools and Beads



Two wooden beads, an empty thread spool and a length of cord can be combined to provide an attractive shade pull. Select beads and cord of the desired color and paint the spool to match or contrast to suit your taste. Wind the cord around the spool, tucking the ends under a few turns to hold them tight. Then tie a knot in the end of another length of matching cord, string one of the beads, the spool and the other bead on the cord and tie another knot to hold the parts securely together. Then, simply tie the cord to the shade. If you don't wish to paint the spool, it can be wound and then the exposed ends colored with crayon.

## Metal Loop on Receptacle Plate Snubs Appliance Cord

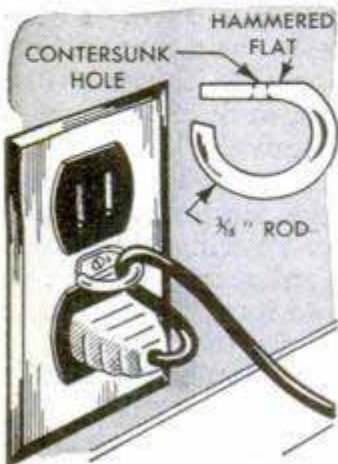

Attached to the plate of a wall receptacle, this metal loop anchors the plug of a portable tool or vacuum cleaner so that it is not pulled from the receptacle whenever the slightest tension is exerted on the cord. The loop is bent from  $\frac{3}{16}$ -in. rod, one end being flattened and drilled to receive the mounting screw of the receptacle plate. The hole is countersunk for the head of the screw. Note that the space between the ends of the

loop must be sufficient to permit passage of the appliance cord. If necessary, extension cords from both outlets can be snubbed simultaneously with the metal loop.

Arthur Trauffer, Council Bluffs, Iowa.

## Neckties Carried in Suitcase Protected by Magazine

When taking a couple of spare neckties on a trip, use a magazine to protect them from becoming wrinkled in the suitcase. Lay the ties flat between the pages of the magazine as shown.



## Floating Jackshaft for Wood Lathe Facilitates Shifting V-Belts

To make it easier to shift the V-belt on my wood lathe when changing speeds, I made this floating jackshaft. The jackshaft maintains tension on the belt and also increases its life, as the belt does not have to be forced over the edges of the pulleys when making changes. The shaft assembly is mounted on a floating hardwood base which slides back and forth on steel rods fastened with nuts between angle-iron mounting brackets. A compression spring

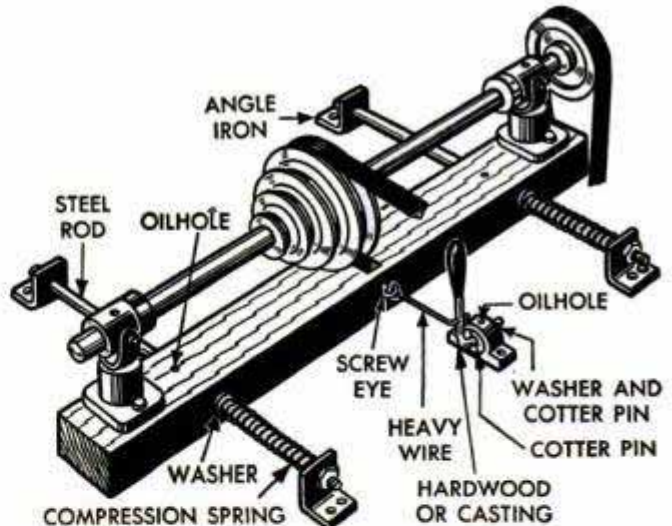

on each rod maintains tension on the V-belt, and this is relieved for shifting the belt by pulling the lever shown in the detail. Note that oilholes are drilled through the base to permit lubricating the sliding mechanism, and also that the jackshaft must be driven from below. If the jackshaft handle is fitted with a hold-down to lock it in the forward position, the lathe can be stopped for frequently checking the work without turning off the motor.

Edward C. Robare, North Adams, Mass.

Used individually as a centerpiece for the small table or in pairs on a buffet or larger table, these plastic and aluminum candleholders will add a touch of elegance to your dining room. The base of the candleholder is a block of transparent plastic approximately 1 in. thick x 3 in. square. After a 1-in.-dia. hole has been bored through the center of the base, the latter is polished to a high luster. Then a 3-in. length of 1-in.-o.d. polished aluminum tubing is pressed into the hole in the base. The hole should be slightly undersize so the tubing is a snug fit. The leaf design is laid out on a sheet of paper according to the half pattern and the paper is cemented temporarily to a sheet of .064-ga. soft aluminum. The sheet metal is cut out roughly, drilling holes at the center ring and also at the small radii to facilitate cutting. After roughing out, the edges are finished to exact shape with fine files. The leaves can be veined by tapping a dull screwdriver blade along lines penciled on the sheet metal. The metal is polished and the leaves curved gracefully, the stems being bent upward as shown in the detail. When the leaves are

## Decorative Candleholder Has Clear Plastic Base Surmounted by Polished-Aluminum Leaf Design

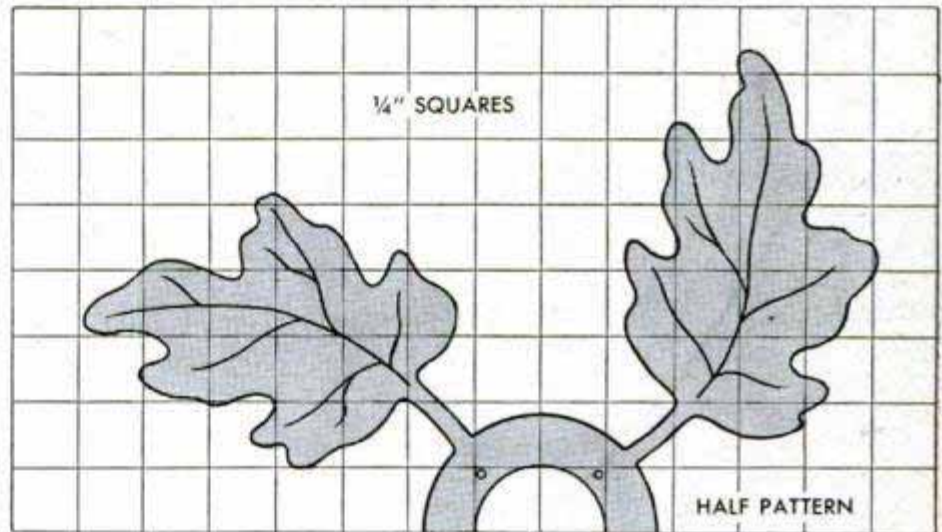
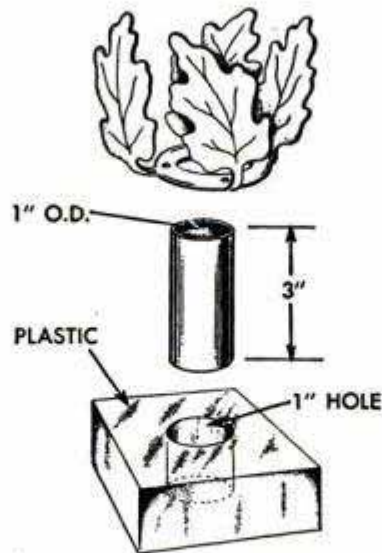

finished, the center ring is slipped over the aluminum tubing and fastened to the plastic base with roundheaded screws driven into undersize holes in the plastic.

finished, the center ring is slipped over the aluminum tubing and fastened to the plastic base with roundheaded screws driven into undersize holes in the plastic.

## Simple Decoy for Crow Hunters Easily Shaped From a Wire Coat Hanger

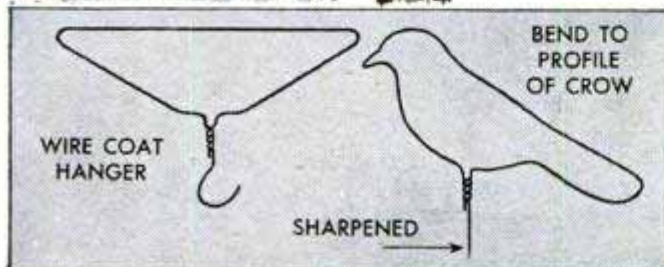

A wire frame bent to the profile of a crow and covered with black cloth results in a quickly made decoy that will lure flocks of crows within shotgun range. Bend the frame from a wire coat hanger, straighten the hook and sharpen the end. Then, cover the frame with a piece of black cloth or a black stocking and press the pointed end of the wire into the top of a fence post or stump. The decoy will bring flocks of crows within range and their excited cawing will lure other crows to the vicinity.

R. A. Jenkins, St. Louis, Mo.

☞ To restore the appearance of parchment-paper shades, first remove dirt with wall-paper cleaner and then rebind the edges of the shades with ribbon or gummed tape.

# FUNNY FACES

As favors at a children's party, these comic heads will bring squeals of delight—and they're so simple that a child can make them. Using the same general idea, a clever adult can fashion hilarious caricatures of friends to provide entertaining place cards

By W. A. Simpson

USING ordinary school drawing paper and coloring with crayon or water color, a number of these original party favors can be turned out in a short time. Making them also affords an entertaining pastime for the youngsters who, after once getting the knack of it, can give free rein to their imaginations and artistic abilities. The first step is to mark off a sheet of paper in squares of the desired size as shown on the opposite page. Use a pencil and mark lightly so the lines can be erased later without difficulty. Then draw the eyes, ears, nose, etc. with pen and ink or directly with color and completely color the design. Cut the head from the sheet as indicated by the solid vertical line and then cut out around the hair and ears. The ears are cut along the solid lines and folded forward along the dotted lines. Cut the necessary slots in the head and cut out the nose and accessories. Assemble and glue the ends of the head to form a cylinder.

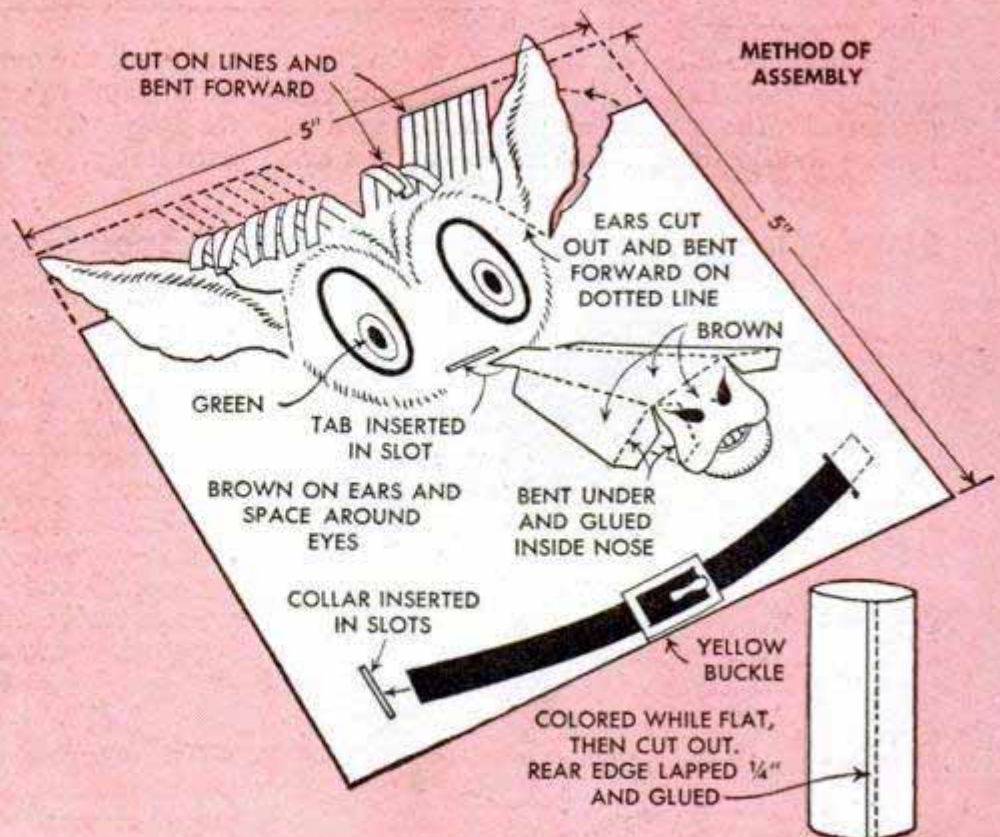



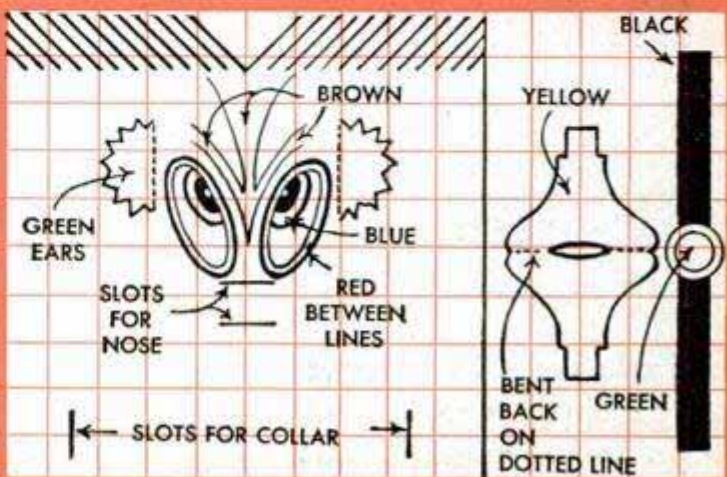
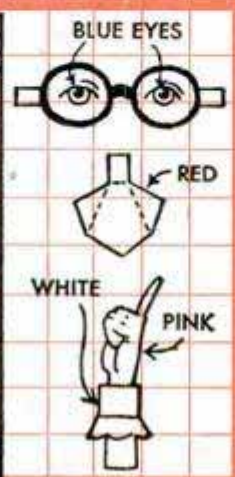
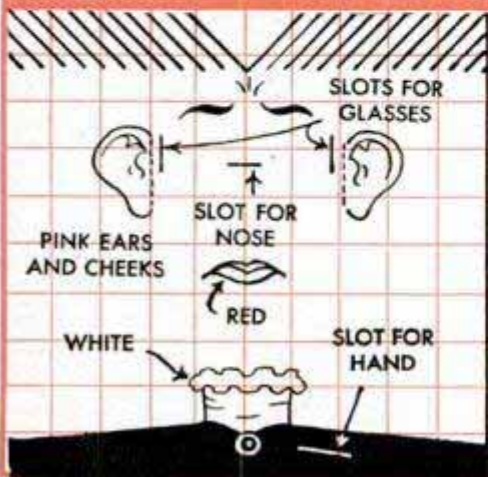
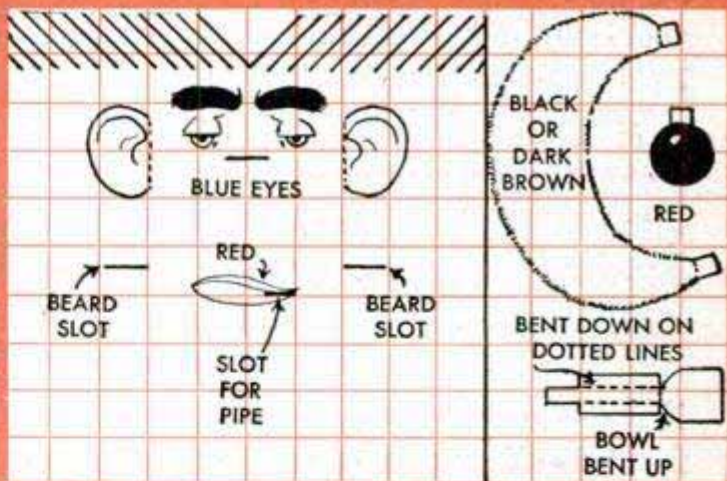
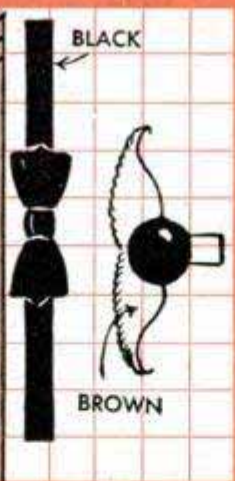
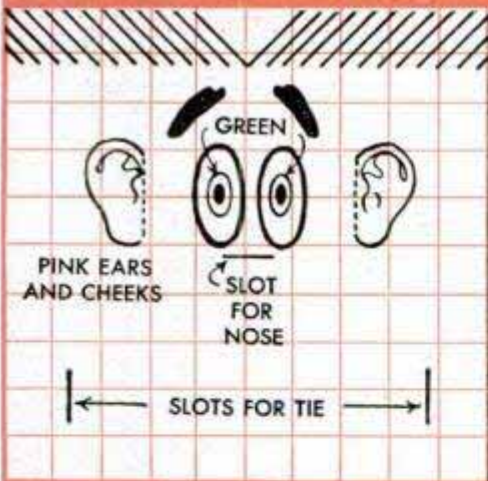
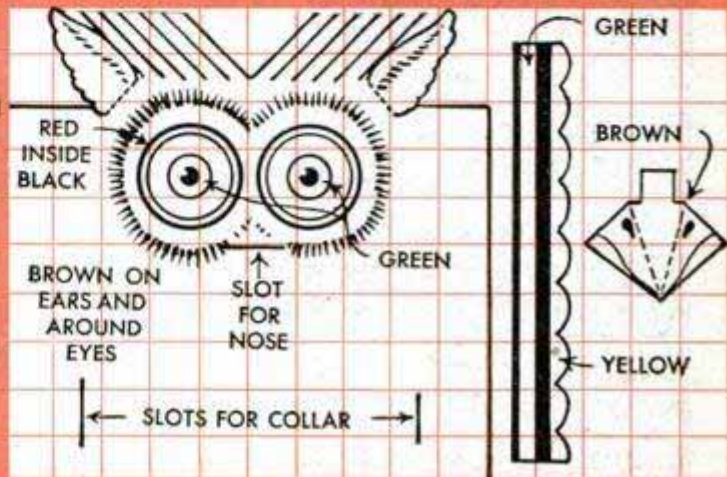
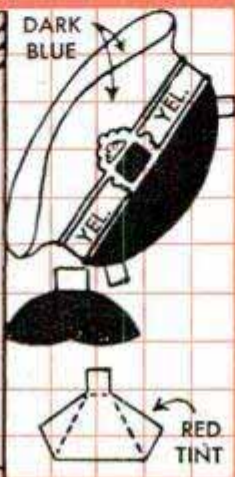
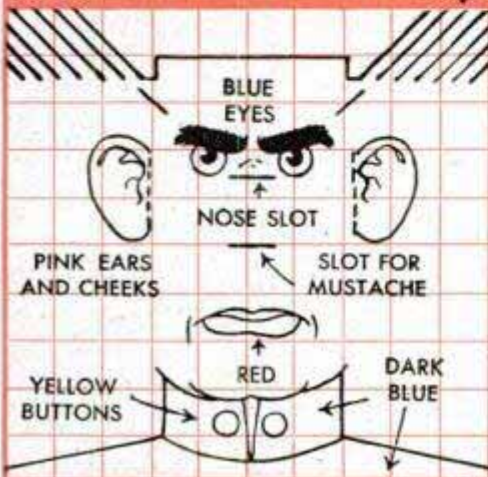
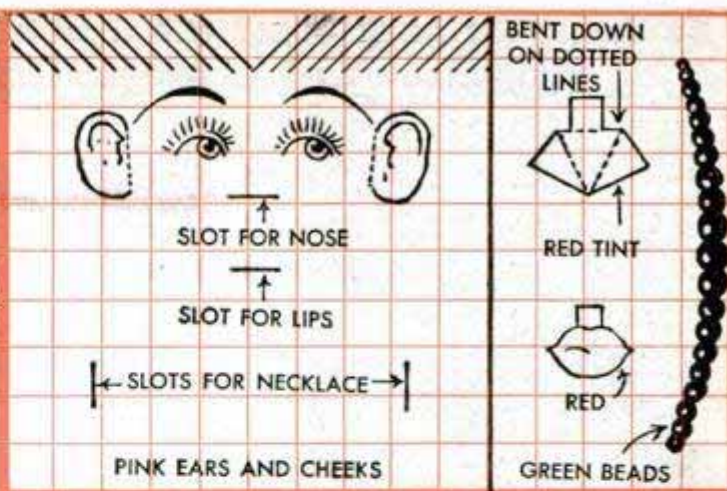
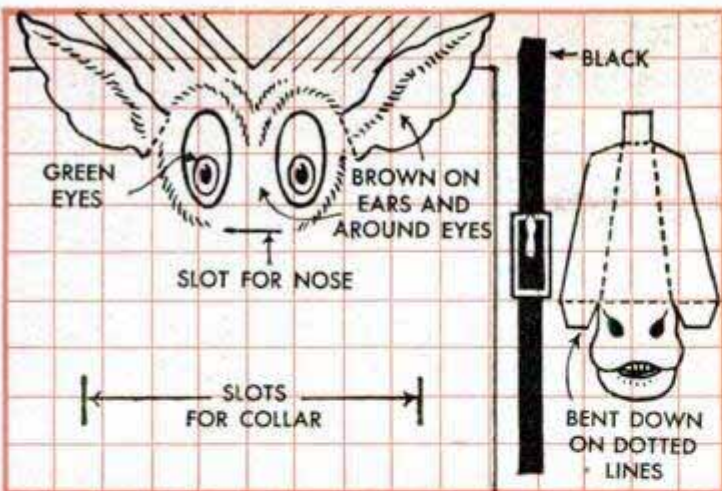

## Vertical Shoe Rack Conserves Closet Space When Mounted in Convenient Spot on Wall

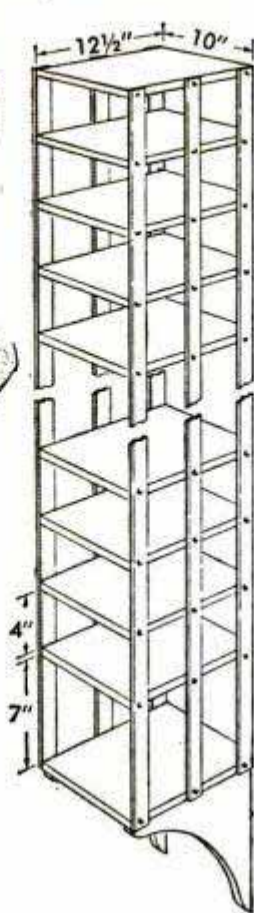

You won't stumble over shoes lying on the closet floor if you install this handy wall rack which holds 10 or more pairs of shoes. The rack is only 10 in. wide and projects 12½ in. from the wall. The height of the lower shelf is 7 in. for high-heel or work shoes and the remaining shelves are 4 in. high. These dimensions, of course, may be varied to suit the style of shoes commonly worn by members of the household. The curved mounting bracket and shelves are made of ½-in. stock or plywood, and three strips of lattice stock on each side hold the unit intact. The mounting bracket is screwed to the wall just above the baseboard, and the top of the unit is simply nailed to the wall or fastened with steel angle irons.—A. J. Price, Canandaigua, N. Y.

## Sawdust Sprinkled Evenly Over Wet Varnish Provides Nonslip Boat Deck

The slippery deck of a sailboat or shell-type iceboat can be given a nonslip surface by coating the dangerous areas with sawdust embedded in wet varnish. If the deck has been newly finished, allow the varnish to dry completely. Then, apply a second coat of varnish to the areas where a nonslip surface is desired. Sprinkle sawdust or coarse sand evenly over the wet varnish and allow to dry thoroughly before using.

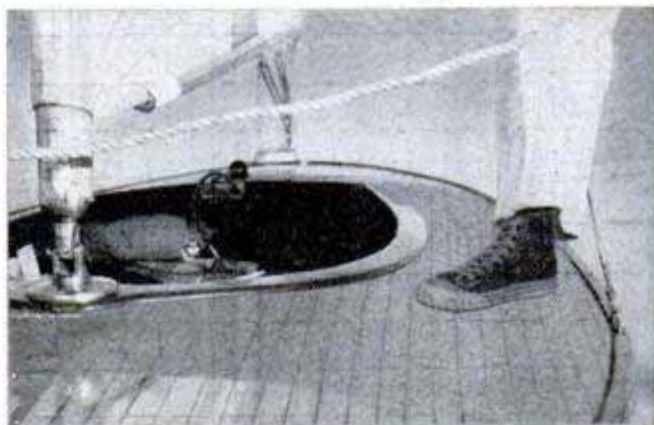

## Toolbox Handle Serves as Reel For Winding Extension Cord

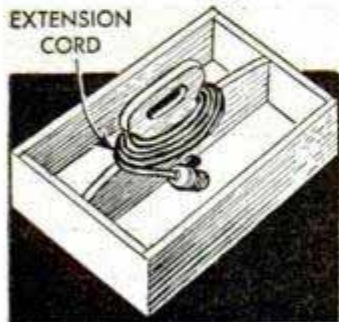

To keep an extension cord from becoming tangled and sometimes buried under an assortment of tools when stored loosely in a toolbox, one man made the center partition of his toolbox into a combination handle and reel. The partition is jigsawed from one piece in the shape shown, a handhole being cut in the top.

Colorful bubbles can be blown by adding a drop of glycerin to the soap solution.

Colorful bubbles can be blown by adding a drop of glycerin to the soap solution.

## Foot Switch Operates Saw

In order to facilitate starting and stopping his bench saw, when both hands are used to hold the work, one craftsman utilizes a high-low dimmer switch from a car to provide a foot switch. The switch is wired in series with the saw motor, one side being "open" and the other "closed."—Leonard Reed, Natick, Mass.

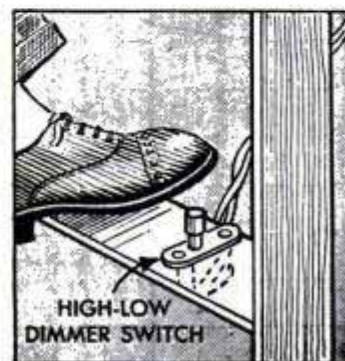

Novel decorative effects are attained by cutting spiral grooves in lengths of dowel. Actually, doing this is easier than you might think, as the job can be done on a circular saw with the simple addition of a wooden fence on the miter gauge. Use a fine-toothed saw and set the miter gauge at an angle, moving the gauge forward so the saw will cut a groove to the desired depth and locking it in place with a C-clamp. Setting the miter gauge at an angle of 75 deg. permits cutting  $\frac{1}{16}$ -in.-deep grooves  $\frac{7}{32}$  in. apart in a 1-in. dowel. An angle of 45 deg. with a 1-in. dowel will result in a spiral about  $\frac{3}{8}$  in. wide and the grooves spaced  $\frac{3}{4}$  in. apart. The appearance of these two spirals is illustrated in the photo. However, various spirals on different sizes of dowel can be determined by experiment. To cut the spiral, hold the dowel against the fence and feed it into the saw, turning it slowly in a clockwise direction. When the spiral has been cut one full turn around the dowel, stop the saw and drive a finishing nail into the fence, as shown, so it will ride in the

## Board Fastened to Bench-Saw Miter Gauge Serves as Guide Fence for Cutting Spirals

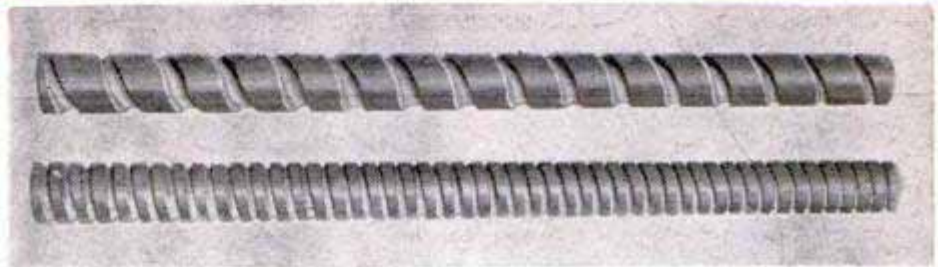
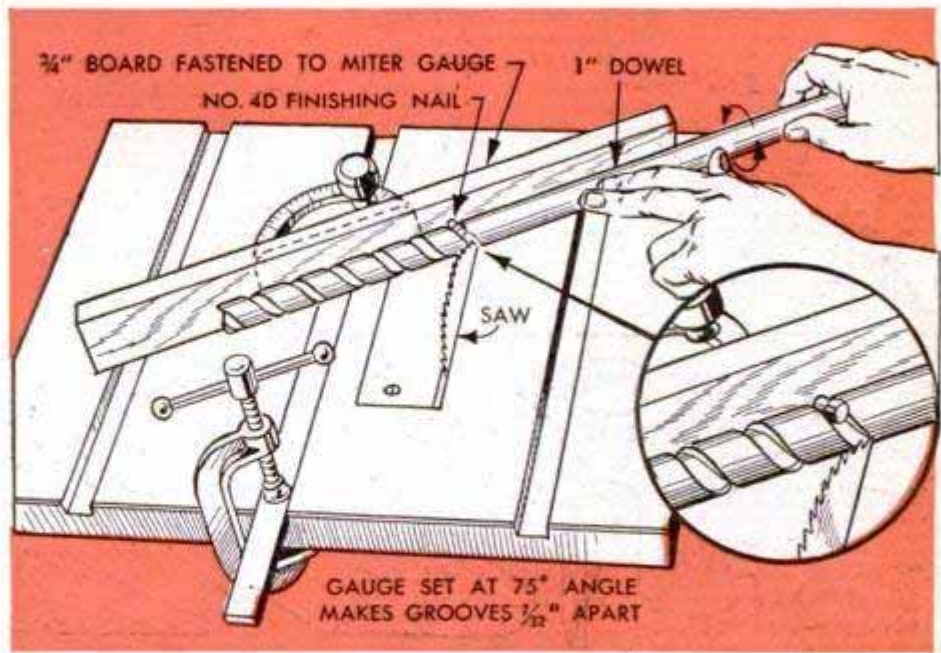

groove. When the saw is turned on and the work fed into it as before, the nail will keep the spacing of the grooves even. After being cut, the grooves can be smoothed with a file and finished with sandpaper, the corners left sharp or rounded as desired.

Dick Hutchinson, El Monte, Calif.

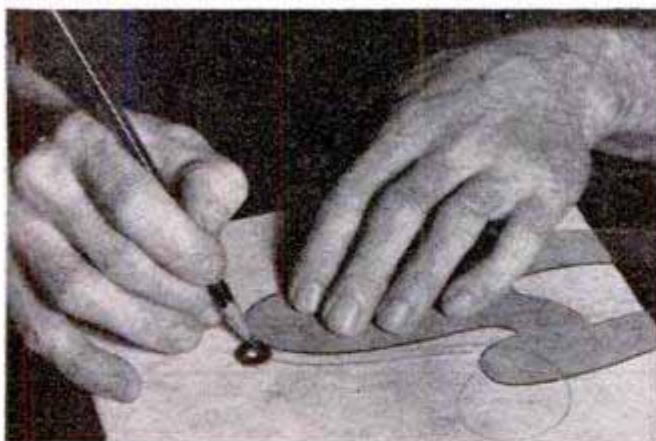

## Washer Facilitates Scroll Layout

When laying out a scroll cutout design, the distance between the lines can be kept uniform throughout by using a washer as shown in the photograph. After the first line is drawn in with a curve, the latter is left in place while the second line is drawn. Washers of different sizes can be used to suit various requirements.

## Cord of Drill Press Concealed By Passing Through Column

If a drill-press extension cord hangs loosely from the motor and interferes with working in the vicinity of the machine, the cord can be concealed by running it through the column of the drill press. A hole is drilled through the top of the workbench or stand directly beneath the column. Then, the cord is brought down the bench top and wired to a switch.

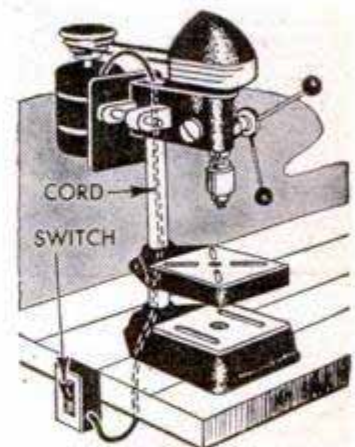

Mrs. Florence Kohl, Houston, Tex.

Ⓛ Dampen ashes before sprinkling them on icy walks so they will not be blown away.

## TOOLS

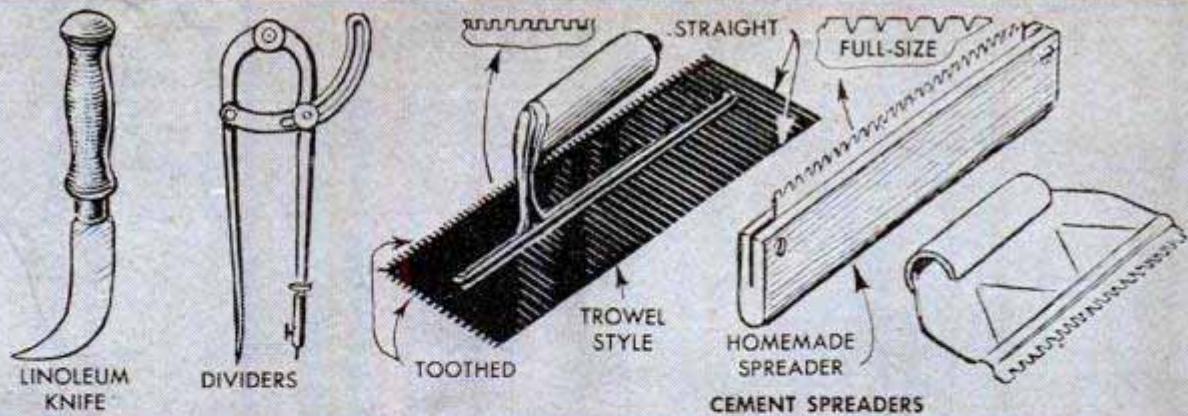

## LINOLEUM

(STANDARD SIZES AND TYPES OF BASES)

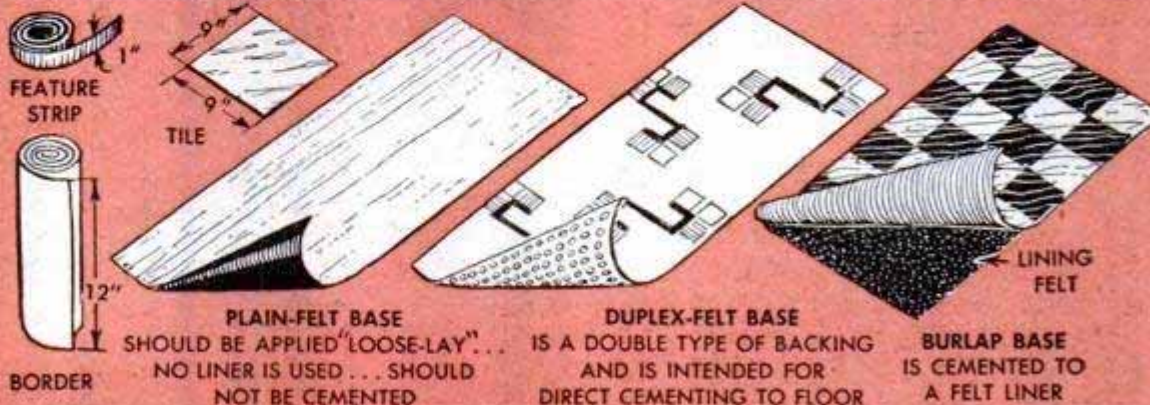

## LINOLEUM

(THE DESIGN)

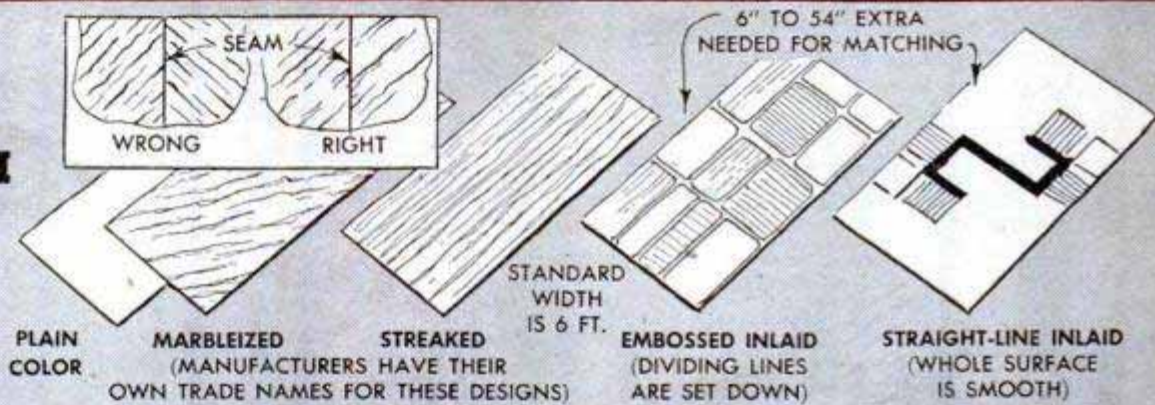

## FIRST POINTERS IN LAYING



## METHODS OF LAYING

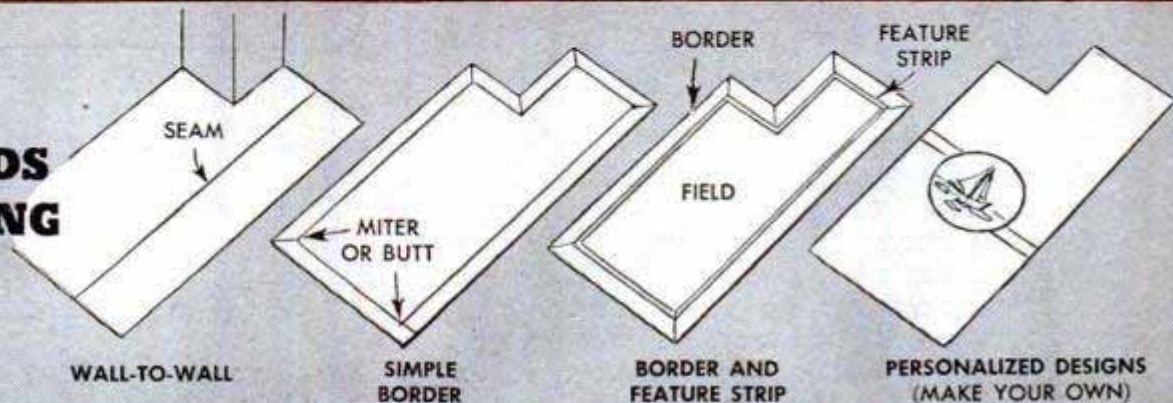

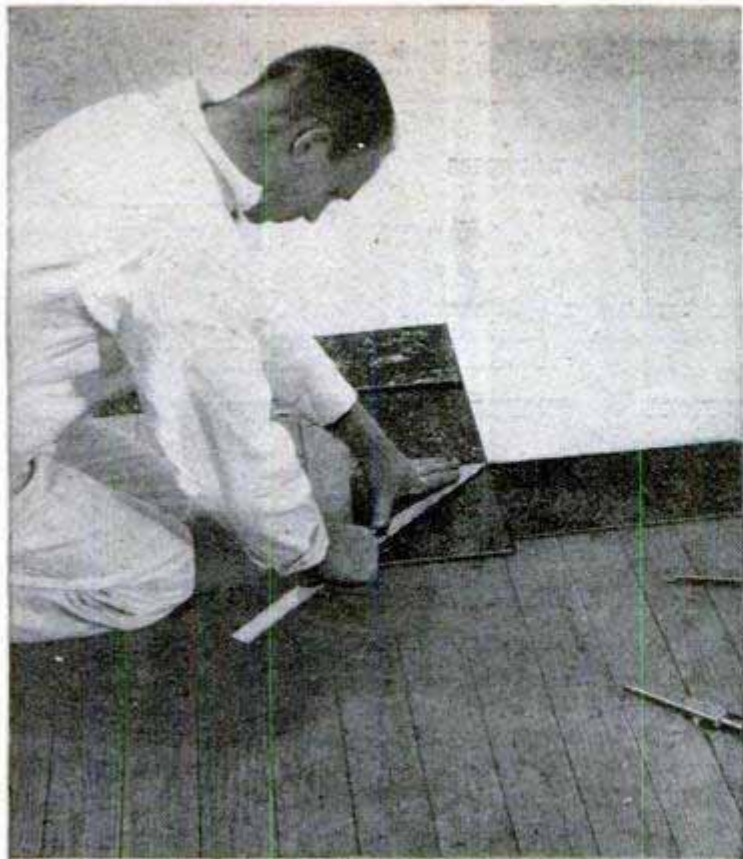

Courtesy Congoleum Nairn, Inc.



# Lay Your Own **LINOLEUM**

By **Sam Brown**

## Part I

**L**AYING your own linoleum is one of the most satisfying of all homecraft jobs because definite results can be accomplished in a comparatively short time. The money saved makes it well worth-while to do the work yourself and the approved procedures are so easy to apply that, by following a few simple directions, you can expect a good floor, even on the first job.

**Types of linoleum:** First of all, study the sketches on the opposite page which cover the fundamental procedure. Then decide what kind of linoleum you want. The cheapest material has a plain felt base and the pattern is usually a printed enamel. This type of floor covering must always be applied "loose-lay," that is, not cemented or tacked to the floor, because it must be free to expand. A better grade comes with a duplex felt back and can be applied either loose-lay or cemented directly to the floor. The best grade of linoleum is built up on a burlap base and is always cemented over a lining felt. All linoleum is stiff and brittle when cold and should not be unrolled until warmed to a temperature of 70 deg. for at least 24 hours. When it is practical to do so, it also is a good idea to allow the linoleum to lie flat for another 24 hrs. after unrolling. In this way, all danger of breaks in

the surface of the linoleum will be avoided.

**Laying wall-to-wall:** This is the most common application and is illustrated by the details on the following page, which also explain the basic operation of scribing. Scribing simply means marking the linoleum to a shape and size to fit the room in which it is to be laid. It is done with a pair of dividers of the type used in woodworking, or with special dividers made for linoleum work. The latter tool is called an overscriber. In laying linoleum floor covering wall-to-wall, begin by removing the shoe mold at the bottom of the baseboard. If the floor is rough, with offsets at the joints, it should either be sanded or planed smooth. Then, cut the first sheet of linoleum about 4 in. larger than needed and fit it in place against one wall, letting the ends ride up on the baseboard. Follow through with the procedure pictured in Figs. 1 to 4 inclusive, which show the methods of scribing quite clearly. A close fit against the baseboards is not advisable in ordinary wall-to-wall installation. It is best to allow at least  $\frac{1}{8}$  in., or better,  $\frac{1}{4}$  in. all around. The gap will be covered when the shoe mold is replaced. Most wall-to-wall jobs will require fitting the linoleum into at least one doorway. If the doorway is of the arched type or if it is fitted with a swinging door, it is common practice to extend the linoleum halfway through. Otherwise, the linoleum is ended at the

# SCRIBING IS BASIC OPERATION ON ALL JOBS

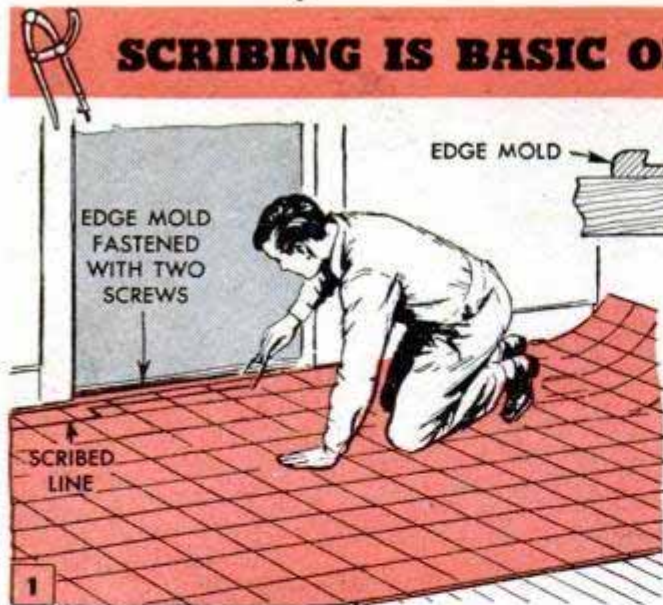

Cut linoleum 4 in. over required length. Lay on the floor with one side about 1 in. from wall and let both ends ride over baseboard. Set dividers at the required opening (Fig. 2) and, with one point of the dividers in contact with baseboard, scribe the line

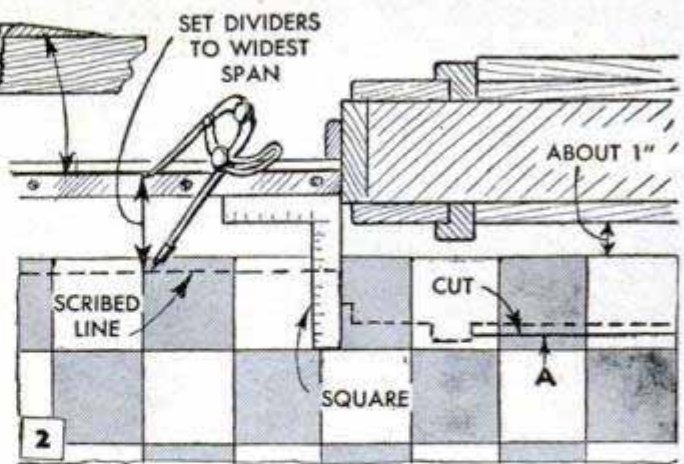

When scribing to fit a doorway, metal edge molding can be temporarily fastened in place with two screws to serve as a guide. Shoe mold will cover the cut at A, so linoleum can be cut from  $\frac{1}{8}$  to  $\frac{1}{4}$  in. beyond the scribed-to-wall mark, making piece easy to fit

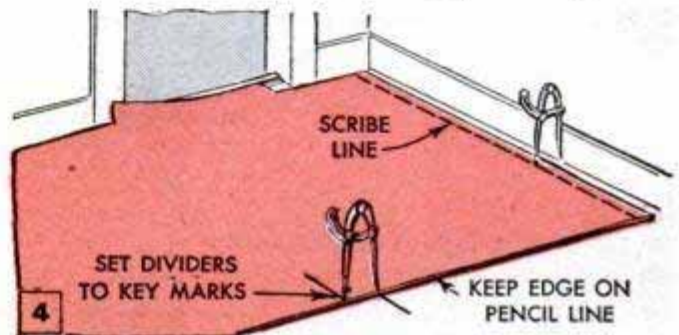
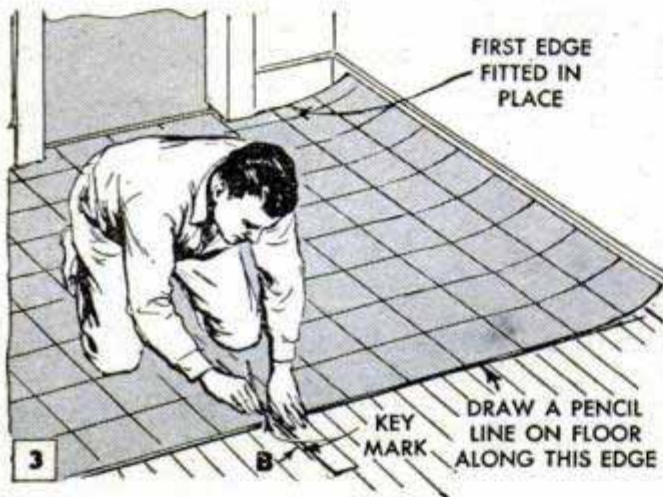

Shift the linoleum lengthwise until it clears one end wall. Set dividers to the exact distance between the key marks and scribe the end wall at this setting

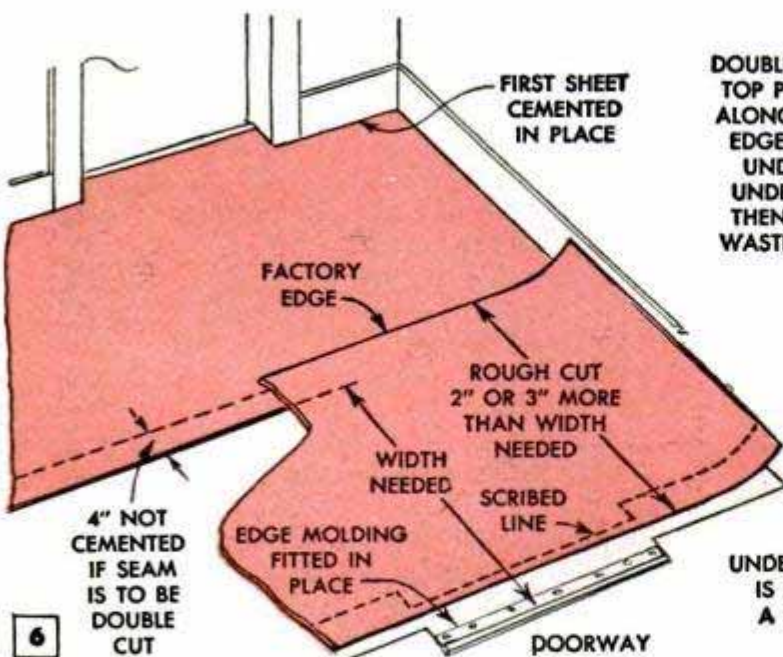

Measure width needed for second sheet and cut linoleum over the required width. Place about 1 in. from wall and scribe as before, using the method in Fig. 2 when doorway is involved. This method is not used on patterned goods as it will destroy pattern register

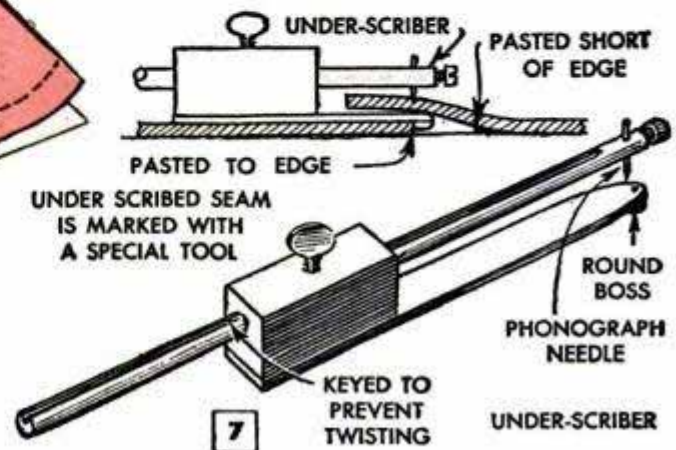
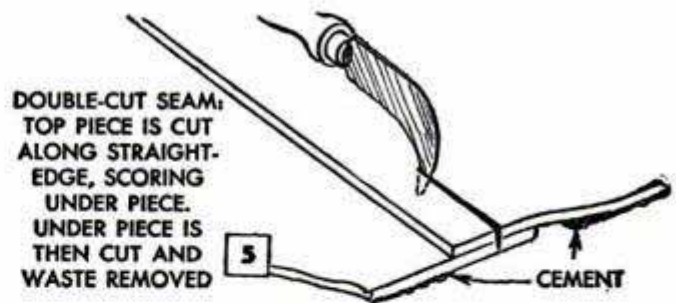

doorstop, Fig. 2. The edge should be protected with a metal molding of the type shown in the upper detail, Fig. 2. This can be fitted before or after laying the linoleum, as desired. As suggested in Fig. 1, fasten the mold with two screws and then scribe to it. If required, it then can be shifted easily.

**Laying second sheet:** The second sheet is fitted as shown in Figs. 5 and 6. When rough trimming the second sheet, be sure to scribe and make the cut parallel with the opposite edge. When fitted in place, the edge at the seam should be parallel with the wall. After fitting the second sheet, there will be an overlap where the two pieces come together, Fig. 6. A neat butt joint, or seam, is made by double cutting as in Fig. 5. A recommended alternate method involves the use of a special tool called an under-scriber, Fig. 7. This tool speeds the scribing job and assures accuracy. When the under-scriber is pulled along with the round boss riding against the edge of the under sheet, the pointer scribes a mark on the top sheet directly above the edge of the under sheet. The top sheet is then cut on the scribed line for a perfect fit. The seam-cutting method used will affect the manner of applying the cement. If the seam is made by double cutting, both edges are left uncemented for a distance of about 4 in. from the edges. After cutting, cement is spread under the projections to complete the job. If an under-scriber is used, the first sheet is cemented to the edge as in Fig. 7. When using either method of cutting, avoid fitting the seam too tightly. It is better to leave them a little loose to prevent ridging or buckling. Then, after cleaning up the surplus cement with a damp cloth, press the edges down to a perfect fit by rubbing with a hammer head covered with a soft cloth.

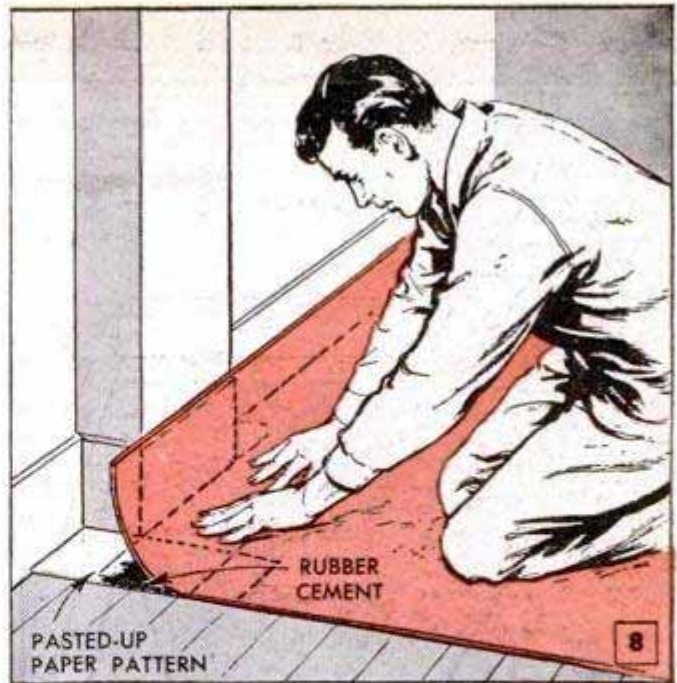

Paper pattern is used for transferring odd shapes



Above, border is scribed to fit contour of the wall. Below, joint is double-cut to produce a perfect fit



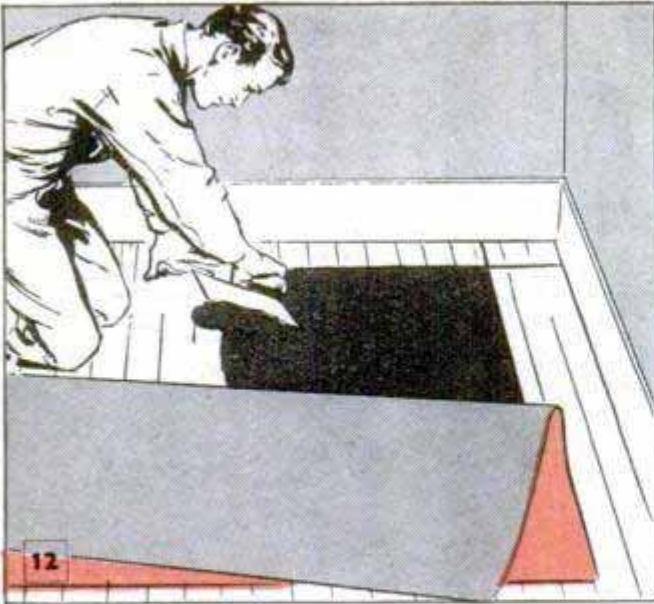

Cement for linoleum field is spread to the chalk line



Above, a straightedge is used to trim field linoleum. Below, scribe is set to exact width of feature strip

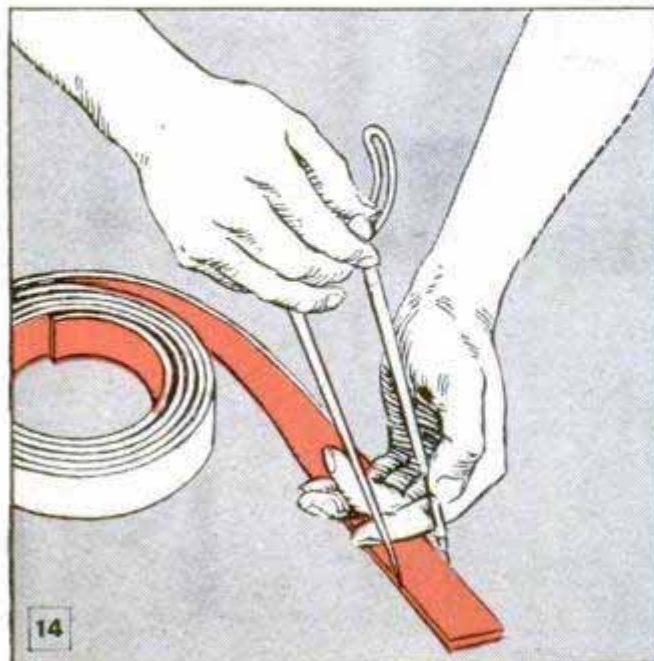

**Fitting with paper pattern:** Sometimes you will run into a job that is difficult or impractical to scribe by ordinary methods. In this case, use of a paper pattern probably will be the solution. To build up the pattern, cut and paste pieces of heavy paper or cardboard together to form the exact shape you want the linoleum to be. Then apply rubber cement or linoleum cement to the face of the pattern and roll the linoleum onto it so that the two stick together firmly, Fig. 8. Then turn the linoleum over and you have the required cutting pattern cemented to the back. This method also works out well when fitting linoleum having a figure or design imprinted or inlaid. In this case, you cannot cut to form a seam in the usual way as this may destroy the design register. Using the paper pattern, the linoleum is cut a little over the required width, the second sheet is butted against the first sheet and then rolled to the wall where it picks up the paper pattern.

**Fitting simple border:** In nearly all border jobs, you have the choice of laying either the field or the border first. Figs. 9, 10 and 11 show the border laid first. Chalk a line all around the room an equal distance from the walls. Use either the scribing or paper-pattern method for marking the border pieces at doorways. After the pieces have been cut out, place them in position and check for fit. Then remove the pieces, one at a time, and spread cement under each one out to the chalk line. Replace all pieces and double-cut the corner seams, using either a miter or plain butt

Place the border against field and scribe to wall, making sure strip does not buckle while being scribed





joint at the corners. Although the miter joint wastes more material, it is by far the neatest and most attractive. After the border has been cemented down, clean up all excess cement and then rough-cut the field material 1 to 2 in. oversize, except, if desired, one factory edge, which can be butted to the border. On the remaining edges use the under-scriber, Fig. 10, to mark a line for the cut above the border. Cut on the scribed lines and finish cementing at the edges of the field. Clean up with a damp cloth and then rub down all joints with a hammer head.

**Border and feature strip:** This attractive style, Fig. 17, requires only a little more time to lay than does the simple border. The method pictured in Figs. 15 to 20 inclusive calls for laying the field first, a procedure which many workers prefer for this installation. Chalk a line around the room a distance from the walls equal to the combined width of the border and strip. Butt one factory edge of the field to the line and trim the other edges about 1 in. oversize. Roll the material back and spread the cement, first on one half of the floor, then on the other, Fig. 12. Be sure to keep the cement inside the line. Bed the linoleum in the cement, pick up the chalk marks with a straightedge and cut the field to the required net size, Fig. 13. Then sand-bag the field and clamp the edges with wooden strips nailed to the floor, Fig. 19. Allow to stand for 24 hrs. Border pieces are now trimmed to a width of about  $\frac{1}{2}$  in. less than the distance between the edge of the field and the wall, Fig. 18. Set the scribe (dividers) to the width of the feature strip, Fig. 14, and, with the border



If essential measurements have been properly made, border and feature strip will fit opening accurately

pressed tightly against the field, scribe as in Fig. 20. If all measurements have been made correctly, the border and feature strip will fit neatly into the opening as in Fig. 16. It should be noted that in border work, the border itself is scribed net to the wall without a gap. The slight pressure fit thus obtained helps to get a good, tight joint between the border and feature strip and between the strip and the field. In some jobs involving a border of the same pattern and color as the field, the linoleum is laid wall-to-wall and the feature strip is cut in. This procedure is sometimes advantageous, depending on the size of the room and the distance from the wall to the strip. Make suitable allowances at the baseboard.

(To be continued)

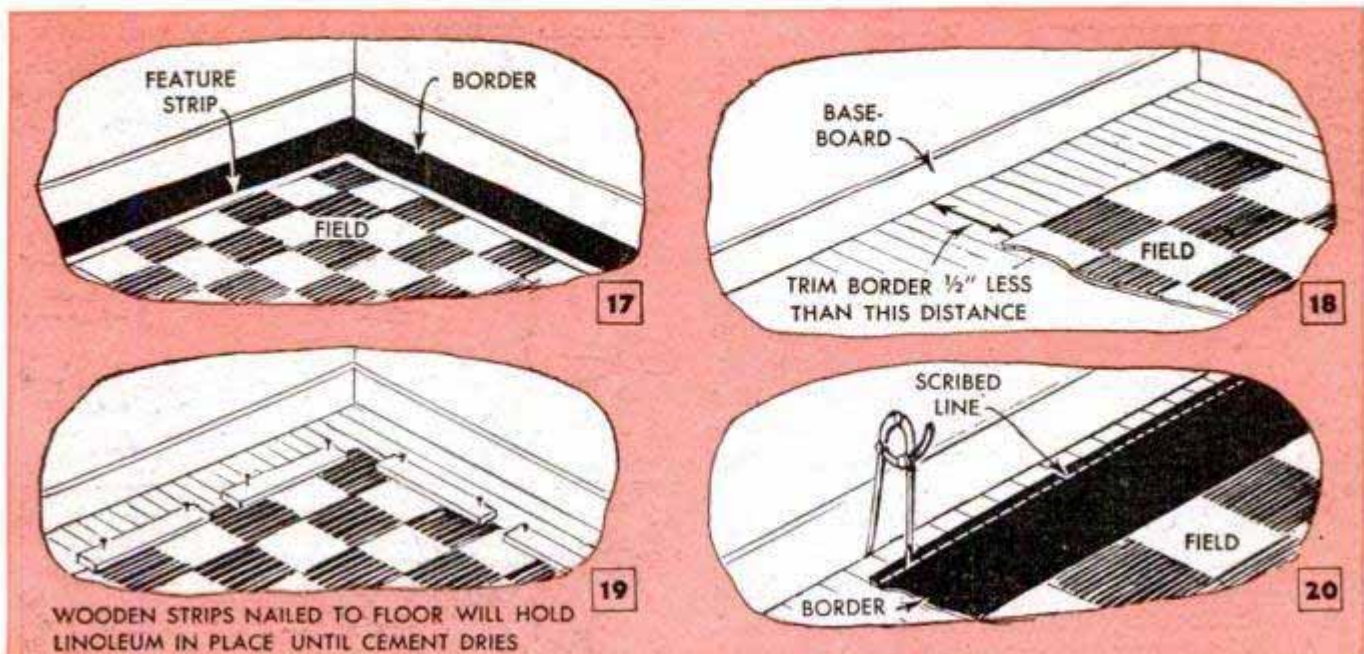

WOODEN STRIPS NAILED TO FLOOR WILL HOLD LINOLEUM IN PLACE UNTIL CEMENT DRIES

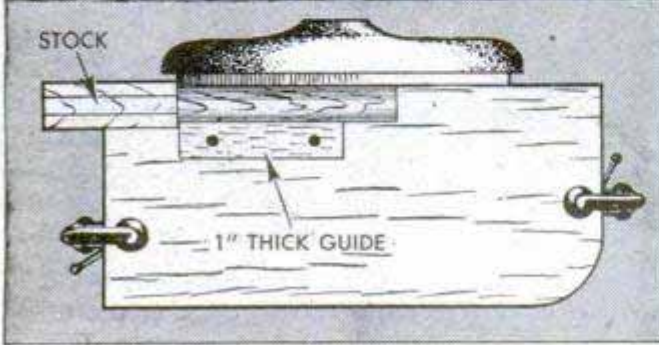
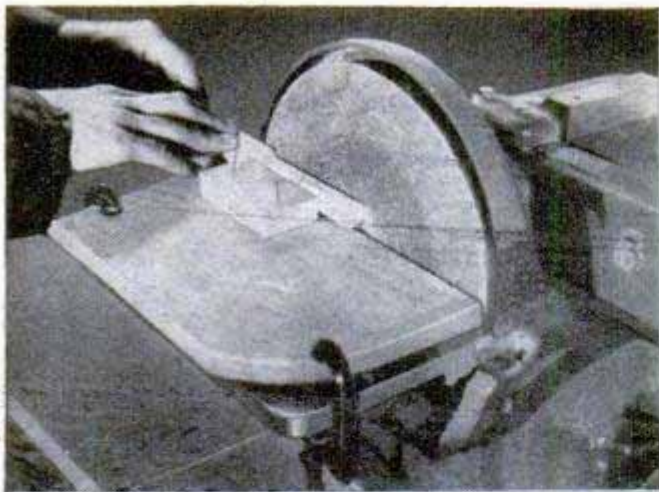

### Turning Dowels on Disk Sander

You don't need a lathe to turn tenons and lengths of dowel if your shop is equipped with a disk sander. Just use a board and cleat clamped to the sander table to aid in holding the square stock against the sanding disk. Tack the cleat close enough to the face of the disk to serve as a rest for roughing off the corners of the work, feeding the work from one side, as pictured, and turning it slowly. Then move the cleat to within  $\frac{1}{32}$  in. over the size of dowel required and run the work through again. The work can be finished smooth with fine sandpaper.

### Horseshoe Provides Ceiling Hanger

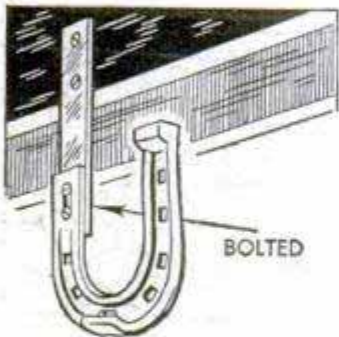

Bolted or welded to flat-iron extensions, a pair of horseshoes can be suspended from a garage ceiling to provide a convenient hanger for an extension ladder. They also can be used to form a rack for clothes poles, pipe and other hard-to-store items. One arm of the horseshoe is cut off, as shown, and the flat iron is fastened to a joist or rafter.

O. H. Hampsch, Oak Park, Ill.

☐ Brush a dust mop well with a whisk broom after using it and it will be preserved in excellent condition.

### Dress Snap Holds Fabric Samples

A number of small pieces of lightweight fabric can be fastened together with a large dress snap. This lessens the possibility of trimmings being mislaid and facilitates carrying cloth samples.



### Keeping Fingernails Clean

Especially for the office worker or salesman whose hands must look well groomed, here is a way to keep the underside of the fingernails clean while tinkering with the car or working in the basement shop. Before starting the job, wash the hands and clean the fingernails. Then scratch the nails across a bar of soap until the space under the tips of the nails is completely filled with soap. When the job is finished, wash up in the usual way and remove the soap from under the fingernails by brushing or with a nail file. The nails which have been protected by the soap will be left clean.—George L. Elston, Kirkwood, Mo.

### Sag Removed From Folding Cot By Straps at Rail Hinges

Installing a leather strap on each side of a folding cot permits spreading its center legs to remove the uncomfortable sag usually found at the center of the canvas. After the cot is set up, the straps are simply drawn tight and buckled to hold the canvas taut. Each end of the strap is fitted with a sheet-metal tab. The lower tab is screwed to the wooden cot leg and the upper one is soldered or brazed to the metal rail hinge.

Louis H. Keding, La Grange, Ill.

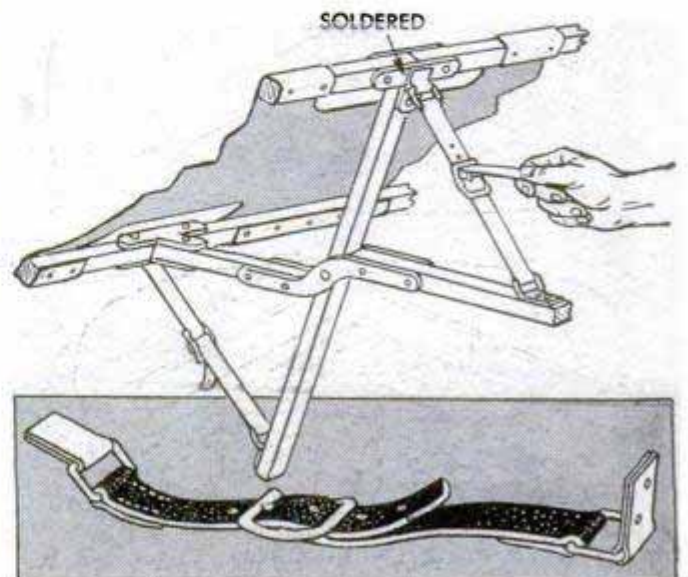

# Wall-Bracket Ivy Holder Made of Aluminum

Filled with real or artificial ivy, this aluminum plant holder is just the thing to enliven a vacant-looking spot on the wall. The bed of the holder is made from a length of 2½-in. aluminum tubing which is cut in half lengthwise. If the aluminum is the type that can be welded, half disks of sheet aluminum may be used to enclose the ends of the bed. Otherwise, pieces of hardwood fastened with escutcheon pins will serve the purpose. The

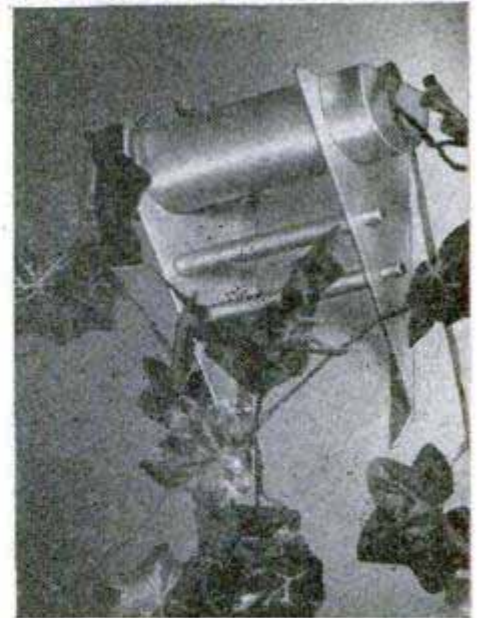
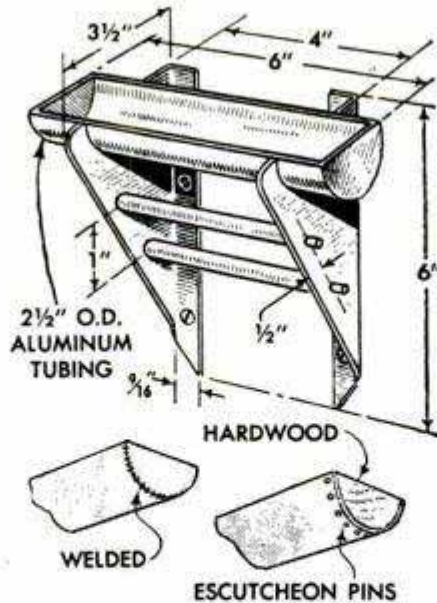

wall brackets are cut and bent from .040 or .064-ga. aluminum and then drilled for two cross braces. The brackets are bent simply by clamping them one at a time between two hardwood blocks and hammering down the edge with a rawhide mallet. Each cross brace consists of two lengths of aluminum tubing. One length, having

a ¼ in. o.d., is a press fit in the holes in the brackets and the other length, ⅜ in. o.d. and ¼ in. i.d., slips over it to provide a spacer. The inner lengths should project about ¼ in. from both sides of the brackets. The holder is finished with fine steel wool and oil and then waxed.

R. J. DeCristoforo, New York City.

## Vacuum Cleaner Plugged Into Dead Outlet Facilitates Replacing Fuse

If the basement lights are not on the same circuit as those in the main part of the house, it sometimes is difficult to tell when a blown fuse has been replaced without going back upstairs to check. To avoid

this extra trouble, plug the vacuum cleaner into one of the dead outlets. Then, by listening for the cleaner to turn on, you will know when you have replaced the right fuse.—Linda Larsen, Ludington, Mich.

## Ink-Bottle Stand Includes Handy Utility Tray Which Forms Nontip Base

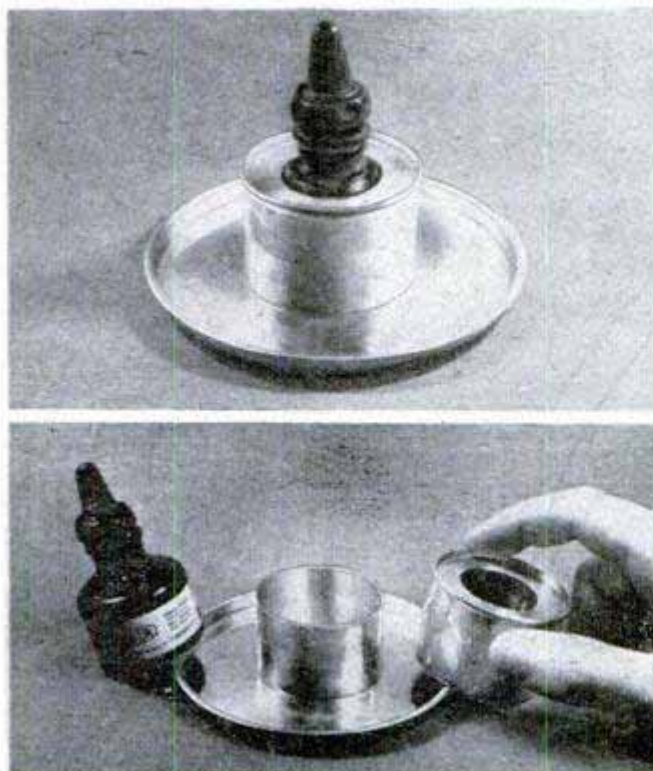

When placed on a desk or clipped to the edge of a drawing board, the wide base of this novel holder prevents accidentally tipping a bottle of drawing ink. The base also serves as a tray for holding paper clips, thumbtacks and spare pens. A large cover from a potato-chip or syrup can forms the base, or tray, and the upper portion of a small can is soldered to the center of the base to provide the container for the ink bottle. The cover which fits snugly over the bottle container is made from the bottom portion of a slightly larger can. Note that a hole is cut in the center of the cover so that it fits over the top of the ink bottle. A suitable clip for attaching the holder to a drawing board can be made by soldering a strip of spring brass to the underside of the base and bending it to fit over the edge of the board.

Robert Scott, Saltsburg, Pa.

Ⓞ Dress snaps are not damaged if they are fastened before garment is washed.

# RUBBING

## *to a final finish*

On home-shop furniture projects the final touch of the craftsman is best expressed in a hand-rubbed finish

By Rollin H. Wampler

**T**HAT GLASS-SMOOTH satiny finish you see on high-grade furniture is still done by skillful hand-rubbing with powdered abrasives. What happens to the surface of the finish during the rubbing process is shown graphically in Fig. 1. Rubbing the dry finish removes brush marks, orange peel (the wavy effect caused by spraying lacquers without the proper retarders), dust specks and bubbles. All are common defects and are almost impossible to avoid in some degree unless the finish can be applied under ideal conditions of dust-free air and rigid temperature control. The first rubbing removes defects and levels the finish, giving it a dull, flat appearance. Then the surface is brought to varying degrees of sheen, or gloss, with a flour-fine abrasive and a final polishing. In current practice the finish is left dull flat on antiques. For period furniture a semigloss is preferred but on modern designs the finish usually is rubbed to a high satin polish.

Although rubbing may be done with a cloth pad, a thick felt pad is best. Felt has just enough "give" to follow slight irregularities without danger of cutting through the finish. Powdered pumice, FFF grade or finer, is commonly used for the first rubbing. Pour the powder into a tumbler of water as in Fig. 2 and allow it to settle before pouring off the water. Mix the sediment to a creamy paste. Some finishers

Brush the paste onto the surface to be rubbed, applying it in a thin film of uniform thickness. Be sure that the brush used is clean and free from grit



BEFORE RUBBING



AFTER RUBBING

1

Pour abrasive powder into a glass tumbler about two thirds full of water and allow to settle. Then pour off most of the water and mix to a creamy paste

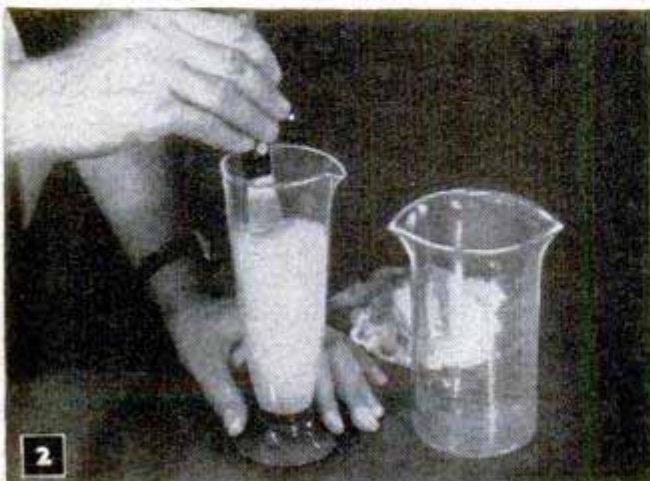

2



3

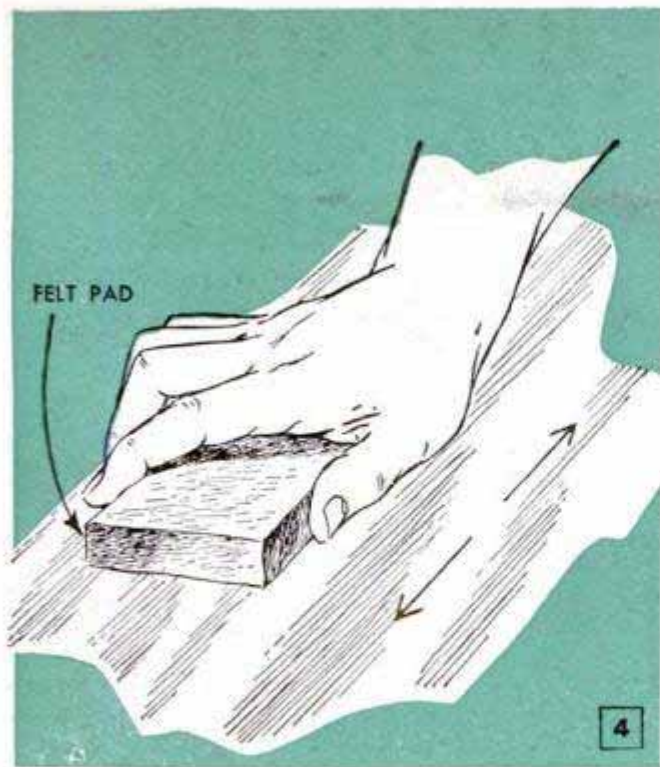

Use a felt rubbing pad for polishing flat surfaces with the grain and make sure that the pad is clean

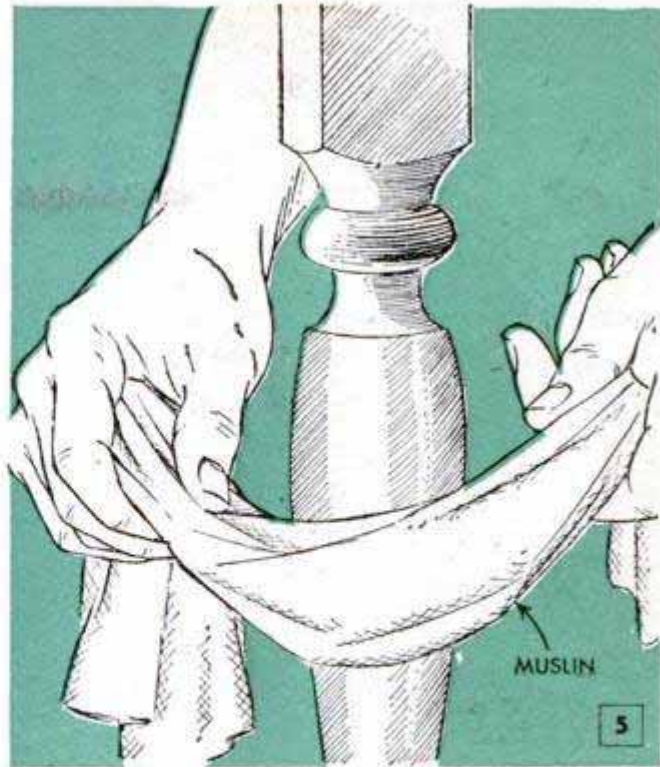

Turnings can be polished with a clean cloth charged with abrasive cream. Use only light polishing pressure

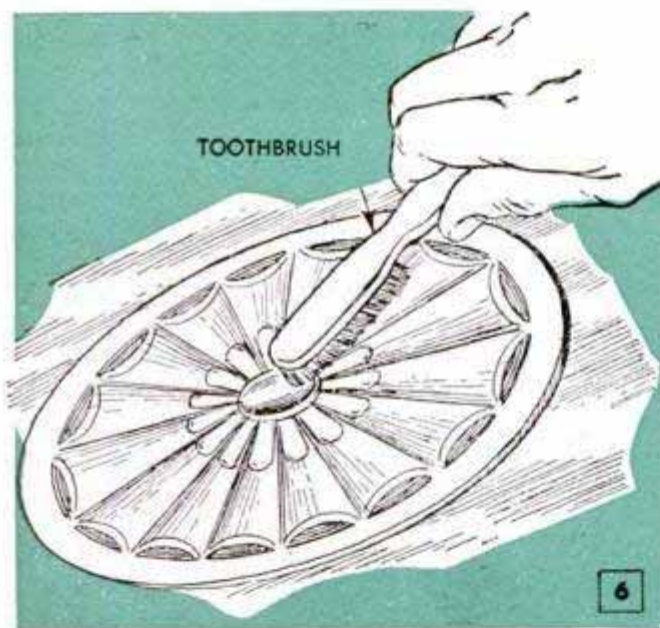

Above, paint small carvings with abrasive cream and polish with a toothbrush. Below, some finishers apply wax with a cloth pad to get a uniform coating

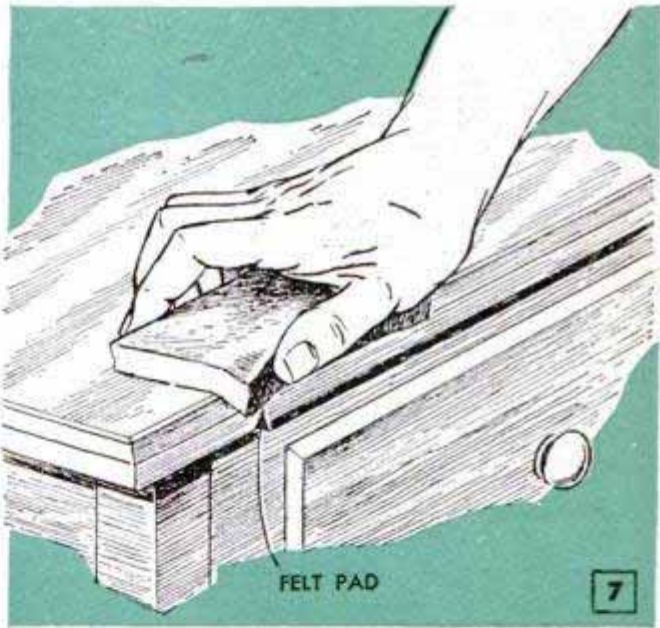

Above, be careful not to cut through finish when sanding or rubbing corners and edges. Below, some finishers prefer to apply paste wax with a steel-wool pad

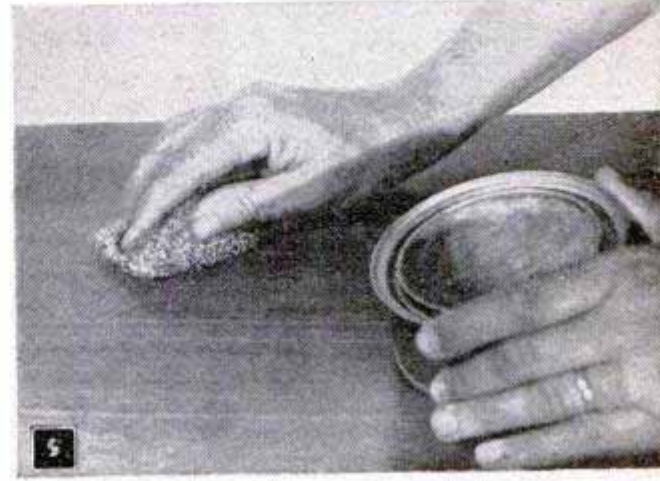

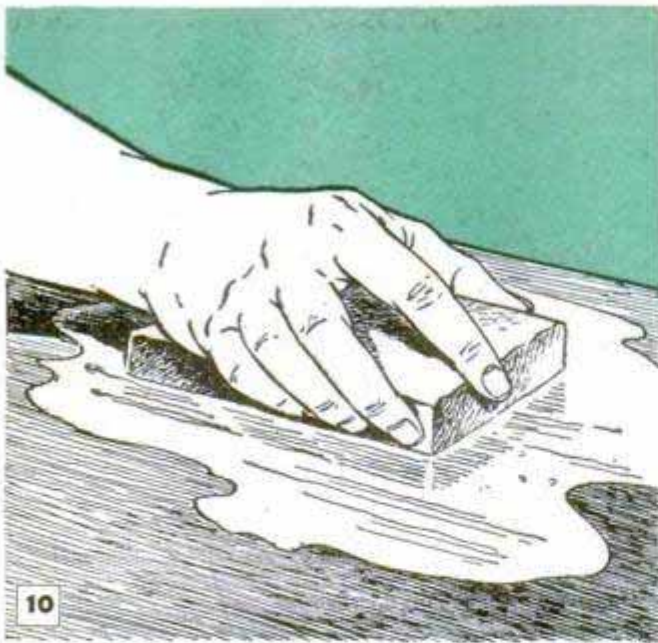

Before polishing certain types of work, finishers go over it lightly with 8/0 wet-or-dry sandpaper and oil



Expert finishers often polish varnished work simply by rubbing the surface with the palm of the hand

prefer rubbing oil instead of water. In either case, mix the powder and liquid to a creamy paste and pour or brush it on the surface to be rubbed, Fig. 3. In rubbing with the abrasive-charged felt pad, use a long sweeping stroke, Fig. 4, each stroke overlapping the previous one about half the width of the pad. Always rub with the grain on straight-grained woods and the long way of the surface on panels or tops having a burlled or butt graining. Be especially careful when working near the edge, Fig. 7, allowing the pad to overlap the edge on only one or two strokes at the most. Otherwise the abrasive may cut through the finish and expose a narrow line of bare wood. Check the progress of the work occasionally by wiping a spot clear of abrasive and examining it carefully in a good light. An easy way to determine the uniformity of the surface is to look across it obliquely. Small areas that are still rough or untouched are easily spotted in this way. When the surface is uniformly flat and feels smooth to the touch of a finger, it is ready for final polishing.

Turned legs, pressed or carved moldings and both overlay and relief carvings require a different treatment. Turnings are rubbed by means of an abrasive-charged muslin cloth as in Fig. 5, special care being taken not to rub the finish off the high places. Small carvings are rubbed with an old toothbrush after painting the surface with the abrasive cream. On large carvings a worn scrubbing brush is often used to advantage. In finishing carvings be careful to brush as much as possible lengthwise of the high places, not across them. This often will require brushing in several directions. As a rule, carvings and the short-radius portions of turnings are left in a

dull-gloss finish, rather than high luster.

Much the same procedure is used in polishing except that a finer abrasive is used. On some types of work, such as colonial designs, a high-gloss wax finish is appropriate. When wax is used, the final abrasive polishing is omitted. Most finishers apply a paste wax with a soft cloth pad as in Fig. 8, but others use a pad of fine steel wool, 0000 grade, as in Fig. 9. By continuous rubbing with the steel-wool pad a fairly heavy film of wax is built up to a uniform thickness. This can be polished to a very high gloss if desired. Before polishing certain types of work, some finishers go over it with 8/0 wet-or-dry sandpaper backed with a felt pad as in Fig. 10. Rubbing oil is applied to the surface as a lubricant and to prevent the fine abrasive paper from clogging. This treatment cuts down any high spots that may have been left by the first rubbing, and gives a flat surface of even greater uniformity. Then the surface is polished by applying a creamy paste of rottenstone and oil with a cloth pad and rubbing with long, uniform strokes. In this final step the finish can be brought to any desired sheen from dull flat to high gloss. The trick is to stop at just the right point. To do this, the finisher must check on the progress of the work at frequent intervals.

After completing one step, the work must be thoroughly cleaned in preparation for the next. Surfaces that have been rubbed or polished with an oil-abrasive mixture must be cleaned with a mild solvent to avoid the discolorations known to finishers as "blushing," or "blooming." Be sure that the finish to be rubbed is thoroughly dry. Most lacquers will require only 24 to 36 hrs. For the rubbing varnishes, 10 days to 2 weeks generally will suffice.

## Wooden Turn Button on Tool-Chest Lid Supports Doors for Planing

Needing a quick method of supporting doors and window sash on edge for planing, one craftsman in remodeling his home found that a wooden turn button fastened to the lid of his heavy tool chest would do the trick. If necessary, regular table-leg braces can be used to hold the chest lid in the vertical position and the weight of the chest will keep the door from slipping. Should the chest have a tendency to slide, rubber feet tacked to the corners will help to hold it stationary.

## Polishing Plastics Quickly

To obtain a high gloss on plastic without the usual buffing, use a paste consisting of a fine abrasive, such as flour of pumice, mixed with a light lubricating oil. Apply the paste with a soft cloth, rubbing until all scratches are removed. Then rub the surface briskly with a clean, soft rag moistened with liquid metal polish. The result will be a brilliantly polished surface.

S. S. Palestrant, Bronx, N. Y.

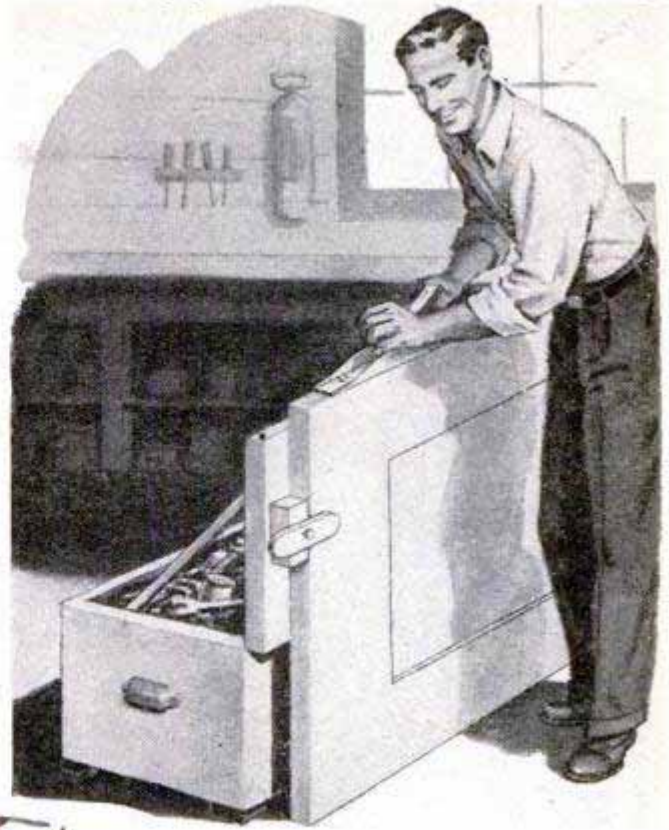

## Novel Metal Piggy Bank Assembled From Flush-Tank Float and Oilcan

Made entirely of scrap parts, this all-metal piggy bank will please the craft-minded youngster. The round body of the pig is made from a flush-tank float and the head from a small oilcan. Cut a hole slightly smaller than the base of the oilcan in one end of the float. Then remove the bottom from the oilcan and, later, solder the can

over the opening in the float. Cut one or two coin slots in the top of the bank, depending on whether or not a partition separates the float into two parts. To cut the slot, drill a  $\frac{1}{8}$ -in. hole at each of its ends, make double saw cuts between the holes and file the slot smooth. Lengths of metal tubing twisted spirally and soldered to the flush-tank float form the four legs and the tail. The eyes of the pig are cut from two roundheaded screws, the shank and threads being cut off so there is just a slight projection of the shank below the head. The screwheads are pressed in undersize holes drilled in the oilcan. The spout is cut from the can cover and a copper disk is fastened over the hole in the cover with sheet-metal screws, the screwheads forming the nostrils of the pig. The ears are cut and bent from sheet copper and soldered to the oilcan. Sheet-metal screws can be used to hold them in place while soldering and do not have to be removed, as when the ears are bent forward the screws will be inconspicuous. Coins are removed from the bank by unscrewing the oilcan cover. However, if the float is divided, coins will have to be removed from the rear compartment with typical piggy-bank-robbing technique, or just one coin slot can be cut and the rear section of the bank not used.

Doris Aller, San Francisco, Calif.

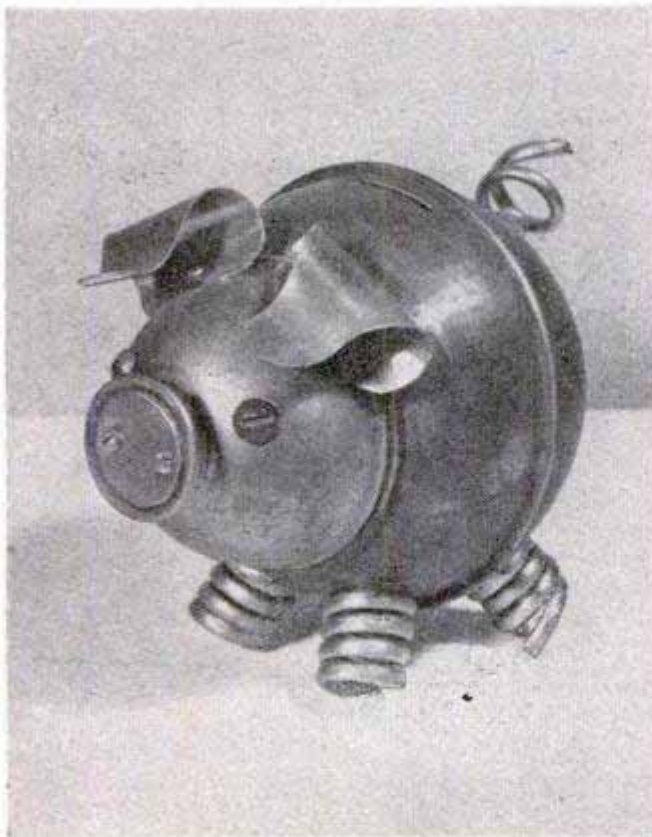

☞ Stale bread soaked in linseed oil is an excellent bait for rattraps.

# PAN-FISHING

By R. A. Jenkins

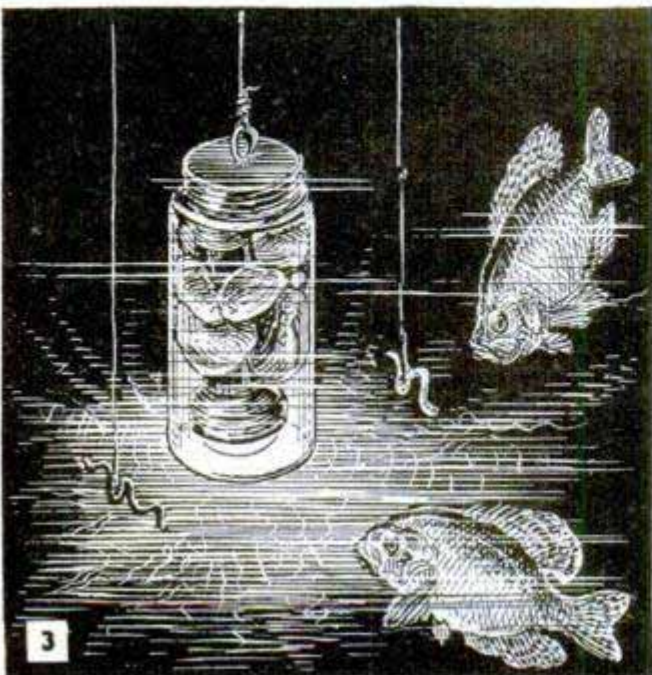
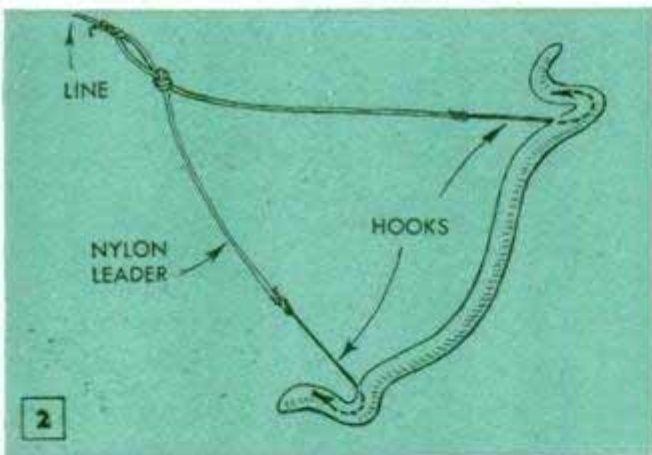

**BY KEEPING** in mind a few simple tricks, you can bring home as many pan fish during the winter months as the best catches you've had throughout the summer. One of the first things to remember about ice-fishing, however, is to dress for it. To keep your feet warm on the ice, fit two or three inner soles cut from an old felt hat, into each boot. Wear two pairs of lightweight woolen socks, as these are warmer than a single heavy pair, and take along several pairs of woolen gloves or mittens so you will always have a dry pair. Waterproofed leather choppers' mitts worn over the wool gloves afford added protection when handling cold, wet lines and fish.

In winter, the location of the fish and whether or not they are biting cannot be judged by the usual rules, such as wind, barometric pressure, or water temperature. The fish seem to show the most action between 10:00 A.M. and 4:00 P.M., but this is not a hard-and-fast rule. If the water is shallow, the fish will take to the deepest holes they can find. Other good fishing spots are near weeds in 6 to 20 ft. of water, off rocky points, in sheltered coves, over sand bars and around spring holes in the lake bottom. An excellent location for catching pike and walleyes is frequently found off the mouth of a stream that flows into the main body of water.

An efficient and inexpensive tool for chopping holes through the ice is made by welding a wide chisel blade to a length of pipe, Fig. 1. A hole is drilled at the top end of the pipe for attaching a leather thong or strong cord, and a loop tied in the end of the thong is slipped over the wrist so the tool will not fall through the hole if it is dropped. Make the holes in the ice about 15 in. in dia. and flare out the edges on the underside so the sharp ice will not fray the line. After cutting the hole, use an old tea strainer to skim the pieces of ice from the water as shown in Fig. 4.

Pan fish bite daintily during the winter, usually nibbling only at the head or tail of a worm. To outsmart the nibblers, fasten a pan-fish hook to each end of an 8-in. nylon leader and knot the center of the leader to form a loop for tying to the line. Then simply impale the ends of the worm on the hooks as in Fig. 2.

In some lakes and rivers fishing through the ice is best after dark. To attract the fish to the bait, lower a tightly capped fruit jar containing a small, lighted flashlight into the water and fish around the light, Fig. 3. Use stones to weight the jar so it



# THROUGH ICE

will sink and tie a line around the rim of the jar or tie it to a screw eye soldered to the jar cover. Another way to attract fish at night or in deep water during the daytime is to tie a small perfume vial to each line just above the baited hook, Fig. 5. The inside of the vial is coated with luminous paint and the vial is capped tightly. The glow of the paint will bring curious fish to the vicinity of the bait. To attract fish to your bait in the daytime, drop a handful of crushed oystershells through a hole in the ice. The shells will glitter on the lake bottom and lure the fish to the location of your bait. These shells usually are available at poultry-supply dealers.

Although bait minnows can be trapped as easily in winter as in summer, most wire and plastic traps freeze under the ice. A serviceable trap can be made from a large fruit jar and the upper half of a quart milk bottle as shown in Fig. 6. Set the trap in shallow channels where the current is swift, anchoring it between two large stones so it is not washed away. The mouth of the trap should face downstream. Several of these traps baited with raw oatmeal or bread crumbs will keep you well supplied with minnows all winter long.

While worms and minnows are the most widely used baits, they are not necessarily the best for pan-fishing through ice. Here are some bait suggestions for sure-fire results. When fish won't take any other bait, use winter-killed honeybees which can be obtained from a local beekeeper. Or, if you can find a wasp nest in the woods, the cold dormant wasps will work as well as bees. Another bait that will give satisfactory results is the meal worm which you can obtain from almost any feed store or grain elevator. Leeches are an excellent bait for game and pan fish and may be purchased from drug-supply houses. One of the best winter baits is had by using small bullheads with the sharp spines and fins snipped off. Game fish are attracted by the blood and quickly notice the lack of sharp spines, attacking at once. As a bait for large pike and walleyes, there is little better than a 4 or 5-in. sucker, chub or perch, and one or two small, red glass beads slipped onto a No. 12 or 14 gold-plated hook will often take pan fish in the winter.

To keep bait worms from freezing in zero weather, carry them in a woolen sock which is half-filled with dry sawdust. Keep the top of the sock closed tightly with a rubber band. Fishlines can be prevented from becoming coated with ice by rubbing them with linseed oil or kerosene before putting them in the water.

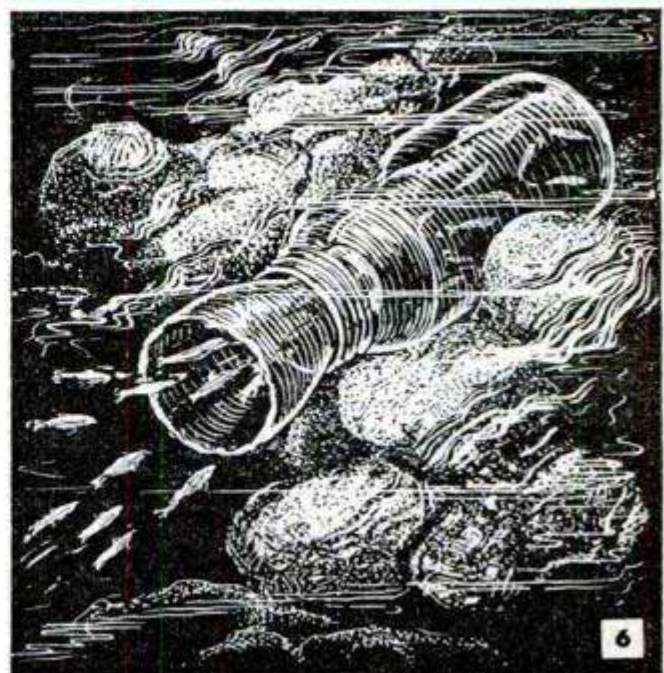
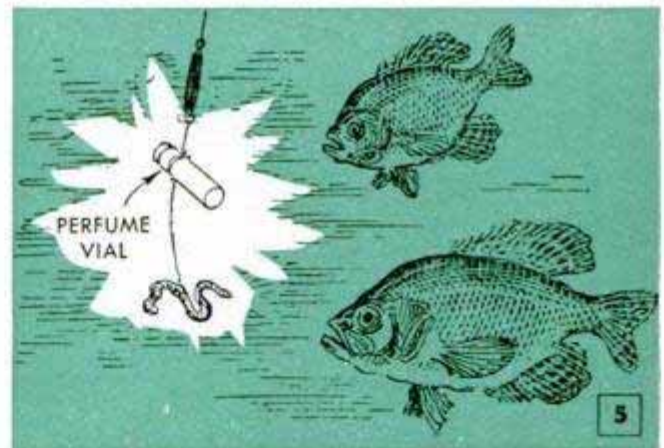

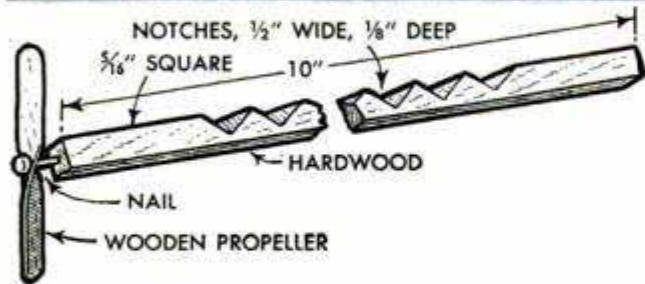
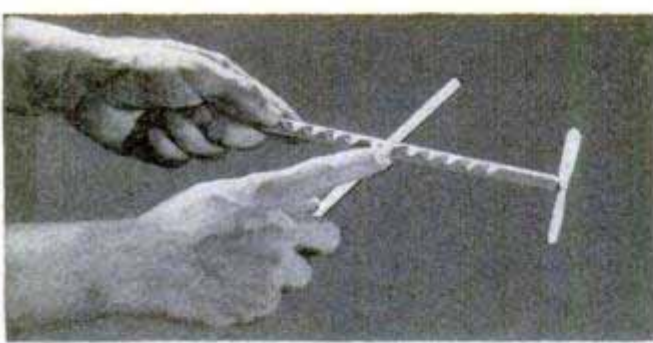

## Direction of Propeller Controlled By Rubbing Notched Stick

Spinning on the end of a notched hardwood stick, this wooden propeller rotates clockwise or counterclockwise, depending on the manner in which a dowel or pencil is rubbed back and forth across the notches. If, while rubbing the stick, the index finger of the hand holding the dowel is placed over the notches so it touches the opposite side of the stick, the propeller will revolve in one direction. When the tip of the index finger is raised off the opposite side of the stick and the thumb or index finger is allowed to brush against the near side of the stick, as shown in photo, the direction of rotation will be reversed. If the fingers are moved inconspicuously so that the rotation is reversed for no apparent reason, the spectators will be at a loss as to what causes the variation. A running conversation about the effect of magnetic lines of force or some other fantastic line of reasoning will make the illusion still more entertaining to the audience.

H. Simermeyer, New York City.

## Tape Holds Beads on String

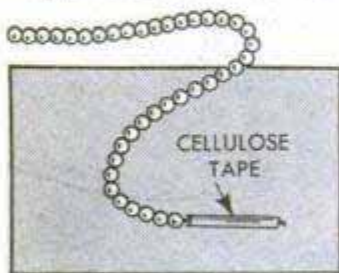

When storing loose beads by stringing them on a length of thread or twine, use a piece of cellulose tape at each end of the thread to keep the beads from slipping off. The tape can be wrapped around the ends or simply folded double with the thread sandwiched in between, thus saving the trouble of untying a knot or cutting the thread every time some of the beads are removed.

## Locking Pliers Form Bench Vise

Attaching a pair of locking pliers to a C-clamp and mounting it on the edge of a workbench provides a neat quick-acting bench vise for holding small work. This setup is particularly useful for holding knives and tool blades for sharpening. The rivet on which the pliers jaws pivot is replaced with a stove bolt and wing nut. The latter hold the pliers between two pieces of sheet steel which are welded to the C-clamp to form a yoke. Two additional pieces of sheet steel are welded to the inside surfaces of the pliers jaws to increase their width. By loosening the wing nut, the pliers can be adjusted to the most convenient working angle.

W. G. Waggoner, Sacramento, Calif.

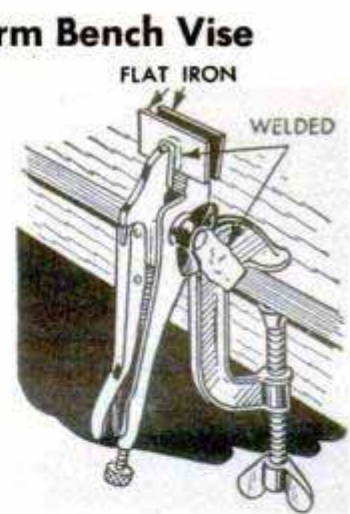

## Paper Aids Drying Wet Shoes

As soon as wet shoes are removed, stuff them tightly with wadded newspaper or tissue paper. This will keep the leather from shrinking and also speed drying. When dry, a leather preservative should be applied to the tops and soles of the shoes.

## Handle for Vacuum Bottle

A length of cord tied to two sheet-metal clips forms a convenient handle for carrying a vacuum bottle. The clips can be cut from a tin can and are bent as shown in the detail, the edges being folded over to make them smooth. Paint or other covering is removed from the

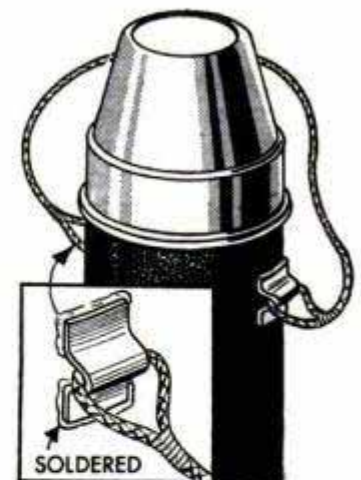

sides of the bottle at the points where the clips are to be attached, and then the latter are soldered to the metal case. The glass bottle should be removed from the case before soldering. Braided metal cable or a length of strong cord will serve as a handle. However, if the cord is used, it is best to braid it with a series of slipknots for added strength.

# Auxiliary FLASH ADAPTER

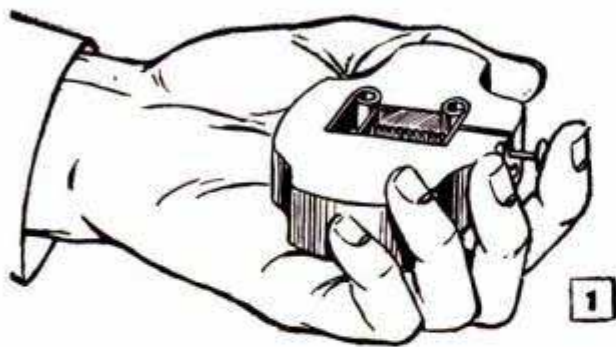

OWNERS of box-type cameras equipped with a built-in flash attachment are not restricted to ordinary flat frontal lighting if this little auxiliary flash adapter is at hand. It permits the flash attachment to be removed from the camera, Fig. 2, and flashed at arm's length to produce more interesting side-lighted shots. An open-and-shut technique is used in taking the picture in subdued light; the shutter is opened, the bulb fired and the shutter closed. The adapter has a push-button switch which is depressed to fire the bulb in the manner illustrated in Fig. 1. A safety catch is installed as in Fig. 3 to prevent accidental premature firing of the bulb when loading. In locked position, the catch fits under the head of the push button. Assembly of the adapter, detailed in Fig. 4, is self-explanatory. A recess is routed in the wooden block for the sheet-brass sockets and contacts. A furniture nail forms a head for the push button.

E. Peter Smith, Los Angeles, Calif.

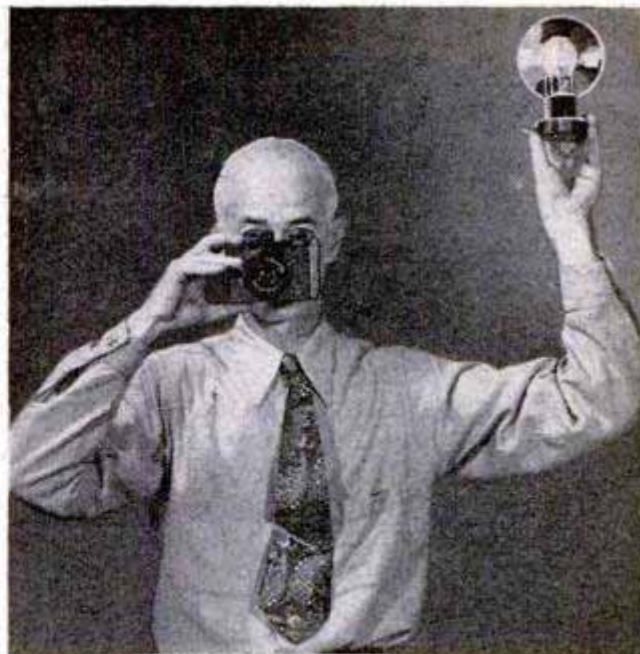

Removed from camera and held overhead at either side, the flash unit when plugged into the adapter permits the shot to be side-lighted for variation

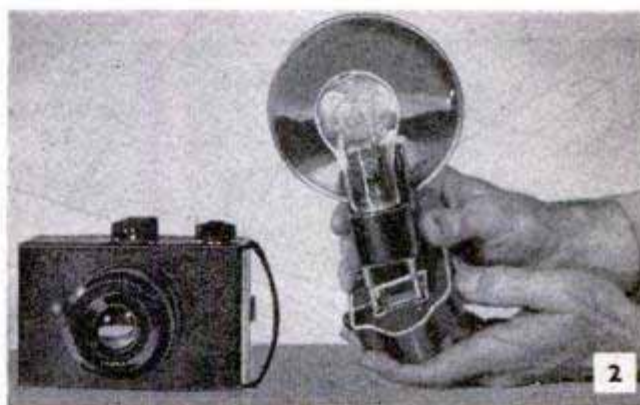

Above, contact prongs on the flash unit fit into sockets formed in the switch. Below, right, note the safety catch which is provided to lock the push button and prevent accidental premature firing of the bulb. A flick of the finger releases the catch

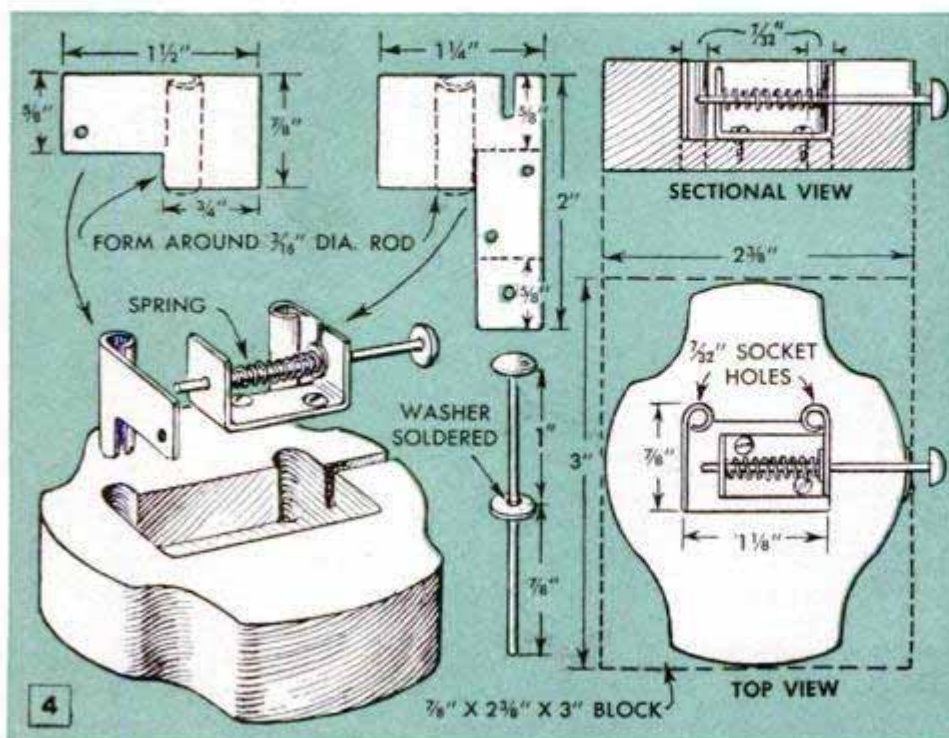

# JIFFY KITCHEN DARKROOM

By *Andé*

WHEN a regular darkroom is not available, processing photos at home is sometimes extremely inconvenient. It's usually a case of having to work either in the bathroom or kitchen with more time devoted to getting ready and, afterward, putting things away than the actual time spent in enjoying the hobby of making your own pictures. When I moved into a studio apartment I found it necessary for the kitchen to serve as both a quick-change darkroom and a place to cook and eat. So here is what I did:

Typical overhead wall cabinets were located above the sink, and this meant that there was insufficient clearance to permit using my enlarger on a small cabinet located next to the sink. To overcome this

problem, I sacrificed the storage space of one of the overhead cabinets, removing the bottom to take the column of the enlarger and allow the lamp house to be extended to its full height. Thus, when the cabinet door is closed the enlarger is inconspicuous and the arrangement contributes considerably to the quick-changeover idea.

Now, the question of what to do for a work counter for my large developing trays. Limited space meant that whatever I used would have to serve a double purpose and also be located conveniently to the sink. A cabinet that could be rolled out of the way seemed to be the answer. Luckily, a movable work cabinet was already installed along an adjacent wall of the kitchen. Being 5 ft. long and having a linoleum top, it was just the thing. All I had to do was to fit it with rubber-tired casters

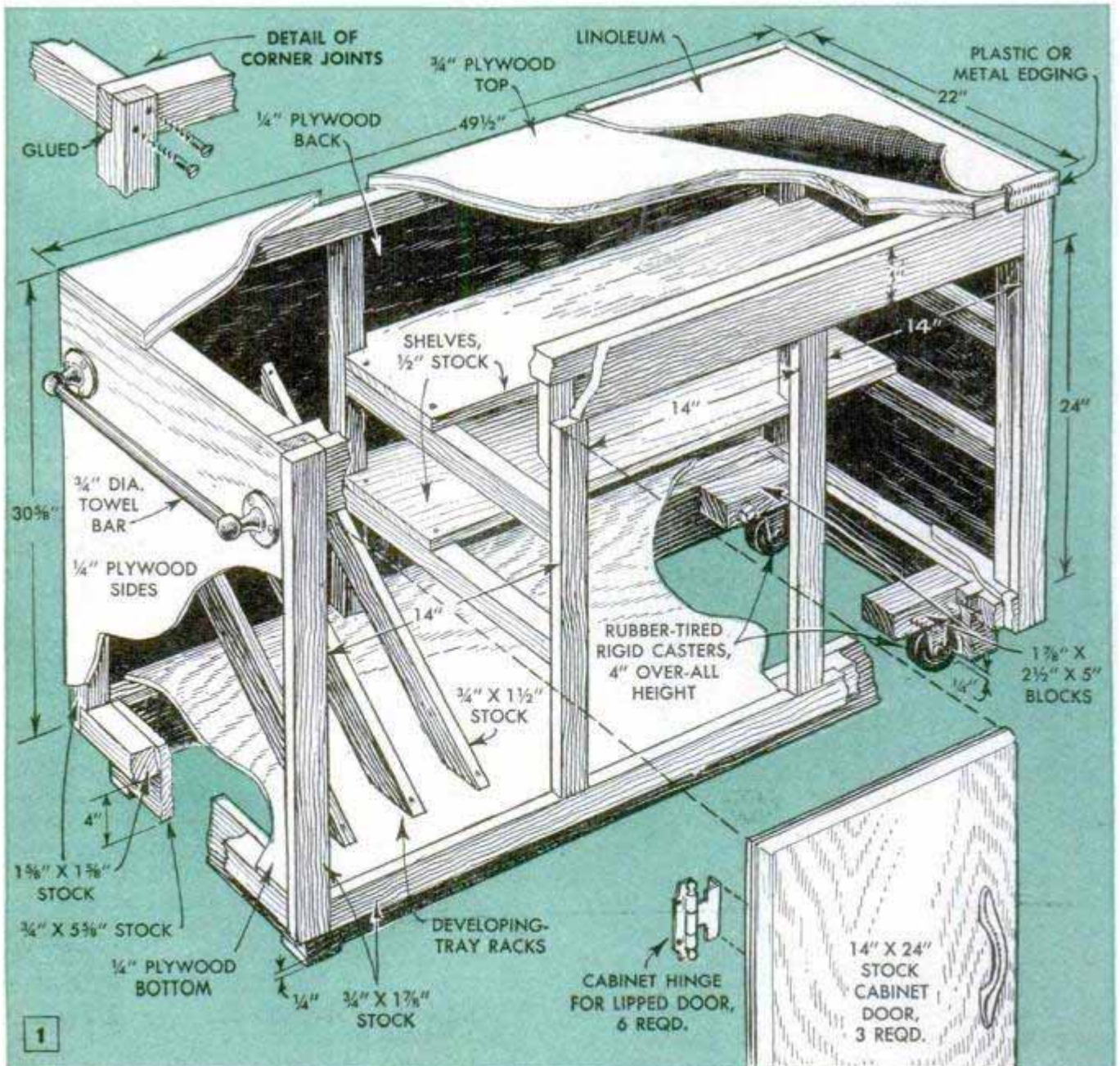

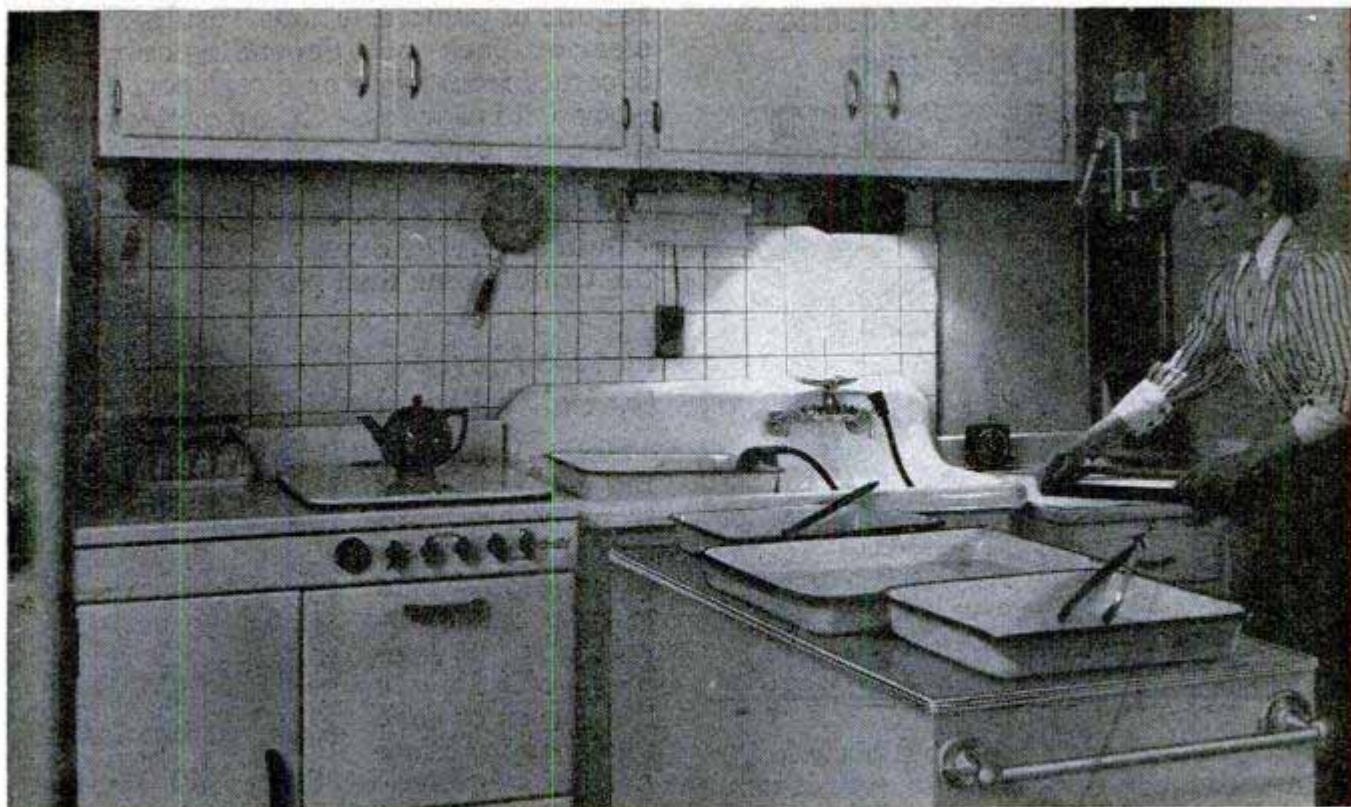

so it could be rolled easily into working position and back against the wall when not in use. Part of the cabinet is used for storing equipment and a towel bar attached at one end also serves as a handle. Placed at right angles to the sink, the cabinet is convenient to a safelight mounted above the sink, running water and the enlarger, as shown in Fig. 2.

If you have a kitchen arrangement where a work counter could be pushed out of the way, you can build a similar cabinet by following the details in Fig. 1. Or, a standard cabinet remodeled a little and painted to match other units in the room will serve the purpose. The cabinet shown makes use of common lumberyard stock and plywood, the top being covered with linoleum and metal edging. One end is devoted to tray storage, and although designed for three doors, one of the compartments can be fitted with drawers for storing small items. Note that only one end of the cabinet is fitted with casters so it will not roll.

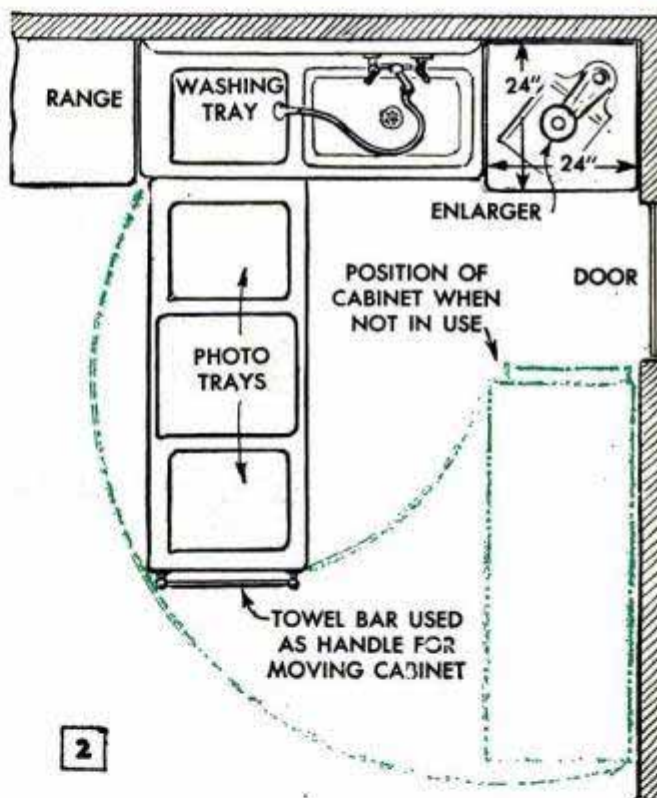

## Refrigeration of Stock Print Developer Results in Brilliant Negatives

Negatives with a greater range of contrast are easily attained by using your kitchen refrigerator as an aid to developing. First store a bottle of standard print developer (D-72) in the refrigerator until cold and then load the developing tank, pouring in the cold stock solution. Set the tank in the refrigerator overnight. No developing action takes place at this time, but the film emulsion absorbs the amount of solution required to develop the image. In the morning, pour out the solution, un-

load the tank and hang up the negatives in total darkness so they can develop at room temperature. After an hour or so, fix and wash them. You will be pleasantly surprised with the crystal brilliance of the negatives. As this is achieved at the expense of grain fineness, negatives intended for extreme enlargement should not be processed in this way. However, with care in drying the negatives, normal degrees of enlargement will be successful.

Martin S. Dworkin, New York City.

## Safelight Mounted on Gooseneck Permits Using Brighter Lamp

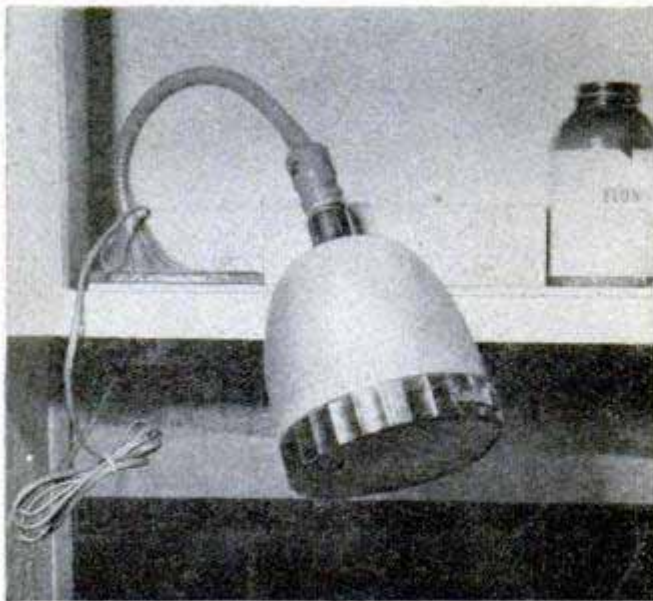

One photographer mounted his safelight on a gooseneck desk lamp to permit using a brighter light than usual and thus facilitate judging the quality of prints in the developer solution. With this arrangement, the light may be swung over the tray momentarily to check the print and then moved to one side so the print will not be fogged. As most lamps of this type have holes drilled through the base, it is a simple matter to screw them to a shelf or wall.

Virginia Hanson, Santa Monica, Calif.

## Solution Bottles Washed After Use To Prevent Chemical Dust

Chemical dust floating in the darkroom air is liable to cause small spots or pinholes on negatives. The dust, which is the dried



residue of photo solutions, results in either clear or black spots depending on whether it comes from hypo or developer. For this reason, it is a worth-while practice to wash down the outside of every photo-solution bottle before putting it away, as the water will remove any droplets of solution which would otherwise dry on the glass and form the troublesome dust particles.

## Photos Marked With Credit Line By Using Flashlight Printer

Helpful advertising can be gained from your commercial photos by using a flashlight to print an inconspicuous but legible credit line in the corner of each photograph. Place



a copy negative of the credit line over the lens of the flashlight so it reads from right to left. Then, cut a piece of opaque black paper to fit over the lens and cut a section from the paper just large enough to expose the credit line. Lay the paper over the negative so the credit line is completely visible and clamp the parts together with the lens retainer. The credit line is printed by pressing the negative tightly to the photo paper and turning on the flashlight. An exposure of approximately 10 seconds is necessary on contact paper and about 2 seconds on enlarging paper. Because light usually is concentrated at the center of a flashlight lens, it may be necessary to use a little dye on the portions of the negative to print uniformly.

Ken Sellers, Columbia, Mo.

## Timer Made From Alarm Clock

When a dark-room timer is not available, a suitable one can be improvised in a few minutes by using an alarm clock. Remove the glass from the face of the clock and slip a rubber band

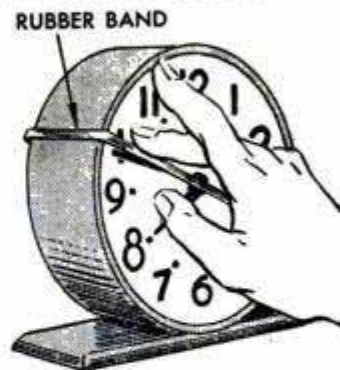

it stretches across the face. Set the minute hand and position the rubber band so the space between them is equal to the desired elapsed time. Then, the time to remove the film from the developer can be checked in total darkness simply by feeling when the minute hand passes under the rubber band.—John H. Jones, Cove, Ark.

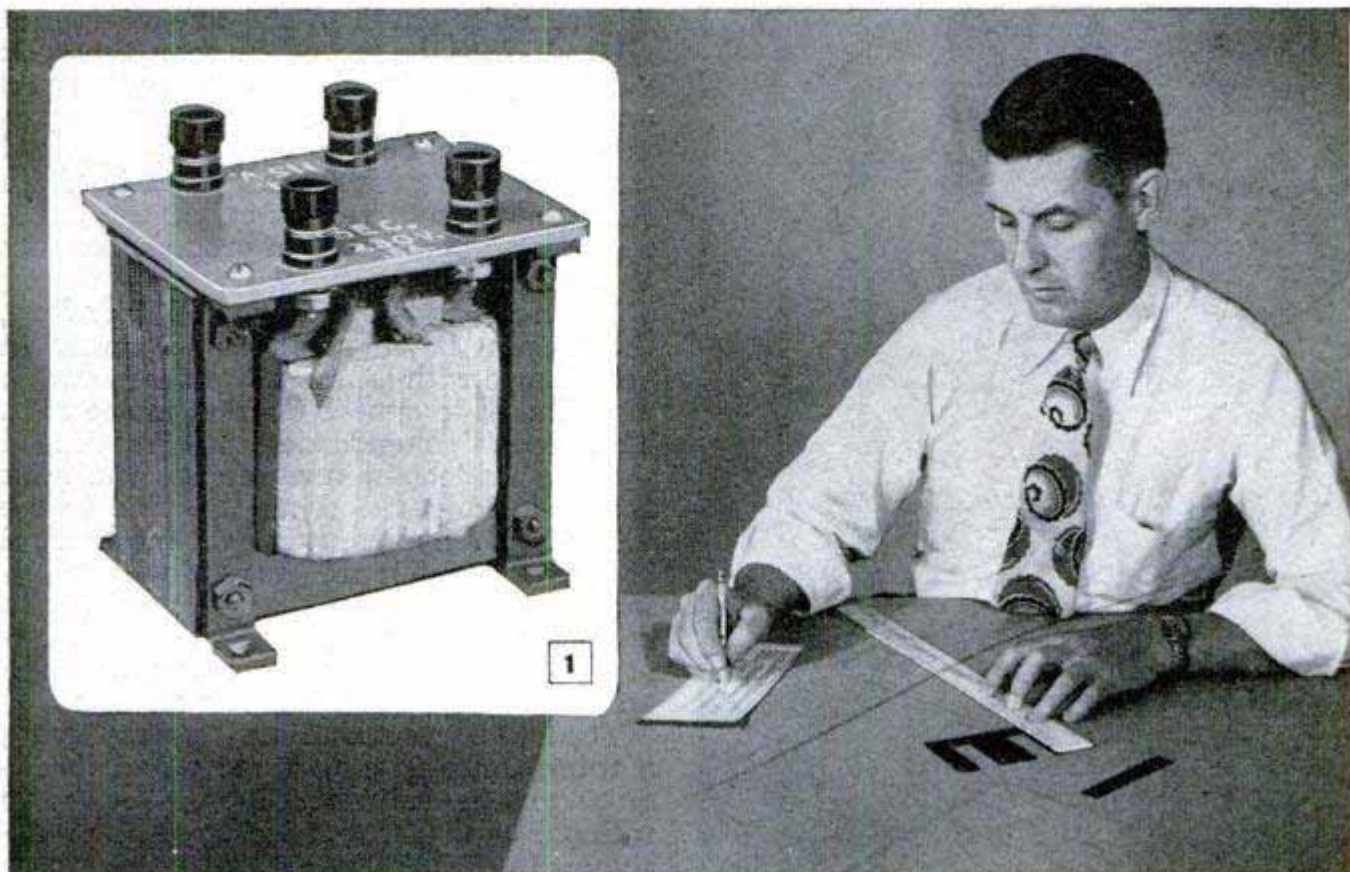

## MAKE YOUR OWN TRANSFORMER

By Harold P. Strand

### PART I—DESIGNING

DESIGNING and making small single-phase transformers, such as the electrical experimenter and radio technician require, is an interesting and educational project. Although transformers of standard voltage rating can be purchased, it is often necessary to obtain special voltages for experimental work or new apparatus. It is far more economical to make the transformer yourself than to have one built to order.

An elementary transformer consists of a laminated iron core on which a coil of insulated wire is wound. The coil may be a single winding with taps, such as an auto transformer, or one with two separate coils as in Figs. 1 and 5. The latter, being the most widely used, will be discussed in this article. As indicated in Fig. 5, one of the coils is called the primary and is connected to the current input. The other coil, from which current is taken, may have more or fewer turns than the primary and is called

the secondary. The core must be built up, or laminated, from thin sheets of silicon steel, because the constant reversal of the alternating-current flux sets up eddy currents in a solid iron core. Therefore, the use of a solid core would result in excessive heating of the transformer. Laminating tends to break up these eddy currents.

Briefly, the theory of transformer operation is as follows: The line voltage sends a current through the primary coil, setting up a magnetic flux—invisible lines of force—in the iron core. As the core also encircles the secondary coil, the flux, which rises and falls in step with the alternating current, cuts through the turns of the secondary and, by the laws of magnetic induction, induces a voltage in this winding. If the secondary circuit is closed by adding a load, a current will flow in the secondary. The voltage induced in the secondary is in direct proportion to the number of turns in that winding as compared to the number of turns in the primary, except for a slight loss which will be explained later. For example, with 100 turns in the primary coil and 200 in the secondary and with 100 volts

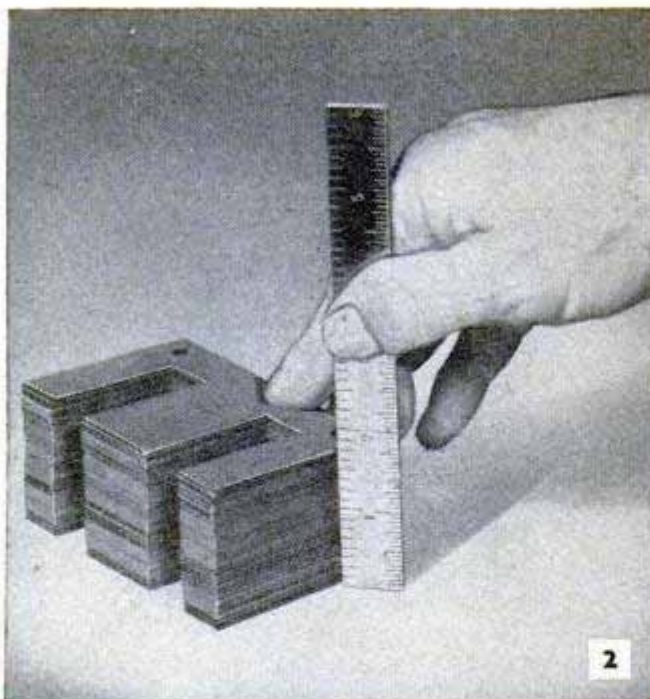

2

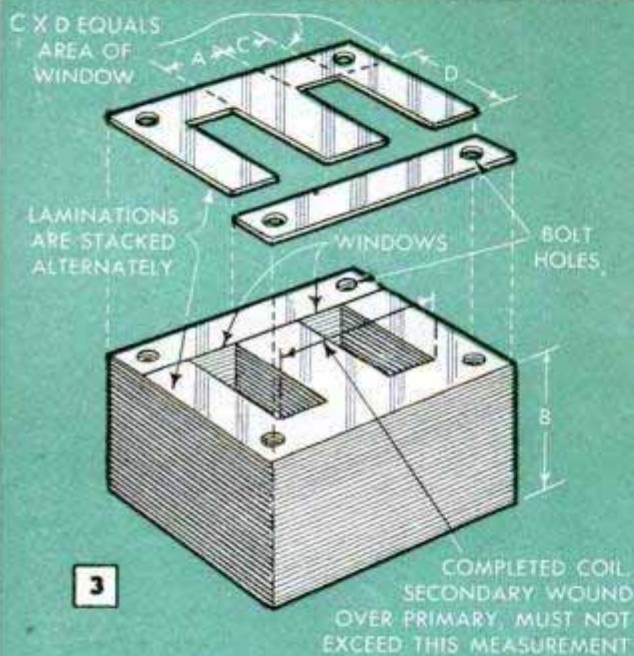

3

**4 AVERAGE TRANSFORMER CORE RATINGS**

Volt-ampere Output	Cross-sectional area in square inches		
	25 cycles	50 cycles	60 cycles
5	0.6	0.3	0.25
10	0.8	0.4	0.3
20	1.2	0.6	0.5
25	1.4	0.7	0.6
50	2.5	1.25	1.0
75	3.5	1.75	1.5
100	4.2	2.1	1.8
125	4.6	2.3	2.18
150	5.0	2.5	2.2
200	5.6	2.8	2.4
250	6.0	3.0	2.6
300	6.6	3.3	2.8
400	7.0	3.5	3.0
500	7.6	3.8	3.4
750	8.8	4.4	4.0
1000	10.8	5.4	4.8

For transformer-grade, silicon-steel sheet metal 26 to 29 gauge.

applied to the primary, 200 volts are delivered at the secondary. The transformer also automatically controls itself. When the line voltage is applied to the primary, a counter E.M.F. (electro-motive force), or voltage, is induced in that winding, which is practically equal to the line voltage at no load. With the secondary open, this back voltage prevents all but a very small amount of current from flowing in the primary. Thus, at no load a properly designed transformer draws practically nothing from the line. This current is called the exciting current and serves to produce the flux in the core.

When a load is placed on the secondary, the current flowing in that coil must, in accordance with Lenz's law, flow in such a direction as to oppose the flux in the core. This opposition tends to reduce the value of the flux which, in turn, causes the back E.M.F. to be reduced. As it is due to the latter that the current is held in check, it is obvious that more current will be allowed to flow in the primary to satisfy the demands of increased load on the secondary. Thus, a transformer acts much like an automatic regulating valve.

The first step to consider when designing a transformer is the core size and its relation to some value of volt-amperes or size rating. For the benefit of the amateur designer, the table, Fig. 4, can be used as a general guide. This does not mean that the table must be followed to an exact degree because, when less iron is used in the core, more primary turns are put on to offset it. Note in the formula, Fig. 6, that the relationship of core area to turns is maintained so that a safe flux density is kept in the core. However, it is not good practice to use an excessive amount of either iron or copper, if losses and efficiency are to be considered. Although transformer cores can be made from straight strips of silicon steel, standard E-type laminations, Fig. 3, which may be purchased or salvaged from a discarded power transformer, are more convenient to use. The principal core dimensions important to any transformer design are the height of the stacked laminations, measured as in Fig. 2, the width of the center leg, A, Fig. 3, and the area of the window space.

The problem that usually confronts the amateur is the number of turns and size of wire required for use with a core on hand to produce a certain voltage output. Suppose, for example, that the width of the center leg of the laminations on hand measures 1 1/4 in., a window opening to one side of this leg measures 5/8 x 1 7/8 in. and also that there are enough laminations to stack tightly to a height of 1 3/4 in. The area of the core is the width of the center leg



(1.25 in.) multiplied by the height of the stack of laminations (1.75 in.), A and B, Figs. 3 and 5, which equals 2.19 sq. in. Using the table, Fig. 4, we find that this falls in a class of about 125 volt-amperes at 60 cycles, the current input required. Were the transformer to be used on a 115-volt line and required to deliver 230 volts at .5 amperes at the secondary leads, we would multiply 230 x .5. This gives 115 volt-amperes which is well within the range of the 125 volt-ampere rating for the core.

To find the correct number of turns for the primary winding, the formula, Fig. 6, is used. Substituting the proper values, the problem condenses to:

$$\frac{10^8 \times 115}{4.44 \times 60 \times 2.19 \times 65,000} = 303 \text{ turns}$$

- In the above,  $10^8$  is taken for 100,000,000
- 115 is the primary voltage
- 4.44 is a factor
- 60 is the frequency
- 2.19 is the core area
- 65,000 is lines per sq. in. of flux density

The result, 303 turns, can be made an even 300. The next step is to divide 300 by the line volts (115) to get the turns per volt. This will be about 2.61. The secondary turns for any output voltage desired are figured by multiplying 2.61 by the desired voltage. In this case, 230 volts are wanted, so  $230 \times 2.61 = 600$  turns.

Iron and copper losses both enter the picture, but the addition of about 4 percent in turns will take care of them. Regulation, or the condition which affects output voltage from no load to full load must also be considered. Usually, about 2 percent more in turns will take care of this condition. So, by adding 6 percent to the 600 turns calculated or a total of 636 turns, the full 230 volts should be obtainable with a .5-ampere load.

The table, Fig. 7, shows the cross-sectional area of copper wires. If the decimal point in the column of circular mils is moved three places to the left, it is possible to quickly determine the ampere capacity of each size. The secondary is to carry .5 amperes and from the table, No. 23 wire at 509 circular mils is the nearest size. To determine the current in the primary, divide the volt-ampere rating, 115, by the primary volts, 115, which gives 1 ampere. Since transformers never run at 100 percent efficiency, an addition of 10 percent or a total of 1.1 amperes is a good estimate. No. 19 wire at 1288 circular mils is the nearest larger size.

(To be continued)

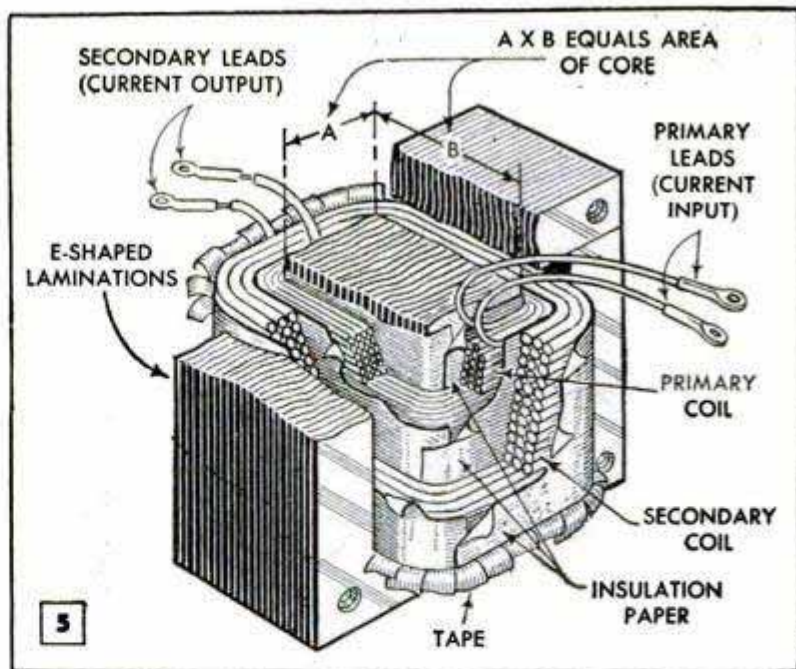

6 FORMULA FOR FIGURING PRIMARY TURNS

$$\frac{10^8 \times E}{4.44 \times f \times A \times Bm} = \text{TURNS}$$

- E - PRIMARY VOLTAGE
- 4.44 - FOUR TIMES THE FORM FACTOR
- f - FREQUENCY, CYCLES PER SECOND
- A - AREA OF THE CORE IN SQUARE INCHES
- B - FLUX DENSITY IN LINES PER SQUARE INCH

7 WIRE TABLE

Gauge	Cross-Sectional Area (bare) Circular mils	Turns per Square Inch (with insulation)
8	16510.	56
9	13090.	72
10	10380.	90
11	8230.	112
12	6530.	140
13	5178.	177
14	4107.	220
15	3257.	276
16	2583.	346
17	2048.	428
18	1624.	534
19	1288.	665
20	1022.	835
21	810.	1042
22	642.	1310
23	509.	1600
24	404.	1980
25	320.	2470
26	254.	3090
27	202.	3870
28	160.	4830
29	126.7	5920
30	100.5	7430
31	79.7	9120
32	63.2	10,000
33	50.1	13,900
34	39.7	17,700
35	31.5	22,200
36	25.0	27,700

Turns per square inch have been calculated from the mil dia. of each size and are close enough to use in estimating size of finished coils.

## Drilling True Burr-Free Holes In Thin Sheet Metal

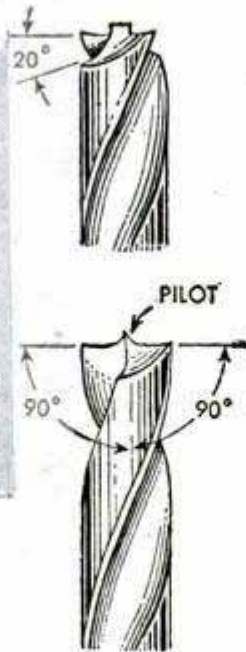

Radio servicemen and tinsmiths will find that a twist drill ground as shown is especially helpful where it is necessary to drill holes to exact diameter in thin sheet metal. As will be seen from the details, the cutting edges are ground square across at right angles to the axis of the drill. The radius of the grinding wheel automatically gives the necessary back clearance to each lip. Ordinary drills up to 1 in. in dia. can be ground in this way and all sizes will cut clean, true holes without leaving a burr on the bottom edge. Prick-punch the work lightly to start the drill.

J. Vincent Smith, Silver Spring, Md.

## Nail Perforates Heavy Directory To Permit Hanging on Wall

To prepare a telephone directory or heavy catalogue for hanging from a wall rack, it is not necessary to make a hole at the corner by perforating a few pages at a time. Just take a hammer and drive a nail of suitable length through the corner of the volume.—Leon Henry, Tacoma, Wash.

## Labeling Transformer Leads

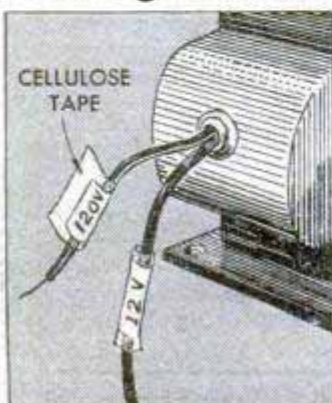

Leads and terminals on transformers and other electrical equipment can be labeled for quick identification by attaching paper tabs with cellulose tape. Print the information on the paper tab, press

the tab face down on the adhesive side of a piece of cellulose tape, and then wrap the tape around the lead or press it against the surface of the part. The label will remain legible indefinitely, but can be removed easily when desired.

Walter E. Burton, Akron, Ohio.

## Filing Corners of Square Bolt Head Adapts It for Hex Socket Wrench

If a square-headed bolt must be driven in a hard-to-reach place, a hex socket wrench may be used by filing or grinding down opposite corners of the bolt head.

After this is done, the bolt head will fit in the hex socket as shown in the left-hand detail. A 12-point socket wrench also will do the trick if the fit is snug and pressure is applied lightly.

Charles H. Hardy, Los Angeles, Calif.

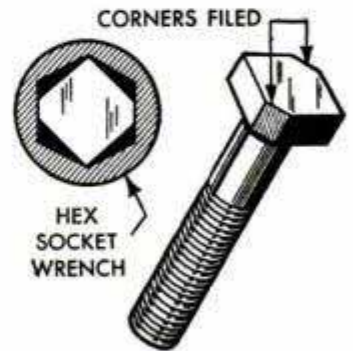

## Farm Gate Offset From Highway Affords Safe Parking Area

Stopping a truck or car on a busy highway to open the gate to the farm lane is dangerous, especially if the gateway is on a curve of the road or on a hill. One farmer solved this problem by building an offset in the fence deep enough to permit driving his truck off the highway before stopping to open the gate. The offset is formed by building wings at an angle to the fence line as shown in the sketch. The gate, of course, is hinged to swing either way.

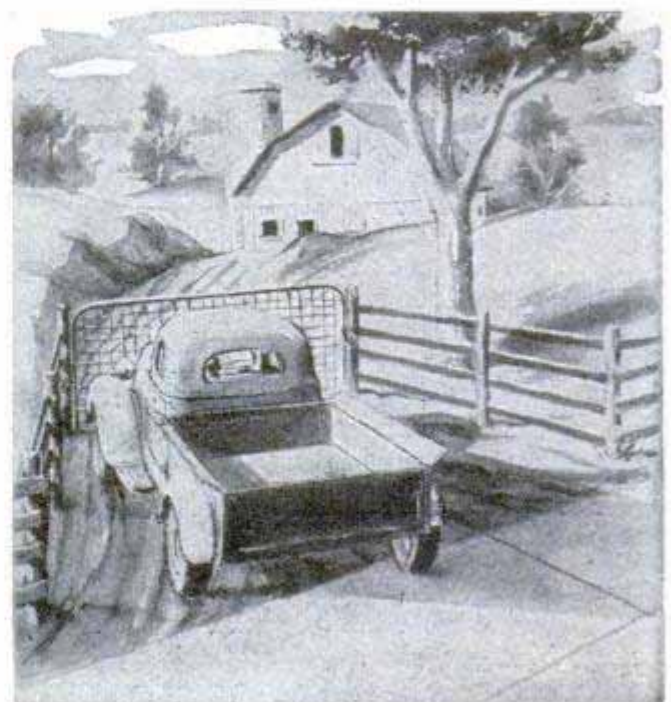

# BALE LOADER

By Hi Sibley



This bale loader is constructed almost entirely of discarded car parts and stock sizes of both angle iron and sheet metal

The neat, trim lines of the bale loader, shown above in operation, will appeal to every farmer who likes to build efficient, labor-saving equipment in his shop

**B**UILT BY Lem Shaw and George Hammerschmidt, California ranchers, this efficient bale loader, coupled to the side of a truck, picks up individual bales from the field and elevates them high enough to enable one man to build a six-tier load on either a truck or trailer platform.

Fig. 1 pictures the offset hitch by means of which the loader is coupled to the side of the truck. The manner in which the loader is towed to and from the field behind the truck or trailer is shown in Fig. 2. Figs. 3 to 15, inclusive, detail the construction and assembly of the unit. First, note in the top view, Fig. 4, that the loader axle is offset to bring the loader as close as possible to the truck. The offset hitch is shown assembled for attachment to the side of the truck



Above, an adjustable offset hitch of special design couples the loader to the side of the truck frame. Below, the loader coupled behind truck for transport

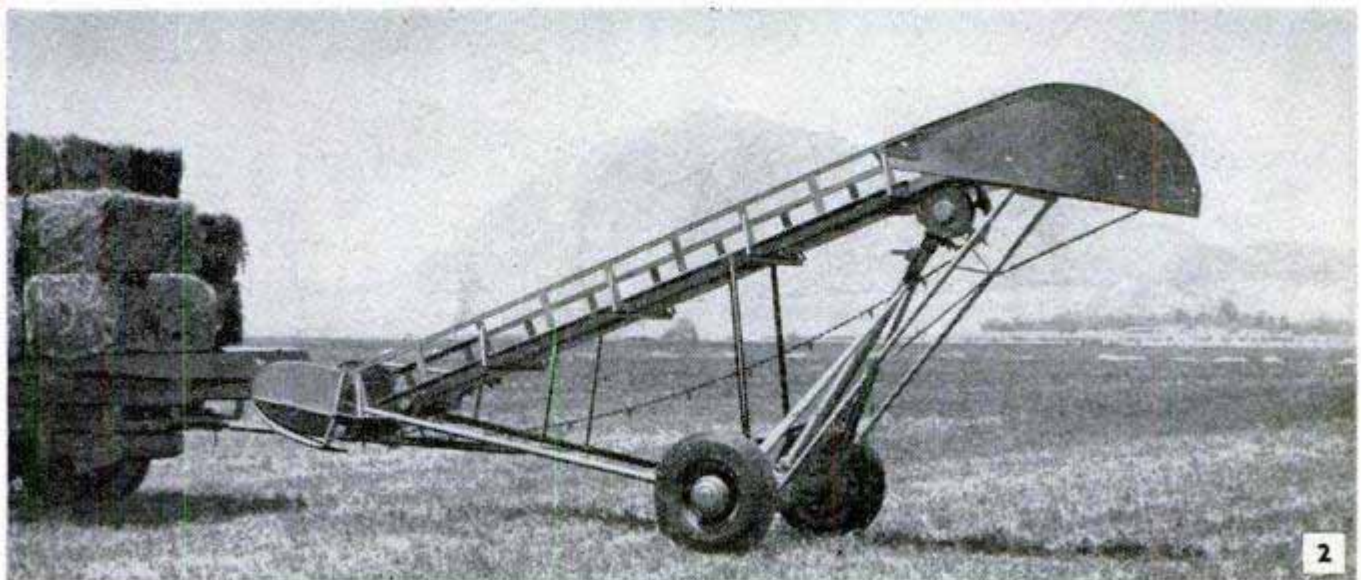

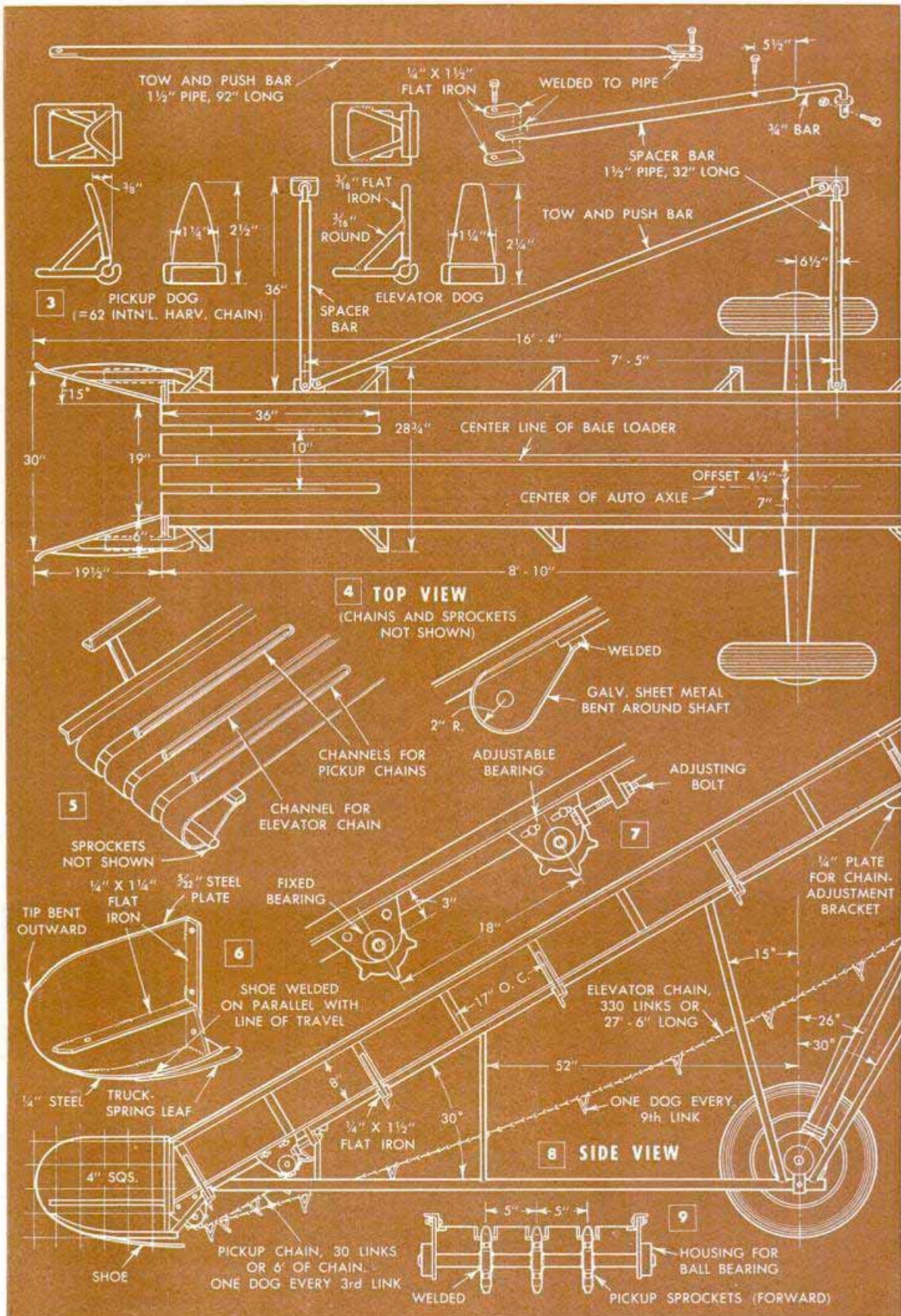

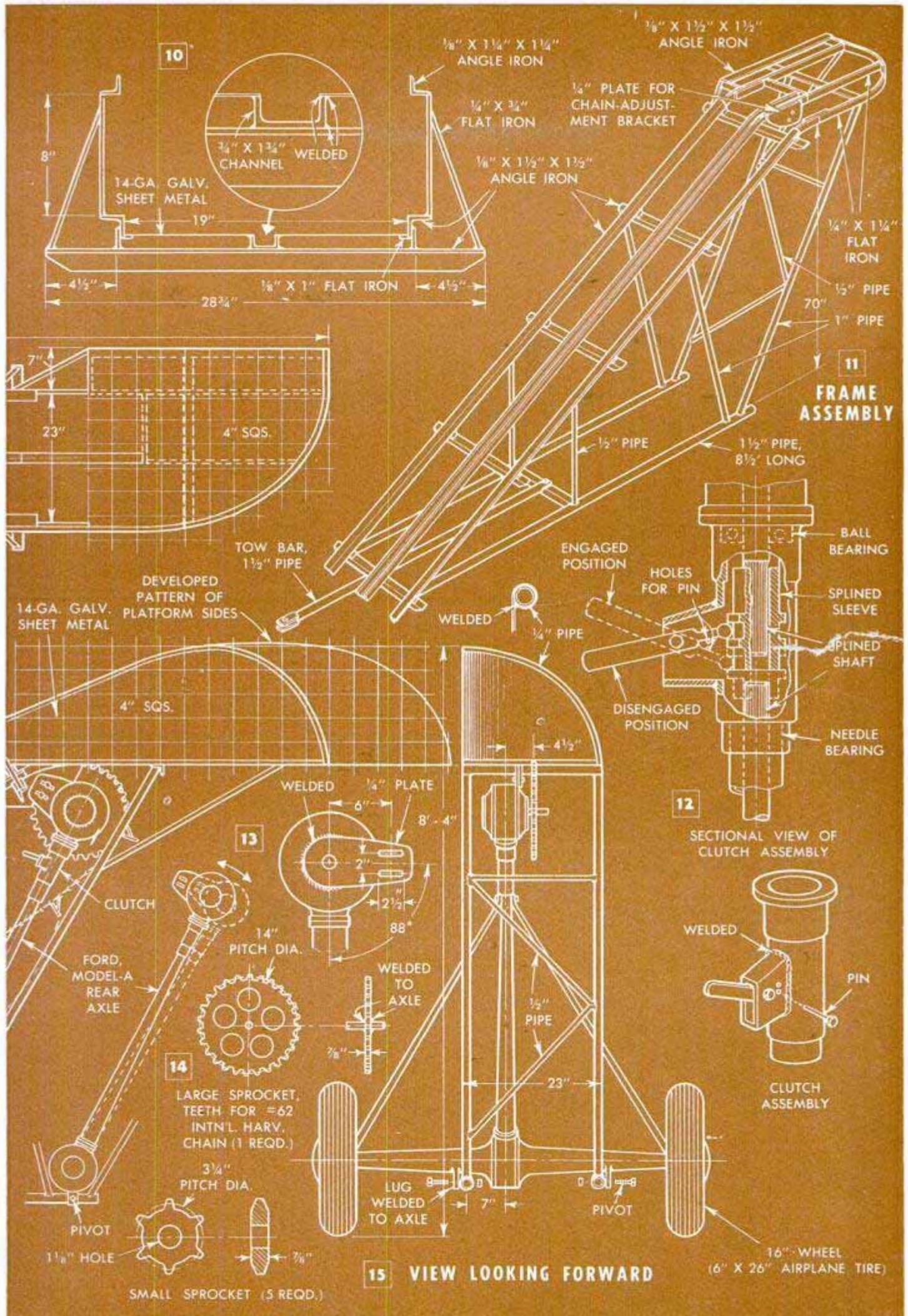



16 Short pickup chains start bale on its way up the elevator bed, or "flight," to the loading platform

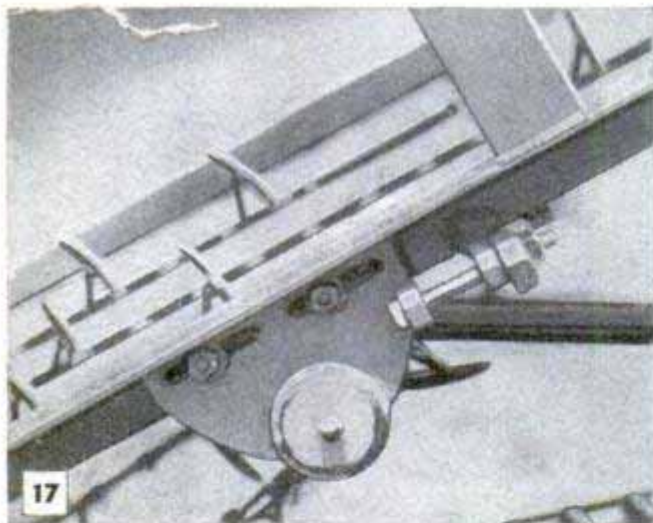

17 Above, chain tighteners are fitted on the pickup idler shaft. Below, ground drive is through car axle

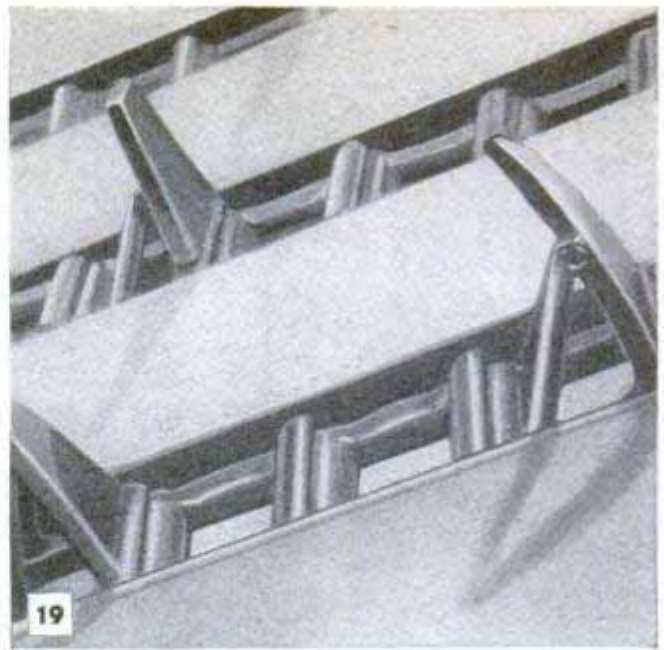
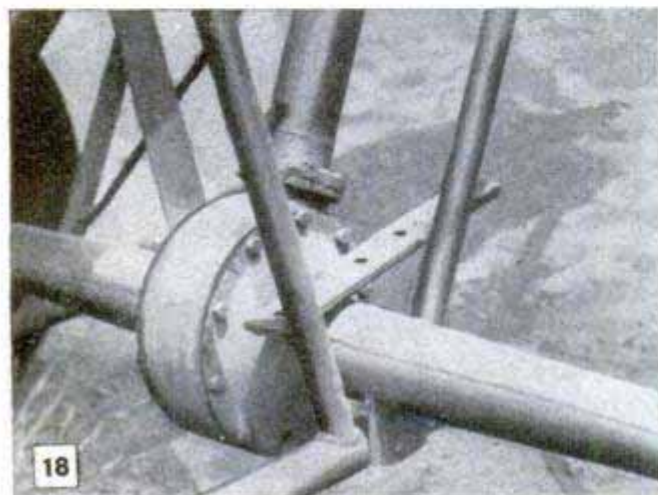

19 Lugs on the pickup chain are curved slightly to release bale. Those on the elevator chain are straight

frame. The parallel spacing bars are adjustable so that the loader can be located to suit the width of the truck platform. The long member of the hitch, top detail in Fig. 3 and also Fig. 11, serves the dual purpose of tow bar when the loader is towed on the road and that of push bar when the hitch is assembled for operation of the loader in the field. The three views of the drive mechanism, Figs. 13, 14 and 15, show the assembly of the drive unit. Note that the offset axle brings the drive sprocket, Fig. 14, in the center of the elevator bed. This position lines up the sprocket with the channel for the elevator chain, Figs. 4 and 5.

Two Ford Model-A rear axles are assembled to form the drive as in Figs. 13, 14, 18 and 21. One axle, with the housings removed, is mounted on the end of the torque tube of the second axle which is used intact, including the radius rods, Fig. 15. The open ends of the upper differential housing are closed with steel plates, welded on. One plate extends to form a mounting bracket, Fig. 13, and is bored and slotted for mounting bolts and for the drive-sprocket shaft. The throwout clutch mounted on the end of the torque tube between the two differentials is assembled from stock parts as in Fig. 12. In addition to the large drive sprocket, Fig. 14, five small sprockets of  $3\frac{1}{2}$ -in. pitch diameter are required to carry the elevating chain and the pickup chains. The pickup chains travel in steel channels welded into the lower end of the elevator bed as in Fig. 5. The pickup sprocket assembly, with fixed and adjustable bearings, is detailed in Fig. 7, and is also pictured in Figs. 16, 17 and 19.

The bottom of the elevator bed, or "flight," is covered with galvanized sheet metal and the sides are built up and braced as in Figs.

4, 8 and 10. Sheet metal forms the floor of the bale platform at the top of the elevator bed, Fig. 20. The sheet-metal guide, or fender, which forms one side and the end of the bale platform, is curved to turn the bale as it slides onto the platform. A layout pattern for cutting the sheet-metal part to correct size is shown in Fig. 8, and the detailed pattern for the bottom of the platform is shown in Fig. 4. Note that a "beading" of  $\frac{1}{4}$ -in. pipe is welded to the top edge of the platform fender, Fig. 15. The wings, or gatherers, Fig. 16, are made up for both right and left sides as in Fig. 6. A shoe is welded to the bottom of each wing to carry the lower end of the elevator. It is important that each shoe be welded parallel with the line of travel, otherwise it will wear rapidly and may cause side draft.

The lugs, or dogs, welded to the elevator chain are straight while those on the short pickup chains are curved back as in Fig. 3. This backward curve is important as it permits the lugs to disengage freely from the bale as they pass downward over the idler sprockets. Tension on the pickup chains should be sufficient to prevent buckling. Chain tension can be changed by adjusting the idler sprockets, Fig. 7.

After the frame and elevator assembly has been completed, the axle assembly is trial-fitted in the frame and mounting lugs are welded onto the axle housings as in Fig. 15. Bolts passing through holes drilled in the lugs and the horizontal members of the frame hold it firmly in position. The upper end of the drive unit is bolted to a lug welded to the platform frame. Slots in the differential lug, or plate, Fig. 13, permit adjustment of the drive sprocket to the proper height with relation to the chain channel. The elevator chain need not run tightly as the weight of the chain ordinarily will give sufficient tension to prevent buckling. Note in Fig. 15 that the tires specified are of the airplane type and are mounted on 16-in. wheels. While tires of this type are satisfactory under ordinary field conditions, it may be necessary at times to use tire chains or casings with high-traction lugs in order to prevent slippage. The truck, or tractor pulling a trailer, should be driven at uniformly slow speed and the unit guided so that the pickup chains engage the end of the bale. To save time, bales which are dropped from the baler crosswise of the line of travel should be straightened before being picked up by the loader. As designed, the loader will pick up the standard size bale either flat or edgewise, depending on how it is dropped. If the larger, three-wire bales are handled, the elevator flight should be made correspondingly wider. Keep the drum and clutch units well lubricated to prevent undue wear on the parts.



Above, rear view showing curved platform fender which turns the bale at top of elevator. Below, differential and clutch are mounted on torque tube

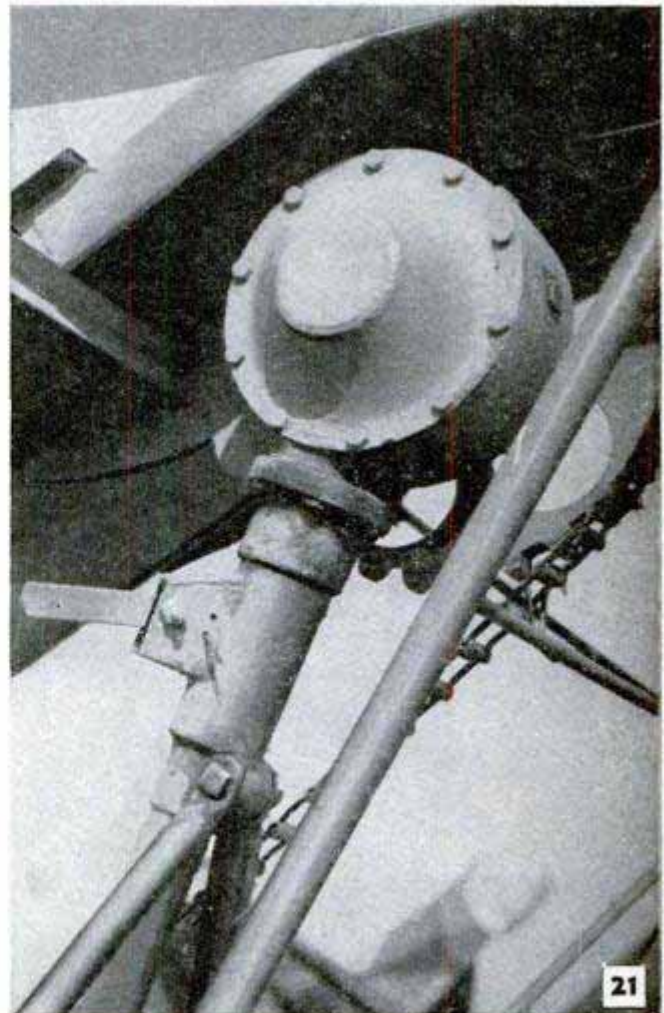

## Floor-Model Drill Press Improvised From Hand Drill and Pipe Fittings

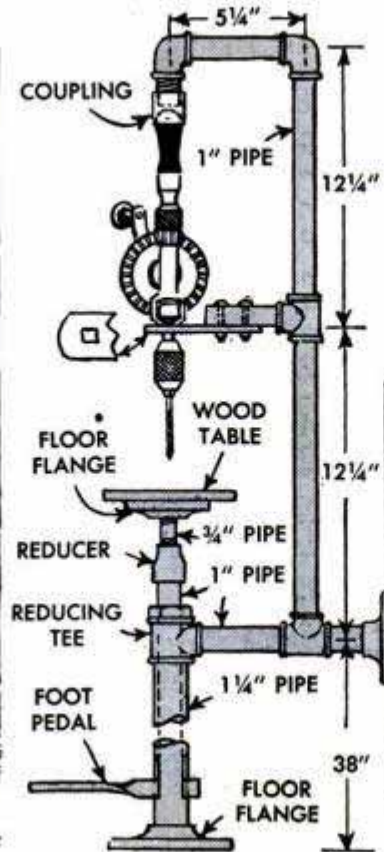

Needing an inexpensive drill press, one carpenter mounted a hand drill on a sturdy floor stand improvised from lengths of pipe and fittings. The drill remains stationary while the table is raised by means of a foot pedal to bring the work in contact with the bit. The unit is supported by a floor flange at the base and another at the rear which is fastened to a stud or basement post. The table assembly is attached to a length of 1-in. pipe which enters a base column of 1 1/4-in. pipe, resting on the foot pedal. The latter is bent from flat iron and inserted through slots cut in opposite sides of the column. The pedal is notched to pivot at the front of the column. The drill is clamped between a flat-iron bracket and a pipe coupling. The frame of the drill is filed square to fit in a square hole in the bracket and the coupling is turned down over the rounded end of the handle to lock the drill in place and align it in the vertical position. — J. A. Sullivan, White Rock, B. C., Can.

## Continuous-Flowing Poultry Fountain Is Supplied by Elevated Water Tank

Desiring a means of providing his flock with a continuous supply of fresh, cool water, a California poultryman came up with this novel drinking fountain. It is supplied from an elevated tank and consists of a horizontal run of 1/2 x 12-in. pipe nipples joined to tees. The nipples are screwed into each of the tees and an elbow is turned onto the end of the last nipple in the run. Then short nipples are screwed

into the tees and into the elbow. Individual drinking cups are formed by screwing 1/2 x 2-in. reducers onto the short nipples as in the detail. By cracking a valve installed in the pipe line, the individual drinking cups fill and overflow continuously. A raised wire floor is placed under the fountain and directly over a sloping slab of concrete leading to a drain. Thus, the overflow is drained away continuously, preventing the spread of waste water and also the incidence of diseases due to dampness. If desired, the fountain can be located at the side of the poultry house and fitted with a hinged cover which can be lowered in stormy weather.

Hi Sibley, Nuevo, Calif.

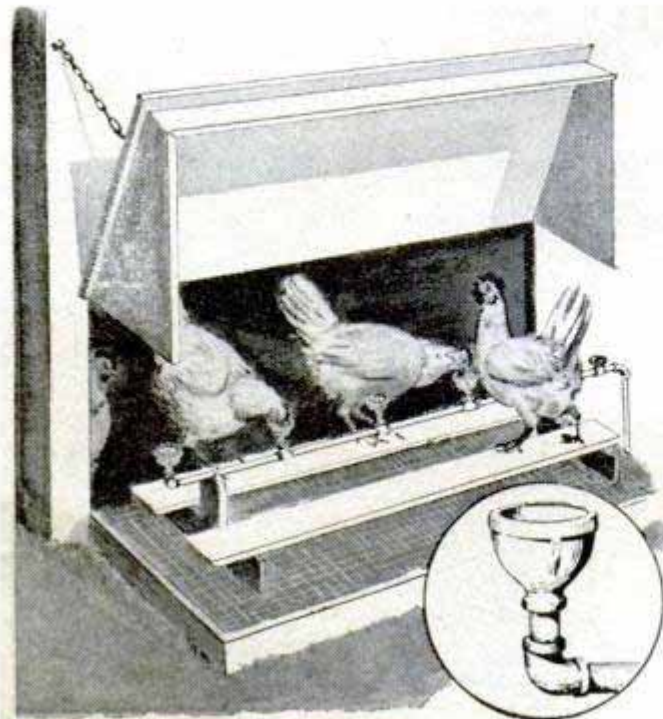

## Stool Utilizes Cultivator Disk

Mounted on legs of 1/2-in. pipe, an old cultivator disk provides an all-purpose stool for use on the farm or in the shop. The legs are welded to the convex side of the disk and are braced with two lengths of 3/8-in. rod, as shown.

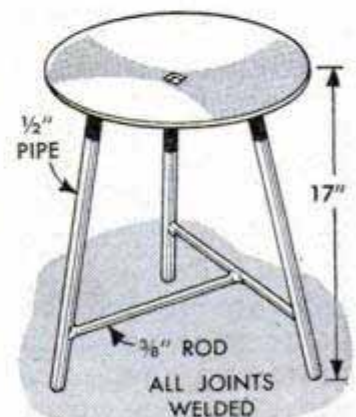



# Large Fruit-Juice Cans Provide Electrode Carrier

Three large fruit-juice cans bolted to a pipe handle form a handy carrier for an assortment of welding rods. The carrier is lightweight and may be set on the ground or hung by the bowed handle from most any convenient projection. Holes are punched or drilled through the sides of the three fruit-juice cans, using the dimensions given in the detail. Then the two parts of the handle are cut from  $\frac{3}{8}$ -in. pipe and welded together. Note that the lower end of the handle is drilled with staggered holes at 120-deg. intervals to register with the holes in the sides of the cans.

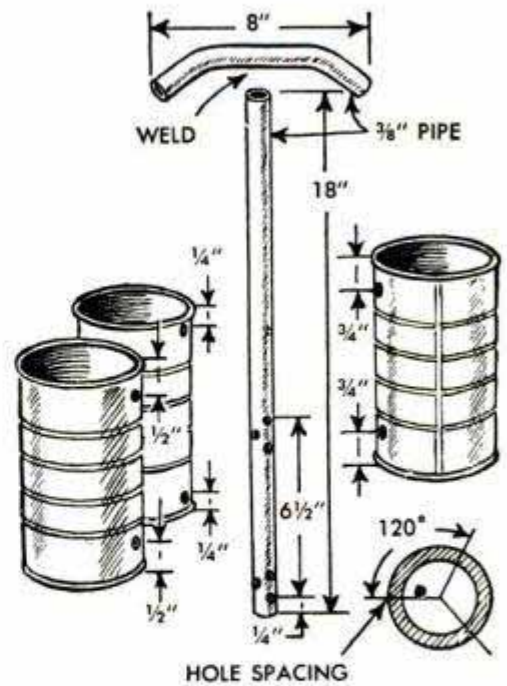
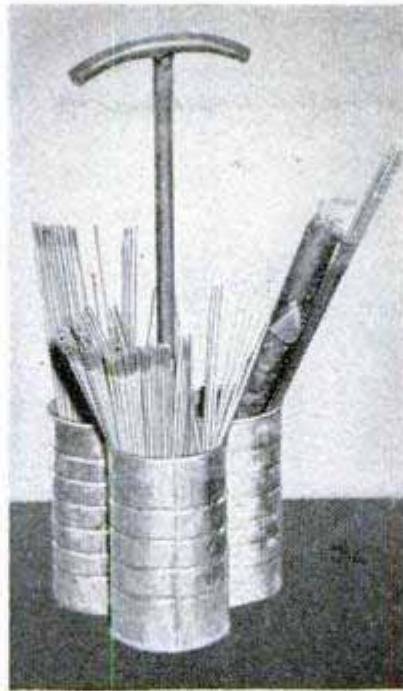

This allows clearance for the  $\frac{3}{4}$ -in. stove bolts which are used to attach the cans to the handle.

If the holes are carefully located, the bottom of the cans will form a flat base for the carrier.—Evan Wright, Topeka, Kans.

# Spring Holder for Threading Tool Results in Mirror-Bright Finish

This spring threading-tool holder will meet the requirements of the critical machinist who is satisfied with nothing less than a mirror-bright finish on his work. A spring holder of this type is practically

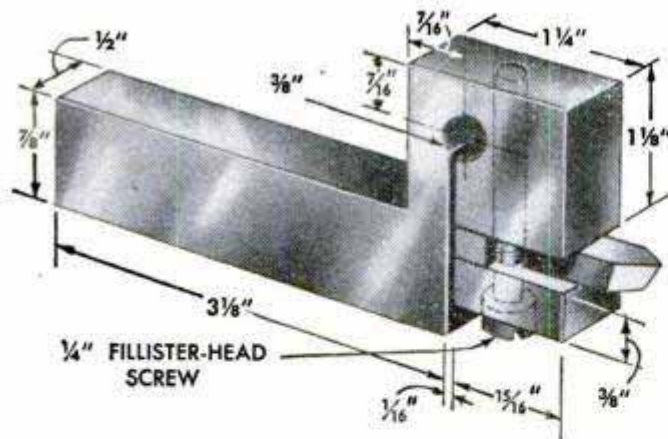

chatterproof, making it especially useful when cutting Acme threads or when using the angular thread-cutting method with a side-cutting tool. Form the body of the holder and the clamp lug either by milling or by sawing and filing the stock to shape. Drill, tap and slot the body and lug as shown. Use a fillister-head machine screw for convenience in tightening the clamping lug. The spacer which is placed between the lug and the body of the holder should be of the same size as the cutting tool. When using a holder of this type, take up backlash in the cross-feed and compound screws and be sure that the compound slides are gibbed up snugly. These precautions will prevent the tool from digging in and spoiling the thread during the finishing cuts.—H. Bergstrom, Evanston, Ill.

# Portable Welding Torch Cuts Tie Wires to Speed Removing Wall Forms

To facilitate removing the wooden forms from poured concrete walls, one contractor uses a portable arc welder to cut the tie wires. This does the job in a fraction of the time necessary when using a hacksaw or wire cutters. The ground lead from the welder is clamped to the wire to be cut and a  $\frac{1}{4}$ -in. welding rod, which serves as an electrode, is simply touched to the wire at the point where it emerges from the form. A man working on the opposite side of the wall can quickly move the electrode from

wire to wire. After the form boards are taken down, the cutting process is repeated to cut off the protruding ends of the wires flush with the surface of the concrete wall.—C. A. Lewis, Saskatoon, Sask., Can.



# DRILLING HOLES in GLASS

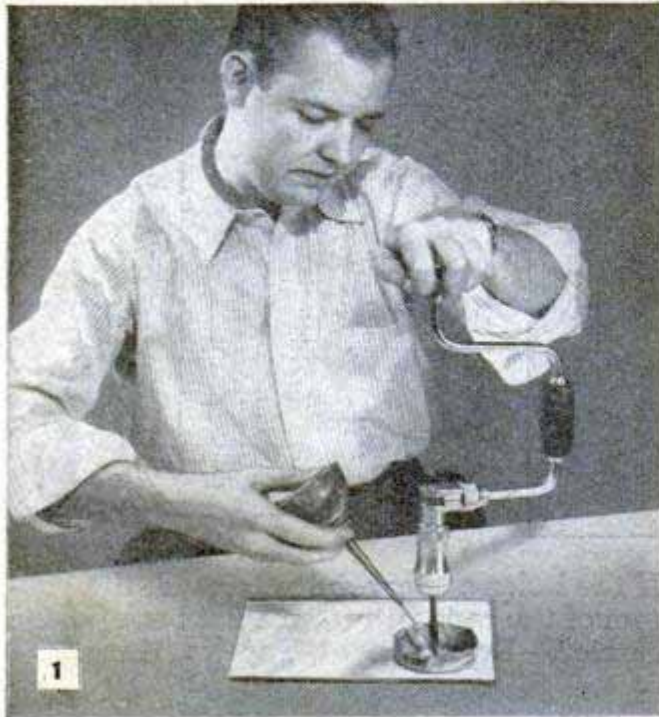

1

A ring of putty placed around the hole to be drilled forms a reservoir for the lubricating agent. Turpentine or camphor oil can be used and you'll find an oilcan is handy for keeping the reservoir filled



2

The file is brought to a long tapering point by carefully grinding each of its three sides



3

The needlelike point is squared off 1/32 in. by touching one corner to the grinding wheel



view shows how the end of a file form a tool for countersinking

Sounds difficult, but like most jobs it's all in knowing how. Ralph E. Moore takes you through the steps in drilling both small and large holes and lets you in on the tricks of the trade that make it so easy

**D**RILLING holes in glass sounds like a job strictly for the local glass shop. But in most cases, the tools used are common ones to be found in the average home shop. It's all in how the tools are handled that makes the difference. Drilling holes up to 1/2 in. in diameter does not require a special glass drill. In fact, the cutting tool is made from nothing more than a common three-cornered file. The file, of course, must be properly ground and extreme care used to avoid drawing the temper. This requires that the grinding be done on a slow-speed wheel, rotating in a water bath to prevent burning the tip of the file. The speed of the wheel should be about 300 r.p.m. and it should rotate in the direction indicated in Fig. 5. A sponge rubbing against the wheel will keep it wet and prevent splattering. In grinding the file, hold it lightly against the wheel and start grinding about 2 in. from the end. Use a sort of stroking motion, pulling the file toward you each time. This is done to each of the three flat faces and will gradually bring the tip to a needle-sharp point. After this, the point is squared off by deftly touching one corner of the file to the wheel. Note the arrow in Fig. 3. The squared tip should not be less than 1/32 or more than 3/64 in. wide. If the tip of the file discolors during grinding, it should be broken off at least 1/4 in. from the end and reground. Otherwise, the temper will be drawn and the tip will not cut. A long taper point, as shown in Fig. 2, provides faster cutting and permits better control in enlarging the hole to the desired size.

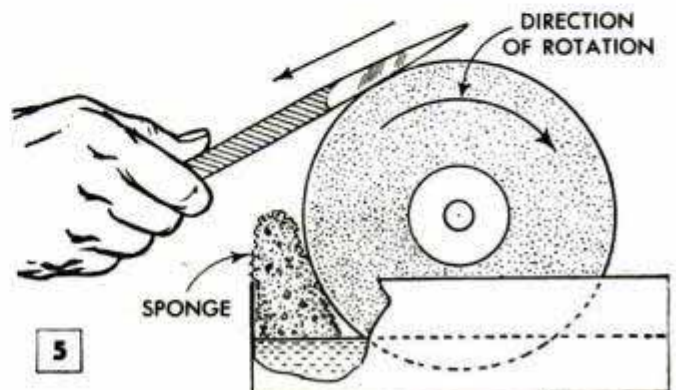

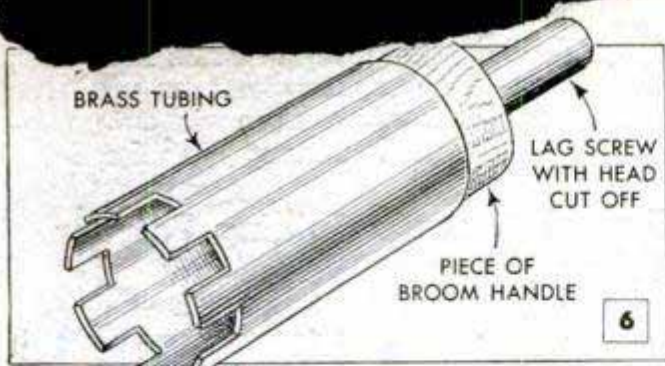

Now, let's test the cutting ability of the file. Take a piece of  $\frac{1}{4}$ -in. plate glass and place it on a flat surface. Holding the file vertically, press down with about 10 or 15 lbs. pressure and twist. If the tip breaks through the polished surface of the glass and makes a gritting sound, it's a good sign that the file has not lost its temper. However, if the point merely wears down without cutting, it must be reground. A file when properly ground will cut 15 to 20 holes before it needs resharpener. Where the job calls for a countersunk hole for a flat-headed wood screw, a tool is made by breaking a large-size file at the center and grinding the end according to Fig. 4. Turpentine or camphor oil is used to lubricate the file when cutting a hole. To retain the liquid, a small dam is formed of putty and placed around the hole to be drilled. Chuck the file in a regular auger brace and start rotating the brace with a firm but light downward pressure. When the drill point pierces the surface of the glass, add the turpentine, Fig. 1. An oilcan is excellent for this purpose. Rotate the brace using about 5 lbs. pressure, swinging it by the top with one hand. The needle point of the file will finally pierce the underside of the glass and when this happens use less pressure and rotate the brace more slowly. Let the glass overhang the edge of the table and continue through. If the point is allowed to embed in the table, you are apt to chip the glass on the underside. Some glaziers recommend finishing the hole from the reverse side as soon as the point of the file breaks through.

Thin glass, such as single and double-strength window glass, should be placed on a heavier piece of glass to provide a good flat surface and drilled with a minimum of pressure, little more than the mere weight of the brace. This is especially necessary when the point of the file is about to break through the work and when a hole is being drilled close to the edge of the glass.

Drilling large holes in glass requires a different technique and tools. The cutting tool required is homemade, Fig. 6, consisting of a length of brass tubing with teeth formed at one end and fitted with an accurately centered shaft for chucking it in

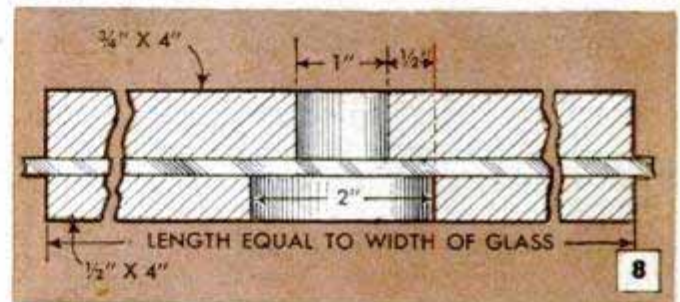
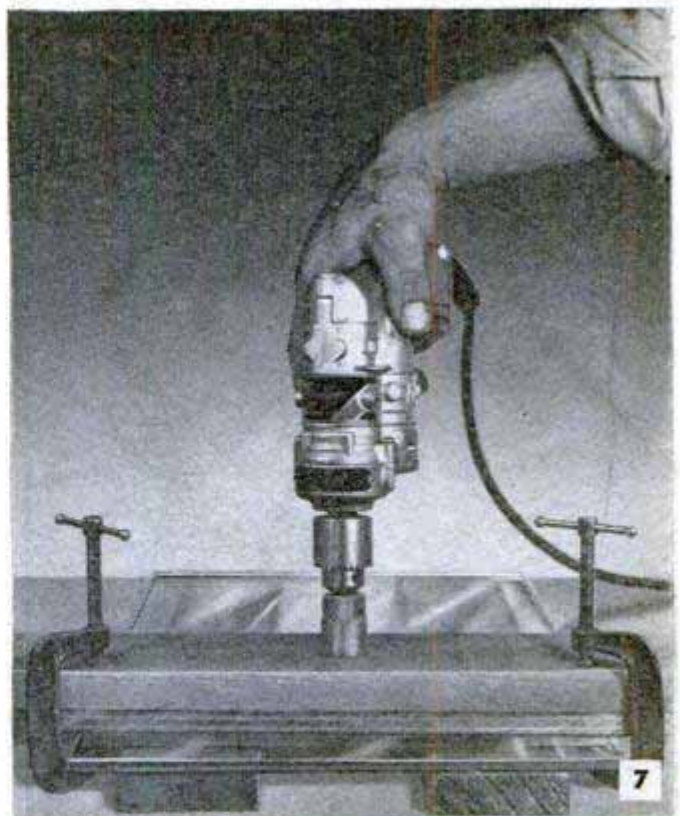

an electric hand drill or drill press. The notches are formed with a hacksaw, the pieces are broken out with pliers and then squared up with a fine file. In using this cutter, the glass is clamped between two wooden guides, Fig. 8. A hole the same size as the cutter is made in the top piece, while the hole in the bottom piece is made larger as shown. In addition to guiding the cutter, the top hole serves as a well which is filled with two tablespoonfuls of silicon carbide or emery dust and enough water to nearly fill the hole. The drill is held vertically as in Fig. 7, using from 5 to 10 lbs. pressure, and the cutter is lifted about  $\frac{1}{8}$  in. every few seconds so that the emery dust has a chance to work under the teeth of the cutter. As the cutter advances, less pressure is applied. The same cutting agent is used when a drill press is employed to cut the hole, but the wooden guide is dispensed with and a dam of putty is substituted as before to retain the emery compound. A speed of 1500 r.p.m. is recommended for holes  $\frac{1}{2}$  to  $1\frac{1}{2}$  in. in diameter, while a slower speed of 800 to 1000 r.p.m. is required for holes of larger size. The teeth of the cutter will dull slightly in use and require touching up occasionally with a file.

## Silage Truck With Flanged Wheels Rolls on Elevated Track

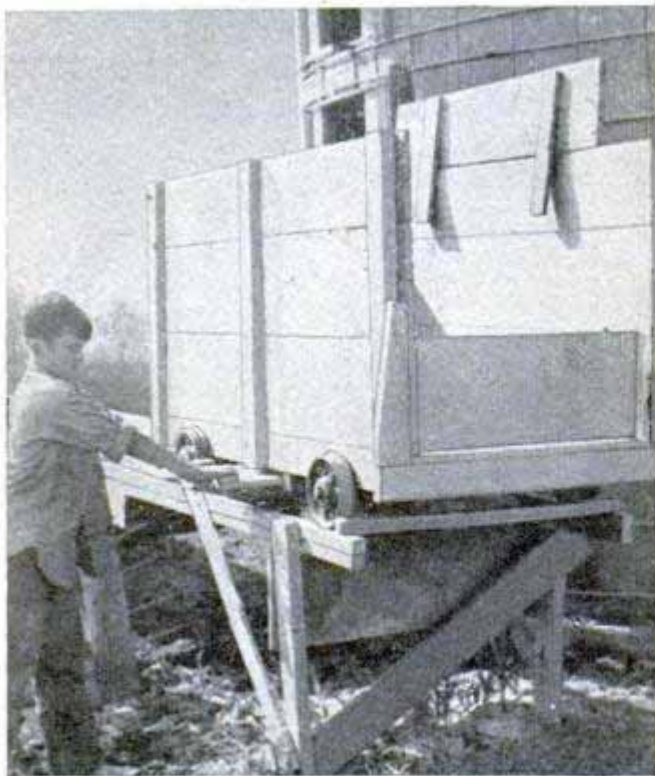

Four flanged wheels found in the junk yard were put to good use by one farmer in making a novel feed truck to run on an elevated track built on top of the feed bunks, which are placed end to end in the feed lot near the silo. The truck box, or hopper, can be any convenient size for holding measured portions of bulky, dry feeds. An adjustable slide covers an opening cut in the bottom of the hopper. By adjusting the slide, the size of the opening is varied to assure even distribution of the feed as the cart is rolled along the track over the bunks. The track is made from 2 x 2s spiked to the tops of the bunks and must be spaced to a uniform gauge throughout its length. The wheels turn free on full-length axles and are held in place with washers and cotter pins.

## Board Tied to Neck Tames Buck



is passed through a hole drilled in the center of the board, and then the rope is tied around the buck's neck. The rope is just long enough so the board rests on the

Having purchased a buck that had lost his fear of man and had become unruly, one farmer controlled him by hanging a piece of 2 x 6 from the animal's neck. A length of rope knotted at one end

ground when the animal stands normally, but when he runs, it interferes with his front legs, slowing him down without harming him.—Kenneth R. Imig, Watseka, Ill.

## Funnel Prevents Spilling Powder When Filling Bottles

Waste is held to a minimum when pouring powdered chemicals into bottles if a wide-mouth funnel is used. The powder is either shaken through the funnel spout or worked through with a glass stirring rod.

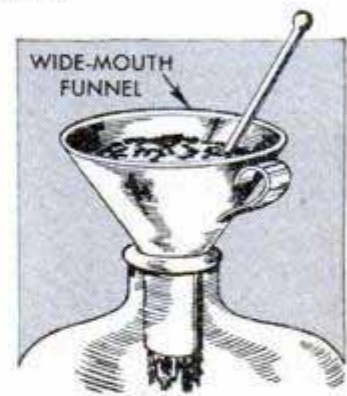

## Index Plate for Wood Lathe

Requiring an indexing plate for an older-model wood lathe not fitted with this handy built-in accessory, one craftsman turned out a simple one-piece pattern from wood and had a special plate cast in aluminum. The casting has a raised section, or boss, which fits into the recess in the large step of the lathe cone pulley. The outer face of the plate is indexed with one row of 32 holes and another of 8 holes. Both rows of holes are equally spaced on 360-degree circles scribed on the surface of the plate. The plate is fastened with four machine screws which are passed through body-size holes drilled in the bottom of the V-groove of the largest step of the cone pulley. The screws turn into tapped holes in the boss as shown in the sectional detail. The index pin is mounted on a spring bracket attached to the lathe headstock with a small bolt.

Herbert E. Pott, Victoria, B.C., Can.

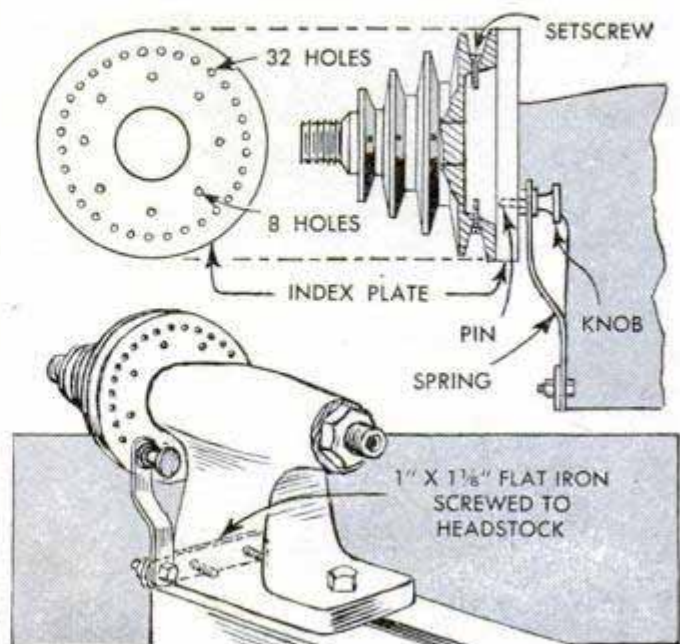

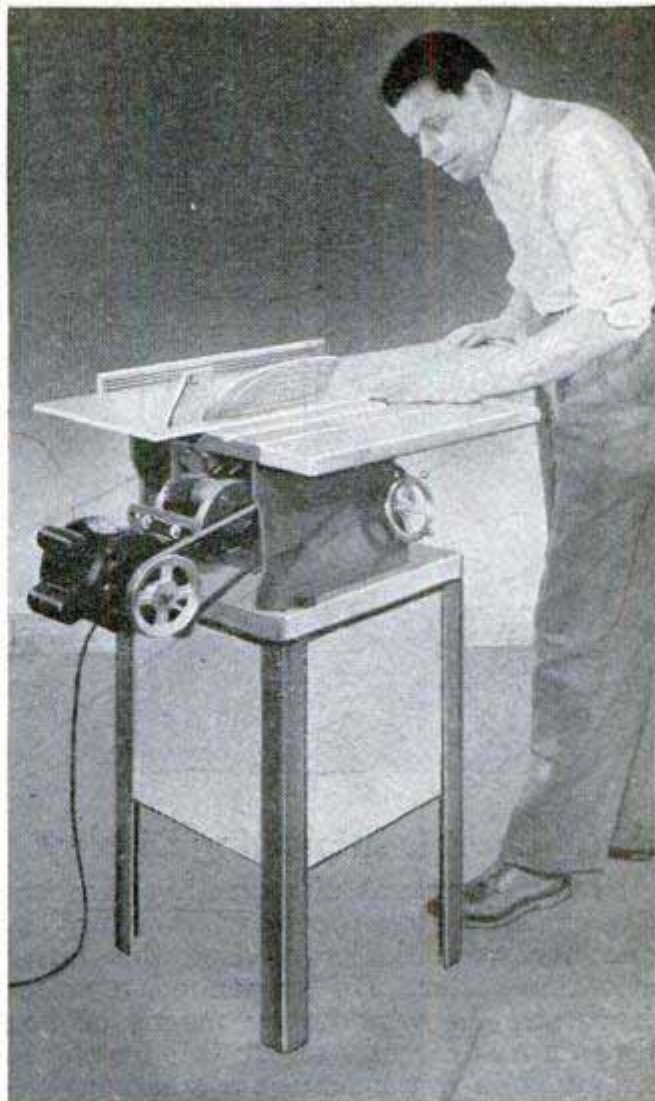
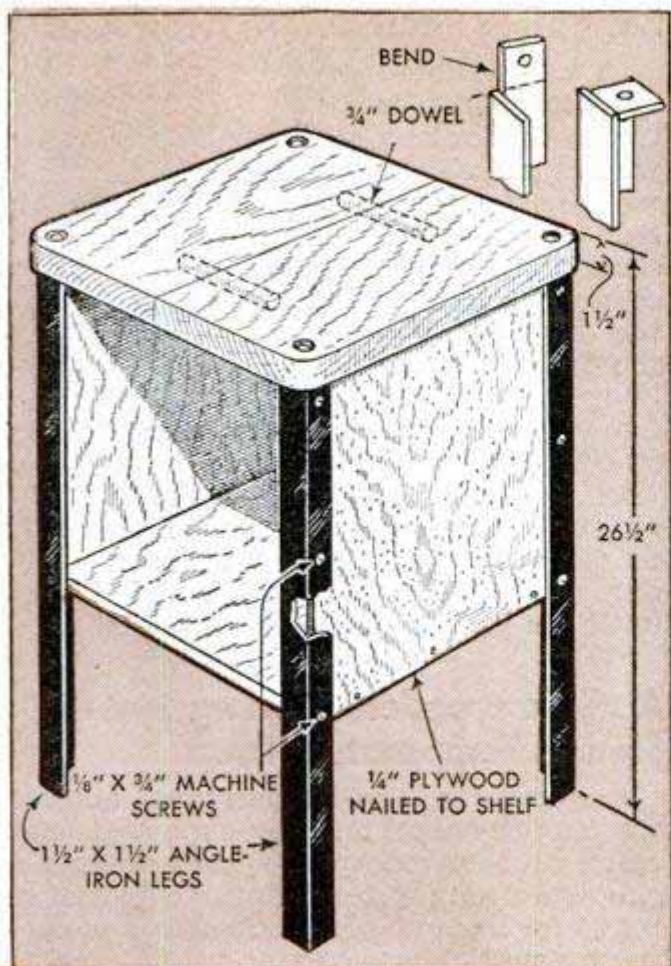

## POWER-TOOL STANDS

**I**F YOU want to economize on the cost of power tools by making your own machine stands, here are two sturdy ones that cost little and are simple to build. The one detailed above is particularly suitable for a tilting-arbor saw, the open front providing a handy shelf on which to place the miter gauge or the fence whenever one or the other is not being used. However, if the stand is made to support a tilting-table saw, a belt slot can be cut in the top for driving the machine from below. The legs are lengths of angle iron which are bolted to a thick wooden top and made exceptionally rigid by plywood panels on three sides. Note how the upper ends of the angle iron are drilled, cut and bent for attaching.

The legs and lower framework of the stand at the right consist of  $\frac{3}{4}$ -in. pipe, the legs being flared at the bottom for added stability and welded at the top to an angle-iron framework covered with plywood. This particular stand is made to order for a tilting-table saw with a hinged motor mount being employed. A lower shelf provides a place to lay accessories, and rubber crutch tips fitted over the ends of the legs reduce vibration. The angle-iron frame supporting the plywood top is formed from one piece, a V-cut being made at three corners to permit making 90-deg. bends.

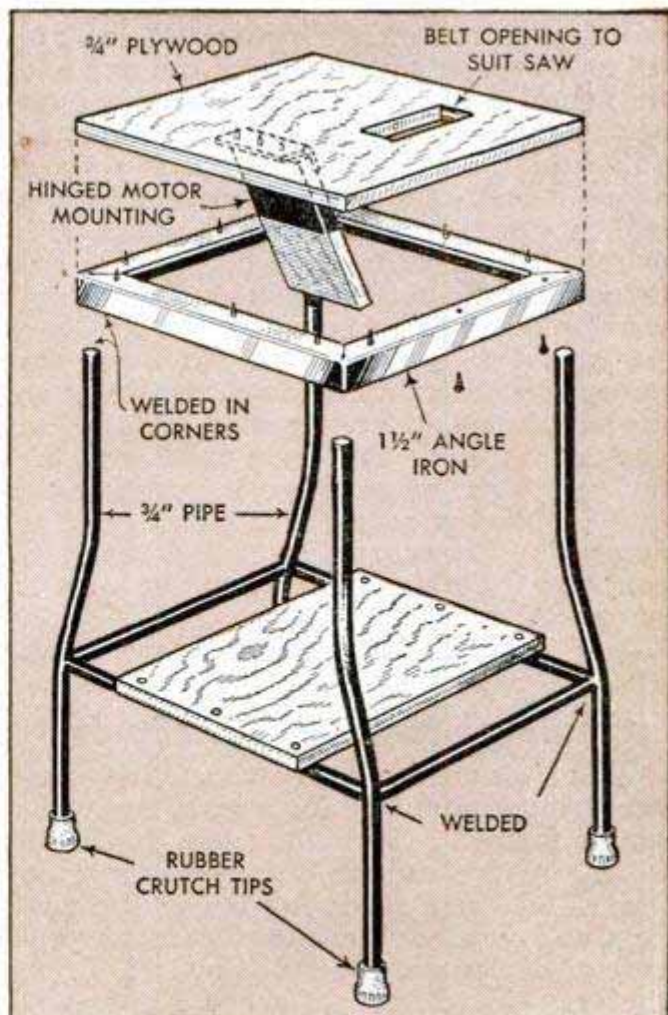

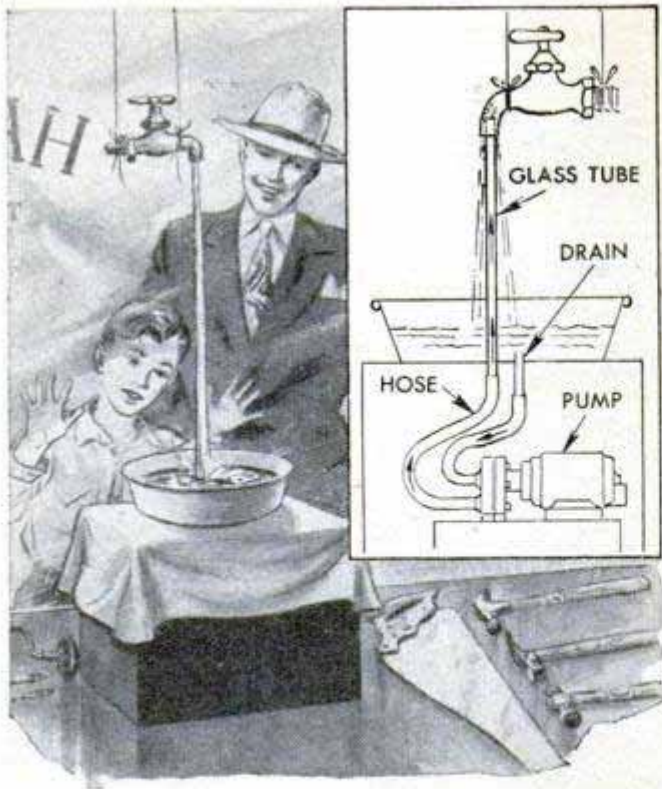

### Trick Faucet Is Interesting Display

Seeking a means of attracting prospective customers to a special window display, one hardware dealer devised this novel attention-getter. He suspended a water faucet in the window by means of fine threads and directly under this he placed a box. The latter houses a small motor-driven centrifugal pump and supports a metal pan containing water. Holes are drilled through the bottom of the pan and the top of the box and two glass tubes are cemented in the holes to form the inlet and outlet to the pump. Both tubes project about 2 in. below the bottom of the pan and they are connected to the pump with rubber tubing. The glass outlet tube extends from the bottom of the container upward into the faucet spout as shown. When the container is filled with water and the pump turned on, water is drawn through the inlet tube to the pump where it is forced upward through the long tube into the faucet spout. From there it gushes back into the pan in a most realistic fashion. The descending stream of water completely conceals the glass tube when the unit is in operation.

Fred Barnes, Ann Arbor, Mich.

### Estimating Number of Wall Studs

When it is necessary to estimate the number of studs required for a wall, I use this simple formula. Divide the length of wall in feet by five and multiply the answer by four. Add extra studs needed at the corners and you have a close estimate, providing, of course, the studs are 16 in. on centers.—Ward Skeen, Larned, Kans.

### Bottoming Short Bolt in Acorn Nut

In cases where an acorn nut is used to lock a wheel or other movable part on a bolt or threaded shaft, the nut will soon work loose if the bolt is too short to bear tightly against the bottom of the nut. This can be remedied by placing BB shot in the hole in the nut. Then, as the nut is tightened, the shot will be mashed, holding the nut in place. If there is insufficient play for the movable part when the nut is tight, add BB shot until the proper clearance is attained.

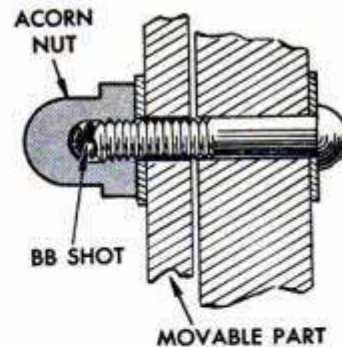

### Audible Brooder Warning System Signals Temperature Drop

Requiring a low-temperature, audible warning signal on an older-type coal-fired chick brooder, one poultryman devised a simple warning system using a temperature regulator from an old incubator as the actuating unit. The regulator, which consists of a "wafer" thermostat with contacts arranged in a frame as shown, is mounted on a low stand at the edge of the hover and wired to cry cells and a buzzer, or doorbell unit. The latter is located in the house to give warning at any time, day or night, should the fire in the brooder stove burn low or go out. The contact points are carefully adjusted to make contact and ring the warning buzzer, or bell, when the temperature falls below 75 degrees.

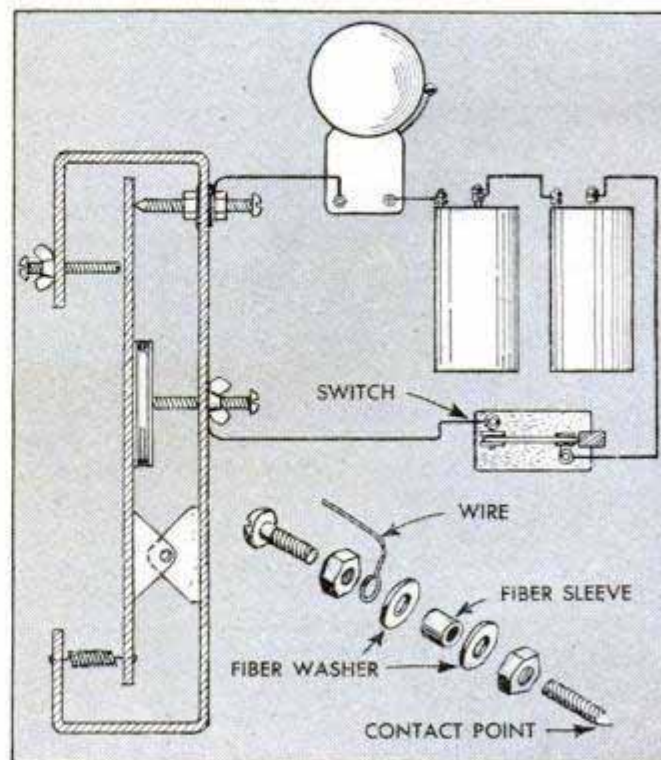

## TV PICTURES PROJECTED ON HOME MOVIE SCREEN

**T**HROWING a 3 by 4-ft. image through a lens in the front of the chair-side cabinet to the screen, this Protelgram-equipped television set, shown in photo A, is one of several big-picture sets now available. The set controls are conveniently placed to be handled from your chair.

Component parts of this television system are illustrated in photo B. The high-voltage power unit is at left; the projection-tube assembly with its focusing coils in the center; the "optical box" with its mirror and lens assembly is at extreme right. This system employs a cathode-ray TV projection tube with a face diameter of only 2½ in., no larger than the compact held by the young lady in photo C.

Diagram D shows how this projection system provides large images that may be thrown on a viewing screen or wall. The picture on the 2½-in. face of the projection tube is reflected from the concave mirror to the plane mirror, then to the cabinet mirror and, finally, to the screen.

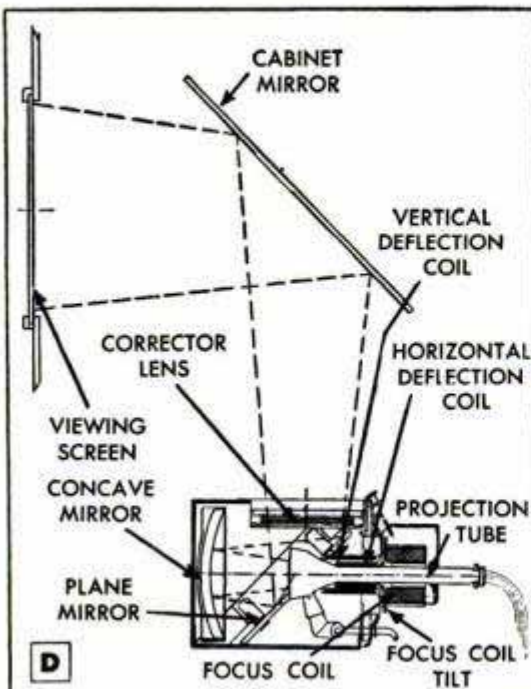
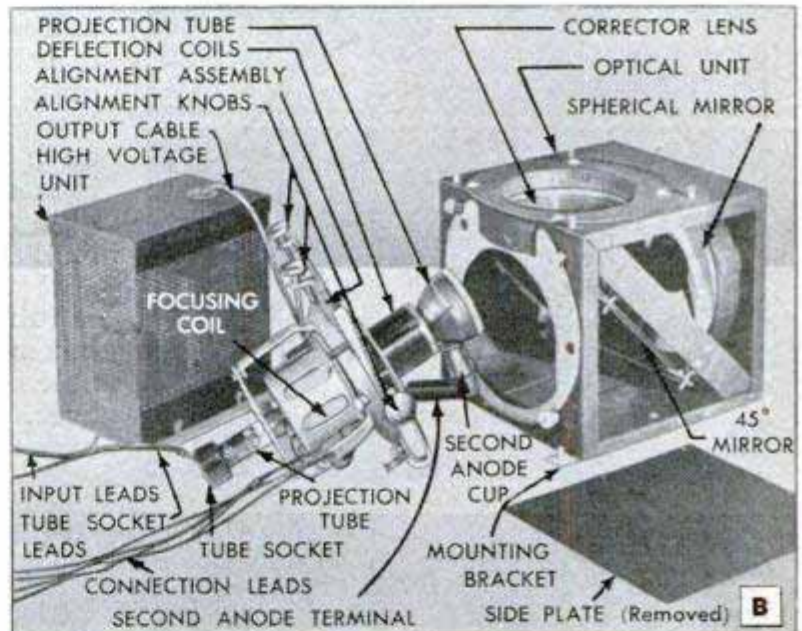
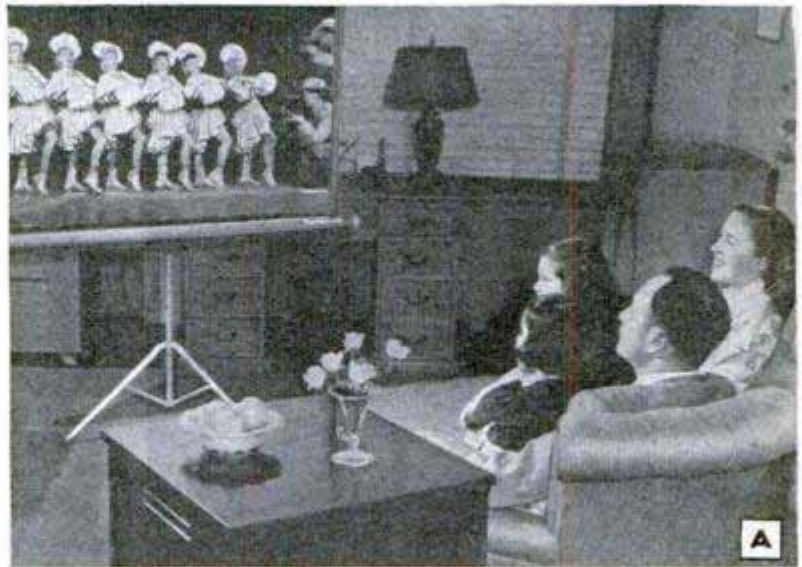

# PHONE TRANSMITTER FOR

By Stan Johnson WØLBV

## PART I

**B**EFORE the war the 160-meter phone band was one of the busiest amateur bands of all, mainly because it was ideal for contacts up to 1000 miles or so, with a reasonable amount of power and a rather simple antenna. This band has been recently reopened for amateur use, a fact which caught many an old-timer, as well as newcomers, with no gear that would work on the band. To provide a practical way to get on 160 meters with a rig which is easy to build, yet operates at 120 watts input, the transmitter illustrated and described was designed. It is assembled on four standard-size chassis bases, and can be installed in a simple wooden rack, as shown in photos A and D.

The construction of the R.F. transmitter and modulator units is complete in Part 1 of this article; the separate power-supply units will be described and illustrated in Part 2 in the March issue. Although built on a metal chassis base only 3 x 7 x 15 inches, the transmitter is a full three-stage unit, with a Pierce oscillator, buffer and final amplifier. For the last stage, a pair of 1625 tubes was chosen as this is a type of tube that many hams have in their junk boxes since they have been widely available from surplus at very low prices. However, they are identical with the 807 tubes except for the tube-base arrangement and

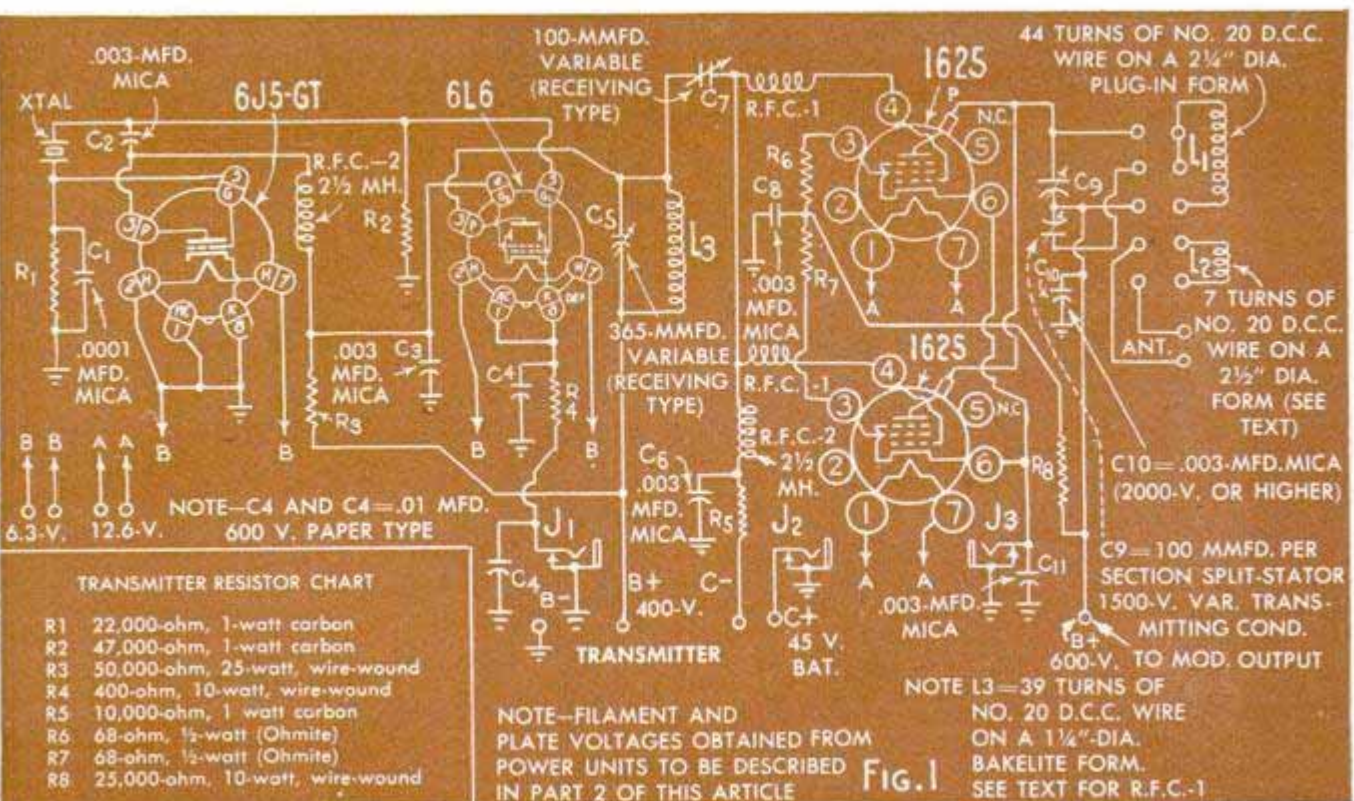
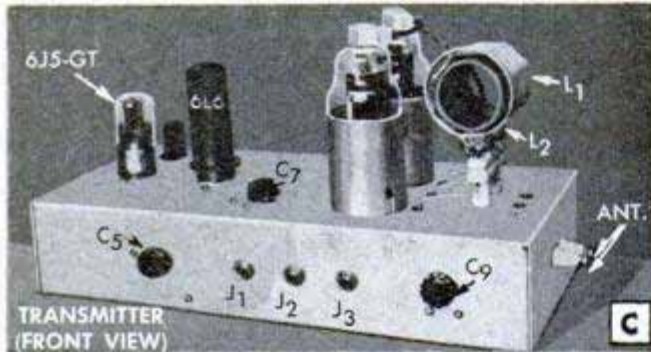
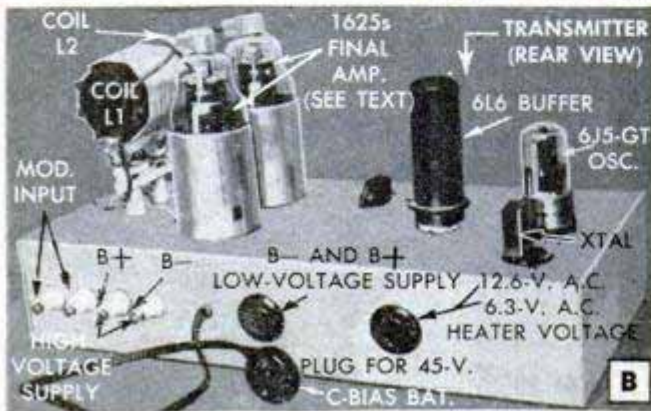
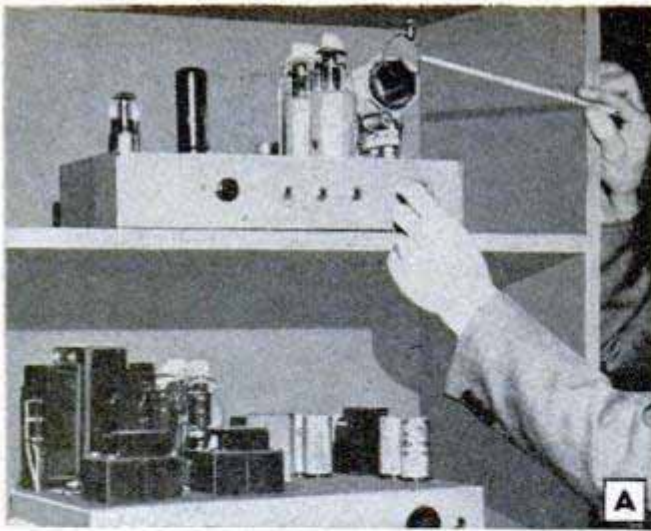



# 160-METER AMATEUR BAND

the filament voltage, requiring 12.6 volts. If desired, the builder can substitute 807 tubes in both the R.F. transmitter and modulator units with no circuit changes, by merely changing to five-prong sockets and lowering the heater voltage to 6.3 volts.

Thanks to the use of the Pierce oscillator, the transmitter has only two tuning controls. The first tunes the plate circuit of the 6L6 buffer; the condenser and coil combination used in this tuning circuit (see Fig. 1) is such that the buffer can be tuned to both 160 meters and 80 meters simply by rotating the variable condenser. This makes it possible to shift to 80 meters simply by changing the plate coil in the final amplifier. To obtain a reasonable "Q" in the amplifier tank circuit, a split-stator variable is used, and the coil so arranged that for 160 meters the two halves of the condenser are connected in parallel across the coil. For 80 meters, only one half need be used; the other half "floating."

(Continued to page 234)

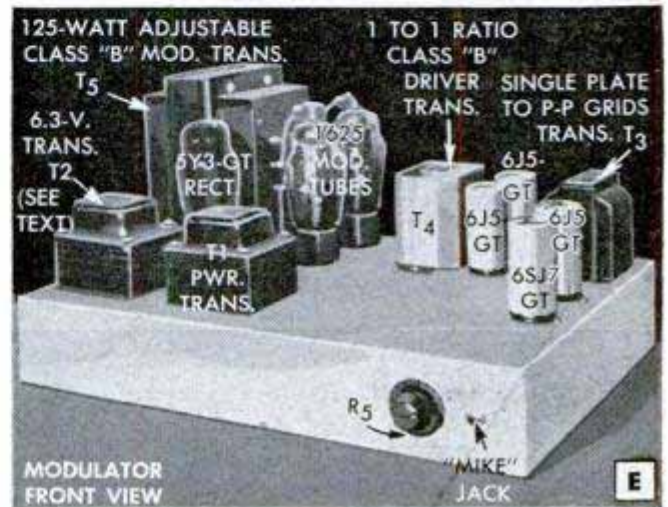
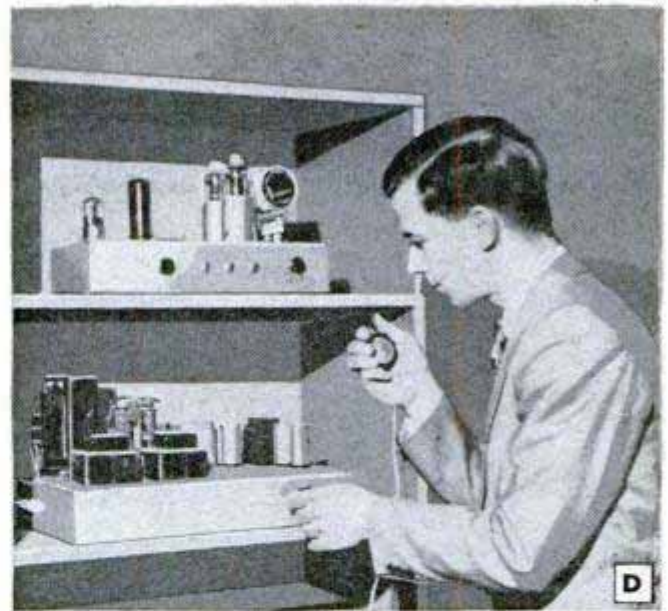

MODULATOR RESISTOR CHART	
R1=1-megohm, 1/2-watt carbon	R8=47,000-ohm, 1-watt, carbon
R2=1500-ohm, 1-watt carbon	R9=12,000-ohm, 1-watt, carbon
R3=250,000-ohm, 1/2-watt carbon	R10=5000-ohm, 10-watt, wire-wound
R4=1 1/2-megohm, 1/2-watt carbon	R11=0-1000-ohm, wire-wound variable
R5=0-1-megohm, volume control, audio taper	R12=10,000-ohm, 10-watt wire-wound
R6=1500-ohm, 1-watt carbon	
R7=800-ohm, 10-watt, wirewound	

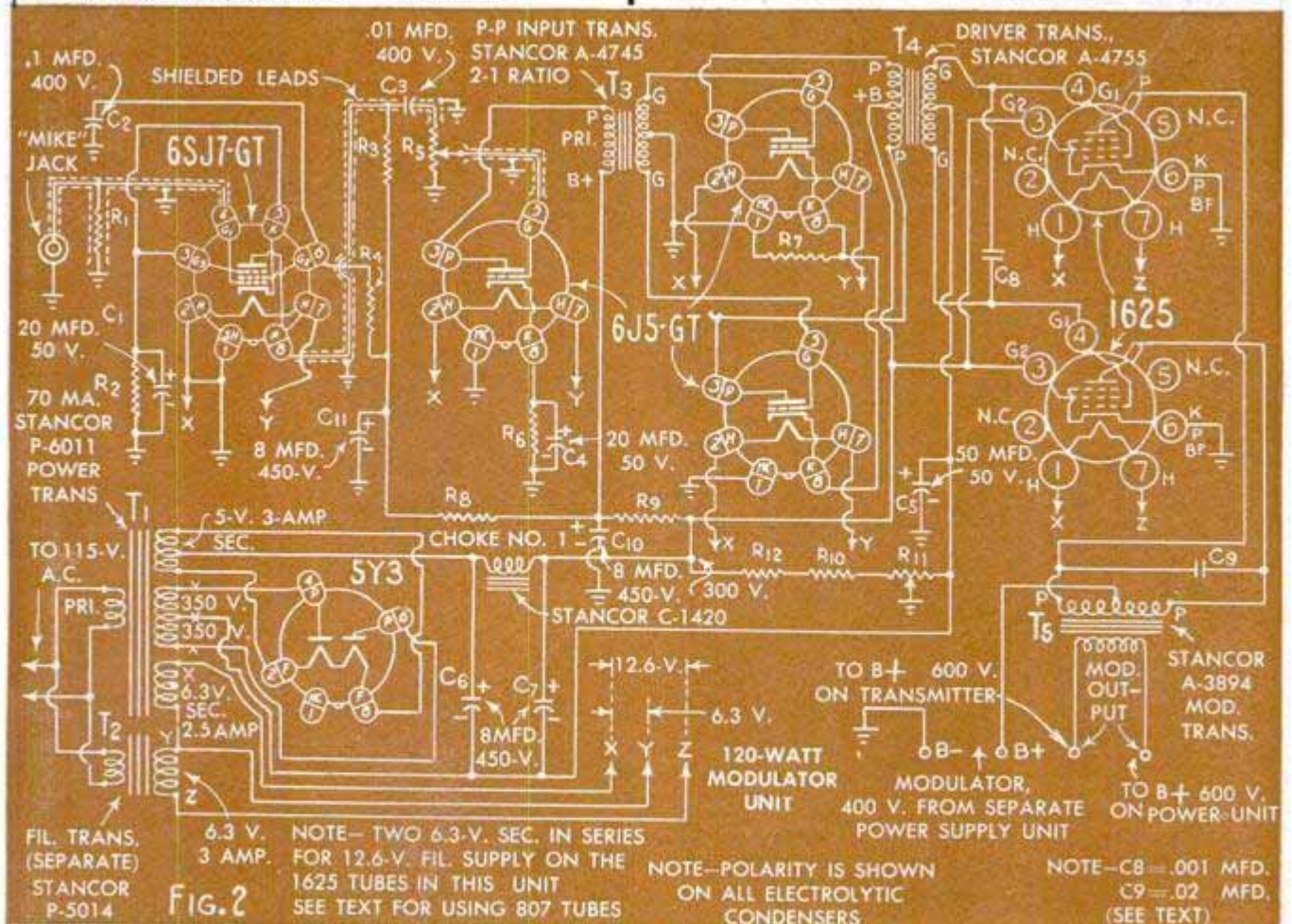

# Radio and Television Today

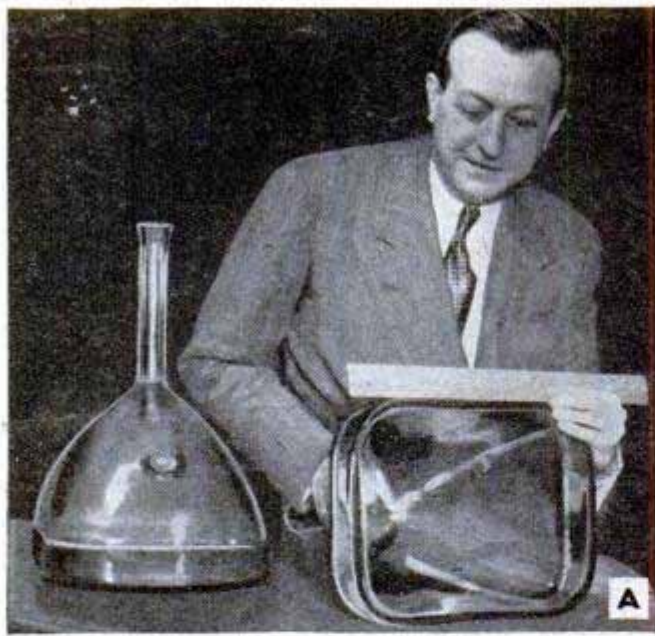

**A**—All-glass rectangular television bulb designed to receive 100 percent of the transmitted TV picture. It parallels the picture shape of modern motion-picture film; relation of width to height, 4 to 3



**B**—Twin-stylus variable-reluctance phonograph cartridge capable of playing conventional and micro-groove records. Changing from one stylus to the other is done by depressing and turning the knob

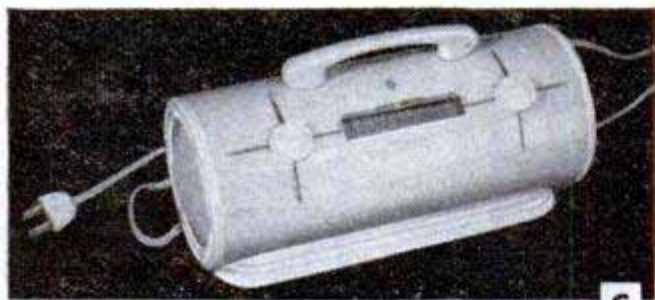

**C**—Truly a dual-purpose radio, this a.c.-d.c. five-tube set has a built-in antenna and will serve in any room in the home as a table model. Then for personalized listening, it may be mounted on the head of your bed and the speaker may be removed from the cabinet as shown and placed under your pillow

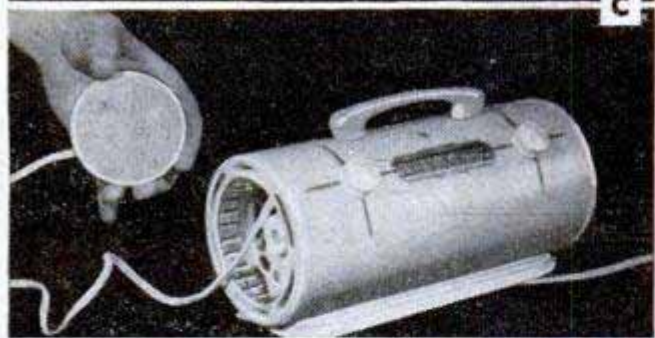

**D**—Television "juke box" permits customers in booths to see 3 minutes of television for 5 cents. Each booth set is a "slave" unit operating from a master set



**E**—Twin-lead lightning arrestor protects television receiver. It can be installed either inside or outside as shown, without wire stripping or cutting

**F**—Portable prospecting unit detects and measures both beta and gamma rays emitted by uranium and other radioactive ores, instead of gamma rays alone

**G**—Voiceraser renews dictating-machine records. Disks may be "erased" and used as many as 50 times

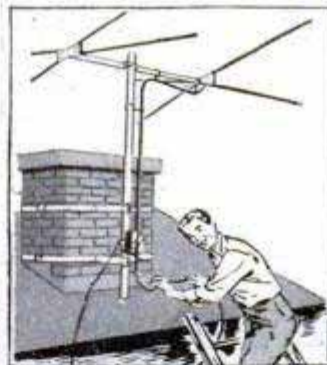

# Less than \$50...a fine Kodak Enlarger

**THE NEW  
KODAK "HOBBYIST"**



**"Cold light" protection for your negatives**—at the touch of a button, the circline fluorescent lamp flashes on. "Integrating-sphere" type lamp house and its special inside coating give uniform light distribution.



**"Squeeze action" control smoothly elevates or lowers the enlarger head.** You can enlarge negative areas up to 7 times.



**As for focusing,** what could be quicker than a turn of the lens. The Kodak Enlarging Ektanon  $f/6.3$  89mm. Lens, with click stops, is velvet-smooth—accurate to a degree.



**ONLY  
\$47.50  
COMPLETE  
WITH LENS  
and including  
Federal Tax**

Enlarging is swell fun . . . ask anyone who does his own work. So see the new Kodak Hobbyist Enlarger at your Kodak dealer's now. It's a great performer at a modest price.

**EASTMAN KODAK COMPANY • ROCHESTER 4, N. Y.**



**New negative carrier simplifies loading**—for negative sizes through  $2\frac{1}{4}$  x  $3\frac{1}{4}$  inches. Kodak Combination Negative Carrier A, masks, and roll-film cups are available accessories.



**Stows away in its own suitcase-type packing case—ideal for closet storage.**

**Kodak**  
TRADE-MARK



# Care and Feeding of Engines

BY S. P. CORP

## WHY CLEAN RING GROOVES?

A ring set is like a football team. If a tackle lets the opposing guard come through to tackle the half-back before he gets a pass away, the whole offense bogs down. If the top compression ring gets stuck in a dirty groove, it can't seal off the combustion chamber. Gases go past and tackle the second ring. This means compression lost, power lost, high temperatures and rapid wear.

With that kind of a strain, the second ring is likely to get stuck in its groove, and away goes your old ball game. Cleaning oil ring grooves, of course, is just as important—particularly the oil holes. You must provide for a full flow of oil through these holes.

## DON'T LET IT HAPPEN!

Rings must slide smoothly and freely in clean grooves. All the sticky, lacquer-like substance known as "varnish," must be cleaned out before fitting new rings.

Figure 1 shows a ring groove cleaner in use. This is the way to clean the bottom of a groove. It won't do a thorough job on the sides. For the sides, the best tool you can use is a piece of an old, broken compression ring. Use the square end and scrape both sides of the groove all the way around, twisting the piece of steel to get close contact.



FIG. 1

## CHECK CLEARANCE

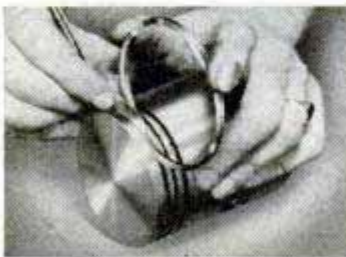

FIG. 2

After cleaning grooves, check clearance with a feeler gauge (Fig. 2). If there is less than .0015 rub ring on emery cloth laid on a face plate to reduce thickness. Clearance should be not more than .004.

**Special caution!** Sealed Power Piston Rings are the best rings made. Sealed Power MD-50 Steel Oil Ring, the only ring with the full-flow spring, does the world's finest job of oil control, even in badly tapered and out-of-round bores. It gives you double the drainage with half the drag. Your dealer has Sealed Power rings or can get them for you.



## Phone Transmitter

(Continued from page 231)

The coil  $L_1$  used in the final is homemade, being wound on a 2¼-in. ribbed form. Coil  $L_2$  is wound on a 2½-in. form. The turns are glued together with china cement and the form removed. If a complete manufactured 150-watt coil is used instead, it should be a type with a variable end link. Enough turns should be removed from the coil so that the amplifier tunes with the condenser fairly well "in." Because the transmitter will probably be used at most stations as an auxiliary to other equipment, no meters are built in. However, meter jacks are provided as will be noted in photo C.  $J_1$  is for measuring the 6L6 buffer cathode current;  $J_2$  for the amplifier grid current and  $J_3$  for

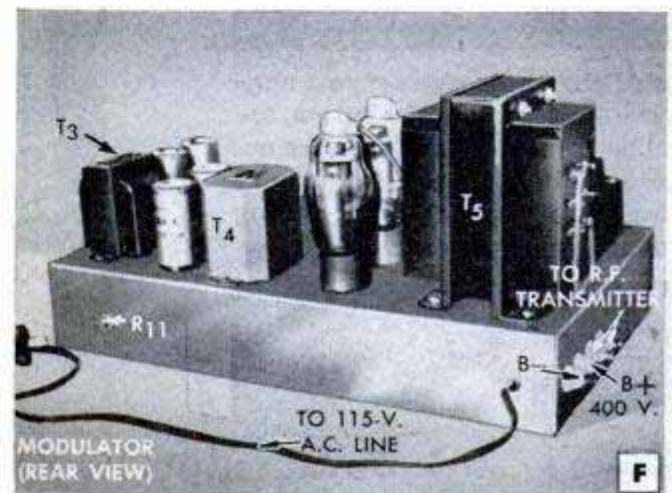

amplifier cathode. The latter serves for most of the metering, as it is roughly equivalent to a plate metering spot (includes screen and grid current, of course).

Photos B and C show rear and front views of the transmitter unit. All parts are specified individually for this transmitter unit in diagram Fig. 1 and its resistor chart; the bottom view appears in photo G. Chokes R.F.C.-1 consist of 17 turns of No. 20 d.c.c. wire wound on 1-megohm, 1-watt resistors. Because the 1625 tubes, like the 807 tubes, are easily overdriven, a variable condenser is used to provide excitation control. This condenser, C7, is operated with the knob on top of the chassis, and when once set to give maximum output it can be left alone. The frequencies which are available in the 160-meter band are different in certain parts of the United States. Therefore, be certain that you know which apply to your part of the country before buying crystals. In operation, the transmitter should be loaded until the cathode milliammeter shows about 220 mils. The 1625 or 807 tubes will take this input with ease. Photo A shows

(Continued to page 236)

**SALESMEN!**

# SALES GOING CRAZY!

Work hard for 7 months  
...then LOAF the rest of the year!

## AMAZING *Underground* SPRINKLER SYSTEM -

Retails for ONLY... \$49<sup>50</sup>

...SWEEPING SALESMEN INTO THE BIGGEST MONEY  
OF THEIR LIVES! "GOLD MINE" FOR DISTRIBUTORS!

Last year, EVERSPRAY created a nationwide sensation — poured spectacular profits into the laps of salesmen everywhere.

This year, the NEW, Improved EVERSPRAY is going to make last year's earnings look like small change! Because *this year*, we offer Salesmen TWO spectacular order getters until now unheard of in the history of Direct Selling.

1. A COMPLETE DEMONSTRATOR you carry right in your pocket.
2. An Everspray SYSTEM complete in every detail that you can

spread out on a prospect's lawn and have in full operation IN LESS THAN 10 MINUTES!

This year—right before a prospect's very eyes—you can show him exactly how his Everspray Underground Sprinkler System is going to work when it's installed in his lawn!

With either one of these two amazing demonstrations you clinch a sale 9 times out of 10. Every home owner who takes a speck of pride in his lawn will want to install an Everspray as quick as it can be delivered to his door!



Everspray installed at North Acres Gardens, Anderson, Indiana

**"People Tell Me I Have the Finest Lawn They've Seen in Years"**

—writes Mrs. L. G. Johnson

"When my Everspray is in operation, people actually stop their cars to watch it and to admire the smooth, velvety green texture of my lawn. I never saw anything like Everspray in all my life."

And R. C. Freeman, Chicago, says: "It's amazing how EVERSPRAY keeps our lawn in tip-top condition all season long. Best of all, I don't have to waste hours of time sprinkling with a garden hose."

## CUSTOMER INSTALLS IN FEW HOURS without damage to lawn!

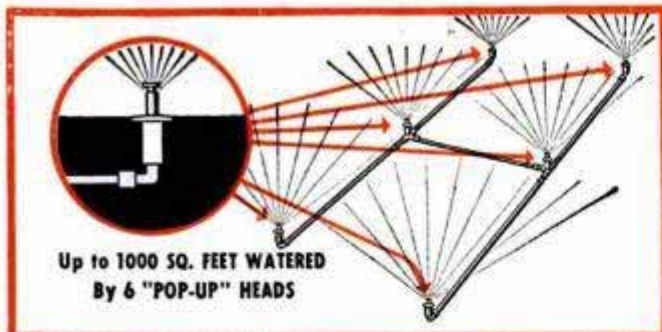

Now, for the first time in history, any home owner—anywhere—can get an Underground Sprinkler System at a price he can afford. Now his lawn can be sprinkled like a million-dollar estate. And look! Everspray is all solid brass and copper. Nothing to rust or wear out. No pipe fitting to do. No plumber's bills to pay. No repairs. No inspection. No maintenance. No freezing

because Everspray drains itself—automatically—every time it's shut off. No wonder home owners by the thousands are rushing to buy Everspray!

No wonder Ray J. Eckenrode says: "EVERSPRAY works like a charm. On the strength of this installation, a neighbor asked me to purchase the same layout for him."

DON'T CALL YOURSELF A SALESMAN IF YOU CAN'T MAKE

### \$60<sup>00</sup> A DAY!

In the NEW Improved EVERSPRAY you've got your hands on the biggest summer seller ever invented. When most lines are dead or dying, Everspray is just coming to life! Our sure-fire "Jack-Pot" Pyramid Sales Plan turns your first sale into TEN or more. Then EXTRA orders start pouring into your hands automatically—without a bit of effort on your part!

**FREE! SEND NAME**

This very minute, send your name on the coupon or penny postcard for beautiful Illustrated Folder that shows pictures of actual Everspray installations, Demonstrator Offer and Details of sure-fire "Jack-Pot" Pyramid Sales Plan. Everything is FREE. No charge now or ever. Time is precious. Send name today.

**CARRY COMPLETE DEMONSTRATOR RIGHT IN YOUR POCKET!**

You can't believe it until you see it. We show you how to use this amazing "POP-UP" Sprinkler Head to make a Demonstration, right before your prospect's very eyes! Special Demonstrator Offer sent FREE. Just mail postcard or handy coupon.



John Oakman, Sales Mgr.  
EVERHOT PRODUCTS CO., (Everspray Division) Dept. 2-B  
2001 Carroll Ave., Chicago 12, Ill.

Rush Illustrated Folder, Demonstrator Offer and details of your "Jack-Pot" Pyramid Sales Plan that offers me an opportunity to make \$59.40 a day on only 3 sales. Everything is FREE and costs nothing now or any other time.

Please send me "Confidential User-Agent Plan"

Name.....

Address.....

City..... Zone.... State.....

## EVERHOT PRODUCTS CO.

(Everspray Division)

2001 Carroll Avenue, Dept. 2-B, Chicago 12, Illinois

use of a loop and flashlight bulb for tuning the final.

Undoubtedly, some hams will use this R.F. transmitter with modulation equipment that they already have. Others will build the simple and highly efficient 120-watt modulator unit illustrated in photos E, F and H. The complete modulator-unit circuit with individually identified and specified parts appears in diagram Fig. 2. Self-powered except for 400 volts from a separate well-regulated power-supply unit, this modulator will furnish about 60 watts of audio which is plenty to modulate the transmitter. However, it is so designed that

by simply increasing the plate voltage to 750 watts it can be used to modulate a 240-watt rig. A little care is advised in wiring the first two audio stages to make certain that the microphone jack is completely shielded, and shielded wire is used for the "hot" leads of the stages—or a.c. hum may be a problem. A small metal can is used for shielding the "mike" jack as will be noted in photo H. Any unused leads in the power transformer should be carefully taped to avoid accidental shorts. The chassis base for the modulator unit is 3 x 11 x 17 in.

The class-B modulation transformer should be a 125-watt adjustable type for  
(Continued to page 248)

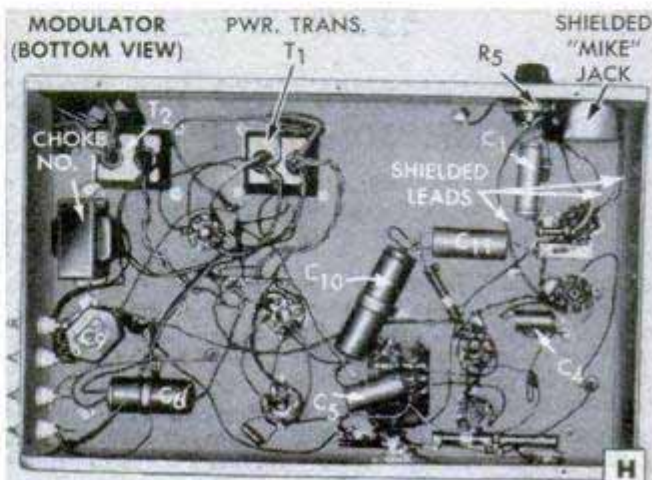
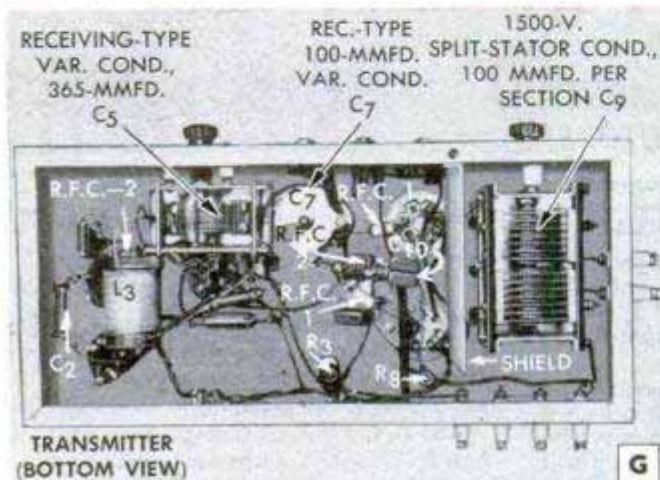

Remember Weldwood Glue when you need dependable wood-to-wood bonds. Quick and easy to mix with cold water . . . tremendously strong . . . stain-free . . . rot-proof . . . and *permanent*. At paint, hardware, variety stores and lumber yards. 15¢, 35¢, 65¢, 95¢ and larger sizes.

**WELDWOOD PLASTIC RESIN GLUE**  
United States Plywood Corporation, New York 18, N. Y.

**ALSO HANDY FOR WOOD HOBBYISTS!**



**Firzite**  
— to give you smooth finishes on fir plywood and other soft woods.

A pre-finishing material that seals the wood pores . . . tames the wild grain . . . virtually eliminates checking and grain raising. An excellent base for stain, paint or enamel. White or clear. White Firzite provides an easy, low-cost way to achieve "blond," "bleached" or "wiped" finishes.



**Satinlac**  
— to preserve the beauty of all woods.

An inexpensive coating for the proper finishing of Weldwood Hardwood Plywood and similar woods. Clear. No brush marks. Brings out all the natural beauty of wood. Does not yellow or darken with age.

FIRZITE and SATINLAC are available from paint, hardware and lumber dealers. Write for leaflet No. 2 on finishing plywood.

# BE A CHAMPION DRIVER

FOLLOW THESE RULES TO STRETCH GAS MILEAGE

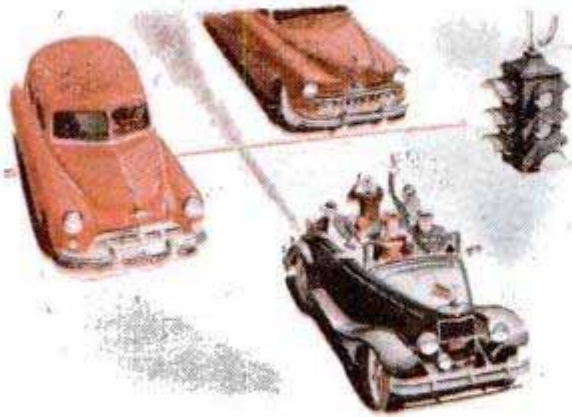

Showoff acceleration proves nothing and is extremely wasteful of gas. Normally this type of driver has to slow down a moment later. Drive steadily—you will arrive at your destination **safe and sound.**



Gas mileage goes down drastically as speeds go up. Table above is based on actual tests of six-cylinder medium-priced cars. Make a habit of driving at conservative legal speeds **because it pays.**



Have your spark plugs tested, cleaned, adjusted regularly, replaced every 10,000 miles. One missing plug in a set of six wastes up to one-sixth of your gas—to say nothing of impairing starting, performance and dependability. You can rely on your Champion dealer **for dependable service.**

A *Champion* driver cultivates driving habits that will increase the pleasure, the performance and the economy of his car throughout its useful life. As one of the most important investments you have, it deserves the best in service and equipment. When you need spark plugs, follow the experts—race drivers, master mechanics, airline and fleet maintenance men, who insist on dependable Champion Spark Plugs . . .

**... BE A CHAMPION DRIVER—IT PAYS.**

**FOLLOW THE EXPERTS—**

*Demand*

Guy Lombardo, famous for "the sweetest music this side of Heaven" and equally noted as a motorboat racing champion says, "I always use dependable Champion Spark Plugs to get the sweetest music out of my engines."



CHAMPION SPARK PLUG COMPANY, TOLEDO 1, OHIO

Listen to the CHAMPION ROLL CALL . . . Harry Wismer's fast sportscast every Friday night, over the ABC network

for **PLEASURE**  
or **PROFIT**



USE

**Starrett**

**PRECISION MEASURING Tools**

You'll tackle any job with greater confidence and turn it out with ease and accuracy with these Starrett Tools. Your distributor can show you the right tools for your job or workshop in the complete Starrett line — tools that will make precision work a pleasure. See them today.



New "Satin Chrome" Micrometer No. 230. 1" capacity, tapered frame, in Sycamore case.



Small Hole Gages No. 830. Set of 5, .125" to .500", in red plastic case.



Combination Set No. 9. 12" blade. Eight handy tools in one.



Toolmaker's Hammer No. 815. With Built-in Magnifying Glass.



Protractor-Depth Gage No. 493-B. Rectangular head, adjustable graduated blade.

**SPECIAL OFFER—Only 10¢ 50-Page "Tools and Rules" Book**

"The Tools and Rules for Precision Measuring," tells how to make accuracy a habit, shows the methods skilled mechanics use. 100 pictures plus many reference tables. Send only one dime. Address Dept. AP.



**THE L. S. STARRETT CO. • ATHOL, MASS., U. S. A.**

**Starrett**

Since 1880... Standard of Precision

MECHANICS' HAND MEASURING TOOLS AND PRECISION INSTRUMENTS • DIAL INDICATORS • STEEL TAPES • HACKSAWS BAND SAWS AND BAND KNIVES • PRECISION GROUND FLAT STOCK

Buy Through Your Distributor

**Five Roads to Doomsday**

(Continued from page 85)

stars and, as we know, the sun is not one of these. Furthermore, we have learned by keeping our eyes glued to telescopes that the same stars become novae again and again. If our sun were going to blow up, it would have done it already. It has had some 3 billion years to make up its mind."

Of all the possible doomsdays, two are bound to happen because they depend on the running down of the universe—a one-way, inexorable process. The earth is slowing down at a rate of  $\frac{1}{1000}$  second per century as a result of friction. As it loses motion, the sun gains rotational motion, and the moon moves out from the earth. Eventually, the length of each day will be increased to a month, and about that time the moon will begin to return earthward.

You've already seen what's liable to happen when that occurs. The chances are that no one will be around to witness it. 'Way before days become a month long, everyone will be well charred from overdoses of sun, or dead of exhaustion from running around the world to avoid it.

Incidentally, the moon can never crash into the earth, so don't give that another thought. The barrier is known as Roche's limit. It's about 10,000 miles above the earth's surface, and is the point at which gravitational forces will be so great that the moon will be torn asunder by them.

More certain than anything, according to planetarium astronomers, is that the sun will burn out. It's bound to, since its energy is being burned up daily. This, of course, will be a gradual process. An ice age will freeze everything solid, and perpetual snows will drift across a forlorn world.

But here again, scientists know, there probably won't be anyone around to witness the interesting change. In his book, "The Birth and Death of the Sun," astronomer George Gamow has spoiled the dream of anyone with hopes of freezing to death due to the sun's demise.

Instead of being frozen, he says, life on earth will probably burn up anyway, since all stars that burn out give one last burst before they go, and the sun at that stage will leap 20,000 or 30,000 degrees.

When will all this happen? Well, barring collisions, the sun is good for another 20 billion years at least. Planetarium officials love to recall the aged woman spectator who, after hearing this, came up to the narrator when the show was over and asked, "Did you say 20 million years?"

"Twenty billion," replied the narrator.

"Oh," said the woman with a sigh of huge relief. "I thought you said 20 million."



# TWO NEW MOTORS by **EVINRUDE**

**Fleetwin**  
with  
**NEUTRAL-FORWARD**  
and **SAFTI-GRIP DRIVE**

7.5 H.P.\*

14 H.P.\*

\*O. B. C. certified  
brake horsepower  
at 4000 R.P.M.

**Fastwin**  
with **GEARSHIFT**  
**NEUTRAL**  
**FORWARD**  
**REVERSE**

and  
**CRUIS-A-DAY**  
**TANK**

Evinrude  
Cruis-a-Day

• Brawny power under finger-tip control . . . new maneuverability, operating convenience, handling ease . . . sharply advanced performance that brings new thrills to boating . . . with these sparkling new models Evinrude again makes outboard history!

**FLEETWIN WITH DUO-CLUTCH:** You start the motor in *Neutral* . . . "idle" whenever you like, at dock or fishing spot . . . press the control button and you're in *Forward*. Full Pivot Reverse and 360° steering for complete maneuverability. Safti-Grip Propeller Drive for trouble-free operation in shoal water. 7.5 certified horsepower\* . . . low trolling speed . . . and exhilarating top throttle performance that "brings out the best" in typical family and fishing boats!

**FASTWIN WITH GEARSHIFT:** 14 horsepower\* for thrilling speeds, heavy loads . . . with *Gearshift* that lets you reverse, idle and maneuver with motor car ease of control! And to give you broad cruising range the Fastwin comes with separate 6-gallon *Cruis-a-Day Tank*. You stow the tank anywhere in the boat . . . and "hook-up" the fuel line to the motor as easily as plugging in a lamp socket!

**SEE YOUR EVINRUDE DEALER:** He will gladly show you the complete line of Evinrude models for 1950 . . . the 1.5 H.P.\* *Sportsman* and 3.3 H.P.\* *Sportwin*, both with exclusive **FISHERMAN DRIVE** that "let's you go anywhere there's water to float your boat." For largest, fastest boats, the 22.5 H.P.\* *Speeditwin* and the 33.4 H.P. four-cylinder *Speedifour*. Look for your dealer's name under "Outboard Motors" in the yellow pages of your phone directory.

**CATALOG FREE!** Write today for full-color catalog of the 1950 Evinrude line.  
**EVINRUDE MOTORS,**  
4404 N. 27th Street,  
Milwaukee 9, Wis.

In Canada:  
Evinrude Motors,  
Peterboro, Ontario



# **EVINRUDE**

FIRST IN OUTBOARDS . . . 41st YEAR



## WINDOW SCREENS THAT ROLL UP AND DOWN like window shades

Once in place—always in place. No putting up... No taking down... No painting... No storing... No repairing.

PELLA ROLSCREENS are easily installed on your present windows. No fitting or cutting necessary. A touch of the finger and ROLSCREENS roll up automatically onto hidden rollers. Inconspicuous. They improve appearance of your home. Make rooms lighter. Keep windows and draperies cleaner. Insect tight. Made of rust-resisting, clear-vision, Alumina wire cloth. 10-YEAR GUARANTEE. Over 2,000,000 in use. Send for interesting FREE Booklet containing easy directions for measuring. Use handy coupon below.

☆ Pella ☆  
**ROLSREENS**  
CASEMENT WINDOWS - VENETIAN BLINDS



Rolscreen Co., Dept. B-9, Pella, Iowa

Please send FREE Booklet on ROLSCREENS. Also Pella literature on Casement Windows  Venetian Blinds . I am building . I am remodeling .

Name.....

Address.....

City.....State.....

Say You Saw It in Popular Mechanics

**KING MIDGET**  
HOME ASSEMBLED AUTO



**WORLD'S LOWEST PRICED AUTOMOBILE!**

80-90 MI. PER GAL.—45-50 MI. PER HR.  
Drive for as low as 50c per week. Precision built parts direct from factory with beautiful all steel body. Get the facts on this amazing small auto—send 25c for detailed circular with large picture, 3 view drawings and price of all parts, or send \$1 (refunded first order) for this plus actual assembly book with 42 photos, drawings; blueprints of snow, ice conversions, information on mini-midget racing, etc.

MIDGET MOTORS MFG. CO., ATHENS 1, OHIO

King Midget is ideal for errands, sports use, to work, short business or pleasure trips, or second-car utility for the whole family; Also tops for mini-midget racing. Room for six footer.

## Clinic



## for Homemakers

As a service to our readers in solving the hundreds of problems pertaining to a home—inside or out—the editors of Popular Mechanics invite you to present your problems to The Clinic Editor for help and advice. Address your questions to The Clinic Editor, Popular Mechanics Magazine, 200 East Ontario Street, Chicago 11, Ill.



### Trimming Grapevine

Q—I have an old, neglected grapevine growing on an arbor which has deteriorated to the point where it must be replaced completely. I can rebuild the arbor easily as it is located in the open, but how can I prune the vine without injuring it? Some of the branches are 15 to 20 ft. long.

D.R., St. Louis, Mo.

A—The first step in reclaiming an old, neglected vine for ornamental purposes is to remove all the dead branches and the small weak shoots with dead tips. Do not cut any of the main branches near the trunk unless they are dead. Remove long, slender branches which have only a few canes near the ends. Then reduce the number of medium and large branches, taking out only those which have the least number of canes. Finally, shorten the length of all the branches left by at least 25 percent. This procedure is only general and applies exclusively to ornamental vines trained on large arbors. Arbor training of a neglected vine should proceed over a period of several seasons. It is not advisable to remove more wood than outlined in the above procedure the first season. When too much wood is removed from an old vine it may produce a great number of weak new shoots from adventitious buds (buds which form at random on the trunk and larger main branches). The vine may be pruned at any time during the dormant period but perhaps the best time is in the late winter or early spring before the sap rises. Never prune the vine during the growing season.

### Painting Stained Shingles

Q—My house is covered with wooden shingles stained a dark brown. I do not know, but I assume this was a creosote stain. At any rate it must have been applied some years ago, as the lower edges of the shingles are beginning to weather. I would like to paint the house white but I'm told that the stain will cause discoloration of the paint. If this is true, is there a sealer available that will prevent this trouble?—J. P., Springfield, Mass.

A—Bleeding of the stain through the oil paint is quite likely even though the stain is old. It is generally safer to seal the surface by using any of the various sealers made especially for this purpose.

(Continued to page 242)

# For Values like this, you've got to come to SEARS!



**Bench Saw**  
(less extensions)  
**Jointer-Planer**  
and Bench only.

JUST **\$9** DOWN

and \$8 monthly  
on Sears Easy Terms

**\$86.50\***

Cash  
\* Prices slightly  
higher west of  
Mississippi  
River



Complete Outfit, as shown  
above and described below

**\$119.00\***

Cash

\$12 Down and \$10 Monthly

The universal Power Tool Bench fits practically all power tools. New! Improved design! Rigid, super-strong welded steel frame. Adjustable in height and for uneven floors. See it today at Sears.

See all you can  
make and repair!

Woodworking jobs of all kinds . . . home and garden furniture, toys, sash, screens, cabinets, shelves, millwork, etc.



What your Bench  
Saw will do!

Indispensable in any shop! Gives your work a professional look. It crosscuts, rips and miters wood or plastics. With proper accessories, it will dado, groove, sand, sharpen or grind. And with a special cut-off wheel, it can cut brick, stone, metal, concrete, etc.



What your Jointer-Planer will do!

Performs same type of edging and surface work as a hand plane, but faster and more accurately! Makes perfect rabbeting cuts for doors, window frames, tables, drawers, cabinets, etc. Ideal for making square tapered cuts on chair legs, etc., and for accurate beveling work.

**FREE!**

SEARS new 1950 Power Tool and Mechanics' Tool Catalogs . . . free! Get yours NOW, at the Hardware Dept. of your nearest SEARS Retail Store!

**We know of NO finer Saw and Jointer Combination in America..so complete..so accurate..so low priced!**

NOW . . . a bench saw and jointer-planer combination at a price that makes it a cinch for you to own! Big **DUNLAP** 8-in. Bench Saw with side-table extensions has 23 $\frac{3}{8}$ x16-3/16-in. working surface, 2 $\frac{1}{2}$ -in. depth of cut. Table tilts 0 to 45°. With 8-in. combination rip and crosscut blade, accurate miter gauge, rip fence, adjustable guard and splitter. **CRAFTSMAN** ball bearing Jointer-Planer planes wood 4 $\frac{3}{8}$ -in. wide; rabbet cuts  $\frac{3}{8}$ -in. deep. Removable guard; rip fence tilts 0 to 45°. **CRAFTSMAN**  $\frac{1}{2}$ -H.P. 1750 R.P.M. ball bearing capacitor motor (110-120 volt 60-cycle A.C.) has  $\frac{1}{2}$ -in. double-end shaft; 8-ft. cord; plug. New **CRAFTSMAN** steel Power Tool Bench, 30 in. long, 16 $\frac{1}{4}$  in. wide; height adjusts 22 to 32 in.; with slide-rail supports and 2 jointer mounting plates. Complete with 5-in. motor pulleys and two V-belts. Compare this power tool combination with any you've seen . . . and you'll KNOW what an unbeatable value it really is at SEARS amazing low price!

See this combination at your nearest Sears Retail Store TODAY!

Buy the tools you need NOW . . . pay on Sears Easy Terms as you use them!

**CRAFTSMAN** and **DUNLAP** Tools by **SEARS, ROEBUCK and CO.**  
Famous for fine quality . . . precision performance . . . low price!

# ARISTOCRAT OF HAMMERS

The nail hammer any tool user will take pride in owning. Fine alloy steel head is forged, scientifically heat-treated and polished. Distinctive octagon neck handle is selected hickory, "Evertite" processed for permanent tightness. Exceptional design provides extra power. Perfectly balanced . . . makes work easier. Use the finest hammer made, Stanley 100 Plus.



Stanley 100 Plus Nail Hammer

## Early American Design Project Plans



Set of 15 Plans 25c

Series A: Cricket, spice cabinet & mirror, knife & fork box, match box, miniature blanket chest, nutmeg box, wall rack, napkin holder, colonial mirror, desk box, miniature cradle, mirror, shelf & drawer, tray, pipe & match box, candle stand. Series B: Miniature cradle tray, trinket box, miniature chest of drawers, spice chest, spice box, corner candle stand, coffee table, book shelf, spice cabinet, salt box, string box, shoeshine cabinet, footstool, kindling box, treasure box.



THE TOOL BOX OF THE WORLD  
Hardware • Hand Tools  
Electric Tools • Steel Strapping

### SEND FOR PLANS...NOW!

Stanley Tools, 120 Elm St., New Britain, Conn.  
(In Canada: Send to Stanley Tool Co. of Canada, Ltd., Roxton Pond, Quebec.)  
Please send me Series A ( ) and Series B ( ) of the Early American project plans. I enclose 25c for each set.

Name.....

Street.....

City and State.....

In applying any sealer, follow the manufacturer's instructions in all details, as the sealer cannot be fully effective unless it is properly applied. Although we could not recommend it as being better than prepared sealers, aluminum paint also will serve this purpose. One coat would probably be sufficient if it can be applied uniformly to cover all the surface to be painted. If the shingles are rough and badly weathered in places, the sealer would probably be best.

#### Basement Flooring

Q—I would like to lay a wooden floor over a concrete floor in a part of my basement. I've been advised by a friend not to do this because moisture will collect under the wooden floor, rotting the wood and causing dampness. How about it; should I forget it, or can the job be done?  
E.Z., Seattle, Wash.



A—Although a wooden floor installed over concrete in the average basement cannot be considered permanent, the wooden floor can be made to give several years of satisfactory service if it is properly laid. The concrete should first be coated with hot tar and then 2 x 2-in. nailing strips (sleepers) are attached to the floor with lag screws turned into masonry fasteners which are set into holes star-drilled in the concrete. Level the strips with a straightedge and jointer plane. The nailing strips are placed about 10 in. apart and should have 1/2-in. holes drilled through each piece about 12 in. apart to permit air circulation under the floor. It's a good idea to coat the strips with tar. Next, lay a subfloor, using tongue-and-groove pine flooring stock. Coat the back of each board with tar as it is laid. Finally, lay waterproof building paper over the subfloor and nail the top floor over this. Be sure to leave openings at the edges where the wooden floor meets the basement walls. Finish the top floor with varnish or paint. If an automatic dehumidifier is used during the summer months, a floor built in this way will last for many years.

#### Peeling Paint

Q—I live in a frame house about 25 years old, and two years ago I had it insulated and painted. Now I notice that the paint is cracking and peeling on the outside window casings. None of the other painted surfaces seem to be affected. What causes the paint to peel only on the casings?  
W.W., Madison, Wis.



A—Probably the most likely cause of the trouble you describe is condensation of moisture in the window-weight pockets at each side of the window frames. The moisture comes from inside the house, not from the outside. In older house construction there usually is a crack between the inner casing and the plaster and also between the plaster and the pulley stile. Moisture enters the weight pockets through these cracks and condenses somewhere on the bare surfaces of the boards, where it is absorbed by the wood. It also can enter under the apron beneath the window stool and thus find its way into the space under the sill. Eventually it will penetrate to the back of the paint film on the outside casings. Presence of moisture at this point will loosen the bond of the paint to the wood, causing the paint to crack and peel as you describe. One practical way to minimize this trouble is to reduce the humidity in the house. Sealing the space between the inside casing and the plaster with calking compound or a prepared crack filler also will help to cure the trouble. Scrape off the peeling paint to the bare wood, and then reprime and repaint.



# TIME-SAVING TOOLS for SHOP and HOME

The Most Versatile Tool a Man Can Own

## MOTO-TOOL

Approx. 25,000 RPM

GRINDS, ROUTS, DRILLS, POLISHES, ETC. Moto-Tools, Kits and Accessories should not be confused with "bargain offers." Compare Dremel Products, feature for feature, with other similar equipment. If ours are not superior in quality, design and performance, we don't want you to buy.

### LOOK AT THESE MOTO-TOOL FEATURES

Dynamically balanced armature eliminates vibration • Oilless (oil-sealed) bearings • Patented automatic chuck lock pin • Snap-type sliding switch • Cord protector • Shockproof bakelite housing • Dust-filtered air-cooling system • Weighs 13 oz. • Plugs into any 110-120 V. AC outlet. Backed by over 13 years use in plants of General Electric • Ford • Remington Arms • Nash-Kelvinator • Westinghouse • Douglas Aircraft, etc. . . . plus a money-back Guarantee if not delighted after 5 days' trial.



PRE-WAR PRICES STILL PREVAIL

MOTO-TOOL KIT No. 2, with 23 accessories including high-speed steel cutters and Model 2 Moto-Tool in natural finish hardwood case . . . \$23.50  
MOTO-TOOL No. 2 with one emery wheel point . . . \$16.50



Portable DRILL PRESS



This 12" high, precision drill press is ideal for model making, wood carving, routing, etc. Utilizes No. 2 Moto-Tool.

Only \$9.95 (Less Moto-Tool)

USE COUPON TO ORDER—If your dealer cannot supply you.

DREMEL MFG. CO., Dept. 110-B, Racine, Wis.

3 TOOLS IN ONE



Only \$14.85 POSTPAID

PATENTED

## Dremel Electric SANDER POLISHER-MASSAGER

Say goodbye to hand sanding and polishing! This miracle machine is so easy to handle, a child can use it. Craftsmen and housewives find (1) As a sander, it takes the effort out of sanding walls, woodwork, furniture, workshop projects, etc. Its straight-line, (non-rotary) action will not burn or scratch surfaces. (2) As a polisher, it does a professional job on waxed surfaces of cars, furniture, etc. (3) As a massager, it's ideal for tired or sore muscles.

### LOOK AT THESE DREMEL FEATURES

Dremel Sander delivers 14,400 strokes per min., weighs only 2½ lbs. It's foolproof (has only two moving parts . . . never needs oiling). Dremel Sander operates on 110-120 Volt AC. Thousands and thousands of satisfied users prove its value.

### SATISFACTION GUARANTEED

Dremel Sander comes complete with 6 sheets assorted grade Garnet Paper for sanding, plus felt pad and sheepskin for polishing. If your dealer cannot supply you, use coupon to order direct from factory. Money back if not delighted after 5 days' trial.

Dremel Mfg. Co., Dept. 110-B, Racine, Wis.



Works Easily in Awkward Places



Sands Flat Surfaces Evenly



Makes Play of Wax Polishing



Soothes Tired Muscles

## FUN FOR BOYS FROM 8 TO 80 DREMEL Electric COPING SAW

CUTS SCROLLS LIKE MAGIC—SANDS AS IT SAWS

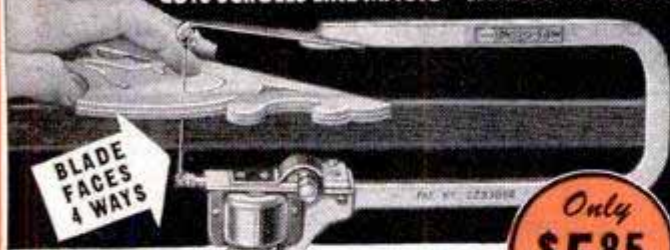

BLADE FACES 4 WAYS

SAFE! AS A HANDSAW

JUST GUIDE IT!

Only \$5.85 with 2 saw blades

FREE PROJECT PLANS

Plans for making six useful, decorative projects packed with each Dremel Electric Coping Saw.

For men who harbor a hobby or do their own repair work . . . for boys who like to make things . . . no other tool will give so much pleasure and satisfaction in the home or workshop for the small amount of money invested as a Dremel Electric Coping Saw. It works in any direction . . . delivers 7,200 strokes per minute . . . so easily, there is no effort . . . so smoothly, work needs no sanding. Saws through ¾" medium-hard wood at a foot-a-minute speed. Touch-of-the-trigger, foolproof action. Only two moving parts, never needs oiling. Operates on 110-120 v. AC. Thousands and thousands of satisfied users.

**MONEY BACK GUARANTEE**—If your dealer cannot supply you, use coupon to order direct from factory for five day trial.

DREMEL MFG. CO., Dept. 110-B, RACINE, WIS.

If Your Dealer Cannot Supply You USE THIS HANDY ORDER FORM

DREMEL MFG. CO., Dept. 110-B, Racine, Wisconsin

- Enclosed find \$\_\_\_\_\_ (check or money order) in full payment for items checked below.
  - Enclosed find \$2. Ship items checked below C. O. D. I'll pay postman balance plus postage and fee.
  - Dremel Sander \$14.85
  - Dremel Moto-Tool
  - Kit No. 2, \$23.50
  - Drill
  - Press \$9.95
  - Dremel Coping Saw \$5.85
  - Dremel No. 2 Moto-Tool, \$16.50
- Send FREE Catalog on  Moto-Tool  Dremel Sander  Dremel Coping Saw

Name \_\_\_\_\_

Address \_\_\_\_\_

City \_\_\_\_\_ Zone \_\_\_\_\_ State \_\_\_\_\_

## Add **BAND SAWING** To Your Shop's Capacity

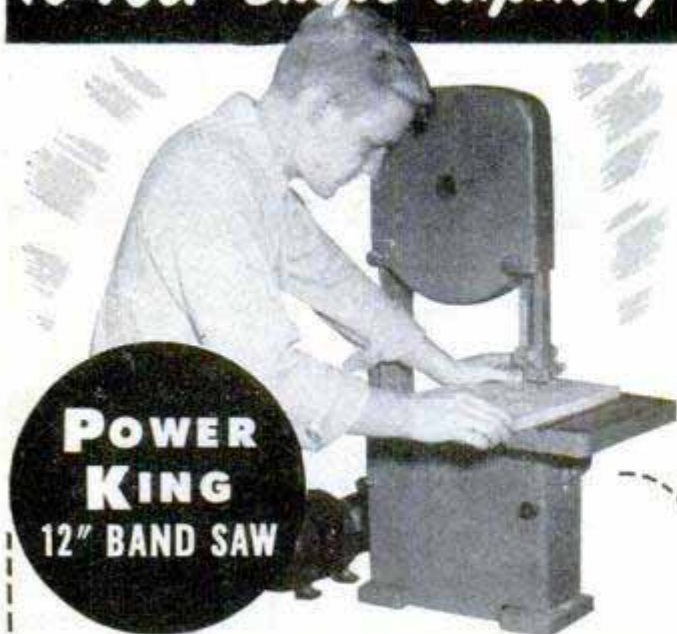

**POWER  
KING**  
12" BAND SAW

Window valances, decorative shelf brackets, outdoor furniture, toys for the youngsters... all kinds of new projects come within your shop's work range with this Power King band saw. And it's really built for the work! Has big 14" x 14" precision-ground table... 12" capacity blade to frame... cuts up to 6½" deep... table tilts 45°... 6 ball bearings, 4 Oilite blade guides... weighs 122 lbs. Built by Atlas

— and only **\$7975\***

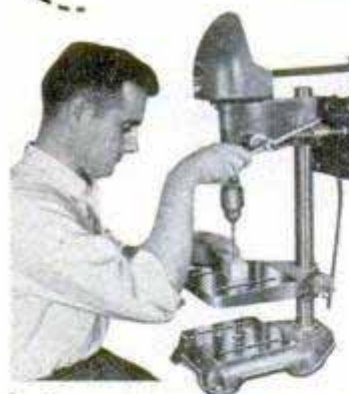

**POWER  
KING**  
11¼"  
DRILL PRESS

The outstanding value among low cost drill presses today is this

Power King No. 611. Jacobs chuck takes drills to ½". Makes fast, easy work of drilling metal, wood and plastics. And low cost accessories are available to help you get "professional" results on mortise and tenon joints, routing, shaping, sanding, carving, inlaying. With six-splined spindle, balanced pulleys, Oilite bronze bearings and ball bearing for end thrust, this PK 11¼" drill will give you good, long service. Built by Atlas

— and only **\$4275\***

There are 8 different tools in the Power King line, recognized in stores by their distinctive green color. Send postcard for complete FREE catalog.

**ATLAS PRESS COMPANY**

235 N. Pitcher St., Kalamazoo, Mich.



**MATCHED PRECISION TOOLS FOR  
WOODWORKING AND MEYALWORKING**

## The Battle of the Great Lakes

(Continued from page 161)

from entering the streams to spawn. The service wants the food fish to have free access to spawning areas, but not the lampreys. How this difficulty will be solved is yet to be learned.

In addition, scientists are worried that lampreys, if prevented from entering spawning streams, may lay their eggs on the lake bottoms. That hasn't occurred yet, as far as is known, but adult lampreys have been caught more than 500 feet below the surface in Lake Michigan. If the killers can adapt themselves to life in fresh water after living in the adult stage for centuries in the ocean, what's to prevent them from changing their spawning habits? And as an additional headache, up to now scientists can't tell the difference between the eggs of a sea lamprey and those of the harmless local species.

Of extreme importance in this underwater war will be the discovery of some natural enemy of the sea lamprey. So far, none has been found.

Chemicals or combinations thereof have been discovered that will kill injurious insects without harming the plants upon which they feed. Along that line scientists and research technicians of the Fish and Wildlife Service are not overlooking the possibility of turning up a poison that will ring down the curtain on lampreys yet will not harm the fish. Efforts will also be made to discover some biological parasite which will have the same effect.

Science is determined to win this war. If the slaughter by sea lampreys isn't halted, our vast inland seas soon may be as devoid of fish life as the Mojave Desert and lake trout may become specimens in aquariums.

## 17-Acre Bargain Counter

(Continued from page 173)

old bed springs, but not for sleeping. Cowboys of Arizona wire them together to make fences.

Other items that have gone to the highest bidder include stovepipes, an alcohol blowtorch, an Erector set, precision instruments for surveyors, a complete set of plumber's cutting dies, a canvas swimming pool used by a movie company and two magic lanterns in vogue around 1900, with slides of Niagara Falls and other scenes that appealed to the young ladies of that day. Auctioned off was a coffee grinder of 1914 vintage, the kind once seen in country stores.

Some mechanical contrivances have not

(Continued to page 246)

**"NEW"  
Better-Than-Ever**

**Atlas  
DRILL  
PRESSES**

**7 TOOLS IN!  
For Your Shop**

★ **NEW**  
4 Ball Bearing  
Equipped Head

★ **NEW**  
Direct Reading  
Depth Stop

★ **NEW**  
Extra Heavy  
Construction

★ **NEW**  
Operating  
Smoothness

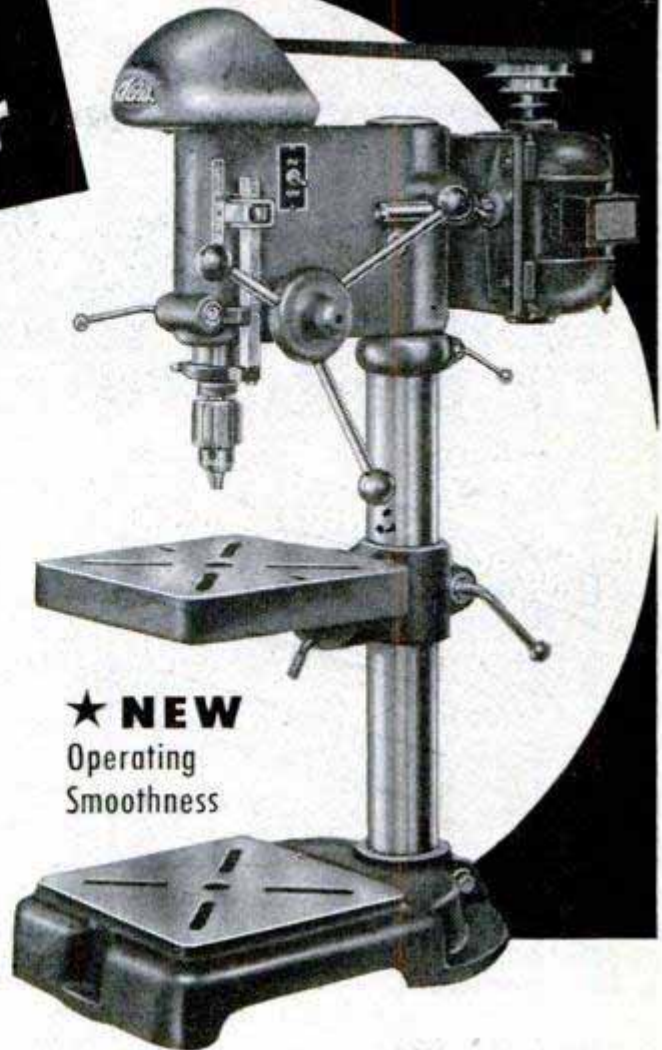

The finest low-priced drill presses in America are ready for your inspection! New improvements, added to the known quality and performance features, make Atlas drill presses better than ever.

The new Atlas is a perfect tool to add new work range to your shop. With low-cost attachments it drills, taps, sands, carves, mortises, shapes . . . gives you clean, precision workmanship on metals, woods, and plastics . . . makes your workshop hours more productive than ever.

Three sizes are available: 12 3/4" bench model, and 15" in bench or floor models. Send the coupon today. See all of the exclusive and special features of the Atlas before you select the drill press for your shop this year.

**FREE CATALOG — Write Today!**

**ATLAS PRESS COMPANY**  
243 N. Pitcher St., Kalamazoo, Mich.

- Please send Atlas Drill Press catalog.
- Literature about Atlas woodworking tools.

Name \_\_\_\_\_

Address \_\_\_\_\_

City, State \_\_\_\_\_

**ATLAS PRESS COMPANY**

243 N. Pitcher St. • Kalamazoo, Mich.



**MATCHED PRECISION TOOLS FOR  
WOODWORKING AND METALWORKING**

**You'll always value these BIG Atlas woodworking tools**



8"-10"  
TILT/ARBOR SAW

**BIG** in capacities — for any size job you want to undertake — **BIG** in value — with many unique performance and construction features — and built to industrial quality standards, these are the tools for commercial quality workmanship in your home shop. Use coupon for latest literature.



10"  
Floor  
Saw



24" Jig Saw



6" JOINTER



12" Wood Lathe.



Belt and Disc  
Sander



Invest  
in your  
future!



## Be Your OWN BOSS In Building Field



**NO SCHOOLING!**

**STEADY WORK!**

**BIG MONEY!**



Stake your claim now to a money-making future—get started in a good, respectable, solid business of your own as a floor surfacing contractor!

This is not difficult—no schooling—no experience needed. Sanders are easy to operate—and you can start making money the first day your machines arrive! Earnings of \$25 and more a day are not uncommon! Hundreds of prospects everywhere in your community—new and old homes. Original investment small—no large overhead—you need no elaborate offices, workshop, storeroom or heavy trucking equipment. Many men operate from their own homes and use regular passenger car to transport equipment from job to job. Pleasant indoor work—steady year 'round—a real opportunity to **MAKE MONEY** and be your own boss! Send for "money-making" booklet entitled "Opportunities in Floor Surfacing"—use coupon and enclose 25c in coin or stamps to cover handling.



# AMERICAN

**FLOOR MACHINES  
PORTABLE TOOLS**

**SEND COUPON  
TODAY**

The American Floor Surfacing Machine Co., 535 So. St. Clair St., Toledo, Ohio

Enclosed find 25c in stamps or coin for booklet "Opportunities in Floor Surfacing", telling me how I can start

my own floor sanding business.

Name \_\_\_\_\_

Street \_\_\_\_\_

City \_\_\_\_\_ State \_\_\_\_\_

yet found a customer, but in time they will. These include a slot machine, a beauty-parlor hair drier, a dish-washing machine and a carbonator for a soda fountain.

Revenue also comes from leasing, to individuals, the booths that dot the grounds in front of the spacious main building. Here, at retail, visitors may buy pet dogs, dry goods, hardware and novelties. Several booths serve food and cold drinks. One man arranged to open a retail shop for store fixtures. His stock arrived, but unfortunately his truck driver mistakenly delivered it to the open-air auction. Fifteen minutes later it had been sold by the auctioneer.

Throngs flock to Auction City because there they can buy articles cheaper than at retail establishments. Most of the goods come from bankrupt stocks. "When 5000 waffle irons are bought at bankrupt price," explains Jeffries, "naturally they can be sold at a much lower price than would be listed in a retail store."

Here, the customer is king in more ways than one. First, he sets his own price. Then, if he is not satisfied with his purchase when he gets home, he can bring it back and get his money refunded.

Visitors find that the "City" has the atmosphere of a county fair. There are recreation facilities for children and grownups, managed by Pat Foxen, a boyhood friend of Jeffries. He operates Ferris wheels, the whip, a miniature roller coaster, a train that holds 100 children and a zoo.

Jeffries and Harris have made a super-auction pay off because they are young men with a vision and enthusiasm. Their interest has never wavered. They have suffered losses, but today their assets have doubled. They believe that America still is the land of opportunity provided one is willing to do his part.

## Focus on the Crash!

*(Continued from page 167)*

brush marks on an automobile which has struck a pedestrian may indicate whether the pedestrian was thrown from the point of impact to where he landed many feet away—or whether he was carried by the car. Debris on the pavement—mud or dirt from fenders, or pieces of metal and glass, or skid marks—usually marks the point of impact.

Night photos of traffic accidents can be made best with flash equipment. Because background will be lost in darkness, your night photos won't tell as much of the story, but they'll be much more valuable as evidence than no photos at all. You may be

*(Continued to page 248)*



# ride the champ!

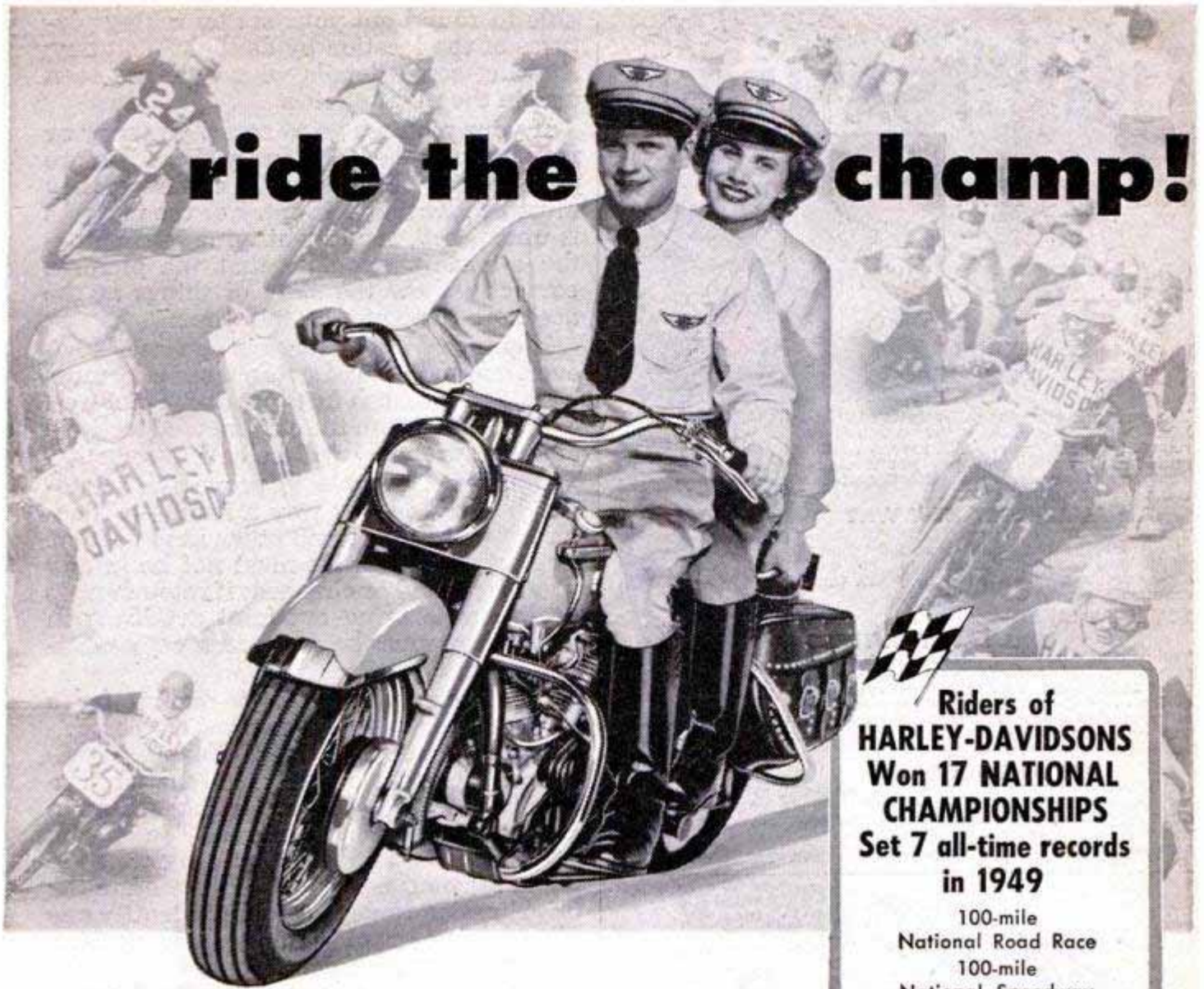

## HARLEY-DAVIDSON *HYDRA-GLIDE* MOTORCYCLE

Choose the motorcycle of the champions, the favorite mount of the racing stars! Experience for yourself the unequalled thrills of champion performance . . . acceleration that shoots you ahead like a rocket . . . power that makes steepest hills seem like straight-aways . . . comfort that lets you ride all day without tiring . . . quality that gives you years of service. Fascinating fun and friends are yours at exciting race meets, hillclimbs, gypsy tours, club events and parties. There's no sport like motorcycling, no motorcycle like the world-champion Harley-Davidson! And you can own one on easy terms! See your dealer today. Mail the coupon now.

Riders of  
**HARLEY-DAVIDSONS**  
Won 17 NATIONAL  
CHAMPIONSHIPS  
Set 7 all-time records  
in 1949

- 100-mile National Road Race
- 100-mile National Speedway
- Jack-Pine National Endurance Championship 45" and 80"
- National Tourist Trophy Championships
- Five Class "C" National Hillclimb Championships
- Track Championships (One-mile track)
  - 10-mile National
  - 15-mile National
  - 20-mile National
  - 25-mile National
- Track Championships (Half-mile track)
  - 5-mile National
  - 7-mile National
  - 8-mile National

**HARLEY-DAVIDSON MOTOR CO., Dept. P, Milwaukee 1, Wisconsin**

Send me free copy of thrilling ENTHUSIAST Magazine filled with motorcycle action pictures and stories; also literature on new models.

Name.....  
Address.....  
City..... State.....

**DEALERS:** Valuable franchises are now available for the full line of famous Big Twins and the 125 Model. This is your opportunity to line up with the greatest name in motorcycles. Write or wire for complete information today.

# with a Binkley *rota-matic* SANDER

YOU SAVE TIME

DO A BETTER JOB

WITH LESS ENERGY



Yes, once you glide the self-rotating BINKLEY SANDER over any flat, beveled, or rounded wood surface, you'll marvel at the professional results you get. You'll easily produce a smoother, more uniform surface, using far less energy!

### AN AMAZINGLY NEW WAY

The BINKLEY "rota-matic" SANDER eliminates all the old "back-breaking" home methods of sanding. For instance, you can sand down a table top in  $\frac{1}{2}$  to  $\frac{3}{4}$  the time ordinarily required.

### STURDILY BUILT—

### WILL LAST FOR YEARS

"rota-matic" sanding disks outwear ordinary sandpaper sheets 20 to 30 times because they rotate, putting each cutting face of the sanding grit to work. This same rotating action makes the disk self-cleaning and even-wearing. Sturdily built of steel—no complicated parts to wear out!

### GET YOURS TODAY

Outfit complete with fine, medium, and coarse grit Disks, easily interchangeable. If your dealer can't supply you—don't wait. Send only \$2.50, we'll ship promptly, postage paid. Money back if not satisfied in every way. Write to—

**BINKLEY MFG. CO., Desk M-3, Warrentown, Mo.**



FLAT SURFACE



BEVEL EDGES



ROUND CORNERS

able to round out your set by taking pictures of the location by daylight next day, showing some details which can be seen also in the night photos.

If your pictures go to court, you may or may not be called to identify them. Before pictures can be admitted to evidence, they must be identified. If entry of the pictures is unopposed, such identifying is simple—the attorneys stipulate that the pictures correctly show the state of things at the accident scene at a certain time.

If entry of the pictures is opposed, however, a foundation of sworn testimony must be laid to establish facts about the pictures. You, the man with the camera who took the pictures, probably will be called to testify.

You must be able to prove the photograph is not in any way a fraud—a "doctored" picture or some other kind of fake. The original negative must not be in any way retouched or changed; if retouching is necessary to bring out faint details, such retouching must be done on a copy negative or on a print.

It is common practice in courts for a police officer who was present at the accident to identify pictures offered in evidence. For that reason, you should take care to include the investigating officers in one or more of your pictures. The officers can be located and identified long after the accident; their names will be signed to the investigation report. Asked to identify one of your photographs plainly showing them at work at the accident scene, the officers can prove they were present at the time the pictures were made and can testify that the pictures correctly represent the scene at that time.



There's one to fit every pocketbook  
\$79.95\*  
POWER CUT  
f.o.b. factory

24" Lawn Keeper

22" Scout

20" Moto-Boy

18" Ace

\*17 1/2" Power Cut

other models up to 71"

for every size  
LAWN



- and anyone in the family can use it!

Write for catalog and name of nearest dealer

The MOTO-MOWER Company

4615 Woodward

Detroit 1, Mich.

## Phone Transmitter

(Continued from page 236)

different modulator and R.F. loads. To provide the proper load for 1625 tubes operating at 400 volts, the transformer should be set up to give a 3200-ohm load plate to plate on the tubes. Of course, for 120 watts input with 600 volts, at 200 mils, the R.F. load is 3000 ohms. The bias resistor R11 should be adjusted to provide —25 volts, as measured at the center tap of the driver transformer when the plate supply for the modulator is 400 volts. Fixed condensers C8 and C9 may require modification to give the best "communication quality." Their purpose is to limit the band of frequencies passed by the modulator. The antenna design is optional with the builder. Detailed student material list R-386 for the complete phone transmitter is available from our Radio and Electronics department, upon receipt of ordinary letter postage.

# SORE MUSCLES?



When muscles are stiff and sore from unusual exercise or strain, use **HEET**®, the liniment that's strong yet does not burn the skin. Wonderful relief from muscular soreness comes as comforting **HEET** quickly starts to penetrate. Just brush it on with the applicator. **HEET** starts at once to ease muscular pain and keeps on working for hours, warms and soothes the painful area.



## FREE TO HOME PLANNERS

"Little Red Booklet" of 29 popular plans sent **FREE** to acquaint you with our **MONEY SAVING** home planning service which includes 1200 Tested Designs; beautifully illustrated plan books; working drawings; material lists; specifications—all at **LOW COST**. Write today for **FREE RED BOOKLET** and complete information. America's pioneer residential plan service.

**Small Homes Plan Book—**  
68 beautiful designs  
**All American Homes—**  
158 tested designs, all types

**TWO POPULAR BOOKS**  
**\$1.00**  
**BOTH FOR**

**L. F. GARLINGHOUSE CO., INC., Box PM-5 TOPEKA, KANSAS**

## FOR BIG MEN ONLY!



**SIZES 10 to 16**      **WIDTHS AAA to EEE**

We specialize in large sizes only—sizes 10 to 16; widths AAA to EEE. Loafers, Wing Tips, Moccasins, Dress Oxfords, House Slippers, High and Low Work Shoes, Rubbers, Sox. Specially designed for large sizes. Satisfaction guaranteed. Sold by mail only. Write Today for **FREE Catalog**.

Write For **FREE CATALOG**

**KING-SIZE, Inc., 265, Brockton, Mass.**

## OTTAWA Tiller & Mower

Patented **Powerful 2 H-P Red Seal Continental Motor.** Attachments for mowing, tilling, power take-off, cultivating and spraying. Lowest prices in history. Two speeds and free wheeling. Thousands in use. Rotary mower only \$89. Made by men with know-how. Now in our 47th year. Free details.

Rotary Mower

**OTTAWA MFG. CO., 5-027 Lawn Ave., Ottawa, Kans.**

## 10 SHELF PLANS

NEW FULL SIZE

New, full size, easily built, beautiful wall shelf plans ready to trace on lumber, cut out and assemble. Corner and wall racks with 1 to 3 shelves. Stores charge about \$75.00 for these shelves. Make money selling them. Finest selection available. **PLUS BONUS** of 48 other novel cut-outs, Dutch Boys, Girls, Toys, etc., etc. **PLUS FREE** latest Handicraft Catalog. Send only \$1 to

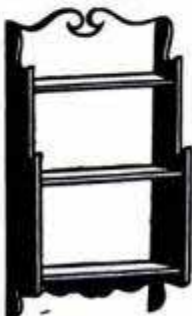

**\$1**



**JACKSON, Dept. 15**  
3933 N. 28th St.  
Milwaukee 10, Wis.



## NO MATTER HOW COLD!

● No more grind, grind, grind on cold winter mornings—your car starts instantly with Casite.

Casite in the crankcase retards congealing of oil, lets your motor spin over, and start, even in sub-zero temperatures. Casite through the air intake conditions your engine for winter operation, frees sticky valves.

### EASES NEW CAR BREAK-IN, TOO

Casite speeds oil to tight spots, protects engine during critical break-in period.

**THE CASITE CORPORATION • HASTINGS, MICHIGAN**

Casite Division, Hastings Ltd., Toronto

## Quick Starting

### IN COLDEST WEATHER

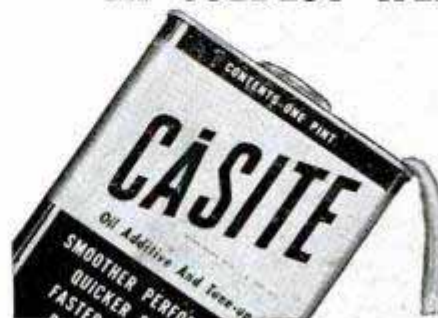

**75¢ A PINT**  
At Garages  
Car Dealers  
Service Stations  
Everywhere

## OR DOUBLE-YOUR-MONEY-BACK

SAY YOU SAW IT IN POPULAR MECHANICS

# BIG WORK SAWED, SANDED, DRILLED, TURNED—WITH HAIRLINE ACCURACY

**Rugged, Multi-Purpose  
SHOPSMITH is complete  
power workshop in one  
compact unit**



51,000 SHOPSMITH owners wholeheartedly agree—you can't beat SHOPSMITH for accuracy, capacity, all-around utility. It does the work of *five* heavy-duty single-purpose tools—actually does it *better*.

SHOPSMITH has precision features found only in highest priced saws, drill presses, lathes and sanders. Four grease-sealed ball bearings in headstock. Induction hardened spindle tip. Centerless ground steel ways. Built-in quality through and through. So compact it fits any 2' x 5' space. So ingeniously engineered you can convert from tool to tool *in less than 60 seconds*.

Takes all standard accessories including shaper-cutters, drum sander, jointer fence and cutter, flexible shaft, dado heads, etc. See SHOPSMITH demonstrated at any Montgomery Ward, leading hardware or department store. And write for *free* 16-page booklet.

**\$169.50**

complete except for motor.  
With special ½-hp., ball-bearing, capacitor-type motor  
(shown) **\$199.50**

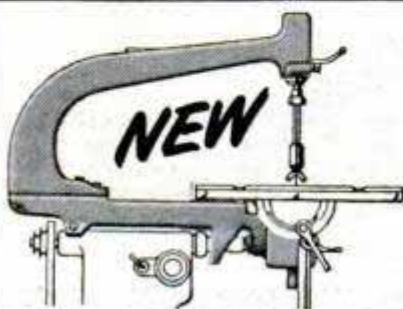
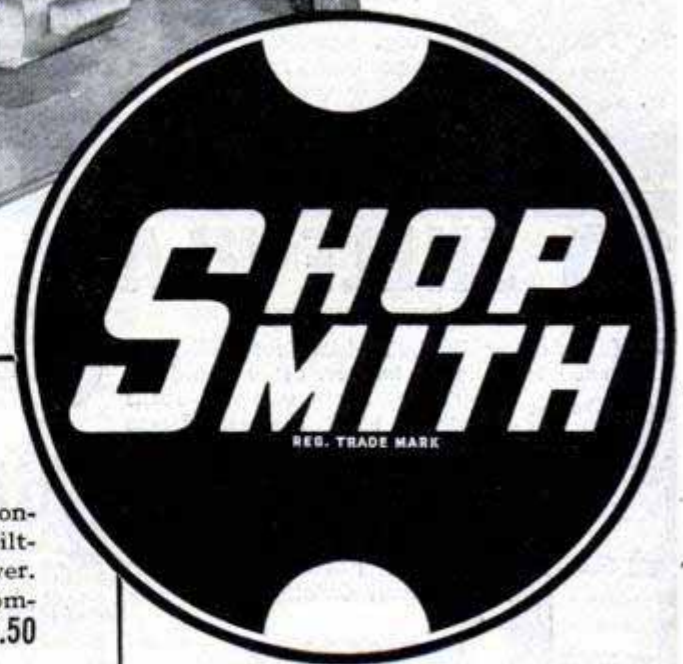

## **JIGSAW for SHOPSMITH**

Heavy-duty, precision construction. 18" throat. Tilting table. Built-in blower. Attaches quickly. Price complete..... **\$29.50**

# 1. 8" CIRCULAR SAW

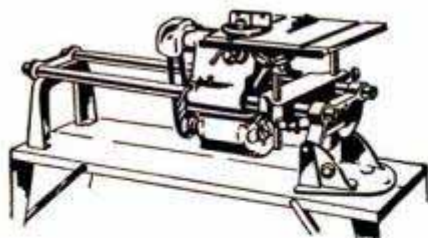

SHOPSMITH saw has capacity and performance equal to or greater than most cabinet shop models. Can cut to center of 8' plywood panels. Effective table width up to 56". Depth

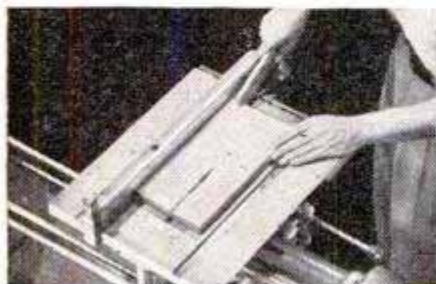

of cut 2 3/4". Sturdy tilting table with ball-crank raiser for precise settings. Precision-tooled miter gauge and self-aligning rip fence.

# 2. 12" DISC SANDER

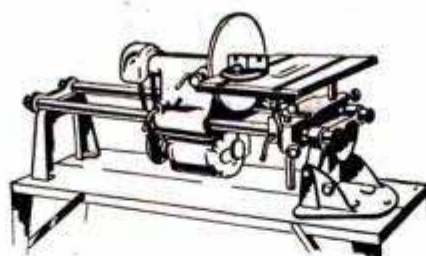

With extendable quill, 12" cast-aluminum disc can be fed into workpiece for safety and accuracy. Extra-large adjustable table measures 14 1/2" x 17". Use miter gauge for accurate



squaring and mitering; rip fence for super-smooth jointing; tilting table for compound-angle sanding. Operator can face work or work from side.

# 3. 33" WOOD LATHE

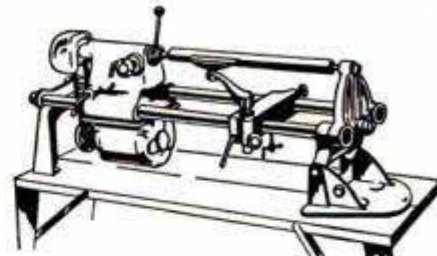

Greater capacity than most other heavy-duty lathes. 15" swing. 33" between centers. 4" quill feed. Swivel-arm tool rest always parallel to ways—no need for constant adjusting.



Quickly adaptable for face plate work. Fine-grain cast-iron headstock slides with fingertip pressure, locks in any position.

# 4. VERTICAL DRILL PRESS

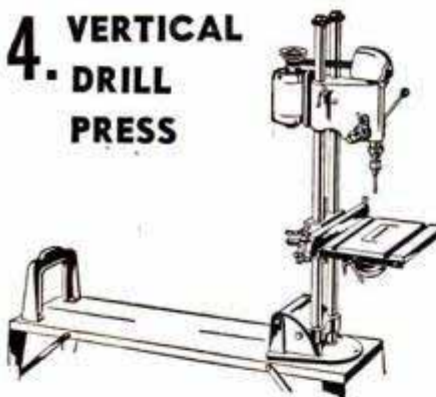

SHOPSMITH drills to center of 15" circle, has a maximum clearance table to chuck of 27", floor to chuck of 57". Jacobs key chuck takes straight shank drills from 5/64" to 1/2" diameter.

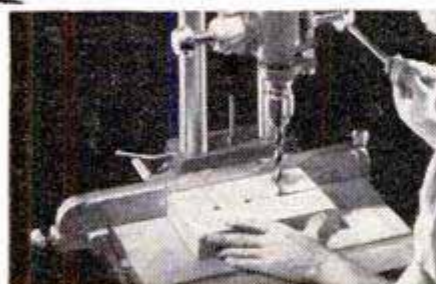

Rugged, 6-spline spindle floats on 4 lifelong, grease-sealed ball bearings. 4" quill feed. Lever fits either side of driving head for right- or left-hand operation. Speeds from 875 to 3500 rpm. Use with or without fence.

# 5. HORIZONTAL DRILL

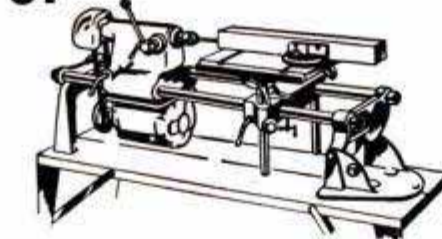

Extremely useful operation possible only with SHOPSMITH. Quill feed up to 4" with adjustable stops. Permits large, heavy pieces to be drilled or mortised quickly, accurately. Handy,

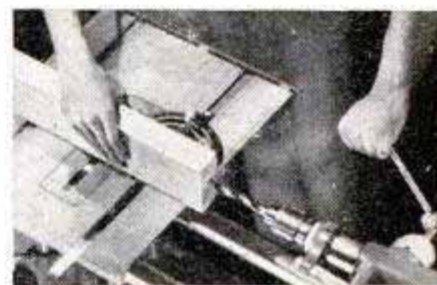

too, for doweling tops for tables. Miter gauge and fence eliminate need for jigs. 36" effective table support. Length of work limited only by size of room.

## SHOPSMITH TAKES ALL STANDARD ACCESSORIES



Fact-packed, 16-page illustrated booklet. Send for it!

Address:

SHOPSMITH, Dept. 111-B, at factory nearest you:  
12819 Coit Rd., Cleveland 8, Ohio, OR  
417 Montgomery St., San Francisco, Calif.

Name \_\_\_\_\_

Address \_\_\_\_\_

City \_\_\_\_\_ Zone \_\_\_\_\_ State \_\_\_\_\_

# get the world's greatest RADIO & TELEVISION CATALOG! **FREE**

**ALLIED'S**  
196-PAGE GUIDE  
TO EVERYTHING  
IN RADIO & TV AT  
LOWEST PRICES



TELEVISION AND  
HOME RADIOS



SERVICE SUPPLIES  
BUILDERS' SUPPLIES



AMATEUR GEAR



AMPLIFIERS, P.A.  
SYSTEMS, RECORDERS

*Everything for Experimenters,  
Builders, Amateurs, Service-  
men, Engineers, Soundmen*

Save money on every radio need! Get the 196-page 1950 ALLIED Catalog featuring the world's largest stocks of top-quality equipment, at low, money-saving prices! Latest TV releases, home radios and radio-phonos, Amateur equipment, PA systems and High-Fidelity Sound, recorders, test instruments, builders' kits—plus thousands of parts, tubes, tools, books and diagrams. Get more for your money from the World's Largest Radio Supply House. Send today for your FREE copy of the 1950 ALLIED Radio Buying Guide!

**ALLIED RADIO** ★

ALLIED RADIO CORP.  
833 W. Jackson Blvd., Dept. 5-B-0  
Chicago 7, Illinois

Rush FREE 196-Page Catalog

Name.....

Address.....

City..... Zone... State.....

**FREE  
CATALOG**

## Probing the Secrets of the Glaciers

(Continued from page 152)

that is constantly replenished from above and constantly dissipated at its terminus.

The ice is plastic because the bulk of it is under pressure at melting temperature, just about at the freezing point. Water in a glacier is at the same temperature as the ice. The temperatures inside a glacier seem to remain the same all through the year. Sub-zero winter temperatures penetrate only 40 or 50 feet into the mass.

Some of this information has been known for a long time, some has been mere theory. All of it was confirmed by the Caltech group.

The scientists took the interior temperature of the glacier with electric resistance thermometers that they lowered into holes as deep as 200 feet. To create the holes they used an electric hot point, similar to a soldering iron, attached to the end of an aluminum pipe. Additional lengths of pipe were added as the hole grew deeper. Electricity for the hot point was supplied by a gasoline-driven generator.

Most studies of Alaskan glaciers have been confined to the terminal areas because these have been the easiest to reach. With aircraft, however, the generating or feeding areas between 5000 and 7000 feet in elevation can now be studied. Here the depths of the annual top layers of snow and firn can be carefully measured.

Last year 14½ feet of new snow was found on top of the previous summer's dust layer on the Seward ice field. This was equal to precipitation of about 80 inches of water. "Last year was a very good year for the Seward ice field," Dr. Robert P. Sharp and Laurence Nobles, Caltech glaciologists, agree. "The glaciers are in a very healthy condition."

Expedition members spent days of study clinging to the walls of 80 and 90-foot crevasses. They dug a 50-foot pit through the firn and created much deeper holes with their hot point.

One of the things that they observed about the transition of partly consolidated snow into ice is that the mass gradually builds its own plumbing system—an interior structure of icy bands and pipes. This happens because the melting of surface snow produces water which percolates down through channels into the snow pack. At various levels it spreads out horizontally and freezes, as does the melt water that stands in the percolation holes.

Some parts of Malaspina Glacier are estimated to be almost half a mile thick but accurate measurements won't be possible

(Continued to page 254)

**NOW** 1950 MODEL of the famous... **HANDEE** TOOL OF 1001 USES at new **LOW PRICE**

It's here—biggest buy of all. First tool of this type and today's finest. The "Cadillac" of small power tools—choice of mechanics and home-crafters everywhere. Make costume jewelry, train and plane models, puppets, tool leather, initial tumbler, internally carve plastics, etc.

**A FINE GIFT**

Handee with 51 accessories in new steel case...

Handee with 7 accessories **\$19.95**

NEW LOW PRICE **24.95**

Here's smooth, controlled power at your fingertips. Handee has 7-bar armature and is perfectly balanced. 25,000 r.p.m. AC or DC. Wt. 12 oz. Order today postpaid on money-back guarantee or write for catalog. Chicago Wheel & Mfg. Co. 1101 W. Monroe St., Dept. PM, Chicago 7, Ill.



A Whole Tool-shop in one hand. Grinds Drills Engraves Polishes Cuts, Routs Saws, Sands

**FREE Bargain Book**

Packed with hundreds of sensational bargains—new and used—in still and movie photo equipment and accessories. Write for your free copy today to **Central Camera Co.** Dept. 8B, 230 S. Wabash, Chicago 4, Ill. Photographic Headquarters Since 1899

**OTTAWA Buzz Master**

**7 MODELS—\$99.00 up**

Greatest offer made in our 46 years of manufacturing. A model to fit your needs and your pocketbook. Free details. **OTTAWA MFG. CO., 2-027 Brush St., Ottawa, Kans.**

No Other Like It!

**SHIP MODELS for Everyone!**

AUTHENTIC KITS FOR BOTH NOVICE AND EXPERIENCED BUILDERS

New "Clipper-Bilt" Kits at only \$3.95 each have carved balsa hulls, die-cut wood parts, tapered masts, finished fittings and simple plans. Send for your kit today. Select Schooner, Clipper, Barque or all 3. \$3.95 ea. Big catalog describes over 30 beautiful ship models, 600 fittings and several authentic, fascinating gun models. Only 35c. Send for yours at once. **MARINE MODEL CO., Dept. G, Halesite, Long Island, N.Y.**

**A TOOL... NOT A BRUSH**

**\$1.00 POST PAID**

**PAINERS' STRIPING TOOL**

Easy to use as a pen! Draws parallel lines, straights, curves, circles with paint, enamel, lacquer, etc. Do your own striping on autos, furniture, toys, bikes, model planes, signs, linoleum... make wall board look like tile. Painters - craftsmen, order today! Type "M" Master Painters' Striping Tool complete with tip for 1/16" stripe, \$1.00. Other tools complete with following tips: 1/64", 1/32", 3/64", 5/64", 3/32", 1/8"; \$1.50 each. Extra tips 75c ea. Entire kit with tool and 7 tips—\$5.00. (COD's postage collect.) Dealers write!

**WENDELL MFG. CO.**  
4234-B Lincoln Ave., Chicago 18, Illinois

**NOW! PAINT STRIPING MADE EASY!**



when you use pliers... you need **CHANNELLOCK**

There are lots of "fussy fix-it" jobs around the house that Dad, Mom or the kids can easily do when Channellock pliers are handy. No matter what—electrical, automotive, plumbing, battery, or anything mechanical—you need Channellock pliers.



Send for Catalog C-14 today.

Channellock's patented tongue and groove joint gives you these "plus" features: Greater Strength, Longer Wearing, Self-Cleaning, Closely-spaced Adjustments, Visible Adjustment, No Wear on Joint Bolt.

**CHAMPION DEARMENT TOOL CO.**  
MEADVILLE, PA.



Only **CHAMPION DEARMENT MAKES**

**CHAN NEL LOCK**

TRADE MARK REG. U. S. PATENT OFFICE

here's the  
**VERSA-VISE**

the versatile vise for every woodworking need

- \* Stands Up
- \* Lies Flat
- \* Turns to the most Convenient Position

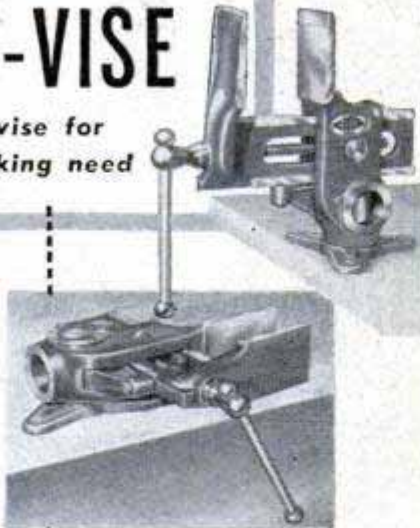

cast semi-steel construction - weighs 16 lbs.

Only \$8.95, f. o. b. Orrville, Ohio. Buy it from your dealer, or send check or money order direct to us for \$8.95 (Ohio customers remit 3% sales tax) and pay the small shipping costs upon delivery. Satisfaction guaranteed or your money back.

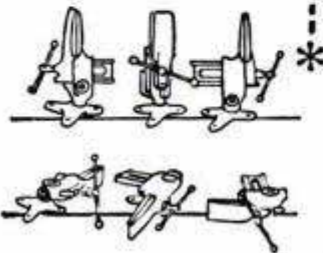

*The Will-Burt Co.* ORRVILLE, OHIO  
Department P

**HUNDREDS OF ITEMS AND IDEAS FOR THE WOODWORKER**

A board or carload—Top grade kiln-dried Mahogany—Walnut—Wh. Hd. Maple—Cherry—Poplar—Aromatic Red Cedar—Red, White and English Brown Oak—Sapeli—Andiroba—Balsa Wood. **NEW LOW PRICES.**

**HARD TO FIND LUMBER**

**BIG NEW NO. 17 CATALOG FOR WOODWORKERS. 144 PAGES OF HARD-TO-FIND SUPPLY ITEMS.**

The finest catalog we ever published. Full of unequalled bargains and useful information.

**Greatest Selection of Fine Domestic and Imported Woods**

Catalog shows in natural color 32 rare and fancy woods, 43 matched veneer designs, multi-colored bandings, inlays, overlays, 275 scroll patterns to choose from, labor-saving machinery and a section for beginner's instruction.

**OVER 100 NEW ITEMS**

My stocks are gigantic—bigger than ever before. Really **FAST SERVICE** on your orders. My new catalog includes a "gold mine" of hard-to-find hardware items. Whatever Wood Craftsmen need—I HAVE IT.

**MAIL COUPON TODAY for GIANT NEW CATALOG #17**

**Only 15c** Refunded on first order.

Harold F. Hunt, President  
**CRAFTSMAN WOOD SERVICE CO.**  
2729 S. Mary St., Dept. A-2, Chicago 8, Ill.

I enclose 15c, to be refunded on my first order. Please send me your big new Catalog No. 17.

NAME \_\_\_\_\_  
ADDRESS \_\_\_\_\_  
TOWN \_\_\_\_\_ ZONE \_\_\_\_\_ STATE \_\_\_\_\_

until a helicopter is used to carry men and equipment to sites on its top. Malaspina is too rough for landings by ordinary planes.

Each expedition used a different seismic technique for taking depth measurements at the upper end of its glacier. Radar looked promising as a way of probing into the ice but the experiments were inconclusive.

The standard seismic method employed in underground mapping was used on the Seward ice field, geophones being used to pick up echoes of gunpowder explosions from the ice-rock interface. The time that elapses between the original explosion and reception of the reflected wave is translated directly into depth. To overcome the absorptive effect of the firn mantle, it was necessary to melt shot holes as deep as 75 feet into the firn. The seismic measurements showed that in its generation area the ice field was as deep as 1975 feet. Correlated with and partly confirmed by gravity-meter measurements, the figures permitted drawing of cross sections of the rock floor.

The American Geographical expedition on Taku Glacier used a new technique that was developed by Dr. Thomas C. Poulter, associate director of Stanford Research Institute, during the time he was a member of the second Byrd expedition to the Antarctic. Instead of burying the explosive charges, Doctor Poulter suspends them in the air a few feet above the ice of firn. Random waves and "background" reflections are materially reduced, permitting accurate measurements of the depths of interfaces of even about the same densities. Taku Glacier was found to be from 800 to 1500 feet deep in portions of its generation area.

Examination and study of glaciers is only one sub-branch of a vast program of arctic research that is underway. The Office of Naval Research has established a permanent arctic research laboratory at Point Barrow where numerous other subjects are being investigated. Often a trivial subject can have important implications.

Why can the arctic tern stand on the ice for long periods without freezing its feet? If a tern is placed in a warmer environment for a time it loses this immunity to cold. Its feet freeze when it is placed on ice again. Similarly, how does a polar bear withstand frigid weather? It has a heavy hair coat, to be sure, but very little if any good warm fur. Hair is hardly an adequate protection.

Presumably some natural chemical process helps arctic animals and birds to adapt themselves to extremely low temperatures. If the secret of this natural process can be learned there is a chance that man will be able to take advantage of it. Then he could live in the North without taking the elaborate precautions he must observe now.



# MIRACLE TOMATO

Yields **2** BUSHELS  
To a Vine



Now—You can grow the world's most amazing Tomato right in your own garden and get from 2 to 3 bushels of delicious, ripe tomatoes from every vine.

## BURGESS CLIMBING TRIP-L-CROP

TOMATO grows 16 to 20 feet high. Huge, meaty, solid fruit, wonderful flavor. Some weigh as much as 2 pounds each. Unsurpassed for canning and slicing. Blight free—drought and disease-resistant. Grows in any garden. Outyields all other varieties.

**TRIAL PACKET OF PELLETED  
BETTER GROWING SEEDS ONLY  
10c—3 FOR 25c POSTPAID.  
ORDER TODAY.**

Write for **FREE** complete  
Catalog listing many unusual  
Seeds, Plants and Bulbs.

**BURGESS SEED & PLANT CO.  
217 T. Galesburg, Mich.**

## MONEY for MEN ALL DATA FREE

THE PLASTEX Industry needs manufacturers on small scale and for big production of Lamp and Clock Stands, Art Goods and Novelties in Plastex and Marble imitation. Experience unnecessary. 1/2c material makes regular 10c store sellers. Rubber moulds furnished for speed production. Small investment brings good returns. Big chain store orders now being placed. Ambitious men have chance for real prosperity. Our Free booklet will interest and benefit you.

**PLASTEX INDUSTRIES, Dept. A  
3400 Third Ave. New York 56, N. Y.**

## NU-WAY HEAVY DUTY CUTTING UNIT

with Timken Roller Bearings

PRICE  
**\$16.50**  
WHY PAY MORE



Build your own rotary type lawn or weed cutter. Take the hard work out of weed cutting. Build yourself an up-to-date weed and lawn mower with the Nu-Way heavy duty unit.

Write for Free Circular—We Supply Cutting Unit Complete  
**TRACTOR-LITE MFG. CO., Spirit Lake, Iowa**

## ARC WELDING

FOR PROFIT OR PLEASURE

60 LBS. OF READY MADE PARTS

Only  
**\$24.95**

### BUILD YOUR OWN HEAVY DUTY WELDER

SAVE  
Buy Only  
NECESSARY  
PARTS

All parts Ready-Made and easy to assemble. You can do all around welding on steel, cast iron and other metals after only a few hours practice. Illustrated instruction manual included. Sold on 30-Day Money-Back Guarantee!

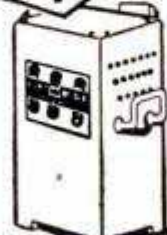

**FREE:** Write today for fully illustrated Pamphlet P-2

**ATOMIC ARC WELDER CO.**  
1037 So. 19th St. OMAHA, NEBR.

Gives 100% penetration. Welds are stronger than original metal. Operates on 110 or 220 AC.

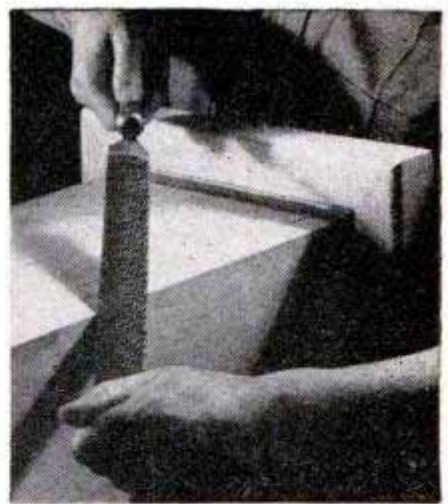

YOU CAN'T BEAT  
IT FOR BITE

**12"  
CABINET  
RASP**

EVEN hardwoods seem to melt away under the crisp, even bite of a Nicholson or Black Diamond Cabinet Rasp. More stock removal per stroke. More strokes for your money. Precisely punched teeth and expert hardening assure long-lasting sharpness. Half Round cross section.

You can get these top-quality rasps at any good hardware store. And while you're at it, look over your dealer's selection of files for every purpose.

### FREE BOOK, "FILE PHILOSOPHY"

—the "a, b, c" of file kinds, use and care . . . 48 interesting illustrated pages. Post-card request brings you your free copy.

**NICHOLSON  
U.S.A.**

**NICHOLSON FILE CO.**  
22 Acorn Street  
Providence 1, R. I.  
(In Canada, Port Hope, Ont.)



**NICHOLSON  
FILES FOR EVERY PURPOSE**

**5 YEAR WRITTEN GUARANTEE**  
**17 JEWEL CHRONOGRAPH**  
 2 PUSH BUTTON

**ORIGINALLY \$71.50**

- Post-War Surplus  
 ● WRISTWATCH  
 ● STOPWATCH  
 ● TELEMETER  
 ● TACHOMETER

Our Price  
 Now Only

**\$21.95**  
 Plus  
**\$2.20**  
 Tax



Precision 4 in 1 Timepiece. Incabloc shock resistant feature. Sweep Second hand. Anti-magnetic. Radium Dial. Stainless steel back. Unbreakable crystal. Perfect for physicians, scientists, technicians, engineers, aviators, photographers, broadcasters, navigators, sportsmen, servicemen, etc. Thousands sold at \$71.50. Order now while they last at this record breaking low price.

**5 YEAR WRITTEN GUARANTEE**  
**17-JEWEL WRIST WATCH** **\$16.95** PLUS \$1.70 TAX

**ORIGINAL PRICE \$59**

**INCABLOC—SHOCK PROTECTED WATER REPELLENT . . .**

Sacrificed Because They're POST-War Surplus Luminous dial . . . sweep second hand . . . Super Accurate . . . Imported Swiss precision movement and case. You get these Men's New 5 Year Guaranteed Watches now for a small fraction of the original price. Don't delay! Order now . . . while they last.

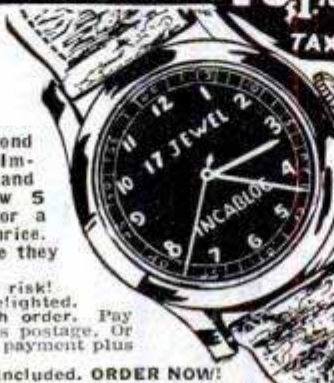

**TRIAL OFFER!** Wear at our risk! Money back in 5 days if not delighted. Send only \$1 down payment with order. Pay balance to postman on arrival plus postage. Or we pay postage if you include full payment plus tax with your order. **FREE! Handsome Expansion Band Included. ORDER NOW!**

**MARYLAND DISTRIBUTORS, Dept. 15**  
 501 EAST BALTIMORE STREET BALTIMORE 2, MD.



**NOW!**  
**EVERYONE CAN MAKE TRAYS..COASTERS..GIFTS OF BEAUTY**

**with PRE-FORMED METAL CIRCLES**

Pre-cut, pre-formed circles of Aluminum and Copper — ready to transform quickly and easily into colorful trays, coasters and other items with the Metal Goods Dek-All Color Kit. No cutting or forming. **IT'S EASY—JUST TRACE ON DESIGN . . . THEN PAINT WITH "DEK-ALL" COLOR SET.** The brilliant colors are chip-resistant, will not wash off.



**WRITE TODAY**  
 for literature  
 and price list

**METAL GOODS CORPORATION**

Dept. P M 5239 Brown Ave. St. Louis 15, Mo.

**Bone Detective**

(Continued from page 125)

skeleton is usually larger than that of a Texan Indian and that the skeletons of the Mexican tribes will be smaller still. During one of Doctor Stewart's jaunts to South America, he discovered that his 12-year-old daughter, with him, was as tall as any Guatemalan Indian.

The condition of Indians' teeth is another puzzler to the scientists. Does a diet of corn mean good teeth, or bad? Are shellfish superior to corn as a staple item in Indians' diet? These questions, in turn, are linked to the vital issue of soil quality. Fresh soil, all agree, produces more nutritious food, while depleted earth will yield considerably less valuable foods.

Every GI who has done a stint in the United Kingdom has noted how much shorter the average Scot, Welsh or English citizen is by comparison with Americans. Yet, these same peoples, emigrating to Australia, Canada, New Zealand or the United States, will produce progeny appreciably taller than their forefathers. Doctor Stewart finds these items more difficult to solve than the cases the law officers regularly turn over to him.

Doctor Stewart refuses to admit to rivaling the famed Sherlock Holmes even with his impressive record. Ever cautious, he will admit only that if he has a number of bones, and if the skull is available, his guess will be "90 percent correct." Before FBI men can receive his nod, they must satisfy his most conservative and scholarly instincts. In Iowa, recently, another killer went to extremes to dispose of the evidence. He broke all the bones and scattered them over a field. The investigators found some bones without a great deal of trouble, but they were returned with the notation that positive identification was impossible. Doctor Stewart kept them at their task, digging and scratching at the earth, until they had literally sifted the field. Finally, enough bits were found to satisfy the Smithsonian's judge. Receiving his assurance that the fragments were human, they confronted the accused with the bones and with Doctor Stewart's report. He broke down, confessed—and another killer went behind bars.

One of the first questions the federal men often ask Doctor Stewart is — "how long has the victim been dead?" This is, again, a very difficult problem, Doctor Stewart points out. Much depends on the condition of the ground, its moisture content, the acidity of the soil, the temperature, etc. Not very long ago, two bodies, presumed

(Continued to page 258)

Can You Equal This Home for **2345**

Shipped Direct from Our Mill



Save 30% to 40% on Your New Home..

**Act Now!**

Don't pay several hundred dollars more than necessary when you build a home! Buy direct from our mill at our low factory price. We ship you the lumber cut-to-fit, ready to erect. Paint, glass, hardware, nails, etc., all included in the price—no extra charges. Plans furnished—also complete building instructions. No wonder our customers write us that we saved them 30% to 40%. Easy terms—monthly payments.

Send for **FREE BOOK** of Liberty Homes

**Handsome Big CATALOGUE**

Pictures wonderful homes in colors at money-saving prices. Designs to suit everyone. Write for your catalogue today.

**LEWIS MANUFACTURING CO.**  
1202 Lafayette Ave., Bay City, Mich.

**STOP AUTO ACCIDENTS**



with new **STOP LIGHT FLASHER!**

MAKES YOUR STOP LIGHT FLASH 115 TIMES A MIN.

**FREE OFFER TO YOU!** The "Stop-It" warns cars behind—makes your stop light flash on & off, on & off! Completely automatic, acts instantly when you step on foot brake . . . attaches in 5 minutes to any car or truck. Approved by safety engineers, used by Police & Fire depts. Non-rusting, dust, oil, vapor, waterproof. Write NOW for free introductory offer—no obligation. Get this amazing "Stop-It" for your car at no cost to you! Dealers, salesmen wanted.

MACCHI & CO., Dept. MB, 927 Larkin St., San Francisco 9, Calif.



**KEEPS BASEMENT PIPES DRY**

Just wrap "NO SWEAT" insulation around water pipes and seal with special Vapor Seal Elastic Tape. Pipes will stay dry even in hot, humid weather. Workshop and darkroom stay dry. Tools won't rust. Easy to apply. No fuss. No mess. No sticky tape. No tools required. Neat, clean, attractive installation. Send \$1.00 for enough to protect 20 feet of 1/2" pipe. Full instructions included. We mail postpaid. **MON-KEY BACK** if you are not completely satisfied.

ASSOCIATED SPECIALTIES, 10658 Gratiot, Detroit 13, Mich.

**SANDING MADE EASY..**

Pat. No. 2265581



with the Handy **Sandrum**  
ALL-METAL DRUM

EASY, QUICK MOUNTING. No locking key or wrenches needed. No cement, glues or wedges. Patented mounting method saves valuable time. Abrasive tightens while in use. Ideal for use on drill presses, grinder stands, electric drills, motor arbors, etc. Drum is 2" in diameter, 2" long. Adapter and drum head joined with 1/2/20 threads. Economical replacement strips cut from standard sheets.

**\$2.50** with adapter and 6 abrasives

Sold on positive money-back guarantee. Order Today.

**STAHL SPECIALTY COMPANY**  
Dept. P 9005 E. 66th Street Kansas City, Mo.

FLIP THE LEVER—YOU'RE IN NEUTRAL



Now!

**NEUTRAL CLUTCH**

in the Famous 5.0 h.p.\* Johnson Outboard Motor



**JOHNSON'S NEW MODEL TN**

Johnson Neutral Clutch and Full Pivot Reverse. Alternate Firing. Dual Carburetion. Sure-fire Shock Absorber Drive. Vari-Volume Pump. Synchro-Control. Ready-Pull Starter. S-l-o-w Trolling—24 other features. *No increase in weight or price!*

\*OBC Certified Brake H. P. at 4000 r. p. m.

Mister, this is *IT!* Neutral is now yours in the outboard motor that is renowned for its performance, its **DEPENDability**—the famous 5 horsepower\* Johnson.

Start in neutral. Flip the lever—you're on your way. Stop, with the motor running. Jockey easily in and out of tight places. *Johnson Neutral Clutch* brings new convenience, new thrills to outboard motoring!

Prices are lower. Get set early for a full season of boating and fishing fun. See your Johnson dealer now. Look for his name under "Outboard Motors" in your classified telephone book.

**FREE HANDY CHART**

Describes all 5 models for 1950, including the 10 h.p.\* Model QD with Gear Shift Control, Mile-Master Fuel Tank . . . Write today!

**JOHNSON MOTORS**  
400 Pershing Road, Waukegan, Illinois  
*Johnson Motors of Canada, Peterboro, Canada*



*If it's not a Sea-Horse, Johnson did NOT make it*

**JOHNSON**  
**SEA-HORSES FOR DEPENDABILITY**

# Last Year's Profit \$3,000!

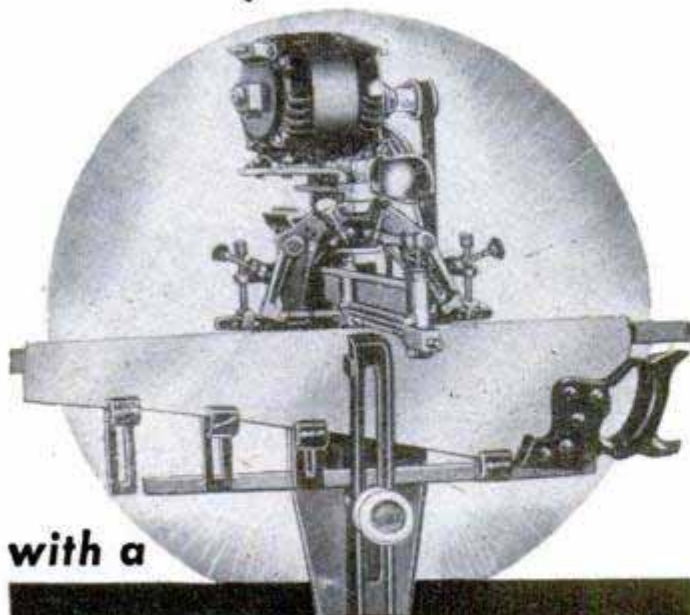

with a

## FOLEY automatic SAW FILER

"Last year's profit amounted to \$3000. Not so bad for a one-man outfit"—from Charles C. Hough. From Ohio James B. Williams wrote us—"I made \$765 last year filing saws, and it sure comes in handy. I do this work in my spare time." Men in communities of all sizes make up to \$2 or \$3 an hour with the Foley Saw Filer working full time or part time. That extra money comes in mighty handy in these days of rising prices.

It's no trick to take care of the saw filing for your neighborhood hardware or lumber dealer—plus looking after the saws for farmers, townspeople, manual training departments and factories. The Foley files all hand saws, also band and cross-cut circular saws. It's a cash business, no canvassing, no eyestrain and no experience needed.

### FREE BOOK

#### Shows How to Start

INDEPENDENCE AFTER 40 shows just how you can start at home in your spare time—work in your basement or garage. It's an immediate cash business that can develop into a full-time repair shop.



Send For **FREE BOOK**

FOLEY MFG. CO., 216-O Foley Bldg.  
Minneapolis 18, Minn.

Send me free book "INDEPENDENCE AFTER 40."

Name \_\_\_\_\_

Address \_\_\_\_\_

to be those of mountain climbers, were found high up on Mount Shasta, but it was impossible to determine, because they were so well preserved, how long they had been dead. And, here were two more of the "lots of bodies" Doctor Stewart referred to which were not readily identified.

Doctor Stewart is apt to be most elated over a tooth, sent in by a friend rummaging about in an Indian grave. Some of these specimens have been found inlaid with a precious metal or "beautified" by running a file across it. South American Indians used to "wow" members of the opposite sex by mutilating their teeth with any one of 36 patterns, or by the judicious use of gold, silver or jade inlays, and such teeth are now "collectors' items." To date, he hasn't found any of these rare specimens on his South American jaunts—but he's still hoping.

Doctor Stewart seems to have a genius for attracting bones, as would seem from the circumstances surrounding a prize collection he snared recently for the Smithsonian. While lecturing in Missouri, he made friends with a radiologist whose hobby was digging in the Indian ruins near his Illinois home. One day, his friend moaned plaintively about the lack of public interest in bodies sans flesh. It seemed that he had garnered some 400 choice Indian skeletons, which no one seemed particularly anxious to have—even for free. Naturally, Doctor Stewart snapped at this offer immediately, making the Smithsonian's 20,000-odd skeletons some 400 richer.

This would seem like a tremendous amount, but Doctor Stewart makes no bones about the fact that a collection of this sort can never have "too much." It seems, he admitted, that some very interesting (from an anthropologist's point of view) skeletons have been arriving at the Smithsonian Institution in Washington minus skulls, which is equivalent to strawberry shortcake lacking whipped cream and strawberries. Naturally, this has been impeding the march of science and vexing anthropologists a good bit. So, if you have a little skull in your home, which has been storing ashes or serving as a letter rack for longer than is decent, you can aid U. S. science by returning the skull to its rightful skeleton, most likely in Washington.

The natives of Guam have long since accepted with resignation the penchant of Americans for collecting souvenirs; so have the denizens of other lands like Persia, India, etc. Not so—Dr. T. Dale Stewart. He expresses gently, but firmly, the hope that Americans will collect Picasso, silver, china or most anything—but will kindly leave his skulls alone.

**O.D. WOOL SHIRTS**  
13 to 15  
**244**

**PANTS**  
28 to 32  
**266**

Used, reg. issue, perfect condition. 100% wool serge. Cleaned & pressed by Q.M. Corp. Add 12c ea. post.

**BRAND NEW KHAKI SHIRTS-PANTS**  
14 to 17  
**259**

Genuine 8.2 chino khaki suntan material. Pants with cuffs. Add 11c post. per garment.

**GEN. NYLON 50 FT**  
**359**

**PARACHUTE CORD**  
3/16" dia. White or khaki. 550 lb. ten. strength. For clotheslines, venetian blind and drapery cords and other uses. Add 4c post.

**50% WOOL HOSE**  
NEW. Medium weight, rugged and warm. Post 3c.

**CUSHION SOLES**  
NEW. 63% wool, double sole. These are known as the desert sox. Khaki and white. Add 4c postage per pr.

**NAVY T-SHIRTS**  
**WHITE**  
**59**

NEW. Combed yarn, full cut, 5 small, medium, and large. 5c postage.

**WAR SURPLUS**  
AND OTHER ORDER FROM THIS AD PLEASE

**BARGAINS**

**MAIL ORDERS**  
Please send remittance with order. Include postage. Guaranteed satisfaction. You are privileged to return an unsatisfactory purchase for refund.

**WATCH CAPS**  
**77c**

NEW. Navy watch caps. Color, blue. 100% pure wool knit. Please add 6c postage each.

**all wool WRISTLETS**  
**13c** 8 PAIR \$1.00

NEW. 100% O.D. wool knit. Ideal for glove and mitt inserts, wristlet replacements, etc. Worth 75c per pair. Add 3c postage per pair.

**1299**

**B-15 Style FLIGHT JACKET**

NEW. Renders greatest warmth per oz. of weight. Mountain cloth outside, pile lined body and sleeves. Genuine mouton collar, 4 pockets—2 outside, 2 inside. Wool knit cuffs and waistband. Add 27c postage.

**SIZZLING SPECIALS**

**ARMY STYLE 6-8 COMBAT BOOTS**

NEW. For sportsmen and outdoor wear. 10" high. Reversed uppers, full oak leather sole, with composition outer sole. Add 27c post.

**DUST MASKS**  
**33c**

New. \$1.50 value. Ideal for millers, farmers, paint and insecticide spraying. Add 6c postage for each.

**GREATEST WATCH VALUE IN USA**

**17 JEWEL Military Style WRIST WATCH**

**BRAND NEW GEN. INCABLOC WATERPROOF SHOCKPROOF**

Non-magnetic, radium dial, sweep second hand. St. steel case. Complete with leather strap. Guaranteed Swiss 17-Jewel movement. A truly remarkable value. Add 15c post.

**1995 PLUS 10% FED. TAX**

**WAR SURPLUS CIRCULAR**

**SEND FOR FREE**

Over 200 War Surplus and other outstanding bargains.

**SIoux FALLS SURPLUS STORE**  
113 NO. PHILLIPS SIoux FALLS, S. DAK.

**AVIATOR'S A-6 STYLE FLIGHT BOOTS**

New. 10" high—leather top, rubber bottom — baby sheep lining, add 27c post.

**1099**

**USED FLIGHT BOOTS**  
Like above—used almost like new—27c post. **695**

**SLEEPING BAGS DOWN & FEATHER**  
Down & Feather filled—water repellent — poplin shell — complete with carrying case—NEW—add 40c post. **13.99**

**GARDEN TRACTOR**

2-3-4H 5H H.P. and NEW 4H H.P. Riding Model Overcasted

• 30 ATTACHMENTS • NO BELTS  
• NO CHAINS • POWER TURNING  
• GEAR DRIVEN

Flows deep furrows. Change attachments in seconds. FREE Insurance Booklet.

Buy Direct • Special Discount  
Send Postcard for Big Free 32-page Catalog

**RED-E TRACTOR CO., Richfield, Wisconsin**  
51 FOND DU LAC RD., RICHFIELD, WISCONSIN

**MAKE YOUR OWN!**  
WITH

**Griffin READYCUT LEATHER PROJECTS**

Over 100 KITS in every kind of Tooling and Carving Leather, accurately cut, all parts included Only Top Grade Leathers used You do the choosing You do the tooling, carving, stamping, the punching and assembling

**SEND FOR COMPLETE CATALOG**  
Please send 10c to cover mailing.

SINCE 1924  
OUT OF THE WEST, THE HOME OF LEATHER CARVING  
**Griffin Craft Supplies**  
5626-A TELEGRAPH AVE.  
OAKLAND 9, CALIFORNIA

**EVERYTHING FOR THE LEATHER WORKER**  
Largest, most complete stock of Leathercraft Tools and Accessories in U.S.A.

**HIDES AND SKINS OF Craft Leathers of every kind if you prefer to cut your own.**

**GOLD BOND**

**WHOLESALE GUARANTEED EXCEPTIONALLY GOOD USED TIRES DIRECT TO YOU**

10% discount on 2 or more tires if you send this ad with order

**TUBE DELIVERED WITH TIRE AT NO EXTRA COST FOR 15" AND 16" PASSENGER TIRES**

Safe — Our tires used on school buses and ambulances

**EXCEPTIONALLY GOOD TREAD — NO RECAPS**  
GUARANTEED FOR 24 MONTHS

600-16—6 ply Military—Mud and Snow Tire.....	\$6.37
600-16 .....	\$5.49
600-16 (6 ply) .....	6.49
650-16 .....	5.49
650-16 (6 ply) .....	6.79
700-16 .....	\$6.79
700-20(10) .....	\$6.69
750-20(10) .....	\$8.25
825-20 .....	16.98
900-20 .....	17.79
1000-20 .....	18.29

**ALL GOOD TIRES**  
GUARANTEED FOR 12 MONTHS

600-16 .....	\$3.59	550-17 .....	\$5.69	700-20(8) .....	\$9.29	825-15(14) .....	\$14.98
650-16 .....	3.89	750-16 .....	8.40	700-20(10) .....	12.48	825-20 .....	11.19
650-15 .....	3.89	600-20 .....	7.98	750-20(8) .....	11.79	900-20 .....	11.89
700-15 .....	3.98	650-20 .....	7.99	750-15(10) .....	11.97	1000-20 .....	12.89

**GOLD BOND SPECIAL — 750-20 MILITARY TIRES**  
Will fit 650 x 20 700 x 20 (8 & 10 ply) 34 x 7 (8 & 10 ply)

Special .....	\$10.49	Guaranteed 12 months	
Superior Quality .....	12.98	Guaranteed 18 months	
Gold Bond Finest .....	14.98	Guaranteed 24 months	
900 x 16 Special .....	9.03	900 x 16 extra .....	11.19

Send check or money order with this ad

**GOLD BOND TIRE CO., Dept. PM 24**  
512 NORTH 1ST ST., RICHMOND, VA.  
"A gold bond written guarantee with every tire"

# GRAVELY



## TRACTOR POWER *for your* SMALL FARM

Are you a slave to the drudgery of your small farm? Free yourself with GRAVELY Power Equipment. POWER does the work, gives you bigger, better crops, more beautiful grounds about your home, with less work! . . . The GRAVELY Plows (ready-to-plant seedbed in one operation); Mows hay, weeds, brush, lawns; Cultivates; Hauls; Saws; Sprays. Power to spare with big 5-HP Engine. Two speeds forward & REVERSE.

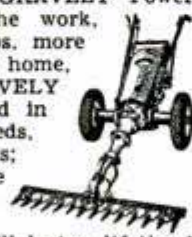

All gear-driven, will last a lifetime! World's finest for 28 years.

**FREE!**



Mail coupon for name of dealer and this big two-color Free Booklet — "POWER VS. DRUDGERY" — that tells you how to put POWER to work on YOUR small farm — how to enjoy your country living without long hours, hard work!

**MAIL TODAY**

GRAVELY MOTOR PLOW & CULTIVATOR CO.  
BOX 263 DUNBAR, W. VA.

NAME \_\_\_\_\_  
ADDRESS \_\_\_\_\_  
TOWN \_\_\_\_\_ STATE \_\_\_\_\_

## Count Off, Americans

(Continued from page 110)

when the business of counting and classifying people already had grown beyond the ability of simple humans to handle. It was almost time to start the 1890 decennial, and the boys hadn't finished the 1880 tallies. A bureau statistician, Dr. Herman Hollerith, came up with the idea of punching holes in various places in cards, to represent facts such as "male," "three children," "farm family," etc. Then he rigged a machine that the cards could go through and automatically be counted and classified according to where the holes were. Today, the same basic system is in use—only now it's almost all electronic, with new and more complex machines appearing all the time. Rows of workers will peck away at 2500 card-punch machines, each one completing the 60 or 70 basic-fact holes in 1000 cards a day. From there the cards go to the sorters and tabulators, which automatically classify and count them according to location of their holes.

These machines are masterpieces of ingenuity. Down in the shops of the Census Bureau there's a man named Tony Berlin-sky, who is busily at work making them more ingenious. "When we finally got a machine to handle 40 columns of facts or 'holes' in a card," he says, "those guys upstairs had to go think of 20 more questions they wanted to ask on the next census—so everything is obsolete. This time I'm rebuilding the multi-column sorters to combine the sorting and tabulating operations. They'll handle 80 columns of facts. I hope it holds 'em for a while. It probably won't, though," he adds soberly.

The inside of Tony's multi-column sorter looks like a vat full of wet, black spaghetti. Basically, the principle is simple enough. The cards move across the top on rollers, pass under a row of 80 microscopic metal brushes, which make contact with the metal roll beneath the card every time they come to a hole. Each contact sets up an impulse which is relayed through a battery of thyrotron tubes where the information is "stored." High-speed relays set off the proper electromagnets, depending on what information has been received. A magnetic trip drops and the card is routed to its proper slot. For instance, if 1500 out of 5000 cards going through the mill represent people who live in two-story houses, and you want that information, then the 1500 cards of two-story people will all land in one slot once the relays are set up. Simple? Tony explains that his reconditioned sorter has more than 10,000 wire connections. He should know; he connected them all.

(Continued to page 262)

## NOW . . . FOR 1/10<sup>th</sup> THE COST

CONVERT ANY DRILL PRESS INTO  
A PLANER • SHAPER • JOINTER  
POWER SANDER • ROUTER

This FREE Book Tells You How

BARRON TOOL COMPANY, INC.  
969 Architects Bldg., Detroit 1, Mich.



SAY YOU SAW IT IN POPULAR MECHANICS

Chronograph Wrist Watch: \$6.75

PLUS TAX

OVERSTOCK SALE



Sweep Second Hand; Precision Workmanship; Rugged Shock-resistant case; Radium hands and numerals; Leather strap. It measures distance, speed of cars, planes, horses and other moving objects. It's a time keeper, stop watch, telemeter, tachometer. ONE YEAR WRITTEN GUARANTEE and full operating instructions enclosed with each watch. SEND NO MONEY. Mail your order today. Pay postman \$6.75 plus 10% Federal tax. Total \$7.43 plus postage. Or send cash (money order or check) with your order and save postage charge.

MARDO SALES CO., Dept. 1706

480 LEXINGTON AVE.

NEW YORK 17, N. Y.

# Best Jig Saw Buy

... any way you look at it

You'll rate this improved 15" Duro Jig Saw a "best buy" by any comparison you make!

**Extra Capacity at Lowest Cost** . . . cuts to the center of a 30" circle . . . cuts material up to 2 1/4" thick . . . needs only 1/4 H. P. motor.

**Smoother Cutting** in all kinds of wood. Cam-activated blade action . . . sealed oil bath for drive mechanism assures "like new" performance year after year.

**Husker Streamlined Frame** of cored cast iron adds rigidity without extra weight.

**Accurate Table Tilting** to 45° on double trunnions . . . quick, easy table locking with one front handle . . . tilt gauge.

**Longer Blade Life** results from longer blade stroke . . . blade guide . . . heat treated blade clamping blocks.

**Other Features** include: air pump to keep work free from sawdust, handy oil cup for spindle lubrication and many more exclusive Duro advantages.

WRITE TODAY FOR FREE CATALOG

describing this low cost Duro Jig Saw . . . plus the complete 1950 line of Duro Power Tools. Fill in the coupon and mail it today sure!

## DURO POWER TOOLS

Duro Metal Products Co.

2656 N. KILDARE AVE. CHICAGO 39, ILLINOIS



E3002 15" Jig Saw

**\$24.95**

Complete with saw blade and pulley



**Duro Metal Products Co.**  
2656 N. Kildare Avenue  
Chicago 39, Illinois

Gentlemen: Please send me details on your 15" Jig Saw . . . also the complete new Duro Power Tool Catalog.

Name \_\_\_\_\_  
Address \_\_\_\_\_  
City \_\_\_\_\_ Zone \_\_\_\_\_ State \_\_\_\_\_

## How To Get MULTIPLE UTILITY When You Buy a SMALL GRINDER

### BUY THE FOREDOM MODEL 100 FLEXIBLE SHAFT MACHINE

the choice of tens of thousands because:— Pencil-size handpiece provides positive, sensitive, finger-tip control, works in hard-to-reach places. Your work always well in view. Precision construction and silencer-equipped flexible shaft assures smooth-running per-

formance. Motor not dwarfed to fit the hand, hence more power, longer motor life. Price only \$16.95. Foot rheostat \$4.85 extra.

**USE IT TO GRIND, POLISH, DRILL, SAW, SAND, CARVE, MILL, CLEAN, ETCH, ENGRAVE, etc. on all metals, wood, plastics, glass, leather, linoleum, etc.**

35" FLEXIBLE SHAFT

**\$16.95**

COMPLETE WITH MOTOR



Model 100

### BUT THAT'S NOT ALL—

For \$4.95 extra get Foredom's new **DRILL PRESS ATTACHMENT**. Magically and quickly converts machine into a power drill press.

**AND FOR ONLY \$3.50 EXTRA** there's Foredom's new **B-R-S ATTACH-**

**MENT**. Makes machine serve 3 **EXTRA FUNCTIONS**—Bench Grinder with angular adjustment, Router with detachable guide for borders, and SHAPER.

Budget your purchase or buy **FOREDOM MULTI-PURPOSE THRESOME** comprising Model 100 Machine, Drill Press Attachment and B-R-S Attachment \$24.95.

**PRESTO-FLEX \$5.95**

### And here's another Amazing

**Foredom Product** Now turn your old motor, drill press or electric drill into a Flexible Shaft Tool with **FOREDOM PRESTO-FLEX** with **PENCIL SIZE** handpiece. Attached or removed in a jiffy! Gets into tight places. Handy 35" overall



length. And—only \$5.95 complete! Precision made. For use on motor, specify motor shaft diameter and add 50c for coupling. (Available for 1/4, 5/16, 3/8, and 1/2" shafts.) No. 50 Accessory Set \$1.50 extra.

**FOREDOM ELECTRIC CO., Dept. 1126-E, 27 PARK PLACE, NEW YORK 7, N. Y.**

**FOREDOM — Used by INDUSTRY — Preferred by HOBBYISTS!**



Dealer Inquiries Invited

## SET THE PACE WITH THE

- Cruises at 45 MPH—with faster pickup than car
- 39" high, 71" long overall, wt., 190 lbs.
- 8 HP motorcycle engine
- 50 miles to the gallon
- Automatic clutch
- Internal expanding brakes — handle-grip throttle controls

**POWELL MANUFACTURING COMPANY**

DEPT. PM250 • COMPTON, CALIF.

**Powell**

**P-81!**

ONLY **\$247<sup>34</sup>**  
AT COMPTON, CALIF.  
EXCISE TAX INC.

Write for **FREE** folder and name of nearest dealer

# WHAT DO YOU WANT?

## A GOOD BUSINESS OF YOUR OWN?

### A HIGH PAY SPARE-TIME JOB?



## FOLLOW THIS PROVED SUCCESS PLAN!

Here is your chance to be your own boss, secure financial independence, build a future for yourself and your family in a profitable business in your own garage or basement. J. S. of Michigan writes, "I figure my profits (last season) at over \$1,000.00." Mr. C. H. R. of Ohio says, "This season I have taken in \$3,688.20." J. P. of Pennsylvania writes "I spent only 40c for a newspaper ad and have done nearly \$500.00 worth of business." Another owner writes, "I have had 4

mowers a day brought to me since last May . . . and do the grinding evenings at an average of \$2.50 each." Think of it! That's \$10.00 an evening in spare time.

If you want to get ahead, make big money, be your own boss. Act Now. Write today for full details of our proved success plan.

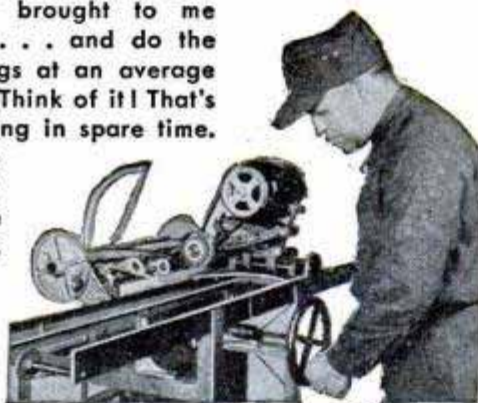

## ONLY ON THE UNIVERSAL LAWN MOWER GRINDER

can the inside face and edge of the stationary blade, and all reel blades, be ground to proper clearance

### ALL IN ONE SET-UP

WITHOUT REMOVING ANY BLADE FROM THE MOWER

. . . that's why this business is simple, easy, and interesting. No experience or long hours of study are necessary. A leading National Magazine says, even an inexperienced worker can do a good job. We furnish complete instructions, everything you need to get started . . . But you must take the first step. Just fill in and mail the coupon below. Do it right now.

ROGERS MFG. CO., DEPT. M-20, LINDSEY, OHIO

## SEND THIS COUPON NOW

ROGERS MFG. CO., Dept. M-20, Lindsey, Ohio  
Please send me full details about the profit possibilities of Lawn Mower Sharpening.

NAME \_\_\_\_\_

ADDRESS \_\_\_\_\_

CITY \_\_\_\_\_ STATE \_\_\_\_\_

Besides sorting, the machine will reject cards with mistakes on them. "If the little 'feelers' register opposing facts," Tony explains, "—for example, if a card says a certain male is two years old, and another hole indicates he has six children—the circuits won't take it. The card is routed to the reject slot. Similarly, if a farmer's card has a hole punched to indicate he got something ridiculous like \$55 a bushel for his wheat, the circuits won't take that either."

Coming up are census machines that will make the others seem like box kites beside jet flying wings. One such electronic nightmare, being developed for Census through the National Bureau of Standards, is a 10,000-tube affair styled after the Eniac computer which was used during the war to calculate the trajectory of missiles while they were still in the air. This fantastic apparatus has a memory, among other things. Instead of taking data from punched cards, it will work by magnetic impulse from a tape which has been magnetically inscribed with the data to be tallied or computed. If there is an error on the tape, the machine will quit working on that problem, but will go right ahead with the rest. When the mistake has been corrected, the machine will pick up the abandoned computation where it left off, and finish it. The uncanny brain works at such a speed that no way has ever been devised to feed data into it fast enough to tax its capacity. This monster will be ready on a test basis to gobble figures in its maw in time for the 1950 census.

Not quite ready yet, but available for the 1960 census, is another electronic marvel that may well simplify census taking so that final figures will be out in months instead of years. It will eliminate manual card punching. The census taker will carry cards, just the right size for the machines, instead of the huge paper form he now totes. As he asks questions, he will mark the card with a metallic ink. Back in Washington, the metallic marks will be "sensed" by the new machine, and automatically punched in all the right places at once.

The manufacturer of the machine is still experimenting with the ink and trying to solve several problems. Likewise the materials from which the cards are to be made are still under test. The cards, which must all be perfectly shaped and edged to go through all the necessary machines, bent, shrank or stretched due to weather when conventional paper stock was used. Little by little these things are being straightened out. The ink is better now, and new plastics are being tried for the cards.

Meanwhile, the Bureau of Census will be too busy to dream about the wonders of

(Continued to page 264)



# You Can Have Local Manufacturing Rights

Here's an outstanding manufacturing opportunity for men with vision, energy and a little capital. Brikrete is sweeping the country because it has beauty, long life and ultra comfort. Truly the world's most modern masonry. Distinctively different. Yet costs less than lumber because it is locally manufactured of local materials by local labor for local building needs.



## 100%-150% Mark-Up on Costs

You can be one of a national chain of local plants. High income potentials. Can be started on moderate investment. Wide-open market. Requires no experience; no skilled labor. We supply all equipment. Easy terms, if necessary. We work with you to put it across. Write for Brikrete Book No. 2 today... free.



Brikrete Associates, Inc.  
4679 Division Ave., S.  
Grand Rapids 8, Mich.

**BRIKRETE**

# CARTWRIGHT'S

Patented

## TRU-CUT TIN SNIPS

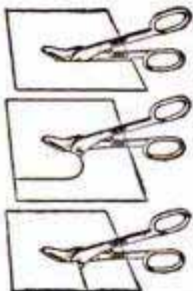

Prompt Delivery



\$4.95 Postpaid on ea. cash orders

### CHECK THESE 10 TRU-CUT FEATURES

1—Cuts perfect circle, right or left. 2—Cuts square points, either right or left. 3—Hands always above metal. 4—Fits the hand, well balanced, light weight. 5—Forward Stop prevents pinched fingers. 6—Guaranteed against mechanical defects. 7—Special "Cup Tension Washer" retains tight fit. 8—Faster, truer, easier cutting. 9—Stays sharp longer. 10—Will cut up to 18 gauge sheet metal.

Send cash, check or money order. \$1.00 deposit on C.O.D.'s. Satisfaction guaranteed.

IF DEALER CAN'T SUPPLY, ORDER DIRECT FROM US

**J. CARTWRIGHT & SON**  
MALAGA, Dept. P.M., CALIF.

Say You Saw It in Popular Mechanics

# Do a Better Job WITH ONE OF THESE EMPIRE LEVELS

Smallest, most handy and accurate level made. "Cigar-shaped" — no sharp corners to tear pocket. Aluminum stock. Only 3 oz. wgt. 9" long. Has Level, Plumb, 45° Vials. No. 26..... \$2.00



## ALUMINUM LEVEL — No. 151

Cast and Machined, a Beautiful Tool, with Patented, Removable Level and Vial. With 2 Plumb, 2 Levels, 2 — 45° Vials. 18".....\$6.40  
24".....\$6.80 28".....\$7.80

Order EMPIRE LEVELS from your local dealer. Write direct for literature.

**EMPIRE LEVEL MFG. CO.**

BOX 97, DEPT. P-256 MILWAUKEE 13, WISCONSIN

# Outboard News

About the new Scott-Atwater **SHIFT** motors

## WHY ROW?

With a Scott-Atwater **Shift** motor, you can start in Neutral, while still tied up at the dock. Then **Shift** to Reverse and back away like a cabin cruiser. The **Shift** is simple, sturdy, foolproof... adds little to motor weight!

## Our motors even turn on their own GAS

All Scott-Atwater **Shift** models with conventional gas tank (1-14, 1-16, 1-20) have automatic gas line and air vent control. When you move the speed control lever to the "start" position, the gas is turned on, the vent opened. When you stop the motor, gas and vent are closed automatically. Never before have outboards been so simple to run.

"Now I use Neutral and Reverse like a taxi driver. My Scott-Atwater **Shift** motor is a honey... don't see how it could be improved!" — Joe Alexander, Madison 5, Wis.



## SHIFT!

Scott-Atwater announces amazing new Model 1-30... now offers 4 **SHIFT** models



America's most advanced outboard—with 1-to-30 m.p.h. performance, the **Shift**, more ball-and-roller bearings than any outboard its size, separate 5-gallon "stowaway" gas tank, exclusive steering-handle control of spark and throttle!

**1-30 SHIFT**  
TWIN · OVER 15 HP  
(TO BE CERTIFIED)  
1 to 30 MPH \$349.50†  
With separate gas tank....

**1-20 SHIFT**  
7 1/2 HP\* TWIN  
1 to 20 MPH \$199.50

**1-16 SHIFT**  
5 HP\* TWIN  
1 to 16 MPH \$179.50†

**1-12 NON-SHIFT**  
3.6 HP\*\* SINGLE  
1 to 12 MPH \$99.50

**1-14 SHIFT**  
4 HP\* SINGLE  
1 to 14 MPH \$149.50†

†WEST COAST PRICE SLIGHTLY HIGHER

\*OBC CERTIFIED @ 4200 RPM \*\*OBC CERTIFIED @ 4000 RPM

SEE FOR YOURSELF...  
SHIFT FOR YOURSELF...

# SHIFT



## to Scott-Atwater

Dept. 35, Scott-Atwater Mfg. Co., Inc., Minneapolis 13, Minn.

Experienced Craftsmen Say:  
**"YOU CAN'T FINISH WITH A DISC SANDER!"**

The disc sander is excellent for roughing, hogging off, removing paint, and for other coarse sanding. But any experienced craftsman will tell you that these same characteristics prohibit its use for finishing, because of swirling, scorching, gouging and other blemishes caused by the disc sander's high speed.

**OSCILLATING MOTION IS THE *only* MOTION FOR A PERFECT FINISH!**

THE DU-FAST® SANDER AND POLISHER produces quick, easy, perfect finishes at low cost. It requires no special skill or knack. You get an industrial type finish on wood, metal, plastics, plaster and composition materials the first time and every time you use DU-FAST! USE DU-FAST TO REMOVE DISC SWIRLS.

Model BDHU 1 attaches in seconds to either the Home Utility 1/4" Electric Drill or the Home Utility 5" Disc Sander-Polisher. (Products of Black & Decker Mfg. Co.) Model SK\*1 fits the Skill Home Shop 1/4" Electric Drill manufactured by Skilsaw, Inc.



**ONLY \$14.95**

(Attachment)  
(Either Model)

\*Pat. Applied For

DU-FAST SANDERS ARE AVAILABLE  
 AT ALL BETTER HARDWARE DEALERS

Manufactured by

**DU-FAST, INC.**

32 EAST FOURTH STREET, NEW YORK 3, N. Y.

**HAGERTY  
 SEA SHELL**  
 only  
**\$35**



**BOAT KIT AT DOWN-TO-WATER PRICE**

• Assemble this handy 8-footer yourself and save half the price of a ready-made boat! Light (65 lbs.) for easy carrying, rowing, towing. Yet the HAGERTY SEA SHELL is ruggedly built to give you years of fun. Carry on your car top to beach or lake. Holds three adults in safety. Takes a small outboard. Ideal for all-around use. Over 15,000 in service.

**SEA SHELL EASY TO ASSEMBLE**

Only ordinary household tools needed. The whole family can have lots of fun assembling the HAGERTY SEA SHELL in a few pleasant evenings. Kit includes pre-cut waterproof plywood and wood parts, screws, oarlocks, seam compound, easy-to-follow instructions. Beam 4 ft., depth 16 ins. Fully guaranteed. Additional kit converts SEA SHELL into lively performing sailboat.

**HAGERTY, 112 Front Street, Cohasset, Mass.**

- Please send FREE booklet, name of nearest dealer.
- Please send SEA SHELL kit, freight collect. Enclosed is \$35.

Name \_\_\_\_\_

Address \_\_\_\_\_

City \_\_\_\_\_ State \_\_\_\_\_

1960. They've got plenty of calculating to do. Already they know, from preliminary surveys, what the 1950 round-up of Americans will show. We will have grown in number by a solid 20 million in the last 10 years—30 years ahead of schedule, due to war babies. Women will outnumber the men by a glorious million for the first time in history. The trend is still Westward, and California will top the 10-million mark in population, which puts her up with New York and Pennsylvania and gives her seven more congressmen. Ten percent of the farmers have deserted their farms to move cityward. And we will find that we're not the homebodies we used to be. Some 70 million of us have moved our dwellings in the first seven years of the decade. Most stayed in the same county—but 25 million got clear out of the county or state.

How does the Census Bureau know all this? Because the job never stops. In between decennial jobs, the bureau is taking surveys of housing, business, agriculture. There's never a dull moment at Suitland. What started out in 1790 as a simple population count has snowballed into the world's biggest continual statistical operation. And the big job every zero year is just one more headache.

**Miracles You'll See  
 In Next Fifty Years**

(Continued from page 118)

travels westward toward Florida, oil is spread over the sea and ignited. There is an updraft. Air from the surrounding region, which includes the developing hurricane, rushes in to fill the void. The rising air condenses so that some of the water in the whirling mass falls as rain.

With storms diverted where they do no harm, aerial travel is never interrupted. And the Dobsons, like everybody else in Tottenville, travel much more than we do in 1950—that is, to foreign countries.

By 2000, supersonic planes cover a thousand miles an hour, but the consumption of fuel is such that high fares have to be charged. In one of these supersonic planes the Atlantic is crossed in three hours. Nobody has yet circumnavigated the moon in a rocket space ship, but the idea is not laughed down.

Corporation presidents, bankers, ambassadors and rich people in a hurry use the 1000-mile-an-hour rocket planes and think nothing of paying a fare of \$5000 between Chicago and Paris. The Dobsons take the cheaper jet planes.

This extension of aerial transportation

(Continued to page 266)

**WAR SURPLUS BARGAINS**

**SHOP by MAIL - SAVE at GROBAN'S**

**LOGAN HEAVY DUTY**

**GEAR TYPE—ALL MANGANESE BRONZE  
INSECTICIDE PUMP**



(ITEM #250)  
**15.00**  
F.O.B. Chicago

For Spraying D.D.T., 2,4-D, Sulphur Compounds, etc. **BRAND NEW.** Pressures up to 200 lbs. and 14 gallons per minute—at 1200 R.P.M. Will not rust, pit, foul or freeze up. Use rubber hose inlet, 3/4" pipe outlet. Equipped with double mounting bracket. Weight, 24 lbs. Dimensions, 8"x7"x10". Standard 1" manganese bronze shaft with keyway. U. S. Gov't Acquisition Cost \$62.00. NOW.....  
**FREE—complete instructions and performance data with each pump.**

**HYDRAULIC CONTROL VALVE**



(ITEM #37)  
**21.95**

**BRAND NEW** control valve with built-in adjustable relief valve, will operate one double-acting hydraulic cylinder or two cylinders as one or a reversible hydraulic motor. Valve handle latches in neutral position. Made of rugged cast aluminum alloy. Open center unloads the pump in neutral position. Throttling control allows operator to regulate the speed of movement of the hydraulic cylinder or motor. Has removable mounting brackets with 4 bolt holes, 3/4" pipe thread connections. Overall dimen.: 12 1/2" H x 8 1/2" D x 8" W. Ship. wt. 17 lbs. Gov't Acquisition Cost over \$100.00. An Excellent Buy. F.O.B. Chicago.....

**AIR or OIL HYDRAULICS**

Use hydraulics on arbor presses, hydraulic presses, hay lifts, manure loaders, lift trucks—push or pull, tilt or turn, press or squeeze, open or close, lift or lower—and other hydraulic and industrial applications. Use with either air or oil... of finest precision workmanship. **BRAND NEW.**

**ITEM #16—**Use these cylinders on farm trucks, bulldozers, hay lifts, manure loaders, etc. Double action, 1 1/2" bore, 2 7/8" stroke. (Will lift 1760 lbs. in 2 seconds with Logan Pump.) Wt. 8 lbs. A \$55.00 hydraulic cylinder value for only... **postpaid 12.95**

**ITEM #17—**Double action, 2 3/4" bore, 8" stroke. (Will lift 4400 lbs. in one second with Logan Pump.) Will withstand 1500 P.S.I. against wall. Wt. 7 lbs. A \$65.00 value... **postpaid 14.50**

**ITEM #15—**Double action, 3" bore, 8 1/2" stroke. All steel hydraulic cylinder, (will lift up to 7000 lbs. in 3 seconds with Logan Pump.) Wt. 12 lbs. A \$78.00 value... **postpaid 19.50**

**ITEM #31.** Double action, 3 1/2" bore, 11" stroke. (Will lift 9600 lbs. in 7 seconds using Logan Pump.) Wt. 15 lbs. **22.50**

**ITEM #42—**Double action hydraulic cylinder, 4" bore, 18" stroke. Rated lift capacity with 1000 P.S.I. input is 12,560 lbs. using Logan Pump. Ship. wt. 30 lbs. AN EXCELLENT VALUE for... **F.O.B. Chicago 32.50**

**HIGH-PRESSURE FITTINGS** for cylinders and valves available at 35c ea. for 3/8" pipe and 50c ea. for 1/2" pipe.

**HYDRAULIC CONTROL VALVE**

**ITEM #24.** Four-way control valve with built-in relief valve, for use with one double action hydraulic cylinder, may be used with 1500 P.S.I. hydraulic system to open and close hydraulic cylinders.



Brand new. Ship wt. 8 lbs. A \$38.00 value... **postpaid 7.95**

**ITEM #26.** Four-way control valve for use with two hydraulic double-action cylinders. Each cylinder may be operated independently of the other or in conjunction with the other. Oil may be locked in any of the cylinders to hold the piston at any required position. Brand new. Ship. wt. 10 lbs. A \$60 value **postpaid 10.95**

**ITEM #28.** A two cylinder double action valve with a unique arrangement, allowing the operator to raise both cylinders simultaneously, to lower them simultaneously or to raise one and lower the other at any predetermined rate and speed. Brand new. Ship. wt. 8 lbs. A \$75.00 value **postpaid 14.95**

**VICKERS MF9 HYDRAULIC PUMP or MOTOR**

complete with mounting kit ready to install  
**\$75.00 value POSTPAID 19.90**

Pump is compact, powerful, rated 1,000 P.S.I., .507 cu. in. per revolution, 8 gal. per min. at 3750 RPM. Change rotation by reversing flow. Delivers up to 6 H.P. Requires 1/2" to 6 H.P. to drive directly or by pulley. **BRAND NEW.**

Mounting kit has been especially designed to provide maximum utility and ease of mounting. MF series Vickers Pumps. Brackets are constructed of heavy steel plate; shaft is made of 1/2" steel with one end splined to fit pump; other end of shaft has machined flat for mounting a standard pulley with 1/2" hole. Shaft runs in oilite bronze bearings.

**PUMP ONLY (ITEM #18) \$14.95 postpaid MOUNTING KIT ONLY (ITEM #38) \$ 4.95 postpaid BOTH AS COMPLETE UNIT (ITEM #39) \$19.90 postpaid**

**ARC WELDER**

250 AMP. MODEL 252

Designed for many years of trouble-free service. Handles anything from light gauge sheet metal to 1/2" plate



ITEM #65

**FOR ANY WELDING JOB, LIGHT OR HEAVY**

This precision-engineered direct current ELECTRIC ARC WELDER is offered at but a fraction of its original value. It can be mounted permanently or easily transported for portable use. Does the job instantly, where and when you need it.

The War Surplus generators for these Arc Welders were built by General Electric, Westinghouse, and Delco-Remy at a cost of over \$300.00. They are light in weight; have oversized lifetime grease-sealed ball bearings; air-cooled commutator; dial type rheostat for easy pinpoint control; high-low range switch; reactor coil for even arc; handles 1/16" to 1/4" rods. Run welder at 2500 R.P.M. from drive pulley or power take-off of tractor, a 7 1/2 H.P. electric motor or a 10 H.P. gas engine. Use two V-belts, or flat belt (on pulley). Continuous welding rating—200 amps.; intermittent rating—250 amps.; 0-30 volts. Now... AT A FRACTION OF ITS VALUE. Price includes double V or flat belt pulley and instruction book. Ship. wt. 107 lbs. Only one or two jobs will pay for entire welder. **F.O.B. Chicago 99.50**

**ACCESSORY KIT** including welding helmet, electrode holder, two 10 ft. cables with clamp, and 5 lbs. of assorted welding rods. (ITEM #66) **F.O.B. Chicago 10.50**

Remember, Satisfaction is Guaranteed

**115 Volt—60 Cycle A.C. LIGHT PLANT GENERATOR**

**IDEAL FOR:** Home Lighting, Hunting, Lodges, Stand-by Electricity, Running All AC Electrical Appliances including: Fans, Motors, Electric Razors, Refrigerators, Incubators, etc.

750 Watts at 1800 RPM using 1 1/2 HP gasoline engine. **0-150 Voltmeter with Regulator;** 1" diameter shaft with keyway for direct or belt drive, carried in two bearings, one bronze and one ball-thrust bearing, and packed separately to prevent damage to generator or shaft while in transit. Protection for emergencies to operate oil burner, stoker, freezer, water pump, and lights. These units, built to exacting Signal Corps specifications, are the answer to your lighting needs. Shipping wt. 60 lbs. **59.50** F.O.B. Chicago

AN OUTSTANDING VALUE

**Logan 4-Way Foot Operated AIR VALVE**

Model 6520 **BRAND NEW.** For double-acting pneumatic devices. Fine for operating air vises, presses, air machinery of many types. Heavy cast construction. Threaded for 1/2" pipe. Dimensions of valve body 8 1/2" L x 5 3/4" W x 7 1/2" H. Net Wt. 28 lbs. Gov't acquisition cost \$42.00. AN OUTSTANDING BUY AT... **15.00** (ITEM #59) F.O.B. Chicago

**FREE: NEW 1950 CATALOG**

**Brand New HANNA Air Cylinder**

Used for heavy duty industrial applications on shop air lines or with low pressure systems. With 100 lbs. of air pressure, will deliver 1900 lbs. pressure at the ram shaft. All steel construction. Adjustable cushions at both ends of cylinder. Shaft dia. 1 1/2". Foot mounting with clevis on ram shaft. 26 1/2" double-acting stroke; 5" bore, 40 1/2" overall length closed, 7" overall width. 89 1/2 lbs. net wt. Gov't. acq. cost \$101.85.



(ITEM #61) AN EXCELLENT VALUE for **39.50** F.O.B. Chicago

**HALE FIRE and IRRIGATION HIGH VOLUME Centrifugal Pump**

FOR FIRE PROTECTION, IRRIGATION, DE-WATERING, INDUSTRIAL USES, FARM USES, ETC.

**PUMPS RATED 500 GALLONS PER MINUTE AT 275 FT. HEAD PRESSURE**

Equipped with 1 1/2" diameter straight splined shaft for direct coupling drive; 4 1/2" threaded suction intake; two 2 1/2" threaded discharge outlets; Hale Pump Co. Model CF volute type; use any 4 or 6 cylinder gas engine direct coupled to pump; dimensions 21" x 24" x 28". Complete with full accessory kit including suction and pressure gauges, priming equipment, and instruction book. Ship. wt. 415 lbs. Gov't. acquisition cost \$425.00.



(ITEM #48) **149.50** F.O.B. Chicago

**WATEROUS PUMP**

Rated 500 gallons per minute at 120 P. S. I. This high efficiency pump is designed for front end mounting on General Motors, Dodge, Studebaker and Ford trucks and comes complete with gear box and power take-off for easy mounting and attachment to crank shaft. Net weight of pump 500 lbs. Shipping weight 1200 lbs. **F.O.B. Chicago... 149.50**

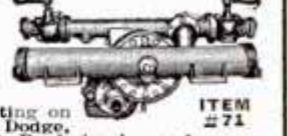

**LOGAN HEAVY DUTY HYDRAULIC PUMP**

**BRAND NEW...** for operating hydraulic cylinders and hydraulic motors on tractors, bulldozers, construction machinery, lift trucks, industrial applications, etc. Delivers 8 GPM at 1200 RPM at 1000 P.S.I. using 5 H. P. Has 1/2" pipe thread inlet, 3/4" pipe thread outlet, 3/4" shaft with flat and keyway for direct or pulley drive. Has flange with 4 bolt holes for convenient mounting. Ship. wt. 22 lbs. Overall dimen.: 7" L x 5 1/2" H x 5 1/2" W. A \$105.00 value. FOR ONLY... **22.50** F.O.B. Chicago



**ORDER DIRECT FROM AD Send Payment or Purchase Order Today** **GROBAN SUPPLY CO. Dept. PM-2 1507 S. MICHIGAN AVE., Chicago 5, Ill.** **ALL ITEMS UNCONDITIONALLY GUARANTEED**

# Walworth *GENUINE* Stillson



- ... Zinc Plated
- ... Perfectly Balanced
- ... Long Life
- ... Latest Metallurgical Improvements
- ... Low Price



— Standard of Quality for Farm . . .  
Home . . . and Industrial Use Since 1869

Get a Walworth *Genuine Stillson*. You'll feel the difference immediately. The angle of the teeth and pivoting frame action gives the wrench tremendous gripping strength. Discover the perfect heft (balance) that has made the *Genuine Stillson* such a popular tool since 1869.

Made of steel that must be up to Walworth metallurgical standards, *Genuine Stillsons* are given the most exacting tests to insure perfection in strength and uniformity in quality.

The inherent strength and toughness in the *Genuine Stillson* is an extremely important safety factor.

But discover for yourself why more people use the Walworth *Genuine Stillson* than any other—get one from your local hardware store today!

*No shop is complete without  
Genuine Stillson Wrenches*

— The Stillson Diamond Trademark  
identifies the  
Walworth *Genuine Stillson*

## WALWORTH

New York, N. Y.

VALVES . . . PIPE FITTINGS . . . WRENCHES

has had the effect of distributing the population. People find it more satisfactory to live in a suburb like Tottenville, if suburb it can be called, than in a metropolis like New York, Chicago or Los Angeles. Cities have grown into regions, and it is sometimes hard to tell where one city ends and another begins. Instead of driving from Tottenville to California in their car—teardrop in shape and driven from the rear by a high-compression engine that burns

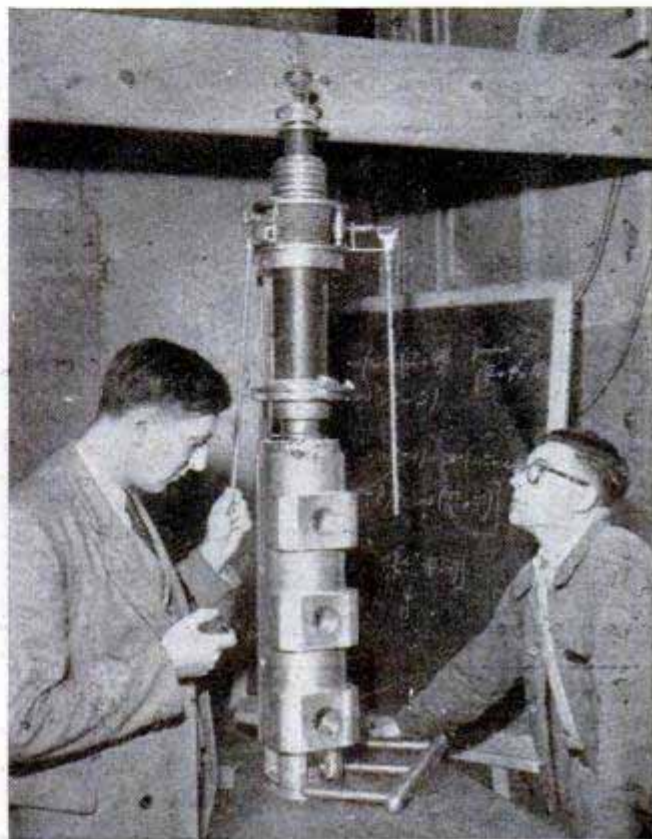

Proton microscope under construction in France probably will magnify objects up to one million times

cheap denatured alcohol—the Dobsons use the family helicopter, which is kept on the roof. The car is used chiefly for shopping and for journeys of not more than 20 miles.

The railways are just as necessary in 2000 as they are in 1950. They haul chiefly freight too heavy or too bulky for air cargo carriers. Passenger travel by rail is a mere trickle. Even commuters go to the city, a hundred miles away, in huge aerial busses that hold 200 passengers. Hundreds of thousands make such journeys twice a day in their own helicopters.

Fast jet and rocket-propelled mail planes made it so hard for telegraph companies all over the world to compete with the postal service that dormant facsimile-transmission systems had to be revived. It takes no more than a minute to transmit and receive in facsimile a five-page letter on paper of the usual business size. Cost? Five cents. In Tottenville the clerks in telegraph offices

(Continued to page 270)

# Home Wo



12" Band Saw  
\$68.95\*

10" Band Saw  
\$39.95\*



Saber Saw \$15.75\*



10" Wood Turning Lathe \$42.50\*



12" Drill Press  
\$44.95\*



7" Tilting Arbor Bench Saw \$39.95\*

12" Floor Model Drill Press  
\$54.00\*



8" Tilting Arbor Bench Saw \$67.50\*



8" Tilting Table Bench Saw \$52.50\*



6" Jointer \$71.50\*

4" Jointer \$39.95\*



Spindle Shaper  
\$44.50\*



Belt and Disc Sander



**SHOPMASTER, INC.**

1214 Third St. S., Minneapolis, Minn.



15" Jig Saw \$24.95\*



10" Floor Model Tilting Arbor Saw  
\$97.50\*

\*Zone 2, less motor.

**PRICED TO EVERY FAMILY PURSE**



She'll enjoy your shop and the money you'll save with

**SHOPMASTER**

woodworking tools

You can start your home workshop with a Shopmaster Saber Saw, like the one pictured above. The cost is less than \$16.00. With it you can cross cut, rip, and do many other complicated sawing operations.

You can add to your shop at any time. All Shopmaster Tools are independent and designed to do specific work. Independent tools are always ready, and require little adjusting. Just flip the switch and you are ready to go. These uniform precision-built tools can be mounted together and powered with one motor if you wish, or can be independently powered.

There is a size of tool for every shop, so make yours a Shopmaster shop.

Send me your new full color catalog giving full details on the complete line of SHOPMASTER "Uniform Precision" Tools, and shop layout sheet.

Name \_\_\_\_\_

Address \_\_\_\_\_

City & State \_\_\_\_\_

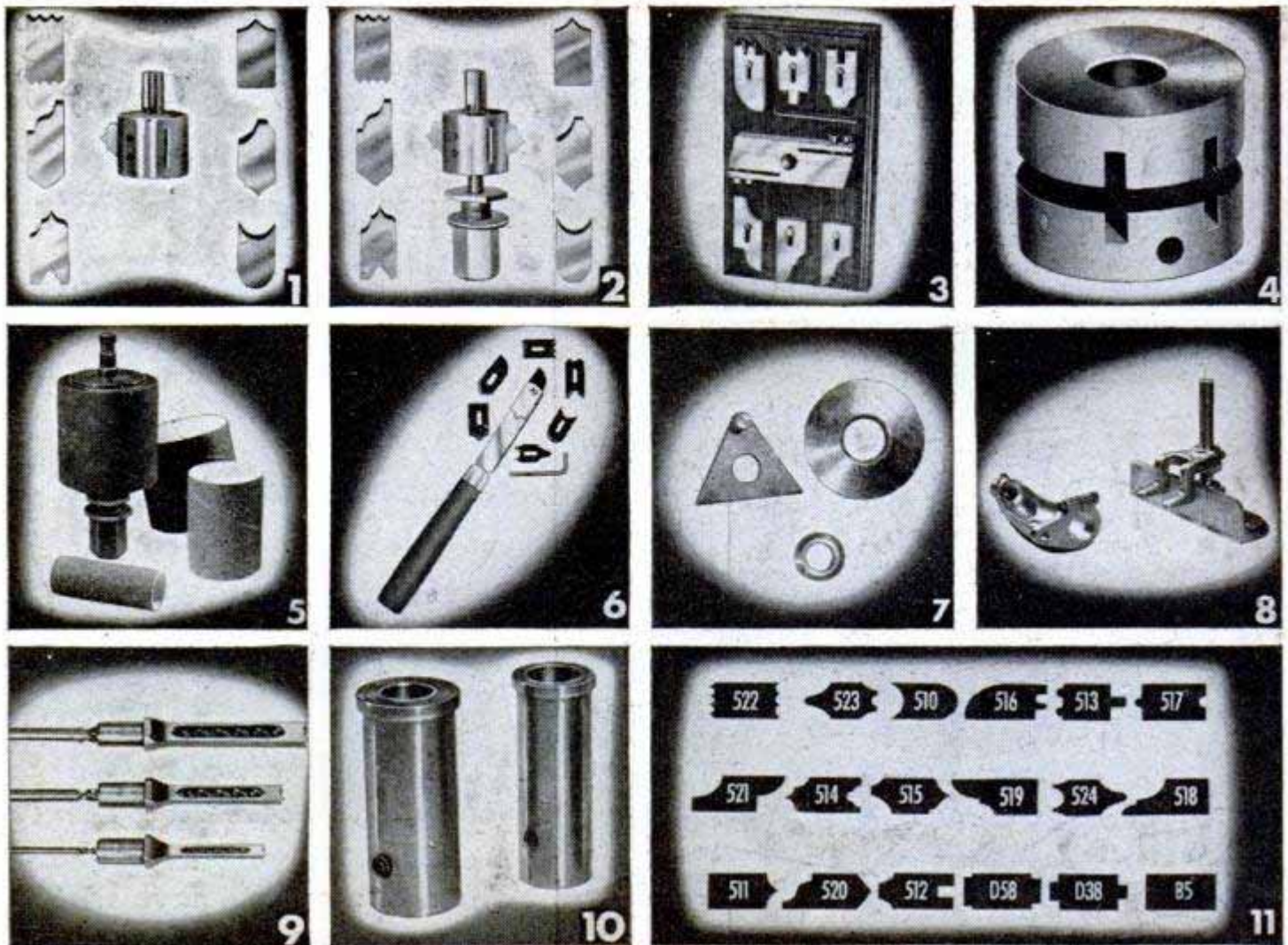

## TOMORROW'S TOOLS . . . TODAY!

At Your Dealer or Order Direct



**1. DRILL PRESS WOODSHAPER, MODEL #50.** For intermittent shaping; makes more than 100 different cuts. Blade can't come out; set screw holds it securely. Complete, as pictured, with 6 single blades. . . . . **\$8.95**

**2. DRILL PRESS WOODSHAPER, MODEL #60.** Heavy-duty shaper. Exclusive pilot bearing eliminates side thrust, chatter, vibration — assures smooth cutting action. Complete, as pictured, with 6 pair blades. . . . . **\$12.95**

**3. CIRCLE SAW WOODSHAPER, MODEL #SA-10.** Solid steel. Absolutely safe—blades locked in position with screws all the way through. In ordering, state diameter of your circle saw shaft. Complete, as pictured, with 6 pair blades and tool rack. . . . . **\$14.95**

**4. ALADDIN COLLETS.** Special collets convert your spindle shaper so you can use low-cost Aladdin woodshaping blades. (For blades, see photo 11, this page.) As pictured. . . . . **\$3.00**

**5. THREE-IN-ONE DRUM SANDER.** 1", 2", and 3" drum sander all in one! "Telescoping" diameters easy to change. Pilot bearing eliminates side thrust, chatter, vibration. Complete with sandpaper sleeve. . . . . **\$6.95**

**6. ALADDIN LATHEMASTER.** Fool-proof factory method of woodturning, adapted and priced for the home workshop for the first time! Even beginners can't go wrong because Lathemaster measures as it cuts. Now one woodturning tool does everything—comes with standard chisel blades as well as new form cutters. Hardwood handle, chrome-plated shank, interchangeable blades of shaper steel. Complete, as pictured, mounted on attractive wood tool rack. . . . . **\$9.95**

**7. ALADDIN DA-DALL.** Now, thanks to Da-Dall's new micrometric adjustment feature, you can change the pitch of your circle saw blade in a matter of seconds and make accurate ornamental and dado cuts. When ordering, state diameter of circle saw shaft. As pictured. . . . . **\$4.95**

**8. MORTISING FENCE & HOLD-DOWN, AND CHISEL HOLDER.** Fence and hold-down (right) make drill-press mortising safer and easier.

Chisel holder (left) eliminates necessity of removing chuck when mortising. No special adapter necessary. Fence and hold-down alone, **\$3.50**. With chisel holder, as shown above. . . . . **\$6.00**

**9. MORTISING CHISELS AND BITS.** For use with your mortising tools, or with Bull Mortising Adapter (see opposite page.) 1/4", 3/8" or 1/2" chisels with bits, **\$6.00** each. Chisels only (1/4", 3/8", or 1/2") **\$4.00** each. Bits only (for 1/4", 3/8", or 1/2" chisels) **\$2.40** each.

**10. ALADDIN TAPER ADAPTERS.** Use in place of drill press chuck for routing, mortising and shaping—wherever side thrust is involved. #2A Morris taper adapter, **\$2.00**. #33 Jacobs taper adapter, **\$1.50**.

**11. ALADDIN WOODSHAPING BLADES.** Specially-selected shaper steel brought to correct hardness to hold keen edges indefinitely. Exclusive money-saving feature: Aladdin blades are double-ground so you can make two standard cuts with each blade. Note that woodshaping tools #50, 60, SA-10 and Lathemaster come only with blades pictured with each tool; when ordering extra blades, order by blade number. All blades shown, **\$1.00** each, (\$2.00 per pair)—except B-5 (\$.75 ea.), ready-hardened blank blade you can grind to shape desired.

All Aladdin Tools are Guaranteed

At your dealer or send cash, check, or money order for prepaid shipment to

**ALADDIN D. MANUFACTURING CO., INC.**

3121 MAIN STREET

(Division of Bertram Engineering Co.)

KANSAS CITY, MO.

Dealers—Write today for new 1950 catalog

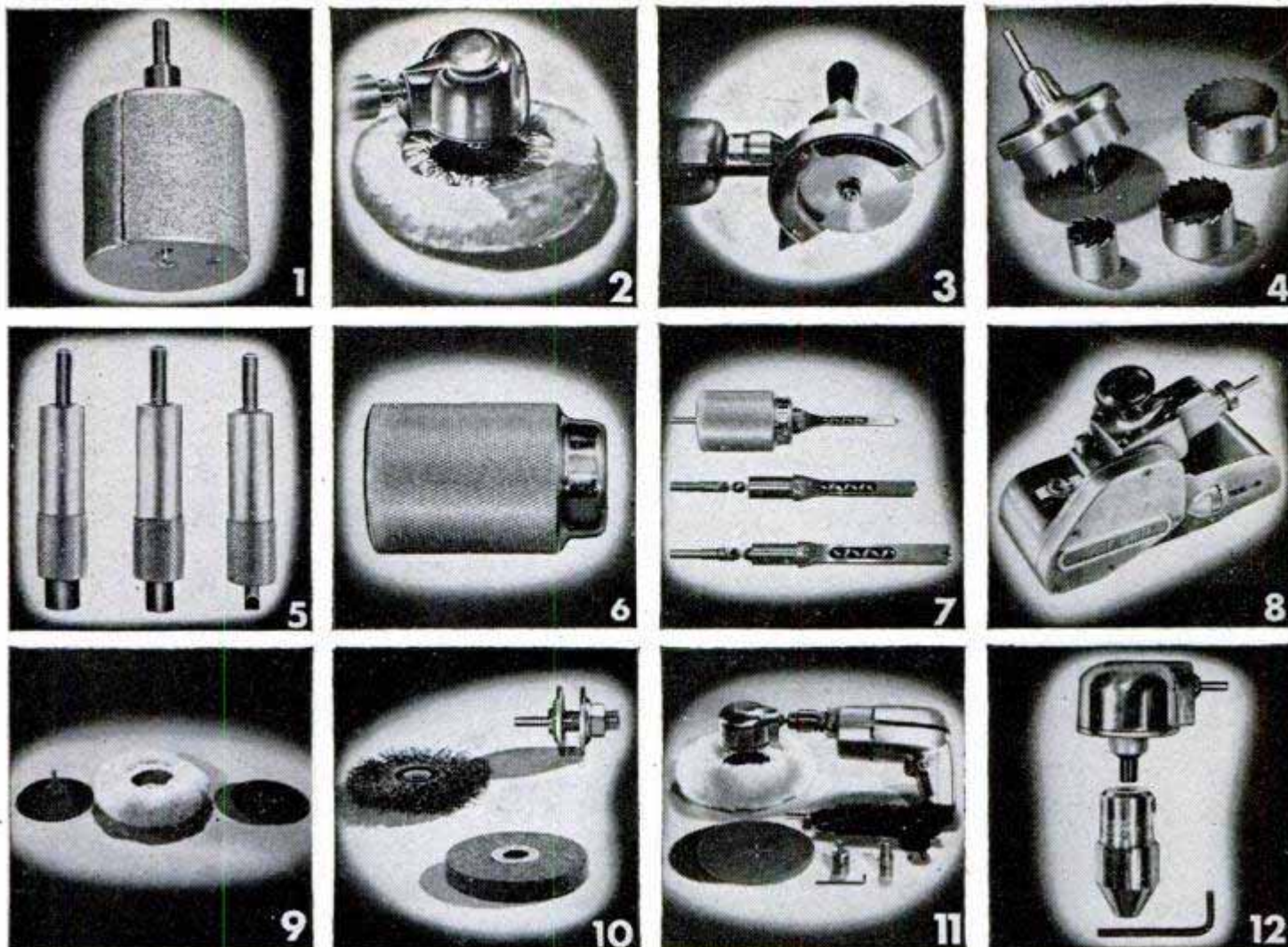

## TOMORROW'S TOOLS... TODAY!

At Your Dealer or Order Direct

**1. BULL DRUM SANDER.** Cut your own strips and save—this 2" drum sander uses ordinary sandpaper! Fits any electric drill or drill press. No wedges or screws—a finger-flick and your strip is on or off!  
Complete..... **\$2.50**

**2. BULL BUFFER.** Handy polisher-sander fits any electric drill or flexible shaft. Exclusive swivel action and gear reduction. Powerful... popular—more than 100,000 in use. Complete, with sheepskin bonnet and 2 sanding discs..... **\$9.95**

**3. BULL ARROW SAW.** Your 1/4" electric drill becomes a powerful, portable saw! One-hand operation; exclusive safety yoke; aluminum casting. Depth of cut: 1 1/8".  
Complete..... **\$9.95**  
(Extra blades \$1.65 each.)

**4. BULL HOLE SAW.** 1", 1 1/2", 2", 2 1/2" holes—with one hole saw! Fits any electric drill or drill press. Cuts cleanly through any 3/4" stock—wood, metal, or plastic. Complete, with arbor and 4 blades.  
as pictured..... **\$4.95**

**5. BULL DRIVER.** Drives screws home in wood or metal in seconds with any electric drill, drill press or flexible shaft. Automatically centers on screw groove; automatic release. (left) Model A—for screws up to #14; (center) Model B—for small machine screws, (right) Model C—hand-center-



ing model with long blade for counter-sunk jobs. All models available in standard or Phillips head. Specify model when ordering.  
Any model..... **\$4.95**

**6. BULL MORTISING ADAPTER.** Your 1/4" electric drill becomes a powerful, portable mortising tool that makes the chips fly! Large end of Bull Mortising Adapter chucks into any 1/4" electric drill or any drill press—small end fits any standard 5/16" shank chisel. As pictured... **\$6.95**

**7. BULL MORTISING KIT.** Complete kit for on-the-job mortising with your drill or drill press! Includes Bull Mortising Adapter and 1/4", 3/8" and 1/2" chisels with corresponding bits, as pictured..... **\$23.90**

**8. SHOPCHIEF BELT SANDER.** Convert your electric drill into a portable belt sander! Handles like a plane. Interchangeable pressure plates and sanding belts do all the work from roughing to finishing. Big, rugged—almost 19 sq. inches of sanding surface! Complete, with 3 pressure pads and 2 sanding belts..... **\$19.95**

**9. BULL ECONOMY KIT.** A bargain—and strictly quality! Use your drill to polish and sand by direct drive with new low-cost kit that includes direct drive adapter, top quality 5-inch flexible rubber disc, finest sheepskin bonnet and 2 aluminum-oxide sanding discs—  
all for only..... **\$2.25**

**10. UTILITY ACCESSORIES.** Make your drill more useful with these handy accessories—1/2" arbor for 1/4" electric drill \$ .98 ea. ... steel wire brush that removes paint, rust and scale \$ .95 ea. ... grindstone \$ .95 ea. Complete kit  
as pictured..... **\$2.50**

**11. BULL BUFFER HOME KIT.** In one kit, everything you need to polish, sand and drill like a professional! Choice of speeds—polish at 800 r.p.m., drill at 1600 r.p.m., sand at 3200 r.p.m. Kit includes (1) 1600 r.p.m. Bull Drill with Jacobs geared chuck (2) Bull Buffer, polisher-sander with gear reduction (3) adapter set for sanding at twice drill speed (4) sheepskin bonnet and 2 sanding discs. As pictured... **\$29.95**

**12. ANGLE-HEAD DRILLING ATTACHMENT.** Now you can drill at right angles in close places! Increases your 1/4" drill to 1/2" capacity. Complete as pictured, with angle-head and Jacobs 1/2" hex key **\$12.95**

All Bull Tools are Guaranteed

At your dealer or send cash, check, or money order for prepaid shipment to

**BERTRAM D. ENGINEERING CO.**

3121 MAIN STREET

Dealers—Write today for new 1950 catalog

KANSAS CITY, MO.

# WHICH END is the REAL OIL THIEF



New piston rings are not a cure-all for oil pumping. Connecting rod bearing clearance worn twice normal throws off 4 times normal oil volume, Worn 4 times correct clearance, throws off 25 times normal oil volume!



Good mechanics will tell you that correction of oil pumping must start where the trouble starts—at connecting rod and main bearings. When worn, instead of correctly metering oil throw-off for internal lubrication, they let excess oil reach combustion chambers. It burns to carbon on rings, pistons, valves and plugs, and performance goes up in smoke! Let new rings do their own job. Order Federal-Mogul Oil-Control Bearings to restore power, pep, economy!



## FEDERAL-MOGUL SERVICE

DETROIT 13, MICHIGAN

Division of Federal-Mogul Corporation

**Control Oil Pumping  
where it starts...replace with  
FEDERAL-MOGUL  
OIL CONTROL BEARINGS**

no longer print out illegible words. Everything is transmitted by phototelegraphy exactly as it is written—illegible spelling, blots, smudges and all. Mistakes are the sender's, never the telegraph company's.

When the Dobsons are sick they go to the doctor, in a hospital, where he has only to push a button to command all the assistance he needs.

In the middle of the 20th century, doctors talked much of such antibiotics as penicillin, streptomycin, aureomycin and about 50 others that had been extracted from soil and other molds. It was the beginning of what was even then known as chemotherapy—cure by chemical means. By 2000,

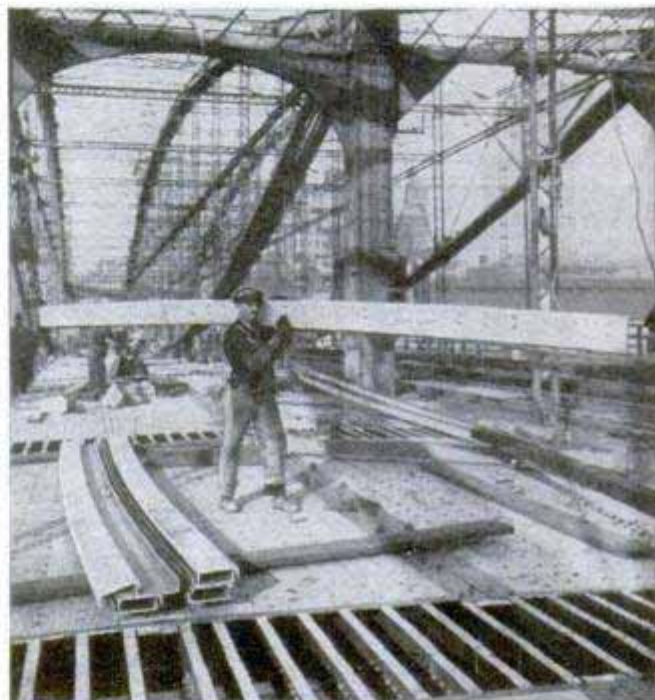

Aluminum Company of America photo

**Huge aluminum girder is swung about with ease. Even today light metals replace steel in some structures**

physicians have several hundred of these chemical agents or antibiotics at their command. Tuberculosis in all of its forms is cured as easily as pneumonia was cured at mid-century.

It no longer is necessary in 2000 to administer the purified extracts of molds to cope with bacterial infections. The antibiotics are all synthesized in chemical factories. It is possible to modify their molecular structure, so that they acquire new and useful properties.

Even in 1950 physicians did not know exactly how a piece of beefsteak is converted by the body into muscle and energy—the process technically known as metabolism. The physician of 2000 knows just what diet is best for a patient. This knowledge, coupled with his knowledge of hormones, enables him to treat old age as a degenerative disease. Men and women of

(Continued to page 272)



## THRILLING NEW SPORT BOAT!

as featured in  
Aug. 15 LIFE  
pages 52-54

# Sailfish

Trade Mark  
SPORTABOUT

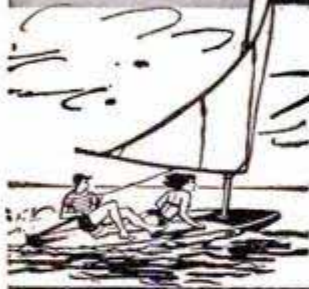

Now the fast, brilliant "Sailfish" comes knocked down for easy home assembly at a big saving! Safe-T-Plane hull can't sink or swamp. Carries conveniently on car top. Precision pre-cut and pre-formed parts of high quality materials go together quickly. All hardware included. **HULL KIT**, \$69.75. **SAIL KIT**, with centerboard, rudder, spars, rigging and finished sail, \$49.75. **ASSEMBLED BOAT**, factory-finished and complete with sail, \$180. All prices are f.o.b. Waterbury, Conn. Illustrated literature on request.

Dept. S., ALCORT, INC., Waterbury, Conn.

## OWN A Printing Business

Cards, Tickets, Stationery, etc. Good profit in spare time. **PRINT YOUR OWN** greeting cards, movie titles, church work, etc. Save money. Easy rules supplied. Raised printing like engraving too. Have home shop. Sold direct from factory only. Pays for itself in short time. Write for free catalog of outfits, and all details. **KELSEY PRESSES, 0-37, MERIDEN, CONNECTICUT**

## SPECIAL OFFER!

LOCK-STITCH  
SEWING AWL

\$1.

Postpaid

Famous, patented lock-stitch sewing awl complete with needles, waxed thread and direction folder. Hundred uses — sewing, repairing leather goods, canvas, belting, harness, saddles, gun cases, awnings, golf bags. Extra needles and thread available. Satisfaction guaranteed or money back. Send currency, check or money order. **Yates Mfg. Co., 611-H Main St., Lake Geneva, Wisconsin**

## Find HIDDEN TREASURES

**GEIGER COUNTERS** for uranium ore detection. **TREASURE DETECTORS** for Gold, Silver, other metals and minerals. Light weight, highly sensitive. None finer at ANY PRICE.

*Detection co.* Dept. 2-B  
5637 Cahvenga, No. Hollywood, Calif.

# FOAM RUBBER

For Experimenters, Home Craftsmen, Hobbyists

**LOWEST PRICES—SAVE 50%**  
16 x 16 x 1 1/2" .. ea. \$1.25  
16 x 22 x 1 1/2" .. ea. 1.55  
18 x 24 x 2" .. ea. 2.00  
24 x 24 x 2" .. ea. 2.75

**AUTO SEAT TOPPER PADS**  
Place on seat cushion and cover with your seat cover.  
24" x 60" x 1 1/2" ea. \$5.00  
24" x 60" x 2 1/4" ea. 7.50

Use for furniture cushion fillers, mattresses, Mattress pads, cushions. Foam Rubber is available in any size or thickness. Send For Free Price List. Immediate delivery. No C.O.D.'s.

**RIOR RUBBER COMPANY, Dept. P-2**  
50 East 22nd St. Chicago 16, Ill.

SAY YOU SAW IT IN POPULAR MECHANICS

## 500 Pages, 7000 Novelties

Send 10c for mammoth, amazing catalog of 7000 novelties. 1-inch thick, roto picture section, 6-color cover. Carnival, circus, world's fair & science exhibit rolled into one! Includes live animals & pets, scientific supplies, hobbies, funmakers, planes & boats, looms, magic tricks, joke articles, unusual seeds, gadget timesavers, cameras, optical goods, projectors, movies, lucky jewelry, religious novelties, telegraph sets, disguises, musical instruments, stamps, coins, puzzles, fortune tellers, radios, experimental sets, auto & bike accessories, Western wear, telescopes, magnifiers, compasses, banks, smokers' gadgets, artists' supplies, printing sets, engines, motors, shockers, knives, billfolds, fireworks, guns, rifles, sports, money makers, swimming helps, 1000 fascinating books, games, locks, live chameleons, rings, exercisers, curious plants, etc., etc. (DeLuxe Hard Bound Library Edition 25c Postpaid.) Regular paper covered edition 10c. (Stamps accepted.) Sent Air Mail, \$1.00. **JOHNSON SMITH & COMPANY, Dept. 217, DETROIT 7, MICHIGAN**

10c

Your Hands are Handier with

# SKIL Home Shop Tools



## SKIL Home Shop Sander-Polisher

Most useful tool you'll ever own! Powerful motor speeds a thousand jobs in your basement, garage or home. Drills, sands, buffs, polishes . . . wood, metals, plastics. With other attachments does wire brushing, stirs paint, grinds, sharpens. Takes out the work, puts in quality on every job. Why be without this handiest helper when your favorite dealer has SKIL Home Shop Sander-Polisher waiting for you now. See him today!

IT DRILLS!  
IT SANDS!  
IT BUFFS!  
IT GRINDS!  
IT CLEANS!

## SKIL Home Shop Saw

Sawing is a cinch with powerful 6 in. SKIL Home Shop Saw . . . very low-priced but fully adjustable for depth of cut and bevel-cutting!

Plugs in anywhere. Rips, cross-cuts, miters 2 in. dressed lumber 10 times faster, easier than by hand. Light, safe, easy-to-use on wood, metals, plastics.

Ask to see SKIL Home Shop Saw today.



See the complete SKIL Home Shop Line!

- DRILLS—1/4 in. and 1/2 in.
- BELT SANDER
- HEDGE TRIMMER
- Bench Drill Stands
- Drill Kits • Saw Tables

BEVELS!  
ADJUSTS FOR  
DEPTH!

# SKIL home shop Tools

SKIL Home Shop Tools  
Made only by  
**SKILSAW, INC.**  
5033 Elston Avenue  
Chicago 30, Ill.

**SKILSAW, INC.**  
Home Shop Division, Dept. C-2  
5033 Elston Ave., Chicago 30, Ill.  
Please send information on SKIL Home Shop Tools and name of my dealer.  
Name.....  
Address.....  
City.....Zone.....State.....

# BUILD YOUR OWN POWER TOOLS

EASILY, QUICKLY... AT LOW COST

## Exclusive GIL-BILT Build-It-Yourself Features

- No machining—build easily with hand tools only
- No blueprint reading — step-by-step pictorial plans, full scale patterns, actual photographs
- Sturdy wood, aluminum, and steel construction
- Capacity and performance of commercial saws selling for \$60 and up

**SAVE \$50 OR MORE**

## GIL-BILT 10-INCH TILTING ARBOR SAW



- 27x28 in. table, 13½ in. capacity in front of blade
- 10 in. blade cuts 3¼ in. deep, tilts full 45 degrees
- Floor model 34" high table always stays level
- New Departure ball bearing arbor, ¾" precision shaft turned down for 5/8" bore blades, alum. housing, shipped ready to run
- Jackscrew and 4½" in. dia. handwheel lowers and raises blade
- Cast aluminum miter gauge and self-aligning rip fence guide

GIL-BILT Metal Parts Kit includes Plans, ball bearing arbor, miter gauge and bar, rip fence guide, dado insert, lock knobs, jack screw mechanism and handwheel, and all other metal parts (less blade)..... **\$20.95**  
 Same Kit with 10" Combination Blade... **\$24.90**  
 Same Kit with 8" Combination Blade... **\$23.90**

## GIL-BILT 8-INCH TILTING TABLE SAW

- 21x27 in. table tilts full 45 degrees, 13 in. capacity in front of blade
- 8 in. blade cuts from 0 to 2½ in.
- New Departure ball bearing arbor, ¾" precision shaft turned down for 1½" bore blades, alum. housing, ready to run
- Cast aluminum miter gauge and self-align, rip fence guide (same as above)



GIL-BILT Metal Parts Kit includes Plans, Ball Bearing Arbor, Miter Gauge and Bar, Rip Fence Guide, Machined Lock Knobs, Tilt Support Segments, and All Other Metal Parts (less blade)... **\$15.95**  
 Same Kit with 8" combination blade..... **\$18.90**

## GIL-BILT 12-INCH BAND SAW



- Cuts to center of 24 inch circle
- Handles stock up to 6 inch thick
- 18x18 inch table tilts 45 degrees
- Lower wheel and drive pulley runs on sealed New Departure Ball Bearings; Upper wheel runs on two 5/8" bore Oilite Bronze bearings
- Upper wheel tension and tilt mechanism of cast aluminum, completely assembled
- Upper and lower blade guides. Each has ball thrust bearing, self-lub bronze jaws
- Rubber tired wheels. Choice of cast aluminum or make-your-own wood wheels on metal hubs
- Uses standard 78 inch blades up to ¾ inch wide
- Fully enclosed mechanism for utmost safety

GIL-BILT Metal Parts Kit includes Plans, rubber tires, ¼ inch blade, hubs for wood wheels, ball bearing spindle, tilt mechanism, guides, table tilt segments and all other metal parts... **\$16.95**  
 Same Kit with two machined ready-to-install 12" cast aluminum wheels..... **\$20.95**

**NO DEALERS — One Low Factory Price**

**COMPLETE PLANS only \$1.00 EACH**

Return in 10 days for full refund if not satisfied. Prices include postage within 600 miles. Over 600 miles add 5%. Send cash, check, or money order for parts kit, or send \$1.00 for Step-by-Step Plans and order kit later less cost of Plans. Plans sent postpaid anywhere in the world.

# GILLIOM POWER TOOLS

P. O. Box 1-PB, Lambert Field, St. Louis 21, Missouri

70 in A.D. 2000 look as if they were 40. Wrinkles, sagging cheeks, leathery skins are curiosities or signs of neglect. The span of life has been lengthened to 85.

In 1950 little was known about a virus beyond the fact that it could slip through a filter so fine that it would hold back any microorganism visible in the optical microscope. The electron microscope, which magnifies from 30,000 to 100,000 times and which substitutes a beam of electrons for a beam of light, has changed all this. In the viruses, little bodies have been detected with this instrument. They are virtually protein molecules. By tying together what chemists have discovered about the structure of protein and what the pathologists see in the electron microscope, such virus diseases as influenza, the common cold, poliomyelitis and a dozen others are cured with ease.

Even in the 20th century hospitals were packed with instruments and machines. The hospitals of 2000 have even more. Instead of taking electrocardiographs, doctors place heart patients in front of a fluoroscopic screen, turn on the X-rays and then, with the aid of a photoelectric cell, examine every section of the heart.

Cancer is not yet curable in 2000. But physicians optimistically predict that the time is not far off when it will be cured.

The nervous diseases are linked up with electrochemical processes in 2000 in a way that is impossible in our time. Such afflictions as multiple sclerosis or palsy are no longer regarded as incurable. There are electrochemical methods of stimulating and reactivating nerves, so that victims of Parkinson's disease are no longer objects of pity. But these sufferers from damaged or degenerate nerves are somewhat like our diabetics who must take insulin regularly to remain alive. A little battery-driven apparatus must be carried in the pocket to provide the stimulus the nerves need.

Any marked departure from what Joe Dobson and his fellow citizens wear and eat and how they amuse themselves will arouse comment. If old Mrs. Underwood, who lives around the corner from the Dobsons and who was born in 1920 insists on sleeping under an old-fashioned comforter instead of an aerogel blanket of glass puffed with air so that it is as light as thistledown, she must expect people to talk about her "queerness." It is astonishing how easily the great majority of us fall into step with our neighbors. And after all, is the standardization of life to be deplored if we can have a house like Joe Dobson's, a standardized helicopter, luxurious standardized household appointments, and food that was out of the reach of any Roman emperor?

**THIS  
5  
ROOM  
READI-CUT  
HOUSE**

**ALADDIN**

**\$1492 FREIGHT PAID**



**SAVE 4 PROFITS ON LUMBER, MILLWORK, HARDWARE AND LABOR**

The Aladdin Read-Cut System of Construction enables you to save 18% lumber waste and up to 30% labor costs, and guarantees you will receive the highest quality dry lumber and a COMPLETE house as specified. You can buy YOUR COMPLETE HOUSE, ALL IN ONE SHIPMENT, direct from our mills and save the in-between profits.

**HOW TO BEAT THE HIGH COST OF BUILDING**

Every hour you can put in on the construction of your Aladdin home means a saving to you of from \$2.00 to \$3.00 per hour on its cost. That means a SAVING of from \$15.00 to \$18.00 for every day you work on it!\*\*\*\* Depending on the size of the house, the carpenter work sums up to from three hundred hours to twelve hundred hours.\*\*\*\* WITH MOST

OF THE SKILLED LABOR ALREADY PERFORMED when you receive your Aladdin Read-Cut, what an opportunity you have to bring down the cost of your new home to practically a pre-war level. Our drawings and instructions cover everything from the foundation up, so you can save any part, or even all labor costs.

IMMEDIATE DELIVERY



**PAY YOURSELF  
THOSE  
HIGH WAGES**

**SEND  
25 CENTS TODAY**

FOR NEW 1950 CATALOG No. M-5  
IN 4 COLORS. ADDRESS NEAREST MILL.

**WHAT YOU GET WITH YOUR ALADDIN**

You get all the lumber cut to fit by fast machinery-production line methods—marked and numbered, ready to erect practically without the use of a saw; also siding, flooring, trim, all millwork, doors, windows, mouldings, glass, hardware, nails, roofing, paint and complete drawings with instructions. Many Aladdin home buyers erect their own houses.

**71  
DESIGNS  
TO CHOOSE  
FROM**

ALADDIN HOUSES ARE NOT PREFABRICATED

**ALADDIN  
GUARANTEE:  
SATISFACTION  
OR YOUR  
MONEY BACK**

**THE ALADDIN CO.**  
BAY CITY, MICH.  
or WILMINGTON, N. C.

**BASS  
IS BEST  
WEEJUNS  
LEISURE  
COMFORT**



**BASS  
IS BEST  
QUAIL  
HUNTERS  
FIELD and STREAM**



**BASS  
IS BEST  
SKI BOOTS  
EXTRA  
CONTROL**



**BASS IS BEST  
SPORTCASINS  
GOOD GOLF STRATEGY**



**G. H. BASS & CO.**  
60 MAIN STREET  
WILTON, MAINE

**DEAF? HEAR BETTER  
Or Pay Nothing**

Don't deny yourself the joys and opportunities of life. Your friends, family, business associates want you to hear. Let a home trial of the new, modern sensation-priced Zenith "Miniature" Radionic Hearing Aid prove you can even hear a whisper. Only \$75.00 complete, ready to wear. Needs no "fitting." Weighs only 6 3/4 oz. See what you save! If any \$200 Hearing Aid outperforms the Zenith in efficiency or economy, your money back—under our 10-Day Return Privilege. For authorized Zenith Hearing Aid Dealer in your locality, consult your classified telephone book; or write for complete coast-to-coast list of dealers. Free descriptive literature and full details on request. Address:

Zenith Radio Corporation, Hearing Aid Division, Dept. 291, 5801 W. Dickens Ave., Chicago 39, Ill.

Makers of World Famous Zenith Radio, FM and Television Sets



# Stop Engine KNOCKS



*Before they dent  
Your Pocketbook*

Add **BARDAHL**  
to Your Crankcase Oil

QUIET that motor by furnishing an extra-tough lubrication cushion! Simply add one quart of BARDAHL to regular oil.

When ordinary oil breaks down under heat and pressure, let BARDAHL come to the rescue. BARDAHL penetrates metal surfaces of engine, relieves critical friction, and holds lubrication in place.

Plenty of knocks and pings disappear with the BARDAHL treatment. You pay fewer repair bills, too.

Ask the best mechanic in town about BARDAHL. He's been using it for years!

**BARDAHL**  
**OIL**

*Reduces Friction  
to a Fraction*

BARDAHL OIL COMPANY  
Seattle • St. Louis



RETAIL PRICE \$125.00

**FACTORY TO YOU \$59<sup>95</sup>**

**SUPERSHOP** the PRECISION BUILT WORKSHOP Lifetime lubricated BALL BEARINGS. All running parts precision GROUND. Compare finest production tools. BIG capacity. Amazing VALUE. Write for FREE catalog, full details, trial plan.

**POWER TOOLS, INC.** 108 YATES AVENUE  
BELOIT, WISCONSIN



**Saves Costly Redecorating!**  
AMAZING INVENTION. Banishes old-style housecleaning mess and moss. No rags—no sticky "dough"—no red, swollen hands. No more dangerous stepladders. Literally erases dirt like magic from walls, ceilings, window shades, upholstered furniture, etc. *Ends rudery!* SAVES REDECORATING!

**SAMPLES FOR AGENTS** Sample offer sent immediately to all who send name at once. A penny postal will do. **SEND NO MONEY—just your name.** KRISTEE CO., 693 Bar Street, AKRON, OHIO.

## NONE BETTER! SUPER DRILL GRINDER



Sharpens round shank drills from 3/32" to 1/2" in diameter, up to 6" long. Grinds old drills like new in 4 different point angles, using hand or power grinding wheels. Money-back guarantee.

Price only \$2.95  
At Dealers or Postpaid

CRANDALL MFG. CO. 1512 W. Slauson, Dept. FA-46, Los Angeles 44, Calif.

## REAL ESTATE BE A BROKER

**PAYS BIG! SEND FOR FREE, BIG, ILLUSTRATED CATALOG NOW!** No obligation. Graduates report making substantial incomes. Start and run **your own business quickly.** Men, women of all ages, learn easily. Course covers Sales, Property Management, Appraising, Loans, Mortgages, and related subjects. **STUDY AT HOME** or in our classrooms in big cities. Diploma awarded. G.I. approved. Nationally known.  
**WEAVER SCHOOL OF REAL ESTATE (Est. 1936)**  
15 E. Pershing Road, Dept. PMB, Kansas City, Mo.

FREE BOOK TELLS HOW

## 55% SAVING IN MAN-HOURS BY USING DAKE 70H PRESS

Here Dake's 70H Hydraulic stamps designs on steel molds for manufacturing rubber bath mats. Results: Time saving of 5 hrs. per plate, no worker fatigue, improved precision, work quality.

### WRITE FOR BULLETIN ON THIS JOB

70H is compact, speedy for pressing, straightening, many assembly jobs.



**DAKE**  
anbor and hydraulic  
**PRESSES**

**DAKE ENGINE COMPANY**  
Grand Haven Michigan



## Chronographs!

MOST VERSATILE WATCH EVER MADE

**\$5.95**

Plus 10% Fed. Tax. Send \$6.55

- ONE YEAR GUARANTEE
- A STOP WATCH
- A TELEMETER
- A TACHOMETER
- A WRIST WATCH
- SWEEP 2nd. HAND
- LUMINOUS DIAL
- SHOCK RESISTANT
- UNBREAKABLE CRYSTAL

AS SHOWN • LOWEST PRICE IN U.S.A.

Send cash, check, M.O. or C.O.D.

**LEONARD DIX CO.** Dept. PM-130, Portland 9, Ore.  
1104 W. Burnside.

### FISHERMAN'S FLY AND BAIT MAKING KIT



Everything you need for making tempting lures and baits, including colored feathers, assorted animal hair, balsa wood, cork, chenille, hooks, wool, thread, wax, sandpaper, vise, cement, ass't. color enamels, camel hair brush. Comes to you with complete instructions. Will double your fishing pleasure. Kits are brand new. Use old winter evenings to make next summer's flies. Shp. wgt. 2 lbs. No. 437. Per Kit..... **\$5.00**

### Type A2 HORSEHIDE JACKET

The leather coat buy of the year! Brand new Army Air Force Type A2 with full length zipper, shoulder straps, knitted waist band and wrists and full satin lining. Finest horsehide—finest tailoring. Order by chest size. Shp. wgt. 5 lbs. No. 201—Each... **\$19.95**

### U.S. Govt. BOLO KNIFE



Extra heavy. For farm, home or jungle use. Blade of Govt. formula cutlery steel. Walnut riveted handle. 3 1/2 inch bill, 10 1/2 inch blade. You'll find hundreds of uses for a Bolo knife. Blade will take and hold a keen cutting edge. Wt. 2 lbs. A112—With Army Sheath **\$2.95**

### WIRE CUTTER

Heavy duty, compound leverage. Cuts up to 1/4 inch wire. Upper jaw acts as feeder to cutting edges. Insulated handles. Ideal for farm fence work and shop use. Shp. wgt. 2 lbs. Stock No. 392—Each **\$1.95**

### Heavy Duty RUBBER GLOVES BRAND NEW

Extra heavy—extra long. Brand new, high quality gum rubber for softness and ease in use. Designed for heavy duty industrial service—protection in handling chemicals, acids, etc. A real bargain at this low price. Stock No. 295—Per Pair, Only **79c**

### SATCHEL POUCH

Heavy canvas pouch. Ideal for toting lunches, shopping, books, etc. Has 11x12 inch pocket. Brand new, guaranteed perfect. Has over size flap with single strap fastener. A113—EACH **\$1.69**

### ALL PURPOSE LIFE PRESERVER BELTS

Brand New! Guaranteed water tight. Use them at the beach on the shore or in the water. Tie together for raft. Use as canoe stabilizer. Belt consists of two air chambers. Inflate automatically with Sparklet cartridges or manually with attached hose. A real bargain at this price. No. 1261. Each..... **\$1.00**

### GENIE HANDCRAFT TOOL KITS

An amazing array of fine handcraft tools for carving, cutting, punching, drilling, sawing, filing, etc. in wood, plastic, soft metal, leather, cloth, cardboard, etc. Each set includes one or two tool holders with positive grip vise chuck, plus an assortment of tools. Small set includes 4 assorted cutting tools. Set No. 442 includes cutting blades, hole punch and saw. Large set includes all knives, saw, plus drills and hole cutters. Sets are attractively boxed in solid wood box.

STOCK NO. 441  
Beginners' set. Consists of 7 tools and handle. Solid box. Set Only..... **\$2.95**

STOCK NO. 442  
Advanced worker's set. Has chuck handle, extra chucks and eleven working tools. Set Only..... **\$6.50**



STOCK NO. 443  
De Luxe set, includes two holders and 22 accessories. A model maker's dream set. Set Only..... **\$9.95**



### CLINOMETER SHOWS DEGREE OF INCLINE

The pendulum acts as a plumb bob. It swings back and forth over a calibrated scale that shows you the degree of incline. Use on signs to show amount of roll—may be used for any purpose where it is desired to determine the degree of incline. Plastic body 12 x 7 inches. Brass pendulum in black finish. Shipping weight 3 lbs. Stock No. 393. Each only..... **\$3.95**

### HAND MICROPHONE

Top quality hand microphone with control button in handle. Highly sensitive. Has rubber covered cord and tel. plug. Fine for use on home recorders, public address systems, etc. Slightly used—perfect. Shp. wgt. 2 lbs. Stock No. 170. Each... **\$1.95**



### TRAILER UNDER-CARRIAGE

#### OVERSIZE TIRES

Build your own trailer for boat, camping gear or delivery service. Fitted with 20x2.125 U.S. Royal Tires. Motorcycle type wheels. Solid steel axle, leaf type springs and body mounting brackets. All brand new! Hiltz not included. Folds to fit trunk of car. Shipped express collect only. No. 199. Ea..... **\$18.95**

### 7 LB. EXPERIMENTER PARTS ASSORT. KIT



Valuable radio and electronic parts by weight—resistors, trimmers, condensers, capacitors, etc., plus stamped out metal chassis. Shipped in chassis form with parts ready to demount as needed. A real bargain surprise pack. No. 130R—7 lbs. **\$1.79**

### G. I. PISTOL BELTS

Of heavy canvas webbing. Adjustable. Eyed all around. Used by perfect. Wgt. 2 lbs. No. 131. Each..... **98c**

No. 130Y—12 lbs..... **\$2.95**

### OXYGEN TANK

Loaded with aviator's breathing type oxygen at 1800 pound pressure. Tank measures 13 1/2 x 5 1/2 inches with rounded ends. Tank is of solid metal fitted with brass release valve at top. Brand new! Loaded—ready for all types of emergency use. Shp. wgt. 13 pounds. Ship cost only. Stock No. 390—Each, **\$3.50** only.....

### CAMERA TRIPOD

Purchased from Govt. Slightly damaged, easily repaired. For camera up to 8x40 lenses. Folds to 32 inches, extends to 58 inches. Needs adapter to mount camera. Wgt. 5 lbs. Stock No. 190. Ea. **\$4.95**

### VEEDER ROOT COUNTING MACHINE

Five wheel type counts to 99,999 and repeat. Nickel finish case. Has 1/2 inch round crank. Use it for any counting job. Brand new. Shp. wgt. 1 lb. No. 241. Each... **\$1.95**

# U.S. WAR SURPLUS AND HUNDREDS OF OTHER BARGAINS

### SILVERED OPTICAL PRISMS

Solid glass, with 1 silvered facet. Precision ground and polished—5 1/2" long, base 2 1/2 in. wide, sides 1 1/2 inches. Free from scratches, abrasions and imperfections. Use in any type optical system—photography, telescopes, etc. Weight each 3/4 lb. A \$25.00 value. Stock No. 556. **\$2.00** Four for **\$5.00**

### MEDICAL STERILIZER

Consists of alcohol burner and sterilizing tray in hinged metal case 11x11x2 1/2 inches. Burner may be used separately. Bright nickel finish. All brand new. A125—Ea..... **98c**

### BERNARD WIRE PLIERS

Paralleled wire cutter at top. Brand new. Wgt. 2 lbs. No. 168. Each **\$1.29**

### BELT AND SHOULDER HOLSTER

Of heavy cowhide. U.S. Gov't. issue. Slightly used but perfect. Specify type wanted when ordering. No. 900—BELT No. 901—SHL'DR. **\$1.95**

### ARMY SLIDE RULE

An accurately calibrated slide rule with two extra slides for quick computation of rate for artillery fire. Measures 18 x 3 inches. Provides for wind direction, deflection, trajectory, etc. Shipping weight 2 lbs. No. 544. **\$2.50** Each only.....

### ELECTRIC MOTOR

Small but powerful. Shaded pole type, designed for fan operation. 115 v. 60 cycle. Has 1/4 inch shaft, one inch long. Operates at 3150 RPM under no load, 2000 RPM under 2.33 amp. current. 6 amp. load. Full load current .6 amp. Ideal for use on toys, window displays, etc. Shp. wgt. 1 1/2 lbs. Stock No. 555—Each **\$1.95** only.....

### MCCLELLAN SADDLE

Brand new! Top grade cowhide, 12 inch seat. Hair orth. Has straps for blanketing. Gun loop and knapsack. Gun loop and sabre loops. Shipping weight 15 lbs. Stock No. A145. Each..... **\$16.95**

### BAYONET BLADE

Fine forged steel. Ground but not polished. May be made into throwing or hunting knife or spear. Blade 6 1/2 x 7 1/2 inches, 1 1/2 inches overall. Will take and hold a fine edge. Shp. wt. 1 lb. No. 664-R—Each..... **49c**

## ORDER DIRECT FROM THIS AD

Values galore! Hundreds of hard-to-find items for home, shop or personal check. Send 25% deposit on C.O.D. orders. No C.O.D.'s on orders for less than \$5.00. Include sufficient postage on parcel-post orders—any overage will be promptly refunded. All quotations F.O.B. Chicago. Used items and materials are guaranteed serviceable and as described. Your money back if not more than satisfied.

**NEW CATALOG** To Cover Postage and Mailing **10c** Dept. PM2  
**STARK'S** 509 So. State St. CHICAGO 5, ILL.

### DECORATIVE CHROME STRIPS

For your car, boat, furniture, etc. Highly polished chrome finished strips with clinched edges for flush mounting to any surface. The 3 pound kit provides approx. 15 pieces in lengths from 6 inches to 3 feet and average 3/4 inches wide. Wgt. 4 lbs. No. R224. **\$2.00** 3 lb. Assort. only.....



### EASY PROFIT IN PAINT SPRAYING

Paints walls, ceilings, screens, furniture and machinery faster, better. All complete as shown less motor. Carry anywhere. Fully guaranteed. Could be used with 1/4 H.P. motor or less. Price \$35.00 less motor F.O.B. Chicago. \$5.00 deposit balance C.O.D. or see your dealer. With motor \$55.00.

**IDEAL AUTOMATIC PUMP CO., Dept. P.M. 8**  
801 W. Washington Blvd. Chicago 7, Ill.

# SPIEGEL SINCE 1865



Thousands of Home and Family Needs

## MEN! SEND FOR THIS BIG CATALOG NOW! SHOP BY MAIL! SAVE ON ALL YOUR NEEDS

Spiegel 632 page Catalog for Spring and Summer 1950 is just packed with things for men . . . all at LOW mail order prices that really save money.

**FOR MEN ONLY**—you'll find wide choice of hobby supplies, tools for the handy man, paints, roofing, mill work and fencing . . . as well as electrical and plumbing supplies and a complete line of auto tires, batteries, supplies and accessories.

Shoes and clothing for dress, sport and work. Page after page of hunting and fishing equipment . . . photographic supplies and jewelry.

In addition, you'll find wide selections of home and family needs. All available on the CASH—30-DAY CHARGE or MONTHLY PAYMENT plan.

## PIN A DOLLAR TO THIS COUPON

Spiegel, Inc., Chicago 9, Illinois. I am enclosing a DOLLAR DEPOSIT. Please send me a copy of the new Spiegel Catalog. I understand my dollar will be returned in the form of a Merchandise Certificate good on any Spiegel Mail Order of \$10 or more.

Name .....

Address .....

Town..... State.....

5-20-23

## HYDRAULIC Power Transmission WITH Infinitely VARIABLE SPEEDS, Clutch and INSTANT REVERSE—OUTPUT TORQUE ADJUSTMENT UP TO 180 inch POUNDS

This positive displacement Hydraulic Torque Converter is the ideal fluid drive with thousands of uses . . . Output Speeds Infinite 0 to 550 R.P.M. . . . in either direction . . . Change Speeds WHILE RUNNING . . . Control and Transmit your power this SMOOTH Oil-Way . . . Will handle 1/4 H.P. to 1 1/2 H.P. Motor. Industrial or Home & Farm Use . . . Cost Government \$300. High Quality Precision Workmanship. Buy this unit to get the most for your money. Case measures 7 1/2" long 7" high 6 1/2" wide. Input & Output Shafts 5/8" dia. Beautiful Red Crackle Finish Case.

### FINGER TIP CONTROL



Shipping Wght. 25 pounds

Only \$54.50

If C.O.D. is requested a 10% deposit must accompany order and we ship F.O.B. Chicago.

1 1/2"-8 thread Lathe Chuck Adapter, \$3 extra

PREPAID 2 quarts oil included FREE

DIRZIUS MACHINE SHOP "S" 1423-25 So. 52nd Ave., Cicero 50, Ill.

## A MAN'S BEST FRIEND IS HIS POCKET KNIFE

All CAMILLUS knives have hand honed blades. Many styles at your dealer's.

**CAMILLUS**  
has the edge!

No. 72  
"WOODWORKER"  
About \$2.25  
3 3/4" closed

CAMILLUS CUTLERY COMPANY, CAMILLUS, N. Y.

## ONE-MAN SAWMILL LESS THAN \$225.00 Easy To Turn Trees Into Money

Makes lumber, ties, shingles, crates, lath, studding, siding



Belsaw Models in 10 to 24 foot sawing lengths.

MECHANICAL FEED, accurate set works and positive dogs. Use tractor or old auto engine for low cost power.

Thousands used for commercial sawing. Pays for itself quickly. Send post card today for FREE booklet, "How To Make Lumber", and Catalog of Woodworking Equipment.

BELSAW MACHINERY CO., 811V Field Bldg. Kansas City 2, Mo.



## BUILD FINE GRANDFATHER CLOCK NOW

The simple sensible Red-i-Kut way as thousands have—SAVE HALF. SHOP TESTED PLANS "SPIRIT OF THE CENTURY" Narrow waist 83" tall or stately "SPIRIT OF AMERICA" straight side model. EASY-TO-FOLLOW photo-pack PLANS tell all—plus BROCHURE of heavy brass weight Westminster, tube chime, movements, dials, solid mahogany case kits. Send \$1.00 today—Both Plans \$1.50 NOW.

KUEMPEL CHIME CLOCK CO., #6 Kuempel Bldg., Minneapolis 16, Minn.

# PISTONS

**ALUMINUM ALLOY.** For Every Make Engine, Any Year, Odd or Foreign! For auto, "hot rod", racing, truck, tractor, motorcycle, scooter, bike, outboard, marine, compressor, industrial. Send sample or specifications.

JUDSON MFG. CO., 1709 Gillingham, Phila. 24, Pa.

## Say You Saw It in Popular Mechanics

## Sand Casting—Forging—Heat Treating—Case Hardening BRONZE FOUNDRY



In your own workshop allows you to design and build your own GASOLINE ENGINES, STEAM ENGINES, STATUARY, ART OBJECTS, SPECIAL TOOLS, NEW INVENTIONS, ETC. You can also make forgings and case harden steel. Your shop is not complete without a FOUNDRYETTE. Three sizes are available capable of making bronze castings of 1 1/2, 3 and 6 pounds weight, aluminum, copper, brass, etc., \$22.50, \$29.50, \$42.00 f.o.b. Kansas City. Domestic gas supply and 110 volt AC or DC energy required for operation. Write for circular.

KANSAS CITY SPECIALTIES CO.

Box 6022, Dept. P-1

Kansas City, Mo.

# MAN'S BEST LAXATIVE

**Grows in Fields  
and Forests**



**10 HERBS IN  
TINY TABLET**

Folks who need help in keeping regular should look to herbs and roots—for the help provided by Nature.

10 such herbs and roots, scientifically compounded, are found in Nature's Remedy, NR Tablets. Countless thousands of folks have found an NR at night the best way to assure regularity in the morning. So gentle—no griping. It is wonderful—leaves you feeling refreshed, invigorated.

Try NR at our expense. 25 tablets 25c. Buy a box at any drug store and try it. If you are not completely satisfied, return the box and unused tablets to us. We will refund your money plus postage.

**PLAIN OR CANDY COATED**

*Nature's Remedy*  
**NR-TABLETS-NR**

**BUILD YOUR OWN  
FAST FREEZER**

**PLANS  
\$1**

It's easy to build this household appliance with LeJay Plans. Made from new or used parts. Save up to 75%. No expert knowledge needed. Plans show 5 sizes and are easy to follow. All details clearly explained. Enjoy making one of these freezers. Mail \$1 for set of plans and catalog. **LEJAY MFG. CO., 447 LeJay Bldg., Minneapolis 8, Minnesota.**



5 sizes  
8 to 40 cu.ft.

**AMAZING NEW  
WOOD-TURNING TOOLS**

**SHARPEN ONCE IN 12-YEARS! (UNDER NORMAL USE)**

These remarkable tools tipped with TUNGSTEN CARBIDE will astound you with their performance. They work FREE HAND equally well in wood, plastic or soft metals—and at the same time hold their razor-like edge almost indefinitely. Tests show that they will turn wood or plastic for days and days CONTINUOUSLY without showing any signs of dulling. They are the finest tools available at any price. Beautifully finished 5" blade—flush ground, polished tip—finest brass tube ferrule—9" hardwood handle—over all length 14"—25 tools to 1/2"x30" skew, spear, r. & l. skewers, turning and parting. Amazingly Low Prices! Write at once for free literature. **JOHNS MFG. CO., DUNELLEN 8, N. J.**

**MYSTERIOUS DEVICE**

**WELDS, BRAZES, SOLDERS, CUTS**  
*quickly...easily*

**The FOUR-WAY  
PORTABLE ARC-WELDER**

**COMPLETE ONLY \$9.95**  
**10 DAY TRIAL 1.0.B.**



**MAKE  
OR REPAIR  
HOME & FARM  
APPLIANCES  
FENDERS  
BICYCLES  
METAL  
FURNITURE  
& 1001 ITEMS**

YOU'LL BE AMAZED by the work you can do on your first job! Plugs into any convenient properly wired 110 volt A.C. or D.C. line. Follow simple directions and work on iron, steel, bronze, brass, aluminum and other metals. Save money doing own repairs. Make money repairing for others.

Thousands of enthusiastic users among maintenance and repair men, farmers, tin-smiths, engineers, home and auto owners, etc. Pays for itself over and over. Order on ten-day trial or send for details.

**FOUR-WAY WELDER CO., Dept. PMF-25  
2326 So. Michigan Avenue • Chicago 16, Illinois**

**FREE Full Details SEND TODAY**

FOUR-WAY WELDER CO., 2326 So. Michigan Ave., Chicago 16, Dept. PMF-25 Please send as checked below.

- Four-Way Welder on 10-day trial. I enclose \$9.95, or I enclose \$\_\_\_\_\_ as a deposit. Ship C.O.D. for balance.
- Illustrated and described details on Four-Way Welder.

NAME \_\_\_\_\_  
ADDRESS \_\_\_\_\_  
CITY \_\_\_\_\_ STATE \_\_\_\_\_

*Handy Hank says:*  
**"Try these slick tricks with PLASTIC WOOD"**

Fill cracks in chairs—

Makes loose joints firm, sands to a smooth finish!



Reset loose hinges—

Replaces rotted wood, tightens loose screws... easy to apply!



Repairs broken toys—

Mend cracks, nicks! Smooth finish!



Also useful in filling cracks in floors, nail and screw holes, repairing loose tiles. Handles like putty... hardens into wood!

**PLASTIC WOOD**

A CELLULOSE FIBRE FILLER

IN CANS OR TUBES



DOZENS OF OTHER USES

SAY YOU SAW IT IN POPULAR MECHANICS

## EXCITING NEWS FOR FISHERMEN



**SPEEDLOCK Handle**



Speedlock Handle—makes attaching the reel as easy as snapping your glove. Exclusive on True Temper Rapier Steel Rods.

● New features—new action—new low prices of True Temper Rapier Steel Rods and Baits are described in this beautiful 4-color Condensed Catalog. It illustrates the most popular and effective rod for each kind of fishing—made from finest rapier steel and clock-spring tempered for unequalled power—speed—action. True Temper is the Rod of Champions—proved by results in the world's greatest fishing contest. True Temper Baits, as preferred by experts, fully illustrated.

Be prepared for fishing fun. Write for free copy today.

## TRUE TEMPER

FOR 25 YEARS

*The Rod of Champions*

FOR EXCITING NEWS, MAIL THIS COUPON TODAY

TRUE TEMPER CORPORATION  
Sporting Goods Division, Dept. 28, Geneva, Ohio  
Please send your new Condensed Rod and Bait Catalog to—

Name \_\_\_\_\_

Street \_\_\_\_\_

City \_\_\_\_\_ State \_\_\_\_\_

## Thompson BEATS the World on BOATS



**Better Built Lower Prices**

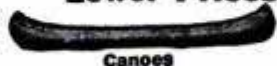

Canoes

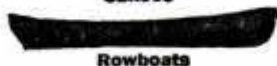

Rowboats

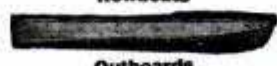

Outboards

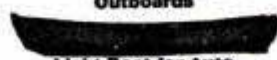

Light Boat for Auto

**Safe Boats With Full Length Spray Rails**  
Keep passengers perfectly dry—even at high speeds. Catalog also shows two new models of "Take-Along" Boats. Two big factories—save you freight.

**CATALOG FREE**  
Write for your copy. State kind of boat in which you are interested.

**THOMPSON BROS. BOAT MFG. CO. (151)**  
213 Ann St. 113 Elm St.  
PESHIGO, WIS. (Write to either place) CORTLAND, N.Y.

## PRESTO! ANYONE CAN MASTER GLAZE

LEAVES HARD GLASS-LIKE FINISH  
EASY TO APPLY  
PROTECTS THE SURFACE  
NO SMEAR OR STREAKS AS WITH WAX  
LASTS SIX MONTHS TO A YEAR



SAVES YOU MONEY

Car Owners! Meet Master Glaze—the sensationally different luster for new and used cars! Not a wax—not an oil polish—not a paint!—nothing that "smears" over the surface.

**MASTER GLAZE** is a unique discovery—a creamy liquid—quick and easy to apply! Gives a hard, glass-like surface. Even gasoline cannot dull it! Lasts six months to a year! Amazing luster—beautiful, sparkling clean and brilliant! Doesn't finger-mark—doesn't smear! A match box full glazes an entire car. Seals the pores—protects! **NOTHING LIKE IT!**

**FREE SAMPLE**

Just send your name and address to

**MASTER GLAZE CO., 7720-681 W. Harwood Ave., Milwaukee, Wis.**

## Hobbyist Catalog



64 pages

WE PAY POSTAGE!

SHIP MODELS... TRAINS... PLANES  
Cars... Art Supplies... Tools...  
Projects... Games.  
U.S.A. and Canada Orders Only.

10¢

write **Braun-Crafts**

1232 ETOWAH, DEPT. PM-6, Royal Oak, Mich.



## Gerstner TOOL CHEST

MACHINISTS — TOOLMAKERS

Don't worry about your tools. Keep them safely in a Gerstner chest. Free Catalog.

**GERSTNER TOOL CHESTS**  
450 Columbia St. Dayton 7, Ohio

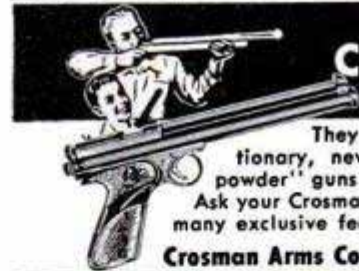

## Seen the NEW Crosman CO<sub>2</sub> PISTOL & RIFLE?

They're sensational... a revolutionary, new idea in "power without powder" guns that is sweeping the country. Ask your Crosman dealer to demonstrate their many exclusive features. Write for literature.

**Crosman Arms Co., Inc. • Rochester 3, N. Y.**



**OUR GUARANTEE**  
OUR TIRES must make good or WE WILL

Tube Given With Each Tire  
**EVERYONE TAKE 10% DISCOUNT ON ALL TIRES**

Be Wise—Read this Before You Buy!  
**OUR EXPERIENCE ASSURES YOU THE BEST BUY IN**

**GOOD USED TIRES**

BUY IN CONFIDENCE—

selected **POPULAR BRANDS**—  
positively NOT Re-caps or Re-molds.

5.50-17 ... \$5.02	6.70-15 ... \$6.75	7.50-16 ... \$7.62
6.00-16 ... 5.02	6.70-16 ... 6.75	7.60-15 ... 7.62
6.50-15 ... 5.02	7.00-15 ... 5.30	7.60-16 ... 7.62
6.50-16 ... 5.02	7.00-16 ... 6.30	8.20-15 ... 8.62

**GOOD TREAD—NO RE-CAPS. THESE TIRES WILL CARRY YOU TWICE AS FAR!**

6.50-20(6) \$9.22	8.25-20(10) 15.52	11.00-20(12) \$16.42
7.00-20(8) 10.52	9.00-20(10) 15.52	11.00-22(12) 18.42
7.50-20(8) 10.52	10.00-20(12) 16.22	32x6 (8) 10.02

750-20 MILITARY 8 PLY REGULAR \$9.62—SUPER \$12.92  
900-16 MILITARY 8 PLY REGULAR \$8.72—SUPER \$10.92

Thousands of Tires Shipped to Satisfied Customers Throughout United States and Many Distant Points. Send This Ad with Check or Money Order. Dep't 2.

**STANDARD 834 N. Broad St., Philadelphia 30, Pa.**



**THE BIGGEST  
VALUE  
ON THE MARKET  
DIRECT FACTORY TO YOU**

# DYNAMIC ARC-WELDER

*Super Charged*

\$40<sup>30</sup> VALUE  
*Only*  
**\$28<sup>50</sup>** F.O.B.



**DOES WELDING, BRAZING, SOLDERING, CUTTING**

This is one of the finest scientifically designed and precision-built genuine heavy duty transformer-welders on the market today! Made by an old established firm. High efficiency, heavy-duty output does work you'd expect from costlier machines. It's **EASY TO OPERATE**. Do expert work in a jiffy by following the simplified instructions furnished. Works on iron, steel, brass, bronze, aluminum or other metals. **OPERATES** from any convenient properly wired 110 VOLT A. C. line. **SAVE TIME AND MONEY** . . . build or repair your own auto, home, farm, or shop equipment and appliances, etc. Make big money doing work for others in spare or full time. **OVER 50,000 SATISFIED USERS** all over the country, hobbyists, maintenance and repair men, farmers, tinsmiths, engineers, home and auto owners. Order today on 10-day trial or send coupon for full details.

**GIFT WORTH \$680 INCLUDED**



**For Prompt Action  
SEND ORDER TODAY**

**SEND TODAY FOR FREE DETAILS**

- Send free details on Dynamic and gift offer.
- Send Dynamic and 10 day trial. Enclosed \$28.50 or \$\_\_\_\_\_ deposit. Send C.O.D. for balance. Include gift offer.

Name.....  
Address.....  
City..... Zone..... State.....

**DYNAMIC WELDER CO., Dept. TD-250, 13 E. 23rd St., Chicago 16, Ill.**

**WRITE FOR YOUR FREE COPY OF THE NEW  
KRW HYDRAULIC PRESS BOOK**

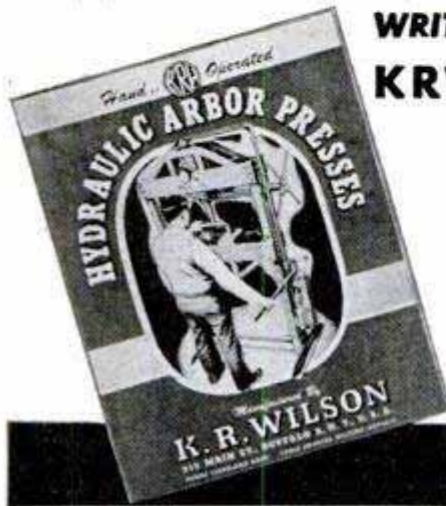

Describes all manner of Production and Shop Work on KRW Hydraulic and Bench Type Presses. Illustrates the new KRW Hand-operated, Electric-operated and Air-operated Hydraulic Presses. 25 to 100-ton capacities.

*Write for your copy today.*

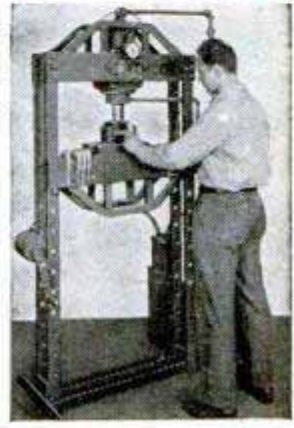

**K. R. WILSON, DEPT. 17, 215 MAIN ST., BUFFALO 3, N. Y.**

**NEW POWER FOR YOUR CAR ENGINE!  
BY CONSTANT BALANCE OF LUBRICATING OIL SUPPLY!**

*Give Your Car this Tonic—  
Add Power, Pep and Performance*

**MARVEL INVERSE OILER**

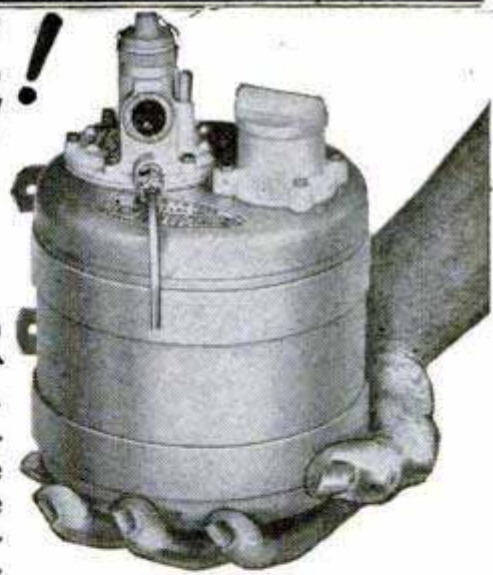

Here's the famous, low cost, auxiliary lubricating system that meters MARVEL MYSTERY OIL to critical upper cylinder engine parts, precisely in accordance with engine load. The compact INVERSE OILER functions inversely to manifold vacuum, retarding feed *visibly* when throttle is closed or at engine idle, an exclusive MARVEL feature! You can keep ring, piston and valve wear down and performance way UP this winter with the sensational MARVEL INVERSE OILER.

Learn about MARVEL MYSTERY OIL too—the famous oil improving Additive for YOUR motor oil that produces a slow idle, faster engine pick-up and an even, power pull. Thousands of car owners are using it in increased volume this winter for engine protection and to keep starts summer quick in cold weather and in ALL gear greases—it flows at 70° below zero!



*The MARVEL INVERSE OILER Is Easily Installed on Most Engines*

**EMEROL MANUFACTURING COMPANY, INC.**  
242 West 69th Street (Dept. P. M.), New York 23, N. Y.

**WRITE FOR THE FACTS NOW!**

Make 100% to 150% Profit!

# MANUFACTURE BUILDING BLOCKS

In Your Own Back Yard



**AMAZING GENERAL BLOCK MACHINE**  
CAPACITY 1000 BLOCKS PER DAY  
Only \$199 LESS MOTOR F.O.B. PLANT  
SHIPPING WEIGHT 400 lbs.

Here is an outstanding opportunity for men of vision and small capital. Cinder and concrete blocks are in great demand. Millions used for homes, factories, public buildings. Sell all you produce at 100% to 150% mark-up.

### PEAK BUILDING DEMAND!

The General Block Machine is amazingly practical, foolproof. Simple to operate indoors or outdoors. Rugged all steel construction. Vibrator mounted in sealed ball bearings. Produces up to 1,000 blocks per day. Superior 3 Core Type that meets all building code requirements. Can produce 4 x 8 x 16, 8 x 8 x 16, 12 x 8 x 16 blocks. All materials obtainable anywhere. All operating instructions and mixing formulas supplied. Full details FREE without obligation.

HOW TO BUILD YOUR OWN CONCRETE BLOCK HOME  
Only \$1 Prepaid

Wonderful Book Written & Illustrated by Experts

## GENERAL ENGINES CO.

DEPT. P5 • 307 HUNTER ST. • GLOUCESTER, N. J.

Includes floor plans for 6 beautiful, easy to build concrete block bungalows. Shows ways to save money. How to lay blocks, lay out building lines, mix concrete, build steps, porches and concrete floors. Mail coupon at once with \$1.

Name.....  
Address.....  
City.....Zone.....State.....



## PAGE Garden Tractor



Catalog sent free.  
WRITE TODAY FOR YOURS!

PAGE DOES IT FASTER - EASIER!

New 1950 line with extra features for spring plowing and dozens of other year 'round uses. *Riding and walking models, 2 to 6 HP. Complete gear with reverse, no cheap belts or chains. Large tires—easy to handle—power turn. New reduced factory prices, \$188 to \$440, with cultivator. Get the benefits of our 25 years' experience!*

### DOES MOST EVERYTHING!

*PAGE tractors can plow, spray, harrow, disc, bulldoze, haul, cut grass and weeds, and do dozens of other jobs!*

FREE Catalog—write at once! Shows many attachments that save time and money!

PAGE DAIRY and FARM EQUIPMENT  
1904 S. 81st Street • Milwaukee 14, Wis.



# FREE! SAMPLE!

That GLOWS IN THE DARK!

## An Easy Way To MAKE BIG MONEY

Be the first to sell sensational luminous house numbers, light switch plates, wall protectors, cord pulls, novelties, etc. Also luminous pictures, ash trays, keyholders, statues, decals, religious, nursery objects, etc. **THAT GLOW IN THE DARK. SELL ON SIGHT.** Get into this new and growing industry. ENORMOUS DEMAND... NO COMPETITION... BIG PROFITS. Represent a large manufacturer, established over 35 years. Write a large for liberal MONEY-MAKING offer and FREE samples to show you HOW THEY GLOW IN THE DARK.  
**Madison Mills, 303 Fourth Avenue DEPT. F-4 NEW YORK 10, N. Y.**

make your own *Gems* 29.50 F.O.B.

All necessary lapidary equipment is furnished, including a super-charged diamond blade for sawing, and all wheels for grinding, shaping and polishing; also complete instructions. The complete equipment as shown, less motor and belt, for only \$29.50, f.o.b., Burlington, Wisconsin. Write today for information and literature.

**B & I MANUFACTURING CO.**  
Dept. S Burlington, Wis.

**WOODWORKERS... Get this!**  
CONSTANTINE MASTER MANUAL

Get the Most Fun From Your Hobby  
Indispensable to woodworkers. Newest, biggest edition, more pages, more color, helpful how-to-do-it articles, pre-war and new items, more bargains. Send 25c today and we will include **FREE! FULL YRS. SUBSCRIPTION** to Chips and Chats, published bi-monthly. Keeps you up-to-date on everything in woodworking, offers big money-saving bargains. Send now.

**ALBERT CONSTANTINE & SON, Inc.**  
791-G East 135th Street, New York 54, N. Y.

**BRUSH PLATING OUTFITS**

for re-plating articles in the home and shop. No tanks necessary. Free particulars.

**GUNMETAL CO., AVE. M, DECATUR, ILLINOIS**

**POWER HACKSAW \$47.21**  
LESS MOTOR F. O. B. Benton Harbor

● Rugged cast iron construction. Wt. 5 lbs. bronze bearings. Saw cut. Auto. return lift. Auto. shut-off. Vise swivels 45°. Cap. 4"x4".

Send for full details and name of nearest dealer.

**EXCEL MACHINE TOOLS BENTON HARBOR, MICHIGAN**  
Dept. PM-20

**SAY YOU SAW IT IN POPULAR MECHANICS**

**FLASH Your Turns**

**ELIMINATE HAND SIGNALLING**  
ENJOY SAFE — COMFORTABLE WINTER DRIVING WITH THE **SIMPLEX DIRECTIONAL SWITCH**

Here is a safe and comfortable way of signalling your intention to make a left or right turn. Flashes from 60 to 80 times per minute.

Kits furnished with all necessary material for perfect installation. No outside mounting of any kind uses your present parking and tail lights. Either of our two models fit most cars from 1942 to 1949.

**A PRACTICAL GIFT FOR MOTORISTS!**

Specify year and make of car. Money back guarantee. Tested and Approved to meet SAE requirements.  
**DEALERS INQUIRIES INVITED**

**\$8.95** Post-paid in U.S.  
Send check or money order. Postage extra on C.O.D.'s

**SIMPLEX SALES COMPANY**  
1303 W. Jackson Blvd. Dept. A-3, Chicago 7, Illinois.

# HERE IT IS -

## the all-new IDEAL LAWNMOWER SHARPENER

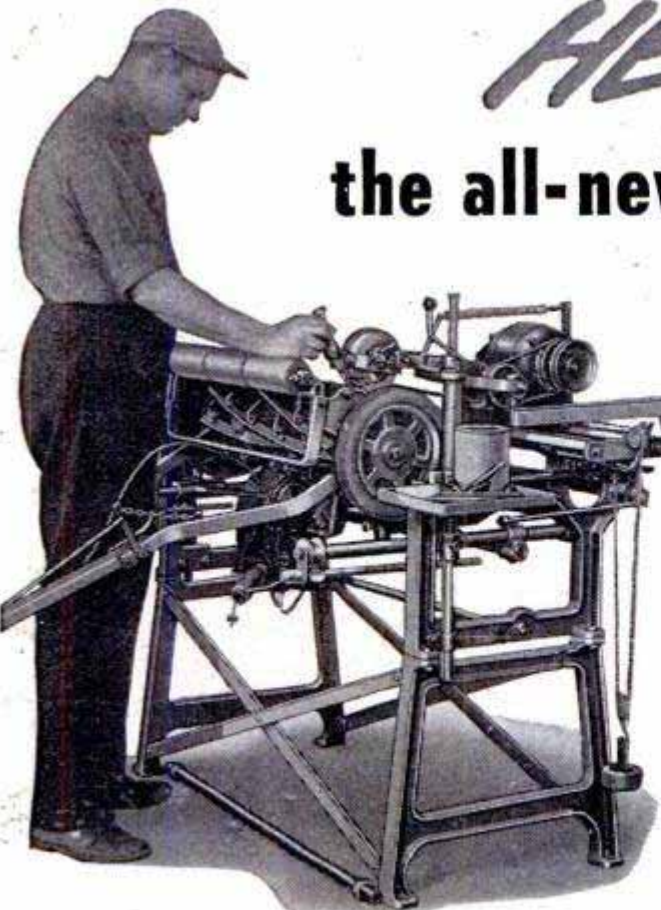

**A Complete Lawnmower Shop in One Machine**

Here it is, after four years of research and development, the **COMPLETELY NEW IDEAL LAWNMOWER SHARPENER**. Designed and built to sharpen post-war and pre-war hand and power lawnmowers with precision and speed, the **NEW IDEAL SHARPENER** includes a tapered-cup grinding wheel for sharpening bed knives and a "lapping-in" reconditioner as standard equipment. Power mowers need not be dis-assembled, engines and handles remain in place during sharpening. Chain hoists or ropes are not needed to support heavy mowers, the **IDEAL** supports the entire weight of the mower within its rugged cast-iron frame. The **IDEAL SHARPENER** is a complete lawnmower shop all in one machine. Send for the **IDEAL CATALOG** describing the new **Model 300 IDEAL LAWNMOWER SHARPENER** and the other machines we manufacture for the lawnmower serviceman.

Model 300 — the result of 48 years experience  
**CATALOG FREE!**

**THE FATE-ROOT-HEATH CO. DEPT. F-3 PLYMOUTH, OHIO**



### ONAN Portable ELECTRIC PLANTS

**FOR CABINS, TRAILERS, CONTRACTORS, BOATS**

Light weight, compact, air-cooled engine-driven. Furnish regular city-type A.C. electricity for lights, appliances, radios, etc. Can be carried by hand. Fit trunk of car. Plug-in receptacles on plant. Larger models for farms, homes, businesses beyond highlines. Catalog shows over hundred models. 350 to 55,000 watts.

*Gasoline or Diesel Powered*

**WRITE FOR CATALOG**  
**D. W. ONAN & SONS INC.**  
5830 Royalston Ave., Minneapolis 5, Minn.

### NEW! JIG SAW FOR LAD AND DAD!



**atkins NATIONAL**

**3 IN 1 ELECTRIC MOTOR DRIVEN**

**JIG SAW... SANDER... FILING MACHINE**

- 10 DAY FREE TRIAL
- Money Back If Not Satisfied!

**\$12.00** POST PAID

Complete with 3 Blades, 3 Project Patterns and 2 Pieces of Wood

- Absolutely SAFE for Youngsters!
- Made of Light Weight Cast Aluminum!

**6 IN 1 UTILITY SET**

4 Screw Drivers & Hammer Combination \$1.00

So handy for any job in the home in the hobby shop. **GUARANTEED RUSTPROOF!** Post Paid



### MAGIC HOOK NO NAILS, SCREWS SELF-ATTACHING BUT NOT A SUCTION CUP

**UP IN ONE MINUTE—PERMANENTLY!**

On any surface — tile, glass, metal, paint, plaster, wood, etc.

**HOLDS UP TO 30 LBS., 100 HOME USES**

Special solvent capsule reactivates powerful, lasting, plastic adhesive. Then just press hook to wall. Accepted by government agencies, leading laboratories. Prompt pre-paid delivery. Money back guarantee. Send today!

5 in lovely pastel gray.....\$1.00  
8 in handsome chromium.....\$2.00

**TON, 801 ROCHELLE PARK, N. J.**

This Jig Saw has *everything* any hobby-minded "boy"—whether 6 or 60—could possibly want! Its A.C. 110 Volt electric motor (3000 revolutions per minute) has plenty of power for sawing—sanding—filing.

Versatile! Table tilts and rotates to cut at any angle—sanding table tilts through 45°—saw, which cuts to center of 16" circle, may be rotated to any position to cut longer lengths. Converts for filing by removing saw blade and arm and inserting 3/4" diameter standard files.

**USE HANDY ORDER COUPON**

**A. L. ATKINS & CO. Dept. PM2**  
4364 Elston Ave., Chicago, Ill.

Enclosed find \$12.00. (Check or money order in full.) Ship 3 in 1 Jig Saw-Sander-Filing Machine at once POST PAID.

Enclosed find \$1.00. (Check or money order in full.) Ship 6-in-1 Utility Set at once POST PAID.

Enclosed find \$2.00 as part payment. I will pay postman balance plus postage upon C. O. D. delivery.

NAME.....  
ADDRESS.....  
CITY..... STATE.....

NEW!

# Klean-Strip Remover Peels Off Paint



Throw away messy, dangerous solvents! Klean-Strip, the new-type remover, needs no after-wash, will neither burn nor explode. Just apply with brush, or spray gun . . . then slide off the loose film. That's all there is to it!

Klean-Strip actually breaks the bond between wood or metal and the finish you want to remove. Peels off any paint, enamel, varnish, synthetic or lacquer. Works fast, leaves the surface clean, smooth and dry, ready for a perfect refinish job.

The next time you buy paint, get a can of Klean-Strip, too! Available at better paint, hardware, and department stores everywhere.

W. M. BARR & CO.  
2354 S. Lauderdale  
Memphis, Tenn.



Clean · No-Wash  
Non-Inflammable

## AMBROID Stays stuck!



When you build or mend with Ambroid—it really sticks. Ready to use, quick drying, waterproof, flexible, transparent, a Hercules for extra strength. Heat and corrosion resistant, too.

Invaluable for assembling or repairing. Leading favorite among hobbyists since 1910. So reliable it is specified for countless uses in big industry.

Keep a tube of Ambroid handy. Ask your dealer—or send 25c for big 2 oz. tube postpaid. Complete satisfaction guaranteed or your money back.

Also 50c 4 oz. tube, Pts., Qts., Gals., for Industrial Use. Build It—Fix It with Ambroid!

**AMBROID CO.**

303 Franklin St. EST. 1910 Boston 10, Mass.

## ACE TOOLS



Be permanently toolled-up for every operation on your Metal Cutting Lathe.

No. 8-A Ace Tool Set for 9" and 10" Swing Lathes—fits shank size 3/4" x 3/4". Includes Turning, Cutting-off, Boring, Knurling and Threading Tools with high speed cutters, blades and wrenches. 8 complete tools in fitted steel case—nothing else to buy. See your local dealer or order direct.

ARMSTRONG BROS. TOOL CO.  
5268 W. Armstrong Ave., Chicago 30, Ill.

\$24<sup>25</sup>

## BURIED TREASURE. MINERALS AMAZING NEW GOLDAK LOCATORS

**SENSATIONAL NEW MODEL!**  
ONLY 11 pounds weight! One hand operation! Money-Back Guarantee of Superiority. Write for full details.

**THE GOLDAK CO.**  
1542 WEST GLENOAKS BLVD.  
GLENDALE 1, CALIFORNIA

World's largest maker of fine locators.



## NEW QUICK-CLAMP 30" BRAKE

Forms angles, flanges, seams. Bends 26 gage steel. Heavier copper and aluminum. Cam locking. Portable, can be clamped to edge of truck. All steel. Wt. 42 lbs. Express Collect. . . \$24.50  
36" size . . . . . \$29.00



12" BRAKE. Fits in vise to form difficult compound bends, up to 20 gage steel. . . \$12.50 PP.

CUTTER. Cuts 18 gage steel any length and width, \$12.50 PP.

SHEET METAL PLIERS. 2 1/2" wide, \$2.00; 5", \$3.00.

IRON BENDER. Forms hooks, braces, eyelets. Bends 1/4x2, \$10.00.

Immediate delivery. Order direct, cash or C.O.D., or send for folder.

VICE BRAKE MFG. CO., P1116 So. 27th St., Omaha 5, Nebr.

## OTTAWA LOG SAW

World's fastest, self-propelled. 8 H.P. air-cooled motor. Falls trees and cuts 'em up. Powerful for belt jobs. Pays for itself quickly. Always a demand for wood. Nothing like it. Write today for FREE details.



OTTAWA MFG. CO., 2-027 Pine Street, Ottawa, Kansas

## UPHOLSTERING SUPPLIES

tools, foam rubber, furniture frames, imitation leather springs, webbing, etc. — direct from wholesaler.

Send for free price list

The Tycon Co. Dept. 2M Chalfont, Pa.

## NEVERSLIP PULLEY

Transmits more power with less-belt wear, unaffected by weather. No pulley covering, no belt dressing required. Replace troublesome pulleys with NEVERSLIPS. All sizes. Money-back guarantee. Ask for NEVERSLIP Pulleys on ALL power machinery you buy. Write for folder and prices.

ROSENTHAL CORN HUSKER CO.  
Box 16 Milwaukee, Wisconsin



## POWERFUL!

### ECONOMY TRACTOR



Lightweight, Low-priced, Big capacity for all jobs, Ideal for small acreage, Implement attachments available. Write for folder

Tractor Features: Adjustable Trend, High Clearance, 7 H.P. Air Cooled Engine, Automatic Clutch, Differential and Transmission.

ENGINEERING PRODUCTS CO.

915-E2 Niagara Court Waukesha, Wis.

## GET THIS **SAFE** ELECTRIC JIG SAW

The safe saw for children yet powerful, versatile enough for homeshops. Easily adjustable. Portable. Thousands in use. Plug in any 60 cycle, 110-120 volt AC outlet—and saw! Arm ADJUSTS to permit cutting ANY LENGTH

1/2" wood, 1/4" plywood, thin metal, plastics. Not a "lumber cutter" but for delicate, fine craftsmanship. No belts, gears, wheels.

Use for family projects or making money. The BASIC homeshop tool. Get yours now with BUILT-



## SYNGRO Electric Jigsaw

SYNGRO CORP., DEPT. SH-25, ROCHESTER, MICHIGAN, U.S.A.

IN MOTOR, 3 blades, cord, plug, \$17.50. At Dealers! If he hasn't, send \$17.50 to factory, we'll ship saw postpaid. See Syncro products pages 291, 297. (Dealers write!)

## TORP JR. Model Airplane Engine

AMERICA'S FASTEST GROWING HOBBY  
AN IDEAL GIFT FOR YOUR YOUNGSTER

Come on, get acquainted with model flying. You'll have fun... if you equip your plane with K & B's Torp Jr. This little engine has everything and is designed for all types of flying, Free Flight, U-Control, Stunt, Speed and Scale... readily adaptable for model race cars and boats. Torp Jr., really easy to operate, yet outperforms any engine in its class.

INFANT Also available The Infant .020. World's Smallest Production made Glo Ignition Engine. This engine, now world famous, is interchangeable with the Torp Jr. Complete with Glo Plug and fuel tank only **\$4.95**

See your model dealer today or for dealer information write to

**K & B MANUFACTURING CO.** 6901 S. Eastern Ave. Bell Gardens, Calif.

**\$5.50**

COMPLETE WITH GLO PLUG AND GAS TANK



Fully Guaranteed Glo Plug Ignition .035 Cu. In. Displacement Turns 15,000 RPM Weighs only 1-1/16 oz. Easy to Start Famous K & B Quality Thoroughly tested in factory and field.

SAY YOU SAW IT IN POPULAR MECHANICS

## AUTOMATIC COMPRESSOR UNIT

COMPLETE OUTFIT WITH SPRAY GUN AND HOSE

SPRAY PAINT YOUR HOME, CAR, GARAGE, ETC.

Use also for spraying insecticides on plants and flowers. 1/2 H.P. heavy duty capacitor motor. AC 110/220 volt, 60 cycle, 2x1 1/4 inch piston type compressor, splash feed lubrication. 12x24 inch tank, automatic pressure switch, CFM 2.8 at 100 lbs. pressure, or 150 lbs. pressure for intermittent duty. Check valve, safety valve, air regulator with gauge and filter, spray gun with 20 ft. air hose and air chuck for inflating tires. V. belt drive. Mounted on 2 wheels, ball bearing, with 2" x 10" pneumatic tires. Portable, with handle. Shipping wt. 90 lbs.

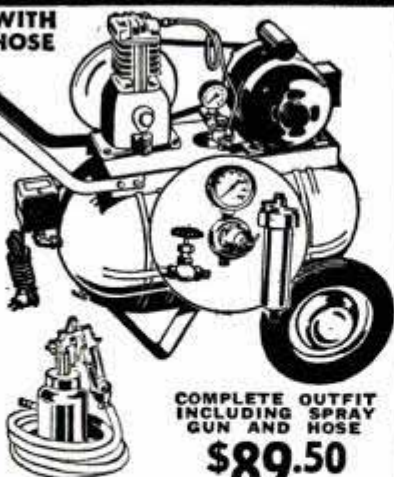

COMPLETE OUTFIT INCLUDING SPRAY GUN AND HOSE

**\$89.50**

PARTS SOLD SEPARATELY

Compressor, \$17.50, wt. 16 lbs. • Automatic pressure switch, \$7.50, wt. 3 lbs. • Regulator, gauge and filter, \$8.50, wt. 5 lbs. • Spray gun, \$9.95, wt. 4 lbs. • Tank, wheels and base, \$17.50, wt. 32 lbs. • 20 ft. hose, \$2.95, wt. 6 lbs. • 1/2 H.P. Cap. motor, \$22.50, wt. 28 lbs. • Air gauge, \$1.75 • Adjustable pop valve, \$1.50 • 1/4" check valve, \$2.75, wt. 2 lbs.

PRICES F.O.B. CHICAGO. Sold on money back guarantee. Send check or money order today. Prompt shipment.

**68 PAGE BOOK!** Motor guide, air compressors, home and factory workshop tool catalog. Send 25c to cover postage and handling, deductible from first purchase.

**WELLWORTH TRADING CO.**

1831 S. STATE ST. Dept. D-2 CHICAGO 16, ILL.

# FREE!

LAFAYETTE'S NEW 164 PAGE CATALOG

The Biggest Bargain Book  
In Radio and Television

Radio and TV Sets—Parts—Tools—Hi-Fi—Public Address—Kits—Test Equipment—Ham Gear—Record Changers—Recorders, etc.

164 pages packed with all new, latest-model, famous-make radio and TV equipment at money-saving prices.

Invest a penny postcard and send for this great new 1950 Lafayette Catalog. Then sit down with pencil and paper and make a price comparison test. Check model for model, and see if Lafayette doesn't save you anywhere from a few pennies to a few dollars on most every item.

If you're a service man, experimenter, ham, hi-fi bug, engineer, set-builder, or serious amateur—send for your 1950 Lafayette Catalog now. It's one of the biggest things in America you can get "for free"!

## SALE! SALE!

Lafayette famous FM-AM

PRICED AT ONLY HIGH-FIDELITY CHASSIS

**\$59.50** with built-in PHONO PRE-AMPLIFIER

INCLUDING WIDE RANGE 12" PM SPEAKER!

Look at these \$300 set features: Latest 11-tube circuit plus rectifier. 10 watts undistorted power output. Phono pre-amplifier permits direct connection of variable reluctance pick-ups. High and low impedance phono input. Tone control. Slide rule dial. Supplied with loop and folded dipole cabinet antenna. 12" PM speaker with Alnico V magnet. 105-125 volts, 60 cycles, AC only. Chassis dimensions: 13x9x9 1/2. Shipping weight: 25 lbs. Complete with tubes \$59.50. 30-day Money-Back Guarantee! If not fully satisfied, return to us within 30 days, and you'll receive full refund, less transportation charges.

NEW YORK: 100 Sixth Avenue and 542 E. Fordham Road (Bronx)  
CHICAGO: 901 W. Jackson Blvd.  
ATLANTA: 265 Peachtree Street  
BOSTON: 110 Federal Street  
NEWARK: 24 Central Avenue

**Lafayette**  
RADIO  
OUR 29th YEAR

RUSH COUPON NOW FOR FREE CATALOG

LAFAYETTE RADIO, Dept. LB-50  
901 W. Jackson Blvd., Chicago 7, Ill.  
or 100 Sixth Avenue, New York 13, N. Y.

Rush me your FREE 1950 164-page Catalog.

Name \_\_\_\_\_  
Address \_\_\_\_\_  
City \_\_\_\_\_ Zone \_\_\_\_\_ State \_\_\_\_\_

PASTE ON PENNY POSTCARD

# Better, Easier, Quicker GROOVE CUTTING or CABINET-MAKING

with *Warren* DADO SAWING WASHERS

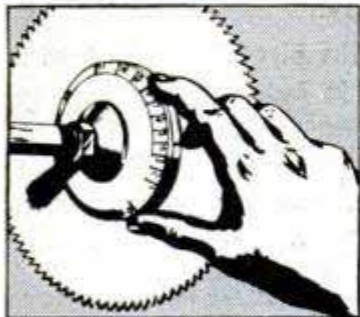

*Just dial*  
DESIRED CUT

Cut accurate, parallel grooves—any width, any angle. Just dial desired width with Micromatic adjustment. Cuts smooth and clean—no burning or chewing to mar fine wood. Just four simple washers. Available in 5 sizes— $\frac{1}{2}$ ",  $\frac{3}{4}$ ",  $\frac{5}{8}$ ", 1",  $1\frac{1}{8}$ ". Free booklet on request. See your dealer or write direct. Absolutely guaranteed! In Canada, send money order for \$4.95 (duty and sales tax extra).

**\$4.95**  
A SET

Dealers, Jobbers, Write for Information!

**WARREN DADO SAWING WASHERS CO.**

70 Medbury, Dept. 22, Detroit 2, Michigan

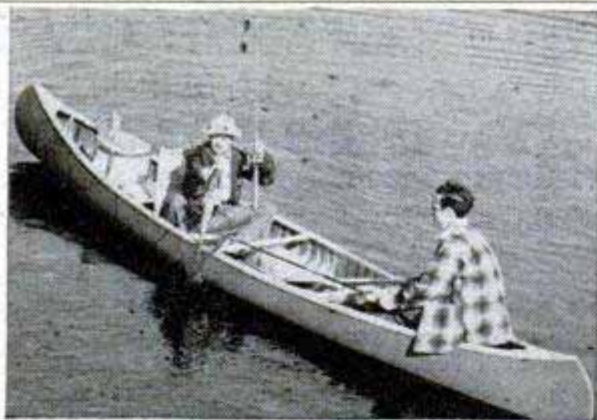

## GLIDE TO THE HAUNTS OF THE BIG ONES

SMOOTHLY and quietly you reach the best spots when your canoe is an easily handled Old Town. Strong yet light, Old Towns are built to give years and years of pleasurable, reliable service.

FREE CATALOG shows all kinds of canoes for paddling, for sailing, for outboards. Also sailboats, outboard boats, dinghies, rowboats. Send for it today. Address Old Town Canoe Company, 642 Elm St., Old Town, Maine.

*"Old Town Canoes"*

Easy way  
to strip  
paint...

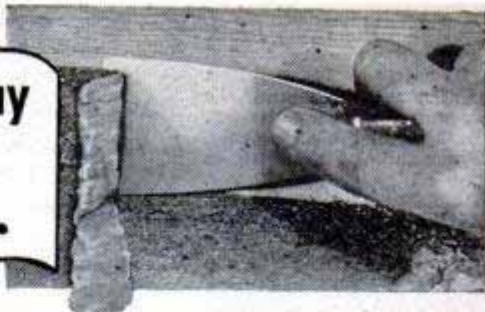

**WONDER-PASTE**, applied with a paint brush, softens up the toughest paint, varnish, enamel or shellac right down to the surface. Comes off clean at every stroke of your putty knife. Try it. At paint and hardware stores. . . Write for leaflet on Wonder-Paste and advice on your particular removing problem.

Wilson-Imperial Company, 119 Chestnut Street, Newark 5, N. J.

## FREE AMAZING NEW BOOK "HOW TO ANSWER ADS"

how to  
answer  
ads

Never before have you seen anything like this. Tells you in simple language the correct way to answer ads. Gets you quicker replies—better results, and greater satisfaction. Will save you time and money and it's ABSOLUTELY FREE. No obligation whatever. Every reader of advertising should have this booklet. Send a postcard for your copy NOW. Advertising Department, Popular Mechanics Magazine, 200 East Ontario Street, Chicago 11, Ill.

## SAVE MONEY

Build this 18 ft. House Trailer yourself \$286.00. Blueprints, Building instructions and 1950 parts catalog 50c. Don't Delay, Write Today



NATIONAL TRAILER EQUIPMENT COMPANY  
Dept. PM-2, 1007 N. WATER STREET, MILWAUKEE, WISCONSIN

## STANDARD GARDEN AND SMALL FARM TRACTORS

Plow Seed Cultivate Mow Hay and Lawns Powerful Gas Tractors for Small Farms, Gardeners, Florists, Poultrymen, Fruit Growers, Suburbanites. 1 & 2 Cylinders High Wheels. Rubber or Steel Tires. Walk or Ride.

Easy Terms—Free Catalog

STANDARD ENGINE CO.  
MINNEAPOLIS, MINN. NEW YORK, N. Y.  
3221 Como Avenue 617 West 26th Street



## GENUINE DIAMOND SCRIBER!

Writes on glass, metals, plastics. Hex. Aluminum 6". Money back guarantee. Agent inquiries invited.

**\$2.00** Postpaid  
CLIPPER DIAMOND TOOL CO., INC. 21-B W. 46 ST., N.Y. 19

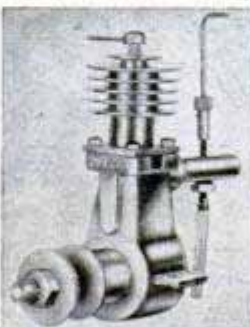

★ ★ ★ ★ ★ ★ ★ ★ ★ ★  
OUR 238th ADVERTISEMENT

## REAL DIESEL ENGINE!

**\$2.95** Ideal for planes, boats, midget cars. Actually runs at 7500 RPM, produces 1/7 HP. Precision machined for smooth operation.

You can't beat this price! Comes in kit form for easy assembly.

MAYBE WE'RE CRAZY, giving away a precision diesel engine, complete with cylinder and piston, carburetor, crankshaft, connecting rod, etc. for ONLY \$2.95.

But we're selling thousands of DEEZILS all over the world, and that keeps our production costs down. DEEZIL is streamlined, compact, rugged. Starts quickly, easy to install, runs for years! Fast delivery if you ORDER DEEZIL TODAY!

Send \$2.95 plus 25c postage  
★ GOTHAM HOBBY CORP., Dept. P, 107 E. 126th St., New York 35, N. Y. ★

★ ★ ★ ★ ★ ★ ★ ★ ★ ★

# Start Small...Grow Big... with Success Equipment

Your big years are right ahead! You can tie in with the great building industry, yet develop your own business manufacturing concrete block, drain tile, brick, roof tile, etc. We'll start you right in the

## Modern Masonry Products

business and help you put it over. We supply complete equipment, built and developed through forty years of dealing with men like you. Helps you build for local market, using local materials and labor. High income potentials. Our line of modern machinery enables you to start small and grow big. Write for new Descriptive Catalog.

### CONCRETE EQUIPMENT CO.

512 Ottawa Ave.,  
Holland, Mich.



## AIR TANK and ACCESSORIES

Air receiver, stainless steel, 12 1/2"x24", 400 lb. test. Ideal for carrying on trucks, autos and wherever compressed air is needed. Equipped with 500 lb. air gauge, tire chuck, 3 ft. highest test air hose, air inflation valve with core for retaining pressure in tank, and fittings. Complete outfit \$6.95. Shipping wt. 20 lbs. Same unit but with 6"x24" tank.....\$5.95

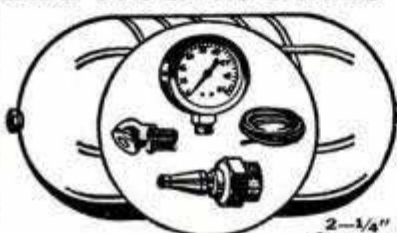

2-1/4" Openings

Prices F.O.B. Chicago. Sold on money back guarantee. Send check or money order today. CATALOG FREE.

### WELLWORTH TRADING CO.

1831 S. STATE STREET, DEPT. D-2 CHICAGO 16, ILL.

**SAVE GAS?**

## FREE TRIAL in your car famous GANE Air-Flow Needle

(Replaces present idle adjustment screw in your carburetor)

New Automotive Discovery—Install them YOURSELF in 5 Minutes

Users report up to 4 EXTRA MILES PER GALLON—comment on SMOOTHER MOTOR, EASIER STARTING, FASTER PICK-UP, BETTER IDLING. (About 1/2 million now in use) However, needles DO NOT show improvement in SOME cars due to type or condition of motor. So try them FIRST for 10 days AT OUR EXPENSE. Check gas mileage and engine performance—if satisfied—send only \$1.50 per needle; (8 cyl. cars take 2) if not satisfied—return them—FAIR ENOUGH? Send card today with name, address, make of car and carburetor—Needles sent Postpaid.

SEND NO MONEY—AMAZING FREE TRIAL OFFER—PAY POSTMAN NOTHING  
NATIONAL AUTOMOTIVE RESEARCH CO. 350 W. Washington Blvd.  
Dept. J-2, Venice, Calif.



## MODERN LAWN MOWER SHARPENER

FOR LAWN MOWER SHOPS  
FIX-IT SHOPS

GOLF COURSES • PARKS  
101 OTHER JOBS

Sharpens All Reel Type Mowers • Hand, Power or Gang • 10 to 20 Minutes • No Dismantling • No Extra Attachments Needed.

All reel type mowers, from 5-inch edgers to 36-inch power mowers, are quickly sharpened to extreme ends of both left and right twist blades.

Handle, wheels, roller and motor remain in place when sharpening is in process. Bed knife is sharpened in same brackets. Grinding head rides on five ball bearing races. Easy to operate. Also sharpens chisels, jointer knives, planer blades. Big profit maker. Own your own business. Send Today for FREE Illustrated Bulletin No. 10-C

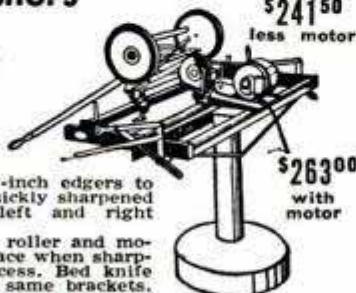

PRICE \$241.50  
less motor

\$263.00  
with motor

ORDER NOW  
Immediate Delivery

MODERN MFG. CO. 160 N. FAIR OAKS AVE.  
PASADENA 1, CALIFORNIA

# MILL IT ON YOUR LATHE



WITH A

## PALMGREN



### MILLING ATTACHMENT

#### Convert Lathe in 10 Seconds

Now—you can do milling, slotting, grinding, grooving, squaring shafts, sawing at angles, and many other important operations on your lathe. PALMGREN MILLING ATTACHMENT is a necessary fixture for small shops, schools and emergency work in large plants. Fits South Bend, Atlas, Craftsman, Logan, Sheldon and all other makes. It has graduation for rotary angle adjustments, also graduated feed and adjustment screw. Easily mounted by straddling lathe's regular tool post. Try one—it will quickly pay for itself.

#### IMMEDIATE DELIVERY

Nos.	Width Jaws	Depth Jaws	Jaws Open	Weight Pounds	Base Opening	Price F.O.B. Factory
150	1 1/2"	1"	1 5/8"	6 1/2	1"	\$18.75
250	2 1/2"	1-7/16"	2 1/2"	11	1 1/4"	24.75
400	4"	1 1/2"	4"	25	2"	39.75



Order from your dealer or jobber. Write for circular No. 354

### CHICAGO TOOL AND ENGINEERING CO.

Mfrs. of PALMGREN PRODUCTS for Over 25 Years  
8365 South Chicago Avenue Chicago 17, Illinois

## AUTO MECHANICS! BOOST YOUR EARNINGS

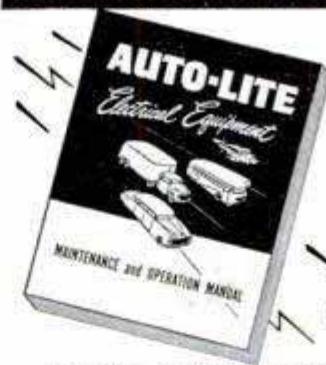

# AUTO ELECTRICAL SERVICE

*made easy!*

### JUST OFF THE PRESS

Contains technical information

Only \$2.00  
Over 200 pages

... packed with latest service methods.

The finest, most completely illustrated full color book on the complete automotive electrical system. Includes full information on the seven basic electrical circuits built by Auto-Lite... Starting—Charging—Ignition—Horns—Windshield Wipers—Instruments—Lighting. Plus Trouble Shooting Charts worth many times the price of the book. Gives you the answer every time.

### SPECIAL! NO MONEY COUPON

THE ELECTRIC AUTO-LITE COMPANY—Toledo 1, Ohio

Yes, send me your "Maintenance and Operation Manual" by return mail. I will pay the postman when he delivers my copy \$2.00 plus postage. (If \$2.00 is enclosed with this coupon, the book will be sent postpaid.) If after 10 days I am not satisfied I may return the book and my money will be refunded.

NAME \_\_\_\_\_

ADDRESS \_\_\_\_\_

THOUSANDS BUILD AT 1/2 THE PRICE



# 20 MODELS U-MAK-IT BOAT KITS

EASY TO BUILD

## ROWBOATS

8 TO 14 FT.

Special Models For Fishermen



## PRAMS

## OUTBOARDS

Fast Round or V Bottoms  
12 TO 16 FT. Newest Assembly Methods

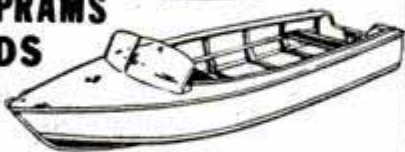

## INBOARDS & CABIN CRUISERS

For Fishing, Racing or Cruising 16 TO 23 FT. Pre-Assembled Frames



SEND 25c (coin)  
ORDER YOUR  
CATALOG TODAY

U-MAK-IT PRODUCTS 703P-WHITTIER ST.  
NEW YORK 59, N. Y.

## NOW! unequalled TILLAGE CONTROL



## WITH THE New MOTORIZED SEAMAN TILLER

Now you can select rotor speed for best tillage (medium, fine, coarse) for each soil and crop. Reason: gear-shift transmission controls rotor speed . . . SEAMAN means adjusted tillage, — secret of high yields. Rocks no problem. Complete tillage generally in one trip. Mixes-in fertilizer uniformly. GET SEAMAN for spring tillage.

Complete story of Seaman Tillage in new FREE BOOK "Benefits of Rotary Tillage." Send for it—now.

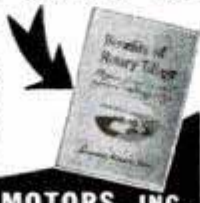

SEAMAN MOTORS, INC.  
364 N. 25th Street  
MILWAUKEE 3, WISCONSIN

# ELECTRIFY any SEWING MACHINE

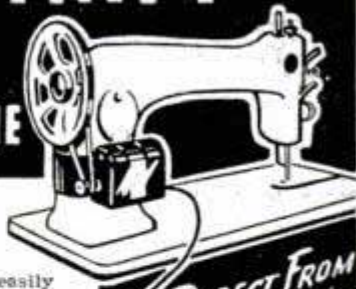

MAKE YOUR PRESENT SEWING MACHINE INTO A MODERN ELECTRIC WITH THIS SIMPLE-TO-INSTALL KIT.

Anyone, including children, can easily attach this unit. Wired and ready for immediate use.

Lowest price conversion unit on the market. This price possible only because you are buying direct from Sewing Machine Conversion Unit Co. GUARANTEED FOR 1 YEAR.

You get:  
• AC-DC Universal Motor • Carbon Type Speed Control Rheostat • 3 Genuine Rubber Belts • Steel Pulley • 2 Mounting Brackets • Underwriters Cord Set with Plug & Socket • Complete very simple instruction sheet.

FREE—Beautiful, non-glare finest quality sew light as a special bonus if you act now. Worth \$2.75.

FREE TRIAL OFFER—If not completely satisfied, return kit within 10 days for full refund immediately. \$12.50 complete including everything postpaid. If C.O.D. send 25% with order, balance C.O.D. plus postal charges. State whether handwheel turns toward or away from you.

DIRECT FROM  
MANUFACTURER

\$12.50  
POSTPAID

SEWING MACHINE CONVERSION UNIT CO., Dept. PM-7  
366 MADISON AVE. NEW YORK 17, N. Y.

## DOUBLE ACTION HYDRAULIC ACTUATING CYLINDER



Also pneumatic. Raise, lower, push, pull machinery, garage doors, dump trucks, bulldozer blades, shovels, other uses. Brand new; war surplus; Has attached high pressure swivel connector. Genuine Bendix Aviation part #402685; 4" bore, 18" stroke, 31" long; solid impeller shaft, 1 1/2" diam.; mounting holes, 5/8" I.D. 100-2000 p.s.i.; fittings 3/8"-16 thread. Gov. cost \$200; a top value; powerful, economical. Only \$24.50 Chicago area. Send check or money order. 25% w. C.O.D.'s. Sh. Wgt. 40 lbs. Satisfaction guaranteed. Order today. Quantity buyers, write for spec. discount.  
STAHLER DISTRIBUTORS, PM-2, 810 Michigan, Evanston, Ill.

Only \$24.50

## HOW TO CUT RAFTERS

New vest pocket book gives lengths, side cuts, plumb cuts, deductions, for all rafters any building from one inch to forty feet wide. Gives numbers to cut on square. All standard pitches from 1 1/2" to 12 up to 17 1/2 and 12 rise. Any one can frame a roof with this great book. Just open book to your pitch page and there in plain print is your lengths cuts and deductions for any pitched roof. Also gives how to figure elevations. How to figure lumber. How to lay out window and door openings. Written by Harry (Dad) Bleam and it's a dandy. Price only \$2.00 each.

Builders' Topics, Dept. PM, 1512 Market St., Seattle 7, Wash.

**MAGNETS** OF ALL TYPES—10c UP  
AMAZINGLY POWERFUL!!  
4 oz. Alnico Magnet, lifts 10 lbs. \$1.10. Our Leader, 15 oz. Magnet, lifts 40 lbs. \$2.50. New alloy—will not weaken! Useful for lifting valuables from tanks, lakes, or rivers easily! 7 small magnets \$1.10 with list of many shop and home uses. Satisfaction guaranteed.  
R. EYRICH, 2566 N. 49TH ST., MILWAUKEE 10, WIS.

## FILE SAWS FOR PROFIT!

### New Rapid Saw Filer

Opens the door to extra income. Easy to operate. Fast, efficient BeMaCo power filer for hand saws. Priced right! Does a beautiful job. Operator has complete control.

### BeMaCo Automatic Saw Set—

Uniformly sets 400 teeth per minute. Perfect hammer and anvil action. No tooth breakage.



WRITE FOR  
DETAILS  
TODAY

BEAVER MFG. CO.

802-J 1515 AVE.

INGLEWOOD, CALIF.



T. M. REG.  
U. S. PAT.  
OFF.

# Snap-on's FAMOUS Ferret Set



**Special Ferret Tools**  
not  
included  
in set



**DOUBLE HEX  
FLEXOCKETS**

Saves a lot of tough work fumbling for hard to get at studs and bolts. Eight sizes: 5/16" to 3/4".



**PLASTIC GRIP  
HANDLE**

A shockproof, plastic handle, 5 1/8" long that is ideal for electric work. Makes your Ferret Set more useful.



**RATCHET ADAPTOR**

Converts any combination of Ferret handle, extension and socket into a reverse action ratcheting tool.

**\$27<sup>65</sup>**

Add Local Sales Tax

This set is way over par in performance... the tools are strong and easily adaptable to a variety of jobs... they squeeze into tight places and get hard-to-reach nuts that defy the ordinary type wrench. INCLUDED IN THE SET: 1/4" and 5/16" single broached sockets; 11 double broached sockets from 3/8" to 7/8"; a speedier wrench, sliding tee, 8" reversible ratchet, nut spinner and universal joint, plus a 3", 6" and 12" extension. All complete in a metal box.

**SNAP-ON TOOLS CORPORATION**

8062-B 28th Avenue, Kenosha, Wisconsin

Enclosed find  check  Money Order or  Company Purchase Order for the \$27.65 Snap-on Ferret Set.

Please send illustrated brochure describing 109 individual Ferret units.

Name.....

Address.....

City..... State.....



**Get largest auto accessory & parts catalog in world.** Over 15,000 items, including Hollywood accessories, hi-speed equipment, rebuilt engines; all parts & accessories for all cars, trucks. New, used, rebuilt! We have that hard-to-get part! Completely illustrated, jam-packed with bargains! Send 25c.

J. C. WHITNEY & CO., 1917 ARCHER AVE., CHICAGO 16

## Stucco Spraying Can Be Your Opportunity



You can build a profitable, lifetime business with Colorcrete. Large waiting market. Work is easy and interesting. Moderate investment; high return. Large waiting market. Full instructions and liberal co-operation.

### Sprayed-On Beauty

Colorcrete is modern beauty treatment for masonry surfaces—exterior and interior. Fuses to concrete, stucco, etc. Applied by air pressure. Range of many smart colors. Proven by 20 years of use on all kinds of buildings.

Write or wire for Opportunity Book.

**COLORCRETE INDUSTRIES, INC.**

570 Ottawa Ave.,  
Holland, Mich.



IT'S a cinch to insulate your home with Gold Bond Rock Wool Batts or Blankets. You'll save a lot of money in fuel bills and keep your house warmer in winter, cooler in summer. Light, easy-to-handle batts slide between rafters or attic floor joists. You get extra fire protection too. Gold Bond Rock Wool Batts and Blankets *can't burn*. Batts are 2 and 4 ft. long, Blankets 8 ft. long. Both come in standard widths to exactly fill the space between framing members. Be sure they're "full-thick" and bear the Gold Bond name for maximum insulation and fire protection. For a free booklet giving details, write Division Y, Department PM-2.

Available at your local Gold Bond Lumber and Building Supply Dealer!  
**NATIONAL GYPSUM COMPANY**  
BUFFALO 2, N. Y.

# PRESSURE QUEEN

*Outperforms them all!*

**T**HE only portable air compressor having 4 cylinders in space usually required for one—absolutely no pulsation. Does more painting in an hour than hand brushing in a day. Lubricates machinery, inflates tires. Ideal for home,

farm, service station, machine shop and contracting painter. Powered by gas engine or electric motor.

*Write for Literature and Prices*

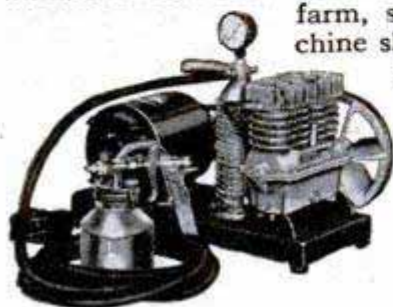

**THE CAMPBELL-HAUSFELD CO.**

1046 RAILROAD AVENUE HARRISON, OHIO

Curved edge tools need  
**CRYSTOLON®**  
round-edge slip



A few strokes on this handy NORTON abrasives stone, and your gouges and combination plane cutter are "rarin' to go" for a clean, fast job. Just one of the many forms in which NORTON abrasives sharpening stones are available. Get one at your hardware store today.

SEND FOR "HOW TO SHARPEN"



18-page booklet packed with diagrams on sharpening home shop tools. Send 10¢ to: Dept. PM-2, Behr-Manning, Troy, N. Y.



**BEHR-MANNING**  
TROY, N. Y.  
NORTON abrasives

# NEED MORE? MONEY?

Thousands already earn big, steady profits selling famous Bostonian shirts, rainwear, hosiery, underwear and other everyday needs for men, women and children. Also new line of Hamilton shoes. No selling experience needed — if you're keen and really want to assure yourself of a steady income, Bostonian will back you and set you up in business. You get big profits, immediate cash and big selling kit. Our Company has tripled its business in the last year. Write now — big Spring season ahead. Bostonian Mfg. Co., Dept. 303, 89 Bickford Street, Boston 30, Mass.

Write for  
**FREE**  
Selling  
Kit

## UTILITY TOOL CASE

especially designed for home-and-farm owners, craftsmen, radio and TV repairmen, fishermen, hunters, campers. Adopted by large utility companies for service men. Resists rust. Made of hard vulcanized fibre with reinforced corners, with removable tray and space for electric or large tools. Strong, durable, light! Solid, comfortable plastic handle. Full 8 inches wide; 9 inches high; two sizes:



17 inch (6 compartments) \$6.25 postpaid.

21 inch (8 compartments) \$6.50 postpaid.

NO C.O.D. Moneyback guarantee if returned within 10 days in good condition.

**WILLHOUR COMPANY**

277 N.J.R.R. Ave., Newark 5, N. J.

## D.C. ARC WELDER

OVER \$300 VALUE AT LESS THAN 1/3

200 Amperes Continuous Duty. Up to 250 amps. Intermittent duty. Easily mounted on your tractor. Welding range from 0-up by dial type control. 1-yr. guarantee with money back 10-day trial period. Write for FREE literature. OR send 35¢ for PLAN "Build Your Welder from Aircraft Generator" literature included.



LEJAY MFG., 847 LeJay Bldg., Minneapolis 8, Minn.

Only \$498



**OTTAWA**  
Mule Team Tractor

Finest low-cost tractor. Costs too little to do without. Engines burn gasoline or kerosene. Starter and lights available. Other larger Models to choose from. Over 4,000 in world-wide use. Time-proved and tested. At low cost they easily mow, plow, disc, harrow, plant, cultivate, etc. Sold only direct to user. Write for FREE details.

OTTAWA MFG. CO., 2-027 Garden St., Ottawa, Kansas

Say You Saw It in Popular Mechanics

## NEW PACKAGED BOATS 1950 KITS



17 New models. Improved design, skiffs, outboards, inboards, sail boats. Tredronic racers, cruisers. 8 to 16 ft., exclusive features. Preassembled frames, Tri-Keel construction, Tredronic bottom, full length spray rails, widest beam, simplified construction, easy to build. World's best boat buy! Send 25¢ for new 1950 literature, or send \$1.00 for literature, plus booklet "Plywood Boats."

## BOAT PATTERNS-BLUE PRINTS

1950 Catalog—over 100 modern designs by famous naval architects. Racing classes, cruisers, inboard, outboard, sail, 6 to 35 ft. Plywood-Steel-Plank. Construction plans, full-size patterns. Send 35¢ for catalog or \$1.00 for catalog and helpful booklet on "Boat Building."

MARINE MART-DEPT. 24-BUFFALO 7, N. Y.

# REDUCED PRICES ON 1950 CROSLLEY CARS!



Now it's easier than ever to own a new Crosley. 1950 prices are down, way down. Station Wagon reduced \$105. Big price reductions on all models. Hundreds of improvements, including Hydradisc (airplane type hydraulic) Brakes and Crosley engine with rugged cast iron block—8 to 1 compression ratio. See, drive the newest Crosley Station Wagon. All steel. Seats 4, or 2 with 1/4 ton load. Gives you 35 to 50 miles on a gallon of regular gasoline plus all new-car economies and safety features! Dealers and driver agents wanted.



**FREE!** Just out! 1950 CROSLLEY CATALOG. Write Crosley Motors, Inc., 2530-HO Spring Grove Ave., Cincinnati 14, Ohio.

**CROSLLEY**

a FINE CAR

"You see them everywhere!"

## CARBURETOR TOO RICH MAKES MOTORIST TOO POOR



Car owners who are wasting money and not getting proper gas mileage due to over-rich mixtures will be pleased to learn how to save gasoline by VACU-MATING over-rich mixtures. VACU-MATIC fits all cars, trucks and tractors. It is automatic and operates on the supercharge principle. Easily installed in a few minutes.

**SALESMEN WANTED!** Big Profits! Send name, address on penny postcard for free particulars and how to get yours for introducing.

VACU-MATIC CO., 7617-1560 W. State St., WAUWATOSA, WIS.



### HANDY CALCULATOR FOR WOODWORKERS.. ONLY 10c

Just set dial, quickly solves countless problems. Converts linear to board feet, compares workability of various woods, shows bit sizes, nail specifications. Also tool sharpening tips, etc. 6" diameter heavily varnished cardboard. Send 10c to Greenlee Tool Co. 2102 Columbia Av., Rockford, Ill.



Look - ONLY \$39.95  
for This 5-in-1 Machine

EQUALS  
\$200  
IN SINGLE  
UNITS

Become an expert craftsman. Operate profitable business at home. Save money on household repairs. Lifetime pleasure for entire family at few cents per hour, making things from wood, metals, plastics.

### HEAVY-DUTY TOOLS AT FACTORY COST

EMRICK is 5 precision power tools in ONE assembly, using ONE Motor. Equals in performance separate units costing up to \$200—yet our price only \$39.95 for everything identified above. Thousands of satisfied customers. Our 52nd year building fine tools.

WRITE FOR FREE Literature on New 1950 features; Reduced Price Specials; and MONEY-BACK, FREE-Trial, Easy Payment Plan. EMRICK, Inc., 1927 Clinton Avenue, Kalamazoo, Michigan.

The saw most  
carpenters use

**DISSTON**

**HELPS YOU  
DO YOUR  
BEST WORK**



The Disston line is complete... correct sizes and types for all your work. You'll be sure of the saw made to standards that have won overwhelming preference from America's carpenters! Here are a few reasons:

**Disston Steel**, made under Disston control, means hardness and temper to make tooth edges last longer.

**Disston Skill** assures finest balance, plus true taper grind for easy clearance, plus uniform tooth edge—big aid to accuracy.

See your Hardware Dealer

EXTRA LONG-LASTING EDGES—  
in any Disston Saw for any work



Disston Back Saw



Disston Coping Saw



Disston Compass Saw



Disston Nest of Saws

### HENRY DISSTON & SONS, INC.

211 Tacony, Philadelphia 35, Pa.

In Canada, write: 2-20 Fraser Ave., Toronto 3, Ont.

**FREE** Disston Saw, Tool and File Manual is a "gold mine" of information about choosing, using and caring for your tools. Send coupon now, for your copy free.

HENRY DISSTON & SONS, INC.,  
211 Tacony, Philadelphia 35, Pa.

Please send me a copy of the Disston Saw, Tool and File Manual entirely FREE.

Name \_\_\_\_\_

St. and No. \_\_\_\_\_

Town and State \_\_\_\_\_



"SAVE IT AND  
FIX IT"

# FIXES

FURNITURE, DISHES, TOYS  
BOOKS AND GLASSWARE

It's transparent, waterproof,  
flexible and durable.  
Get a tube  
today.



## DUCO CEMENT

REG. U. S. PAT. OFF.

## Make up to \$4<sup>00</sup> an Hour THIS EASY WAY



### with FOLEY LAWN MOWER SHARPENER

"At \$2.00 a mower the Foley makes me \$4.00 an hour and I am still under doctor's care. How many men punching time clocks can earn \$4.00 an hour?"—FRANK S. RILEY. "Will have my machine paid for and more than \$300 clear this season"—says A. W. Bishop.

Why don't you get into this steady CASH business? The Foley Lawn Mower Sharpener does a beautiful job on all hand and power mowers, without removing handles, which saves time and enables you to sharpen up to 3 or 4 hand mowers per hour at \$1.50 to \$3.00 each, and 1 or 2 power mowers at \$5.00 to \$8.00 each. Foley prices are only \$98.50 to \$139.50 and the Foley builds you a steady repeat business. Easy payments if desired.

**FREE BOOK—"HOW TO SHARPEN POWER MOWERS"** shows just how to sharpen any make of power lawn mower with the Foley. Mail coupon today—we'll also send FREE PLAN telling how to start your own business without previous experience. No salesman will call.

**FOLEY MFG. CO.,** 207-0 Foley Bldg.,  
Minneapolis 18, Minn.  
Send FREE BOOK "How to Sharpen Power  
Mowers", and FREE PLAN on lawn mower  
business.

NAME \_\_\_\_\_

ADDRESS \_\_\_\_\_



## I need 500 Men to wear **SAMPLE SUITS**



### PAY NO MONEY— SEND NO MONEY

My values in made-to-measure suits are so sensational, thousands of men order when they see the actual garments. I make it easy for you to get your own suit to wear and show—and to **MAKE MONEY IN FULL OR SPARE TIME!** MY PLAN IS **AMAZING!** Just take a few orders at my low money-saving prices—that's all! Get your own personal suit, and make money fast taking orders. You need no experience. You need no money now or any time. Just rush your name and address for complete facts and **BIG SAMPLE KIT** containing more than 100 actual woolen samples. It's **FREE!** Send your name and address today!

### STONE-FIELD CORP.

532 S. Throop St., Dept. B-876, Chicago 7, Ill.

Pioneers

Leaders

**AIR RIFLES**

## BENJAMIN

**AIR PISTOLS**

WITH SAFETY LOCK

SEND FOR FREE FOLDER OF LATEST MODELS TODAY

If you want a REAL GUN for PRACTICAL USE inside or outdoors, get a **SAFE—CLEAN—ECONOMICAL—BENJAMIN** with Adjustable Power and Amazing Accuracy. Use **BENJAMIN H-C PELLETS** for BEST RESULTS in all rifled models. **WRITE AT ONCE.**

**BENJAMIN AIR RIFLE CO.,** 812 MARION ST., ST. LOUIS 4, MO.

### NEW GOVT. SURPLUS **HOIST and WINCH**

Originally made to be used on B-29s for lifting bombs. Mounted on welded steel base, can be attached to truck body or any solid base. Ideal for lifting or moving loads onto trailers, trucks or tractors or for machine shops, garages or warehouses. Capacity 2,000 lbs. Equipped with ratchet for holding load and 18 ft. 3/16" steel cable. Shipping wgt. 50 lbs. **FOB, K.C., Mo. Quantity discounts 6 or more.**

**\$29<sup>95</sup>**



Send check or M.O. for immediate delivery. No COD's

### AMERICAN AUTO PARTS CO., INC.

1830 LOCUST DEPT. PM9 KANSAS CITY, MO.

## New 1950 Plastics Supplies Catalog

Just off press. Get details on Plexiglas, Lucite, rods, sheets, tubes, Acetates, cements, dyes, buffs, molding sets, tools, carving kits, everything in plastics. Lowest prices. Price 10c, stamps or coin, with ad for catalog.

Plastics Mfg. & Supply Corp., Dept. PM-2, 4707 Euclid Ave., Cleveland, Ohio

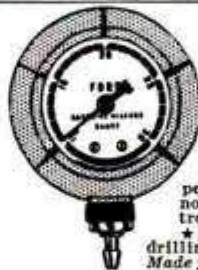

## Auto GASOLINE MILEAGE GAUGE \$5.00

SAVES 1 GALLON IN 10

REDUCES OTHER OPERATING COSTS

Shows actual gas mileage at all speeds \* Eliminates fuel wasting habits \* Shows how to get most miles per gallon and makes driving more economical \* Quickly detects minor engine troubles before they become serious

\* Installed in a few minutes "no drilling"—no special tools \* Made for all cars—Specify make and model—Enclose Check or Money Order \* 10 day Money Back Guarantee

## AUTO - magic LIGHTER \$3.95

Fits any car! Install it yourself under dashboard. Humidifier keeps 25 cigarettes fresh. Lights and dispenses to driver or passenger. We pay postage—Enclose Check or Money Order. 10 day Money Back Guarantee



Southwest Specialty Co. 308 1/2 N. HARWOOD DALLAS 1, TEXAS

# TOOL BARGAIN OUTFIT

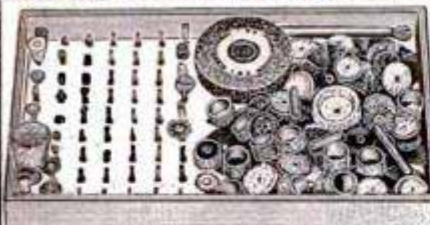

**The Master Kit**  
fits all hand grinders  
for **CUTTING,**  
**SHAPING, GRINDING,**  
**POLISHING** Wood,  
Metal or Plastic  
**\$50 Value**

Complete **\$9.75**  
in Sturdy **Post Paid**  
Compact **in U.S.A.**  
Container

**AT NO EXTRA COST!**  
High Speed Steel  
Rotary File (list  
\$2.55) included if  
you order now.

**NOTE:** This Master Kit  
is brand new.  
Get yours now while  
the getting's good!  
Rush Check or M. O.

- 3 Grinding Wheels 1 to 3" in diameter
- 12 Mounted Stones 1/8, 3/32, 1/4" Shanks
- 9 Rotary Cutters 1/8 and 3/32 Shanks
- 30 Miniature Rotary Cutters 3/32 Shank
- 10 Cut off Discs and Grinding Wheels
- 1 Drum Sander 1/2" Shank
- 15 Abrasive Bands for Drum Sander
- 15 Leather & Felt Polishing Wheels—1/2 to 1" in diameter
- 15 Felt Polishing Cylinders with Mandrel
- 25 Abrasive Sanding Discs 1 1/2 to 2" dia.
- 3 Rubber Wheels 7/8" diameter
- 2 Speed Drills 3/32 Shank
- 2 Mandrels 1/8 and 3/32" Shanks
- 3 Bristle Brushes
- 1 Rotary Wire Wheel Brush
- 1 Circular Saw on Mandrel 1/8" Shank
- 2 Rubber Cylinders with 3/32" Mandrels
- 150 other items—all new and valuable

## 2 CIRCULAR SAWS

ON 2 MANDRELS—BOTH AT  
ONE RECORD BREAKING PRICE **\$1.50**  
1" diameter saws on 1/8" Man-  
drels. For cutting wood, plas-  
tic, or soft metals. Order at  
once! Send Check or Money  
Order for this big bargain.



4 in. CIRCULAR SAWS, 1/2" arbor holes... 2 for \$1.50

SCHUPACK SUPPLY CO., 7331 Cottage Grove, Dept. M-2, Chicago 19, Ill.

Send 10c for Illustrated Bargain Catalog

## BUILD YOUR OWN POWER LAWN MOWER

WRITE  
FOR  
**FREE**  
Building  
Instructions  
The Rite-Way  
Mower  
Attachment



**WHY PAY MORE FOR  
FACTORY BUILT MOWERS?**

Now anyone can save time and effort  
mowing field or lawn by building their  
own whirl type Power Mower. Build it  
in a short time with parts and instructions  
we furnish. Requires no special tools.

**WRITE TODAY FOR  
FREE BUILDING INSTRUCTIONS**

T & H Mfg. Co., Inc.  
Dept. MPB-2, 811 E. 31st St.  
Kansas City, Mo.

## Free Booklet on FLEX-O-SHAFT

illustrating this all-purpose power machine with hand-piece that  
handles as easily as a pen. Motor with switch, foot-operated rheostat,  
and 66 accessories at special low price. Write

**F. W. STEWART MFG. CORP.**

Dept. A 4311 Ravenswood Ave. Chicago 13, Ill.

Always write your name and full address  
clearly when answering advertisements



It's easy to hone keen edges on chisels and  
plane blades. Precision adjustment for ANY  
ANGLE of bevel. Roller glide makes strokes  
uniform across stone. Light, strong—ideal  
for craftsmen, hobbyists, carpenters. For  
Honing Device combined with genuine Norton  
Abrasive Keen-Cutting oil-filled stone send  
\$4.25 (Shipped Postpaid)

SEND US  
**\$2.42**

(Honing  
Device only)

**BURGI BROS., REXFORD, N. Y. POSTPAID**

**SAVE TIME!  
AND WORK!** **MAKE EXTRA!  
MONEY!**



**EASY TO  
OPERATE**

**SHAW  
"DU-ALL"**

and **"PEPPY PAL"**  
**GARDEN TRACTORS**

**PLOW**



**HARROW**



**CULTIVATE**



**MOW**



**RIDE**

AW-2

**SHAW  
MFG. CO.**

These sturdy walking and riding  
tractors ideal for dozens of uses around  
the farm, orchard, garden, golf course,  
estate and poultry farm.

### DO DOZENS OF JOBS

Shaw Du-All or Peppy-Pal tractors do  
many jobs quickly and easily. Plow,  
cultivate, harrow, mow, disk, bulldoze,  
spray, grind, haul and saw wood. New  
uses discovered every day.

### BUILT FOR RUGGED WORK

Sturdy, extra-strength construction  
means low upkeep, long life. Patented  
tool control allows quick shift for crook-  
ed rows. Attachments easy to change  
with improved "Jiffy Hitch."

### CHEAP TO OPERATE

Operates on a few cents an hour. Soon  
pays for itself in time and labor-saving  
plus low initial and operating costs.

### LOW FACTORY PRICES

Buy direct or through your dealer! Al-  
most anyone who has a garden can af-  
ford a Shaw Du-All or Peppy-Pal.  
Full year's guarantee.

### RIDING TRACTORS

Four models, from 5 to 12 H. P., 58 in.  
wheelbase, 36 in. wide, 24 in. plant clear-  
ance. Hand or electric starter. Improved  
steering device, brakes enclosed in differ-  
ential housing shaft. Standard hitch for  
trailers and wagons. Plow, harrow, culti-  
vator, cutter bar, snow plow, bulldozer  
available.

**PROMPT SHIPMENT** No waiting  
— order now for immediate delivery.

**FREE:** Illustrated folders giving  
complete details and price  
lists. Write today:

4502 Front St., GALESBURG, KAN.  
668-G North 4th St., COLUMBUS, O.

## HELPFUL BOOKS

Send post card asking for **FREE** catalog  
Popular Mechanics Press, 200 E. Ontario, Dept. 601, Chicago 11

## SAND! MASSAGE! POLISH!

Exclusive  
**DOUBLE  
ARC  
MOTION!**



14,400  
RAPID  
POWER  
STROKES  
A MINUTE

New  
**SYNCR**  
ELECTRIC

Only \$14.50  
**SANDER  
POLISHER  
MASSAGER**

Amazing new device for light sanding, polishing and  
body massaging ready! SYNCRO sands, polishes in  
tight places, corners, around mouldings and on flat,  
curved or irregular surfaces. Just guide it! Easily  
adjustable. 60 cycle, 110-120 volt AC. With 10  
sheets sandpaper, fabric, lambswool pads, cord,  
plug, \$14.50 at Dealers! If he hasn't, send \$14.50  
to factory, we'll ship Sander postpaid. See other  
Syncro products pages 283, 297. (Dealers write!)

**SYNCR CORP., ROCHESTER, MICH., U.S.A.**

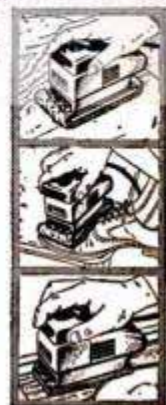

OVER THE BACK FENCE Buy SAVAGE

MOWING IS A CINCH  
WITH MY NEW SAVAGE!  
QUICK-STARTING-NO GROUND SHOCK  
OR VIBRATION-AND IT'S  
SO EASY TO OPERATE!



**SAVAGE** 21-Inch YARD CHIEF  
SAVAGE ARMS CORPORATION, Lawn Mower Div., Chicopee Falls, Mass.

For all the measuring  
at home...in the workshop  
...on the Job

USE STREAMLINE... The only rule in all  
the world with ALL these features:

Direct-reading inside  
measure... Lever brake for hold-  
ing readings... Large 7/16" claw  
tip for easy, out-of-reach measur-  
ing... Markings and graduations  
on both sides of finest grade tem-  
pered steel blade... Functionally  
streamlined lifetime chromed steel  
case. See STREAMLINE... Try  
STREAMLINE at any Hardware  
store carrying better grade tools.  
Or, if you prefer, enclose your  
check or money order with the  
coupon below.



**MASTER**

REG. U.S. PAT. OFF.

WOOD AND STEEL TAPE RULES

Master Rule Mfg. Co., Inc. PM-2  
201 Main Street, White Plains, N. Y.

I enclose \$2.25 for the 6 ft. Streamline  
\$2.50 for the 8 ft. Streamline  
Engrave my name (75c extra). Please print clearly:

NAME.....  
ADDRESS.....  
CITY..... STATE.....



**2  
DRILLS  
IN 1**

This at-  
tachment gives  
you two drills in one. It  
converts any 1/4 inch electric  
drill to 1/2 inch capacity.  
Reduction gears reduce the drill speed 5  
to 1, the average speed of a 1/2 inch drill,  
and thereby increases the power. Absolu-  
tely indispensable for all shop work

and home craftsmen. Satisfaction guaran-  
teed. Order yours now. .... **\$11.95**  
Send check or Money Order with order. post  
Jobbers write for special information. paid  
**G. M. CO. MANUFACTURING, INC.**  
1308 43rd AVE. LONG ISLAND CITY 1, NEW YORK

**S** AGENTS 300% Profit **SIGN LETTERS**  
For Store Fronts and Office Windows. Anyone can  
put them on. Free Samples. Liberal Offer to Gen-  
eral Agents.  
**METALLIC LETTER CO., 430 N. Clark, Chicago 10**

**LOOK! MARKS-ALL MECHANICAL SHOP PENCIL**



Heavy duty precision-made mechanical shop pencil. Marks on any glazed  
surface. Writes on plastics, metals, glass, china, cellophane—anything!  
Fitted with extra long quality black or red lead. Thumb-pin control for  
instant supply of fresh lead. Extra red or black leads \$2.25  
per tube of 4. Shipped postpaid. Money back guarantee. **\$1.00**  
**STUDWELL PRODUCTS COMPANY, Dept. 310**  
70 EAST 45TH ST. NEW YORK 17, N. Y.

**RAZOR BLADE BARGAIN**

Buy your double-edge razor blades retail at wholesale prices. Made  
of fine surgical steel and precision ground. GUARANTEED—complete  
satisfaction or your money refunded. Order yours today—introductory  
offer 100 blades for only \$1.25.  
**MYLOMO AGENCY, P. O. Box 59, Bronx 53 N. Y.**



**\$2.95  
EACH**

**NOW! FILE YOUR OWN SAWS**

Do expert saw filing at home. Precision  
filing easy without experience. Two  
simple adjustments. Keeps any hand  
saw extra sharp and true-cutting. Com-  
plete with file. Money back guarantee.  
Cash with order, prepaid. (COD postage  
extra.) Order today. \$2.95.  
**ANOTHER SPEEDCOR TOOL**  
**THE SPEED CORP. PM-2**  
512 N.E. 73 Ave., Portland 16, Oregon

**FLASHBULBS CAN EXPLODE!**

**PLAY SAFE!** Use a **BROOKS FLASHIELD** on your flash reflector.  
Standard model with diffuser, \$2.25. **BLUE FILTER** to fit standard  
model, for color work, 50c. **JUNIOR FLASHIELD**, \$1.50. Buy from  
your dealer. Send penny postcard for literature.  
**BROOKS MFG. CO., 5902-B Argus Road, Cincinnati 24, Ohio**

**SAVE UP TO 25% ON QUALITY BALL-BEARING WHEELS!**

Bilt-Rite wheels roll smoothly and easily, are  
semi-pneumatic, ball-bearing, painted red;  
guaranteed top quality—and you save up to  
25%! Compare Bilt-Rite's quality and price  
—then get your order in today! Dealer  
inquiries invited.

BILT-RITE BARGAINS on BALL-BEARING WHEELS			
(For 1/2-inch Axles)			
6 x 1.00.....	\$1.30	10 x 1.25.....	\$1.95
8 x 1.25.....	1.65	10 x 1.75.....	2.15
8 x 1.75.....	1.80	10 x 2.00.....	2.45
(For 5/8-inch axle)			
6 x 2.00.....	\$3.95	8 x 2.50.....	\$4.45
		10 x 2.75.....	Only \$4.65!



**Bilt-Rite Guarantee**  
No better wheels  
are made regardless  
of price; 10 day re-  
turn privilege.

If size you need isn't listed, write for Folio A  
ORDER TODAY—Send cash, check, or M.O.—Pay postage on arrival.

**BILT-RITE WHEEL COMPANY**  
520 EAST MISSOURI AVE. KANSAS CITY 6, MISSOURI

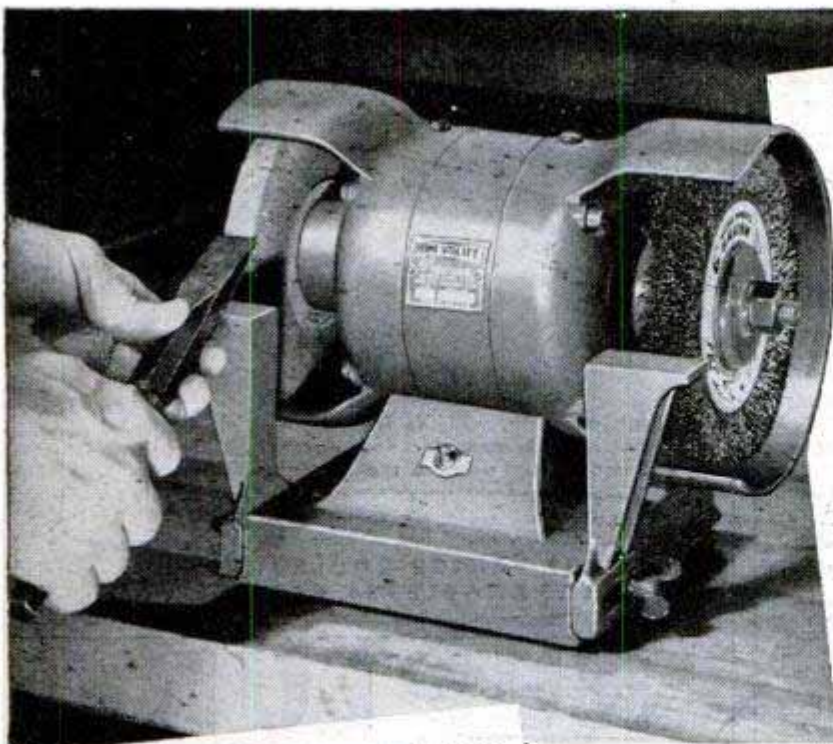

# NEW

## HOME-UTILITY 6" BENCH GRINDER

### \$38<sup>00</sup>

#### SPEEDS UP

- Tool Sharpening
- Grinding — Cleaning
- Wire Brushing

### Compare These Features Before You Buy

- Constant speed Home-Utility 1/4 h.p. motor gives plenty of power.
- Sturdy die-cast housing and wheel guards; substantial base on rubber feet.
- Tool rests locked in base grooves with winged nuts for easy adjustment.
- Full-size ball-bearings on rotor and wheel spindles, protected from dust and grit, for smooth running.
- A quality tool throughout; engineered by BLACK & DECKER, world-famous maker of electric tools for over 39 years!

THE new Home-Utility 6" Bench Grinder is one of the handiest, most useful tools you can buy for your home or farm shop. It does a whole raft of jobs like keeping tools sharp and clean; grinding minor welding jobs; removing rust, old paint, gummy dirt deposits; preparing surfaces for painting; polishing plated metal surfaces. Comes equipped with medium grinding wheel and wire wheel brush; also drives cotton buffing wheels and other attachments, available at slight extra cost.

See the **NEW Home-Utility 6" Bench Grinder** at your Hardware, Electrical or Implement Dealer.

**WRITE TODAY** for your free copy of our helpful "How-To-Do-It" booklet. Gives many useful hints on workshop and repair jobs. Write to: THE BLACK & DECKER MFG. Co., Dept. H2M, Towson 4, Md.



For Home • Farm • Shop • Tool Kit



1/4" DRILLS



1/2" DRILLS

# ELECTRIC HOME-UTILITY TOOLS



5" SANDER-POLISHERS



6" SAWS

## Cars and Trucks **START INSTANTLY**

WITH A  
**Stewart-Warner Electric Fuel Pump**



Save Your Battery with instant starts—every time! Stewart-Warner's Electric Fuel Pump fits any car or truck. Feeds a steady, even flow of fuel into your engine as soon as you switch on the ignition. Thousands now in use!

Easy to install. Complete fittings supplied. Do it yourself or see your local Carburetor Shop or Service Garage.

**FREE—Illustrated Booklet on request**  
Stewart-Warner Corp., Dept. J10  
1840 Diversey Pkwy., Chicago 14, Ill.  
Please send **FREE** Illustrated Booklet  
on the dependable new Stewart-  
Warner Electric Fuel Pumps.

Name.....

Address.....

City..... Zone..... State.....

For Cars  For Trucks

World's Largest Stocks  
of Jeep Parts

Write For Your  
Special Requirements—  
We Can Fill Any Order!

The King of Jeeps

**LOWEST PRICES IN AMERICA ON  
GUARANTEED JEEP PARTS!**



**COMPLETE  
TRANSFER  
CASE**  
A1195-  
GPW7700  
REBUILT  
(Outright)  
**\$120.00**  
(Exchange)  
\$95.00



**STARTER-  
Auto Lite**  
No. MZ4113  
A1245-  
GPW11001  
New  
**\$26.50**  
(Replacement  
Type) \$18.50



**DUAL  
WINDSHIELD  
WIPER  
KITS**

Complete with 2 motors  
Trico-SP-2467

**\$5.45**



**WINTER SPECIAL  
USED CANVAS TOPS**  
Slightly  
Soiled  
A3216—  
GPW1152700  
**\$12.50**



**WATER PUMPS**  
639992-GPW8501  
Brand New  
Outright  
**\$5.75**

**New Low Price!**



**BRAND  
NEW  
CAPSTAN  
WINCHES**  
6000 lb.  
capacity.  
Accurately  
machined

gears provide for smooth efficient  
operation. Suitable for both  
front or rear mounting. May be  
used on amphibious jeeps or  
trucks. All units are brand new  
and fully guaranteed.

**\$17.50** | 6 or **\$15** ea.  
Each | more

**TERMS:** Net cash with order.  
Open account to rated firms only.  
C.O.D. shipments should have  
25% deposit with order. All  
prices are F.O.B. our yards,  
Chicago, Illinois

**BIG, FREE CATALOG  
Write For Your Copy  
Today**

Thousands of other parts  
and accessories available.  
**SHOP BY MAIL** — Order di-  
rect from this ad today.

**BERG TRUCK & PARTS CO., INC.**  
1601 So. Wabash Avenue, Dept. M-2, Chicago 16, Ill.  
Cable Address . . . JEEP KING

**The JIFFY metal CABINET**

**YOUR ANSWER TO  
SMALL ITEMS STORAGE**  
at home, office, and shop  
(IDEAL GIFT, TOO)

So handy to keep nuts,  
bolts, screws, nails,  
parts, washers, stamps,  
hobbyists' needs, etc.,  
at your fingertips.



THIS 32 DRAWER UNIT ONLY **\$5.95** POSTPAID

Stop searching, get a 32 or 64 drawer Jiffy to keep those  
small items that usually get mislaid. Spot welded steel,  
gray enamel finish, metal drawer guides. Dividers included  
with aluminum drawers make possible three compartments  
per drawer. Looks good anywhere Send check or money  
order, please—no C. O. D.'s. Prices below. Your money  
refunded if not satisfied. Dealers write for quantity discount.

**SPECIFICATIONS**

**32 Drawer Unit**  
6" Deep  
12 3/4" Wide  
15 1/4" High  
**64 Drawer Unit**  
6" Deep  
25 1/2" Wide  
15 1/4" High  
**Drawer Size**  
1 1/4" Deep  
2 3/4" Wide  
6" Long

**WITH ALUMINUM  
DRAWERS**

**Dividers and Index  
Cards Included**

One piece rustproof alumi-  
num drawers for heavy  
service—good for work  
bench and industry use.

**32 drawer - \$8.95**  
**64 drawer - \$15.95**

OHIO ORDERS ADD 3% SALES TAX  
Marproof Rubber Feet included with all cabinets!  
POSTAGE PAID

**WITH CARDBOARD  
DRAWERS**

Suitable for most  
home uses. Heavy  
board kraft covered.  
Metal drawer pulls.

**32 drawer \$5.95**  
**64 drawer \$9.95**

3% SALES TAX  
included with all cabinets!  
POSTAGE PAID

**KAYTEE PRODUCTS, Dept. M, Box 588, Canton, O.**

**BURR HAND SAW FILER**

Makes More  
**PROFITS**

Easy to  
Operate

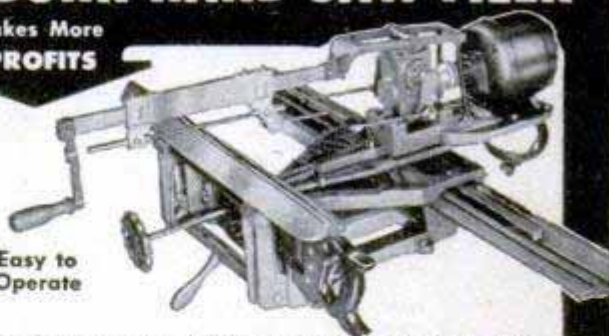

Fast, accurate, will file from both sides. Operator  
controls file arm. No saw carrier or adjusting  
screws to fuss with. A money-maker in any shop.

**BURR MFG. CO.**

8933 VENICE BOULEVARD  
LOS ANGELES 34, CALIF.

**WRITE  
TODAY!**

**RUPTURE**



**RELIEF...OR YOUR MONEY BACK**

Simple, easy to wear truss  
made by old surgical house.  
You risk nothing. Write for  
free booklet. Don't delay.

**WEB TRUSS CO. Dept. M-2 Hagerstown, Md.**

**Vickers Constant Displacement  
HIGH PRESSURE PUMP**

Use it for any type liquid pumping job 375 gal. per hr. at  
3750 R.P.M. 1000 pounds pressure per sq. in. Can be used as  
hydraulic motor O. Acq. \$100.00.

Brand new directions incl. Wt. 7 lbs. . . . . **\$8.95** Post-  
paid

**CHECK AND RELIEF VALVE** . . . . . **\$2.50** Post-  
paid

Send check or Money order. No c.o.d.'s.

**GENERAL SALVAGE COMPANY**

DEPT. 17, 2922 E. 27th ST. KANSAS CITY, MO.

**\$4.95 REAL ENGINE VALUE**

A miniature gas engine that really operates.



Thousands of Buzz "B" gasoline engines have been  
sold at twice the price. Now is your chance to  
buy a real 1/6 H.P. gas engine for only \$4.95.  
Turns up over 8,000 r.p.m. For boats, planes,  
midget cars, etc. Guaranteed and ready to run.  
Includes Champion spark plug and tank. Send  
only \$1.00, engine shipped collect for balance,  
same day.

**WRITE FOR FREE CATALOG OR  
SEND 10c FOR NEW MAMMOTH ILLUSTRATED  
CATALOG OF THOUSANDS OF HOBBY ITEMS.**

America's Hobby Center, Inc., Dept. B-20, 156 West 22nd St., N. Y. 11

Make Money  
SELLING  
Eshelman  
Kulti-Mowers  
and DOING  
GARDEN  
WORK

PLOWS  
CULTIVATES  
HARROWS  
HAULS  
SPRAYS  
MOWS  
CUTS  
ROLLS  
RAKES



FOR BETTER  
**LAWNS**  
and **GARDENS**  
also POWER MOWERS  
and RIDING TRACTORS  
Women can operate it.

Write to Dept. 51  
Eshelman Co.  
119 Light St., Balto. 2, Md.



**Make Concrete Blocks and Bricks**

New superior method makes square, true, easy-to-lay units which will  
pass any building code. Small investment, high production, big profits.  
One \$30.00 machine will make four 5"x8"x12" blocks per minute—  
1000 per day. Pays for itself in a few days. Sell blocks or save  
2/3 building cost by making and laying your own.

POST CARD BRINGS FREE FOLDER

**Economy Manufacturing Company**  
Dept. P Stone Mountain, Georgia



# MAKE MONEY at HOME

FULL or  
PART TIME

Start your own business making beautiful, salable, wood or plastic carvings in your own home, full or part time. With the amazing new Carvit Duplicator it's easy and fun to be your own boss, or supplement your pay with easy, interesting work at home.



## MAKE and SELL

**Ash Trays Ad Displays Carved Pipes**  
**Book Ends Jewelry Religious Articles**  
**Plaques Signs Wooden Dishes**

Sell homes, friends, gift stores, department stores, novelty shops, mail order, offices, etc. Big profits... steady repeat business!

## 20 MINUTES - YOU'RE AN EXPERT

That's all it takes to be an expert on the Carvit. From one inexpensive, dime-store master model, you can create scores of beautiful carvings in rare woods, exotic plastics, each worth many times the cheap original. Don't miss this opportunity for fun and profits. Order today from your local hardware dealer or send coupon.

**CUT COUPON  
and  
MAIL TODAY**



## The DUMORE COMPANY

Dept. B-51 Racine, Wisconsin

- Please send complete information on the Carvit and indexing attachment for 3-dimensional carving.
  - Please send one Carvit. \$48.50 enclosed.
  - Please send one Carvit with index attachment for 3-dimensional carving. \$58.25 enclosed.
- Shipping charges C.O.D.

NAME.....  
ADDRESS.....  
CITY..... STATE.....

DC-1

## TURN YOUR SPARE TIME INTO CASH!

## "Wellworth" Sensational Offer! Reg. \$60.50 WESTINGHOUSE AIR COMPRESSOR

Model T-1 Brand New — 2 CYLINDER PISTON TYPE.  
Operates with 1/2 H.P. Motor or equivalent gas engine.

Compressor, pressure tank, air gauge, air chuck, 20-ft. hose, pop valve, copper tubing with 4 brass flared fittings for connecting compressor to tank, 4-way cross and 3 nipples.

COMPLETE OUTFIT, wt. 52 lbs.....

**\$32.50**

COMPRESSOR SEPARATELY, \$21.50  
EQUIPMENT LESS COMPRESSOR, \$12.50

Compressor has 2" bore, 1 1/2" stroke, ball bearing, 3.27 CFM at 600 R.P.M. Capacity up to 6.54 CFM. Size 9" x 11 3/8" x 8 5/8". Wt. 26 lbs. Ideal for spraying paints, insecticides, etc., inflating tires, operating air tools, and other uses. All new equipment. U.S. government surplus. Replacement parts available. Amazing buy. Don't miss it.

Prices f.o.b. Chicago. Sold on money back guarantee.  
Send check or money order today. Prompt shipment.

**WELLWORTH TRADING CO.** 1831 S. STATE ST., Dept. D-2  
CHICAGO 16, ILL.

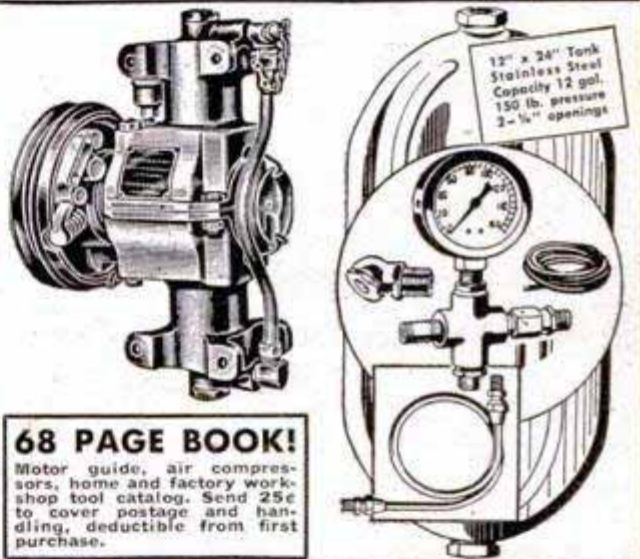

## 68 PAGE BOOK!

Motor guide, air compressors, home and factory workshop tool catalog. Send 25c to cover postage and handling, deductible from first purchase.

## Sensational New Electric ① WELDER ② CUTTER!

FOR 110-115 AC or DC • WELD—BRAZE—CUT—SOLDER—HEAT TREAT  
INSTRUCTIONS INCLUDED

WAS \$15—NOW ONLY \$12!!

**BOTH  
only  
\$12**

The **WELDRITE** Combination—tested and proved by countless commercial and amateur users, is now offered direct to you at the amazingly low price of only **\$12.00**. No Gas—No Gauges—No Spark Lighter needed. Always ready for immediate use—Just plug **WELDRITE** into 110-115 AC or DC outlet. Uses standard welding and brazing materials. **WELDRITE** furnished complete with Converter Unit, #1 Single Holder for welding metal to 3/16" thickness, using up to 3/32" rod, and #2 Double Holder with Copper Coated Carbon Electrodes for Brazing, Cutting, Heat Treating, etc. Starting welding

materials and instructions included. Ideal for home workshop. Invaluable for garages, repair shops, farms, etc. **SEND NO MONEY! 10 DAY TRIAL.** Order your **WELDRITE** Electric **WELDER-BRAZER-CUTTER** C.O.D. today. Pay postman **\$12** plus postage charges (wt. 4 lbs.) or send **\$12** and we pay postage. Either way, if not satisfied, return **WELDRITE** in 10 days for refund, less postage charges. **WELDER HOOD**—Approved Arc Welding lens—only **\$3.95**. Calif. orders add 2 1/2% tax.



## CALIFORNIA TECHNICAL PRODUCTS CO.

Dept. A-2, 448 So. Hill St., Los Angeles 13, Calif.

## M-SCOPE TREASURE -MINERAL LOCATORS

WRITE FOR FREE, ILLUSTRATED 16-PAGE BOOKLET

M-Scope Treasure-Mineral Locators, Geiger Counters. New Low Prices, unsurpassed in efficiency. Full factory guarantee. Immediate shipment.

YOU CAN PURCHASE THESE INSTRUMENTS ON A MONTHLY PAYMENT PLAN



URANIUM

**FISHER RESEARCH LAB., INC., PALO ALTO, CALIF.**



GOLD

# Speed Way

## Portable Bench and Hand GRINDERS

**No. 117 Bench Grinder \$14.95**

A capable bench grinder for general home and workshop use. Long life, air cooled motor. 1 "coarse" and 1 "fine" 4 1/2" x 3/8" wheels in 1-piece cast aluminum housing with sliding switch, rubber feet, cord and plug.

**G. A. Kit \$13.95**

"16 tools in 1." A No. 129 Electric Hand Grinder with 3/32" and 1/4" collets and 16 mounted stones, cutting burrs, wheels and disks.

**No. 128 Bench Grinder \$29.95**

Industrial quality 1/4 H.P. shaded pole A.C. motor. Special adjustable rests have formed-in angle guides for correct grinding of drills, bits, chisels, and blades. Two 6" x 3/4" grinding wheels operating at efficient speed. Completely encased in die cast aluminum housing. Plastic eye shields, mounted switch, 3-wire (Underwriter Approved) cord and plug.

Write for Circulars and name of your local dealers.

**SPEEDWAY MFG. CO.**

1863 South 52nd Ave. CICERO 50, ILLINOIS



where and when you need it!

Portable heat-makers that really make cold rooms comfortable. Just plug into electric outlet. Completely automatic, with trouble-free thermostatic control. Made of cast iron just like a stationary radiator. Will last a lifetime. Gives steady heat just where you need it! And only when you need it! Clean, odorless. Three sizes, AC or DC, \$57 to \$78 FOB factory. It will pay for itself in comfort, safety and convenience. Learn the whole story of this efficient heater—use the coupon below.



Listed by Underwriters' Laboratories, Inc.

Ideal for:

- Bedrooms • Rumpus Rooms • Bathrooms • Camps and Offices • Nurseries • Sick Rooms • Work Shops • Sun Porches

### BURNHAM Portable ELECTRIC STEAM RADIATOR

Burnham Corporation, Electric Radiator Div.  
Irvington, N. Y. Dept. PM-25  
Please send folder telling more about the Burnham Portable Electric Steam Radiator.

Name \_\_\_\_\_  
Address \_\_\_\_\_  
City \_\_\_\_\_ State \_\_\_\_\_

MONEY BACK GUAR.



**7x50 PRISM BINOCULARS**  
PRECISION OPTICS—BRAND NEW

**\$36\***

**6x50 ACHROMATIC FIELD GLASSES**  
**\$16\***

\*20% Federal Tax

Send for Free Catalog of Binoculars, Telescopes and Microscopes

**BROWSCOPE CO.**

Dept. 2M, 24 W. 45th St. New York 19, N. Y.



**\$\$ EXTRA PROFITS! \$\$**  
**Flocks & Sandblasts**

Dual Purpose Spray Gun! Uses only 25 lbs. Air Pressure

• Thousands of uses in Home, Shop, Industry: Makes Auto Interiors Clean & New, Lines drawers, Marproofs lamp bases, Refinishes any object. All in colorful Flock. Etch & Frost windows, glassware, etc. Removes Paint & Rust from Autos, Tools. Guaranteed! Send \$19.75 or write for free information. Flocking supplies!

**BLASTO SPRAY GUN MFG.**  
Dept. PM-2, 7007 Haas Avenue, Los Angeles 47, Calif.

**FREE** Circular describing the famous Burgess Vibro-Sprayer for painting furniture, walls, autos, etc. No motor or compressor. LOW COST! 110-volt AC. Gives professional spraying results! Send letter or postcard for full information and price.  
**FOSTER PRODUCTS, Dept. 5G264; 179 Wooster St., N.Y. 12**

### MUSGRAVE ALL-JOB DOKTER

Cuts weeds, brush, grass. Fells trees, saws wood, cultivates, sprays, etc. Travels under its own power. Low in price. Circular FREE.



Choice of 2.3 or 6 H. P.

**MUSGRAVE MANUFACTURING CO.**  
2961 ARNETT RD. SPRINGFIELD, OHIO

### LAWN ORNAMENT-NOVELTY PATTERNS

28 Lawn Ornament Patterns, 25c. Other patterns; 15-20" high; Dutch Girl, Dutch Boy, Pirate, Bull Terrier, Mexican Girl, Mexican Boy, Dwarf, Penguin, Flower Girl, 10c each. 25 Novelty Patterns, 30c. All 62 Full Size Patterns, \$1.00 Postpaid. Strother Pattern Service, Dept. BN-8, Box 128, Belington, W. Va.

### Freeland METAL BOATS

Rugged, low up-keep boats that feature electronic seam weld; spray rails, styrofoam safety floats; removable flooring.



Models from \$65.00. Write Dept. 72 for folder, prices.

GALVANIZED STAINLESS STEEL

**FREELAND SONS CO. Sturgis, Mich.**

Always write your name and full address clearly when answering advertisements

### HOLLYWOOD MUFFLER

THE TONE YOU LOVE TO HEAR

### MORE SPEED—POWER—MILEAGE

are yours with a Hollywood Muffler . . . plus a tone you'll love to hear! Not a gutted muffler. Easy to install.

Hollywood Muffler: Trade-mark Reg. U. S. Pat. Off.

IMPROVED DESIGN  
PRECISION MADE  
ELECTRIC WELDED!



Outlasts ordinary mufflers 3 to 1

Ford, Chevrolet, Plymouth \$6.00

All other cars . . . . . \$8.00

Duals, Ford & Merc. \$24.50. Also Fender Skirts, \$10.95. Order direct. Send check or M.O. and save postage.

Dealers Write **WILKINSON MUFFLER CO. 811 WILT STREET FT. WAYNE, IND.**



# SYNCRO

The  
*Electrified*  
**HONE**  
that  
**M-O-V-E-S!**



SYNCRO hones sharp hundreds of articles in homes, shops, farms. Yes, 240 strokes a second, 14,400 rapid, gentle honing strokes a minute! No belts, wheels, gears, 60 cycle, 110-120 volt AC. Both hands free to hold work. Easily adjustable stroke! Ideal birthday, personal gift. With 3 interchangeable Honing Stones, Cord, Plug, \$10.50 at DEALERS. If he hasn't, send \$10.50 direct to us, we'll ship Sharpener postpaid. Satisfaction Guaranteed. See other Syncro products, pages 283, 291, this issue! (Dealers write!)

**SYNCRO CORPORATION**

DEPT. HH-25, ROCHESTER, MICHIGAN, U. S. A.

## SENSATIONAL BARRON SPEED-VISE!



**PERMANENT—PORTABLE**

Slickest, handiest, most useful all-metal work bench vise. A workshop "must" for—  
PLANING • SAWING • DRILLING •  
SANDING • FILING • ETC.

Only  
**\$175**

Include 20c  
for shipping

Won't mar, mark or dent woods, plastics, metals. No piece too small or too large. 10 Day Money Back Guarantee.  
**BARRON TOOL CO. • DETROIT 1, MICH.**

## MACHINE SHOP EQUIPMENT



• The No. 49 edition of the famous Center Tool Co. Catalog is now ready! Every workshop owner should have a copy. 240 pages full of illustrations, descriptions, and prices of the latest tools made by best known manufacturers in U. S. You pay the cost of printing—50c. We refund your 50c with your first order of \$10.00 or more. Prompt delivery on most tools. Send check or money order today!

**CENTER TOOL CO.**

153 Centre Street, Dept. C, New York 13



### Motor Oil Changes

**ENTIRELY UNNECESSARY**  
after attaching

**"RECLAIMO"** The World Famous  
(Die Cast Aluminum) **HEATED** Oil-Filter  
and Re-Refiner!!

Makes short work of solids and liquid impurities—after 150 miles you won't believe it's the same oil! **REMEMBER—**  
"Oil does not wear out mechanically", states U. S. Bureau of Standards.

Convince yourself—just read our "Oil Facts", 32 pages, FREE on request.

**RECLAIMO MFG. CO.**

5083 Elston Ave., Dept. 22, Chicago 30, Ill.  
Dealers Wanted

**Be Independent! Have your own business. Make \$300.00 to \$500.00 extra profit monthly**

# arc welding

**"Pays for Itself" terms puts you in business with but little cash outlay**

Why tie yourself down to routine work and limited pay when on-the-job arc welding is in such demand? Contractors, builders, farmers, businessmen gladly pay big money to men who have their own welders. HOBART'S new gas engine driven welders make your services even more valuable with faster, better welding. They run lights, motors, tools besides.

**Gas Drive Arc Welder**



**Generator Only . . .**

The same type generator used in HOBART'S complete factory built welders is available if you want to "Build Your Own" portable gas drive welder. Made in all sizes and types. Saves \$\$\$\$ and lets you get started right away with minimum investment.

HOBART builds A.C. and D.C. Welders for shop or field. Write name and address in margin and send today for details.

**A.C. Welder, transformer type**

**HOBART BROTHERS CO., Box M-20, Troy, Ohio**

"One of the world's largest builders of arc welders"

### Hobart Training at Low Cost

Don't turn away from this fine opportunity if you lack welding experience. Let the HOBART Welding School help you become expert in short while. Low tuition, fully approved under G.I. Bill of Rights.



## HOBART WELDERS

# Head Noises? Hard of Hearing?

Try this simple  
Home Treatment

Many people have written us that our home treatment brought them blessed relief from the miseries of Hard of Hearing and Head Noises due to catarrh of the head. Many were past 70! For proof of these amazing results, write us today. **Nothing to wear.** Treatment used right in your own home—easy and simple.

**THE ELMO CO.**  
Dept. 476  
Davenport,  
Iowa

**SEND NOW FOR PROOF  
AND 30 DAY  
TRIAL OFFER**

Use this →

# PARAGON SPRAYER

FOR 10 DAYS

WRITE FOR SPECIAL OFFER

Spray your own fruit trees, and growing plants. Kill lice and parasites on poultry and stock. Disinfect and whitewash pens, barns and out-buildings. Destroy weeds. Easy-working. Self-straining, non-clogging. Paragon Sprayer stands steady on uneven ground.

Income from renting or spraying for others will bring you extra profits year after year.

No. 3; 12-gallon capacity with pipes, hose, nozzles and truck \$29.95.

To take advantage of early spraying write, phone, or wire today for our special proposition.

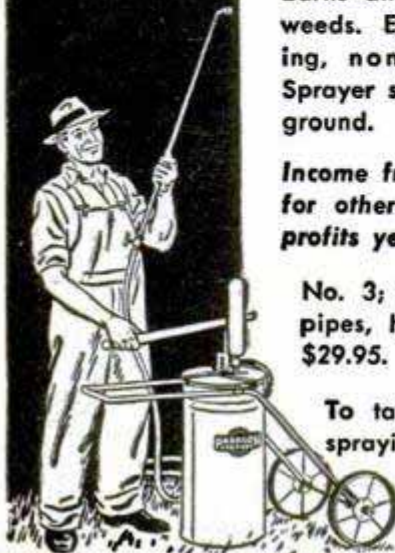

## THE CAMPBELL-HAUSFELD CO.

45 State Ave., HARRISON, OHIO



## For Loose Caster Guides

Remove the guide, fill the hole with a putty-like mixture of Smooth-On No. 1 Iron Cement and drive the guide back in. It will stay in place, because Smooth-On, in hardening, expands slightly and takes hold tight. Use Smooth-On for tightening other loose parts and also for stopping leaks in boilers, furnaces, piping, radiators, etc. Buy Smooth-On No. 1 in 1 3/4-oz., 7 oz., 1 lb., 25 lb., or larger sizes at your hardware store. If they haven't it, write us.

## FREE Repair Handbook

Shows how to save time and money, making many household repairs. 40 pages. 170 pictures. Clear directions. Send today. SO-313

SMOOTH-ON MFG. CO., Dept. 37B  
570 Communipaw Ave., Jersey City 4, N.J.

Do it with

# SMOOTH-ON

THE IRON CEMENT OF 1000 USES



## BUILD PRACTICAL PROJECTS FROM DETAILED PLANS

Easy to follow, completely dimensioned

### ATTRACTIVE BIRD HOUSES

- M20 Mt. Vernon Style—31 Family House—Plans \$1.00
- M15 Tower Style—12 Family (Illustrated) " .75
- M10 Castle Style—8 Family Martin House " .50
- BH5 Group of 4 Houses—2 Wren—Woodpecker—Bluebirds. All 4 on 1 Plan .50



### CAPE COD CHAIRS



TRELLISES, ARBORS, DUTCH WINDMILLS, C, A, PLANS 50c each. All 3—only \$1.00  
12 different trellis designs, Plans of all 12 only .50  
Four fine lawn figure patterns: Dutch Boy, Tulip Girl, Holland Pair and Sunbonnet Girl—all four patterns only \$1.00

Send 10c for Catalogue Illustrating Over 100 Fine Projects  
CRAFTSMAN'S MODEL CO., Dept. P13, Delafield, Wis.

## ATTENTION VISE OWNERS

TAPER-GRIP Provides Positive Gripping of Any Tapered or Non-Paralleled Objects in Your Vise!

Prevents swiveling, wriggling, slipping. Fits any type of vise or clamp. No mounting—simple to install. Just place between object and vise. TAPER-GRIP automatically compensates for any irregular shape in the object. Sturdily constructed. Will last a lifetime.

**\$1.98**  
Postpaid in U.S.A.

H. C. HELLMER COMPANY, Dept. M-2  
750 W. JACKSON BLVD. CHICAGO 6, ILLINOIS

## OIL FILTER ELEMENTS . . 7c

Here's News! Ordinary toilet paper makes an ideal oil filter. Laboratory tests prove it cleans oil faster and better than popular makes of filter elements. All you need is a simple set of Retlif Adapter Plates and you can start using toilet paper rolls (costing about 7 cents) in your present oil filter. For proof and descriptive literature, send name and address to:

RETLIF OIL FILTER CORPORATION  
1237 No. Highland DEPT. PM-2 Los Angeles, Calif.

Reduce RADIO NOISES

NEW CLEAR-TONE LINE-NOISE ELIMINATOR

**SIMPLY PLUG** Radio or Appliance cord into Noise Eliminator & plug into wall socket. Enjoy reception FREE from many distracting noises. Send No Money, pay postman \$1 on. (2 for \$1.75) plus postage or send cash & we'll mail postpaid. Try 5 days, money back if not delighted. RAND SALES, 688 Lee Street, Dept. A-4, Des Plaines, Ill.

## WAR SURPLUS AND OTHER BARGAINS

### PNEUMATIC RIVETER & CHIPPING HAMMER

Mfg. by Ingersoll-Rand, Chicago Pneumatic and The Pistol grip. Ideal for fender, brake lining, concrete breaking work. Like new. Six rivet sets and bucking bar included, making a complete combination. Weight 9 lbs. . . . . Each \$6.95

<b>MICROMETERS</b>	Chrome plated, precision engineered and carefully toolled to give long life. All new.	<b>HIGH SPEED DRILLS</b>	All New. Fractional & numbered. Orig. Val. \$15. Nationally known brand. Ass'd. sizes. Set 30, \$3.50
0-1" capacity . . . each \$2.25			
1-2" capacity . . . each 3.50			
2-3" capacity . . . each 5.50			
3-4" capacity . . . each 6.50			

**ELECTRIC BELLS**—Vibrating type, high pitch. 115 V., 60 Cycle. Ideal for use indoors or outdoors—on ranches, for schools, plant installations, as signal systems, burglar alarm systems, etc. Nationally known Mfr. ALL NEW in original Pkgs. Solid brass clapper and 8 1/2" gong. Weight 8 lbs. Govt. cost about \$67.50. Close out at— \$7.95.

Send check, money order or cash. 25% deposit required on C.O.D. orders. All prices, F. O. B. Culver City, Calif. Send 25c for Illustrated Catalog.

AIRBORNE SALES CO., INC. DEPT. PM 2-O CULVER CITY CALIF.

## BE A HIGH-PAID MAN IN YOUR COMMUNITY WITH THIS LONG NEEDED INVENTION

Earn up to \$10,000 or more per year! Nothing to invest! Be your own boss!

U.S. Pat. D 153853  
D 153854

A worldwide product needed by every home, business and farm... priced to sell quickly! Automatic Red Comet goes into action as soon as fire starts... smotherers fire without human aid. It's a sales 'natural'!

### FREE SALES KIT

Demonstrator units, sales literature, etc., furnished you FREE. Handsome leather-type kit. Tried and proved, it will make you an independent businessman. ACT NOW! Someone in your community will be appointed soon. Write for details, today!

## RED COMET, INC.

521 R. C. Bldg. Littleton, Colorado



## SUMP PUMPS 2,200 GALLON CAPACITY

**1 1/4" outlet - No screen to clog - fool proof**

The time tested Lokomona sump pump is absolutely automatic—has a special fool proof trap at the intake—rubber bearing at the bottom. Made of aluminum castings, it's 42" high and carries a 1/4 H.P., 110 V. A.C. heavy duty motor. The pump is designed for continuous dependable service. Any standard motor will fit this pump. Order yours today. COD. If cash with order, we pay postage.

**\$36.00 COMPLETE**  
**\$22.00 LESS MOTOR**  
**\$18.00 PUMP ONLY**

**MONEY BACK GUARANTEE**

LOKOMONA PUMP CO., P.O. BOX 86, ROYAL OAK 1, MICH.

## AMERICA'S BEST Geiger Counters FOR LOCATING URANIUM....

Equip yourself with the best. OSSCO Geiger counters are famous for locating rich strikes. Sensitive models as low as \$79.

Write Dept. X for details and prices

OMAHA SCIENTIFIC SUPPLY CO.- 3601 N. 24 TH, OMAHA, NEBR.

## EXPORT PAYS BIG

World Trade firm offers men and women plan for big pay positions or unlimited-profit businesses of their own in Export-Import. Mail order. World-wide without capital, from home, or travel abroad. Write today for Free Book. State if veteran. Airmail reaches us over night. The Mellinger Co. 1418-AT Westwood, Los Angeles 24, Calif.

**DENTIST DRILLS** used assorted cleaned and re-cut. Can be used on wood, metal, plastic. In any chuck. 3 dozen, \$1.50; 6 dozen, \$2.75; Gross, \$4.75. Postage prepaid. Sold on money back guarantee.

**KNIGHT DENTAL PRODUCTS**  
6754 N. Sheridan Road Chicago 26, Illinois

## Yes, More Brilliant Than a Diamond!



No Other Gem Like It!  
Amazing New Discovery

Write today for the full story of the latest miracle of science, discovered in the laboratories of one of the world's largest corporations. The story of the Kenya Gem that so closely resembles a diamond that only an expert can tell the difference.

They are more brilliant than the finest diamond of equal size, yet you can now own an unmounted Kenya Gem for only \$24 (1 carat) to \$96 (4 carats); also beautiful rings and earrings for as little as \$45. **Easy Payment Terms.**

Kenya Gems are the marvelous discovery you read about in The Sat. Eve. Post, Jewelers' magazine and N. Y. Times, "the only thing on earth more brilliant than a diamond." Write today for FREE illustrated literature.

**KENYA LABS, Dept. 282**  
18 W. Chelton Ave. Philadelphia 44, Pa.

## GARDEN TRACTORS

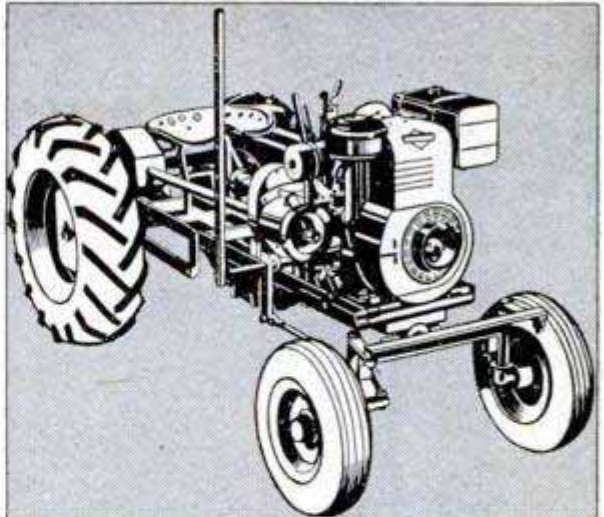

## LOOK--SPEEDEX AGAIN PAVES THE WAY TO LOWER PRICES IN GARDEN TRACTORS

**FOUR--** MODELS 1.9 H. P., 3 H. P., 5 H. P. and our famous 8 H. P. four wheel riding type.

Prices start at only \$119.50 to \$350.00 for the powerful 8 H. P. Rider

**ALL--** Speedex Garden Tractors are built with enclosed gears running in oil, powered with popular-make engines and equipped with the latest type rubber tires.

**JUST--** for the asking we will mail you absolutely FREE a circular illustrating and describing these tractors.

**WHY--** not write today. Please use a penny post card.

**SPEEDEX GARDEN TRACTOR CO.**  
BOX 216-D1 Ravenna, Ohio  
P-1149-34

## NOW! a complete TABLE SAW for only \$16.95!



(Less Motor)

- For CROSS CUT
- RIPPING
- MITER
- GROOVE
- DADO

**SPECIFICATIONS**  
TABLE SIZE.. 18x20  
Total Height. 12 1/2"  
Size of Saw Blade  
Furnished (8" blade can be used)... 7"  
Depth of Cut... 1 3/4"  
Saw Arbor Shaft 1/2"  
Bearings... Oil-Lite  
Saw Speed... 4000 r.p.m.  
Recommended Motor Pulley... 5"

**UNHEARD-OF VALUE!** High-quality table saw that cuts to exact dimensions. Neither blade nor table tilts. All parts except saw blade and mechanical units made of specially-treated hardwood that is guaranteed against defect for one year! Metal parts cadmium-plated to prevent rust. Fence extends full length of table, can be used on either side of blade. Miter gauge graduated for 15°, 30°, 45° cutting. Complete, less motor, only \$16.95! Motors available. Get your order in today!

WE PAY POSTAGE WHEN CASH ACCOMPANIES ORDER  
Free! Write today for your new Home Workshop Catalog or "How to Start Your Home Workshop"

**FORSLUND PUMP & MACHINERY CORP.**  
1721 MAIN STREET Dealer Inquiries Invited KANSAS CITY, MO.

The better tools  
you need  
for a better job!

# x-acto

KNIVES and TOOLS



Exactly the blade and tool for a more expert job, quicker, easier.

**HOBBY DRILLS**  
**FILES, SAWS, PLIERS**  
**"C" CLAMPS, BLOCK PLANES**  
**HAMMERS, SCREW DRIVERS**  
and dozens of others

Knives from 50¢. Sets from \$1.  
At art, hobby, gift, hardware, dept. stores.  
Write for free illustrated catalog.

Reg. U. S. Pat. Off. X-acto Crescent Products Co., Inc.  
440 Fourth Ave., N. Y. 16



## New ARMY MINE DETECTOR

An/PRS-1 is a portable device for detecting metallic and non metallic objects. Metals, Buried Cables and sewer Tile.

Our Special Price **\$26.40**  
with battery  
\$17.50 without battery

By lengthening dipole rods operator will be able to increase the depth sensitivity. This unit comes complete with spare tubes, antenna dipole and reflector, and instructions manual, in wooden chest 9½" height x 28¼" length x 15½" depth. Weight in operation is only 22 lbs. LESS Batteries. Power supply: Three 45 volt and one 6 volt batteries. Uses standard batteries. Original COST \$364.00. Shipping weight appr. 80 lbs. F.O.B. New York. No C.O.D.'s. Send Order to:



### COLUMBO TRADING CO., INC.

304 CANAL ST. DEPT. P.M. NEW YORK, 13, N.Y.

Make Personalized **HOUSE, LAWN MARKERS** For Fun Or Profit



17 new silhouette cutouts (3 shown plus 14 other novel designs) complete alphabet and numbers, ready to trace onto wood. Sawing is easy. Marker with name or address is distinctive personalized gift or addition to your own home. Make markers for fun and to sell. Set of 17 full-size, ready-to-use patterns, alphabet numbers, only \$1.00, postpaid. Money Back Guarantee.

Clip This Ad and Mail With **CRAFTPLANS** Dept. P-156, Chicago 5, Ill. Dollar Bill or Check TODAY 1321 S. Michigan Ave.

## Build your own JET ENGINE!



SEND NO MONEY

Order these plans today  
1. JET PROPELLED BICYCLE. Assemble your own. Photo and instructions \$1.00.  
2. HOW TO MAKE EXPERIMENTAL JET ENGINES. Seven sheets drawings with information and instructions \$2.95.  
3. BOTH OF ABOVE in one order \$3.75. SEND NO MONEY. Order both at once \$3.75 C.O.D. in USA plus e.o.d. postage. Send check or Money Order and we pay postage. Get other information too. Rush Order.

J. HOUSTON MAURIN, Dept. 55, Tipp City, Ohio

## AMAZING OIL FILTER - SAVES \$\$\$



**LIFETIME POROUS METAL CARTRIDGE** - Saves replacement costs. Gives positive oil cleansing action. Non-absorbent... save a full quart of oil in every oil change. Fits all cars. \$8.50 post paid. Easy installation • Free literature. **MONEY-BACK GUARANTEE** Filterall Co., Inc., 4408 San Fernando Road • Glendale 4 • California

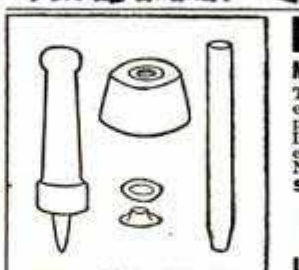

## HANDI-GROMMET-KIT

Make Your Own Repairs To Your Canvas This Kit is complete with Tools and 4 dozen Grommets for making quick, easy repairs to TENTS, AWNINGS, TARPAULINS, BOAT SAILS, SHOWER CURTAINS, etc. Grommets are available in either Natural Brass or Nickel Finish.

Size	I.D. Hole	Price	Send check or M.O. Shipped postpaid.
0	1/4"	\$2.00	
1	5/16"	2.25	
2	3/8"	2.35	
3	7/16"	2.50	

LORD & HODGE, MIDDLETOWN, CONN.

SAY YOU SAW IT IN POPULAR MECHANICS

## HULL AUTOMOBILE COMPASS

READY ANSWER

WHEN THE QUESTION IS DIRECTION

Beaconlite illuminated .....\$5.95  
Streamline standard .....\$3.95  
At your dealer's. Write for literature.

HULL MFG. COMPANY, P.O. Box 246-D2, Warren, Ohio



**1/4" Electric Drill Special** \$19.95 Guaranteed Value  
Complete with 7 Carbon Drills—from 1/8" to 1/4". ALSO 7 High Speed Drills 1/8" to 1/4" — In Attractive Box — Hurry — Quantities Limited. ONLY **\$15.99**

**5" Rubber Backed Sanding and Polishing Kit**  
consisting of 1/4" shaft. Soft oversized Lambswool Pad. 5" Rubber Disc & 3 Sanding Discs. Designed for use with 1/4" Electric Drill Satisfaction Guaranteed or money cheerfully Refunded **ONLY \$2.95**

**Special 1/4" Black & Decker Electric Drill** — the Above Polishing Kit, and 7 Assorted Sizes 1/4" Drills. All for Special Price **\$19.95**

**CENTURY'S NEW WOOD BITS**  
The only drills expressly made to drill holes up to 1/4" Dia. in wood with 1/4" electric drills. Shipped Prepaid in U.S.A. **set \$3.95**

**5 Pc. WOOD BIT SET for 1/2" ELECTRIC DRILL** Only **\$8.45**  
Includes 1/2" - 5/8" - 3/4" - 7/8" - 1" Carbon Drills — 1/2" Round Shank SET

We are Authorized Distributors of the Complete Line of BLACK & DECKER Home Utility Drills — Sander-Polisher and Accessories. Send for Complete Black & Decker Home Utility Tools Catalog

C.O.D. Orders Accepted only with 25% Deposit. All Shipments Prepaid if Money Accompanies Order. MAIL ORDERS TO:  
**CARL-SONS and COMPANY**  
DIVISION OF CARL-SONS BEST HARDWARE  
1627-29 N. DAMEN AVE. CHICAGO 47, ILL.

# WAR EQUIPMENT MAIL SALE!

WE PAY ALL FREIGHT AND MAIL CHARGES

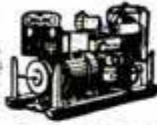

## POWER PLANTS

110-V, 60-C, 3,000-W. Remote switch electric self starter. Easily made full automatic. Army's finest plants. Full instructions. Ideal for farmers, sportsmen, contractors. New condition. Fully guaranteed. Get catalog for details. Cost Gov't. \$756 . . . Sale Price, \$345

• **GUY CABLE AND TURNBUCKLE.** 12' flexible steel cable with 14" turnbuckle. 100s uses. Fix sagging buildings, guy television antennas. Gov't Cost \$1.10. **\$4.39** Sale Price, 15 for . . . . .

• **HYDRAULIC CYLINDERS,** 2 1/2" bore, 17" stroke. Excellent for loaders, graders, etc. Gov't Cost, \$87.50 **\$11.60** Sale Price . . . . .

• **WELDER.** 220-volt, 60-c, a-c. Genuine ALLMAND. 0 to 250 amp. Complete with cable, holder, mask, rods, etc. **\$149.50** Sale Price . . . . .

• **CENTRIFUGAL PUMP.** Stainless steel shaft. 3/4" outlet, 1" inlet. Dozens of uses. Sale Price . . . . . **\$6.50**

• **MALL ELECTRIC CHAIN SAW.** One-man saw zips through big timbers. Operates off home 115-v AC-DC current. Only **\$95**



## INDUSTRIAL ENGINES

New 1-cyl., Briggs 3.5 heavy duty, air cooled. Excellent for boats, garden tractors, weed sprayers, elevators, pumps, scooters, saws, etc. Complete instructions. Cost Gov't. \$130 **Sale Price . . . . \$75.50**



## WINCH 3000 Lb.

Low cost power for all kinds of hoisting, loading, etc. Used by leading truck lines for loading. Ideal also for farmers, merchants, factories. Wonderful for use on boats, boat docks, trucks, jeeps. Easily mounted. 12"x14", 9" high. New finest steel and bronze gears. 80-to-1 power ratio. Drive with old car 6-v Starting motor, power take-off, fan pulley, etc. Cost Gov't. \$95 **Sale Price . . . . . \$24.95**

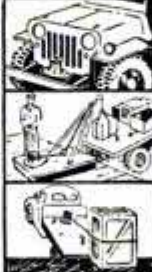

**BUY DIRECT BY MAIL AND SAVE!**

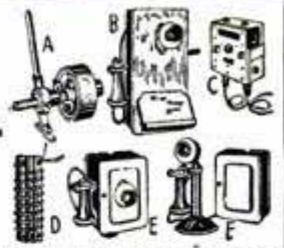

- A. Utility Clutch, up to 6.5 h.p. **\$13.95**
- B. Magneto Rural Telephones. . . **12.40**
- C. Burglar Alarm System. . . . . **6.99**
- D. Fire Alarm System. . . . . **9.90**
- E. 2000-watt 110-volt Elements. . . **.99**
- F. City Wall or Desk Phones. . . . . **4.99**
- G. Rotary Gear Pumps. . . . . **3.95**
- H. Briggs 1.5 h.p. Engine. . . . . **49.50**
- I. Multi-Speed 110-V, 60-C Motor **8.75**

- Dozens of electronic, hydraulic, mechanical bargains. Electrical drills, saws, etc.
- Bargains in electrical appliances, motors, home workshop tools, etc.
- Inventory Closeout, finest electrical appliances—grills, toasters, waffle irons, coffee makers, stoves, irons, etc. Overnight shipment.

**ORDER DIRECT FROM THIS AD. SATISFACTION GUARANTEED. OR, RUSH CARD FOR FREE CATALOG TODAY!**



**BURDEN SALES COMPANY**  
804 "O" ST. LINCOLN, NEBR.

# CUT-TO-FIT HOMES CUT BUILDING COSTS

**ORDER NOW SAVE UP TO 1/3**

Build your own home and save the builders' profit—plus savings in lumber and labor with Sterling Ready-Cut-Homes. Anyone can assemble with simple, easy to follow plans furnished. Every house complete with all lumber, roofing, nails, glass, hardware, paint, doors and windows marked ready to erect. Freight paid. Complete building plans ready for filing at low cost. Sold separately if desired. Write today!

CHOICE OF 57 DESIGNS



PRICED FROM \$1885 UP

Send 25c for NEW COLOR CATALOG

INTERNATIONAL MILL AND TIMBER CO.  
DEPT. P.M.-250, BAY CITY, MICHIGAN

*New Easy Way TO MAKE*

# BIG MONEY! AT HOME

Costs You Only 5¢-You Get \$5.00

FULL OR SPARE TIME



Now is the time to cash in on this big-paying easy-to-operate year 'round business, and you need no experience! Metallize Baby Shoes in real GOLD, SILVER, BRONZE, and PEARL. Everything furnished so YOU can start earning money in just one week—up to \$1,000 per month full time or \$50 to \$75 per week spare time—at \$5 per hour. They will last FOREVER, and there are 5 million eager customers every year, waiting to buy. **DETAILS FREE**—Send no money—a post card with your name will bring all the facts. Don't pass up this opportunity to start your own business on a shoestring—so **ACT NOW**. Write at once to

- Big Income
- Huge Demand
- Sales Plans
- Future Security
- Your Own Boss
- Money Back Guarantee
- Most Successful Name in Metallizing



**FREE!**

Course includes FREE—two actual metallized Baby Shoes guaranteed to be the most attractive on the market—or a pair of your own Baby Shoes metallized if you prefer

*Write Now*

**KIKYAVI COMPANY, Dept. PM-2, 2111 West Manchester, Los Angeles 44, California**



# COMPLETE LOCKSMITH SHOP \$99.00

NEW POPULAR STANDARD EQUIPMENT

**START YOUR SHOP NOW!** AT HOME, GARAGE, BASEMENT, OR KEY DEPARTMENT TO YOUR PRESENT BUSINESS

- 1 Precision key machine complete with three cutters
- 1 Heavy plywood key display board with 100 hooks
- 1000 Popular key blanks and cut keys
- 3 Locksmith Instruction books
- 1 Automotive lock manual
- 1 Assortment of pins and springs
- 1 Assortment of disc tumblers and springs
- 1 Misc. set of locksmith tools

**ALL FOR ONLY \$99.00 — EASILY WORTH \$130.00!**

Slightly higher out of U. S. A. 25% deposit on C.O.D. orders. Start making money at once! Order your outfit today! Complete satisfaction guaranteed. Write for FREE Catalog today!

REPAIR SHOP SERVICE • Box 264-A • Skokie, Illinois

# SAND-O-BLOK

PAT. & PAT. PEND.

*the sensational*  
**New Sander**  
with an adjustable radius!



Now for the first time, Sand-O-Blok gives you an amazing hand sander that sands contoured and irregular shapes as well as flat surfaces. A Neoprene rubber sleeve wraps around a plastic wedge-shaped block and cushions the sandpaper. By rotating the rubber sleeve around the body, the radius at each end can be changed for intricate contour sanding.

A Neoprene rubber sleeve wraps around a plastic wedge-shaped block and cushions the sandpaper. By rotating the rubber sleeve around the body, the radius at each end can be changed for intricate contour sanding.



Sand-O-Blok can be adapted to a wide variety of uses. Use it on flat or curved surfaces. Comes equipped ready for use. Price \$1. Additional sandpaper sleeves available in coarse, medium and fine Garnet paper that wears and wears.

Note how rubber sleeve changes radius—from  $\frac{1}{8}$ " at the narrow end to  $\frac{3}{4}$ " at the opposite end. An internal cam action expands the sander as the slotted "lock" is tightened to keep sandpaper from slipping. A brand new idea. Coin, washer, screwdriver, etc., tightens or loosens lock.



Write for catalog. See Sand-O-Blok at your hardware dealer or where Sand-O-Flex sanding wheels are sold. Both are products of...

**MERIT PRODUCTS, INC.**  
4373 Melrose Avenue, Los Angeles 27, Calif.

SAY YOU SAW IT IN POPULAR MECHANICS

WE FURNISH ALL MACHINED METAL PARTS, EVERY SCREW, NUT, BOLT, WASHER, AND COMPLETE PLANS FOR THIS...

**BIG 10" POWER SAW**



**\$9.95**  
LESS GUARD AND WOOD

POST PAID ANYWHERE IN U.S.A.

FULL \$9.95 REFUND IF NOT SATISFIED WITHIN 10 DAYS

ASSEMBLE IT YOURSELF WITH SIMPLE HOUSEHOLD TOOLS!

TABLE 24" x 20" • TILTS TO 45°  
CUTS 0" TO 3/4" DEEP • TAKES 10" BLADE

COMPLETE PLANS (WITHOUT PARTS) 10¢

**MARCUS • POLLAK** DEPT. 44 ROYERSFORD, PA.

## HYDRAULIC PUMPS

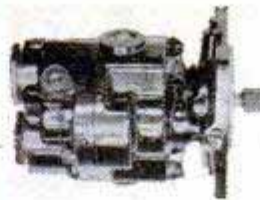

Pesco Model 1P730 Positive displacement gear type. Capacity 178 GPM @ 1500 RPM and 2000 PSI. Brand new.  $\frac{3}{4}$ " inlet and outlet pipe connections.  $\frac{5}{8}$ " drive spline. Priced at only \$8.73. Quantity discounts.

## VEEDER ROOT COUNTERS

Brand new. Counts up to 99,999. Reset mechanism operated by key and protected with lock. Key furnished. Works as rocker or complete revolution counter. Priced at only \$3.95. Quantity discounts.



## TAPER SHANK DRILLS



10 High Speed Morse Taper Shank Drills up to  $\frac{1}{2}$ ". New and slightly used surplus. Sharpened. \$25 value for only \$4.00.

10 Carbon Steel Morse Taper Shank Drills up to 1-3/16". New and used surplus. Sharpened. \$45 value for only \$9.89. Both sets for only \$12.25.

All merchandise is sold with money back guarantee and is shipped POSTPAID

**T & T TOOL** 101 WEST ARCHER TULSA, OKLAHOMA



## The New VISE-GRIP WRENCH

Does Jobs No Other Tool Can Do!

Double-lever action LOCKS jaws to work with tremendous grip. Or quickly adjusts to powerful non-locking action. New Involute Jaw Curve holds all shapes—nuts, rounds, irregular shapes, with unbelievable ease. Knurled Jaw Tips grip to the very tip. Has Thin Nose and Super Wire-Cutter. With cutter—No. 7W, 7-in., \$2.25; No. 10W, 10-in. \$2.50. Without cutter—No. 7C, 7-in., \$1.85; No. 10C, 10-in., \$2.25. If not at your dealers, order direct. Postage paid if money accompanies order.

MANUFACTURED ONLY BY

**PETERSEN MFG. CO., INC.**

DEPT. P2 DeWITT, NEBR.

## JET POWER YOUR CAR!

Merrick's Multi-jet fuel atomizer gives your car worlds of added power... quicker starting and take-off... smoother, quieter performance... plus more miles per gallon of gas. Install it yourself in a few moments in manifold. Try it for ten days and if you are not delighted with results, return it. Will gladly refund money. When ordering give make and year of car. Prepaid any place—\$7.75

**MERRICK ENGINEERING CO.**  
6700 IMPERIAL AVE. SAN DIEGO, CALIF.

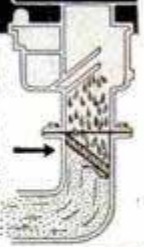

## WESTINGHOUSE AIR COMPRESSORS

Lowest-Ever Closeout Price!

WESTINGHOUSE Reg. \$60.50 **18.50** FOB Pk

Model T-1, brand new, complete—Surplus Special at amazing low price. Westinghouse Double-piston type, 6.54 volume. Mount on truck or car engine—or operate with  $\frac{1}{2}$  HP motor. For farm, home, industry and painters. Full Instructions. Send check or money order. Shipping weight 26 lbs.

We Carry a Full Line of Spare Parts

**NATIONAL STORES** 200 Smithfield St., Dept. 31 PITTSBURGH 22, PENNA.

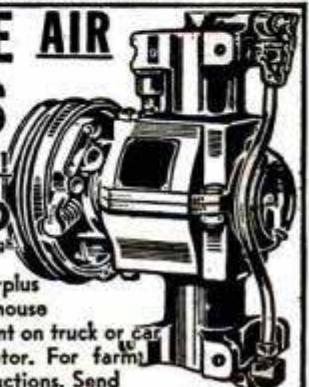



## UNIVERSAL ELECTRIC MOTOR

110 VOLT 60 CYCLE  
CAR SHAVER MOTOR  
DYNAMOTOR:



Here's a truly multi-use motor . . . Ideal for meeting a wide variety of practical needs! It can be used as a dynamotor to supply 110 Volt DC (Approx. 15 Watts) from 6 Volt DC—for operating most types of AC-DC electric shavers or radios from your auto battery, and for many other power uses. Or, it can be converted easily to a 110 Volt 60 cycle motor, approx. 1/25 HP at 3500 RPM—to operate grinders, buffers, polishers, fans, models, etc. Used as a generator it will supply various voltages depending upon speed of rotation; and as a dynamotor, 18 Volt DC input; output 450 Volt 60 MA. DC. Motor is ball bearing construction, 7"x4" size, with 1"x3/16" shaft at one end and 1/2"x3/16" shaft on other end. Instructions furnished.

ORDER #PM-1020 (Postpaid U.S.A.) . . . . . **\$3.50**  
Motor Converted to 110 Volt 60 cycle:  
ORDER #PM-1120 (Postpaid U.S.A.) . . . . . **\$3.95**

### PERMA-GUM TYPE 57 RB SEALING COMPOUND

Ideal waterproof sealer for such uses as refrigeration, boats, home building, engines (around spark plugs, coils, etc.), and wherever a moisture proof seal is required. Not affected by heat or cold. Always pliable, will not harden or crack. Knife grade. Original Gov't. cases, 24 quart 2 1/2 lb. cans to a case. Shipping Wt. 72 lbs. Case: F.O.B. Lima, O. **\$5.00**  
Sample Quart Can: ORDER #PM-1320 (Postpaid U.S.A.) . . . . . **\$1.00**

GAS ENGINE GENERATOR: 30 V. DC. See our ad p. 289 Oct. PM for details #PM-420. F.O.B., Lima. **\$49.50**

DELCO GAS ENGINE GENERATOR: 12 V. DC. Read details in ad p. 289 Oct. PM #PM-520. F.O.B., Lima. **\$59.50**

GASOLINE or OIL HEATER UNIT: Forced air. See details our ad p. 298 Nov. PM #PM-920. F.O.B., Lima. **\$19.95**

ALL ITEMS ARE GOV'T. SURPLUS! SEND FULL REMITTANCE FOR \$1 to \$3.95 ITEMS \* OTHERS: 25% DEPOSIT, BALANCE C.O.D.

## FAIR RADIO SALES

132 SOUTH MAIN STREET LIMA, OHIO

## 5 YEAR WRITTEN GUARANTEE BULOVA 15 JEWEL

ONLY  
**\$14.95**  
Plus \$1.50  
Tax

ORIGINALLY  
SOLD AS HIGH  
AS  
**\$59.50**



Also Choice Of  
• BENRUS  
• LONGINES  
• WALTHAM Choice  
• or ELGIN **\$14.95**  
WATCHES

Genuine Bulova, Benrus, Longines, Waltham, Elgin and other famous wrist watches in latest style Yellow Gold Cases. You get these unredeemed 5 year guaranteed lifetime quality famous make watches now at truly enormous savings because we bought out SURPLUS STOCKS of leading New York and Maryland Jewelers. Order now, while they last. State make preferred. Order men's or ladies.

**TRIAL OFFER! WEAR AT OUR RISK!**  
Money Back in 5 Days If Not Delighted!  
**SEND ONLY \$1** down payment with order. Pay balance to postman on arrival, plus postage. Or we pay postage if you enclose \$14.95, plus \$1.50 tax. **HANDSOME EXPANSION BAND INCLUDED WITH PREPAID ORDERS.** Order now.  
**MARYLAND DISTRIBUTORS, Dept. 25**  
501 E. Baltimore St. Baltimore 2, Md.

15 or 17  
JEWEL  
WRIST  
WATCH

Waterproof,  
Shockproof  
with Swiss  
Precision  
Movement.  
Originally  
\$30:

**OUR PRICE**  
NOW **\$9.95,**  
plus \$1, tax

**FREE FOLDER!**  
America's best  
Watch and Diamond  
Ring Values. Wholesale  
prices to user  
direct.

## GET THIS SUIT AS A BONUS!

YOU PAY 1/2 • WE PAY 1/2

Sell popular Smith tailored-to-measure suits. Make up to \$10-\$15 daily, taking orders from friends. As an extra bonus, get your own suit at HALF wholesale cost. No experience needed. Send for FREE selling kit and sample line. Send no money. Write fully, state age, etc.

**W. D. SMITH & CO., Dept. D**  
833 W. Jackson Blvd., Chicago 7, Ill.



## HIGH POWER TELESCOPE

60 POWER - ALUMINUM TUBES - OPENS TO 33"

Variable Power Eyepiece Adjustable  
to 15X, 30X and 60X.

**\$4.50** Leather Case Included

5 Sections. 4 Ground & Polished Lenses. Also used as 50X Microscope. Ready to use; only \$4.50 POSTPAID.  
**BROWNSCOPE CO., Dept. 2M, 24 W. 45th St.**  
NEW YORK 19, N. Y.

## FULLY GUARANTEED TIRES COST LESS

Nationally famous FIRE-  
STONE, GOODRICH, U.S.  
ROYAL, GOODYEAR, and  
other makes. Trucking  
Fleets and Busses buy  
from PYRAMID with confidence. Every tire selected  
and inspected for  
your safety.

### NEW TREAD SNOW TIRES

NO CHAINS NEEDED!  
Hundreds of Sharp, Heavy, Cleats  
that grip and bite into snow and ice.

600x16	7.95	670x15	9.95
650x16	8.95	710x15	10.45
650x15	9.95	760x15	10.95
700x15	10.95	820x15	11.95

Regular Treads—Tube Given FREE  
with Every Tire—10% Disc. to Vets

550x16	3.48	700x15	3.69	700x20	8.98	84x7 (10)	9.48
600x16	3.48	700x16	4.98	32x6 (8)	8.98	825x20	11.45
650x16	3.59	750x16	6.48	32x6 (10)	10.89	900x20	11.60
650x15	3.59	600x20	7.68	750x20 (8)	8.09	1000x20	12.59

Regular Treads—AAA	Premium	Grade—Guaranteed	Longer Service
600x16 5.19	700x16 6.19	700x20 10.89	34x7 (10) 12.98
650x16 5.19	750x16 7.59	32x6 (8) 10.69	825x20 14.68
650x15 5.09	600x16 (6) 6.45	32x6 (10) 12.48	900x20 14.98
700x15 5.29	650x16 (6) 6.95	750x20 (8) 10.68	1000x20 15.98
820x15 6.99	900x16 8.89	1100x20 13.98	1000x22 17.59

### MILITARY "ALL-PURPOSE" TREADS

900x16 8.65	750x20 8.95	1100x20 16.95
900x20 13.95	1000x20 14.95	1400x20 22.95
600x16 MILITARY "NEW TREAD" TIRES 7.95	750x20 MILITARY "NEW TREAD" TIRES 19.45	

Largest stock of used tires in the East.  
Thousands of satisfied customers. Tires  
shipped to all parts of the world. Mail  
orders given personal attention.  
**SEND MONEY ORDER OR CHECK  
WITH ORDER.**

## PYRAMID TIRE CO.

1333-35 North 5th St.  
Dept. M, Phila. 22, Pa.

## SURPLUS STEEL BENCH LEGS

MAKE YOUR OWN BENCH  
Used But In Good Condition

High	Wide	Each	High	Wide	Each
28 1/2"	x 28 1/2"	\$1.79	28 1/2"	x 29"	\$1.99
28 1/2"	x 34 1/2"	\$2.69	31"	x 40"	\$3.79



\$1.79 each  
28 1/2" x 28 1/2"

Cross Braces: 5 ft. . . . . \$1.25 8 ft. . . . . \$1.75 10 ft. . . . . \$2.00

Prices F.O.B., K. C., Mo. No C.O.D.'s.

SEND 10c FOR NEW 72 PAGE JAM PACKED CATALOG

## ATLAS EQUIPMENT CO.

229 S.W. BLVD. Dept. PM2 KANSAS CITY, MO.

*Always write your name and full address  
clearly when answering advertisements*

## SANDEE

Mufflers—All Ford, Chev., Ply. . . . . \$4.45  
All Buick, Pont., Olds., Chrys.,  
Dodge, Hudson, K.F., Pack., etc. . . . . \$5.45

V-8 and Merc. Duals  
(32-49 incl.)

**\$15.95**



STONE

DEALERS  
WANTED

**SPORTONE  
MUFFLERS**  
(Pats. Pend.)

Beautiful  
SANDEE  
Fender Skirts  
**\$9.95**

DURABILITY

A SANDEE Sportone will outlast two ordinary mufflers and  
give More Power! More Speed! More Mileage!—plus a tone  
quality unsurpassed.

Please ship (item): \_\_\_\_\_ Price: \_\_\_\_\_

Car and Year: \_\_\_\_\_ Name: \_\_\_\_\_

Address: \_\_\_\_\_

**SANDEE MUFFLER CO. 5643 Corryne Pl. Culver City, Calif.**

# PALMGREN



**No. 000 ANGLE VISE**  
For MILLING—DRILLING—GRINDING  
FITTING—FILING

Solve Difficult Angle Jobs

Quick, accurate set-ups at any angle. End make-shift methods—time loss—rejections. Ideal for tool rooms or home workshop. Accurately machined and graduated. Once set it stays locked. Jaws of steel—plain or grooved. PRICE \$12.05 complete with Swivel Base. Write for other styles and sizes.

## DRILL PRESS VISES

For tool room, machine shop, school shop, home shop or repair shop. Accurately machined. Best semi-steel castings. Adjusting screw of hardened steel with fine pitch thread and long bearing. Jaws of steel, grooved or plain. Sizes 1 1/2" — 2 1/2" — 4" Jaws.



No. 6  
1 1/2" GROOVED STEEL  
JAW. \$4.

## No. 83 ROTARY TABLE with . . . DUAL CROSS FEED and ROTARY FEED



Has 8" Circular Table with full 360° movement and 4" crossfeed travel. Free moving adjusting wheels and dials graduated in degrees. Crossfeed adjusting screws have Acme threads with adjustable dials graduated in thousands. Four slots in base and key slots for bolting to table.  
No. 83 Rotary 8" Table . . . \$49.50  
No. 82 Dual crossfeed—with out rotary . . . \$39.75

**IMMEDIATE DELIVERY** Write for Circular No. 12 — Order from dealer or direct postpaid if he can't supply.

## CHICAGO TOOL AND ENGINEERING CO.

8365 South Chicago Avenue Chicago 17, Illinois  
Telephone — Saginaw 1-9675

**WHY DO  
IT BY  
HAND?**

LET *Bready*  
DO THE WORK!



1 1/2 H.P.  
and 2 1/2 H.P.  
Models

FROM  
ONLY  
**\$149.50**  
F.O.B.  
FACTORY

**BREADY GARDEN TRACTOR** does your gardening, mows lawn, trims weeds, plows snow—plus many other jobs. Powerful, yet economical to run. Easy-guiding. Frees you from back-breaking hand work the year around! Write today for free folder & name of dealer.

## THE BREADY TRACTOR & IMPLEMENT CO.

BOX 230 • SOLON, OHIO

## PARTS FOR MILITARY TRUCKS

4 or 6 Wheel Drive at a SAVINGS—  
1/4 ton to 20 ton.

Parts List Available on Most Makes  
Military Trucks and Jeep Models  
Write stating model of Truck



## JEEP TOPS and CURTAINS

Supply Limited (Weatherizing Kit), complete top with back curtain and side curtains with doors. 5 windows. Waterproof O. D. color, shipping weight 40 lbs. Never again at such low price  
**\$49.50**  
Wonderful value. F.O.B. K.C.

## TRAILER AXLE

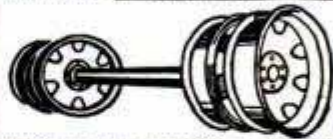

Heavy duty trailer axle, suitable for many types of trailer construction. Also excellent for building of heavy farm trailers and wagons. It is a 12,000 lb. capacity square type straight trailer axle complete with Timken roller bearings, hubs, and 6 hole 750 x 20 Budd Wheels. Without brakes. Axle is 2 inches square and 69 inches between wheel mounting flanges. Std. width. Write for quantity prices, 6 or more.

With Single Wheels. \$59.50 With Dual Wheels. \$69.50

**GAS TANK** Utility, 6 qts.—New Surplus. \$2.10  
Cylindrical 5 1/2" x 15 1/2", complete.

Brand New **HYDRAULIC JACKS** Walker, 3 ton. Complete, limited supply, ea. \$9.95

**WINCH CABLE, 1/2", 250 ft.** \$30.00

Hundreds of Other Truck & Jeep Parts and Supplies  
All prices quoted good 30 days FOB, Kansas City, 25%  
Deposit Required on All Orders.

## American AUTO PARTS CO.

1830 LOCUST — DEPT. PM  
KANSAS CITY, MISSOURI.



## PLYWOOD BOAT KITS



**\$67.50**

(Freight  
Included)

Build the 12 ft.  
V-Bottom "Sportsman"  
as shown. Ready-cut kits include all hardware, paint, etc. Send for free folder on all models as low as \$29.95, freight included.

## TAFT MARINE WOODCRAFT

Dept. "R," 636 39th Ave. N.E. Minneapolis 21, Minn.

## STOPS LEAKS PERMANENTLY

Cut your fixture replacement, water and fuel bills with Economy Renewable Seats. Make economical, permanent repairs quickly and easily with the Junior Kit (illus.). Repair bathroom, kitchen and laundry fixtures. Everything you need included in steel box. This is a natural for the "Fixit" shops—get extra income from making permanent repairs on your customers' faucets.

Senior Master Kit also available—repairs faucets and valves up to 1" pipe.  
Write for illustrated circular and prices.



## NEW "JIG-A-VISE"

3 tools in one—a Jig . . . a Jack, and a Vise. Ideal for handymen, model makers, home workshops. Use it for holding any piece for drilling, finishing, assembly. Assures accurate work as all surfaces are ground true. Write for complete information and illustrated circular.

## ECONOMY VALVE SEAT CO.

3122 N. California Ave., Chicago 18, Ill.

**JUST DIAL**  
**SIZE DESIRED**

**"QUICK-SET" Dado**  
13/16" 3/4" 5/8" 1/2" 3/8" 1/4"

**and all sizes inbetween**

Safe—not a makeshift saw adaptor, but a precision-built complete tool. Cuts accurately over 25 different width smooth grooves. Just dial the size desired without removal from arbor. No blade vibration, chatter, burning or chewing of wood.

pat. pend.

**Quickly changed to fit 1/2" - 5/8" and 3/4" arbor**

**Adaptable for Right or Left shaft rotation.**

Users tell us the high-speed woodworking tool-steel knives remain sharp 4 to 5 times longer than conventional Dado's.

**\$19.75** SHIPPED POSTPAID WHEN FULL PRICE ACCOMPANIES ORDER.  
\$1.00 Deposit required on all C.O.D.'s  
Dealers - Agents write for details of this FAST SELLER

**C & G TOOL COMPANY**  
533 W. Windsor Glendale 4, California

**WHEELS - WHEELS**

- 5" Disc Wheel 5/8" Tire 5/16" or 3/8" Sleeve.....30c ea.
  - 6" Disc Wheel 5/8" Tire 5/16" or 3/8" sleeve.....35c ea.
  - 7" Disc Wheel 3/4" Tire 3/8" sleeve.....45c ea.
  - 8" Disc Wheel 1 1/4" Tire 1/2" sleeve.....70c ea.
  - 7" Disc Wheel 1" Tire 1/2" ball bearing.....80c ea.
  - 8" Disc Wheel 1 1/4" Tire 1/2" ball bearing.....\$1.00 ea.
  - 8" Disc Wheel 2" semi-pneum. T. 1/2" B.B.....\$1.35 ea.
  - 10" Disc Wheel 1.75 semi-pneum. T. 1/2" B.B.....\$1.50 ea.
- Above wheel prices include hub cap.
- 10" Aluminum Wheel 2 3/4" semi-pneum. T. 1/2" B.B.....4.50 ea.
- Plus Postage, 20% - C.O.D.'s accepted.

**UNITED WHEEL STAMPING CO., PM-2**  
2756 W. 115th STREET CHICAGO 43, ILLINOIS

**MARCOT KEY MACHINE**

Immediate Delivery

MARCOT No. 8 KEY MACHINE, mounted on Cabinet, less motor, \$ 95.00  
Auto Code Book and Depth Keys. 12.50  
100 Dz. Popular Key Blanks... 60.00  
Set - Key File, Follow-Through Rods, Lock Picks, Bit Key Gauge, Thimble, Pins, Springs..... 10.50  
"Locksmith Trade Books"..... 6.75  
How to Open Locks without Keys or Picks; Secret of Locksmithing; How to Make Keys by the Impression Method; Master Key Systems.  
**TOTAL COST.....\$184.75**

A. J. MARCOTTE CO., 1200 N. Kedzie Ave., Dept. PM, Chicago 51, Ill.

**MEN! WOMEN!**  
**New Car given as Bonus!**



**TAKE ORDERS for Nationally Advertised NYLONS**

**GUARANTEED NINE MONTHS**

Sensational Guarantee creating a tremendous demand for Wilknit Nylons! If they run, wear out or even snag from any cause whatever... within NINE MONTHS... depending on quantity... they are replaced FREE OF CHARGE. No wonder it's easy to quickly build up fine, steady, year-round income. Earnings start immediately. Look at these exceptional figures—Ralph Shearer made \$67.11, first week—Mrs. Paul Estes, \$42.92—Mrs. Ivey Gentry, \$43.37. Doris Jensen in addition to making as much as \$17.00 in a single day, earned two cars as EXTRA BONUSES. Learn how you can make money in your full or spare time without a bit of previous experience.

**SEND NO MONEY... Just Hose Size**

When you send for Selling Outfit, I also send your choice of Nylons or Socks for your personal use. Don't lose a minute. Rush name on penny postcard for full money-making facts on Sensational Sales Kit. Send hose size, too. Lowell Wilkin, WILKNIT HOSIERY CO., 302 Midway, Greenfield, Ohio

**EARNED \$120.00 in 1 WEEK Plus 2 NEW CARS**

That's the exceptionally fine record of Chas. Mills with the famous Wilknit line of men's, women's & children's hosiery—Owner of New Chevrolet as a bonus open to EVERYONE. Send name for facts FREE.

**DELTA MILWAUKEE HOMECRAFT®**



Model No. 37-510  
**\$89.20**

motor and switch rod extra  
Price subject to change without notice  
**Low down payment delivers!**

*Saves space!*  
*Saves money!*  
**Delta® Homecraft Saw-Jointer Combination**

Two precision-built tools on a single stand, using one motor. Takes floor space of only 25 1/4" x 28 1/4". Husky 8" tilting-table saw cuts stock up to 2 1/4" thick. Rip to center of 15" panel, cross-cut, angle-saw, bevel-saw, dado and make mouldings. Jointer planes up to 4" wide, rabbets 1/4" deep. Fence tilts 45° to right or left. See your Delta Homecraft dealer today!

**POWER TOOL DIVISION**  
**Rockwell Manufacturing Company**  
680B East Vienna Avenue  
MILWAUKEE 1, WISCONSIN



**Free Book!**  
"How to Start Your Home Workshop." Write for your copy today.

**"ROCKET PERFORMANCE" FOR ANY CAR**

The revolutionary new VAPOJET is designed on the war developed principle of WATER INJECTION. It offers an ideal, INEXPENSIVE way to gain superior performance from any car. For the owners of new cars with HIGH COMPRESSION engines, VAPOJET gives extra power with low octane gas. Thousands of VAPOJETs are now in use and users report better pick-up, smoother running, power and BIG mileage increases on regular gas. Complete, easily installed kit fits all cars, boats and stationary engines and is backed with a 30 day money back GUARANTEE.

Patent No. 2,188,175

**VAPOJET MFG. CO.**

11424 Biona Dr. Dept. PMC-2  
Los Angeles 34, California  
AGENTS WANTED

Designed to Give

- More Speed
- More Mileage
- More Power

Eliminates carbon & "ping."  
Reduces wear.

**Order Today**  
Only **\$9.75** post paid.

Send check or money order and save postage. \$1 deposit on C.O.D. List car, year, and no. of cylinders.

# "BEST SURFACE POPPING LURE IS HULA POPPER"



—SAYS WORLD FAMOUS  
OUTDOOR WRITER  
ROBERT PAGE LINCOLN

"I took these four bass from Thunder Bay River, Alpena, Mich., on your Hula Popper. Have seen a great number of small and large mouth taken with it here. It's the best surface popping lure made."

Pops, plunks, jerks, twitches with full control. Skirt squirms like crazy. Choice 7 colors.

live bug. Drives bass

**HULA POPPER**

(Casting Size) — 5/8 oz.

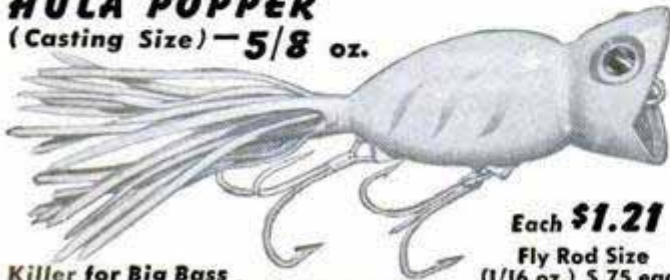

Each \$1.21

Fly Rod Size  
(1/16 oz.) \$.75 each

Killer for Big Bass

Also in 3 FIREPLUG® FINISHES \$1.45 each.

Extra Hula Skirts (small) — Choice 11 Colors — \$.17 each

► WRITE FOR FREE FULL-COLOR BAIT CATALOG

**FRED ARBOGAST & CO., INC.**

1652 WEST NORTH STREET • AKRON 3, OHIO

## NEW SHERRILL COMPASS

\$25.00 VALUE

PRICE

**\$5.95**

Postage Paid



## ARMY TANK COMPASS

These compasses were built to rigid government specifications for modern army tanks and are known for their high degree of efficiency and ruggedness. It is a very useful instrument for universal installations, such as boats, planes, cars, trucks, tractors, etc.

These compasses are new in original cases with compensators, calculator, adjustable mounting brackets, and instruction book. Compass size 5" high by 3 1/2" dia., weight 1 lb. 6 oz. This is truly a fine compass and a real value for only \$5.95 postpaid.

Send for Free Catalog on home utility power hand tools, products of Black & Decker, electric drills, portable electric saws, etc. The best medium priced electric tools for less. Also many surplus bargains. We pay all postage on power hand tools.

All orders filled promptly, pay by check or money order, 25% deposit on C.O.D.'s.

**ARMY SURPLUS SALES OF FRESNO**

(The Fresno Hardware Co.)

1820 TULARE STREET Dept. 32 FRESNO, CALIF.

## STOP WASTING PRECIOUS WATER! STOP THAT "RUNNING TOILET" . . .



The NEW guide to a perfect seal

Order **FLUSH-FIX** . . Now!  
**TANK BALL and GUIDE ASSEMBLY**

- EASY TO INSTALL—NO TOOLS NECESSARY
- DOUBLE GUIDE INSURES POSITIVE SEATING
- SAVES WATER—PAYS FOR ITSELF

**JUST \$1.50 . . .** Sent parcel post prepaid to any destination in the U. S. A. Satisfaction guaranteed.

Send check or money order to  
**"FLUSH FIX"; P. O. Box 3013**  
LINDEN HILLS STA.; MINNEAPOLIS, MINN.  
No CODs please

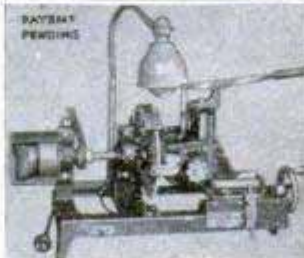

## ACCURATE WRIST WATCH

GUARANTEED

You Too, will be proud to wear this classy new wrist watch imported from Switzerland. Made by precision artists that insure a perfect time-piece. Case is chromium plated with a stainless steel back that resists moisture and shocks. Big SWEEP SECOND HAND. LUMINOUS dial that can be seen in the dark. . . . **\$4.98**

FREE: At no extra cost we will include a Brand New STAINLESS STEEL STRETCH WATCH BAND and a 1 year guarantee against mechanical defects. Send \$5.00. We Pay Postage.

MARDO SALES CO. 480 Lexington Ave., Dept. 1706-C  
New York 17, N. Y.



## Start a NEW BUSINESS!

or Add to your present  
Repair Business

**SHARPEN DULL PIPE WRENCHES**

PIPE TAPS & DIES  
"GUM" CIRCULAR SAWS  
Write for Information

**J. C. MOORE INDUSTRIES**

BOX M 276 FREDONIA, PA.

## 25 POWER-PRECISION MICROSCOPE

COMPOUND OPTICAL SYSTEM

using 4 precision lenses.

**\$2.79**

A Professional Instrument. Pocket Size. 5" long.



Postpaid

Ideal for

Machinists • Hobbyists • Photographers • Engineers • Students • Naturalists

ALUMINUM CASE Money-back GUARANTEE—Same Day Shipment  
**MICROSCOPE & LENS CO.** Dept. PM-8, 170 Nassau St., New York 7, N. Y.

## BOMB HOIST



Ideal for garages, truck loading, machine shops, home work shops, etc. Wt. 7 3/4 lbs. 1500 lb. capacity—30 to 1 ratio. Dimensions, 6 1/2 x 5 1/2 x 6. Pulley will hold 18 ft. 3/16" 7x19 cable or 16 ft. 1/4" cable. Rust-proof all bronze bevel cut gears. ONLY \$9.95! For \$2.50 extra we can furnish larger pulley that takes up to 35 ft. of 3/16" cable or 25 ft. of 1/4" cable. Also available, 3/16" 7x19 hi-carbon galv. air craft control cable—52 ft. Same in 1/4"—7 1/2 ft. Special Hi Power 1/4" electric drill. Reg. \$18.95. Now, \$12.95. Both items postpaid. Money-back guarantee. C.O.D.'s with \$1.00 deposit.

B & M DISTRIBUTING CO., P.O. Box 1343, Dept. B-16, Tacoma, Wash.

## SPEED & MILEAGE MANUAL

140 Illustrations



Easily Get Super Speed, Acceleration, Mileage—Top Racing Performance From Any Automobile!

Famous New Book shows simplified Soup-up Methods—Speed Tuning—Economy Secrets—Customizing Plans—Latest Track Proven Methods for all cars! Tells how to build your own SPEED

EQUIPMENT! FAST SPORT CARS! "CALIFORNIA HOT RODS"! 200 H.P. ROAD & TRACK CONVERSIONS! Complete Instructions on building inexpensive Superchargers! Dual Manifolds! "Water Injectors"! High Compression Heads! Twin Mufflers! Economizers! All about—Fast Engines, Gas Saving, Restyling, "Cam Secrets," Multiple Carburetion, Fuels, Porting, Ratios, Frames, "Offys"! BRAND NEW METHODS, Plans, Formulas, "Racing Tricks"! "STOCK CAR SPEED SECRETS"! Reveals 100 ways to save gas! Shows latest "HOLLYWOOD CUSTOM STYLING"! Streamlined! Sport Changes! Lowering! Speed! Conversions! Including—California Roadster Plans! Racer Diagrams! Working Drawings! Performance Charts! Graphs! Beautiful Photographs! Etc.!

ALL THREE \$1.98 Postpaid

Large manual (plus) "California Equipment Catalog" and Racing Handbook.  
**ALMQUIST AUTOMOTIVE ENGINEERING, Milford 73, Pa.**

**NOW** A 5 ROOM HOME ANYONE  
CAN BUILD COMPLETELY for only

**\$2895.**

F.O.B. Marlette,  
Michigan

Complete  
Information  
**FREE**  
Send Us  
A Post Card



The "Scotchman" is the result of over 40 years of lumber and building experience. Available in 2 and 3 bedroom models.

We have proven its value and the great savings possible with our system time and again near our plant. See for yourself how we can give you a complete house for so little. Write today. You'll be amazed—you'll be pleased. It's your chance to get your own home NOW.

**L. H. RIEDEL LUMBER CO.**  
DEPT. A1 • MARLETTE, MICH.

**Gadgeteers! Inventors! Hobbyists!**

**HERE'S THE "BUY" OF THE YEAR!**

**6 BIG**  
ISSUES!

NEWS  
PHOTOS  
IDEAS

NEW  
DIFFERENT  
EXCLUSIVES

**6 NEW**  
GADGETS!



**\$2.00**

SELECTED AND SENT  
IN SIX MONTHS BY  
THE WORLD FAMOUS  
GADGET-OF-THE-MONTH  
CLUB, INC.

**COMBINATION OFFER**— Good only for limited time and may be revoked without notice.

To introduce the new "Inventors & Gadgeteers" magazine, we are making this unusual offer of a six-months subscription, worth \$1.50, plus a six-months trial subscription in the world famous Gadget-of-the-Month Club—ALL FOR JUST \$2.00!

INVENTORS & GADGETEERS MAGAZINE is a thorough, practical publication devoted to the needs of inventors, gadgeteers, designers, engineers, homework shop enthusiasts, and the great horde of American gadgeteers and tinkers. It's NEW! Nothing like it ever before published! It's the trade-paper for gadgeteers, inventors, etc. Published monthly. Contains exclusive features, news stories, etc., on The Inside of Inventing, Trade Marks, Inventions Needed, U. S. Patent Laws, Selling Inventions, Manufacturing Inventions, Review of Successful Inventions and Gadgets, many other fascinating and profitable articles each month. You can't afford to miss a single issue! Trial membership in the world famous Gadget-of-the-Month Club sends you a new, exclusive, practical, patented, never-before-on-the-market nationally labor-saving gadget, six in six months! The retail value of the six gadgets sent is unconditionally guaranteed to be far greater than the membership fee or your money will be cheerfully refunded. Send in your order today! Only \$2.00 for the combination offer of six big issues PLUS six-months trial subscription to world famous Gadget-of-the-Month Club. Act now! Fill in the coupon and mail NOW!

**25¢**  
SAMPLE COPY

INVENTOR & GADGETEER PUBLISHING CO.  
6600-M Lexington Ave., Hollywood, Calif.

Enclosed is my \$2.00. Please enroll me as a subscriber to Inventor & Gadgeteer, and in addition send a six-months trial membership of the world-famous Gadget-of-the-Month Club. Enclosed is \$.25. Send a sample copy of Inventor & Gadgeteer. (Add 25% on all Canadian and Foreign Orders.)

NAME.....  
STREET.....  
CITY.....STATE.....

**SAY YOU SAW IT IN POPULAR MECHANICS**

**You Read About it! NOW OWN**  
**America's Most Wanted Car Accessory**

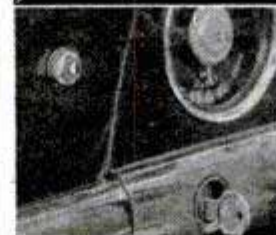

**"Oil-Spy"**

**AN EVER WATCHFUL EYE  
ON YOUR OIL LEVEL  
YOUR CHEAPEST INSURANCE  
AGAINST DAMAGED MOTORS**

**Measures Oil Level  
Accurately & Automatically**

Now you can know right away when your oil level goes down too low. This inside-the-car-on-the-dash accessory ends for all time the bothersome, time-consuming chore of having to check your oil with a dip-stick. Every car on the road needs one. The Oil-Spy never lets you down. Flashes on an amber light when oil is 1 qt. low, a warning red light when oil falls 2 qts. low. Easy to install. Installed by replacing plug in crankcase. A factory approved accessory.

**Most Valuable Car Accessory  
Since the Automatic Transmission**

Motorists have long wanted it. You read about it in the Nov. '48 issue of Popular Mechanics. Now it's available for every car. Protect the life of your \$300 or more motor. Not only is it useful but it looks very neat on your dash. Stop guessing about oil level. Be sure. Get an Oil-Spy.

**ORDER NOW! FITS ALL CARS**

Send cash by registered mail only. When ordering C.O.D. send \$2.50. Pay postman balance on arrival. We pay postage when remittance sent with order. State make, model, year of car. Shipped complete with full directions for installation.

**\$9.95**

**YOU MUST BE SATISFIED AFTER 10 DAYS TRIAL OR YOUR MONEY BACK**

**GARBISCH-EDGINGTON, INC.**

465 M-2 Hippodrome Annex Cleveland 15, Ohio

**SHARPEN CIRCULAR SAWS  
LIKE AN EXPERT**



No experience needed. Two simple adjustments. Gets hollow-ground, cross-cut or combination saw blades true and sharp. Fits 6" to 12" blades with 1/4" to 13/16" centers. Includes file and complete instructions. \$6.95 postpaid. (Check or money order) C.O.D.s postage extra. Guaranteed—Money back if not satisfied after 10 day trial. A money maker for fix-it shops. Soon pays for itself. Order today. Free folder. **SURE SHARP MFG. CO., Dept. M-20**  
P. O. Box 24 Santa Ana, Calif.

**\$6.95**

**DRAINS CELLARS, WASH TRAYS  
CIRCULATES OIL**



Pumps 1800 GPH 300 gal.  
30' high, use 1/8 to 1/2 HP **\$6.50**  
motor. Will not clog.

Postpaid if cash with order.  
(Add 50c for west of the Mississippi.)

Thousands in use since 1936

**LABAWCO PUMPS, BELLE MEAD 7, N. J.**

**AMAZING-NEW-ELECTRONIC  
HAND SHOCKER**



Enjoy hours of harmless entertainment at home and at work. Inclosed in a plastic, pocket size case.

**\$2.98** BORN MFG. CO.  
P.O. Box 461  
C.O.D. TIMES SQ. STA.  
in U.S.A. NEW YORK CITY

**WORKSHOP MOTOR BARGAIN**



**• 1/4 H. P. ONLY \$6.50 •**  
General Electric, Leland, Delco, Westinghouse, Sunbeam, and others. Induction type motors. Alternating current, 110 Volt, 60 cycle single phase. Like New. Fully Guaranteed, some shop worn, many brand new. Every one a whale of a bargain. F.O.B.

**THE VAPORITE Automatic HUMIDIFIER for Warm Air Furnaces**

THERMOSTATICALLY controlled water supply puts more moisture in the air. Easily installed in bonnet of air furnace. Complete with THERMOSTAT Water Control Valve, Tubing and parts for complete installation. GIVES HEALTHIER AIR.

\$15. Value

ONLY

**\$7.50**

Postpaid

We have large stock of Standard & Special Motors; all sizes. Write for BARGAIN MOTOR CIRCULAR and SAVE MONEY.

**C. MARSHALL SALES**

3546 W. Fullerton Ave., Dept. P-2, CHICAGO 47, ILL.

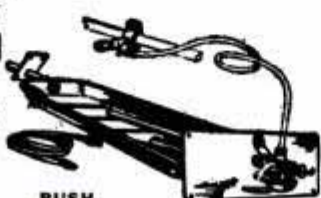

RUSH  
ORDER

# World's Lowest Cost Dependable, Powered Transportation!

The New 1950

**Cushman**  
MOTOR SCOOTER

**75**  
MILES PER GAL.



Greatest Scooter VALUE Ever Offered

"My Cushman takes me everywhere—quickly—AT AMAZINGLY LITTLE COST!" Own, maintain and operate it for only  $\frac{3}{4}$ ¢ a mile! Cheaper than bus fare—and no long waits. Parks anywhere. Wonderful for getting to work, school or market—making deliveries—or just taking pleasure spins.

New flashy 1950 Cushmans are ruggedly built, beautifully streamlined. You'll be proud to say "I own a genuine Cushman!" And how you'll boast of the economy!

SEE your Cushman dealer for demonstration. Or, rush card for free folder with full details.

**CUSHMAN MOTOR WORKS**

Dept. M2, Lincoln, Nebr.

SAY YOU SAW IT IN POPULAR MECHANICS



BETTER MEASURE WITH **LUFKIN**



## ALL THREE "MIKES" NOW CHROME-CLAD HELPS YOU SEE RIGHT—BE RIGHT!

Now you can get all 3 types of Lufkin "Mikes" with the special Chrome-Clad Visibility-Plus finish. In blinding sun, or dim shop corner, the Lufkin Chrome-Clad finish absorbs disturbing reflections... resists both rust and wear. Markings stand out razor-sharp! Get "Better Measure With Lufkin"—see your dealer soon. Write Dept. M for fascinating, educational booklet, "The Amazing Story of Measurement!" Enclose 10¢ (no stamps) to cover handling.



BUY **LUFKIN**

TAPES • RULES • PRECISION TOOLS • FROM YOUR DEALER  
**THE LUFKIN RULE CO.**  
SAGINAW, MICH. NEW YORK CITY BARRIE, ONTARIO

## "Wellworth" BLOWER at Bargain Price

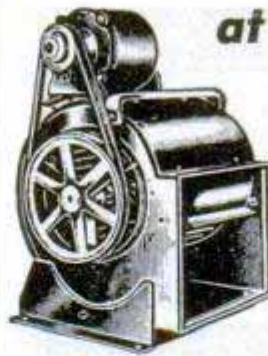

Quiet operating. Double wheel inlet, double width blower. For heating, ventilating, cooling, air washing, exhausting and forced draft.

DIMENSIONS: 10" wheel; outlet  $13\frac{1}{8}$ " x  $11\frac{3}{8}$ "; inlet  $8\frac{3}{4}$ ". Height 19". Width 18". Depth  $16\frac{1}{2}$ ". C.F.M.  $\frac{1}{4}$ " S.P. 1600; outlet vel. 1575; motor  $\frac{1}{4}$  H.P. with overload relay; cord & plug, 110 v. 60 cy. AC. **\$39.50**  
Ship. Wt. 67 lbs. Special price...

## 140 CFM "WELLWORTH" BLOWER

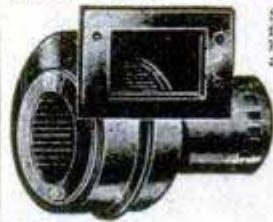

Single-inlet blower that gives top performance on heating, ventilating, exhausting, cooling, drying and similar applications.  $5\frac{1}{8}$  x 4" mounting flange with  $2\frac{1}{2}$ " square discharge.  $3\frac{1}{2}$ " dia. blower wheel powered by direct-connected  $1\frac{1}{16}$  H.P., 110V., 60C., A.C. motor with conduit box and 20' leads.  $7\frac{1}{2}$ " wide less flange by  $7\frac{1}{2}$ " H. x  $6\frac{3}{4}$ " D. Suited for hundreds of new and replacement uses. Shpg. wt. 6 lbs. **\$14.20**

50 CFM BLOWER **\$8.95**  
 $2\frac{1}{2}$ " Discharge.....

## 68 PAGE BOOK!

Sold on money back guarantee. Send check or money order today. Prompt shipment.

Motor guide, air compressors, home and factory workshop tool catalog. Send 25¢ to cover postage and handling, deductible from first purchase.

**WELLWORTH TRADING CO.**

1831 S. STATE ST., Dept. D-2 CHICAGO 16, ILL.

## ALL-PURPOSE SMALL MOTORS



**D-2** Converts to 110 V AC in ten minutes, diagram included, contains integral gear box having four  $\frac{1}{4}$ " drive shafts turning simultaneously at the following speeds: 4000 RPM—Grinders, buffers, flexible shaft tools, etc. 150 RPM—Wrapping fishing rods, slow speed tools. 25 RPM—Dev. tray rocker for photo darkroom. 5 RPM—Turning barbecue spits. Adv. disp. beams. **\$5.95**

A thousand other uses around the Work Shop. ONLY CONVERTED TO 110 VOLTS AC..... **\$7.95**

**D-1** Converts to 110 V AC in ten minutes, diagram included, has shaft with squirrel cage blower, also gear reducer with 2 shafts and pulleys at the other end. 1001 uses. Only..... **\$4.95**

**6 V. MOTOR** A real beauty, removed from aircraft. Type used for auto fan. Many uses. Ea. **\$1.50**

All prices F.O.B. Chicago. 30% deposit required on all C.O.D. Orders. Write for free catalog.

**NESCORP ELECTRONICS** Dept. PM-2, 2635 West Grand Avenue Chicago 12, Illinois

## SAW SHARPENER

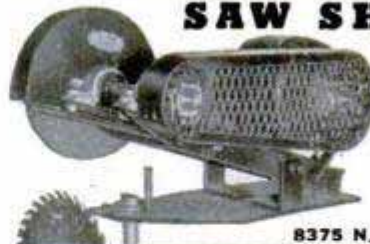

Table model, adjustable for any degree of bevel. Takes saws up to 20" and can be used to face off inserted point teeth and other type saws.  $\frac{1}{4}$  h.p. motor, total weight only 60 lbs.

**\$64 F.O.B. Portland**

**P. T. HOBBS Machinery**  
8375 N. Interstate Ave., Portland 3, Ore.

## CONVERT HAND MOWERS TO POWER MOWERS

Takes less than 3 hours

The Handy-Dandy Lawn Mower Kit fits any hand mower from the 16 to the 20 inch size. Complete with all necessary parts. Kits can be purchased separately, complete with engines or complete with Pennsylvania mower.

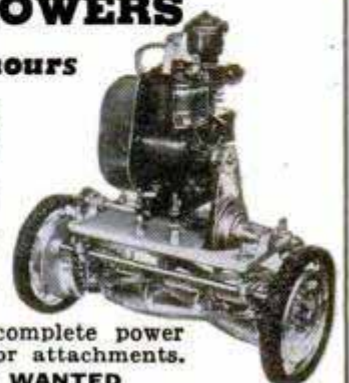

Also manufacturers of a complete power mower and garden cultivator attachments.

DEALERS WANTED

**LE CLAIRE MFG. CO., Le Claire 1, Iowa**

**Better Sights FOR BETTER "SHOTS"**

For faster, more accurate sighting equip with a combination of

**MARBLE'S SIGHTS**

Sheard "Gold" Front Sight \$1.75

Standard Front Sight \$1.25

Flat Top Rear. Price \$2.00

Semi-Buckhorn Rear Price \$2.00

No. 69 Flat Top Sporting Leaf. \$2.00

Marble's Flexible Rear Sight, with automatic spring joint. Can be locked down. With 2 discs. Price \$5.50.

At your dealer, or write for Catalog

**Marble Arms & Mfg. Co.**  
578 Delta Ave. Gladstone, Mich. (588)

**AMAZING FISHERMAN'S DU-ALL**  
Performs Practically ANY Job!

not a gadget, . . . but a **PRECISION MADE, HIGH QUALITY, STAINLESS STEEL TOOL!**

Razor Sharp Knife Edge Leather case protects hand.

Bottle Opener

Fastens Split Shot Sinkers

5/16" Open End Wrench Fits standard castle nut on reels

Hook Disgorger

Two Members Dis-engage QUICKLY... EASILY to do any DU-ALL job!

Tack Remover

Standard Pliers

10" Caliper Measure

Wire Cutter

Fish Scaler

6" Measure

Screw Driver

At better dealers everywhere. A fisherman's dream come true . . . this astounding new tool that performs any and all of your fishing chores. 12 tools in 1! Invented by a fisherman . . . precision made especially for fishermen! Does everything except catch the fish for you. Order your Du-All now, while the supply is ample. Send check or Money Order, and we'll send your Du-All immediately, postpaid. Or, send order and Du-All will be shipped C.O.D. plus postage and handling.

**\$2.95**  
POSTPAID

**FISHERMAN'S "DU-ALL" Company**  
16911 LIVERNOIS AVENUE DETROIT 21, MICHIGAN

**LEARN THE STARS THIS EASY WAY WITH THE STARSCOPE!**

This new, easy way to observe the stars is fascinating, entertaining and educational. The STARSCOPE registers illuminated images of constellations plus star names, by apparent projection, in their correct positions in the heavens (ORION pictured). Instructions, two batteries and 30 interkeyed charts give year round sky coverage. Recognize your birth sign; Aries, Taurus and Gemini now visible.

Order your STARSCOPE today! **\$3.95** Post Paid

**POLARIS D. & M. CO., LINDEN, MO.**

**NO BRUSH! NO MESS! NO MIXING! JUST PRESS THE BUTTON AND PAINT LIKE A PROFESSIONAL!**

**SPRAYZIT—**  
The Sensational New Plastic-Paint Bomb That Sprays High Quality Plastic Paint!

**QUICK EASY \$2.98** Per Can

Postpaid anywhere in U.S.A.

You Can Paint Anything with a **SPRAYZIT PAINT BOMB**

- 4 Bombs will paint the average car like new.
- Furniture • Radiators • Walls
- Small Pieces
- Hundreds of Daily Uses.

Your Choice of the Following Glossy Colors  
Black, White, Grey, Red, Yellow, Green, Blue, Gold, Aluminum and Clear. Use **SPRAYZIT Clear Finish** for a scuff resistant, protective coating over paint, linoleum, chromium, etc.

Specify Colors Wanted When Ordering

W. E. WARREN MFG. CO., Dept. M-1  
139 N. CLARK STREET, CHICAGO 2, ILLINOIS

**SAY YOU SAW IT IN POPULAR MECHANICS**

**WORLD'S LOWEST PRICED ADDING MACHINE**

**VEST POCKET SIZE IDEAL FOR INCOME TAX!**

**FREE TRIAL ONLY \$2.95**

TOTAL COST SEND NO MONEY **FREE!**

Fits vest pocket or purse. Guaranteed accurate. Operated as easily, and as reliable, as machines costing many times as much. Not a toy. Precision made, very durable—guaranteed for life against defects in construction. You positively can't buy a calculator of equal quality for as little money. **ACCEPTED AS THE FINEST LOW PRICED CALCULATOR FOR OVER 35 YEARS!** Operates with a flick of your finger. Adds, subtracts, multiplies, divides—counts up to one billion. Pays for itself over and over in mistakes avoided, and time saved. **MAKES IDEAL GIFT.**

Sold on a positive money back guarantee. Send only \$2.95. Calculator sent postpaid, or send name and address and pay postman \$2.95 plus postage. **MONEY BACK IN 10 DAYS IF NOT DELIGHTED!** (If outside U. S., send \$3.50.) **AGENTS WANTED.**

**CALCULATOR MACHINE CO., (Mfrs.)**  
Dept. 223, P.O. Box 248, Glenview, Illinois



## \$60 FIRE EXTINGUISHER \$14.95

For homes, factories, shops, etc. Fine air pressure type surplus fire extinguisher, with 1 gallon carbon tetrachloride, ready for use. Underwriters approved. Tested for 400 lbs. pressure, operates at 100 lbs. pressure. Outfit includes tank, gauge, hose, nozzle, hand pump and hanging bracket. To operate open valve—air pressure in tank throws stream considerable distance. Easily refilled. Measures approx. 6 in. diameter, 24 in. high. By express only, not mailable. Shp. wt. 35 lbs. A wonderful value. NOW ONLY.....

## \$14.95

## CO2 FIRE EXTINGUISHER

Hand type, filled with CO2 and reconditioned. Shipped Express only, shipping wt. 15#, only.

## \$9.95

## FAIRCHILD A10 SEXTANT, \$5.95

AAF War Surplus, included is the A10 Sextant, wood carrying case and battery case. These are used condition, no operational warranty given; they are just as received. We do guarantee a good bubble assembly.....

## \$5.95

FAIRCHILD A10-A SEXTANT, w/case, as above, \$7.95  
Sextants prepaid for 75c additional.

## \$4.95 BOX CAMERA, \$1.50

Built to sell for \$4.95; metal box camera. Takes 12 pictures per standard #620 or 120 load, picture size 2 1/4 x 2 1/4". All new. Postpaid.....

## \$1.50

## AIRCRAFT CONTROLLER (DC MOTOR)

24V DC, .01 hp, rpm 7000, torque 200 psi, reversible, stroke 45 seconds; by Barber-Colman, #2066, size 3 1/2" x 8". Reconditioned. Shipping wt. 5#.....

## \$2.95

## FLAP ACTUATOR W/DC MOTOR

24V, 11,000 rpm, Lear #108, low speed take-off. Reconditioned. Shipping wt. 5.2#.....

## \$3.95

All F.O.B. Houston. Send Check, cash, Money order

**AERO PARTS SUPPLY, Dept. PM-1**  
8102 LOCKHEED ST. HOUSTON 17, TEXAS

## BRIMMS PLASTI-LINER

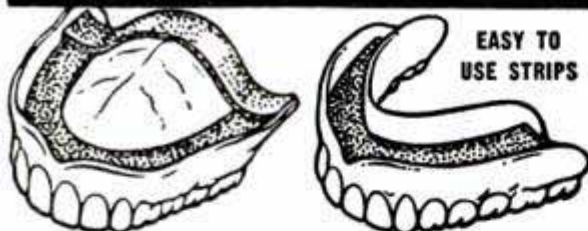

EASY TO  
USE STRIPS

One application  
**MAKES FALSE TEETH FIT**  
for the life of your plates

If your plates are loose and slip or hurt...if they rock and cause sore gums...you need *Brimms Plasti-Liner*. *Brimms Plasti-Liner* gives instant relief, perfect fit and lasting comfort. Lets you eat anything... talk freely without embarrassment. Ends forever the mess and bother of temporary "stickums" that last a few hours or days.

**EASY TO USE...REFITS FALSE TEETH PERMANENTLY**  
Lay soft *Plasti-Liner* strip on upper or lower plate. Bite and it molds perfectly. Tasteless, odorless, harmless to you and your plates. *It hardens to your plate for lasting fit and comfort.* Even on old rubber plates, *Plasti-Liner* gives good results six months to a year or longer. Removable as per directions. *Guaranteed satisfaction or your money back.*

**SEND NO MONEY** Order a \$2.25 package to reline both upper and lower plates. Or a \$1.25 package to reline one plate. Pay your postman when he delivers. Or send money now and save C. O. D. charges. Generous sample of special plate cleaner included free.

PLASTI-LINER CO., Buffalo 11, N.Y., Dept. 43-0

## WAR SURPLUS - U.S. SIGNAL CORPS

Genuine EE 8 Portable Telephones  
Telephone Wire - Equipment



## Big Annual Money-Saving SALE

Amazingly simple to install your own private telephone system with portable telephones and wire. All you do is string wire, attach phones to each end and you are ready to ring and talk up to 1 mile! Add up to 6 phones on main line for dependable 2-way communication around HOME, FARM, SHOP, CONSTRUCTION PROJECTS, FACTORIES, etc. Powered by standard flashlight batteries. Phones checked for perfect operation. Fully guaranteed.

BRAND NEW EE8 Phones (Formerly \$21.50) NOW.....\$17.50 ea.

LIKE NEW. Each phone thoroughly reconditioned like new.

Used, Reconditioned, Excellent. Ea. \$9.95 SPECIAL: 2 for \$24.50

BRAND NEW EE99A TELEPHONE REPEATERS EA. ....\$18.50

TELEPHONE WIRE. Prices slashed to near wholesale cost.

W110B Grade I unused, new, stored in open. Weatherproof, durable, 2-conductor, twisted telephone wire, insulated. Many extra uses for this handy item.

ONE MILE REELS, formerly \$27.50 mile.....SPECIAL \$21.00

1/2 MILE REELS, formerly \$14.25 ea.....SPECIAL \$11.00

500 FOOT COILS, formerly \$3.95.....SPECIAL \$ 3.00

1,000 FOOT COILS, formerly \$7.25.....SPECIAL \$ 5.75

W110B Grade II, unused, outer layer wire stained, weathered, but when removed inside layers perfect. Good for years of service.

ONE MILE REELS, formerly \$27.50 mile.....SPECIAL \$17.50

1/2 MILE REELS, formerly \$14.25 ea.....SPECIAL \$ 9.00

W130 Lightweight Assault wire, 2-conductor. TWO MILE REELS, unused, NEW. (10,500 ft. continuous) wt. only 85 lbs. A Real Special. Formerly \$57.50 reel.....SPECIAL \$37.50

BRAND NEW 1/2 MILE REELS. Wt. 16 lbs. Formerly \$15.....SPECIAL \$12.95

1/4 MILE REELS slightly weathered, unused NEW.....\$ 4.95

Write for Free Folder. Sale on Field Telephone parts. Other specials!

All prices F.O.B. Sacramento. No C.O.D. California residents add 3% for sales tax. Small orders sent postage collect plus small handling charge.

## SEND CHECK OR MONEY ORDER **LORIS SALES**

P. O. BOX 1896-B-2

SACRAMENTO, CALIFORNIA

## POWER MOWERS & KITS

FREE PLANS



3 Wheel Model

4 Wheel Direct Drive

LOW FACTORY PRICES DIRECT TO YOU

on America's finest Lawn Mowers and Easy-To-Assemble Kits and Parts. TRIANGLE Mowers are quality-built and powered high for easy cutting and long wear.

### SAVE MONEY 3 WAYS

1. Buy complete assembled mowers in 3 or 4 wheel models. 18" and 20" sizes.
2. You assemble complete mower from our precision built Kits and Parts.
3. Build your own from our FREE PLANS using Triangle Kits, Parts, Engines, Wheels, Etc.

WRITE TODAY for full facts, Free Plans, Parts List, and LOW, Factory Prices.

**TRIANGLE MFG. CO.**  
Dept. M-A, Box 185  
Fort Scott, Kansas

## Every Electric Drill A PORTABLE SAW

CAN BE USED WITH ONE HAND!  
JUST TRY IT! YOU WON'T USE A HAND SAW ANYMORE.  
"ARCO-SAW" FITS ANY 1/4" ELECTRIC DRILL  
"ARCO-SAW" is a rugged precision woodcutting tool with right angle gear drive. (No clumsy direct drive with drill sideways.) Works like high priced Portable Saw. EXCLUSIVE SAFETY YOKE connects drill and saw, ABSOLUTELY SAFE TO USE. All Parts Guaranteed.

## \$9.95

compl. with 4" "Hycarbon" Blade.

Patent Pending

Cuts 1 1/8", 2 x 4 BY TURNING OVER

Another Sensational "ARCO" Buy! Top Quality CIRCULAR SAW BLADES at Lowest Prices on the Market.

"HYCARBON"—MASTER QUALITY, of finest TEMPERED STEEL, HANDFILED

4" Crosscut (3/8" bore fits "ARCO-SAW") \$1.60  
6" Crosscut, Rip or Combination..... 2.00  
7" Crosscut, Rip or Combination..... 2.50  
8" Crosscut, Rip or Combination..... 3.00  
Specify 1/2, 3/4, 1" bore. Add 30c for Skill, Mall bores.



DEALERS: Write for name of nearest wholesaler.

ORDER YOURS TODAY at your Dealer or send M.O. or Check. 5 DAY MONEY BACK GUARANTEE

**ARROW METAL PRODUCTS CO.**

Dept. PM-2, 140 West Broadway

New York 13, N. Y.



# SAVE UP TO 85% IN WAR SURPLUS from "GADGETEERS" HEAVEN

### TV Antenna KIT

Set up your own antenna at tremendous savings! Kit contains all parts & instructions

Model "A" KIT - Features "V" Cone conical type head with 8 ft. x 1 1/2" Hard Aluminum mast. **7.75**

Model "B" DeLux Kit - Has phenolic head with Di-pole separator. Patented receiving elements. 8 ft. aluminum mast, reflector, 60 ft. lead-in wire, 25 ft. guy wire and full instructions. **12.25**

### 16mm MOVIE GUN CAMERA

Has semi-telephoto 1 3/8" (35 mm) lens with yellow filter - 3 shutter speeds for normal (16 frames) semi-slow motion (32 frames) and slow motion (64 frames per second). Uses any standard Eastman film magazine or Type "G" AAF magazine. Takes Black & White or Full color pictures. Operates on 24V (dry cell batteries) & require slight conversion for hand use. Diagram furnished. Cost Gov't \$235.00 - NOW **24.50**

### CONVERTED GUN CAMERA

Fully re-conditioned with start switch on front. Choice of finishes - Gray, Black, Blue **33.95**

### VIEW FINDER

Calibrated for above lens **8.75**

FILM - Standard, type "G" magazine - Fits gun camera and many other standard 16mm cameras - Loaded with 50 ft. black and white film - Price includes processing. **2.25**

### 16 POCKET VEST

Sturdy, Yet Light Wt. Satin Lined with Tie Straps, 14 Outside Pockets, Plus Knife, gun, or Tool, Leather Holder, 2 large 11" x 8" Pockets

Inside, Wonderful Hunting, Fishing, or Mechanic. A Stool **\$2.49**

### HUNTING KNIFE

6" chrome vanadium blade handle, leather grip. In leather sheath **\$5.95** Value for ONLY **\$1.89**

(Like Above) 5 in. polished blade **1.69**  
With Parkerized black Finish **\$1.49**

### BOLO KNIFE

10" x 2" Parkerized blade. 5" Gripp'd Handle. Weight 1 1/4 lbs. . . . Ideal for Hunting, Clearing Brush or Trails. With Case **\$1.19** ea.

### Hand COMPASSES

#152 - MATCHBOX - both jewel & liquid floating dial **39c**

#153 - NEW!!! JEWEL Watch Pocket Compass **1.55**

#154 - WRIST STRAP Compass . . . . . **69c**

### Hand Mike

Highly Sensitive with thumb control button on handle. Ideal for home recorders, public address systems, etc. Comp. with 2 ft. rub. cd. & phone plug. **1.39**

### Loose Leaf BINDER

3 metal post. Cylindrical locking heavy duty 3/16" fabricated hinged cover. End identification window. Ideal for price books, salesmen catalogues, photo albums, students, publications, Reference books, etc. Will hold 500 sheets, 8" x 11". **59c** ea.

50 Page Binder Band Fillers for **25c** Extra.

### PLASTIC PARALLEL STRAIGHT EDGE

with handle and rubber pads for fast slip-off on each section. A must for navigators, mechanics, draftsmen, and engineers. . . . You've never seen 'em at **97c** ea.

### PALLEY SUPPLY CO

6321 SAN FERNANDO RD. DEPT. P.M.-2 GLENDALE 1, CALIF

### NYLON PARACHUTES

Make your own Dresses Lingerie-Blouses and Uniforms: - from this fashionable Genuine Nylon. Each chute contains enough Nylon. (approx. 50 sq. yds.) for a year's supply of underclothes. ONLY **\$14.95**

Half of the above canopy **\$8.95**

### 7 Jewel - sweep sec. hand metal face. Radium Dial & Numbers # SW-1

**\$7.95**

### 15 Jewel - Waterproof. Radium dial & hands. sweep sec. hand. stainless steel screw back. A terrific Buy at

**\$12.95**

### 17 Jewel - AUTOMATIC WINDING-SHOCKPROOF-WATERPROOF-SWISS WATCH.

Sweep sec. hand. stainless steel screw back. radium dial & hands. Body movements kept it properly wound. **\$23.95**

### Chronograph

17 Jewel - One of the finest made anywhere. Cased in Switzerland. Sweep sec. hand. stop & re-set buttons. Measures distance. airspeed, groundspeed, races. Ideal for the sportsman. **\$21.95**

Special at #CH-1

### Navigators WATCH

AN 5740 - NEW! Made for AAF by Hamilton. Has 24 hour and a 60 second dial - 21 Jewel movement. Black face & white numerals. Sweep sec. hand. Stainless steel case. Pocket size. No. NW-1 ONLY **\$39.95**

### HANDY REPAIR KIT

Here's one for every purpose! & useful tools...a steel trimming knife-pair of genuine WISS Heavy Duty scissors, - a sealing roller for cementing fabrics, 2-1/2" half round files & a burnishing brush. Ideal for wallpaper, linoleum, etc. Comes in compact cloth roll. A 9.50 Value For **3.29**

### FOAM RUBBER

Molded & pre-shaped. Can be cut to fit your Chair seat, Boat, Auto, Truck or Trailer Seats. Ideal for All Sports Events.

25" x 62" x 1 1/2" . . . . . **\$6.45**  
25" x 65" x 2" . . . . . **\$8.45**  
25" x 65" x 1 1/2" . . . . . **\$7.45**

FOAM RUBBER ADHESIVE - Specially prepared to cement all types of foam rubber. . . . . per gal. **\$1.55**

### Genuine LEATHERETTE

To cover Chairs - Nooks - Auto Seats, etc. **1.29**

SPECIAL! 54" Ivory Leatherette per yd. WIDTH - COLORS - PRICE (per. run yd.)

36" Grey, Brown, Black . . . . . **\$1.19**  
36" Lt. Green, Dark Green, Blue **1.65**  
54" Red, Grey, Lt. Blue, Yellow **1.89**

### NAVIGATORS LAMP

A handy light for desk, work bench, chart table, engine room, etc. Can be used on 6-12-24-110 V by changing bulb. 3 ft. shaft has 4 joints to adjust position. . . . ONLY **\$2.95**

### RADIO HEADSET

HS-16A - New! Low Impedance 200 Ohm headset. Ideal for amateur radio, crystal sets, or professional use. Adj. earphones, extra long 5' plug-in cord. **2.25** ea.

HS-30U - Two Magnetic Type receivers in watertight brass case. Soft rubber inserts in each receiver to fit into wearers' ear. Pliable steel head band. Ideal for communications, divers, workers in noisy compartments, etc. NEW **1.59**

### CLAMP-ON ANYWHERE LAMP

With adjustable ball and socket swivel head, rubber covered cord and wall plug.

Wonderful for Indoor Photography, Floodlights, Baby Spot or Large Spot, Personal Bed Reading, Workbench, Garage, etc. Lamp Alone **99c**

Highly Polished 9" diameter Parabolic Reflector or 5" diameter Spot Reflector at Only **85c** ea.

### Genuine ARMY AIR FORCES SUNGLASSES

HERE'S THE REAL McCOY! ARMY AIR FORCE 6 base, Precision Polished & Ground, Glare-free lens with leather case to be attached to belt. Gold plated adjustable frame. ONLY Pearlized sweat bar & pads. **\$3.95**

### NIGHT DRIVING GLASSES

With 57mm yellow amber, 6 base lenses. Optically Precision Ground and Polished! Your doctor will recommend these. Not a Cheap "Process" Lens. Reduces headlight glare & Sharpens "object focus" during night driving.

In Men's size or Ladies Harlequin style. ND-1 **\$16 VALUE \$4.59**

SAME GLASSES but clip-ons. Fit-over style without temple bars **\$4.59**

### Aviators (AN-6300) Windproof & Dustproof GOGGLES

Rubber or chamois covered frame. Clear Amber or Green GROUND LENSES are inter-changeable. Adjustable nose bar. Ideal for Flying, motorcycling, etc. **1.69**

### GO-1 GOGGLE KIT

NEW! U.S. Navy - One piece Sponge rubber frame. With 4 polaroid lenses. 2 green, 1 clear, 1 red. A fine snow goggle. . . **89c**

### STATIONERY & PEN KIT

Contains Air Mail Stationery 25 envelopes & Fountain Pen with 14K Gold Plated point. A VALUE!! **33c**

### START A PROFITABLE PLASTIC HOBBY

Kit #1 contains 2 lbs. plexiglass & Lucite sheet in various shapes, 1 oz. bottle of clearset cement, and 5 bottles of colors in Orchid, Red, Yellow, Peach, etc. Also a Plastic Handbook of uses & instructions. This set easily worth \$5.50. Our Price **\$2.19**

Kit #2 contains 1 1/2 lbs. of plastic sheet, a 1 oz. bottle of clearset cement, and the Plastic Handbook. A \$2.50 Value for ONLY **99c**

### Plexiglass & Nacrolite clear plastic shts.

NASCOLITE - Full sheets app. 1/8" x 37 1/2" x 49 1/2", app. 10 1/2 lbs. each **\$12.50**

PLEXIGLASS - Full Sheet 5/16" x 36" x 24" . . . Per Sheet. **\$13.00**  
5/16" x 36" x 48" . . . Per Sheet. **\$25.00**

Fabricators write in for our special quantity prices, all above are new & unused. Also inquire about other large stocks of Plastics.

### CHEMISTRY SET

Made for Chemical Warfare Division for testing water, etc. A handy addition to the chemistry lab. or an exciting experiment for the amateur. Set includes test tubes, complete instructions, 15 different items. Packed in attractive lucite box with cover & dividers. . . . **\$1.39**

### New Stewart-Warner Heater

Compact Car-like Gasoline fired heater with motor, fan blower - Automatic Thermo Switch, Copper element, glow type spark plug - Manufactured by Stewart-Warner. 24 V D.C. - Can operate on 6 Volt Battery. Ideal for Auto, Boats, Light Aircraft, Etc. SW 2 A Steal at . . . . . ONLY **\$6.95**

92 PAGE CATALOG  
War Surplus - Tools, Machinery, Raw Materials, Clothing, etc. Illustrated with valuable info., tables, charts & data. Send 25c to cover handling & postage.

### B-15 Style JACKET

That "HOT" JACKET You'll be proud to Wear! Water repellent, wind resistant, Nile Green cambed Gov't. Zeelon sanforized Poplin. Full sturdy zippered front with 100% wool pile lined sleeves & body. Two slash pockets & large Mouton Fur Collar. Ribbed cuffs and bottom. **\$10.95**

Sizes: 36 to 46  
Boy's sizes: 6 to 18. **\$8.95**

### D-1 AIR CORPS JACKET

Genuine All Leather Flying Jacket. Fleece lined body & sleeves. Has full zipper and two slash pockets. Completely re-conditioned & cleaned.

A warm rugged jacket for Hunter, Farmer, etc. Sizes: Small, Med, large. A real Gov't. Surplus Value **8.95** ea.

### FLIGHT COVERALLS

Made especially for the NAVY of tan BYRD cloth. Strong, durable, yet light. Has 2 large breast pockets. One sleeve pencil pocket and 4 large zippered leg pockets. Full zippered front and tailored waist. Sizes: Small, Med., Large. A re-issue in Splendid condition. . . . . **4.95**

Air Corp. NYLON COVERALLS. Light wt. 8 pockets. Full zipper front. Sizes: Small, med., large. No. 480-A **6.95**

### FLYING SUIT or Blue Bunny SUIT

For hunting, winter sports, skiing or "bundling". As coveralls for cold outdoor, or farm work, 100% woven wool with extra flannel inner lining for double warmth & utility. Wiring so fine, flexible it does not interfere with movement. Can be used with or without heating or can be plugged into car, tractor, or truck battery. Sizes 36 thru 44. **\$3.49**

### FLYING HELMET

All New! Winter type with fleece or chamois lining. Has ear puffs & chin cup. Ideal for pilots, cycle-drivers, sportsmen, etc. **1.95**

NEW! All leather, chamois lined with chin cup. For winter or summer. **1.59**

### AIR CORP CAP

All leather, sheepskin lined for cold weather. Turn down flap for ear protection. Leather bound long visor. Small, Medium, & Large. **\$2.98**

### MITTENS - Sheepskin lined; leather outer cover.

For outdoor or winter work. Small, Medium, and Large. **\$2.69**

### NAVY ARCTIC Jacket

Foul Weather Ahead, Mate! Be ready - with this EXTRA HEAVY LEATHER JACKET. Fully lined with heavy SHEEP-SKIN pel. Fur collar has storm tabs. Two patch pockets, adjustable waist, zipper closure, knit cuffs. Sizes 36 thru 44. In Excellent Condition. **Now 24.50**

COST GOV'T. APPROX **80c**

Order from this Ad. All sales final. All Prices F.O.B. Los Angeles. Pay by M.O. or Check. P.O.'s Accepted. from D & B. firms. Deposit with C.O.D.'s.

LARGEST FIRM OF ITS TYPE IN THE WORLD

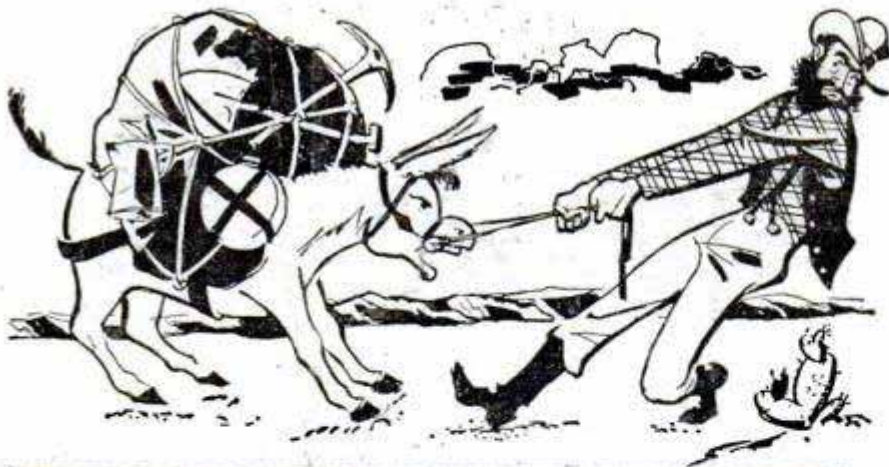

# Why Struggle with poor equipment? USE

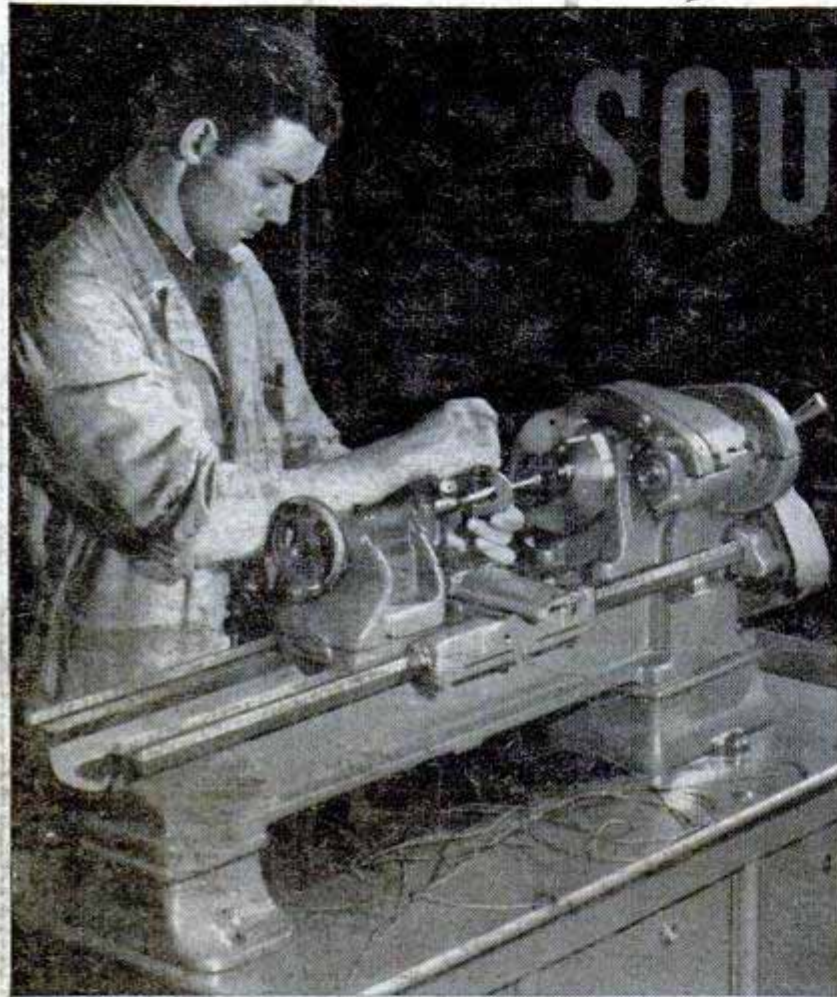

# SOUTH BEND

Close tolerances come without a "fight" on a South Bend Lathe. Regardless of the operation you'll find that you can get exact dimensions everytime without slowing up. It's another example of "quality counts." You can always depend on a South Bend to turn out better work. It's built right — it's accurate, versatile and easy to operate. In the long run, it will actually cost you less for you get more and better service. You can't buy a "cheap" machine tool and expect to get satisfactory performance — "cheap" tools are never economical.

10" X 3', 1" COLLET, BENCH LATHE with metal bench; switch and 3 ph., 60 cy., 220 V., 3/4 h. p. motor; f.o.b. factory. **\$99435**  
 Time Payments: \$249.35 down, \$65.80 for 12 months.  
 Other lathes from \$160 to \$2490, less electrical equipment.

**SOUTH BEND LATHE**  
 SOUTH BEND, INDIANA  
 Building Better Tools Since 1906



### Send for Information

10" BENCH LATHES

LATHE TOOLS AND ATTACHMENTS

TIME PAYMENT PLAN



9" BENCH LATHES

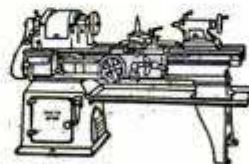

10" TO 16" FLOOR LATHES



14" DRILL PRESSES

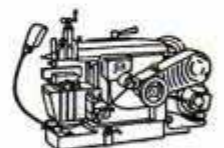

7" BENCH SHAPER

TURRET LATHES  
 1/2" and 1" Collets

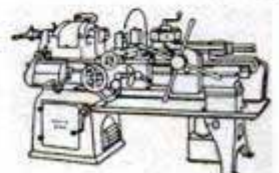

Name \_\_\_\_\_

Street \_\_\_\_\_

City \_\_\_\_\_ Zone \_\_\_\_\_ State \_\_\_\_\_

# NOW EASY TO START A Big Business ON A SMALL INVESTMENT



## WARNER SUCCESS PLAN Gives exact instructions showing you

- How to start in spare time
- How to use home as headquarters
- How to bring in the business
- How to do real METALIZING in genuine GOLD, SILVER, or BRONZE, by the easy Warner Method
- How to start without risking your job
- How to pyramid your profits
- How to be sure of steady, big income.

Don't turn this page until you've given serious thought to your future. In the uncertain years ahead, the men who own their businesses are the ones who will be happiest. A small start now easily can lead you to complete independence, freedom from time clocks, freedom from fear of lay-offs, freedom from the limits of a pay check.

Now, while you can do it without risk—now is the time to investigate the exceptional opportunity offered you by the Warner Success Plan. Looking into the market, checking up on the possibilities for big sales and big profits will not cost you anything. Isn't this the time to lay the foundation for a future of complete independence—a life of happiness—a steady, dependable income?

## METALIZING BABY SHOES AND OTHER KEEPSAKES

offers an exciting new opportunity to men or couples who want personal independence

If you'd like the feeling of being boss instead of being bossed—the Baby Shoe business is made to order for you. Just think of the appeal. A mother's love for her child—her desire to preserve forever the tiny shoes in which her baby took its first toddling steps. No wonder orders come easy and fast. No wonder profits are big. Then think of the future. Fifteen Million babies in the last five years—three million last year—millions more next year. As long as babies are born, this business will prosper—in good times or bad. Think of the fun. Every job is different, interesting. And when you deliver a job and collect the money, you get a tremendous glow of satisfaction out of the mother's happy exclamations over your work. There's not another business I know of that offers you such big rewards in cash, in security, in a future, in independence that can be started on such a shoestring. You'll be glad you saw this ad—IF YOU SEND THE FREE COUPON.



## READ THE ENTIRE PLAN

### 7 DAYS AT MY RISK

#### DON'T SEND A PENNY NOW — Just Send Your Name

This is one of the most fascinating businesses you can imagine. There are 15 MILLION pair of baby shoes waiting right now to be METALIZED. The opportunities are unlimited. The future is very big. And it's a business in which the whole family can have fun helping. A perfect business for man and wife to start—or for two partners. And I want you to read the whole Plan at my risk. Don't spend a cent unless you go ahead.

I want every serious minded man to let me show what I've done in our own shops here in Chicago—reveal the exact facts about the profits to be made and the way to make them. I don't want you to spend a cent for supplies until you've studied the facts, talked them over with the family, and satisfied yourself that this is the ONE BIG OPPORTUNITY FOR YOU. That's why I allow you to read all trade secrets contained in the Warner Success Plan at My Risk. If you don't go ahead, you don't pay a cent.

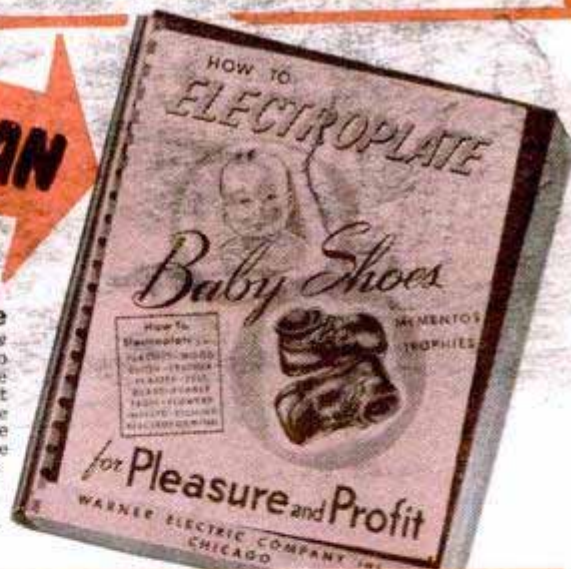

### WE SUPPLY EVERYTHING

You don't have to go "hunting" when Warner is behind you. We supply all materials, all mounts, chemicals, and metals. And you get the low prices made possible by our big quantity purchases and our own manufacture. You send for just what you need—and never have any big investment tied up in stock.



### \$5.00 AN HOUR

Yes, it's possible for one man to turn out enough work to make \$5.00 an hour for his time. Think of how that pyramids when a partner or the whole family works.

#### Old Established Firm Backs You Up

The Warner Electric Company just celebrated its 26th year of success. You get a Real Start when you "join up with Warner"—you get real Guidance to Success.

**Warner Electric Co., Dept. 32**  
1512 Jarvis Ave., CHICAGO 26, ILL.

### ALL FACTS FREE! MAIL!

Raymond E. Brandell, Mgr., Warner Electric Co.,  
1512 Jarvis Ave., Dept. 32, Chicago 26, Ill.

As long as it doesn't cost me a cent, I am willing to read the facts, investigate, then give you my decision. Send the facts by next mail. No cost to me now or at any other time.

NAME \_\_\_\_\_

ADDRESS \_\_\_\_\_

CITY \_\_\_\_\_ Zone \_\_\_\_\_ STATE \_\_\_\_\_

NOTED THROAT SPECIALISTS REPORT on 30-Day Test of Camel smokers...

# Not one single case of throat irritation due to smoking **CAMELS!**

Yes, these were the findings of noted throat specialists after a total of 2,470 weekly examinations of the throats of hundreds of men and women who smoked Camels—and only Camels—for 30 consecutive days.



Meet Miss RITA TENNANT, secretary, who recently made the 30-Day Test of Camel MILDNESS under the observation of a noted throat specialist.



Although she's smoked many brands, Rita changes to Camels for her 30-Day Test. Her throat is examined every week by a specialist.



Ah! Saturday—office closed! Rita calls time-out for a Camel and confides: "I am delighted to be making the test. Camels taste so good!"



30th day, final examination! Her doctor reports no throat irritation due to smoking Camels! Rita says: "Smoking is fun with Camels!"

**IT'S FUN!** Smoke Camels—and only Camels—for 30 days. Let your throat tell you about Camel mildness. Let your taste tell you about Camel's wonderful flavor.

YES, MY DOCTOR'S REPORT JUST PROVED WHAT MY OWN THROAT TOLD ME ABOUT CAMELS—THEY'RE SO MILD! AND THEY TASTE SO GOOD!

Rita Tennant

R. J. Reynolds Tobacco Co.,  
Winston-Salem, N. C.

Start your own 30-Day Camel MILDNESS Test Today!