

BLUEPRINT FOR TOMORROW

By Charles F. Kettering

POPULAR MECHANICS

MAGAZINE

WRITTEN BY



JAN.
25 CENTS
30c IN CANADA

SEE PAGE 6

for mango
Merry Christmas!
GIVE
WAR BONDS

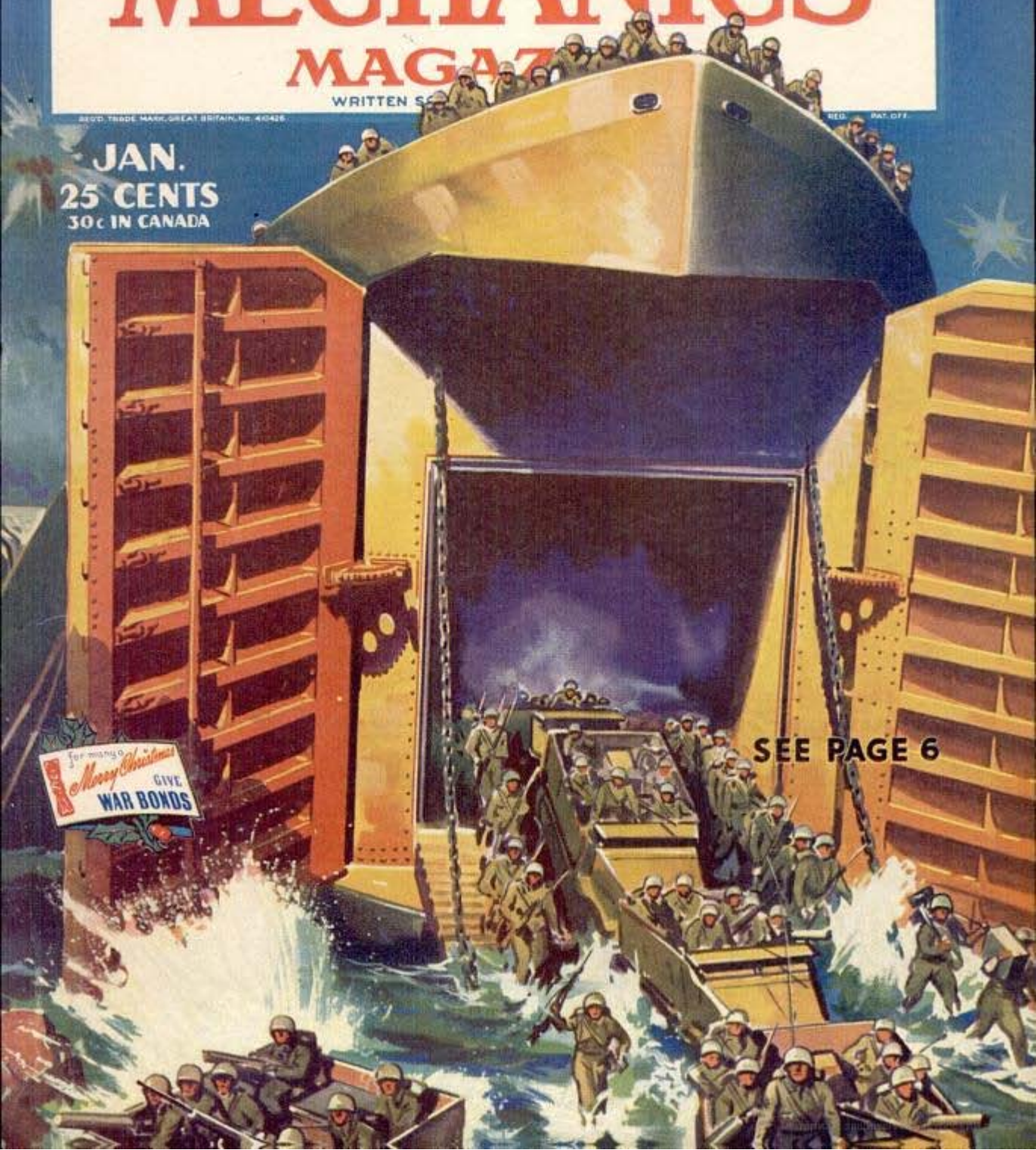

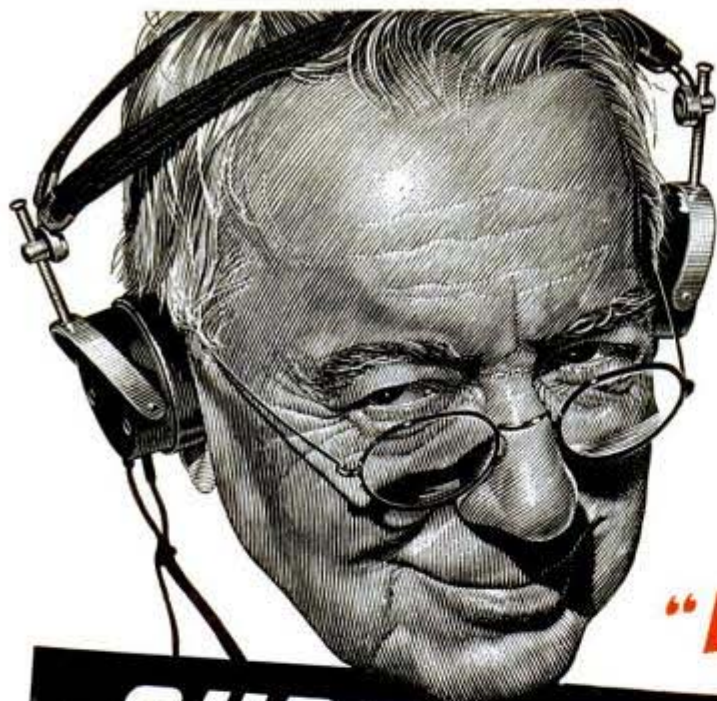

"Electronics?"

**SURE! We've had it in
our home for twenty years**



You're not being fooled by what you've read and heard about the wonders of Electronics. We have been enjoying the miracle of Electronics these many eventful years. *Where? How? Why*—that radio in our living-room and the one in our car is an electronic device. So the next time anyone talks to you about Electronics . . . you just be smart and say, "Sure, I have an *electronic device* right now . . . it's *my radio*."

Motorola Radio engineers who built those fine pre-war home and car radios were pioneers in Elec-

tronics. They have added much to their wealth of electronic knowledge in the development and production of Radar and Radio Communications Equipment for our Army and Navy. And for the duration, the production of these weapons for Victory will be Motorola's full time job.

We cannot tell you what the post-war Motorola Radio will look like, but we can tell you that it will look and sound swell. Meanwhile, let's keep all that Victory stuff coming off the production lines! *And let's buy all the War Bonds we can!*



For the continued development and production of Radio Communications and other special Electronic equipment for our Armed Forces, the Motorola organization has been awarded two stars for their Army-Navy "E" Flag. Motorola is proud of the part it has been privileged to play in the speeding of Victory.

Motorola RADIO
GALVIN FOR HOME & CAR
MFG. CORPORATION - CHICAGO, ILLINOIS

WARTIME ANNOUNCEMENT!

Revolutionary RADIONICS Product of Great Importance

For All Hard of Hearing - their Friends and Families



Zenith Radio Corporation

CHICAGO

OFFICE OF
E. F. McDONALD, JR.
PRESIDENT

To: Manpower Authorities, Employers, Physicians,
Parents, Teachers and Hard of Hearing.

Our country's manpower crisis calls for everyone's maximum efficiency. Since I lost the hearing of one ear in an accident twenty years ago, I have been acutely conscious of the handicaps of the hard of hearing. While pioneering in radio I have for some years directed Zenith's research toward development of the best wearable hearing aid that science could produce.

My own company has spent millions, the radio industry tens of millions for research. This research has been paid for by scores of millions of purchasers of radio sets.

We, with this technical knowledge and engineering skill, now bring to the hard of hearing a new precision aid — the ZENITH RADIONIC; an instrument of the highest quality.

A hearing aid is essentially a part of a radio receiver. It wires the human body for sound. It is composed of a crystal microphone and parts of a radio receiver set reduced to miniature size and manufactured with watch-like precision. For many years it has seemed to me incredible that the public could buy a complete radio receiver for \$29 or less with which they could hear the words whispered in Europe, Asia, or South America, but people with deficient hearing have paid \$100 to \$200 for a comparably good hearing aid to hear the human voice across the room.

Zenith's facilities and methods for precision mass production of radio sets, Radionic devices, etc., enable it to bring this superb hearing aid within the reach of all.

Eye-glasses, like hearing aids today, were once the luxury of the few. What the optical companies have done to make the finest spectacles available to everybody at low cost, Zenith is now prepared to do for the hard of hearing — to bring with the aid of modern radionic science a highly perfected hearing aid within the reach of the masses.

ZENITH RADIONIC — low cost battery upkeep wearable hearing aid — complete with miniature radio tubes, crystal microphone and batteries — will sell for \$40 — about one-quarter of the price of the better vacuum tube instruments of today. Hereafter no one, child or adult, need be without a hearing aid because it is too high-priced. There are ten million people, of whom over three million are children in our schools, who are hard of hearing.

Even if Zenith never makes a dollar at this low price, it is willing to take its pay in the good will of the hard of hearing, their families and their friends. Thus begins a revolution in hearing aids — a revolution to "lower the cost of hearing" within the reach of all.

E. F. McDonald, Jr.

President,
Zenith Radio Corporation



This One



PHFW-B06-HFZQ

Материал защищен авторскими правами

\$40⁰⁰

READY TO WEAR
COMPLETE

—WITH RADIONIC TUBES
—CRYSTAL MICROPHONE
AND BATTERIES

... Liberal Guarantee

★

TO PHYSICIANS: A detailed scientific description will be sent upon request. Further technical details will appear in medical journals.

★

There are cases in which deficient hearing is caused by a progressive disease and any hearing aid may do harm by giving a false sense of security. Therefore, we recommend that you consult your otologist or ear doctor to make sure that your hearing deficiency is the type that can be benefited by the use of a hearing aid.

★

.....
The Zenith Hearing Aid can be supplied only by your Zenith franchised Optician or Optometrist (no home calls or solicitations).
.....

Write for Free Descriptive Booklet

ADDRESS DEPT. PM-1, HEARING AID DIVISION

ZENITH RADIO CORPORATION • CHICAGO 39, ILLINOIS

JANUARY, 1944

1A

LET'S GET GOIN'!



**DOUBLE YOUR MONEY BACK
IF YOUR CAR FAILS TO START
WITH CASITE IN THE CRANKCASE!**

★ Don't wear out your precious battery on a hard-to-start motor these cold winter mornings. Add Casite to the crankcase and get summer starting every day, all winter long.

Casite guarantees it—or double your money back!

Over a million car owners accepted this challenge last winter, and eliminated winter-starting trouble to their complete satisfaction.

Follow their example. Ask your car dealer, service station, or garage for Casite's guaranteed winter-starting tune-up today.

THE CASITE CORPORATION • HASTINGS, MICHIGAN

CASITE

CLEANS OUT MOTORS • KEEPS MOTORS CLEAN

We Guarantee

We guarantee that any motor capable of being started in a warm room will start in the coldest weather when Casite is added to the crankcase. Add Casite according to instructions. If your car fails to start, you get **double your money back** by filling out guarantee certificate and mailing it to the Casite Corporation, Hastings, Michigan. Maximum refund is \$1.30 per pint, which is twice the nationally advertised price of Casite.

Popular Mechanics Magazine

Registered in U. S. Patent Office and Canada

H. H. WINDSOR, Founder

H. H. WINDSOR, Jr., Editor and Publisher

January, 1944

Vol. 81, No. 1

Next Month

ROLLING swiftly, smoothly along wooden rails, the Diesel-driven freight train approaches a trestle from which an arctic spring flood has washed out a 100-foot gap. Halting at a highway crossing, the engineer retracts steel pilot wheels and steers his rubber-tired engine and cars along the road. This is the rail-and-road line to Alaska projected in the February issue by Col. E. S. Evans, industrialist who supervised overseas loading for the U. S. Army in the last war. He regards Alaska as the new frontier, proposes to span mountains, ice and muskeg with auto-railers driven on "floating" wooden tracks.

Where Oxygen Ends

BACK in the covered wagon days of the west, the pioneers toted six-shooters for protection. This is the decade of the covered wagon in the substratosphere, and the pioneers wear oxygen masks and electric suits for protection. A February feature, "Up Where the Oxygen Ends," describes the acute tummy-aches, delirium, and aerobolism that you, a "deep-air" animal, would suffer four miles up, and how our pilots survive it.

Mr. Fix-It With Wings

ONE Boeing engineer flew 2,000 miles to salvage parts from wrecked bombers. A Pratt & Whitney factory representative had to chase a flight of planes 7,000 miles to make modifications. Airplane doctors from American plants are performing operations at battle fronts around the world. Read about them in "Flying Trouble Shooters" next month.

IN THIS ISSUE

Blueprint for Tomorrow	1
Windjammers of the Sky	8
How Japan Will Be Defeated	18
The Last Mile Is the Hardest	27
Plant Magic	34
Uncle Sam's Tom Thumb Navy	40
Photos Without Film	50
Winged Lightning	56
Trailing the Range Robbers	66
The Red Metal of War	70
Grasshoppers With Teeth	76
They Don't Stay Sunk	83

Where-to-Buy-It Index Starts on Next Page

Your Victory Home

THERE has been a lot of loose talk and glib prophecy about the palace you'll live in after the war. Next month a Purdue University housing authority gets down to earth in an article discussing "Your Victory Home." Since you'll have to pay for it, he suggests some improvements that should be available at your price—simple radiant-heating units, fluorescent paints that will require less electricity for lighting, new waste disposal systems, shop-assembled wiring systems, kitchen stoves that won't waste two-thirds of the heat; and if you can afford it, summer cooling equipment.

Daredevils of the Deep

PRECARIOUS is a mild word. That steel cask the Navy diver stumbles over on the sunken destroyer's deck may turn out to be a depth charge itching to go off. His hands may freeze with more than cold as he feels the nose of an unexploded torpedo. Hot air from tanks in a tropic sun may cause him to swoon 100 feet down, arctic air may freeze his lifeline. For a thrill, read next month's story of Navy divers.

Published monthly by POPULAR MECHANICS COMPANY, 200 East Ontario Street, Chicago (11), Ill., U. S. A. Single copy in the United States, 25 cents; subscription rates in United States and possessions, and countries of the Pan-American Postal Union, \$2.50 a year. Single copy in Canada, 30 cents; subscription rates, \$3.00 a year. To all other countries add \$1.00 a year over United States prices for overseas postage. If you plan to move, notify us at least 60 days in advance so you will not miss an issue. Give both old and new addresses. Entered as Second Class Matter, September 15, 1903, at the Post Office at Chicago, Illinois, under Act of March 3, 1879. Entered as Second Class Matter at Post Office Dept. Canada.

Copyright 1943, by Popular Mechanics Company. Copyright under International Copyright Union. All rights reserved under Pan American Copyright Union. Printed in the United States of America



... if you think slow starting is tough on you ... here's what it does to that precious automobile engine of yours ...

Slow starts are annoying to you—but they are more than annoying to your engine. With the oil drained off from the bearing surfaces of the cylinder walls of the engine—you step on your starter. Metal rubs against metal—that means excessive cylinder wear. **WHAT TO DO?** Add Pyroil—just 1 ounce to 5 gallons of gasoline (also put 1 pt. of Pyroil in the crankcase). It provides a cylinder wall lubricant that stays put on the cylinder wall. That means quicker starting—that means less wear on the engine—and your nerves. Put it in today. You'll notice the difference—and so will your car.

YOUR GUARANTEE

12 years' acceptance by foremost authorities—race drivers—explorers—engineers.

DISTRIBUTORS: Check and Mail Coupon for Franchise Facts



3-Ounce Size

PYROIL COMPANY

51 Pyroil Bldg., LaCrosse, Wisconsin

I want my car to last and run properly until Victory. Please tell me more about Pyroil and how it can accomplish this for me.

Send details of your Plan for Distributors

Name

Address

City or Town State

WHERE-TO-BUY-IT INDEX

Where no name and address appear directly under an item, the product is not believed by us to be commercially available

Land torpedo used by Nazis.....	5
Soft wood converted to hard "plastic".....	5
Landing ship has hinged nose.....	6
Larger screen for television.....	6
Normandie refloated.....	7
Night lookout school for sailors.....	7
U. S. seeks way to skin nut meats.....	13
Army uses portable pipeline.....	13
Kapok pads float Bren gun carrier.....	13
Web-footed engineers.....	14
First "true" compass for planes.....	16
Cable guides land torpedo.....	16
Airfield mats used for road.....	17
Pre-pasted cedar wallpaper.....	17
United Wallpaper Factories, Inc., 3330 W. Fillmore, Chicago.....	17
No machine can detect bad eggs.....	26
Lifting bag and riveter repair "Forts".....	26
Lifeboat dropped by parachute.....	26
Vibrator helps start cold plane.....	26
Rolling bomb runs wild.....	32
Textiles made mildew-resistant.....	32
"Bustle" lifts carrier stern.....	33
Description of average soldier.....	33
Bicycle built for three.....	38
Aerial "Queen Mary" planned.....	38
Electric iron steams clothes.....	38
Explosive for gas mine.....	39
Concrete semisubmarine.....	39
Air Jet quiets waves.....	44
New high-speed industrial camera.....	44
Two-speed, two-stage supercharger.....	45
Tricks of the battlefield wrecker service.....	46
Dummy sniper operated from pit.....	48
Self-cleaning shoe for ski troops.....	48
Special stratosphere grease.....	49
Face shield for hard hat.....	49
B. F. McDonald Co., 1250 S. Hope St., Los Angeles 15, Calif.....	49
Big fan for wind tunnel.....	49
Floating crane unloads ships.....	49
"Inside-out" tool kit.....	54
Variable speed drive for motor.....	54
Graham Transmissions, Inc., 2706 N. Teutonia, Ave., Milwaukee.....	54
Chemical "overcoat" for zinc.....	54
Hooded screen for daylight movies.....	54
Radiant Mfg. Corp., 1140 W. Superior St., Chicago.....	54
Up and over with tank destroyers.....	55
Model power boat races.....	60
Electrical "nurse" guards pipeline.....	61
Portable garage without doors.....	61
Shouting with the fingers.....	62
Battery sets off "Bazooka" rocket.....	64
Theodolite checks plane speed.....	65
Mirrored light shows plane's altitude.....	65
Skin cream for "flash burns".....	65
Chemical makes glass nonreflecting.....	69
Remote control grease stations.....	74
Farval Corp., 3249 E. 80th St., Cleveland, Ohio.....	74
Liberator has stinger in nose.....	74
Tuning fork tests pilot for fatigue.....	74
Camouflage cafeteria.....	75
"Fingers" boost Fortress bomb load.....	80
Working model of locomotive.....	80
"Sky hook" removes propellers.....	81
"Searchray" inspects parcels.....	81
North American Phillips Co., Inc., Dobbs Ferry, N. Y.....	81
Scale counts ration stamps.....	82
Toledo Scale Co., Toledo, Ohio.....	82
Bender has two-way operation.....	82
O'Neil-Irwin Mfg. Co., Minneapolis 15, Minn.....	82
Midget wind tunnel for classroom.....	82
Comet Model Airplane Co., 129 W. 29th St., Chicago.....	82
Glider has steel-tube frame.....	88
X-ray shows effect of "bends".....	88
Television receiver units.....	141
Lafayette Radio Corp., 901 W. Jackson Blvd., Chicago.....	141
Plastic cased electric drill.....	144
Independent Pneumatic Tool Co., 600 W. Jackson Blvd., Chicago.....	144
Small oil filled tubular-type fixed condensers.....	144
Aerovox Corporation, New Bedford, Mass.....	144

Craftsman and Shop Notes Index

ART AND ARTIST	
Improved ink-bottle stopper.....	117
Yardstick level aids sign painter.....	128
Pocket comb holds show cards while drying.....	130
AUTOMOTIVE	
Priming cup in air filter aids starting.....	96
Driver's back cushion swings out of way.....	106
Windshield cleared with antifreeze.....	113
Improved timing-chain lubrication.....	127
Tailboard cleats aid in handling crates.....	138
Spreader for inspecting tires.....	140
FARM	
Knocker to clean post hole digger.....	117
Electric pig brooder.....	127
Handle to carry electric motor.....	128
Blocks hold eggs in incubator.....	128
Double barn doors operate as unit.....	130
FURNITURE	
Hanging console table.....	89
Colonial bed.....	110

(Continued to page 6A)

"I was one of the guys who helped prove that we could build synthetic tires like that"

"Me and my old jalopy back home took part in that 80,000,000-mile road test months before Pearl Harbor"



"Sure!" said the sergeant, "I picked up a set down at Brown's Service Station. He said it was a test B. F. Goodrich was making. Those tires were more than 50% synthetic rubber—Ameripol, I think they called it.

"Well, it turned out that a lot of other people with cars had been in on the test, too—and all together we rolled up 80,000,000 miles. I guess we got a few things started in the synthetic line."



We're no longer building those early passenger car tires in which approximately half the rubber was synthetic. In today's tires, under the Government rubber program, more than 99% of the rubber is Government synthetic—"GR-S."

But the 80,000,000-mile road test gave us a three-year head start in testing tires made with synthetic rubber—under actual driving conditions. It was of vital importance to the whole synthetic rubber program.

Can you get synthetic tires today? Perhaps, if you qualify. But our fighting forces still need every ounce of rubber they can get. Help them by making your present tires last!

In war or peace
B.F. Goodrich
FIRST IN RUBBER



A few of the many companies that helped make this test

American Can Co.	General Baking Co.	Pet Milk Sales Corp.
Baltimore & Ohio Railroad	Gulf Oil Corporation	Railway Express Agency
The Borden Co.	Geo. A. Hormel & Co.	Socony-Vacuum Oil Co.
General Outdoor Advertising Co.	Kellogg Company	Standard Brands, Inc.
	New York Telephone Co.	The Texas Co.

Awards to 7 plants



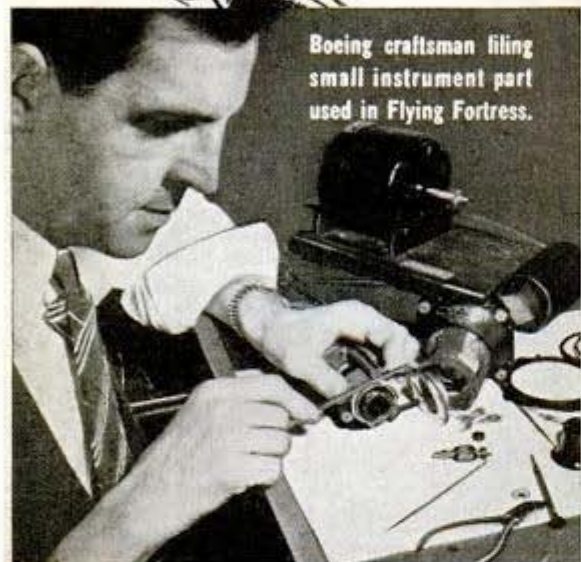

Boeing craftsman filing small instrument part used in Flying Fortress.

BOMBS FOR BERLIN AIMED FROM SEATTLE

• The uncanny accuracy with which a bomber holds its course, finds its target, drops its bombs, is rooted far behind the fields of conflict. It springs from the minds, eyes and hands which create the precision instruments that guide pilot, navigator and bombardier.

• As indispensable as these vital instruments themselves are the precision files which aid in their assembly. It is equally essential for the mechanic to know how to select and use *The right file for the job.*

• At Boeing and other factories, Nicholson and Black Diamond Files of many types, sizes and cuts help to shape thousands of parts to speed the victorious flights of our valiant air forces. Looking for a high-earning job in America's great aircraft industry? Know your files and get ahead!

FREE BOOK, "FILE PHILOSOPHY"—Newest and most authoritative book of its kind—48 interesting illustrated pages on kinds, use and care of files. Lots of other information.

NICHOLSON FILE CO., 22 Acorn St., Providence 1, R. I., U. S. A.
(Also Canadian Plant, Port Hope, Ont.)

NICHOLSON FILES FOR EVERY PURPOSE

NICHOLSON
U.S.A.
MADE IN U.S.A.

HAND TOOLS

Linotype slug cleans file.....	106
Marking-gage extension.....	108
Tightening chisel handles.....	112
Scraper to remove wire insulation.....	114
Combination compass and trammel.....	129
Notched oilcan spout opens oil-cup lids.....	130
How to carry steel rule in pocket.....	130
Method of cutting heavy sheet metal.....	131

HOUSEHOLD

How to see inside chimney.....	91
Warning light tells when stoker is empty.....	92
Modernizing old gas range.....	93
Solving home problems.....	94
Repairing pen point.....	96
Binder for magazines.....	97
Yule decorations between sash.....	103
Forced-air draft for water heater.....	108
Gas engine runs stoker in emergency.....	109
Locating streaks on windows.....	112
Add water through teakettle spout.....	113
Charged water bottle as fire extinguisher.....	114
Dispenser made from fruit jar.....	116

OFFICE

Finger holes for letter files.....	128
Identifying addressograph plates.....	138

PHOTOGRAPHY

Taking close-up pictures.....	118
Paper handled with vacuum cup.....	122
Two clocks used as timer.....	122
Easter-egg dyes tone prints.....	122
Pocket in case holds lens tissue.....	122
Cardboard frame aids in composing picture.....	122
Photos removed from frames easily.....	122

POWER TOOLS

Longer life for grinding wheels.....	123
Gears and gear cutting.....	132
Drillpress jig prevents work turning.....	138
Four-place lathe turret.....	139
Spring stop for drillpress table.....	140

RADIO AND ELECTRICITY

Television receiver chassis and power supply.....	141
Homemade parts for two crystal sets.....	142
Old tube prongs as tip connectors.....	144
How to keep kinks out of phone cords.....	144
Spare tube socket used as a common chassis ground.....	144
Stand-off lead-in insulator from a porcelain tube.....	144
Speaker converted to microphone for sound detection.....	144
Filament voltage tester for students.....	144

STORE AND SHOP

Using long thin welding rods.....	117
Customers select glasses from window.....	126
Drill and tap stored in button set.....	126
Handy way to display books.....	128
Magnetic base for dial-type indicator.....	129
Ledge on counter stops coins.....	130
Stopper for acid carboy.....	130
Kinks that help delivery boys.....	131
Buttresses protect warehouse doors.....	131
Glass jug holds sales cards.....	140

TOYS, GAMES AND NOVELTIES

Stills are adjustable in height.....	97
Card-table golf.....	104
Military chess set.....	113
Improving your set of chessmen.....	114

WOODWORKING

Hardening lathe center holes.....	92
Tape backed sandpaper for scrollwork.....	108

MISCELLANEOUS

Use rosin flux for brass or copper.....	91
Combination book and carrying case.....	91
Meat grinder reconditions modeling clay.....	91
Mortar joints insulate stone buildings.....	92
Microscope slide holders.....	92
"Ruler" to measure map distances.....	93
Stock supports bike safely.....	96
Picture has third dimension effect.....	96
Application of wood filler.....	102
Game carried on shower-curtain hooks.....	102
Lattice-type step supports.....	102
Greeting cards have perforated designs.....	103
Carved fireplace bellows.....	107
Buttons from walnut shells.....	108
Carfare pocket on handbag.....	109
Crayon marks aid in soldering seams.....	114
Electric wind indicator.....	115
Metal balls cleaned with bottle.....	117
Offset anchor stakes are easy to pull.....	117
Rack made from old ring gear.....	126
Carrying handle for sawhorse.....	140
Extension for paper trimmer.....	140

IMPORTANT NOTICE

It is the intention of this magazine to provide its readers with information regarding the latest developments in the mechanical arts. We take no responsibility as to whether the disclosures contained in our articles are covered by patents and advise readers to investigate this subject before making, using, or selling any of the products, machines, or processes described in order to avoid possible liability for patent infringement.

TO THE MAN WHO WANTS SUCCESS

after the WAR!

If you want success and security when peace comes, prepare for it now. Make sure that you have the trained ability that employers will want and pay for in the post-war adjustment.

As business converts back to civilian goods, there will be urgent call for accountants, bookkeepers, salesmen, sales and credit correspondents, traffic managers, marketing men, secretaries, office managers and legally trained executives.

For 35 years, LaSalle has been training adults in their spare time for such positions.

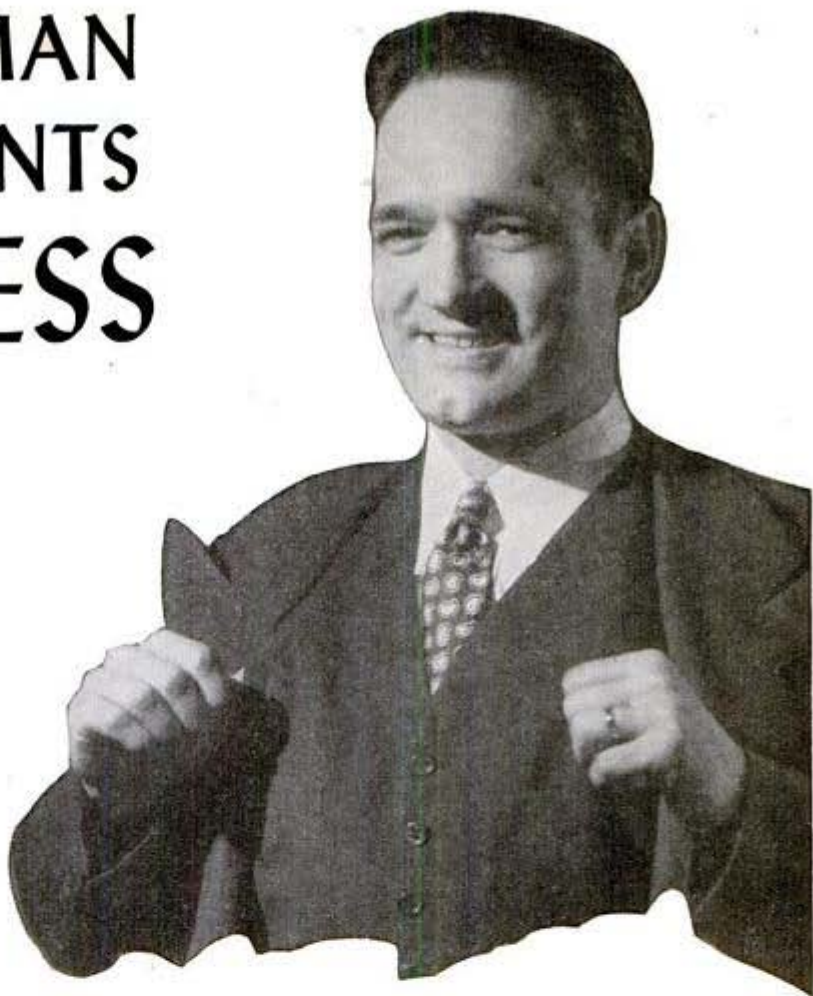

It knows how. It can train you—quickly, thoroughly, at moderate cost, without interruption to your present work.

Mark the coupon below for our free booklet about the field of your interest. It costs nothing to get the facts and they may lead you to larger security and success—now and after the armistice whistles blow.

LASALLE EXTENSION UNIVERSITY

A Correspondence Institution

DEPT. 164-R

CHICAGO 15, ILL.

I am interested in knowing what your training is and how it can help me in the post-war adjustment. Please send me your free booklet on the field I have marked at right.

- Accounting
- Bookkeeping
- Salesmanship
- Business English

- Law: LL.B. Degree
- Business Law
- Office Management
- Business Correspondence
- Stenotypy: machine shorthand

- Traffic Management
- Executive Management
- Foremanship
- Industrial Management

Name..... Age.....

Position..... Address.....

City and State.....



THE GREATEST
POWER ON
EARTH !

The Magic of Mind

WERE the great personages of the past victims of a stupendous hoax? Could such eminent men of the ancient world as Socrates, Pericles, and Alexander the Great have been deluded and cast under the spell of witchcraft—or did the oracles whom they consulted actually possess a *mysterious faculty of foresight*? That *the human mind can truly exert an influence over things and conditions* was not a credulous belief of the ancients, but a known and demonstrable fact to them. That there exists a wealth of infinite knowledge just beyond the border of our daily thoughts, which can be aroused and commanded at will, was not a fantasy of these sages of antiquity, but a dependable aid to which they turned in time of need.

It is time you realized that the rites, rituals and practices of the ancients were not superstitions, but subterfuges to conceal the marvelous workings of natural law from those who would have misused them. Telepathy, projection of thought, the materializing of ideas into helpful realities, are no longer thought by intelligent persons to be impossible practices, but instead, *demonstrable sciences*, by which a greater life of happiness may be had.

One of America's foremost psychologists and university instructors, says of his experiments with thought transference and the powers of mind—"The successes were much too numerous to be merely

lucky hits and one can see no way for guessing to have accounted for the results." *Have you* that open-minded attitude of today which warrants a clear, positive revelation of the facts of mind which intolerance and bigotry have suppressed for years? *Advance with the times*; learn the truth about your inherited powers.

Let this free book explain

The Rosicrucians (NOT a religious organization) have been leaders in introducing the ancient wisdom of mental phenomena. Established throughout the world for centuries, they have for ages expounded these truths to those thinking men and women who sought to make the utmost of their natural faculties. Use the coupon below—avail yourself of a pleasing book of interesting information which explains how you may acquire this most *unusual* and *helpful* knowledge.

The ROSICRUCIANS (AMORC)

USE THIS COUPON

Scribe V. N. H.
The Rosicrucians, AMORC,
San Jose, California.

I am sincerely interested in knowing more about this unseen, vital power which can be used in acquiring the fullness and happiness of life. Please send me, without cost, the book, "THE MASTERY OF LIFE," which tells me how to receive this information.

Name _____

Address _____

State _____

INTERNATIONAL CORRESPONDENCE SCHOOLS

OFFER YOU LOW-COST

SPECIAL TRAINING

FOR SUCCESS IN MODERN BUSINESS AND INDUSTRY

TECHNICAL COURSES

Air Conditioning Schools

Air Conditioning
Heating
Plumbing
Refrigeration
Steam Fitting

Chemistry Schools

Chemical Engineering
Chemistry, Analytical
Chemistry, Industrial
Chemistry,
Mfg. Iron and Steel
Pulp and Paper Making

Civil, Architectural and Structural Engineering Schools

Architecture
Architectural Drafting
Bridge and Building
Foreman
Bridge Engineering
Building Estimating
Civil Engineering
Concrete Engineering
Contracting and Building
Highway Engineering
Retail Lumberman
Structural Drafting
Structural Engineering
Surveying and Mapping

Electrical Schools

Electrical Engineering
Electric Wiring
Gas and Electric Welding
Industrial Electrician
Lighting Technician

Power House
Practical Telephony
Radio, General
Radio Operating
Radio Servicing
Telegraph Engineering

Internal Combustion Engines Schools

Automobile Technician
Aviation
Diesel-Electric
Diesel Engines
Gas Engines

Mechanical Schools

Airplane Drafting
Foundry Work
Heat Treatment of Metals
Inventing and Patenting
Machine Shop Practice
Mechanical Drafting
Mechanical Engineering
Metal Pattern Drafting
Mold Loft Work
Reading Shop Blueprints
Sheet Metal Worker
Ship Drafting
Ship Fitting
Shop Practice
Steel Mill Workers
Tool Designing
Wood Pattern Making

Railroad Courses

Air Brake
Car Inspector
Locomotive Engineer
Locomotive Fireman
Railroad Car Repairer
Railroad Section Foreman

Steam Engineering Schools

Boiler Making
Combustion Engineering
Engine Running
Marine Engines
Petroleum Refining Plant

Steam Electric
Steam Engines

Textile Schools

Cotton Manufacturing
Textile Designing
Woolen Manufacturing

BUSINESS and ACADEMIC COURSES

Academic Schools

Arithmetic
College Preparatory
First Year College
High School
Higher Mathematics
Illustrating

Cost Accounting
Foremanship
Salesmanship
Secretarial
Stenography
Traffic Management

Business Schools

Accounting
Advertising
Bookkeeping
Business Correspondence
Business Management
Cert. Pub. Accounting
Commercial

Civil Service Schools

City Letter Carrier
Post Office Clerk
Railway Postal Clerk

Language Schools

French
Good English
Spanish

If you can read and write,
and are willing to study,

WE CAN TEACH YOU!

• *Special service and attention are always given to the student who may need extra help in order to understand.*

REASONABLE TERMS
MAY BE ARRANGED



The successful man DOES today what the failure INTENDS to do tomorrow. Mail this coupon NOW!

Special Tuition Rates for Members of the Armed Forces

INTERNATIONAL CORRESPONDENCE SCHOOLS

BOX 5680-J, SCRANTON 9, PENNA.

Please send complete information on following subject:

(Write above Technical, Business or General Educational Subject in which you are interested.)

Name _____ Age _____

Address _____

City _____ State _____

Employed by _____

Present Position _____

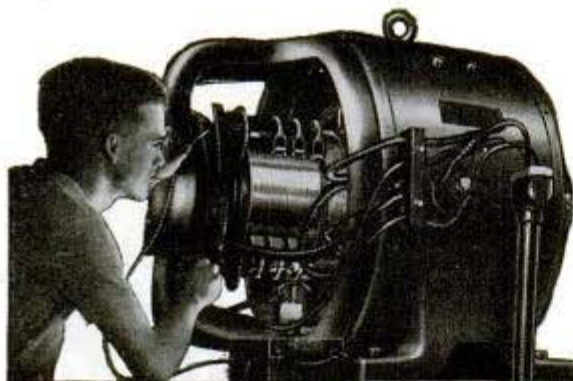

MEN *whether you are* **16** **OR UP TO** **50**
PREPARE FOR A GOOD WAR-TIME JOB
... WITH A PEACE-TIME FUTURE!

Trained Electrical men are needed now. It's not how young you are, or how old you are. The question is have YOU the training to hold a good war-time job today—and to insure your future after the war?

Learn **ELECTRICITY** IN 12 WEEKS ON REAL MOTORS, GENERATORS, ETC.

COYNE TRAINING is easy, practical. Located in Chicago, heart of vast war industries, Coyne has behind it 44 years of "know-how" in training successful men. Mail coupon now!

"Learn-by-Doing" in the Great Coyne Shops

Get ready for a big future the quick Coyne Way—by actual work on full-size electrical equipment, not by correspondence. Learn wiring, motors power plants, switchboards, auto and aircraft electricity, etc. Be an "All-Round Electrical Man"—for big opportunities!

Start Now—Pay Later

My "Pay-Tuition-after-Graduation" plan enables you to start right away, and pay for your tuition in easy payments when finished. If you need part-time work to help defray expenses while here, I'll help you get it.

You Don't Need Experience or Advanced Education!

Coyne Training is simplified. Many fellows with no experience or advanced education owe their present good jobs to my easy, step-by-step methods. You'll find Coyne boosters wherever Electricity is known!

Get My Free Book!

Let me send you my big illustrated book showing how I help you get the training you need for a good Electrical job. It's FREE—no obligation—no salesman will call. Send the coupon today!

H. C. LEWIS, Pres.
COYNE ELECTRICAL SCHOOL
 500 South Paulina Street,
 Dept. 14-72, Chicago 12, Ill.



H. C. LEWIS, President
COYNE ELECTRICAL SCHOOL
 500 S. Paulina St., Dept. 14-72, Chicago 12.

Send me your Free Book. Tell me about your Special Radio-Electronics Training at no extra cost, and Pay-Tuition-after-Graduation offer.

NAME.....
 ADDRESS.....
 CITY..... STATE.....

Special Offer! **RADIO and ELECTRONICS** Now Included!

No extra cost for valuable extra 3 to 6 weeks training—big field of new opportunities!



PHYSICALLY HANDICAPPED OR PARTLY DISABLED MEN!
 We have facilities for you. Write for details.

Mechanically Inclined Men **HOME APPLIANCE REPAIRING** *Offers Big Money-Independence*

America's War Made Industry

Restriction of manufacturing has meant that the men who know Home Appliance Repairing—fixing refrigerators, vacuum cleaners, washing machines, motors, welding, nickel plating, etc., etc., are reaping a steady, daily stream of dollars and building for themselves a permanent profitable business.

No Previous Experience Needed

The ability to hold and use a tool plus an ambition to make money is all that you need to become a successful Repair Shop Owner.

Full Time or Spare Time

Work as many hours as you want. \$5.00—\$6.00 an hour often made.

New Course Tells All

Our new course on Home Appliance Repairing . . . profusely illustrated shows you in simple, easy to understand language how to make all repairs, build tools you need and how to get business to come to you. Price of course is so low that your savings on your own household repairs will quickly pay for it. Send today for complete FREE literature on how you too can get started.

CHRISTY SUPPLY CO.,

2835 N. Central Ave., Dept. D-503, Chicago

TRAIN
Your VOICE!
Results GUARANTEED

We build, strengthen the vocal organs—not with singing lessons—but by sound, scientifically correct silent and vocal exercises and absolutely guarantee complete satisfaction with results. Write for Voice Book, FREE. Sent to no one under 17 years old unless signed by parent.

PERFECT VOICE INSTITUTE, Studio 1351, 64 E. Lake St., Chicago, Ill.

INTRODUCING-New Victory Model
HANDIWELD ELECTRIC
ARC WELDER **RETAILS ONLY \$1.95**
FULLY GUARANTEED

PLUGS INTO LIGHT SOCKET

Victory Model Handiweld Arc Welder operates from 110 volts, A.C. or D.C. current same as other arc welders higher priced; generates tremendous heat to weld all metals. Not a toy welder that uses carbons, but actually uses standard and coated rods—sizes 1/16" and 3/32". However, due to Priorities a generous supply of 1/16" rods only are supplied with the welder. Guaranteed not to burn out. Repairs fenders, auto bodies, radiators, machinery parts, etc. Take Victory Model Handiweld anywhere to job, operate right from light socket. You'll find a thousand uses for this welder around your home, garage, workshop. Also in garages, factories, repair shops, tin shops, mechanics, inventors, plumbers, farmers, etc. Order a "Victory Model" Handiweld now.

SEND NO MONEY We'll rush one to you with rods, helmet, operating instructions, and all necessary parts with the exception of a large jar and a small piece of extension cord; these most everyone has. Pay postman only \$1.95 plus a few cents postage. If not delighted return Victory Model Handiweld in 5 days from receipt and money paid for it will be refunded promptly. Rush your order now.

KUMFY PRODUCTS INC., Dept. Z-202, Cincinnati, Ohio

AUDELS AIRCRAFT WORKER . . . \$1

Answers Your Questions on 1—Aircraft Materials, Terms, Parts. 2—Blueprints, Working Drawings. 3—Mathematics, How to Figure. 4—Layout & Bending. 5—Tools & Machines. 6—Riveting, Spot Welding & Hints. 7—Fabrication, Angles, etc. 8—Assembly, Fuselage, Wing & Final—How to Use Tools. 9—Tables & Data, Symbols, Army & Navy Specifications, etc. 240 Pages Illus.

AUDELS SHEETMETAL PATTERN LAYOUTS . . . \$4

Developed by Experts for Sheet Metal Workers, Layout Men & Mechanics. A Practical Encyclopedia in 10 Sections, size 7 x 10 x 2—1125 Pages—350 Layouts—1600 Illustrations. 1001 Key Facts. Fully indexed for ready reference in answering your layout problems. Covers all phases of sheet metal work including Pattern Cutting, Pattern Development & Shop Procedure.

AUDELS SHEETMETAL WORKERS HANDY BOOK . . . \$1

Practical inside information. Fundamentals of Sheet Metal Work. 388 pages. Illustrated. 11 sections. Clearly written. Essential & important facts, figures, pointers in everyday language. Ref. Index.

AUDELS WELDERS GUIDE . . . \$1

A concise, practical text on operation & maintenance of all welding machines for all mechanics. Over 400 pages, illustrated. Covers all methods of electric and acetylene welding including airplane work.

AUDELS ANSWERS ON BLUE PRINT READING . . . \$2

For Mechanics & Builders. Covers all types of blue print reading including ship & airplane. 376 pages, fully illustrated.

AUDELS NEW MACHINIST & TOOLMAKERS HANDY BOOK . . . \$4

Covers modern machine shop practice in all its branches. 5 practical books in 1. New from cover to cover. Tells how to set up & operate lathes, screw and milling machines, shapers, drill presses and all other machine tools. 1600 pages, fully illustrated. 5 x 8 1/2 x 2. Indexed. 5 sections. 1—Modern Machine Shop Practice. 2—Blue Print Reading & How to Draw. 3—Calculations & Mathematics for Machinists. 4—Shop Physics. 5—How to Use the Slide Rule. 60 chapters. Easy to read and understand. A shop companion that answers your questions.

AUDELS MATHEMATICS & CALCULATIONS FOR MECHANICS \$2

Mathematics for home study or reference. 700 pages, 550 illus. Practical mathematics from beginning. How to figure correctly. Easy, correct methods covering a complete review. Ill. & Indexed.

AUDELS AUTOMOBILE GUIDE . . . \$4

A practical quick ready reference book for auto mechanics, service men, operators & owners. Explains theory, construction & servicing of modern motor cars, trucks, buses & auto type Diesel engines. 1540 pages, fully illustrated. 55 chapters. Indexed. A standard book for mechanics. New fluid drive covered.

AUDELS DIESEL ENGINE MANUAL \$2

A practical, concise treatise with questions and answers on the theory, operation and maintenance of modern diesel engines including General Motors 2 cycle Diesel. 384 pages, fully illus., flexible binding, pocket size. All details plainly brought out, this book is of extreme value to engineers, operators & students.

AUDELS RADIOMANS GUIDE . . . \$4

A key to the practical understanding of radio including Frequency Modulation, Television, etc., Aircraft & Marine Radio. For radio engineers, servicemen, amateurs. 772 pages. 400 Illustrations & Diagrams. Photos. Review Questions & Answers, Reference Index. Authentic, clear, concise.

AUDELS HANDY BOOK OF PRACTICAL ELECTRICITY . . . \$4

For maintenance engineers, electricians & all electrical workers. 1440 Pages, 2600 Illus. Covers important electrical information in handy form—including Marine Wiring, Radio Principles, Welding. Indexed. A Key to a practical understanding of electricity.

AUDELS CARPENTERS & BUILDERS GUIDES—4 Vols. . . . \$6

A practical illustrated trade assistant on modern construction for carpenters, joiners, builders, mechanics and all woodworkers. 4 vols., 1600 pages, 3700 illustrations, flexible covers. Each volume pocket size. Sold separately \$1.50 a vol.

AUDELS PLUMBERS & STEAMFITTERS GUIDES—4 Vols. . . . \$6

A Practical Trade Assistant & Ready Reference. Explains in plain language & by clear illustrations, diagrams, charts, graphs, pictures principles of modern plumbing practice including Marine Pipe Fitting and Air Conditioning. 4 Vols.—1670 Pages—3842 Diagrams. Each Vol. Pocket Size. Sold Separately \$1.50 a Vol.

AUDELS WIRING DIAGRAMS . . . \$1

210 Pages. Illustrated. Gives practical facts on wiring of electrical apparatus. It explains clearly in simple language how to wire apparatus for practically all fields of electricity. Each diagram is complete & self-explanatory. Highly Endorsed Pocket Companion.

AUDELS ELECTRONIC DEVICES . . \$2

Tells What You Want to Know About Electric Eye. Easily Understood. Covers photo-electric cells & their applications. Amplifiers, illumination, frequencies, voltage, photocell, tubes, Ohm's Law, wiring diagrams, etc.

AUDEL, Publishers, 49 W. 23 St., N. Y. 10



AN AUDEL GUIDE IS A GOOD FRIEND!
Use the brains and experience of others in these Guides of the Trades. Save time and money with right methods, short cuts, labor saving ideas. CHECK NOW! You can look over any Audel Guide in your home. Start the Easy Payments if satisfied.

----- CUT HERE ----- MAIL ORDER

THEO. AUDEL & CO., 49 W. 23rd St., New York 10
Please mail me for 7 days' free examination the books marked (X) below. I agree to mail \$1 in 7 days on each book or set ordered, and to further mail \$1 a month on each book or set ordered until I have paid purchase price.

- If I am not satisfied with Guides I will return them.
- Audels PUMPS, HYDRAULICS & AIR COMPRESSORS \$4.
 - Audels WELDERS GUIDE 1.
 - Audels BLUE PRINT READING 2.
 - Audels SHEET METAL WORKERS Handy Book 1.
 - Audels SHEET METAL PATTERN LAYOUTS 4.
 - Audels AIRCRAFT WORKER 1.
 - Audels MATHEMATICS and CALCULATIONS 2.
 - Audels MACHINISTS & TOOLMAKERS Handy Book 4.
 - Audels DIESEL ENGINE MANUAL 2.
 - Audels MECHANICAL Dictionary 4.
 - Audels AUTO GUIDE 4.
 - Audels MARINE ENGINEERS HANDY BOOK 4.
 - Audels SHIPFITTERS Handy Book 1.
 - Audels MARINE Engineers Guide 3.
 - Gueths MECHANICAL DRAWING COURSE 1.
 - Rogers Mechanical DRAWING and Design 2.
 - Audels MILLWRIGHTS and Mechanics Guide 4.
 - Audels CARPENTERS and Builders Guides (4 vols.) 6.
 - Audels PLUMBERS and Steamfitters Guides (4 vols.) 6.
 - Audels MASONS and Builders Guides (4 vols.) 6.
 - Master PAINTER and DECORATOR 2.
 - Audels GARDENERS & GROWERS GUIDES (4 vols.) 6.
 - Audels ENGINEERS and Mechanics Guides 12.
 - Nos. 1, 2, 3, 4, 5, 6, 7 and 8 complete 12.
 - Audels Answers on PRACTICAL ENGINEERING 1.
 - Audels Answers on REFRIGERATION 2.
 - Hawkins Aids to ENGINEERS EXAMINATION 2.
 - Rogers MACHINIST GUIDE 2.
 - Audels WIRING DIAGRAMS 1.
 - Audels Handy Book of PRACTICAL ELECTRICITY 4.
 - Audels ELECTRICAL POWER CALCULATIONS 2.
 - Hawkins ELECTRICAL Guides at \$1. each 10.
 - Audels ELECTRONIC DEVICES 2.
 - Audels ELECTRIC Dictionary 2.
 - Audels RADIOMANS GUIDE 4.
 - Audels NEW ELECTRIC LIBRARY at \$1.50 a Volume 4.
 - Vols. I, II, III, IV, V, VI, VII, VIII, IX, X, XI, XII.

Name _____
Address _____
Occupation _____
Employed by _____ P M



Be a Radio

More Now Make \$50 a Week

J. E. SMITH
President
National Radio
Institute
Our 30th year!

I Train BEGINNERS at Home for Good Spare Time and Full Time Radio Jobs

VITAL JOBS LIKE THESE GO TO MEN I TRAINED



Communication Station Operator
"Am with the Civil Aeronautics Administration as Aircraft Communicator at the Shreveport Airways Communication Station. Have a lifetime position, with pension after 25 years on job." —

JESSE N. ROBERTS, Box 1076, Shreveport, La.



Chief Operator Broadcasting Station
"Before I completed your lessons, I obtained my Radio Broadcast Operator's license and immediately joined Station WMPG where I am now Chief Operator." —

HOLLIS F. HAYES, 327 Madison St., Lapeer, Michigan.



\$200 a month in own business
"For several years I have been in business for myself making around \$200 a month. Business has steadily increased. I have N.R.I. to thank for my start in this field." —

ARLIE J. FROEHNER, 300 West Texas Avenue, Goose Creek, Texas.



1st Lieutenant in Signal Corps
"I cannot divulge any information as to my type of work, but I can say that N.R.I. training is certainly coming in mighty handy these days." —

ARTHUR W. ANDERSON (Address omitted for military reasons).



\$10 per Week in Spare Time
"I am doing spare time Radio work. Am averaging around \$500 a year. Those extra dollars mean so much—the difference between just barely getting by and living comfortably." —

JOHN WASHKO, 97 New Cranberry, Hazleton, Penna.



Radio Service Manager of 4 Stores
"I was working in a garage when I enrolled with N.R.I. I am now Radio Service Manager for M... Furniture Co. for their 4 stores." —

JAMES E. RYAN, 119 Pebble Court, Fall River, Mass.

Here's your chance to get a good job in a busy wartime field with a bright peacetime future! There is a real shortage today of trained Radio Technicians and Operators. So mail the Coupon for a FREE copy of my 64-page, illustrated book, "Win Rich Rewards in Radio." It describes many fascinating types of Radio jobs; tells how N.R.I. trains you at home in spare time; how you get practical experience by building real Radio Circuits with **SIX BIG KITS OF RADIO PARTS** I send!

There is a Shortage of Radio Technicians. Many Good Jobs are Open!

There's a big shortage today of capable Radio Technicians and Operators. Fixing Radios pays better now than ever before. With new Radios out of production, fixing old sets, which were formerly traded in, adds greatly to the normal number of servicing jobs.

Broadcasting Stations, Aviation and Police Radio, and other Radio branches are scrambling for Operators and Technicians. Radio manufacturers, now working on Government orders for Radio equipment, employ trained men. The Government, too, needs hundreds of competent civilian and enlisted Radio men and women. You may never see a time again when it will be so easy to get started in this fascinating field.

Be Ready to Cash in on Jobs Coming in Television, Electronics

Think of the NEW jobs that Television, Frequency Modulation, Electronics, and other Radio developments will open after the war! You have a real opportunity. I will train you to be

You Build These and Other Radio Circuits with 6 Big Kits I Send!



SUPERHETERODYNE CIRCUIT (above) Preselector, oscillator-mixer-first detector, I.F. stage, diode detector-a.v.c. stage, audio stage. Bring in local and distant stations on this circuit you build yourself!

MEASURING INSTRUMENT (below) you build early in Course. Use it in practical Radio work to make EXTRA money. Vacuum tube multimeter, measures A.C., D.C. and R.F. volts, D.C. currents, resistance, receiver output.



A. M. SIGNAL-GENERATOR (above) Build it yourself! Provides amplitude-modulated signals for test and experimental purposes. Gives valuable practice!

By the time you've conducted 60 sets of Experiments with Radio Parts I supply, made hundreds of measurements and adjustments, you'll have valuable PRACTICAL Radio experience for a good full or part time Radio job!

FIND OUT ABOUT THIS TESTED WAY

Technician

Than Ever Before . . .

ready to cash in when Victory releases the amazing wartime Radio developments for peacetime uses!



Extra Pay in Army, Navy, Too

Men likely to go into military service, soldiers, sailors, marines, should mail the Coupon Now! Learning Radio helps Service men get extra rank, extra prestige, more interesting duties, much higher pay. Also prepares for good Radio jobs after service ends. Over 1,700 Service men now enrolled.



Many Beginners Soon Make \$5, \$10 a Week EXTRA in Spare Time

Right now, probably in your neighborhood, there's room for more spare and full time Radio Technicians. Many N.R.I. Students make \$5, \$10 a week EXTRA money fixing Radios in spare time while learning. I send EXTRA MONEY JOB SHEETS that tell how to do it!

My "50-50 Method"—half building and testing real Radio Circuits, half learning from easy-to-grasp, illustrated lessons—is a tested, proven way to learn Radio at home in spare time. Think how much practical experience you'll get by building the "Superhet" and Measuring Instrument illustrated at left—by conducting 60 sets of experiments on these and other Circuits you build with parts I supply! Within a few months you can be ready to run your own Spare Time Shop, fix the Radios of your friends and neighbors—get paid while learning!

Find Out What N.R.I. Can Do For YOU

MAIL THE COUPON BELOW for my FREE 64-page book. It is packed with Radio facts, things you never knew about opportunities in Broadcasting, Radio Servicing, Government Radio, and other Radio fields.

You'll read a description of my Course—"50-50 Method"—6 Experimental Kits—Extra Money Job Sheets. You'll see the fascinating jobs Radio offers and how YOU can train at home. No obligation—no salesman will call. If you want to JUMP YOUR PAY—Mail Coupon at once in an envelope or pasted on penny postcard! J. E. SMITH, President, Dept. 4AP, National Radio Institute, Washington 9, D. C.

Set Servicing pays many N.R.I. trained Radio Technicians \$50 a week. Others hold their regular jobs and make \$5 to \$10 extra a week fixing Radios in spare time.

Training Men for Vital Radio Jobs

Mail this to get 64 page book FREE

J. E. SMITH, President, Dept. 4AP,
National Radio Institute, Washington 9, D. C.

Dear Mr. Smith: Mail me FREE, without obligation, your 64-page book, "Win Rich Rewards in Radio," which points out Radio's opportunities and tells how you train men at home to be Radio Technicians. (No salesman will call. Please write or print plainly.)

Age.....

Name.....

Address.....

City.....State.....

TO BETTER PAY



Broadcasting Stations employ N.R.I. trained Radio Technicians as operators, installation, maintenance men and in other capacities and pay well.



THIS Free Book HAS HELPED HUNDREDS OF MEN MAKE MORE MONEY

"YOU ARE UNDER ARREST"



**There's a Thrill
in Bringing a
Crook to Justice
Through
Scientific**

CRIME DETECTION

I have taught thousands of men and women this exciting, profitable, pleasant profession. Let me teach you, too, *in your own home*. Prepare yourself in your leisure time to fill a responsible, steady, well-paid position in a very short time and at very small cost. What others have done you, too, can do.

53%
of all
**American
Bureaus
of
Identification**

Be A
**FINGER
PRINT
Expert**

Employ I.A.S. students or graduates. "I will teach you Finger Print Identification—Firearms Identification—Police Photography—and Secret Service." That's what I told the men who now handle jobs in Identification Bureaus throughout the nation.

And now I repeat, **THIS** time to **YOU** . . . Just give me a chance and I'll train you at home to fill an important position in the fascinating field of scientific crime detection. It is not expensive or difficult to learn. Now is the time to start. War conditions make it necessary to guard against sabotage by enemy aliens. Finger Print identification is one of the recognized means of uncovering them. The need of more Finger Print experts is evident. Fit yourself now to help win the war and later on to hold down a fine job as a recognized expert in Crime Detection.

FREE! "BLUE BOOK OF CRIME" It's a thriller, filled from cover to cover with exciting information on scientific crime detection. It tells about some of the most interesting crimes of modern times, and how the criminals were brought to justice through the very methods which you are taught at I.A.S. The book will tell you, too, how at a cost so low you shouldn't even think of it, you can get started on this important work without delay. Don't wait. Clip the coupon and send it along today.

INSTITUTE OF APPLIED SCIENCE
Dept. 1351, 1920 Sunnyside Ave. Chicago 40, Ill.

CLIP AND MAIL COUPON NOW

INSTITUTE OF APPLIED SCIENCE, 1920 Sunnyside Ave., Dept. 1351, Chicago 40, Ill.

Gentlemen: Without obligation, send me the "Blue Book of Crime," and complete list of Identification Bureaus employing your students or graduates, together with your low prices and Easy Terms Offer. (Literature will be sent **ONLY** to persons stating their age.)

Name

Address

Age

Quick! Get into DRAFTING now



Learn At Home From An Engineer

With industry working feverishly—the field for DRAFTSMEN is bigger than ever! Get into a better job with more pay and fascinating, pleasant work. I will train you at your home in your spare time until you are holding a better paying position as Draftsman. My practical training in drafting also includes a working course in Industrial Designing valuable on new products, improving, restyling and modernizing—all extremely important and profitable to draftsmen. Write for full illustrated details and booklet. Give your age.

ENGINEER DOBE, Division 3371 Libertyville, Illinois

LEARN WATCH REPAIRING



AT HOME. By our modern and original system of instruction you can learn every part of the **WATCH REPAIRING TRADE AT HOME.** Prepare yourself for a well-paying position or start in business after completing our course of instruction. Good watch repairers are in demand and generally earn very good salaries. For particulars apply to the Wisconsin School of Watch Repairing 524 E. Mason St., MILWAUKEE 2, WIS.

STUDY ENGINEERING AT HOME

With A Chartered Educational Institution

Courses in **ENGINEERING:** Electrical, Civil, Mechanical, Drafting, Architectural, Steam, Aeronautical, Radio, Structural, Mining, Industrial, Highway, Petroleum, Marine, Chemical.

Courses in **ARTS AND SCIENCES:** Philosophy; Education; Letters; Public Health; Medical Jurisprudence; Psychology; Sociology; Physics; Chemistry; Geology; Pol. Science; Theology; Law; Business and Commerce; Accounting; Mathematics; Statistics; Agriculture.

McKinley-Roosevelt Incorporated, 4610-TC, Sheridan Road, Chicago, 40

THERE'S MONEY IN CARTOONS!

RAYE BURNS will teach you HOW to CREATE ORIGINAL CARTOONS at home that you may SELL! Course contains 26 lessons and over 600 Illustrations. All for Only..... **\$2.85**

Send name and address for free details.

RAYE BURNS SCHOOL, Dept. M, Box 1298, CLEVELAND 3, OHIO



Write for my Free Book, "How to Become an Expert Penman," which shows what others have accomplished by taking my Course. Enclose 10c for one of my Favorite Pen Points and your name with a beautiful flourish I send bird written on a card. Write today.

T. M. TEVIS, Box 25K, Chillicothe, Mo.

LAW

STUDY AT HOME FOR PERSONAL SUCCESS and LARGER EARNINGS. 31 years expert instruction—over 100,000 students enrolled. LL.B. Degree awarded. All texts furnished. Easy payments. Send for **FREE BOOK**—"Law and Executive Guidance."

AMERICAN EXTENSION SCHOOL OF LAW
Dept. 37-M 8 East Huron St. Chicago, Ill.

Short-Cut Mathematics

COMBINED WITH
Practical Mechanics Simplified

NEW 2-in-1 reading course! Now you can learn the speedy, simplified system of calculation used by draftsmen, engineers, accountants, "master minds" on the stage. Learn easy way to multiply 4 figures by 4 figures without using old-fashioned multiplication; add long columns of figures this lightning short-cut method. Learn horsepower, slide rule, micrometer, logarithms, wood measure, puzzles, etc., etc. Large illustrated volume complete with answers, only \$1 postpaid. Satisfaction or refund.

FREE Complete details... mail coupon TODAY!

Nelson Co., 321 S. Wabash, Dept. A-300, Chicago
Please send free details about "Short-Cut Mathematics and Practical Mechanics Simplified." No obligation.

Name

Address

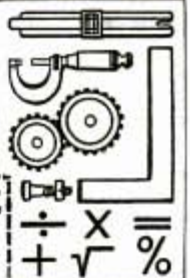

INVENTORS

NOW Is the Time to PATENT and SELL Your Invention

Get
FREE COPY

Now, more than ever before, is the right time to patent your invention. Why? Because manufacturers everywhere presently engaged in war production are looking ahead to the future by buying up patent rights now, so they will have new and attractive items to make and sell for civilian consumption as soon as the war is over. This is what happened during and after the last war. Hence, the smart thing for you to do is to look ahead to the future too. Protect your invention by applying for a patent now, so you will be in position to cash in on an outright sale, or on the royalties your invention will bring.

Patent Guide Shows What To Do

Our "Patent Guide for the Inventor" answers many important questions concerning Patents that inventors constantly ask. It tells what facts, details, drawings, sketches, etc. are necessary to apply for a Patent; how to protect your invention through dated and witnessed disclosure; how to do this AT ONCE to safeguard your rights; how Patent Office Records can be checked to determine whether the invention is probably patentable before filing fees need be paid; discusses costs involved and a practical way these can be paid as the application progresses. It tells how some inventors secured financial backing; how many simple inventions have proved large commercial successes; how Patents covering improvements also can be profitably utilized and marketed; tells countless other facts of interest.

Why You Need Expert Assistance

The Patent Laws were enacted for your benefit—to give you protection for the features of your invention which are Patentable. But these features must be legally and concisely set forth in the form of "claims." This phase of the procedure is so complex that the Patent Office advises the Inventor to engage a competent Registered Patent Attorney. We maintain a large staff—carefully trained registered patent attorneys—expert draftsmen—experienced searchers—to serve you. We have been serving inventors for more than 20 years.

Take First Step Now

With the Patent Guide you will receive also Free a "Record of Invention" form which will enable you at once to establish the date of your invention, before you file your Patent application. This step costs you nothing yet may be vital to your success. Remember—in Patent Matters, ACTION is IMPORTANT. Delay can be costly. Mail the coupon in an envelope, or paste it on a penny postcard NOW.

CLARENCE A. O'BRIEN & HARVEY B. JACOBSON

"Worthy of your Trust"

Registered Patent Attorneys
41-A Adams Building
Washington, D. C.

Get This
FREE BOOK

IMMEDIATELY MAIL COUPON TODAY!



48
PAGES
Over 150
Mechanical
Movements

CLARENCE A. O'BRIEN & HARVEY B. JACOBSON

CLARENCE A. O'BRIEN & HARVEY B. JACOBSON

Registered Patent Attorneys before the United States Patent Office
41-A Adams Building, Washington, D. C.

Please send me your 48-Page "Patent Guide for the Inventor" and your specially prepared "Record of Invention" form FREE. This request does not obligate me.

Name _____

Address _____

City _____ State _____

(Please write or print plainly.)

HERE IS YOUR SUCCESS CHANCE BE A RADIO-ELECTRONIC TECHNICIAN



**SPRAYBERRY
TRAINS YOU QUICKLY
FOR WAR
AND
PEACETIME
WORK**

**You Do Practice-Giving Experiments with
FULL RADIO SET REAL EQUIPMENT**

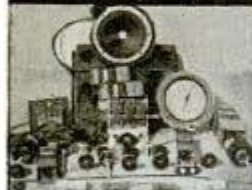

The offer I make you here is the opportunity of a lifetime. It's your big chance to get ready for a wonderful future in the swiftly expanding field of Radio-Electronics INCLUDING Radio, Television, Frequency Modulation, and Industrial Electronics. Be wise! NOW is the time to start. No previous experience is needed. The Sprayberry course is short, intensive, and interesting. It starts right at the beginning of Radio. You can't get lost.

YOU GET A DUAL-PURPOSE RADIO SET

I supply you with Radio Parts which you use to gain pre-experience in Repair work. These same Parts are used for testing and for Signal Tracing, etc. You'll find my Course and Equipment fully described in the catalog offered below.

**YOURS FREE
THESE TWO
VALUABLE BOOKS!**



• Prepares You
for a Business of Your Own . . . or
Good Radio Jobs, Civilian or Military

I make it easy for you to learn Radio Set Repair and Installation Work . . . by practical, proved, time tested methods. I teach you how to install and repair Electronic Equipment, and give you the broad fundamental principles so necessary as a background no matter what branch of Radio you wish to specialize in. Soon you'll be qualified for a good paying job in one of the nation's Radio plants doing war work OR, if you enter the Army, Navy, or Marines, my training will help you win higher rating and better pay. Let me prove what Sprayberry training can do for you.

**JUST OFF
THE PRESS!**

**"How to Test and Repair
Radio Sets Without Meters"**

Developed in the Sprayberry Laboratory, this instructive volume tells about an amazingly simple, yet efficient method for Radio trouble-shooting and repair without use of regular equipment made scarce due to war. Send for this FREE book now while the supply lasts and along with it I will send you another big FREE book describing my Radio-Electronic training.

MAIL COUPON

SPRAYBERRY ACADEMY OF RADIO
F. L. Sprayberry, President
Box 500RA, Pueblo, Colorado

Please rush my FREE copies of "HOW TO TEST AND REPAIR RADIO SETS WITHOUT METERS" and "HOW TO MAKE MONEY IN RADIO."

Name..... Age.....

Address.....

City..... State.....

(Mail in plain envelope or paste on penny postcard)

15 Minutes a Day!

Give me just this
and I'll prove I can make you
A NEW MAN!

I'M "trading-in" old bodies for new! I'm taking men who know that the condition of their arms, shoulders, chests and legs—their strength, "wind," and endurance—is not 100%. And I'm making NEW MEN of them. Right now I'm even training hundreds of soldiers and sailors who KNOW they've got to get into shape FAST!

Only 15 Minutes a Day!

Are you ALL MAN—tough-muscled, on your toes every minute, with all the up-and-at-'em that can lick your weight in wildcats? Or do you need the help I can give you—the help that has already worked such wonders for other fellows, everywhere?

All the world knows I was ONCE a skinny, scrawny 97-lb. weakling. And NOW it knows that I am the holder of the title, "The World's Most Perfectly Developed Man." How did I do it? How do I work miracles with the bodies of other men in only 15 minutes a day? The answer is "Dynamic Tension," the amazing method I discovered and which changed me from a 97-pound weakling into the champion you see here!

In just 15 minutes a day, right in the privacy of your own home, I'm ready to prove that "Dynamic Tension" can lay a new outfit of solid muscle over every inch of your body. Let me put new, smashing power into your arms and shoulders—give you an armor-shield of stomach muscle—strengthen your legs into real columns of surging stamina. If lack of exercise or wrong living has weakened you inside, I'll get after that condition, too, and show you how it feels to LIVE!

Charles Atlas

—actual photo of the man who holds the title, "The World's Most Perfectly Developed Man."



Charles Atlas—America's Greatest "Builder of Men"

Among all the physical instructors and "conditioners of men" ONLY ONE NAME STANDS OUT. That name is Charles Atlas!

In every part of the country Charles Atlas is recognized as "America's Greatest Builder of Men." Thousands upon thousands have put their physical development into his capable hands!

And now that the call is for men capable of helping America meet and conquer any national emergency, many thousands of others (even those already in their country's Army and Navy) are calling upon Charles Atlas to build the kind of men America vitally needs!



MAIL THIS COUPON NOW!

FREE This Famous Book that Tells You How to Get a Body that Men Respect and Women Admire

My book, "Everlasting Health and Strength," tells you exactly what "Dynamic Tension" can do. And it's packed with pictures that SHOW you what it does. RESULTS it has produced for other men. RESULTS I want to prove it can get for YOU! If you want to learn how you can actually become a NEW MAN, right in the privacy of your own home and in only 15 minutes a day, then man!—get this coupon into the mail to me as fast as your legs can get to the letterbox! CHARLES ATLAS, Dept. 8A, 115 East 23rd St., New York 10, N. Y.

CHARLES ATLAS, Dept 8A
115 East 23rd St., New York 10, N. Y.

I want the proof that your system of "Dynamic Tension" will help make a New Man of me—give me a healthy, husky body and big muscular development. Send me your free book, "Everlasting Health and Strength."

Name.....
(Please print or write plainly)

Address.....

City..... State.....

Check here if under 16 for Booklet A.

Buy War Saving Bonds and Stamps regularly.

INVENTORS

This **BOOK**

and **INVENTION RECORD**
(Cost You Nothing)
FREE BOOK



HOW TO PROTECT, FINANCE and SELL YOUR INVENTION

Our **FREE BOOK** and other literature available to our clients—gives you complete details on how to "ready" your invention for money-making. It tells you how others did it—who they went to for finances—how they arranged partnerships—how they made contacts with manufacturers—how they dictated royalty arrangements—how much money they made—how you can find a market. Our new **FREE BOOK** discloses sources of quick revenue if your invention is patentable and saleable with profit possibilities.

THE FIRST STEP

The first step in getting your invention ready for market is to make a dated record of it on our "Invention Record" Form. This Form properly filled out and witnessed will be invaluable to you later in establishing the date of your invention should need for such evidence arise. We will be glad to send you our "Invention Record" and have it witnessed in this office when you return it with disclosure of your device. This service costs you nothing—and it immediately puts you on record as the originator of your device.

Protect Your Invention NOW!

We have many letters in our files from manufacturers requesting inventions. Today's demand for new devices is tremendous—added to by emergency needs. Protect your invention now with a U. S. Patent. By acting promptly you may prevent another inventor getting in ahead of you at the Patent Office here in Washington. The first step is to make a sketch and description of your invention on our "Invention Record," have it witnessed and mail it to us. We will then make a Search of the U. S. Patent Office files to ascertain whether we can get patent protection for you. This is a step you should make NOW—before another steps in ahead of you and walks away with a patent.

MAIL

COUPON TODAY!

McMORROW & BERMAN
PATENT ATTORNEYS
135-S Albee Building, Washington 5, D. C.

Send me your NEW FREE Book, "How to Protect, Finance and Sell Your Invention," and specially prepared "Invention Record" form at once. I understand that this request does not obligate me.

NAME.....
ADDRESS.....
CITY..... STATE.....

Write or Print Name Clearly

INTERNATIONAL CORRESPONDENCE SCHOOLS

- | | |
|--------------------------|-------------------------|
| Blueprint Reading | Mechanical Engineering |
| Foundryman | Patternmaking |
| Heat Treatment of Metals | Shop Practice |
| Machinist | Toolmaking |
| Mechanical Drafting | Welding, Gas & Electric |

OTHER TECHNICAL COURSES

- | | | |
|--|---|---|
| Air Conditioning Schools
Air Conditioning
Heating
Plumbing
Refrigeration
Steam Fitting | Electrical Schools
Electrical Engineering
Electric Wiring
Gas and Electric
Welding
Industrial Electrician
Lighting Technician
Power House
Practical Telephony
Radio, General
Radio Operating
Radio Servicing
Telegraph Engineering | Mold-loft Work
Reading Shop
Blueprints
Sheet Metal Worker
Ship Drafting
Ship Fitting
Shop Practice
Steel Mill Workers
Tool Designing
Wood Pattern Making |
| Chemistry Schools
Chemistry, Analytical
Chemical Engineering
Chemistry, Mfg.
Iron and Steel
Pharmacy
Pulp and Paper Making | Internal Combustion Engines Schools
Air Pilot
Automobile Technician
Aviation
Diesel—Electric
Diesel Engines
Gas Engines | Railroad Courses
Air Brake
Car Inspector
Locomotive Engineer
Locomotive Fireman
Railroad Car Repairer
Railroad Section Foreman |
| Civil, Architectural and Structural Engineering Schools
Architecture
Architectural Drafting
Bridge and Building Foreman
Bridge Engineering
Building Estimating
Civil Engineering
Concrete Engineering
Contracting and Building
Highway Engineering
Retail Lumberman
Structural Drafting
Structural Engineering
Surveying and Mapping | Mechanical Schools
Airplane Drafting
Foundry Work
Heat Treatment of Metals
Inventing and Patenting
Machine Shop Practice
Mechanical Drafting
Mechanical Engineering
Metal Pattern Drafting | Steam Engineering Schools
Boiler Making
Combustion Engineering
Engine Running
Marine Engines
Petroleum Refining Plant
Steam Electric
Steam Engines |
| | | Textile Schools
Cotton Manufacturing
Textile Designing
Woolen Manufacturing |

BUSINESS AND ACADEMIC COURSES

- | | | |
|---|--|--|
| Academic Schools
Arithmetic
College Preparatory
First Year College
High School
Higher Mathematics
Illustrating | Bookkeeping
Business Correspondence
Business Management
Certified Public Accounting
Commercial Cost Accounting
Foremanship
Salesmanship
Secretarial Stenography | Tax Accountant
Traffic Management
Civil Service Schools
City Letter Carrier
Post Office Clerk
Railway Postal Clerk
Language Schools
French
Good English
Spanish |
|---|--|--|

INTERNATIONAL CORRESPONDENCE SCHOOLS BOX 5679-J, SCRANTON 9, PENNA.

Please send me complete information on the following subject:

(Write above Technical, Business or General Educational Subject in which you are interested.)

Name..... Age.....

Home Address.....

City..... State.....

Present Position.....

Special Tuition Rates for Members of the Armed Forces

When the new man moves around you—

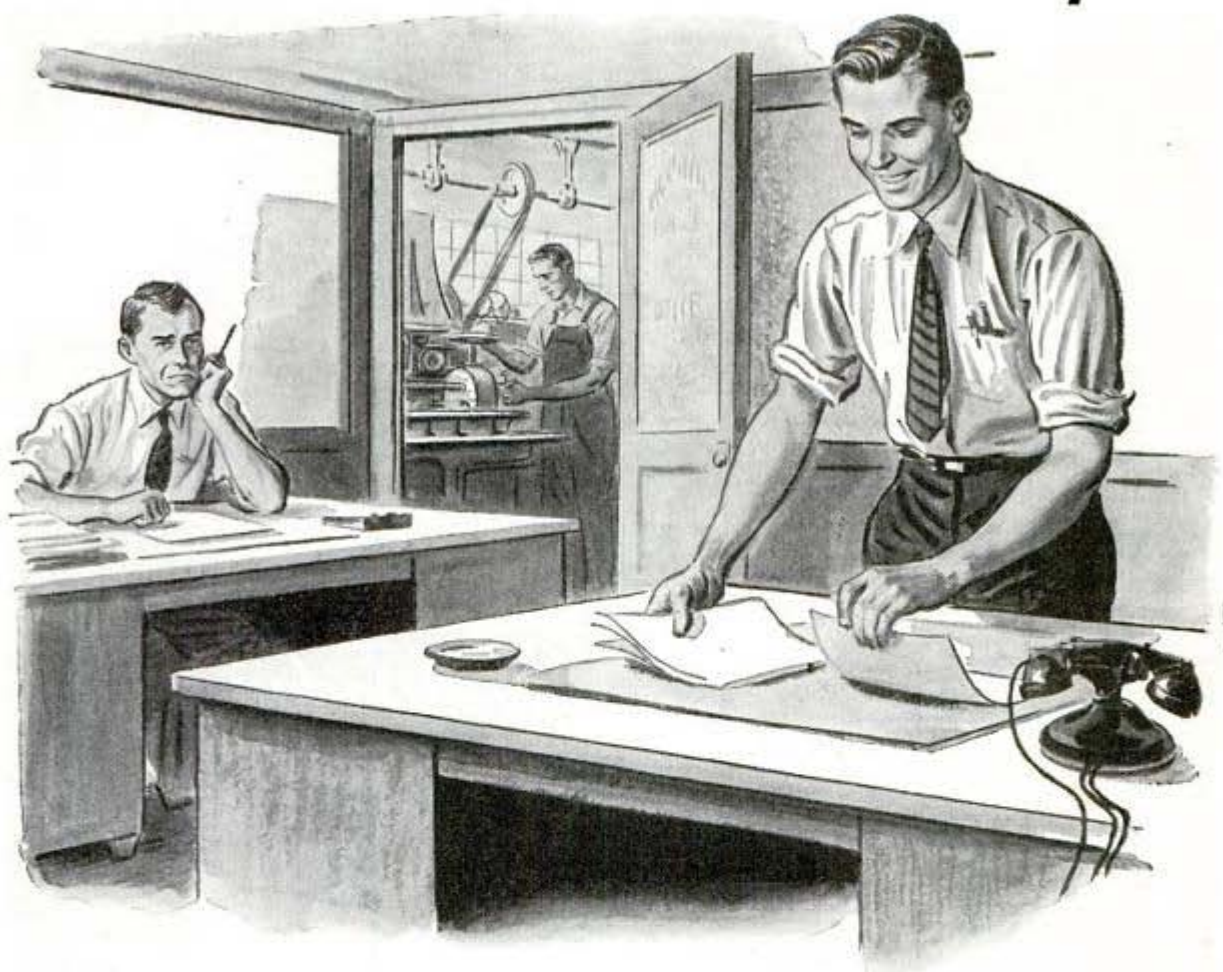

YOU remember the day Vince Benedict started in Factory Office. You remember his early weeks when you "broke him in." Today he's clearing off the old desk and moving into a job ahead of yours. You've been ten years longer with the company and you can't understand it.

Do some realistic checking up and you'll find that Benedict has been *training* himself for the demands and responsibilities of larger positions. It isn't too

late for you to do the same by taking an I. C. S. Shop Practice Course.

Thousands of successful Americans have acquired their all-important Shop Practice training from the world-famous International Correspondence Schools. The man who has moved around you quite possibly sent in this coupon once. *And it wouldn't be surprising if the man who employs you both is a former I. C. S. student.* Many employers are.

INTERNATIONAL CORRESPONDENCE SCHOOLS, BOX 5679-J, SCRANTON 9, PENNA.

MAIL THIS COUPON! *It brings you full information on I.C.S. advantages. It can be the turning point of your career!*

MEN AND WOMEN!

Has your war work given you
an idea for a patentable

INVENTION?



An "invention" doesn't necessarily have to be a complicated, technical mass of machinery . . . most inventions are the outgrowth of an "idea" that someone had to do something better, faster or cheaper. It's possible that you've figured out a gadget . . . or an improvement on a machine . . . that will help someone do it "easier, faster, cheaper."



MAYBE YOU CAN CASH IN ON IT!!

The only difference between you and a successful, money-making inventor may be that he went ahead and DID SOMETHING ABOUT IT! Most professional inventors turn their inventions over to a reliable Registered Patent Attorney whose trained staff is equipped to secure a strong patent for the inventor with the greatest possible speed and at a minimum of expense. When you hold a patent you have the right to exclude others from making, using or selling your invention for a period of 17 years . . . which means that no one can cash in on your invention without your permission, no manufacturer can make money on it without buying your patent or paying you a satisfactory royalty unless he wishes to risk a suit in court. Furthermore, most manufacturers refuse to consider an invention for commercialization unless the inventor has first filed for his patent. Don't let the fact that it may be a simple invention bother you . . . remember the paper clip, nothing but a twisted wire . . . but today, it is an almost indispensable piece of office equipment.

**NEARLY A HALF-CENTURY of
Patent Experience--At your Service!**

NOW is the time to use your initiative! Your first step, which costs you nothing and doesn't obligate you . . . is to write TODAY . . . right now . . . for our two big books, 64 pages of facts and information, which tell just how to go about getting a patent; how to market it; what kind of sketch or model is needed; how to make a proper disclosure; 115 mechanical movements; etc. Do you want to cash in on your invention? It's UP TO YOU!

MAIL COUPON NOW!



VICTOR J.
EVANS & Co.

Merlin M. Evans

REGISTERED PATENT ATTORNEYS
MAIN OFFICE: 830-A MERLIN BLDG.
WASHINGTON 6, D. C.

Please send me your books, "Patent Protection" and "How to Sell an Invention" without cost or obligation:

NAME

ADDRESS

CITY AND STATE

Say you saw it in Popular Mechanics!

POULTRY PAYS

IN
PATRIOTISM
PROFITS
PLEASURE

Learn at home, the EASY, SCIENTIFIC, and INEXPENSIVE way. Our course covers ALL phases of Poultry raising, including plans for buildings, breeding, hatching, culling, sexing, caponizing, marketing, judging, exhibiting, and many others, etc., as planned by Harry M. Lamson, former Senior Poultryman for the United States Department of Agriculture.

In the past twenty years, we have helped thousands of students to establish poultry farms, to increase profits on established plants, to secure positions in the many branches of the Poultry business, and many just to enjoy a small, profitable, breeding plant.

The Government needs your help for its huge requirements for Poultry and eggs. Sec'y. Wickard wanted 200,000,000 extra chickens this year. Later he called for 4 billion pounds of chicken for meat alone. 28% jump over 1942! And more eggs per bird—8% more eggs! We can teach you the EASY, SCIENTIFIC, and PROFITABLE way to assist this program.

Write TODAY for catalog "How to Raise Poultry For Profits." It fully explains courses and easy payment plan.
NATIONAL POULTRY INSTITUTE
Dept. 50-H, Adams Center, N. Y.



Send Today

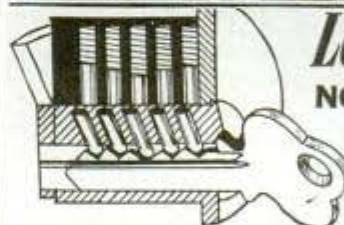

Locksmithing NOW MADE EASY!

New course for practical men, mechanics, carpenters, fix-it shops, etc. Learn to fit keys, pick locks, de-code, make masterkeys. It pays. Send name for FREE details. No obligation—write today! Nelson Co., 321 S. Wabash, Dept. A-702, Chicago.

Get into the BAKING BUSINESS

Bakers make good money! Now 7th Industry in wages! Nearly depression-proof, New home study Baking Course qualifies you. Common school education sufficient. If you're ambitious, write for FREE BOOK, "Opportunities in Baking."



National Baking School, 1315 Michigan, Dept. 1351, Chicago

JIU-JITSU HOW TO LICK THE BIG GUY

Guaranteed Learn Easily Quickly step by step. Send 10c to-day for trial lesson, full details.

MODERN SCHOOL OF JIU-JITSU, Dpt. A, 5 W. 52 St., N. Y. 19

STAMMER ?

This new 128-page book, "Stammering, Its Cause and Correction," describes the Bogue Unit Method for scientific correction of stammering and stuttering—successful for 43 years. Benj. N. Bogue, Dept. 1808, Circle Tower, Indianapolis 4, Ind.

GET THIS
FREE
BOOK!

EARN MONEY PAINTING PORTRAITS



● No previous training or talent necessary. Unique Stuart System teaches you, by mail, in 10 simple, easy-to-follow lessons, to make excellent charcoal and oil likenesses. Detailed guidance for your every step. Send for free book today.

STUART 121 Monument Circle, Rm. 614, Indianapolis 9, Ind. STUDIOS, Please send me free book and outline of lessons.

Name _____
Street _____
City _____ State _____

New!

COYNE "Learn-by-Doing" Shop Course RADIO Operating and ELECTRONICS



AIRCRAFT RADIO



BROADCASTING



ELECTRONICS



MEN!
whether you're
16 OR UP TO **50**
TRAIN AT COYNE
ON REAL RADIO
EQUIPMENT!

GET READY NOW FOR A GREAT VICTORY FUTURE

I'll Finance Your Training



TALKING PICTURES



POLICE RADIO



TELEVISION



RADIO RECEIVERS

The end of the war will open up vast new opportunities in RADIO OPERATING AND ELECTRONICS. Prepare now with Coyne "Learn-by-Doing" shop training in this big field. Not by correspondence, but actual experience on real Radio and Electronic apparatus.

START NOW—PAY LATER!

I make it easy for you to come to Chicago for my practical training. Don't let lack of money hold you back! You can pay tuition AFTER YOU GRADUATE. I'll even help you secure part-time work while at Coyne to help pay living expenses. My plan has aided thousands—coupon brings complete details.

Prepares for Gov't License

Many of the better Radio jobs require U. S. Govt. license. Coyne has prepared hundreds of men for this test. Our graduates hold good positions in broadcast stations, air transport, police radio and motion picture studios.

Train on Real Radio and Electronic Apparatus

At Coyne, you operate real up-to-the-minute Radio and Electronic equipment. Experts show you each step, train you thoroughly. You'll learn to send Code rapidly—do actual trouble-shooting on Television, short-wave and electronic devices. With this training you get my LIFETIME EMPLOYMENT SERVICE. I train you for a real job, then help you get it!

Facilities for Men Partly Disabled or with Physical Handicaps. Write for details.

H. C. LEWIS, President

COYNE ELECTRICAL SCHOOL RADIO DIVISION

500 S. Paulina Street, Dept. 14-3H, Chicago 12

SEND FOR MY FREE BOOK!

Find out all about the sensational new future for Coyne-trained Radio Operators and Industrial Electronic Specialists. My FREE BOOK is full of photos and job information. There's a place in this vast field for YOU. Age, lack of experience bars no one. Coyne has been training men 44 years—is nationally famous. Act now. Use handy coupon. No obligation; no salesman will call. Don't delay. Send it today!

Get the FACTS!

See How Easily YOU can get my Radio Shop Training! MAIL COUPON



H. C. LEWIS, Pres.,
RADIO DIVISION
COYNE ELECTRICAL SCHOOL, Dept. 14-3H
500 South Paulina St., Chicago 12, Ill.

Without obligating me, send your FREE BOOK, "Your Future in RADIO", and tell me about your "Pay-After-Graduation" plan.

NAME.....

ADDRESS.....

CITY.....STATE.....

DRAFTING



GET THIS
Free TRIAL LESSON
Send Coupon



TO PROVE TO YOU how easy it is to learn Drafting at home by the Chicago Tech method, this 40 year old technical college will send you a *Free Trial Lesson in Drafting*. No charge for this Lesson now or later.

Mail Coupon Below

Get ready for a peacetime career. Look into the opportunities in Drafting. Read the want-ads for proof of the urgent demand for draftsmen in the aircraft, machinery, electrical and building fields. The draftsman always comes first on any new project in industry,—in peace or wartime.

The Draftsman—"The Key Man"

No new machines can be built, no airplanes constructed, no bridges or buildings erected, no ships or submarines launched until the draftsman has completed his work. Real immediate opportunities exist in Drafting—the profession upon which all construction is vitally dependent. Drafting is clean, interesting, well paid work. Investigate today what Drafting offers you.

Learn in Spare Time,—at Home! (or at the College in Chicago)

With our easy step-by-step method (and the tools we furnish) you can learn in your spare time at home. Convenient terms. Now is the time to prepare in Drafting for peacetime opportunities. Send the coupon or a post card for the Trial Lesson and complete information,—all FREE.

CHICAGO TECHNICAL COLLEGE

A-205 Tech. Bldg., 2000 S. Michigan Ave., Chicago 16, Ill.

Yes,—please send me *FREE* Trial Lesson in **DRAFTING**

- | | |
|---|--|
| <input type="checkbox"/> Aircraft Drafting | <input type="checkbox"/> Machine Drafting |
| <input type="checkbox"/> Electrical Drafting | <input type="checkbox"/> Structural Drafting |
| <input type="checkbox"/> Architectural Drafting | <input type="checkbox"/> Building Construction |

Name.....

Address.....

City..... State.....

Occupation..... Age.....

Law!

LEARN AT HOME

Are you adult, alert, ambitious, willing to study? Investigate **LAW!** We guide you step by step—furnish all texts, including 14-volume Law Library. Training prepared by leading law professors and given by members of bar. Degree of LL. B. conferred. Low cost, easy terms. Send NOW for Free, 48-page "Law Training for Leadership."

LASALLE EXTENSION UNIVERSITY, Dept. 14-L, Chicago
A CORRESPONDENCE INSTITUTION

TRI-STATE COLLEGE

B. S. Degree in 27 Months

Distinguished for technical 2 1/4-year courses in Civil, Electrical, Mechanical, Chemical, Radio, Aeronautical Engineering; Business Administration, Accounting, and Secretarial Science.
MEN AND WOMEN—3 yr. high school students with good record admitted. Special Preparatory Department. Modern laboratories, latest equipment. Low tuition. Low living costs. Cosmopolitan student body. 60th year. Enter March, June, September, January. Write for catalog, 414 College Ave. **ANGOLA, INDIANA**

LEARN MEAT CUTTING At Home—In Spare Time

Get into the vital meat industry. Concise, practical Home Training based on 25 years proven instruction methods used at National's famous resident school. Prepares you for bigger pay as Meat Cutter, Supervisor, market manager or more money in your own store. Go as rapidly as your spare time permits. Diploma. Start NOW to turn your spare hours into money. Send for FREE bulletin today. No obligation.

National School of Meat Cutting, Inc., Dept. U-43, Toledo 4, Ohio

WILL YOU WEAR THIS SUIT

and Make up to \$12 in a Day!

Let me send you a union tailored to measure suit **FREE AS A BONUS**. Just follow my easy plan and take a few orders. Make up to \$12 in a day easily. No experience—no house-to-house canvassing necessary. Big opportunity—full or spare time.
Send for Samples—**FREE OF COST**. Write today for **FREE ACTUAL CLOTH SAMPLES** and "sure-fire" money-getting plans. For quick action write fully giving age, etc. Send no money. **W. J. COITIN, PROGRESS TAILORING CO., 500 So. Throop St., Dept. A-216, Chicago, Ill.**

Learn PHOTOGRAPHY at Home

Splendid opportunities. Prepare in spare time. Easy plan. No previous experience needed, common school education sufficient. Send for free booklet "Opportunities in Photography", particulars and requirements.

American School of Photography
1315 Michigan Ave., Dept. 1351, Chicago, Ill.

Correspondence Courses in RADIO and ELECTRICAL ENGINEERING

LOW AS \$25

ELECTRICAL ENGINEERING. Get good grasp of wide electrical field. Modern. Very understandable. Theory made easy.
RADIO ENGINEERING. Extra fine course in radio, public address, photo-electric work. Trains you to be super-service man, real vacuum tube technician. Tuition **ONLY \$25**, other courses. Deferred payment plan. Servicemen needed badly.
Write for free copies of school catalogs, student magazines, etc.
FREE LINCOLN ENGINEERING SCHOOL, Franklin, Stn., Box 61—PG1
(Formerly at Lincoln, Nebr.) **WASHINGTON, D. C.**

SAVE RUBBER

Easy to fix cuts, bruises, worn spots in tires. **SO-LO** also mends shoes, raincoats, boots—anything of rubber, leather, cloth.

MEND the HOLE for 1¢
SPREADS ON like butter Dries tough overnight. Flexible Non-skid. Waterproof. Won't come off—guaranteed
So-Lo AT HARDWARE & 10c STORES

PLASTICS

THE GREAT *New* FIELD OF OPPORTUNITY
PLASTICS ENGINEERS AND TECHNICIANS NEEDED
IN NOT ONE BUT MANY CLASSES OF INDUSTRY

● Leaders in science and industry have long been saying, "Keep your eye on Plastics." But now the time for action has arrived. The future of huge possibilities has already begun. Developments in Plastics for hundreds of wartime uses have set the pace for revolutionary changes in peacetime production of thousands of products.

**THIS IS YOUR
BIG CHANCE**

Today there's a big need in vital war production for those who are trained in Plastics. From one to a hundred articles made of Plastics must be supplied for every man in our fighting forces. Start training now in Plastics Engineering, in spare time in your own home. Fit yourself for a responsible, well-paid position. Help to win Victory. And at the same time you will be preparing for even greater opportunities when the war is over.

There is scarcely an industry in which these so-called "miracle materials" will not play an important part. After the war many old materials, methods and skills will be replaced. Acquire the all-important "know how." Be in a position to step into one of the key jobs.

**YOU CAN LEARN
WHILE YOU EARN**

Turn at least part of your leisure time into money. Qualify at home for a larger income in an interesting career. Build greater security for your future in a vocation that looms large on the horizon of the new industrial era. Hours you might otherwise waste can put you well on your way toward lasting success.

It's easy to find out about Plastics training. To get details and outline of study prepared by specialists, and about the school that has helped thousands to success during the past 46 years, write us or check and mail the coupon. Send today. The sooner you take this easy step, the sooner you will reach your goal and reap the rich rewards.

**AMERICAN SCHOOL OFFERS
COMPLETE TRAINING SERVICE
IN MANY SUBJECTS**

You who have not completed high school or have missed vocational training in college, and who cannot spare time to go away to school, can complete your education in your choice of many subjects. Several of these are listed in the coupon at right. Check the subject in which you are interested, fill in your name and address, clip and mail the coupon today.

AMERICAN SCHOOL

Dept. G-145, Drexel at 58th Street, Chicago 37

PRACTICAL, EFFECTIVE HOME - STUDY TRAINING SINCE 1897

Take This First Easy Step

CHECK, CLIP AND MAIL COUPON NOW

AMERICAN SCHOOL, Dept. G-145, Drexel at 58th, Chicago 37, Ill.
Without obligation, Please send FREE and postpaid, bulletin and details of the Subjects checked.

- | | | |
|--|---|--|
| <input type="checkbox"/> PLASTICS ENGR | <input type="checkbox"/> Accounting and C.P.A. | <input type="checkbox"/> Drafting and Design for Men and Women |
| <input type="checkbox"/> Refrigeration | <input type="checkbox"/> Cost Accounting for Manufacturing | <input type="checkbox"/> Radio |
| <input type="checkbox"/> Architecture and Building | <input type="checkbox"/> Bookkeeping | <input type="checkbox"/> High School |
| <input type="checkbox"/> Practical Plumbing | <input type="checkbox"/> Private Secretary | <input type="checkbox"/> Air Conditioning |
| <input type="checkbox"/> Automotive Engineering | <input type="checkbox"/> Diesel Engineering | <input type="checkbox"/> Shipbuilding |
| <input type="checkbox"/> Aviation Drafting | <input type="checkbox"/> Surveying & Topographical Drafting | <input type="checkbox"/> Mechanical Eng. |
| <input type="checkbox"/> Aviation | <input type="checkbox"/> Sheet Metal Pattern Drafting | <input type="checkbox"/> Shop Management |
| <input type="checkbox"/> Business Mgmt | <input type="checkbox"/> Electrical Engineering | <input type="checkbox"/> Tool Making |
| <input type="checkbox"/> Railway Training | | <input type="checkbox"/> Better Foremanship |
| | | <input type="checkbox"/> Machine Shop Operations |

Name..... Occupation.....
Address..... Age.....
City..... State.....

The set of
books
that makes



MASTER MACHINISTS and leads to bigger pay!

This big home-study and reference course gives you the practical facts on machines and methods you need to advance in machine shop work. Take advantage of the other man's experience as found in books, to solve your problems, increase your efficiency, with

The AMERICAN MACHINISTS' LIBRARY

6 volumes—2368 pages—2516 illustrations

(A combined home-study course and reference library)

This library of machine shop practice was written for practical men. It gives you the best methods for every kind of machine shop work. It fully explains lathes, drills, and other machine tools and their operation, automatic screw machines, speeds and feeds, gear design and production, jigs and fixtures, punch and die work, metal surfacing, etc., etc. Plainly written—completely illustrated—the best kind of help to the machine shop man who wants to advance himself.

No money down—special price—easy payments.

EXAMINATION COUPON

McGraw-Hill Book Co., 330 W. 42nd St., N. Y. 18

Send me for ten days' examination the American Machinists' Library. If satisfactory I will send you \$1.50 in 10 days and \$3.00 monthly until the price of \$19.50 is paid. If not wanted, I will return the books postpaid. (To insure prompt shipment write plainly and fill in all lines.)

Name
Home Address
City and State
Position
Name of Company PM-144

AUDELS Carpenters and Builders Guides 4 vols. \$6



Inside Trade Information for Carpenters, Builders, Joiners, Building Mechanics and all Woodworkers. These Guides give you the short-cut instructions that you want—including new methods, ideas, solutions, plans, systems and money saving suggestions. An easy progressive course for the apprentice and student. A practical daily helper and Quick Reference for the master worker. Carpenters everywhere are using these Guides as a Helping Hand to Easier Work, Better Work and Better Pay. To get this assistance for yourself, simply fill in and mail the FREE COUPON below.

Inside Trade Information On:

How to use the steel square—How to file and set saws—How to build furniture—How to use a mitre box—How to use the chalk line—How to use rules and scales—How to make joints—Carpenters arithmetic—Solving mensuration problems—Estimating strength of timbers—How to set girders and sills—How to frame houses and roofs—How to estimate costs—How to build houses, barns, garages, bungalows, etc.—How to read and draw plans—Drawing up specifications—How to excavate—How to use settings 12, 13 and 17 on the steel square—How to build hoists and scaffolds—skylights—How to build stairs—How to put on interior trim—How to hang doors—How to lay floor—How to paint



THEO. AUDEL & CO., 49 W. 23rd St., New York City

Mail Audels Carpenters and Builders Guides, 4 vols., on 7 days' free trial. If O.K. I will remit \$1 in 7 days, and \$1 monthly until \$6 is paid. Otherwise I will return them. No obligation unless I am satisfied.

Name
Address
Occupation
Reference PM

Say you saw it in Popular Mechanics!

HOW TO GET AND KEEP GOOD EYESIGHT



Do you want perfect 20/20 vision? Would you like to throw away your glasses? Great numbers of men, women and children have improved and strengthened their eyes by using the famous Ross-Rehner Method, a tested and proven system of home eye exercises for correcting nearsightedness, far sightedness, color blindness and astigmatism.

Get Better Eyesight—Without Glasses

Now you can get the entire system, profusely illustrated, including a complete Eye Testing Kit, with charts to show weekly improvement. If your book store does not have it, send one dollar. Delivered postpaid, subject to return in 5 days if you are not satisfied. Order today.

SAVE YOUR EYES



HALL PUBLISHING CO.
BLOOMFIELD HILLS 2, MICHIGAN

ENGINEERING DEGREE IN 27 MONTHS

INDIANA
TECHNICAL
COLLEGE

Courses in Aeronautical, Chemical, Civil, Electrical, Mechanical, and Radio Engineering. One-year courses in Radio and Drafting. Government-approved Ground School courses. Prep courses without added cost. Low tuition. Large industrial center. Opportunity to earn part living expenses. Enter Mar., June, Sept., Dec. Catalog. 514 E. Washington Blvd., Ft. Wayne 2, Ind.

FIX ANY RADIO

Learn quickly to repair all radio sets. New, different Comparison method permits you to do expert work almost immediately. No previous radio knowledge needed. Introductory training included. Simple, picture suggestions tell you where to look for faults and how to make the repair. No testers needed for most jobs. Manual 8 1/2 x 11 in., 112 pages, 16 blueprints, 1,000 hints, 10-day trial. New, 1943 edition. Only \$1.50 postpaid. Money back guaranteed.

SUPREME PUBLICATIONS 328 S. Jefferson St. CHICAGO 6, ILL.

Learn Public Speaking

At home—in spare time. Many overcome "stage-fright," gain self-confidence and increase earning power, this easy way. Write for free booklet, *How to Work Wonders With Words* and requirements.

North American School, Dept. 1351
1315 Michigan Av. Chicago, Illinois

Learn to Write

Begin today. Write now for our Free Book, "How to Become a Good Penman." It contains specimens and tells how others learned to write in spare time. Enclose 10¢ for your name beautifully written and a pen point suitable for shaded writing. Write today.

THE TAMBLYN SCHOOL OF PENMANSHIP
X441 Ridge Building, Kansas City, Mo.

REFRIGERATION SERVICE MECHANICS COURSE

Learn at home—how to start your own repair shop on little capital. No previous experience needed. Common school education sufficient. Splendid opportunity for older men. Prepare now for after the war. FREE illustrated booklet.

MECHANICS TRAINING SCHOOL, Dept. P-1, 4701 W. Pico, Los Angeles 6, Calif.

BIGGER PAY THAN EVER!

Local "Store Route" Plan pays men like you big money—steady!—in wholesale business of your own. No car necessary. Sell Vitamins to stores of all kinds. New low retail price, 7 for 10¢, opens vast rich field. Handle this salesman, plus 200 other quick profit items. Many nationally advertised. No experience needed. Amazing facts FREE. Write TODAY!

WORLD'S PRODUCTS CO.
Dept. 10-N Spencer, Indiana



MONEY for MEN FREE

ALL DATA FREE

THE PLASTEX Industry needs manufacturers on small scale and for big production of Lamp and Clock Stands, Art Goods and Novelties in Plastex and Marble imitation. Experience unnecessary. 1/2¢ material makes regular 10¢ store sellers. Rubber moulds furnished for speed production. Small investment brings good returns. WE ARE NOW PLACING BIG CHAIN STORE ORDERS WITH MANUFACTURERS. Ambitious men have chance for real prosperity. Our FREE booklet will interest and benefit you.

PLASTEX INDUSTRIES, Dept. P, 1055 Washington Av., New York 56, N.Y.

RICH REWARDS FOR THOSE WHO KNOW PLASTICS



BE A PLASTICS TECHNICIAN



Do you want action *now*—in a vital, growing war-time industry . . . helping to turn out fighting planes and jeeps and bombs and tanks? There's a big demand for men and women plastics technicians to fill important war industry positions . . . and if you start your training now—at home—you may qualify for a place in this vital part of the war program.

LOOK TO THE FUTURE

Even more important is the question—what will you do when the war is over? Will you be among those fighting for jobs that may no longer exist? Or will you be well on your way to a permanently profitable career, or established in your own business, with plastics?

Build your personal post-war plans on a sound knowledge of plastics. This country is already in the Plastics Era. The future of the plastics industry is so rich that some predictions seem exaggerated and fantastic . . . but the fact remains that plastics have proven themselves and are vital in the production of airplanes, autos, furniture, radios, trains, clothing, electrical appliances and equipment, machinery, tools, and hundreds of other products.

CHOOSE YOUR FIELD... Enter it thru PLASTICS

You should be able to see for yourself what plastics will mean in virtually every field—the possibilities that will be available to those trained in plastics. Now is the time to prepare for your chosen field, as a plastics technician.

LEARN AT HOME

Make your increased hours at home pay you dividends. You can easily fit into your spare time your training for a career in plastics. You won't need to lose one minute from your present work . . . simply devote a few hours each week to enjoyable home study, like thousands of other men and women are doing who are helping their country while helping themselves. The Plastics Institute course is an easy, practical tested method which will help fit you for this promising and interesting field . . . and if you are now working with plastics, it equips you for advancement. During the entire course your training is supervised by men well known in the plastics industry, in which they have been recognized as authorities for years.

TIME IS PRICELESS—ACT NOW!

Find out how the Plastics Institute can help YOU. Mail the coupon for your copy of the large FREE, illustrated booklet, the "World of Plastics." It is crammed with valuable information about plastics, tells about the new plastic airplanes and other uses for this revolutionary new material . . . as well as about the opportunities for YOU in plastics. Decide NOW to let plastics point the way to YOUR success . . . send the coupon TODAY.

STUDENTS REPORT SUCCESS

"I wish to acknowledge, with thanks, the receipt of my final examination papers, my certificate of graduation, and the lesson binders you sent me.
"I have really enjoyed your excellent course of study, and the friendly help and cooperation you have given me, and feel that the time and money expended on my training has been well worthwhile."
R.F.P.

Plastics INDUSTRIES TECHNICAL INSTITUTE

1221 Chanin Bldg.
New York

626-E LaSalle-Wacker Bldg.
Chicago

190 So. Alvarado St.
Los Angeles

AMERICA'S ORIGINAL
PLASTICS SCHOOLS

MAIL COUPON FOR FREE BOOK

Plastics Industries Technical Institute
626-E La Salle-Wacker Bldg., Chicago

Gentlemen: Please send me the booklet "World of Plastics" and information on your training program. I understand there is absolutely no obligation.

Name _____ Age _____

Street _____

City _____ State _____

Dept. 1



GET THIS INTERESTING BOOK "WORLD OF PLASTICS" SENT FREE

GET FULL DETAILS NOW

War days are OPPORTUNITY DAYS for YOU . . . in Accounting . . .

If you like to work with figures and are earnestly ambitious, accounting today offers you unparalleled opportunity—to serve your country and to profit.

For there just aren't enough bookkeepers and accountants to fill the needs of government and industry. There are thousands of new and vacant jobs. These jobs pay well and they are open to both men and women. Moreover, this need will continue through the war and the post-war adjustment period.

Ask us to prove this—and to show you how you can grasp this opportunity quickly.

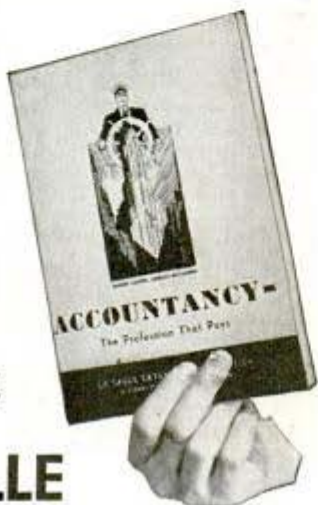

Ask for this free 48-page booklet

LASALLE EXTENSION UNIVERSITY A Correspondence Institution

Dept. 164-H CHICAGO

I want to know what opportunity there is for me in Accounting now and how I can prepare for it. Send me your free booklet and any other pertinent information.

Name.....Age.....

Present Position.....

Address.....

LEARN TO DRAW CARTOONS BIG MONEY EASY, PLEASANT WORK!

Let CHAS. H. KUHN with 25 years actual experience in drawing a daily newspaper cartoon, teach you how to Create, draw and sell your work. 52 complete lessons—one sent each week. Start on the road to fame and fortune now—Write Today!

Complete Course Only \$7.50

KUHN SCHOOL OF CARTOONING
420 Murphy Building Indianapolis 4, Indiana



Why It Pays To LEARN PHOTOGRAPHY NOW

Never before so many job and career opportunities! Photographers needed in business, industry, science. N.Y.I. graduates winning promotion, higher pay in Armed Forces. Quality at America's largest, oldest school. Resident or home study. FREE catalog describes commercial, portrait, motion picture and color courses. Write today!



N. Y. INSTITUTE OF PHOTOGRAPHY, Dept. 49, 10 W. 33 St., New York 1, N. Y.

PLASTICS DESIGN ENGINEERING

Wartime applications have proved the peacetime possibilities of PLASTICS. Get ready now for this big postwar opportunity. Prepare yourself for a highly paid position in Plastics Industrial Engineering. Complete home training course now available. Send name and state age. OHIO INSTITUTE OF TECHNOLOGY, Box P-134, Greenville, Ohio



A SIMPLIFIED ART ANATOMY OF THE HUMAN FIGURE

ONLY \$1 POSTPAID
The book they're talking about! One of the most informative books of its kind for both student and professional artists. Charts, notes, and over 350 drawings show detailed studies of every part of the body, posed and in action. HOUSE OF LITTLE BOOKS, 156-160 Fifth Ave., New York

IF YOU STAMMER

you owe it to yourself to send for our free book. 11,000 cases corrected. Est. 41 years. No hand swing. Millard Inst. of Normal Speech, 2303 W. Wis. Ave., Milwaukee, Wis.



IF I SEND YOU THIS SUIT FREE AS A BONUS -

Will You Wear It and Show It to Friends?
I need a reliable man in your town to wear a fine made-to-measure, all-wool DEMONSTRATING SUIT—advertise my famous Union clothing—and take orders. You can make up to \$12.00 in a day. My line contains over 100 quality fabrics, all sensational values, guaranteed. You need no experience or money. I supply everything required FREE. Write today, telling about yourself—age, etc., for FREE OUTFIT. STONEFIELD, 1300 W. Harrison, Dept. A-816, Chicago

Say you saw it in Popular Mechanics!

An Audel Guide!

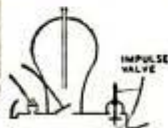
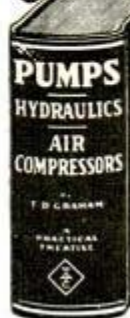

PUMPS-HYDRAULICS-AIR COMPRESSORS

JUST OUT! 3 BOOKS IN ONE—OVER 1650 PAGES, 1654 ILLUSTRATIONS, WITH QUESTIONS AND ANSWERS. COMPLETE PRACTICAL CONCISE INFORMATION FOR ALL ENGINEERS AND OPERATORS.

PART 1—PUMPS—850 Pages: All types—Centrifugal—Rotary—Reciprocating Pump: Their Theory, Construction, Operation and Calculations. Air and Vacuum Chambers—Power Pumps—Air Pumps—Jet Condensers—Surface Condensers—Condenser Auxiliaries—Condenser Operation—Calculations—Cooling Ponds—Cooling Towers—Water Supply—Hydraulic Rams—Special Service Pumps—Automotive Fire Pumps—Dredges—Codes. 942 Illustrations.

PART 2—HYDRAULICS—320 Pages: Hydraulic Physics—Drives—Machine Control—Accumulators—Elevators—Hydraulic Airplane Control—Automobile Brakes—Shock Absorbers—Presses—Turbines. Many new uses explained. 310 Illustrations.

PART 3—AIR COMPRESSORS—404 Pages: Compression of Air—Compressor Classification—Parts, Types—Inter and After Coolers—Regulating Devices—Installation—Lubrication—Operation—Maintenance—Blowers—Super-Chargers—Pneumatic Hand Tools—Ready Reference Index and Tables. 402 Illustrations.

Free Examination

TO GET THIS ASSISTANCE FOR \$4 COMPLETE YOURSELF SIMPLY FILL IN AND MAIL YOUR ORDER TODAY 4 ONLY \$1 NO.

AUDEL, Publishers, 49 West 23 St., New York 10, N. Y.
Send postpaid AUDELS PUMPS, HYDRAULICS, AIR COMPRESSORS (\$4). If I decide to keep it, I will send you \$1 within 7 days; then remit \$1 monthly until purchase price of \$4 is paid. Otherwise, I will return it promptly.

Name.....
Address.....
Occupation.....
Employed by..... P.M.

NOW!

WHILE THEY LAST!

VALUABLE HOME TRAINING KITS TO HELP YOU LEARN **RADIO** ELECTRONICS COMMUNICATIONS



YOU USE THIS AND OTHER EQUIPMENT . . .

DeFOREST'S TRAINING loans you a wide variety of Radio parts and sub-assemblies for your use at home. You work out scores of Radio circuits and Electronic experiments quickly and easily—by means of DeFOREST'S unique "block system." You experiment with Light Beam Transmission, you build an Aviation Band Radio Receiver, Wireless Microphone, Code Picture Set, an intriguing "Electric-Eye" device—and many other projects. This gives you valuable, practical experience to round out DeFOREST'S exclusive 3-WAY TRAINING METHOD.

IMPORTANT! The supply of these DeFOREST'S "block system" Home-Training Kits is limited. They will go to those who enroll first. You know Radio parts are hard to obtain. But once you have them, you can work out the theories you've been studying and actually see why and how Radio works. Don't delay! Mail the coupon TODAY!

DeFOREST'S TRAINING, INC. CHICAGO, U.S.A.

LET THEIR EXPERIENCE GUIDE YOU



Dr. Lee DeForest
—supervised the
Preparation of
DeForest's Training.

PUT
YOURSELF
IN THIS
PICTURE



Dr. Herman A.
DeVry—Visual
Education Pioneer
—founded De-
Forest's Training.

NOW you can get DeForest's practical SHOP-METHOD training aid—to work with AT HOME. Prepare for good jobs in America's BILLION DOLLAR Radio industry—for opportunities in the Army and Navy—and for the many new after-the-war Electronic developments.

Send today for DeFOREST'S big, FREE book—"VICTORY FOR YOU!" Learn about our exclusive 3-Way Combination Method: How you get (1) the use of HOME TRAINING FILMS and a movie projector, (2) HOME LABORATORY EQUIPMENT and (3) 90 loose-leaf lessons in Radio, Communications and Electronics, prepared under the supervision of Dr. Lee DeFOREST, often called "the father of Radio." "Learn by seeing"—the Visual, home-movie way—was pioneered by DeFOREST'S TRAINING'S founder, the late Dr. Herman A. DeVry, inventor of the portable motion picture projector, pioneer in visual (motion picture) education and founder of the DeVRY CORPORATION, manufacturers of motion picture sound and Electronic equipment.

DeFOREST'S effective Employment Service offers you a practical way to make your start in Radio and Electronics, once you are trained. If you are 17 or over, mail the coupon below.

Learn by Seeing FASTER • EASIER with the aid of HOME MOVIES



Project dramatic, easy-to-learn-from, action motion pictures right in your own room. Learn radio with the aid of DeFOREST'S exclusive Home-Movie-Training method. Learning is fun . . . more effective. Military Services and Industry use films to speed training. Don't wait! Get this kind of training NOW . . . TODAY—from DeFOREST'S.

DeFOREST'S TRAINING, INC.,
2535-41 N. Ashland Ave., Dept. J, Chicago, U.S.A.

Please send me—FREE and WITHOUT OBLIGATION—your illustrated book, "VICTORY FOR YOU!" showing me how I can get your Home-Movie Training and Home-Laboratory Kits.

Name..... Age.....
Address..... State.....
City.....

Mail this Coupon

Learn this Profitable Profession



**IN 90 DAYS
AT HOME**

Money-Making Career Open to Men and Women, 18 to 50

Hundreds of men and women between 18 and 50 make \$10 to \$20 in a single day giving scientific Swedish Massage and Hydro-Therapy treatments. There is big demand from doctors, hospitals, sanitariums and clubs. Graduates earn large full time incomes from those or in private practice in their own offices. Others make good money from home treatments given in spare time. Learn this interesting, money-making profession in your own home, through our home study course. Same instructors as in our nationally known resident school. You can win independence and prepare for future security by qualifying for your Diploma. Course can be completed in 3 to 4 months. Many earn while they learn. Begin your training at once.

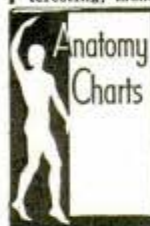

Anatomy Charts & Booklet FREE

Enroll now and we will include, at no extra cost, many needed supplies. Fit yourself to help meet growing demand for massage now and after the war. Send the coupon at once for complete details, Anatomy Charts and 32-Page Illustrated Booklet, FREE, postpaid.

THE COLLEGE OF SWEDISH MASSAGE
Dept. 164, 100 East Ohio St., Chicago 11, Illinois

Please send me FREE and postpaid, Anatomy Charts, 32-page Booklet and complete details on Home Training.

Name.....

Address.....

City..... State.....

DRAFTSMEN NEEDED NOW



Industry is clamoring for more draftsmen for the job can't start until plans are drawn. Buildings, airplanes, machines, guns, tanks, bridges, all start on the drafting board, so it's no wonder that every good draftsman has a fine job. Yes, more draftsmen are needed NOW. The pay is good and the opportunities for advancement great.

Learn at Home in Spare Time

Begin now to turn spare hours into money. Be a draftsman, the connecting link between a mechanic and an engineer. Enjoy the wonderful opportunities for promotion that exist now. No experience or artistic talent is needed. You don't have to leave your present job while learning. Use spare time.

American School, Dept. DD145, Drexel Ave. at 58th St., Chicago 37, Ill.

Gentlemen: Send me FREE information covering special training in subjects checked below. No obligation on my part.

- | | |
|--|--|
| <input type="checkbox"/> Drafting and Design for Men and Women | <input type="checkbox"/> Electrical Engineering |
| <input type="checkbox"/> Cost Accounting for Mfg. | <input type="checkbox"/> Diesel Engineering |
| <input type="checkbox"/> Architecture and Building | <input type="checkbox"/> High School Course |
| <input type="checkbox"/> Automotive Engineering | <input type="checkbox"/> Plastics |
| <input type="checkbox"/> Business Management | <input type="checkbox"/> Mechanical Engineering |
| <input type="checkbox"/> Railway Training | <input type="checkbox"/> Aviation <input type="checkbox"/> Radio |
| | <input type="checkbox"/> Shipbuilding |

Name.....

Address.....

AVIATION FOR YOUR CAREER PLUS WAR SERVICE



Both

AT THE SAME TIME

Before you are 18, MAKE YOURSELF THE KIND OF MAN THE AVIATION INDUSTRY OR THE AIR SERVICES WANT... THE KIND THEY CANNOT DO WITHOUT... so you can ADVANCE RAPIDLY. Since 1929, Curtiss-Wright Tech has been specializing in modern and progressive training for Aeronautical Engineers and Master Aviation Mechanics. (No flying involved.) Write for full information. Include name, address and date of birth. Dept. PM-1



CURTISS TECHNICAL WRIGHT INSTITUTE

GRAND CENTRAL AIR TERMINAL
Glendale (Los Angeles Co.) California

THIS TOWER OVERLOOKS AVIATION'S MOST DISTINGUISHED SCHOOL OF AERONAUTICS

MAGIC LIQUID MAKES PHOTOS APPEAR

On Scarfs, Ties, Stationery, Etc.

Reproduces any snapshot on cloth, leather, wood, paper. Simply apply liquid. Like magic photo appears within 2 minutes in broad daylight. Harmless to negative. Won't wash off. Full colors included. Complete kit for 100 photos only \$1.29. Send no money, just name. Pay postman \$1.29 plus few cents postage on delivery. (Canada \$1.50 money order only.) Order today.

L & M Mfg. Co. Dept. 289, Neave Bldg. Cincinnati 2, Ohio

LEARN MACHINIST TRADE TOOL & DIE MAKING

In completely equipped Shops. Also short, special Shop courses for essential War jobs. Learn on actual Shop work. For FREE BOOK, write Dept' PM-1. ALLIED SCREW MACHINE CO. (School Div.) 609 W. Lake, Chicago, Ill.



DRAW for MONEY

BE AN ARTIST!

Trained Artists are Capable of Earning \$30, \$50, \$75 a week

Use Your Spare Time to Prepare for a Profitable Art Career! COMMERCIAL ART, DESIGNING and CARTOONING—all in ONE complete home study course. No previous Art experience necessary—we teach you step by step—hundreds have profited by our practical method. TWO ART OUT-FITS FURNISHED. Full information in colorful, FREE BOOK, "Art for Pleasure & Profit"—tells all about our course, service, what our graduates say—and commercial opportunities for you in Art.

FREE BOOK gives details!

WASHINGTON SCHOOL OF ART
Studio 121 K, 1115 15th St., N.W., Wash. 5, D. C.
Send me your booklet and full particulars about your course.

Name..... AGE.....

Address.....

City..... State.....

Watch **MIDWEST RADIO**... *After Victory*

FOR ADS LIKE THIS



BUY MORE WAR BONDS

SAVE UP TO 50%
on this new **MIDWEST Radio**
FACTORY-TO-YOU



PUT THIS CHASSIS IN YOUR PRESENT CABINET

and there will be
MIDWEST'S FAMOUS 30 DAYS HOME TRIAL



MIDWEST RADIO CORPORATION
 CINCINNATI, OHIO

SEND FOR **FREE CALENDAR**

An attractive 4-color calendar with International Time Calculator will be sent FREE on your request if accompanied by 10c in stamps or coin for which we will send you a War Savings Stamp.



To all its old friends and customers . . . and to the rising generation, too, Midwest Radio Corporation makes this pledge: Once Victory has been won . . . once the needs of our Armed Forces for radio and electronic instruments has been met and production for civilian demands is approved . . . Midwest will again be back with its world-famous Factory-To-You plan for buying highest quality radio and electronic equipment—at a saving up to 50%.

Watch MIDWEST RADIO . . . After Victory!

MIDWEST RADIO CORPORATION
 DEPT. **15-G** ESTABLISHED 1920 CINCINNATI, OHIO

Do you want

→ .. to go to College?

→ .. or to enter a Profession?

(Such as Accounting, Architecture, Nursing, Dentistry, Teaching, Social Work, Osteopathy, Beauty Culture, Optometry, Embalming, Chiropody, Law, Medicine, etc.)

→ .. or get an Office Position?

To get anywhere, you practically MUST finish High School FIRST. You can complete our simplified High School Course in SPARE time at home, as FAST as your time and abilities permit. Equivalent to resident school work—prepares you for college, pre-professional examinations, business, industry. Standard texts furnished. Diploma. Credit for H.S. subjects already completed. Single subjects if desired. Low tuition, easy terms. American School, Chicago, est. 1897—endorsed by educators. Finish your high school education NOW. Write TODAY!

High School Course at Home

Many Finish in 2 Years

American School, Dept. H145, Drexel Ave. at 58th St., Chicago 37, Ill.

Gentlemen: Send me FREE information covering special training in subjects checked below. No obligation on my part.

- | | |
|--|--|
| <input type="checkbox"/> High School Course | <input type="checkbox"/> Diesel Engineering |
| <input type="checkbox"/> Cost Accounting for Mfg. | <input type="checkbox"/> Drafting and Design for men & women |
| <input type="checkbox"/> Architecture and Building | <input type="checkbox"/> Plastics |
| <input type="checkbox"/> Automotive Engineering | <input type="checkbox"/> Private Secretary |
| <input type="checkbox"/> Business Management | <input type="checkbox"/> Mechanical Engineering |
| <input type="checkbox"/> Electrical Engineering | <input type="checkbox"/> Aviation |
| <input type="checkbox"/> Elec. and Gas Refrigeration | <input type="checkbox"/> Salesmanship |
| <input type="checkbox"/> Air Conditioning | <input type="checkbox"/> Shipbuilding |
| <input type="checkbox"/> Railway Training | |

Name.....

Address.....

Keep that "TICKING" Car

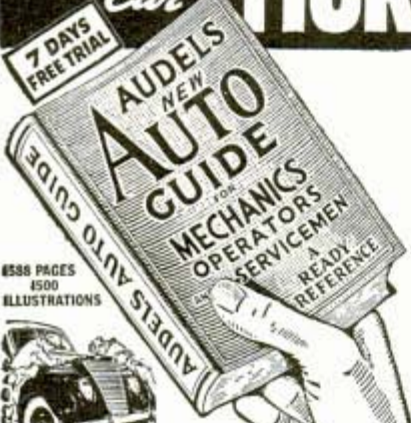

5888 PAGES
1500 ILLUSTRATIONS

Every operator and mechanic needs AUDELS AUTO GUIDE.

This book saves time, money and worry. Highly endorsed. It presents the whole subject of auto mechanics:

- 1—Basic principles
 - 2—Construction
 - 3—Operation
 - 4—Service
 - 5—Repair
- Handy Size, Easily understood.

NEW FLUID DRIVE, HYDRAULIC SHIFT AND DIESEL ENGINES FULLY COVERED

Over 1500 pages—1540 illustrations showing inside views of modern cars, trucks and buses with instructions for all service jobs.

4 ASK TO SEE IT!—To Get This Assistance for Yourself Simply Fill in and Mail Coupon Today.

4 COMPLETE • PAY ONLY \$1. A MONTH ←
AUDEL Publishers, 49 West 23rd St., New York
MAIL AUDELS NEW AUTO GUIDE for free examination. If O. K. I will send you \$1 in 7 days; then remit \$1 monthly until price of \$4 is paid. Otherwise I will return it.

Name.....

Address.....

Occupation.....

Employed by..... P.M.

Say you saw it in Popular Mechanics!

SUPER JU JITSU



NOW GET TOUGH DOUBLE-QUICK!

Learn how YOU can be dangerous. Lick brutes twice your size with only your bare hands, even when they are armed. This powerful fighting system is unbelievably efficient. You don't need ox-like muscles—it's brains that count! New, easy self-study course at amazing low price. Free-trial offer and money-back guarantee. Hurry! Write today for FREE DETAILS. Nelson Co., 321 S. Wabash, Dept. A-502, Chicago

Burpee's VEGETABLES

5 of Burpee's Best—Carrot, Lettuce, Beet, Radish and Tomato—a 10c-Pkt. of seeds of each, all 5 postpaid for just 10c—send dime today!

Burpee's Seed Catalog Free.
W. ATLEE BURPEE CO.
Philadelphia 32, Pa. or Clinton, Iowa

5 PACKETS 10¢

BURN YOUR NAME ON TOOLS

WITH THE ARKOGRAF

PROTECT YOUR TOOLS FROM THEFT
Write with electricity any name or design on the hardest and finest tools and instruments or any metal, like writing on paper with pen or pencil. These pens used by mechanics, engineers, machine shops. Complete Outfit \$3.50—Prepaid Anywhere. Interesting illustrated circular free. Write today. ARKOGRAF PEN CO., 3927 S.E. Stark, Portland 15, Ore.



AT HOME!

Learn to color photos and miniatures in oil. No previous experience needed. Good demand. Send for free booklet, "Make Money at Home" and requirements.
NATIONAL ART SCHOOL
1315 Michigan Ave. Dept. 1351 Chicago

CHEMISTRY CATALOG 7,000 ITEMS

Everything for the study of Science, Chemistry and Biology. Send 25c for our BIG Catalog describing 7,000 items including materials and apparatus for every scientific need.
STANDARD SCIENCE SUPPLY COMPANY
1234 North Paulina St. Chicago, Ill.

Only 25¢

PLAYS

Send for FREE catalog of 123 plays, copiously illustrated. Non-royalty plays, also tested plays on a percentage-royalty basis. Playbook exchange. Row-Peterson plays are nationally famous for their high quality. Ask for live drama newspaper, "Landscape"—it is free.
ROW, PETERSON & COMPANY
1509 Ridge Ave. Evanston, Ill.

OTTAWA LOG SAW

Write for FREE BOOK



PUT THIS OTTAWA to work for you. MAKE MONEY! Wood is valuable.

Does more than 10 men. Easily operated. Falls trees—and saws limbs. Use 6-hp. engine for other work.

SAW 10 to 20 CORDS A DAY

OTTAWA MFG. CO.
127 Wood St. Ottawa, Kans.

Train for

VICTORY

TRAINING

BE A MASTER WORKMAN

Interesting, illustrated, easy-to-understand pamphlets on the Techniques of Tool Use. Acclaimed "the most valuable training material available today."

CHECK YOUR SELECTIONS—SENT POSTPAID
5 FOR \$1.00 9 FOR \$1.50 25c EACH

AMERICAN INDUSTRIAL PUBLISHERS
Dept. PM, Fairmount-Cedar Bldg., Cleveland, Ohio

Please send me, postpaid, the TRAINING FOR VICTORY pamphlets I have checked.

Brooming Technique Contour Milling Threading Technique
 Drilling Technique Planer and Shaper Welding Technique
 Inspection Technique Thread Grinding Tapping Technique

I enclose \$1 for 5 \$1.50 or 9 25c for 1. (Coin or stamps should be carefully wrapped.)

NAME.....
ADDRESS.....
CITY..... STATE.....

"Position 'X' evacuated! - TRAINED MEN advance now!"

● GET READY FOR YOUR OPPORTUNITY ... IT'S HERE! Radio technical men are needed everywhere; afield in action, and at home in industry! Trained men are needed in the Army, Navy, and Air and Signal Corps, Government Defense Service and Civilian fields. Now, in answer to repeated demands for Trained Radio Technicians.



RADIO

NEEDS YOU
in many fields

SHOP METHOD HOME TRAINING

ELECTRONICS—TELEVISION

More than 50,000,000 Radios in use. More than ever before, because of the shortage of new equipment, they must be serviced. Over 800 Broadcasting Studios employ trained Radio Technicians. Electronics, a whole new industry, based on Radio principles, is growing at an amazing pace. Television, too, will soon need its own corps of trained men. Get Ready NOW. Here is your opportunity to get into a permanent field of fascinating and profitable employment.



COMMAND ANY OF THESE JOBS—Radio Expert, Electronics Engineer, Radio Broadcasting, Studio Technician, Television Technician, Aviation Radio, Ship & Harbor Radio, Remanufacturer, Industrial Sound

National Schools has extended its famous Shop Methods so you can qualify right at home. You can quickly prepare to be of greatest service to your country and yourself. Yes, right at home, in your spare time.

For 39 years National Schools has trained ambitious men for Top Pay trades. Squarely behind your Home Training are the modern, completely-equipped Training Shops of National Schools where we develop and prove every Shop Method Assignment sent to you. Every phase of your training is personally supervised by an established Faculty of practical, experienced instructors and engineers. They have developed progressive methods of training you in your own home, based on actual shop practice. Unique training facilities give you Home Training based on Resident School Shop principles—methods not available from any other source, to our knowledge. You'll be amazed when you receive our Complimentary Lesson and full details.



GET ON THE TECHNICAL FRONT

Unique training facilities give you Home Training based on Resident School Shop principles—methods not available from any other source, to our knowledge. You'll be amazed when you receive our Free Lesson and full details. MAIL THE COUPON TODAY!

RADIO EQUIPMENT INCLUDED

You receive modern experimental apparatus.

KEEP PRESENT JOB WHILE LEARNING

Regardless of previous education or age, you can Train for Radio. Continue your present job. Earn while you learn. If subject to Military Service, all the more important that you get pre-training.

FREE LESSON

& OPPORTUNITY BOOK

Mail Coupon for new Opportunity Book which gives full details about the big future of Radio, Electronics and Television, and how you can qualify. Also Free Lesson to demonstrate how easy you can learn. No obligation.



NATIONAL SCHOOLS

Los Angeles
California

ESTABLISHED
1905



MAIL OPPORTUNITY COUPON FOR QUICK ACTION

National Schools, Dept. 1-PM (Mail in envelope or 4000 So. Figueroa, Los Angeles, Calif. paste on penny postal)
Mail me FREE, without obligation, one Lesson and Opportunity Book, with full details about how I CAN become a RADIO Technician.

NAME _____ AGE _____

ADDRESS _____

CITY _____ STATE _____

— THE START TO SUCCESS COUPON

LEARN

AIRCRAFT DRAFTING

from **RYAN**

TRAIN NOW IN LEISURE TIME BY NEW HOME STUDY METHOD

Now is the time to prepare for Essential War Work and a Brilliant Peacetime Career in Aviation. Ryan's tested methods of instruction will train you thoroughly — yet quickly, in spare time. No higher education or experience necessary. A complete Aeronautical Drafting outfit is included with your training, at no extra cost.

LIFETIME CAREER AT BIGGER PAY

The aircraft industry needs Draftsmen and Engineers Now and for the Big Tomorrow in Aviation. Men who today hold ordinary routine jobs will be important figures in the aircraft plants tomorrow. Prepare yourself now. Send coupon for Free book entitled "New Horizons of Opportunity." To save time send air mail.

FREE
24-page
BOOK

Ryan Aeronautical Institute,
421 Lindbergh Field, San Diego, California.

Gentlemen:

Please send me your FREE 24-page book, "NEW HORIZONS OF OPPORTUNITY," and full information on R. A. I., including cost of training, and job opportunities.

Name..... Age.....

Street.....

City..... State.....

ELECTRICAL BOOKS

shipped
FREE



10
BIG BOOKS

FOR EXAMINATION
MODERN
ELECTRICITY
INCLUDING RADIO
AND REFRIGERATION

Here's great news for anybody interested in Electricity. NEW 18th edition of Applied Electricity brought right down to date with NEW Electrical subjects fully covered, including Electrical Blue Print Reading. 10 big Volumes and all shipped FREE for examination.

New Edition
For Beginners
and Experts

Over 3000 pages — hundreds of illustrations — the most complete work of its kind we have ever published. Dynamos, motors, power stations, wiring radiators, everything electrical explained so anyone can understand it.

BIG FIELD! Big Demand!

Big Pay! Men who understand electricity are urgently needed in thousands of War Production Industries, Airplanes, ship building, arms plants, machine shops—practically every industry depends on electricity and men who know this subject make big money. Pleasant, fascinating work, easy to learn and do; learn with these books. Send coupon for a set for FREE examination and see for yourself.

SEND NOW

[A year's consulting privileges with our engineers now given to all buyers of this famous Cyclopaedia of Electricity.]

AMERICAN TECHNICAL SOCIETY
Vocational Publishers since 1898

American Technical Society, Dept. E119, Drexel at 58th St., Chicago 37
Send for 10 days' free use, 10 volume set of New 18th Edition, Applied Electricity, including a certificate entitling me to consulting privileges for one year. I will pay the delivery charges only on the books. If I wish I may return them in 10 days and owe you nothing, but if I keep them, I will send \$2.00 after 10 days, then \$3.00 a month until the total price of only \$29.80 is paid.

NAME.....

ADDRESS.....

CITY..... STATE.....

Please attach letter stating age, occupation and name and address of employer and give at least one business man as reference. Men in service, also please give home address.

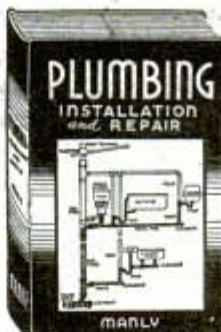

PLUMBERS NEEDED

This practical book shows you how to do your own plumbing and make needed repairs. You can pick up extra tin money from spare time jobs, besides learning a profitable trade in great demand now and after the war. Covers plumbing systems, fixtures, water closets, drainage, vents, sewers, etc. Complete in every detail. Over 200 pages and 153 illustrations.

ORDER TODAY Pay postman \$1.50 plus C.O.D. Charges. Postage prepaid if cash in advance. **\$1.50**

FRED'K J. DRAKE & CO.
Dept. PM-1, 600 W. Van Buren St., Chicago, Ill.

Drake books sold by all leading booksellers

POWERFUL VISION — LONG RANGE



6—POWER TELESCOPE \$2.49

Perfect for spotting ships, planes; watching sporting events, people, birds, etc. Genuine black life-time plastic eyepieces with scientifically-ground 33 mm. lens. Objects 600 yards away appear as 100 yds. distant. Simple to focus on both moving and stationary objects. 15 DAYS FREE TRIAL. If not fully satisfied, return for refund. SEND NO MONEY. Just pay postman \$2.49 plus few cents postage on delivery. Cash orders sent postpaid! Don't wait—production of telescopes may be curtailed as it has been on binoculars.

Vogue Telescope Co., 7759 S. Halsted, Dept. B-609, Chicago

Inventions Wanted Patented or Unpatented

Inventions can now be safely sold without patenting expense. If you have a practical, useful idea for sale, either unpatented or patented, write

Chartered Institute of American Inventors
Dept. 4, 631 Pa. Ave., N. W. Washington, D. C.



MODEL Railroads—Aircraft—Racers Ship Models—Shop Practice

Devoted to model building, operating, racing exclusively! Numerous construction projects for advanced or beginners. Profusely illustrated, detailed building plans. If sold out at news-dealer or hobby shop, enjoy publishers' INTRODUCTORY OFFER!

Special 5 MONTHS for only \$1.00

MODEL CRAFTSMAN (Dept. M) Ramsey, N.J.

MACHINIST WANTED

Who own lathes at home or small shops for War Contract Work. Also Turret Lathe, Mill and Slapper Work. Material Furnished. Good Pay.

SOUTHERN PRODUCTS, INDEPENDENCE 10, MISSOURI



PINS 55¢ up RINGS \$1.50 up

For your class or club. Over 300 designs. Finest quality.

Write Dept. N, Metal Arts Co.
Rochester, N. Y.

FREE CATALOG



FIBRE ARMS AND LEGS!

Light, correctly fitted, strong and comfortable. Natural appearance. Braces for all deformities. Scientific design. Fair Terms.

BUCHSTEIN-MEDCALF
610-3rd Av. S., Minneapolis, Minn.

"730 SHAVES FROM 1 BLADE"

AMAZING NEW BLADE SHARPENER



New sharpener for all makes of double-edge razor blades performs miracles! "Not necessary to change blades," writes one user. Another says, "Have used 1 blade over 730 times." RAZOROLL really sharpens blades because it strokes on leather, gives keen, smooth shaving edges. No rust-work. Blade held at correct angle and proper pressure—automatically. Just turn crank to sharpen blade. No gears. Well made. Handsome, compact, sturdy. Weighs few ounces. Will last years. Makes ideal gift.

Only \$1.00

SEND NO MONEY! Pay postman only \$1 plus few cents postage. Use RAZOROLL for 5 days and if you're not delighted with smooth, velvet shaves you get, return RAZOROLL and we'll return your dollar. Hurry—order today.

RAZOROLL COMPANY
620 North Michigan Avenue, Dept. 501, Chicago, Illinois

Say Fred, be sure to get this Taxidermy book. You will surely be interested. It's now sent free.

LEARN TO MOUNT BIRDS & ANIMALS - BE A TAXIDERMIST

THAT WAS A GREAT HUNTING TRIP, BILL, ALL THE DUCKS WE WANT. BUT IT SEEMS A SHAME TO THROW AWAY THIS BEAUTIFUL PLUMAGE.

THAT'S JUST WHAT I'VE BEEN THINKING—JIM, I'M GOING TO WRITE TO THE NORTHWESTERN SCHOOL OF TAXIDERMISTRY AND SEE IF I CAN'T LEARN TO MOUNT MY BEST TROPHIES.

WELL, I SEE YOU REALLY ARE TAKING UP TAXIDERMISTRY IN EARNEST, BILL.

THAT'S RIGHT, JIM—AND I'VE NEVER HAD SO MUCH FUN IN MY LIFE. I'VE ACTUALLY DOUBLED THE PLEASURE I GET FROM MY HUNTING AND REALLY HAVE SOMETHING TO SHOW FOR IT.

COME IN THE HOUSE AND I'LL SHOW YOU SOME OF MY WORK.

I'VE SOLD MANY BOOK-ENDS, LAMPS, ASH-TRAYS, PIPE RACKS, AND SO ON TO SPORTSMEN FOR THEIR DENS — I'VE LEARNED TO TAN FURS FOR CAPS, SCARFS AND RUGS, AND — BEST OF ALL — INSTEAD OF THROWING AWAY THOSE COW-HIDES, I TAN THEM INTO LEATHER FOR BELTS, HARNESS AND STRAPS.

BUT WASN'T TAXIDERMISTRY HARD TO LEARN, BILL?

HARD? NOT A BIT, AFTER YOU GET THE HANG OF IT. WHY JIM, TO ME TAXIDERMISTRY IS THE GRAND-EST HOBBY IN THE WORLD. I'VE MADE AS HIGH AS \$75 PER MONTH IN MY SPARE TIME, MOUNTING TROPHIES FOR HUNTERS. WHY DON'T YOU TAKE IT UP?

I'M SURE GOING TO — WHAT'S THAT ADDRESS? I HAD NO IDEA WHAT I'VE BEEN MISSING.

Amazing Pleasure and Profits in This Art

YOU LEARN IT EASILY, QUICKLY, BY MAIL IN SPARE TIME
Men, boys, women,—Study Taxidermy. Taught by Experts.
ALL SECRETS revealed. It will amaze and delight you.



Hunters — Fisherman

Save your game trophies. They are Valuable. Mount them for home and den. Have a Museum. Win fame as a Taxidermist. Make undreamed-of money in spare time . . . You learn to mount (stuff) expertly, Birds, Animals, Fish, Game-Heads, just like life. That is Taxidermy. You can be a Taxidermist. Will you? Surely you are interested. Mail Coupon right now for the astonishing Free Book.

Our Students Succeed

This old reliable school has graduated 250,000 students with uniform satisfaction. If we have taught this VAST number, you MUST agree that we can teach YOU also. We offer you with PRIDE our success in teaching this vast number. We KNOW you will be delighted. So SEND COUPON TODAY FOR FREE BOOK.

Mail Coupon

Or a postcard will do. No obligation on your part. The beautiful Book, with hundreds of entrancing Pictures is Free. Do not miss this wonderful opportunity to obtain the marvelous and valuable book, FREE and POST-PAID. Write today. State your Age.

NORTHWESTERN SCHOOL OF TAXIDERMISTRY
3371 Elwood Bldg., Omaha, Neb.

Wild Game Not Needed

You can use common animals and birds; squirrels, rabbits, little chicks, puppies, kittens, pigeons, even frogs. Mount them in human and humorous groups. Real Fun; and profitable, too. This is known as Craft and Novelty taxidermy; it's included in our unique lessons. It's Marvelous. Write the school this minute!

Is Taxidermy Profitable?

We believe that NO OTHER BUSINESS offers such large spare-time profits. Many students earn \$40 to \$100 a month from SPARE TIME ALONE. They sell their mounts. They mount for others. INVESTIGATE THIS WONDERFUL spare-time money-maker.

Learn Tanning

Tan fine harness, sole and chrome leathers; also furs with the hair on. Expert Methods, easily learned. Save Money making your own leathers; Make Money tanning for others. Quick Sure Profits. The Free Book tells about it. Send coupon.

FREE BOOK

Northwestern School of Taxidermy,
3371 Elwood Bldg., Omaha, Neb.
Send me your free illustrated book, "How to Mount Game." Also tell me how I may learn this fascinating art easily and quickly by mail. No obligation. State your age.

Name _____ Age _____
Address _____



SEND COUPON TODAY FOR WONDERFUL FREE BOOK

LEARN ARC WELDING



— in just a few weeks!

• Learn the practical way, by doing, at one of the country's finest trade schools. Fully equipped to train you to pass tests for profitable war plant jobs.

A NON-PROFIT INSTITUTION backed by a long-time leader in the welding field. Individual booths, machines and instruction. Costs you only for materials used. Train now for this highly essential war work and a promising future.

The HOBART SCHOOL OF ARC WELDING

HOBART BROTHERS COMPANY
Box M-141 TROY, OHIO



Send for Complete information on Schedules and Prices...

HOBART "One of the World's Largest Builders of Arc Welding Equipment."

STUDY AT HOME

With A Chartered Educational Institution

Courses in **ENGINEERING**: Electrical, Civil, Mechanical, Drafting, Architectural, Steam, Aeronautical, Radio, Structural, Mining, Industrial, Highway, Petroleum, Marine, Chemical.
Courses in ARTS AND SCIENCES: Philosophy; Education; Letters; Public Health; Medical Jurisprudence; Psychology; Sociology; Physics; Chemistry; Geology; Pol. Science; Theology; Law; Business and Commerce; Accounting; Mathematics; Statistics; Agriculture.
 McKinley-Roosevelt Incorporated, 4610-UC, Sheridan Road, Chicago, 40

MOTORISTS Wanted!



TO MAKE THIS UNIQUE GAS SAVING TEST

Will you permit us to send you at our risk the Vacu-matic, a device which auto owners everywhere are praising? Install it on your car. Test it at our risk. Unless it trims dollars off your gas bills by saving up to 30% on gasoline consumption, gives more power, quicker pickup and faster acceleration, the test will cost you nothing.

Automatic Supercharge Principle
 Vacu-matic is entirely different! It operates on the supercharge principle by automatically adding a charge of extra oxygen, drawn free from the outer air into the heart of the gas mixture. It is entirely automatic and allows the motor to "breathe" at the correct time, opening and closing as required. Saves up to 30% on gas costs, with better motor performance.

FITS ALL CARS
 Constructed of six parts fused into a single unit, adjusted and sealed at the factory. Easily and quickly installed by anyone in a few minutes.

AGENTS Get Yours FREE

FOR INTRODUCING. Here's a splendid opportunity for unusual sales and profits. Every car, truck, tractor owner a prospect. Send name and address now for big money making offer and how you can get yours FREE.
 The Vacu-matic Co., 7617-879 W. State Street, Wauwatosa, Wis.

LEARN MONEY-MAKING CARTOONING

IN SPARE TIME — by Easy Picture Chart Method
 Same Simplified Method that has helped train creators of "Ferry & Pirates," "Freckles," "Out Our Way," "Winnie Winkle," "Reg'lar Fellers," "Strange As It Seems," "The Neighbors," and many others. Earn while learning. Send 10c for Picture Chart (to test your ability), and full details. (State age.)
THE LANDON SCHOOL, 4401 National Bldg., Cleveland 14, Ohio



LAW

STUDY AT HOME for PERSONAL SUCCESS and LARGER EARNINGS. 31 years expert instruction—over 100,000 students enrolled. LL.B. Degree awarded. All texts furnished. Easy payments. Send for FREE BOOK—"Law and Executive Guidance."
AMERICAN EXTENSION SCHOOL OF LAW
 Dept. 37-M 8 East Huron St. Chicago, Ill.

Got a HOT idea?



OR A SWELL GADGET?

Let's get together—our Engineering and Production Staff and our Unlimited Financing will develop and promote your brain-child for P. W. P. and arrange for patent. You are fully protected—Specializing in Plastics, Electronics, Metal or Wood. Write Today.

ADDRESS DEPT. H BOX 2745, KANSAS CITY, MO.

RADIO ENGINEERING

Broadcasting, Servicing, Electronics, Aviation, Marine & Police Radio taught thoroughly. 48 weeks' Engineering course equivalent to 3 years' college radio work. School established 1874; all expenses low. Co-educational. Catalog free.
Dodge Institute, Dept. D, Valparaiso, Ind.

BRUSH PLATING OUTFITS

for autoparts, reflectors, faucets, bicycles. No tanks necessary. Free particulars.
GUNMETAL CO., AVE. M, DECATUR, ILLINOIS

PATENT YOUR IDEAS

SEND FOR FREE BOOK — HOW TO OBTAIN A PATENT
 Written by Former Member Examining Corps (1922-24) U. S. Pat. Office.
CARL MILLER, Registered Patent Attorney
 Former Member Examining Corps U. S. Patent Office
 Woolworth Bldg., Dept. 14-A, New York — Bond Bldg., Dept. 14-A, Washington, D. C.

PATENTS AND TRADE MARKS

C. A. SNOW & CO.
 Registered Patent Attorneys Since 1875
 Write for Free Book and "Certification of Invention" form
 427 SNOW BUILDING, WASHINGTON 1, D. C.

PATENTS Protect Your Idea:

By securing FREE my "PROOF OF INVENTION" folder. *Exceptional Personal Service.* Excellent References. Established 1906.
E. E. VROOMAN, 871 Woodward Bldg., WASH., D. C.

To PROTECT Your INVENTION — Use this coupon, NOW

Delays are dangerous and may be very costly. My personal service assures prompt action, strict confidence, and a minimum of expense. I suggest that you send me a model or drawing, or sketch and description of your invention, and \$5.00. I will make a search and report

promptly as to its patentability and send you a copy of my 72-page booklet. Or, if you prefer to read my booklet first, mail the attached coupon at once. I will also send my "Record of Invention" form. (Over 40 years experience as a Registered Patent Attorney.)

L. F. Randolph, 302-D Columbian Bldg., Washington, D. C.
 Please send me at once, free of charge, your 72 page booklet and "Record of Invention" form.

A PERSONAL CONFIDENTIAL PATENT SERVICE

Name.....
 Address.....



DO ANY JOB.. EASIER.. QUICKER MAKE MORE MONEY

Here is the HELP YOU NEED . . .
Now and After the War!



**FREE TRIAL
IN YOUR
OWN HOME**

Used by Army, Navy, Other
Government Departments, 200
Schools and Industrial Firms

Get ready now for lasting success and patriotic service in America's vast production army. Be ready for keener job competition in after-war days. Top-ranking jobs and many advantages await you if you prepare NOW. Here is the help you need—EASY—QUICK—AT LOW COST. Thousands of successful men have already used these famous books—beginners and experienced men alike. You too, can get from them the special knowledge needed for good jobs in a half-dozen vital, important fields. This is your OPPORTUNITY.

Select the Books YOU Need Now!

**SEND NO MONEY: We Ship Anywhere in U. S. and
Refund Deposit Paid Postman if Not Satisfactory.**

REFRIGERATION

No new refrigerators being made. None for years. Millions must be kept going. Owners will pay big for competent service. Get **MODERN GAS AND ELECTRIC REFRIGERATION**, the non-technical guide to all types of refrigerators and get your share of this new profit. Get a job or start your own service business. This book will help you make money anywhere.

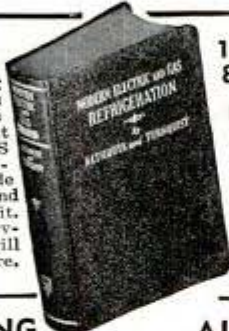

17 Diagrams in 6 and 8 colors, 408 pictures

Big—Almost 1000 Pages

New Printing Now Ready!

Makes all refrigeration service, maintenance and repair simple as A B C. Rush order while supply lasts. Price \$5.00.

MODERN WELDING



430 Pages
277 illus.
Practical and Non-Technical

Just published. Newest book on all types of welding and heat treatment of metals. By Althouse and Turnquist, recognized as leading specialists in training men for production jobs. Covers everything you need to know. Prepare for best pay jobs. Price \$4.00.

AIRCRAFT SHEET METAL WORK

A brand new and practical manual that gives all the needed information for best pay jobs on all metal airplanes. Prepared from personal experience in training men for big airplane plants. 130 pages, 30 pictures, 51 full page projects. \$2.50.

AIRPLANE WELDING

New 2nd edition of this famous book by J. B. Johnson, Materials Division, Wright Field. The authoritative and practical book on Airplane welding and materials brought right up to date. 420 pages, 193 pictures. \$3.50.

ELECTRIC WIRING

Complete practical instruction on every phase of house wiring in one handy volume. Goes further than most books on subject. Hand-book style. Electric Code. 400 pages, 669 illustrations. \$2.50.

DYKE'S CARBURETOR BOOK

The standard guide for a generation. New edition covers engine tune-up, ignition, carburetion, fuel pump, valves, etc. 244 pages. 540 illustrations. \$3.00.

AUTO BODY AND FENDER REPAIR

Owners will spend big money to keep cars looking new because few new cars available. This book is a practical money-making guide, ideal for shop owners and every man who wants a share of the millions to be spent in keeping old cars looking new. Auto Body and Fender Repairs contains 325 pages, 232 illustrations. Covers methods, tools, etc., in plain, simple language. Price \$3.00.



SHEET METAL LAYOUT

Makes sheet metal layout work so simple that anyone can learn. Thousands of men badly needed for this big-pay work now. Even more after the war. Get this new instructor and get into the easiest, cleanest and best paying part of all sheet metal work. 143 jobs worked out in drawings and carefully explained. Size of book 8 1/2 x 11 inches. Price \$3.00.

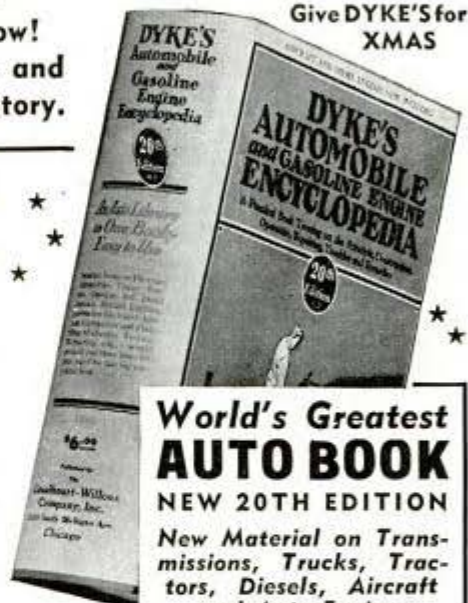

Give DYKE'S for XMAS

World's Greatest AUTO BOOK

NEW 20TH EDITION

New Material on Transmissions, Trucks, Tractors, Diesels, Aircraft and Auto Engines

Now with millions of cars needing repairs and thousands of men needed to do the work, you need the famous DYKE Auto Book more than ever before. Brand new 20th Edition covers all principles, construction, repair, adjustment, testing, troubles and remedies of all cars. World's biggest book value \$6.00.

Over a half million copies of 32 editions of Dyke's have been sold. Gives specifications of old and newer cars.

This big book, a complete auto library in one volume, has 1483 pages—4600 illustrations and diagrams—weighs 6 pounds.

SEND NO MONEY! Mail Coupon

GOODHEART-WILCOX CO., 2007 S. Michigan Ave., Chicago 16, Ill.
Send books checked, C.O.D. I will pay postman, plus few cents charges. If any book is not satisfactory I will return in 5 days and you will refund money paid you.

- | | |
|--|---|
| <input type="checkbox"/> Gas & Electric Refrigeration . . . \$5.00 | <input type="checkbox"/> Sheet Metal Layout . . . \$3.00 |
| <input type="checkbox"/> Modern Welding . . . \$4.00 | <input type="checkbox"/> Elect. House Wiring . . . \$2.50 |
| <input type="checkbox"/> Dyke's Auto Book . . . \$6.00 | <input type="checkbox"/> Dyke's Carburetor Book \$3.00 |
| <input type="checkbox"/> Aircraft Sheet Metal . . . \$2.50 | <input type="checkbox"/> Body and Fender Repair \$3.00 |
| <input type="checkbox"/> Airplane Welding . . . \$3.50 | <input type="checkbox"/> Shop Mathematics . . . \$1.50 |
| | <input type="checkbox"/> Volume 1 . . . \$1.50 |
| | <input type="checkbox"/> Volume 2 . . . \$1.50 |

If remittance accompanies order we will pay all postage charges under same return privilege.

Name

Address

City..... State.....

GOODHEART-WILCOX CO., INC., 2007 S. Michigan Ave., Chicago 16, Ill.

**WORLD'S
BEST
WANT AD
MEDIUM**

CLASSIFIED Advertisements



Advertisements in this section, 35 cents per word, each insertion, minimum 10 words, payable in advance

To be inserted under proper classification in February issue, copy should be in our office December 8th

February issue on sale January 1st
Popular Mechanics Magazine, 200 East Ontario Street, Chicago, Illinois

Popular Mechanics Magazine, 200 E. Ontario St., Chicago, Ill.

Dear Mr. Johnson: Let me state with all sincerity that I consider your magazine the best of all. I have tried all the other publications similar to yours with a result of nothing plus. It may interest you to know that every ten word ad I run at \$3.50 per insertion actually brings in a profit of from \$12.00 to \$15.00. I think that I would be crazy to stop advertising in Popular Mechanics, it's tops in my opinion based on proven results. You may use this letter in any way you desire. With all best wishes, I am cordially yours,
Eddie Edwards,
Magic Key Method

AUTOMOBILES—MIDGET CARS

EXTREMELY Simple method of high rate battery charging. 10 to 150 amperes. Garage and service stations can assemble from materials in stock. Easy simple plans \$2.00. Earl Clifford, 585 20th St., Oakland, Calif.

1943 **IGNITION** Supercharger \$3.50. Fast starting, mileage, pep. EG Sales Mfg. Co., 60 John St., New York.

RENEW Car batteries inexpensively. Instructions \$1.00. Popular Service, Racine, Wisconsin.

AUTOMOBILE Racing book, fifth edition, well illustrated. Instructions on building bodies, frames, engines. Ford A and B conversions. Plans, AAA rules, specifications. Roadster racing, Indianapolis cars. \$1.00 postpaid, \$1.15 C.O.D. Ray Kuns, Dept. 47, Madisonville, Cincinnati, Ohio.

PROFESSIONAL Midget racers, motor-scooters, midget cars. Parts, plans. Handbook catalog—50 illustrations, plans—20c. Midwest, 2557 Charlestown, Toledo, Ohio.

AUTO SUPPLIES AND EQUIPMENT

WHIRLIGAS Turbinator, \$3, gives cyclonic, vaporizing whirl to carburetor mixture entering motor, thereby permitting carburetor readjustment for economic motor operation. Wrench installs 15 minutes. Give auto make, year. If not surprisingly pleased return for immediate refund. John Hanley, 5719 Lorraine, Detroit 8, Mich.

CLYMER Chromed spotlight for automobiles, motorcycles, boats, hunters, trigger switch, pistol grip, very powerful off any 6-8 battery. Reduced to \$5.00 postpaid. Clymer's finest aluminum pistons, V-8 or Model A \$2.00 each. California combination set dual mufflers, V-8 and Mercury, saves gasoline, beautiful deep tone. \$20.00 complete. Clymers, 2125 W. Pico, Los Angeles 6, Calif.

1,000 **MOTORISTS** Needed to make gas saving test. Up to 30% savings. For free test offer write Vacu-matic Carburetor Co., 7617-882 W. State St., Wauwatosa, Wis.

AUTOMOBILE Heaters — for starting cold motors. Saves gasoline — to plug in light socket. Only \$1.95 postpaid. Harris Machinery, Minneapolis, Minn.

USED Parts (guaranteed) all cars. Describe needs fully; immediate reply. Victory, 2439 1/2 Gunnison, Chicago.

ATTENTION: Run your car on (Gas) without alteration to your carburetor or gasoline system. Photo, blue prints and literature, giving approximate cost, size of tank, pressure, mileage, instructions, etc. \$1.25. Harper's Machine Shop, 218-22nd Street, Dunbar, W. Va.

THIS Victory gasoline economizer will increase your mileage on any car, bus or truck to 31% or better. Send 25c coins for complete detailed instructions, diagrams. Modern Advancement, G.P.O. Box 674, New York 1, N. Y.

PLATING Outfits for auto parts. Connect to a battery. No tanks used. Free particulars and proofs. Gunmetal Co., Ave. J, Decatur, Ill.

AUTO TRAILERS

PLANS \$1.00 Each. House, sport, camp, utility trailers. Catalog 10c. Jim Dandy, Box 125-A, Wausau, Wisconsin.

MOTORCYCLES, BICYCLES, MOTOR-SCOOTERS AND SUPPLIES

PLANS, Drawings, specifications, instructions for building attractive motor-scooter complete \$2.00. For electrically driven bicycle \$1.50. Postpaid. Clymers, 2125 W. Pico, Los Angeles 6, Calif.

GIFT Books mailed overseas for you! Motorcycle book—192 page manual "Questions-Answers" complete servicing information Harley's, Indians, Hendersons, Servicycles, Villiers including war models, \$1.10. "Motorcyclists Workshop" \$1.50. "Two-Stroke Motorcycles" \$1.50. "Historical Motorcycling Facts" \$1.00. "Automobile Racing" \$1.10. "Modern Motorcycle Mechanics and Speed Tuning" 435 pages, care American, English motorcycles \$2.50, with drawings, specifications U. S. Army Jeep, German war motorcycles \$3.00. All postpaid. Clymers, 2125 W. Pico, Los Angeles 6, Calif.

THE Ideal Christmas gift for motorcyclists. Send him the book, "Modern Motorcycle Mechanics," 435 pages, 300 illustrations, the most up-to-date and complete book on motorcycles ever issued, \$2.50 postpaid. Nicholson Brothers, Saskatoon, Canada.

SPEED—"How to Obtain It" just published, 160 pages, full details, cams, ballancing, timing, valves, pistons, racing technique, world's greatest speed tuning book. \$1.50 postpaid. Clymer's, 2125 W. Pico, Los Angeles 6, Calif.

LARGE Manual how to build scooter, midget trailer, etc. Circular 10c. Craftsmann Books, Box 1153PM, Milwaukee 1, Wis.

SAVE Gasoline, build a motorbike cheap. Send 25c for complete plans. Motorbike Service, 2108 McLean, New Albany, Ind.

RECAP Motor-scooter tires. Information folders 10c. Clymers, 2125 W. Pico, Los Angeles 6, Calif.

20, 24, 26 X 2.125 **TIRES** \$2.50. Tubes \$1.50 postpaid. Pulver's Sporting Goods, Hudson, N. Y.

MOTO-SCOOT Parts for 1936 to 1941 models. Tires and tubes on ration certificates. New centrifugal clutches now available. American Moto Scoot Company, 1305-23 W. Carroll Ave., Chicago, Ill.

WHEELS And tires—General utility 10x27 1/2 wheel and tire, ballbearing, semi-solid, pre-war rubber, \$8.95. Send dime for list. Cycle Transport Co., 1241 S. Michigan Ave., Chicago 5, Ill.

NEW And used parts, pistons, chain for Harley-Davidson motorcycles. McCann's, 2104 Texas Street, El Paso, Texas.

ELECTRIC Bikes use no gas. \$2.00 buys plans, pictures. Build your own easily. Paul Dunn, 2207 Elmwood, Buffalo, N. Y.

100 **MILES** Gallon! Motor-scooters, motorcycles, Whizzer bicycle engines, midget automobiles, gasoline engines. No priority necessary. Full information, prices, illustrated catalog one dime. Clymers, 2125 W. Pico, Los Angeles 6, Calif.

AVIATION

PROPELLERS Of quality—Quick service. All types, sizes. Specializing in 3 blades for sleds, boats. Lists free. Standard Aircraft, Ft. Worth, Texas.

NEW Lightplane manual. Sportplane manual, lightplane blueprints, etc. Circulars 20c. Craftsmann Books, Box 1153PM, Milwaukee 1, Wis.

HEATH Parasol \$185; Aeronca \$200; Cub \$200. Send 25c for fall war-bargain catalogue giving location of these and almost 100 others. Used Aircraft Directory, Athens, Ohio.

WELDING, SOLDERING, PLATING

ARC Welders wanted by the thousands. Learn with 516 page lessons manual. Over 500 how-to-do-it photos. \$2.00 copy. Money-back guarantee. Hobartweld, Box M-1334, Troy, Ohio.

BUILD d.c. Arcwelder without rewinding armature. Plans \$1.00 each. 25 to 600 amperes from vehicle motors, light plant generators, automobile starter-generators. Welders Club, AB-3432 M-Mart, Chicago.

NEW Model electric welder 110 volt a.c.-d.c.; will weld all metals; easy to use; full directions. Complete with power unit, flame and metallic arc attachments, carbons, fluxes, rods, mask; all for \$19.95. Used by the navy. Marvel Electro Welder Mfg. Co., 193-MP Center St., New York City.

ARC Welder. Build yourself for less than \$1.00. Materials available. Complete plan \$1.00. International, 6347 Parnell Avenue, Chicago, Ill.

WELDING, Cutting, aircraft welding and soldering equipment. Electric arc welders. Superior Oxy-Acetylene Co., Hamilton, Ohio.

SLIGHTLY Used arc welders. Recommended by R.E.A. Guaranteed. Forney Mfg. Co., Fort Collins, Colo.

BATTERIES, GENERATORS, ETC.

EDISON Batteries. Light, Power. Fifteen year life. Five year guarantee. Complete lighting plants. Free literature. See Jay Company, 321 Yonkers Avenue, Yonkers, New York.

ELECTRICAL SUPPLIES, EQUIPMENT

ELECTRIC Strip heaters: suitable automobiles, printing presses, tank heating. Saves gasoline in cold weather. Plugs into light socket. Postpaid \$1.95. Harris Machinery, Minneapolis, Minn.

LEARN To wind electric motors. Simplex, Box 260-F, Pontiac, Michigan.

FOR Motors, welders, generators, other electrical items. Write LeJay Mfg., 847 LeJay Building, Minneapolis, Minn.

FIBRE-BAKELITE Washers, strips, small pieces. Large assortment for insulation. Ideal for electricians, radio mechanics, hobby workshops. Over 1000 pieces. Satisfaction guaranteed. Special \$1.98. Limited supply. Order now. Wid-ran Distributors, 224 West Hubbard, Chicago.

GUARANTEED Factory rebuilt electric flat irons, 6 lb. size \$5.75, Marko, 2924 Logan Blvd., Chicago 47, Ill.

ELECTRIC Cincinnati: Writes-engraves all metals. \$1.00 postpaid. Beyer Mfg., 4515-H Cottage Grove, Chicago.

MACHINERY, TOOLS AND SUPPLIES

CONCRETE Building block machines and molds. Easy payments. Catalog free. Concrete Machine Co., 5129 South Compton Ave., St. Louis, Mo.

NOW—Lewis castings, materials, blueprints are available on M.E.O. ratings for building mills, shapers, vises, drill presses and many other useful machine tools. Hundreds of shops are realizing greater profits from war work with Lewis tools. Write for illustrated catalog describing 23 items—enclose 10c covering mailing cost. Lewis Machine Tool Co., Box 116, Station A, Dept. M36, Los Angeles 31, California.

DRILLS. We reclaim and grind your broken and dull drills with factory accuracy. Particulars free. Chaffee, 2001 Fremont St., Minneapolis, Minn.

STEEL Beam trammels for draftsmen, engineers, mechanics. Circular free. Clair Company, Box 92M, Blythebourne Station, Brooklyn, N. Y.

10" **STEEL** Wire wheel brushes, interchangeable centers for buffing \$2.50 postpaid, smaller sizes less. McCann's, 2104 Texas Street, El Paso, Texas.

WHIPPLE Tool Grinder. Lathe tool bits precision ground to any degree of angle or radius. Whipple Mfg. Co., Spirit Lake, Iowa.

TURRET Tool post for 9" lathes—\$25.00. Heavy drill press vises—\$10.00. No priorities needed. Moneyback guarantee. C.O.D. Southern Products, 12, Independence, Missouri.

TWIN Cylinder air compressors \$12.50. Various motors. Hoffmann, 2740 Coy, Cincinnati, Ohio.

SCREWS, Nuts, bolts, washers, rivets, brackets, etc. Handy assortment for mechanics, garages, household use, work-shops. Over 1000 pieces, 5 full pounds. Satisfaction guaranteed. Special \$1.98. Limited supply. Order now. Widran Distributors, 212 West Hubbard, Chicago.

BUILD Your tractor from second-hand automobiles. Convert your horse drawn farm equipment into tractor drawn equipment. Nolan's Garage, East Wareham, Mass.

WANTED: Machinery (chemical, metal-lurgical) mills, jacketed kettles and tanks, mixers, speed reducers, motors, hydraulic presses. Forward full information. Metal-lurgical Products Co., 34th and Moore Sts., Philadelphia, Penna.

DIAL Indicators for sale \$8.50 C.O.D. For defense shops or machinists only. Write Amity Products, Box 241A, Waltham, Mass.

RECLAIM Dull and broken drills with Nu-Way Drill Grinder. Circular free. Tractor-Lite Mfg. Co., Spirit Lake, Iowa.

INDEX Heads for sale. Very inexpensive. Sixty-two different divisions. Used on small lathes, drill press, milling machines, etc. Make gears, hobbs, cutters, etc. Very accurate, and durable. Not a toy. Used by defense schools and hobbyists. Write for free folder. Long's Index Heads, 2117 East B St., Torrington, Wyo.

NEW Caliper, direct reading, speeds up defense work, cheap. Free illustrated circular. Factory, 811-G East 31st, Kansas City, Mo.

15" x 5" WILLARD Lathe with gap. No. 2 Pratt & Whitney hand milling machine. four step cone drive. Write for full particulars. Cincinnati Machinery & Supply Company, 217 E. Second St., Cincinnati, Ohio.

GRIND Drills like factory: attachment for bench grinder. Cheap. Factory, 811-B East 31, Kansas City, Mo.

ENGINES, MOTORS, DYNAMOS

NEW 5 And 10 K.V.A. 4 cyl. automatic Kohler electric plants, other used plants in a.c. and d.c. to 10 k.w. Will buy used Kohler electric plants in d.c. or a.c. E. F. Schmalz, 215 Wyoming Ave., Kingston, Penna.

AUTHORIZED by W.P.B. to sell inventory of a.c. and d.c. midget motors—Both geared to 4 r.p.m. Shaft speed 1250 r.p.m. 100 volts. Idea for timing devices, displays, models. Bargain price. a.c. motor \$2.00, prepaid. Length 3" height 2 1/2" width 2 1/2" d.c. \$3.00 prepaid. Length 5 1/2" height 2 1/2" width 3". McLaren Products Company, 114 N. W. First Street, Evansville 8, Indiana.

BIG Pay jobs in welding. Complete welding lessons and reference book, 516 pages, 41 lessons, \$2.00 copy. Money-back guarantee. Hobartweld, Box 1335-M, Troy, Ohio.

WINDING Data, 225 motors, single and three phase, \$1.00. Motor Data Co., Box 7631, Kansas City 3, Mo.

BOATS, OUTBOARD MOTORS, ETC.

NEED Motors for parts. Will pay \$35.00 cash in advance for Johnson model A-25. Other models in proportion. Ass Gallupe, Fort Fairfield, Me.

TWELVE Foot flat bottom rowboat. Complete plans 25c. Catalog boat building plans 10c. The Rudder, 15 Murray Street, New York.

USED Outboard motor parts. Outboard Exchange, 1194 Remsen Ave., Brooklyn, 12, N. Y.

MARINE Power—Easily convert any Ford motor (domestic and foreign) with Osco parts and kits. Complete catalogue 25c (coin). Osco Motors Corp., 3637-29 N. Lawrence Street, Philadelphia, Penna.

FULL Size, cut to shape boat patterns, blueprints. 7 1/2 - 38 feet. Illustrated "Build a Boat" catalog, 10c (coin). "How to Build Boats" book, \$1.00. Cleveland Boat Blueprint Co., Station A-66, Cleveland, Ohio.

OUTBOARDS — Save 1/2. Good used parts, all makes and models. Bargains rebuilt motors. Crandall Hicks Co., 959 Commonwealth, Boston, Mass.

BOAT Designers are highly paid professionals. Complete course by mail. Catalog. Westlawn, Montville, N. J.

ATHLETIC EQUIPMENT—BODY BUILDING COURSES

BE Strong, muscular, full of pep. Amazing new body-building course. Write Olympic System, Dept. M, Waterville, Maine.

BAR-BELLS, Exercise equipment. Courses. Special offers! Free booklet. Good Barbell Co., 3281-PM Watson Rd., St. Louis (9), Mo.

SUPER Ju-Jitsu—lightning defense and attack system. Sensational new home study course now ready! Learn to lick brutes twice your size with only your bare hands. Free details. Nelson Co., Dept. 508, Chicago.

SPORTING GOODS, GUNS, FISHING TACKLE, ARCHERY, TRAPPING

SPOT Cash for your guns or ammunition! Or trade for merchandise in our winter "Guaranteed Bargain Catalog," featuring thousands of guns and "hard-to-get" items; send 25c for catalog (re-fund with first order). We pay more, sell for less because we handle thousands of guns in all models, gauges, calibers, both new and used, from \$5 to \$1000. We also buy or trade reels, rods, outboards, binoculars, cameras, radios, watches, diamonds. Name your own price! Describe your merchandise fully. Money back guarantee, backed by two generations of honorable dealing. Klein's Sporting Goods, 504H South Halsted, Chicago.

FREE Catalog, flies, lures, materials. Supreme Mfg. Company, Amarillo, Texas.

ARCHERY Equipment: Catalogue free. Mid-West Archery, 2209-A East 15th, Chicago.

GUNSMITHING Readily learned at home. Earn extra money repairing neighborhood's firearms. Free catalog 25¢ firearm and gunsmithing textbooks. Samworth, Plantersville, South Carolina.

FOXES—Nine in one day. Trap slyest furbearers. Particulars free. Guaranteed. Write, Estabrook, Sherburne, Vermont.

GUN Bluing, plating, checking, refinishing. Gunrebu, 322M Plant, Tampa, Florida.

ELEVEN Good box traps. Complete blueprints, 30c. Wesho-Uco, Box 51, Detroit, Mich.

TIN-CAN Silencer makes 22 sound like airgun. "Teluhoo" plans \$1.00. Spencer Laboratories, Akron 3, Ohio.

BOWS—Arrows for recreation, hunting, fishing. Beautiful archery instruction book, 90 pages, 50 illustrations, only 50c. Illustrated catalogue free. Archery, 617 South State, Chicago.

ANTIQUES, RELICS, INDIAN GOODS, CURIOS

THOUSANDS Indian arrows, tools; "rainbow variations." Don McKillop, Regina, Sask.

RELICS, Minerals, coins, miniatures, Catalog 5c. June's Antiques, Northbranch, Kansas.

ANTIQUÉ Firearms, swords, daggers, powderhorns. Lists free. Nagy, 8-B South 18th, Philadelphia, Penna.

MINERALS, Coins, stamps, Indian relics, pistols, old glass. Catalogue 5c. Vernon P. Lemley, Las Cruces, New Mexico.

MUSEUM Supply catalogue 25c. Indian relics, identification chart, fossils, curios, den decorations. American Museum Supplies, 6601 Oshkosh, Chicago 31, Illinois.

INDIAN Relics, coins, bills, gems, crystals, curios, etc. Illustrated catalog 5c. 100 ancient arrowheads \$3.00. H. Daniel, Hot Springs, Ark.

INDIAN Relics, beadwork, coins, curios, minerals, old glass. Catalog 5c. Indian Museum, Osborne, Kansas.

SWORDS, Rapiers, daggers, pistols, armor, illustrated catalog 25c. Robert Abels, 860-A Lexington Ave., New York.

FIELD GLASSES, TELESCOPES, MICROSCOPES

MICROSCOPES, Scientific laboratory equipment—bought, sold, repaired, exchanged. Catalog 10c. George Klein, 225 Fifth Avenue, New York.

POWERFUL Telescope lens kit—Consists 3" diameter 75" focus objective—50X and 100X astronomical eyepieces—mounting directions. Optical parts finished. Builds six foot refracting telescope in evening of easy work. Guaranteed show moon's craters, rings Saturn, moons Jupiter, double stars, etc. While they last \$1.95 postpaid or C.O.D. plus postage. With 50X terrestrial eyepiece \$2.95. Pfeesgor Optical Company, P-1, Sunbury, Penna.

INSPECTOR'S Lenses magnify and leave hands free. Magni-Focuser Binocular Eye-shade magnifies object three times actual size. Sharp focus about ten inches from forehead. Send \$8.50 for ten-day trial. Money-back guarantee. Shipped postpaid. N. L. Huebsch, Box 83, East Williston, N. Y.

MICROSCOPES, Telescopes, binoculars; all scientific, chemical, laboratory apparatus—bought, exchanged. Exclusively our business for fifteen years. Not get-rich-quick speculators. Trial will show that we know apparatus; highest prices paid. Harry Ross, 64 West Broadway, New York.

BINOCULARS, Field glasses, telescopes, hobby. Buy, sell, trade. Write. Paul Schweer, Donnellson, Iowa.

MICROSCOPES! Research, industrial, amateur, accessories. We sell, buy, repair, exchange. Inquiries invited. National Microscope Exchange, 119 Chambers St., New York, N. Y.

ASTRONOMICAL Telescopes, binoculars, cameras, microscopes; bought, sold, repaired. Send 10c for list of instruments desired. Rasmussen, Box 294, Amsterdam, N. Y.

DOGS, PETS, BIRDS, RABBITS

WILD Geese, ducks, pigeons, peafowl, rabbits. Prices free. Jewel Game Farm, Danville, Ill.

RAISE Highly profitable Angora rabbits. Multiply fast. Wool \$8.50 pound. Plenty markets. Particulars free. White's Rabbitry, Marion, Ohio.

GIANTSTRAIN Raccoons — America's finest minks. Bred females. Catalog 10c. Shady Fur Farm, Springfield, Minnesota.

PUPPIES, Also supplies, what do you need? Books colored pictures, descriptions 108 recognized breeds, 35c. Royal Kennels, Chazy, N. Y.

MONEY Raising rabbits. Investigate. Folder 10c. Close Rabbitry, Tiffin, Ohio.

STANDARD Rabbit Journal, Milton, Pa. 3 years \$1.00, sample dime.

MAMMOTH Chinchilla rabbits—Complete information portfolio. Rabbit Journal, fur samples, 25c. Illustrated book, 50c. Melv. Behrens, Pearl River, N. Y.

RABBITS For profit booklet, 10 cents silver. Bonnie's Bunnyland, Mastic, New York.

MOST Beautiful fur. Small investment. Large profit. Free illustrated booklet. Willow Brook Farm, R. D. 15, Sellersville, Penna.

RAISE Your own meat—also make money raising pigeons. Booklet dime. Gebhardt Farm, Muscatine, Iowa.

PEDIGREED White Flemish Giants. 5 month doe \$12.00. Buck \$10.00. Concrete feed or water crocks 25c each, dozen \$2.50. Stamp for reply. Twing Hill Rabbitry, 117 Saxton River Road, Bellows Falls, Vt.

RABBITS: Flemish Giants, New Zealand. Reasonably priced. "Franklin Young, Riverhead, Long Island, New York.

BIRD fanciers, American Canary Magazine Monthly. Year's subscription \$2.00. 2839-P N. Halsted St., Chicago 14, Ill.

RAISE Rabbits for profit. Magazine puts you in touch with markets. Copy 10c. Booklet describing twenty breeds, and magazine for three months 25c. Address Small Stock Farmer, Dept. 3, Pearl River, N. Y.

SEEDS AND NURSERY STOCK

DAHLIAS, Ask for book 400 varieties. Springfield Dahlia Farm, R. 2, Box P, Grand Rapids, Mich.

FARMS, FARM LANDS, REAL ESTATE

\$4.00 MONTHLY Buys 40 acres, productive land; near town. Price \$150.00. Also larger tracts south Missouri. Free list. Box 425-P, Carthage, Mo.

STROUT'S Big farm catalog! 68 pages describing hundreds of properties in 18 states from Maine to Florida and west to the Mississippi—many pictures, rock-bottom prices. Write today for this money-making time-saving book. Free. Strout Realty, 255-P 4th Ave., New York 10, N. Y.

40 ACRES Good land—\$250.00. \$10.00 down. \$10.00 monthly. R. W. Stewart, Inverness, Florida.

PRE-WAR Bargains in Wisconsin, Minnesota lands! 2663-A Rutherford, Hollywood 26, Calif.

OZARK Land; \$3 acre; terms. Williams Realty, Mt. Vernon, Ill.

OBTAIN Free fertile South American lands yielding four annual crops, tropical fruits, rubber, livestock. Write. Valles, 311 Church St., New York.

SEE The Highlands of Louisiana where winter brings no idle acres. Choice cut-over land at low prices with terms. Send for descriptive book without obligation. Long-Bell Farm Land Corporation, 896 R. A. Long Bldg., Kansas City, Mo.

SACRIFICE Virgin Missouri lands \$1 acre. Hurry. Armstrong, Shook, Mo.

GOOD Farm bargains. Washington, Minnesota, Montana, Idaho, Oregon, North Dakota. Dependable crops, favorable climate. Write for literature, lists describing typical farms. Specify which state. J. W. Haw, 119 Northern Pacific Ry., St. Paul, Minn.

40 ACRES. Near White River, unimproved; poultry land. \$190. \$5 down, \$5 monthly. Free list and literature. Hubbard, 216 Grossman Bldg., Kansas City, Kans.

FARM MACHINERY AND SUPPLIES

PRINTS and instructions for building garden tractor \$1. William Tanger, Bellefontaine, Ohio.

SAVE Money on tractor parts, new, used. Inquire today, specifying parts needed, tractor make, model, year. Irving's Tractor Lug Co., Galesburg, Illinois.

POULTRY, FARM SUPPLIES

BABY Chicks, champion mated. 52 varieties, 7 hybrids, licensed inspected, blood-tested. Rush postal, large colored book, low prices. Berry's Farm, Route 12, Clarinda, Iowa.

YOUR Greatest poultry problem will look simple when you read American Poultry Journal regularly. 500,000 poultrymen do, why not you? Only 25c year, 5 years \$1.00. American Poultry Journal, 523 S. Clark, Chicago.

MODERN Poultry Magazine operating experimental farm guides in growing, laying, marketing. Year 25c; 5 years \$1.00. Subscribe today! Poultry Tribune, Dept. 151, Mount Morris, Ill.

KNOW How to raise poultry for profit. Read Northeastern Poultryman. Every issue packed with helpful hints and practical suggestions. Latest articles on breeding, feeding, and management. Read nationally. Subscribe now. 1 year 65c; 2 years \$1.00. Northeastern Poultryman, 4M Park St., Boston 8, Mass.

PROFITABLE OCCUPATIONS

BOOKKEEPERS: General ledger and tax report experience. Operate permanent, profitable accounting service for the smaller business. Part or full time. Simplified method. Write now! L. A. Bell, 1400 West 25th Street, Cleveland 13, Ohio.

MECHANICALLY Inclined men—Own and operate general appliance repair shop. Complete, illustrated course shows you how. Welding, refrigeration, motor repair, how to get business, etc., all phases covered. Free literature. Christy Supply Dept. 436, 2635 N. Central Ave., Chicago.

LOCKSMITHING Course—Practical in-expensive lessons for handy men. Just out! Fit keys, pick locks, de-code, make masterkeys. Satisfaction guaranteed. Send for free details, Nelson Co., Dept. 708, Chicago.

WELDING course. Learn with 1942 trade school text manual. 516 pages. Over 500 photos. \$2.00 copy. Money-back guarantee. Hobart Weld, Box M-1333, Troy, Ohio.

MUSHROOMS grown in boxes. Instructions 25c. Spawn \$1.00. Gordon, 553 William, Winnipeg, Canada.

CLEAN UP building plastic houses. More money than you ever dreamed of. Build your own. Build for others. Details free. Plastics, Box 872, Wilmington, California.

LEARN Refrigeration service. Open your own shop. Complete illustrated course reasonable. Small capital required. Free booklet. Mechanics School, Dept. PM3, 4701 West Pico, Los Angeles 6.

ANNOUNCING New home study course in commercial baking. Good field. Nearly depression proof. Common school education sufficient. Send for free booklet "Opportunities in the Baking Industry" and requirements. National Baking School, 1315 Michigan, Dept. 3438, Chicago.

\$40.00 WEEKLY. Made growing mushrooms, fresh, dried. Dominion patent 331583. Free spawn. North American, 169P Yonge, Toronto, Canada.

BOOKS, PERIODICALS, PICTURES, POSTCARDS

"RAILROAD Books." Latest. Best. Illustrated folder free. Kalmbach Pub. Co., Dept. PM, Milwaukee 3, Wis.

OZARK Guide, Lonsdale, Arkansas. For sportsmen, homeseekers, folklorists. Year, \$1.00.

EDUCATIONAL Books, not found in book stores. Write today. Erkinainen Sales, 3160-PM Archer, Chicago.

"YOUR Model Railroad." A beginner's book about this most interesting hobby. 30 pages packed with pictures, plans, descriptions. Retail for 25 cents. You can have one free for 3 cent stamp. Kalmbach Pub. Co., Dept. PM, Milwaukee 3, Wis.

EXCELLENT Sparetime profits handling subscriptions—2500 magazines. Confidential catalogue, starting supplies free. Pines Subscriptions, Flushing, N. Y.

BOOKS. (Out-of-print, new, used) quickly supplied. Many 35c bargains. Catalogue. T. Jamkowski, 18870 Marx Ave., Detroit 3, Mich.

BOOKS bought, sold, exchanged. Perhaps we have the very book you've been looking for. Send dime for list. Major Book Mart, Box 862, Port Angeles, Wash.

THINK And Grow Rich—is the very book you'll want to read and study. Price \$2.00 post paid. Maume Sales Service, 1009 E. Creighton Ave., Port Wayne 5, Ind.

20 THRILLING "Pin-Up" beauties from original Hollywood photos (exclusive release) \$1.00. Libman Co., Dept. PM, Box 7833, Del Valle Sta., Los Angeles.

WANTED To buy. National Geographic Magazines before 1907. Earl Frank, 1464 North Karlov, Chicago.

USED Technical and educational books bought, sold, rented. Catalog free. Educational Exchange, Henagar, Alabama.

YOU Can do it too. Put yourself in the big money. A wonderful book. Details free. Frank J. Newton, LaGrange, Ill.

ART Pictures. Dozen 25c coin. Curtis Specialties, Box 1916, Denver, Colorado.

WHAT Every Mason wants. We have Masonic books for Blue Lodge, Chapter, Commandery, Scottish Rite and Shrine. Our rituals are used the world over. Send for free catalog of books and rituals for Masons, Odd Fellows, Knights of Pythias, Knights of Columbus, Elks, etc. Ezra A. Cook, Publisher, Inc., P.O. Box 796, J1, Chicago 90, Ill.

A RATIONAL View of Life—This unique book 50c. Benjamin Seibert, Urbana, O.

CHINESE Physicians, secrets, 165 pages, rare illustrations, unpublished truth, secret healing arts, peculiar custom. \$1. Write Garding Lui, Box 6227, Metropolitan Station, Los Angeles, California.

DEADLY Judo. Most fearsome fighting technique known. Complete course (fully illustrated). Special \$1.00. Variety House, Box 56-D, Station N, New York City.

WANT To convert grams to ounces—minutes to radians—B.T.U. to kw hrs.? Let the Engineer's Pocket Diary and Address Book containing tables of conversion factors for engineers save you time. Handy pocket size—only \$1.00 postpaid. Room 901, General Electric Building, New York 22.

HAVE Fun! Pretend you're in Washington, D. C.? 25c (coin) prepays 3 postcard views. (20—\$1.00). You write message, address, attach stamps. return—free re-mailing. Hawkins, Seven Randolph Place.

25 ARTISTIC Pictures; lists books, novelties. 50c. Western Sales, Hillstreet Building, Los Angeles-14.

MAGAZINES—Business, vocational, diversion. Current single copies. Choose from 569 different publications covering aviation, automotive, air conditioning, beverage, building, electrical, insurance, live stock, music, photography, plumbing, printing, radio, refrigeration, upholstery, watchmaking and more than 150 other fields. List with prices free. Commercial Engraving Publishing Company, 34C North Ritter, Indianapolis 1, Indiana.

5c BUYS Back-dated magazines. Foreign, domestic, arts. Catalogs 10c. Ciccone's Magazines, 863 First Ave., New York 17, N. Y.

ARTISTIC Girl pictures. Real models. 40 photos for \$1.00 postpaid. All different, postcard size. C. A. Scott, P.O. Box 342, Covington, Ky.

"100 SELLING Ideas." A regular \$1.00 book on money-making plans, business secrets. 25c postpaid. Joseph Royer, 15-M How Street, Haverhill, Mass.

HELPFUL Books for your trade, hobby or business. List free. Helpful Book League, 1239 Broadway, New York 1, N. Y.

40 POWER Tools You Can Make. Book giving full details \$1.25. Popular Mechanics Press, (C-43), 200 E. Ontario, Chicago.

SELF-EXPLAINING Bible; Illustrated circular free. Box 446-P, Minneapolis, Minn.

DRUNKENNESS is a disease which responds to treatment. Medical skill plus human sympathy prove successful with liquor and drug cases. 60 years experience. Write for free booklet. P. M. Nelson, The Keeley Institute, Dwight, Ill.

GAMES, ENTERTAINMENT

READY—New 68th Annual Digest of plays, entertainment-game books, operettas, minstrel shows—songs, skits, recitations—everything for your home talent shows. A necessary entertainment source book for families, individuals, schools, dramatic clubs, lodges, churches—any organization—for all occasions—all ages. Strictly limited edition. Send only 10c (covering postage-handling) for yours now! T. S. Dennis & Company, (Established 1876), 225 North Wabash, Dept. 9-C14, Chicago 1.

MAGIC TRICKS, PUZZLES, JOKER NOVELTIES

TUMBLING Blocks—Fascinating puzzle and coin trick. Satisfaction guaranteed. 25c coin. Dreisbach, 617 North Saint Elmo, Allentown, Penna.

AMAZING Mystifying tricks. Make money. Entertain friends. Big magic package 25c. Pioneer Magic Studios, 4418-PM Clarence, St. Louis 15, Mo.

WOW! \$25.00 Worth of laughs for only 25c. Six different novelty signs made to set on office or school desks. Millers, 265 Glessner, Mansfield, Ohio.

SURPRISE Your pals. Your name (or theirs) in screaming headlines, front page Hollywood newspaper 25c. 4 alike 50c. Lefavor, Printer, Arrowhead Springs, San Bernardino, Calif.

FIVE Mind reading acts, 8 magic tricks, 2 handwriting graphocharts, 3 fortune telling charts all for \$1.00 postpaid. Circulars free. Brain's Book Shop, 118P Washington Ave., Endicott, N. Y.

MINDREADING Pays. Professional medium's method, \$1. Magical Enterprises, Roseville, Mich.

MYSTIFY Your party guests with 24 tricks illustrated on 24 cards, 25c. Auerbach, 14 E. 34th, New York City.

TRICKS. Make them yourself, five complete drawings and instructions one dollar. Aldeen, 190 Ward St., New Brunswick, N. J.

CLOUDS Of smoke and many other amusing mystifying tricks from finger tips and empty hand. Just reach in the air and produce clouds of smoke—hundreds of them; also genuine snow falls and spin ribbons 5 ft. long—it's entertaining, it's sensational. All you need is my harmless mystic paste that liquefies as you rub and tap it into action, see magic dealer or send 50c for my full 35 performance tube, 3 \$1.00, while they last. M. C. Regan Laboratories, Calif., N. J.

JUMPING Spot bars, amazing pocket trick, 35c. P.O. Box No. 313, Springfield, Mass.

BE A magician. Large professional magic catalogue of latest tricks 25c. Ireland, C-109 North Dearborn, Chicago 2.

LEARN Ventriloquism, 3c stamp brings particulars. Smith, 801 Bigelow, Peoria, Illinois.

HOLLYWOOD Special Magicians button, catalogue, ghost illusion and free trick for 25c. Magic House of Charles, Box 888 Hollywood, California.

QUALITY Magic since 1907. Send 25c for catalog. Thayers, Box 1785 Wilshire LaBrea Station, Los Angeles, Calif.

500 TRICKS You can do! Douglas' famous catalog of 500 tricks, 128 pages, now only 10c. America's fastest service on magic for pocket, parlor, stage, professional, amateur. Douglas Magic Shop, Box 274, Dallas, Texas.

EARN Money in any crowd. Call names of strangers, tell unspoken questions. Professional course mind reading, spirit writing, etc., \$1. Henderson, Box 341, San Bernardino, Calif.

MAGIC Tricks, puzzles, books, cards, punch boards. Catalog 10c. Specialty, Box 671, St. Louis 1, Mo.

MAGICIANS' Headquarters. 216-page catalog, pocket, parlor, professional tricks. 25c. Kanter's, M-1311 Walnut, Philadelphia.

WORLD'S Largest professional magic shop keeps you in touch with latest tricks. To receive mailings send 25c for 1943 catalog. Holden, 220 W. 42nd St., New York.

NEW Vanishing key and catalog 25c. Sterling Magic, 345 John R., Detroit, Mich.

COINS, TOKENS, CURRENCY

10 INDIAN Head cents, different dates, also price lists, 35c. Schultz, 1053 Richmond, Cincinnati, Ohio.

WE Buy Indian cents, Lincoln cents. Old rare coins wanted. Highest prices paid. Send 10c today for new 1943 price catalogue of all U. S. coins. American Rare Coin Co., Dept. 1, Transportation Bldg., Chicago.

COMPLETE Set Lincoln cents minus 1909 S.V.B.D. in album \$3.50. Wonderful Christmas gift. William Sexton, Box 172, Santa Maria, California.

CENTS 100 Years old 25c. Indians, 10 different 25c. San Francisco mint Lincolns 10 different 25c. new silver dollar \$1.50. 1943-S cent and nickel 15c. Big illustrated coin book 50c. Coin Shop, Box 77, Alameda, Calif.

FIVE Foreign bills 25c; twenty-five different, \$1.00. Beffel, Box 37, Ottawa, Ill.

INDIAN Heads, large cents, fine other coins, price list 3c. Leo Greenstreet, Union, Mo.

A NICE Collection of 25 foreign bills for only \$1.00. Myron Bushnell, P. E. Bld., B. B. 15, Room 540, 6th Main St., 14, Los Angeles, Calif.

3 COINS And lists 10c. Oddehon, Box 44-Overland, St. Louis, Mo.

RARE United States coins. List 10c. Sandy's, 753 Gardenia, Long Beach 4, California.

OLD Money wanted. Will pay fifty dollars for nickel of 1913 with Liberty head (no buffalo). We pay cash premiums for all rare coins. Send 4c for large coin folder. May mean much profit to you. Numismatic Co., Dept. 20, Fort Worth, Texas.

ENCASED Postage stamps used as money from Germany-Austria, metal frame, celluloid covering, very scarce, 10 different \$1.00. ALI-Nation, 157N West Lake, Chicago, Ill.

50,000 COINS, Medals, Confederate bills. Lists free. Nagy, 8-D South 18th, Philadelphia, Penna.

INDIAN Head penny with list 10c. Charles Banker, Salina, Kansas.

FREE Coin list. Harry Elsholz, Box 9014, Pittsburgh 24, Penna.

U. S. Coin packets, \$1.00 each: Two half cents; five large cents; three flying eagle cents; fifty Indian cents; five 2c pieces; five 3c pieces; four half dimes; one 20c piece; two quarters before 1860; half dollar before 1840; six Civil War tokens. Special, all eleven for \$10. Ben's Coin Company, 72 West Washington, Chicago 2, Ill.

GET Profit and pleasure in collecting old coins. Send 10c for 66-page illustrated coin catalog. You'll be delighted with it. Send for it now. B. Max Mehl, 370 Mehl Bldg., Fort Worth, Texas. Largest rare coin establishment in U. S. Established 43 years.

25 DIFFERENT Indian cents \$1.10. Large fall catalogue 8c. Bebee Coin Company, 1180 East 63rd, Chicago.

COMPLETE Catalogue of all U. S. coins 1/2c to \$1.00. 75 illustrations, 3500 quotations. Price 10c. James Randall, 341 South Dearborn, Chicago.

COMMEMORATIVE \$1/2—Texas, Kentucky, York, Elgin, Cleveland, \$1.50 ea. Illustrated catalogue 10c. Norman Shultz, Salt Lake City, Utah.

FREE! Foreign coin, banknote and coin collectors illustrated catalog to approval service applicants. Send 3c postage. Tatham Coinco, Springfield-125, Mass.

I MAY Have just the scarce U. S. coins you want. Send me list. "Meet me by mail." William H. Kenworthy, Waterville, Maine.

STAMP COLLECTING

POSITIVELY Greatest free offer—Latest Scott's International \$4.00 Stamp Album—covering entire world, contains 36,000 illustrated, descriptive spaces, Scott's 1944 Standard \$5.00 Catalogues "Philately's Encyclopedia"—absolutely free to applicants for foreign approvals becoming customers. Plymouth, A-9, Bell, California.

100 DIFFERENT Including scarce airmail triangle, 3c to approval service applicants. Avalon Stamp Co., Dept. M, Springfield 8, Mass.

FINE Approvals, freshly mounted. Fast, personal service. Tell me what countries you prefer and I'll send their stamps. Skinner, 345 East Ocean, Long Beach 2, Calif.

LIBERIA 1937 Animal triangles, 6 different catalog 42c, only 15c to approval applicants. Western Stamps, Box 4042, Los Angeles 24, California.

150 DIFFERENT U. S. stamps for \$1.00. 250 different U. S. stamps for \$2.00. Approvals. H. E. Codwise, Box 5, Melrose Highlands, Mass.

3,000 U. S. Foreign \$2: Approvals; Griest; 409 Oak, Davenport, Iowa.

220 U. S. Stamps on approval. We pay return postage. Southern Stamp Co., Box 70, Miami, Florida.

300 STAMPS—Dime, to approval applicants. Fair Stamp Company, Bristow, Oklahoma.

\$5000.00 AVAILABLE To buy stamp collections, job lots, dealers stocks, etc. MKeigwin Company, Vineland, N. J.

10 PINE U. S. 1862-1903 3c. Weston, Box 20, Oklahoma City, Oklahoma.

SPAIN, 50 Different, only 10c to approval applicants. Paul Rawden, Box 2920, Westville, New Haven, Conn.

STAMP Exchange for adults. Free leaflet. Liberty Stamp Exchange Circle, 127 Nassau Street, New York 7.

MEKEEL'S Stamp News trial 26 weeks 25c. Box 1660, Portland, Maine.

LATIN-AMERICA—Nice packet 100 different, only 10c with approvals. "Crescent Stamps," London, Canada.

FOREIGN Censored envelopes, 3 for 25c (none sold out U. S.) Plummer, P.O. Box 99, Westfield, Mass.

10 SIAM Only 5c! With approvals. Benton Ryan, Middletown, Conn.

FREE Ecuador packet for return postage. Approvals sent. Ephriam, 914 Sherman, Evanston, Illinois.

BETTER Grade United States approvals. Low prices. Box 488, Minneapolis.

1,000 GRABBAGS 15c each. 8 different \$1. Zandy, 630 Binghamman, Reading, Pa.

50 DIFFERENT U. S., many commemoratives, 5c. Gerhardt, 2804 Rio Grande, Austin, Texas.

STAMPS Cataloguing \$4.04 only 25c. Burtis, 125 Greenwood, Trenton, N. J.

EIGHT Attractive airmails only 3c. with approvals and bargain lists. Gaydos, Kenosha, Wis.

FREE 25 South American. Approvals. Atwood Stamp Co., Box 1962, Atlanta, Georgia.

LOWEST United States stamp prices. Free catalogues. Creevey's, Hazleton, 367, Penna.

UNITED States exclusively! Attractive-ly priced approvals upon request. Return postage paid. Tropical, 720 NW 61st Street, Miami-38, Florida.

\$5.00 COOLIDGE, 500 Well mixed U. S., all 49c postpaid. Miner, South River, Wilkes-Barre, Penna.

SIX Commemoratives, 3c with approvals. Turbyll, 513-W 29th, Norfolk 8, Va.

PHILATELIC Shopping News—bargains galore! Free copy. Stamporium, 2660 Rochester, Detroit 6, Michigan.

100 ALL Different U. S. 10c. Monjar, 1750 Fairmont, Cincinnati, Ohio.

WASHINGTON Bicentennial set 5c. U. S. and foreign approvals accompany. Yukum's, Box 1327, San Antonio, Texas.

LIBERIA Beautiful pictorial set 10c with approvals. Vargo Stamps, Racine, Wis.

PENNY Approvals for general collectors my specialty. Chas. Creek, Woodland Hills, Calif.

DEALERS—Wholesale list. Postage 3c. Frank's, 5031 Queensberry, Baltimore, Md.

500 UNITED States, commemoratives, airm. general, others. 35c coin. Vogue Studio, 818 Hennepin, Minneapolis, Minn.

SEND 100 Different stamps with 25c. Receive 200 different good stamps. Fred Quatsak, 1242 Kelson, Pittsburgh-16, Pa.

FREE! U. S. bargain catalogue; complete national parks 25c; famous Americans 78c; airmails 18 different \$1.20. Jennella, 3921 Hereford, Saint Louis, Missouri.

MISSION Mixtures 1 lb. \$1.00. Zipper, 3226 Parade, Erie, Penna.

SPECTACULAR Approval service for collectors using International Junior or Modern albums. Loewy, Arcadia, Calif.

500 U. S. Well mixed, many commemoratives, 70 varieties guaranteed, only 25c. Hogan's Stamp Shop, Ashland, Wis.

175 U. S. Commemoratives, airm. etc. 10c. 500—25c. Box 457, Newark 1, N. J.

FINE Approvals, state country preferred. John A. Kinnear Co., 561 Empire Bldg., Seattle 4, Wash.

80c VALUE—U. S. souvenir sheet, telegraph stamp almost 60 years old, 25 more different U. S. Only 10c to new applicants for my U. S. approvals. Steger, 1165 Downing, Denver, Colorado.

\$2.00 FOREIGN Lots consisting of 100 better grade stamps, old and new, many high catalogue. Great value for collection or traders. Send \$2.00 today. Ewing, 109 N. Dearborn, Chicago 2, Ill.

WANTED United States stamps. Used. Unused. Collections. Accumulations. Creevey's, Hazleton, Penna.

DANDY United States approvals. Write immediately. Sullivan, Endicott Arcade, St. Paul, Minnesota.

WEEKLY Stamp Magazine, 26 weeks, 25c. Stamp Journal, Kalamazoo, Mich.

STAMP Tong, watermark detector, perforation gauge, 5c to approval applicants. W. Darby, Box 1896, University, Alabama.

LIBERIA Airs C4-6 (3) 10c with 1/4, 1/2, 1c approvals. Carroll's, 745A W. 45th, Los Angeles 37, Calif.

APPROVALS High grade United States and foreign. Cal's Stamp House, Roseville, Michigan.

EXCELLENT Pictorial approvals. Reasonably priced. Crown Stamp Company, Box 331, Toronto, Canada.

FIND Stamps worth fortunes! Six big items! "Queer Countries" packet; Djibouti, Qwalior, etc. Packet scarce Russia, catalog price 50c! Fine packet of 25 different British Colonies—Turks and Caicos Islands, Hyderabad, Jamaica, etc. United States \$4.00 and \$5.00 high values. Big "Far East" packet of 20 different stamps from Dutch Indies, Siam, Philippines, etc. Illustrated 32 page booklet—tells where to look for, and sell, stamps worth up to \$10,000 apiece! Everything for only 5c to approval service applicants! Mystic Stamp Company, Department 80-R, Camden, New York.

WASHINGTON Bicentennial, 12 var., complete 10c. Herman Kleinman, Jenkintown 4, Penna.

60 DIFFERENT United States 10c. Pricelist free. Seidenberg, Baroda, Mich.

UNITED States, Canada, Newfoundland approvals upon request. Dan Hayden, 1007 N. Evans St., Bloomington, Ill.

127 DIFFERENT Stamps including Free Fighting French, Haiti, Johore, Perak, only 10c to approval applicants. Reich Stamp Co., 4647 Kenmore, Chicago, Dept. M7.

WORLD'S Largest diamond and triangle stamps, free stamp magazine, trips from fighting Free French, 25 stamps from 25 different United Nation countries, pictorials, airmails, big bargain 5c with approvals, Capital Stamps, Dept. 2, Little Rock, Ark.

LIQUIDATING—Approval remnants, sets, packets—500 mixed \$1.00. Beacon Sales, Maynard, Mass.

U. S. Mixture, 5 lbs. \$1.75. Postage extra. U. S. price list. Stanley Gibbons, 38-P Park Row, New York.

FREE United States price list. Postage 3c. Mark Hanna, 335 - 5th Avenue, Pittsburgh, Penna.

HOW To start a stamp business and wholesale lists 3c. Shepard Service, 3760 Merchandise Mart Station, Chicago.

FREE! Western Hemisphere packet. Postage 3c. Owens, 806 Welsh, Bay City, Michigan.

FREE! Pony Express set (facsimiles). Postage 3c. Roberts, 406 Building, Bay City, Michigan.

FREE! British Empire packet. Postage 3c. Williams, 606 Archer, Bay City, Mich.

STAMPS From 57 countries—10c. Approvals. Liberty Stamp Co., Kirkwood 22, Missouri.

FREE Your choice of any 10 stamps from our first U. S. approval selection. Illustrated list included. Cosmopolitan Stamp Company, Dept. 6M, 1457 Broadway, New York City.

FREE! Canadian sets, royal visit, George VI, George V, coronation, jubilee, others, to approval applicants. Ensign, Box 118-M, South Orange, N. J.

55 DIFFERENT United States 5c with approvals. Bookman, Box 145-M, Maplewood, N. J.

SOLOMON Islands, Seychelles, Nejd, Caymans, Manchukuo, Brunel, Everything 3c with approvals. Viking, 130 (Z) Clinton St., Brooklyn, N. Y.

STAMPS, Superb selection sent on approval, attractive prices. Fred Herzberg, 168 Oak, Elmhurst, Ill.

CANADA 100 Different 25c—approvals all countries. Lists. Victoria Stamp Co., London 4, Canada.

1000 MIXED U. S. old and new 25c. 2 lb. \$1.00. Weatherby, Troy, Ohio.

WOW! \$10.00 Worth of fun for only 10c! 500 foreign stamps, unsorted and unpicked (mostly on bits of paper) just as received from the church missions and other sources. Africa, So. America, Australia, China, Philippines, Dutch Indies, and other countries are represented. Includes a few commemoratives, airmails, and stamps cataloging up to 25c or more each! The biggest package of fun in stampdom—and you might find something really valuable! Price only 10c to serious approval applicants! Money back if not delighted. Jamestown Stamp Co., Dept. No. 22, Jamestown, New York.

118 DIFFERENT Stamps including commemoratives, charities, airmail, sets, etc. 3c with approvals. We buy stamp collections. Badger Stamp Co., Milwaukee P-3, Wisconsin.

PENNY Approvals, that satisfy. Neil Gronberg, Box 5441-P, Philadelphia 43, Penna.

19th CENTURY U. S. commems. Civil War revenues, battleship \$5 and \$10 stamps free to U. S. approval applicants. Metropolitan Stamps, 198-C Broadway, New York.

FREE! Leeward Is., Cayman Is., Turks and Caicos plus 60 different mint Geo. VI coronation poster stamps, to approval service applicants sending 3c postage. Tatham Stampco, Springfield-30, Mass.

A \$2,000 Stamp plus 50 different, 3c with approvals. Knopp, Box 1381, Bristol, Conn.

FREE! The Stamp Finder! Send today for the big new edition, fully illustrated, enabling you instantly to identify all difficult stamps! Also fine packet strange, fascinating stamps from Bosnia-Herzegovina, Monaco, Patiala, Cyprus, etc., including maps, ships, animals and strange scenes. All free to approval applicants inclosing 3c postage. Garcelon Stamp Company, Box 900, Calais, Maine.

SMOKY Mountain commemorative sheet, largest U. S. stamp issued, and 33 U. S. including commemoratives, airmail, revenues, etc. Catalogs 75c—To approval applicants for 5c. Curhan Stamp Company, Gloucester, Mass.

500 UNITED States for 10c! 500 U. S. A.—absolutely unpicked and unsorted—just as received from church missions. Many varieties, including commemoratives, airmails, high values up to \$5.00 denomination! Price only 10c to approval applicants! Money back if not delighted. Swan Stamp Co., Dept. 69B, Dunkirk, N. Y.

FREE! Complete "United States" stamp catalog with 1,000 illustrations! Send 3c for postage. Harris & Co., 137 Transit Building, Boston, Mass.

VICTORY Packet free—Includes stamps from Tanganyika, British Cayman Islands, animal, scarce babyhead, coronation, early Victorian, airmail, map stamps, with big catalogue—all free. Send 5c for postage. Gray Stamp Company, Dept. PM, Toronto, Canada.

MEXICO Census commemorative set free with approvals. Pladon Stamps, 1717-M Idaho, Toledo, Ohio.

WHOLESALE Supplements to dealers for 10c postage. Hundreds of bargains. Grossman Stamps, 102 West 42nd, New York.

UNITED States approvals complete coverage, fine quality, attractive prices. Seminole Stamps, Box 436, Coconut Grove, Florida.

HOBBIES AND COLLECTIONS

GENUINE Arizona ruby and desert sapphire, send quarter for both. Mineral Specimens Company, Box 2651, Phoenix, Arizona.

FREE! Collectors fun-fast magazine, 5c postage. "Hobby Humor"—P. Liberty, N. Y.

COLLECTOR Will buy ship's negatives. Send descriptions. Scozzafava, 511 West 135th, New York.

NEW Gland stimulating vitamin. Details accompanying "Colchicine" offer. See "Chemistry."

UNUSED Match book covers, 100 all different \$1.00. 35 Royal Flash covers \$1.00. Free list. Charles Edelman, 1311C East 84, Cleveland 3, Ohio.

NEW—15 Different match covers 10c. Box 202, Rochester 1, N. Y.

BEAUTIFUL Stones removed from rings, etc. 100 assorted \$2.00. Lowe's, Box 311, St. Louis, Mo.

CAMERAS, PHOTO SUPPLIES

WE Pay top prices for used cameras and photographic equipment. Turn your idle camera, enlarger, printer, lenses, developing equipment, etc., into cash. Just send us a list of what you have. State make, model, age, condition. We will write you at once, telling you what we'll pay. Prepare your list today. Send to Central Camera Co., (Photographic Headquarters since 1899), 230 S. Wabash Ave., Dept. A-16Z, Chicago, Illinois.

MAKE Money in photography. Learn quickly at home. Easy plan. Previous experience unnecessary. Common school education sufficient. Booklet and requirements free. American School of Photography, 1315 Michigan, Dept. 3432, Chicago.

BASS Says: War time proves Bass leadership. Amazing selection of finest still cameras—Leica, Contax, Korelle reflex, Argus, new and used still available. Write for quotations. Satisfaction guaranteed or your money refunded. Bass buys 'em, sells 'em, trades 'em. Bass Camera Company, Dept. AG, 179 W. Madison St., Chicago, Illinois.

WE Pay peak prices for cameras, lenses, movie cameras, movie projectors, movie lenses, binoculars. Don't wait! Write full particulars, describe condition, or send in via railway express collect for free estimate or c.o.d. with inspection privilege. If not purchased your property will be returned to you prepaid, insured. Aramac Camera Co., Dept. M, 1 East 43rd St., New York 17, N. Y.

CAMERAS, Lenses, Highest offers. Moggill's, 64 West 48th, New York 19.

OIL Coloring photographs a fascinating hobby or profitable business. Learn at home. Easy simplified method. Previous experience unnecessary. Send for free information and requirements. National Art School, 1315 Michigan, Dept. 3441, Chicago.

NATIONAL Graflex Model 2—\$80.00. Telephoto lens \$46.00. 3 1/4x3 1/4. Busch Pressman F6.3 Kodak Anastigmat in Kodamatic shutter. 8 Graphic film holders \$84.00. Korona 5x7 view 3 film holders F4.5 B & L Tessar Voluta shutter \$74.00. Many other bargains. We pay cash for your camera—send it for our liberal offer. Barbeau, Oswego, N. Y.

CASH! Spot cash for cameras, lenses, binoculars, movie or still, sound projectors. Send full description by mail, or wire for prompt cash offer. Over 30 years of dependability insures honorable dealings. Bass Camera Company, 179 West Madison Street, Chicago, Illinois.

HAVE You a camera? Send ten cents for recent number of our big magazine, showing how to make better pictures and earn money. American Photography, 116 Camera House, Boston, Mass.

PHOTO FINISHING

IMMEDIATE Service! Pictures returned same day order received. Smashing low pre-war prices! Sixteen guaranteed deckled-edge Velox prints from roll, 25c. Or one colored or two plain enlargements free with 8 deckled-edge prints, 25c. 16 reprints from negatives 25c. Candid rolls developed. Magic-Eye timed, vaporated, and enlarged to 3x4 on deckled-edge Velox paper—36 exp. 35mm. \$1.00; 18 exp. 60c; 16 exp. No. 127, 50c; 8 exp. Bantam, 25c. Reprints, 3x4, 3c each. We have new, perfect 35mm. film! Low prices. Free mailers, details on request. American Studios, Dept. 606, LaCrosse, Wis.

ROLL Developed, photo album, 2 enlargements, 8 prints 25c. Geppert Studios, Dept. 1-3, Des Moines, Iowa.

REPRINTS 2c Each (fifty or more), less than fifty 2 1/2c each. Finest workmanship; fast service. Mercury, A-109 North Dearborn, Chicago 2.

SEND Negative and 10c for a 1944 photo calendar and a photo birthday card. Young Photo Service, 405-B, Albany, N. Y.

ROLL Developed—16 guaranteed prints, two coupons on enlargements, 25c. Cameras repaired—send them for estimate. Smart Photo, Winona, Minnesota.

16 BEAUTIFUL Oversize deckledged prints and two enlargements with first order 25c. Owlphoto MI, Weatherford, Oklahoma.

YOUR Favorite kodak pictures enlarged, size 5x7, 10c; three for quarter, coin. Send best negatives (film) today. Address Geppert Studios, Dept. A-3, Des Moines, Iowa.

PHOTOGRAPHY For pleasure and profit. Prepare at home. Common school education sufficient. Write for information and requirements. American School of Photography, 1315 Michigan, Dept. 3451, Chicago.

16 SPARKLING Lifetone prints, 2 beautiful Hollywood enlargements, free Leatherette frame and photo wallet only 25c. Free photo album with first order. Lifetone Studios, Dept. A-139, Des Moines, Iowa.

FOR Fast roll film developing service write for safety film mailer. Three 5x7 from photo \$1.00. Abbey Studios, St. Louis 3, Mo.

ROLL Developed and 8 beautiful enlargements 2 to 6 times larger—deckled edge—high gloss. Any 8 exposure roll 25c coin. Reprint enlargements 3c each. Alden Photos, 94-3 Astor Station, Boston, Mass.

XMAS Cards from own negatives 65c dozen. Send negative for sample. Films developed and 16 prints or 8 prints and 2 enlargements 25c. Crystal Photo Service, Box L, Crystal Lake, Ill.

BIGGEST \$1.00 Value in 35 mm. finishing today. 36 exposure fine grain 3 1/4x4 1/2 enlargements; deckled, embossed margin and date. Eighteen exposures 75c; sixteen exposure splits 55c. Free mailers. 8 exposure rolls in beautiful deckled contact finish with embossed wide margin. 25c. Mailbag Film Service, Box 5440A, Chicago 80.

FILMS Scientifically developed plus 8 beautiful 4x6 enlargements, 30c complete. Photo-Service, 107 Dewey St., Newark, N. J.

VELOX Deckle reprints 2c. Rolls developed, two deckle edged prints each negative, 25c. Two 5x7 enlargements 25c. Summers Studio, Unionville, Mo.

8 BEAUTIFUL Enlarged prints (nearly postcard size) or 16 regular prints 25c. 35mm. rolls enlarged 3 1/4x4 1/2, \$1.00. Burton Studios, 55-M, Roscoe, New York.

EVERY Picture an enlargement! 8 sparkling deckle-edge enlargements and roll developed 25c coin; 116 size or smaller; enlarge reprints 3c. Enlarge Photo, Box 791D, Boston, Mass.

BEAUTIFUL 4x6 Pictures 3 1/2c each, from 116 and 120 negatives, 3 1/4x4 1/2 from all other sizes. All work guaranteed. Overnight service. Roll developed and 8 pictures 30c. Roll 12 pictures 45c. Roll 16 pictures 60c. Enlargements on double weight portrait paper 5x7—30c, 8x10—50c. Copies made from any picture 75c. Pacific Photo Service, Box 666, San Francisco, Calif.

THREE Prints each good negative, 6 to 8 exposure rolls, 30c, 12, 16, 18 exposure rolls, 50c. Reprints, 3c. Fred D. Eastman, Bode, Iowa.

8x10 SILK Finish enlargement—25c. Send negative. Irving Studio, 4006A Irving Park, Chicago.

MOTION PICTURES AND SOUND EQUIPMENT

100' 16MM. Used sound film, \$1.00 post-paid. Write for list of complete subjects. Blackhawk Films, Dept. PM8, Davenport, Iowa.

NOW is your opportunity to turn your useless junk into real American dollars. I buy obsolete motion picture mechanisms, such as Edison, Pathe, Lubin, Monarch, etc. Dunston, 306-33 St., Norfolk, Va.

GUARANTEED Fresh movie film! Three spools double 8mm. \$3.45! Six spools Univex \$2.90! Daitite loading! (Limit six each type.) Will ship c.o.d. Catalog. Eso-S, 3945 Central, Kansas City 2, Missouri.

WANTED: Castle films 8mm. Give subjects and price. Box 179, Park Ridge, Ill.

SEND Stamp for 16mm., 8mm. catalogue. Sterling's, 679 Northampton, Easton, Pennsylvania.

PANCHROMATIC Film, Weston 24 100 ft. double 88, \$3.90; 16mm. \$3.80. We do processing. Free circular. Genera Co., Davenport, Iowa.

8MM.-16MM. Silent-sound; all latest subjects. Films rented everywhere. Free catalogue, (sample film 10c). Garden Film, 317 West 50th, New York.

DEALERS 16mm. Films. Sample, catalogue, dime. Paramount, 204 East Broadway, Monmouth, Illinois.

WANTED. Movie projectors, 300 wt. up. Top prices. United, 2309 Lawrence, Toledo, Ohio.

RELIGIOUS Films only. New prints. Screenart, 723-7th Ave., New York.

8MM.-16MM. Films. Free catalogue (sample film 10c). Parkway Exchange, 1593 Union Street, Brooklyn, New York.

16MM. Sound subjects \$3—8mm. 50c. 10c for lists. Holmes, 3596 Main, Riverside, California.

AMERICA'S Best home movie subjects, catalog, generous sample film dime. Trans-American Sales, Morristown, New Jersey.

"LORELEI"—Featuring seven Hollywood queens. 8mm. 50 ft., \$2.00; 16mm. 100 ft., \$4.00. Complete lists, glamour sample, 10c. Jenkins, 392-P, Elmira, N. Y.

SILENT 8-16mm. Sound projectors. Highest prices paid. Moggill's, 64 West 48th Street, New York 19.

FREE. Movie film catalog. Sample 10c. Goodwill Company, Jackson, Tennessee.

8-16 MM. Film-subjects — Black and white and color; sound or silent. Largest selection ever compiled: 75c to \$100. Write for new, deluxe 1944 catalog—profusely illustrated! 25c (coin) refunded first purchase. Hollywood Movie Supply, Hollywood, Calif.

MOVIES: Gorgeous Kodachrome subjects. Also black and white comedy, sports, glamor. Lists free. Glamor sample dime. Keeley, 42-PM, Corning, N. Y.

"BATTLE Of Italy" and MacArthur's victory at Lae, westerns, comics, dramas, 8 and 16mm. 3c stamp. Excel Home Movies, 634 Acklin, Toledo 10, Ohio.

SILENT 35mm. Films! Lists 3c. Demsey, 1613 Stewart, Youngstown, Ohio.

NEW Film lists and exchange plan. Paramount Mfg. Company, Dept. G-120, Box 224, Backbay, Boston 17, Mass.

JOIN Our new Home Movie Film Club. Silent or sound 8-16mm. films exchanged at lowest rates. Particulars free. National Film Exchange, Sta. E-Broadway, Toledo, Ohio.

I BUY, Sell, rent, swap s.o.f., 8 and 16mm., silent. Bargain list monthly. Wanted one dozen sound projectors. Harvey R. Iris, Box 539, Brockton 65, Mass.

MOVIE Film processing: Write for information and sample. Cory Film Service, R. 6, Kalamazoo 86, Mich.

41 BRINGS "Surprise" assortment 8mm. colorful titles! Guaranteed. LeMoine Films, Nevada, Missouri.

8MM., 16MM. Rentals, silent 40c per reel; sound features \$4.95. Free lists. National Cinema, 71 Dey St., New York.

"THE World's Greatest Passion Play" 8mm., 16mm. and 35mm. Specify silent or sound. Rent or purchase, include stamp. Hemenway Film Co., 33-F Melrose St., Boston 11, Mass.

MOVIE Film, 100' 16mm. \$1.90-25' double 8mm. \$1.25, developing included. Ambassador, 479-A Quincy Street, Brooklyn, N. Y.

ALL Makes camera films, 100 ft. 16mm. \$2.00. 8mm. 25 ft. double \$1.25. Developing free. Also complete movie subjects available. Free catalog. Star Safety Film, 630 - 9th Ave., New York.

LEARN Movie projection, management. Free catalog. Give age. Theatre Institute, Elmira, N. Y.

BASS Says: Leadership in the cine field is apparent in war times. Here ready—your choice of 8 mm. and 16 mm. apparatus. Write for quotations. Your old equipment is worth real money in trade—describe please. Or we buy for cash and pay immediately on receipt. Write to headquarters. Bass buys 'em, sells 'em, trades 'em. Satisfaction guaranteed or your money refunded. Bass Camera Company, Dept. A, 179 W. Madison St., Chicago, Illinois.

MUSIC AND MUSICAL INSTRUMENTS

POPULAR Piano, authentic, individualized course. Free bulletin. Write Dept 1-P, Eastern Schools of Music, Steinway Hall, New York City 19. Bernard Spencer, B.S., M.A., Director.

ACCORDIONS: New and used, bought, sold and repaired at wholesale prices. Cash and terms. New 90 page accordion method \$2.20. Del Principe, 307 So. Wabash, Chicago.

HAWAIIAN Guitar music. List on request. Golden Gate Publications, 1724 Telegraph, Oakland 12, California.

ACCORDIONS. All makes. New and used. Write American Accordion Co., 31 S. Cicero, Chicago.

PIANISTS-ORGANISTS: Quickly improve technique, sightreading, accuracy, memorizing, playing through mental-muscular co-ordination. Free booklet. Broadwell Studios, Dept. 44A, Covina, Calif.

PLAY Harmonica. No musical knowledge required. Complete course \$2.00. Satisfaction guaranteed. Send Jimmy Dugan's Harmonica Club, Box 6393, Cleveland, Ohio.

ACCORDIONS \$69.50. Buy and sell all makes. 60% discount. 44 N. Albany, Chicago.

LEARN Popular piano! Write Magic Key, 111-A Broadway, Glendale 4, Calif.

SONGWRITERS! Send your poems for our offer and free "Rhyming Dictionary." Phonograph records made. Vanderbilt Music Studios, Box 112, Dept. 2-A, Coney Island, N. Y.

SONGWRITERS—Free book, "The Key to Your Future." Write Variety, 2, Salem, Indiana.

POEMS Wanted for musical setting. Send poem for immediate consideration. Five Star Music Masters, 630 Beacon Building, Boston.

MUSIC Composed to words. Wonderful proposition. Bauer Bros., Oshkosh, Wis.

MUSIC Arranged. Songs published. Frank Wildt, Music Publisher, Lancaster, Pennsylvania.

FREE Stamps for details. Walter Hoenes, Dept. PMM, Cologne, New Jersey.

POEM Writers. Young expert pianist-composer arranger desires collaboration with new writers. Inquire, Bob Standing, Box 34, Verdun, Quebec, Canada.

FLASH. Amateur song writers send poems to Prairie's Music Service, 205 North Townsend St. (Apt. 12), Syracuse, N. Y.

HOW To sell songs. Bonafide instructions \$1.00. Free details. Andy Toce, 22 Burton St., Hartford 5, Conn.

LEARN Popular piano! Play hit songs in boogie-swing style. Pianists, send dime for sample arrangement. Home-study folder free. Christensen Studios, 751 Kimball Hall, Chicago 4, Ill.

PHONOGRAPH Records, slightly used, 20 cents each. Chas. Hoodwin Co., 4419 Broadway, Chicago, Illinois.

SONG Poems wanted. Write for free booklet, instructions. Song Service, 331-C West 46th, New York.

POPULAR Piano in 12 lessons. Kelly School, 1781 Oak Street, San Francisco, Calif.

SONGWRITERS! Amazing, outstanding proposition. Hibbler, C5, 2157 N. Avers, Chicago.

GOOD Music composed to good words. Music printing. Reginald Belcher, Chatham, New Jersey. Established 1916.

SONG Poems wanted. Free examination. McNeil, Master of Music, 510-PM South Alexandria, Los Angeles, Calif.

OUTSTANDING SONGwriting service. Roscoe Barnhart, 1320 48th, Des Moines, Iowa.

BEFORE Sending your poem to be set to music "know your composer." Free booklet. Al. Moquin, 2110 Beachwood Dr., Hollywood 28, Calif.

WANTED! Lyrics, melodies for songs. We arrange, publish, sell. Superior Song Studios, Passaic, N. J.

SONGWRITERS—Send poem for immediate examination and free rhyming dictionary. Richard Brothers, 24 Woods Building, Chicago.

SONG Poems wanted: Write for free instructive booklet outlining opportunities. United Music Corporation, Dept. 14, Salem, Indiana.

SONGWRITERS. Write for free booklet, profit sharing plan. Allied Music, 204 East Fourth, Cincinnati, Ohio.

WRITE Songs. Big money and reputation. Write for information. J. Gordon Pub. Co., 261 N. Hoyne, Ave., Chicago.

RADIOS, SUPPLIES, INSTRUCTION

LOWEST Prices. Radio tubes, parts. Free bargain lists. Potter, 1314-P McGee, Kansas City 6, Mo.

REVISED Plans 18 long distance crystal sets, with "Radiobuilder"—25c. Laboratories, 363-C Hampton, Hayward, Calif.

"RADIO Construction and Repairing"—441 page, illustrated workbook—\$2.50. Wellersdick, Box 303, Thomaston, Conn.

BRAND New portable radios \$13.50. Other bargains. Bryant Radio, 915 Bryant Ave., The Bronx, New York City.

DX Almanac lists every broadcast station, all wavebands, through world, 50c. 15 Ellamere, Worcester, Mass.

CRYSTAL Radio experimenters. Write Hulet, 29 East 39th St., New York.

PREPARE Yourself now for a well paying radio position after the war. Obtain your FCC commercial radiotelephone and telegraph licenses through our home study courses, written for the man who has forgotten higher mathematics. An easily read, easily understood course. Moderate tuition fee. Write for particulars. American Radio Institute, 44 East 23rd Street, New York, N. Y.

RADIO Service men and experimenters send for our giant radio catalogue. Save dollars. United Radio Co. (1000M), Newark, N. J.

BUSINESS OPPORTUNITIES

EXPERIENCED Bookkeepers, accountants, college men, teachers, may earn \$500 to \$5000 fees as cost consultants, installing new modern practical cost systems. Learn direct from Philadelphia firm of successful professional cost consultants and industrial analysts. Practical, profitable. Ten comprehensive parts or lessons, \$5.00 per lesson. Write or register through W. C. Moore, 111 Oak Terrace, Merchantville, N. J.

LEARN Movie projection, management. Free catalog. Give age. Theatre Institute, Elmira, N. Y.

MOLDMAKING—Plaster Casting. Complete formulas—fully illustrated. 25c. Ideal Service, RM-1, Park Ridge, Ill.

LEARN Credit and collection agency business; our complete ten lesson course contains over 25,000 typewritten words; \$5.00 postpaid, or first lesson, with full index of subjects covered, 50 cents. Educational Extension Service, Box 1945, Wilshire-Labrea Station, Los Angeles.

INCORPORATE Your business. Delaware laws. Many advantages, free details. Tax Research Bureau, Inc., Delaware Trust Building, Wilmington, Delaware.

START Home business making statuary, plaques, art goods, novelties, souvenirs, concrete pottery, garden furniture, artificial marble flooring, liquid marble. Make your own flexible molds. Amazing profits. Valuable folder free. Creative Publishers, (PM1), Glencoe, Illinois.

EARN \$2.00-\$3.00 Hourly doing simplified tax bookkeeping locally. Expanding opportunities. Write: Thrift-Tee, Danville, Illinois.

SELL Books by mail. Easy profits. Lytle Supply Co., Avenue 11, Fredericksburg, Ohio.

SUCCESSFUL Mailorder letters, circulars, campaigns, planned, written. Long, diversified experience, exploiting books, merchandise, publishing, cosmetics. Investigate! Finkle Advertising, 1201 1/2 South Ogden, Los Angeles 35, California.

ATTRACTIVE Signs, showcards, professionally lettered with aid of Speedway Lettering Patterns. Modern styles, many sizes. Sample alphabet 10c. Display Letters Co., Box 28M, Brooklyn 9, N. Y.

START Your own business on our capital. Always your own boss. Hundreds average \$3,000 to \$5,000 annual sales year after year. We supply stocks, equipment on credit. 200 home necessities. Selling experience unnecessary to start. Wonderful opportunity to own pleasant, profitable business backed by world wide industry. Write: Rawleigh Co., Dept. A-U-PMMB, Freeport, Ill.

WINNING Dollar-getting schemes, tips, opportunities, formulas, 2 magazines, 72pp., 10c; 45th year. "Schemer," Alliance, Ohio.

MAIL Order business course shows you how to make money, spare or fulltime. Teaches professional mail order technique—not penny-catching schemes. Free details. Nelson Company, Dept. 402, Chicago.

MECHANICALLY Inclined men—Own and operate general appliance repair shop. Complete, illustrated course shows you how. Welding, refrigeration, motor repair, how to get business, etc., all phases covered. Free literature. Christy Supply Dept. 136, 2835 N. Central Ave., Chicago.

WORK For yourself! Build a business by mail. We show you how! Particulars free. E. Minnick, Timberville, Va.

JOIN National Mail Order Guild. Helps you start "legitimate sideline" mail business. Inside facts. Write. Central Enterprises, Simpson 1, Kansas.

MAILORDER Pays well. Opportunities galore. Magazine, literature, 10c. Dorothy, Orchard, Wheeling W. Va.

TESTED Business plans. Latest books. "Catalog dime." Russell, 912-A Anniston, Sylacauga, Alabama.

GREAT Fun with fascinating mail order business of your own. Start small, grow big. Details free. Plan 25 cts. Haller, 436 N. Y. Ave., Brooklyn 25, N. Y.

DISTRIBUTE Vitamins and minerals. Wholesale 1000 tablet prices. 8 vitamin and 3 mineral tablet combination \$3.95. Calcium tablets \$2.50. Iron tablets \$3.50. Mineral tablets \$3.50. Wheat germ perles \$3.75. Health book, retails \$2.00. Sample 50c. Free catalog. National Diet Co., Portland 4, Oregon.

MAKE Money at home raising guinea pigs. Booklet free. Taylors Guinea Pig Farm, Hapeville, Georgia.

EXTRAORDINARY Opportunities. Literature, big mail. 10c. Lloyd's, 230 Bankers Investment Bldg., San Francisco, Cal.

HOMEWORKERS—\$50.00, \$75.00, \$100.00 Weekly. Castwood plastic gifts, plaques, novelties. Material, molds, instructions furnished. Sample large scottie, woodcut mold model with illustrated molding circular, catalogue hundred new flexible molds \$1.00 postpaid. Plastic Products, 1410 N. Belmont, Chicago.

TURN Accounts into cash. Good income; quick results. National Collectors, Newark, Ohio.

HOME Business—Brand new plan—Hurry! Send stamp. Dalton, Box 3363, Terminal, Seattle.

FOR Sale, mail-order business idea. Houston Maupin, Tipp City, Ohio.

SELL By mail. Instructive folder free. Edwin D. King, 4216-A You Street, Sacramento, California.

INTERESTING Magazine 5c. Co-publishers wanted new writers. Renick, Holland, New York.

MAKE Money selling books by mail, spare time, start small, grow big, grand opportunity. Kraft Publications, Aurora 2, Missouri.

250 PRESENT-DAY Opportunities, 75 pages, 25c. Ten war-time plans, 10c. Home Industries, 1318 So. 30th, Omaha, Nebr.

OUR Bulletins are interesting and profitable. Details free. Derryhoyle House, Natick, Mass.

GIANT Mail, extra cash ideas 10c. Distributors, 730 West Giff, Peoria 5, Illinois.

THOUSANDS Of articles wholesale. "Supply Source Directory" 10c. Ideal Service, D-1, Park Ridge, Ill.

OTHERS Are doing it, why not you? Analyze handwriting for pleasure and profit. Lesson free. Enclose stamp for free personal analysis. Dr. Bunker, Joplin, Mo.

FORGET Canvassing! Home business, profits immense. Amazing details, 3c. Service (5) Drawer 339, Butte, Montana.

GET Into mail selling. Prepare for future. Start sideline business now. Send 50c for big folio and one year subscription to my mail order magazine. Grover S. Thomas, Rt. 3, pm., Windsor, N. C.

UNHEARD Of opportunity to enter "big time" mail order business. June, 101-M Beech, Holyoke, Mass.

BEGINNERS Mail order and local business plans and formulas, five books that shows you how for \$1.00 postpaid. Circulars free. Brain's Book Shop, 118P Washington Ave., Endicott, N. Y.

FOR Sparetime income get "Mailorder World." Sample copy, 10c; 3 months 25c. Southern, Waynesboro, Georgia.

QUICKEST, Cheapest, shortest way to learn mailorder business, 4,500 word folio 25c. Greatest non-advertising plan in existence. Particulars free. Hoffmann, 2740 Coy, Cincinnati, Ohio.

OPERATE Rental business. Complete course tells how. Taylor, 1006 1/2 Franklin, Tampa, Florida.

BRAND New book—68 pages, 40,000 words—300 tested moneymakers, business secrets, successful mailorder plans, formulas, wholesale supply sources—25c, moneyback guarantee. Smith Publications, 213 Comstock, Syracuse, N. Y.

GET Into mail selling. Prepare for future. Start sideline business now. Splendid opportunities. Interesting, profitable propositions immediately available. Progressive Magazine tells how! Free details and premium offer. Sheboygan Publishing Co., Sheboygan, Wisconsin.

SELL Vitamins by mail from your home. Send 10c for complete information. We show you how to build a profitable business. Cayol Foods, 812 LaSalle, Minneapolis, Minn.

FOR YOU! Variety, mail business opportunities. Write! Katz, 4294 N. Kimball, Chicago.

HOW To get free advertising, to can strawberries without cooking, 2 big mail order magazines, Ozark farm bargain list, Aunt Laura's candy recipes, giant opportunity mail. All for dime. Circulars mailed dime hundred. Ozark Press, Mountain View, Mo.

LEARN Refrigeration. Open your own shop. Be independent after the war. Common education sufficient. Illustrated course shows how. Booklet free. Mechanics School, Dept. PM, 4701 West Pico, Los Angeles 6.

MEN, Finest formula 50c. Waterless hand soap and paint cleaner. Worrow Chemical Co., 5438 N.W. 3 Ave., Miami, Fla.

AGENTS—To mail our literature. Good profits. Home business, Maywood, 1133 Broadway, New York.

READ Robert Collier's home mail order methods. Get 31 day trial offer. Dowpomp, 1217 Park Row Building, New York.

PAYING Mail business—Stamp brings proof. General Publications, Ossining, N. Y.

START Your own magazine agency at home. No capital required. Write for particulars and supplies. American Readers' Service, Hatfield, Penna.

"HOW To Make Simple Molds and Plaster Plaques." Profit in popular novelties! Booklet 25c. Plastercraft, 1406 E. 43rd St., Cleveland, Ohio.

COLOR Cement with chemicals. Make artistic cement garden ornaments Hollywood style. Sample 10c. Hollywood Cementcraft, 8527 Wonderland, Hollywood, 46, Calif.

KARAKUL Sheep are profitable. Write: Addis A. Kelley, Maywood, California.

CHARTERS: Delaware; best, cheapest; free forms. Colonial Charter Co., Wilmington, Del.

MAKE Money at home in spare time by mail. Write Gordon Publishers, Box 23, Pawtucket, R. I.

DRUNKENNESS Is a disease which responds to treatment. Medical skill plus human sympathy prove successful with liquor and drug cases, 60 years experience. Write for free booklet, P. M. Nelson, The Keeley Institute, Dwight, Ill.

WEBER Typewriter Mechanics School. Simplified homestudy-repairing increasing. Canton, Ohio.

PLASTEX Industries offers industrious men an opportunity to start a business of their own, manufacturing art goods, novelties, souvenirs, etc., in Plastex and marble imitation. 5c material makes \$1 articles. Rubber moulds furnished for speed production. Small investment brings good returns. We are now placing big chain store orders with manufacturers. Write for interesting booklet mailed free. Plastex Industries, Dept. A, 1085 Washington Ave., New York.

HOW And where to obtain capital. Fully explained, particulars free. Star Service, Wapakoneta, Ohio.

127 WAYS To make money, in home or office, business of your own. Full particulars free. Elite Co., 214 Grand St., New York.

BRUSH Plating outfits connect to a battery. No tanks necessary. Good paying business at home plating autoparts, bathroom fixtures, bicycles, reflectors, silvering mirrors. No shop or experience required. Outfits furnished. Free booklet. Gunnmetal Co., Ave. H, Decatur, Ill.

LIQUID Marble; snow-white, multi-colored. Glazed. Unglazed. Composition flooring. Lifetime wear. Any color. No priorities. Flexible molds. Plaster casting. Go into the big money now. Full information given free. Write Compo-Tex, Box 786, St. Louis, Mo.

SELL Names by mail! Pays big profits! Information free! Morganroth, Box 2104, Bridgeport, Conn.

"GUARANTEED Mail Profit Demonstration"—10c (coin). Warrades, Oak Park (1026), Illinois.

YOU Too can learn how to make, mold or cast real plastics. Send stamped envelope Box 498, Gainesville, Texas.

SILK Screen business. Print the dresses you like, school, posters, cards, etc. Send money order for your copy \$1.00. L. Shores, 2339 Warren, Chicago.

MONEYMAKING OPPORTUNITIES

HELP Win the war first! Then man, you'll like silvering mirrors, reflectors! Making sparkling chipped glass nameplates. Outfit prices. Sprinkle, Plater, V60, Marion, Indiana.

IF YOU want to swap-buy-sell anything, send for Swappers Guide. It's full of opportunities all over America. 20c copy. Free advertising. Swappers Guide, 610 N. St. Joseph, Evansville, Ind.

GROW Dwarfed trees few inches high. For yourself or sell. Instructions 15c. Charles McGuire, P.O. Box 628-G, Seattle, Wash.

MAKE Your own Flexible Molds. Statuary, Art Goods, Novelties, Artificial Marble Flooring, Liquid Marble. Literature free. Kemico, 1-M, Park Ridge, Ill.

MECHANICALLY Inclined men—Own and operate general appliance repair shop. Complete, illustrated course shows you how. Welding, refrigeration, motor repair, how to get business, etc., all phases covered. Free literature. Christy Supply Dept. 1136, 2835 N. Central Ave., Chicago.

MAKE Extra money at home. Details free. Lumco, Kimball, Nebr.

POPCORN Candies formulas, 22 delicious varieties. Hot sellers. \$1.00. LaPlant, Menominee, Michigan.

EARN Money evenings, copying and duplicating comic cartoons for advertisers. Adservice, Argyle, Wisconsin.

AGENTS, Salesmen, home workers, get new offers. We send names everywhere. 25c lists yours. Hudson Service, 1472 Broadway, New York.

125 DANDY Ways to make money. Broadside, stamp. Crown Books, Charlotte 2, Mich.

BOOKKEEPING Service—Earn money at home with bookkeeping service for small business firms. Cupp, 515 Highland Ave., Houston, No. 9, Texas.

7 LEADING Mail order magazines—25c. Novel Enterprises, Reno 2, Nevada.

"FREE Inspection." Popular sparetime moneymaking booklet. Quality Distributors, Yeaton, Penna.

PROFITABLE Home-work. Woodcraft sample 10c. Particulars free. Woodcraft, 1320 Lindsay, Gainesville, Texas.

127 MONEYMAKING Plans. Home, office. Own business. Free information. National Enterprises, 815-N Douglas, Nashville 4, Tennessee.

GET Your mail order start by joining the National Mail Order Guild. They tell you all the facts—what sells by mail—who buys by mail and how to reach them. They help you every step of the way. Send for full information. No obligation. A. J. Shutt, P.O. Box 269, New Castle, Indiana.

DETECTIVES Earn big money. Experience unnecessary. Particulars free. George Wagner, M-125 West 88th, New York.

SELL By mail. Complete selling plan, descriptive list 10c. M. Graham, Warwick, New York.

SELL Envelopes by mail, wholesale. Big profits. Write Omaha Envelope Service, Dept. A, 4721 California, Omaha 3, Nebr.

BOOKKEEPERS Earn money at home posting journal entries. Ellis, Cedar Grove, North Carolina.

52 PAGE Mailorder magazine, ten cents. Loren Hollenberg, Roseville, Ill.

PERFUME Instructions furnished. Start mail order or local business. Particulars free. Dr. Abell, Parkway Bldg., Pasadena, Calif.

GIANT Mails 6c; Mail Sale Magazine 4c; opportunity mail free. Harvey Teeple, (PM), Decatur, Ind.

PUBLISH Your own magazine. Hand-some 52 page format, well edited, illustrated. Cost low as \$1.00 month. Brings you prestige, profits. 10c brings sample, details. National, Ord, Nebr.

LEARN Metascience. Remarkable drugless healing. No manipulation. No apparatus. Unbelievable simplicity and results. Inexpensive correspondence course. Write Metascience, De Land, Florida.

EARN Money at home! Thousands do! "Home Worker Magazine" tells how. Sample, 25c. Sizemore, Box 7, 4917 North Kostner, Chicago.

KNACK Of making money in any business, job or profession. No selling. Easily mastered. We show you how. Information free. Better Sales Co., P.O. Box 35, Sta. E, Cincinnati 19, Ohio.

FORMULAS, PLANS, ETC.

PRESERVE Your eggs in a fresh condition six to twelve months. Directions, 25c. James Vick, Church Road, Virginia.

NEW Gland stimulating vitamin. Details accompany "Colchicine" offer. See "Chemistry."

"LUMINOUS Paint" shines in dark. Easily made. 100 other formulas, plans—all 25c. Soap-making course (20 formulas) \$1.00. Resilvering mirrors, formula 20c. Ideal Service, 301, Park Ridge, Ill.

FREE Formula catalog. Latest money makers. Western Chemical, Salem, Ore.

MAKE Fast selling products. No machinery. "Chemist Approved Formulas." Literature free. Kemico, 15, Park Ridge, Illinois.

MONEY-MAKING Formulas for beginners, demonstrators, etc. Lists free. Viggiano, Chemist, 6556 Ladson, Pittsburgh, Penna.

REAL Manufacturing formulas. Lists free. Cummings, Chemist, Gordon Ave., Syracuse, N. Y.

FORMULAS—Latest, best. Analysis. Literature free. Belfort, Engineering Building, Chicago.

AUTHENTIC Formulary 924 pages (illustrated). 10,000 money making formulas, recipes, instructions, substitutes. \$2.00 postpaid or C.O.D. (foreign \$2.35). Catalog, Adams Brown Company, Chestnut Hill, Massachusetts.

CHEMISTRY

FREE Chemical catalogue. Enclose 3c postage. Greenwood, 398 Broadway, New York.

COLCHICINE—Evolution chemical creates new mutant plants. Illustrated booklet plus Experiments magazine 25c. Questok, Wellesley, Mass.

WINN'S New Idea Home Laboratory Chemical Kits and apparatus outfits for home experimenting. Send 5c for literature and retail supply catalogue. J. H. Winn Co., Dept. 501, 124 W. 23rd St., New York.

288 PAGE Apparatus catalog sent for 75c. Chemical catalog, 10M items, 25c. Laboratory Materials, 7321 Vincennes, Chicago.

LUMINOUS Paints, large samples ten colors 25c. Stamps acceptable. Spectroscopes, electroscopes, etc., catalog 10c. Hammer Laboratories, Denver 7, Colorado.

GLASSWARE, 25 Pieces \$1.00, 15 chemicals \$1.50. Catalog, Rankin, Glover Bldg., Kansas City, Mo.

FREE Catalog: Chemistry, mineralogy, biology, optics. Special book sale: "How to Make Chemical Laboratory." Send \$1.00. Tracey Laboratories, Evanston, Ill.

CHEMISTRY Laboratory apparatus and chemicals for industrial, analytical, and private experimental laboratories. Complete chemical laboratory supply service for correspondence school students. Send 3c for free 48-page catalog of chemicals and apparatus. Dept. M-43, Biological Supply Co., 1176 Mt. Hope Ave., Rochester, New York.

SPECTROSCOPE For quick chemical analysis \$2.50. Kutting Sons, Campbell, California.

AGENTS WANTED

AMBITIOUS School seniors—Sell classmates the "top" in graduation name cards. Best commissions. Free cards. Agencies going like wildfire. Hurry! Craft-cards, Box 235-L, Pittsburgh 30, Penna.

WRITE For big package actual sample fabrics and styles absolutely free: dresses, lingerie, hosiery, shirts, etc. Take orders. Commissions big. Send no money. Write for your free line today. Melville Company, Dept. 3751, Cincinnati, Ohio.

GOLD Lacquered window sign letters. New styles. Absolutely beautiful. Free samples—catalogue. Atlas, 7941 Halsted, Chicago.

AGENTS—It's new—It's hot. Everyone wants radiant plastic lunch kit. Sample on trial. Commissions advanced. We deliver. Collect. Condon, Box 157, Upper Darby, Penna.

PLATING Outfits for autoparts, reflectors. Connect to a battery. No tanks necessary. Free booklet and particulars. Gunmetal Co., Ave. N. Decatur, Ill.

START Your own business on our capital. Always your own boss. Hundreds average \$3,000 to \$5,000 annual sales year after year. We supply stocks, equipment on credit. 200 home necessities. Selling experience unnecessary to start. Wonderful opportunity to own pleasant, profitable business backed by world wide industry. Write Rawleigh Co., Dept. A-U-PPMA, Freeport, Ill.

EXCLUSIVE Territory fire extinguishers moderately priced. Established 1885. Firstaid, 1824 Fourth Avenue, Los Angeles 6, California.

LUMINOUS Paint (shines in dark). Profitable seller to thousands of homes, stores, offices, and factories. Details. Ward, 97C, Saybrook, Connecticut.

CALL On friends with greeting card assortments; Easter, birthday, other occasions. Personal stationery, gift wrappings. Big profits. Experience unnecessary. Samples on approval. Wallace Brown, 225 Fifth Avenue, Dept. D-4, New York.

HANDY Hair trimmer. Sells like wild. Trims as you comb. Saves barber bills. Samples sent on trial. Kristee 131, Akron, Ohio.

MIDGET Bible charms. Literature free. H. Tooker, 630-M Chestnut, Hamilton, Ohio.

"PIN-UPS," Glorious girls. Postcard size. Samples 25c. Big bargain assortment \$1.00. Clover Novelty, 31-D, Hollis 7, N. Y.

MAKE Extra money selling our "Victory Stamps." Complete samples, instructions, 25c. Fred Quatsak, 1342 Kelton, Pittsburgh 16, Penna.

AGENTS. Big line including food products. Fast selling premium and bargain deals. Low prices. Send card for big outfit offer with gift. Ho-Ro-Co, 2775 Dodder, St. Louis, Mo.

AGENTS: Stamping names on pocket-key protectors. Sample check with your name, address, 25c. Stamping outfits. Emblem checks, check-fobs, name plates. Hart Mfg. Co., 303 Degraw St., Brooklyn, N. Y.

LIFETIME Business! Manufacture simple products! Profits 500 to 5,000%! Information free! Thermopwks, Peoria 4, Ill.

SEND Stamp for bargain sheet on 30 useful Xmas gift items from 25c to \$12.50. Goldshield Products, Dept. M, 350 Greenwich Street, New York.

"GUARANTEED Local Business Demonstration"—10c (coin). Waraides, Oak Park, (1026), Illinois.

EVERYONE With anyone in the service wants a personalized honor scroll and service record. Timely, fast sellers, profitable. Complete data on request or \$2 gets sales kit with samples and this amount refunded upon return of kit or after \$20 sales. Harry N. Latz Service, 242 West 55th Street, New York 19, New York.

MEDICINE Men! Sell products under your private label—Tonics, liniments, herbs, tablets, etc. Complete line of popular products. Purchase direct. Low prices. Rapid Service. Norman N. Bell & Co., 126 Lexington, Dept. P-12, New York City.

WHOLESALE Sources, 500,000 articles. Free directory. Maywoode, 1133 Broadway, New York.

PLAYING Card game, 250% profit. Sample game 25c. Box 842, Denver 1, Colo.

SCHOOL Seniors—Sell America's most beautiful, distinctive graduation name cards. Positively highest commission. Lowest prices. Free sample kit. Printcraft, 1423 E. Elm Street, Scranton, Penna.

MAGIC Cleaner and laundry soap deal. Hotter than a firecracker. Big profits! Sample free. Bestco, 5007 Irving Park, Chicago.

EXCELLENT Sideline for printing salesman. Decalcomania name plates in small quantities. Also, make money applying initials on automobiles. Free samples. "Ralco," 1483 Washington, Boston (18), Mass.

AGENTS—300% Profit selling gold leaf window letters; stores and offices. Free samples. Metallic Letter Co., 438-B North Clark, Chicago.

FREE Water and our concentrates, makes flavors, lotions, shampoos, 72 products, labels, bottles furnished. Qualco, E-20030 Russell, Detroit.

ELITE Collection contains 127 plans for starting own business; home, office. Descriptive booklet free. Elite Co., 214 Grand St., New York.

HIGH-GRADE SALESMEN

UNUSUAL Salesmen for an unusual job. It's permanent, practically a business of your own, becoming more and more valuable. It's selling but selling largely by counseling. You are backed by strong national advertising and by many user-boosters. No priority troubles, and war conditions work with you in many ways. Requirements: good personality and character; a will to work. Liberal commission arrangement. LaSalle Extension University, nationally famous correspondence institution. Write fully about yourself to Elton Borton, 4103 S. Michigan, Chicago 15.

ADVERTISING Book matches—World's largest "direct selling" book match factory offers advance cash earnings calling on every type of business. Men or women. Experience unnecessary. Full, part time. Low prices. High quality. Quick deliveries. Powerful patriotic display. Special designs for army camps and naval stations. Repeats. Free kit, instructions. Match Corp. of America, 3433 West 48th Pl., Dept. E-1, Chicago 32.

NEW. Fast seller, store, agents, copyrighted pictorial layout. U. S. presidents, historical data, sample 10c. Meyart, Box 844, St. Louis, Mo.

SALESMEN—Saleswomen—6c (cost to you) article sells on sight to workers everywhere for 25c. \$6 to \$10 day easy. Send 25c coin for sample, and full details. Brumley Products, Dept. P, 1026 Champa, Denver, Colo.

SELL Famous "Re-Zil-Arch." Write, Everett Foot Cushion Company, Everett, Mass.

ADVERTISING Book matches. America's largest manufacturer of union label book matches. Fast selling line. Large sales producing kit. Sample matches. Complete cut catalog, 17 color combinations makes selling easy. Commission in advance. Superior Match Company, 7530 Greenwood, Dept. M-1, Chicago.

SALESMANAGER. Educational memberships. Mechanical society. Big percentage. Permanent. No traveling. Cities. Airmail your application. Noble B. Martin, 610 Mead Bldg., Portland 4, Oregon.

STEADY Or part time employment for reliable men selling mineral mixtures to farmers and livestock feeders. Liberal commissions. Lucas Mineral Company, Castanea, Penna.

BLADES—Best quality, factory prices. Details free. Ace Blades, Buffalo, N. Y.

SALESMEN: Have real money making opening. Fits into war program. Old progressive firm. Dept. "F," Box 392, Dallas, Texas.

HELP WANTED

MEN 20-45 Yrs. to work on railroad rail testing service cars. Those under 38 must be draft deferred. Job entails constant traveling. Electrical-mechanical experience preferred. Also stewards; salary plus all living expenses. Those now in 100% war work not considered unless released. Arrangements will be made for personal interview in your vicinity. Write full details to Personnel Department, Sperry Products Co., 1505 Willow Ave., Hoboken, N. J.

EDUCATIONAL AND INSTRUCTION

GOOD Jobs for you in hotel and institutional field, wartime housing, food and recreation projects. Thousands of men and women—all ages—needed for well-paid positions that offer color, excitement, ever-new and fascinating duties. Already built or under construction are over 3 billion dollars worth of government social and recreational buildings, officers' clubs, etc. Record-breaking business in hotels, clubs, institutions means even greater opportunities. Lewis school receiving calls for managers, hostesses, executive housekeepers, purchasing agents, stewards, housing supervisors, cafeteria directors, etc. Previous experience proved unnecessary! No need to leave your job to qualify. A good grade school education, plus Lewis Training qualifies you, at home, in spare-time. Our National Placement Bureau helps to place you—and under our amazing Certified Job Plan—actually guarantees you will "make good" when placed. Write today for free book! Lewis Hotel Training School, Room CA-368, Washington 7, D. C. (First and only school of its kind—Now in its 28th year.)

"HOW To Break and Train Horses"—A book every farmer and horseman should have. It is free; no obligation. Simply address Beery School of Horsemanship, Dept. 1101, Pleasant Hill, Ohio.

LEARN Angora rabbit wool production: Very profitable, also handicraft, spinning, etc. Wool \$10 a pound, rabbits easy to raise. 20 lesson course teaches you. Details 3c stamp. International Institute, Box 667, Salem, Oregon.

BEAUTIFUL Penmanship—Interesting spare-time course. Hotel School, 33 Michigan, Dobbs-Ferry, New York.

MAGIC Shorthand and typewriting. Complete. Easy. Send 50c. Faneuil, 397 Ferry St., Malden, Mass.

EXCEPTIONAL Opportunity. Operate a collection agency-credit bureau. Quickly learned. Many make \$5,000 yearly. up. Write Cole Associates, Syracuse, N. Y.

GOOD "Used" educational books on all subjects bought, sold, rented, exchanged. Satisfaction guaranteed. Complete details and 84-page illustrated bargain catalog free. Write Nelson Company, Dept. 268, Chicago.

MAKE Up to \$25-\$35 week as a trained practical nurse! Learn quickly at home. Booklet free. Chicago School of Nursing, Dept. M-12, Chicago.

WELDING—Electric arc. Learn profitable trade quickly through actual practice. Individual welder instruction at bare cost of materials. Full particulars free. Valuable welding lessons book 50c. Hobart Welding School, Box M-1332, Troy, Ohio.

DETECTIVE Training. Phillips Secret Service, 1917-B N. Kenneth, Chicago, Ill.

ENJOY Health. Become professional equilibriumist. Free health book. Write! Knoff, 2154CM North 52nd Street, Milwaukee, Wisconsin.

HOME Study course, drugless therapy. Free literature. Inst. of Drugless Therapy, Tama, Iowa.

LEARN Shoe rebuilding. Practical. Low tuition. Investigate. Gusias Trade School, 3803 Lake St., Chicago.

SECRET Investigation. Experience unnecessary. Detective particulars free. George Wagner, M-125 West 86th, New York.

NEEDED—More trained machinists. Prepare yourself now, big paying jobs, essential trade. Big future. Spare time, basic home training. Amazing new book \$3.00 postpaid. Sign, Farmington, Mo.

MATHEMATICAL Short-cuts. Forty lesson course \$1.00. Easily mastered. Slide rule free. Vocational Institute, Box 434, Duluth, Minnesota.

SHORTHAND In ten lessons. Sample. Kee-Way System, Dept. 444P, Syracuse 1, N. Y.

BECOME A Doctor of Psychology (Ps. D.) Teach secret of contentment, happiness. Solve mental worries. Free book. College of Universal Truth, 5651-B North Ashland, Chicago.

WRITERS—If you want to be more successful, send for "Writing For Profit," and learn how. It's free. Writer's Correspondence Club, 30 W. Washington, Chicago, Illinois.

REFRIGERATION Service course. 24 illustrated manuals. Booklet free. Mechanics School, 4703 West Pico, Los Angeles 6.

PREPARE Now for the avalanche of America's post-war billions in business enterprises. Get set to secure your share. Study financial understanding. Study money. Particulars free. Educational Books, 237 N. Rutan, Wichita, Kansas.

LEARN To sing beautifully through modern voice culture. Literature free. Ferris, 317A So. Hartford, Bremerton, Wash.

EARN Certified Grapho-Analyst degree analyzing handwriting. Students report earnings up to \$1.00 an hour sparetime. \$75.00 weekly full time. Graduates in employment, credit agencies, police departments, courts, business and in private practice as personal problem and vocational advisors. Fully illustrated Grapho-Analyst and 3000 word illustrated lesson free. Institute, Box 1150, Joplin, Mo.

USED Educational books on all subjects sold, rented, also bought and exchanged. Moneyback guarantee. Write today for free catalog and details. Lee Mountain, Pisgah, Alabama.

NEW Writers wanted to re-write ideas in papers, magazines, books. Splendid opportunity to "break into" profitable writing field. Rush postcard for free details. Comfort Writer's Service, 210-P South Seventh (2), St. Louis, Mo.

MEDICAL Laboratory technicians in great demand. We train you in your spare time, in your own home. You can practice while studying. Write for free catalogue. Imperial Technical Institute, Box 973-E, Austin, Texas.

DRUNKENNESS Is a disease which responds to treatment. Medical skill plus human sympathy prove successful with liquor and drug cases. 60 years experience. Write for free booklet. P. M. Nelson, The Keeley Institute, Dwight, Ill.

LOCKSMITH Course. Lock picking, key fitting, etc. \$1.00 prepaid. Locksmith, Canadian, Texas.

RADIO Engineering, broadcasting, servicing electronics, aviation, marine and police radio taught thoroughly. All expenses low. Co-educational. Catalog free. Dodge Institute, Dept. R, Valparaiso, Ind.

CARTOONING, COMMERCIAL ART, SHOWCARD WRITING, SIGN PAINTING

CARTOONING. Learn quickly at home. New, easy method. Originate comic characters instantly. Prepared by successful cartoonists. Complete course \$2.85. Details free. National Artists, P.O. Box 4248-A, Dallas, Texas.

CARTOONING: Easy method course—36 lessons, 1,000 illustrations, complete \$2.85. Sample lesson sheet free. Home Instructions, 3456 West 116th St., Chicago 43.

SIGNS Painted—all kinds. Write for information. Hunter Signs, Westboro, Mass.

BEST Complete cartoon course with artists kit—\$2.00. Membership Cartoonists Association free. Cartoon Publishers, West Springfield, Mass.

TRY Professional black ink. Supreme for lettering, fine drawing. Desk bottle, 50c. Meub, 1944 Lomavista, Pasadena 4, Calif.

CARTOONING Course:—30 illustrated lessons, over 500 sketches, \$1.00 postpaid. Montes Studio, Box 892, Pasadena, Calif.

CHALK Talks. Laugh producing program, \$1.00. Catalog 10c. Balda The Cartoonist, Oshkosh, Wisconsin.

BUSINESS SERVICE

HOLLYWOOD. Movieland prestige mail address. Business and personal mail received and forwarded daily. Only \$2.00 monthly. Mary Ennis, Box 2967, Hollywood 28, California.

WE Collect notes. Accounts everywhere. No charge unless collected. May's Collection Agency, Somerset, Ky.

COURTNEY'S Mail Service, Box 828, Gary, Ind. Receives, re forwards business, personal mail. \$2.00 monthly. (Letters, post cards mailed 10c, 3 for 25c.)

USE Our Washington, D. C., office for your business, personal mail. Complete receiving, re forwarding service, \$2.00 monthly. Hawkins, Seven Randolph Place.

ADVERTISING AGENCIES, LETTER WRITERS, FOR ADVERTISERS

ARTISTS: Scores of them. Best talent. Full or part time. Send for directory. Associated Chicago Artists, 840PM No. Michigan, Chicago.

COMMERCIAL Art, advertising illustrations, any purpose. Trade-mark, letterhead or label designing. Reasonable prices. Baker Studios, 3302 Dodge, Omaha, Nebraska.

24 WORDS, 30 Newspapers \$2.00. Good-all, 37 Gardner, Vallejo, California.

ADVERTISING Placed, any publication, lowest rates, complete agency service. Skilled advertising—merchandising counsel. Ratelist and booklet, entitled "Advertising Results For Sale" free. Baker Agency, 3302 Dodge, Omaha, Nebraska.

SPECIAL Low-costing, most effective, inexpensive advertising. Write Van Scoy, 1501 West 11 Place, Los Angeles.

ADVERTISE Profitably: \$15 reaches 5,000,000 Sunday newspaper readers with 24-word ad. Newspaper, magazine, mailing-list ratebook, free. Chicago Advertising Agency, 20-PA West Jackson, Chicago.

ADVERTISE: 24 Words, 149 newspapers, \$6.50. Lists free. Advertising Bureau, 4815-G Cottage Grove, Chicago.

INCH Display advertisement, 50 magazines, year \$15. Wood's Popular Services, Atlantic City, (N. J.)

FREE—New Advertisers Rate Guide. 44 pages. Includes everything. Lowest rates. E. H. Brown Advertising Agency, Merchandise Mart, Chicago.

ADVERTISING Placed all magazines, newspapers U.S.A., Canada. Lowest rates. Free service. 54-page catalog free. Baker Advertising Agency, A-189 W. Madison, Chicago.

FREE—"Amazing New Book"—"Profits From Classified Advertising." Tells how and what to advertise. Be sure to read this book before you invest one cent in advertising. Remember—it's free! Write for your copy now. P. W. Johnson, Classified Advertising Manager, 200 East Ontario Street, Chicago, Illinois.

TYPEWRITERS, DUPLICATORS, OFFICE DEVICES

DUPLICATORS And supplies. Office appliances, etc. Write Dixiegraph, King, N. Carolina.

DUPLICATORS, Dictaphones, folders, addressograph, other office machines. No priority. Bought, sold, repaired. P. M. Pruitt, 425 N. LaSalle, Chicago.

"PRINTOMATIC" Self-feeding rotary stencil post card printer, complete, \$9.50. All makes duplicator supplies. Literature free. Pittsburgh Typewriter Supply, 336-R Fourth Avenue, Pittsburgh 22, Penna.

RUBBER STAMPS AND OFFICE SUPPLIES

ONE Line 15c, two lines 25c, three lines 35c. Excello Sales, Dept. B, Box 500, Shreveport, Louisiana.

3 LINES 30c; Cushioned, indexed, 35c. Signatures \$1.50. Stamprite, Wauwatosa, Wis.

KNOB Handle, cushioned, 2 lines 30c, 3—40c. Stamp Works, Centerport, N. Y.

PRINTING, MULTIGRAPHING, MIMEOGRAPHING, GUMMED LABELS

MIMEOGRAPHING Cheap! One day service. Send stamp for samples, prices. Sawyers, 732X, Gainesville, Fla.

DISTINCTIVE Stationery, reasonably priced. Samples free. Stump Print, South Whitley, Indiana.

\$1.00 EACH Postpaid; 200 8½x11 letterheads; 6¼ envelopes; postcards; statements. Benneville, 907 West Roosevelt, Philadelphia 40, Penna.

69c POSTPAID, 50 Letterheads and envelopes. 110 of both \$1.00. Yutz Press, Pottsville, Pennsylvania.

FIRST Quality printing—Reasonable. Particulars free. Treaster Printing, Milroy, Pennsylvania.

125 LETTERHEADS And 125 envelopes, \$1.50 prepaid. Gago Print Shop, Box P1544, Muskogee, Oklahoma.

\$2.00 POSTPAID; 200 8½x11 Good bond letterheads and 200 6¼ envelopes. 500 of each \$4.75 postpaid. Mero Products, Box 344, Punksutawney, Penna.

FREE Samples printing values! Anything you need. Fast service. Reasonable. Reporter, Chelsea, Oklahoma.

5000 ELEGANT Envelope enclosures, \$4.50; 1000, \$2.00. All printing lowest prices. Samples. Goodprint, Harrisonburg, Va.

200 BOND Letterheads, envelopes, 89c. 2000—\$5.98. Samples. Joseph Johnson, 1382-A Fifth Ave., New York 29.

BETTER Grade printing reasonable. Estimates on anything. Economic Press, Leonia, N. J.

500 ¾x2¼ FOUR Line gummed stickers, 25c. Moritz Printery, Saginaw, Mich.

PRINTING OUTFITS AND SUPPLIES

PRINT At home. 10c will bring a complete catalog of presses, type and supplies. P. Peiffer & Company, 6 Columbia St., Newark, N. J.

PRINTER'S Supply bargain catalog. Send stamp. Bradshaw, 3214-P Huron, Chicago 24.

PROFESSIONAL Stencil postcard printer, complete, \$2.45 postpaid. Challenge Association, B-12, Cincinnati.

INEXPENSIVE Home-made printing press. Details free. Novelty Shop, Downsview, Louisiana.

PRINTING Outfits and supplies. Send stamp for details or dime for complete illustrated supply book. Kelsey, Inc., W-11, Meriden, Conn.

USED Presses, type, supplies. Lists 3c. Turnbaugh Service, Loysville, Penna.

PATENT ATTORNEYS

"INVENTOR'S Guide," 100 mechanical movements, free; advises on patenting, selling inventions. Frank W. Ledermann, 154 Nassau Street, New York.

PATENTS. Protect your idea by securing free "Proof of Invention" folder. Exceptional personal service. Established 1906. E. E. Vrooman, 871 Woodard Bldg., Washington, D. C.

INVENTORS—Before disclosing your invention to anyone send for form "Evidence of Conception"; "Schedule of Government and Attorneys' Fees" and instructions. Sent free. Lancaster, Allwine & Rommel, 411 Bowen Building, Washington, D. C.

INVENTORS: Learn now—without obligation—how to protect and sell your invention. Secure free "Record of Invention" form with instructions for making disclosure and establishing date of your invention—and new free book "Patent Guide for the Inventor," containing complete information about patent procedure and how to sell inventions; giving illustrations of many successful inventions; over 150 basic mechanical movements. Delay may be costly. For prompt confidential service—write today to Clarence A. O'Brien & Harvey Jacobson, Registered Patent Attorneys, 41B-A Adams Building, Washington, D. C.

PATENTS—Trade marks, Preliminary advice, book and disclosure form free. Personal service. Irving L. McCathran, 315 McLachlan Bldg., Washington 1, D. C. Registered Patent Attorney.

L. F. RANDOLPH, 302-B Columbian Bldg., Washington, D. C. Low cost. Book and information free.

"PATENT—Particulars" and blanks, free, airmailed. Sterling Buck, Park-North Avenues, Baltimore 17, Md. Government-registered 37 years.

INVENTORS—First things come first. Your first move toward securing a patent on your invention is acquiring full information on what to do. Our two books "Patent Protection" and "When and How to Sell Your Invention" contain this information and other helpful data. Get them immediately, together with our "Evidence of Invention" form. They cost you nothing, you assume no obligation. Write now to Victor J. Evans & Co., Registered Patent Attorneys, 831-A Merlin Building, Washington 6, D. C.

PATENTS. Promptness assured. Wilfred E. Lawson, 1524 K Street N. W., Washington, D. C.

FOR INVENTORS

NEW Gland stimulating vitamin. Details accompany "Colchicine" offer. See "Chemistry."

INVENT Uses world's amazing wonder mineral, experimental quantity 30c. Chapman Laboratories, Box 665, Colorado Springs, Colo.

INVENTORS—Information on what to do first toward securing a patent on your invention is of vital importance. "Patent Protection" and "When and How to Sell Your Invention"—two valuable, richly illustrated books—explain fully what to do first, and a lot more. Get this information quickly together with "Evidence of Invention" form. All three will be sent to you free. Write immediately to Victor J. Evans & Co., Registered Patent Attorneys, 832-A Meridian Building, Washington 6, D. C.

INVENTORS. Industry needs your ideas now! Two reasons—1. Manufacturers are getting ready now for post war sales and production. 2. Right now, manufacturers are seeking products their expanded facilities can handle; factories must have products to take up the slack after war orders stop. Your chance comes with patent protection now—delay may endanger your chance. Get our new free Inventor's Book today and valuable "Invention Record" form. This request does not obligate you. Act now. Write today. McMorro & Berman, Patent Attorneys, 1342 Albee Bldg., Washington 5, D. C.

INVENTORS: Learn now—without obligation—how to protect and sell your invention. Secure free "Record of Invention" form with instructions for making disclosure and establishing date of your invention—and new free book "Patent Guide for the Inventor," containing complete information about patent procedure and how to sell inventions; giving illustrations of many successful inventions; over 150 basic mechanical movements. Delay may be costly. For prompt confidential service—write today to Clarence A. O'Brien & Harvey Jacobson, Registered Patent Attorneys, 41A-A Adams Building, Washington, D. C.

INVENTORS: New military and commercial inventions urgently needed by manufacturers. Write for particulars. Chartered Institute, Dept. 4-A, Washington, D. C.

INVENTORS: Receive thousands of dollars more for your invention immediately. Free information. Ray's Designing Service, 1220 Park Row Bldg., New York, N. Y.

I SELL Patents. Established in 1900. Charles A. Scott, 773PM Garson Ave., Rochester, N. Y.

CASH For practical ideas and inventions. Mr. Ball, AB-9441 Pleasant, Chicago.

INVENTIONS WANTED

INVENTORS: Have you a sound, practical invention for sale, patented or unpatented? If so, write Chartered Institute of American Inventors, Dept. 4-D, Washington, D. C.

ATTENTION! Have you a waste product, byproduct or sensible mechanical idea or device with wide commercial possibilities? Address Matt, 1412 Great Northern Bldg., Chicago.

ALL Kinds. We have facilities and finances to make and sell your ideas, both mechanical and chemical. Send model, sample, details and wishes. General Sales & Supply Company, 110 East Main St., Madison 3, Wisconsin.

PATENTS Wanted, developed, financed, engineered. Outright-royalty basis. Electronic Research Corporation, 800 West Washington, Chicago.

INVENTIONS Wanted. Patented and unpatented so as to be manufactured with power presses. H. Solomon, Inc., 75 Spring Street, New York City.

FOUNTAIN Pen—have you developed a new type? We have connection with manufacturer prepared to buy outright or produce on royalty basis product of this type meeting approval. Patent your idea and contact us. Post War Planning Department, Pacific National Advertising Agency, 605 Union Street, Seattle, Washington.

WANTED—New tools for automotive and aircraft work. Will buy patents or designs outright or as finished tools. Give details. Betterfit Tools, Box 56, New Britain, Conn.

CASH For inventions, patented, unpatented. Mr. Ball, A-9441 Pleasant, Chicago.

WANTED—Meritorious patented, unpatented inventions. Booklet references, free. Invention Reporter, 5B-11236 So. Fairfield, Chicago.

MANUFACTURING

MODELS—Small lot manufacturing. Metals, plastics, etc. Milburn, Burlington, Kentucky.

HELPFUL Books on hundreds of subjects. Catalog free. Popular Mechanics Press, (C-43), 200 E. Ontario, Chicago.

PATENTS FOR SALE

PATENT Pending self-closing cap for collapsible paste tubes. Made mostly of plastic. Can be manufactured simple and sold by the thousands. Will sell cash or royalty. Write Charles L. Carl, Box 91, Bourbon, Indiana.

FOR Sale. Simple plastic mineral-ord gold pan. Different colors. Not likely to be improved on. Write for descriptive circular. Pat. applied for. McKenzie, 1834 S. W. 5th Ave., Portland 1, Oregon.

CASH Or royalty—patent applied for—kerosene or fuel oil carburetor. Adaptable for any car. Economical driving. All fuel utilized. Clarence Fry, Culver, Indiana.

MODELS AND MODEL SUPPLIES

COMPLETE Kits ship models, coach models, covered wagon. All parts cut to fit—no shaping required—tack hammer only tool needed. Everything included—sails, wire, and rigging. Send 3c stamp for catalog. Miniature Ship Models, Dept. R, Perkassie, Penna.

PLANES, Boats, hundreds of hobby items. Catalog 3c. America's Hobby Center, Dept. B14, 40 E. 21st St., New York 10, N. Y.

CATALOG 50 Engines, model railroad supplies, 25c refunded. Howardeo, A2417 North Ashland, Chicago.

ILLUSTRATED Price list. Models, supplies 5c. Model Builders Supply, Hutchinson, Kansas.

YOUR Invention developed to a saleable article. 50 years experience. Dies, tools, miller. R. Backer & Co., 308 E. 3rd, Cincinnati, Ohio.

MODEL Kits and supplies, catalog 10c. Steve Patti Co., 1443 W. Forest Home Ave., Milwaukee 4, Wisconsin.

SHIP Model kits and fittings. Complete line Fisher model yacht equipment. All Boucher, Fisher, Marine Model and Ideal kits, fittings and blueprints at standard prices. Most complete stock in New England. James Bliss & Co., Inc., 220 State Street, Boston, Massachusetts.

SHIP Models and yacht supplies complete. Large 64 page catalogue 20c. Bill Wild's, 510 East 11 St., New York City.

RAILWAY Models, complete line informative catalogs O gauge, 104 pages, 25c; HO, 48 pages 15c. Walthers, 247 Erie, Milwaukee, Wisconsin.

CATALOG Of helpful books free. Send name and address. Popular Mechanics Press, (C-43), 200 E. Ontario, Chicago.

HOME CRAFTSMEN

SQUAREKNOTTERS! Make belts, handbags, etc. Quality cord samples with catalog, free. Beginners book, catalog and samples 10c. Special Regular \$1 book with 50c beginners outfit, all for \$1. P. C. Herwig Co., Dept. J-43, 121 Sands St., Brooklyn, N. Y.

28 LAWN Ornament patterns 25c. Other patterns: 15"-20" high; Dutch girl, Dutch boy, pirate, bull terrier, Mexican girl, Mexican boy, dwarf, penguin, flower girl, 10c each; 3 for 25c. 25 novelty patterns 30c. All 62 full size patterns \$1.00 postpaid. Strother, Box 383-FC, Belington, W. Va.

LUCITE And Plexiglas still available. Make Christmas gifts. Plans, instructions free. Cut to size or \$1.00 bargain assortment. Transpostal, 21 Follen, Boston 18, Mass.

NOVELTIES From scrap wood; 25 patterns 25c. Patterns, kits, lists 5c. Lynds, Medway, Mass.

WOODEN Baby walker, plans 50c. Chester Company, 3719-E 28th, San Diego, California.

CRAFTSMEN Make your hobby pay! Reproduce original works of anything, using Roni-Rub's Flexible Moulds \$1.50 pound. Carve large Carvabloc, with directions and patterns, 50c. Make toys and lawn ornaments with 3-color-patterns 25c. All sent postpaid and guaranteed. Roni Studios, Inc., Whitestone, New York City.

PATTERNS—Jigsaw. Three little novelty whatnots 15c postpaid. Tollie's Shop, 309 9th Ave. S. E., Aberdeen, S. D.

CATALOG: Tools, decal transfers. Patterns novelty furniture, lawn ornaments, silhouettes, letters and numerals. Other lines. 500 articles finely illustrated. Write Wo-Met Shop, Ashburn, Georgia.

WOODWORKING Power tools—Make them yourself from old auto parts, pipe fittings, scraps. Sanders, drill presses, lathes, saws, etc. Complete details on 40 tools in 96-page book \$1.25. Popular Mechanics Press, (C-43), 200 E. Ontario, Chicago.

WATCHES, OLD GOLD, JEWELRY

HIGHEST Prices for old gold—Mail your teeth, watches, jewelry. 100% full cash value mailed day shipment received. Satisfaction guaranteed or articles cheerfully returned. Information free. Chicago Gold Smelting Company, 300-P Champlain Building, Chicago.

GENUINE Diamonds, out-of-pawn low prices, wonderful values. Unredeemed loans and big buying power enable us to offer beautiful gems at prices far less than original cost. Shipped free for inspection, appraisal. Send for free list showing fine diamonds at startling low prices. Lloyd J. Butler, President, Prudential Loan Association, 133-LO North Clark St., Chicago 2.

GOLD \$35.00 Ounce. Mail old gold teeth, diamonds, jewelry, watches. Receive cash by return mail. Satisfaction guaranteed. Free information. Dr. Weisberg's Gold Refining Company, 1500-Q Hennepin, Minneapolis, Minn.

WATCHES, Materials, tools, jewelry, diamonds—bought—sold. Catalogue, Gales, Box 1000, Chicago.

TOBACCO, SMOKERS' SUPPLIES

\$5 AND \$4 Leftovers of blended smoking tobaccos. Only \$1.75 per pound. Send for free catalog and trial offer. Sidney Ram, 59 West Monroe, Dept. K-20, Chicago 3, Illinois.

FREE To pipe smokers—For a new pipe smoking thrill, write us your brand of tobacco and get free package mild, tasty, natural-flavored "Green River." Pete Moberly, Box 967, Owensboro, Kentucky.

WANTED—MISCELLANEOUS

CASH For bicycle engines, outboards, motorcycles, scooters, gasoline engines, exercycles. Describe, quote prices. Clymers, 2125 W. Pico, Los Angeles 6, Calif.

WANTED To buy Atlas milling machine. Atlas shaper. Havens and Martin, Box 5229, Richmond, Virginia.

WANTED: Automobile catalogs and boat and marine engine catalogs. Anything prior to 1930. Send list of what you have. D. Cameron Peck, 140 West Ontario, Chicago.

ACCORDION—Any condition. Give description, price. Chaton, 600 Blue Island, Chicago.

WANTED—New or used 12x4 tire, tube and rim. Leslie Dickerson, Bradford, Ill.

MERCURY—Highest war prices paid. Any quantity or quality. Free information and containers. Or, ship mercury today. Wholesale Terminal, Norwood, Mass.

MERCURY (Quicksilver)—Cadmium, bismuth, tungsten, molybdenum, cobalt, vanadium. Write for quotations stating quantity. You'll receive guaranteed prices. Metallurgical Products Co., 35th and Moore Sts., Philadelphia, Penna. Established 1909.

WE Pay you well for "anything" you wish to sell: merchandise; jewelry; tools; instruments; equipment. Justice Jobbers, Box 150, Chicago.

MERCURY (Quicksilver). We pay \$1.50 per pound. Western Metal Co., Bloomington, Illinois.

HUNDREDS Of helpful books. Catalog free. Popular Mechanics Press, (C-43), 200 E. Ontario, Chicago.

PERSONAL

MEN, Feel vitally fit! Amazing time-tested course helps stimulate entire system, restoring youthful pep and vigor in many cases. No medicine. No surgery. Benefits assured on money-back guarantee. Free information sent in plain, sealed envelope. Send name, address today to Basic Methods, 675 Elliot, Denver 4, Colo.

"GRUVED Letters" correct poor penmanship—few hours. Write. Ozment, 9, St. Louis, Mo.

PLAY Chess by mail with experts. Moves forwarded promptly. Send \$1.00 for trial game. Instructions included. Paul Eberts, 4220 West 16th, Little Rock, Ark.

MEXICAN Legal matters reliably handled. Box 240, Juarez, Mexico.

ASTROLOGY! Trial reading. Send birthdate and dime. "Delmar," Crescent Beach, B. C., Canada.

DO Your feet hurt? Itch? Burn? Sweat? Smell? Simple guaranteed home treatments eliminate these inconveniences. Read "Why Your Feet Hurt," \$1.00 postpaid. Educational Books, 237 N. Rutan, Wichita, Kansas.

PSORIASIS Sufferers: Pixacol has brought relief when everything else failed. Caution: Use only as directed. Apply externally, dries quickly, convenient. Try regular \$1 bottle without investing a cent! Write: Pixacol, Box 1298, Cleveland 3, O.

DEVEX Formula for athlete's foot. Helps heal broken tissues. Stops itching. Relieves soreness. Leaves feet soft, smooth. Sample. Devex, 7814 Franklin, Cleveland, Ohio.

SLEEP Tight every night with Sleep-Rite, soft waxen ear noise stoppers. Sample free. Dowpom, 1215 Park Row Building, New York.

RUPTURED? Improved appliance reduces. Often cures. No truss. Free trial. Earles Company, Flint, Michigan.

WANTED: Advertisements, news and court documents about missing heirs. Chaffee, 110 N. Franklin, Chicago 6.

CHARLES HERR. Please come home or write. Daddy, Mother and Alan.

AMAZING Dental plate cleaner. Double action. Brush free. Details post card. Dentos, 318-18 Ave. S. E., Minneapolis 14.

BIRTH Certificates, marriage, death, estate, other records all states. Also persons located. Write Bureau of Records, 308 Washington, Chicago 6.

FALLING Hair, its cause and prevention, is fully explained in an informative and educational pamphlet entitled "How to Keep Your Hair Till Ninety." For free copy write, James Hilton, 4819 Fourth Ave., Brooklyn, N. Y. 20.

DR. DILLINGHAM'S Chiroprodists' prescription relieves where others fail. Athletes foot. Send 50c. Sixty Park Place, Newark 2, N. J.

LIVE Longer, feel better, enjoy life. Free information. Fairchild Company, Mt. Vernon, Ohio.

BUY Vitamins direct. Save. Postcard. Matoska Products, White Bear, Minn.

DRUNKENNESS Is a disease which responds to treatment. Medical skill plus human sympathy prove successful with liquor and drug cases. 60 years experience. Write for free booklet. P. M. Nelson. The Keeley Institute, Dwight, Ill.

MISCELLANEOUS

RARE Garden seeds—Climbing tomatoes, climbing cucumbers, victory packets, 25c each. Green Valley Gardens, 126 North Main, Tulsa 3, Oklahoma. List free.

ANY Book (new, used, out-of-print, rare) promptly supplied! Lowest prices! Send for free bargain catalogues! Old Prof's Book Shop, M16 Arcadia Court, Pontiac, Mich.

START "Soap Factory" at home. No machinery. Amazing opportunity. Literature free. Kemico, SM-1, Park Ridge, Ill.

NOW, You can make your own printing cuts by simple, easy "Plastoplate" process. No messy chemicals, Adayservice, Argyle, Wisconsin.

BOOKS, Miscellaneous list free. Gowdy, 11 Princeton St., East Boston 28, Mass.

MAKE Delicious Carmelcorn, formula, 35c. Frank Shilling, 1017-M Dueber, Canton, Ohio.

MIDGET Bible 10c. Robert Renshaw, 222 Jeffrey St., Chester, Penna.

I WANT to send you proof of the wonderful pulling power of Popular Mechanics Magazine's classified pages. What's your proposition? Write me today. P. W. Johnson, Manager Classified Advertising, 200 E. Ontario St., Chicago.

UNUSUAL Novelties, samples 10c. Modern, Box 2, Station B, New York City-2.

BIG Mail for you. Latest moneymaking offers, opportunities, catalogs, magazines. Name listed in directory 10c. Ideal Service, 101-M, Park Ridge, Ill.

FREE—Stories. Boys, girls send postcard. David Berg, 659 Churchhill Road, Bridgeport, Conn.

UNPAINTED Wall plaques 2½c up. Write Oman, 642 Broadway, St. Paul, Minn.

MEND Socks, shirts without sewing. Use hot Batiron and our treated cloth patches. Complete 25c. Korn, 350 Irving, Brooklyn, N. Y.

LEARN Basic facts "Why Your Feet Hurt." Be sensible! Discard useless remedies! Information. Dulco, 324 Pitt, Pittsburgh 21, Penna.

ENGINEERS, Tracers, students. New design of ruling pen permits longer use between refills. Present pens reconditioned. New pens on market later. Circular on request. Walter S. Knight, Dravosburg, Penna.

GREAT Fun. Make believe you are in New York, Chicago, Miami, Canada. 3 cards sent, you write, return. I mail in New York, 25c; 7-50c. Letters 15c. Receiving, forwarding. Souvenirs, samples, information 10c. Agents wanted. Haller, 436 N. Y. Ave., Brooklyn 25, N. Y.

MAMMOTH Big mail—Magazines, etc. 10c. Directory, 319 So. Marengo, Pasadena, Calif.

NEEDED Civilian goods, supplies scarce! Everyone buy-sell-swap anything. Easily. No commissions charged. Write Hughes Service, Shillington, Penna.

RECEIVE Mails, magazines, samples. Your name in numerous mailing lists 10c. Howard, 396 Broadway, New York

25 RIP-ROARING Fun cards, 25c. L. Geer, Safford, Arizona.

FREE Catalog of Alaska novelties, Alaska Specialties Company, Ketchikan, Alaska.

MAKE Big money! Anyone can tattoo with our outfits. Instructions included. Free illustrated literature. Write Tatuco, 651 South State, Chicago.

GET Humorous Alaska license to hunt Japs. Send 50c. A remarkable novelty. Alaska Sportsman, Ketchikan, Alaska.

'44 ESQUIRE Desk calendars—Twelve Varga girls 50c. Esquire Agent, 1919 Girard, Philadelphia, Penna.

MEDICAL Laboratory technicians in great demand. We train you in your spare time, in your own home. You can practice while studying. Write for free catalogue, Imperial Technical Institute, Box 973-J, Austin, Texas.

FUN And profit for home craftsmen. Over 600 projects. Everything from book ends to fireplaces described in set of four What to Make books. Per set, cloth edition \$5.00; paper \$2.00. Popular Mechanics Press, (C-43), 200 E. Ontario, Chicago.

It's Going to be a Real Christmas for Everybody Getting CLEVELAND MODELS

Vo-Sik "CORSAIR"
Navy fighter. Span 30 3/16". C-D Master Kit SF-70 \$3.50

Lockheed P-38 "LIGHTNING"
Deadly interceptor due to its super-speed, high ceiling, and terrific diving power. Span 38 3/4". C-D Master Kit SF-85 \$4.00

Republic P-47 "Thunderbolt"
The "Flying Battleship." Over 425 mph. 40,000 ft. ceiling. Span 30 3/4". C-D Master Kit SF-81 \$4.00

Lockheed "HUDSON" Bomber
Used for bombing, fighting, reconnaissance. Called "Old Boomerang" by British, for it usually comes back from all raids. Big 49 1/2" span. C-D Master Kit SF-96 \$7.50

No. Amer. "MUSTANG" (P-51)
Tough, vicious fighter. First American fighter over Germany itself. 350 mph. Span 27 3/16". C-D Master Kit SF-91 \$3.00

Build These Big 36" Industrial Training Models of War Planes

Bell "AIRACOBRA"
D e a d l y "cannon- plane". Span 25 1/2". C-D Master Kit SF-70 \$3.00

Curtiss "HELLDIVER"
Navy scout bomber. Also dive bomber. Span 23 1/2". C-D Master Kit SF-80 \$3.50

Build these big 3-ft. span models. Each a realistic beauty.

Kit T74: Messerschmitt ME-109
Kit T-75: Bell "Airacobra"
Kit T77: Curtiss P-40 "Warhawk" (shown)
Kit T78: Hawker "Hurricane"
Kit T79: Lockheed P-38 "Lightning"
Kit T91: P-51 "Mustang"

Each Complete Kit, only \$1.50

Grumman F4F "WILDCAT"
"Ace of the Pacific". Regular "wildcat" in action. Span 24 1/2". C-D Master Kit SF-83 \$3.00

Douglas SBD "DAUNTLESS"
World's hardest hitting dive bomber. Used by Navy and Marines. Span 30 3/8". C-D Master Kit SF-89 \$3.50

Build the Biggest \$1.00 Plane in U.S.—Huge 7-Ft. Span

SUPER CONDOR Soarer
"Stronger, longer flights, more graceful lines, construction simplified. Easier than ever to build. Kit E-5019, only \$1.00"

See your dealer first. If he can't supply you, order direct. Include 15c extra for packing—postage charge on all orders. Send 5c for catalog (none free).

CLEVELAND MODEL & SUPPLY CO. "World's Largest Mfrs. of Quality Model Aircraft Since 1919" 4508D5 Lorain Ave., Cleveland 2, Ohio

Big, New HANDBOOK answers HUNDREDS of RADIO QUESTIONS

Save time, trouble, and error in radio engineering—get help from Frederick E. Terman, whose books are authorities in many leading radio schools and laboratories. New reference manual gives you wealth of essential theory, up-to-date standards, practice, and data, especially organized for use in practical radio and electronic problems.



Just Published—TERMAN'S RADIO ENGINEERS' HANDBOOK

One of the most complete works of its kind ever published—13 big sections: Tables, Mathematical Relations, Units; Circuit Elements; Circuit Theory; Vacuum Tubes and Electronics; Vacuum-tube Amplifiers; Oscillators; Modulation, Demodulation; Power-supply Systems; Transmitters, Receivers; Radio Waves; Antennas; Radio Aids to Navigation; Measurements—profusion of descriptions, fundamentals, formulas, procedures used in actual design, tables, diagrams, etc. Use it often—for data needed in routine problems of design and practice, or investigation of special problems. Get quick, dependable answers to your questions, when you need them. TRY IT OUT, FOR 10 DAYS FREE.

Over 1000 Pages
869 Illustrations
6x9—\$6.00

Send this McGraw-Hill Coupon—today.

McGraw-Hill Book Co., 330 W. 42 St., N.Y.C. 18

Send me Terman's Radio Engineers' Handbook for 10 days' examination on approval. In 10 days I will send \$6.00, plus few cents postage, or return book postpaid. (Postage paid on cash orders.)

Name.....
Address.....
City and State.....
Position.....
Company..... PM-1-44

9 BIG BUILDING BOOKS



SHIPPED
FREE FOR
EXAMINATION

Learn to draw plans, estimate, be a live-wire builder, do remodeling, take contracting jobs. These 9 practical, profusely illustrated books cover subjects that will help you to get more work and make more money. Architectural design and drawing, estimating, steel square, roof framing, construction, painting and decorating, heating, air-conditioning, concrete forms and many other subjects are included.

BETTER JOBS — BETTER PAY

Keep busy now at good pay, and be prepared for after-war building boom. Big opportunities are always for MEN WHO KNOW HOW. These books supply quick, easily understood training and handy, permanent reference information that helps solve building problems.

UP-TO-DATE EDITION

These books are the most up-to-date and complete we have ever published on these many subjects.

Coupon Brings Nine Books FREE For Examination

AMERICAN TECHNICAL SOCIETY Vocational Publishers since 1898
Dept. G119 Drexel at 58th Street. Chicago 37, Ill.

You may ship me the Up-to-Date edition of your nine big books, "Building, Estimating, and Contracting" without any obligation to buy. I will pay the delivery charges only, and if fully satisfied in ten days, I will send you \$2.00, and after that only \$2.00 a month, until the total price of only \$29.50 is paid. I am not obligated in any way unless I keep the books.

Name.....
Address.....
City..... State.....

Please attach a letter stating your age, occupation, employer's name and address, and that of at least one business man as a reference. Men in service, also please give home address.

MAKE BIG MONEY at HOME! NEW INVENTION Electroplates by Brush



Now Plates
CHROMIUM
Too!
FREE
SAMPLE and
BOOKLET
EXPLAINS ALL

New, patented invention makes possible big earnings AT HOME. Replate auto-parts—worn articles in homes, stores, hotels, restaurants, etc., with durable, sparkling, new coat of metal—with stroke of brush. Easy, simple, quick. Genuine Gold, Silver, Nickel, Cadmium, etc. Everything furnished. Outfit complete, ready for use. No shop required. Clear from \$2 to \$5 an hour in lifetime business. Small investment starts you in business. Steady repeat. Machine can pay for itself in week. Send TODAY for FREE SAMPLE and illustrated BOOKLET how you can have a life income from a business of YOUR OWN built upon satisfied customers. Act at once!

WARNER ELECTRIC COMPANY
663 N. Wells St., Chicago, Ill., Dept. 309

WOOD WORKERS

AMAZING BOOK FOR YOU

Harold Hunt, famous authority on wood, wants to send you his big revised No. 14 Catalog. 124 pages chock-full of wood-working tips and ideas. 12 pages of rare woods in natural colors. UNEQUALED BARGAINS in imported and American woods, veneers and ALL kinds of supplies. Send only 10c to cover postage and handling.

CRAFTSMAN WOOD SERVICE CO.
2729 S. Mary St., Dept. A-41, Chicago 8, Ill.

only
10¢



SEE BEFORE YOU BUY



Diamond-dazzling Zircons from the Mines of far-away Mystic Siam. *Effortless and inexpensive.* Stand acid; cut glass; full of FIRE! Thrilling beauty in exquisite mountings for Lady or Gent. Sent on trial. Write for catalogue now.

NATIONAL ZIRCON
CO., Dept. 528,
Wheeling, W. Va.

Catalog
FREE!

What Every Mason Wants



We have Masonic books and lodge supplies for Blue Lodge, Chapter, Commandery, Scottish Rite, and Shrine.

OUR RITUALS ARE USED THE WORLD OVER. Send for free catalog of books and rituals for Masons, Odd Fellows, Knights of Pythias, Knights of Columbus, Elks, etc. E2RA A. COOK, Publisher, P.O. Box 796, P.D., Chicago 90, Ill.

ARTISTS MAKE MONEY

Find out your ability. Send name, age, occupation and address for Free Vocational Art Test.

ART INSTRUCTION, INC. (Formerly Federal Schools)
1134 Art Instruction Building, Minneapolis, Minnesota

QUICK CASH for YOU

INTRODUCING AMAZING AUTOFYRSTOP

—the remarkable new combination automatic and manual fire extinguisher and alarm that is setting records. TREMENDOUS MARKET. Sells on 2-minute demonstration to defense plants, homes, schools, stores, etc. LOW PRICED.

Big Profits. Write for FREE facts. EXPERIENCE NOT NECESSARY. AUTOFYRSTOP CO., Dept. M-144, 2035 Washington Ave., Philadelphia, Pa.



KILLS
FIRE
BY ITSELF

● THIS AD IS ADDRESSED TO YOU!

That idea of yours may mean your fortune; don't pass it up! That new shop tool, household appliance or other mechanical item may be just what the post-war era wants. Your idea may need development; perhaps it's ready for patenting or manufacture. It makes no difference to this nationally-known organization with ample engineering, production, financial, sales and distribution facilities looking for ideas for manufacture and sale in the post-war era. If patent on your idea hasn't been applied for, have it witnessed and then write us about it completely or with a minimum of detail, as you please. But whatever you do, DO SOMETHING about that idea! Write in confidence NOW to

P. O. BOX 217 STA. C TOLEDO, OHIO

Only 50c MAKES AND SAVES MONEY FOR YOU

NEW 1944 BOOK FOR EVERY MAN WHO USES TOOLS

One of these books is issued each year and is a reprint of articles published in our Shop Notes Department. It contains cream of experience of years, of hundreds of our country's most successful mechanics. Get this great book from your News Dealer, or send 50c to

POPULAR MECHANICS PRESS
Dept. 506 • 200 E. Ontario • Chicago



★ ★ ★

MAKE YOUR OWN POWER TOOLS at Low Cost from old Auto Parts, etc.



A New Edition Featuring TOOLS of WOOD

Now you can have a good lathe, drill press, circular and band saw and other power tools in your home workshop, at a cost of only a few dollars each. Make them yourself from old auto parts, discarded sewing machines and other odds and ends that cost little or nothing. Get this new book—"Forty Power Tools You Can Make." Costs only \$1.25 postpaid. This book gives every detail in plain language you can understand and follow. Hundreds of pictures and plans show every step to follow in making the power tools you want. Actual photographs of finished machines included. Send \$1.25 today. Money back if not satisfied.

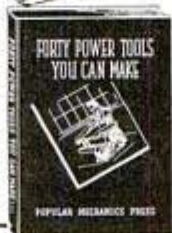

MAKE EVERY POWER TOOL NEEDED IN YOUR HOME WORKSHOP

Some of the power tools you can make are:

- | | |
|--------------------|------------------------------|
| 2 Band Saws | 2 Drill Presses |
| 9 Sanding Machines | 1 Scroll Saw |
| 2 Circular Saws | 3 Wood Turning Lathes |
| 1 Metal Lathe | 3 Grinders |
| 1 Power Hack Saw | 1 Shaper or Moulding Machine |
| 1 Jig Shears | 1 Vibrating Pencil |
| 1 Cut-Off Wheel | and others |

Information too, about pulleys, belts, motors and drive methods. Just published. No other book like it. Order today.

POPULAR MECHANICS PRESS

Dept. 509 • 20 E. Ontario Street, Chicago

JANUARY, 1944

Free 7-Day Offer!

AUTO MECHANICS!

REPAIR ANY MAKE CAR—TODAY!

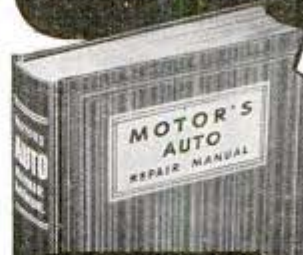

Helps EVERY Mechanic—even experts—do repair jobs easier, quicker

Explains every auto repair operation STEP-BY-STEP. Easy-to-use! Hundreds of photographs, diagrams, drawings, show exact "how to do it" of repairs, adjustments, replacements. All jobs on every model since 1935! Engine; Electric, Fuel, Cooling, Lubrication Systems. Clutch, Transmission; Universals; Rear End; Wheels, Brakes; Knee Action; Shock Absorbers, Springs; Body; Free Wheel, Overdrive, Fluid Coupling!

Explains Every Repair Job on Every Model of All These Cars—1935 through 1942!

American Bantam:
Auburn: Austin: Buick:
Cadillac: Chevrolet:
Chrysler: Cord: DeSoto: Dodge: Ford:
Graham: Hudson:
Hupmobile: Lafayette:
LaSalle: Lincoln: Lincoln Zephyr: Mercury:
Nash: Oldsmobile:
Overland: Packard:
Pierce Arrow: Plymouth: Pontiac: Reo:
Studebaker: Terraplane: Willys.
200,000 Facts, 450 Charts, 900 Photos, Drawings, Diagrams. Size 8 1/2 x 11 in. Published by MoToR, The Leading Automotive Business Magazine.

150 FACTORY BOOKS IN ONE!

Imagine a COMPLETE COLLECTION of ALL official shop procedure manuals, prepared by each car manufacturer's own engineers! That's what you GET in this book! Open the manual to the car you want—you'll find everything to show the right way to do the job. This is the factory shop manual used by the U. S. Army, trade, technical and vocational schools.

SEND NO MONEY

Simply fill out coupon below. Mail it today and a copy of MoToR's up-to-the-minute New Auto Repair Manual will be sent to you at once for 7 days Free Examination.

Same FREE 7-Day Offer
MoToR's Truck Repair Manual!
1400 pictures, 905 pages, 300,000 facts. Used by U. S. Armed Forces. Strong, Fabrikoid binding, size 8 1/2 x 11. Covers 10,000 models, 1936-1942. ALL DIESELS, Hesselmanns, Diesel Fuel Injection Systems, etc., etc.

MoToR Book Dept., Desk A1, 572 Madison Ave., New York 22, N. Y. Rush to me at once: (check box opposite book you want).

MoToR's AUTO REPAIR MANUAL (formerly "MoToR's Factory Shop Manual"). If O.K. I will remit \$1 in 7 days, \$1 monthly for 4 months, plus 35c postage with final payment (\$5.35 in all). Or I'll return book in 7 days. (Foreign, remit \$7 with order.)

MoToR's TRUCK REPAIR MANUAL. If O.K., I will remit \$2 in 7 days, \$2 monthly for 3 months, plus 35c postage with final payment (\$8.35 in all). Or I'll return book in 7 days. (Foreign, remit \$11 with order.)

Name _____ Age _____
Address _____
City _____ State _____

Check here if enclosing full payment. WE pay 35c postage. Same 7-Day Return Privilege.

49A

FASTER NUT DRIVING

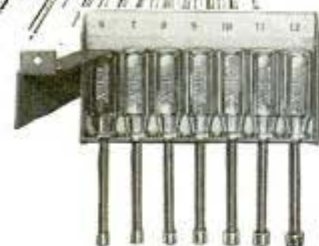

SIX SIZES
 ☆
SIX DIFFERENT COLORED HANDLES
 ☆
COMPLETE IN LOCKABLE METAL TOOL HOLDER

You can well be proud of this set of tools—and their efficient performance, on all kinds of electrical work! Each size of nut driver has a handle of a different color. No fussing around for the correct size—just select the color. Handles of special plastic are resistant to electrical shock and fire. Sockets are precision formed, deep enough to handle two nuts. Sizes range (in 32nds) for nuts from 3/16" to 3/8". Supplied in sturdy metal holder which can be wall mounted and locked. Ask your radio, electrical or hardware dealer or write Dept. J.

PARK METALWARE CO., INC.

Orchard Park, New York



QUALITY TOOLS
 PREFERRED BY THE EXPERTS

PALMGREN ANGLE VISES



Solve Difficult Angle Jobs

Quick, accurate setups at any angle. End makeshift methods—time loss—rejections. Ideal for tool rooms or home workshop. Accurately machined and graduated. Once set, it stays locked. Jaws hardened steel—plain or grooved. Sizes 1 1/2" to 8" Jaws. Orders filled on plant priority ratings only. You may qualify. Write,

Chicago Tool & Engineering Co.
 8365 South Chicago Ave.
 Chicago, Ill.

Send for Free Circular "101 ANGLE OPERATIONS" describes complete line, gives many uses.

for Drilling
 Milling
 Grinding
 Fitting
 Filing

PRECISION WORK AT ANY ANGLE

LEARN *The Modern Way To Write* **EASY**

IN ONE SIMPLE LESSON I will show YOU how to improve your penmanship! Start today! Write now! Enclose \$1.00 for lesson and YOU will also receive free YOUR name beautifully written and also two pens for plain and shaded penmanship. Remember—you are judged by your writing! Let me prove I can make YOU a better penman! Write today!

THE CARL BRUNO SCHOOL OF PENMANSHIP
 DEPT. 777 5035 GLORIA AVE. ENCINO, CALIF.

Handy Mail Order List

Little Library of Useful INFORMATION

5 for \$1.00
12 for \$2.00
25¢ Each

- Here at amazingly low cost is the practical help and information you have always wanted. Articles in previous issues of Popular Mechanics have been classified according to subject and are now available in these handy reprint booklets.
- How to Use Measuring Tools—Micrometers, Calipers, etc.—106.
 - Power Driven Saws—74.
 - Drill Presses, Grinders, Etc.—79.
 - Wood, Metal Turning—Lathes—81.
 - Filing Machine, Hack Saw, Cutoff Wheel, Shaper—82.
 - Lathe Tools You Can Make—101.
 - Workbenches—Tool Cabinets—47.
 - Spray Painting—94.
 - From Pattern to Casting—91.
 - Tool and Saw Sharpening—92.
 - Sharpening Drills, Wood Bits—90.
 - Successful Wood Turning—32.
 - How to Read Blueprint—71.
 - Metal Turning Lathe Kinks—99.
 - Operating a Metal Lathe—100.
 - Heat Treating, Hardening—102.
 - Working With Glass—103.
 - Servicing Elec. Motors—75.
 - Electromagnets & Solenoids—44.
 - Transformer Construction—41.
 - The Boy Electrician—43.
 - Soldering and Brazing—17.
 - Arc and Spot Welders—5.
 - Electroplating With Nickel, Chromium, Cadmium, Etc.—86.
 - Plating Leather, Wood, etc.—87.
 - Lower Your Fuel Costs—31.
 - Curing Leaky Basements—45.
 - Fitting Home Game Room—55.
 - Indoor & Outdoor Fireplaces—88.
 - Backyard Gardening—39.
 - Lawn and Garden Novelties—72.
 - Trellises, Pergolas, Fences—76.
 - Lawn and Garden Furniture—77.
 - Playground Equipment—73.
 - Concrete Garden Furniture—6.
 - Making Serving Trays—53.
 - Sanders—80.
 - House Wiring—89.
 - Treasure Finders—13.
 - Hanging Wallpaper—38.
 - Built-in Fixtures—78.
 - Bird Houses—7.
 - Magazine Racks—49.
 - Clock Cases—50.
 - Book Ends—52.
 - Small Tables—54.
 - Smoking Stands—56.
 - Decks—58.
 - Book Cases—59.
 - Action Toys—66.
 - High Flying Kites—67.
 - Telescopes—20.
 - Metal Craft—28.
 - Working With Plastics—61.
 - Simple Home Improvements—104.
 - Ridding Home of Insect Pests—107.
 - Children's Room Furniture—51.
 - Jigsawed Novelties—57.
 - Doll House & Doll Furniture—60.
 - 25 Shelves You Can Make—64.
 - Novelties Turned on Lathes—62.
 - Inlay Pictures—Veneering—63.
 - Wood, Soap Carving—85.
 - Windmills & Weathervanes—68.
 - Lamps from Wood, Metal—69.
 - Home Work Opportunities—19.
 - Wood Trainers—27.
 - Boats—14 ft. Outboard—2.
 - Boats—14 ft. Sail Dinghy—26.
 - Boats—21 ft. Sloop—46.
 - Rowboats, Small Dinghy—83.
 - Small Sail Boats—84.
 - Two Outboard Runabouts—85.
 - Build Own Canoe, Kayak—30.
 - Build Class-E Ice Yacht—22.
 - Auto Kinks, Shortcuts—10.
 - Building Trainers—27.
 - Motor-Driven Midget Cars—34.
 - Stop Auto Electrical Troubles—95.
 - Photo Printers and Dryers—25.
 - Photo Darkroom Equipment—96.
 - Trick and Table Top Photos—97.
 - Cosmetic Formulas—12.
 - Food Products Formulas—15.
 - Metal Plating and Coloring—21.
 - Re-Silvering Mirrors—70.
 - Chemical Experiments—93.
 - Log Cabins, Tourist Houses—14.
 - Trapping Small Animals—33.
 - Farm and Garden Tractors—8.
 - Building Extra Attic Rooms—23.
 - Attractive Basement Rooms—24.
 - Small Looms—37.
 - Gem Cutting—42.
 - Photo Enlargers—1.
 - Photo Kinks—98.
 - Cleaning Formulas—11.
 - Taxidermy—9.
 - Maps—29.
 - Training Dogs—35.
 - Small Furnaces—36.

Check Titles Wanted, Write Name and Address in Margin and Mail to **POPULAR MECHANICS PRESS, Dept. 508, 200 E. Ontario St., Chicago**

FUN AND PROFIT FROM YOUR HOME WORKSHOP

New 1944 "WHAT TO MAKE" is now ready. One of these books is issued each year and is a reprint of articles which have been published in our "Craftsman" Department. Hundreds of ideas that can be used around your home workshop in one handy, 224-page volume. Get book from your Newsdealer or send 50c to

POPULAR MECHANICS PRESS
 Dept. 505, 200 E. Ontario, Chicago

Choose Your ARC WELDER

Compare feature by feature and you'll choose Hobart on its exclusive features alone. For Hobart is truly "Simplified", yet nothing has been eliminated. Hobart is still a quality-built welder made to do every welding job better. Thousands are now in war plants speeding work, making stronger products. They can do the same for you.

PLAN NOW! Design for Post-War made easier with Hobart's new "Practical Design for Arc Welding". Ask to be placed on the mailing list to receive this free design service.

HOBART BROS. CO., Box M-14, Troy, O.

HOBART "SIMPLIFIED" ARC WELDERS

HOBART "One of the World's Largest Builders of Arc Welders."

Note: PROMPT DELIVERIES made on suitable priorities. Send yours when ordering.

...by checking it for these 8 VITAL ESSENTIALS

- Speed
- Long Life
- Electric Bill
- Low Operating Cost
- Who Uses Them?
- Now How Repeat Business Do They Get?
- Efficiency
- Ability to "take it"
- Who's Who
- Simplicity
- ABC



NAMECHAIN

Personalized
KEY CHAIN
Spells YOUR NAME in full

DURABLY CONSTRUCTED
IN GOLD PLATE

The Perfect Gift

Each Namechain made to your order . . . up to 16 letters allowed. Individually packed in Gift Box. Orders filled in one day. Sent Postpaid for \$3.00.

Namechain Mfg. Co.
19 E. Pearson St., 11 Chicago

IDEAL CHRISTMAS GIFTS



No. 3132
Heavy Sterling Silver
\$10.00

New — Blue or Red Stone Set Navy ring, in gift box, \$10.00. State finger size and stone color wanted. NAVY PIN. (Right) Gold filled, \$2.50; 10K Solid Gold, \$5.00. Pictures actual size. Prices include federal tax and postage. Satisfaction guaranteed.



U. S. N. PIN
No. 397

Send for Service Jewelry Circular, Free
HERFF-JONES-CHICAGO, INC., Mfg. Jewelers, Dept. P, 32 W. Randolph, Chicago 1

TIME & MOTION STUDY

30 MILLION WORKERS AND SOLDIERS will compete with you in peacetime unless you train now. Low cost professional training. Time and Motion study is insurance for present and future big pay jobs. Increase vital war work now with methods improvements. Write for details now.
INDUSTRIAL ENGINEERING COLLEGE
4000 Washington, Chicago (24) Illinois

PEPSI-COLA HITS THE SPOT

TOMBSTONES \$10.95 UP FREIGHT PAID
High Quality Granite and Marble, Lettered, Guaranteed. Write for Free Catalog and samples of stone. Without Delay. Order By Mail.
U. S. MARBLE & GRANITE CO., A-18, ONECO, FLA.

Tired Kidneys Often Bring Sleepless Nights

Doctors say your kidneys contain 15 miles of tiny tubes or filters which help to purify the blood and keep you healthy. When they get tired and don't work right in the daytime, many people have to get up nights. Don't neglect this condition and lose valuable, restful sleep.

When disorder of kidney function permits poisonous matter to remain in your blood, it may also cause nagging backache, rheumatic pains, leg pains, loss of pep and energy, swelling, puffiness under the eyes, headaches and dizziness.

Don't wait! Ask your druggist for Doan's Pills, used successfully by millions for over 40 years. They give happy relief and will help the 15 miles of kidney tubes flush out poisonous waste from your blood. Get Doan's Pills.

ELECTRICIANS! RADIO MEN!
TRY THIS AMAZING NEW
TROUBLE-SHOOTING MANUAL 5 DAYS FREE

500 Shop Prints Cover Every Kind of Electrical or Radio Job!

JUST OFF THE PRESS — a completely different type of practical guidebook for Electricians and Radio Men! Crammed full of time-saving, pay-raising shortcuts. Shows you how to install—service—repair any electrical or radio equipment quickly and correctly. Needed by war workers, men in armed forces. For beginner or old timer. Easy. Accurate. Practical. Pays for itself—mail coupon for 5 DAY FREE TRIAL.



'Step by Step' Method Saves Time, Errors

Here for the first time is an utterly NEW WAY TO SHOOT ELECTRICAL OR RADIO TROUBLE—the "Step-by-Step" method created by one of America's Leading Electrical Schools Fully explained in streamlined course never before published. If you want real trouble-shooting "know-how", this is it!

FREE—1 Yr. Technical Service, Any Problem

Act now and I'll include 1 year of Personal Counsel from the Coyne staff—technical advice by mail on any Electrical or Radio problem. This service alone may be worth hundreds of dollars to you!

SEND NO MONEY

Coupon brings this big 8½x11 inch, handsomely bound book RISK FREE. Test it on the job 5 days. If not delighted and amazed, return it at my expense and you won't owe me a penny! YOUR copy is ready—send coupon TODAY.

4 GREAT BOOKS IN ONE!

- 1 Brand new "Step-by-Step" Trouble-Shooting Course.
500 Shop Prints and Wiring Diagrams covering every Electrical and Radio field—D.C., A.C., Motors, Armatures, Auto Ignition, Radios, Electronic Controls, Television, Refrigeration, Air Conditioning.
- 2 Electrical and Radio Dictionary of over 1200 Terms, Formulas, Tables, etc.
- 3 Spare-Time Job Training Course.
- 4 You'll wonder how you ever got along without this sensational book!

5 DAY FREE TRIAL COUPON!

H. C. LEWIS, Pres., COYNE ELECTRICAL SCHOOL, 500 S. Paulina St., Dept. 14-3, Chicago 12, Illinois

Send me the new COYNE ELECTRICAL AND RADIO TROUBLE SHOOTING MANUAL, postpaid. Within 5 days after it comes I'll either return it or send you \$3.00, and then \$3 a month until total of \$8.95 is paid. Coyne pays all shipping charges.

Name.....
Address.....
City.....State.....
Occupation.....

SAVE 10% Send cash price, \$8.00, if preferred —you save more than 10%. Same 5-day free trial and return privilege.

7-DAY FREE TRIAL EXAMINATION
Amazing 3-VOLUME bound set
 Complete Instructive Course

SEND NO MONEY
PRACTICAL MACHINIST TRAINING
 FOR EXPERTS & BEGINNERS
 EASIEST WAY TO GET KNOWLEDGE



Machine Tools fully described, demonstrated. Lessons in all kinds of bench work. Instructions to tool up, operate machines. Hundreds of short cuts. Enable you to get Expert's Pay.

Compiled by practical machine shop experts—"Modern Machine Shop Training"—shipped absolutely FREE for 7-day examination. Actual Lesson Assignments, shop tested, with same training principles and instruction as given students in our huge Los Angeles shops. Hundreds of illustrations, diagrams, charts, tables. Beginners and experts need this proved Course. Mail Coupon at once and also receive FREE, 7 Drafting Lessons, Machinist's Dictionary and 2 Shop Math. Texts.

NATIONAL SCHOOLS, Los Angeles



MAIL COUPON FOR 3 BIG VOLUMES - SEND NO MONEY

NATIONAL SCHOOLS, Dept. 1-K 4000 S. Figueroa St., Los Angeles 37, Calif. Paste on Penny Postcard

Ship your 3-VOLUME MODERN MACHINE SHOP TRAINING COURSE postpaid. Within 7 days after receiving Course (and Bonus Gift) I will either return shipment, and owe you nothing; or if satisfied, I'll send \$3.00, and \$3.00 a month until total of \$13.50 is paid (final payment, \$3.50). You may deduct \$1.25 if you enclose cash (\$11.25) with this Coupon. Same return privilege.

NAME

ADDRESS

CITY..... STATE.....

OCCUPATION..... AGE.....

FREE! LATEST, MOST COMPLETE RADIO PARTS CATALOG



EVERYTHING in RADIO and ELECTRONICS for War Training, Maintenance or Repair

It's the most complete, up-to-date BUYING GUIDE available! It contains latest "supply data" on radio and electronic parts available without priority for repair and replacement—plus everything in war training kits, books and equipment! Whatever you need—you'll save time by getting in touch with ALLIED first. Send for this big free catalog today.

RADIO'S FINEST BOOK VALUES

- Specially prepared to aid radio training in schools and industry. Full of valuable data. Send for all six!
- Radio Formulas and Data Book No. 37-752...10c
 - Dictionary of Radio Terms No. 37-751...10c
 - Radio Circuit Handbook No. 37-753...10c
 - Radio Builders' Handbook No. 37-750...10c
 - Simplified Radio Servicing No. 37-755...10c
 - Radio Data Handbook No. 37-754...25c
 - All Six Books No. 37-799...75c

ALLIED RADIO CORP.

833 W. Jackson, Dept. 5-A-4, Chicago 7

ALLIED RADIO

The Dennison Handy Helper Says:
"PLAN TO BUY U. S. WAR BONDS AND STAMPS REGULARLY ... AND STICK TO IT"

Dennison

GUMMED LABELS STICK TO IT, TOO
 DENNISON MFG. CO., Framingham, Mass.



Jungle CHOKING STICK FREE
 WITH EVERY COPY OF NEW COURSE ON **COMMANDO JIU-JITSU**



You don't know Jiu Jitsu if you haven't had this amazing new book by Irving Kahn, Marine Corps Instructor. Contains more than 150 photographs and drawings. Reveals complete facts about Malay Jungle Fighting with vicious, deadly holds, "throws" and blows made possible by New Choking Stick technique. Never before published. Practice Choking Stick FREE, with course if you hurry. Send name and address. We will ship this astonishing book AND your full size, 18 inch Choking Stick COD. Pay postman only \$1.98 plus postage. Money back if you return outfit in five days. This is no child's play, but the genuine Commando method for use when real fighting tactics are necessary. Rush name and address now. Be master of the newest and latest hold.

WILCOX & FOLLETT, 1255 S. Wabash Ave., Dept. 21, Chicago (5), Ill.

Always write your name and full address clearly when answering advertisements.

GENUINE U. S. BARGAINS



- O. D. WOOL BLANKETS (USED) . . . \$2.95
- McLELLAN SADDLES (USED) . . . 5.95
- U. S. ARMY PUP TENTS (USED) . . . 3.50
- Slightly Used Army Caisson Wheels with Axles, 56" high, weight per pair with Axle, 322 lbs. \$37.50

Thousands of Other Bargains in Military, Outdoor & Sport Goods for Hunter, Farmer, Scout Send 10¢ for 32-page catalog returned with first order.

A and N SUPPLY CO.
 4724 LESTER ST. RICHMOND, VA.

WANTED! Men and women to learn following big pay trades in 2 to 8 weeks: Machinist, Auto-Diesel, Refrigeration, Air Conditioning, Welding, Body and Fender, Aviation. We pay room and board. Write us, specifying trade interested in. Established 1902. 41,000 graduates. **GREER SHOP TRAINING, Dept. 114, 2017 S. Wabash Ave., Chicago.**

ITALIAN ACCORDIONS



Hand Made. Very best. Lowest prices. Buy Direct from Factory and Save Money. Send name and address for FREE catalog.

ITALIA & P. SOPRANI ACC. MFG. CO.
 323 W. POLK ST., DEPT. PM-1, CHICAGO, ILL.

WRITE FOR OUR TOOL DATA SHEETS
WILLIAMS
 SUPERIOR DROP-FORGED TOOLS
 J. H. WILLIAMS & CO., BUFFALO, N. Y.

don't WORRY

Why put up with years of needless discomfort and worry? Try a Brooks Automatic Air Cushion. This marvelous appliance permits the opening to close, yet holds reducible rupture securely, comfortably—day and night. Thousands report amazing results. Light, neat-fitting. No hard pads or stiff springs to chafe or gouge. Made for men, women and children. Durable, cheap, **Sent on trial** to prove it. Never sold in stores. Beware of imitations. Write for Free Book on Rupture, no-risk trial order plan, and proof of results. All correspondence confidential. **BROOKS COMPANY, 158-C State St., Marshall, Mich.**





WELDERS MICROMETER

Every WELDER Should Own One!

Accurate calibration of BUTT and FILLET TYPE WELDS. Checks sizes of convex or concave fillets, also permissible tolerance of butt weld reinforcements. Eliminates rejections—saves time and electrodes. Pocket size precision instrument of chromium plated steel with dimensional marking in clear print.

NOW \$3.

ORDER DIRECT FROM THIS AD ONLY.
Welding Symbols Chart Included FREE
CHICAGO TOOL and ENGINEERING CO.
8365 South Chicago Ave. CHICAGO, ILL.



BUILD a BOAT

- Row Boat—12 Foot
- Dinghy—8 Foot
- Dinghy—14 Foot Sailing
- Training Ship—6 Foot
- Sea Sled—5 Foot
- Outboard—12 Foot
- Cruiser—18 Foot
- Bicycle Boat—Sectional
- Row Boat—Sailing
- Dinghy—16 Foot
- Canoes—12 Foot
- Sailing—12 Foot
- Outboard—12 Foot
- Outboard—Runabout
- Pontoons—Ice Yacht

FOR PLEASURE OR PROFIT DESCRIBES 17 LOW COST BOATS

Get this outstanding book and build a boat at home for your own use or to sell at a profit. You can do it. Just the boat you've always wanted—power, sail or row boat—17 different kinds and sizes.

Order BUILD A BOAT on postal card and pay only \$1.50 plus postage on delivery. Return in 5 days if not pleased and get money back. Or send \$1.50 with order. (Outside U. S. \$1.70 with order.) Order today.

POPULAR MECHANICS PRESS
Dept. 507, 200 E. Ontario St., Chicago

Say you saw it in
POPULAR MECHANICS

KEY TO A PRACTICAL UNDERSTANDING OF ELECTRICITY

\$1 PER MO.

• AUDELS HANDY BOOK OF ELECTRICITY

\$4 HANDY SIZE

For Engineers, Electricians, Students and all interested in Electricity. A quick, simplified, ready reference, giving complete instruction and practical information. Easy to understand. A reliable authority and a handy helper that answers your questions.

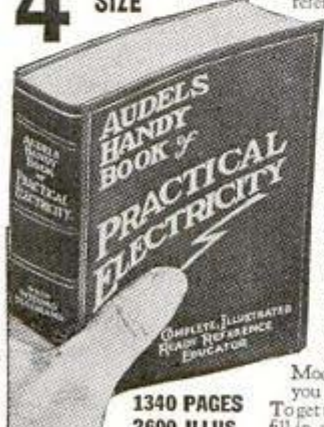

• INSIDE TRADE INFORMATION ON

- The Rules and Laws of Electricity
- Maintenance of Machinery
- A. C. and D. C. Motors
- Armature Winding and Repair
- Wiring Diagrams
- House Lighting
- Power Wiring
- Cable Splicing
- Meters
- Batteries
- Transformers
- Elevators
- Electric Cranes
- Railways
- Bells
- Sign Flashers
- Telephone
- Ignition
- Radio Principles
- Refrigeration
- Air Conditioning
- Oil Burners
- Air Compressors
- Welding, and many

Modern Applications explained so you can understand.

1340 PAGES To get this assistance for yourself, simply
2600 ILLUS. fill in and mail the FREE COUPON below.

THE O. AUDEL & CO., 49 West 23rd Street, New York
Please send me "Auvels Handy Book of Practical Electricity" for free examination. If satisfactory, I will send you \$1 in 7 days, then \$1 monthly until \$4 is paid. Otherwise I will return it.



READ FOR PROFIT!

Name _____
Address _____
Occupation _____
Reference _____ P M



"Good Pictures" BRING YOU TOGETHER

AWARDED TO PLANT 2 OPTICAL DIVISION

THERE can be no greater joy for our fighting men than the pictured scenes of the things he is fighting for . . . from the candles on the dining table, lighted to speed his return, to all the familiar memories of the country he calls home. Send him Pictures.

"Good Pictures"

This 56-page booklet is published by Argus to help solve the problems of exposures, lens, films, etc. Get your copy by sending 25c to Argus, Ann Arbor, Michigan, Dept. 5.



ANYONE, ANYTIME CAN MAKE PHOTO-COPIES QUICKLY

The most USEFUL copying method ever perfected

The accuracy, ease and speed with which A-PE-CO photo-copies are made by anyone, are creating hundreds of new users. This modern, versatile, low-cost method makes photo-exact copies of anything written, printed, drawn or photographed. Experience proves that A-PE-CO quickly pays for itself.

A-PE-CO PHOTO-COPIER \$55.00

LEGALLY ACCEPTED PHOTO-COPIES OF

- Letters
 - Records
 - Blueprints
 - Shop Orders
 - Pictures
 - Receipts
 - Drawings
 - Documents
- Same-size copies of anything up to 18" x 22". Eliminates errors. Saves steno-copying, tracing, proofreading. No camera, focusing, film or moving parts. Any employee quickly becomes expert. Lowest investment in equipment. Use on any desk or table. You need A-PE-CO. Let us show you how you can use it to expedite office and shop copying. Immediate delivery. See why thousands are in satisfactory use. Send for A-PE-CO folder—today.

AMERICAN PHOTOCOPY EQUIPMENT CO.
2849 No. Clark St. Dept. GF-1 Chicago 14, Illinois
Representatives in principal cities and Canada.

FIGHT WITH WAR BONDS



"and now... Good Luck and Good Hunting"

This is the day I've looked forward to since I was seventeen . . . this is the day I win my wings.

Mom and Dad are waiting there. Dad's standing tense and straight and tall, and his face looks proud and grim, as though the General were talking to him.

"... they tell me you're hot pilots and navigators and bombardiers. And it is well you are..."

As we marched in, Mom waved and I caught the white flutter of her handkerchief out of the corner of my eye. In a moment or two she's going to cry—just a little—like she did the night we talked it all out, she and Dad and I, when I told them I wanted to fly.

"... to your families, I say—ours is the safest military flying of any of the world's air forces."

And now here on the parade grounds, with the shadows falling and the bright flag whipping in the sky, I remember Dad said, "Son, your Mother and I won't stand in your way. If this is what you want to do—do it with all your heart and soul and God be with you. I wish I were your age—so I could fly and fight."

"And I say to you cadets, get the enemy in your sights and let him have it..."

Now, in just a minute, we'll right face and walk up to the platform under the flag. And the General will hand me the parchment, and then he'll pin silver wings on my blouse and return my proud salute.

"The world has never before seen a team like the Army Air Forces..."

Thinking of all the days and nights packed with hard work . . . our college training . . . the numberless flights with patient instructors . . . the painstaking way we were taught to fly safely on instruments, how,

flying wing tip to wing tip, we were brought together closer than brothers . . . I understand what our General means. The Army Air Forces are more than planes, more than men, more than machines—a *great team* with one aim, one object, one goal.

"... to sweep the skies clear, so free men may walk with their heads up and without fear..."

And as the last man receives his wings and the gun booms out and we stand retreat and the flag comes slowly down, I'll thank God *my* father and mother gave me the chance to win my wings . . . belong to the greatest group who ever fought or flew . . . gave me a future and a career!

"And now, gentlemen, we have work to do—and I leave you . . . good luck—and good hunting."



If You are 17... Go to your nearest Aviation Cadet Examining Board today . . . if you can qualify for the Air Corps Enlisted Reserve, you will receive Enlisted Reserve insignia but will not be called for training until you are 18 or over.

When called, you'll be given 5 months' training (after a brief conditioning period) in one of America's finest colleges . . . then go on to eight months of full flight training. When you graduate as a Bombardier, Navigator or Pilot—you will receive an extra \$250 uniform allowance and your pay will be \$246 to \$327 per month.

Meanwhile, . . . you should see your local Civil Air Patrol officers about taking C.A.P. Cadet Training—also your High School principal or adviser about the recommended courses of the Air Service Division of the H. S. Victory Corps. Both will afford you valuable pre-aviation training.

(Essential workers in War Industry or Agriculture—do not apply)

U. S. ARMY RECRUITING SERVICE

"Nothing'll Stop the Army Air Corps"

"KEEP 'EM FLYING!"

For information regarding Naval Aviation Cadet Training, apply at any Naval Aviation Cadet Selection Board or any Naval Recruiting Station; or, if you are in the Navy, Marine Corps or Coast Guard, apply through your commanding officer . . . This advertisement has the approval of the Joint Army Navy Personnel Board.

New Accurate 10" Slide Rule

Magnifying Indicator

Instruction Book
FREE

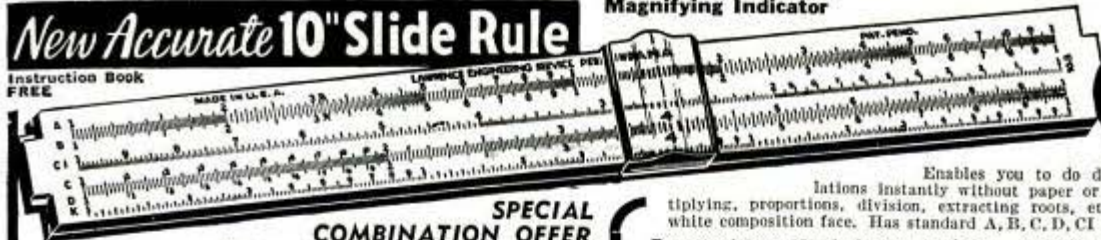

50¢

SPECIAL COMBINATION OFFER

Standard 10" Slide Rule and Instruction Book; Pocket Calculator for adding and subtracting up to 999,999; 6" Transparent Protractor and Graph Rule graduated in centimeters and inches.

—ALL 3 for \$1.00 cash (\$1.10 Foreign) POSTPAID.

New "TRIG" 10" Slide Rule, with Pocket Calculator and Transparent Protractor, **\$1.50 (\$1.60 Foreign) POSTPAID.**

Enables you to do difficult calculations instantly without paper or pencil—multiplying, proportions, division, extracting roots, etc. Accurate, white composition face. Has standard A, B, C, D, CI and K scales.

For complete outfit, including slide rule, 28-page illustrated instruction book, carrying case, send 50¢ (60¢ Foreign). New "TRIG" 10" Slide Rule, with same six scales as above plus S, L, and T scales on Reverse of Slide for problems in Trigonometry; Gummel Finish Indicator; complete instructions—\$1.00. Mailed postpaid. Satisfaction Guaranteed or money refunded. (See Special Combination Offer.) Order NOW.

HEWIG CO., Box K-143, Grand Central Annex; New York City

PRECISION GAGE BLOCKS

8 Millionths Accuracy
Guaranteed

Indispensable in interchangeable manufacture, in testing and setting tools, in checking micrometers. ULTRA-CHEX are now available in nine block sets as illustrated.

Every toolmaker and mechanic can now afford his own set of gage blocks. Order now to turn out highly precise work, reduce rejections, save material. The ULTRA-CHEX set consists of the following blocks: .0625", .100", .125", .200", .250", .300", .500", 1", 2", enabling you to make up 331 combinations.



BECOME A BETTER CRAFTSMAN BY ORDERING ULTRA-CHEX NOW!
Price with optical flat... \$27.50 Price without flat... \$19.50

ASK FOR NEW FOLDER "THE USE OF GAGE BLOCKS"

GEORGE SCHERR CO. 128A Lafayette St. New York, N. Y.

Always write your name and full address clearly when answering advertisements.

WITTE ENGINES

A REAL Money Maker

for farm or factory. Uses cheap liquid fuels. Pays for itself out of savings.



LOG SAW



Easy Terms

SAWS EM DOWN CUTS EM UP

MAKE MONEY

Start a wood sawing business—turn spare timber into cash. Factory prices; cash or terms; FREE Catalog.

WITTE ENGINE WORKS
1600 Oakland Ave. KANSAS CITY 3, MO.

there's a Real Story in the basically improved design of the

DURO Band Saw



Despite its unusually low price, this heavy DURO 16-inch production Metal Cutting Band Saw has many special features not found in machines costing several times as much. It is ideal for cutting tubing, extruded shapes, bar stocks, metal sheets, casting gates, plastics, brake linings, hard rubber, slate, fibre and many other materials. Can be adjusted to obtain standard wood cutting speeds by a flip of a lever. Some of its special features include: Heavy machined cast iron trunnion; special roller blade guides which reduce blade crystallization and lessen blade breakage; new design which permits all adjustments to be made from front while saw is in operation; New Departure Ball Bearings; machined dove-tailed ways with adjustable steel gibs; many other advantages. Metal cutting speeds: 236 and 596 R.P.M. Wood-cutting speeds: 2360 and 5960 R.P.M. Available on priorities only.

Send for New DURO Catalog

For full details and prices on the DURO 16" Metal Cutting Band Saw send for latest DURO CATALOG using coupon below. Also lists specifications and prices of complete line of DURO single and multi-spindle Drill Presses, Circular Saws, Jointers, Routers, Shapers, Grinders, Lathes, Scroll Saws, Flexible Shaft Units and Portable Electric Drills.

THE DURO METAL PRODUCTS COMPANY
2696 N. Kildare Ave., Chicago 39, Illinois

Gentlemen: Please send me FREE copy of latest DURO Catalog giving full specifications on new DURO 16" Metal Cutting Band Saw and other DURO Machine Tools.

Name.....

Address.....

City.....State.....

DURO TOOLS

MACHINE TOOL DIVISION

ALSO MAKERS OF DURO HAND TOOLS



There's Been a Big Change

Almost any old-timer will give battle if you question the advantages of living in the old days. But few will deny that change in the *mechanical* world was inevitable, and good.

Take tapered roller bearings. Tyson found the way to add more rollers around the raceway—developed a heavy-duty bearing which solved many an industrial and transportation problem.

Actually, a Tyson "All-Rolls" Bearing has *thirty percent more rollers*, on the average, size for size. Obviously, this means greatly increased load capacity. Many users say bearing life is doubled.

You can depend on it—Tyson is the most advanced, strongest, longest-lived bearing ever built.

The big name in bearings today is . . . TYSON!



TYSON BEARING CORPORATION, MASSILLON, OHIO

COUNT THE ROLLS • THE ROLLS COUNT



Tyson

TODAY'S HEAVY-DUTY BEARING

★ BUY MORE WAR BONDS ★

Popular Mechanics Magazine

REGISTERED IN U. S. PATENT OFFICE AND CANADA

WRITTEN SO YOU CAN UNDERSTAND IT

Mr. Colver

729

Vol. 81

JANUARY, 1944

No. 1

BLUEPRINT for TOMORROW

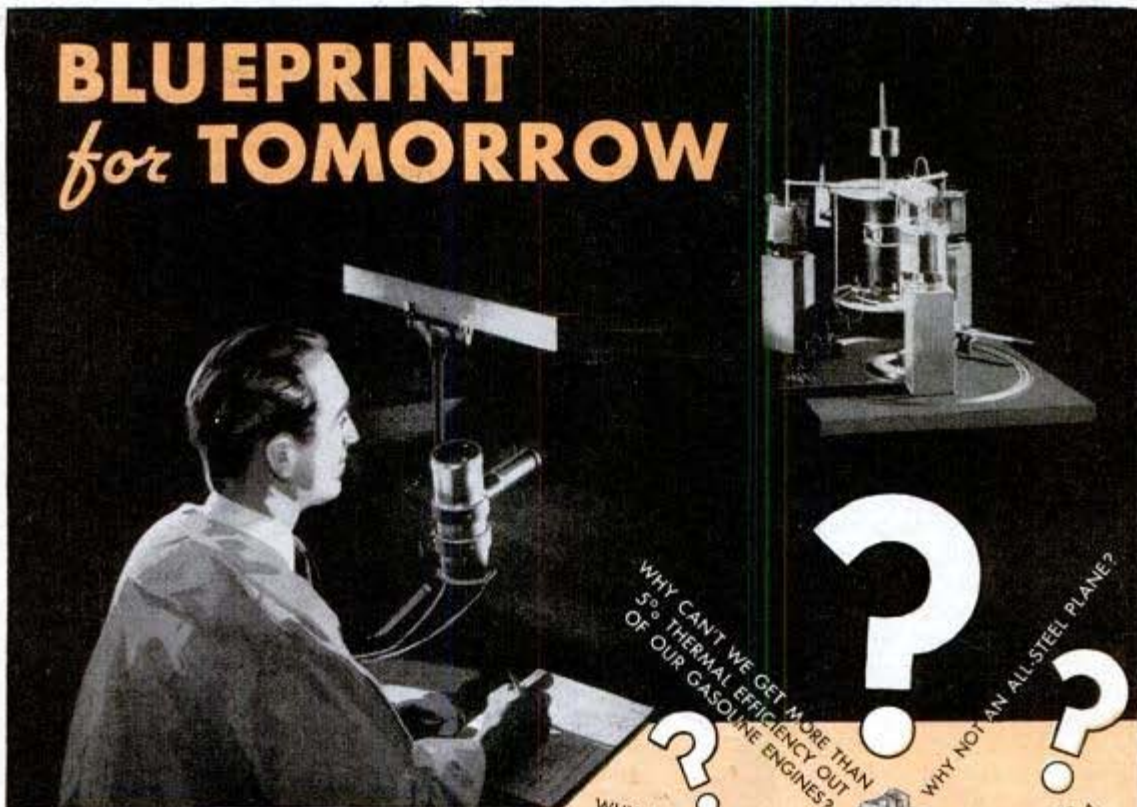

By Charles F. Kettering

Vice-President, General Motors Corp.
Chairman, National Inventors Council

Washington, D.C.

SOMEbody has said there are more than 300 postwar planning groups in the country. Well, that isn't enough. There ought to be 130,000,000 postwar planning groups. Every man ought to be his own.

We have a simple test to distinguish between postwar planning and postwar wishing. If the plan presupposes that human nature is going to be different after the war, it is pure wishing—and should be thrown out.

On this basis, very little real postwar planning is being done. When you take the wishing out of most postwar planning, there isn't very much left. If

To succeed, an inventor must learn how to fail intelligently, whether he be a physicist in a laboratory, above, or an artisan in his own shop



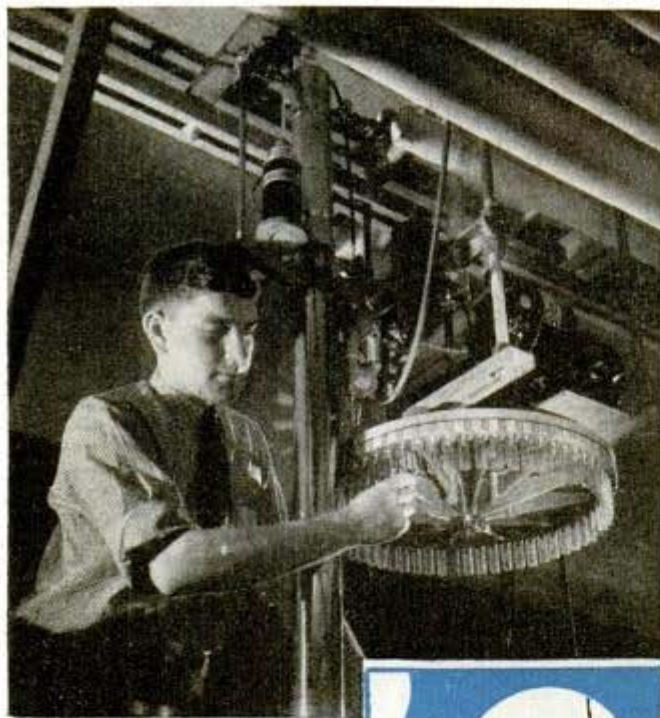

Fractionating apparatus at General Motors Research Laboratory

our planning is to mean anything at all, we have to remember that the fundamentals of human nature are going to remain exactly the same after the war as they are now.

The human race has been on earth for at least a million years. Yet it wasn't until about 10,000 years ago that we first learned how to make an "X" mark on the wall of a cave, and we got up to that point from the start without benefit of science, medicine or anything like them. I think that this observation is important because it illustrates the normal time rate of change of human nature. Education, religion, and science accelerate the effects of the change, but they don't necessarily alter the fundamental time rate.

A fundamental part of all biology is continuity. If you plant a pea in your Victory Garden you expect it to come up peas. You don't expect it to

say: "Because there is a war on, I'll change my nature and be a chrysanthemum now."

If you buy a dog, you expect him to act like a dog.

A fellow laid on my desk the other day a study showing that since 640 B.C. the world has been at war about one-third of the time. None of these wars except this last one has affected human nature in the slightest. This last one has changed our thinking a little, but it hasn't changed human nature.

As you know, I am chairman of the National Inventors Council. Out of our experiences has come a notion that we can educate people to be inventors. The way to do it is to teach people how to fail intelligently. That is all you have to do to be an inventor.

We have made two or three surveys that show that the more education a man has, the less likely he is to invent. It should be exactly the other way, but we think we know why it isn't.

The average person, from the time he is six years old until he is graduated from college, is examined three or four times a year—and if he flunks once, he is disgraced throughout his community.

These are some of the automotive developments of Mr. Kettering and General Motors



ETHYL GAS

CHROME PLATING

SELF-STARTER

FOUR WHEEL BRAKES



TWO WAY SHOCK ABSORBERS

So his whole education is based on the idea that it is a terrible disgrace to fail.

But the only time you ever succeed when you are an inventor is the last time you try. Invention is 99.99 percent failure. So if we want more inventors, we will teach people how to fail intelligently.

We have made a mistake by letting people think there is something sacred about engineering and research and science. They

expect too much of us. A research man is just a professional amateur. He is an amateur in that he is doing a thing for the first time—and he is going to do it just as poorly as anybody ever did anything for the first time.

Research is a straight case of cut and try—and I think we have oversold it as being something that can pull things out of a hat. We've somehow fostered the idea that science is conquering nature. That isn't true. When a scientist conquers something, he bends his knee and does exactly what nature asks him to do. He has learned that conquering is submission. You can't get nature to do anything it wouldn't do ordinarily, no matter how noted a scientist you may be.

We think we've learned an awful lot about navigation. But a bat can fly perfectly around all sorts of obstructions with a blindfold over his eyes. When that phenomenon was investigated, it was finally discovered that if the bat's ears were plugged, he couldn't fly so very well—and if his mouth were taped shut he couldn't fly at all.

It was found that the bat navigates by supersonics. He gives out a high frequency wave and it echoes back, and he turns his

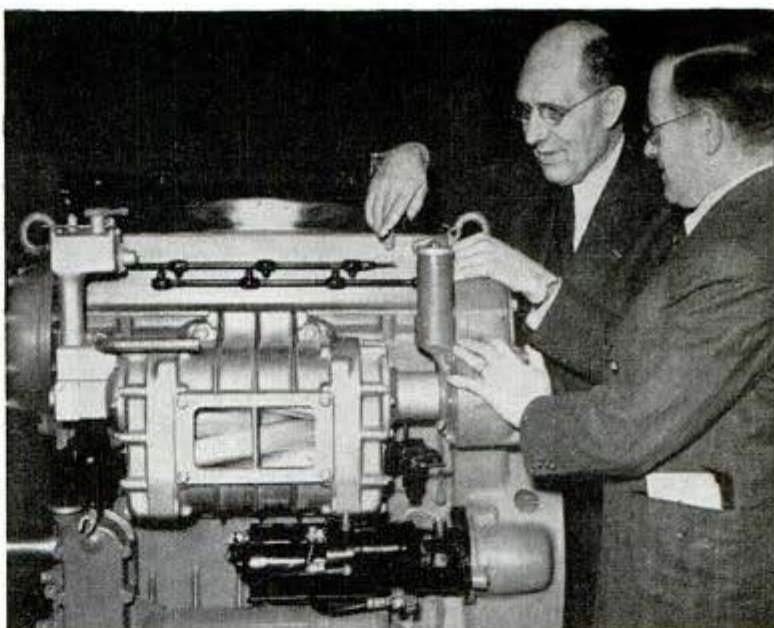

Mr. Kettering and R. K. Evans (top) inspect General Motors lightweight Diesel. Below, bat uses "supersonic echo" to avoid obstacles in darkness

head and gets either a phase balance or an intensity balance. That tells him where an obstruction is, and he doesn't go that way.

He can put out sound frequencies up to 90,000 cycles per second. Our ears are sensitive only up to about 20,000 cycles per second so, of course, we can't hear the sounds the bat hears. It's only recently that we've even learned how to measure high frequency sound waves of this kind. So it begins to look like we're not so smart after all, because the bat, who is only a dumb animal, has already been using our latest developments for thousands of years.

I have hauled pigeons

Spectrograph helps analyze light from burning gases in an engine

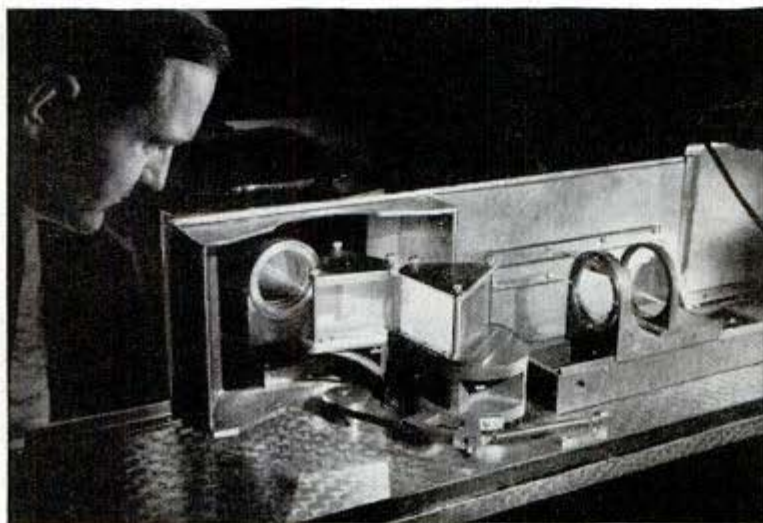

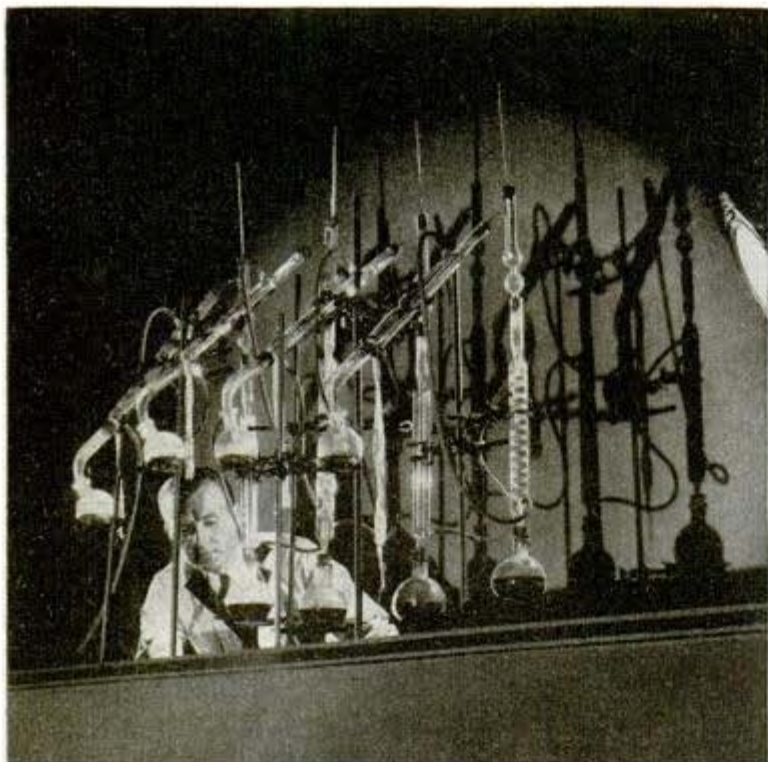

Chemical apparatus used in polymerization, the changing of the molecular structure of hydrocarbon fuels to forms of more desirable antiknock value

to Detroit many times, collected from Dayton, Xenia and Springfield. They had no gyros, no speed indicators, or anything else, but they flew back home all right. Again, they were dumb animals! We're surely smarter than they are, but I'd hate to trust myself to a pilot who had as few navigating aids as a homing pigeon.

Take the geese and ducks which come to

Postwar farm vehicle might be tractor with removable treads, convertible into a light car, Kettering hints



Michigan. They get here within a day or so of the same day every year—without the help of any weather department. If there is a north wind, they will be a day late; if a south wind, they will be a day early, if no wind they will be on time.

I have always had a rule for myself: Never fly when the birds don't, because they have a lot of experience.

I have pointed out these things about dumb animals because I sometimes think we get ourselves so completely detached with slide rules and things of that kind that we begin to believe that is where engineering began. But it didn't. Engineering has been going along pretty well for a long, long time.

The automobile industry is fundamentally a power industry. Our job is to get more horsepower

for less fuel. The fundamental efficiencies of the units we work with are an untouched thing.

In the automobile industry we are getting only about 5 percent thermal efficiency out of the cars we drive around. We have 95 percent left to work on. Some people will pull out a slide rule and tell you we can't improve that ratio a bit. I don't believe that for a minute.

I told a friend the other day that, after the war, I think we will produce a Diesel

71645

engine with 50 percent thermal efficiency. Right away, out came the slide rule, and he said: "You can't do it. The second law of thermodynamics is against you."

I said: "I don't know what that is. The only thing I know about the second law of thermodynamics is that you can't push on something that is going faster than you are."

I think you can calculate to find the framework in which you are going to work, but then you have to work the problem out specifically. One of the difficulties in all our technological education is that we try to set down formulas for calculating specific devices before we understand the basic principles.

I was talking, the other day, to a fellow from one of the big steel companies. He said he didn't know what was going to happen to the steel business, what with the increased facilities for producing aluminum and magnesium and plastics and all that sort of thing.

"Why does that worry you?" I asked him.

"There is a lot of research going on," he said, "in all these other materials."

"Why isn't there a lot of research going on in the steel business?" I asked.

"There isn't much more you can do with steel," he said.

Well, I can't understand that. We want stainless steel, and we want all sorts of new kinds of steels. A friend asked me what we are doing in development of aluminum automobiles. I said:

"We aren't doing anything. And just to start an argument, I will bet you even money that we will have a steel airplane as soon as we will have an aluminum automobile."

He was shocked. He said:

"You can make a thing a lot lighter out of aluminum than steel. Steel weighs three times as much as aluminum."

"I know that," I said, "but steel is five times as strong."

Too often, we get stamped into thinking that some of our rules of thumb are absolute laws of nature. It is the airplane that is important and it should be made from the materials best suited to it regardless of what they are.

(Continued to page 160)

JANUARY, 1944

Land Torpedo Invented by Nazis Defends Posts Along Coasts



Firing torpedo from so-called German fortress along the coast

Using torpedoes as a land weapon is a military innovation claimed by the Germans. Nazi experts say the torpedo, hitherto used only as an underwater or aerial weapon, can be used to greater advantage as a land weapon. Tubes for firing torpedoes have been installed at special fortified points along European coasts, according to reports. They are manned by torpedo experts and artillerymen.

71828

Soft Woods Converted to Hard "Plastic" That Will Neither Warp Nor Swell

Sticking drawers, doors or windows made of wood may be a thing of the past with a new impregnating treatment that makes soft woods as hard as plastic. The treated wood will not warp or swell and is so hard that it may be substituted for steel in certain textile machinery parts. The process, developed by E. I. du Pont de Nemours & Company, consists of impregnating the wood with resin-forming chemicals that react with the wood cellulose to change the properties of the wood. In the past, resin solutions, such as lacquer, were used to fill the wood cells but the properties of the wood were not fundamentally altered.

☐ The pupil of the human eye can expand to about 60 times its fully contracted area.

S. V. J. F. T. Berliner
Gamma Dept.
Wilmington, Del.

7126

Landing Ship Unloaded Through Hinged Nose

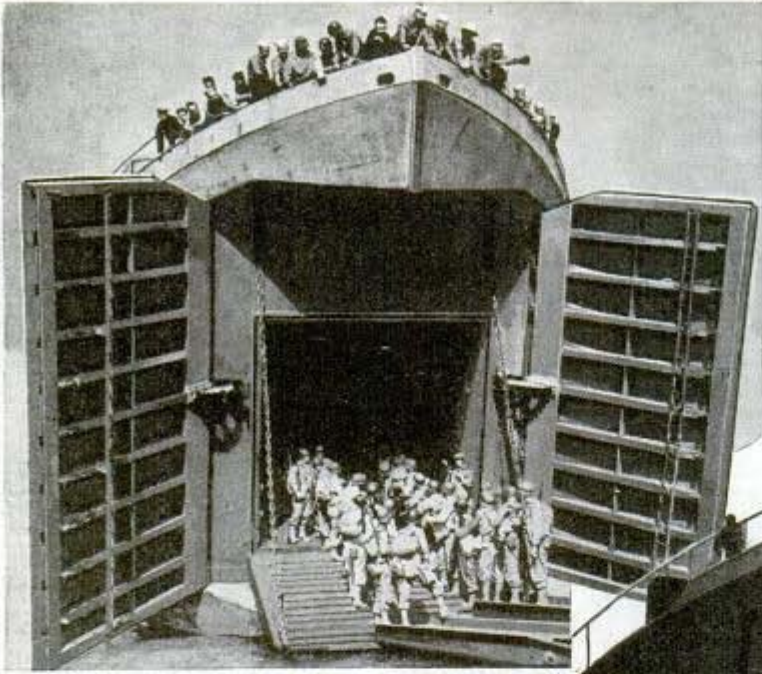

When an American tank landing ship reaches an invasion shore, it disgorges its load of men and equipment through hinged doors which form the prow. Left, showing the doors open, and ramp down to form gangway. Below, how the bow doors look closed for voyage



Yankee troops by the thousands knew that the nose of the LST (landing ship, tank) held a secret before the Navy made the fact public. For this type of craft was used from the beginning of the American invasions to put armed, ready-to-fight Yanks and their equipment ashore. Afloat, the LST's nose trimly cleaves the water, giving scant hint of its double life. But once the craft has pushed up onto a hostile beach the nose sections swing wide—they are in reality two huge, hinged doors. When they are open a ramp inside is lowered. And over this ramp streams the complement of men and weapons.

712

Larger Screen for Television Designed for Postwar Sets



Image is projected through lens to mirror on underside of lid

Postwar television sets may be equipped with an enlarged translucent screen 13½ by 18 inches. The image is projected through a lens to a mirror on the underside of the television cabinet's uptilted lid. It is reflected from the mirror to the viewing screen. The new screen, developed by RCA laboratories, is expected to further the popularity of television, for the scope of television subjects in the past has been somewhat limited by the size of the projected picture.

☐ The retina of the human eye is about 3,000 times as sensitive as the fastest photographic film.

Merrill, Chapman & Scott
N. Y. C.

71 849

Salvaged Normandie Floats Again on Even Keel

Floating again on even keel, after one of the most complex salvage operations in history, the former luxury liner Normandie has been towed from Pier No. 88 in New York harbor to a naval base for refitting. The 54,000-ton ship, which was renamed the U.S.S. Lafayette, burned and capsized Feb. 9, 1942. It took 20 months and four and a half million dollars to raise the ship which may still see service as a troop transport before the war ends. The salvage work was carried on while the ship pivoted on a rock shelf, and at one time it was feared the hull might crack in two. Careful balance was maintained during operations which included removing 29,000 tons of superstructure and hundreds of tons of mud and water.

The U.S.S. Lafayette, better known as the Normandie, may see service before war ends

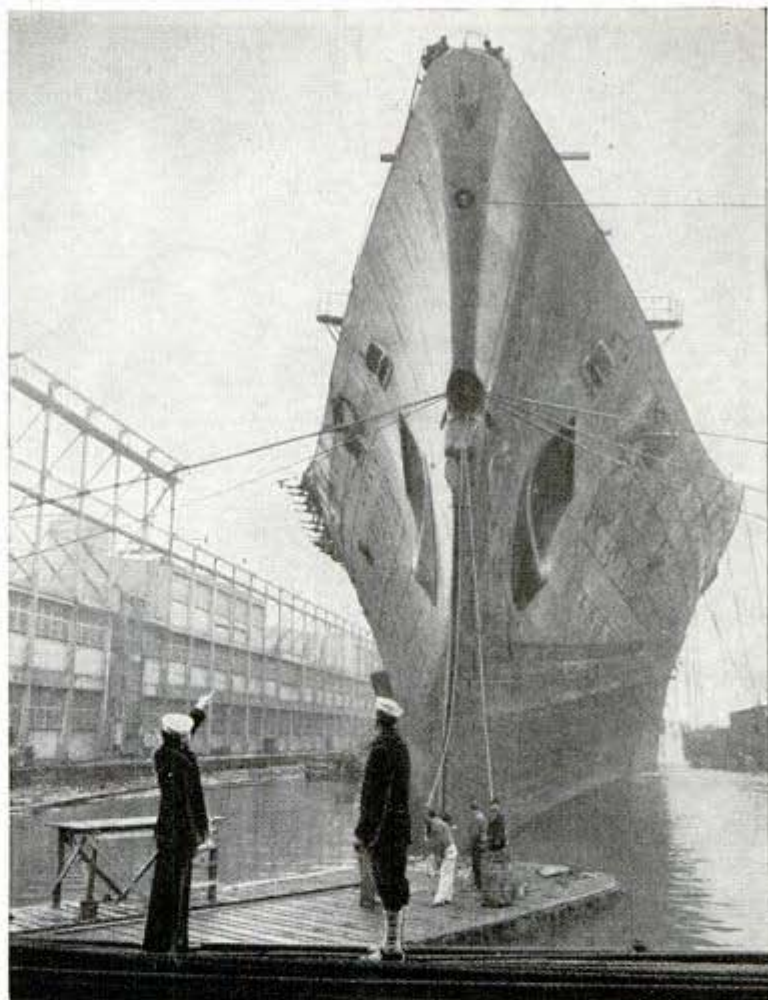

71 644

Night Lookout School for Sailors Helps Spot Ships in Dark

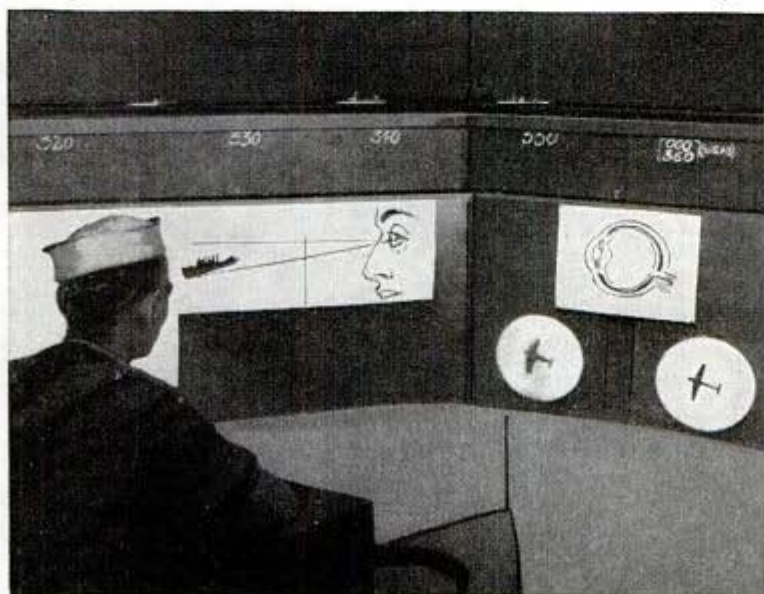

On walls of lecture room models appear as they would in semi-darkness

Officers and men who man America's new destroyer escorts are trained to recognize all types of ships, gunfire, and lights at a special night lookout school on the East Coast. On a dim and realistic horizon in the lookout room, they watch ship models that have only a dim light behind them. If the student recognizes a battleship he sings out the type of ship and position: "Battleship two points off the starboard bow." The men wear glasses with red lenses during a lecture that precedes the test, so that when the lights are turned out they will be accustomed to the dark.

JANUARY, 1944

Destroyer Escort School
U. S. Navy
Norfolk, Va.

Chas. C. Stinson
3872 Franklin Ave., Los Angeles, 27, Calif.

7621

WINDJAMMERS of the SKY

U. S. Naval Air Station
Moffett Field, California
By:



of the air and free ballooning is a sport unlike any other in the world. But Navy Balloon No. 03546 was not on a pleasure cruise this trip. Lt. Steelman's crew consisted of naval aviation cadets who were learning to pilot the Navy's big anti-submarine patrol blimps. Free ballooning is the basis of their education. Their ability to maneuver the two-engined blimps depends on how well they learn their lessons in lighter-than-air. In case of engine failure they could use their knowledge to handle a blimp exactly like a free balloon. You might suppose that a balloon is at the mercy

Basket of free balloon at Moffett Field gets change of crew. Below, instrument box for navigation boasts altimeter, clock

SOME mysterious force in the atmosphere had taken charge of the big free balloon and was treating it like a child's rubber ball. The student pilot in the wicker basket below the bag was worried. He had been ordered to take it up to the 500-foot level but every time he rose to 150 feet something batted the balloon earthward again. It rose and fell as if it were bumping along in slow motion under a solid roof. Lt. George N. Steelman, free balloon officer in charge, grinned and explained the trouble. He told his student crew "There's a stratum of air of different temperature overhead that won't let us through. Spill out two handfuls of sand and see if that helps." It did. The few ounces of ballast that were tossed over the side lightened the balloon enough for it to ascend steadily through the layer of air. At 500 feet the craft encountered a northwest breeze and began to drift along toward San Jose.

Free balloons are the sailing vessels



Материал, защищенный авторским правом

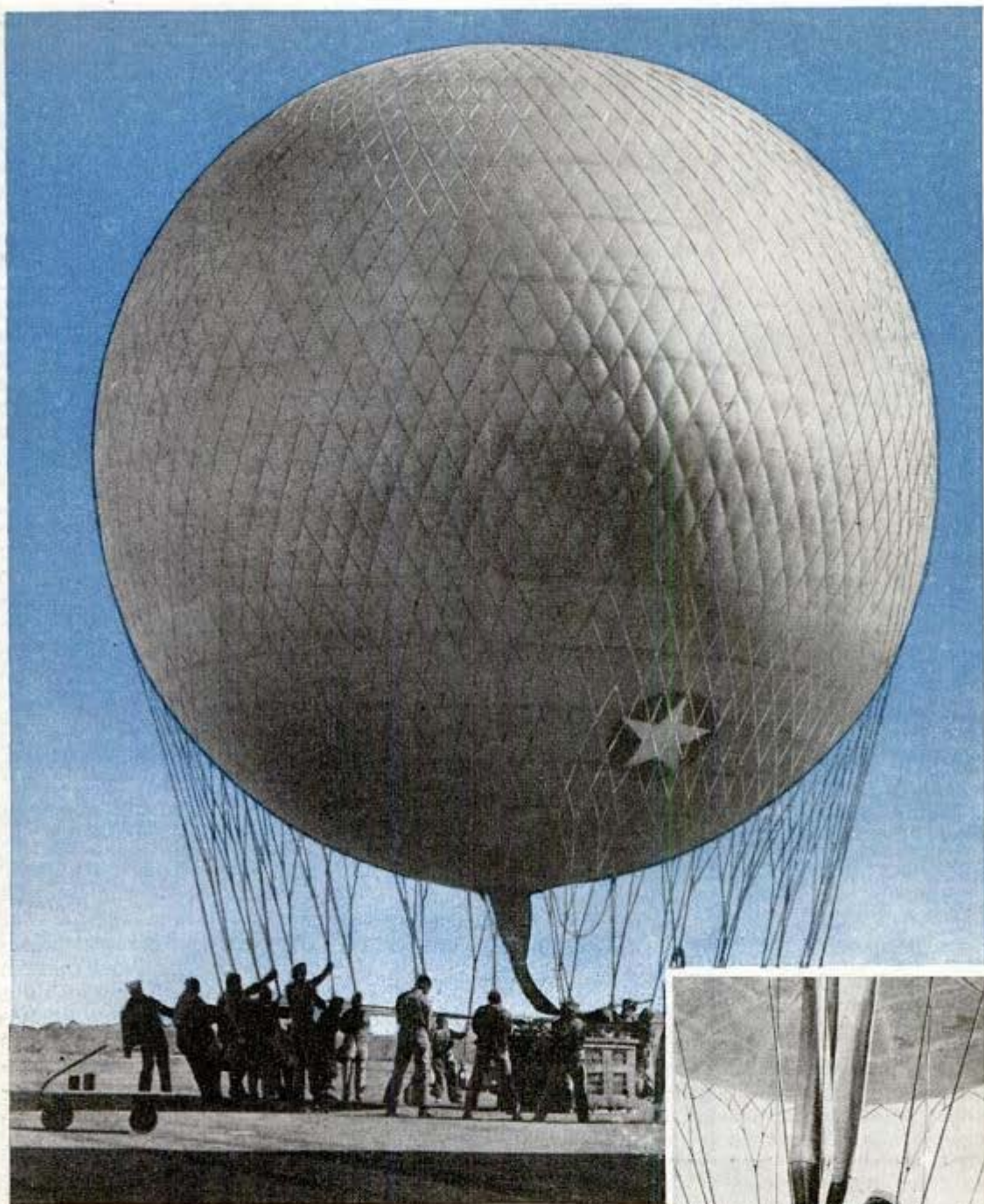

Pressure of the hydrogen gas within distends the balloon into a perfect sphere. Right, inspecting "appendix" left open in flight

of the winds. But at such lighter-than-air bases as Moffett Field in California the aviation cadets learn that this isn't necessarily so. They learn that within reason they can maneuver a balloon to travel in any desired direction and that not infrequently they can bring it back to land at the spot from which it took off.

By now Steelman's balloon was over San Jose and he wanted to change his course to the west. He started fishing for a wind. Over the side he dropped small pieces of tissue paper and watched them as they streamed one after another toward the ground. Halfway down they veered toward the east. There was a wind down there



U.S.A. Brownth, 12th Naval District

Public Relations



Down for lunch, balloon crew "walks" basket along highway

but it was going in the wrong direction.

"Out two handfuls," he ordered.

Two handfuls of sand went over the side. There was no sensation yet the bubble on the statoscope instrument that shows changes in barometric pressure indicated that the balloon was rising. At 1,000 feet the balloon's shadow on the ground started to move toward the west. Steelman had the wind he wanted.

"Valve one second," he directed. A cadet pulled on a line, opening the valve at the top of the bag long enough for one second of hydrogen to escape. That leveled the balloon off

Hydrogen storage flasks are anchored in concrete holder

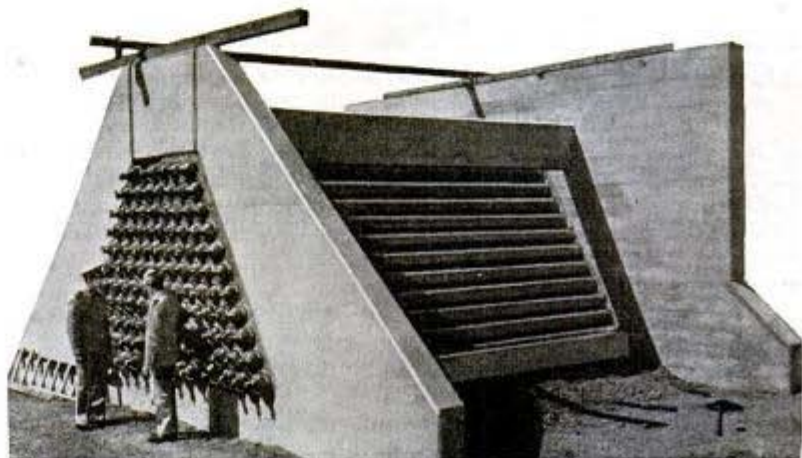

at the new altitude. Free ballooning seems like a quiet, peaceful sport and yet there are a hundred and one tricks that Steelman must teach his students. Every bit of knowledge that he can impart from his 2,000 hours of experience in flying and racing the big bags will aid them in their careers.

A free balloon moves with the wind, so except for an occasional flurry when the wind changes direction, the bag seems to remain in a dead calm. And there is no sound from its flight. The creak of the cordage, the patter of the carrier pigeons' feet in their wooden box, and noises that rise from the ground are all you hear.

Still, free balloon enthusiasts have a few wild tales they can tell, such as the time when Lt. Steelman found himself at the mercy of a whirlwind. His balloon began to spin around as if it were attached to the periphery of a merry-go-round. The basket and drag rope were streaming out almost horizontally. Gas spilled from the open appendix so rapidly that the balloon was sinking in spite of all the ballast that was released. The wild ride ended safely close to the ground where the cyclonic force of the wind was weaker.

The most thrilling adventures of all were back in the days of the international balloon races. These races were for the greatest possible distance and so the two-man crews let wind and temperature

take charge, hesitating to valve out even a second's precious gas at any time. In spite of the fact that they knew they would encounter sub-zero temperatures at high altitudes they usually wore nothing but shorts, to save weight.

Steelman and Capt. T. G. W. Settle starved themselves down almost to skin and bones for the 1928 race and refused to carry an oxygen supply because of the weight of the containers. They were carried up to 18,000 feet and then a thunderstorm took charge, lifting them up to 21,000 feet and then dropping them down again at so great a speed that they passed bags of sand that they had tossed out a moment earlier to prevent just such a descent.

The Navy's training balloons are of 35,000 cubic feet capacity and are inflated with hydrogen because of its great lifting power. A pilot, first and second sandmen, log keeper, and valveman make up a crew. Thirty-one bags of sand, weighing 30 pounds each, are carried as ballast, permitting several flights to be made during a day so that several crews may receive training. The balloon's basket is also fitted with the statoscope instrument, a clock, and a 225-foot-long drag rope. At low altitudes over hilly country the drag rope can be used as automatic ballast, for the balloon is relieved of the weight of as much rope as is allowed to drag on the ground. Thus a pilot who is dragging part of his drag rope over the ground can climb when he encounters a hill by paying out more rope, hence lightening the balloon, and if he wishes to descend the other side of the



Spilling sand ballast over the side to speed ascent of balloon. Below, landing in field as blimp watches





Ground crew "walking" balloon out of hangar. Pulling on rip cord (below) to collapse the balloon after landing



hill he retrieves enough rope to cause the balloon to settle.

Aviation cadets average seven instruction rides each plus at least one ride in which they are in complete charge. Each must be able to land his bag gently, a trick that isn't as easy as it looks and that is accomplished by valving enough gas to cause the balloon to drop, and then judiciously dropping sufficient ballast to ease the fall and finally bringing the balloon almost to equilibrium as it approaches the ground.

Learning how to ascend through a temperature inversion is easy but learning how to descend through the same kind of freak condition and to do it safely is more difficult. After a balloon has been forced up through cold air into a layer of warm air it is just as reluctant to descend again as it was to make its initial climb.

The only way to get down is to valve enough gas to cause the balloon to fall through. That is easy, then the pilot must immediately estimate the amount of ballast that he must jettison to check the elevator-like descent and prevent a crash landing.

A free balloon is the most sensitive vehicle in which man ever rode. Not only does it react to the slightest change

71742

in equilibrium, it responds to the faintest breeze and to the slightest variation in temperature. If allowed to seek its own altitudes during a low-level crosscountry flight, a balloon would perform an erratic series of ups and downs. The heat radiating from a plowed field would send it toward the sky, but cool air above an adjacent orchard will cause it to descend again as soon as it drifts over the trees. Heat waves from a concrete highway have a pronounced effect and the balloon seemingly floats up and over an invisible hurdle when it crosses such a highway. In time a balloon pilot acquires a feel of his vehicle that helps him anticipate its movements and to control its course.

The cadets who graduate from Steelman's lighter-than-air cruises have a certain confidence that they didn't possess before. "Any one can fly an engine," they remark, "but you need horse sense to be able to fly a free balloon."

717

"Skin" Nut Meats And You'll Ease Butter Supply

Experts of the Department of Agriculture in Washington are seeking someone with a peculiar talent. They want information on how you can skin the kernels of black walnuts, hickories and pecans quickly and completely. Ground fine, these nuts make butters that help piece out our wartime dairy supply. They particularly want to get rid of little spots of skin adhering to the kernel, as these detract from the esthetic attractiveness of the butter, though not from its taste.

U.S. Dept. of Agriculture
Washington, D. C.

Army Uses a Portable Pipeline To Carry Oil to Front



One man can handle 20-foot section of flexible pipe used to supply army

One of the "secret weapons" that helped push the Germans out of North Africa and Sicily was a portable pipeline that supplied advancing units with fuel or water. The pipe, developed by the Shell Oil Company, is lightweight and flexible. One man can handle a 20-foot section. The steel is so flexible it can be bent around trees, and can be laid at the rate of 10 to 30 miles a day. Pumping stations are located at intervals of about 20 miles. It is made in four- and six-inch diameters, the latter having a capacity of 25,000 gallons daily. One of the desert pipelines in Africa was more than 300 miles long.

50 ft. 21 ft. 21 ft.

716

Kapok Pads Float Bren Gun Carrier While Its Tracks Act as Rudders

Troops at a British school of military engineering have devised various expedients for transporting their heavy military equipment across rivers and lakes. In one instance, a Bren gun carrier made the water crossing supported by kapok floats. The rotating tracks of the gun carrier were used for steering.



Kapok pads keep Bren gun carrier afloat, while tracks are used to steer

made in England

71408

The WEB-FOOTED ENGINEERS

*Major Julian Lyzette
2007th Signal Coy. Ohio
Ordained Dayton, Ohio*



Modern-day shock troops must build, as well as fight. It is not enough to effect a landing on the beaches or river banks held by the enemy—the way must also be paved for the troops that are to follow. Infantry above have “forced” river crossing, and leap with fixed bayonets out of their boats to establish bridgehead

Assault boats used by the engineers lead a versatile existence. Above, a platform is laid across a pair of them to form a light ferry capable of carrying peep. The impromptu ferryboat is paddled across the river
Signal Corps photos



Oceans are no more obstacles than are rivers. Truck above is driven to beach from barge that ferried it ashore from ship at anchor

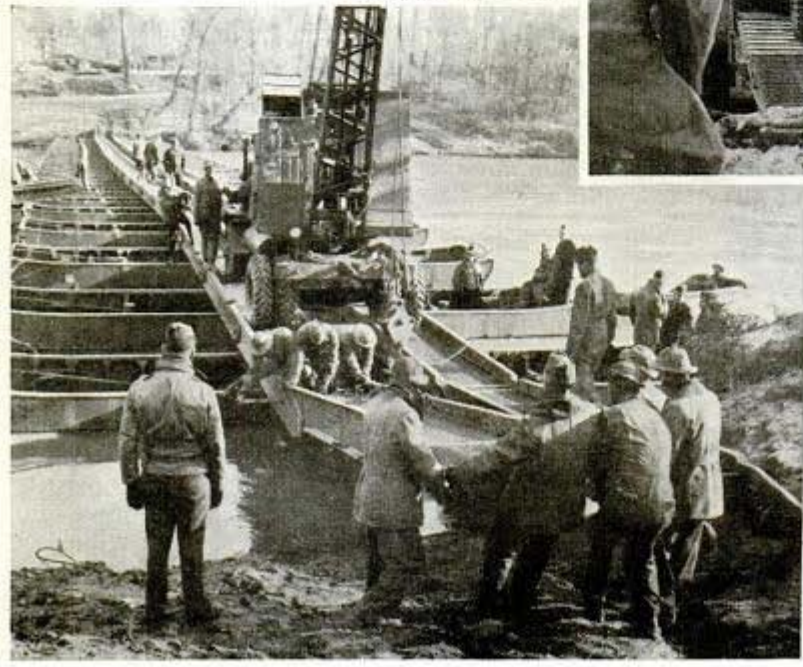

It's in the traditional engineering job of bridging enemy streams that this web-footed unit shines, left. A “bridge of boats” supports treadways laid across a stream where bridgehead has already been secured. Heavy equipment may use this span

Amphibian Command men, right, rush ashore with markers, to indicate the spread of their installations, as a guide to gunners on Navy craft laying down protective barrage from offshore. Markers also help to guide later landings



Below: Markers in place, the men speedily lay down a wire roadway which keeps vehicles from sinking into the sand



Now the roadway is laid, and the commanding officer's jeep (right) is driven ashore, so that he may personally supervise progress of the operations



Roadways of the type in picture below can be laid almost as rapidly as the wire can be unreeled. Mechanized equipment rolls up it into action



First "True" Compass Guides Fliers to Target

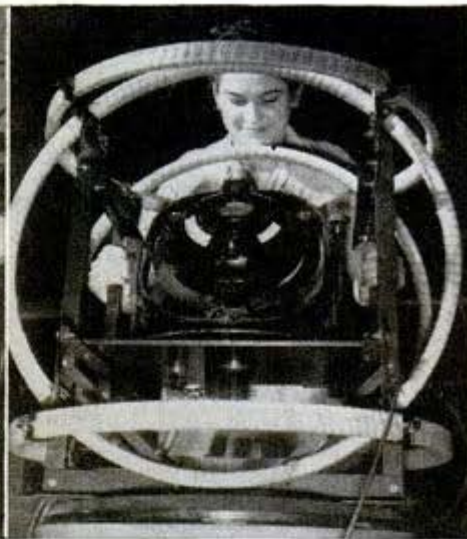

Compass transmitter is shown on the tail of the plane (top left) with master dial on the nose, amplifier in center. Above, testing new compass; left, "fins" used on the compass



cording to W. A. Reichel, director of engineering for the Bendix company. The needle will not lag or overshoot during a turn, nor does it "hunt" back and forth in rough weather. It functions perfectly within 300 miles of either pole, regions where magnetic compasses are useless. This factor is expected to play an important part in postwar aviation along arctic routes. Because the transmitter of the compass can be located at a distance from the indicating dial, it can be installed on a plane where it will not be affected by metal parts, such as armor plate, that impair the accuracy of the standard compass. As many compass dials as are needed for the crew can be mounted in a bomber. Development of the compass was made public only after one of the instruments fell into enemy hands. Bendix officials believe it will be impossible for the enemy to duplicate the performance of the compass during this war.

Carl Piper & Associates
10 E. 40th St.
N.Y.C. 16

Hailed as the greatest advancement in its field in 4,500 years, the Gyro Flux Gate compass is guiding U. S. bombers to remote enemy targets and home again. The new compass, developed by the Bendix Aviation Corporation, requires no "correction card" which is necessary with magnetic types because it gives the "true" reading. This eliminates the danger of error by pilot or navigator in the heat of combat. The flux gate compass uses the earth's magnetic field to develop minute electrical impulses which, when amplified, turn the compass indicator. The impulses are taken in through the "flux gate" which receives and rejects the magnetic flux from the earth. The flux gate is a triangular-shaped coil attached to the bottom of a gyroscope which keeps the unit on a horizontal plane. This compass will not go off its reading when a plane dives or climbs rapidly, ac-

Widely known

Land Torpedo Guided by Cable Is Nazi Antitank Weapon

Nazis in Russia have introduced an anti-tank land torpedo, resembling a small tank and about the size of a motorcycle sidecar, operated by remote control. The torpedo carries about 150 pounds of explosive in its nose, and at the rear has a reel of cable that leads back to an operator, in a shelter up to 1,500 yards away. By means of electricity, the operator guides the machine and sets off the explosive. The best Russian defense has been to cut the cable.

152 W. 42nd St.
N. Y., N. Y.

M. Elliott

71737

Steel Airfield Mats Become "Armored Road"

Tests of the practicality of steel highways are under way near Darien, Conn. Steel grating, similar to the landing mats laid down for combat airfields, was installed in a stretch 48 feet long and 22 feet wide, in the first practical test of "steel armoring" under normal passenger and truck traffic use. The technique calls for attaching steel grating panels, each 2 feet by 12½ feet, filling the mesh with ordinary construction sand, then applying a coating of road oil. Spokesmen of the Irving Subway Grating Co., manufacturers of the steel-type roadway, foresee its use especially in a network of secondary roads, and particularly in districts where weather conditions



Landing-mat type of steel grating is laid for test roadway and graveled

result in frequent washouts and other impairments of normal road conditions.

Pre-Pasted Cedar Wallpaper Transforms Clothes Closet

Ordinary clothes closets are changed to cedar closets with a ready-pasted wallpaper that retains the cedar odor. The paper is made from cedar wood which the

finished product resembles with variegated grain and realistic knots. No special tools are required to hang the paper; it is merely dipped in a tub of water to wet the adhesive on the back and then pressed against the wall. The paper comes machine-trimmed. It can also be used for lining chests and bureau drawers.



Dipping cedar wallpaper in tub of water wets the adhesive on the back and it is ready for hanging on closet wall (left). No special tools are needed



Eye and Nose Beat Machines Spotting Bad Eggs

Many a mechanical marvel has been devised with more sensitiveness than its human inventor, but science has yet to evolve anything better than the human eye and nose for detecting bad eggs. The problem is a vital one in an egg-drying plant. No one has yet endowed a mechanical egg breaker with the ability to smell out and discard bad eggs. Experts still do the job by keen sense of smell and observation.

United Wall Paper
Factories, Inc.
3330 W. Fullmore
Chicago, Ill.

7. v Oliver, captain U.S.N. (Ret)
401 old Post Office Bldg.
Pittsburgh, Pa.

77647

HOW JAPAN WILL BE DEFEATED



U. S. Navy photos

A Navy dive bomber comes home safe from a Pacific raid. Below, a destroyer claims two Jap ships and five planes downed in combat

By Frederick L. Oliver

Captain, U. S. Navy (Retired)



JAPAN did not make the momentous decision to strike simultaneously against the world's two greatest naval powers in the belief that its outnumbered force of battleships, cruisers, and destroyers could prevail against the battle line its enemies could muster.

We now know the Japanese based their hope of quick victory on airpower projected from carriers and island air bases. They were so confident of success that, misled by early triumphs, they were foolish enough to visualize Hawaii, Alaska, and the west coast of the United States as ripe plums practically within their grasp, and even indulged in the bombastic prophecy of peace terms being dictated by them in the White House.

By astute dissemination of misleading information and rumors over a period of years,

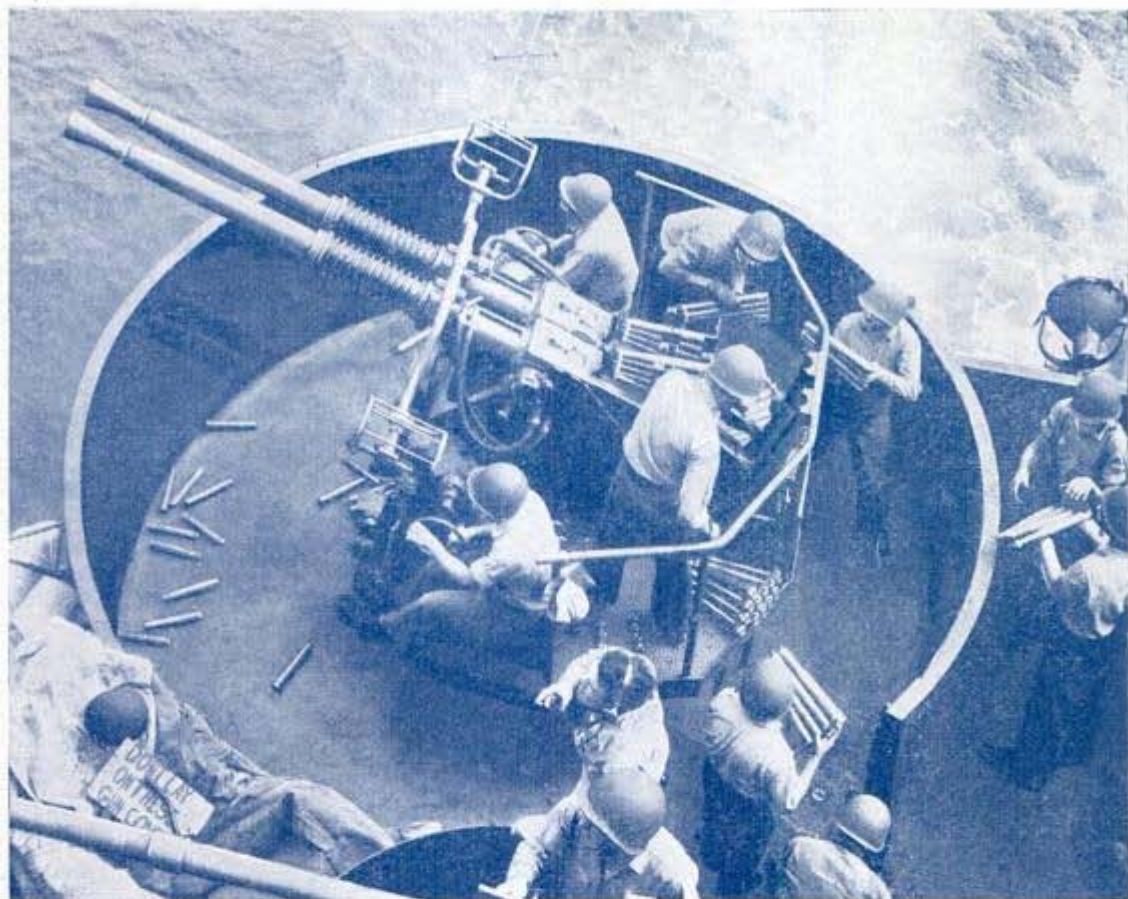

Bluejackets pass the ammunition to feed a 40-millimeter Bofors antiaircraft gun aboard an aircraft carrier

Japan had concealed the extent to which it had developed its airpower, and succeeded in creating the impression that great difficulty was experienced in obtaining well qualified pilots, in particular pilots who could successfully operate from carriers.

As a result of clever propaganda and the security of information afforded by racial characteristics and language difficulties, Japan was able to enter the war with a much greater carrier and air strength than

had been considered possible. It does seem that we were remiss in not having reached a more considered estimate of what to expect from Japan's repeated attempts to bring about the outlawing of airplane carriers, the secrecy with which its naval building program was shrouded, and its spy complex.

In launching the unexpected attack on Pearl Harbor, the Japanese gambled on delivering a blow that would practically im-

PT boats sweep the seas with guns, torpedoes, depth charges





Old Glory still flies above the Hornet after a Jap dive bomber has crashed into signal bridge during the battle of Santa Cruz Islands. Below, one of the fast-growing fleet of escort carriers

mobilize the United States Navy, and they succeeded to an extent probably beyond the expectations of the most air-minded Japanese admiral. Fortunately they did not follow up the advantage with a thrust in force to seize the Hawaiian Islands. Why they passed up their golden opportunity will not be known until Tokyo's archives can be scrutinized.

The prewar Pacific Ocean naval campaign plans of the United States should have and unquestionably did provide for all likely contingencies, but the possibility of incurring what amounted to an immobilization of our force of battleships without a corresponding or greater loss being inflicted on Japan probably was given little thought, and it is to the eternal credit of our Navy that it promptly put into effect plans which utilized its remaining strength to good advantage. Relief of the Philippines, Guam and Wake was out of the question, but a succession of spectacular effective raids on widely separated Japanese outposts not only resulted in sinking several enemy carriers, but left Japan to speculate where the next blow would fall, and prevented a total



mobilization of its naval forces for the operations that struck at Midway and the Aleutians.

Japanese airpower successfully paced the campaigns which overran the Philippines, Singapore, Burma, and the Netherlands East Indies and portions of Melanesia. In these areas the Allies did not have sufficient air strength to counter the pent-up flood of planes so unexpectedly loosed by Japan, and making additional planes available was contingent on transportation facilities as well as the diversion of effort between the two main theaters of war in accordance with the overall strategy adopted. This strategy gave top priority in planes to the European area, and in the Pacific we had to operate against Japan with such resources as could be made available.

It was immediately apparent that Japanese designs on Australia must be frustrated at all costs, and that our long line of communication over which supplies flowed



Gunner of Navy fighter plane gives his weapon a last swing before takeoff

to the South Pacific must be made safe.

Japan had lost no time in advancing the island bastions which form the outer defenses of its homeland. Strategic Rabaul in New Britain was an early conquest, and the project was afoot to overrun all of New Guinea to provide bases from which the invasion of Australia could be projected. In addition, an ambitious island by island advance through the Solomon Group was

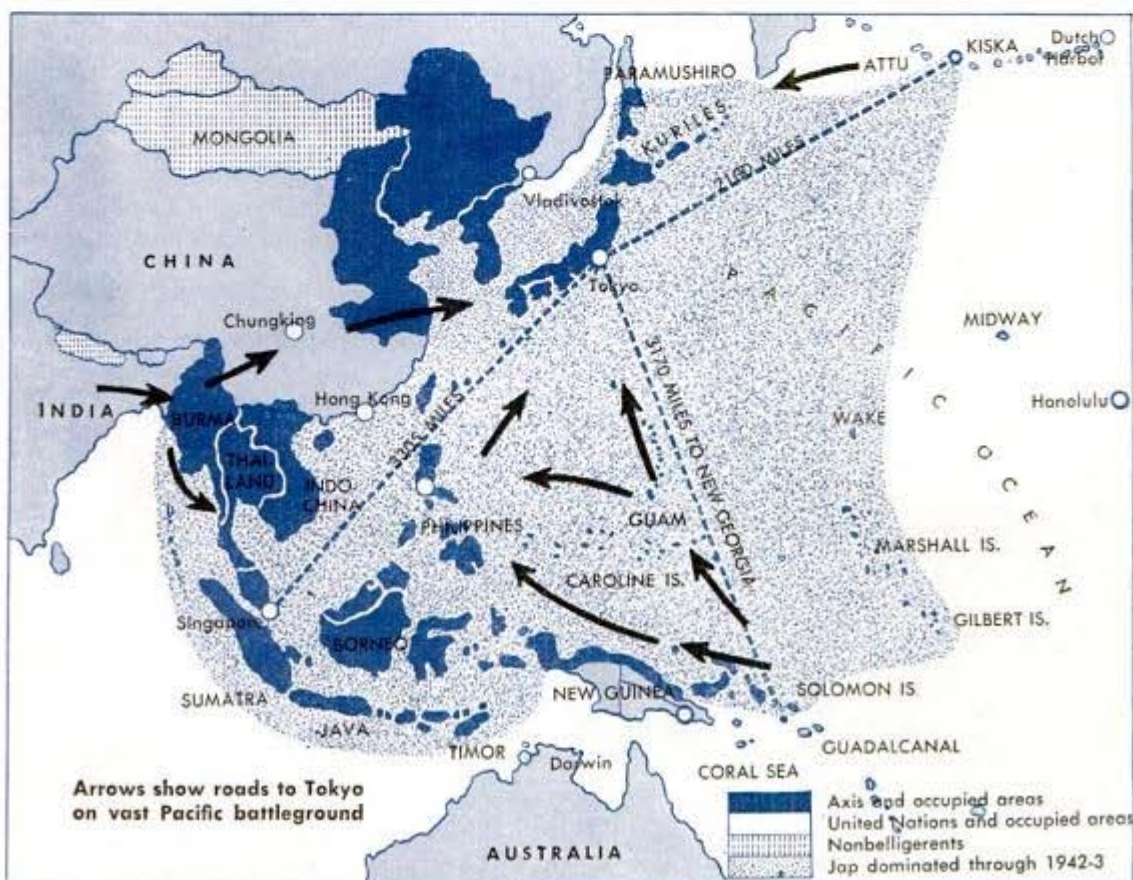

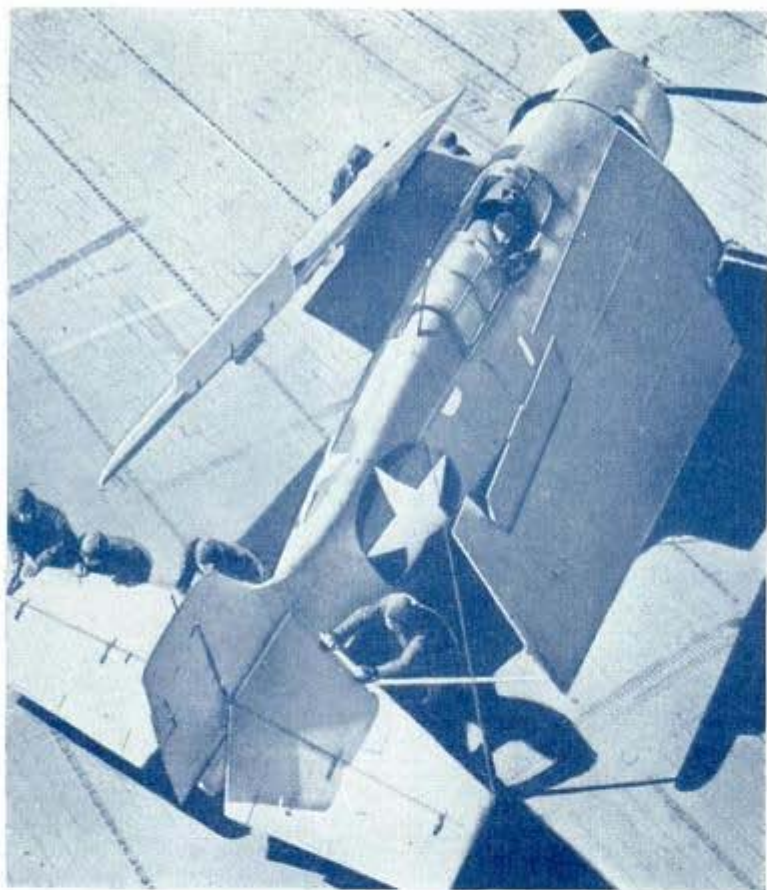

Pushing a Grumman "Wildcat" from carrier's elevator to takeoff position

undertaken with the ultimate objective of gathering in the New Hebrides, New Caledonia, the Fiji group and probably Samoa, thereby placing the Japanese astride the long Allied supply line from Honolulu.

These projects were nipped in the bud by the last ditch stand in Southeastern New Guinea which developed into a valiant Allied push that has all but eliminated the

Japanese as a factor in New Guinea, and the now historic campaign that ejected the Nipponese from Guadalcanal.

Our attack on Guadalcanal was exquisitely timed when the airfield under construction by the Japanese was within a few days of completion. Due to unforeseen difficulties, reinforcements and supplies were slow in arriving, but American grit prevailed over Japanese fanaticism, and the previously invincible Nipponese warrior had his ego deflated. How far the virus of defeat will percolate among the Japanese remains to be seen, but no nation can experience such a one-sided and devastating trouncing by land, sea, and air as the Japanese underwent in Guadalcanal and the subsequent actions in the Solomons without loss of morale.

In particular was demonstrated the weakness of Japanese aviation—the arm to which Japan had looked for reaping an early victory. Not only were Japanese planes tumbled out of the skies at a ratio at times of as high as 25 or more for every United States plane, but their loss of planes reached such a staggering total that Japanese air strategy must be in course of revision.

Japan is becoming more and more unable

At one of the South Pacific island stepping stones to Tokyo a crane helps a truck ashore from a supply barge



to cope with the growing United States sea and air power in the Western Pacific and the Aleutians. Its losses of planes and ships, both naval and commercial, have been in excess of replacements, whereas Allied strength in all categories increases daily.

The strategy open to us in the Pacific hinges to a certain extent on the progress of the war in Europe, but it is interesting to examine the various possibilities.

Japan is an island empire. It is as much dependent on sea-borne transportation as Great Britain, and its lines of communications must be afforded protection by its navy and air strength. How much remains of the Japanese Navy and air force we do not know, because there are no reliable statistics of Japan's pre-war strength, its losses, and replacements. However, there is good reason to believe that both of these arms are greatly reduced in strength, and in addition it is evident that the present crop of Japanese fliers is distinctly inferior in skill, training, and technique to the carefully trained aviators who manned the vast number of planes Japan has lost since Pearl Harbor. The Japanese fleet has become increasingly reluctant to offer battle, and well it may, because all that stands between Japan and defeat is the remains of a once formidable fleet. Consequently the primary strategy of the Allies in the Pacific is to destroy the Japanese fleet either piecemeal or in a major engagement.

Whatever strategy is adopted in the Western Pacific will have the ultimate objective of striking at the Japanese Islands,



From the Flight Control post on one of our newest carriers the Flight Operations Director watches a Douglas "Dauntless" dive bomber get away



Torpedomen watch from the turret above a destroyer's quadruple tubes. Below, flame and metal spew from 40-millimeter Bofors anti-aircraft guns—rapidfire automatics that have an impressive record against Jap planes



because there lies the core of Japanese resistance, and in order to dissipate the Japanese menace for all time it is necessary that the myth of their homeland being inviolate be dispelled.

The following courses of action in the Pacific are open to the Allies either singly or in various combinations:

1. Attack Japan via China.
2. Attack Japan from the Aleutians, possibly making use of Siberian bases.
3. Isolate and take strategically located Japanese bases in the Mandated Islands, and eventually retake the Philippines to provide bases from which Japan's vital lines of Communication can be severed.
4. Wage a war of attrition on

Bristling with 3-inch guns, 20-mm. Oerlikon anti-aircraft guns and depth charges, destroyer escorts (right) are deadly against subs. Below, pilot and gunner were unhurt when this "Dauntless" nosed over on the carrier's deck

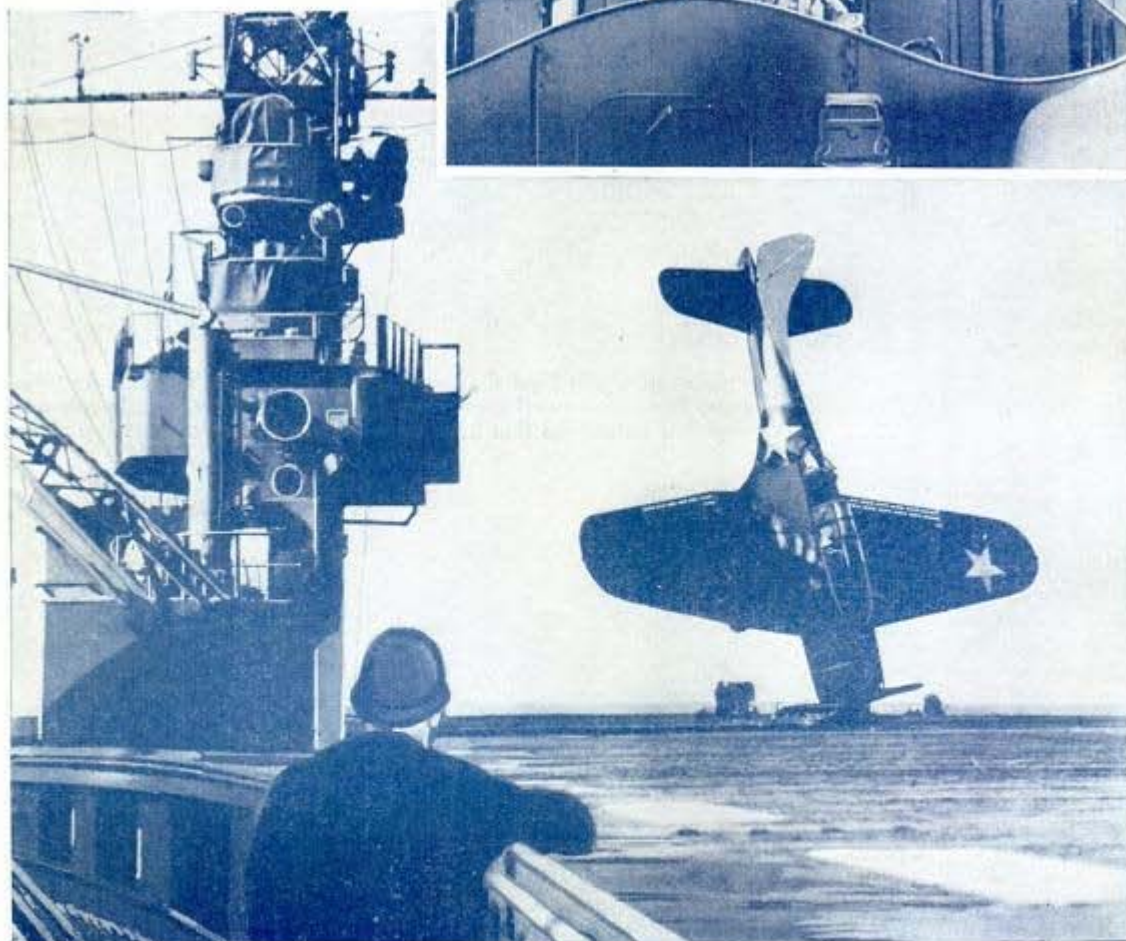
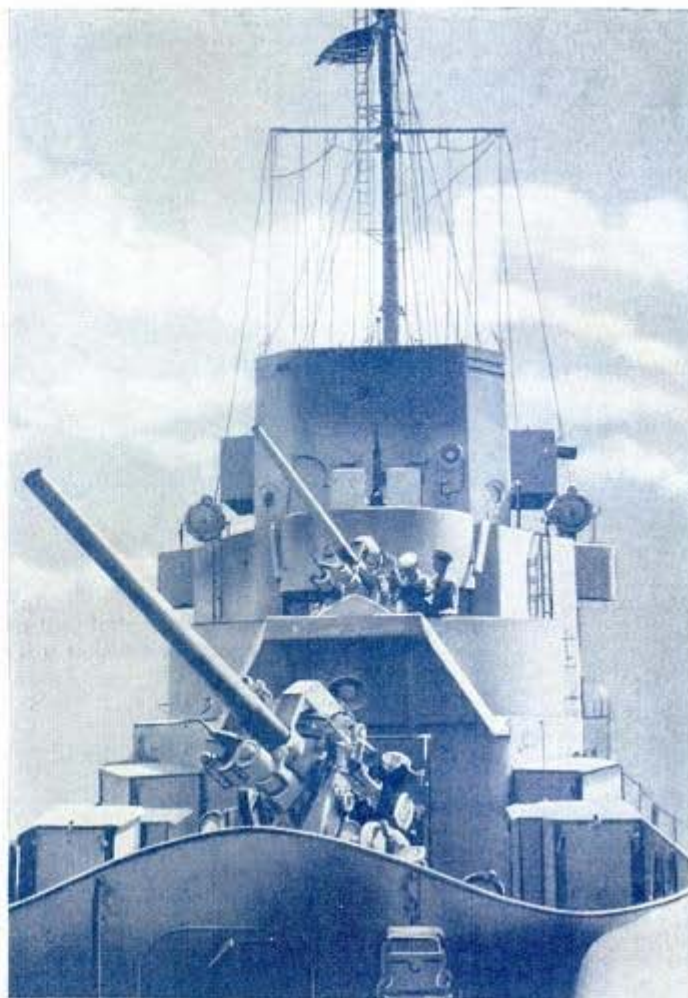



Japanese naval and merchant vessels.

5. Make a direct attack on the Japanese Archipelago.

Examining these procedures in order, we find the route into China is long and tortuous except by sea, and there the Japanese Navy stands in the way. The project of reopening the Burma Road seems definitely set for the near future, but let there be no delusion about the capacity of this route. In good repair and under expert supervision it cannot handle sufficient supplies to support a major campaign. The most that can be expected from the Burma Road is transportation of enough gasoline to maintain an air force in China strong enough to prevent Japanese planes from operating in that area, fly nuisance bombers over Southern Japan, and provide

(Continued to page 156)

Flash-protected muzzles of twin .50-caliber guns on PT boats swing in wide arc against Jap planes

One of the Navy's "Fletcher Class" destroyers, built in 1940, knifes along the road to Tokyo

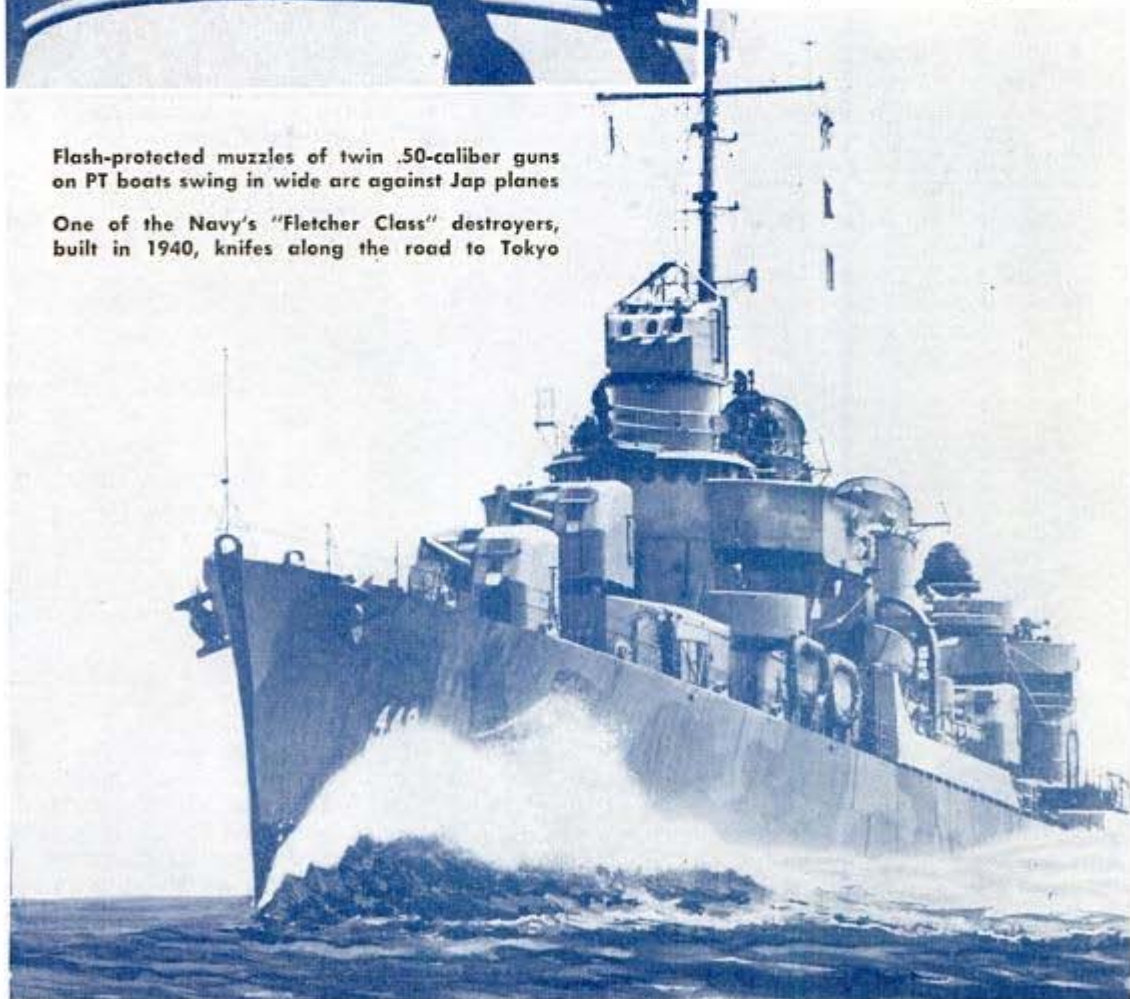

Lifting Bag and Poppet Riveter Repair "Forts"

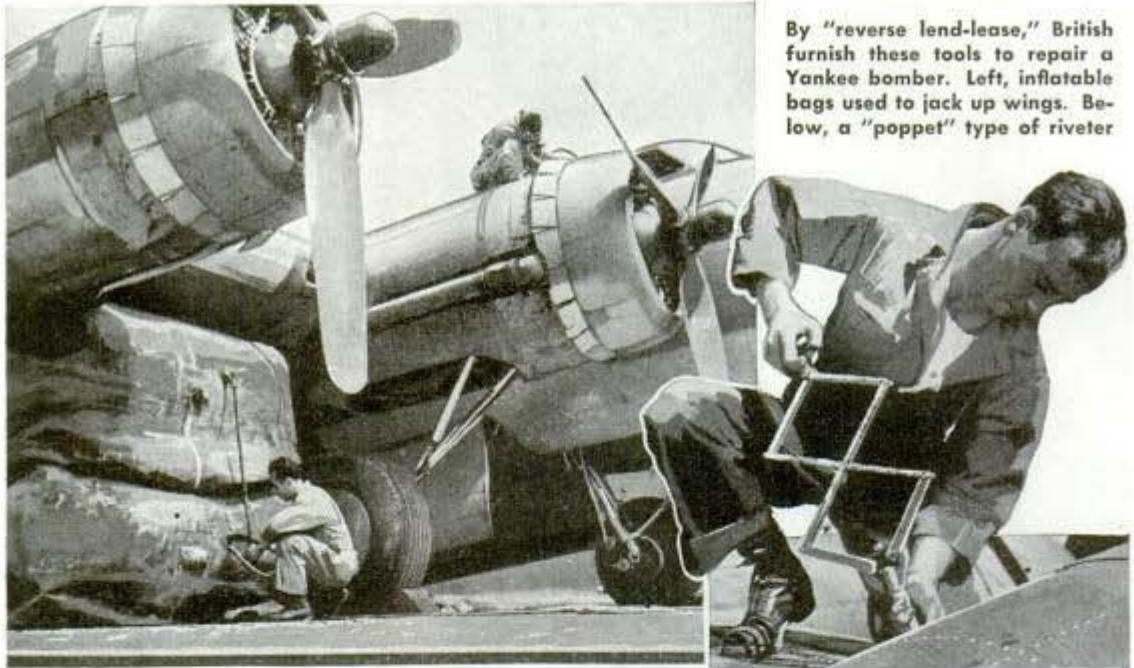

By "reverse lend-lease," British furnish these tools to repair a Yankee bomber. Left, inflatable bags used to jack up wings. Below, a "poppet" type of riveter

Flying Fortresses based in Britain are kept in fighting shape, in part, with tools supplied in Britain by a variety of "reverse lend-lease." One such implement is a poppet riveter, in appearance of pantograph or

lazy-tongs construction. Another is a lifting bag, or inflatable jack. Deflated bags are placed beneath the wing of the Flying Fortress, then pumped up. Expansion of the bags lifts the wing to facilitate repairs.

71613

Lifeboat Dropped by Parachute Has Motors and Supplies

Fliers adrift on rafts at sea are rescued with an airborne lifeboat developed by a British aviator. The boat, which has two motors, is designed for dropping by parachute. It is carried under the fuselage of a rescue plane, and when cut loose drifts

slowly down. The lifeboat has special buoyancy tanks to keep it afloat and prevent capsizing. No matter how it strikes the water, it will right itself. Compartments in the hull contain the motors, clothing, medical supplies, food, flares, gasoline, radio, and sails and oars in case of engine failure.

71546

Modified Vibrator Helps to Start Cold Plane

To provide positive ignition for aircraft engines, regardless of weather conditions, General Electric engineers have designed a starting vibrator. Transformer action within the magneto steps up the low voltage current supplied by the vibrator, providing high-voltage output which assures instant ignition. The vibrator is automatically disconnected from the ignition circuit after starting.



Lifeboat floats down to crew on raft who have abandoned sinking bomber

Mr. C. W. Moore
1362 N. Dearborn
Chicago, Ill.

71674

The LAST MILE IS the HARDEST



HERE'S where the mules take over.—Or they might be camels, or dog teams, or natives, if the trucks can't make it. Or Yankee soldiers with packs on their backs.

The route may be through treacherous tropical undergrowth or knee-deep mud, over mountains, icy trails or blown up roads, across deserts or rivers with logs for bridges. Shells may be bursting, enemy bombers or fighters may be overhead.

Such are the conditions often encountered on the tough, often heart-breaking, last few miles of the route that millions of tons of supplies and munitions travel to the fighting fronts of the world.

Of the thousands of miles these supplies must travel "from producer to consumer," the last lap, from unloading on enemy-held shores or from supply depots to the first line, is by far the most difficult and dangerous, and that in no way discounts the hazards of transportation by ship or plane through submarine-infested waters and bomber-infested areas.

Once munitions, food and other war materiel are landed

Army mules wade reluctantly ashore at a Sicily beachhead to do their part in toting supplies over the mountain trails of the invaded island. Below, loading ammunition aboard an American vessel





A tractor (seen on opposite page) hauls ashore a 105-millimeter howitzer to plaster Japs in South Pacific

or reach supply stations, practically every method of transportation ever used by man is employed. As the Army and Navy Ordnance Departments put it, "when a fighting man in the front lines needs a gun, a tank, a can of soup, or a shoe lace, the armed services must float (ship), fly (plane), roll (truck and train), trot (horse, mule or other beast of burden), or carry it pick-a-back (manpower) from American factories to the battlefield."

In New Guinea and the Aleutians, much

of the task is up to man, dog or mule. In no other way can snow or mud or dense jungle be traversed. Natives are employed whenever possible, and most of them are eager to trade their services for American money or merchandise.

Trucks, tractors and their drivers have done a remarkable job of getting supplies to the front. In the closing days of the battle for Tunisia, when moving ammunition into the front lines was of vital importance, truck drivers remained at their

machines until they collapsed from exhaustion. Eight hundred tons of ammunition were transported every day to one supply point alone. Approximately 1,000 2½-ton trucks were required for this task.

American railroad equipment has done its bit. Lieut. Col. Edward T. Barrett and his crew took an old and wheezy locomotive up a narrow-gauge track in Tunisia to deliver ammunition when the only fuel available was cork. On the return trip, the train was strafed by planes, but the engineer "pulled the throttle wide open downhill" and little harm was done.

Rations for boys at battle front move along a New Guinea trail

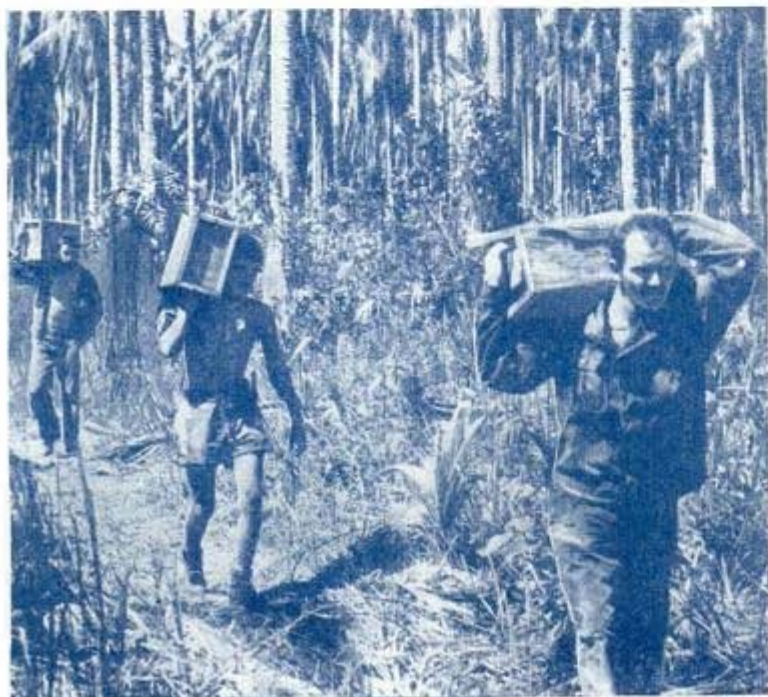

and Arctic cold each require a different method of transportation and packaging and storing supplies to protect them against cold, sandstorms, dampness and bombing or attack. Use of natives requires identification of packages by symbols so that the laborer, who understands not one letter of English, can keep straight in his head where the boxes are to be delivered.

Astronomical figures issued by the Army Service Forces show that something more



The airplane, of course, has introduced new ways of transporting supplies as well as men, just as the truck came into its own in the first world war, and as the railroad appeared on the scene as a vital war factor in the Civil War. Huge transports ferry supplies to the front lines, often dropping them by parachute.

The magnitude of the supply job has created new problems in packing, storing, and even marking. Jungle damp, desert heat



Signal Corps photo
Camels driven by natives haul supplies to U. S. Army in India

New Guinea natives in outrigger canoes ply from shore to ship





An "LCM" craft puts ashore a 10-wheel cargo truck on an African beach

than three and one-third million tons a month are being moved to training camps and fighting fronts. Some 700,000 different items, ranging from tanks and big guns to soap and spoons, must be shipped from points of production to use. The Army and Navy must regulate this movement so that at each point of military activity there is a balanced supply of needed items with a large enough cushion of extras to meet emergencies with, at the same time, no oversupply standing idle.

Keeping books on the vast flow of supplies from factories through warehouses and supply stations overseas into the hands of fighting forces is one of the huge, though little-known jobs connected with carrying the war to the enemy.

Under the direction of the Stock Control Division of the Army Service Forces, the flow of this vast tide of equipment is kept

in line through an indexing system operating in the more than 500 stations where supplies are handled. Reports are tied in with those of the 126 major supply installations of the procuring branches of the Army Service Forces, and thus provide a continuous inventory check. As shifts develop in the scope of activity at a depot, or the number of men stationed in the territory it serves, the flow of material can be readjusted at once so that necessary items can be stepped up or an excess flow cut down.

The stock control system, which is similar to the inventory control bookkeeping methods of large corporations, has been designed to operate efficiently at home, abroad or near the battle fronts. Thus, no matter where troops are stationed, a supply depot in that area has on hand a continuously ample stock of needed supplies and munitions. Statistics on the rate of wear and tear and necessary replacement of items of different types, or on the same item in training areas as compared with the field of combat, and elabo-



The "duck," versatile amphibious truck, runs up on a New Caledonia shore with boxes unloaded from ship. Right, a fleet of ubiquitous jeeps makes its daily "special delivery" mail and supply run in New Guinea

Signal Corps photos



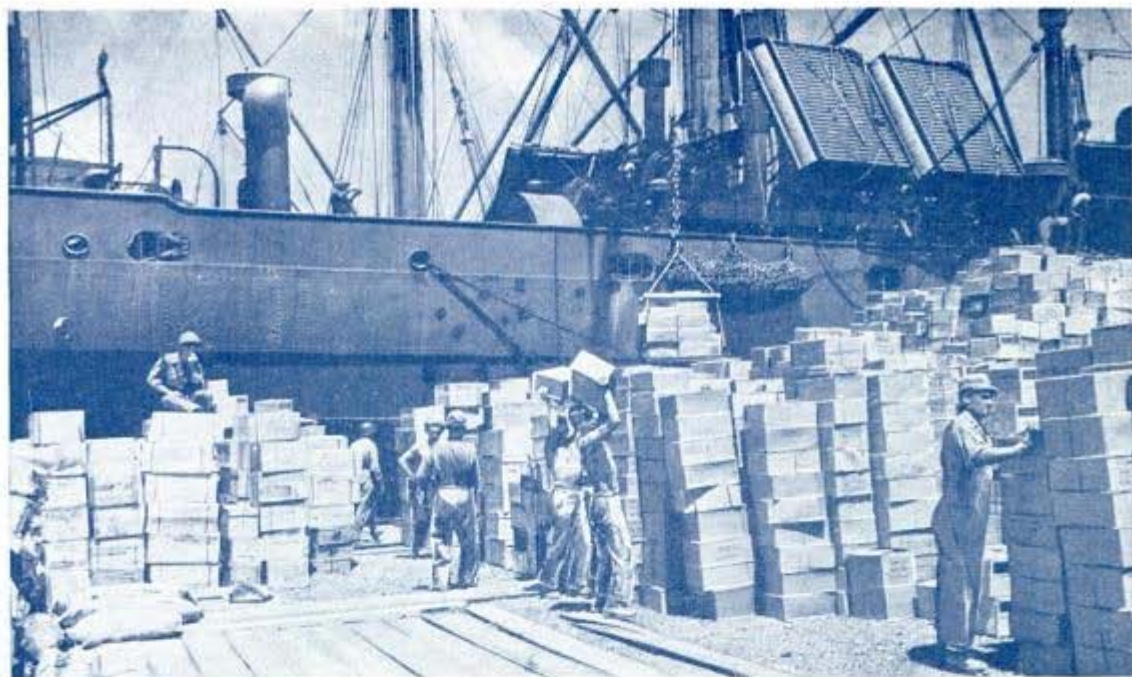

Heaps of stuff from back home are unloaded on a wharf in New Caledonia, big U. S. base in the South Pacific

rate studies of the necessary minimum of extra supplies, commensurate with safety in the conduct of the military operation all were utilized in formulating present-day procedures.

Many steps have been taken to effect economies in packing and transporting supplies, especially food. As an example, after Army beef has passed the inspection of the Veterinary Service of the Medical Corps, bones, excess fat and tallow are removed from the carcass as the first phase of the process by which the Army saves 30 percent in wasted weight and bones.

Maintenance of adequate and always-ready service and repair facilities near the front lines is another vital part of keeping battle front supply channels in constant operation. If a truck, loaded with munitions or food, breaks down or gets mired, it

either must be repaired or pulled out immediately, or removed as an obstacle to other trucks, in which case a replacement must be at hand to carry the original load.

A surprisingly large proportion of trucks and other equipment are shipped overseas "knocked down," and are assembled in or near actual war zones. One plant abroad assembled 14,000 vehicles in five months. These assembly depots maintain large stocks of repair parts which are shipped as needed to sub-stations nearer the front from which supplies are dispatched on their last lap to the combat forces.

When the going is toughest, when mud or jungle or enemy fire bogs down even tractors, when an intelligent mule would gallop for cover and a plane couldn't land ammunition even by parachute, the fighting man himself does the transportation job.

Westbound, this cargo plane brought a load of steel mats to build a new air field somewhere in New Guinea. Eastbound again it will take aboard the soldiers waiting under wing, just relieved of duty



722 March
 6626 Franklin Ave.
 Chateau, Des Fleurs, Hollywood, Calif. 71 783

Rolling Bomb Runs Wild Among Enemy Troops

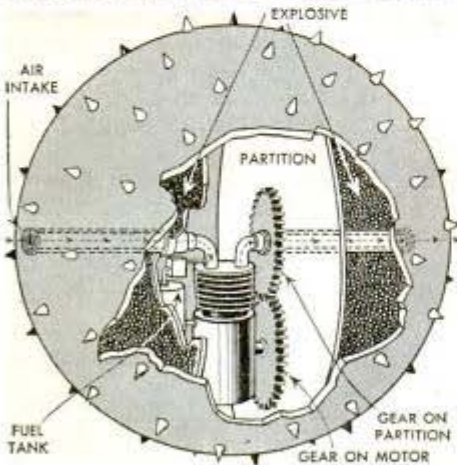
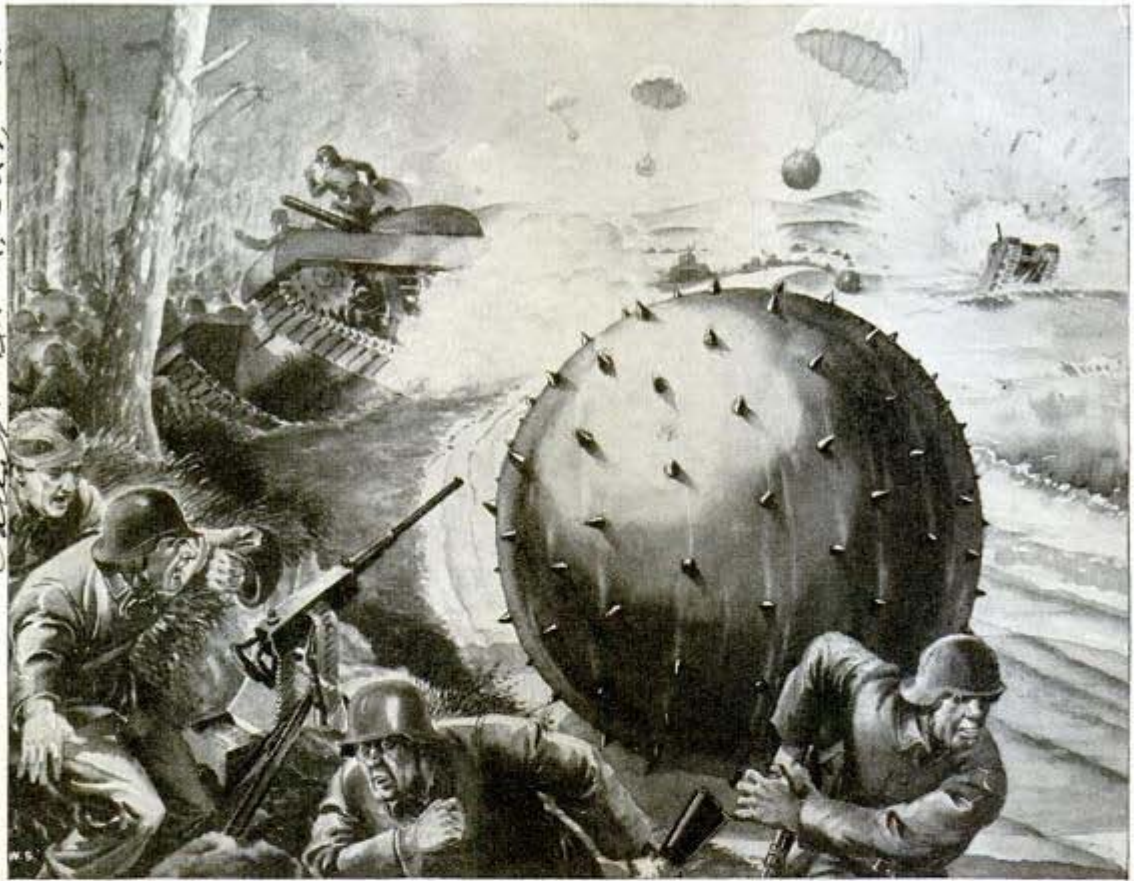

Dropped by parachute, spiked bomb continues to roll. Cutaway shows how motor makes it creep off center, causing it to move

Dropped by parachute, and rolling erratically among enemy forces, to explode no one knows when nor where, a rolling bomb invented recently is meant to spread terror among enemy troops. It is studded with projecting spikes, to give it a better grip on the ground. Its motion comes from an internal-combustion engine suspended inside the sphere. This engine's operation causes it to "creep" off the center of gravity, and the sphere moves to compensate; thus, continuous motion is achieved. Since its direction of travel is dependent upon its center of gravity, and that changes with every obstruction it encounters, the path of the bomb would be completely unpredictable.

Mildew in Textiles Is Overcome by Inexpensive Chemicals

Textiles are made completely antiseptic, and given lasting resistance to bacteria and fungi by use of an inexpensive chemical formula, now being applied to safeguard military equipment from mildewing. Besides millions of yards of duck, mosquito netting, ground cloth, Signal Corps material and other military fabrics, over 20 million pairs of shoes have been given linings treated to eliminate loss from mildew, as

well as to safeguard the shoe lining from the organism associated with athlete's foot. The chemical process first makes the cloth antiseptic, so that it may, as it were, have a "clean start." Next, the process imparts a high degree of immunity to the attack of both bacteria or fungi, either of which may weaken or even destroy fabrics. Specifically, the treatment safeguards against the attack by the common saprophytic fungi.

Galloway & Co.,
 N. Y., N. Y.

304 C. 23rd

Mrs. V. L. Conrad, 2148 Yorkshire Rd.
 Columbus, Ohio
 No. 2, 327, 621

71 814

"Bustle" Lifts Carrier's Stern for Safe Launching

"Hull No. 350½," or "Little Audrey" is the name of a strange supplementary craft used at the Kaiser Company's Vancouver shipyards. In reality, it is a "bustle" for the yard's escort aircraft carriers. By utilizing it, the yard prevents possible damage to the ship's plates during launching. The problem arose because of the Columbia River's habit of varying 20 feet or more in depth between high and low water. During low periods, about four months each year, the water's depth is insufficient to float the ship before it comes to the end of the ways. These ways were originally constructed for Liberty ships, but the yard was later turned over to the construction of escort carriers. In shallow periods, then, the stern of a launched ship would sink abruptly and the bow rise, leaving the huge vessel teetering on the edge. After such a rough launching, doubtless buckled plates would be found. The carrier also has a "transom stern," with relatively little buoyancy, aggravating the problem. One solution would have been to build the 12 ways 80 feet farther into the river, but this would have tied up the ways for some three months, and cost about \$250,000. Instead, C. F. Haughey, naval architect, in 11 days designed and built a steel pontoon, costing only \$15,000, weighing 90 tons, but with a buoyancy of over 500 tons. It tucks neatly beneath the stern of a carrier, and has the effect of raising the river level about three feet. When the ship is safely launched, the pontoon is removed from beneath the hull.

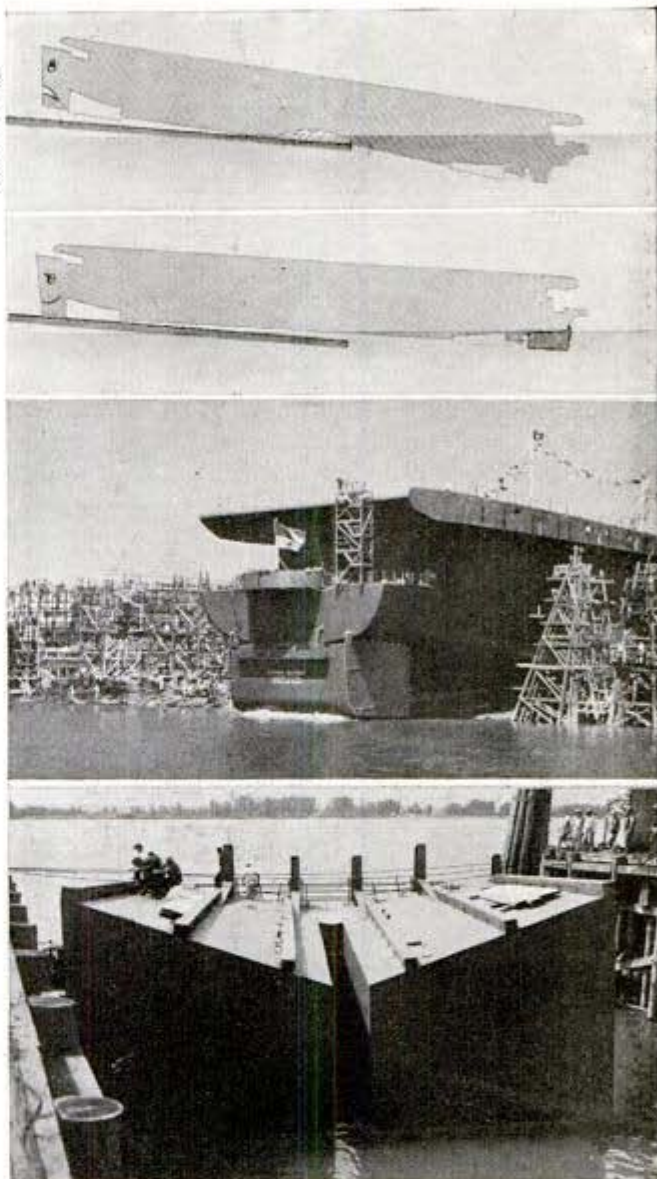

In shallow periods, launched carrier teetered on edge of ways, top. Floating "bustle" raises stern, second drawing. "Bustle" is steel pontoon, shown at launching and (bottom) in closeup

71770

Composite Soldier Is 5 Feet, 8 Inches, Weighs 144 Pounds

From averages compiled in the Philadelphia Quartermaster Depot, this is a description of the average Army recruit: He is 5 feet, 8 inches tall, weighs 144 pounds, has a chest measurement of 33¼ inches, a 31-inch waistline, wears a size 9½D shoe and a size 7 hat. After a few months in the Army, he puts on weight, expands his chest measurement, and wears a shoe one-half size larger. To keep him in fighting trim for the first year, the Quartermaster Corps spends \$226.30 for his food, \$190.23 for his clothing, \$57.42 for his individual equip-

ment and \$27.11 for his barrack equipment, a total of \$501.46. His food averages 62 cents a day. Regular G. I. clothing costs from 5 cents for a cotton handkerchief to a top of \$15.50 for a wool overcoat. Individual equipment costs from 5 cents for a "dog tag," to \$22.07 for three woolen blankets. Barrack equipment ranges from a 31-cent pillow case to a \$7.16 bedstead.

☐ In one hour, a 4-engined bomber burns as much gasoline as the average family automobile uses in six months.

PLANT MAGIC

WITH half a teaspoonful of chemicals you may become a plant wizard and play tricks on nature that Luther Burbank never achieved.

You can create giant flowers and fruits, stunt other plants into dwarfs only a fraction of their normal size, and grow freaks that may develop into new and valuable types.

You can bring sick plants back to life, produce "fatherless" tomatoes that contain no seed, and even cause a plant to grow roots high on its stalk. Then, if you like, you may dig this plant up and replant it upside down, with the foliage buried and with the roots in the air. After a period it will adjust itself and start new branches above ground.

All these things and more can be done with the aid of newly discovered synthetic plant hormones and vitamins. Some of the things these chemical compounds do are pretty mysterious or, as one farmer puts it, "We don't understand all we know about them." Essentially they are tools by which the growth of plants may be regulated.

Translate that statement into

By: George C. Warner
181 C. California St.
Pasadena, Calif.



Chemical applied to tomato plant's stem causes roots to appear out of place, on the stem itself



Cutting from tomato plant that grew roots in air—planted upside down, but still growing. Branches to come will grow upright



Agricultural miracles are being accomplished by use of synthetic plant hormones and vitamins. In two pictures above experimenter shows how plant may be made to grow topsy-turvy. At left, chemicals produce tremendous root on a small tomato plant. In five weeks roots filled the pot, dangled out of hole



Chemicals caused varied growth in citrus fruit, above. Interbreeding may develop desirable characteristics. Left, growth hormones injected into an already frost-proofed cinchona shrub, source of quinine

other words and it means that agriculture has found a way to grow and harvest larger crops of better quality. Chemicals are being used to induce sprouts to break through the ground faster, to develop larger root systems for sturdy growth, and to achieve uniform, ripened fruit. Some of the new hormones aid in the control of pests. Others may be used to slow down normal

growth, something that can save a crop if unseasonal warm weather starts it growing before the danger of frost is past.

One hormone sprayed on apple trees makes the fruit "stick" until they are ripe, eliminating losses from fruit drop and windfalls. It is even possible to prevent some vegetables from sprouting in storage by spraying the bags with one of the new substances.

These miracle-producing compounds are known by such technical names as indole-acetic acid, levulinic acid, naphthalene-acetamide, and Vitamin B-1, among other vitamins.

George C. Warner, who did the original research in the use of Vitamin B-1 on plants, uses these and other substances to do lots of things that "can't be done" in his laboratory in Pasadena, Calif. Warner squirts a drop of liquid in a vase, and the cut flowers that it contains remain fresh for a week. He soaks camellia cuttings, extremely hard to root, in a waterlike liquid before planting them, and they develop healthy root systems in a couple of weeks. With Vitamin B-1 and other chemicals he can grow roots on practically any cutting



Attaching cotton wicks, left, that take up chemical from glass tubes to leaves of plant, which absorb it. Below, treating tree with solution to make it bear earlier in the year

that has live bark on it, and make it grow. Vegetables, flower plants, shrubs, and trees that he treats mature faster, have better appearance, and are sturdier than are plants that receive no treatment.

Today you can duplicate many of the miracles that Warner and other research men are performing. Many of the chemicals they use are on the market, usually made up into mixtures that contain various growth-stimulants, and are for sale at many seed stores and agricultural establishments.

Different mixtures are used for different purposes and you should specify a type that has been tested for the results you desire. In a few cases you may be disappointed, for not all plants receive as high a stimulation from the hormones as do most others. Too, the chemicals can't produce startling results in soils that are highly alkaline.

Follow the directions sparingly in using any of the new growth-stimulants. One drop of solution to five gallons of irrigation water or spray is the usual dose. A strong concentration of indole-acetic acid, for instance, kills a plant. A weak solution of the same material stunts a plant and makes it mature as a dwarf, while an extremely weak solution of the same material has an opposite effect and makes the plant flourish.

To experiment with developing new characteristics in plants you use a different kind of chemical from those mentioned above. Colchicine is one substance in this group. Colchicine is an active poison, extracted from the root of the autumn crocus, and was once a popular gout remedy. Your druggist can order colchicine for you. Like the other plant chemicals, a tiny bit is all you need. One gram of colchicine dissolved into a pint of distilled water, to be diluted



Below, roots of derris plant, source of insecticide acclimated to California by the magic of chemistry



further for use, or 10 mg. of colchicine mixed into one gram of lanolin fat, is enough for many experiments. Keep either mixture off your hands and face, for it is a dangerous internal poison.

Colchicine seems temporarily to paralyze the process of cell division in a plant and this causes a doubling of the chromosomes in the parts affected. Chromosomes are a plant's heredity factors, hence any change in their number also changes the characteristics of the plants. These changes become apparent in the second generation.

You may soak seeds for a few hours or days in a dilute solution of colchicine, dry them, then plant as usual. It's hard to predict exactly what the results will be. No doubt the plant will grow into a twisted, malformed specimen and grow flowers of odd appearance.

The seeds from these flowers are the ones that may produce oversized foliage and giant flowers and fruit. Save the seed and re-plant them. Possibly the seed will be sterile; possibly the seed will produce plants that bear earlier, or that are drought resistant, or



Distillation apparatus to extract oils from tissue of plants

that have other new characteristics. The only way to learn results is to follow the experiment through.

Instead of soaking seed in the solution you may use a few drops of it in water as a spray, applying it to plants several times a week over a period, with

(Continued to page 148)

How chemicals are injected into tree tissue—here, an acclimated papaya

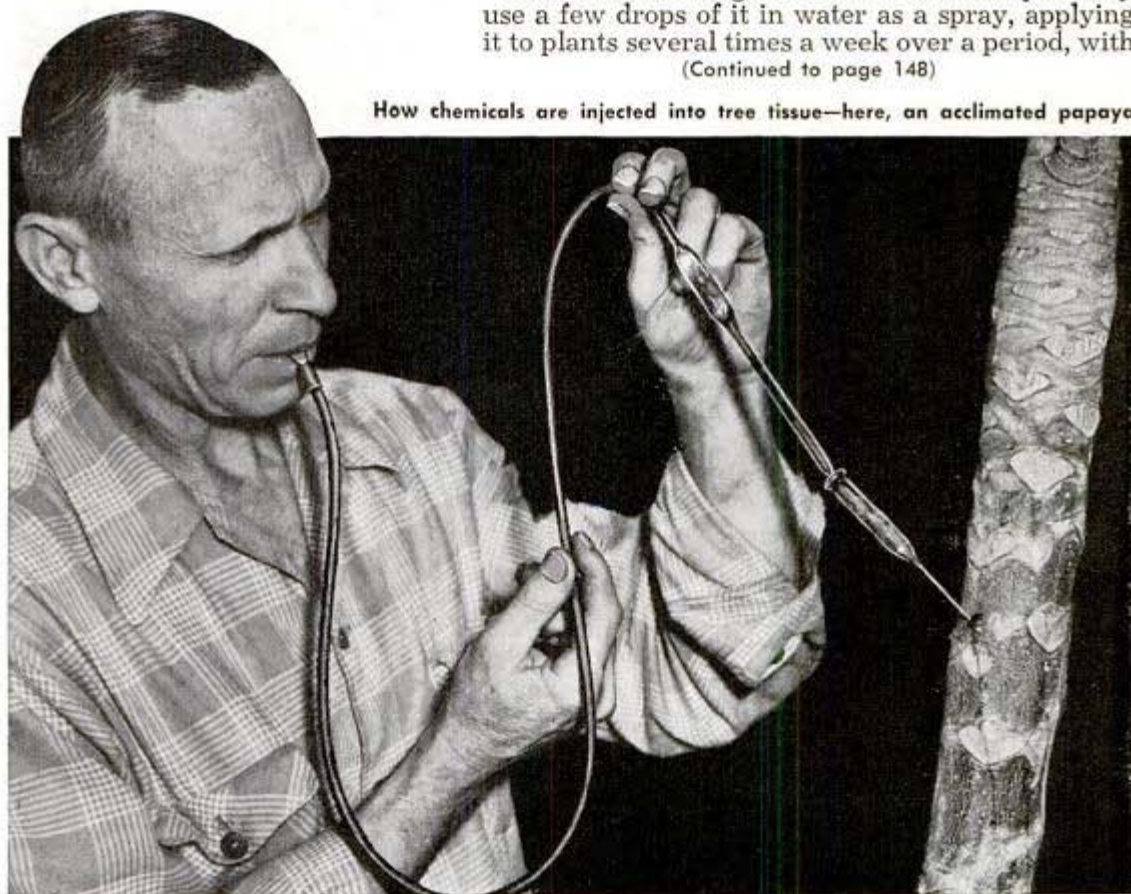

71625

Bicycle Built for Three Has "Bathtub" for Baby



Metal joins bicycles and supports a special car for the baby

One family solved its transportation problem by joining two ordinary bicycles with metal tubing which also supports a "bathtub" for carrying the baby. The baby's de luxe compartment is equipped with a windshield and overhead awning. The non-tip, triple seater was built by John Pittman of Burlington, N. J.

71790

Plan Aerial 'Queen Mary' For \$200 Ocean Trip

Construction of a 130-ton "Queen Mary" of the skies for transatlantic service has been authorized by the British Ministry of Aircraft Production. It will be built by the Bristol Aeroplane Co., builders of Blenheim, Beaufort and Beaufighter warplanes. Though details are secret, the huge airliner is expected to be revolutionary in structure, motive power, and shape. Its special motors will total 20,000 horsepower, and its cruising speed will be about 250 miles an hour. It is expected to carry 150 passengers across the Atlantic for about \$200 a person.

71648

Electric Iron Steams Clothes and Switches to Dry Ironing

Dampening of cloth before ironing is eliminated with an electric iron that projects horizontal jets of steam. The flip of a switch turns off the steam, and the iron

is ready for conventional dry ironing. It is provided with a thermostatic control. This timesaver will not be manufactured for general distribution until after the war.

71764

Surefire Exploder for Gas Mine Withstands Friction or Flame

Developed as a peacetime mining product, an exploder for chemical land mines will give the Axis plenty of trouble if poison gas is introduced in the last stages of World War II. The exploder, known as primacord, can be laid for miles on land or in water. The cord explodes at the rate of three-and-a-half miles a second. It withstands friction, and can be hammered and burned without exploding. Primacord has been widely used by the Corps of Engineers in demolition work. Enemy troops can be slowed by gas mines, just as they are today by land mines and booby traps.

Write to the firms listed in the Where-to-Buy-It index, page 4A, to learn more about products described in this magazine. Say You Saw It in Popular Mechanics.

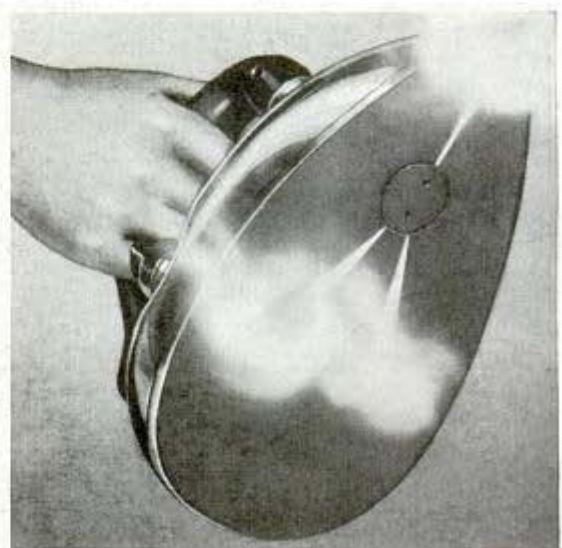

Flipping switch turns on horizontal jets of steam to dampen the clothes before starting dry ironing

Concrete "Semisubmarine" Cruises at 20 Knots



Superior performance and lower construction cost are claimed for the concrete, cigar-shaped cargo vessel pictured here. It is termed a semisubmarine, because of its shape and because of the fact that in the water it rides about three-fourths submerged. Streamlining, with consequent low skin friction, is said to be responsible for its unusual speed. Its weight is 2,200 pounds, and it is powered with two Ford V-8 engines, yet it has been timed at 16 to 20 knots. Much higher speeds, however, would be possible with marine engines of more horsepower, Hal B. Hayes, inventor and builder, maintains. Above, the craft was built outdoors, in a field. Right, details of construction of the hull. The ship is constructed almost entirely of a patented mixture of concrete, applied over a wire mesh, internally supported by previously cast rings of concrete

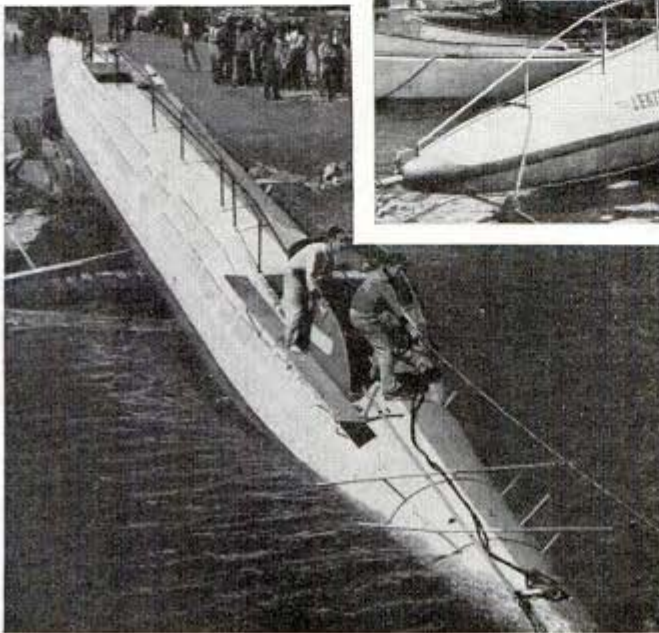
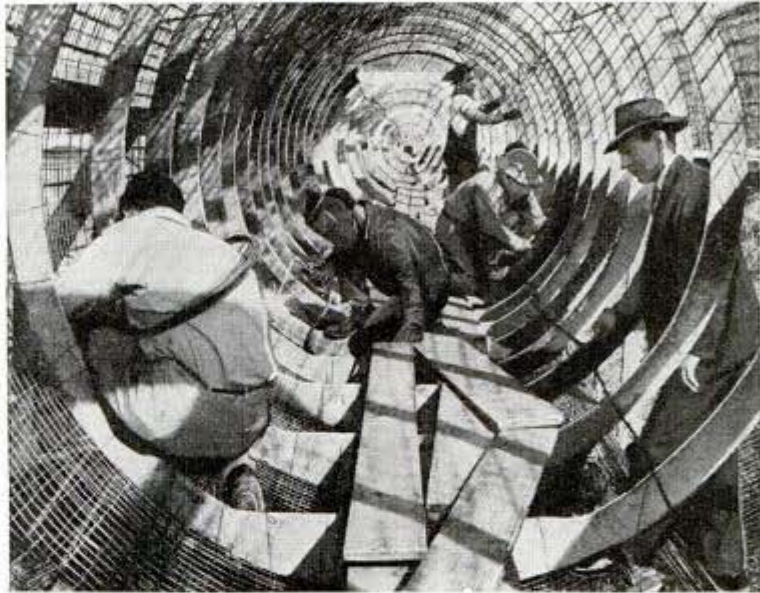

Views of the semisub at launching, left, and afloat, above, emphasize its unusual design. It is 125 feet long; its beam is only seven feet. Using the same design, the inventor says he could build a ship similar to the 10,500-ton Liberty class in less time, using only a tenth as much critical materials. Such a craft would be 700 feet long, with a beam of 40 feet. With the same power as the Liberty ships, Hayes says its speed would be in excess of 50 knots. The inventor also has offered to close the hatches of his experimental craft and turn it completely on its side in the water. Its design is such that it will then instantly right itself, he says

*Inventor Hal B. Hayes
Sub launched at Richmond,
Calif.*

Mr. Grant

11398

UNCLE SAM'S TOM THUMB NAVY

*American Forest Products Industries, Inc.
16 East 43rd St.
N. Y. N. Y.*

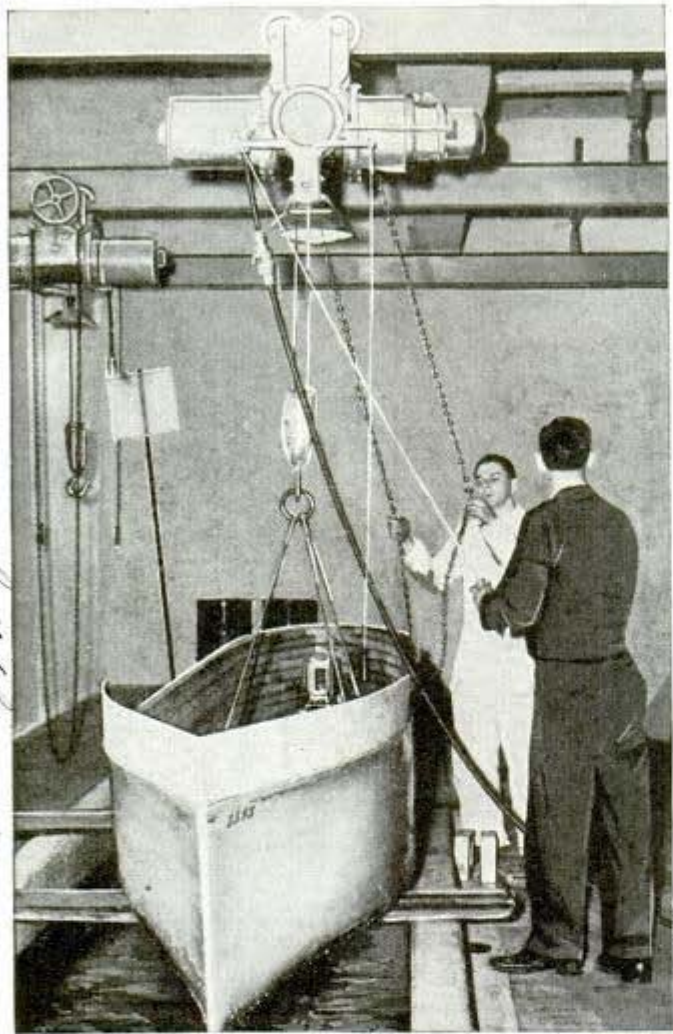

with hand tools 200,000 board feet of western pine per year serve as the control key to the battle supremacy of American ships. A \$400 western sugar pine model may save years of time, millions of dollars and thousands of fighting men's lives.

The Navy's model basin, one of 40 in the world, is the newest, built to produce the greatest test accuracies. Our allies, with model basins of their own, send over plans of their fighting ships to be modeled and tested at Carderock.

At all foreign test basins the models are made of paraffin. Ours are made of sugar pine, Idaho white and Ponderosa—all western white pines. There could be no worse military practice than to tie a key operation to a material wholly controlled by a potential enemy. We control the source of western pine, available in no other part of the world. American operators grow it on 10,000-acre tree farms. Other nations make shift with paraffin models.

At left, hoisting a model hull from the basin after a test. Below, model builders put finishing touches on a miniature ship
U. S. Navy photos

AIRCRAFT carriers lost in battle might still be alive if they had been able to dodge a little faster, pivot out of the path of an enemy bomb or torpedo. They needed the footwork of a boxer dodging a fist. Maneuverability is the surface vessel's best answer to attack.

Our new flattops have it. The new Lexington, Yorktown and other carriers just built or building can play tag with enemy tinfish like a frisky waterbug.

For these new seagoing airfields were built to designs tested and perfected in the Navy's David W. Taylor Model Basin at Carderock, Md. The intricate details of design of the 1943 carriers are a secret our enemies would like to break open. What they do know is that our naval architects demonstrated exactly how these ships will behave in action long before the keel was laid—for the design was created and proved in 20-foot models made of wood. At Carderock 75 skilled woodworkers carving



Until about 1870 no one could know, before a ship had its trial runs, just how it would perform—its speed, maneuverability or cost of operation. Then William Froude, an English engineer, began building models to scale and amassing comparison data by towing them at various rates of speed. Performance depends on size, sleekness and shape of the hull; on weight, superstructure arrangement, power plant, shaft and propeller design. Froude found that a model built to exact geometrical scale and towed to a certain ratio of speed would tell the designer what the full-sized ship would do. Some nations were slow in adopting his teachings. A few years before the last war visitors saw tied up at a Hamburg, Germany dock a brand new luxury liner consigned to rust. Its first transatlantic trip proved it could not meet competitive speeds and earn its fuel. Model tests would have averted that failure.

The Carderock basin is a massive laboratory embracing five towing canals. Its monolithic concrete walls are joined directly to bed rock, helping to insure accuracy by virtually eliminating vibration.

A layman untutored in marine mathematics might guess that a model one-tenth the size and with one-tenth the power of a full-sized ship would have the same rate of speed as the large vessel. That is not the case. Froude evolved a formula of "corresponding speeds." If a model is built exactly to geometric scale and towed under laboratory conditions, the "corresponding speed" is the square root of the ratio of the length of the model to the length of the



↑
The famed battleship Oregon was scrapped recently, but it lives in a Carderock model

Women are building scores of ship models on 1 to 500 scale for identification study
↓

Allen Briggs *Mary Jester*



Here, in miniature, is the Japanese fleet—the carrier *Soryu* at top—reproduced to help Navy airmen and deck officers recognize them

full-sized ship, multiplied by the given speed of the large craft. A 14-foot model towed at 3.85 knots has the corresponding speed of a 500-foot ship running at 23 knots. A 10-foot model of a 100-foot ship, towed at 20 knots, corresponds to a ship speed of 63 knots. By similar computations in model tests the engineers learn how much resistance to the water the large ship will offer at any given speed and how much propulsive power is necessary.

Water resistance consists partly of fric-

This is the towing carriage on Carderock's deep basin. The tower is part of electric power supply system

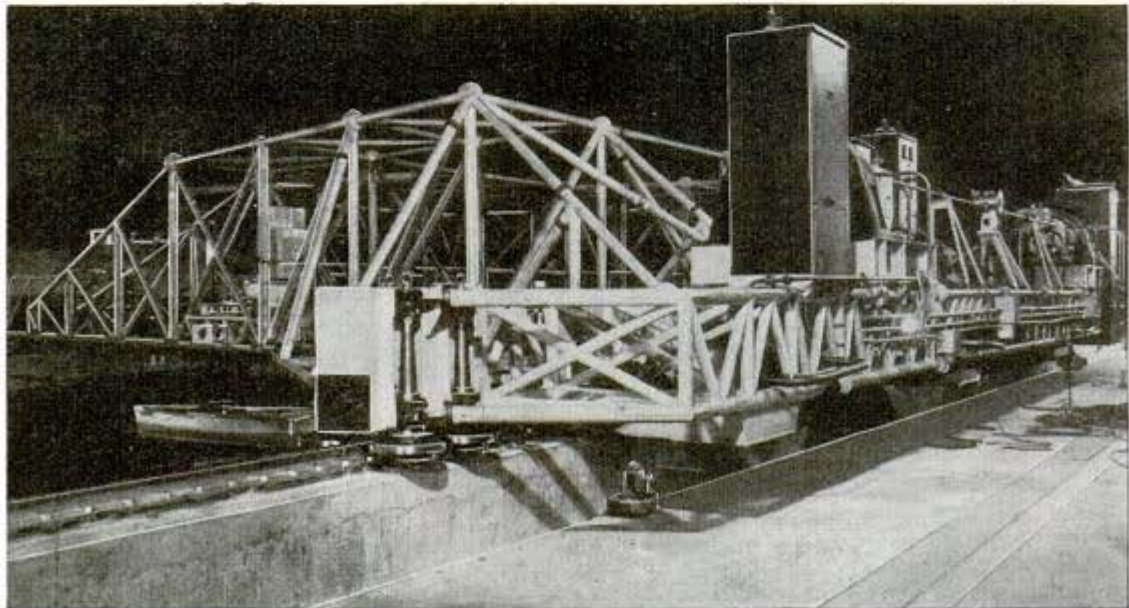

tion between the water and the subsurface hull, partly of residual resistance caused by waves, eddies and other disturbances created by the hull form. Frictional resistance can only be decreased by producing a smoother hull surface and decreasing the underwater area. The residual resistance can be lessened by changing hull design.

When Congress authorized the heavy cruisers of the Salt Lake City class, requirements were 10,000 tons displacement with speed as high and better sea-keeping characteristics than any existing destroyers. That problem was the model tester's dish. A series of wood models were tested, changed and tested again, and came out with an en-

tirely new underwater stern, a new mid-ship section and a bulb bow. Full-sized vessels made 32 knots.

That is the sort of development born of test-model practice, which is producing new ships for this war. Destroyer escorts are in point. They are new, designed expressly for convoy duty, created to quell U-boats. Equal in fighting power to last war's destroyers, they are smaller, much faster, and can spin almost within their own length to catch a dodging submarine.

Almost at the other extreme of new design are invasion ships, big armed vessels built to carry battle cargo. Some carry tanks. Arrived at a hostile shore, down goes the front end of the vessel's hold to make a steel bridge over which armored land fortresses roll to blast out a beachhead. Somewhat smaller vessels are designed to put foot soldiers ashore with equal speed. The first of these got their baptism of fire in North Africa.

Demands on the designers of the new aircraft carriers were enormous. Decks big enough to deploy more than 100 warplanes. Elevators that can deliver planes from storage deck to flight top in less than 10 seconds. More spacious holds to carry more gasoline, protected with new types of equipment and better fire control, all adding to deadweight. Heavier underwater armor. Altogether, a ship with displacement raised to 25,000 tons, able to make longer voyages and carry more airplane fuel than any before designed, and be the fastest and most maneuverable carriers afloat.

The woodworkers who make the Carderock models are all old patternmakers. A hull model is built up in rough outline of two-inch thick planks pinned together with wooden dowels. Then it is taken down and the wood layers smeared with water-



Skilled patternmakers using hand tools carve geometrically accurate models in western pine of combat and merchant ships

proof resin glue applied hot. Reassembled, the block is placed in a 1,200,000-pound press; after 16 hours in the press it is solid. Then it is blank-contoured in a profiling machine, the only machine tool used. The rest of the modeling is skilled handwork with gouge, chisel, spoke shave, plane, sandpaper.

Once a model has been perfected it is kept on file until the ship it represents is out of commission. Wood models can be stored safely for decades without distortion. The standard model is 20 feet long; some have been 60 feet long. The 20-foot model weighs a ton. Equipped with motors serving also as dynamometers, test propellers, and driven at full model speed of six knots (corresponding to 33 knots for a 600-foot ship) the rudder is turned full over and the model brought up after a 90 degree turn,

(Continued to page 146)

Ballasting a model to bring it to proper waterline before giving it a self-propulsion trial

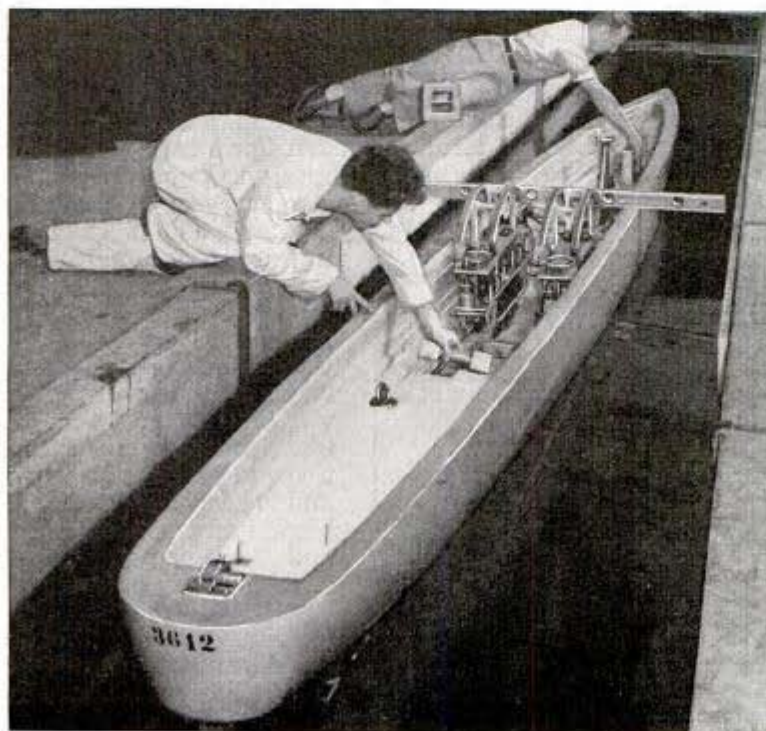

Pat. # 2,325,937

Submerged Air Jet Quiets Waves Beside Ship

Inv. Major Philip Brasher, Kent, Conn. 71682



Compressed air jet (inset) creates "water dam" in path of approaching waves, calms them for plane landing

Calm areas at sea, sufficiently large to permit the landing of a seaplane alongside a ship, may be produced by the use of air under pressure. As described in a patent issued to Philip Brasher of Kent, Conn., the method involves the creation of an upwardly moving wall, or dam, of air and

water, in the path of the waves approaching the ship. This dam is effected by the discharge of air from a flexible conduit towed by the ship. In such a quiescent area, the water would be sufficiently calm for lowering a plane into the water for a takeoff, and also to permit a landing.

Film Travels at 70 Miles an Hour in Industrial Camera

With a top speed that exposes 8,000 "frames" a second, the film in a movie camera developed by the Bell Telephone Laboratories travels 70 miles an hour. This camera, manufactured by the Western Electric Company, reveals the secrets of mechanical parts that move at lightning speed. It has a continuous film drive, as

distinguished from the stop-expose-advance cycle of ordinary cameras. Exposure of the frames is accomplished by a revolving prism acting as an optical compensator. The camera, using 8 mm. and 16 mm. film, has detected hidden flaws in signal relay devices in telephones, weak parts in equipment broken experimentally before the



camera, and factors causing noisy operation in machines operating at high speed. It has even been used to study the action of the vocal cords in reproducing speech. The versatile camera has a film travel range from three to 70 miles an hour, and is adaptable to either black and white or color, and the photography of self-luminous objects.

☞ Farmers and railroads use 40 million pounds of weed killing chemicals in an average year.

"Shooting" vocal cords with mirrors; at right, telephone breakage test

44 Western Electric Co.
195 Broadway
N. Y., N. Y.

7 641

Special "Lung" Lifts Fighter Two Miles Higher

INTERCEPTION ZONE FOR HIGH-FLYING BOMBERS



ALTITUDE LIMIT WITH 2-SPEED, 2-STAGE SUPERCHARGER



PILOTS NEED OXYGEN IN UPPER ZONE

ALTITUDE LIMIT WITH 2-SPEED SINGLE-STAGE SUPERCHARGER



EFFECTIVE CEILING ANTI-AIRCRAFT FIRE



AT THIS POINT, SUPERCHARGER AUTOMATICALLY SHIFTS TO SECOND SPEED, INCREASING ALTITUDE RANGE BY TWO MILES



ALTITUDE LIMIT WITH SINGLE-SPEED, SINGLE-STAGE SUPERCHARGER



ALTITUDE LIMIT WITHOUT SUPERCHARGER



STRAFING, DIVE BOMBING ZONE

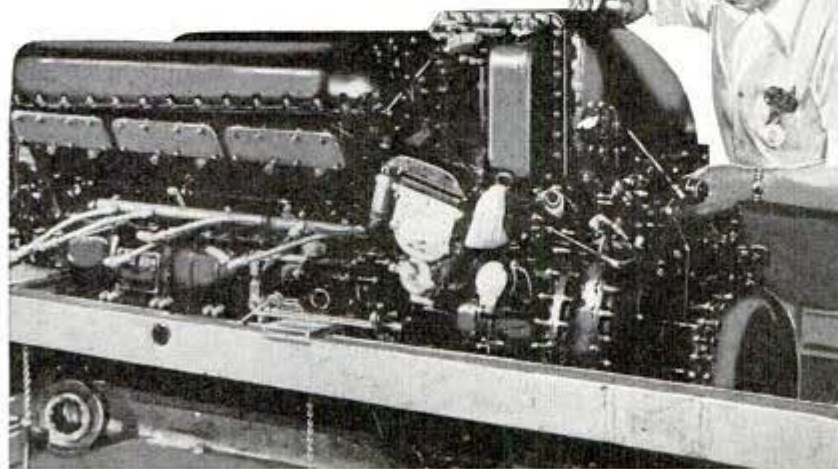

Above, fitting heated units of supercharger to shaft; left, adjusting the supercharger

charger. In the two-stage supercharger, the first rotor compresses the air comparable to that of a single-stage supercharger. The air then passes to the second rotor which compresses it to six times the surrounding atmospheric pressure, enabling the plane to fly more

Aerial warfare has zoomed two miles higher into the stratosphere with an improved engine and supercharger now powering the North American P-51 Mustang fighter. The new type Rolls-Royce engine, built by the Packard Motor Car Company, incorporates a two-speed, two-stage supercharger. In the past, similar engines also used in P-40 Warhawks, British Hurricane fighters, the big Lancaster bombers, and Mosquito fighter-bombers, have featured a two-speed, single-stage super-

than 10,000 feet higher. The new operating altitude is believed to be higher than that achieved by any enemy fighter plane. Speed, armament, and weight are also restricted, but in a recent test the plane flashed across a field at about 25 feet and was out of sight in 15 seconds. The two-stage supercharger is housed in a regular supercharger unit at the rear of the engine with a cooling device directly forward. The air, heated by intense compression, must be cooled before delivery to the engine.

TRICKS of the BATTLEFIELD

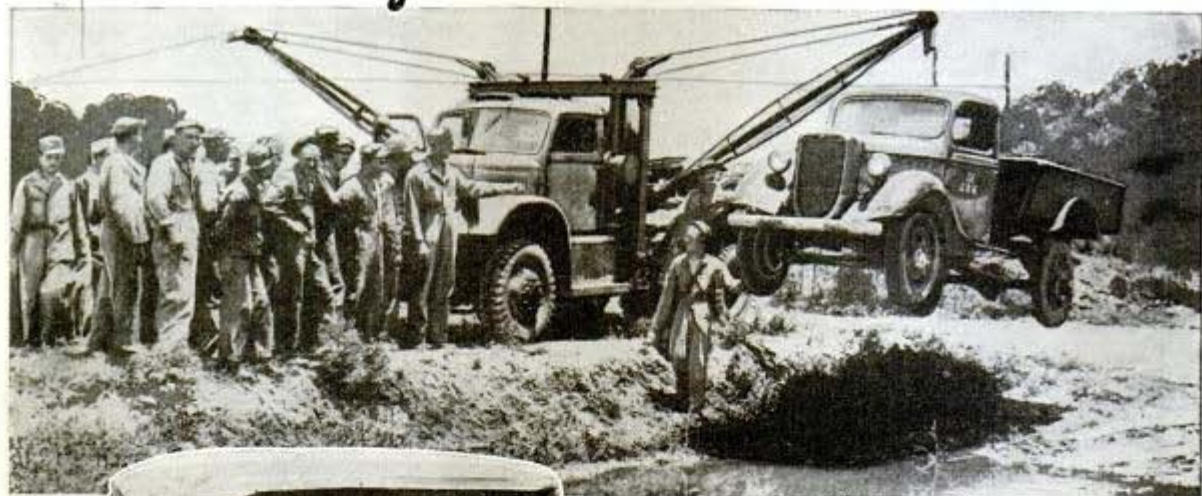

Yarnaffe

At an Ordnance depot in Texas, soldiers learn to remove damaged trucks and other vehicles from a battlefield. Tricks of the wrecker service are pointed toward maximum speed and minimum additional damage. Above, a wrecker lifts truck out of ditch. It can raise 5 tons from deep ravine

Vehicle minus rear wheels (above) can limp from battlefield on two logs in a slanting position with front wheel drive pulling car

Right: With this method, a truck loaded with TNT can be righted safely. Using both booms of wrecker, truck is eased gently to ground

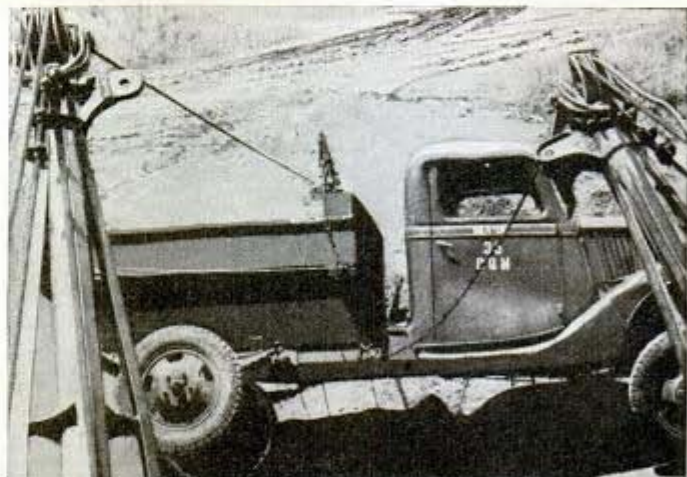

The hookup shown below is used to evacuate vehicles that have no wheels. Notice how the cables lift rear as well as front of the car



WRECKER SERVICE



Lifting an Army car with a derrick that is more often used to lift large objects into trucks. The boom is free to swing around the mast. This is one of many devices with which the graduates of wrecker course are familiar



Timbers crossed in shape of an "X" (above) lift the front end of a heavy truck off ground with its own power. Timbers are attached as shown in inset, and holes dug to receive feet of frame. Backing up truck forces timbers upright. To completely suspend vehicle (left) a third member added to frame prevents fore and aft movement

Below, small vehicle is pulling two large cargo trucks that have their brakes locked with tires sliding. The trick is done with a small winch, its power multiplied with rigging shown at right

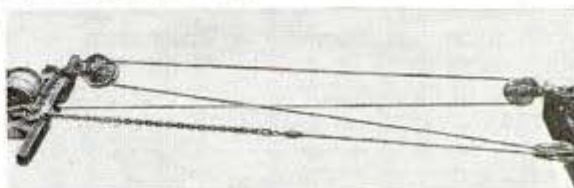

71658

Nov. 1626
30 Rockefeller Plaza
N. Y. 20, N. Y.

Dummy Sniper Operated From Pit As Safeguard Against Bullets



Dummy-operator stands in pit to avoid sharpshooters' bullets

When soldiers at a Northwest fort demonstrated the storming of a supposed Nazi-held town, they were on constant lookout for "snipers," dummy figures representing Nazi sharpshooters. With customary alertness, the Yanks filled the dummies with lead as soon as they showed at windows of the "Blitzburg" homes. As a protection against live bullets, operators of the dummies were stationed in pits, from which they yanked cords that made the "snipers" appear.

Copy Nov. 21, 1944
at 7th Street Wash.

troops in World War I often caused accidents. The tread of the sole is designed in such a way that the boots automatically clean themselves of ice and snow each time they are flexed.

Grease for Substratosphere Has Special Soap Base

It looks like ordinary butter, but the grease that keeps airplane controls working smoothly in substratosphere cold or desert heat is anything but ordinary. Developed by Standard Oil Company of New Jersey scientists, this grease lubricates smoothly through a temperature range from 75 degrees below zero Fahrenheit to 175 degrees above. The grease, which has a special soap base, withstands pressure as well as temperature variations. The entire production of this lubricant, known as Beacon Lubricant M-285, is now allocated to the armed forces, but it is expected to play an important role in postwar stratosphere flying.

Face Shield for Hard Hat Snaps to Clipped Frame

Attachable to any protective hard hat is a plastic visor that adds face and eye protection. Its two-piece construction consists of the visor and a frame assembly. The frame clips permanently to the brim of the safety hat, and the visor is attached to this band by means of three snap fasteners, whenever face or eye protection is desired.

Shoe for Ski Troops Cleans Self With Special Rubber "Tread"



Perfect traction on stone and ice is provided with a self-cleaning rubber sole and heel designed for ski troopers' boots. The rubber sole, developed by the

Goodyear Tire & Rubber Company, not only wears longer than the conventional steel cleats, but weighs less and is noiseless. Muffled steel cleats used by mountain



Plastic face shield clips to fixed frame on hard hat

48 1144 C. Market St.
Akron, Ohio

POPULAR MECHANICS
B. F. McSmall Co., 1250 S. Hope St.
Los Angeles 15, Calif.

71 708

Stratosphere Fan Blows Air 500 Miles an Hour

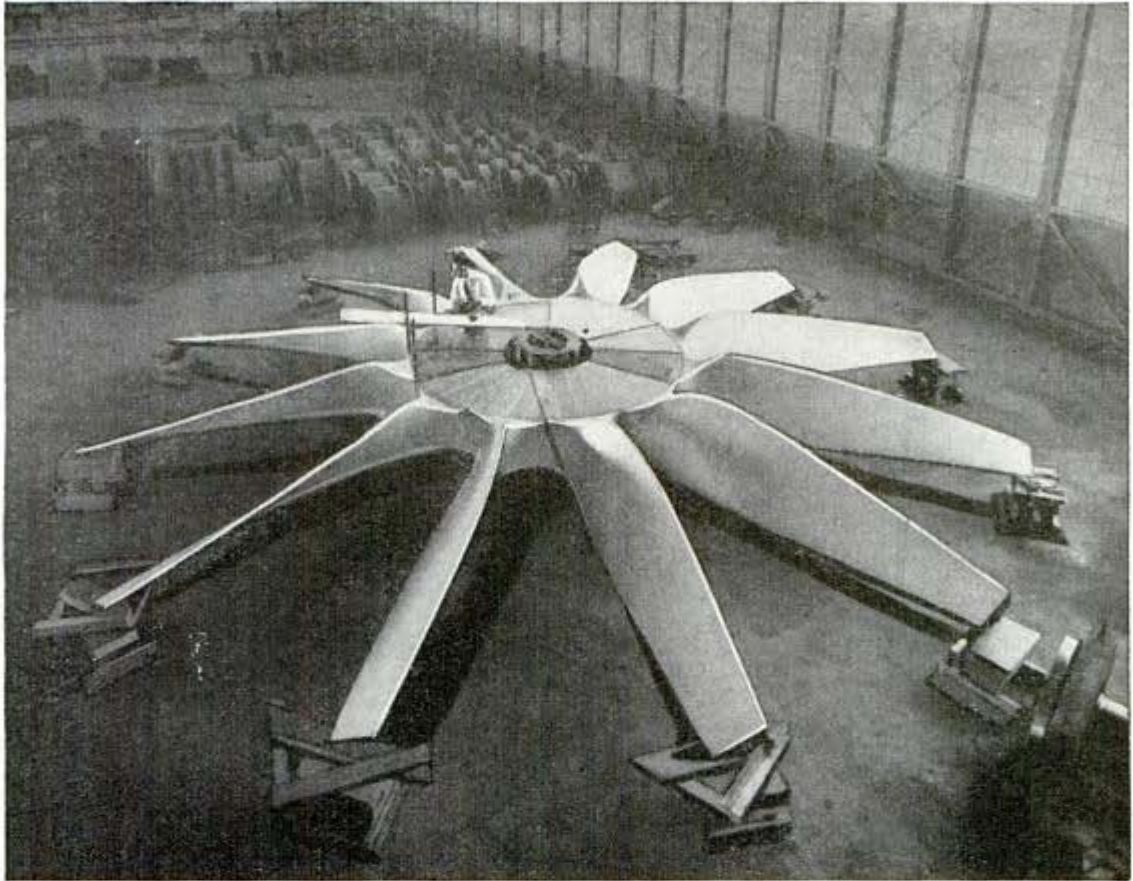

Wind-tunnel blasts up to 500 miles an hour are possible with this fan, powered by an 18,000-horsepower motor

Twelve enormous blades of laminated wood form the fan for a high-altitude experimental wind tunnel being built by the National Advisory Committee for Aeronautics at Cleveland. The fan will produce wind velocities of 500 miles an hour. A complete aircraft engine nacelle can be mounted in the 20-foot throat of the tunnel. The air pressure and temperature may

be reduced to those corresponding to any altitude up to at least 30,000 feet, where the pressure is only 8.9 inches of mercury and the temperature is 48 degrees below zero. An 18,000-horsepower motor drives the fan. Others totaling about 30,000 horsepower, drive the refrigerating and vacuum pump equipment. The tunnel will accommodate engines of up to 4,000 horsepower.

Floating Crane With 30-Ton Lift Unloads Ship's Cargo

At ports lacking docking facilities, war materials are unloaded with a crane mounted on a barge. The crane-barge, specially built for the army, can lift 30 tons with power supplied by a 100-horsepower Diesel engine. It is designed to operate close to cargo ships.

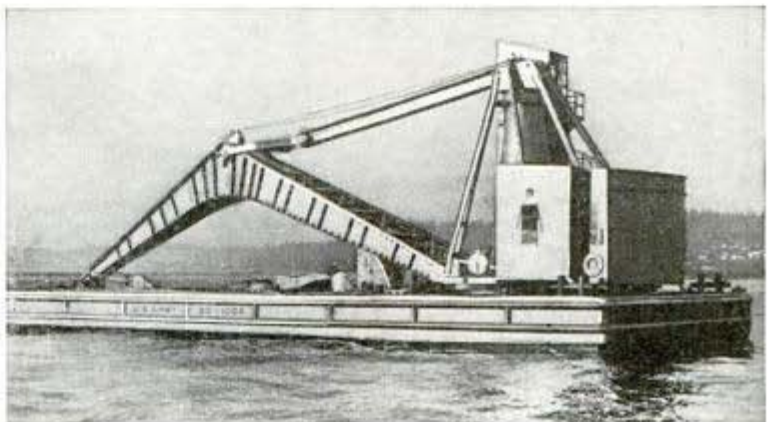

Crane-barge built for army makes it possible to unload supply ships at remote ports lacking docking facilities

*Printer - Willamette Co.
Edmonds, Wash.*

PHOTOS *without* FILM



Top to bottom, paper negative taken by synchronized flash; print from paper negative, and enlargement made from it

CAMERA film is scarce today, but by using photographic enlarging paper in place of film you may still take as many pictures as you wish. Sensitized paper is coated with an emulsion similar to that on film and is suitable for the ordinary run of snapshots, and may even be used for time exposures or synchro-flash shots.

The disadvantages of paper as a negative are that it is much less sensitive to light than is film, hence requires greater exposures, and it has much coarser grain. On the other hand, paper is not rationed, is cheap, may be developed by inspection under a photographic yellow safelight, and produces pictures quite satisfactory for most purposes.

Use projection paper instead of contact paper, because the latter is even more insensitive to light. A single weight paper with a glossy surface in Grade No. 2 or No. 3 will provide detail plus contrast, although you may experiment with papers that are harder or softer in quality.

Paper film is not satisfactory in the inexpensive fixed-speed cameras because these don't permit the greater exposures that are necessary, and in miniature cameras it is difficult to wind the stiff paper around the small spools. In most other cameras, however, paper may be used without trouble.

For a cut film camera, cut the paper to the same size as the film you have been using and insert it in the film holder. To load a roll film camera with paper you need two film spools. Cut several strips of enlarging paper from an 8x10 sheet to a width that fits the camera spools. Glued end to end, these strips will provide a continuous strip long enough for several exposures. Seal the exposure number hole in the camera's back with adhesive tape to prevent fogging the paper. By placing an old strip of exposed film in the camera you can check on the number of turns necessary to move the film enough to prevent double exposures.



Above, inserting paper into film spool, emulsion side in. Below, load paper negative in darkness or by safelight



Old camera above was modernized with flash gun, range finder, new front shutter, and other accessories. Below, retouching air brush uses compressor and tank units from refrigerator

To load the camera with paper, simply load one film spool with the paper strip, emulsion side in; lead the balance of the strip across the back of the camera and attach its end to the empty spool as usual. The whole job must be done under a yellow safelight in the darkroom.

Operate the camera exactly as if it were loaded with ordinary film but remember that your exposures must be greater than with film. Try $1/10$ th of a second instead of $1/50$ th of a second, or shoot at $1/25$ th and open the diaphragm several more stops than usual. Enlarging paper is comparable in speed to color film. Try a number of different exposures, keeping a record of what you do, to learn the optimum exposure.

Develop your paper negative in a standard developer solution, by inspection under a yellow safelight. Fix it in hypo and wash and dry it in the usual way.

The result will be a negative image on opaque paper. However, this image is more trans-





Ordinary "8x10" is converted into an enlarger with homemade lamp house

parent than it appears to be. Use it exactly as if it were an ordinary film in making a print, placing it emulsion to emulsion against an unexposed piece of the same grade of paper in a printing frame. An exposure five or six times longer than with film will give good results and will provide a key for the correct exposure time. Develop and fix the exposed paper positive print in the ordinary manner.

The negative paper image may even be used for enlarging. A test exposure several times longer than with film will indicate the length of exposure required. Grain, which results mainly from the texture of the paper negative, will be noticeable in the enlargement and produces a quite artistic effect if the enlarged print is made on rough paper.

This winter can be a good time to make some improvements in your darkroom equipment. One camera fan converted a big 8x10 studio camera that he uses for copy work into an enlarging projector, simply by building a wooden lamp house that is attached to the camera's back when needed. The ground glass and plate holder at the rear of the camera are removed and the lamp house is then hinged into place. The negative holder slides into an opening at the front of the lamp house.

If you wish to make photographic copies of letters or documents you may build your own photostat machine. This produces true duplicates without the usual intermediate step of making a neg-

ative although, like blue printing, blacks and whites are reversed. A photostat of this page would have white letters on a black background.

The photostat camera described here is compact, costs no more than a few dollars in addition to its lens, and performs work of professional quality. Essentially the camera consists of a box with one end hinged to open so that the material to be copied may be thumbtacked to its inner surface. Offset lamps illuminate this surface.

Beyond the midway point in the box is a sliding plywood partition, mounted on shoulders padded with felt so that no light may leak past the edges. A lens, even one from a moderately priced camera, is mounted in a hole in the center of this partition.

The image of the letter or document to be copied passes through this lens and strikes a front-silvered mirror mounted at an exact 45 degree angle at the far end of the box. From this surface the image is reflected through a glass window directly above the mirror. Photostat paper or photographic contact paper pressed emulsion side down on the glass window will be printed just as in a contact printer, and

Homebuilt paper holder for enlarging or copying made of shallow tray with tacky surface of hardened hectograph compound



may then be developed and fixed by ordinary procedure. A small piece of ground glass, say 5x7 in., placed ground side down on the window may be used for focusing and inspecting the image, then removed to permit making the print.

Dimensions of the box and its optical system depend on the focal length of the lens. The distance from the copy board to the lens must be twice the focal length of the lens, and the distance from the lens to the center of the diagonal mirror must equal the focal length of the lens. The distance from the center of the mirror to the top of the glass window must likewise equal the lens's focal length. Thus an 8-inch lens must be placed 16 inches in front of the copy board, with the mirror eight inches beyond and with the glass window eight inches above the center of the mirror.

For a lens of this focal length a box with outside dimensions of 14x14x31 inches will do very well. Stop the lens down to f:11 and slide the lens partition back or forth until the reflected image is the size of the original material. An automobile stoplight switch, actuated by pressing down the wooden cover over the glass window, may be used to switch on interior lights to make an exposure. Inside surfaces must be dead black.

The photographic industry pro-

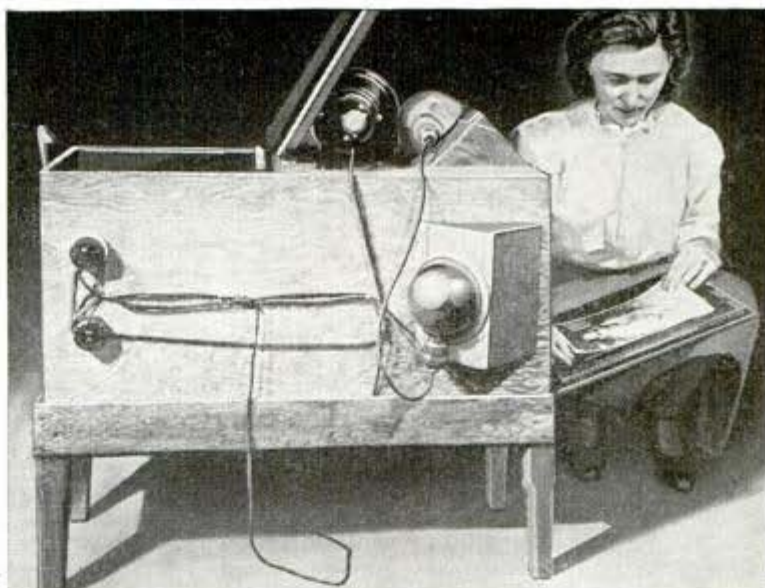

Placing a photograph on work board of the photostat machine for copying

duces a wide range of special papers, some of them scarce as film. Reflex copy paper is one. It has the unique ability to copy by reflected light. Reflex paper is placed in contact with the document to be copied, an exposure from an overhead light source is made, and the paper is then developed. From this a positive print may be made.

Direct positive paper is coated with a reversal emulsion so that it may be exposed as if it were negative film. It is then developed, bleached, and re-developed in special solutions to make a positive print.

Cut-away diagram shows interior arrangement and construction of photostat machine

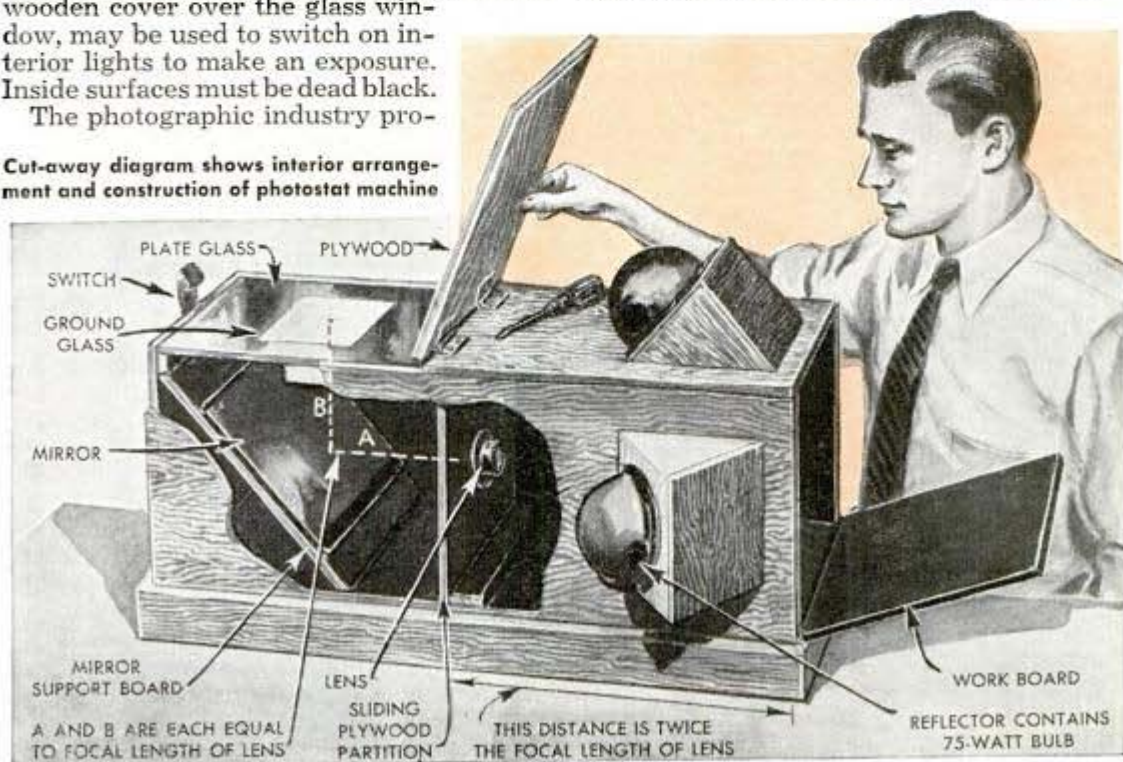

766

"Inside-Out" Kit for Tools Holds Them Within Reach

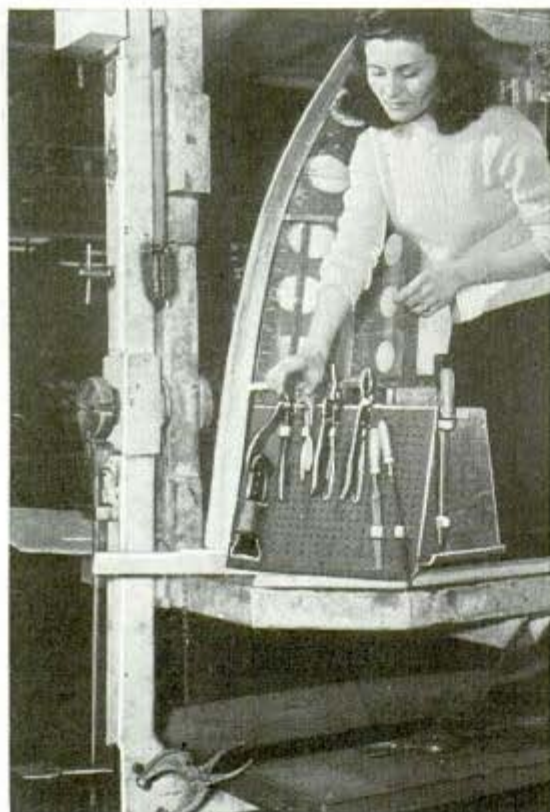

Clips inserted in perforations hold worker's tools

Aircraft workers can increase their output with a portable tool kit that is made "inside-out." The tools, held by removable clips that are inserted in perforations in the kit, are always visible and within easy reach. The inside-out construction was suggested by employees of the Murray Corporation of Detroit, Mich.

767

Drive for "Flea-Power" Motor Reverses Self in Jiffy

For motors of the "flea-power" class, not exceeding one-fifteenth horsepower, a variable speed drive transmission has been



Unit designed for motors of fractional horsepower

54 Grabow Transmission, Inc.
2706 N. Dentonia Ave.
Milwaukee, Wis.

developed which can be reversed without reversing the motor. The unit, complete with motor, weighs only eight pounds. The input shaft turns at 3,600 r.p.m., and has an output speed from 700 r.p.m. to zero. The reversal is said to be instantaneous and shockless while the speed is maintained at a constant level. Speed is controlled by a hand wheel or lever.

762

Chemical "Overcoat" for Zinc Releases Essential Chromium

Zinc and cadmium surfaces are protected with a new anti-corrosive chemical, releasing much essential chromium for military purposes. The chemical, developed by the Rheem Research Products Laboratories in Baltimore, forms a thin coating which is not injured by bending or twisting. Articles dipped in the solution take on an olive drab color. Tests conducted by army engineers show that the coating affords protection against salt spray and humidity at high temperatures.

7676

Films Shown in Broad Daylight On Hooded Projection Screen

Clear pictures in daylight, with the windows of the audience room wide open for ventilation, if desired, are possible with the

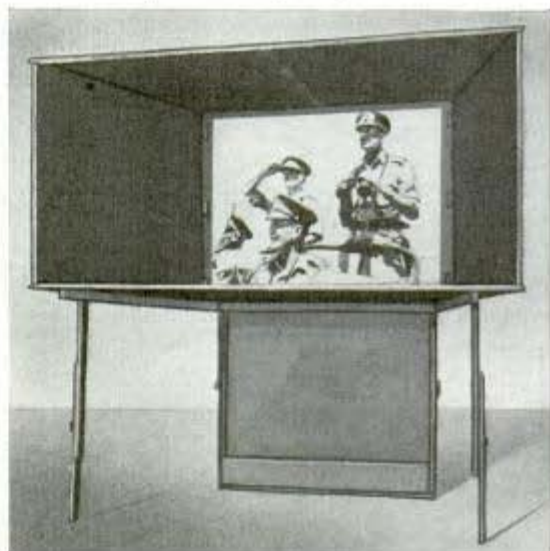

Clear pictures may be seen in daylight on this screen

use of a daytime projection screen. A normal audience of 125 to 150 can view the screen, which is portable, readily set up, and adjustable to four heights. Such daytime screens are used to train military classes and to teach civilian workers. Their use is said to eliminate drowsiness and lack of attention that results from showing films in darkened rooms, with windows so heavily curtained that ventilation is poor.

POPULAR MECHANICS

Radiant Mfg. Corp.
1140 N. Superior St.
Chicago, Ill.

It's "Up and Over" With the Tank Destroyers



To the men of the Tank Destroyers, there are no insurmountable obstacles. Using only the tools they carry, together with those accessories likely to be found in the field, they are prepared to demonstrate mobile warfare—with a capital "M." Above, vehicle in simulated shell crater gets a lift from an "A frame." Stout timbers, lashed at one end are leaned astraddle the bumper of stalled vehicle. A chain or cable runs from bumper over apex of "A" to winch on a second vehicle. When winch pulls the "A frame" to vertical position, it also raises stalled vehicle out of pit. Right, with wheel blown off, log supports rear end



For slopes up to 45 degrees, each vehicle can hoist itself over crest by winding up on winch (above) cable anchored to tree or boulder atop hill



Jeeps are converted into a variety of "trolley car" to bridge a stream. Dismounted troops cross and hold opposite bank, while a 10-ton wrecker backs to high spot on bank, where its big cable is unwound, and snaked across river and fastened. Two snatch blocks are put on slack cable, and jeep is suspended from them, making an improvised trolley. The wrecker tightens its cable, lifting jeep until the cable runs across stream on a downward slant. Then vehicle is pulled across—and when wheels touch opposite bank, it drives away

Signal Corps photos

WINGED LIGHTNING



Ordnance crew servicing P-38's nose artillery—four .50-caliber machine guns and one cannon

MORE people in foreign lands have seen America's twin-tailed fighter plane than have Americans at home. Practically every new P-38 is flown or shipped to a theater of operation as soon as it gets its factory flight check.

Back from the fighting fronts are coming some remarkable stories about this two-motored fighter. In the South Seas a P-38 pilot flew his rugged plane into a Zero and right through it, scattering the Jap all over the sky, then returned to his base with only minor damage. In the same area another P-38 pilot after exhausting his ammunition deliberately used one of his propellers to saw the tail off a

Zero. In fact, quick-eyed young American pilots gravely discuss the best way to use one propeller as a weapon in plane-to-plane combat,

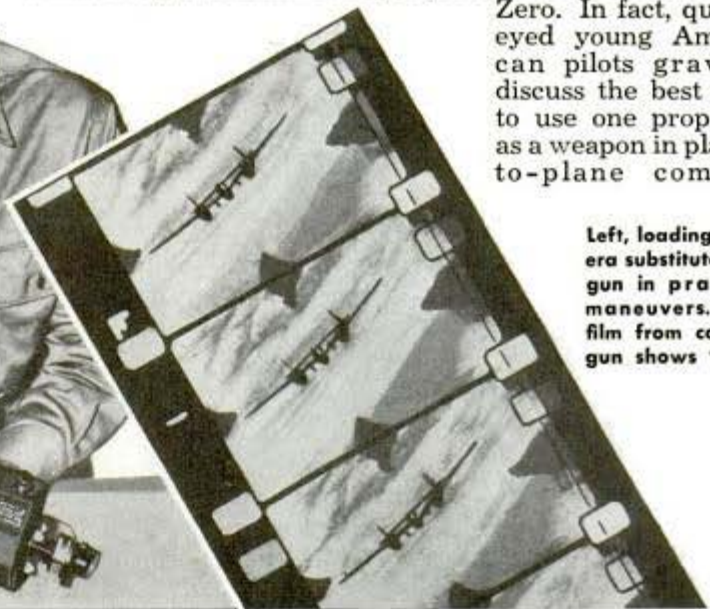

Left, loading camera substituted for gun in practice maneuvers. The film from camera gun shows "hits"

knowing that they can get back to base on the other engine.

In Africa when the pilot of a P-38 returned to his field with the tips of one propeller bent back and that engine shut down he explained that he had flown so low in strafing an enemy motor column that he had unintentionally dug one propeller into the ground. During that same campaign another pilot hit a telephone pole at such an angle that his plane flipped over on its back and went hurtling along upside down only a few feet off the ground. The pilot cautiously pushed his control wheel forward to "dive" the plane upward and gain some altitude, then

In high-altitude regalia, complete with oxygen mask and goggles, pilot is ready for takeoff. Below, P-38s in formation



rolled right side up again and returned home.

Although the P-38 Lockheed Lightning was designed to operate at 35,000 feet or higher, it has also made a name for itself as a fighter at tree-top height. It was designed as a pursuit and interceptor, yet on occasion it is now used as a tactical bomber and can carry a surprising bomb-weight under its wings. Even today its maximum top speed hasn't been published aside from the statement that during a dive the airplane enters the air compressibility range before it

Pilot's armament includes personal revolver, two demolition bombs, fragmentation bombs, cannon, and the four machine guns





Ordnance officer inspecting gun controls in P-38 cockpit. Button on arm of wheel fires 20-mm. cannon; button on back of wheel fires machine guns

attains maximum velocity. One report is that a P-38 was dived at such a terrific speed that the leading edge of its wing was caved in by the pressure of the air.

This plane is so fast that from the ground the roar of its engines seems to come from half a mile or more behind it. At high speed its wing tips cut vapor trails in the atmosphere in making turns. Bullets from the plane's machine guns behave differently than when fired from a stationary point on the ground because their speed is the sum of their own muzzle velocity plus 65 percent of the plane's speed. The guns are sighted-in for flat trajectories.

Ordinarily an automatic cannon shoots out a long thin muzzle blast of flame when it is fired. On the P-38 this muzzle blast is compressed into a fat egg-shaped flame because of the plane's forward speed.

You don't climb into the cockpit of a P-38, rev up the engines, and take off the way you would in a basic trainer. This fighting plane is far more complicated and to fly it you must have a dozen times the knowledge, say, of a pilot of the first World War.

To begin with, even if you are inside a closed cockpit, you are bundled up so that not a square inch of your body is exposed. For a high altitude mission you wear a

Pilot climbs into plane dressed for sub-stratosphere where temperatures drop to 70 below zero and thin air lacks oxygen

fur jacket, trousers, boots, and gloves in addition to your flying suit. Over all this goes your Mae West life jacket and over that your parachute. You put on a leather helmet with self-contained earphones and throat mike for the radio, and you wear rubber-padded goggles and an oxygen mask. Strapped to your leg is a bail-out oxygen cylinder that you will connect to your face mask if you must leave the plane at high altitude.

There is a double purpose in covering yourself so completely. You need such protection against the cold at high altitude in spite of the cockpit heater. And you need to

be completely covered if you are going into combat at any altitude. If an incendiary bullet should start a cockpit fire, your covering will protect you during the time you need to struggle free and escape from the plane.

Wearing all this gear, you just fit snugly into the seat. You are comfortable even though there's not much room for shifting around. The cockpit is so completely filled



with instruments and equipment that small mirrors are fitted into the corners to permit you to read some of the dials on the instrument board.

You plug in your throat mike and earphones, hook on to the plane's oxygen supply, and adjust your seat belt. Now you throw the plane's master electric switch, turn on the radio, and push the button for today's secret radio frequency. You open the fuel tank valves, turn on the booster pumps that fill the fuel lines, check the mixture controls and propeller governor settings, then prime the engines with straight shots of gas. The engines have been kept warm by the ground crew and you start them by winding up the inertia starters with the plane's batteries. You come back on the throttles to check plugs and magnetos, you glance at the fuel gauges, release the brakes, and move out to the runway.

There is still a lot to do before you begin your accelerated takeoff. When you get your okay from your flight leader or from the tower you roll forward a couple of feet to straighten your nose wheel, then pump up the brakes to hold the plane down while you run up the engines to the point where the superchargers cut in. In a sense you



Student pilot gets a "piggy-back" ride in one-man P-38. The students are squeezed in for demonstration flights on the plane's radio shelf

are building up flying speed while standing still, enabling the plane to hurl itself forward like a rocket the instant you release the brakes. But first there are still a few final chores to do. You check both sets of engine instruments, the settings of the control surface trim tabs, roll up the window and make sure that the cockpit hatch lock is secure, that the fuel pumps are on, and that the fuel valves are turned to the takeoff tank positions.

All this sounds like half an hour's work but you have learned to do it in much less time than it takes to describe. It takes

no more than a couple of minutes from the time the alarm siren sounds for you to be in the air.

The plane jumps toward the sky like a scared jackrabbit when you pull it off the runway. While close to the ground you realize that you are literally strapped to nothing more than the howling engines. At higher altitudes rough air jars as if you were riding a speed boat. In sharp turns you black out momentarily.

To speed up their education an instructor takes student pilots on "piggy

(Continued to page 154)



These pressed metal shells will be joined to form auxiliary gas tanks for the long range P-38s

Model Power Boats Race in Wartime London



A popular stay-at-home sport for war-weary Londoners is model boat racing on the pond in Victoria Park. The fans yell themselves hoarse as the tiny craft flash over finish lines in races timed to the hundredth part of a second. Competitor (above) easing his model steambot into the water is master of a Thames tug of which his boat is a replica. The fancy craft getting all the attention (left) is a model of the Royal Sovereign, a pleasure steamer frequented by thousands on peacetime holidays. Here pressure is being pumped into boat which runs on flash steam. Below, a model owner wades in to stop his speeding boat. Tiny engines run up to 20,000 revolutions a minute as they whip over pond



*Model Power Boat Association
Victoria Park, Hackney,
London, England*

Electrical "Nurse" for Pipeline Guards Pumps

One glance at the control desk at pumping stations along a 1,700-mile pipeline stretching from Texas to the East Coast shows the operator what valves are open or closed. The electrical "nurse," built by Westinghouse, also takes the temperature of motors, pumps and bearings and feels the "pulse," or pressure, in the pipe. The top of the control desk is made of semi-transparent plastic with illuminated arrows on the station diagram showing the route of the oil. If a pump gets hot or develops abnormal temperature, a tiny red bulb flashes on to show the trouble spot on the diagram. Automatic controls stop the electric motor operating the overheated pump, close valves leading into the pump, cause other valves to open and re-route the oil around the idle unit. Under the plastic desk top are some 60 pea-sized lamps, green, amber or red, connected with valves, thermometers and pressure gages.

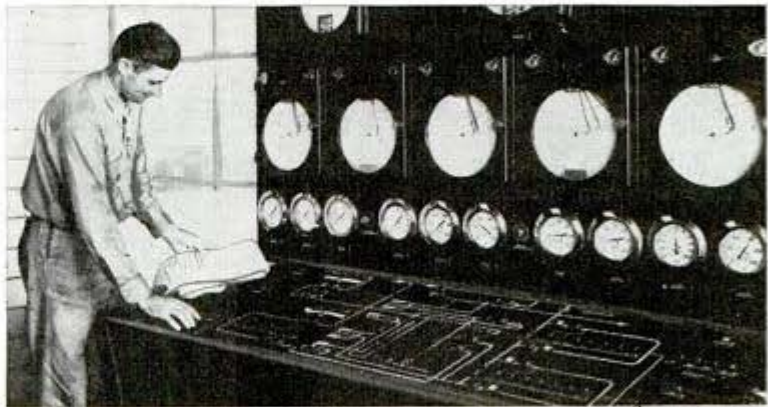
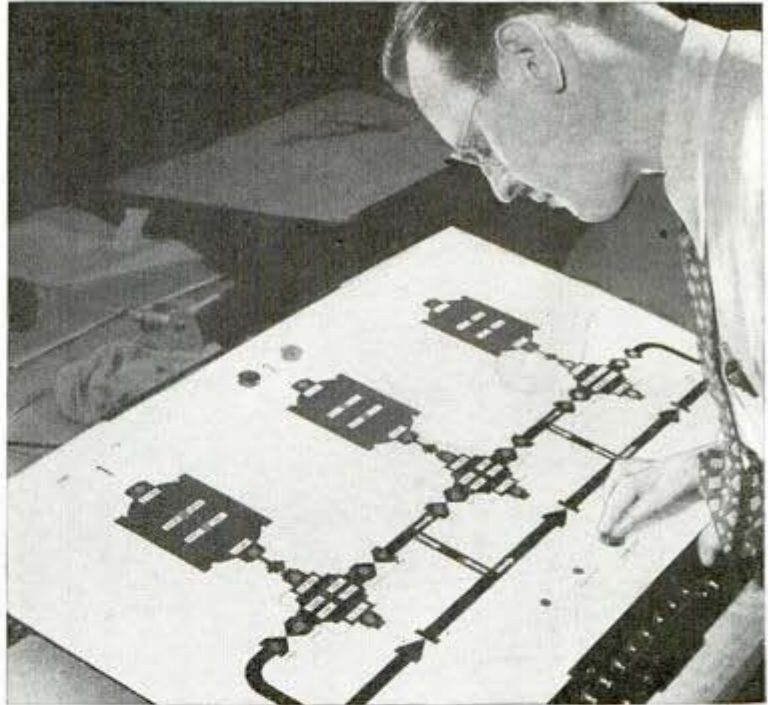

Colored lights flash danger signals on the control desk of pipeline pumping station

71646

Portable Garage Without Doors Lifts for a Car to Enter



Adjusting the weights for tilting up one end of the garage

Covered with sheet metal or oil-cloth with a wire backing, a prefabricated portable garage is designed without doors. To permit entrance and exit of automobiles, one end of the garage is tilted up by weights and pulleys. The structure, which is 18 by eight feet, is anchored to two wooden posts and requires only four concrete blocks for a foundation. The framework is of laminated wood. Easily erected with a small wrench and screw driver, it can also be used as a summer cottage, according to James D. France, Montclair, N. J., who recently was granted a patent on the invention.

26 Orange Rd. 61

Mr. Alfred Preis
5/24/44 to the Signal Box Hollywood, Calif.

SHOUTING with the FINGERS



Because man can't outshout the roar of an airplane motor, a new language of signs has grown up along the flight ramps. Nobody knows how it got started, but it is fairly well standardized now and even boasts a special series of "handies" for a ship with de-icers. The man standing before the plane at left, for example, is signaling "raise the fuel pressure." This is done with a clenched right fist and left hand, palm down and lower, parallel with the ground. It's easy on the voice

The masterpiece of pantomime (right) with two fingers held close to the mouth as in smoking indicates motor is smoking

Most murderous gesture of the 30 in general use is the one at lower right. Throat-cutting motion means "cut your engines"

Man (below) with a finger in his mouth and holding up another is signaling "de-icing sequence No. 1 working O.K."

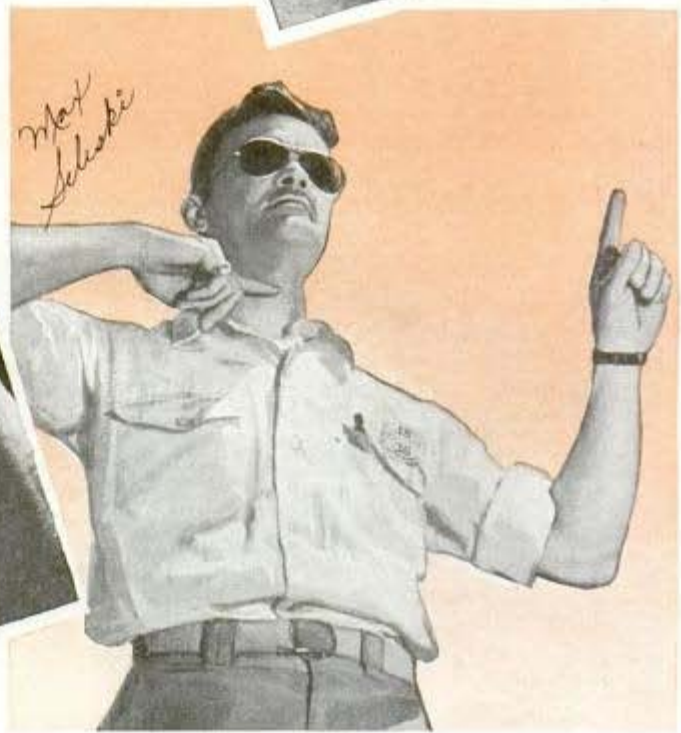
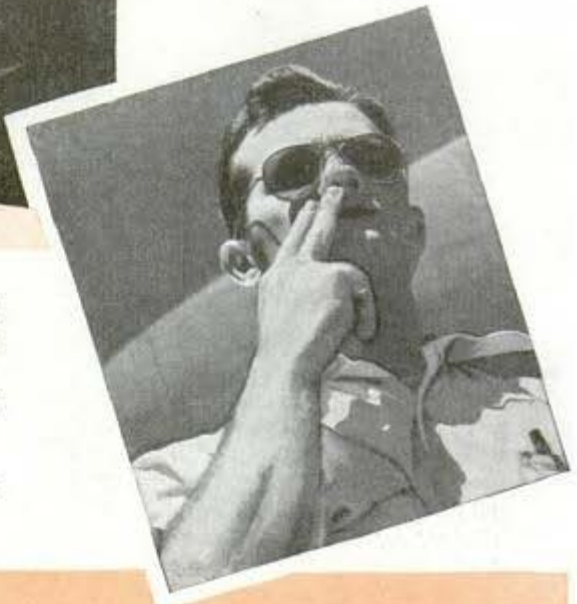



Palms up, used for the bombers, means "Hey, bud, raise the bomb bay doors." Below, too lean a fuel mixture is indicated by fingers pointing to corners of eyes

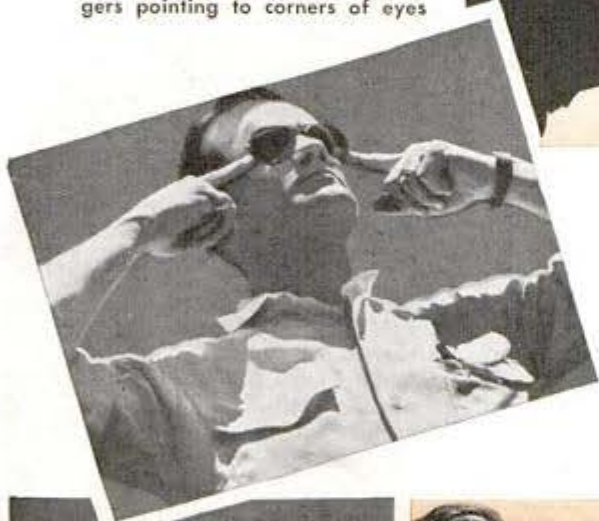

"Lower the oil pressure and be quick about it," is the message conveyed by circle made with fingers

Man holding nose (bottom left) is telling crew mate mixture is too lean and smells none too fragrant

The "A" made with fingers (bottom at center) indicates the auto pilot hydraulic pressure adjustment

Below right, gripping right forefinger in the left fist means "hurry up and pull out that battery plug"



Battery in "Bazooka" Sets Off Rocket Charge



While Nazi propagandists were bragging about secret weapons that never materialized, the U. S. Army produced the rocket gun known as the "bazooka." It has the wallop of a 155-mm. cannon. The guard on the front of the gun (left) is used to protect the operator from flying particles as rocket projectile leaves the barrel. Soldier, below, is demonstrating the right technique in holding the gun. The metal tube is about 50 inches long and less than three inches in diameter. A battery sets off gun's propelling charge



Two-man bazooka team (left) will be ready for action when rocket, which resembles small aircraft bomb, is placed in tube. Attached to the tube are a shoulder stock and front and rear grips for the firer, together with sights and the battery. When the launcher trigger is squeezed, the battery sets off charge. The rocket is about two feet in length and is composed of an explosive head, tube for the propelling charge and finned tail. It pierces tank armor

Lt. Col. Douglas Parmenter, Chief, Publications Branch, War Dept. Washington 25, D.C.

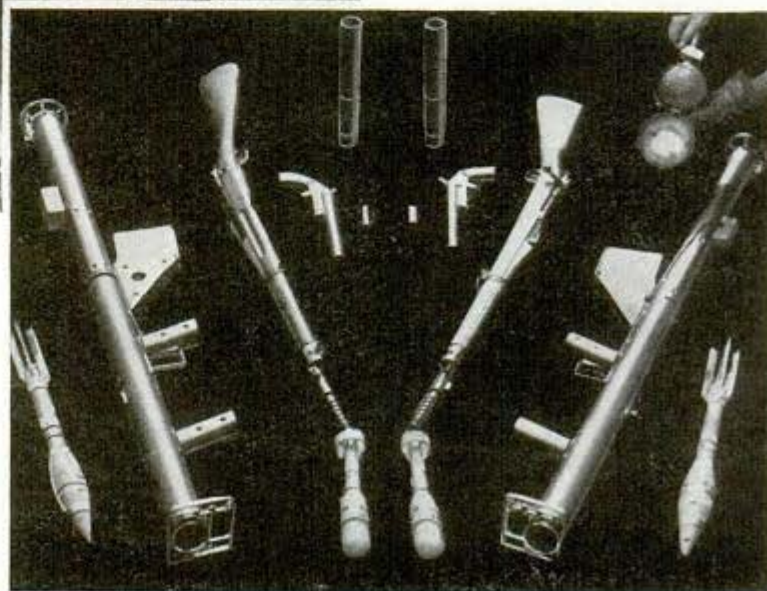

U. S. Signal Corps photos
Display of weapons (right) flanked by the tank-smashing bazooka shows comparative size. Next to it is the rifle grenade launcher. Other arms shown include the Very pistol and flare launcher. A great advantage of the bazooka in tank warfare is its light weight, making it an ideal weapon in places inaccessible to the big anti-tank guns. One bazooka team captured six Nazi tanks

*Development of New Navy Experimental Tanager section,
North American Aviation, Inglewood, Calif. 71610*

Theodolite Checks the Air Speed on Test Flight

Test flight engineers at North American Aviation use a theodolite to check air speed on their newest warplanes. The instrument is little more than a viewing frame for following a moving plane, and it is equipped with a pencil and graph paper. The observer studies a plane through a telescope lens and follows it as it flies back and forth over the field at a given altitude. A solenoid switch in the theodolite breaks the circuit every one-quarter second, deflecting the pencil upward for time interval measurement. The pilot flies at several different air speeds, all of which are recorded on the graph. The air speed calibration is obtained from the temperature at the height of the plane, plus the height data on the graph and the air speed meter reading of the plane. Gauging the height on the graph also serves to check the pilot's altimeter.

As engineer follows speeding plane through telescopic lens, time intervals are recorded on graph paper

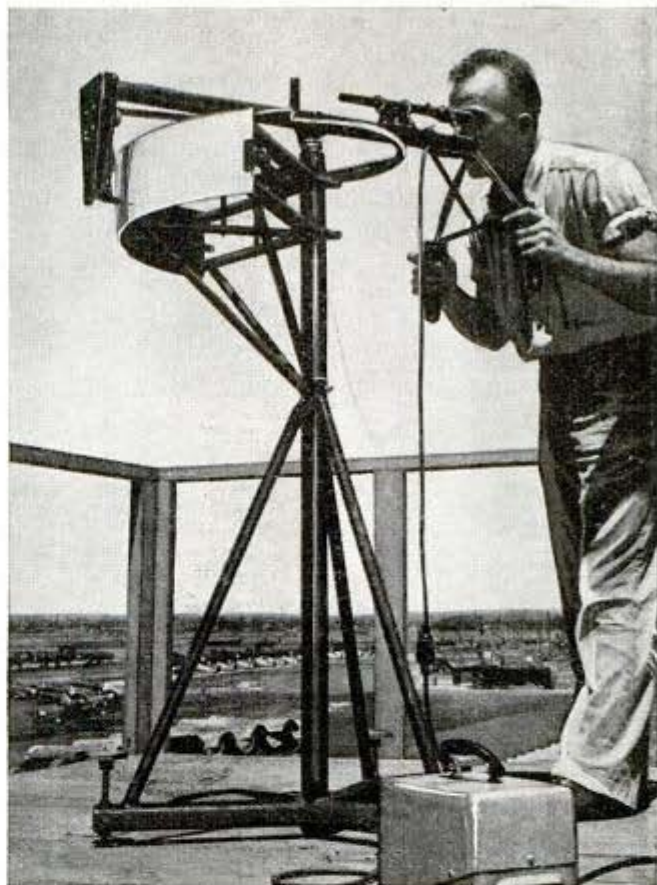

Mirrored Light Reveals Landing Plane's Altitude to Pilot

For night landings, especially on a blacked-out airfield where the danger of misjudging altitude might cause an accident, a simple arrangement of wing lights and a mirror may be used as a rough "altimeter," according to a recently issued patent. Embedded in the wing as close to the

horizontal axis as possible, the lights throw pencil beams downward. Beams can be so fixed that when the plane reaches the altitude of about 6 feet, 10 inches, a mirror mounted on the cowling reflects two spots of light from the ground into the pilot's line of vision. As the plane descends farther, the spots merge into one another, and become a single spot when the plane is about three feet off the ground. The merging dots tell the pilot how far his wheels are above the landing strip.

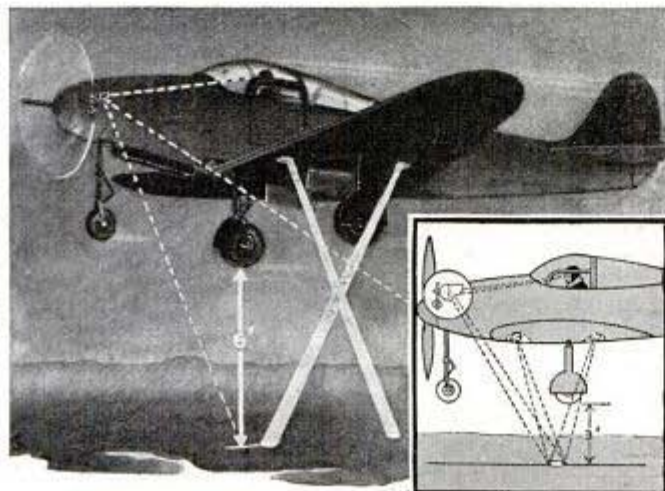

As light dots merge in nose mirror, pilot lets the plane down

JANUARY, 1944

Cream for "Flash Burns" Protects Navy Gunners

"Flash burns" inflicted on gunners by the terrific heat accompanying the explosion of a big gun are prevented with a special skin cream developed by the Navy. The cream is applied to face, neck, forearms, and hands. An ounce and a half is said to afford one man complete protection against heat of 1,000 degrees Centigrade.

used by Navy 65

TRAILING the RANGE ROBBERS

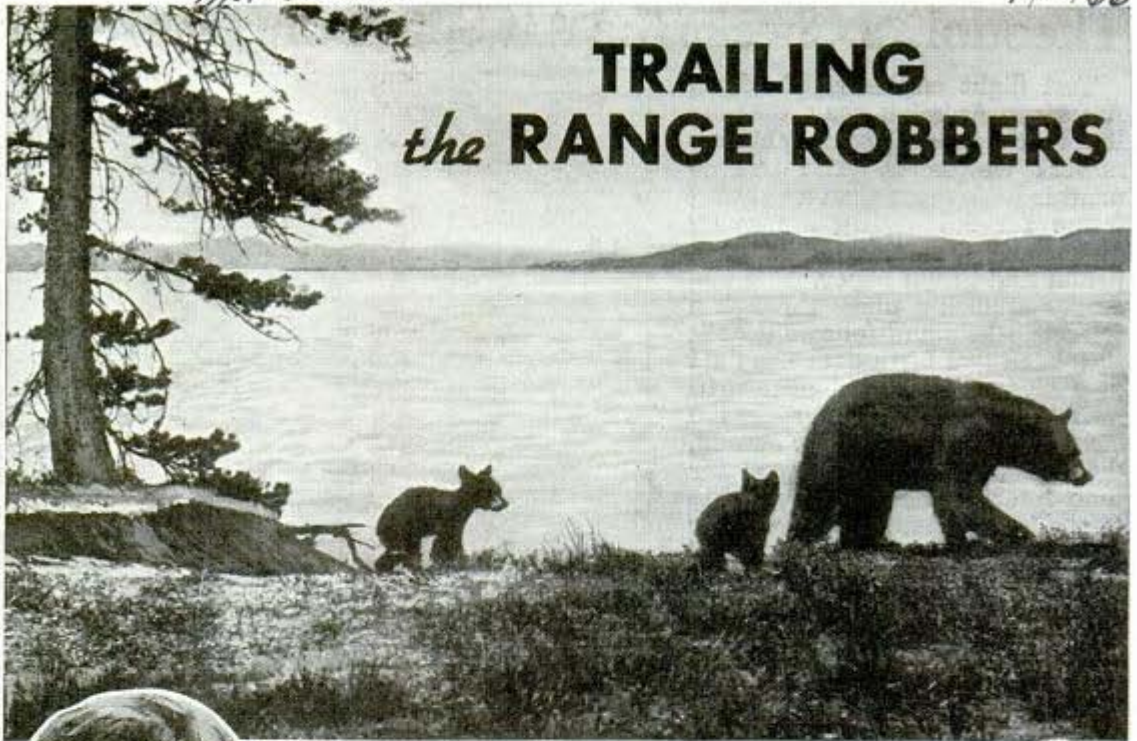

Predators, animals that destroy crops and flocks, like bears, above, and wolves (cub at left) are controlled by U. S. government



and all the other carnivores that prey upon stock, poultry, game and crops. The word is predator.

In the words of Dorr D. Green, chief of the division of predator and rodent control of the Fish and Wildlife Service:

"Any outdoors man is interested in preserving wild life. But mankind has a place in nature's economy too. And since man has come to stay, he's got to be protected against the animals that threaten his livelihood."

Thus, in the spirit of protection and control, the government established the check on predators 28 years ago. It isn't anything new; wolf-bounty laws go back to 1630.

Timber wolves have become a lesser menace, but coyotes, like other predators, actually seem to thrive alongside of man, in part on things that man brings—

chiefly his flocks. Coyotes have spread east of the Mississippi, probably through the stupidity of tourists who brought whelps home, and set them free when the pups became grown.

A total of 111,076 coyotes had to be destroyed last year. Chief reason is that, depending on the season, up to 18 percent of a coyote's normal diet is sheep.

TO THE visitor from the East, the coyote's yap has a romantic sound. "Takes you back to the old frontier days," the visitor says. "The wild and woolly west."

But to the stockman, the shepherd, the poultry farmer, the hunter of the Fish and Wildlife Service of the Department of the Interior, it isn't so romantic. To all of them, just one word describes the coyote

Wildlife Service
Dept. of Interior
Washington, D.C.



Porcupines, snowbound in trees, girdle and kill them

Other predators trapped, shot, or poisoned included 10,957 lynx and bobcat, 791 wolves, 639 bears, and 204 mountain lions. The total of 123,667 predators is completely apart from the tens of thousands of ground squirrels, prairie dogs, pocket gophers, moles, meadow and pine mice and common house mice and rats killed under the program of rodent control.

Control does not mean extermination. Often, a hunter may be sent out to get one particular animal. Thus, bears are not commonly predators—defining as a predatory animal the one that “conflicts most dangerously with the interests of man.” But when a late spring frost kills the berry crop that would otherwise satisfy the bear, he will turn predator, and become a wanton killer, too, slashing down from 20 to 50 sheep in a flock at one time, just out of sheer blood lust. Trapping a single bear often ends the slaughter in a whole neighborhood.

Eliminating predatory animals is a matter of dollars and cents. In areas where there is no predator control, losses to sheep flocks run as high as 20 percent, compared with about 5 percent under control. The controls now in effect save some 3,700,000 sheep and lambs a year, saving their meat and wool.

Control of the carnivores is the romantic side of the story, but it should not eclipse the rodent program. Rats every



Mountain lions (above) are holding their own; about 200 to 300 have to be destroyed each year because of their taste for lamb. Below, setting loop of snare

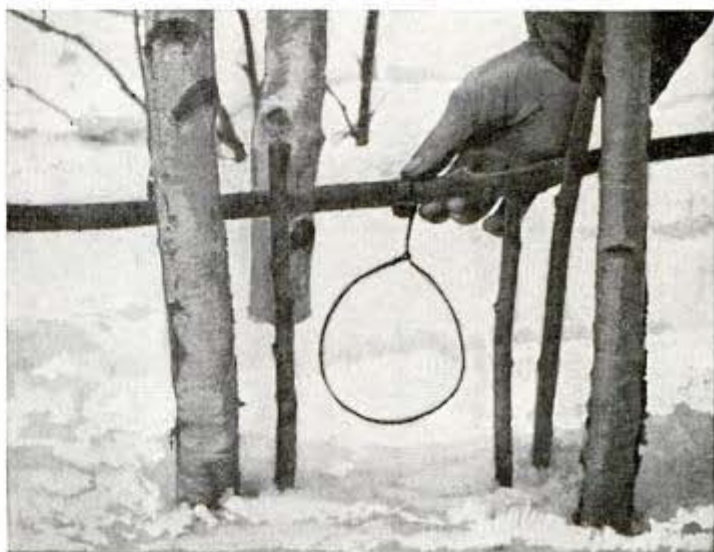

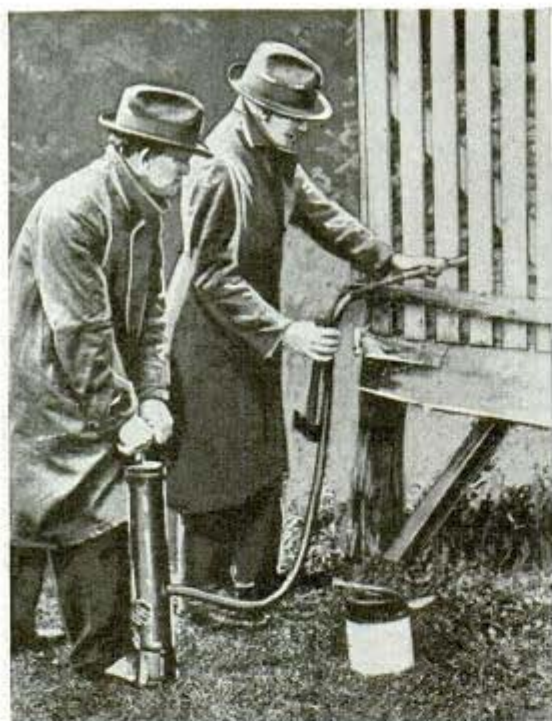

Above, a rat-infested corn crib treated by predator controllers

year destroy food, feed, cloth and poultry valued at an estimated \$189,000,000. Before rat-control work on a Galveston pier, half of the 84,000 sacks of flour stored there were being fouled or damaged. Afterward, only two sacks were destroyed.

Ground squirrels ruin feed and forage. After a three-year battle with these pests on an area in the Caribou National Forest in Idaho, half again as many head of stock could be fed on the range as before the control began.

In numerous orchards of the northeast, as many as three trees out of four are girdled by pine mice below ground or meadow mice above. Porcupines, too, aren't always the quaint, humorous characters of the kiddies' story books. In Arizona, one estimate was that 27 percent of the trees suitable for timber needed urgent porcupine con-

trol. Porky gets stranded by snow in the upper branches of jackpines, and to while away the long days—as well as to content his stomach—he girdles the branches and boles of the tree, and in numerous instances kills young plantation pine trees as well as natural-reproduction stock.

Predator and rodent control is a cooperative procedure. A state, county, a stockman's association, a farming group, or an individual generally puts up about two-thirds of the cost of a control program, and federal funds supply the other third.

"When control has been attained in a locality to the degree that depredations of predators or rodents are no longer acute, financial co-operation is reduced accordingly," the Fish and Wildlife Service points out.

Though mountain lions, or cougars, are easily the most glamorous of the predators, fewer lions are taken than almost any other pest. The lion likes venison on his table. It's only occasionally that he'll stalk sheep or calves—though he relishes a young colt. Cougars are holding their own. They are

taken chiefly in the Southwest, a steady 200 to 300 every year. Sometimes a really bad cougar shows up, like the one in Idaho that destroyed \$700 worth of lambs from flocks grazing within a radius of 15 miles.

The 11 Western states all harbor predators of one sort or another. Over their 761 million acres, coyotes and rodents particularly revel in spoils. But their 37,000,000



Left, prairie dog, the western pest. Below, setting traps for coyote, No. 1 predator. Bottle holds luring scent



Rifle Iron Ranch
40 miles south
of Bitter Creek, Wyoming
POPULAR MECHANICS

sheep and lambs—75 percent of the nation's total—are vital for meat and wool.

A Colorado rancher recently lost 40 lambs in two weeks to a crippled coyote, seeking easy game. An Arizona rancher lost 15 percent of his sheep during a drive of 25 miles. Nevada ranchers reported losses of up to 35 percent of their lambs from a band of 5,000 sheep.

Hunters and sportsmen have a prime interest in controlling predators. During one year, by Forest Service estimates, predators destroyed 129,152 big game animals on the national forests alone. In Los Padres National Forest in California, coyote predation was called a major threat to deer herds. Ground squirrels, destroying food and cover, also make life difficult for game birds.

Trapping, hunting with guns and dogs, and poisoning are the chief methods of eliminating predators. In the Old West, ranchers would faithfully drop poison in every carcass found on the range, in hope of destroying a coyote returning to his kill. Such indiscriminate use of poison has been roundly condemned, because of its threat to game and fur animals. The Fish and Wildlife Service urges that poison be set out only under expert supervision.

Coyotes are also controlled by denning and trapping. An experienced hunter tracks the parent coyote back from its kill or its waterhole. Between April 5 and June 15 whelps may usually be found in the dens, and the parents often can also be caught with traps.

Trappers go to elaborate lengths to remove all "man smell" from the trap and set. The trap may be buried in an old manure heap, as is the "setting cloth," a square of canvas on which the hunter kneels while preparing the set. A scent attractive to coyotes—and bobcats as well—is made of ground up fish that has been permitted to putrefy. This is sprinkled on a stick or piece of brush near the set.

Bobcat depredations in parts of Arkansas in recent years have made hog-raising impracticable. Bobcats also raid sheep herds, especially during lambing season, killing the lamb with a characteristic vicious bite on the back of the neck or head. A single bobcat has been known to kill 38 lambs in one night, in a feline spirit of wanton slaughter.

Romantic animals, these carnivores, providing a living link back to the colonial days when America was wilderness. Remembering the bison, no lover of the American tradition would want them destroyed. The Fish and Wildlife Service holds that only by expert control can the predators be kept in their proper wilderness niche, if man is to get a break too.

Glass Made Non-Reflecting By Secret War Chemical

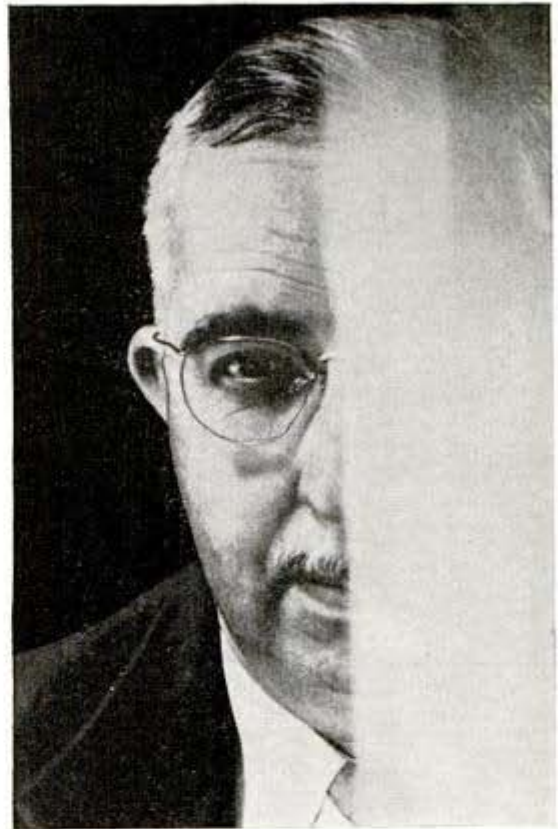

Subject above is photographed through a glass panel whose left half was made chemically non-reflecting

Ordinary glass transmits about 92 percent of light, the remaining 8 percent being lost through surface reflections. Much of this "lost" light is saved by the use of a surfacing treatment, whose chemical composition and method of application are now secret because of their military applications. The technique permits the making of large areas of glass and other light-reflecting materials nonreflecting. In post-war applications, auto accidents could be lessened by surfacing windshields to reduce light reflections that blind the driver. Spectacle lenses would become less conspicuous; show windows and cases would display their contents without distracting reflections; pictures, framed or unframed, would show to better advantage; camera lenses would produce better pictures if treated. Even the glare from the faces of clocks and watches could be reduced.

Names and addresses of makers or sellers of commercial products described in this magazine are listed in the Where-to-Buy-It index, page 4A. Write to them for additional information and be sure to Say You Saw It in Popular Mechanics.

American Optical Co. 69
Southbridge, Mass.

The RED METAL of WAR

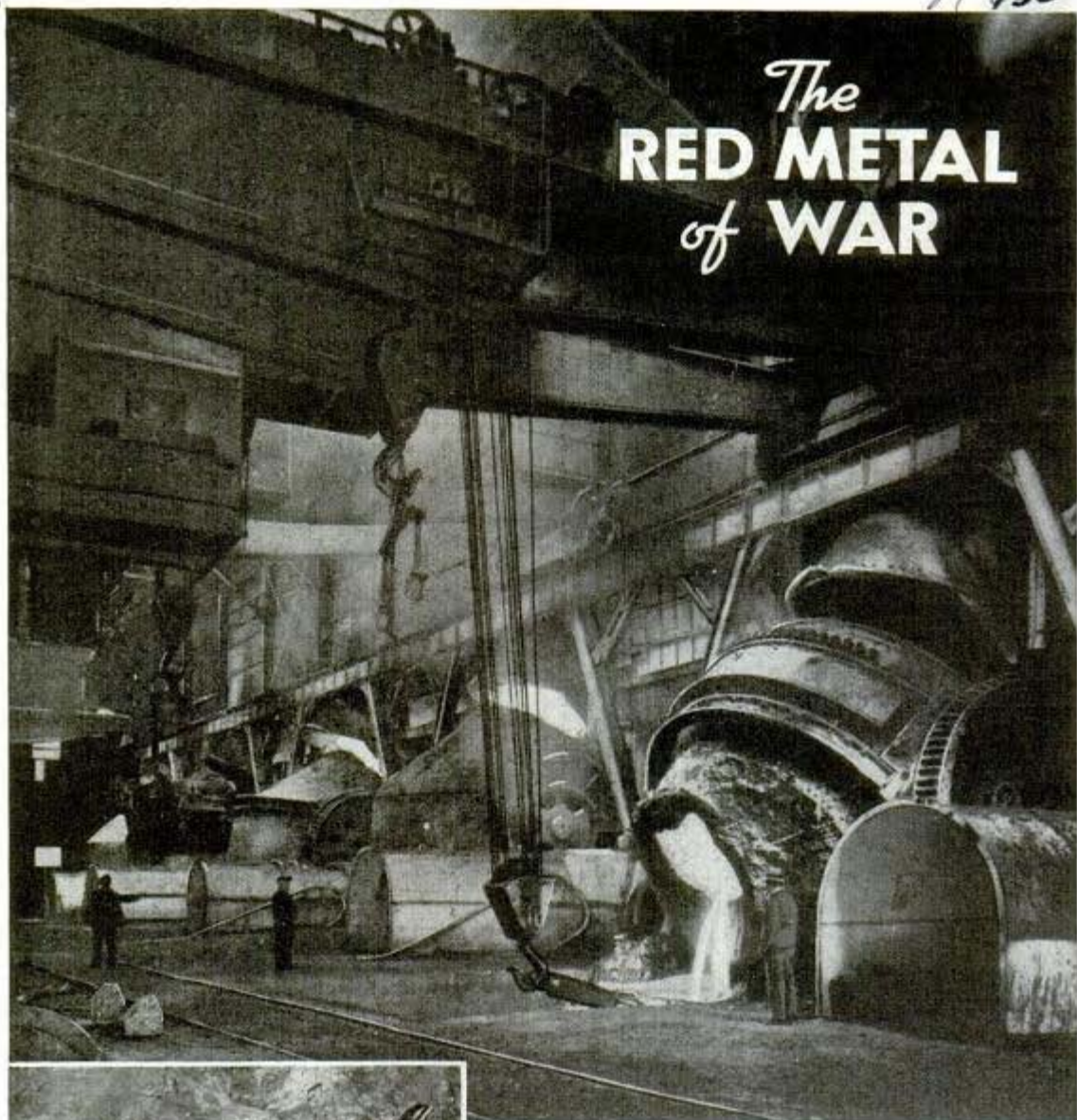

Copper and Brass Research Association
 Pouring from giant converters is molten copper, a precious war metal. Left, copper miner drilling holes for blasting

WHEN the 300 odd pieces of sheet copper were riveted together in New York harbor nearly 60 years ago to form the Statue of Liberty, little was it supposed that the same red metal one day would become of immeasurable value in a battle to uphold the ideals for which the giant figure stands.

Yet that is just what has happened. Because of its primary importance in war production, copper now ranks with steel and aluminum at the top of the list of essential war materials. And because of the tremendous wartime demand, copper has taken its place as one of the world's truly precious metals. Silver frequently is used as a substitute for copper in war products.

With its closely related alloys, brass and bronze, copper is indispensable in practically the entire range of fighting equipment. It is used in

munitions and guns of all types, in planes, tanks, ships, for all communication facilities, in buildings and camps, and in machine tools and other production equipment. Two and one-half miles of copper wire are used in a bomber in addition to other copper parts that sometimes account for one-tenth or more of the plane's total weight. Two million pounds of copper are used in a battleship, 800 pounds in a tank.

The United States is the world's largest producer of copper, and output is being pushed to the limit. The red metal is being imported from South America in quantities that tax shipping facilities. Latest figures place the available supply at more than 2,500,000 tons. Every effort is being made to conserve the metal, to find substitutes, to collect copper scrap. Civilian consumption has been cut to the bone.

But in spite of all these things, the military demand alone is estimated at 8 percent more than the supply. When absolutely necessary civilian needs are considered, the excess of demand over supply is reported to be about 25 percent.

Copper conservation measures and substitutes have gone a long way toward stretching the copper supply. The red metal has been placed at the top of the list in all scrap collection drives, and substitutes include glass, plastics, iron and steel, porcelain enamel, gold, silver, Bakelite, zinc and wood.

Time was when milady's lipstick case was copper; now it is plastic, silver, gold, wood or paper. Giant bronze castings have given way in many instances to steel, iron or cadmium-base die



There's a lot of copper in those .50-caliber cartridges (above). Munitions industry is the largest single user



Left, nose plugs in the 500-pound "Bundles for Berlin" contain copper. Here plugs in bombs are being tightened

Below, woman "machine gunner" firing test round of .50-caliber cartridges in proof house of an ordnance plant

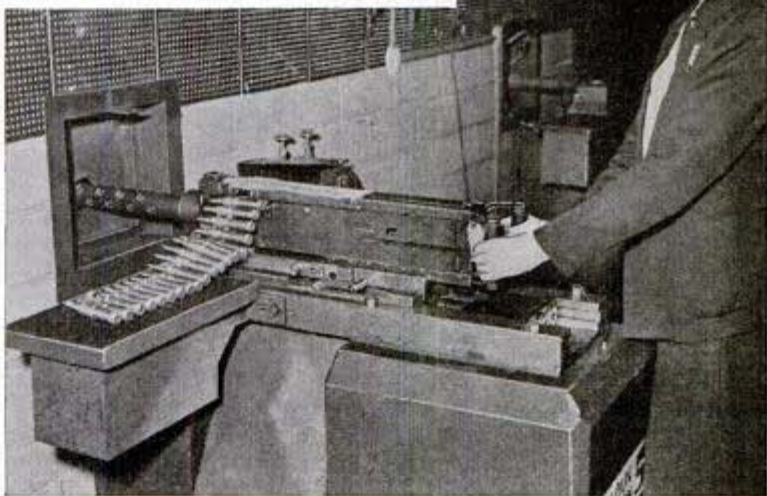



Westinghouse photo

This "torture rack" determines amount of "creep" in molecules of copper bar under stress. Below, "carrier" telephones save copper by sending as many as 16 messages over a single wire

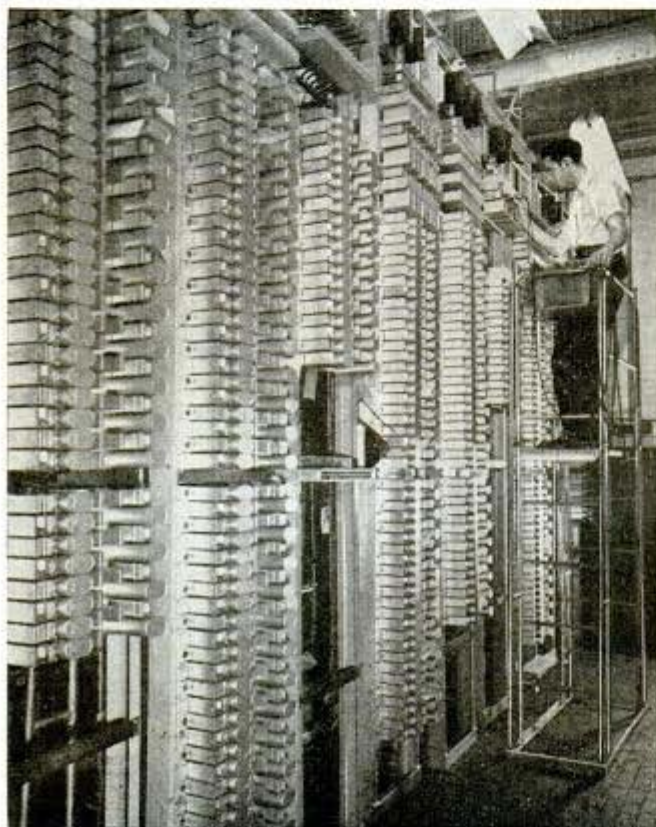

castings, and even lead. Even dog tags used to be copper, but the tags you see today are likely to be plastic. In many instances—electric light bulb bases, for example—a core of steel is used with only a plating of brass instead of solid brass.

Some of the substitution measures have brought startling results.

Elimination of the brass in ferrules that hold lead pencil erasers, it is reported, saved enough metal to make about 13,000,000 brass cartridge cases, and elimination of brass in shoe eyelets has provided material for 1,000,000 shell cases.

In Detroit, the Edison Company devised a method of straight-line home wiring that saved an average of four pounds of copper on each of 11,000 homes built in the last two years. Plastic printing plates have grown in favor, and a recent study by the War Production Board showed that a considerable amount of electrolytic copper may be saved by the use of such plates which are said to be satisfactory for up to 50,000 impressions.

By eliminating unnecessary frills in scores of articles from hairpins to industrial power trucks, manufacturers in 1942 saved 1,700 tons of copper, according to the WPB. Simplification orders affected more than 300 products. For example, sizes or types of valves and fittings have been reduced from 4,030 to 2,500; electric light bulbs from 3,500 to 1,700; heavy forged hand tools, from 1,150 to 357; water coolers from 27 to 8; auto storage battery types from 100 to 16; fluorescent lighting fixtures from 200 to 2.

Even the nation's money has felt the copper pinch. New copperless pennies are in circulation, as are new five-cent pieces with 25 percent less copper than formerly. The wartime pennies are made of zinc coated steel, taking the place of the old pennies which were 95 percent copper. Last year, 4,600 tons of copper were used in minting pennies.

The new "nickels" are 35 percent silver, 56 percent copper and 9 percent manganese. Formerly they were 75 percent copper and 25 percent nickel. We have, thus, a nickelless nickel, containing far less copper, and releasing large

Yanks in Iceland help conserve metal by packing all the empty shells after they have been fired



quantities of both nickel and copper for war production.

Because of its high conductivity, copper is the foundation upon which the electrical and communications industries are built, and in these fields the red metal is one of the most difficult to replace. To a large extent, there is no commercially accepted substitute for its current-carrying uses.

A large percentage of all the copper used goes into these two industries. Although not as ductile as silver or gold, a copper billet 4 by 4 by 53 inches will draw into a 2,500-mile strand of 42-gage wire. But in only four minutes, a machine gun will consume some 30 pounds of copper in bullets, enough for a mile and a half of telephone wire.

The modern steam locomotive contains some 8,000 pounds of copper, but an electric locomotive may employ as much as 75,000 pounds. Large steamships and naval vessels contain much copper; 3,000,000 pounds of the red metal, for example, were used in building the Queen Mary. Since modern war equipment is largely mechanical, the demand for copper for tanks, trucks and other automotive type equipment may be gaged by the fact that in peacetime the automotive industry was the second largest user of copper in the world.

Probably the largest single use of copper

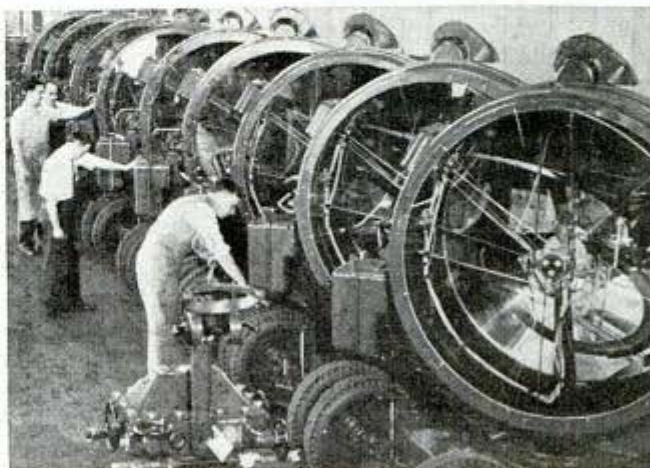

Reflectors in giant anti-aircraft searchlights contain copper

in war production is in small-arms ammunition and artillery shells. It is estimated that 525,000 tons of copper were required for the fabrication of brass sheets for munitions this year. Some large shell cases now are made of steel instead of brass as a result of new methods which save several million pounds of brass every year. (Brass is an alloy of copper and zinc, and bronze is an alloy chiefly of copper and tin).

"Drafting" of U. S. Treasury silver to replace copper is an example of how the red metal has come to be precious. Recently, 17,000 tons of treasury silver were released.

Substitutes of silver for copper are being

(Continued to page 146)

Farnal Corp.
3249 E. 18th St.
Cleveland, Ohio

N 600

Remote Control Oil Blocks Lubricate Bearings

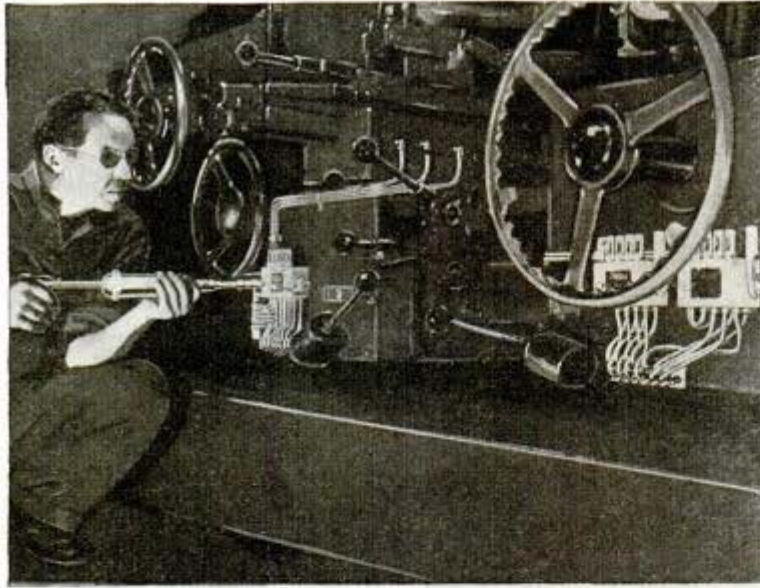

Up to 10 bearings are lubricated at one time by multiple valve blocks

Bearings on machine tools and similar equipment may be lubricated, regardless of location, through centrally placed distributing blocks, for which a manual or power-operated portable gun serves as a central pump. Valve blocks each serve from two to 10 bearings, and lubricant lines lead from the blocks to individual lubricating points. A valve handle on the centrally located block directs the flow of the lubricants, either oil or grease, and an indicator on each valve piston indicates the positive delivery of the lubricant.

N 598

'Stinger' in Nose of Liberator Is Two-Gun Electric Turret

Thirteen projectiles a second can be fired from each of the two 50-caliber machine guns mounted in a new electrically operated turret mounted in the nose of Liberator (B-24) bombers. So adaptable is the Emerson turret that it can be installed in either the bomber's nose or tail. Inside it, the gunner has a visibility of almost 360 degrees. He expends little effort in aiming, as an electric motor moves the turret. Without this mechanical "stepping-up," his strength would be insufficient to hold the guns on the target accurately.



Liberator's nose turret can fire 26 projectiles a second from twin guns

N 776

Tuning Fork Tells Examiner When Pilot Is Too Fatigued to Fly Safely

With a modified tuning fork, Maj. Aaron Roth believes he can readily ascertain when a pilot is reaching a dangerous level of fatigue and needs to be temporarily grounded. The fork has a frequency of 128 cycles, and intensity of 70 decibels, and with normal persons its vibrations can be perceived by the fingers for the duration of 35 seconds. In using the "neurometer," as it is called, the examiner strikes the fork, making it vibrate, then places it against the

patient's upturned fingers, noting the exact time. When the patient can no longer feel the vibration, the time is again noted. In general, the vibration sense at the fingers is lessened when the fingers are cold, when they have been strenuously exercised, or in general fatigue.

Compressed air at 3,000 pounds pressure per square inch is used to charge and eject torpedoes from their tubes.

74 Developed by Major Aaron Roth, M. C., U. S. Army. Details reported in War Medicine, military medical journal

POPULAR MECHANICS

5-35 N. Dearborn, Chicago.

Ford Motor

Cafeteria Style Camouflage Served Up at Camp



Soldier students of camouflage at Camp Edwards, Mass., learn the right and wrong ways to employ this military art at a "camouflage cafeteria." This is an arrangement of exhibits that advance from simple form to the most complicated means of fooling the enemy. Observers are led to the exhibits by wired paths. Above, man at right merely sought partial concealment in ruined building. In the other photo he used materials at hand to blend into the surroundings. From the front view, even the rifle is hard to detect

Just because a fellow is daubed up with green paint is no guarantee that the enemy can't spot him in a jiffy. The man demonstrating faulty camouflage (below) is wearing a suit designed to blend with living foliage and he has taken a position behind some withered brush. His face is smeared, but he has taken off his helmet. Another error is white tape showing on rifle. In the other photo, soldier uses same equipment against a live background of foliage to demonstrate almost perfect concealment. Try and find his gun

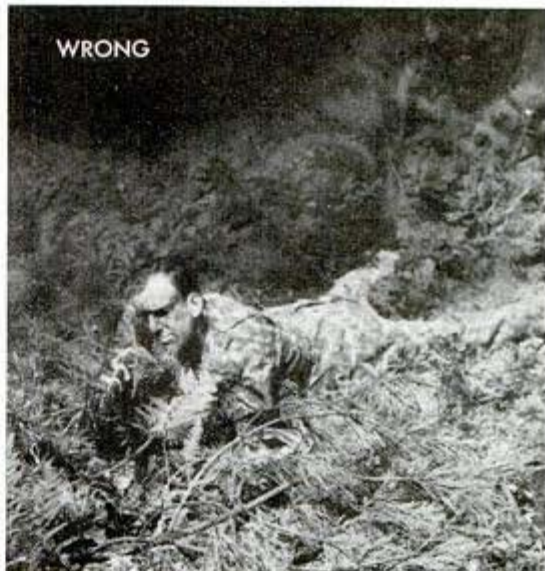

GRASSHOPPERS *with* TEETH



C. A. P. pilot taking aim at a stock-killing coyote

TWILIGHT on the Gulf of Mexico had been picked by the skipper of a Nazi U-boat as the time to torpedo another American merchant ship. While he was surfacing for the kill, just one miscalculation marred the plan. As his periscope broke the peaceful waters of the Gulf, a tiny plane—much too small to be so far from shore—swung sharply to challenge

located on a slight rise of ground and was temporarily safe—but no one could tell for how long. Crews worked feverishly filling sand bags. Sand was plentiful. Bags were not. Highways were closed to motor traffic, and no flying field was available. Using a small strip of highway that was not yet under water, C.A.P. planes from the Terre Haute, Ind., squadron made 22 flights

this pink "pig boat." The U-boat crash dived and another American ship with cargo and crew was saved.

More than 150 such episodes are credited to the Civil Air Patrol whose members have officially logged more than 20,000,000 miles of wartime flying. Of course, not all Axis submarines are pink. This one apparently had been prematurely forced from its base with only a coat of red lead which sun and salt water had changed to a sickly pink.

During this year's floods, the patients in an overcrowded hospital fearfully watched rising waters. The building was

Pilot lowering hook to pick up a message on the fly—a handy trick in districts observing radio silence



Streamers are attached to message container tossed overboard

bringing in bags with which the hospital was saved. This flying was done with a visibility of less than one-quarter mile and a ceiling of not quite 400 feet.

Overworked agents of the F. B. I., too, have looked to C. A. P. for help and received it. Saboteurs and other criminals have been speedily brought to book. Hastily summoned by the F. B. I., a courier pilot from Cincinnati flew G-men on the trail of an escaped felon. Hedgehopping to a landing in a small pasture, this pilot unloaded his passengers. Then, circling for observation, he continued his job by assisting in locating the fugitive from the air while the G-men closed in from the ground.

Not all jobs are so spectacular. Night and day and in weather so thick that even birds might choose to walk, constant patrol is maintained along the Mexican border. So, too, is patrol maintained along many miles of our vital oil pipe lines which carry fuel to ports for shipment to war zones.

Out West, new techniques for relieving the meat shortage have been developed. With coyotes becoming increasingly bolder

Right, C. A. P. officers demonstrate commando technique. Below, catching message tossed from a plane



and attacking live stock, action was necessary. Flying low over the prairies, many a coyote was flushed. Then the pilot circled to get behind the animal. Turning sharply from right to left to avoid over-running him as he fled, the pilot jockeyed into position where his observer could shoot him down. And since these coyotes bring an eight-dollar bounty, a landing was made, the animal skinned, and the hide brought back. While such flying had its hazards, it was probably the fleas from the coyote that worried the boys most.

Forest fires which threaten our lumber reserves are frequently spotted by C. A. P. patrols. In the vicinity of a fire, visibility

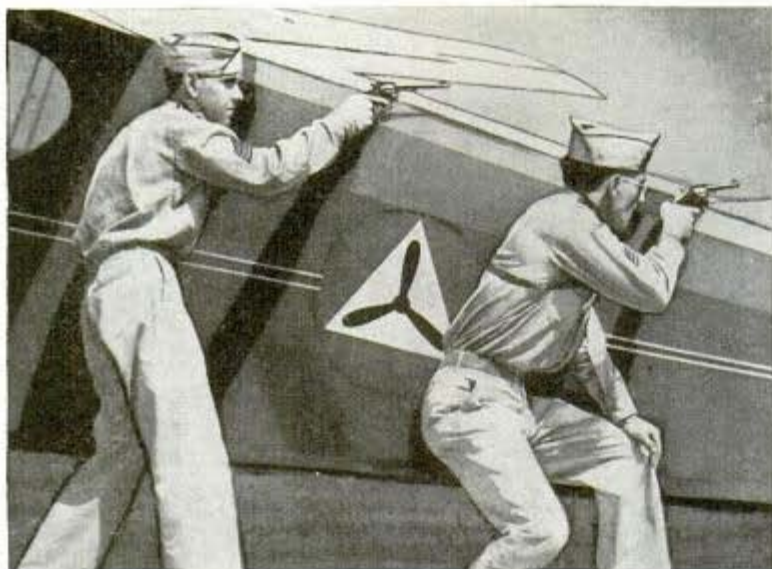

Alert courier pilots are prepared to defend their cargo with small arms

is bad, forced landings deadly dangerous, and air turbulence at its worst. Not only do pilots spot such fires, but by communication with ground forces they direct their activities until the fire is under control.

Towing targets over rookie anti-aircraft batteries isn't the safest job in the world. One pilot who has flown countless hours on such duty returned to base one day with only 18 feet of tow line left behind his plane. Miscalculating in some manner, the ground crew had sent a burst too close. The pilot was angry—not for personal reasons—but because the broken line interrupted this training work! With a new target and line he took the air again to fly back and forth while the rookies developed their firing skill.

Of course, not all C. A. P. jobs are flying work. The basic training required of all members takes more than 230 hours, in classroom, field, and air. Part of this work is in communications, and knowledge of code recently enabled an Indiana man and his wife to save an army pilot and his ship. Circling in a blinding snow storm, the pilot was striving vainly to find a field. With the headlights of their car, the C. A. P. couple flashed a message that enabled the pilot to land safely on a nearby farm.

Many C. A. P. units work out elaborate missions between ground members and pilots. With mountain peaks often claiming the lives of fliers, the New Hampshire wing has squadrons whose members include expert skiers. These mountaineers are directed to objectives by their flying partners.

A C. A. P. cavalry unit of the Nevada wing demonstrated the value of ground-air technique. Hearing

Signalman controlling traffic during mass maneuvers—some total over fifty planes

that an army bomber had crashed, the entire C. A. P. organization of the state was called out. The wrecked bomber was soon spotted from the air. As it was impossible to land in the vicinity of the plane, C. A. P. pilots directed their mounted members to the scene. Had there been any survivors, complete medical care could have been provided, for first-aid training is required of every member and the Nevada unit had a fully equipped motorized dispensary.

A war plant in Detroit was recently threatened with a shut-down for want of parts. This particular branch was rushing production on a new weapon. To continue production required picking up certain material in Muncie, Ind., and taking it to Warren, Ohio, for processing. From Warren it had to be carried to Detroit for assembling, and it seemed impossible to get this critically needed material in time. Not only was it provided in time, but the production schedule was actually put five days ahead as a result of C. A. P. courier service.

If you see C. A. P. planes flying near



Army ordnance proving grounds, give them a wide berth. They may be nothing more or less than "flying munition dumps." It is no military secret that samples of munitions are taken constantly to various army arsenals and proving grounds for testing. C. A. P. pilots are called on for this hazardous duty. Though their load may not be large, it is deadly and deserves all the respect due a stick of T.N.T.

Of course, accidents happen. When this was written, 30 C. A. P. members had given their lives and 73 planes had been lost. Flying coastal patrol, carrying munitions, hedge-hopping for coyotes, tracking criminals, transporting blood plasma, serums, and other medical supplies in storm areas can hardly be considered the safest kind of work.

Only Russia and the United States allow civilian flying in wartime. Civilian aviation in Russia has been an important source of pilots for the Russian Air Force. This has been largely true in the United States, too. Long before Pearl Harbor, Earle L. Johnson, now Major Johnson of the Army Air Forces, commanding all 48 wings of the Civil Air Patrol in the United States, saw that our thousands of small planes had

great possibilities for good or evil. To dramatize his fear that these ships might be used for sabotage, he took off in his plane and, with small sand bags, "bombed" a vital defense plant.

Quick action followed. Airports were guarded—private planes grounded. There were 100,000 civilian pilots in this country at that time and about 25,000 light planes. Many of these pilots were soon in the armed forces, but there were others eager to serve as civilian fliers. So, under the Office of Civilian Defense, C. A. P. organized the country into volunteer flights,

(Continued to page 150)



C. A. P. cadets study aircraft controls on a model before leaving ground

Regular members of army antiaircraft unit rigging sleeve target to be towed 1,800 feet behind C. A. P. ship

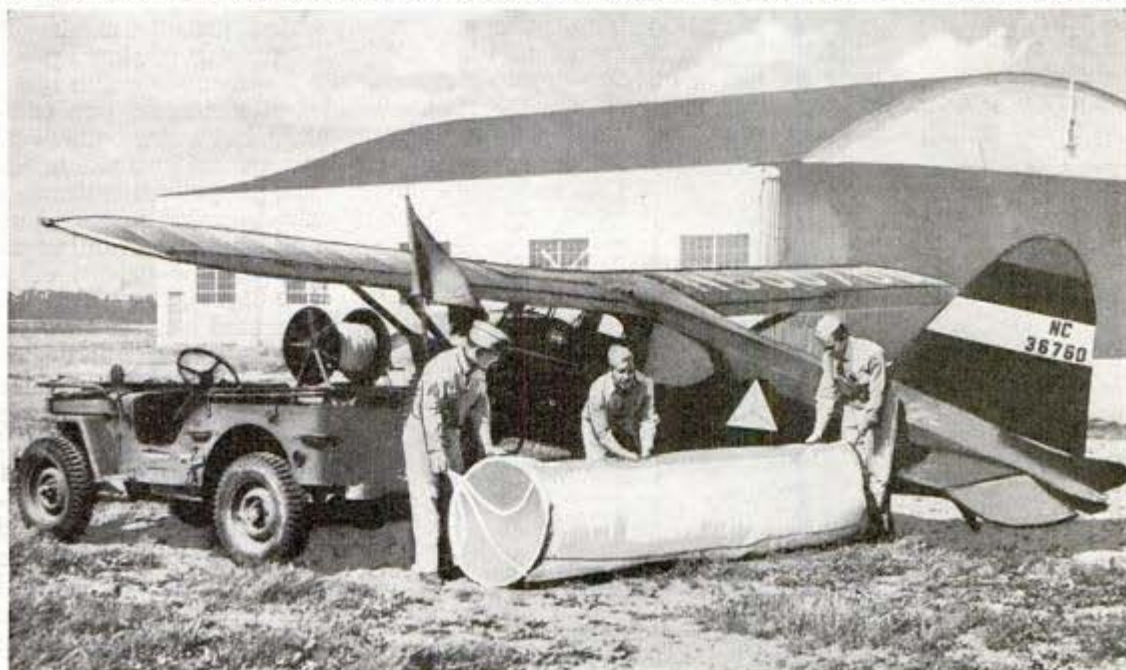

Boeing Aircraft Co.
Seattle, Washington

71599

"Fingers" Boost Fort's Bomb Load to 10 Tons



Arrows point to one of the two external bomb racks mounted beneath wing of Fortress, increasing bomb load

Forklike fingers extending beneath the wings of the Flying Fortress are external bomb racks, whose use makes the plane a vastly more destructive nemesis of the Axis. For with the external bomb racks,

together with the bombs carried inside the fuselage, the B-17's can now transport a bomb load of about ten tons. The big Boeing craft thus becomes one of the greatest load-carriers now in operation.

71573

Working Locomotive Model Took 10,000 Hours to Build

Ten thousand hours of labor, all by hand, went into the making of a working model of a huge Class H freight and passenger locomotive operated by the Chicago and North Western Railway Company. The maker, John F. Lindsey of Chicago, is a chewing gum wrapper by trade, but formerly was a machinist. The model works in every detail, and was made of machine

steel and bronze castings without the use of blueprints. All dimensions were taken from the original engine. It is equipped with a two-cylinder booster engine under the cab, air-operated gear transmission, and is built for 250 pounds of steam pressure. Among the hand-made parts are a superheater, hot water heater, two two-stage air compressors, hot water boiler feed

pump, boiler feed injector, poppet valve throttle, air-operated reverse gear and sander, bell and whistle, turbine-driven electric light generator, air-operated booster throttle, air brakes on all 5-inch drivers, booster and tender wheels, oil pump for cylinders, with leaf springs for all axle boxes. The boiler is built of 1/8-inch steel, riveted and welded. So closely was the original engine copied that even the brake shoes are renewable on the hand-made model.

400 W. Madison
Chicago, Ill.

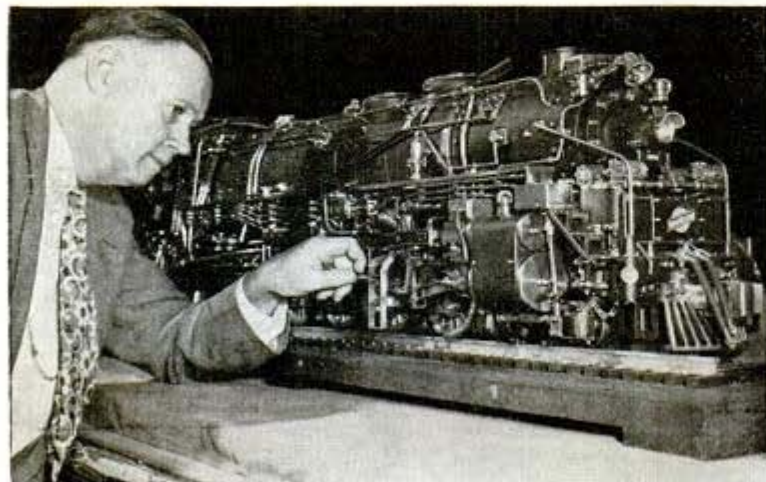

Complete in every working detail is this hand-made model of locomotive

John F. Lindsey
11448
Chicago, Ill.

'Sky Hook' Removes Propeller by Tractor Power

When one of the 440-pound, three-bladed propellers of a Liberator bomber at the Ford Willow Run plant must be removed or replaced, a tractor-driven "sky hook" wheels out and does the job on the spot. Formerly, to change a propeller outside the factory, workmen were forced to haul out cumbersome steel platform ladders, and to commandeer a truck to haul the prop to where it was wanted. The new hoist utilizes a stock Ford tractor, and can dash out on the field with tools aboard, run up an 11-by-4 foot platform, lift off the prop and carry it back to the hangar. The prop-hoist works on a hydraulic system. An oil tank is mounted on the rear of the tractor; the hydraulic pump which delivers the pressure is driven from the tractor engine through a standard power take-off shaft in the rear of the engine. The platform and hoists are regu-

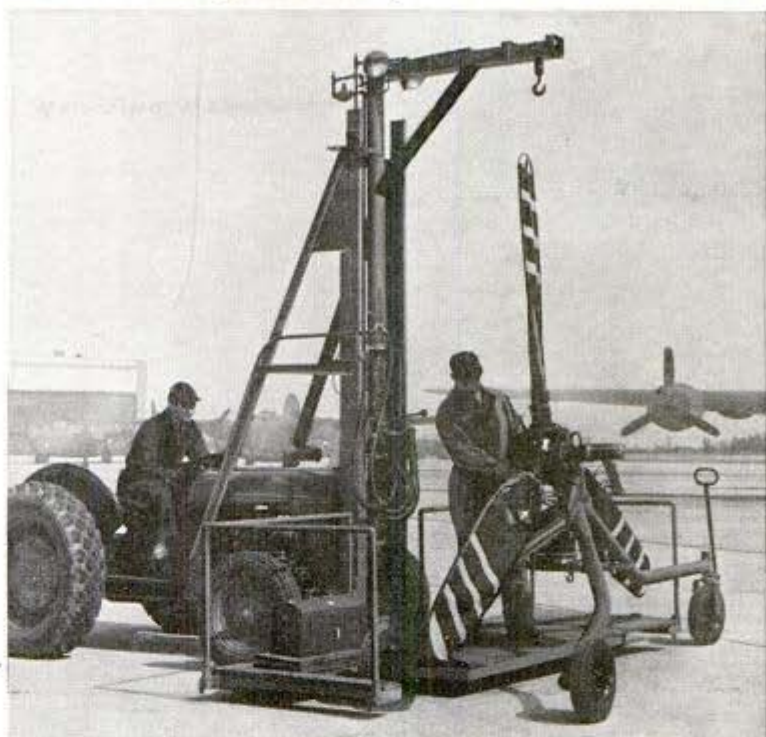

Tractor-driven hydraulic hoist removes the propeller and carries it away

lated by valves. The crane may be raised 17 feet 6 inches from the ground, and the working platform, large enough to hold five men, can rise more than 6 feet.

M. Cohen

"Searchray" With an Electronic Eye Inspects Any Parcel

Suspicious packages and luggage can be inspected without danger to the inspector with an anti-sabotage weapon known as "Searchray." It provides instantaneous,

non-destructive, fluoroscopic and radiographic internal examination of packages. It might be used in war plants, to examine incoming and outgoing parcels, luggage and the like, as well as in air and rail express offices, post offices, customs houses and police stations. To operate, it is plugged into a standard power source, the compartment door is opened, the object to be inspected is placed inside. Then the door is closed, and a push on the control button provides an instant view of the internal structure through an eye-level viewer. Safety of the operator is assured by a rayproof, shockproof housing for the cabinet, which occupies less than five feet of floor space.

N 568



Routine examination of war worker's lunch box by "Searchray"

Write to the firms listed in the Where-to-Buy-It index, page 4A, to learn more about products described in this magazine. Say You Saw It in Popular Mechanics.

*Industrial Electronics Div.
North American Philips Co., Inc.
419 Fourth Ave.
N. Y., N. Y.*

71604

Scale Counts Ration Stamps With Adjustable Indicator



Special chart shows exact number of stamps in scoop

Ration stamps are counted in lots up to 5,000 with a direct-reading scale. This time-saver is 400 times faster than hand counting. To operate the scale, a known quantity of stamps is weighed and the indicator on the special chart is set by hand to register the exact number. Repeated lots can be weighed by placing them in the scoop and reading the chart.

71588

Bender With 2-Way Operation Cold-Forms Metal Shapes

Designed especially for aircraft and marine installation is the Di-Acro Bender, which forms intricate shapes in chrome molybdenum, duralumin, and other low-ductile materials. The danger of fracture, and inherent strains that otherwise occur during cold forming, is obviated by allowing for the development of radii at the points of forming. The model incor-



Bender cold-forms metals without danger of fracture

82 O'Neil-Irwin Mfg. Co.
 Minneapolis, 15,
 Minn.

Comet Model Airplane
 Supply Co. 129 W. 29th St.
 Chicago, Ill.

porates a two-way operating feature that permits the ready reversal of the unit to eliminate interference from conflicting ends of material that may develop during formation of complicated shapes. Its capacity is one-half inch round cold rolled steel bar, formed cold to one-inch radii or larger, with proportionately greater capacity of more ductile materials.

71605

Small Planes "Fly" in Classroom In Midget Wind Tunnel

Similar in design to the great wind tunnels used to test new models of airplanes, a wind tunnel for aviation classes demonstrates the theory of flight. While students watch the effects of airflow through a window in the tunnel, measuring instruments record in ounces the amount of "lift" and "drag" on a model plane. Various experiments may be performed with the tunnel with the aid of airfoils, scale models, drag plates, spheres and streamlined shapes. The

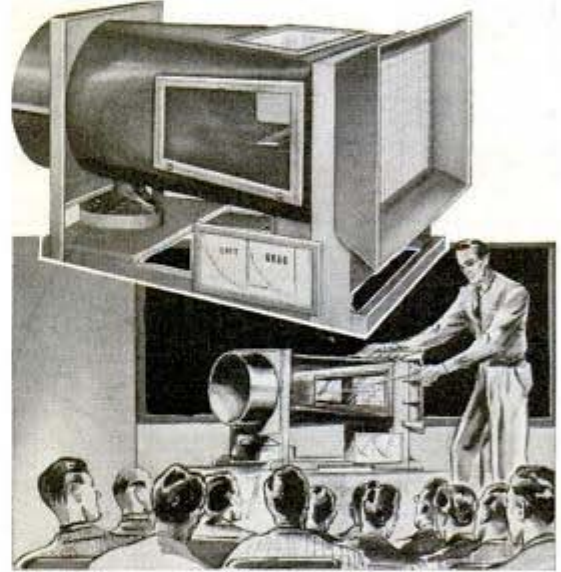

Students observe effects of airflow through window

value of reducing "skin" friction for example, is shown by comparing the effects of airflow on a model with a rough surface and another with a smooth finish. The tunnel makes clear how the presence of a partial vacuum above the wing and high pressure underneath lifts a plane into the air. The classroom wind tunnel is 41 inches long, 27 inches wide and 26 inches high. It can be used with a 16-inch fan or small electric motor. The tunnel has a special propeller and the airflow is straightened out with a honeycomb at the entrance.

Breakfast food, candy, and a sweet powder-mix for ice cream and pie are being made from the sweet potato.

Prof. L. M. Ware
 Alabama Polytechnic Institute
 Auburn, Ala.

Talado Scale Co., Toledo, Ohio

They DON'T STAY SUNK

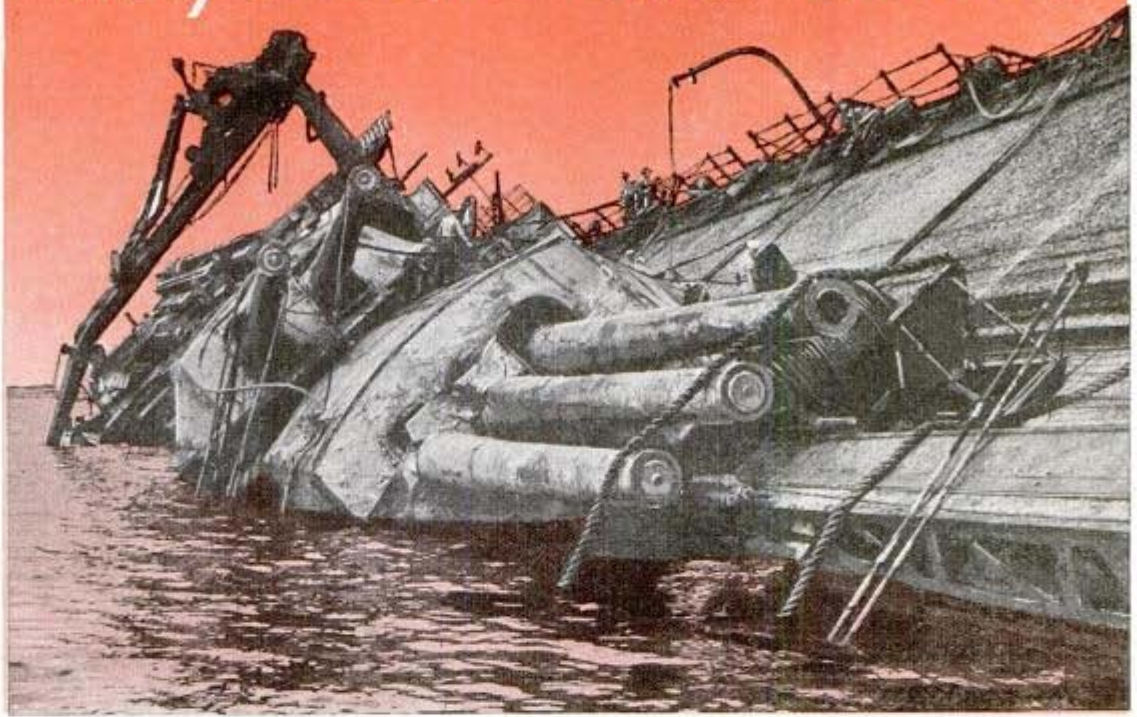

Above, raising the barnacled battleship Oklahoma at Pearl Harbor. Below, repairing propeller of a merchant vessel at Todd Shipyards

By James Colvin

"THE cheapest and best way to build a ship is to repair one already built."

Thus Rear Admiral Ben Moreell, chief of the Navy's Bureau of Yards and Docks, tells why ship repairmen, though largely anonymous, have been among America's most important warriors of the production line.

During the worst of the submarine blitz, the Nazis claimed sinkings running as high as a million tons of ships a month. But during that same period one company alone, for instance, Todd Shipyards Corp., was turning out in new and repaired ships more ocean-going tonnage than even the Axis claimed. In a year's time, the Todd organization turned out 15,000,000 tons of new, converted, or repaired ships.

The Nazi submarine claims were probably part sheer lie and part misconception.

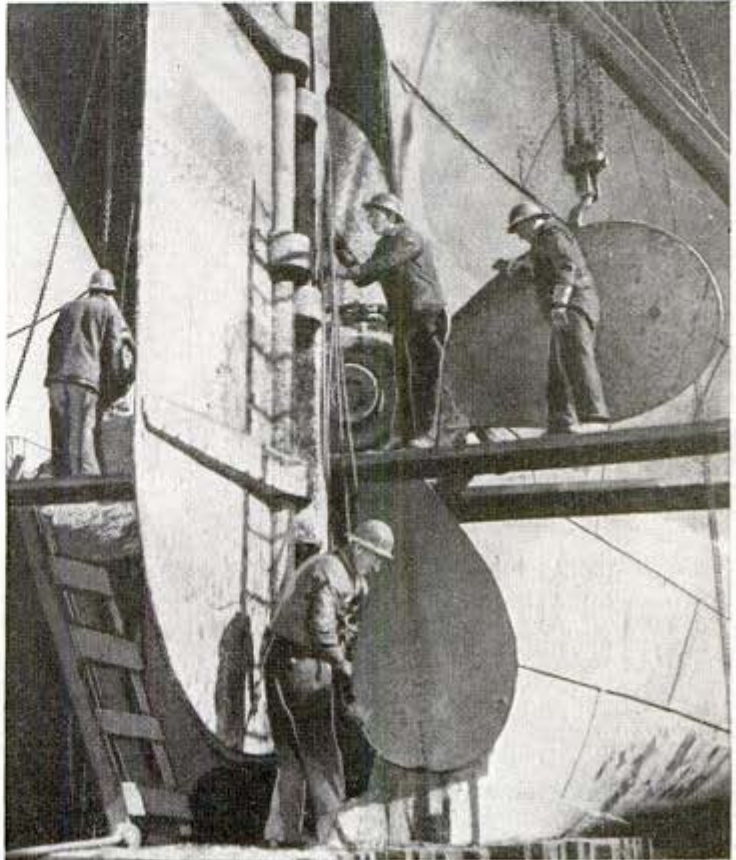

*Ben Moreell
Mr. Colvin*

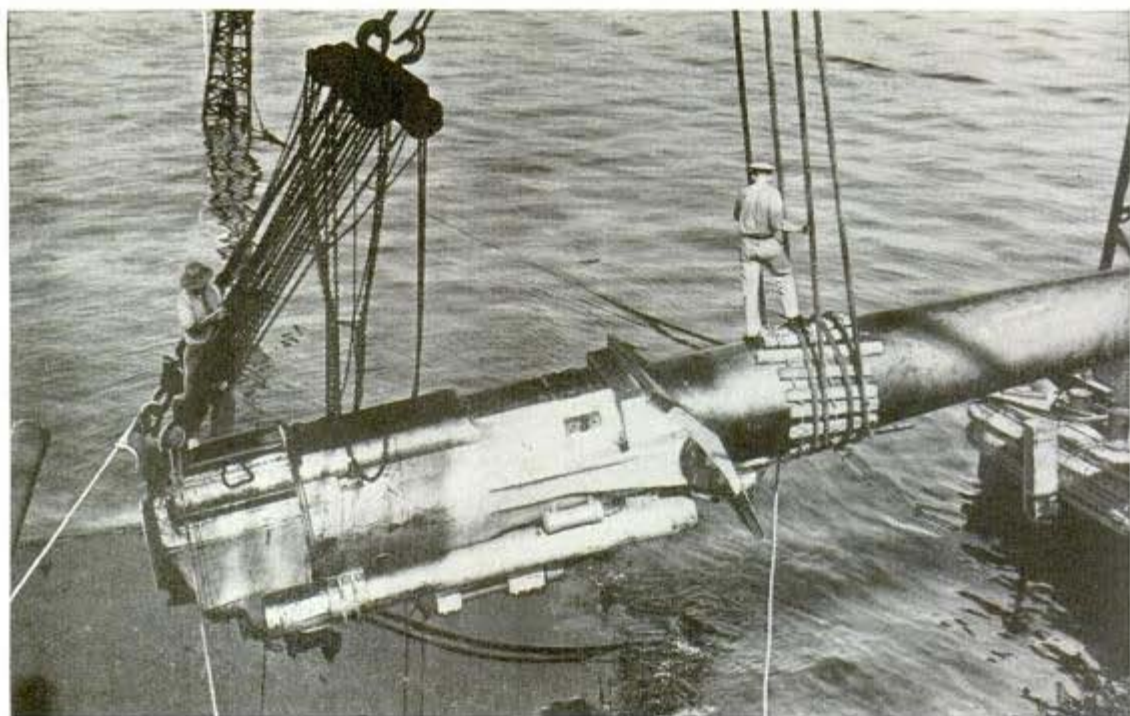

One of the big guns is swung away from battleship California, hit at Pearl Harbor

They hit more ships than they sank, and even some they sent to the bottom have been raised, repaired, and sent back to sea.

Out of service a ship is merely a hulking, unwieldy mass of metal and machinery. But every repaired ship sent back to sea is the equivalent of a new vessel added to the ocean fleet. And, as often as not, a ship is better after it's repaired than it was before, for repair often includes modernization.

Most spectacular ship-repair achievement was the recovery of all but three of the 19 war vessels and auxiliaries blasted

by the Japs at Pearl Harbor. Some of these battle casualties were back in service in days; others not for months.

Here is how Rear Admiral William R. Furlong, commandant of the Pearl Harbor Navy Yard, describes the task:

"You need all kinds of people for salvage. You must have divers, burners, mechanics who can work in diving suits under water, pumpers, electricians, and laborers. Once the ships are floated, all types of artisans more or less rebuild the ship."

"All types of artisans" is an understatement. Blacksmiths, ship fitters, dock masters, carpenters, machinists, welders, riggers, riveters, painters, engineers, pipe fitters, electricians, plumbers, steamfitters, turbine bladers — these are a few.

The comeback at Pearl Harbor is unsurpassed in history of maritime engineering. It was more difficult than the British task of salvaging the captive German ships scuttled at Scapa Flow after the first World War, because the German vessels had not suffered bomb or torpedo damage, while, inside and out, some of the ships pounded at Pearl Harbor

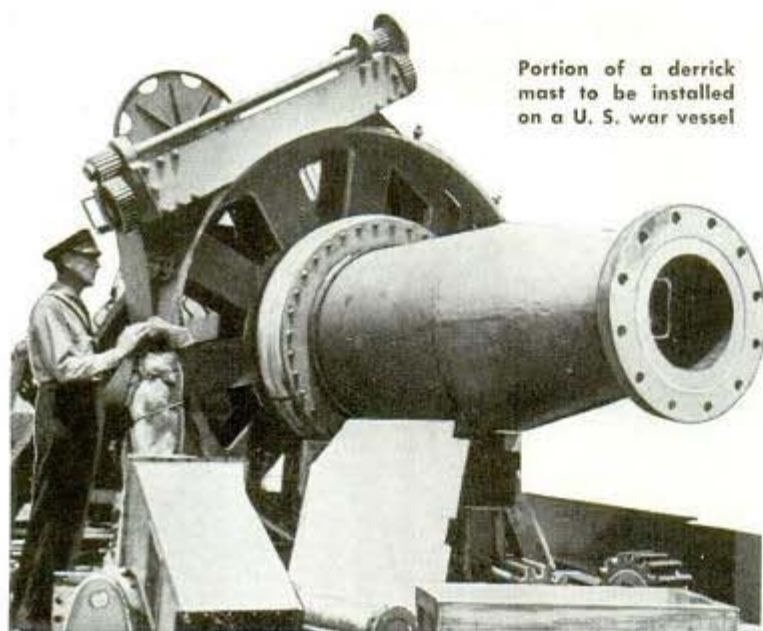

Portion of a derrick mast to be installed on a U. S. war vessel

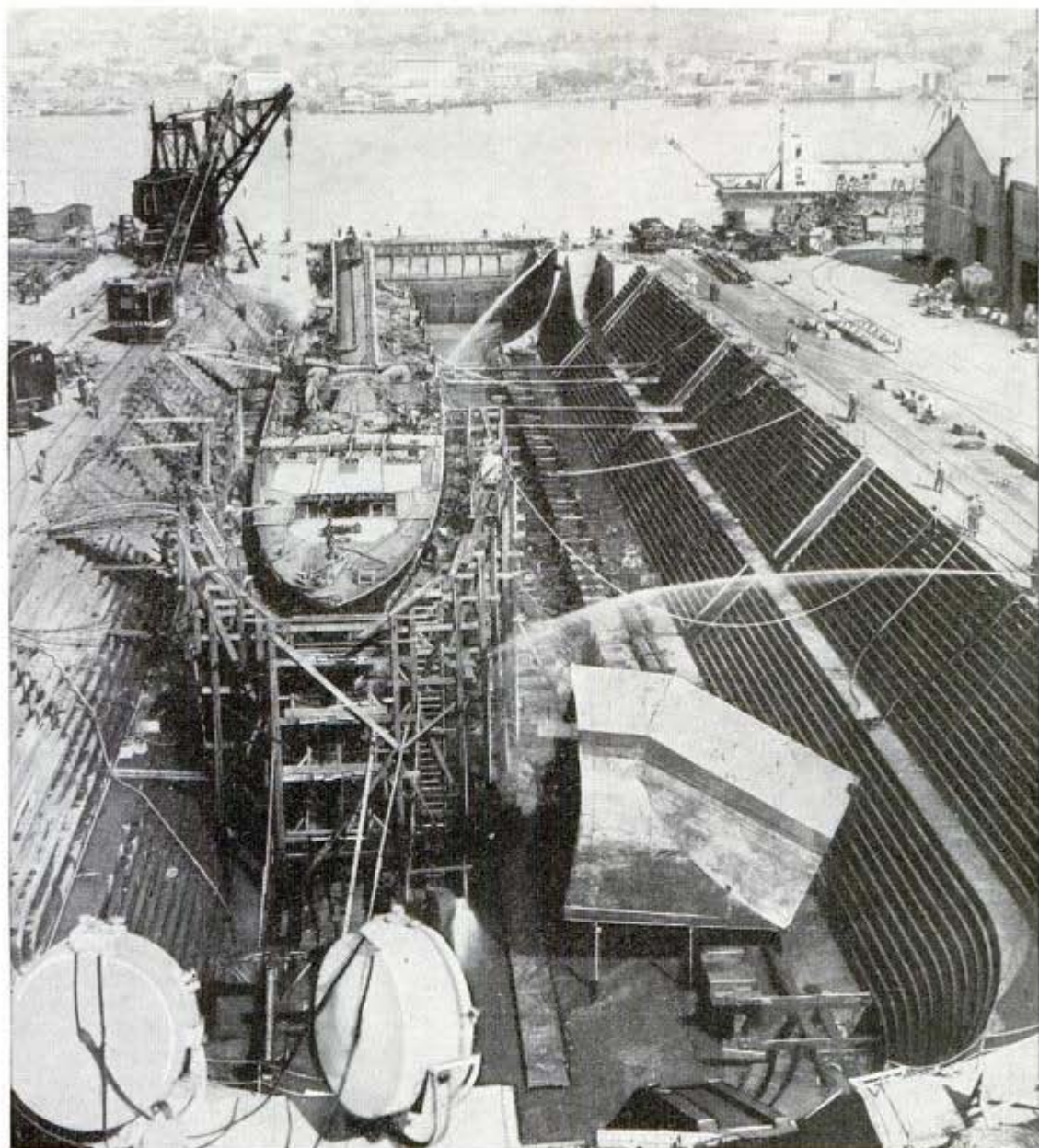

In drydock, the U.S.S. Shaw is fitted with a new nose. At right, temporary bow used in trip from Hawaii

were a shambles. Wiring, machinery, furnishings were jumbled topsy-turvy inside them. They were silted up with mud, and everywhere coated so thick with gummy fuel oil that divers had to work largely by sense of touch. Oil fouled everything. But it also preserved metal under water, and made salvage of parts feasible.

Sensational as was the Pearl Harbor achievement, it is being repeated in miniature day by day in shipyards that are the repair bases for merchantmen of the United Nations.

In some respects, these jobs are more difficult. For the Navy knew all about the ships sunk at Pearl Harbor. The Navy had supervised their building, had blueprints of

their construction. But consider the case of a torpedoed merchantman. Perhaps she is registered under the Norwegian flag, and is an old craft. The original plans of her construction are moldering somewhere in conquered Norway.

With no blueprints, repairmen must determine how she's built, and make their estimates of damage and plans for repair on the spot. They crawl over the wreck taking measurements, testing plates to see which must be replaced, and which may be faired by heating and pounding with heavy steel hammers.

Perhaps all that can be seen of damage from the outside is a few holes in the deck, or a few rivets shorn off and plates blown

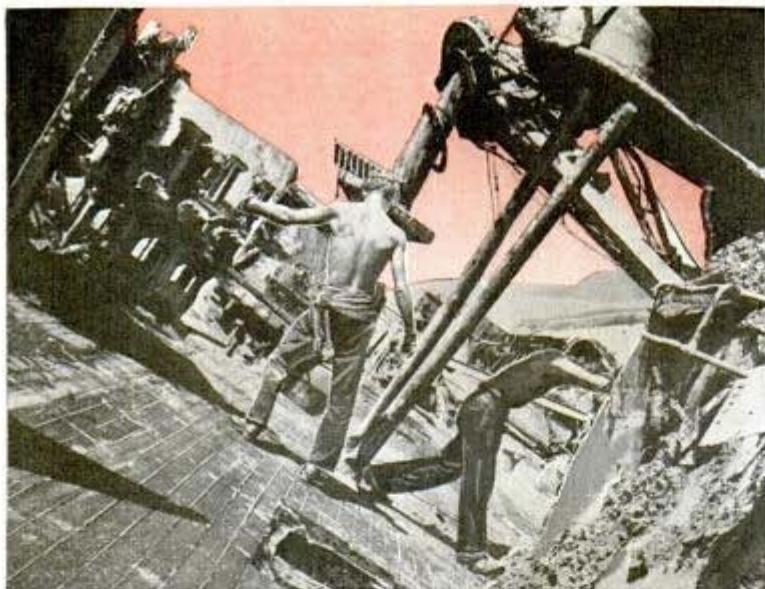

Immersed 17 months, the Oklahoma was silted, its deck fouled with mud

away. But an exacting examination will disclose weakened and bent ribs, a strained keel, water-fouled engine and boiler rooms.

In one case at Todd Shipyards, 92,000 rivets had to be removed to get rid of bent frames and condemned plates. In that same repair job—a big one, but not untypical—the bilge keels had to be renewed, the whole stern overhauled, the top gudgeon for the pintle of the rudder removed and replaced, the lower portion of the bent frame heated and faired in place. A new rudder was built, and four new blades of the propeller installed.

All piping lines carried near the damaged portions of the hull had to be examined, and repaired or replaced as required. Main engines were removed and all cylinders, bearings and guides opened up for testing. All packing, metallic and soft, was renewed. All reversing and other gear was overhauled. The crank shaft was trued up, and the thrust shaft, boilers, and oil-burning equipment tested.

It sounds like a mammoth job, and it was. But it would have taken 100 times as long to build the same ship from scratch, and she left the yard a better vessel, with improvements to ventilating, electrical and wiring systems. These improvements were suggested by years of experience. Ship repair, in fact, has wisely been termed 99 percent experience and 1 percent theory.

Todd is proud of another job, a record-breaker. Sixty-four feet of

Main pump control panel used for pumping a graving dock dry, also for flooding it

this vessel, the complete stern—including rudder, stern frame, propeller, tail shaft, two lengths of intermediate shaft and the section's machinery and fittings—were lost when she was rammed. As guides to reconstruction, the rebuilders had only a small-scale outline of the ship—telling little more than its shape—a deck plan and a photograph. Yet from these hints, the afterpart of the ship was completely rebuilt and she was ready for service in 18½ days!

Then there was the ship with the jackknifed keel.

When raised after an explosion, she was found to have a buckled keel, with the bow 9 feet 2 inches higher than the buckled spot, and the stern 6 feet 6 inches higher.

Delicate part of her repair job was settling the ship into drydock in such a way that she would not break apart. Yet so carefully was the water pumped out that, when the drydock was emptied, her entire keel fell neatly in place along the blocks.

The graving dock, essentially a short channel cut into the shore, is the heart of such repair work. First, the dock master must study the docking plan of the arriving ship. This plan shows her underwater contours, and allows him to arrange keel blocks and bilge blocks along the floor to cradle the ship. Then the dock is flooded to the level of the ocean, and the gate is moved out of the way.

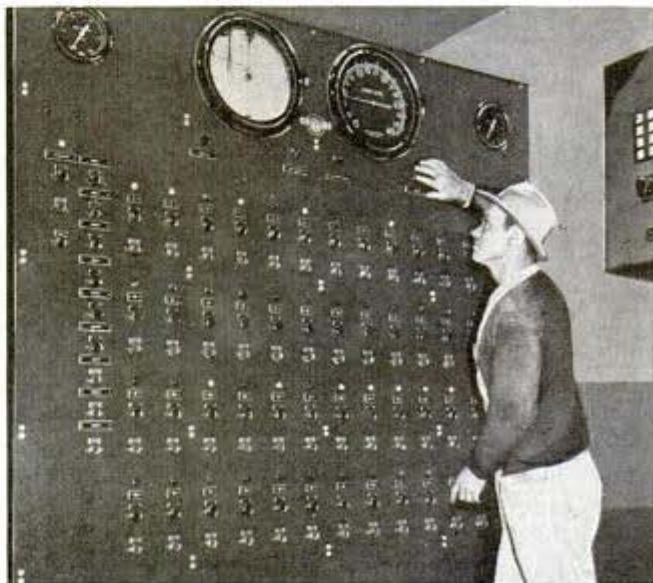



Result of the "deed that will live in infamy"—the U.S. Nevada burning and beached after Jap attack

The dock master directs the moving of the ship into the dock, and its positioning exactly over the blocks. The sea gate is hauled shut. Pumps begin the hours-long job of pumping it dry.

Drydocks themselves are only the operating tables of the marine hospitals. Adjacent are auxiliary piers, machine shops and fabricating shops, where anything from armor plate to tiny jewel bearings used in instruments can be serviced. Railroad cars, railway cranes and big gantry cranes run on tracks between the shops and the docks.

Concrete walls of the graving docks often contain galleries with connections for electric current, fresh water and sea water, compressed air, steam and gas.

The Navy disclosed months ago that it

had under construction seagoing drydocks, big enough to accommodate battleships. Their construction was part of a program involving the building of 183 new docks, both floating or graving, or stationary.

Each section of these seagoing drydocks is a ship's hull in itself, with living space inside for the crews. Each section can be towed at 10 knots; it was even deemed feasible to make each section self-propelling. At their destination, submersion machinery "sinks" them beneath the surface.

Sections can be joined until the whole accommodates up to 100,000 tons. A battleship could be floated inside, and when the water was pumped out, repaired on the spot. They were made sectional for two

(Continued to page 154)

Comeback of the Nevada: With temporary repairs at Pearl Harbor, she steams for a drydock on mainland

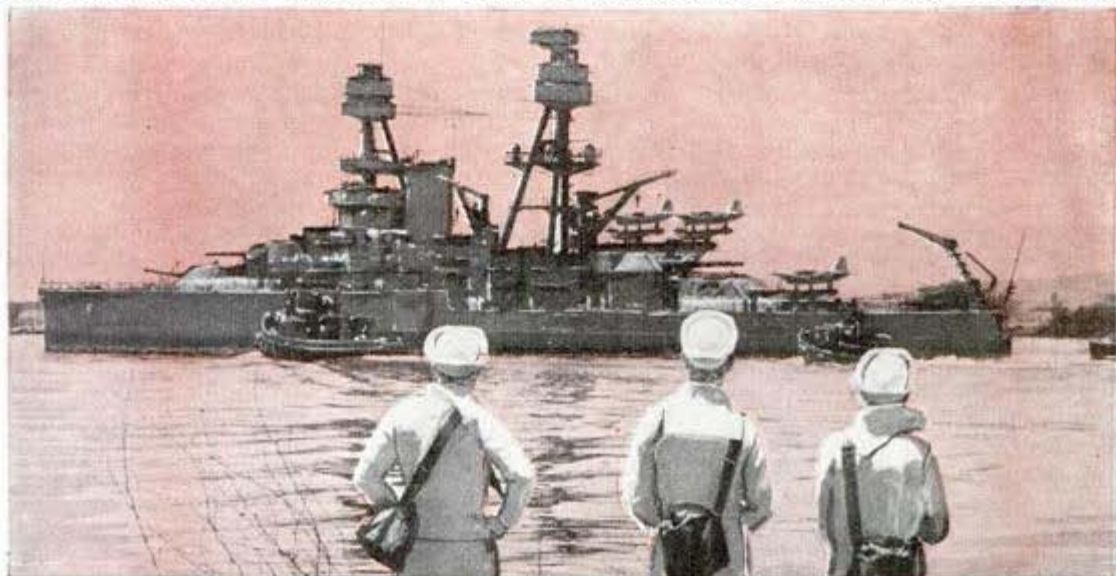

71 515

Ocean-Hopping Glider Has Steel-Tube Frame

Dearborn, Mich
Glider pilot's view of towing plane, taken over Ford airport, left. Lower left, "flying freight cars" peel off for a landing. Below, nose of glider opens to permit exit of jeep

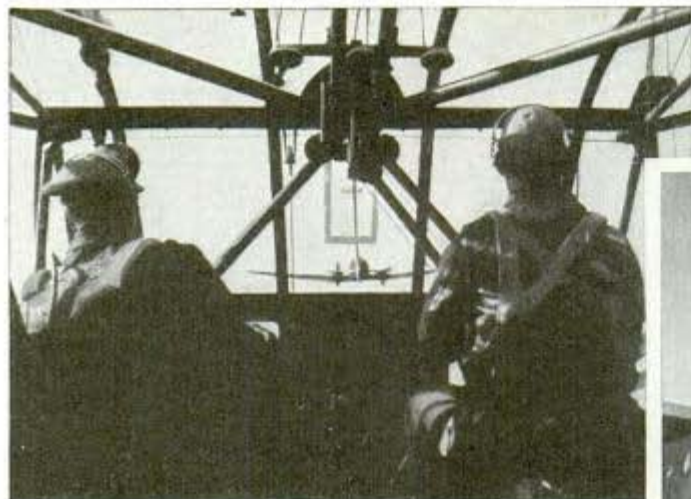

a Douglas C-47 transport, and the glider were American made, but the crews of both were from the Royal Air Force Transport Command. The flight was of 3,500 miles, from Montreal to Britain, and consumed only 28 hours, with an unreported number of stops. The glider carried

Conservation of the scarce light metals was of primary importance in the design of the model CG4A glider, of the type that was recently towed across the Atlantic in history's first air-freight ocean crossing. Created by Waco, the craft has subsequently been mass-produced by firms that once made pianos, furniture, and automobiles, as well as aircraft. In the interests of conservation, its framework is made of tubular steel. Parts are of aircraft spruce and mahogany plywood; the skin is of long-fiber cotton fabric, and fixtures of plastic and wood. It is a big craft, with a fuselage 52 feet long, a wingspread of 84 feet, and a cargo-carrying capacity of one and one-half tons. As an alternative to that much freight, it can haul directly into battle 15 soldiers, and their combat equipment. Demand for this craft, and for a smaller one used in training, brought directly into the war program many workers with woodworking skills that had not previously been utilized in the battle of production. Airworthiness of the CG4A was conclusively proved in the ocean hop. But earlier, in rehearsal runs, it had shattered all records by a non-stop towed flight of 1,177 miles. Both the towing plane for the ocean hop,

a pay load of vaccines, radio, aircraft and motor parts across the ocean. In the heavy clouds, pilot and co-pilot of the motorless craft frequently lost sight of the towing plane, and could judge their position in the air only by watching the towrope.

71 745

X-Ray Shows Effect of "Bends" Suffered at High Altitude

In decompression chambers which simulate flying at 38,000 feet, changes in the heart, lungs, joints and muscles are recorded on X-ray films. These changes, called "bends" by divers, are caused by the expansion of dissolved gases in the body. The X-ray transformer is located outside the test chamber with cables connecting it to the X-ray tube mounted on an adjustable stand inside. When the subject is ready to be X-rayed, he steps before the tube and places a plate holder containing a film 14 by 17 inches over wrist, knee, or stomach as directed. The operator outside turns a switch and the exposure is made. The films reveal surprisingly large gas bubbles, especially in the stomach where gas expands about six times at altitudes of seven or eight miles.

Dr. A. C. Day
Northwestern University



The CRAFTSMAN

Hanging **CONSOLE TABLE**

Beautiful companion piece for a hall mirror. Fastens to wall like a shelf to save floor space

By Charles E. Troutt

A DAINTY overlay gives pleasing richness to this graceful console table, which goes well below a mirror, but can be used alone equally well to dress up a bare wall. To make it, first glue-dowel two or three pieces of $\frac{5}{8}$ -in. stock edge-wise for the semicircular top detailed in Fig. 6. If you wish, you can build this up of cheap wood and cover it with fancy-figured veneer, matching it carefully in an

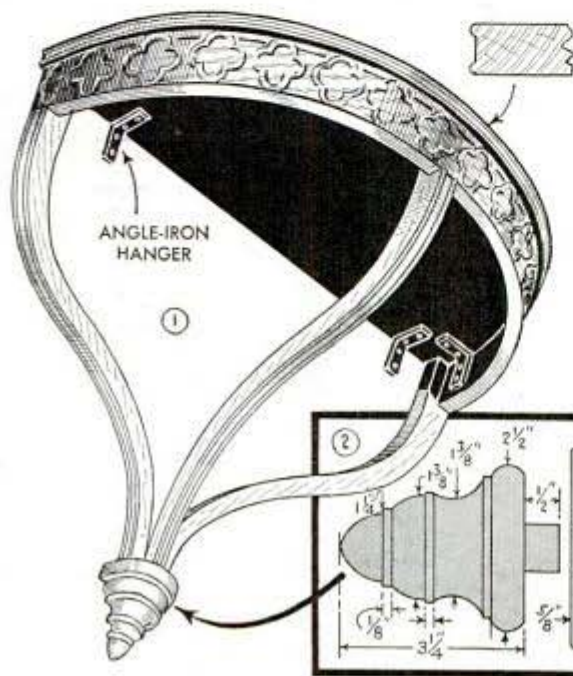

attractive pattern. In this case, you must also glue a veneer of the same thickness, but of cheaper grade, to the underside of the work to prevent warping. A small bead shaped around the top and bottom of the edge as in Fig. 1, adds a nice finish.

Next, you build up the laminated apron to which the overlay is glued. This is done by gluing together five $\frac{1}{8}$ by $2\frac{1}{4}$ -in. strips of pine and clamping them to a semicircular form as in Fig. 3. Start by clamping three of the strips



③ METHOD OF FORMING LAMINATED APRON

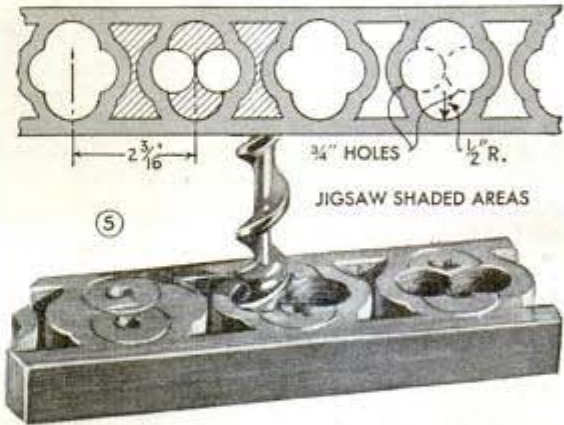
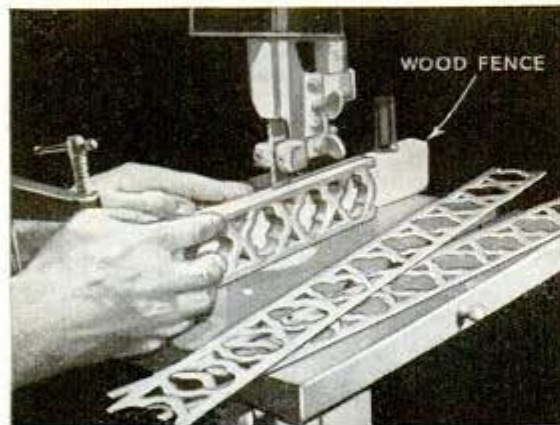

⑤

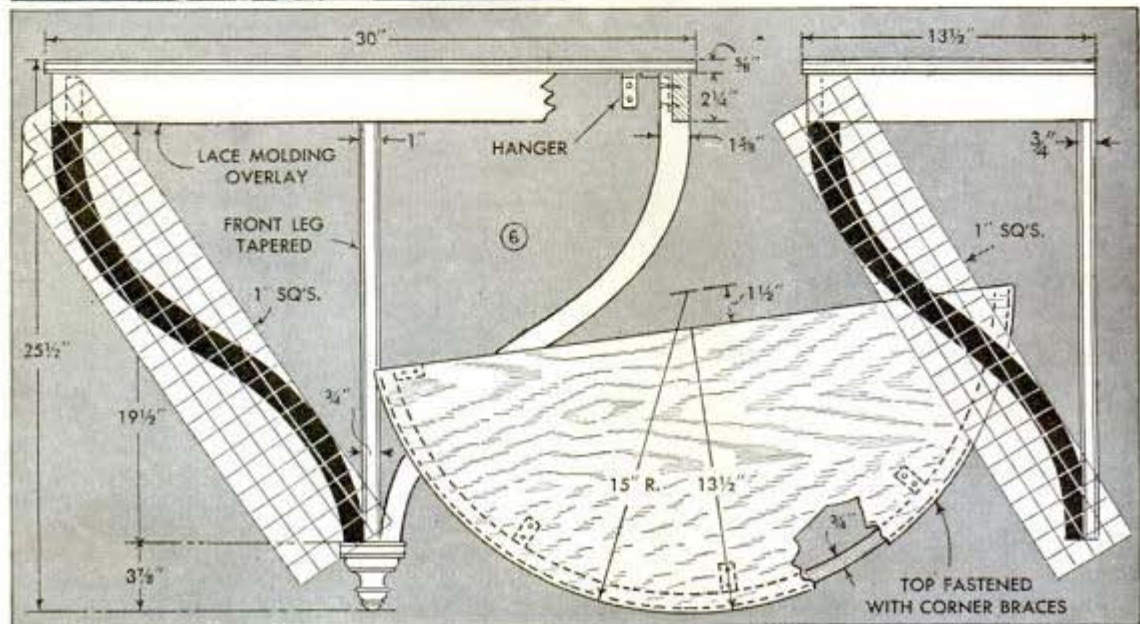

first, then add the others when the glue has dried. By steaming, or possibly just sponging, the apron can be built up of three strips $\frac{1}{4}$ in. thick. Next, you face both the inside and outside surfaces of the pine core with regular $\frac{1}{32}$ -in. veneer, the outside being covered with finished stock to back the overlay which is added next. The overlay is made by cutting the design in a piece of $\frac{3}{4}$ -in. walnut and slicing off $\frac{3}{32}$ -in. strips on a bandsaw as in Fig. 4. Uniformity of the circular openings in the overlay is had by using a wood bit as in Fig. 5 instead of sawing. As each strip is bandsawed, sand the face of the block smooth before making the next cut. Although the original overlay was cut from a short block and applied in several pieces, the strip can very well be made in one piece. Coat the strip sparingly with glue, so that when clamping it in place, excess glue will not ooze out into the openings.

The three "legs" can be cut from a board measuring 1 by 10 by 26 in. Note that the front leg has a different curve than the

others and that it tapers from 1 in. at the top to $\frac{3}{4}$ in. at the bottom. After the side legs are dressed down to $\frac{3}{4}$ in., run the beads in, the edges to match those in the top. The legs terminate at the bottom in a two-part "split" turning, the upper part of which consists of a disk cut off at the back and fastened with a screw driven up into each leg. The lower part is likewise cut flush at the back after being turned and is glued in a blind hole in the bottom of the disk. Fig. 6 shows how the legs are notched and attached to the apron with screws from the inside and also how metal corner brackets are used to fasten the top. In mounting the table to a wall, locate the hanging brackets to permit the screws to be driven into studs.

A prepared varnish which resembles a hand-rubbed finish upon drying, is good to use in finishing the table, as it will save the work of rubbing down the overlay.

Rosin Flux Is Best To Solder Brass Or Copper

The problem of soldering many substances is not too little heat so much as using an iron far too hot. Rosin is used for a flux in soldering either copper or brass, not so much for its noncorrosive qualities, but because it allows the use of a much cooler iron. The next time you solder any of these materials use sal ammoniac and note how much hotter your iron must be to make a good job of the work. This increase in heat soon burns off the tip of the iron or pits it so badly that much of the copper is lost.—L. H. Georger, Buffalo, N. Y.

Combination Book and Carrying Case For Technical Men Who Travel



Officers and engineers in the armed forces, and others who move to different locations frequently, will find this portable case handy for their technical books. When closed, it provides a substantial carrying case that will stand shipping and when opened on a desk or table it serves as a bookcase. The case is made of $\frac{3}{4}$ -in. plywood of dimensions to suit the largest book to be accommodated. The ends are cut diagonally as pictured, and long, heavy screws are used for the assembly. Trunk fittings are put on both ends. The handle is bolted on the part that becomes the back when the case is used as a bookcase. Shellac and varnish provide a good finish.—Carroll E. Bradberry, Berkeley, Calif.

Meat Grinder Reconditions Modeling Clay

A teacher of an art class found that modeling clay could be mixed or reconditioned much easier by running it through a meat grinder or a food chopper than could be done by hand. Usually, it was necessary to run the clay through the chopper two or three times. Any binder that was required to bring the clay to the desired consistency was added as the clay passed through the chopper, which mixed it in thoroughly.



☞ To see inside a chimney, hold a mirror at an angle inside the smokepipe hole and you can see to the chimney top.

Light Warns When Coal Gets Low In the Stoker Hopper

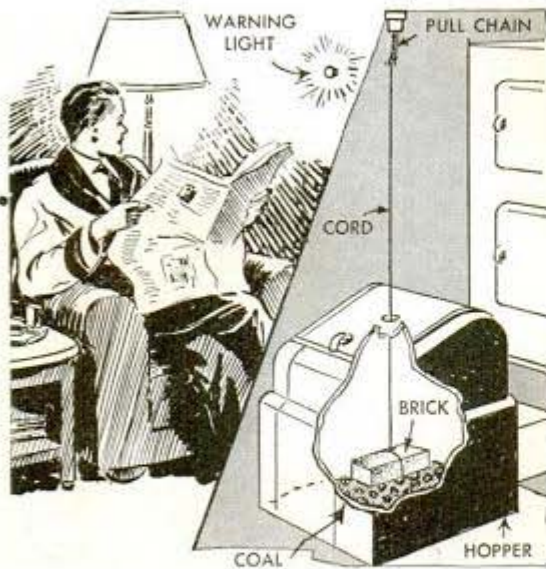

If you sometimes forget to fill the hopper of your automatic stoker, a light located in a conspicuous place in the house and controlled as shown will serve as a warning to fill the hopper. A pull-chain switch is located on the basement ceiling directly above the center of the stoker hopper and is wired in the lamp circuit. Then, a brick or other suitable weight is attached to the pull chain of the switch by means of a length of strong cord, which passes through a tiny hole in the cover of the stoker. The cord should be just long enough so that the weight will operate the switch when the fuel level in the hopper reaches a predetermined height. Of course, the brick must be removed and placed on top of the fuel each time the hopper is filled.

—John W. Gunn, Winnipeg, Can.

Lathe Center Holes in Soft Wood Hardened for Easy Turning



Any tendency of the lathe tail-stock center to enlarge the hole in soft wood when turning it so that the work cannot be trued accurately, can be avoided by hardening the wood surface at this point with silicate of soda. After locating the

center of the work and before putting it in the lathe for turning, apply the silicate of soda liberally where the lathe center will

contact the work. This treatment permits thorough lubrication at the point of contact between the lathe center and the work and allows the latter to be supported snugly between the lathe centers.

W. T. M. Concrete Mortar Insulates Stone Building

When building a cabin or cottage of field stone, it is best to avoid the use of any stones that are wide enough to reach across the entire thickness of the wall. Cold penetrates such stones rapidly, depending on their porosity, and makes the building hard to heat. Furthermore, moisture may condense on the inner surface of the wall, and in extreme cold weather may even form ice on the walls. However, if smaller stones are used, making one or more mortar joints necessary across the thickness of the wall for each layer of stone, the mortar, being highly porous, will act as insulation.

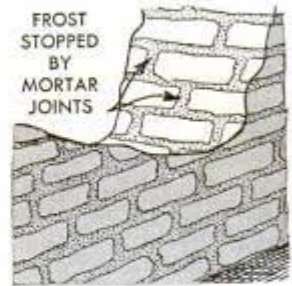

Storing Microscope Slides

Made easily from thin cardboard, the holder shown will help to keep your microscope slides in order and protect them from breakage. To make a holder, use a piece of cardboard 5 in. square. Draw a line across it 1½ in. from one end and fold it along this line. At 1½-in. intervals, staple the folded cardboard, beginning ¼ in. from one edge. Holders for more slides can be made by adding 1½ in. to the width of the cardboard for each extra pocket.

—H. F. Whittaker, Toronto, Ont., Can.

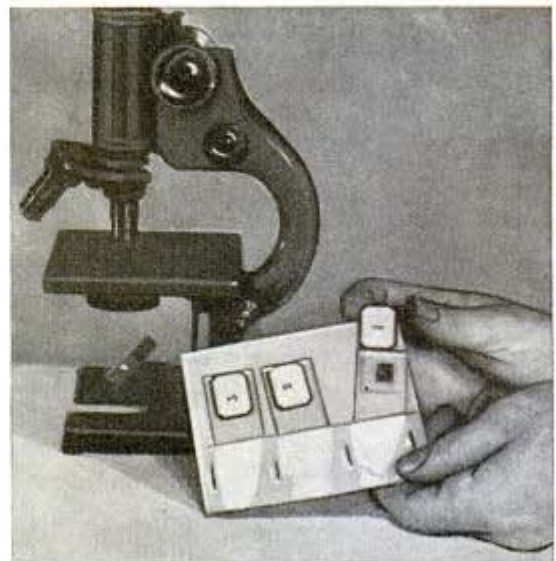

Gas Range Converted to Modern Vertical Type

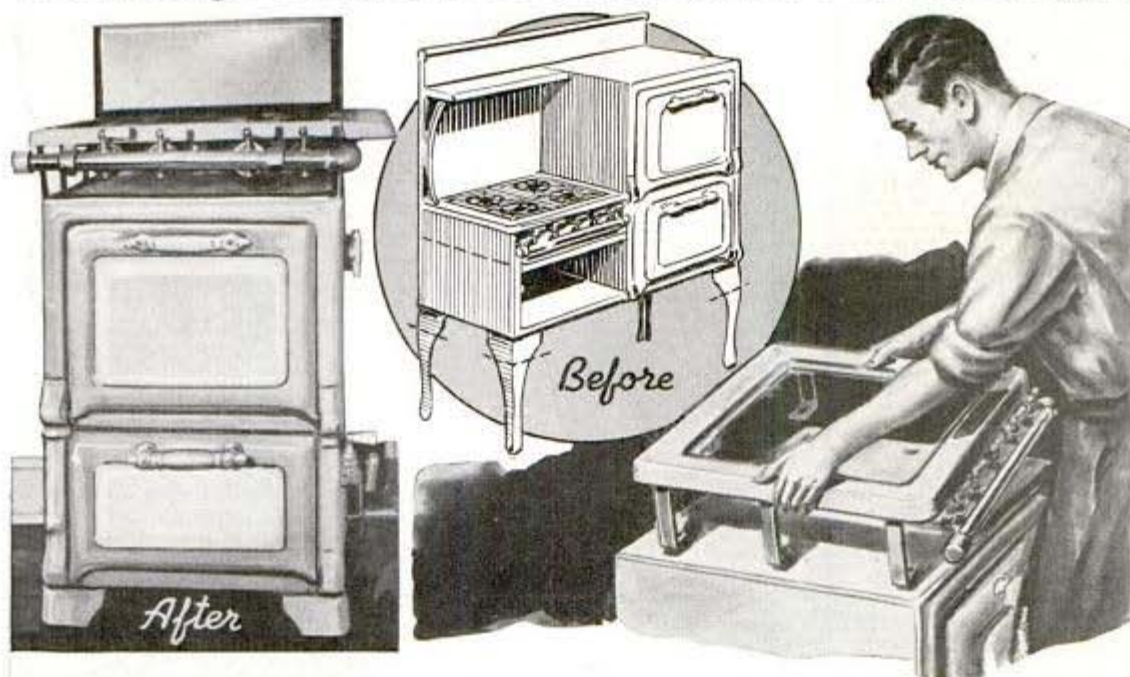

Needing a small gas stove of the vertical type for use in a basement apartment, I converted an old-style gas range complete with oven and broiler. To do this, I first removed the burners and their supports as well as all back and side parts. Then I sawed through the stove frame next to the oven and broiler, leaving them intact in one unit, which was used for the

new stove. After mounting the burners on top of the oven by means of suitable supports bent from flat iron, the frame was cut down to the desired size and riveted together to support the stove thus formed. The legs, of course, were cut off to give the stove the desired height, after which the gas line was connected to both the cooking burners and the oven.

—Lawrence Oncley, Winfield, Kan.

Rolling "Ruler" to Measure Irregular Distances on a Map

Measuring distances on maps is simplified with this unusual ruler, on which the rotations of a small knurled wheel of known circumference are shown on a scale.



To make a measurement, run the ruler over the line to be measured, note the number of wheel revolutions, and then multiply this number by the circumference of the wheel in inches to get the length of the line. Now, by multiplying the length of the line in inches by the number of miles per inch, as indicated on the map scale, you get the length of the line in miles. It will simplify your problem if the wheel used has a circumference of exactly 1, 2 or 3 in. Also, it will be necessary to divide the circumference in an equal number of divisions so that fractions of wheel revolutions will be indicated. The divisions are best indicated by scores on one side of the wheel. In calibrating the ruler, start with the wheel at the limit of the threads on the shaft, and make a line on the scale parallel with one edge of the wheel, repeating this operation for each wheel revolution across the scale. Marking the first line with zero, and numbering every fifth line thereafter will simplify reading the scale.



With a wooden "tong" like this one, which is cut to grip the neck of a hot-water bottle, you'll not be taking a chance of accidentally scalding your fingers when filling it



Sleeve linings are smoothed with less difficulty while pressing if a wire coat hanger, bent as shown, is inserted into the sleeve. The hook makes a convenient handle

Solving HOME



When sprinkling laundry for ironing it damp, the pieces that are not color-fast can be kept from staining the others, and from drying out, by wrapping in waxed paper

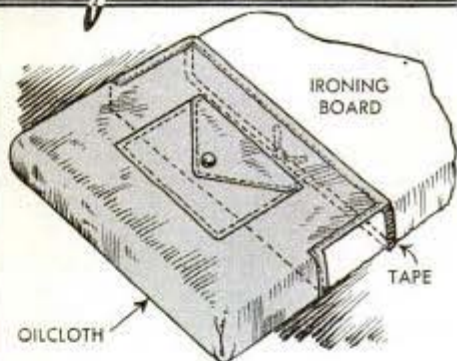

Above: To keep an ironing board from becoming soiled if it rests on the floor in storage, pull an oilcloth slip cover over the end. An attached pocket keeps a pressing cloth handy. Below: It's easy to find a key in your purse if you tie it to a bead or button, which is left hanging outside when the purse is closed



An eggbeater can be operated much faster without splattering, if the whipping is done in a fish bowl, as the crowning top of the bowl serves to catch the flying drops

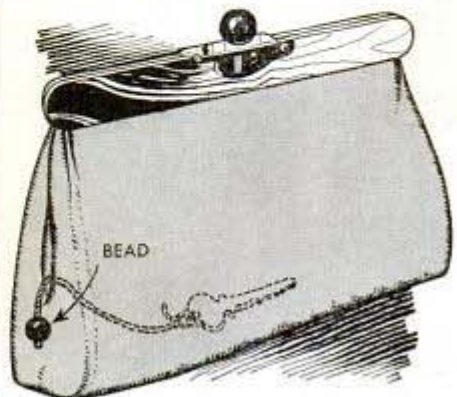



Paintbrush cleaning is simplified by working the brush over a piece of discarded screen wire cut and bent as shown to fit into the can containing the paint solvent



A neat and convenient way to hang a small stepladder on the back of a closet door, is to fasten spools to the ladder to hook over wire coat hooks screwed in the door

PROBLEMS

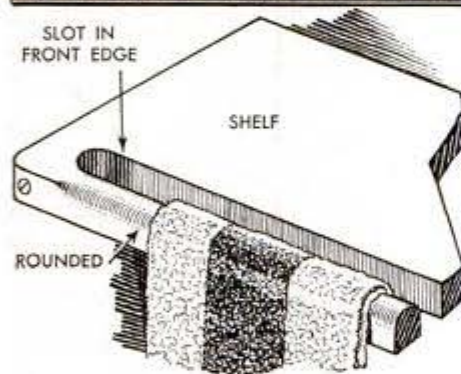

Above: You can incorporate a towel rack into any shelf simply by cutting a slot the full length of the shelf, part of which is illustrated. A long screw in each end reinforces it. Below: Most sprung bobby pins can be renewed as often as necessary if grasped with pliers at the end as shown and the sprung tips pressed together.

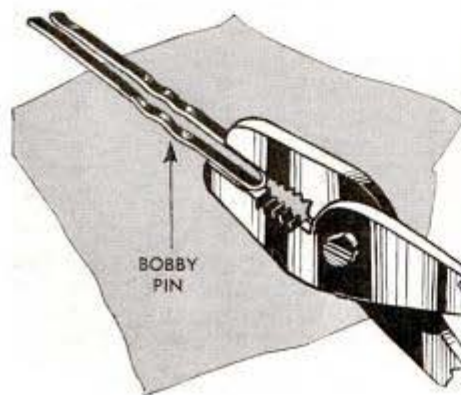

To prevent a window shade from flapping when the top sash is lowered, fasten a metal turnbutton to the underside of the sill so that the cord can be wedged under it

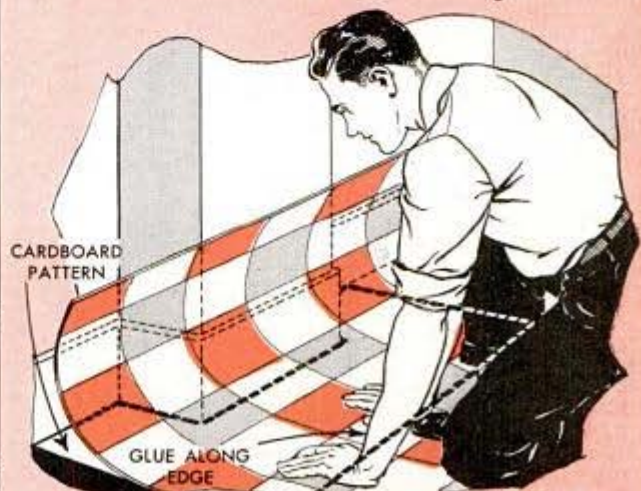

It's easy to fit linoleum around a chimney or pipes if a pattern, coated with glue, is placed on the floor so that it will stick to the back of the linoleum for marking

Simple Stock Holds Your Bicycle Securely in Vertical Position

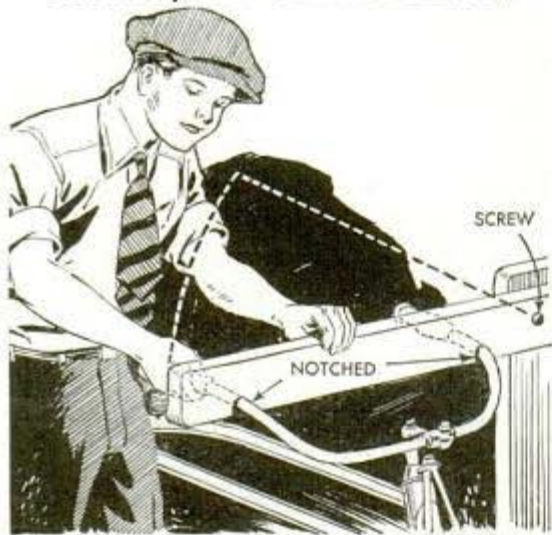

Instead of leaning a bicycle against a post, building or similar support where it may fall, provide this simple stock, which will hold it securely. The stock consists of a length of 2 by 4-in. wood, which is notched to fit over the handlebars and is pivoted by means of a screw or bolt to a post, or even the side of a building.

Built-Up Picture Has Depth Effect When Displayed on a Wall

You will be surprised at the third dimensional effect produced in this picture, which is easy to make and requires little material. First, photograph a person well in the foreground, with regular room appointments in the background. Then, have the person step out of the scene and, with-

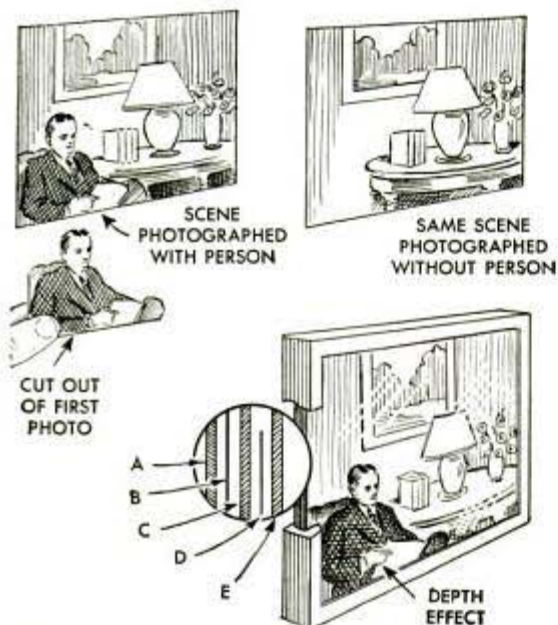

out disturbing any of the properties, photograph the background. When the prints are made, cut the picture of the person from the first photo and mount it on the front of a piece of glass. Mount the photo of the background on the back of the same piece of glass. Next, make a frame, using stock that can be rabbeted deep enough to accommodate a piece of cardboard and two pieces of glass. Now, assemble the parts in the frame as indicated in the circular detail, first the glass front E, then glass C with photos B and D mounted on it, and lastly cardboard A, which serves as a backing to hold the assembly in the frame.

—Opie Read, Jr., Chicago.

Priming Cup in Top of Air Filter Aids in Starting Cold Car

To facilitate starting my car motor on extremely cold mornings, I installed a priming cup in the top of the air filter so that a small amount of gasoline could be

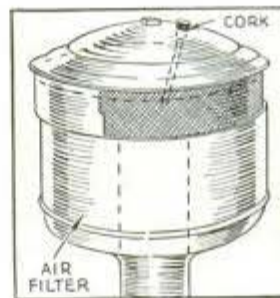

injected into the carburetor easily. The cup consists of a length of tubing fastened in a hole drilled through the top of the filter and the felt pad underneath the top. A spring-cover oil cup of the type used on starters

and generators was soldered to the upper end of the tube to prevent dust from entering. Another method of doing this is to drill a hole through the top of the filter and felt pad and keep the hole closed with a small cork.

—Albert G. Clarke, San Jose, Calif.

Repairing Point on Fountain Pen

If you accidentally drop your fountain pen and bend its point, it often can be repaired with a pocket knife. If the nibs of the pen are bent but not broken, insert the end of the knife blade about $\frac{1}{8}$ in.

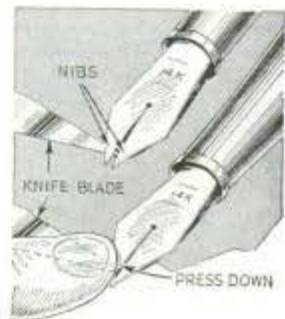

under one nib and apply pressure with the thumb as indicated. Repeat the operation on the other nib. With care the point can be restored to perfect alignment by this method.

—Thos. K. MacDonell, Coconut Grove, Fla.

"Book Binder" Holds Your Favorite Magazines

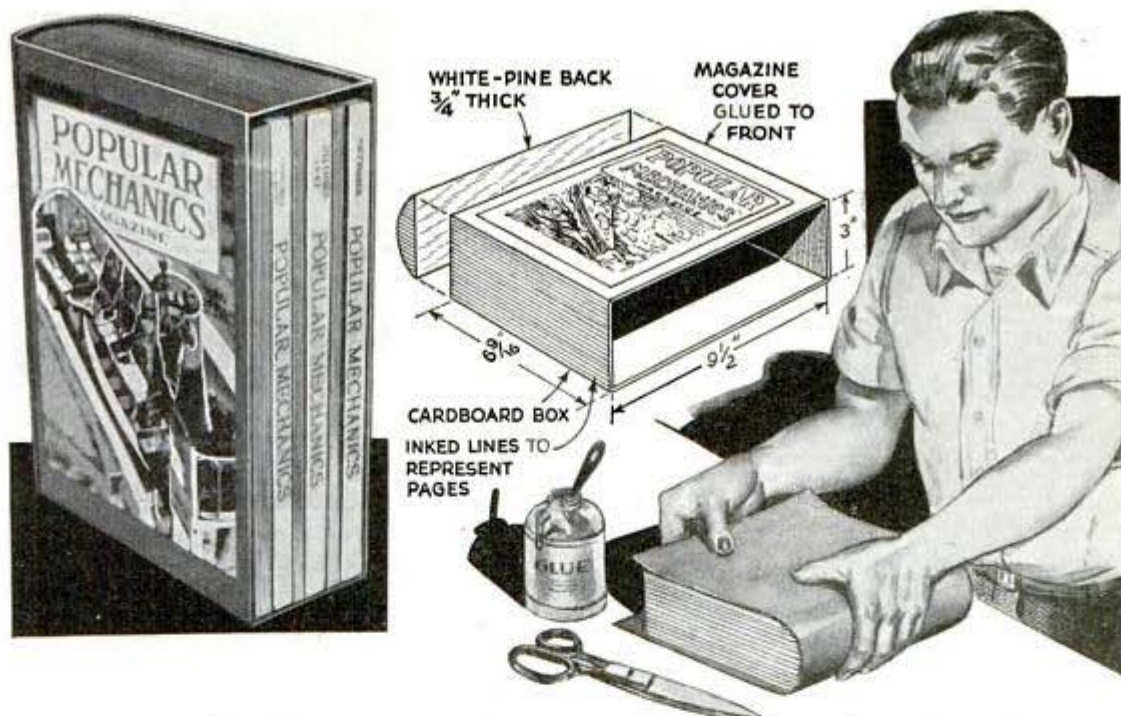

Copies of your favorite magazine will always be in neat order and conveniently at hand if you file them in a number of holders or binders like this one, which can be kept right in your bookcase, or between book ends. Being nothing more than a cardboard box with the rear side open, the binder is provided with a rounded wooden block at the front side to simulate the ap-

pearance of a book. Inking closely spaced lines at the ends to imitate pages, and providing a cloth cover further the deceptive appearance. While the binder can be made to take a magazine of any size, it is best suited to one of a size comparable to most books. Usually, a binder wide enough to accommodate six issues is the most convenient.—Walter E. Burton, Akron, Ohio.

Stilts Instantly Adjusted in Height to Suit Skill of Users

Fitted with steps that can be adjusted from 1 to 3 ft. above the ground, these stilts are of great help to a beginner as the steps are set low while he is learning and are raised when he becomes more skillful. Also, the stilts are ideal where they are used by several boys of different ages, as the steps can be adjusted instantly to suit the various users. Each step is held in position by a wire loop that fits notches cut in opposite sides of the stilt. Two headless nails, projecting from the inside edge of the step, slide in a slot to keep the step from moving sideways, the slot being made by sawing from the lower end of the stilt up through the center for a distance of 3 ft. A short, horizontal block set into the inside edge of the step flush with the surface prevents it from tilting. To adjust a step, raise the lower end so that the wire loop loosens and can be moved up or down to a different notch.

—Frank S. Leitch, Stamford, Conn.

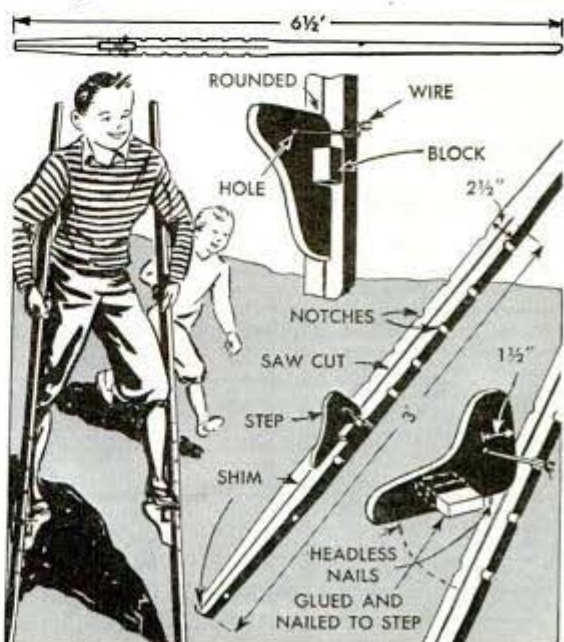



A SAME-COLOR FILLER

B DARK-COLOR FILLER

C LIGHT-COLOR FILLER



Application of

By Sam Brown

WOOD having open pores, such as oak, walnut and mahogany, requires a coat of paste wood filler to build a level surface for the application of top finish coats. Besides this prime purpose, the filler plays an important role in coloration and in emphasizing the grain. The color of the filler usually is a shade darker than the stained color of the wood, producing the effect

shown in photo A above. A very dark, nearly black filler often is used to bring out the grain, photo B, while white and brightly colored fillers are used for novelty effects as in photo C.

Mixing the filler: Filler is purchased in 1, 5 and 25-lb. cans, and also in pint and quart containers. The material is in heavy paste form, the mix consisting mainly of silex (powdered rock quartz), together with a small amount of linseed oil and japan drier. Before use, the paste is thinned to the desired consistency as needed with naphtha or gum turpentine, Fig. 1, the amount of dilution depending on the size of the pores to be filled. Obviously, large pores require a thicker mix than small ones. Table No. 2 is a partial guide to the mix required for various domestic and im-

Mixing the filler-

1

Paste wood filler is thinned with naphtha or gum turpentine to resemble thick paint



Brushing the filler-

2

Apply a liberal quantity of filler; brush thoroughly in the direction of wood grain

PROPORTIONS FOR MIXING VARIOUS QUANTITIES OF FILLER

TABLE NO. 1

HEAVY MIX (16-LB. BASE)			MEDIUM MIX (12-LB. BASE)			THIN MIX (8-LB. BASE)		
APPROX. AMT. NEEDED *	PASTE	THINNER	APPROX. AMT. NEEDED *	PASTE	THINNER	APPROX. AMT. NEEDED *	PASTE	THINNER
2 GALS.	16 LBS.	1 GAL.	1 GAL., 3 QTS.	12 LBS.	1 GAL.	1½ GALS.	8 LBS.	1 GAL.
5 PTS.	5 LBS.	2½ PTS.	3 QTS.	5 LBS.	3 PTS., 5 OZ.	1 GAL.	5 LBS.	5 PTS.
2 QTS.	1 QT.	1 QT.	2 QTS., 10 OZ.	1 QT.	2 PTS., 10 OZ.	3 QTS.	1 QT.	2 QTS.
2 PTS.	1 PT.	1 PT.	1 QT., 5 OZ.	1 PT.	1 PT., 5 OZ.	3 PTS.	1 PT.	2 PTS.
1 PT.	1 LB.	½ PT.	1 PT., 2 OZ.	1 LB.	10½ OZ.	1½ PTS.	1 LB.	1 PT.
½ PT.	½ LB.	4 OZ.	9 OZ.	½ LB.	5¼ OZ.	12 OZ.	½ LB.	½ PT.

* 1 PINT THINNED FILLER COVERS APPROX. 35 SQ. FT.

FILLER MIX REQUIRED FOR VARIOUS WOODS			TABLE NO. 2
NO FILLER NEEDED	THIN FILLER	MEDIUM FILLER	HEAVY FILLER
BASSWOOD	ALDER	AMARANTH	ASH
CEDAR	BEECH	AVODIRE	BUBINGA
CYPRESS	BIRCH	BENIN	CHESTNUT
FIR	BOXWOOD	BUTTERNUT	KELOBRA
HEMLOCK	CHERRY	MAHOGANY	LOCUST
MAGNOLIA	GUM	ORIENTALWOOD	MAHOGANY (Phil.)
PINE	IRONWOOD	PRIMA VERA	OAK
POPLAR	MAPLE	PURPLEHEART	PADAUK
SPRUCE	SYCAMORE	ROSEWOOD	TEAK
WILLOW	TUPELO	WALNUT	TAMO
		ZEBRAWOOD	

FILLER *in Finishing*

ported woods. Table No. 1 gives proportions for heavy, medium and thin mixtures in various quantities. Only enough filler needed for the job at hand should be mixed, as the thinned filler thickens after a few hours and becomes useless. Mixing by exact weights (Table No. 1) is always good practice. The heavy mix (16 lbs. of paste per gallon of thinner) can be approximated in any quantity by adding thinner in the same volume as the paste. The heavy mix should not be confused as meaning a heavy-bodied material. Actually, the consistency is no heavier than varnish. The first step in mixing is to spade thoroughly the original paste in the container with a putty knife, then add a very small amount of thinner and stir again until thoroughly mixed. After the initial mixing, increasingly larger amounts of thinner can be added and stirred in until the mix is the proper consistency. Do not make the mistake of adding a lot of thinner at the start, as this makes mixing doubly difficult. Use naphtha for thinning if you want the filler to set up quickly for wiping, and use turpentine to hold the coat open longer. Or, you can mix the two liquids together if desired, making the proportions suitable to obtain the desired results. A small amount of boiled linseed oil can be added to hold the coat open for 30 or 40 minutes. The reverse of this—a very quick-setting filler—can be obtained by adding a small amount of japan drier.

Brushing the filler: Use a short-bristle brush of convenient size. Apply filler liberally, brushing thoroughly with the grain of the wood as shown in Fig. 2. Do not cover more than 8 to 10 sq. ft. of surface at one time, otherwise you will get ahead of the wiping and cleaning-up operations that follow.

Padding-in: As soon as spots on the



3 *Padding-in-*

This is done easily with a felt pad, which is used with a circular motion to pack the filler tightly into the pores of the wood



4 *Towing-off-*

Cuts surplus filler from wood surface and is done as soon as the filler starts to dry



5 *Wiping-*

This is done with the grain to remove all remaining traces of filler on the surface

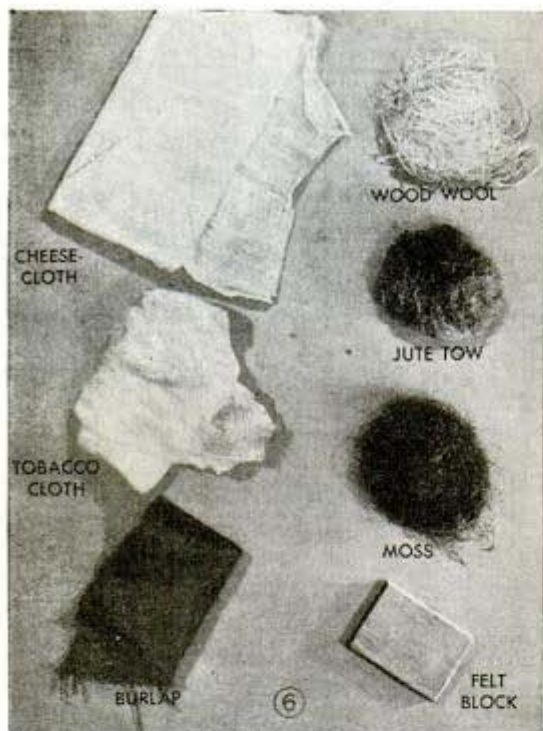

Wipers-

These are for removing surplus filler from the work and can be any cheap, coarse material. Open-weave cloth wipers are cleanest to use but most expensive

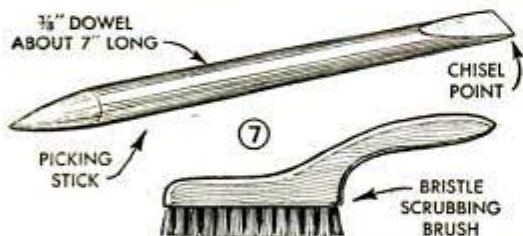

filled surface being worked become dull, the filler coat is ready for wiping. Do not wait until the whole surface becomes dull as this will make the job more difficult. The first stage in cleaning off the surplus filler is padding-in. This is done with a felt block or a smooth pad of cloth, the motion of the pad being circular but mostly across the grain, Fig. 3. This operation does not

CHEESE CLOTH is an excellent wiper but is a little too expensive for regular work. Open-mesh grade is best **TOBACCO CLOTH** is unbleached cheesecloth. This provides an excellent wiper and is clean to use. Cheapest grade gives best results because of its open mesh **BURLAP** is an old favorite for wiping. It is clean to use and cuts the filler level with wood surface. The cheaper grades are best because of more open mesh **WOOD WOOL** or excelsior in the finer grades is very inexpensive and makes an excellent wiping material. The coarse grades will scratch fine cabinet woods **TOW** from jute fibers is good, inexpensive wiper. Breaking up of material can be avoided by dampening **MOSS** costs more than tow but it hangs together much better; is a cleaner as well as a faster wiper **FELT BLOCK** is for padding-in before towing-off filler. It should be 1/2 in. thick, or thinner piece wood-backed

STANDARD FILLER COLORS TABLE NO. 3

BLACK: Add drop black to natural filler. Suitable for blackwood or dark mahogany.

WHITE: Color natural base with zinc oxide. Used for limed oak and similar effects on chestnut and ash.

LIGHT BROWN: Tint with Van Dyke brown to required shade. Can be used on any light brown-color wood.

DARK BROWN: Van Dyke brown with a touch of drop black. For walnut, mahogany, etc. Suitable for any medium to dark-color wood.

WALNUT: Half and half Van Dyke brown and burnt umber.

LIGHT RED: Use any red color (Indian red) in oil or japan, toning darker or lighter with drop black or zinc white.

DARK RED: Equal parts of burnt umber and rose pink. Add drop black for darker shade. Used for Sheraton mahogany or any other red finish where dark pores are desirable.

AMBER: Tint natural base with yellow or orange oil colors. Suitable for ambered walnut, harvest wheat mahogany and other bleached finishes.



Coloring the filler-

Pigment colors ground in oil of japan are used for this purpose, usually only a very small quantity of color being required to produce the desired shade

clean off the filler. Instead, it is intended only to force or pack the filler into the wood pores. You can do a very good job of padding-in with the heel of your hand. Many finishers omit padding-in altogether, proceeding directly after application to towing-off, Fig. 4, in which the surplus filler is packed into the wood and cut off level with the surface in one operation.

Towing-off: The work is towed-off with tow, moss, burlap or any other coarse, cheap material (see Fig. 6). Wiping is done across the grain, as shown in Fig. 4. The pad of wiping material should be turned around or refolded frequently to bring a clean surface in contact with the filler. The work should be cleaned thoroughly and progressively from one end to the other, not just half-wiped all over and then gone over again. If the filler has set up too hard for easy wiping, the surface of the work or wiping pad can be moistened with naphtha or the whole surface can be recoated with filler, which will tend to soften the filler coat underneath.

Wiping: Final wiping is done with the grain of the wood, using any soft lintless cloth, Fig. 5. This serves to remove any slight traces of filler missed in towing-off. The cloth can be moistened with benzine for a final wipe. Inside corners and other hard-to-reach places can be wiped clean with a picking stick as shown in Figs. 7 and 8. The stick consists of a short dowel having a round point at the end and a chisel edge at the other. A bristle scrubbing brush is useful for cleaning filler from intricate carvings, but in no case should it be used when the work can be wiped. If one coat of filler fails to fill the pores flush with the surface, apply another, tow-off as before and wipe lightly to avoid pulling out the filler.

The finishing schedule: The place of filler in the finishing schedule is best told by following a typical complete schedule. Staining usually is the first operation. The stain coat should be sealed with a wash coat of shellac or lacquer (1 part shellac or lacquer to 6 parts thinner). The work is sanded lightly with 5/0 paper when dry and, after a thorough cleaning with a duster or compressed air, it is ready for the filler coat. The filler coat should dry 6 hours if the filler is the quick-drying type. If a slow-drying type is used, 24 to 36 hours drying time should be allowed. The dry filler coat then is sealed with a light coat of shellac or lacquer sealer. When dry, this is sanded lightly, after which the work is given a full-bodied coat of varnish (varnish finish) or lacquer sealer (lacquer finish). This coat fills any tiny open pores, and should be sanded thoroughly to a flat, smooth surface. Top coats of varnish or lacquer complete the finish.

Filler colors: Paste filler can be obtained in all standard wood colors, also white and natural (the color of pale linseed oil). Common colors such as walnut, oak and



Turned work-

Turnings can be towed-off while the work is rotating at slow speed in the lathe. The work should be sanded very smooth as any sandpaper rings will pick up and hold filler. Turnings on furniture are towed-off by hand

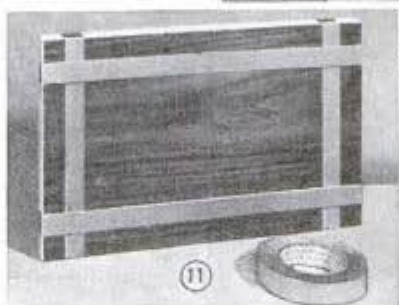

mahogany are best purchased ready-mixed. These can be shaded lighter or darker to suit by adding a small amount of pigment color ground in oil or japan, and the natural filler can be shaded any color desired by adding oil or japan colors. The color should be mixed separately, using a very small amount of turpentine, Fig. 9, after which it can be added to the filler, preferably through a strainer. Table No. 3 gives formulas to mix colored fillers for various finishes.

Staining filler: Filler that stains and fills in one operation can be made by adding a small amount of oil stain to the paste filler. This is sometimes useful when exact monotone effects are desired, but generally is considered a short-cut practice suitable only for cheap work.

Turnings: Any turning that is a complete project in itself, such as a candlestick, can be filled and then towed-off with the work rotating at slow speed in a lathe as shown in Fig. 10.

Two-toning: One of the many methods of producing two-tone work can be done with filler. Areas to remain light are masked with tape after the whole panel has been stained, Fig. 11. The filler then is applied, Fig. 12, and when the tape is removed it produces the effect shown in Fig. 13, the

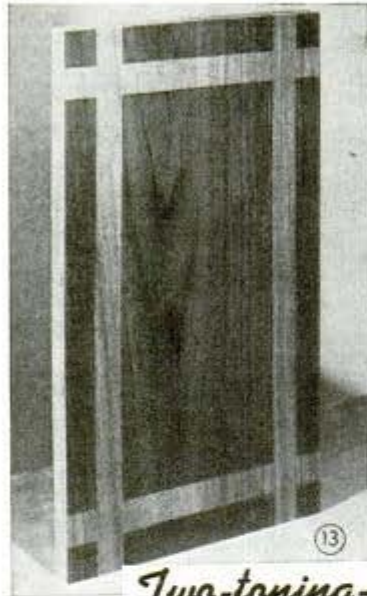

Two-toning-

This is done by masking areas to remain light and then applying filler in the usual manner

FILLER DEFECTS		TABLE NO. 4
Defect	Cause	Remedy
PIN-HOLES	Usually too thick filler which bridges pores. Trapped gas in pores then explodes forming miniature volcano.	Use a thinner filler. Avoid use of japan in mixing. Dust work thoroughly before filling.
RAISED GRAIN	Filler not given enough drying time. Also, in lacquer finish, the use of a filler not suitable under lacquer.	Allow plenty of drying time. Use 5/0 paper to sand off surface fuzz before and after staining.
GRAY PORES	Moisture in wood. Not enough drying time. Filler too light in color.	Check moisture content of wood. Always use filler as dark or darker than stain.
STREAKED CLOUDY FINISH	Filler not cleaned off completely. Use of wood turpentine instead of gum turpentine in mixing filler.	Moisten wiping rag with naphtha for final wipe of filler coat. Use gum turps or naphtha for mixing filler.

protected areas standing out both because they are lighter and also because they were not filled. For sharper contrast, a small amount of oil stain can be added to the filler.

Filler defects: The four most common finishing defects traceable to improper application of filler are described in Table No. 4. Augmenting this table and summarizing good filler practice, the finisher should observe the following general rules: Don't make the filler too heavy; it should have enough fluidity to sink to the bottom of the pores. Stick to one brand of filler and mix it the same way every time for any certain wood. Allow plenty of drying time; the two types of paste filler are commonly described as 4-hour and overnight-dry, but it is advisable to increase these minimum schedules by about half. Don't worry about a special type of filler for use under lacquer. If the filler has been made within the last two years, it will be formulated for compatibility with the lacquer finish as well as synthetic or varnish.

Lattice-Type Step Stringers Are Neat and Save Material

Instead of using heavy stock for stringers when building wooden steps, try the type shown. They give a neat appearance, take less material and in most cases will last longer than the heavier ones. In case they

eventually need repairing, less work and money will be required, as it may be necessary to replace only one or two of the narrow strips to make a good repair. Any kind of 1-in. wood strips 2 or 3 in. wide can be used. If the steps are to be more than 2½ ft. long it is best to use a support at each end and one in the center. Give the supports two or three coats of paint and then nail them in place, using a stone or brick foundation to support the lower edges. Apply the treads and risers in the usual manner.—F.P.Schofield, Ardsley, Pa.



Game Hooked to Hunter's Belt

Ordinary shower curtain hooks, with one end sharpened, are handy for carrying birds, rabbits and other small game. With the hook slipped through your belt loop, the sharpened end holds the game without danger of losing it. Some hunters consider this method superior to the use of game pockets in a hunting coat.

—George Bacon, Stevens Point, Wis.

Realistic Winter Scenes Between Window Sash

Evergreen branches and other greens used in decorating windows during the yuletide will not only stay fresh longer if placed between the storm and window sash, but they can be arranged to produce realistic winter gardens and landscapes. One of the simplest ways of decorating a window is to frame it with evergreen branches, using a length of light wire and giving it a couple of turns around each branch to hold and keep them spaced. The wire then is tacked to the storm-window frame. With just a little more work, a novel evergreen-



forest scene can be created by using a small birch or pine log, with attractive bark, to hold the evergreen branches vertically as shown at the left. The log is flattened on one side to keep it from rolling and holes are drilled in the upper side to take the branches, which are arranged at different heights to resemble a forest. A winter landscape that is still more interesting can be created as shown in the circular detail. Here layers of white cotton are used to

produce snow banks at the ends of the window with a valley between them. A cardboard road can be made to run diagonally through the valley. Small figures of paper or wire dressed in bright scraps of cloth and engaged in skiing or tobogganing add life to the scene. Small branches of evergreen stuck in the cotton simulate trees, and there may be room for miniature cardboard houses with colored cellophane windows and lights inside.

Novel Greeting Cards Produced by Perforating the Designs

Greeting cards that are decorative and unusual in appearance can be made by perforating them with a small punch to expose

different colors of paper underneath. The simple design on the Christmas card illustrated is a good example. Here a novel effect was produced by perforating the name in the card, and also by perforating the tree design to simulate lights and a star, after which an underlay of red paper was glued behind the card to show through the perforations.



A star cutout at the tree top was underlaid with gold foil. Different colored lights could be simulated on the tree by first making only a few perforations and then adding the red paper, after which more perforations are punched through the card and red paper to expose still another color of paper and so on as different colors of paper are added.

PLAYING GOLF

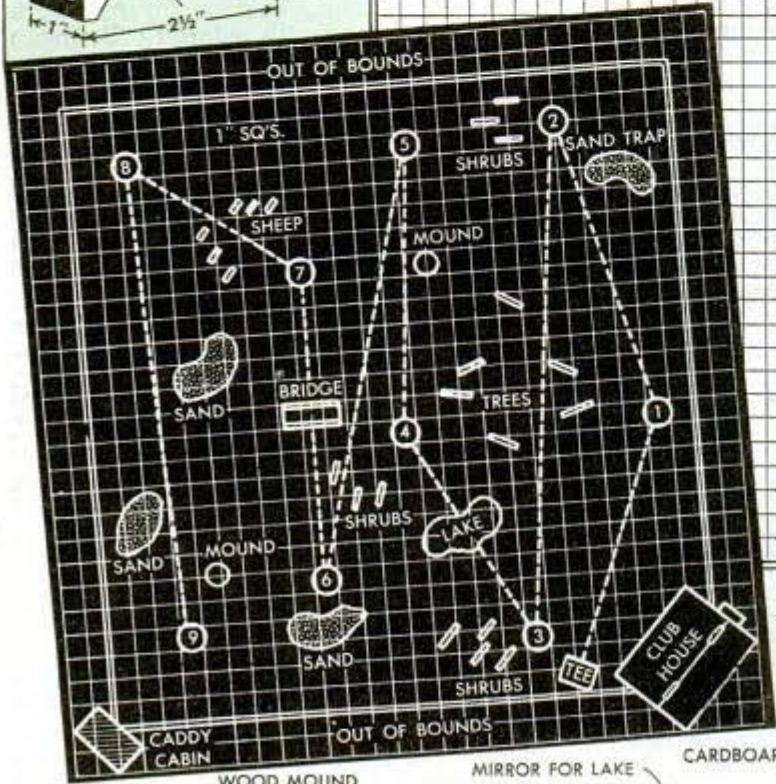
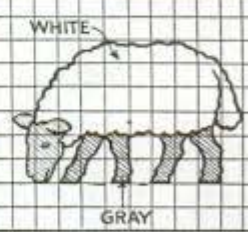
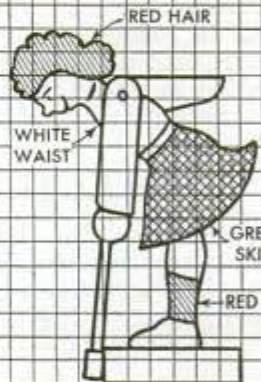
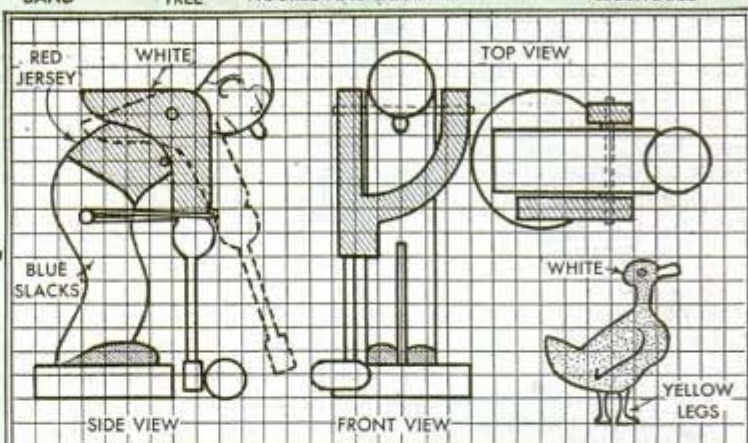
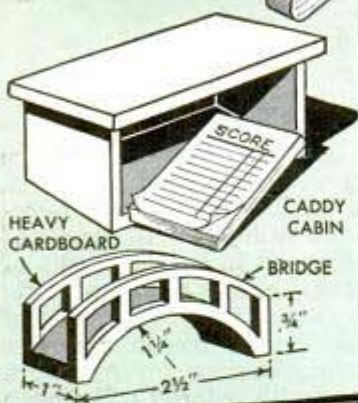
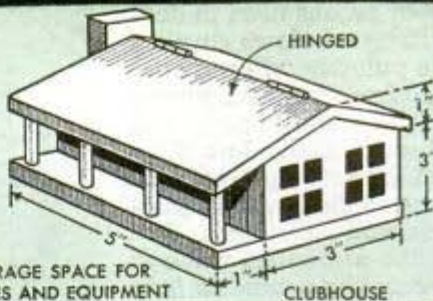
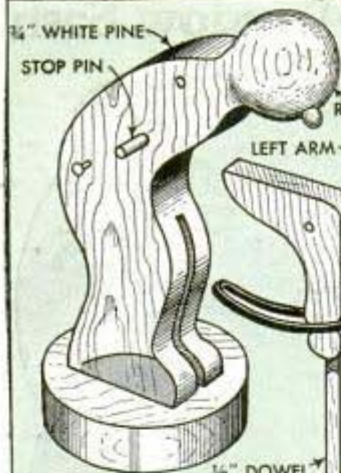

on a Card Table



Miniature nine-hole course entertains young and old; takes little storage space

MANY hazards in this novel table-top golf course make hole-in-one shots almost as difficult and exciting to score as in the real game. It is played according to standard rules, using a small marble for a golf ball, which is driven by a club held by a "golfer" and manipulated by a player. The course is built on a wooden base to fit the top of a card table and has a hinged-roof clubhouse in which playing equipment is kept when the game is stored away. If plywood can not be had, any $\frac{3}{4}$ -in. scrap wood, glued edgewise, will do for the base, as it is covered with heavy cardboard, such as sign-writer's stock. Glue and tack this to the base and lay out the nine holes on it according to the plan view. Each hole is bored $\frac{1}{4}$ in. deep with a sharp 1-in. bit, after which the "mirror" lake and "sandpaper" traps are set-in flush. The strip around the edge of the base can extend below the edge also to keep it from shifting on the table. Green desk-blotter stock is

used for the fairways and greens and is cut to leave a 2-in. out-of-bounds margin all around. Use rubber cement, or glue, sparingly, to stick it to the cardboard, then cut the holes neatly with a razor blade and give the lake an irregular shoreline.

Both man and woman golfer are made the same way, the right arm of each extending to provide a lever to swing the club. In use, the golfer is held down with the thumb and second finger while the forefinger depresses the lever, pushing the ball rather than striking it. A rubber band, stretched from the arm to a nail in the body, improves control in putting. Make two of each golfer for a foursome and paint each differently for identification. Scroll-saw the trees, shrubs, sheep and geese from $\frac{1}{4}$ -in. wood, and paint the caddy cabin and clubhouse white with red roofs. Tee markers are metal disks soldered to wires.

Back Cushion Used by Car Driver Swings Out of the Way

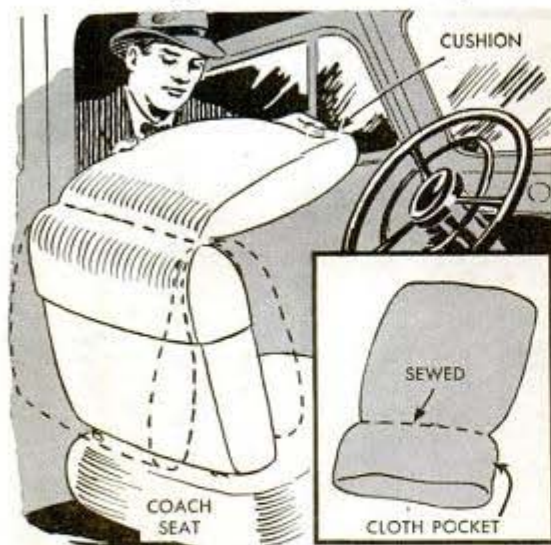

If the front seat of your car has a divided back, and you like a cushion for your back at times, sew a cloth pocket to the upper end of the cushion. The pocket can be slipped over the back of the seat to keep the cushion in place, and will permit it to be swung over the seat out of the way when not in use.

Dirty File Teeth Cleaned Easily With Linotype Slug

A linotype slug, which can be obtained at almost any printing shop, makes a satisfactory substitute for scraps of copper, commonly used to clean files. The file is permitted to rest on a bench top while being held firmly with one hand as shown. The other hand is then used to draw the slug across the file while downward pressure is being applied to scrape particles of metal out of the teeth.

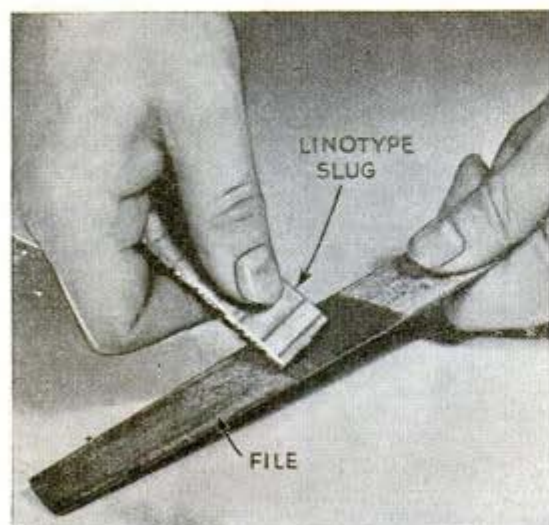

Easily carved in soft pine with a jackknife

By E. J. Tangerman

REMINISCENT of colonial days, this novel bellows with its carved Indian head and beaver pelt is especially in keeping with a colonial fireplace. The design incorporates the beaver's tail and the head-dress feather as handles, and the Indian's mouth is puckered to appear to be blowing although the air actually comes out through the mouth of a carved bear head fastened to the lower end. Both sides of the bellows are cut practically alike, the Indian side being a little wider at the neck and the pelt side about $\frac{1}{2}$ in. longer to stagger the hinge joint and also to extend into a rabbet cut in the bear's head. A piece of 1 by 8-in. white-pine shelving is excellent to carve the sides from and if it contains a knot or two, so much the better. Both feather and tail are tapered from the center to the sides and all other edges are rounded. A $\frac{5}{8}$ -in. hole forms the Indian's mouth, or air inlet, and is covered on the back with a flap valve which is simply a square piece of thin leather tacked to the upper lip with two tacks. The hole through the bear's head where it joins the sides should be hollowed out or flared as shown in the detail to assure a good entrance to the outlet.

Carving is done in very low relief, consisting largely of V-grooves made with a pocket knife. Rib cuts in the feather, the markings on the tail and toes and the eye openings are made smaller than the other cuts. The photo and sectional details will show you the right contour to duplicate. Fur is simulated on the beaver pelt by countless small gouge cuts made over the whole surface, except the paws. To compensate for the two small filler blocks glued to each side of the flared opening, the Indian's neck is whittled down at this point to fit flush with the bear's head.

Suede is best for the bellows, but imitation leather or canvas, if available, can be used, although the latter will have to be sealed with paint or oil. The details show how the leather is tacked to the sides and handles with plain tacks spaced 1 in. apart, after which the edges are folded back about $\frac{1}{2}$ in. or so and held with ornamental upholstery nails spaced about 2 in. apart.



Carved FIREPLACE BELLOWS

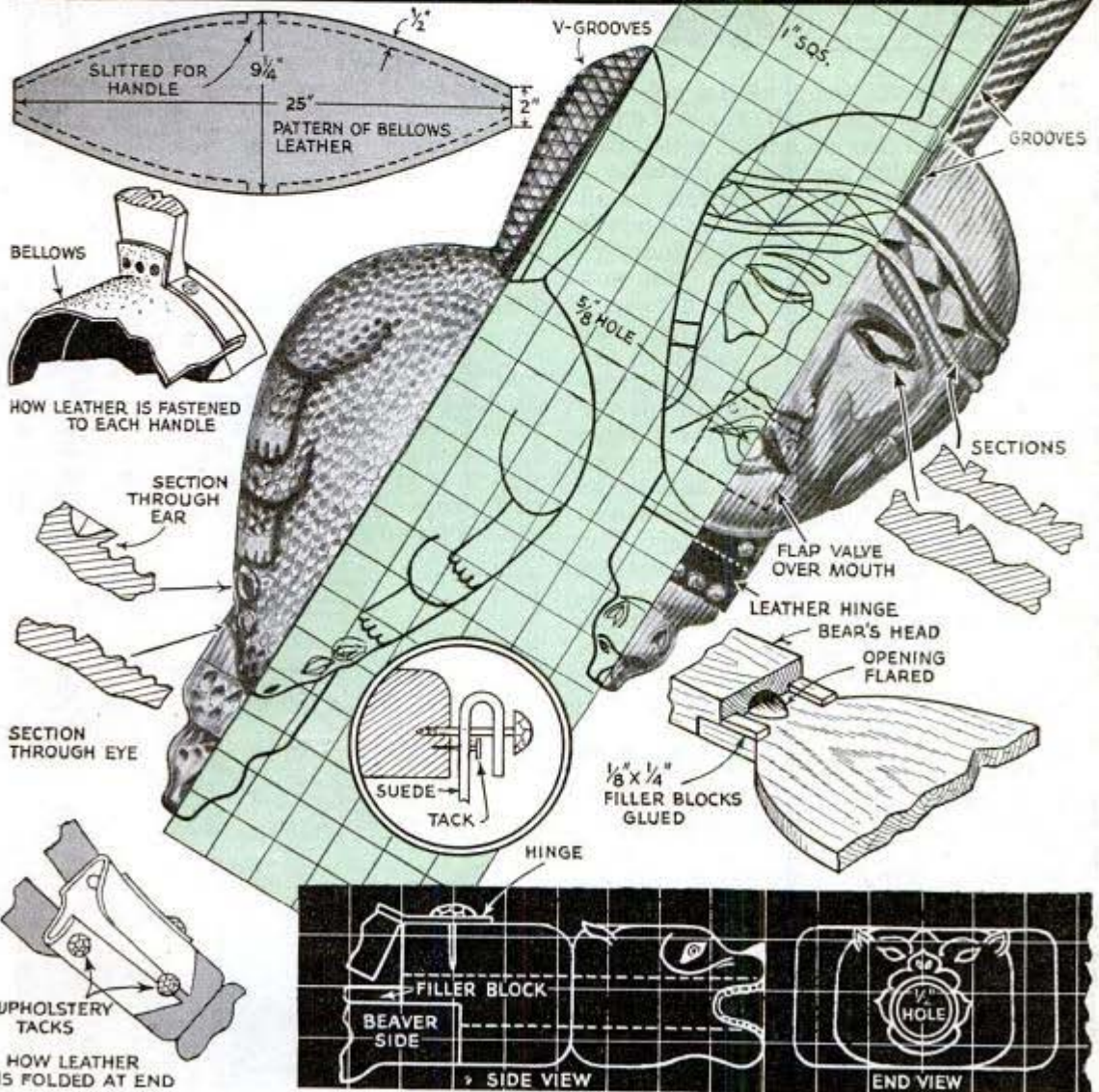

Close Control of Water Heater By Using Forced-Air Draft



If you heat your water with a pot-type stove or laundry stove and have had trouble keeping the fire controlled satisfactorily, or have to burn fuel that is too expensive or not now available, you can install a blower to provide forced-air draft, which will control the fire automatically and permit burning inexpensive fuel. All you need is a 6-volt auto defroster blower, a bell-ringing transformer and an aquastat. The installation is made as shown in the details. If you already have a transformer to operate your doorbell, current for the blower can be taken from the transformer without disconnecting it from its present circuit. If desired, a small 110-volt blower can be used by wiring a relay in the 6-volt circuit in place of the small blower. The relay then is controlled by the aquastat and in turn acts as a switch to control the 110-volt blower. With this latter installation, one side of the 110-volt blower circuit is wired through the relay.

—Austin N. Cranfield, Oceanside, N. Y.

Buttons From Black Walnuts

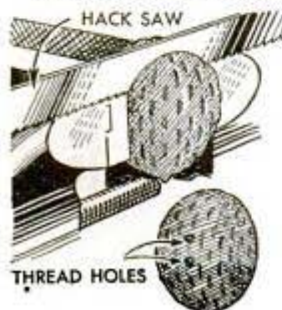

Attractive buttons for a sweater, a heavy sport dress, or similar garments can be made from black walnuts. After matching the walnuts for size, a side is cut from each one with a hack

saw. To do this, grip the walnut in a vise so that it projects from the ends of the jaws. If the nut is placed correctly, the ends of the jaws can be used as a guide for the saw blade. Then, dress down the edge of the sawed-off section with a file to the desired shape and size. Also, file away the rough ridges from the outer surface, remove the kernel partitions, and drill two small holes for attaching the button. Finally, scrub the surface with a rough brush to bring out the rich brown color of the shell. Tinted buttons can be made by applying colored ink with a soft polishing cloth.

—George A. Smith, Quarryville, Pa.

Tape-Backed Abrasive Paper Sands Scrollwork Easily

The usually tedious job of sanding scrollwork and the waste of paper can be avoided to some extent by using strips of abrasive paper backed with adhesive tape. The tape reinforces the paper so that it can be worked into the tightest places, and also makes it possible to use the paper either flat or rolled.



Extension on Marking-Gage Slide To Scribe Irregular Work

One carpenter who wanted to use a marking gage on thick work that had a molded edge similar to that shown, put a hardwood extension on the gage slide so that it would reach to the lower surface of the edge. The extension can be attached easily by doweling.

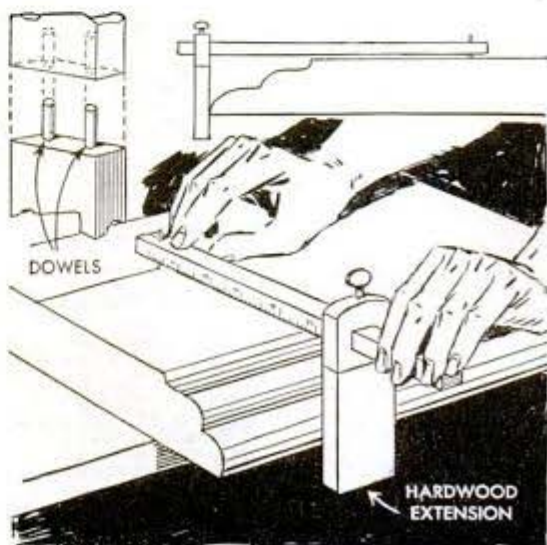

Handy Carfare Pocket on Glove or Handbag

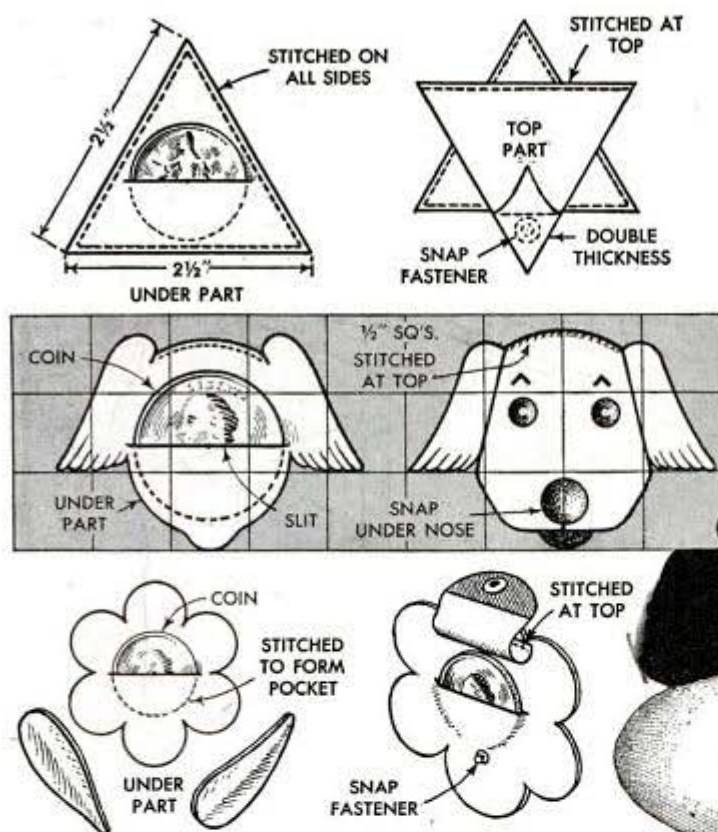

Attached to the back of your mitten, glove or handbag, one of these decorative little purses will keep coins handy for carfare or other purposes. The suggested designs appear to be purely ornamental, but each one has a coin pocket concealed under a flap that forms part of the design. Leather from old gloves, belts or handbags, or felt from a hat are the best materials, although any kind of material that does not ravel when cut is satisfactory. The star-shaped purse in the upper detail consists of two triangular pieces. One has a slot cut the size of a quarter or nickel, and is stitched on all three sides to the glove or handbag. The other piece provides the flap to cover the coin. A few stitches at the top edge and a snap fastener at the lower corner of the flap keep the purse closed securely. A

small piece of material sewed to the corner of the flap will reinforce it and provide backing for the snap. In the lower detail, the flower-design purse has the slot cut in a scalloped circular piece that represents petals, the flap being held in place by a few stitches at the top and a snap fastener at the bottom. Stems and leaves are scraps of material or yarn stitches. Light colored petals with a dark center make an attractive design. The faithful pooch shown in the squared detail has ears cut in the piece underneath with a coin slot in the center.

—Bess Livings Lee, Alamosa, Colo.

Automatic Stoker Powered by Gas Engine in Emergency

Our home heating plant is fired by an automatic coal stoker, which sometimes is made inoperative for hours or even several days because of severe sleet storms. To operate the stoker during such emergencies, I use a small gasoline engine. The single pulley already on the stoker motor was replaced with a double one so that the engine could be belted to the motor, run-

ning the belt out through a hole cut in the stoker casing. With this arrangement, the engine operated the stoker by merely rotating the motor. Changing from motor to engine was just a matter of putting on the belt. Of course, all automatic controls are inoperative when using the engine, which must be controlled manually.

—John W. Belsley, Morton, Ill.

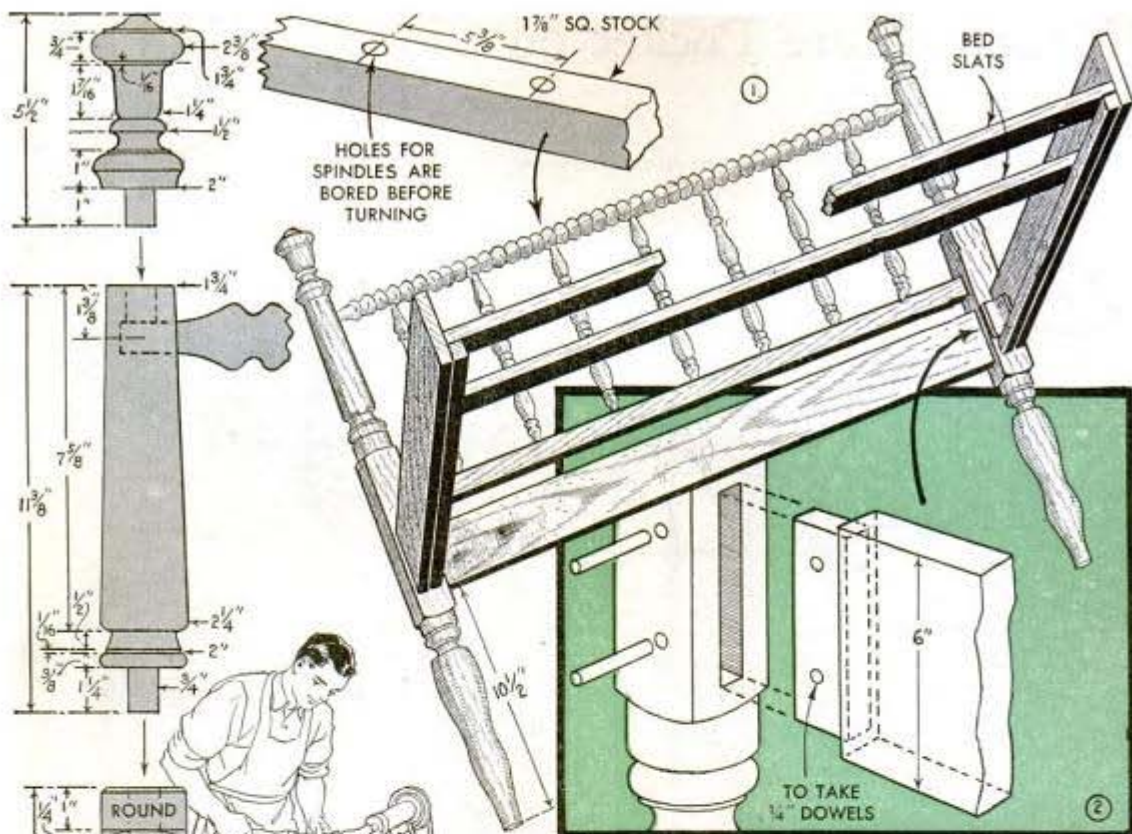

You Can Turn This

Simplified adaptation of Jenny Lind style—a good lathe job for beginners

By Wallace W. Buffmire

CHARMINGLY quaint in ruddy maple, this colonial four-poster bed also works up beautifully in walnut or mahogany. Except for mortising and tenoning the rails, the whole job can be done in a lathe. Construction is practically the same whether the bed is a single, twin, three-quarters or full size, only the number of spindles varying with the width. Fig. 4 gives the width for standard springs of the four sizes. The type of spring used will determine whether bed slats are needed, as some springs are made to rest on top of the rails.

Each post is made up of four sections as detailed in Fig. 3. However, if the capacity of your lathe permits, the two center sections can be turned in a single length of 2 1/4-in. square stock and the top and bottom sections turned separately and doweled to it. Solid turning squares are best

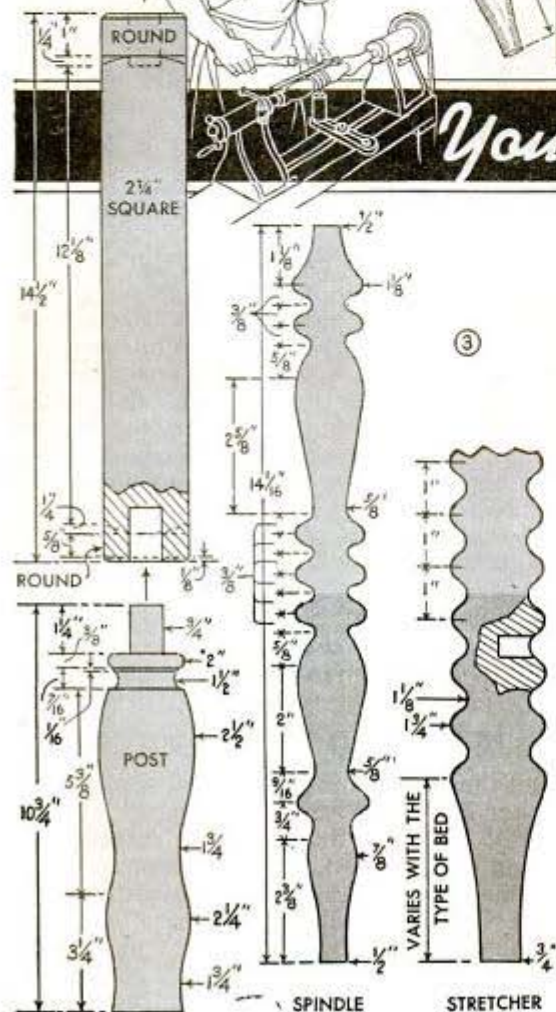

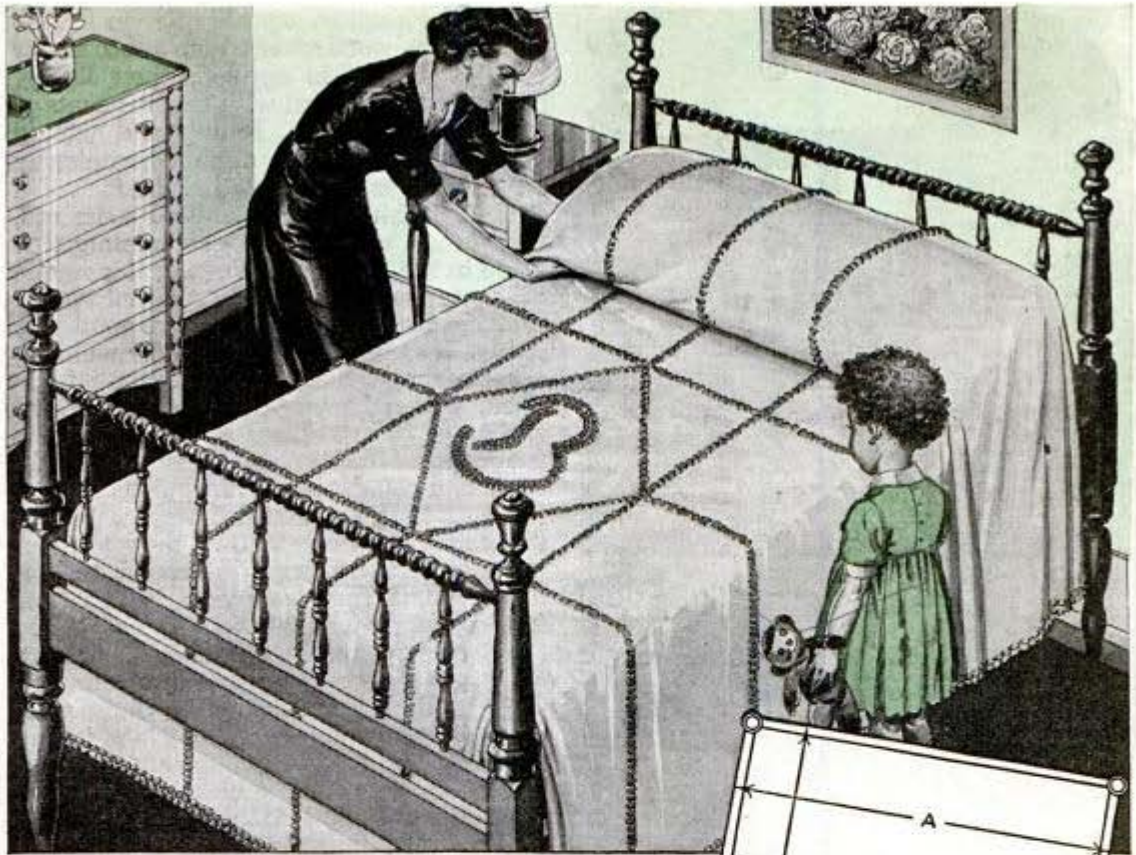

COLONIAL BED

for the posts, but where these cannot be had, built-up stock will do, providing the pieces are properly jointed and a good resin-type glue is used. It is best to bore the holes for the stretcher tenons while the work is square, especially so in the case of the stretcher itself, Fig. 1. In turning each post, as well as all other duplicate parts, try to match each one as closely as possible, using calipers frequently to check the work at respective points. A jig consisting of a wooden strip having brad points projecting from one side and spaced to correspond with the drawing, will serve as a master pattern to use in marking off duplicate turnings lengthwise. If the posts are made in four sections, care must be used in centering the holes in the ends of the square sections, so that adjoining parts will be in alignment. Fig. 2 details how the end rails are cross-pegged in mortises cut in the posts. The narrow rail above it is about $1\frac{1}{2}$ in. wide, and is pegged in the same way. In the case of the two front posts, the holes for the pegs should be made blind so that the dowels will not show on the face of the post.

While the chart at the right gives both inside and overall widths of five standard-size beds, it's best to measure the spring which you plan to use

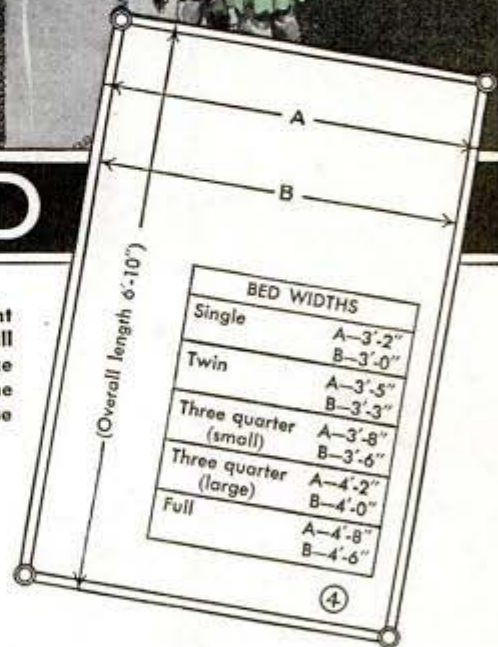

Both head and foot are exactly alike. In assembling each one, glue the spindles to the stretcher and narrow rail first, then glue this to the posts as a unit at the same time the end rail is fitted. There are various type bed-rail fasteners available, one of which is shown in Fig. 6. In fitting them, locate the socket part on the posts to bring the top of the spring about 18 in. above the floor. The spring should be at hand in determining this as it will make a difference if the spring sets inside the rails.

The finish to apply depends upon the effect desired and the kind of wood used. Whether stained or left natural, walnut and



mahogany require a paste filler to fill the pores of the wood, over which a thin sealer coat of shellac is applied, then lightly sanded and followed with several coats of high-grade varnish. Filling and wiping all turnings can be done conveniently while they are in the lathe. In fact, if a French polish of shellac and oil is desired, the turned work can be completely finished in the lathe. In following this method, you must be careful to see that tenons are kept free of shellac to assure good glue joints. If spraying equipment is available, a satin-sheen, lacquer finish can be applied. Here the work is filled as before and a coat or two of lacquer sanding sealer is applied as in Fig. 5. Because of the light body of a clear lacquer finish, it is important that the pores be filled perfectly flush. If upon close examination they are not completely filled, apply a second coat of filler. When the sealer coat is dry, it is sanded lightly with 7-0 paper, then dusted and sprayed with several coats of gloss lacquer, thinned 50 percent with lacquer thinner. Undercoats of gloss lacquer are preferred in building up a good body, as they contribute to a clearer finish. A fairly good imitation of a hand-rubbed finish is obtained by using a flat lacquer as a final top coat. This dries with a soft, satin luster, requiring no rubbing. "Orange peel" texture in the finish, which results when the gun is held too far from the work, or when the air pressure is too low, can be corrected to some extent by spraying the final top coat lightly with plain lacquer thinner. This has been found effective in leveling off the pebbled coat.

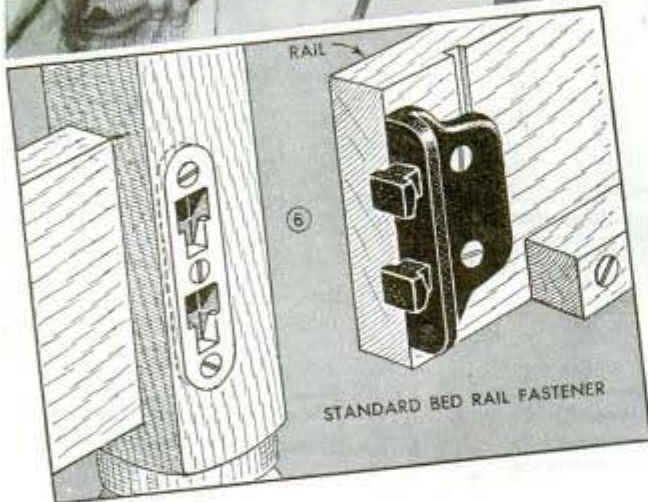

Barbs in Chisel Ferrule Embed to Hold Handle Securely

100 W.P.
 Annoyed by having the ferrules of a set of wood chisels become loose on the handles, I corrected the trouble by peening or notching the inner edges of the ferrules with a cold chisel as indicated. Tiny prongs or barbs formed by this procedure became embedded in the wood when the handles were forced into place to hold them securely.—G. E. Hendrickson, Argyle, Wis.

Window Streaks Located Easily

When washing windows it is a good idea to dry them on the outside by stroking the cloth up and down, and on the inside by stroking the cloth horizontally. Then, if there are any streaks you can tell at a glance whether or not they are outside or inside the window.

—Benj. Nielsen, Aurora, Nebr.

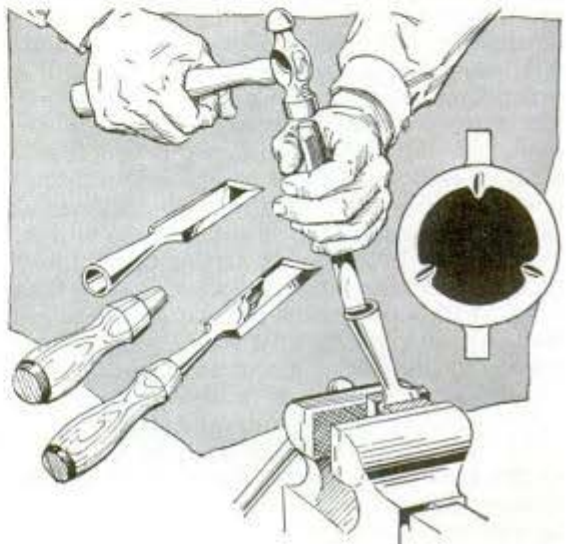

Military Chessmen Maneuver on "War Map"



HOW WAC IS TURNED AND CARVED

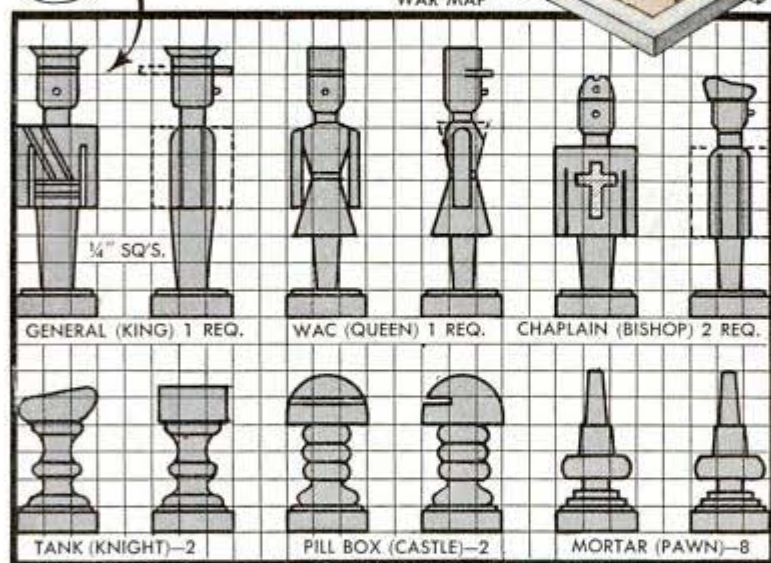

Chess "goes to war" in the form of a novel military set, which is played in the usual way but on a map "battlefield" with army figures representing king, queen, bishop, etc., of a regular set. A complete set totals 32 pieces. One set of 16 is turned in walnut or other dark wood and a duplicate set in a contrasting wood, such as maple. The general, WAC and chaplain are carved as indicated after turning. The playing board consists of a colored map glued to plywood which is ruled off in squares and painted with transparent colors to produce a checkerboard

Sleet on Windshield Removed Quickly With Anti-Freeze

When parked during a rain or sleet storm at nearly freezing temperature, and you find your windshield coated with ice, you can remove it quickly to permit clear vision by applying some anti-freeze solution of the kind having an alcohol base. This will be convenient if you are using such anti-freeze in your cooling system, since it is a simple matter to dip a rag in the radiator and then apply it to the ice. However, in doing this, care must be taken to avoid getting the solution on the finish of the car, as this may be attacked by the alcohol.



☞ Add water through the spout of a hot teakettle instead of removing the cover which may allow steam to burn your hand.

Scraper to Bare Insulated Wire Closes Like a Jackknife



You'll find this scraper very handy for removing insulation from wire, and it can be carried in your pocket just like a jackknife. The two blades are broken from the ends of an old hacksaw blade so that the two holes can be used in pivoting them to a handle. This is shaped from a small wood block as indicated, the blades being pivoted in the handle with their toothed edges facing so that good scraping edges are provided when the blades are opened to a V-shape.—R. Eyrich, Milwaukee, Wis.

Chessmen Improved by Weights Placed in Their Bases

An ordinary set of chessmen having large bases can be improved by weighting them with lead or linotype metal, the latter being available in small amounts from

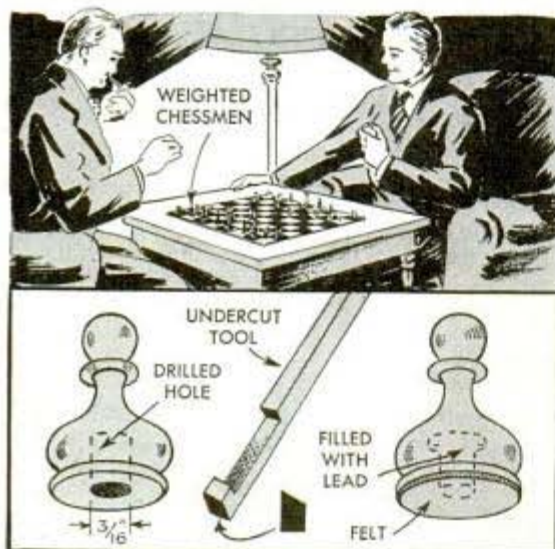

most print shops. To apply the weights, first put each chessman into a well-padded vise and bore into the base with a $\frac{3}{16}$ -in. drill, being careful not to cut too deeply. Mark the drill for depth with a narrow strip of tape. To obtain uniform weight, all the holes should be the same depth, and they must be undercut to anchor the metal. This can be done with a tool shaped like the one shown. The main thing about the undercut is to have it square at the bottom to avoid up-and-down play of the metal. After melting the metal, pour it into the holes and when it has hardened, glue disks of leather or felt to the bottoms of the chessmen. Kid from a lady's old glove is excellent for the purpose. Before gluing on the disks you may care to refinish the men by polishing them with rottenstone and felt, repainting if necessary, and then varnishing them.

—A. D. Pitney, Chicago.

Bottle of Charged Water Used As Small Fire Extinguisher



A bottle of charged water, such as is used for mixing beverages, provides an emergency fire extinguisher if it is fitted with a short hose and nozzle. You will find that pressure inside the bottle is sufficient

to throw a stream of water nearly 30 ft. The quart size bottle of water is sufficient to extinguish most small blazes when used properly.

Crayon Marks Confine Solder To Sheet-Metal Seams

Beginners who experience difficulty in confining solder to a narrow, neat band when making long seams in sheet metal, will find that a grease-crayon mark on each side of the seam will do the trick. The solder will not flow beyond the marks unless an excessive amount is used, in which case it can be removed easily, as solder will not adhere to the metal under the marks. By taping two crayons together, a line can be made on each side of the seam in one operation.

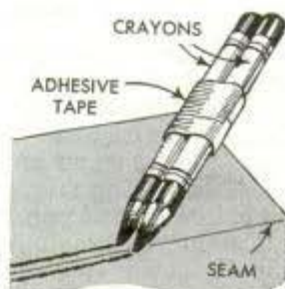

Electrical Indicator Blinks WIND SPEED and DIRECTION

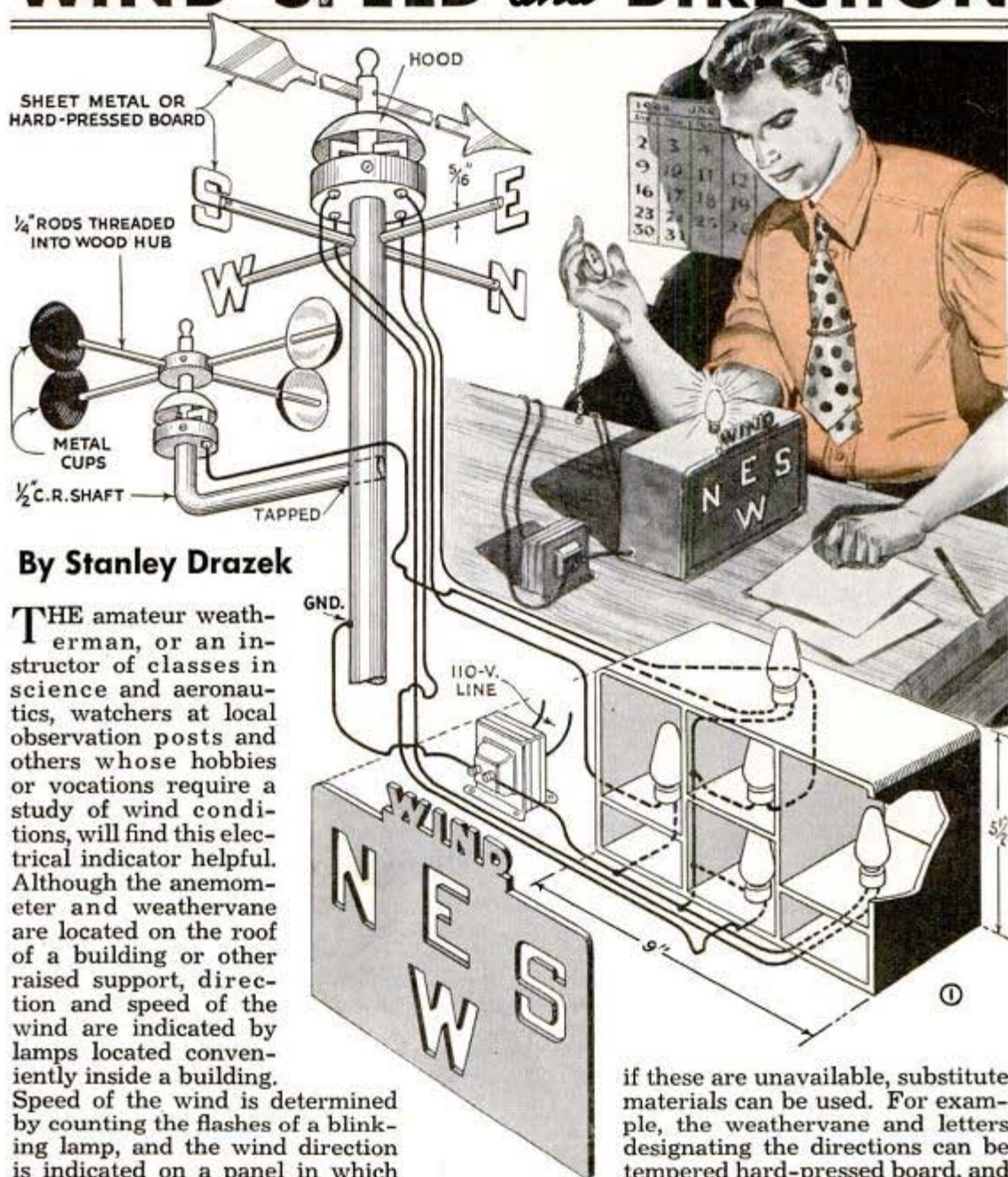

By Stanley Drazek

THE amateur weatherman, or an instructor of classes in science and aeronautics, watchers at local observation posts and others whose hobbies or vocations require a study of wind conditions, will find this electrical indicator helpful. Although the anemometer and weathervane are located on the roof of a building or other raised support, direction and speed of the wind are indicated by lamps located conveniently inside a building. Speed of the wind is determined by counting the flashes of a blinking lamp, and the wind direction is indicated on a panel in which the letters N, E, S and W are jigsawed. A lamp behind each letter lights up whenever the weathervane, which acts as a switch to close the electrical circuit, points in the direction designated by one of the letters.

Although construction of the indicator may seem difficult at first glance, it is quite easy. Naturally, steel shafting is best for the main standard and the arm supporting the anemometer, and brass or copper is best for the rest of the exposed parts, but

if these are unavailable, substitute materials can be used. For example, the weathervane and letters designating the directions can be tempered hard-pressed board, and the small rods supporting the letters and also the anemometer cups can be hardwood dowels. Also, it is possible to use wood for the standard and arm. If this is done, short shafts must be inserted in their upper ends to provide bearings. And, of course, the short rotating shafts of the vane and anemometer must be metal to withstand wear. If regular spun-metal wind cups for the anemometer are unavailable, the bowl parts of large spoons will serve, but they all must be of the same size and shape.

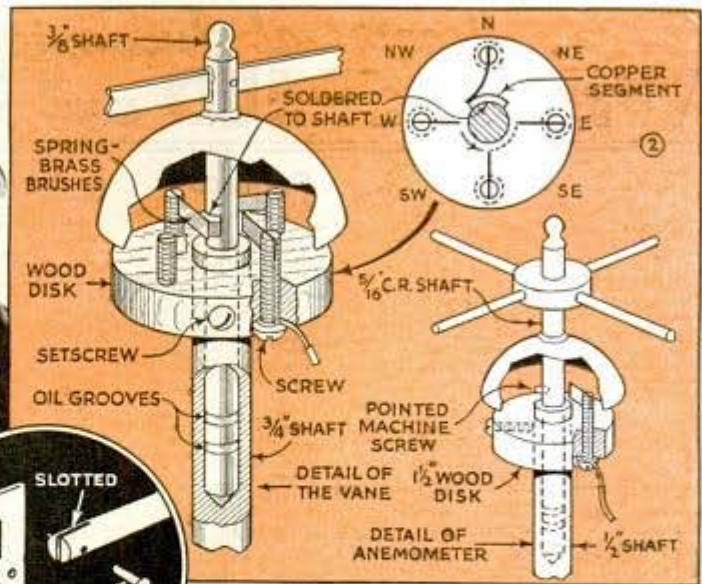

Fig. 2 shows how the pointed shafts of the anemometer and weathervane work in the drilled ends of their standards to reduce friction to a minimum. Notice that grooves near the lower ends of the shafts serve as oil reservoirs, which make frequent lubrication unnecessary. Reference to the left-hand detail of Fig. 2 will show you how to construct the weathervane brush assembly, which consists of four brushes mounted on a wooden disk, the latter being locked on the upper end of the standard with a setscrew to permit adjustment. The brushes are strips of spring brass or copper clamped in the slotted ends of screws turned up through the disk. The brushes make contact with a single-segment commutator sweat-soldered to the vane shaft. It is very important that the segment width be equal exactly to one quarter of the vane-shaft circumference, and that the segment center be exactly in line with the vane. In this way, when the indicator is wired as in Fig. 1, only one lamp will show on the indicator panel when the vane points north, east, west or south, as the commutator contacts only one brush. But, if the vane points between two of these directions, the brush will contact two adjacent brushes and two lamps will show. For example, a northeast wind would cause the north and east lamps to show. A sheet-metal hood protects the brush assembly.

Construction of the anemometer mounting and brush assembly are similar to that for the vane, except that only one brush is used, and the commutator consists of a

pointed screw. One contact is made for each revolution, thus causing the lamp to flash once for each revolution. The easiest way of calibrating the anemometer is to fasten it above the front of a car and drive on a calm day, counting the revolutions of the anemometer at various speeds. This data is recorded on a scale, which is placed near the indicator to aid in computing the wind speed by anyone counting the flashes of the lamp for 1 min. Electric current for the indicator is supplied by a 6-8-volt transformer, and Christmas-tree bulbs and sockets are used for the lamps at the indicating panel.

Handy Dispenser From Fruit Jar

Where small, measured amounts of materials, such as tea, coffee, soap flakes, etc., are to be poured from containers, this easy-to-make dispenser will come in handy, as all you have to do is tip it upside down to

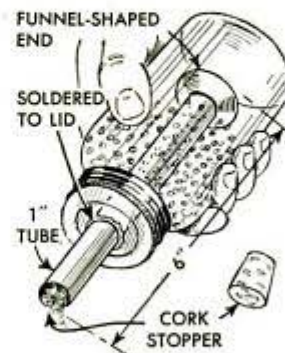

pour out the predetermined amount. A fruit jar is used and the lid is fitted with a tube as shown, the lower end of which is provided with a concave or cupped piece of tin of a size to hold the desired amount of material to be dispensed.

When the dispenser contains a material from which air should be excluded, a cork can be inserted in the end of the tube and a rubber can be used under the jar lid.

Improved Stopper for Ink Bottle



Time lost in using both hands to remove the stopper from a bottle of drawing ink can be saved by altering the stopper as shown so that it can be removed with one hand. To do this, remove the cork portion of the stopper and cement a lead disk

in its place. The surface of the disk must be flat and smooth to make a good seal.

Jumper Wire Makes It Easy to Use Long Thin Welding Rods

Long thin welding rods of the coated type that have to be clamped in the torch at one end often have a tendency to vibrate and make it difficult to strike an arc. To avoid this trouble, I use a jumper wire which is fastened to the torch and to the end of the rod by means of battery clips. With this arrangement, the rod can be gripped in the torch close to the lower end and thus eliminate vibration. The jumper is made either of heavy insulated wire or from three or four lengths of lamp cord having the ends bared and soldered together to produce a cable heavy enough to carry the required current safely.

—Fred Pinkus, La Crescenta, Calif.

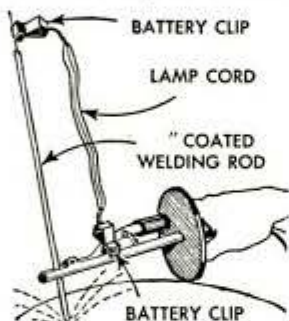

Rotating Offset Anchor Stake Loosens It for Pulling



Steel stakes used to anchor power windlasses and other heavy machines usually must be driven into the ground so firmly that they are difficult to remove without some special pulling device. However, if the stakes are offset near the top as shown, they can be rotated to loosen them even in the hardest ground, and thus facilitate their removal.

Posthole Auger Cleaned Easily On Portable Knocker

Having a number of postholes to dig in clay soil, which was difficult to remove from the auger, one farmer used a knocker like the one shown. It is merely a disk from an old disk harrow which is fitted with a pipe tee and three nipples as indicated, the pipe assembly being locked into the axle hole of the disk with a pipe nut placed on each side.



Valve Balls Cleaned in Bottle



Cleaning and polishing of ball bearings and brass balls used in certain types of valves can be done easily by using a bottle. This should have a mouth slightly smaller than the diameter of the ball to be cleaned. Fine valve-grinding compound is applied around the edge of the bottle mouth, after which the ball is rotated against it with the palm of the hand.



TAKE IT CLOSE-UP *by Fred G. Korth*

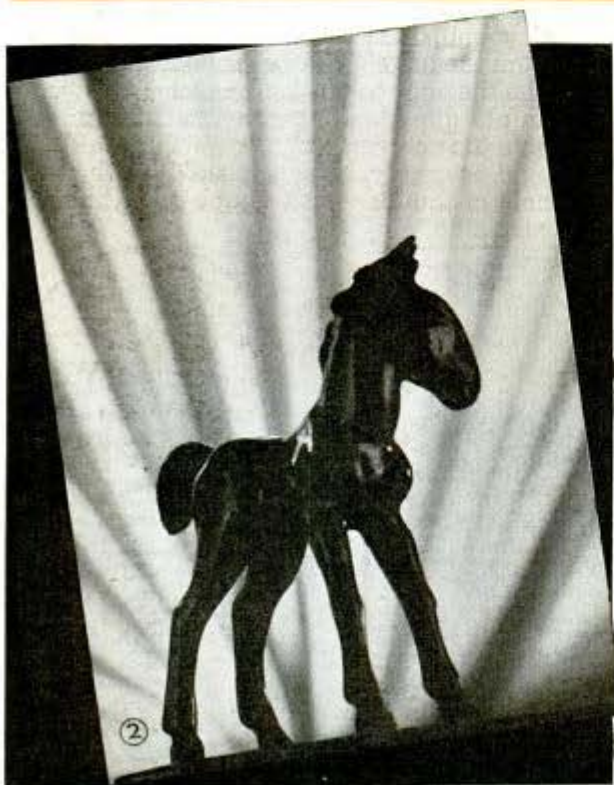

TAKING a subject close-up is the secret of creating attention-getting photos and the best way to make photos tell stories. Anything not essential in a picture and which does not tend to emphasize the theme, definitely detracts from the effectiveness desired. Therefore the photographer must avoid getting too much in a picture, a common fault of beginners.

Suppose you choose the subject "Spring" for a photo, and you are walking in the woods looking for a picturesque curve in the path or for a small brook reflecting the sun and the trees. Having this in mind you are apt to include too much in the picture. So, instead of continuing with this angle in mind, just step over to one of the trees and look for a twig with some buds. Then focus on this alone. Be sure that the background does not detract and try to keep it out of focus. Snap the picture and you have your shot of Spring. What is more representative of it than buds appearing on a tender twig? Photos of this type

reveal details that the average person has no time to detect and to observe.

If you love pets, you may have taken numerous photos of them in various poses—playing, stretching, yawning, jumping and perhaps creeping up on prey. However, take a close-up as shown in Fig. 1, and everybody will notice the “soulful” eyes, the fur and the whiskers. Such a shot is one of the easiest to get and one of the best for effect. It is simply good close-up photography. Taking a photo of the whole cat would probably give the idea of “just another alley cat” but a photo of the face only avoids this impression. In this case all rules of composition seem to be violated as both halves are identical and there is



← Wrong ↑ Right ↓

Although repetition is sometimes used to emphasize, the countless spirea blooms above just convey the idea of a profusely blooming shrub—not the idea of a flower. To emphasize the latter, take a closeup of one or only a few blooms as in Figs. 3 and 5

no diagonal or S-curve; yet the effect obtained depends on the fact that much has been eliminated. Elimination of confusing masses and lines from pictures brings the observer to the point you want to stress—and in many cases the only point worth showing.

Figs. 3, 4 and 5 illustrate what to do and what not to do in getting photos of flowers. In Fig. 4, a spi-



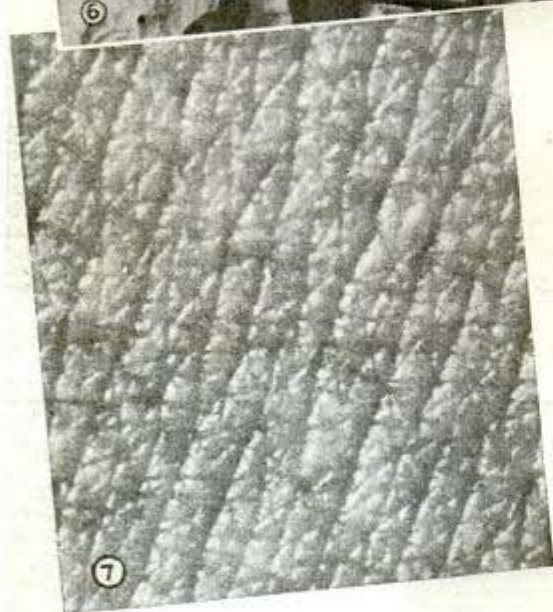

satin background was softened by being kept out of focus. With the same piece of satin you can produce draped effects such as shown in Fig. 8, merely by hanging the cloth over the back of a chair. One light for texture and shadows must be placed fairly close, with a second light near the camera to illuminate the cloth from the other side and to lighten up the deep shadows. Another novel experiment in close-up photography is shown in Fig. 6. Here a number of crackers were laid down like the shingles on a roof. The lighting arrangement was somewhat similar to that used for Fig. 8.

Human skin offers possibilities. Although seen constantly, every day, few people have looked at it carefully under a magnifying glass. Fig. 7 shows human skin enlarged seven times actual size. A subject such as this needs magnification to reveal the delicate texture. A camera having a ground glass and an extension bellows is needed for this kind of photography. With a bellows extension twice the focal length of the lens, you can photograph objects up to their actual size. For a double-size image you need a triple extension, and for a triple size image, a quadruple extension, etc. If your large camera has a double extension, you can fit it with the lens of a miniature camera or enlarger, which combination will enable you to get pictures of many magni-

Three examples of texture effects in closeups: Fig. 6 shows crackers arranged in shingle fashion while Fig. 7 shows a patch of human skin seven times actual size. Soft, pleasing effect of draped satin as in Fig. 8, is obtained by proper use of highlights and shadows

rea bush is covered with blooms but not one can be seen well enough to be appreciated. Fig. 6 shows five roses each having distinctive lines and masses, making it possible for anyone to appreciate their delicacy. More interesting and effective however, is the close-up shown in Fig. 3, where a single chrysanthemum is pictured and only part of the flower is included. Note how the radiating lines of lights and shadows produce a pleasing effect.

Many other subjects offer possibilities for close-up photos. Fig. 2 is a shot of a 2-in. chromium-plated horse mounted on the edge of an ash tray. A piece of satin, arranged in a fan shape was used as a background. A single lamp was used to illuminate the background and no light was directed on the horse. However, the latter was kept in sharp focus while the



fications. Of course, there will be a comparatively dim image on the ground glass because the light has a longer distance to travel inside the camera and consequently the exposure must be correspondingly lengthened. For taking a picture at double extension so the image is actual size, you read the exposure meter, assuming that you are using one, at two stops smaller than for an infinity setting. For each further magnification, you double the exposure again or read one full stop smaller. For example, if you have a 4 by 5-in. camera equipped with a 2-in. lens taken from a miniature camera, and you are to take a picture of some buttons four times their actual size, you may have a normal exposure of $\frac{1}{20}$ second at stop f:11. However, due to the long bellows extension, the effective opening is five stops smaller—or f:64, requiring an exposure of $1\frac{3}{8}$ seconds. Subsequent enlargement of the resulting negative will make possible pictures of buttons more than eleven times actual size. One New York fashion house used a large photo mural consisting of just a few buttons.

Another example of close-up photography is shown in Fig. 9. To emphasize the idea of playing chess, only a few chess pieces and a hand were included. From an angle of composition, such a photo is much easier to take than one which includes the players. In cases where you use a hand in a setting such as in the chess photo, the model will be unable to hold the hand in the right position for any length of time, while you are busy arranging the lights. Therefore you should provide some kind of rest for the arm, such as a couple of books, where it will be out of camera range.

A still-life subject is shown in Fig. 10. It was arranged on the floor so that an unduly high tripod was not needed for the



Theme of Fig. 9 is "Chess Playing," brought out strongly by closeup of few pieces and hand moving queen. Photo including more pieces, background and players would distract attention and involve composition problems



Still-life taken from above was spot-lighted from side opposite camera to produce shadows in front of cookies but the use of a fill-in light below camera kept these shadows from being dense black

camera. A small spotlight was directed downward from the opposite side and a photoflood in a reflector served to light up the shadows on the lower front portion of the basket. The spotlight was equipped with a photoflood bulb to avoid a sharp spot of light. The fill-in lamp lighting the front should be made weaker than the spotlight by locating it farther from the subject or by hanging one or two layers of tissue paper on the reflector in front of the bulb. The fill-in light also must be low enough to prevent it throwing cross shadows.

Finger Marks on Paper Avoided By Using a Vacuum Cup



Unightly finger marks will not get on your photographic paper if you use a small vacuum cup to lift it from the box and place it in position for printing. For convenience, the vacuum cup is mounted on a suitable handle. After the paper is in place, a slight side motion of the hand will release the cup.

Two Clocks Serve as a Timer In the Photo Darkroom



If you use a common clock instead of an interval timer in your darkroom, it is unnecessary to depend on your memory to remove films from the developer. The end of the developing time can be indicated beforehand

on a second clock by setting the hands ahead. The second clock does not have to be in running order. Any old timepiece will do if the hands can be turned.

—J. Modroch, Danbury, Conn.

Easter-Egg Dyes Tone Photos

Easter-egg dyes provide an inexpensive and satisfactory method of toning photographic prints in different colors. The strength of the solutions used for coloring eggs usually is too strong for use as a toner, and must be diluted considerably. The diluted solutions will tone prints in about 5 minutes. If the tablet form of dye

is used, the tablet must be pulverized and dissolved thoroughly or small particles will cause spotting. The addition of vinegar, which is recommended for coloring eggs, is not necessary for toning prints.

—John Karlovic, Chicago.

Pocket in Lid of Camera Case Carries Lens Tissues

Lens tissues always will be available if you keep them in a pocket in the lid of your camera case. The pocket can be made of cloth, Cellophane or paper, fastened to the inside of the lid with strips of tape.



Still-Life Pictures Composed With Cardboard Frame

Composition of still-life or other subjects is simplified by using a cardboard



frame through which to view the subject before the picture is taken. Several frames are cut in proportion to the size of the film used and the size of the subject. By holding different frames in front of the proposed picture, you can

see just how much to take in without wasting film for trial shots. The frames are especially convenient for composing arrangements of flowers and tabletop scenes.

Photos Easily Changed in Frame When Held by Two Bow Sticks

To simplify changing photos in frames in his display case, one photographer uses thin strips of hickory instead of nails to hold the photos in place. The strips are cut a little longer than the inside width of the frames so that they will be bowed slightly when they are inserted in the frames as indicated.

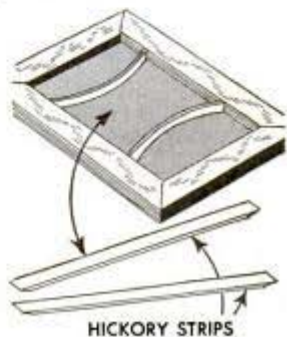



SHOP NOTES

Longer Life for **GRINDING WHEELS**

By W. C. Lammey

IN SEVERAL respects a grinding wheel is much like a circular-saw blade. Unless the circle of the saw teeth is concentric with the spindle and at right angles to it, the blade will not do satisfactory work. Essentially the same thing is true of a grinding wheel. Fig. 2 shows two common defects, due usually to wear and neglect, which can cause continued grinding-wheel trouble. You will notice that in neither case can you remove the wheel from the spindle, even after dressing, and replace it with assurance that it will run true. In detail A, the bushing is a loose fit on the spindle, either worn unduly or damaged by rough handling. Under this condition, the wheel will be out of true concentrically, that is, in relation to the spindle. Even though such a wheel is dressed carefully, the grip of the spindle flanges cannot be relied on to hold it true, especially under heavy stresses. In the second case, detail B, a section of the blotter on one side has been worn away. This throws the wheel out of true laterally, or sideways, and any undue tightening of the spindle nut in an effort to correct the fault may result in pressures which are dangerous in high-speed wheels. New blotters are fairly easy to apply by first scraping away all that remains of the worn blotter as in Fig. 4. Then cut new

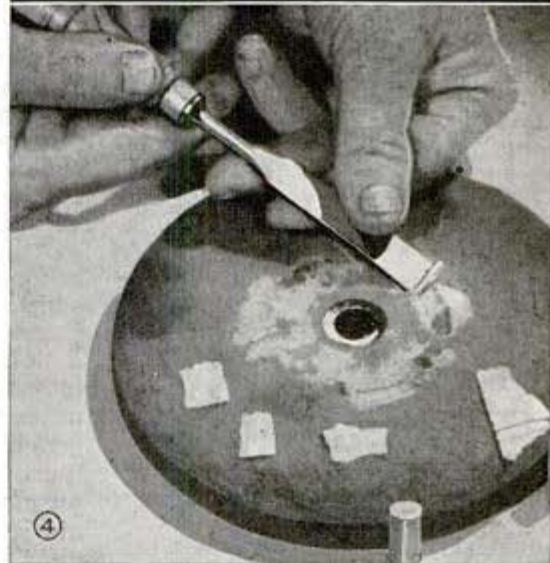
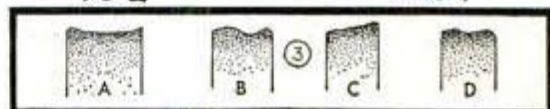
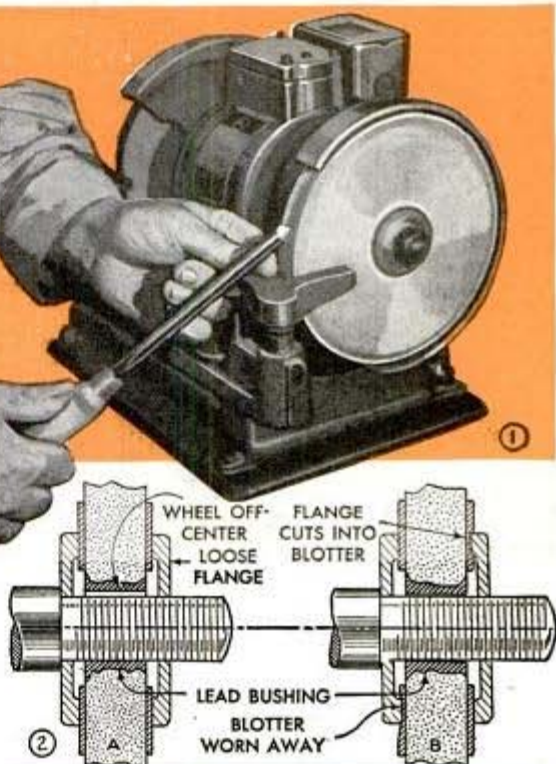

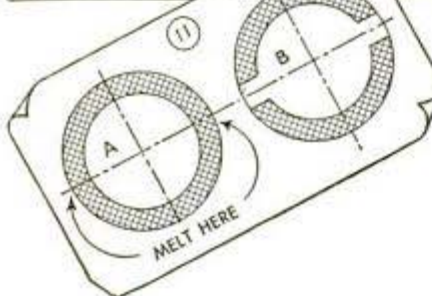
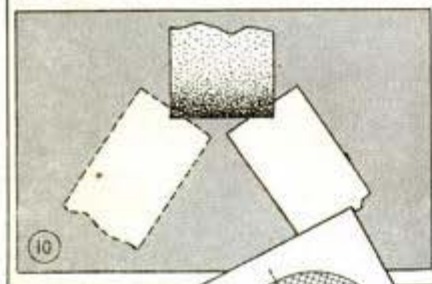
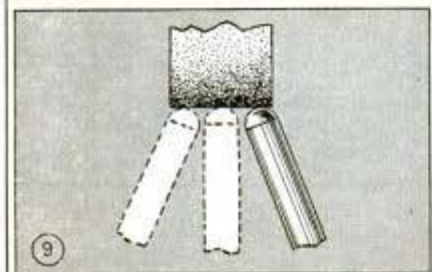
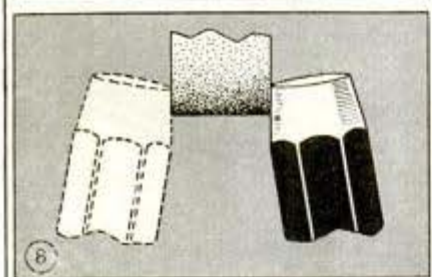
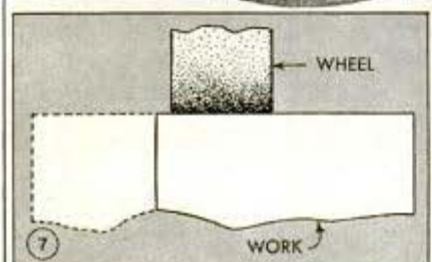
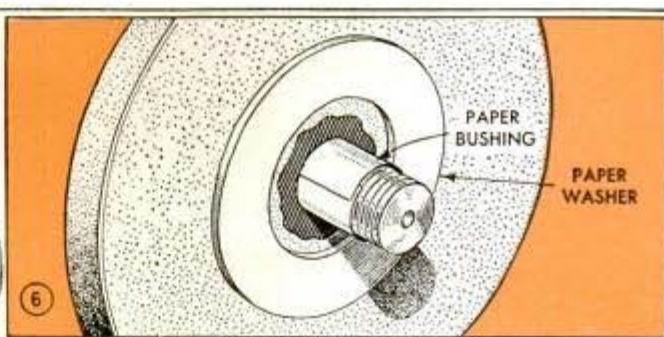
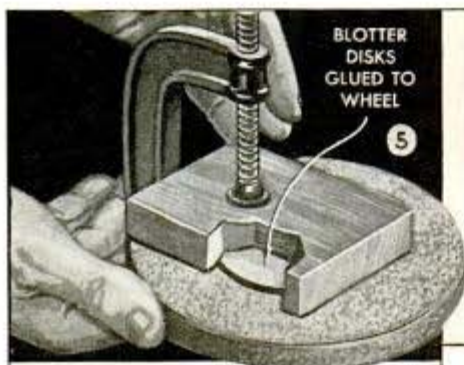

disks from blotter paper to the same internal and external diameters as the originals and glue these to the wheel with a C-clamp and a block as in Fig. 5. Most any glue will serve. Although in an emergency heavy paper or thin cardboard will do, blotter paper is best. However, if available, it is better to use the ready-cut blotters usually obtainable from the manufacturer of the wheel.

Renewing a bushing is a somewhat more extended operation. Where time permits it is perhaps advisable to return the wheel to the manufacturer for this job. But where it is necessary to keep the wheel in operation, one can, with care, do the work in his own shop. Sometimes, if the lead bushing is not worn too badly or distorted, it is possible to keep a wheel in service simply by wrapping a single thickness of suitable weight paper around the spindle as in Fig. 6. Where it is necessary to re-bush the wheel, proceed to remove the old bushing as at A and B in Fig. 11, first melting away the metal on opposite sides and then removing the balance with a sharp chisel. When doing this, care must be taken not to chip or crack the wheel. After this has been done, one can improvise a bushing chuck as in Fig. 15, by using a square piece of hardwood, true on both sides and somewhat larger each way than the diameter of the wheel. Bore a hole at the exact center of the block to take a bushing arbor, which may be a short length of steel shafting. Generally manufacturers recommend that the hole through the wheel bushing be from .002 to .005 in. larger than the diameter of the spindle as in Fig. 16. The latter must be measured and the arbor made accordingly. The arbor also must be a snug fit in the hole in the chuck, and must stand at right angles to the surface. Fit three adjustable clamps on the chuck as in Fig. 15. Place the wheel as shown and center it. Coat the arbor with a thin film of heavy grease, being sure that the grease is distributed evenly with no lumps or ridges at any point. Then make a bushing "cleaner" from a small piece of sheet metal to fit over the arbor as in Fig. 17. Adjacent to the arbor hole drill another small hole in the cleaner to serve as a pouring "sprue." Incidentally, it should be remembered that the proper grade of lead for bushings of this kind is of a pronounced grayish color when hot. Soft, thick lead, which is unsuitable for wheel bushings, is of a greenish, purple color when molten. Both lead and babbitt are used to bush grinding wheels, lead being the most common, although large cup wheels and

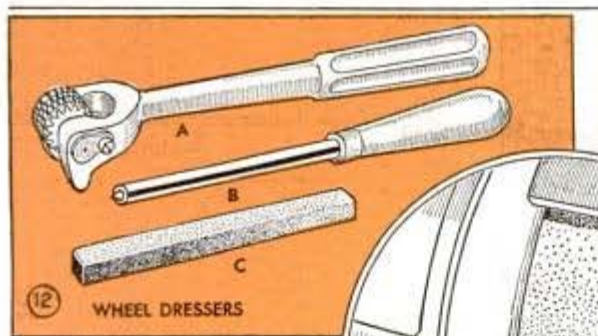

coarse wheels subject to heavy pressures often are bushed with babbitt. After the bushing has been poured, wait a few seconds for the lead to set, then swing the cleaner a quarter turn or so to shear off any excess. Carefully remove the wheel from the chuck and very gently drive out the arbor with a wood mallet, taking the greatest care to avoid distorting the bushing. Finally, to finish the job, the bushing is trimmed and undercut with a sharp chisel as in Fig. 18 so that no part of it projects beyond the sides of the wheel, Fig. 19. If necessary after this operation, disks of new blotting paper should be put on the wheel. When replacing a wheel on the spindle, it's very important to avoid drawing the spindle nut too tight. A light pressure on the wrench usually is sufficient as the nut tends to tighten when the wheel is in use.

A careful operator can do much to prevent undue wear on the wheel. Fig. 3 shows in somewhat exaggerated form some of the common shapes a wheel will wear into in a very short time unless some effort is made to distribute the wear of continuous grinding operations. Figs. 1, and 7 to 10 inclusive suggest several practical ways of doing this. Avoid varying pressures and unduly heavy pressure. When necessary to grind on the side of the wheel, Fig. 8, shift alternately from one side of the wheel to the other where practical. And when grinding a part or tool that is less in width or diameter than the thickness of the wheel, move the work across its face, as in Fig. 9, or on both edges as in Fig. 10, when grinding a V-groove and similar work.

Truing or dressing a wheel is simply another of those "careful" operations. There are, in general, three types of wheel dressers in use. Nearly everyone is familiar with the first of these, which is shown at A in Fig. 12. In use, this dresser generally is placed on the tool rest as in Fig. 13, with the two projections "hooked" over the edge of the rest. Raising the handle of the dresser as in Fig. 14, the loose rollers are brought into contact with the wheel face. In this way one has a fairly positive control over the pressure applied. The second type, which is widely used but quite expensive, is the diamond dresser shown at B. This consists of a small industrial diamond mounted in a handled holder. Many skilled operators use this dresser freehand, but for average work it is perhaps better to support it on the tool rest. When truing the face of the wheel the diamond should contact the surface slightly below the horizontal centerline of the

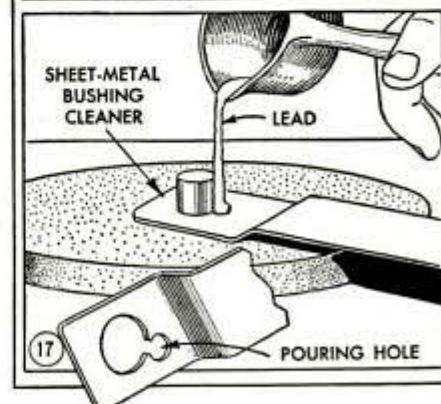
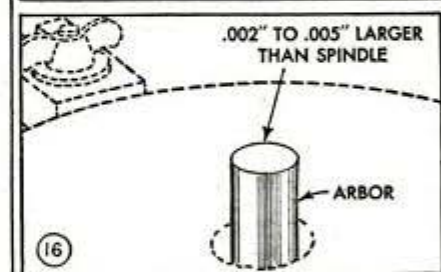
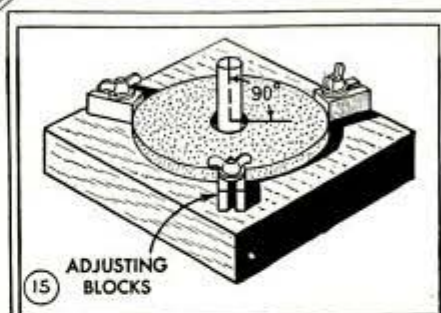
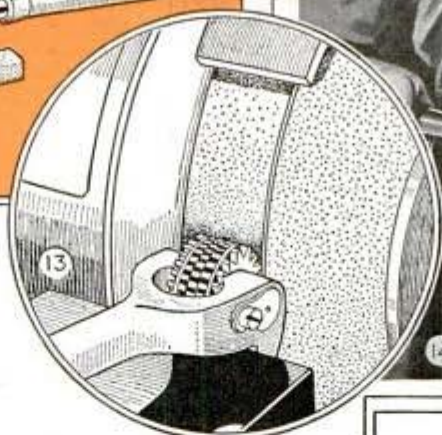
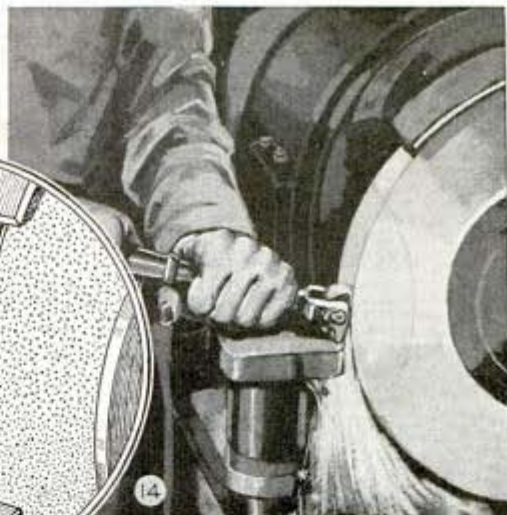

The latter is so adjusted that by raising the handle of the dresser as in Fig. 14, the loose rollers are brought into contact with the wheel face. In this way one has a fairly positive control over the pressure applied. The second type, which is widely used but quite expensive, is the diamond dresser shown at B. This consists of a small industrial diamond mounted in a handled holder. Many skilled operators use this dresser freehand, but for average work it is perhaps better to support it on the tool rest. When truing the face of the wheel the diamond should contact the surface slightly below the horizontal centerline of the

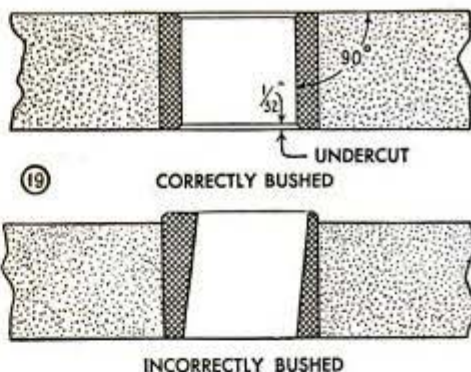

wheel. The third type of dresser, C, is simply a coarse-grained abrasive "stick" especially made for the purpose by manufacturers of abrasives. Both these latter dressers "cut" very fast and for this reason they should be used with care.

Customer Selects Sunglasses Unaided From Show Window

In order to increase sales of sunglasses without taking too much of his time waiting for his customers to make their selections, one merchant stuck some of the glasses to his show window as indicated. These were placed inside the window and were located at various heights so that it was easy for anyone to look through them. A photoflood lamp directed on artificial snow inside the window, produced a brilliant reflection, thus enabling the customer to pick glasses suitable to protect his eyes under any weather conditions.



Drill and Tap Stored in Base Of Toolmaker's Button Set

If you fit a sliding cover over the hollow base of your toolmaker's button set, a storage space will be provided for the tap and



drill used in making the button clamping screws. Having the correct size of drill and tap at hand with the set will save the time lost in looking for them, and will avoid the use of a drill and tap of the wrong size which may damage the clamping screws, or make it necessary to substitute

Rack Made From Old Ring Gear

When a rack and pinion are needed for a mechanical movement and no rack is available, often one can be made by straightening an old ring gear of the type used on the flywheel of a car motor. Of course, a rack made in this way may not be accurate and may not stand up under hard use, but it will be satisfactory where it is used for short periods of time, or where the movement is slow. To straighten the gear, heat it to a red heat and then carefully straighten it in a vise or by hammering, taking care not to misshape the teeth. If there is a tendency for the teeth to close when the gear is straightened, bring the gear to a white heat and run the pinion over the teeth, pressing it down firmly. This action will tend to spread them to mesh more correctly with the pinion teeth. The pinion, of course, must have teeth of the same shape and spacing as those on the gear. As heating softens the gear, it should be hardened by heating to a cherry red and then plunging it into water.

Electric Pig Brooder Increases Your Profits

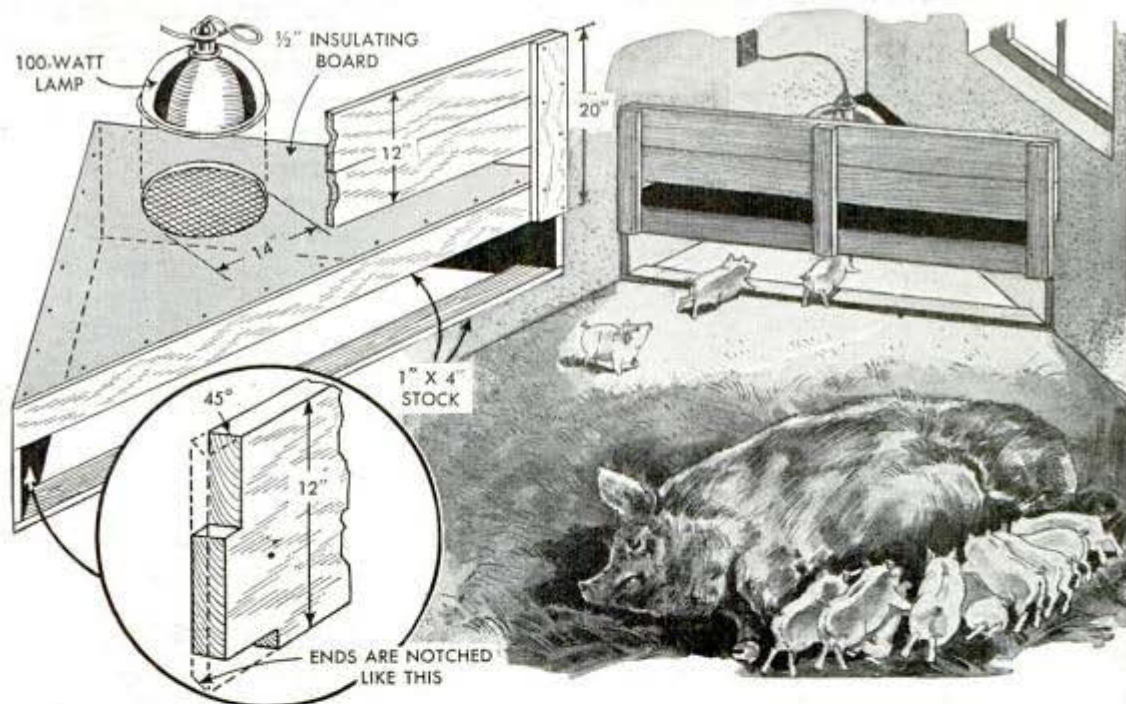

Loss of little pigs within a few days after farrowing can be reduced greatly by use of an electric brooder such as this one, which is recommended by the Rural Electrification Administration, U. S. Dept. of Agriculture. Besides protecting the pigs against chilling, the brooder also reduces the chances of the sow crushing them. Used in any weathertight building that otherwise is suitable, the brooder produces a steady, reliable heat. Naturally, heat requirements will vary with outside temperatures, but in general a 100 to 150-watt bulb will be sufficient. Experience has shown that it is best to place the sow in the brooder building a day or two before farrowing, and to operate the brooder for several hours before the pigs arrive. In

most cases, it is necessary to keep the pigs inside the brooder for several hours after arrival to be sure that they will be warm and dry. After this period, they will have to be put in by hand until they learn to go voluntarily. Ordinarily, the heat should be kept on for ten days, not including the time before the arrival of the pigs. The triangular brooder fits into one corner of the building and can be made from scrap boards. Insulating board is ideal for the top. The lamp and its reflector fit over a screened opening in the top, and are plugged into an electrical outlet in the building, using a heavily insulated cord of sufficient size to carry the current. For sake of safety, the brooder should be bolted to the building walls, or otherwise secured.

Life of Timing Chain Prolonged by Improved Lubrication

On some truck motors where the timing chains failed prematurely it was found that the only source of lubrication was by means of vapors rising from the crankcase. To provide better lubrication, a line was run from the clean-oil side of the oil filter to the top side of the timing chain case as indicated, a hole being drilled in the upper part of the case and then tapped to take a fitting to which the line was attached. In this way, filtered oil performed a lubricating function on its way back to the crankcase and thereby corrected a very aggravating problem.

—Jack A. Nelson, Des Moines, Ia.

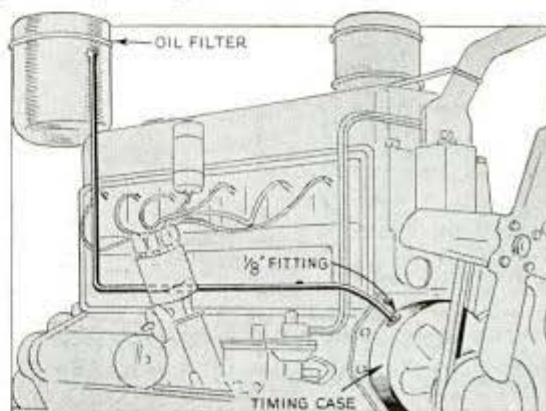

Yardstick Level Aids Sign Painter In Layout Work on Window

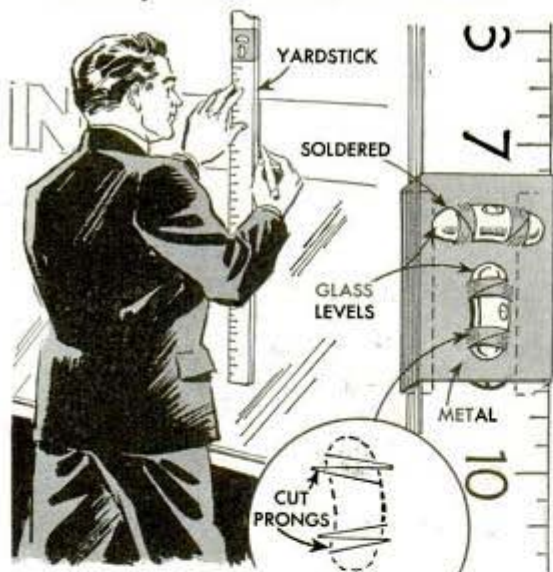

Used either in a vertical or horizontal position, this improvised level has been very helpful in my work as a sign painter, especially in getting layout work square on surfaces such as large windows and signs. Two glass levels, a piece of sheet metal and a yardstick or other straight-edge are required. After bending the metal to provide a sleeve with a snug, sliding fit on the yardstick, small prongs are cut in the metal and bent over the levels to hold them in place. It may be necessary to solder down the prong tips to hold the levels tightly. But before doing this, the accuracy of the entire assembly should be checked with a long carpenter's level.

—C. B. Wing, Jr., St. Ignace, Mich.

Handle to Carry Electric Motor Improved From Heavy Wire

On farms and other places where one motor is used on several different jobs, the Rural Electrification News suggests using a carrying handle improvised from two

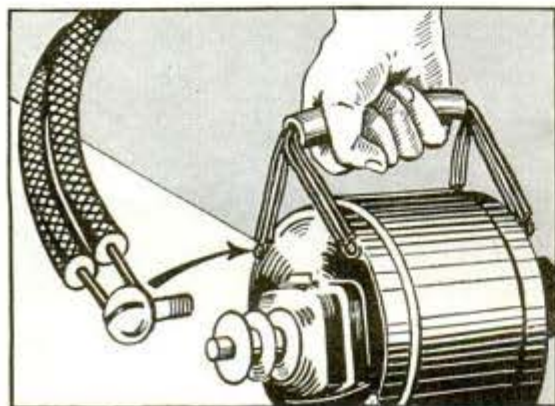

lengths of heavy insulated wire and a piece of pipe or hose as shown. Both lengths of wire are doubled, then run through the pipe or hose and the ends slipped under the bolts that attach the ends of the housing.

Finger Holes in Large Letter Files For Easy Removal From Shelf

Difficulty of removing large, book-shaped files from a shelf, especially a high one, can be overcome by cutting a couple of finger holes in the edge of the file as indicated. The holes enable you to get a good grip with the fingers for pulling a file from between others on the shelf.

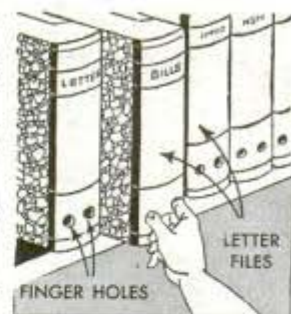

Rolling Eggs in Incubator Trays Prevented by Wooden Blocks

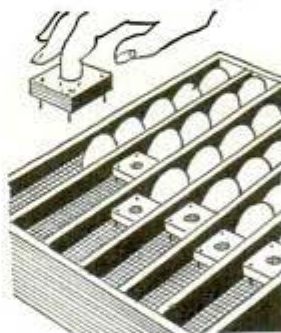

Although incubator trays may be filled with eggs so they can't roll about when first placed in the machine, the fertility test later will eliminate enough to leave many vacant spaces in the trays. To avoid having the eggs

roll and break after this time, wads of paper often are used to keep the eggs close together. A better method is to use wooden follower blocks. These have finger holes drilled in the centers for easy lifting, and each one has a small nail at each corner to engage the meshes of the wire tray bottoms to keep the blocks in place.

Handy Way to Display Books

To hold books conveniently for his window display, one store owner uses metal book ends, the vertical parts of which are bent at an angle of about 45 degrees. In use, the bent portion of the metal is slipped between the back cover and pages, thus holding the book at a convenient angle for reading the title.

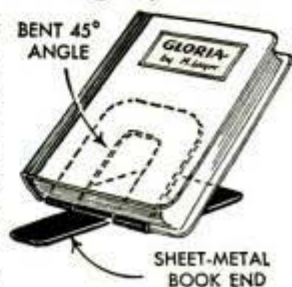

Magnetic Base Supports Dial-Type Test Indicator

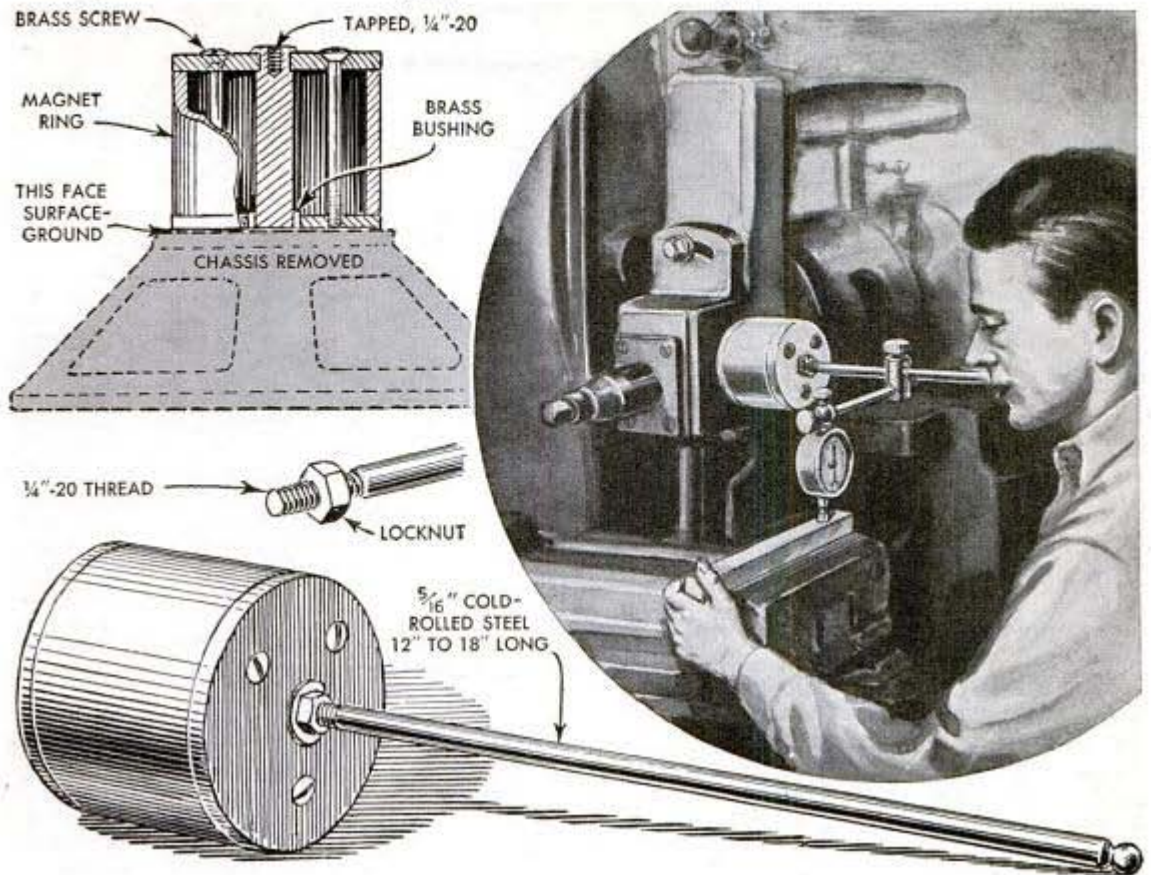

With a magnetic base like this one attached to a dial indicator, any flat spot on a machine tool, either horizontal or vertical, provides a suitable surface to set it for convenience* in testing work in a planer, lathe, grinder, etc. It is improvised at small cost from an old radio loudspeaker of the type having a permanent field magnet, which is removed by taking the assembly apart and breaking the spot welds holding

the lower plate to the chassis. Before re-assembling, this plate should be surface-ground so that good contact is had wherever it is placed. The space around the magnet core is filled with a brass bushing, after which a hole is tapped in the top to take a rod supporting the indicator. When not in use, the device should be set on an iron surface to preserve its magnetism.

—Peter W. Mueller, St. Louis, Mo.

Beam Compass Doubles as Trammel to Ink or Scribe Metal

Circles of practically any size can be drawn in pencil, inked or scribed on metal with this combination beam compass and trammel by simply interchanging the pencil with a draftsman's ruling pen or a center punch. Its capacity is limited only by the length of the rod, which is threaded at the end for coupling extensions. A fuller ball provides a neat knob to protect the threads. If the handle of the ruling pen is too small to fit the pencil holder, it can be wrapped with a few turns of adhesive tape.

—Arthur Trauffer, Davenport, Ia.

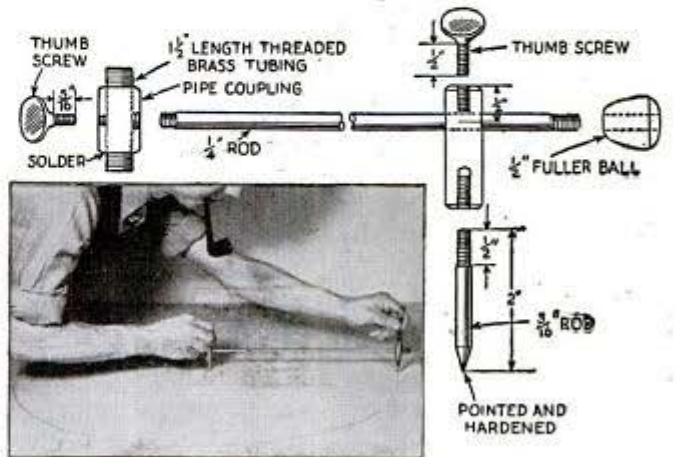

Hinged Ledge on Cashier's Desk Serves as Coin Stop



Sloping-top desks that often are used by cashiers in banks and offices, can be improved for this purpose by hinging a small ledge to the lower edge. Then, when counting and packaging coins, the ledge can be turned over the edge of the desk to prevent coins from rolling onto the floor. When not in use, the ledge hangs down out of the way.

Show Cards Dried in Pocket Comb



the cards spaced so they do not touch, and make them easy to remove.

To hold a number of small show cards for drying, one artist inserts them between the teeth of a pocket comb, which is tacked to the back board of his work table. The teeth of the comb keep

Tumbler With Beeswax in Bottom Substitutes for Carboy Stopper

After misplacing the stopper for an acid carboy, one workman made a good substitute by putting a little melted beeswax in the bottom of a glass tumbler, which then was inverted

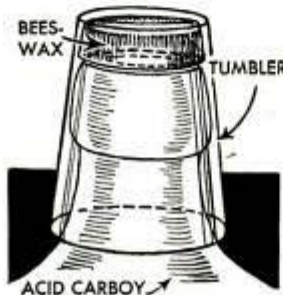

over the mouth of the carboy. The soft beeswax made a good seal between the tumbler and carboy. Also, it was found that the substitute stopper saved time when used on other acid bottles that had to be opened frequently during working hours as only one hand was required to remove the tumbler, whereas both were needed to remove the regular stopper.

Extra Hook Holds Double Doors To Operate as One Unit

If it sometimes is desirable to have double barn doors open or close as a unit, this can be accomplished by attaching an extra hook and staple to the inside of the doors as shown. The hook should be attached to the lower door so that it will drop down out of the way when not in use.



Spring-Hinged Cover of Oil Cup Opened by Notched Oilcan Spout



Instead of using both hands to open and fill oil cups of the type that have spring-hinged covers, cut away part of the oilcan spout at the end as indicated. This will enable you to raise the cover by pushing the spout end under it, in which position oil will run from the spout into the cup without changing the position of the oilcan.

Flexible Steel Rule Partly Opened Is Easy to Remove From Pocket

In order to have his flexible steel rule instantly at hand and easy to remove from his pocket, one carpenter pulls out the end for a distance of several inches from the case. In this position, the end of the rule is inserted into the rule pocket of his overalls where it is carried safely with the case projecting for easy removal.

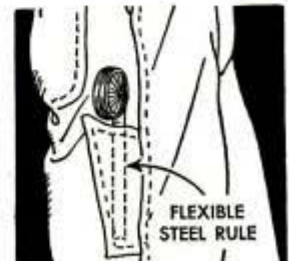

Three Kinks That Help Bicycle Delivery Boys

Boys who make store deliveries on bicycles fitted with large baskets will find that these kinks enable them to do their work more easily. The problem of carrying bottled goods or merchandise that is crushed easily is solved by fitting canvas bags or pockets to the ends of the basket as shown in detail A. Where several small deliveries are made at one trip, three or four light wood boxes made to fit inside the basket as shown in detail B will hold the individual orders. When several orders are placed in the basket, a removable basket as in C provides a tray for carrying the orders into homes.

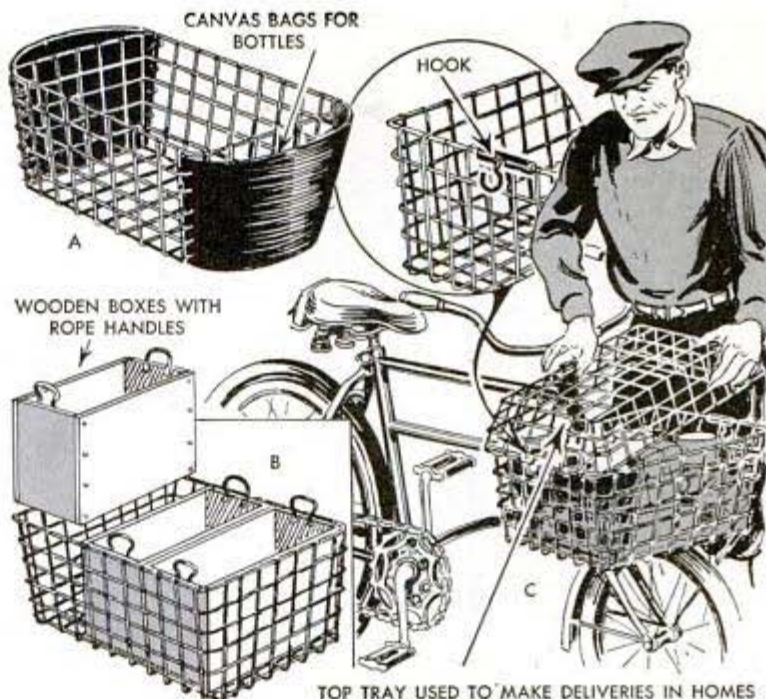

Buttresses Protect Frames of Loading Doors at Warehouse



Damage to the sill and frames of a loading door, which was caused by trucks backing into it, was avoided at the warehouse of a storage company by the use of concrete buttresses. These were made on each side of the doorway and projected a foot or so above the sill as indicated, to assure contact with truck bodies of various heights. Heavy sheet metal was used to sheath the frame on its inner surfaces and above the buttresses. This arrangement not only improved the appearance of the doorway, but also reduced maintenance cost to a minimum. If desired, a concrete step can be provided between the buttresses for entrance to the door. A piece of heavy plate metal bridges the space between the door sill and the truck.

Angle Iron on Bench Edge Is Handy for Shearing Heavy Sheet Metal

If you have to cut a large piece of sheet metal that is too heavy for regular hand shears, try the following method: Just screw a length of angle iron, such as an old bed rail, to one edge of your bench. Then use the iron as a shearing edge in combination with a wide shearing chisel as shown. Place the work on the bench with the shearing guide line at the edge of the angle iron and clamp the work in place with a board or wood strip screwed to the bench top.

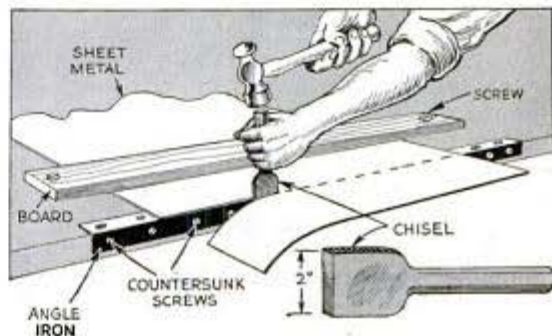

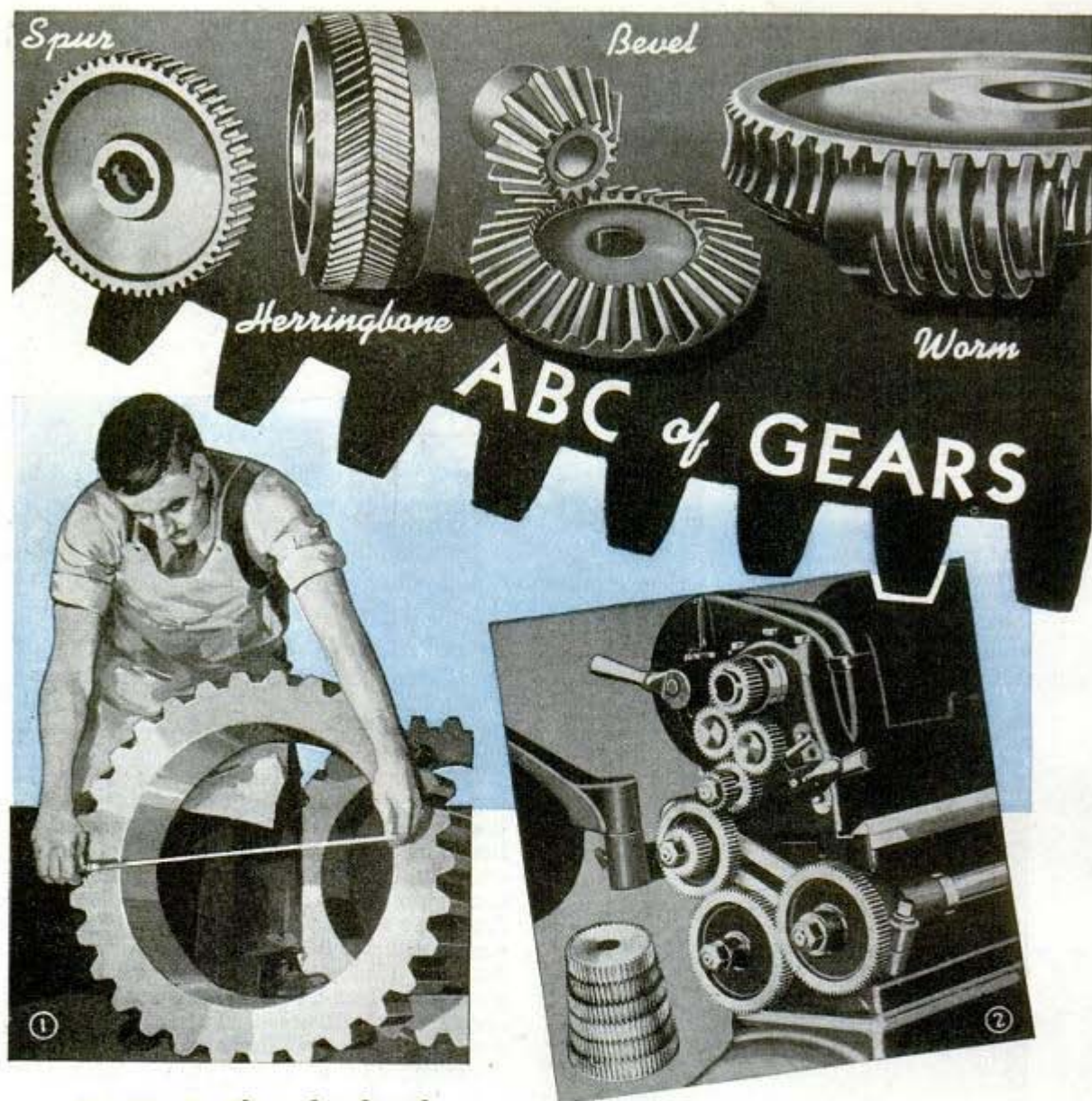

By H. J. Chamberland

GEARs play a highly important role in many products where it is necessary to transmit power from one part to another within a limited space, especially in the case of machine tools. With this in view, any machine-shop worker should know something about gears and the nomenclature involved, inasmuch as he may be put to working in connection with their production, and certainly will have occasion at some time or other to make use of them. However, in this article, which covers the subject of gears only in an elementary way, most information relating to gear design will be omitted.

Common types of gears: Depending upon requirements, gears are made in various types and sizes. Their success or failure,

and also their length of service, depend to a great extent on the material from which they are made and the heat treatment given, while their efficiency of operation is governed largely by the accuracy of the tooth form. Spur gears, shown in the heading and also in Figs. 1, 3 and 12, are the most common in use. Their teeth are cut straight across, parallel to the axis of the blank disk from which they are machined. The diameter of the bore of a gear must be checked with considerable accuracy, for which purpose vernier calipers are used as shown in Fig. 1. Other types of gears are known as helical (or spiral), herringbone, bevel and miter (a 45° bevel gear) and worm gears, which are shown in the heading. The smaller gear of a pair is called a pinion; a gear at the source of power is

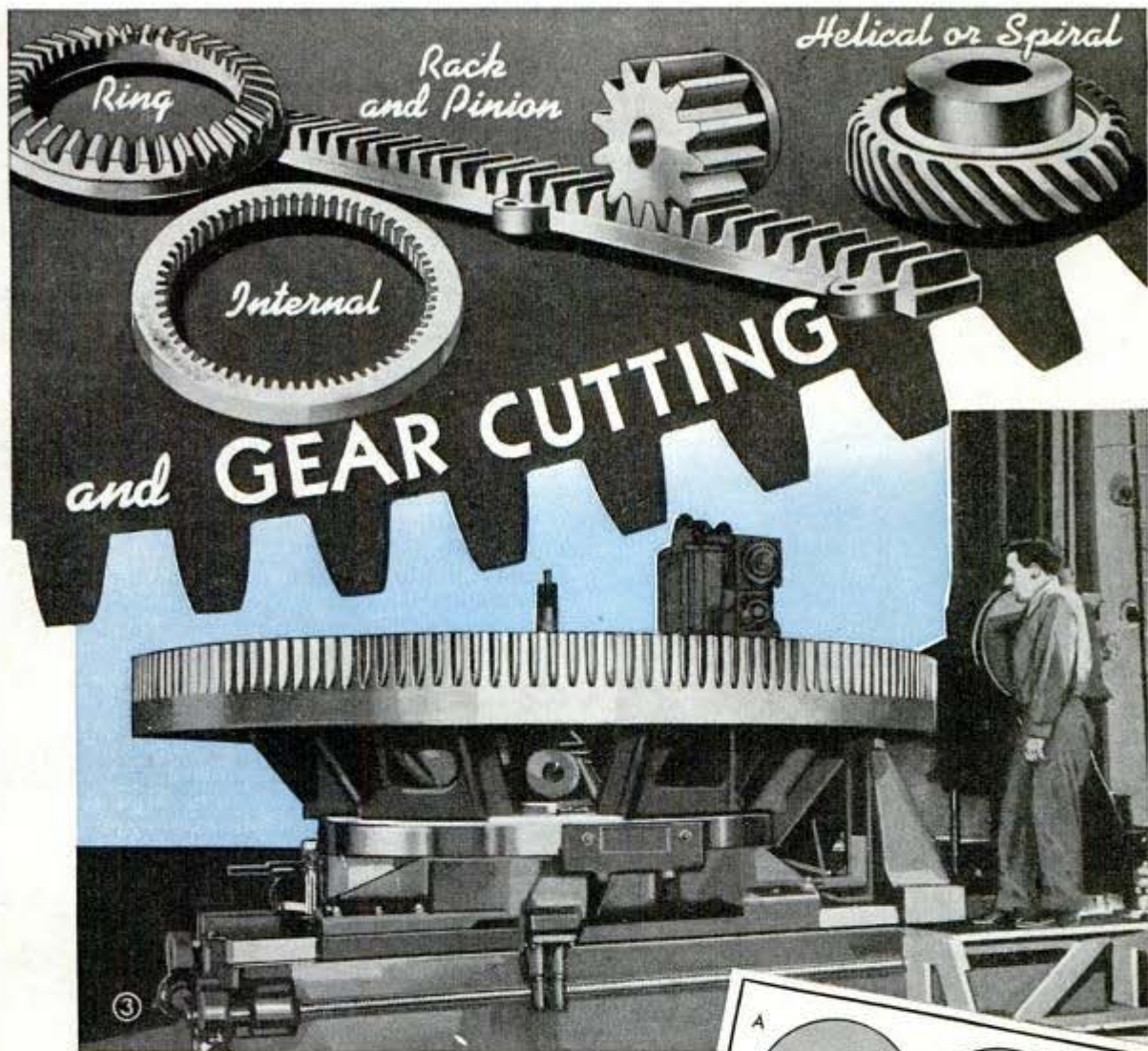

referred to as a driving gear or a driver, while one to which power is transmitted from the driver is called a driven or follower gear. A "train" of gears consists of several arranged in any combination, as for instance a train of gears found in a screw-cutting lathe as in Fig. 2.

Gears versus frictional wheels: If two disks or wheels are held so that their circumferences contact each other as shown in detail A of Fig. 4, a rotation of one will cause the other to rotate, provided the friction between the two is sufficient. Obviously, some power can be transmitted in this way but where it is necessary to transmit considerable power, friction alone between the surfaces is undependable, as there may be slippage. This inefficiency is basically the reason for having gears, which are simply disks or wheels to which teeth are added so that intermeshing gears can rotate without slippage, power being transmitted by the teeth. You will note from

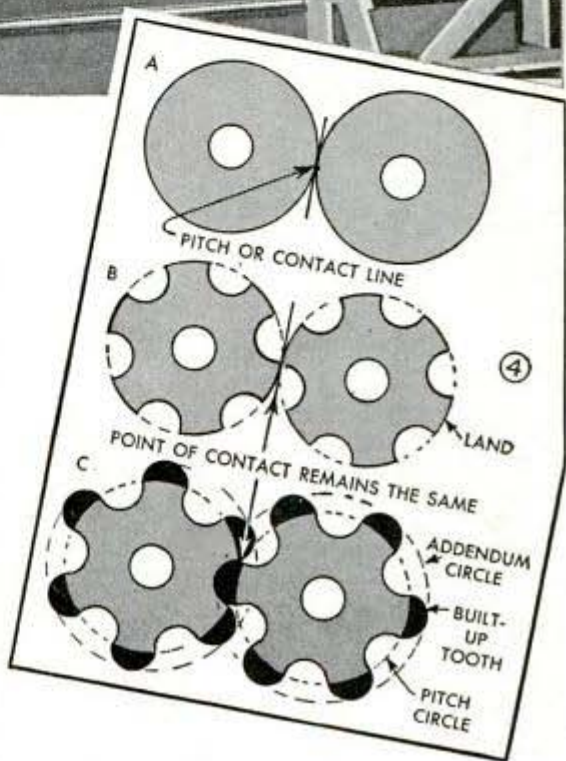

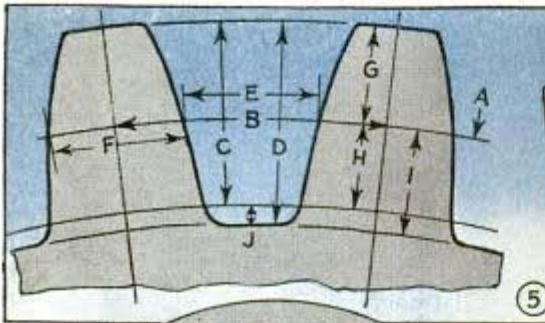

A—Pitch line or pitch circle
 B—Circular pitch or distance between centers of two adjacent teeth, measured along pitch circle
 C—Working depth of gears
 D—Full depth of teeth
 E—Width of spacing between adjacent teeth, measured along pitch line
 F—Thickness of tooth at pitch line
 G—Depth of addendum or face
 H—Working depth below pitch line or flank
 I—Space below pitch line or dedendum
 J—Clearance

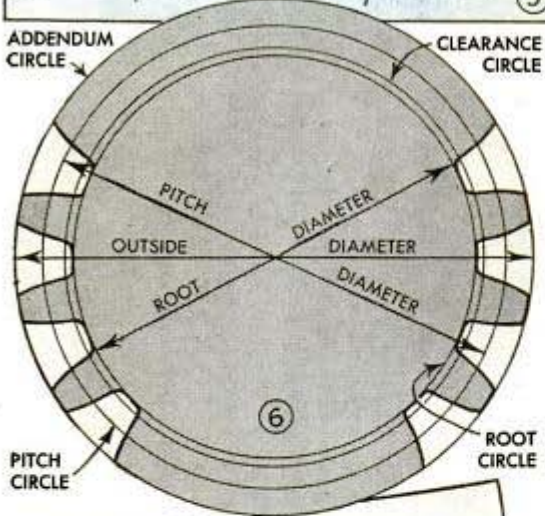

Symbol Definition
 P —Diametral pitch or number of teeth per inch of pitch diameter
 P' —Circular pitch
 N —Number of teeth
 D —Outside diameter
 D' —Pitch diameter
 f —Clearance at bottom of tooth
 D'' —Working depth of tooth
 D'' + f —Full depth of tooth
 D''' —Bottom diameter
 D''' + f —Addendum
 s —Dedendum
 s + f —Thickness of tooth on pitch line

diameter of the disks in detail A of Fig. 4. This is known specifically as the "pitch diameter," while the circumference of the disk becomes the "pitch circle" of the gear. Fig. 6 shows the three diameters of a gear and the relating circles, while Fig. 7 gives gear symbols.

Diametral pitch: With the meaning of pitch diameter and pitch circle established, it is easy to understand what is meant by "diametral pitch," a term designating the tooth size of a gear. It is not an actual dimension but it is the ratio between the number of teeth on the gear and its pitch diameter in inches. Thus, a 4 diametral pitch gear has four times as many teeth as it has inches of pitch diameter. If the latter were 12 in., there would be 48 teeth on the gear. In other words diametral pitch is the number of teeth per inch of pitch diameter. Spacing and size of the teeth can be determined readily from this information.

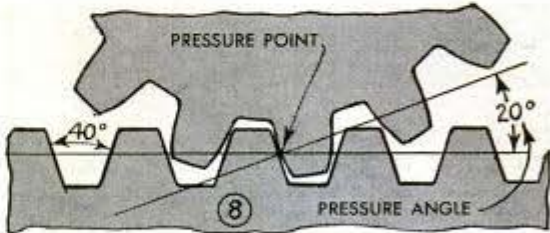

details B and C of Fig. 4 just how gears having the same diameter as the disks in detail A, are evolved. A number of equal-size, semicircular portions are cut out equidistantly on the circumference of the disks, after which the cut-out pieces are joined to the disks on the intervening spaces or "lands" along the circumference, to form teeth. Note that in the transformation from disks to gears, the center-to-center distance has remained the same, but that the outside diameter of the gears is greater than the diameter of the disks.

Pitch circle and pitch diameter: When referring to the size of gears, as in machine-design drawings, it is not the outside diameter which is meant, nor the inside or "root" diameter along the bottom of the teeth, but the diameter at the approximate center of the teeth—in other words, the

No. of cutter	Amount of teeth cut
1	From 135 teeth
2	" 55 teeth to 134 teeth
3	" 35 " " 54 "
4	" 26 " " 34 "
5	" 21 " " 25 "
6	" 17 " " 20 "
7	" 14 " " 16 "
8	" 12 " " 13 "

(10)—HOW GEARS ARE SIZED

TO FIND DIAMETRAL PITCH (P)
when number of teeth and outside diameter are known. Add 2 to number of teeth and divide by outside diameter. Example: 40 teeth and $10\frac{1}{2}$ in. diameter: 40 plus 2 divided by $10\frac{1}{2}$ in. equals 4. Ans. 4 diametral pitch.

TO FIND CIRCULAR PITCH (P')
when diametral pitch is known. Divide 3.1416 by diametral pitch. Example: 4 diametral pitch: 3.1416 divided by 4 equals .7854 in. Ans. .7854 cir. pitch.

TO FIND NUMBER OF TEETH (N)
when outside diameter and diametral pitch are known. Multiply outside diameter by diametral pitch and subtract 2. Example: $10\frac{1}{2}$ diameter and 4 diametral pitch: $10\frac{1}{2}$ in. multiplied by 4 and minus 2 equals 40. Ans. 40 teeth.

TO FIND OUTSIDE DIAMETER (D)
when number of teeth and diametral pitch are known. Add 2 to number of teeth and divide by diametral pitch. Example: 40 teeth and 4 diametral pitch: 40 plus 2 divided by 4 equals $10\frac{1}{2}$. Ans. $10\frac{1}{2}$ in. outside dia.

TO FIND PITCH DIAMETER (D')
when number of teeth and diametral pitch are known. Divide number of teeth by diametral pitch. Example: 40 teeth and 4 diametral pitch: 40 divided by 4 equals 10. Ans. 10 in. pitch dia.

TO FIND CLEARANCE (f)
when diametral pitch is known. Divide 1.57 by diametral pitch. Example: 4 diametral pitch: 1.57 divided by 4 equals .392 in. Ans. .392 clearance.

TO FIND FULL DEPTH OF TOOTH
(working depth plus clearance) when diametral pitch is known. Divide 2.157 by diametral pitch. Example: 6 diametral pitch: 2.157 divided by 6 equals .3595 in. Ans. .3595 full depth of tooth.

TO FIND THICKNESS OF TOOTH AT PITCH LINE (t)
when circular pitch is known. Divide circular pitch by 2. Example: 1.047 circular pitch: 1.047 divided by 2 equals .523 in. Ans. .523 thickness of tooth.

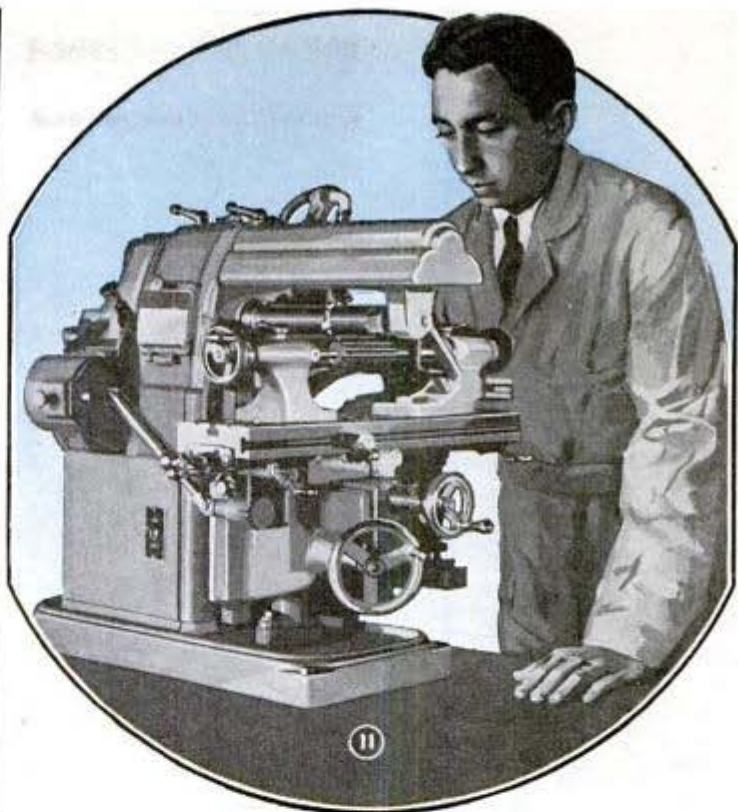

Circular pitch: On large gears, the tooth size may be designated by the term "circular pitch." This is the distance between the centers of two adjacent teeth measured on the pitch circle as indicated by B in Fig. 5. To translate this into equivalent diametral pitch, you divide 3.1416 by the circular pitch. Or, if you desire to know the circular pitch when only the diametral pitch is given, you simply divide 3.1416 by the diametral pitch. For examples, refer to Fig. 10. The number of teeth on the circumference of a gear is largely determined by the amount of power that must be transmitted from one gear to another, and the strength of the gear teeth themselves. The angle at which the gear teeth press against teeth of a mating gear or rack is called the pressure angle as indicated in Fig. 8. In gear-cutting practice, pressure angles of $14\frac{1}{2}$ and 20 degrees are commonly used. For calculating the size of gears, there are eight important formulas and examples listed in Fig. 10. These can be applied without much knowledge of mathematics. However, to go deeper into gearing such as computing helical, bevel, worm gears, as well as the more complicated types, one must expect to deal in geometrical terms.

Gear-cutting sets: If the teeth of all gears had to be cut with separate cutters, a considerable and prohibitive investment for cutters would be required. Hence, for the sake of economy and simplification, a system is in practice whereby sets of cutters, each comprising eight cutters for each pitch, will handle all problems. Fig. 9 shows the comparative increase in radius between a No. 5 and a No. 8 cutter of the 8-diametral pitch set. The tooth form of a cutter of a set remains fixed and this cutter will produce the precisely correct tooth form only on a gear of certain diameter and number of teeth.

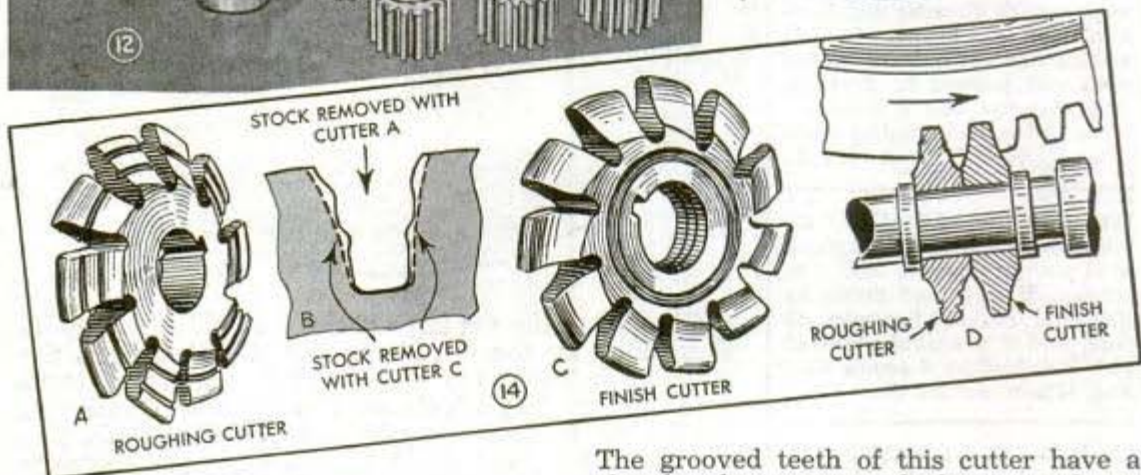
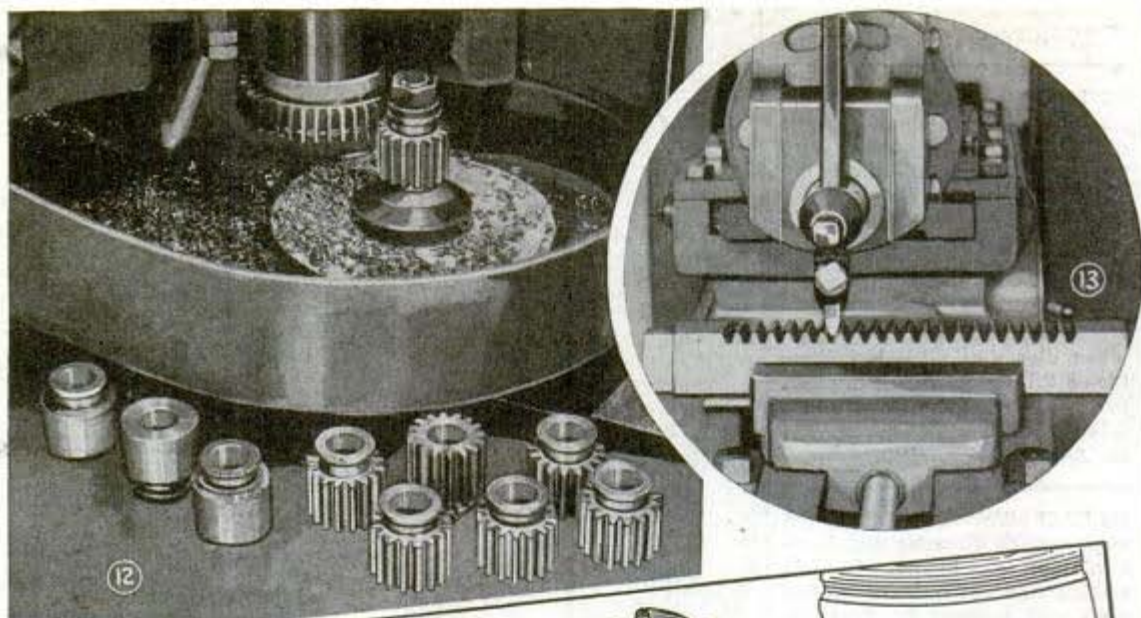

Each cutter of a set is designed to be perfectly correct for the lowest number of teeth in the range it covers. For example, a No. 2 cutter, which cuts from 55 to 134 teeth, has the correct curve for 55 teeth, so the more teeth this cutter has to cut the more rounded will be the teeth of the gear because the length of the bearing on each tooth decreases as the number of teeth increases. Naturally, gears cut according to this procedure cannot be expected to operate as smoothly as they would when having their individual or theoretical curve.

Gear-cutting procedures: Gear teeth are cut by milling, hobbing and shaping. Hobbing, a specialized form of milling and gear shaping, is done in a machine having no connection to a conventional shaper. The operation is similar to a milling operation and small gear cutters are often cut in gangs as shown in Fig. 11 by completing each flute with a single cut. Larger gears usually are made by cutting them singly, using a roughing or stocking cutter first, detail A of Fig. 14, and then a regular finish cutter as shown in detail C. The effect of the roughing cutter is shown in detail B.

The grooved teeth of this cutter have a chip-breaking action, which permits faster and cleaner cutting with very little stock remaining for finishing. When cutting gears of large size, both cutters may be operated in a gang as shown in detail D, in which case the cutters do their work simultaneously and at a marked saving in time.

The hobbing method of gear cutting shown in Fig. 16 is continuous rather than intermittent as with a plain cutter, which requires indexing for each tooth. The cutting tool is a hob, which resembles a worm gear except that it has cutting teeth and produces equally spaced teeth on a cylindrical surface. The hob and the gear blank revolve at correct relative speeds by means of gearing, the hob advancing uniformly to cut teeth with the correct pitch.

The most productive method of gear cutting is by shaping, as in Fig. 12. A gear shaper uses a cutting tool which is essentially a hardened gear with its teeth properly relieved. When starting to cut a gear, the cutter is first fed down against the edge of the blank to proper depth, after which it reciprocates at a speed of about 800 strokes per minute while both gear blank and cutter revolve and the teeth on the

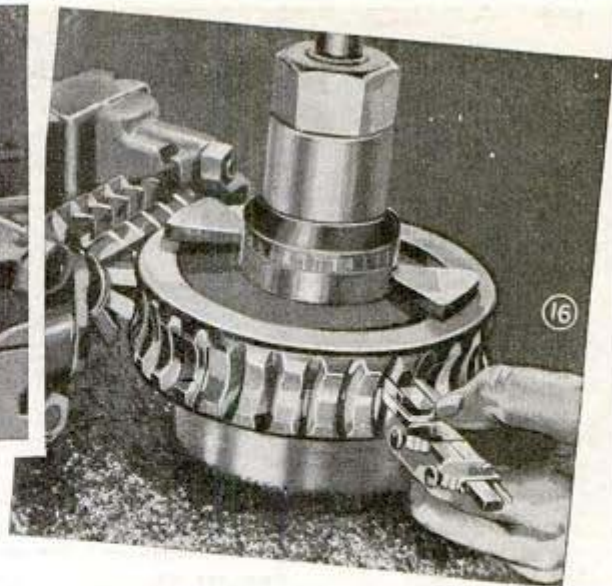
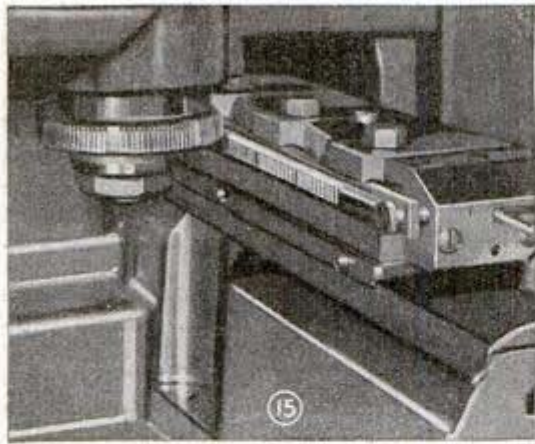

blank are cut in one rotation of the blank. However, often two cuts are taken for extremely precise tooth forms. This method is efficient, as one cutter of any pitch will cut any number of teeth of that pitch, whereas a formed cutter will cut but a limited number of teeth.

As shown in Fig. 13, teeth in gear racks are often produced in regular shapers and even planers with a tool bit formed accordingly. This procedure is rather slow, as each tooth must be cut separately, but the procedure is practical to duplicate a broken or worn part. In quantities, racks are cut as shown in Fig. 15. The herringbone gear being cut by the shaping method in Fig. 17 actually comprises two helical gears with teeth angles in opposite directions. Such a gear is often made in two parts with a milling cutter or end mill, but can be cut also by shaping. Helical (or spiral) and herringbone gears are used extensively to transmit heavy loads with extreme quietness, as for example in autos. Except for somewhat more involved computation of tooth form, these gears can be machined as easily as spur gears.

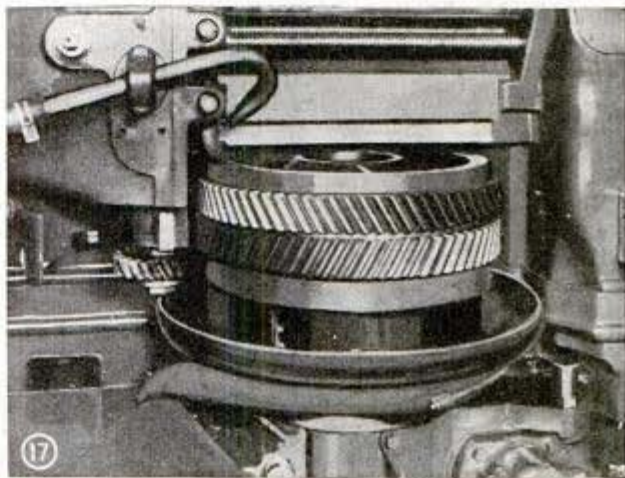

A bevel gear has its teeth cut on an angular face to transmit power to shafts set at an angle to each other. When both shafts are at an angle of 45 degrees, the gears are known as miter gears. In this the teeth are usually straight but they also can be cut spirally for increased strength and driving power plus smooth operation. The cutting of bevel gears involves a different problem than other types due to the difference in diameter at both ends of the gear blank. The diametral pitch of bevel gears is that of the larger end of the teeth but the pitch gradually changes toward the smaller end. Due to this change in pitch, bevel gears can be cut accurately only by shaping if quantity is involved. However, for quality, the teeth can be milled to their greatest

extent and the small ends finished by filing them to produce their shape as nearly correct as possible. This latter course requires extreme care since the maximum bearing point of those gears should be at the small end.

Worm gearing is also somewhat different than other forms of gearing. As shown in Fig. 16, it consists of a screw and worm wheel, the latter being somewhat similar to a helical gear with its face concaved to match the form of the screw thread. When a hobbing machine is not available, worm wheels may be cut by milling. In this case the procedure is to set the milling machine table at the proper angle, after which the operator proceeds to rough the teeth with a cutter of predetermined diameter by repeatedly indexing and feeding the wheel against the cutter vertically. Then the correct tooth form is produced as in Fig. 18, with a hob fitted to an arbor and the assembly revolving freely between centers with the teeth of the hob meshing with the rough teeth of the wheel. In this case how-

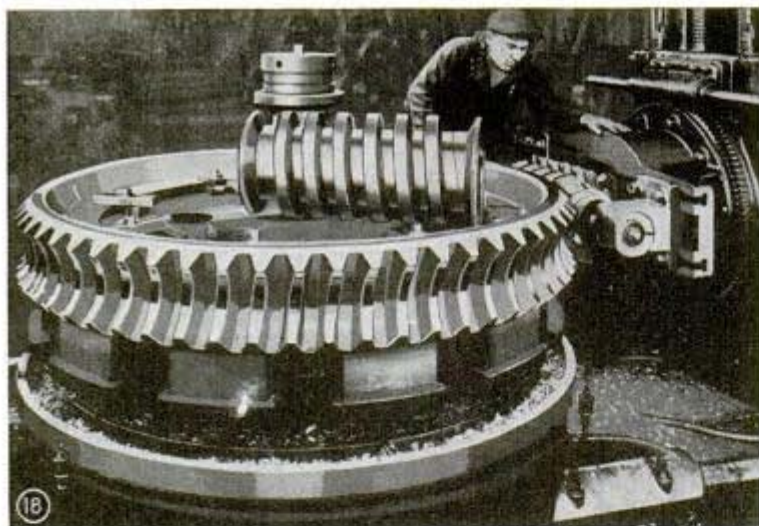

ever a machine of the vertical boring mill type was used. Fig. 16 is a regular hobbing machine setup and the depth of tooth is shown being checked with a gear-tooth vernier. The worm wheel also, shown in Fig. 18 presents no form cutting difficulties. The screw form can be produced in this or in another type of milling machine with a hob or plain-formed cutter, in a hobbing machine, in a specially tooled gear shaper or in a lathe.

Notched Hinge on Drill Press Prevents Work From Turning

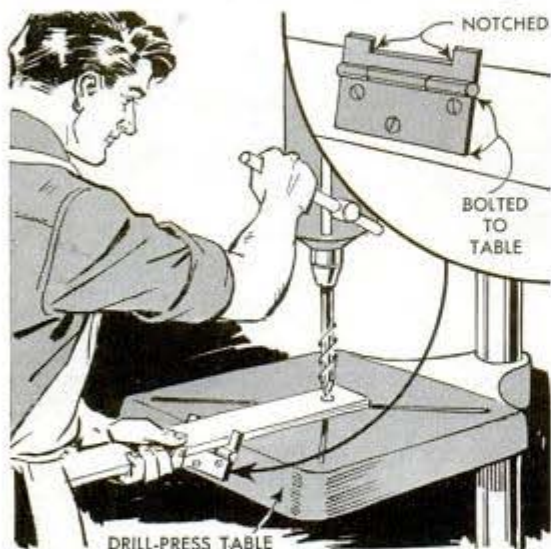

A convenient stop to help prevent work from turning on a drill press is provided by welding a small butt hinge to the front side of the table. The upper half of the hinge is notched and is left free to swing up or down out of the way as necessary.

Addressograph Plates Identified By Different Colors of Paint

Business firms using addressograph metal name plates for addressing mail will find the following method of identifying them a space and money saver, especially when there are many separate mailing lists of customers for different purposes. With this method, it is unnecessary to have two or more plates for one customer whose name may appear on more than one list, because the plates for all lists are kept in one large

alphabetical file. Then, whenever certain lists are desired, the plates marked with the color identifying this list are withdrawn and used. To apply the identifying color, simply take out all the plates in one list, line them up and paint a colored stripe about $\frac{1}{4}$ in. wide across the top edges so that a little color is left on the edge of each plate. When the plates are replaced in the large file this list can be found easily by looking for the band of identifying color. Each list is marked with a different color.

—David O. Munroe, Chicago.

Iron Cleats on Truck Tailboard Raise Crates for Easy Sliding

The difficulty of inserting the hands, or the beak of a hand-truck, under a heavy crate in a truck for unloading may be overcome by bolting curved strips of flat iron to the inside of the board as shown. The crate may be slid onto these and at the same time be elevated to the desired height.

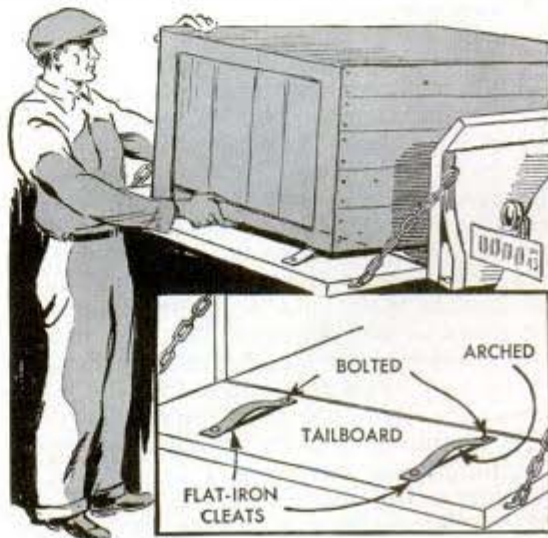

4-Place TURRET

Fits Lathe Carriage

WHILE revolving turret heads usually are considered production tools, the particular turret pictured in Fig. 1 will be found handy for general lathe work. When provided with stub boring bars, it will handle almost all jobs of internal boring or threading. If fitted with a three-jaw chuck or Morse-taper adapter in one of the tool holes, the turret provides a means of drilling or reaming from the lathe carriage where a power feed seems desirable. Start the construction by making the base. As shown in the drawing, Fig. 2, the base and central stem are turned in one piece. Next, the indexing element, which consists of a $\frac{7}{16}$ -in. steel ball and a $\frac{1}{8}$ by $\frac{1}{2}$ -in. spring, is set into the base as indicated, to engage recesses in the tool block as shown in Fig. 3. Then the tool block is turned and is bored in the center for a snug rotating fit around the stem of the base. Put a sharp-pointed pin in the index hole and rotate the tool block to scribe a line on the bottom. On this line, index and drill the four recesses to take the index ball. Use a standard $\frac{3}{8}$ -in. bolt for locking the assembly in the lathe compound, welding or pinning the bolt to a square piece of metal, to fit the T-slot in the compound. Finish all the rest of the construction except drilling the holes

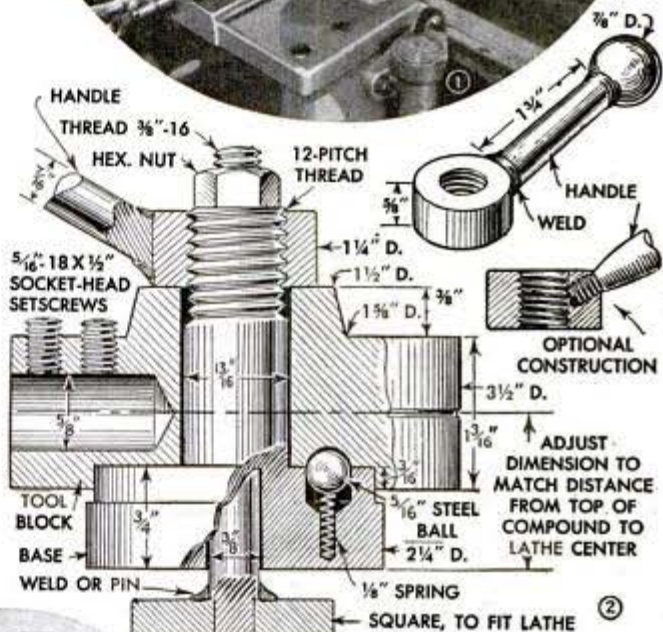

in the tool block. These holes are drilled with the turret head fitted to the lathe compound. The base of the turret should be rotated so that the first hole drilled comes between any two of the index recesses. The indexing element then sets the position of the three remaining holes, the drill working from the headstock as shown in Fig. 4. Take great care in drilling the tool holes. Tool holes of $\frac{5}{8}$ in. in diameter are recommended, as this size takes the smaller sizes of standard turret accessory tools, which you may want to purchase or make. Tools with smaller shanks or with Morse-taper shanks can be held in bushings or taper-shank adapters, which you can make up as occasion requires.

Handle Between Legs of Sawhorse Makes It Easy to Carry



Anyone who has occasion to carry a sawhorse to and from work that is located at some distance from the shop, or who has to carry a sawhorse about on jobs that cover considerable area, will find that a handle like the one shown makes the job easier. The handle consists of a length of dowel or small pipe fastened into holes drilled in the leg braces.

Extension for a Paper Trimmer Doubles Its Capacity

One workman who often had to use a paper trimmer on work that was considerably longer than the trimmer board, made an extension for the board like the one shown. This arrangement permitted the

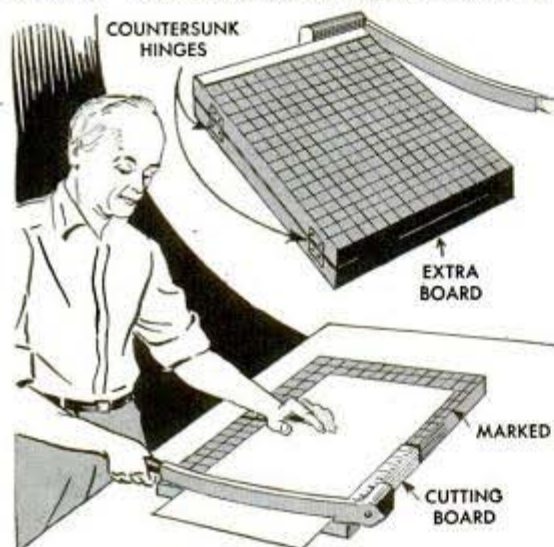

measuring and trimming of the long work without excessive loss of time. If the trimmer is supported on short legs or a stand-ard, they will have to be removed or similar supports provided for the extension. When not in use, the extension, which is hinged to the end of the trimmer board, can be folded under it out of the way.

Glass Jug Holds Display Card For Self-Service on Counter

One merchant was able to save time for his clerks by providing self-service for items attached to display cards. The cards of merchandise were taped around glass jugs as indicated and set on the counter.

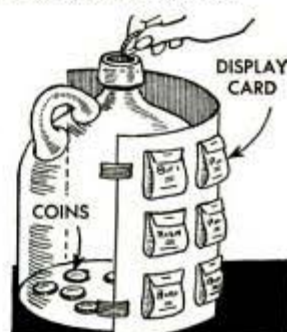

A few coins dropped inside the jugs suggested to the customer that he could serve himself.

Stepped Spreader Holds Tire Open While Installing Blowout Patch

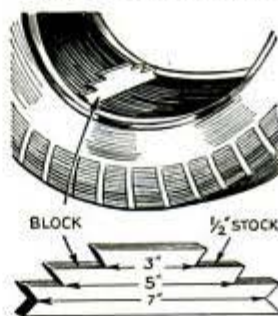

Mechanics who have considerable tire repairing to do will find this simple spreader handy for keeping a tire spread while inspecting it or while installing a blowout patch. The spreader is stepped so that it

can be used on a wide range of tire widths, and is made from a 1/2-in. wood block.

Spring Stop in Drill Press Table Prevents Work From Turning

This simple spring stop will help keep work from turning on a drill-press table, and can be pushed down and to one side out of the way when not needed. The stop consists of a short length of clock spring carrying a bolt at one end, which projects through a hole in the drill table. The other end of the spring is bolted to the underside of the table.

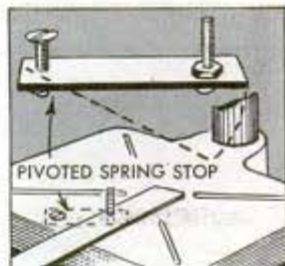



Television Receiver Units

ALTHOUGH about twice the size of ordinary console receiver units, the modern television chassis and power supply is not as large or as complicated as the average radio student and experimenter thought they would be, considering that they are designed for both sight and sound reception.

The RCA model TRK-120 television chassis shown in the photo provides complete sound and picture (Pix.) channels for 5 bands, as follows: 44-50 MC, 50-56 MC, 66-72 MC, 78-84 MC, and 84-90 megacycles. The overall "video" or picture band width is 4 megacycles. Scanning is interlaced, producing 30 frames, or complete pictures of 441 lines each, 30 times a second.

Delivering 7,300 volts d.c. for the cathode-ray receiving tube anode, and other necessary operating voltages, the separate power supply unit is connected to the television chassis by means of heavy

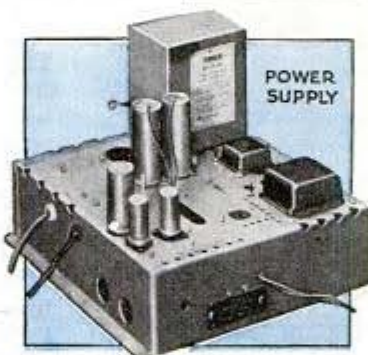
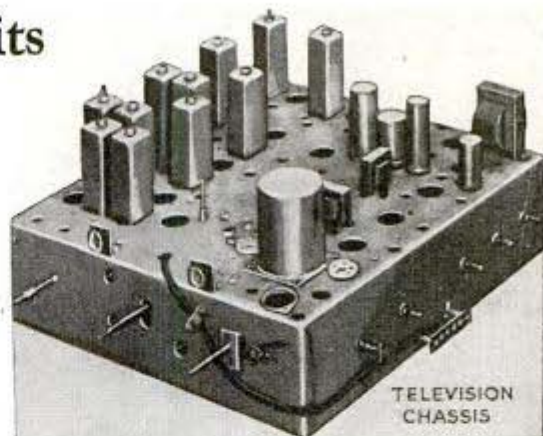

well insulated cables. This power unit measures 15 by 13¼ by 10 in. overall; the television chassis base is 16 in. wide, 17 in. long and 4½ in. high. No tubes are shown in these units which have been available to radio training schools and experimental laboratories.

The television chassis layout, showing all tube types and their location, appears in Fig. 1, with the exception of the type 1803-P4 twelve-inch television tube which is mounted separately; the power supply unit employs one 5U4G and one 2V3G tube. Although there seems to be a multiplicity of controls, many of them only require an initial setting, after which all tuning and adjusting for both sight and sound is done with the comparatively few controls located at the front. The television tube may be mounted for direct viewing or the image may be reflected by a mirror.

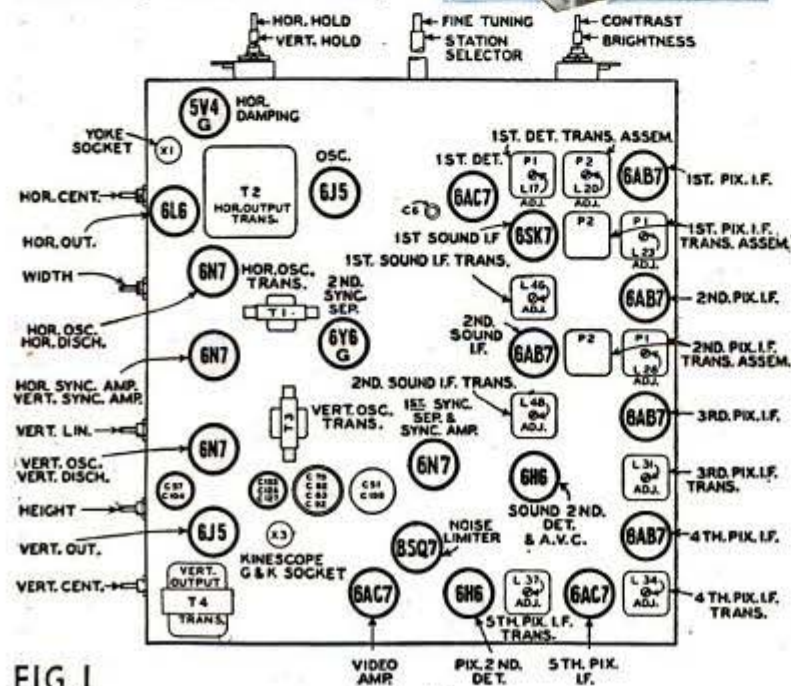
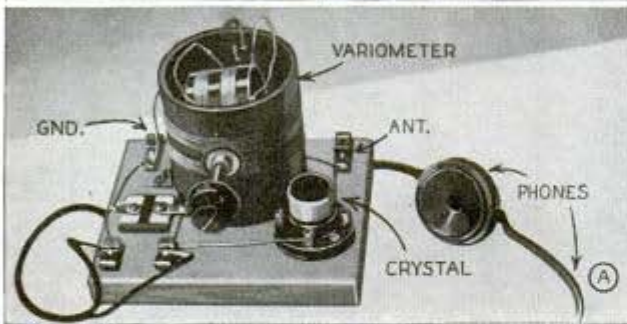

FIG. 1

MAKE THE PARTS FOR

By Lawrence B. Robbins



MOST radio students and experimenters have a variety of odds and ends of useful parts for making experimental hookups, and often fill in the gaps with noncritical materials that are available from radio mail order supply houses. The newcomer in radio who does not have a stock of parts but does possess a good pair of headphones, can just about start from scratch with either of the two simple crystal sets to be described.

Although some of the material for these receivers was salvaged from an old discarded broadcast receiver, practical duplicates of the coils, condensers and crystals can be made from scrap materials as detailed in Figs. 2, 3, 4, 6 and 8. The schematic circuit diagram for set No. 1, shown in photo A, appears in Fig. 1. This set employs variometer tuning, thus doing away with the usual variable condenser. The variometer is merely a continuous winding distributed on two cardboard coil forms, the smaller of which will turn on an axis inside the larger. This unit may be wound with any small size enamel-, cotton- or silk-covered wire as detailed in Fig. 2 and assembled as shown in Fig. 5. The wire can be salvaged from an old filter choke or audio transformer, but preferably of slightly larger size if available; anything from about No. 24 to 32 may be used. However, the leads from the stator to the rotor sections of

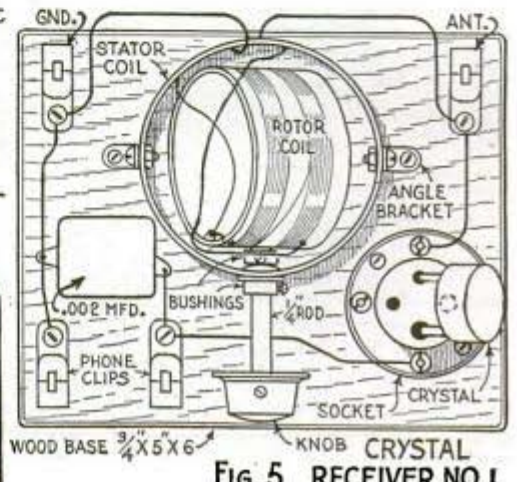
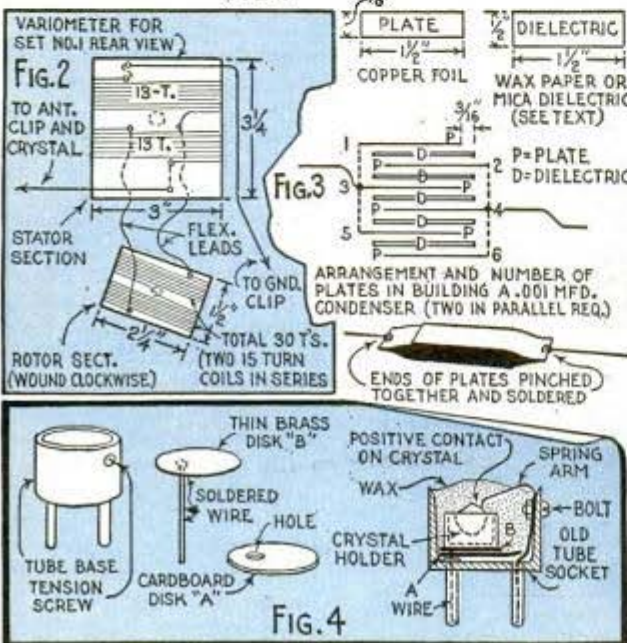
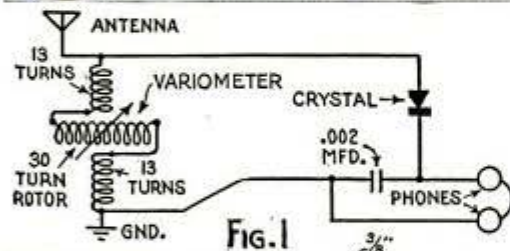

FIG. 5 RECEIVER NO. 1
POPULAR MECHANICS

THESE CRYSTAL SETS

the variometer must be flexible and long enough to permit 360 degree rotation. The rotor shaft may be extended through both sides of the stator coil form for simpler construction. Please note that the rotor coil is wound in the opposite direction from the stator coil. Both coils are close-wound and the separation between the divided windings is about $\frac{1}{4}$ inch.

The .002 mfd. fixed condenser shown is a single standard unit. If the homemade variety detailed in Fig. 3 is used, two of the completed units are assembled and connected in parallel to give approximately the same capacity. Copper foil can be obtained from reflecting insulating sheets available from building supply firms. These sheets of foil are mounted on heavy paper which is stripped off and cut to size with a safety razor blade. Alternate the foil plates and waxed paper dielectric, assemble as shown and tape each completed unit with "Scotch" tape. Mounted galena crystals and Fahnestock spring clips, are available from "dime" stores or mail order firms; suitable clips often can be salvaged from old dry batteries. The crystal may be be used with an adjustable "catwhisker" or it may be mounted as a fixed crystal detector assembled in a 4-prong tube socket, with crystal holder spot-soldered to metal disk "B" and sealed with melted wax, as detailed in Fig. 4. This assembly permits use with a 4-prong tube socket as illustrated in Fig. 5; and most commercial fixed crystals may be used in the same socket.

Both sets are assembled on well shelled baseboards of the same dimensions. Set No. 2, shown in photo B, uses but one coil form, see Fig. 8, wound with the same size wire; the other parts are the same as in set No. 1 with the exception that a "book-type" homemade tuning condenser is employed, and may be connected either as shown in Fig. 7 or Fig. 9. All construction details are clearly given in Figs. 6 and 9. If sheet mica is not available for the center dielectric sheet, thin insulating fiber sheet may be used. As the knob is turned the upper plate is pulled away from the lower to vary the capacity and tune the receiver. Detailed material list R-321 is available to student beginners from Popular Mechanics radio department without charge, if desired.

Under ordinary conditions, with a good long and high outdoor antenna, and a ground connection on a nearby cold water pipe, the receiving range lies within a radius of 25 miles or more, for either set. Best distant reception is obtained at night.

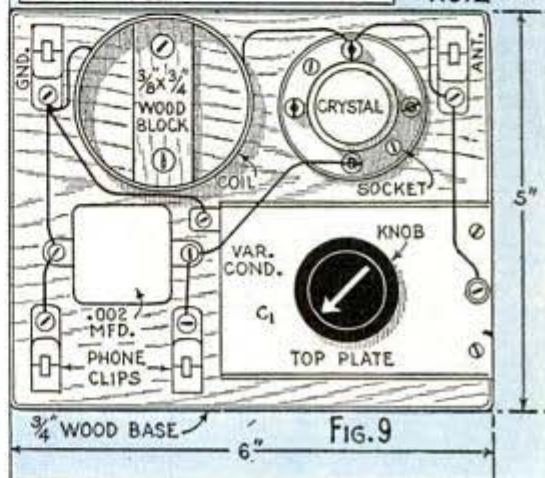
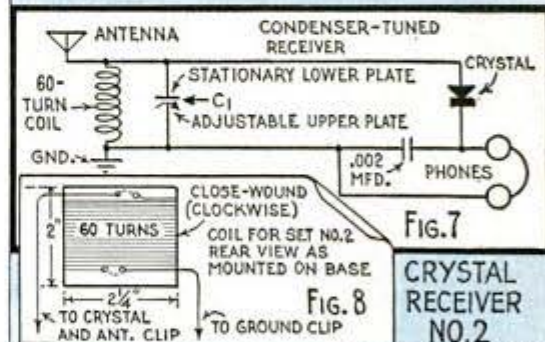
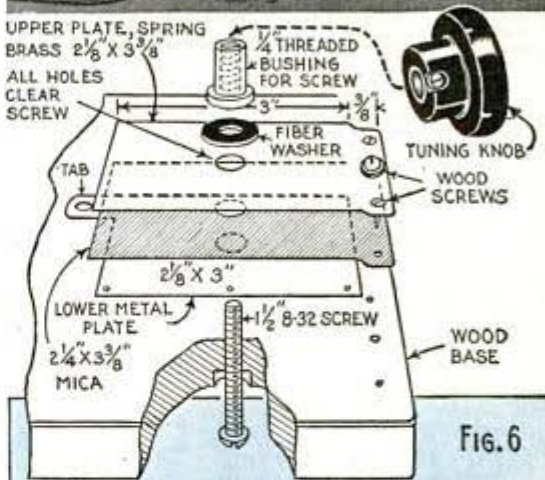
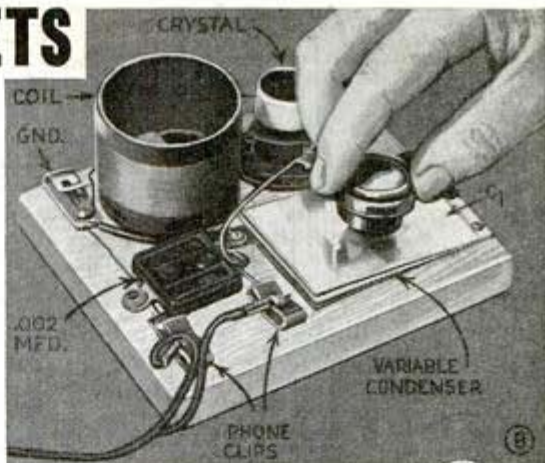

Helpful RADIO SUGGESTIONS



(A) Troublesome kinking headphone cords can be kept in perfect working order by means of a "non-kinking" plastic device, commonly used on telephone cords, as illustrated in the photos and sketch. A short length is twisted across the point where the cords divide. Some army and navy operators use an additional length extending down to the phone plug. (B) An old octal tube socket makes a good common ground terminal when wired as shown. When remodeling old sets, or using old chassis bases for new circuits, an extra socket is usually available for this one-point ground used in best wiring practice

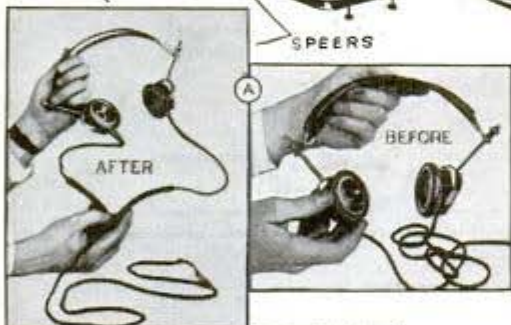

(C) This compact and lightweight $\frac{1}{4}$ in. portable electric drill has a plastic grip handle, field case and gear case. Designed for cooler operation in hot weather and in close quarters, it is claimed to permit faster work. (D) Filament voltage tester for students to test socket circuit connections to prevent tube burnouts caused by incorrect A and B voltage wiring. The 10c pilot light may burn out but expensive hard-to-get tubes are saved

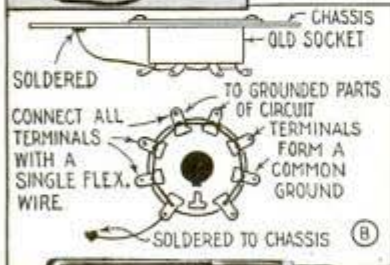

(E) Miniature oil-filled tubular-type metal-cased fixed condenser now used as alternate for the scarce flat mica type. They are claimed to meet all standard specifications for paper dielectric condensers previously used as mica replacements and are supplied in capacities from .001 to .01 mfd. rated from 300 to 800 volts. (F) Stand-off insulator for antenna lead-in, made from an ordinary porcelain tube insulator and a piece of stiff wire

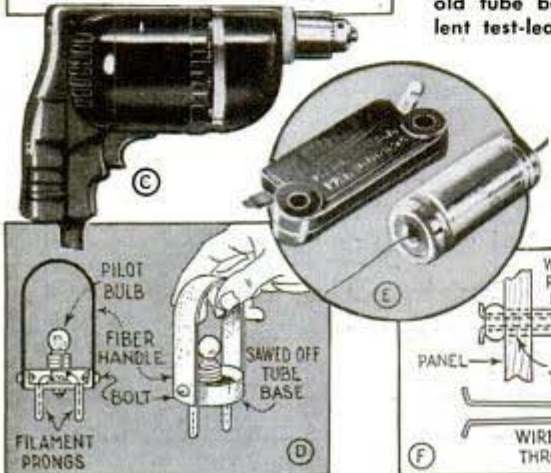

(G) Prongs removed from an old tube base make excellent test-lead tip connectors

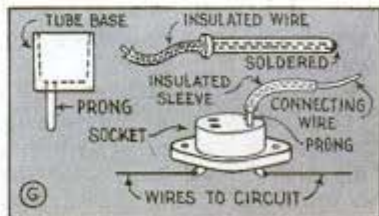

(H) Speaker is converted to a microphone for sound detecting unit; has a built-in amplifier



TOUGH... BUT OH SO GENTLE

Keep it
Sweet!



★ IT'S A
PRIVILEGE
TO BUY
WAR BONDS

★ A sweet running car is music to the ears. It means the motor is operating efficiently; that it will last for a long, long time. That's mighty important these days when a breakdown may leave you without a car, indefinitely.

It's simple to keep your motor running sweet when you watch it carefully and

get it to your motor service man — before it goes *sour*.

At the first sign of ring failure, have him install a set of Hastings Steel-Vent piston rings. They stop oil-pumping, check cylinder wear, and restore gasoline economy.

HASTINGS MANUFACTURING COMPANY, HASTINGS, MICH.
Hastings Mfg. of Canada, Ltd., Toronto

HASTINGS

U. S. PAT. 2,148,997

STEEL - VENT

Tough on oil-pumping
Gentle on cylinder walls

PISTON RINGS



Dear Bill:

I'm the guy up front

This is the outfit for an old oyle fan! I thought I knew motorcycles, but the Army's teaching me plenty!

I'm riding an Indian -- as usual. What a machine! Our operations course is plenty tough but Indian's got the guts to take it -- and for easy handling and safety, give me Indian any day!

Incidentally, Indian's got some swell new improvements. It'll be a really great machine to ride when this war's over. Regards to the gang!

INDIAN MOTORCYCLE COMPANY, SPRINGFIELD, MASS.



BUY WAR BONDS NOW

★ ★ TO BUY AN INDIAN LATER ★ ★

Uncle Sam's Tom Thumb Navy

(Continued from page 43)

with the bow striking the concrete wall. That would disintegrate a paraffin model.

The test equipment consists of five basins—long, narrow canals—with towing carriages and dynamometers. The largest is 963 feet long, 51 feet wide, 22 feet deep. Accurate to thousandths of an inch, the carriage rail actually follows the curvature of the earth so there is no variation from end to end in gravity pull. Other basins are especially for tugboats and river craft, high speed motorboats, naval flying boats and the like. In one, turning tests are made in the dark, with lights hung on the model's bow and stern and a movie camera recording the performance. Air resistance of a ship's superstructure can be tested by towing the model upside down.

Three-fourths of the work today is secret. In the model shop, woodworkers are carving forms for antisubmarine warfare, submarine targets, minesweeping devices. The cargo ships hatching in yards throughout the nation were incubated from Carderock's wooden models. Here a foreign destroyer is being scaled in a 30-foot model, big enough for tests that will find its weaknesses in detail. There a standard warship will try out a new superstructure. And here is a new speedboat offered by a famous American designer, its hull shape suggesting that it may challenge the speed of Navy aircraft. In one workshop girls are building recognition models to teach our sailors and fliers to identify ships at a distance by a split-second glance.

The fighting Navy America is swiftly building to sweep the seven seas clean of Axis craft got its auspicious start in pine models cruising the vaulted indoor canals of Carderock.

The Red Metal of War

(Continued from page 73)

made in brazing alloys by the General Electric Company. These alloys require high temperatures for joining metals. One type of brazing alloy, widely used before the war, was composed mainly of copper, the remainder being silver and phosphorus. Now alloys with copper content as low as 16 percent are in general use. A typical alloy consists of 50 percent silver, 16 percent zinc, 18 percent cadmium and only 16 percent copper.

Plastics of one type or another are being used for such products as tubing (a principal copper product), flashlight cases,

(Continued to page 148)



HERE'S YOU IN A SUB

Like to take a good crack at a German or Jap warship—personally? Then look at the illustration below.

There's a place for you there—right inside a U. S. sub.

Of course you can't be there actually and physically. But you *are* represented.

The bonds you bought paid for that periscope.

The goods you conserved, the scrap and fats you saved, helped to release that torpedo to do its deadly work.

Your blood may save the lives of members of this very crew.

You can make this sub, or any other fighting unit, more effective. Buy more Bonds . . . conserve and

save . . . give blood . . . the more you do, the sooner you'll enjoy the richer, fuller life that's coming for us all when this war is over.

For example: Are you a camera enthusiast? Universal promises finer-than-ever cameras easily within your means, new thrills in picture-making . . . thanks to new feats of engineering achieved in furnishing the Army, Navy, Marines and United Nations with fine precision optical equipment.

And other manufacturers, in other fields, are bursting with similar promises for *their* after-Victory products, eager to bring them to you soon.

But first, let's all take our places in that sub—today!



There's only one flag
we're prouder of!

UNIVERSAL CAMERA CORPORATION

NEW YORK • CHICAGO • HOLLYWOOD

Makers of Precision Photographic and Optical Instruments • Peacetime Manufacturers of Cinémaster, Mercury, Corsair Cameras

HANDKERCHIEF TEST PROVES VITAL ZONE

Spotless

NO MATTER HOW OFTEN YOU SMOKE IT

HESSON GUARD

W.D. & H.O. MILANO \$1

IT'S CUSHION SEALED

NO GOO CAN PASS HESSON GUARD

STOP

GOO



UNIQUE GIFT ITEM

15 EXPERIMENTAL LENSES

Plus 50 PAGE Idea Booklet to Help You . . .

(All Lenses New—Edges very slightly chipped)
... make your own telescopes, magnifiers, dummy camera, photo cells, rifle scope, detachable reflex viewfinder for 35-mm camera, telephoto lens, photographic gadgets, for experimental optics, copying and ultra-closeup shots and hundreds of other exciting experiments.

EDMUND SALVAGE COMPANY
27 W. Clinton Avenue, P. O. Audubon, New Jersey

Set 602-H

Only

\$2.60

Postpaid

SOLDIERS, SAILORS & WAR WORKERS



Your Watch with a Broken Crystal Is Useless Exposed to Damage from Glass and Dust.

PROTECT YOUR WATCH—Avoid costly repairs—Go to any jeweler—ask for a G-S FLEXTM CRYSTAL 100% BREAK-PROOF—Any size—Any shape. Can be fitted while you wait. Mfgs. of military water-proof watches, gauges, instruments now use G-S FLEXTM made of GOVT APPROVED PLASTICS. Same materials are used for all G-S FLEXTM CRYSTALS.

GERMANOW-SIMON MACHINE COMPANY, Rochester, N. Y.

jewelry, pumps, household utensils, and a long list of other common items.

Is all the now precious copper shot away in bullets lost forever? By no means, according to B. B. Caddle, secretary of the Copper and Brass Research Association, who reports that a great amount of brass cartridge cases and artillery shells are being reclaimed and shipped back to the United States for remelting.

That copper has come to be regarded as the newest precious metal is the result of a situation that seems paradoxical, yet is easily explained. America has the greatest reserve of copper ore in the world, produces half the world's output, and has ten times the amount owned by Germany. But there is a copper shortage.

If that appears in the light of the unbelievable, however, Mr. Caddle explains:

"This year the United States' production of ammunition alone will require more copper than was consumed for all purposes during 1929, and that does not include the requirements of copper for Army and Navy planes and a multitude of other purposes."

And 1929 was a booming industrial year.

Plant Magic

(Continued from page 37)

similar results. It is always scientific to grow a number of untreated seeds or plants in a "control" plot so that you can compare treated and untreated plants.

The alternative method is to use the colchicine-lanolin paste for local application to plants that are already growing. Smear a small amount of paste on the plant's stalk with a toothpick. Or apply it to the growing tips or to one branch. Shortly the part that has been treated will begin to swell. A treated branch grows larger and faster than do the others. Save the seeds from this plant to learn what changes are caused in the next generation.

Roots will sprout from the stalk at the point where paste is applied. This is the experiment in which you may then remove the plant from the soil and rebury it wrong end up. The roots produced by the colchicine will grow in the earth.

Acenaphthene, available at druggists, is a nonpoisonous substance that has similar though less pronounced results. Bury a few crystals of it near a plant. A small amount of powdered sulfanilamide dissolved in water often imparts disease resistance to future generations.

One field in which chemicals and hormones have vast possibilities is in acclimatizing plants so that they will flourish

(Continued to page 150)

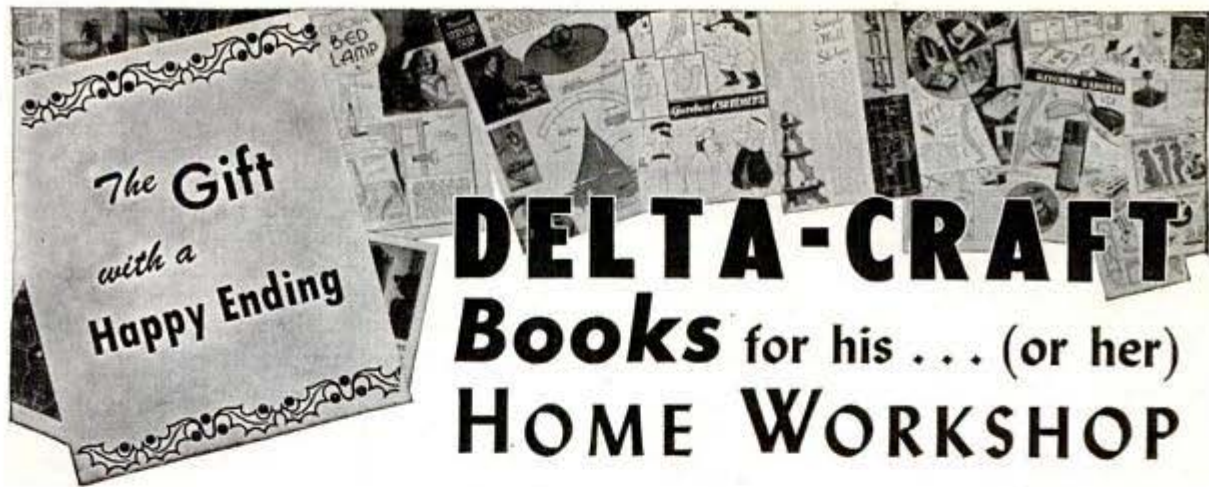

The Gift
with a
Happy Ending

DELTA-CRAFT Books for his . . . (or her) HOME WORKSHOP

... a source of endless pleasure, pride and profit

Here is a gift to quicken the heart of any man or woman, boy or girl who loves to make things. It is America's greatest collection of homecraft "know-how." Books in various combinations, to suit any enthusiast and any gift budget — pointing the way

to fun, healthful recreation, and home beautification. . . . Every project, every idea has been worked out carefully in Delta's own shop. And the cost of the books is low. Your gifts of Delta-Craft books will be mailed postpaid with cards bearing your name. . . . So look over your gift list now, and check the home workshop fans. Fill out the coupon below, and send it with your check or money-order today. Don't forget to include a gift for yourself.

GROUP "A"—Operating Manuals for Better Results with Power Tools . . .
A complete library on tools and operations. Close to 50 pages, more than 200 illustrations in each book. How to get extra speed, accuracy, greater safety. Getting the most out of your: *Lathe*—Data on Spindle, Faceplate, and Spiral Turnings; etc. *Drill Press*—Laying out work; Routing, Shaping; drill sizes, speeds, etc. *Circular Saw and Jointer*—Ripping; Saw Projection; Cross-cutting; etc. *Shaper*—Adjustments; Guides, Patterns; Jigs, Fixtures; etc. *Band Saw and Scroll Saw*—Band Saw Blades; Ripping Curves; Tilt Table; etc. *Abrasive Tools*—Grinder, Buffer, Belt Sander, Disk Sander, attachments, etc.

Group "A" Set of six books..... \$150

GROUP "B"—Classified Designs . . . A Whole Book on Each Subject!
Projects arranged for quick reference. Hundreds of plans and pictures show "How to do it."
21 Lovely Lamps. Popular designs.
19 Charming Chairs. Handsome, durable pieces. *One Evening Projects*. Dandy novelties, quickly built. *Garden Furniture and Novelties*. A swell collection. *40 Fine Tables*. The finest of shop projects. *Furniture Designs*. Desks, beds, wardrobes, etc. *Novelties*. Small items. Profitable, interesting. *Toys, Games, Playground Equipment*. Real money-makers. *Small Furniture*. Attractive footstools, magazine racks.

Group "B" Set of nine books..... \$150

Group "D"—Six Manuals and nine project books..... \$240

Practical Projects—What to Make and How to Make It . . .
Material for many hours of enjoyment — most popular projects from Delta-Craft publications. Nine books, as many as 41 projects in each. About 350 projects, at less than 1/4¢ apiece. Completely illustrated and described to make construction easy. Modern furniture, lamps, garden furniture, games, toys, etc. Sold only in combination with manuals above.

GROUP "E"—"How to Plan a Home Workshop" . . .
Fifty-six pages, helpful, practical. Detailed plans; pictures; guidance in selecting tools, building cabinets, etc. **"Making Money With Delta Tools"**: What to make—how to make it—where to sell it, as full-time business or side-line. **"Practical Finishing Methods"**: Step-by-step instruction on any type of finish for any material. Staining, polishing, bleaching, varnishing, etc. 64 pages.

Order these three books 85¢ for only

The DELTAGRAM
— the magazine for home craftsmen . . .
Six times during the year, this information-filled magazine brings a welcome reminder of your thoughtfulness. Packed with plans, projects, shop ideas, methods, news. Not included in combination of 27 books. Order separately. Check the coupon.

SAVE 55¢
Total cost of the 27 books shown here is \$4.75. But you can save 55¢ by ordering ALL 27 at a special price of \$4.20. Check group "F" in coupon below.

Full year — 6 big issues 50¢

DELTA MILWAUKEE Power Tools

Editor, Delta-Craft Publications — THE DELTA MFG. CO., 681A E. Vienna Ave., Milwaukee 1, Wis.

I am enclosing check or money-order for..... (full amount) covering books checked below.
 I am enclosing gift card or cards. You are to supply gift card(s) bearing my name.

Group "A"—6 Operating Manuals.....\$1.50 Group "D"—6 Manuals and 9 Project Books \$2.40
 Group "B"—9 Classified Project Books..... 1.50 Group "E"—3 Books..... .85
 Group "C"—3 Combination of "A" and "B" 3.00 Group "F"—All 27 books shown..... 4.20
 "The Deltagram"—year's subscription..... .50

My Name is.....
 Address.....
 City..... (.....) State.....
 Send books to (name).....
 Address.....
 City..... (.....) State.....

Use separate sheet for additional orders

**YOUR After-WAR
TA-PAT-CO
SLEEPING BAG**



**LIGHTER • WARMER
MORE COMPACT**

In a soldier's sleeping bag weight and bulk must be reduced to the very minimum without sacrificing warmth and comfort. When your sporting goods dealer shows you the after-war Ta-Pat-Co you'll see how completely it fills these requirements for our fighting forces. And of course you'll immediately want to add one of these lighter, warmer, more compact sleeping bags to your outdoor sports equipment.

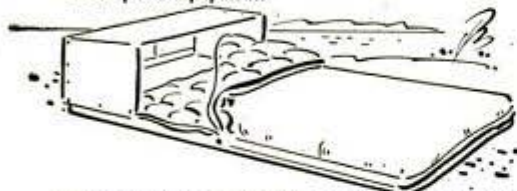

**THE AMERICAN PAD AND TEXTILE COMPANY
GREENFIELD, OHIO**

*In peace and in war the leading manufacturer of
Sleeping Bags and Life-Save Equipment*

**CUSTOM BUILT
for the FUTURE**

* When the last shot is fired, you'll want a new HULL COMPASS—a new model, incorporating Hull's wartime engineering improvements.

HULL MFG. CO., P. O. Box 246-D1, WARREN, OHIO

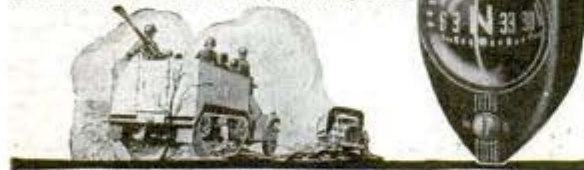

**Burpee's GIANT
ZINNIAS**

Double-Flowered
Scarlet, Lavender, Yellow
and Rose, 5 inches across.
Easy to grow. The four best
colors, a 15c-Pkt. of seeds
of each, 6c value, all 4 postpaid
for just 10c. Send dime today!

**4 PACKETS
10c**

Burpee's Seed Catalog Free—Flowers and
Vegetables for your Victory Garden.

**W. ATLEE BURPEE CO.
PHILADELPHIA 32, PA. or CLINTON, IOWA**

**LEPAGE'S
GLUE**

**LEPAGE'S MODEL AEROPLANE GLUE
LEPAGE'S LIQUID SOLDER**

2749 Walnut St., Lancaster, Pa. Calif.

in new climates, as in introducing tropical plants into areas where heavy frosts occur. Floyd L. Cooper, a member of the Plant Culture League in California, has been able to harden coffee plants, cinchona plants from which quinine is extracted, papaya trees, and other foreign specimens so that they flourish under conditions that usually kill or stunt them.

Tests conducted at the Oklahoma Experiment Station, Stillwater, Okla., to learn the effect of synthetic hormones on domestic crops produced the following results: 838 pounds of cotton per acre against 581 pounds per acre, 42 bushels of corn per acre against 28 bushels, double production of cowpeas, an additional ton of alfalfa per acre, and 16 tons of beets per acre as compared to 5.6 tons per acre in an untreated check plot. The techniques used included seed treatment, spraying and dusting.

Seedless-fruits are created by applying growth chemicals to the flowers. Tomato and egg plant respond particularly well. The hormone replaces natural pollen in developing the fruit, and produces tomatoes that are seedless and mild in flavor.

Every day, new ways by which the new substances can help agriculture are being found. For instance, with synthetic hormones it is not necessary to fertilize fields as heavily as in the past. The hormones enable the plants to make better use of smaller quantities of fertilizer. Synthetic hormones may prove to be the agricultural discovery of the century.

Grasshoppers With Teeth

(Continued from page 79)

squadrons, and groups serving under a wing commander in each of the 48 states. Little by little the original restrictions grounding all private planes were lifted.

The early days were difficult, but with characteristic American ingenuity the original C. A. P. members carried on. That they have done a job is evidenced by the fact that the Civil Air Patrol is now an auxiliary of the Army Air Forces.

Members of the Civil Air Patrol wear regulation army uniforms with the insignia of the C. A. P., a three-bladed red propeller in a white triangle mounted on a blue circle with the letters U. S.

Military courtesy is one of the first bits of training the new recruit receives. How to wear the uniform, how and whom to salute, and how to conduct oneself in a military manner is of prime importance. Ground work in aircraft maintenance, interior guard duty, communications, navigation,

(Continued to page 152)

THE SAME CHARACTER— IN DIFFERENT UNIFORM



Once he was the center of the All-American line—now the colorful jersey, the cheering grandstands are far behind. Today he's dressed for harder, fiercer action. He's still the same character—only his appearance has changed. Plumb, too looks different in it's new "service" uniform.

But Plumb quality has not changed! You'll always recognize Plumb by its character and quality—by the graceful lines of each perfectly balanced tool and by the ease and speed with which it works. Master craftsmen have designed these tools to do your job quicker and better. Plumb quality remains the same—only the fine finish has gone for the duration, eliminated by government order.

Fayette R. Plumb, Inc.,
4837 James Street,
Philadelphia 37, Pa.



PLUMB TOOLS ILLUSTRATED, Top to Bottom, Nail Hammer, Blacksmith's Hand Hammer, Ball Pein Hammer, Half Hatchet.

Quality Comes *FIRST*
PLUMB
is *FIRST* in Quality

PLUMB

HAMMERS • HATCHETS • AXES • SLEDGES



with a **SANDING STICK** and **JACOBS CHUCK**

Most of the interior cuts made with a scroll, jig, or fret saw require sanding or smoothing to remove irregularities. Round and half-round files and sanding sticks have been used by hand for this work, but the hand method is slow and tedious. Using a sanding stick, as illustrated, speeds up this work immeasurably and improves the quality.

Sanding sticks are easily made up in any shop. With the drill press supplying the power, both hands are free to guide the work.

To Get The Most Out of Your Drill Press or Lathe — get this New Book

The operation outlined briefly here is one of nineteen covered in detail in our new booklet just off the press. Printed in color and containing 49 illustrations, it shows how the set-ups are made, illustrates the tools used, and in some instances tells you how to make the tools themselves. If you have a workshop you will want the valuable ideas this book contains. If you are planning a shop of your own for after-the-war, you will want the booklet now to help you plan.

10¢

19

UNUSUAL USES

FOR YOUR

DRILL PRESS
OR LATHE



Jacobs Chucks

WORLD'S LARGEST PRODUCERS OF DRILL CHUCKS

Jacobs Mfg. Co.
114 Jacobs Road, Hartford 1, Conn.

Please send me the booklet immediately.
I am enclosing 10¢ to cover handling and
mailing costs.

meteorology, military drill, and use of small arms are also in the training program.

A false notion that exists is that by joining the C. A. P. a person will be taught to fly. This is not true. Nor does service in the C. A. P. exempt anyone from the draft. Actually, it has made many more acceptable for military service. No salaries are paid though an allowance of eight dollars a day for expenses is provided for pilots on active duty. Planes are paid for by the hour when flying government missions.

Ships range in size from the Cub on up. Nothing under 90 horsepower can be used on coastal patrol. Horsepower, however, is no guarantee against trouble. Pilot Dan Meyer and Observer Billet of Detroit learned this the hard way on patrol. Unable to make land, they pancaked into the sea near a tanker. Despite the skill with which the crash landing was made, their plane ripped open and sank almost instantly, but the crew of the tanker quickly brought them aboard. Another C. A. P. patrol plane with engine trouble was just able to make the beach of an island inhabited by wild boars. Although there was no meat shortage, there was a water shortage. Containers dropped from the air by fellow pilots broke open and spilled the precious water. Finally, another pilot dropped a cake of ice to the marooned men. Days later they were able to take off in their repaired plane.

In coastal planes too small to carry a life raft, an anti-barracuda bag is provided. It is made of canvas and secured to a large inner tube. The theory is that the unlucky pilot who is forced down at sea can seek refuge by standing in this bag so that barracuda and other fish will have less opportunity to nibble on him. Standard equipment includes these bags, a knife, and life jacket. It was only through unwitting German co-operation that one group of pilots was able to make sea flights some time ago. They were grounded until eight life jackets floated up on the beach with eight German corpses. Patrol started at once.

Two C. A. P. pilots recently were awarded the Army Air Medal by President Roosevelt. These men, Hugh Sharp, Jr., and Edmond Edwards, both of Delaware, were on coastal patrol when they observed a fellow C. A. P. pilot who had been forced down in heavy seas. With their own amphibian craft partially disabled by the landing, these two men rescued the pilot and taxied through dirty weather for five hours until picked up by the coast guard.

Whether on a mission of mercy or in a death battle with a submarine, the C. A. P. is in there fighting. That's why the little planes are called "grasshoppers with teeth."

Ingenious New Technical Methods

Presented in the hope that they will
prove interesting and useful to you.

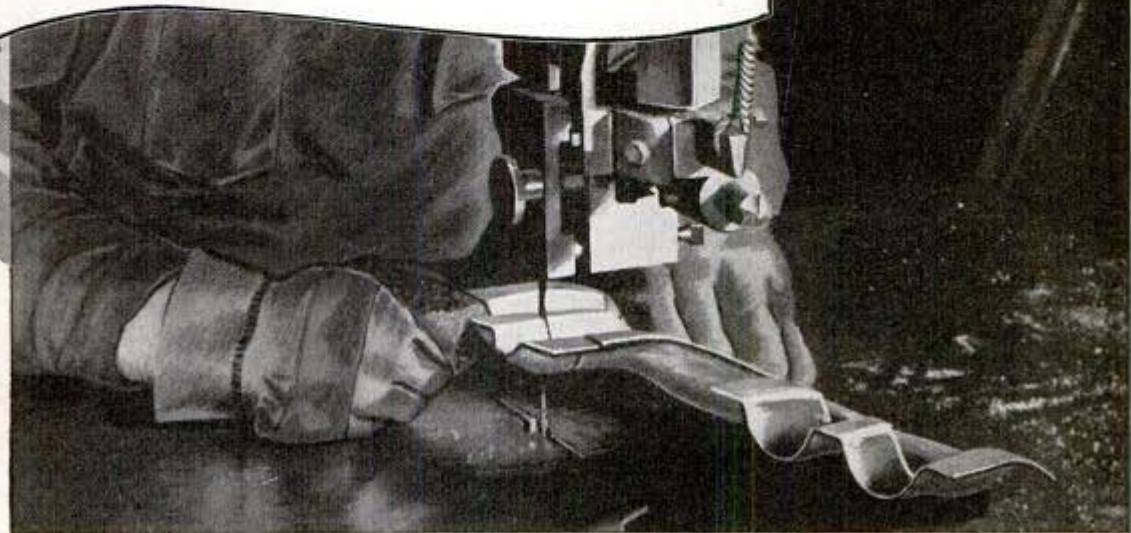

Hard Steels Cut by Heat Generated by Super High Saw Speeds

Ordinary band-saws, when operated at unbelievable high speeds up to 12,000 feet per minute, cut through hard steels and alloys by heat generated from the friction of the saw against the metal to be cut. The cutting effect is more that of burning through the metal than actual cutting. The heat generated is sufficient to melt or burn out the metal in the saw cut but not enough to draw the temper on the sides.

The hardness of either saw or metal to be cut is of little importance. Thin metal sheets are cut like paper, and plates up to one inch in thickness can be cut at speeds of ten inches per minute.

We hope this has proved interesting and useful to you, just as Wrigley's Spearmint Gum is proving useful to millions of people working everywhere for Victory.

*You can get complete information
about this method from Bell Aircraft
Corporation, Buffalo, New York.*

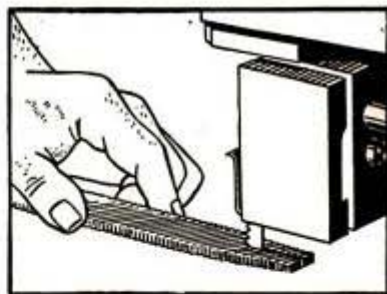

Proof of ability of new method
to cut hard materials is demon-
strated by operator cutting a file.

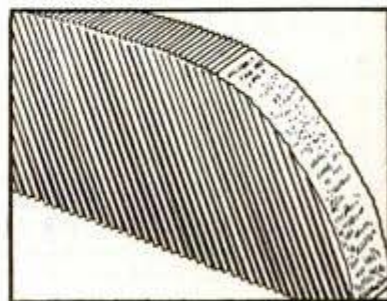

The temper of curve cut section
shown above is unaffected.

X-63

RED-ITCHY SKIN?

watch out—it's often

ECZEMA

**Home
Treatment
Promptly
Relieves
Torture!**



First applications of wonderful soothing medicated *liquid Zemo*—a Doctor's formula—quickly relieve the intense itching burning of Eczema, Psoriasis and similar annoying skin and scalp irritations due to external cause. Zemo also aids healing. Amazingly successful for over 35 years! Apply anytime—doesn't show on skin. First trial of clean, stainless *liquid Zemo* convinces! 3 different sizes. Buy Extra Strength Zemo for stubborn cases. All drugstores.

ZEMO

WHEN YOU BUY FLASHLIGHT BATTERIES ASK FOR
"EVEREADY" FRESH DATED BATTERIES

The word "Eveready" is the registered trade-mark of National Carbon Co., Inc.

"Many days I \$16
earn as much as 16"

"I bought a Foley Saw Filer, one year later had all debts paid and also \$400 on a new home. Many days I earn as much as \$16," says J. H. Kellogg. W. L. Tarrant writes: "I left my old job last September and in 10 months have filed 2,159 saws. We have a lovely business worked up and cannot keep up with the work."

There are hundreds of saws to sharpen in your community, — used in homes, by carpenters, farmers, schools, mills, factories, etc. You can file them so much faster and better with a Foley.

—make up to \$2 or \$3 an hour. All hand saws, also band and circular saws can be filed. No eye-strain, no experience needed with the FOLEY AUTOMATIC SAW FILER.



FREE PLAN shows how to start this steady cash business now during war-time, and be ready for the big peace-time building boom that is sure to come later. No special priority application required—delivery guaranteed. Send coupon today—no salesman will call.

FOLEY MANUFACTURING CO.

116-4 Foley Bldg., Minneapolis 13, Minn.
Please send FREE PLAN on saw filing business.

Name.....

Address.....



Winged Lightning

(Continued from page 59)

back" rides. The P-38 is a single seater but there is cramped room for a student behind the pilot's seat, on the shelf that holds the radio sets. On such a flight the instructor shows the student what to do when an engine is shot out, how he can trim the ship with the control tabs and handle it like a single-engine plane.

A P-38 pilot is not only a flier but a one-man army by himself. He may use more ammunition in a day than an infantry soldier may use during the whole war. Four .50-caliber machine guns and a 20-mm. cannon project from the nose of his ship. Under his wing he can carry a couple of demolition bombs as well as a cluster of anti-personnel fragmentation bombs. This armament equips him to attack enemy bombers or fighters, defend friendly bombers, or come right down to the ground and bomb and gun enemy installations.

There's one thing that puzzles a new pilot—his guns carry ammunition enough for only half a minute's shooting. But he soon learns that this ammunition is enough for a long fight. Because of his speed and the speed of enemy aircraft he can rarely keep a target in his gunsight for more than a fraction of a second at a time. He fires in short bursts. Some pilots have shot down half a dozen Japs on a single flight.

They Don't Stay Sunk

(Continued from page 87)

reasons: First, a single battleship-size floating drydock wouldn't go through the Panama Canal, and, second, it would be too easily lost. If one floating section is sunk, the others can continue to their destination.

Although American yards are turning out more ships than all the remainder of the world combined, even this production wouldn't supply the world's theaters of war without efficient repair service. Rear Admiral Emory S. Land, chairman of the Maritime Commission, told workers at the Todd Erie Basin Dry Docks, Inc., in presenting the commission's "M" flag.

He disclosed then that those workers alone had repaired 540 ships within one year's time and that one-million-plus tons of shipping have been rebuilt!

The skill of the shipwright is an ancient one in America. The first ocean-going craft, the Virginia, was built on the Maine coast in 1607, years before the Mayflower arrived. The skill that made the American flag familiar in every world port has proved itself in the nation's hour of peril.



TOOL NOTES

Maintenance
and Repair
Suggestions to
Prolong Tool Life

No. 14 PICKING THE PROPER TOOL FOR THE JOB

Next to knowing how to use tools, it is important to know which particular tool of a type to use for a given job or operation. With this in mind the next few issues of **TOOL NOTES** will cover this subject graphically.

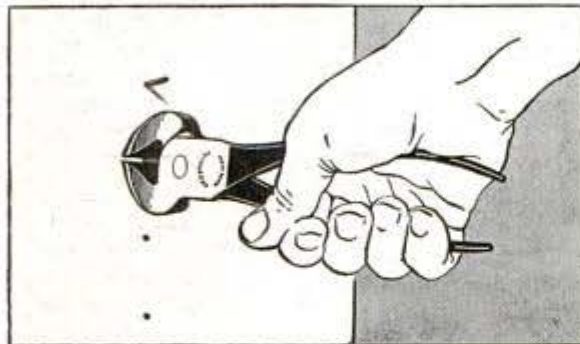

Where wire must be cut off close to a wall or other flat surface from which it protrudes, use **CRESCENT END CUTTING NIPPERS**. They make possible an almost flush cut because they are designed for that purpose. Example: cutting concrete form wires.

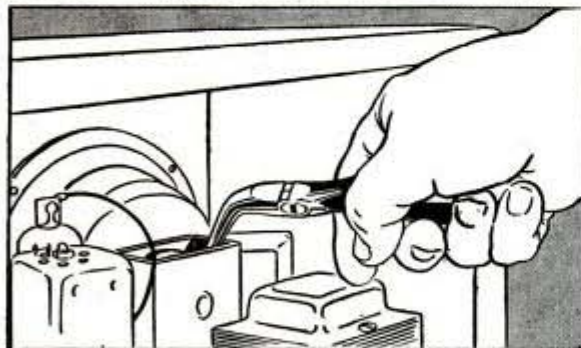

When you must work around obstructions or into tight, out of the way corners where fingers cannot reach, use **CRESCENT CURVED NEEDLE NOSE PLIERS**. They're designed to provide a good grip on small objects. Example: assembling radio sets.

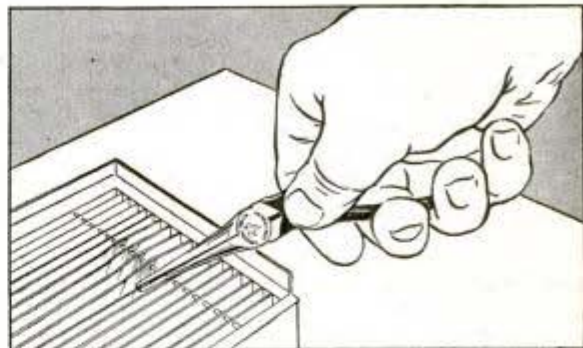

The broad, flat, long jaws of **CRESCENT'S DUCK BILL PLIERS** not only provide excellent gripping power on flat surfaces, but will "reach in" and "work" where clearance is extremely limited. Example: straightening and spacing metal fins.



CRESCENT SLIP-JOINT PLIERS are a general-purpose tool, having excellent gripping power over a wide capacity range because of their adjustable jaws. Ideal for holding or turning round pieces. Example: loosening a "frozen" adjustment screw.

MAIL THE COUPON FOR FREE REPRINTS

This is No. 14, in Crescent's **TOOL NOTES** Series. These informative advertisements providing practical information for users of hand tools, are available either punched to fit a standard 3-ring binder or suitable for bulletin board and classroom use. Coupon request will receive prompt attention.

CRESCENT TOOL COMPANY, JAMESTOWN, N. Y.

CRESCENT TOOLS
Give Wings to Work

.....
Crescent Tool Co., Jamestown, N. Y. D-6

Please send your "Tool Notes" Series
 for Bulletins for 3-ring binder

Name _____

Address _____

City _____ State _____

Mortite

UTILITY TAPE

BETWEEN YOU and THE COLD

New pliable plastic stops leaks, saves fuel. Weatherstrips windows, doors, baseboards—caulks casements; makes packing, gaskets.

Easy to apply. Unrolls like ribbon. Just press into place and it stays put. Does not crack, chip, dry out or shrink.

About 80 ft. to a roll. At stores, or \$1.25 prepaid \$1.40 west of Rockies).

Send for Circular



STOPS THAT DRIP

A sure cure for condensation drip from tanks, pipes, walls, ceilings, etc. Apply with brush, trowel or spray. At stores or

\$1.90 for 1 gal. prepaid (\$2.10 west of Rockies). Free Circular.

J. W. MORTELL CO., 522 Burch St., KANKAKEE, ILL.

New OTTAWA WOOD SAW

For Tractors



—Makes wood sawing fast and easy. Can cut enough wood to pay for itself quickly. Easily moved while attached. Big heavy blade. FREE details.

LOW PRICE

OTTAWA MFG. CO.
W127 Oak Ave., Ottawa, Kans.

BUILD-ARC WELDER FROM OLD GENERATOR

For Light or Heavy Work. 30-200 amperes. Complete PLANS 35c. Send today and we'll include FREE our Big NEW Catalog.

LEJAY MANUFACTURING CO.
1347 LeJay Bldg., Minneapolis, Minn.



ONAN ELECTRIC PLANTS

Electricity for Any Job—Anywhere

ONAN GASOLINE DRIVEN ELECTRIC PLANTS provide electricity in locations where it is not otherwise available, and for emergency standby service. Thousands of units are doing a winning job in the war.



Sizes from 350 to 35,000 watts. A.C. 50 to 800 cycles, 110 to 660 volts. D.C. 6 to 4000 volts. Also dual A.C. and D.C. output models. Details gladly furnished.

D. W. ONAN & SONS

1089 Royalston Ave. Minneapolis, Minn.

How Japan Will Be Defeated

(Continued from page 25)

sufficient supplies to keep China in the war.

The northern route via the Aleutians is a long haul, and the Japanese have only recently evacuated Kiska Island, putting us in full control of the area. The tentative bombing raids made on Paramushiro, Japan's most northern base in the Kurile chain of islands, may be preliminary to an attack in force. It would be possible to work down the Kuriles and eventually be in position to launch attacks on the main Japanese islands. This method would have the advantage of utilizing the shortest line of communication between the United States and any Japanese objective, but the Japanese Navy would have to be reckoned with. Too much confidence should not be placed in the use of Siberian bases. The matter of supplying them with gas, oil, bombs, and other material is difficult. Perhaps it was for a similar reason that the raid on the Ploesti oil fields was made from Egypt rather than a Russian base which would have cut some 700 miles from the 2,400 miles that had to be flown.

The difficulty of jumping from island to island has been demonstrated in the Guadalcanal and Munda campaigns. We were inexperienced in combat, and for a time had difficulty in putting supplies into Guadalcanal, but there was no such alibi for Munda where it required more than a month for a vastly superior force to knock out some 5,000 Japanese.

What can be expected when we tackle Rabaul or Truk where the Japanese have had ample time to develop strong defenses, and can be depended on to offer strenuous resistance? Such a campaign can be successfully waged, but the time and effort necessary can be put to better use. An out and out attack on the Philippines will result in a major campaign that will ravish the archipelago from end to end.

A war of attrition has been underway since the beginning of the war with beneficial results. Japan has lost more than 500 ships of various categories, over 200 being merchant vessels. Most of its carrier strength has been sunk or severely damaged. Several battleships, more than 40 cruisers, and destroyers by the dozen have gone down. In the Solomons since June 30 of this year 6 or 7 cruisers and 15 to 17 destroyers were accounted for. This toll is telling. In place of cargo ships the Japanese have now begun to use small barges where there is danger of attack.

Reports have been circulated that a

(Continued to page 158)

GROGGY

ABOUT WHAT BATTERY TO BUY?



GET THE BATTERY EXPERTS CHOOSE

It's easy to decide what battery to buy. Be guided by the experts who select batteries for the world's toughest transportation jobs. A million-mile trans-ocean flying record has just been established by a Pan-American Clipper equipped with Auto-Lite batteries.

Auto-Lites, too, are specified for service with our fighting

forces wherever dependable power counts.

Gasoline rationing demands better performance than ever of your battery. Get the longer life . . . the extra power you need. Make your next battery an Auto-Lite—specified as original equipment by leading automotive engineers.

"Million-Mile"
Clipper uses
Auto-Lite Bat-
teries for all
its ocean-span-
ning flights.



AUTO-LITE
means
AUTO-LIFE

TOLEDO, 1 AUTO-LITE BATTERY CORPORATION OHIO

Manufacturing Plants at: Niagara Falls, Indianapolis, Atlanta, Oakland, Oklahoma City, Toronto

BUY WAR BONDS

AUTO-LITE BATTERIES



DAMN THE BOTTLE- NECKS

*Full
Speed
Ahead!*



Making only Chicago Mounted Wheels and small Grinding Wheels—maintaining the highest quality—shipping orders promptly—**This is our Job, our Battlefield.**

With full WPB approval, we stopped making all large sizes and fixed our sights on wheels 3" in diameter and under.

We worked around the clock, 24 hours a day, and in a short time were able to fill orders on time—And, our central location cuts time in transit. Today, there is no waiting. With the Army-Navy E at our masthead, we are going full speed ahead.

Hande Tool of 1001 Uses and Hi-Power Grinders are still available to all who have priorities.

Send for Free Catalog

CHICAGO WHEEL & MFG. CO.

108 S. ABERDEEN STREET, CHICAGO 7, ILLINOIS



MAKE MONEY! Sell Warm **LEATHER** Jackets

Hundreds of prospects near you; sportsmen, workers in lumber yards, warehouses, stock rooms, war plants, etc. Men of action demand their snug warmth, free-action comfort, sturdy construction.

COMPLETE LINE
Leather and wool jackets, work shirts, 250 shoe styles for men and women. Liberal Commissions. Write today for FREE SALES OUTFIT.

MASON SHOE MFG. CO.
Dept. M-230, Chippewa Falls, Wis.

TRAILER AXLES, HITCHES, AND PARTS

● If you are interested in purchasing trailer axles, hitches, and other trailer parts, contact us promptly. Complete house trailer blue prints, \$1.00. Write for free literature.

HAMMER BLOW TOOL COMPANY, Dept. 101, WAUSAU, WIS.

TO FIT ALL POPULAR MOVIE CAMERAS!

FILM FOR SALE!

REG. 2¹⁵ DOUBLE 8...BLACK and WHITE
8 mm. MOVIE FILM...25 ft. **1.99**

REGULAR 9.50 BLACK and WHITE
16 mm. MOVIE FILM...100 ft. **4.19**

DEFENDER PROJECTION PAPER

REG. 95¢...all Grades
8x10 DOUBLE WEIGHT...**81**

REG. 95¢...all Grades
5x7 DOUBLE WEIGHT...**39**

FLASH BULBS.

NO PRIORITY
and PHOTO
FLOODS

#1 FLOOD...15
#2 FLOOD...30

ORDER THESE GE and
WABASH LAMPS NOW

8 mm CAN and
REEL...both **39**

WRITE FOR BROCHURE
FOR BARGAIN PRICES \$1.25

AHRENS and DeMERCHANT.
154-156 E. NINE MILE, FERRISDALE, MICH.
Camera Merchants, Supplies and Accessories

dearth of rice in Japan has been caused by insufficient shipping to transport this staple from Burma and Indo-China. The war of attrition is working, but the Japanese still fight.

A direct attack on the Japanese homeland sounds chimerical, but perhaps it is the quickest way to win. However, it cannot be undertaken until the Japanese fleet is out of the way.

Admiral Ernest J. King, Commander-in-Chief of the United States Navy, was recently reported as having forecast powerful and crippling blows on strategic Japanese positions in the Pacific. He remarked that our operations in the Pacific have been more than holding efforts in that they were offensive in principle. He then went on to say that the plan is being followed to undertake further offensive operations designed to cramp the enemy's communications and inflict material damage.

Between the lines of this statement can be read the basic plan of campaign that probably will be followed. The first objective is the Japanese fleet and air force. Attacks on widely separated Japanese positions such as Rabaul, Paramushiro, and Burma can be developed into simultaneous campaigns. The defense of any of these areas will require all the support that can be afforded by the Japanese Navy and air force. In other words it is expected that these arms will be forced to give battle. Such was one of the unheralded objectives of the Guadalcanal campaign, and the resultant destruction of Japanese planes and naval units was in accordance with expectations.

It has been estimated that by the beginning of 1944, the Allies can muster in the Pacific a naval force of about seven times the strength of Japan's in most categories. This strength will permit every point taken under attack by the Allies to be served by a naval force strong enough to handle whatever disposition of forces Japan makes of its navy. If the Japanese decide to support with their entire navy any one threatened area at the expense of the others, the result will be one big bag of Japanese ships for the Allies. If Japan disperses its fleet, the several forces will be dealt with separately. Should Japan desert its outposts by withdrawing its fleet to the security of home waters, then one or another of the several Allied campaigns can be pushed to conclusion. Japan will be virtually blockaded by disruption of its lines of communication, and supplies without limit can be poured into Chinese ports.

If the Japanese "save face" by sending

(Continued to page 160)



Bill will remember that smile...

... it will make him a better fighting man ... because far away, remembering it, Bill will think of his family safe and secure at home.

This winter thousands of servicemen like Bill won't be here to enjoy the comforts of their homes. But they are mighty glad they insured those comforts by purchasing Perfection Oil Heaters, Water Heaters and Ranges. Bill and the others know that Perfection Oil-burning appliances are built to *last*—to give economical, dependable service for the duration and long afterwards.

At present, we at Perfection are making war materials for the Armed Forces ... materials into which we're putting the same fine quality that has made the name Perfection a symbol of dependability to families like Bill's. But the government has authorized us to manufacture also a *limited number of Perfection Portable Oil Heaters and Water Heaters* to meet *essential* civilian needs at home.



YOU MAY BUY A PERFECTION ROOM HEATER OR WATER HEATER NOW



A limited quantity of these low-cost Utility Room Heaters—and also Perfection-made Puritan Water Heaters—are now on sale at your nearby Perfection Dealer's. He will be glad to assist you in making application for a purchase certificate, but please do not apply if your present Perfection Oil Range or Heater can be repaired.

Shortly after the first of the year, your Perfection Dealer may have Perfection Stoves and Ranges for sale. Meanwhile, you will find a complete line of Perfection WICKS and REPLACEMENT PARTS at his store. Remember that only genuine Perfection Wicks and Replacements will insure you fine, long-lasting Perfection service.

Buy More War Bonds

PERFECTION STOVE COMPANY

7616-B PLATT AVE.
Cleveland, Ohio

The Mark of Quality

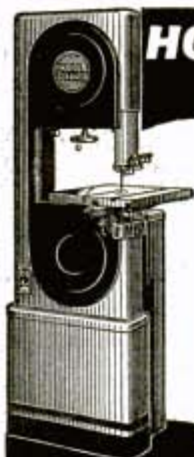

HOW TO OBTAIN SHOP TOOLS

at the earliest possible moment and
**PAY FOR THEM OUT OF
PATRIOTIC SAVINGS
IN WAR BONDS**

Own versatile, low-cost, sturdy
Boice-Crane
Band Saws - Saw Jointers
Jig Saws - Spindle Shapers
Belt Sanders - Spindle Sanders
Drill Presses - Lathes
Thickness Planers

Write today for folder on the

*Boice
Crane*

PURCHASE PRIORITY PLAN

a safe, convenient plan for forward-looking shop men and home craftsmen.

With manufacturers now engaged 100% in war production, the pent-up demand for shop tools is tremendous. You can avoid prolonged waiting for your tools, or the necessity of buying something less satisfactory, by reserving a preferred delivery position now. Use this convenient coupon to get details.

BOICE-CRANE CO.
943 Central Ave., Toledo, Ohio

Please send, without obligation or cost, details of the Boice-Crane Purchase Priority Plan, together with a copy of your catalog on shop tools.

NAME _____
STREET _____
CITY _____

110-VOLTS AC from DIRECT CURRENT

with KATO KONVERTERS. Furnish standard 110-v AC from 32, 110, or 220-v. DC. Good deliveries on sizes 350 through 1500 watts on priority orders. Good deliveries on 5, 7½, 15 & 25 KW AC generators. Mfr.'s of motor generators, frequency changers and high frequency generators.

KATO ENGINEERING CO.
34 Elm Street, MANKATO, MINN., USA



New Designs in FRANZITE GRIPS

Modernize Your Gun! Improve Your Score!

Most durable grips made. Positively unbreakable! For Colt, Smith & Wesson, Hi-Standard, Ortgies, Luger & Mausers in a wide choice of beautiful designs in ivory, pearl, walnut, onyx, etc. Low prices. FREE CATALOG. Dealers Wanted.

SPORTS, INC., (Mfrs.) 2850 N. Clark St., Dept. P-1, Chicago, Ill.



AUTO ENGINE SPEED CONTROL GOVERNORS

Give constant speed to any make of auto or truck engine, regardless of load changes, when used for power. Fully guaranteed. Simple instructions. Oil ring bearing \$13.00. Ball bearing \$19.50. Prepaid. Montreal branch, 7546 Wiseman St. Latin Amer. East Asiatic Co. Free circulars. **CANDEE, 2641-M S. Hill, Los Angeles-7**

their fleet out to destruction, it will be possible to effect Allied landings in Japan. We have learned how to handle such matters, and fighting across the cleared fields of Japan is to be preferred to the muck, insects, and heat of the tropics, and should incur no greater loss in personnel, perhaps less.

All we need to permit us to initiate a campaign that will end with a parade of triumphant Allies down Tokyo's Ginza is control of the sea and air in the vicinity of the Japanese Archipelago.

(The opinions contained in the above article are those of the writer and are not to be considered as reflecting the views of the Navy Department or of the naval service at large.)

Blueprint for Tomorrow

(Continued from page 5)

Looking ahead and being dissatisfied with what you are doing is most essential. Keep going even though progress is slow. Anything can pass a thing that is standing still.

Research is really nothing more than the fundamental art of sample making. The only danger I think we have in the postwar era will be a lack of understanding between engineering and management as to the essentials of long-range research and sample-making.

We have got so systematized that we don't understand that getting ideas cannot be run on a mass production basis. If we don't get that out of our heads, we are going to weaken the very position we have attained today. You cannot budget long-range research.

Some day we are going to get out a vote of thanks to the Army and Navy engineers for the job they did during peacetime—when they didn't have any money because everybody knew there wasn't going to be another war.

They made samples—knowing just as well as you and I that they weren't necessarily the best samples in the world—but they were samples. They had been run. Our big progress when war came was due to the fact that we had those working samples to start from.

If you can get people to take a long-range look at what can be accomplished through research and engineering, and if you can get an understanding between management and research, you can write your ticket for almost any kind of a world you would like to have, and I think you will get it.

(To learn where to buy commercial products described in these pages, see the index.)

POPULAR MECHANICS

Your Long Distance call may have gone to New Guinea

Telephone lines are the life-lines of an army. Bell System men and materials are helping to keep those lines unbroken on many battlefronts.

So if a Long Distance call gets delayed once in a while, you know there's a good reason.

The additional equipment that could be used here is serving the soldiers over there.

BELL TELEPHONE SYSTEM



U. S. Army Signal Corps installing switchboard in New Guinea

**WAR NEEDS
THE WIRES**

If the Long Distance circuit you want is busy — and your call isn't really urgent — it will help if you will cancel it.

If it must go through, we'll appreciate your cooperation when the operator says: "Please limit your call to 5 minutes."



HOW TO ...

Save Fuel THIS WINTER WITH SMOOTH-ON



Air leaks . . . below or above the furnace, or in the flue . . . are a frequent cause of fuel waste.

Stop these leaks . . . reduce your fuel bills . . . help to conserve fuel . . . by one application of SMOOTH-ON . . . easily and quickly, without dismantling any parts. The expansive property of SMOOTH-ON tightly fills all openings and makes an iron-hard seal which is not loosened by expansion or contraction.

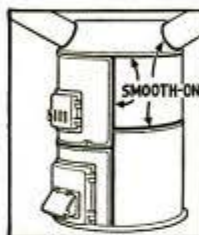

SMOOTH-ON is equally effective for stopping leaks of steam, water or air due to cracks, in boilers, heaters, pumps or piping . . . makes low-cost lasting repairs of equipment that you cannot replace because of war-time conditions.



This many-purpose iron repair cement also stops leaks in automobile radiators or engine cylinders, and tightens loose fixtures, tool handles and hardware. Be sure to buy a can today and be prepared for repair emergencies.



Buy Smooth-On No. 1 in 1 3/4-oz., 7-oz., 1 lb. and larger containers from your dealer, or if necessary from us. For your protection, insist on Smooth-On, used by professional repair men since 1895.

FREE BOOK

Get your copy of our latest 40 page illustrated handbook. Shows how to make repairs quickly, economically. Just send the coupon.

Smooth-On Manufacturing Co., Dept. 37
570 Communipaw Ave., Jersey City 4, N. J.
Please send the FREE Smooth-On Handbook.

Name.....
Address.....
1-44.....

Do it with SMOOTH-ON

Say you saw it in Popular Mechanics!

MAKE BIG MONEY SAWING WOOD NOW!

350 Cuts
a Minute



OTTAWA ONE-MAN TRACTOR SAW

Turn wood lots into cash; help save other fuels to win the war. Use Ottawa—fastest cutting; easiest way. Cuts large and small logs, fells trees. Thousands in use. Built to last with special heavy stiff saw blade. Positive safety clutch control, driven from any power take-off.

OTTAWA MFG. CO., D-127, Forest Ave., Ottawa, Kansas

FREE BOOK
and
Price List

NEVERSLIP PULLEY

Transmits more power with less belt wear; unaffected by weather. No pulley covering, no belt dressing required. Replace troublesome pulleys with NEVERSLIPS. All sizes. Money-back guarantee. Ask for NEVERSLIP Pulleys on ALL power machinery you buy. Write for folder and prices.

ROSENTHAL CORN HUSKER CO.
Box 16-144 Milwaukee, Wisconsin



MASCOT SLIDE RULE

Fits the pocket. Quickly solves any problem in multiplication, division, proportion. Gives the square, the square root, logarithm and reciprocals of all numbers. Trig scales give sines and tangents of numbers. Fine black graduations on white celluloid. Price in fabricoid case \$1.00, in leather case \$1.25. Money back if not satisfied. Special offer to agents and dealers.



TAVELLA SALES CO., 19 West Broadway, New York, N. Y.

A HARLEY-DAVIDSON for Me After Victory!



Buy War Bonds NOW -- and own a new Harley-Davidson after Victory! You'll thrill to greater performance than ever, made possible by the severe tests of war-time action! Write today for FREE copy of "Enthusiast" magazine filled with motorcycle pictures and stories.



HARLEY-DAVIDSON MOTOR CO., Dept. P, Milwaukee, Wis.

\$20.00
COMPLETE

ENGINES IN STOCK



The G. H. Q. miniature gasoline engine that really operates is still available. Over 15,000 sold in the last year. 1/5 H.P. Complete with flywheel and propeller, fuel, 15 accessories and full instructions. Fully bench tested and ready to run. For boats, planes, midget cars, etc. Send only \$1.00—Shipped Collect C.O.D. same day. Send 25c for Catalog of hundreds of hobby items.

GHQ MOTORS, Dept. BV, 40 East 21 St., New York 10, N. Y.

PAINT STRIPING TOOL

Try it! See the Added Beauty

ONLY
\$1.00
POST
PAID

With this NEW TOOL (not a brush) everyone can now draw lines with paint. Used on autos, models, toys, tiled walls, cabinets, furniture, linoleum floors and all home workshop projects.

As easy to use
as a pencil



Send only \$1.00 for complete tool for painting a 1/16" wide stripe, including an adjustable guide, operating instructions, etc. C. O. D. price \$1.25. Tool uses paint, enamel, lacquer, etc. Patented interchangeable tips are available for wider or narrower stripes.

Every Painter and Craftsman Should Own One. Send for your tool today. Use it. If you are not satisfied that you have added character as well as beauty to your work, return the tool and we'll refund your money promptly.

Dealers: Write for literature, etc.
WENDELL MFG. CO.

2531 N. Ashland Ave. Chicago, Ill.



EVINRUDES

ON THE HOME FRONT

*help battle an enemy
deadly as the Japs!*



TREACHEROUS enemy of all mankind is the malaria-bearing *Anopheles* mosquito . . . dreaded alike in New Guinea's jungles and fox holes, and in many a sector of the home front.

Along the placid back waters of Tennessee Valley's vast man-made lakes, the battle against *Anopheles* goes on endlessly. The war-busy population of this new industrial "Ruhr of America" must be protected from the ravages of malaria . . . and the Tennessee Valley Authority has energetically fought the *Anopheles* wherever it breeds!

Fleets of spray boats propelled by outboard motors are a strategic and highly effective weapon in this vital work. Outboards drive these boats from bases to "battle grounds". Outboards speed the inspectors on their rounds, and are useful in many other phases of Malarial Control Operations.

Throughout America, in countless unspectacular but essential services, peacetime Evinrudes are handling their jobs quietly and efficiently. Today Evinrudes are being produced exclusively to meet the specialized requirements of our fighting forces. After Victory there will again be Evinrudes for all . . . brilliant new Evinrudes packed with performance to surpass the finest you've known before!

EVINRUDE MOTORS, Milwaukee, Wisconsin

Evinrude Motors of Canada, Peterboro, Canada



**EVINRUDE
OUTBOARD MOTORS**

★ HELP SPEED VICTORY . . . BUY MORE WAR BONDS

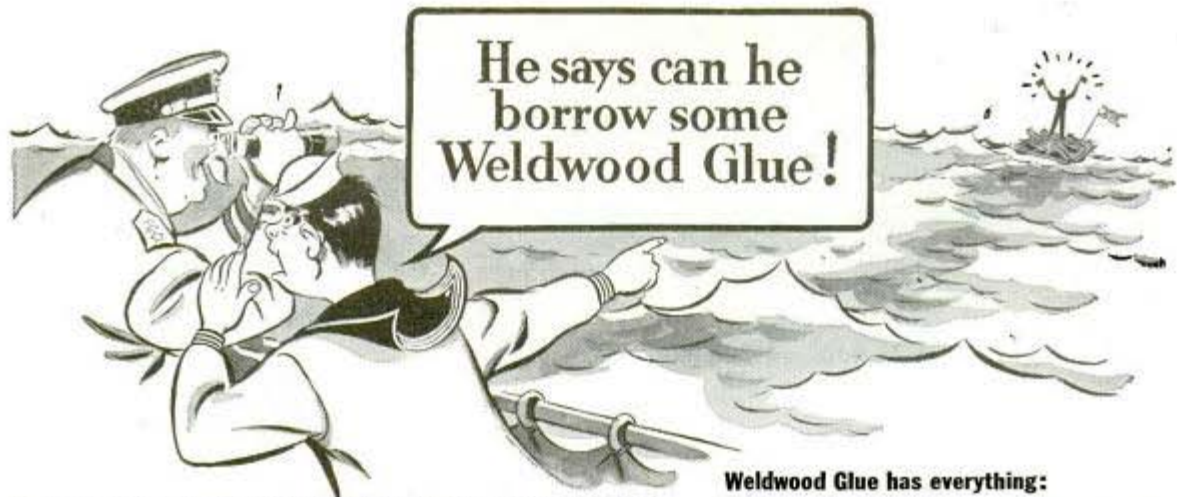

You may never need to hold a life raft together with Weldwood Glue, but you'll find it's the handiest adhesive you ever used at your home work bench.

In fact, this easy-to-use plastic resin glue is a honey for hobbyists. Mixed just by adding tap water to the powder, it can be used immediately, is cold-setting (work can be handled in a few hours) and it makes a permanent bond!

Waterproof, rot-proof and bacteria-proof, Weldwood glue won't stain, or mar the most delicate color or finish.

Your hardware store or lumber dealer has handy packages of Weldwood Glue in 10¢, 25¢, 50¢ and 85¢ (1 lb.) sizes. Get a can today or send 25¢ and your dealer's name for a trial 3½ oz. sample. Supply limited, due to Uncle Sam's war needs.

UNITED STATES PLYWOOD CORPORATION

(Weldwood Glue Dept. 14) 103 Park Avenue, New York 17, N. Y.

Weldwood Glue has everything:

1. Tremendous Strength.
2. Waterproof, Bacteria- and Rot-proof.
3. Quick and Easy to use. No heating. No waiting.
4. Economical.
5. Applied Cold, quick setting.
6. Stain-Free.



"Makes the glue line the SAFETY line"



Model Builders Attention!

	V	V-2	V-3
Hex	1/2"	3/8"	5/16"
Thread	3/8"-24	1/4"-32	1/4"-32
Thread Length	7/32	7/32	5/32
Weight, Grams	8	3 1/2	2 1/2

Actual Size V-Plug

Champion spark plugs for model gas engines give the same dependable performance as their larger counterparts. Silliment sealed. Sillimanite insulator. Alloy needlepoint electrodes for easy starting. One-piece construction.

CHAMPION

SPARK PLUG COMPANY • TOLEDO, OHIO

DO YOU WANT a permanent business profession of your own? Then BECOME A FOOT CORRECTIONIST. Earnings in this greatly needed profession run as high as \$50-\$100 weekly after a few weeks home training—not medical or chiropody—no further capital needed, no goods to buy. 47th year. Write for free booklet.

Stephenson System of Foot Correction
28 Back Bay, Boston, Mass.

WORLD'S LOWEST PRICED ADDING MACHINE
Ideal XMAS GIFT—GUARANTEED ACCURATE. Not a toy. Operates with only a finger flick. Adds, subtracts, multiplies, divides. Counts up to ten million. Pays for itself over and over. Ideal Gift—for Business, Income Tax and School use. MONEY BACK GUARANTEE. Send name and address. Pay postman only \$2.50 plus postage. (Send full cash if outside U. S.) Money back in 10 days if not delighted. AGENTS WRITE.

CALCULATOR MACHINE COMPANY (Mfrs.)
DEPT. 149, P. O. BOX 1118 CHICAGO, ILLINOIS

KRW ARBOR PRESSES BENCH TYPE AND HYDRAULIC
NEEDED IN EVERY SHOP—SAVE TIME AND MONEY—DO BETTER WORK, QUICKER.

No shop is complete without a small arbor press. Pressing and squeezing operations can be done better and faster on a KRW Arbor Press. Stop using vise and sledge hammer methods—they generally deliver spoiled work in the end. KRW Factory-To-You Prices give you greater value for your money. Order today.

KRW Bench Type Arbor Presses, 3 sizes

No. 37-P	1/2 Ton	\$13.25*
No. 37-O	1 Ton	\$23.00*
No. 37-N	3 Ton	\$33.00*

*Prices F.O.B. Arcade, N. Y. Slightly higher west of Rockies. Stand illustrated extra.

K R W Hydraulic Presses are built in 25, 50, 60 and 75 ton sizes. Prices start at \$198.00*.

K. R. WILSON, 17 Lock St., BUFFALO 2, N. Y.
Builders of Shop Equipment for Ford Dealers Since 1916

Atlas 7-INCH SHAPER

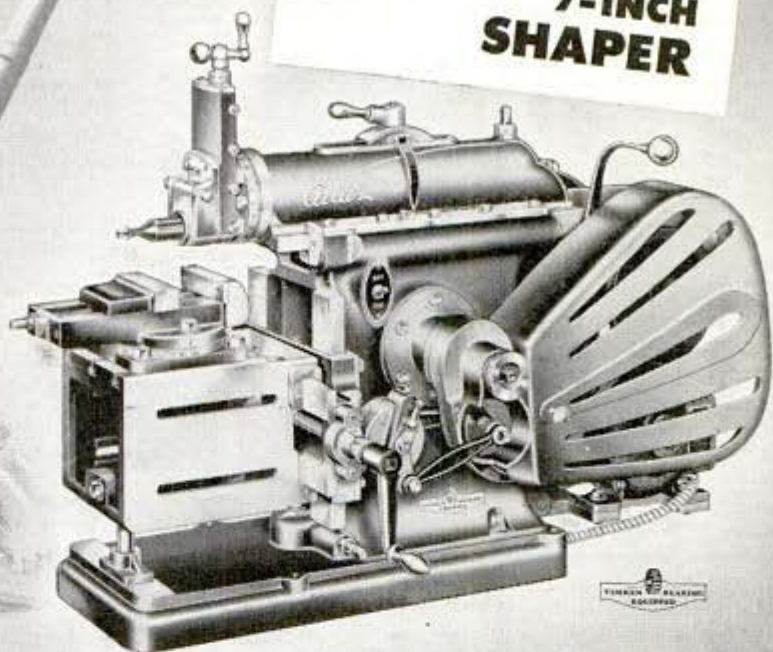

BASIC PRECISION WEAPON in the BATTLE of PRODUCTION

Precision breeds precision! A thousandth inch error on the ground means a clean miss three miles in the air. That's why every gun part has to be "split hair" to specifications. In thousands of war plants — and in mobile machine shops of our armed forces — Atlas machine tools deliver that victory-winning kind of precision.

One favorite in this family of dependable producers is the modern, compact Atlas Shaper. It handles all shaping operations within a 7" stroke, and in plant after plant has released larger machines for jobs better suited to their capacities.

Atlas machine tools are now tested veterans in the battle of production. Remember their flexibility . . . their low cost . . . their dependable accuracy and ease of operation when shop equipment is again available for you.



ATLAS PRESS COMPANY

143 NORTH PITCHER STREET • KALAMAZOO 13D, MICHIGAN



LATHES



MILLING MACHINES



DRILL PRESSES

★ BUY WAR BONDS NOW ★
FOR A NEW *Atlas* SHOP
AFTER THE WAR



NOW a DYNAMIC HEAVY DUTY INDUSTRIAL WELDER

Saves VALUABLE TIME and MONEY!

AMAZINGLY SIMPLE & EASY TO OPERATE
This portable Dynamic Welder—easily carried right to the job—plugs into any convenient, properly wired 110 volt light circuit—works on Iron, Steel, Brass, Bronze and other metals—has eight metallic and carbon arc welding heat stages—does work you would think only possible with a larger, more expensive machine.

DESIGNED TO DO HIGH GRADE WELDING INEXPENSIVELY
Maintenance Men; Farmers; Mechanics; Machine Shops; Foundries; Auto, General Repair and Job Welding Shops; using the Dynamic find it so indispensable and useful that they cannot afford to be without it. If inexperienced, you can easily learn to do a variety of high grade welding jobs by following the practical, simplified operating and welding instructions furnished.

for Only \$23.50 COMPLETE

Once you see a Dynamic in operation you won't be without it. Its simplicity will amaze you. In a year the Dynamic only costs you about 6¢ a day.

Comes complete with helmet, rods, cables, electrode holder and operating instructions, etc.

Write today for free priority assistance and particulars on how to qualify for one of these amazingly low-priced welders. Act now while they are still available. Get details on our 10-day trial offer.

DYNAMIC WELDER CO., 2226-T Silverton Road, Chicago 16, Ill.



I'LL TAKE THE WHITE ONE EVERY TIME



EASY TO READ—easy to clean, unconditionally guaranteed for one year. The crack-proof white surface is bonded to the steel—protects it from rust. 25, 50, 75, 100 ft. lengths. Sold by hardware, building material, mill supply dealers everywhere. Write for folder. **KEUFFEL & ESSER CO., Hoboken, N. J.**



LOOK FOR THIS DISPLAY

K&E WYTEFACE STEEL MEASURING TAPES

PROTECTION FROM RUST TOOLS — GUNS — LOCKS, Etc.

For years hunters have used Fiendoil to keep their guns clean and free from rust . . . equally effective on all metal articles.

At Your Sports or Hardware Store
In 35¢, 2 oz. Bottle

FIENDOIL

McCAMBRIDGE & McCAMBRIDGE CO.
Baltimore



WAR WORKERS-WIN "PRODUCTION AWARDS"

Dremel Moto-Tools are used on hundreds of jobs, in thousands of war plants, because they are such great time and labor savers. Sharpening tools . . . cleaning dies, castings, cores and welding points . . . grinding, polishing, burring and finishing . . . these are but a few of Moto-Tool's many capabilities. Only Moto-Tool has all these features—27,000 r.p.m. (assures better work and lengthens life of cutters); shockproof (bakelite) case; oil-less (oil-sealed) bearings; fan-cooled motor (can't overheat). Order Moto-Tools and accessories at your dealer, or direct on 10-day trial. Money-back guarantee. If you need a Moto-Tool in your work, ask your employer for a priority number. **Catalog FREE.**

Kit No. 1 with 23 high grade accessories and Model 1 Moto-Tool in hard-wood case **\$17.50**

Kit No. 2 same as above with Master Model 2 Moto-Tool **\$23.50**

SYNCRO

Torpedoes the Axis!

Syncro Electric Jig Saws are busy torpedoing the Axis in the shape of SYNCRO-machined parts for submarines, bombers, tanks, guns, etc. Meanwhile Syncro research guarantees better Syncro Saws for you after Victory!

SYNCRO WORLD'S SAFEST SAWS



SYNCRO DEVICES, INC.
3265 Bermuda Ave.
Dept. PW-14
Ferndale 20, Michigan

HOLD-E-ZEE AUTOMATIC GRIP SCREWDRIVERS

Hold, start and set-up screws in unhandy places. Gripper instantly released by spring action, sliding up out of way when not in use. Finest materials thru-out. High quality blades; many have transparent, insulating unbreakable handles (Glasite).

No more expensive than ordinary screw drivers. Models for recessed-head screws. Handiest ever. Get one today. At hardware, auto supply, or electrical stores.

UPSON BROS., INC. 86 EXCHANGE ST. ROCHESTER, N. Y.

GRAY HAIR VITAMIN NOW \$1.95

NO MORE PAY

No dyes—No drugs—Hair grew out in Natural Color in almost nine out of ten test cases just taking one tablet Calcium Pantothenate Vitamin each day.

Why pay \$3.50 to \$5.00 for the famous "Gray Hair Vitamin"?

SEND NO MONEY. Just send name and address. We will ship 100 10-mg. tablets (100 days' supply) genuine standard quality Calcium Pantothenate Vitamin C.O.D. for \$1.95 plus few cents postage. Guaranteed same quality as used in National Tests or money back.

LILEE PROD. CO., 2017 S. Michigan Ave., Dept. 91, Chicago, Ill.

READY CUT HOMES

Still Available . . .

Really need a home? You can get one—now—in many areas, necessary equipment included. We'll show you how to get government permission, and save \$500 average, on a modern production method home—easily assembled. Information on FHA financing. If you plan to build—now or later—send 25c showing 75 modern low priced full color home plans; and get on your complete building plans ready now for filing with application at moderate cost. Write.



Dept. PM-14
INTERNATIONAL MILL
& TIMBER CO.
Bay City,
Mich.

NEW COLOR CATALOG
FOR ONLY
25c



STEAM MARINE ENGINE



A precision built and engineered single cylinder model engine. Reverse or clutch gear. Automatic oil and water pumps. Scale $\frac{1}{4}$ " to 1". $11\frac{1}{2}$ " x $6\frac{1}{2}$ " (not a toy). A counterpart of and operates at pressures comparable to Modern Marine Construction.

Send \$2.50 for 14 pages scale drawings,

including 2-photographs, cut-away illustrations of engine assembly and parts and two types of boilers, a total of 10-pages, $8\frac{1}{2}$ " x 11" and 4-pages, 15 " x 22 ", with Manual of machining instructions . . . Or . . .

- For 2-Views and descriptive literature. Send 25c
 - Rough Castings Kit, with all above. Send \$12.50
- Also now available, Ship-Model Scale Drawings.
Write Model Division, 212 North Division Bldg.

The THOMPSON ENGINEERING CO., Grand Rapids 2, Mich.



GERSTNER TOOL CHESTS

Their better construction is fully appreciated by good Mechanics. Free catalog for machinists and toolmakers.
GERSTNER TOOL CHESTS
444 Columbia St. Dayton 7, Ohio

Build a STURDY WORK BENCH from complete working plan in Stanley Set No. 11. Includes 4 other good plans. Now 14 Sets to choose from. EACH SET OF 5 PLANS ONLY 10c

STANLEY TOOLS Division of The Stanley Works
114 Elm St., New Britain, Conn.

SHAW and "Peppy-Pal" "DU-ALL" GARDEN TRACTORS

● 1 to 9 H.P. Circulars on request War limits production . . . We supply repairs for all SHAW tractors sold in our 39 years in business. Write for your needs.

BUILD YOUR OWN RIDING TRACTOR—"WAR HORSE"



by using old auto parts, powered by 3 H. P. Briggs and Stratton or other engine, larger or smaller, as shown here; or walking type Garden Tractor $\frac{1}{2}$ to 3 H.P.; or convert truck or auto into Farm Tractor. Plans for building any one of above postpaid for \$1.00 (state which wanted) or all 3 for \$2.00. Money Back Guarantee!

SHAW MFG. CO., 4501 Front St., Calesburg, Kansas
6680 No. 4th St., Columbus, O., 5812-G Magnolia Ave., Chicago, Ill.

DECORATIVE Decalcomania TRANSFERS



Imported Designs of all Sizes and Types—Flowers, Fruits, Figures, Birds, Dogs, Horse Heads, Ships, Juvenile, for Furniture, Doors, Walls, Trays and what not. Catalog with 890 illustrations in color sent for 25c. Deductible on first order of \$1 up.
L. C. WELLS, Dept. PM-41, 25 East 26th Street, New York, 10.

INVENTORS

Now

IS THE TIME TO PATENT & SELL YOUR INVENTION

Now, more than ever before, is the right time to patent your invention. Why? Because manufacturers presently engaged in war production are looking ahead to the future by buying up patent rights now, so they will have new and attractive items to make and sell for civilian consumption as soon as the war is over. This is what happened during and after the last war. Hence, the smart thing for you to do is to look ahead to the future too. Protect your invention by applying for a patent now, so you will be in position to cash in on an outright sale, or on the royalties your invention will bring.

"PATENT GUIDE" SHOWS WHAT TO DO

Our Free "Patent Guide" contains complete information about patent procedure and how to sell inventions. It tells you how to find out whether your invention is probably patentable; what steps to take in order to obtain patent protection for your invention; how to arrange for the profitable sale of your invention; and how to secure financial backing if necessary. Our "Patent Guide" also gives many illustrations of successful inventions; how many simple improvements on already existing inventions proved to be large commercial successes; contains countless other items of vital interest to all inventors including the illustration of over 150 basic mechanical movements. With our "Patent Guide" you also will receive free a "Record of Invention" form with instructions for making disclosure and establishing date of your invention.



TAKE FIRST STEP NOW

Send for your free "Patent Guide" today. Remember—action is important—delay may be costly. Mail the coupon in an envelope or paste it on a penny postcard NOW.

CLARENCE A. O'BRIEN & HARVEY B. JACOBSON

Registered Patent Attorneys
41R-A Adams Building, Washington, D. C.

CLARENCE A. O'BRIEN & HARVEY B. JACOBSON

Registered Patent Attorney before the United States Patent Office
41R-A Adams Building, Washington, D. C.

Please send me your 48-Page "Patent Guide for the Inventor" and specially prepared "Record of Invention" FREE. This request does not obligate me.

Name

Address

City.....State.....

(Please write or print plainly)

Say you saw it in Popular Mechanics!

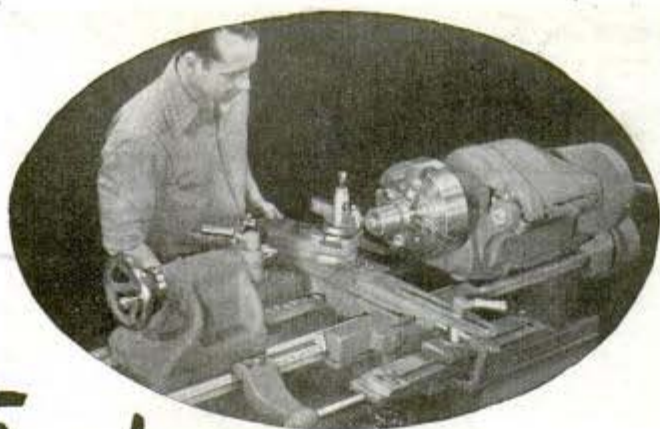

Be First ON THE POST-WAR PRIORITY LIST for South Bend Lathes



When your order is received, we will issue a numbered Post-war Priority Certificate. As soon as materials and manpower are released for civilian production, South Bend Lathes will be shipped in accordance with the Priority Certificates. Certificate holders will receive the first South Bend Lathes to be thus released, up to 80% of our production. The remaining 20% will be reserved for returning service men who may need lathes.

All standard South Bend Lathes, embodying the improvements developed in meeting exacting war production needs, will be available. No revolutionary models or design changes are to be expected. There will be no price increase—unless material or labor costs, or other conditions beyond our control, require it.

Here is a practical first step in putting your post-war plans into action. South Bend Lathes are made in a variety of sizes and types, 9" to 16" swing. Send for Catalog No. 100-C and full information on this plan. Choose the lathes that meet your needs... place an order now, and be sure of earliest possible delivery.

Post-war employment and prosperity depend upon quick resumption of normal peace time civilian activities, production, and services. To furnish lathes first to those who will be ready to use them (but cannot qualify for a war-time priority) South Bend Lathe Works now offers a practical post-war priority plan.

To take advantage of this plan, place an order now for the lathes you want. No down payment, no deposit is required. Should conditions necessitate, you may cancel the order at any time. All we ask is that it be placed in good faith.



Buy War Bonds Now... Save for Lathes

SOUTH BEND LATHE WORKS
South Bend 22, Indiana • Lathe Builders For 37 Years



14 $\frac{1}{2}$ " South Bend Lathe
Bed Lengths: 5', 6', 7', 8', 10'

13" South Bend Lathe
Bed Lengths: 4', 5', 6', 7'

Series 1000 South Bend
Turret Lathe, 10" Swing

9" South Bend Lathe
Bed Lengths: 3', 3 $\frac{1}{2}$ ', 4', 4 $\frac{1}{2}$ '

10" South Bend Lathe
Bed Lengths: 3', 3 $\frac{1}{2}$ ', 4', 4 $\frac{1}{2}$ '

16" South Bend Lathe
Bed Lengths: 6', 7', 8', 10', 12'

PRINTED BY POPULAR MECHANICS COMPANY, CHICAGO, ILL., U. S. A.

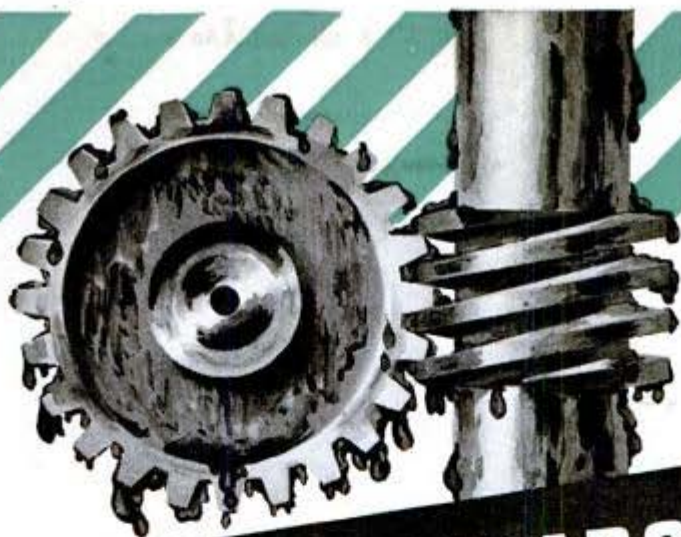

GREASE for GEARS but NOT for SHAVING

Grease is great for machines, but men hate to put it on their faces. That is why so many men are switching from ordinary brushless to the new Mennen Brushless Shave — it's a cream, not a grease! Get it in either jar or tube.



A Novel Radio Program
"Ed Sullivan Entertains"
CBS Monday nights
7:15 pm EWT 9:15 pm MWT
6:15 pm CWT 8:15 pm PWT

THEY'VE GOT WHAT IT TAKES!

Star Gazer

He's the navigator
of a Flying Fortress...
and he's the shootin'est
man on the ship!

"Shooting the stars."

Give him two stars to shoot at and a pencil, and the navigator can tell you the plane's position in 30 seconds!

He doubles in lead, 100! Come enemy fighters, the navigator mans one of the machine guns in the Fortress's nose.



CAMELS
CHECK WITH
ME ALL WAYS—
THEY'VE GOT
THE FLAVOR
AND
MILDNESS
THAT ADD UP
TO STEADY
PLEASURE!



Check Camels
with your
"T-Zone"

The "T-ZONE"—Taste and Throat—is the proving ground for cigarettes. On the basis of the experience of millions of smokers, we believe you will like the extra flavor that only Camel's blend of costlier tobaccos can give. We believe your throat will confirm the findings of other Camel smokers.



Camels



FIRST IN THE SERVICE

With men in the Army, Navy, Marine Corps, and Coast Guard, the favorite cigarette is Camel. (Based on actual sales records.)

R. J. Reynolds Tobacco Company, Winston-Salem, N. C.

CAMELS
ALWAYS HAVE
A FRESH APPEAL
TO ME...AND
THEY'RE SO EASY
ON MY
THROAT



She calibrates air navigation instruments—and Jane Hammond, Autoflight Corp. technician (above), shares the airman's preference for Camels.