

Tough Guys

a **POPULAR
MECHANICS**

MAGAZINE

WRITTEN SO YOU UNDERSTAND IT

REG. TRADE MARK GREAT BRITAIN NO. 410426

EST. 1902



FEB.
25 CENTS
30c IN CANADA

SEE PAGE 7

 **BUY UNITED STATES
WAR SAVINGS
BONDS AND STAMPS**

Casite Guarantees—

SUMMER STARTING THIS WINTER

or Double Your Money Back

● Motorists, here's the good news you've been waiting for—*guaranteed* winter starting.

No more grind, grind, grind to drain your battery and waste gasoline. Casite guarantees you summer starting all winter long or *Double-Your-Money-Back*.

Just add Casite to your winter grade oil and then watch your engine leap to life at the touch of the starter button—in coldest weather.

Most good service stations or garages have Casite. A pint is sufficient for most cars—and costs only 65c.

THE CASITE CORPORATION • HASTINGS, MICH.

We Guarantee*

that any motor capable of being started in a warm room will start in the coldest weather with Casite in the crankcase.

*Subject to these simple conditions:

If the crankcase capacity of your motor is six quarts, or less, you are to put one pint of Casite in the oil and add a pint at the end of each 1000 miles driven. Maximum refund amount for failure to start will be \$1.30, which is twice the nationally advertised price of Casite, 65c per pint.

If the crankcase capacity is more than six quarts, you are to put two pints of Casite in the oil and add a pint at the end of each 1000 miles driven, unless you change oil, in which case add two pints. In this case, maximum refund amount will be \$2.60, which is twice the nationally advertised price of two pints of Casite.

HERE'S PROOF

Pittsburgh Testing Laboratory tested a badly sludged motor at zero without Casite. Motor failed to start seven out of eight times. After adding Casite, same motor started promptly every time.



FOR QUICK STARTING HORSEPOWER

Get CASITE

Some good news about Tin we think you should know

IT'S NO SECRET that the Japs are camped on 80% of the world's tin supply and that America is facing a critical tin shortage.

You have been asked to salvage every single tin can you use—to save every possible ounce of this vital war material. But, today, there is *good* news about the tin you salvage—and we believe you should know that news.

This is it: A new electrical process makes the tin used in tin cans go 3 times farther now than it did before.

Tin plate was formerly made by dipping thin steel sheets in molten tin. It produced a satisfactory coating, but used more tin than was really necessary.

American engineers devised a new method—*electroplating* the steel with pure tin—and the result was a coating that required only *one third as much tin*.

But the new tin plate had disadvantages. It was porous and did not provide complete protection against the acids in certain kinds of food.

Then Westinghouse stepped in.

Our research men and engineers, in co-operation with engineers of the steel industry, found a way of using *radio waves* to *heat* the dull, imper-



fect surface so that the tin fused almost instantly into a smooth, protective coating.

And the process is fast. A single machine can turn out enough tin plate in 18 minutes to cover an area the size of a football field!

This new device is a typical example of *electronics at work*—a result of Westinghouse electrical research and “know-how.” Already it is being installed in mills that turn out tin plate for a third of all the nation’s food cans.

Naturally, this does not mean that there is less need for you to salvage your old tin cans. On the contrary—*more than ever*, tin is needed to protect the food supplied to our fighting men all over the world.

Westinghouse Electric and Manufacturing Company, Pittsburgh, Pa.

Westinghouse

PLANTS IN 25 CITIES—OFFICES EVERYWHERE

"AN URGENT CALL FOR YOU"

"Please do not make Long Distance telephone calls to war-busy centers unless it is really necessary."

That helps keep the lines open for war messages and war's on the wires these days. When we can get telephone materials again we'll give you all the wires you desire. Many thanks.



BELL TELEPHONE SYSTEM



Popular Mechanics Magazine

Registered in U. S. Patent Office and Canada

H. H. WINDSOR, Founder

H. H. WINDSOR, Jr., Editor and Publisher

February, 1943

Vol. 79, No. 2

IN THIS ISSUE

New Magic From Test Tubes	1
"Mummy" Foods for Victory	8
Here Come the "Cats"	19
Robot Guardians of Billions	28
"Mustang" Admirals in the Making	34
Tough Guys	40
Glass Pinch Hits for the Whole Team	50
Riding the Fast Mail	56
Jungle Mechanics (Part 1)	66
Adventures of the Inshore Patrol	74
12,000,000 Meals a Day	82
Fighting That Tired Feeling	92

Where-to-Buy-It Index Starts on Next Page

My Boys Shoot Down Zeros

SIX Flying Fortresses coming home from a job over the Pacific spotted a flight of 18 Jap Zeros peeling off overhead. The big Forts sailed straight on their course as the Japs came down. Then the Yank gunners let loose, and 17 Zeros were blasted out of the sky. The 18th ran for home. That's one of the tales recounted by a U. S. Air Corps officer and flying instructor in a thrill-packed feature next month. The Japs, he says, don't carry parachutes; it's not honorable to be captured. He tells of planes that dish out 200 bullets per second, flying with wingtips almost touching.

Longest Road in the World

ONE-THIRD of the way around the world from Fairbanks, Alaska, lies Buenos Aires; between them, with only a half dozen gaps in Central America uncompleted, lies the longest road in the world. The story of the 16,000-mile Pan-American Highway is an epic of hemisphere cooperation, vital to us in a war of communications. Read it in the March issue.

Next Month

WE DON'T advise trying it, but you can drop a heavy weight on a chunk of TNT without exploding it. Similarly, this strange stuff rides a shell serenely undisturbed by the bang of leaving a cannon or the impact of piercing a battleship's side, but inside its target the TNT bursts into a tornado of destruction. Until a year ago we made it from coal tar. Now it's a petroleum by-product. Dr. C. M. A. Stine, a vice president of the DuPont company, tells some interesting sidelights of this "Tornado in a Bombshell" in a March story.

Bomber's Seeing Eye

PILOTS of the Flying Fortresses call their navigators "high-altitude bookkeepers." Maybe theirs is just a desk job, but the desk is alongside the bomb rack. The fellows up in the cockpit have plenty of respect for the navigator, for every pilot and bombardier knows that man with the sextant and map and drift indicator can guide him to Rabaul or Stuttgart and back. Read "Back Seat Driver in a Bomber" next month.

Ready for the Worst

NO ONE wants to use poison gas. For one thing, it is primarily a defense weapon, and Allies and Axis alike want to keep the offensive. But we're ready to use it and fight it if we must. One defense is a "zoot suit" so airtight men have lost 10 pounds in 30 minutes wearing it. News of gas warfare is told in a March article, "Preparing for the Worst."

Published monthly by POPULAR MECHANICS COMPANY, 200 East Ontario Street, Chicago, U. S. A. Single copy in the United States, 25 cents; subscription rates in United States and possessions, and countries of the Pan-American Postal Union including Spain, \$2.50 a year. Single copy in Canada, 30 cents; subscription rates, \$3.00 a year. To all other countries add \$1.00 a year over United States prices for overseas postage. Changes in address must be reported to us immediately to eliminate delay. Entered as Second Class Matter, Sept. 15, 1903, at the Post Office at Chicago, Illinois, under Act of March 3, 1879. Entered as Second Class Matter at Post Office Dept., Canada.

Copyright 1943, by Popular Mechanics Company, Copyright under International Copyright Union. All rights reserved under Pan American Copyright Union. Printed in the United States of America

HOW TO TAKE CARE OF YOUR CAR NOW

Make the slogan meaningful: *Care for your car for your country!* Remember, you'll have new tires before you have a new car.



VITAL INNER PARTS OF AN ENGINE LEFT STANDING ARE DRAINED OF LUBRICATION



When a car is idle, lubricants drain from its engine. Corrosion, rust, and other contaminants attack vital parts. Keep your engine alive. See that it gets periodic work-outs from now on.

Start the engine easily. Don't race it. Serious wear can occur in starting. That is, unless you have protected your engine with Pyroil Lubrication Process.

A FEW OUNCES OF PYROIIL IN THE CRANKCASE AND IN THE GASOLINE TANK GIVE YOUR CAR PROTECTION YOU CAN DEPEND ON

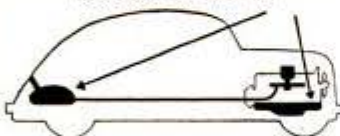

It's different when you have Pyroil in your engine. Inner parts even while standing, retain a highly protective film of Pyroil. This is unlike your regular lubricant. Pyroil protection shields the delicate surfaces of engine parts against corrosion, rust, acid-etching, and other damage. *And your engine starts easier in cold weather, with Pyroil.*

So, put the engine of your car into the gloved hands of Pyroil, today. Have a car still in the running—efficient, dependable—when victory comes! Manufactured and guaranteed by Pyroil Company, W. V. Kidder, Founder, 52 Pyroil Bldg., LaCrosse, Wisconsin, U. S. A.



INVEST AT LEAST 10% EVERY PAY DAY IN WAR BONDS

DISTRIBUTORS: CHECK AND MAIL COUPON FOR FRANCHISE FACTS.

INSTRUCTION COUPON—HOW TO CARE FOR YOUR CAR, NOW

PYROIL COMPANY
52 Pyroil Bldg., LaCrosse, Wisconsin

Please send me complete instructions on the correct care of my car, with Pyroil.

Send details of your Plan for Distributors

Name

Address

City..... State.....

WHERE-TO-BUY-IT INDEX

Where no name and address appear directly under an item, the product is not believed by us to be commercially available

Cargo ship catapults planes.....	5
Clock tells time by lights.....	5
Dummy cockpit teaches pilot to escape.....	6
Ten ways to stretch gas.....	6
Counter checks car passengers.....	6
"Sea Skimmer" to chase submarines.....	7
Lengthened sedan carries 15.....	7
Models of Nazi bombs.....	12
Nylon bristles for paintbrushes.....	12
Faucet turned off by weight of bucket.....	12
U. S. Equipment Co., 2634 S. Michigan Ave., Chicago	
Four-in-one machine-gun mount.....	13
Phantom models speed training.....	13
Cause of oil breakdown.....	13
Tricks for troops.....	14
Bomber crew "bails out" on land.....	16
Asbestos-lined concrete forms.....	16
U. S. Rubber Co., Rockefeller Center, New York	
"Tank" office sells war bonds.....	17
Rack aids in transcribing Stenotype notes.....	17
Stenotype Co., 4104 S. Michigan Ave., Chicago	
Swamp glider rescues downed fliers.....	17
"V-mail" speeds letters to soldiers.....	18
Scale aids first-aid students.....	27
Carson Pirie Scott, State and Monroe, Chicago	
Flip-down shield for car mirror.....	27
Blue Star Auto Stores, 2007 S. State St., Chicago	
Home for war workers.....	32
Plywood trainer saves metal for warplanes.....	33
Jeep converted to ambulance carries four.....	33
Floating hotel houses capital workers.....	38
Ship built in hole in ground.....	38
"Fortress" fleet crowds calendar.....	39
Jeep lights veiled by Plexiglas.....	45
Pin-up hat holder for car or tent.....	45
Blue Star Auto Stores, 2007 S. State St., Chicago	
Guns on wheels.....	46
"Jungle mudders" man swamp guns.....	48
"Gatling gun" helps turn out shells.....	48
Power lines carry raid alarms.....	48
General Electric Co., Schenectady, N. Y.	
"Flying jeep" loads on truck.....	49
Glass fibers camouflage war plant.....	49
Driving glasses have adjustable lenses.....	49
Robuck, Roebuck & Co., State and Van Buren, Chicago	
Car door repair panel.....	55
Blumenthal Bros 1631 Michigan Ave., Chicago	
Vanadium extracted from rock.....	55
Flight training films in kit.....	60
Jam Handy Co., 2821 E. Grand Blvd., Detroit, Mich	
"Heating pad" for plane wings.....	60
Corrugated asphalt wall siding.....	60
Certain-Teed Products, 120 S. LaSalle St., Chicago	
Teaching a 16-inch gun to speak.....	61
Battleship-carrier has extensible flight deck.....	62
Air Corps mechanics keep 'em flying.....	64
Barrage balloon is "bottle fed".....	65
Safety guides for derailed train.....	65
Americans getting "fish eyes".....	65
Bomber gunners in dress rehearsal.....	72
Auto body made of plywood.....	72
Sliding ramp for ambulance.....	73
Seaplane given fresh-water bath.....	73
Mushroom extract used to treat blood pressure.....	73
"Dodge-em" car tows planes on carrier.....	77
Wire spools serve as tractor wheels.....	77

(Continued to page 6A)

ARMY-NAVY "E" AWARD TO

Atlas

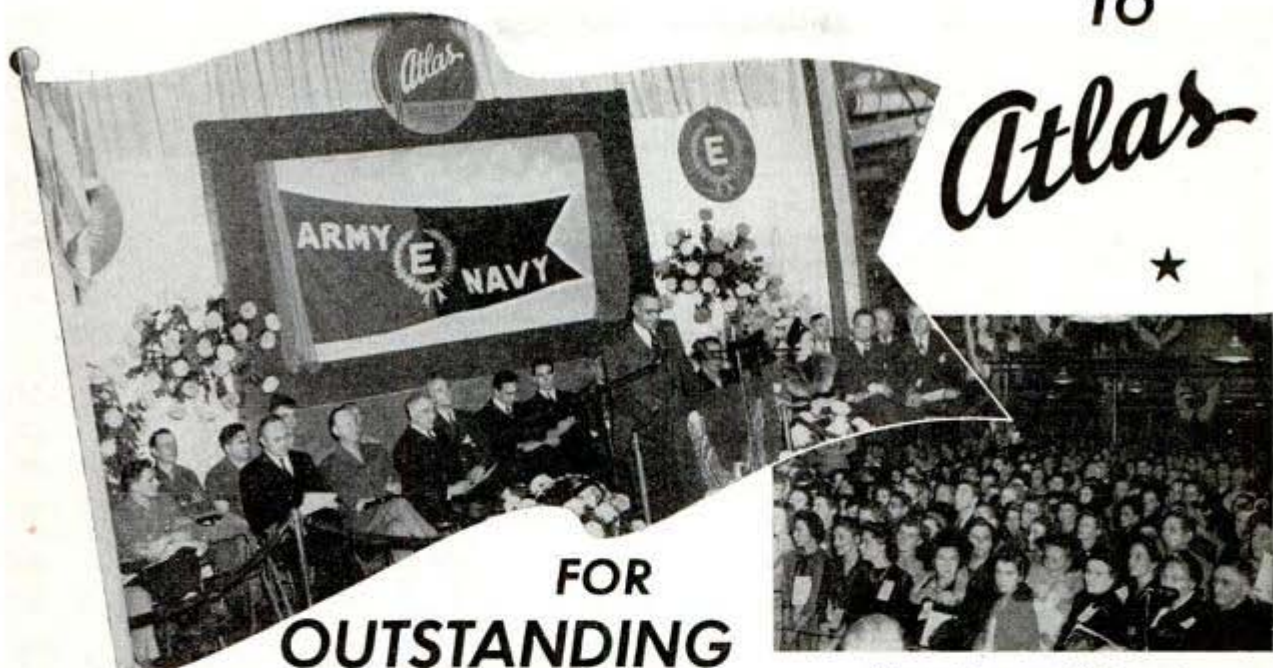

*Atlas employees and their guests
at the award presentation.*

FOR
**OUTSTANDING
PRODUCTION**

★ ★ **OF THESE VITAL WAR TOOLS**



6"-10" LATHES



MILLING MACHINES



DRILL PRESSES

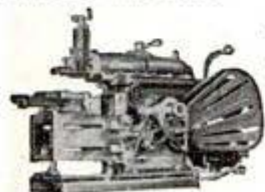

SHAPERS

THE men and women of Atlas proudly wear the Army-Navy "E" today. Over them fly two flags — Old Glory and the official pennant for excellence in war production. The "E" indicates high performance standards, but you can bet everyone in this organization is working hard to make the Atlas record even better. It's our part of the big job of licking Hitler and Hirohito!

This "excellence in production" means excellence in quality as well as quantity. Atlas Lathes, Milling Machines, Shapers, and Drill Presses have proved themselves thousands of times in war plants — and under the tough operating conditions of the Army and Navy mobile maintenance forces. Make a note of that in your "Want List" for the time when Atlas Equipment will again be available for non-war use. Atlas Press Company, 243 North Pitcher Street, Kalamazoo, Michigan.



**VICTORY
FIRST!**

- THEN Atlas TOOLS FOR YOU

FEBRUARY, 1943

This One



24J8-T72-JC4W

5A

Исторический музейный фонд

(Continued from page 4A)



... the drink with
QUICK FOOD ENERGY

The backbone of the army.....	78
Deflated tire gives alarm.....	80
Pull-up strap lifts face shield.....	80
Western Reserve Lab., 34 Climax Bldg., Cleveland, O.	
Desk shelf holds typewriter.....	80
Commercial Furniture Co., 2739 W. Chicago Ave., Chicago	
Germans use aluminum river barges.....	80
Motorcycle "hybrid" tows gun.....	81
"Eyeshades" hide floodlights on coast.....	81
Ragweed is source of oil.....	81
Electro-brain checks plane's wiring.....	87
Box keeps army matches dry.....	87
Glass-topped training glider.....	88
Hospital train carries 65.....	88
"Black light" tests gas masks.....	88
Floating drydock.....	89
Collapsible barrel saves shipping space.....	90
Planters Mfg. Co., Portsmouth, Va.	
Precision grinding adds life to cutting tools.....	90
Adjustable "hammer head" socket wrench.....	90
Belmont Radio Supply Co., 1921 Belmont Ave., Chicago	
Cable to raise sub and other patents.....	91
Tool ejects rivets one at a time.....	96
Murray Corp., 7700 Russell St., Detroit, Mich.	
Sandpaper holder shaped like file.....	96
Keeler Mfg. Co., 2410 S. Keeler Ave., Chicago	
Automatic acetylene gas "gun".....	96
Gas Gun Co., Inc., P. O. Box 287, Salem, Ore.	
Radio cabinet touch-up kit.....	155
General Cement Manufacturing Co. Rockford, Ill.	
Thermostatic switches.....	158
Technical Appliance Corp., 17 E. 16th St., New York City	
Geared type vernier dial.....	159
Bud Radio, Inc., 5205 Cedar Ave., Cleveland, Ohio	
Desk radio with clock.....	160
Lullaby Furniture Co., 666 Lake Shore Drive, Chicago	
F-M radio antenna.....	160
General Electric Co., Schenectady, N. Y.	
Electronic resistance limit bridge.....	160
Radio City Products Co., 127 W. 26th St., New York City	
Fluffy down from cattail fibers.....	178

Craftsman and Shop Notes Index

ART AND ARTISTS

Clamp holds T-square on drawing board.....	101
Triangle used as protractor.....	112
Curtain rod helps draw ellipse.....	120
Eraser used as pencil-lead pointer.....	122
Hinged tray for artist's colors.....	134

FARM

Splitting wedge made from auto-spring leaf.....	100
Simple latch for partition door.....	126
Wire guard keeps chickens out of barn.....	143
Tractor exhaust pipe altered to prevent fire.....	144
Coulter attachment covers loose trash.....	144
Spring holds grain sacks while filling.....	154

FURNITURE

Chest vanity.....	97
Desks for tiny tots.....	105
Converting round table to drop-leaf type.....	107
Two phonograph-record cabinets.....	108
Colonial table lamp.....	111
Ash trays for fisherman's den.....	113
Combination cabinet and breakfast table.....	119
Nest of tables.....	121

(Continued to page 8A)

WORK for YOURSELF as well as the Boss!

... Right now
is the **BIG CHANCE** for YOU

You've got a job—you're making money right now. Sure—but why don't you buckle down and put in the next three or four months' spare time in getting set for a better job—and more money? Plants need Foremen—and how—just build on what you've got and be a Foreman—on the road up.

Three or four short months give you Foremanship training. All you need do is to apply yourself, without interfering with your present job. Send for our FREE book. It tells how you can prepare—how you can be a successful FOREMAN through our "FOREMANSHIP FOR VICTORY" training.

This training is as streamlined as an armored division. It is interesting, concise, and right to the point. You need it right now.

What You Study Tonight—You Can Use Tomorrow

This is not merely "a set of books"—because we guide you step-by-step through each lesson of the course. Through our Problem Method you solve actual Foremanship problems—problems which the Foreman faces every day and which he has to take care of. And you can apply what you learn today on the job tomorrow. How long you take to complete this course is up to you—you can go as fast or as slowly as you choose.

In addition to ambitious men who want to be Foremen, lots of experienced production men and foremen who want to do a better job are taking this training. Our instructors are capable and experienced production men who understand Foremanship and its problems thoroughly.

You know as well as we do that the need for workers is today probably the greatest in our history. The Foreman—the boss in the shop or factory—the man who directs and sees that the work is turned out—that the production line is kept moving—he is the man who knows, and for that reason the man who gets the bigger pay.

Send for FREE booklet today. It places you under no obligation at all, and may be the means of your further success in business.

LASALLE EXTENSION UNIVERSITY A Correspondence Institution

Dept. 264-MF Chicago

Kindly send me your free booklet and details about your Foremanship Training for Victory.

Name

Position

Address



free!
Coupon will bring
a 48-page booklet
by return mail . . .

TRAINING COVERS 12 BASIC SUBJECTS

- The Foreman and His Job in the Victory Plan
- Training the Working Force
- Managing the Working Force
- Leadership and Handling Men
- Planning and Scheduling Production
- Getting the Work Out
- Greater Efficiency Through Job Analysis
- Greater Efficiency Through Time and Motion Study
- Greater Efficiency Through Elimination of Waste
- Handling and Safeguarding Material, Tools, and Equipment
- Cost and Record Control
- Handling Problems of Rights and Grievances



LEARN TO FLY for Uncle Sam!

Never was it more opportune for you to get into aviation! By taking flight instruction and mechanical training now, you become most useful to Uncle Sam, and assure yourself a successful military career and peacetime future.

Start today! Learn to fly in the famous Piper Cub Trainer . . . the plane in which thousands of military pilots and mechanics received their initial training. You can learn with as little as 8 hours of dual instruction . . . whether you are 16 or 60!

Contact your local airport to get mechanical training. See the Piper Dealer there for a flight demonstration.

Get This Booklet on "HOW TO FLY"

This booklet, "You, Too, Can Fly," has been especially prepared by a government-certificated flight instructor. It clearly explains the basic flight principles. Send for your copy today!



 **PIPER**
POINTS THE WAY TO
WINGS FOR ALL AMERICA

MAIL COUPON TODAY

PIPER AIRCRAFT CORPORATION
DEPT. PM23, LOCK HAVEN, PENNA.

Please send me the booklet "You, Too, Can Fly!" and Piper catalog for which I enclose 10c in stamps or coin for postage-handling.

NAME.....

ADDRESS.....

CITY..... STATE.....

(Continued from page 6A)

HAND TOOLS

Altered wrench adjusted quickly.....	116
Farming pliers to repair O-gauge track.....	114
Holder for steel wool.....	114
Homemade linoleum knife.....	114
Miter box has pivoted saw guide.....	118
Altered saw cuts insulating material.....	119
Cutting disks with coping saw.....	125
Tool to remove flooring.....	126
Auger brace holds rods for pointing.....	134
Slotted drill makes holes in marble.....	138
Auxiliary anvil improves micrometer.....	145
Offset prick punch is safer.....	152
Clip for machinist's scale.....	153

HOME IMPROVEMENTS

Hanging thick doors on thin casing.....	100
Removing window and door trim.....	106
Slots in screen frame provide drainage.....	112
Repairing old furniture.....	115
Increasing life of porch curtains.....	126
Linoleum walk on roof protects covering.....	126

HOUSEHOLD

How to hull peas easily.....	101
Solving home problems.....	102
Gripper retrieves small articles.....	104
Reducing holes in salt shaker.....	104
Kitchen table anchored with window antirattlers.....	106
Brush used as darning egg.....	106
Scored linoleum is easier to cut.....	110
Phonograph needles hold backing in picture frame.....	113
Knee pads protect child's clothing.....	119
Magnet holds cabinet door closed.....	120
Shelves of wood and glass.....	120
Quick way to chop walnuts.....	120
Ant poison containers.....	122
Two wall cabinets.....	125
Boil clothesline before using.....	125
How to carry shopping bag.....	129
Rubber cement on shoes prevents accidents.....	143

OFFICE

Creased paper holds labels in typewriter.....	110
Notebook leaves hold cards for copying.....	112

PAINT AND PAINTING

Straightening paintbrush bristles.....	111
Removing whitewash.....	113
Treating concrete before painting.....	124
Tape protects printing on paint can.....	143

PHOTOGRAPHY

Negative viewer over darkroom sink.....	130
Clips provide place to store lampcord.....	130
Edge printer borders photos.....	131
Extension for pack adapter.....	132
Soap removes marks from color film.....	132
Camera mount for making stereos.....	132
Novel photos from reticulated negatives.....	133
Table-top tripod steadies miniature camera.....	133

POWER TOOLS

Clamp straightens scratch brush.....	100
Reducing speed of lathe.....	106
Flexible-shaft grinder.....	135
Adjustable stop for shaper or jointer.....	137
Cleaning hollow lathe spindle.....	140
Drill press spindles stored in column.....	140

(Continued to page 10A)



DRAFTING

SPRINGBOARD TO SUCCESS!

MANY men today are using drafting boards to help win this war! • The International Correspondence Schools Courses in Mechanical or Architectural Drafting have fitted many hundreds of ambitious men for better jobs in this well-paid field! • All I. C. S. Courses (covering 400 business and technical subjects) are prepared by leading *practical* authorities, constantly revised to meet new developments. *Yet the cost of I. C. S. training is surprisingly low.* • It's not too late for *you* to start—help your country, help yourself! Mail this coupon *today!*

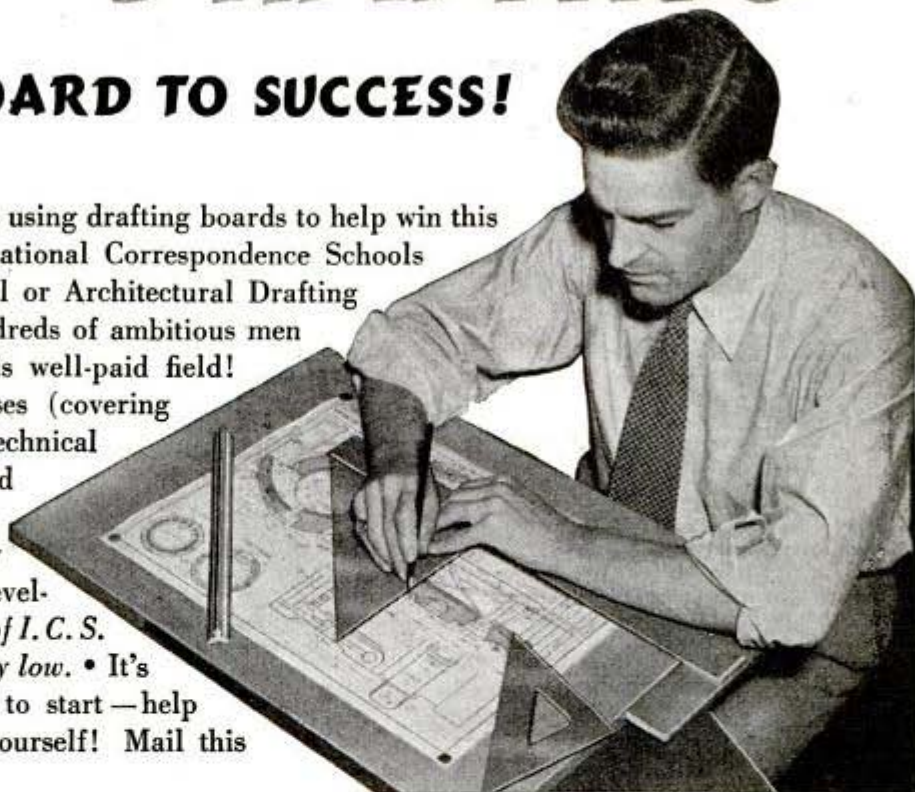

INTERNATIONAL CORRESPONDENCE SCHOOLS HELPING TO TRAIN AMERICANS FOR VICTORY

BOX 5653-J, SCRANTON, PENNA.

Without cost or obligation, please send me booklet and full particulars about the course *before* which I have marked X:

SPECIAL
TUITION RATES
FOR MEMBERS
OF THE
ARMED FORCES



- | | | | |
|---|---|--|--|
| <input type="checkbox"/> Airplane Drafting
<input type="checkbox"/> Architectural Drafting
<input type="checkbox"/> Electrical Drafting
<input type="checkbox"/> Mechanical Drafting
<input type="checkbox"/> Ship Drafting
<input type="checkbox"/> Structural Drafting
<input type="checkbox"/> Blueprint Reading
<input type="checkbox"/> Air Brake
<input type="checkbox"/> Air Conditioning
<input type="checkbox"/> Architecture
<input type="checkbox"/> Auto Engine Tune-up
<input type="checkbox"/> Auto Technician
<input type="checkbox"/> Aviation <input type="checkbox"/> Aviation Mechanic
<input type="checkbox"/> Boilermaking

<input type="checkbox"/> Accounting <input type="checkbox"/> Advertising
<input type="checkbox"/> Bookkeeping
<input type="checkbox"/> Business Correspondence
<input type="checkbox"/> Business Management
<input type="checkbox"/> Cartooning <input type="checkbox"/> Civil Service

<input type="checkbox"/> Advanced Dressmaking
<input type="checkbox"/> Foods and Cookery | <input type="checkbox"/> Bridge Engineering
<input type="checkbox"/> Chemistry <input type="checkbox"/> Coal Mining
<input type="checkbox"/> Civil Engineering
<input type="checkbox"/> Concrete Engineering
<input type="checkbox"/> Contracting and Building
<input type="checkbox"/> Cotton Manufacturing
<input type="checkbox"/> Diesel Engines
<input type="checkbox"/> Electrical Engineering
<input type="checkbox"/> Electrician
<input type="checkbox"/> Electric Lighting
<input type="checkbox"/> Foundryman <input type="checkbox"/> Heating
<input type="checkbox"/> Heat Treatment of Metals
<input type="checkbox"/> Highway Engineering
<input type="checkbox"/> House Planning

<input type="checkbox"/> College Preparatory
<input type="checkbox"/> Commercial
<input type="checkbox"/> Commercial Illustrating
<input type="checkbox"/> Cost Accounting
<input type="checkbox"/> C. P. Accounting

<input type="checkbox"/> Home Dressmaking
<input type="checkbox"/> Professional Dressmaking and Designing | <input type="checkbox"/> Industrial Metallurgy
<input type="checkbox"/> Locomotive Engineer
<input type="checkbox"/> Machinist <input type="checkbox"/> Inspector
<input type="checkbox"/> Management of Inventions
<input type="checkbox"/> Marine Engines
<input type="checkbox"/> Mechanical Engineering
<input type="checkbox"/> Mine Foreman
<input type="checkbox"/> Navigation <input type="checkbox"/> Patternmaking
<input type="checkbox"/> Plastics <input type="checkbox"/> Plumbing
<input type="checkbox"/> Public Works Engineering
<input type="checkbox"/> Pulp and Paper Making
<input type="checkbox"/> Radio, General
<input type="checkbox"/> Radio Operating
<input type="checkbox"/> Radio Servicing

<input type="checkbox"/> First Year College
<input type="checkbox"/> Foremanship <input type="checkbox"/> French
<input type="checkbox"/> Good English
<input type="checkbox"/> High School
<input type="checkbox"/> Managing Men at Work

<input type="checkbox"/> Home Economics Courses
<input type="checkbox"/> Home Dressmaking
<input type="checkbox"/> Professional Dressmaking and Designing | <input type="checkbox"/> R. R. Section Foreman
<input type="checkbox"/> R. R. Signalman <input type="checkbox"/> Refrigeration
<input type="checkbox"/> Sanitary Engineering
<input type="checkbox"/> Sheet Metal Work
<input type="checkbox"/> Shipfitting <input type="checkbox"/> Shop Practice
<input type="checkbox"/> Steam Electric <input type="checkbox"/> Steam Engines
<input type="checkbox"/> Steam Fitting
<input type="checkbox"/> Structural Engineering
<input type="checkbox"/> Surveying and Mapping
<input type="checkbox"/> Telegraphy <input type="checkbox"/> Telephony
<input type="checkbox"/> Textile Designing
<input type="checkbox"/> Toolmaking <input type="checkbox"/> Tool Design
<input type="checkbox"/> Welding, Gas and Electric
<input type="checkbox"/> Woolen Manufacturing

<input type="checkbox"/> Railway Postal Clerk
<input type="checkbox"/> Salesmanship
<input type="checkbox"/> Secretarial <input type="checkbox"/> Spanish
<input type="checkbox"/> Showcard and Sign Lettering
<input type="checkbox"/> Traffic Management

<input type="checkbox"/> Tea Room and Cafeteria
<input type="checkbox"/> Management, Catering |
|---|---|--|--|

Name..... Age..... Address.....
 City..... State..... Present Position.....

Canadian residents send coupon to International Correspondence Schools Canadian, Limited, Montreal, Canada
 British residents send coupon to I. C. S., 71 Kingsway, London, W. C. 2, England

1917 WAR TELEPHONE

RUN BY



1943 WAR RADIO

RUN BY



For Instance . . .

849
in
19
pe
an
th
wi
fo
St

... during the Dieppe raid, Gen. Roberts commanded from headquarters on a destroyer.
... along a nine-mile front wireless [radio] messages could be heard coming in . . .
... a smoke shield was ordered for troops on the "west beach" . . . the [radio] order was given to the Fighter Command . . . two hundred miles away . . . WITHIN A FEW MINUTES Douglas Bostons were dropping a heavy pall of concealing smoke . . . (news item)

Interesting!

Watch for radio use in the war news—you'll find it in the air—on the ground—and at home!

WITHOUT radio, the movement of war would still be anchored by telephone lines—the physical hazards of the courier and visual signals.

Now war moves swiftly over the whole face of the earth—instantaneous radio communication thru the ether instead of over copper wires has blasted the barriers of space and time.

So today all our radio production centers on war use.

But what of tomorrow—what effect will this have upon the future—after victory?

One thing is certain—it will revolutionize and speed the great new future form of transportation.

Radio has never been universally necessary in transportation before. In automobiles—on trains—it has been entertainment—in boats it has been a great aid but not an essential.

But today for the future, in that great, new universal transportation that is forming itself—the airplane—radio is essential as the engine itself.



Zenith's leadership in the radio industry has been established by a constant achievement of "firsts." Repeatedly, ideas "brand new" when Zenith "first" introduced them, later became essentials on all radios. And that same "forward thinking" of engineers and factory and organization now concentrates on war production of the thing we know—radio—exclusively radio. We are progressing—we learn every day—and this new experience will inevitably reflect itself when Zenith again produces for peace.

For over seven years Zenith Radio Corporation has advertised on short wave sets—"Europe, South America or the Orient—every day or your money back." It has never been called upon for a refund.

—a Zenith Radio Dealer near you is giving reliable service on all radios—regardless of make.

ZENITH RADIO CORPORATION—CHICAGO

(Continued from page 8A)

Jigs for sharpening circular saws.....	141
Tap wrench used as drill-press vise.....	144
Shelf between lathe ways.....	145

RADIO AND ELECTRICITY

First aid for home receivers (Part 9).....	155
Two modern crystal receivers for beginners.....	156
Radio set acts as automatic fire alarm.....	158
Paper clamp makes soldering iron holder.....	159
Holes in baffle for bass reflex effect.....	159
Powder-puff headphone pads.....	159
Resistor or choke holder from soldering lugs.....	159
Making calibration marks on bakelite panels.....	159
Code "blinker" made from spring clothes pin.....	159

STORE AND SHOP

Bicycle loading platform.....	129
Calibrated bin for glass.....	138
Crowning truck wheels protects floor.....	138
Sales cards suspended from shade roller.....	140
Neat holders for type-case labels.....	143
Nonskid footboards for machine shop.....	145
Portable unit for lettering price tags.....	145
Screen holds pin tags for lettering.....	154

TOYS AND NOVELTIES

Matchbox flashlight.....	101
War game shooting target.....	123
Pirate-chest cigarette dispenser.....	127
Child's "movie" stage from shoe box.....	129
Valentine favor and place card.....	137

WOODWORKING

Stop holds board on edge for planing.....	100
Keeping machine bold from turning in wood.....	110

MISCELLANEOUS

Holder on wheelbarrow for sickle.....	100
Record of salesman's calls kept on map.....	104
Truing stand for bike wheel.....	104
Hot dogs served from sled.....	107
Stepladder locked for carrying.....	110
Tacks hold crutch tips in place.....	112
File boxes store magazines.....	112
Preventing loss of billfold.....	114
Bracket holds fishing rod on wall.....	120
Repairing pool table.....	122
Supports to keep cello in place.....	122
Tape reinforces notebook pages.....	122
Handy wrench for screw caps.....	126
Ripping lumber from concrete forms.....	138
Nali carrier from keg.....	138
Metal clip holds clock on shelf.....	138
Storage battery repair.....	139
Red signal summons foreman.....	140
Tacks stitched in flag don't get lost.....	143
Cradle holds oil drum on bench.....	144
Locking sign on hook.....	144
Shortcuts in die making.....	146
Chain stop for dump-truck endgate.....	152
Sidewalk signs weighted with sand.....	152
Sign painter's shelf sticks to window.....	153
Tape holds wire grill while soldering.....	153

IMPORTANT NOTICE

It is the intention of this magazine to provide its readers with information regarding the latest developments in the mechanical arts. We take no responsibility as to whether the disclosures contained in our articles are covered by patents and advise readers to investigate this subject before making, using, or selling any of the products, machines, or processes described in order to avoid possible liability for patent infringement.

**AUDELS NEW
MACHINISTS
HANDY BOOK
NOW READY!**

Prepare!

**A KEY TO
MODERN SHOP PRACTICE**

PRACTICAL INSIDE INFORMATION

For Every Machinist, Toolmaker, Engineer, Machine Operator, Mechanical Draughtsman, Metal Worker, Mechanic or Student. This 1600 Page Handy Book Covers Modern Machine Shop Practice in All Its Branches.

**A COMPLETE INSTRUCTOR WITH
READY REFERENCE INDEX**

New from Cover to Cover. Tells How to Operate and Set Up Lathes, Screw & Milling Machines, Shapers, Drill Presses & All Other Machine Tools.

**5 PRACTICAL BOOKS IN ONE!
60 FULLY ILLUSTRATED CHAPTERS**

Covering: **1**—Modern Machine Shop Practice. **2**—Blue Print Reading and How to Draw. **3**—Calculations & Mathematics for Machinists. **4**—Shop Physics. **5**—How to Use the Slide Rule.

...ASK TO SEE IT!...

THEO. AUDEL & CO., 49 West 23rd St., New York
Mail AUDELS MACHINISTS & TOOLMAKERS HANDY BOOK, Price \$4 on 7 Days Free Trial. If O. K. I will remit \$1 in 7 days and \$1 Monthly until \$4 is Paid. Otherwise I will return it.

Name _____
Address _____
Occupation _____
Reference _____ P.M.

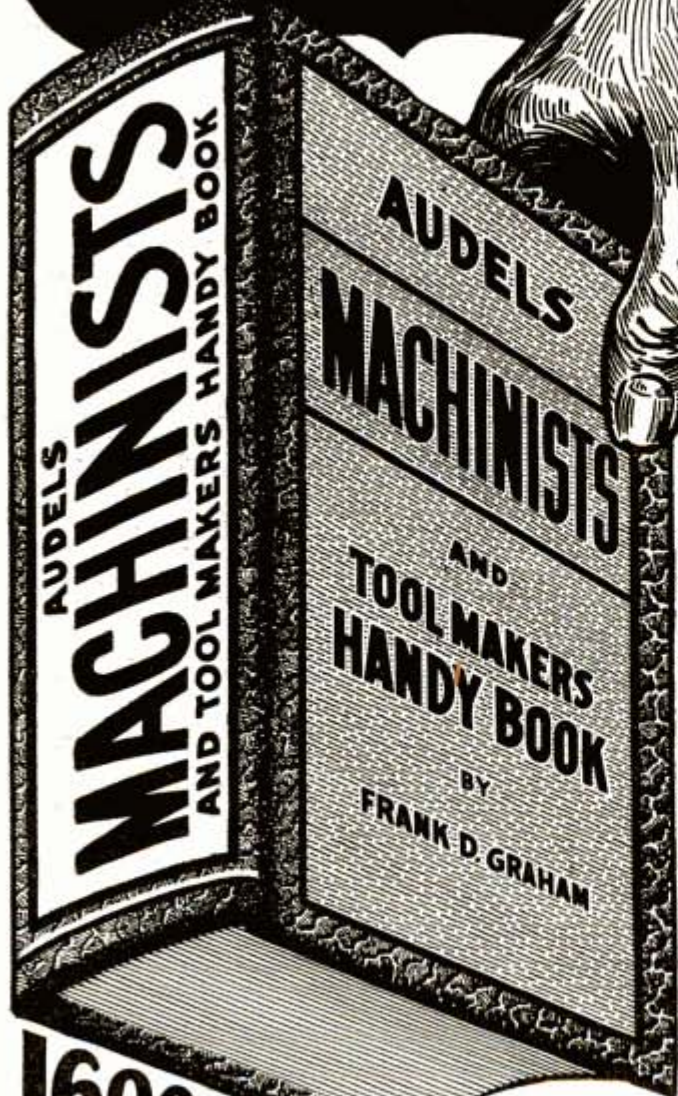

1600 PAGES
FULLY ILLUSTRATED

A SHOP COMPANION THAT ANSWERS YOUR QUESTIONS
Easy to read and understand—flexible covers—Handy size 5 x 6½ x 2—a ready reference that answers your questions accurately.

TO GET THIS ASSISTANCE FOR YOURSELF SIMPLY FILL IN AND MAIL COUPON TODAY **\$4 COMPLETE** PAY \$1 A MONTH ONLY

THEO. AUDEL & CO., 49 W. 23rd St., New York

Be a Radio

MANY MAKE \$30,



J. E. SMITH
President
National Radio
Institute
Est. 28 Years

Train BEGINNERS at Home for Good Spare Time and Full Time Radio Jobs

Here's your opportunity to get a good job in a busy wartime field with a bright peacetime future! There is a shortage today of trained Radio Technicians and Operators. If you're in a rut, worried because your present job offers no chance to get ahead—find out about RADIO!

Mail the Coupon for the FREE Lesson from my Radio Course described below. It shows you why N.R.I. training offers a quick way to more pay. And with this Lesson I will send you FREE my 64-page, illustrated book, RICH REWARDS IN RADIO. It describes many fascinating types of Radio jobs, tells how N.R.I. trains you at home in spare time, explains the unique training method which I have developed and perfected during my 28 years of teaching Radio by mail.

ACT NOW! Many Beginners Quickly Earn \$5, \$10 a Week Extra in Spare Time

Many N.R.I. Students make \$5, \$10 EXTRA MONEY fixing Radios in spare time while learning. I send EXTRA MONEY JOB SHEETS that tell how to do it!

Right now, probably in your neighborhood, there's room for more spare and full time Radio Technicians. The Radio repair business is booming, because no new Radios are being made. Many Radio Technicians are starting their own FULL time Radio businesses . . . making \$30, \$40, \$50 a week.

Other trained Radio men take good-pay jobs with Broadcasting Stations. Many more are needed for Government jobs as Civilian Radio Operators, Technicians, Radio Manufacturers need trained Technicians to help fill Government wartime orders. Aviation, Commercial, Police Radio and Loud-speaker Systems are live, growing fields. And think of the NEW jobs Television, Frequency Modulation, and other Radio developments will open after the war! I give you the Radio knowledge required for jobs in these fields.

Men I Train Win Success Like This

\$10 a Week in Spare Time



"I repaired some Radio sets when I was on my tenth lesson. I really don't see how you can give so much for such a small amount of money. I made \$600 in a year and a half, and I have made an average of \$10 a week — just spare time." JOHN

JERRY, 1337 Kalamath St., Denver, Colorado.

Salary Increased \$1,800 Year in Radio



"I have been regularly employed in Radio since my graduation. I have been Chief Engineer of three broadcast stations, and at present time am Chief Engineer of WDOB. My salary has increased \$1,800 per year since entering Radio and credit is given you for your excellent training." JULIUS C. VESSELS, Station WDOB, Chattanooga, Tenn.

\$200 a Month in Own Business



"For several years I have been in business for myself making around \$200 a month. Business has steadily increased. I have N. R. I. to thank for my start in this field." ARLIE J. FROEHLER, 300 W. Texas Ave., Goose Creek, Texas.

FREE Lesson in RADIO

Here is a Partial List of Subjects this Lesson Teaches

With 31 Photos, Sketches, Radio Drawings

How superheterodyne receivers work

How to remove tubes, tube shields

Three reasons why radio tubes fail

Electrodynamic loudspeaker: How it works

Replacing damaged cone

Recentering voice coil

Remedies for open field coil

Output transformer construction, repair

Gang tuning condenser: Construction of rotor, stator

How capacity varies

Restraining dialcord

Straightening bent rotor plates

I.F. transformers—What they do, repair hints

How to locate defective soldered joints

Inside story of carbon resistors

Paper, electrolytic, mica, trimmer condensers

How condensers become shorted, leaky

Antenna, oscillator coil facts

Power transformer: construction, possible troubles

GETTING ACQUAINTED WITH RECEIVER SERVICING

Installing power cord

Troubles of combination volume control, on-off switch

Tone controls

Dial lamp connections

Receiver servicing techniques

Checking performance

Testing tubes

Circuit disturbance test

Isolating defective stage

Locating defective part



FIND OUT ABOUT THIS TESTED WAY

Technician

\$40, \$50 A WEEK

How "the N. R. I. Method" Paves the Way to Good Pay

The up-to-the-minute Radio Technician must have BOTH a theoretical knowledge and a practical understanding of how to apply Radio principles. I give you thorough training in Radio Theory . . . show you how to use your knowledge. "The N.R.I. Method" trains you from the ground up—covers Fundamentals thoroughly: Radio Terms, Symbols, Diagrams, Receiver Troubles, Servicing, Television, FM Receivers, Transmitters, Cathode Ray Oscilloscopes, Electronic Controls, etc., are just a FEW of the subjects you'll cover before you finish my Course!



Extra Pay in Army, Navy, Too



Men likely to go into military service, soldiers, sailors, marines, should mail the coupon now! Learning Radio helps men get extra rank, extra prestige, more interesting duties, MUCH HIGHER PAY. Also prepares for good Radio jobs after service ends. Hundreds of service men now enrolled.

A Great School Helps You Toward The Rich Rewards in Radio

Throughout your training, the staff and resources of the world's largest private institution devoted entirely to training men for Radio will be squarely behind you. N.R.I. has stuck to the one job of teaching Radio for 28 years. My entire staff of more than 100 people devotes full time to Radio training. Our combined efforts have made the Course so interesting, with hundreds of pictures, charts, and diagrams—so easy-to-grasp, with special teaching methods designed especially for home training—that we believe you will be "old friends" with Radio almost before you know it.

Find out What N.R.I. Can Do For YOU

MAIL THE COUPON. I'll send you the FREE Lesson and my 64-page illustrated book, RICH REWARDS IN RADIO. They're packed with Radio facts, things you never knew about opportunities in Broadcasting, Radio Servicing, Manufacturing, other Radio fields. You'll read a description of my Course—Extra Money Job Sheets—Consultation Service—other special N.R.I. training features. You'll see the fascinating jobs Radio offers and how to learn Radio at home. You'll read many letters from men I trained, telling what they are doing, earning. And you'll have my FREE LESSON to keep. No obligation. Just MAIL THE COUPON.—J. E. SMITH, President, National Radio Institute, Dept. 3BP, Washington, D. C.

Broadcasting Stations employ N.R.I. trained Radio Technicians as operators, installation, maintenance men and in other capacities and pay well.



THIS Free Book HAS HELPED HUNDREDS OF MEN MAKE MORE MONEY

Set Servicing pays many N.R.I. trained Radio Technicians \$30, \$40, \$50 a week. Others hold their regular jobs and make \$5 to \$10 extra a week in spare time.

Training Men for Vital Radio Jobs

Mail this to get 64 page book FREE

J. E. SMITH, President, Dept. 3BP
National Radio Institute, Washington, D. C.

Dear Mr. Smith: Mail me FREE, without obligation, your sample lesson and 64-page book, "Rich Rewards in Radio," which points out Radio's opportunities and tells how you train men at home to be Radio Technicians. (No salesman will call. Please write or print plainly.)

Age.....

Name

Address

City..... State..... 4FR-2



TO BETTER PAY

To those who think LEARNING MUSIC is hard...

MY COUNTRY 'TIS OF THEE,
SWEET LAND OF LIBERTY

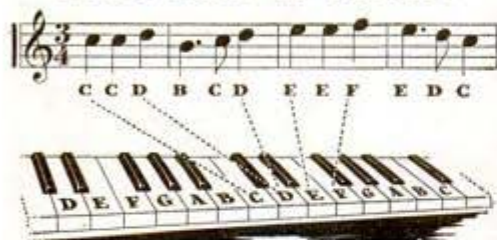

Strike these notes and you're playing
"America". TRY IT—IT'S FUN



Enrolling for 3rd Course

I learned more from your course than many of my friends who studied under private teachers have for years. The fact that I've already taken 2 courses and am now enrolling for a third should speak for itself.

*F. A. S., Indiana



Plays from Start

Your advertisements are true to the letter. I can actually play my favorite instrument even though I'm only at the beginning. How can I ever express my joyful gratitude.

*F. R. O., Illinois

*Actual names on request.
Pictures by Professional Models.

Easy as A·B·C this print and picture way

• Perhaps you think learning music is a tedious grind. It isn't any longer! Long hours of practicing humdrum scales and hard-work exercises are over and done with.

You have no excuses . . . no alibis whatsoever for not getting started toward musical good times *now!* For, through a new, easy, pleasant method, you can now learn to play right at home—without a private teacher—for only a few cents a day.

Learn to Play by Playing

The lessons come to you by mail from the famous U. S. School of Music . . . complete instructions, large, clear diagrams and all the music you need. You study with a smile. You learn to play by playing real tunes by note. And it's all so easy to understand. First you are *told* how to do a thing. Then a picture *shows* you how. Then you do it yourself and *hear* it.

If you're tired of just looking on at parties—if you've envied those who could entertain

others—if learning music has always been a never-to-come-true dream—let this time-tested home-study method come to your rescue.

Over 700,000 people have studied music this modern, easy as ABC way. And remember, no matter what instrument you choose, the cost will average only a few cents a day.

Our illustrated Free Booklet fully explains this remarkable course. It shows how you can learn to play quickly, and for a mere fraction of the cost of old, slow methods. So decide which instrument you want to play and mail the coupon today. The fascinating Free Booklet will be sent to you at once together with a "Print and Picture" Sample. Instruments supplied when needed, cash or credit. U. S. School of Music, 72 Brunswick Bldg., New York City.

FREE! PRINT AND PICTURE SAMPLE AND ILLUSTRATED BOOKLET

U. S. School of Music, 72 Brunswick Bldg., N. Y. City
Please send me Free Booklet and Print and Picture Sample.
I would like to play instrument checked below.

(Do you have instrument.....)

Piano	Accordion	Trumpet	Ukulele,
Violin	Mandolin	Trombone	or any
Guitar	Saxophone	Tenor Banjo	Other Instrument
			(PLEASE PRINT)

Name.....

Street.....

City..... State.....

Note! If you are under 16 yrs. of age, parent must sign coupon

Save 2c—Stick Coupon on penny postcard

Home Training helps YOU WIN!



Right Now

there is a tremendous shortage of skilled men in all branches of industry. Draftsmen, electricians, machine designers, tool makers, machinists are needed and the pay is big. Executives, too, foremen, superintendents, managers are wanted to help complete our tremendous production program.

War Production Demands Better Men

It is a duty you owe your country, yourself, and your family. You should know more and more about your job. You should be prepared to advance and to accept the responsibilities of the men ahead of you so that they in turn may climb and, climbing take you with them. No matter what your present job, you should learn to do it better or learn how to do the job of the man ahead of you. You need to know *both theory and practice* to make our tremendous war plants more productive. Yes, indeed, you are needed and *needed badly* right now.

Draftsmen, Electricians, Machine Designers, Machinists, Foremen, Superintendents, Managers Can All Profit by Home Study . . .

No matter what your trade or profession there is a better place for you in industry. You can get the training needed right in your own home.

AMERICAN SCHOOL
Dept. G245, Drexel at 58th St.,
CHICAGO, ILLINOIS

Use Spare Time, Learn At Home

As little as one-half hour a day can produce surprising results in giving you a better education, more practical and theoretical training which will be reflected in your pay envelope. Never in the history of the world have there been so many opportunities for trained men, nor has it been so easy to get this training. The American School was founded over 40 years ago to provide home study for men and women who missed the opportunity to go to high school or college and to make it possible for you to **LEARN AS YOU EARN.**

Rewards Are Great

Government figures show that graduates of specialized training of college grade, average over \$40 per week more than grade school graduates. If you missed this college training, then here is your opportunity to get specialized training at home. More than 150 noted educators, engineers, and executives helped to prepare American School Courses. This instruction is now available to you at a relatively low cost and on *very easy* monthly payments. Write now for details. Clip and mail the coupon—there is no obligation.



MARK, CLIP AND MAIL THIS COUPON NOW!

Get facts FREE..

(No Cost). All you have to do to find out about this type of training, to get the details and the outline of study, with histories of the successes of other men, is to send the coupon. There is no cost and no obligation of any kind. Let this great school, one of the pioneers in the home study field, explain the methods which can do so much for you. Get this information now so that you can get started quickly on the road to the fulfillment of a real ambition, and be of the greatest possible help in this present emergency.

AMERICAN SCHOOL, Dept. G245, Drexel at 58th, Chicago

Without obligation. Please send FREE and postpaid, bulletin and details of the Subjects checked.

- | | | |
|--|---|--|
| <input type="checkbox"/> Air Conditioning | <input type="checkbox"/> Accounting and C.P.A. | <input type="checkbox"/> Drafting and Design for Men and Women |
| <input type="checkbox"/> Refrigeration | <input type="checkbox"/> Cost Accounting | <input type="checkbox"/> Radio |
| <input type="checkbox"/> Architecture and Building | <input type="checkbox"/> Practical Bookkeeping | <input type="checkbox"/> High School |
| <input type="checkbox"/> Practical Plumbing | <input type="checkbox"/> Private Secretary | <input type="checkbox"/> Plastics |
| <input type="checkbox"/> Automotive Engineering | <input type="checkbox"/> Diesel Engineering | <input type="checkbox"/> Shipbuilding |
| <input type="checkbox"/> Aviation Drafting | <input type="checkbox"/> Surveying & Topographical Drafting | <input type="checkbox"/> Mechanical Eng. |
| <input type="checkbox"/> Aviation Engineering | <input type="checkbox"/> Sheet Metal | <input type="checkbox"/> Shop Management |
| <input type="checkbox"/> Business Management | <input type="checkbox"/> Pattern Drafting | <input type="checkbox"/> Tool Making |
| | <input type="checkbox"/> Electrical Engineering | <input type="checkbox"/> Better Foremanship |
| | | <input type="checkbox"/> Machine Shop Operations |

Name..... Occupation.....
Address..... Age.....
City..... State.....

AMERICAN SCHOOL

Dept. G245, Drexel at 58th Street, Chicago

6 big books
ON **AVIATION**
shipped Free
FOR EXAMINATION

★ Get into Aviation with the help of this brand new cyclopedia. Aerodynamics, Soaring, Parachutes, Propellers, Ignition, Aircraft engines, Blueprint reading, Welding, Weather maps, Aerial photography, Air instruments, and hundreds of other subjects, all well covered.

For Beginners or Experts

Every man interested in flying should have these books. Written in simple language by a group of experts. Quiz questions and answers help to make this a complete reading course in Aviation. The drive to Victory has opened up tremendous opportunities in the fastest growing industry today, with hundreds of opportunities for good jobs at big pay. Send the coupon for free examination. The complete set will be sent to you promptly.

Consulting Service Included

A full year's consulting privilege with our engineers now given without extra charge to every buyer of these books.

AMERICAN TECHNICAL SOCIETY, Dept. H-219
Vocational Publishers since 1898.
Drexel at 58th St., Chicago, Ill.

Send for 10 days' trial BRAND NEW 6 volume set, Aviation. I will pay the delivery charges only. If I wish I may return books in ten days and owe you nothing, but if I decide to keep them I will send \$2.00 after 10 days, then only \$3.00 a month until \$10.80, the total price, is paid. Send brand new edition which includes Aviation Blueprint Reading and free consulting service for one year.

Name

Address

Please attach letter, stating age, occupation, employer's name and address and that of at least one business man as a reference.

AUDELS Carpenters and Builders Guides
4 vols. \$6

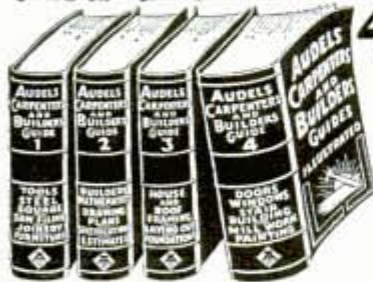

Inside Trade Information for Carpenters, Builders, Joiners, Building Mechanics, and all Wood workers. These Guides give you the short-cut instructions that you want—including new methods, ideas, solutions, plans, systems and money saving suggestions. An easy progressive course for the apprentice and student. A practical daily helper and Quick Reference for the master worker. Carpenters everywhere are using these Guides as a Helping Hand to Easier Work, Better Work and Better Pay. To get this assistance for yourself, simply fill in and mail the FREE COUPON below.

Inside Trade Information On:

How to use the steel square—How to file and set saws—How to build furniture—How to use a mitre box—How to use the chalk line—How to use rules and scales—How to make joints—Carpenters arithmetic—Solving mensuration problems—Estimating strength of timbers—How to set girders and sills—How to frame houses and roofs—How to estimate costs—How to build houses, barns, garages, bungalows, etc.—How to read and draw plans—Drawing up specifications—How to excavate—How to use settings 12, 13 and 17 on the steel square—How to build hoists and scaffolds—skylights—How to build stairs—How to put on interior trim—How to hang doors—How to lath—lay floors—How to paint



THEO. AUDEL & CO., 49 W. 23rd St., New York City

Mail Audels Carpenters and Builders Guides, 4 vols., on 7 days' free trial. If O. K. I will remit \$1 in 7 days, and \$1 monthly until \$6 is paid. Otherwise I will return them. No obligation unless I am satisfied.

Name.....

Address.....

Occupation.....

Reference..... P.M.

TRI-STATE COLLEGE

Degree in 2 1/4 years

B. S. Degree in Civil, Electrical, Mechanical, Chemical, Radio, Aeronautical Engineering; Business Administration, Accounting, Secretarial Science. Short diploma courses (36 weeks) in Surveying, Drafting. Courses open for the duration to students who have completed 2 or more years of high school. Special Preparatory Dept. Cosmopolitan student body. Approved by Civil Aeronautics Administration for flight training. Distinguished for 2 1/4-year technical courses. Men and women. 60th year. Tuition, living costs low. Demand for graduates exceeds supply. Enter March, June, Sept., Jan. Catalog. 423 COLLEGE AVE., ANGOLA, IND.



ENGINEERING

GET INTO THE BAKING BUSINESS!

National Baking Institute announces a new home study course in commercial baking. Baking now America's fifth industry in wages. Nearly a depression-proof business. Good field for ambitious men. Common school education sufficient. Send for free booklet "Opportunities in Commercial Baking" and requirements.

NATIONAL BAKING INSTITUTE
1315 Michigan Ave., Dept. 1352, Chicago, U. S. A.



Learn To MOUNT BIRDS

Tan SKINS, Make Up FURS

Be a Taxidermist. Double your hunting fun. We teach you at Home. Mount Birds, Animals, Pets, Heads and Fish. Save your hunting trophies; decorate home and den. **MAKE MONEY.** Mount and Krome-tan for others. Big sparetime profits. **INVESTIGATE TODAY.**

FREE BOOK with 100 game pictures, 48 pages. Hunters, get yours! It's Now Free. Send postal card TODAY. This Minute. State your AGE. NORTHWESTERN SCHOOL OF TAXIDERM: Dept. 3372, Omaha, Nebr.



FUNDS FOR WAR BENEFITS!
Easy to raise with plays and

Minstrels Comedy Stunts & Plays

Unique First Parts for complete show with special songs and choruses. Make-up. Catalog Free.

T. S. Denison & Co., 225 N. Wabash, Dept. 19, Chicago

Learn to Write

Begin today. Write now for our Free Book, "How to Become a Good Penman." It contains specimens and tells how others learned to write in spare time. Enclose 10c for your name beautifully written and a pen point suitable for shaded writing. Write today.

THE TAMBLIN SCHOOL OF PENMANSHIP
X421 Ridge Building, Kansas City, Mo.

RADIO ENGINEERING, broadcasting, aviation and police radio, servicing, marine and Morse telegraphy taught thoroughly. 48 weeks' engineering course equivalent to three years' college radio work. School established 1874. All expenses low. Catalog free.

The Dodge Institute, Dept. D, Valparaiso, Ind.

LAW STUDY AT HOME for PERSONAL SUCCESS and LARGER EARNINGS. 31 years expert instruction—over 100,000 students enrolled. LL.B. Degree awarded. All texts furnished. Easy payments. Send for FREE BOOK—"Law and Executive Guidance."

AMERICAN EXTENSION SCHOOL OF LAW
Dept. 26-M 8 East Huron St., Chicago, Ill.

MONEY for MEN ALL FREE

THE PLASTEX Industry needs manufacturers on small scale and for big production of Lamp and Clock Stands, Art Goods and Novelties in Plastex and Marble imitation. Experience unnecessary. 1/2c material makes regular 10c store sellers. Rubber moulds furnished for speed production. Small investment brings good returns. WE ARE NOW PLACING BIG CHAIN STORE ORDERS WITH MANUFACTURERS. Ambitious men have chance for real prosperity. Our FREE booklet will interest and benefit you.

PLASTEX INDUSTRIES, Dept. P, 1045 Washington Ave., New York, N.Y.



Will You Let Me PROVE I Can Make YOU a New Man?



LET ME START SHOWING YOU RESULTS LIKE THESE

<p>5 inches of new Muscle</p> <p>"My arms increased 1 1/2", chest 2 1/2", forearm 7/8". —C. S., W. Va.</p>	<p>What a difference!</p> <p>"I have put 3 1/2" on chest (normal) and 2 1/2" expanded." —F. S., N. Y.</p>
<p>Here's what ATLAS did for ME!</p> <p>John Jacobs BEFORE John Jacobs AFTER</p>	<p>For quick results I recommend CHARLES ATLAS</p> <p>"Am sending snapshot showing wonderful progress." —W. G., N. J.</p>
<p>GAINED 29 POUNDS</p> <p>"When I started, weighed only 141. Now 170." —T. K., N. Y.</p>	

CHARLES ATLAS

Awarded the title of "The World's Most Perfectly Developed Man" in international contest—in competition with ALL men who would consent to appear against him.

This is a recent photo of Charles Atlas showing how he looks today. This is not a studio picture but an actual untouched snapshot.

Here's What Only 15 Minutes a Day Can Do For You

I DON'T care how old or young you are, or how ashamed of your present physical condition you may be. If you can simply raise your arm and flex it I can add **SOLID MUSCLE** to your biceps—yes, on each arm—in double-quick time! Only 15 minutes a day—right in your own home—is all the time I ask of you! And there's no cost if I fail.

I can broaden your shoulders, strengthen your back, develop your whole muscular system **INSIDE** and **OUTSIDE**! I can add inches to your chest, give you a vice-like grip, make those legs of yours lithe and powerful. I can shoot new strength into your old backbone, exercise those inner organs, help you erase your body so full of pep, vigor and red-blooded vitality that you won't feel there's even "standing room" left for weakness and that la y feeling! Before I get through I'll have your whole frame "measured" to a new, beautiful suit of muscle!

What's My Secret?

"Dynamic Tension!" That's the ticket! The identical natural method that I myself developed to change my body from the scrawny, skinny-chested weakling I was at 17 to my present super-man physique! Thousands of other fellows are becoming marvelous physical specimens—my way. I give you no gadgets or con-

traptions to fool with. When you have learned to develop your strength through "Dynamic Tension" you can laugh at artificial muscle-makers. You simply utilize the **DORMANT** muscle-power in your own God-given body—watch it increase and multiply double-quick into real solid **LIVE MUSCLE**.

My method—"Dynamic Tension"—will turn the trick for you. No theory—every exercise is practical. And, man, so easy! Spend only 15 minutes a day in your own home. From the very start you'll be using my method of "Dynamic Tension" almost unconsciously every minute of the day—walking, bending over, etc.—to **BUILD MUSCLE** and **VITALITY**.

FREE BOOK "Everlasting Health and Strength"

In it I talk to you in straight-from-the-shoulder language. Packed with inspirational pictures of myself and pupils—fellows who became **NEW MEN** in strength, my way. Let me show you what I helped THEM do. See what I can do for YOU! For a real thrill, send for this book today. **AT ONCE, CHARLES ATLAS, Dept. 82, 115 East 23rd St., New York, N. Y.**

CHARLES ATLAS, Dept. 82
115 East 23rd St., New York, N. Y.

I want the proof that your system of "Dynamic Tension" will help make a New Man of me—give me a healthy, husky body and big muscular development. Send me your free book, "Everlasting Health and Strength."

Name.....
 (Please print or write plainly)

Address.....

City..... State.....

Check here if under 16 for Booklet A.



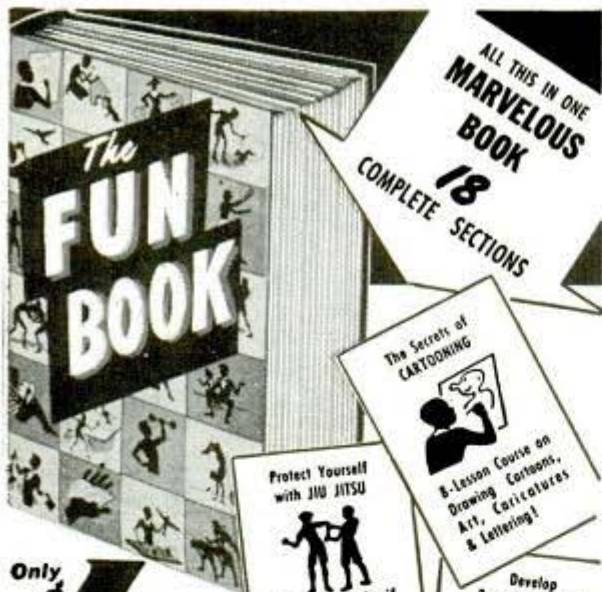

Only
286 Pages
Hundreds of
Illustrations

Here for the first time in ONE-BIG-BOOK are all the exciting, interesting Activities—Sports—Hobbies—Games—Magic—Art—Puzzles—Stunts—Craftsmanship—Jiu Jitsu—Money-Making Plans—Acrobatics—etc., which are part of every energetic, regular fellow.

Only room in this "ad" to illustrate 8 of the 18 separate sections. In addition to these shown, there are: TUMBLING AND ACROBATICS—TAG PUNCHING TECHNIQUE—INDOOR & OUTDOOR GAMES—RECOMMENDED STORIES & LITERATURE—"SPOTTING" AIRPLANES—BUILDING MODEL PLANES—BE THE LIFE OF THE PARTY—SCIENCE OF WRESTLING—LEARN VENTRILOQUISM—101 MONEY-MAKING PLANS. Each section written by an authority.

You can learn a cowboy roping routine; become a "whiz" at ping-pong; learn to draw funny cartoons; build equipment and furniture for games, "den" and home; teach your dog tricks; defend yourself with jiu-jitsu; perform a "magic" show; etc., etc. A million things to do and fun to enjoy—for indoors and outdoors—summer or winter—alone or with your crowd.

ALL THIS IN ONE
MARVELOUS
BOOK
18
COMPLETE SECTIONS

Protect Yourself
with JIU JITSU
Fear no attack, if
you'll learn these
amazing grips as
taught to Marines,
Soldiers and G-Men!

The Secrets of
CARTOONING
8-Lesson Course on
Drawing Cartoons,
Art, Caricatures,
& Lettering!

Develop
Powerful Muscles
Keeping Strong and
Healthy plus exer-
cises for develop-
ing strength and
power!

It's Fun To
BUILD THINGS
Complete plans and
directions for
making many use-
ful articles!

How to Handle
A ROPE
Like a Cowboy
A Champion teaches
you tricks with a
Lariat!

Boxing
for Self-Defense
A complete course
in tactics, blows and
strategy to become
a skillful boxer!

How to Train
YOUR DOG
Dogs, their care and
training; technique
for teaching obey-
ance and tricks.

Playing Winning
PING-PONG
Lessons on strokes,
position, serve, and
every element for
perfection!

Never
before
such
an
amaz-
ing
book—
never
before
such
a
remark-
able
value. 286
Thrill-
Packed
PAGES—over
300 ILLUS-
TRATIONS!
Special—only
\$1.00 (or C.O.D.
plus 20c postage).
Money back guar-
antee! MAIL THE
COUPON NOW!

KNICKERBOCKER PUB. CO., Dept. BP2
92 Liberty St., New York, N. Y.

Rush me a copy of THE FUN BOOK. I am enclosing \$1.00 in full payment. If not delighted, can get my money back at once.

Name

Address

City & State

Check here if you desire book to come C.O.D. and will pay \$1.20 on delivery.

Not everyone
does as well
as Charles—
for he



TOOK IN \$217
in 10 DAYS
WASHING WALLS

6 times faster and better than by hand.

Charles Stelle took in \$217 first 10 days. We want more men to go into business for themselves. Customers everywhere. Homes, schools, offices, stores, churches, lodges, hotels, all have walls that need washing. You don't have to rent a store for you operate this business from your home. Dozens of men have written of large earnings for specific periods in their busiest seasons. They don't do this every day, every week, or every month, and allow a small amount for materials, but you can see how easy it is to get into this wonderful business.

Harold Jones writes: "I landed a \$40 job the first day."

E. C. Traber says: "Made \$400 in two weeks."

C. Irons got a \$905 school job. This is a repeat order.

L. Borch says: "First two jobs netted me \$26."



Easy Payments

It takes only a small amount to get started in this money-making business. No experience necessary. Any ambitious man who wants to be in business for himself with wonderful opportunities for big earnings should get started NOW.

SEND FOR FREE INFORMATION

There is No Obligation.
MANUFACTURING CO.

VON SCHRADER

772 Pl., Racine, Wis.

ENGINEERING DEGREE IN 27 MONTHS

INDIANA TECHNICAL COLLEGE

Courses in Aeronautical, Chemical, Civil, Electrical, Mechanical, and Radio Engineering. One-year courses in Radio and Drafting. Approved by C.A.A. Prep courses without added cost. Low tuition. Large industrial center. Opportunity to earn part living expenses. Enter March, June, Sept., Dec. Catalog. 523 E. Washington Blvd., Ft. Wayne, Ind.



DRAW for MONEY

Be An ARTIST!

Trained Artists Are Capable of Earning

\$30-\$50-\$75 A WEEK

Use Your Spare Time to Prepare for a Profitable Art Career!

It's pleasant and interesting to study Art the W.S.A. way. **COMMERCIAL ART, ILLUSTRATING and CARTOONING**—all in ONE complete home study course. No previous Art experience necessary—we teach you step by step—hundreds have profited by our practical method. **TWO ART OUT-FITS FURNISHED.** Full information in colorful **FREE BOOK, "Art for Pleasure & Profit"**—tells all about our course, service, what our graduates say—and commercial opportunities for you in Art.

FREE BOOK gives details!

WASHINGTON SCHOOL OF ART
Studio 122 F, 1115 15th St., N. W., Wash., D. C.

Without obligation, please send me your free book.

Name AGE

Address

City State

WAR SAVINGS BONDS
SOLD AT THIS WINDOW

"I BUY ONE EVERY PAY-DAY!"

• "I figure there are two good ways for a married man with kids to help his Uncle Sam right now.

• "One way is to do his job better than ever before—help to outproduce the Axis, and 'keep 'em flying!' That's why I enrolled for an I. C. S. Course in my line of work a few months ago. Already, the training I've acquired is helping me to be a better soldier on the industrial front!

• "And with the extra money I'm earning as a result of modern I. C. S. training, I'm buying a War Bond every pay-day! The whole family's buying War Stamps. Why don't you mail this coupon, and find out how a low-cost I. C. S. Course can increase your job efficiency, and make you worth more to your country in this battle of production? *Do it today!*"



INTERNATIONAL CORRESPONDENCE SCHOOLS

HELPING TO TRAIN AMERICANS FOR VICTORY

BOX 5654-J, SCRANTON, PENNA.

Without cost or obligation, please send me booklet and full particulars about the course *before* which I have marked X:

SPECIAL
TUITION RATES
FOR MEMBERS
OF THE
ARMED FORCES



TECHNICAL AND INDUSTRIAL COURSES

- | | | | |
|--|---|---|--|
| <input type="checkbox"/> Air Brake | <input type="checkbox"/> Contracting and Building | <input type="checkbox"/> Management of Inventions | <input type="checkbox"/> Sanitary Engineering |
| <input type="checkbox"/> Air Conditioning | <input type="checkbox"/> Cotton Manufacturing | <input type="checkbox"/> Marine Engines | <input type="checkbox"/> Sheet Metal Work |
| <input type="checkbox"/> Airplane Drafting | <input type="checkbox"/> Diesel Engines | <input type="checkbox"/> Mechanical Drafting | <input type="checkbox"/> Ship Drafting |
| <input type="checkbox"/> Architectural Drafting | <input type="checkbox"/> Electrical Drafting | <input type="checkbox"/> Mechanical Engineering | <input type="checkbox"/> Shipfitting <input type="checkbox"/> Shop Practice |
| <input type="checkbox"/> Architecture | <input type="checkbox"/> Electrical Engineering | <input type="checkbox"/> Mine Foreman | <input type="checkbox"/> Steam Electric <input type="checkbox"/> Steam Engines |
| <input type="checkbox"/> Auto Engine Tune-up | <input type="checkbox"/> Electrician | <input type="checkbox"/> Navigation <input type="checkbox"/> Patternmaking | <input type="checkbox"/> Steam Fitting |
| <input type="checkbox"/> Auto Technician | <input type="checkbox"/> Electric Lighting | <input type="checkbox"/> Plastics <input type="checkbox"/> Plumbing | <input type="checkbox"/> Structural Drafting |
| <input type="checkbox"/> Aviation <input type="checkbox"/> Aviation Mechanic | <input type="checkbox"/> Foundryman <input type="checkbox"/> Heating | <input type="checkbox"/> Public Works Engineering | <input type="checkbox"/> Structural Engineering |
| <input type="checkbox"/> Blueprint Reading | <input type="checkbox"/> Heat Treatment of Metals | <input type="checkbox"/> Pulp and Paper Making | <input type="checkbox"/> Surveying and Mapping |
| <input type="checkbox"/> Boilermaking | <input type="checkbox"/> Highway Engineering | <input type="checkbox"/> Radio, General | <input type="checkbox"/> Telegraphy <input type="checkbox"/> Telephony |
| <input type="checkbox"/> Bridge Engineering | <input type="checkbox"/> House Planning | <input type="checkbox"/> Radio Operating | <input type="checkbox"/> Textile Designing |
| <input type="checkbox"/> Chemistry <input type="checkbox"/> Coal Mining | <input type="checkbox"/> Industrial Metallurgy | <input type="checkbox"/> Radio Servicing | <input type="checkbox"/> Toolmaking <input type="checkbox"/> Tool Design |
| <input type="checkbox"/> Civil Engineering | <input type="checkbox"/> Locomotive Engineer | <input type="checkbox"/> R. R. Section Foreman | <input type="checkbox"/> Welding, Gas and Electric |
| <input type="checkbox"/> Concrete Engineering | <input type="checkbox"/> Machinist <input type="checkbox"/> Inspector | <input type="checkbox"/> R. R. Signalman <input type="checkbox"/> Refrigeration | <input type="checkbox"/> Woolen Manufacturing |

BUSINESS COURSES

- | | | | |
|--|--|--|---|
| <input type="checkbox"/> Accounting <input type="checkbox"/> Advertising | <input type="checkbox"/> College Preparatory | <input type="checkbox"/> First Year College | <input type="checkbox"/> Railway Postal Clerk |
| <input type="checkbox"/> Bookkeeping | <input type="checkbox"/> Commercial | <input type="checkbox"/> Foremanship <input type="checkbox"/> French | <input type="checkbox"/> Salesmanship |
| <input type="checkbox"/> Business Correspondence | <input type="checkbox"/> Commercial Illustrating | <input type="checkbox"/> Good English | <input type="checkbox"/> Secretarial <input type="checkbox"/> Spanish |
| <input type="checkbox"/> Business Management | <input type="checkbox"/> Cost Accounting | <input type="checkbox"/> High School | <input type="checkbox"/> Showcard and Sign Lettering |
| <input type="checkbox"/> Cartooning <input type="checkbox"/> Civil Service | <input type="checkbox"/> C. P. Accounting | <input type="checkbox"/> Managing Men at Work | <input type="checkbox"/> Traffic Management |

HOME ECONOMICS COURSES

- | | | |
|---|---|--|
| <input type="checkbox"/> Advanced Dressmaking | <input type="checkbox"/> Home Dressmaking | <input type="checkbox"/> Tea Room and Cafeteria Management, Catering |
| <input type="checkbox"/> Foods and Cookery | <input type="checkbox"/> Professional Dressmaking and Designing | |

Name..... Age..... Address.....
City..... State..... Present Position.....

Canadian residents send coupon to International Correspondence Schools Canadian, Limited, Montreal, Canada
British residents send coupon to I. C. S., 71 Kingsway, London, W. C. 2, England

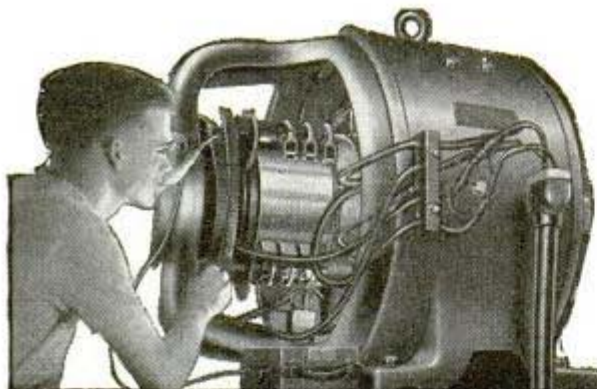

MEN *whether you are* 16 or 50

YOU ARE VITALLY NEEDED IN OUR NATIONAL VICTORY PROGRAM

Trained Electrical men are needed now. It's not how young you are, or how old you are. The question is—have you the training to hold a particular job that must be filled.

Learn **ELECTRICITY** IN 12 WEEKS

ON REAL MOTORS, GENERATORS, ETC.,
Ill Finance Your Training

Electricity is the mighty power behind our Victory Program. Trained Electrical men are needed in the armed forces and in industry. YOU are needed—whether you are in the draft or deferred. PREPARE FOR YOUR PLACE this amazingly easy way. "Learn By Doing" in 12 weeks. You don't need much money—I'll finance your training.

"Learn-By-Doing"

Coyne training is EASY, PRACTICAL! Here you can train in 12 weeks—not by books or lessons, but on real actual electrical machinery and apparatus. You "Learn by Doing" on real motors, generators, switchboards, and all types of practical electrical equipment. Get your training first—then pay for it in easy monthly payments after your training period is over. If you are short of money to pay for living expenses while you are in school, we'll get you a part-time job so you can "earn while you learn". After you graduate, we give you LIFETIME EMPLOYMENT SERVICE.

Right now I'm including an extra 4 weeks' Radio Course at no extra tuition cost.

Get the Facts

This school is 43 years old—Coyne training is tested and proven. Mail the coupon and let me send you the big, free Coyne Book and my complete story about how I help you get the training you need for a good-pay electrical job. This does not obligate you. No salesman will call. So act at once. Just mail coupon.

H. C. LEWIS, President
COYNE ELECTRICAL SCHOOL
500 So. Paulina St., Dept. 23-72, Chicago, Ill.

H. C. LEWIS, President
COYNE ELECTRICAL SCHOOL
500 S. Paulina Street, Dept. 23-72, Chicago, Ill.

Send me your Free Book and tell me about your plans to help me.

NAME.....
ADDRESS.....
CITY STATE

WELDERS WANTED!



Men and Women ELECTRIC ARC— OXY-ACETYLENE

Skilled Welders earn up to \$15 a day. The demand now greater than the supply. Learn this highly paid trade in 3 weeks by actual shop work. One of America's leading schools. Established 1902. 7 floors of shops. Endorsed by welding industry. Limited number of students. 3 weeks course in Electric Arc or Acetylene Welding, including room and board, only \$205. Course covers minimum requirements of U. S. Office of Education for War Production Workers, and the American Welding Society Code. Write or wire for reservation. Ask for "Welding Facts." State age.

GREER COLLEGE

DEPT. 123, 2024 SOUTH WABASH AVE., CHICAGO

LEARN WATCH REPAIRING



AT HOME. By our modern and original system of instruction you can learn every part of the **WATCH REPAIRING TRADE AT HOME.** Prepare yourself for a well-paying position or start in business after completing our course of instruction. Good watch repairers are in demand and generally earn very good salaries. For particulars apply to the Wisconsin School of Watch Repairing 524 E. Mason St., MILWAUKEE, WIS.

STUDY **ENGINEERING** AT HOME

With A Chartered Educational Institution

Courses in **ENGINEERING:** Electrical, Civil, Mechanical, Drafting, Architectural, Steam, Aeronautical, Radio, Structural, Mining, Industrial, Highway, Petroleum, Marine, Chemical.
Courses in **ARTS AND SCIENCES:** Philosophy; Education; Letters; Public Health; Medical Jurisprudence; Psychology; Sociology; Physics; Chemistry; Geology; Pol. Science; Theology; Law; Business and Commerce; Accounting; Mathematics; Statistics; Agriculture.
McKinley-Roosevelt Incorporated, 4610-TC, Sheridan Road, Chicago

Learn this Profitable Profession



in 90 Days at Home

Hundreds of men and women of all ages 18-50 make \$10.00 to \$20.00 in a single day giving scientific Swedish Massage and Hydro-Therapy treatments. There is a big demand from Hospitals, Sanitariums, Clubs, Doctors and private patients as well as opportunities for establishing your own office.

Learn this interesting money-making profession in your own home by mail, through our home study course. Same instructors as in our **NATIONALLY KNOWN** resident school. A diploma is awarded upon completion of the course. Course can be completed in 3 to 4 months. High School training is not necessary. Many earn big money while learning. The Army and Navy need hundreds of men and women trained in Massage and Physiotherapy.

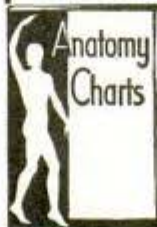

Anatomy Charts & Booklet FREE

Enroll now and we will include uniform coat, medical dictionary, patented reducing roller and Hydro-Therapy supplies without extra cost. The reducing course alone may be worth many times the modest tuition fee.

Send coupon now for Anatomy Charts and booklet of photographs and letters from successful graduates. These will all be sent postpaid—FREE.

THE College of Swedish Massage
Dept. 264—100 E. Ohio St., Chicago
You may send me FREE and postpaid, Anatomy Charts, booklet containing photographs and letters from graduates, and complete details of your offer.

Name.....
Address.....
City..... State.....



INVENTORS AMERICA NEEDS YOUR IDEAS

In War and in Peace

Your country—in fact the whole civilized world—is in crying need of new ideas—these new ideas, **YOUR IDEAS**, must lead not only to victory in war but to prosperity in the peace which will inevitably follow. **TIME MARCHES ON**—today's inventions are tomorrow's craftsmanship, and post-war prosperity and re-adjustment will demand the creation of thousands of simple things that will win recognition—perhaps wealth—for you. **TIME MARCHES ON** and you march with it—or it passes you by.

Peace Is Coming

Factories now converted to War Production for the duration are already buying new inventions. They must take up **NEW IDEAS** in order to continue in business when the war ends. That's the time when new improved articles will be rushed onto the market and the lucky patent holders will reap the profits.

NOW IS THE TIME TO PATENT YOUR INVENTION

No matter who you are, where you are—no matter what your invention is, **NOW** is the time to apply for a patent. By delaying you may not only lose your rights, but you may miss some immediate opportunity of making money. When a house is burning down, it's too late to get fire insurance. When a market already exists for your invention, then it may be too late for you to apply for a patent.

A PATENT NOW MEANS POST WAR PROFITS

Remember that you can sell your patent rights now, regardless whether or not your invention can be made and marketed for the duration, because manufacturers are buying patents today in order to have new merchandise on the market as soon as priority restrictions are removed. Remember, too, a Patent is good for 17 years. So get the **FACTS** by writing for our free "Patent Guide". Be safe — not sorry!

THIS 48-PAGE BOOKLET FREE

Our free "Patent Guide" gives you all the information you need to know about protecting your invention. Send for your **FREE** copy today. This step costs you nothing, yet may be vital to your success. Remember—in Patent matters **ACTION** is **IMPORTANT**. Delays can be costly. Mail the coupon in an envelope, or paste it on a penny postcard **NOW** to **CLARENCE A. O'BRIEN & HARVEY B. JACOBSON**, Registered Patent Attorneys, 31-B Adams Building, Washington, D. C.



CLARENCE A. O'BRIEN & HARVEY B. JACOBSON

Registered Patent Attorneys, Adams Bldg., Washington, D.C.

CLARENCE A. O'BRIEN & HARVEY B. JACOBSON

Registered Patent Attorneys before the

United States Patent Office

31-B Adams Building, Washington, D. C.

Please send me your 48-Page "Patent Guide for the Inventor" and your specially prepared "Record of Invention" form **FREE**. This request does not obligate me.

Name

Address

City..... State.....

(Please write or print plainly)



POPULAR INVENTIONS

For Your Home

Where-to-Buy-It index of commercially available Popular Inventions appears on page 28A

Discontinued State and Madison, Chicago

Disappearing Rack for Towels Drops Into Wall Holder

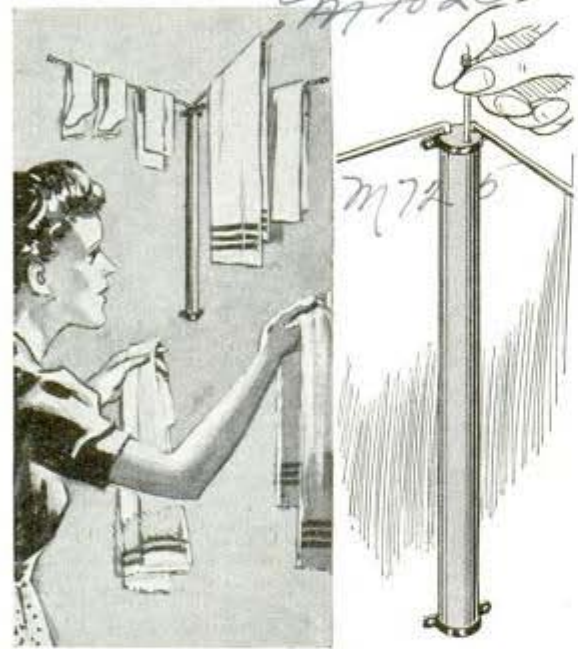

Bumping into towel racks when they are not in use can be eliminated with hanger rods that drop back into a metal tube. The tube, containing three 10-inch rods, is attached to a wall in a vertical position. The rods are lifted from the top of the tube and brought forward where they may be fanned out to hold several towels. This is a space saver for the small kitchen or bathroom.

Ice Cubes Ejected From Tray By Contraction of Metal

Melting away a good portion of the ice cube to remove it from the freezing tray will not happen with a tray patented recently by Thomas Barish of Jamestown, N. Y., which uses the freezing process to loosen the cube. The secret of the automatic action is in the use of two metals in the container, one of which contracts more than the other as their temperature is lowered. During the freezing, the corrugated

walls of the cup straighten out somewhat, thus drawing the walls away from the ice. This action is opposite to that of the ordinary ice tray which contracts throughout and grips the ice tighter. In addition, the bimetal bottoms of the cups bulge downward, and in a dropping temperature the bottom straightens out and may even bulge upward, lifting the ice cube. However, since the metals are nickel-steel and copper, it is not probable they will be in production until after the war.

Traveling Sprinkler Propels Itself By Winding Cable on Drum

If you have a lawn or grassy field 400 feet long and 100 feet wide, an automatic traveling sprinkler now available can water it in one trip. Needing no attention after it has been set and the water turned on, the sprinkler propels itself by winding a cable,

(More Popular Inventions on page 24A)

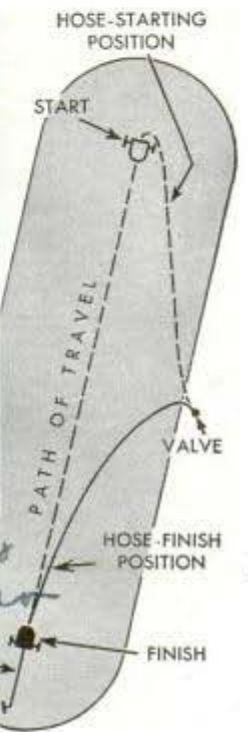
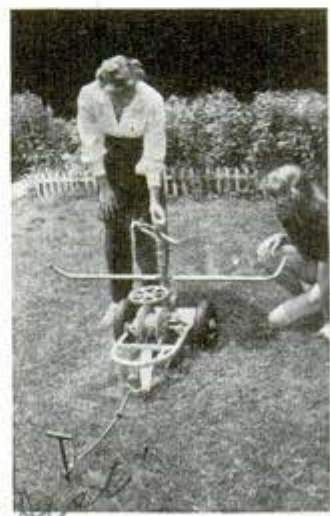

FREE WITH THIS OFFER

33 POWER TELESCOPE LENS KIT



You can now own a genuine high powered telescope by making it in one evening of easy work. It is included FREE with this Special Offer of "Wonders of Science, Simplified." All the optical parts are completely finished for a refracting, astronomical telescope over 4 feet long. You can see the mountains and craters on the moon, the ringed planet Saturn, Jupiter and double stars, etc. See airplanes, ships and hundreds of other interesting sights. Makes objects miles away appear close. Complete lens kit contains 2" diameter ground and polished objective lens and 33 power eyepiece lens made in the good old U.S.A. with full directions for mounting. Read how you can get your 33 power telescope lens kit FREE with this offer.

3 GREAT VOLUMES BOUND TOGETHER CONTAIN 1,000 PICTURES AND 15 BOOKS

This fascinating work contains three thrilling volumes bound together. It is packed with a thousand pictures which simplify its contents. Think of it—dozens and dozens, hundreds and hundreds of scientific pictures. Pictures of all kinds on Mechanics, Astronomy, Physics, Biology, etc.—dynamic diagrams, panoramic illustrations, and action-photographs up to 100 square inches in size! These hundreds and hundreds of dazzling illustrations cram three gorgeous volumes—and each of the three volumes is almost a foot high, and when opened, over a foot wide!

HUNDREDS OF PHOTOGRAPHS, MAPS, DRAWINGS, ETC.

3 Volumes Bound in 1

Volume I—PARTIAL CONTENTS WONDERS OF NATURE

- BOOK 1. History & Mystery of Astronomy**
How Men Used to Think of Earth and Sky
How the Solar System Originated
Enormous Size of Some Stars, etc.
- BOOK 2. Oddest Phenomena on Earth**
Spouting Fountains of Boiling Water
A Marvelous Mountain of Solid Salt
- BOOK 3. Watching the World Change**
How Continents and Oceans Were Formed
How We Know Ground Sinks and Rises
Strange Tale of a Buried Town
- BOOK 4. Weather Secrets Simplified**
Storms on Sun and Storms on Earth
The Strange Antics of a Ball of Fire
- BOOK 5. Wonderland of Nature**
The Regions of Frost and Fire
The Inside of an Active Volcano

Volume II—PARTIAL CONTENTS WONDERS OF POPULAR SCIENCE

- BOOK 6. Pictorial Outline of Progress**
Nearly Two Centuries of Steamships
Queer Forerunners of the Motor-Car
Development of Modern Locomotives
- BOOK 7. Amazing Adventure in Science**
Mystery of the Burning Glass
Marvels of the Electro-Magnet
Wonders of the Infra-Red Rays, etc.
- BOOK 8. Seven Wonders of Modern World**
How Telescopes Bring Things Near
How Microscopes Make Things Big
The Latest Methods of Television
- BOOK 9. Manual of Simplified Experiments**
Science Experiments for Everybody
Experiments With Simple Chemicals
- BOOK 10. How Great Inventions Work**
Inside of a Great Modern Steamship
A Big Coal Mine With the Lid Off
How a Submarine Sinks and Rises

Volume III—PARTIAL CONTENTS WONDERS OF LIFE

- BOOK 11. Prehistoric Creatures**
Life on Earth 30 Million Years Ago
Life on Earth 250,000 Years Ago
- BOOK 12. Marvels of Plant Life**
Plants That Catch and Eat Insects
Strange Freaks of Plant Growth
- BOOK 13. Strangest Fish in the Sea**
Some Nightmares of the Deep Sea
Queer Fishes That Crawl on Land
- BOOK 14. The Animal Wonder Book**
The Animal the World Nearly Lost
The Ugliest of All the Animals
- BOOK 15. Man—Miraculous Machine**
The Wonderful Way the Brain Works
What Your Body Looks Like Inside

WONDERS AND MYSTERIES OF SCIENCE IN THRILLING STORY AND 1,000 PICTURES

You can now enter the wondrous world of tomorrow. You can now go on thrilling tours through the wonderland of Science. Here is the telescope, the microscope, the spectroscope. Here are tours through talking picture studios and television studios. Here is aviation opening up the new world of speed and distance. And here, too, is the photo-electric cell, the marvelous eagle eye that will make men of the future supermen. These and hundreds of others are all yours in the **THREE EXCITING VOLUMES of Wonders of Science, Simplified.**

YOUR FRIENDS WILL ADMIRE YOU

Through the simplicity of the text, the tremendous record of Science is brought lavishly before you. The mightiest marvels of mankind thrill you as you read their stories. Invention, Geography, Zoology, Engineering, etc.—they are so simple and easy to understand. No wonder every person who has read and mastered this exciting wonderbook becomes a "walking encyclopedia" and is looked up to by his friends as a "scientific wizard."

BIG FREE OFFER—SEND NO MONEY

These three great, profusely-illustrated volumes of "Wonders of Science, Simplified" (bound together) formerly sold for \$5.00. But it is offered to you now for only \$1.98 plus postage. Act at once and we will include FREE with your order the 33 power long distance telescope lens kit described above. You take no risk because you must be 100% delighted or you may return for full refund within five days. **ACT NOW**—as this offer is limited to the supply of 33 power telescope lens kits available. This offer may never be yours again. So **RUSH COUPON AT ONCE.**



METRO PUBLICATIONS, Dept. 136
50 West 17th St., New York

Send me a copy of "Wonders of Science, Simplified" (three dazzling volumes bound together, over 1,000 illustrations) . . . also include my long distance telescope lens kit with this order. I will pay postman \$1.98 plus postage on arrival. If I am not satisfied I may return them within five days for full refund. Canadian orders \$2.50 in advance.

NAME

ADDRESS

Check here if you are enclosing \$1.98, thus saving mailing costs (same guarantee).



TODAY'S INVENTORS
WILL PROVIDE THE KEY TO
Tomorrow's Better
Living Standards

Mr. and Mrs. Average American are going to enjoy home conveniences far above pre-war standards when Victory is won. Amazingly efficient dish-washing machines . . . electric-eye operation of household tasks . . . finer, more functional furniture, etc. The household appliance field is going to enter a period of vigorous advancement. And . . . you ingenious inventors, you men with ideas that will give pleasure, save labor or save money . . . are going to cash in! The man who TODAY gets his patent application prepared and prosecuted . . . who takes advantage of today's unique opportunity . . . will be in position to win riches in the peace to come!

NEARLY A HALF-CENTURY of
Patent Experience--At your Service!

Remember . . . a strong patent may enhance the commercial value of your invention. This old, established firm of competent patent attorneys will help you get a strong patent at very moderate cost! **WRITE US TODAY!**

READ HOW

to get your invention patented, how to sell it. 115 mechanical movements illustrated and explained. With books, we also send free "Evidence of Invention" form.

SEND COUPON NOW!



VICTOR J. EVANS & Co.

Merlin M. Evans
REGISTERED PATENT ATTORNEYS

MAIN OFFICE: 730-B MERLIN BUILDING WASHINGTON, D. C.

Pittsburgh Office: 521-N Empire Building
Los Angeles Office: 738-N Security Building.

Send me free copies of your books "Patent Protection" and "When and How to Sell an Invention"—also important "Evidence of Invention" form.

Name

Address

City and State

.....

SEND FOR THESE FREE BOOKS TODAY!

POPULAR INVENTIONS

For Your Home

(Continued from page 22A)

up to 300 feet in length, on a drum powered by water pressure. Speed of travel can be adjusted from 35 to 65 feet per hour, and the nozzle revolves slowly and independently of the forward motion of the sprinkler. Nozzles of various sizes are capable of covering a path 82 to 144 feet wide, depending upon the water pressure. When the sprinkler reaches the end of its cable, an automatic shut-off stops the flow of water and the turning of the drum. Small and light, the unit is easy to handle and move about. It is a time and labor saver for watering athletic fields, airfields, golf courses and large lawns.

*Ref. Co. Inc. 4723 S. Hoover
 Los Angeles, Calif.*
Hose Snaps on Faucet Quickly
With Two-Piece Coupling



Handy where garden hose connections must be opened and closed frequently, a two-piece coupling permits connections to be made and broken in a jiffy without tedious screwing and unscrewing. The inexpensive fittings consist of a flanged collar threaded for the standard hose coupling, and a grooved collar which screws onto the faucet. A leakproof seal between these two

(More Popular Inventions on page 28A)

POPULAR MECHANICS

Learn **RADIO** COMMUNICATIONS—ELECTRONICS

Faster ... Easier ... With the Aid of

MOTION PICTURES *In Your Own Home*



DE FOREST'S TRAINING HELPS YOU TO GET AHEAD IN MILITARY SERVICE

Students and graduates are given a timely service that is aiding many to get into interesting, vital Radio Communications work in the armed forces—with opportunities for higher pay and better ranking. Thousands of our enrollees are now serving Uncle Sam, many of them enjoying important advantages because of their previous training.

CODE

An Important Feature

A demand exists for Radio Operators in both military and civilian life. DeForest's Training will prepare you for various Radio Operator's License examinations.

START A SERVICE AND REPAIR BUSINESS OF YOUR OWN

Trained men are needed to keep the millions of Radio sets in operation during the war years and afterwards.

DE FOREST'S TRAINING OFFERS YOU A VALUABLE FREE EFFECTIVE EMPLOYMENT SERVICE which has already started hundreds of students and graduates in the Radio and Electronics industry.

DeForest's Training offers you this unusual advantage to help you prepare quickly for today's many opportunities.

"One picture is worth ten thousand words"—states the old Chinese proverb—and probably few sayings are closer to the truth.

That is why DeForest's Training furnishes you with a 16 mm. motion picture projector together with a number of reels of film which are loaned to you for study purposes.

While war industries and the armed forces are now using movies more than ever to train men quickly and better, DeForest's Training has long been preparing men for Radio and Electronics with the aid of motion pictures.

It's so much easier . . . more interesting, too, when you can "learn by seeing", you owe it to yourself to get complete details about DeForest's Training valuable "film-way" aid to learning Radio and Electronics. Simply send the coupon below. There's no obligation.



Above: **DR. LEE DE FOREST**—who supervised the preparation of DeForest's Training—is one of the world's greatest scientists and inventors in Radio and Electronics.

SUCCESSFUL THREE-WAY METHOD *Assures Better Training*

You receive a time-tested proved combination of

1. Modern, loose-leaf lesson material.
2. Visual training by means of motion pictures in your own home.
3. The privilege of additional practical training on various types of commercial equipment in our Chicago Laboratory.

WOMEN: Real opportunities also exist for you in Radio and Electronics. Write for descriptive literature on our specialized training for women.



DeFOREST'S TRAINING, INC.

occupies and owns this modern, well equipped building and laboratory in Chicago where residential training is also being given ambitious men and women. DeForest's Training is affiliated with the DeVry Corporation, internationally known manufacturers of high grade Sound Motion Picture and Electronic equipment. This affiliation is valuable from a practical industrial slant . . . helps keep training up to industry's needs and changes.

**SEND TODAY FOR VALUABLE
NEW BOOKLET**

"Victory For You"
in **RADIO . . . Communications...Electronics.** This handsomely illustrated up-to-the-minute new book will bring you a timely picture of these many opportunities and show you how to make your start with the aid of valuable "Visual Training."



DeFOREST'S TRAINING, INC.
2531 North Ashland Avenue, Dept. A, Chicago, Ill.

Please send me free illustrated book entitled "Victory for You" in Radio. No obligation, of course.

Name Age

Address

City State

Dept. A. Paste coupon on penny postcard or mail in envelope.

AN INFANT INDUSTRY ... SUDDENLY MATURED PLASTICS

Get In at the Start—and Grow

Plastics is a new industry which the nation's war needs is forcing to quick maturity. Already Plastics are indispensable in practically every branch of the Service—Aircraft, Ordnance, Chemical, Marine, Signal Corps, etc. Opportunities? Nearly everything, from homes to clothing, from gadgets to tools, will be affected by Plastics.

Spare Time Training Now Ready

The time to get started is now. You can prepare at home, in your spare time, to take your place in an infant industry that even now is leaping into prominence. A new, practical training plan is now ready to help you realize your ambitions and build your future security. Act now. Don't delay. Mail this coupon today.

AMERICAN SCHOOL, Dept. P245,
Drexel Ave. at 58th St., Chicago, Ill.

Send me FREE information covering special training in subjects checked below. No obligation on my part,

- | | |
|---|--|
| <input type="checkbox"/> Plastics | <input type="checkbox"/> Aviation |
| <input type="checkbox"/> Electrical Engineering | <input type="checkbox"/> Automotive Engineering |
| <input type="checkbox"/> Drafting and Design | <input type="checkbox"/> Architecture & Building |
| <input type="checkbox"/> Diesel Engineering | <input type="checkbox"/> Shipbuilding |
| <input type="checkbox"/> Mechanical Engineering | <input type="checkbox"/> Business Management |
| <input type="checkbox"/> Accounting & Auditing | <input type="checkbox"/> Radio |
| | <input type="checkbox"/> High School Course |

Name.....

Address.....

Learn WELDING This Easy Way!

AUDELS NEW WELDERS GUIDE

Contains Important Facts and Essential Information!

- WELDING METHODS
- WELDERS
- ELECTRIC
- OXY-ACETYLENE
- THERMIT
- UNIONMELT
- SHEET METAL
- SPOT
- PIPE
- PRESSURE VESSELS
- VARIOUS METALS
- AIRPLANE
- HARDENING-FACING
- CUTTING
- EYE PROTECTION

Just Out!

\$1

Every Welder Should Own This New, Useful Book containing clear, concise, practical information, pointers and facts relating to modern practice in all Branches. Easy to read and understand—over 400 pages Fully Illustrated—flexible cover—pocket size—a Ready Reference that Answers Your Questions accurately—Money Back if not O.K. To get this assistance for yourself, order copy today.

THEO. AUDEL, Publishers, 49 W. 23rd St., New York
Please mail AUDELS WELDERS GUIDE (Price \$1). If satisfactory, I will remit \$1 on its safe arrival, otherwise I will return the book.

Name.....

Address.....

Occupation.....

Employed by..... P.M.

PAY-RAISING — EXTRA MONEY BOOKS

Use these books to prepare for a better job—bigger pay—to start a profitable spare time or full time business of your own. Popular Mechanics specializes in supplying outstanding books on many subjects. As new books of merit appear, we will revise this list.

- How to Read Blueprints**
New self-help book starts with language of blueprints and leads up to reading actual shop plans \$1.50
- How to Get a Rating or Commission**
In Army, Navy, Coast Guard \$1.00
- Modern Welding Practice**
Very latest information on all kinds of welding \$3.50
- Garden Book**
Build own trellises, lawn furniture, nreplaces, ornaments, etc. \$1.00
- Forty Power Tools**
Build own saw, drill, lathe, sander, etc. from scraps—save money \$1.25
- Shop Notes Library**
Four big volumes including new 1943 edition (224 pages—28 in color); over 1900 articles on money-making & money-saving ideas \$1.95
- Welding, Brazing and Soldering**
How to build and use arc, spot welders; tricks of soldering. \$1.25
- Running a Milling Machine (new)** \$1.50
- How to Train Shop Workers (new)** \$1.25
- Autopower**
Convert old auto generators into motors, welders, etc. \$1.00
- Tool Design**
New book on production tools \$4.50
- Modern Refrigeration**
Electric, gas. Be service expert \$5.00
- Dyke's Auto Encyclopedia**
(includes Diesels, airplane engines)
World's greatest book for mechanics \$6.00
- Shop Metal Work**
Self instruction in all phases \$2.50
- Armature Winding**
Construction, winding, repairing AC & DC Motors, generators \$2.00
- Build Your Own Boat**
Describes 17 popular boats—rowboats, sailboats, plywood outboard, etc. 192 pages \$1.25
- Forging Practice** \$1.50
- High School Self Taught**
4 yr. course in one vol. \$1.89
- Carpentry & Joinery**
Learn modern methods \$2.00
- Foundry Work** \$2.00
- What to Make**
4 Big Books, including New 1943 issue. 812 pages of popular handicraft projects. De Luxe Cloth \$5.00
Paper \$1.95
- Practical Furniture**
Finishing \$1.25
- Machine Shop Work**
Modern methods, construction, use of tools, machines \$2.75
- Blueprint Reading**
For building trades \$1.25
- Painting & Decorating** \$1.50
- Pattern Making**
Wood, metal \$2.00
- Henley's Formula Book—1942 ed.**
Includes new formulas on plastics, paints, plating, cosmetics, photography \$4.00
- Five Acres and Independence**
How to make money on small farm \$2.50
- Knots, Ties, Splices**
For everyone who uses rope \$1.00
- Lathe Training**
New book \$1.35
- Plastics**
New books on manufacture and use \$3.00
- Your Car**
Hundreds of simple car repairs, short-cuts. Fix it yourself and save money \$1.25
- Elementary School Subjects**
For home study \$1.89
- Modern Radio Servicing** \$5.00
- 1001 Ways to Use Concrete**
Do work for yourself, others save, make money \$1.98
- Oil Burner Handbook**
New book takes guesswork out of servicing \$2.50
- Steel Square Pocket Book**
Best methods of using \$1.00
- Architectural Details**
For every type of building \$1.50
- Photo Guide**
Construct own equipment, gadgets. Make better photos \$1.25
- Easy-to-Make Toys** \$1.85
- Welding, Electric** \$1.25
- Welding, Oxy-Acetylene**
Welding, cutting \$1.25
- Metallurgy** \$1.50
- Fluorescent Lighting**
New manual on construction, installation, repair \$3.00
- Industrial Camouflage Manual**
Concealing military objectives \$4.00
- American Machinists' Handbook**
World's most used technical book \$4.00
- Machinery's Handbook**
Established standards and practices \$6.00
- Grinding Practice**
Grinding machines and abrasive wheels \$3.00
- Jig and Fixture Design** \$3.00
- Air Conditioning Metal Layout** \$3.75
- Rope's Calculator**
Figuring made easy 50c
- Plane Trigonometry Made Plain**
Explains "how" and "why" \$2.75
- Plumbing Installation and Repair**
Intended for those without previous training \$1.50
- Aircraft Sheet Metal Workers Manual** \$2.00
- Money Making Formulas**
3,262 ways to transform simple ingredients into useful products \$2.00
- Judo, 30 Lessons in Modern Jiu-Jitsu** \$2.50
- Spanish Self-Taught** \$1.00
- How to Play Piano by Ear** \$1.00
- Modern Watch Repairing and Adjusting** \$2.50
- Winters Engraving Book**
Practical course in jewelry engraving \$3.50

MAIL THIS COUPON TODAY

Just check the books you want, write your name and address below, and mail this advertisement. It is your order blank. When postman hands you books, pay him the price and few cents postage. Outside U. S. A. enclose remittance and include 15% additional for shipping charges. Ask for big FREE catalog of helpful books.

Name.....

City..... State.....

Address.....

Mail to Popular Mechanics Press
Dept. 456—200 East Ontario St., Chicago, Ill.

DEFENSE WORKERS!

PUT THESE TWO NEW BOOKS ON YOUR MUST LIST!

LEARN MORE—
PRODUCE MORE—
EARN MORE—

Volume Production Depends Upon Correct Measurements and Checking



METHODS OF MEASUREMENTS FOR DEFENSE WORKERS

Machinists—Engineers
Mechanics—Draftsmen
Inspectors—Foremen
Sheet Metal Workers
Tool and Die Makers
Army and Navy Technicians
CHECK TOLERANCES — INSPECTION MEASUREMENTS — CUT DOWN REJECTIONS . . .

GO TO THE TOP IN YOUR JOB

Complete Technical, Engineering and Mechanical Data for Every Kind of Lathe Set-up and Operation.

WAGES FROZEN?

Increase production . . . your individual rate of earning . . . work faster . . . have fewer rejections by understanding precision manufacturing practices.



ENGINE LATHE OPERATIONS

For the man who wants to get ahead. Improve your worth to your company, to the Defense Program by completely mastering every set-up, every operation and procedure for faster and more precise production with all kinds of lathes and all lathe attachments. Be able to supervise set-ups and operations . . . instruct others in the correct use of the lathe and attachments for all kinds of work.

DETAILED INSTRUCTION WITH ILLUSTRATIONS AND CHARTS MAKE IT EASY FOR ALL TO UNDERSTAND AND MASTER THESE OPERATIONS:

- | | |
|--|--|
| How to Locate Centers with the Hermaphrodite Caliper | How to Drill Center Holes with Work Supported on the Dead Center |
| How to Locate Centers with the Center Square | How to Mount and Remove Faceplates |
| How to Locate Centers with Dividers and Surface Plate Gage | How to Mount Work between Centers |
| How to Locate Centers with Surface Plate and Surface Gage | How to Mount and Remove Lathe Centers |
| How to Locate Centers with a Bell Center Punch | How to Drill Center Holes with the Drill Press |
| How to Test Accuracy of Center Punch Marks | How to Grind and Set a Rough Turning Tool |
| How to Drill Center Holes with Work in a Chuck | How to Rough Turn Stock between Centers |

COMPLETE . . . ONLY \$1.98 — NOTHING MORE TO PAY

If you want to improve your knowledge of shop practices . . . prepare for foremanship of your department . . . get a better job and higher pay . . . the \$1.98 you invest in this book will pay you big dividends. Order your copy today . . . return it in 5 days for complete refund if you don't admit it to be worth twice what you pay for it.

METHODS OF MEASUREMENT

The First Time a Book of This Kind Has Ever Been Published

The complicated problems of measurement and calculation confronting all skilled and semi-skilled workers, members of the Army and Navy technical staff, now simplified with this new complete manual of Mechanical, Physical and Geometric measurements.

Equips you for Supervision . . . Inspection . . . better paying technical positions . . . a better rating . . . higher pay

CONTAINS THE BASIC DATA OF MANY BOOKS

Price Complete, Only \$1.98

This book shows you how to make quick accurate measurements, mathematically and with measuring instruments and gages.

- | | |
|--|---|
| How to Make Lineal Measurements | The Use of Sheet Metal Gages |
| How to Use Inside and Outside Calipers | Correct Use of Wire Gages |
| Proper Reading of Hermaphrodite Calipers | Right Way to Use Drill Gages |
| Correct Use of Vernier Calipers | The Use of Thickness Gages |
| Figuring Geometrical Measurements | How to Determine Weights and Volumes |
| How to Use the Common Protractor | How to Measure Density of Solids |
| How to Read Common Vernier and Bevel Protractors | How to Calculate Density of Liquids |
| How to Make Calculations from Measurements | How to Figure Specific Gravity of Solids |
| How to Use Pitch and Thread Gages | How to Figure Specific Gravity of Liquids |
| | How to Determine Elasticity |
| | How to Measure Tension |
| | Figuring Stress and Strain |
| | Measuring Tensile Strength |

THIS FIRST EDITION IS LIMITED — SO HURRY! !

Order your copy today. If you are not satisfied, return in 5 days for complete refund. Use handy coupon.

USE THIS COUPON FOR "ENGINE LATHE" MANUAL

WILCOX & FOLLETT CO.
1255 So. Wabash Ave., Dept. PM-2
Chicago, Illinois

Please send me postpaid your new book, "Engine Lathe Operations" and a FREE Protractor Scale and Rule. Enclosed is check or money order for \$1.98 to cover complete payment. I can return the book in 5 days if I am not completely satisfied.

NAME _____

ADDRESS _____

CITY _____ STATE _____

Check here if you wish book to be sent C.O.D. (Postage and C.O.D. charges extra.)

BOTH FREE

IF YOU ACT NOW!!!

This Precision-made Protractor and a Machinists Scale—both, with English and Metric readings will be sent free with either book.



USE THIS COUPON FOR "METHODS OF MEASUREMENT"

WILCOX & FOLLETT CO.
1255 So. Wabash Ave., Dept. PM-2
Chicago, Illinois

Please send me postpaid your new book, "Methods of Measurement" and a FREE Protractor Scale and Rule. Enclosed is check or money order for \$1.98 to cover complete payment. I can return the book in 5 days if I am not completely satisfied.

NAME _____

ADDRESS _____

CITY _____ STATE _____

Check here if you wish book to be sent C.O.D. (Postage and C.O.D. charges extra.)

INVENTORS

This BOOK

and INVENTION RECORD (Cost You Nothing) FREE BOOK



HOW TO PROTECT, FINANCE And SELL YOUR INVENTION

Our FREE BOOK and other literature available to our clients—gives you complete details on how to “ready” your invention for money-making. It tells you how others did it—who they went to for finances—how they arranged partnerships—how they made contacts with manufacturers—how they dictated royalty arrangements—how much money they made—how you can find a market. Our new FREE BOOK discloses sources of quick revenue if your invention is patentable and saleable with profit possibilities.

THE FIRST STEP

The first step in getting your invention ready for market is to make a dated record of it on our “Invention Record” Form. This Form properly filled out and witnessed will be invaluable to you later in establishing the date of your invention should need for such evidence arise. We will be glad to send you our “Invention Record” and have it witnessed in this office when you return it with disclosure of your device. This service costs you nothing—and it immediately puts you on record as the originator of your device.

Protect Your Invention NOW!

We have many letters in our files from manufacturers requesting inventions. Today's demand for new devices is tremendous—added to by emergency needs. Protect your invention now with a U. S. Patent. By acting promptly you may prevent another inventor getting in ahead of you at the Patent Office here in Washington. The first step is to make a sketch and description of your invention on our “Invention Record,” have it witnessed and mail it to us. We will then make a Search of the U. S. Patent Office files to ascertain whether we can get patent protection for you. This is a step you should make NOW—before another steps in ahead of you and walks away with a patent.

MAIL

COUPON TODAY!

McMORROW & BERMAN

REGISTERED PATENT ATTORNEYS BEFORE U.S. PATENT OFFICE
135-B Albee Building
Washington, D. C.

Send me your NEW FREE Book “How To Protect, Finance and Sell Your Invention” and specially prepared “Invention Record” form at once. I understand that this request does not obligate me.

NAME

ADDRESS

CITY STATE

Write or Print Name Clearly

POPULAR INVENTIONS

For Your Home

(Continued from page 24A)

is formed by clipping the flanged hose-collar into the groove of the faucet collar. The coupling can be disconnected easily by sliding out the lower piece. If the hose is used with several different faucets, each one may be fitted with the coupling device.

“Jell” Meter Aid for Jelly Making Takes Out the Guesswork

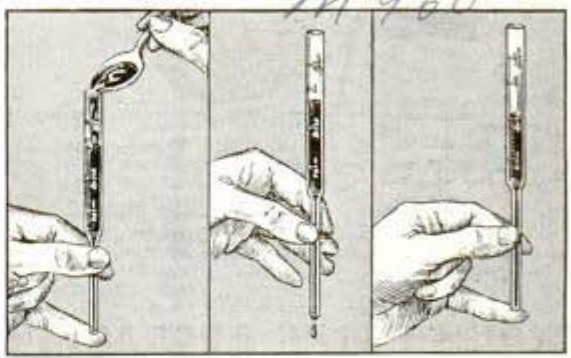

You can quit guessing when making jelly if you possess a “jell” meter that tests the fruit juice and tells how much sugar should be added, and also whether pectin is needed. The instrument is a glass tube with a pin-size hole running through its lower half. In making a test, the larger half of the tube is filled with juice while the opening at the lower end is closed with the finger. When the tube is full, the lower end is unstopped permitting the juice to flow out for one minute. The top section of the tube has gaugelike markings with figures, 1/2, 3/4, 1, 1 1/4, and the figure indicated by the final level of the juice determines how many cups of sugar should be added. If all the juice flows out of the tube within the minute, that is a warning to add pectin to the watery batch. An instruction book explains how to test for jellies, jams and marmalade.

WHERE-TO-BUY-IT INDEX OF POPULAR INVENTIONS

- Disappearing towel rack.....22A
The Boston Store, State and Madison, Chicago
- Tray ejects ice cubes.....22A
- Traveling automatic sprinkler.....22A
Buckner Mfg. Co., 7658 Calumet Ave., Chicago
- House coupling makes quick connection.....24A
Kuplex, Inc., 4723 S. Hoover St., Los Angeles, Calif.
- “Jell” meter helps jelly making.....28A
The Jelmeter Co., Bridgeton, N. J.

moved - no address.

FREE 7-DAY OFFER!

AUTO MECHANICS..

FLEET OWNERS... SERVICE STATIONS... REPAIR SHOPS

NOW REPAIR ANY MAKE CAR

**Save Repair Time - Handle
More Jobs - Make More Money!**



**MoToR's Famous FACTORY SHOP MANUAL Gives
You ALL Service, Repair, Tune-Up, Adjustment,
Replacement Facts on Every Car Built Since 1935!**

HERE's every repair fact you need to know about ANY make car that comes into your shop—new 1942 or 8-year-old jalopy! Nearly 200,000 quick-indexed "how-to-do-it" service and repair facts; tune-up and adjustment data; tables of measurements, clearances, specifications. Clear, step-by-step language. Nearly 1,000 drawings, diagrams, cut-away pictures that make every instruction easy as A-B-C. 600 pages, size 8½x11 inches.

Cars today need *quicker* service. No more new models—repair jobs will be tougher. War plants making mechanics scarce—more work and more money for YOU, if you can handle it.

That's why you need this famous FACTORY SHOP MANUAL now, and that's why we want you to examine it first, at our risk!

**Like 150 Factory Manuals
in One!**

MoToR's Factory Shop Manual gives you all the "dope" from 150 manufacturers' official manuals—all in one handy book! Just look up the job, the model, the make, and go to work. Special binding keeps book open at any page, for "work-while-you-read."

This same Factory Shop Manual is the one used by U. S. Army, trade and technical schools the country over, auto servicemen everywhere. Makes a good mechanic an expert—saves experts valuable time, trouble, money! Right NOW—to see how this book can help you get at each job *easier*, do it *better*, finish it up *faster*—send coupon below for a FREE examination copy of MoToR's Factory Shop Manual. You don't have to pay a nickel if you're not satisfied with it!

**Published by MoToR, The Leading
Automotive Business Magazine**

**Clear, Pictured, Step-by-Step
Instructions Covering Every Job
on Every Car Built Since 1935!**

Nearly 200,000 service and repair facts on all makes. 600 pages, with over 50 pages of text, charts, illustrations covering all models of carburetors.

Over 450 charts, tables covering important specifications, clearances, measurements, arranged in handy form, including: TUNE-UP CHART; VALVE MEASUREMENTS; COMPRESSION PRESSURE; TORQUE WRENCH READING; STARTING MOTOR; ENGINE CLEARANCE; MAIN & ROD BEARING JOURNAL DIMENSIONS; GENERATOR; CLUTCH & BRAKE SPECIFICATIONS; FRONT END MEASUREMENTS, etc., etc.

Detailed, pictured instructions on ENGINES; ELECTRIC SYSTEMS; FUEL SYSTEMS; COOLING SYSTEMS; LUBRICATING SYSTEMS; TRANSMISSIONS; AXLES; FRONT ENDS; KNEE ACTION; SHOCK ABSORBERS; SPRING, BODIES; FREE WHEEL; UNIVERSALS; REAR ENDS, etc., etc.

**Same FREE 7-Day Offer
Applies on MoToR's New
TRUCK REPAIR MANUAL!**

For all mechanics regardless of experience; for truck specialists, truck service stations, fleet owners. Covers EVERY job on EVERY truck made since 1936! Contains 1400 pictures, 900 pages, 300,000 facts based on manufacturers' own official manuals. Already in use by Armed Forces, and truck service men. Warranted to contain every essential fact you need to know. Waterproof binding, size 8½x11.

Covers all types of Gasoline Engines; all types of Diesels and Hestelmans. All types of Diesel Fuel Injection Systems. All procedures described in easily-understood text and clear pictures: Fuel Systems, Governors, Lubrication Systems, Ignition Systems, Starters, Generators, Clutches, Transmissions, Axles, Torque Dividers, Transfer Cases, Brakes, Steering, etc., etc.

Offered on same FREE 7-Day examination as Factory Shop Manual. Check box in coupon at right.

**SEND NO
MONEY
Mail Coupon**

See for yourself how the Manual pays for itself the first few days you use it! And if not satisfied, return book without cost or obligation. Send coupon TODAY! MoToR Book Dept., Desk 12, 572 Madison Ave., New York, N. Y.

FREE 7-DAY TRIAL

MoToR Book Dept., Desk 12, 572 Madison Ave., New York, N. Y. Rush to me at once: (check box opposite book you want).

MoToR's FACTORY SHOP MANUAL, If O.K. I will remit \$1 in 7 days, and \$1 monthly for 4 months, plus 35c delivery charge with final payment (\$5.35 in all). Otherwise I will return book in 7 days. (Foreign, \$6, cash with order.)

MoToR's TRUCK REPAIR MANUAL. (Described at left). If O.K., I will remit \$2 in 7 days, and \$2 monthly for 3 months, plus 35c delivery charge with final payment (\$8.35 in all). Otherwise I will return book in 7 days. (Foreign, \$10, cash with order.)

Name.....Age.....

Address.....

City.....State.....

Employer.....

SAVE 35c! Check here if enclosing payment. We will then pay delivery charge. Same return privilege.





Know Electricity as Experts Know It—and Get an Expert's Pay!

What about your future? Who is safe today? Surely not the man who is contented to stand still! Know your job thoroughly—prepare yourself for jobs ahead. To do just this thousands of men have used

The Croft Library of Practical Electricity

The Croft Library is a complete electrical educator. It is founded on practice—on 20 years of shirt-sleeve experience—on work as it is actually done. It is jammed from cover to cover with the kind of hard-headed facts you want. Written so that the beginner can easily understand it, yet so sound, so thorough, that it is the daily guide of 30,000 highly paid electrical workers and engineers. Croft tells you the things you need to know about motors, generators, armatures, commutators, transformers, circuits, switchboards, distribution systems—electrical machinery of every type—wiring for light and power—wiring of finished buildings—underwriters and municipal requirements—illumination in its every phase—the most improved methods of lighting—lamp and lamp effects, etc.—how to do a complete job, from planning it, to completion.

No money down—easy payments

Fill in and mail the coupon attached and we will send you the entire set of seven volumes for ten days' examination on approval. We take all the risk—you assume no obligation. If you decide to keep the books, send \$3.00 in ten days and the balance at the rate of \$3.00 a month. Send the coupon NOW and see the books for yourself.

EXAMINATION COUPON

McGraw-Hill Book Co., 330 W. 42nd St., New York

Send me for ten days' examination on approval the Croft Library of Practical Electricity, 7 vols. If satisfactory I will send you \$3.00 in 10 days and \$3.00 monthly until the price of \$18.00 is paid. If not wanted, I will return the books postpaid. (To insure prompt shipment write plainly and fill in all lines.)

Name.....
Home Address.....
City and State.....
Position.....
Name of Company..... PM-2-43

DRAFTSMEN NEEDED Now



Industry is clamoring for more draftsmen for the job can't start until plans are drawn. Buildings, airplanes, machines, guns, tanks, bridges, all start on the drafting board, so it's no wonder that every good draftsman has a fine job. Yes, more draftsmen are needed NOW. The pay is good and the opportunities for advancement great.

Learn at Home in Spare Time

Begin now to turn spare hours into money. Be a draftsman, the connecting link between a mechanic and an engineer. Enjoy the wonderful opportunities for promotion that exist now. No experience or artistic talent is needed. You don't have to leave your present job while learning. Use spare time.

American School, Dept. DD245, Drexel Ave. at 58th St., Chicago, Ill.

Gentlemen: Send me FREE information covering special training in subjects checked below. No obligation on my part.

- | | |
|--|---|
| <input type="checkbox"/> Drafting and Design for Men and Women | <input type="checkbox"/> Electrical Engineering |
| <input type="checkbox"/> Accounting and Auditing | <input type="checkbox"/> Diesel Engineering |
| <input type="checkbox"/> Architecture and Building | <input type="checkbox"/> High School Course |
| <input type="checkbox"/> Automotive Engineering | <input type="checkbox"/> Plastics |
| <input type="checkbox"/> Business Management | <input type="checkbox"/> Mechanical Engineering |
| <input type="checkbox"/> Aviation | <input type="checkbox"/> Radio |
| | <input type="checkbox"/> Shipbuilding |

Name.....
Address.....

Do You Make Mistakes in English?

EVERY time you speak or write you show just what you are. Mistakes in English reveal you as a person who lacks education and refinement. Lack of language power prevents you from presenting your thoughts in the strongest possible way. No matter what you do, real command of English will help you to your goal. Stop making mistakes in spelling, punctuation, pronunciation. Increase your vocabulary.



WONDERFUL INVENTION

Only 15 minutes a day with Sherwin Cody's new invention—and you can actually SEE your English improve. It teaches by HABIT—makes it easier to do the RIGHT way. Wonderful self-correcting lessons include spelling, punctuation, grammar and expression.

FREE BOOK ON ENGLISH Lack of language power may easily be costing you thousands of dollars every year. See what Mr. Cody can do for you; it costs nothing to find out. Mail a postal card or letter this very minute for free book, "How You Can Master Good English in 15 Minutes a Day". It will prove a revelation to you. WRITE NOW. Address:

Sherwin Cody School of English, 52 Searle Bldg., Rochester, N.Y.

TRAIN

Your VOICE!

Results GUARANTEED

We build, strengthen the vocal organs—not with singing lessons—but by sound, scientifically correct silent and vocal exercises and absolutely guarantee complete satisfaction with results. Write for Voice Book, FREE. Sent to no one under 17 years old unless signed by parent.

PERFECT VOICE INSTITUTE. Studio 1352, 64 E. Lake St., Chicago, Ill.

CIVILIAN JOBS now open for AIRCRAFT INSTRUMENT MEN

Army and navy aircraft maintenance depots (under Civil Service), Air Transport Command, airlines, aircraft plants, instrument manufacturers... all are calling for thousands of civilian mechanics and technicians. High-salaried jobs and big opportunities for aircraft instrument men.

You get the same instrument text books studied by our resident students... covering construction, maintenance, overhaul, testing, installation of the many aircraft instruments. This fascinating, profitable course can be completed in 25 weeks or less. Moderately priced. Write.....

American School of Aircraft Instruments, Dept. M-2, 3903 San Fernando Rd., Glendale, Calif.



LAW STUDY AT HOME

Legally trained men win higher positions and bigger success in business and public life. Greater opportunities now than ever before. Big corporations are headed by men with legal training.

More Ability: More Prestige: More Money

We guide you step by step. You can train at home during spare time. Degree of LL. B. Successful graduates in every section of the U. S. We furnish all text material, including 14-volume Law Library. Low cost, easy terms. Get our valuable 48-page "Law Training for Leadership" and "EVIDENCE" books FREE. Send for them NOW.

LaSalle Extension University, Dept. 264-L Chicago
A Correspondence Institution

LEARN MEAT CUTTING

At Home—In Spare Time **FIRST LESSON FREE**

Get into the meat business. Prepare AT HOME for permanent BIG-PAY jobs, not temporary employment. Thousands of opportunities for Meat Cutters, market managers or store of your own. National's famous HOME STUDY course based on 25 years experience. Low cost. Easy terms. First lesson sent FREE. See for yourself how easy it is to train for a bright future. Write for FREE lesson today. No obligation. Send for it NOW!

NATIONAL SCHOOL OF MEAT CUTTING, Inc., Dept. U-39, Toledo, Ohio

war squabs book free

Why meat worry? Grow squabs. Nothing easier to raise, nothing better to eat, says Uncle Sam. Ready to eat or sell in 25 days. Royal squabs sell at POULTRY TOPS, large profit. Send 3-ct. stamp to pay postage on new big 194 FREE BOOK, war food starter, low prices, easy directions, RICE FARM, 640 H ST., MELROSE, MASS.



IF I Send YOU THIS FINE SUIT—

Will You Wear It and Show It to Friends?

I need a reliable man in your town to wear a fine made-to-measure, all-wool DEMONSTRATING SUIT—advertise my famous Union clothing—and take orders. You can make up to \$12.00 in a day. My line contains over 100 quality fabrics, all sensational values, guaranteed. You need no experience or money. I supply everything required FREE. Write today, telling about sources of sale, etc., for FREE OUTFIT. STONEFIELD, 1300 W. Harrison, Dept. P-116, Chicago

Get into **RADIO** now!



SHOP METHOD HOME TRAINING
fully qualifies you for bigger pay jobs

More than 50,000,000 radios in use. They need servicing. Over 800 Broadcasting Studios employ trained radio technicians. The movie industry and thousands of theatres employ Sound Experts. Factories are adopting audible address systems. The Air Lines and Government need Trained Men. Here is your opportunity to get into a permanent, profitable field of enjoyable work.

BIG OPPORTUNITY FOR NATIONAL GRADUATES

Shortages in trained, skilled men run into the hundreds of thousands. One of the biggest fields is **Radio**, with its many fascinating branches. War-time demands for Radio men are tremendous and will continue unabated after the war. That's important to you. You want training in a field that will continue to advance. National Schools offers you a time-tested method of Home Training which has helped thousands of men to more pay, and unlimited opportunity in the growing RADIO Industry. You can actually start earning in Spare Time, even while you are training for a good permanent job as a RADIO Technician. You need training. National can definitely help you. Simply send the Coupon and we will mail you a FREE Specimen Lesson and Big Opportunity Book so you can judge for yourself just how you can be helped to bigger pay and a Life Career of Success.



COMMAND ANY OF THESE JOBS
Radio Expert
Radio Broadcasting
Sound
Industrial Electronics
Studio Technician
Television Technician

**Step up in life!
Be independent!
Insure your success!**

Keep your present job while learning. National brings to you the same proven instruction methods as used at the School. No dull text books.



YOU GET HOME TRAINING FROM A REAL, ESTABLISHED TECHNICAL TRADE SCHOOL

For 38 years National Schools has trained ambitious men for Top Pay trades. Squarely behind you are the modern, completely-equipped Training Shops of National where we **pre-test** and **prove** every instruction sent to you. Every phase of your training is **personally supervised** by an established Faculty of practical, experienced instructors and engineers. They have developed progressive methods of training you in your home comparable to actual shop practice. Unique training facilities give you Home Training based on Resident School Shop principles—**methods not available from any other source**, to our knowledge. You'll be amazed when you receive our Complimentary Lesson and full details. **Send the coupon at once.**

MEN SUBJECT TO MILITARY SERVICE AIDED BY TRAINING

Radio Training helps men get extra rank, extra pay in war service. Every man eligible for service should mail coupon. Many Service Men now enrolled.



Regardless of your age, you can enroll.

DUPLICATE THE SUCCESS OF THESE GRADUATES WITH U. S. GOVT.

"I have been accepted by the U. S. Federal Communications Commission at a starting salary of \$1800.00 per year, thanks to National Training."

PRICE G. GARNER
San Diego, Calif.

\$3000.00 PER YEAR

"I am married now. Just going fine. My pay this year is over the \$3000.00 mark."

LEO BROMBEREK
Lenont, Ill.

WITH BIG CONCERN

"I got a job with International Telephone & Radio Co. It's a good, straight salary position. Delighted with your training."

DOUGLAS NIELSEN
Jamaica, N. Y.

THOUSANDS OF GRADUATES ATTRIBUTE THEIR SUCCESS TO NATIONAL TRAINING

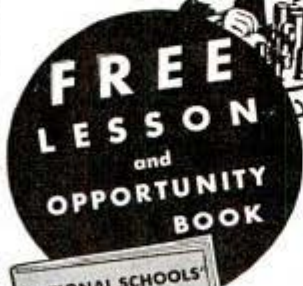

NATIONAL SCHOOLS

Los Angeles, California

Established 1905



"I will train you in your spare time to qualify as a Radio Expert."

J. A. ROSENKRANZ
President

MAIL COUPON FOR LESSON & BOOK

National Schools, Dept. 2-M.
4000 So. Figueroa, Los Angeles, Calif.

(Mail in envelope or paste on a Penny Postal.)

Mail me **FREE**, without obligation, one Lesson and Opportunity Book, with full details about Radio Training.

NAME _____ AGE _____

ADDRESS _____

CITY _____ STATE _____

REQUEST FULL DETAILS

Know Your Arc Welding!

Bring yourself up-to-date on Arc Welding methods, procedures, techniques and equipment with this sensational 1942 manual. Hundreds of pages of illustrations and diagrams "show you how" . . . and the text tells you in clear, concise, style. For experts and beginners alike. It'll be worth a hundred times its cost to you.

\$2.00

Postpaid

Write Today! **HOBART Bros., Box M-23 Troy, Ohio**

Complete Manual and Ready-Reference Text. 516 pages 512 Illustrations

... Easy to read and understand.



Send for Your Copy Today!

Once you look it over you'll want it always at your fingertips. Remember, it can make the best operator even better.

Ask about FREE enrollment in the HOBART Trade School. One of the finest in America.



5 Days FREE Inspection • Most Valuable Book on Welding ever published!

HELP YOURSELF GET THE JOB YOU WANT IN THE ARMY!

PASS HIGH ON THE INDUCTION "I.Q." TEST



Everyone entering the Service must take a General Classification "Intelligence" Test. A high mark on this test helps you toward the **JOB YOU WANT** and **OFFICER TRAINING**.

"PRACTICE FOR THE ARMY TESTS"

is a book containing complete and simplified material along the lines of the questions given on the test . . . tells how to answer them quickly, easily—costs only \$1.50. Get a thorough preparation **RIGHT AWAY** if you're about to enter the Service.

Free Trial Coupon

ARCO PUBLISHING CO.
480 Lexington Ave.
Dept. 1202, New York, N. Y.

Please rush copy of "Practice for the Army Tests" to me. If I am not satisfied after 5 days, I will return book for a full refund.

- I will pay postman \$1.50 plus postage, on arrival.
- I enclose \$1.50 (Postage is free)

NAME

ADDRESS

CITY..... STATE.....



PATENTS AND TRADE MARKS
C. A. SNOW & CO.
Registered Patent Attorneys Since 1875
Write for Free Book and "Certification of Invention" form
427 SNOW BUILDING, WASHINGTON, D. C.

PATENT YOUR IDEAS HOW TO OBTAIN A PATENT
SEND FOR FREE BOOK
Written by Former Member Examining Corps (1922-24) U. S. Pat. Office.
CARL MILLER, Registered Patent Attorney
Former Member Examining Corps U. S. Patent Office
Woolworth Bldg., Dept. 23-A, New York—Bond Bldg., Dept. 23-A, Washington, D. C.

MAKE MONEY AT HOME!
Learn to color photos and miniatures in oil. No previous experience needed. Good demand. Send for free booklet, "Make Money at Home" and requirements.
NATIONAL ART SCHOOL
1315 Michigan Ave. Dept. 1352 Chicago

JIU JITSU 3 LESSONS 10¢
Investigate the course experts buy. Amazing low price. Send 10c today for 3 trial lessons, full details.
MODERN SCHOOL OF JIU JITSU, Box F-88, Forest Hills, N. Y.

Become a Doctor of PSYCHOLOGY
Win the degree of Ps.D. Teach the secret of contentment, happiness. Solve mental worries. Experience the revelation of truth. Chartered college. Individual help. Write for **FREE** book. **COLLEGE OF UNIVERSAL TRUTH, 20-B E. Jackson Blvd., Chicago.**

Learn PROFITABLE PHOTOGRAPHY
Modern, practical training. You "learn by doing." For pleasure or career. Unusual wartime opportunities. Black & White, Motion Picture, or Color photography. 33rd year. Free Booklet.
10 West 33 St. (Dept. 49) New York City

Learn CARTOONING
FREE TRIAL LESSON! Cash in on your sense of humor—**AT HOME—BY MAIL.** Have fun! Make money! No experience needed to start. Write today for **FREE** LESSON, mailed postpaid. No obligation.
Moon Gag-Cartoon School, Dept. M, Argyle, Wisconsin.

52 BREEDS BERRY'S New POULTRY BOOK
BERRY'S Champion-Mated, Hand-Picked CHICKS, also **SEXED, STARTED, 52 Breeds, 7 HYBRIDS, TURKEY POULTS.** All Iowa Inspected, BWD Tested. **Over 400 Prizes—30 Shows! LOW PRICES.** In Business 45 years. **Beautiful POULTRY BOOK FREE,** stamps appreciated.
BERRY'S POULTRY FARM, Ex. 29, CLARINDA, IOWA

To PROTECT Your INVENTION - Use this coupon, NOW

Delays are dangerous and may be very costly. My personal service assures prompt action, strict confidence, and a minimum of expense. I suggest that you send me a model or drawing, or sketch and description of your invention, and \$5.00. I will make a search and report

promptly as to its patentability and send you a copy of my 72-page booklet. Or, if you prefer to read my booklet first, mail the attached coupon at once. I will also send my "Record of Invention" form. (Over 40 years experience as a Registered Patent Attorney.)

L. F. Randolph, 302-D Columbian Bldg., Washington, D. C.
Please send me at once, free of charge, your 72 page booklet and "Record of Invention" form.

A PERSONAL CONFIDENTIAL PATENT SERVICE—
Name.....
Address.....

Quick! Get into DRAFTING now



All working tools, including drawing table, sent to you at once—furnished free with course.

Learn At Home From An Engineer

With industry working feverishly—the field for DRAFTSMEN is bigger than ever! Get into a better job with more pay and fascinating, pleasant work. I will train you at your home in your spare time until you are holding a better paying position as Draftsman. My practical training in Drafting also includes a working course in Industrial Designing valuable on new products, improving, restyling and modernizing—all extremely important and profitable to draftsmen. Write for full illustrated details and booklet. Give your age.

ENGINEER DOBE, Division 3372 Libertyville, Illinois

FREE

MUSIC LESSONS



Learn to play your favorite instrument, amazing PROVEN way—right at home. No special talent needed! Win fame, success, popularity! Name instrument you want to play so we can send you FREE LESSONS FREE.

Accordion, Guitar, Piano, Saxophone, Mandolin, Banjo, Clarinet, Trumpet, Cornet, Voice, etc. Write today for FREE LESSONS and FREE LITERATURE. State age!

NATIONAL ACADEMY OF MUSIC 1525 E. 53rd St. Dept. 240-N, Chicago, Ill.

ANY BOOK IN PRINT!



Delivered at your door. We pay postage. Standard authors, new books, popular editions, fiction, reference, medical, mechanical, children's books, etc.—all at guaranteed savings. Send card now for Clarkson's 1943 Catalog.

FREE Write for our great illustrated book catalog. A short course in literature. The buying guide of 300,000 book lovers. The answer to your reading problem. FREE if you write NOW—TODAY!

CLARKSON PUBLISHING COMPANY Dept. PM-43, 1253 So. Wabash Ave., Chicago, Ill.

New York Established 1902
Electrical School
 Ask for free illustrated booklet
 44 West 17th St., N. Y. C.

Get This Book Free If You STAMMER

Every stammerer should have the new 128 page book "Stammering, Its Cause and Correction." Sent free to stammerers. It describes the Bogue Unit Method for the scientific correction of stammering and stuttering. Method successfully used at Bogue Institute for 42 years—since 1901. Endorsed by physicians. Write for full information. No obligation. Benjamin N. Bogue, Dept. 1347 Circle Tower, Indianapolis, Indiana.

PLAYS
 Send for FREE catalog of 144 pages, copiously illustrated. Non-royalty plays also tested plays on a percentage-royalty basis. Playbook exchange. Row, Peterson plays are nationally famous for their high quality. Ask for live drama newspaper, "Lagniappe."—it is free.
 ROW, PETERSON & COMPANY
 1909 Ridge Ave. Evanston, Ill.

America Needs Men Trained for TOOL & DIE MAKING, MACHINIST & SCREW MACHINE TRADES

HARRY LEBESON PRESIDENT & FOUNDER
 ALLIED School offers you short intensive, Practical training courses in Our fully equipped Shops. Learn on Actual Jobs! Easily, Quickly. Learn Days or Evenings. Enter anytime. FREE Employment Service and opportunity to earn while learning. Write for FREE Book "Practical Machine Shop Training."
ALLIED SCREW MACHINE CO., (School Division)
 609 West Lake Street, Dept. PM-2, Chicago, Illinois

SPRAYBERRY RADIO TRAINING includes FULL EQUIPMENT

Experience Easily Acquired at Home



You Do Practice-Giving Experiments, Many Special Features... ALL Designed to Help You Make Fast Progress.

SPRAYBERRY Training starts right at the beginning of Radio... unfolds each subject in a simplified, logical, understandable style. You easily learn Television, Frequency Modulation, Signal Tracing, Mobile Radio (Auto-Tank), Aviation Radio, Electronics, Facsimile Radio, Radio Set Repair and Installation work.

Training Prepares You for a Business of Your Own... or Good Radio Jobs—Civilian or Military

The important and fascinating field of Radio offers many opportunities to the man who wants to get ahead. My Training will help you win quick promotion in the Army or Navy... will fit you for a bright civilian career. SPRAYBERRY Methods are thorough and practical. Your training will not interfere with your present duties.



You Get a Dual-Purpose Radio Set

I supply you with Radio Parts which you use to gain pre-experience in Repair work. These same Parts are used as a Modern Signal Generator and for Signal Tracing, etc. You'll find my Course and Equipment fully described in the catalog offered below.



No Previous Experience Needed

It makes no difference what your education has been. I can fit you quickly for a good-paying Radio job. I make it easy for you to grasp Radio principles and remember them. Your success is my full responsibility.

Earn While You Learn

My BUSINESS BUILDERS show you how to put your equipment to actual use in handling Money-making Radio Service Jobs shortly after you begin Training.

THE SPRAYBERRY COURSE IS SOLD UNDER MONEY-BACK AGREEMENT

RUSH COUPON for BIG FREE BOOK

SPRAYBERRY ACADEMY OF RADIO
 F. L. Sprayberry, President
 610-B University Place, N. W.
 Washington, D. C.

Please rush my FREE copy of "HOW TO MAKE MONEY IN RADIO"

Name..... Age.....

Address.....

City..... State.....

(Mail in envelope or paste on penny postcard)

NEWS



Increased production means

More Jobs for MACHINISTS and bigger pay for men who know their work

This big home-study and reference course gives you the practical facts on machines and methods you need to advance in machine shop work. Take advantage of the other man's experience as found in books, to solve your problems, increase your efficiency, with

The AMERICAN MACHINISTS' LIBRARY

6 volumes—2368 pages—2516 illustrations
(A combined home-study course and reference library)

This library of machine shop practice was written for practical men. It gives you the best methods for every kind of machine shop work. It fully explains lathes, drills, and other machine tools and their operation, automatic screw machines, speeds and feeds, gear design and production, jigs and fixtures, punch and die work, metal surfacing, etc., etc. Plainly written—completely illustrated—the best kind of help to the machine shop man who wants to advance himself.

No money down—special price—easy payments.

EXAMINATION COUPON

McGraw-Hill Book Co., 330 W. 42nd St., New York

Send me for ten days' examination the American Machinists' Library. If satisfactory I will send you \$1.50 in 10 days and \$3.00 monthly until the price of \$19.50 is paid. If not wanted, I will return the books postpaid. (To insure prompt shipment write plainly and fill in all lines.)

Name.....
Home Address.....
City and State.....
Position.....
Name of Company..... PM-2-43

Always write your name and full address clearly when answering advertisements.

PLUMBERS & STEAM FITTERS

Audels Plumbers and Steamfitters Guides



4 Vols. \$6

A practical, illustrated, Reference Library and Study-Course for Master Plumbers, Journeymen and Apprentices Steamfitters, Gas Fitters and Helpers, Sheet Metal Workers, Draughtsmen, Master Builders, Engineers and all Building Trade Students. This valuable set of handy, pocket-size Guides explains in practical concise language and well-done illustrations all the principles, advances and short cuts of the Plumbing and Heating trade—based on modern practice. Contains careful, detailed instructions

on how to figure and estimate various jobs. Use FREE COUPON below to examine, without obligation, this valuable work.

INSIDE TRADE INFORMATION ON:

Soldering, tinning, joint wiping, bending, heating. Pipe—iron—steel, threading. Mathematics, tables, physics. Materials—iron, steel, copper, brass, lead, tin, antimony, etc. Sheet metal—galvanized—plate. Sanitation, syphonage, tanks. Drains, sewage, purification. Fixtures—bath—kitchen. Pipe fittings, soil pipe, tools. Laying out work. Rounding. Screwed fittings, flanges, joints. Pipe bending, examples. Elbows. Heating, ventilation, air conditioning, refrigeration. Water supply, mains, wells, tanks. Gas-fittings. Sheet metal work, problems, methods. Brazing, heating, lead burning. Welding, various welds, methods. Blacksmithing, forges, tools. Air Conditioning.

THEO. AUDEL & CO., 49 W. 23rd St., New York City

Mail Audels Guides, 4 vols., on 7 days' free trial. If O. K. I will return \$1 in 7 days, and \$1 monthly until \$6 is paid. Otherwise I will return them. No obligation unless I am satisfied.

Name.....
Address.....
Occupation.....
Reference..... P.M.



POULTRY PAYS

IN PATRIOTISM PROFITS PLEASURE

Learn at home, the EASY, SCIENTIFIC, and INEXPENSIVE way. Our course covers ALL phases of Poultry raising, including plans for buildings, breeding, hatching, culling, sexing, caponizing, marketing, judging, exhibiting, and many others, etc., as planned by Harry M. Lamon, former Senior Poultryman for the United States Department of Agriculture.

In the past twenty years, we have helped thousands of students to establish poultry farms, to increase profits on established plants, to secure positions in the many branches of the Poultry business, and many just to enjoy a small, profitable, breeding plant.

The Government needs your help for its huge requirements for Poultry and eggs. Sec'y. Wickard wanted 200,000,000 extra chickens this year. Later he called for 4 billion pounds of chicken for meat alone. 28% jump over 1942! And more eggs per bird—8% more eggs! We can teach you the EASY, SCIENTIFIC, and PROFITABLE way to assist this program.

Write TODAY for catalog "How to Raise Poultry For Profits." It fully explains courses and easy payment plan.

NATIONAL POULTRY INSTITUTE
Dept. 50-2, Adams Center, N. Y.



Send Today

RADIO OPERATORS WANTED

Be a "key" man. Learn how to send and receive messages in code by telegraph and radio. Army, Navy and Commerce needs thousands of men. Good pay, adventure, interesting work. Learn at home quickly through famous Candler System. Write for FREE BOOK.

CANDLER SYSTEM CO.
Dept. 5-B, Denver, Colo., U. S. A.

LOOK! Baby Chicks

THOUSANDS WEEKLY ALL YEAR. Finest quality & Layers in 40 breeds. Hybrid Baby Pullets and Cockerels, B. W. D. Tested. Ducksling, Goslings, Baby Turkeys, Guinea. In business 30 years. Catalog free. ORDER NOW. Make BIG money raising NABOB QUALITY CHICKS.

NABOB HATCHERIES, BOX M, GAMBIER, OHIO

"MY JOB'S IMPORTANT! IS YOURS? AIRCRAFT INSTRUMENT MEN NEEDED AT ONCE!"

PREPARE in AVIATION'S MOST VITAL BRANCH

AIRCRAFT INSTRUMENTS

HOME STUDY—LEARN BY DOING!

Practical, complete training—on actual instruments furnished by the school—qualifies you for well-paying positions with manufacturers, airlines and instrument service and repair stations.

Send for CATALOG today...

EASTERN AIRCRAFT INSTRUMENT SCHOOL

"Largest in the East"

DEPT. 10 116 NEWARK AVENUE JERSEY CITY, N. J.

HOW TO GET INTO AVIATION—NOW

by C. S. (Casey) Jones

NO. 3 in a series of advertisements describing the free training and opportunities now available in aviation. Addressed to the thousands of men and women who wish to prepare themselves for war service in this key industry.



C. S. JONES

An architect drafting aircraft parts...a real estate salesman at a lathe...a housewife operating a drill...all over the country men and women are learning new skills, finding new interest and usefulness in the industry which is of first importance in winning the war.

Aircraft Manufacturing offers innumerable opportunities today—in training and in jobs. Requirements vary

some, but in general men and women, married or single, 18 years of age up, U.S. citizens and not now employed in war industry are eligible. Free tuition and pay during the training period are offered.

Companies building airplanes—such as Consolidated in San Diego, Curtiss-Wright in Buffalo, United Aircraft in East Hartford—are accepting applications from their respective localities for training courses of which the following are typical:

Pre-Factory Training: You become an employee of

3 in 1 RADIO TUNER

Only \$1.00 Postpaid



1. Aerial Eliminator
2. Antenna Tuner
3. Wave Trap

Eliminates hums, clicks, static caused by electrical appliances, rain, wind, etc. Replaces old, ineffective outside aerials. Move your radio anywhere. The 3 in 1 improves the reception of weak stations, separates interfering stations, gives you greater volume and distance. Uses no power, lasts life of radio. Also works on battery radios. Takes minute to connect. 5 DAY FREE TRIAL. SEND NO MONEY. Simply pay Postman \$1.00 plus few cents postage or we will send postpaid for one dollar bill. Vogue Eliminator Co., 7759 S. Halsted, Dept. E-255, Chicago.

THERE'S MONEY IN CARTOONS!

RAYE BURNS will teach you HOW to CREATE ORIGINAL CARTOONS at home that you may SELL! Course contains 26 lessons and over 600 illustrations. All for Only \$2.85

Send name and address for free details.

RAYE BURNS SCHOOL, Dept. M, Box 1298, CLEVELAND, OHIO

Short-Cut Mathematics

COMBINED WITH
Practical Mechanics Simplified

NEW 2-in-1 reading course! Now you can learn the speedy, simplified system of calculation used by draftsmen, engineers, accountants, "master minds" on the stage. Learn easy way to multiply 4 figures by 4 figures without using old-fashioned multiplication; add long columns of figures this lightning short-cut method. Learn horsepower, slide rule, micrometer, logarithms, wood measure, puzzles, etc., etc. Large illustrated volume complete with answers, only \$1 postpaid. Satisfaction or refund. Amaze friends with your magic-like mental powers.

FREE Complete details... mail coupon TODAY!

NELSON CO., 500 Sherman St., Dept. B-300, Chicago

Please send free details about "Short-Cut Mathematics and Practical Mechanics Simplified." No obligation.

Name _____
Address _____

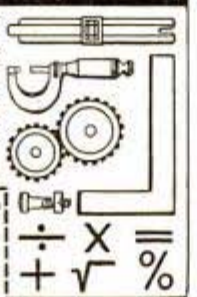

the plant and enter a selected vocational school for training in such skills as

Electrical Sub-assembly...Power Sewing...Machine Shop Work...Tube Bending...Riveting...Sheet Metal Work.

Up-Grading: Extra training which you receive as an employee, to fit you for a better job. Part of this training is on your own time. Courses include Blueprint Reading...Aircraft Engine Mechanics...Drafting...Radio Repair and Maintenance. Supervisory training is also given, on plant time, in foremanship and inspection.

Application for Pre-Factory Training may be made to the employment office of your nearest aircraft plant. Information can also be obtained from the local office of the U. S.

Employment Service.

C. S. Jones
President

ACADEMY OF AERONAUTICS, La Guardia Field, N. Y. C.
CASEY JONES SCHOOL OF AERONAUTICS, Newark, N. J.

Engineering and Design courses still open for private enrollment to qualified applicants. Mechanics courses devoted exclusively to military and government contract training.

Training the Key Men of Tomorrow in Aviation

U.S. GOVERNMENT JOBS.

START \$1260 to \$2100 Year

Thousands War Appointments Now Being Made

Become
Railway Postal Clerks
City Mail Carriers
City Postoffice Clerks
Ass't Statistical Clerks
Junior Clerks
Junior Custodial Officers
Stenographers—Typists
Border Patrolmen
Etc.

FRANKLIN INSTITUTE
Dept. W-173
Rochester, N. Y.

Rush to me, entirely free of charge, 32 page book with: (1) a full description of U. S. Government jobs; (2) a list of U. S. Government Jobs; (3) Tell me how to qualify for a job.

32-Page Civil Service Book **FREE**

Mail Coupon today—**SURE**

Name.....
Address.....
Age.....

★ Say you saw it in Popular Mechanics!

Here I am At Work

Making Good Money
at a big Aircraft Plant
thanks to this



DRAFTING

THE KEY TO ALL WAR AND PEACETIME INDUSTRY

LEARN in Spare Time—At Home!
(or at the College in Chicago)

Yes, this free lesson proved that drafting is easy, mighty interesting work . . . convinced me I didn't need special talent to get into this well-paid profession . . . proved beyond a doubt that Drafting by the fascinating C.T.C. method can be mastered easily AT HOME IN SPARE TIME.

So I enrolled. I learned Drafting *at home*,—in my spare time. Today I feel secure in my job as an Aircraft Draftsman. The War Production Program has increased the demand for Aircraft Draftsmen, Machine Draftsmen, Architectural Draftsmen, Electrical Draftsmen and Structural Draftsmen. For Draftsmen always come first on any new project in manufacturing and industry . . . and in those new Aircraft plants and Ship-building yards, Draftsmen can't be replaced with machines. What's more, I'm slated for promotion and more pay—but if I wish, I can be independent . . . go into business. And, as a draftsman, I have a peace time future as well as a good job now.

Here's a tip: Mail the coupon or drop a card for the free trial lesson. Do this today—and drafting will take care of you tomorrow.

A few hours of pleasant home study every week—that's all. NO interference with your present job! With Chicago Tech's help, you train yourself step by step. This tested method,—developed over 39 years of C.T.C. progress,—will fit you for a job in months—just the kind of a job you've wanted.

TRAIN FOR PROMOTION—and More Money

ALL WAGES and salaries have been fixed by new Federal Law. The only manner in which an employee can get more money is through increased responsibilities and more important duties. Get this: the only way in which your employer can pay you more money by law—is through promotion—by giving you more responsibilities. And the best manner to secure promotion is through training yourself to be more valuable.

To prove to you how easy it is to learn Drafting by the Chicago Tech method, we'll send you a Trial Lesson FREE. No charge for this lesson either now or later. Send a post card or the coupon now for FREE TRIAL LESSON in Drafting.

39 Year Old College in
Modern Well Equipped Home

Chicago Technical College has graduated hundreds of successful draftsmen, engineers and technicians since its founding nearly 40 years ago. During that time, its educational standards and instruction have been of the highest. Chicago Technical College occupies a unique place in the educational world in that it offers both residential and Home Study courses. In its new home on Michigan Avenue in Chicago the College has modern well-equipped shops, laboratories and drafting rooms where hundreds are in training for promotion in its day and evening classes. You can get this same high grade training in Drafting right in your own home. Keep your present job and train for a better one. Mail the Coupon today!

WOMEN!

Girls and women are also taking good positions in drafting rooms at same high base pay as men. Find out if you are qualified. Send the Coupon.



CHICAGO TECHNICAL COLLEGE

B-204 Tech Bldg., 2000 So. Michigan Avenue, Chicago, Illinois
Member National Home Study Council



YOU GET THIS
COMPLETE DRAWING
OUTFIT

Without a penny extra. All the tools you need, including drawing table. With this outfit you can put your ideas on paper quickly and with accuracy. With training, you're all set to master drafting in months—not years—at home, and you can use these very same instruments as a draftsman later.

MAIL THIS COUPON

CHICAGO TECHNICAL COLLEGE

B-204 Tech Bldg., 2000 So. Michigan Ave., Chicago, Ill.
Please send me Free Trial Lesson in DRAFTING showing how to learn at home by C.T.C. plan for a good job in aircraft and other war industries. No obligation, of course.

Name
Address
City State
Occupation Age



CLASSIFIED Advertisements



Advertisements in this section, 35 cents per word, each insertion, minimum 10 words, payable in advance
 To be inserted under proper classification in March issue, copy should be in our office January 8th
 March issue on sale February 1st
 Popular Mechanics Magazine, 200 East Ontario Street, Chicago, Illinois

YOU'LL PROFIT
 By reading and answering the classified ads in this section. Hundreds of opportunities to make and save money.

Popular Mechanics Magazine, Chicago, Ill.
 Dear Mr. Johnson: We cannot refrain from telling you the truth, that the amount of inquiries we receive from your magazine is far beyond expectation, and more than doubled the inquiries we received from other magazines in the field. The cash orders we receive from the inquiries of your magazine are far greater than from three other magazines even of larger circulation. We have so much confidence and faith in your magazine. Our ad has appeared in every issue of Popular Mechanics for the last four years.
 Respectfully yours,
STAR SERVICE

AUTOMOBILES—MIDGET CARS

LEE Vaporizers \$2—increase your mileage. Money back guarantee. Install any car 15 minutes. Lee Power Cycle, Watertown, Wis.

ANTIFREEZE. Enjoy permanent positive protection. Cheap, plentiful, safe. Easily prepared. No brines or chlorides. Complete instructions one dollar. J. E. Dick, Box 5641, Indianapolis, Ind.

RECONDITION Your car with rebore substitute! Piston expansion needless! Devereaux, Box 212-J, Battle Creek, Mich.
R & R Mfg. Co., Robert M. Roof, Chief Eng., Anderson, Ind. Racing cars, midget boat, speed equipment. Catalogue 25c, fuel data 75c, instructions \$1.00.

SAVES Gas and oil. Doubles mileage obtained. Guaranteed, scientific, proven tablets. Year's supply \$1.00. Smyth, 4721 California, Omaha, Neb.

SAVO-GAS. Biggest moneymaker yet. Quarter brings sample. Marshall, Box 151, Beeville, Texas.

MORE Service from your car. Stamp appreciated. Clement, 80RR Gorsline, Rochester, N. Y.

OPEN Garage doors from your car. Simple. Efficient. Inexpensive. Make it yourself. Full instructions. Blueprints, 50 cents. Gilbert, 76 Wells Avenue, East Hartford, Conn.

AUTOMOBILE Racing book, fifth edition, well illustrated. Instructions on building bodies, frames, engines. Ford A and B conversions. Plans, AAA rules, specifications. Roadster racing, Indianapolis cars. \$1.00 postpaid, \$1.15 C.O.D. Ray Kuns, Dept. 47, Madisonville, Cincinnati, Ohio.

WHIRLOAS Superchargers, \$3, increase mileage 20%; power 10%. Refund guarantee. University test. Any car; give make, year. Wrench installs 15 minutes. Good results with 30% fuel oil mix. John Hanley, Manufacturer, 5719 Loraine, Detroit, Mich.

PROFESSIONAL Midget racers, motor-scooters, midget cars. Parts, plans. Handbook catalog—50 illustrations, plans—20c. Midwest, 3622B North Troy, Chicago.

NEW Scientific tablet! Increases mileage 20%-40%. \$1 box treats 180 gallons. Cash or C.O.D. (500-1000 extra miles.) Results guaranteed. Details free. (Agents write.) Gas-O-Lubri, A3338 Manderson, Omaha, Nebr.

AUTO SUPPLIES AND EQUIPMENT

1943 IGNITION Supercharger \$2.50. Fast starting, mileage, pep. EG Sales Mfg. Co., 60 John St. New York.

FUEL Oil conversions. All cars. \$59.50. Fuel cost savings 50-70%. Buckley Company, Taunton, Mass.

THE Lord's coming! 30 proofs free. Scheall, 263X, Duluth, Minnesota.

"NU-POWER" Stretches your gasoline. Adds more miles. Mix with your gasoline. Three bottles \$1.00 prepaid. Master Sales, Box 731, Lincoln, Nebraska.

AUTO Parts—New or used. Price of any part on request. New mufflers our specialty. Meyer's Auto Parts Co., 820 Dryades St., New Orleans, La.

RECLAIM Used oil without cost. Particulars. F. Gerwin, Alva, Okla.

PLATING Outfits for auto parts. Connect to a battery. No tanks used. Free particulars and proofs. Gunmetal Co., Ave. J, Decatur, Ill.

AUTO TRAILERS

BUILD Your own house trailer. Have exactly the kind and size you want, arranged and equipped the way you want it. Save money and have a better trailer. Thousands of smart people have built from Jim Dandy plans. Send 10c today for Jim's interesting trailer plan catalog illustrating 7 streamlined and conventional models of house trailers with floor plans, collapsible tent trailer and utility trailer any of which you can build yourself. The plan you select costs only \$1.00. Send dime today for catalog. Jim Dandy, Box 125-A, Wausau, Wisconsin.

MOTORCYCLES, BICYCLES, MOTOR-SCOOTERS, SUPPLIES

CONVERT Your bicycle to electric power-bike. Practical plans \$1.00. Lee Power Cycle, Watertown, Wis.

BUILD Electric bicycle without gears, chains, welding. Retains pedals, brake. Amazingly powerful. New plans \$5c. Howard Klaus, 1369 Missouri St., Pittsburgh, Penna.

"MODERN Motorcycle Mechanics," 436 page book, 200 illustrations, just published. Extensively covers—Operating, maintenance, complete reconditioning. American and British motorcycles. \$2.50 postpaid. Descriptive folder free. Nicholson Brothers, Saskatoon, Sask., Canada.

SAVE Gasoline, tires! Motor-scooters, motorcycles, bicycle motors, midget automobiles, gasoline engines. No priority necessary. Illustrated catalog one dime. Clymers, 307 West Pico, Los Angeles, Calif.

BICYCLES. Parts, tires. Also scooter tires, all sizes. Send dime for list. Cycle Transport Co., 1241 So. Michigan Ave., Chicago, Ill.

AVIATION

A & E Mechanics Manual prepares for "multiple choice" examinations. \$3.00 postpaid or C.O.D. Aviation Publishers, Box 503, Studio City, California.

AIRPLANES. Motors, crackups, salvage. Send 25c for big winter war-bargain directory just out. Aircraft Directory, Athens, Ohio.

ABSOLUTELY First time offered, improved, genuine geodetic plans for simplified, two in one construction of our Baby Airliner low wing, flight tested, amazing performance, introductory price, per set \$7.50, information free. Standard Aircraft, Ft. Worth, Texas.

PROPELLERS—All types, sizes. Latest design, 3 blades, for sleds, boats. Factory prices. Standard Aero Craft, Ft. Worth, Texas.

BATTERIES—GENERATORS—ETC.

EDISON Lifetime storage batteries for light and power. Eliminate acid battery diseases. Long guarantee. All kinds rebuilt generating plants, motors, and miscellaneous articles at bargain prices. Free interesting literature. T. Hawley Smith Co., Croton Falls, N. Y.

EDISON Batteries. Light, Power. Fifteen year life. Five year guarantee. Complete lighting plants. Free literature. See Jay Company, 321 Yonkers Avenue, Yonkers, New York.

ELECTRICAL SUPPLIES—EQUIPMENT

MOTORS, Generators, welders, fencers, other electrical items. Priority unnecessary. Write LeJay Manufacturing, Minneapolis, Minn.

MICROPHONE Cable, single conductor. Also copper wire No. 42-0027, enameled, 1/2 lb. spools. Oahu Publishing Company, 2108 Payne Avenue, Cleveland, Ohio.

SAVE Gasoline—Buy electric motors through mail. Alternating and direct current, fractional horse power. Send dime for wholesale catalog. CMCO, 514 Van Buren, Chicago.

TWO Alnico magnets—Instruction book —75c. Terry Sales, Central Station 1676, Toledo, Ohio.

ELECTRIC Pencil: Writes-engraves all metals. \$1.00 postpaid. Beyer Mfg., 4515-H Cottage Grove, Chicago.

WELDING—SOLDERING—PLATING

ARC Welders wanted by the thousands. Learn with 516 page lessons manual. Over 500 how-to-do-it photos, \$2.00 copy. Money-back guarantee. Hobartweld, Box M-234, Troy, Ohio.

WELDING Outfits—Aircraft, sheet-metal, heavy duty soldering outfits. Superior Oxy-Acetylene Co., Hamilton, Ohio.

WELDERS "Standard" measuring gauges improve work, prevent mistakes. Drawings 50c war stamps. Welder, 1341A "E"-St., Napa, Calif.

BUILD d.c. Arcwelder without rewinding armature. Plans \$1.00 each. 25 to 600 amperes from vehicle motors, light plant generators, automobile starter-generators. Welders Club, AB-3432 M-Mart, Chicago.

MACHINERY—TOOLS—SUPPLIES

INDEX Heads for sale. Very inexpensive. Sixty-two different divisions. Used on small lathes, drill press, milling machines, etc. Make gears, hobbs cutters, etc. Very accurate and durable. Not a toy. Used by defense schools and hobbyists. Write for free folder. 2117 East B St., Torrington, Wyo.

BUILD Your own milling machines and shapers from Lewis castings. Finished tools suitable for war sub-contracting. Prices so low you can build several machines at cost of one ready-made machine. Lewis Machine Tool Company, P.O. Box 116, Sta. A, Department M-26, Los Angeles, Calif.

STEEL Beam trammels for draftsmen, engineers, mechanics. Circular free. Clair Company, Box 92M, Blythbourne Station, Brooklyn, N. Y.

NEW Caliper, direct reading, speeds up def-nse work, cheap. Free illustrated circular. Factory, 811-G East 31st, Kansas City, Mo.

CONCRETE Building block machines and molds. Easy payments. Catalog free. Concrete Machine Co., 5129 South Compton Ave., St. Louis, Mo.

WANTED Urgently, need all kinds and sizes, machine shop equipment, tools and gauges. Will pay highest prices. Jack Katcher, 403 Guaranty Building, Detroit, Michigan.

FOR Sale, new and used drills, reamers, milling cutters. Write P.O. Box 493, Flint, Mich.

RECLAIM Dull and broken drills with Nu-Way Drill Grinder. Circular free. Tractor-Lite Mfg. Co., Spirit Lake, Iowa.

13" x 5" WILLARD Lathe with gap. No. 2 Pratt & Whitney hand milling machine, four step cone drive. Write for full particulars. Cincinnati Machinery & Supply Company, 217 E. Second St., Cincinnati, Ohio.

GRIND Drills like factory: attachment for bench grinder. Cheap. Factory, 811-B East 31, Kansas City, Mo.

ENGINES, MOTORS, DYNAMOS

"CATERPILLAR" Diesel engine, 44 horsepower power unit "V" belted to 30 K.V.A. single and three phase generator, excellent condition. Price \$2650.00. Have other larger and smaller electric systems, what do you need? H. L. Phillips, Glen Moore, Penna.

BIG Pay jobs in welding. Complete welding lessons and reference book. 516 pages. 41 lessons. \$2.00 copy. Money-back guarantee. Hobartweld, Box 235-M, Troy, Ohio.

WINDING Data, 225 motors, single and three phase, \$1.00. Motor Data Co., Box 7631, Kansas City, Mo.

BOATS, OUTBOARD MOTORS, ETC.

REBUILT Outboard motors. Fully guaranteed. Hundreds to pick from. Send 10c for complete list. Boat design book 15c. Buy now before prices advance. Chicago's largest dealer. Masters & Son, 214 West Chicago Avenue, Chicago.

TEN Plywood boat plans 50c. Catalog boat building plans 10c. The Rudder, 15 Murray Street, New York.

OUTBOARD Motors, used parts. Outboard Exchange, 1194 Remsen Ave., Brooklyn, N. Y.

BOAT Designers are highly paid professionals. Complete course by mail. Catalog. Westlawn, Montville, N. J.

OUTBOARDS — Save 1/2. Good used parts, all makes and models. Bargains rebuilt motors. Crandall Hicks Co., 969 Commonwealth, Boston, Mass.

ATHLETIC EQUIPMENT—BODY BUILDING COURSES

SUPER Ju-Jitsu—lightning defense and attack system. Sensational new home study course now ready! Learn to lick brutes twice your size with only your bare hands. Free details. Nelson Co., 500 Sherman, Dept. B-508, Chicago.

SUPER System of natural physical training. Free booklet. Harry Good, 3261-PM Watson Road, St. Louis, Mo.

BE Strong, muscular, full of pep. Amazing new body-building course. Write Olympic System, Dept. M, Waterville, Maine.

SPORTING GOODS, GUNS, FISHING TACKLE, ETC.

"PRACTICAL Riot-Gun Instruction"—72-page manual, written by Capt. Frank Baughman, firearms expert, FBI. Covers detailed instructional program for training police, plant guards, state militia and minute men in proper use of shotguns, for law-enforcement only. First and only handbook exclusively on police and military use of shotguns. Illustrated, pocket sized, 25c, coin or stamps. Full information about membership benefits, free. National Rifle Association, 1610-H, Rhode Island Ave., Washington, D. C.

FREE Catalog, fly tying and lure making materials. Flies, streamers, bugs, lures, wholesale prices. Supreme Mfg. Company, Amarillo, Texas.

THE Lord's coming! 30 proofs free. Scheall, 263X, Duluth, Minnesota.

SEND 10c For large list used guns. Frayseth's, Willmar, Minn.

"E-Z-STER"—Radically new principle in sled construction, increases coasting pleasures 100%. Easily built, small cost; copyrighted drawings and instructions tells all. Details free. Aquarian Age Industries, Mohawk, N. Y.

ARCHERY Equipment: Catalogue free. Mid-West Archery, 2209-A East 75th, Chicago.

USED Guns, bought, sold, exchanged. List stamp. Howe Fur Company, Coopers Mills, Maine.

FIELD GLASSES, MICROSCOPES, TELESCOPES

ASTRONOMICAL Telescopes, binoculars, cameras, microscopes; bought, sold, repaired. Send 10c for list of instruments desired. Rasmussen, Box 294, Amsterdam, N. Y.

LENSES—Build your own telescope, field glass, microscope, rifle scope, etc. Assortment of fifteen lenses—\$1.00 post-paid. Thirty lenses—\$2.00. Sixty different lenses—\$5.00. Slightly chipped on edge. Satisfaction absolutely guaranteed. American Lens Company, 1313-M Vine Avenue, Park Ridge, Illinois.

ANTIQUES, RELICS, INDIAN GOODS, CURIOS

CASH For antique buttons. Collins Company, 230-E Bowman, South Bend, Indiana.

25 GENUINE Indian arrowheads. \$1.00. Catalog. Geo. Holder, Glenwood, Ark.

INDIAN Relics, coins, bills, gems, crystals, curios, etc. Illustrated catalog 5c. 100 ancient arrowheads \$3.00. H. Daniel, Hot Springs, Ark.

INDIAN Relics, beadwork, coins, curios, minerals, old glass. Catalog 6c. Indian Museum, Osborne, Kansas.

TAXIDERMY

TAXIDERMISTS Supplies. New large catalog 10c. Nowotny's, 1401 Broadway, San Antonio, Tex.

DOGS, PETS, BIRDS, RABBITS

BIRDS? Get American Canary Magazine monthly. Year, \$1.00. 2839-P North Halsted, Chicago.

ANGORA Wool rabbits. Finest pedigree breeding stock. Kovalevsky, Madison, New Hampshire.

ST. BERNARD Puppies. Champion sired beauties. Franklin Young, R4, Riverhead, Long Island, New York.

RACCOONS, Minks, foxes, skunks—"America's finest." Bred females. Catalog, 10c. Shady Fur Farm, Springfield, Minnesota.

FARMS—FARM LANDS—REAL ESTATE

SPORTSMAN'S Camp on dandy stream; \$1600—In hunting, fishing country, just off macadam highway, village 2 miles; 90 acres, part tillable, valuable woodland; sturdy cabin building, stone fireplace, spring affords water; photo page 28 big catalog. Write for free copy. Strout Realty, 255-P 4th Ave., New York City.

SOUTH Mo "Ozark-Land" \$3 acre. List. Williams Realty, Mt. Vernon, Ill.

10 ACRES Fronting paved highway \$100. \$5.00 down \$5.00 monthly. R. W. Stewart, Inverness, Florida.

CATALOG New Mexico real estate 10c. Write Box D, New Mexican, Santa Fe, N. M.

CANADIAN Tax sale lands for a dollar an acre and up. Small monthly payments. Farms, timber, hunting and fishing camps, minerals. Limited number of properties. Write at once for free illustrated booklet. Tax Sale Service, Room 613, 72 Queen St., W. Toronto, Canada.

SEE The Highlands of Louisiana where winter brings no idle acres. Choice cut-over land at low prices with terms. Send for descriptive book without obligation. Long-Bell Farm Land Corporation, 896 R. A. Long Bldg., Kansas City, Mo.

GOOD Farm bargains. Washington, Minnesota, Montana, Idaho, Oregon, North Dakota. Dependable crops, favorable climate. Write for literature, lists describing typical farms. Specify which state. J. W. Haw, 119 Northern Pacific Ry., St. Paul, Minn.

40 ACRES. Near White River, unimproved; poultry land. \$190, \$5 down, \$5 monthly. Free list and literature. Hubbard, 216 Grossman Bldg., Kansas City, Kans.

ORLANDO, Florida. 5 acres on main highway; good fruit and vegetable land; easy terms; free booklet. Department Y, Box 1944, Orlando, Florida.

FARM MACHINERY AND SUPPLIES

BUY Tractor parts now! Large stock. New or used. Quick service; low prices. Free 52 page catalog. Irving's Tractor Lug Co., Galesburg, Illinois.

POULTRY AND FARM SUPPLIES

LEARN About wartime poultry raising. Real profits can be yours raising poultry the "American Way." Monthly helps and suggestions, short cuts that save time and money, free bulletins, personal help from poultry experts and monthly Poultry Magazine published since 1874. Cost less than 3 cents monthly, 25c year; 5 years \$1.00. Send coin or stamps today. American Poultry Journal, 537 So. Clark, Chicago.

RAISE Turkeys for profit. Newest brooding, feeding, dressing, growing, marketing methods. Nation's only all-turkey magazine. One year, \$1. Turkey World, Deak 70, Mount Morris, Ill.

CHICK Raisers profit by reading America's leading poultry magazine. Newest ideas on brooding, feeding, disease control, marketing. One year 25c; five years \$1. Poultry Tribune, Dept. 22, Mount Morris, Ill.

CHICKS And poulters champion mated. 52 varieties, 7 hybrids, licensed inspected, bloodtested. Rush postal, large colored book, low prices. Berry's Farm, Route 12, Clarinda, Iowa.

COLONIAL Chicks. World's largest production means lowest prices. Leading breeds. Catalog free. Colonial Poultry Farms, Pleasant Hill, Mo.

PROFITABLE OCCUPATIONS

RAISE Angora rabbits. Wool selling \$6.85 pound. Booklet free. Taylors Rabbitry, Hapeville, Georgia.

STANDARD Rabbit Journal, Milton, Pa. 5 years \$1.00, sample dime.

WELDING Pays. Learn with 1942 trade school text manual. 516 pages. Over 500 photos. \$2.00 copy. Money-back guarantee. Hobartweld, Box M-233, Troy, Ohio.

\$40.00 WEEKLY. Made growing mushrooms, fresh, dried. Dominion patent 331583. Free spawn. North American, 169P Yonge, Toronto, Canada.

MECHANICALLY Inclined men—Own and operate general appliance repair shop. Complete, illustrated course shows you how. Welding, refrigeration, motor repair, how to get business, etc., all phases covered. Free literature. Christy Supply, Dept. 425, 2835 N. Central Ave., Chicago.

RAISE Angora rabbits—wool brings \$5.00 pound. Particulars free. Grinstead's, Edwardsville, Illinois.

OLD BOOKS WANTED

WE Pay up to \$5000 each for old books, also high cash prices for old magazines, letters, newspapers. A single story book, school book, old Bible, travel book, history, almanac, etc., that looks worthless may bring you \$50, \$100 or \$500 in cash. Thousands wanted. Send 10c now for latest price list. American Book Mart, Merchandise Mart, Dept. 309, Chicago.

BOOKS, PERIODICALS, PICTURES, POSTCARDS

SELF-EXPLAINING Bible: Illustrated circular free. Box 446-P, Minneapolis, Minn.

FREE—100 Page book catalog. New and used college and home study text and reference books at a saving. Est. 1902. College Book Co., Dept. M, Columbus, O.

BOOKS (Out-of-print, new, used) supplied quickly. T. Jamkowski, 18870 Marx Ave., Detroit, Michigan.

BUSINESS, Trade, diversion magazines. All current copies. 437 different publications, representing 122 trades, professions, hobbies, etc., to choose from. List with prices free. Commercial Engraving Publishing Co., 34C North Ritter, Indianapolis, Indiana.

ACTION Pictures—Favorite orchestra leaders, vocalists. 25c; 5, \$1.00. Arsene, 1585-P Broadway, New York, N. Y.

POSTCARDS, Used, Unused, American, foreign. list 3c, samples dime. Nugent, P-101 North Third, Richmond, Va.

BACK Number magazines. Ewen's, 118-01 200th Street, St. Albans, N. Y.

"DOG World" \$2.00 year. Miss Rycza, 2385 Castle, Cleveland, Ohio.

MACHINIST'S Reference book \$1.00 postpaid. G. A. Knudsen, 523 - 48th St., Brooklyn, N. Y.

MAGAZINE Back number bargains. 35 different comics, detective, western, 15 Popular Science Aviation, Photography, National Geographic, 10 Esquires or 7 Fortunes \$1.00. Express charges collect. Retail; wholesale catalog 3c. Corey's Exchange, 355 N. Clark, Chicago, Ill.

BACK Dated magazines (foreign, domestic). Books—latest fiction. Used, new textbooks. Catalogs 10c (refunded). Ciccone's, 863 First Ave., New York, N. Y.

FREE Book with each and every book you buy. Save money on magazines. Book and Magazine Club, 315 Fifth Avenue, New York.

MAKE Your own herb medicines. Beautiful illustrated recipe book 10c. Botanics, Box 777, Evergreen Park, Illinois.

ANY Book (new, used, out-of-print, rare) promptly supplied! Lowest prices! Send for free bargain catalogues! Old Prof's Book Shop, M16 Arcadia Court, Pontiac, Mich.

REBINDING: We bind magazines, old books, Bibles, hymnals. Heckman Bindery, Dept. D, North Manchester, Indiana.

MAGIC TRICKS, PUZZLES, JOKER NOVELTIES

FLASH! You can now get the baffling square puzzle for only 10 cents coin—20 for \$1.00, while the supply lasts. Ray Specialty Service, 1009 Henry, Detroit, Michigan.

DOLLAR Magic set free with gigantic catalogue 25c. Magex, 4462 Germantown, Philadelphia.

CATALOGUE 10c. Tricks you can do. Magicraft, 2625 Yale, Houston, Tex.

SPIRIT Cabinet, talking skull, driverless automobile. War exhibitions. Baughman, Warren, Ohio.

MYSTIFYING Tricks free. H. F. Willis, Box 1704, Cleveland, Ohio.

SEND Ten cents for large list of tricks selling for one dollar and less. Thayer's, Box 1785 Wilshire-LaBrea Station, Los Angeles, Calif.

MYSTIFY Everyone! Become professional magician! Mindreading, State mystery. Catalogue amazing secrets, dime. Neimar, 2851 Milwaukee, Chicago.

500 TRICKS You can do, only 10c! Brand new tricks for pocket, parlor, stage, with cards, coins, thimbles, balls, professional apparatus, books, illusions. Send 10c for Douglas's famous book of 500 tricks. Douglas Magic Shop, Box 274, Dallas, Texas.

WORLD'S Largest professional magic shop keeps you in touch with latest tricks. To receive mailings send 25c for 1943 catalog. Holden, 220 W. 42nd St., New York.

MAGIC Tricks, puzzles, jokers, books, catalog 10c. Specialty, Box 671, St. Louis, Mo.

LEARN Ventriloquism, 3c stamp brings particulars. Smith, 801 Bigelow, Peoria, Illinois.

HOLLYWOOD Special! Magicians button, catalogue, ghost illusion and free trick for 25c. Magic House of Charles, Box 888, Hollywood, California.

NEW Vanishing key and catalog 25c. Sterling Magic, 345 John R, Detroit, Mich.

BE A magician. Large professional magic catalogue of latest tricks 25c. Ireland, C-109 North Dearborn, Chicago.

MAGICIANS' Headquarters. 216-page catalog, pocket, parlor, professional tricks, 25c. Kanter's, M-1311 Walnut, Philadelphia.

GAMES—ENTERTAINMENT

FUNDS For war benefits! Easy to raise with plays, operettas, musical comedies, complete minstrel first-parts with song programs, blackface skits, vaudeville acts, monologs, dialogs, recitations, juvenile plays and songs, musical readings, entertainments, make-up goods. Catalog free. T. S. Denison & Co., 225 N. Wabash, Dept. 11, Chicago.

COINS, TOKENS, CURRENCY

15 DIFFERENT Coins 25c. Oddehon, Box 44, Overland, St. Louis, Mo.

OLD Money wanted. Do you know that coin collectors pay up to \$100.00 for certain U. S. cents? And high premiums for all rare coins? We buy all kinds. Send 4c for large coin folder. May mean much profit to you. Numismatic Co., Dept. 20, Fort Worth, Texas.

\$5, \$10, \$20 CONFEDERATE Notes, 25 cents each. Beffel, Box 37-E, Ottawa, Ill.

10 INDIAN Head cents, different dates, also preclists, 35c. Schultz, 1053 Richard, Cincinnati, Ohio.

LORD'S Prayer, Ten Commandments, or Crucifixion, engraved on real pennies, 12c each, 3-25c. Lohman, 825 Lima, Burbank, Calif.

GET Profit and pleasure in collecting old coins. Send 10c for 56-page illustrated coin catalog. You'll be delighted with it. Send for it now. B. Max Mehl, 370 Mehl Building, Fort Worth, Texas. Largest rare coin establishment in U. S. Established 43 years.

COMMEMORATIVE \$1's. Columbus, Stone Mountain, Long Island \$1.00 each. Large illustrated catalogue 10c. Norman Shultz, Salt Lake Utah.

FREE! Foreign coin, banknote and large 50 page illustrated coin catalogue to approval service applicants. Send 3c postage. Tatham Coinco, Springfield-125, Mass.

OLD Money wanted. Big premiums paid. 1,000 quotations. Catalogue 10c. Allan Appell, Sedalia-6B, Missouri.

I MAY Have just the scarce U. S. coins you want. Send me list. "Meet me by mail." William H. Kenworthy, Waterville, Maine.

OLD STAMPS WANTED

I WILL Pay \$100.00 each for 1924 1c green Franklin stamps, rotary perforated eleven (up to \$1,000.00 each unused). Send 6c today for large illustrated folder showing amazing prices paid. Vernon Baker, (32-P.M.), Eylria, Ohio.

STAMP COLLECTING

SCARCE Samoa, Persak, Albania, Free French, Georgia, Guatemala, Malaya, Costa Rica, Bolivia, Anzac, etc. 10c to approval applicants only. John Cobleigh, 9235 Abington Road, Detroit, Michigan.

WOW! \$10.00 Worth of fun for only 10c! 500 foreign stamps, unsorted and unpicked (mostly on bits of paper) just as received from the church missions and other sources. Africa, So. America, Australia, China, Philippines, Dutch Indies, and other countries are represented. Includes a few commemoratives, airmails, and stamps cataloging up to 25c or more each! The biggest package of fun in stampdom—and you might find something really valuable! Price only 10c to serious approval applicants! Money back if not delighted. Jamestown Stamp Co., Dept. No. 22, Jamestown, New York.

FOREIGN Pictorials, commemoratives, etc., classy variety, 100 different 5c. Approvals. Getche, 1040 N.E. Eighteenth, Minneapolis.

ABSOLUTELY Free two Confederate States of America stamps (facsimiles) to approval applicants giving references! Geo. Wentz, San Marcos, Texas.

START Collecting U. S. bureau pre-cancel stamps. 500 mixed containing about 200 varieties \$1.00. Tracy Newton, Deatur, Georgia.

FREE! The Stamp Finder! Send today for the big new edition, fully illustrated, enabling you instantly to identify all difficult stamps! Also fine packet strange, fascinating stamps from Bosnia-Herzegovina, Monaco, Patiala, Cyprus, etc., including maps, ships, animals and strange scenes. All free to approval applicants inclosing 3c postage. Garcelon Stamp Company, Box 900, Calais, Maine.

19TH CENTURY U. S. commems, Civil War revenues, battleships, 55 and \$10 stamps, 1943 illustrated U. S. catalogue. Free to U. S. approval applicants. Metropolitan Stamps, 198-P Broadway, New York.

SENSATIONAL Combination offer! Big packet 105 different including Iceland, Manchukuo, Ecuador (American flag in full colors), Danzig; airmails, commemoratives, triangle stamp, \$4 United States; complete set United States telegraphs, cataloging 20c. Packet British Colonies, including Gwalior, Hyderabad, Burma (new country) jubilee and coronations, Scarce Far Eastern republic cataloging 50c. Big illustrated lists of other bargains. Total cat. log price over \$3.00! All for only 5c to approval applicants! World-Wide Stamp Company, Department 600-N, Camden, New York.

FREE—Your choice of any 10 stamps from our first U. S. approval selection. Illustrated list included. Cosmopolitan Stamp Company, 1457 Broadway, Dept. M, New York City.

PHILIPPINES—17 Different including pictorials, 10 cents with approvals. Swedell, 3038 Harriet, Minneapolis, Minn.

206 DIFFERENT Stamps including Kedah, Haiti, Cochín, Albania, Johore, Perak only 10c to approval applicants. Reich Stamp Co., 4647 Kenmore, Chicago, Dept. M3.

SERIOUS Approval applicants send 5c for six beautiful sets—plus extra gift. Manchester Stamp Company, Dept. P, Manchester, Connecticut.

500 WORLDWIDE—Large variety—Tunisian, Algerian, Morocco, ten different beautiful Australian commemoratives—Everything 10c. Approvals. McCurdy, 2505 Highland, Salt Lake City Utah.

UNPICKED Mixtures; large variety; 6500 U. S., \$1.00. 5000 U. S. 1870-1939, \$1.50. 6000 British, \$1.25. 3500 Canada, \$1.0. 2000 foreign, \$1.00. Satisfaction guaranteed. Kuhn, 3712 85th, Jackson Heights, N. Y.

U. S. 25 different commemoratives, only 5c. To serious U. S. approval applicants. Bedrin, 1746 Andrews Ave., New York City.

SOLOMON Islands, Seychelles, Nejd, Caymans, Manchukuo, Brunel, Turks Caicos. Everything 3c with approvals. Viking, 130-Z Clinton Street, Brooklyn, N. Y.

1000 MIXED Poster stamps and patriotic labels \$1.00. Rooney, 116 Prince Street, New York City.

333 ASSORTED United States—5c. Approvals. Utechts, 1143-G North Keeler, Chicago.

HIGH Grade approvals, by country. Cal's Stamp House, Roseville, Michigan.

EUROPE, 40 Years old—10 different 5c; 20, 10c; 50, 25c. No approvals. Elsea, Bowling Green, Ohio.

UNITED States approvals. Large selection at lowest net prices. Stamp Company, Albany, New York.

NEWFOUNDLAND—50 All different \$1.00. Charles Campbell, Ford Hotel, Toronto, Canada.

FREE! Stamp wallet sincere approval buyers. These, 10526 Anzac, Los Angeles, Calif.

GOYA Nudes (2 vrs.) 8c. Approvals. Millhiser, 7724 Abbott, Pittsburgh, Penna.

WANTED. Collections, accumulations. Send description. Leslie Stamp Company, Haverhill, Mass.

U. S. Approvals—Large stock—Parks complete 19c. Box 488, Minneapolis.

WORLD'S Smallest airmail—diamond and triangle stamps, free stamp magazine, also magnifier to study your stamps, with large collections of stamps from scarce countries. A bargain, 5c with approvals. Capital Stamps, Dept. 2, Little Rock, Arkansas.

WE Buy stamp collections, paying \$5.00 to \$2,500.00 cash. 40,000 varieties available on our approvals from 1/4c up. PKEigwin Company, Vineland, N. J.

TEN Dominican Republic commemorative, 10c, with approvals. Read, 3401 Farnell, Chicago.

FINE Approvals, freshly mounted. Fast, personal service. Tell me what countries you prefer and I'll send their stamps. Skinner, 345 East Ocean, Long Beach, Calif.

U. S. \$2.00 stamp No. 572 (perf. init.) 10c to applicants for U. S. approvals. M. Haycock, 8931 Metropolitan Ave., Forest Hills, N. Y.

50 DIFFERENT Brazil, 15 cents with approvals. Quality Stamp Service, Waverly, N. Y.

20 DIFFERENT Foreign commemoratives 5c! Approvals. Bentoni Ryan, Middletown, Connecticut.

NEWFOUNDLAND Dollar special buys, 40 different catalog \$2.50. Califax, 807 South Westlake, Los Angeles, California.

15 AIRPLANE—War weapon stamps, 10c. Approvals. Smith, 237 East 8th, Roelle, N. J.

FREE Canada war stamps with approvals. Rheau, 8949 Routhier, Montreal, Canada.

FORTY Stamps 5c with approvals. Ute Stamps, 1012 W. Cucharas, Colorado Springs, Colo.

FREE! Western Hemisphere packet, Postage 3c. Owens, 806 Welsh, Bay City, Michigan.

APPROVALS Any country. Want lists filled. Melbees, 149-36 Beech, Flushing, N. Y.

FIFTY Different Portuguese Colonies 10c. Approvals sent. Prall, Hackettstown, New Jersey.

PICTORIAL Packet 3c when requesting our bonus approvals. Gericke, Box 324, Gary, Ind.

POSITIVELY Greatest free offer—Latest Scott's International \$4.00 Stamp Album—covering entire world, contains 35,000 illustrated, descriptive spaces; Scott's 1943 Standard \$4.00 catalogues "Philately's Encyclopedia"—absolutely free to applicants for foreign approvals becoming customers. Bargain Stamp Service, Palm Springs, California.

FREE! Russia war set. Postage 3c. Williams, 606 Archer, Bay City, Michigan.

81c FOR Nothing! Scarce set of four Russian commemoratives (catalog value 81c) plus giant illustrated bargain lists. All absolutely free to serious approval applicants for name and addresses of three stamp-collecting friends. Pittaco, Dept. 31-B, Framington, Massachusetts.

26 DIFFERENT French Colonies 5c, with approvals. Excel, Box 1315, Chicago.

AGENTS Wanted to sell stamps, no investment. William Waugh, 2140 N. N.W., Washington, D. C.

FREE! Pony Express set (facsimiles). Postage 3c. Roberts, 406 Building, Bay City, Michigan.

3 CUBA Sets 10c with approvals. Perrell, 1610 So. Third, Maywood, Ill.

LIBERIA Triangles No. 242-7 (6) 10c with 1/4-1/2-1c approvals. Carroll's, 745 W. 45th St., Los Angeles, Calif.

U. S. Approvals. Low priced stamps. Stamp Agency, Y-104 Dunlap, Pittsburgh, Penna.

1000 MIXED U. S. old and new 25c, 1 lb. 55c, 2 lbs. \$1.00. Weatherby, Troy, Ohio.

FIVE Airmail triangles, 5c, with approvals. Avalon Stamp Company, Springfield-30, Mass.

FREE 100 Stamps with approvals. Thompson, 27 Glenwood Place, East Orange, N. J.

TEN Crazy-shaped stamps, 3c with approvals. Knopp, Box 1381, Bristol, Conn.

LATIN-AMERICA—Nice packet, 100 different, only 10c with approvals. "Crescent Stamps," London, Canada.

500 UNITED STATES for 10c! 500 U. S. A.—absolutely unpicked and unsorted—just as received from church missions. Many varieties, including commemoratives, airmails, high values up to \$5.00 denomination! Price only 10c to approval applicants! Money back if not delighted. Swan Stamp Co., Dept. 69B, Dunkirk, N. Y.

10 DIFFERENT Burma and Nicaragua Will Rogers set complete for only 5c to approval applicants. Wonder Lake Stamp Co., Ringwood, Illinois.

LOWEST United States stamp prices. Free illustrated catalogue. Creevey's, Berwick, Penna.

FREE! Complete "United States" stamp catalog with 1,000 illustrations! Send 3c for postage. Harris & Co., 137 Transit Building, Boston, Mass.

60 DIFFERENT—United States 10c. Pricelist free. Seidenberg, Baroda, Mich.

VICTORY Packet free—Includes stamps from Tanganyika, British Cayman Islands, animal, scarce babyhead, coronation, early Victorian, airmail, map stamps, with big catalogue—all free. Send 5c for postage. Gray Stamp Company, Dept. PM, Toronto, Canada.

MEXICO Census commemorative set free with approvals. Pladon Stamps, 1717-M Idaho, Toledo, Ohio.

WHOLESALE Supplements to dealers for 10c postage. Hundreds of bargains. Grossman Stamps, 102 West 42nd, New York.

FREE! Leeward Is., Cayman Is., Turks and Caicos plus 60 different mint Geo. VI coronation poster stamps, to approval service applicants sending 3c postage. Tatham Stampco, Springfield-30, Mass.

UNITED States approvals complete coverage, fine quality, attractive prices. Seminole Stamps, Box 436, Coconut Grove, Florida.

WEEKLY Stamp magazine, thirteen weeks, 10c. Stamp Journal, Kalamazoo, Mich.

A REAL Bargain. Specially prepared packet containing 150 different foreign and 65 different U. S. stamps; catalog value about \$5.00; pamphlet which tells you "How to Make Your Stamp Collection Properly" and large bargain lists, all for only 23c postpaid. Queen City Stamp Co., Room 36, 604 Race St., Cincinnati, Ohio.

PENNY Approvals, that satisfy. Neil Gronberg, Box 5441-P, Philadelphia, Penna.

GIANT Packet 136 all different from Africa, South America, South Sea Islands, etc. Includes Nicaragua airmail, two scarce unused United States cataloging 2c, triangle and animal stamps; many others. Also includes fine collection 25 different British Colonies—Charkari, Jamaica, Johore, etc. and United States \$4 and \$5 high values. Total catalog price over \$4.00! Everything for only 5c to approval applicants! Mystic Stamp Company, Department 80-A, Camden, New York.

SEND Postage for free United States price list. Stanley Gibbons, 38-P Park Row, New York.

CANADA 100 Different 25c—approvals all countries. Lists. Victoria Stamp Co., London, 4, Canada.

SMOKY Mountain commemorative sheet, largest U. S. stamp issued, and 33 U. S. including commemoratives, airmail, revenues, etc. Catalogs 75c—7c to approval applicants for 5c. Curhan Stamp Company, Gloucester, Mass.

STAMPS Wanted by thousands of our readers. Your ad in this space will bring you some nice orders. One advertiser sold 150,000 stamps. Write for positive proof. F. W. Johnson, Classified Advertising Manager, Room 301, 200 East Ontario St., Chicago.

HOBBIES AND COLLECTIONS

HOBBYISTS! The Hobby Spotlight Magazine has departments on stamps, coins, matchcovers, cigar bands, book, circusiana and many other hobbies. Whatever you collect, you need it. Sample copy—25c; whole year—\$1.00. Spotlight Publications, Box 163J, Oakland, Maryland.

UNUSED Book match covers, 100 all different. \$1.00. Free list. Charles Edelman, 1311C East 84, Cleveland, Ohio.

FREE Gold ore. Send stamp, name, address. Miner, 675 Eliot, Denver, Colorado.

GENUINE Arizona ruby and desert sapphire, send quarter for both. Mineral Specimens Company, Box 2651, Phoenix, Arizona.

JOIN Matchbook club, 25c. Free covers. Box 101-B, Rochester, N. Y.

COLCHICINE—Evolution chemical creates new mutant plants. Illustrated booklet—plus Experiments Magazine 25c. Questok Wellesley, Mass.

COLLECT Postcards from everywhere. Fascinating, interesting, instructive. Join Exchange Club, 25c. 10,000 Calif. views, list 3c. Hollywood assortment 15c. Lamar, 821 1/2 Lima, Burbank, Calif.

20 DIFFERENT Cactus plants postpaid, \$1.00. Eulalia Turner, Azusa, Calif.

BEAUTIFUL Jewelry stones removed from rings, etc. 100 assorted \$2.00. Lowe's, Box 311, St. Louis, Missouri.

NEW—15 Different match covers 10c. Box 202, Rochester, N. Y.

CAMERAS AND PHOTO SUPPLIES

STILL Available at Central—Hundreds of bargains in cameras and supplies. Send for free illustrated catalog listing still and movie cameras, films, lenses, enlargers, meters, supplies—at tremendous savings—all guaranteed. Trade in your old camera or equipment. Write for your free copy of newest money-saving bargain book—just out! Limited edition. Hurry! Central Camera Co. (Photographic Headquarters since 1899), 230 S. Wabash Ave., Dept. B-16Z, Chicago, Illinois.

TRAVEL Kodachromes. 2" x 2". National parks, world's fairs, etc., sold on money-back basis. Request catalog hundreds of subjects. Elk Studio, Elkton, Maryland, Department C.

NO More wasted film or unnecessary expense. Take pictures you can be proud of. Sell to magazines and newspapers. Make good money wherever you live. Easy, low cost, home study course shows you how! Free catalog. Universal Photographers, Dept. 10, 10 West 33 St., New York City.

SPEED-O-COPY Groundglass focusing attachment for Leica, Contax, Argus C-2 and C-3. Send for literature. D. Paul Shull, Dept. PM-2, 240 So. Union Ave., Los Angeles, California.

MAKE Money in photography. Learn quickly at home. Easy plan. Previous experience unnecessary. Common school education sufficient. Booklet and requirements free. American School of Photography, 1315 Michigan, Dept. 3431, Chicago.

BASS Says: War time proves Bass leadership. Amazing selection of finest still cameras—Leica, Contax, Korelle relex Argus, new and used still available. Write for quotations. Satisfaction guaranteed or your money refunded. Bass buys 'em, sells 'em, trades 'em. Bass Camera Company, Dept. AG, 179 W. Madison St., Chicago, Illinois.

HAVE You a camera? Send ten cents for recent number of our big magazine, showing how to make better pictures and earn money. American Photography, 116 Camera House, Boston, Mass.

CAMERA Repairing. Bellows made to order. Shutters repaired. Bellows made to fit all standard cameras! United Camera Co., Inc., A-1515 Belmont, Chicago.

CASH! Spot cash for cameras, lenses, binoculars, movie or still, sound projectors. Send full description by mail, or wire for prompt cash offer. Over 30 years of dependability insures honorable dealings. Bass Camera Company, 179 West Madison Street, Chicago, Illinois.

ALL Makes camera films, 100 ft. 16mm. \$2.00, 8mm, 25 ft. double \$1.25. Developing free. Also complete movie subjects available. Write for catalog. Star Safety Film, Film Center Building, New York.

PHOTO FINISHING

35 MM. Fine grain developed 36 big sparkling 3 1/2 x 5 enlargements \$1.25. Reload 35c. Photoshop, Linton, Ind.

ENLARGEMENTS From negatives, two 5x7 25c (coin). Garrett's, Pittsburgh, Kansas.

BEAUTIFUL 8x10" Enlargement—25c. And you can get another free. Empire Photos, Adams Center, New York.

16 SPARKLING Lifetone prints, 2 beautiful Hollywood enlargements, free Leatherette frame and photo wallet only 25c. Free photo album with first order. Lifetone Studios Dept. A-239, Des Moines, Iowa.

FREE 8" x 5" Enlargement—no extra cost! Thrifty Dan the Camera Man will send you one doubleweight portrait quality 8" x 5" enlargement—absolutely free of extra cost—if you order another 8" x 5" enlargement—for only 15c. You get two enlargements for 15c! Made from your negative. Send stamps or coin. Satisfaction guaranteed or money refunded. Immediate service. No waiting. No red tape. Offer limited, one to person. Thrifty Dan the Camera Man, Dept. 301, Grand Rapids, Mich.

35 MM. Argus, Leica, etc., (except "Mercury") 36 exposure rolls, fine grain developed (Eastman DK-20) and beautifully enlarged to 3" x 4" glossy prints, 90c. Cartridge reloaded with Eastman Plus X, 35c. 18 exposure rolls, 55c, reload 20c. Films permanently protected by revolutionary Cryolyte process. 24-hour service. Satisfaction guaranteed. Free mailing bags, sample print. Write Technifinish Laboratory, 672 Brown St., N. W., Rochester, N. Y.

"CHOICE Of the Stars." Sixteen Hollywood prints with each eight exposure roll developed—25c enlargement coupon. Hollytints, P-1350, Hollywood, California.

ROLL Developed and 4x6 oversize glossy Velox prints, 8 exposure 30c; 12 exposure 45c; 16 exposure 60c. Overnight service. Clemet Photo Service, 1318 W. Columbia Ave., Philadelphia, Penna.

DOUBLE Size prints—quality work—your roll 8 expose 30c, 12 expose 40c, 16 expose 55c. Reprints 3½c each. Calif customers add sales tax. We pay return postage. Get our low price on enlargements and copy work. All work guaranteed. Everlasting high gloss finish. Overnight service. Pacific Photo Service, Box 666, San Francisco, Calif.

BEAUTIFUL Enlargement from each picture on roll 25c. Cut Rate Photos, Dept. B-4, Janesville, Wisconsin.

ENLARGEMENTS—8x10" 25c. Send negative. Guaranteed. Look Photo, Andover, Mass.

READY-TO-FRAME 6x4 Enlargements, 5c! Hand colored 20c—from your negative, 16 reprints your negative, 25c. Kodak roll developed with 16 guaranteed deckle-edge Velox prints 25c! 36 exposure 35mm. roll developed, vapo-rated, enlarged to 3x4, \$1.00. 3x4 reprints, 3c each. Immediate service! Free mailers! American Studios, Dept. 510, LaCrosse, Wis.

PHOTOGRAPHY For pleasure and profit. Prepare at home. Common school education sufficient. Write for information and requirements. American School of Photography, 1315 Michigan, Dept. 3452, Chicago.

EIGHT Beautiful enlarged prints (nearly postcard size) or 16 regular prints 25c. 35mm. rolls enlarged 3¼x4½ \$1.00. Burton Studios, 55M, Roscoe, N. Y.

EVERY Picture an enlargement! 8 sparkling deckle-edge enlargements and roll developed 25c coin; 116 size or smaller; enlarge reprints 3c. Enlarge Photo, Box 791D, Boston, Mass.

BIGGEST \$1.00 Value in 35 mm. finishing today. 36 exposure fine grain 3¼x4½ enlargements; deckle, embossed margin and date. Eighteen exposures 75c; sixteen exposure splits 55c. Free mailers. 8 exposure rolls in beautiful deckle contact finish with embossed wide margin, 25c. Mailbag Film Service, Box 5440A, Chicago.

16 BEAUTIFUL Oversize deckled prints and two enlargements with first order 25c. Owphoto M1, Weatherford, Oklahoma.

REPRINTS 2c Each, 100—\$1.50. 6 or 8 exposure rolls developed 2 prints each exposure 25c. 36 exposure 35mm. rolls fine grain enlarged prints \$1.00. Mailing bags free. Mercury, A-109 North Dearborn, Chicago.

8 EXPOSURE Rolls, giant size 25c; 16 exposure rolls, 50c. Mayfair Photos, Box 261-K, Toledo, Ohio.

ROLLS Developed: Two prints each negative 25c. Reprints 3c each. Summers' Studio, Unionville, Mo.

THREE Prints each good negative, 6 to 8 exposure rolls, 30c. 12, 16, 18 exposure rolls, 50c. Reprints, 3c. Fred D. Eastman, Bode, Iowa.

ROLL Developed and 8 lustrous distinct flash permanent Velox glossy prints 25c—reprints 3c each. Fotoprint Service, Box I, Roanoke, Virginia.

8x10 SILK Finish enlargement—25c. Send negative. Irving Studio, 4006A Irving Park, Chicago.

FILMS Scientifically developed with 8 4x6 enlargements 30c. Send for price list and mailbag. Photo-Service, 107 Dewey St., Newark, N. J.

MOTION PICTURES AND SOUND EQUIPMENT

RENT By week, 8mm., 16mm. films. New catalogs. Lowest rates. Dayton Film, 2227 Hepburn, Dayton, Ohio.

16MM. KODACHROME "End" titles, 3 for \$1.00. With fadeout, 50c each. Guy Hazelton, 7936 Santa Monica Blvd., Hollywood.

SOUND Features \$10.00 up, programs rented. Projectors \$25.00. Free lists. Simpson Films, Miamisburg, Ohio.

\$1 BRINGS "Surprise" assortment 8mm. colorful titles! LeMoine Films, Nevada, Missouri.

35MM. ZENITH Sound projectors for sale. Landow, Beachway, Keansburg, N. J.

FREE, 1943 Movie catalog; sample films 10c. Goodwill Company, Jackson, Tenn.

OUTSTANDING 35mm. sound features. Shorts. Demsey, 1223 Berkley, Youngstown, Ohio.

RELIGIOUS Films, 16mm. sound silent. Screenart, 729 7th Ave., New York.

MOVIE Library, 8mm., 16mm., 35mm. Religious, educational, sports, comedies, travel. Request catalogs. Cameras, projectors, buy, sell, exchange. Time payments. Mogulls, (Established 1914), 64 West 48th, New York.

DEVELOP Your own movies. Save 50%. Bulk films. Developers. Genera Company, Davenport, Iowa.

16MM.-8MM. Silent-sound film for rent. Large rental catalog 10c. National Cinema, 71 Dey St., New York.

COMPLETE 16MM. sound subjects, \$1. (Need splicing.) All sizes film, bought, sold, exchanged. Catalogue-sample film—10c. International-M, 2120 Strauss, Brooklyn, N. Y.

100 FT. 8mm. Subjects 98c. Spring Films, Hopkinton, Mass.

BASS Says: No shortage of Cine Cameras at Bass. Largest stock in the country of 8 mm. and 16 mm. silent and sound. We have them new and used. Bell & Howell double 8, used F:3.5 lens, \$37.50; Keystone double 8, F:3.5 lens, \$26.50; Revere Turret Model 99, F:2.5 lens like new, \$62.50; Cine Kodak 16 mm. Model B, F:3.5 lens, \$22.50. Bass buys 'em, sells 'em, trades 'em. Write for condensed Cine price list. Satisfaction guaranteed or your money refunded. Bass Camera Company, Dept. A, 179 W. Madison St., Chicago, Illinois.

8 AND 16MM. film-subjects—Black and white and color—sound or silent. Largest selection ever compiled, 65c to \$200. Write for new deluxe 1943 catalog—profusely illustrated! 25c (coin or stamps)—refunded first purchase. Hollywood Movie Supply Company, Hollywood, California.

"THE World's Greatest Passion Play." 16 and 35mm. Specify sound or silent. Rent or purchase. Hemenway Film Co., 33-F Melrose St., Boston, Mass.

35MM. 16MM. Sound silent projectors, film. Savarese, Woodcliff Lake, N. J.

8-MM.-16MM. Silent-sound; all latest subjects. Films rented everywhere. Free catalogue (sample film 10c). Garden Film, 317 West 50th, New York.

WANTED: Used equipment for cash. Films, cameras, projectors, etc. Peters, 41-C South Fourth, Allentown, Penna.

8MM.-16MM. Films. Free catalogue (sample film 10c). Parkway Exchange, 961 Eastern Parkway, Brooklyn, New York.

MUSIC AND MUSICAL INSTRUMENTS

"PICTURED Piano Playing." No notes—sensational results guaranteed—10c sample. Picture Piano, Wallace, Idaho.

LEARN Piano—Fascinating chord system minus monotony. Rare information. Write "Piano Bill," 207 Ossington, Toronto, Ontario.

LEARN Popular piano! Write Magic Key, 111-A Broadway, Glendale, Calif.

MUSIC Composed, song printed. Reginald Belcher, Chatham, New Jersey. Established 1910.

SONGS—Song poems wanted. No charge for melodies. Marketing service. Hollywood Recording Studios, 87024 Preuss Sta., Los Angeles.

SONG, Song poem writers: Before spending any money on marketing your songs or song poems get complete details about "Tips to Song Writers." Saves you unnecessary time and expense. Write me today. Ken Rasmussen, PM-3, Box 481, Hollywood, California.

POEMS Wanted for musical setting. Send poem for immediate consideration. Five Star Music Masters, 630 Beacon Building, Boston.

SONGWRITERS: We offer complete service. Melody writing, recording, radio broadcast, marketing. Screenland Records, Box 1247E, Hollywood, Calif.

GOT Words for a song? I'll write music! David Ahlstrand, Kettle River, Minnesota.

SONGWRITERS: Send poems for offer and free rhyming dictionary. Phonograph records made. Vanderbilt Studios, Box 112-F.J., Coney Island, N. Y.

SONGWRITERS—Get the facts. Free informative booklet, plan. Write today. Song Service, 331-C West 46th, New York.

ACCORDIONS. Dealer prices. Fur coats. Discount prices. Write Metro, 44 North Albany, Chicago.

CASH For your old musical instrument regardless of condition. Accordions, oboes, saxophones, bassoons, clarinets, English horns, trumpets and other horns. Look around your home now! Turn your old instruments into cash. Tell us what you have to sell. Get our price. Write or send instrument. Gretsch & Brenner, Inc., 42 East 20th Street, New York City, N. Y.

FREE Deal—Special importance to songwriters. Jackson, B-9441 Pleasant, Chicago.

SONG Poems wanted: Write for free booklet outlining your opportunity. United Music Corporation, Dept. 14, Salem, Indiana.

SONGWRITERS! Amazing outstanding offer. Hibbeler, C5, 2157 No. Avers, Chicago.

SONGWRITERS, Write for free booklet, profit sharing plan. Allied Music, 204 East Fourth, Cincinnati, Ohio.

SONGWRITERS—Send poem for immediate consideration and free rhyming dictionary. Richard Brothers, 24 Woods Building, Chicago.

MUSIC Composed to words. Rhyming pamphlet on request. Phonograph recording of completed songs. Send poem for consideration. Keenan's Studios, Dept. PM, Box 2140, Bridgeport, Conn.

WANTED! Lyrics, melodies for songs. We arrange, publish, sell. Superior Song Studios, Passaic, N. J.

MUSIC Composed to words. Wonderful proposition. Bauer Bros., Oskosh, Wis.

LEARN Swing piano! Postal brings free folder. Christensen, 451 Kimball Hall, Chicago.

WRITE Songs. Big money and reputation. Write for information. J. Gordon Pub. Co., 201 N. Hoyne, Ave., Chicago.

RADIOS AND SUPPLIES

REVISED Plans 18 long distance crystal sets with "Radiobuilder"—year, 25c. Laboratories, 1406-C 77th Avenue, Oakland, California.

RADIO Service men and experimenters send for our giant radio catalogue. Save dollars. United Radio Co. (1000M), Newark, N. J.

RADIO Communications courses qualifying for all federal licenses. Home study and resident courses. American Radio Institute, 1123 Broadway, New York, N. Y.

BUSINESS OPPORTUNITIES

NO Age limit, new business, every office a prospect, office furniture leg guard protection for women's hose, dresses, men's trousers, cost three cents to make, sells for fifty cents and one dollar the pair. Materials found in any town, no priorities required. Only five dollars capital necessary. Satisfy yourself, ask office workers in your city. Mail one dollar for complete information and sample pair. Baskin, 1905 15th Avenue S., Minneapolis, Minn.

OPEN Raleigh routes are scarce but in so vast an organization expansion creates new opportunities. If ambitious, willing to start with good earnings and increase rapidly write for full information. We supply sales, advertising literature—all you need. Raleigh Co., Dept. B-118-PPMB, Freeport, Ill.

START Home business making statuary, plaques, art goods, novelties, souvenirs, concrete pottery, garden furniture, artificial marble flooring, liquid marble. Make your own flexible molds. Amazing profits. Valuable folder free. Creative Publishers, (PM2), Glencoe, Illinois.

SUCCESS Says hello to you! Your own boss, your own business, right at home! A—azing new mail order course shows you. Tiny capital starts you. Thrilling details free. Century, 152 W. 42nd Street, New York.

PROFITABLE Mail order information for stamped envelope. Ellico, 1554 Sierra Lane, Stockton, California.

UNPAINTED Wall plaques, statues, novelties, bookends. Request wholesale lists. Omann, 642 Broadway, St. Paul, Minn.

MAKE Money by mail. Work home. Fascinating literature free. Wright, 83-C Maple Avenue, Irvington, New Jersey.

CASH-IN 300 Moneymakers, 25c post-paid. Quality Distributors, 668 Fern, Yeadon, Penna.

CAPITAL Seekers—Interested in raising \$25,000 or more for a legitimate project should write to Amster Leonard, Fox Theater Bldg., Detroit, Michigan.

START Well paying mail order business at home. Full particulars free. General Sales, 149-A East 16th, New York.

MILLION Articles. Buy wholesale. Valuable directory 10c. Ideal Service, D-2, Park Ridge, Ill.

START Lettering in home. White-collar profession. Professional Products Company, Madisonville, Cincinnati.

MAIL Order business course shows you how to make money, spare or fulltime. Teaches professional mail order technique—not penny-catching schemes. Free details. Nelson Company, 500 Sherman, Dept. B-402, Chicago.

10,000 PINT Cans, 5,000 wax cans, lithographed. Sell empty or fill with polish and wax, sell at cost. Consolidated, 1943 North California, Chicago.

\$10,000 YEARLY Using formula from Schemer Magazine, Alliance, Ohio. Formula, Schemer 12 months, just \$1.00.

THE Lord's coming! 30 proofs free. Scheall, 263XB, Duluth, Minnesota.

OWN Your own profitable home, office, mail business. Over 100 golden opportunities now open to you. Exciting information free. Profitable Enterprises, Cobleskill, N. Y.

MAKE Your own Flexible Molds. Statuary, Art Goods, Novelties, Artificial Marble Flooring, Liquid Marble. Literature free. Kemico, 2-M, Park Ridge, Ill.

WILL Buy or finance mail order business or correspondence school course. Give complete details. Art White, 800 Broadway, Cincinnati.

FOR An extremely profitable lifetime business, operate a collection agency-credit bureau. Many make \$4,000 yearly, up. Write Cole Associates, Syracuse, N. Y.

DOLLARS Daily! Start home; mail-order; businesses. Details. Duffy, Covington, Ky.

MAKE Extra money at home. Use your spare time. Literature free. Write now. Hodges, 321 E. 41st, Chicago, Ill.

FREE—200 Clever mallorder, homework, local business offers—all snappy money-makers. Lewis Co., 828-M Carpenter, Oak Park, Illinois.

"HOW To Make Simple Molds and Plaster Plaques." No rubber required! Booklet 25c. Plastercraft, 1408 E. 43rd St., Cleveland, Ohio.

MAIL Order merchandise distributor opening. Your own business. Big profits. \$75 necessary. Dean, 747 Kingsley, Pomona, Calif.

WANTED County representatives—Sensational 100% profit 50c seller Storm-Proof Cigarette-Cigar and Pipe Lighter, employing charcoal principle—"More wind blows—more lighter glows." Everybody wants one because everybody smokes. Men, here's that useful, non-competitive money-maker you have been looking for. Write—Storm-Proof Lighter Company, 126 Lexington Avenue, New York.

SAVO-GAS. Biggest moneymaker yet. Quarter brings sample. Marshall, Box 151, Beville, Texas.

STIONS And showcards easily and expertly painted with letter patterns. Many sizes and styles. Write for descriptive folder. John Rahn, A1330 Central Ave., Chicago.

MANUFACTURE In your home. Finished product sells for 25c, cost 3c. Sample and details 25c coin. United Products, Ridgeville, Indiana.

MONEY Making opportunities galore 20c. Bryant's, Box 2638, Denver, Colo.

LEARN Your body chemistry. Discover your talents. Interesting, profitable study. Particulars free. W. Gooley, 3910 N. Bell, Chicago.

\$50.00, \$100.00 WEEKLY Using sawdust. Stamp appreciated. Clement, 80R Gorsline, Rochester, N. Y.

HOMEWORKERS — \$50.00, \$75.00, \$100.00 Weekly. Castwood gifts, plaques, novelties. Material, molds, instructions furnished. Sample woodcut, mold model with illustrated molding circular, catalogue new flexible molds, 25c postpaid. Castwood Products, 2110 Lawrence, Chicago.

IMPRINTS Without cash! Free premiums for your customers. No more advertising bugaboo! Dollar orders filled for you free! Newest and fastest selling line in mail order. Rush dime for full particulars and we'll include sample copy of one of our best 25c plans—a plan that really works. T. Hickey, 604M S. Evergreen Avenue, Kankakee, Illinois.

MECHANICALLY Inclined men—Own and operate general appliance repair shop. Complete, illustrated course shows you how. Welding, refrigeration, motor repair, how to get business, etc., all phases covered. Free literature. Christy Supply, Dept. 125, 2835 N. Central Ave., Chicago.

AMAZINGLY Successful mallorder plan. Work at home. Pays well. Literature and valuable plan 10c. Leonard Publishers, 255 West 93rd Street, New York, N. Y.

EXTRA Income—Plenty mail selling opportunities. Write Katz, 4254 N. Kimball, Chicago.

AGENTS—To mail our literature. Good profits. Home business. Maywood, 1133 Broadway, New York.

FULL Or sparetime propositions galore in "Money Making Business Starters." A \$1.00 book you can have for 25c prepaid. Order today. I. W. Meeks Pub. Co., Box 792, Weed, Calif.

5 MOST Read mail order magazines 20c. Armand Cartier, 695A North, Pittsfield, Mass.

2c DAILY Operates New York office under your own name. Co-operative Offices, 126 Lexington Avenue, New York.

MAKE Artificial marble, glazed tiles, plaques, figurines, sanitary flooring, pottery, novelties. Brilliantly colorful samples free. (Also—Selfhelp arts, wealth culture, psychology, hypnotism.) Payn, 945 Grande Vista (Room 101), Los Angeles, Calif.

MAKE Money collecting money. Good income; quick results. National Collectors, Newark, Ohio.

LIQUID Marble—Colorful, glazed! Mold, brush, spray! Composition floors, rubber-lastic molds. Particulars free. Marbleizing Service, Edwardsville, Illinois.

BRUSH Plating outfits connect to a battery, no tanks necessary. Almost as simple as painting. Your opportunity to make good income plating autoparts, bathroom fixtures, reflectors, mirrors. Get free proof and particulars that put you in a paying business of your own. Gunmetal Co., Ave. H, Decatur, Illinois.

WEBER Typewriter Mechanics School. Simplified homestudy-repairing increasing. Canton, Ohio.

PLASTEX Industries offers industrious men an opportunity to start a business of their own, manufacturing art goods, novelties, souvenirs, etc., in Plastex and marble imitation. 5c material makes \$1 articles. Rubber moulds furnished for speed production. Small investment brings good returns. We are now placing big chain store orders with manufacturers. Write for interesting booklet mailed free. Plastex Industries, Dept. A, 1085 Washington Ave., New York.

STATUARY: Make all kinds. Simple process. Make and install artificial stone flooring in color. Liquid marble. Other money-makers. Write promptly. Literature free. Compo-Tex, Box 786, St. Louis, Mo.

HOW And where to obtain capital. Fully explained, particulars free. Star Service, Wapakoneta, Ohio.

POPCORN And potato chip machines. We help start men and women in business. Long-Eakins, 1960 High, Springfield, Ohio.

CHARTERS: Delaware; best, cheapest; free forms. Colonial Charter Co., Wilmington, Del.

127 WAYS To make money, in home or office, business of your own. Full particulars free. Elite Co., 214 Grand St., New York.

START Home business making concrete garden furniture, pottery, bird bath, flower boxes. Amazing profits. Illustrated instruction book 25c. Popular Mechanics, 200 E. Ontario, Chicago.

MONEYMAKING OPPORTUNITIES

LICK After-war layoffs! Establish sparetime home business—added income now; future security. Free details scores successful money-making plans. Co-Operative Service, 734 Ashland, Buffalo, N. Y.

MONEY Making, spare or full time plans in Opportunist Magazine, 10c brings sample copy. Opportunist Magazine, Box 631, Baltimore, Maryland.

DOLLAR Orders filled free! Investigate! Cutler Publishers, (3189), Reading, Penna.

MAKE Money operating mail-order home business! Proven, professional plans \$1 Mack Wright, 189 W. Madison, Chicago.

EARN Money evenings, copying and duplicating comic cartoons for advertisers. Adservice, Argyle, Wisconsin.

ATTENTION. Make money selling own soap products. Ten formulas for \$1.00. J. E. McCray, 211 E. 32 St., Savannah, Ga.

PROFITABLE Home-work. Fascinating sample and details 10c. Woodcraft Projects, 1320 Lindsay, Gainesville, Texas.

MOLDMAKING—Plaster Casting. Complete formulas—fully illustrated. 25c. Ideal Service, RM-2 Park Ridge, Ill.

SPARETIME Opportunities. Details free. Phil Bruce, Box 341c, Palo Alto, Calif.

GIANT Mails 6c; Mail Sale Magazine 3c. Opportunity mail free. Harvey Teeple, (PM) Decatur, Indiana.

FIVE Different money making magazines 10c. Loren Hollenberg, Roseville, Ill.

MAN. You'll like silvering mirrors, reflectors! Making sparkling glass nameplates. Outfit prices. Sprinkle, Plater, M287, Marion, Indiana.

MANUFACTURE From Phospholene. Cleaning fluid 3c a gallon, and 10 fast sellers. Send 25c for booklet and sample. Western, 201 Climax Bldg., Cleveland, Ohio.

REAL Cash instead of promises! Lose no time. Investigate the Commercial Reporter Plan. Entirely new methods build real mail order business. Very small capital. Full information 10c. Act at once. F. H. Martin, 2417-P Jefferson Avenue, Saint Albans, W. Va.

SELL By mail. New books. New imprints. Samples 10c. Fowl Printing, Muncie, Indiana.

START Your own business home or office. 101 formulas of easy to make products 25c. Crittenden, 125 Lincoln, Lombard, Ill.

SAVO-GAS. Biggest moneymaker yet. Quarter brings sample. Marshall, Box 151, Beville, Texas.

TIRED Of working for others? Be your own boss! Dimes, quarters, dollars by mail! Free particulars. "Novel Enterprises," P.O. Box 457, Reno, Nevada.

YOUR Name printed in 10,000 "Big Mail" directories 25c. Checking copies sent. Alesse's, 15881 Log Cabin, Detroit, Michigan.

LEARN Metascience. Remarkable drugless healing. No manipulation. No apparatus. Unbelievable simplicity and results. Inexpensive correspondence course. Write Metascience, De Land, Florida.

MONEYMAKING Ideas—Latest books—Bargain catalog free. Popular Mechanics, 633 St. Clair, Chicago.

FORMULAS, PLANS, ETC.

LATEST Formulas. Details free. H. Tooker, 630 Chestnut, Hamilton, Ohio.

MAKE Fast selling products. No machinery. "Chemist Approved Formulas." Literature free. Kemico, 15, Park Ridge, Illinois.

FORMULAS For sale. Everyone of these new, different formulas is a money maker! A post card will bring you interesting details. A Burk, 1788 East 2nd Street, Brooklyn, New York.

10,000 FORMULAS; Money-makers. 924 page volume. \$1.75. Ideal Service, 179, Park Ridge, Ill.

COLCHICINE—Evolution chemical creates new mutant plants. Illustrated booklet—plus Experiments Magazine 25c. Questok, Wellesley, Mass.

"LUMINOUS Paint" shines in dark. Easily made. 100 other formulas, plans—all 25c. Ideal Service, 302, Park Ridge, Ill.

MECHANIC'S Magic paste soap. Formula 25c. F. Gerwin, Alva, Oklahoma.

MAKE That precious coffee go twice as far. Guaranteed formula \$1. Ralph Brooks, Arkansas, Wis.

FORMULAS Money-making opportunities. Postcard brings you amazing information. Fairchild Company, Mt. Vernon, Ohio.

REAL Manufacturing formulas. Lists free. Cummings, Chemist, Gordon Ave., Syracuse, N. Y.

AUTHENTIC Formulary 924 pages (illustrated). 10,000 money-making formulas, recipes, instructions, substitutes. \$1.75 postpaid or C.O.D. (foreign \$2.10). Catalog 3c. Adams Brown Company, Chestnut Hill, Massachusetts.

FORMULAS—Latest, best. Analysis. Literature free. Belfort, Engineering Building, Chicago.

CHEMISTRY

WINN'S New Idea Home Laboratory Chemical Kits and apparatus outfits for home experimenting. Send 5c for literature and retail supply catalogue. J. H. Winn Co., Dept. 502, 124 W. 23rd St., New York.

HANDBOOK For chemical experiments, hundreds of experiments, illustrated, 50c. Experiment booklet 10c. Reading Scientific Company, Reading, Penna.

FREE Catalog. Chemistry, mineralogy, microscopes. Special: 28 piece chemistry set, send \$1.00. Tracey Laboratories, Evanston, Illinois.

CHEMISTRY Laboratory apparatus and chemicals for industrial, analytical, and private experimental laboratories. Complete chemical laboratory supply service for correspondence school students. Send 3c for free 48-page catalog of chemicals and apparatus. Dept. M-43, Biological Supply Co., 1176 Mt. Hope Ave., Rochester, New York.

SPECTROSCOPE For quick chemical analysis \$2.50. Kutting Sons, Campbell, California.

HELP WANTED

SPECIAL Work for women. Demonstrate lovely dresses in your home. Earn to \$23 weekly, and own dresses free. No investment. Give age, dress size. Fashion Frocks, Desk 52140, Cincinnati, Ohio.

MEN, 20-35 Years. High school education, electrical-mechanical maintenance experience preferred. Position entails constant traveling, long periods from home on rail testing equipment. Salary plus all living expenses. Write full details, education, personal background, experience, draft status to Personnel Department Sperry Products, Inc., Hoboken, N. J.

DO You want a steady job with good pay? Work for U. S. government. Complete list of available positions, qualifications required and how to prepare for a civil service job. \$1.00. Guidance Service, Crosby, North Dakota.

AGENTS WANTED

WRITE For free fabric samples amazing stainproof tablecloths. Clean with damp cloth. Require no ironing. Beautiful patterns. Look expensive, long wearing, low priced. Commissions big. Also complete dress line. Melville Company, Dept. 3502, Cincinnati, Ohio.

SELL 50 For \$1.00 name imprinted stationery with matching envelopes—free samples. Odd cards 2½c. Birthday, all occasion greeting card assortments 35c up. Cards for boys in service. Special offer. New England Art, North Abington, F-363, Mass.

SELL Dresses at low prices! Hundreds sensational bargains. Actual samples free. Send dress size, age. Harford, Dept. R-365, Cincinnati, Ohio.

SELL By mail! Books, novelties, bargains! Big profits! Particulars free! Fiffo, 438 North Wells, Chicago.

WE Pay you \$25 for selling fifty \$1.00 assortments birthday, all occasion cards. Tremendous demand. Write for samples. It costs nothing to try. Cheerful Card Co., 10-A, White Plains, N. Y.

DON'T Be a job hunter—Start your own business on our capital. No hard-times; no layoffs; always your own boss. Hundreds average \$3,000 to \$5,000 annual sales year after year. We supply stocks, equipment on credit. 200 home necessities. Selling experience unnecessary to start. Wonderful opportunity to own pleasant, profitable business backed by world wide industry. Write Rawleigh Co., Dept. B-U-PPMA, Freeport, Ill.

BIG Money taking orders; shirts, ties, hosiery, underwear, pants, jackets, sweaters, uniforms, etc. Sales equipment free. Experience unnecessary. Nimrod, 4922-AN Lincoln, Chicago.

SCHOOL Seniors sell graduation name cards to classmates. Large commissions. Bonuses. Free cards. Free samples. Address Manheim Card, Manheim, Penna.

AGENTS Champion sample belt, 25c; information, 3c. Leathercraft, 844 W. Baltimore, Baltimore, Md.

SCHOOL Seniors—Sell America's most beautiful distinctive graduation name cards. Positively highest commission. Lowest prices. Free sample kit. Printcraft, 1423 E. Elm Street, Scranton, Penna.

CALL On friends with greeting card assortments; Easter, birthday, other occasions. Personal stationery; gift wrappings. Big profits. Experience unnecessary. Samples on approval. Wallace Brown, 225 Fifth Avenue, Dept. T-34, New York.

DON'T Buy razor blades until you get our low wholesale prices. Write, Tharp, 914 Lexington, Cumberland, Md.

STRANGE Chemical sponge cleans wallpaper like magic. Banishes housecleaning drudgery. Sensational seller. Samples sent on trial. Rush name. Kristee, 125, Akron, Ohio.

200% PROFIT. Millions of prospects. Details free. H. Tooker, 630 Chestnut, Hamilton, Ohio.

FOR Quick cash without canvassing, write, Terrill, B-2, Bogard, Mo.

"CAR Watchman" prevents thieves from stealing tires—gas—equipment. Amazing invention. Whirlwind seller. Big profits. Write quick. Northwest Electric Co., B-10, Pukwana, So. Dak.

AGENTS—Whirlwind profit opportunity. Finest silk Nylon, and Rayon hosiery. Big selection. Very latest styles and colors. Replacement guarantee. Your own hose free with large outfit. Rush hose size, name today. Wilknit, Dept. DB-37, Greenfield, Ohio.

BIG Clothing bargains for big profits. Used dresses 10c, men's suits \$1.00, shoes 12½c, men's overcoats 50c. Over 100 sensational values. Experience unnecessary. Free wholesale catalog. Superior, 1250-EO Jefferson, Chicago.

SELL "Eagle Album Pages" with your own titles. Samples 10c. Manzo, 568 S. 18th, Newark, N. J.

EXCELLENT Sparetime sideline! Substantial profits! Pines, 144-34 70th Avenue, Flushing, N. Y.

LUMINOUS Paint. Profitable 50c seller. Details, Ward, 97C, Saybrook, Connecticut.

ELITE Collection contains 127 plans for starting own business; home office. Descriptive booklet free. Elite Co., 214 Grand St., New York.

FAST Sellers, big profits. Write Dissell, 4667 Rockwood Road, Cleveland, Ohio.

AGENTS 5c; Retail 25c. Inventor, 35PM North 9th, Columbus, Ohio.

MAKE \$10-\$20 Daily selling \$10 Accident and Health \$10,000 Policy. Renewals! Leads! Universal Policy, P. 11 Commerce St. Newark, N. J.

SAVO-GAS. Biggest moneymaker yet. Quarter brings sample. Marshall, Box 151, Beeville, Texas.

ANTI-FREEZE! Make-sell yourself, yourself. Many other manufacturing processes. Special offer! Thermowks, Peoria, Ill.

PEP-O-GAS Increases mileage. \$1.00 box will last several months. Sell product yourself. Information free. Dodd Products, 600 San Saba St., Coleman, Texas.

EARN Extra money. New 10c item, every man needs. Send \$1.00 for 20 on approval. Hawkins Specialties, 537-P South Dearborn, Chicago.

I WILL Give you \$5.00 worth full size packages foods, groceries, soap, etc. Free if you agree to show friends and others. Amazing spare time money making opportunity. Write Zanol, 8815 Monmouth, Cincinnati, Ohio.

WHOLESALE Sources. 500,000 articles. Free directory, Maywoode, 1133 Broadway, New York.

RELIABLE People wanted to place eggine in stores and appoint agents. Used the same way as eggs in baking and cooking at 10 cents dozen. Full size package and particulars 10 cents postpaid. Morrissey, 4417-21 Madison St., Chicago, Ill.

MAKE Money applying initials on automobiles. Also, sideline salesmen for short run decal name plates. "Ralco," 1483 Washington, Boston, Mass.

AGENTS. Big line including food products. Fast selling premium and bargain deals. Low prices. Send card for big outfit over with gift. Ho-Ro-Co, 2737 Dodier, St. Louis, Mo.

FREE Water and our concentrates, makes flavors, lotions, shampoos, 72 products, labels, bottles furnished. Qualco, E-20030 Russell, Detroit.

SCHOOL Seniors—Sell graduation name cards. America's largest, fastest-selling, low-priced display. 35% commission. Free cards. Universal Engraving & Printing, Box 745-PM, Pittsburgh, Penna.

AGENTS—300% Profit selling gold leaf letters; stores and offices. Free samples. Metallic Letter Co., 438-B North Clark, Chicago.

USED Men's shoes 14c, hats 12c, pants 28c, dresses 10c, winter coats 50c, fall coats 35c. Bargain catalog free. Portnoy, 566-V Roosevelt, Chicago.

AGENTS: Stamping names on pocket-key protectors. Sample check with your name, address, 25c. Stamping outfits, Emblem checks, check-fobs, name plates. Hart Mfg. Co., 303 Degraw St., Brooklyn, N. Y.

DO You want agents for your proposition? Your ad in this space will place your message before hundreds of men seeking fast-selling products. My folder "How to Secure Agents," is filled with proof. I'll gladly send you a copy free. F. W. Johnson, Manager Classified Advertising, Popular Mechanics Magazine, 200 E. Ontario St., Chicago.

GET A better job. Our books will help you advance. Bargain catalog free. Popular Mechanics, 633 St. Clair, Chicago.

HIGH-GRADE SALESMEN

MIDDLE Aged business men or salesmen to join 75 who earned \$400 to \$2,000 in a month. No priority restrictions. Half-million dollar company, established over two decades, has opening for men capable of interviewing public officials, heads of industries, army camps, schools, churches, stores, large growers and farmers in cities and surrounding towns. Car not essential as many of our men travel by bus. We deliver your orders, collect for them and advance your earnings daily. Priorities in other lines greatly benefit us as no priorities in our line. Men who were "bankrupt" when they started with us, now have homes and security. Big season starts soon. Rush name, age for particulars. Vice President, Box 711-AB, Fort Worth, Texas.

PLASTIC Arch shoes that mold themselves to fit the feet. Sensational money-makers. Exclusive territory. Extra cash bonus. Samples furnished free. Ortho-Vent, Desk A, Salem, Va.

QUICK Cash profits for you! Dramatic two-minute demonstration sells it! Makes real money demonstrating amazing Autofyrstop, combination automatic and manual fire extinguisher and alarm. Holds unequalled records. Tremendous market. Sell to defense plants, homes, schools, stores, etc. Experience unnecessary. Details free. Autofyrstop, Dept. M-23, 2035 Washington Ave., Philadelphia, Penna.

SALESMEN: Have real money making opening. Fits into war program. Old progressive firm. Dept. "P," Box 392, Dallas, Texas.

ADVERTISING Book matches at sensational low prices. 2500 books printed black on silver with customer's ad \$6.95 including tax, your commission. Free selling outfit. Chicago Match Company, Libertyville, Ill. Dept. PM2.

BIG Commissions—selling to stores celluloid pricing tickets, metal shelf moulding. To restaurants, menu covers, signs. P. Pricing Press, 124 White St., New York.

PRICE Tags for grocers, meat markets, liquor and drug stores. 50% advance comm. Price Tag, 1445 Montrose, Chicago.

ADVERTISING Book matches, America's largest manufacturer of union label book matches. Fast selling line. Large sales producing kit. Sample matches. Complete cut catalog, 17 color combinations makes selling easy. Commission in advance. Superior Match Company, 7530 Greenwood, Dept. M-2, Chicago.

SALESMEN—Fast selling collection system. Good commissions. Stephens Service, Box 703, Athens, Ga.

REPRESENT America's greatest producer of union label calendars, business stationery, price markers, etc., for every retailer, at prices that defy any and all competition. No priorities. No rationing. Big commission. Outfit free. National Press, 545 Randolph, Chicago.

PATENT Solicitor to represent old established firm. Part time. No experience necessary. Liberal commissions. Write W.A.S., 332 Wells Building, Milwaukee.

EARN Money in your spare time taking subscriptions to Popular Mechanics. Unlimited possibilities, every family a prospect. Easy to sell. Bonus paid in addition to liberal commission. Send postcard for further details today. Circulation Dept., Popular Mechanics Magazine, 200 E. Ontario St., Chicago.

EDUCATIONAL AND INSTRUCTION

MAKE Up to \$25-\$35 week as a trained practical nurse! Learn quickly at home. Booklet free. Chicago School of Nursing, Dept. K-1, Chicago.

"How To Break and Train Horses"—A book every farmer and horseman should have. It is free; no obligation. Simply address Berry School of Horsemanship, Dent, 1102, Pleasant Hill, Ohio.

AVIATION Home study, aircraft construction and maintenance. Modern Aeronautical Institute, 210 Douglas Bldg., Windsor, Ont.

NEW Writers wanted to re-write ideas in papers, magazines, books. Splendid opportunity to "break into" profitable writing field. Rush postcard for free details. Comfort Writer's Service, Dept. FK-149, St. Louis, Mo.

MATHEMATICS Without figuring. 400,000 problems solved by graphica' method. Whole numbers, fractions and decimals. Price \$2.00. C. Beaver, 1016 So. Westlake Ave., Los Angeles, California.

BUSINESS College self-taught. Book-keeping, accounting, shorthand, typewriting, commercial law, business mathematics, filing, civil service. Complete \$50.00 course only \$2.98. Vocational Institute, Box 434, Duluth, Minnesota.

DRAFTING Course \$1 complete. Trigonometry \$1. Slide rule \$1. Giles, Dept. PM-3, 1326 Myers, Burbank, Calif.

HOME Study course, drugless therapy. Free literature. Inst. of Drugless Therapy, Tama, Iowa.

FREE Illustrated lesson handwriting analysis. Examination free. Alga, Linn Creek, Mo.

SECRET Investigation. Experience unnecessary. Detective particulars free. George Wagner, M-2640 Broadway, N. Y.

WELDING—Electric arc. Learn profitable trade quickly through actual practice. Individual welder instruction at bare cost of materials. Full particulars free. Valuable welding lessons book 50c. Hobart Welding School, Box M-232, Troy, Ohio.

RENT Latest technical books. Lowest rates—catalogue free. Merritt, Box 655, Springfield, Ohio.

BECOME A real estate broker. Write Jack Stein, Sarasota, Fla.

FREE—A complete I.C.S. lesson pamphlet on Blue Print Reading! Unusual money-making opportunities in this booming field today. Experience, first-hand, the thrill and satisfaction of mastering a first step to success. International Correspondence Schools, Box 5655-J, Scranton, Penna.

BECOME Finance man. Particulars free. Nebraska Finance Co., Lincoln, Nebraska.

LOCKSMITH Course. Lock picking, key fitting, etc. \$1.00 prepaid. Locksmith, Canadian, Texas.

CLINICAL Laboratory technic taught in your own home. Practice outfit supplied. Bulletin free. Imperial Technical Institute, Box 973-E, Austin, Texas.

LEARN Telegraphy! Splendid opportunities now prevail. All expenses low. Catalog free. Dodge Institute, Dept. M, Valparaiso, Indiana.

RADIO Engineering, broadcasting, aviation and police radio, servicing, marine and Morse telegraphy taught thoroughly. All expenses low. Catalog free. Dodge Institute, Dept. R, Valparaiso, Ind.

CARTOONING, COMMERCIAL ART, SHOWCARD WRITING, SIGN PAINTING

BEST Complete cartoon course with artists kit—\$1.00. Membership Cartoonists Association free. Cartoon Publishers, West Springfield, Mass.

AMAZING Cartoon businesses for amateurs. Hartman, 2438 W. Lincoln, Nebr.

CARTOON! Complete course \$1! Johnny Warren, N7509 Smith, Spokane, Wash.

EARN Money evenings, copying and duplicating comic cartoons for advertisers. Ad-Service, Argyle, Wisconsin.

CREATE Cartoons. Over 350 illustrations, 11,000 words, \$1.00 postpaid. Hetzler, Dept. P2, Box 407, Rochester, N. Y.

CARTOONING Course—36 lessons, 6 booklets, 816 illustrations, only \$2.80. Tenpleton Studios, Elgin, Illinois.

CARTOONING Course—30 illustrated lessons, over 500 sketches. \$1.00 postpaid. Montes Studio, Box 892, Pasadena, Calif.

CHALK Talks. Laugh producing program, \$1.00. Catalog 10c. Balda The Cartoonist, Oshkosh, Wisconsin.

ADVERTISING AGENCIES, LETTER WRITERS, FOR ADVERTISERS

A WINNING, Warm, human letter can bring success! Written for you by noted expert, author "Master Letter Writer." Ad-Man Davison, Westport, Connecticut.

ADVERTISEMENTS, Sales literature, printing, \$12.50 up. Martin, 171R Madison, New York City.

24 WORDS, 35 Newspapers \$2.00. Goodall, 37 Gardner, Vallejo, California.

MAIL Order sales skyrocketing. Cash producing ads, letters, folders, etc., prepared. Best pullers, lowest rates. Free product analysis. Van De Mark, Times Star Tower, Cincinnati.

MAIL-ORDER Or agent ad reaching 1,000,000 families throughout United States \$15.40 inch. Newspaper, magazine, mailing-list, rate-book, free. Chicago Advertising Agency, 20-PM West Jackson, Chicago.

ADVERTISE: 24 Words, 149 newspapers, \$6.50. Lists free. Advertising Bureau, 4515-C Cottage Grove, Chicago.

FREE—New Advertisers Rate Guide. 44 pages. Includes everything. Lowest rates. E. H. Brown Advertising Agency, Merchandise Mart, Chicago.

ADVERTISING Placed all magazines, newspapers U.S.A., Canada. Lowest rates. Free service. 54-page catalog free. Baker Advertising Agency, A-189 W. Madison, Chicago. Established 29 years.

FREE—"Amazing New Book"—"Profits From Classified Advertising." Tells how and what to advertise. Be sure to read this book before you invest one cent in advertising. Remember—It's free! Write for your copy now. F. W. Johnson, Classified Advertising Manager, 200 East Ontario Street, Chicago, Illinois.

BUSINESS SERVICE

CHICAGO Mail address: \$1 monthly—Receiving, reforwarding your business, personal mail. General, 30 West Washington. (Established 1919.)

TYPEWRITERS, DUPLICATORS, OFFICE DEVICES

TYPEWRITERS, Adder, mimeograph, multiphraph, addressograph. Send for free lists of machines that will help you at half price. Pruitt, 28 Pruitt Bldg., Chicago.

RUBBER STAMPS, OFFICE SUPPLIES

3 LINES 30c, Signatures \$1.50, 500 printed statements or envelopes, \$1.50, postpaid. Stamprite, Wauwatosa, Wis.

KNOB Handle, cushioned, 2 lines 30c, 3-40c. Stamp Works, Centerport, N. Y.

SUPERIOR: Cushioned, indexed, three lines 35c, four 50c. Signatures \$1.50. Slocum, 814 Bradley, Peoria, Illinois.

PRINTING, MULTIGRAPHING, MIMEOGRAPHING, GUMMED LABELS

THE "Big 300" personal stationery package for \$1.00 post paid—200 sheets bond paper, 6x9 size, 100 envelopes—Name and address printed on both. Ray Specialty Service, 1009 Henry, Detroit, Mich.

MIMEOGRAPHING—Letters, pricelists, formulas, instructions. Lowest prices. Lem's Letter Shop, 5710 Stanton, Detroit.

200 STATIONERY \$1.09. Stamp for samples. Weber, Printer, Emma, Missouri.

1000 6 1/2" PRINTED Envelopes \$3.00 delivered. Korten Printing, Grand Rapids, Michigan.

HAMMERMILL Letterheads, envelopes, billheads, statements. Samples free. Drew Press, Box 423-R, Greensboro, N. C.

FIRST Quality printing—reasonable. Samples. Treaster Printing Service, Millroy, Pennsylvania.

5000 ELEGANT Envelope slips, \$3.75; postcards, \$8.75; 6x9 circulars, \$8.25. All printing low prices. Samples. Goodprint, Harrisonburg, Va.

CENTRAL West Printers—Leading mail-order printers and mailers—3226-P Jackson, Chicago.

HAMMERMILL Letterheads, envelopes, any color, 39 type styles. Free particulars. Woodruff's, 217-A4 Lewis, Duluth, Minn.

\$1.00 POSTPAID, 100 8 1/2x11 Bond letterheads and 100 envelopes. Benneville, 907 West Roosevelt, Philadelphia.

500 3"x4" PARCEL Post labels \$1.10. Colorpress, 2025 Temple, Detroit.

SPECIAL! 200 Bond letterheads, envelopes, 89c. Joseph Johnson, 1382 Fifth Ave., New York City.

6x9 CIRCULARS—1000, \$2.95. All kinds printing. Lowest prices. Reporter, Chelsea, Oklahoma.

500 3/4x2 1/4 FOUR Line gummed stickers, 25c. Moritz Printery, Saginaw, Mich.

125 8 1/2x11 LETTERHEADS And 125 6 1/4 envelopes neatly printed \$1.25. John Ferreira, 220 Almy St., New Bedford, Mass.

WANTED Printing of all kinds by thousands of our readers. Your ad in this space will bring you some nice orders. Write for positive proof. P. W. Johnson, Classified Advertising Manager, Room 304, 200 East Ontario Street, Chicago.

PRINTING OUTFITS AND SUPPLIES

WE Defy any duplicator to beat Screen-O-Press. Reproduces typewritten letters, halftones, printing. Lettersize \$4.89. Anthony Unis, Peoria, Ill.

INEXPENSIVE 6x9 Printing press. Details free. Novelty Shop, Downsville, Louisiana.

PRESSES, Type, illustrations, strip-material, cabinets. Complete supplies. Bargain bulletins. Send stamp. Bradshaw, 3214-P Huron, Chicago.

PRINT Your own cards, stationery, circulars, advertising. Save money. Simple rules furnished. Print for others, nice profit. Junior outfit \$8.25, senior outfits \$17.38. Details free. Kelsey, Inc., T-11, Meriden, Conn.

PRINT At home. 10c will bring a complete catalog of presses, type and supplies. P. Peiffer & Company, 6 Columbia St., Newark, N. J.

BARGAINS—Presses, type, supplies. Send stamp. 159 Harvard, Cambridge, Mass.

USED Presses, type, supplies. Lists 3c. Turnbaugh Service, Loysville, Penna.

PATENT ATTORNEYS

INVENTORS: Learn now—without obligation—how to protect and sell your invention. Secure free "Record of Invention" form for establishing date of your invention—and free book "Patent Guide for the Inventor" containing complete information about patent procedure and selling inventions; giving illustrations of many successful inventions; over 150 basic mechanical movements. Delay may be costly. For prompt, confidential service—write—Clarence A. O'Brien & Harvey Jacobson, Registered Patent Attorneys, 31B-B Adams Building, Washington, D. C.

PATENTS Secured. Two valuable booklets, "Patent Protection" and "When and How to Sell an Invention" together with valuable "Evidence of Invention" form sent free. Write immediately to experienced patent counselors, Victor J. Evans & Co., 731-B Merlin Bldg., Washington, D. C.

FREDERICK J. Larson, Registered Patent Attorney, 7346 Forsythe Blvd., St. Louis, Missouri.

PATENTS—Trade marks. Preliminary advice, book and disclosure form free. Personal service. Irving L. McCathran, 315 McLachlen Bldg., Washington, D. C. Registered Patent Attorney.

I SELL Patents. Established in 1900. Charles A. Scott, 773PM Garson Ave., Rochester, N. Y.

PATENTS. Protect your idea by securing free "Proof of Invention" folder. Exceptional personal service. Established 1906. E. E. Vrooman, 871 Woodard Bldg., Washington, D. C.

L. P. RANDOLPH, 302-B Columbian Bldg., Washington, D. C. Low cost. Book and information free.

INVENTORS—Before disclosing your invention to anyone send for form "Evidence of Conception"; "Schedule of Government and Attorneys' Fees" and instructions. Sent free. Lancaster, Allwine & Rommel, 411 Bowen Building, Washington, D. C.

"PATENT-Particulars" and blanks, free, airmailed. Sterling Buck, Park-North Avenues, Baltimore, Md. Government-registered 36 years.

"INVENTOR'S Guide" 100 mechanical movements, free; advises on patenting, selling inventions. Frank W. Ledermann, 154 Nassau Street, New York.

FOR INVENTORS

PATENT Your idea! Write immediately for two free illustrated books, "Patent Protection" and "When and How to Sell an Invention." 68 pages of valuable information for inventors. No obligation. Address: Victor J. Evans & Co., 732-B Merline Bldg., Washington, D. C.

INVENTORS: Learn how—without obligation—how to protect and sell your invention. Secure free "Record of Invention" form for establishing date of your invention—and free book "Patent Guide for the Inventor," containing complete information about patent procedure and selling inventions; illustrating over 150 basic mechanical movements. Delay may be costly. For prompt, confidential service—write—Clarence A. O'Brien & Harvey Jacobson, Registered Patent Attorneys, 31A-B Adams Building, Washington, D. C.

CAN Inventors make money today? In 1941 alone over 4,000 assignments of patents a month were made by inventors to manufacturers or individuals. This shows today's demand for new patented inventions. Write for our free book, "Protect, Finance and Sell Your Invention." Special form "Invention Record" also mailed free. No obligation. McMorro & Berman, 134-P Albee Building, Washington, D. C.

COLCHICINE—Evolution chemical creates new mutant plants. Illustrated booklet—plus Experiments Magazine 25c. Questok, Wellesley, Mass.

INVENTORS: New military and commercial inventions urgently needed by manufacturers. Write for particulars. Chartered Institute, Dept. 4-A, Washington, D. C.

CASH For practical ideas and inventions. Mr. Ball, AB-9441 Pleasant, Chicago.

SELL Your patent through a small classified ad in Popular Mechanics. Many inventors have found buyers in this way. Ask me for proof—I'll gladly send it to you. F. W. Johnson, Manager Classified Advertising, 200 E. Ontario St., Chicago.

INVENTIONS WANTED

INVENTORS! Have you good, patentable ideas? Write Metzler, 11 West 42nd, New York.

INVENTORS: Have you a sound, practical invention for sale, patented or unpatented? If so, write Chartered Institute of American Inventors, Dept. 4-D, Washington, D. C.

CASH For inventions, patented, unpatented. Mr. Ball, A-9441 Pleasant, Chicago.

WANTED—Meritorious patented, unpatented inventions. Booklet, references, free. Invention Reporter, 5B-11236 So. Fairfield, Chicago.

YOUR Ad in this space will bring amazing results. I'll prove it to you. Write at once for interesting information. F. W. Johnson, Room 300, 200 East Ontario St., Chicago.

PATENTS FOR SALE

EARTH-TAMPER Patent No. 2-266-604. Tom Murphy, Mt. Healthy, Ohio.

I WANT to send you proof of the wonderful pulling power of Popular Mechanics Magazine's classified pages. What's your proposition? Write me today. F. W. Johnson, Manager Classified Advertising, 200 E. Ontario St., Chicago, Ill.

MANUFACTURING

MODELMAKERS, Diemakers, brass-workers, machinists, turnstiles, circulars, Baum's Specialties, Kansas City, Mo.

MODELS—Small lot manufacturing. Metals, plastics, etc. Milburn, Burlington, Kentucky.

MODELS, MODEL SUPPLIES

SHIP And yacht model fittings, sails, blueprints. Send 20c for illustrated catalog. A. J. Fisher, 1002-7 Etowah Ave., Royal Oak, Mich.

MODEL Railroad shop. Big 36 page complete catalog 10c. Dept. PM, Dunellen, New Jersey.

RAILWAY Models, complete line informative catalogs O gauge, 112 pages, 25c; HO, 48 pages 15c. Walthers, 247 Erie, Milwaukee, Wisconsin.

SHIP Models and yacht supplies complete. Large 56 page catalogue 15c. Bill Wild's, 510 East 11 St., New York City.

SHIP Model kits and fittings. Complete line Fisher model yacht equipment. All Boucher, Fisher, Marine Model and Ideal kits, fittings and blueprints at catalog prices. Most complete stock in New England. James Bliss & Co., Inc., 220 State Street, Boston, Massachusetts.

HOME CRAFTSMEN

28 LAWN Ornament patterns 25c. Other patterns; 15" -20" high; Dutch girl, Dutch boy, pirate, bull terrier, Mexican girl, Mexican boy, dwarf, penguin, flower girl, 10c each; 3 for 25c. 25 novelty patterns 30c. All 62 full size patterns \$1.00 postpaid. Strother, Box 383-EG, Bellington, W. Va.

1000 TELUHOW Plans tell homeworers about building 1000 projects. List 10c. C. King, E. Kingston, N. H.

THE New Shebel Saw Filer produces saws that have no equal. Send for full information. A. P. Shebel, 730 S. 2nd St., Milwaukee, Wis.

GET Free leathercraft instruction pamphlets, prices of leathers, tools, projects. Fascinating hobby. Make beautiful gifts. Leather samples 5c. Wilder & Company, 1938 Crosby, Dept. 2F, Chicago, Illinois.

LEATHERCRAFTSMEN: Send 10c for new handbook and catalogue of tools and supplies. E. A. Sweet Company, Inc., Leathercraft Division A-66, 148 State Street, Binghamton, N. Y.

KNOCKDOWN Cedar chest, lumber, veneers, illustrated catalog 10c. Giles Kendall Co., Decatur, Ala.

CATALOG—Patterns plywood novelties, lawn ornaments, silhouettes, letters and numerals. Decal transfers, handy hand tools, new power sander. Other lines, 500 articles finely illustrated. Write today. Wo-Met Shop, Ashburn, Georgia.

FREE—Big list of helpful books. Popular Mechanics Press, 200 E. Ontario St., Chicago.

WATCHES, OLD GOLD, JEWELRY, ETC.

GOLD \$35.00 Ounce. Mail old gold teeth, diamonds, jewelry, watches. Receive cash by return mail. Satisfaction guaranteed. Free information. Dr. Weisberg's Gold Refining Company, 1500-Q Hennepin, Minneapolis, Minn.

ZIRCON Diamonds, beautiful, inexpensive. Catalog free. Box 388/205, Wheeling, W. Va.

HIGHEST Prices for old gold—Mail your teeth, watches, jewelry. 100% full cash value mailed day shipment received. Satisfaction guaranteed or articles cheerfully returned. Information free. Chicago Gold Smelting Company, 300-P Champlain Building, Chicago.

ELECTRIC SHAVERS, RAZORS, BLADES, SHARPENING

SHICK Injector users, enjoy smooth shaving, resharpen blades with converted Autostrop razor. Simple Instructokit 60 cents. Manorwood Specialty Co., 9930 Morgan St., Chicago, Ill.

35 FIRST Quality razor blades and everlasting sharpener. 50c. Rasmussen, Boonville, Missouri.

SURVEYING INSTRUMENTS

GUARANTEED Factory rebuilt transits and levels for sale (cash or terms) or rent (with purchase option). We will repair, trade, or buy old instruments. Ship prepaid for estimate and valuation. For complete information write for list M82. Warren-Knight Co. (Manufacturers of Transits and Levels), 136 N. 12th St., Philadelphia, Penna.

FOR SALE—MISCELLANEOUS

ARMY And Navy rejects. Army coats \$5.00, sizes S, M, L. Army Air Corps sheep-skin lined leather flying helmet \$4.50 U. S. Navy sheep-skin lined destroyer coats \$20.00. U. S. Army Air Corps flying mittens \$10.00. U. S. Navy oil skin suits \$6.00. U. S. Navy sheep-skin zipper flying boots \$13.50. U. S. Navy jungle flying helmets \$2.50. U. S. Army summer flying suit, all zipper \$15.00. U. S. Marine Corps rain coat \$6.00. Prices on quantities on application. All sheep-skin lined leather flying suits. U. S. Army Air Corps specification. Price on request. Priority number necessary. Schofield's, Commercial Square, East Weymouth, Mass.

WANTED—MISCELLANEOUS

CASH For used optical, mechanical, scientific instruments. Gordon's, 162-PB Madison, Chicago.

CASH-TRADE For anything. Catalogue, dime. Toole's, 101 Adams, Evansville, Ind.

WE Buy shop, scientific, photographic, office, equipment; jewelry. "Anything," Justice Jobbers, 190 North Wells, Chicago.

MERCURY (Quicksilver) \$1.50 per pound. Any condition. Western Metal Co., Bloomington, Illinois.

MERCURY (Quicksilver), tungsten, molybdenum, cadmium, high speed tool steel, bismuth, purchased in any quantity. Write for quotations. Metallurgical Products Co., 35th and Moore Sts., Philadelphia, Penna. Established 1909.

PERSONAL

187 OUTSTANDING Health and vitality helps and facts of 16 leading health authorities, 50c postpaid. Money-back guarantee. Cole Associates, Publishers, Syracuse, N. Y.

BIRTH Certificates, all ages, any state, ten (10) day service. Enclose postage. Herndon J. Thompson, Dept. (D324), Davis, Oklahoma.

ASTOUNDING Prophecies of war, duration and outcome predicted. Hagen, 1418-D Peden, Houston, Tex.

VITAMINS. Anti-Orey, B Complex wheat germ oil, etc., direct to you. Save. Send postcard. Matoska Products Co., White Bear, Minn.

PSORIASIS Sufferers: Pixacol, used only as directed, has brought relief when everything else failed. Applied externally, dries quickly, convenient. Try regular \$1 bottle without investing a cent! Write: Pixacol, Box 1298, Cleveland, Ohio.

PERSONALIZE Your letters with Photostamps, 100—\$1.00. Schyllander, Station C, Toledo, Ohio.

DRUNKENNESS Is a disease which responds to treatment. Medical skill plus human sympathy prove successful with liquor and drug cases. 60 years experience. Write for free booklet, P. M. Nelson, The Keeley Institute, Dwight, Ill.

MEXICAN Legal matters. Wm. Cocks, Amer. Atty., 1736 ElPaso, Texas.

MISCELLANEOUS

SUPERWAX Preserves, waterproofs canvas, rope, leather. Dresses, shoes, Waxers cars, skis, metal, wood, 1½ lbs., \$1. Complete directions. Superwax, Box 1492-A, Milwaukee, Wis.

THE Lord's coming! 30 proofs free. Scheall, 263XKM, Duluth, Minnesota.

WORLD'S Fastest money maker, Bottle vanilla flavor in your spare time. Tharp, 914 Lexington, Cumberland, Md.

HEATING Costs cut 50%! Guaranteed. Sworn statement, circulars 10c. Rosensweig, RR10a-1, Cincinnati.

WOVEN Glass bookmark 10c. Modern, Box 2, Station B, New York.

BIG Mail for you. Latest moneymaking offers, opportunities, catalogs, magazines. Name listed in directory 10c. Ideal Service, 135-M Park Ridge, Ill.

INFORMATION For treasure seekers. Write. Wyss, 104½ Francis, St. Joseph, Mo.

INFORMATION. Any subject. Moderate rates. The Roxbys, Research Specialists, 747 So. New Hampshire Ave., Los Angeles.

RECEIVE Mails, magazines, samples. Your name in numerous mailing lists 10c. Howard, 396 Broadway, New York.

"TO H— with Hitler" signs. Americans show your spirit. Display this poster! 10c. Nealon Advertising, 1953 N. Myrtlewood, Philadelphia.

HELP Yourself through Everybody's Friend, 6536 Ravenna Ave. NE, Seattle, Wash. Copy, big mail, 10c. Display inch advs. \$1.00.

MAKE Pants creases last longer. Formula, quarter. Premier System, Box 1608-M, Hollywood, California.

MEDICAL Laboratory technicians in great demand. We train you in your spare time, in your own home. You can practice while studying. Write for free catalogue. Imperial Technical Institute, Box 973-J, Austin, Texas.

1001 SHORTCUT FACTS that save
you time and labor in your war job

TECHNICAL HANDBOOK

FOR SOLVING PROBLEMS IN SHOP OR FACTORY

Gives you, at a glance, the tables of data, conversion factors and related information which you need in your everyday shop or factory work.

THE FACTS AT YOUR FINGERTIPS:

Fractions • Decimals • Method of Extracting Square Root
Solution of Formulas • Problem Solving • Significant Figures
• Units of Measurement • Tables of Natural Trigonometric Functions
• Solving Triangles • Metric English Equivalents • Plane Figures
• Solids • Logarithms and Their Use • Gas Laws • Specific Heats of Materials
Melting Points and Coefficient of Linear Expansions • Composition
of Common Alloys • Atomic Weights • Instructions for Use of the Slide Rule
• Square Root and Squaring Different Standards for Wire Gages • U. S. Standard Gage for Steel Sheets, etc.



PRENTICE-HALL, Inc.,
Dept. TN-1, 70 Fifth Ave., N. Y. C.
Send me.....copies of **TECHNICAL HANDBOOK**, postpaid. I enclose \$1.00.
Send C.O.D. I will pay postman \$1.00 (plus small shipping charges). In either case I may return the book within 5 days for any reason whatsoever and my money will be refunded in full.

NAME
ADDRESS

Do you want

- ➔ ..to go to College?
- ➔ ..or to enter a Profession?
- (Such as Accounting, Architecture, Nursing, Dentistry, Teaching, Social Work, Osteopathy, Beauty Culture, Optometry, Embalming, Chiroprody, Law, Medicine, etc.)
- ➔ ..or get an Office Position?

To get anywhere, you practically **MUST** finish High School **FIRST**. You can complete our simplified High School Course in **SPARE** time at home, as **FAST** as your time and abilities permit. Equivalent to resident school work—prepares you for college, pre-professional examinations, business, industry. Standard texts furnished. Diploma. Credit for H.S. subjects already completed. Single subjects if desired. Low tuition, easy terms. American School, Chicago, est. 1897—endorsed by educators. Finish your high school education **NOW**. Write **TODAY!**

High School Course at Home

Many Finish in 2 Years

American School, Dept. H245, Drexel Ave. at 58th St., Chicago, Ill.

Gentlemen: Send me **FREE** information covering special training in subjects checked below. No obligation on my part.

- | | |
|--|--|
| <input type="checkbox"/> High School Course | <input type="checkbox"/> Diesel Engineering |
| <input type="checkbox"/> Accounting and Auditing | <input type="checkbox"/> Drafting and Design for men & women |
| <input type="checkbox"/> Architecture and Building | <input type="checkbox"/> Plastics |
| <input type="checkbox"/> Automotive Engineering | <input type="checkbox"/> Private Secretary |
| <input type="checkbox"/> Business Management | <input type="checkbox"/> Mechanical Engineering |
| <input type="checkbox"/> Aviation | <input type="checkbox"/> Radio |
| <input type="checkbox"/> Electrical Engineering | <input type="checkbox"/> Salesmanship |
| <input type="checkbox"/> Elec. and Gas Refrigeration | <input type="checkbox"/> Shipbuilding |
| <input type="checkbox"/> Air Conditioning | |

Name

Address

Occupation

Reference

VICTORY-MINDED MEN WANTED

When Victory Is Won



At this time all your energy and ability are rightly being devoted to the service of America in winning the war. Our entire production facilities are engaged 100% in the same cause. When the story of victory is written, we will again serve the peace-time needs

of America for Fyr-Fyter Extinguishers. In looking for a peace-time occupation, remember we will again have ambitious men to act as distributors for an approved and enlarged line of Fyr-Fyter Extinguishers. Make a note of our name and address now. Clip this article and save. You will want it the day the last shot is fired.

FYR-FYTER

THE FYR-FYTER COMPANY
Dept. E, Dayton, Ohio

PRACTICAL AUTO INFORMATION

Keeps Cars Rolling by Making Repairs and Adjustments Easy!

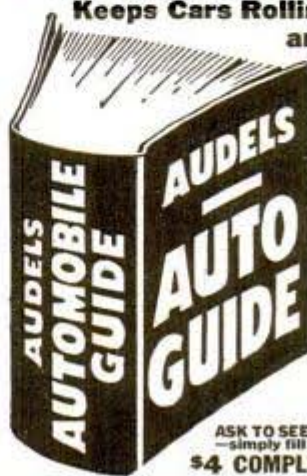

AUDELS AUTO GUIDE
For Every Mechanic, Driver, Owner and Repair Shop.

Sent on 7 Days Approval
Shows How to Tune Up—Keep Brakes Safe—Batteries Powerful—Tire Mileage Up—Save Gas—Lubricate Correctly.

ANSWERS YOUR QUESTIONS
Contains all you need to know about 1—Construction, 2—Operation, 3—Service, 4—Repair of Modern Motor Cars, Trucks, Buses & Diesel Engines in every detail.

NEW FLUID DRIVE TREATED
Easy to understand—1540 Pages, 1540 Illustrations. Gives definite directions on How to handle service jobs.

ASK TO SEE IT—Get this information for yourself—simply fill in and mail coupon today.
\$4 COMPLETE • PAY ONLY \$1 A MO.

AUDEL, Publishers, 49 West 23rd St., New York
Mail AUDELS AUTOMOBILE GUIDE (\$4) for free examination. If O. K., I will send you \$1 in 7 days; then remit \$1 monthly until \$4 is paid. Otherwise, I will return book promptly.

Name

Address

Occupation

Reference

P. M.

WATCH ★ ★ ★ ★ MIDWEST

AFTER THE WAR IS WON ★ ★ ★
FOR SENSATIONAL ADVANCEMENTS
AND FEATURES SUCH AS - - -

SUPER BAND - SPREAD TUNING*



***A
MIDWEST
SENSATION IN
1942—BUT WAIT
TILL YOU SEE THE
MIDWEST OF
TOMORROW**

OUR ENTIRE PRODUCTION FACILITIES
ARE NOW DEVOTED TO MANUFACTURING
RADIO EQUIPMENT FOR OUR ARMED FORCES
BUT...WHEN VICTORY IS WON

**YOU'LL BE BUYING YOUR MIDWEST RADIO
DIRECT FROM THE FACTORY**

FOR VICTORY



BUY
UNITED
STATES
WAR
BONDS
AND
STAMPS

SAVING UP TO **50%**
WILL BE JUST AS POPULAR AS EVER

Yes, Sir. Thousands upon thousands of people all over the U. S. were buying super powerful Midwest Radios direct from our factory until "Pearl Harbor" and if the many letters we are still receiving every day is an indication, the direct-to-user-plan will be more popular than ever after the War is won.

FREE

FOR A
LIMITED
TIME ONLY



A beautiful 12" x 8" "Old Glory" Calendar in full colors, absolutely free if you send 10 cents for a U. S. War Savings Stamp. Just send a dime or 10¢ in postage stamps and your Calendar and War Savings Stamp will be sent promptly.

MIDWEST RADIO CORPORATION
DEPT. 15A CINCINNATI, OHIO

97 Booklets filled with Money and Time-Saving Helps

Little Library of Useful INFORMATION

Here at amazingly low cost is the practical help and information you have always wanted. The booklets are written in non-technical language and photos and diagrams illustrate every detail. Only simple tools are required to make and enjoy things you might not otherwise afford. Check Titles wanted, clip ad and mail today.

5 for \$1.00
12 for \$2.00
25¢ Each

WORKSHOP EQUIPMENT

Power-Driven Saws—74: Complete details on scroll saw, two circular saws, sliding cut-off saw, bandsaw.
Drill Presses, Plane, Grinders—79.
Sanders—80: Complete constructional details on 8 useful machines.
Wood & Metal-Turning Lathes—81: Two wood lathes, small metal-turning lathe.
Filing Machine, Hack Saw, Cutoff Wheel, Shaper—82.
Metal Lathe Tools You Can Make—101.
Workbenches & Tool Cabinets—47.
Spray Painting—94: Constructing spray guns, compressor, using spray gun.
From Pattern to Casting—91: How to make your own patterns and small castings.

SHARPENING—USING TOOLS

Tool and Saw Sharpening—92.
Using & Sharpening Drills & Wood Bits—90.
Successful Wood Turning—32: All the information you need to master this art.
How to Read Blueprints—71: Tells you how to understand signs, symbols, and lines.
Metal Turning Lathe Kinks—99: Simple homemade tools, time and labor-saving shortcuts you can use.
Operating a Metal Turning Lathe—100.
Heat Treating & Case Hardening—102.
Working with Glass—103: Cutting, drilling, etching, blowing.

ELECTRICAL

Rewinding & Servicing Electric Motors—73: Repairing and rewinding a.c. and d.c. motors. Locating trouble. Converting auto generators into 110 v. a. c. motors.
House Wiring—89: All the information you need to do a complete wiring job or install extra outlets.
Electromagnets & Solenoids—44: Designing and building.
Transformer Construction—41: Easy-to-understand instructions for all kinds of transformers.
The Boy Electrician—43: Easy-to-build motors, experiments.
Soldering & Brazing—17.
Arc & Spot Welders—5: Building and operating 110 v. a. c. arc and spot welders.
Treasure Finders—13: Build your own treasure finder and metal locator. Details for both large and small radio types.

ELECTROPLATING

Electroplating with Copper, Nickel, Chromium, Lead, Zinc, Cadmium—86.
Plating Leather & Other Non-Metallic Objects—Plating with Gold, Silver, Alloys—87.

HOME IMPROVEMENTS

Building Extra Rooms in Attic—23.
Attractive Basement Playrooms—24.
Lower Your Fuel Cost—31: Practical kinks that will save you hundreds of dollars.
Hanging Wallpaper—38: Tricks of hanging wallpaper, removing old paper, etc.
Curing Leaky Basements—45.
Fitting Home Game Room—55: Construct own game & tennis tables, shuffleboard court, action game, portable playrooms.

Built-In Fixtures—78: Step and space-saving kitchen units, built-in beds, corner cabinets, vanities, linen chest.
Constructing Indoor & Outdoor Fireplaces—88: Stone fireplaces, portable mantels, garden fireplaces.

GARDENING

Backyard Gardening—39: Selecting, planning and getting the best results.
Lawn & Garden Novelties—72: Jig-sawed ornaments, parkway numbers, sundials, flower boxes.
Trellises, Pergolas, Fences—76.
Lawn & Garden Furniture—77: Modern bent-tube furniture, arbor and seat combinations, swings, lawn chairs.
Playground Equipment—73: Two playhouses, ferris wheel, roller coaster, treadmill, play store, slide, two merry-go-rounds.
Colored Concrete Garden Furniture—6: Garden benches, pottery, flower boxes, bird baths and sundial pedestals in colored concrete. How to build small concrete mixer.
Bird Houses—7: Easy to build homes for all kinds of birds.
Farm & Garden Tractors—8: Two tractors you can build from old automobile parts.

CRAFT WORK—HOBBIES

Complete how-to-make-it instructions for hundreds of practical projects.
Magazine Racks—49: Ten attractive racks.
Clock Cases—50: Large Hall, Colonial wall and mantel, ship's wheel, miniature grandfather, desk, Spanish style banjo.
Serving Trays for Every Occasion—53: Fourteen different designs.
Children's Room Furniture—51: Twelve attractive pieces.
Book Ends—52: Ten designs offer good selection.
Small Tables—54: Modern and colonial styling.
Smoking Stands—56: Seven designs given.
Jigsawed Novelties—57: Sewing kits, string holders, place-card holders, plywood kitchenware, plant and flower holders, coin banks, door stops, drawer pulls.
Desks—58: Colonial writing desk, two modern-type desks, student's study desk of plywood, combined chest and writing desk.
Book Cases—59: Eight designs.
Doll House & Doll Furniture—60.
25 Shelves You Can Make—64.
Novelties Turned on Lathe—62.
Inlay Pictures—Veneering—63.
Whittling and Wood & Soap Carving—65.
Action Toys—66: 21 easy-to-make toys.
High Flying Kites—67.
Windmills & Weathervanes—68.
Lamps in Wood, Metal, Plastic—69: Selection of 14 designs.
Home Work Opportunities—19: Simple handicraft with money-making possibilities.
Telescopes—20: Reflecting telescope you can build for less than \$10.00.
Metal Craft—28: Brass tapping and making of novelties both decorative and useful.
Small Looms—37: Building hand looms for weaving rugs, etc.; leather novelties.
Plain & Novelty Wood Finishing—40.
Gem Cutting—42: How to cut and polish semi-precious stones.

BOAT BUILDING

Build a boat at home—you can do it
14 Ft. Outboard Runabout—2: Here is a fast 14 foot V-bottom boat. Suitable for motors of 4 to 24 hp., estimated cost, \$30 to \$40.
14 Ft. Sailing Dinghy—26: This 14-foot boat combines strength and light weight. It carries 140 sq. ft. of canvas and weights, about 350 pounds. Actual photographs and diagrams illustrate every detail.
21 Ft. Sloop—46: Every fact needed by the amateur boat builder to construct this craft which carries eight to ten persons.
Rowboats, Bicycle Boat, Small Dinghy—83: All the information you need to construct four low-cost boats.
Small Sail Boats—84: 12-ft. sailing dinghy, 6-ft. "training ship" for young sailors, how to sail a boat.
Two Outboard Runabouts—85: 14-Ft. family outboard weighs about 400 lbs. and 12-ft. plywood outboard weighs about 110 lbs. Both are V-bottom type.
Build Your Own Canoe, Kayak, Surfboard—30: Complete details on 16-ft. Canadian-type canoe, 17-ft. kayak, and 12-ft. hollow surfboard.
Fast Class-E Ice Yacht—22: Build your own Class-E ice yacht. Every detail of construction carefully explained.

AUTOMOBILES

Automobile Kinks and Shortcuts—10: Money-saving hints on upkeep and operation.
Building Trailers—27: Small Streamlined house trailer; several utility trailers.
Motor-Driven Midget Car & Scooter—34: Both use gas engine of washing machine type.
Curing Auto Electrical Troubles—95.

PHOTOGRAPHY

Save Money by constructing your own photo equipment.
Photo Enlargers—1: Condenser lens type; simple vertical; horizontal.
Photo Printers & Dryer—25: Describes three practical printers, timer and negative dryer.
Photo Darkroom Equipment—96: Cabinets, light-tight box, timer, agitator, washer, trimmer.
Picture Projector, Trick & Table Top Photograph—97: Projectors that enlarge magazine illustrations and shop drawings. Tips for table toppers, photomontages, tricks.
Photo Kinks—98: 63 time and money-saving ideas you can use.

FORMULAS

Transform simple ingredients into useful products
Cleaning Formulas—11: For woodwork, automobiles, brushes, wallpaper, chimneys, etc.
Cosmetic Formulas—12: Hand lotions, creams, rouge, bath salts, beauty clay, lipsticks, etc.
Food Products Formulas—15: 100 formulas for making every-day necessities.
Metal Plating & Coloring—21: Dozens of formulas for metal plating, coloring and decorating.
Re-Silvering Mirrors—70: Formulas for silvering and coloring.

MISCELLANEOUS

Chemical Experiments—93: Easy-to-perform experiments. Inexpensive lab.
Taxidermy—9: How to prepare skins and obtain life-like poses.
Log Cabins & Tourists Cottages—14: Year-round log cabins; inexpensive tourists' cabin.
Magic for Everybody—29: Simple tricks to puzzle your friends.
Trapping Small Animals—33: How to lure fur bearers, prepare bait and traps, dress skins.
Training Your Dog—35.
Small Furnaces—36: Build own gas or electric.

Books Sent C.O.D. Anywhere in United States

Just check the booklets you want (minimum C.O.D. order \$1.00), write your name and address below, and mail this advertisement. It is your order blank. When postman hands you booklets, pay him the price and few cents postage. Outside U. S. A. enclose remittance and include 15% additional for shipping charges. Ask for big FREE catalog of helpful books.
 (If you send payment with order we pay postage, U. S. currency or stamps may be mailed if carefully wrapped. Same money-back guarantee)

Name
 City State

Address
Mail to Popular Mechanics Press, Dept. 455 - 200 East Ontario St., Chicago, Ill.

NEW BOOK ON PLASTICS
now ready



PLASTICS FROM FARM AND FOREST
by E. F. Lougee

At Last! A non-technical Plastics book, written in a clear, practical, understandable way, by the well known authority E. F. Lougee, former Editor Modern Plastics Magazine. Profit by information in this intensely interesting and instructive book, entitled "PLASTICS from FARM and FOREST." No other like it anywhere. Describes many fascinating and amazing experiments in Plastics; and tells of the big opportunities both now and in the future. Do you want to know

Only \$2.00

how blankets, hats and buttons are being made from skim milk; how corn cobs and sugar cane waste is being turned into wall board and molded products; how soy beans are made into automobile parts; how walnut shells find their way into Plastics and dynamite? These subjects, and many others, are explained in LOUGEE'S Book. Get the facts on Plastics. Order this important book TO-DAY! 10 Days Inspection FREE.

SEND NO MONEY

Don't delay—Book shipped C.O.D. anywhere in U.S.A. Simply pay postman \$2.00 plus small C.O.D. and postage charges. (If you send cash in advance we pay postage). In either case, if you are not fully satisfied, return the book in 10 days and we'll refund your money immediately. Mail your order NOW!

PLASTICS INSTITUTE
221 NO. LA SALLE ST., DEPT. M • CHICAGO, ILLINOIS

Inventions Wanted
Patented or Unpatented

Write us if you have a sound, practical invention for sale, patented or unpatented. It can now be safely sold without patenting expense.

Chartered Institute of American Inventors
Dept. 4, 631 Pa. Ave., N. W. Washington, D. C.

ELECTRICAL BOOKS
shipped FREE



10 BIG BOOKS

FOR EXAMINATION MODERN ELECTRICITY INCLUDING RADIO AND REFRIGERATION

Here's great news for anybody interested in Electricity. NEW 18th. edition of Applied Electricity brought right down to date with NEW Electrical subjects fully covered, including Electrical Blue Print Reading. 10 big Volumes and all shipped FREE for examination.

New Edition For Beginners and Experts

over 3000 pages—hundreds of illustrations—the most complete work of its kind we have ever published. Dynamometers, motors, power stations, wiring radiators, television, everything electrical explained so anyone can understand it.

BIG FIELD! Big Demand! Big Pay!

Men who understand electricity are urgently needed in thousands of War Production industries. Airplanes, ship building, arms plants, machine shops—practically every industry depends on electricity and men who know this subject make big money. Pleasant, fascinating work, easy to learn and do; learn with these books. Send coupon for a set for FREE examination and see for yourself.

SEND NOW

A year's consulting privileges with our engineers now given to all buyers of this famous Cyclopedia of Electricity.

AMERICAN TECHNICAL SOCIETY
Vocational Publishers since 1898

American Technical Society, Dept. E219, Drexel at 58th St., Chicago
Send for 10 days' free use, 10 volume set of New 18th Edition, Applied Electricity, including a certificate entitling me to consulting privileges for one year. I will pay the delivery charges only on the books. If I wish I may return them in 10 days and owe you nothing, but if I keep them, I will send \$2.00 after 10 days, then \$3.00 a month until the total price of only \$29.80 is paid.

NAME.....

ADDRESS.....

CITY..... STATE.....

Please attach letter stating age, occupation and name and address of employer and give at least one business man as reference.

FEBRUARY 1943

EVERY WORD CONTAINS
A HIDDEN STORY OF ITS ORIGIN

Alert!

Once meant,
On the watch-tower!

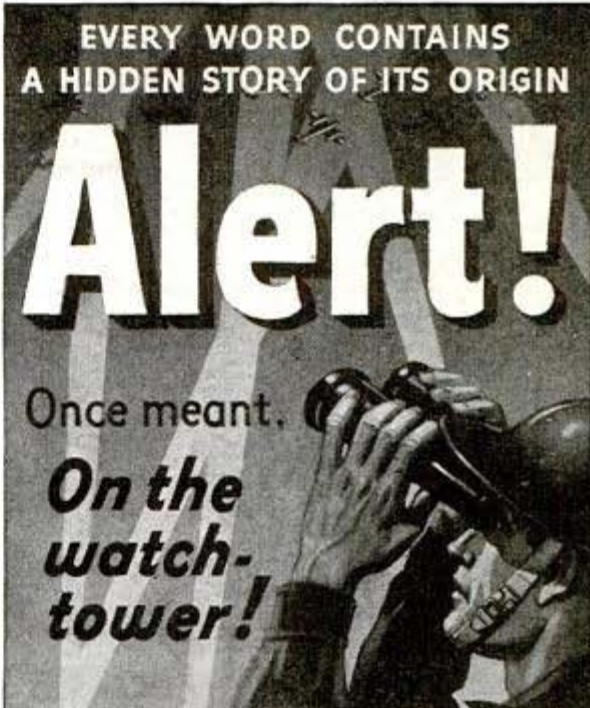

A LERT, now meaning "air raid alarm!", comes from early French *à Perte*, "on the watch." This, in turn, came from Italian *all'erta*, "on a watchtower or height." When the first field hospital was organized to follow an army, the French called it *hôpital ambulante*, "walking hospital," from the Latin *ambulare*, "to walk." Eventually *hôpital* was dropped and *ambulante* became *ambulance*, a vehicle for conveying casualties. *Sabotage*, now the malicious hindrance of production, comes from French *saboter*, "to work carelessly"—originally, "to tread with wooden shoes, or *sabots*."

Both you and your children will enjoy the hundreds of fascinating word origins in WEBSTER'S NEW INTERNATIONAL DICTIONARY, Second Edition—The Merriam-Webster.

These colorful word histories are just one feature of this greatest of all knowledge books. Its completeness makes it truly the *Foundation Book for Home Education!* The more questions you and your children bring to it, the more you will be amazed at the range and scope of the information furnished by its hundreds of encyclopedic articles, by over 200 outstanding authorities. It seems almost unbelievable that such a vast fund of knowledge could be packed into one book! And, in addition, you learn everything you want to know about words, 600,000 of them, 122,000 more than any other dictionary.

You have long wanted this great question answerer; now is the time to get it. Ask any bookdealer to show you the *Genuine Webster—The MERRIAM-Webster—identified by the Circular Trade-Mark.* Write for free illustrated booklet of interesting word origins to G. & C. Merriam Co., 226 Federal St., Springfield, Mass.

Advt. Copyright by G. & C. Merriam Co.

the Genuine Webster

WEBSTER'S
NEW INTERNATIONAL
DICTIONARY
Second Edition



Say you saw it in *Popular Mechanics!*

War days are OPPORTUNITY DAYS for YOU

... in Accounting ...

If you like to work with figures and are earnestly ambitious, accounting today offers you unparalleled opportunity—to serve your country and to profit.

For there just aren't enough bookkeepers and accountants to fill the needs of government and industry. There are thousands of new and vacant jobs. These jobs pay well and they are open to both men and women. Moreover, this need will continue through the war and the post-war adjustment period.

Ask us to prove this—and to show you how you can grasp this opportunity quickly.

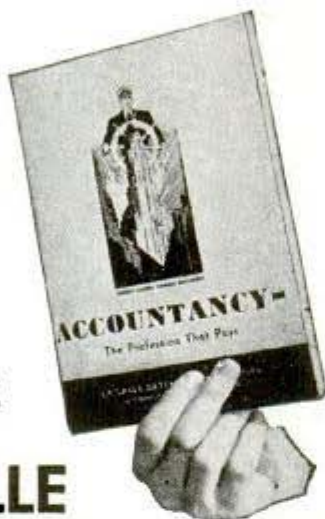

Ask for this free 48-page booklet

LASALLE EXTENSION UNIVERSITY A Correspondence Institution

Dept. 264-H CHICAGO

I want to know what opportunity there is for me in Accounting now and how I can prepare for it. Send me your free booklet and any other pertinent information.

Name.....Age.....

Present Position.....

Address.....

LEARN MONEY-MAKING CARTOONING

Same Simplified Method that has helped train creators of "Terry & Pirates," "Wash, Tubbs," "Out Our Way," "Winnie Winkle," "Regular Fellers," "Strange As It Seems," "Secret Agent X-9," and many others. Earn while learning. Rush 10¢ for Picture Chart (to test your ability), and full details. (State age.)
THE LONDON SCHOOL, 4382 National Bldg., Cleveland, Ohio



PARKS AIR COLLEGE PARKS AIRPORT EAST ST. LOUIS, ILL.

Offers YOU COLLEGE and PROFESSIONAL TRAINING
Majoring in AVIATION

Accredited by the Illinois Superintendent of Public Instruction. Included since 1938 in The Directory of Colleges and Universities, issued by the U. S. Office of Education. U. S. approved as a Commercial Ground and Flying School and Mechanics' School. Accredited by and cooperating with the United States Army Air Corps in giving flight and mechanical training. Open to high school graduates.

FOUR courses lead to B.S. degrees in Professional Piloting, Aviation Operations, Maintenance Engineering, Aeronautical Engineering.

TWENTY-TWO TRAINING PLANES are used in professional flight training which prepares graduates for airline flight operations.

FACULTY of 104 specialists in various fields of aviation.

Enrollment limited to a total of 300 commercial aviation students. Capacity enrollment of 870.

Airport, 25 buildings devoted to school purposes exclusively. Dormitories and dining hall at the College.

Spring term March 29. Send postcard for new 64-page catalog.

16th YEAR Registrar, Dept. PM-2
PARKS AIR COLLEGE, East St. Louis, Ill.

Learn to Speak SPANISH FRENCH, GERMAN OR ITALIAN This Quick, Easy Way



ONLY 15 MINUTES A DAY! Know a second language for better business or social position; read foreign books; really enjoy travel. Speak like a native. Now FUN to learn quickly, easily at home as thousands have! Write today for free book. "The Cortina Short-Cut." State language interested in.

CORTINA ACADEMY, SUITE 842, 105 WEST 40th STREET, NEW YORK CITY

Learn TOOL DESIGN

Qualify quickly as a Machine or Tool Designer by home-study in spare time. Entire defense program depends largely upon the machine and tool designer. After defense boom, machine and tool designers will be equally necessary for reconstruction. Many now making \$100 to \$125 a WEEK. Rapidly expanding industry calling for more machine and tool designers than now available. Learn quickly with our step-by-step lessons supervised by a recognized professor of machine tool design. Rush name and address today for complete facts on Machine or Tool Design. Learn what these fields offer you and how quickly you can qualify for a big pay position. No obligation. State age. A penny postal will do—but hurry.

Ohio Institute of Technology, Box 90, Greenville, Ohio

Correspondence Courses in RADIO and ELECTRICAL ENGINEERING LOW AS \$25

ELECTRICAL ENGINEERING. Get good grasp of wide electrical field. Modern. Very understandable. Theory made easy.
RADIO ENGINEERING. Extra fine course in radio, public address, photo-electric work. Trains you to be super-service man, real vacuum tube technician. Tuition ONLY \$25, either course. Deferred payment plan. Experiment kits furnished.

FREE LINCOLN ENGINEERING SCHOOL, Box 531-P-50, Lincoln, Nebr.

FIBRE ARMS AND LEGS!

Light, correctly fitted, strong and comfortable. Natural appearance. Braces for all deformities. Scientific design. Fair Terms.

BUCHSTEIN-MEDCALF 610-3rd Av. S., Minneapolis, Minn.

Learn PHOTOGRAPHY at Home

Splendid opportunities. Prepare in spare time. Easy plan. No previous experience needed, common school education sufficient. Send for free booklet "Opportunities in Photography", particulars and requirements.

American School of Photography
1315 Michigan Ave., Dept. 1352, Chicago, Ill.

LEARN A BIG PAY TRADE MAIL COUPON!

in 2 to 8 WEEKS!

We Pay Room and Board

To meet the great demand for men and women at high wages, we have inaugurated intensive training courses in the trades listed here. Learn in 2 to 8 weeks by actual shop work. One of America's leading schools. Established 1902. 7 floors of shops. Over 40,000 graduates. Many employers send their men and women here for intensive training. Free employment service. Mail coupon for "Shop Training Facts."

GREER SHOP TRAINING

Dept. 223, 2024 S. Wabash Ave., Chicago, Ill.

Send "Shop Training Facts" describing trade checked below:

- | | |
|---|---------------------------------------|
| <input type="checkbox"/> Auto-Diesel | <input type="checkbox"/> Body-Fender |
| <input type="checkbox"/> Welding | <input type="checkbox"/> Machine Shop |
| <input type="checkbox"/> Refrigeration | <input type="checkbox"/> Tool and Die |
| <input type="checkbox"/> and Air Conditioning | <input type="checkbox"/> Aviation |

Name.....

Address.....

Age.....

FREE
LARGE
WORK
MODEL

WOMEN • STUDY • **MEN**
AT HOME
YOUR CHOICE OF A CAREER
AIRCRAFT CONSTRUCTION
AIRPLANE MECHANIC
DENTAL REPAIR MECHANIC

COMPLETE
\$3.98
COURSE

Thoroughly Illustrated—Quickly—Easily—Self-Taught
No High School or College Education Necessary

Our Courses are Complete in Every Detail. Home study makes it possible to **EARN WHILE LEARNING**. Write for particulars, or send money order for prompt delivery of the course and work model course that you desire. Get started at once for a better job, with more pay.

**HOME STUDY INST., 236 W. 55th STREET,
DEPT. A-22, NEW YORK CITY, N. Y.**

LEARN AT HOME TO MOUNT BIRDS



Animals, Heads, Fishes, Pets; to TAN. Be a Taxidermist. Profit and FUN. Hunters, save your valuable TROPHIES. Mount ducks, squirrels, everything. Learn to TAN for leather and furs. Wonderful HOBBY. Have a HOME MUSEUM.—BIG PROFITS mounting for others. INVESTIGATE NOW.

FREE BOOK With 100 fine game pictures. NOW absolutely FREE. Write TODAY.

Send Postal TODAY for FREE BOOK. State AGE. N. W. SCHOOL OF TAXIDERMY, Dept. 3372, Omaha, Neb.



Learn Public Speaking

At home—In spare time. Many overcome "stage-fright," gain self-confidence and increase earning power, this easy way. Write for free booklet, *How to Work Wonders With Words* and requirements. North American Institute, Dept. 1352 1315 Michigan Ave., Chicago, Illinois

ARTISTS MAKE MONEY

Find out your ability. Send name, age, occupation and address for Free Vocational Art Test. ART INSTRUCTION, INC. (Formerly Federal Schools) 2133 Art Instruction Building, Minneapolis, Minnesota



ITALIAN ACCORDIONS

Hand Made. Very best. Lowest prices. Buy Direct from Factory and Save Money. Send name and address for FREE catalog. ITALIA & P. SOPRANI ACC. MFG. CO. 323 W. POLK ST., DEPT. PM-2, CHICAGO, ILL.

WILL YOU WEAR THIS SUIT



and Make up to \$12 in a Day!

Let me send you a fine union tailored-to-measure tailored suit FREE OF ONE PENNY COST. Just follow my easy plan and show the suit to your friends. Make up to \$12 in a day easily. No experience—no house-to-house canvassing necessary. Big opportunity for you—full or spare time.

SEND FOR SAMPLES—FREE OF COST Write today for FREE ACTUAL SAMPLES and "sure-fire" money-getting plans. For quick action write fully, giving age, etc. Send no money. W. J. COFFIN, PROGRESS TAILORING CO., 500 South Throop Street, Dept. P-216, Chicago, Illinois.

EARN MONEY PAINTING PORTRAITS



No previous training or talent necessary. Unique Stuart System teaches you, by mail, in 10 simple, easy-to-follow lessons, to make excellent charcoal and oil likenesses. Detailed guidance for your every step. Send for free book today.

STUART STUDIOS,

121 Monument Circle, Room 623, Indianapolis, Ind.

Please send me free book and outline of lessons.

Name _____

Street _____

City _____

State _____

TRAIN NOW FOR RADIO

...but read this before you buy!

You can pay all sorts of prices for radio training. You can read all sorts of advertising claims. But why guess? Get your training from this one book that has given more people their basic radio training than any other ever published—the one book that is more widely used for home study, and by Army, Navy and civilian schools and colleges than any other.

THE MOST TRAINING FOR YOUR MONEY

... AS PROVED BY ANY COMPARISON!

For Ghierdi's famous RADIO PHYSICS COURSE is 36 courses in one—written so clearly you can't fail to understand them—and explaining everything from basic electrical principles to the newest things in Radio, Television, etc. It is bigger, better illustrated, more complete, easier to study—972 pages, 508 illustrations, 256 self-testing review questions.

Send for IT ON TRIAL! Compare it with any other radio book at any price. You be the judge!

Sold at a fraction of the price you might expect to pay!

972 pages \$5 Complete, ONLY



MONEY-BACK GUARANTEE

★ Going to be Inducted? ★ Radio Training will prove your key to higher Army-Navy pay—faster promotion—more interesting duty. Thousands of Ghierdi-trained men attest this fact.

5-DAY FREE TRIAL—You Can't Lose

RADIO AND TECHNICAL PUBLISHING CO., Dept. PM-23 45 Astor Place, New York, N. Y.

Send me your RADIO PHYSICS COURSE, \$5 enclosed. Send C.O.D. In either case, if I am not fully satisfied, I may return the book in 5 days and receive my money back.

Name _____
Address _____
City _____ State _____

SUPER JU JITSU

WHEN THIS HAPPENS TO YOU...

NOW—YOU CAN DESTROY Your Enemy Quick!



DO THIS

BE A ONE-MAN BLITZ! Strike with Command lightning! You don't need ox-like muscles to use Super Ju Jitsu, most powerful of all defense and attack methods. **Technique** is the deadly secret. Brains count—not size, not strength. Almost miraculously efficient.

Gain Self-Confidence

KNOW how YOU can lick brutes twice your size with your bare hands only, even when they are ARMED with gun, knife, club. Get ready now for any emergency—protect your loved ones. Amazing self-study course teaches you double-quick. No boring exercises needed.

Send for Exciting Details—Free!

Startling Low Price. Satisfaction Guaranteed or your moneyback. Mail coupon now.

FREE NELSON CO., 500 Sherman Street DEPT. B-502, CHICAGO, ILL.

Please rush me free the hard-hitting details about "Super Ju Jitsu." No obligation on my part.

NAME _____

ADDRESS _____





MACHINE SHOP MEN

Learn to set up and run ANY kind of machine; **MAKE MORE MONEY NOW** by learning quickly **HOW TO DO THINGS** which usually take years of study and practice. The demand for **SKILLED men** is **ALREADY** ahead of the supply, then what **WILL IT BE** a month or two from now?

Needed NOW!

Bigger Pay Don't miss this chance to qualify for promotion, don't miss this Big Opportunity which is yours almost for the asking. Eight Big Books chockful of important mechanical facts told simply and clearly. Over 3000 pages, nearly 3000 illustrations cover every subject fully, including Tool Making, Pattern Making, Foundry Work, Mechanical Drawing, Forging, Machine Shop Practice and Management, and hundreds of other subjects.

8 Big Books (Up-to-date Edition) Sent FREE to you for examination. With them we send a **Big Binder** of 867 pages with 293 original shop tickets and over 1300 illustrations. These show, step by step, how to set up and run almost any kind of job and are in **addition** to the 8 books. Decide in your own home or place of business whether or not you want to keep them, check up on any facts you want to. Note their great **MONEY MAKING** value, then, if you want them, pay on the easiest kind of payments. A year's consulting privileges with our engineers now given with these books without extra charge.

American Technical Society, Vocational Publishers since 1898.

American Technical Society, Dept. 5219, Drexel at 58th St., Chicago
You may send me the 8 big books and binder of shop tickets for free examination. I will pay the delivery charges only, unless I decide to keep them in which case I will send \$2.00 in ten days and \$3.00 per month until the total price of only \$34.50 is paid. If I return them in 10 days I will owe you nothing. You also agree to send me a certificate entitling me to consulting privileges with your experts for one year without extra charge.

Name.....
Address.....
Please attach a letter stating age, occupation, employer's name and address and that of at least one business man as reference.

WANTED Radio Men for BIG PAY JOBS

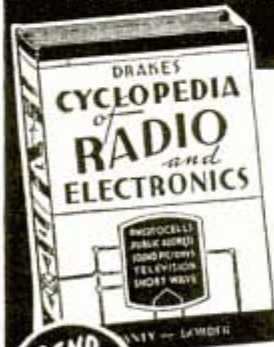

Thousands of Radio Technicians needed for industry and our Armed Forces—NOW. This home study book—the "Radio Men's Bible"—will enable you to qualify for advancement and big pay.

Here is a complete course in Radio and Electronics—written in simple, non-technical language—easy to understand.

COMPLETELY REVISED INCLUDES FREQUENCY MODULATION

Covers radio transmission and reception—sound pictures—short wave—public address systems—television—photo cells. More than 500 articles, complete in themselves—over 1,100 additional definitions and references. Each section divided with cross references to related subjects. 1,000 pages—1,178 illustrations—130 tables—105 graphs.

SEND NO MONEY
5 DAY EXAMINATION

PAY AS YOU LEARN
Start to-day to qualify for a bigger, better job and real money.

MAIL THE COUPON NOW!

Drake Publishing Co., Dept. PM2, 600 W. Van Buren St., Chicago, Ill.

Send me Drake's Cyclopaedia of Radio and Electronics, price \$5.00. I will pay postman \$1.00 plus charges, (postage paid if cash in advance) and remit \$1.00 per month until full price, \$5.00, is paid. If not satisfied I will return book within 5 days and my \$1.00 will be refunded.

Name.....
Address.....
City..... State.....
Position.....
Company.....

Say you saw it in Popular Mechanics!

BE A GOVERNMENT LICENSED AIRPLANE AND ENGINE MECHANIC

Train Now at LINCOLN

You can prepare at this Lincoln Government Approved School to earn up to \$3600 a year as Government Licensed Airplane & Engine Mechanic. Exceptional opportunities in civilian war service positions with Airlines, Airport Operators and Aircraft Factories. Men interested in foreign service positions can earn up to \$6000 per year. High School education sufficient. We train you and assist Graduates in locating positions. **WRITE TODAY** for complete information.

LINCOLN AERONAUTICAL INSTITUTE
672 AIRCRAFT BLDG. LINCOLN, NEBRASKA

LACO OIL BURNER 19th YEAR

Send for free folder, low prices on LACO Oil Heater, Oil Furnaces, Gun-Type Burner for furnaces. Purchasable where no fuel restrictions exist to replace worn-out units or Heaters where other means are unavailable. (Subject to further restrictions.) No more after present stock gone. Write NOW!

Laco Oil Burner Co., 124 Union Ave., Griswold, Iowa

IT'S FUN TO MAKE THINGS OF WOOD

CONSTANTINE'S MANUAL TELLS HOW TO DO IT
Beginner or expert will find many helpful hints and tips on veneering, woodfinishing, cabinet making, carpentry, etc. Constantine Master Manual for Woodworkers and Big Bargain Book describes and illustrates over 100 different kinds of wood and 980 different items for you. **ALL AT MONEY SAVING PRICES.** A source of supply for anything in wood regardless of quantity. Send only 25c in stamps or coin. 25c refunded or credited on first order so Manual costs you nothing. **ALBERT CONSTANTINE & SON, INC.**
791-N E. 135th St. New York, N. Y.

U. S. War Industries say "GIVE US MORE TRAINED MEN"

AIRCRAFT AND ARC WELDING

Uncle Sam demands an increase in war production of 40%—50%—100% and more! It's a **MUST**—and every plane, tank, ship and other fighting machine has to be made and manned by **trained men.** Whether you are drafted or not, you can serve your country better—and earn bigger pay—if you enter our

6 WEEKS—6 MONTHS SPECIAL WARTIME COURSES

in **AIRCRAFT AND ARC WELDING**, or others for **AVIATION MECHANICS, ELECTRO TECHNICIANS, DRAFTSMEN, RADIO OPERATORS AND TECHNICIANS.** Don't be content with hit-or-miss jobs with poor pay when in a short time you can become a specialist with an expert's pay—and get a better rating if drafted. Send coupon today.

Ask about Loan Plans and opportunity to earn

\$1,040

while attending college.

MILWAUKEE SCHOOL OF ENGINEERING

Institute of Electrotechnics

PM-243 North Broadway and E. State, Milwaukee, Wis. Without obligation, send Free Booklet, "Golden Opportunities in Defense Work." Also tell me How to Become an

{ } Arc Welding Operator { } Aircraft Technician
{ } Aircraft Welder { } Aircraft Draftsman
{ } Welding Technician { } Radio Operator
{ } Electro Technician { } Radio Technician
() Earns \$1,040 While Learning

Name..... Address.....

City and State..... Age..... **PM-243**

NOT ALL DO AS WELL BUT **\$779.81**

LAST MO.

GROSS IN MY OWN BUSINESS



reports G. E. Carpenter. L. A. Rowe says he took in \$148 in first week. He is 61 years old. L. T. Jordan says that he has had weeks running close to \$400. J. W. Benson says his best day was \$54.50, while E. C. Thomas reports that he took in \$1,100 in 18 days. Read these reports and note what a livewire can do in his busy seasons. Electricity does the work. Washes rugs beautifully on customer's floor. Hundreds of customers in your own vicinity and nearby towns.

EASY TERMS

Equipment is not expensive. Pay part down—balance monthly. No shop necessary. We want more honest, ambitious men to get into this wonderful business for themselves. Every machine guaranteed.

FREE BOOK

Send today for booklet illustrating rug washer and telling how you can earn large profits at prices below other methods; how you can build a permanent business; and how you can pay on easy terms.

VON SCHRADER MFG. CO.
102 Pl., Racine, Wis.



MATHEMATICS MADE PLAIN
for the practical man

This complete study and practice course presents the kind of mathematics needed by the man who wants something that he can apply to the every-day problems of his job. It brings him a clear, simple, and usable knowledge of the essentials of the subject—a step-by-step treatment of mathematics without needlessly involved explanations and methods.

- covers arithmetic, geometry, algebra, and trigonometry in one convenient volume
- shows practical uses of mathematics — explains fundamentals and methods that simplify and shorten work
- easy to study, written in simple terms, handily groups related instructions, examples, solutions, and practice problems

Famous home-study course now revised and enlarged

Palmer and Bibb's
PRACTICAL MATHEMATICS FOR HOME STUDY

3rd Edition, 695 pages
Makes mathematics YOURS with more than **3500** drill exercises and problems and answers. Price only \$4.00

Nowadays the man with a knowledge of practical mathematics has the edge in the trades, machine shop, drafting room, in the armed forces, in factory production and inspection, etc. Improve your chances this quick, easy way, with this tested book that thousands of men have used with success.

FREE TRIAL — SEND NO MONEY — JUST MAIL COUPON

McGRAW-HILL BOOK CO., 330 W. 42 St., N. Y. C.

Send me Palmer and Bibb's Practical Mathematics for Home Study for 10 days' examination on approval. In 10 days I will send \$4.00, plus few cents postage, or return book postpaid. (Postage paid on cash orders.)

Name
Address
City and State
Position
Company PM-2-43

ELECTRICIANS
Earn More Money!



Amazing **3 Volume ELECTRICAL ENCYCLOPEDIA**

FREE-7 Day Trial

1200 Big Pages. 2000 Subjects. 2000 Pictures. Handsome Red and Gold Binding.

AUTHORITATIVE—EASY—COMPLETE

Here, at last, is the PRACTICAL, EASY-TO-USE ELECTRICAL ENCYCLOPEDIA especially written for the workaday Electrician or Mechanically-inclined man. Provides desired facts at your fingertips. A practical study-at-home Reference Set. **AUTHORITATIVE**—Prepared by experts who know Electricity and know how to tell you about it in plain understandable words. **PRACTICAL**—Used regularly on the job by hundreds of Electricians, Service Men, Radio Men, Air Cadets, Students, Maintenance Men. **EASY**—Plenty of how-to-do-it pictures and easy-to-follow words. **COMPLETE**—A world of Electrical knowledge packed into 3 volumes.

RADIO-TELEVISION INCLUDED

Covers EVERYTHING ELECTRICAL from magnetism and signal systems to armature winding, A.C. and D.C. motors, generators, electronics, automotive electricity, refrigeration, Diesel electricity, telephones, etc. . . . also includes Radio and Television. Tells how to build, troubleshoot, make repairs. Easy-to-understand words TELL how each job is done. Plenty of pictures and simple diagrams SHOW how it's done. YOUR ELECTRICAL and RADIO QUESTIONS answered quickly, completely, clearly. This is not a correspondence course. No written lessons or examinations or tests to be sent in. You study at home when you have the time and it will always serve as a reference set when you want to look up any electrical problem.

FREE! WITH ENCYCLOPEDIA
One year of personal technical service by mail.

IF YOU ACT NOW, we'll include a Certificate entitling you to 1 year of Technical Service. This means you have the privilege of writing to us for technical advice on any electrical subject.

ASK TO SEE THEM

You don't have to risk a penny. To get your set promptly, just mail coupon. Examine the three big volumes for 7 days. If at the end of that time you don't agree they're the best practical electrical set you ever saw regardless of price, then return the books and YOU WON'T OWE A CENT. If you decide to keep them, send \$3 after 7 days and \$3 a month until the advertised price of \$12.00 is paid. We prepay shipping charges. Mail the coupon now. THIS OFFER IS LIMITED. Act today!

LEWIS 500 South Paulina Street
Dept. 23-R6, Chicago, Ill.

MAIL COUPON NOW

LEWIS, 500 S. Paulina St., Dept. 23-R6, Chicago, Ill.
Send me the big 3-volume Coyne Electrical Reference and Instruction Encyclopedia. Within 7 days after receiving the books, I'll either return them or send you \$3 and \$3 a month until advertised price of \$12.00 is paid. We prepay shipping charges.

NAME.....
ADDRESS.....
CITY.....STATE.....
OCCUPATION.....AGE.....

SECRETS ENTRUSTED TO A FEW



The Unpublished Facts of Life

THERE are some things that can not be generally told—*things you ought to know*. Great truths are dangerous to some—but factors for *personal power and accomplishment* in the hands of those who understand them. Behind the tales of the miracles and mysteries of the ancients, lie centuries of their secret probing into nature's laws—their amazing discoveries of *the hidden processes of man's mind*, and *the mastery of life's problems*. Once shrouded in mystery to avoid their destruction by mass fear and ignorance, these facts remain a useful heritage for the thousands of men and women who privately use them in their homes today.

THIS FREE BOOK

The Rosicrucians (not a religious organization), an age-old brotherhood of learning, have preserved this secret wisdom in their archives for centuries. *They now invite you to share the practical helpfulness of their teachings*. Write today for a free copy of the book, "The Mastery of Life." Within its pages may lie a new life of opportunity for you. Address Scribe G.G.F.

The ROSICRUCIANS
(AMORC), SAN JOSE, CALIFORNIA, U. S. A.

STUDY AT HOME

With A Chartered Educational Institution

Courses in **ENGINEERING**: Electrical, Civil, Mechanical, Drafting, Architectural, Steam, Aeronautical, Radio, Structural, Mining, Industrial, Highway, Petroleum, Marine, Chemical.
Courses in **ARTS AND SCIENCES**: Philosophy; Education; Letters; Public Health; Medical Jurisprudence; Psychology; Sociology; Physics; Chemistry; Geology; Pol. Science; Theology; Law; Business and Commerce; Accounting; Mathematics; Statistics; Agriculture.
McKinley-Roosevelt Incorporated, 4610-UC, Sheridan Road, Chicago

AVIATION CAREER



Offers You
A GREAT FUTURE!

Complete Aeronautical Engineering or Master Aviation Mechanics training in the heart of the Aircraft industry. Graduates obtaining immediate employment. No flying involved. Aviation's foremost school, established in 1929. Located on Grand Central Air Terminal. For full information, address Department PM-2



**CURTISS
TECHNICAL**  **WRIGHT
INSTITUTE**

GRAND CENTRAL AIR TERMINAL
GLENDALE (LOS ANGELES) CALIF.

THIS TOWER OVERLOOKS AVIATION'S MOST DISTINGUISHED SCHOOL OF AERONAUTICS

LAW STUDY AT HOME for PERSONAL SUCCESS and LARGER EARNINGS. 31 years expert instruction—over 100,000 students enrolled. LL.B. Degree awarded. All texts furnished. Easy payments. Send for FREE BOOK—"Law and Executive Guidance."
AMERICAN EXTENSION SCHOOL OF LAW
Dept. 26-N, 8 East Huron St., Chicago, Ill.

ELECTRICITY MEN NEEDED

Electricians are needed everywhere. Hollywood studios alone claim shortage 200 men. This is a live money making profession. Learn at home, spare time. Easy payments. Selective Employment service. Write for FREE Bulletin. No obligation.

AMERICAN SCHOOL

Dept. EE245 Drexel at 58 St., Chicago

Shop MATHEMATICS

You Need it to Earn TOP PAY and ADVANCE

When you know mathematics you advance faster. Get this short cut to success in any production work. New method used in training thousands of men in Detroit and other cities brings quick results even if without high school education. Vol. 1, SHOP ARITHMETIC, \$1.50. Vol. II, SHOP GEOMETRY, ALGEBRA, TRIGONOMETRY, \$2.00. Sent postpaid if you remit with order, or pay postman on delivery. Rush order now.

Goodheart-Willcox Co., Dept. 12, 2009 S. Michigan Ave., Chicago

FIX Your TIRES



So-Lo SAVES RUBBER

Use "plastanoid" SO-LO to fix cuts, bruises, worn spots in tires. SO-LO also mends shoes, raincoats, boots—anything of rubber, leather, cloth.



MEND the HOLE for

SPREADS ON like butter. Dries tough overnight. Flexible. Non-skid. Waterproof. Won't come off—guaranteed.

So-Lo AT HARDWARE & 10c STORES **1¢**

New Jobs! More Jobs! FINGER PRINTING IS GROWING FAST

Look What's Happening!

1923
In 1923 there
were only

393

Identification Bureaus
in the United States

1929

In 1929 there
were

604

Identification Bureaus
in the United States

1942
In 1942 there
are

1453

Identification Bureaus
in the United States



T. G. Cooke

"I have trained the men who
run 43% of all these Bureaus"

... And Now Defense Work Demands Still MORE Experts

If it's quick action you want—good pay NOW and BETTER pay later—if it's steady work you want, whether times are bad or good—war time—peace time, any time—become a Finger Print Expert. City, county, state and federal need for men of this exclusive profession is constantly increasing! See for yourself how many more Identification Bureaus there are now than there were just a few years ago.

You Can Learn Quickly

Finger Printing is easy to learn. But it isn't something anybody can do expertly without training. That protects you. It IS learned rapidly. Not much time is needed. You can begin right now and qualify as a Finger Print Operator almost before you know it, and once you've graduated, you'll have something no one can ever take from you—a profession for the rest of your life!

Here Are the Facts

Forget the Defense urgency—forget all the new finger printing jobs opened by the war emergency. Just look at the regular normal growth and expansion of the finger printing profession. In 1923 there were 393 Identification Bureaus in the United States, as stated above. In 1929 it grew to 604. At the end of 1929 there were 604. At the close of 1937 there were 979, and at the beginning of 1942 there were 1453 official Identification Bureaus in this country and—43% of these bureaus are run by graduates of the Institute of Applied Science. Yes, 43%—almost half! We believe this to be a world's record.

The Cost of Training is Extremely Low

It's not like learning many other things . . . no long years of study—no heavy expenses. Learning to become a finger print expert costs you very little—so little you'll wish you'd started

in this extremely important profession a long time ago. And you can get this training on the payment plan if you want to. Seize this chance—begin by mailing the coupon—get started—be through and ready in plenty of time to cash in on the opportunities in finger print work.



FREE BLUE BOOK OF CRIME

This book takes you right on the inside of Scientific Crime Detection, tells you about finger printing, firearms identification, police photography and explains just how many types of crime are cleared up. It will be sent to you entirely free of charge. The coupon below brings it.

INSTITUTE OF APPLIED SCIENCE
1920 Sunnyside Ave., Dept. 1352, Chicago, Ill.

INSTITUTE OF APPLIED SCIENCE
1920 Sunnyside Ave., Dept. 1352, Chicago

Gentlemen: Without any obligation on my part whatever, send me the Confidential Reports of Operator No. 38, also illustrated "Blue Book of Crime," complete list of 840 bureaus employing your graduates, together with your low prices and Easy Terms offer. (Literature will be sent ONLY to persons stating their age.)

Name

Address

Age

WONDERS OF AMERICA

Pilot's Pinwheel!



THIS QUEER MACHINE TESTS A FLYER'S ABILITY TO WITHSTAND HIGH-SPEED TWISTS, TURNS, AND DIVES. THE DEVICE WILL TURN UP TO 54 TIMES PER MINUTE



YOU'D HARDLY BELIEVE IT, JUDGE ROBBINS, BUT THOSE MEN WERE WHIRLING FASTER THAN THE BLADES OF A SMALL ELECTRIC FAN

REMINDS ME OF HOW I ONCE WENT AROUND IN CIRCLES LOOKING FOR THE RIGHT PIPE TOBACCO



SAME HERE. EXTRA-MILD, GOOD-TASTING PRINCE ALBERT FIXED THAT FOR US ALL RIGHT, EH, JUDGE?

PRINCE ALBERT IS THE **NO-BITE SMOKE** — SO MILD — EASY ON THE TONGUE

P.A. FOR **RICH TASTE, TOO** — IT'S BETTER TOBACCO

SEE HOW SMOOTH THE P.A. CRIMP CUT PACKS, DRAWS

IS THAT BOY LEARNING TO WALK A TIGHT-ROPE?



HE MIGHT AS WELL BE ON THAT SHAKY PLATFORM. HE'S TRYING TO KEEP A PIN-POINT IN A TINY HOLE WITHOUT TOUCHING THE SIDES. IT'S A TEST FOR SELF-CONTROL WHILE FLYING

PRINCE ALBERT STANDS WAY OUT IN THE PIPE-SMOKER'S TEST. IT'S THE MOST COMPLETE ENJOYMENT OF PIPE-SMOKING THAT I KNOW

THAT GOES FOR P.A. IN ROLL-YOUR-OWNS, TOO. THERE'S NO EQUAL TO ITS SMOOTH MILDNESS AND GOOD, RICH TASTE

50
PIPEFULS
OF FRAGRANT
TOBACCO
IN EVERY
HANDY POCKET
PACKAGE OF
PRINCE ALBERT

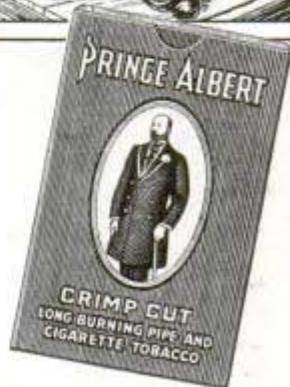

PRINCE ALBERT

Con: Allen Warren Elliott
7 Park Ave, NYC.

Popular Mechanics Magazine

REGISTERED IN U. S. PATENT OFFICE AND CANADA

WRITTEN SO YOU CAN UNDERSTAND IT

Vol. 79

FEBRUARY, 1943

No. 2

NEW MAGIC From TEST TUBES

IF YOU have ever watched a magician working his miracles on the stage, you can better understand what is happening in the world today.

The magician excites you with his actions and talk and attracts your attention to one hand while his other hand works apparently impossible feats.

The war is like the magician. Our attention is attracted on one hand by battles, shortages, rationing, taxes. Meanwhile the other hand—which is chemistry—is preparing new magic from test tubes which will probably astound all of us before we are much older.

Many of the wartime chemical developments are so far-reaching that eminent scientists state we will hardly recognize our civilization as soon as peace lifts the lid off the boiling cauldron of chemical discovery.

One foremost scientist, Dr. Charles M. A. Stine, a vice president of the DuPont Com-



Airplane tires of DuPont rayon cord, above, are 20 pounds lighter. Below, manufacturing a tough, lacquer-covered fabric

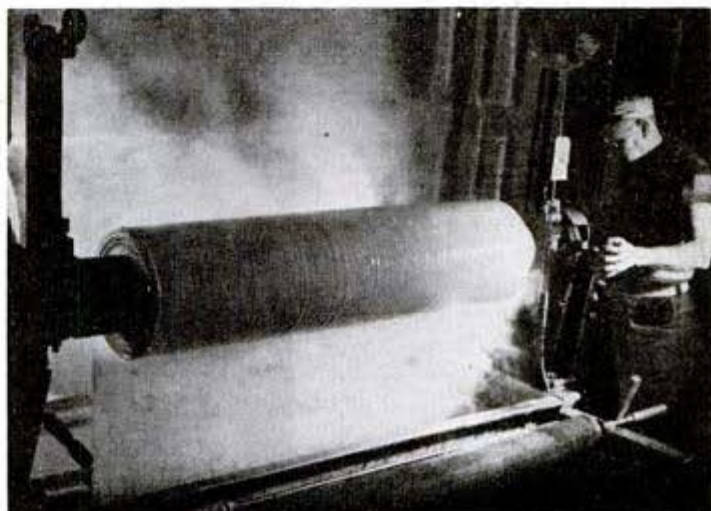

"Fabrikoid" - DuPont 1

FEBRUARY, 1943

Иллюстрация: записанный авторские права

cordura rayon

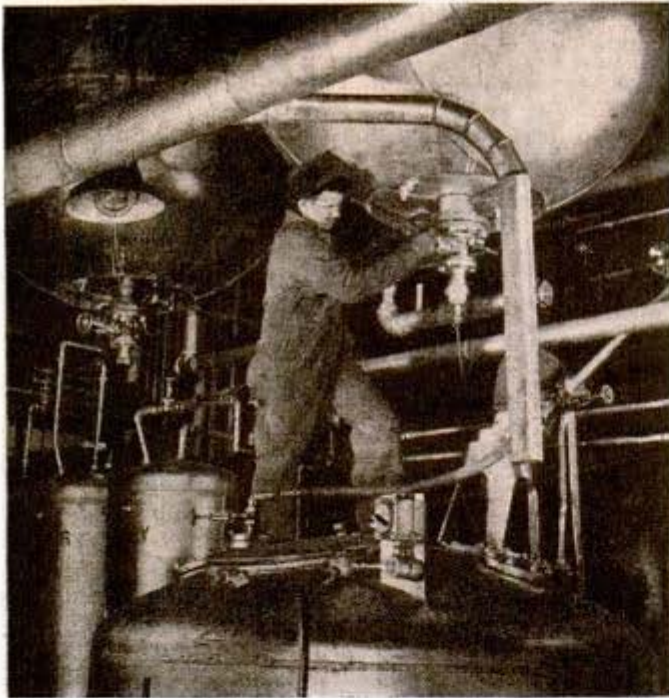

OEM photo

Standing on a "blow down" tank in a Goodrich synthetic rubber plant, a worker taps latex from the blending tank above

Aaron D.

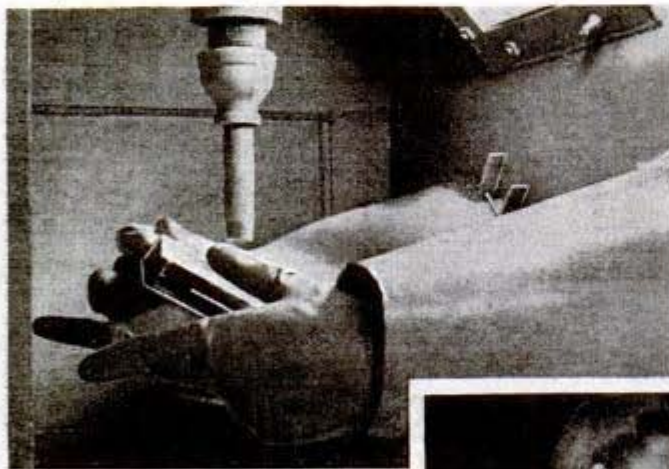

Resistoflex

Plastic rubber sheets protect a worker's arms (left) from sand blast in war plant

Installed with stapler (inset), window panes of wire screening sandwiched between cellulose acetate will withstand blast of 150-pound bomb exploding eight feet away

Monsanto Chemical Co.

"Vnelite"

pany, asserts our automobiles have aged technically at least 20 years in the past few months because of what has been learned in the first year of war. Post-war cars will have sealed cooling systems developed for war planes. Research in metals will cut automobile weights in half. New fuels will give 50 miles to the gallon.

The high-pressure synthesis of ammonia, he says, has made the manufactured fertilizing chemicals so plentiful that agriculture will be

completely revolutionized. Using the new building blocks developed only recently from air, coal and water, we will have glass which won't break, but will float; wood that won't burn, and plastics stronger than metals; shoes without leather; window screens without wire; machinery bearings minus metal.

New methods of aluminum processing have raised production to seven times the output which it took 50 years of research to reach. Petroleum processing has made every motor in existence out of date and fuels have exceeded our octane scale in power rating. Magnesium, a lightweight metal extracted from sea water, has climbed out of the curiosity class and our capacity for producing it is double our aluminum output for 1939.

The production of rubber substitutes from petroleum, alcohol, coal and limestone may reasonably wipe out the rubber tree as an important economic factor. New type houses will be painted with strange paints. New fabrics will produce

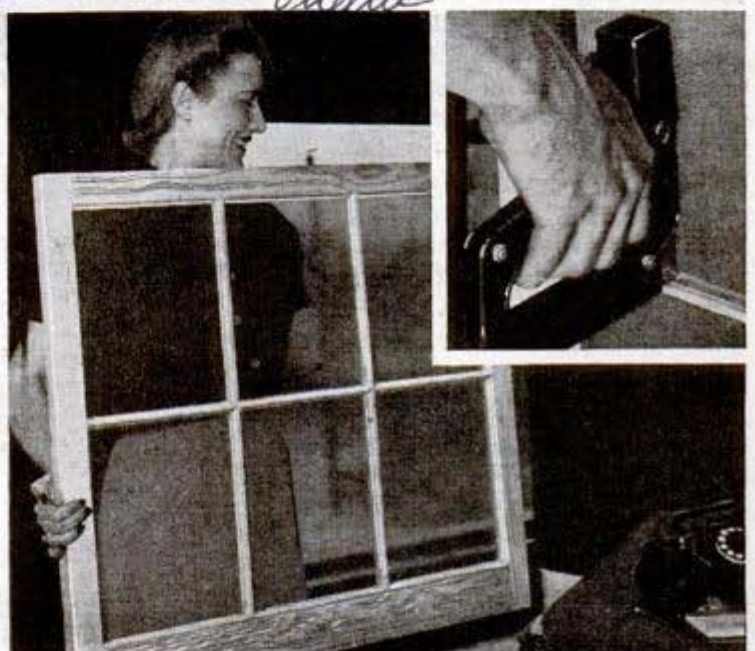

clothing that cannot be imagined now.

Other chemists see steel's future principal use as cutting and wearing edges with newly developed lighter metals replacing it in trains that ride as if on air and bridges and houses of comparative feather weight. Blankets of fluffy glass and inexpensive furniture of plastics are predicted.

Though many current developments are reserved for war use and are secrets, it is no secret that the rapid development of plastics has already brought the number of successful ones beyond the 1,500-mark, each plastic having some advantage over the other and over pre-war materials. Shoes, aprons, capes, heel pads, jackets, umbrellas, shower curtains, key chains, garment bags, bathroom fixtures, faucets, and hundreds of familiar objects are being made with plastics for the first time.

Proof of the future is already mirrored in the present miracles produced by chem-

Nylon yarn must be of uniform weight, and is weighed by sample on a glass-enclosed precision scale

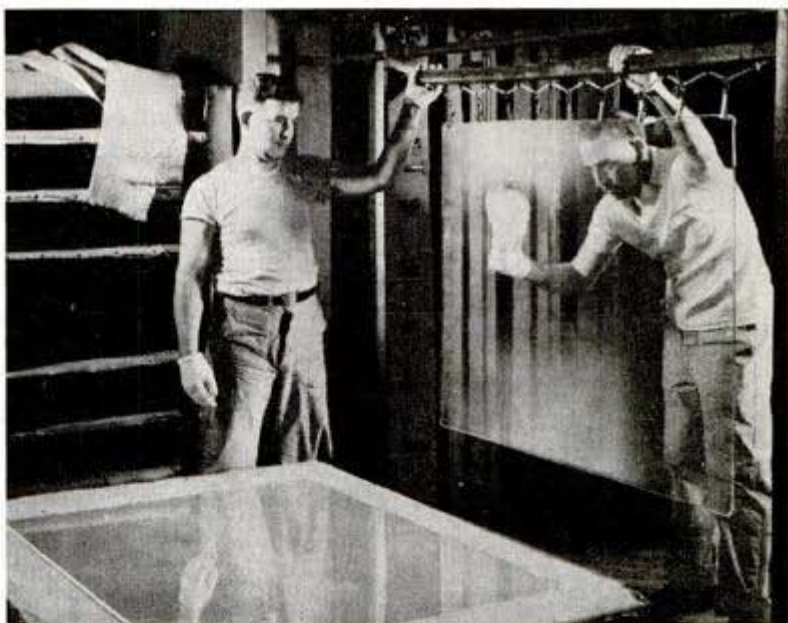
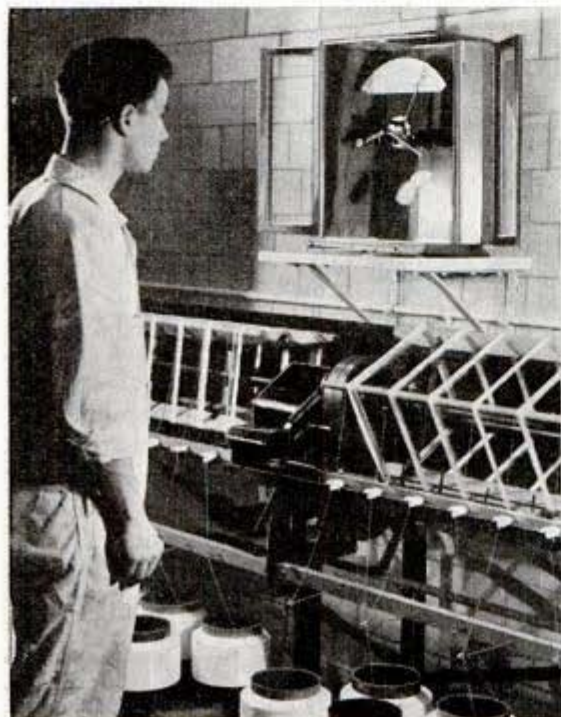

DuPont's Lucite, a plastic made under 5 tons per square inch pressure, has gone to war in transparent aircraft turrets and cockpit enclosures

istry. Du Pont scientists estimate that a bridge of ships spanning the Atlantic Ocean, spaced about a mile apart, would be required to bring to America only five of the many vital war products which have been produced synthetically since the last war. These are rubber for transportation, dyestuffs for uniforms and camouflage, fibers for parachutes, powder bags and many industrial uses, camphor, for medi-

In a dye laboratory a printing machine which prints only for test purposes, runs off a roll of wallpaper

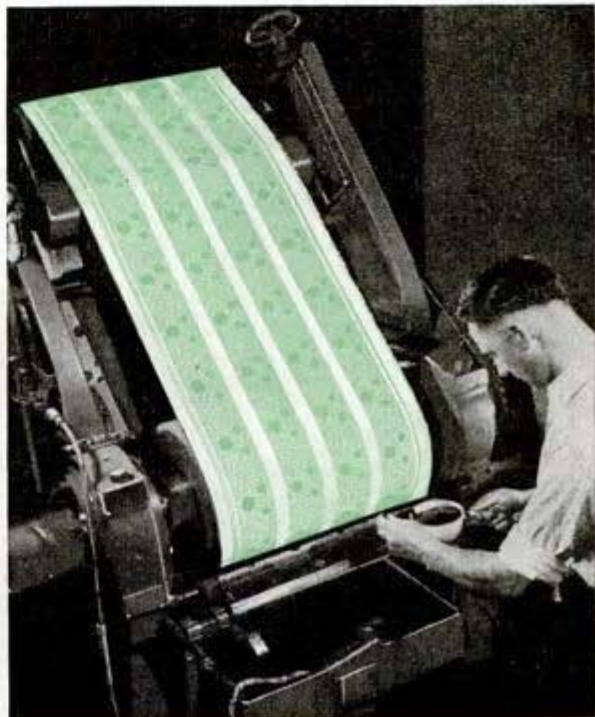

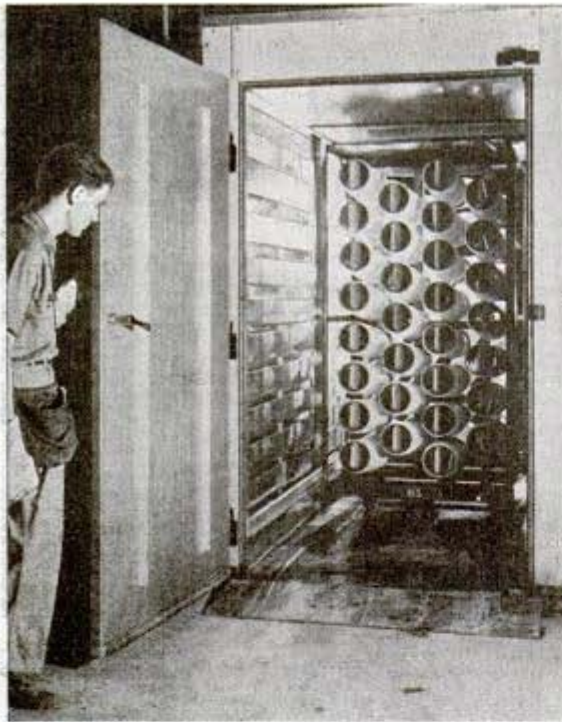

Baking nylon yarn to set the twists before winding it for test, inspection and shipment to war industry

cine and chemical uses, and nitrates for explosives and fertilizers. The chemical manufacture of nitrogen alone has saved for other purposes the cargo capacity of more ships than the Axis powers have sunk during the war.

Some idea of the importance of nitrogen, which is obtained from the air, may be gathered from the fact that every 600-pound bomb requires 85 pounds of it and a 24-foot torpedo would be just a hunk of steel without 100 pounds of nitrogen. A

16-inch gun shoots 120 pounds of nitrogen at the enemy.

Many of our chemical discoveries which had commonplace uses in peacetime have gone to war, just as many wartime discoveries will be converted to peaceful uses later on.

Ammonia, which the housewife used to clean windows, woodwork and tile, now has at least 2,000 industrial uses connected with the war. It is an ingredient in explosives, hardens metals for tanks, planes and guns, helps make nylon, can be turned into fertilizers, is useful in the manufacture of plastics which are made into noses, gun turrets, navigation blisters and other transparent sections of war planes.

This chemical helps in refining petroleum products by neutralizing acids harmful to stills, increases the sterilizing effect of chlorine in drinking water, is an important part of a combination of chemicals used for fireproofing, acts to form the bubbles in sponge rubber, and is important in the manufacture of dyes, among other things.

Other familiar products of chemistry have joined the fight. A colloid treated fabric, Celastic, used in peacetime to give strength and resiliency to box toes of shoes, now serves to speed military production by making possible quick and easy repairs and changes in patterns for metal castings. Looking like a piece of cotton blanket, the fabric can be moistened, shaped and on drying will harden in any desired form.

The cellulose hood which protected your milk bottle in peacetime is now serving as a cover for the open ends of fuel and hydraulic lines and other pipes and tubes during assembly and shipping, replacing plugs. Made of a wood base, this plastic cap is painted bright red so it cannot be overlooked in assembly operations. It also serves as a seal to warn of tampering if broken. Placed on wet, it dries and shrinks tightly in a few minutes.

The fluid your neighborhood dry cleaner used to take spots out of a vest has been improved for war use and is applied in huge quantities to degrease metal parts, from hair-size radio tube fila-

(Continued to page 181)

Transparent plastic gloves, resistant to oils and solvents, are made of this elastic, synthetic resin—a rubber substitute



POPULAR MECHANICS

Resistoflex

Wright drank water

*Some Newspictures, Inc.
461-8 av NYC.*

Cargo Ship Launches Fighters From Catapult

m 971

British convoys are protected from enemy bombers far out at sea by fighter planes catapulted from the decks of cargo vessels. After shooting down one or more of the bombers and breaking up an attack, the fighter pilot bails out and is picked up by one of the escort ships. The plane is lost, but every lost fighter generally has cost the enemy two or more bombers. In the United States, some freighters have been converted to auxiliary aircraft carriers for use on convoy duty.

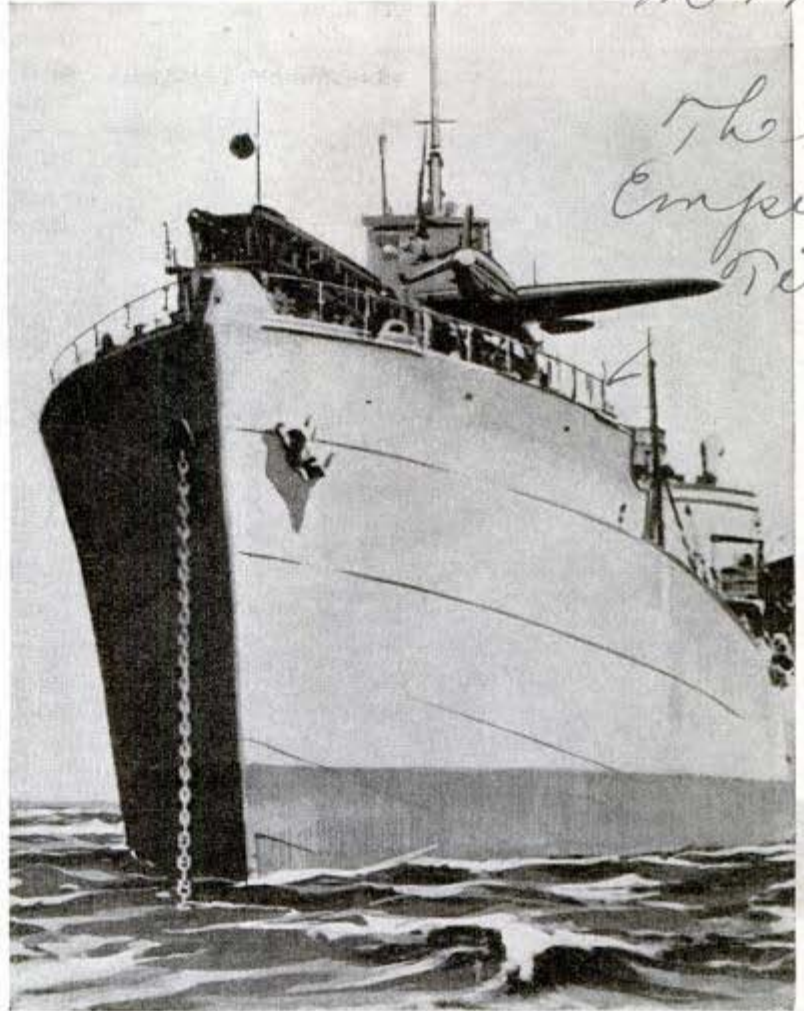

The Empire Tide

This British merchantman carries deadly surprise for enemy bombers attacking ships in convoy. Fighter planes are launched from catapult on deck. After driving off foe, pilots bail out and are rescued. Fighter craft are not recovered

Electronic Clock Without Motor Tells Time by Lights

m 1038

Having no moving parts—no motors, wheels, mainspring or hands—an electronic clock installed in the new RCA laboratories

in Princeton, N. J., indicates time by lights. The timepiece, containing more than 170 electronic tubes, plugs into an electric outlet

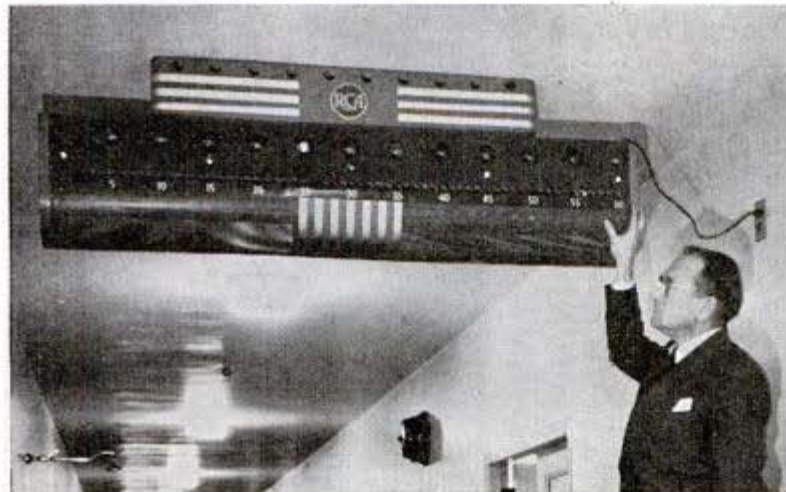

and the 60-cycle current provides pulsations for flashing lights on and off to show the time in terms of seconds, minutes and hours. Scientists who have examined it believe it may form the basis for household clocks of the future.

30 Rochester Pk. N.Y. 10024

Lights going on and off across electronic clock "tick off" the seconds

☐ Strawless "straw hats" for 1943 that look like straw, feel like straw and will not collapse in the first summer rain, are being woven of cotton.

FEBRUARY, 1943

*Dr. V.K. Zworykin
Asst. Dir. Res.* *Frank Lee Co
Danbury, Conn.*

Dummy Cockpit of Sinking Plane Teaches Pilot to Escape



Cadet learning to escape from an airplane after crash in sea

Pilots are trained to escape from a sinking airplane with a dummy cockpit developed at Sand Point Naval Air Station near Seattle. First, the cockpit is suspended in a pool by ropes while the pilot, wearing flying suit and parachute, straps himself in. At a signal, the "fuselage" is allowed to sink. The pilot unsnaps the safety belt, pushes himself clear and swims away.

Ten Ways to Stretch Your Gas Listed by Auto Experts

Gasoline rations can be stretched as much as 50 percent, according to the War Engineering Board of the Society of Automotive Engineers, if the motorist will follow a 10-point system of correct and careful driving. Not only gasoline, but undue wear and tear on tires, brakes and mechanism will be saved by a scrupulous adherence to the rules. Here they are: (1) Drive at moderate speeds, 30 miles per hour being suggested; (2) accelerate moderately; (3) use brakes only when necessary; (4) avoid idling engine unnecessarily, "racing" the motor, "pumping" the accelerator

and excessive use of choke; (5) use lightest lubricants recommended for engine, transmission and differential; (6) keep chassis and parts well lubricated; (7) keep ignition system, carburetor and air-cleaner clean and in good condition; (8) keep motor properly tuned, brakes adjusted and wheels aligned; (9) keep cooling system thermostat at proper setting, and (10) keep tires inflated to five pounds above specified pressures.

Counters Tally Riders In Passing Cars

Passenger loads in passing automobiles are counted easily by four ordinary three-key traffic counters mounted on a board. One such counter is sufficient to tally the number of cars, and if desired the operator may keep track of three different types of vehicles. For taking a record of passengers, the four counters provide a total of 12 tabulating keys, which are numbered consecutively from one to 12. The operator simply notes the number of passengers in a car and punches the key bearing the corresponding number. At the close of the test period the total shown for each key is multiplied by the number of the key to obtain the total persons carried by cars in each group.

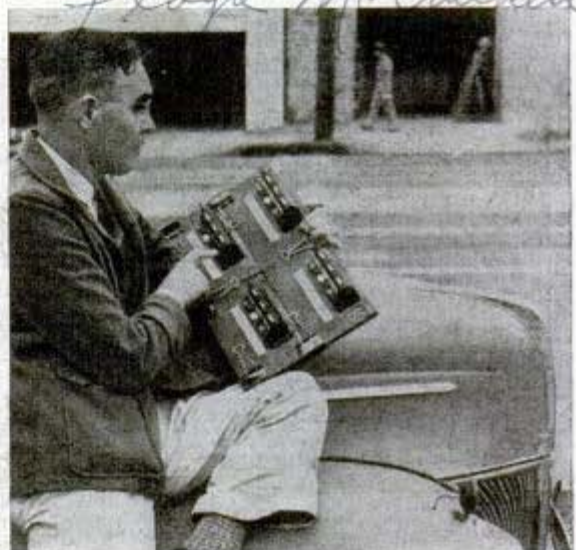

Four three-key counters make 12 separate records

City specialist Douglas Jackson

29th 39 2021 nyc

Ino. Antoine Dazha, Dazha
Eng., 1712 Industrial Trust Bldg
"Noiseless" Sea Skimmer to Battle Submarines
Providence, R.I. m 1053

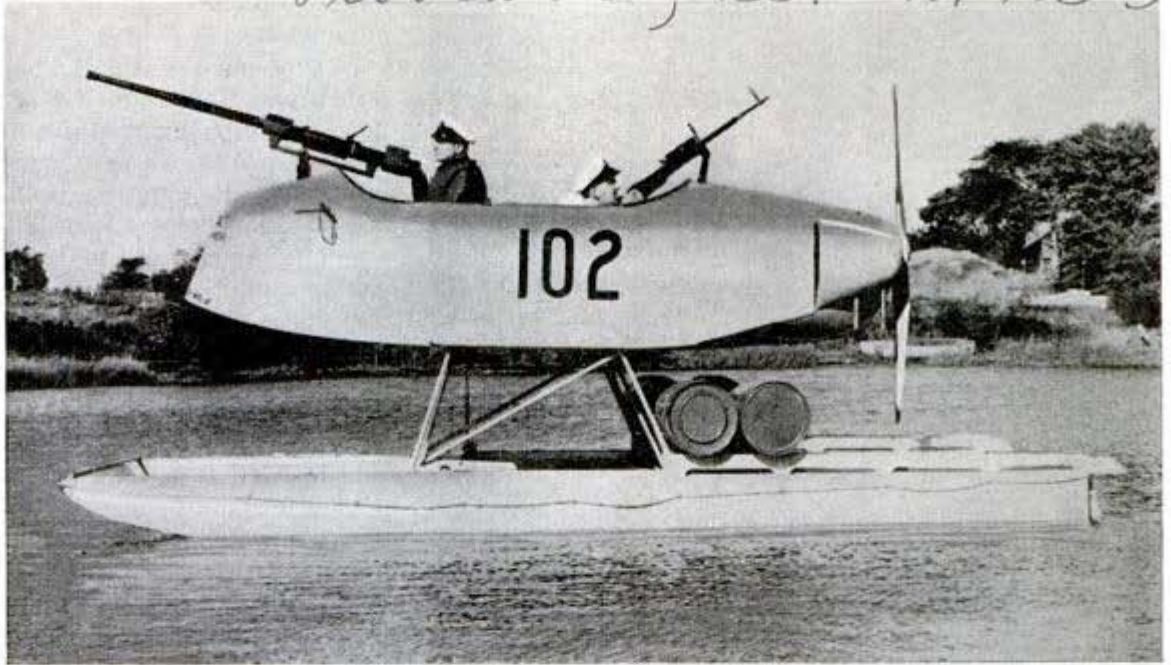

"Sea skimmer," armed with guns and depth bombs, can stalk subs without fear of detection by sound

Gliding swiftly over water, the "sea skimmer," designed to fight submarines, does not transmit telltale noises through the water since it is driven by an air propeller instead of water screw. Manned by a crew of two and reaching a claimed speed of 50 miles an hour, the sub-chaser carries a 20-millimeter Oerlikon cannon, a machine

gun and four depth charges. The latter may be replaced by torpedoes. It is said the hydroglider handles easily in rough seas, and it can be hoisted aboard a vessel as easily as a lifeboat. Except for engine and propeller, the craft is built of non-strategic materials, and could be made by the thousands in mass production.

Sedan Is Cut in Two and Rebuilt to Carry 15 Passengers

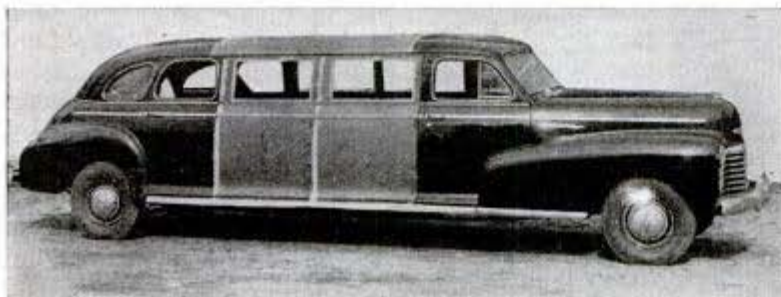
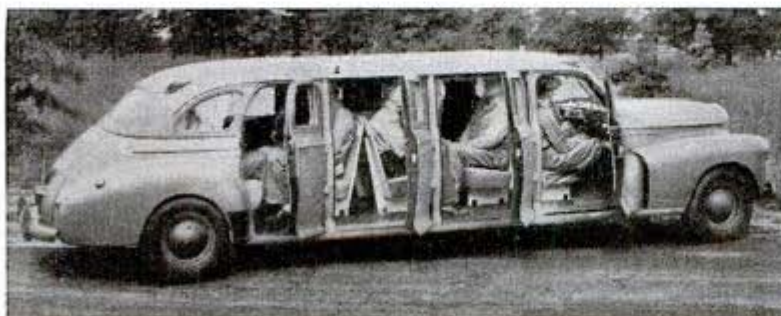

m 1059
 Capacity of a four-door passenger sedan was tripled by cutting the car in two and inserting a six-foot extension in order to carry workers to war plants. Three additional seats are made of plywood and most materials in the extension, including white ash and tempered Masonite, are non-critical. The converted sedan requires oversized tires and either replaced or strengthened front and rear springs.

Top, rebuilt sedan with additional seats; lower view shows the extension

Of the passenger cars used on farms, 30 percent are 10 or more years old.

FEBRUARY, 1943 *Fitzgibbon Coach Co*
Muskegon, Mich

Thos E Stimson Jr 3872
Franklin Ave Los Angeles Calif

"MUMMY" FOODS

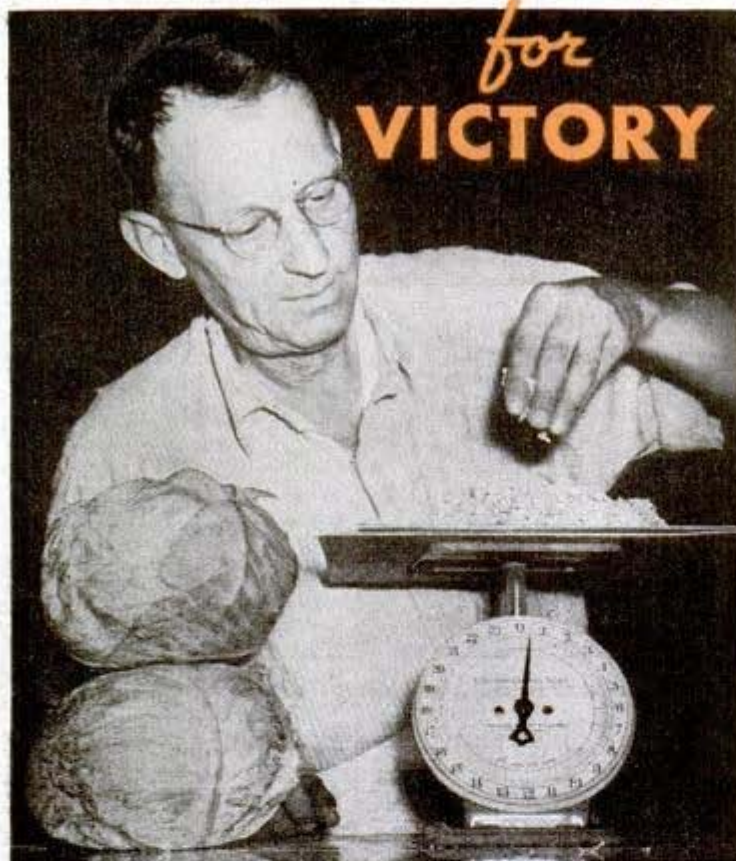

Five pounds of cabbage (left) are dehydrated into a handful of chips of equal food value but weighing under a half pound

Heat and humidity must be carefully controlled, temperatures being lowered gradually as the vegetables become dehydrated

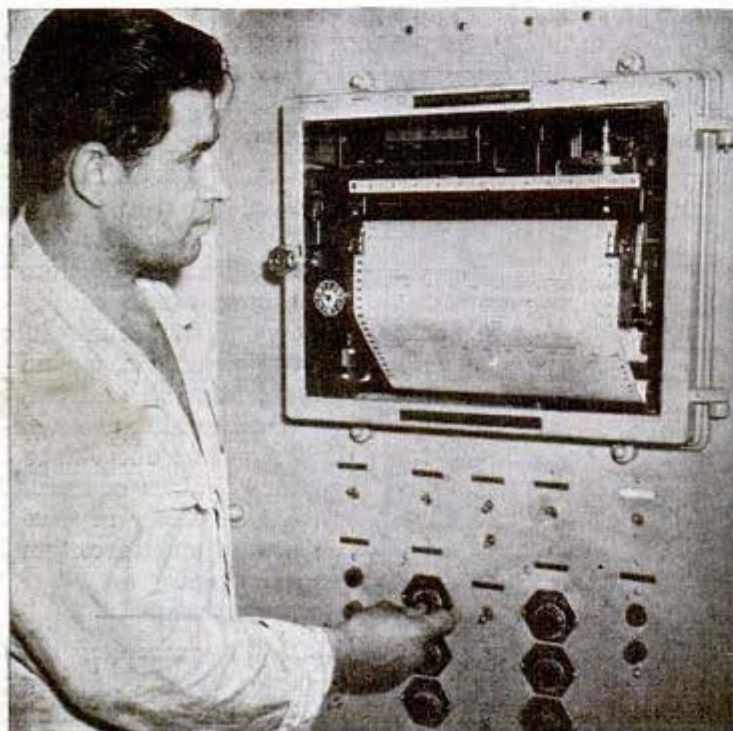

A HEARTY meal, in its latest form, takes up no more room than a package of cigarettes.

Out of such a small container you might get a large bowl of soup, big helpings of mashed potatoes and hamburger steak, and plenty of beets and carrots. Just add water to the package of dried, compressed food chips and you have the makings of a tasty, full sized meal. You might even have a slice of dehydrated fruit candy bar for dessert.

Dehydrated dinners aren't put up in handy packages yet but it's only a question of time. All the ingredients are being made.

American housewives buy dehydrated soups at the rate of about 100,000,000 packages a year. American soldiers eat scrambled eggs made from dehydrated powder, a five-ounce package equal to a dozen eggs. A five-gallon can of tomatoes swells to a quarter of a ton when water is added. Soldiers eat corn that gains four times its dehydrated weight when water is added.

Londoners are eating meat loaves and stews that crossed the Atlantic as tiny shreds of dried meat. Milk, butter, citrus juices, as well as potatoes, peas, spinach, and a host of other vegetables are dehydrated to conserve shipping space. Dehydration plants are producing millions of tons of dried vegetables and other foods per year, mostly for shipment abroad. One ship loaded with dehydrated food can carry upwards of a dozen times more food than a ship loaded with bulk. The chances are, if the war lasts a long time, that increasing numbers of dehydrated foods will take the places of canned foods on the shelves of American grocery stores.

Ref. office of Director College of Agriculture, U. of Calif., Berkeley, Cal.

Inspector wearing a dust mask sorts a handful of dried chips that were a bucket of tomatoes



Food is bulky because it is mostly water. Dehydration removes most of the water content, transforming such a food as sliced carrots into small dried shavings that resemble wood chips. Soak these chips in water several hours and they swell to their original size and appearance.

What do "rehydrated" foods taste like? Generally speaking, they compare pretty well with food preserved by canning or freezing. Some of the flavor and aroma of the original fresh product may be missing but the taste is essentially the same. Vegetables properly dehydrated retain their mineral values as well as much of their vitamin content.

Dehydrated rations were shipped to France during the first World War but complaints came back that the foods were tough and unpalatable and didn't keep well. Since then the Department of Agriculture, universities, and commercial dehydration concerns have studied the process and corrected these objections. Test meals prepared from dehydrated foods have been served to groups that accepted them without question.

At a commercial dehydration plant, truckloads of vegetables fresh from the field are first washed and then trimmed by a crew of girls who remove all tough stalks and injured parts. An endless belt then carries the vegetables to a chopper that slices or shreds the food into small pieces. These are spread over trays and wheeled into a steam room for a blanching

Forming bars of dried fruit mixture. Each bar provides a full meal as emergency army ration

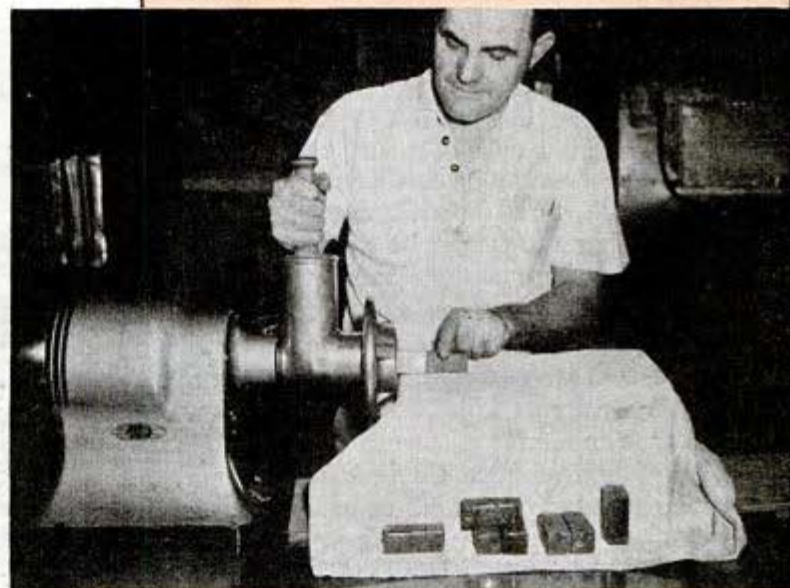

Vegetable	Types	Preparation	Steam Blanch
Cabbage	Savoy, Danish, No krauts	Shred into 1/2-inch wide strips	Until ribs are translucent, 3 to 4 minutes
Carrots	Highly colored such as Morse Bunching	Slice or cube	Same as above
Greens	Spinach, kale, chard, beet tops, mustard greens	Whole leaves. Remove heavy mid-rib of chard	2 to 4 minutes
Onions	Strong types such as Ebenezer, White Portugal, or Red or White Creole	Slice 1/2-inch thick	None
Rutabagas	Amer, Purple Top, Bangholm, Early Neckless	Slice or cube	4 minutes
Beets	Dark red types such as Detroit Red	Slice or cube	Steam cook 30 to 40 minutes, then peel and slice or cube
Sweet Potatoes	Most types	Slice or cube, then wash thoroughly in cold water	Until translucent, about 6 minutes. Use wood or non-metallic trays throughout
White Potatoes	Mealy types such as Idaho Russet	Slice or cube, then wash thoroughly in cold water	Until translucent, about 3 minutes
White Potatoes (Precooked)	Same as above	Rice into small pieces	Steam cook until soft, then rice for drying

The chart above reveals the varying treatments given some of our common vegetables in dehydrating



Rats are used to learn effect of dehydration on meat's growth-promoting value

U. S. Department of Agriculture photo

a press, further reducing their volume. Experimentally, dried foods are being packaged under vacuum in Pliofilm and paper containers.

An experimental emergency ration being tried out by the army consists of a small bar similar to a candy bar, composed of dehydrated fruits and other dried ingredients. Each bar is the equivalent of a full meal. It may be eaten with no preparation and the soldier is not even thirsty when he finishes.

Another use for dehydrated foods is in the compounding of concentrates, rich in vitamins and minerals, for use as dietary supplements. Anabolic Food Products, Inc., of Glendale, Calif., grow certain vegetables in soil that has been enriched with desired minerals, then dehydrate the matured vegetables and grind them into

process that seals in the flavor and color. After a few minutes of this precooking the trays are wheeled into the dehydration chamber where a controlled flow of hot air removes nearly all the moisture. Sliced carrots are changed into tiny dried chips. The final step is to pour the chips into five-gallon tins, forcing carbon dioxide gas into the tins to remove the oxygen of the atmosphere before sealing. Dehydrated foods prepared and stored this way will keep for years.

Right now most foods must be shredded or minced into small pieces for proper dehydration. One avenue of research is directed toward drying larger units so that cuts of meat such as steaks and roasts can be dehydrated. Most foods, too, must be dehydrated while raw. Then they must be soaked for several hours to restore them to their full volume before they are cooked. Research is being carried on to find the best way to precook them before dehydration. This would reduce the time needed to prepare a meal from dehydrated foods. Some dried foods are squeezed into small cakes in

powder, to be placed in capsules together with other ingredients.

There is no reason why you shouldn't dehydrate your own vegetables if you wish.

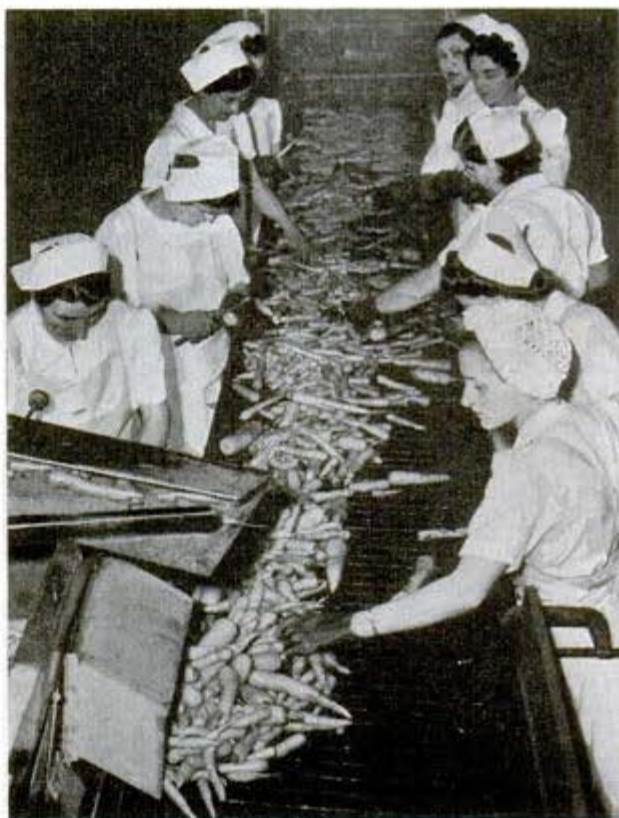

Washing, sorting and trimming carrots, first steps in a California vegetable-drying plant

It is even possible to dry fruits and vegetables in the oven of a stove, provided the door is left partly open for circulation. The temperature must not be allowed to rise above 140 degrees.

Better results are obtained by using a wooden cabinet-type dryer that you can build yourself, with an oil stove for the heating unit. Such a cabinet may be 8 or 10 feet high and 1½ by 2 feet in cross section. The walls are plywood, with a door in front. The food is spread on trays racked inside the cabinet. Each tray consists of a lath frame with a galvanized iron screen bottom, over which is spread a piece of cheesecloth. The trays are shorter than the runways, so they may be staggered, one against the back, the next against the front, and so on. This leaves an open, circuitous air channel for the ascending hot air. The bottom of the dehydrator, above the oil stove, is left open but has a "heat spreader" in the form of a square metal plate suspended above the heater. This spreads the hot air so that it ascends evenly. The top of the dryer is left partly open, having a three-inch-wide ventilation hole running across the top to allow vapor from the vegetables to escape.

(Continued to page 171)

Placing a tray of corn in test dehydrator

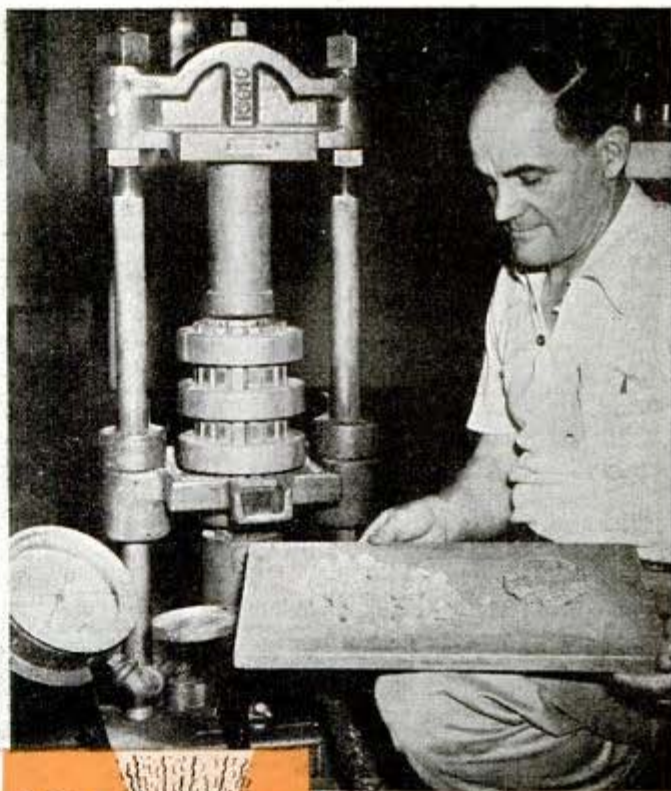

↑
Double handful of dried carrots at left of board comes out of press as small compact cake seen at right

←
Drawing illustrates a natural-draft evaporator for home drying of vegetables or fruits in any climate

↓
Baffles seen in the end of the commercial dehydrator, below, are used to control the flow of the warm air

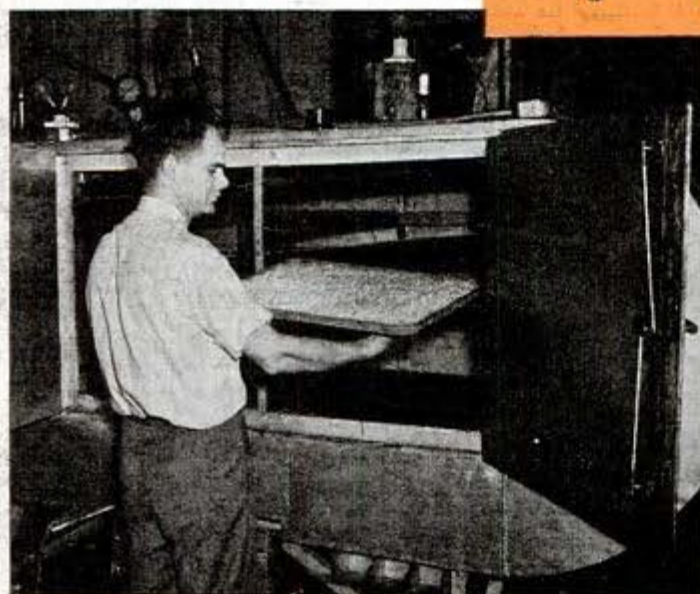

Acme Newspictures Inc
461 - 8 av, nyc.

Replica of Nazi Aerial "Block Buster" Stands Sixteen Feet High



Taking measure of model of big Nazi bomb weighing about 5,500 pounds

"Max" is the biggest member of a family of Nazi bombs reproduced by Columbia Studios and placed on exhibition in Los Angeles by the Civilian Defense organization. The bombs range in size from 50 to 2,500 kilograms, the latter equalling about 2 $\frac{3}{4}$ tons. This huge bomb, 16 feet high and 12 feet around, can demolish six square blocks.

Nylon Bristles for Paintbrush Wear Three Times Longer

Synthetic bristles of tapered nylon have been developed with the resiliency and toughness of the natural product, and they wear three times as long. The bristles can be cleaned with ordinary paint cleaners and will not deteriorate in storage. Development of this synthetic product—the goal of chemists for many years—was accom-

plished in the laboratories of the Du Pont Company. Tapering of the bristle is achieved by pulling a nylon filament from a special spinning device at a controlled speed, the size of the bristle varying with the speed of pulling.

Pail on Tap Hook Shuts Off Water When Filled

At filling stations where full water buckets are kept on hand for replenishing radiators, an automatic valve that may be attached to any water faucet can save time of attendants. It is not necessary to stand around and watch a bucket being filled, because the increased weight will close the valve when the bucket is nearly full. The attendant simply hangs the empty bucket on the hook and goes about his other duties. The automatic faucet is adjustable for small and large containers, and it does not interfere with ordinary uses of the outlet such as attaching hose and filling other containers, since the faucet may be turned on and off by hand.

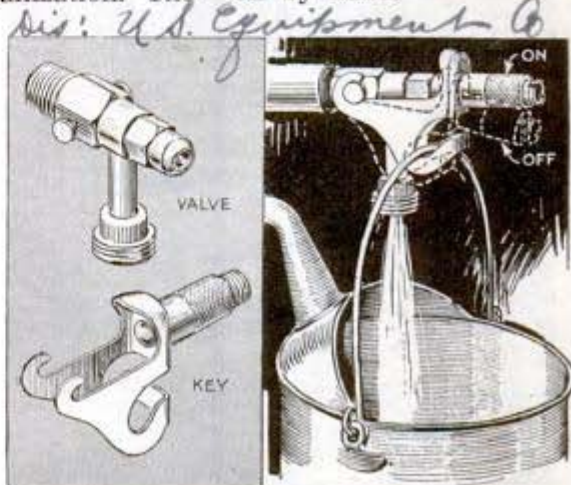

Full bucket pulls key downward to shut off faucet

Ed DuPont de Nemours Co
Wilmington, Del.

POPULAR MECHANICS
2634 S. Michigan
Chicago, Ill.

*Acme Newspictures Inc.
461-8 av, nyc.*

Four-in-One Antiaircraft Gun Focuses Its Fire

Four streams of bullets from multiple gun mountings will present a hot reception to any Jap planes attacking Australia's east coast. This quartet of Lewis machine guns, devised by the artificer of an antiaircraft battery, has its four barrels fixed at an angle that will produce a concentration of fire at a predetermined point. A touch of the master trigger flings four lanes of simultaneous gunfire spelling death to an enemy raider within range.

Four streams of bullets from multiple antiaircraft gun converge upon an enemy plane



Phantom Models Speed Training in Tool-Design Course

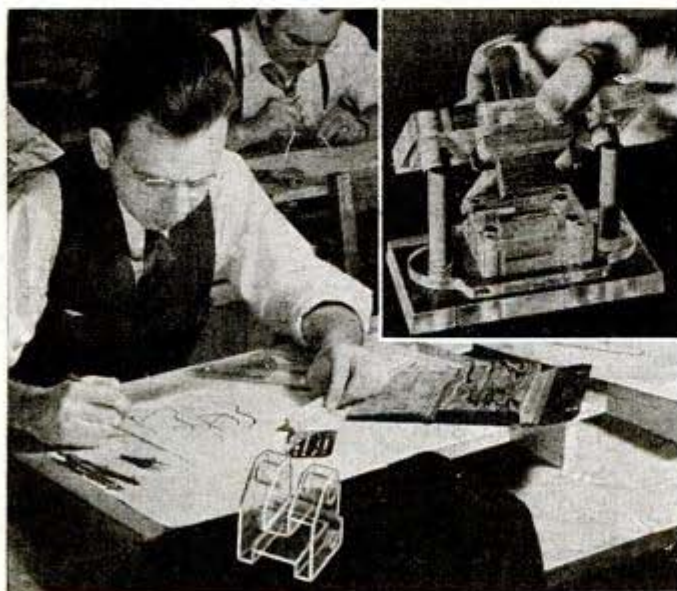

Students can literally "see through" complex problems in tool design with models made of transparent plastic. Training men for war production jobs is cut to a minimum of time with these models which reveal details of complicated shapes and mechanism. In die design, for example, models show the working of every hidden part during a stamping operation. Models made under the sponsorship of the extension service of Pennsylvania State College are being distributed to training centers of the U. S. Office of Education.

State College, Pa.
Using plastic model to speed tool design; inset, model of die

Breakdown of Lubricating Oil in Engines Traced to Tiny Particles

Blame for the breakdown of lubricating oil has been fixed on the heated metal of the engine, unburned gasoline and oxidation products of the oil itself, but R. G. Larsen and F. A. Armfield of the Shell Development Company, now point out as the real culprit the tiny black particles that flow in all long-used oil. These originate in many ways, since they consist of micro-

scopic bits of metal worn off the engine parts, dust from the air, and especially the chlorides of iron and bromine which arise from the use of leaded gasoline. The black particles act as catalysts, aiding the oil to contract an undesirable union with oxygen followed by deterioration. The experiments of the two men pointed to the importance of a good filter.

Allen Warren Elliott 7 Park Ave
n.y.c.
TRICKS for TROOPS
m. 1029



It is no military secret that U. S. inventors have gone "all out" for the armed forces. Below, folding mess kit of aluminum opens to form two dishes



Gasoline-driven drill (right) is intended for service in bombed cities where electric power has been disrupted. Left, desk-in-trunk for officers in the field is a big help

Something wrong with the perspective here? No, it's just the telephone poles which have been sawed off, giving an odd effect. The men on the poles are being trained as communication experts by the U. S. Army Signal Corps. The machine in foreground is for wire stringing. Many lives are saved during training with the short poles, for fall from the top is only a few feet. In every branch of military service experts are constantly on the alert to guard against injury to the men now being trained

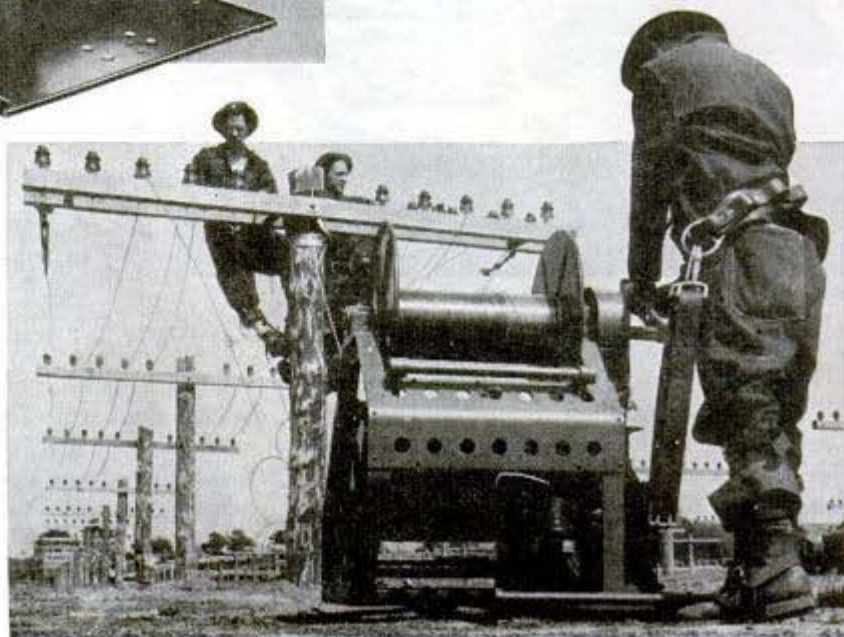

Russell Peck, Red Cross
field officer

Rubber "overalls" (below) are slipped over sailor's regular clothes when order comes to abandon ship. Suit has a "built-in" flashlight; soles of the shoes are weighted to keep wearer upright

made by
B. F. Goodrich



This specially designed desk is used by the Red Cross in field. It is collapsible, can be set up in a jiffy and weighs only 15 pounds. It holds typewriter

Patricia Hartnett



U. S. Rubber Co

The double-tube life belt above is so light it can be worn on duty about ship. It is inflated by squeezing tubes together which releases buoyant gas. Left, demonstrating how army's new folding wood chair can "take it." Formerly these chairs were made out of steel



*Acme Newspictures, Inc.
46 - 8 av, NYC.*

Bomber Crew "Bails Out" on Land for Practice

m1081

Should the crew of a Royal Air Force bomber be forced to "bail out" on the sea, they will know what to do even if it is their first experience. Practice for the maneuver of launching a rubber boat from a bomber begins on dry land, and after they learn all the motions the crew members continue the training on water in order to reduce the chance of mishap after the unlucky ones are forced down.

British bomber crew in rubber boat in the sand practice the art of launching a life raft so they will make no fatal errors when it may be their turn to "bail out" into the open water



Whitley bomber

Concrete Made Weatherproof by Absorbent-Lined Form

m1064

Water and air bubbles are removed from the surface of concrete by lining the forms with an absorbent material which is peeled off, leaving a smooth weather-resistant finish. The lining strengthens the concrete and eliminates brushing and scraping. It is made of special material faced with fabric and is stapled easily to wood forms. In tests, samples of concrete made with the form linings withstood a bombardment with sharp steel grit, while other samples which had been cast with ordinary wood forms wore away rapidly, some of them as much as one quarter of an inch in one minute.

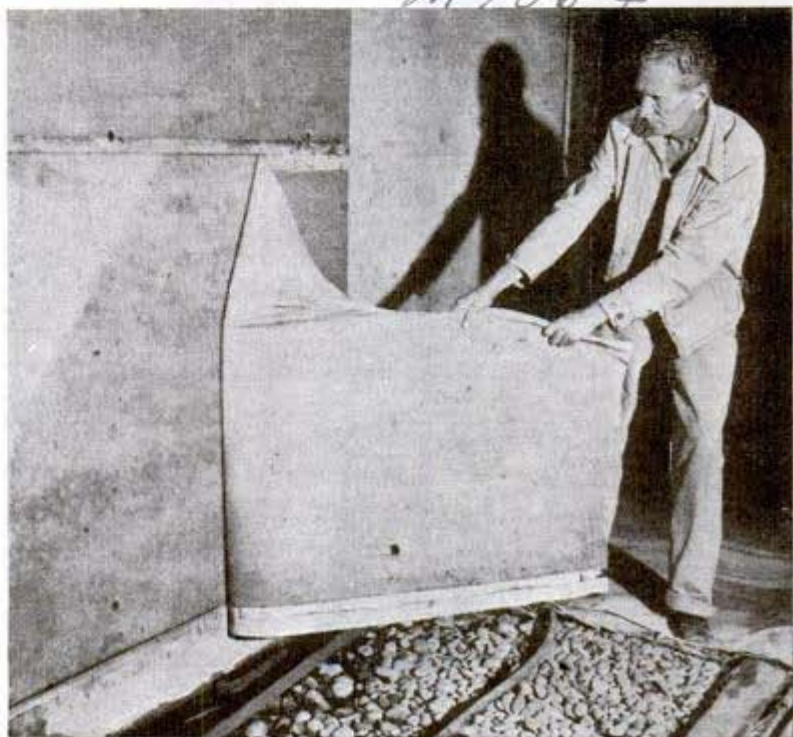

Peeling off absorbent lining which leaves smooth weatherproof surface

designed by E. B. Nulcebus and Wallace Nyberg, Peoples Federal Savings and Loan Co. Peoria, Ill.

"Tank" in War Bond Drive Offers Curb Service

Peoria Broadcasting Alliance

Using the M-3 war tank, commonly referred to as the "General Grant," as a model for its office, radio station WMBD in Peoria, Ill., has come down to the sidewalks to sell war bonds and stamps in addition to its campaign over the air. Erected near the curbing, the simulated tank has windows facing the sidewalk as well as the street so it may serve both pedestrians and motorists. The riveting effect on the tank-booth was achieved by use of roofing nails, the over-all construction being of plywood.



"Tank" booth sells war bonds and stamps to pedestrians and motorists

Rotating Rack for "Stenotypist" Holds Notes in Easy View

"Stenoscrite"



Transcribing notes made on a Stenotype—the mechanical shorthand writer—may be simplified with a rack that holds the note tapes at eye level for easy reading by the typist. The holder consists of two trays and a rotating easel which picks up the note tape from one tray and deposits the finished portion into the other. When the typist finishes transcribing the notes from the two folds of tape visible, she flips a wheel to lift the next two folds into view.

Rotating easel holds Stenotype note tape at eye level of typist. Twirling the wheel turns arm end over end, causing it to deposit finished portion of tape into one tray and pick up fresh notes with little loss of time

"Swamp Glider" Rescues U. S. Army Fliers Forced Down in Marsh

When an army flier crashes in swampy areas near Langley Field, Va., he is rescued with a "swamp glider" that draws only six inches of water. The craft skims over shallow water that is impassable for land vehicles and ordinary boats. Resembling a cross between a row boat and a small plane, the glider is powered with an airplane motor and propeller. It can attain a speed of 45 miles an hour shortly after a "takeoff."

Maj. J.R. Sifton, in charge fleet. m 992



Airplane motor and propeller speed this craft over the water

Acme newspaper 461-8 av, n.y.c.

Stenotype Co., 410 15th St. Chicago

*2112 7th St. S. Seattle 7 Park
Ave. N.Y.C.*

Tiny Films Speed "V-Mail" to Men Overseas



The sergeant is photographing a stack of letters which will be carried on a reel of microfilm for speedy delivery by plane or ship to Yanks overseas
Photos by U. S. Army Signal Corps



Making enlargements, above, from microfilm is one step in processing the new "V-Mail." Left, continuous rolls of prints pass through machine which develops, washes, and dries the letters which are then ready to be cut. V-Mail results in a tremendous saving in valuable cargo space. The two-way service handles millions of letters to and from men in armed forces



Right, developing and drying film; the lower reel is for developing, the upper for drying. Forty-five pounds of film, which would occupy the space of one mail sack, contain about 150,000 one-page letters. The unfilmed letters would fill some 37 mail bags weighing 2,575 pounds. Where apparatus for developing the microfilms is not available abroad the V-Mail is developed in the U. S. and then shipped, effecting a saving of about 1,000 pounds on 150,000 letters. Army officials laud the V-Mail as a great builder of morale—which can't be weighed

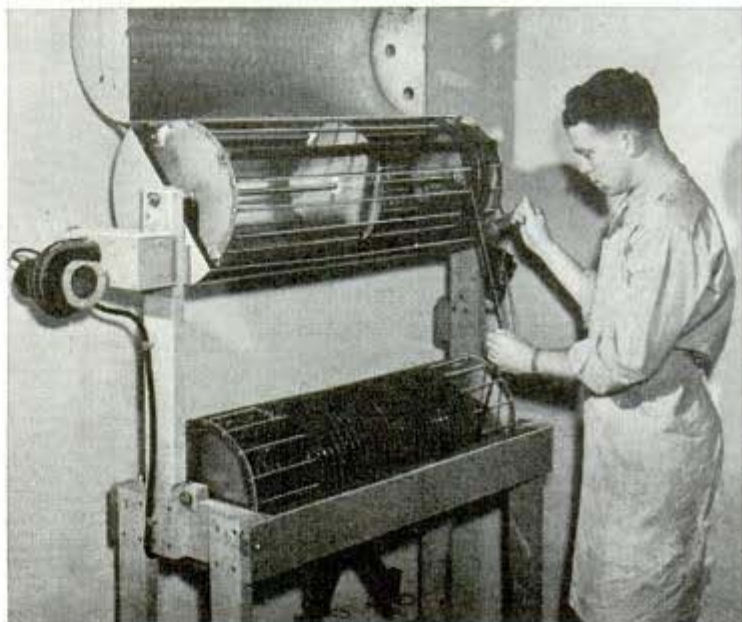

Con: A. J. Hamilton, 1155 Akron St, San Diego, Calif

"HERE COME THE 'CATS!'"

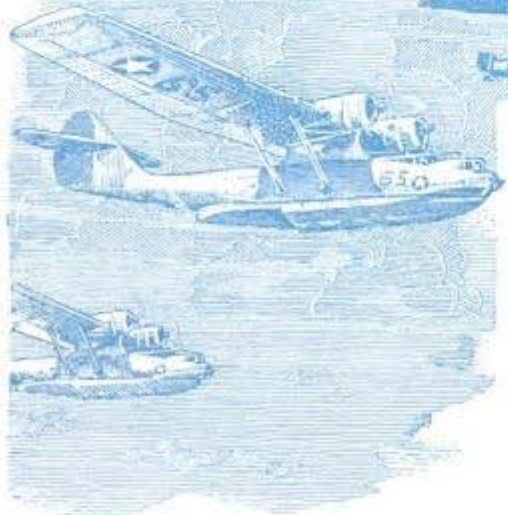
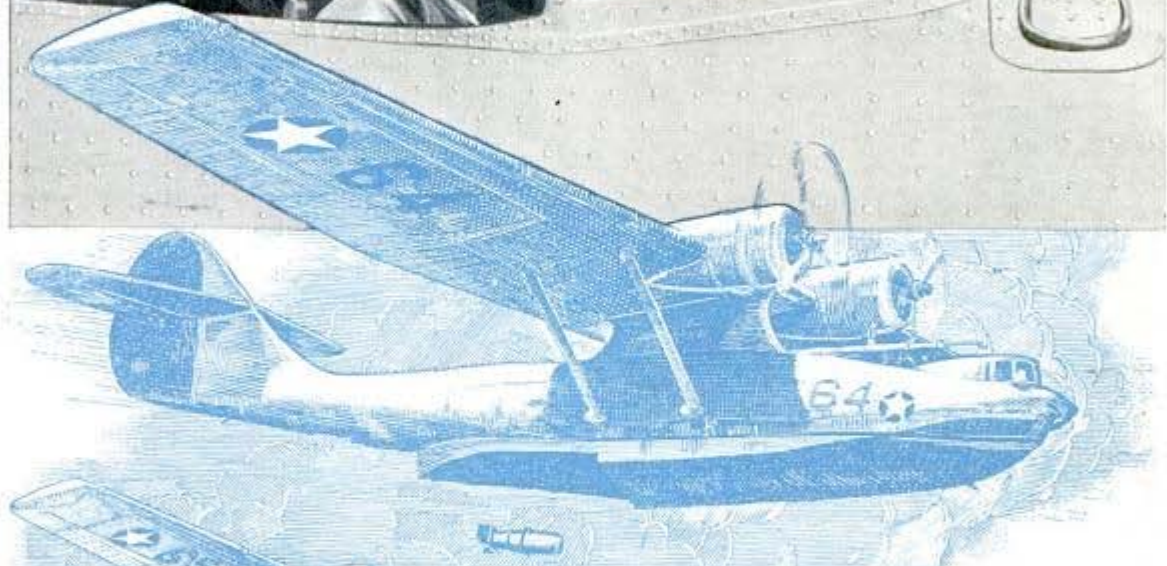

With both motors roaring and her pilots (top) on the alert, the high winged Catalina flying boat is ready to patrol vast ocean distances or drop bombs on enemy ships or bases

M 1022
THE Consolidated Catalina winged its way into Page 1 headlines on May 27, 1941. On that day one of the big American-built flying boats was patrolling the North Sea. It carried the red-white-and-blue roundel of the RAF, but an American naval officer was aboard as observer.

The Catalina shot through a rift in the clouds and all aboard got the thrill of their lives. Below was the biggest battleship ever seen.

"The Bismarck!" was the awed cry that went through the plane.

The German battleship wheeled sharply to port and then let go with all her anti-aircraft fire. Nazi bullets riddled the Catalina's mid-section, but none hit a vital spot. The plane stayed aloft and relayed radio messages to units of the British fleet. Although the German battlewagon

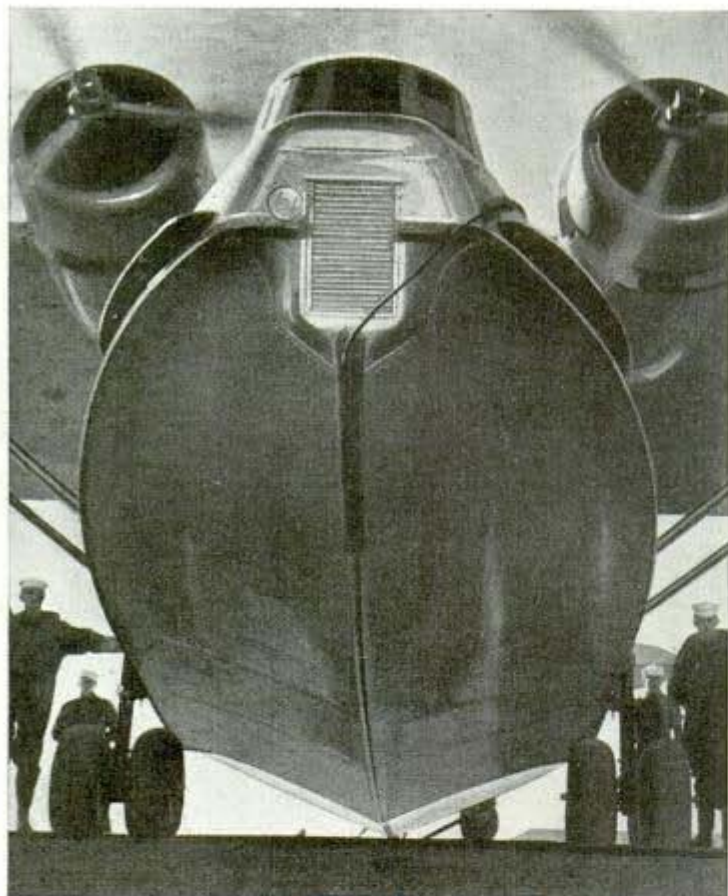

tried to escape, the American-built flying boat hung doggedly on her tail for 27 hours.

Deep-water navy men as well as aviators give credit to the Catalina for spotting and trailing the Bismarck—the first link in a stirring chain of events which finally led to her destruction.

Since then the "Cats" have made history. They've written glorious deeds of heroism and courage in the skies and waters of the North Atlantic, the South Atlantic, the Mediterranean, the Caribbean, the Philippines, the Dutch East Indies, Australia, Midway and the Aleutians.

Curiously enough, all this has happened since the Catalinas were declared "obsolete"!

In 1939 engineers at the Consolidated plant in San Diego took careful appraisal of the Catalinas—or PBY as the navy calls it—and passed sorrowful judgment. By all that was holy in aviation, a ship five years old should automatically be considered outmoded.

Ready to go down a ramp into the ocean, this 15-ton "Cat" is surrounded by beach crew who will remove "beaching gear" in the water. The plane can take off from either land or sea, a great advantage

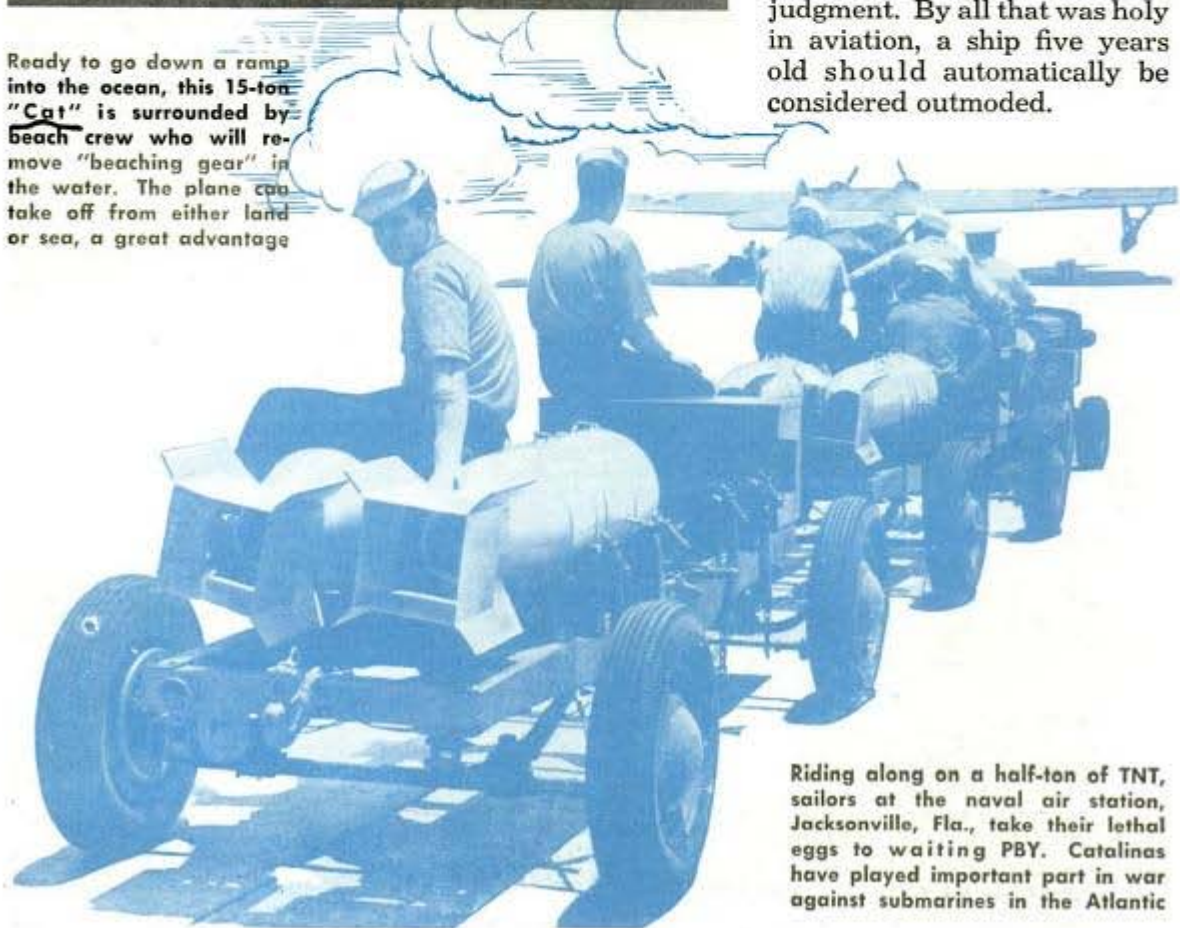

Riding along on a half-ton of TNT, sailors at the naval air station, Jacksonville, Fla., take their lethal eggs to waiting PBY. Catalinas have played important part in war against submarines in the Atlantic

Navigator charting course at his desk in the clouds must know the position of flying boat at all times

Two months later, however, Consolidated engineers changed their minds and put the Catalinas back into production. The long, sleek hulls on the assembly line in San Diego today are essentially the same ship designed in 1934 and declared obsolete in 1939.

Then the Catalinas proceeded to prove that the engineers' faith in them was not unjustified. They've become one of the most versatile planes the navy possesses. Originally designed for patrolling long distances over open water, these jack-of-all-trades planes have been used as heavy bombers, fighters, torpedo carriers and even as dive bombers!

Before January 1, 1940, 88 PBY's had spanned the 2,553 miles from San Diego to Honolulu nonstop, in groups of 12 or 14. An equal number were flown from San Diego to Coco Solo, covering 3,087 miles, nonstop. Termed "routine transfers of men and equipment" by the navy, these flights carried more than 1,200 men as members of their crews—giving some idea of the magnitude of performance and an indication of what the same ships are doing today.

The Catalina is a twin-motored, high-wing flying boat that can take off from land



Two seamen (right) remove inspection platform under watchful eye of a chief petty officer. Bomb dolly, below, is pulled under wing of "Cat" with tractor. One man handles a 500-pound bomb with ingenious pulley

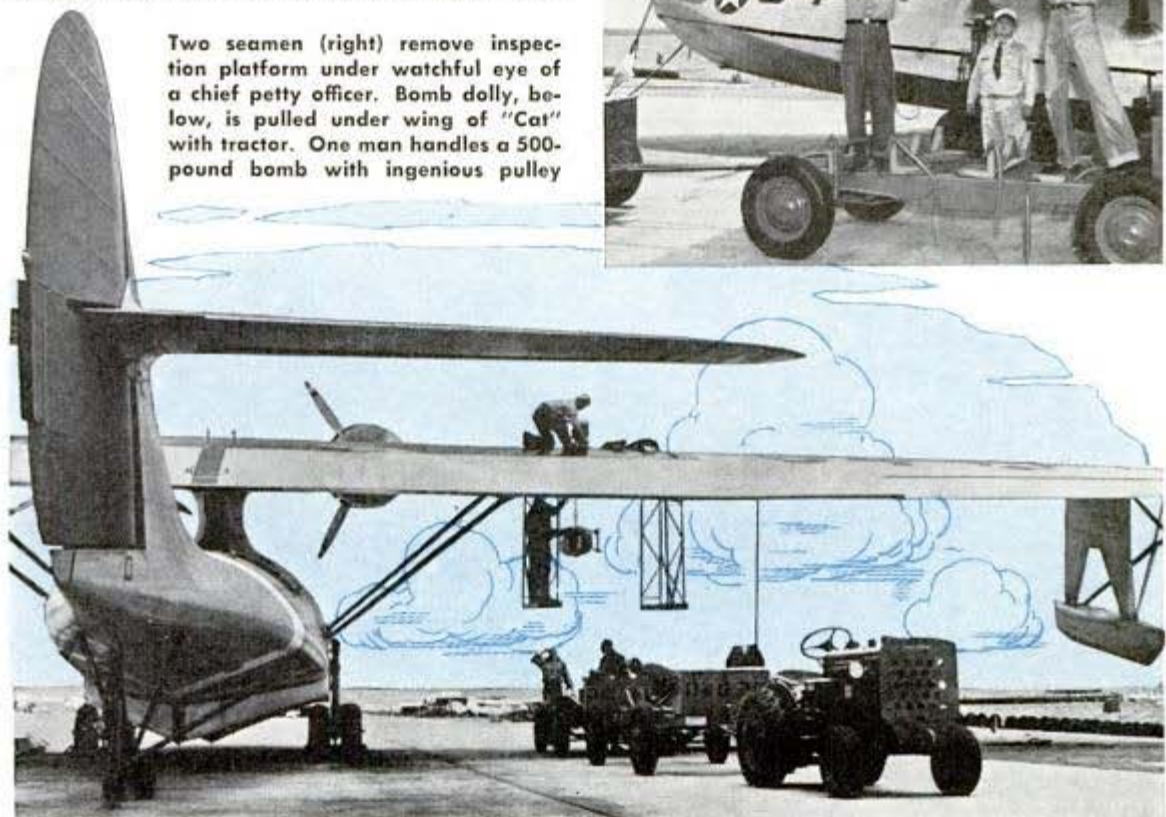



Here are two of PBV crew's best friends—a parachute and the "galley." This meal, prepared in flight, consists of bacon, eggs, toast and coffee. Below, the big flying boat under its own power is approaching brink of ramp that leads to water. Note bombs under wing



or water. Its fuselage is 60 feet long, its wing span is 100 feet and it weighs 15 tons. Speed is more than 200 miles an hour and the range is 4,000 miles. It carries a crew of seven—pilot, assistant pilot, navigator, third pilot, radioman, and two machinists.

"Here come the 'Cats!'" —spoken in guttural German or sputtering Japanese—is a fearful cry.

But "Here come the 'Cats,' God bless 'em!"—spoken in American accents, clipped British and Australian speech, soft Chinese or warm Russian—is an answer to a prayer.

What have the Cats done in this war? Just listen:

Patwing 10 started out as a U. S. Navy patrol wing of 42 planes when the Japs hit the Philippines. Three months later it reached Australia with only two of the original group. Already Patwing 10 has become a legend in the jungle islands of the South Pacific.

Men of Patwing 10, said

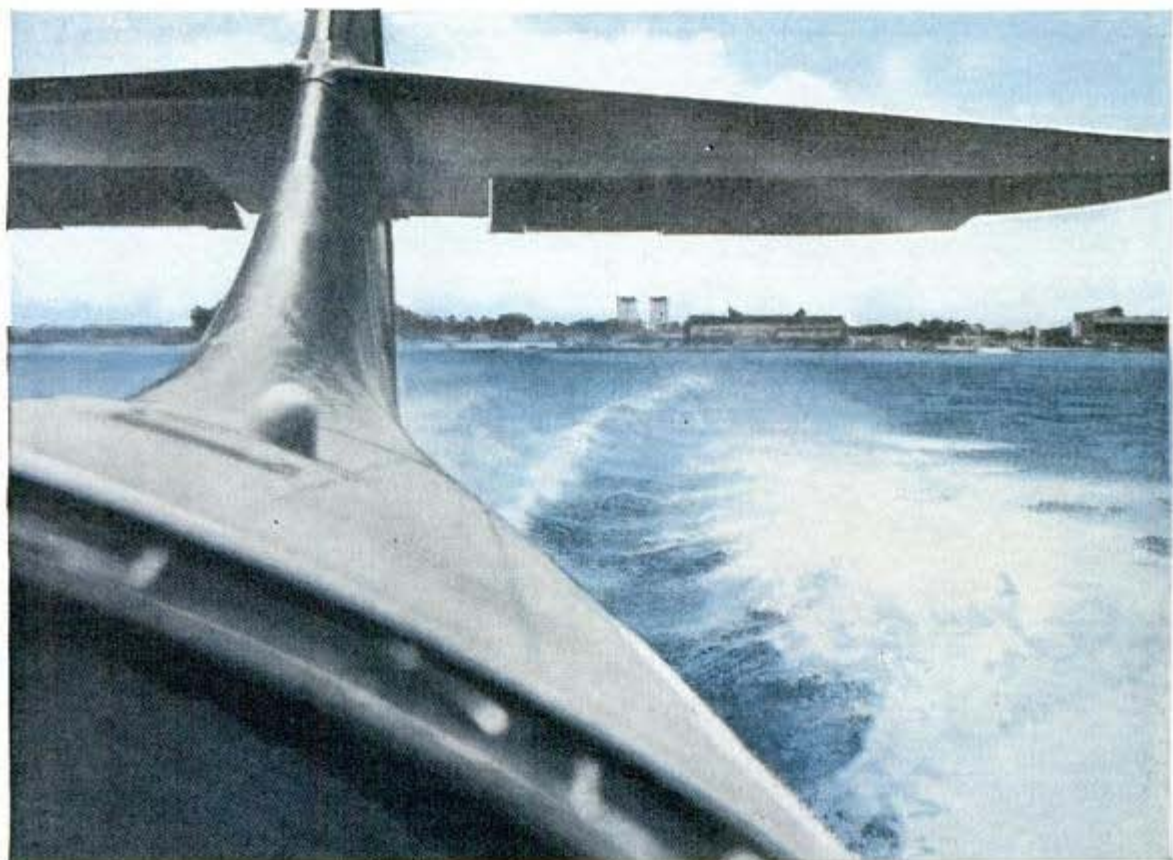

"Excuse my spray," says the Catalina as she roars across the bay for a takeoff. Right, inspecting bomb-attaching mechanism with a detachable platform hooked to bottom of wing. Planes also can carry a torpedo bomb, but how is military secret

official navy reports, "flew into hell and sometimes flew out again, but more often they swam out, or crawled out of the steaming jungle with Japanese machine gun bullets kicking up flurries in the beach sand!"

Told that Japanese warships were 150 miles off Luzon on December 8, 1941, planes of the navy's flying wing flew down on the enemy from the sun and dropped bombs on two battleships and four destroyers. The lumbering Cats didn't have time to stick around and see what damage was done. They drummed back to their base at Cavite. But that base had been fired.

Chief Machinist's Mate Mike Kelly, one of the heroes of Patwing 10, says:

"The Japs finally hunted our bases down and we went to another base, and still another, moving





Carrying "beaching gear" back to ramp after plane has been eased into water. Members of beach crew wear special rubber suits in cold weather

south all the time, still patrolling, but each night coming to roost at a new position."

Kelly says that on one occasion six ships of the wing took off for what seemed to be a perfect setup—a Japanese cruiser, some destroyers and transports, all of which were without fighter protection. They found the ships, but Jap Zeros were hiding in the clouds above.

"They started to dive on us, but we kept our course and went in to bomb the vessels below," Kelly said.

Another group of bombers had already attacked. Antiaircraft guns were barking. One plane in Kelly's section went down. The other two escaped. Not so with the other section of the flight—all were knocked into the water. But even after the Catalinas were downed, it was hard to sink them.

John Cumberland, aviation machinist's mate, tells of what happened to the flying boat he was in when it was forced down.

"We plugged up shell holes," he says simply, "and floated for 30 hours before we were picked up."

On another occasion, a Catalina piloted by Machinist's Mate C. M. Richardson was attacked by nine

Japanese fighters after it alighted in the water. There were 700 holes in the ship, but Richardson was wounded only in the leg and hand.

In Australia, Air Minister A. S. Drakeford reported that the Catalinas had done a remarkable job in checking the Japanese southward sweep and would "occupy a place of honor in the history of air war."

Halfway around the world at Gibraltar, another Catalina gave a brace of Nazis all the fighting they could stomach. On patrol duty over "the Rock," the PBY cruised slowly through a

seemingly deserted sky.

Suddenly, out of nowhere, four German planes came down. The pilot of the PBY banked his ship, went into a climb. The Germans were below him and the gunners went into action. One by one the Nazi planes fell away. The PBY completed its patrol and returned to its base. Next day

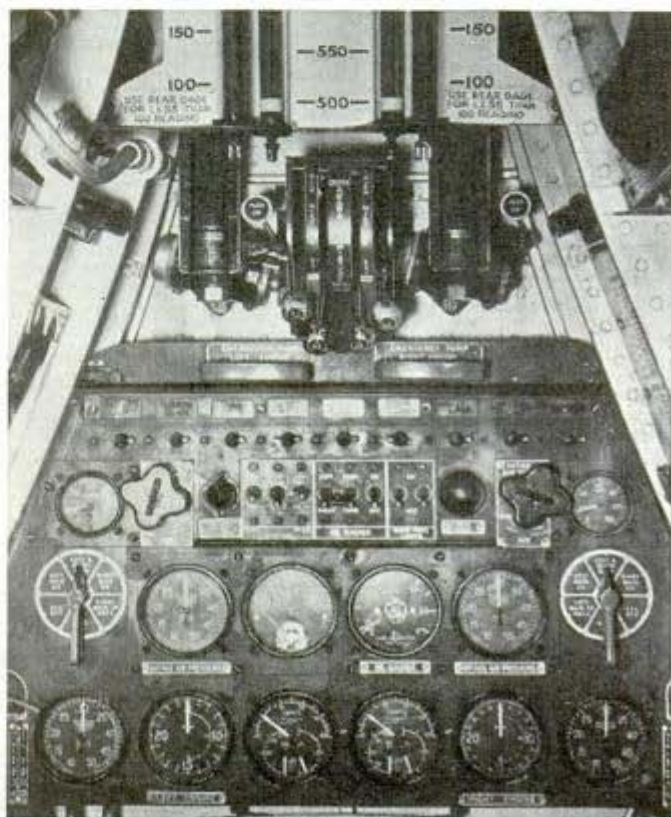

This instrument board in PBY "tower" is used by the mechanic to keep close watch over plane. Any defect is detected quickly

all four German ships were found on the beach near Lisbon.

Additional proof of the Catalina's sturdiness and flyability is seen in the amazing report of a routine Atlantic crossing. Cruising at 18,000 feet, the plane's automatic controls jammed with the starboard aileron full down. The 30,000 pound ship went into a full spiral—hurtling toward the icy water. Just 800 feet above the heaving ocean the other aileron fluttered away, balancing the ship and righting it.



Pilot and co-pilot (above) dressed for high altitude travel head crew of seven. Below, "streaming" target

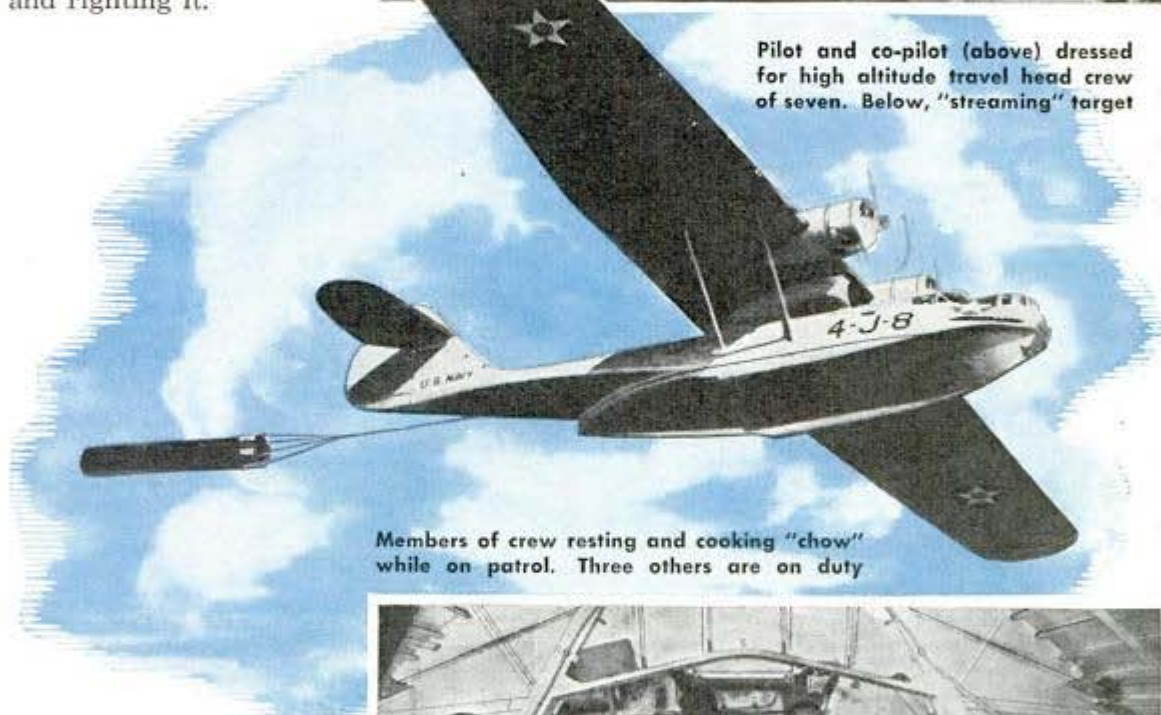

Members of crew resting and cooking "chow" while on patrol. Three others are on duty

With radio, two ailerons and wing tip missing, the pilot miraculously put the 15-ton Catalina back on its course and completed the trip to England.

The famous Catalinas have done their part in the war against submarines, too. Down below the equator not long ago an Italian submarine surrendered to Brazilian authorities at Natal. It was reported that the sub





Mechanic is seen through window in "tower" which is nerve center of navy's big flying boat

routine patrol, that discovered the Japanese invasion armada off Midway. Circling over the Nip fleet three times without being detected, a young navy lieutenant sent in the report which put the navy's warships on the alert.

Then Catalinas were given another task. Four PBY's were selected for a daring night torpedo attack, the first on record for this plane. Some 40 volunteers, under the direction of Lt. William

hoisted the white flag after being battered by bombs and depth charges dropped by Catalinas.

The "Cats" were in the thick of the Midway battle. It was a Catalina, flying on

Richards, were picked for the job.

Torpedoes were rigged on the Catalinas—where, is a navy secret—and they went in against the Jap ships under the cover of darkness. A direct hit was scored on an

Loaded for patrol duty that may cover 4,000 miles of open sea, the PBY rides proudly out on the water where "ground" crew detaches beaching gear to await return of plane from U-boat hunt



8,000-ton troop transport and an unidentified ship.

During the Midway battle the pilots of the PBY's were in the air 20 hours a day and the ground crews got almost no sleep. This meant a terrific strain on men and planes. But the American airmen proved to be just as tough as the Catalinas.

When the smoke of Midway had begun to clear, the Catalinas were given a third important job. For 10 days they scoured the shark-infested waters, searching the ocean for yellow rubber life rafts. During that time they rescued 27 American pilots.

As in the battle of Midway, the Catalinas were the first to contact the Japs in the fog-bound Aleutians. The PBY's continually harassed the enemy in addition to furnishing reports of position, taking photographs and watching every Jap move.

When there seemed to be a shortage of bombing and fighting planes, the pilots of the "Cats" cheerfully assumed their duties.

Some amazing tales have come out of the Aleutians about the sterling performance of the "Cats." One day a Catalina found a large Japanese submarine on the surface and let a bomb go from 400 feet. This was risky because a lumbering PBY can't get away from the explosion at this close distance. She blasted the sub but one of the plane's engines was disabled by her own bomb and she limped home on a single motor. The flying boats were even used as dive bombers—something their designers had never dreamed of. Over Kiska the pilots would force the nose of the big crates downward and go rumbling through the soup like a landslide.

The heavy planes would shoot out of the clouds over the Japs and release their bombs. After the bombs had fallen clear, it took the strength of both pilot and co-pilot to heave back on the yoke to pull the juggernaut out of her earthward plunge. The big planes would pull out with their panels flapping like a circus tent in a high wind.

Another time a Catalina was hit squarely by a Japanese anti-aircraft shell. By all odds, it should have exploded. But it didn't. It made a neat hole through one side of the fuselage and out the other.

Hundreds of stories can be told—and will be told—about the ruggedness and durability of the Consolidated Catalinas. One navy pilot summed it up when he said:

"If I ever get in a spot where I'm forced to choose just one plane—give me a 'Cat!'"

*Des: Carson Paris
Spall Co, Montreal
State, Chicago*
**Scale Measures the Pressure
For Artificial Respiration**



Amount of pressure on "torso" is revealed by scales

First-aid students are taught to apply the correct pressure in giving artificial respiration with a unit consisting of a torso replica and precision scale. The student learns to apply the necessary amount of pressure in accordance with a patient's age, weight and injury, as well as how to determine the proper timing. Tests show that many students practicing the Schafer method of resuscitation apply pressures as high as 150 pounds.

**Flip-Down Shield for Car Mirror
Stops Reflected Glare**

Glare from bright headlights reflected into the driver's eyes from his rear-view mirror can be reduced by clamping a celluloid shield to the mirror. Crimped to a metal piece which in turn is hinged to a pair of snap-on clamps, the shield may be flipped downward to cover the mirror, or upward out of the way.



Colored shield for mirror may be raised out of way

*2007 S. State
Chicago*

Mr. Whitaker

ROBOT GUARDIANS of BILLIONS



m 889

24:

Photos courtesy of Underwriters' Laboratories

Engineers "turn burglar" with oxyacetylene torch to test resistance of combination lock on a vault door

IT'S 3 a.m.—the favorite hour for burglars. A man with a black satchel clutched under his coat takes a quick look up and down the deserted street and slips into the shadows of the alley.

He chuckles to himself. No cruising police cars. No stray pedestrians. The cop on the beat won't be along for another 20 min-

utes. Down the alley looms a four-story department store and on the third floor he knows is a steel safe containing between \$3,000 and \$5,000 in cash.

The burglar, no amateur, had "cased" the place a couple of days before. He learned there were electric alarms on the doors and windows and he figured there would be one on the skylight. (A jail term had taught him that the wires could not be cut without sounding an alarm.) He had also discovered that the place was without a watchman. The job was a cinch—he thought.

In three minutes the burglar is on the roof of the store. He had pulled himself up a rain spout and then swung over to the fire escape. He avoided the lower end of the fire escape because he



Testing sensitivity of microphone hidden inside a safe

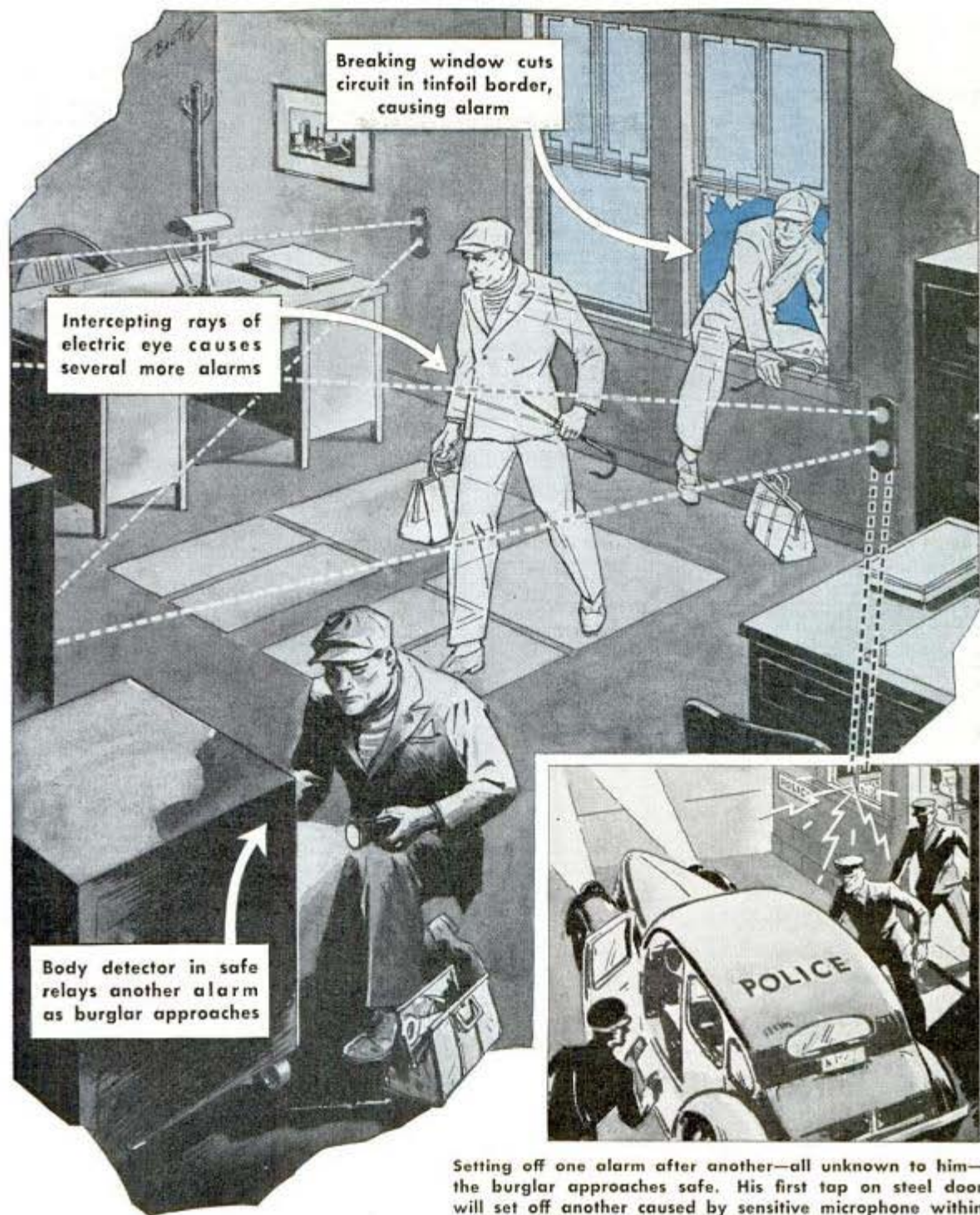

Setting off one alarm after another—all unknown to him—the burglar approaches safe. His first tap on steel door will set off another caused by sensitive microphone within

knew that, too, was equipped with an alarm that would go off if the framework were pulled down.

He sets his bag down carefully—which is wise. It contains caps, fuses and nitroglycerin in addition to a crowbar, hatchet, chisel, screwdriver, rope, wire, oxyacetylene cutting torch and various other tools.

After cutting a hole through the roof, he lowers himself into the building. The man looks carefully about for one of the tricky

photoelectric beams that had cost him another jail term. He knows the "black light" is almost invisible until you come into its direct ray; then the beam is broken and the alarm is sent.

Satisfied there is no electric eye in the place, the exconvict hurries down the stairs and makes his way into the office where the safe is located. He opens his kit, almost leisurely, and appraises the square dark object. He looks close to make sure there



Attempting to "defeat" an electrically protected outdoor alarm box with an electric drill in one of testing rooms at Underwriters' Laboratories

is no wooden cage around the safe—a contraption filled with thousands of tiny copper wires that send an alarm if broken or displaced a few inches.

The burglar runs his gloved hand over the combination lock on the door. He isn't naive enough to think he could feel out the combination like the fictional Jimmy Valentine. Locks haven't been made for a long time that can be worked by feel, no matter if a fellow sandpapers all the skin off his finger tips to make them sensitive.

Not a bad safe, this, he decides. Almost sporting. Might take all of 15 minutes to open it with the torch and nitroglycerin.

Two minutes later he jumps as the scream of sirens warns that something has gone wrong. Police and private guards swarm into the building and it is flooded with light. He knows the place is surrounded. Without taking time to gather up his valuable tools, he hides in a clothes closet. There the police find him.

The burglar probably never found out what action of his caused the alarm. It was so simple he

Applying torch to inner compartment of safe after shell of concrete is chipped away

wouldn't have believed it—the mere presence of his body a few inches from the safe. The safe contained one of the new supersensitive devices that operates like the old radio sets that howled when a hand was placed on them. The body detector, as it is called, gives an alarm when a person either approaches or touches a safe where it is installed. Its basic principle is radio frequency. The safe is connected with a nearby control set and acts as an antenna.

That is just one of the automatic alarms that are on duty in daylight or

blackout guarding billions of dollars worth of valuables—money, jewels, furs and merchandise of all kinds—from an army of 500,000 burglars, robbers and thieves at large in the United States. They commit 1,000,000 crimes a year that cost the nation 15 billion dollars.

A burglary (forceful entry of premises), a robbery (intimidation such as a holdup), or a theft (pilfering) takes place every 30 seconds of each hour every day of the year. One took place somewhere while you were reading the last couple of paragraphs.

Pitted against this army of criminals is an array of intricate protective devices that

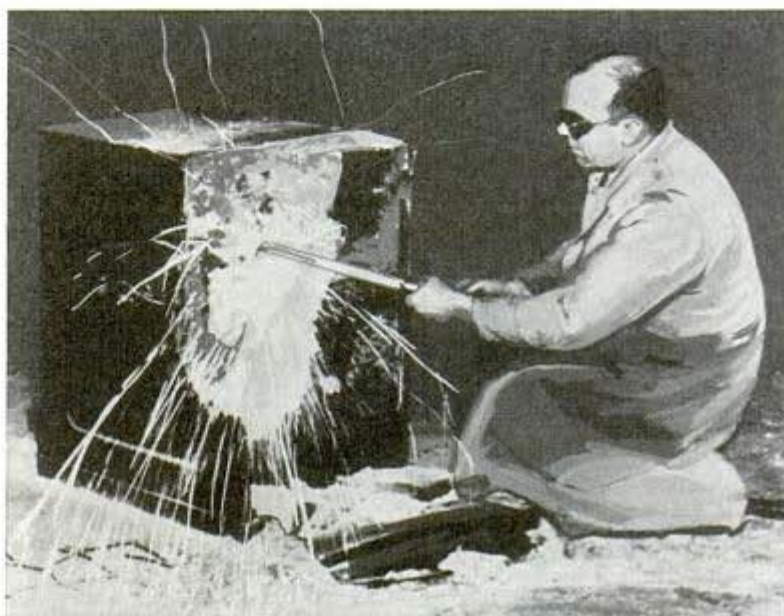

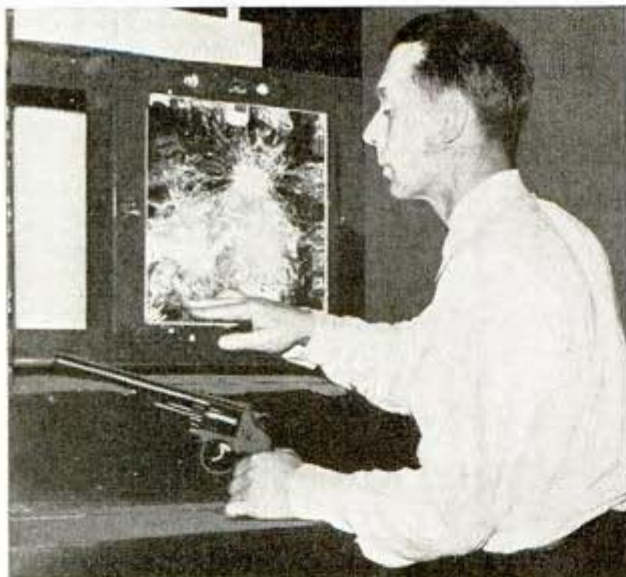

Sample of bulletproof glass after three bullets were fired at it from powerful revolver in engineer's hand



Firing at bullet-resisting glass in laboratory range. Various weapons are used for the tests

are the brain children of electrical wizards. There's no guesswork about the approved alarm systems. They are effective because each has been subjected to severe tests by engineers at Underwriters' Laboratories in Chicago, New York and San Francisco. The company also certifies installations and has men in the field constantly investigating the services of protective agencies.

When a new alarm is developed, it is installed in the laboratories and the engineers "turn burglar." First, they study the layout of the protected area and the circuit diagram. Then they go to work with tools that would be the envy of the Lone Wolf, himself. Sometimes a new device gets a high rating after the first test; more often, defects are found and the alarm is turned back to the manufacturer for correction. Then a new test is made and the system rated according to the amount of protection it affords.

Once the burglar or robber had only to cut the wires of an alarm system and his worries were over. Today most alarms—body, sound and heat detectors, photoelectric beams, pneumatic alarms and others—are built on a "closed circuit" that relays a signal the moment it is cut.

(Continued to page 176)



The locking mechanism of this money chest resisted "fishing expedition" with fine wire after hole had been cut in top. Below, oxyacetylene torch is used on steel panel in wall of vault to determine if microphone on other side of wall will "hear" the noise made by attack, thus causing instant alarm

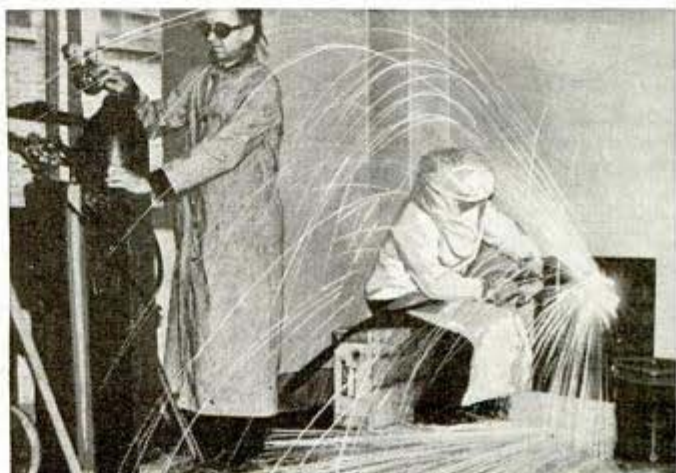

"Tank" Home Built for War Workers at \$1,500

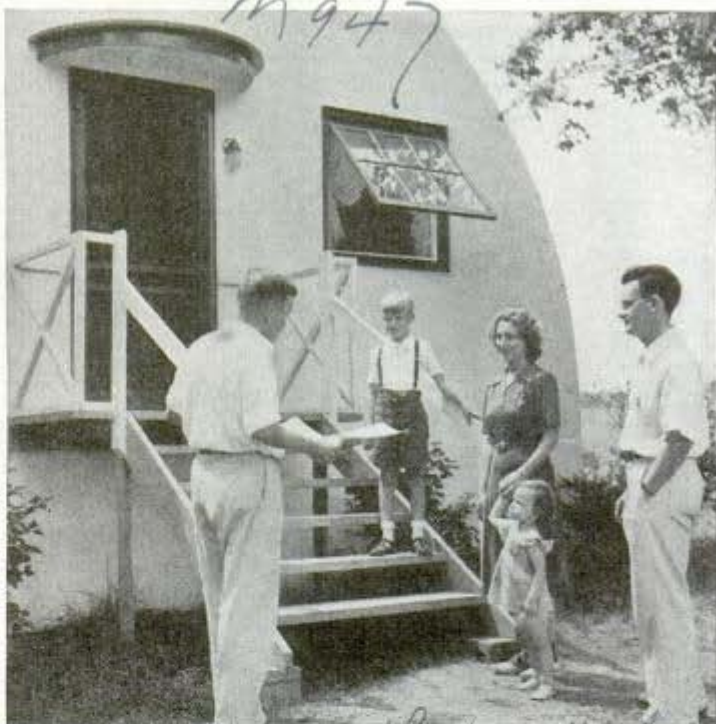
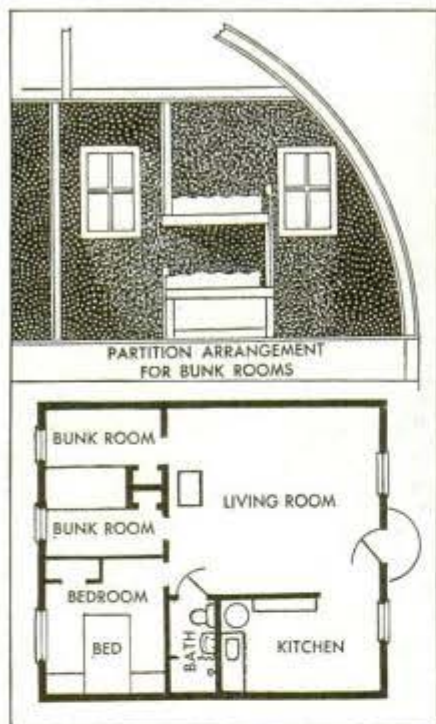

Paradise Grove, Lafayette, Ind.

To meet the need for temporary homes for war workers' families, Purdue Research Foundation has designed a house which six men can build in a week at a cost, fully equipped, of \$1,200 to \$1,500. Above is the entrance; at upper left, floor plan and cross section show accommodations for man, wife, boy and girl. Only 350 pounds of critical materials are required. Well insulated with glass wool between the outer ½-inch Gypsum wallboard and inner ¾-inch wallboard, the house can be heated by an estimated 2½ tons of coal per year



Cellarless, the house is set on field-cast concrete piers, its wood frame sheathed with fire-proof wallboard (at right) and coated with special emulsified asphalt (above) in which sand is imbedded. Over this goes white cement paint. Toilet, lavatory, shower, sink and laundry tubs are provided. A special floor joist spanning full width of the house serves as bowstring of the framing members, eliminating piers in middle of the structure



*Ryan Aeronautical Co.
 Lindbergh Field San Diego
 Calif.
 M 723*

Plywood Trainer Saves Metal for Warplanes

With body, wings and tail constructed of wood, the new Ryan PT-25, a primary training plane developed for the U. S. Army Air Corps, comes close to the goal of eliminating all strategic materials in military aircraft. Little special equipment is required in forming the plywood body, since cold-setting urea formaldehyde glues are used, needing no ovens, baking, complex forms or other "tricky" handling. Standard size flat plywood sheets are employed for all parts of the airplane, except the leading edge of the outer wing panel where molded plywood is used. The wood is waterproof, fire-resistant and not subject to fungus growth, with a weight-to-strength ratio greater than many high-grade steels. Exterior surfaces

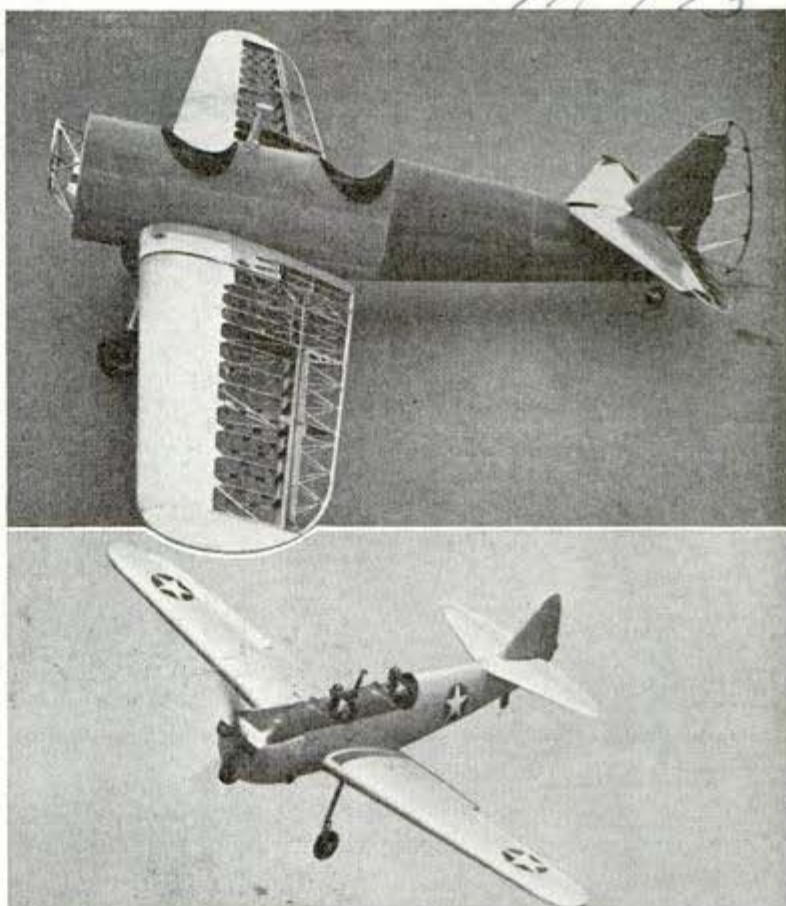

Top, plywood plane without covering or engine; bottom, finished and in air

are "armored" against the elements by a lightweight fabric covering stretched over the plywood skin. The only place where any strategic materials are used is the engine cowling which represents less than

two percent of the plane's total weight. It is reported that the ship is light and responsive to all controls, and is capable of easily performing every known military and aerobatic maneuver.

Jeep Converted to Ambulance Carrying Four Stretches



It takes only a few minutes to convert an army jeep into a stretcher carrier with wooden frames that fit over its hood and rear compartment. Four stretchers are strapped to the frames. This method of transporting casualties is efficient for short trips when the terrain is not too rough, according to officials of the Army Medical Corps.

Motorized "handy man" of the army—the jeep—adds ambulance duty to score of uses

Ch. 5. 700 Milton, 11-7-48.
Ensigns and Av. Los Angeles Cal
m 7 66

"MUSTANG" Admirals in the Making



An ensign shows cadets one of the 5-inch guns widely used by the Navy

AFTER the battle of the Coral Sea, a reporter approached Rear Admiral Wilson Brown and the conversation went something like this:

"I notice quite a number of officers who did not attend Annapolis took part in the battle. How did they stack up, sir?"

Admiral Brown replied: "You can tell your readers those fine young Naval Reserve officers are splendid. Afloat and ashore they rank with the best!"

These words of praise from Admiral Brown, formerly head of the U. S. Naval Academy at Annapolis, are a justification of a 17-year-old program to build a backlog of officers to be called in time of war. In 1925 the Naval Reserve and the Naval R. O. T. C. program were organized. The Naval Reserve was established to enroll former World War officers and specialists in civilian life. The Naval R. O. T. C. was intended to

Future officers of the U. S. Navy don masks for a training stroll through billowing clouds of gas



train capable college men as potential officers.

Today thousands of Naval Reservists and R. O. T. C. graduates are standing watches on the bridges of warships, flying naval patrol and bombing planes and doing administrative work at navy bases.

There is Ens. Anthony Akers, lanky 27-year-old Texan who graduated from the University of Texas and attended Northwestern University's V-7 program. He was a skipper of one of the P-T boats in Philippine waters.

One night Ensign Akers piloted his little torpedo boat into Subic Bay through Japanese mines and bamboo nets which foul propellers. A Jap tanker loomed in the darkness. Akers gave a curt order and two torpedoes went straight for their target. After this daring feat, the Texan was chosen to skipper one of the four torpedo boats which whisked General Douglas MacArthur out from under Japanese noses at Corregidor.



Keeping a sharp lookout from the crow's nest. Part of a cadet's training is learning to identify enemy ships and airplanes

Naval Reserve officers performed many deeds of valor at Pearl Harbor. Secretary Knox singled out an unnamed naval reserve ensign who took command of a motor launch. Through the hail of shrapnel and machine gun fire, the ensign rescued almost 100 men who had been blown overboard from a battleship. During the height of the attack, the propeller of the launch suddenly jammed. Cool as ice, the young Naval Reserve officer directed the work of disengaging the propeller as flames from the oil-covered bay licked around his craft. He was cited by his captain for "initiative, resourcefulness, devotion to duty, and personal bravery."

Heroes? Yes—but typical of the young naval reserve officers serving with the U. S. Navy on fighting fronts all over the world.

Uncle Sam is now creating the mightiest armada in history. With the fall of France, the United States set out to build a "two-ocean" fleet—368 ships costing \$4,000,000,000. Last June Congress approved a "seven-ocean" fleet of 550 more vessels costing another \$8,500,000,000!

To man this gigantic fleet, the navy will need thousands of highly trained officers. The Naval Academy at Annapolis can supply



The submarine service gets its share of Naval Reserve officers

With rifles slung on their backs, cadets learn to scale landing nets. The exercise builds muscle and makes them surefooted

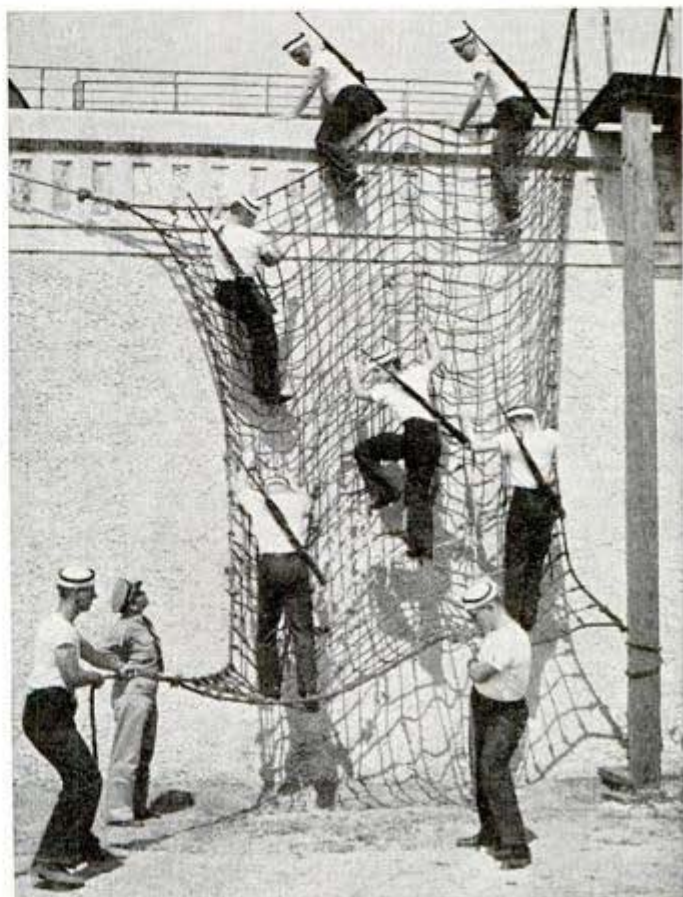



Flying cadets learn early how to manipulate their parachutes

only 700 or 800 a year. So the Navy has begun to tap a rich vein of officer material: the American college man.

Right now, thousands of men on college campuses are preparing for careers in the navy. And it won't be long before they'll be taking their places beside other non-Annapolis officers fighting on the sea and in the air.

The Naval R. O. T. C. program was launched in 1925 at Harvard, Yale, Northwestern, Georgia Tech, and the University of California. Since then it has been established at 22 more institutions. Some of them in such dry-land places as the University of Oklahoma and the University of New Mexico—but that's not surprising, since the Middle West has always furnished the highest percentage of sailors for Uncle Sam's Navy.

About 5,000 potential admirals will be studying under Naval R. O. T. C. supervision this year. The V-1 program at about 500 other colleges and universities will enroll 80,000 students. V-7 courses for college graduates are already turning out hundreds of ensigns.

Let's take a look at the Naval R. O. T. C.

It's quite a memory feat to learn the patterns and colors of signal flags—but a battle may depend on it

program, which furnished a basis for the V-1 and V-7 programs. The navy is pretty choosy about the youngsters it selects for R. O. T. C. training. It wants smart boys between the ages of 14 and 26 with plenty on the ball—those who lead in student activities and at the same time get good grades. A board of officers of the regular navy, most of them Annapolis graduates, selects the candidates who apply for R. O. T. C. They look for physical fitness, potential qualities of leadership, intelligence and a reasonable certainty that the student will stay in school four years. Only freshmen or sophomores are accepted. The Naval R. O. T. C. comprises four years of hard study—mixed in with plenty of fun.

The course is divided into two parts. The two-year basic course for freshmen and sophomores includes such subjects as naval history, ordnance, seamanship, communications, electricity, and navigation. In the advanced course, the junior year is devoted primarily to navigation; the senior year consists of gunnery, electricity, engineering, aviation, naval administration, and military law.



The cadets are required to take at least one period of summer training to test in a practical way the theory buzzing around in their skulls. In peacetime this summer training assumes the proportions of a pleasure cruise to such travel-folder lands as Hawaii, Alaska, Panama, or Cuba. But last summer (and for several summers to come) the training was on dry land.

"The boys really learn more on dry land than on cruises," an officer said recently. "When at sea, 90 percent are seasick the first few days and 10 percent are seasick all the time. This way none of them suffer mal de mer and bad weather doesn't interfere with training."

In their white enlisted men's uniforms—distinguished only by the blue band around their caps—the



Officers will not have to load guns, but they must be familiar with the routine

Cadets climb the rigging of a former pleasure yacht now on patrol duty in the Pacific



The .45 automatic pistol is an officer's weapon; cadets must learn to use it safely

cadets go through a stiff, three-week training period of work, study, sleep, and eat. They work and study as apprentice seamen at \$50 per month. Thus, when they get to be officers, they'll appreciate the enlisted man's point of view.

They row small boats and handle small craft under sail. They learn to repair and shoot .45 automatic pistols, .30 caliber machine guns, and 5-inch deck guns. With rifles and packs slung over their backs they clamber up and down landing nets. They bone up on the theory of poisonous gas and then don masks to walk through clouds of the stuff.

During his four-year course in

(Continued to page 167)

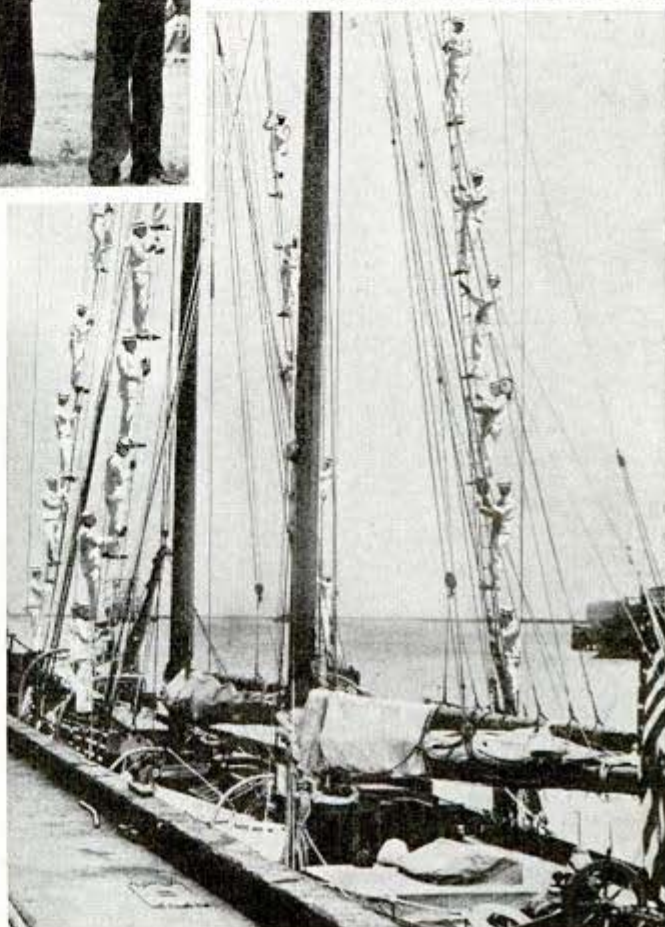

Attached to San Francisco Marine Ave. S. W.

Floating Hotel Houses War Workers in Capital

M 183

acme #61 - 8 av, nyc

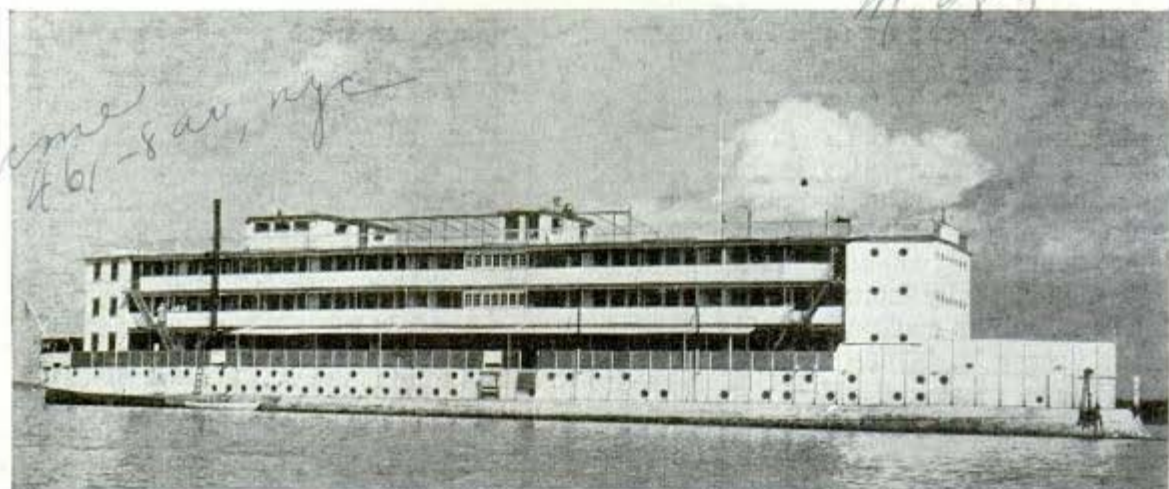

Hotel boat augments living quarters for the vast army of government employes now in Washington

To relieve the shortage of housing at Washington, D. C., a floating hotel has been moored at the Potomac shore. The 265-foot boat, originally costing \$350,000, has five decks, three of them containing 75

rooms approximately 15 by 15 feet each. Some of the rooms have baths, and all are equipped with running water and lavatories. On top is a sundeck, and the lower deck includes dining room and dance floor.

Ship Built in Hole Is Launched by Filling Hole With Water

M 765

acme #61 - 8 av, nyc

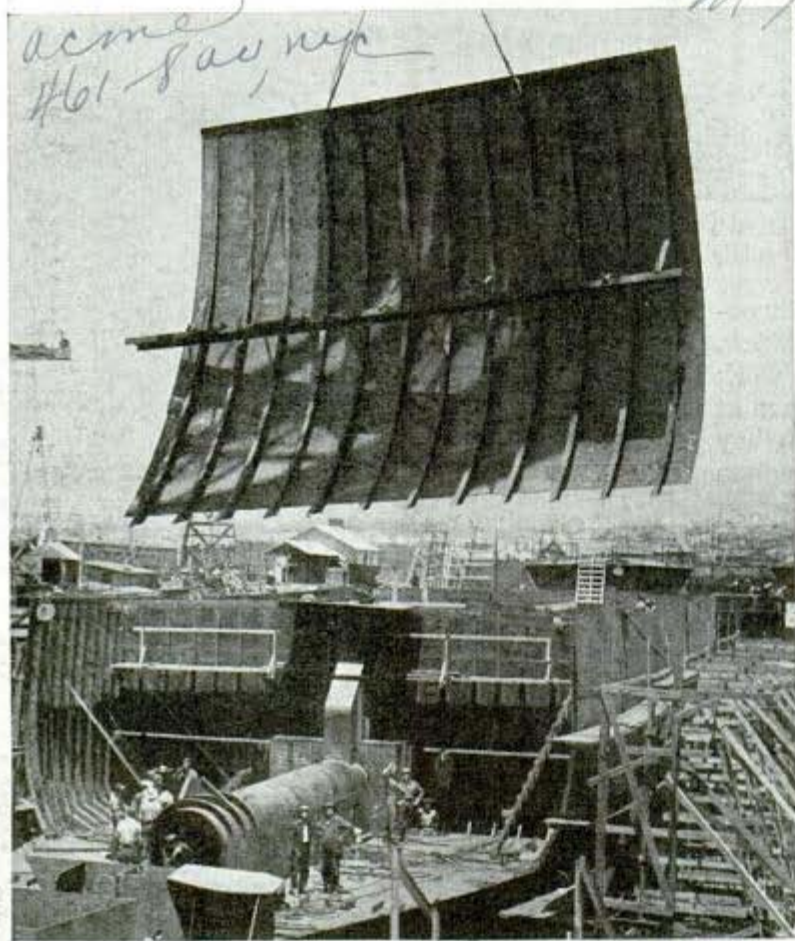

Merchant vessels are being built much faster by digging a spacious hole in the ground and there erecting the ship, instead of building it high on the ways whence it must slide down into the sea. Prefabricated ships constructed in this way by one company are completed in about 30 days, and the work involves fewer hazards. The danger of greased ways, for instance, is eliminated, since the ship can be floated out on water released into the hole.

Keel for this vessel was laid in a hole in the ground to avoid the time-honored though risky method of launching by sliding the ship down the ways. Instead, it is launched by filling the hole with water

*Pacific Bridge Co
San Francisco, Cal.*

*Boeing Airplane Bureau
Seattle, Wash.
m 913*

Boeing "Fortress" Fleet Crowds the Calendar



Bold innovations in manufacturing methods have put production of "Flying Fortresses" far ahead of schedule at the Boeing plant. Instead of a long assembly line, Boeing breaks up the process into seven major assembly operations, joins the completed installations only at the end, saving factory space that would be occupied by swarms of assembled Fortresses with 104-foot wing spread and 70-foot body. By this efficient use of space, Boeing produces more pounds of plane per square foot of factory space than any other manufacturer. At upper left, dense rows of main fuselage sections are fitted with complete installations. Upper right, completed bodies ready to have wings, engines and guns installed. Their next stop will be the firing line

The eighth in the series of Flying Fortresses tries its wings over Mt. Rainier, above. At right, inboard sections of the wings in their special assembly department where motors and other parts are added. Production has more than doubled since Pearl Harbor. Spectacular advances in technique have contributed to this speedup. Exhaust outlet cowlings once made by drop hammer required 30 minutes work; a multiple action press now produces the part in 15 seconds. Wing jigs that took up vast floor space are installed vertically, skyscraper fashion. Workers have made 5,000 suggestions to help production

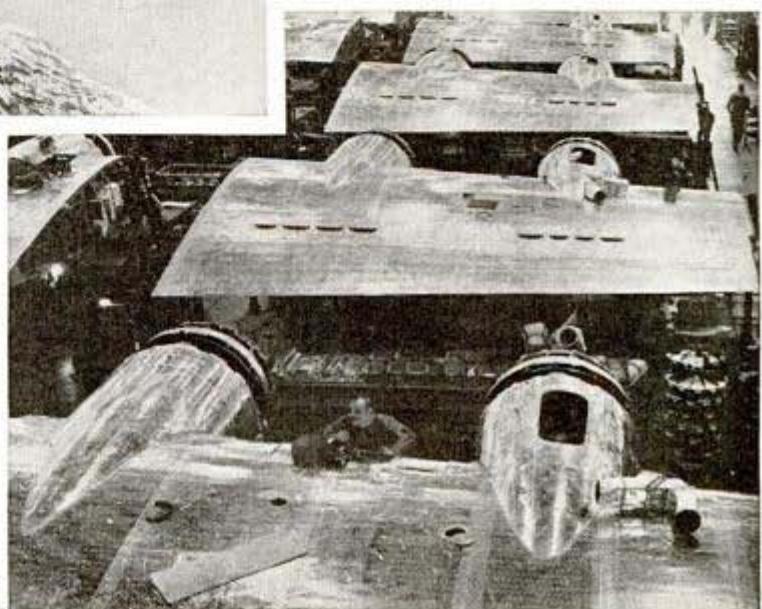

TOUGH GUYS



tough young men in training camps are listening to tougher instructors who bark:

"Bust 'em in the eardrums! Kick 'em in the stomach! Break their spines! Gouge, choke, twist and smash 'em."

Shocked? Some of them are at first. But they are taught that it's not a footrace at a Sunday School picnic for which they are preparing, or a Marquis of Queensberry affair. It's war. The rules are made by war sense, the crux of which seems to be:

"Kill or be killed. Capture or be captured."

Every soldier, sailor, marine or coastguardman knows that perhaps some day, alone and barehanded, he may have to face a desperate and tricky foe. When that day comes, Uncle Sam intends to see to it that his boys have better than an even chance.

That is why they are being taught a new brand of fighting. Call it hand-to-hand, close-in, rough and tumble, commando tactics or what have you, but the fact

By
Wayne Whittaker

With bush knife, machete and a wary eye for Japs, the mud-smeared trooper is ready for action. Commando technique, below, for disarming invader

TAKE jujitsu, combine it with barroom and commando tactics, add a dash of American ingenuity and you have the formula for developing the deadliest fighter the world has ever known. He's Uncle Sam's soldier, sailor or marine trained for invasion against a foe that fights dirty.

They asked for it, the Nazis and Japs—especially the Japs with their bodies painted green in the jungles of Bataan; the Japs who carry small razor-sharp knives in their loin cloths to slit the throats of their captors, and who know the bone-breaking tricks of judo.

From coast to coast



Pub Lawrence Dean
Pub Lloyd Taylor
Sgt Howard Belland
POPULAR MECHANICS

all of columns 2 to 3



remains it's plain dirty fighting.

Instructors in the art of the foul blow include such men as Col. Anthony J. Drexel Biddle, veteran of the Marine Corps, who combines bayonet practice with jujitsu; Capt. W. E. Fairbairn of the British Army, who drilled the commandos; Dr. Francois D'Eliscu, formerly of Columbia and New York universities, who specializes in the use of a five-foot sash cord; Col. J. Prugh Herndon, commander of the Bushmasters in Panama; Commander L. S. Perry, director of the Naval Academy's physical training program; Lt. Jack Dempsey, former heavyweight boxing champion, and many others.

The first rule is never to strike with clenched fist. Hold the hand stiff, fingers straight, and strike with the hard edge of the hand between little finger and wrist. Use a chopping motion and aim for the enemy's Adam's Apple, side or back of the neck, the base of his spine, his kidneys,

Here's a lesson in coolness under bayonet attack demonstrated by Col. A. J. Drexel Biddle who instructs marines

Two marine parachutists show how to keep in top shape with a few turns on the mat
U. S. Marine Corps photo



Langley, Va.

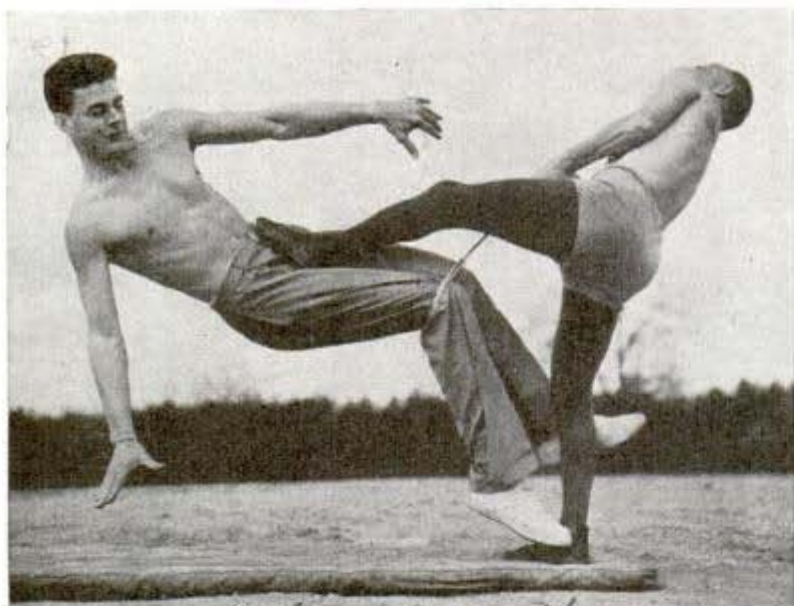

Columbia U
Dr. Francois D'Eliscu demonstrating anti-Jap "rope trick." Above, rope is looped around knees, victim kicked backward. Right, ends of rope are tied around throat

biceps or forearm. With a little practice you can break a bone with this blow.

Then there's the chin jab delivered with the heel of the hand with fingers spread to reach the opponent's eyes. When it comes to kicking, the men are taught never to kick forward, but always to the side for greater force. A side kick just below the knee cap is followed up by scraping down the shin to the instep and topped off with your weight on the enemy's foot to break the small bones.

If your foe is flat on his back take a flying jump for the "bronco kick." Knees are drawn up and when your feet are about eight inches above his body shoot the legs out straight to deliver a smashing blow. (Dummy figures stuffed with grass are used in practice for this one.)

A vicious attack can be made from behind by jumping on a man's back with a sharp kick to the back of his knees as a quick follow-up. He doubles up like a jackknife and if you twist at the same time the spinal cord is severed.

Another back-breaker is delivered by approaching an opponent from the left side and seizing him by passing your right arm over his chest and your left arm under his legs behind the knees. Lift him up and

take a short pace forward with your right foot. Then smash him down on your bent right knee with all the weight of your body.

It's easy to see that these are not parlor tricks. Practicing any of them on friends would be like a high school chemistry student experimenting with TNT. That is why all military classes in hand-to-hand combat have expert instructors.

The men are taught how to break holds during a surprise attack, how to disarm the enemy if he

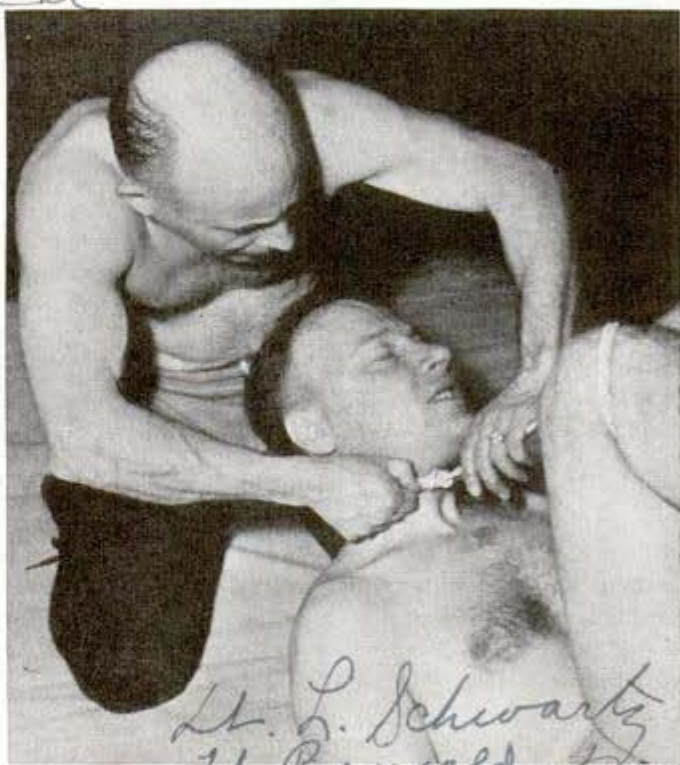

H. L. Schwartz
H. Ringold, Tex

approaches with gun or knife, how to lead a prisoner with a thumb hold that requires little pressure. They learn that the most vulnerable spots on the human body are the solar plexus, groin, throat and chin.

Suppose a Jap attacks from behind, grabbing a sentry around the throat with his left forearm, his right hand upraised to stab. The right elbow of the alert marine will swing back like lightning into the Jap's solar plexus, doubling him up before he can deliver a death blow. Then the Jap will be polished off by being pulled over



Army officer shows two ways to meet the charge of an enemy in hand-to-hand combat. Left, foe is caught by wrist and sailed over officer's back to land neck first. Right, smashing foe in face with a well-placed knee. Below, demonstrating Capt. Fairbairn's "back breaker" hold

the marine's shoulder and smashed to the ground on his head. This is only one of scores of defensive moves taught to the marines by Maj. Dick Hanley, former football coach at Northwestern University.

If a sailor is seized from in front with his hands pinned to his sides, all he has to do is remember Rule Nine in "Method of Self Defense"; "Kick him in the shins. Stamp on his foot. Bump him in the face with your forehead. Work your hands into the pit of his stomach and force his body backward. Then knee him." The sailor is also laconically reminded to "remain calm and collected throughout any crisis."

The paratrooper who may be dropped behind enemy lines is taught to make a silent approach to a sentry and "eliminate" him without firing a shot or hurling a hand grenade. Cupped hands strike simultaneous blows over both ears, bursting one or both eardrums and probably resulting in a mild form of concussion. Before he recovers from the blow he is caught in one of a dozen strangle holds.

The men are taught to make use of simple weapons that are as innocuous at first glance as a short rope, a wire loop or a stick. Capt. Fairbairn, author of "Get Tough—How to Win in Hand-to-Hand Fighting" (Appleton-Century, New York, \$1), teaches a deadly technique with a small stick. A sharp

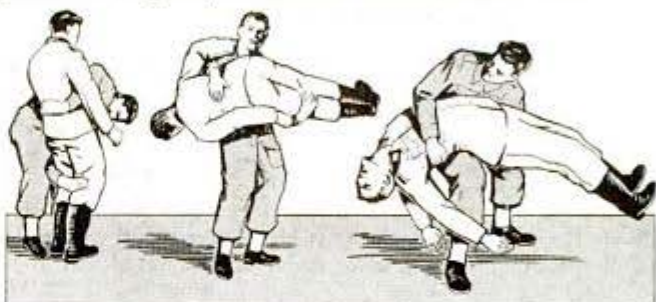

Above and below, the navy's "rough and tumble" tactics reveal fine points of throwing man by heel twist and toe hold





Navy instructor rehearses "Nazi reception" with cadet. Left, locking foe's right arm to body, he delivers sharp blow under chin, knees victim. Right, using heel of hand for "snout punch"

blow is delivered to the stomach followed by a jab to the neck. If you miss the neck, the stick which is held in both hands is used to rip across the enemy's face with all your weight behind it.

A bizarre form of "jump the rope" is taught by Dr. D'Eliscu. He uses a five-foot sash cord which he calls a "hog tier." After kicking the enemy in the stomach, the rope is looped around his knees and the loose ends drawn about his neck. If the victim doesn't strangle himself with his own struggles, the process is hastened by sitting on his face and pushing forward on his knees.

Another deadly weapon is a length of wire with a wooden handle on each end. It can be looped over a sentry's head and pulled taut with one motion. The piano-wire garrote with weighted end needs no description to explain its gruesome use or effectiveness.

Machetes, curved knives, tommy guns,



Sketch from Capt. Fairbairn's book "Get Tough" shows a "rib crusher" Courtesy Appleton-Century Co.

high powered rifles and hand grenades are used by American Bushmasters, named for the venomous jungle snake, and Pioneer troops. The Pioneers are picked men from the combat engineers who will clear a path for advancing troops. With mud-blackened faces, ferns and brush stuck into their hats and collars, they creep forward to establish bridgeheads and demolish enemy installations. If they lose their bush knives or guns they can fall back on the Army's version of jujitsu for protection.

One of America's most colorful and least known soldiers of World War II is the Bushmaster. He is as much at home in the Panama jungles as he once was at 42d street and Broadway, or State and Madison streets, or Main street and the county highway. His tactics are borrowed from native jungle fighters, the American Indian, British Commandos, exponents of judo and the Shanghai underworld. His average age is

22 and his favorite weapon is the long-bladed machete.

The jungle commando moves through the bush like a green shadow, flicking his wrist to cut a path with his knife. With his fellow Bushmasters, he disappears from civilization for weeks at a time. The men know how to sustain themselves on wild fare supplemented by concentrated "iron ration" carried in their packs. When they are not testing their camouflage against aerial observers, making camp in a swamp, or working out an intricate code of communications, they practice jujitsu or improve on the native's technique with the machete. The Bushmaster bows to no man in the art of hand-to-hand fighting and any unwary Jap who crosses his path would probably never know what hit him.

One of the prerequisites for efficiency in dirty fighting is excellent physical condition. An extension sports program helps keep the armed forces fit. Baseball, football, boxing, wrestling, tennis, fencing, swimming and other sports serve as both recreation and physical training. Many famous athletes, including Commander Gene Tunney of the Navy, are leaders in the programs designed to build strong fighting men.

Many colleges and universities are expanding their sports programs during the war and some have added classes in "personal defense." The latter is aptly termed "dirty fighting" by the students.

The University of Illinois has a course called PEM 58 which teaches prospective soldiers how to execute the "front choke, groin slam, back flip, wrist breaker, eye gouge" and a few other tricks never before mentioned in faculty circles. The students are taught that the soldier who observes the rules of a gentleman in personal defense is just using poor judgment and probably will be killed or captured. Only the tough guys survive.

The average redblooded American loves a fair fight and good clean sport, but right now he's out to show a below-the-belt, rabbit-punching enemy that if it's a dirty fight he wants, that's exactly what he's going to get.

¶ You can obtain additional information about products described in this magazine by writing to the firms listed in the Where-to-Buy-It index. Say You Saw It in Popular Mechanics.

FEBRUARY, 1943

*Rohm and Haas Co.
515 Greenway
Philadelphia, Pa.*

Plastic Lens on "Jeep" Light, Hides Rays From Enemy



Shields make "jeep" lights invisible from the air

Army "jeeps" can use their headlights at night without risk of being seen by aerial observers, if the lamps are equipped with special lenses made of Plexiglas—the same plastic that protects airplane gunners from the elements and bullets. The unbreakable lenses pass enough light for safe driving but not enough to be seen from the air. They are also used on taillights.

Pin-Up Hat Rack for Car or Tent Fastens on Wall or Ceiling

Equipped with pins for attaching it to fabric surfaces, as in an automobile or tent, a hat holder now available is easy to install on the ceiling or side walls. The pins are mounted at the ends of two parallel metal strips, which are connected by a pair of fine spring coils.

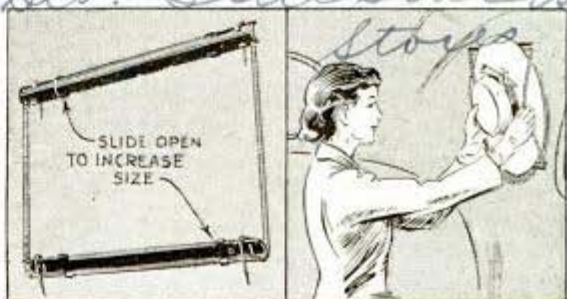

Hat holder, left, can be used in automobile or tent

*2007 S. State
Chicago*

45

GUNS ON WHEELS



This giant of the field artillery, an M-1 155 mm. gun, is the latest and heaviest mobile unit in actual service. It has range of more than 15 miles. The gun rolls along on 10 rubber tires and is towed by a tractor. One major advantage is that it can be moved without dismantling—thus it is ready to blaze away at enemy positions without delay. The army's hard-hitting field artillery prepares the way for break-through by infantry. Big brother of the M-1 is the 240 mm. howitzer shown below ready for action as its gun crew runs to firing positions. This gun is broken down into several loads for transport. An effective long range weapon, it is used for battering heavy fortresses



↑ Modern warfare hasn't become so mechanized that the army can dispense with old stand-by—the mule. Here gun crews are unloading barrel of 75 mm. pack howitzer, lighter than standard field artillery piece





↑ Swinging a big shell toward breech of 240 mm. howitzer with heavy crane. The shell is lifted to movable track which eases it up to the breech to be followed by powder propelling charge. Right, the 155 mm. gun lifts its nose to maximum elevation just before firing. One member of gun crew attaches firing lanyard, or rope, to the breech and in few seconds a command to fire will send the heavy shell hurtling out of the barrel. Members of the gun crew must be strong as well as dependable



↑ Leading mule carrying wheels and breech of 75 mm. pack howitzer. It takes six mules to move a gun

The "tank destroyers" (below) are half-track war machines mounting 75 mm. guns. The one in center has stopped to fire its big gun in maneuvers. These units are extremely mobile, hard to hit. Each carries heavy machine gun and some tommy guns

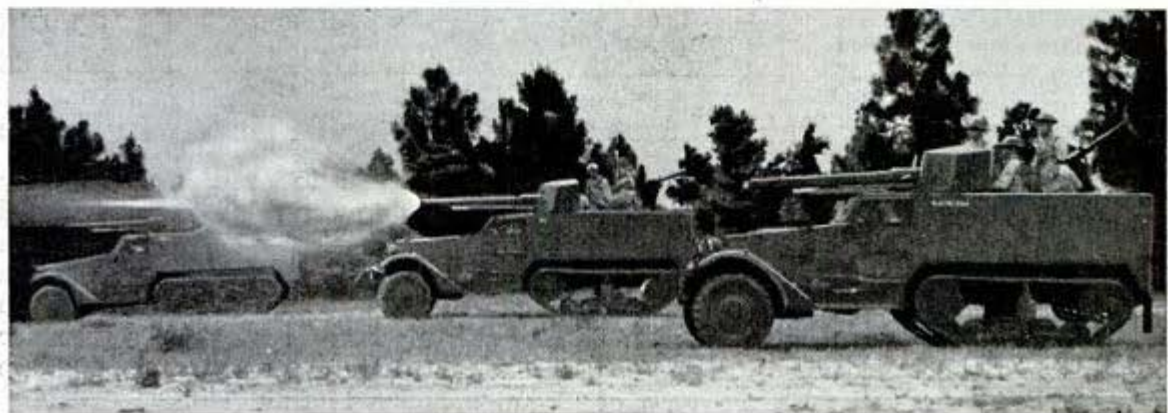

Doc 1061-8 ad, sup

"Jungle Mudders" Man Guns Hidden in Swamp



Located in the swampy terrain of Caribbean outposts are big guns manned by U. S. soldiers of the coast artillery known as "jungle mudders." The men, toughened by months of training in all phases of jungle warfare, are some of Uncle Sam's most formidable and resourceful fighters. The guns they operate are expertly camouflaged and from the air appear as part of the jungle foliage.

To observers a few hundred feet up, this big gun located in tropic swamp at Caribbean outpost is just part of the dense jungle foliage

Production-Line "Gatling Gun" Helps Turn Out Shells

Far behind the battle lines, a multi-barrel "gun" is doing its bit in supplying shells for armed forces of the Allies throughout the world. It looks so much like a weapon that the men who operate it refer to it as "the Gatling gun of the production line." In reality it is a multiple spindle automatic screw machine, performing operations on shell bodies, and is used by a firm that formerly made cash registers.

Doc 1061-8 ad

This machine is not as menacing as it looks, but it makes shells that eventually find their way to the "real thing"

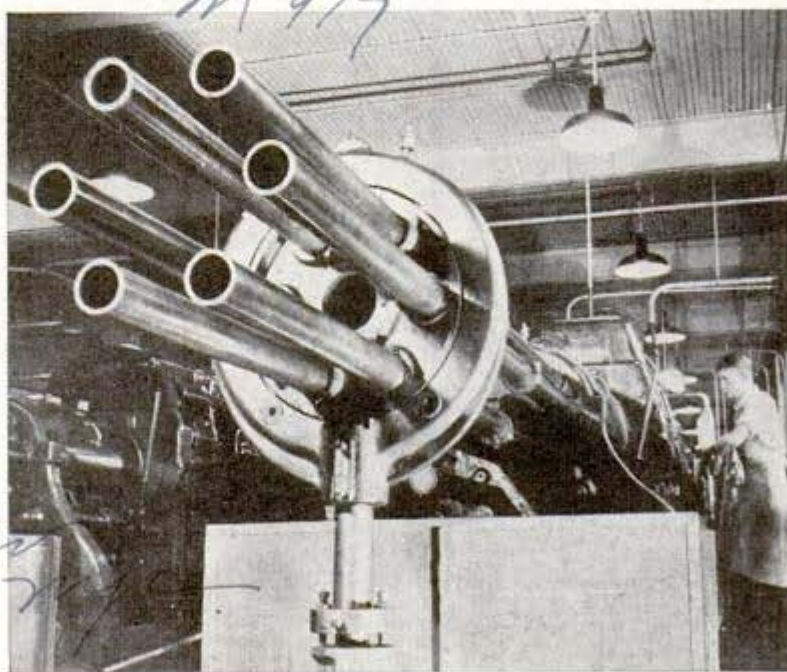

Power Lines Carry Raid Alarms to Handy Plug-In Buzzer in Home

Both audible and visible warning signals are given with a home alarm which is operated by a special control board attached to the carrier-current transmitter at a power station. Designed for air raid wardens and civilian defense officials, the warning device can be plugged into the house circuit. It is operated with the type of

M 1073

equipment used to send impulses over power lines to control street lights and would relieve telephone lines during an emergency. The alarm is equipped with a buzzer and a rotating colored dial. The dial shows white for all clear, yellow for preliminary caution, blue for advance caution, and red for air raid.

Rome - #61-8 av, nyc

"Flying Jeep" Comes Apart to Load on Truck

When the U. S. Army's "flying jeep" can't be flown to location, they take it apart, load it on a truck and haul it with equipment to the scene. The plane is a small artillery liaison craft now being used in the European war theater. Quickly dismantled and assembled, the tiny ship can land or take off on very small fields, whether they be smooth or rough. On a truck it makes a compact load, its wings lying parallel with the fuselage.



"Flying jeep" assembled for flight (top), and being transported on truck

Thin Glass Fibers Help Camouflage War Plants

Lightweight glass fibers, thinner than a human hair, are used to cover metal-mesh camouflage nets over vital war plants. The flexible fibers which are resistant to weather and fire are painted with designs that blend with the surroundings. The glass-covered nets are supported by a special framework.

Anti-Glare Glasses for Driving Adjust to Fit Conditions

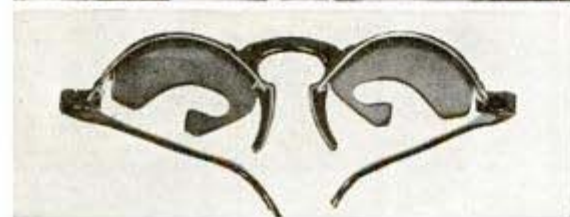

Equipped with adjustable, oddly shaped lenses, driving glasses now available can be changed quickly to fit the wearer and shield the eyes against glare from any angle. For night driving, for instance, the purple lenses may be adjusted to split the road so as to cover headlights of oncoming cars to the driver's left, while leaving the vision unobstructed directly in front. The lenses also may be shifted to take care of daytime glare whether from the left, right or overhead. The plastic lenses are held in slots of the half-rims by friction.

Lenses may be shifted to cut glare from any angle

To learn where to buy commercial products described in these pages, see the index.

Some discontinued

GLASS PINCH-HITS *for*

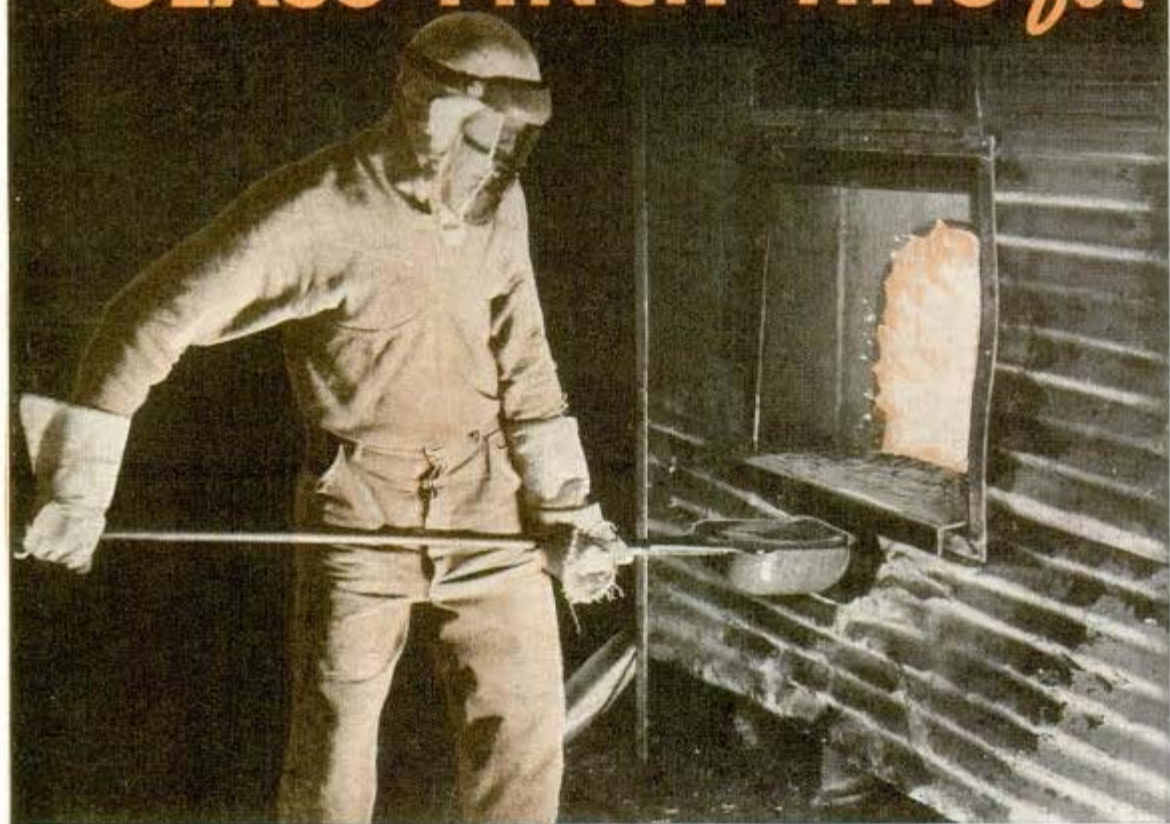

Talbot O
It's warm work ladling white-hot molten glass from a furnace at Owens-Corning Fiberglas plant. Below, a worker employed by Libbey Glass Company over a half century polishes the edge of a fine crystal vase



M 857
By Roderick M. Grant

IT'S LIGHT as a bubble and tough enough to stop machine gun bullets. It's as old as Rome and as new as next week. You can wear it, cook in it, live in it. To sailors and surgeons it's a lifesaver. To you it's—glass.

Glass is as vital as Sunday, but you are so completely surrounded by it that you seldom are aware of it until the mirror drops off the wall or a baseball shatters the window. If you read some morning that the Japanese had cut off our sources of glass and that it would be rationed like rubber or tin or armor steel—army first, you last—you would begin to think about how nice glass was.

Very fortunately, Japan can't do that to us. For as long as there are lime and soda ash and dunes of silica sand in America there will be glass; and there are better things to worry about than the end of our lime and soda ash and sand.

Glass is one of the oldest materials invented by man, dating back, according to legend, to a band of shipwrecked Phoeni-

the **WHOLE TEAM**

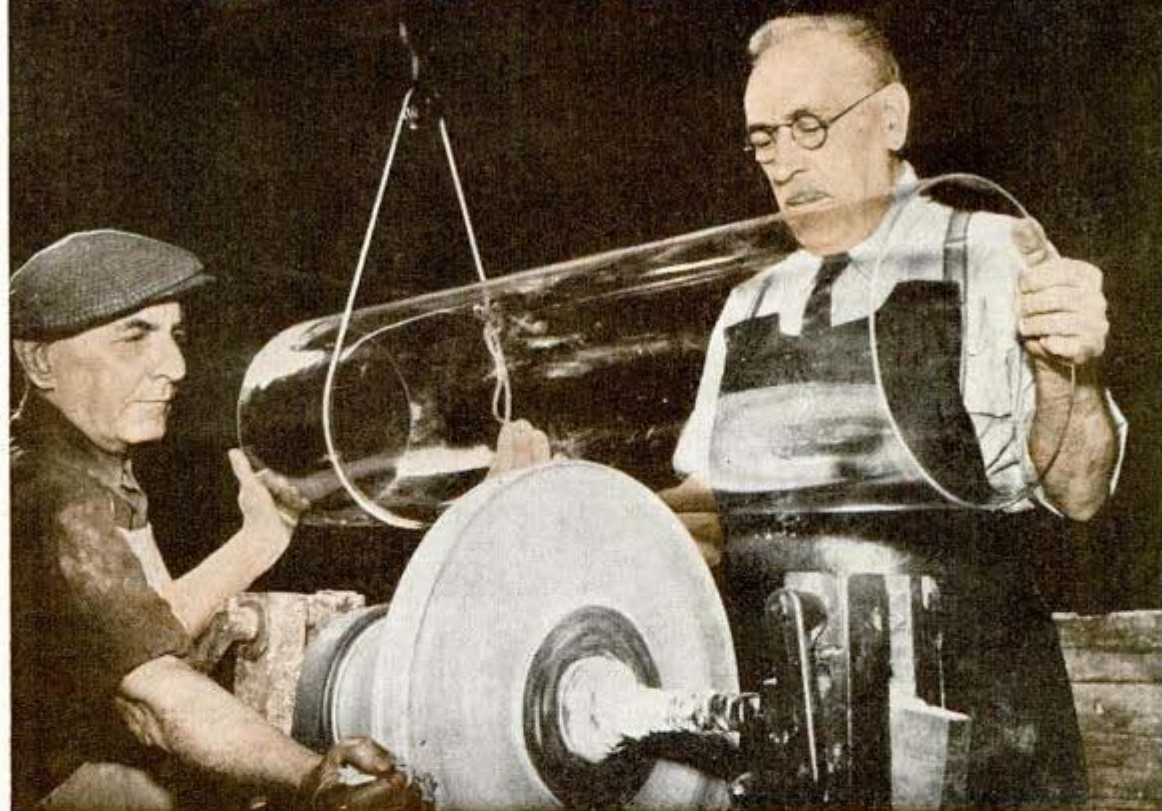

cians who cooked their picnic supper in a pot set on blocks of soda on the sandy shore of a Syrian river and were amazed to see sand and soda fuse into a stream of molten glass. Mesopotamian craftsmen were shaping colored glass into things of beauty 5,000 years ago, and windows of flat glass were found in the ruins of ancient Pompeii.

But after doing business in a conventional way for a few thousand years, the partnership of Soda Ash and Sand has branched out in the last few years into strange avenues of trade. It is like a small boy who suddenly discovers he has muscular talent and immediately takes up football, swimming, badminton, golf, tennis, pole vaulting and the ballet, and excels at them all.

Glass ceased to be merely the stuff of window panes and spectacles and goblets when about 10 years ago Owens-Illinois Glass Company, and later Corning, began spinning out tenuous glass fibers for air filters, insulating wool and textiles. It was insinuating itself more and more into other people's business when it coiled itself into springs with the resilience but not the rusting properties of metal springs; when it was shaped into fire-resistant building

Navy ships are made from blueprints turned out 20 feet a minute by blueprint machine cylinders of special glass hand-blown at Corning Glass Works. Below, a new liquid coating prevents glass from splintering

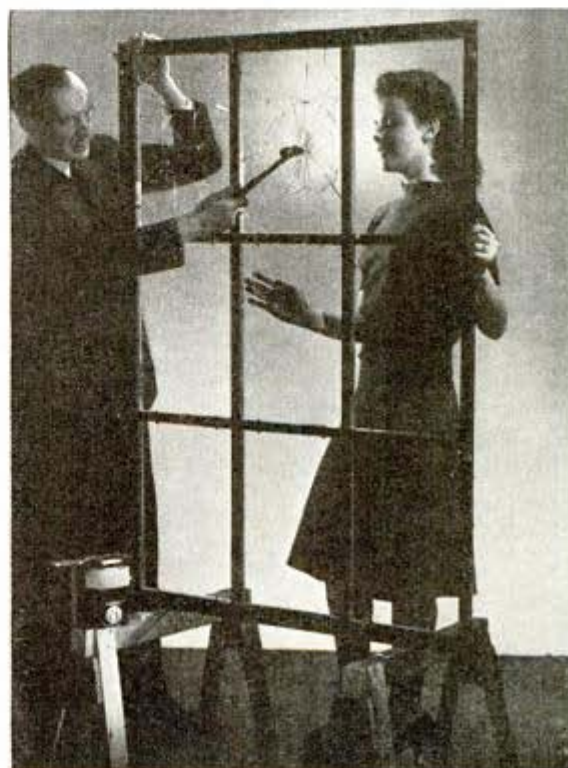



Made of a blast-cushioning glass fiber material, this mattress was designed to protect electrical switchboards and instruments from bombings

blocks, and tried as a substitute for steel in reinforcing concrete—a project still experimental but nevertheless in work.

Right now it is treading on the toes of rubber and cork and kapok, but a nation hungry for these scarcities is ready to welcome the new Foamglas, developed by Pittsburgh Plate Glass and Corning. Foamglas is a lifesaver in more ways than one. Weighing one-fifteenth as much as ordinary glass, it is a mass of airtight glass cells, permanently buoyant in water, well suited for life jackets, rafts or boats. It is "raised" somewhat as yeast raises bread.

Glass is mixed with a small amount of pure carbon; heated, it softens and the carbon combines to form a gas that puffs up the molten glass into a mass of bubbles that "jells." There's plenty of work for Foamglas to do in the war—in lifesavers, ponton bridge floats and the like; afterwards, its principal job will be to insulate cold storage plants, ice cream factories, dairies, etc. Being solid and moistureproof

Preparing to ship cartons of Fiberglas, versatile material used for heat and sound insulation
OEM photo by Palmer



it is unaffected by the vapor of low temperature rooms, and it is easily sawed and worked with ordinary tools.

Modern war would not be modern without glass. "Golden plate glass" originally intended for decorative mirrors turns out to be ideal for filtering out ultraviolet rays that sunburned warplane pilots in the stratosphere. Two-ton range finders optically ground by Bausch & Lomb are the eyes of the battleship's big guns—and those of the U.S.S. North Carolina are described as the finest in the world. The glass pot on your stove is a cousin of

the heat-tempered glass of army searchlights that withstands the terrific heat of 800,000,000 candlepower light on one side while a blizzard slashes the outside with snow. The slots of tanks are protected by thick glass that will stop a machine gun bullet, and portholes of ships are made of a tough glass that will bend but not break under the impact of a wave. In the test tube and retort, the factory window and incandescent lamp, the microscope, telescope, binoculars, the aerial camera lens and the X-ray, in the new blast-cushioning fibrous glass for blackouts and a thousand

other applications, glass is doing its vital work in the war.

It is functioning quite importantly, too, as an all-but-universal substitute. When the flat glass business was suddenly flattened by loss of the automobile window market, Libbey-Owens-Ford and Pittsburgh Plate Glass and other companies in that field began a search for other markets. They are finding their versatile product a ready stand-in for such widely different priority materials as silk and steel, aluminum and asbestos, syn-



thetic plastics and tin and rubber.

Chrome went out and glass came in as a reflector for headlights and searchlights. Sound studios turned to glass instead of aluminum for the bases of recording platters. Double-glazed, insulated doors for frozen food and ice cream cases and display cabinets replace metal, hard rubber and porcelain enamel. Glass buttons "front" for shell and plastics. Glass storage batteries save hard rubber. Several companies are making hard glass bearings to fill the gap left by restrictions on sapphire jewel bearings for instruments. Road signs may be made of glass if metal is further restricted.

Don't assume that glass is just a pinch hitter without a chance of



Skillful use of ancient tools contributes to fine qualities of handmade occasional pieces at Libbey Glass factory. The craftsman above, known as a servitor, draws out a heavy gob of molten glass to be formed into an exquisite modern vase. To make Fiberglas, a marble is drawn into a continuous filament that would reach from New York to Philadelphia; over 100 filaments are woven to make the finest workable strand. Glass yarn is twisted and plied on standard textile machinery, below, in one step of the manufacture of glass fabric. Glass textiles are made into clothing and fireproof curtains, but principally into tape and cloth for electrical insulation. OEM photo by Palmer.



*W. L. Lacey
Office of Civilian Control*

*M. R. Jensen
Owens-Corning*



A fibrous glass board that can be sawed is used in a window installation

getting into the regular lineup. In many cases glass is in there to stay.

Owens-Corning Fiberglas, for example, has developed a glass thread for surgical sutures, which surgeons believe will end the danger of infections. Catgut and silk used to sew a wound sometimes become the focus of infections, and there are objectionable factors about stainless steel and

gical sponge makes it possible to locate by X-ray a sponge left in a wound.

While the war gave an initial jolt to the flat glass trade, it gave a lift—although with new problems—to the bottle makers. The industry has jumped from an annual production of 68,000,000 gross of containers to 80,000,000 gross. Reads like a nice wartime boom, doesn't it? But it isn't all velvet.

The industry can't expand to take care of increased demand, for it's hard to get machinery; the automatic bottle-blowing machine invented by Michael J. Owens in 1903 has grown into an intricate monster of 10,000 parts forming bottles faster than you say Owens-Illinois Glass Co. The conquest of Malaya and the Indies not only meant less tin for cans and so more bottles for food, but it brought headaches to the bottle cappers. Plastic caps or other seals for bottled foods and fluids must be found. To speed production, fancy shapes are being eliminated and food and drug bottles standardized in plain shapes and fewer sizes. The "deceiver" bottle, made to look like a lot and hold less, is a war casualty unlamented by you and me and the glass industry. The new bottles are lighter and stronger, cost less to ship and to

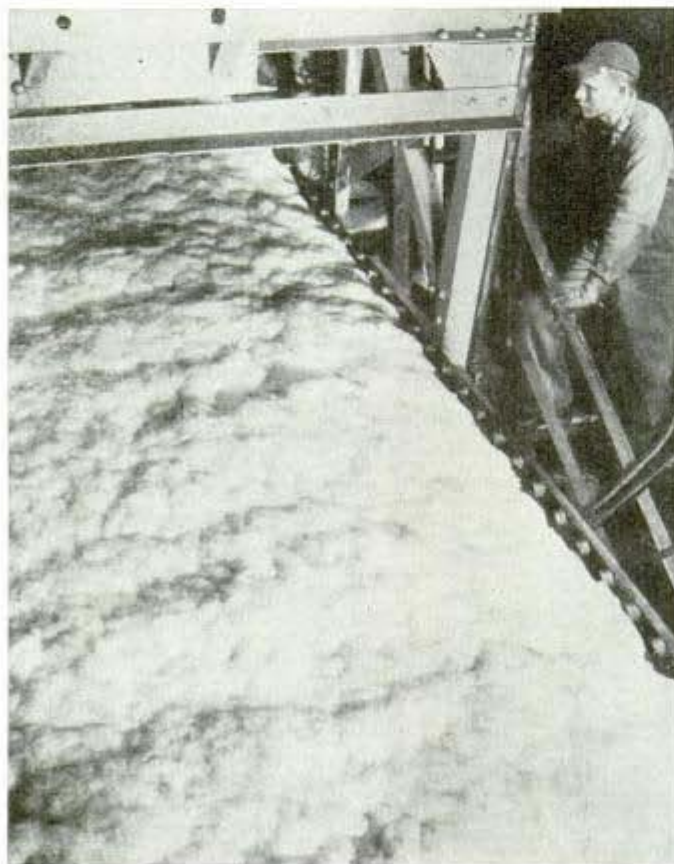

Looking more like a blanket of fleece than of glass, this heat-insulating glass "wool" is made to Army and Navy specifications

*Blumenthal 300
1631 7th Ave. N.W.
Chicago*

Repair Panel for Car Door Is Easy to Install

pack, take up less space—like the Duraglas milk bottle, one inch shorter and five ounces lighter than its more breakable predecessor, and the new quart fruit jar which weighs half as much as a conventional jar. The milk bottle once had a life expectancy of 34 round trips from dairy to you, but it'll live longer hereafter.

If it has been your ambition to live in a glass house and throw stones, your day is at hand. The things they are doing with glass today are little short of miraculous. You think of it as a brittle material. Yet, toughened by heat treatment, it can support the weight of an elephant; stones thrown against it rebound harmlessly. Some types will withstand a heavy impact, but disintegrate almost to powder when tapped with a hammer. Heat-treated glass like that in your stove-top utensils can be placed on a cake of ice and have molten iron poured into it without cracking.

In England they are already planning glass houses for the postwar rebuilding. Chemists have learned how to mix ingredients for glass walls or windows that will admit just the proportion of ultraviolet and infrared rays desired.

When you're ready to build and decorate that glass house, here are a few things you might include, as a starter—some of them revivals, some born of war metal shortages, some just out of the laboratories:

Glass roofing shingles; glass-windowed, glass-topped stoves with glass-walled ovens evenly lighted; moistureproof, verminproof, fire-resistant insulation; glass "blackboards" for the youngsters, glass bulletin boards for the kitchen; double-glazed windows that admit healthful sun rays and shut out heat; glass shelves and kitchen counters; tempered glass fireplace screens; glass-block walls and partitions; spun glass draperies, silken and flameproof; glass chandeliers, back in vogue in place of scarcer brass; workshop lathes bedded in tempered glass tougher than cast iron; glass "hardware" for doors, sparkling Flex-glass trim on columns; glass-tiled baths; glass agitators for the washing machine; a basement window greenhouse; toaster and waffle iron of glass cemented to metal; springboards of glass for the glazed swimming pool, and a bubble-glass lifejacket on the side; glass chairs, glass bed springs.

But there's one thing that stumps the glass chemists. They haven't cooked up a variety you can eat. Give them time.

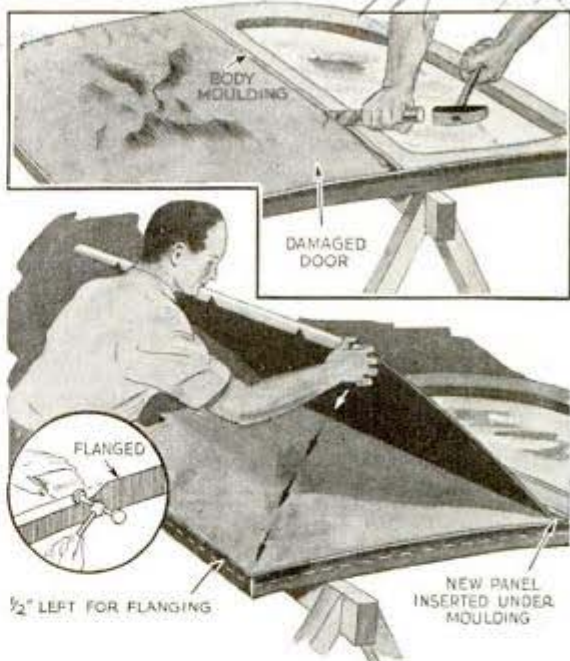

Old panel cut off, new one is slipped under molding

To replace a banged-up automobile door is slow these days because of uncertain deliveries, besides being costly. This delay and expense can be lessened by installing a metal panel now on the market in place of the damaged one. The panels come ready to be mounted, fashioned to fit different makes of cars.

Vanadium Needed to Make Steel Extracted by New Methods

Augmenting the supply of vanadium, heretofore obtained primarily from foreign sources, a new extraction process developed by Dr. J. Perry Morgan of the Standard Oil Company of New Jersey, working under the direction of Prof. Arthur W. Hixson of Columbia University, makes it possible to recover large quantities from Idaho phosphate rock used in the manufacture of fertilizer. The discovery comes at a time when the supply of the metal is becoming inadequate because of large demands for vanadium in toughening iron and steel for armor plate, machine tools and automotive parts. The ores are too low-grade to be worked for the vanadium alone, but it is said that the metal can be extracted profitably and with satisfactory speed as a by-product in making fertilizer.

*sample for 1937-8
clean*

*977
James Morgan*

By: O'Connell & ...
P. R. Co., 560 Main St., Los Angeles

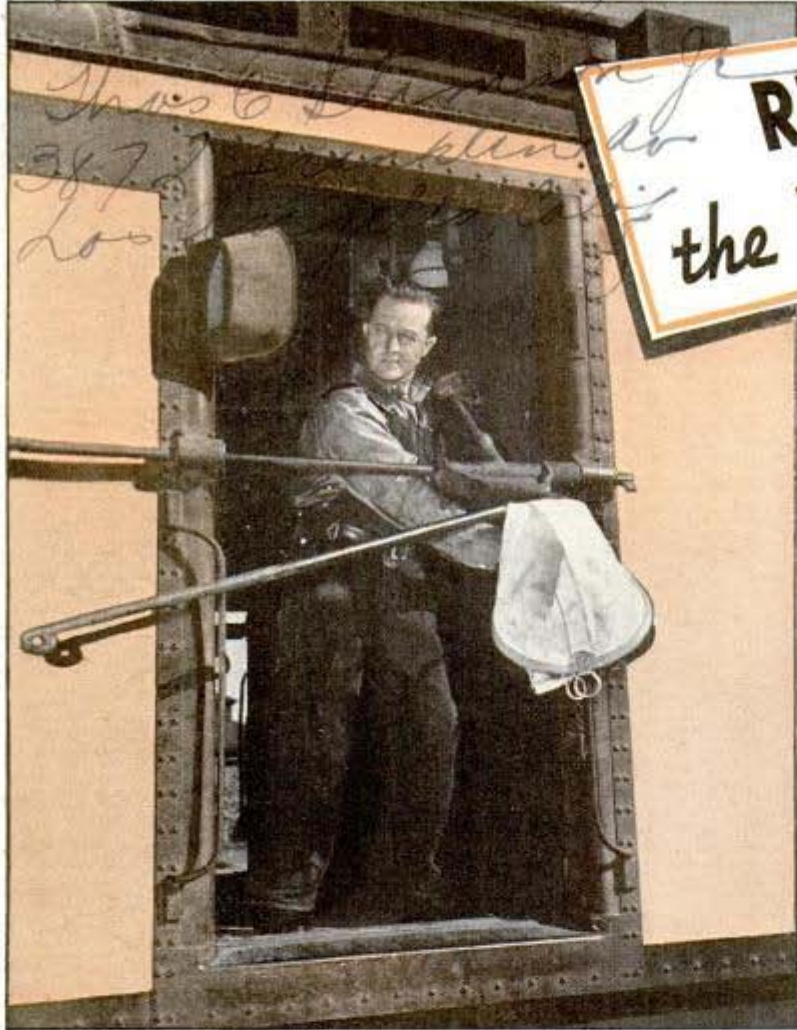

**RIDING
the FAST MAIL**
M 861

THE PASSENGER in the "rider" car was getting a fast trip. The wheel clicks drummed in his ears and he held on as the train rounded a curve.

The "Fast Mail and Express," Santa Fe's Number 7 out of Chicago for Los Angeles, was on time and the engineer was hurrying to keep it so. Its schedule to the coast is five minutes over 48 hours, next to the fastest streamliner time on the road. The train roared past some luxurious passenger coaches parked on a siding to let it by, then began to pick up more speed as it straightened out on a long downgrade.

Railway mail clerk sights through cinder guard window for mail at station, which is picked up by metal arm. Below, armed clerks transfer mail bags to car



Number 7's big passenger-type steam engine was pulling nearly 20 cars. One was a railway post office car, five were filled with "destination" loads of stored mail, and the rest except for the rear-end rider car were carrying express. In the post office car the armed mail clerks balanced themselves against the centrifugal pull of the curves and scarcely paused in their work of sorting bundles of letters into the pigeonholes and swaying pouches. One of them, hearing the long whistle that announced the approach to a town, opened the side door and swung out the pick-up arm that would snatch a

bag of west-bound mail from the mail crane at the station.

Passengers are carried on Number 7 only as an accommodation. The engineer hasn't time to gentle his train for comfort when he stops or starts at division points. You sleep, if you can, by stretching out in your seat. You eat out of lunch boxes for which the conductor has telegraphed ahead.

Carrying and delivering the United States mails is a giant, complicated, and never-ending

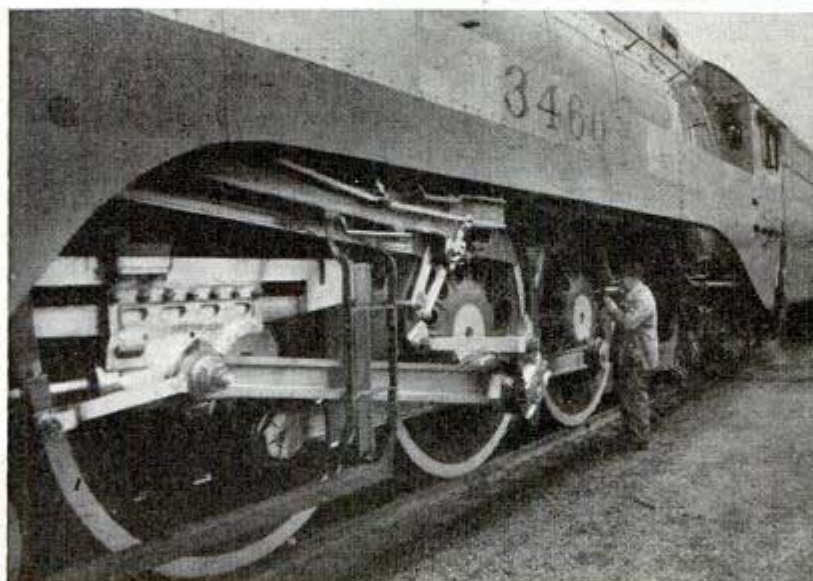
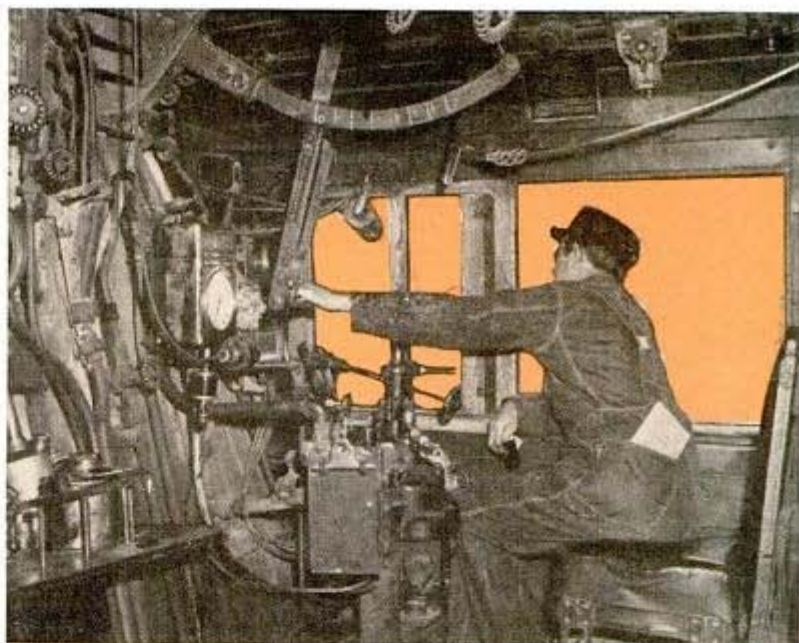

↑
Watching the signal board, the engineer of a heavy passenger-type locomotive grasps the throttle to start the Santa Fe "Fast Mail" on its 48-hour dash two-thirds of the way across continent

No. 3460, which hauls the mail on the Chicago to Los Angeles run, is a fast steam engine with a streamlined "jacket." Its driving wheels are seven feet in diameter

←
At the Los Angeles Union Station the mail trains are shunted from the main trunk lines directly to a post office siding. Below is the interior of the control tower governing the maze of tracks

task. Each letter of all the billions that are posted each year must be routed so that it will reach its destination in the shortest possible time. For postal purposes the United States is divided in 15 divisions, each of these areas containing districts that in turn consist of various post offices. Postal employees pick the best route for each letter by consulting what is called a standpoint scheme. This outlines the primary routing a letter should





Air mail being loaded on plane here, travels faster but the bulk of the nation's tremendous mail cargo still travels by railroad

Unloading sacks of mail from a storage car to moving conveyor belt which takes it to sorting platforms inside the post office



receive and gives the number of the train that should start it on its way.

Nearly all fast trains these days carry some mail. In addition there are the special trains that carry mail and express almost exclusively. When Santa Fe's Number 7 pulls out of Chicago each night bound for southern California, other fast through trains are also leaving for other western destinations. At the same time, trains carrying western mail are leaving the coast for eastern points.

There may be half a dozen or more clerks at work in each railway post office car. Each car contains 744 letter distribution boxes as well as 210 racks and overhead boxes for newspapers and parcels. Distribution en route consists mostly of sorting the last-minute mail that has come on board unsorted, and in routing letters that have been picked up at way stations.

The railway post office clerks work all sorts of odd hours, based on a 40-hour week. Sometimes they spend 15 hours on duty, other times only five or six. Sometimes they make a round trip of



The conductor at the rear of the "rider" car gives the engineer the "highball" signal. The "Fast Mail" carries no sleepers



Inside the railway post office car, left, clerks are busy sorting and distributing the last-minute mail. The wire chief of the Santa Fe railway, right, tests telegraph circuits essential to on-time operations

nearly all the way across the country, then lay off for a couple of days, and sometimes they work steadily for several such trips before taking a rest.

At an important distribution point such as Los Angeles, other mail clerks work at a frenzied pace when a mail train is shunted down the special track back of the post office building. Bags of mail are tossed from the storage cars onto an endless conveyor belt that carries them inside the post office to distribution platforms. One sack may be destined for Los Angeles, another for a nearby army camp, a third must be chuted to a waiting mail truck that delivers it to a suburban electric line. Fifteen minutes in inspecting and tossing the heavy sacks wears a crew of men out, then another group tries to keep up with the flow of sacks while the first group rests.

The railroads, of course, are only one of the many kinds of conveyances that carry the mail. The post office department uses or contracts for whatever kind of transportation is fastest or available. The United States mails are carried by rail, airplane, steamer and

speedboat, on horseback, by dog sled in the north, and even, as was the case at Corregidor, by submarine. Many sparsely settled sections are served by so-called "star routes" on which responsible individuals contract to deliver letters and packages by the best means available.

(Continued to page 169)



Pneumatic tubes at a railway telegraph office dispatch train orders to train crews

Baltimore

Flight Training Films in Kit Cover Score of Subjects

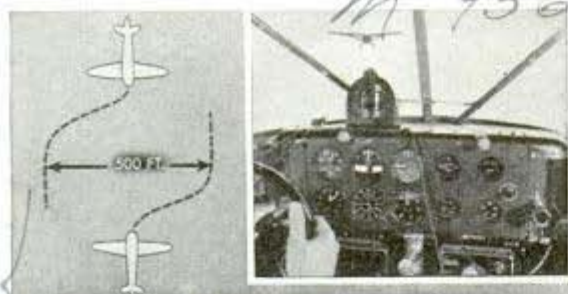

If you approach another airplane coming toward you from ahead, or head on, both you and the other pilot **turn to the right** and pass at a horizontal distance of at least 500 feet.



Copyright Jam Handy Picture Service, Inc.

Slide films help train pilot and aviation mechanic

Slide films that cover three branches of aviation training, including pilot instruction, engine mechanics and maintenance, are contained in handy kits. The pre-flight pilot training kit has films on aircraft regulation, traffic, flight instruments, weather, navigation and other subjects. The films are based on the official ground school material of the Civilian Pilot Training Program and approved by the Civil Aeronautics Administration.

"Heating Pad" for Plane Wings Takes Out the Wrinkles

Operating on much the same principle as an electric heating pad, a giant heater takes the wrinkles out of riveted sheets of aluminum after they are placed on the wing of an airplane. Wrinkling and buckling are caused by the pounding of rivet hammers. The heater, developed by the Glenn L.

Martin Company, fits snugly over the wing and raises the temperature of the aluminum "skin" to 140 degrees. This causes expansion which takes out the wrinkles and buckles. Before the metal cools it is stitch-riveted around the edges and along the ribs, which keeps the skin taut.

Corrugated Asphalt Wall Siding Replaces Metal Sheets

Made entirely of non-critical materials, a new moistureproof durable corrugated asphalt siding is now available for outside walls where steel normally had been used before metals were restricted. It may be applied to many types of buildings, such as factories, warehouses, sheds, and barns. The siding is made by soaking two sheets of heavy felt in a resino-bituminous saturant, and then binding them with a high-melting-point asphalt adhesive. It is said that, due to the high melting point of the materials, the corrugations will not flatten out during hot summer weather either while the sheets are in storage or after being applied to the wall. Asbestos roof coating should be brushed or sprayed on the wall immediately after installation.

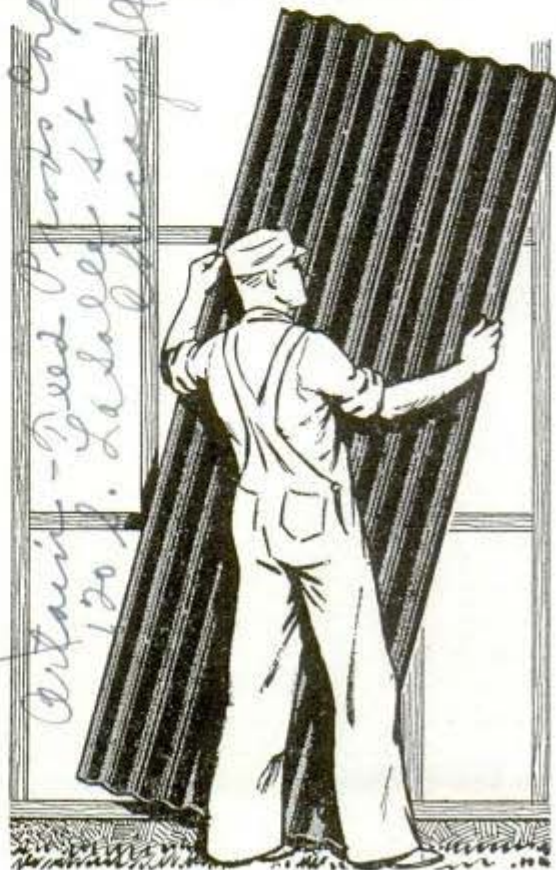

Asphalt takes place of metal in outside wall siding

182 of E. Grand Blvd
Detroit, Mich

M 956

M 994

Artway - Reed Photo Corp
120 S. La Salle St
Chicago

Public Relations Dept

Coast Artillery Teaches a 16-Inch Gun to Speak

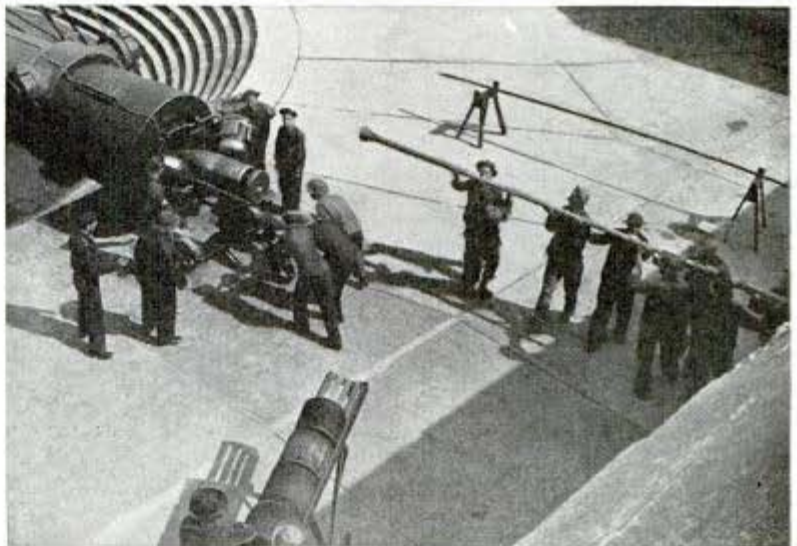
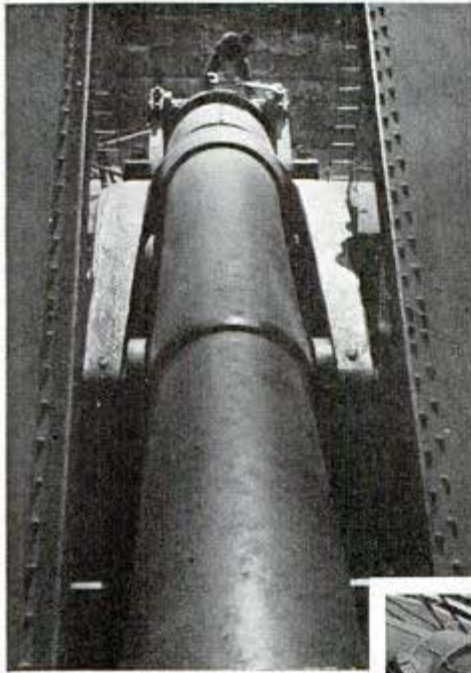

It takes a crew of 42 men to man the big 16-inch guns that guard America's coasts. When the gun commander yells "Fire!" a 2,000-pound shell, propelled by 800 pounds of powder, hurtles forth for a maximum distance of 28 miles. The terrific recoil of the gun, which brings it down 15 feet to loading position, severely strains its foundation. Above, a member of crew tightens a giant nut. Top right, gun pointer sighting through a telescope. His right hand grips firing lever which is pulled up

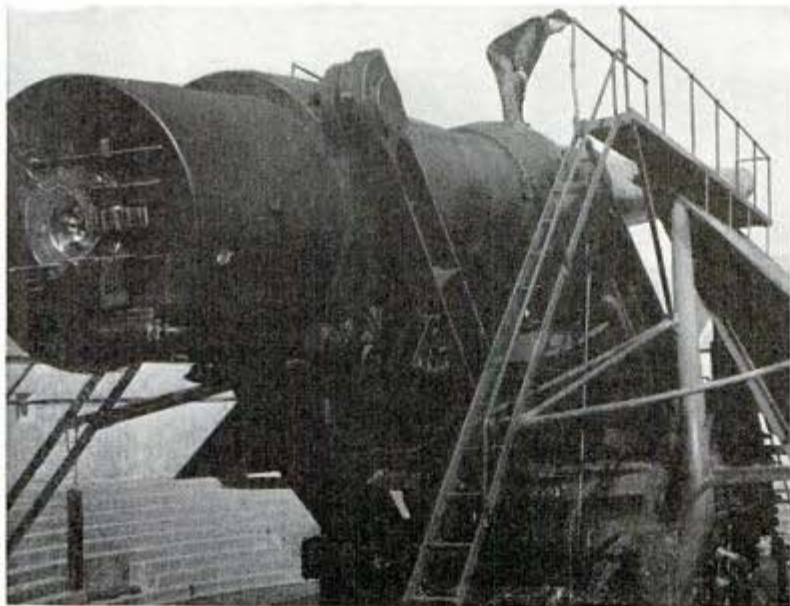

Above, loading the 16-inch go-liath requires teamwork of high degree. As the shell enters the breech, the ramming rod is lifted to position to force it deep into gun. Then powder bags are pushed up against the shell. Before loading, the temperature of the powder is taken, for the higher the temperature, the higher the propulsive power. At left, the gunner, who just stepped off the "bridge," yells directions down to the sergeant who is giving the mechanical workings of the gun a final check before firing. The gun must be ready for action at all times—as well as the crew. Seacoast batteries are on a 24-hour alert for the duration of the war. Drills are held without warning and at a signal men rush to various posts

London Electric type Agency
134 Fleet St London England
Battleship-Carrier Could Guard Itself in Action

m 9/16

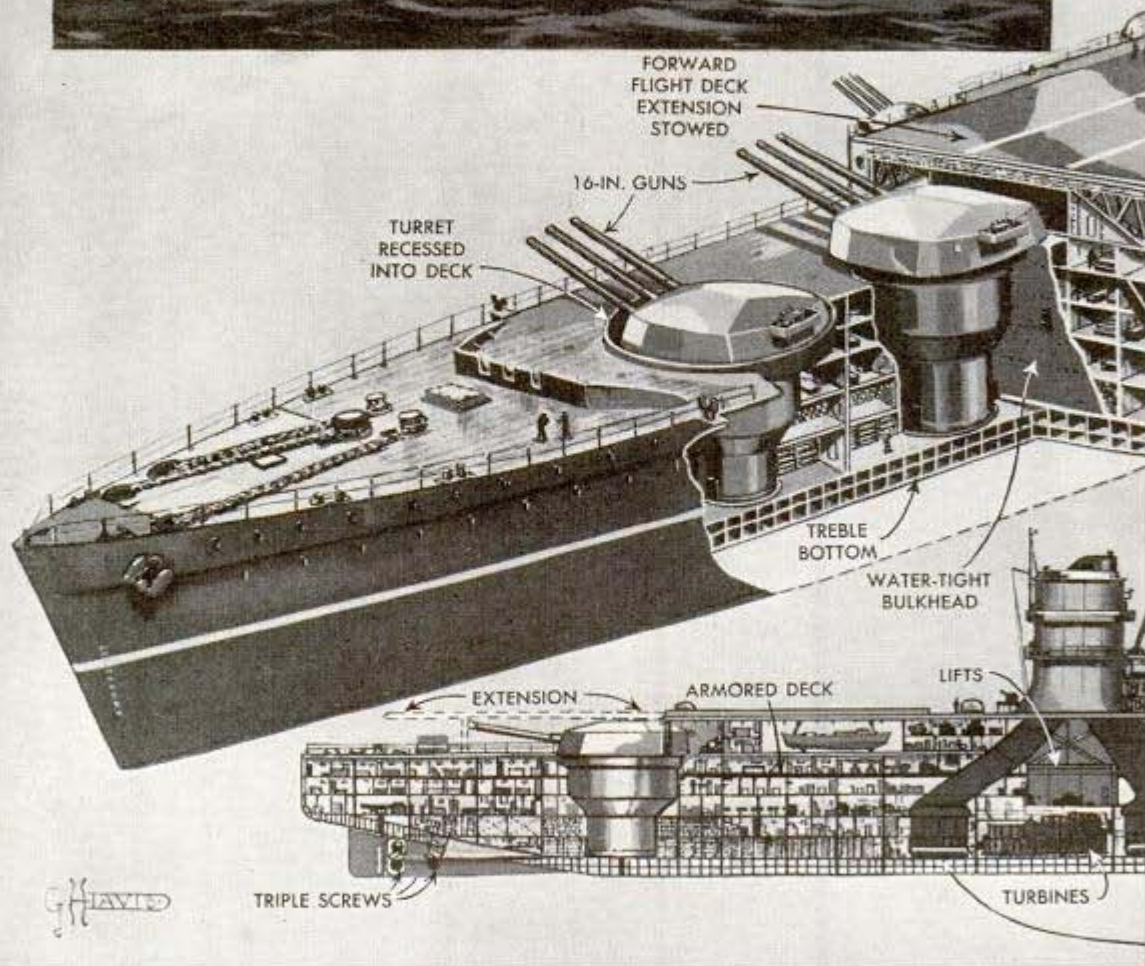

Vulnerability of the aircraft carrier in its present form, coupled with the helplessness of the most powerful battleship without guardian airplanes, have inspired a proposal in England for a combination battleship-carrier armed with turrets of 16-inch guns which could be recessed into the deck to accommodate an extensible flight deck. It would be a tremendous vessel of probably 45,000 tons, incorporating the full armament of the dreadnaught, both

primary and secondary, and would be heavily armored against attack from above or below, with a treble bottom, antitorpedo belts and liberally protected throughout by numerous watertight bulkheads. A ship with these combined functions would necessarily be huge, requiring the immense storage capacity for shells and powder magazines to supply the big guns and anti-aircraft batteries on a long cruise plus the tremendous space needed for hangars, air-

Extensible Flight Deck Covers 16-Inch Turrets

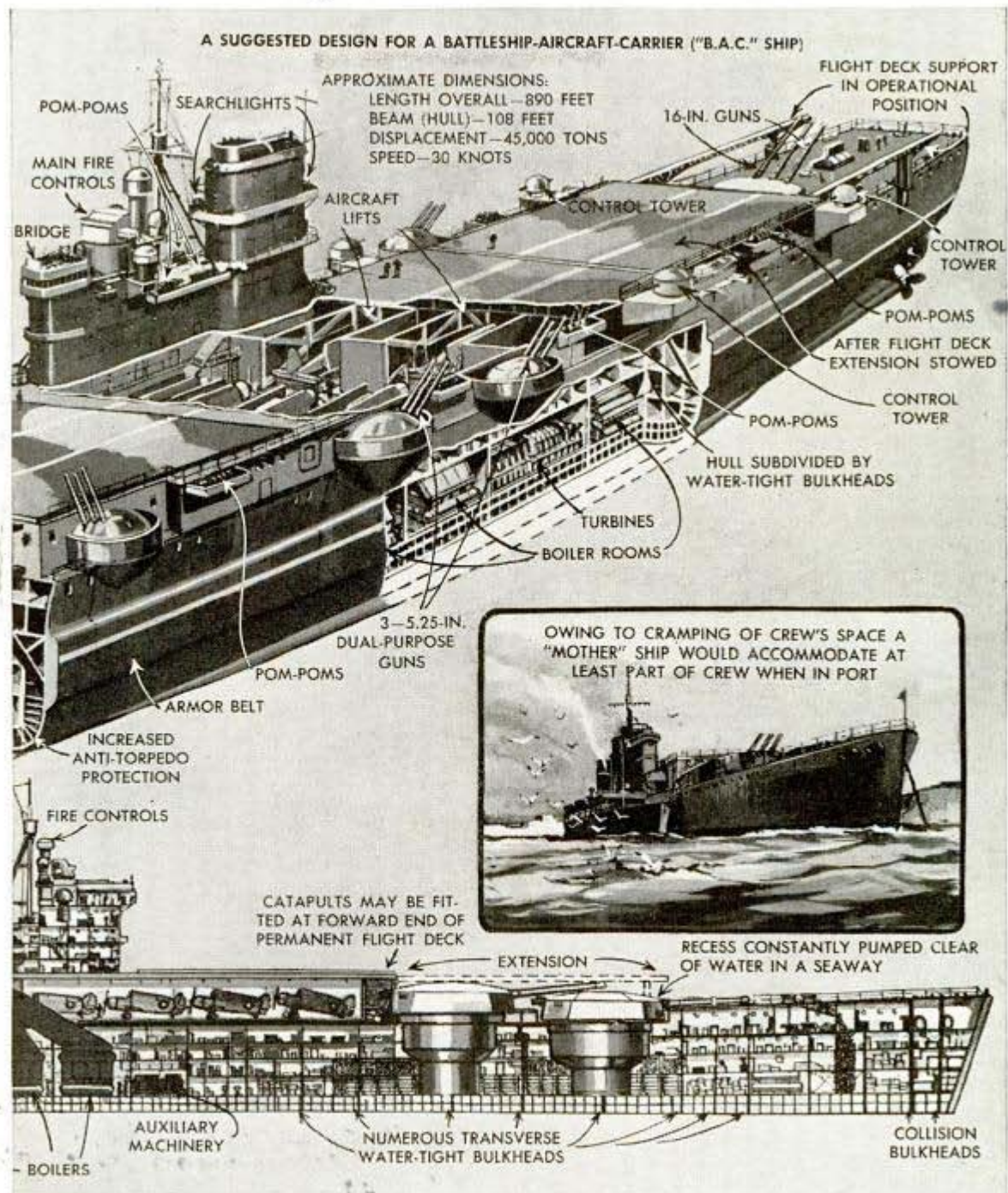

craft repair shops and gasoline storage tanks belowdecks. The compromise would inevitably cramp the quarters of the crew. The battleship-carrier's brood would likely comprise about 15 fighter planes plus two or three torpedo-reconnaissance craft. The central portion of the upper deck would be a permanent flight deck, perhaps with catapults at the forward end. From this permanent deck the extensible sections would extend fore and aft, rolling on

steel bridgework supports which pivot against the end of the permanent deck when not in operation. A heavily armored deck at the level of the hangar floor would protect the vital parts of the vessel from aerial bombs. Two elevators from hangar to flight deck would shuttle the aircraft quickly. The single funnel and the "island" structure for the bridge and main fire controls would be placed at one side as they are on present aircraft carriers.

It's Brawn and Brains That Keep 'Em Flying

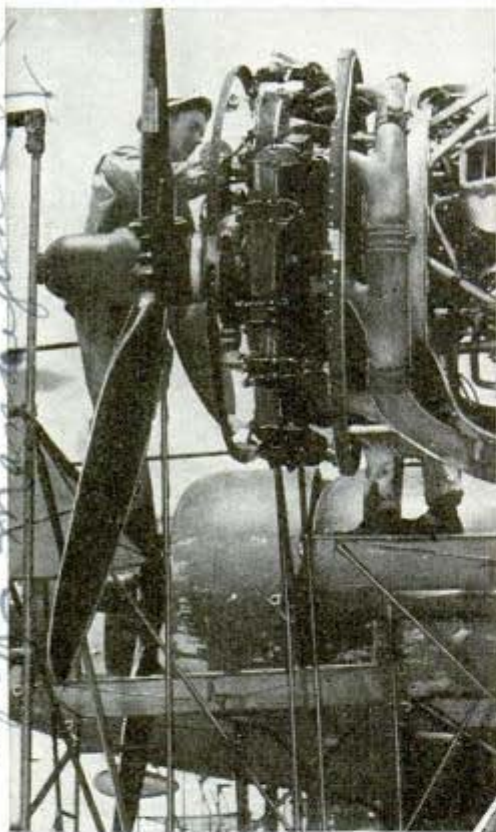

Keep 'em flying is a tough assignment if you mean keeping the Flying Fortresses equipped with efficient power plants. It takes a high degree of technical skill to adjust the four engines, as at left, and a liberal amount of muscular strength to replace "tired" engines with new ones, above, when the mammoth ships return from long bombing missions



Photos, Southeast Army Air Corps Training Center

At a southern training center for the U. S. Army Air Corps, the mechanics who restore "pep" to the hearts of war-weary ships cannot be convinced that their work is more than a mere sideshow, shunning any praise for themselves but thrilling at the news that a Fortress has found its mark. Framed in the circular engine mount, above, one of the great ships, carrying wounds of battle, awaits the replacement this corporal and private are pushing along. Left, top being replaced on big crate after removal of its burden, a powerful engine. These crates then go back to their starting point for another new engine

*Corp. Alex. Halston
Dartmouth*

*Mr. John Bacon
The Magazine*

*Office of Asst. Chief of Staff G-12
Maxwell Field, Ala.*

Barrage Balloon Is "Bottle Fed" Through Nose

Inflating the big barrage balloons that protect coastal cities against low-flying enemy planes is called "feeding the baby" by crew members. The "bottles" are hydrogen gas cylinders. Rubber hoses attached to the cylinders carry the gas to twin manifolds which relay it to the balloon's "appendix" located in the nose. The crews maintain that the huge balloons exhibit individual traits, especially when they are aloft, and many of them are named.

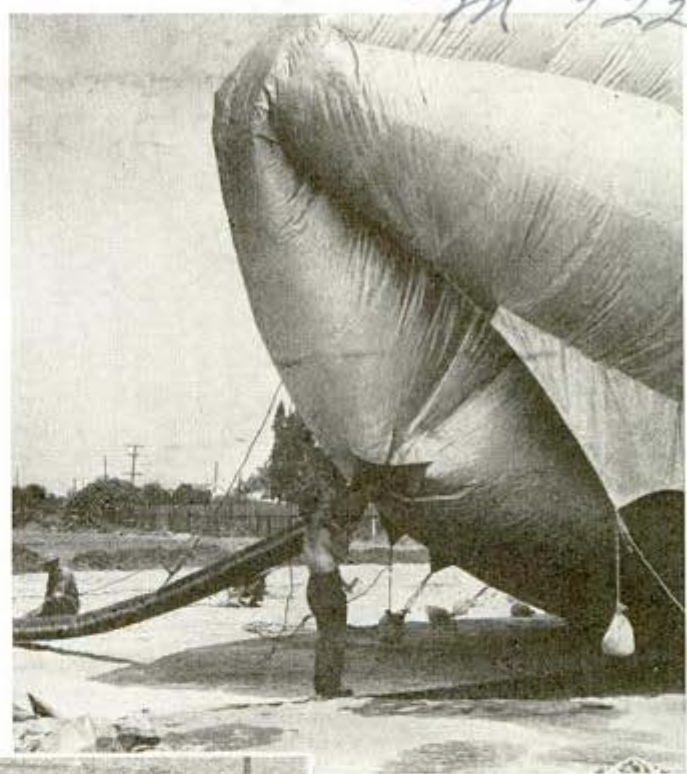

"Feeding the baby" is what crew members call the process of inflating giant barrage balloon → with hydrogen gas. Rubber hoses attached to cylinders carry gas to balloon's "appendix" in nose ↓



Americans Growing Near Sighted Due To Indoor Life

America is fast becoming a near-sighted nation, says the Better Vision Institute of New York City. From the beginning of history human eyes had been adapted to far vision, but today most adults spend many hours reading newspapers, magazines and books—all close, hard work for the eyes. More and more, people are moving into indoor occupations most of which require close focusing. This evolution from a far-looking to a near-looking race is gradually bringing about a change that will make our eyes function like those of fishes, whose vision is sharpest when fixed on objects near the end of the nose.

*m 1024
630-5 am*

Derailed Train Clings to Railroad Tracks By Safety Guides on Cars

Danger to lives and property when derailments occur on railroads is being greatly reduced by equipping cars with a patented safety guide that keeps a derailed train from jack-knifing, turning over or slithering its cars all over the landscape. Developed by the Southern Pacific Railroad, the guide consists of a simple vertical flange built into the trucks of passenger coaches and extending downward to about 4½ inches above the top of the rail. Its action, in case the wheels jump off the rails, is to skid along the rail and force the trucks to remain in line with the tracks and the car body. This, it is pointed out, would prevent the wheels from turning at an angle that would throw the car sidewise or cause it to run off the roadbed.

*Railway Age
Sept 4 1942*

JUNGLE MECHANICS



The crocodiles will get you if you don't watch out, so the African pygmies cross perilous rivers on rope swings fashioned from tough vines. Pulled high to a scaffold on one bank, the dwarf swings to the opposite with the greatest of ease

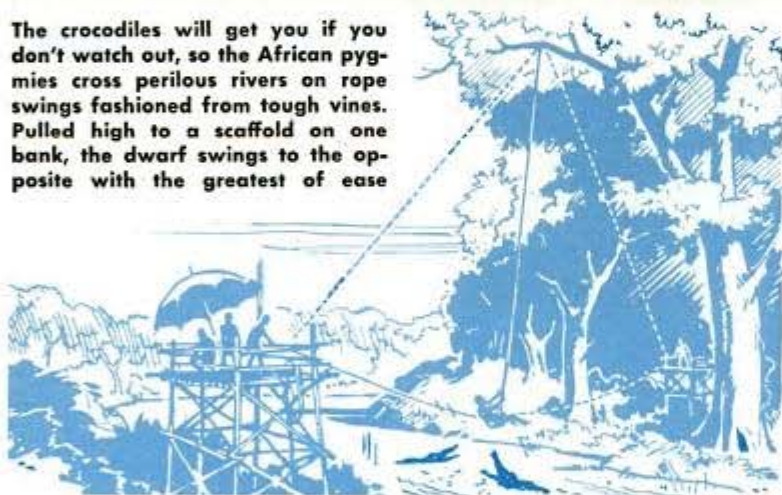

By **Attilio Gatti**

Author of "Great Mother Forest" and other books, and leader of ten scientific expeditions into Africa

Stockbridge
PART I
Mass.

IN THE dim light of an African dawn, a score of ponderous grey masses are vaguely discerned trampling through what was, last night, the prospering garden of a small tribe of natives. It is a herd of elephants. Their trunks have ravaged corn and bananas; tusks have dug for peanuts and sweet potatoes; enormous feet have indifferently crushed what capacious stomachs had not devoured.

Finally, satisfied, the oldest female gives a trumpeting order and the herd slowly ambles away.

Immediately, at the other end of the clearing, a group of huts comes to life. Shields used as doors are removed; eyes cautiously scrutinize the surroundings; from each hut a man emerges, followed by his wives and children. They see the garden devastated; the food, which should have lasted them through the dry season, destroyed.

What can these few little men do against a herd of giant pachyderms, nine or ten feet high at the shoulder, every one a ten- or twelve-ton mass of steely tendons and tough hides and seven-foot tusks? All these men have for weapons are a few tiny arrows, a knife or two, some puny spears which they have made out of ironwood and scraps of metal obtained by a primitive smelting of iron ore.



An ear trumpet made of a large leaf improves reception on the jungle tom-tom "telegraph line"

But they are not as helpless against their hereditary enemy as they seem. They have astounding ingenuity and resourcefulness, those Ueles. They—and all the millions of their African brothers — possess a wealth of wisdom and courage; of inventive imagination; of knowledge of the laws of nature; and they have uncanny ways of using them.

Finally the chief speaks. "The old female must be killed," he says. He points to a footprint, then nods to a hunter.

"Koboko," he says, "shall kill her."

The group dissolves. They know that until the leader is disposed of, the herd will keep returning. But the elephants have a good memory. If their leader is killed immediately after the devastation of the garden, the others will remember the lesson for a long time.

So Koboko checks the sharpness of his spear point, and is off on his mission. He has no other weapon than that spear.

An hour later Koboko reaches a thick entangle-

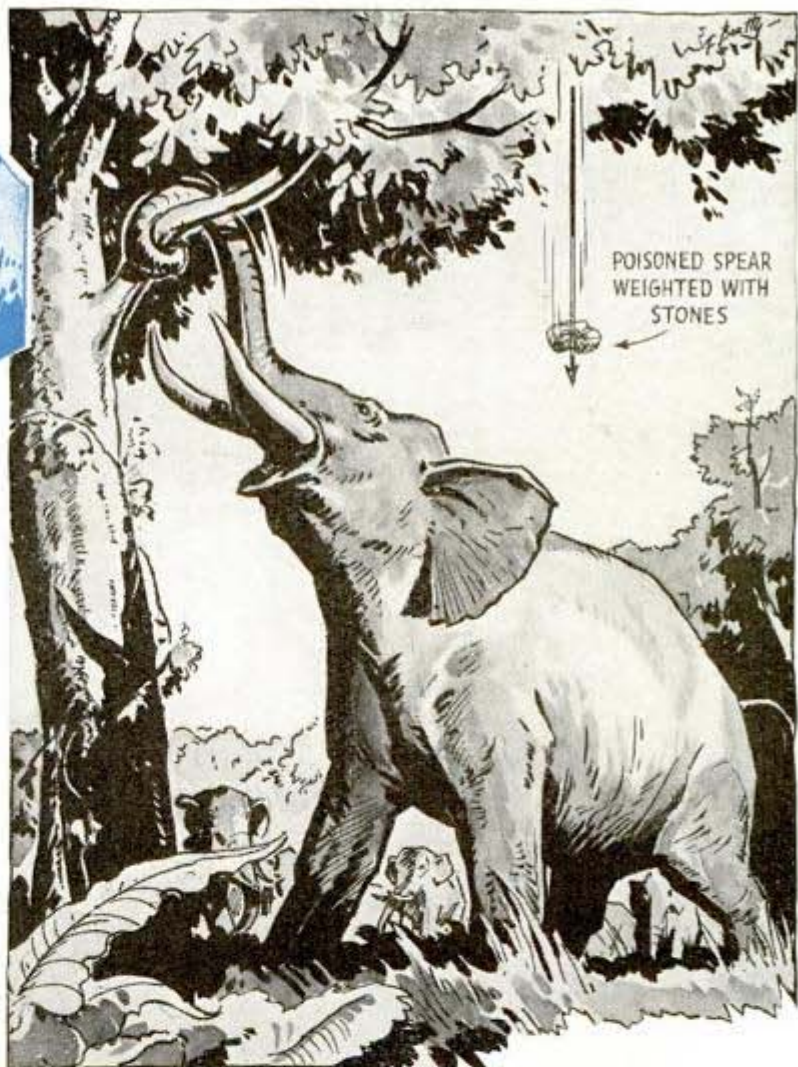

No human arm could thrust the spear through an elephant's hide, but weighted with rocks and suspended so it will drop when the beast shakes a favorite tree, it pierces and kills quickly. Below, friends show regret as a suitor (in middle) is about to apply for the hand of a bride

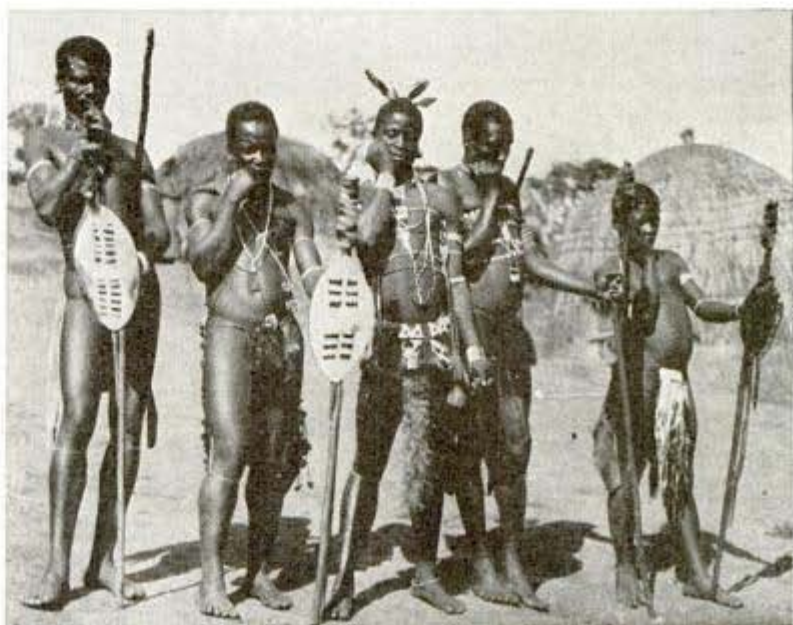



The Maker of Musical Instruments of the Azandes plays his homemade guitar, ingeniously fashioned of wood and lizard skin with creepers for strings. Below, Gatti party explores Rhodesian caves in search of rock paintings by ancient Bushmen



ment of vegetation, dives into it. The herd is leisurely taking its ease in the coolest, dampest shadows of the jungle. The elephant's eyesight is poor, but its senses of smell and hearing are extraordinarily developed. A breeze carrying the hunter's scent, the snapping of a twig heard by one of the immense fanning ears will bring 200 tons of maddened, charging elephants upon him.

Koboko is a shadow gliding through the shadows. A long detour brings him around a flank of the herd to a position just leeward of the leader, the old female he must kill. Of course, he knows elephants—what they like best, how the oldest female always gets the finest food. He finds

a tree covered with tender leaves, judges position and distances, decides it is suitable.

Instantly he begins to convert that spear, which if thrown would only scratch the elephant's hide, into the most deadly weapon. The point is thickly smeared with a vegetable paste, highly poisonous, but effective only if it reaches the blood stream. Koboko gathers some stones, deftly ties them with creepers to the spear handle, near the point. Another length of creeper he passes through a hole in the handle. Carrying the "loaded" spear in one hand, he climbs up a liana, until he reaches a chosen branch. There, straining to avoid any noise, he uses the creeper in the handle to tie the spear to the branch. The strength of the creeper is calculated just to hold its heavy burden—and to break at the slightest shaking.

Cautiously Koboko retreats to the ground. Ahead of the herd, the great female is advancing toward the tree. She cannot see him, yet, but she seems to feel some forewarning of danger. Her trunk curls and uncurls. Her ears are cocked, like sails, making, with

There's plenty of music in the jungle—a log hollowed out by ants makes an excellent drum, handy for sending telegrams



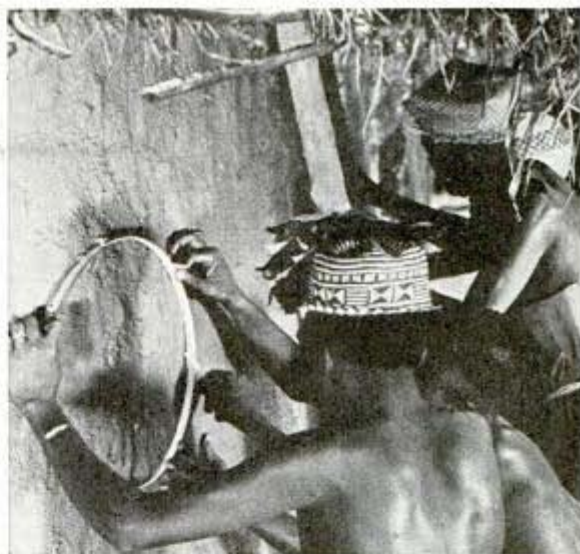
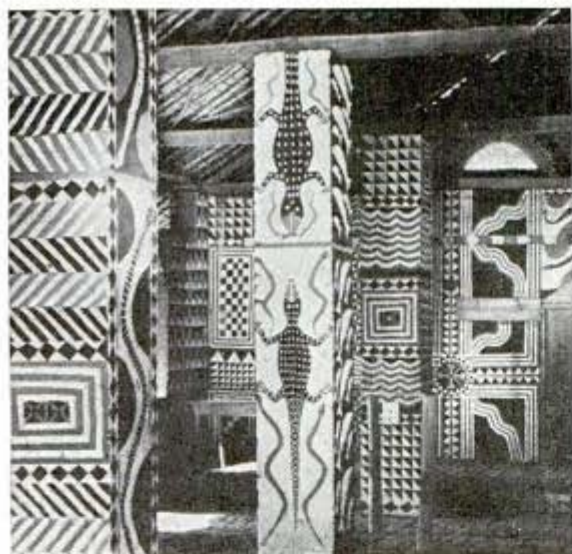

Mangbetus decorate their huts with chalk, charcoal and pigment, first tracing the designs on the wall (right)

the head, a frightening spread of some 15 feet.

Koboko melts away, creeping slowly at first, making sure the wind is carrying his scent away from the herd. Then he walks faster and faster, trying to retrace the trail of his detour.

Before long a crash stops him. He hears a deafening, spine-chilling trumpeting. The old female has reached for the tender leaves of the tree he chose. Perceiving the scent of a recent human presence, she has grabbed a branch with her trunk, madly shaken it. The creeper has broken. The spear, its penetrative power augmented by the weight of the stones and by the directness of its fall, has pierced her back.

A few minutes, and she will be dead. The

herd, bewildered without its leader, is already trotting away in confusion.

Once sure that all the elephants have gone, Koboko must communicate with his far village. He searches for a tree whose inside the white ants have gutted and devoured. His sharp eyes don't take long to find one. He hammers it with his fists to test it, breaks off two branches and with them beats the improvised trunk-drum.

"Tom—Tom—Tom-tom-tom," throbs the tree until Koboko thinks the message has reached the villagers. Then he "signs" it, three staccato beats everyone knows as his own, and waits for an answer.

But the distance is great, the vegetation interferes with his reception. He makes a funnel of a huge leaf, applies it to his ear.

Mrs. Gatti rides in style on one of her husband's expeditions into a region of Africa unreachable by roads





A hollow stalk provides a pipe for smoking dry seeds

Through it, the answer pours in clearly. He recognizes the "signature" of the chief. Soon the tribe will come and cut to pieces the mountain of flesh he has secured.

While he waits, Koboko decides on a fire and a smoke. He looks around for some dry leaves and branches and for a rock which contains "the power of fire," as his people call the flint. Two leaves he pulverizes between his palms. The resulting powder he deposits on a slab of flint-stone,

which he strikes again and again with a smaller rock, until smoke emanates from the powder. He blows and blows, until the fire communicates to a leaf, then to others, then to branches.

In a few minutes a good fire is blazing. Koboko finds a magongo stalk, which is hollow, and some hairy seeds of mifonde, which to the Ueles is almost as good as tobacco. He loads and lights his improvised pipe and puffs luxuriously near the warmth of the flames.

His mind does not dwell upon the hair-raising danger from which he has just emerged unscathed. More practically and intelligently, it envisions the bustling that will soon follow when the tribe reaches him. The women will build a huge grill of iron wood branches, under which a fire will be kept going day and night, until all the elephant meat is dried and smoked to a crisp for long preservation.

He thinks about the delight of the trunk, which by right will be his to eat; the hairs of the tail which he will weave into bracelets for himself and his wives; about the heavy tusks out of which twenty different implements will be made, some to soften the boiled bark of trees and obtain from it supple loinclothes; others to crush seeds and dried bananas in wooden mortars; others to be carved into earrings, bracelets, necklaces, ankle rings and amulets for women and children, into narrow points and knives and spatulas with which to mix poisons.

It is to this resourcefulness and adaptation to his lush but treacherous world, that the African native owes his survival, and his—on the whole—extraordinarily care-free, happy existence. Money and shops,

Elephants have poor vision, keen smell and hearing. Hunter and cameraman must be silent and stay downwind



to all practical purposes, do not exist for him. The jungle is his only source of supplies. Ingenuity, craftsmanship are the currencies by which he obtains what he needs.

Take, for instance, the Maker of Musical Instruments of the Azandes of Northern Congo. The guitar he makes is a thing of harmony and primitive beauty such as you would probably like to own, and be proud to have made with your own hands.

His workshop is a stool in the shadow of a tree. His tools, all of which he has made of wood and iron hammered into shape with stones, are chisels, scalpels and a couple of round irons, which, when red hot, can burn holes in soft wood. His raw materials are an L shaped, 36-inch-long piece of wood; a two-foot, straight stick of hard wood $\frac{3}{8}$ inch in diameter; the dried skin of a big lizard; some lengths of twine-size creeper.

(Continued to page 164)



Tribesmen tie up an offending member of the clan for a court hearing
The village orchestra presents an African symphony on handmade horns



A dwarf kills a giant gorilla by luring it into a spear thrust into the ground, point up, and well hidden by vegetation

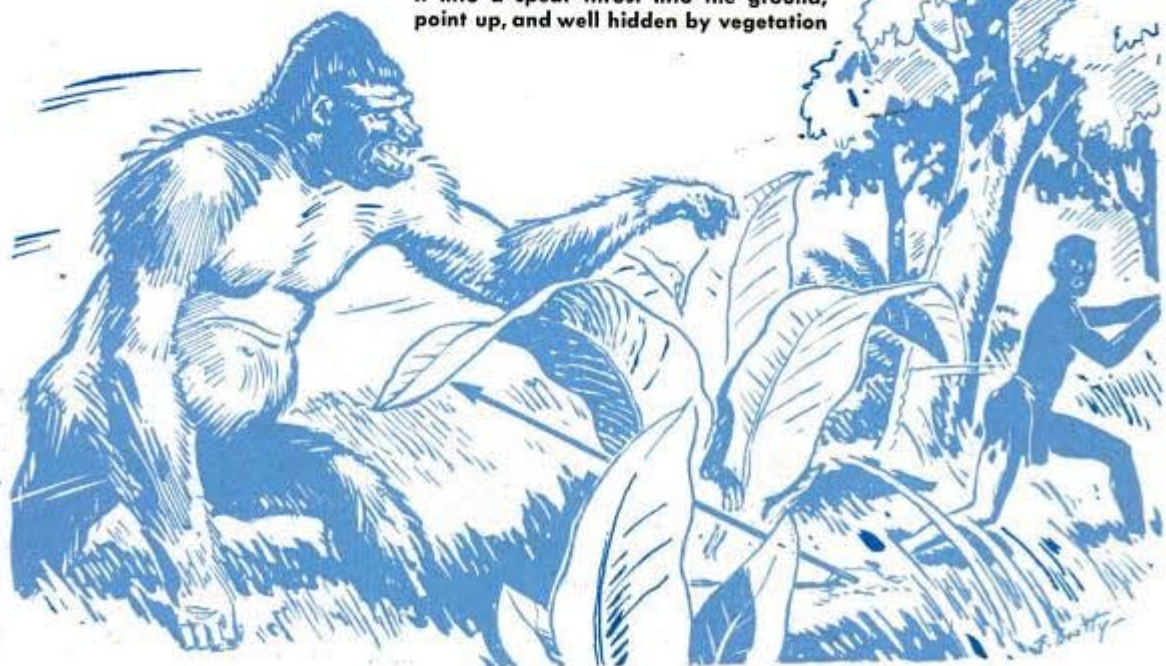

Some - 461 - pad nice

High-Altitude Fighting Rehearsed in Full Dress

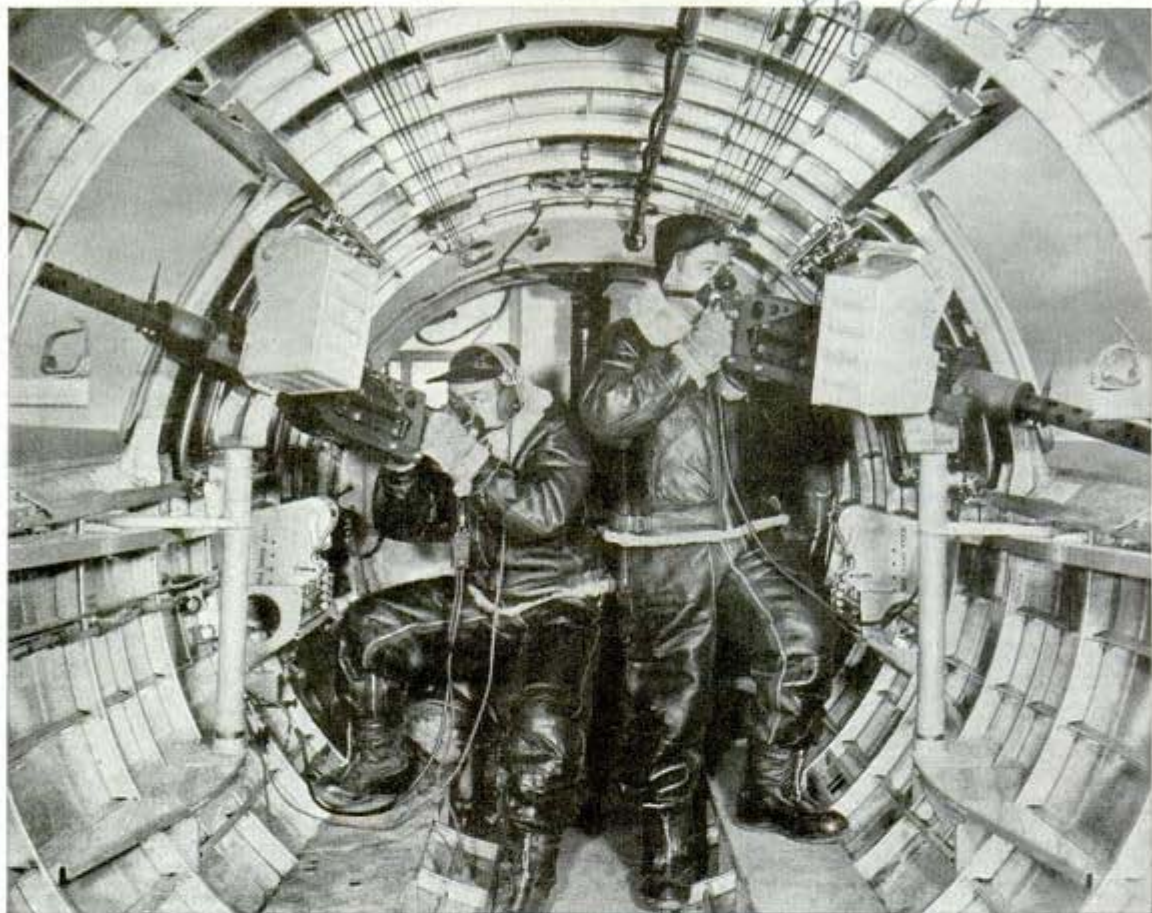

Bomber gunners, in final stages of training, learn to work under handicap of high-altitude togs

Before hopping to the front for combat duty, aerial gunners in dress rehearsal are given a turn at large caliber machine guns aboard a Boeing Flying Fortress as part of a month of final training. Wearing the

complete equipment they will use in actual warfare at high altitudes, the machine gunners fire at targets painted on cliffs near the bomber operations base as they practice their duties and learn teamwork.

Auto Body Made of Plywood Hints of Tomorrow's Car



Car with plywood body weighs 600 pounds less than all-metal construction

Experimenting with substitutes for steel in automobile construction, Ray Russell of Grosse Pointe Park, Mich., has produced a car made of laminated waterproof bonded plywood. There are two layers of plywood, one running fore and aft, while the other runs diagonally, the sheets being cemented together with waterproof bonding resin and riveted at all seams. The skeleton is a framework of steel

904 Penniston

*not on market
Chry. chassis and motor.*

*Ref. Dr. W. Green
Dr. E. Pennerbaum
W. Johnson
Kalamazoo Mich*

tubing bent to shape and welded to the chassis. All wheels, enclosed within the body, can be reached for tire changing through hinged flaps. The car weighs 2,500 pounds, which is about 600 pounds lighter than a similar one of metal construction. While the auto represents one step in experimental body lines and construction details, it is not suggested for mass production in its present form.

Sliding "Ramp" for Ambulance Makes Loading One-Man Job

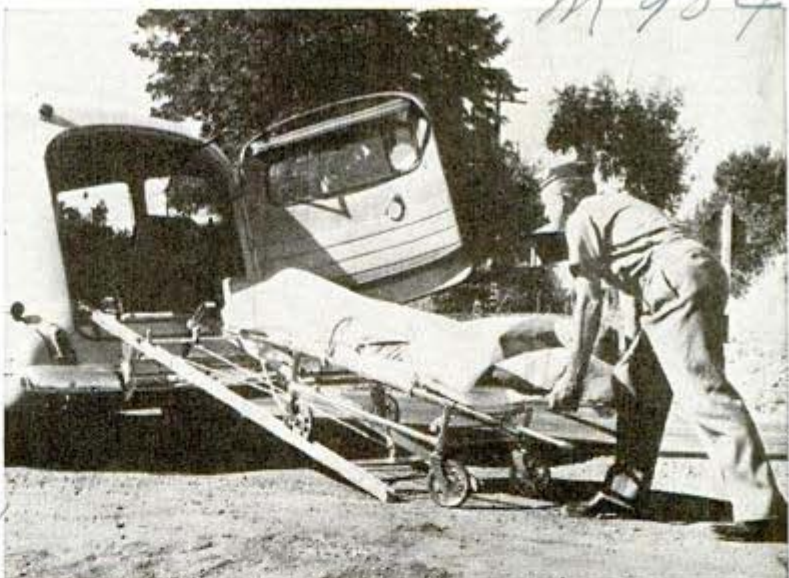

Rolling stretcher onto ramp which lifts and slides into the ambulance

Stretcher patients are loaded into an ambulance and unloaded by one man with a ramp arrangement consisting of two double sets of U-shaped tracks. Two of the units are fastened to the floor of the ambulance and the other two, fastened together by bars, slide into this fixed track. For loading, the sliding track is pulled out and one end is lowered to the ground. The stretcher cart is wheeled onto the track and locked on with a special device. Then the sliding track is lifted to the level of the floor track and pushed into the ambulance. The loader was invented by the driver of an ambulance operated by the Amador Post of the American Legion, Amador County, Calif.

*Joe Navarros
Sutter Creek Calif.*

Mushroom Extract Used to Treat Blood Pressure

High blood pressure may be reduced by injecting a compound extracted from ordinary mushrooms into the blood stream, according to experiments. Chemists who developed the treatment worked on the theory that blood pressure is caused by chemicals that cause the arteries to contract. The new compound, called tyrosinase, oxidizes these chemicals.

m 976

Seaplane Is Given a Fresh Water Bath With an Upside-Down Shower

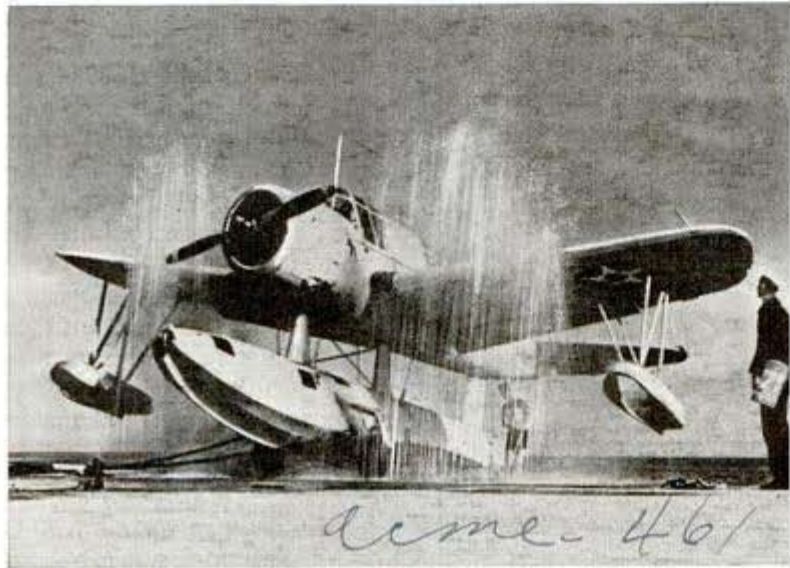

After alighting in salt water, planes at the Naval Air Station at Corpus Christi, Tex., get a shower bath in fresh water. This is accomplished with a water pipe that is extended beneath the planes and shoots a spray upward. Fresh water is used in the upside-down shower because sea water would only add to the accumulation of corrosive salty stains.

Washing salt stains from a seaplane with fresh water sprayed upward from pipes beneath ship

*same 461
Fav, me*

Thos E. Strimason Sr., 3872
Franklin Ave, Los Angeles, Calif

ADVENTURES *M 806* of the INSHORE PATROL

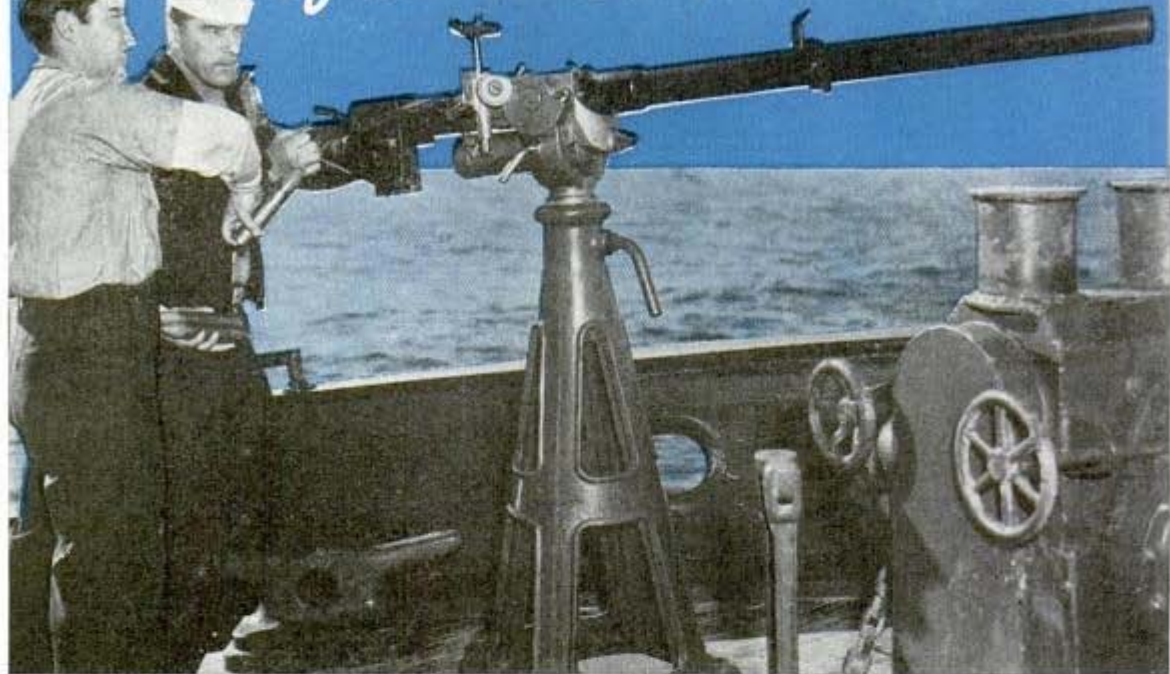

Gunners aboard a mine sweeper of the "inshore patrol" rehearse rapid-fire work with a small deck gun

DAWN was just breaking when the armed minesweeper left her dock in a western harbor. Down channel, a gate boat drew aside the torpedo net to let her through. Beyond the torpedo net lay the submarine net, its floating top studded with spikes that would rip the bottoms out of any enemy mosquito boats that might try to skim over it at high speed. A second gate boat opened this barricade.

By the time the sweeper had made her way through the harbor's own protective minefield, outside the nets, the work of sweeping the harbor approaches to destroy any mines that our enemies might have laid during the night was ready to begin.

Two large metal floats, called "pigs," were dropped overboard at the ends of steel cables. Sea otters, metal grids equipped with cutting knives, followed, and the minesweeper moved ahead, paying out cable until the steering vanes of the sea otters had pulled them 300 yards apart, astern of the sweeper.

Then the sweeping work began. Any moored mine within reach of the cables would be released when the serrated knife of a sea otter cut its mooring line. Bobbing up to the surface, the mine would be exploded by machine-gun fire.

But moored mines are only one of the underwater weap-



The commander focuses his glasses on a suspicious object on the horizon from wheelhouse of a minesweeper



L.H. Lee

Patrolling the Atlantic coast at 43 miles an hour with torpedo tubes, antiaircraft guns, depth charges and machine guns ready. Below, a sailor brings up a drum of "a-a" cartridges



Radioman on a mine sweeper signals by searchlight to a patrol boat off the California shore

ons of modern warfare. There are also magnetic mines that lie dormant on the bottom until the attraction of a ship's metal hull makes them rise and explode against the ship. The most recent sort of mine is the acoustic type that is actuated by the beat of a ship's propeller. Ordinary sweeping operations are ineffective against such mines as these. The minesweeper has been fitted with special gear to combat them.

Out at sea, the sweep against moored mines ended, the sweeping gear is brought back on board and the ship once more begins to plow back over

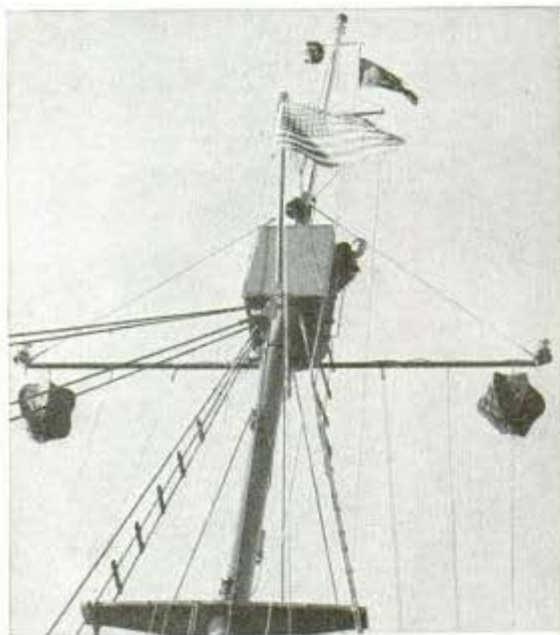

From his post in the crow's nest the lookout aboard one of the "sweepers" keeps a sharp eye open for surface vessels, airplanes and mines

"Pig" buoy is afloat with flag attached while crew lowers sea otter grid over side. Grid stretches sweeping cable at angle from stern and knife cuts mine loose

Resembling a winged torpedo, the paravane is put over side as sweeper starts on its dangerous mission of hunting and harvesting mines

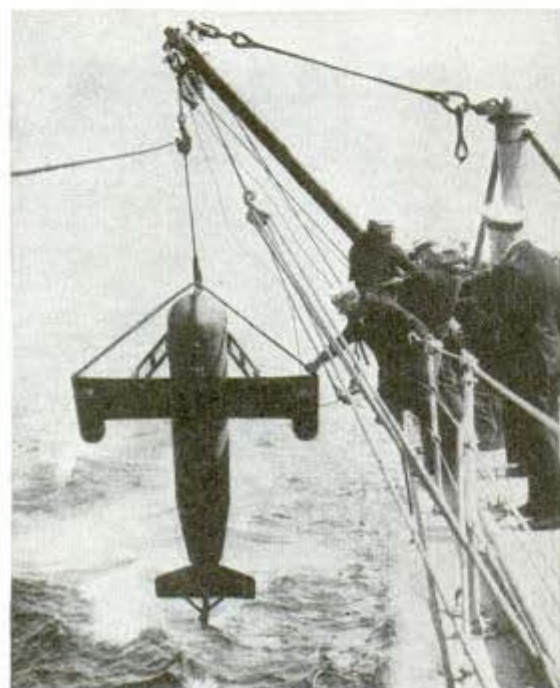
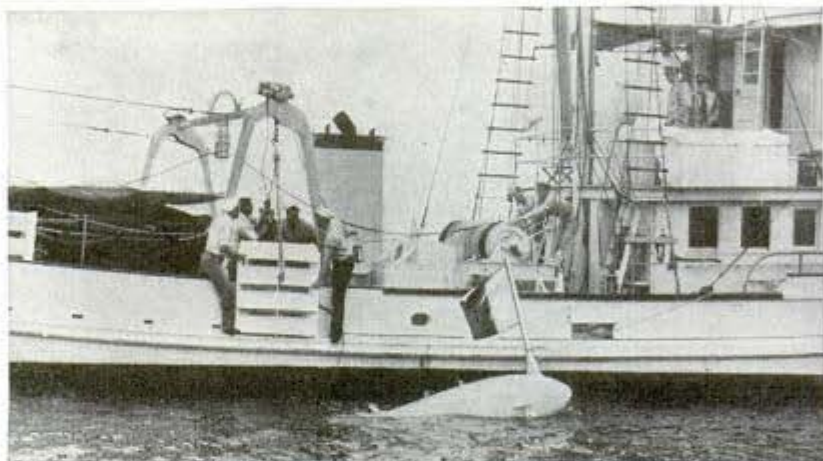

the same area she has just swept. When the minesweeper finishes her sweeping duties for the day, her crew is satisfied that the channel has been swept clear of any hidden dangers that might threaten shipping.

Minesweeping is only one of the many activities of the inshore patrol. Few people know of this department of the Navy and of the important coastal protection work it performs. Small power boats that patrol our harbors, on guard against possible sabotage, are members of the inshore patrol.

Ex-Coast Guard cutters, running without lights after dark and with depth charges stacked on their sterns, prowl along the coasts. These too are members of the inshore patrol.

The sailors who operate the vessels of this branch of the service are picked men.

Mostly recruited from civilian life, they have been chosen because of their experience with small boats. Most of them are as familiar with their home waters as they are with their own back yards. They know the way the current runs behind a certain reef, the direction to steer to make a narrow entrance channel after dark, and they need no charts to help them work their boats past hidden rocks. Many of them can navigate in their home waters after dark or in fog as well as they can on clear days. They need such ability now, because all the usual aids to navigation have been discontinued. Even the clappers on the bell buoys have been tied down for the duration of the war.

If you have done any commercial fishing or have operated a small boat there is a chance that you can join the inshore patrol. Even yachting experience, sail or

(Continued to page 178)

*British Combene Photos Ltd.
271 Madison Ave NYC*

"Dodge-'Em" Car Tows Plane on Carrier Deck



Midget car that "turns on a dime" backs into position to tow fighter plane across British carrier's deck

Fighter planes are towed on the deck and elevators of the British carrier H.M.S. Illustrious with a small American-built tractor. Similar to the carnival "dodge-

'ems," the tractor has three wheels and is maneuvered easily in close quarters. The tractor speeds operations by the deck crew when split seconds mean life or death.

Wire Spools Serve as Wheels for a Homemade Tractor

Lack of standard tires ^{built by} did not seriously handicap John H. Sauter, Essex, Md., in completing his homemade

tractor for his spare-time farm. In place of ordinary wheels he has substituted the round ends of big spools used for handling and transporting telephone wire. They are strongly made of wood, are inexpensive, punctureproof, and give excellent mileage. The rear wheels, slightly larger in diameter than the front ones, gain increased traction from short chains fastened at right angle to the tread. Consisting primarily of a discarded automobile, the homespun tractor represents only a small cash outlay but has proved to be an efficient substitute for a costly power plant in operating a small farm.

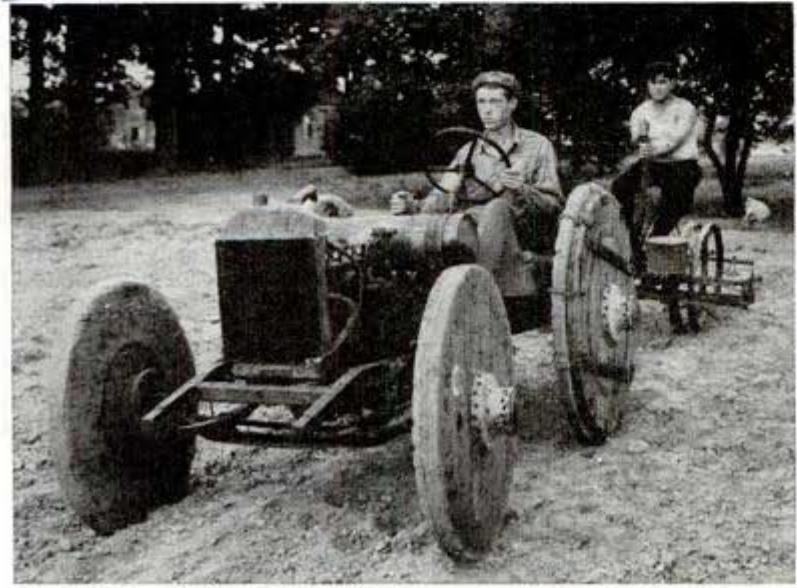

These tractor wheels came from big spools that carried telephone cable

CS 11
Andy Arnold
68
Stacy, Brooklyn NY
I Bo
Pe Elmer R
Stull, Elizabeth NJ

The BACKBONE of the ARMY



The infantry soldier knows that no matter how many tons of bombs are dropped on enemy territory the battle isn't won until he takes possession. Doughboys of mechanized warfare take blitz, guerilla and commando tactics in stride, fight in groups or single handed. Top left, tank commander with tommy gun in hand hops out to engage foe at close range. Above, camouflaging a mortar with brush. Note machete



Three-man radio reconnaissance team in jeep (above) pauses to receive message from headquarters. Aerial observers reported something suspicious near by and these scouts are told to investigate. Left, observer-scout attached to intelligence unit climbs tree to get good look at enemy position

Pe Char & Meyers



This hard-hitting infantry unit closes in on "enemy" during maneuvers after foe's position has been battered with big guns: The soldiers will capture men still resisting and attack will be over quickly. Right, soldier training for invasion is making a dash through shallow water after landing with his buddies of the infantry engineers in rubber boats

Life. Fred W. Werner

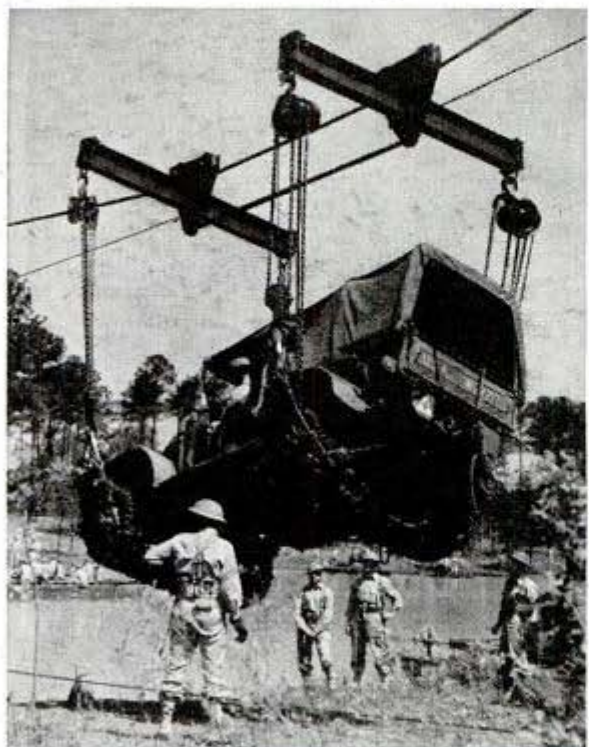

↑ Ferrying big truck across river on aerial cable is one way to save rubber—also time. The driver can stay right in seat and when truck lands on other side of the stream he just steps on starter and keeps rolling. Right, engineers moving 37mm. antitank gun across river on lightweight raft. They follow behind infantry units

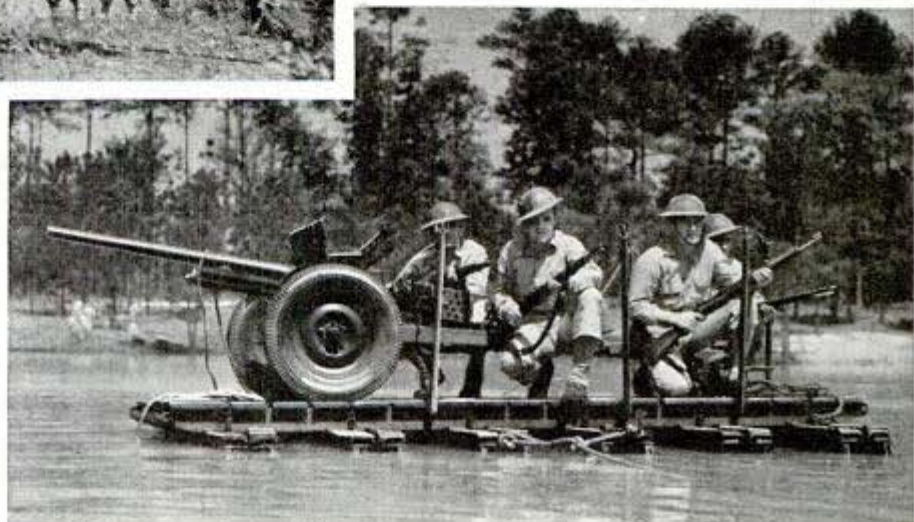

*Mr. Leon K. Rykken
M 931*

Deflated Tire Gives Alarm With Wire Banging Fender



Special lock releases wire when air in tire is low

Warning of a dangerously deflated tire is given by a wire rim that fastens around the wheel with a special lock. When air in the tire is low the lock springs one end of the wire loose so it can bang the fender.

Pull-Up Strap Lifts Face Shield So Hands Won't Soil It

In lifting it away from the face, hands need not touch an all-transparent face shield equipped with a tape by which it may be raised. Attached to the top of the acetate plastic shield, the tape extends over

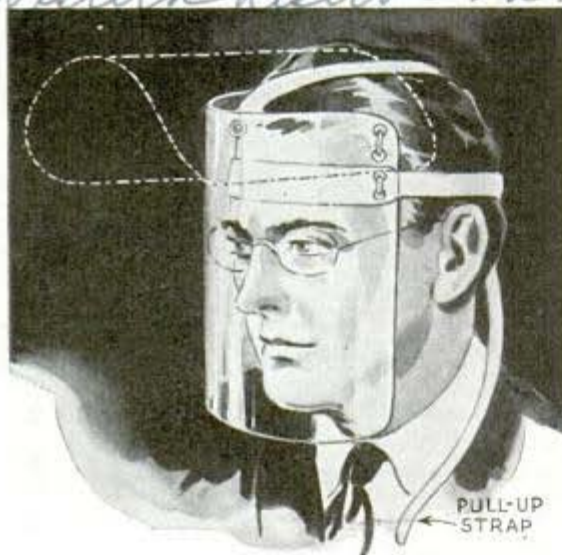

Pull strap and up goes shield away from the face

80

*24 Cleve Bldg
Cleveland Ohio*

the top of the head and down the back. A jerk of the tape swings the shield upward to a horizontal position where it may be carried until ready to use it again, thus avoiding the nuisance of dirtying or smearing the shield each time it is adjusted.

Shelf to Support a Typewriter Fits Flat-Top Desks

Flat-top standard office desks may be converted quickly into typewriter desks by installing a strong, roomy platform that gives smooth operation to the typewriter because of its rigidity. Without the use of screws or bolts, metal expansion grips are



Installing shelf converts desk to hold typewriter

spread easily by screwdriver or coin to secure the board in the shelf slide. It may be attached on either side of the desk. Since no holes need to be drilled, the desk does not become marred by its installation.

Aluminum Barges for River Use Reported Built in Germany

Germany is building barges of aluminum for canal and river transport, according to a naval journal in Argentina. The boats not only have a shallower draft than iron barges, but carry greater loads in proportion to their weight. A 200-ton aluminum barge can carry about 1,500 tons more cargo annually than a corresponding ship built of iron, it is reported by German technical experts.

Naval Mech Sept 42
POPULAR MECHANICS

1329

U.S. Army - H61-100, Sup.

Motorcycle "Hybrid" Tows Axis Guns in Africa

M 801

Resembling a cross between a motorcycle and a tractor, an enemy vehicle captured during desert fighting in Africa is being studied by the British. The front, with single wheel and handle bars, is built like a motorcycle and the rear like a tractor. It is somewhat similar to U. S. Army scout cars that run on half-track and rubber-tired wheels. The Axis forces used the motorcycle-tractor to tow small guns and carry soldiers.



This captured Nazi vehicle for desert warfare is combination motorcycle-tractor

"Eye Shades" Hide Floodlights From Subs Along Coast



Lawrence Bondin, electrician

Floodlights in the yards of the Federal Shipbuilding Dry Dock Company at Kearny, N. J., are equipped with visors, similar to eye shades, that bend the light beams below the horizon. This reduces the sky glow that silhouettes ships for lurking submarines along the coast. At the same time, the dimmed lights permit night production to go ahead at full speed.

Attaching visor to a floodlight in shipbuilding yard on coast hides the glow from subs and permits night workmen to "keep 'em rolling"

Ragweed Seeds Help in the War Effort by Yielding Valuable Fats

Oil closely resembling that obtained from soybeans, and superior to some oils formerly imported, can now be obtained from ragweed, generally known as the main source of discomfort for hay fever victims. The discovery was made by G. F. Roedel and M. T. Thornton, chemists at Purdue University. No new machinery is needed,

the ordinary grain combine harvesting the ragweed and commercial extractors taking the oil from the seeds. Extracted oils have immediate value as fatty oils now scarce due to increased war needs and the dearth of imports. It is believed the ragweed product would have slightly better drying properties in paints than soybean oil.

Lafayette Ind

12,000,000 MEALS A DAY



"Now you're cookin' with gasoline," say the doughboys inspecting field range that can be transported easily. Left, a typical supper for soldier includes soup, meat, salad and bread



of today is streamlined and mechanized, but it rides, flies, parachutes, skis and hurtles "on its stomach" just as it marched in the days of Washington and Grant.

The exact number of men in uniform, of course, is a military secret. There is talk that the Army will be increased to 7,000,000 or 8,000,000 men. The War Department, how-

IF THERE are any members of the Quartermaster Corps who have studied astronomy, it would come in handy these days for the corps is dealing in astronomical boxcar figures that stagger the imagination of most civilians.

Its biggest job is feeding the army. If you have any doubts about that just ask any soldier from private to general. The army

ever, let it be known last summer that there would "soon" be more than 4,000,000 in training. To the Quartermaster Corps, an army of 4,000,000 means 12,000,000 meals a day (4,380,000,000 a year) and the daily purchase of some 20,000,000 pounds of food to be served in camps, posts and stations, as as field or emergency rations wherever United States troops may be on the far-



flung battlefronts of World War II.

This has been called a "quartermaster's war." The business of maintaining supply lines carrying mountains of nourishing food to soldiers in home camps and 12,000 miles away, in desert and jungle and Arctic regions, is a giant task. It has been taken in stride by the Quartermaster Corps under the direction of Major General Edmund B. Gregory. Purchase and distribution are only part of the picture. Meals by the million are balanced with an eagle eye on vitamin content and the corps has developed revolutionary methods of processing foods, including dehydration.

The army eats more meat than any other single food item. Each soldier consumes nearly one pound a day. That means 4,000,000 pounds of meat for the daily mess and 1,460,000,000 pounds for one year. A year's supply would fill 36,500 refrigerator cars that would reach from Chicago to Louisville.

↑
A lot of applesauce—composite picture of 10,000,000 apples and a soldier at work

Trio from Fort Benning making bouillon and coffee by pouring hot water over powders furnished with new parachute rations

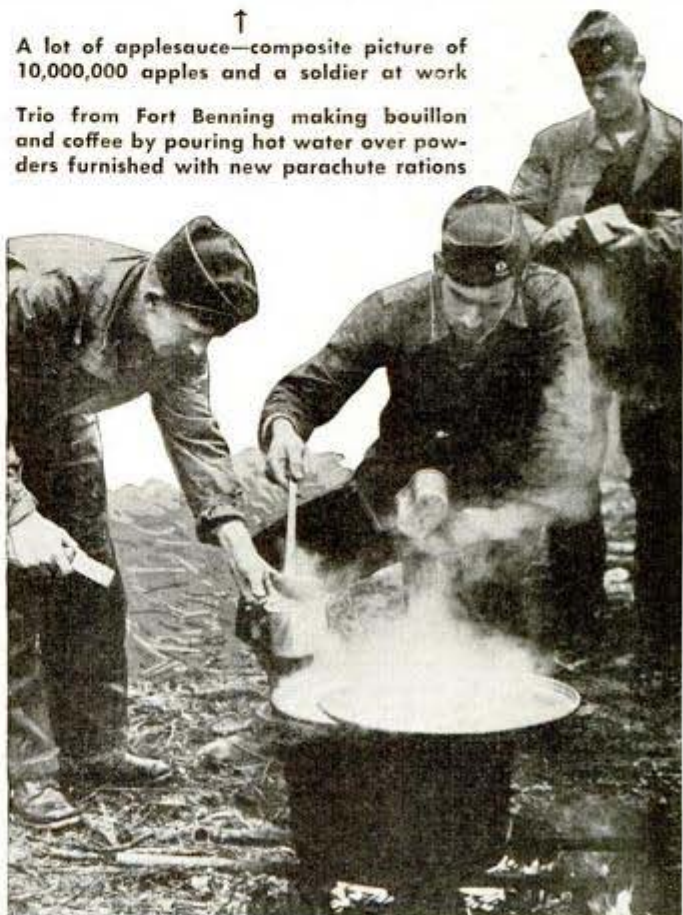



The smiles on the faces of these recruits lined up for chow testify that they know what's coming up will be plenty tasty



Long columns of supply trucks (above) of Quartermaster Corps carrying tons of food. It takes 720,000 pounds of bacon when an army of 4,000,000 sits down to breakfast. Below, roasting coffee for half of army at Chicago Quartermaster Depot where special blends are prepared—men in South like more chicory



When the army sits down to a breakfast of bacon and eggs, the cooks (one for every 50 men) have dished out 720,000 pounds of bacon and 8,160,000 eggs. It takes more than a billion pounds of potatoes to feed the men in khaki for a year and 584,000,000 loaves of bread. Food items such as salt and pepper, which are hardly worth listing in family budgets, soar into the millions in the quartermaster's books. A year's supply of salt is 29,200,000 pounds, and 9,600,000 four-ounce boxes of pepper are required. These computations for an army of 4,000,000 are based on official figures for the needs of units of 100 men.

Feeding the army starts with the preparation of a master 30-day menu in the offices of the quartermaster general in Washington. There is no guesswork about this menu. It is prepared by the best dieticians that can be had and provides the proper vitamins in quantity and variety and the required amount of calories. Recommendations of the Nutrition Committee of the National Research Council have been adopted as a minimum standard.

The master menus are sent out, usually three months in advance, to the quartermasters in the nine corps areas. They make up the menus for their own areas in accordance with local supplies, but never falling below the standards of the master menu.

A typical menu for one day consists of a breakfast of oranges, assorted cereals, fresh milk, bacon and eggs, fried potatoes, muffins, bread, butter, jam and coffee; a dinner (always served at noon) of barley soup, breaded veal cutlet, gravy, au gratin potatoes, buttered asparagus, sliced tomato salad with mayonnaise, bread, butter, ice cream, cookies and tea; a supper of baked beans with thick

Army bakers turning out just a few of the 584,000,000 loaves of bread eaten by our soldiers in a year—they like white best

sliced bacon, hot cole slaw, buttered beets, bread, butter, strawberries, beverage.

One quartermaster jokingly remarked that the meals are so well balanced the only complaint he hears is "not enough beans"—a far cry from 1917.

Foods purchased by the army fall into two general classifications: nonperishable and perishable. Nonperishable foods are purchased by three central procurement agencies, or depots, in Jersey City, Chicago and San Francisco. Perishable foods (about 65 percent) are purchased in some 30 quartermaster market centers that are scattered strategically from coast to coast. The purchase order for most foods calls for delivery direct to the camp or station where they are to be used.

When the food arrives at the camp it is placed in storerooms or huge refrigerators, some of the latter being large enough to hold a 10-day supply of perishable foods for 15,000 men.

Three distinct types of rations are served to the armed forces—garrison, field and emergency. Garrison and field rations are called A and B, respectively, and the emergency rations are C, D and K. The garrison ration of



The chocolate bar above, officially known as Ration D, weighs only four ounces, has 600 calories. Left, huge steam vats assure well-cooked soldier fare

peacetime has generally been supplanted today by the regular army field ration as set up in the master menu.

The newest and most widely acclaimed emergency ration was originally called the "parachute ration" and is now simply known as Ration K. It was developed in the Subsistence Research

Laboratory of the Chicago Quartermaster Depot, the only laboratory of its kind in the country. The K ration is packed in three separate boxes containing breakfast, dinner and supper. It contains two kinds of biscuit, canned meats, coffee tablets, concentrated bouillon, lemon juice powder, chocolate bar and chewing gum. The gum isn't there just to satisfy an American habit. Chewing reduces consumption of water, an important factor in combat areas.

The K ration is packed in a special box developed in the Chicago laboratory. The container has a waxlike coating that resists a temperature of 135 degrees Fahrenheit and will not crack or chip if the mercury falls to 20 below zero. It is also resistant to vermin, moisture and poison gases and will stand rough treatment.

This ration, once intended for paratroops only, was adopted as regular emergency chow after exhaustive tests at Fort Benning and on Mount Rainier. Three hundred ski troops participated in the experiment on Mount Rainier conducted by the Mountain and Winter Warfare Board from Fort Lewis. The five-day test included every type of mountain maneuver simulating war conditions. The men were accom-

Developed as special ration for paratroops, Ration K has been adopted as a regular field ration. Here are shown breakfast, lunch and dinner which men in action find is satisfying. Below, a trooper opening compact field ration

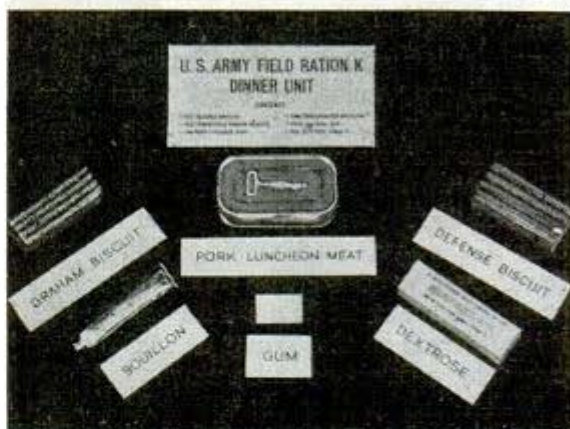

panied by doctors, biochemists, physiologists, technical experts and high ranking officers.

The ski troops were split into three groups. One was fed the K ration, another the K ration supplemented by dehydrated soups, fruits, cereals and beverages; the third group was fed the regular Army C ration consisting of six tins (two for each meal) filled with stew, hash, meat and beans, crackers, biscuits, hard candies and soluble coffee.

The men were carefully examined before and after the experiment and it was found that those on the K ration retained the required amount of sugar and protein content in their blood and were able to meet the demands of fast-moving combat. The men also said it tasted good, was satisfying, and ideal for carrying in a pack. It's the most popular emergency ration today.

Another emergency fare, known as D, is a concentrated chocolate bar. The principal ingredients are cocoa fat, oat flour, artificial thiamin chloride (vitamin B₁), skim milk powder, sugar and chocolate.

The creation of the K and D rations, as well as improvements on the others, are just a few of the accomplishments of the Chicago Subsistence Laboratory headed by Col. Rohland A. Isker. Into this spotless laboratory manned by a staff of experts come food samples from all over the world. The foods are tested for their keeping qualities (temperature and humidity cabinets reproduce almost any climate), for purity, for nutrition and taste. The motto of the laboratory is:

"If it doesn't look right and taste right, no matter how many vitamins or calories the food contains, we will not serve it to the soldiers."

The staff is not content with testing foods developed elsewhere. Recently, one of the specialists decided that the soldier in the desert or tropics deserved something better than a sloppy piece of butter for his bread. Melted butter, he argued, makes anybody irritated. He set to work with some research workers from a private concern and the result is a butter that will not melt under a heat of 110 degrees.

The staff refuses to talk about any experiments that are under way. To the visitor who asks a bacteriologist or chemist what he is doing, the reply is:

"The enemy probably would like to know, too. What we are working on is a military secret. The type of experiment we are conducting might give Hitler or the Japs a clue to where the army will strike."

Canned bacon that has resisted a three-year test, frozen beef that has all bones removed and lightens work in mess kitchens are two comparatively recent developments. The big emphasis in the laboratory, however, is on dehydrated foods.

The dehydration of foods—removal of water—is just in its infancy and the army

(Continued to page 162)

FEBRUARY, 1943

Time-Saving Electro-Brain Checks Plane's Wiring



"Magic eye" points out flaws in electrical hookup

Checking and double-checking the maze of electrical installations in Lockheed planes, a task heretofore requiring 16 to 20 hours, is now accomplished in 15 minutes with an electro-brain tester developed by John E. Browne, aviation engineer. On the control board a "magic eye" flashes a warning light to the shorted or broken wire, solving the continuity of the hundreds of circuits where there are as many as 36 pins to one plug, or 100 or more loose wire ends which pass through various conduits to fuse panels and equipment.

Army Matches in a Floating Box Light After Month in Water

Troops will be able to strike a light in the most adverse weather conditions when they carry a floating match box developed by the War Department. The box, holding 20 matches and equipped with striking bars, is made of a strong synthetic resin. Cylindrical in shape, it is three inches long and $\frac{3}{4}$ inch in diameter, having a small emergency compass at one end. After soaking in water for more than a month, its interior and contents remain undamaged, and no matter how wet the box may be the matches can be struck by friction from the striking bars.

87

Acme 461-8 avo, m.c.

Glass-Topped Training Glider Built With Dual Control

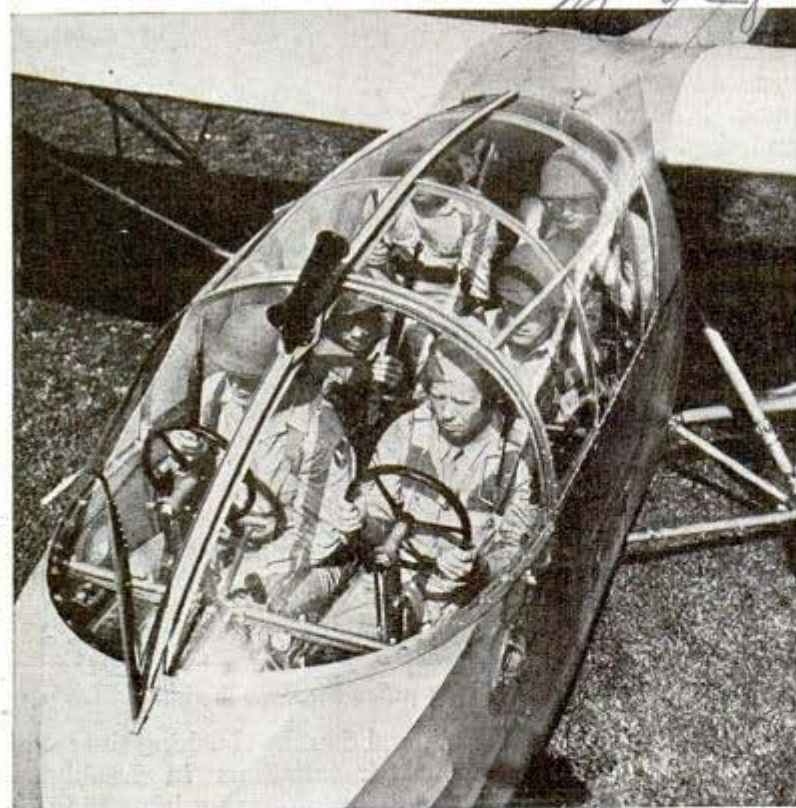

Instructor and student sit side by side in nine-place training glider

Glider pilots and crews are trained by the U. S. Army Air Corps in a nine-place glider equipped with dual control and a fuselage with a transparent top. After preliminary training in this craft, the men graduate to the new 15-man gliders which are now in mass production. The larger glider will be our first line of offense in invading enemy territory.

"Black Light" Tests Mask For Leaks by "Gas Glow"

Leaks in gas masks are detected quickly with fluorescent chemicals that glow under ultraviolet light. Finely powdered anthracene is one of the fluorescent chemicals used in tests conducted by Jack De Ment, Portland, Ore., originator of the process. The powder is filtered into the test chamber and leaks in fabric, mechanism or edges of the mask are revealed by

a bright green glow under "black light." Liquids and vapors may be used instead of powder, depending on the type of gas, smoke or fog for which the mask is intended. It is claimed that this method of testing may eliminate one of the serious bottlenecks in the mass production of masks.

U. S. Hospital Train For Soldier Sick Holds 65 Men

Equipped to fill every medical need of soldier patients in transit, a new five-car army hospital train has accommodations for more than 65 men. The three center cars are wards with double-deck beds and the end cars are commissary and operating room. The rolling hospital is staffed with a score of nurses and medical officers.



Army's five-car hospital train has wards and operating room

*Lt. Harry E. Rieseberg -
5127 Fountain Av. Hollywood*

Floating Drydock Would Hoist Sunken Vessels

M 1036 Caly

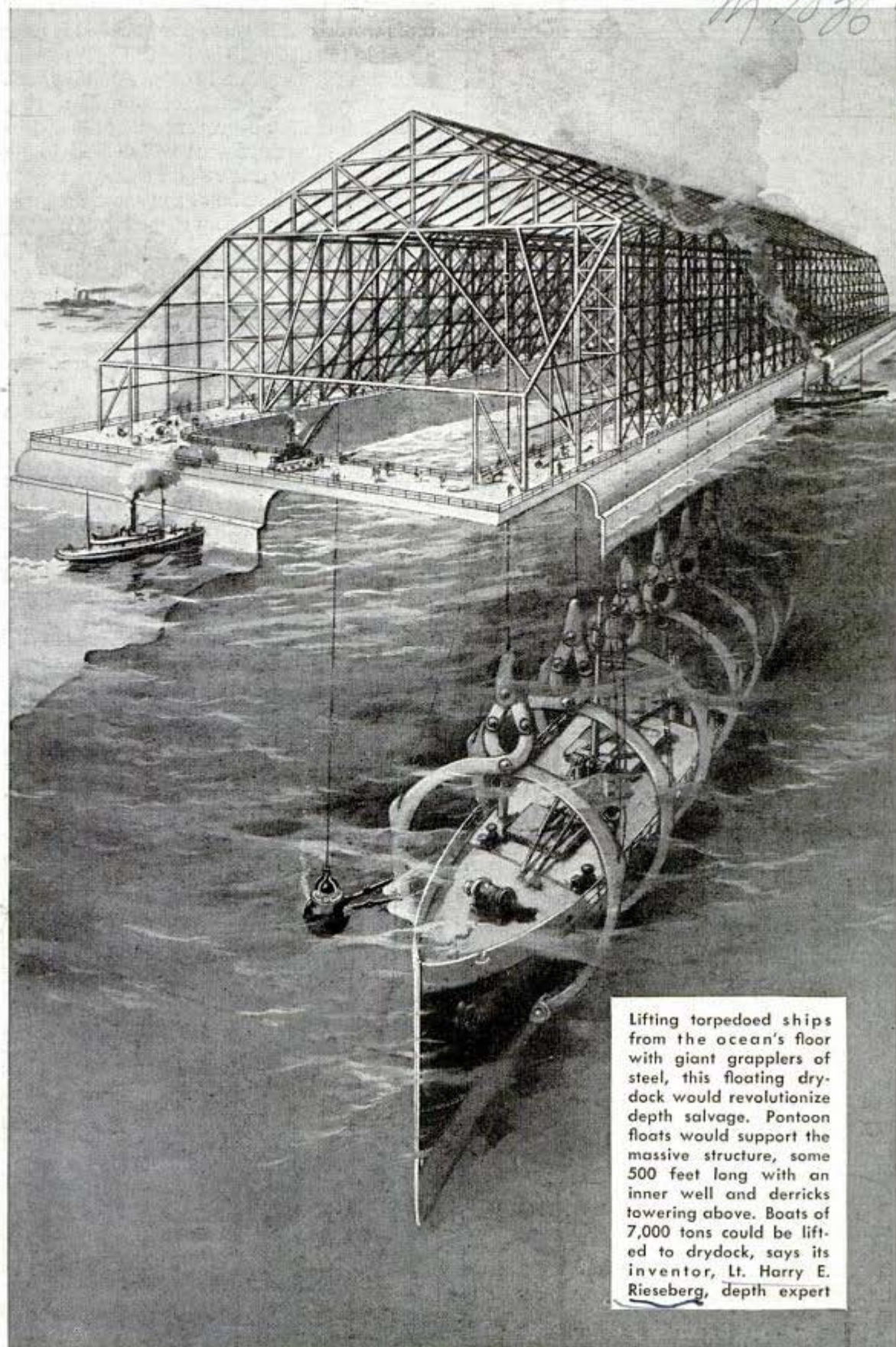

Lifting torpedoed ships from the ocean's floor with giant grappers of steel, this floating drydock would revolutionize depth salvage. Pontoon floats would support the massive structure, some 500 feet long with an inner well and derricks towering above. Boats of 7,000 tons could be lifted to drydock, says its inventor, Lt. Harry E. Rieseberg, depth expert

*Planters Supply Co.
Portsmouth Va.*

Folding Barrel Saves Space When Shipped Empty

M 740



Unpacking barrel, top; flat, it takes little space

Valuable wartime shipping space on railroads, wasted when empty barrels are returned to their owners, can be saved with a collapsible barrel of fir plywood which separates into flat sections when knocked down. It is put together and taken apart easily by means of removable pins that lock the hoops together.

Precision Grinding Adds Life To Cutting Tools

M 990

Precision grinding of cutting tools, which means a new tool shape with a highly polished, mirrored finish, is adding life to tools used in war industries, with a saving in high-grade tool steel as well as man hours formerly lost in frequent regrinding. Specially designed fixtures now hold 18 tools at a time for automatic grinding, and additional fixtures hold them one at a time for a slight final grind on a very fine stone, followed by an ultra-fine polishing operation. This new form of tool reduces friction and decreases wear since it breaks up chips quickly into short, small pieces so

there is no long contact between the hot chips and the tool, with consequent cooler cutting. In one case where hand-ground tools would cut 13 gears per grind, it is now possible to cut 200 to 500 of the same gears with precision-ground tools. Another tool needed regrinding after cutting 30 shafts, while the machine-ground tool cuts 200 to 300 shafts. A third tool which had to be reground after each cut on a large engine part now machines 28 of the same forgings before regrinding. Developed by Wright Aeronautical Corporation of Paterson, N. J., precision grinding is applicable to all high-speed lathe tools, and full details are being released by the Wright company to other manufacturers.

30 Rockefeller Plaza, N.Y.C.

"Hammer Head" Socket Wrench Adjusts to Any Size

M 835

With a grip shaped to take either square or hexagonal nuts, an adjustable socket wrench opens and closes its jaws for various size nuts when the handle is twisted. It provides good leverage and a firm hold on nuts with "burred" corners. The head is shaped like a hammer and actually can be used as a hammer by inserting a special fitting in its jaws. Two hammer heads are supplied, one of solid steel and the other of resilient plastic for work on piston pins, auto bodies and fenders. Attachment bars also may be inserted to turn nuts having recessed heads, such as differential, transmission and oiling plugs.

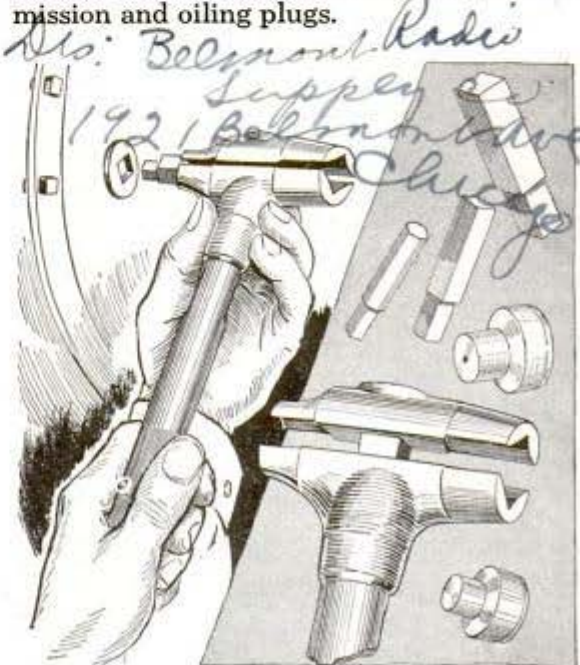

Wrench turns nuts or uses illustrated attachments

Cable Unit to Raise Sub Is Among New Patents

*Francis P. Chaussee
Missoula, Mont.*

The antiskid device, below, has a rotating wheel that flings chains beneath the tire when the controlling rod is released

M 7 93

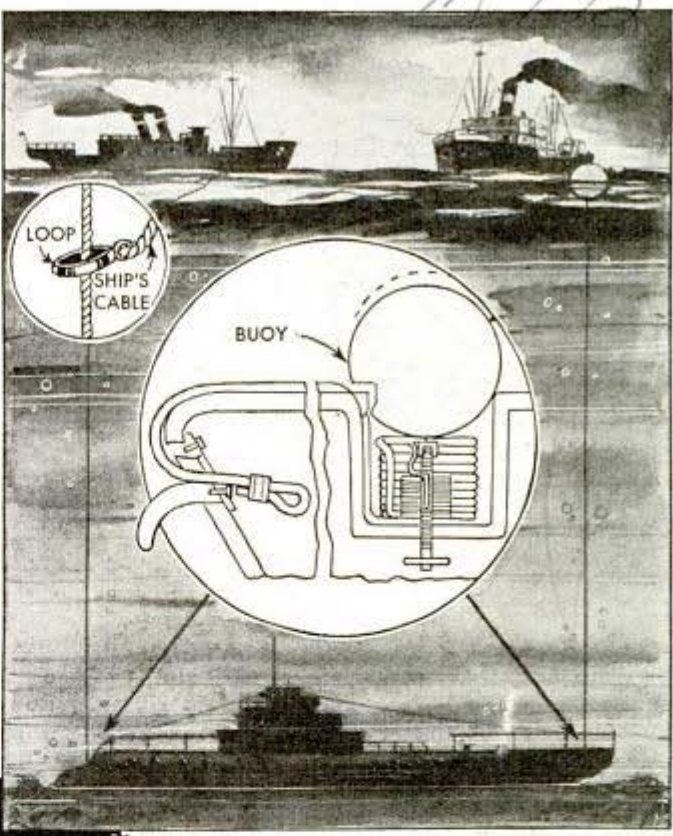
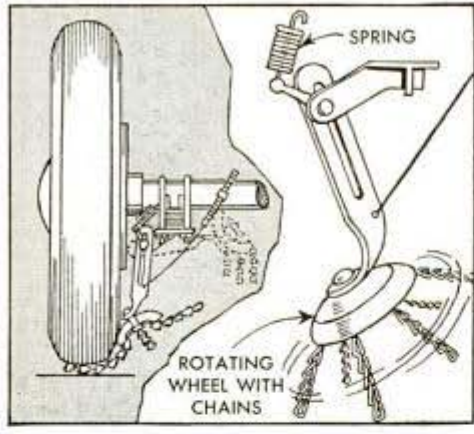

Two ships would be able to raise a sub horizontally with a recently patented cable unit. Buoys attached to the stern and bow of the sunken sub could be released from within. They would rise to the surface carrying lines for guiding heavy cables from each ship to hooks at each end of the sub. With their winches the rescue ships can then haul the craft horizontally to the surface

*George Earl Kneel
Los Angeles, Calif.*



The date indicator, above, is adjusted to any average sized calendar. A rod with ring on the end swings back and forth or slides upward

*John Chelster
Sharon, Pa.*

The armrest for automobile doors, in sketch, has a light in one end that goes on when the door is opened. Articles on this page were among patents recently granted, but no other information is available for prospective buyers

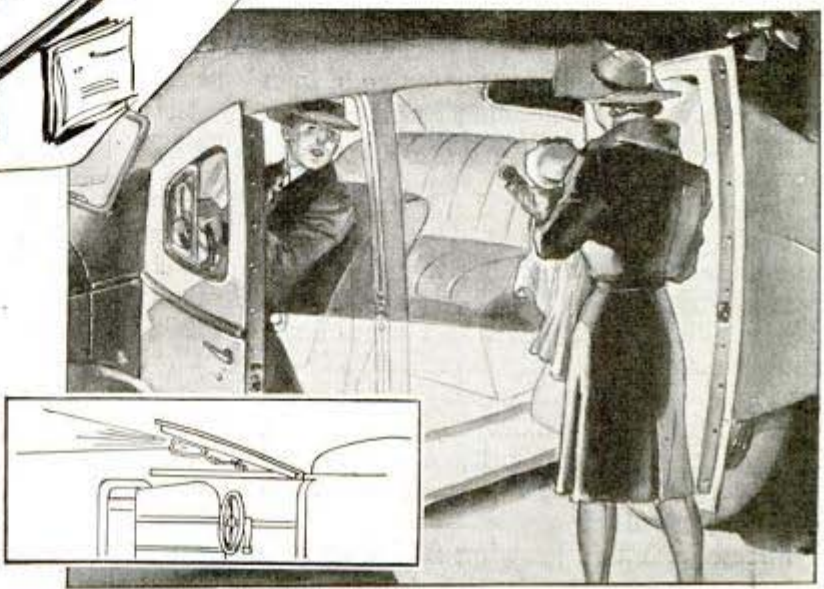

Con: *Willis ...* *Illcat 7*
Parbo or ...

FIGHTING *that* TIRED FEELING

M. 6. 42

*Western Elec & Mfg Co
So. Cal. works*

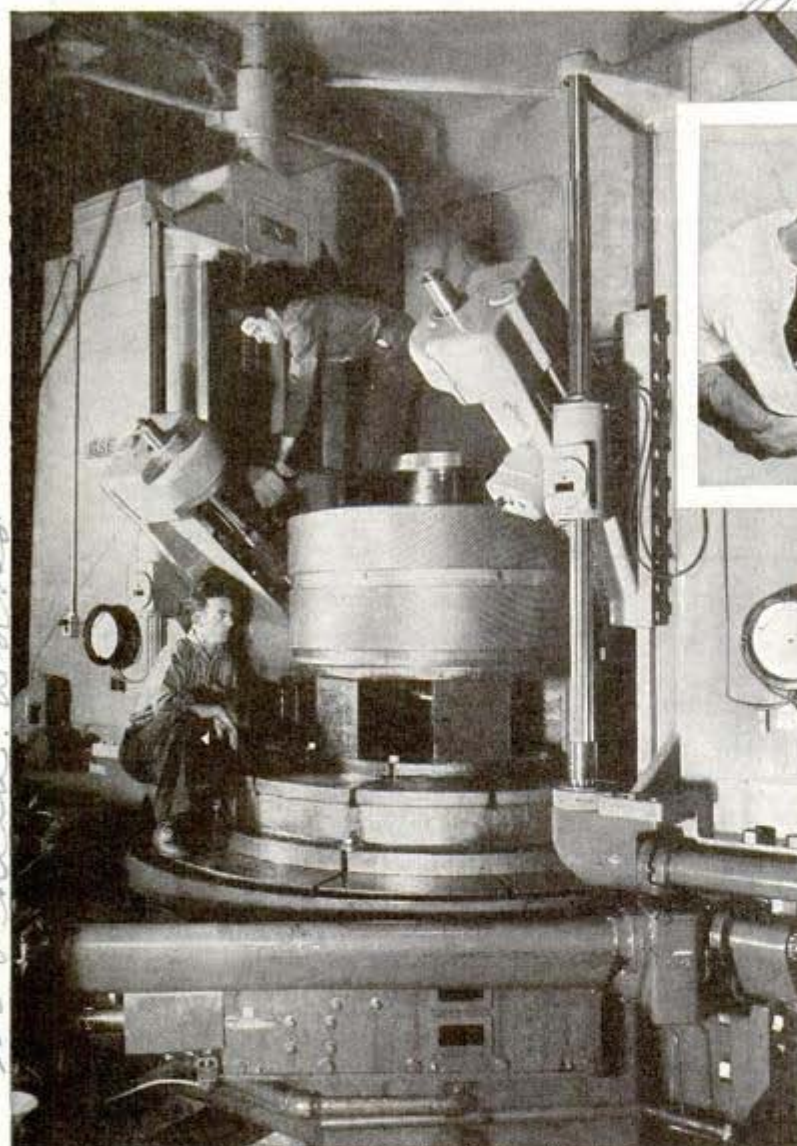

Lack of sunshine is a cause of fatigue which ultraviolet lamps can remove. Above, Westinghouse men "meter" solar rays

There's no "heat fag" in this sealed room, left, where marine gears are cut for seven days at a constant temperature

hospitals, colleges and research laboratories are starting a far-reaching investigation of this puzzle of modern civilization. If you do feel abnormally tired on the job, it may interest you to know that investigators in one organization alone, the National Safety Council, have already found thirty reasons for your fatigue. Other re-

UNCLE SAM needs every ounce of man power at the machine that can be exerted at home in behalf of the armed forces abroad.

The metal machine is doing its war job with its usual efficiency. But too many human machines tire under the stress of a normal day of toil. The body should replenish and repair itself and should not show serious daily fatigue until it is thoroughly worn out and aged. But it often does—right in its prime. Too frequently, loss of output, accidents, illness, labor turnover, lack of morale and general inefficiency result.

Faced with this growing factor as war pressure increases, scientists in factories,

search experts have added more to the list.

Some scientists divide fatigue into three categories. One is ordinary physical fatigue which results from muscular exertion without enough replenishment, rest and relaxation. Another is that lassitude which grows in an ailing body. Still another is nervous fatigue.

Most of us who have manual jobs think daily muscular fatigue is normal, but the experts believe it is not unless we are past the prime years or have an especially hard task. A whole plant, or even a department cannot be overworked without a jump in accident rates, an increase in rejected workmanship or a drop in output. These would stop production in a hurry.

Westinghouse

The truth is that the average body, like the average gasoline motor, uses only about a quarter of the energy obtained from burning the fuel which is the food eaten, wasting the rest in the form of heat. As in the gasoline motor we must carry around a cooling system to get rid of the excess heat which could be turned into energy. Still we feel fatigue.

One reason many of us tire toward the end of the day is that we gear our bodies to do a certain amount of work, like the milkman's horse which is ready to head for the barn when the customary route has been covered. We can step this ratio up by a regular after-hour session of sports like baseball, bowling or tennis unless we are past 35. Then a walk or a game of billiards might be more like it. This leaves us ready for more exertion when the whistle blows at the plant. The theory is that we tire on the job because we need extra exercise, particularly that which tones up muscles not used in our work. On the other hand, over-exertion at sports is a reason for much fatigue on the job.

Another idea which has swept through large industrial plants recently is that workers should forget the old adage about digging their graves with their teeth. The new order is to eat four or five times a day and take the extra food in the form of

Experimenters make a time-motion study to determine how a manual task can be performed more efficiently and less tiringly



X-ray unit making a picture a minute detects lung troubles causing fatigue

A worker in a transformer plant takes candy pill containing vitamins A and D

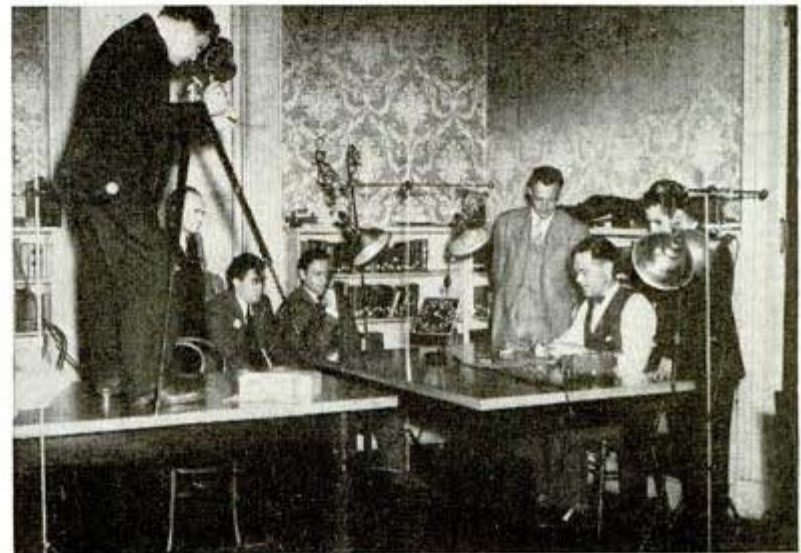

Westinghouse
Newark, N. J.



Aptitude test at General Electric plant prevents misplacing workers who tire rapidly if unfitted for task

snacks, even if it is only a piece of candy. Rolling snack bars are becoming a familiar part of the American industrial scene. Soldiers are fed a hard candy with high citric acid content. The inference is that we have been letting human boiler pressure die down at intervals when the throttle is wide open.

Plant managers who would have been surprised a year ago to have an employee ask for time out for a glass of milk, cup of coffee or tea now send such drinks around, particularly on the night shifts when toilers seem to tire more easily. Management has

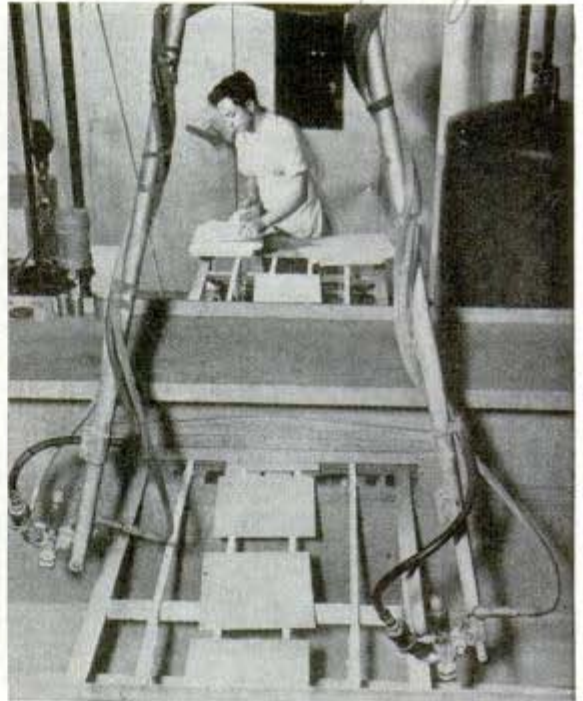

Worker is protected from fatigue-producing fumes as automatic spray guns apply plastic paint to aluminum

learned that a mid-morning and mid-afternoon pause to give the body a chance to relax and recoup increases output.

Even when drinks and snacks are not passed around, in many cases a rest period with music is provided twice a day. The idea is that you get tired on the job because you work too steadily, even though not too hard. The body needs an interval to clear the muscles of toxins set up by exertion.

Another reason why you get tired on the job even if you do eat five times a day may be that you do not eat enough vitamins and minerals. Many companies recognize the importance of in-plant feeding and are trying to oust the time-worn dinner pail with its doughnuts and sandwiches in favor of hot meals with plenty of vegetables and fruits. Cafeterias are running on three shifts in many war plants.

Vitamins in pill form are furnished free to workers in some plants. One recent union contract included a provision for the daily supply of vitamins. A pioneer in this field was the Westinghouse organization which began to feed



Westinghouse
E. Pittsburgh plant

Handy material trays, electric screwdrivers suspended overhead, and conveyors eliminate waste motion and save effort

*Westinghouse
News, n. j.*

its electric appliance plant employees vitamin A to furnish visual purple and relieve eye strain.

Another late development is a campaign by the Wisconsin Alumni Research Foundation to acquaint factory physicians with the discovery that compounds of copper and iron fed to workers will lessen fatigue and boost production. Addition of calcium and phosphorous elements is also advocated by scientists. Salt helps prevent heat fag, so sodium chloride tablets are provided in many plants.

Tufts College scientists, searching for an anti-gray hair chemical, found it in para-amino-benzoic acid. They also found a brand new pep-giving substance in the same acid.

These discoveries apply mostly to physical fatigue of the muscular variety. But it appears also that there is a long list of factors under the heading of nervous fatigue.

One is the fitting of the right man into the wrong job—or into a job which belongs to a woman. General Electric Company discovered by aptitude tests that in dozens of jobs a woman could out-produce a man without becoming tired. The men were shifted to spots where they were better suited and their productive activity increased, too.

Experiments have shown that dislike for the job will actually produce fatigue—as will dislike for the foreman and the fellow worker.

Monotony, which is necessary if man must be geared to a machine, is another cause of fatigue. The necessity for repeated uniform movements inhibits the fulfillment of personal desires and the exercise of personal ability so that the worker becomes bored, particularly if he is of the nervous, alert type.

Westinghouse was a leader in the movement to relieve monotony and nervous tension. War work has been set to music at the

(Continued to page 162)



Music played over loudspeakers helps speed agile fingers
A "handcuff" prevents accidents that fatigue might cause



Dirt and fumes in the eyes, ears, nose and pulmonary tract would wear down and slow down the worker, so this American Airlines man is masked as he cleans motor parts with air gun



*Murray Corp. of America
7700 Rushmore St.
Detroit, Mich.*

"Pencil" Tool Ejects Rivets One at a Time in Holes

711 825

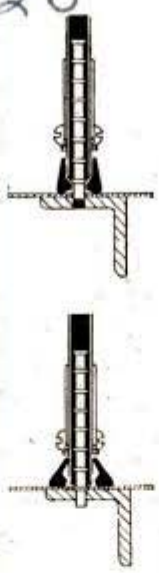

Lorraine Mc Finch

Automatic feeder prevents dropping of small rivets

Fumbling and dropping of rivets is eliminated with an automatic pencil-shaped injector that feeds one rivet at a time. It holds approximately 65 rivets. To operate, the jaws of the tool are placed over the hole and a slight downward pressure shoots a rivet into place. The feeder can be handled easily with one hand and war workers report that it has speeded riveting by as much as 25 percent.

Square-Shank Tool for Sandpaper Operates Like a File

Sanding inside corners and other hard-to-reach places can be accomplished easily with a long, square-shaped sandpaper holder now available. Handled like a file, the holder consists of a square, hollow

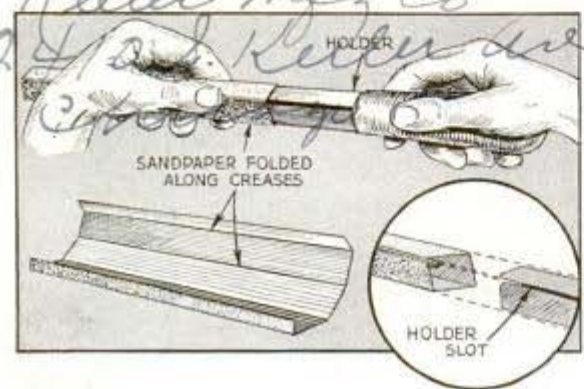

Sandpaper fitted to square shank is rubbed like file

metal tube, slit along one edge for gripping the paper. Sandpaper cut and creased ready for insertion is furnished, although the user may prepare his own refills without difficulty. Properly installed, the sandpaper holds firmly and may be rubbed vigorously without being dislodged.

Automatic Acetylene Gas "Gun" Lights at Pull of Trigger

Equipped with a "self-starter," a pistol-shaped acetylene torch blazes as soon as the trigger is pulled. Like an automobile engine, it is dormant when not in use, but a spark from a flint starts it instantly. Weighing 20 ounces, and being 6½ inches long and 5½ inches high, the "gun" is handy for lead and silver soldering, sweating terminals on electric cables, leading

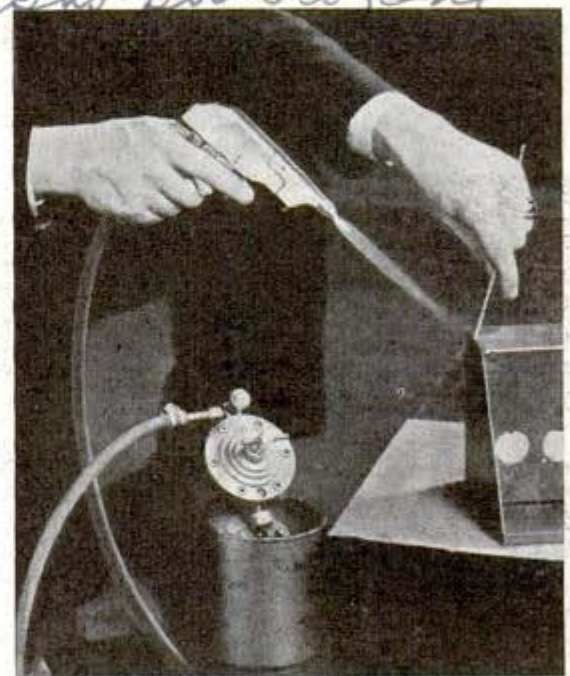

Pull of trigger automatically lights acetylene torch

joints in plumbing, aluminum soldering in aviation plants, and many other uses. Acetylene gas from a tank keeps flowing as long as the trigger is held back, and there is a trigger lock for use on long-time jobs. A slight pressure against the trigger releases the lock to extinguish the flame.

Names and addresses of makers or sellers of commercial products described in this magazine are listed in the Where-to-Buy-It index. Write to them for additional information and be sure to Say You Saw It in Popular Mechanics.



The CRAFTSMAN

You can make this CHEST VANITY

Beautiful little companion piece for chest or highboy. Combines an easel-type mirror with a convenient drawer in which to keep jewelry or handkerchiefs

By D. W. Martin

CHIPPENDALE in motif, this little vanity goes best with period furniture, yet it need not match the style of chest on which it is set to look appropriate. Beauty of grain shows to excellent advantage as can be seen in Fig. 1, which pictures the chest made of curly cherry. Assemble the lower part containing the drawer first. Fig. 2 shows this as a simple box measuring 3 by 7 by 14 in. Note that the bottom of it extends $\frac{3}{8}$ in. all around to provide sufficient stock for shaping the edges. If a shaper is not at hand, you can gain practically the same effect by using stock molding, mitering it at the corners and nailing it to the edges. Also, dowels may be substituted for the blind mortise-and-tenon joints.

Each foot can be bandsawed from a single block or made up of two separate pieces. The former method is typical in cutting the cabriole (Queen Anne) leg, where one profile is cut and the waste tacked back on before cutting the second profile. For this, blocks $1\frac{1}{4}$ by $2\frac{1}{2}$ by $2\frac{1}{2}$ in., with the grain running the short way, are required. Lacking a bandsaw, you can follow the mitering method detailed to the right of Fig. 3. Here $1\frac{1}{4}$ -in. square stock is cut into 3-in. blocks, after which one end of each block is mitered 45 degrees before running the

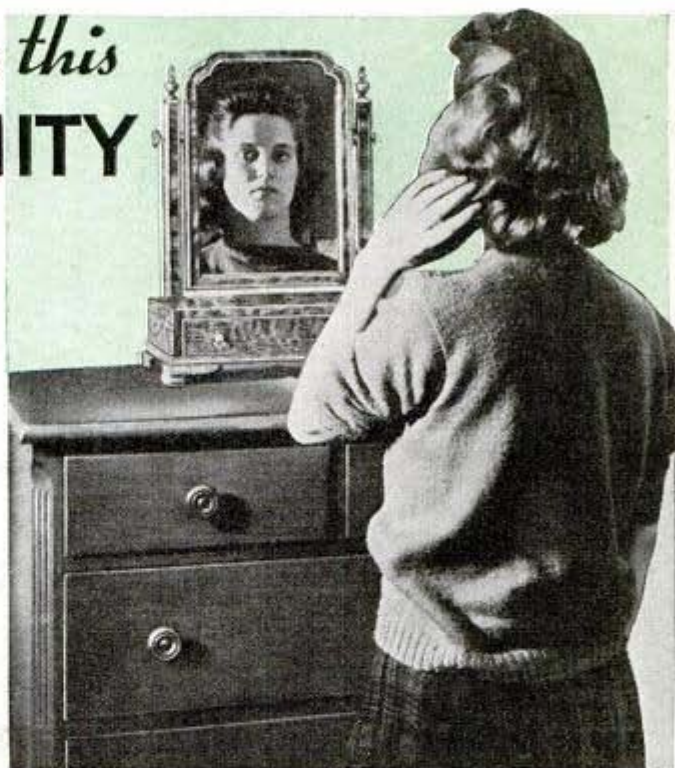

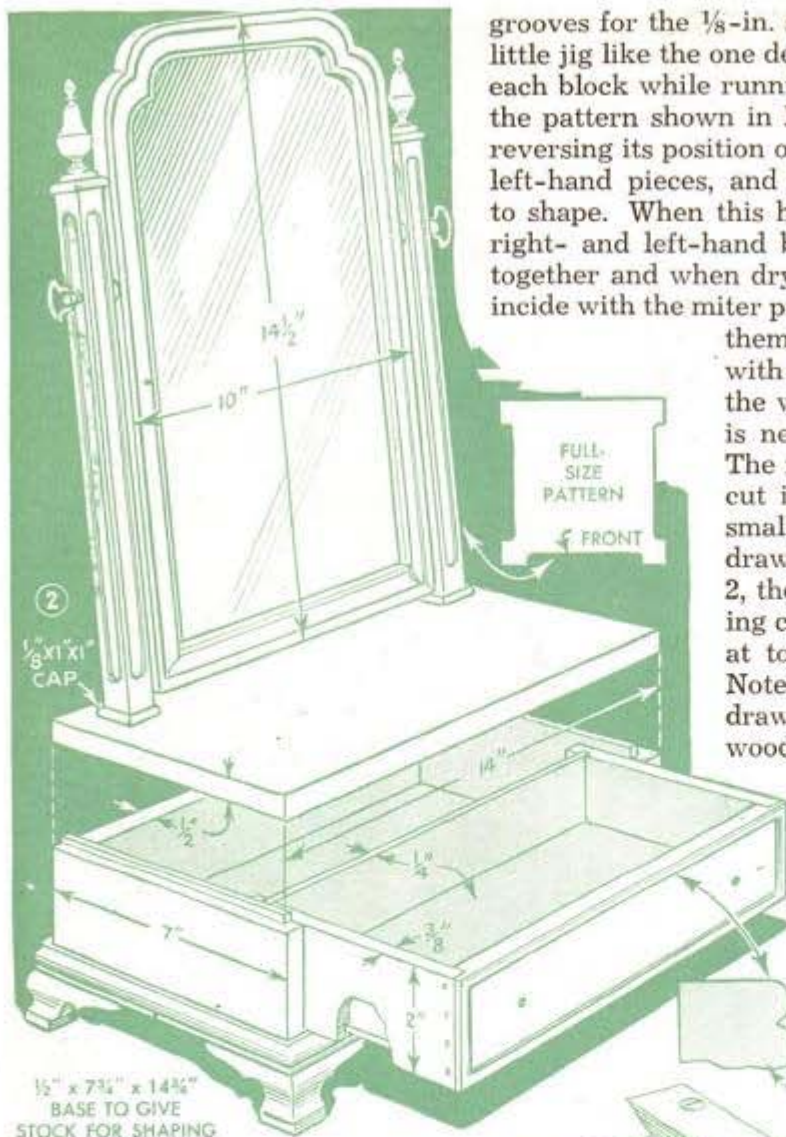

1/2" x 7 3/4" x 14 3/4"
BASE TO GIVE
STOCK FOR SHAPING

The edges of the base should be shaped before locating the position of the end mortises

grooves for the 1/8-in. splines as shown in Fig. 5. A little jig like the one detailed in Fig. 3 will help hold each block while running it through the saw. Now, the pattern shown in Fig. 4 is traced on the work, reversing its position on four of the blocks to obtain left-hand pieces, and the blocks are scroll-sawed to shape. When this has been done, corresponding right- and left-hand blocks are splined and glued together and when dry, the faces are carved to coincide with the miter profile of the pattern. To carve

them, start rounding the top edge with a small block plane, planing the wood away until each surface is nearly flush at the miter line. The reverse curve of the profile is cut in a similar manner, using a small gouge or round file. The drawer is made according to Fig. 2, the overall size of the front being cut to allow a 1/16-in. clearance at top and sides of the opening. Note that the bead encircling the drawer front is cut right in the wood. Running the sharp nail point of a marking gauge back and forth along the edge of the work carefully will score the inner line of the bead, leaving the outer edge simply to be rounded with a file or sandpaper.

Now to make the mirror frame: The top corners

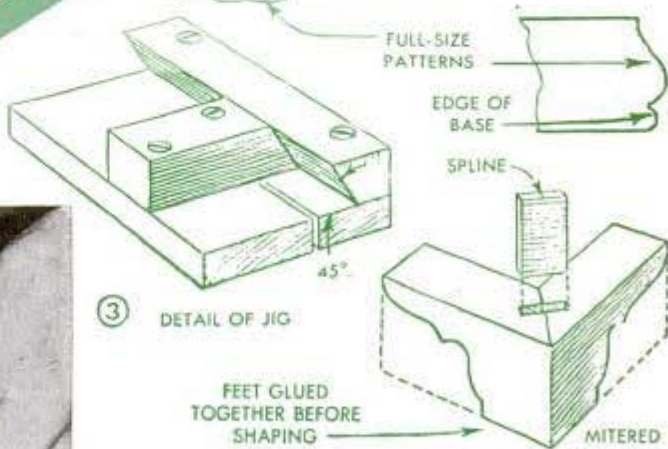

③ DETAIL OF JIG

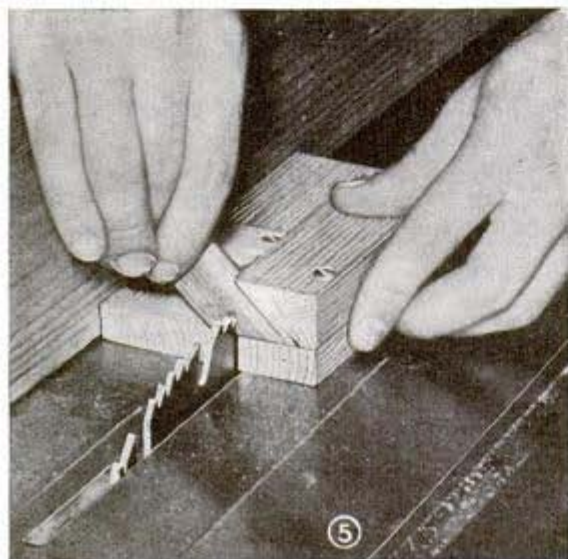

④ FULL-SIZE PATTERN OF FOOT — MAKE FOUR RIGHT HAND AND FOUR LEFT

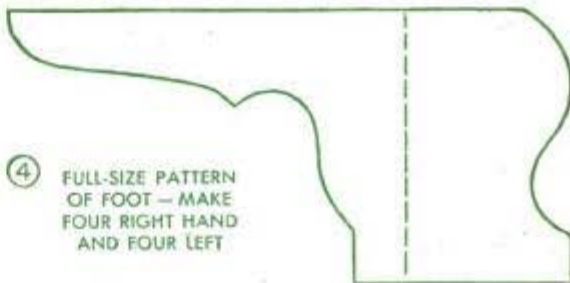

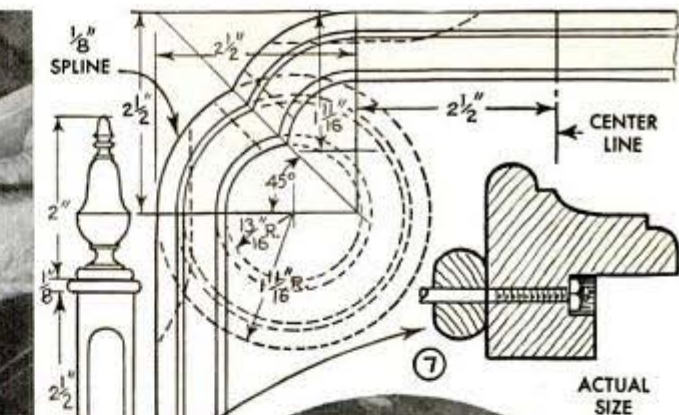
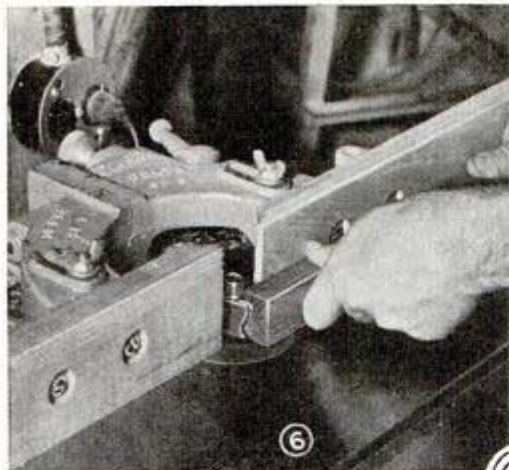

consist of two segments cut from a wood ring, which is turned to coincide exactly with the shape of the adjoining molding. Run the molding first as in Fig. 6. Next, proceed to turn the ring, first cutting the mirror rabbet in the back, then reversing the work to shape the face. The latter requires the use of a simple wooden chuck to hold the centerless disk to the faceplate. The chuck, which consists of a block attached to the faceplate, should be recessed at a slight angle so that the disk can be pressed squarely in place. A template of the pattern given in Fig. 7, or better still of the molding itself after shaping, will help in turning the ring to line up exactly with the shoulder cuts of the adjoining molding. Careful cutting will enable you to get the four segments required from one ring. A set-up similar to the one shown in Fig. 8 will do to clamp the frame in gluing it together. This consists of four wooden cleats nailed squarely to a bench top or other flat surface with clearance being allowed at the top and one side for the insertion of wedges between cleat and frame. As the upper corners of the frame cannot be nailed, it is necessary to spline each one. The center spline holding each pair of segments together is inserted prior to assembly of the complete frame, but those in the top and sides are fitted afterward by running saw cuts through the corners of the segments and part way into the adjoining molding. The splines are left extending and later trimmed and sanded flush. Remaining are the mirror posts, which are shaped according to Figs. 2 and 7 and doweled to the base at a slight backward slant as shown in Fig. 9. Two little glue brackets give additional support to the posts, and turned finials top the upper ends.

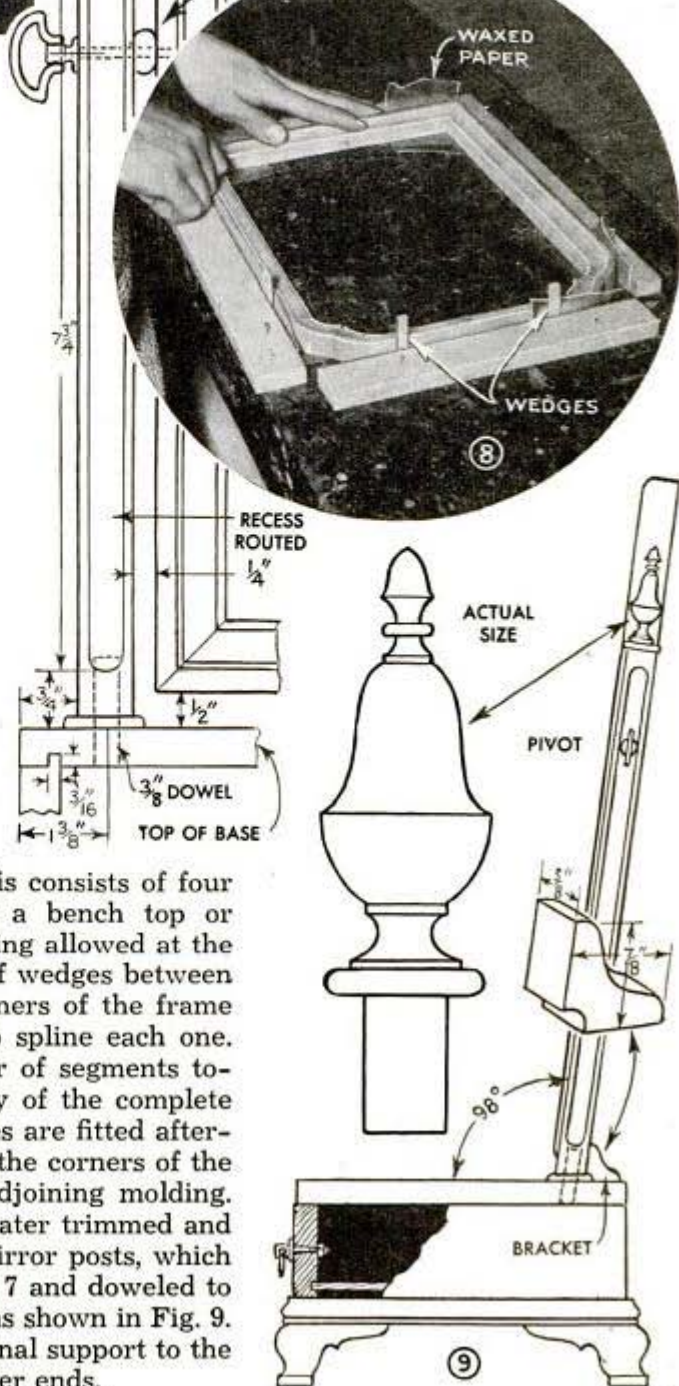
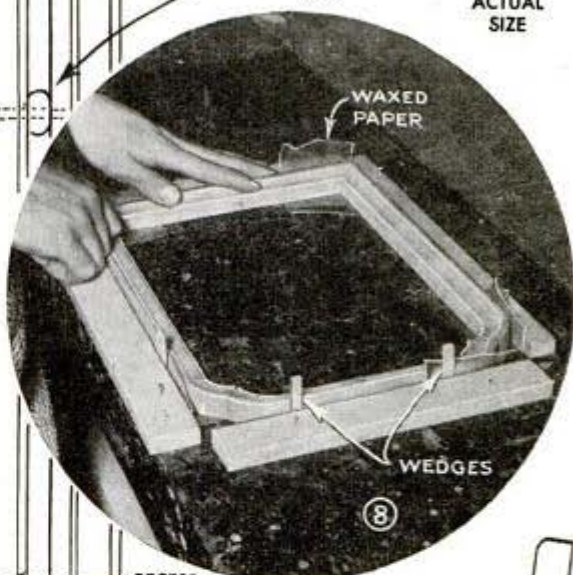

Handy Stop on End of Sawhorse Supports Board for Planing



The usefulness of an ordinary sawhorse is increased considerably by fitting it with a stop which can be slid out of the way when not in use. Such a stop consists of a short piece of wood beveled on each side to fit snugly between two similarly beveled hardwood blocks attached to the sawhorse. In use, the stop is driven up and the work to be planed fastened to it with a C-clamp.

Clamp Protects Scratch Brush When Stored in Toolbox

When a wire scratch brush is carried in a box with other tools, the bristles can be protected by putting the brush in this clamp. The clamp also is helpful in straightening the bristles after they have been bent in use. The two wood disks have a diameter a little larger than that of the



brush. On the inner surfaces of the disks are fastened plywood rings, which are cut out in their centers to take the flanges of the brush. This permits the bristles to be squeezed tightly.

Easy Way to Hang Thick Door On Thin Frame

Instead of blocking out the hinges when hanging a screen or other door that is thicker than the frame, try reversing the hinges as shown. Just remove the hinge pin and turn one half of the hinge over and insert the pin. This will offset the hinge sufficiently to make the use of blocks unnecessary.

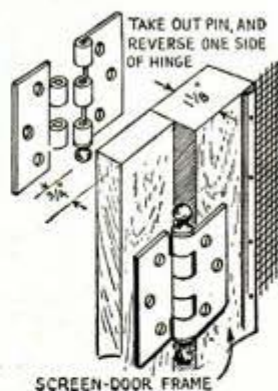

Twisted Leaf of Auto Spring Makes Splitting Wedge

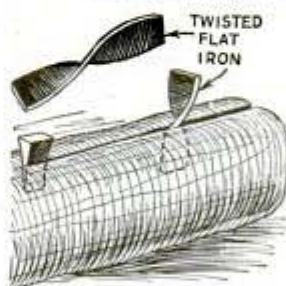

Light, efficient wedges with which to follow up a regular metal wedge when splitting logs can be made from lengths of auto-spring leaves. These are heated and twisted in the manner indicated. The thin ends of the wedges make it easy to start them.

Grass Sickle Is Carried Safely Under Wheelbarrow Body

To keep small children from picking up his grass sickle and possibly injuring themselves with it, one gardener carries the tool on the underside of his wheelbarrow. A broom clamp attached to the bottom serves as a holder for the handle, while the end of the blade is slipped under a leather strap.



Miniature Flashlight Is Improvised in Matchbox

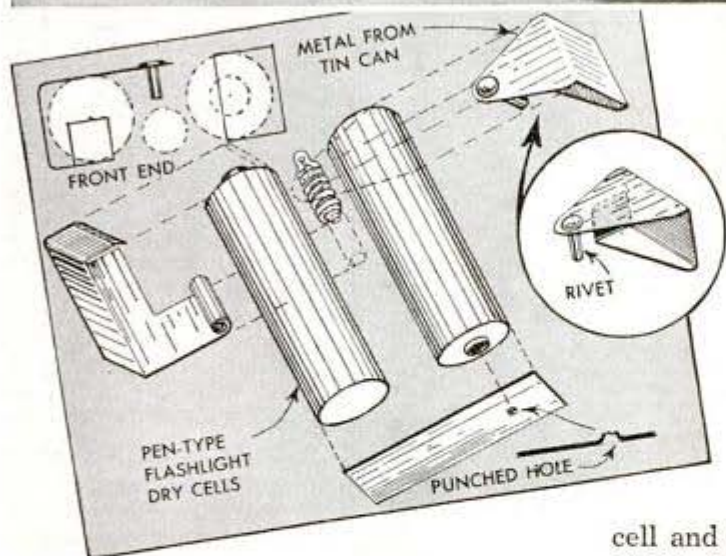

Contained inside of a penny matchbox, a couple of pen-type flashlight cells, a bulb and three sheet-metal contacts will provide you with a serviceable, vest-pocket flashlight. The bulb should be the kind designed to light on two cells, and should be one that has a tiny lens cast right in the glass so that it throws a narrow, concen-

trated beam of light. Punch a small hole in the drawer of the matchbox to take the tip of the bulb and reinforce the edges of the hole with fingernail polish. The straight piece of metal at the lower end of the drawer must make contact with the center or positive pole of one cell and the shell or negative pole of the other. The two bent contacts at the other end of the box connect the cells to the bulb, the rivet on the end of one serving the purpose of a switch when it is depressed against the screw portion of the bulb. A hole is cut in the side of the box to provide clearance for the head of the rivet. The matchbox housing can be replaced easily if it should become worn or broken.

T-Square Held on Drawing Board With Clothespin Clamp

To keep a T-square in position on a tilted drawing board, I use a clamp made from a spring-type clothespin. The square can be removed from the board or slid to any position on it instantly by merely squeezing the clamp to release its grip on a wood strip, which is nailed to the edge of the board as shown. After cutting off one jaw of the pin, it is screwed to the head of the T-square.—C. F. Winn, Washington, D. C.

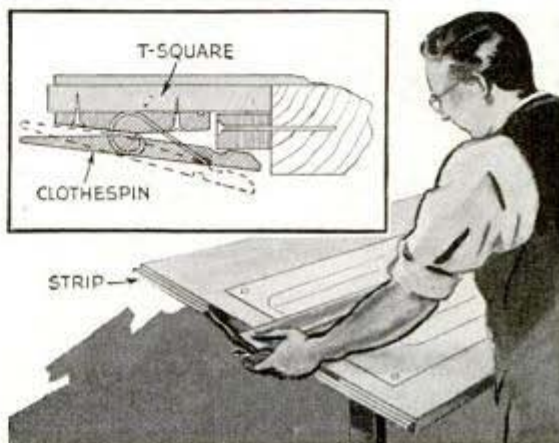

☞ To hull peas easily, pour boiling water over the pods, then put them through the clothes wringer.

Solving HOME



Long wire hooks prevent folding screen from collapsing when bumped against or pushed by children

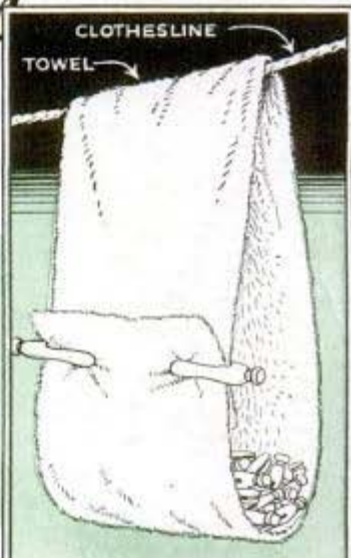

An emergency bag to keep clothespins handy on a clothesline can be made by pinning the ends of a large towel together over the line as indicated

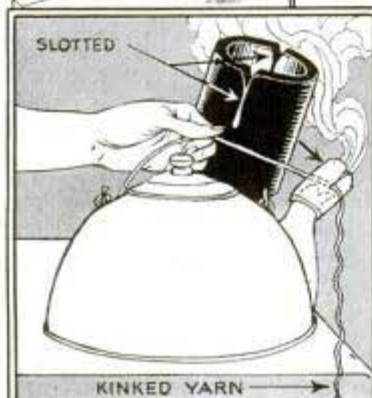

Straightening used yarn is easy if it is steamed by pulling it through a slotted hose, which is slipped over the end of a teakettle spout



Left: The job of waxing floors, table tops, etc., is simplified by polishing with a cloth wrapped around a small sandbag to add weight. Below: Wires tied horizontally to cords, which are fastened to a window-shade roller, provide an indoor drying rack that can be raised and lowered



Impressions formed in a meat loaf with a wire potato masher help hold moisture to prevent the crust from drying out. The impressions also add a decorative touch and provide guide lines that aid in slicing the loaf uniformly



PROBLEMS



Marring of a window casing when raising or lowering a venetian blind can be avoided by pieces of felt glued to the ends of the bottom crosspiece

Storing a toy-train track without dismantling it completely is no problem if it is hung on pegs on the back of a closet door as at the right. Below, a mirror mounted at the inspection door of a gas hot-water heater will enable you to adjust the flame without kneeling

Linoleum tacked across joists is a good substitute for metal in making furnace cold-air returns

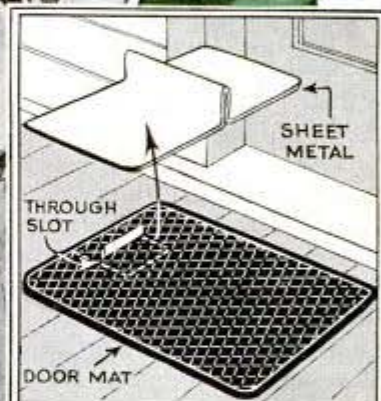
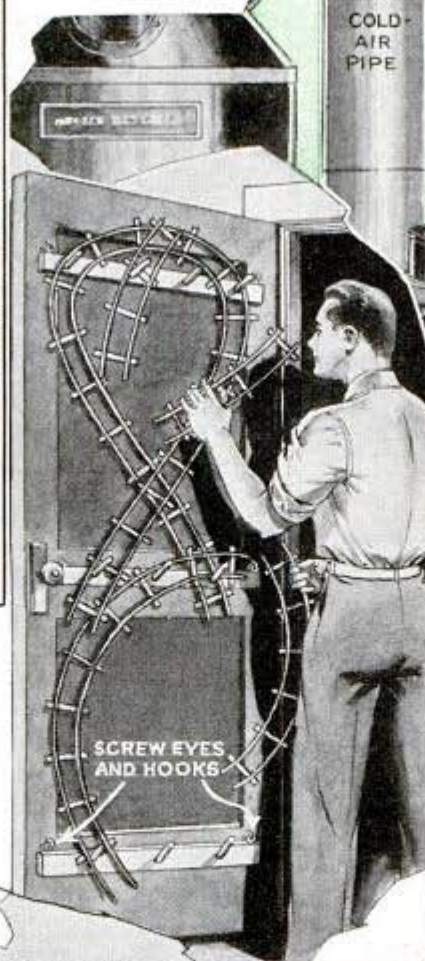

Bent as indicated above and inserted through a slot in a doormat, a strip of sheet metal provides a safe, handy foot scraper right on the mat



If a vacuum cup of suitable size is available, it can be used to clean clogged holes in a salt shaker by moving the cup up and down over them as above

Gripper Removes Small Articles From Hard-to-Reach Places

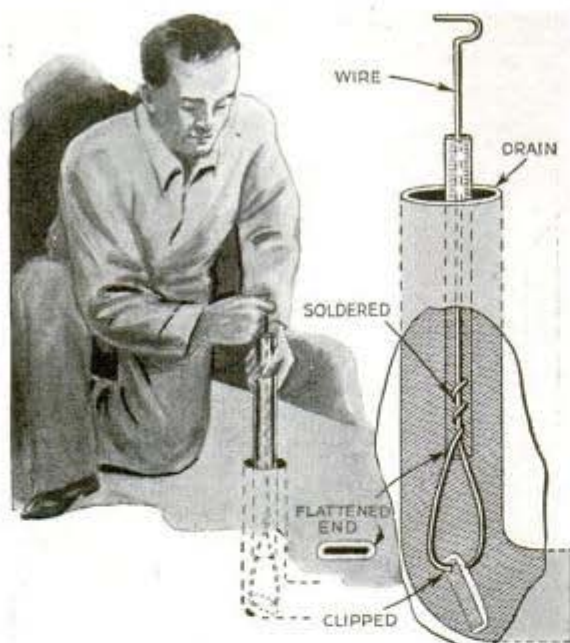

Small articles that have been dropped in inaccessible places such as drains can be retrieved with this simple gripper. It is made from a length of heavy wire inserted into a pipe or tube. Jaws are formed on one end of the wire as indicated to fit into the flattened end of the tube. In use, pushing the wire down so that the jaws extend well out of the tube allows them to open, and pulling up on the wire closes them.

Record of Salesman's Calls Kept With Auto Road Map

Salesmen who travel in unfamiliar territory can plan their calls and keep a record of them on their road map by simply placing the map on a piece of softwood and then slipping rubber bands over the ends. After planning stops in a certain community, these are indicated by pushing

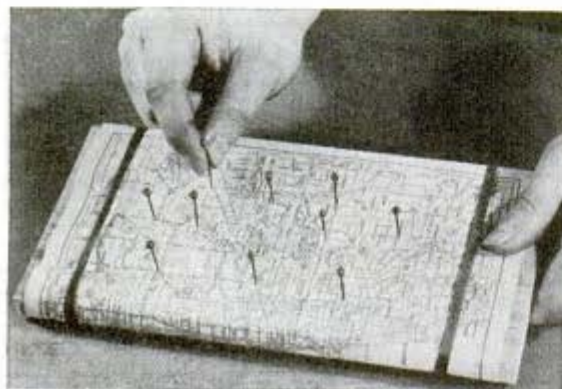

straight pins through the map and into the wood at the desired positions. When a call has been made, a visual record of it can also be kept by substituting pins with different colored heads. In selecting a piece of wood for the purpose, it's a good idea to get one that will slip into the glove compartment of the car.

Reducing Holes in Salt Shaker

If you have a shaker that delivers salt too fast, it is a simple matter to plug some of the holes. First, wash the shaker to remove all the salt and dry thoroughly. Then merely stop up the desired number of holes with fingernail polish, applying it from the inside of the shaker.

—Kenneth Murray, Colon, Mich.



Bicycle Wheels Trued on Stand Assembled From Old Fork

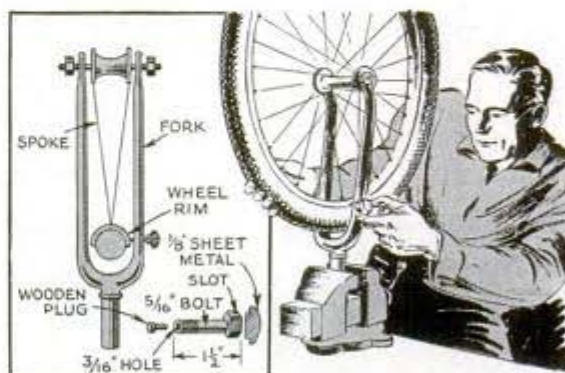

Bicycle owners who do their own repair work can true wheels that get out of line if a stand of the type shown is assembled from a discarded fork. One side is drilled and tapped to receive a bolt, the end of which is also drilled to accommodate a small wooden plug. The latter can be shaped from a piece of softwood as its purpose is to provide a tip on the bolt or gauge that will not scratch wheel rims. Adjustment of the gauge is made easy by soldering a small piece of sheet metal to the bolt head which permits turning it without a wrench. When in use, the stand is held rigid by clamping it in a vise.

—Ivan J. Stretten, Detroit, Mich.



DESKS for TINY TOTS

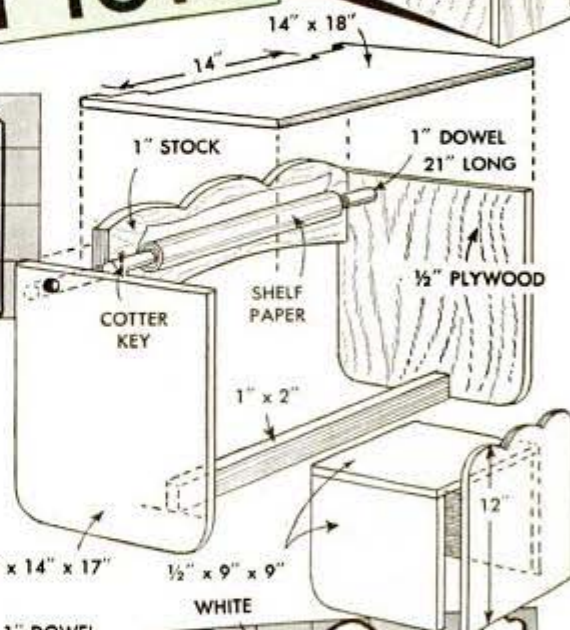
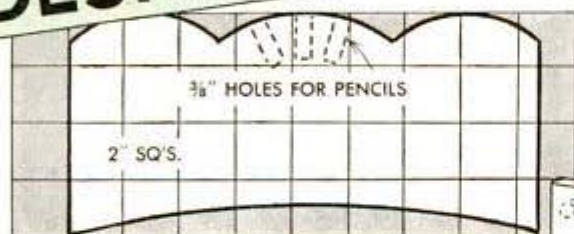

Either of these desks will delight your youngster. Both have rolls of paper for writing and drawing, and are built inexpensively of plywood. As shown above, one is of boxlike construction, while the other has jigsawed figures for the ends. Chairs to match are given for both desks

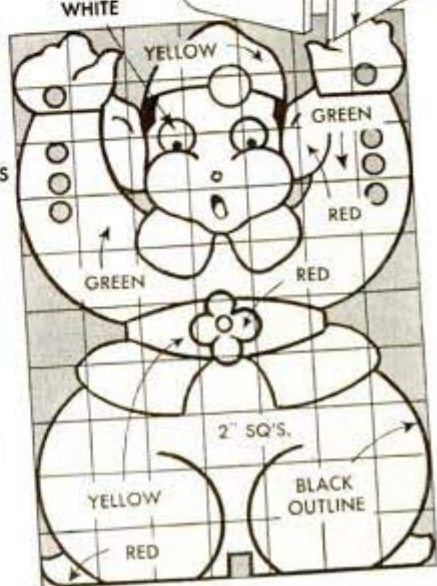
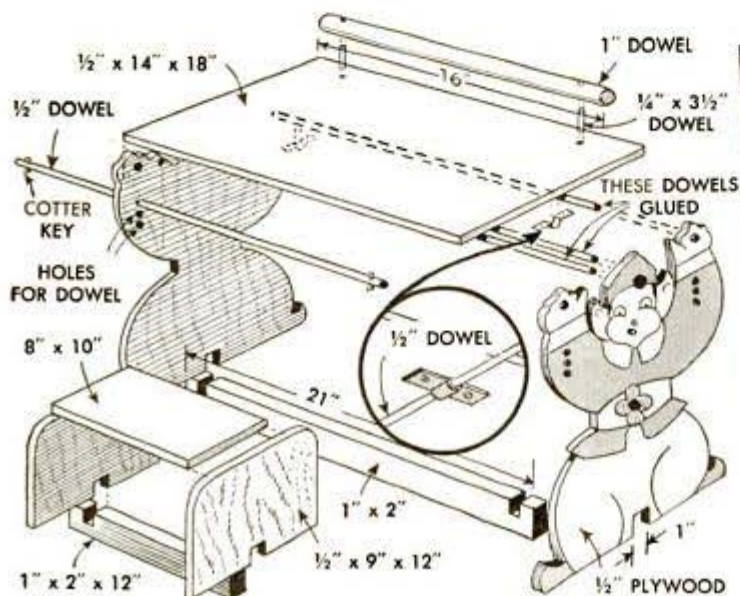

Reducing Speed of Wood Lathe To Use It for Drilling

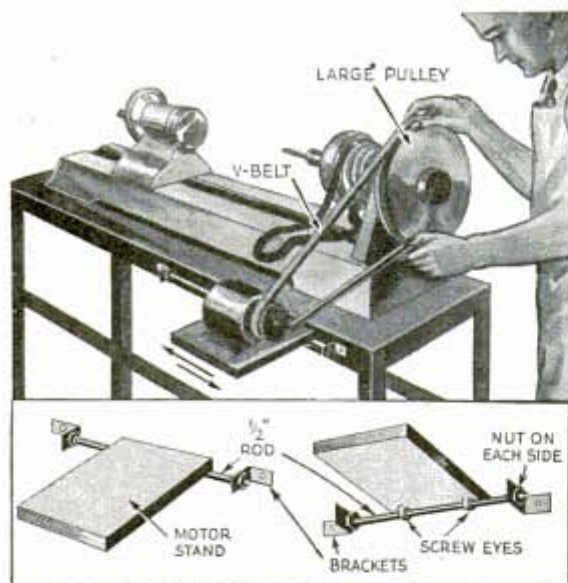

The problem of reducing the speed of a woodturning lathe to use it for drilling was solved by one home workshop owner as shown. A large wooden pulley was placed on the outboard end of the lathe spindle, and the motor was put on a sliding mount. With this arrangement, the motor could be moved sideways easily to drive either the wooden pulley or the step pulley on the lathe. The motor mount was made as shown, using a couple of brackets to support a long iron rod to which the motor stand was attached with a couple of heavy screw eyes. The motor mount "floats" to keep the belt tight.

Kitchen Table Anchored Securely By Window Antirattlers

If your kitchen worktable is on casters, which permit it to move when rolling pie dough, etc., just attach window antirattlers

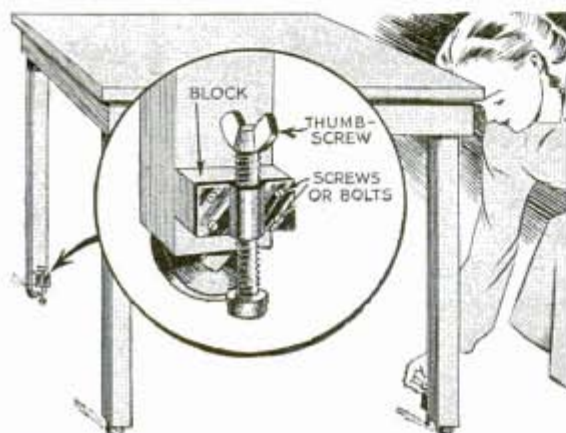

of the type shown to two of the legs. These are screwed to wooden blocks, which are fastened directly to the legs with long screws or bolts. To anchor the table in one position turn the thumbscrews down until the rubber tips rest on the floor. With this arrangement, no damage is done to the linoleum and the holding devices are hardly noticeable as they are mounted on the inside of the legs.

Brush Serves as Darning Egg When Mending Sweater

To hold together the torn edges of a sweater, or other loosely knit garment, in a handy position for mending, try a small vegetable brush, or hair brush, instead of

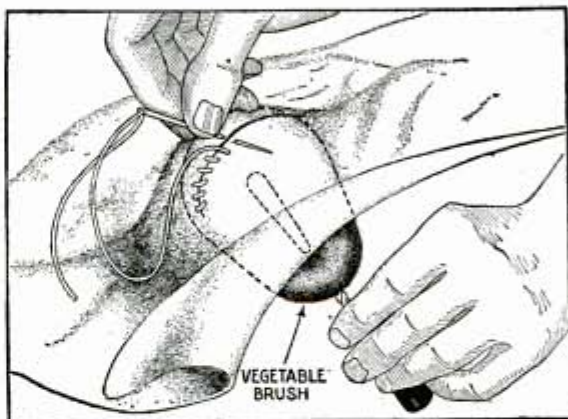

the usual darning egg. The bristles of the brush will penetrate the knit fabric to hold it so that a darning needle can be worked through the material without interference from any solid surface.

Interior Wood Trim Removed Without Marring Finish

When you have to remove interior wood trim from doors and windows, just drive the nails on through the wood with a nailset or straight punch. This avoids splitting the wood or splintering the edges with a pry bar.



At the same time, it gets rid of the nails and permits the wood to be removed without the surface being marred by dents and scratches.

Hot Dogs Served From Sled on Skating Pond

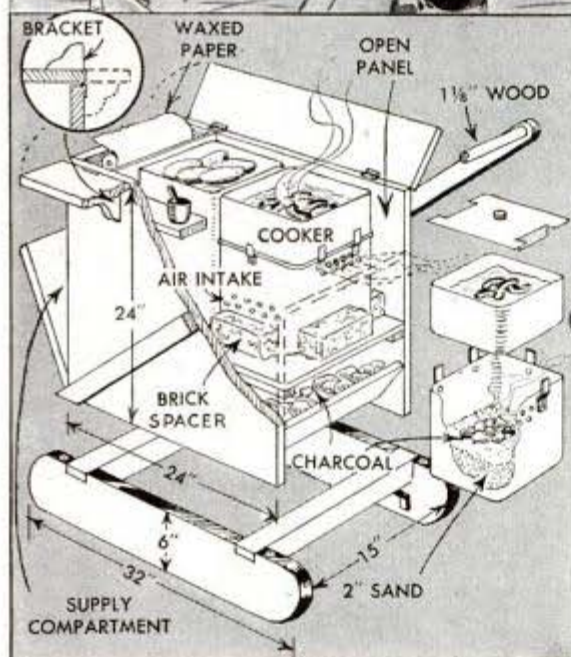
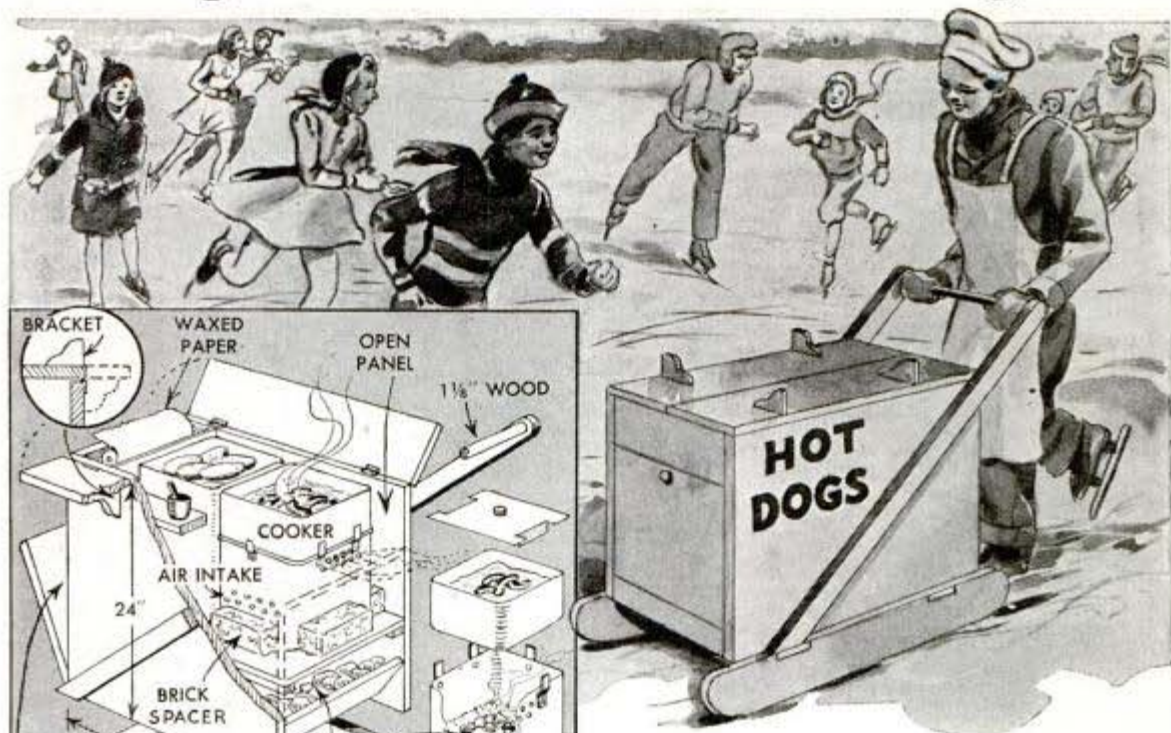

With this sled you can go right out on the ice to serve sizzling hot dogs to skaters. The body of the sled is nothing more than a box screwed to a pair of runners, which are assembled and braced as shown in the detail above. The top of the box is in two parts, which are hinged to swing outward and form service counters, brackets being screwed to the counters to rest against the sides of the box and support them in a horizontal position. Cooking equipment consists of a firepot to burn charcoal, a cook-

er, and an oven to keep buns warm. The equipment can be made from square or rectangular cans. In the original sled, empty gasoline tins were cleaned and used. The firepot has 2 in. of sand in the bottom on which the fire is built, and vent holes are provided near the top and bottom for air inlets and outlets. Tabs are riveted to the upper edges of the pot to support the cooker, the entire cooking assembly resting on bricks, which are placed on a shelf located high enough above the bottom of the box to raise the cooker flush with the oven top. A trough under this shelf stores charcoal. A compartment at the rear end of the box holds knives, paper and other accessories, and a narrow shelf between the oven and side of the box takes care of mustard and relishes.

Old Round-Top Table Converted Into Drop-Leaf Table

Here is an easy way to convert a round-top dining table into a drop-leaf table. Cut the top to form two leaves, and then remove four triangular pieces from the curved apron at each point where it is cut, so the leaves may fold. Next, screw the hinges in place. Two hardwood leaf supports should be pivoted as shown to swing back when the leaves drop.

—R. F. Gomoll, Chicago.

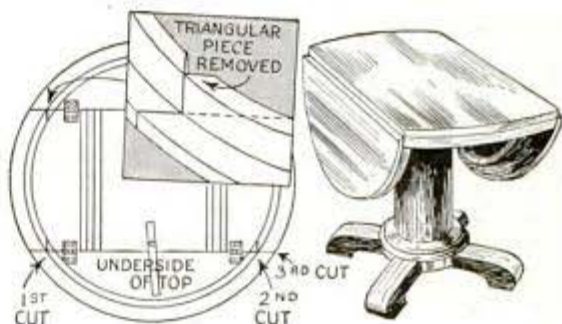

PHONOGRAPH RECORDS

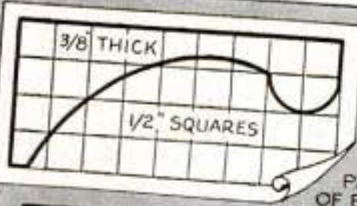

PATTERN OF BRACKETS

MATERIAL LIST

- 1 pc.— $\frac{3}{4}$ x $14\frac{1}{4}$ x $17\frac{1}{2}$ in.—Top
- 2 pcs.— $\frac{11}{16}$ x $\frac{3}{4}$ x 15 in.—Molding
- 1 pc.— $\frac{11}{16}$ x $\frac{3}{4}$ x 19 in.—Molding
- 2 pcs.— $\frac{1}{2}$ x 2 x $13\frac{3}{8}$ in.—Frame
- 1 pc.— $\frac{1}{2}$ x $1\frac{1}{4}$ x $18\frac{1}{2}$ in.—Frame
- 1 pc.— $\frac{1}{2}$ x $1\frac{1}{4}$ x $15\frac{1}{4}$ in.—Frame
- 2 pcs.— $\frac{3}{4}$ x $1\frac{1}{4}$ x $16\frac{3}{4}$ in.—Drawer frame
- 2 pcs.— $\frac{3}{4}$ x $1\frac{1}{2}$ x $12\frac{1}{2}$ in.—Drawer frame
- 1 pc.— $\frac{1}{4}$ x $12\frac{1}{2}$ x $14\frac{1}{2}$ in.—Dust bottom
- 2 pcs.— $\frac{5}{8}$ x $\frac{3}{4}$ x 12 in.—Cleats
- 6 pcs.— $\frac{5}{8}$ x $1\frac{1}{2}$ x 12 in.—Cleats
- 2 pcs.— $\frac{3}{4}$ x $1\frac{3}{8}$ x $13\frac{5}{8}$ in.—Tri. cleats
- 2 pcs.— $\frac{3}{8}$ x 2 x $4\frac{1}{2}$ in.—Brackets
- 1 pc.— $\frac{3}{4}$ x $13\frac{7}{8}$ x $16\frac{3}{4}$ in.—Shelf
- 1 pc.— $\frac{3}{8}$ x $\frac{3}{4}$ x $15\frac{1}{2}$ in.—Facing strip
- 4 pcs.— $1\frac{1}{4}$ x $1\frac{1}{4}$ x $26\frac{3}{4}$ in.—Posts
- 2 pcs.— $\frac{3}{8}$ x $12\frac{3}{4}$ x 19 in.—Panels
- 2 pcs.— $\frac{1}{4}$ x $\frac{3}{4}$ x 12 in.—Bottom mold
- 1 pc.— $\frac{1}{4}$ x 16 x $19\frac{1}{2}$ in.—Back
- 2 pcs.— $\frac{1}{2}$ x $3\frac{1}{2}$ x $13\frac{3}{4}$ in.—Drawer sides
- 1 pc.— $\frac{1}{2}$ x 3 x 15 in.—Drawer back
- 1 pc.— $\frac{3}{4}$ x $3\frac{1}{2}$ x $15\frac{1}{2}$ in.—Drawer front
- 1 pc.— $\frac{1}{4}$ x $13\frac{1}{4}$ x 15 in.—Drawer bottom



SHelf ACCOMMODATES 8 TWELVE-RECORD OR 20 THREE-RECORD ALBUMS. DRAWER IS FOR CATALOGS AND ACCESSORIES



SPADE FOOT AND TAPER ARE FORMED WITH A CHISEL

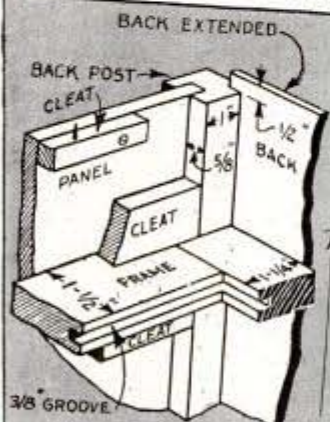

DUST BOTTOM OMITTED CORNER OF FRAME IS NOTCHED TO FIT AROUND POST

DETAIL OF REAR CORNER

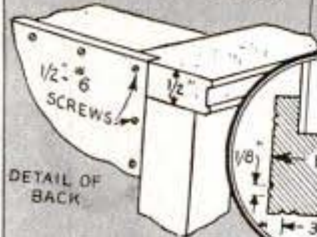

DETAIL OF BACK

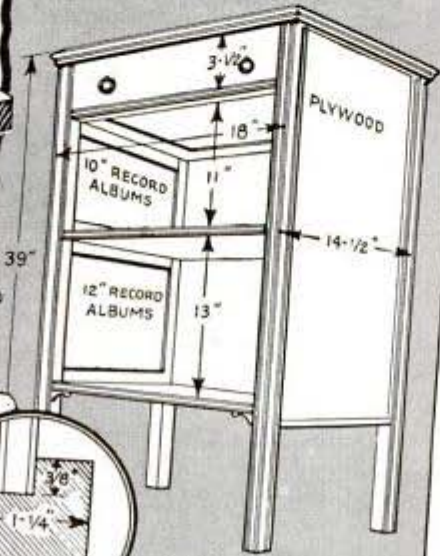

TWO-SHELF CABINET NOTE-CONSTRUCTION & SIZES IDENTICAL EXCEPT HEIGHT



THE TOP ASSEMBLY IS SECURED WITH SCREWS

REEDED CORNER POSTS MAY BE SUBSTITUTED FOR SPADE-FOOT TYPE FOR EITHER SIZE CABINET

Linoleum Scored With Ice Pick Is Easy to Cut



The difficulty of cutting thick linoleum, even with a sharp knife, can be overcome by first scoring the surface with the sharp point of an ice pick or similar tool. The pick point grooves the material so there is less for the knife to cut through, making it easier to keep the blade on the mark and pull it through the sticky center portion.

Small Labels Held in Typewriter By Creased Sheet of Paper

When you have a number of small labels to address on a typewriter, considerable time can be saved by inserting a creased sheet of paper in the machine to hold them, making it unnecessary to run each label under the platen. In use, the paper is turned up until the crease is in position to receive the bottom of the label. Then, it is



turned back to bring the label into position for typing. If the crease is perfectly horizontal, each label will be squared automatically when it is inserted.

Sash Lock on Side of Stepladder Keeps It Closed for Carrying

Instead of using a screen-door hook to keep a stepladder in a closed position when in storage or while you carry it, install an ordinary sash lock where the legs come together. Locks of this type do not open easily if the ladder is turned upside down and there are no pointed ends to catch on your clothing.



Flattened Monkey-Wrench Screw Provides Quick Adjustment



Time lost in adjusting a monkey wrench, when tightening nuts of different sizes led one workman to grind off the threads on one side of the adjusting screw. This was done so that the movable jaw

could be released and slid to the desired position quickly, after which it is locked in place by giving the screw a half turn.

Machine Bolt Kept From Turning By Fence Staple

If you have to use an ordinary machine bolt instead of a carriage bolt in wood, you can keep it from turning by driving a fence staple at the edge of the washer.

The staple is then bent over so that it presses against one side of the bolt head as shown.

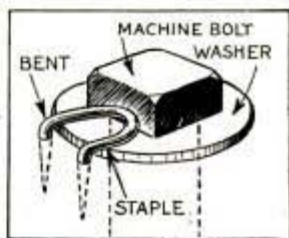

Creased Book Leaf Holds Cards While Typing Data From Them



To hold postcards or file cards conveniently for reading while copying data from them, one stenographer folds and creases a page of her note book. The book, opened to stand in the usual position, supports the cards at a convenient height.

Saw Cuts in Lower Screen Rail Provide Drainage Openings

During heavy rainstorms, tight-fitting screens often trap water between them and the sash in such quantities that it works under the sill and runs down the wall inside the house. The best remedy for this is not to loosen the screen, but rather to saw several shallow slots in the lower rail of the screen frame to provide for escape of the trapped water.

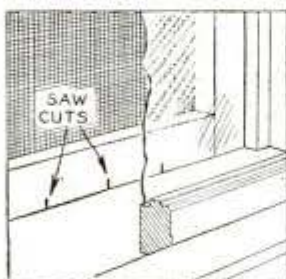

Rubber Tip Secured to Crutch By Large Tacks



If rubber crutch tips have a tendency to slip off, especially when using crutches on soft ground, drive three rubber-headed tacks into the crutch where the tip slips onto it. The tack heads

enlarge the crutch so that the tip fits tightly. If tacks are not available, you can use small brads, which are driven into the crutch at an angle to serve the same purpose, although they will not be as satisfactory as the tacks.

Windows Are Cut in File Boxes For Storing Magazines

File boxes with windows cut in them provide handy containers in which to store magazines that you want to keep.

A given number of issues can be kept in each file, the windows permitting the data on the edges of the magazines to be read easily. Celluloid or Cellophane should be glued or stitched over the window openings to keep out dust. If a short cloth or leather strap is riveted to the top of the file near the front edge, it will be easy to remove from between other file boxes.

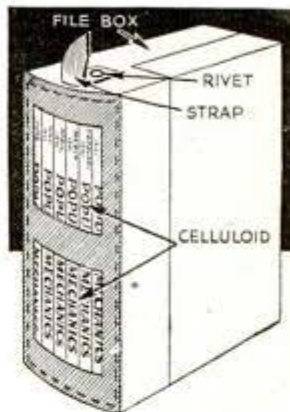

Triangle Serves as Protractor

By putting degree markings on a 45-degree triangle, it can be used as a protractor. The figures can be scored in the celluloid or they can be inked on a strip

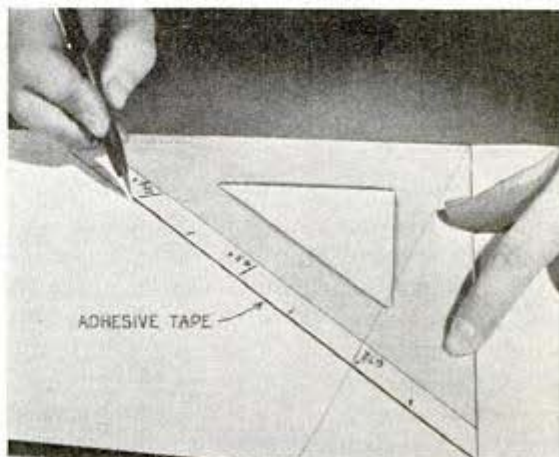

of adhesive tape, which is then applied to the edge of the triangle as shown. The readings are taken from the lower point of the triangle through the line marking at the top.

Colonial Table Lamp to Match Your Pine Room

Made of either pine or maple wood, this quaint table lamp really comes into its own in Colonial surroundings. A piece of $1\frac{1}{8}$ by 7 by 24-in. wood will provide sufficient stock for the lamp. Begin with the base, which has the top surface scooped out along all four sides. This work can be done best with a sharp knife or a spokeshave. Holes for the peg legs are drilled into the base at angles of 70 degrees. It's best to use a jig or guide for this to assure uniformity. The legs are whittled to shape and have tenons on the upper ends, which are slotted for wedges to lock them securely in the base. A piece $1\frac{1}{8}$ by $1\frac{1}{4}$ by 10 in. will do for the standard, which is shaped as shown. It is attached to the base with a mortise-and-tenon joint. To provide for a lampcord, a hole is drilled vertically through the standard, coming out

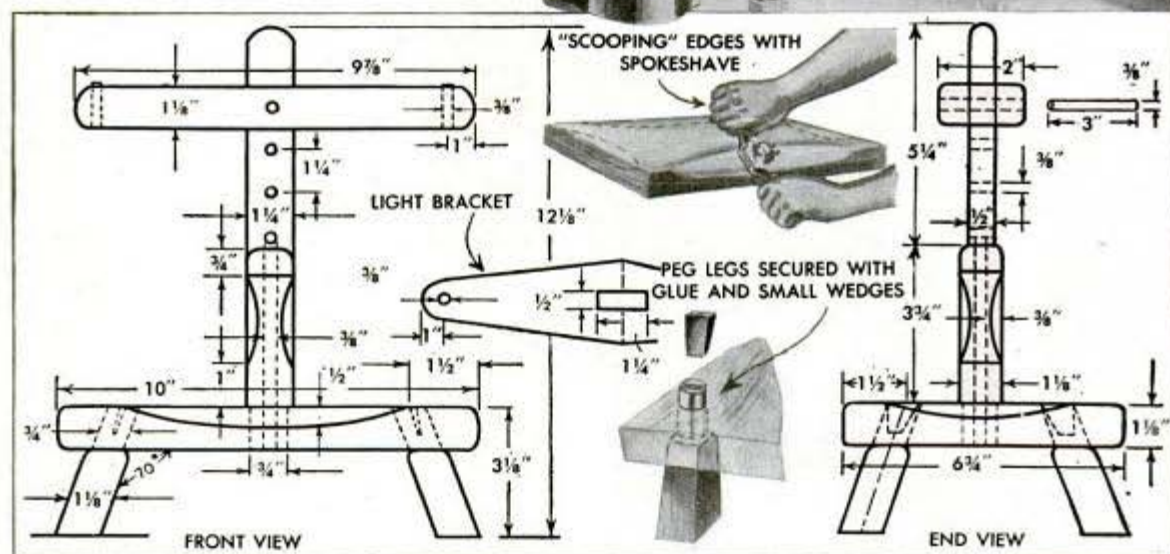
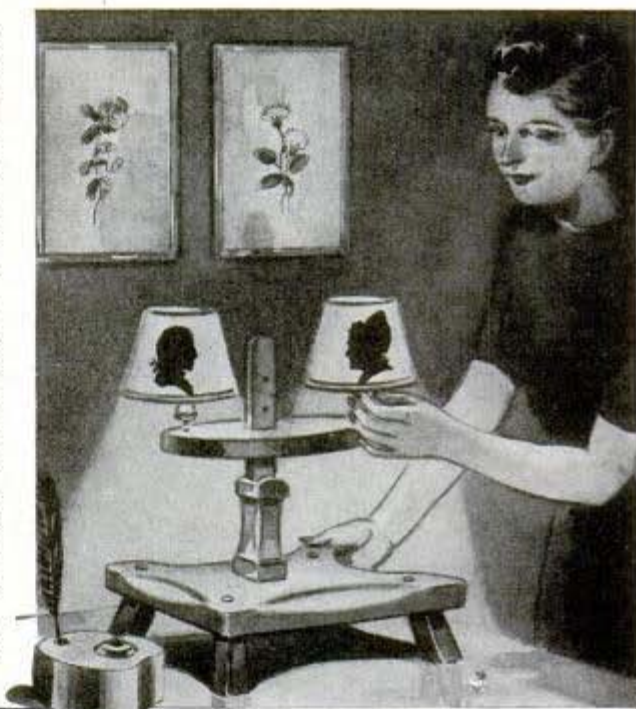

at the upper part of the shouldered portion. The lamps are supported on a bracket, which is mortised to slide on the standard. The latter is drilled at intervals for a pin, which passes through the bracket to provide height adjustment for the lamp. Short $\frac{1}{8}$ -in. pipe nipples, screwed into holes near the bracket ends, take the lamp sockets. The finished work should be well sanded, dulling all sharp edges carefully and rubbing the surface parts thoroughly. Sand with the grain at all times. If the lamp is made of pine, finish it with a solution consisting of orange shellac, 1 part, white shellac, 1 part, and alcohol, $\frac{1}{3}$ part.

Three coats will do. Allow about 6 hrs. drying time between coats and rub thoroughly between coats with fine steel wool. Then polish with furniture wax.

Straightening Paintbrush Bristles

If the bristles of a paintbrush become crooked from neglect, often they can be straightened by dipping them in melted paraffin. Allow the brush to remain untouched for about 24 hrs., then straighten the bristles by smoothing them with the fingers. A few hours later, wash out the wax with turpentine.

Marine Ash Trays for the Fisherman's Den

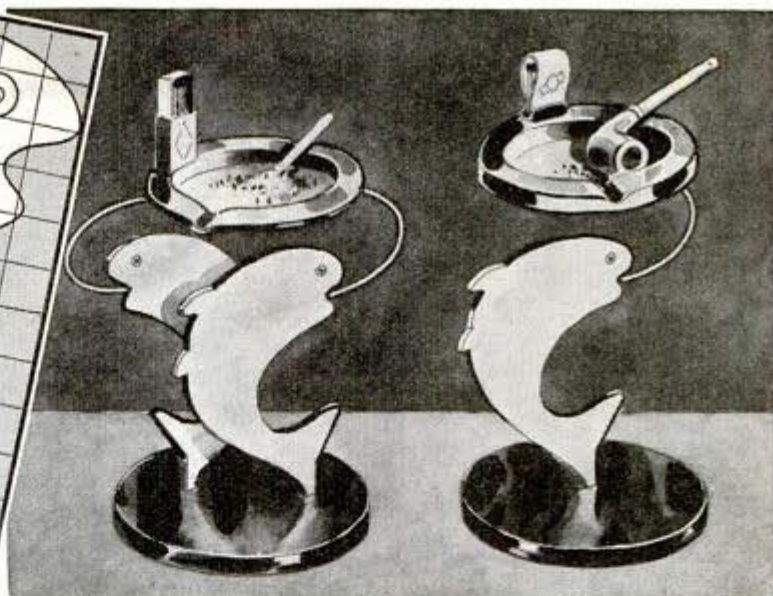
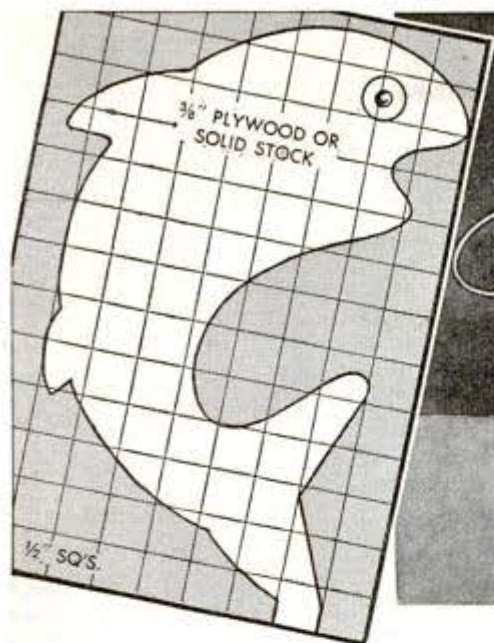

Suitable for a sportsman's den, or a play room furnished in marine style, these ash trays can be made of either plywood or solid stock. Fish cutouts are used for standards and are the same for both trays, except that two of them are required for making the double standard. Tenons are formed on the lower ends of the fishes' tails and are mortised and glued into the bases. Lengths of looped wire inserted into holes in the mouths of the fishes support the trays on the standards. Finishing the trays is a matter of choice as they can be painted or stained and varnished. If you like, they can be given a realistic appearance by painting scales and fins on the fish.—M. G. Winterton, Fort Lewis, Wash.



Starch Coating Makes Old Whitewash Easy to Sweep Off



If you have a surface from which you want to remove old whitewash, try the following method, which is much simpler and easier than washing it off with water. First, apply a thin wash coat consisting of starch, alum and glue. Allow this to dry thoroughly, which causes the whitewash to curl up so it can be brushed off.

Old phonograph needles may be used instead of brads to hold the cardboard backing in place in picture frames. The sharp points are more easily pushed into the wood, and the tapering ends tend to keep the cardboard flat against the picture.

Forming Tool For O-Gauge Track Made From Pair of Pliers

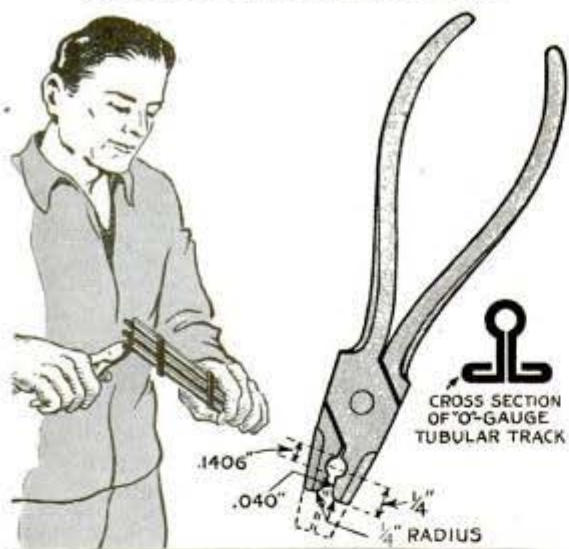

After tubular track has been connected and disconnected several times, the ends become enlarged so that the connecting pins fit loosely. To assure tight connections and good contacts, a pair of small pliers can be altered to reform the track ends. First, grind off the ends of the plier jaws. Then clamp the jaws in a vise and drill a $\frac{1}{16}$ -in. hole between them. After this has been done, run a hack-saw blade from the jaw ends to the hole. This provides clearance for the rail flange, and the hole fits around the upper part of the track.

Loss of Billfold Is Prevented By Attaching It to Chain

If you are in the habit of carrying a billfold in your hip pocket, here's a good way to guard against the possibility of losing it. Just take the billfold to a local shoe repair man and have him put an eyelet in one



corner so that it can be attached to the end of a key chain. Most chains of this type are long enough to reach around to the hip pocket and also permit free access to the contents of the billfold.

Fresh Paint Removed From Trim With Steel Wool in Holder

Here is an effective tool for removing fresh paint from the trim of doors and windows after decorating the walls. If paint gets into the grain of hardwoods, even when they have been finished, it is very difficult to remove. To make the tool, first flatten one end of a short length of metal tubing, and then force steel wool into the open end, forcing it down until it projects from the flattened end. Now dip the holder in turpentine and you can remove paint smears without leaving a trace.



"Drawknife" Assures Neat Edges When Laying Linoleum

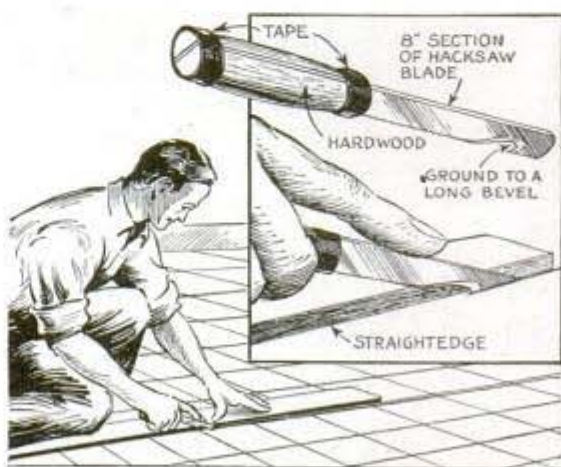

Made from a discarded hacksaw blade, this "drawknife" cuts through linoleum easily without tearing or tedious trimming. Because it is sharpened with only one bevel it hugs a straightedge tightly, yet, due to the thinness of the blade, you can follow a curved line accurately. Just break a hacksaw blade to a length of about 8 in., grind off the teeth and then grind an edged notch near one end. Tape rounded pieces of hardwood to the blade to form a handle.

Plastic Surgery on OLD FURNITURE

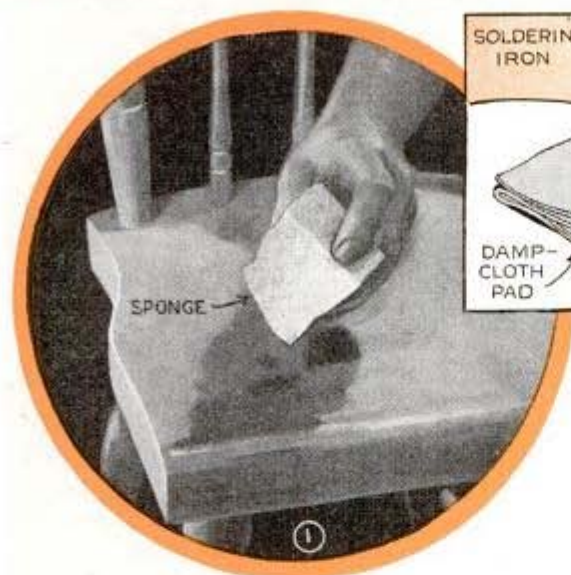

MANY pieces of fine furniture, abandoned because of being broken, seemingly beyond the possibilities of repair, or so badly checked and marred that they need a complete refinishing job, can be brought back to "life" and usefulness by the average home mechanic.

Scratches and checked finishes: Varnished finishes, especially those on table tops, Fig. 3, suffer considerably from everyday usage. If there is only superficial damage such as light scratches, water marks and checking, you can do wonders in renewing the old finish with a liquid called amalgamator which can be obtained at some well-stocked painting supply houses. This liquid applied to the surface softens the old varnish or enamel, causing

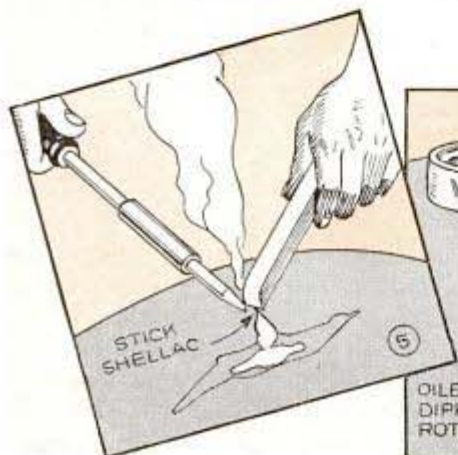



Checks in wood are first filled with wood putty, then top-dressed with stick shellac to match the finish, Fig. 9. Knotholes are filled with nonshrinking paste crack filler, Fig. 10. For sealing seams as at drawer bottoms, use caulking compound, Fig. 11

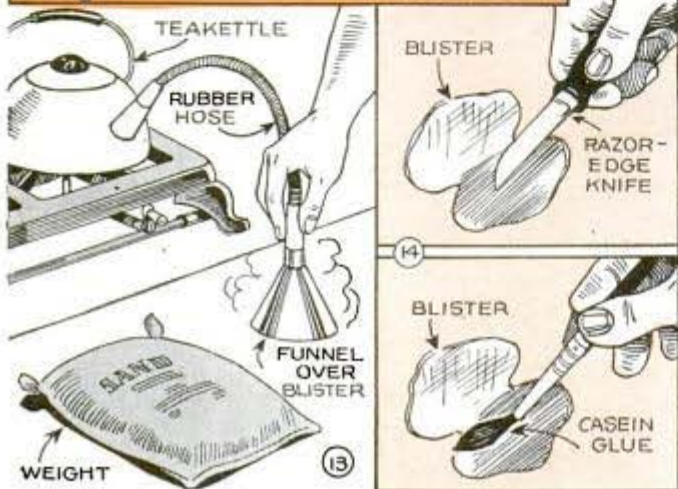
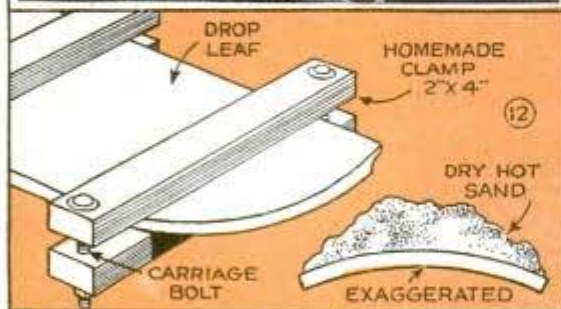

it to flow and level itself, after which it hardens again. Checked surfaces are thoroughly scrubbed with mild soap, using a stiff-bristle brush to remove all dirt from the cracks, and when dry, the amalgamator is flowed on like thin varnish. After this has dried, the renewed surface can be waxed and polished.

Removing dents: If there are shallow dents in the wood, the varnish of the dented surface is removed carefully to bare the wood. Then a few drops of water are applied to the wood as in Fig. 1. The water swells the compressed wood fibers so that they will return to their original position. If simple soaking does not remove a dent, try the heat process. Moisten the wood as before and after the water has penetrated the fibers, put a pad over the dent and hold a hot soldering iron or flatiron on the pad as in Fig. 2. Expansion of the wet wood fibers under the influence of heat should do the trick. Then stain to match and varnish where the finish was scraped off. When dry apply amalgamator to blend the edges of new and old varnish.

Scars and gashes: Ugly scars and gashes are filled with wood cement commonly known as stick shellac. A stick of appropriate color to match the finish—or cement from different sticks blended together—is softened by means of a soldering iron as in Fig. 5 so that it drops into the gash. Do not heat the cement too much or it will char. Heat should be just enough to flow it without bubbling. After filling the gash flush with the surrounding surface, smooth the ce-

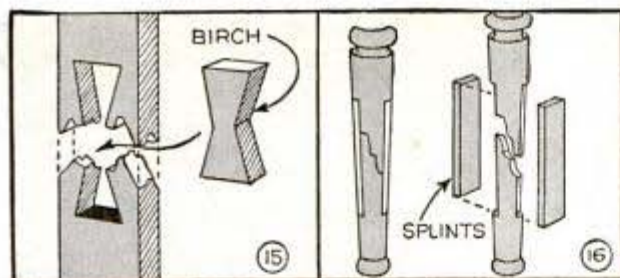

Fractures of legs may be repaired with a double wedge as shown in Fig. 15, but if the legs are too slender you can apply splints as in Fig. 16. Repair pieces should be same kind of wood. Often, corner blocks, glued and screwed in place will hold legs rigidly, Fig. 17

ment with a spatula as in Fig. 4, which should be heated over an alcohol burner, Fig. 7, but do not use a candle or other flame as it contains soot which will ruin the cement. After the latter has hardened, rub the surfaces with an oiled felt pad dipped in rottenstone to remove the glaze as in Fig. 6.

Checks, cracks and knotholes: Checks in the wood are unsightly but do not seriously weaken the wood. First fill them to slightly below the finish level, Fig. 9, with fresh plastic wood or sawdust mixed with casein glue. When dry, apply stick shellac to match the finish. Cracks and knotholes not in highly-polished surfaces can best be filled with a non-shrinking paste crack filler applied with a spatula as in Fig. 10.

Regluing and filling seams: On a job involving extensive repairs, pieces should be reglued and clamped as in Fig. 8. The edges should be scraped clean of old glue before applying fresh glue. Caulking compound settles the old problem of shrunken drawer backs, Fig. 11, as it never gets hard but remains elastic, yet keeps the gap well plugged.

Warping: Curved pieces of wood such as found on drum tables and circular-table aprons can be returned to their original shape if you make use of the natural tendency of the wood to warp. As shown in the photo above Fig. 12 a piece of carpet is laid on the convex side and hot water is applied, while the other side is kept dry, allowing free circulation of air. When the wood has reached the desired curvature, place it in clamps or forms to hold it in position until dry. The same method works in reverse to take the warp out of table leaves, Fig. 12. Here a wet pad is put on the concave surface so that wood fibers on this side will absorb moisture and expand. Watch the progress and clamp the leaf when it is straight, leaving it clamped overnight. Should

WEAK LEG JOINTS CAN BE REINFORCED WITH CORNER BLOCKS GLUED AND SCREWED TO THE LEG AND RAILS

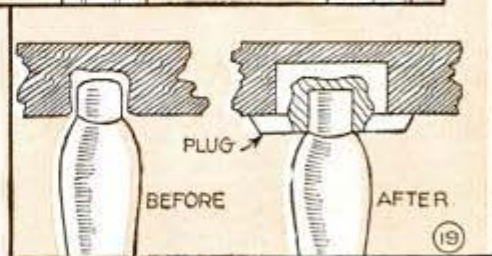
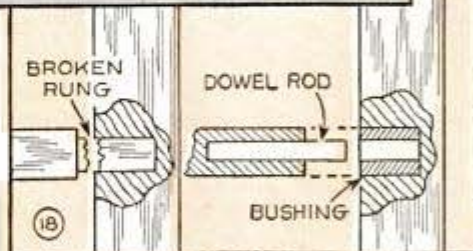
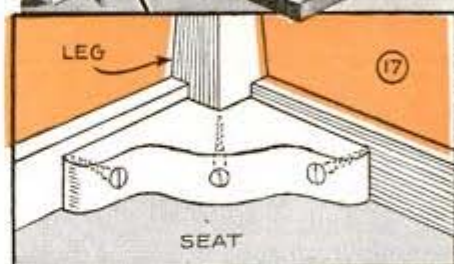

the leaf be bent too far so that it is warped in the opposite direction, hot, dry sand will bring it back as shown in the detail of Fig. 12.

Blisters on veneer: Old veneer is very brittle. If loose or blistered, the wood must be steamed to a pliable state before it can be worked, taking care not to soften the glue that is still holding. A simple steamer can be improvised as shown in Fig. 13. Then a sharp knife is used to cut the blister open as in Fig. 14, after which

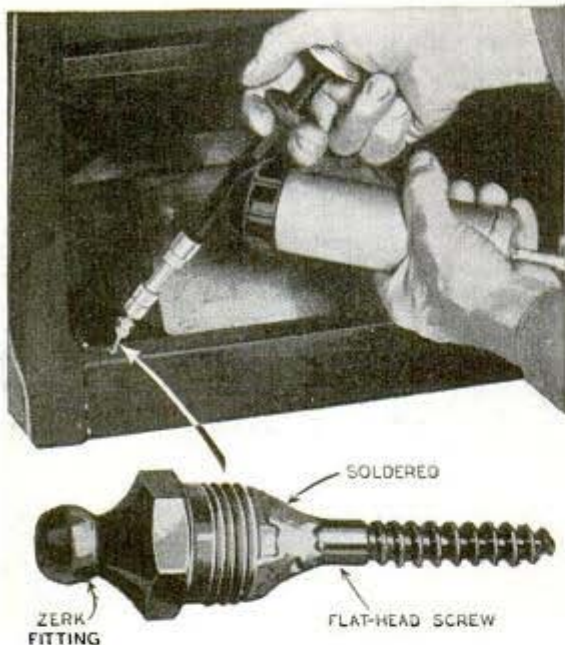

Fig. 20: Simple fitting on grease gun permits glue to be forced into loose joints after drilling small hole

glue is applied and the wood pressed down in place again, working fast to get the job done before the wood dries out and breaks. Excess glue squeezed out at the edges is wiped away and a bag of sand is placed on the spot as a weight. When dry, sand, stain and revarnish the surface.

Repairing fractures: Fractures sometimes require reinforcing pieces when repairs are made. In Fig. 15, a double wedge of hardwood such as birch, is glued in a mortise cut out to make a snug fit. After applying glue liberally, press the wedge in

place and clamp securely. Dress down when dry. Splints such as shown in Fig. 16 are set in pieces that are too slender for a double wedge.

Leg joints and chair rungs: When a leg of a chair or table is weak and needs reinforcement, corner blocks glued and screwed in place, Fig. 17, are sometimes the best solution. If the chair has a rung broken at the tenon, the socket is bored out to a size a little larger than it was originally and a snug-fitting bushing is glued in place. The bushing is bored to receive a dowel which is also fitted into a hole bored in the rung after the tenon has been cut off flush, as in Fig. 18. Then glue is applied and the dowel pressed or driven home. A hopelessly enlarged socket in a chair seat can be restored by boring out the socket and installing a plug, which is bored to take the leg tenon, the latter being turned down to fit as shown in Fig. 19. In some cases where the glue in the joints has loosened but it is not advisable to take the piece apart for regluing, glue can be forced into the joint. First a small hole is bored at some inconspicuous point to break into the loose joint. Then, with a simple fitting on a grease gun, as shown in Fig. 20, glue can be forced into the hole. The fitting consists of a wood screw with a small hole drilled through it lengthwise, which is soldered to the regular grease fitting. The screw is turned partly into the passage hole after which pressure is applied to the gun to force out the glue.

Inexpensive Miter Box of Wood Has Pivoted Saw Guide

With this homemade miter box the saw is swung either left or right to get the different angles. The base of the box is made of $1\frac{1}{2}$ -in. stock and the back is made of $1\frac{1}{4}$ -in. wood. A $\frac{3}{4}$ -in. dowel notched to take the saw is pivoted into a hole at the back. The notch should be of a depth to permit the saw teeth to just barely touch the base. Holes are drilled near the front edge of the base at various angles from the notched dowel to take a $\frac{1}{2}$ -in. dowel, which serves as a stop for the side of the saw. In use, the stop is set in the hole representing the angle at which the work is to be cut and the saw is placed in the notched pivot pin, after which the saw is held against the stop while making the cut.

—Morris Birge, Rochester, Minn.

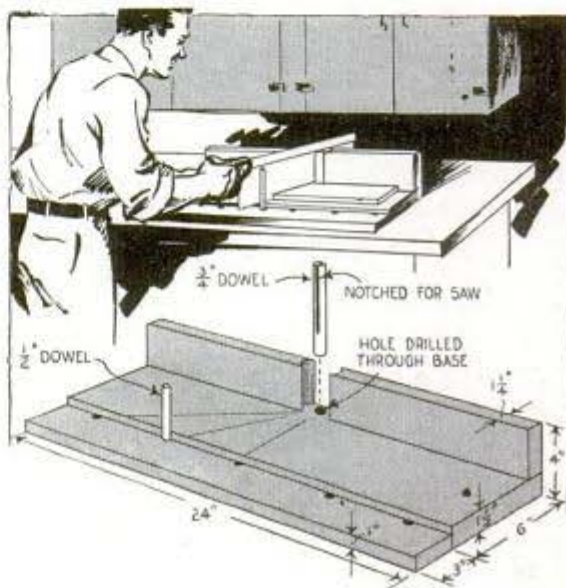

Cabinet Folds Down to Provide Breakfast Table



Owners of kitchens that are too small to accommodate breakfast tables will find this combination table and cupboard a solution to the problem of serving breakfasts and light lunches. Instead of the usual doors on the cabinet, the entire front opens downward to a horizontal position where it serves as a table supported by a folding leg at the outer end. The table consists of

a wooden frame hinged to the cabinet base and covered with $\frac{1}{2}$ -in. plywood or two thicknesses of hard-pressed board glued together. Two false cross strips divide the frame into three panels. The table leg is hinged at the top of the center panel and folds against it to simulate a decorative overlay when the cabinet is closed.

—Harry Robinson, Lansing, Mich.

“Bread-Knife” Edge on Back of Saw Cuts Insulating Bats

Difficulty in cutting insulation of the bat type was overcome by one carpenter who found that the work could be done easily with an old handsaw that had the back edge ground to resemble a bread knife. On some kinds of bats, the saw will cut better if the edge is left a little rough.

☐ Pads to protect the knees of small children while using roller skates will avoid many bruised knees and torn stockings. The pads are made by stitching several thicknesses of cloth together and sewing elastic to the upper and lower corners so the pads can be slipped over the legs.



Telescoping Curtain Rod Aids In Drawing Various Ellipses

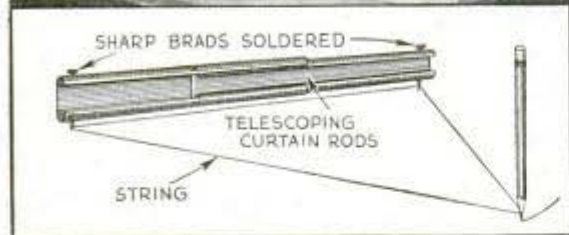

You'll find a length of telescoping curtain rod and a piece of string handy in drawing ellipses, as the rod can be adjusted instantly to make an ellipse of almost any desired size. As an aid in holding the rod firmly on the work, sharp pointed brads or nails are soldered to the ends. In use, the rod is adjusted to the desired length, after which a pencil is used inside the string loop to draw an ellipse in the usual way. If ellipses of various sizes are duplicated frequently, time can be saved by marking the adjustment on the rod for each size.

Magnet Holds Cabinet Door Shut When Latch Is Worn

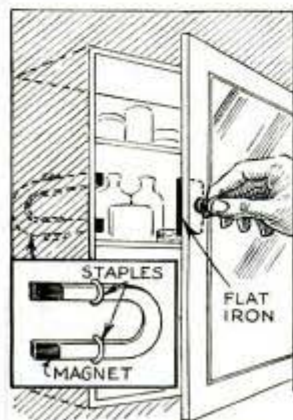

Where cabinet doors have a tendency to swing open after the latches are worn slightly, small horseshoe magnets, available at ten-cent stores, provide a good means of holding them shut. All you need to do is fasten the magnet inside the cabinet and then screw a piece of flat iron to the door directly opposite the magnet. In this way, the trouble can be corrected without installing new latches, which sometimes involves the drilling of

new holes, leaving the old ones exposed in a position where they cannot be covered or plugged easily.

—Will F. Kelley, Michigan City, Ind.

Fishing Rod Hung Safely on Wall With Window-Shade Bracket

A handy bracket for hanging a fishing rod on a wall can be had by utilizing a window-shade bracket. This is nailed to the wall, and the rod is slipped, is enlarged and the edges are smoothed with fine abrasive paper to avoid marring the finish on the rod tip.



Attractive Shelves of Fretwork Made of Glass and Wood

Sawed from plywood or other suitable material, these shelves are just the thing to help break up a plain wall. After enlarging the design on paper laid off in 1-in.

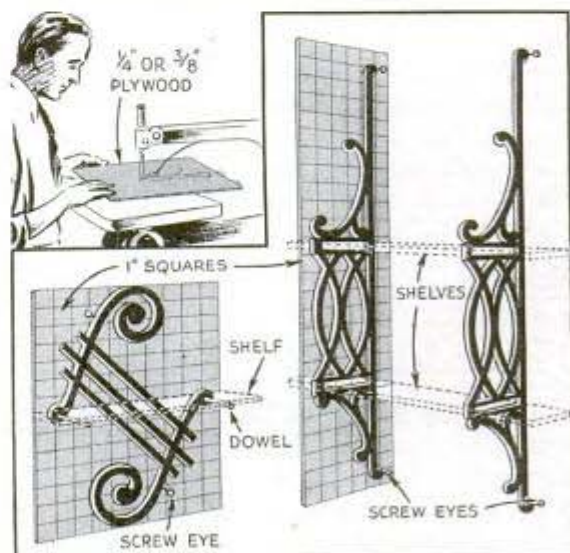

squares, cut it out and use the paper as a full-size pattern to transfer the design to wood. The small pieces of plate glass for the shelves usually can be obtained inexpensively in the form of scrap from your local glass dealer.

☛ A quick way to chop walnuts or other nut meats is to place them in a paper bag and roll with a rolling pin.

NEST of TABLES



EACH TABLE IS A COMPLETE UNIT



PYRAMIDED FOR CORNER WHATNOT

THERE is a place in almost every home for three multi-purpose tables which, in addition to the arrangements shown, can be hung on walls individually as whatnot shelves. Each table has two closed sides at right angles to each other and an open front, rounded at an 18-in. radius. As the curved edges must be flush when the tables are nested, the tables are of different sizes as shown in the lower detail. The arcs for the three sets of curved edges are struck from pivot points located on the diagonal center line, 4, 5 and 6 in. from either straight edge of the largest table top.



ALL THREE TABLES NESTED AS ONE

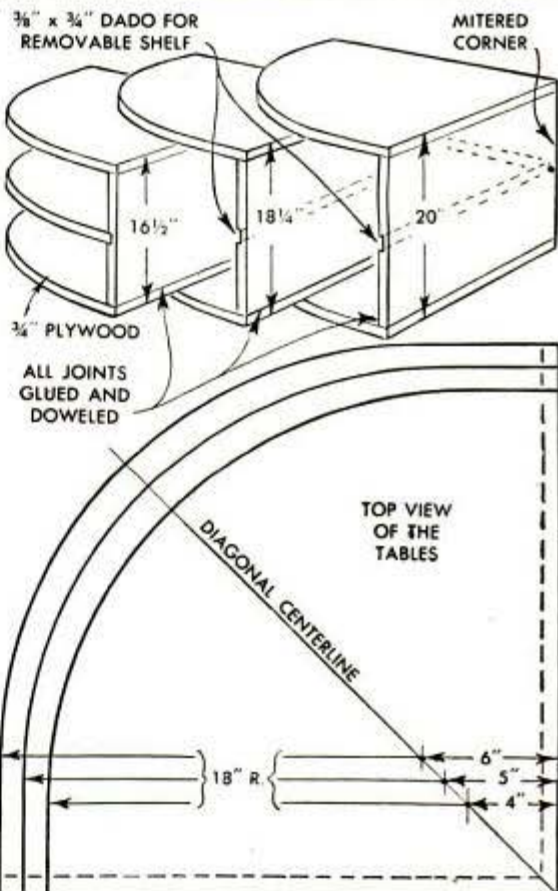

Cloth on Pool Table Repaired So That Tape Is Invisible



If the cloth on the cushions of a pool table becomes torn, it can be repaired with tape so that the latter does not show. First cut the tape to size, then work it under the cloth as shown with the adhesive side toward the cloth. Next carefully pull the torn edges of the cloth together and press them firmly against the tape.

—Leo D. Salmon, Chillicothe, Ohio.

Slipping of Cello on the Floor Avoided by Supports

If you play a cello or other string instrument that rests on the floor in front of you, a support like one of those above will be helpful in keeping the instrument in place. The support in the upper detail is merely a length of webbing rolled at one end to provide a pad for the foot of the cello to rest on, the other end being inserted under a chair leg to hold it. The support in the lower detail works on the same principle, and consists of a length of small chain hav-

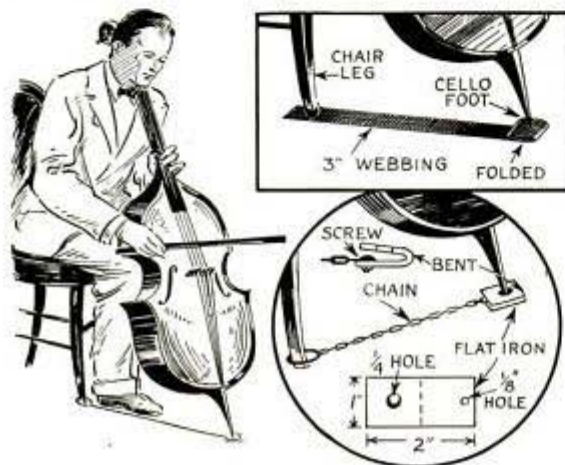

ing a large link at one end to fit over a chair leg and a folded piece of thin flat iron at the other end, which is drilled for insertion of the cello foot. If desired, a wooden block could be substituted for the flat iron.

Torn Pages in Loose-Leaf Book Reinforced With Tape

A student prevented the loose leaves of his note book from tearing out by applying a strip of cellulose tape along the back edge of each sheet before perforating it. The tape serves as a reinforcement for the punched holes

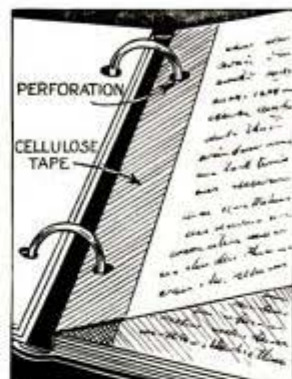

in the paper, strengthening them so that they will not tear out under ordinary use.

Sandpaper Inside Pencil Eraser Provides Good Lead Pointer



Artists and others who work with sharply pointed pencils will find that a good pointer for the lead can be made by cutting a strip of sandpaper and rolling it into the open end of a slip-on eraser. In use, the end of the pencil is inserted into the eraser and rotated to point the lead.

Safe Containers for Ant Poison

Simple containers for ant poison that will protect pets and small children are improvised quickly from discarded

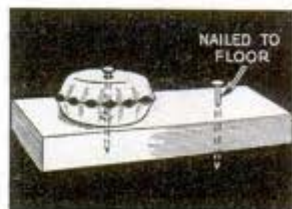

bottle caps, small blocks of wood and a few nails. All you need to do is punch a hole in the center of each cap, fill half of them with poison and assemble in pairs as shown. Being small, they can be nailed to the floor in out-of-the-way places.

War-game SHOOTING TARGET

WITH this up-to-date shooting gallery for the basement range, parachutes float down from the sky as an endless motor convoy of trucks and tanks moves past, providing lively, interesting targets for the airgun marksman. The simple mechanism is powered by a small motor and the speed of the figures can be regulated by the size of the pulleys. Old lumber is suitable for the framework or enclosure. The backdrop, clouds and revolving disk can be of heavy cardboard or wallboard. To conserve on metal, hardwood dowels will do for axles and the bearings may even be of hardwood. The trucks, tanks and parachutists, detailed in Figs. 1, 2 and 3, should be made of sheet metal or hard-pressed board so that the BB shot will register a hit by an audible "ping," in contrast to the dull "spat" it makes when striking the wallboard backdrops or disk.

As shown in Figs. 4 and 5, a wooden spider supports the

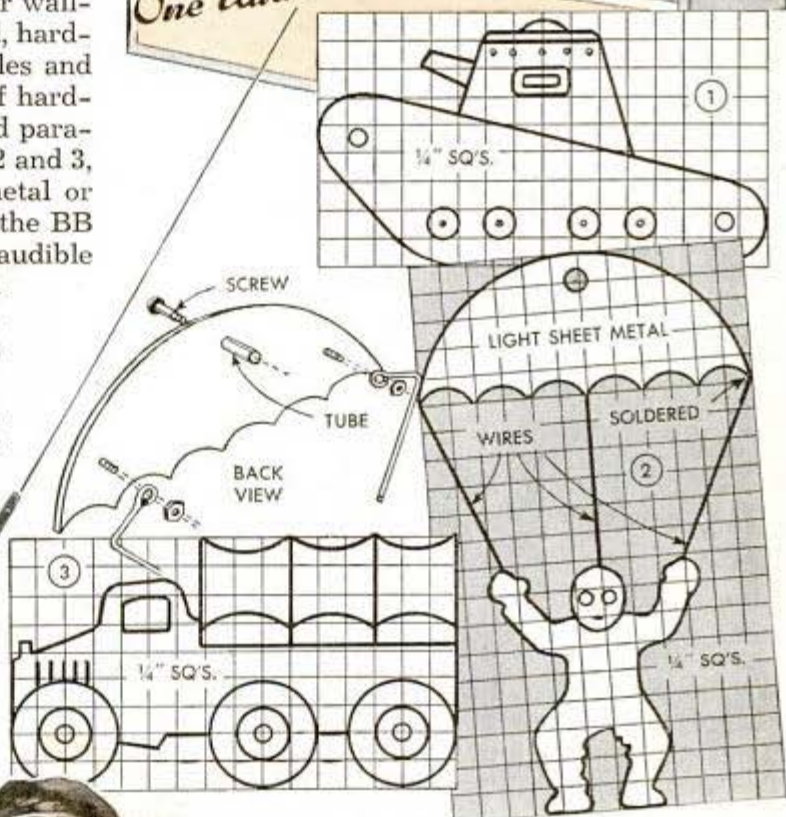
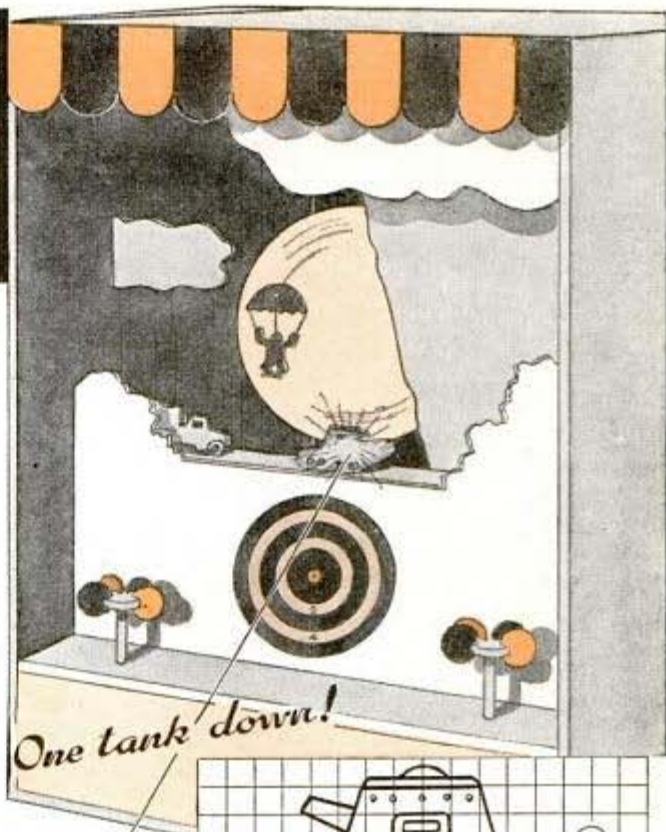

large center disk. To it the parachutists are pivoted, one near the end of each arm. Tanks and trucks are tacked to hinged wooden blocks—preferably of balsa—and these must be arranged carefully so that the impact of the shot will knock them over. The blocks may have to be consid-

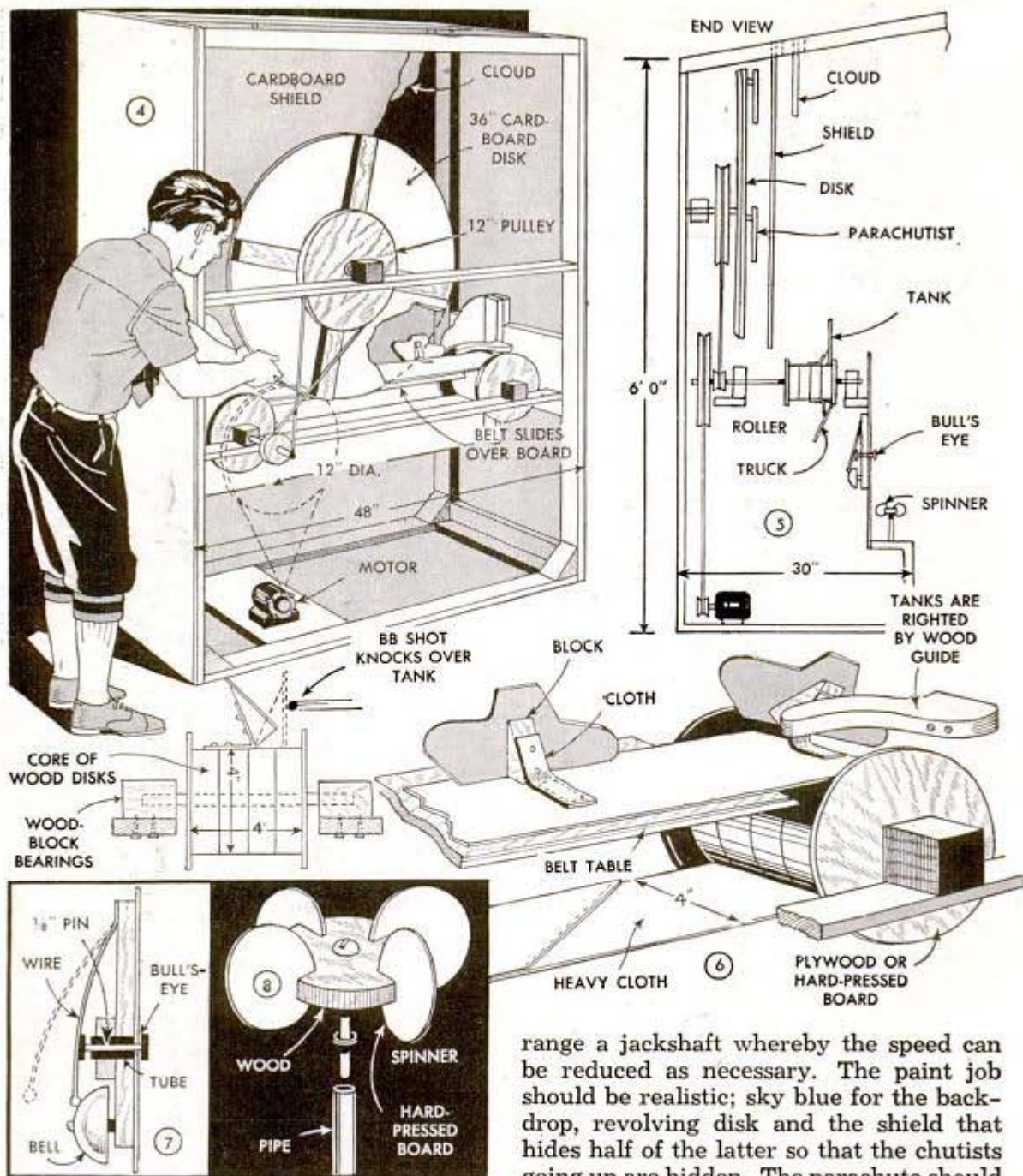

erably smaller than shown in Fig. 6. The cloth or leather hinges are glued or riveted to a heavy cloth belt, which is carried on two wooden rollers flanged at their ends. Coming up over the roller, the tanks and trucks are righted by means of a curved wooden guide or "brush."

A lathe is not necessary to make the pulleys, although a turned job is best. You can cut them with a compass saw and form a groove for a cord belt with a rasp. Use as small a pulley as possible on the motor and if the convoy still travels too fast ar-

range a jackshaft whereby the speed can be reduced as necessary. The paint job should be realistic; sky blue for the backdrop, revolving disk and the shield that hides half of the latter so that the chutists going up are hidden. The parachute should be white, the chutist gray or drab and the foliage green. The bull's-eye target, which rings a bell as detailed in Fig. 7, should be red and white, while the four spinner disks, made as shown in Fig. 8, can be red, white, blue and yellow. A suitable back wall should be provided whether the gallery is used in the basement or outdoors.

ⓘ Before painting new concrete floors, the alkali in the concrete must be neutralized by applying a solution consisting of zinc sulphate, 4 lbs., and water, 1 gal. Wash with hot water after 4 hrs.; paint when dry.

Two Bric-a-Brac Cabinets for Wall or Corner

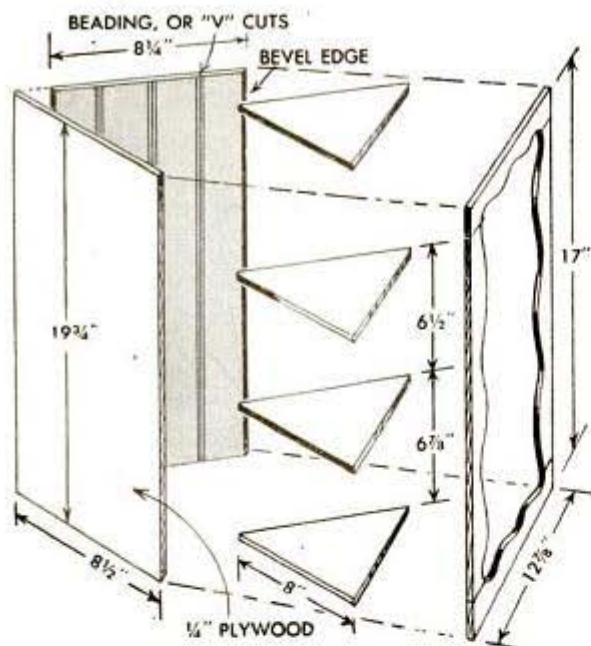

These decorative wall cabinets provide ample protection for bric-a-brac displayed within them. The sides, backs, tops and bottoms of the cabinets are made from 1/4-in. plywood, and the shelves and front trim may be maple, walnut, mahogany or other cabinet woods suitable for a stained-and-varnished finish. Notice that the backs are beaded to help carry out the colonial effect of the scrolled front trim. The cabinet interiors are painted flat white. After drying, this is followed with a thin wash of Van Dyke brown oil color reduced in turpentine. Before this is dry, it is wiped with a soft cloth, leaving brown in depressions and on part of the surface areas to produce an antique bone-white effect that sets off curios to excellent advantage.

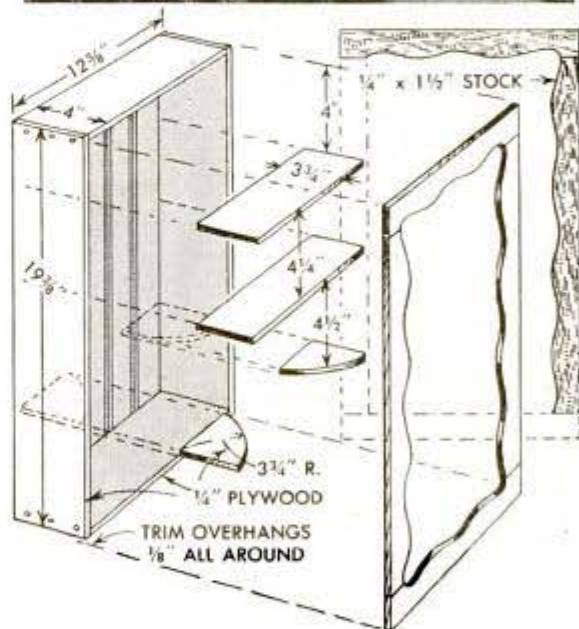

Disks Cut From Plywood Accurately With a Coping Saw

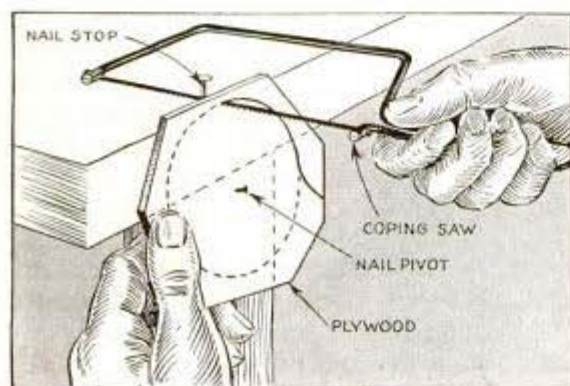

To cut a disk accurately from plywood with a coping saw, scribe the circle with a compass, start the saw blade into the wood, and then pivot the work vertically to the workbench so that the saw blade rests horizontally on the bench top. A nail is driven into the bench against the back of the blade and the work is rotated against the blade while the saw is operated.

☐ A new clothesline should be boiled for about 1/2 hr. before using it. This helps prevent stretching and tangling.

Life of Porch Curtains Increased By Guide Strips Behind Them

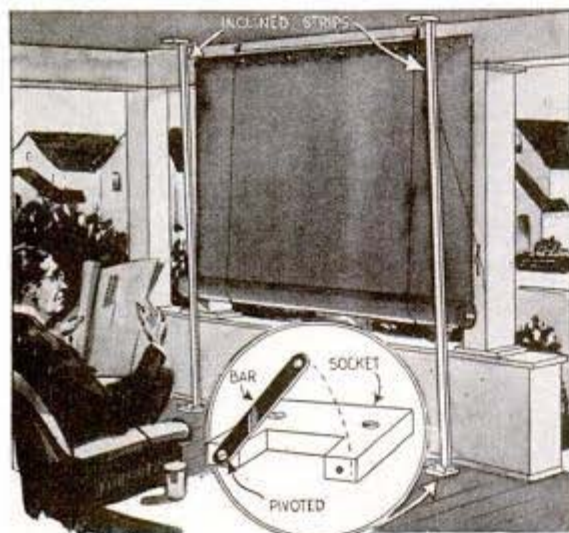

To prevent porch curtains of the drop-roll type from being torn by the wind, one home owner assembled removable guides to hold them in place. These consist of inclined strips that are held by wooden sockets made as shown in the circular detail. Before screwing the sockets to the porch floor and ceiling, care should be taken in measuring so that the strips slant toward the top enough to allow room for the curtain roll as it increases in size when pulled up.—L. B. Robbins, Harwich, Mass.

Auto-Spring Leaf Serves as Tool To Loosen Old Flooring

A handy tool for removing old flooring can be made from a section of auto-spring leaf by bending and tapering one end of it as shown. In use, the tool is driven un-

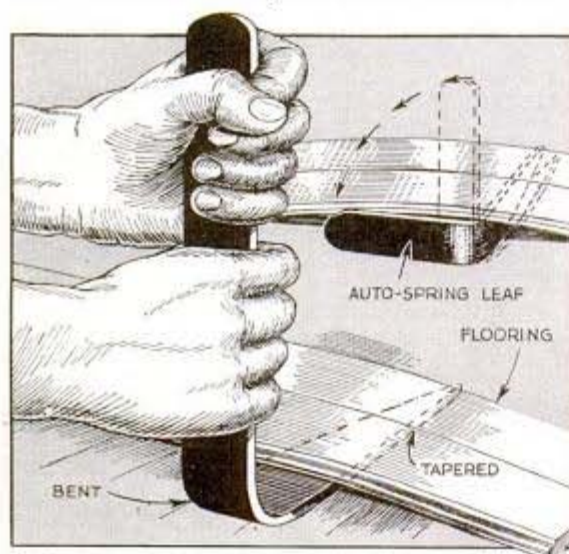

der the flooring with the handle in a vertical position, after which it is pushed down to loosen and raise the boards.

Simple Latch for Partition Door

Needing a number of latches for the swinging doors in poultry-house partitions, one poultryman made them from short lengths of heavy wire. These were bent to the shape indicated and stapled to the inside face of the



door frame. A nail driven part way into the door stile serves as a stop to keep the latch in a horizontal position.

"Wrench" Loosens Screw Caps

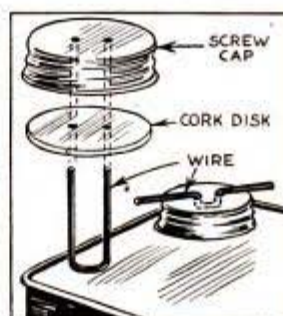

Bent to the shape shown, a length of wire is handy for opening and closing screw caps on cans that are used frequently. The wire is attached to the cap by bending it to a U-shape, after

which two holes are punched or drilled in the cap to receive the ends of the wire. When in place, the ends are bent outward in opposite directions to provide convenient handles for turning the cap.

Linoleum "Flagstones" on Roof Protect the Covering

If you have a flat roof that is walked on occasionally, 2-ft. squares of old linoleum applied to the roof about 6 in. apart will protect the covering. The linoleum can be applied with asphalt asbestos roofing cement, and the top surface of the squares can be painted to preserve the finish. You will find that linoleum squares are better for this purpose than boards, as water will run off in any direction without collecting in pockets and eventually causing the covering to decay.

—Benjamin Goldberg, Brooklyn, N. Y.

Pirate-Chest CIGARETTE DISPENSER

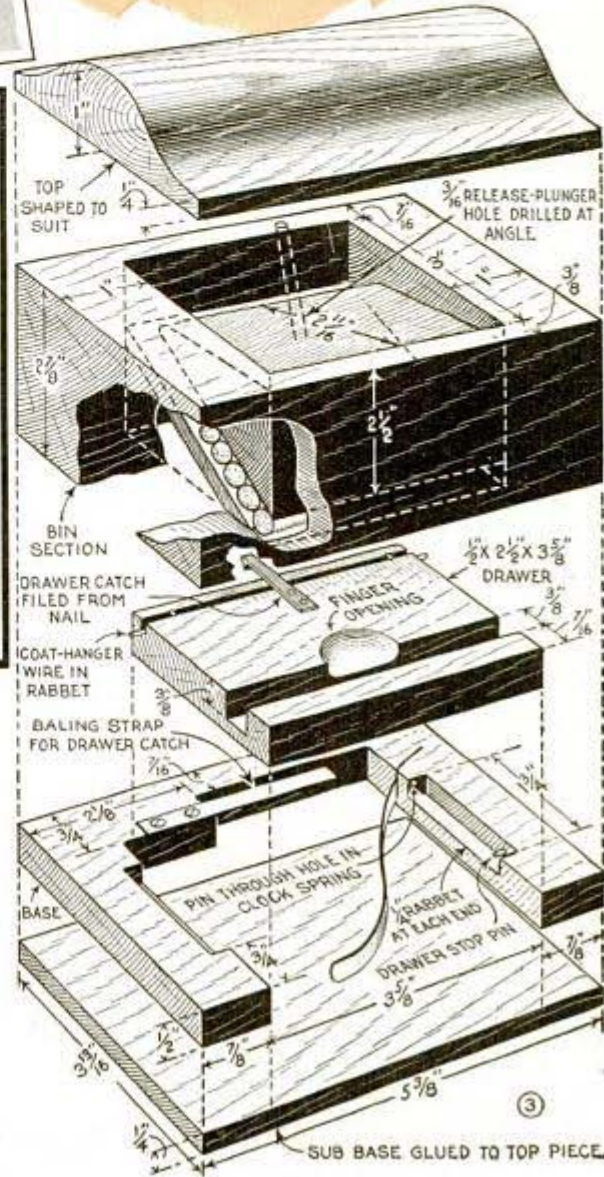
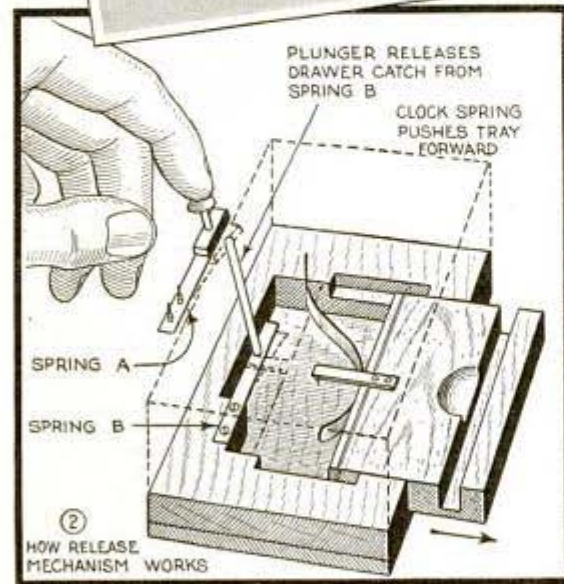

PRESS a button and out slides a little tray containing a cigarette—that's all there is to getting a cigarette from this dispenser. The completed dispenser is shown in Fig. 1, while the various parts in their correct relation of assembly are shown in Fig. 3.

To begin construction, first make the bin section from a solid block. Tapering the sides of the chest is done as in Fig. 6 when all the parts have been glued together. After the bin block is cut as indicated, glue in a triangular piece. Under this set in a thin piece at an angle to provide a channel down which the cig-



aretttes move. Next is the sliding tray and base, the tray being moved forward by a spring when the release mechanism is operated by pressing the button in the dispenser lid. As the spring and release mechanisms are installed before assembling the various parts, it is well to study Fig. 2, which shows the working arrangement of the mechanism.

Both the tray and the base are made of $\frac{1}{2}$ -in. stock, but the tray must be sanded down about $\frac{1}{32}$ in. in thickness so that it can slide freely between the bin and base. Groove the tray near the front to hold a cigarette and near the back to take a wire, such as that from a coat hanger. The wire is held loosely in the groove by two brads, which are driven from the back end of the tray through the groove and above the wire. The latter projects at both ends to fit in rabbets made in the base ends. This arrangement serves as a tray guide and also provides a bearing so the tray will slide easily. Stop pins near the front ends of the rabbet prevent the tray from sliding out too far.

Now attach a piece of clock spring to one side of the base as indicated so that it presses firmly against the tray when the latter is in the closed position. Also, screw a piece of spring metal, such as a piece of baling strap, to the back of the base as indicated to engage a catch, which is filed from a nail and attached to the rear part of the tray. Glue the base to the sub base, put the tray in place and then glue this assembly to the bin section.

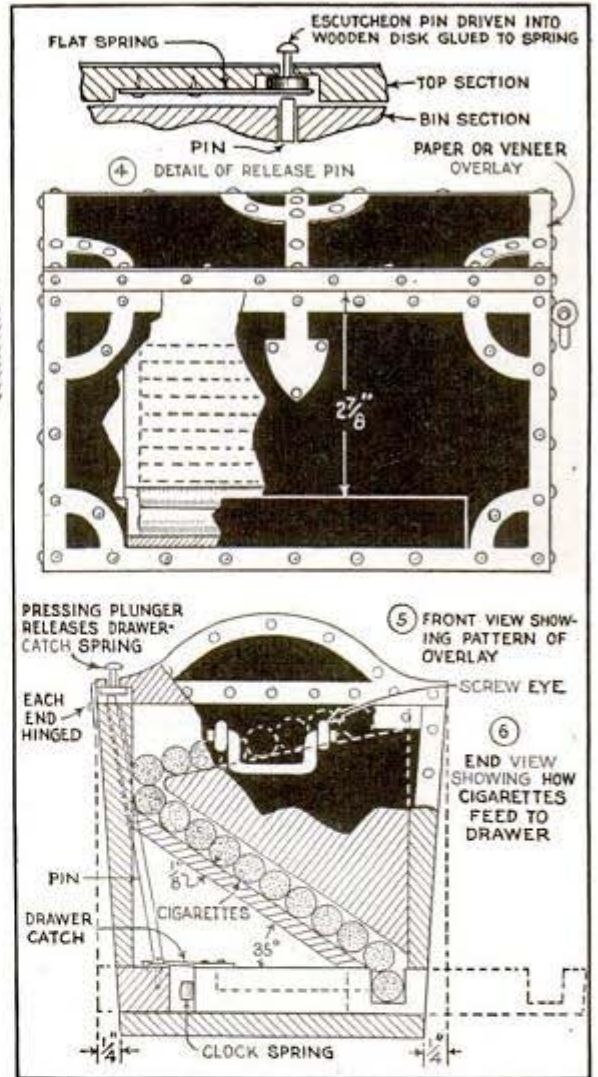

Before shaping the lid, drill down vertically and at an angle through the rear side of the bin section for a plunger, which must rest on the release spring for the tray catch. The plunger projects slightly above the bin section where it engages a release pin. This is assembled by using an escutcheon pin driven into a wooden disk, which rests on a flat spring as in Fig. 4, the assembly being set into a recess in the underside of the lid at the rear side. Now, complete the lid and hinge it to the bin section. Finish the chest to suit and apply the decorative trim as in Fig. 5. Thin brass or copper is the best trim, but if this is unavailable, paper or veneer will do. After polishing the trim and nailing it in place, give it a coat of transparent lacquer. This will prevent the metal from rusting or tarnishing. Attaching the handles completes the job. These are shaped from wire and are fastened in place with tiny screw eyes.

Child's Home "Movie" Stage From a Shoe Box

Children can make their own movies with this stage, which consists of a shoe box containing a lamp and a tissue-paper screen. Pictures are sketched on the paper or traced on it from catalogues and magazines, and are colored lightly to suit. Then the paper is wound on a large spool and slipped over a dowel running through the box from top to bottom near one end. To show the movies, the paper is unwound slowly onto another spool and dowel located near the opposite end of the box. The lamp is located at the rear, and light from it is diffused through the screen, making the pictures stand out in color as they pass

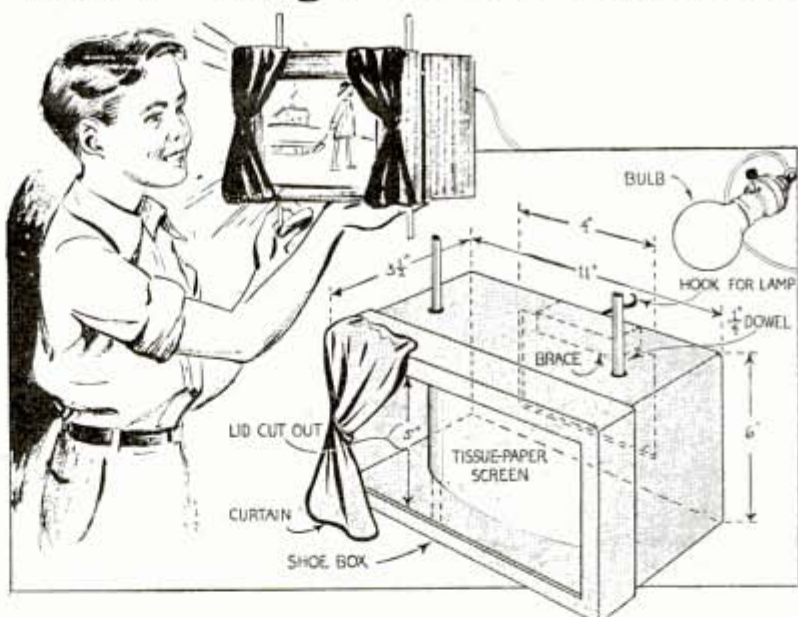

an opening cut in the lid of the box. Curtains on each side of the opening help to produce the stage effect.

—Myrtle Ekelund, Chicago.

Bicycle Loading Platform Speeds Up Delivery Boy's Work

Owners of grocery stores and other establishments using bicycles to make deliveries will find this simple loading platform handy. It provides a place to store the orders as they are filled, and it supports

the bike while loading the basket. Construction is simple, as the platform is made of 1-in. lumber and is supported by six short legs of 2 by 4-in. stock. An X-brace on the underside, also of 2 by 4-in. stock, provides rigidity. If desired, the legs can be fitted with casters so that the platform can be moved about easily.

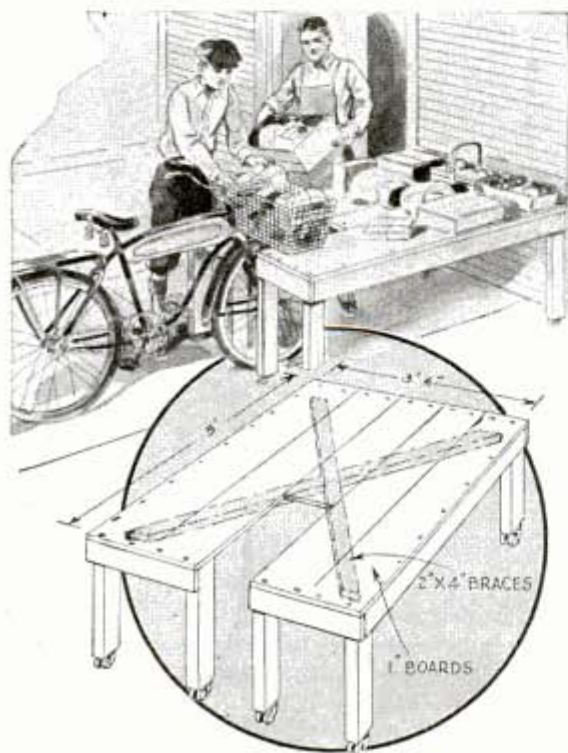

How to Carry Shopping Bag

As curtailment of deliveries for the duration has made it necessary for many of us to carry our purchases from stores, a durable cloth shopping bag is needed. When this is made or purchased, have one of the handles longer than the other. In this way, the long handle can be pulled through the short one to close the top of the bag and prevent loss of the contents. Also, the hand can be slipped through the looped handle so that most of the weight is on the wrist thus making the bag easier to carry.

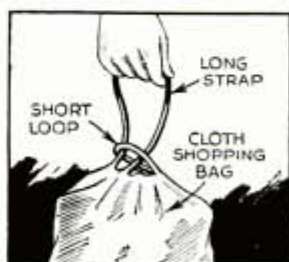

Negative Viewer Is Made Quickly From an Old Film Hanger

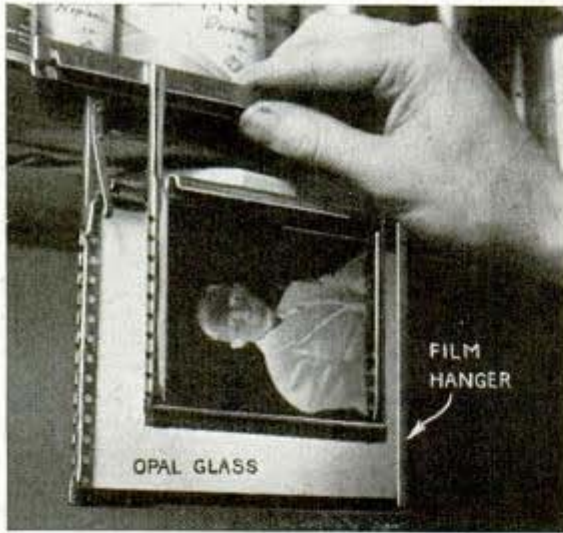

Mounted on the edge of a shelf over the darkroom sink, this negative viewer can be used without dripping water and solutions on the floor. It consists of an old film hanger and a piece of opal or ground glass hung in front of a light bulb. All wiring, sockets and switches mounted near the sink should be insulated carefully.

Lampcord Wound on Reflector Is Always at Hand

You will always have a convenient place to wrap the cord of a photoflood light if you attach four small metal clips to the edge of the reflector. The strips are about $\frac{1}{2}$ by 3 in. Only one screw is needed in each strip, as one edge bears against the reflector rim and prevents twisting.

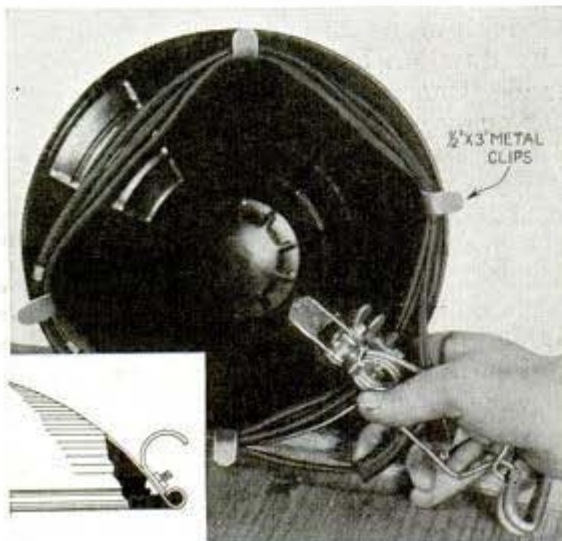

Photographer's Edge Printer

Plain or decorative borders on photos are produced easily with the edge printer shown on the opposite page. To make them, the photographer simply inserts the prints, pulls the handle of the platen down a fraction of an inch and closes a switch for the necessary exposure. Normally, black borders are satisfactory, but by making a portion of the printer top removable—piece A in Fig. 1—and providing various inserts, you can produce different effects. Deckle-edge borders are produced by a sheet-metal mask having a wavy edge extending slightly over the front portion of the slit. Dots to locate ring holes on prints that may be filed in loose-leaf binders, can be printed with an opaque mask that covers all of the light opening except where the holes are located. If one of the inserts is fitted with a piece of glass extending over the opening, you can use strip negatives to print your name and address, file numbers, or other matter on the edges of the prints. A small piece of cellulose tape will hold such a negative in place on the printer top.

The printer contains a 60-watt tubular lamp, the light passing through a slit in the top. Inside length of the box should not be less than $18\frac{1}{4}$ in. to provide enough space for the lamp and sockets, and the distance from the top surface of the lamp to the upper surface of the slit should be about 2 in. No danger exists from enclosing the lamp in such a small space as the lamp will be on intermittently only for a moment at a time. Paint the top surface a dull black—other parts may be any color. A wood stop is provided on the platen as detailed in Fig. 3. If desired, the stop can be made adjustable for various widths of borders. When no pressure is being exerted on the handle, the platen should rest so that its front edge is about $\frac{1}{8}$ in. above the top surface of the box to permit insertion of the print. To keep the platen raised, a strip of springy sheet metal is mounted under the edge. Velvet or other soft cloth on the underside of the platen provides even pressure and assures a light seal. A red pilot window that indicates when the lamp is on, and a small switch are mounted on the front of the box as shown in Fig. 2. A diagram of electrical connections is given in Fig. 4.

—Walter E. Burton, Akron, Ohio.

EDGE PRINTER

borders your photos

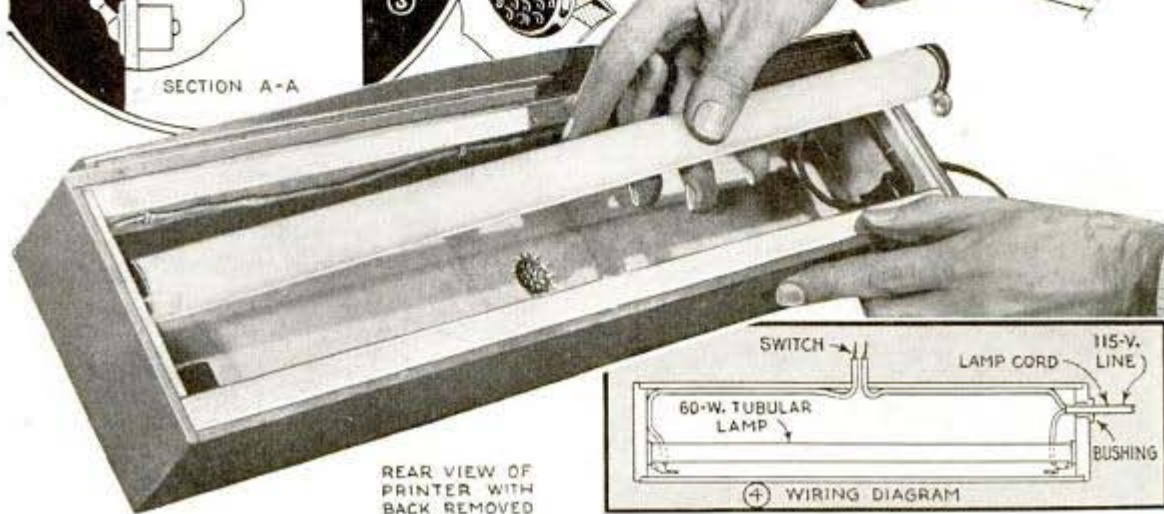
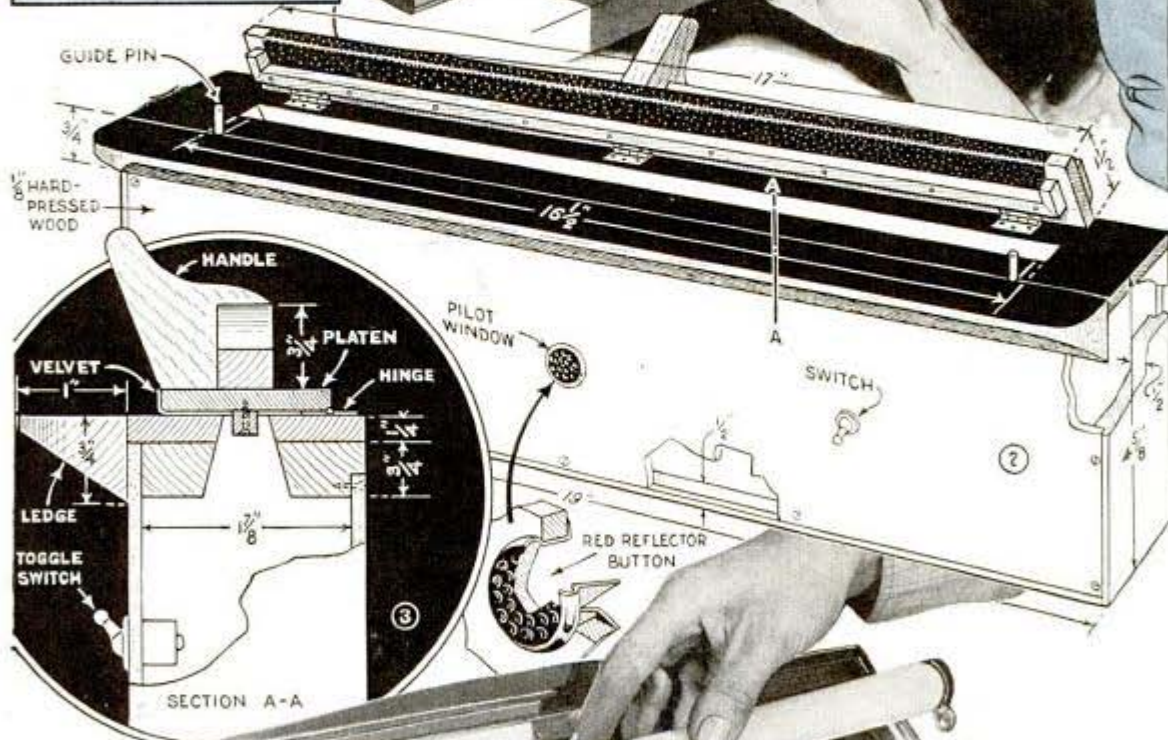
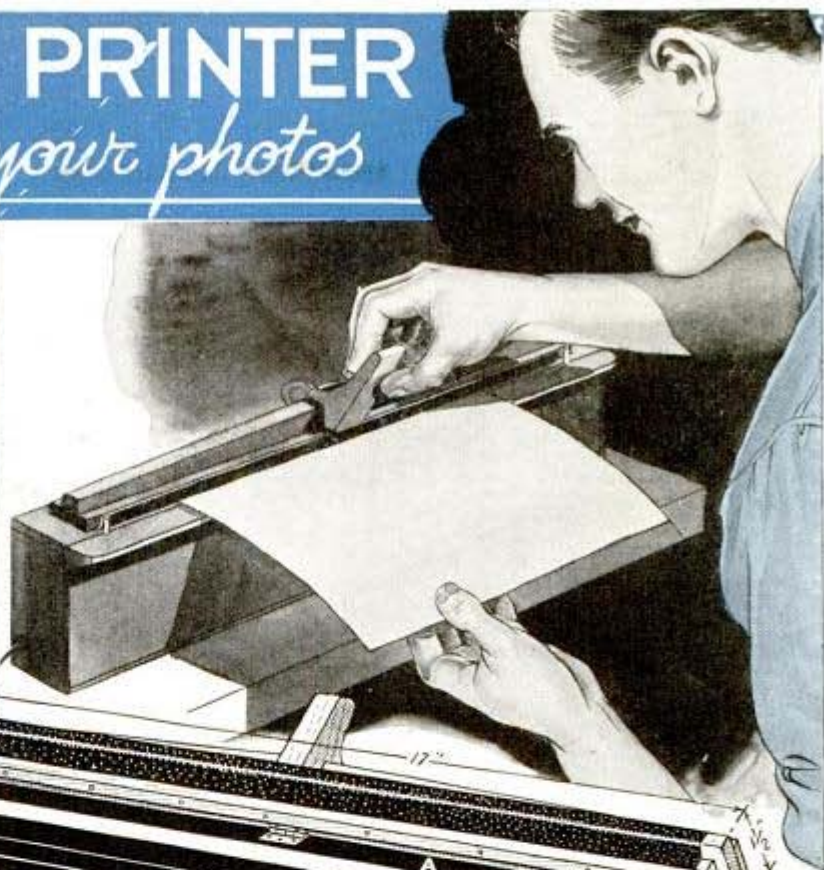
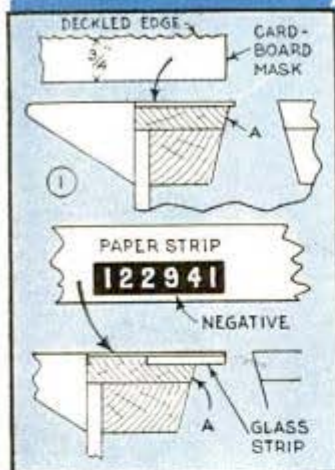

Metal Extension on Pack Adapter Tears Tabs Off Straight

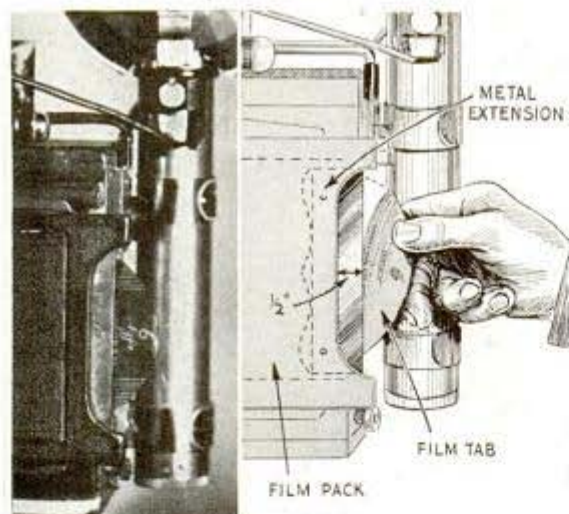

Before attaching the extension shown to my film-pack adapter, the tabs of the pack contacted the rounded edge of the spring back of the camera when they were torn off, causing them to tear with ragged edges. To avoid this, I riveted a small piece of sheet metal on the adapter to extend $\frac{1}{2}$ in. beyond the edge of the spring back. Now the tabs can be torn off straight and without the risk of the paper "bunching up" and causing light leaks.

—E. W. Odom, Dallas, Texas.

Scatched Color Film Salvaged With Soapy Solution

A color transparency, made virtually useless by a large finger mark or a maze of tiny scratches, often can be restored to usable condition by the application of a mild soap-and-water solution or a lens cleaner of the soapy type. Flow cleaner on gently with a sable brush. Instantly the gelatin will curdle and become pebbly in texture.



Do not touch it again, but place the film in gently running water until the soap has been washed out. Hang the transparency up to dry and, as the gelatin returns to its normal condition, the blemishes will have vanished. Deep scratches will remain, as will those on the celluloid side. The treatment can be applied only once, as the soap removes the protective lacquer coating. To prevent further injury, mount the film between cover glasses at once.

Sliding Camera Mount for Stereos Made From Combination Square

An inexpensive combination square, altered as shown, provides a means of moving the camera horizontally for taking stereoscopic photographs. The steel rule is shortened to $5\frac{1}{2}$ in. and the piece holding

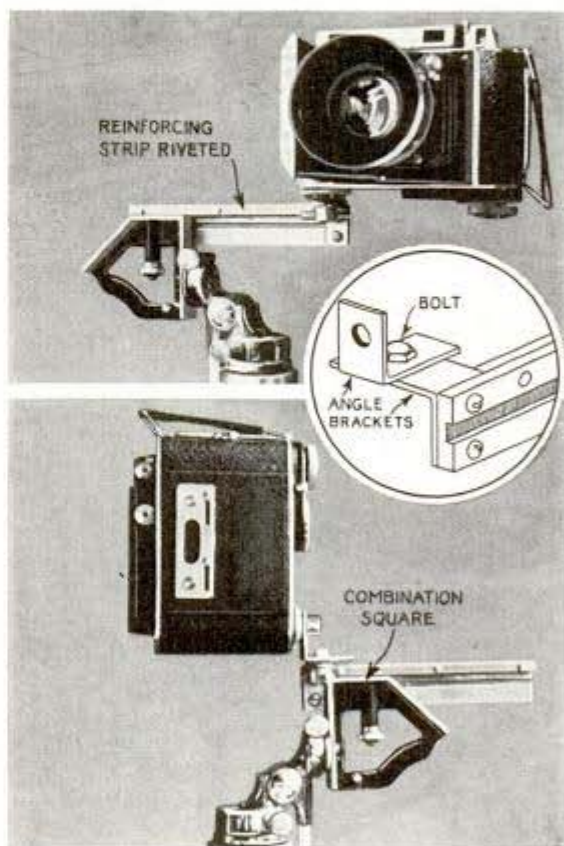

the clamp is drilled and tapped for the tripod screw. The camera is held on the end of the rule by an angle bracket and a short tripod screw. A $\frac{1}{4}$ -in. steel reinforcing strip riveted along the top edge of the rule reduces the chance of vibration. This arrangement makes it easy to move the camera the exact distance required while keeping it perfectly horizontal.

—T. R. Wiley, Piqua, Ohio.

Reticulated Negatives Make Unusual Pictures



Reticulation—the swelling and cracking of the emulsion on a photographic film caused by dipping it in a solution or water that is too warm—is carefully avoided by photographers, but it can be controlled and used to make novel pictures. Only negatives that are not wanted for any other purpose can be used, as once they are reticulated they cannot be used again for making a straight print. Dip the film alternately in hot water, 140 to 200 degrees,

F., and in cold water, observing the effect. The longer the dipping is continued, the more pronounced will be the effect. Care must be used not to continue the soaking too long in the hot water or the emulsion will loosen from the film base and slide off. Use a clothespin on one corner of the film to hold it during the dipping process. The two prints reproduced above were made from the same negative before and after reticulation.—Fred G. Korth, Chicago.

Small Tripod Held on Chest Steadies Miniature Camera

A lightweight miniature camera can be held with minimum movement by mounting it on a table-top tripod and placing the legs of the tripod against the chest, as shown. The three-point support gives the camera almost unbelievable steadiness, permitting long exposures when necessary.

—P. M. Bruner, Sausalito, Calif.

TELL YOUR FRIENDS

through the medium of Popular Mechanics just how you solved that little tricky problem encountered in your home, work or hobby. Money and labor-saving ideas, shortcuts to do things quickly and more efficiently, wrinkles that others will appreciate knowing—that is the kind of information we try to pass along on these pages. Just send us a clear sketch or photo with a brief description giving the essentials. For those ideas that are suitable we will send you a check. Those we cannot use will be returned. Address Homecraft Editor.

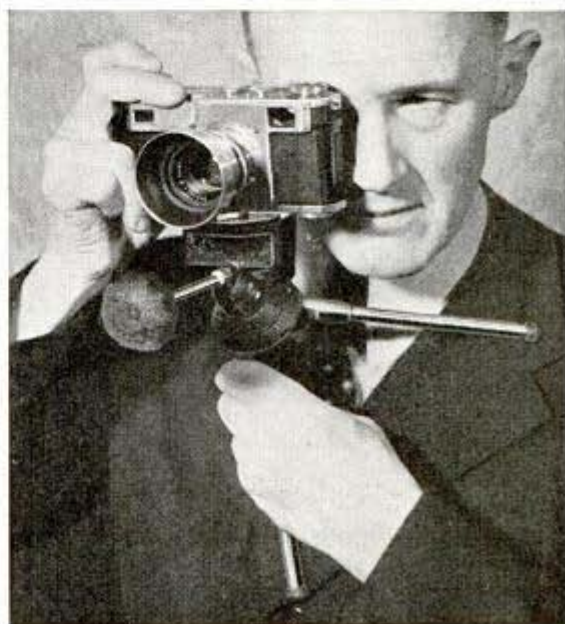

Hinged Jar Tray on Artist's Table Swings Out for Access to Jars



One artist keeps his jars of water colors and similar equipment in a tray hinged to the side of his table. In this way, the tray can be swung out within easy reach so that

he can work directly from the jars without picking them up and setting them on the table or drawing board.

Rods Held in Auger-Brace Chuck While Pointing Ends With File

Having several short brass rods to point with a file, and not wishing to mar them in the jaws of a vise, I fastened an auger brace in the vise so that the chuck extended horizontally. With the brace in this position, a rod could be held firmly in the chuck to point the end with a file. The same arrangement can be used in holding screws, bolts, etc., thus permitting them to be gripped and removed quickly.



—G. E. Hendrickson, Argyle, Wis.

SAVE MONEY BY MAKING YOUR OWN PHOTO EQUIPMENT

Here, in one handy volume, is a reprint of the best of the photo articles published in *Popular Mechanics*. This Guide tells how you can make camera and darkroom equipment and numerous time-saving gadgets. Included also are articles by successful photographers on color photos, speed shots, use of shadows, lighting, composition, water and snow scenes, retouching, trick and table photography. Price. \$1.25.

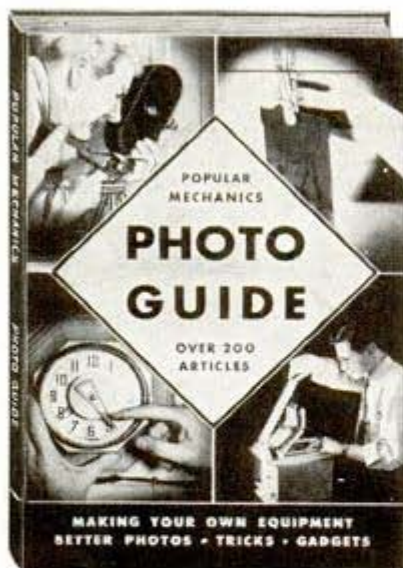

Other Helpful Books

- Forty Power Tools You Can Make**—Shows how to make forty different machines, such as lathes, drill press, jig, band and circular saws, sanders from pipe fittings, auto parts, etc. \$1.25.
- Your Car**—Add thousands of miles of life to your car and operate it economically. 192 pages of money and labor-saving ideas, short cuts. For motorists, service men. \$1.25.
- 1001 Ways to Use Concrete**—Do work for yourself, others. Save, make money. \$1.98.
- Garden Book**—Build your own trellises, fences, lawn furniture, outdoor fireplaces, attractive ornaments, etc. \$1.00.
- Welding, Brazing and Soldering**—How to construct equipment and use it efficiently. \$1.25.
- The Boy Mechanic**—For any boy. Tells how to build midget auto, boats, models, games, craftwork. \$2.00.
- Build a Boat for Pleasure or Profit**—17 low-cost boats—power, sail, row. No experience needed. \$1.25.
- Shop Notes**—The mechanic's guide. Lathe operation, drafting, shop practice, using tools, welding, autos, electricity, etc., time and money-saving shortcuts. Set of 4 books (Shop Notes for '43, '42, '41, '40) \$1.95. Single volumes 50c.

What to Make—Shows how to make hundreds of things in spare time for fun or profit. Furniture, craft-work novelties, etc. Set of four books, Volumes 1, 2, 3 and 4 (812 interesting pages) de luxe cloth \$5 per set. Single volumes \$1.25. Paper edition, per set \$1.95. Single volumes 50c.

Order from this list. Ask for FREE book catalog. Money refunded if you're not satisfied

Popular Mechanics Press, Dept. 447, 200 East Ontario Street, Chicago, Illinois



SHOP NOTES

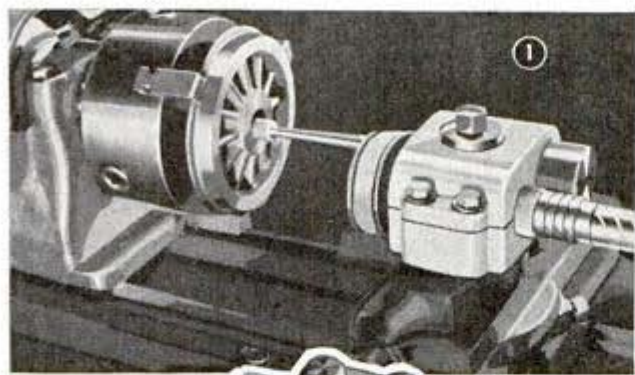

High-Speed **FLEXIBLE-SHAFT GRINDER** *fits compound rest on lathe*

SMALL shops that do not have and cannot purchase a regular lathe toolpost grinder will find that this flexible-shaft grinder, which is comparatively easy to make, is useful for most small jobs as shown in Fig. 1. Mounted on the compound rest of a lathe, the unit can be adjusted on its pivot to work at any angle. Provided with a long spindle and small grinding wheel, it will get at places that are deep and difficult to reach. It operates at approximately 15,000 r.p.m., which is satisfactory for most work.

A standard flexible shaft is used so that you have to make only the base, spindle, spindle housing, pulley, belt and mounting clamp. A closeup view of the unit is shown

in Fig. 2. The base can be cast or it can be built from a solid piece of cold-rolled steel. In the latter case the ends can be left square instead of being rounded. Fig. 4 gives the dimensions of the unit. In making yours, some of the dimensions may have to be altered, depending on the size of the flexible shaft available and on the bearings that you may have at hand. The holes are bored in the lathe. The large hole for the spindle can be machined accurately with a boring bar held between centers while the base is mounted on the lathe toolpost slide as shown in Fig. 3. It is in this position that the grinder will be mounted in actual use, and boring the hole as just explained assures that the center

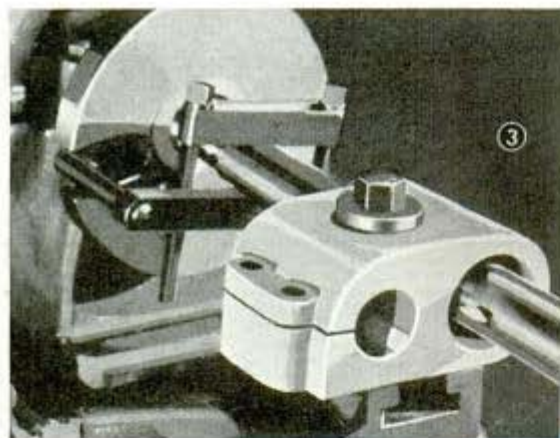

line of the spindle will be at the exact center height of the lathe.

To mount the base on the toolpost slide, it will be necessary to drill a hole vertically through the base to take the pivot bolt, which screws into a flanged bushing. This, in turn, fits a counterbored square plate that slides in the toolpost slot. Details of the pivot clamp are given in Fig. 4 and the three parts comprising it are shown in the photo above Fig. 7. The spindle housing is

made up of cold-rolled steel cut to length and having a center hole drilled lengthwise as indicated in Fig. 5. The recess at each end is bored to receive the ball bearings, which are used as plug gauges to obtain a firm push fit on the spindle. The spindle, including the small pulley on it, is turned from a solid rod of tough, hard steel. Here again the bearings are used, this time as ring gauges, to bring the shaft to a light drive fit in the bearings. The end caps are made from thin steel disks, which may be threaded to screw into the

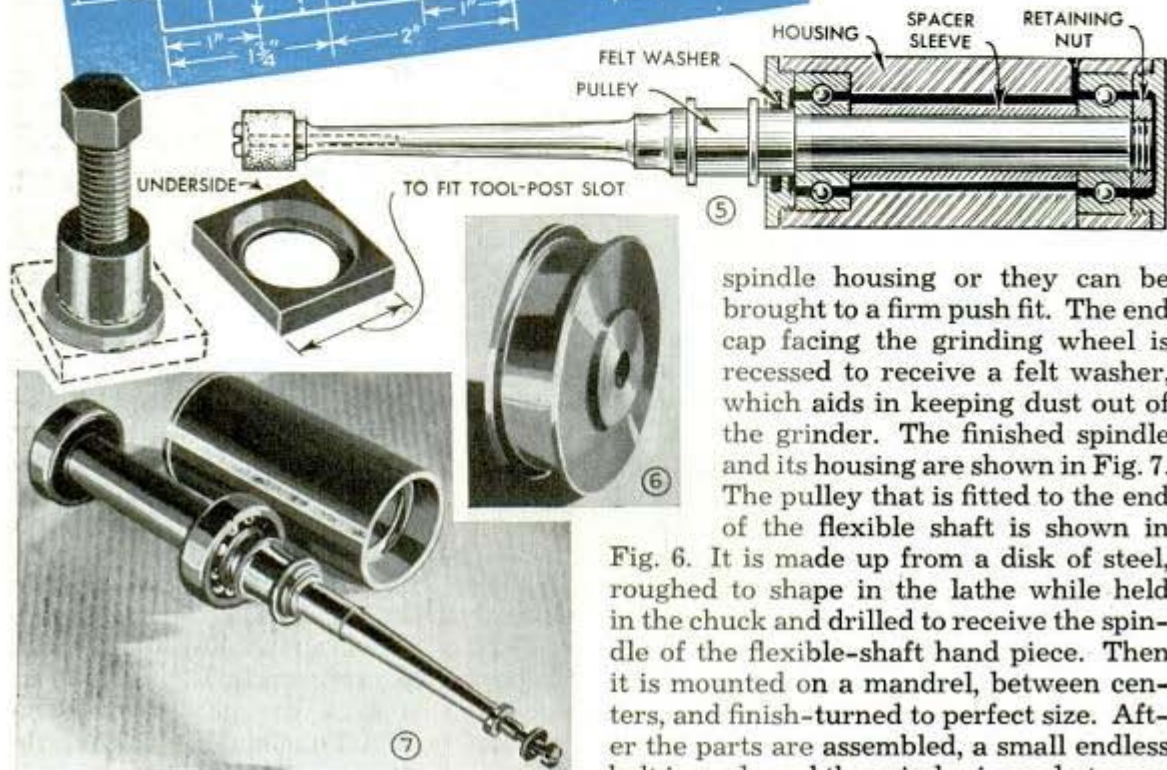
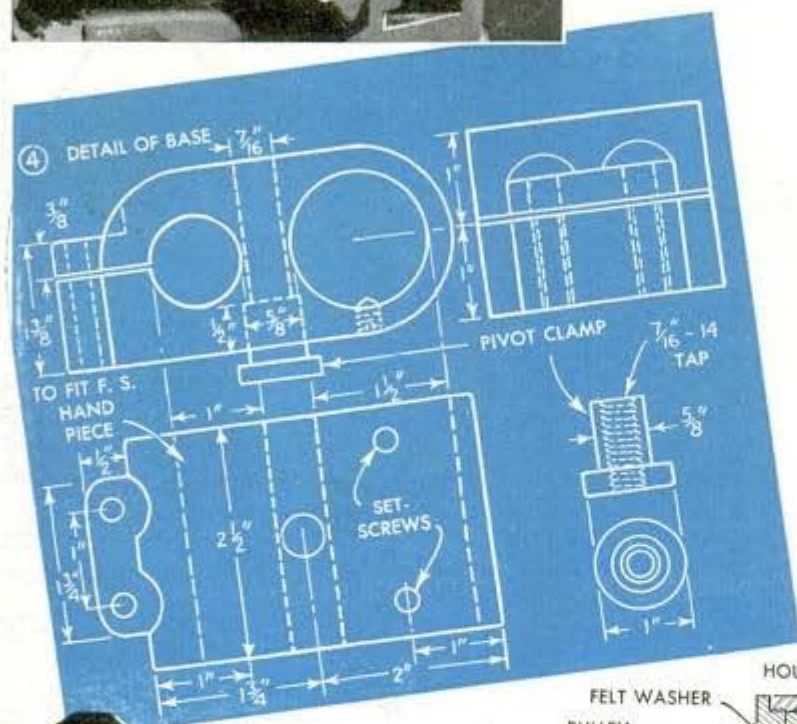

spindle housing or they can be brought to a firm push fit. The end cap facing the grinding wheel is recessed to receive a felt washer, which aids in keeping dust out of the grinder. The finished spindle and its housing are shown in Fig. 7. The pulley that is fitted to the end of the flexible shaft is shown in

Fig. 6. It is made up from a disk of steel, roughed to shape in the lathe while held in the chuck and drilled to receive the spindle of the flexible-shaft hand piece. Then it is mounted on a mandrel, between centers, and finish-turned to perfect size. After the parts are assembled, a small endless belt is made and the grinder is ready to use.

Adjustable Stop Unit Fits on Shaper or Jointer

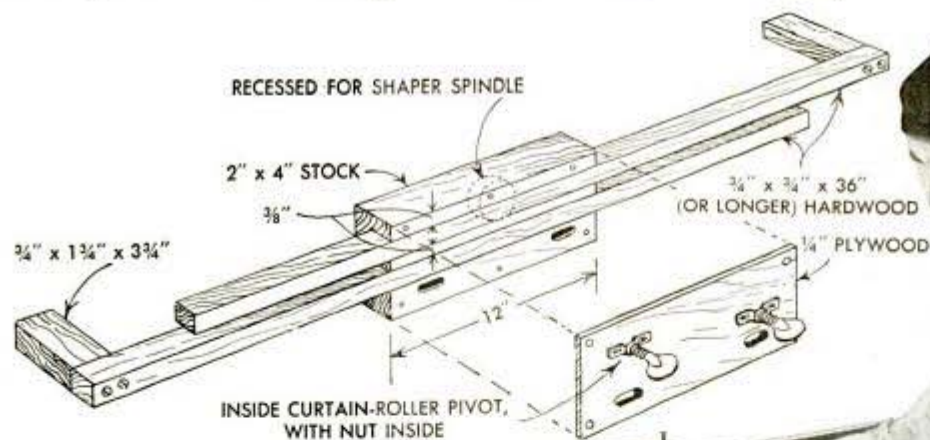

This detachable unit for use on a shaper or jointer greatly simplifies such jobs as stop-chamfering and grooving, recessing, etc., which require stops at both ends of the piece being worked. Usually such stops are improvised and, if the work is long, they must be carried by "outriggers" attached to the fence or table. The advantage of this unit is that it is adjustable for various lengths of work, and can be attached to either shaper or jointer in a few moments. It consists of two hardwood bars, provided with stops. The bars slide in grooves cut in a 2- by 4-in. block and can be locked in position with wing screws passing through a piece of plywood, which fits over the grooves and is screwed to the block. When the unit is used on a shaper as shown in the upper photo, the cutter and fence are adjusted first and then the unit is attached to the top of the fence by means of wing screws passing through slots in the block. To use the adjustable stop on a jointer, it is

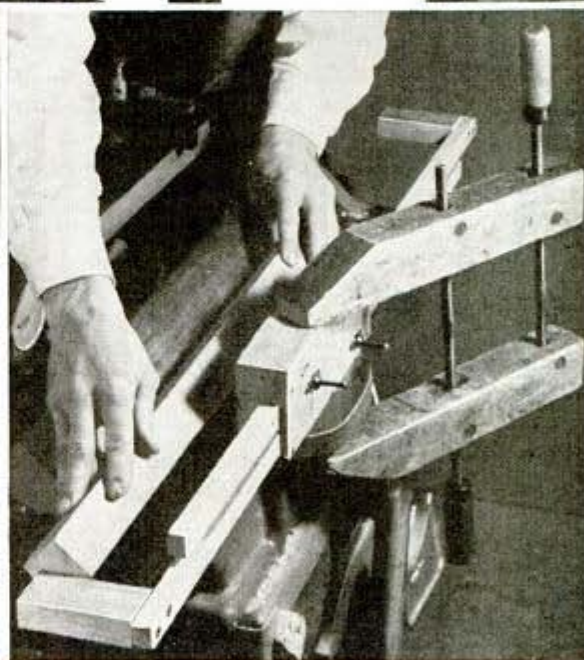
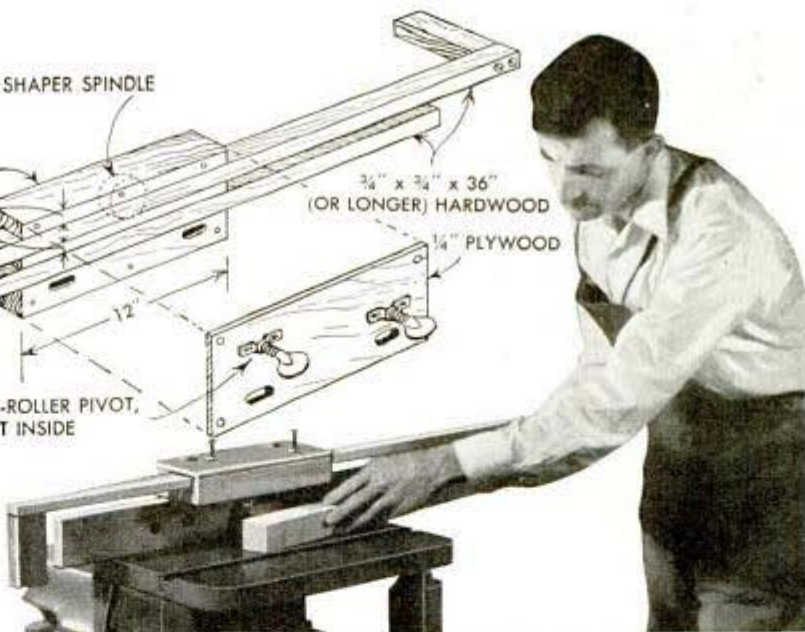

clamped in position as shown in the lower photo.—E. M. Love, Monterey Park, Calif.

Amusing Valentine Favor and Place Card Made From Marshmallows



This amusing little favor gives your guests the "stop" sign and shows them where to sit. To make it, the bottoms of two marshmallows are moistened slightly and placed at the back edge of a place card. Bits of toothpick hold the marshmallow body in position. Pipe-cleaner arms are tipped with heart-shaped hands, which may be purchased already gummed or cut from red paper. A large red heart serves as a head, and one gummed reinforcement ring cut to the desired shape provides the nose, mouth and eyes.—Benj. Nielsen, Aurora, Nebr.

Partitions of Glass Storage Bin Calibrated as Aid in Selection

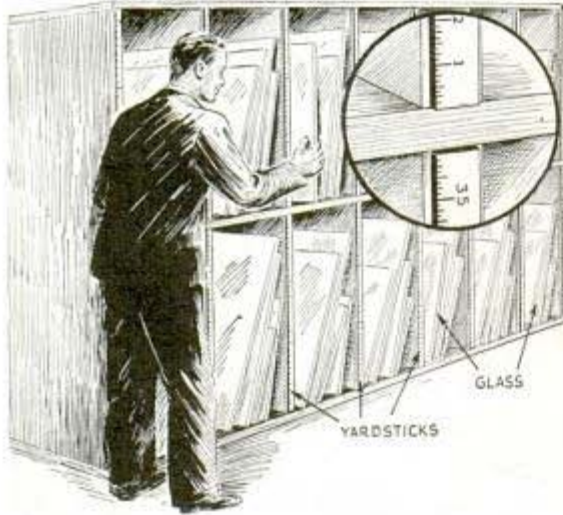

Merchants who stock numerous sizes of glass panes in partitioned bins will find that a desired size of pane can be selected instantly if the edges of the partitions are marked off in inches. In this way, a glance at the partition and the upper edge of the pane will show its approximate width or height. A good way of calibrating the partitions is to tack yardsticks to them.

Wheels of Push Truck Crowned To Avoid Marring Floor

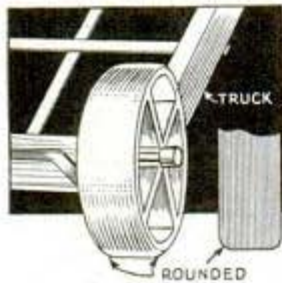

In factories and department stores where push trucks are used, marring of the floors by the truck wheels when making sharp turns can be avoided by crowning the outer surfaces of the wheel rims. This can be done by rounding the edges of the wheel rims with a file or grinding wheel.

outer surfaces of the wheel rims. This can be done by rounding the edges of the wheel rims with a file or grinding wheel.

Twist Drill Slotted at the Point Makes Holes in Marble

A stone cutter who frequently had to drill round, true holes in marble found that a slot ground across the point of a

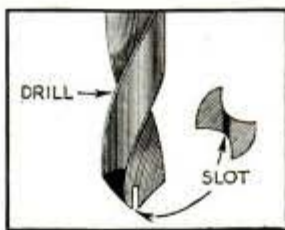

high-speed twist drill enabled him to do the work quickly and accurately in a drill press. Although the drill will cut well dry, a few drops of kerosene will speed up the work and reduce wear on the drill bit.

How to Save Wear on Saw Blade When Ripping Concrete Forms

Next time you rip boards that were used for concrete forms, you can save a lot of wear on the saw by setting the blade so that it

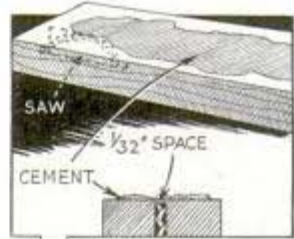

lacks about $\frac{1}{32}$ in. of cutting through the work. In this way, the teeth of the saw blade do not come in contact with the cement, which eliminates frequent sharpening. The thin sliver left on the edge of the boards can be scraped or planed off.

Cut-Down Keg Handy Carrier For Nails on Job



For carrying a supply of nails about on a job, one carpenter cut down an empty keg as shown in the drawing. All the staves were sawed off at the center of the keg except two, which

were left full length opposite each other. A hand grip, shaped from wood, was nailed to the upper ends of the long staves.

Clip Holds Alarm Clock on Shelf

To keep an alarm clock from being worked off a shelf by vibration of machinery in his shop, one workman bent flanges on a scrap piece of sheet metal to fit over the base of the clock and tacked it to the shelf. The clip keeps the clock securely in place, yet allows it to be removed easily.

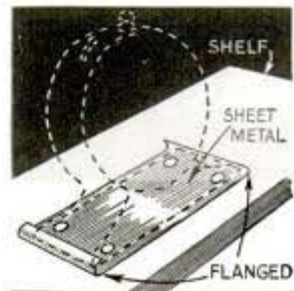

Simple Storage-Battery Repair You Can Make

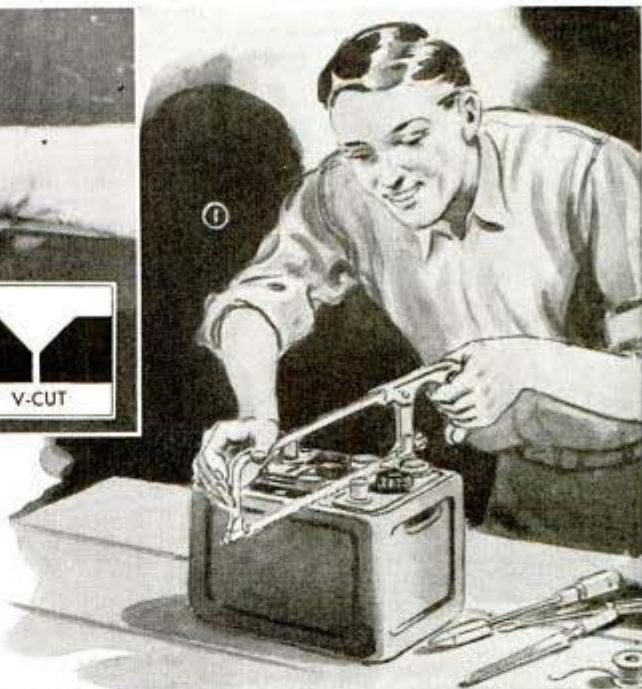
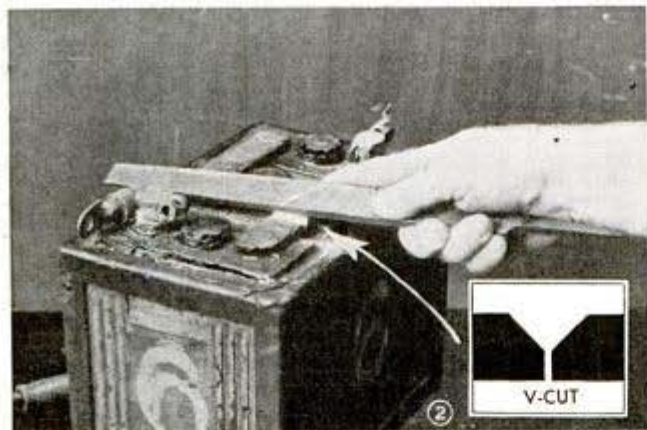

In many cases of failure of one cell in a storage battery, the trouble is nothing more than a short circuit caused by broken insulation between the plates, or by inactive material from the plates being deposited in the bottom of the cell case to a height sufficient to reach the bottoms of the plates and "short" them. In such instances, anyone can make a repair that will prolong the life of the battery many months. Naturally, the repaired battery will not be equal to one that has been rebuilt, but the repair costs nothing to make and will help in material conservation. First, determine which cell is faulty by using a voltmeter, or by connecting a 2-volt flashlight bulb across the posts to each cell in turn. The one that lights the bulb the least brilliantly is the one at fault. Then cut the connecting straps with a hack saw, Fig. 1, and groove the upper edges of the saw cuts with a file as in Fig. 2. Now, remove the sealing compound around the edge of the cell, saving the compound for later use. Lift the cell and prop it in a position for the acid to drain into the case. Avoid getting the acid on your hands or clothing. If you do, wash it off immediately with water, or neutralize it with a saturated solution of water and baking soda. Then examine the insulating separators between the plates for damage, especially near the lower ends. If a faulty separator is found, remove the damaged part and replace it with a strip cut from one of the extra separators used to wedge

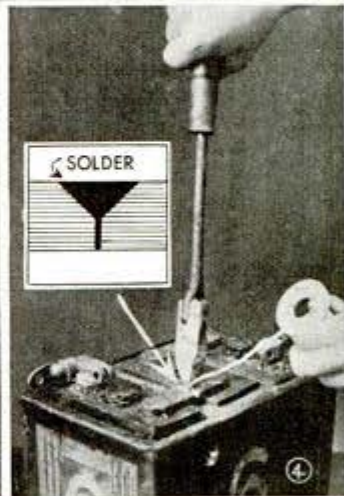
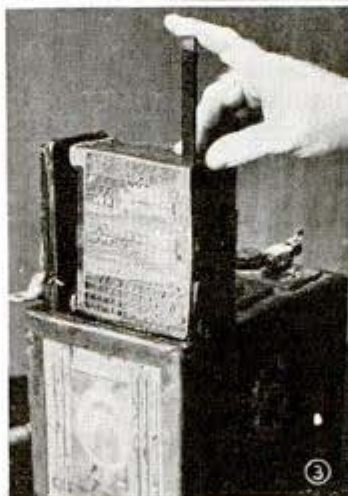

the cell tightly in its case, Fig. 3. A piece of wood from a berry box will do if the battery has no extra separators. If no damaged separator is found, remove all the inactive material from the bottom of the case—do this whether or not the separators are at fault—and replace the cell. Solder the connecting straps together as in Fig. 4, and replace the sealing compound. You can do this by putting each piece on a soldering iron just hot enough to melt it so that it will flow into place. It is a good idea to run the iron around the entire battery case to close any cracks that might have been opened by vibration. Now, either have the battery charged, or put it in the car and bring it to full charge with the generator.

Sales Cards Supported by Roller Easily Lowered for Removal

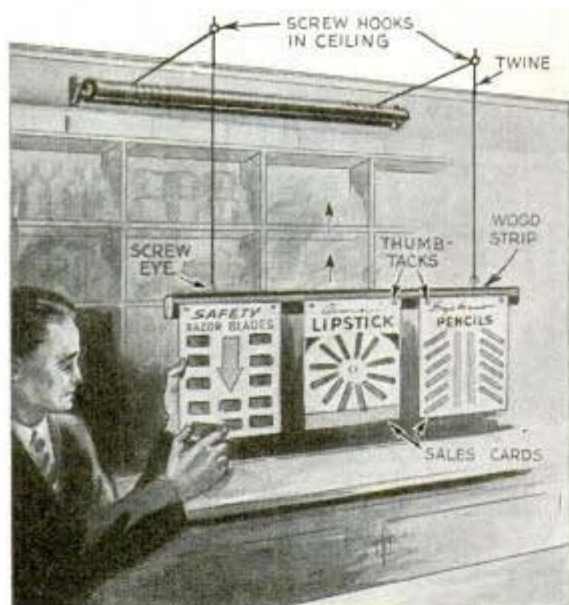

To keep sales cards of safety-razor blades and other small articles conveniently at hand above the counter and out of the way, one merchant fastened two lengths of stout twine to a shade roller mounted on the wall near the ceiling. The twine passed through screw hooks in the ceiling and supported a wood strip horizontally on which the cards were attached with thumbtacks. In use, the cards are pulled down for easy selection of the desired articles, then raised out of the way.

Hollow Lathe Spindles Cleaned With Piece of Oiled Felt

When turning precision work in your lathe, it is possible that a chip or rust spot in one of the hollow spindles might throw a center out of alignment and damage a

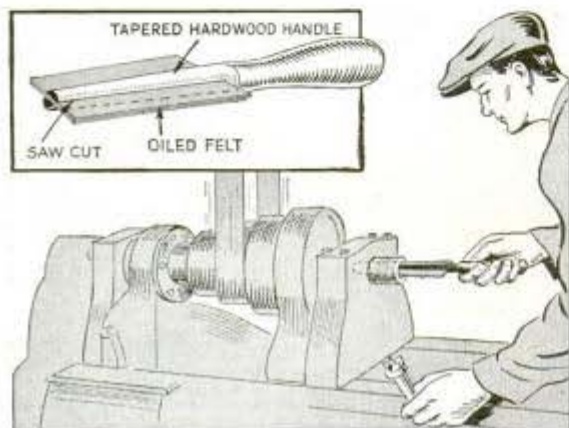

costly piece of work. To guard against this, assemble a two-sided brush to clean the spindles before inserting tapered centers. It is made by turning a hardwood handle to the shape indicated after which a piece of oiled felt is slipped into a slot cut in the tapered end. When cleaning the headstock spindle, it is only necessary to hold the brush in place while the lathe is running. However, when using it in the tailstock spindle, it is turned by hand.

Red Signal Summons Foreman On Construction Job

Instead of calling to the foreman when he is needed in the office for consultation, one engineer on a large construction job uses a red signal for the purpose. This

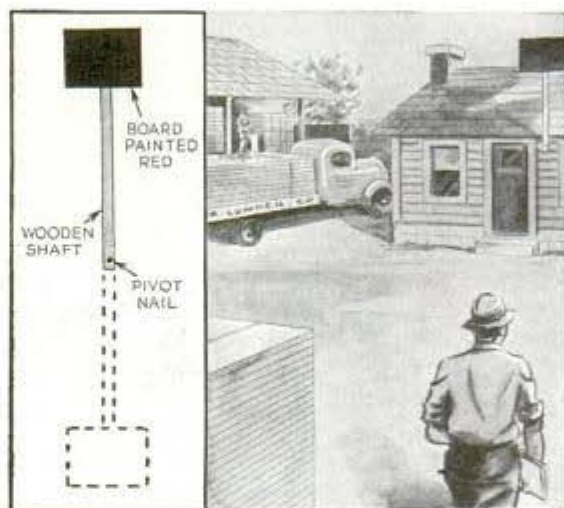

consists of a wooden board or red flag attached to the end of a long shaft which is pivoted near the office door. Stops just above the pivot point serve to keep the signal in a vertical position when raised.

Two Extra Drill-Press Spindles Stored in Hollow Column

If your drill press has a hollow standard or column, you can store in it the interchangeable spindles used for holding router bits, mortising chisels, shaper cutters, etc. Simply drill a wooden plug to take the spindles and force it tightly into the top end of the standard.

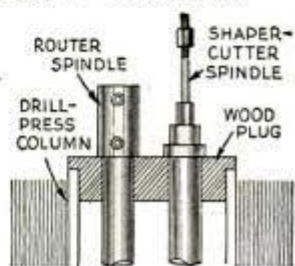

JIGS *for sharpening* CIRCULAR SAWS

SHARPENING circular saws accurately becomes a simple matter if you have access to a lathe and scroll saw on which the job is done with the aid of easily made wooden jigs. Pictures on this page show the steps in sharpening a hollow-ground blade. Before sharpening, the blade must be jointed and cleaned. Jointing of the cutting teeth is done while the saw is being run, the table having been raised so that an abrasive stone on the table can be brought directly over the rotating blade as shown in Fig. 2, to remove the least possible amount of metal from the edge in order to bring the saw to a perfect circle. Jointing of the raker teeth is done by filing them as shown in Fig. 3, using a block of hardwood to guide the file horizontally. Naturally the saw is at rest while this is being done. The table should be adjusted so that the raker teeth will be filed $\frac{1}{64}$ in. shorter than the cutting teeth. Cleaning can be done with an old toothbrush, dipped in alcohol or lacquer thinner. All traces of resinous pitch must be removed.

Filing the teeth of a hollow-ground blade is done on a scroll saw as shown in Fig. 1, using an auxiliary wood table to hold and guide the



① HOLLOW-GROUND BLADE IS EASILY SHARPENED BY FILING ON SCROLL SAW

blade, the table having a center part that slides as indicated in Fig. 5. The table shown was dimensioned for a 14 by 14-in. scroll-saw table. For saws of other makes you may have to alter the size and the location of the slide. One or two C-clamps are used to hold the table in place securely.

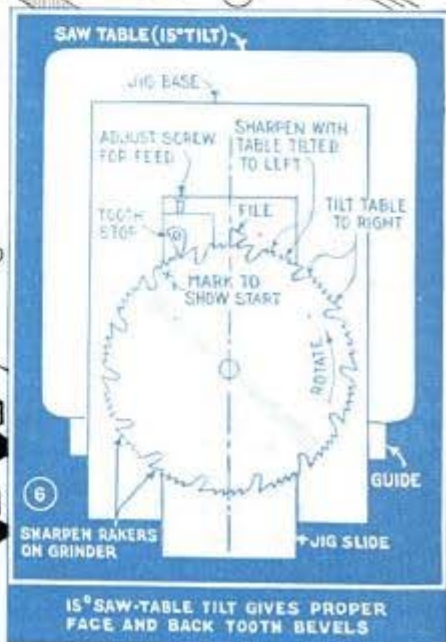
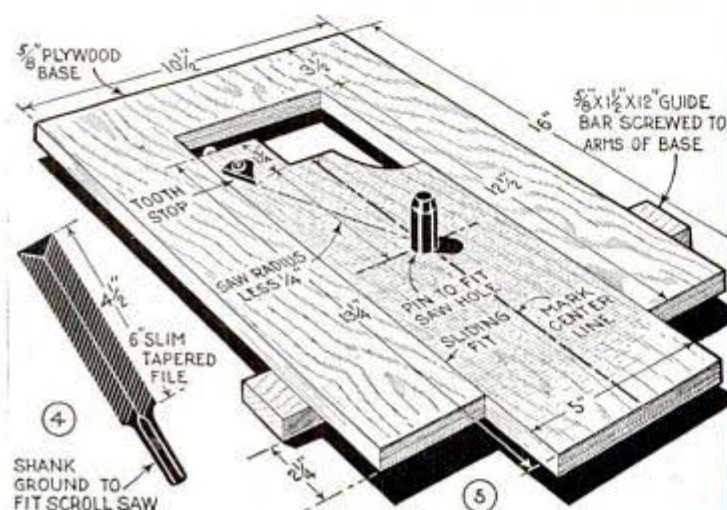
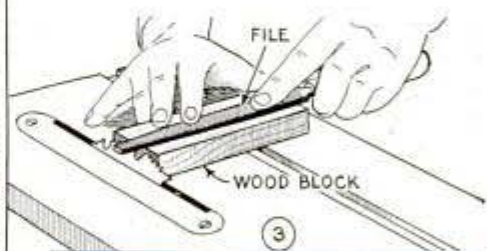



THE SLIDE REST ON LATHE PROVIDES A QUICK AND ACCURATE MEANS OF SHARPENING RIP AND COMBINATION SAWS

The scroll-saw table is tilted at a 15-degree angle to the left, and the wood table is clamped in place so that the centerline on the slide will line up with the edge of a 6-in. slim, taper file, Fig. 4, which is held in the saw chuck. In this position, two teeth in each group can be filed as shown in Fig. 6. Then, with the saw table tilted to the right, also 15 degrees, the jig is re-clamped to bring the centerline of the slide again in line with the edge of the file. In this position, the remaining teeth of each group are filed. The file, tooth spacer and screw controlling infeed are not changed. Rakers are ground across squarely, the job being done freehand on a bench grinder, watching carefully to remove just the highlight caused by jointing.

A lathe provides the means of sharpening rip and combination saws, the general method being shown in Figs. 7, 8 and 9. A wood table to hold the saw in a horizontal position, level with the center of the grinding wheel, is bolted to the slide rest of the lathe. The table has a pin or stud that fits snugly in the arbor hole of the blade, to keep the blade in the same position as the work progresses. You can use a C-clamp on the slide to

serve as a depth stop for grinding as shown in Fig. 9. A 1/4 by 6-in., 60-grit wheel is the right size to use for grinding saw blades. The angle on the first tooth should be set for 1/4 pitch as indicated in Fig. 10. A nail driven into the wood table serves as a tooth stop, the saw blade being raised and moved over toward the left to grind the faces of the teeth and toward the right when grinding the backs of the teeth. See Figs. 10 and 12. Backs of rip-saw teeth are ground squarely across or with a 5-degree bevel as shown in Fig. 11. The clearance angle for the backs of rip-saw teeth is ascertained by

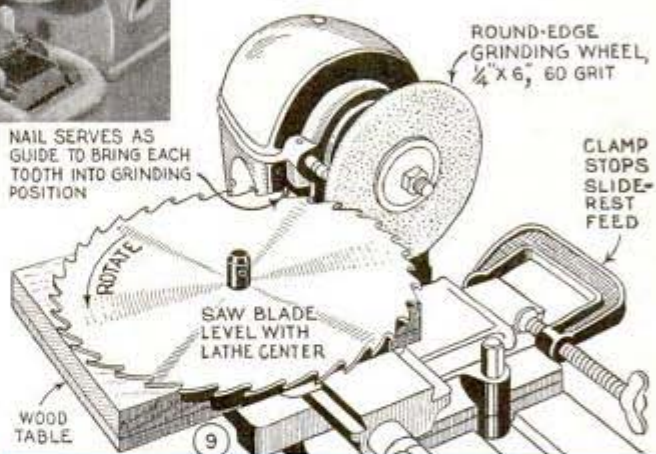

holding a straightedge against the side of the wheel and adjusting the position of the blade so that the side of the wheel is on a straight line from the tip of one tooth to the tip of the fifth following tooth. Adjustments for this purpose are made with the slide rest as shown in Fig. 13. Combination saws are ground similar to rip saws except that the teeth are slightly smaller and the teeth backs are always beveled about 10 degrees. Some saws also have a 10-degree bevel on the tooth face. For the angle grinding, the set-up is the same as before except that a block must be slipped under the wood table in order to obtain the required bevel.

Name and Number on Paint Can Protected for Reference



As most paint has the name and number printed on the outside surface of the can, it is a good idea to protect this lettering so that it can be used for reference if necessary to re-order. A good way to protect the lettering is to cover it with cellulose tape before opening the can. Then if the outside of the can becomes smeared, the tape can be stripped off to reveal the information.

Neat Type-Case Label Holders Cut From Curtain Rod

Instead of gluing identification labels to his type cases, one printer made neat holders for them by screwing short lengths of telescoping curtain rod to the fronts of the cases. This enables him to print the labels on cardboard strips and slip them into the holders so that they can be changed from one case to another quickly without making new ones.



FEBRUARY, 1943

"Invisible" Guard on Barn Door Keeps Chickens Out

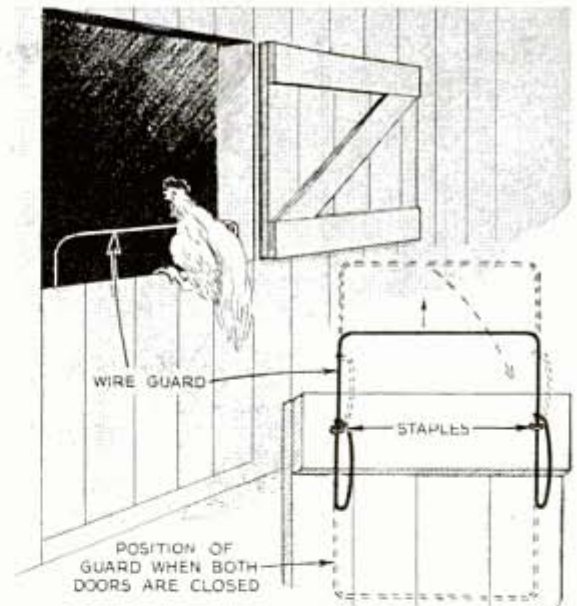

Where it is advisable to leave the top half of a barn door open, chickens can be kept from flying over the lower half by use of a wire guard. This consists of a length of wire bent as shown and fastened to the inside of the door with two staples. In use, the guard is merely lifted to vertical position so that the loops drop down on their staple supports to hold it erect, with the center portion about 4 in. above the top of the door. Chickens attempting to enter the barn will aim their flight toward the top edge of the door where they will hit the guard and fall back.

Tacks Stitched in Hem of Red Flag For Attaching to Long Poles

Attaching a red flag to the end of a long telephone pole when hauling it is done quickly by one line-crew foreman who uses a couple of large thumbtacks for the purpose. To prevent loss of the tacks, they are stitched permanently in the hem along the top of the flag as shown.

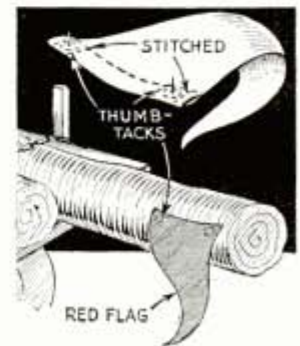

Many accidents caused by children falling on polished floors can be avoided by coating the shoe soles with rubber cement.

143

Auto-Spring Leaf Provides Cradle To Hold Oil Drums on Bench



The problem of holding oil drums and similar containers on his workbench for welding, cutting and soldering was solved by one mechanic who used the short leaf of an auto spring to make a simple cradle. The leaf is adapted by welding a pivot bolt in the center of it, after which a hole is drilled in the bench top to take the bolt. With this arrangement, the work can be rotated or turned end for end quickly without danger of it rolling off the bench.

Altered Exhaust Pipe of Tractor Prevents Fire in Hayfields

With tractors having low-mounted horizontal exhaust pipes there is often danger of fire when the machine is driven astride dry windrowed hay, as in pulling a loader

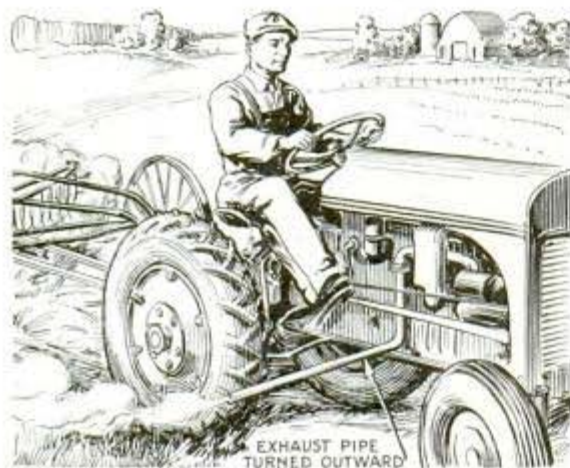

or side-delivery rake. To offset this hazard, one farmer removed the regular exhaust pipe assembly and substituted a shorter pipe which he bolted to the manifold at an angle so that the hot exhaust gases were conducted to the side of the tractor, outside the line of the drivewheel.

Tap Wrench Used as Substitute For Drill-Press Vise

In an emergency you can use a tap wrench as a drill-press vise to grip small pieces of rod or bar stock. If necessary, the wrench can be clamped by using hook bolts through the slots of the drill-press table.



Plow Coulter Attachment Aids In Covering Trash

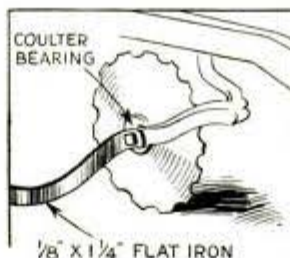

Confronted with the problem of plowing under vegetable roots and short lengths of cornstalks that lie loosely on top of the ground, one farmer attached a short wing of flat iron to each coulter bearing as shown. This was bent back at an angle and adjusted to about 1 in. above the ground.—W. C. Lammey, Sandwich, Ill.

Swinging Sign Locked on Hooks By Auto-Valve Springs

Difficulty in keeping a swinging sign from being blown off its supporting hooks led one workman to use a couple of discarded auto-valve springs to correct the trouble. These were slipped over the screw hooks of the sign and compressed so that the hooks could be



slipped through the eyes. When released, the springs snap into the position shown, keeping a slight tension on the hooks which prevents them from slipping out.

Tool Shelf on Ways of Lathe

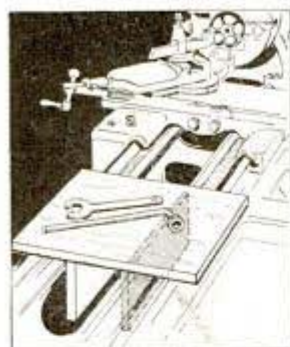

Made to fit between the ways of your lathe, this shelf provides a handy place to lay tools and small parts where they are within easy reach. The shelf is removed or replaced instantly, and consists of a

plywood top to which two blocks are attached on edge to fit between the lathe ways. In this way, the shelf can be moved back and forth as desired.

—Wm. N. Clements, Geneva, N. Y.

Metal Lath Stapled on Foot Board Provides Nonskid Surface

After working in a number of machine shops where foot boards are used in front of machines, I assembled a nonskid one which is especially useful where considerable oil and grease gets on the floor. The covering consists of a strip of metal lath, stapled at the ends to hold it in place securely. This provides a surface for the platform to keep the workman's feet from slipping on oil-soaked boards.

—Charles H. Miller, Oakland, Calif.

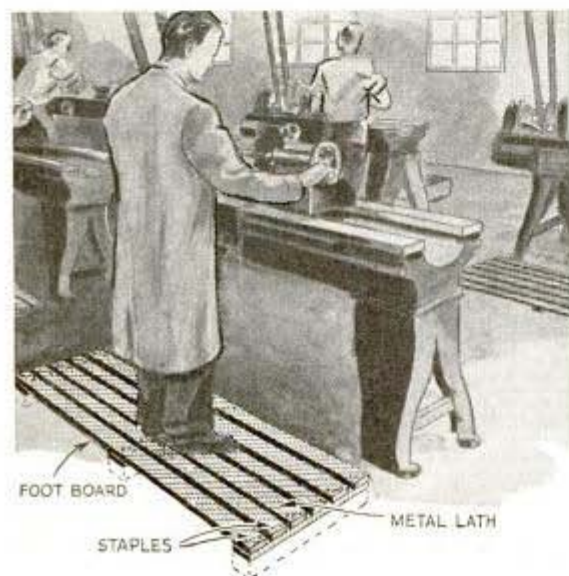

Portable Unit Holds All Supplies For Lettering Price Tags

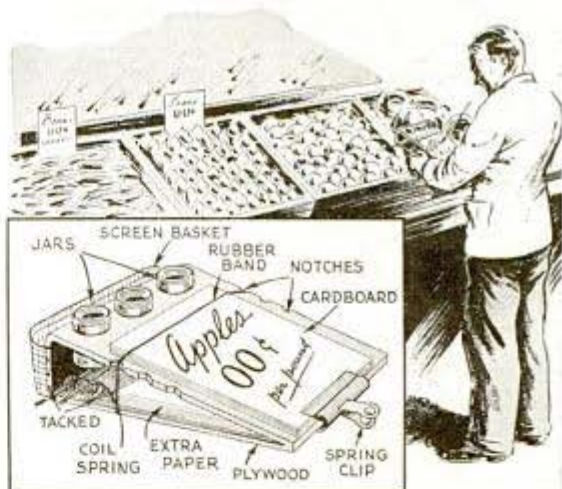

Price tags and signs for items in grocery stores and fruit markets are lettered quickly with this portable unit, which includes all of the supplies needed. It is made by cutting three holes near the bottom of an ordinary clip board for show-card color jars after which the board is attached to a wooden base. A coil spring serves as a handy place to keep brushes, and an improvised wire basket holds the jar caps when they are removed. Room is also provided for extra paper as shown. In use, the cards are held securely by the clip and rubber band which can be adjusted easily to permit lettering near the top of the card.

Auxiliary Anvil on Micrometer To Get Accurate Readings

If you experience difficulty in getting accurate readings with a large micrometer because of a tendency of the micrometer to incline from the perpendicular of the axis of the work, this auxiliary anvil will help avoid the trouble. Also, the anvil facilitates applying the micrometer and removing it from the work. Dimensions of the anvil are optional and it can be made to suit the user. Care must be taken in its construction if accuracy in its readings is to be obtained.

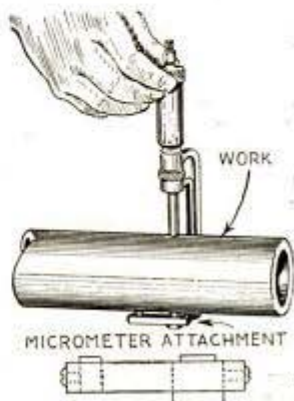



Shortcuts in DIE MAKING

Some of the essentials all prospective punch-press operators should know. Also includes basic data on making dies, including modern methods that save both time and material.

By H. J. Chamberland

MANY parts of household appliances, kitchen pots and pans, parts of your car and even of your shoes are products of a machine known as a press. In its operation one downward stroke of the ram brings a punch down on sheet stock placed on a die, and the stamping that results is formed according to the shape of the punch and die. This one-stroke operation applies to press work in general, but an exception is the so-called drawing-press

work in the manufacture of ammunition shells, pans and kettles, etc., which are shaped by a series of operations to prevent tearing the metal. There are many designs of presses ranging in size from small bench models to monsters that are operated hydraulically. The most commonly used type of punch press is the inclinable type shown in Fig. 1.

Punches and dies: As the basic purpose is to punch identical pieces in quantity, a punch-and-die set must be made up specially for each stamping job. The work of making such sets is known as die making. In use, a punch is fitted to a holder

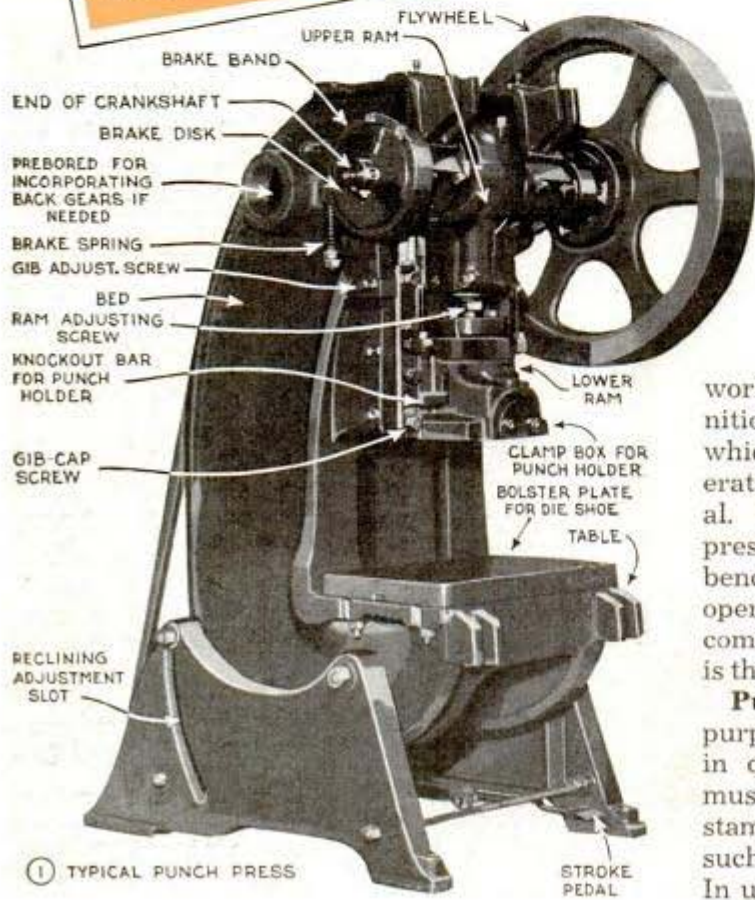

① TYPICAL PUNCH PRESS

STROKE PEDAL

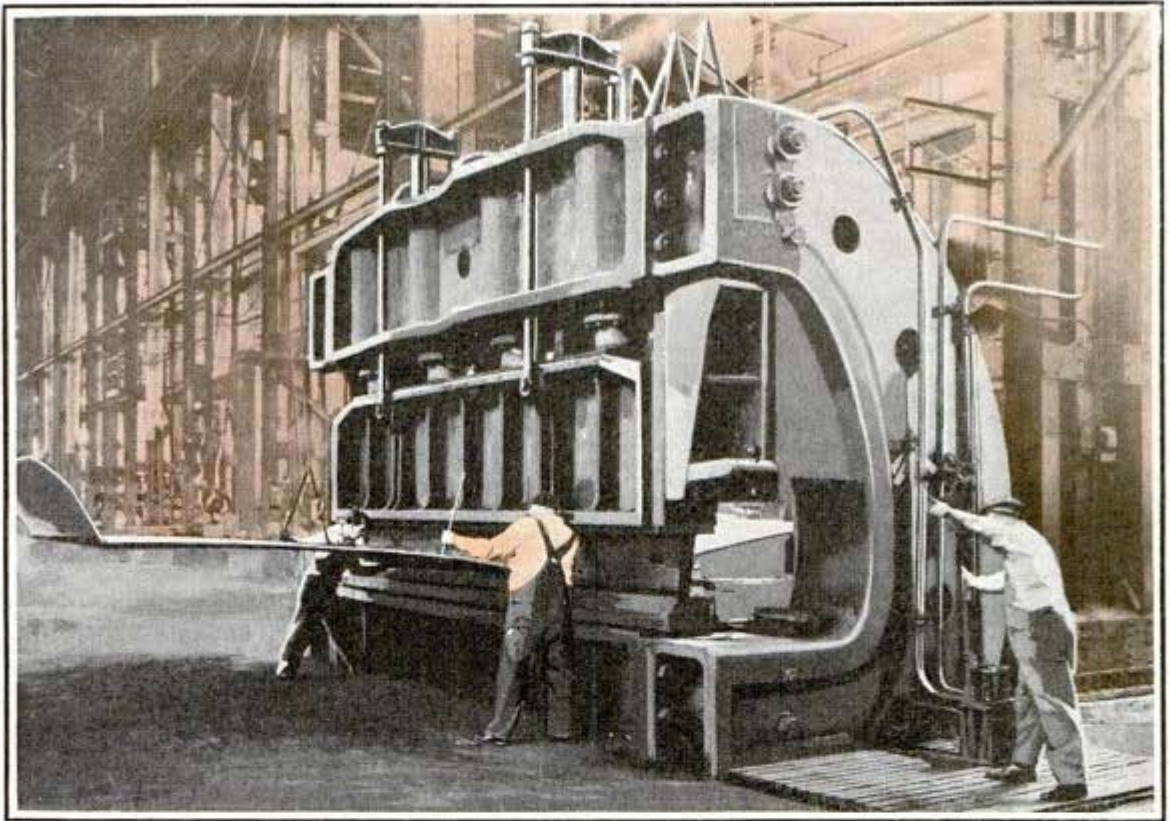

secured in the clamp box on the ram by means of its post or shank. The corresponding die is fitted to a shoe, which is bolted to the bolster of the machine table. Blanking punch-and-die sets consist of solid plates of die steel, machined internally as dies and externally as punches. Piercing punches are fitted to a punch plate, which is attached to the punch holder, while dies are made in the form of disks fitted to a die plate, which is fastened to the die shoe. Alignment between a punch and die is obtained by means of two or four leader pins. Usually, these are attached to the die shoe, but occasionally they are fitted to the punch holder to compensate for misalignment due to excessive wear in the ram mechanism. It is claimed that this reversed procedure greatly lessens the chances of stripping the cutting edges of a punch and die. Fig. 3 shows four standard sets of punch holders and die shoes. Type A has two leader pins, both at the rear. Type B has one leader pin at the front and another one diagonally across at the back, and is recommended for feeding work from the front. Type C has four

Punch presses vary in size from small bench models to monsters such as the one above

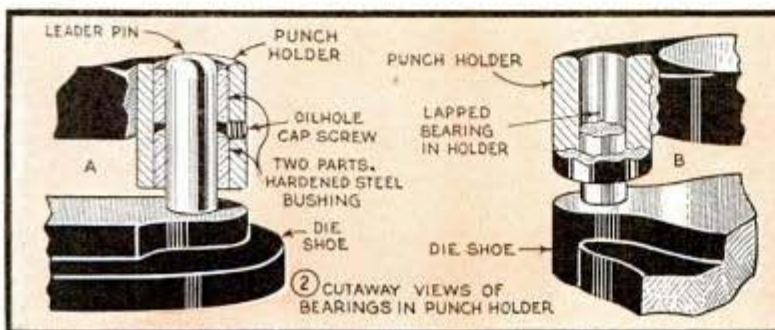
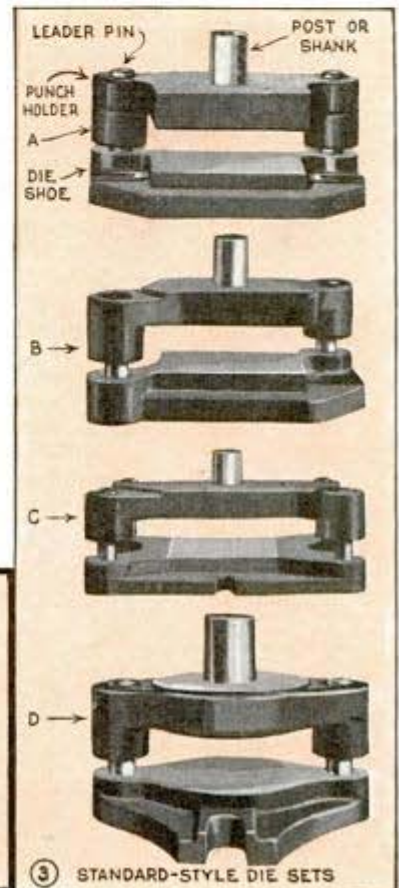

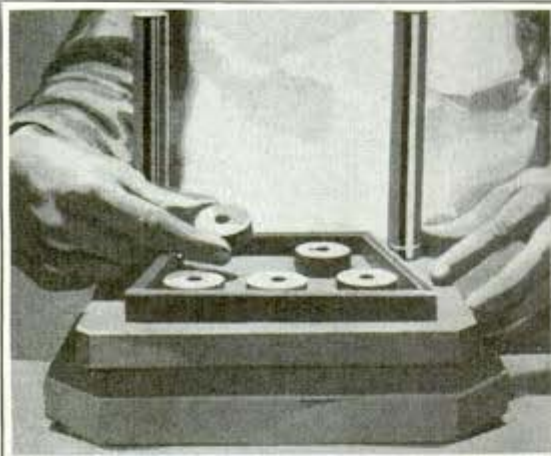

④ HEIGHT OF FENCE ON DIE PLATE IS THE SAME THICKNESS OF DIE DISKS

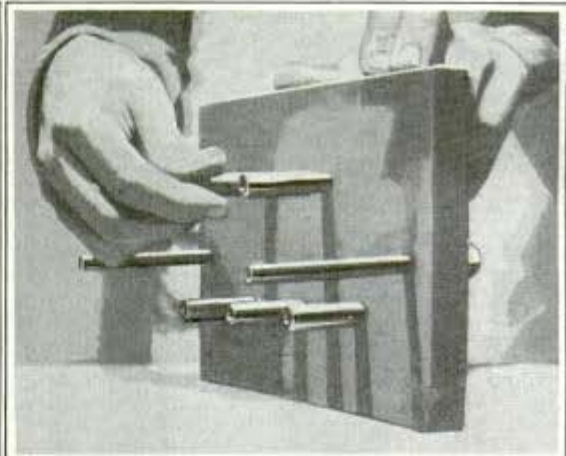

⑤ HARDENED AND GROUND PUNCHES ARE LOCATED IN MASTER PLATE

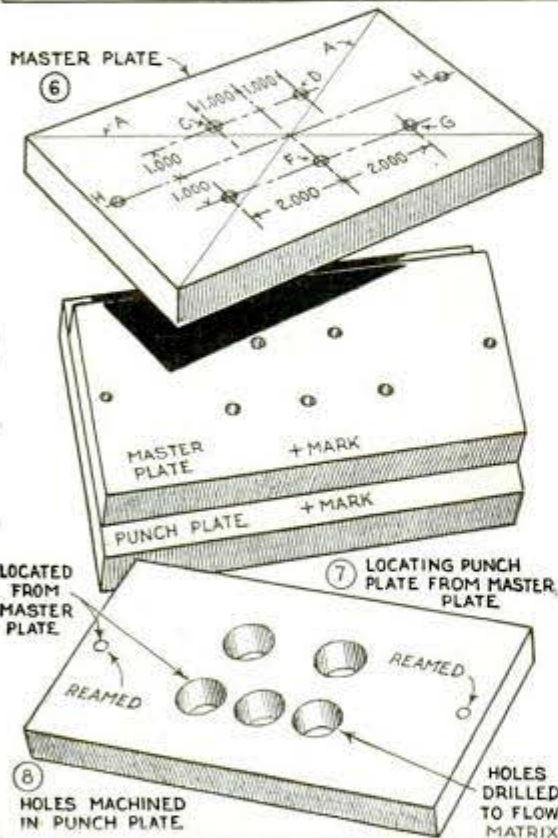

leader pins and is well adapted for heavy work, while type D, having two heavy leader pins, is especially convenient for circular or oval-shaped punches and dies. A perfect sliding fit must exist between the leader pins and their bearings in the punch holder. Punch holders having two-part, hardened-steel bushings as shown in Fig. 2-A, can be lubricated well, and the bushings can be replaced when they are worn. However, many punch holders do not have such bushings, as for example the one shown in detail B. In this case the bearings are bored in the punch holder and are given a highly lapped finish to avoid premature wear and to hold a film of oil.

Making a piercing punch-and-die set: A master layout plate such as the one shown in Fig. 6, is made by a skilled die maker. After squaring and surfacing the master plate, he proceeds to lay out the exact locations of the holes from a center point at the intersection of lines A. All five holes C, D, E, F, and G are bored next in a milling machine or jig borer. Then holes H are

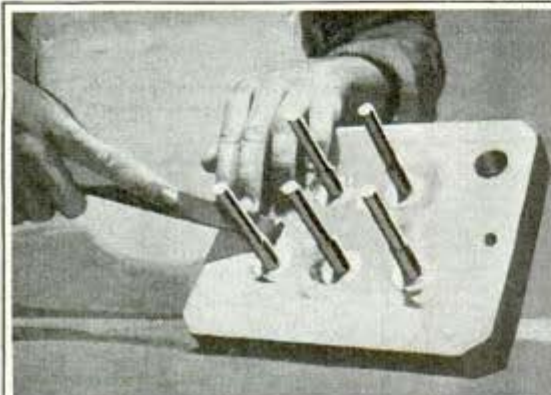

⑨ SCRAPING OFF EXCESS MATRIX FROM HOLDER PLATE AFTER SECURING PUNCHES

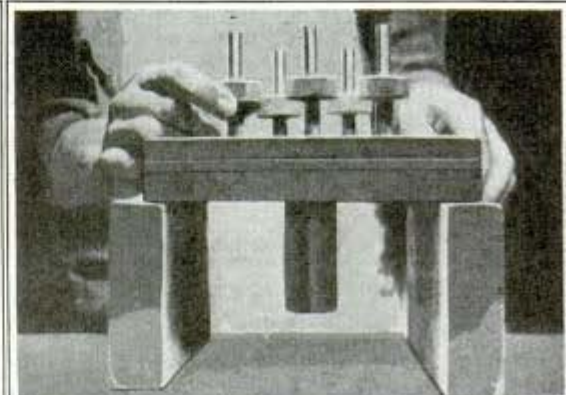

⑩ HARDENED AND INTERNALLY-GROUND DIE DISKS ARE PLACED ON PUNCHES

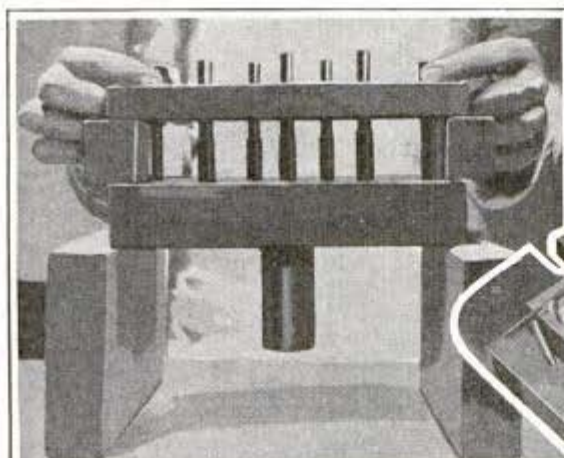

11 ALIGNING PUNCH-HOLDER ASSEMBLY WITH MASTER PLATE SET-UP

located, drilled and reamed, these being required for future alignment purposes.

After this has been done, the average machinist who has a bench lathe, drill press and a metal-cutting band saw, can proceed in making the set by following carefully the steps of a simplified modern method: First, centralize the master plate with the punch plate as shown in Fig. 7, the latter having been squared and surfaced. Mark both the master and the punch plate as indicated so that they will not be reversed or turned end for end later. Clamp both plates together and drill all seven holes through the punch plate with correctly ground drills the same size as the holes, which, for example, are all $\frac{3}{8}$ in. in size. Then insert pieces of $\frac{3}{8}$ -in. drill rod as alignment pins in holes H, after which you remove the clamps. The next step is to drill the five punch holes three to four times larger than the shanks of the punches, as shown in Fig. 8.

Assuming that hardened and ground punches and die disks have been made up previously, the punches are secured temporarily to the punch



12 Band-sawed punch and die at top mounted on punch holder and die shoe in center

13

Approximate capacity of crankshaft at bottom of stroke of well-designed punch press

Crankshaft diameter		Tons
in inches		
$1\frac{1}{8}$		6
$1\frac{1}{2}$		$7\frac{1}{2}$
$1\frac{3}{8}$		9
$1\frac{3}{4}$		$10\frac{1}{2}$
$1\frac{7}{8}$		12
2		14
$2\frac{1}{8}$		16
$2\frac{1}{4}$		18

14

Approximate pressure to punch a 1" dia. hole in soft steel, high-carbon steel and brass

Thickness of Stock	Pressure in pounds		
	Soft steel	High carbon	Brass
$\frac{1}{32}$ "	5890	8835	4123
$\frac{1}{16}$ "	10768	16198	7559
$\frac{1}{8}$ "	20532	30924	14432
$\frac{1}{4}$ "	39270	58905	27489
$\frac{3}{8}$ "	58905	88357	41233
$\frac{1}{2}$ "	78540	117810	59978

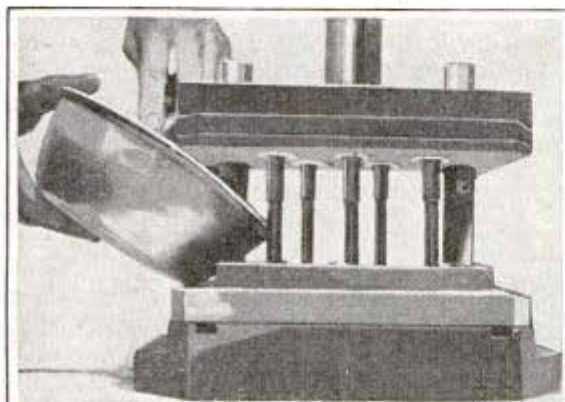

15 LOCATED DIE DISKS ARE SECURED BY FLOWING MATRIX INTO FENCE



16 COMPLETED PUNCH AND DIE READY FOR SURFACE GRINDING ENDS OF PUNCHES AND DIE PLATE

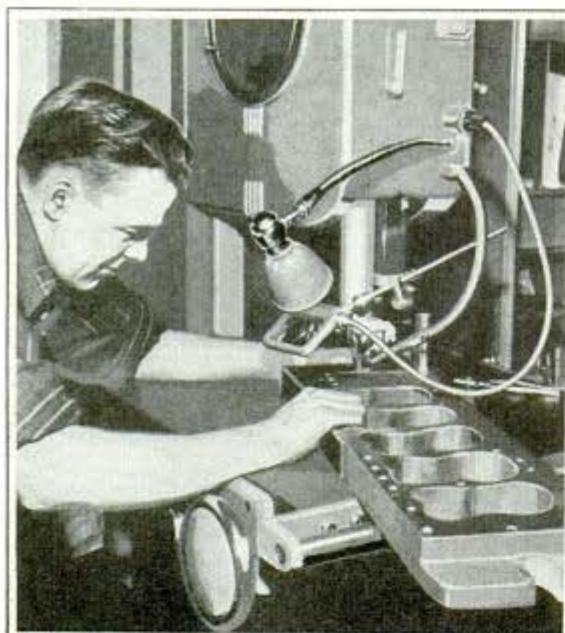

17 BAND-SAWING OPENINGS IN DIE SHOE USED FOR BLANKING SIX-CYLINDER HEAD GASKETS

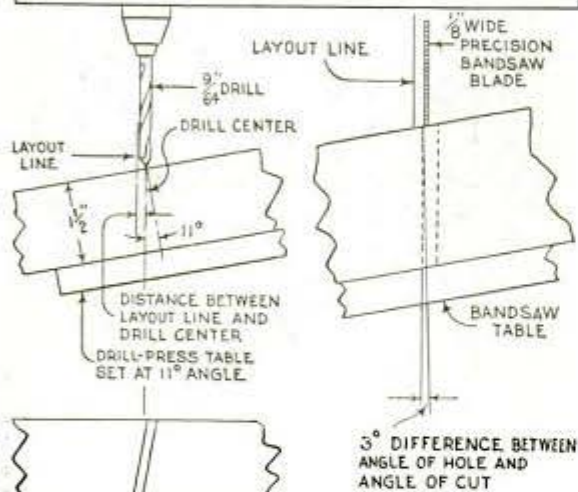

18 HOW STARTING HOLE IS DRILLED IN RELATION TO LAYOUT LINE

19 HOW SAWING IS DONE IN RELATION TO STARTING HOLE

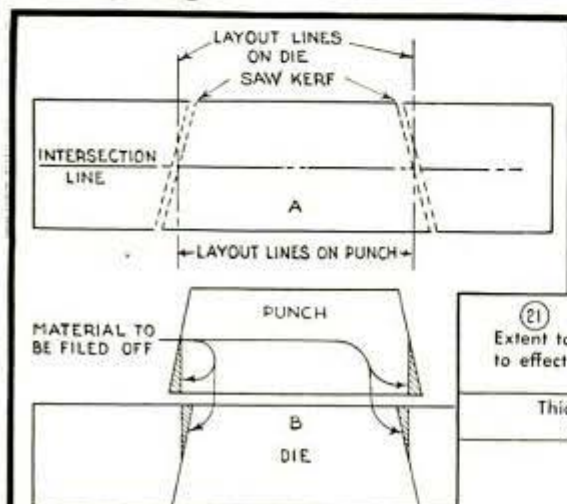

20 HOW PUNCH AND DIE APPEAR AFTER SAWING OPERATION

21 Extent to which the punch has to penetrate to effect complete severance of the slug in soft steel

Thickness of Stock	Percentage of Penetration
1/2"	.87
3/16"	.75
1/8"	.62
1/4"	.50
3/8"	.44
1/2"	.37

holder with a quick-setting paste consisting of sal ammoniac, 1 part, sulphur, 2 parts, and fine steel filings, 8 parts, mixed with water to a suitable consistency. Insert the punches in the holes of the master die plate as shown in Fig. 5. Then place the punch holder on two supports as shown in Fig. 11, to clear the shank or post. If the job is just an experimental one and the set is not to be used, fill the enlarged holes entirely with the paste at this time. However, on a working set, the paste is put in the enlarged holes only to a depth of about 1/4 in., as the rest of the space is to be filled with a special copper-alloy matrix metal, which melts at 250 degrees Fahr. Invert the master plate carefully so that the punches will not drop out, and locate it on the punch holder by means of the locating pins. Press the punches down to the bottom of the enlarged holes and allow the mixture to harden, after which the master plate is removed. Then the melted copper-alloy matrix is poured into the remaining space above the dried paste that holds the punches. When the matrix metal—or the paste if you are using the latter entirely—has hardened, the excess is scraped off as shown in Fig. 9.

Before locating the die disks and pouring the matrix around them, you make up a metal fence as shown in Fig. 4. This should be as high as the thickness of the die disks. Use solder to close the corners of the fence. After the fence has been placed on the die shoe, slip the die disks on the punches as shown in Fig. 10. Again invert the assembly carefully to retain the disks while aligning the punch holder with the die shoe by means of the leader pins. There should be a clearance of at least 1/2 in. between the disks and the fence. To secure the disks temporarily, you need the same paste used to hold the punches, but this time it is thinned so that it can be poured easily from a pan as shown in Fig. 15, to a depth of about 1/8 in. around the disks and between them and the fence. After the paste has

hardened, remove the punch holder and fill up the space between the disks with the copper-alloy matrix for a working set, but only with

22 Data for sawing die steel to make punch and die from same piece of stock

Thickness of die steel	Angle of starting hole	Angle of cut	Distance from die layout line to center of saw kerf	Distance from die layout line to center of starting hole	Diameter of drill	Width of saw	Resulting amount of straight side on punch and die
1	14°	11°	3/32	1/8	9/64	1/8	3/8
1 1/4	12°	9°	3/32	1/8	9/64	1/8	15/32
1 1/2	11°	8°	7/64	9/64	9/64	1/8	9/16
2	10°	7°	1/8	3/16	13/64	3/16	13/16

(all dimensions given in inches)

the paste or even plaster of paris for an experimental job. Fig. 16 shows the completed punch-and-die set. The last operation is to surface-grind the die plate and the ends of the punches.

As a matter of information concerning punch presses, Fig. 13 gives a table from which you can estimate the tons of pressure that a press produces in relation to its crankshaft size. Fig. 14 gives the approximate pressures in pounds required to punch a 1-in. hole in sheets of soft steel, high-carbon steel and brass of various thicknesses. The extent that a punch must penetrate soft-steel sheets of various thickness is given in Fig. 21.

Blanking punch and die: Another modern development is that of making a blanking punch-and-die set from one piece of steel. The work is done on a metal-cutting band saw as shown in Fig. 17, and the method saves both time and material. Fig. 12 and also the photos at the top of the first page of this article show punches and dies produced by this method. The upper details in Fig. 12 show a punch and die separately, the center details show them attached to the punch holder and die shoe, and the lower detail shows a number of stampings produced with the set. The first part of the job in making such a set is done by an expert die maker; he squares and surfaces the blank and then outlines the shape of the cut which is located accurately with measuring tools or from a template. Depending on the thickness of the die steel, a starting hole is drilled at a predetermined size and angle. See Fig. 22. The size of the drill hole determines the width of the saw. Fig. 18 shows a hole being drilled at an angle in 1 1/4-in. stock. In this case a 9/64-in. drill was used and the distance between the layout line and the drill center was also 9/64 in. When band-sawing, the band-saw table is tilted a few degrees less than the drill-



25 Scrap allowances for blanking

Thickness of stock	Diameter of blanks	Scrap allowed on the side	Scrap allowed between blanks
.013 to .057	Up to 10	1/8	1/16
	10 to 20	3/16	3/32
	20 to 30	1/4	1/8
	and over		
.057 to .081	Up to 10	5/32	3/32
	10 to 20	7/32	1/8
	20 to 30	5/16	5/32
	and over		
.081 to .128	Up to 10	3/16	1/8
	10 to 20	1/4	5/32
	20 to 30	3/8	3/16
	and over		

(all dimensions in inches)

ing angle, as shown in Fig. 19. In this case, the difference in angle was 3 degrees. From Fig. 20-A, showing the cut completed, you will note that the layout line intersects the die layout line at the center of the plate, the die layout line is also the punch layout line as can be seen when the punch and die are placed in the position shown in Fig. 20-B. An equal amount



of stock remains on both punch and die to be filed off to complete the work. Fig. 23 shows a band-filing machine being used for this purpose, while Fig. 25 gives scrap allowances usually permitted for blanking.

When resharpening die plates on a surface grinder as in Fig. 24, they need not be removed from the die shoes. Use plenty of coolant so excessive heat will not be generated. Grinding dies dry is likely to invite so-called wheel cracks, which damage costly dies beyond repair. Piercing punches are never removed from a punch holder for resharpening; the holder is held on a magnetic chuck as in Fig. 26 when resurfacing the tops of the punches.

Chain Stop on Truck Endgate to Spread Gravel Uniformly

Although dump-truck bodies are regularly fitted with a fixture for adjusting the endgate to a given opening, the chain tends to slip out of the locking slots, especially after the latter become worn. One truckman, who specializes in road work and graveling driveways, fitted the endgate of his truck with a special chain latch as shown. To spread gravel or crushed stone to any desired depth on a driveway, he drops a given number of links in the chain, then places the last link over the hook welded to the endgate. Then he raises the body, releases the endgate and drives forward. Since the endgate is held at a given opening the material is spread uniformly.

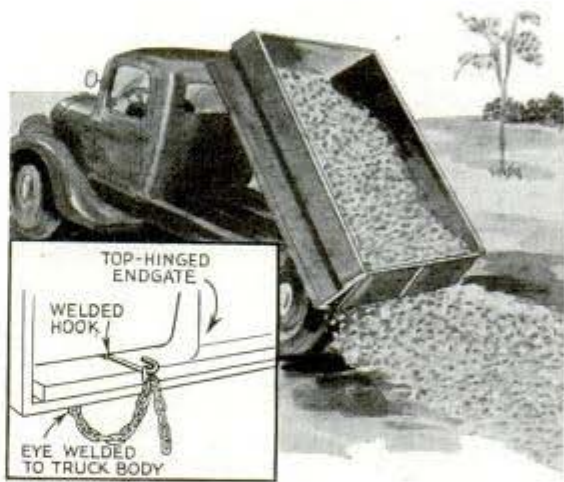

Sign Kept in Vertical Position on Sidewalk by Sand-Weighted Base

Difficulty in preventing his sidewalk sign from being tipped over by the wind led one filling station owner to fit a trough between

the sign uprights as shown. This was then filled with sand which provided sufficient weight to hold the sign in place.



Offset Prick Punch Is Safer

In rapid production work where a number of holes must be marked in sheet metal with a prick punch, one is less likely to injure the fingers when striking the punch with a hammer if

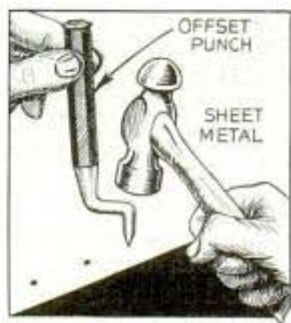

a punch of the type shown is used. There is less chance of such a punch flying out of the hands if struck a glancing blow.

Clip on Mechanic's Scale Triples Its Usefulness

Greatly increasing the usefulness of a machinist's steel pocket scale, this little sliding clip, serves a threefold purpose: First, it holds the scale securely in a pocket within easy reach so that it is not likely to be lost or misplaced. Second, the clip, which has tabs bent to fit snugly on the scale, will remain in any adjusted position, enabling the clip and scale to be used as a convenient depth gauge. Third, the edges of the clip may be ground to serve as gauges, as indicated in the upper left-hand detail, and a 60° notch provides a handy guide for grinding thread-cutting tools.—Will. F. Kelley, Michigan City, Ind.

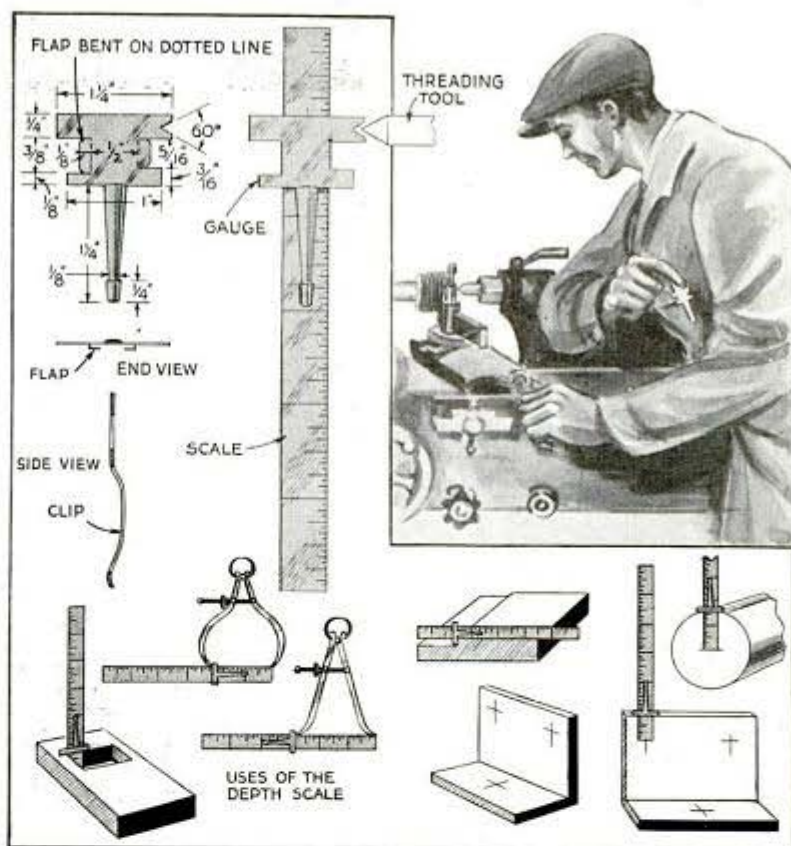

Sign Painter's Accessory Shelf Sticks to Window Glass

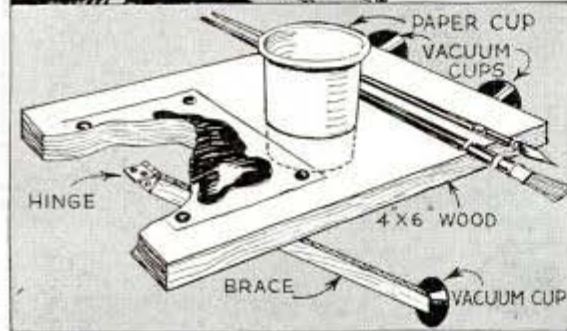

Fitted with three vacuum cups so that it can be stuck to a window in any desired position, this shelf keeps a sign painter's materials conveniently at hand. Two of the cups are fastened at the rear edge of the shelf and the third to a hinged brace, which keeps the shelf horizontal.

Tape Holds Wires in Position To Make Grills

If you want to make a grill by soldering wires or small rods together, a couple of strips of adhesive tape will be found handy for keeping them in position while using the

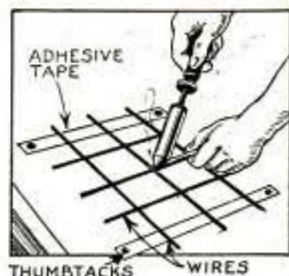

soldering iron. The tape strips are thumb-tacked to a smooth, flat surface and the rods spaced on them, the adhesive surface of the tape keeping them securely in place.

Sacks Held Under Grain Spout By Auto-Spring Leaf

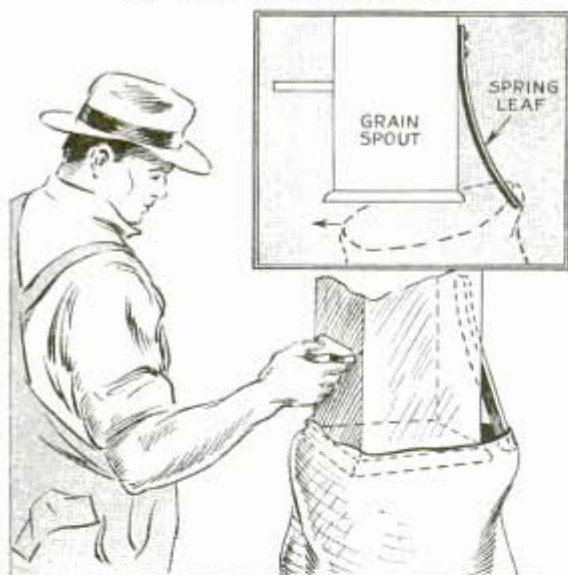

When filling a number of sacks from a large grain spout, they can be held securely by attaching half of an auto-spring leaf

to the back or side of the spout. In use, a sack is slipped over the projecting spring end after which it is pulled back and hooked over the opposite side of the spout. To prevent slipping, it's a good idea to tack strips of quarter-round molding around the end of the spout.

Wire Screen Holds Pin Tags For Price Writing

Difficulty of holding sharp-pointed pin tags conveniently for marking them led one merchant to employ a section of screen wire to hold them safely. The wire is tacked

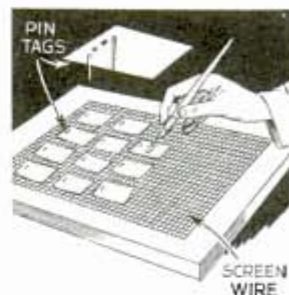

to a wooden frame for ease in handling, and the pins of the tags are inserted through the mesh of the wire.

How to Build a Farm Tractor in Your Spare Time

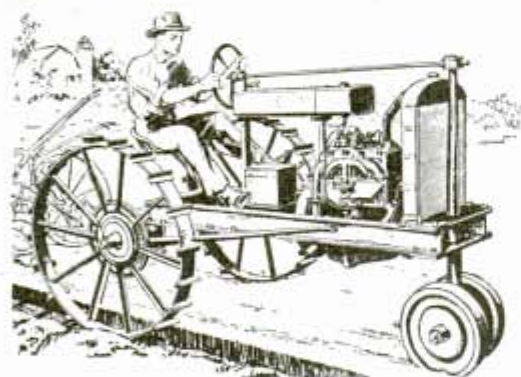

Having plenty of power to pull a two-bottom plow and other implements, this farm tractor, built from old car parts, includes a Ford model-A motor and twin transmissions giving six speeds forward. Wrenches, hacksaw and drill are about the only tools needed—welding can be done at your local machine shop. Set of three 17 by 22-in. plans, Nos. 1024 to 1026 incl., containing construction details and material list will be sent postpaid upon receipt of 75c.

OTHER BUILD-IT-YOURSELF PLANS

Dutch Windmill—1059, 25c
Lawn Chair—1058, 25c
Jigsawed Ornaments—1051, 25c
Porch Chair and Table—1028, 25c
Two Barrow Chairs—924, 25c
Lawn and Garden Furniture—920 to 922, collection of seats, swings, arbor-and-seat combinations, 75c
Artistic Dog Houses—826, 25c
Dutch Windmill Tool House—890, 25c
Bird Houses—884 to 886, 20 designs, 75c
Five Wren Houses—1065, 25c
Trellis Suggestions—639, 25c
Lawn Arbor and Trellis—715, 25c
Sunbonnet Girl Cutout—35c

Ornamental Wood Fences—798, 799, 50c
Circular Arbor and Gate—637, 25c
Flower Boxes—1061, 25c
Sand Box and Wading Pool—708, 25c
Outdoor Fireplaces—917, 25c
Log Cabin Construction—916, 25c
12-Ft. Utility Rowboat—707, 25c
Two Cedar Chests—795, 25c
Gun Cabinet—991, 25c
Queen Anne Coffee Table—526, 25c
Dutch-Style Breakfast Set—822, 25c
Priscilla Sewing Cabinet—617, 25c
Corner Book Shelves—1029, 25c

Order plans by number and title. Send 3c stamp for new catalog of popular handicraft plans

Popular Mechanics Magazine, Dept. 448, 200 East Ontario Street, Chicago, Illinois

RADIO



First Aid for Home Sets

PART IX

AS CONSOLE receivers usually are placed in the living room of the home, the cabinet should be kept polished and free from scratches so that it does not detract from other room furnishings. In most cases it is an expensive and highly finished piece of furniture that is in constant use. Most servicemen are equipped with a touch-up kit similar to the one in the photo; this consists of a scratch filler stick; French varnish and emulsion; scratch remover and polish; white, walnut and ivory enamel; dark walnut stain; fine sandpaper and steel wool, in the numbered order shown. Many of these items are available from your paint or hardware stores, and right now your local radio serviceman is too busy with more important repair jobs.

Diagrams Figs. 1 and 2 illustrate a first aid hint for radio students and experimenters who are capable of locating trouble and repairing defective stages in their receivers. Defective audio transformers are easily replaced with emergency resistance-coupled stages for which all resistor and condenser values are given in Fig. 1. Condensers (C) are 600-volt paper types, resistors (R) are $\frac{1}{4}$ watt. They may be pre-assembled as shown in Fig. 2.

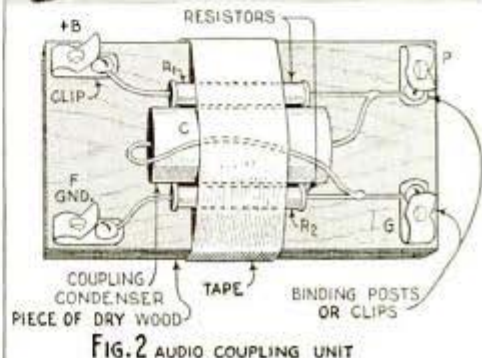
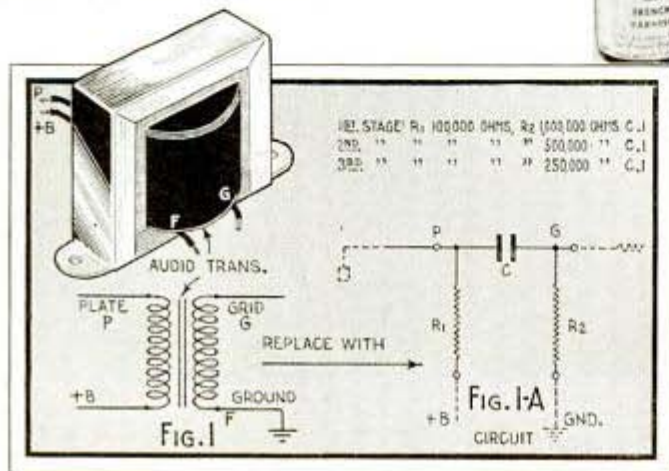

TWO MODERN CRYSTAL SETS



CRYSTAL sets have always been "naturals" for the beginner because they are extremely easy to build and require only a few inexpensive materials. Many more advanced students like to experiment with them, for the same reason that an expert trout fisherman will penalize himself by using a 4½-pound line. There is a real thrill to pulling in signals with a receiver which depends entirely upon power it picks up from the air.

The first set to be described, No. 1, is designed especially for use in cities where there are several broadcasting stations. This set, shown in photo A, we will call the "Big Town" Selector. Thanks to the use of 3 hand-wound coils and two noncritical tuning condensers it is more selective than the average crystal receiver. The original model, tested in a large city where there were five local stations, brought in all five with good strong signals and no interference. An ordinary crystal set brings in only two of the strongest ones and those on top of each other. The simplified and schematic diagrams for this set are given in Figs. 1 and 2.

Set No. 2 is the "Loudspeaker Special" and this is designed especially for loudspeaker reception from the strongest station in a given locality. It consists

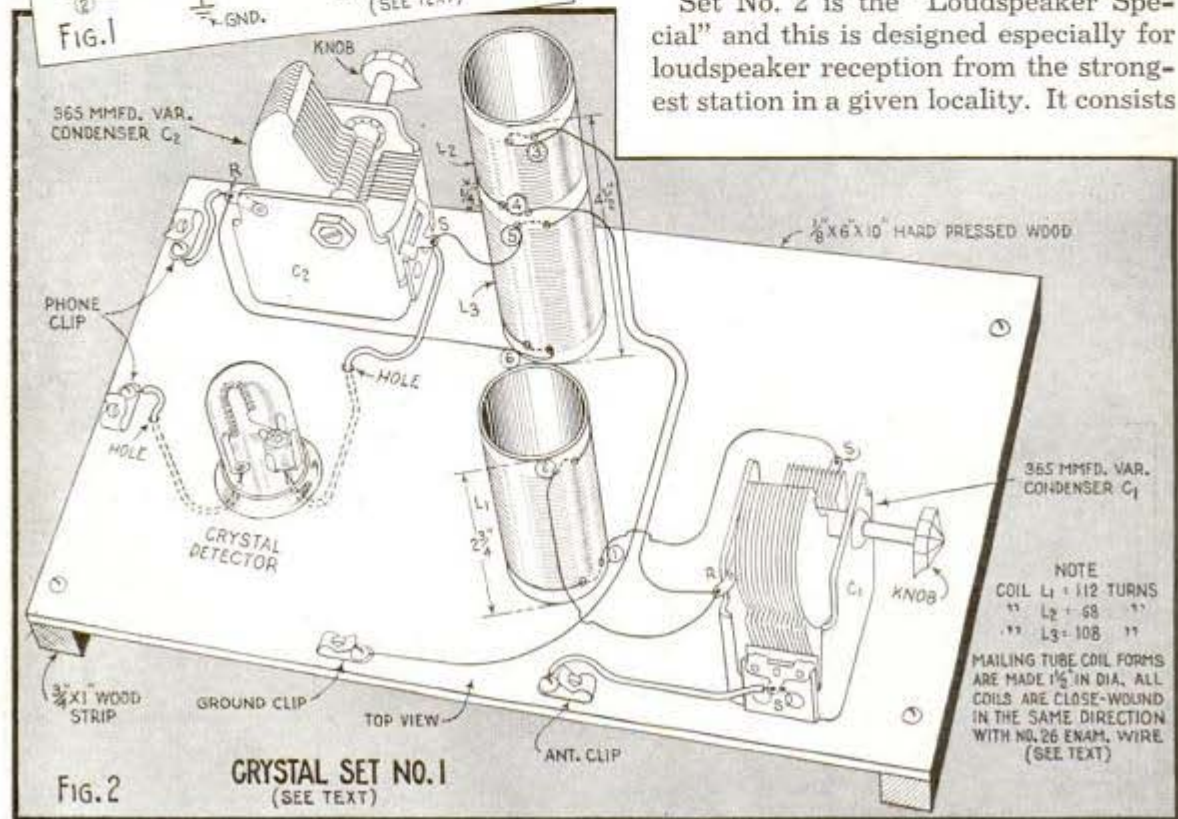
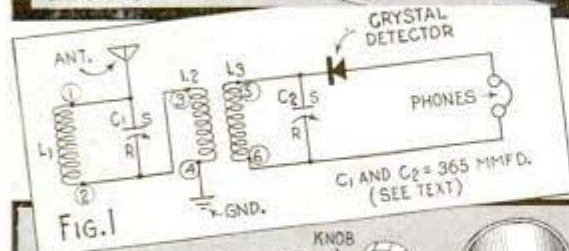

for BEGINNERS

of a simple crystal detector circuit coupled by means of an audio transformer to a 1-tube a.c.-d.c. amplifier. This audio stage merely amplifies the signal picked up by the crystal detector. Headphones may be used instead of the speaker without any changes in the circuit. The schematic circuit diagram for set No. 2 appears in Fig. 3, and the simplified wiring diagram is shown in Fig. 4.

Starting with set No. 1, the first step is to wind the coils. Noncritical "junk-box" parts are employed; the wire may be any gauge of salvaged wire from No. 22 to No. 30 and may have any type of covering, enamel, double or single cotton, or silk covered. The coils are wound on ordinary mailing tubes approximately 1½ in. in diameter, the length varying slightly depending upon the type of wire used. Punch two holes with an ice pick to anchor the starting end and thread the wire through the holes; then, with someone holding the spool of wire you are winding from, rotate the coil and wind the wire on evenly, counting each full turn. When the necessary number of turns have been wound on punch two more holes in the form and anchor the wire. Leave several inches of wire at the beginning and end of each coil

(Continued to page 172)

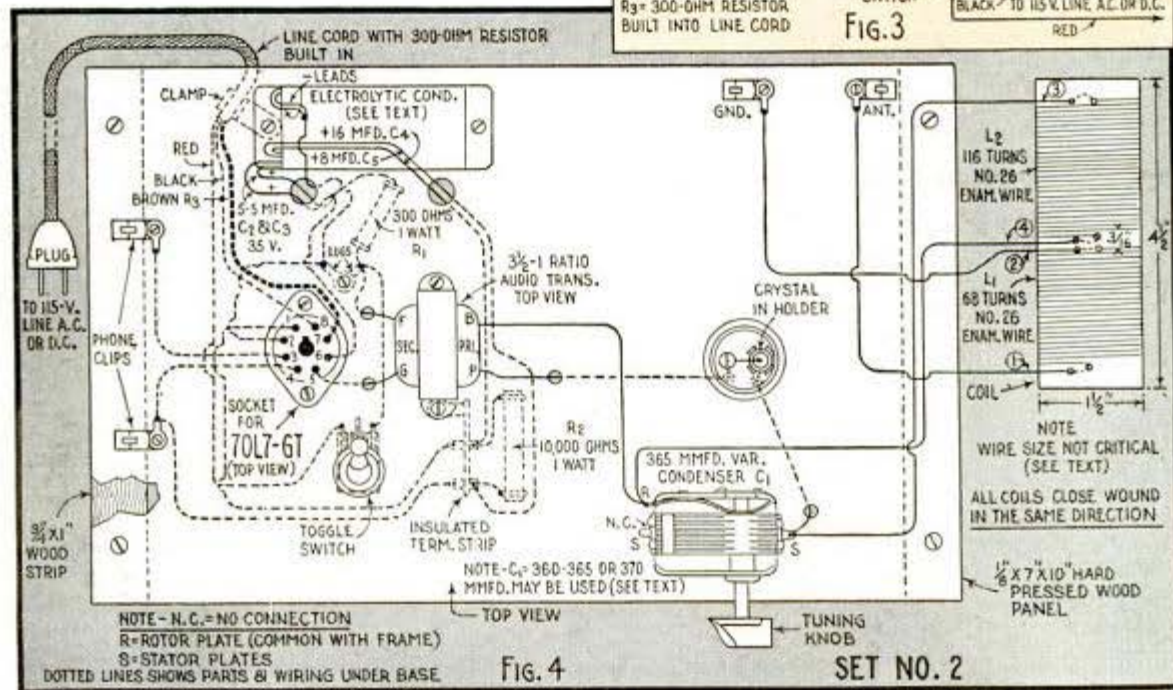
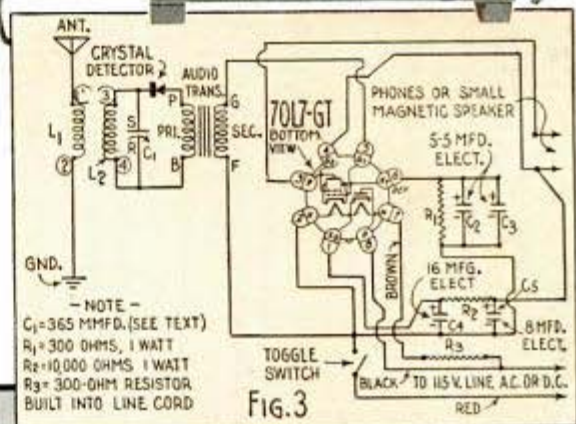

Radio Receiver Acts as Automatic Fire Warden

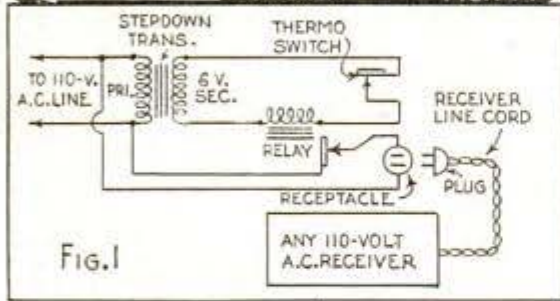
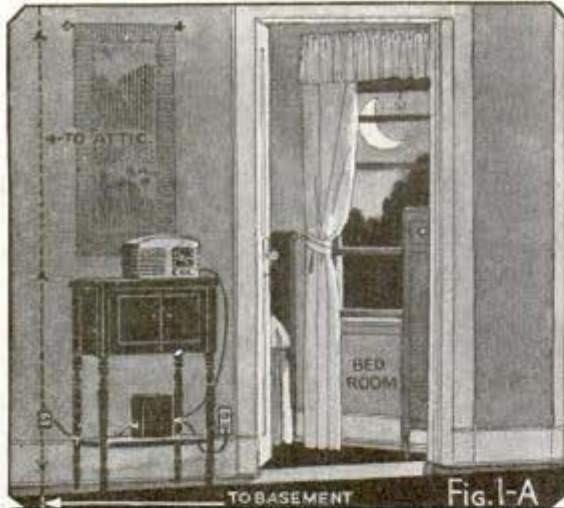

THREE DETECTOR HEADS (THERMO SWITCHES) CONNECTED IN PARALLEL

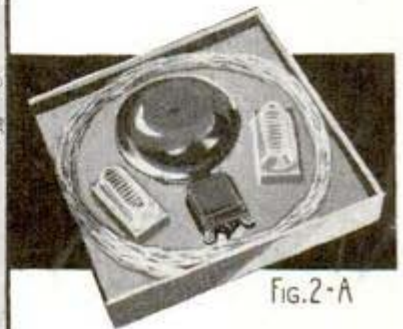
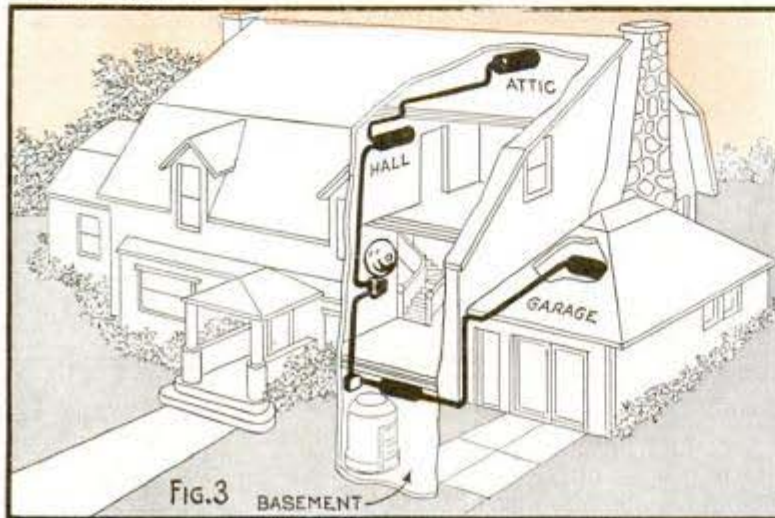
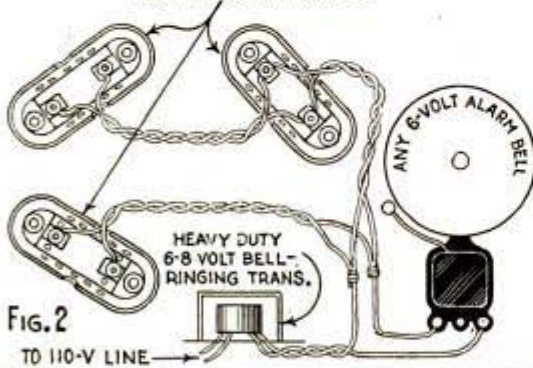

FIRE, dangerous at any time and now a powerful tool of enemy saboteurs, should be held to a minimum by employing fire-detection apparatus of any available type. A radio receiver tuned to a powerful 24-hour local station with volume turned "full on" provides an effective automatic alarm when power to the set is controlled by thermal switches and a relay connected as in Fig. 1. A number of these "thermo" switches may be connected in parallel and located in various parts of the home as indicated in a similar alarm bell system shown in Figs. 2, 2-A and 3.

Both systems are based on thermal switches of simple types. Each switch or "detector head" contains a bi-metallic strip which curls and closes its contacts when temperature rises above a certain point. These sensitive units should be located high up on the walls of the various rooms, attic and basement wherever fire is likely to occur. The arrangement shown in Figs. 1 and 1-A employs a 6-volt stepdown transformer operating on the 110-volt a.c. house-lighting circuit to energize the relay that closes the power circuit to operate the radio receiver that is plugged into the robot fire warden receptacle. Sketch, Fig. 1-A, shows the relay and transformer housed in a small case placed near the radio receiver, and plugged into the wall outlet for the 110-volt primary connections. An ordinary wall outlet box and receptacle is provided for the extended "thermo" switch circuit which is run in standard conduit.

Where a very loud alarm is required in large homes or shops, the bell system illustrated in Figs. 2, 2-A and 3 is effective. The "Fyre-Scout" thermostatic switches, Fig. 2-A, are enclosed in neat and compact enameled housings.

Practical RADIO HINTS

(1) Two ordinary 3-in. powder puffs act as soft cushions or pads for headphones worn by short-wave listeners and radio operators who stand long watches. In addition to relieving uncomfortable pressure, they also help to exclude outside noise. Holes $\frac{3}{4}$ in. in diameter are cut in the center which is then stitched as indicated in the photo to prevent the filler from creeping out



Powder puff centers over diaphragm opening in phone cap

(2) Calibration marks on Bakelite panels made by drilling shallow holes with a $\frac{1}{8}$ -in. drill; rub white crayon into the holes and wipe panel clean. (3) Additional holes in speaker baffle for bass reflex effect. (4) Resistor or r.f. choke holder made from large round-hole soldering lugs; mount the lugs on a small strip of Bakelite, countersinking the screw heads on the underside as shown. (5) Student's "firefly" code blinker made from a spring clothespin, penlight battery and a miniature penlight bulb mounted in a radio dial bulb socket. The spring-metal battery mounting unit A provides the negative contact at front; another contact strip at rear bears against the positive end. All connections are shown in Figs. 1, 2 and 3. The metal hood B is painted black inside and out, and is slit at one end for a snug fit to direct all light in a forward beam. Contacts are made with machine screws, spring tension should be eased for free opening and closing to "blink" dots and dashes

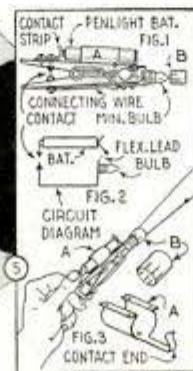
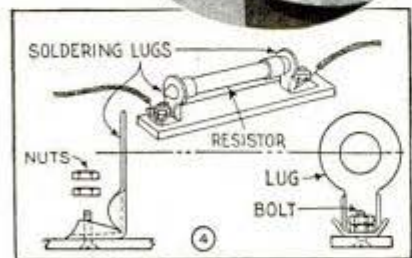

(6) Large paper clamp altered to make soldering iron support for bench. (7) Precision gear-driven dial for instruments requiring extreme accuracy of calibration

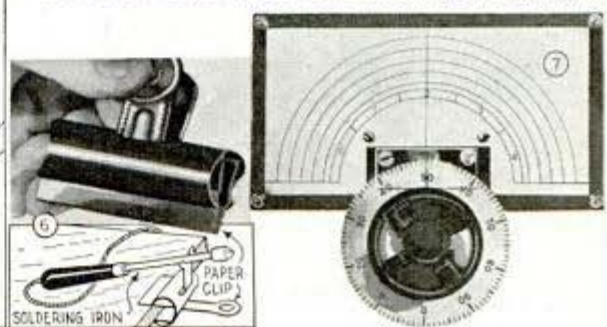

Showerlike F-M Radio Antenna



Looking something like a new type of shower ring, this frequency-modulation antenna at station W47NY radiates energy of practically uniform pattern in all directions without resorting to additional and costly arrangements previously required to gain the same results. It consists of upper and lower circular elements each being a quarter wavelength long. It is easily mounted on a pole of suitable diameter and grounded to that pole so there is protection from lightning. It is said to cover a wide frequency range with one physical structure. The design of this unusual F-M transmitting antenna also provides for sleet melting, if desired.

Radio and Clock in Desk Drawer



Part of a complete bedroom ensemble in an unusual aviation motif, this desk was designed to house a standard 5-tube a.c.-d.c. receiver and an electric clock in one of the drawers. The set occupies only part of the drawer

space. All necessary ventilation is provided for, and the receiver plugs in with the clock at the rear of the desk. The same general idea is often employed by radio experimenters and servicemen who install an old radio chassis in a drawer of the workbench in order to get the receiver out of the way and still have it available when a program of special interest is on.

Portable Resistance Limit Bridge

Operated by self-contained batteries, this direct-reading resistance limit bridge speeds up precision resistance tests to meet exact specifications of allowable percentage variation for so many of the resistors used in military equipment. No skill is required to operate the instrument beyond



accurate observation of the scale reading. Four dry batteries, carried within the case, furnish the tube filament current and the operating voltages. In addition to the on-off switch at the right, there is a safety switch above the meter, that opens the filament circuit when the cover is closed.

Blueprints covering simplified radio construction articles in this and past issues are available for 25c each. Many popular tested circuits for beginners, students and experimenters may be built with used parts. Detailed material lists can be obtained from Popular Mechanics Radio Department upon receipt of postage.

NEXT MONTH—Little Giant Three for Beginners. Hand-wound coils and non-critical parts are used in the 1943 student model of this popular a.c.-d.c. broadcast receiver. Truly a "wartime" student project that shows what can be done with a simple T.R.F. circuit. Also—**Code Practice Receiver and First Aid for Home Sets.**

NEW "DELTA" Complete Home Workshop Library

1400 Photographs and Drawings

A practical, up-to-the-minute, modern workshop library containing over 1400 photographs and line drawings—covering every phase of operation and maintenance of every major workshop motor-driven tool—with hundreds of special operations explained—valuable shop hints, short cuts, and scores of time-saving tables. Tells how to obtain unusual results, how to solve shop kinks and problems and how to keep your tools and accessories up to top efficiency. Every operation "shop-tested" by practical craftsmen.

What you get in this Modern Workshop Library

Circular Saw & Joiner—Ripping; Saw Projection; Use of Moulding Fence; Crosscutting; Mitering; Cutting to Length; Resawing; Rabbeting; Tilt Table Operations; Taper Ripping; Spine Grooves; Cutting Curves; Production Work; Pattern Sawing; Cove Cutting; Long Work; Gang Saws; Simple Tenoning Jig. The Moulding Head and its use; the use of Abrasive Wheels, Dado Head, Tenoning Jib; Common Wood Joints; Jointer Operations; Jointing an Edge; Side Pressure Jointing an End; Surfacing; Rabbeting; Beveling; Taper Jointing; Tapering in the Round; Stop Chamfering.

Lathe—Wood turning, metal turning and metal spinning, including: Spindle Turning; Faceplate and Chuck Turning; Special Turning Operations; Post Blocking; Oval Turnings; Split Turnings; Turned Boxes; Duplicate Turning; Spiral Turnings; Hollow Spirals, Fluting and Reeding; Use of Lathe attachments; Jigs and Fixtures; Wood Finishing; Metal Turning Operations; Spinning Equipment; Methods of Working; Special Spinning Chucks and Appendix containing tap drill sizes; Polishing Materials; Decimal Equivalents; Table of Taper Cuts; Grinding Angles for Wood Turning.

Band Saw & Scroll Saw—Ripping and Resawing; Use of Standard Fence; The Ripping Blade; Ripping Curves; Tilt Table Operations; Cutting off with Fence and Gage; Use of Stop Rod; Cutoff Block; Using Clamp attachment; Crosscutting Wide Stock—Cutting Circles; Jig Construction; Cutting Glue Blocks; Round Corners; Circular Rails; Sanding; Compound Band Sawing; the Cabriole Leg; Compound-Sawed Turnings; Ornamental Work; Sawing in Multiple; Ripping Thick Stock; Split Dowels; Tapering Jigs;

FREE...Extra Gift

With every order for the Delta Modern Workshop Library we include a Free copy of "How to Make Money with Delta Tools."



Marking Turning Squares; Pattern Sawing; Beveled Curves Metal Cutting; Scroll Saw Operations; Sanding and Filing.

Drill Press—Methods of Laying Out Drill Press Work; Use of Wood Bits; Sanding Drums and Grinding Wheels; Drill Practice in Wood; Use and Grinding of Twist Drills; Drilling and Tapping in Metal; Routing, Shaping and Mortising on the drill press; Miscellaneous drill press operations and special useful ideas.

Abrasive Tools—Buffer, Belt and Disk sander attachments—Explanation of Different Abrasives; How to Sharpen Tools; Grinding Shaper Cutters; Grinding Twist Drills; How to Use Sanding Drums, Cut-Off Wheels.

Shaper—Shaper Adjustments Cutters and Collars; Shaping with guides; with collars; with patterns; Use of Forms; Jigs and Fixtures; Application of Shaper Cutters; Grinding Shaper Cutters.

Practical Finishing Methods

Tells how to do every possible finishing operation—how to prepare the work, how to stain, fill varnish—lacquer. Proper use of spray gun and brush. How to finish metal, how to mix your own low cost materials. Silk screen process. Secret methods developed over many years.

Examine this Library at our risk! Send Coupon Today



ONLY \$2.00 Complete



You can inspect the Delta Modern Workshop Library without risking a penny. Simply fill out and mail coupon today. When the complete library, plus the FREE extra gift book arrives, postpaid, inspect it thoroughly. If you aren't fully satisfied in every way—you can return the library—and every penny you have paid, including return postage, will be promptly refunded—without question

Modern Workshop Library Div.
The Delta Manufacturing Company
680-B E. Vienna Ave., Milwaukee, Wis.

Gentlemen: I enclose \$2 for which please send me complete Modern Workshop Library, postpaid, plus FREE gift book. It is understood that if I am not fully satisfied, I can return the library and you will refund every penny I paid, including return postage.

Name.....
Address.....
City.....State.....

Fighting That Tired Feeling

(Continued from page 95)

Lamp Division of Westinghouse to boost morale and prevent fatigue. Loudspeakers play marches, tangos and swing for five and a half hours a day while hundreds of the plant's men and women employes turn out communications equipment for the armed forces. Band music, intended as a "musical pep cocktail," greets the workers arriving for the various shifts and continues for 15 minutes. Five half-hour periods of music are scheduled during the eight-hour shift, one at lunch time and the rest timed to coincide with periods of "let-down" or fatigue. Music during the fatigue periods acts as a stimulant, reports show. Popular music is the favorite in the Meter Division, partly because the tempo of modern tunes seems to fit the rhythm of operators assembling small parts. In one instrument testing section where there is less noise and no machinery, workers prefer waltzes, Hawaiian melodies and light classics. Women workers find music more helpful in their work than men.

Outside influences which cause lack of sleep and physical exhaustion are another cause of fatigue. The honky-tonk dance halls which have sprung up near defense plants are being offset with high class recreational activities by huge war contract

plants such as Federal Shipbuilding and Drydock Company and Electric Boat Company where fatigue on the job would hamper the war at sea.

Systemic poisoning from noxious fumes is a common cause of that tired feeling, but it is fast disappearing with the advent of air conditioning. Worry is another factor that makes you tired on the job. Bad health, bad habits, bad housing conditions, noise, vibration, waste motion, improper and inefficient methods of picking up and carrying heavy objects, close protracted mental concentration, eye strain, posture, workbenches set at wrong heights, lack of illumination, working rooms which are too hot or too cold, lack of pleasant outside interests such as a hobby, insufficient fresh air and misfit clothing all contribute to that exhausted feeling.

One corporation even discovered that replacing concrete floors with springy asphalt stepped up production.

Little by little the scientists employed by the industrial giants of America are whittling away at these causes of fatigue because it helps you, it helps them and most of all right now that extra ounce of energy helps back up the fighting men of the nation.

12,000,000 Meals a Day

(Continued from page 87)

experts predict that their experiments will have some revolutionary effects on civilian food processing after the war.

The process isn't so simple as it sounds, for almost every food requires different treatment to retain an attractive appearance and flavor as well as nutritive value.

Dehydrated vegetables lose about nine-tenths of their weight. This is a vital factor in supplying food to an overseas army when ships are at a premium. For example, 27,000,000 pounds of potatoes can be reduced to 3,000,000 pounds and save at least 500,000 cubic feet of cargo space. This amounts to more than the capacity of two cargo ships. Dehydrated foods also lend themselves to air transport for bolstering supply lines during an emergency.

The army guards figures on the amounts of dehydrated foods now being produced

for overseas consumption. The Agriculture Marketing Administration, however, announced that lease-lend distribution up until last July 1 included 169,703,950 pounds of dried skim milk and 184,168,495 pounds of dried eggs. One pound of dehydrated eggs is equivalent to three dozen liquid eggs.

The Quartermaster Corps estimates that a soldier eats 1,800 pounds of food a year, compared with the average civilian consumption of 1,400 pounds. This costs the army \$190 a year per man, or 52 cents a day. When Uncle Sam reaches for the check for a year's rations for 4,000,000 men, the figure is \$760,000,000.

That's one bill the taxpayers aren't kicking about. They want the American soldier to be the best fed in the world.

The Quartermaster Corps says that he is.



THE OLD TOWN WAY

Paddle the sparkling waters of a sunny lake, rest in the cool pools of a shady cove, lost in a world of peace and contentment. Let your Old Town Canoe be your guide through all the woodland waterways. Light and well balanced. Quick to respond to the softest dip of the paddle. Easy to keep and built to last for many years.

FREE CATALOG illustrates boats for sport, sailboats, and all kinds of canoes, dinghies and outboards. Write today. Address: Old Town Canoe Company, 932 Main Street, Old Town, Maine.

"Old Town Canoes"



You bet they have! The red-blooded riders of these great motorcycles are getting action and adventure on every fighting front . . . roaring off on Ranger raids, scouting, convoying troops, doing courier duty and other jobs where Indian's dependable power and strength and guts are vital to success.

These men will be satisfied with nothing less than Indians to ride when this war's over; and they, and you, will get them . . . the greatest motorcycles Indian has ever built.

Because every Indian is a fighting Indian today, there are no new machines available. But maybe your local Indian dealer has some good reconditioned buys. See him today . . . and, if you're a rider already, see him regularly to help keep your present motorcycle in A-1 shape.

INDIAN MOTORCYCLE COMPANY, SPRINGFIELD, MASS.



**BUY WAR BONDS NOW
★ ★ TO BUY AN INDIAN LATER ★ ★**

See you saw it in Popular Mechanics!

Model Builders Attention!

	V	V-2	V-3
Hex	1/2"	3/8"	5/16"
Thread	3/8"-24	1/4"-32	1/4"-32
Thread Length	7/32	7/32	5/32
Weight, Grams	8	3 1/2	2 1/2

Actual Size V-Plug

Champion spark plugs for model gas engines give the same dependable performance as regular Champions. Sillimanite sealed. Sillimanite insulator. Alloy needlepoint electrodes for easy starting. One piece construction.

CHAMPION

SPARK PLUG COMPANY • TOLEDO, OHIO

IN STEP WITH UNCLE SAM

SYNCRON Electric Jig Saws enlist with Uncle Sam for the duration . . . making parts for tanks, submarines, planes, guns—producing precision machine tools, fixtures, gauges, production parts. Laboratory research guarantees **BETTER SYNCRON Saws** for you after Victory! See Dealer for available Syn-cro Saws.

SYNCRON WORLD'S SAFEST SAWS
SYNCRON DEVICES, INC.
3265 Bermuda, Dept. PM-23, Ferndale, Michigan

**USE THE SAME GLUE YOUR
GOVERNMENT USES FOR AIRPLANES**

LEPAGE'S WATERPROOF *plastic resin* GLUE

★ **IT'S WATERPROOF**

... joints submerged in water a year show no signs of yielding.

★ **IT'S STRONG**

... glue stronger than the wood it joins. Wood gives way but the glue will not yield.

★ **IT'S EASY TO USE**

... in 30 seconds glue is ready for use. Mixes readily with hot or cold water.

Buy a can Today!

4 HANDY SIZES
10¢ 25¢ 50¢ 85¢



**Full Stock of Leather on
Hand
IDEAS for LEATHER
Projects**

Send for big 16-page Idea Catalog FREE. Full of suggestions on materials, tools, and projects in

Leather • Wood Carving • Archery • Gifts. We have plenty of Leather, Immediate Shipments for All Orders.

J. C. LARSON & CO.

180 No. Wacker Drive, Dept. 180-D, Chicago, Illinois



Jungle Mechanics

(Continued from page 71)

He chisels and chips away at the L shaped wood until one arm of it becomes a sort of cylindrical, long neck surmounted, purely for art's sake, by a roughly carved head. In this neck he burns five holes, tightly fitting in each a short section of the stick, as the register of one of the five chords—the creepers which he will fasten with a knot beneath the lizard skin. The other arm of the L is carved and hollowed to form a sort of spoon, over which the lizard skin, softened in water, is tightly stretched by another piece of creeper, passed, like a shoe string, through small holes punched around the skin's contour, then bound around the base of the neck and the guitar is ready for a tune.

Look at the Azande's cousins, the Mangbetus. Their huts are made of poles planted in the ground, mud crammed between the poles, and a thatched roof. The Mangbetu decorates his walls with a method so simple, with such gay effect, that you might use it yourself, to beautify some small building in your backyard.

All the Mangbetus—or you—need is some chalk, powdered charcoal, some orange, red, purple, brown ochras and plenty of imagination and free hand. Each of these colors is mixed with water in a separate container. Each is applied with a brush made of an antelope's tail. The tracings may represent animals, waves, crosses, triangles, straight or curved or zigzagging stripes. The final effect is as modernistic, exotic and pleasing as could be desired.

The deeper one penetrates the equatorial jungle the harder Nature fights back.

Biting ants are as long as a toe. Stinging beetles as big as a fist. Venomous spiders half as big as this page. Wild hogs are five feet at the shoulder, crocodiles 26 feet long, baboons weighing hundreds of pounds, leopards ten feet from nose to tail-tip.

Worst of all, here lives the giant gorilla, the most belligerent of apes. It is a colossus of formidable might and almost human cunning, often heavier than 600 pounds, topping six feet six inches in stature.

And what race of supermen can withstand the dangers of such a world? What extraordinary weapons do they possess to fight off the monsters prowling through their land? Those "supermen" are the

Test-O-Lite the MODERN TROUBLE SHOOTER



← THE NEON GLOW

... LOCATES TROUBLE INSTANTLY in electric circuits, fuses, cut-outs, motors, radios, appliances. Tests everything electrical from 100 to 550 volts. Indicates hot or grounded wires. Tells AC from DC. Far superior to ordinary clumsy test bulb.

↑ PUTS "FINGER" ON THE TROUBLE SPOT -- QUICKLY

Saves precious time. Indispensable in shop or home. Has patented safety features. Vest pocket size with clip. Life-time guarantee. List \$1.50

L. S. BRACH MFG. CORP.
55 Dickerson St. Newark, N. J.



FUSES



MOTORS



OUTLETS

dwarfs, 4 feet 6 inches high, not 90 pounds in weight. Their weapons are bows with a creeper for cord, little arrows smeared with vegetable poison, small spears cut from a straight branch.

The elephant, the buffalo, the okapi, the giant hog, would smash and crush the dwarf hunter daring to approach them. But each of these can be killed easily, once it is imprisoned in a deep hole. The dwarfs dig hundreds of such pits. Light sticks cover the pit, leaves are spread over this trel-lis, then dead leaves and branches, manure, antheaps, clods of moss until not even the most suspicious eyes can detect a difference from the surrounding ground.

If the dwarf must cross a stream in which crocodiles abound, he ties some long lianas together, climbs up a convenient tree and fastens the liana to a solid branch. At the hanging end he makes a rough seat.

The rest of the tribe, from another tree, pull him high with another liana, then they let go. At dizzy speed the flying dwarf swings down toward the water, soars up toward the treetops on the opposite shore. He grasps a branch, fastens to the seat a heavy piece of wood and lets the whole contraption swing back to the starting point for another passenger.

Next month, I will tell you how the African native wins over the "tank" of the jungle, the rhino. I will tell you of the "grand piano" of the veldt, and of the six-legged ostrich.

But first listen to the furious roars of a giant gorilla, who has just discovered a lonely hunter. The dwarf is running for his life. The gorilla lunges ahead, crashing through every obstacle. What chance has the poor little dwarf? He hesitates a second. Swiftly he has planted his spear-handle in the ground, stone point angled toward the approaching gorilla. It's hidden in the vegetation. The ape rushes ahead, stretches his long arms—and lets out a scream of agony. He is impaled on the unnoticed spear. The poison on the stone point works instantly.

The dwarf, panting, halts. His tribe is already running to share the meat of the gorilla. And to celebrate his victory, he picks two red flowers of the mukho tree, rakishly sticks them through the hole across the cartilage of his nose!

(Concluded next month)

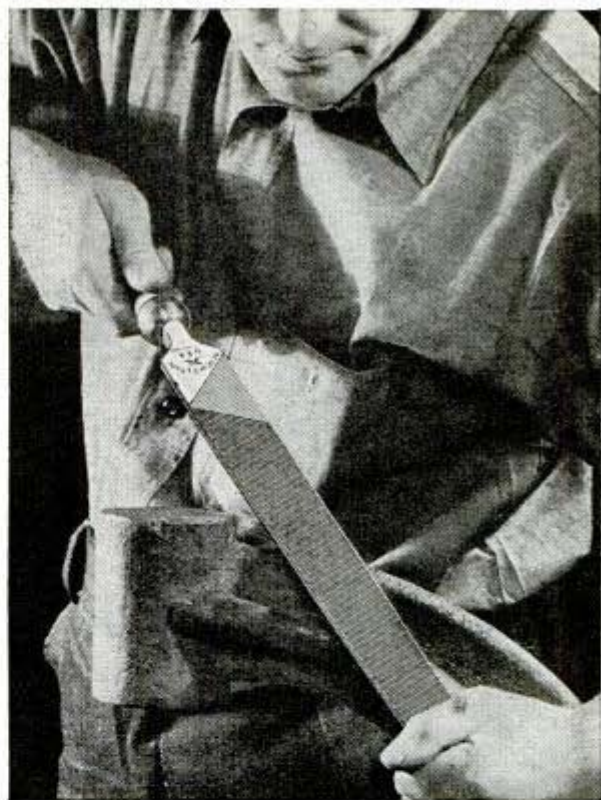

... and what about making files last longer?

Cars—tires—tools—implements—machines . . . more and more insistently comes the warning note to *make them last longer*. Neither file-using manpower nor the high-grade steel required in the manufacture of files should be wasted through file misuse or abuse.

It is the patriotic duty of every file-using mechanic, farmer, repairman to get the most out of every file. Nicholson has a book which can aid in doing precisely that. It's called "A FILE FOR EVERY PURPOSE"—and it's free. Twenty-five interesting, profusely illustrated pages about files—their many kinds, proper use, proper care and how to select *The right file for the job*.

And when buying files, remember: No files in all the world can yield a greater number of efficient strokes per file or per dollar than the brands which carry the sweeping guarantee of *Twelve perfect files in every dozen*—NICHOLSON and BLACK DIAMOND. At hardware and mill-supply houses.

NICHOLSON FILE CO., 22 ACORN STREET
Providence, R. I., U. S. A.

(Also Canadian Plant, Port Hope, Ont.)

NICHOLSON
FILES FOR EVERY
PURPOSE

NICHOLSON
U.S.A.
MADE IN U.S.A.

★ Cushman ★

is speeding the
VICTORY PROGRAM



3 MODELS

doing—saving countless steps . . . priceless time! Ten times as fast as walking—up to 35 miles per hour! Cheapest transportation—100 miles per gallon! Most convenient—stop and park anywhere. Earning their service stripes by carrying officers and key men for inspection and check-up of bases, camps, forts and defense plants—delivering orders, mail, prints, repairs, supplies, parts.

Cushman has extended its experimental and research work to perfect an even better machine—sturdier, more reliable, more comfortable—to meet severe war needs. So, though you cannot buy one today, without a high priority, you are assured an even finer Cushman—an even greater value—when they are again available.

Your present Cushman must serve you for the duration—so protect it! Lubricate and service it regularly—care for it. Follow your instruction book religiously. If you need a new copy, see your Cushman dealer or write us for a free copy.

CUSHMAN MOTOR WORKS, Dept. P-2, Lincoln, Nebr.

ONE-MAN SAWMILL LESS THAN \$100.00



Turn Trees into Money with a BELSAW

Three capacities: 10, 14 and 20 feet. Accurate set works, positive dogs. Hand or power feed. Runs on log power—many owners use old auto engine. Pays for itself quickly—thousands in commercial service, everywhere. Write for free lumber handbook and catalog of mills, supplies, tools, saw blades and woodworking equipment.

Makes Lumber, Shingles, Lath, Fies, Crates, All Forms Lumber
BELSAW MACHINERY CO., Dept. 1811-B, 3542 Main St., Kansas City, Mo.

EMPIRE "TORPEDO" LEVELS

HANDY HOUSEHOLD TOOL
Smallest and Handiest Accurate Level Made. "Cigar-shaped," can't tear pockets. Walnut stock, Has Level, Plumb, and 45° vials, 9" long. Light weight, strong. No. 44 only \$1.10. Order from local dealer. Write for literature.

EMPIRE LEVEL MFG. CO., DEPT. P-211 717 SOUTH SIXTH STREET MILWAUKEE WISCONSIN

BRUSH PLATING OUTFITS

for autoparts, reflectors, faucets, bicycles.
No tanks necessary. Free particulars.

GUNMETAL CO., AVE. M, DECATUR, ILLINOIS

OWN A Printing Business

Cards, Tickets, Stationery, etc. Good profit in spare time. PRINT YOUR OWN greeting cards, movie titles, church work, etc. Save money. Easy rules supplied. Junior Press \$8, Senior Outfits from \$17.38. Have home shop. Raised printing and Embossing too. Sold direct from factory only. Write for free catalog and all details. KELSEY, INC., X-37, MERIDEN, CONN.

LEGS—ARMS—BRACES

The best money can buy—our 133 employees wear 174 appliances. Write us your needs.
Mpls. Artificial Limb Co. 406-6th Ave. S. Minneapolis, Minn.

MONEY IN RABBITS—CAVIES

WE BUY and put you in touch with other markets. Catalog and copy of magazine 10c. Or send 25c for Book Catalog and Price List and Year's Subscription to the AMERICAN SMALL STOCK FARMER. OUTDOOR ENTERPRISE CO., BV 919, PEARL RIVER, N. Y.

Only 50c MAKES AND SAVES MONEY FOR YOU

NEW 1943 BOOK FOR EVERY MAN WHO USES TOOLS
New SHOP NOTES is biggest and best ever issued. 224 Pages, 18 in colors, 500 pictures and plans. Will help on your job. Get this great book today from your news dealer or send 50c to address below. Front by its facts, ideas, shop kinks, short cuts. No other book like it anywhere.
POPULAR MECHANICS PRESS
Dept 459 • 200 E. Ontario Street • Chicago



Sagging of Clothesline Prevented By Wire Coat Hanger

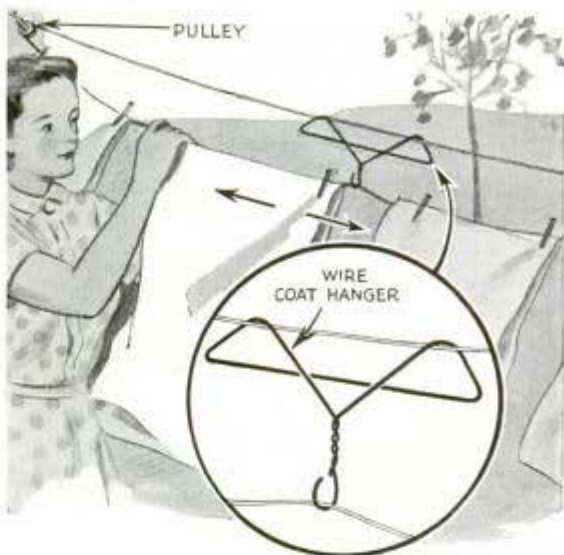

Where it is necessary to use a double clothesline that runs on pulleys between upper porches of apartments, sagging of the lower line can be prevented by using a sliding support bent from a wire coat hanger. The double loop of wire over the upper line slides along while the lower section is pulled in or out, thus making both sections carry the weight.

Strips of Tape on Glass Graduate Prevent Fingers Slipping



To guard against accidentally dropping a glass graduate when your fingers are wet or greasy, merely attach two strips of wide adhesive tape on opposite sides of the graduate. These will provide just enough friction to prevent slipping and they can be removed quickly whenever desired.

—William Swallow, Brooklyn, N. Y.

"Mustang" Admirals in the Making

(Continued from page 37)

Naval R. O. T. C., a cadet usually attends two summer training periods. When he gets his sheepskin from his university, he also gets a commission as an Ensign in the United States Naval Reserve. He is called into service immediately and paid approximately \$216 per month if single, \$252 per month if married.

The V-1 program is slightly different from R. O. T. C. Students aged 17 to 19 who are in an accredited college or university, or who are about to enter one, are eligible. These V-1 students will be freshmen and sophomores and will study what they want—as if they were regular college students. However, they will be strongly urged to take mathematics, history, natural sciences, and physical education.

In March these students take a qualifying examination. The Navy has set a goal of 80,000 students to be enrolled under this program. If the goal of 80,000 enrollees is attained, thousands of additional college men will be available for officer training—above the minimum needs of the navy at present. But as the course and duration of the war cannot be predicted, these minimum figures probably will be revised upward. Taking no chances, the navy is seeking to train sufficient officers to meet any eventuality.

The V-1 program will permit students to remain in college while being trained as future naval officers. But the Navy's program does not call for a commission gratuitously given to any student enrolled in this program. Navy standards are high, and those that fail to measure up will be called to active service immediately as enlisted men. With their college training, however, they should advance to petty officer ratings in a very short time.

Under the V-7 program, college graduates, 19 to 27 years of age who have the required amount of mathematics, are given training leading to ensign's commissions at special schools at Annapolis, Chicago, and New York City.

After a preliminary conditioning period of 30 days, V-7 cadets are put through a stiff three-month program of officer training. They are called "90 day wonders"—

(Continued to page 169)

FURNACE? LEAKING?

... Repair it with
SMOOTH-ON

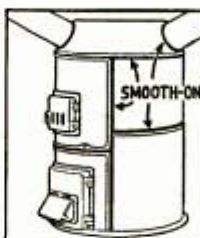

Get SMOOTH-ON in 1 3/4-oz., 7-oz., 1-lb. or 5-lb. can from your hardware store or from us.

Leaks of air, steam, water or flue gases can be tightly and lastingly sealed with SMOOTH-ON No. 1. The repair is easy to make . . . does not require heat, special tools or dismantling . . . and you can do it yourself. SMOOTH-ON seals leaks of water or steam in piping and radiators, too. This many-purpose iron cement . . . used by professional repair men for more than 45 years . . . is also useful for stopping leaks in automobile radiators, for sealing cracks in gear and crank cases, and for innumerable odd jobs such as tightening loose fixtures, handles and parts of apparatus.

War-time conditions make SMOOTH-ON more of a household necessity today than ever before. For your protection and for assurance of speedy, lasting repairs, insist on SMOOTH-ON, and keep a can handy for emergencies.

FREE

40-Page Repair Handbook

Full of ingenious, practical repair short cuts that save time and money as well as unreplaceable equipment. 170 diagrams and simple concise instructions. Write today for your FREE copy.

MAIL THE COUPON



Smooth-On Manufacturing Co., Dept. 37
570 Communipaw Ave.,
Jersey City, N. J.

Name

Address

2-43

Free

Do it with SMOOTH-ON

WANTED AT ONCE!

WEATHER STRIP, ROCK WOOL AND CALKING INSTALLERS

Work Near Your Home! Good Pay!



Fuel rationing and the Government drive to save fuel has created an unprecedented immediate demand for Chamberlin Insulation Products—Weather Strips, Rock Wool, Storm Sash and Calking. That means we need installers, perhaps right in the city or section where you live. No age limit. If you are a weather stripper, an insulation applicator, a calker or a carpenter willing to learn our trade and work at good, steady wages for a 49 year old national concern, drop us a line right away and we will put you in touch with the manager of our nearest factory-branch. To do our work you will probably need a car and some tools if we hire you for our weather strip department. When writing, give us your age, previous employment record and two or three local references.

CHAMBERLIN METAL WEATHER STRIP COMPANY, INC.

Branches In All Principal Cities

General Offices 1377 La Brosse, Detroit, Mich.



BE FAIR TO YOUR HAIR Want better looking hair? Embarrassed by falling dandruff, itching scalp? Then try VITABRUSH, new electric driven scalp brush that gives your scalp a vigorous and invigorating "workout" in just three minutes of fun. Cleans scalp. Stimulates blood supply. Restful. Pleasant. Write today for complete information and satisfaction-guaranteed offer. Hershey Mfg. Co. 163 South La Salle St., Chicago

Now Only \$9.95

REAL ENGINE VALUE



The G. H. Q. is a miniature gasoline engine that really operates. Over 15,000 sold in the last year. Now is your chance to buy the New Improved 1943 model for \$9.95. Absolutely complete with coil, condenser, plug, instructions, etc. Fully bench tested and ready to run. For boats, planes, midget cars, etc. Send only \$1.—Shipped Collect C. O. D. same day. Send for FREE circular or 6c for Jumbo catalog of hundreds of plane, boat and hobby items.

GHQ MOTORS, Dept. BX, 40 East 21 St., New York, N. Y.

OTTAWA LOG SAW \$39 SIX BOOK FREE



PUTS THIS OTTAWA to work for you. MAKE MONEY! Wood is valuable. Does more than 10 men. Easily operated. Falls trees—saws limbs. Use 5-hp. engine for other work. Write for FREE Book.

OTTAWA MFG. CO. 6427 Wood St., Ottawa, Kans.



ARC WELDING!

516 Pages, 512 Illustrations. A New DAILY GUIDE for operators and managers doing vital war work. Explains **NEWEST TECHNIQUES, METHODS, PROCEDURES and MATERIALS.** With charts, diagrams, tables to show you best methods for metals and positions involved.

\$2.00 POSTPAID

Order Your Copies at Once!

This Complete and Authoritative book **ANSWERS** your every welding question. You'll actually use it as a daily guide because it's chucked full of valuable last minute welding information. It'll put you straight, in words and pictures, on EVERY welding operation.

192 pages of Arc Welding Lessons This one section is a gold-mine within itself. Shows student correct methods of present day applications. Brings the expert up-to-date. You can't afford to waste a day, so get your copy NOW!

HOBART Bros., Box M-231 Troy, Ohio
"One of the World's Largest Builders of Arc Welders"

not in disparagement, but in genuine respect.

How high will these non-Annapolis officers go? Since 1900 there have been only a few non-Annapolis admirals in the Navy. But Vice Admiral Chester Nimitz (himself a former Naval R. O. T. C. instructor at the University of California) predicted not long ago before the House Naval Affairs Committee:

"Probably many of the admirals of the future American Navy will never have been to Annapolis." They'll come from the "mustang" ranks now in training in our colleges and universities.

Riding the Fast Mail

(Continued from page 59)

Railway post office cars served as the model for the new highway postal service between Washington, D. C., and Harrisonburg, Va., in which regular mail distribution is carried on inside large postal trucks while traveling along the highway. Picking up railroad mail on the fly was the origin of a similar idea used by an east coast feeder air line before war started. Instead of landing at a field to pick up a small amount of air mail, the mail plane swooped down to pick up with a grapnel hook a mail sack attached to a line that was suspended between two poles.

Conveyor-belt systems are used in most large cities for sorting and stacking the mail, and in New York and Boston much of the mail moves between branch post offices through pneumatic tube systems. The main New York post office, for instance, is tied in with 21 of its larger branches with a double line of 8-inch pneumatic tubes. Bundles of letters are placed in carriers that resemble small milk cans and these move at 35 miles per hour through the tube system, being relayed from one station to the next until each carrier reaches its destination.

Every day, the New York post office receives, dispatches and delivers upwards of 14,500,000 pieces of ordinary mail, 132,000 registered pieces, 72,000 parcel post packages, and 260,000 pounds of newspapers and magazines. Canceling machines that handle 600 letters per minute are one of the many mechanical devices used to handle the daily mountains of postal matter.

(Continued to page 170)

Better model-making-
better arts and crafts-

WITH THIS
REVOLUTIONARY KNIFE

The very knife-design makes you do a better job. The handles make your fingers deft. Super-keenness makes effortless cutting on hard woods, cardboards or plastics. Special blade-shapes make X-ACTOS follow guide lines easily; and surgical sharpness minimizes splitting. NOW, at first sign of dulling, instant change to a new blade renews the surgical keenness. Re-blade to re-sharpen.



No. 1 X-ACTO knife for light, delicate work. 3 styles of blades. Complete with one blade. 50c. With 5 extra assorted blades. \$1.00

No. 2 X-ACTO knife for heavy cutting—3 styles of blades. Complete with one blade. 50c. With 5 extra assorted blades. \$1.00

No. 42 Double Set 2 handles. 12 blades. \$2.00.

No. 82 Fitted wooden chest 3 handles, 12 blades. \$2.50.

GET FREE BOOK, TELLS "HOW" to build Model Planes prepared by experts. Profusely illustrated, simple, easy to follow instructions. Build solid models for Army and Navy spotter planes. Write for **FREE "How to build Model Planes"**. Send 5c to cover handling and postage. At your local Hobby Shop, Hardware or Department Store or order direct. Extra Blades 50c for pack of 5

X-ACTO
CRESCENT PRODUCTS CO.
440 Fourth Ave., New York, N.Y.
Dept. PM



X-ACTO knife
RE-blade to RE-sharpen



TRAILER AXLES, HITCHES, AND PARTS

• If you are interested in purchasing trailer axles, hitches, and other trailer parts, contact us promptly. Complete house trailer blue prints, \$1.00. Write for free literature.

HAMMER BLOW TOOL COMPANY, Dept. 102, WAUSAU, WIS.

NEW Grinding Attachment

For 8" to 16" Metal Lathes. Build it Yourself.

At last, a precision grinder within your means. You save 2/3 by finishing our semi-machined castings, on your own lathes. HURON handles both internal and external grinding. Accuracies to .0002". Mirror finish, easily obtained. Grinds wire, pistons, bushings, shafts, hard or soft, holes, lathe centers, sharpens reamers, milling cutters. Does accurate drilling; taps; refiles; scores of other uses, for home workshops, gunsmiths, machine shops. Write for FREE illustrated folder and price list of supplementary items. Mention your lathes.

Huron Machine & Tool Co., Dept. B, Yale, Mich.



Semi-Machined Castings
Only \$645

**MANY NEVER
SUSPECT CAUSE
OF BACKACHES**

This Old Treatment Often
Brings Happy Relief

Many sufferers relieve nagging backache quickly, once they discover that the real cause of their trouble may be tired kidneys.

The kidneys are Nature's chief way of taking the excess acids and waste out of the blood. They help most people pass about 3 pints a day.

When disorder of kidney function permits poisonous matter to remain in your blood, it may cause nagging backache, rheumatic pains, leg pains, loss of pep and energy, getting up nights, swelling, puffiness under the eyes, headaches and dizziness.

Don't wait! Ask your druggist for Doan's Pills, used successfully by millions for over 40 years. They give happy relief and will help the 15 miles of kidney tubes flush out poisonous waste from your blood. Get Doan's Pills.



No More Damage from Condensation or Sweating Pipes, Water Softeners, Tanks, Walls, Ceilings and Air Ducts

NO Drip **A SURE CURE**—This sensational plastic cork coating prevents condensation drip from metal, concrete, brick, wood, plaster or composition surfaces. Permanently protects metal against rust and corrosion, thus prolonging life of pipes, tanks, etc. Forms a moisture-proof, insulation type coating. Apply with brush, trowel or spray.

Stucco-like finish requires no maintenance and can be painted any color. A gallon covers about 30 feet of 1" O.D. pipe. Comes in 1, 5 and 55 gallon drums.

Get at Hardware, Plumbing, Mill Supply Dealers or send \$1.90 for 1 gal. prepaid. Write for Free Handbook. **J. W. MORTELL CO., 522 Burch St., Kankakee, Ill.**



WHY WEAR DIAMONDS

When diamond-dazzling Zircons from the Mines of faraway Mystic Siam are so **effective and inexpensive?** Stand acid, cut glass, full of FIRE. Thrilling beauty, exquisite mountings. Examine before you buy. Write for FREE Catalogue. Address **NATIONAL ZIRCON CO., Dept. 250, Wheeling, W. Va.**

Catalog FREE!

Wonder-Tone NOISE ELIMINATOR

Just attach to your radio (long, short wave) and enjoy reception free from distracting noises. Send-No-Money Pay Postman 60c plus postage or send 60c and we'll send postpaid. Return in 5 days for refund if not delighted.

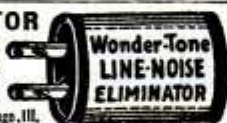

WONDER-TONE COMPANY, Dept. 25, 7078 N. Clark St., Chicago, Ill.

CRESCENT TOOLS

Give Wings to Work

ASK YOUR
HARDWARE
DEALER

BUILD YOUR GRANDFATHER CLOCK NOW

Send 35c for Simple SHOP TESTED COPYRIGHTED BLUEPRINT. The Simple Sensible Red-I-Kut way as thousands have. DIME brings PLANS and sixty picture "HOW" Book pricing money face brass weight Westminster, tube chime movements showing nice beautiful colonial grandfather cases. Build now. Avoid Govt. Freeze. Save half. HURRY! **KUEMPEL CHIME CLOCK CO., Bldg. 73, Guttenberg, Iowa**



Get this Handy OHMITE Ohm's Law Calculator!



10¢

Figures Ohms, Watts, Volts, Amperes—Quickly, Easily!

Solves any Ohm's Law Problem with one setting of the slide. Requires no slide rule knowledge. All values are direct reading. Scales on two sides cover the range of currents, resistances, wattages and voltages commonly used in Radio and Electrical Work. Size 4 7/8" x 9".

Send only 10c in coin to cover cost of handling. **OHMITE MFG. CO., 4931 Flournoy St., Chicago, Ill.**

In all, the 250,000 employees of the nation's post office department moved 29 billion pieces of mail totaling 3,125,000 tons through its 44,095 post offices and 6,553 branches during the fiscal year ended June 30, 1941. This was a great increase over 1940 and the volume of mail since last year has likewise increased considerably. First class mail makes up about half the total. Air mail accounts for less than one percent although air mail is increasing to such a volume that the air lines are establishing special air mail and express departments.

War has complicated the handling of the mails, first by the unprecedented amounts of material that must now be handled. Too, the post office department and the railroads have the task of trying to maintain normal mail schedules even though emergency troop trains disrupt ordinary train movements. Mail trains are the last to be tied up when schedules must be changed temporarily.

Another complication is the military camps and training establishments that spring up almost overnight. These must all be provided with efficient mail service. Mail volume at a small town may jump from hundreds of letters to hundreds of thousands of letters a day when an army camp is built nearby. Usually the post office department is warned ahead of time when such mass movements occur with the result that postal facilities literally follow the troops around.

Delays are often unavoidable in handling navy mail. All large navy ships have a small post office on board and even carry ordinary post boxes in which outgoing mail may be deposited. For administrative purposes all such ships are classed as branches of the New York post office, no matter in what part of the world they may be and even if such ships have never visited New York. All navy mail is handled in and out of the nearest shore station. Mail from ships at sea and abroad is brought to the United States by naval transport and supply vessels.

"Neither snow, nor rain, nor heat nor gloom of night stays these swift couriers from their appointed rounds," has been taken as its motto by the post office department. No matter where you are, the department's business is to see that mail addressed to you is delivered as rapidly and as safely as possible.

"Mummy" Foods for Victory

(Continued from page 11)

To dehydrate food in such a cabinet, select vegetables in prime condition, free of wilt, and pick them just before you are ready to proceed. Some varieties dehydrate and keep better than others, and a good rule is that the most brightly colored varieties stand dehydration best. Heavy stalks, skins, and outer leaves should be removed. First wash and then cut such vegetables as carrots, beets, potatoes, cabbage, or tomatoes into small pieces, or slices $\frac{1}{4}$ -inch thick. Corn trimmed from the cob, peas, or spinach leaves need no such cutting.

Next blanch the material by steaming it. This may be done by filling a colander or wire basket not more than half full with the material and placing this in a kettle containing an inch of water, not enough to wet the vegetables. Put on the cover and boil vigorously. This steaming continues for from 2 to 10 minutes, until each piece is heated through. Test by removing a piece from the center of the container. It should feel soft but not completely cooked.

The blanched pieces are then spread, not more than half an inch thick, on the cheesecloth of the drying trays. Stagger the trays in the dryer. The thermometer on the lower tray should be kept between 140 and 150 degrees. Complete dehydration requires 4 to 12 hours and must continue until the food becomes bone dry and brittle. The trays should be rotated every half hour or so to insure even drying. Heat should be reduced during the last stages to prevent scorching.

After cooling, the dried food must be stored in moistureproof and insectproof containers, sealed from air with cellulose tape or paraffin. A small piece of Dry Ice may be dropped in each container and allowed to evaporate completely before the food chips are poured in. This provides a carbon dioxide atmosphere in which the dry food will keep for years without deterioration. Additional information on how to build home dehydrators and use them may be found in the U. S. Department of Agriculture Farmers' Bulletin No. 984 or in the pamphlet "Drying of Vegetables and Fruits in the Home" that may be obtained from the Office of the Director of the College of Agriculture, University of California, Berkeley, Calif.



LONG ago the last production line stopped on Evinrude's peacetime products . . . so that the skill of every worker, the output of every machine, could be wholly centered on the war effort.

Many vital products are included in Evinrude's soaring "volume for Victory" . . . and it is no secret that outboards are among them! We are frankly glad of that. With 33 years of experience to aid us, the job of building fine motors for all of Uncle Sam's services is obviously "right down our alley."

We're giving the job all we've got . . . in research, engineering, manufacture. And after Victory the Evinrudes you again can buy will be the finer for it . . . in every feature and detail, worthy off-spring of a fighting breed! EVINRUDE MOTORS, 4995 North 27th Street, Milwaukee, Wisconsin.

*Evinrude Motors of Canada,
Peterboro, Canada*

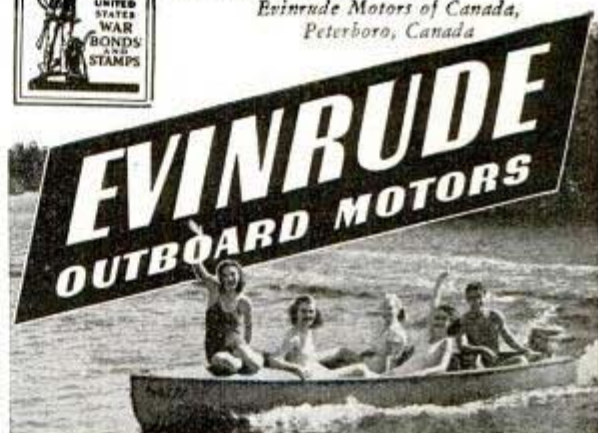

DRILL PRESS OWNERS!

HERE'S 1 TOOL WITH 5 DISTINCT USES
THE BARRON MULTI-PURPOSE
ROTARY WOOD PLANER



PLANES & SURFACES • PANELS & BEADS
 ROUTS & GROOVES • RABBETS • TENONS

\$7.50
 COMPLETE

Converts ANY drill press into a time saving, low cost planer, paneler, tenoner, etc. Surface finishes all types of tough grained and knotty surfaces to agate smoothness. Safe! Guaranteed harmless to drill press. Thousands now in use. **SOLD ON MONEY BACK GUARANTEE.** Full refund on 5 day trial. Shipped prepaid on receipt of \$7.50—or C.O.D. **YOU RISK NOTHING.** Free literature.

STEEL TOP AUXILIARY DRILL PRESS TABLE

Has 300 sq. in. smooth working surface. Equipped for shaper and many other important workshop uses—a real buy at **\$5.95**



Barron Tool Co., 369 Architects Bldg., Detroit, Mich.

EVERYTHING IN RADIO!

FOR REPLACEMENT PARTS AND RADIO BOOKS
 Send Your Orders To Allied

NEW—Allied's Radio Formula & Data Book—**10c**

ALLIED RADIO CORP.

833 W. JACKSON BLVD., DEPT. 5-B-3, CHICAGO

★ **ALLIED RADIO** ★

SHAW and "Peppy-Pal"
"DU-ALL" GARDEN TRACTORS

• 1 to 9 H. P. Circulars on request. War limits production . . . We have repairs for all SHAW tractors sold in our 39 years in business. Write us for your needs.

YOU CAN BUILD YOUR OWN GARDEN TRACTOR

\$1.00 brings our plans, postpaid, telling how to build a garden tractor (Chiefly by welding and bolting up scrap steel), for cultivating, light plowing, etc.

SHAW MFG. CO., 4502 Front St., Galesburg, Kansas
 668-G No. 4th St., Columbus, O.; 5812-G Magnolia Ave., Chicago, Ill.



New Designs in
FRANZITE GRIPS

Modernize Your Gun! Improve Your Score!

Most durable grips made. Positively unbreakable! For Colt, Smith & Wesson, Hi-Standard, Ortgies, Luger & Mausers in a wide choice of beautiful designs in ivory, pearl, walnut, onyx, etc. Low prices. **FREE CATALOG.** Dealers Wanted.

SPORTS, INC., (Mrs.) 2850 N. Clark St., Dept. P-2, Chicago, Ill



AMAZINGLY POPULAR
NEW COMMANDO
 Military Style Shoes

Crash through to biggest shoe profits in years with sensational new soft-as-glove leather Military Shoes for Men of Action—also hundreds of other fast-selling styles for men and women, for dress, work, sport. Rush name and address for **FREE SAMPLE OUTFIT**, and Tested Sales Plans.

VICTOR THOMAS SHOE CO.
 610 W. Van Buren St., Dept. V-79, Chicago, Ill.



FREE SALES KIT

Wood workers: Here it is! Harold Hunt's big revised No. 14 wood catalog! Latest **UP-TO-DATE IDEAS** for experts and amateurs; **SPECIAL BARGAINS** in rare woods, veneers, and **ALL** kinds of supplies. 124 pages—12 of rare woods in color. Get posted. Send only **10c** to **CRAFTSMAN WOOD SERVICE CO.** 2729 S. Mary St., Dept. A-30, Chicago, Ill.

Two Modern Crystal Sets

(Continued from page 157)

for connections to various parts of the circuit. All coils are wound in similar fashion.

The coils and other parts for the set are mounted on the simple hard pressed wood baseboard which is supported by small wood cleats, as shown in Fig. 2. Mount the variable condensers (C_1) and (C_2) in any convenient way, usually by means of a short machine screw up through the baseboard. Some types will require a small panel. The exact capacity of the variable condenser is not important, any condenser with 20 or more plates will work. The crys-

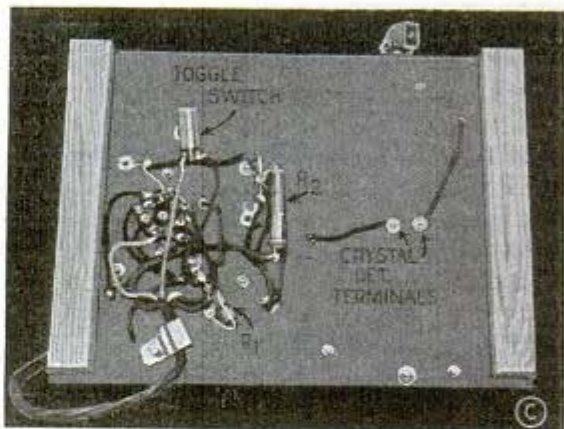

tal detector may be any adjustable type. Mount the coils on the baseboard with China cement or small angle brackets. Fahnestock clips provide connecting terminals for the antenna, ground and headphones. Follow Fig. 2 for wiring carefully and make sure that one end of coil (L_1) connects to the stationary plates (S) of the variable condenser (C_1) and the other end to the rotating plates (R). The rotating plates are common with the condenser frame and the connection may be taken at any convenient point on the frame if a soldering lug is not provided. Use rosin-core wire solder, and flexible insulated hookup wire for all circuit connections. Ordinary bell wire may be used if no other is available. To test the set, use a good outside antenna about 100 ft. long and run the ground to a clamp on the nearest cold-water pipe. Clip in the headphones, and set the two variable condensers at approximately half capacity each, and adjust the crystal detector to a sensitive point. Then tune both variables until the signal you

(Continued to page 174)



HARLEY-DAVIDSON MOTORCYCLES

BUY WAR BONDS NOW!

So you can become
a Harley-Davidson
owner after Victory
is won!

Today, our entire efforts are devoted to the production of military model Harley-Davidsons — motorcycles that stand up under the grueling punishment of war. Tomorrow, when days of peace return, we will be producing the best Harley-Davidsons that money can buy — rugged, dependable motorcycles for business, police and sport.

HARLEY-DAVIDSON MOTOR COMPANY
Department P MILWAUKEE, WISCONSIN

BUILD THE BIGGEST \$1.00 PLANE IN U.S.

Giant 7-Foot Cleveland Condor Soaring Glider

You can't get a better design for learning principles of advanced soaring flight. Easily built. Soars for hours. Kit VE-5019, only... **\$1.00**

4-Ft. Cleveland Eaglet

Unusually good model of a secondary type glider. Patterned after "Baby Bowlius". Easily built. Kit VE-5018, only... **50c**



If your dealer can't supply you, order direct. Enclose 15c extra on orders for less than \$1.00.



Send 5c for Catalog (none free)

Be Sure to Build These Six New Big 3-Foot Famous War Models

Kit T74—Messerschmitt ME-109; Kit T76—Bell Airacobra P-39; Kit T77—Curtiss P-40 "Warhawk"; Kit T85—P-38 "Lightning"; Kit T78—Hawker "Hurricane"; Kit T91—P-51 "Mustang".....Each only **\$1.50**



CLEVELAND MODEL & SUPPLY CO., INC., 4508C15 Lorain Ave., Cleveland, Ohio

END TOOL RUST WORRIES



RIG-Universal stops rust when others fail. Quick, easy to use. Used by Mfrs., Labs., etc. Unexcelled for TOOLS, dies, hinges, locks, chrome, battery terminals or anything that rusts! Also good for guns. Tube 25c.—write RIG, 5646 Lake Park Ave., Chicago, Ill.

WHEN YOU BUY FLASHLIGHT BATTERIES DEMAND

"EVEREADY" FRESH DATED BATTERIES

The word "Eveready" is the registered trade-mark of National Carbon Co., Inc.

New Accurate 10" Slide Rule

Magnifying Indicator



Instruction Book FREE

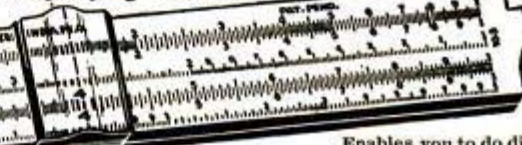

50c

SPECIAL COMBINATION OFFER
Slide Rule and Instruction Book; Pocket Calculator for adding and subtracting up to 999,999; 6" Transparent Protractor and Graph Rule graduated in centimeters and inches. **ALL 3 for \$1.00 cash** (\$1.10 Foreign) Postpaid.

Enables you to do difficult calculations instantly without paper or pencil—multiplying, proportions, division, extracting roots, etc. Accurate, white composition face. Has standard A, B, C, D, CI and K scales. For complete outfit, including slide rule, 28-page illustrated instruction book, carrying case, send 50c (60c Foreign). Mailed postpaid. Satisfaction guaranteed or money refunded. (See Special Combination Offer) **Order NOW!**

HEWIG CO., Box 143-G, Grand Central Annex, New York City

Make BIG MONEY AT HOME!

NEW Invention Electroplates by BRUSH



Now Plates CHROMIUM!

ALSO GOLD, SILVER, NICKEL, COPPER, ETC.

War Increases Demand—You Profit!

New, patented invention makes possible big earnings AT HOME. Replate auto-parts—worn articles in homes, stores, hotels, restaurants, etc., with durable, sparkling, new coat of metal—with stroke of brush. Easy, simple, quick. Genuine Gold, Silver, Nickel, Cadmium, etc. Everything furnished. Outfit complete, ready for use. No shop required. Clear from \$2 to \$5 an hour in lifetime business. Small investment starts you in business. Steady repeat. Machine can pay for itself in week. Send TODAY for FREE SAMPLE and illustrated BOOKLET how you can have a life income from a business of YOUR OWN built upon satisfied customers. Act at once!

WARNER ELECTRIC COMPANY
215 W. Ohio St., Chicago, Ill., Dept. 207

FREE BOOK & SAMPLE

WARNER ELECTRIC CO., 215 W. Ohio St., Chicago, Ill., Dept. 207
Gentlemen: Send me Free Sample and Illustrated Booklet.

Name _____
Address _____
City _____ State _____

GRAY HAIR VITAMIN NOW \$1.95

No dyes—No drugs—Hair grow out in Natural Color in almost nine out of ten test cases just taking one tablet Calcium Pantothenate Vitamin each day.

Why pay \$3.50 to \$5.00 for the famous "Gray Hair Vitamin"? SEND NO MONEY. Just send name and address. We will ship 100 10-mg. tablets (100 days' supply) genuine standard quality Calcium Pantothenate Vitamin C.O.D. for \$1.95 plus few cents postage. Guaranteed same quality as used in National Tests or money back.

LILEE PROD. CO., 2017 S. Michigan Ave., Dept. 92, Chicago, Ill.

BIG MONEY BUILDING MEAD'S NEW PORTABLE OUTBOARD BOAT



IN A FEW DAYS AT HOME!

Build this light 50 lb. tough, durable, seaworthy portable Outboard Ki-Yak! Take it anywhere by hand or car. Safe, dependable, trouble-free. More speed per horsepower, more miles per gallon. MEAD'S perfected metal-ribbed, cut-to-fit construction kit guarantees successful assembly quickly, easily, economically. New 60 lb. OR-4 uses oars, sail, motors, 9 h. p. or less. Also 3 "OK" paddle—sail models from 20 lbs. to 45 lbs. Double Paddle or Oars INCLUDED with your Ki-Yak! Write for FREE lavishly-illustrated circulars, low Factory-To-You Prices!

MEAD GLIDERS, 15 S. Market St., Dept. 8-23 CHICAGO, U. S. A.



AUTO ENGINE SPEED CONTROL GOVERNORS

Give constant speed to any make of auto or truck engine, regardless of load changes, when used for power. No better governor can be made. Fully guaranteed. Complete, simple instructions. Oil ring bearing \$12.50. Ball bearing \$19.00. Montreal branch, 7546 Wiseman St. Free circulars. **CANDEE, 129-32 Llewellyn St., Los Angeles**

want to hear is loudest. You will find that condenser (C₁) tunes in the stations, and (C₂) is useful for cutting out the unwanted stations. In the original model the tip end of one of the plates of condenser (C₁) was bent so that with the condenser completely closed it shorts out. This is useful when it is desired to get the strongest possible signal from the highest-powered local station. This can be done with a switch if preferred.

Set No. 2 uses a simpler detector circuit, the signal from the crystal detector being fed to a 70L7-GT amplifier tube. The same general construction details are followed for this set. All parts are noncritical; the audio transformer may be any ratio near

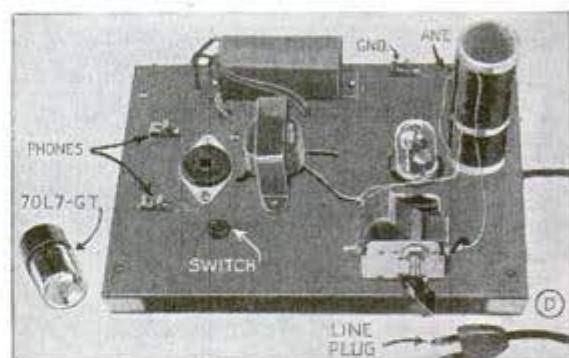

the one given. The electrolytic condenser block may contain two 5 mfd. or 10 mfd. low voltage condensers C₂ and C₃ which are connected in parallel; 150-200 v. C₄ and C₅ are not critical. Any electrolytic condenser block with the same voltage ratings and more capacity may be used. A common type is an a.c.-d.c. block with one 16 mfd. section and one 12 mfd. at 150-200 volts and two 10 mfd. sections at 35 volts. The line-cord resistor should be 300 ohms but 290 or 310 will work. A detailed list of the noncritical materials used in both sets is available from Popular Mechanics radio department without charge.

Wiring for set No. 2 is more complicated and will require some care if this is your first set. Photos B, C and D show the arrangement of parts above and below the base. Check every connection carefully with diagrams Figs. 3 and 4 as you wire. Use the same type of antenna and ground; any small magnetic speaker may be used. With headphones there will be some hum and the signals will be very loud from strong local stations, however slight detuning will reduce the volume. The blueprint number for these sets is R-311.

Study This Picture

IT REPRESENTS FREEDOM. It represents our liberty to do those things we choose to do—to buy, with our earnings, the comforts that appeal to us—and to enjoy them as we will.

It represents the American way of distributing fine things with equality. The factory watchman, the mill superintendent, the millionaire yachtsman—all may and DO drive the same model Sea-Horse. All enjoy the same perfection of performance.

It represents the things which will be ours again when the war is won. In the meantime there is work for us to do.

For our part we have stopped the production of outboard motors for civilian use. We are working 100% on certain war items for which our experience in building precision products has fitted us.

All to the end of winning the earliest possible victory—so we can get back to those things we hold dear—including golden hours on the water.

JOHNSON MOTORS • WAUKEGAN, ILLINOIS
Johnson Motors of Canada, Peterboro, Canada



JOHNSON SEA-HORSES
for **DEPEND**ability

TOOLS to build Airplanes

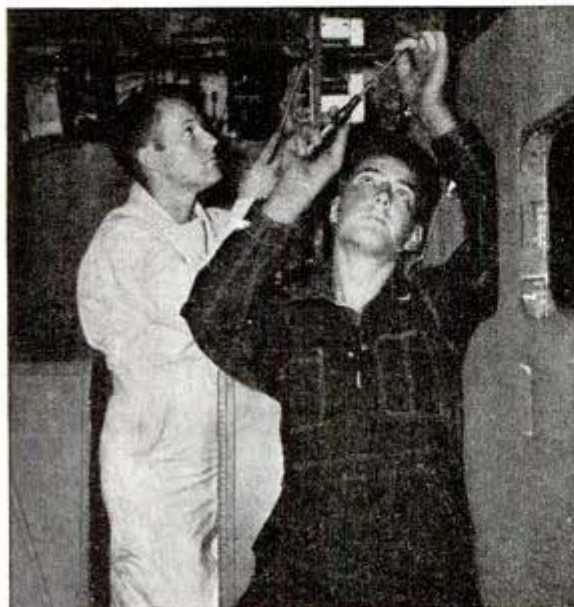

The swarms of airplanes needed to speed the doom of the Axis could never be built nor serviced without *hand tools*—hammers, screw drivers, planes, breast drills, chisels—the same types of hand tools you use on the job every day. Stanley Tools are being used in tremendous quantities by airplane plants, air bases and training fields, carriers, and by every flying field on the fighting fronts.

Because of this demand, tools for normal use are necessarily scarce. Buy them only for essential use. Stanley Tools, Division of The Stanley Works, New Britain, Connecticut.

STANLEY
Trade Mark

Photo - Courtesy Colliers



STANLEY TOOLS
"The Tool Box of the World"

READY CUT HOMES

Still Available • You can get one—
 Really need a home? You can get one—
 now—in many areas, necessary
 equipment, included application
 We'll show you how to get
 government permission, and
 save \$500 average, on a mod-
 ern production method. Informa-
 tion easily obtained. If you plan
 to build—now or later—send 25c
 on FHA financing. Catalog
 new for Sterling Homes Catalog
 showing 75 modern low priced
 home plans; full government
 on your way for complete building
 priority. Complete building with
 plans ready at moderate cost.
 Write.

Dept. P.M.-23
**INTERNATIONAL MILL
 & TIMBER CO.**
 Bay City,
 Mich.

**NEW COLOR CATALOG
 FOR ONLY
 25¢**



WAR VOLUNTEERS

Materials to build famous WITTE Log Saws and Engines are now needed for war equipment. America's victory program has first call at the large WITTE factory. After victory these money-makers will again be available. They're worth waiting for. . . .

WITTE ENGINE WORKS
 Kansas City, Missouri

USED BY THE U.S. GOVERNMENT
 SAVES 50% DOWN CUTS 1/2 THE UP

*WITTE has been serving America for 72 years.



WITTE LOG SAWS and ENGINES



POWERFUL VISION - LONG RANGE TELESCOPE

20 days free trial Postpaid or C.O.D. **\$2.19**



Objects 500 yards away appear as 100 yards distant, 5 miles as 1 mile! Telescope closed is less than 1 foot. Persons who seem 1 inch high to the naked eye, will appear 5 inches high. Scientifically ground 33mm lens. Handsome case included! Try for 20 days—if not satisfied return for full refund.
Vogue Telescope Co., 7759 S. Halsted, Dept. P-216, Chicago.

DOOR-EASE STAINLESS STICK LUBRICANT

EASES STICKING DOORS

Use Door-Ease—like a crayon—for things that stick or squeak... doors, drawers, windows, latches and friction catches, screws, zippers, etc. Clean, weather-proof, long lasting! — Door-Ease Mfrs., Muskegon, Michigan.

10¢ in metallic container at Hdw., Auto Accessory, Dept., and Dime Stores.



don't WORRY

ABOUT RUPTURE

Why put up with years of needless discomfort and worry? Try a Brooks Automatic Air Cushion. This marvelous appliance permits the opening to close, yet holds reducible rupture securely, comfortably—day and night. Thousands report amazing results. Light, neat-fitting. No hard pads or stiff springs to chafe or gouge. Made for men, women and children. Durable, cheap, **Sent on trial** to prove it. Never sold in stores. Beware of imitations. Write for **Free Book on Rupture**, no-risk trial order plan, and proof of results. All correspondence confidential.
BROOKS COMPANY, 158-B State St., Marshall, Mich.



Robot Guardians of Billions

(Continued from page 31)

Two young hoodlums in Forth Worth, Tex., recently discovered the effectiveness of the closed circuit. They climbed a pole and cut the burglar alarm wires in front of a store and before they could jimmy the door private guards and the police arrived. When wires are cut detectives know amateurs have been at work.

A pneumatic system for vaults or small rooms that are almost airtight sends an alarm when the air pressure is disturbed. This can be caused by opening a door or window or cutting a hole in the vault. A small fan set in the wall creates a partial vacuum and when the outside atmosphere rushes in the air pressure is changed, setting off the alarm.

Microphones suspended from the ceiling of vaults respond to sound waves caused by an acetylene torch or the blow of a hammer. The police, in answer to a radio call from headquarters, usually arrive on the scene before the "yegg" knows an alarm has been given.

The flame of the cutting torch, which has a theoretical temperature of 7,800 degrees Fahrenheit, activates an alarm that responds to heat. Other automatic systems release tear gas before a vault if a burglar tampers with the door.

Many vault walls of steel and reinforced concrete are strung with electric wires not more than four inches apart. These fortresses have walls from six inches to six feet thick and steel doors that frequently weigh tons. A vault in a Cleveland institution has doors that weigh 180 tons each with hinges that alone tip the scales at 40 tons.

Automatic time locks, set from 15 minutes to 72 hours, take no chances with human failure. Most of the locks begin working automatically at 10 p.m. just in case a careless employee forgets to set them when the doors are closed. The time lock was the answer of protective engineers to criminals who either blew off combination locks with explosives or forced custodians to operate them.

Before the development of automatic alarms, bankers relied on some ingenious and cumbersome means to guard their money. Vaults beneath the Bank of England in London were recessed with water-

proof enclosures so they could be flooded for protection. The burglars' tools would have had to include a diving suit.

All a burglar needed to blow up a safe in the old days was a crack 4/1,000-inch wide and a few ounces of nitroglycerin. His task today isn't so simple with a new safe composed of an outer layer of sheet steel, six inches of reinforced concrete, an inner lining of copper at least one-half inch thick, and two and a half inches of tool steel. At Underwriters' Laboratories this safe resisted an attack with tools, torch and explosives for one hour.

That may seem a comparatively short time to the average citizen, but to safe-breakers it is an eternity. Most burglaries and robberies, timed to the split second, average between three and five minutes.

When one considers a few of the hurdles a burglar faces before he gets near a vault, safe or even a storeroom, it is easy to understand why he shies away from protected premises. Some 15,000 banks, whose alarm installations are certified by Underwriters' Laboratories, haven't had a single "break" in 10 years. Even a bag carried by bank messengers is designed to foil robbers. Ten seconds after it is snatched from the hands of a messenger four blank cartridges explode and smoke billows forth.

Windows are guarded with tinfoil charged with electricity, or dowel screens lined with tiny wires. Doors and walls are wired so any disturbance breaks the current and causes an alarm. The new doors made entirely of a sheet of glass look vulnerable to attack, but if struck with a sharp instrument the glass is tempered so it "explodes" into small cubes with a terrific noise. Destruction of the door sets off an alarm.

The electric eye, used both outside and indoors, takes its toll of burglars, arsonists, saboteurs and prowlers daily. It may be located along a fence, before a bank of windows or doorway, or criss-crossed along the floors of a building to cover every few feet of space. Invisible rays developed to operate in fog are helping protect U. S. harbors against sabotage. Where and how they operate are military secrets. The rays are guarding defense plants and arsenals. Officials well remember that during World War I sabotage by German agents caused damage of \$150,000,000 in this country.



IMPROVE YOUR SKIING

• Good skiing demands sturdy, accurately designed skis. That is why most experts use and recommend Northland Skis. Only in Northlands will you find the finest woods, hand craftsmanship, the newest designs. Naturally you'll ski better on Northlands.

Send 10c for 48 page Ski Manual. 84 illustrations. Tells you how to ski... edited by Hannes Schneider.

NORTHLAND SKIS

World's largest ski manufacturers

95 Merriam Park, St. Paul, Minnesota

AUTOMATIC STOP GAUGE



For Bench and Engine Lathes

Accurately stops carriage at any set point for production of duplicate pieces. Prevents spoiled work. Easy to attach to lathes.

Pat. Pending
AMERICAN PRODUCTS CO.
Dept. PM1, 2287 Holters Ave.—N. Y. City

DETAILS IN
FREE FOLDER

ARTIFICIAL ARMS—LEGS

WRITE FOR FREE BOOK showing how CARNES ARTIFICIAL arms, legs have PUT THOUSANDS BACK ON THE PAYROLL. Every limb made to fit individual amputation. World-wide recognition of merit since 1904. BOOK SENT FREE—advise whether interested in leg or arm—no obligation, send for it now.

CARNES ARTIFICIAL LIMB CORP.

Dealers and Representatives Everywhere

908 East 12th Kansas City, Mo.

BACK TO
EARNING
with
CARNES
ARMS
LEGS

BUILD YOUR OWN ARC-WELDER

For Light or Heavy Work

No rewinding necessary—use coils taken from old auto generators. Works on 110 or 220 A.C. Has 20 different heats. Complete plans and BIG Catalog 35c.

LEJAY MFG. CO., 3347 LeJay Bldg., Minneapolis, Minn.



521 ITEMS TO HELP YOU MAKE MONEY!

with WORK UNIFORMS, AND SO MANY, MANY OTHERS

War work means huge demand from millions of men and women for MASTER fine work garments. Be our local dealer. Take orders in spare time. Huge selection of smart industrial clothing. Advertising embroidered on garments creates quick demand. Some single orders bring our men as much as \$75. No experience necessary. We supply everything. Write immediately for FREE Outfit. Geo. Master Garment Co., Dept. D-72, Ligonier, Indiana



DIE-LESS DUPLICATING

Many small parts can be formed without dies, to duplicated accuracy of .001" with DI-ACRO Precision Machines, — Benders, Brakes, Shears—saving Man Hours and Critical Materials. Write us on your business letterhead for catalog — "Metal Duplicating Without Dies."

O'NEIL IRWIN MFG. COMPANY
341 8th Avenue S.
Minneapolis, Minn.



Always write your name and full address clearly when answering advertisements.



**SAVING
MINUTES
WHERE
MINUTES COUNT!**

IN THE arsenals of war production, "Yankee" Fine Mechanics' Tools save time, work, trouble, and money—not only because good mechanics use them, but also because they make good mechanics *better!* Even the humdrum jobs of driving screws, drilling holes or tapping threads are speeded up because these tools are *made for speed* . . . for doing little jobs in a big way. And behind their ingenuity is more than a half century of proved performance in plants and shops and homes the nation over. We can't make "Yankee" Tools fast enough to meet war-time demand, so protect the tools you have. Use them wisely and they'll treat you well.

"YANKEE" SPIRALS



Simple. Compact. Strong. A size for every purpose.

"YANKEE" TOOLS
make good mechanics better
North Bros. Mfg. Co., Phila., U. S. A.
Established 1880

Makers, also, of "Yankee-Handyman" Tools



SAVE TOOLS
Protect them in a genuine Gerstner Chest.
Free Catalog to Toolmakers and Machinists
GERSTNER TOOL CHESTS
443 Columbia St. Dayton, Ohio



**OTTAWA
TRACTOR
SAW**
Falls Tree—Cuts Log
Fits rear power take-off shaft.
Drive thru gear reduction. 18-in. stroke,
10-ga. blade. Economical, saws to profit. **FREE Circular
and Price List**
OTTAWA MFG. CO., 1827 Forest Avenue, OTTAWA, KANSAS

ONAN ELECTRIC PLANTS
ALTERNATING AND DIRECT CURRENT



Produce Current, same as City Power Lines, for FARMES,
SCHOOLS, THEATRES, PUBLIC BUILDINGS . . .
Operate Lights, Radios, Motors, All Appliances.
Over 40 STOCK MODELS—150 to 50,000 Watts.
Any Voltage—Any Frequency.
Combination A. C. - D. C. Types.
Manual, Full Automatic and Self-Starting. \$99 up.
shipped—COMPLETE, READY for OPERATION.
THOUSANDS IN USE IN ALL PARTS
OF THE WORLD.
Write for Complete Details.
D. W. ONAN & SONS
107 N. Royallton Avenue - MINNEAPOLIS, MINN.

Adventures of the Inshore Patrol

(Continued from page 76)

power, on inland waters as well as at sea, counts in your favor. Right now the small boat navy is being recruited up to full strength and if you can qualify for enlistment there may be special advantages in it for you.

For one thing, you will serve in the naval district in which you enlist, where your local knowledge is the most valuable. Possibly you will continue to live in your home town. For another thing, your own past experience probably will make it unnecessary for you to spend a month at a naval training station and so you go on active duty at once. Again, you will receive a rating based on your own past experience. That means that you may be sworn in as a coxswain or a bosun's mate, instead of as an apprentice seaman, and with correspondingly larger pay.

Even if you haven't had small boat experience there may still be a place for you in the inshore patrol. The small boat navy needs well qualified amateur radio operators. All of its vessels are equipped with two-way sets and many of them in addition have special military radio-type equipment. The service is also looking for ex-seamen, Diesel engineers, electricians, plumbers, and carpenters, among other trades, for there is plenty of work to do around the boats and they must be kept in sea-going condition. To enlist in the M-2 classification, the reserve group being described here, you must be between the ages of 17 and 50.

The inshore patrol operates mine layers, mine sweepers, station vessels, net tending vessels, harbor patrol boats, dispatch boats, and coastal patrol boats. Many of these were built for their particular duties while others have been converted from fishing boat and pleasure boat hulls. Many of the mine sweepers, for instance, were tuna clippers or purse seiners rebuilt and refitted for their present duties. Pleasure boats ranging from small, fast cabin cruisers 30 feet long, that make ideal dispatch boats, to large sailing yachts 150 feet or more in length, capable of offshore duty for weeks at a time, have been donated by their owners to the Navy for the duration of the war. The Navy accepts them "as is," refits them

for their own work, maintains them in good condition, and will restore them "as is" to their owners when the war is over. It sometimes happens that the owner of such a boat volunteers both himself and his ship, in which case he is assigned in charge of his own vessel because he is well qualified to operate it.

But don't get the impression that the work of the inshore patrol is something like pleasure boating. You go to sea in foul weather as well as fair and you take a beating when the water is rough. On the stern of a mine sweeper you will be working up to your hips in water when a wave comes over the low rail.

Such duties as mine sweeping, for instance, become monotonous after you have swept the same area day after day. Yet there is always a thrill to it and an ever-present element of danger. In spite of all her protective gear a mine sweeper takes a chance on being destroyed by a mine, for it is her own hull that does part of the sweeping.

On patrol duty you go out hunting for enemy submarines and occasionally you find such a target. In such work as this the surface vessels co-operate with the blimps and the army and navy bombing planes that maintain a constant aerial watch offshore. Now and then there may be a special assignment, such as escorting a convoy, or lying close to the beach at a spot where spies may try to get ashore.

The small boat navy is seeing action today. With enemy craft operating on both coasts there are plenty of adventures, although most such stories can't be told until after we have won the war.

Fluffy Down From Cattail Fibers Is Water-Resistant Stuffing

By processing the fibers of the common cattail plant, a fluffy, lightweight and water-resistant down has been produced by Dr. C. F. Burgess after 10 years of experiment. It is said the new product could take the place of imported materials, now under strict priorities, for stuffing such objects as toys, sporting goods and upholstered furniture. Because of its buoyancy in water and good insulating quality, cattail down may also be used for life preservers and as padding for airplanes and tanks.

One Sure Way to Save Gas and Oil

1 BURD "Graf-Flox" PISTON RINGS

2 BURD VALVE PACKING

3 BURD SKIRT EXPANDERS

Make your gas and oil go farther. Stretch your ration card with Burd 3-Way Reconditioning Service: (1) Have Burd Piston Rings installed. They are self-lubricating, non-scoring, requiring no run-in period. (2) At the same time put in Burd "Kureslap" Piston Expanders. They are flexible, yet force piston to conform to cylinder shape. (3) Complete the job with Burd Valve Packing. Keeps valve stem lubricated, and seals combustion chamber. For "all-out" motor economy—go all the way with Burd 3-Way Reconditioning.

BURD 3-Way RECONDITIONING SERVICE

Burd Piston Ring Co., Rockford, Ill., Associate Co., Liberty Foundries Co., Mfrs. of HaDees Heaters

COUPON BRINGS HANDBOOK FREE

Handy HANDBOOK

Burd Piston Ring Co., Dept. PM., Rockford, Ill.

Please send information on advantages and economies of Burd 3-Way Motor Reconditioning Service. Also copy of "Auto Serviceman's Handy Handbook."

Name

Address

City..... State.....

THE U. S. ARMY KNOWS ITS WAY OVER STRANGE LAND

★ Quick, accurate directions are highly important to the modern, fast-moving army, and our fighting men are prepared for any situation. The HULL STREAMLINE COMPASS is used by U. S. Army motor vehicles as one of the means for knowing the way. HULL STREAMLINE AUTO COMPASSES are not, for the duration, available to civilians except from present dealer stocks.

HULL MFG. CO., WARREN, OHIO
P. O. Box 246-D2

BRONZE FOUNDRY Schools and Home Workshops

Make your own castings of aluminum, copper, bronze, silver. Foundry sets are available in three sizes including 2400 Deg. F. Inast Furnaces. \$17.50, \$24.00, \$34.50, f.o.b. Kansas City. Free Circular.

KANSAS CITY SPECIALTIES CO.
P. O. Box 6022, Dept. P-25 Kansas City, Mo.

WORLD'S LOWEST PRICED ADDING MACHINE Free Pocket Size FREE TRIAL ONLY \$250

IDEAL FOR INCOME TAX GUARANTEED ACCURATE. Not a toy. Operates with only a finger tick. Adds, subtracts, multiplies, divides. Counts up to ten million. Pays for itself over and over. Ideal Gift—for Business, Income Tax and School use. **MONEY BACK GUARANTEE.** Send name and address. Pay postman only \$2.50 plus postage. (Send full cash if outside U. S.) Money back in 30 days if not delighted. **AGENTS WRITE.**

CALCULATOR MACHINE COMPANY (Mrs.)
DEPT. 138, P. O. BOX 1118 CHICAGO, ILLINOIS

Wanamaker & Wanamaker

FEBRUARY, 1943

547 N. Michigan, Chicago

GORMON-RUPP COMPANY

Selects **WITTE**
DIESEL ENGINES
for Dependable, Low Cost Power

9 H. P. Centrifugal Pump Produced by GORMON-RUPP CO., Mansfield, Ohio—Powered with WITTE DIESEL ENGINE—(Below) Another example of how pumping equipment manufacturers depend on WITTE Diesel Engines for dependable, low-cost power.

In the many instances where these famous WITTE Diesel Engines have been used as power units in connection with other manufacturer's pumping equipment, they have always added to the dependability, efficiency and long-life, low-cost service of the complete equipment.

Today, WITTE Diesel Engines, as well as WITTE Dieselectric Plants, are being produced exclusively for America's war effort and are serving freedom's cause in many parts of the world. But certain victory for America is ahead, and then these tested and proved power units will again be available for all.

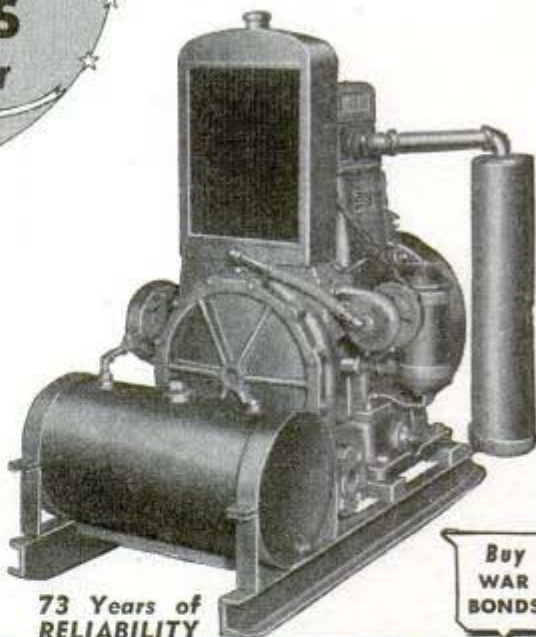

Buy
WAR
BONDS

WITTE ENGINE WORKS
1742 OAKLAND AVENUE KANSAS CITY, MISSOURI
LARGEST BUILDER OF SMALL DIESELS

73 Years of
RELIABILITY

GS TOOL CHESTS

GS Tool Chests are used by thousands of mechanics to safeguard their valuable precision tools. Illustrated is Solid Oak Chest 20" x 9" x 13 1/4" with 7 drawers and TWO LOCKS for complete safety. Price \$13.50 plus shipping charges. QUICK DELIVERY to workers in war plants. Extra discounts on quantity orders. INQUIRE. SEND YOUR ORDER IN TODAY.

Write for four page folder.



GEO. SCHERR CO.

128A LAFAYETTE ST. - NEW YORK

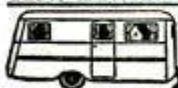

Complete Plans and Building Instructions, 25c

TRAILER BUILDERS' PARTS CATALOG

We'll save you money on everything. Largest and most complete trailer builders' supply house in the United States. Member TRAILER COACH MFRS. ASSOC. Send 10c for parts catalog. NATIONAL TRAILER EQUIPMENT CO. 719 N. Seventh St. Milwaukee, Wis.

PINS FOR YOUR CLUB!
Beautifully Styled—Low Prices!
Make your members more conscious of their membership. Write for free catalog. Shows 300 styles, sterling and gold plate on sterling. Choose a design suitable for your group. No order too small. Quality leader for 48 years. Write today!
BASTIAN BROS. Dept. 85, Rochester, N. Y.

BURN YOUR NAME ON TOOLS WITH THE ARKOGRAF
PROTECT YOUR TOOLS FROM THEFT
Write with electricity any name or design on the hardest and finest tools and instruments of any metal, like writing on paper with pen or pencil. Thousands used by mechanics, garages, machine shops. Complete Outfit \$3.50—Prepaid Anywhere. Interesting illustrated circular free. Write today. ARKOGRAF PEN CO., 3927 S.E. Stark St., Portland, Ore.

Always write your name and full address clearly when answering advertisements.



KRW ARBOR PRESSES BENCH TYPE AND HYDRAULIC

NEEDED IN EVERY SHOP—SAVE TIME AND MONEY—DO BETTER WORK, QUICKER.

No shop is complete without a small arbor press. Pressing and squeezing operations can be done better and faster on a KRW Arbor Press. Stop using vise and sledge hammer methods—they generally deliver spoiled work in the end. KRW Factory-To-You Prices give you greater value for your money. Order today.

KRW Bench Type Arbor Presses, 3 sizes

No. 37-P 1/2 Ton, \$13.25*
No. 37-O 1 Ton, \$23.00*
No. 37-N 3 Ton, \$33.00*

*Prices F.O.B. Arcade, N. Y. Slightly higher west of Rockies. Stand illustrated extra.



KRW Hydraulic Presses are built in 25, 50 and 75 ton sizes. Prices start at \$198.00*



K. R. WILSON, 17 Lock St., BUFFALO, N. Y.

Builders of Shop Equipment for Ford Dealers Since 1916

E. J. ... The ...
New Magic From Test Tubes

(Continued from page 4)

ments to bulky sections of tanks. Oil and grease dissolve in it like sugar in water.

The Cellophane which came on your peacetime packages is now laminated to a light cotton fabric, replacing the coat of grease used in the last war to prevent rust and corrosion and keep out dirt. By wrapping a rifle or gear before shipment, hours of labor spent removing grease at the receiving end are saved.

Butacryte, the plastic layer in your automobile safety glass, is now a rubber substitute in raincoats, water bags, hospital sheeting, life rafts and belts, food carriers, waterproof and oil resistant clothing for sailors, in the sound dampening of pickup microphones and as a plywood adhesive.

While the nation has been worrying about the rubber shortage and transportation problem, Du Pont chemists, by discovering a high-strength yarn called Cordura, have increased the load capacity of American planes by cutting as much as 20 pounds off the weight of an airplane tire. The strength of this cord, a rayon product, is lopping millions of pounds from the weight of combat vehicles and permits them to roll with a smaller skin of rubber over the Cordura fabric. So strong is this fabric that a huge army car can run miles on a flat before the casing comes apart.

On the industrial war front, thousands of chemical discoveries are adding to the war effort. One is a flexible, elastic and resilient synthetic resin combination which is replacing rubber and proving more efficient. This plastic, Resistoflex, came from experiments by RCA chemists. It already has fifteen important uses, among them plastic gloves, which not only resist the action of grease and solvents, but are transparent, which improves efficiency. It stands up well in sandblasting hoses.

Chemical "balloons" are now recovering from low-grade minerals quantities of vital copper, zinc, lead, nickel, tungsten, chromium and other strategic metals. Working of low-grade deposits formerly thought of little value is made possible by so-called froth flotation. Chemicals with an affinity for the grains of ore lift them in a bath from the worthless "gangue" or residues with which ores are associated in the earth.

(Continued to page 182)

... Practice Dept
NEW GLUE holds on all fronts!



Uncle Sam approves Weldwood Waterproof Glue for use in his boats and planes*. No wonder... it welds wood and other fibrous materials permanently. Yet requires no heating, waiting or special equipment. Add tap water to powder, stir - and use. Ideal for home repairs... won't dry out in heated rooms. At hardware, chain stores, lumber yards - 10c, 25c, 50c and 85c; or send 25c with your dealer's name for sample can.

UNITED STATES PLYWOOD CORPORATION
World's Largest Producer of Plywood
 Weldwood Glue Dept., 103 Park Avenue, New York, N.Y.

Compare These Amazing Qualities

1. Tremendous Strength
2. Waterproof
3. Rot and bacteria-proof
4. Economical
5. Stain-free
6. Quick and easy to mix

"Makes the glue line the SAFETY line"

*APPROVED for aircraft by U. S. Army, U. S. Navy and Civil Aeronautics Authority when properly applied.



WELDWOOD
 PLASTIC RESIN
WATERPROOF GLUE

NOW ANYONE CAN SAND THEIR OWN FLOORS at a BIG SAVING!

Now it's easy to have a professional job of floor refinishing without drudgery, without the inconvenience of waiting to get the job done and at small cost. The new CLARKE SANDER which you can rent from a local dealer at a small daily charge is almost as easy to operate as a vacuum cleaner. It whisks away the old finish, makes your old floor look like a newly laid floor sanded to a satin finish. Write for the name of dealer in your community who rents them.



RENT
 this easy to operate, highly efficient sander

CLARKE SANDING MACHINE CO · Muskegon, Mich.

FILING SAWS for FACTORY

The FOLEY SAW FILER is in use by U. S. Army, Navy, Air Force, hundreds of War and manufacturing plants.



A FOLEY Automatic Saw Filer files hand, circular and hand saws better than the best hand filer. Foley filed saws cut faster, stay sharp longer. They increase sawing production 25% to 40% in plants, mills, factories. The Foley cuts down filing time, saves on files and reduces saw breakage. Write for literature.

FOLEY MFG. CO., 216-3 Foley Bldg., Minneapolis, Minn.

NEW *Amfile* for PHONOGRAPH RECORDS

- ★ Holds Records Upright
- ★ Individual Compartments
- ★ Easier to Find and Put Away

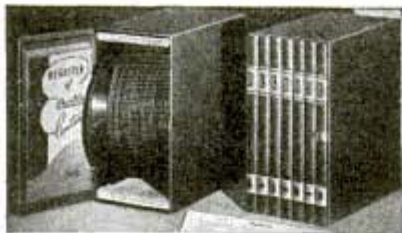

PROTECT YOUR PRECIOUS RECORDS

Here's a brand new Home Sweet Home for them. You'll like this beautiful, well built cabinet that looks like a matched set of books. Each record stands upright and does not come in contact with its neighbors. Records are easy to get at—will not break, bend or become warped. The sensitive surfaces are protected against scratches and scrapes.

Filing and finding made easy by simple numbering system. Sets of numbers and contents register included—even a child can keep records in order.

Attractively finished in pin seal simulated leather. Choice of 4 colors, maroon, blue, green or black. Each cabinet is 5 1/2" wide and holds 25 records.

For 10" Records..... **\$2.75** | For 12" Records..... **\$3.25**

At Stores or Sent Postpaid on 10 Days Money-Back Trial.

AMBERG FILE & INDEX CO.
Filing Specialties Since 1868
1702 Duane Blvd., Kankakee, Ill.

ORDER TODAY

You'll be delighted with the new Amfile—Best Gift of the Year for a Friend or Yourself

FREE Catalog

Class pins, club pins, rings and emblems. Finest quality. Reasonable prices from 55c up. Write today. Dept. N, Metal Arts Co., Rochester, N. Y.

TAPE your CORNS

and Callouses with COMFITAPE for quick relief, eases pain, gently absorbs hard growths without injury to healthy tissue. Big spool, 60 sq. inches to clip and apply. Send \$1 and if not delighted after using, get full refund. COMFITAPE, Dept. 14 Burlington, Vt.

BUILD THESE PROJECTS

For garden or lawn. Easy to build. Easy to sell. Detailed Blueprint Model B-25 Dutch Windmill 50c; Model OM-60 Old Mill, 85c. Lawn Figure Patterns—Sunbonnet Girl, Dutch Boy, Tulip Girl, Holland Fair, 30c each, all 4—\$1.00. Catalog illustrating many models, send 10c, today.

CRAFTSMAN'S MODEL CO., Dept. P-68, 2030 N. 41st St., Milwaukee, Wis.

RAISE GUINEA PIGS

MAKE MONEY. Thousands needed—War demand great. We supply breeders and buy the young. Write today for FREE illustrated bulletin. **RESEARCH SUPPLY CO., Dept. F-5, 2436 W. York St., Phila., Pa.**

MONUMENT

Genuine Granite or Marble. \$12.50 UP. Order Direct By Mail and save. Don't wait. U. S. MARBLE & GRANITE CO., A-19, Oneco, Fla.

BIG FREE CATALOG

Freight Paid anywhere in U.S.A. Lettered. Guaranteed. Free Catalog & samples of stone.

DO YOU

WANT a permanent business profession of your own? Then **BECOME A FOOT CORRECTIONIST.** Earnings in this greatly needed profession run as high as \$50-\$100 weekly after a few weeks home training—no medical or chiropody—no further capital needed, no goods to buy. 47th year. Write for free booklet.

Stephenson System of Foot Correction

28 Back Bay, Boston, Mass.

Copper and zinc for shells, lead for bullets, copper for wire, vanadium, nickel, tungsten and molybdenum for special steels; manganese, chromium and a host of other vital metals are now obtained by froth flotation.

Puffed-up sand has been converted into excellent insulating material. A new chemical process removes copper coatings from steel scrap without injuring the base metal. A synthetic chemical, urea, stops splitting and checking of lumber during drying.

Chemistry is working wonders on the home front, too. Du Pont has a coated fabric which glows in darkness. It may be cut into luminous strips to mark doorways, staircases, handrails, fire extinguishers, arm bands, etc. With a glue backing, it may be applied to any surface and removed just as easily.

A new type window pane which contains no glass has been developed by Monsanto Chemical Company. Made of wire mesh sandwiched between two sheets of plastic, it will withstand the explosion of a 150-pound bomb eight feet away without shattering. It can be applied by merely stapling the pane into a regular window frame.

Wood impregnated with chromated zinc chloride has been found to resist decay, termites and fire and this discovery by Du Pont is increasing the value of timber for defense housing, hangars, barracks, and armories.

The scarcity of metals has only served to increase the beauty of newly equipped bathrooms, for Lucite fixtures of transparent plastic, are now in production.

Cellophane laminated cans replace metal cans, and Cellophane bag-in-a-box containers carry heavy liquids for cooking, such as egg yolks and fluid chocolate.

Collar and cuff fabrics are stiffened and made more serviceable by being laminated with nylon sheets. Clothing, drapes, curtains, upholstery and hundreds of similar items are rendered flameproof by treatment with a Du Pont chemical which does not alter the appearance of the fabric, but in some cases actually improves its wearing qualities.

Just as the recent chemical discoveries for peaceful use have aided the nation in time of war, the remarkable discoveries which have followed Pearl Harbor will make the world a better place to live in when the troops come marching home.

MOTORISTS *Wanted!*

TO MAKE THIS *UNIQUE* ... GAS SAVING TEST

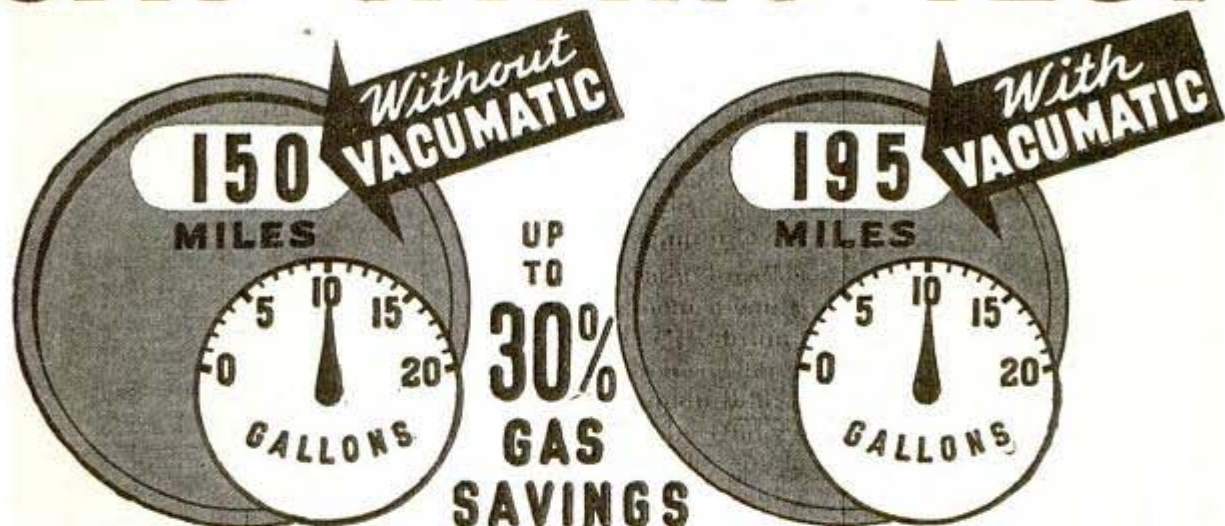

Car Owners: You are invited to make a gas saving road test with the Vacu-matic on your own car, with the absolute understanding that unless it proves to you that it will save you up to 30% on gas and improve your car performance, the test will cost you nothing. Investigate this remarkable discovery that trims dollars off gasoline bills—gives you worthwhile gas savings—more power—quicker starting—more miles on less gas.

Automatic Supercharge Principle

Vacu-matic is *entirely different!* It operates on the supercharge principle by automatically adding a charge of extra oxygen, drawn free from the outer air, into the heart of the gas mixture. It is entirely automatic and allows the motor to "breathe" at the correct time, opening and closing *automatically* to save dollars on gas costs.

Proven By Test

In addition to establishing new mileage records on cars in all sections of the country, the Vacu-matic has proven itself on thousands of road tests and on dynamometer tests which duplicate road conditions and record accurate mileage and horse power increases.

Fits All Cars—Easy to Install

Vacu-matic is constructed of six parts assembled and fused into one unit, adjusted and *sealed at the factory*. Nothing to regulate. Any motorist can install in ten minutes. The free offer coupon will bring all the facts. Mail it today!

The Vacu-matic Co., Wauwatosa, Wis.

Sworn Proof of Gas Savings

This certifies that I have carefully read 300 original letters received from Vacu-matic users testifying to gas savings up to 30%, many reporting added power, smoother running, and quicker pick-up. These letters are just a small part of the larger file of enthusiastic user letters that I saw at the company offices.



Signed

Marion O. Clark
Notary Public

AGENTS Get Yours FREE For Introducing

Vacu-matic offers a splendid opportunity for unusual sales and profits. Every car, truck, tractor, and motorcycle owner a prospect. Valuable territories now being assigned. If you help us introduce it to a friend, you can obtain your own free. Check and mail coupon today.

SEND THIS *Free Offer* COUPON

THE VACU-MATIC COMPANY
7617-768 W. State St., Wauwatosa, Wis.

Please send full particulars about VACU-MATIC, also how I may obtain one for my own car FREE. This does not obligate me in any way.

Name

Address

City..... State.....

Check here if interested in Agency Proposition.

HOW TO GET THE MOST OUT OF YOUR LATHES

No. 4 in a series of suggestions made by the South Bend Lathe Works in the interest of more efficient war production

Keep Your Lathes in Trim

The old proverb, "An ounce of prevention is worth a pound of cure", is as applicable today as when first expressed by some long forgotten sage. Lathes and other modern precision tools must be "kept in trim" if they are to give the long, trouble-free service that is expected of them.

Although the adjustments required to "keep the lathe in trim" are few and simple, they are important and should not be neglected. And even though the lathe is rigidly constructed and will stand some rough handling, it should be protected from unnecessary abuse.

Power Transmission

Maximum efficiency as well as maximum production depends on the effective transmission of power to the lathe spindle. The motor, being the source of power for the lathe, should develop its full rated power and should operate at a uniform speed. If for any reason the line voltage drops below the rating for which the motor is constructed, the motor will not deliver full power. For this reason the current should be checked at the motor occasionally and the correct line voltage maintained.

To transmit the power from the motor to the lathe spindle efficiently, all belts must be properly adjusted. If the belts are too loose they will slip, and if they are too tight they will cause loss of power through friction. The belts should be just tight enough to transmit the required power without slipping. Precision belt tension adjustments provided on South Bend Lathes make it easy to keep the motor V-belts and flat cone pulley belts properly adjusted.

Dovetail Slide

All dovetail slides on South Bend Lathes are equipped with gibs which

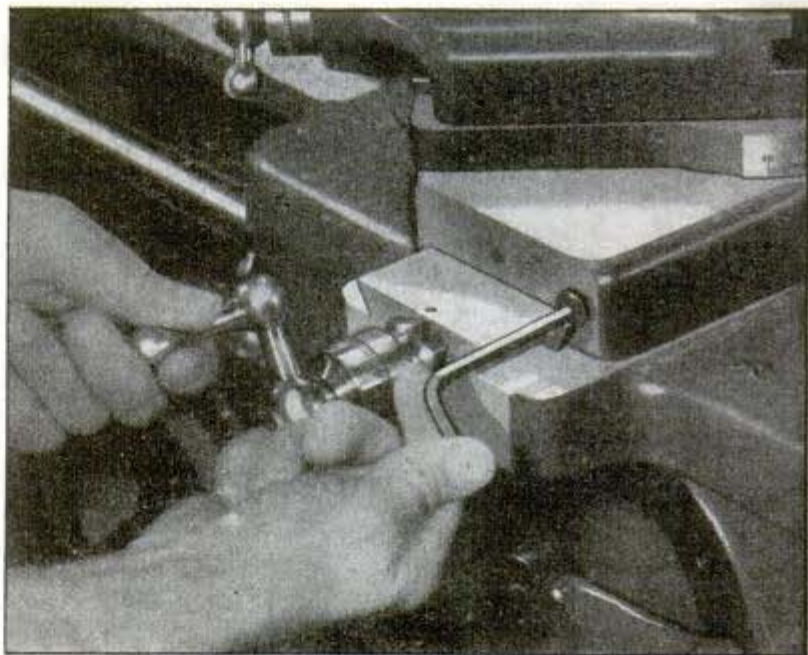

Adjust the dovetail gibs to insure accurate work

may be adjusted to eliminate play. When the adjustment of the dovetail gibs is neglected, looseness of the slides may cause the tool to chatter or may result in inaccurate work.

The gibs should be tight enough to assure the necessary rigidity, but not tight enough to bind and make the dovetail slides hard to operate.

Tailstock Adjustment

The alignment of the tailstock top should be checked frequently as any misalignment will cause the lathe to turn a taper. To test alignment, place a bar of steel, 1 inch or larger in diameter, between centers and machine two collars of equal diameter not less than 4 inches apart. Then, take a very light finishing cut across both collars without changing the setting of the cutter bit. Measure both collars with a micrometer. Any difference in the diameters indicates misalignment. Correct the alignment

by turning the tailstock top set-over screws until both collars can be turned to the same diameter.

Don't Abuse the Lathe

Just because the lathe is made of iron and steel is no reason to expect it to stand abuse. Never use the lathe bed as an anvil. Don't use a crowbar to straighten a shaft between the lathe centers. Never rap chips out of a file by striking it on the lathe bed or tailstock.

Write for Bulletin H4

Bulletin H4 giving more detailed information on keeping the lathe in trim will be supplied on request. Also reprints of this and other* advertisements and bulletins in this series. State quantity wanted.

- *H1, "Keep Your Lathe Clean"
- H2, "Oiling the Lathe"
- H3, "Installation and Leveling of the Lathe"



SOUTH BEND LATHE WORKS

South Bend, Ind., U. S. A.

Lathe Builders for 36 Years



PRINTED BY POPULAR MECHANICS COMPANY, CHICAGO, ILL., U. S. A.

AUDELS PRACTICAL ELECTRICITY

FOR MAINTENANCE ENGINEERS, ELECTRICIANS AND ALL ELECTRICAL WORKERS. PRICE \$4

HERE IS ELECTRICAL INFORMATION IN A HANDY FORM

COVERING:
 ELECTRICAL ENERGY
 MECHANICAL ENERGY
 Current Effects—Magnetism
 MAGNETIC INDUCTION
 D. C. Motors—Dynamoes
 A. C. Motors—Alternators
 ALTERNATOR
 CONSTRUCTION
 Armature Winding
 Armature Repairing
 WIRING DIAGRAMS
 Reverse Current Relays
 Overload Relays
 Differential Power Relays
 Undervoltage Relays
 Temperature Relays
 ELECTRIC POWER
 TRANSMISSION
 Underground Wiring
 Cable Splicing
 Switches—Electric Bells
 TRANSFORMERS
 HOUSE WIRING
 Diagram of Connections
 Rectifiers—Converters
 Power Factors
 WATT-HOUR METERS AND CONNECTIONS
 Watt-Hour Rules
 Meters and Instruments
 Circuit Breakers—Fuses
 Rheostats and Starting Devices
 STORAGE BATTERIES
 Electrolysis—Insulators
 Electric Lighting
 FLUORESCENT
 Sign Flashers
 NEON SIGNS
 Electro Plating
 RADIO PRINCIPLES
 RADIO QUESTIONS AND ANSWERS
 Radio Tubes—Photo Electric Cells
 Electric Cranes
 POWER WIRING
 Substations—Power Station Plans
 Plant Management
 AUTOMATIC TELEPHONE
 Automatic Telephone Switchboards
 The Telegraph, Relay System and Codes
 ELEVATORS AND CONTROLLERS
 Elevator Wiring and Operating Instructions
 MARINE WIRING
 Electric Ship Drive
 ELECTRIC RAILWAYS
 Electric Heating
 AIR CONDITIONING
 Motion Pictures
 Domestic Refrigeration
 Air Compressors
 OIL BURNERS
 Pumps—Wiring Calculations
 Soldering—Brazing
 WELDING
 Electro-Therapeutics—X-Rays
 Automobile Starting
 Automobile Lighting Systems
 Ignition
 Electrically Operated Tools
Ready Reference Index

YOUR OPPORTUNITY!

"AUDELS HANDY BOOK OF PRACTICAL ELECTRICITY," endorsed by hundreds of experienced workers, you too can profit by the personal ownership of this good book, containing the practical information that every electrical man can use. Clear—concise—explaining the essential facts, figures and rules used in good general practice—and fully illustrated.

**1440 PAGES
 2600 ILLUS.**

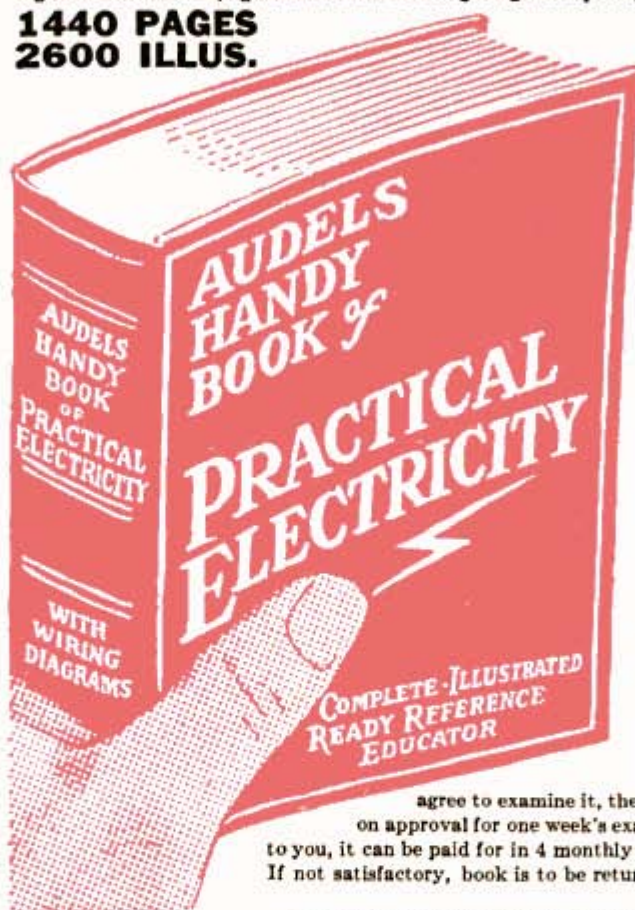

A Practical, Quick, Ready Reference. Gives complete instruction and inside information on electrical subjects. Every point clearly explained in plain language and with diagrams. Subjects arranged progressively for the student, and complete index makes information instantly available to professional workers for ready reference. A time and money saver. A competent and dependable guide and helping hand. Sooner or later this handy book will answer important questions and help you to handle efficiently all kinds of electrical problems.

"AUDELS HANDY BOOK OF PRACTICAL ELECTRICITY" is bringing a helping hand to hundreds of workers and if you will

agree to examine it, the book will be sent to you on approval for one week's examination. If found O.K. to you, it can be paid for in 4 monthly payments of \$1.00 each. If not satisfactory, book is to be returned in one week.

**TO GET THIS ASSISTANCE FOR YOURSELF
 SIMPLY FILL IN AND MAIL COUPON TODAY**

ASK TO SEE IT!

THEO. AUDEL & CO., 49 West 23rd St., New York
 Mail AUDELS HANDY BOOK OF PRACTICAL ELECTRICITY (Price \$4) on 7 Days' Free Trial. If O.K. I will remit \$1 in 7 days and \$1 monthly until \$4 is paid. Otherwise I will return it.

Name _____

Address _____

Occupation _____

Reference _____ P. M.



THEO. AUDEL & CO., 49 W. 23rd St., N. Y.



WHERE A CIGARETTE
COUNTS MOST

It's CHESTERFIELD

• BUY •
U.S. BONDS
STAMPS

MILDNESS and TASTE
that's what the real pleasure of smoking adds up to
Up at dawn or to bed at dawn...fresh or fagged,
more smokers every day are finding this out
...for *Real Smoking Pleasure* it's Chesterfield's
Milder, Better Taste every time.