

The Emergency Patrol

POPULAR MECHANICS



MAGAZINE

WRITTEN SO

MARCH
25 CENTS
30c IN CANADA



SEE
PAGE 1

BUILDING
the
"LIBERTY"
FLEET





A true experience of
R. S. McILWRAITH,
Libby, Montana



**"THE SAVAGE BEAST
HAD ME CORNERED!"**



1 "A TERRIFIC CRASH startled me right out of bed one night as I slept in the cook house of the mining camp where I work," writes Mr. McIlwraith. "Half awake, I rushed into the kitchen to investigate—and found a huge bear had broken in and was tearing into our food supplies.



2 "MADDENED by my interruption and savage from hunger, the great creature started for me. My only thought was to get away from him—and fast—as these big cinnamons can be bad medicine in close quarters. I darted back into my room. Then to my horror I realized that the bedroom windows were too small for me to get through.

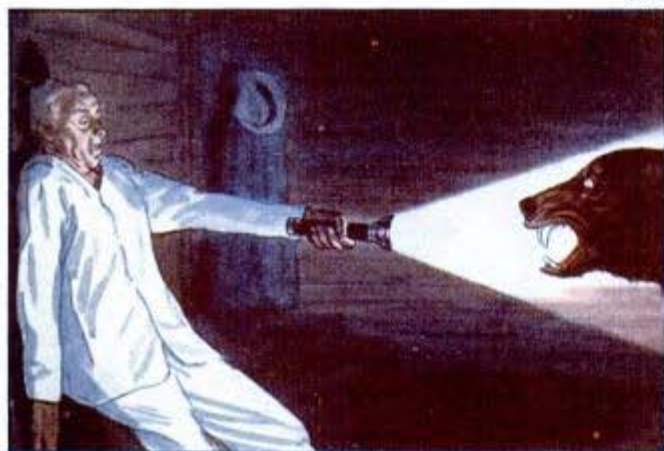

3 "IN A NIGHTMARE of panic, I broke out in a cold sweat. Then I remembered my flashlight. Desperately, I grabbed it from a shelf, whirled and flashed it full in the bear's face. He stopped short. Baffled growls came from his dripping jaws . . . and he turned and lumbered out of the shack. It's my hunch that I was one step from being mincemeat when I picked up that 'Eveready' flashlight with its dependable fresh DATED batteries.

(Stunned) *R. S. McIlwraith*



The word "Eveready" is a registered trade-mark of National Carbon Company, Inc.

FRESH BATTERIES LAST LONGER... Look for the DATE-LINE

NATIONAL CARBON COMPANY, INC., 30 EAST 42nd STREET, NEW YORK, N. Y.

Unit of Union Carbide and Carbon Corporation



New Workshop Library



ONLY
\$2⁰⁰
Complete

● A practical, up-to-the-minute, modern workshop library containing over 1400 photographs and line drawings—covering every phase of operation and maintenance of every major workshop motor-driven tool—with hundreds of special operations explained—valuable shop hints, short cuts, and scores of time-saving tables. Shows you how to operate all major motor-driven tools, how to use all accessories properly, how to perform every important operation, how to obtain unusual results, how to solve shop kinks and problems and how to keep your tools and accessories up to top efficiency. Every operation "shop-tested" by practical craftsmen. The greatest shop book value in years. Read the partial list of contents below—and then mail the coupon TODAY!

What you get in this Modern Workshop Library

Circular Saw & Jointer—Ripping; Saw Projection; Use of Moulding Fence; Crosscutting; Mitering; Cutting to Length; Resawing; Rabbeting; Tilt Table Operations; Taper Ripping; Spine Grooves; Cutting Curves; Production Work; Pattern Sawing; Cove Cutting; Long Work; Gang Saws; Simple Tenoning Jig. The Moulding Head and its use; The use of Abrasive Wheels, Dado Head, Tenoning Jig; Common Wood Joints; Jointer Operations; Jointing an Edge; Side Pressure Jointing an End; Surfacing; Rabbeting; Beveling; Taper Jointing; Tapering in the Round; Stop Chamfering.

Lathe—Wood turning, metal turning and metal spinning, including: Spindle Turning; Faceplate and Chuck Turning; Special Turning Operations; Post Blocking; Oval Turnings; Split Turnings; Turned Boxes; Duplicate Turning; Spiral Turnings; Hollow Spirals, Fluting and Reeding; Use of Lathe attachments; Jigs and Fixtures; Wood Finishing; Metal Turning Operations; Spinning Equipment; Methods of Working; Special Spinning Chucks and Appendix containing tap drill sizes; Polishing Materials; Decimal Equivalents; Table

of Taper Cuts; Grinding Angles for Wood Turning.

Band Saw & Scroll Saw—Ripping and Resawing; Use of Standard Fence; The Ripping Blade; Ripping Curves; Tilt Table Operations; Cutting off with Fence and Gage; Use of Stop Rod; Cut-off Block; Using Clamp attachment; Crosscutting Wide Stock—Cutting Circles; Jig Construction; Cutting Glue Blocks; Round Corners; Circular Rails; Sanding; Compound Band Sawing; the Cabriole Leg; Compound-Sawed Turnings; Ornamental Work; Sawing in Multiple; Ripping Thick Stock; Split Dowels; Tapering Jigs; Marking Turning Squares; Pattern Sawing; Beveled Curves Metal Cutting; Scroll Saw Operations; Sanding and Filing.

Drill Press—Methods of Laying Out Drill Press Work; Use of Wood Bits; Sanding Drums and Grinding Wheels; Drill Practice in Wood; Use and Grinding of Twist Drills; Drilling and Tapping in Metal; Routing, Shaping and Mortising on the drill press; Miscellaneous drill press operations and special useful ideas.

Abrasive Tools—Buffer, Belt and Disk sander attachments—Explanation of Different Abra-

FREE—
Extra Gift



With every order for the Delta Modern Workshop Library we include a Free copy of "How to Make Money with Delta Tools". Extremely valuable. Gives numerous examples of successful money-making plans used by owners of low cost tools.

sives; How to Sharpen Tools; Grinding Shaper Cutters; Grinding Twist Drills; How to Use Sanding Drums, Cut-Off Wheels.

Shaper—Shaper Adjustments Cutters and Collars; Shaping with guides; with collars; with patterns; Use of Forms; Jigs and Fixtures; Application of Shaper Cutters; Grinding Shaper Cutters.

Practical Finishing Methods

The book that every shopman has been waiting for. Tells how to do every possible finishing operation—how to prepare the work, how to stain, fill varnish—lacquer. Proper use of spray gun and brush. How to finish metal, how to mix your own low cost materials. Silk screen process. Guide on every finishing operation giving secret methods developed over many years.



Examine this Library at our risk—Send Coupon

DELTA MILWAUKEE

You can inspect the Delta Modern Workshop Library without risking a penny. Simply fill out and mail coupon today. When the complete library, plus the FREE extra gift book arrives, postpaid, inspect it thoroughly. If you aren't fully satisfied in every way—you can return the library—and every penny you have paid, including return postage, will be promptly refunded—without question.

Modern Workshop Library Division (681-C)
The Delta Manufacturing Company
600-634 E. Vienna Ave., Milwaukee

Gentlemen: I enclose \$2 for which please send me complete Modern Workshop Library, postpaid, plus FREE gift book. It is understood that if I am not fully satisfied, I can return the library and you will refund every penny I paid, including return postage.

Name.....
Address.....
City.....State.....

This One



QL20-27T-T44P

"The Marines have Landed"

and
**CRESCENT
TOOLS**
went with
them



OFFICIAL MARINE CORPS PHOTOS.—Down the cargo net, (above) from the deck of a Navy transport, go America's pride—our United States Marines. Shortly after this picture was taken, "the situation was well in hand."

The Marines establish a beach-head. (left) This toughest of all fighting jobs has been a specialty of the U. S. Marine Corps since they first landed at the Bahamas in 1776.

The modern fighting force is one vast machine—Jeeps, Tanks, Trucks, and a multitude of other mechanical devices including Higgins landing boats of the Marine Corps. To keep this mechanical army in a high state of efficiency, it takes tools—good tools like Crescent.

If you find a scarcity of Crescent Tools at your hardware store, it is because our soldiers, sailors and marines have plenty of them. So, too, do thousands of defense plants working all out for America's fight against world aggression. So bear with us, old customers and new; we want to serve you, but we know you want us to serve the nation first. The harder we all work now the sooner there will be plenty of tools for everyone.

CRESCENT TOOL COMPANY JAMESTOWN, N. Y.

CRESCENT TOOLS
Give Wings to Work

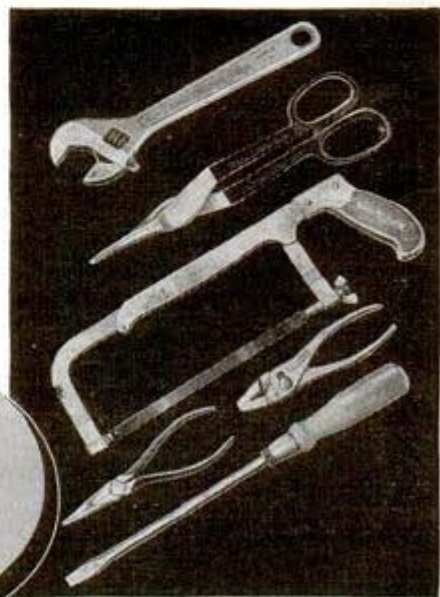

CRESCENT & CRESTOLOY WRENCHES, PLIERS, SCREWDRIVERS, SNIPS, HACKSAWS, ETC., ETC.

Popular Mechanics Magazine

Registered in U. S. Patent Office and Canada

H. H. WINDSOR, Founder

H. H. WINDSOR, Jr., Editor and Publisher

March, 1942

Vol. 77, No. 3

IN THIS ISSUE

Future Sources of Power	1
Super Sailors for the Subs	8
Flying Wings Are Coming	14
Color at Work	17
The Emergency Patrol	26
How to Cut Your Heating Bill	34
Kilowatt—the New Hired Hand	40
X-Rays in Overalls	46
Building the Liberty Fleet	50
Tomorrow's Plane Takes Shape	56
The Battle for Safety	66
Glass "Eyes" Give Men Super Vision	72
The Truth About Lightning	82
Rubber From Milkweed	88
Throwing Light on the Darkroom	92

Where-to-Buy-It Index Starts on Next Page

What to Do in a Blackout

WHEN the sirens howl and the yellow light of the "alert" in army interceptor headquarters changes to the blue light of the blackout, the important thing is not to become excited. There are certain steps you should take, before and during the blackout. They are outlined for you in a timely article next month, which also gives you a glimpse of California in the dark. Before the emergency, store some water in sterile containers, and lay in candles and flashlight batteries. Plan a "darkroom"—lighted inside, dark from outside. Read this article for helpful advice.

Call to Battle Stations

UNCLE SAM'S mighty fleet goes into action. From the deck of an airplane carrier, fighter, scout, bomber and torpedo planes roar into the sky. Destroyers screen the battle line, submarines stalk enemy transports, battleships lash out with salvos of 16-inch shells. In the April Colorado section you'll see the Navy in action—eight pages in color.

Next Month

RAISING a small, club-shaped .22-caliber rifle to his shoulder, a marksman took careless aim at an armor-steel target and fired. The bullet went clear through the slab of steel. Any ordinary "22" would hardly knock down game bigger than a rabbit. This high-velocity "super-22" will kill any big game by hydrostatic shock, even if it strikes a leg. The powder charge is terrific; the tiny bullet liquefies and literally flies into dust when it hits. Read about this sensational new weapon in the April issue.

10,000,000 "Hellos"

BIGGEST potential traffic tangle in the world is in New York's telephone system. But it never snarls. Daily calls are flirting with the ten-million mark. At the peak, 300 to 400 numbers are dialed every second. A feature next month tells of the technical magic that controls this gigantic traffic flow: a new "electrical brain" that connects your call, pulp-insulated wires so slender that 4,242 fit in a cable no bigger than your wrist.

Outwitting Saboteurs

DURING the last war, saboteurs started fires with "pancakes" of burlap soaked in self-igniting chemicals. Now they're dropping glass marbles that catch the sun's rays in their universal focus, and lead cigars whose hidden chemicals are a "delayed fuse" for a destructive blaze. But there are ways to outwit the saboteur. Read the April story and be alert.

Published monthly by POPULAR MECHANICS COMPANY, 200 East Ontario Street, Chicago, U. S. A. Single copy in the United States, 25 cents; subscription rates in United States and possessions, and countries of the Pan-American Postal Union including Spain, \$2.50 a year. Single copy in Canada, 30 cents; subscription rates, \$3.00 a year. To all other countries add \$1.00 a year over United States prices for overseas postage. Changes in address must be reported to us immediately to eliminate delay. Entered as Second Class Matter, Sept. 15, 1903, at the Post Office at Chicago, Illinois, under Act of March 3, 1879. Entered as Second Class Matter at Post Office Dept. Canada.

Copyright 1942, by Popular Mechanics Company. Copyright under International Copyright Union. All rights reserved under Pan American Copyright Union. Printed in the United States of America



PYROIL CAN HELP YOU MAKE YOUR CAR LAST LONGER

*During the Storms and Cold of Winter
Pyroil's Protection is Especially Valuable*

Now that it is vital to keep your car in better shape, let Pyroil help you. With proper care the car you own today can last for years and give excellent service.

For one thing, Pyroil makes your car start easier when the engine is cold. That means less possibility of damage to parts; less drain on the battery.

Acid and corrosive attack are held responsible for much of engine wearout. Pyroil prevents corrosion from getting a toe hold in your engine.

Gum, sludge and hard carbon are common yet destructive contaminations Pyroil cleans these out!

Pyroil is highly economical to use. Only three ounces in gasoline tank and twelve ounces in crankcase will protect your car for hundreds of miles of driving!

Let Pyroil help you make your car last longer. Ask at your service station or garage for a trial test today. Send coupon below for interesting new literature concerning the many benefits of this famous super lubrication process. Manufactured and Guaranteed by Pyroil Company, W. V. Kidder, Founder, 53 Pyroil Bldg., La Crosse, Wisconsin, U. S. A.



Keep 'em rolling with Pyroil!

FREE: Two brief but important-to-you message folders, "CONSERVING TRANSPORTATION," and "CLEAN OUT THAT ENGINE NOW!" Send coupon below and receive these Free.

DISTRIBUTORS:
CHECK AND MAIL COUPON FOR FRANCHISE FACTS.

PYROIL COMPANY
53 Pyroil Bldg., LaCrosse, Wisconsin

Please send me a copy of each of the two new message folders, "Conserving Transportation," and "Clean Out that Engine Now."

Send details of your plan for Distributors.

Name.....

Address.....

City or town..... State.....

WHERE-TO-BUY-IT INDEX

Where no name and address appear directly under an item, the product is not believed by us to be commercially available

Folding crane for tractor.....	5
Willamette Hyster Co., 2902 N.E. Clatskanie St., Portland, Ore.	
Push-button cigarette case for auto.....	6
Portable fuel pump for drum.....	6
Tokheim Oil Tank & Pump Co., Ft. Wayne, Ind.	
Testing street vibration.....	6
Concrete over balloon forms igloo.....	7
Plastic figures cut with saw.....	12
Service Industries, Inc., 2025 S. Calumet Ave., Chicago	
Body temperatures vary.....	12
Album for viewing color slides.....	12
Von Lengerke & Antoine, 9 N. Wabash Ave., Chicago	
Wooden "bricks" for wall building.....	13
Arthur Morgan, Paso Robles Ave., Los Altos, Calif.	
Fixed telescope focused by movable mirror.....	16
Powerful 57-ton tank.....	25
Space-saving hat and coat rack.....	25
Cuyler Mfg. Co., 4115 Ravenswood Ave., Chicago	
Retreading lengthens tire life.....	32
Power shovel has transparent cab.....	33
Army lays mines by coal chute.....	33
"Normandie" as airplane carrier.....	38
Pocket-size heat lamp.....	38
Spartan, Inc., Beech and Kenilworth Aves., Cincinnati, Ohio	
Color photos aid in fruit shipments.....	38
Skyscraping camera truck.....	39
Portable landing lights for Army.....	39
Trailer home for defense workers.....	44
Dial shows mileage between cities.....	44
W. C. George, Box 343, DeFuniak Springs, Fla.	
Infrared coating for flashlight.....	44
Fezandie & Sperrle, 205 Fulton, New York City	
Mule-ambulance carries casualties.....	45
Gas-works model.....	45
Fireboat rides trailer inland.....	48
Hanley Engineering Service, Prospect, Ohio	
Odors removed from gasoline.....	48
Chisel holder absorbs shocks.....	48
M. E. Cunningham Co., 115 E. Carson St., Pittsburgh, Pa.	
Model engine has 18 cylinders.....	49
Wheels tested at superspeed.....	49
Rolling sling for injured dog.....	54
Window sign unit.....	54
Red Chief Industries, 2326 S. Michigan Ave., Chicago	
Brake control for railroad wheels.....	54
American Brake Shoe & Foundry Co., 230 Park Ave., New York	
Heat lamps thaw frozen radiators.....	54
The Fostoria Pressed Steel Corp., Fostoria, Ohio	
Fluorescent lamps depict bomber.....	55
Silent static drag for car.....	55
Electric Service Supplies, 17th and Cambria, Philadelphia, Pa.	
Flexible bead for doorway arch.....	59
National Gypsum Co., Buffalo, N. Y.	
Soldering kit splices electric wires.....	59
Jiggers, Inc., 215 W. Illinois St., Chicago	
Chair and table unit.....	60
Fenske Bros., 1315 S. Michigan Ave., Chicago	
Dog's identity carried in tube.....	60
Sears Roebuck & Co., State and Van Buren, Chicago	
Transparent blocks for glass buildings.....	60
Pittsburgh Corning Corp., Grant Bldg., Pittsburgh, Pa.	
Space-saving chairs.....	61
The Robert H. James Mfg. Co., South Euclid, Ohio	
"Smoke rings" shot from gun.....	61
Air whistle "puffs" aid navigation.....	61
Shark killers' club.....	62

(Continued to page 8A)

MARCH 1942

AIRPLANE

Fighter, cockpit (Hurricane), Messerschmidt	71 Mar.
Landing lights, portable, invisible overhead	39 Mar.
See bomber	
Tomorrow's takes shape	56 Mar.
Windshield, twin, for air liner	90 Mar.
Wings, flying	14 Mar.
Album, reflected light, for viewing color slides	12 Mar.
Ambulance on mule for army	45 Mar.

AUTO

License plates, long term, save steel	80 Mar.
Baby carriage mirror keeps infant amused	90 Mar.
Black light guides army trucks at night	81 Mar.
Blocks, hollow wooden for wall building	13 Mar.
Bomber, supercharger rotor tests	49 Mar.
Bottle opener with retainer cup	22a Mar.
Cake knife with V-shaped blade lifts pieces	24a Mar.
Camel's hump stores fat, not water	198 Mar.
Camera truck has 20-foot tower and rubber fenders	39 Mar.
Carbon in gasoline engines reduced with zinc oxide	25 Mar.
Chair and table, coupled, hold lamp and books	60 Mar.
Chairs, space saving, nested into one	61 Mar.
Chess game for blind	70 Mar.
Chisel holder absorbs shock from blows	48 Mar.
Cigarette case, push button in steering wheel	6 Mar.
Clothing, antiseptic, aids health	76 Mar.
Coal heater extension changes to oil burner	95 Mar.
Coat steamed and reshaped by pressing form	96 Mar.
Coils, high frequency iron core for tuning	159 Mar.

[The page contains extremely faint and illegible text, likely bleed-through from the reverse side of the document. The text is scattered across the page and cannot be transcribed accurately.]



Can this happen to YOU?

It was the President talking—telling George that while he would like to give him the job—to promote him to an executive position, it was impossible to do so.

This was a bitter blow to George—he had known for some time there would be a vacancy in his department—the department manager was moving up—a new department head would be appointed. By seniority George was entitled to the job, had been counting on it.

It would mean more money—those unpaid bills would be taken care of—the children would have more advantages—there would be travel, recreation, social activities.

George had been a fine, loyal employee for twelve years—doing his assigned tasks well—hoping by faithful service to win some day an executive position with his company.

Now all of these hopes were being swept away—as in a dream he heard his chief continue—“You see, George, in these days it is ability to produce that counts. You’re not ready to take on the bigger job—you have made no preparations which would enable you to fill it properly. The man who is going to get that job is Martin. He has been with us only four years, but during that time he has not only been studying the relationship of his department to

the business as a whole, but he has been studying and preparing himself at home.”

Poor George—no one to blame but himself. Business is full of “Georges”—men who do not realize the importance of preparing definitely for promotion. They forget that long experience on one job does not necessarily prepare them for the job above. And almost never do they reach the executive job and the bigger money.

Fortunately, there is a way—simple, practical, thoroughly proved by thousands—for the “Georges” to make sure of promotion. Modern home study—the LaSalle way—gives them rather quickly the knowledge and ability to handle the job ahead. It does not interfere with their present job—instead it helps. It is moderate in cost and intensely interesting.

In fairness to yourself—

If you are one of the men in business doing routine work—going along in a low pay job, there is one thing, in fairness to yourself, you should do right away—and that is—**FILL IN AND MAIL THE COUPON BELOW AT ONCE.** It can be the turning point in your business career toward the bigger rewards business is willing to pay to the man who is trained. Our FREE booklet “TEN YEARS PROMOTION IN ONE” is most inspiring. Don’t let a postage stamp and one minute stand between you and full details regarding our training and opportunities to which such training leads.

LaSalle Extension University

A CORRESPONDENCE INSTITUTION

Dept. 364-R

Chicago

I am tired of being like “George.” I want at least to investigate the possibilities of home study for me. Send me FREE, “Ten Years Promotion in One” and your free 48-page booklet on the business field I have checked below.

- | | | |
|---|---------------------------------------|--|
| <input type="checkbox"/> Accounting | <input type="checkbox"/> Foremanship | <input type="checkbox"/> Industrial Management |
| <input type="checkbox"/> Executive Management | <input type="checkbox"/> Law | <input type="checkbox"/> Business Law |
| <input type="checkbox"/> Traffic Management | <input type="checkbox"/> Salesmanship | <input type="checkbox"/> Business Correspondence |

Name..... Age.....

Present Position.....

Address.....



(Continued from page 6A)

Why SMOOTH-ON

is a war-time necessity
in every household

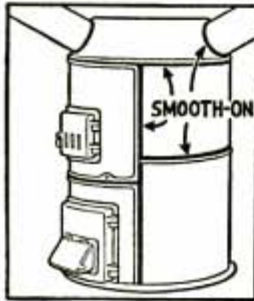

Household Repairs



Auto Repairs

New boilers, tanks, heaters, radiators, piping . . . all these and other household equipment are now hard to get and costly. Automobiles, too, and even tools and small household hardware and utensils must be carefully conserved and kept in good condition as long as possible.

With Smooth-On No. 1, you can make innumerable repairs yourself to keep your household equipment and automobile operating better and longer, and also to save much time and money. Cracks in machinery castings; leaks of water, steam, oil and gas; loose parts, handles, etc., that cause trouble, can all be quickly and lastingly repaired with a little Smooth-On . . . the iron repair cement of a thousand uses.

Be sure to send the coupon TODAY for FREE Handbook showing the many ways in which Smooth-On can help your household now above all times.

Buy Smooth-On in 1 1/4-oz., 7-oz., 1-lb. and larger cans from your dealer or if necessary from us. For your protection, insist on Smooth-On, used by repair men for 47 years.

FREE BOOK

Get your copy of our latest 40 page illustrated handbook. Shows how to make repairs quickly, economically. Just send the coupon.

Smooth-On Manufacturing Co., Dept. 37
570 Communipaw Ave.,
Jersey City, N. J.

Please send the FREE Smooth-On Handbook.

Name

Address

3-42

MAIL IT TODAY

Do it with **SMOOTH-ON**

Vacuum brush for venetian blinds.....	64
Premier Div., Electric Vacuum Cleaner Co., Cleveland, Ohio	
"Squeezed" food saves shipping space.....	64
Folding trailer in auto trunk.....	64
A. Marney, P. O. Box 236, Buena Park, Calif.	
Streamliner model engine.....	65
Typewriter has variable type.....	65
Ralph C. Coxhead Corp., 333 Sixth Ave., New York City	
Tank destroyer has 75-mm gun.....	65
Portable fluorescent lamp.....	70
Day-Ray Products, South Pasadena, Calif.	
Chess game for the blind.....	70
Braille Institute, 741 N. Vermont Ave., Los Angeles, Calif.	
Paint brush holder fits jar.....	70
Sears, Roebuck & Co., State and Van Buren, Chicago	
Cockpit of fighter plane.....	71
Scrub brush for carpet.....	76
Kwik Products Co., Inc., 32 W. 22nd St., New York City	
Self-antiseptic clothing.....	76
Adjustable glass drawing board has light.....	76
A. B. Dick Co., 720 W. Jackson Blvd., Chicago	
Calibrating "noise" meter.....	77
General Electric Co., Schenectady, N. Y.	
Rotary Crawler scours pipe lines.....	77
Corona Sheet Metal Works, Corona, Calif.	
Tanks refueled from air.....	77
Trucks move landscape in big bowl.....	78
Long-term license plates.....	80
Hydraulic tube mines gold.....	80
Bernhard Bros., 1941 E. Colorado St., Pasadena, Calif.	
Lights simplify music chart.....	81
Blacklight guides army trucks at night.....	81
Keese Engineering Co., 7200 Santa Monica Blvd., Los Angeles	
Self-lighting memo pad.....	85
Utility Stationery Stores, 300 N. Michigan Ave., Chicago	
Dispenser top on shoe-shine bottle.....	85
Pittsburgh Applicator Co., Box 7341 Oakland Sta., Pittsburgh	
Pedal driven water bike.....	86
Gauge checks furnace draft.....	86
Bacharach Instrument Co., 7000 Bennett St., Pittsburgh, Pa.	
Tachometer "feels" motor speed.....	86
James G. Biddle Co., 1211 Arch St., Philadelphia, Pa.	
Spiders work for national defense.....	87
Mirror in baby carriage.....	90
Baseboard has built-in conduits.....	90
Charles E. Barnes & Son, 4320 Osage Ave., Philadelphia, Pa.	
Scissors blade has rule in inches.....	90
Sears, Roebuck & Co., Chicago	
Twin windshield on plane stops window icing.....	90
Small-size grain thresher.....	91
Turner Mfg. Co., Statesville, N. C.	
Hospital in trailer to follow army.....	91
Birtcher Corp., 5087 Huntington Dr. No., Los Angeles, Calif.	
Coal burner extension can use oil.....	95
Burnham Boiler Corp., Irvington, N. J.	
Miniature jungle grows in bottle.....	95
Stanley Hansen, 1602 So. East St., Indianapolis, Ind.	
Metal frame presses coats.....	96
U. S. Hoffman Mach. Corp., 105 4th Ave., New York City	
Changes in living foreseen.....	96
Soldering tool has pivoting head.....	96
McKinley-Mockenhaupt Co., 626 W. Jackson Blvd., Chicago	
Armored power rheostat.....	159
Ciarostat Mfg. Co., Inc., 285 N. Sixth St., Brooklyn, N. Y.	
Iron-core coils for permeability tuning.....	159
Henry L. Crowley & Co., 1 Central Ave., West Orange, N. J.	
Cleaning brush for home recorder.....	159
Recordit Company, 555 Bedford Ave., St. Louis, Mo.	
All-way loudspeaker baffle.....	160
RCA Manufacturing Corp., Camden, N. J.	
Portable set has telescoping drop front.....	160
Montgomery Ward & Co., Chicago	
Lamp radio in aviation motif.....	160
Lullabye Furniture Co., 686 Lake Shore Drive, Chicago, Ill.	
Portable photo-cell counting assembly.....	160
Worner Products Corp., 1019 West Lake St., Chicago, Ill.	

(Continued to page 10A)

Mountain Pen 1947
Irishater Pen Co.
155 N. Clark St. Chicago

Color at work. (Coloroto)	17 Mar
Crane, folding for tractors handles large load	5 Mar.
Cutouts from plastic for easy sawing	12 Mar.
Darkroom, throwing light on	92 Mar.
Dog carries card in tube on collar	60 Mar.
Dog, rolling sling permits spine to heal	54 Mar.
Door arch easy to shape with flexible bead	59 Mar.
Drawing board, adjustable glass lighted from beneath	76 Mar.
Ear, right, does not hear pitch left ear hears	80 Mar.
Engine, tiny 18-cylinder spins 5-foot propeller	49 Mar.
Eyes, glass, give man super vision	72 Mar.
Fireboat rides trailer ashore	48 Mar.
Flower tray	22a Mar.
Fluorescent lamp, portable, in plastic tube	70 Mar.
Fluorescent lamps depict bomber in pageant	55 Mar.
Food, squeezed, saves space in shipping	64 Mar.
Fountain pen produces ink when filled with water	197 Mar.
Fruit jar humidor	22a Mar.
Fruit ripeness told by color photos	38 Mar.
Furnace draft gauge checks flue and chamber	86 Mar.
Gas works model tests plans	45 Mar.
Gasoline, odors removed by low cost process	48 Mar.
Gold sucked up by river by hydraulic tube	80 Mar.
Gun, coast defense recoil mechanism F	39 Mar.

[The page contains extremely faint and illegible text, likely bleed-through from the reverse side of the document. The text is scattered across the page and cannot be transcribed accurately.]

What are YOU doing to defeat America's enemies?



Not all of us can serve our country in uniform.

But every man in America can serve Uncle Sam by doing his job more efficiently than ever before — and thus help to outproduce the gangster nations, and smash “totalityranny” on the industrial front, as on the military and naval fronts!

It is your duty to secure the sound, practical training that will help you to perform your job better! There are several ways you can secure this training — and one which has proved its worth during the past

50 years is the International Correspondence Schools.

Right now, more than 100,000 Americans are studying I. C. S. Courses in 400 different subjects. For a few dollars monthly, and a few hours of their spare time each week, they are getting the *modern training* that will help them do their present job better, and fit them for a more responsible position in their line of work.

Join the army of trained men that is helping to outproduce the Axis! Mail this coupon for information — right now!

INTERNATIONAL CORRESPONDENCE SCHOOLS

HELPING TO TRAIN AMERICANS FOR VICTORY



BOX 5629-J, SCRANTON, PENNA.

Without cost or obligation, please send me a copy of your booklet, “Who Wins and Why,” and full particulars about the course *before* which I have marked X:

TECHNICAL AND INDUSTRIAL COURSES

- | | | | |
|--|--|---|--|
| <input type="checkbox"/> Air Brake | <input type="checkbox"/> Contracting and Building | <input type="checkbox"/> Marine Engines | <input type="checkbox"/> Sanitary Engineering |
| <input type="checkbox"/> Air Conditioning | <input type="checkbox"/> Cotton Manufacturing | <input type="checkbox"/> Mechanical Drafting | <input type="checkbox"/> Sheet Metal Work |
| <input type="checkbox"/> Airplane Drafting | <input type="checkbox"/> Diesel Engines | <input type="checkbox"/> Mechanical Engineering | <input type="checkbox"/> Ship Drafting |
| <input type="checkbox"/> Architectural Drafting | <input type="checkbox"/> Electrical Drafting | <input type="checkbox"/> Mine Foreman | <input type="checkbox"/> Shipfitting <input type="checkbox"/> Shop Practice |
| <input type="checkbox"/> Architecture | <input type="checkbox"/> Electrical Engineering | <input type="checkbox"/> Navigation | <input type="checkbox"/> Steam Electric <input type="checkbox"/> Steam Engines |
| <input type="checkbox"/> Auto Engine Tune-up | <input type="checkbox"/> Electric Lighting | <input type="checkbox"/> Patternmaking <input type="checkbox"/> Plumbing | <input type="checkbox"/> Steam Fitting |
| <input type="checkbox"/> Auto Technician | <input type="checkbox"/> Foundryman <input type="checkbox"/> Heating | <input type="checkbox"/> Practical Telephony | <input type="checkbox"/> Structural Drafting |
| <input type="checkbox"/> Aviation <input type="checkbox"/> Aviation Mechanic | <input type="checkbox"/> Heat Treatment of Metals | <input type="checkbox"/> Public Works Engineering | <input type="checkbox"/> Structural Engineering |
| <input type="checkbox"/> Boilermaking | <input type="checkbox"/> Highway Engineering | <input type="checkbox"/> Pulp and Paper Making | <input type="checkbox"/> Surveying and Mapping |
| <input type="checkbox"/> Bridge Engineering | <input type="checkbox"/> House Planning | <input type="checkbox"/> Radio, General | <input type="checkbox"/> Telegraph Engineering |
| <input type="checkbox"/> Chemistry | <input type="checkbox"/> Industrial Metallurgy | <input type="checkbox"/> Radio Operating | <input type="checkbox"/> Telephone Work |
| <input type="checkbox"/> Civil Engineering | <input type="checkbox"/> Locomotive Engineer | <input type="checkbox"/> Radio Servicing | <input type="checkbox"/> Textile Designing |
| <input type="checkbox"/> Coal Mining | <input type="checkbox"/> Machinist | <input type="checkbox"/> R. R. Section Foreman | <input type="checkbox"/> Toolmaking <input type="checkbox"/> Welding |
| <input type="checkbox"/> Concrete Engineering | <input type="checkbox"/> Management of Inventions | <input type="checkbox"/> R. R. Signalman <input type="checkbox"/> Refrigeration | <input type="checkbox"/> Woolen Manufacturing |

BUSINESS COURSES

- | | | | |
|--|--|--|---|
| <input type="checkbox"/> Accounting <input type="checkbox"/> Advertising | <input type="checkbox"/> College Preparatory | <input type="checkbox"/> First Year College | <input type="checkbox"/> Railway Postal Clerk |
| <input type="checkbox"/> Bookkeeping | <input type="checkbox"/> Commercial | <input type="checkbox"/> Foremanship <input type="checkbox"/> French | <input type="checkbox"/> Salesmanship |
| <input type="checkbox"/> Business Correspondence | <input type="checkbox"/> Commercial Illustrating | <input type="checkbox"/> Good English | <input type="checkbox"/> Secretarial <input type="checkbox"/> Spanish |
| <input type="checkbox"/> Business Management | <input type="checkbox"/> Cost Accounting | <input type="checkbox"/> High School | <input type="checkbox"/> Showcard and Sign Lettering |
| <input type="checkbox"/> Cartooning <input type="checkbox"/> Civil Service | <input type="checkbox"/> C. P. Accounting | <input type="checkbox"/> Managing Men at Work | <input type="checkbox"/> Traffic Management |

HOME ECONOMICS COURSES

- | | | |
|---|---|--|
| <input type="checkbox"/> Advanced Dressmaking | <input type="checkbox"/> Home Dressmaking | <input type="checkbox"/> Tea Room and Cafeteria Management, Catering |
| <input type="checkbox"/> Foods and Cookery | <input type="checkbox"/> Professional Dressmaking and Designing | |

Name.....Age.....Address.....
 City.....State.....Present Position.....

Canadian residents send coupon to International Correspondence Schools Canadian, Limited, Montreal, Canada
 British residents send coupon to I. C. S., 71 Kingsway, London, W. C. 2, England



U.S. GOVERNMENT JOBS.

START \$1260 to \$2100 Year

Prepare Immediately
for
EXAMINATIONS

Thousands Appointments Each Year

Railway Postal Clerks

Railway Postal Clerks get \$1,900 the first year of regular employment, being paid on the first and fifteenth of each month. (\$79.17 each pay day.) Their pay is automatically increased yearly to \$2,300 and \$2,450 in large organizations. Advance may be had to Chief Clerk at \$2,700 a year. (\$112.50 each pay day.) Men 18 to 35.



3 Days On — 3 Days Off — Full Pay

Railway Postal Clerks on long runs usually work 3 days and have 3 days off duty or in the same proportion. During this off duty their pay continues just as though they were working. They travel on a pass when on business. When they grow old, they are retired with a pension.



City Mail Carriers, Post Office Clerks

Clerks and Carriers now get \$1,700 the first year of regular employment and automatically increase \$100 a year to \$2,100. Open to Men—Women 18 to 48.

Many Other Positions

Many other positions are obtainable. Rural Carriers—Stenographers—Typists—Assistant Statistical Clerks—Accountants—Messengers—Border Patrolmen—etc. Those wishing these positions should qualify at once. Prepare now for 1942 examinations.

Get Free List of Positions

Fill out the following coupon. Tear it off and mail it today—now, at once.

This investment may result in your getting a big-paid government job.

FRANKLIN INSTITUTE, Dept. G174, Rochester, N. Y.

Rush to me, entirely free of charge (1) a full description of U. S. Government Jobs; (2) Free copy of illustrated 32-page book, "How to Get a U. S. Government Job"; (3) List of U. S. Government Jobs; (4) Tell me how to qualify for one of these jobs.

Name.....

Address.....

Use This Coupon Before You Mislay It. Write or Print Plainly.

(Continued from page 8A)

Craftsman and Shop Notes Index

ART AND ARTISTS

Ellipse drawn with string and dividers..... 99
Inset borders ruled with curtain rod..... 116
Easy way to stipple show cards..... 138

AUTOMOTIVE

Servicing car generators..... 141
Shovel aids in changing truck tire..... 143
Armatures held for inspection..... 143
Tractor carburetor adjusted from driver's seat..... 143

CAMPING, HUNTING, FISHING

Carrier made from boat oars and pipe..... 106
Camp stove from steel rods..... 108
Shoulder pads ease strain of carrying packs..... 109

FARM

Adjustable lead rope for animals..... 112
How to build good fences..... 116
Funnel dasher mixes spraying solution..... 130
Pulling pipe stakes from ground..... 138
Emergency insulator for electric fence..... 140
Gearwheel keeps gates from sagging..... 140
Cobs clean concrete floor in dairy..... 144
Tractor shocks absorbed when stretching wire..... 154

FURNITURE

Kneehole desk..... 97
Cricket footstool..... 103
Leather-covered table..... 110

HAND TOOLS

Waste material kept out of wall openings..... 99
Stop block to measure short work..... 106
Tool handle leaded in place..... 106
Small ball bearings handled easily..... 108
Chisels held for honing..... 108
Two strong clamps for various work..... 137
Welding-rod carrier..... 145
Self-marking try square..... 154

HOME IMPROVEMENTS

Making downspout screens easy to clean..... 99
Opening both cellar doors avoided..... 104
Sash glazing..... 104
House number in porch railing..... 112
Copper tubing used as radiator pipe..... 118

HOUSEHOLD

Solving home problems..... 100
Cellulose tape holds small parts for gluing..... 102
Doorstops make chair seat higher..... 106
Inexpensive shoe rack..... 108
Heel of paring knife cuts orange skins..... 112
Silencing typewriter noise..... 113
"Aged" wallpaper for patches..... 115
Picnic dishes marked with nail polish..... 118
Tags identify phonograph records in holder..... 128
Inexpensive music stand..... 129
Holding twine while wrapping packages..... 130

MODELMAKING

Modelmakers' anvil from solder..... 102
Bobby pins as clamps for modelmakers' use..... 118
"Starlet"—a model yacht..... 120

PHOTOGRAPHY

Home equipment for processing film..... 131
Colored tape marks film holders..... 131
Portable photo lights in case..... 133
Notched plastic cup aids weighing..... 134
Finding pinholes in bellows..... 134

POWER TOOLS

Leveling light shop machines..... 128
Rubber hose aids in filing circular saw..... 130
Lathe dial shows cutting speed..... 135

(Continued to page 12A)

Hat and coat rack, space saving, on wall	25 Mar.
Heat lamp, pocket, tans faster than sun	38 Mar.
Heating bill, how to cut	34 Mar.
Hollywood Bowl, trucks move landscape	78 Mar.
Hospital for modern army	91 Mar.
Humidor for fruit jars	22aMar.
Igloo, concrete, formed over balloon	7 Mar.
Infra red coating for flash bulbs	44 Mar.
Kilowatt, new hired hand, electric farm	40 Mar.
Lamp in aviation motif	160 Mar.
Lightning, truth about	82 Mar.
Litter ambulance carried on mule	45 Mar.
Living, change in our seen as result of advances	96Mar
Locomotive, model streamliner runs 20 m. p. h.	65 Mar.
Mileage dial shows distance between cities	44 Mar.
Milkweed, rubber from	88 Mar.
Mines planted by army with coal chutes	33 Mar.
Music chart for children simplified by lights	81 Mar.
Noise meters adjusted by blowing whistle	77 Mar.
Normandie cast in role of aircraft carrier	38Mar.
Oil burner made from coal heater	95 Mar.
Outlets, electric, added with conduit	90 Mar.
Paint brushes preserved in sealed jars	70 Mar.
Patrol, Emergency, New York City.	26 Mar.

1. The first part of the document discusses the importance of maintaining accurate records of all transactions. It emphasizes that every entry should be supported by a valid receipt or invoice to ensure transparency and accountability.

2. In the second section, the author outlines the various methods used to collect and analyze data. This includes both primary and secondary research techniques, as well as the use of statistical software to process large datasets.

3. The third section provides a detailed overview of the results obtained from the study. It highlights key findings and trends, as well as any unexpected observations that may have arisen during the data analysis phase.

4. Finally, the document concludes with a series of recommendations based on the research findings. These suggestions are intended to guide future research and to inform decision-making in the relevant field.

AUDELS NEW MACHINISTS HANDYBOOK NOW READY!

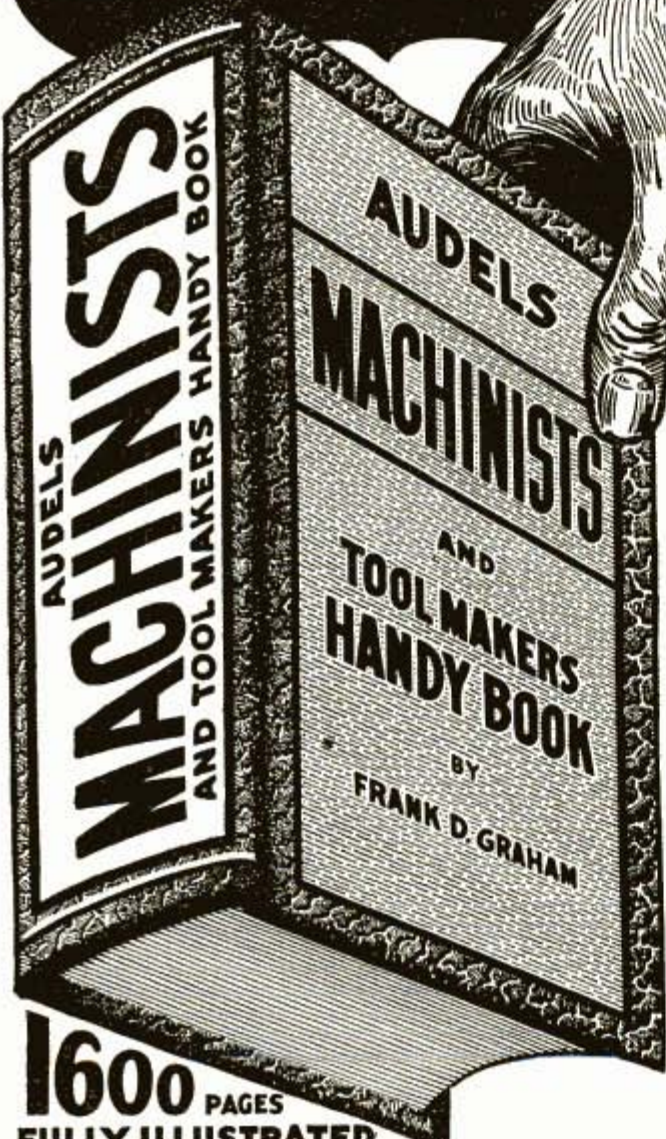

Prepare!

**A KEY TO
MODERN SHOP PRACTICE**

PRACTICAL INSIDE INFORMATION

For Every Machinist, Toolmaker, Engineer, Machine Operator, Mechanical Draughtsman, Metal Worker, Mechanic or Student. This 1600 Page Handy Book Covers Modern Machine Shop Practice in All Its Branches.

**A COMPLETE INSTRUCTOR WITH
READY REFERENCE INDEX**

New from Cover to Cover. Tells How to Operate and Set Up Lathes, Screw & Milling Machines, Shapers, Drill Presses & All Other Machine Tools.

**5 PRACTICAL BOOKS IN ONE!
60 FULLY ILLUSTRATED CHAPTERS**

Covering: **1**—Modern Machine Shop Practice. **2**—Blue Print Reading and How to Draw. **3**—Calculations & Mathematics for Machinists. **4**—Shop Physics. **5**—How to Use the Slide Rule.

...ASK TO SEE IT!...

THEO. AUDEL & CO., 49 West 23rd St., New York
Mail AUDELS MACHINISTS & TOOLMAKERS HANDY BOOK, Price \$4, on 7 Days Free Trial. If O. K. I will remit \$1 in 7 days and \$1 Monthly until \$4 is Paid. Otherwise I will return it.

Name _____
Address _____
Occupation _____
Reference _____ P.M.

**1600 PAGES
FULLY ILLUSTRATED**

A SHOP COMPANION THAT ANSWERS YOUR QUESTIONS
Easy to read and understand—flexible covers—Handy size 5 x 6½ x 2—a ready reference that answers your questions accurately.

TO GET THIS ASSISTANCE FOR YOURSELF SIMPLY FILL IN AND MAIL COUPON TODAY

**\$4 COMPLETE
PAY \$1 A
ONLY 1 MO.**

THEO. AUDEL & CO., 49 W. 23rd St., New York

AVIATION CAREER

Offers You

A GREAT FUTURE!

Complete Aeronautical Engineering or Master Aviation Mechanics training in the heart of the Aircraft industry. Graduates obtaining immediate employment. No flying involved.

Aviation's foremost school; established in 1929. Located on Grand Central Air Terminal. For full information, address Dept. PM-3.



**CURTISS WRIGHT
TECHNICAL INSTITUTE**

GRAND CENTRAL AIR TERMINAL
GLENDALE (LOS ANGELES) CALIF.

THIS TOWER OVERLOOKS AVIATION'S MOST DISTINGUISHED SCHOOL OF AERONAUTICS

Not everyone
does as well
as Charles—
for he



**TOOK IN \$217
in 10 DAYS
WASHING WALLS**

● Newly invented machine washes walls 6 times faster and better than by hand.

Charles Stelle took in \$217 first 10 days. We want more men to go into business for themselves. Customers everywhere. Homes, schools, offices, stores, churches, lodges, hotels, all have walls that need washing. You don't have to rent a store for you operate this business from your home. Dozens of men have written of large earnings for specific periods in their busiest seasons. They don't do this every day, every week, or every month, and allow a small amount for materials, but you can see how easy it is to get into this wonderful business.

Harold Jones writes: "I landed a \$40 job the first day."

E. C. Traber says: "Made \$400 in two weeks."

C. Irons got a \$905 school job. This is a repeat order.

L. Bach says: "First two jobs netted me \$26."



Easy Payments

It takes only a small amount to get started in this money-making business. No experience necessary. Any ambitious man who wants to be in business for himself with wonderful opportunities for big earnings should get started NOW.

SEND FOR FREE INFORMATION

There is No Obligation.

VON SCHRADER

MANUFACTURING CO.

773 Pl., Racine, Wis.

(Continued from page 10A)

Blocks held on faceplate.....	138
Drill press speed-reducing unit.....	139
Removing waste pieces of jigsaw cutouts.....	145
Metal-cutting saws.....	146

RADIO AND ELECTRICITY

Sealing wires in outlet plug.....	118
Concentrated training for radio operators.....	155
1942 "Little Giant" three-band receiver.....	156
Complete "wireless" record player in cigar box.....	158
Simple chassis rack on workbench.....	159
Soldering iron pilot light and control switch.....	159
Hinged beam-type receiving antenna.....	159
Tuning dial from old variable condenser plate.....	159
Clothespin soldering vise.....	159
Blueprinting small charts and diagrams.....	159

STORE AND SHOP

Slotted box aids in soldering grill.....	114
Tape holds type form together.....	138
Dustproof trays for jewelry parts.....	138
Simple workbench lamp.....	139
How to stencil grain sacks.....	140
Rubber finger stalls aid in candling eggs.....	140
Avoiding loss of small parts.....	140
Notched coat hanger carries dozen garments.....	144
Paperweights from linotype slugs.....	144
Rubber pad under telephone.....	144
Rubber disks stop holes in grain sacks.....	145
Attaching tags to bolts of cloth.....	153
Pencil clip on oilcan holds it to pocket.....	153
Sales banners hung on hangers.....	153

TOYS AND NOVELTIES

"Iceland destroyer".....	107
Corner whatnot shelf.....	109
Turned picture frame.....	119

WOODWORKING

Glued-up blanks for variegated turnings.....	113
Sliver vents dowel for driving.....	130
Trick in puttying nail holes.....	144

MISCELLANEOUS

Lapidaries chisel press.....	102
Test tube used as balance scale.....	102
Adjustable hasp for padlock.....	102
Separating watch and handkerchief in pocket.....	104
Sealing putty can.....	109
Ruling squared paper quickly.....	112
Plastic dish improves chemical scales.....	112
Envelope moistener from test tube.....	114
Carriage bolt kept from turning.....	114
Jar of oil steadies plumb bob.....	114
Seedlings transplanted with post-hole digger.....	114
Finishing touches on the backyard swing.....	115
Letter-writing board for blind persons.....	115
Garden rake used to spread roofing tar.....	116
Hat reinforced to protect crease.....	118
Holding paint cans on stepladder.....	119
Tire casing makes bicycle holder.....	119
Spreading seamed tubing.....	128
Tool rack on top of stepladder.....	128
Crutch tips from old tires.....	130
Locating leaky gas valves.....	136
Getting exact weight of load of coal.....	137
Lumber-yard inventory simplified.....	153

IMPORTANT NOTICE

It is the intention of this magazine to provide its readers with information regarding the latest developments in the mechanical arts. We take no responsibility as to whether the disclosures contained in our articles are covered by patents and advise readers to investigate this subject before making, using, or selling any of the products, machines, or processes described in order to avoid possible liability for patent infringement.

Be a RADIO Technician

Many make **\$30 \$40 \$50** a week

I Train *Beginners* at Home for Good Spare Time and Full Time Radio Jobs



J. E. SMITH, President, National Radio Institute, Established 27 years

Here is a quick way to more pay. Radio offers a way to make \$5, \$10 a week extra in spare time a few months from now, plus the opportunity for a permanent job in the growing Radio industry. There is an increasing demand for full time Radio Technicians and Radio Operators. Many make \$30, \$40, \$50 a week. On top of increasing civilian interest in Radio, the Radio Industry is rushing to fill hundreds of millions of dollars worth of Government Orders. Clip the Coupon below and mail it. Find out how I train you for these opportunities.

Jobs Like These Go To Men Who Know Radio

The 882 broadcasting stations in the U. S. employ thousands of Radio Technicians with average pay among the country's best paid industries. Repairing, selling, servicing, installing home and auto Radio receivers (there are more than 50,000,000 in use) gives good jobs to thousands. Many N. R. I. trained Radio Technicians take advantage of the opportunities to have their own full time or spare time service or retail Radio businesses. Think of the many good jobs in connection with Aviation, Commercial, Police Radio and Public Address Systems. N. R. I. gives you the required knowledge of Radio for these jobs. N. R. I. trains you to be ready when Television opens jobs in the future. Yes, N. R. I. trained Radio Technicians make good money because they use their heads as well as their hands. They are THOROUGHLY TRAINED. Many N. R. I. trained men hold their regular jobs, and make extra money fixing Radio sets in spare time.

Radio parts, half studying my lesson texts—makes learning Radio at home interesting, fascinating, practical.

Extra Pay in Army, Navy, Too



Every man likely to go into military service, every soldier, sailor, marine, should mail the Coupon Now! Learning Radio helps men get extra rank, extra prestige, more interesting duty at pay up to 6 times a private's base pay. Also prepares for good Radio jobs after service ends. IT'S SMART TO TRAIN FOR RADIO NOW!

Find Out How N. R. I. Teaches Radio and Television

Act today. Mail coupon now for 64-page Book. It's FREE. It points out Radio's spare time and full time opportunities and those coming in Television; tells about my Course in Radio and Television; shows more than 100 letters from men I trained, telling what they are doing and earning. Find out what Radio offers you. Mail coupon in envelope or paste on penny postcard—NOW.

J. E. SMITH, President
Dept. 2CP
National Radio Institute
Washington, D. C.



Broadcasting Stations employ N. R. I. trained Radio Technicians as operators, installation, maintenance men and in other capacities and pay well.

Set Servicing pays many N. R. I. trained Radio Technicians \$30, \$40, \$50, a week. Others hold their regular jobs and make \$5 to \$10 extra a week in spare time.



Loudspeaker System building, installing, servicing and operating is another growing field for N. R. I. trained Radio Technicians.

I Trained These Men



\$10 a Week in Spare Time
"I repaired some Radio sets when I was on my tenth lesson. I really don't see how you can give so much for such a small amount of money. I made \$600 in a year and a half, and I have made an average of \$10 a week—just spare time." JOHN JERRY, 1729 Penn St., Denver, Colorado.



Makes \$50 a Week
"I am making around \$50 a week after all expenses are paid, and I am getting all the Radio work I can take care of, thanks to N. R. I." H. W. SPANGLER, 126 1/2 S. Gay St., Knoxville, Tenn.



Operates Public Address System
"I have a position with the Los Angeles Civil Service operating the Public Address System in the City Hall Council. My salary is \$170 a month." R. H. HOOD, R. 136, City Hall, Los Angeles, Calif.

Beginners Soon Learn to Make \$5, \$10 a Week Extra in Spare Time

Nearly every neighborhood offers opportunities for a good part time Radio Technician to make extra money fixing Radio sets. I give you special training to show you how to start cashing in on these opportunities early. You get Radio parts and instructions for building test equipment, for conducting experiments which give you valuable practical experience. You also get a modern Professional Radio Servicing Instrument. My 50-50 method—half working with

THIS FREE BOOK HAS HELPED HUNDREDS OF MEN MAKE MORE MONEY



RICH REWARDS IN RADIO

This Coupon is Good For ...
One FREE Copy of My Book

J. E. SMITH, President, Dept. 2CP,
National Radio Institute, Washington, D. C.

Mail me FREE, without obligation, your 64-page book "Rich Rewards in Radio." (No salesman will call. Write plainly.)

NAME..... AGE.....

ADDRESS.....

CITY..... STATE.....

Be An ARTIST!



LEARN TO DRAW

—at home in your spare time

The fascinating field of Art offers commercial opportunities to men and women. Trained Artists are capable of earning \$30, \$50, \$75 a week. We teach you right at home for a successful career in—

COMMERCIAL ART ILLUSTRATING CARTOONING

For 28 years W. S. A. graduates have been "making good" in Art—WHY NOT YOU? No previous Art experience necessary. Included with training are: Two Art Outfits, Life Class Book, & booklet "How To Sell Your Art Work" Write for FREE BOOK—"Art for Pleasure and Profit," fully describes course of training. Mail coupon today.



FREE BOOK gives details!

Washington School of Art, Studio 123A
1115—15th St., N. W., Washington, D. C.

Yes! I am interested in your course. Please send me information in your Free Book, "Art for Pleasure and Profit."

Name..... Age.....
Address.....
City..... State.....

AUDELS Carpenters and Builders Guides 4 vols. \$6



Inside Trade Information for Carpenters, Builders, Joiners, Building Mechanics and all Woodworkers. These Guides give you the short-cut instructions that you need—including new methods, ideas, solutions, plans, systems and money saving suggestions. An easy progressive course for the apprentice and student. A practical daily helper and Quick Reference for the master worker. Carpenters everywhere are using these Guides as a Helping Hand to Easier Work, Better Work and Better Pay. To get this assistance for yourself, simply fill in and mail the FREE COUPON below.

Inside Trade Information On:

How to use the steel square—How to file and set saws—How to build furniture—How to use a mitre box—How to use the chalk line—How to use rules and scales—How to make joints—Carpenters arithmetic—Solving mensuration problems—Estimating strength of timbers—How to set girders and sills—How to frame houses and roofs—How to estimate costs—How to build houses, barns, garages, bungalows, etc.—How to read and draw plans—Drawing up specifications—How to excavate—How to use settings 12, 13 and 17 on the steel square—How to build hoists and scaffolds—skylights—How to build stairs—How to put on interior trim—How to hang doors—How to lay floors—How to paint



THEO. AUDEL & CO., 49 W. 23rd St., New York City

Mail Audels Carpenters and Builders Guides, 4 vols., on 7 days' free trial. If O. K. I will remit \$1 in 7 days, and \$1 monthly until \$6 is paid. Otherwise I will return them. No obligation unless I am satisfied.

Name.....
Address.....
Occupation.....
Reference..... P.M.

ARREST HIM, OFFICER! I'LL HAVE COMPLETE FACTS ON THE OTHER FELLOW TONIGHT!



Secret Service Operator No. 38 is on the job... FOLLOW HIM through all the excitement of his chase after the counterfeit gang. Write NOW for

FREE Confidential Reports No. 38 Made to His Chief!

It may open your eyes to the great opportunity for YOU as a well paid Finger Print Expert. The kind of work you'd like. Excitement! Travel! Thrills! A REGULAR MONTHLY salary. REWARD MONEY. Graduates of this school HEAD 43% of all

Identification Bureaus in U. S.! Write for Free Reports, Finger Print Book, low prices. Easy Terms Offer.

Literature will be sent only to persons stating their age.

INSTITUTE OF APPLIED SCIENCE
1920 Sunnyside Ave., Dept. 1353 Chicago, Illinois

LEARN WELDING



Both Electric Arc and Acetylene by practical Shop-Plan method in a few short weeks. No text-books. You learn by doing. Finest equipment. Low tuition. Pay-After-Graduation-Plan. Also, courses in Auto Mechanics, Collision Work, Metal Finishing, etc. Illustrated literature free. Write today.

MICHIGAN TRADE SCHOOL
3738 Woodward, Detroit, Mich.

FREE 32 PAGE CATALOG

Regain Perfect Speech, If You

STAMMER

Every stammerer should have the new 287 page book "Stammering, Its Cause and Correction." Sent free to stammerers. It describes the Bogue Unit Method for the scientific correction of stammering and stuttering. Method successfully used at Bogue Institute for 41 years—since 1901. Endorsed by physicians. Write for full information. No obligation. Benjamin N. Bogue, Dept. 1336 Circle Tower, Indianapolis, Indiana.

Learn AUTO-DIESELS

Practical, tested training. Backed by 36 years experience. Course includes Auto Mechanics, Diesel Service and Operation, Diesel Power Generation, Machine Shop Practice, Auto Electric, etc. Flexible plan to meet specific needs of those with or without jobs. Oldest, largest trade school in West qualifies you and helps you get a good pay job. Transportation allowed to L. A. Earn room and board while learning. Request Free Catalog.

NATIONAL SCHOOLS Dept. PMA-3
Los Angeles

CARTOONING PAYS WELL

Exclusive instruction by an internationally known cartoonist makes it easy to learn at home. Write for details of the course. Please state age.

NATIONAL SCHOOL OF CARTOONING
437 Penton Bldg. Cleveland, Ohio

Learn PHOTOGRAPHY at Home

Splendid opportunities. Prepare in spare time. Easy plan. No previous experience needed, common school education sufficient. Send for free booklet "Opportunities in Photography", particulars and requirements.

American School of Photography
1315 Michigan Ave., Dept. 1353, Chicago, Ill.

MAKE MONEY AT HOME

RUBBER MOLDS Low as 6¢ EA.

Amazing rubber mold-making outfit makes perfect flexible molds of plaques, ash trays, book-ends, etc. Molds cost from 6¢ to 25¢ each. Each mold makes hundreds of novelties and gifts to sell up to \$1.00 apiece! No experience necessary. Quick and easy. Start profitable business in your home... sell to stores, gift shops, friends, resorts, road stands, by mail. Full or spare time. "Molders Handy Book" and list of buyers FREE. Write



SO-LO WORKS
Dept. G-827 Cincinnati, Ohio

America Can't Wait Industry needs you NOW

Defense Program Needs Trained Men

There is a tremendous shortage of skilled men in almost all branches of industry. Draftsmen, electricians, machine designers, machinists, are wanted for good jobs at fine pay. Executives too; foremen, superintendents, managers, are needed right now to handle the enormous demand for finished products of all kinds. If you are already in one of these fields, you owe it to your country, to your family, and to yourself to make yourself even more valuable, to climb and climb fast and help put through the most important program we have ever had to face.

Opportunities Everywhere

Home building, ship building, manufacturing plants, great utility projects, road building—everywhere you look you find a demand for men—not just ordinary workers, but men who know more than their fellows, who are better at their jobs, who know both theory and practice and can therefore train other men, thus rising to more and more important stations and being of greater and greater help. Practically every industry is included in those needing MEN, trained men, skilled men, men with ambition and punch.

Learn at Home

Over 40 years ago we developed a system of home study which has helped thousands of men to important positions in the mechanical and business world. Those of you who have missed college training, who haven't the time to go away to school, who must **LEARN AS THEY EARN**, can get education in your particular field—yes, education of college grade right in your own home. Best of all, you can study when you have the time, and above everything else you will have the commendation and the respect of your employers in doing so. Rest assured that every superintendent, every factory manager, every general manager will have his eye on the man who pushes forward, who recognizes the great need of the day, and who has made up his mind to be one of the first to make good.

Get the Facts

(No Cost) All you have to do to find out about this type of training, to get the details and the outline of study, with histories of the successes of other men, is to write us or send the coupon. There is no cost and no obligation of any kind. Let this great school, one of the pioneers in the home study field, explain the methods which can do so much for you. Get this information now so that you can make up your mind quickly to get started on the road to the fulfillment of a real ambition, and so that you may be of the greatest possible help in this present emergency.

Rich Rewards

In bidding for skilled men now, industry of all kinds, everywhere in the United States is offering top pay. They want the best men and they are willing to pay for their services. But remember this, you not only have opportunities for bigger pay than you probably ever hoped for, but the chances for advancement are even greater. Foremen, superintendents, factory managers, must be drawn from the ranks, and surely you know that the man who studies, who tries to know everything there is to know about his job will be picked first. Best of all, under the present training program, with the tremendous need for skilled men you don't have to look too far in the future for:

Results
Come
Quickly

Business Welcomes Applications from American School Advanced Students and Graduates

Whenever trained men have been badly needed, business has been quick to say, "We welcome applications from American School advanced students and graduates." We maintain an employment placement service to help put you in touch with the best openings, and we make no extra charge of any kind for this service. Write now for an outline of home study training courses; check the coupon indicating your preference and mail it promptly.

Mark, Clip and Mail This Coupon NOW!

AMERICAN SCHOOL, Dept. G345, Drexel at 58th, Chicago

Without obligation. Please send FREE and postpaid, bulletin and details of the Subjects checked.

- | | | |
|--|---|---|
| <input type="checkbox"/> Air Conditioning | <input type="checkbox"/> Retail Merchandising | <input type="checkbox"/> Drafting and Design |
| <input type="checkbox"/> Elec. & Gas | <input type="checkbox"/> Cost Accounting | <input type="checkbox"/> Radio and Television |
| <input type="checkbox"/> Refrigeration | <input type="checkbox"/> Practical | <input type="checkbox"/> High School |
| <input type="checkbox"/> Architecture | <input type="checkbox"/> Bookkeeping | <input type="checkbox"/> Home Economics |
| <input type="checkbox"/> and Building | <input type="checkbox"/> Economics of | <input type="checkbox"/> Courses |
| <input type="checkbox"/> Plumbing and | <input type="checkbox"/> Direct Selling | <input type="checkbox"/> Business Law |
| <input type="checkbox"/> Steam Fitting | <input type="checkbox"/> Private Secretary | <input type="checkbox"/> Liberal Arts |
| <input type="checkbox"/> Automotive | <input type="checkbox"/> Diesel Engineering | <input type="checkbox"/> Mechanical |
| <input type="checkbox"/> Engineering | <input type="checkbox"/> Surveying & Topo- | <input type="checkbox"/> Engineering |
| <input type="checkbox"/> Aviation Drafting | <input type="checkbox"/> graphical Drafting | <input type="checkbox"/> Shop Management |
| <input type="checkbox"/> Aviation Engineering | <input type="checkbox"/> Sheet Metal | <input type="checkbox"/> Tool Making |
| <input type="checkbox"/> Business Management | <input type="checkbox"/> Pattern Drafting | <input type="checkbox"/> Better Foremanship |
| <input type="checkbox"/> Accounting and C.P.A. | <input type="checkbox"/> Electrical | <input type="checkbox"/> Engine and Boiler |
| <input type="checkbox"/> Salesmanship | <input type="checkbox"/> Engineering | <input type="checkbox"/> Work |

Name..... Occupation.....

Address..... Age.....

City..... State.....

AMERICAN SCHOOL

Dept. G345, Drexel at 58th, Chicago

SPRAYBERRY RADIO TRAINING INCLUDES FULL EQUIPMENT

Experience Easily Acquired
At Home!



You Do Practice-Giving Experiments... Many Special Features... ALL Designed To Help You Make Fast Progress

SPRAYBERRY Training starts right at the beginning of Radio... unfolds each subject in a simplified, logical, understandable style. You easily

learn Television, Frequency Modulation, Signal Tracing, Mobile Radio (Auto-Tank), Aviation Radio, Electronics, Facsimile Radio, Radio Set Repair and Installation work.

Training Prepares You For A Business Of Your Own... Or Good Radio Jobs At Excellent Pay

The great fascinating and progressive field of Radio offers many opportunities to the man who wants to get ahead. My Training is designed to give you quick access to these opportunities. SPRAYBERRY Methods are thorough and practical. Your Training will not interfere with your present work.

No Previous Experience Needed

It makes no difference what your education has been. I can fit you quickly for a good-paying Radio job. I make it easy for you to grasp Radio principles and remember them. Your success is my full responsibility.

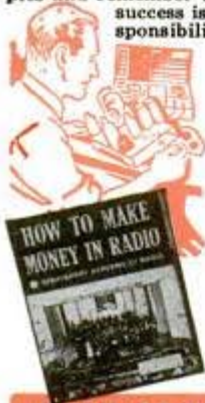

You Get Professional Test Equipment Plus Complete Radio Set

With the Radio Parts given (everything needed to build a Complete Receiver)... you conduct interesting informative experiments with your own hands. Also you are supplied a modern TESTER-ANALYZER.

Earn While You Learn

My BUSINESS BUILDERS show you how to put your equipment to actual use in handling money-making Radio Service Jobs shortly after you begin Training.

THE SPRAYBERRY COURSE IS SOLD UNDER MONEY-BACK AGREEMENT

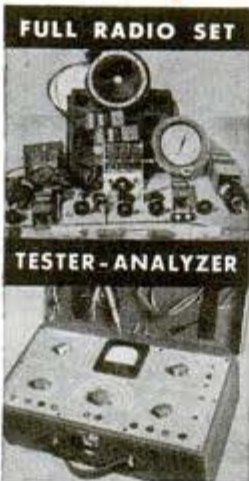

RUSH COUPON for BIG FREE BOOK

SPRAYBERRY ACADEMY OF RADIO
F. L. Sprayberry, President
510-C University Place, N. W.
Washington, D. C.

Please rush my FREE copy of "HOW TO MAKE MONEY IN RADIO".

Name..... Age.....

Address.....

City..... State.....

(Mail in envelope or paste on penny postcard)

PARKS AIR COLLEGE
PARKS AIRPORT EAST ST. LOUIS, ILL.

Offers YOU COLLEGE and PROFESSIONAL TRAINING
Majoring in AVIATION

Accredited by the Illinois Superintendent of Public Instruction. "Included in the Accredited Higher Institutions 1938, issued by the U. S. Office of Education, Federal Security Agency." U. S. approved as a Commercial Ground and Flying School and Mechanics' School. Accredited by and cooperating with the United States Army Air Corps in giving flight and mechanical training. Open to high school graduates. FOUR courses lead to B.S. degrees in Professional Piloting, Aviation Operations, Maintenance Engineering, Aeronautical Engineering. TWENTY-TWO TRAINING PLANES are used in professional flight training which prepares graduates for airline flight operations. FACULTY of 82 specialists in various fields of aviation. 1569 graduates. Enrollment limited to a total of 300 commercial aviation students. Capacity limited to school purposes exclusively. 100-acre airport, 25 buildings devoted to school purposes exclusively. Dormitories and dining hall at the College. Spring term March 30. Send postcard for new 64-page catalog.

15th YEAR Registrar, Dept. PM-3
PARKS AIR COLLEGE, East St. Louis, Ill.

ENGINEERING DEGREE IN 27 MONTHS

INDIANA
TECHNICAL
COLLEGE

Courses in Aeronautical, Chemical, Civil, Electrical, Mechanical, and Radio Engineering. One-year courses in Radio and Drafting. Approved by C.A.A. Prep courses without added cost. Low tuition. Large industrial center. Opportunity to earn part living expenses. Enter March, June, September, or December. Catalog. 532 E. Washington Blvd., Ft. Wayne, Ind.

LEARN WATCH REPAIRING



AT HOME You can learn by our modern and original system of instruction every part of the Watch Repairing Trade at home. Prepare yourself for a well paying position or start in business after completing our course of instruction. Good watch repairers are in demand and generally earn very good salaries. For particulars apply to the Wisconsin School of Watch Repairing 524 E. Mason St., Dept. A, MILWAUKEE, WIS.

GET INTO THE BAKING BUSINESS!

National Baking Institute announces a new home study course in commercial baking. Baking now America's fifth industry in wages. Nearly a depression-proof business. Good field for ambitious men. Common school education sufficient. Send for free booklet "Opportunities in Commercial Baking" and requirements.

National Baking Institute
1315 Michigan Ave., Dept. 1353, Chicago, U. S. A.



Learn PHOTO-ENGRAVING



We teach you quickly, at home in spare time. Earn while you learn. Establish your own profitable business with equipment we furnish, or work for others at good salary. Cuts in this magazine made by process we teach. Send for your copy of our big illustrated catalog. It's free! THE AURORA SCHOOL OF PHOTO-ENGRAVING Tasoer' Bldg. (Dept. PM-38) Aurora, Mo.

Learn CARTOONING

FREE TRIAL LESSON! Cash in on your sense of humor—AT HOME—BY MAIL. Have fun! Make money! No experience needed to start. Write today for FREE LESSON, mailed postpaid. No obligation. Moon Gag-Cartoon School, Dept. D, Fall Creek, Wis.



MONEY for MEN ALL FREE



THE PLASTEX Industry needs manufacturers on small scale and for big production of Lamp and Clock Stands, Art Goods and Novelties in Plastex and Marble imitation. Experience unnecessary. 1 1/2c material makes regular 10c store sellers. Rubber moulds furnished for speed production. Small investment brings good returns. WE ARE NOW PLACING BIG CHAIN STORE ORDERS WITH MANUFACTURERS. Ambitious men have chance for real prosperity. Our FREE booklet will interest and benefit you.

PLASTEX INDUSTRIES, Dept. P, 1085 Washington Ave., New York, N. Y.



DRAFTING

SPRINGBOARD TO SUCCESS!

MANY of American Industry's most successful men got their start at the drafting-board and progressed to positions of responsibility and leadership.

The International Correspondence Schools Courses in Mechanical or Architectural Drafting have fitted many hundreds of ambitious men for better jobs in this well-paid field!

All I. C. S. Courses (covering 400 business and technical subjects) are prepared by leading practical authorities, constantly revised to meet new developments. Yet the cost of I. C. S. training is surprisingly low.

It's not too late for you to start building a brighter future! Check and mail this coupon today!

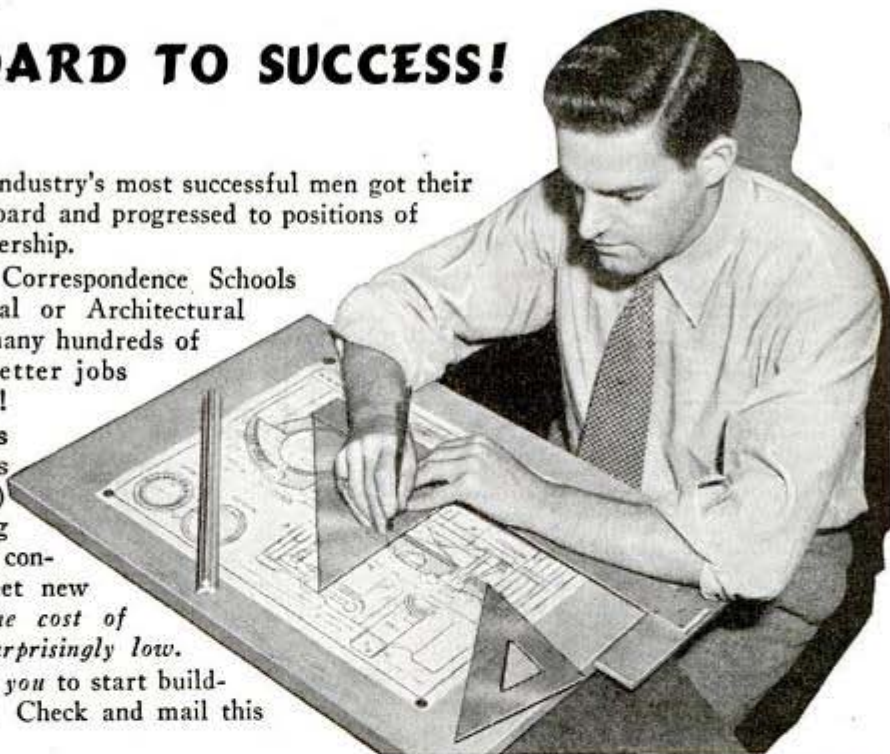

INTERNATIONAL CORRESPONDENCE SCHOOLS HELPING TO TRAIN AMERICANS FOR VICTORY



BOX 5630-J, SCRANTON, PENNA.

Without cost or obligation, please send me a copy of your booklet, "Who Wins and Why," and full particulars about the course before which I have marked X:

TECHNICAL AND INDUSTRIAL COURSES

- | | | | |
|--|--|---|--|
| <input type="checkbox"/> Air Brake | <input type="checkbox"/> Contracting and Building | <input type="checkbox"/> Marine Engines | <input type="checkbox"/> Sanitary Engineering |
| <input type="checkbox"/> Air Conditioning | <input type="checkbox"/> Cotton Manufacturing | <input type="checkbox"/> Mechanical Drafting | <input type="checkbox"/> Sheet Metal Work |
| <input type="checkbox"/> Airplane Drafting | <input type="checkbox"/> Diesel Engines | <input type="checkbox"/> Mechanical Engineering | <input type="checkbox"/> Ship Drafting |
| <input type="checkbox"/> Architectural Drafting | <input type="checkbox"/> Electrical Drafting | <input type="checkbox"/> Mine Foreman | <input type="checkbox"/> Shipfitting <input type="checkbox"/> Shop Practice |
| <input type="checkbox"/> Architecture | <input type="checkbox"/> Electrical Engineering | <input type="checkbox"/> Navigation | <input type="checkbox"/> Steam Electric <input type="checkbox"/> Steam Engines |
| <input type="checkbox"/> Auto Engine Tune-up | <input type="checkbox"/> Electric Lighting | <input type="checkbox"/> Patternmaking <input type="checkbox"/> Plumbing | <input type="checkbox"/> Steam Fitting |
| <input type="checkbox"/> Auto Technician | <input type="checkbox"/> Foundryman <input type="checkbox"/> Heating | <input type="checkbox"/> Practical Telephony | <input type="checkbox"/> Structural Drafting |
| <input type="checkbox"/> Aviation <input type="checkbox"/> Aviation Mechanic | <input type="checkbox"/> Heat Treatment of Metals | <input type="checkbox"/> Public Works Engineering | <input type="checkbox"/> Structural Engineering |
| <input type="checkbox"/> Boilermaking | <input type="checkbox"/> Highway Engineering | <input type="checkbox"/> Pulp and Paper Making | <input type="checkbox"/> Surveying and Mapping |
| <input type="checkbox"/> Bridge Engineering | <input type="checkbox"/> House Planning | <input type="checkbox"/> Radio, General | <input type="checkbox"/> Telegraph Engineering |
| <input type="checkbox"/> Chemistry | <input type="checkbox"/> Industrial Metallurgy | <input type="checkbox"/> Radio Operating | <input type="checkbox"/> Telephone Work |
| <input type="checkbox"/> Civil Engineering | <input type="checkbox"/> Locomotive Engineer | <input type="checkbox"/> Radio Servicing | <input type="checkbox"/> Textile Designing |
| <input type="checkbox"/> Coal Mining | <input type="checkbox"/> Machinist | <input type="checkbox"/> R. R. Section Foreman | <input type="checkbox"/> Toolmaking <input type="checkbox"/> Welding |
| <input type="checkbox"/> Concrete Engineering | <input type="checkbox"/> Management of Inventions | <input type="checkbox"/> R. R. Signalman <input type="checkbox"/> Refrigeration | <input type="checkbox"/> Woolen Manufacturing |

BUSINESS COURSES

- | | | | |
|--|--|---|--|
| <input type="checkbox"/> Accounting | <input type="checkbox"/> Advertising | <input type="checkbox"/> College Preparatory | <input type="checkbox"/> First Year College |
| <input type="checkbox"/> Bookkeeping | <input type="checkbox"/> Business Correspondence | <input type="checkbox"/> Commercial | <input type="checkbox"/> Foremanship <input type="checkbox"/> French |
| <input type="checkbox"/> Business Management | <input type="checkbox"/> Business Management | <input type="checkbox"/> Commercial Illustrating | <input type="checkbox"/> Good English |
| <input type="checkbox"/> Cartooning <input type="checkbox"/> Civil Service | <input type="checkbox"/> C. P. Accounting | <input type="checkbox"/> Cost Accounting | <input type="checkbox"/> High School |
| | | <input type="checkbox"/> Management of Inventions | <input type="checkbox"/> Managing Men at Work |

HOME ECONOMICS COURSES

- | | | |
|---|---|--|
| <input type="checkbox"/> Advanced Dressmaking | <input type="checkbox"/> Home Dressmaking | <input type="checkbox"/> Tea Room and Cafeteria Management, Catering |
| <input type="checkbox"/> Foods and Cookery | <input type="checkbox"/> Professional Dressmaking and Designing | |

Name.....Age.....Address.....
City.....State.....Present Position.....

Canadian residents send coupon to International Correspondence Schools Canadian, Limited, Montreal, Canada
British residents send coupon to I. C. S., 71 Kingsway, London, W. C. 2, England



Know Electricity as Experts Know It—and Get an Expert's Pay!

What about your future? Who is safe today? Surely not the man who is contented to stand still! Know your job thoroughly—prepare yourself for jobs ahead. To do just this thousands of men have used

The Croft Library of Practical Electricity

The Croft Library is a complete electrical educator. It is founded on practice—on 20 years of shirt-sleeve experience—on work as it is actually done. It is jammed from cover to cover with the kind of hard-headed facts you want. Written so that the beginner can easily understand it, yet so sound, so thorough, that it is the daily guide of 59,000 highly paid electrical workers and engineers. Croft tells you the things you need to know about motors, generators, armatures, commutators, transformers, circuits, switchboards, distribution systems—electrical machinery of every type—wiring for light and power—wiring of finished buildings—underwriters and municipal requirements—illumination in its every phase—the most improved methods of lighting—lamps and lamp effects, etc.—how to do a complete job, from estimating it, to completion.

No money down—easy payments

Fill in and mail the coupon attached and we will send you the entire set of seven volumes for ten days' examination on approval. We take all the risk—you assume no obligation. If you decide to keep the books, send \$3.00 in ten days and the balance at the rate of \$3.00 a month. Send the coupon NOW and see the books for yourself.

EXAMINATION COUPON

McGRAW-HILL BOOK CO., 330 W. 42nd St., New York

Send me for ten days' examination on approval the Croft Library of Practical Electricity, 7 vols. If satisfactory I will send you \$3.00 in 10 days and \$3.00 monthly until the price of \$18.00 is paid. If not wanted, I will return the books postpaid. (To insure prompt shipment write plainly and fill in all lines.)

Name.....
Home Address.....
City and State.....
Position.....
Name of Company..... PM-3-42

Say you saw it in Popular Mechanics!

AUDELS DIESEL QUESTIONS & ANSWERS

ASK TO
SEE
IT!

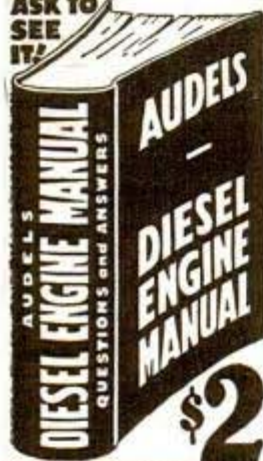

THIS BOOK IS OF VALUE
TO ENGINEERS,
TO OPERATORS

Answers Your Questions in simple, concise language on Diesel Operating & Maintenance—Engine Starting—Air Starting Valves. Fuel Spray Valves—Inlet and Exhaust Valves—Valve Timing—Fuel Pumps—Fuel Injection Compressors—Starting Air Compressors—Scavenging Air Compressors—Pistons and Piston Rings—Cylinders—Lubrication—Cooling Systems—Fuel Oil—The Engine Indicator—Governors—Engine Reversing—Semi-Diesel Engines—High Speed Diesel Engines—Answers On Operation—Horse Power Calculations, Including Two-Cycle Diesel Engines. ALL DETAILS ARE PLAINLY BROUGHT OUT. Saves fuel and operating trouble. 384 Pages, FULLY ILLUSTRATED.

TO GET THIS PRACTICAL
ASSISTANCE FOR YOURSELF
MAIL COUPON TODAY

AUDEL, Publishers, 49 West 23rd St., New York
Please mail a copy of AUDELS DIESEL ENGINE MANUAL. If satisfactory, I will remit \$2 on its safe arrival, otherwise I will return the book.

Name.....
Address.....
Occupation..... P.M.

TRI-STATE COLLEGE

Degree in 2 1/4 years

B. S. Degree in Civil, Electrical, Mechanical, Chemical, Radio, Aeronautical Engineering; Business Administration, Accounting, Secretarial Science. Short diploma courses (36 weeks) in Surveying, Drafting. Special Preparatory Department for those who lack required high school work. Cosmopolitan student body. Approved by Civil Aeronautics Administration for flight training. Distinguished for 2 1/4-year technical courses (Non-essentials eliminated). 59th year. Tuition, living costs low. Defense needs call for engineers. Demand for graduates exceeds supply. Enter March, June, Sept., Jan. Catalog. 432 COLLEGE AVE., ANGOLA, IND.



ENGINEERING

LAW STUDY AT HOME

Legally trained men win higher positions and bigger success in business and public life. Greater opportunities now than ever before. Big corporations are headed by men with legal training.

More Ability: More Prestige: More Money

We guide you step by step. You can train at home during spare time. Degree of LL. B. Successful graduates in every section of the U. S. We furnish all text material, including 14-volume Law Library. Low cost, easy terms. Get our valuable 46-page "Law Training for Leadership" and Evidence books FREE. Send for them NOW.

LaSalle Extension University, Dept. 364-L Chicago
A Correspondence Institution



Learn Profitable Profession in 90 days at Home

Earnings of Men and Women in the fascinating profession of Swedish Massage run as high as \$40 to \$70 per week but many prefer to open their own offices. Large incomes from Doctors, hospitals, sanitariums and private patients come to those who qualify through our training. Reducing alone offers rich rewards for specialists. Write for Anatomy Charts and booklet—They're FREE.

THE COLLEGE OF SWEDISH MASSAGE
30 E. Adams St., Dept. 364, Chicago



Begin today. Write for our New Free Book, "How to Become a Good Penman," it contains specimens and tells how others learned to write in spare time. Enclose 10c for a Professional Pen Point and your name beautifully written. Write today.

THE TAMBLYN SCHOOL OF PENMANSHIP
441 Ridge Building Kansas City, Mo.

Learn Public Speaking

At home—in spare time. Many overcome "stage-fright," gain self-confidence and increase earning power, this easy way. Write for free booklet, *How to Work Wonders With Words* and requirements. North American Institute Dept. 1353 1315 Michigan Ave. Chicago, Illinois

AMAZING NEW ELECTRIC ARC WELDER

RETAILS ONLY \$2.95 COMPLETE

FULLY GUARANTEED

PLUGS INTO LIGHT SOCKET

Amazing new HANDI-WELD Electric Arc Welder—operates from 110 volt A.C. or D.C. same as other arc welders higher priced—generate tremendous heat to weld all kinds of metal. Not a hot welder that uses carbons, but actually uses standard coated rods—size 1/16" and 3/32". Generous supply furnished with welder. Guaranteed not to burn out. Repairs fenders, auto bodies, radiators, pre-busted small castings and machinery parts. Take HANDI-WELD anywhere to job, operate from light socket. Sturdily built of finest materials to last years. Fully guaranteed by Big Manufacturer.

SEND NO MONEY! You'll find a thousand uses for the HANDI-WELD around your home, garage, work shop. Also by garages, factories, repair shops, mechanics, farmers, inventors, tin shops, plumbers, etc. Order HANDI-WELD now. Send no money. We'll rush one to you complete with rods and coxles. Pay postman only \$2.95 plus few cents postage. If not delighted, return HANDI-WELD in 5 days from receipt and money paid for it will be refunded instantly. Rush your order now. KUMFY PRODUCTS INC., Dept. D-202 Cincinnati, Ohio

Here I Am At WORK

Making
GOOD MONEY
thanks to this

Free
TRIAL
LESSON
IN



DRAFTING

Yes, this free lesson **proved** that drafting is easy, mighty interesting work . . . convinced me I didn't need special talent to get into this well-paid profession . . . **proved** beyond a doubt that Drafting by the fascinating C. T. C. method can be mastered easily **AT HOME IN SPARE TIME.**

So I enrolled. Today I feel secure in my job. The **National Defense program** and rising business have increased the demand for Machine Draftsmen, Architectural Draftsmen, Electrical Draftsmen, Structural

Draftsmen and Aircraft Draftsmen. For draftsmen always come first on any new project in manufacturing and industry . . . and in those new Aircraft plants and Shipbuilding yards. Draftsmen can't be replaced with machines! What's more, I'm slated for promotion—but if I wish, I can be independent . . . go into business.

Here's a tip: Mail the coupon or drop a card for the free trial lesson. Do this today—and drafting will take care of you tomorrow.



YOU GET THIS COMPLETE DRAWING OUTFIT

without a penny extra. These are quality instruments—the kind that professional draftsmen use. With them you can put your ideas on paper quickly and with accuracy. With training, you're all set to master draftsmanship in months—not years—at home, and you can use these very same instruments **some** day as draftsman.

CHICAGO TECHNICAL COLLEGE

C-203 Tech Bldg., 2000 So. Michigan Avenue, Chicago, Illinois

LEARN AT HOME IN SPARE TIME

A few hours of pleasant home study every week—that's all! No interference with your present job! With Chicago Tech's help, you train yourself step by step. This tested method—developed over 37 years of C. T. C. progress—will fit you for a job in months—just the kind of job you've wanted.

Get this: Terms are low. You can't honestly say "I can't afford it." There isn't a reason why you shouldn't mail us the coupon today. When you get your **FREE TRIAL LESSON**, you'll say, "I never knew learning could be so easy and enjoyable." If you are 17 years or older, send for our trial lesson.

MAIL THIS COUPON

CHICAGO TECHNICAL COLLEGE
C-203 Tech Bldg., 2000 So. Michigan Avenue, Chicago

Please send me **FREE Trial Lesson in DRAFTING** and show me how I can prepare for a good position **in spare time AT HOME.** No cost or obligation for this Trial Lesson either now or later.

Name _____ Age _____

Address _____

City _____ State _____

INVENTORS *for*

Act Now TO PROTECT YOUR INVENTION WITH U.S. PATENT

SMALL IDEAS MAY HAVE Large Commercial Possibilities

Inventions do not have to be complicated to be profitable. The 10c stores flourish on simple Patented products which are commercially successful. The zipper, safety pin, thumb tack, paper clip, collar button—all are simple yet familiar inventions—brought their inventors rich rewards. If you have an invention—act now to protect it. Send for our FREE "PATENT GUIDE".

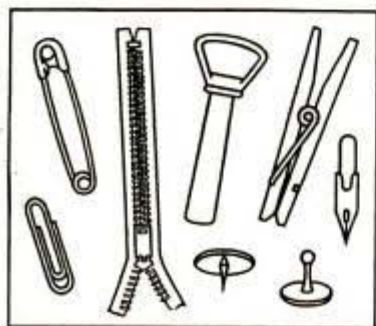

CLARENCE A. O'BRIEN
21-C Adams Building, Washington, D. C.
Registered Patent Attorney before U. S. Pat. Office

Free Patent Guide

TELLS HOW TO OBTAIN PATENT AND MARKET INVENTION

If you have invented something, if you are interested in inventing something, you need our new 48-page "PATENT GUIDE" that gives the entire Story of Patents. It tells you about new phases of invention, how others succeeded, how the patent laws protect you, how to market your invention, where to obtain finances, and how to arrange for royalties from the sale of your invention.

PRACTICAL BENEFITS OF THIS "PATENT GUIDE"

You will find 6 complete pages illustrated with simple inventions that have succeeded in six different fields of industry. Over 100 illustrations are in this book. You will read the stories of ten (illustrated) of America's most famous inventors. You will find an experienced and thorough survey of market conditions affecting the inventor—showing the possibilities for commercial invention today.

If you expect to realize profits from your invention you must protect it with a U. S. patent. Otherwise you may find that all your time and labor have been lost, because it often happens that other inventors are working on the same invention. If you have an invention, or an ambition to invent—get the information on obtaining patent AT ONCE!

FREE "RECORD OF INVENTION" FORM

When you send for your FREE "PATENT GUIDE", we include, also Free, our specially prepared "RECORD OF INVENTION" form, on which you can quickly make and date a sketch and description of your invention. This "disclosure" as it is called, may be absolutely invaluable as evidence for you, should your rights ever be contested. Be sure to get it and use it.

CLARENCE A

REGISTERED PATENT ATTORNEY • BEFORE U. S. PATENT

Do You Make Mistakes in English?

EVERY time you speak or write you show just what you are. Mistakes in English reveal you as a person who lacks education and refinement. Lack of language power prevents you from presenting your thoughts in the strongest possible way. No matter what you do, real command of English will help you to your goal. Stop making mistakes in spelling, punctuation, pronunciation. Increase your vocabulary.

WONDERFUL INVENTION

Only 15 minutes a day with Sherwin Cody's new invention—and you can actually SEE your English improve. It teaches by HABIT—makes it easier to do the RIGHT way. Wonderful self-correcting lessons include spelling, punctuation, grammar and expression.



FREE BOOK ON ENGLISH Lack of language power may easily be costing you thousands of dollars every year. See what Mr. Cody can do for you; it costs nothing to find out. Mail a postal card or letter this very minute for free book. "How You Can Master Good English in 15 Minutes a Day". It will prove a revelation to you. WRITE NOW. Address:

Sherwin Cody School of English, 53 Searle Bldg., Rochester, N. Y.

TIRED OF WORKING FOR OTHERS BE A LANDSCAPE ARCHITECT



Make this healthful, creative, profitable outdoor work your career! Interesting hobby, too! Study at home in your spare time. Lessons include: Garden Design, Landscape Horticulture, Mapping and Field Work, Plant Materials, etc. Many opportunities for trained men and women. Write today for free booklet "Success thru Landscape Training."

American LANDSCAPE School
6296 Grand Ave., Des Moines, Ia.

New York Established 1902
Electrical School
Ask for free illustrated booklet
44 West 17th St., N. Y. C.

Quick Action!

SEND TODAY

You Can Patent Improvements

GET FREE 48-PAGE PATENT GUIDE and Record of Invention Form

MAIL COUPON NOW TO CLARENCE A. O'BRIEN
Registered Patent Attorney
BEFORE U.S. PATENT OFFICE

Clarence A. O'Brien, 21-C Adams Building, Washington, D. C.
 Please send me your Big, Free 48-Page "Patent Guide for the Inventor" and your Specially Prepared "Record of Invention" form. This request does not obligate me.

NAME.....
 ADDRESS.....
 CITY..... STATE.....

(Please write or Print Plainly)

In Machinery, Articles, Designs, Formulas, Etc. If New

Every year thousands of patents are granted. Very few, however, represent the discovery of entirely new principles. Most of them provide new methods of doing some every-day thing in a better way—changes for greater efficiency, usefulness, adaptability, or beauty in some previously Patented thing. These IMPROVEMENTS are patentable if new, and actually represent new inventions. These improvement Patents offer large chances for profit if commercially useful. The business world wants improved products and services.

OUR SERVICES TO YOU

We are Registered Patent and Trade-Mark Attorneys, serving Inventors all over the United States and abroad. Our Organization is complete. We have experienced Patent Attorneys, Draftsmen and Searchers to serve your interests. We can act as your adviser in all Patent Matters. Our fees are very reasonable—we can arrange convenient terms of payment. It is our custom to permit clients to pay for our services in installments as the application progresses in our office. Our complete service is described in Our "Patent Guide". Mail Coupon for it NOW.

GET FREE "PATENT GUIDE"—MAIL COUPON NOW

If you have an invention in the making—if you simply have the crude elements of an invention in mind—you should get our "PATENT GUIDE" without delay. It will guide you every step of the way—from the preliminary search stage to the issuance of the final patent grant. This book contains twenty-five chapters describing in plain man-to-man language the story of obtaining a patent and selling an invention. This book is absolutely FREE—just tear off the above coupon or write us a letter or postcard TODAY!

Get These FREE



MAIL COUPON NOW

. O'BRIEN *Worthy of Your Trust*

OFFICE • 21-C ADAMS BUILDING • WASHINGTON, D. C.

U. S. GOVERNMENT JOBS

\$1260 to \$2100 FIRST YEAR

RAILWAY POSTAL CLERKS



Many other Government Jobs. City and Rural Carriers — Postoffice Clerks — Border Patrolmen — Accountants — Stenographers — Typists—etc. Prepare Now for 1942 Examinations.

FRANKLIN INSTITUTE, Dept. G-195, Rochester, N. Y.

Sirs: Rush to me, without charge, copy of 32-page book, "How to get a U. S. Government Job," list of positions, and full particulars telling how to qualify for them.

Name.....

Address..... Age.....

POPULAR INVENTIONS

For Your Home

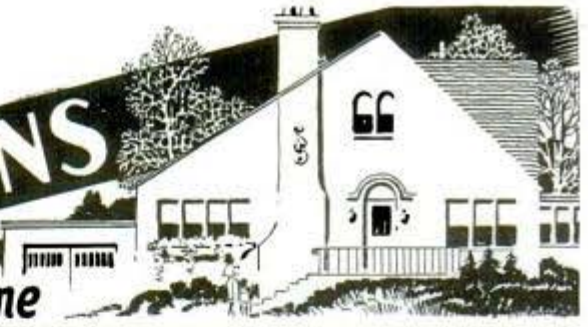

Humidor Suspended in Fruit Jar Prevents Drying of Food



Primarily intended for storing popcorn, but useful also in preserving other foods or smoking tobacco, a humidifier fitting the neck of standard fruit jars keeps the contents from drying out. For best corn-popping results, there should be some moisture within the kernel, and keeping the top of the humidifier damp will maintain the proper humidity within the jar.

Retaining Cup on Bottle Opener Prevents Squirting of Liquid

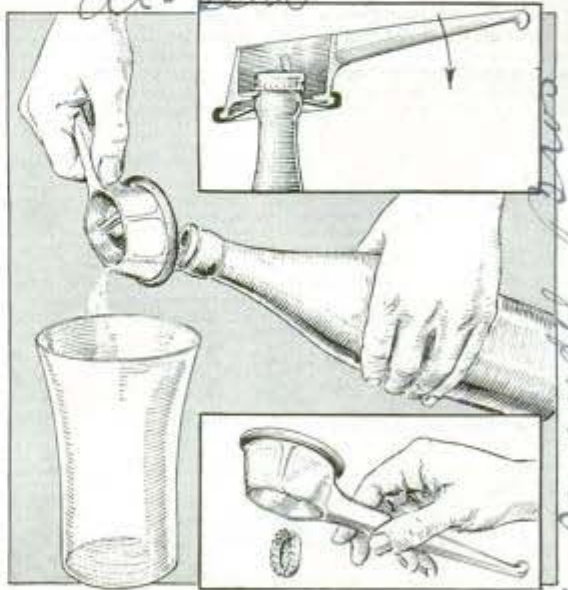

Tray for Short-Stemmed Flowers Holds Them Upright in Grill

Equipped specially to accommodate fresh flowers with short stems, a tray serves as a centerpiece without obstructing the view across the table. The tray is covered with a white enameled grill through which the stems are placed so the ends remain submerged in water.



With a bowl-shaped retainer and a flexible rubber shield that seals itself about the bottle neck, an opener for carbonated beverage bottles prevents the contents from squirting and holds any liquid that may fizz over. In opening a bottle the rubber shield slides past the cap, and the opener is operated like any other, except that the cap need not be removed completely if beverage effervesces violently.

(More Popular Inventions on page 24A)

22A Chicago Merchandise Mart

POPULAR MECHANICS
The Melldale Co
Stanford Conn

*Dr. S. Mc Kinnon, 607 S. Col
Canned Bells, Iowa
1298
1321
1321
Piper Cupper + Brass Co
230 Park Ave. New York
breakable ensemble
sold by Marshall Field*

Over 700,000 people have studied music this easy way

YES, OVER 700,000 delighted people have studied music this quick, easy, inexpensive way. Some are now on the stage, others on the radio, and thousands more are enjoying new pleasure and popularity by being able to play. Isn't this convincing proof of the success of the new U. S. School of Music method? Many students didn't know one note from another. Yet in a short time they learned to play their favorite instrument. And they found learning this modern way amazingly

easy, and loads of fun. What countless others have done, YOU, too, can do!

Right from the start you learn real tunes by note. First you are *told* how to do a thing. Then a picture *shows* you how to do it. Finally you do it yourself and *hear* how it goes. Almost before you realize it, you are playing your favorite pieces. No private teacher could make it clearer.

FREE BOOKLET EXPLAINS ALL

Best of all it costs less than 7c a day. That includes everything . . . *no extras* of any kind. Don't miss any more fun. Learn to play your favorite instrument and surprise your friends. Music, you know, makes most any party a success. Those who can play are invited everywhere. So get started on the way to musical good times NOW!

If you want to be a "hit" at every party . . . if you really *do* want to play your favorite instrument . . . fill out and mail the coupon below, asking for our Free Illustrated Booklet and Print and Picture Sample. These show you how quickly and easily you can learn music in your own home at little cost. Instruments supplied when needed, cash or credit. U. S. School of Music, 73 Brunswick Bldg., New York City. (Established 1898—44th year)

EASY AS A-B-C
— costs less than
7¢ a day



U. S. SCHOOL OF MUSIC,
73 Brunswick Bldg., New York City

I am interested in learning the musical instrument checked. Please send me your illustrated booklet explaining how I can learn at home, for as little as 7c a day.

Piano	Trumpet	Cornet
Violin	Trombone	Piano Accordion
Cello	Tenor	Plain Accordion
Mandolin	Banjo	Hawaiian Guitar
Saxophone	Ukulele	Other instrument

Have You Instrument?

Name

Address

City

State

Learn TOOL DESIGN

Quality quickly as a Machine or Tool Designer by home study in spare time. Entire defense program depends largely upon the machine and tool designer. After defense boom, machine and tool designers will be equally necessary for reconstruction. Many now making \$100 to \$125 a WEEK. Rapidly expanding industry calling for more machine and tool designers than now available. Learn quickly with our step-by-step lessons supervised by a recognized professor of machine tool design. Rush name and address today for complete facts on Machine or Tool Design. Learn what these fields offer you and how quickly you can qualify for a big pay position. No obligation. State age. A penny postal will do—but hurry.

Ohio Institute of Technology, Box 52, Greenville, Ohio

Learn To MOUNT BIRDS

Tan SKINS, Make Up FURS

Be a Taxidermist. Double your hunting fun. We teach you at Home. Mount Birds, Animals, Pets, Heads and Fish. Save your hunting trophies; decorate home and den. **MAKE MONEY.** Mount and Krome-tan for others. Big spare-time profit. **INVESTIGATE TODAY.** Rush name and address today for **FREE BOOK** with 100 game pictures, 48 pages. Hunters, get yours! It's **Now Free.** Send postal card **TODAY**. This Minute! State your AGE.

NORTHWESTERN SCHOOL OF TAXIDERMISTRY, Dept. 3373, Omaha, Nebr.

LEARN MONEY-MAKING CARTOONING

Same Simplified Method that has helped train creators of "Terry & Pirates," "Wash Tubbs," "Out Our Way," "Winnie Winkle," "Reg'lar Fellers," "Strange As It Seems," "Secret Agent X-9," and many others. Earn while learning. Rush 10c for Pictures Chart (to test your ability) and full details. (State age.)

THE LONDON SCHOOL, 4203 National Bldg., Cleveland, Ohio

America Needs Men Trained for TOOL & DIE MAKING, MACHINIST & SCREW MACHINE TRADES

HARRY LERESON PRESIDENT & FOUNDER

ALLIED School offers you short intensive, Practical training courses in Our fully equipped Shops. Learn on Actual Jobs! State Approved. Learn Days or Evenings. Enter anytime. **FREE** Employment Service and opportunity to earn while learning. Write for **FREE Book** "Practical Machine Shop Training."

ALLIED SCREW MACHINE CO., (School Division)
609 West Lake Street Dept. PM-3 Chicago, Illinois

ELECTRICAL BOOKS

shipped **FREE**

10 BIG BOOKS

FOR EXAMINATION **MODERN ELECTRICITY INCLUDING RADIO AND TELEVISION**

Here's great news for anybody interested in Electricity. NEW 17th. edition of Applied Electricity brought right down to date with NEW Electrical subjects fully covered. 10 Big Volumes and all shipped **FREE** for examination.

For Beginners and Experts

over 3000 pages—hundreds of illustrations—the most complete work of its kind we have ever published. Dynamos, motors, power stations, Radios, television, everything electrical explained so anyone can understand it.

Big Field! Big Demand! Big Pay! Men who understand electricity are urgently needed in thousands of industries. Autos, airplanes, machine shops—practically every industry depends on electricity and men who know this subject make big money. Present, fascinating work, easy to learn and do; learn with these books. Send coupon for a set for **FREE** examination and see for yourself.

SEND NOW [A year's consulting privileges with our engineers now given to all buyers of this famous Cyclopedic of Electricity.]

AMERICAN TECHNICAL SOCIETY
(Publishers—Home Study Courses)

American Technical Society, Dept. E319, Drexel at 58th St., Chicago

Send for 10 days' free use, 10 volume set of Applied Electricity. You also agree to send me a certificate entitling me to consulting privileges for one year. I will pay the delivery charges only on the books. If I wish I may return them in 10 days and owe you nothing, but if I keep them, I will send \$2.00 after 10 days, then \$3.00 a month until the total price of only \$29.80 is paid.

NAME

ADDRESS

CITY

STATE

Please attach letter stating age, occupation and name and address of employer and give at least one business man as reference.



MACHINE SHOP MEN

Learn to set up and run ANY kind of machine; MAKE MORE MONEY NOW by learning quickly HOW TO DO THINGS which usually take years of study and practice. The demand for SKILLED men is ALREADY ahead of the supply, then what WILL IT BE a month or two from now?

Needed NOW!

Bigger Pay Don't miss this chance to qualify for promotion, don't miss this Big Opportunity which is yours almost for the asking. Eight Big Books checkfull of important mechanical facts told simply and clearly. Over 3000 pages, nearly 3000 illustrations cover every subject fully, including Tool Making, Pattern Making, Foundry Work, Mechanical Drawing, Forging, Machine Shop Practice and Management, and hundreds of other subjects.

8 Big Books (Up-to-date Edition) Sent FREE to you for examination. With them we send a Big Binder of nearly 800 pages with 267 original shop tickets with 1200 illustrations. These show, step by step, how to set up and run almost any kind of job and are in addition to the 8 books. Decide in your own home or place of business whether or not you want to keep them, check up on any facts you want to. Note their great MONEY MAKING value, then, if you want them, pay on the easiest kind of payments. A year's consulting privileges with our engineers now given with these books without extra charge.

American Technical Society, Publishers—Home Study Courses.

American Technical Society, Dept. 5319, Drexel at 58th St., Chicago
You may send me the 8 big books and binder of shop tickets for free examination. I will pay the delivery charges only, unless I decide to keep them in which case I will send \$2.00 in ten days and \$3.00 per month until the total price of only \$34.80 is paid. If I return them in 10 days I will owe you nothing. You also agree to send me a certificate entitling me to consulting privileges with your experts for one year without extra charge.

Name.....
Address.....
Please attach a letter stating age, occupation, employer's name and address and that of at least one business man as reference.

PLUMBERS & STEAM FITTERS

Audels Plumbers and Steamfitters Guides



4 Vols. \$6
A practical, illustrated, Reference Library and Study-Course for Master Plumbers, Journeymen and Apprentice Steamfitters, Gas Fitters and Helpers, Sheet Metal Workers, Draftsmen, Master Builders, Engineers and all Building Trade Students. This valuable set of handy, pocket-size Guides explains in practical concise language and well-done illustrations all the principles, advances and short cuts of the Plumbing and Heating trade—based on modern practice. Contains careful, detailed instructions

on how to figure and estimate various jobs. Use FREE COUPON below to examine, without obligation, this valuable work.

INSIDE TRADE INFORMATION ON:

Soldering, tinning, joint wiping, bending, beating. Pipe—iron—steel, threading. Mathematics, tables, physics. Materials—iron, steel, copper, brass, lead, tin, antimony, etc. Sheet metal—galvanized—plate. Sanitation, siphonage, tanks. Drainage, sewage, purification. Fixtures—bath—kitchen. Pipe fittings, soil pipe, tools. Laying out work. Roughing. Screwed fittings, flanges, joints. Pipe bending, examples. Elbows. Heating, ventilation, air conditioning, refrigeration. Water supply, mains, wells, tanks. Gas-fittings. Sheet metal work, problems, methods. Bracing, heating, lead burning. Welding, various welds, methods. Blacksmithing, forges, tools. Air Conditioning.

THEO. AUDEL & CO., 49 W. 23rd St., New York City

Mail Audels Plumbers Guides, 4 vols., on 7 days' free trial. If O. K. I will remit \$1 in 7 days, and \$1 monthly until \$6 is paid. Otherwise I will return them. No obligation unless I am satisfied.

Name.....
Address.....
Occupation.....
Reference..... P.M.



POPULAR INVENTIONS

For Your Home

21366 (Continued from page 22A)

Coiled Taper in Candleholder Is Unwound as It Burns



Storing a yard-long taper coiled about a metal pin, a candleholder supplies many hours of light. As the tallow burns away, the taper may be fed upward by turning a crank.

21187

Cake Knife With V-Shaped Blade Lifts the Piece It Cuts

Bent in the form of a "V," the blade of a new cake knife cuts a wedge from a cake in one stroke, and then by squeezing the tonglike handle you can pick up the piece intact. Slices can be cut smaller by applying pressure on the handle.

(More Popular Inventions and Index on page 46A)

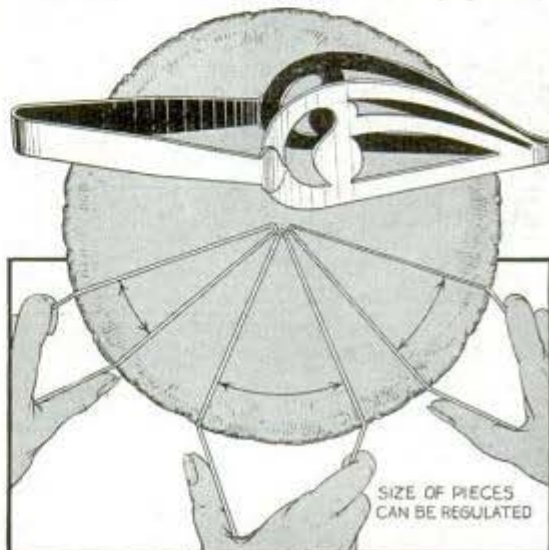

SIZE OF PIECES CAN BE REGULATED

Mandel Bros
POPULAR MECHANICS
Chicago

DEFENSE PRODUCTION

.. a golden opportunity for

INVENTORS

Read this quotation which was lifted directly from a recent issue of a daily newspaper. If you happen to be one of the 30,000 who submitted your invention and had it refused—don't be discouraged. Many of those inventions doubtless have immense commercial possibilities right now in American industry although they are at present not usable by the U. S. Army and Navy.

America's Defense Production program presents a golden opportunity for inventors with practical, workable ideas. Manufacturers are crying for speed—and more speed—for substitute materials—for short cuts in operations and improvements in production machinery. In every home, government priority is fast forcing housewives to use substitutes and makeshift devices in place of ordinary household items now unobtainable. Every walk of life is offering unlimited possibilities to the ingenious, capable, common-sense inventor. And—don't forget—the new materials and devices adopted now because of necessity will be preferred after this emergency has passed—and will become necessities in our daily lives. If the Army and Navy cannot make use of your invention, possibly **Industry can.** And the time to act—to safeguard your idea for commercialization—is **NOW!**

"Little Ideas" of the Average Man often highly successful

Yours doesn't have to be a big, revolutionary idea to be successful. Thousands of "little ideas" conceived by men in everyday walks of life have made them fortunes. The simple paper clip has made its inventor fabulously wealthy; the crinkly hairpin was patented by an "average" husband who never once thought of himself as an inventor;

This is one of the world's largest firms of Registered Patent Attorneys—Established 1898 — 44 years of helpful service to inventors.



68 pages of facts for
INVENTORS

... and the important
Evidence of Invention Form!

COUPON BRINGS YOU THESE 2 BOOKS **FREE!**

WASHINGTON DAILY NEWS

Oct. 1, 1941—"Col. L. B. Lent, chief engineer of the national inventors council, said that of some 30,000 inventions submitted to the Department of Commerce, about 100 had been turned over to the Army and Navy. Of these about a dozen are 'red hot' he said."

the idea of the compact hand camera came to a bank clerk; a dentist invented the stock ticker. Look around you—notice the devices that are sold every day over the 5 & 10c store counters—study the operations in your own office or shop for little improvements that could be made in equipment you're using constantly. Remember—it's often the "little idea" that holds the biggest commercial possibilities.

Protect your Invention with a U. S. Patent

We're ready to send you Free, these two valuable advisory books—"Patent Protection" and "When and How to Sell an Invention"—68 pages of helpful facts for inventors. They tell you clearly what your first steps are in applying for protection under the U. S. Patent Laws and how to commercialize your patent. Don't let another day go by without sending for these helpful books which may save you many dollars and valuable time. With the books we include also, a vitally important document—an "Evidence of Invention" form. Send for all three—Today.

ACT NOW DELAY MAY BE COSTLY

VICTOR J.
EVANS & Co.

Merlin M. Evans

REGISTERED PATENT ATTORNEYS

MAIN OFFICE: 630-C, VICTOR BUILDING,
WASHINGTON, D. C.

Pittsburgh Office: 521-N, Empire Building
Los Angeles Office: 738-N, Security Building

Rush by return mail, FREE copies of your books "Patent Protection" and "When and How to Sell an Invention"—also "Evidence of Invention" form.

Name.....

Address.....

City and State.....

NOT EVERYONE DOES AS WELL but—\$148 First Week GROSS IN HIS OWN BUSINESS

is what L. A. Rowe reports. We want reputable, honest men. You need no special experience but you must be industrious and courteous. We will help you get into a high-grade business of your own where you will be your own boss. No shop necessary. Rug Washer cleans rugs beautifully on customer's floor. Machine is very simple. Electricity does the work. Simply clean a few rugs. These customers tell others and give you their future work. There are hundreds of prospective customers in your vicinity and nearby towns. Send coupon for booklet explaining everything.

WHAT OTHERS HAVE DONE

The following instances of maximum gross earnings, for stated periods, by exceptional operators, are an indication of what can be done by a live-wire in his busiest seasons. These earnings do not reflect continuous operations and of course are not net. In addition to any other expenses a small amount should be allowed for depreciation and supplies.

\$148 first week. Had no job; now in own business doing fine—L. A. Rowe. Have had weeks close to \$400; sure glad I got machine—L. T. Jordan. Last month I took in \$779.81; my best day was \$57.48—G. E. Carpenter. Have had machine 3 months; 1st month \$25; next 2 about \$800—M. Gorski. My biggest month was \$500 to \$600 but can't do it every month—W. F. Baron. Past 6 weeks worked about 5 hours daily and did \$320—M. E. Pullen. Made \$150 in 2 days; going to Florida today on \$200 job—G. Sears. \$54.50 best day; had machine 3 years; am 71 years old—J. W. Benson. \$192.50 in 14½ days; have had machine 4 weeks—A. G. Bassinger. \$203.78 in 30 hours. Your method "Hit the spot" here—C. Lever. \$42.50 in 8 hours. Am very well pleased with machine—O. C. Dahl. Took in \$1,100 in 18 days; now have 3 machines—E. C. Thomas.

FREE BOOK—Mail Coupon NOW!

VON SCHRADER MFG. CO., 103 Pl., Racine, Wis.

Send at once (no obligation) your free booklet illustrating rug washer and telling how I can own my own permanent business; how I can earn large profits at prices below other methods; how I can become financially independent in a short time; and how I can pay on easy terms.

Name.....
Address.....
City..... State.....

"NEVER A COMPLAINT"

A. C. Canfield writes, "We have all the business we can handle—and not yet one complaint." That's the nicest part of this business—customers are more than satisfied.

Every Machine Guaranteed

These machines have been manufactured since 1918 and are used by many successful operators throughout the world. They are GUARANTEED.

EASY TERMS

The complete equipment is inexpensive. A reasonable down payment brings everything to you and the balance is paid monthly. From the start you have your own business—one that is profitable and of which you can be proud.

VON SCHRADER MFG. CO., 103 Pl., Racine, Wis.

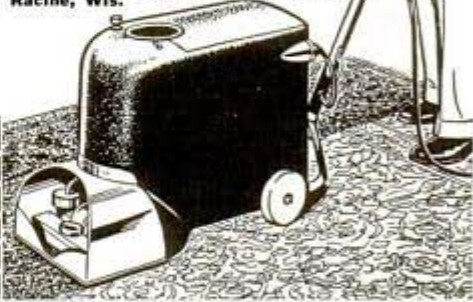

AVIATION

MORE DRAFTSMEN NEEDED on planes, motors, equipment. Big pay. Special *Aviation Drafting* course trains you QUICKLY at home in spare time. FREE Bulletin. No obligation. Address
American School, Dept. A-345, Drexel at 58th, Chicago

Short-Cut Mathematics

COMBINED WITH
Practical Mechanics Simplified

NEW 2-in-1 reading course! Now you can learn the speedy, simplified system of calculation used by draftsmen, engineers, accountants, "master minds" on the stage. Learn easy way to multiply 4 figures by 4 figures without using old-fashioned multiplication; add long columns of figures this lightning short-cut method. Learn horsepower, slide rule, micrometer, logarithms, wood measure, puzzles, etc., etc. Large illustrated volume complete with answers, only \$1 postpaid. Satisfaction or refund.

FREE Amaze friends with your magic-like mental powers. Complete details... mail coupon TODAY!

NELSON CO., 500 Sherman St., Dept. C300, Chicago
Please send free details about "Short-Cut Mathematics and Practical Mechanics Simplified." No obligation.

Name.....
Address.....

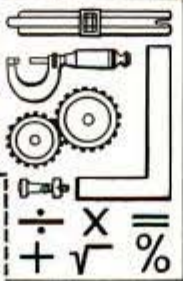

STUDY AT HOME

With A Chartered Educational Institution

Courses in Arts; Sciences; Philosophy; Education; Public Health; Medical Jurisprudence; Psychology; Sociology; Physics; Chemistry; Geology; Pol. Science; Theology; Law; Business Training; Accounting; Statistics; Agriculture. ENGINEERING. Electrical, Civil, Mechanical, Drafting, Architectural, Steam, Aeronautical, Radio, Structural, Industrial, Highway, Petroleum, Mining, Marine; Chemical Engineering. McKinley-Roosevelt Incorporated, 4610-UD, Sheridan Road, Chicago

LACO Oil Burners

18th Year!

Send postcard or letter for free folder and very low prices on LACO's Nu-Comfort Room Oil Heater, Gravity and Forced-Air Furnaces, Gun-Type Burner for furnaces. Newly improved. Clean, quiet, automatic. Thousands of users, everywhere. WRITE!

LACO OIL BURNER CO., 123 Union Ave., Griswold, Iowa

AUTO-MECHANICS & WELDERS

Auto Mechanics and Welders are in big demand. Complete courses in arc and acetylene welding, body and fender bumping, spray painting and metal finishing. Pay after graduation plan. Special low rates. Write today.

MICHIGAN TRADE SCHOOL
3748 Woodward Ave. Detroit, Mich.

FREE
32 PAGE
CATALOG

See you saw it in Popular Mechanics!



GEE what a build!
Didn't it take a long
time to get those muscles?

SHOWER

No SIR! - ATLAS
Makes Muscles Grow
Fast!

Will You Let Me PROVE I Can Make YOU a New Man?



CHARLES ATLAS

Awarded the title of "The World's Most Perfectly Developed Man" in international contest—in competition with ALL men who would consent to appear against him. This is a recent photo of Charles Atlas showing how he looks today. This is not a studio picture but an actual untouched snapshot.



LET ME START SHOWING RESULTS FOR YOU

5 inches of new Muscle

"My arms increased 1 1/2" chest 2 1/2", forearm 3/4"
—C. S., W. Va.

What a difference!

"Have put 3 1/2" on chest (total) and 2 1/2" expanded."
—F. S., N. Y.

Here's what ATLAS did for ME!

John Jacobs BEFORE **John Jacobs AFTER**

For quick results I recommend CHARLES ATLAS

"Am sending snapshot showing wonderful progress."
—W. G., N. J.

GAINED 29 POUNDS

"When I started, I weighed only 141. Now weigh 170."
—T. K., N. Y.

Here's What Only 15 Minutes a Day Can Do For You

I DON'T care how old or young you are, or how ashamed of your present physical condition you may be. If you can simply raise your arm and flex it I can add SOLID MUSCLE to your biceps—yes, on each arm—in double-quick time! Only 15 minutes a day—right in your own home—is all the time I ask of you! And there's no cost if I fail.

I can broaden your shoulders, strengthen your back, develop your whole muscular system INSIDE and OUTSIDE! I can add inches to your chest, give you a vise-like grip, make those legs of yours lithe and powerful. I can shoot new strength into your old backbone, exercise those inner organs, help you cram your body so full of pep, vigor and red-blooded vitality that you won't feel there's even "standing room" left for weakness and that lazy feeling! Before I get through with you I'll have your whole frame "measured" to a nice, new, beautiful suit of muscle!

What's My Secret?

"Dynamic Tension!" That's the ticket! The identical natural method that I myself developed to change my body from the scrawny, skinny-chested weakling I was at 17 to my present super-man physique! Thousands of other fellows are becoming marvelous physical specimens—my way. I give you no gadgets or contraptions to fool with. When you have learned to develop your strength through "Dynamic Tension" you can laugh at artificial muscle-makers. You simply utilize the DOR-

MANT muscle-power in your own God-given body—watch it increase and multiply double-quick into real, solid LIVE MUSCLE.

Only 15 Minutes a Day

My method—"Dynamic Tension"—will turn the trick for you. No theory—every exercise is practical. And, man, so easy! Spend only 15 minutes a day in your own home. From the very start you'll be using my method of "Dynamic Tension" almost unconsciously every minute of the day—walking, bending over, etc.—to BUILD MUSCLE and VITALITY.

FREE BOOK

"Everlasting Health and Strength"

In it I talk to you in straight-from-the-shoulder language. Packed with inspirational pictures of myself and pupils—fellows who became NEW MEN in strength, my way! Let me show you what I helped THEM do. See what I can do for YOU! For a real thrill, send for this book today. AT ONCE. CHARLES ATLAS, Dept. 8R, 115 East 23rd St., New York City.

**CHARLES ATLAS, Dept. 8R
115 East 23rd St., New York, N. Y.**

I want the proof that your system of "Dynamic Tension" will help make a New Man of me—give me a healthy, husky body and big muscular development. Send me your free book, "Everlasting Health and Strength."

Name
(Please print or write plainly)

Address

City..... State.....

Do you want

- ➔ .. to go to College?
- ➔ .. or to enter a Profession?
- ➔ .. or get an Office Position?

(Such as Accounting, Architecture, Nursing, Dentistry, Teaching, Social Work, Osteopathy, Beauty Culture, Optometry, Embalming, Chiropody, Law, Medicine, etc.)

To get anywhere, you practically MUST finish High School FIRST. You can complete our simplified High School Course in SPARE time at home, as FAST as your time and abilities permit. Equivalent to resident school work—prepares you for college, pre-professional examinations, business, industry. Standard texts furnished. Diploma. Credit for H.S. subjects already completed. Single subjects if desired. Low tuition, easy terms. American School, Chicago, est. 1897—endorsed by educators. Finish your high school education NOW. Write TODAY!

High School Course at Home

Many Finish in 2 Years

American School, Dept. H345, Drexel Ave. at 58th St., Chicago, Ill.

Gentlemen: Send me FREE information covering special training in subjects checked below. No obligation on my part.

- | | |
|--|---|
| <input type="checkbox"/> High School Course | <input type="checkbox"/> Diesel Engineering |
| <input type="checkbox"/> Accounting and Auditing | <input type="checkbox"/> Drafting and Design |
| <input type="checkbox"/> Architecture and Building | <input type="checkbox"/> Liberal Arts |
| <input type="checkbox"/> Automotive Engineering | <input type="checkbox"/> Private Secretary |
| <input type="checkbox"/> Business Management | <input type="checkbox"/> Mechanical Engineering |
| <input type="checkbox"/> Aviation | <input type="checkbox"/> Radio and Television |
| <input type="checkbox"/> Electrical Engineering | <input type="checkbox"/> Salesmanship |
| <input type="checkbox"/> Elec. and Gas Refrigeration | <input type="checkbox"/> Business Law |
| <input type="checkbox"/> Air Conditioning | <input type="checkbox"/> Retail Merchandising |

Name

Address

NEWS

Increased production means



More Jobs for MACHINISTS and bigger pay for men who know their work

This home-study course gives you the practical facts on modern machines, up-to-date methods, you need to advance in machine shop work. Take advantage of the other man's experience as found in books, to solve your problems, increase your efficiency, with

The AMERICAN MACHINISTS' LIBRARY

6 volumes—2368 pages—2516 illustrations

(A combined home-study course and reference library)

This library of machine shop practice was written for practical men. It gives you the best methods for every kind of machine shop work. It fully explains lathes, drills, and other machine tools and their operation, automatic screw machines, speeds and feeds, gear design and production, jigs and fixtures, punch and die work, metal surfacing, etc., etc. Plainly written—completely illustrated—the best kind of help to the machine shop man who wants to advance himself.

No money down—special price—easy payments.

EXAMINATION COUPON

McGraw-Hill Book Co., 330 W. 42nd St., New York

Send me for ten days' examination the American Machinists' Library. If satisfactory I will send you \$1.50 in 10 days and \$3.00 monthly until the price of \$10.50 is paid. If not wanted, I will return the books postpaid. (To insure prompt shipment write plainly and fill in all lines.)

Name

Home Address

City and State

Position

Name of Company



Easier THAN EVER

To Master, this New 1942 P-A 21 Major Improvements

*Just touch a key and blow normally; you can't miss. So easy, and such beautiful tone. Nothing to compare with these new P-A Saxes, Clarinets, Trumpets, and other P-A instruments. Fully guaranteed; your success assured. See your music dealer or write direct for beautiful FREE BOOK. No obligation. Easy terms. Greatest fun, easiest with P-A. PAN-AMERICAN 1420 303 P-A Bldg. Elkhart, Ind.

Have You Tried a P-A in the Last 30 Days?

GET THIS GREAT CATALOG OF MAGIC



Amazing tricks, mystifying and spooky stage and party illusions. Easy to do—no skill—perfect instructions. Fool your friends. Loads of fun. Add 'life' to any party. 256 pages. 550 illustrations. Mail 50 cents for catalog, credited on your first order for \$3.00 or more.

NATIONAL MAGIC COMPANY Studio 309, 119 S. State St., Chicago, Illinois

Be a DRAFTSMAN-Designer

Prepare for Essential work—get into Big Pay Industry through Drafting and Design. There is need for well trained Draftsmen to meet Industrial and Defense demand. Get Practical Work Training from an Engineer at your home—until competent, and holding a good pay position. Tools furnished with training at reasonable cost. Write today for full details. State your age.

ENGINEER DOBE, DIV. 3373, LIBERTYVILLE, ILLINOIS



Auto-Diesel

Master a real trade. Auto Mechanics, Diesel Mechanics, Air Welding, Acetylene Welding, etc. Let us train you to be an expert Auto-Diesel Mechanic and help you get a good job. The cost to you is reasonable. Learn on modern equipment with tools under experienced instruction. Real shop work. Steam heated buildings. Rooms and board in our steam heated dormitory. We pay your fare to Nashville. For free catalog write.

Nashville Auto-Diesel School, Dept. 75 Nashville, Tenn.



THERE'S MONEY IN CARTOONS!

RAYE BURNS will teach you HOW to CREATE ORIGINAL CARTOONS at home that you may SELL! Course contains 26 lessons and over 600 illustrations. All for Only, . . . \$2.85

Send name and address for free details.

RAYE BURNS SCHOOL, Dept. M, Box 3583, CLEVELAND, OHIO

5¢ EACH LITTLE BLUE BOOKS

Send postcard for our free catalogue. Thousands of bargains. Address: HALDEMAN-JULIUS CO., Catalogue Dept., Desk M-859, GIRARD, KANSAS

EARN THE DEGREE Doctor of Psychology (Ph.D.), Doctor of Divinity (D.D.), many others. Courses in business, accounting, law, etc. Low fees. Send for large Bulletin and student picture-folder AT ONCE. No obligation whatever.

TEMPLE BAR EXTENSION COLLEGE 1411 Fourth Avenue, Dept. 4-R, Seattle, Washington, U. S. A.



LOOK! Baby Chicks

THOUSANDS WEEKLY ALL YEAR. Finest quality & Layers in 40 breeds. Hybrid Baby Pullets and Cockerels, B. W. D. Tested, Ducklings, Goslings, Baby Turkeys, Guineas. In business 30 years. Catalog free. ORDER NOW. Make BIG money raising NABOB QUALITY CHICKS. NABOB HATCHERIES. BOX M. GAMBIER, OHIO

we-do-it-with SQUABS

Raised in ONLY 25 DAYS. Why breed for small-profit trade when luxury markets want all the squabs you can ship, every day in year? NEW BOOK tells how, pretentious detailed accounts of large profits. Send 3c stamp for mailing, ask for FREE eye-opening book. RICE FARM, 640 H St. MELROSE, MASS.



MAKE POULTRY PAY YOU A GOOD LIVING FOR LIFE



POULTRY RAISING PAYS GOOD PROFITS FOR THOSE WHO KNOW ITS SECRETS

Healthful, interesting occupation for whole or part time in country, village or city suburbs. Open to young and old. With independence of low wages, uncertain employment, un congenial labor, with a Poultry Business of your own.

PROVED METHODS BRING SUCCESS FROM START

Harry M. Lamon, nationally known Poultry Expert, former Senior Poultryman U. S. Dept. of Agriculture, quickly trains ambitious men and women for Poultry Success from start. His famous Home Study System, endorsed by thirty leading Agricultural schools. Fascinating study, easy to learn, complete in every detail, shows valuable success secrets used by leaders, how they avoid losses. How to start in small way. Make business grow from sale of Poultry, Eggs and Baby Chicks. Big, ever increasing demand. Or prepare for a good job in large poultry plant. Established nearly twenty years—a multitude of graduates attest the success of his time-tested methods.

Mr. Harry Lamon has prepared a big 32 page illustrated book "How to Raise Poultry for Profit", telling how you can attain success in the poultry business. He offers to send it free to anyone interested in learning the splendid money-making opportunities in Poultry Raising. If you are "not sure" on your future, send for this Free Book—today.

Address: Harry M. Lamon, President, NATIONAL POULTRY INSTITUTE, Dept. 50-7 Adams Center, N. Y.

FREE BOOK TELLS HOW

A multitude of poultry-raisers large and small are making money in this most interesting and profitable occupation. Whether you have ever kept chickens or not—whether you have ten hens or ten hundred, you should read this FREE BOOK. It's yours for the asking.



IMPORTANT Message To INVENTORS

We Will Send You Our

FREE BOOK

"HOW TO PROTECT YOUR INVENTION" and Invention Record Form



Our laws favor the inventor who makes a dated record of his invention, and

who is diligent in filing his patent application. You owe it to yourself, if you value your invention, to make an accurate, dated, and witnessed record of your invention, and then take steps to apply for a patent just as quickly as possible.

PERSONAL SERVICE

Hence, our service can be important to you: As soon as you write us, we send, by return mail, an "Invention Record" form for you to fill out. And then, when you return it to us, our prompt and personal service begins: We personally direct the search of the Patent Office Records. Personally supervise the preparation and filing of your application and the handling of your case. There is no lost motion, no lost time.

PATENT AND SELL YOUR INVENTION

We handle your case skillfully and thoroughly with a view to securing the best possible patent for you—giving you the full benefit of our training as patent attorneys and our years of experience serving hundreds of inventors. We make personal calls at the Patent Office when required. And beyond this, we will endeavor to give you useful hints and suggestions on selling your invention.

WRITE US TODAY...

When your invention comes to us it is strictly confidential. All correspondence is handled personally by us. We take a personal interest in your success, so you can write us fully.

IMPORTANT TO GET STARTED RIGHT

Know how the laws protect you, and what steps to take. We will send you Complete FREE Booklet "How to Protect Your Invention", and FREE "Invention Record" Form. Write us, or mail this coupon today—McMorrow and Berman, Registered Patent Attorneys, 135-X Barrister Building, Washington, D. C.

MAIL COUPON NOW

Correspondence Courses in RADIO and ELECTRICAL ENGINEERING LOW AS \$25

ELECTRICAL ENGINEERING. Get good grasp of wide electrical field. Modern. Very understandable. Theory made easy. **RADIO ENGINEERING.** Extra size course in radio, tubes, address, photo-mechanic work. Train you to an super-service man, real vacuum tube technician. Tuition ONLY \$25, either course. Deferred payment plan. Experiment kits furnished. Write for free copies of school catalogs, student magazines, etc. **FREE LINCOLN ENGINEERING SCHOOL, Box 931-P-39, Lincoln, Nebr.**

Free WELDING



Welding offers immediate opportunities for better pay. Learn at home in spare time. Dynamic electric welder furnished for home use. Intensified shop training later. Also day and evening classes. Send for free trial lesson.

CHICAGO TECHNICAL COLLEGE
C-602, Tech Bldg., 2000 S. Mich. Ave., Chicago, Ill.

BECOME AN EXPERT MEAT CUTTER



Greater opportunities! Thousands of firms are needing expert Meat Cutters. Train in 6 weeks at famous National School. It's quick, easy to learn Meat Cutting by ACTUAL PRACTICE in big National cutting rooms and retail department. No previous experience or advanced education necessary. **NO PAY UNTIL** Union card guaranteed. Employment service FREE. Train free. Pay later. Easy terms. Write TODAY for FREE catalog and plans to help you get ahead!

National School of Meat Cutting, Inc., Dept. U-28, Toledo, Ohio

42nd YEAR ENGINEERING DEFENSE COURSES

Short, intensive Defense courses in Aircraft, Sheet Metal, Mechanical, Structural, Architectural Drafting; Electricity; Power Plant; Arc, Aircraft Welding. One and Two-Year courses in Aeronautical, Electrical, Mechanical, Structural, Architectural, Civil Engineering. B.S. Degree 3 Yrs. Low tuition and living costs. Part-time work for room and board. Thousands successful graduates. Extensive equipment. Theory and practice. Non-essentials omitted. No home study courses. Catalog free.

FINLAY ENGINEERING COLLEGE
1001 Indiana Ave., Kansas City, Mo.

McMORROW & BERMAN

REGISTERED PATENT ATTORNEYS BEFORE U. S. PATENT OFFICE
135-X Barrister Building Washington, D. C.

Send me your NEW FREE Book "How to Protect Your Invention" and specially prepared "Invention Record" form at once. I understand that this request does not obligate me.

Name.....
Address.....
City..... State.....

Write or Print Name Clearly

TRAINED MEN NEEDED IN ELECTRICITY AND RADIO

"LEARN BY DOING" IN THE
FAMOUS COYNE TRAINING SHOPS

"I'LL FINANCE YOUR TRAINING"

PRACTICAL TRAINING ON FULL SIZE
EQUIPMENT. NO PREVIOUS EXPERIENCE
OR ADVANCED EDUCATION NEEDED.
MAIL COUPON NOW FOR BIG FREE
BOOK. LEARN ABOUT THE "DAY
AFTER GRADUATION PLAN" "PART
TIME EMPLOYMENT PLAN" AND
"JOB AFTER GRADUATION SERVICE."

MAIL COUPON TODAY FOR BIG FREE
BOOK AND ALL THE DETAILS ABOUT
COYNE TRAINING AND THE OFFER I'M
MAKING TO HELP FELLOWS GET AHEAD.

H. C. LEWIS, PRES. COYNE ELECTRICAL SCHOOL
500 SO. PAULINA ST. CHICAGO

CHICAGO, ILLINOIS, DEPT. 32-72H
SEND FREE BOOK AND ALL THE FACTS
ON COURSE CHECKED BELOW.

ELECTRICITY RADIO

NAME -----
ADDRESS -----
CITY ----- STATE -----

MECHANICS

KNOW
YOUR
CAR

NEW FLUID
DRIVE FULLY
EXPLAINED

Ask
to
See it!

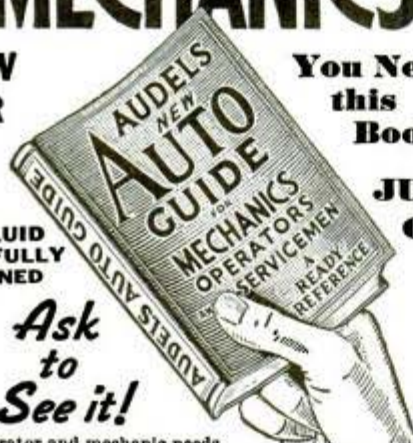

You Need
this
Book

JUST
OUT!

Every operator and mechanic needs
AUDELS NEW AUTO GUIDE. This book saves time, money and
worry. Highly endorsed. It presents the whole subject of auto
mechanics: 1—Basic principles, 2—Construction, 3—Operation, 4—
Service, 5—Repair. Easily understood. Over 1500 pages—1540 illus-
trations showing inside views of modern cars, trucks and buses
with instructions for all service jobs. Diesel Engines fully treated,
fully illustrated. To Get This Assistance for Yourself Simply
Fill In and Mail Coupon Today.

4 COMPLETE • PAY ONLY \$1. A MONTH ←

THEO. AUDEL & CO., 49 WEST 23rd STREET, NEW YORK
Please send me postpaid AUDELS NEW AUTOMOBILE GUIDE (\$4) for free exam-
ination. If I decide to keep it, I will send you \$1 within 7 days; then remit \$1 monthly
until purchase price of \$4 is paid. Otherwise, I will return it to you promptly.

Name -----
Address -----
Occupation -----
Reference ----- P.M.

Make Your Own MODERN Furniture



Here's a complete, new book
of instruction that tells how,
Written by leading authority,
it's the most thoro and prac-
tical book of its kind. Includes
working drawings, description
of parts, bill of materials and
step-by-step directions for
making each piece. Chapters on
woodfinishing include blonde
finishes. Clear, simple, non-
technical. Designs are origi-
nal, authentic moderns.

Order Now—postage prepaid if
cash with order.

POPULAR MECHANICS PRESS
Dept. 367, 202 E. Ontario,
Chicago

250 pages, 8 1/2 x 11, Cloth \$3.00
Sold on Money-Back Guarantee

AIRCRAFT WELDING ENGINEERING

Defense Industries offer Outstanding
Opportunities to properly trained Weld-
ing Technicians (1 year), Aircraft
Draftsmen (1 year), Aircraft Welders
and Arc Welding Operators (3 months).
Learn by Doing. "Ask how to earn
\$1040 while learning."—Write for free
64-page Illustrated Book—"Dawn Of
A Giant Industry." Mention course de-
sired.

MILWAUKEE SCHOOL OF ENGINEERING
P.M. 342-N, Broadway & E. State, Milwaukee, Wis.



Always write your name and full address
clearly when answering advertisements.



FREE BOOKLET answers the many questions bound
to be in your mind about where you stand in relation
to the war—about how you can serve your country
well, and still plan for a secure, successful future. It
tells why YOU—by entering the aircraft industry—
can be NECESSARY to your country's victory. For
your free copy of this helpful booklet, airmail your
request NOW to

AERO INDUSTRIES TECHNICAL INSTITUTE
5253 W. SAN FERNANDO RD., LOS ANGELES, CALIF.

MAKE YOUR OWN
POWER TOOLS
at Low Cost
from old Auto Parts, etc.



New Book Will Save Hundreds of Dollars
Shows How to Make Forty Tools

Now you can have a good lathe, drill
press, circular and band saw and other
power tools in your home workshop, at
a cost of only a few dollars each. Make
them yourself from old auto parts, dis-
carded sewing machines and other odds
and ends that cost little or nothing. Get
this new book—"Forty Power Tools You
Can Make." Costs only \$1.25 postpaid.
This book gives every detail in plain language
you can understand and follow. Hundreds of pic-
tures and plans show every step to follow in
making the power tools you want. Actual pho-
tographs of finished machines included. Send
\$1.25 today. Money back if not satisfied.



MAKE EVERY POWER TOOL NEEDED IN YOUR HOME WORKSHOP

Some of the power tools you can make are:

2 Band Saws	2 Drill Presses
9 Sanding Machines	1 Scroll Saw
2 Circular Saws	2 Wood Turning Lathes
1 Metal Lathe	3 Grinders
1 Power Hack Saw	1 Shaper or Moulding Machine
1 Jig Shears	1 Vibrating Pencil
1 Cut-Off Wheel	and others

Information too, about pulleys, belts, motors and drive methods.
Just published. No other book like it. Order today.

POPULAR MECHANICS PRESS

Dept. 371

200 E. Ontario Street, Chicago

Learn Turret Lathe Operation!

Send for the New **TURRET LATHE OPERATOR'S MANUAL**

Offered as the Most Authentic and Complete Text Book on Turret Lathes and Turret Lathe Operation

Every man interested in metal turning—old-timer, learner, apprentice, student—can improve his knowledge and handle tooling setups and metal turning jobs more effectively after reading this authoritative volume. Written expressly for shopmen by men who have spent the greater part of their lives in building, operating, and improving turret lathes and turning methods. Easy to read. Easy to understand. Covers all phases of metal turning. Explains methods. Suggests short cuts. Contains tables on feeds, speeds, tool angles, threads. A de luxe edition sold far below cost by America's largest manufacturer of turret lathes.



240 Pages!
Over 350
Illustrations
and Drawings
Only \$1.00 Postpaid in U. S. A.
Elsewhere \$1.50

Operators' Service Bureau of THE WARNER & SWASEY COMPANY • Cleveland, Ohio, U. S. A.
I am enclosing \$_____ for an Operator's Manual.

Name _____
Address _____
c _____

Mail your order

FISHING TACKLE

ALL SPORTING GOODS
LOW PRICES



For sportsmen, big Free 148-page Catalog and Fisherman's Guide. Contains Fishing Calendar. Every item top quality; money-back guarantee. Fishing Tackle, Baseball, Golf, Tennis, Archery, Guns and Clothing. Typical values—

\$7.00 Split Bamboo Fly Rod, 2 tips	\$4.45
\$4.50 One-Piece Solid Steel Casting Rod	\$2.88
\$4.25 Automatic Fly Rod Reel	\$2.65
\$1.55 Nylon 25 yard Fly Line—Light Amber	98¢
\$1.35 Nylon 50 yard Casting Line	89¢
\$1.20 Asst. of Bass, Spinner & Bucktail Flies	65¢
\$1.25 Bleeder Casting Bait with 12 tablets.	35¢

Free Catalog Send today for big illustrated Catalog with hundreds of bargains to save you real money. WRITE TODAY for FREE 148-PAGE CATALOG. **GATEWAY SPORTING GOODS CO.** 840 Gateway Bldg., Kansas City, Mo.

DRAFTSMEN NEEDED NOW



Industry is clamoring for more draftsmen, for the job can't start until plans are drawn. Buildings, airplanes, machines, guns, tanks, bridges, all start on the drafting board, so it's no wonder that every good draftsman has a fine job. Yes, more draftsmen are needed NOW. The pay is good and the opportunities for advancement great.

Learn at Home in Spare Time

Begin now to turn spare hours into money. Be a draftsman, the connecting link between a mechanic and an engineer. Enjoy the wonderful opportunities for promotion that exist now. No experience or artistic talent is needed. You don't have to leave your present job while learning. Use spare time.

Employment Service Included

Students who take our home study drafting course are entitled to our employment service without extra charge. We are in constant touch with many great firms needing men, and in times like these Industry welcomes applications from American School advanced students and graduates. The total tuition cost is low and the monthly payments are easy. Write today for free bulletin outlining our instruction and giving you the details of our selective employment service. No obligation of any kind. Write today.

AMERICAN SCHOOL
Drexel Avenue at 58th St. Dept. DD345 Chicago

RADIO ENGINEERING, broadcasting, aviation and police radio, servicing, marine and Morse telegraphy taught thoroughly. 48 weeks' engineering course equivalent to three years' college radio work. School established 1874. All expenses low. Catalog free. **The Dodge Institute, Dept. D, Valparaiso, Ind.**

I'LL GIVE YOU this fine Suit



FREE of a penny's cost as soon as you sell six

Amazing Bonus Suit plan adds to Big Cash Profit of Strong salesmen. Learn how YOU can get your full share of easy profits caused by rush to buy while wool is still available. Get BIG CASH COMMISSIONS and YOUR OWN FINE TAILORED-TO-MEASURE SUIT FREE AS EXTRA BONUS with every SIX you sell neighbors and friends. Write TODAY. Reserve territory. Get FREE Sales Outfit.

Herbert A. STRONG Tailoring Co.
2242 Wabansia Chicago, Ill.

STUDY ENGINEERING AT HOME

With A Chartered Educational Institution

Courses in ENGINEERING: Electrical, Civil, Mechanical, Drafting, Architectural, Steam, Aeronautical, Radio, Structural, Mining, Industrial, Highway, Petroleum, Marine, Chemical Engineering, Arts, Sciences; Philosophy; Education; Public Health; Medical Jurisprudence; Psychology; Sociology; Physics; Chemistry; Geology; Pol. Science; Theology; Law; Agriculture; Business Training; Accounting; Statistics. McKinley-Roosevelt Incorporated, 4610-TD, Sheridan Road, Chicago

LEARN A BIG PAY TRADE

in 2 to 8 WEEKS!

We Pay Room and Board

To meet the great demand for men at high wages, we have inaugurated intensive training courses in the trades listed here. Learn in 2 to 8 weeks by actual shop work. One of America's leading schools. Established 1902. 7 floors of shops. Many employers send their young men here for intensive training. Free employment service.

GREER SHOP TRAINING

Dept. 232, 2024 S. Wabash Ave., Chicago, Ill.

Send "Shop Training Facts" describing trade checked below:

- | | |
|---|---------------------------------------|
| <input type="checkbox"/> Auto-Diesel | <input type="checkbox"/> Body-Fender |
| <input type="checkbox"/> Welding | <input type="checkbox"/> Machine Shop |
| <input type="checkbox"/> Refrigeration | <input type="checkbox"/> Tool and Die |
| <input type="checkbox"/> and Air Conditioning | <input type="checkbox"/> Aviation |

Name _____

Address _____

Age _____

PATENTS

Booklet Free Highest References
Promptness Assured Best Results

Send drawing or model.

ALL BUSINESS GIVEN PROMPT AND PROPER ATTENTION

Listed Patent Lawyer in the latest editions of the Rand-McNally Directory of Bankers and Bank-Recommended Attorneys, published by Rand-McNally & Co., Chicago, Ill.; American Lawyers Annual, Cleveland, Ohio; Bankers Service Legal Directory, published by Bankers Service Co., Boston, Mass.; and the Snow-Church Directory Co. Lawyers List, published in New York City.

WATSON E. COLEMAN, Victor Building, 724 Ninth Street, N. W.
REGISTERED PATENT LAWYER **WASHINGTON, D. C.**

INVENTORS PATENT YOUR IDEAS SEND FOR FREE BOOK



HOW TO OBTAIN A PATENT

Written by a Former Member of the Examining Corps (1922-24) of the U. S. Patent Office. If you want to profit by your idea, you should take steps to apply for a U. S. Patent at once. Your first step is to get this Free Book. This interesting illustrated book contains valuable information you should have. It tells you fully how to obtain a patent on your idea in the quickest way. With this Free Book you will also receive a "Record of Invention" form on which you can easily record your idea. Personal and Confidential Service: Your case will be personally handled only by a Registered Patent Attorney who is also a Former Member of the Examining Corps of the U. S. Patent Office. All communications confidential.

MAIL COUPON TODAY for FREE PATENT BOOK and RECORD OF INVENTION Form.

CARL MILLER
REGISTERED PATENT ATTORNEY
FORMER MEMBER EXAMINING CORPS U. S. PATENT OFFICE

Woolworth Bldg., 35th Floor, Dept. 32-A, New York City
MILLER BUILDING, Dept. 32-A, WASHINGTON, D. C.

Please send me your Free Book, "How to Obtain a Patent," and your "Record of Invention" form.

NAME.....

ADDRESS.....

PATENTS—TRADE MARKS

All cases submitted given personal attention
Form "Evidence of Conception" with instructions
for use and "Schedule of Government
and Attorneys' Fees"—FREE!

LANCASTER, ALLWINE & ROMMEL
Patent Law Offices

412 Bowen Bldg. Washington, D. C.

BE PREPARED! SHOOT NEW BENJAMIN TARGET PISTOL



NEW Streamlined Hand Pump
—Longer Shot Barrel—Larger Grip—
More Power—Accurate—Practical—
Economic—Safe—Clean—Quiet.
No smoke or fumes. **Bolt Action—**
Hammer Fire—Hair Trigger—Safety
Lock. Single Shot BB with 1 lb. shot
\$9.00, Single Shot Cal. .177 or .22 rlfed—
with 300 pellets \$10.50; Holder \$2.00. Also a complete line of Benjamin Genuine
Compressed Air Rifles for BB and Cal. .177 or .22 pellets. No license required. Ask your
dealer for a demonstration. Write today for complete specifications and free targets.
BENJAMIN AIR RIFLE CO., 890 Marion St., St. Louis, Mo., U. S. A.

ELECTRICITY MEN NEEDED

Electricians are needed everywhere. Hollywood studios alone claim shortage 200 men. This is a live money making profession. Learn at home, spare time. Easy payments. Selective Employment service. Write for FREE Bulletin. No obligation.

AMERICAN SCHOOL

Dept. EE345 Drexel at 58 St., Chicago

HELP DEFENSE—PROFIT YOURSELF

Produce more eggs and chickens at new high prices. American Poultry Journal tells how. 5 years \$1.00, 6 months 10c. Coin or Stamps.
American Poultry Journal, 552 S. Clark, Chicago



52 BREDS BERRY'S New POULTRY BOOK



BERRY'S Champion-Mated, Hand-Picked CHICKS, also SEXED, STARTED, 52 Breeds, 7 HYBRIDS, TURKEY POULTRY. All Iowa Imported, BWD Tested. Over 400 Prizes—30 Shows! LOW PRICES. In Business 45 years. Beautiful POULTRY BOOK FREE, stamps appreciated. BERRY'S POULTRY FARM, Rt. 29, CLARINDA, IOWA



NEW POPULAR MECHANICS BOOK CATALOG

Give yourself the lift you need with pay-raising, extra money books. Every man who reads Popular Mechanics will want this new, big illustrated catalog of the world's BEST practical books on trades, professions, opportunities, crafts and hobbies. You must see it to appreciate its value. Send your name and address on penny post card. Do it today.

SEND YOUR
NAME TODAY

POPULAR MECHANICS PRESS
Dept. 372, 200 E. Ontario St., Chicago

Say you saw it in
POPULAR MECHANICS

To PROTECT YOUR INVENTION—Use this coupon, NOW

Delays are dangerous and may be very costly. My personal service assures prompt action, strict confidence, and a minimum of expense. I suggest that you send me a model or drawing, or sketch and description of your invention, and \$5.00. I will make a search and report

promptly as to its patentability and send you a copy of my 72-page booklet. Or, if you prefer to read my booklet first, mail the attached coupon at once. I will also send my "Record of Invention" form. (Over 38 years experience as a Registered Patent Attorney.)

L. F. Randolph, 302-D Victor Bldg.,
Washington, D. C.
Please send me at once, free of charge, your 72 page booklet and "Record of Invention" form.

Name.....

Address.....

A PERSONAL CONFIDENTIAL PATENT SERVICE—

PAY-RAISING — EXTRA MONEY BOOKS

Use these books to prepare for a better job—bigger pay—to start a profitable spare time or full time business of your own. Popular Mechanics specializes in supplying outstanding new books of merit appear, we will revise this list.

- BUILDING INSULATION (new)**
Covers heat and sound \$3.00
- FORTY POWER TOOLS**
(Just Published)
Build over saw, drill, lathe, sander, etc. from scraps—save money \$1.25
- SHOP NOTES LIBRARY**
Five big volumes including new 1942 edition (224 pages—28 in color); over 1500 articles on money-making & money-saving ideas \$2.45
- WELDING, BRAZING AND SOLDERING (Ready March 1st)**
How to build and use arc, spot welders; tricks of soldering \$1.25
- RUNNING A MILLING MACHINE (new)** \$1.50
- MOTOR'S FACTORY SHOP MANUAL (1942 ed.)**
Covers 480 pas. cars, 350 trucks \$4.00
- HOW TO TRAIN SHOP WORKERS (new)** \$1.25
- FINANCING DEFENSE ORDERS** \$2.50
- GOD MECHANIC SELDOM GETS HURT**
Shop safety \$0.50
- PRACTICAL SHIP PRODUCTION (new ed.)** \$3.00
- FURNISHING HOME GROUNDS**
Build own garden furniture, etc. \$1.00
- A THOUSAND WAYS TO MAKE \$1.00**
Tested methods that work \$2.50
- TOOL DESIGN**
New book on production tools \$4.50
- TIN SMITH'S HELPER**
Seams, piping, gutters, etc. \$3.00
- MODERN REFRIGERATION**
Electric, gas. Be service expert \$5.00
- AUTO BODY AND FENDER REPAIRS**
Shows how to do professional job \$3.00
- DYKE'S AUTO ENCYCLOPEDIA (includes Diesels, airplane engines)**
World's greatest book for mechanics \$6.00
- SHEET METAL WORK**
Self instruction in all phases \$2.50
- ARMATURE WINDING**
Construction, winding, repairing AC & DC Motors, generators \$2.00
- BUILD YOUR OWN BOAT**
Just published. Describes 17 popular boats—rowboats, sailboats, plywood onboard, etc. 192 pages \$1.25
- FORGING PRACTICE** \$1.50
- HIGH SCHOOL SELF TAUGHT**
4 yr. course in one vol. \$1.89
- CARPENTRY & JOINERY**
Learn modern methods \$2.00
- FOUNDRY WORK** \$2.00
- WHAT TO MAKE**
3 Big Books, 588 pages of popular handicraft projects \$1.47
- PRACTICAL WOOD FINISHING**
Shows woods in full color, describes new finishes \$1.25
- MACHINE SHOP WORK**
Excellent book on approved methods \$2.75
- BLUEPRINT READING**
For machine trades \$1.50
- BLUEPRINT READING**
For building trades \$1.25
- PAINTING & DECORATING** \$1.50
- PATTERN MAKING**
Wood, metal \$2.00

- TOOL MAKING**
For beginners, advanced workers \$3.50
- FIVE ACRES AND INDEPENDENCE**
How to make money on small farm \$2.50
- KNOTS, TIES, SPLICES**
For everyone who uses rope \$1.00
- PLUMBING**
Designing and installing \$3.00
- ELECTRIC WIRING**
Includes estimating and new code \$2.50
- HOUSE CONSTRUCTION**
Gives every step in home construction \$2.89
- MACHINISTS' AND TOOL MAKERS HAND BOOK**
New 1600-page book, machine shop practice in all branches \$4.00
- FORD V8 CAR AND TRUCK**
Repairing, operating \$3.00
- 1001 WAYS TO USE CONCRETE**
Do work for yourself, others, save, make money \$1.98
- STEEL SQUARE POCKET BOOK**
Best methods of using \$1.00
- DE LUXE SMALL HOMES**
New plan book shows 210 popular designs \$1.00
- MODERN HOME CRAFT**
New 250 page book on modern furniture \$3.00
- BLACKSMITHING**
Complete course \$1.25
- YOUR CAR**
New 192-page auto-owners guide describes hundreds of simple car repairs, shortcuts, how to operate car economically \$1.25
- ARCHITECTURAL DETAILS**
For every type of building \$1.50
- BIRD HOUSES**
Simple, attractive, permanent \$1.50
- EASY-TO-MAKE TOYS**
Sixty-seven projects \$1.85
- PRACTICAL BRICK LAYING** \$1.75
- WELDING, ELECTRIC**
Forge, thermit, resistance, etc. \$1.25
- WELDING, OXY-ACETYLENE**
Welding, cutting \$1.25
- METALLURGY** \$1.50
- RADIO PHYSICS COURSE**
Fundamentals made plain \$5.00
- AMERICAN MACHINISTS' HANDBOOK**
Standard data, methods \$4.00
- SIGN PAINTING** \$3.00
- AUDELS DIESEL ENGINE MANUAL** \$2.00
- TECHNICAL BULLETINS**
Simplified data for Practical Men
- SILVER SOLDERING AND BRAZING** \$1.00
- REWINDING ELECTRIC MOTORS** \$1.00
- FLEXIBLE MOLDS FOR CASTING NOVELTIES** \$1.00
- WORKING WITH PLASTICS** \$1.00
- MIRROR SILVERING** \$1.00
- SMALL ELECTRIC LIGHT PLANTS, CONSTRUCTION** \$1.00
- HEAT TREATMENT OF IRON AND STEEL** \$1.00
- DESIGNING AND BUILDING TRANSFORMERS** \$1.00



Amazingly Easy Way to LEARN RADIO

STUDY AT HOME FOR GOOD PAY JOB



22 Large Lessons; 243 Practical Hints; Data on 210 Tubes; Review Questions. Size 8 1/2 x 11 inches. Printed in 1941.

This is your chance to get into Radio. These easy-to-understand lessons, with 317 pictures, diagrams, and illustrations, cover every phase of radio. You will find the training remarkably easy to grasp and use.

RADIO COURSE BOOK

This home-study manual has helped others like you to secure better work in radio factories, servicing, communications, in War Industries, Navy and Army. These money-saving lessons will give you the essential training needed. Includes extra information on short-wave, television, signal-tracing, and mobile sets. You may examine the complete manual, containing all the lessons and review questions, in your own home without any risk or obligation.

WORTH MORE
"You should get more money for the course. The first week I studied, I made \$10.00 repairing sets. I have repaired 100 radios to date." Robert C. Hammel, Dayton, Ohio.

EASY TO MASTER
"I started to repair radios when I was on the 12th lesson. It took me two months to master your course." Roger Langlois, Montreal, Canada.

Practical Instructions
The lessons are clear, practical, interesting, easy to master and use. No special education or previous experience required. You will enjoy learning important radio facts and doing real radio work after the 14th lesson.

Satisfaction Guaranteed
Take advantage of our "no-risk" trial offer. Send trial coupon. You will receive the complete Course for 10 days examination. Begin your radio study without any obligation. If you are pleased, the complete Course Manual is yours to keep for only \$2.50, full price.

No Risk TRIAL ORDER COUPON

SUPREME PUBLICATIONS, 328 S. Jefferson St., Chicago, Illinois
Ship the complete Radio Course Book for 10 days use.
 I am enclosing \$2.50, ship postpaid. Send C.O.D. I must be satisfied or you will refund my money in full.

Name: PM-M-C
Address:

FREE COPY of AIR POWER

—and full information, new Victory Courses, aircraft and engine mechanics, construction, drafting; also home study. Simplified, compressed, but more thorough than ever before. Also shipyard welding. On million dollar airport. Thousands of Graduates working. Gov't. Approved Courses. Write or wire.



Dept. 8
Alh. Airport
Alhambra,
Cal.

WESTERN AIR COLLEGE

INVENTORS FREE Patent Facts

Protect Your Idea! This Free Inventors' Kit Shows You How —
Your ideas may be worth money! Get facts first and save time and money. Competent advice on patent procedure is essential to good results. Our 67 years' experience enables us to explain everything you need to know about protecting and commercializing your idea. Prompt, confidential service and results. Mail coupon today for free set of booklets as shown and Special "Certification of Invention" form (covers first important patent step).



C. A. SNOW & CO.
Registered Patent Attorneys Since 1875
123 SNOW BLDG., WASH., D. C.
Please send me the free books and form mentioned without cost or obligation.

NAME.....
ADDRESS.....

← MAIL THIS COUPON FOR FREE BOOKS

MAIL THIS COUPON TODAY

Just check the books you want, write your name and address below, and mail this advertisement. It is your order blank. When postman hands you books, pay him the price and few cents postage. Outside U. S. A. enclose remittance and include 15% additional for shipping charges. Ask for big FREE catalog of helpful books.

Name.....
City.....
Address.....
Mail to Popular Mechanics Press
Dept. 366—200 East Ontario St., Chicago, Ill.

Say you saw it in Popular Mechanics!

How Big Is YOUR PAY-CHECK?

If you earn under \$3,000, Higher Accountancy may be the answer for you

"THE size of my pay-check? What business is it of yours?" Perhaps that's the first reply that comes to your mind.

But—stop a moment. It really *is* our business—to help men just like you. In fact, it's been our business here at LaSalle for 33 years.

If your pay-check isn't all that you'd like it to be, why not consider accountancy? Why not become a member of this well-paid and respected field? Why not, in short, prepare yourself to earn real money—insure a good home for your family—a new car—an education for the growing youngsters—a bank account for a rainy day . . . these and many more of the precious things in life?

Maybe you're one of those ever hoping for "breaks" that will give you a higher standard of living. Yet that's precisely what most of 30,000,000 other employees in this country are doing.

Not all of them, of course. Here and there you find ambitious men who aren't depending on luck to carry them ahead. They're following a tested path to increased earnings—leaving nothing to mere chance. They're *training* themselves for better jobs—every week spending a few hours in serious but interesting study at home.

Some day, as expert bookkeepers and later as accountants, these determined men will have standing and a considerably larger income—in a profession that pays and pays well.

Why don't *you* do as they are doing—take advantage of LaSalle training? Even though you do not know the fundamentals of bookkeeping now—you nevertheless may have an excellent opportunity to master accountancy. Many others have done it.

Perhaps you're asking yourself, "But don't these others possess natural ability that I lack? Don't I need a special talent for all this?"

Ask rather, "If I do my part, won't I get results, too?"

You will! What it takes is intelligence, serious study and work—not genius. Under the LaSalle system you solve problems by simple steps . . . from day to day, as an expert accountant does. You use the same basic principles. And when these problems become difficult and puzzle you, you get counsel that could be matched only through personal coaching by a battery of experts in a big accounting house.

In a comparatively short time, you train yourself in Elements of Accounting, Principles of Account-



ing, Auditing, Cost Accounting, Business Law, Organization, Management and Finance. The training—complete and intensive all the way—takes you right into C.P.A. coaching if you desire.

Later, when you're an accountant, it may be possible to go into business for yourself as a public accountant and be independent. Or, if you choose to work for someone else as an executive accountant, it will may be for a salary several times that which you draw now.

Write for this FREE book

If you're tired of pinching pennies, investigate accountancy and LaSalle training. There isn't a faster, less expensive or more convenient method to master accountancy. Fill in the coupon and mail. We'll send you our 48-page book, "Accountancy, The Profession That Pays."

Then, when you read all the facts, you yourself will be able to judge best whether you have the will to study and apply your best efforts—toward a more secure future.

LaSalle Extension University A Correspondence Institution

Dept. 364-HR

Chicago, Ill.

I want to earn a bigger salary—through accountancy training. Send me, without cost or obligation, your 48-page book, "Accountancy, The Profession That Pays."

Name.....

Present Position..... Age.....

Address..... City.....



CLASSIFIED Advertisements



Advertisements in this section, 35 cents per word, each insertion, minimum 10 words, payable in advance
 To be inserted under proper classification in April issue, copy should be in our office February 9th
 April issue on sale March 1st
 Popular Mechanics Magazine, 200 East Ontario Street, Chicago, Illinois

YOU'LL PROFIT

By reading and answering the classified ads in this section. Hundreds of opportunities to make and save money.

Popular Mechanics Magazine,
 200 East Ontario Street,
 Chicago, Illinois

Dear Mr. Johnson:—You will be interested in hearing that, at a recent meeting, twenty-six members of this association voted Popular Mechanics the best classified advertising medium of any. The preference was approximately six to one for your magazine. This is especially significant when you consider that our members use or have used practically every classified advertising medium in the United States
 Yours—very truly,

(Original letter on file in our office)

ILLINOIS ASSN. MAIL ORDER MEN
 Earl B. Jenkins, Sec'y

AUTOMOBILES—MIDGET CARS

AUTOMOBILE Racing book, fifth edition, well illustrated. Instructions on building bodies, frames, engines. Ford A and B conversions. Plans, AAA rules, specifications. Roadster racing. Indianapolis cars. \$1.00 postpaid, \$1.15 C.O.D. Ray Kuns, Dept. 39, Madisonville, Cincinnati, Ohio.

WHIRLGAS Superchargers, \$3. Increase mileage 20%; power 10%. Refund guarantee. University test. Any car; give make, year. Wrench installs 15 minutes. John Hanley, Manufacturer, 5719 Loraine, Detroit, Mich.

GASOLINE Saving device, 25c to \$1.00 Ford 1928-1942. Chevrolet 1932-1942. Walert Co., 3429 N. 10th St., Milwaukee, Wisconsin.

PROFESSIONAL Midget racers, two-passenger roadsters. Midget motorcycles, motorscooters, parts, plans, wheels. Handbook catalog—125 illustrations, plans—20c. Midwest, Box 1958-CT, Chicago.

ATTENTION Auto buyers—Good cars are scarce. Our lifetime experience will show you how to judge car values. This information will surprise you. It contains ideas of the trade not generally known. Send \$1.00 to Car Craft P.M., 597 Pine St., Meadville, Penna.

FORD Owners and mechanics—learn how to make your old brakes work like hydraulics. Stop chatter, groans. Costs less than \$5 bill. Free details. Super Brake Floater Company, 4022-P Lake St., Chicago.

SEAL-MATIC Reconditions motors without new rings! Devereaux, Box 212-J, Battle Creek, Michigan.

FREE—Big list of helpful books. Popular Mechanics Press, 200 E. Ontario St., Chicago.

AUTO SUPPLIES AND EQUIPMENT

USED Auto parts, half price, all cars. Century Parts Company, 1712 LaFayette, St. Louis, Missouri.

RECLEAN Used oil without cost. Particulars, F. Gerwin, Fairview, Okla.

1942 **IGNITION** Supercharger \$1.75. E G Sales Mfg. Co., New York.

NEW Oil saver 10c. Amazing! Dudevle, 102 Greenwich, Stamford, Conn.

PLATING Outfits for auto parts. Connect to a battery. No tanks used. Free particulars and proofs. Gunmetal Co., Ave. J. Decatur, Ill.

AUTO TRAILERS

ALL About trailers, construction, parts, supplies, etc. 64 pages vital information for anyone interested in home trailers. Send 25c. Stepes Co., 2801PM 14th, Kansas City, Mo.

READY Now—Plans for nine new Jim Dandy Trailers including six modern house trailers. Catalog 10c. Also new edition of Trailer Builders Manual and catalog of parts, supplies and equipment. Price 25c. Both 35c postpaid. Trailer Supply Co., 5120-A Fulton St., Wausau, Wis.

MOTORCYCLES, BICYCLES, MOTOR-SCOOTERS AND SUPPLIES

MOTORCYCLISTS. We can save you money on parts and accessories. Bargain list and decal free. Illustrated Henderson list 10c. Triangle, 1111 Washington, Chicago.

SEND 10c For Handbook of Information. Lists new and used parts for Indian, Harley, Ex-Hen, Boots, 622 East Grand, Des Moines, Iowa.

BUILD Comet motorscooter now! Save 70%. We supply cycle parts. Literature, drawing 15c. Comet Cycle Company, Box 3032, Madison, Wisconsin.

MOTORCYCLES. Reconditioned. New, used, parts and accessories. All makes. Large stock. Bargains. Illustrated catalog, 15c. Indian Motorcycle Sales, Kansas City, Mo.

MOTORCYCLE. Parts, accessories. Most complete stock. New and used. We specialize on mail orders. What do you need? 35 page catalog 10c. Whitman Motorcycle & Supply Co., 405-9 Southwest Blvd., Kansas City, Mo.

PISTONS And parts, new and used, all models. Catalogue and wings pin 10c. Ballak, 811 N. 9th, St. Louis, Mo.

AVIATION

PROPELLERS—Special sled 3 blade, all types, sizes, lists free. Ford motor conversion diagrams, 25c. Lightplane literature, supplies, Standard Aircraft, Ft. Worth, Texas.

A. & E. Mechanic's Manual illustrated text covering car and both ratings. Authentic typical "Multiple Choice" (with answers) examinations in appendix. Third edition just off press only \$3.00 postpaid or C.O.D. Quiz System, 1435 Flower So., Glendale, Calif.

PROPELLERS. For sleds, aircraft, boats, dehydrators. Catalog 10c. Banks Propellers, R.F.D. 7, Ft. Worth, Texas.

BUILD And fly your own motorcycle powered monoplane, home. Easy, cheap. Tested plans, guaranteed, \$1.00. Aerotech, Dearborn, Mich.

BATTERIES, GENERATORS, ETC.

BUILD Electric plant operated by wind from automobile generator. Complete plans and 1942 catalog 10c. LeJay Manufacturing, 447 LeJay Building, Minneapolis, Minn.

GENUINE Edison batteries for light power. Non-acid. Fifteen year life. Five year unconditionally guaranteed. Low prices. Complete lighting plants. Free literature. See-Jay Company, 82 Sterling Avenue, Yonkers, New York.

EDISON Lifetime storage batteries for light and power. Eliminate acid battery diseases. Long guarantee. All kinds re-built generating plants, motors, and miscellaneous articles at bargain prices. Free interesting literature. T. Hawley Smith Co., Croton Falls, N. Y.

ELECTRICAL SUPPLIES—EQUIPMENT

1/2 HORSE, 3450 Speed, repulsion induction alternating motors \$10.75; 500 watt alternating generators \$24.50; other sizes. Butler Electric, 1885 Milwaukee, Chicago.

FREE! 1942 Catalog—1000 electrical bargains. LeJay Manufacturing, 847 LeJay Building, Minneapolis, Minn.

ALNICO Magnets. Circulars 5c. Terry Sales, Central Station 1676, Toledo, Ohio.

UNIQUE, Profitable. New use for electric clocks. Unlimited applications. Information 25c. Experimenters' Laboratories, Portland, Indiana.

ELECTRIC Pencil: Writes-engraves all metals. \$1.00 postpaid. Beyer Mfg., 4515-H Cottage Grove, Chicago.

ELECTRIC Light and power system, 110 volt, 1500 watt. Kohler, good condition. Price \$175.00. H. L. Philips, Glen Moore, Chester Co., Penna.

WELDING—SOLDERING—PLATING

MAKE 300 Amp. a-c welder for \$25.00. Plans for 5 sizes, 60 to 400 amps. \$1.00. Information dime. Hi-Point Electric, Bellefontaine, Ohio.

BUILD D.C. arc-welder, without re-winding armature; light plant generators; D.C. motors; automobile generators. Plans \$1.00 each. Welders Club, AB-3432 M-Mart, Chicago.

SAVE 50% On a.c. welders. Plans. Holger's Service, Canton, Kans.

BUILD Low cost ac-dc welder. Plans 25c. Frazee 547 Fulton, San Francisco, Calif.

MACHINERY, TOOLS AND SUPPLIES

BUILD Your own machine tools. Lewis furnishes semi-finished castings for bench milling machine and shaper; rough castings for 23 metal and woodworking tools. Shop-tested materials and professional blueprints. Never a complaint on quality, design or price! Send 10c—New 1942, 32 page illustrated catalog. Lewis Machine Tool Co., Dept. M-15, Box 116, Station A, Los Angeles.

HARD-TO-GET Hardware for defense: over 1,000 piece assortment. Screws, nuts, bolts, washers, rivets, brackets, etc. All plated—first quality. Satisfaction guaranteed. 5 pounds special \$1.98. Limited supply. Manufacturers Products, 208 West Hubbard, Chicago.

SLIDE Rule 50c, 10", accurate, 6 scales, magnifying indicator, instruction book—postpaid. H. E. Wiggins, 56 W. 45th, New York.

GRIND Drills like factory: attachment for bench grinder. Cheap. Factory, 811-B East 31, Kansas City, Mo.

BUILD Your own lathe grinder, castings, building instruction \$2.50. Particulars 10c. Star Machine Shop, Kingfisher, Oklahoma.

ONE Inch micrometers, \$5.00 C.O.D. Costes, 1220 South 9th Ave., Birmingham, Ala.

MICROMETERS—All sizes finest quality. \$5.95, 2" \$6.60, etc. Also other precision tools. Supply limited. Circulars 10c refunded first order. Newkirk, 2709 Ivy Drive, Oakland, Calif.

WANTED Used Atlas shaper or equivalent. CCH, Mill St., Orange, Mass.

MACHINISTS Tool chests at bargain prices. Circular free. Cepuder, 3602 Wesley, Berwyn, Ill.

WANTED: No. 50, No. 55, and No. 65 Heald cylinder grinders, also Landis and Norton crankshaft grinders. State serial numbers and lowest cash prices. Box 90, Station I, Cincinnati, Ohio.

DRILL Grinding attachment. Price \$8.85. Used with bench grinder. Literature on request. Tractor-Lite Co., Sidney, Iowa.

CONCRETE Building block machines and molds. Easy payments. Catalog free. Concrete Machine Co., 5129 South Compton Ave., St. Louis, Mo.

13"x5" WILLARD Lathe with g.p. No 2 Pratt & Whitney hand milling machine. Four step cone drive. Write for full particulars. Cincinnati Machinery & Supply Company, 217 E. Second St., Cincinnati, Ohio.

ENGINES, MOTORS, DYNAMOS

GOVERNORS—Auto engine speed control. Candee, 129-X Llewellyn, Los Angeles.

SMALL High speed universal motors, 1/10 h.p. Supply limited, \$2.50 postpaid. McConnell, 701 Wolff, Racine, Wis.

WINDING Data, 225 motors, single and three phase, \$1.00. Motor Data Co., Box 7631, Kansas City, Mo.

AIR Compressors 1 1/4"x1 3/4" \$6.00; 2x2 \$7.00; 2 1/2"x2 \$8.00; electric drills 1/4 in. \$5.95. Free folder. National, 1915 S. State, Chicago.

1/2 H.P. Capacitor motors, 3600 r.p.m., \$9.75. Other alternating and direct current bargains. CMCO, 1111 Washington, Chicago.

AC AND DC generators, motors, exhaust fans. State your needs. Queen City Electric, 519 South California, Chicago.

BOATS, OUTBOARD MOTORS, ETC.

BOAT Blueprints and full size cut-to-shape paper patterns. \$3.75 up. Latest designs, all type pleasure boats. 8-38 ft. Illustrated "Build a Boat" catalog. 10c. (Book "How to Build Boats." \$1.00; marine hardware catalog. 10c.) Cleveland Boat Blueprint Co., Station A-66, Cleveland, Ohio.

SHIP Draftsmen needed. Low cost home study. Tredwell Lyle, Naval Architect, Sarasota, Florida.

KAYAKS, Outboards, rowboats, duckboats, Weldwood Ready-cut Kits. Catalog F. Cre-Craft Boats, Millburn, New Jersey.

FORD-Mercury-Zephyr marine conversions. Catalog 10c. Lehman Engineering Company, Dept. D. Newark, N. J.

NEW Type electric outboard motor made from auto generator. Uses car battery. Complete plans 10c. LeJay Manufacturing, 547 LeJay Building, Minneapolis, Minn.

\$9.75 UP! America's biggest Kayak values. Safe! Sturdy! Dedham Kayaks, Dedham, Mass.

BUILD Your own boat with knock-down frames. Easy to put together. Save 2/3 builder's cost. Big boat catalog—25c. Brooks Boat Co., Dept., PP, Saginaw, Mich.

TEN Plywood boat plans 50c. Free catalog boat building plans. The Rudder, 15 Murray Street, New York.

MARINE Conversion parts for all auto engines. Buy here and save. Conversion Parts Company, 278 Adams Street, Boston, Mass.

BOAT Designers are highly paid professionals. Complete course by mail. Catalog. Westlawn, Montville, N. J.

OUTBOARDS—Save 1/2. Good used parts. All makes and models. Bargains re-built motors. Crandall Hicks Co., 959 Commonwealth, Boston, Mass.

SPORTING GOODS, GUNS, FISHING TACKLE, ARCHERY, TRAPPING

HUNT, Sell, 42 important minerals; laboratories, schools. Explorer book gives field tests. 50c postpaid. Cooperation, Scout, Box 65, Colorado Springs, Colo.

FREE Streamer fly catalog. Camera patterns. S. Smith, Seneca, Penna.

BARGAINS! Gun catalog 5c. Camera catalog 10c. Fishing and archery catalog 5c. Golf-tennis catalog 10c. Warshall's, First-Madison-PM, Seattle.

ARCHERY Equipment: Catalogue free. Mid-West Archery, 2209-A East 75th, Chicago.

MAKE Flies, rods. Profitable pleasure. Instruction books. "Fly Tying" 10c. "Rodmaking" 10c. Materials catalog free. Wilpmarths, Roosevelt, N. Y.

"RAISE Earthworms for Profit." Information free. Stamp appreciated. Bureau Zoological Research, 106 "P" Broadway, Peoria, Ill.

ATHLETIC EQUIPMENT—BODY BUILDING COURSES

BAR-BELLS, Exercise equipment. Courses. Special offers! Free booklet. Good Barbell Co., 4676a PM, So. Grand, St. Louis, Mo.

NOW—A posture-corrective device that helps relieve backache, constipation, tiredness, headache. Statements on record. Write Posture-Aid, DPM, 509 Centre, Dallas, Texas.

ANTIQUES, RELICS, INDIAN GOODS, CURIOS

GLASS, Books, minerals, curios, catalog 5c. Junes Antiques, Northbranch, Kansas.

SWORDS, Pistols, daggers, armor list 10c. Robert Abels, 860A Lexington Ave., New York.

CHINQUILLA'S Indian Craft Museum. Handiwork of all Indian tribes. Jamaica, N. Y.

FIVE Different Indian tools 50c. Catalog 5c. The Sisters Store, Northbranch, Kansas.

INDIAN Relics, beadwork, coins, curios, minerals, old glass. Catalog 6c. Indian Museum, Osborne, Kansas.

FIELD GLASSES, TELESCOPES AND MICROSCOPES

100 POWER Telescope, complete lens kit, \$2.25. Includes 3" diameter 75" focal length ground and polished objective lens and two mounted eyepieces, 50X and 100X. All optical parts completely finished. Makes 6 feet long high powered refracting telescope. Easily made in one evening. See the mountains and craters on the moon, Saturn, moons of Jupiter, etc. Instructions included. Only \$2.25 postpaid. Brownscope, Dept. M, 125 W. 45th St., New York.

LENSES—Build your own telescope, field glass, microscope, telescope etc. Assortment of fifteen lenses—\$1.00 postpaid. Slightly chipped on edge. Satisfaction absolutely guaranteed. American Lens Company, 324 North Mayfield, Chicago.

ASTRONOMICAL Telescopes, binoculars, cameras, microscopes; bought, sold, repaired. Send 10c for list of instruments desired. Rasmussen, Box 294, Amsterdam, N. Y.

DOGS, PETS, BIRDS, RABBITS

BLACK English Shepherd, dogs and puppies. Shipped on approval. Breeder 20 years. 10 cts. for pictures and prices. Chanute Kennels, Chanute, Kansas.

BEAUTIFUL Pure white police dogs. Ansonia Kennels, Mose, N. Dak.

CHAMELEON, Turtle, treefrog, newt, 25c each. Instructive catalogue. Quivira Specialties, Winfield, Kansas.

ST. BERNARDS—All breeds—Details free! Book 108 colored pictures, descriptions recognized breeds, 35c. Royal Kennels, No. 91, Chazy, N. Y.

BIRDS? Get American Canary Magazine monthly. Year, \$1.00. 2839-P North Halsted, Chicago.

TREES, SHRUBS, PLANTS, HERBS

EVERGREEN Tree seedlings for spring planting. Certified. Hardy. Good quality. Order early. Suncrest Evergreen Nurseries, Johnstown, Penna.

FARMS—FARM LANDS—REAL ESTATE

FARMS! Catalog 1290 bargains Wisconsin to Maine and south to Florida mailed free. Strout Realty, 255-p 4th Ave., New York. For west coast catalog write us at 453-P So. Spring, Los Angeles, Calif.

GOVERNMENT Land \$1.00 acre up. Information all states 25c. National Tax Service, 1037A Majestic Bldg., Detroit.

40 ACRES Near White River, unimproved; poultry land, \$190, \$5 down, \$5 monthly. Free list and literature. Hubbard, 216 Grossman Bldg., Kansas City, Kans.

SEE The Highlands of Louisiana. Choice cut-over land selling at low prices on liberal terms. Descriptive book sent upon request. Long-Bell Farm Land Corp., 878 R. A. Long Bldg., Kansas City, Mo.

TWENTY Acres good land \$75.00, \$5.00 down, \$5.00 monthly. Highway front tracts 10 acres \$100.00, \$5.00 down, \$5.00 monthly. R. W. Stewart, Inverness, Fla.

GOOD Farm bargains. Washington, Minnesota, Montana, Idaho, Oregon, North Dakota. Dependable crops, favorable climate. Write for literature and lists describing typical farms for sale. Specify state. J. W. Haw, 119 Northern Pacific Ry., St. Paul, Minn.

CANADIAN Tax sale lands for a dollar an acre and up. Small monthly payments. Farms, timber, hunting and fishing camps, minerals. Limited number of properties. Write at once for free illustrated booklet. Tax Sale Service, Room 613, 72 Queen St. W., Toronto, Canada.

FARM MACHINERY AND SUPPLIES

BUILD Powerful tractor of used parts. Buick motor, Fordson tractor axle. Starter, lights. Pulls Fordson equipment. Drawings, instructions \$1.50. L. C. Zellers, Route 1, Rochester, Michigan.

POULTRY AND FARM SUPPLIES

BROOD Chicks early for big poultry profits. Learn successful management methods from America's leading poultry magazine. Five years \$1.00, one year 25c. Agents wanted. Poultry Tribune, Dept. C-55, Mount Morris, Ill.

LOW Factory prices on poultry equipment. Wire fabrics. Free 100-page catalog. Bussey Pen Products, 5149 West 65th Street, Chicago.

PROFITABLE OCCUPATIONS

ANNOUNCING New home study course in commercial baking. Good field. Nearly depression proof. Common school education sufficient. Send for free booklet "Opportunities in the Baking Industry" and requirements. National Baking Institute, 1315 Michigan, Dept. 3433, Chicago.

PRODUCE At home essential pet food, nearly all profit, sell by mail; we buy surplus, details dime. Voegt, 264 Linden Blvd., Brooklyn, N. Y.

COMPILE Mailing lists for us. Unlimited opportunity, particulars dime. E. Staley, Libby, Montana.

INCREASE Income with Angora Wool Rabbits! Steady profits, start right! Our instruction manual tells how. Illustrated catalog, wool samples, 10c. Clay's Farm, Spokane, Wash.

WARTIME Plan! Will you give us 5% first \$600 you make? Afternoons free! Work home. \$1,000 month reported (exceptional—fulltime). Expect surprise! National, Box 1240, San Bernardino, Calif.

MECHANICALLY Inclined men—Own and operate general appliance repair shop. Complete, illustrated course shows you how. Welding, refrigeration, motor repair, how to get business, etc., all phases covered. Free literature. Christy Supply, Dept. 414, 2835 N. Central Ave., Chicago.

START Knitting business in your own home. Complete machine only \$39.50. Ainslie Co., 750 Grand St., Brooklyn, N. Y.

RAISE Angora rabbits—wool brings \$5.00 pound. Particulars free. Grinstead's, Edwardsville, Illinois.

YOU'LL Like resilvering mirrors, tableware, making chipped glass nameplates, signs. Outfit prices. Sprinkle, Plater, 288, Marion, Indiana.

\$40.00 WEEKLY. Made growing mushrooms for us, fresh, dried. Dominion patent 331583. Free spawn. North American, 169P Yonge, Toronto, Canada.

ANGORA Wool rabbits pay, America's fastest growing industry. Start now. Dakota Rabbitry, Oakes, North Dakota.

BOOKS, PERIODICALS, PICTURES, POSTCARDS

CURRENT Copies of business, trade and occupational magazines. Over 350 different publications to choose from. List with prices free. Commercial Engraving Publishing Company, 34C North Ritter, Indianapolis, Indiana.

MYSTERY, Western, detective, sport, love, movie, picture, comics, back dated magazines. Choice 25 different \$1.00. Reader's Digest 50c complete year, 10 different Esquires \$1.00, 6 different Fortunes \$1.00, 15 different National Geographic \$1.00. Magazines sent express charges collect. Special dates reasonably priced. Catalog 3c. Corey's Exchange, 22 W. Ontario St., Chicago, Ill.

"GREETINGS From," scenic, post offices, nearly all states. 3 for 10c. Mrs. Perley G. Coltran, 123 Foster St., Burlington, Vt.

OUTDATED Magazines 5c (foreign, domestic)—Art studies—100,000 used, new technical books. (Bought, rented, exchanged). Catalog 10c (refunded). Cicerone's Magazine Exchange, 863 First Avenue, New York City.

MECHANICS Reference book for machinists \$1.00 postpaid. G. A. Knudsen, 523 - 48 St., Brooklyn, N. Y.

ART Pretty girl pictures. Nifty new series. Complete set 18 pictures \$1.00. Sample package 25c. Each picture full postcard size 5 1/4 x 3 1/4. Harlem, Box 10, Station J, New York, Dept. A-15.

ANY Book (new, used, out-of-print, rare) promptly supplied! Lowest prices! Send for free bargain catalogues! Old Prof's Book Shop, 116 Arcadia Court, Pontiac, Mich.

BACK Number magazines, also book bargains, list 10c. Magazine Mart, Roslyn, N. Y.

ARTISTIC Photographs, List, sample, dime. Parisette, 44 Nunn Building, Rochester, N. Y.

OLD BOOKS WANTED

WE Pay up to \$5000 each for old books, also high cash prices for old magazines, letters, newspapers. A single story book, school book, old Bible, travel book, history, almanac, etc., that looks worthless may bring you \$50, \$100 or \$500 in cash. Thousands wanted. Send 10c now for latest price list. American Book Mart, Merchandise Mart, Dept. 209, Chicago.

GAMES—ENTERTAINMENT

WRITERS! Send 10c for "Story Writing Self Taught," Worth \$10.00. Gagnon Co., Dept. 61, 541 S. Spring, Los Angeles, Calif.

PLAYS, Operettas, musical comedies, complete minstrel first-parts with song programs, blackface skits, vaudeville acts, monologs, dialogs, recitations, juvenile plays and songs, musical readings, entertainments, make-up goods. Catalog free. T. S. Denison & Co., 203 N. Wabash, Dept. 11, Chicago.

MAGIC TRICKS, PUZZLES, JOKER NOVELTIES

VENTRILOQUISM. Secrets revealed. Home study course. Free particulars. Fred Maher School of Ventriloquism, 1707 Casgrain Avenue, Detroit, Michigan.

MAGIC Tricks, jokes, novelties—five card trick secrets and list 3c stamp. Hawkins Specialties, 537-B So. Dearborn, Chicago.

LIT Cigarettes disappear (not up sleeve) with Master Cigarette Vanisher! \$1.00 postpaid. Amazing details free. Scheetz, 981 Branch, Sellersville, Penna.

DOLLAR Magic set free with gigantic catalog 25c. Magex, 4462-P Germantown, Philadelphia.

HITLER In exile! Sensational novelty! 25c coin. Novelty House, 3541 North 28th, Omaha, Nebr.

BE A magician. Large professional magic catalogue of latest tricks 25c. Ireland, C-109 North Dearborn, Chicago.

HOUSE Of 1000 mysteries! Famous coast to coast! Professional magic! Tricks! Joker's novelties! Two big catalogs combined into one giant edition! 600 illustrations! Only 10c. Vick Lawston, Dept. J21, Queens Village, N. Y.

TRICKS You can do! For pocket, parlor, stage. With coins, cards, cigarettes, ropes, balls, thimbles, apparatus. Magical books, illusions. Send 10c for latest 100 page catalog of 500 tricks, which includes free 10 select pocket tricks. Send 10c today. Douglas' Magicland, Box 274, Dallas, Texas.

HOLLYWOOD Special! Magicians button, catalogue, ghost illusion and free trick for 25c. Magic House of Charles, Box 888, Hollywood, California.

MAGICIANS Catalog newest tricks 10c. Sterling Magic Co., 345 John R., Detroit, Mich.

MAGICIANS' Headquarters. 216-page catalog, pocket, parlor, professional tricks. 25c. Kanter's, M-1311 Walnut, Philadelphia.

EARN Money in any crowd. Call names of strangers, tell unspoken questions. Professional course mind reading, spirit writing, etc. \$1. Henderson, Box 341, San Bernardino, Calif.

TRICKS You can do. Free catalogue. Magicraft, Harrisburg Station, Houston, Texas.

WORLD'S Largest professional magic shop keeps you in touch with latest tricks. To receive mailings send 25c for 1942 catalog. Holden, 220 W. 42nd St., New York.

OLD STAMPS WANTED

I WILL Pay \$100.00 each for 1924 1c green Franklin stamps, rotary perforated eleven (up to \$1,000.00 each unused). Send 6c today for large illustrated folder showing amazing prices paid. Vernon Baker, (23-PM), Elyria, Ohio.

STAMP COLLECTING

SENSATIONAL! Six beautiful giant-size diamond shaped stamps from Tannu Tuva. Also six rare Katipunan (Philippine Revolutionary government) stamps cataloging \$1.20 and scarce \$2.50 United States stamp. Only 10c to new customers. Barker, Box 448M, San Francisco, Calif.

WOW! \$10.00 Worth of fun for only 10c! 500 foreign stamps, unsorted and unpicked (mostly on bits of paper) just as received from the church missions and other sources. Africa, So. America, Australia, China, Philippines, Dutch Indies, and other countries are represented. Includes a few commemoratives, airmails, and stamps cataloging up to 25c or more each! The biggest package of fun in stampdom—and you might find something really valuable! Price only 10c to serious approval applicants! Money back if not delighted. Jamestown Stamp Co., Dept. No. 22, Jamestown, New York.

FREE—World's only octagonal (eight-sided) stamp and royal visit set complete to approval applicants. Charles Cleaveland, 806 North Humphrey, Oak Park, Ill.

500 UNITED States for 10c! 500 U.S.A.—absolutely unpicked and unsorted—just as received from church missions. Many varieties, including commemoratives, airmails, high values up to \$5.00 denomination! Price only 10c to approval applicants! Money back if not delighted. Swan Stamp Co., Dept. 69B, Dunkirk, N. Y.

84c FOR Nothing! Scarce set of four Russian stamps cataloging 84c plus giant illustrated bargain lists. All absolutely free for the names of three friends who collect stamps. Frederick A. Fitts, Framingham, Massachusetts.

26 DIFFERENT Guatemala including Quetzal bird airport 10c. Approvals, E. P. Johnson, Box 267, Morgan Hill, Calif.

FINE Approvals, freshly mounted. Fast, personal service. Tell me what countries you prefer and I'll send them stamps. Skinner, 345 East Ocean, Long Beach, Calif.

UNITED States approvals complete coverage, fine quality, attractive prices. Vermorel Stamps, Box 436, Coconut Grove, Florida.

JUGOSLAVIA Charity set complete B23-5, 5c with approvals. Stamp Collectors Service, Box 325, Dept. "M," Church Street Annex, New York.

NEW 1942 Bargain packet—Over 100 different stamps; includes strange "mystery stamp" now prohibited in United States mail; stamps you'll treasure from Aserbaljan, Georgia, Transcaucasia, etc. Complete packet for only 5c to approval applicants. Cactus Jr. Approvals, Box 1870-M, Tucson, Arizona.

INVESTMENT In stamps bear dividend. Latin-American approvals and gift set airmails, dime, Latin-American, Box 93, Hayward, Calif.

500 FOREIGN Or U. S. 10c. Approvals, Box 324, Middleboro, Mass.

UNPICKED! 100 U. S. revenues on documents—10c! (700—50c.) Vanvoorhis, Hyndman, Penna.

FREE! Ten commemoratives with foreign approvals. Lucas, Five Broadway, New York.

FREE Grab bag with approvals. Stamp, Box 77, Audubon, N. J.

SENSATIONAL Combination offer! Big packet 105 different including Iceland, Manchukuo, Ecuador (American flag in full colors), Danzig; airmails, commemoratives, triangle stamp, \$4 United States; complete set United States telegraphs, cataloging 20c. Packet British Colonies, including Gwalior, Hyderabad, Burma (new country) jubilee and coronations. Scarce Far Eastern republic cataloging 50c. Big illustrated lists of other bargains. Total catalog price over \$3.00! All for only 5c to approval applicants! World-Wide Stamp Company, Department 600-N, Camden, New York.

FREE Packet and mint airmail set. Approvals, Bridger, New Windsor, Illinois.

WATERMARK Detector, perforation gauge, free. Approvals, Porter, Box 184m, Duncan, Okla.

JUVENILES—Free stamps for details send 3c stamp. Cameron Stamp Co., 1455 Cameron Court, Atlanta, Ga.

100 DIFFERENT British Colonies—Stamps from the four corners of the world—Special—10c to approval applicants. Official Stamp Co., Fairlawn, N. J.

WHOLESALE Supplements to dealers for 10c postage. Hundreds of bargains. Grossman Stamps, 102 West 42nd, New York.

BRITISH Colonial mint approvals! Lists free! Joseph Negreen, 108-56P, 67th Drive, Forest Hills, N. Y.

FREE, Beautiful packet British Colonials with airmails, etc., only 10c with approvals. Estates Stamps, Foxlake, Wis.

NEW Zealand—20 different 4c. Approvals. Crown Stamps, 795 Elizabeth, Pasadena, California.

15 SETS 10c. JL Stamp Company, 6 Elmwood Blvd., York, Penna.

45 DIFFERENT Latin America—5c. Northeast, Box 6618, Kansas City, Mo.

VICTORY Packet free—Includes stamps from Tanganyika, Borneo, animal, scarce babyhead, coronation, early Victorian, airmail, map stamps, with big catalogue—all free—send 5c for postage. Gray Stamp Company, Dept. PM, Toronto, Canada.

112 DIFFERENT Stamps, includes maps, ships, triangle, air mails, 5c with approvals. F. Thrasher, Macedon, N. Y.

SCARCE Set! Lists, approvals—3c. Manchester Stamp Company, Manchester, Connecticut.

66 DIFFERENT United States—10c. Approvals. Utechts, 1143D North Keeler, Chicago.

75% DISCOUNT Approvals. Fine stamps. No junk. Riedel, Greensburg, Penna.

FREE Premium to approval applicants sending 3c. E. Gericke, Box 324, Gary (2), Indiana.

20 MEXICO 3c With approvals 1/2c up. Josiab Babcock, St. Joseph, Mich.

SEYCHELLES, Nejd, Caymans, Manchukuo, Brunel, Turks Caicos, British Solomons (Cannibland). Everything 3c with approvals. Viking, 130-Z Clinton St., Brooklyn, N. Y.

GOYA Nudes (2 vs.) 5c. Approvals. Millhiser, 7724 Abbott, Pittsburgh, Penna.

125 DIFFERENT U. S. commemoratives, etc., for 25c. Steger, Peotone, Ill.

THICK Packet stamps with odd shapes 10c. Approvals. Kellerman, R.R.10, Sta. M, Box 476, Cincinnati, Ohio.

U. S. Accumulations. 1861-1917. Big variety denominations, colors, perforations, watermarks 500-\$1.00. 1927 Presidentials only higher denominations including dollar 500-\$1.00. 500 commemorative 75 varieties high denomination bicentennials, parks, famous Americans 500-\$1.00. Corey's Exchange, 22 W. Ontario St., Chicago, Ill.

UNITED States price catalogue. Surprise packet 5 cents. Approvals. Gobrecht, 205 Anderson, Joliet, Ill.

LOWEST United States stamp prices. Free illustrated catalogue. Creevey's, Berwick, Penna.

FREE United States illustrated catalog. Mozzan, 505 - 5 Ave., N. Y.

NETHERLANDS 25 Different, Minerva triangle 10c. Approvals. Hermes Stamps, Box 276, Hempstead, N. Y.

50 FREE Kwangchowan, etc. Album 3c. Bullard, 13 Winter Hill, Mass.

WIN Free stamps—Fascinating contest—Every approval applicant wins—No obligations—Try your ability. Mutual Stamp Service, Fellows, California.

100 DIFFERENT Beautiful foreign 5c. Approvals. Getche, 2730 Garfield, Minneapolis.

200 WORLD Wide 15c. Arthur Mantel, 2020 Excelsior, Hopkins, Minn.

60 DIFFERENT U. S., including commemoratives, airmail 10c. No approvals. Seidenberg, Baroda, Mich.

20 DUTCH Indies 10c, when requesting approvals. Cyerman, 177 Huron, Brooklyn, N. Y.

PENNY Approvals that please. McKee, 128 E. Robbins, Covington, Ky.

8 BEAUTIFUL Liberia official bicolours 10c with approvals. Collectors' Stamps, Box 4083, New Orleans.

UNITED States and foreign approvals sent on request. Carl C. King, 25 Winemere St., Springfield, Mass.

SMOKY Mountain sheet with 10 beautiful commemoratives, approvals 5c. Stamp Shop, 809 Holland Bldg., St. Louis, Mo.

WEEKLY Stamp magazine, thirteen weeks, 10c. Stamp Journal, Kalamazoo, Mich.

UNITED States. Hard to get, yet inexpensive stamps in our approval books. 1500 varieties in stock. Southern Stamp Co., Box 70-M, Miami, Fla.

THREE Mint sets 3c. Approvals. Turner, 60 Howard, Atlanta, Ga.

2 BAHREIN 11c (rare British colony). Fanter, 6328 Woodland, St. Louis.

3c BRINGS 50 Different foreign plus surprise set, bonus approvals. Dunn, Box 30P, Royal Oak, Michigan.

PHILIPPINES—17 Different including pictorials, 10 cents with approvals. Swedell, 3038 Harriet Ave., Minneapolis, Minn.

U. S. Stamps on approval—Stock 95% complete. Box 488, Minneapolis.

YOUR Packet 100 different stamps 5c. Approvals. Quality Stamps, Englewood, Colorado.

NEW Way to exchange duplicates! Become a participant of our Exchange Circle and you can select leisurely at home without money from stamps sent to you by fellow participants. No dues. Write now for free information XIV! Liberty Stamp Exchange Circle, 30 East 92nd St., New York.

300 DIFFERENT 25c; 600, 50c; 1000, \$1.25; 2000, \$3.50. Fred Onken, 630 79th St., Brooklyn.

FREE Stamps to collectors—United States internal revenues on original documents including \$1-\$2-\$4-\$5-\$10 stamps plus 40 page illustrated U. S. price—Check list to U. S. approval applicants. Enclose postage. Metropolitan Stamps, Dept. P, 198 Broadway, New York City.

BRAZIL, 55 Different, 10c. Approvals. Pickering, Box 7648M, Kansas City, Mo.

1000 MIXED 15c; Genuine Saxony 15c; Hamburg 25c. Ajax, Box 6009, Kansas City, Missouri.

POSITIVELY Greatest free offer—Latest Scott's International \$4.00 stamp album—covering entire world, contains 36,000 illustrated, descriptive spaces; Scott's 1942 standard \$3.50 catalogue "Philately's Encyclopedia"—absolutely free to applicants for foreign approvals becoming customers. Bargain Stamp Service, Indio, California.

COMPLETE Set of U. S. national parks only 17c to approval applicants. B. Fittsco, Framingham, Mass.

A REAL Bargain. Specially prepared packet containing 150 different foreign and 65 different U. S. stamps; catalog value about \$5.00; pamphlet which tells you "How to Make Your Stamp Collection Properly" and large bargain lists, all for only 23c postpaid. Queen City Stamp Co., Room 36, 604 Race St., Cincinnati, Ohio.

100 UNITED States 20c with approvals. Walker, 5130 N. Williams, Portland, Ore.

6000 WORLDWIDE Packet \$1. U. S. foreign packets 10c. Griest, 409 Oak, Daventport, Iowa.

40,000 VARIETIES Foreign stamps available on approvals 1/4c up. Representative selection on request. Adults only. PKElwin Stamp Company, Vineland, N. J.

TEN Crazy-shaped stamps. 3c with approvals. Knopp, Box 1381, Bristol, Conn.

20 DIFFERENT Large U. S. commemoratives and 50 different British Colonies for 3c postage, to approval applicants. Palm Stamp Co., Seybold Building, Miami, Florida.

BEST One cent approvals in America. Elvin Stanton, Niantic, Conn.

1000 MIXED U. S., old and new, 25c. Weatherly, Amherst, Ohio.

FREE! Complete "United States" stamp catalog with 1,000 illustrations! Harris & Co., 137 Transit Building, Boston, Mass.

FREE. Unmatchable world collection containing desirable British Colonial commemorative issue complete. Valuable South American set exploiting colorful natural resources. Bi-colored pictorial issue from mysterious Indian Ocean island. Rampant lion of Bohemia issue, plus 100 different stamps, many from subjugated European countries, only 3c to approval applicants. Friendly Philatelists, Box 4428P, Philadelphia, Penna.

WORLD'S Smallest airmail—diamond and triangle stamps, free stamp magazine, also magnifier to study your stamps, with large collections of stamps from scarce countries. A bargain. 5c with approvals. Capital Stamps, Dept. 2, Little Rock, Arkansas.

60 DIFF. Mint Geo. VI coronation poster stamps plus scarce Cayman Is., Leeward Is., Turks and Caicos, etc. 3c to approval service applicants. Tatham Stamp & Coin Co., Springfield-30, Mass.

SEMI-POSTALS. The hard to get stamps. 25 different, including sets; 5c with approvals. Lyman, 95 Nassau Street, New York.

50 ASIA 10c. Big 50% discount approvals. Coverts, 39 State St., Rochester, N. Y.

SPECIAL Airmails—23 different, including zeppelin, triangles, Latin-America, etc. 5c with approvals. Continental Stamp Co., Dept. B, Sandy Hook, Conn.

\$1.00 (CAT. Price) for 1c! Two mint U. S.A., cat 20c; "queer countries" packet (Djibouti, Manchuria, etc.); scarce set Russia, cat. 75c. Everything for only one cent to approval applicants! Garcelon Stamp Company, Box 400, Calais, Maine.

SMOKY Mountain commemorative sheet, largest U. S. stamp issued, and 33 U. S. including commemoratives, airmail, revenues, etc. Catalogs 75c—To approval applicants for 5c. Curhan Stamp Company, Gloucester, Mass.

WILL Rogers and U. S. flag—Panama showing "Old Glory" in natural colors, and Nicaragua Rogers; diamond and triangle stamp. North Mongolia diamond (world's largest), Pope Pius "peace" stamp, slave colony, genuine Far Eastern Republic, Thailand, Antipodes, "puppet" country, animals, airmails, etc., all 5c with approvals. Belmont Stamp Co., Dept. 8, Washington, D. C.

CANAL Zone—Panama Canal commemorative and Ecuador with U. S. flag in natural colors, also "bullfight" stamp, Chinese "midget," giant diamond, "Christ" triangle, "earthquake" airmail, Mozambique, Morocco, Ex-Nazi colony, stamps showing giraffe, Royal Air Force pilot, etc.—all 5c with approvals. Potomac Stamp Co., Dept. 1, Washington, D. C.

FREE! Complete Canada royal visit with approvals. Chester, Box 545-P, Utica, N. Y.

SOUTH American—100 different 10c—with approvals. Davis, Silver Lake, Ind.

STAMP Dealers, your ad here will bring wonderful returns. Ask me for proof. F. W. Johnson, Manager, Classified Advertising, Popular Mechanics Magazine, 200 E. Ontario St., Chicago.

GIANT Packet 136 all different from Africa, South America, South Sea Islands, etc. Includes Nicaragua airmail, two scarce unused United States cataloging 20c, triangle and animal stamps; many others. Also includes fine collection 25 different British Colonies—Charkari, Jamaica, Johore, etc. and United States \$4 and \$5 high values. Total catalog price over \$4.00! Everything for only 5c to approval applicants! Mystic Stamp Company, Department 80-A, Camden, New York.

SEND Postage for free United States price list. Stanley Gibbons, 38-P Park Row, New York.

CANADA 100 Different 25c—approvals all countries. Lists. Victoria Stamp Co., London, 4, Canada.

PENNY Approvals, that satisfy. Neil Gronberg, Box 5441-P, Philadelphia, Penna.

ZEPPELIN And 24 airmails 5c with approvals. Paltra, Fordham Station, New York.

COINS, TOKENS, CURRENCY

OLD Money wanted. Will pay \$100.00 for 1894 dime, S. mint, \$50.00 for 1913 Liberty head nickel (not buffalo). Big premiums paid for all rare coins. Send 4c for large coin folder. May mean much profit to you. Numismatic Co., Dept. 20, Fort Worth, Texas.

WE Buy Indian cents, Lincoln cents, old money. Highest cash prices. Send 10c today for new 1942 catalogue of prices we pay for all wanted U. S. coins, American Rare Coin Co., Dept. 1, Transportation Bldg., Chicago.

OLD Mexican coin and list 10c. Box 514, Beeville, Texas.

SIX Different coins 10c. Oddehon, Box 44, Overland, St. Louis, Mo.

LARGE Copper cents 100 years old 25c, 5 different \$1.00, 10 different Indians 25c, 100 assorted \$2.00, 10 different Lincolns San Francisco mint 25c, 28 different 75c, large value book 50c, list 3c. Coin Shop, Box 77, Alameda, California.

BARGAINS! United States coins all different dates. 5 half cents \$1.00; 10 large cents \$1.00; 30 Indian head cents \$1.00; 7 copper nickel cents \$1.00; 7 two cent pieces \$1.00; 8 3c pieces \$1.00; 7 half dimes \$1.00; 4 different commemorative half dollars \$3.00. Worthy Coin Corp., 23 Cornhill, Boston, Mass.

COIN Card collector's our price list is free. Write Hanson's, 1326 Main, Kansas City, Missouri.

COMMEMORATIVE 8 1/2c. Columbia, Lincoln, Stone-Mountain, Lonx-Island, Cleveland, \$1.00 each. Large illustrated catalogue 25c. Norman Shultz, Salt Lake, Utah.

TOP Prices paid for rare Lincoln and Indianhead pennies. Also certain other American and foreign coins. Begin today to accumulate all money which you believe might be valuable. Send 10c for complete buying catalog showing prices I pay. Allan Appel, Sedalia, Missouri.

GET Profit and pleasure in collecting old coins. Send 10c for 56-page illustrated coin catalog. You'll be delighted with it. Send for it now. B. Max Mehl, 370 Mehl Building, Fort Worth, Texas. Largest rare coin establishment in U. S. Established 42 years.

FREE! Foreign coin, banknote and large 50 page illustrated coin catalogue to approval service applicants. Send 3c postage. Tatham Coinco, Springfield-125, Mass.

I MAY Have just the scarce U. S. coins you want. Send me list. "Meet me by mail." William H. Kenworthy, Waterville, Maine.

PRICE List of U. S. coins, bills and collectors' accessories 10c 75 illustrations, 2500 quotations. James Randall, 341 South Dearborn, Chicago.

10 INDIAN Head cents, different dates, also princelists 35c. Schultz, 1053 Richmond, Cincinnati, Ohio.

HOBBIES AND COLLECTIONS

BEAUTIFUL Jewelry stones removed from rings, etc. 200 assorted \$2.00. Lowe's, Box 525, Chicago, Ill.

MATCH Hobby "Bulletin," membership blank, stamp. Box 1111, Rochester, N. Y.

BEAUTIFUL Assorted jewelry stones, (new) 200 for \$2.00, postpaid. Moore, 651 South State, Chicago.

EXCHANGE Your duplicate stamps, match covers, etc. with collectors everywhere. List, swappers, dime. (Mention hobby.) Secretary, Box 2166, Denver, Colo.

UNUSED Book match covers, 100 all different \$1.00. Free list, Charles Edelman, 1311C East 84, Cleveland, Ohio.

TWENTY Different cactus plants postpaid \$1. Art Glover, San Dimas, Calif.

HOBBY Books—Latest titles—Bargain catalog free. Popular Mechanics, 633 St. Clair, Chicago.

CAMERAS, PHOTO SUPPLIES

CAMERAS Bought, sold, exchanged. Bargains in new, used, trade-ins, demonstrators, etc. Candid camera with built-in flash low as \$4.95. Leicas, Contax, Grafex, movie outfits, etc., at like savings. Hundreds of values to choose from. Bargain list free! Powell's, 155 W. Randolph St., Chicago.

35MM. Bulk film! 25 ft. Eastman Plus X \$1.00! Reloaded cartridges—3 for \$1.00 postpaid. Order now. Pacific Coast Film Co., 1508 N. Sierra Bonita, Hollywood, Calif.

CAMERAS And supplies. Free illustrated catalog listing everything photographic—still and movie cameras, films, lenses, enlargers, meters, supplies—at tremendous savings. Hundreds of bargains. All guaranteed. We take your old camera or equipment in trade. Write now for your free copy of our newest money-saving bargain book—just out! Limited edition. Hurry! Central Camera Co. (Photographic Headquarters since 1899), 230 S. Wash. Ave., Dept. C-16Z, Chicago, Illinois.

BASS Says: Astounding buy, exclusive here, latest Argus C3 with coupled range finder, synchro flash, 50 mm. F:3.5 lens, also 75 mm. Bausch & Lomb telephoto F:5.6 also coupled to range finder, \$82.50 value; price \$60.50, unconditionally guaranteed. Cowhide Eveready case, \$4.75. V. P. Ihagee Deluxe, F:4.5 lens, Prontor shutter, big value at \$16.75. Send for yours quick while they are available. Write for quotations and advise what you have to trade. We pay cash for good cameras, lenses, binoculars. Don't trade until you write Bass Camera Company, Dept. AG, 179 W. Madison St., Chicago.

CAMERA Repairing. Bellows made to order, shutters repaired. Bellows made to fit all standard cameras! United Camera Co., Inc., A-1515 Belmont, Chicago.

HAVE You a camera? Send ten cents for recent number of our big magazine, showing how to make better pictures and earn money. American Photography, 116 Camera House, Boston, Mass.

SOLAR Enlargers for prize winning prints. Amazing performance. Enlarging treatise free. Ask your dealer. American made by Burke & James, Chicago, Illinois.

MAKE Money in photography. Learn quickly at home. Easy plan. Previous experience unnecessary. Common school education sufficient. Booklet and requirements free. American School of Photography, 1315 Michigan, Dept. 3432, Chicago.

OIL Coloring photographs a fascinating hobby or profitable business. Learn at home. Easy simplified method. Previous experience unnecessary. Send for free information and requirements. National Art School, 1315 Michigan, Dept. 3441, Chicago.

SPEED-O-COPY Groundglass focusing attachment for Leica, Contax, Argus C-2 and C-3. Send for literature. D. Paul Shull, Dept. PM-3, 240 So. Union Ave., Los Angeles, California.

PHOTO FINISHING

EVERY Picture an enlargement! 8 sparkling deckle-edge enlargements and roll developed 25c coin; 116 size or smaller; enlarged reprints 3c. Enlarge Photo, Box 791, Dept. PM, Boston, Mass.

ULTRA Modern 2-tone gray leatherette frames. While they last, your favorite negative enlarged to size 4x6 and framed, 50c—2 for 75c or 5x7, 75c—2 for \$1.00. Superior Finishers, Monroe, Wisconsin.

REPRINTS 20 For 25c, 50 for 50c. Queen City Service, Dept. 8, Box 7, Niagara Square Station, Buffalo, N. Y.

FREE—Popular Mechanics readers: Your first roll developed and printed free with sparkling Lifetone prints plus free Hollywood enlargement coupon and Leathertone photo album all free with this ad (10c for return mailing appreciated). Nu-Art Studios, Dept. B339, Des Moines, Iowa.

READY-TO-FRAME Enlargements, 5c! Hand colored, 20c!—from your negative. 16 reprints your negatives. 25c. Kodak roll developed with 16 guaranteed deckle-edge Velox prints, 25c! 36 exposure 35mm roll developed, vapo-rated, enlarged to 3x4, \$1.00! 3x4 reprints, 3c each. Immediate service! Free mailers! American Studios, Dept. 310, Lacrosse, Wis.

SPECIAL Limited offers! If you enclose this advertisement, 4 enlargements from 4 negatives 10c coin; folio enlargements 18c each postpaid. Enlarge Photo, Box 791, Dept. PM, Boston, Mass.

ROLL Developed and 16 prints, or 8 prints and 2 enlargements, 25c. Candid 35mm. film developed and 36—3x4 prints, \$1.00. 18 exposure roll, 60c. Mercury Studios, Dept. 21, 109 N. Dearborn, Chicago, Ill.

PHOTOGRAPHIC Books—Latest titles—Bargain catalog free. Popular Mechanics, 633 St. Clair, Chicago.

YOUR Choice: 16 regular size prints or 8 double-size prints (nearly post card size) from 8 exposure roll or negatives—25c. 24 hour service. Satisfaction guaranteed. Willard Studios, Box 3535 A, Cleveland, Ohio.

THREE Prints each good negative in roll. 25c. Reprints, 3c. Fred D. Eastman, Bode, Iowa.

ROLLS Developed two prints each and two free enlargement coupons, 25c; reprints 2c each; 100 or more 1½c. Summers' Studio, Unionville, Mo.

ROLL Developed and 4x6 oversize glossy Velox prints, 8 exposure 30c; 12 exposure 45c; 16 exposure 60c. Overnight service. Clemet Photo Service, 1318 W. Columbia Ave., Philadelphia, Penna.

PHOTOGRAPHY For pleasure and profit. Prepare at home. Common school education sufficient. Write for information and requirements. American School of Photography, 1315 Michigan, Dept. 3451, Chicago.

OIL Coloring photographs a fascinating hobby or profitable business. Learn at home. Easy simplified method. Previous experience unnecessary. Send for free information and requirements. National Art School, 1315 Michigan, Dept. 3431, Chicago.

FOR The discriminating amateur—8 exposures rolls, 2 prints each 25c. Miniature rolls enlarged 3 to 6 times, 8 exposures 25c, 16 exposures 50c, 35mm, 36 exposures, 3x4 enlargements \$1.00. Unexcelled quality, prompt service. Paramount Photo, 1583 First Ave., New York.

PROMPT Service! Roll developed, two prints each negative 25c. Hensch Studios, Harrisburg, Penna.

16 BEAUTIFUL Oversize deckledged prints and two enlargements with first order 25c. Owlphoto M1, Weatherford, Oklahoma.

EIGHT Beautiful enlarged prints (nearly postcard size) or 16 regular prints 25c. 35mm. rolls enlarged 3½x4½ \$1.00. Burton Studios, 443M, Roscoe, N. Y.

TWO Sets of "Deckledge" prints with every roll finished—25c. Very finest quality. Deckledge reprints 2c each. Brown Photo Company, 1910-42 Emerson, Minneapolis, Minnesota.

DOUBLESIZE Prints. Your roll developed and 8 double size prints 25c; from 116, 120, or 127 size negatives you receive 4x6 inch prints. All smaller sizes receive 3½x4½ inch prints. 16 exposure rolls 50c; 12 exposure rolls 35c. Reprints 3c each. "Our Guarantee." Everlasting Hi-gloss finish. Overnight service. Pacific Photo Service, Box 666, San Francisco, Calif.

BEAUTIFUL Enlargement from each picture on roll 25c. Cut Rate Photos, Dept. B-4, Janesville, Wis.

PHOTO Enlarger—Make it yourself. Costs little. Simple to make. Illustrated instruction book 25c. Popular Mechanics, 200 E. Ontario Street, Chicago.

IDEAL Photos beautifully finished wide border deckle edge, 25c roll of 8 and free enlargement. Ideal Photos, Box 2255, Paterson, N. J.

ROLL Developed and 8 lustrous distinct finish permanent Velox glossy prints 25c—reprints 3c each. Fotoprint Service, Box 1, Roanoke, Virginia.

16 SPARKLING Lifetone prints, 2 beautiful Hollywood enlargements, free Leathertone frame and photo wallet only 25c. Free photo album with first order. Lifetone Studios, Dept. A-339, Des Moines, Iowa.

8x10 SILK Finish enlargement—25c. Send negative. Irving Studio, 4066A Irving Park, Chicago.

MOTION PICTURES AND SOUND EQUIPMENT

AMBITIOUS? Show talkies theatreless communities. Sound equipment. Weekly programs rented reasonably. Roshon, State Theatre Bldg., Pittsburgh, Penna.

35MM. Sound \$1.00 up. Silents 50c. Reisinger, 2418 Kenock, Baltimore.

BARGAINS! Silent. Sound. 35mm. films! Demsey, 1223 Berkeley, Youngstown, Ohio.

RELIGIOUS Films, 16mm. Sound. Silent. Screenart, 729 - 7th Ave., New York.

SAVE 50% On movies. Bargain circulares. Genera Company, Davenport, Iowa.

JAPS Bomb Pearl Harbor! Actual movie scenes. 16mm. sound and silent. Many others. Swank's, 618 North Skinner, St. Louis, Mo.

VICTOR 16mm. Sound projector like new (\$345.00 model) on terms \$3.63 weekly. Ampro, Bell-Howell, others, easy terms. Joe Louis, other championship fights, complete uncut 16mm. sound silent, \$1.21 weekly. 35mm. DeVry sound outfit \$2.27 weekly. 8-16mm. film library. Muggill's, 64 West 48th, New York.

35MM. SOUND Silent projectors, film accessories. Savarese, Woodcliff Lake, N. J.

"REMEMBER Pearl Harbor" in 8-16mm film, silent and sound. Bargains in silent and sound projectors. Films rented everywhere. Free illustrated catalogue (with sample film 10c). Garden Film, 317 West 50th, New York.

8-16-35MM. Films. Bought-sold-exchanged. Silent-sound \$2 up. Odd reels \$1.50. Catalogue, sample film 10c. International, 2120 Strauss, Brooklyn, N. Y.

LEARN Movie projection, management. Free catalog. Give age. Theatre Institute, Elmira, N. Y.

REDUCED! 8mm.-16mm. (Illustrated catalogue, dime.) Megifilms, 340-U West 29th, New York.

MOVIE Camera film 25' double 8mm. 98c, 100' 16mm. \$1.50. Also fast indoor panchromatic. Ambassador, 479-A Quincy Street, Brooklyn, N. Y.

NATIONALLY Advertised 8mm.-16mm. movie cameras, projectors, films. Cash or terms. Send stamp for catalogue. Don Elder's, M-739 Boylston St., Boston, Mass.

FILM Bargains; lists 3c. Clifford Hoffman, 57 Broad, Albany, N. Y.

FILMS, Cameras, projectors, etc. Peters, 41-C South Fourth, Allentown, Penna.

DEVELOP Your own movies. Complete, illustrated instructions 15c. Corona Laboratories, 1028 New York Ave., Brooklyn, N. Y.

MONEYMAKER! "The World's Greatest Passion Play." 16mm. and 35mm. Specify sound or silent. Rent or purchase. Superior than Oberammergau play. Hemenway Film Co., 33-F Melrose Street, Boston, Mass.

ESO-S 8mm. Movie films 50% less! Spooled ready for use; bulk. Ask for D-2 catalogue. Eso-S, 3945 Central, Kansas City, Missouri.

USED 16MM. sound film—100 feet, \$1.00. postpaid. Blackhawk Film, Davenport, Iowa.

BASS Says: Shrewd buyers send for the new Bass Cine Bargaingram No. 245, an 84-page catalog exclusively cine. The new Reverse Double 8 with F:3.5 lens at \$38.50. is the buy. The RCA 16mm. SOP news reel camera at \$275.00. Write Cine Headquarters for your copy of this great free book. We pay cash for good used movie equipment. Bass Camera Company, Dept. A, 179 W. Madison St., Chicago, Ill.

8MM.-16MM. Films. Free catalogue (with sample film 10c.) Parkway Exchange, 961 Eastern Parkway, Brooklyn, New York.

8-MM. 100-Ft. subjects 98c. Spring Films, Westboro, Mass.

MUSIC AND MUSICAL INSTRUMENTS

LEARN Popular piano! Write Magic Key, 111A Broadway, Glendale, California.

PHONOGRAPHS Repaired, all makes. Returned day received., Epstein's, 50 First St., New York, N. Y.

PIANO By ear. Free booklet. Write Day-V-Way, Dept. 8-A, Dearborn, Mich.

SONGWRITING, Arranging, best service. Novel ideas. Fore's, 2841 Franklin, Denver.

SONGS—Song poems wanted. No charge for melodies. Free examination. Hollywood Recording Studios, 87G14 Preuss Sta., Los Angeles.

IMITATE Musical instruments in one lesson. Copyrighted. Send 50c in coin to Young's Novelty Co., P.O. Box 1193, Baltimore, Maryland.

SONGS, Poems wanted. Unlimited opportunities. Free examination. Recordings made. Songs published royalty basis. Write today. Radio Music Company, 6912 Hollywood Blvd., Hollywood.

POEMS Wanted, submit for consideration. Five Star Music Masters, 630 Beacon Building, Boston.

PHONOGRAPH Records 10c. Catalogue. Paramount, AW-358 East Market, Wilkes-Barre, Pennsylvania.

SONGS Composed, arranged. Excellent beginners proposition. Basil Alt, Ottoville, Ohio.

SONG Writers course. Shows how \$1.00. Song Bureau, Box 1907-B, Washington, D. C.

PHONOGRAPH Records 10c. Free list. Hoodwin Company, 4419 Broadway, Chicago.

SONG Hits! Song poems wanted. Free recording if accepted. Write for free DeLuxe Rhymer. DeLuxe Music Service, Box 3163-P, Bridgeport, Conn.

MUSIC Composed, song printed, recorded. Reginald Belcher, Chatham, New Jersey. Established 1910.

SONGWRITERS—Write for free book. Send song poems. Variety, Salem, Ind.

SONGWRITERS! Words, melodies. Amazing offer. Hibbeler, C-5, 2157 No. Avers, Chicago.

SONGWRITERS. Write for free booklet. Profit sharing plan. Allied Music, 7608 Reading Cincinnati, Ohio.

WANTED! Lyrics, melodies for songs. We arrange, publish, sell. Superior Song Studios, Passaic, N. J.

MUSIC Composed to words. Wonderful proposition. Bauer Bros., Oshkosh, Wis.

LEARN Swing piano! Postal brings free folder. Christensen, 451 Kimball Hall, Chicago.

MUSIC Composed to words. Rhyming pamphlet on request. Phonograph recording of completed songs. Send poem for consideration. Keenan's Studios, Dept. FM, Box 2140, Bridgeport, Conn.

SONG Poems wanted. Free examination. McNeil, Master of Music, 510-PM South Alexandria, Los Angeles, Calif.

WRITE Songs. Big money and reputation. Write for information. J. Gordon Pub. Co., 201 N. Hoyne Ave., Chicago.

SONGWRITERS' Opportunity—Free booklet "Getting Ahead in Songwriting." Write today. Song Service, 43-C Park Place, Brooklyn, N. Y.

DUO-FLEX Reeds for clarinets, and saxophones eliminate your reed troubles. Write for circular. Duo-Flex Reeds, 1204 1st Ave., Evansville, Ind.

SONGWRITERS: Send poem for our offer and free rhyming dictionary. Richard Brothers, 24 Woods Building, Chicago.

RADIOS, SUPPLIES, INSTRUCTION

COMMERCIAL Radio licenses speedily obtained through non-mathematical, easily understood, home study radio course. Moderate tuition fee. American Radio Institute, 1123 Broadway, New York.

RADIO Hints, 32 page lesson, 10c. Supreme Publications, 328 South Jefferson, Chicago.

RADIO Service men and experimenters send for our giant radio catalog. Save dollars. United Radio Co., (1000 M.) Newark, N. J.

REVISED Plans 18 distance crystal sets, with "Radiobuilder"—year. 25c. Laboratories, 1406-C 77th Avenue, Oakland, California.

MONEYMAKING OPPORTUNITIES

MAKE Extra money writing fillers, gags, short articles. Free literature. Richard Publishing, 4340 Maple, Dallas, Texas.

MAKE Money by mail. Stamp brings facts. Graham, Real Estate Trust, Philadelphia.

EARN Money evenings, copying, duplicating cartoons for advertisers. Ad-Service, Argyle, Wis.

MAKE Your own Flexible Molds. Statuary, Art Goods, Novelties. Artificial Marble Flooring, Liquid Marble. Literature free. Kemico, 103-M, Park Ridge, Ill.

TWENTY Dollars daily reclaiming lube. Boisset, Box 483, New Orleans, La.

BOOKKEEPERS (Experienced) for profitable accounting work. Ralph Lee, Vicksburg, Michigan.

MANUFACTURE: For us or sell direct to homes and public buildings, a new invention, made from discarded tin cans. Retail for 50 cents. Full particulars and sample \$1.00. Albright Specialty Co., Burbank, Calif.

OPERATE Mail order business. New office specialty. 67% profit. Not sold in stores. Particulars free. Fidelity Mercantile, Inc., Roanoke, Virginia.

100,000 ARTICLES. Buy wholesale. Valuable supply source directory 10c. Ideal Service, D3, Park Ridge, Ill.

WARTIME Plan! Will you give us 5% first \$600 you make? Afternoons free! Work home. \$1,000 month reported (exceptional—fulltime). Expect surprise! National, Box 1240, San Bernardino, Calif.

WHOLESALE Sources. 500,000 articles. Free directory. Maywoode, 1133 Broadway, New York.

\$24,000 RICHER: Used three formulas from "Schemer Magazine." Alliance, Ohio. Six copies (288pp) just 40c.

RAISE Guinea pigs, thousands needed. We supply breeders and buy the young. Free details. Research Supply, 2436 W. York Street, Philadelphia, Penna.

OPERATE A mail order business at home! Zillman, 4446 North Kidare Avenue, Chicago, Ill.

EARN Money at home! Thousands do! "Home Worker Magazine" tells how. Sample, 25c. Sizemore, Box 7, 4917 North Kostner, Chicago.

BE A metascientist. Remarkable drugless healing system. No manipulation, no apparatus. Inexpensive correspondence course. Free information. Metascience, Deland, Florida.

YOU'LL Like resilvering mirrors, tableware, making chipped glass nameplates, signs, Outfit prices. Sprinkle, Plater, 287, Marion, Indiana.

BUSINESS OPPORTUNITIES

HAVE You outstanding accounts? Why not collect them yourself with the Checkboard System? Satisfaction guaranteed. Creditors Service, Moorcroft, Wyoming.

MECHANICALLY Inclined men—Own and operate general appliance repair shop. Complete, illustrated course shows you how. Welding, refrigeration, motor repair, how to get business, etc., all phases covered. Free literature. Christy Supply, Dept. 114, 2885 N. Central Ave., Chicago.

MAKE Cuts from photos and drawings. Simple. Inexpensive. Both processes \$1.00. Lucius Dawson, Box 20PM, Station "J," New York.

END Money worries. Build your own business at home Making Beautiful Glass and Illuminated Signs—Mirrors—Emblems—Picture Mounts. No expensive equipment needed. Experience not required. Expert will show you how. Write immediately. Cheney Sign System, Park Ridge, Ill.

OPERATE Mail order business at home. Details dime. Maples, 3418 South Marshfield, Chicago, Illinois.

YOUR Own business anywhere! 1000 tips—25c! M. Lillie, Washington Bridge, P.O. Box 134, New York.

BE Your own boss—Make big money—All or spare time. Learn to paint signs, write show cards. Particulars free. Oliver Hiatt, Elwood, Indiana.

ADVERTISING Paper. \$50 weekly. Proof, examples, \$1. Letts, Buchanan, Michigan.

SECRET Information. Learn how to cast beautiful white sparkling marble. Send \$1.00. Edmund Bishop, 6709 Beloit Rd., West Allis, Wisconsin.

PRODUCE Luminous house numbers, switch-plates, etc., non-technical; \$1.00 complete. Luco, 3402 Market, San Francisco.

A 3-CENT Stamp will bring information that can make you independent. Powers Service, 475 Fifth Ave., New York.

INCORPORATE Your business. Delaware laws. Many advantages. Free details. Corporation Fiscal Co., Wilmington, Del.

START Home business making statuary, plaques, art goods, novelties, souvenirs, concrete pottery, garden furniture, artificial marble flooring, liquid marble. Make your own flexible molds. Amazing profits. Valuable folder free. Creative Publishers, (PM3), Glencoe, Illinois.

MEN—Women start candy kitchen in your home. Full or sparetime. Folder free. Thompson Co., Baldwin, Michigan.

"RUBBER Molds." Make them yourself. Formulas, instructions 25c. Ideal Service, RM-3, Park Ridge, Ill.

\$75.00 WEEKLY Income operating route Automatic Merchandisers. Send 50c for catalog, instructions. Asco, 140 H Astor Street, Newark, N. J.

HOME Craftsmen. Assemble and sell Dillabaugh Plywood Rowboats for big profits. I furnish material, parts, instructions. You assemble in spare time. Write today for proposition. C. R. Dillabaugh, 7920 Mallory, Portland, Oregon.

MAN Wanted to supply Rawleigh's household products to consumers. We train and help you. Good profits for hustlers. No experience necessary to start. Pleasant, profitable, dignified work. Write today. Rawleigh's, Dept. C-53-PPM, Freeport, Ill.

OUTSTANDING Opportunity; profitable, permanent. No canvassing. McArthur, Drawer 339(5), Butte, Montana.

INVENTORS—We successfully sell inventions, patented and unpatented. Write us, if you have a practical, useful idea for sale. Chartered Institute of American Inventors, Dept. 4-C, Washington, D. C.

CALIFORNIA Nut coated raisins, make sell, sample, details dime, or, one defense stamp. W. L. Small, Los Molinos, Calif.

CONVERT Tin cans into steel scrap, valuable tin, by chemistry. Process and sample \$1.00. Forty formulas 50c. Harry D. Cater, 455 Washington St., Denver, Colo.

"MAIL Order Digest"—Opens closed doors to beginners and established. Sample copy 10c. Mako Sales Co., 5226 Tennessee, St. Louis, Mo.

3 MOST Read mail order magazines. 3 months 25 cents. Armand Cartier, 695 North, Pittsfield, Mass.

"SNOW-WHITE," "Tinted," Multi-Colored! Liquid Marble makes beautiful glazed tile effects in bathrooms and kitchens. Other uses. Make and apply Insul-Tex Composition Flooring. Lifetime wear. Moul-Dex flexible molds. Quicker. Better. Cheaper. Make your own at low cost. No priorities. Details free. Compo-Tex, Box 786, St. Louis, Mo.

GOOD Paying business silvering mirrors, plating autoparts, reflectors, bicycles, bathroom fixtures by late method. Free particulars and proofs. Gunmetal Co., Ave. H, Decatur, Ill.

"LUMINOUS Paint" shines in dark. Easily made. 150 other formulas, plans—all 25c. Ideal Service, 303, Park Ridge, Ill.

PROFITABLE Home business resilvering mirrors easily learned, almost unlimited opportunities, no experience necessary, complete instructions \$2.00. Joyce Mirror Co., Canfield, Ohio.

\$50—\$100 WEEKLY Using sawdust. Stamp please. Clement, 943 Arthur, Rochester, N. Y.

A RED Hot money maker. Guaranteed to make money quick. Invest \$2.50 take in \$15.00 to \$20.00 weekly. Start small, grow big. No selling. This amazing information for dollar bill. Fleck, Box 306, Columbia City, Indiana.

WEBER Typewriter Mechanics School. Instructions simplified by mail. Canton, Ohio.

OPERATE Route used 1c, 5c candy bar, peanut gum vendors, \$1.50 up. Northside Company, Indianapolis, Iowa.

GUARANTEED Mailorder letters, circulars, campaigns expertly planned, written. Big "blitzkrieg" results! Low cost! Les Finkel-Advertising, 1013P Los Angeles, Los Angeles, California.

SINGLE-INGREDIENT Formulas. No manufacturing! Information free. B. Kinford, Fort Lauderdale, Florida.

METALLIZING Baby shoes makes you money! (Non priorities process.) New! Simple. Fascinating. Small investment, fine profits! Free details. Novelty Metalizers, Box 933M Church St. Annex, New York.

FREE—Big list of helpful books. Popular Mechanics Press, 200 E. Ontario St., Chicago.

PLASTEX Industries offers industrious men an opportunity to start a business of their own, manufacturing art goods, novelties, souvenirs, etc. in Plastex and marble imitation. 5c material makes \$1 articles. Rubber moulds furnished for speed production. Small investment brings good returns. We are now placing big chain store orders with manufacturers. Write for interesting booklet mailed free. Plastex Industries, Dept. A, 1085 Washington Ave., New York.

BRUSH Plating outfits connect to a battery, no tanks necessary. Almost as simple as painting. Your opportunity to make good income plating autoparts, bathroom fixtures, reflectors, mirrors. Get free proof and particulars that put you in a paying business of your own. Gunmetal Co., Ave. H, Decatur, Ill.

HOW And where to obtain capital. Fully explained, particulars free. Star Service, Wapakoneta, Ohio.

MAIL Order business is your opportunity. Many began small, now earn thousands yearly. No personal contacts. Boundless selection. Have had over 40 years experience; will help you succeed. 25c brings two valuable booklets. None free. B. Brenner, 257 S. 21st, Philadelphia.

POPCORN And potato chip machines. We help start men and women in business. Long-Eakins, 1960 High, Springfield, Ohio.

COLOR Concrete with chemicals. Washing wells. Stucco-rock. Benches. Spin concrete potters. Cement artistry. Garden ornaments. Cold glaze. Concrete paints. Marbling. Sample 10c. Hollywood Cement Craft, 8527 Wonderland, Hollywood Calif.

MAKE Colorglazed concrete pottery, cemetery products, tiles, floors. Basement waterproofing. Other projects. Booklet, colorplates, details 10c. National Pottery, Minneapolis, Minnesota.

LIQUID Marble—Colorful, glazed! Mold, brush, spray! Composition floors, rubber-lastic molds. Particulars free. Marbleizing Service, Edwardsville, Illinois.

CHARTERS: Delaware; best, cheapest; free forms. Colonial Charter Co., Wilmington Del.

ELITE Collection of business plans, contains 127 tested plans and scores of formulas. Start own business; home office. Particulars free. Elite Co., 214 Grand St., New York.

WHERE To buy at lowest wholesale prices. Information free. Yorena, Box P-312, Bayonne, N. J.

127 WAYS To make money, in home or office, business of your own. Full particulars free. Elite Co., 214 Grand St., New York.

YOUR Ad in this space will bring amazing results. I'll prove it to you. Write at once for interesting information. F. W. Johnson, Room 300, 200 East Ontario St., Chicago.

YOU'LL Like resilvering mirrors, tableware, making chipped glass nameplates, signs. Outfit prices. Sprinkle, Plater, 127, Marion, Indiana.

FREE—200 Clever mailorder, homework, local business offers—all snappy money-makers. Lewis Co., 828-M Carpenter, Oak Park, Ill.

2c DAILY Pays for New York office under your own name. Co-Operative Offices, 126 Lexington Avenue, New York.

START A business at home. Learn airbrush painting. Send \$1.00 complete instructions. Bernadac, Northport, N. Y.

SPECIALTY Manufacturing — 1000% profit! Formulas especially designed small businesses. Little capital, no machinery. Brochure free. Victor J. Race, Norwalk, Connecticut.

WORK For yourself and make all the profits. We show you how. Suggestions free if you are interested. Hutter, 1085 Anderson Avenue, New York, N. Y.

WILL You give us 5% first \$500 you make? Afternoon, free! Work home. \$1,000 month reported (exceptional—full-time). Expect surprise! Also wartime plan! National, Box 1240, San Bernardino, Calif.

MAKE Artificial marble, glazed tiles, moldless pottery sanitary flooring, chemically stained cement, superhard figurines, rubber molds. Cement secrets. Samples 3c; expect surprise. Payne, 945 Grande Vista (Room 101), Los Angeles, Calif.

MOLD Plastic novelties. Big profits. Rubber molds furnished. 24-page catalog and instructions free. Plastic Arts, 711 Neely, Muncie, Ind.

MAKE Money by mail, the way we do. Free information. Maywood, 1133 Broadway, New York.

SELL Books by mail on commission. No stock to carry. Orders come to you. Maywood Publishers, 1133 Broadway, New York.

FORMULAS, PLANS, ETC.

FORMULAS. Correspondence invited. Literature free. Garda, 264 Ninth, Paterson, N. J.

PRACTICAL Manufacturers formulas. Analysis, free literature. B-Flegg, 219 Donlands, Toronto.

MAKE Fast selling products. No machinery. "Chemist Approved Formulas." Catalog free. Kemico, 12-P, Park Ridge, Illinois.

AUTHENTIC Formulary, 924 pages. (Illustrated.) Recipes, instructions;—10,000 money-making products. \$1.50 postpaid or C.O.D. (Foreign \$1.85.) Adams Brown Company, Chestnut Hill, Mass.

FORMULAS—Technical, general, guaranteed. List free. W. S. Mann, Chemical Engineer, Healdsburg, California.

65 SINGLE Ingredient formulas. Simple—no manufacturing. Help given all purchasers. Rush 1.00. Expect bargain. Sent airmail postpaid. Formulas-A, Box 1158, Providence, R. I.

SINGLE-INGREDIENT Formulas. No manufacturing! Information free. A. Kindford, Fort Lauderdale, Florida.

FORMULAS, Analytical service. Catalog free. Thaxly Co., Washington, D. C.

CHEMISTRY Laboratory apparatus and chemicals for industrial, analytical, and private experimental laboratories. Complete chemical laboratory supply service for correspondence school students. Send 3c for free 48-page catalog of chemicals and apparatus. Dept. M-43, Biological Supply Co., 1176 Mt. Hope Ave., Rochester, New York.

REAL Manufacturing formulas. Lists free. Cummings, Chemist, Gordon Ave., Syracuse, N. Y.

ELITE Formulas and plans; make and sell your own products. Descriptive booklet free. Elite Co., 214 Grand St., New York.

NEW Money making formulas book tells how to go into business for yourself. Send for free details. Popular Mechanics, 200 E. Ontario, Chicago.

CHEMISTRY

WINN'S New idea chemical kits and apparatus outfits for students, big value. Free literature and catalog of chemicals and laboratory supplies. Scientific books at big discount. Send 3c return postage. JE-3 Winn, 124 W. 23rd, New York.

CHEMISTS. Chemical questions answered 25c. Formulas, analyses. Lewitsky, 26 Erwin Place, New Britain, Conn.

FREE Catalog; chemistry, mineralogy, biology, microscopes. Tracey Laboratories, Evanston, Illinois.

FREE List chemicals, apparatus, supplies. Delta Sales Co., Chalmette, La.

CHEMICALS—5c Quantities, apparatus, catalog 5c. Fleischer's Laboratories, Medford, Mass.

SPECTROSCOPE For quick chemical analysis \$2.50. Kutting Sons, Campbell, California.

HELP WANTED

BIG Uniform manufacturer seeks man to contract restaurants, beauticians, doctors, nurses, factories, offices, homes, others. Offer exclusive, patented styles; unsurpassed workmanship. Leads furnished. Permanent. Outfit free. Hoover, 251 W. 19th, Dept. BL-10C, New York City.

WOMEN Wanted! You can make money supplying consumers with the well known Rawleigh products. We supply stocks, equipment on credit; and teach you how. No experience needed to start. Over 200 easily sold home necessities. Large repeat orders. Permanent, independent, dignified. Many women now making splendid incomes. Full or spare time. Write Rawleigh's, Dept. C-144-PPM, Freeport, Ill.

RELIABLE Man or woman wanted to call on farmers. Some making \$100.00 in a week. Experience unnecessary. Write McNess Company, Dept. 589, Freeport, Ill.

FREE—Big list of helpful books. Popular Mechanics Press, 200 E. Ontario St., Chicago.

AGENTS WANTED

AGENTS—Salesmen. 200% profit. New 10c collar support every man needs. Sell stores and direct. Sample 10c. Details free. Also other new items. Hawkins, 537-P So. Dearborn, Chicago.

FAST Selling emblem of honor for relatives and friends of soldiers and sailors. Men and women send for sales plan. Landseire, 10 Murray St., New York City.

AIR Ventilated leather belt 50c (75c value); 85c (\$1.25 value). Postpaid cash with order. Manufacturer, 844 W. Baltimore, Baltimore, Md.

SELL Dresses low as \$1.24. Hundreds sensational bargains. Actual samples free. Send dress size, age. Harford, Dept. H-356, Cincinnati, Ohio.

CALL On friends with greeting card assortments; Easter, birthday, other occasions. Personal stationery; gift wrappings. Big profits. Experience unnecessary. Samples on approval. Wallace Brown, 225 Fifth Avenue, Dept. J-34, New York.

SELL Nylon hosiery and famous snag-protected silk hosiery. Sensational profit opportunity. Write fully for free selling outfit. American Mills, Dept. H-198, Indianapolis, Indiana.

WRITE For free fabric samples amazing stainproof tablecloths. Clean with damp cloth. Require no ironing. Beautiful patterns. Look expensive, long wearing, low priced. Commissions big. Also complete dress line. Melville Company, Dept. 3177, Cincinnati, Ohio.

FREE Water and our concentrates make 72 products. We supply labels, bottles. Enormous profits. Qualco, E-20030 Russell, Detroit.

I WILL Give you \$5.00 worth full size packages foods, groceries, soap, etc. Free if you agree to show friends and others. Amazing spare time money making opportunity. Write Zanol, 6240 Monmouth, Cincinnati, Ohio.

DON'T Be a job hunter—Start your own business on our capital. No hard times; no layoffs; always your own boss. Hundreds average \$3,000 to \$5,000 annual sales year after year. We supply stocks, equipment on credit. 200 home necessities. Selling experience unnecessary to start. Wonderful opportunity to own pleasant, profitable business backed by world wide industry. Write Rawleigh's, Dept. C-U-PPM, Freeport, Ill.

SPECTACULAR Demonstrator. Make-sell sensational new cleaner. Details. O-Belfort, Engineering Building, Chicago.

SELL Individualized belts, buckles. Over thousand emblems to choose. Fast money maker. Repeat business. Write today special outfit offer. Hook-Frost Specialties, Box 1425, Providence, Rhode Island.

"REMEMBER Pearl Harbor" calendar. Uncle Sam spans Jap. Sells 35c. Sample 15c. Tuclaw, Stanhope, New Jersey.

SCHOOL Seniors—Sell graduation cards. America's largest, fastest selling display. 30% commission. Free cards. Universal Engraving & Printing, Box 745-M, Pittsburgh, Penna.

AGENTS—To mail our literature. Good profits. Home business. Maywood, 1133 Broadway, New York.

HELP National defense! Sell Exolene. Powerful mile increasing, anti-knock. Saves gasoline, motors, repair bills, money. Thermox, Peoria, Ill.

SELL Guaranteed monuments. Large commission daily. Prices defy competition. No investment. Exclusive territory. Mihelich Monuments, St. Cloud, Minn.

THIS Man's idea is a God-send to folks who need money. Laugh at "War-Pig." 25c complete. You make 1000% profit. Money back without question if not entirely satisfied. Send quarter to Ontario Enterprises, U. S. Post Office Box 575A23, Rochester, New York.

WANTED Men and women everywhere to work for an old reliable firm. We pay \$50.00 a week, age is unlimited. Write for territory with samples 27x51-in. send 25c coin, and addressed envelope, with 3c stamp. Akron Rug Co., 5 N. Adams St., Akron, Ohio.

CALL On dairies. Sales repeat monthly. Carleton Sales, East Hartford, Conn.

ENGRAVED Name plates, numbers, signs, etc., easily sold, profits large. Brett Bros., Winthrop, Mass.

AGENTS: Stamping names on pocket-protectors. Sample check with your name, address, 25c. Stamping outfits, Emblem checks, check-fobs, name plates, Hart Mfg. Co., 303 Degraw St., Brooklyn, N. Y.

AGENTS—300% Profit selling gold leaf letters, stores and offices. Free samples. Metallic Letter Co., 438-B North Clark, Chicago.

YOU'LL Like resilvering mirrors, table-ware, making chipped glass nameplates, signs. Outfit prices. Sprinkle, Plater, 128, Marion, Indiana.

AMBITIOUS School seniors—Sell classmates the "tops" in graduation name cards. Best commissions. Free cards. Agencies going like wildfire. Hurry! Craftcards, Box 235-L, Pittsburgh, Penna.

AGENTS. Big line including food products. Fast selling premium and bargain deals. Low prices. Send card for big outfit with gift. Ho-Ro-Co., 2701 Dodier, St. Louis, Mo.

AMAZING Cleaner! Makes cleaning easy. Premium deals gets orders. Free sample. Zimco, 5007 Irving Park, Chicago.

WINDOW Sign letters. New "Roman" style. Large sizes, penny each. Absolutely beautiful. Free samples. New catalogue. Atlas, 7941 Halsted, Chicago.

GAS Stations want this new patented necessity. Knipp, Long Beach, California.

GOOD Paying business silvering mirrors, plating autoparts, reflectors, bicycles, bathroom fixtures by late method. Free particulars and proofs. Gunmetal Co., Ave. N. Decatur, Ill.

BIG Money applying initials on automobiles. Easiest thing today. Free samples. If you sell printing and advertising specialties we have an excellent sideline featuring Decalcomania name plates in small quantities. "Ralco," 727 Atlantic Ave., Boston, Mass.

SELL Natural "B Complex Vitamin Tablets." Big opportunity. Special offer to agents. 15 day trial size \$1.00. Youth Kist Vitamins, 5302 N. Kedzie, Chicago.

DO You want agents for your proposition? Your ad in this space will place your message before hundreds of men seeking fast-selling products. My folder "How to Secure Agents" is filled with proof. I'll gladly send you a copy free. F. W. Johnson, Manager Classified Advertising, Popular Mechanics Magazine, 200 E. Ontario St., Chicago.

HIGH-GRADE SALESMEN

MEN—More money for you. Sell bulk handsoap. Free details. Tom Good Products, 138PM South Central Ave., Marshfield, Wisconsin.

BIG Money daily. Sell business stationery, advertising specialties, book matches, gummed tape, 700 other necessities to stores, offices, professional men. 33-1/3% profit paid daily. Biggest best line of its kind. No experience needed. Big outfit free. Wilfens, 2130 Gladys, Department 43, Chicago.

BIG Commissions—selling to stores celulooid pricing tickets, metal shell moulding. To restaurants, menu covers, signs. P. Pricing Press, 124 White St., New York.

ADVERTISING Book matches. America's largest manufacturer of union label book matches. Fast selling line. Large sales producing kit. Sample matches. Complete cut catalog. 13 color combinations makes selling easy. Commission in advance. Superior Match Company, 7530 Greenwood, Dept. N-3, Chicago.

SELL Big Four Safety System through organizations. Prevent accidental destruction. Vital for victory. Sample packet 25c (coin). A. F. Hoppe, Cedar Falls, Iowa.

ADVERTISING Book matches—World's largest "direct selling" book match factory offers advance cash earnings calling on every type of business. Experience unnecessary; full, part time. Low prices for high quality; quick deliveries, help you get orders. Good repeat profits. Free kit, instructions. Match Corp. of America, 3433 West 48th Pl., Dept. E-3, Chicago.

MAN With car to establish retail store route. Openings almost every locality. Handle orders for nationally known manufacturer-jobber. Average 50% commission. Steady big pay opportunity. Sales experience unnecessary. World's Products Co., Dept. 103, Spencer, Ind.

SALESMEN—Sell line glass calendars. Kirstein, 158 Monroe, Rochester, N. Y.

CALENDARS. Fans, novelties—Beautiful complete lines all sizes, including jumbos, samples free. Start now, be first in field. Fleming Calendar Company, 6530 Cottage Grove, Chicago.

EXCELLENT Opportunity selling our complete line of brushes, largest commissions. Write for sales plan. Wire Grip Sanitary Brush Company, 2300 5th Ave., New York.

NEW Specialty—Sells every business and professional man. Four \$15 sales daily pay \$270 weekly. Farrell cleared over \$1,000.00 monthly. Write, F. E. Armstrong, President, Dept. FM, Mobile, Ala.

BLADES—Big profits. Best quality. Factory prices. Ace Blades, Buffalo, N. Y.

EARN Money in your spare time taking subscriptions to Popular Mechanics. Unlimited possibilities, every family a prospect. Easy to sell. Bonus paid in addition to liberal commission. Send postcard for further details today. Circulation Dept., Popular Mechanics Magazine, 200 E. Ontario St., Chicago.

EDUCATIONAL AND INSTRUCTION

IMMEDIATE Openings for arc welder students in expanded famous Lincoln School. Big opportunity for learning arc welding. Now in big demand. Bright future. Write Lincoln Welding School, Dept. WS, 12818 Coit Road, Cleveland, Ohio.

WELDING—Electric arc. Learn profitable trade quickly through actual practice. Individual welder instruction at bare cost of materials. Full particulars free. Valuable welding lessons book 50c. Hobart Welding School, Box M-321, Troy, Ohio.

TRADE Journals, large list. See our advertisement under Books, Periodicals, Commercial Engraving Publishing Co.

FOR An extremely profitable lifetime business, operate a collection agency-credit bureau. Inexpensive short course. Write Cole Associates, Syracuse, N. Y.

WELDING Opens the way to good pay and future in important industries. Growing need for trained welders. Prepare now. Practical, personal training spare time at home and Chicago. Write for free facts. Utilities Engineering Institute, 1314 Belden, Dept. 123, Chicago.

ENJOY Health. Become professional acrobat. Free health book. Write! Emil Knoff, 2154MM North 52nd Street, Milwaukee, Wis.

CLINICAL Laboratory technic taught in your own home. Practice outfit supplied. Bulletin free. Imperial Technical Institute, Box 973-E, Austin, Texas.

AIRCRAFT Training. New, simplified courses. Aircraft, engine mechanics, const., drafting, Shipyard welding. Also home study. Free copy, Airpower. Western Air College, Dept. 9, Alhambra, Calif.

BECOME An accountant! Short inexpensive course. Write to Cantrell's Institute, 1002 Berkeley, Pueblo, Colorado.

LEARN Shorthand-typing easily. Both books, 30c. Clifton, 272P, McKinney, Tex.

WATCHMAKING—Learn. Material instructions for start and wholesale supply catalog, all \$1.00. Refund not satisfactory. Stewart's, 721 Olive, St. Louis, Mo.

BASE Eight arithmetic and money. Free leaflets. E. M. Tingley, Oak Park, Illinois.

LEARN Telegraphy! Splendid opportunities now prevail. All expenses low. Catalog free. Dodge Institute, Dept. M, Valparaiso, Indiana.

ZEND. Mystic, secret language learned easily in month. Practically short as English. Instructions 25c. Two booklets 40c. Zenda, Burbank, California.

RADIO Engineering, broadcasting, aviation and police radio, servicing, marine and Morse telegraphy taught thoroughly. All expenses low. Catalog free. Dodge Institute, Dept. R, Valparaiso, Ind.

NEW Writers needed! Free test shows your ability. It's fun! We show what to write, help you sell. Rush postcard. No obligation. Comfort Writer's Service, Dept. 786-J, St. Louis, Mo.

PREPARE For post office examinations. For free literature write Lakeview Preparatory School, Department P, 1280 East 114 Street, Cleveland, Ohio.

BEST Pay trades all times; short terms. Low cost. Catalogue free. Clean interesting work. Decorating, paperhanging, graining, marbling, sign and pictorial work. Chicago Painting School, 102 West Lake Street, Chicago.

MACHINISTS And tool makers urgently needed in Cleveland. If interested in learning these trades, write Krause Engineering Co., 272 Hanna Bldg., Cleveland, Ohio.

SECRET Investigation. Experience unnecessary. Detective particulars free. George Wagner, M-2640 Broadway, N. Y.

LOCKSMITH Course. Lock picking, key fitting, etc. \$1.00 prepaid. Locksmith, Canadian, Texas.

BECOME A Doctor of Psychology (Ps. D.) Teach secret of contentment, happiness. Solve mental worries. Free book. College of Universal Truth, 20-B East Jackson, Chicago.

DISSATISFIED? Find out definitely what job or profession you are best fitted for. Write Vocational Interest Service, Box C-24, 224 Sullivan St., New York.

TOOL Designing pays big. Home study course. Low cost. Easy terms. Free booklet. Ohio Institute of Technology, Box 53, Greenville, Ohio.

WELDING. Soldering, plating books—Latest titles—Bargain catalog free. Popular Mechanics, 633 St. Clair, Chicago.

PLAYS, STORIES, MANUSCRIPTS

1942 **HUMOR** Market folio. Over 100 paying markets for jokes, cartoons, humorous poems, stories, addresses cartoonists wanting gags, ideas, etc.—25c. 1942 poetry, greeting verse market folio (over 150 paying markets)—25c. Market folios. Complete services—all writing fields. Particulars free. Bierman, 7 East 42nd Street, New York, New York.

STORIES, Novels, poems wanted for publication. Many eager markets. Author will help you sell. Manuscripts marketed, revised, typed. Christopher Carr, 3636A Chestnut, Philadelphia, Penna.

CARTOONING, COMMERCIAL ART, SHOWCARD WRITING, SIGN PAINTING

YOU Can learn cartooning easily from cartoonist's originals. Harris, 3541 North 28th, Omaha, Nebr.

EARN Money evening, copying, duplicating comic cartoons for advertisers. Ad-Service, Argyle, Wis.

BECOME Cartoonist overnight! Don't copy! Originate comic characters instantly! Have fun! Make money! Rush name for free details! National Artists, 801-A North Marsalis, Dallas, Texas.

FEN and ink drawings. Let us draw your advertising and catalogue illustrations, from photos, copies or objects. Best work and fair prices. Heraldic Studios, 1914P Oakdale Avenue, Chicago, Ill.

CARTOONING Course—30 illustrated lessons, over 500 sketches, drawing paper, pens and pencils, complete, \$1.00 postpaid. Montes Studio, Box 965, Pasadena, Calif.

BUSINESS SERVICE

MAIL Address, your name, \$1.00 monthly. Kay, Stimson Building Los Angeles, Calif.

CHICAGO Mail address: \$1 monthly—Receiving, reforwarding your business, personal mail. General, 30 West Washington. (Established 1919).

SAN FRANCISCO Reforwarding service; prompt, bonded, obliging; \$1.00 month. 3402 Market St.

HAWKINS Mail Service, Washington, D. C., will receive-reforward your mail from 908d Fourteenth.

ADVERTISING AGENCIES, LETTER WRITERS, FOR ADVERTISERS

ADVERTISE Profitably: \$15 reaches 5,000,000 Sunday newspaper readers with 24-word ad. Newspaper, magazine, mailing-list ratebook, free. Chicago Advertising Agency, 20-PA West Jackson, Chicago.

ADVERTISE: 24 Words, 149 newspapers \$6.50. Lists free. Advertising Bureau, 4515-C Cottage Grove, Chicago.

FREE—New Advertisers Rate Guide, 44 pages. Includes everything. Lowest rates. E. H. Brown Advertising Agency. Merchandise Mart, Chicago.

ADVERTISING Placed all magazines, newspapers, U.S.A., Canada. Lowest rates. Free service. 54-page catalog free. Baker Advertising Agency, A-189 W. Madison, Chicago. Established 29 years.

TYPEWRITERS, DUPLICATORS, OFFICE DEVICES

"NEW Process" stencils for all duplicators \$2.30 quire of 24.5 quires \$9.50. Used office stencil duplicators, typewriters, \$15.00 up. Self-feeding post card stencil printer \$8.10. Write Pittsburgh Typewriter Supply, Department K-22, Pittsburgh, Penna.

TYPEWRITERS. Adder, mimeograph, multigraph, addressograph. Send for free lists of machines that will help you at half price. Pruitt, 28 Pruitt Bldg., Chicago.

RUBBER STAMPS AND OFFICE SUPPLIES

SUPERIOR. Indexed. Two lines 25c, three 35c, four 50c. Slocum, 814 Bradley, Peoria, Illinois.

MAKE Your own rubber stamps, complete instructions, drawings formulas, 25c. Harvey, 1616 E. 14th, Oakland, Calif.

CUSHIONED 3 Lines 35c. Signatures \$1.50. Lentz, Box 402, Youngstown, Ohio.

RUBBER Stamps. All kinds. Catalog free. Illinois Rubber Stamp Works, 2913-PM North Rockwell, Chicago.

KNOB Handle, cushioned. 2 lines 30c, 3-40c. Stamp Works, Centerport, N. Y.

3 LINES 27c; Cushioned, indexed, 35c. Stampworks, Wauwatosa, Wis.

2 LINES 25c, 3 Lines 35c. Stamp Works, Auburn, Nebr.

PRINTING OUTFITS AND SUPPLIES

INEXPENSIVE 6x9 Printing press. Details free. Novelty Shop, Downsville, Louisiana.

PRINT Your own cards, stationery, circulars, advertising. Save money. Simple rules furnished. Print for others, nice profit. Junior outfit \$8.25, senior outfits \$16.55. Details free. Kelsey, Inc., T-11, Meriden, Conn.

PRINT At home. 10c will bring a complete catalog of presses, type and supplies. F. Peifer & Company, 6 Columbia St., Newark, N. J.

BARGAINS — Presses, type, supplies. Send stamp, 159 Harvard, Cambridge, Mass.

USED Presses, type, supplies. Lists 3c. Turnbaugh Service, Loysville, Penna.

PRINTING, MULTIGRAPHING, MIMO- GRAPHING, GUMMED LABELS

GOOD Printing reasonably priced. 500 letterheads, blotters, statements, envelopes, cards, \$1.50. Let us know your printed requirements for our low estimates. Write today! Birchwood Printers, East Paterson, N. J.

FOLDERS—All sizes, lowest prices. Envelope size, \$1.60 thousand. Samples. Goodprint, Harrisonburg, Va.

DISTINCTIVE Job printing. Particulars free. W. D. Treaster, Milroy, Penna.

PERSONAL Stationery—100 envelopes, 200 sheets (100 unprinted) \$1.25. Trafeflet Printing Co., 12211 Steel, Detroit, Mich.

NOTEHEADS—2-Color printing. Colored bond—1000, \$3; 500, \$2. 5 1/2 x 8 1/2. Adams-Mullins, Big Laurel, Va.

1000 LETTERHEADS, Circulars, etc., \$1.95 each. Samples free. Thriftprint, Box 318, Chicago.

MIMEOGRAPHING—500 8 1/2 x 11 copies \$1.75. Postage extra. Samples. L. H. Cusack, Fulton, N. Y.

5000 PRINTED Envelopes, \$8.50; 1000 letterheads and envelopes, \$5.50. Economy, 30 East 23rd, New York.

LETTERHEADS, Statements, 6 3/4 envelopes, postcards, 200—\$1.00 postpaid. Benneville, 907 West Roosevelt, Philadelphia.

CENTRAL West Printers—Headquarters for dollar specials, 3226-P Jackson, Chicago.

DISTINCTIVE Printed stationery—200 note size, 100 envelopes, \$1.00 postpaid. Other quotations given. Victory Press, Indianapolis, Iowa.

200 5 1/2 x 8 1/2 LETTERHEADS, 100 Envelopes \$1.00. Mail Printing, Danvers, Mass.

HAMMERMILL Letterheads, envelopes, all colors, 32 styles type. Free particulars. Woodruff's, 217A Lewis, Duluth, Minn.

BETTER Printing, business-professional stationery, labels, stickers. Dobbs, Williamsburg, Kansas.

100 8 1/2 x 11 LETTERHEADS, 100 6 3/4 Envelopes \$1.00. C. F. Cramer, Box 993, Chicago.

WILL Exchange mimeographing for anything of value. What have you? Dollar Letter Service, 180 West Washington, Chicago.

QUALITY Printing in dollar packets. Samples. Economy Press, LaCrosse, Wis.

EVERYTHING Printed, wholesale prices. Free list, Midwestern Printing Co., Springfield, Missouri.

500 STICKERS, 2 1/2 x 3 3/8, 25c. New catalog. Labels. Cott's, Waverly, Kansas.

QUALITY Printing, mimeographing—unsurpassed. Low prices. Samples free. Fame Press, Lathrop, Calif.

500 3/4 x 2 1/4 FOUR Line gummed stickers, 25c. Moritz Printery, Saginaw, Mich.

JOB Printing. Quick, reasonable. Samples. Atlantic, Box 653-H, Rock Hill, S. C.

WANTED Printing of all kinds by thousands of our readers. Your ad in this space will bring you some nice orders. Write for positive proof. F. W. Johnson, Classified Advertising Manager, Room 304, 200 East Ontario Street, Chicago.

PATENT ATTORNEYS

68 PAGES OF facts for inventors. Two valuable advisory books specially prepared for men with ideas. "Patent Protection" tells you steps to take quickly without cost. "When and How to Sell an Invention" gives you six basic ways to commercialize your patent rights. Both books sent free. Write us today in confidence. Victor J. Evans & Co., Registered Patent Attorneys, 651-C Victor Building, Washington, D. C.

INVENTORS: Take first step toward protecting your invention—without obligation. Write for free "Record of Invention" form for establishing date of invention. We also send free—48 page book, "Patent Guide for the Inventor"—telling importance of prompt action, confidential search service; how to sell and market inventions; details of convenient payment plan. Send for free "Patent Guide" and "Record of Invention" form today. Clarence A. O'Brien, Registered Patent Attorney, 218-C Adams Building, Washington, D. C.

INVENTORS—Patent your invention. Secure book, "Protect, Finance and Sell Your Invention." No obligation. McMorrow and Berman, Registered Patent Attorneys, 1349 Barrister Building, Washington, D. C.

"INVENTOR'S Guide," 100 mechanical movements, free; advises on patenting, selling inventions. Frank W. Ledermann, 154 Nassau Street, New York.

L. F. RANDOLPH, 302-B Victor Bldg., Washington, D. C. Low cost. Book and information free.

PATENTS. Booklet free. Highest references. Best results. Promptness assured. Watson E. Coleman, Patent Lawyer, 724 Ninth St., Washington, D. C.

INVENTORS—Before disclosing your invention to anyone send for form "Evidence of Conception"; "Schedule of Government and Attorneys' Fees" and instructions. Sent free. Lancaster, Allwine & Rommel, 411 Bowen Building, Washington, D. C.

FOR INVENTORS

INVENTORS: Take first step toward protecting your invention—without obligation. Write for free "Record of Invention" form for establishing date of invention and free "Patent Guide for the Inventor"—telling importance of prompt action, confidential search service; how to sell and market inventions; details of convenient payment plan. Send today for free "Patent Guide" and "Record of Invention" form. Clarence A. O'Brien, Registered Patent Attorney, 21A-C Adams Building, Washington, D. C.

TWO Valuable books about patents and selling inventions—free. See Victor J. Evans advertisement under "Patent Attorneys" classification.

SCIENTIFIC Advice on inventive ideas. Send stamped envelope for particulars. Consult-Aid, Box 64, Braintree, Mass.

INVENTORS—Patent your invention. Secure book, "Protect, Finance and Sell Your Invention." No obligation. McMorrow and Berman, Registered Patent Attorneys, 1348 Barrister Building, Washington, D. C.

INVENTORS—What have you to sell? Manager, 35P North Ninth, Columbus, Ohio.

SAVE Money; time, worry, before you patent! Market invention quick system \$1.00. Inventor's Guide, LaCrosse, Wis.

ALBERT E. Dieterich, registered Patent Attorney, successor to Fred G. Dieterich Co., 511B Colorado Bldg., Washington, D. C. Inventor's Handbook on Patents mailed free on request.

WE Locate buyers meritorious patented, unpatented inventions. If will sell, reply immediately. Descriptive booklet, references, free. Invention Reporter, 5A-11236 South Fairfield, Chicago.

HAVE You a sound, practical invention for sale, patented or unpatented? If so, write Chartered Institute of American Inventors, Dept. 4-A, Washington, D. C.

I SELL Patents. Established in 1900. Charles A. Scott, 773PM Garson Ave., Rochester, N. Y.

CASH For practical ideas and inventions. Mr. Ball, AB-9441 Pleasant, Chicago.

SELL Your patent through a small classified ad in Popular Mechanics. Many inventors have found buyers in this way. Ask me for proof—I'll gladly send it to you. F. W. Johnson, Manager Classified Advertising, 200 E. Ontario St., Chicago.

INVENTIONS WANTED

WANTED Immediately, several unpatented inventions. Send name and address only for instructions. Invention-Service Company, Dept. A, Professional Arts Building, Hagerstown, Maryland.

WOULD You like steady income from unpatented ideas? Write Hendrixon, Argyle, Wisconsin.

CASH For inventions. Patented, pending, unpatented. Write: Universal Guaranty Company, Box 772, Lancaster, Penna.

SMALL Inventions wanted by manufacturers. I'll help you sell your invention. Write for free circular. Stanley Hull, 7829-K Euclid Avenue, Cleveland, Ohio

SIMPLE. Practical inventions wanted by manufacturers, patented or unpatented. For information write Chartered Institute of American Inventors, Dept. 4-D, Washington, D. C.

CASH For inventions, patented, unpatented. Mr. Ball, A-9441 Pleasant, Chicago.

PATENTS FOR SALE

HAND Operated mixer, patented. Mixes flour and shortening for pie in 30 seconds, mash and beats potatoes, lifts vegetables whole from pot, cleans with a swish in water. Cheap to manufacture, one continuous convolution of wire. Shape, spherical. Alfrida Jensen, 3939 No. Bernard Street, Chicago.

PLASTICS Putty gun, dispenses uniformly, continuously. T. Pasanen, Franklin Mine, Mich.

SCREW Bolt lock for doors; rain and waterproof padlock. Anton Rober, 504 West Concordia, Milwaukee, Wis.

TRACTION Device for rubber-tired tractors, entirely new. Carl Nelson, Dyars, Iowa.

MANUFACTURING

MODELS—Small lot manufacturing. Metals, plastics, etc. Milburn, Burlington, Kentucky.

HOME CRAFTSMEN

SQUAREKNOTTERS! Make belts, handbags, etc. Quality cord samples with catalog free. Beginners book, catalog and samples 10c. Special! Regular \$1 book with 50c beginners outfit, all for \$1. P. C. Herwig Co., Dept. J-32, 121 Sands St., Brooklyn, N. Y.

GET Free leathercraft instruction pamphlets, prices of leathers, tools, projects. Fascinating hobby. Make beautiful gifts. Leather samples 5c. Wilder & Company, 1938 Crosby, Dept. 3F, Chicago, Illinois.

KNOCKDOWN Kits—Walnut, plastic, carved, inlaid—furniture, lamps, novelties. Ship models. Machinery. 40-page catalog, 10c. Woodcraft Service, Plainview, Minnesota.

49 LAWN Ornament patterns, some 21" high, 20 novelty patterns, 20 silhouette patterns, 89 patterns \$1.00. Modern Woodcraft, Saginaw, Mich.

MAKE Money building bird houses. Great demand. Illustrated instruction book 25c. Popular Mechanics, 200 East Ontario, Chicago.

DEFENSE Work for home shops. New pamphlet. Illustrates home shops making defense items for profit. 1750 words, 6 photographs. Send dime. Craftsman, 118 Worth Street, New York.

15 PULL Size what-not patterns 25c coin. Albright Service, M6901 Railroad Ave., Omaha, Nebr.

LEATHERCRAFTSMEN! Send 10c for new handbook and catalogue of tools and supplies. E. A. Sweet Company, Inc., Leathercraft Division, A-55, 148 State Street, Binghamton, N. Y.

28 LAWN Ornament patterns 25c. Other patterns: 15"-20" high; Dutch girl, Dutch boy, pirate, bull terrier, Mexican girl, Mexican boy, dwarf, penguin, flower girl, 10c each; 3 for 25c. 25 novelty patterns 30c. All 62 full size patterns \$1.00 postpaid. Strother, Box 383-DH, Bellington, West Virginia.

DO Modern light furniture finishing for yourself or as a business. New method and materials give beautiful artistic finish. Easy! Fascinating! Send for free sample and details concerning inexpensive kit and instructions. Peter Jensen, Box 164, Washington Bridge Station, New York, N. Y.

LEATHERCRAFT Headquarters. Leather, tools and instructions for you to make most anything in leather. Also archery and woodcraft supplies. Send for catalog. J. C. Larson Co., 180 N. Wacker Drive, Chicago, Ill., Dept. 180-D.

KNOCKDOWN Cedar chest, lumber, veneers, illustrated catalog 10c. Giles Kendall Co., Decatur, Ala.

MAKE Beautiful Mexican plaques, 20 patterns, complete instructions 25c. Mexican Artcrafts, Eagle Pass, Texas.

1000 TELUHOW Plans, explained. For homecrafters of all ages. Classified list, 10c. C. King, E. Kingston, N. H.

BLACKOUT Headquarters! Venetian blind supplies, shades, curtains for window protection. Wholesale catalog 10c. "Manufacturing Booklet" \$1.00. "Roberta," Gloversville, New York.

CRAFTSMEN! Be sure read advertisement of Wo-Met Shop, page 184.

WOODWORKING Power tools - Make them yourself. Lathe, scroll saw, saw table, drill press, portable sander, bandsaw, motorized plane. Complete details only 25c. Popular Mechanics Press, 200 E. Ontario Street, Chicago.

MODELS AND MODEL SUPPLIES

LEARN To enjoy your spare time. Get the greatest Scale Model Railroad Data Book ever published. Act quickly, and send 10c to Scale-Craft & Co., Libertyville, Ill., Dept. P.M.

LATEST Engine catalog 25c. Refunded. Howardco, A-2417 North Ashland, Chicago.

MODEL Railroaders, send 25c for copy of Model Railroader Magazine and 32-page booklet, "Your Model Railroad." Model Railroader, 1561 W. Pierce, Milwaukee, Wisc.

MODELMAKER'S Knife; extra keen, ebony cocobolo handle. 60c postpaid. "Bermoco," Berwyn, Maryland.

FREE! New big catalog of record breaking models. 52 picture packed pages, drawings and other information make this a modeler's reference book. Includes airplanes, speed boats, race cars, radio control. Enclose 10c handling charge. Berkeley, Dept. PM, 230 Steuben Street, Brooklyn, N. Y.

TRAINS—"O" catalog 25c, "HO" 10c. Walthers, 247 Erie, Milwaukee.

POWER Models. Railways, traction engine, steam and gasoline engines, all accessories, metals, tools. 84 page catalog 35c. Chas. Cole, Ventura, Calif.

MINIATURE Steam locomotives, new catalog listing all builders' needs 25c. Little Engines, Wilmetton, California.

CARVED Hull ship model kits. Ship and yacht model fittings; model yacht sails. Illustrated catalog 20c. A. J. Fisher, 1002-M Etowah Ave., Royal Oak, Mich.

SHIP Model kits and fittings. Complete line Fisher model yacht equipment. All Boucher, Fisher, Marine Model and Ideal kits, fittings and blueprints at catalog prices. Most complete stock in New England. James Bliss & Co., Inc., 220 State Street, Boston, Massachusetts.

WATCHES, OLD GOLD, JEWELRY, ETC.

100% PROFIT Selling 42 important minerals. Explorer book gives field tests, 50c postpaid. Market cooperation. Lowrey, Box 65, Colorado Springs, Colo.

OPALS—Collectors' parcels \$5.00. Lapidaries' parcels \$5.00. Catalogue free. Norman Seward, Melbourne, Australia.

5000 REBUILT Watches! Free catalogue—Diamonds, Jewelry, (3c postage). The New York Jobbers, 74 Bowery, Dept. M, New York, N. Y.

ELGIN, Waltham watches \$3.50. Make big money. Free watch and jewelry catalog. Plymouth Jewelry Co., 163-F Canal St., New York.

GOLD \$35.00 Ounce. Mail old gold teeth, diamonds, jewelry, watches. Receive cash by return mail. Satisfaction guaranteed. Free information. Dr. Weisberg's Gold Refining Company, 1500-Q Hennepin, Minneapolis, Minn.

GEMS, Agates, minerals, jewelry. Six rough gemstones—emerald, sapphire, garnet, topaz, fireopal, agate, \$1.00 postpaid. Catalog. Hill Co., Route 7, Salem, Oregon.

WATCHMAKERS' Materials, tools, jewelry—bought, sold. Best prices for old gold, diamonds. Free catalog. Ben Segal Company, Box 150, Chicago.

WANTED! Gold, silver, platinum, diamonds, mercury, etc. Ship, Simon's Jewelry, 353 Old Arcade, Cleveland, Ohio.

HIGHEST Prices for old gold—Mail your teeth, watches, jewelry. 100% full cash value mailed day shipment received. Satisfaction guaranteed or articles cheerfully returned. Information free. Chicago Gold Smelting Company, 300-P Champlain Building, Chicago.

I WANT To send you proof of the wonderful pulling power of Popular Mechanics Magazine's classified pages. What's your proposition? Write me today. P. W. Johnson, Manager Classified Advertising, 200 E. Ontario St., Chicago, Ill.

TOBACCO—SMOKERS' SUPPLIES

CHEWING, 4 Pounds \$1.80. Smoking, 3 pounds \$1.20. Postpaid, Belmont Farms, Chatham, Va.

RAZORS, BLADES, SHARPENING

100 HIGH Quality double edge blades, \$1.00; 250, \$2.00. Stanton, Box 263, McKeesport, Penna.

FOR THE HOME

REBUILT Vacuum cleaners—all makes that look run, guaranteed like new. Special General Electric \$10.95. U. S. Vacuum Cleaner Company, Jacksonville, Fla.

DEPEND Yourself against air raids. Lava emergency kit, 9 1/2" x 4 1/2" x 3 metal box, 12 hygrade sterilized articles, \$1.80 postpaid C.O.D. Lava, 1824 Davidson, New York City.

1001 WAYS To Use Concrete. Send for large free illustrated folder describing new Popular Mechanics book covering every known use of concrete for the home, farm, building, business and industry. Popular Mechanics Press, Room (C40), 200 E. Ontario St., Chicago.

FOR SALE—MISCELLANEOUS

SPRAY Paint, insecticides, lacquer, with your vacuum cleaner. Sprayer \$2.45. Literature 10c. Vacuum, Box 81, Clifton, N. J.

WANTED—MISCELLANEOUS

CASH For old buttons. Information free. 230-E Bowman, South Bend, Ind.

MERCURY (Quicksilver). Tungsten, molybdenum, cadmium, nickel anodes, tin, pewter, rare and semi-rare metals, metallic residues, purchased in any quantity. Write for quotations. Metallurgical Products Company, 35th and Moore Streets, Philadelphia, Penna.

HIGHEST Prices for used cameras, binoculars, microscopes, drawing sets, tools, any optical or scientific instrument. Satisfaction guaranteed. Gordon's, 163-M Madison, Chicago.

CASH For anything. Justice Jewelry Jobbers, 190 North Wells, Chicago.

PERSONAL

ARGENZIO'S Foot comfort tablets—Endorsed by users from Alaska to Argentina. Trial packet 10c. Mako Sales Co., 5226 Tennessee, St. Louis, Mo.

WIN Prize money; booklet—"Successful Contesting" shows how, 10c postpaid. Bulletin listing \$100,000.00 prizes included. World Publishers, 4515-B Cottage Grove, Chicago.

CONTESTANTS! Puzzlers! See our ad under "Miscellaneous." Anglo-American Research, Los Angeles.

NASAL Ailments; send name and address for free booklet on Bullock's discovery. National Laboratories, Benj. Franklin Station, Washington, D. C.

MEXICAN Legal matters, William Cooke, Reliable American Attorney, El Paso, Tex.

REMOVE Your own tattoos, write Tattoo Supply House, 651 South State, Chicago.

DEVELOP Your mind's "eye." Unlimited possibilities! 25c postpaid. Plattco, Manchester, Iowa.

MISCELLANEOUS

ZIPPER Ripp envelopes at last. Make them yourself. Free particulars. Zipper Ripp Envelope Mfg., 114 Virginia Ave., Hempstead, N. Y.

SEND 10c Stamps, for illustrated catalog on hard-to-find merchandise. All items selected by experts for utility, value and profits. Goldshield Products, Dept. PM, 350 Greenwich St., New York.

TATTOOING Outfits. Write today. Zeis Studio, 728 Lesley, Rockford, Illinois.

HEATING Six rooms \$20 yearly. Information 10c. Rosenweig, Route 10A5, Cincinnati.

EVERY American should read "The Dictator's Doom" and "Ultimate Hope," two prophetic "symphonies" of human destiny; 25c each. Stanley Reynalson, 1823 "P" St., Sacramento, Calif.

BIG Mail for you. Latest moneymaking offers, opportunities, catalogs, magazines. Name listed in directory 10c. Ideal Service, 124-M, Park Ridge, Ill.

RECEIVE Gigantic mails, magazines, samples. Your name in numerous mailing lists 10c. Howard, 396-Q Broadway, New York.

CONTESTANTS! Puzzlers! "Words-Within-Words," a fascinating word-building puzzle, offers thousands of dollars worth of contest prizes. Send 10c for copyrighted double-check computing method and other valuable information. Anglo-American Research, Box 44, Los Angeles, Calif.

NEW 17,000-Word "inside story" of mailorder business. Only 50c postpaid. Satisfaction guaranteed. Hayes, Box 1433-S, Oakland, Calif.

UNIVERSAL Transparent triangle and ratio at a glance protractor, complete 0 to 90 degrees, \$1.50 postpaid. Refund if not 100% satisfied. Trigoscope Instrument Co., 614 5th Ave., Coraopolis, Penna.

STOP Breaking rimless glasses! Buy Super-Safe spectacle case 60c. Box No. 3, Buffalo, N. Y.

STEREOSCOPIC (Three dimensional) art photos. Particulars for stamp. Oddity House, St. Petersburg, Fla.

START Profitable tattooing and removing business. Free instructions. Write Tatuco, 651 South State, Chicago.

COATS Of arms and crests, correctly painted in colors or black and white, from heraldic description or furnished copy, \$10.00 and up. Highest grade work. Heraldic Studios, 1914P Oakdale Avenue, Chicago, Ill.

TATTOOING. Engraving outfits. Illustrated list free. Percy Waters, Anniston, Ala.

START Home business making concrete garden furniture, pottery, bird bath, flower boxes. Amazing profits. Illustrated instruction book 25c. Popular Mechanics, 200 E. Ontario, Chicago.

NOW IS THE TIME TO GET INTO AVIATION TRAIN AT LINCOLN THE COMPLETE AVIATION SCHOOL

Earn \$2000 to \$5000 a year! Prepare NOW at this

- Commercial Pilot
- Flight Instructor
- Airline Mechanic
- Aeronautical Engineer
- Aircraft Inspector
- Airport Mechanic
- Airplane Draftsman
- Airplane Assembler
- Airplane Factory Worker
- Aircraft Welder

Lincoln Government Approved School not only for immediate employment essential to national defense, but for a REAL career in Aviation AFTER the war. Our Graduates placed as fast as we can train them. Choose YOUR field from the 10 courses shown and WRITE TODAY for complete information.

LINCOLN AERONAUTICAL INSTITUTE
593 Aircraft Bldg., Lincoln, Nebraska



WELDERS WANTED!

ELECTRIC ARC—OXY-ACETYLENE
Skilled Welders earn \$8 to \$15 a day. The demand now greater than the supply. Learn this highly paid trade in 2 weeks by actual shop work. One of America's leading schools. Established 1902. 7 floors of shops. Endorsed by welding industry. Limited number of students. 2 weeks course in Electric Arc or Acetylene Welding, including room and board, only \$104. Write or wire for reservation. Ask for "Welding Facts." State age.
GREER COLLEGE, Dept. 132, 2024 S. Wabash Ave., Chicago

FIBRE ARMS AND LEGS!
Light, correctly fitted, strong and comfortable. Natural appearance. Fair terms.

BUCHSTEIN-MEDCALF CO.
610 South Third St. Minneapolis, Minn.

Scientific Design

MONEY IN RABBITS — CAVIES

WE BUY and put you in touch with other markets. Catalog and copy of magazine 10c. Or send 25c for Book Catalog and Price List and Year's Subscription to the AMERICAN SMALL STOCK FARMER. OUTDOOR ENTERPRISE CO., BV 919, PEARL RIVER, N. Y.

FREE BIG 60 PAGE GUITAR BOOK

Get this FREE GIBSON BOOK that tells you how to learn to play like the professionals by sending this ad to
GIBSON, INC., 342 Parsons St., Kalamazoo, Mich

Alvin Roy

Always write your name and full address clearly when answering advertisements.

HANDY RADIO Watch Size Complete Only **\$1.99**

No TUBES—No BATTERIES BUILT-IN SPEAKER

At last! Amazing Handy Radio with built-in speaker! No bigger than a dollar watch! Weighs only 2 ozs. Fits vest pocket or purse. All standard broadcasts. Sensitive-super-audio crystal—no tubes, no batteries. Easy, accurate tuning. **GUARANTEED. SEND ONE AS A GIFT TO YOUR FAVORITE "BUCK PRIVATE"** (Son, Brother, Sweetheart) He'll enjoy it.

Send No Money
Handy Radio comes complete, ready to listen in, with instructions and miniature built-in phone for enjoying programs in private without disturbing others. Complete, 100-foot aerial included FREE for extra loud volume. Operates anywhere—no electric connections! Just snap wires to bed spring or any metal connection. **SEND NO MONEY!** Mail order and pay postman only \$1.99 plus few cents postage on delivery. Use 5 days. Your money back immediately if not delighted! Rush your order today!

Kumfy Products, Inc., Dept. B-911, Cincinnati, O.

"It is the BEST Handy-Sized Dictionary!"

ACTUAL use proves that WEBSTER'S COLLEGIATE defines all the most commonly used words—IS the BEST. 1,300 pages; 110,000 entries; 1,800 pictures. \$3.50 to \$8.75 depending on bindings. Buy of your dealer or direct from publishers. Mail coupon for FREE Quiz and Picture Game. G. & C. Merriam Company, 901 Federal Street, Springfield, Massachusetts.

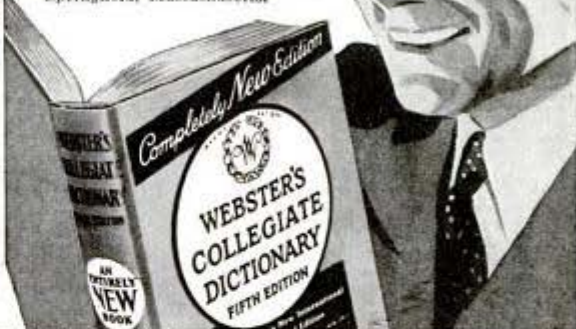

G. & C. Merriam Co., 901 Federal St., Springfield, Mass.

Please send me FREE Quiz and Picture Game, also full information about Webster's Collegiate Dictionary, Fifth Edition.

Name.....

Address.....

NEW ELECTRIC LIBRARY

\$1.50 A VOLUME

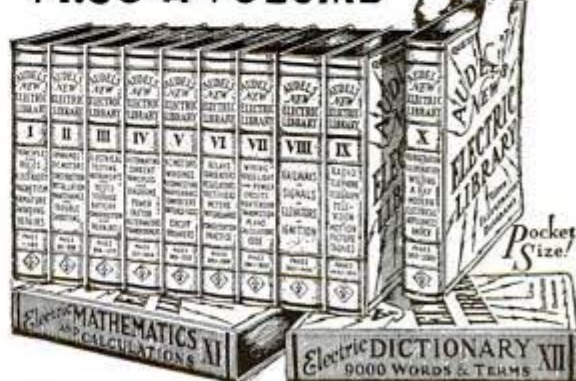

WHAT ELECTRICIAN WANTS TO EVERY

KNOW!
Is easily found in AUDEL'S NEW ELECTRIC LIBRARY. Electricity made simple as ABC. Up-to-date, trade dope for the expert and ALL electrical workers. Questions, answers, diagrams, calculations, underwriter's code, design, construction, operation and maintenance of modern electrical machines and appliances FULLY COVERED.

All available at small cost, easy terms. BOOK-A-MONTH service puts this NEW information in your hands for 6c a day. You can start your subscription with any volume. Write TODAY for electric Folder and FREE TRIAL offer.

THEO. AUDEL & CO., 49 W. 23rd St., New York City

Mail Vol. I, Electric Library on 7 days' free trial. If O. K. I will remit \$1.50, otherwise I will return it. I also request you to mail one book each month on same terms. No obligation unless I am satisfied.

Name.....

Address.....

Occupation.....PM

LIVE DANGEROUSLY

--- said Nietzsche, Philosopher

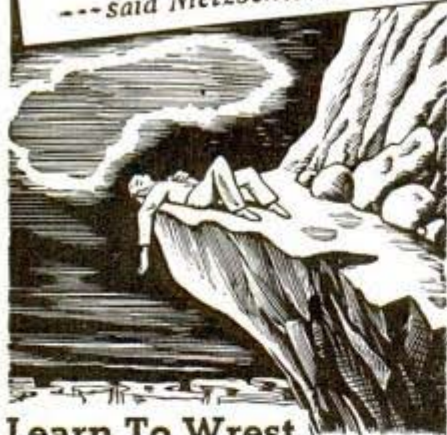

Learn To Wrest The Utmost From Life!

DON'T HOLD BACK—life is yours to live and enjoy each conscious moment. Not in a sheltered, routine living, but only in a tempest of life's forces—which challenges every element of your nature—will you receive that inspiration, those ideas, which will bring you personal supremacy and happiness. *Live boldly but knowingly*—learn to utilize nature's laws to the fullest extent.

A FREE Book of Facts

Let the Rosicrucians (not a religious organization) show you how to direct *little-known* laws of life and mind—used by the sages for centuries. Write for the free book, "The Secret Heritage" today. Address Scribe: C. I. N.

The ROSICRUCIANS (A M O R C)
San Jose, California, U. S. A.

Learn PROFITABLE PHOTOGRAPHY

Modern, practical training. You "learn by doing." For pleasure or career. Black & White, Motion Picture, or Color photography. 32nd year. Free Booklet.

NEW YORK INSTITUTE OF PHOTOGRAPHY (Dept. 49) New York City
10 West 33 St.

FOREMEN, SUPERINTENDENTS PRODUCTION MEN

Study

INDUSTRIAL MANAGEMENT

Millions of men pouring into new or expanded factories require thousands more production executives to supervise them. That spells real opportunity for you if you are ambitious. You can step up to a better job. Your present experience and ability may need only a fuller knowledge of production and management principles and methods. LaSalle training in *Industrial Management* will help you greatly. It is interesting, condensed, practical—planned for men like you. You can study it in your spare time, at home—and at moderate cost. If you want to get ahead, ask for our free 48 page booklet on Industrial Management—it gives full details. Send this ad or write today.

LASALLE EXTENSION UNIVERSITY A Correspondence Institution

Dept. 364-MF, CHICAGO

POPULAR INVENTIONS

For Your Home

21365 (Continued from page 24A)

Knife Spiraling Through Potato Makes Chips for Frying



Paper-thin potato chips can be made quickly with a slicer that cuts through the potato with a rotary motion. At one end of the blade is a screw, like an ordinary wood screw, which bores into the center of the potato. Once the screw has been started, the finger is inserted in the other end of the blade and the rotating motion begins. Going 'round and 'round as it is pulled downward by the screw, the sharp edge of the blade pares off a thin slice in the form of a continuous spiral.

WHERE-TO-BUY-IT INDEX OF POPULAR INVENTIONS

- Fruit-jar humidor 22A
D. T. McKinnon, Council Bluffs, Ia.
- Tray holds short-stemmed flowers..... 22A
Revere Copper & Brass Co., Merchandise Mart, Chicago
- Retaining cup on bottle opener..... 22A
Mandel Brothers, State and Madison Sts., Chicago
- Candleholder stores coiled taper..... 24A
C. S. Keating Co., Room 1457, Merchandise Mart, Chicago
- V-shaped cake knife 24A
Mandel Bros., State and Madison Sts., Chicago
- Spiral slicer makes potato chips..... 46A
Marshall Field & Co., State St. and Wabash Ave., Chicago

INVENTIONS WANTED

PATENTED OR UNPATENTED

Practical and useful new inventions, or novel improvements on previously protected devices, can now be safely marketed without patenting expense.

We have successfully helped inventors for over 17 years in selling their unpatented ideas to manufacturers, with positive safeguards under Federal Court decisions. Send for complete information about this co-operative association. Experienced staff to give you personal service. References: Dun & Bradstreet, Thomas' Register of American Manufacturers, etc.

CHARTERED INSTITUTE OF AMERICAN INVENTORS
DEPARTMENT 4, BARRISTER BUILDING WASHINGTON, D. C.

MAKE OLD RADIOS NEW

You can easily, quickly improve the tone of any radio, get greater distance, stop interference, add new radio features found only in high priced modern sets. New, large manual illustrates in easy-to-understand way how to modernize every radio—large or small. Improve your own radio by following the details of 32 job sheets. Make money by modernizing radios for others. Complete manual of simplified instructions, only \$1.00, postpaid. Money back guaranteed. SUPREME PUBLICATIONS, 328 S. Jefferson St., Chicago, Ill.



BUILD A BOAT

- Row Boat—12 Foot
- Dimby—8 Foot
- Training Ship—6 Foot
- Sea Sled—9 Foot
- Outboard—12 Foot
- Cruiser—16 Foot
- Bicycle Boat—Kayak
- How Boat—Sectional
- Dimby—Sailing
- Canoe—16 Foot
- Sailing—12 Foot
- Outboard—Runabout
- Pontoon—Ice Yacht

FOR PLEASURE OR PROFIT

NEW BOOK—17 LOW COST BOATS

Get this brand new book and build a boat at home for your own use or to sell at a profit. You can do it. Just the boat you're always wanted—power, sail or row boat—17 different kinds and sizes.

Order BUILD A BOAT on postal card and pay only \$1.25 plus postage on delivery. Return in 5 days if not pleased and get money back. Or send \$1.25 with order. (Outside U. S. \$1.45 with order.) Order today.

POPULAR MECHANICS PRESS
Dept. 363, 200 E. Ontario St., Chicago



It's Easy To Be A Contractor

Learn to estimate, to plan buildings, to take contracting jobs, and make money on them. Here are 9 up-to-the-minute books on building, estimating, and contracting which cover in an interesting way, the subjects that carpenters, builders, and contractors should know to make the most out of their jobs. Roof Framing, The Steel Square, Architectural Drawing and Design, Estimating, Painting and Decorating, Heating, Air Conditioning, Building, Contracting, Concrete Forms and other subjects are all well covered.

"Boss" Carpenters in Demand Up-to-Date EDITION

Vast public works jobs, immense projects, and the rapid growth of home building, are making jobs for MEN WHO KNOW HOW. These books give you quick training. With them you shouldn't be afraid to tackle any job, for needed facts can be found in a hurry.

These books are the most up-to-date, complete we have ever published on these subjects.

Coupon Brings Nine Books FREE For Examination

AMERICAN TECHNICAL SOCIETY (Publishers—Home Study Courses)
Dept. G319, Drexel at 58th Street, Chicago, Illinois

You may ship me the Up-to-Date edition of your nine big books, "Building, Estimating, and Contracting" without any obligation to buy. I will pay the delivery charge only, and if fully satisfied in ten days, I will send you \$2.00, and after that only \$3.00 a month, until the total price of only \$29.80 is paid. I am not obligated in any way unless I keep the books.

Name.....

Address.....

City.....State.....

Please attach a letter stating your age, occupation, employer's name and address, and that of at least one business man as a reference.

Burn Your Name On Tools Electro Name Etcher Only

Protect valuable tools from thieves and tool borrowers! Electro Etcher BURNS your name, any design, permanently on tools, instruments, any metal. Easy! Simple as writing with pen or pencil. SEND NO MONEY! Rush order today. Pay postman only \$1.00 plus few cents postage on delivery. Use 5 days—money back if not delighted. Electro Name Etcher, Dept. B-600, 254 Robb St., Cincinnati, O.



3 VOLUMES \$1.47
Single Volumes 50¢

MORE FUN AND PROFIT FROM YOUR SHOP

Make extra spare time profits and enjoy happy workshop hours with the Home Craftsmans Library. Now complete in three volumes with the new 1942 book. In all, 588 pages packed with instructions, diagrams, valuable data and 1500 pictures showing what to make and how to make it. Any volume 50 cents. Complete set, 3 volumes, \$1.47 postpaid.

New 1942 Book Has 300 Projects • 28 Color Pages
1942 Book includes Musical Door Chimes, Porch Lights, and House Numbers, Brass and Iron Work, Basement Plans, rooms, Many kinds of Furniture, Toys and Games, Photographic equipment, etc. 300 projects in all. Order today with volumes one and two.
POPULAR MECHANICS PRESS, Dept. 368, 200 E. Ontario St., Chicago

BROOKLYN YMCA TRADE SCHOOL



Short Trade Courses, including Defense trades, offered day or evening, 5 to 10 week courses qualify you for Defense Jobs. Full Shop Equipment. Unexcelled Instruction. Fireproof Dormitories. Special Privileges. Check your interests on coupon to receive free literature.

- Aircraft Construction
- Machinist
- Mechanical Pre-Engineering
- Diesel Engines
- Diesel Pre-Engineering
- Mechanical Drafting
- Auto Mechanic
- Refrigeration
- Television and Radio Mechanic
- Architectural Drafting
- Armature Winding
- Welding
- Tool and Die Making
- Oil Burner
- Talking Pictures
- Electrical

MAIL COUPON

1123 Bedford Ave., Dept. P. M.
Brooklyn, New York City, N. Y.

Name.....

Address.....

ELECTRICAL TECHNICIANS

Urgently Needed!

BLISS

In industry—in Army and Navy—electrical technicians win better jobs and ratings. Bliss training combines theory and practice in classrooms and laboratory. Students construct motors; install wiring, test generators, motors, transformers, electronic tubes. Practical mechanical drawing included.

Qualifies graduates to enter all branches of electrical work; aids advancement. Bliss graduates have excellent jobs as technicians, supervisors, engineers; hold ratings and rank in Army, Navy, in communications and electrical work. Dormitory; campus. **50th Year** (begins Sept. 30). Send for Vocational Chart.

REGULAR COURSE COMPLETE IN ONE SCHOOL YEAR

ELECTRICAL SCHOOL

133 TAKOMA AVE., WASHINGTON, D. C.



Train Your

VOICE

Results GUARANTEED



We build, strengthen the vocal organs—not with singing lessons—but by fundamentally sound and scientifically correct silent and vocal exercises and absolutely guarantee complete satisfaction with results. Write for wonderful Voice Book, sent FREE. Learn how you can train Your Voice at home. Sent to no one under 17 years unless signed by parent.

PERFECT VOICE INSTITUTE
Studio 1353, 64 E. Lake St., Chicago, Ill.

HOW TO PICK YOUR BEST CAREER

Don't Choose Your Lifework Blindly

There is a career that will fit you like a made-to-measure suit. And science can show you how to find it! Our new methods will discover your natural talents and tell you, in advance, what career they best fit you for. **FREE** Send for FREE booklet explaining how you can use this new proven system to achieve greater success and happiness.

Vocational Guidance Associates, Dept. 13-A, 25 N. Mentor, Pasadena, Calif.

Make Bigger Money NOW! IN AUTO REPAIR WORK

Enormous demand for repair work is pounding at shop doors right NOW! Millions of cars MUST be made to last. The man who can fix ANY make of car is in the money today. Now you can do ANY job on ANY model or make of car since 1935, including all 1942's—with this most complete, easy-to-understand shop manual of clear, simple, official instructions ever published! Step by step, MoToR's 1942 Factory Shop Manual, JUST PUBLISHED, tells exactly what to do. Shows, in more than 900 Photos, 450 Charts and Tables, 200,000 Facts. 603 big pages! Like 150 factory books in ONE—a complete collection of ALL official shop manuals. 30 makes, 502 models!



Carburetors, Pumps, Gauges, Generator, Clutches, Engine, Electric, Fuel, Cooling, Transmission, Wheels, etc., etc.

SEND NO MONEY

Satisfaction guaranteed. Simply fill out coupon below. Mail TODAY. Your copy of MoToR's 1942 Factory Shop Manual will be sent at once. On delivery pay postman only \$4 plus few cents postage. See IRON-CLAD MONEY BACK GUARANTEE printed below. Rush coupon NOW to: MoToR BOOK DEPT., Room 509F, 572 Madison Ave., N. Y. C.

MoToR BOOK DEPT., Room 509 F, 572 Madison Ave., New York, N. Y.

Rush me MoToR's 1942 Factory Shop Manual. On delivery I will deposit with postman only \$4 (plus few cents C.O.D.) with understanding that if not fully satisfied I may return Manual within 7 days (in its original condition) and you will promptly refund my \$4.

NAME _____ YOUR JOB _____
ADDRESS _____
CITY _____ STATE _____

CHECK HERE if enclosing \$4 (check, money order) WITH coupon. We then pay postage. Same Money-Back Guarantee.



YOUR UNCLE SAM NEEDS YOU

YOU CAN SERVE HIM BEST by starting training now for a high paying job as a necessary man in essential industries or in the military service—aviation—welding—Diesel engineering—ship building—seamanship—machine shop practice—automobile mechanic—electrical construction—building trades—radio—accounting—typing—secretarial practice—law—chemistry—physics—and hundreds of other subjects. Complete home-study and practice units as low as 49¢ postpaid. Money back if not satisfied. Write for our free catalog of success opportunities now!

HOME STUDY BOOK COMPANY
Dept. 132, 13th Street at Wabash Avenue, Chicago, Ill.

ARTISTS MAKE MONEY

Find out your ability. Send name, age, occupation and address for Free Vocational Art Test.

ART INSTRUCTION, INC. (Formerly Federal Schools)
3132 Art Instruction Building, Minneapolis, Minnesota

LEARN HOW TO BOX

New book "PUSH YOURSELF" gives you simplified and proven boxing instruction program. Price \$1.50. Write FRANK GILMER, Box 202, Libertyville, Ill.

Always write your name and full address clearly when answering advertisements.

AUDELS BLUEPRINT READING

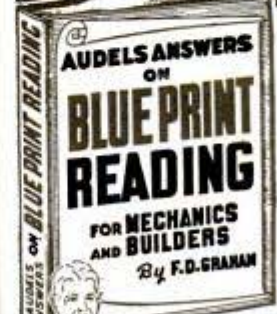

JUST OUT—FOR THE MAN WHO WORKS FROM BLUE PRINTS

"The Blue Print of Today is the Machine of Tomorrow." AUDELS ANSWERS ON BLUE PRINT READING covers All Types of plan reading including AIRCRAFT & SHIP BUILDING—tells How to Easily Understand Working Drawings.

What to look for first. Tells what each Line and each Symbol Means. The relation of one part to another. How to Understand Scales & Specifications. How to Make a Sketch. How to Make Blue Prints. A Key Book for Every Mechanic, Builder & Draughtsman—352 pages—It's New, Comprehensive. Fully Illustrated. Gives Short Cuts, Helps, Hints, Suggestions, Questions and Answers.

ASK TO SEE IT!

To get this assistance for yourself, simply fill in and mail coupon today. **\$2**

AUDEL, Publishers, 49 West 23rd St., New York
Please mail AUDELS BLUE PRINT READING (Price \$2). If satisfactory, I will remit \$2 on its safe arrival, otherwise I will return the book.

Name _____
Address _____
Occupation _____
Company _____



PLASTICS

**OFFER YOU
A PERMANENT FUTURE
NOW! More than ever**

WAR brings a vital, growing need for men and women who know Plastics and how to use them in Defense work.

The demand for synthetics in ordnance and armament will increase with tremendous speed—creating ever new opportunities for profitable careers.

A knowledge of Plastics can take you into many industries engaged in Defense—then when peace comes, this knowledge will be even more useful—in automotive... aircraft... radio... furniture... building... and the hundreds of civilian industries where plastics are used.

For the fascinating story of Plastics in war and peace, write TODAY for free, illustrated literature.



PLASTICS INDUSTRIES TECHNICAL INSTITUTE

31-26 Queens Blvd. Long Island City, N. Y.
513 S. Western Avenue Chicago, Illinois
190 S. Alvarado Street Los Angeles, California

PLASTICS INDUSTRIES TECHNICAL INSTITUTE

Please send your illustrated literature and detailed information on Plastics and training at Plastics Institute or in my own home.

Years High School? _____ College? _____

Name _____ Age _____

Address _____

City _____ State _____ M-32

TOMBSTONES

DIRECT TO YOU \$9.95 UP
● Genuine beautiful **ROCKDALE** Monuments, Markers, Satisfaction or Money Back. Free lettering. Free catalog. Freight paid. Compare our prices. **Rockdale Monument Co. Dept. 572 Joliet, Ill.**



ITALIAN ACCORDIONS

HAND MADE. Very best. Lowest prices. Direct from Factory Representative. Send your name and address for FREE catalog. **ITALIA & P. SOPRANI ACC. MFG. CO. 323 W. POLK ST., DEPT. PM, CHICAGO, ILL.**

Say you saw it in
POPULAR MECHANICS



TECHNICAL BOOKS

Every man who reads Popular Mechanics will want this new, big, illustrated catalog of practical and money-making books. A few of the subjects covered are: Blueprint Reading, Carpentry, Painting, Decorating, Drafting, Plumbing, Auto Repairing, Aviation, Welding, Tool Making, Sheet Metal Work, Spare-Time Money Making, Hobbies, Craftwork.

SEND NO MONEY! JUST MAIL POST CARD! Write your name and address on a penny post card and mail today! This big catalog will be rushed to your home. Only limited edition printed. Send now!

POPULAR MECHANICS PRESS
Dept. 318, 200 E. Ontario St., Chicago

JUST PUBLISHED

SAVE UP TO 50% FACTORY-TO-YOU



9 BANDS (ON 6 DIAL SCALES)

20 TIMES EASIER FOREIGN TUNING with SUPER BAND SPREAD RADIO!

PUT THIS CHASSIS IN YOUR PRESENT CABINET

\$19.75 COMPLETE with SPEAKER, TUBES, PUSH-BUTTON TUNING, MAGNA TENNA LOOP AERIAL... READY TO PLAY

UP TO \$50.00 TRADE-IN

THINK of it . . . 20 times easier to tune . . . 10 times more sensitive than ordinary radios! Crystal-Clear High Fidelity Tone. Famous 30-day trial plan fully protects you and enables you to prove Midwest's amazing new 1942 Super Spread Band performance in your own home, without obligation. Write today. Your name on a 1¢ postal card will do. Send for big FREE 1942 Catalog, showing Radios, Radio-Phonos, Home Recorders — from \$12.95 to \$212.50.



UP TO 16 TUBES E-Z TERMS

MIDWEST RADIO CORPORATION
DEPT. 15-K CINCINNATI, OHIO

"What can I do?"



LIKE millions of other Americans, I've asked myself one question repeatedly ever since these fateful words popped out of my radio:

"Japanese planes have bombed Hawaii!"

"Daily, nightly, I've turned this question over and over in my mind—with the reading of every news bulletin on the air and the appearance of every epic headline.

"What can I do—here at home?"

"What can I do—while Americans are fighting and dying in the far reaches of the Pacific for freedom and for me?"

"What can I do?"

"I've looked in my shaving mirror for an answer—and found none.

"I've seen only the perplexed face of a middle-aged man—a man too old to bear arms.

"I've glanced at my hands, too,

a thousand times, only to learn a brutal truth.

"They are soft and white—strangers to the production line where only skilled hands are wanted now."

"What can I do?"

"Only last night I found the answer as my eyes fell on my wife's knitting bag and my ears caught the click of her knitting needles.

"I could give to the Red Cross. I could answer its urgent call for funds, now so sorely needed.

"I could give to the limit of my means to aid and comfort those who are giving so much more.

"Yes—I could do something. Not much—but something.

"And I have—today."

Give and give generously—to your local chapter—to volunteer solicitors. Give when you can, where you can, as much as you can.

SEND CONTRIBUTIONS
TO YOUR
LOCAL CHAPTER



AMERICAN RED CROSS
WAR FUND CAMPAIGN

THIS PAGE CONTRIBUTED TO THE AMERICAN RED CROSS BY THE PUBLISHERS

Popular Mechanics Magazine

REGISTERED IN U. S. PATENT OFFICE AND CANADA

WRITTEN SO YOU CAN UNDERSTAND IT

Vol. 77

MARCH, 1942

No. 3

21336



FUTURE SOURCES of POWER

Washington, D.C.

Dr. Charles G. Abbot of Smithsonian Institution standing beside flash boiler—a solar power plant. In foreground is toy cooker in which tiny cakes can be baked. Mirrors concentrate sun's rays

By Prof. C. C. Furnas

School of Engineering, Yale University

RAYS of the sun shower as much energy on the earth's surface in one minute as the entire human race utilizes in one year. Despite the presence of this bountiful and unusual flow of energy, a large part of the struggles of the human race are concerned with acquiring and controlling

sources of power. Evidently our state of development in the utilization of power is still rather crude.

Suppose our oil and coal supplies were to become exhausted; we know that water power never would be sufficient for our needs; we know, too, that wind, tides, waves and other sources of power would be inadequate—so, what chance have we of getting our power from the sun?

MARCH, 1942

1

2/3/36

Mr. Phillips Thomas

Wessling

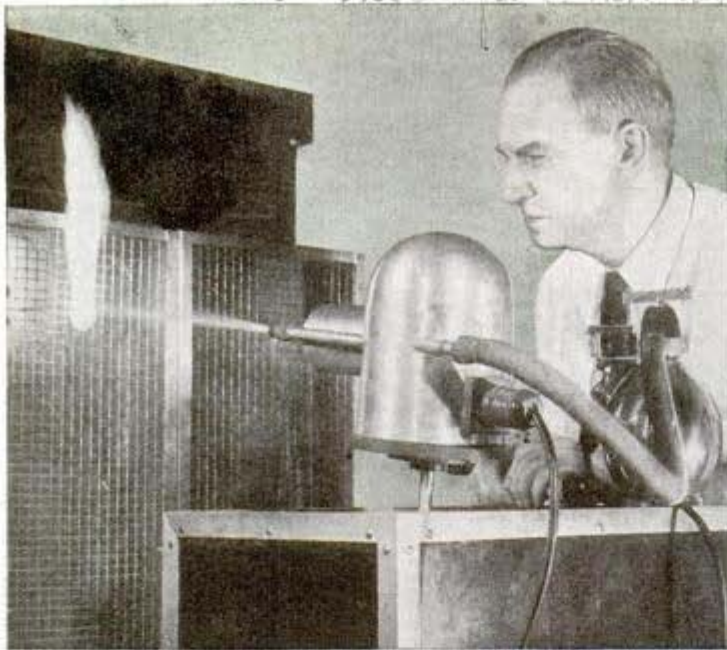

Photo-tube like one which causes this robot to move across wire screen until it "sees" fire, then squirts water at flame, might be key to utilization of sun's energy

inside—if the management had enough ingenuity to utilize it. But no one has developed that ingenuity yet.

One of the obvious possibilities for direct utilization of solar energy lies in photoelectric cells—commonly called electric eyes. Thus far photoelectric cells have operated with microscopic efficiency and have been very expensive. If someone can make revolutionary improvements in the efficiency and can cut the cost of construction away down, we

The average intensity of solar energy falling on the United States amounts to about 0.1 horsepower per square foot. The energy falling on one square yard of roof would more than operate all the electrical household appliances, including lights, of the average family—if it could be directly utilized. Most factories have enough energy falling on the roof to operate the machinery

might have something there. At present the prospects are discouraging, but one hesitates to say such utilization is forever impossible. Even with the items of efficiency and cost brought under control, the matter of storage of energy during periods of darkness would be troublesome. Large storage reservoirs of water might solve this problem, pumping water to high levels in

Measuring inside diameter of inner frame for hydrogen cooled turbine generator

Atomic power appears distant; here are steel balls that represent atoms in crystal

August Engle
H. H. Stetson

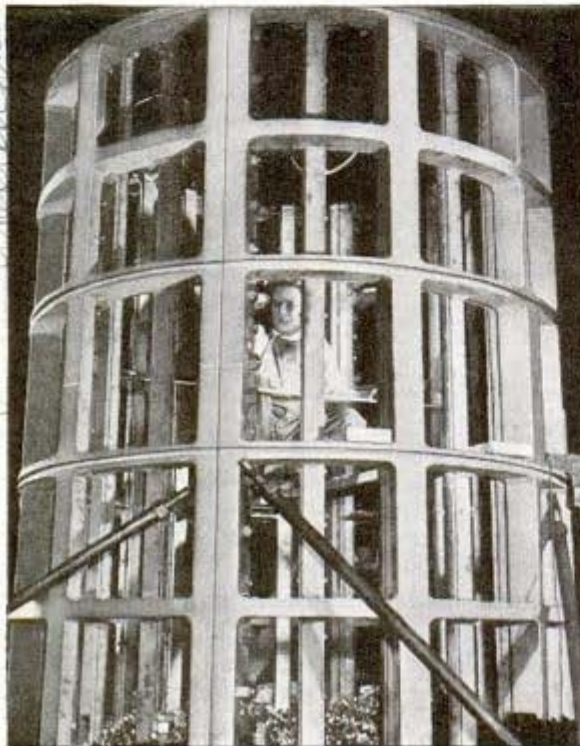

Mr. Ralph D. Johnson
Physicist

213.36

John Kelcher. Woolenhouse

daylight hours and using it in water turbines during darkness. The over-all efficiency of such storage can be about 70 percent.

The simple and obvious device of using focused sun's rays to heat a liquid has been toyed with for a long time. Solar boilers of various degrees of impracticality have been the children of many inventors' minds and the subjects of many patents. Dr. Charles G. Abbot of the Smithsonian Institute has a small solar power plant with revolving parabolic mirrors for which he claims an electrical energy production efficiency of about 15 percent. We'll have to do better than that if the sun's rays, which are not at very high intensity to begin with, are to be a practical source.

On the other hand, solar energy may very well be on the verge of being practical

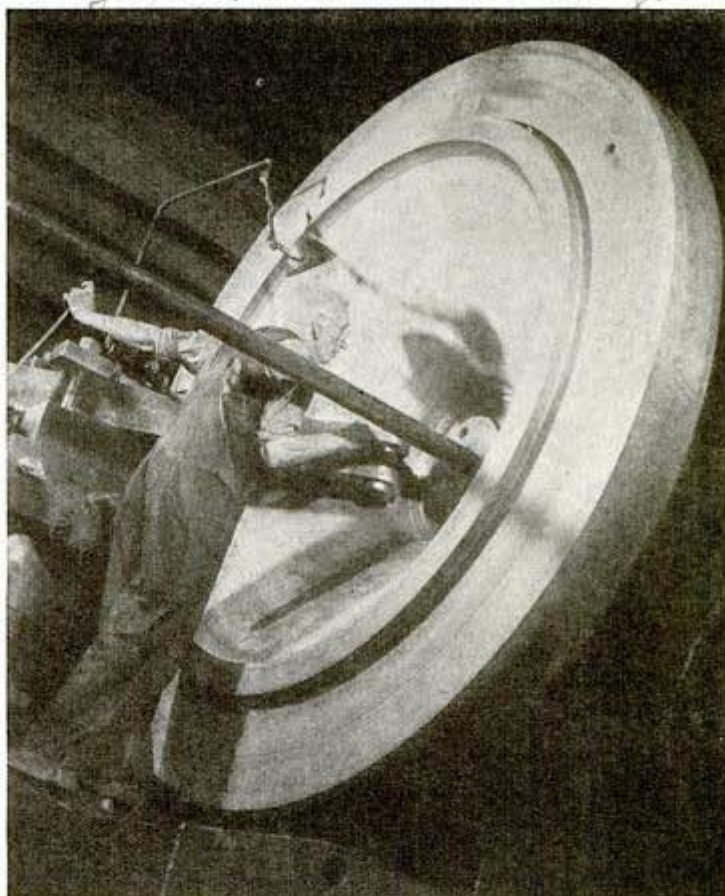

Shaft flange of generator capable of producing 36 ↑ million watts of electricity at Tennessee Valley dam
Westinghouse photo

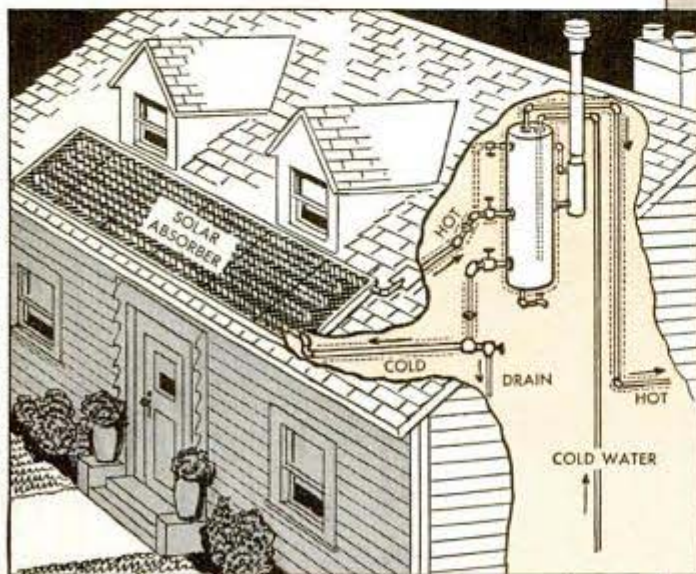

Sketch of home water heating system in which the rays of the sun are utilized

Courtesy U. of California

Large plant at right is used for converting wind power into electrical energy

Courtesy S. Morgan Smith & Co.

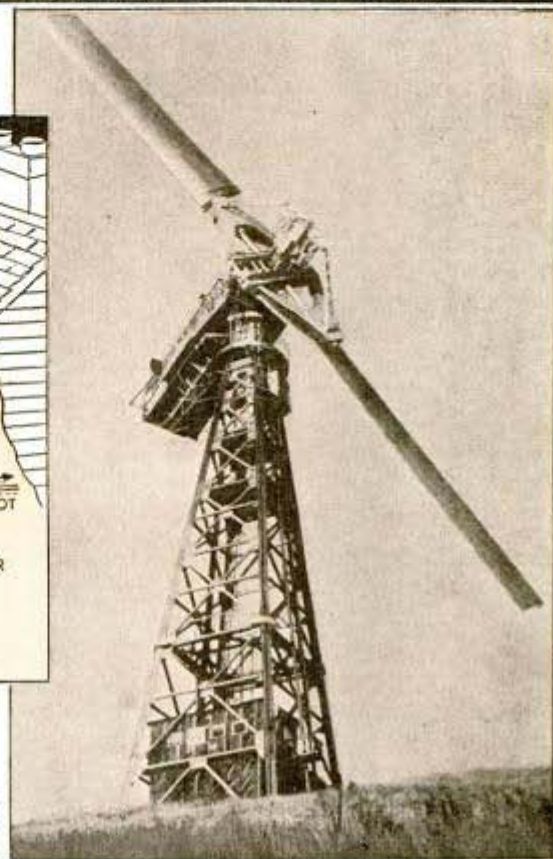

MARCH, 1942

York, Pa.

Jan 1942-7

2/13/36

Mr. E. W. Mendenhall, Asst. Dir. of Research, NSF

E. W. Beegs - Westinghouse



Measuring strength of ultraviolet radiations in the July sunshine

Institute of Technology began experimentation along this line some time ago.

These ideas are interesting, but here is one that I consider the best — men should try to do efficiently what nature has been doing inefficiently for a billion years — utilize photochemical reaction. The basis of all life is some photochemical reaction thought to be

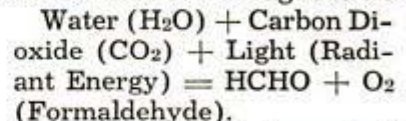

The formaldehyde immediately forms simple sugars which then serve as the basic material for the multitude of complex compounds in plants. What we should like to do would be to take some such simple compound as formaldehyde formed with the help of radiant energy, put it in an electrochemical cell, expose it to oxygen, and

Westinghouse

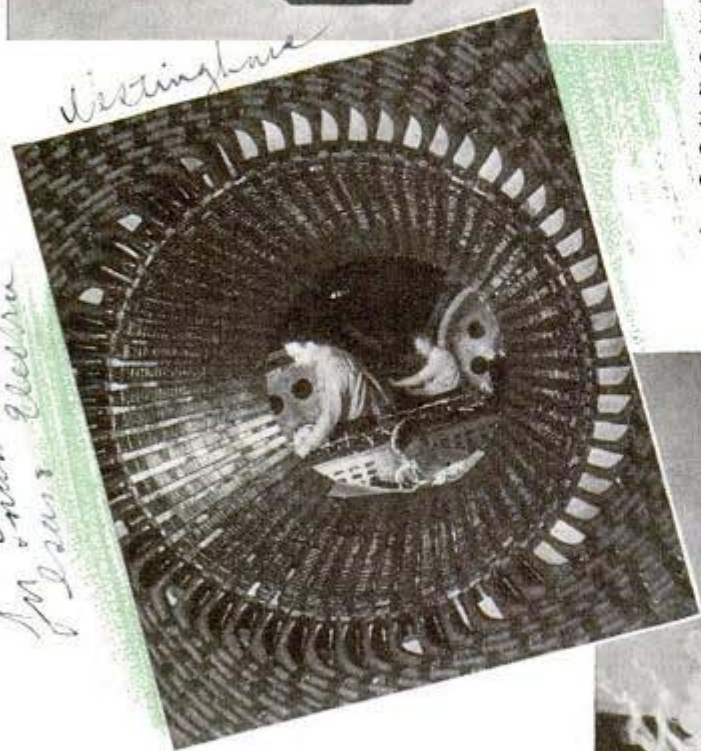

W. S. Swinville
Mass. Electric

← Soldering coil ends on stationary part of a big turbine generator

Out of the chemist's test tubes may come key to future power supply

for heating of buildings where a high potential is not important. The storage capacity must be sufficient for weeks or even months of operation. A basement full of hot water, periodically reheated by sun's rays, might be possible but it hardly sounds practical. I think that a closed cycle employing a low-boiling liquid might better serve for such storage. First costs would be high, but operating costs might be cut to the vanishing point. The Massachusetts



Mr. E. Bruce Asherof Westinghouse

21336

then reverse the above reaction and get back the stored energy as electrical energy—at high efficiency. Formaldehyde can be oxidized in a cell in a basic solution to give formic acid and a small amount of electrical energy. Perhaps all that is needed is a proper catalyst to complete the oxidation to CO_2 and water and get back all the stored energy. The catalyst which nature uses for performing the photosynthesis of the above equation is chlorophyll. That's the best catalyst known, but it's very poor. Plants are very inefficient storers of energy. Even the most luxuriant plants have an energy storage efficiency of less than two percent. We ought to do a lot better than that.

It's a wide open field, this study of photosynthesis and the study of oxidation cells which will reverse the reaction. That's the reason it's hopeful. The systems which might be used would not have to be limited to organic compounds. It may well be that inorganic compounds offer the most hope. The satisfactory system would need to be one that is as light sensitive as the chemicals on a photographic film, as easily reversible as a lead storage cell. If such a photochemical-electrical system can be developed, the problem of energy capture and storage would be solved. The storage of the energy would be simply that of storing chemical compounds. We are used to doing that with coal.

If we wait too long to start working on the problem, we may be caught short as other supplies of energy dwindle. We are using something over a billion barrels of oil per year; the known reserve of oil in the ground is 12 to 15 billion barrels. True, new discoveries are being made constantly, but they are not quite keeping pace with use, so the pinch of partial depletion may come sooner than the optimists anticipate. When the pinch comes, there are several possibilities to be considered. First, getting all the petroleum out of the ground. Even with the best production methods, over half of the original petroleum deposit still stays in the ground after the well has gone dry. If someone will devise an inexpensive means of taking this oil out of the ground, he will lengthen greatly the life of our resources. Second, there is shale oil. There are many billions of tons of oil shale in this country which when heated will yield from half a barrel to two or three

(Continued to page 187)

MARCH, 1942

21352

Folding Crane for Tractor Handles Large Loads

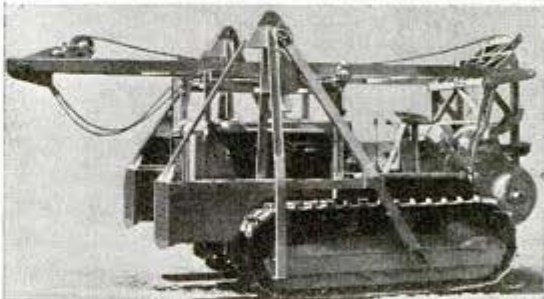

Crane, top, hoisting huge canvas roll. Bottom, it does not interfere with use of tractor when folded

Your tractor now can be fitted with a folding crane which is always ready for service, yet may be lowered out of the way so it does not limit the vehicle for other purposes. It can be mounted easily on several types of standard tractors, and it takes only a minute or two to lift the 20-foot boom for crane service or to lower and fold it on top of the tractor. The crane is made in four models, three with 20-foot booms and one with a 15-foot boom, with lifting capacity up to 10 tons. A large circus uses the boom for lifting huge rolls of canvas and other heavy objects, as well as raising mired trucks and wagons. Then, with the boom folded, the tractor is available for towing and spotting wagons.

Willamette Hyster Co., 2902 N. E. Clackamas St.,
Portland, Oregon

21332.

Push-Button Cigarette Case Built Into Steering Wheel



Arrow points to cigarette ejected by pressing button

For convenience of the driver, a cigarette case built into the De Soto automobile makes it easy for him to reach for a "smoke." The holder forms part of the molded-plastic steering wheel, and at the touch of a button it "hands" out a cigarette. It dispenses 14 before it needs refilling.

21338

Safety Gasoline Pump for Drum Refuels Auto Quickly

Danger involved in filling fuel tanks from a drum is reduced with the use of a hand-operated rotary pump now available. The portable pump, weighing about 20 pounds, locks firmly on any gasoline drum.



Hand pump makes filling station out of gasoline drum

21327
Cmt. Milton F. J. ...
425 Kasota Bldg. ...

It is designed to meet the needs of farmers, truckers and other large gasoline consumers who store fuel in drums on their own premises. The fuel is drawn upward through a pipe extending to the bottom of the drum and is delivered to the tank through an eight-foot hose, giving the user the facilities of a filling station.

21327

"Falling Pin" Seismograph Shows Degree of Street Vibration

To study the vibrations of a street in St. Paul, Minn., city officials unearthed a long-unused "falling pin" seismograph, a little-known instrument once employed in testing the degree of ground vibrations

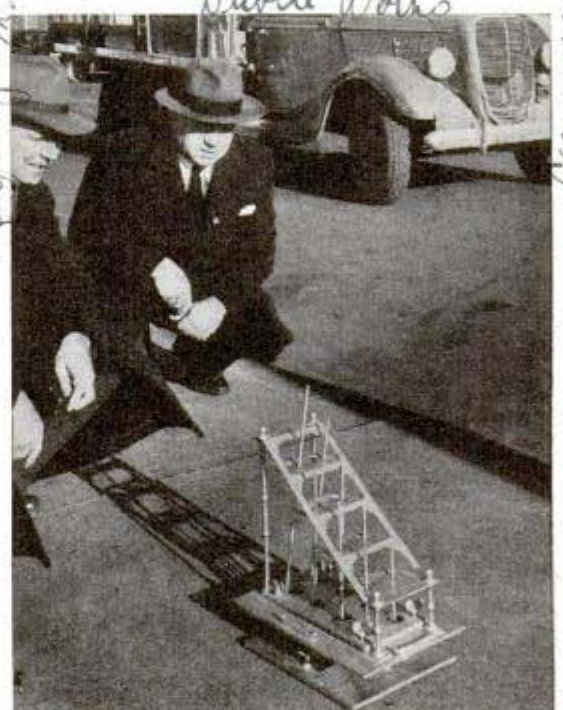

Number of pins toppled shows severity of vibration

during blasting operations for excavations and other works. Residents nearby had complained of the rumble of passing trucks and asked that heavy vehicles be barred from the street. The instrument, mainly a small sheet of plate glass, was erected on the sidewalk in level position with the aid of four set screws. Stood upright on the glass were eight quarter-inch steel rods ranging in height from five to 12 inches. Had the street been afflicted by "traffic ague," all of the rods would have fallen; but in this instance, passing vehicles caused only the tallest rods to topple, indicating vibration was not excessive.

Cmt. Sterling ...
New Center Bldg. ...

Sobheim Oil Tank & Pump Co.
Fort Wayne, Ind.

Comm. Milton ...

Concrete "Gunned" Over Balloon Forms Igloo

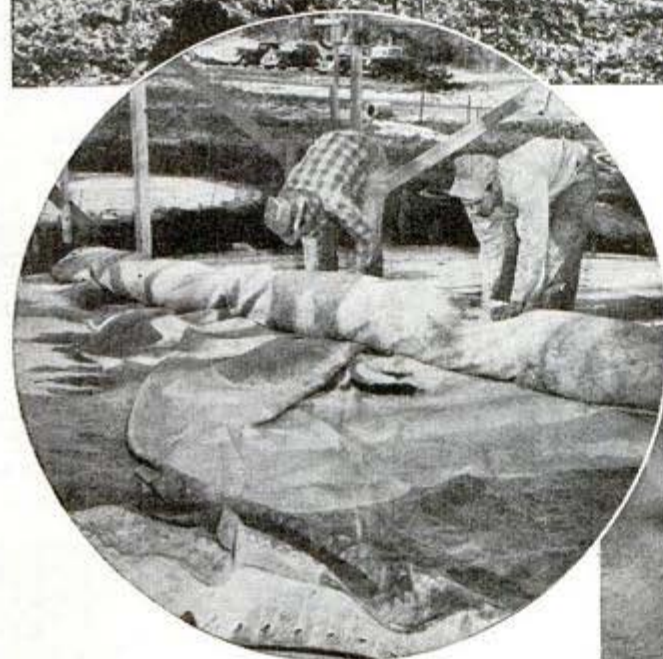

At Falls Church, Va., a colony of unique concrete igloos offers economical housing for war-industry workers. One hemisphere contains two bedrooms, the other a living room; between is an entrance hall, bath and kitchen

Over a concrete base, workmen lay out the rubber-fabric form to be inflated, then sprayed with concrete

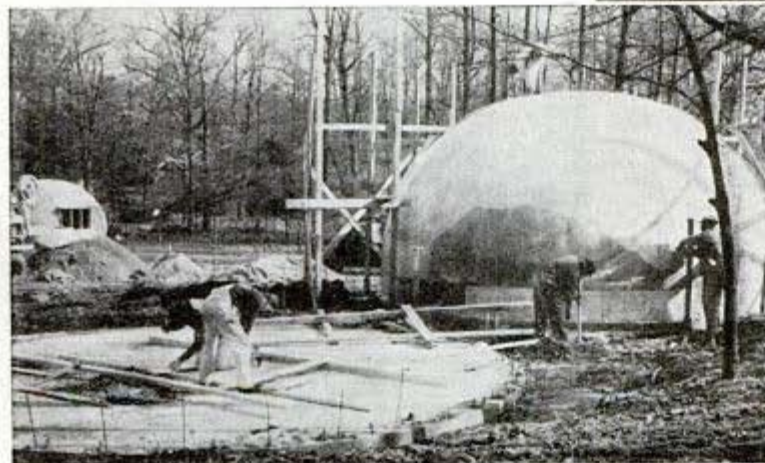
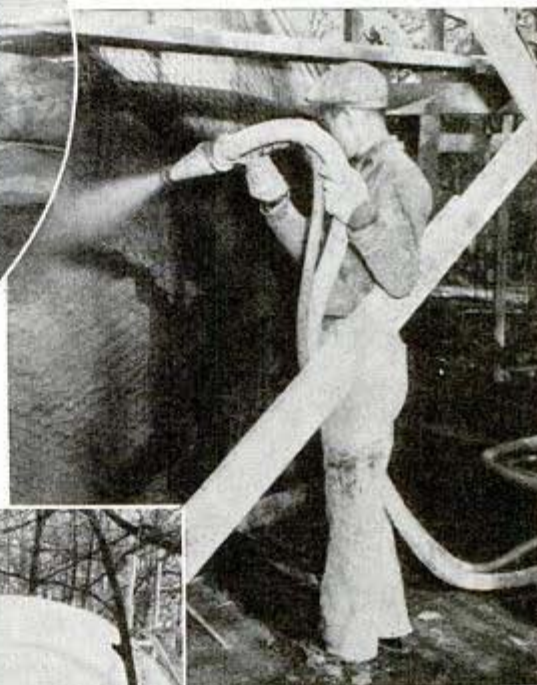

At left, inflated form is being covered with wire mesh; above, Gunite operator shoots concrete over it. Goodyear designed the balloons, which can be a hemisphere or semi-cylinder in shape. It is estimated that 200 houses could be erected in 90 days, using only four forms, which are removed and used again as concrete house takes shape

Sure + Rubber G. this

21238

Warren Ellott, 343 & 39th
New York
Cint. Allen

SUPER SAILORS for the SUBS



IT TAKES iron men to operate the steel fish which comprise the submarine fleet. Just now, with the nation's shipyards turning out underwater craft at a new high rate, the critical problem is to find super-sailors for the subs.

Many are being trained at a remarkable school which the navy operates at the submarine base near New London, Conn., on the Thames River. Huge as it is, with building after building giving the appearance of a large league university, the school has done well up to now to turn out two or three new submarine crews a month, so fine do its mills of knowledge grind.

Before a man can be considered for sub service, he must have passed rigid navy recruiting tests, entered the service, served long enough

Flag hoists are used to teach meaning of signal flags used on warships

Deck scene aboard a submarine; note crew members manning the gun ↓

Right, dummy helps teach how diving dress is worn, also how to descend



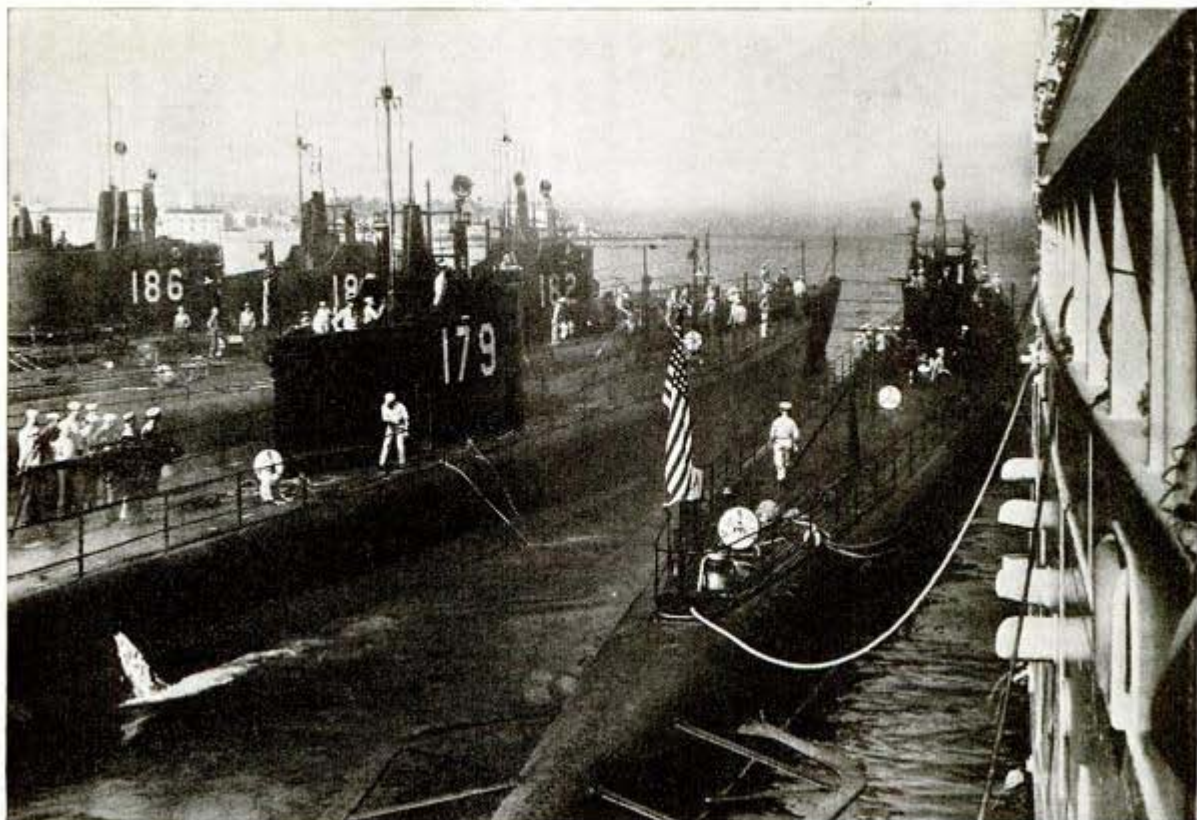

Some of the newer types of American submarines tied up at their base

Student turns globe to learn effect of earth's rotation on axis of gyroscope

to get a fine record, and then must have made up his mind that the extra hazards and discomforts which naturally go with undersea fighting are especially attractive to him.

"Be reliable" is the slogan of the training station and signs bearing these words are scattered throughout the buildings. But the secret of the success of its graduates at their chosen careers is that it is not enough for a man to be reliable at one submarine job. He must be reliable at two tasks at least, so that one crew of 40 men is the equal of 80 or more. A gunner, for example, might double as a quartermaster and he must be perfect in both jobs.





This is single cell of submarine battery; it weighs about 1,600 pounds

man failure at a critical moment aboard a submarine. If these doctors can find nothing the matter with him, the supreme test comes—the compression chamber. When they finish this test, five out of every hundred candidates pack their bags and go back to the surface ships where they belong. They have everything it takes, perhaps, except the ability to stand pressure which always builds up when a steel fish slides below the surface of the sea.

It seems that because of one ailment or another, sometimes so trivial as to escape notice, the tubes which run through the bones of the head become clogged or closed. When air at a pressure of 50 pounds enters one of these tubes and is suddenly blocked, the pain which builds up is excruciating and the compression chamber test discovers whether this condition exists.

Half a dozen men, more or less, are placed in the chamber. Steel doors clank shut, making it airtight. Then compressed air is gradually fed into the chamber. The men are told to raise a hand if they feel pain, or have trouble in standing the pressure. Most of them stand it quite well.

Occasionally a sailor will raise a hand, indicating pain. He will be told to blow

But, for this double reliability and double competence, Uncle Sam pays extra salary and many a sailor, not interested in the long grind which it takes to become a chief petty officer on a surface ship, swings into the exciting submarine branch. That is, he swings to the submarine branch if he has already demonstrated in the navy that he is the type who can be depended upon in a pinch.

Presuming that he has passed the navy examinations, served efficiently, shown his dependability and is finally accepted as a candidate for the submarine school, one day he packs his bag and travels to New London.

The first thing he finds here is that all of his physical tests, which permitted him to enter the navy, count for nothing. A corps of physicians pound and thump, prod and poke, seeking a physical defect which may cause hu-

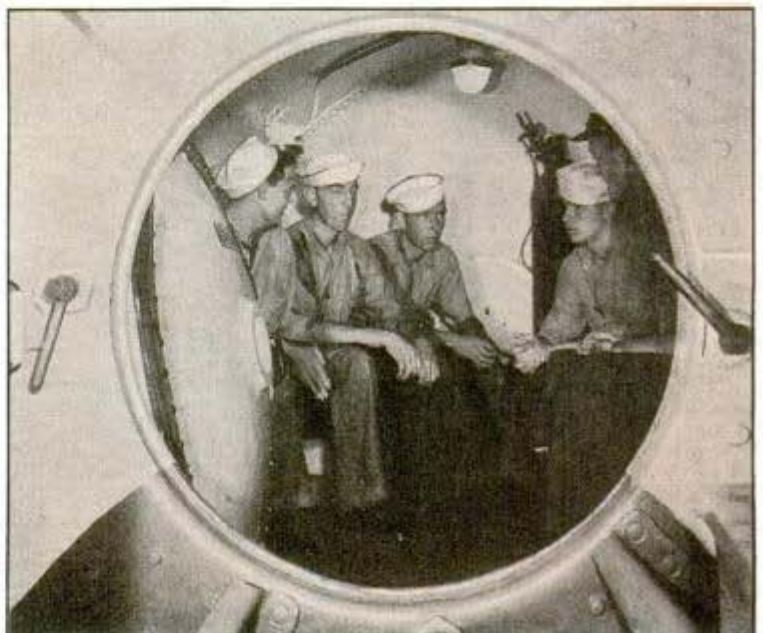

Group of candidates about to be tested in the compression chamber

his nose lustily. This often clears the tubes. Or he will be shown how to grind his jaws sideways, which may relieve his discomfort. But once in a while none of these standbys helps and the candidate will turn pale with pain, often scream with agony. A signal is given, the pressure is dropped, he is led out of the chamber—and that is the end of the submarine service for him.

Another interesting test is given in a water-filled steel tower at the base. The candidate, wearing artificial lungs with attachments clamped over his face, is led into a lock, or airtight chamber at the bottom of the tower. The chamber's outer door is closed and, at a signal, the inner door is opened. Water rushes in and when the chamber is filled, the sailor is supposed to shove out calmly and rise to the surface of the water at the top of the tower. Most of the men have no trouble if they have passed the compression chamber test.

(Continued to page 186)

Candidates not only scrub their uniforms, but diving dress, too

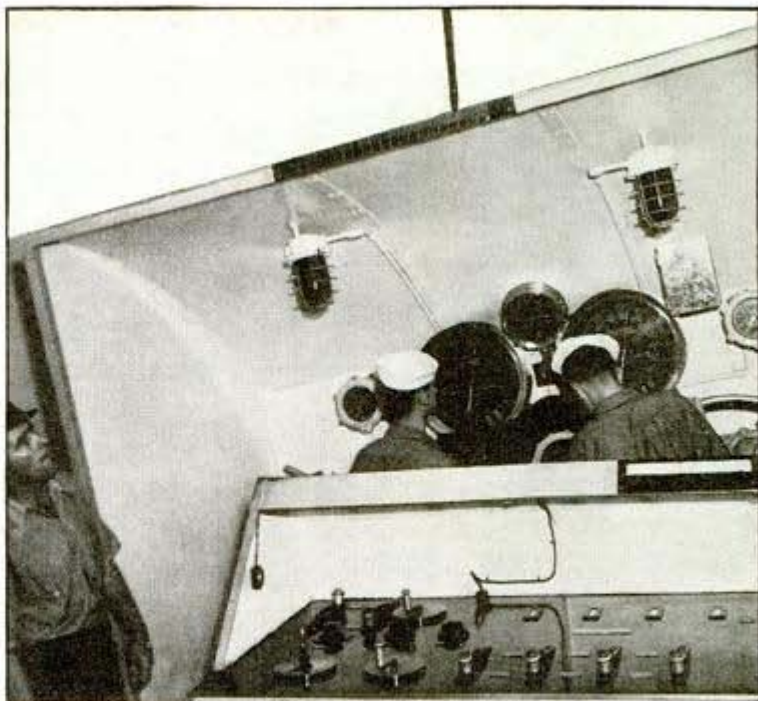

Training device being used by candidates to obey instructions to surface ship. Inclinometer (atop hood) shows the upward angle
Trainee taking orders from instructor in course designed to teach him how to answer control signals; controls are like those on sub

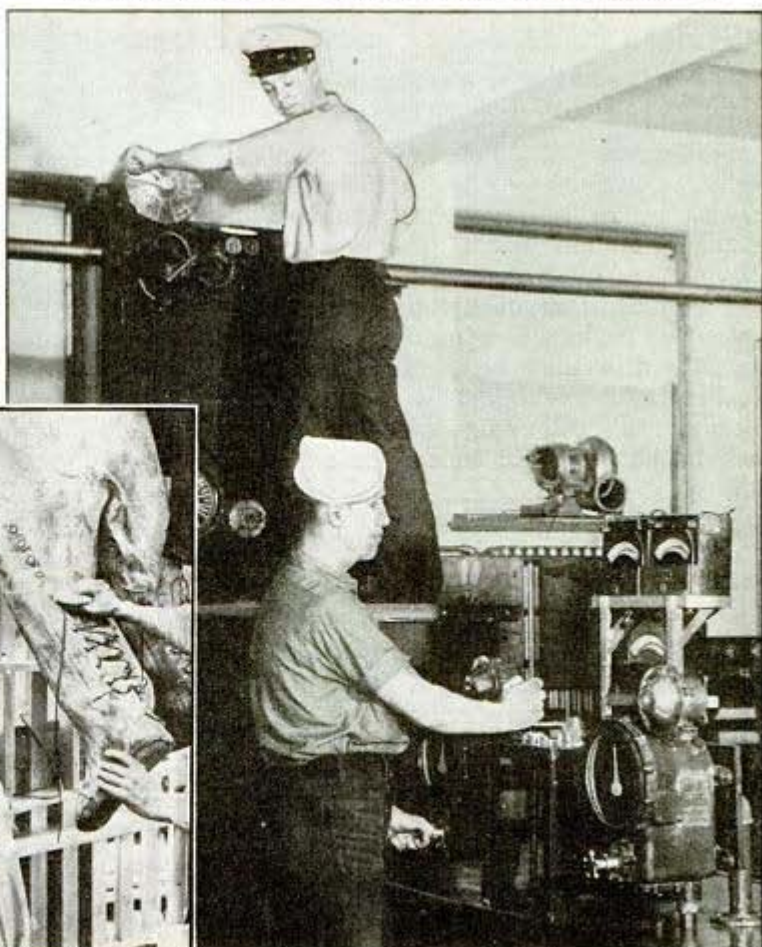

21351.

Cut-Out Figures of Plastic Outlined for Easy Sawing

Service Cut Out



Sawing figure from plastic sheet requires only care in following the outline. Foreground, two samples

Craftsmen with little experience can produce artistic cut-outs from plastic sheets by simply following the outlines stamped on the sheets. The projects include lawn ornaments, bird houses, wall decorations, signs, cabinets, plaques, trays, magazine racks and window boxes. Made in Masonite they range from 12-by-12 inches to 18-by-24 inches. The only tool needed is a scroll or jig saw, and the edges can be shaped with sandpaper or a file.

21181

Body Temperature Low at Night, High in Mid-Afternoon

After taking their temperatures 10 times daily for a year, two physiologists at University of Chicago, Drs. N. Kleitman and A. Ramsaroop, have reported that their average body temperature was at its peak in mid-afternoon and coldest in the middle of the night. The extremes did not always occur at the same hour each day, and the body-temperature range during 24 hours varied from less than one, to more than two degrees Fahrenheit. These levels were

not affected by changes in external temperature when it remained below 70 degrees, but above that point body temperature would fluctuate with the external temperature. By shifting their sleeping periods three to four hours forward or backward, the scientists found they could shift the time of the daily temperature extremes. The transition required one to two weeks.

21372

Album for Viewing Color Slides Uses Reflected Light

Without removing them from the album, an entire collection of Kodachrome transparencies can be inspected with daylight or any desk lamp as the light source. Each page of this special looseleaf album consists of two hinged rows of frames holding the slides. To examine any row of pictures, you raise the frame and slip under it a combination mirror and ground celluloid unit. When the viewer faces the light source, light strikes the horizontal mirror and is reflected through the celluloid to the Kodachrome slide, illuminating it.

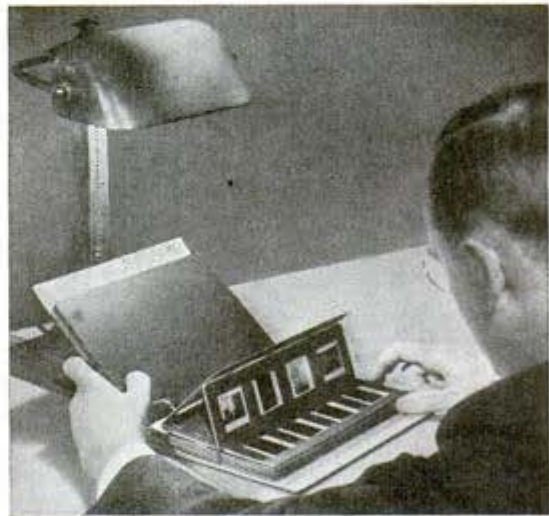

Mirror base of triangular unit seen in lower photo reflects through ground glass under Kodachrome

Desk: Von Lengerke & Antoine, 9 N. Wabash, Chicago

*Service Industries Inc
2025 S. Cabimet
Chicago*

*Service
Cut Out*

*Service
Cut Out*

*Service
Cut Out*

L1333

Hollow Wooden Blocks Simplify Wall Building

Hollow wooden blocks glued together introduce a new method of building without the usual framework, with the additional advantage of broad flexibility of design. Called Plycell blocks, they have a basic face-size of 12-by-12 inches, although other dimensions are available to meet special design needs. So true are their proportions that the "bricks" are said to be self-aligning, the only essential being that a level foundation be prepared. For instance, the manu-

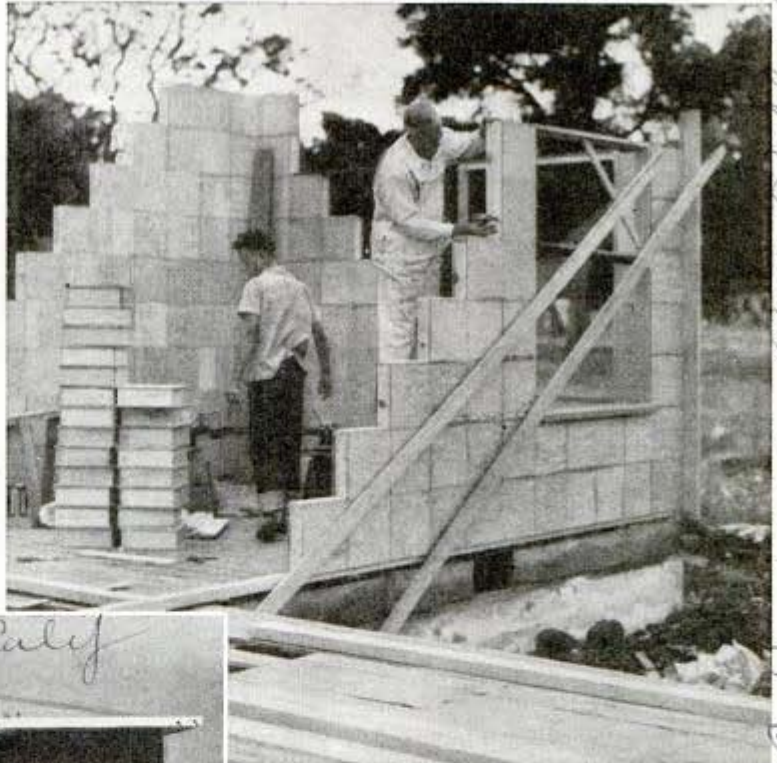

Lightweight blocks of wood are easy to handle and fit into wall, above. Left, view of completed house

good insulation, but this may be filled with insulating materials to meet specific requirements. To allow for plumbing, wiring, and so forth, the inside plywood faces may be left unattached until after such installations have been made.

facturer states that the first building erected did not have a single wall lined or trued during construction. All units are wooden frames to which are glued plywood faces that project equally on all sides, forming a continuous groove to receive splines by which one is joined to the other with case-in glue. However, blocks may be designed for attachment by other means if desired. Dead-air space within each block provides

Furred spaces can be provided for plumbing and heating wherever necessary. All doors, windows and built-in features become united with the blocks as if molded in one piece. There is hardly any limit to the possible interior and exterior wall finishes, since the units lend themselves for special prefinishing treatment in the factory or the desired finish can be applied after completion of the structure.

Plant Cuttings Take Root Quickly When Their Stems are Lacerated

Gardeners who want faster rooting from plant cuttings might try abusing the stems, according to recent experiments with coleus and other plants. Using a razor blade Prof. Carl D. LaRue of the University of Michigan slashed the cut ends of some stems almost to a pulp. For comparison a second group was left with the ends clean-cut. Both groups were kept in a

moist chamber for 48 hours, and then the lacerated plants were separated from others before being set out to strike root. The stems which had been badly gashed proved uniform in producing more roots than the clean-cut stems. In a second test, Prof. LaRue made an extract from plant wound tissue with which he treated the ends of cuttings. This, too, had a stimulating effect.

Science Service 9/19/41

at Bell Haven Calif

L1058

Ann Arbor

Arthur C. Morgan, Pass Obles Ave. Calif.

L1369 *Capt. Thomas G. Stinson Jr*
3872 Hawthorne Ca
(See Jan. 1942 25) Los Angeles.

FLYING WINGS ARE COMING



THE old prospector rubbed his beard and squinted in amazement.

"It's the heat," he muttered. "There just ain't any airplane like that."

Swooping over the California desert was something that looked to him like a monstrous pterodactyl. It had to be an airplane, he finally decided, because he could hear the motors. But it was the queerest the desert had ever seen. It didn't have any tail.

What the prospector had stumbled across was a secret test flight of a new plane that no one except a few Army officers and Northrop Aircraft officials knew about. It was a flying wing that some engineers expect will revolutionize aircraft design. Some predict today's conventional airplane will become as extinct as the pterodactyl that the new flying wing resembles. Already Northrop is getting into volume production on the type.

Designers have been trying to perfect a practical flying wing for dec-

Above, a closeup of center section of the flying-wing plane with Northrop in cockpit. Openings admit air to carburetor and to cool engines



Side view, above, shows tips rebuilt horizontally into the wing; notice extreme thickness of the center section. Spear projecting from apex of wing in the photograph below is the air-speed indicator tube

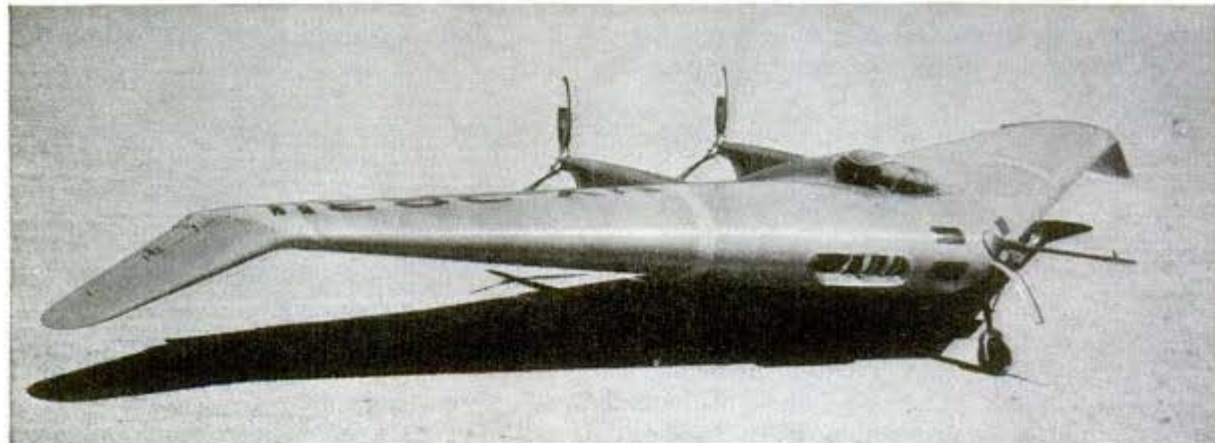

Ref: Lyle Manton
Public Relations Office
Northrop Aircraft Co.
Hawthorne, Calif. 21369



ades because such a craft is about one third more efficient than an ordinary airplane. The conventional tail and fuselage are hindrances to efficient flight, but the tail group has been necessary for control, and the fuselage necessary to hold the tail behind the wing. Both elements form a drag that holds the wing back from the speed it could attain by itself.

A number of flying wings have been built, one as early as 1914, but all were hard to control. Even a flying wing needs control surfaces and the only places to put them are at the wing tips. This creates a short coupling that results in bad spinning characteristics. Such flying wings are perfectly stable in smooth air but

(Continued to page 190)

In flight, the great sweepback of the wing is seen. Notice control surfaces in wing tip and the clean lines of this craft when its tricycle landing gear is retracted. Below, its pusher engines hidden from this angle, it is shown in contrast with a conventional monoplane



L1329

Fixed Telescope Focused by Movable Mirror

Miss Dorothy Bevin



↑
Mirror, center, may be turned to bend ray from any star into ten-inch lens of telescope

← "Seeing end" of telescope. Dials, left and right of eyepiece, control movement of mirror

matically turns the mirror so it reflects the image of the selected star into the 10-inch objective lens of the telescope. Delicately balanced mechanism that controls the mirror is powered by nine electric motors of $\frac{1}{20}$ horsepower or less. Pressure of a button then

One of the world's most unusual telescopes, never pointing to the heavens since it is immovably mounted in horizontal position and constantly pointing northward, has been set up for visitors at Buhl Planetarium in Pittsburgh, Pa. The siderostat telescope, as it is known, can be focused on any star or planet that may be in position for observation. This is accomplished with the aid of a mirror mounted directly in front of the telescope. Instead of aiming the 12-foot tube, the observer merely adjusts a pair of dials according to instructions in a guide book and thus auto-

causes the mirror to follow the star across the sky. Pushing another button starts a recorded voice's story of the star at which the spectator is looking. While gazing into the eyepiece, the visitor sits in an enclosed room. Actually there are six interchangeable eyepieces, ranging from 65 to 490 power. These various powers have different uses. For instance, 490 power might be put on the telescope when viewing a comet invisible to the naked eye, and the 65-power used for looking at Saturn or Jupiter. The instrument is not for experts, but for the enjoyment of the general public.

*Arthur L. Strafer
Director*

*Owned by Legation
Scientific Club.*

16 1201 W. Wrightwood
Chicago

19 L1040

COLOR AT WORK



Formulas for colored paints are worked out in laboratory prior to large-scale mixing in paint division of Pittsburgh Plate Glass Co.

2222 *Ernest C. Boyd*

L1040 Leggett

Color bands identify different elements in bit of metal or other substance analyzed with spectrograph



Colored light in a show window may attract more passersby than white light, even if the same wattage is employed. Electric signs in brilliant colors get more attention than those using ordinary incandescent lamps. Of course, novelty is a powerful factor in attention value.

Even the packing house finds it wise to use color. Traditionally the walls of packing house showrooms have been white and the sawdust-covered floors yellowish. Looking at white surfaces produces a gray after-image and looking at yellow results in other objects taking on a bluish tinge. Thus, beef in the showrooms seemed gray-blue, quite un-

By Matthew Luckiesh, D.Sc., D.E.

Director of Lighting Research Laboratory,
General Electric Company

Nela Park Cleveland Ohio

KNOWINGLY or not, everyone demands color. The appeal of color is utilized, consciously or not, by everyone who produces for sale anything in which color is naturally or even artificially a factor. Artists, craftsmen, manufacturers and merchandisers utilize the powers of color and colors. In advertising and merchandising, the appeal of color has naturally been given much attention. In these activities, color has adequately been proved to have definite monetary value.

Operators of restaurants, tea rooms, taverns and night clubs believe that dim lighting—subdued coloring—induces guests to linger; that lighting with lamps producing a rosy glow seems to soften the guests—and ease their purse strings.

attractive to the meat purchaser. The color engineer steps in and paints the walls blue-green and covers the floors with green sawdust; the contrasting after-effect accentuates the redness in the meat and increased sales result—another illustration of how color is being put to work.

In five years a publication increased its income from colored advertisements 75 times; four-color pages of advertising increased from about a dozen to more than 1,400 annually, proving the appeal of color.

Small articles made of plastics are colored during the manufacturing process



see journal 1944 & calculator

Sometimes more work will be done where muscular activity is required if the proper colors are employed. Exhaustive tests have shown that red has a stimulating effect on human beings, with less stimulation for orange, yellow, green and blue, in order. Taking ordinary white light as 100 percent, the tests showed the increase in muscular activity: 104 percent under blue illumination; 121 percent under green; 130 percent for yellow; 159 percent for orange and 187 percent for red.

W. E. B. Cochrane

Colors can perform many services in the factory—aid sanitation, encourage group hygiene, relieve monotony, make work rooms seem cooler, stimulate workers and contribute toward productivity, contentment and happiness. Painting machines and parts of them in certain colors will tend to reduce accidents; painting the surroundings appropriately will make the workers more cheerful. To feel cool is highly desirable in places where work is performed, so we might apply a "cool" color scheme such as: gray green for dado and lower portions of columns and possibly for machinery; medium tint of pea green for upper walls and other large vertical surfaces; near-white for the ceiling—either a mere suggestion of yellowish green or even a cream, and a medium tint of pea green for structural beams to give the feeling of support. If there are many beams, aluminum paint may be satisfactory—and it gives a modern touch.

A combination of warm and cool color schemes is obtained by means of light buff or partially subdued yellow on the upper walls and a shade of yellowish green on the lower



Westinghouse
Spectrograph uses photographic film in analyses of unknown materials

Closeup of portable color-and-light demonstrator developed by General Electric Company, Nela Park, for home lighting specialists -
Cleveland, Ohio



21040

Model cars enable the Ditzler Color Co. to show auto makers how colors will look on the finished product. This is a natural-color photograph



greenish blue. The warm colors are those between scarlet and yellow, with the maximum warmth in the region of yellowish orange or orange. Use of the cool colors and of cheering colors which are at a maximum in yellow, would seem appropriate in hospitals.

In the general office there is no outstanding point of attack. Exposure, simplicity, maintenance and lighting are all worthy of consideration in

20 walls. A band separating the upper and lower walls may be of light brown or of a shade of yellow green.

In the hospital, glossy white has reigned a long time, owing to a narrow efficiency viewpoint. A glossy paint is washed easily and white not only suggests cleanliness, but reveals the lack of it. Since nature is relied upon as an aid to getting well, hospitals should bear some semblance to that which is natural. This means the substitution of a reasonable degree of colorfulness for the unnatural white. Cool or warm color schemes are readily utilized; the cool colors being those between violet and green, with a maximum coolness near a

a color scheme. Some light should come directly from the ceiling or an equivalent. Perhaps the common extreme plainness of ceilings should be relieved by means of simple painted or molded patterns. In general there is no justification for lack of colorfulness. The cool color schemes appear to be more generally applicable in the work-world, notwithstanding the prevalence of very subdued buffs. Northern exposures in an ideal office building might well have windows glazed with glass of a warm yellowish tint—not amber. In summer, when the windows are open, this warmth of color vanishes, but is present in winter because the windows are closed.

Insulated wires are colored differently to distinguish one circuit from another

E. E. Telensien studied



This striking color shot shows tank in which various liquids form color mixture. (Photo courtesy Pittsburgh Plate Glass Co.)

Lorant Glass Pullatman

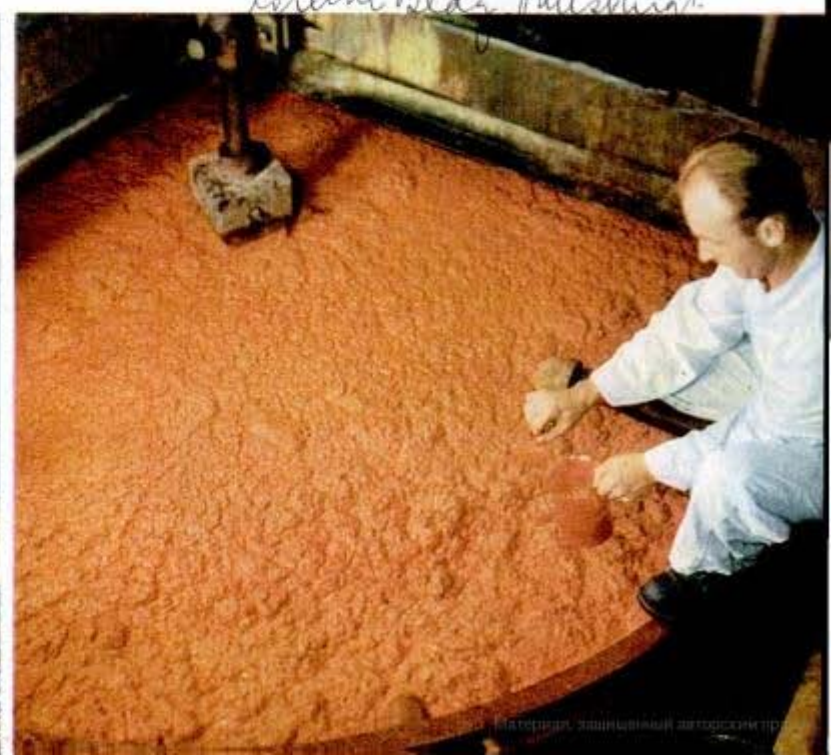



Striking example of how colored illuminants are employed to "paint" buildings attractively at night

21
L1040

Desk tops might be painted a warm gray or in other subdued colors but they should not be dark colors. There is no reason why typewriters and adding machines should not be colorful, at least warm grays. Executives will find office production greater, workers more cheerful and fatigue less if the surroundings satisfy the esthetic sense, if the furniture and the machines are appropriately colored and if the lighting is such as to reduce eyestrain. Ease of seeing is a phase of considerable breadth, including not only vision but impressions.

In fields where colored or tinted light is desirable, the fluorescent lamp has opened

Working with colored plastics in General Electric laboratory





21040
ad may 1942

up entirely new and interesting possibilities. The fluorescent lamp is a tube in which a powder is activated by ultraviolet rays. Functioning as a transformer, the powder absorbs these short-wave, invisible ultraviolet rays and re-radiates this energy at greater wavelengths which become visible within the color ranges of the spectrum. Differences in the chemical content of the powder result in different colors of emitted light, making it possible to produce colors from the pastel tints to rather pure ones. One type produces the nearest approach to natural daylight ever achieved by an efficient artificial illuminant for general lighting purposes.

Stores, offices, factories, theater interiors, hotel dining rooms and lobbies, specialty shops, art galleries and numerous other establishments are putting color to work with the aid of this tubular lamp. Color discrimination and many forms of color-matching are done under light from daylight fluorescent lamps.

Any merchant would be able to serve his customers better by installing a color-demonstrating box, which he can have made at a low expenditure. A simple form consists of two compartments. In one are installed colored lamps—red, green, blue, yellow and white—with switches and louvers to control the individual lamp so that combinations of colors may be produced. A diffusing glass separates the lamp compartment from the other compartment and into this second compartment (with white walls) the customer may look at the color which is being produced. By proper records or scales the merchant may duplicate the same color at any time. The color box

Pat. 2238316. circ. in card file under "Color Helm" is a handy device for anyone dealing with colors.
 Fratelle Inc. Ridgewood, N.Y.
 58 W. 40th St. New York City
 Chicago Artists Supply Co. 578 Wacker



Colored particles employed in paint are dried by means of filter press, shown in use

would be a valuable aid in helping customers to choose materials to reproduce the color or to harmonize with it.

The automobile is an outstanding example of the growing demand for color and of the manufacturer's reaction to that demand. In the early days of auto body building, only a few colors were used, with the manufacturers offering a great preponderance of black cars. That a great change has occurred is perfectly plain to anyone who watches the rainbow-hued parade along our highways today. When few colors were used in the industry, they were presented in small swatches glued to a pocket-sized card. As time went by, color folders became the order. Then came a new idea—colors in small cabinets with individual color swatches visibly filed according to color family. This arrangement was forced into the background by metal panels which carried a better picture of the actual finish. Then one company began displaying color on quarter-size replicas of motor car doors, following up this idea with model cars in one-eighth size. The miniature automo-



biles are the result of an effort to bring out the over-tones and under-tones of colors as affected by highlights and shadows.

Streamline trains, street cars, trackless trolleys and buses also reflect the growing demand for color, both inside and out. Most of the gay-hued trains carry capacity loads of passengers and crowds still throng the right-of-way of one brightly-painted streamliner that has been in service many months.

Another way in which color has been put to work is found in the story of an oil company doing an export business in India.

One version of simple color-demonstrating box that merchants would find handy. Observer looks through aperture until color desired is created by means of light combinations

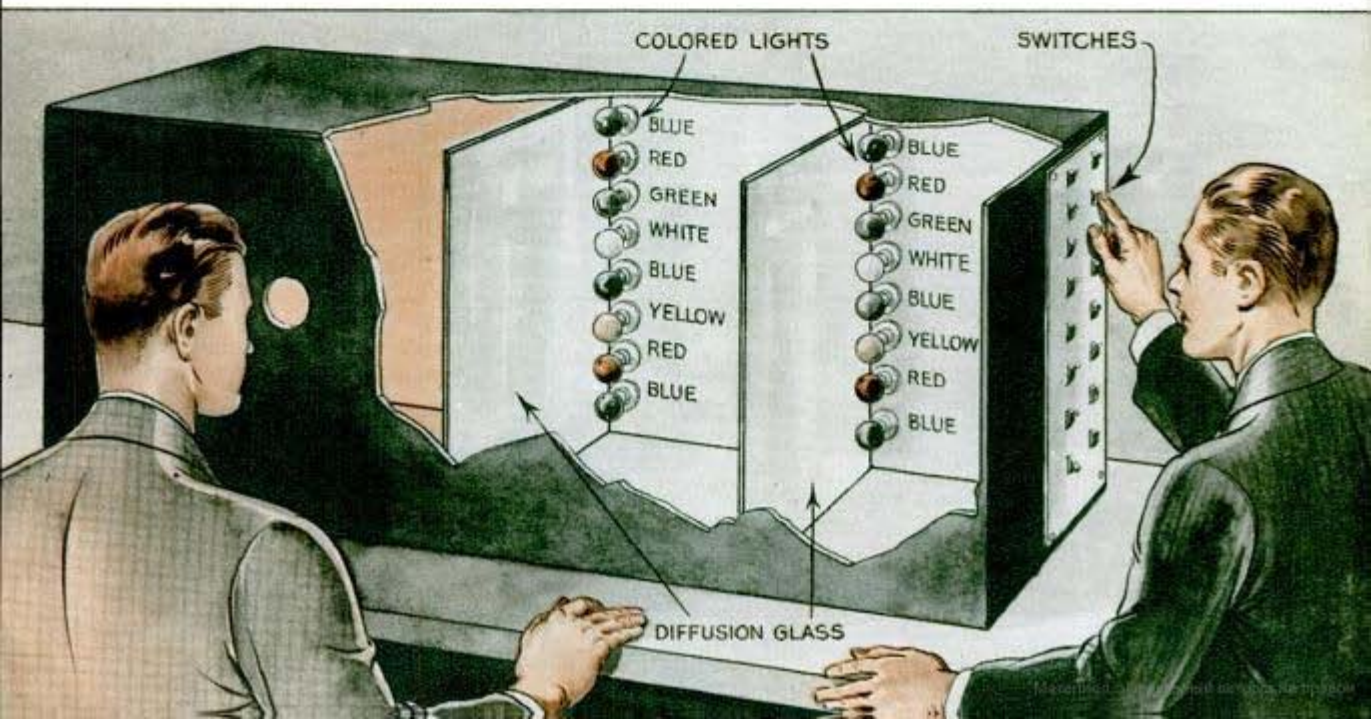

21040

Color photo of fluorescent tubes under test in General Electric plant



Oil was sold in tins for use in lamps at the time this trade was inaugurated. Apparently someone advising the company knew that the natives held the monkey in high esteem and that they liked red. So a red monkey was printed on the sides of the can in which the oil was sold. The result was that the natives hung the tins in their humble huts for enjoyment of the red color and in reverence of the monkey. Undoubtedly more oil in that kind of can was sold in India than in other kinds, for obvious reasons.

The possibilities of color application are virtually unlimited. Paints, dyes and light are the sources of many thousands of colors, tints and shades. For instance, if only reflected color is considered, such as in painting and decoration, 10,000 colors are available. One dictionary of color contains specimens of 7,000 colors, with the color charts of paint, dye and silk manufacturers showing still less. The 10,000 reflecting colors are increased to an almost unbelievable number when the influence of lighting is taken into account, because each color becomes a different color, in the broad sense, when the intensity of illumination is altered. Thus a very extensive series of shades of any color is produced by changes in level of illumination. Compared with this series, that ranging from white to black on an artist's palette is meager indeed.

Interior decorators must
(Continued to page 176)



The author originating appropriate color schemes for enjoyment of color in work-world

21362

57-Ton Tank Displays Mighty Crushing Power



This could happen to an enemy truck attempting to impede the United States Army's latest heavy tank

Another defiant fighter was welcomed to the armored ranks of the United States Army when the first 57-ton tank of the M-1 type rolled off the assembly line at the Baldwin Locomotive Works in Eddy-

stone, Pa. In one of its first demonstrations the Big Bertha of mobile weapons smashed a truck under its tracks as if it were an eggshell. Production of this tank has been speeded to meet the nation's war needs.

Space-Saving Hat and Coat Rack Fastens to Wall or Door

Closet space can be saved with a hat and garment holder which may be attached to the back of a door or on the wall. The hat rest is shaped to fit inside the crown of the hat, and the arm is notched for hangers.

Zinc Oxide May Reduce Carbon In Gasoline Engines

Zinc oxide may be the means of reducing or eliminating carbon to a minimum in gasoline engines, according to a patent assigned to the Standard Oil Development Corporation of New York. The inventors claim that if the parts on which carbon usually forms are coated with zinc oxide, they will resist the deposits of carbon. The zinc oxide coating may be applied in various ways: the parts may be electroplated, subjected to vapors of metallic zinc, or galvanized by treating them with molten zinc. The zinc is finally converted into zinc oxide by an oxidizing agent.

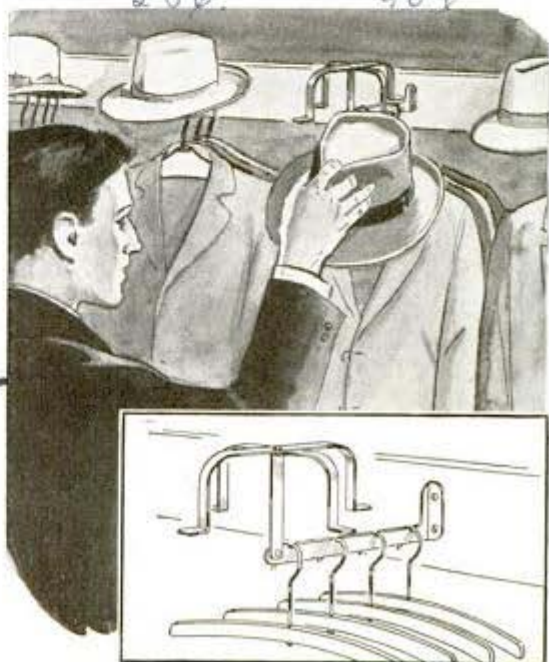

Hat and garment rack shown in inset may be mounted on wall or behind the door to save space in closet

MARCH, 1942

26 Broadway
New York City

Patented by Edward B. Beck
Elizabeth, N.J.
21323
256 408
Cryler Mfg. Co.
4115 Ravenswood Chicago

The EMERGENCY PATROL



Volunteer antiaircraft squad follows planes over city with searchlights ↑

Police sergeant in emergency car directs rescue drill over loudspeaker ↓



WAR quickly taught Europe the airplane had at last brought conflict to the doorsteps of the civilian and not even the most efficient army, navy and air forces could prevent bombing behind the battle front.

But not until the United States found itself actively engaged did the nation begin to realize that just as the armed forces could not prevent air attacks on cities, neither could experienced firemen and policemen handle the emergencies brought about by explosive and incendiary bombs in which 1,000 fire bombs usually mean 100

21361

bomb fires. Regardless of the efficiency of the trained forces, civilians must take a hand in their own defense. The time may come when every able-bodied American citizen, male and female, will be required to assume some protective duty in the army behind the army.

The bigger the city, the better the target. This was discerned early by officials of America's largest metropolis, New York City, with 7,500,000 people exposed to attack. For more than a year, behind the facade of business as usual, a feverish campaign of preparedness for civilian defense had been going on.

The day America entered the war, over 115,000 air raid wardens, more than 25,000 auxiliary firemen, and thousands of technical specialists—a civilian defense army numbering more than 200,000—were ready for duty in New York City.

From this blueprint the rapidly expanded civilian defense army of the nation has been constructed,

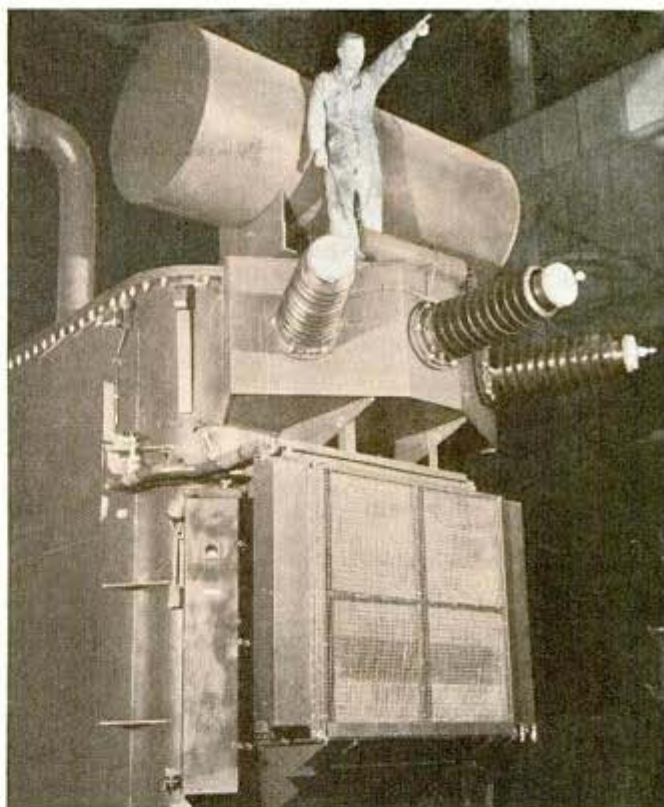

Mobile transformer capable of supplying electricity for city of 70,000 can be rushed by rail wherever power shortage exists

Volunteer firemen, below, attach trailer fire pumps to taxicabs



MARCH, 1942

27

*Dr. E. P. Whitehead
In American Board of...*

Warab Portable Sanders Road Breaker.

Warab - Sales, chas
420 Lexington Ave New York 17 1361



Holding a sandbag in front of his face for protection, a civilian fireman drops it on an incendiary bomb. This should smother it in two minutes

One member of rescue squad (right) wields a portable, gasoline-driven drill to loosen a wall while another attacks the woodwork with an electric saw

From the tops of skyscrapers around New York, thousands of air-raid wardens—many with "walkie-talkie" radios (below)—watch for enemy planes



with its now familiar homespun firemen, air raid watchers, communications experts, and rescue squads.

What may be in store for the average American as the civilian defense program expands is indicated by the intensive advanced training given volunteer auxiliary firemen in New York. To ordinary fire fighting, first aid, morale building, house wrecking and rescue work, were added new problems inflicted by war hazards. They were taught that every building over 75 feet high in New York is required to have a water tank on the roof, with a standpipe reaching to the sidewalk. If a blast shattered the water main, they were to fasten a hose to the lower end of a standpipe and attach it to the engine. A 5,000-gallon standard tank provides a 20-minute stream.

Fire department lectures dealt with the hypothetical situation in which all the mains had been shattered near the center of Manhattan island and several large fires were burning. The men were shown how hose lines could be stretched to the Hudson river and the

East river and water pumped for many blocks by relay pumpers every 2,500 or 3,000 feet. Civilian firemen studied the location of bathing pools, the use of portable tanks and stationary water supply vats, bucket brigades and stirrup pumps. They were given instruction on emergency treatment for smoke inhalation and burns and first aid for fractures and wounds. They were instructed in the use of splints for fractures and tourniquets to stop bleeding, and how to apply bandages.

Practicing in gas masks, firemen learned the necessity for decontamination after exposure to mustard gas, the fact that blisters caused by Lewisite gas must not be broken or they will form again, and the first rule in treatment of tear gas—to keep from rubbing the eyes.

Air raid watchers spent hours spotting "enemy" planes from skyscrapers. First aid groups clambered through wreckage with "victims" on stretchers. Decontamination experts practiced on gas-impregnated ground. In the army information center, calls were received from many of the 1,500 observation posts around New York, and along the Atlantic seaboard 40,000 civilian spotters helped chart the course of aircraft simulating attack on New York City.

Meanwhile engineers were appraising the vulnerability of the city with the most large buildings of any civilized community. They found these very skyscrapers were the greatest safety factor in the city. Except for the top six floors and the vicinity of roofs on setbacks, no better air raid shelters could be planned than the tall buildings, because the path of a dropped bomb is oblique and it is likely to be diverted from the side of a building if it strikes. Above three floors, the danger from flying debris would be



↑ Steel-helmeted doctors and nurses of New York City hospitals practice and train others for emergency first aid work

↓ Volunteer firemen go after an incendiary bomb with acetylene torch to cut roof, rope for rescues and two-way radio



21361



↑ Emergency calls about utility damage clear through this liaison office



← Volunteer decontamination squad neutralizes a gassed area with sand and chloride of lime

New York's emergency car is equipped with rescue and wrecking tools, oxygen and masks

nil. Half a dozen supporting columns could be blasted from a structure like the Empire State Building and it would stand firmly, they estimated. Concrete and steel floors would resist bomb penetration.

The city's 11,000 taxicabs were organized into an emergency group which volunteered for evacuating women and children, giving first aid, and transporting fire-fighting equipment if needed. Technical, engineering and art schools inaugurated classes in camouflage and light control, and disguise of strategic buildings, air field, gun emplacements and raid shelters.



Patrolmen in New York City are trained to work in gas masks →

dummy mines usually, but with active mines substituted and exploded occasionally to complete their training.

Detailed plans for supplying the metropolitan area with the necessary 40,000,000 pounds of food daily were worked out by William Fellowes Morgan, Jr., Commissioner of Markets, and his staff. Maps and statistics were drawn to show how, for example, if the Holland Tunnel were smashed, foodstuffs ordinarily carried through this artery could be lightered across the Hudson river, or trucked over a bridge. Systems were worked out so that several weeks' supply of essential foods will be available, and questionnaires filled out by wholesalers indicated how much provender would be necessary if transportation lines to the outside were crippled.

Civilians were advised to duck under a stout table if caught in a vulnerable building during an air raid; to keep suitcases packed ready for a quick departure; keep bathtubs full of water, have stir-

(Continued to page 193)



Above is one of the probationary firemen wearing an oxygen type helmet, in which he can virtually "eat smoke." More than 25,000 auxiliary firemen are being trained for war work



At left, a squad of the auxiliaries piles aboard an emergency truck for a fire-fighting drill

21389

Retreading Lengthens Tire Life, Saves Rubber

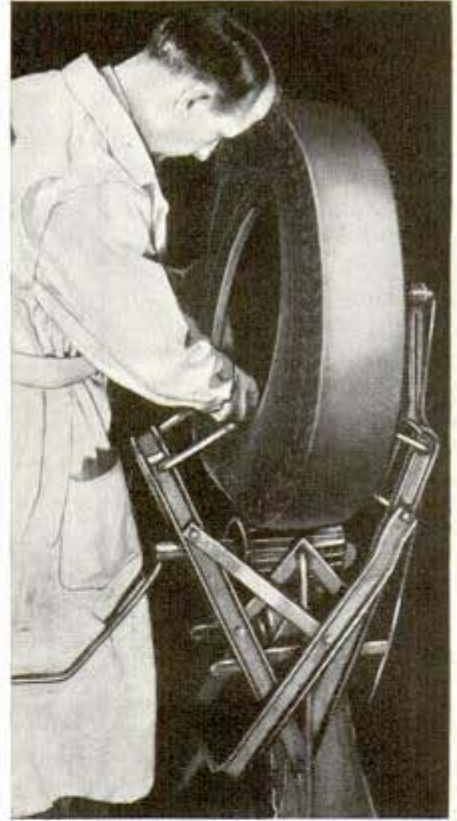

With rubber precious and tires rationed, motorists can add 80 percent to tire mileage at half the original cost by retreading. First step (top) is to buff off old rubber tread

Above, inspecting tire before deciding to retread. Below, at left, applying new tread to casing; right, vulcanizing tread in a mold, without heating sidewall or shoulder. About half as much rubber is used as in new tire

Photos from Firestone Tire & Rubber Co.
Chromalux



21264

Power Shovel Designed With Transparent Cab

not on market



Plastic bodied power shovel, with transparent cab, will have telescoping arm as shown in sketches

Industrial Designers, 664 N. Maple

Previous notions of design and established precedents were set aside by designers in creating the body for an entirely different power shovel. As drawn by Barnes & Reinecke of Chicago, industrial designers, the structure is of colored molded plastic, to be capped by an unbreakable crystal-clear cupola from which the operator would have full vision in all direc-

tions. Broad tracks, operated independently forward or backward, would give the vehicle easy maneuverability in deep mud and on rough ground. The shovel would swing at the end of a telescoping tubular steel boom, to provide a wide range of digging operations from a given setting. A compact thousand-horsepower Diesel motor would furnish power.

21260

Army Plants Mines With Coal Chutes Mounted on Trucks

In recent maneuvers at Wadesboro, N. C., men of Company C, Fifth Engineers, used a simple means for laying land mines intended to stop tanks and scout cars. Common coal chutes were mounted at the rear end of the trucks and the antitank mines were fed to the road one at a time while on the go.

Engineers of United States Army experimenting with the use of ordinary coal chutes, mounted at the rear of trucks, to accelerate the laying of antitank mines. Strewn in the path of an advancing or pursuing army, these land mines would slow up tanks and other motorized vehicles



chute

1227

How to CUT Your HEATING BILL



Putting storm windows on your house will save as much as 63.8 percent of the heat escaping through windows. Below, taking temperatures at floor and at the ceiling. Differences exceeding four degrees indicate inefficient heating



Blowing insulation into wall results in saving as much as 72.6 percent of the heat escaping there

also Johns. Manville Co 22 E 40th Street
782 Baker Bldg. Minneapolis



1712 8th Ave. Minneapolis

By Milton Figen

HUNDREDS of millions of dollars worth of fuel are wasted annually in this country by home owners and dwellers who fail to take advantage of common and long accepted devices for saving heat. Among such devices are insulation, weather stripping and storm windows.

Exactly what do these forms of protection against heat waste mean for the average home?

Milton S. Wunderlich, chief of the research staff of the Insulite Company, Minneapolis, Minn., and owner of what he calls the "Electric Skin House," has been using this house for six years as a laboratory to determine exactly where heat losses occur in the average home and how much they amount to. He has gone to considerable expense in equipping his home to test not only the different ways in which heat es-

Builder Exchange Bldg.

capas but also the effectiveness of the different devices commonly used to check this escape. Most important among Mr. Wunderlich's equipment are the instruments which, because of their hyper-sensitivity to temperature changes, have gained his home the name of Electric Skin House.

These instruments are called "thermocouples." One hundred and thirty-nine of them are distributed over the house. Inconspicuous to the uneducated eye, the thermocouples are simple loops of delicate wire composed of two differing metals. Each thermocouple has a "detecting" end and a "receiving" end. The detecting ends, when ex-



"Electric Skin House" with locations of thermocouples indicated. Number at left of each line in lists is number of thermocouples at that particular location
 Courtesy Insulite, Minneapolis

Using potentiometer at switchboard in basement, the Wunderlichs are able to take readings of temperatures existing in 139 different parts of their dwelling

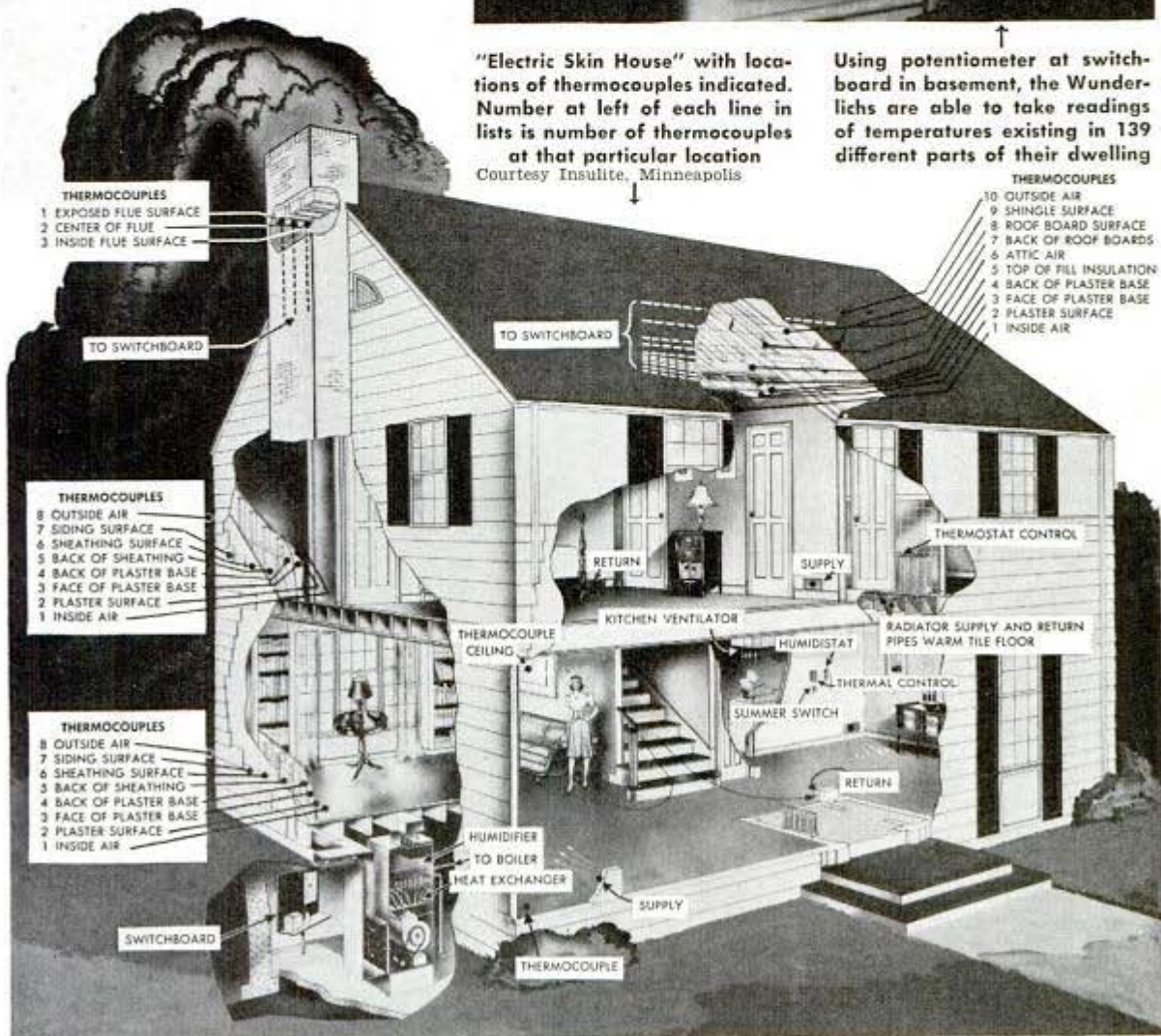

21227

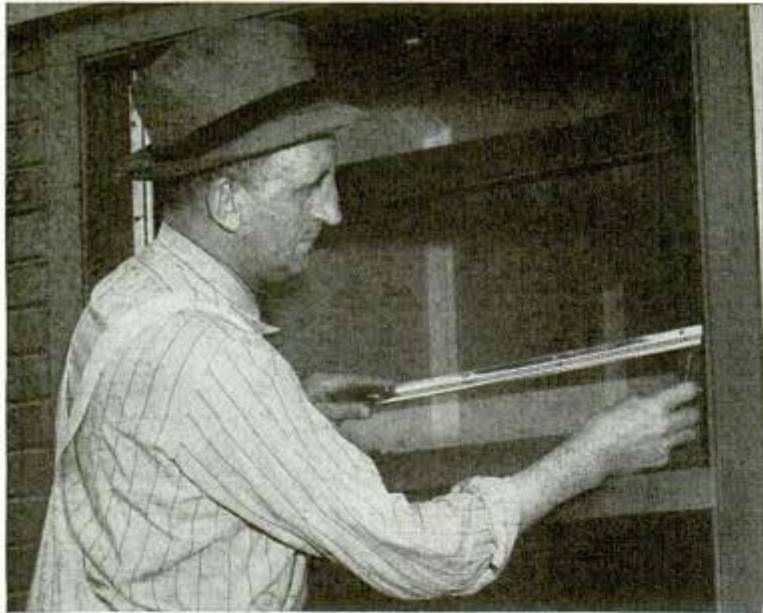

By installing weather stripping, average dweller can save as much as 45.6 percent of heat lost through cracks around windows and doors

all four outside walls, as well as in the ceiling and roof, loop ends were placed in groups of eight and ten at graduated depths through these exposed parts of the house. By thus being able to read temperatures existing in the interior of the walls as well as on their surfaces, Mr. Wunderlich could calculate the resistance to the escape of heat offered by the various materials of which the walls were composed. The same is true with regard to ceiling and roof. Once the "resistances" were measured, the exact amounts of heat lost through each square foot

posed to temperature changes at the points where they are located, generate a small electric flow. This flow can be measured at the receiving ends with an instrument called a potentiometer and the degrees of heat or cold existing at the opposite or detecting ends of the thermocouples are thus calibrated. All receiving ends are located at a central terminal board, somewhat resembling a telephone switchboard, located in the basement.

By seating himself at this central terminal board, Mr. Wunderlich is able to "plug in" his potentiometer and check up on the temperatures existing at 139 points in his home. The installation of this electric skin thermocouple system has given him, in effect, more power to "feel out" his home and to study its reaction to all kinds of weather changes than any man has ever had before.

The installation entailed the stringing of more than 12½ miles of the delicate wiring. The "couples" detect temperature changes at all points of the house where heat losses are likely to occur. In

of the "shell" of the home was easily determined.

Still other thermocouples were so placed as to detect not heat loss to the outside but any variations existing in the temperature of the heat being distributed through the interior of the home. For this purpose at least four "couples" were placed in each room: one in each vent delivering heat, one in each vent exhausting heat, one at an outside corner of the ceiling and one at an outside corner of the floor.

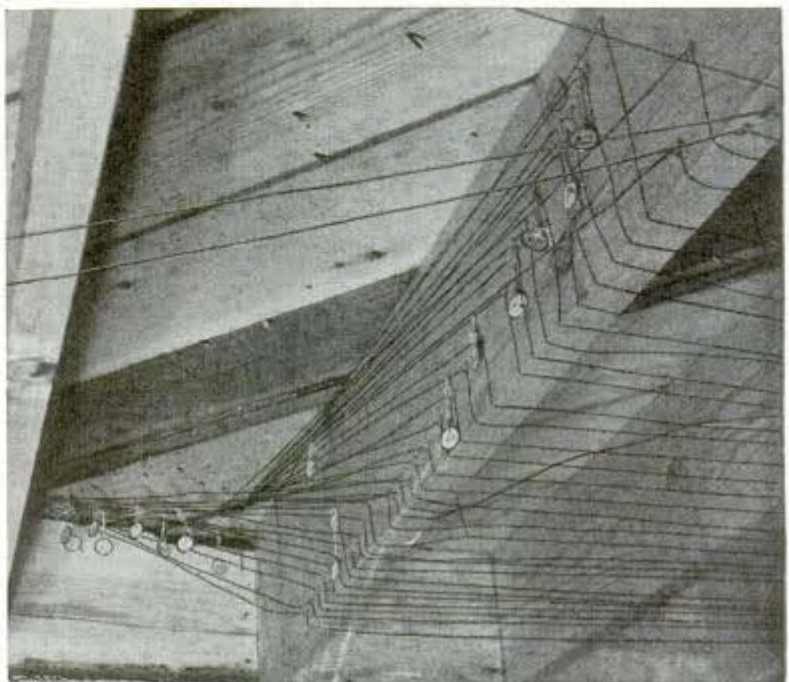

Closeup of thermocouple wiring attached to basement ceiling; 12½ miles of such wiring is in the house

L1227



Double candle test, with candle at bottom and another at top of the stairs, indicates drafts; constant, draftless heat is efficient



Wood fiber insulation board not only is protection against attic heat loss but also is good plaster base for walls of extra attic room

Proper insulation of attic will save the average dweller as much as 71.4 percent of all the heat escaping through roof of house

From these thermocouple readings, other tests made, and accurate records of fuel consumption kept, a wealth of illuminating information comes to light, information helpful to everyone who would like to cut the cost of his fuel bills.

Completely insulated in both walls and attic, the eight-room 23,000-cubic-foot Electric Skin House costs \$72 a year to heat. The heating season lasts seven months. Average daily temperatures run around 30 degrees F. All window and door openings are thoroughly weather stripped. The home has two stories, is of wood construction. A combination of air conditioning and steam heating is used. Oil is used for fuel. Factors to be borne in mind in judging the home are that it is considerably above average in size; it has all standard protections against heat losses (insulation, weather stripping, storm windows); also, the home is exposed on all sides with nothing to serve as windbreaks; and, finally, the automatic character of the heating controls (thermostat) helps to keep the fuel consumption down.



Effective as weather stripping is, the largest single source of heat loss is through the cracks around windows and doors. Approximately 29.7% of all heat escaping from the house is lost in this way. In dollars and cents this loss equals \$21.38 a year. But if the weather stripping were absent the loss would be \$39.30 a year. Saving in heat prevented from escaping through cracks is \$17.92 or 45.6%.

Storm windows cut down by 63.8% the heat loss through windows, from \$46.70 to \$18.50. But still, the second largest single source of heat loss in the house is windows. About 25.7% of all heat escaping is through

(Continued to page 166)

21281

"Normandie" Cast in Role of Aircraft Carrier

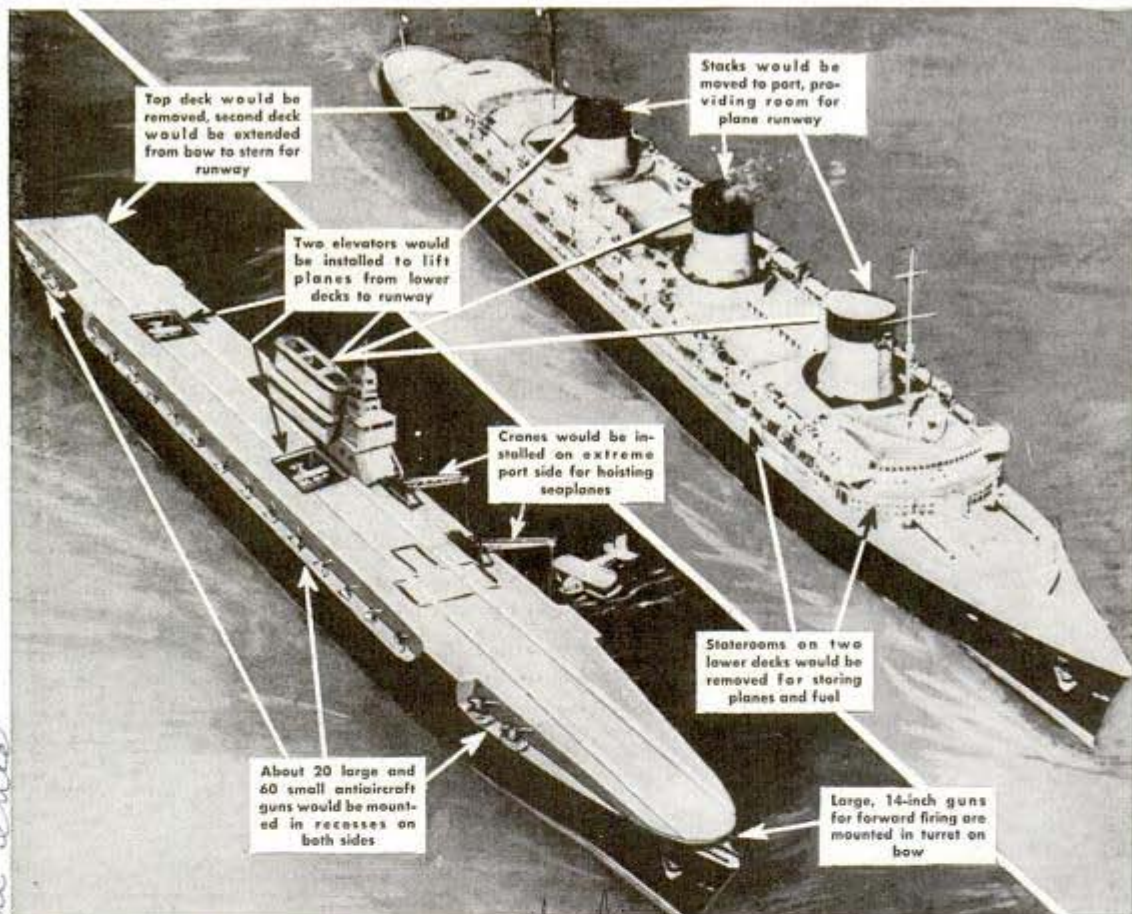

Sketches show French liner "Normandie" before transformation, and how she would look as a carrier

United States naval experts reveal that it would be possible to rebuild the huge French liner "Normandie" into an aircraft carrier within six months. Compared with this, it would require two years to con-

struct so large a fighting ship. The conversion would cost five to eight million dollars. As a carrier, the ship would probably accommodate about 75 airplanes and carry a crew of 2,500.

Heat Lamp to Fit in Pocket Tans Faster Than Sunlight

Tiny but powerful, a miniature heat lamp that may be carried in the coat pocket is

claimed to provide as much sun tan in three minutes as July sunshine does in thirty minutes. The unit is equipped with a high-powered mercury-arc lamp which emits both infrared and ultraviolet rays.



Heat lamp open for use and folded to fit the pocket

Color Photos Tell Fruit Ripeness At Both Ends of Shipment

Color photography is being used by fruit handlers in studies to determine the best time and conditions for picking, storing and shipping fruit. Plums or pears, for instance, are picked at a given stage of ripeness, photographed and loaded into refriger-

POPULAR MECHANICS

U. of California College of Agriculture, Davis, Calif.

Sperti. Inc. Beech and Kintwood and Cincinnati Ohio

with help of Agricultural and D.A.C.

L 1252.

Christian Science Monitor

erator cars in California. Some are put in the warmest place, others in the coldest, and temperatures are recorded automatically all the way across the continent. In New York the fruit is photographed again, and the two pictures show what happened to the color in transit. The experiments are expected to help growers select fruit of the proper ripeness for picking and to find the best temperature for shipping and storing.

L1241

Camera Truck Has 20-Foot Tower and Rubber Fenders

Photographers for the Chicago "Times" can "shoot" the news from a skyscraping platform that extends 20 feet in the air. The hydraulic lift is mounted on a photo-truck, and access to the platform is through a trap door in the roof. The truck has flexible rubber fenders over the rear wheels, eliminating a frequent source of repair bills.

General motor

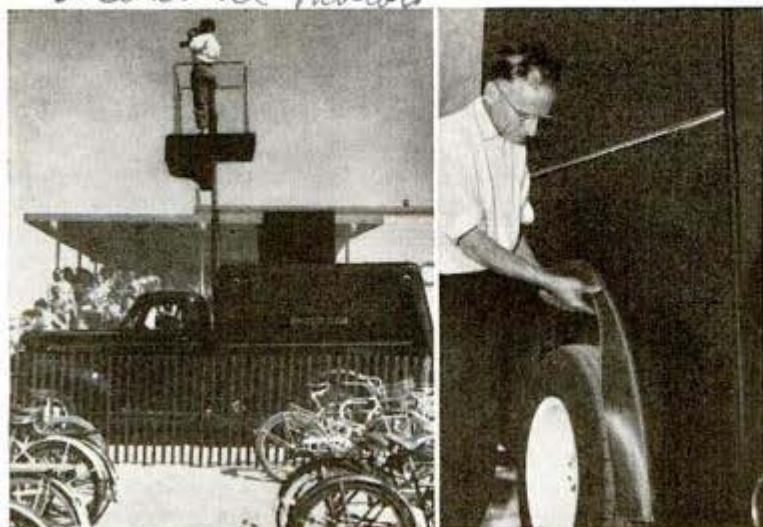

Left, shooting picture from hydraulic lift; right, the rubber fender

MARCH, 1942

Portable Landing Lights Invisible To Planes Flying Overhead

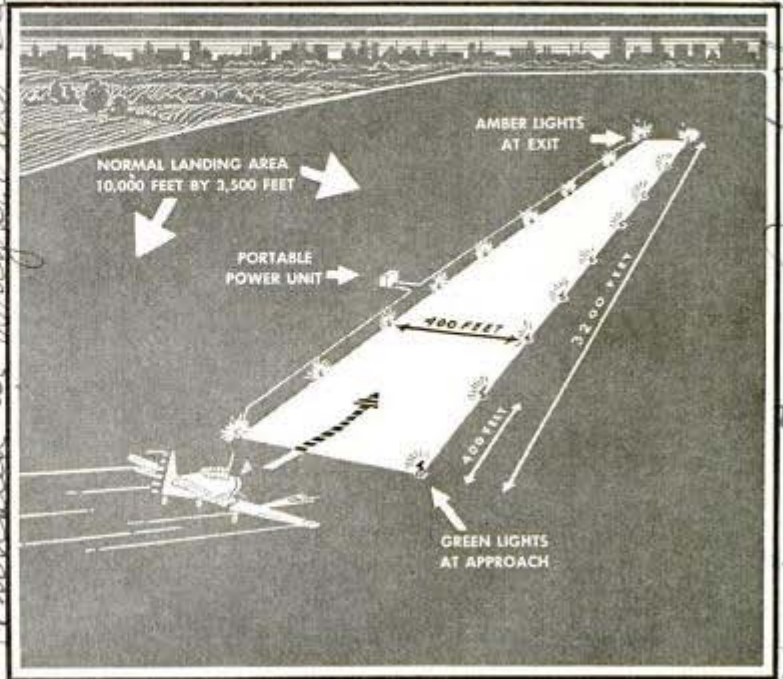

Lights on runway can be seen only by pilot making low-altitude approach

Only the pilot who drops down to enter the runway approach can see new-type portable landing lights put into use by the United States Army Air Forces. In fact, they cannot be observed even from a low-flying plane directly overhead. Each hooded light looks like a plump duckling squatting on the ground with a light in its beak. Its beam does not shoot across the landing lane but parallel to it, green lights being arranged at the entrance and amber at the exit. The system calls for steadiness and an accurate approach, but landings are smooth and safe. The lighted area is 400 feet wide and

3,200 feet long. The light standards and the portable power plant can be set up ready for use in 30 to 40 minutes to convert any smooth plot of ground into an emergency night landing field. They can be "rolled up" ready to be moved in ten minutes.

ⓈThe recoil mechanism of a 16-inch coast defense gun, which can hurl a one-ton shell 30 miles, is capable of stopping a 20-ton railroad car traveling 60 miles an hour within five feet.

Compressed Air Nov. 1941

Headquarters, Randolph Field

L 1222.

Leggett

KILOWATT - The New Hired Hand



Ultraviolet bulbs in reflectors provide artificial light with rays as beneficial to poultry as those from sun

Small portable electric motor performs farm tasks like shelling corn and hoisting hay

Carl Herman Otto manager
Electric House - Electric Poultry Farm - also



DOWN on the farm a new hired hand is reducing drudgery and making money for the boss. Silent, tireless and on the job 24 hours a day, this worker demands no high wages, accomplishing for five cents the same amount of mechanical work that any man can do in eight hours. Kilowatt is the name of this efficient helper.

Kilowatts flowing through the power lines serving more than 2,000,000 of America's farms are changing the agricultural picture in an amazing fashion. Hitched up to various equipment and appliances, they perform in a few minutes the tasks that once meant hours of dreary labor. And the farmers who are making the fullest use of electricity today are the farmers who are making the most money.

Electricity is measured by what is

Westinghouse
Lamp Div. 150
13 roadway
New York

called a "kilowatt-hour." For the farmer, one kilowatt-hour, used with the proper equipment, will lift 7½ tons of hay into a haymow, churn 100 pounds of butter, wash the dishes for 40 meals or milk 30 cows. And that will cost approximately five cents, less in some communities where rates are lower.

Just how can the farmer make money by using electricity? Let's take a look at poultry raising. On one test farm, where a time clock turns lights on and off to maintain a 12-hour working day, egg profits are 10 to 30 percent greater than before electricity was employed. "Wired help" now wakes the chickens, keeps baby chicks warm, heats their water, grinds and mixes feed, grades and cleans eggs and encourages egg production by turning a ventilating fan that keeps the hens comfortable on warm days. Electric brooders, egg cleaners, portable motors and egg graders enabled this farmer to increase his flock of chickens and double the egg output without increasing the number of hired hands. And the cost? One egg per day pays for the electricity



Here the portable motor does the lifting, enabling one man to handle the hay (Westinghouse photo)

*Electric hay hoist - Universal
Towst Motor Co Cedar Falls
Iowa*

Good lighting is essential in the barn; ultraviolet lamps may be used to supply sunlike rays for sheep in winter

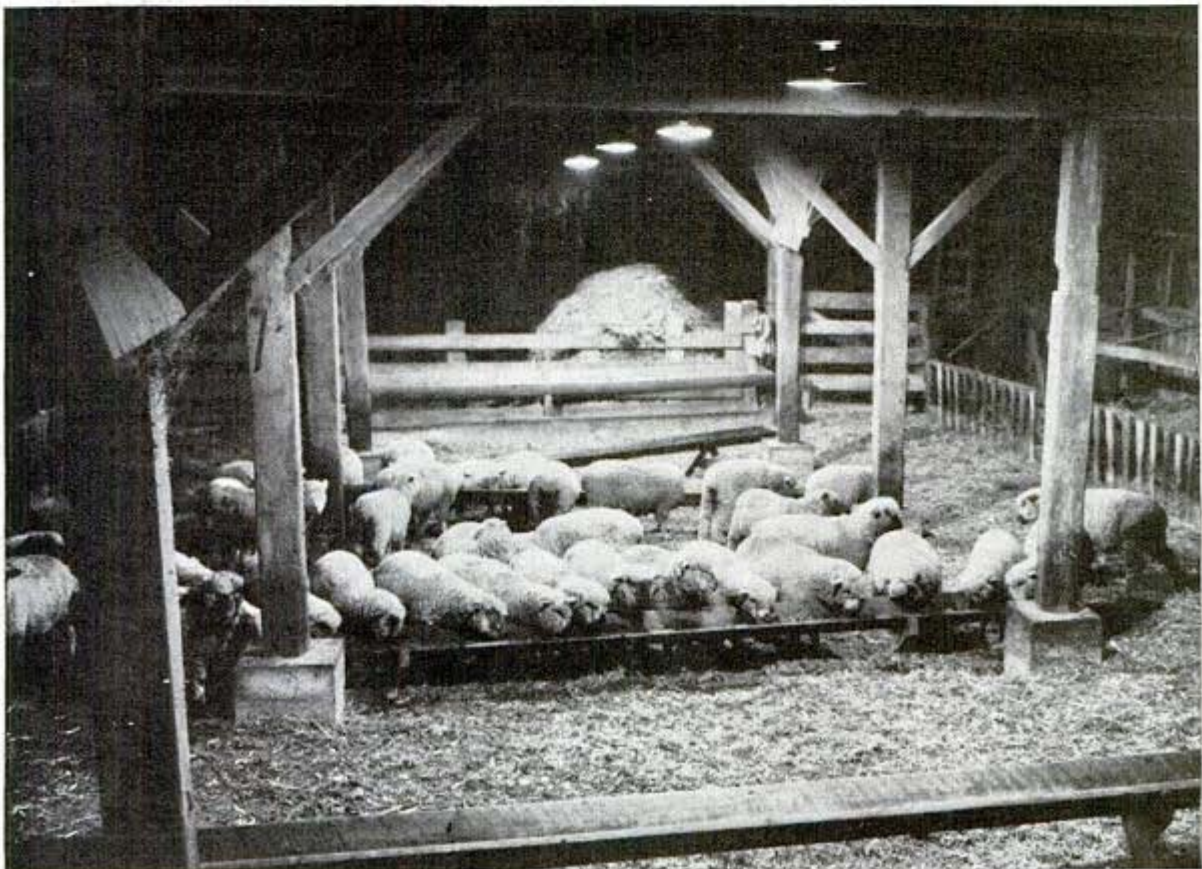

21222

Wesley R. Peckelham farming
farm near Webster, N.Y.

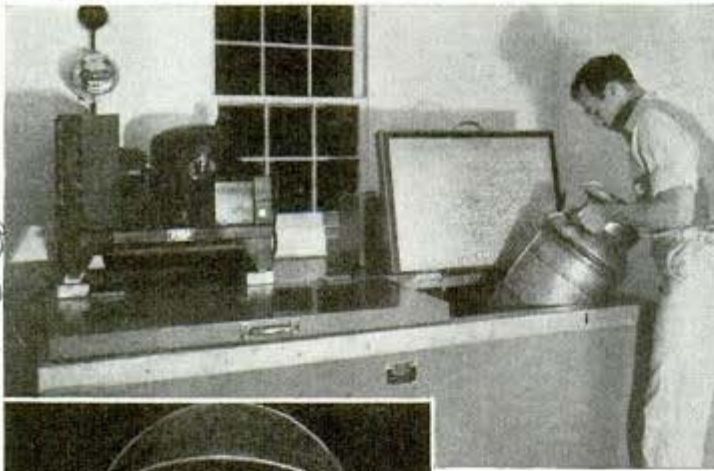

↑
Electric milk cooler eliminates waste of well water formerly required for the same job—and cools the milk better

←
Electric lamp attracts insects and metal grille, charged with 4,000 volts, electrocutes them as they fly into this trap

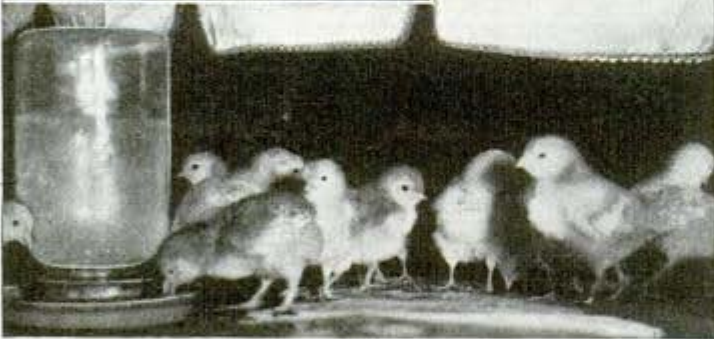

Electrical mother for these chicks (above) is brooder that takes place of 40 hens. Electrically operated pipeline milker saves labor, frees hired men for other work

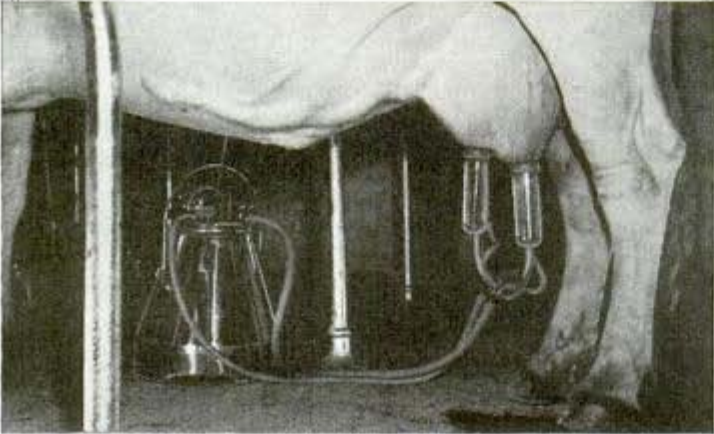

used for lighting and for warming water for 300 laying hens.

But that's not all the story. If the farmer uses lamps especially designed to emit ultraviolet rays—they are commonly known as sunlamps—he not only gets more eggs but they have stronger shells, greater food value, better taste and better hatching possibilities. Ultraviolet rays do for the chickens what cod liver oil does for children—makes them healthy, vigorous and fast growing. One 250-watt sunlamp burned three or four hours a day will irradiate 100 chickens with noticeable benefits. And in brooders ultraviolet bulbs furnish heat as well as the health-giving dose of sunshine. One 60-watt lamp burned 10 hours a day will serve 100 chicks.

On a Massachusetts farm chicks treated with sunlamps become salable broilers two weeks earlier than other chicks, and eggs from irradiated birds show greater hatchability than those from untreated hens.

In the calving pen, where sick animals must often be doctored and tended, a heat lamp, emitting warm, dry infrared rays, eliminated fetching pails of warm water to the barn, wringing out cloths and applying them. The heat lamp is safer to use, because there is not the danger of catching cold that follows the use of wet applications, especially in cold weather, and is easier to use, in addition to being effective. The heat lamp brings livestock relief from congestion, soreness and pains.

For the calves' pen, a sunlamp installation is recommended. Mounted three or four feet above the calves, a sunlamp burned two hours a day will do the animals as much good as a couple of

L1222

Charles J. Wendig,
one of the owners of
Westinghouse Farm Supply
New Hope

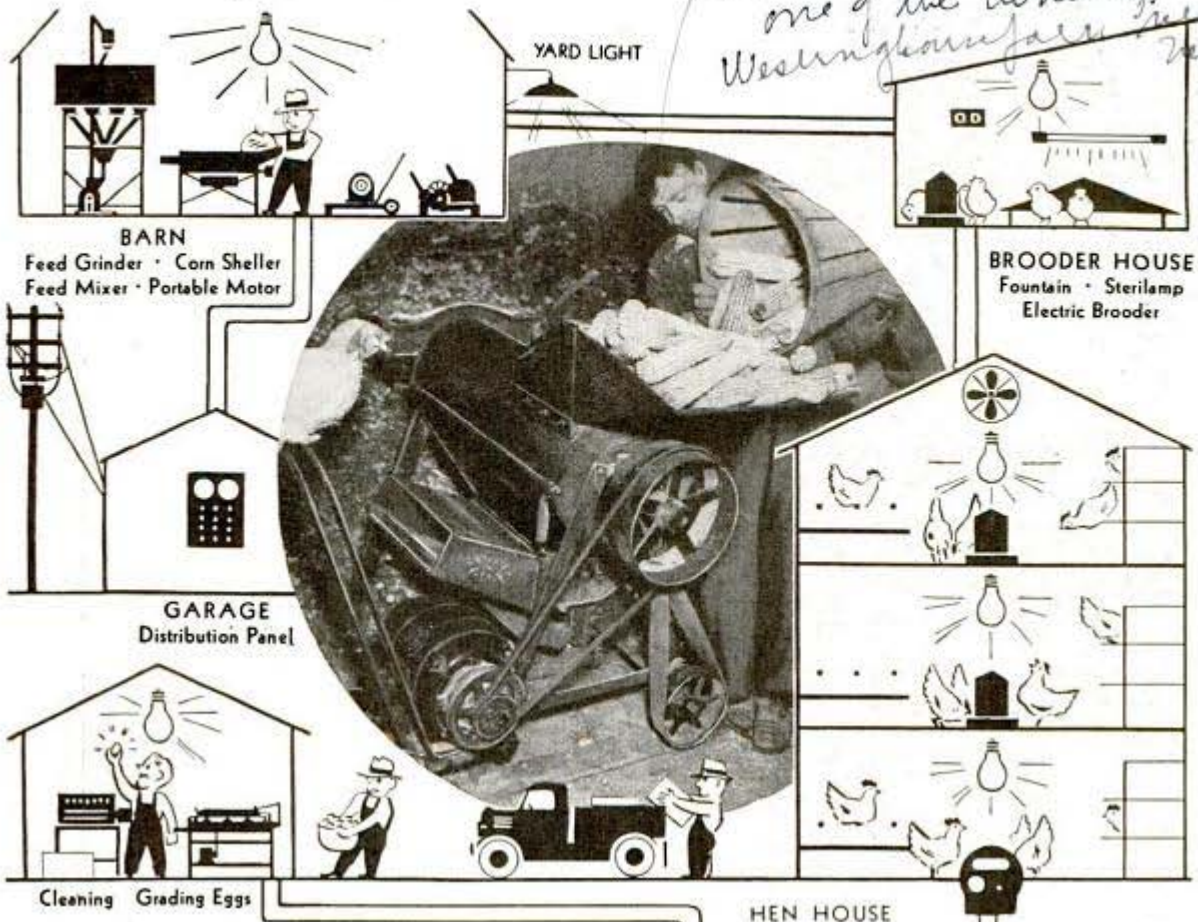

Drawings show some of tasks electricity can do on a poultry farm. Circle, using an all-purpose two-horse-power motor to drive corn sheller

Ultraviolet light in the brooder is good for growing pigs; thermostat controls lamp (General Electric photo)

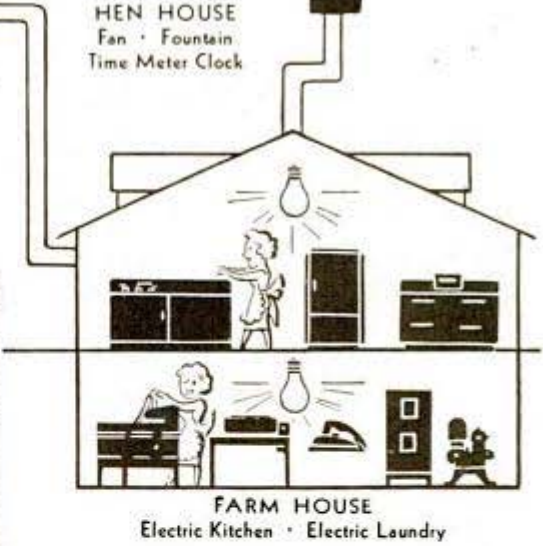
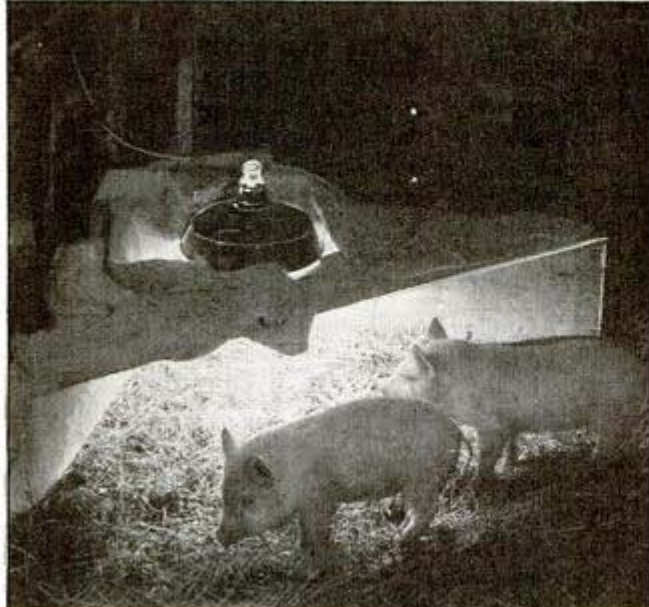

hours in the outdoor summer sunshine. Here, as in the henhouse, ultraviolet produces beneficial effects, the calves being sturdy, healthy and fast-growing. If the farmer's three little pigs are to reach the market in condition to bring a good price, he would be wise to use a heat lamp in the brooder—a 250-watt lamp that provides heat as well as light

(Continued to page 168)

Palace Mobile House -
Palace Travel Coach Corp
308 Pembell
Road, Filad.
 \$1249
 Acme
 \$1256

Two Rooms and Kitchen Fold Up Into Trailer

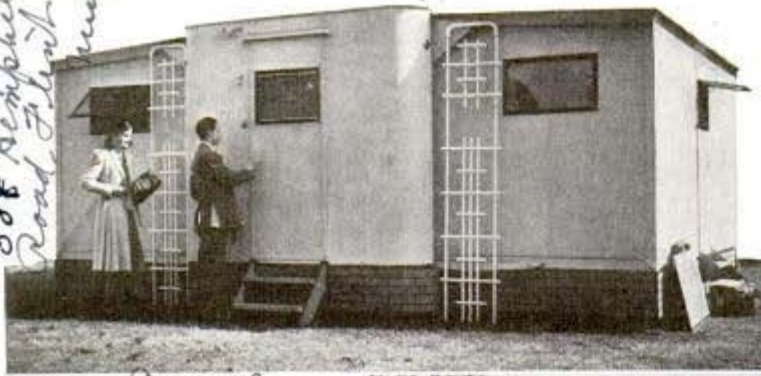

← Trailer fully opened is given a homey appearance by trellises flanking the doorway

After selecting the homesite, owner unfolds trailer to make two rooms and kitchenette



Providing homes for defense workers in communities where large industries spring into being overnight is a problem which the Farm Security Administration may solve by supplying rolling cottages for migrant families. The newest type trailer measures 20 by 8 feet when traveling on the highway, but unfolds to 20 by 19 feet for light housekeeping. A small family can live in its two rooms and

kitchenette and enjoy many of the comforts of a permanent home.

Mileage Dial Shows Distances Between Cities by Car



Tourists may help themselves to information about the mileage to their destinations by dialing an "information dispenser" just introduced. Installed at a filling station, it saves the time of attendants who might be asked to look up answers to such questions. The motorist simply turns the outer rim, which is printed with the names of towns mostly inquired about, until the name of the town he wants comes opposite the pointer. This automatically brings the mileage to that town into view in a slot. Of course, the wheel must be calibrated to give the correct mileages from the city in which it is to be set up.



Infrared Coating for Flashbulbs Aids "Blackout" Photography

Amateur photographers wishing to take infrared or "blackout" pictures can now coat ordinary flashbulbs with an infrared solution anyone can prepare. The chemicals, each properly weighed, are packed in

To find mileage, motorist turns outer dial (top) until name of the city appears opposite arrow (bottom)

W.C. George,
Box 43, St. Francis Spring
Florida
 \$1274

POPULAR MECHANICS
F. J. Zandier & Sperry
 205 Fulton

L1196. *Cm. Arthur J. Larson,
Box 341, Portland, Ore*

Model of Gas Works Tests Plans For Building Large Plant

separate envelopes. All necessary ingredients except water and glycerine are supplied, since glycerine is easy to obtain. One package contains enough chemicals to coat about 50 flashbulbs. Another simple method of using the solution is to make an infrared filter by dipping into it a piece of celluloid, about one-quarter inch thick, and large enough to cover the front of the reflector.

L1223

Ambulance on Mule Carries Casualty Back to Camp

When men participating in American war games recently were injured or became ill, they were carried back to evacuation hospitals on the backs of mules. This method was used by the 97th Field Artillery Battalion which still finds a place in the modern mechanized army for the mule. For the trip through woods with its human burden, the mule packed a litter on its back.

Marston R. E.



Litter on the back of a mule makes a safe ambulance for injured soldier

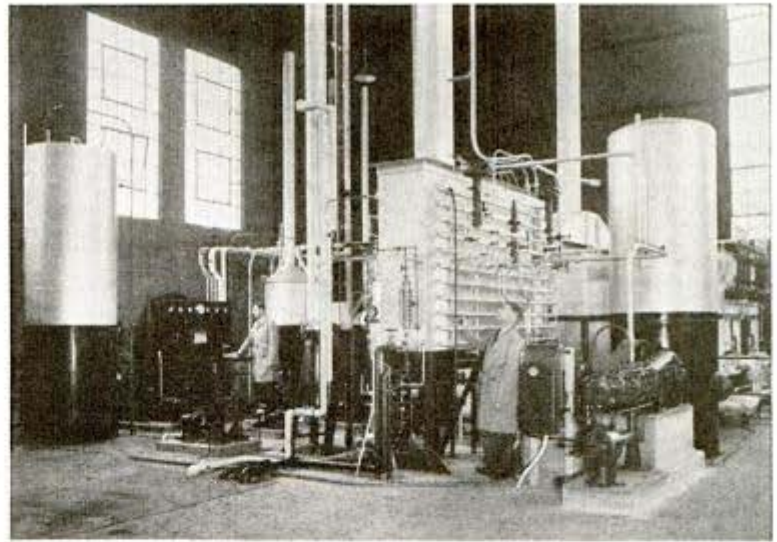

This "miniature" plant tests new industrial processes for oil refinery

Many a model railroad builder may regard with envy the work of super-model builders who constructed a working miniature of a complete gas works. Built for industrial purposes, the model or pilot plant tries out new methods of cracking oil-refinery residuum, or waste oil, thus bridging the gap between test-tube experiments and expensive large-scale equipment used by the Portland Gas and Coke Company of Portland, Ore. For instance, with the pilot plant it was demonstrated that lampblack, which periodically clogged the gas generator, could be burned out by admitting oxygen as the gas-making cycle ends and while the lampblack still glows white-hot. Formerly it was necessary to shut down the plant and laboriously scrape off the accumu-

lation, a very costly operation. After months of work with this pilot plant, engineers built another and more advanced experimental unit, which proved so foolproof that \$1,500,000 was authorized for a chemical plant which will yield not only gas but ethylene, butylene, propylene and other hydrocarbons, as well as by-products such as benzol for motor fuel, toluol for solvents and TNT, petroleum coke, naphthalene, high-grade road tar, briquet fuel and commercial lampblack.

21235. General Electric Co. Schenectady, N.Y.

X-RAYS in OVERALLS

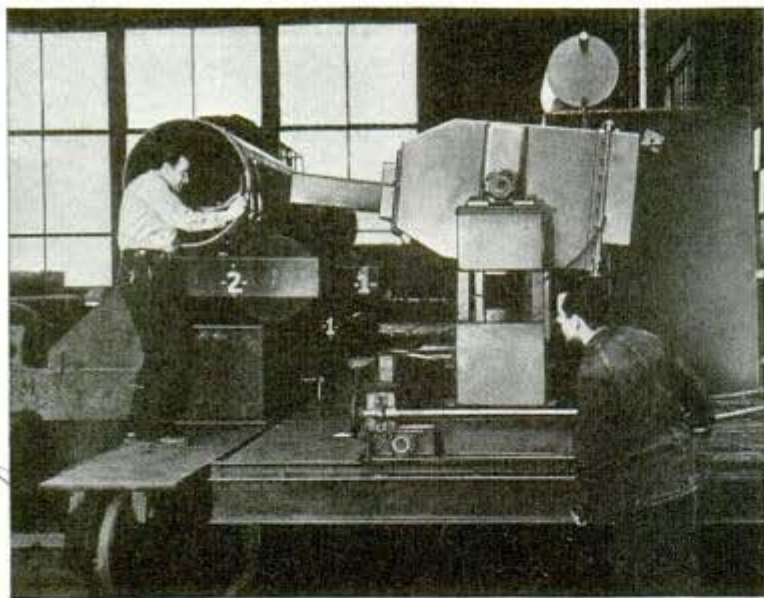

One operator places an X-ray film inside a big steel pipe while the other trains the X-ray tube on it. The resulting radiograph will show up internal flaws in the metal, which otherwise might fail in use

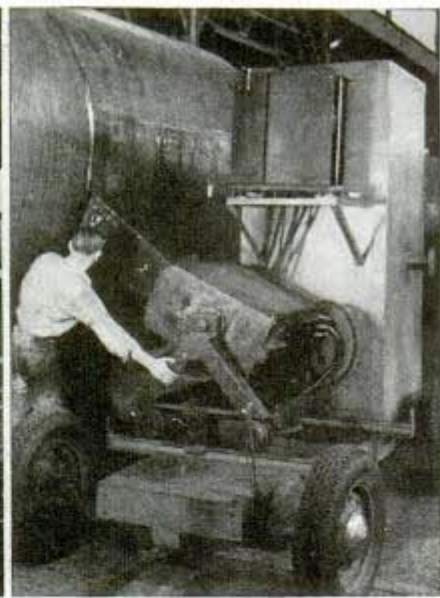

Here a mobile X-ray unit is rolled up to a huge boiler casting to turn its seeing eye on it

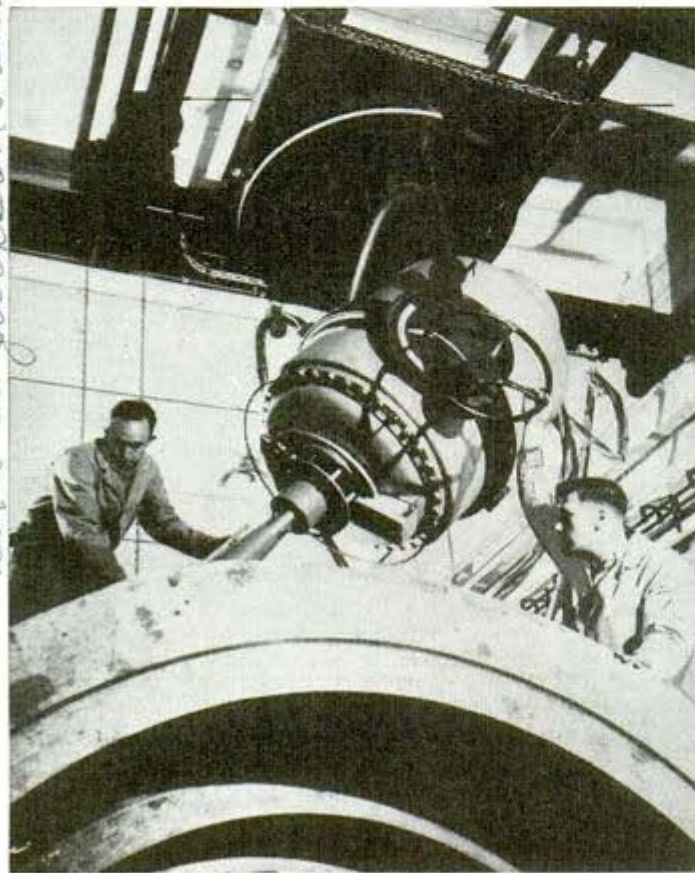

The million-volt industrial X-ray machine is turned at a 45-degree angle to inspect a casting in the General Electric laboratory

X-RAYS were born on the eve of the Spanish-American war, came of age medically in the hospitals back of World War battlefronts, and are finding their place industrially in the din of today's drive to forge an impregnable America. In the last few months a half dozen of the most potent X-ray machines yet devised, their million-volt electronic glance capable of peering through eight inches of steel, have been put to work in factories and foundries. While these giants of the breed are detecting deep-hidden flaws in battleship armor or high-pressure boiler drums or testing welds eight inches thick, smaller members of the family are turning their 5,000-volt seeing eyes upon thin aluminum sheet for fighter planes, producing micro-radiographs of metal structure and measuring stresses in magnesium, brass and aluminum by X-ray diffraction technique.

The range of usefulness for

(Continued to page 164)

POPULAR MECHANICS

General Electric X-Ray Corp. Chicago
2012 W Jackson Blvd

21235

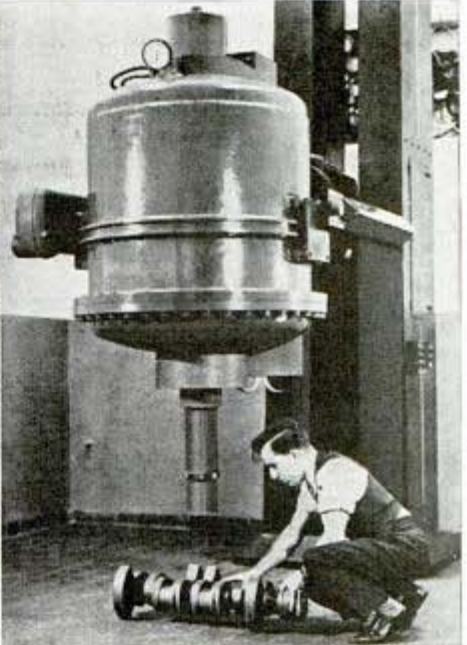
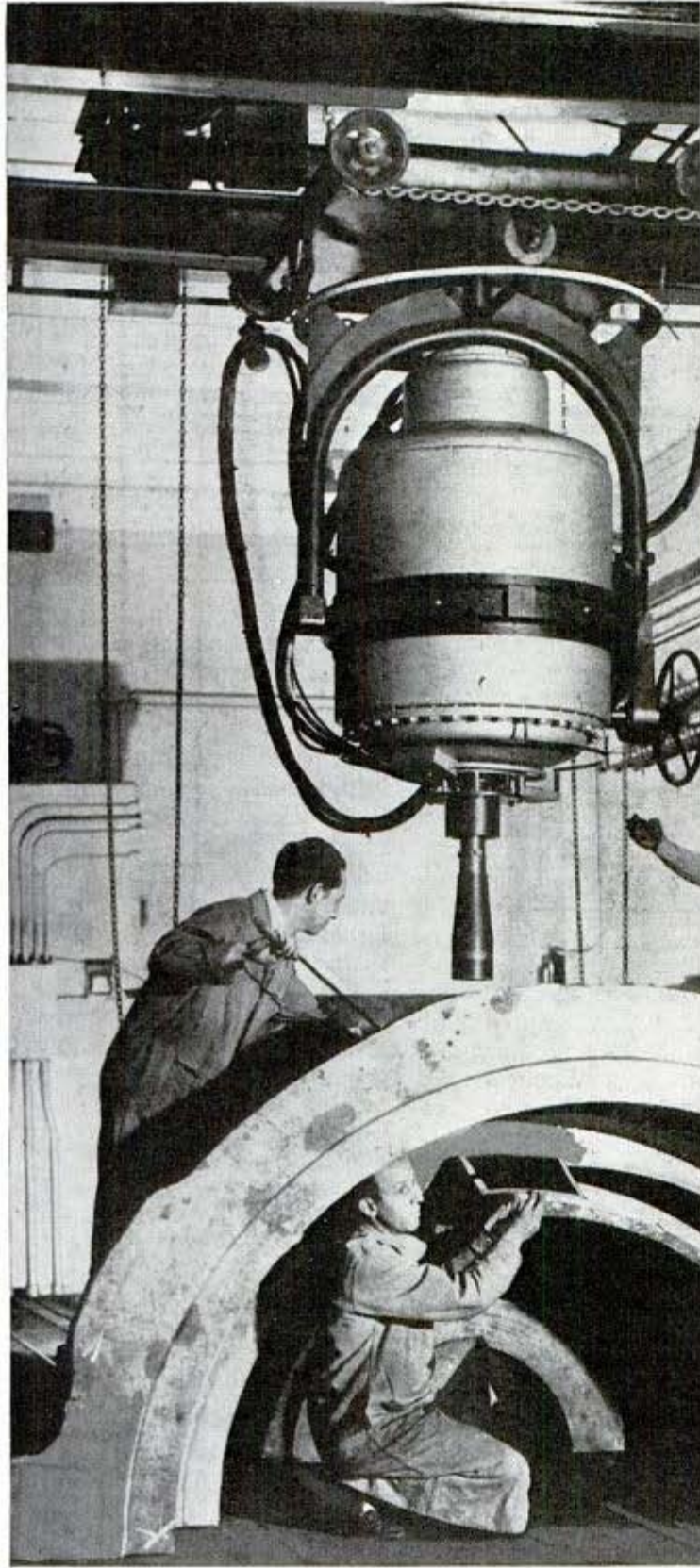

↑ Steel crankshaft for a 2,000-horsepower engine is examined under 1,000,000-volt tube at Ford Motor Company laboratory

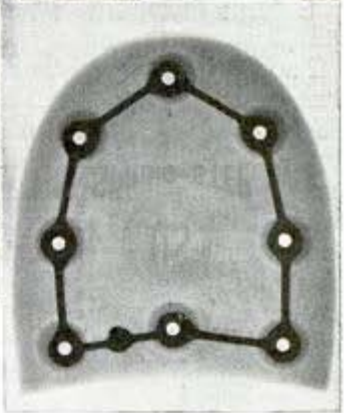

Above, one man checks the mounting height of tube above a huge casting, another directs positioning, third places film. Right, an X-ray picture checks the position of metal washers inside a molded rubber heel

21258

Fireboat Rides Trailer Ashore To Fight Flames Inland

Central Shore Fire Tug

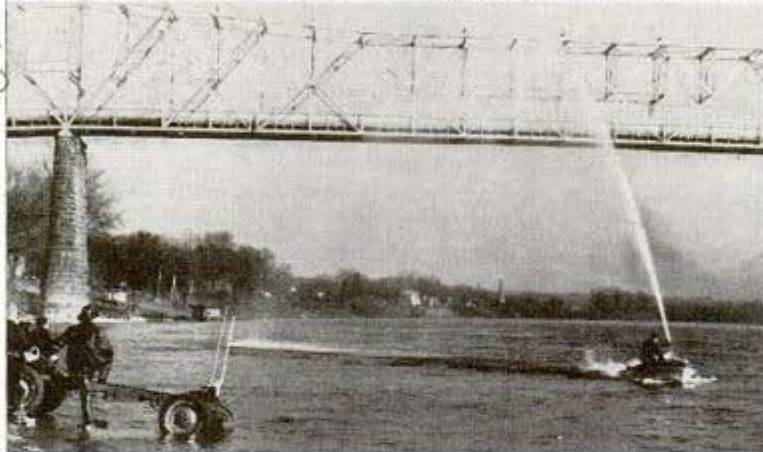
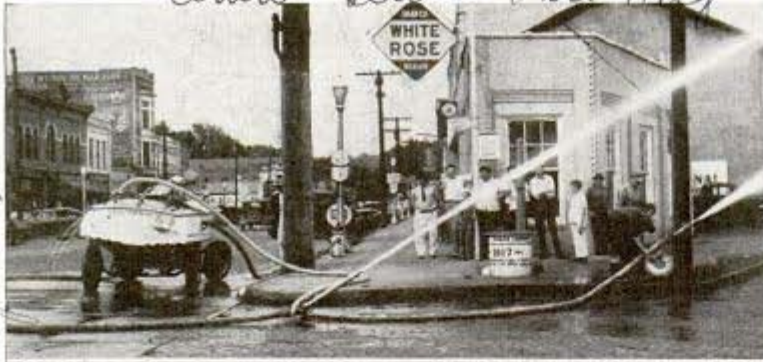

Fireboat (top) on trailer, fighting shore fire, and (bottom) on the water

Ready to combat fires far ashore as well as on the water, a 16-foot fire tug is hoisted aboard a trailer for overland trips. In the water the boat is propelled by a jet from the fire hose stream. Being without a conventional propeller it operates in shallow water without injury. The motor is powerful enough to produce 800 gallons of water per minute.

tracts the mercaptans without affecting desirable qualities of the fuel. The method, available to the entire industry by a licensing agreement with the Universal Oil Products Company, involves the use of a mixture of water, caustic soda and methanol. In this process, which is simple and cheap, there is little or no loss of the solvent, and it may be used indefinitely.

21144

Holder for Chisels Absorbs Shock From Blows

For safety in holding chisels, punches and similar tools, a special holder permits the hand to be kept far enough from the hammer blows to prevent injury, and also takes up the shock so no vibration reaches the hand. It is a tubular piece housing a rubber-tipped piston that is actuated by a strong spring. This presses the chisel against an angular stop, so it may be held erect at all times. A trigger releases the spring tension for inserting or removing a chisel.

Henley Engineering Service Co. Sheet Metal

Pittsburgh, Pa. Carson

21253

Odors Removed From Gasoline By Low-Cost Process

Sulphur compounds found in all gasoline, known to chemists as mercaptans, give off an odor so objectionable that the gasoline must be deodorized before it reaches the motorist. Until recently, this was done by merely converting the mercaptans into compounds which are odorless, but they were permitted to remain in the gasoline. However, as these mercaptans and odorless compounds were having a harmful effect on the effectiveness of ethyl fluid added to gasoline, a way to remove them was needed. Now the Atlantic Refining Company reveals discovery of a solvent which ex-



Spring grip for chisel keeps hand from danger zone

M. J. Cunningham Co. 11756

260 S Broad St Philadelphia

L1305 Cont: *eland w. Roberts / Kent*
330 S. Lincoln St. / Kent Ohio

Tiny 18-Cylinder Engine Spins 5-Foot Propeller

Fashioning all the tools himself and casting the parts needed from special aluminum and brass alloys, Lawrence H. Strayer of Kent, O., constructed an 18-cylinder engine in his home workshop. Since the engine, which weighs 24 pounds and develops seven horsepower, is too large and powerful for an ordinary model plane, the builder intends to test its ability to fly a glider. Patterned after the Wright Whirlwind, the engine is a double-bank, radial type, and is air cooled. The compact miniature power plant measures only eleven inches across and has a stroke of one and one-eighth inches. In testing the engine, the inventor connected it to a five-foot propeller which it was able to turn at 2,500 revolutions per minute.



Model of 18-cylinder radial engine was built in home workshop

L1302.

Metal Wheels Spin to Destruction in Test of Bomber Part

Safety in the operation of high-speed rotors used in superchargers of high-altitude bombing planes is the goal of experimenters at General Electric research laboratory, where heavy metal wheels are spun in a "vacuum bottle" until they fly apart. With virtually no air resistance to overcome, a five-pound turbine, driven by compressed air, can turn a 20-pound wheel

at speeds up to 1,000 revolutions per second. At that tremendous speed, every pound of weight on the rim of a wheel one foot in diameter exerts a centrifugal pull of more than 100 tons, and wheels often burst with the force of an explosion, throwing fragments, which may weigh several pounds, with as much energy as the projectile of a small naval gun. In order to withstand such pounding, the vacuum chamber has massive steel walls, and it is sometimes lined with lead bricks to minimize damage to the fragments which are examined for information concerning the nature of the breaks. In making tests below the breaking point the rotor is coated with a brittle varnish that will crack at the points of stress. The cracks occur at right angles to the direction of the stress, and their number indicates the relative magnitude of the stresses.

Scheuchly, NY

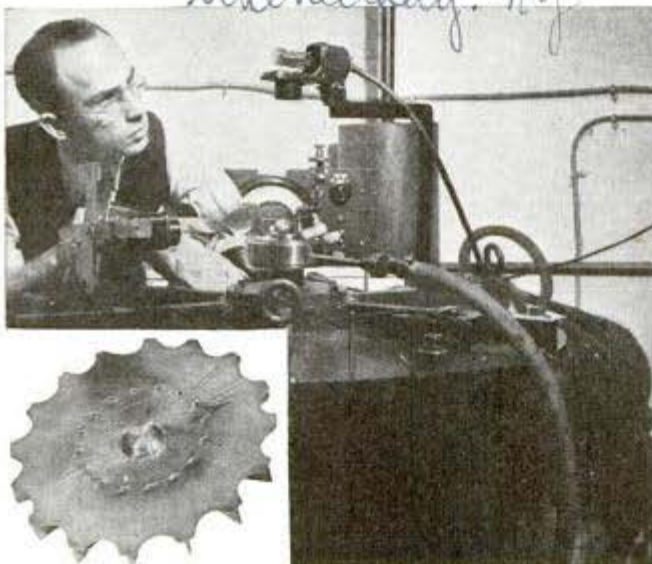

Science Service 11/15/41

Adjusting mechanism which includes mirrors and photocell to measure speed. Inset, varnished rotor after high-speed test

Write to the firms listed in the Where-to-Buy-It index, to learn more about products described in this magazine. Say You Saw It in Popular Mechanics.

Building the "LIBERTY" FLEET



29 74
Blocks supporting a new ship ready for side launching drop out of the way when a button is pressed

A riveter rams one home into the hull of a vessel

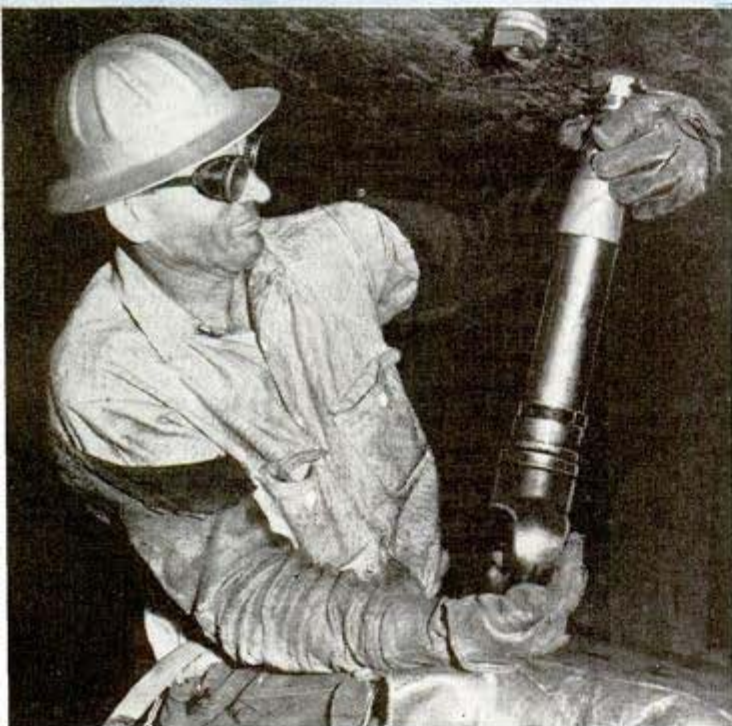

TWENTY years have elapsed since America built its last great merchant fleet and many new ideas about ship construction have been developed since.

This new knowledge is being applied to the hundreds of ships America is building today. Our new vessels will carry more cargo at faster speeds and use less fuel than the famous "Hog Islanders" that were built during the first world war.

Three hundred and twelve vessels of a new emergency cargo class have been ordered, and the chances are many hundreds more will be built before the greatest shipbuilding program in history ends. In addition to this and the vast construction program under way for the Navy, shipyards have expanded their ordinary "50 ships a year" schedule. In all, 759 merchant ships of 2,000 tons or over were under construction or order last summer. A construction rate of 5 million tons a year of seagoing ships is expected by 1943.

The emergency class, designated as EC "Liberty" ships, are trim vessels

2994 Capt. Thomas E. Himsogl, Jr.
3872 Franklin Ave, Los Angeles



designed for simplicity in construction and maintenance. They will be 441 feet long, of 10,500 dead-weight tons, with a speed in excess of 11 knots. Including gunners, each will carry a crew of 54. Defensive armament will include paravanes that are towed from the bows to ward off mines. Crew quarters are amidships instead of at one end, are insulated against heat and cold, and in some cases have forced ventilation. Stub masts not as tall as the radio pole over the deckhouse will be used for cargo handling. The ships will have watertight bulkheads, fire detection apparatus, and refrigeration apparatus.

The "Liberty" ships will be powered with 2,500-horsepower steam engines of triple-expansion reciprocating type. All auxiliary gear such as steering gear and cargo winches will be steam-operated. Old-fashioned in some respects, the engines are of advanced design

At a Long Beach shipyard a new ship splashes sideways into the sea. Beyond is a forest of oil-well derricks

This is the automatic seam welder which has to a great degree done away with riveting in ship construction

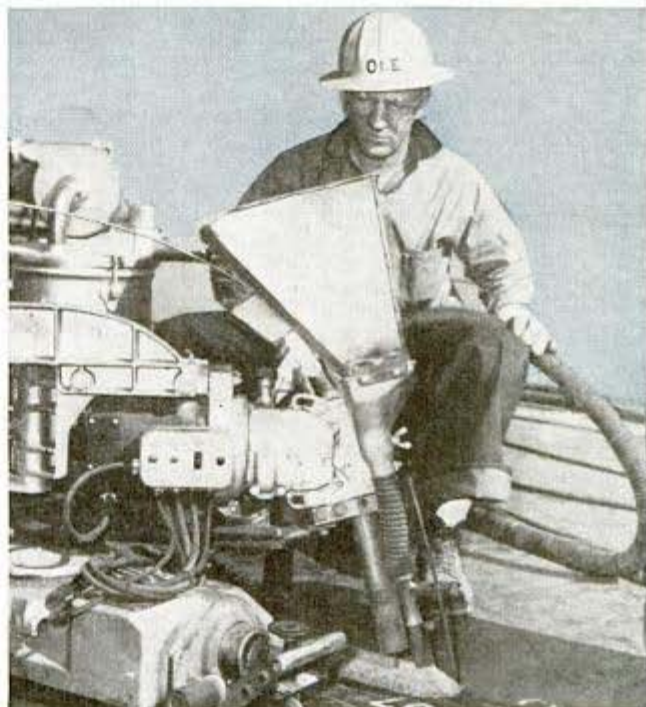

MARCH, 1942

U.S.

Maritime Information 51
Maritime Commission
Washington, D.C.

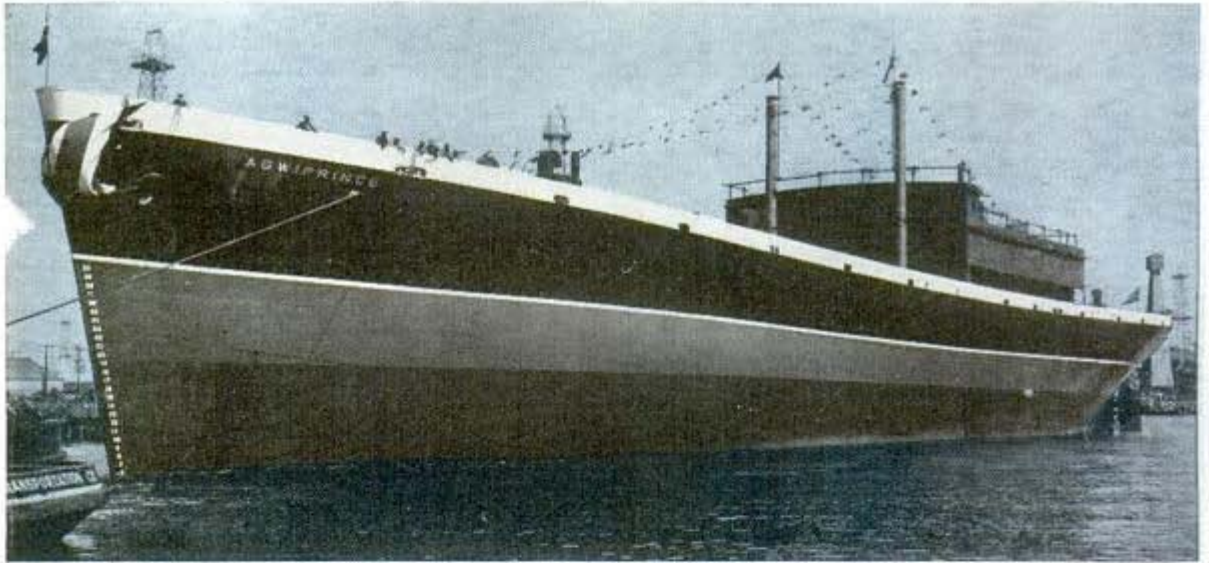

The newly launched "Agwiprince" is towed to fitting-out dock and a new keel is laid on the ways it left

and will be economical. They must be used because the country's turbine and Diesel manufacturers are already swamped with orders. All the machinery will be self-oiling. Oil fed boilers are to be insulated by casings inside of which incoming air for the fires is to be preheated.

Two years or more are needed for building a ship in ordinary times. During the first world war some vessels were launched six months after their keels were laid, setting construction records that were thought never would be broken. Such records are too slow for us now and the EC ships will slide into blue water within three or four months after they begin to take shape.

During the last war prefabricated sections of ships were built in shops around the country, then shipped to the yards. This time, prebuilt sections are being assembled in shops adjacent to the ways, then lowered by crane into the ship.

It used to require some 2 million rivets to build a ship; these added weight and drag to the structure. The Libertys will be virtually all-welded construction, reducing weight, adding to construction speed, eliminat-

ing projecting rivet heads and overlaps on the hull, and providing a hull that will bend under impact instead of tearing apart at rivet points.

Meanwhile, construction of scores of C-1, C-2, and C-3 cargo and cargo-passenger ships, as well as dozens of high speed tankers, has been speeded up. The C class vessels range from 7,500 to 12,500 deadweight tons, powered by Diesels or steam turbines, and are among the most efficient and economical vessels in the world. These ships are being custom-built for various trade routes. More time must be taken with them because such things as turbines and reduction gears, for instance, require months of painstaking manufacture.

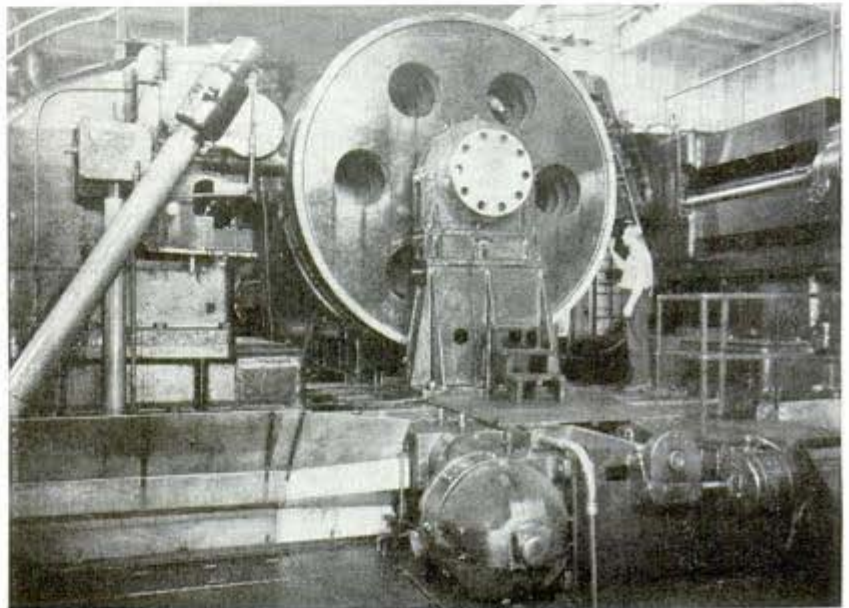

Marine speed reduction gear being cut on large gear hobbing machine in General Electric plant

2974

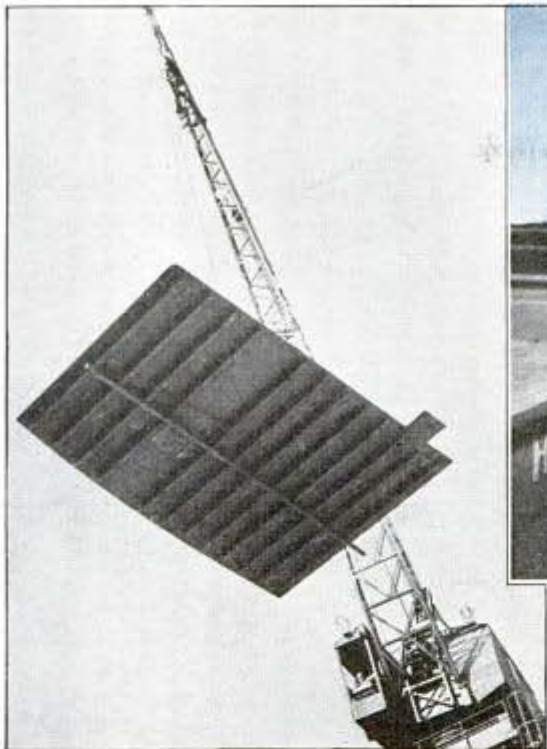

Above, a welder assembles a prefabricated part of a ship. Left, a crane moves a prefabricated section into position

A reduction gear set must have teeth machined to ten-thousandths of an inch because any defect would magnify itself, causing vibration in the propeller shaft. Gear teeth are cut in a special shop where the temperature is held close to 72 degrees F. The gears are not brought into this shop until they have been slowly cooled or warmed to the same temperature in an ante room. Even the temperature of the lubricating oil that feeds the cutting machines is controlled. The process of cutting a gear, which may take over 285 hours, must be continuous. An interrupted cut might ruin the gear.

The C vessels have normal speeds of 14 to 16½ knots and are 30 to 50 percent faster than our first war-time fleet, yet have essentially the same operating costs.

The superiority of the modern ship is shown by a comparison of two recent voyages, one by the 20-year old "Crown City" and the other by the new "Challenge." Over the same route, from New York to Port Said, Bombay, Calcutta, and return, the "Challenge" left New York 26 days after her older rival. Both arrived back

home the same day. Operating costs were about the same and the "Challenge" carried 1,000 tons more cargo than the "Crown City."

To build this great fleet, new shipyards are being constructed on all three coasts. Work is being scattered among many small

(Continued to page 184)

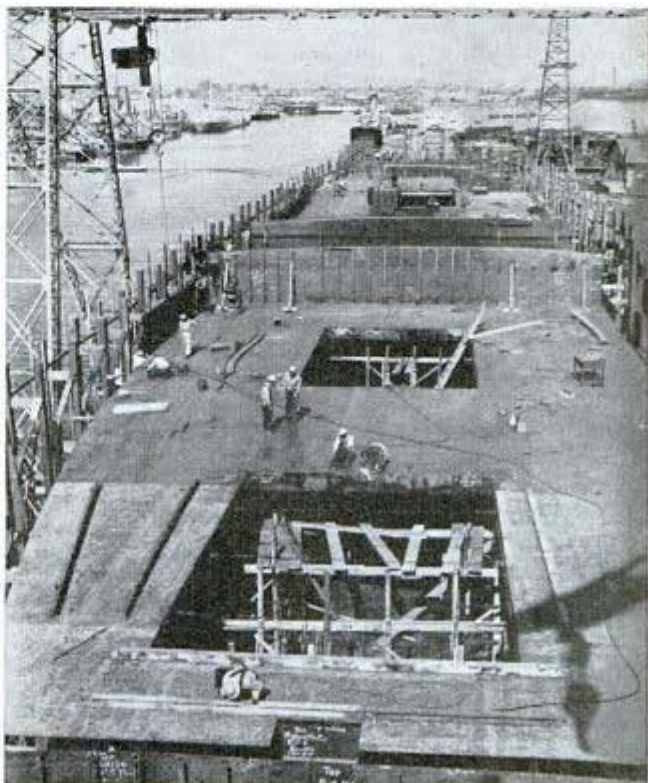

Completing one of the lower decks of a new merchant vessel

21324

Rolling Sling for Injured Pet Permits Spine to Heal



Doggie sling carries all the weight so pet may walk about without risk of straining its fractured spine

A fractured spine does not stop "Lady," a Doberman pinscher, from tagging along on hikes over the sidewalks of Manhattan. Her mistress, Mrs. Andre Duvallon of New York City, has provided a sling, or cradle, to support the dog as it walks. Adjusted by ropes passing through pulleys at the top of a frame equipped with casters, the sling may be hoisted just high enough so Lady's feet barely touch the walk.

Sign Held on Glass by Vacuum Uses Cardboard Letters

Rubber suction cups hold a new window sign on the glass of show cases or display windows. The sign portion consists of a



Lettering sign, and, bottom, how it looks in window

Chicago 3-32
Michigan

long metal holder with tracks to receive letters and numerals cut from cardboard. It permits changing the message or position of the sign as often as desired.

2983

Cause of Flat Railroad Wheels Ended by Brake Control

Sliding of railroad wheels when brakes are applied presents a twofold problem, since it lessens the braking effect and also flattens the wheels, which are expensive to repair. This difficulty has been solved on the Burlington's Twin Zephyrs by installing an electric brake control, developed by American Brake Shoe and Foundry company, that releases the wheel as soon as the brakes lock it. To accomplish this, electric relays automatically compare the speed at which associated pairs of wheels are rolling. When an abnormal difference occurs, as when one or both pairs of wheels may be sliding, the air brake pressure is reduced until the slipping wheel starts rolling at a speed equal to the others.

21313

Infrared Heat Focused on Auto Thaws Frozen Radiator



Heat rays from infrared lamps thaw frozen radiator

Heat radiating from three infrared lamps mounted on a special stand, is capable of quickly thawing out frozen radiators on autos, trucks and tractors. Since each lamp, backed with a gold-plated reflector, can be focused independently, the heat rays may be concentrated on a small area for thawing car heaters and water pump connections, warming oil and grease, or drying wet spark plugs and upholstery.

POPULAR MECHANICS
The Poplar Press
Steel Corp. Poplar, Ohio

Red Chief Industries
2326 S. Michigan
Chicago

21319. Cont. April Road, 5424 Cornell
Chicago

Fluorescent Lamps Depict Bomber in Pageant

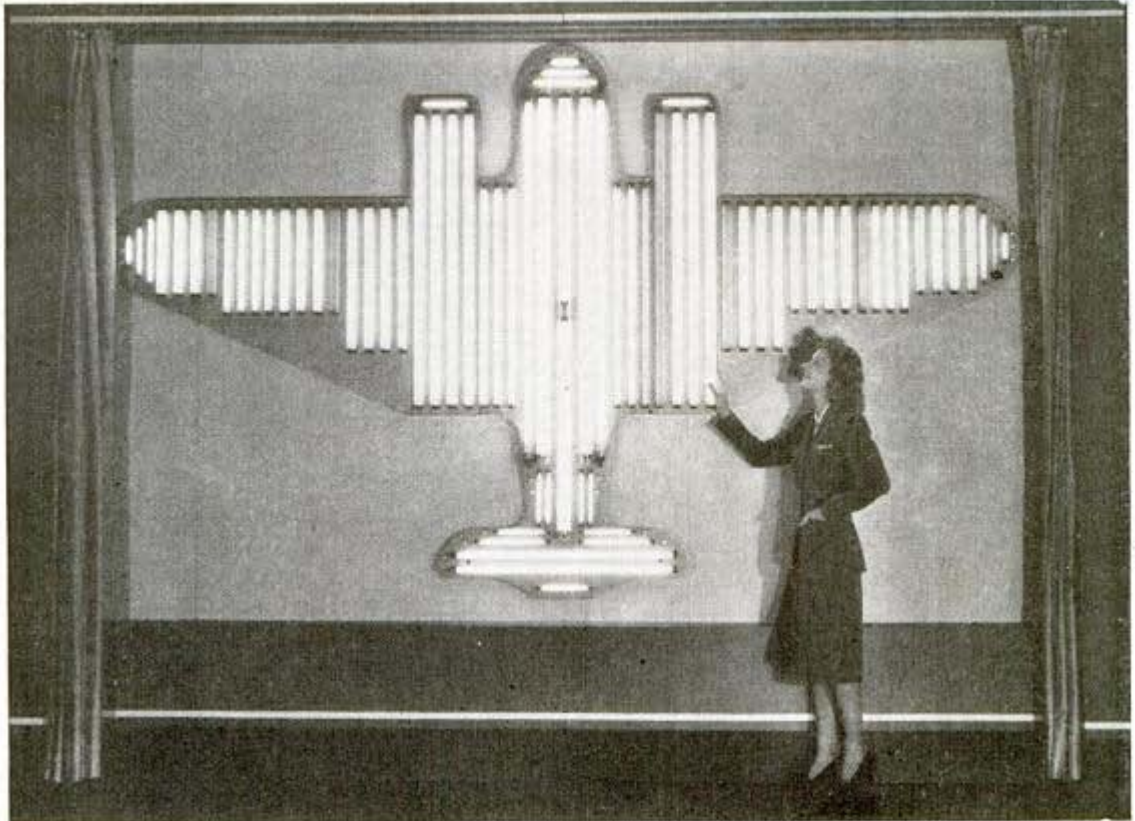

Spread out in the form of a bomber, this display shows 74 types of fluorescent lamps used by industry

"Painted" with brilliantly colored bars of light, the figure of a twin-motored bomber is pictured by a novel display of fluorescent lamps in a war pageant. In the layout are 74 different types and sizes of lamps, mak-

ing approximately 125 feet of fluorescent tubing. The display, created by General Electric company, is a feature in the production, Wings of Vision for Defense, which will be exhibited in principal cities.

Silent "Static Drag" for Car Takes Place of Noisy Chain

Static accumulations in an automobile can be dissipated silently with a compound rubber drag now on the market. It is a

strap 1½ by 30 inches fitted with an eyelet for bolting to a metallic underpart of the car. A good conductor of electricity, it drains electrical charges into the ground. Although a dry pavement is a poor "ground," the average car passes over enough railway tracks and manhole covers to get rid of static. Trucks and buses use steel chains to accomplish the same purpose, but because of their clanking noise, few passenger cars are so equipped. The new dissipator is light in weight and is said to have excellent wearing qualities.

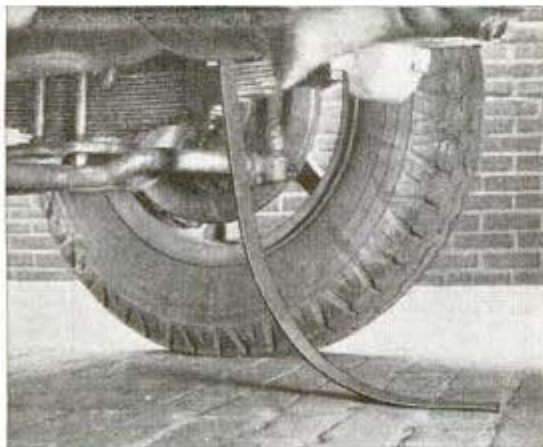

Automobile drag made of compound rubber scrapes along pavement noiselessly, conducting accumulated static charges of electricity from car body into the ground

MARCH, 1942

Electric Service Supplies Co. 55
17th and Cambria, Phila

Lg 44

Thomas E. Stinson, Jr.
3872 Franklin Ave
Los Angeles

TOMORROW'S PLANE TAKES SHAPE

Manta Aircraft Co, 540 N. La Brea
Los Angeles, Calif

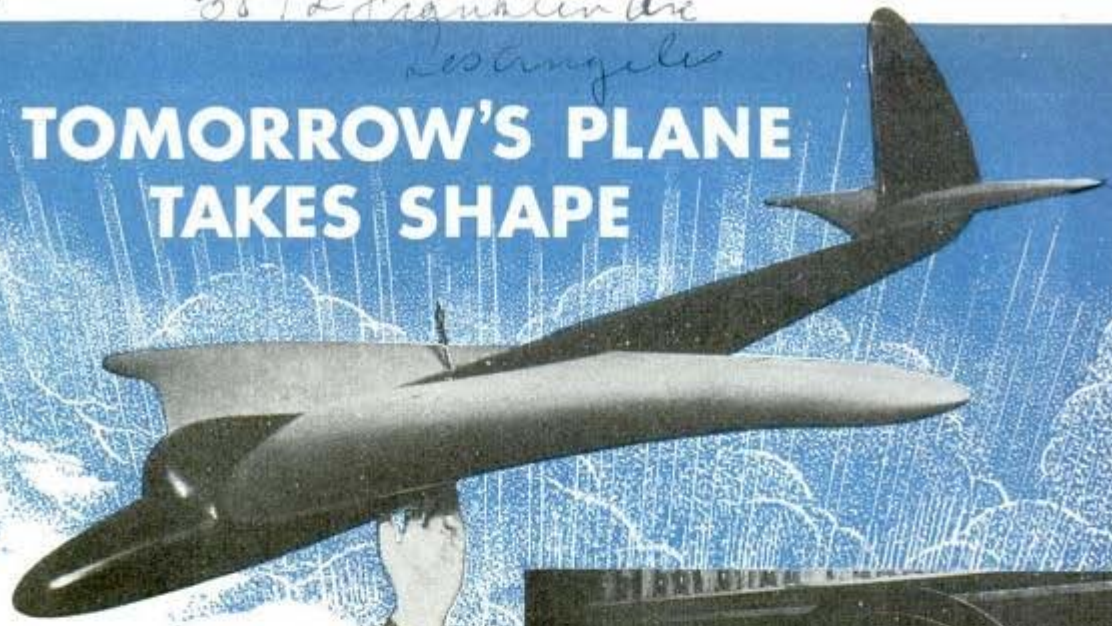

D. R. Davis, designer of a new "family" of airfoils, with wind-tunnel model of fast "manta ray" fighter

NOT content with having built larger and probably faster airplanes than any other country, American aeronautical genius is buckling down to the job of beating its own world records.

Airplanes that will dive as fast as sound itself are on the drafting boards. Giant transports larger than the B-19 "hemisphere defender" are under construction. More important than any such single project are the multitudes of refinements that are making flight safer and more efficient than ever before.

Progress in high-speed design is now a military secret, although several concerns are working on interceptor airplanes that will fly well in excess of the 400-miles-per-hour-plus top speeds of present pursuit planes. Much of the secret work the factories are now doing will be available for commercial aircraft in the future.

Next spring Lockheed expects to test fly



Landing map of flight recorder enables ground watcher to guide oncoming plane directly to the airport

Spinner starts plane wheel rolling before it lands



Roberts Aircraft Engineering Co
203 N. Lake, Burbank, Calif

1944.



Spot welding sub-assembly of plane

the first of a group of "Constellation" transports it is building for TWA and Pan American. These giant air liners will carry 64 passengers in regular service and will have a loaded weight of 83 tons. Their speed will be in the 300 mile per hour range, with a 4,000 mile cruising radius, and they are designed to operate at 30,000 feet altitude. Both the cabins and engines will be supercharged. The giants have been designed by TWA engineers and by Howard Hughes' engineering staff.

One development that promises to influence future design is the so-called Davis wing now being used on Consolidated bombers. This particular wing shape adds some 15 percent to an airplane's efficiency. In the case of a 100,000-pound transport in which the airplane weighs 50,000 pounds and the remaining 50,000 pounds is equally divided between fuel and pay load, an additional 15,000 pounds of carrying capacity are provided by the wing. This permits the plane to carry 40,000 pounds of cargo instead of 25,000 pounds, a gain of 60 percent without sacrifice of speed or range and with no increase of horsepower. Or with the original cargo a 60 percent increase in fuel capacity may be had.

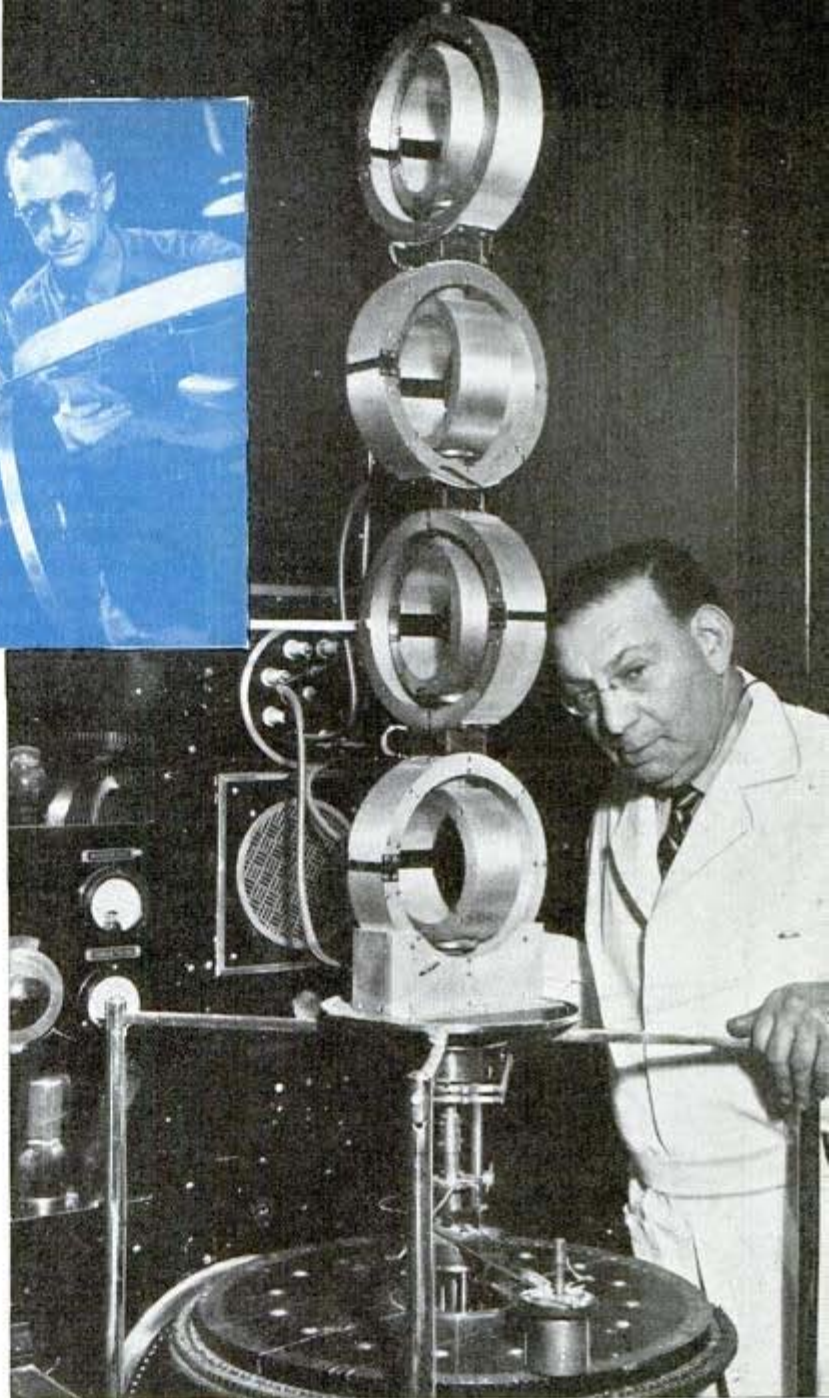

These directional fading coils help ground watcher locate plane in air

Developed by D. R. Davis, the long-range wing is one of a family of curves that may be laid out from an original formula that expresses the most efficient mechanical action. In effect the new wing shapes reduce drag, to some extent taking the brakes off airfoil sections. Ordinarily when a fuselage and tail group are attached to a wing the drag of the whole structure becomes twice the drag of the wing alone. With the Davis airfoil sections an increase of only 40 percent in drag occurs.

One of the new wing curves, called the

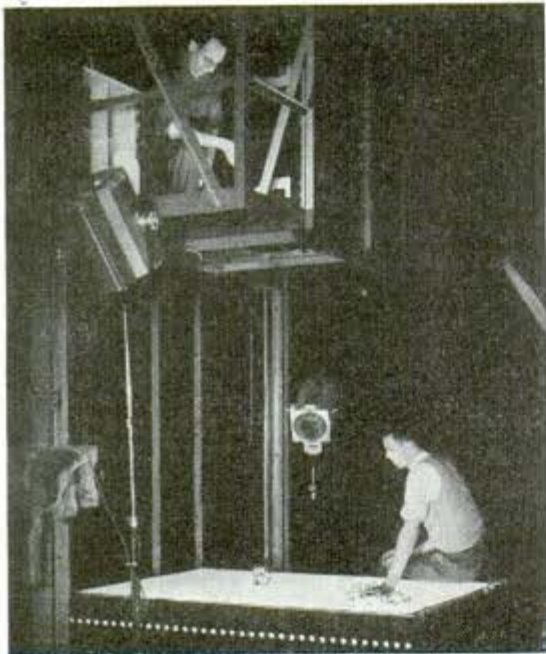

The vertical camera above has been adapted for making photo templates in airplane construction

Below, an aeronautical designer works out a new airfoil curve from intricate mathematical formula

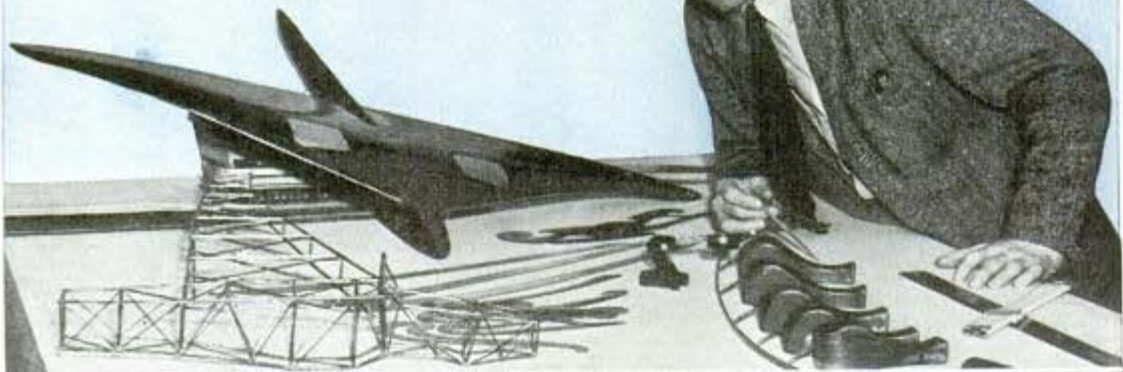

Manta because of its resemblance to the manta ray, is being used in the building of a new fighter airplane that is characterized by a single low-horsepower engine and yet carries heavy armament at high speed and can climb to extreme heights.

Flight recorders such as are being used in England to locate and track invading planes promise to become a useful safety measure in the future. Improvements are being made to the Spitz flight recorder, an apparatus developed in the United States and one that works partly on different



Behind the strip map of a flight recorder is this bewildering maze of electrical wiring

principles from the British type. The recorder reveals to a watcher on the ground the distance to the airplane he is tracking, the direction it is traveling, and its speed. The plane's location appears as a tiny dot of light on a map, allowing the watcher to radio the pilot the position of his plane and, in the event that he is lost, what courses he should steer.

The principles of the flight recorder may also be applied to determining the positions of fog-bound ships, for locating submarines under water, and even for learning the exact locations of all the police radio cars in a large city.

The passenger transports that we watch in the air today seem to be the same airplanes as were flying two and three years ago, and so they are, in external appear-

2944

21276

ance. Actually scores of minor improvements have been made to them with the result that horsepower has been going up, operating efficiency has been increased, and in particular, air travel has been made safer. Airway radio beacons and markers have been changed to ultra-high frequencies, assuring more reliable operation.

To reduce the glare from lighted instrument panels, ultraviolet "black light" is used to fluoresce radioactive paint with which the instruments are painted. Maps and charts are being treated chemically for similar results. Transparent plastic wing-tip sections, lighted inside, are being tested as a replacement for ordinary wing-tip lights, now that airplane speeds are rising to a point where the usual red and green running lights need greater range.

Fast landings by heavy transports impose terrific loads on tires, bearings, and landing gear. Better control during landings, as well as reduction of wear and tear, is the purpose of a new wheel spinner that starts the landing wheels rotating at 40



Engines and nacelles being tested in a wind tunnel

miles per hour before they touch ground. A small hydraulic motor inside the wheel builds up tire speed in ten seconds.

Two years ago the plastic airplane was being hailed as an important development because it seemed that such planes could be built faster and cheaper. The talk died, but since then much work has been done on them. One new system forms the whole wing skin as a unit that slips over the rib assembly like a glove. Molding the units into shape by means of hot water pressing against rubber blankets is one new system that may bring construction costs down. The method permits positive control of both heat and pressure.

Door Arch Is Easy to Shape With Flexible Bead



Fitting plaster bead over doorway to form an arch

Shaping plastered arches over doorways and windows can be simplified with a bead made of flexible material. The bead fits over the door corners and remains rigid, except at points where the flange may be slit with shears for bending. It can be bent by hand to the desired shape. According to the manufacturer, the bead provides an excellent key for plaster and saves up to one-half the usual material and labor costs.

Soldering Kit in 'Nutshell' Splices Electric Wire Connections

Electric wires may be spliced quickly with a self-contained soldering unit that holds enough solder for one connection and generates its own heat. Solder and flux are sealed within a waterproof shell. It is only necessary to push the wires into the shell, and ignite it with a match. Heat from the burning shell flows the solder into the splice, then the burned shell drops off, leaving a cleanly soldered connection.



Slip shell on wires, light it, and splice is soldered

Jiggers, due 215 W. Illinois

Roberts Aircraft Co. 203 N. Lake Burbank Calif

National Supply Co. Buffalo, N.Y. 192 Delaware.

Chicago

L1300

Coupled Table-and-Chair Holds Lamp and Books



Combined table-and-chair has a shelf to hold books

Built as an inseparable unit, a combination table and upholstered chair is connected rigidly in a convenient range for reading. The chair and table may be used in the living room to hold a reading lamp and books or magazines, in a hallway or outer office as a reception piece, or may serve as a telephone set with space for the phone, books and writing material.

Dog Carries His "Card" in Tube Fastened to His Collar

Dog owners who want to assure safe return of lost pets can fasten a new identification



Dog's identification is rolled up and sealed in tube

fication tube to the dog's collar. Made of nickel-plated steel, it withstands battering and seals the contents against rain. A stranger finding the dog can learn its master's identity by unscrewing the tube and removing a slip of paper with his name, address and telephone number. The tube is equipped with an eyelet for convenience in securing it to the collar.

Windows Built Into Glass Walls With Transparent Blocks

Transparent glass blocks are now available for use as windows in glass buildings whose walls only admit the penetration of light. Although they do not give clear-cut vision, the new "window blocks" permit a general view of traffic and people in motion out-of-doors, thus dispelling that "shut-in" feeling sometimes experienced by those within a glass building which per-

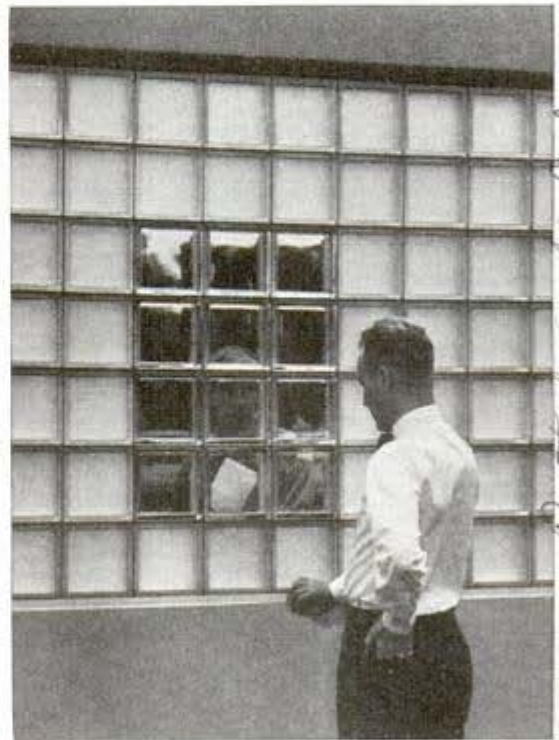

Window in glass building made of transparent blocks admits no outside vision. Easily installed without need of special frames, both in glass walls and walls of other material, the transparent blocks contain a dead-air space for insulation.

Look in the index to find where to buy articles described in this magazine. Say You Saw It in Popular Mechanics.

*Heinrich Pop. 1315-d
Mechanical Chemistry*

L1304

*Dist: George B. Mitchell
& Co. Chicago*

*Putzberg by Corning
Pottery Co. Pa.*

*L 1308 Robert H. James Mfg Co
South Euclid, Ohio
Four in. Hand ped*

Space-Saving Chairs May Be Nested Into One

Four matching chairs that telescope one over the other into a unit may be separated for use at a bridge table when guests arrive. Being of the same height, the chairs may be placed side by side for use as sectional pieces. A metal molding all around the bottom permits the chairs to be glided with ease. Upholstering over the entire chair is applied in the form of a slip cover, fastened underneath by the molding. After guests leave, the four chairs are nested, forming one piece. They are also furnished in sets of two.



Four chairs, nesting one inside the other, are all of the same height so they may be used separately or set side-by-side, as in the inset, to form sectional pieces

L1301

"Smoke Rings" Shot From a Gun May Rid Cities of Soot

Engineers are blowing invisible rings of air, like the smoke rings blown by a cigar smoker, in a unique experiment that may some day rid cities of the factory smoke nuisance. This research project is under way at the Westinghouse laboratories.

Dr. Phillip S. Thomas

These air rings, shot from a "machine gun," whirl out with enough velocity to extinguish a candle flame several feet away. The gun discharges rings at two per second when its back is tapped with a hammer. The engineers are seeking a method of shooting factory smoke high into the sky and thus keep clear the air over industrial centers.

L1306



Fast whirling rings of air, shot from gun in background, snuff out candle flames. Idea some day may be applied to city smoke

Belmont, Mass

"Puff" From Air Whistle Aids Navigation

For safety where boat traffic is heavy, a whistle that gives both an audible and visible signal has been introduced by John Hays Hammond, inventor. When sounded, the whistle emits a long, dense, white plume that remains in view long after the blast dies away. The cloud, consisting of finely ground aluminum stearate, is ejected by air pressure from a metal cylinder that can be attached to any air whistle. According to the inventor, the visible signal is an aid to navigation, since it can be traced to its source when many whistles are blowing at the same time.

Compressed Air Magazine Nov. 1941

21262 Camp by La Jolla, 35 ft.
Raymond Ave. Pasadena, Calif.

SHARK KILLERS' CLUB

The Bottom Scratchers
San Diego, Calif.



Still wearing their flipper fins, and with their face plates lifted, two members of a unique San Diego swimmers' club come in from a sea hunt with fish that will form part of a dish of "Chapine," a thick chowder made of filets of various fish, octopus, and abalone meat pounded wafer-thin; this is boiled in highly seasoned tomatoes and served in abalone shells. Only five men have qualified for this shark killers' club by swimming a half mile out into the Pacific, diving 35 feet to bring up an abalone shell in each hand, and later bringing to the surface, barehanded, a shark not under four feet long. No knives or spears are permitted in this test. On regular shark hunts they carry three-pronged spears and a knife

Three of the five club members, above, bring in their morning catch of two sharks and several smaller fish. Often they paddle the surfboard far beyond the breakers, then dive deep for big game



Above, one of the sportsmen straddles a surfboard carrying a catch of abalones. The diver swims to the floor of the sea and pries the shells loose from the rocks with a blunt knife. At left, notice the knife hanging from wristlet. On one occasion one of the men became "handcuffed" on the bottom when his knife was wedged between two rocks; by a desperate backward lunge with feet braced against the rocks he was able to break the line and escape. In another adventure the line from a spear was wound around a diver's ankle and a big shark towed him deep until he was able to whip out his knife and sever the tangled line

Islen are
organizer
of club

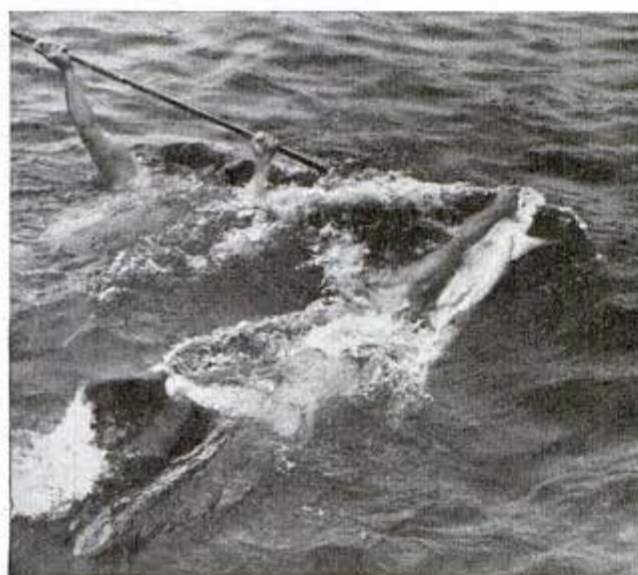

Harpooned by one man, a shark fights to get away just as a fellow member of the club—churning the water with his rubber fins—rushes up to get in on the kill. One member has two great tiger sharks to his credit, killed in a furious battle off the Mexican coast. The 14-foot spears have flexible shafts



The fight is on! A shark, six feet or more long, has been harpooned by one swimmer while the other is sinking his knife into a vital spot as the great fish thrashes in an effort to shake free. The score isn't always in favor of the men, for sometimes the sharks tear the fingers and flesh of their attackers

Slashed from beneath with one of those razor-sharp knives, the shark at right was out of the battle quickly. These swimmers are so adept at underwater work that they are sometimes called on to free ship propellers which have been snarled by chains or cables; they succeed where mechanical devices fail

21303

Brush for Venetian Blinds Dusts Difficult Corners

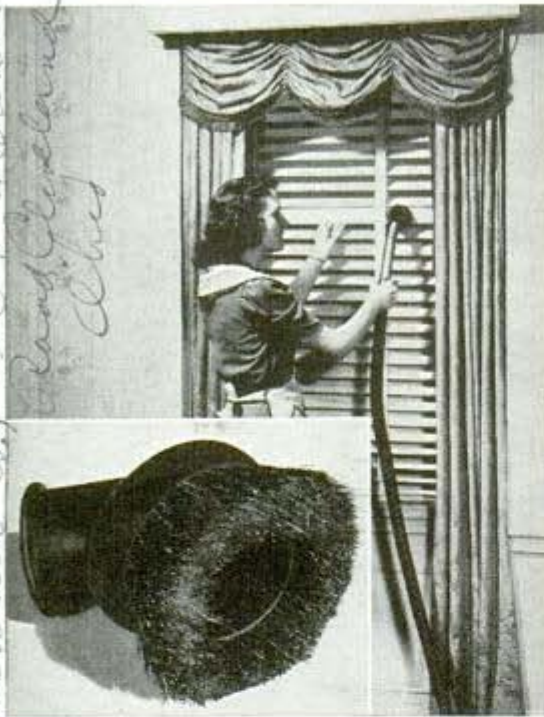

Curved mounting helps reach all corners with brush

Fitting any vacuum sweeper, a small round brush aids in removing dust from venetian blinds. The rubber housing of the brush slips over the nozzle of the vacuum sweeper, and the tilted neck presents the brush at a proper angle for dusting overhead surfaces.

"Squeezed" Food Saves Space In Shipping to War Zone

Wartime shipping, requiring the movement of large quantities of food to Britain, poses the problem of "squeezing" great masses of supplies into a small space. Removing water from some products is one method. For instance, 200,000,000 pounds of skim milk were dried before loading. Eggs may be shipped in like manner, and both the dried eggs and milk are returned to useable form by replacing the water, although bakers use part of the food in dried form. One shipment of 150,000,000 dozen eggs was concentrated to a fraction of the natural shell bulk by breaking the eggs into metal cans in which they were sealed and frozen. They needed merely to be thawed for use. Orange juice also is subjected to the squeezing process. Con-

centrated to about seven times normal strength by removal of water, 1,000,000 gallons were reduced to 180,000 gallons of thick, sirupy liquid. Much of this went to Britain where the addition of water restored it to palatable orange juice.

21288

Folding Trailer Built Into Auto Can Be Stowed in Trunk

Small enough to slide into the trunk compartment of an automobile, a built-in folding trailer can be pulled out and towed whenever needed. A swiveling wheel, attached to the trailer body by a hinge, can be swung downward and locked in running position, the roomy tray tripling the luggage capacity of the car. Equipped with tail-light and reflector, the trailer slides in and out of the trunk on two slotted rails bolted to the floor.



Sliding trailer from trunk (top), and ready to go

POPULAR MECHANICS

A. Smarney, Box 236

Pre mier Ltd. Electric Vacuum Cleaner Co. 1734 Fairbank Road Cleveland Ohio

Dept. of Agriculture. Release No. 1222

Buena Park Calif.

21309. Built by Albert J. Wagner & Son
Plainville, Illinois
Letter sent Miss Peggy Barr
6/8/42

Model Streamliner Runs 20 Miles in One Hour

Built to scale, a 20-foot working model of a streamline locomotive develops 40 horsepower at 150 pounds of steam pressure. It is a copy of the engine that hauls one of Chicago and North Western Railway's crack trains, the **Challenger**, between Chicago and the Pacific coast. With two bushels of coal for fuel, it can run 20 miles in one hour. It has 4 by 5-inch cylinders, 14-inch drivers, a 14-inch gauge, and weighs 2½ tons.

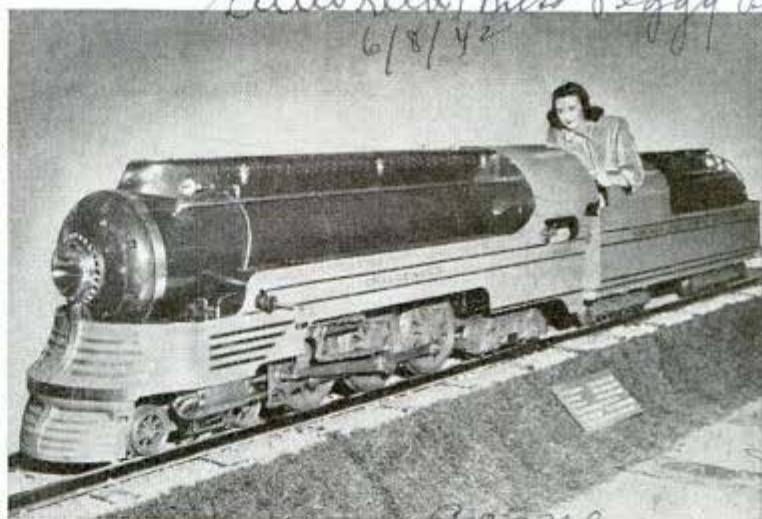

Miniature streamline locomotive can run 20 miles on two bushels of coal

Typewriter With Variable Type Speeds Defense Plans



Lettering huge defense plans, which is usually done by hand, can be performed faster with a writing machine, operated like a typewriter. It is equipped with variable type of many fonts, easily changed to suit the job. With this typewriter it is possible to letter in half a day a set of drawings which would require four to six days of work by hand. The machine handles paper up to 12 feet long and six feet wide.

Typewriter for lettering drawings accommodates tracing cloth or paper 12 feet long and six feet wide. Many different type faces are available and change from one to another to fit each case is made quickly

75-Mile-an-Hour "Tank Destroyer" Packs a 75-Millimeter Cannon

Capable of transporting a 75-millimeter gun at 75 miles per hour, a new streamline war monster is called a "tank destroyer" by the inventor, William Bigley of Hoboken, N. J. Eight wheels turn the mobile fighter's tracks. Its structure follows the basic design of the tank invented by J. Walter Christie.

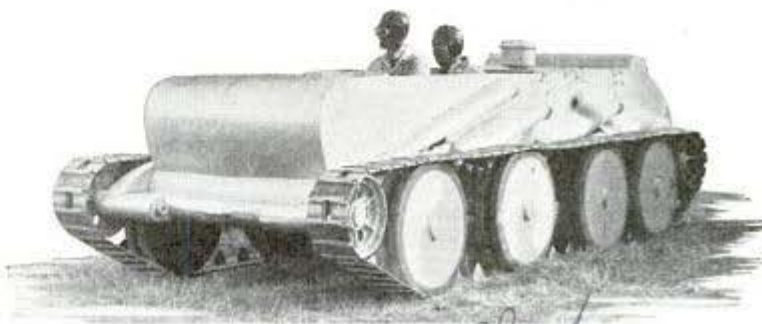

Track-laying "tank destroyer," equipped with an airplane engine capable of driving it at 75 miles an hour, is designed to carry a 75-mm. cannon

Paul Allen Warren

The BATTLE for SAFETY

*393 E. 83rd St
New York*

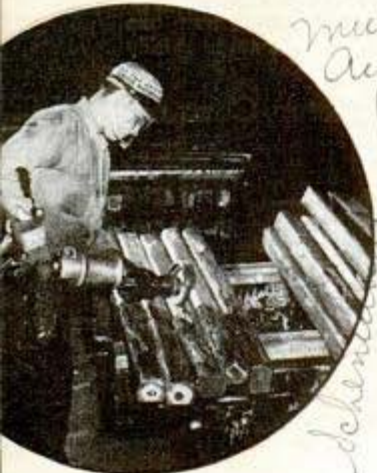
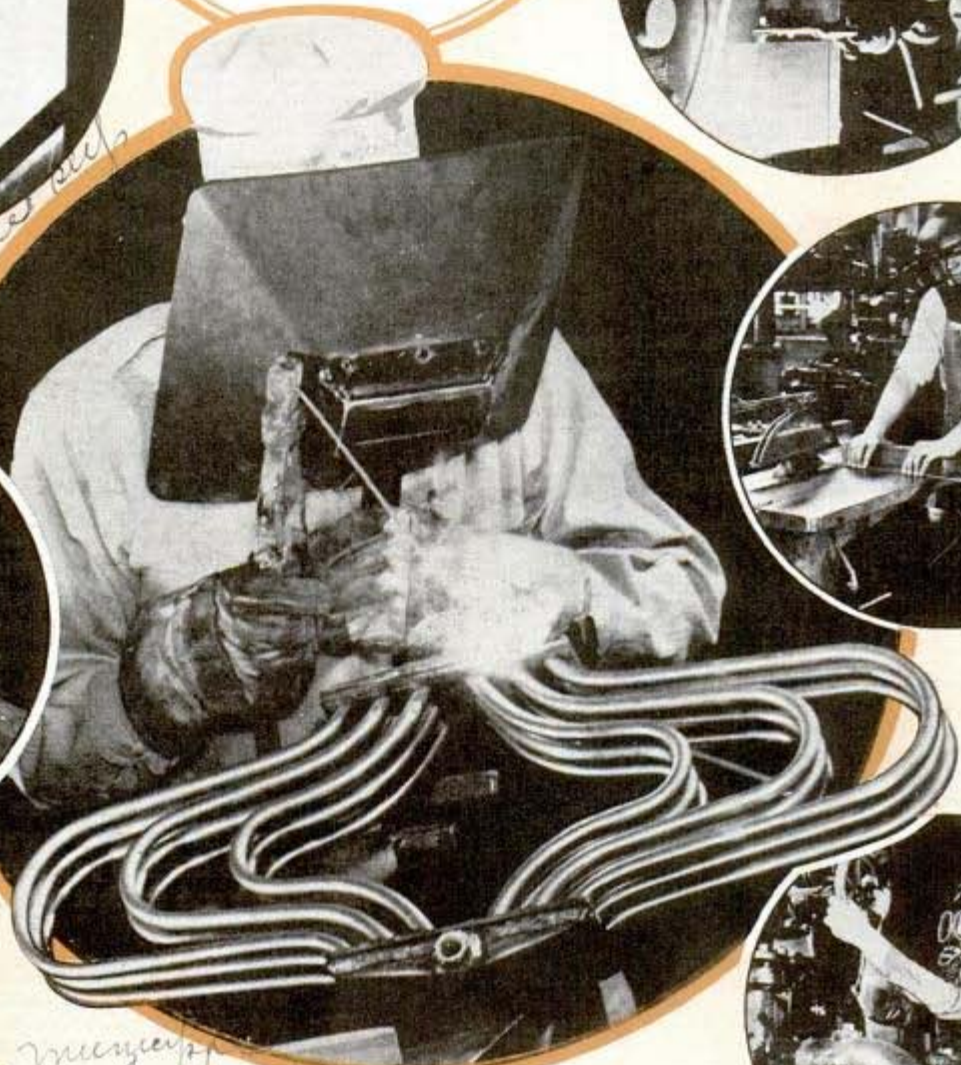

Millions of industrial workers are fighting a battle for safety; for every worker killed or injured is a war casualty. In the center, an American Airlines welder works behind a face protector. Left, top to bottom: General Electric welder wears ventilated helmet; safety mask, marred by accident, saved Lockheed Aircraft man from serious injury; transparent mask guards eyes while grinding. At right, top to bottom: electric precipitator tests purity of air around welder; face guard with laminated glass; pipeline repair man wearing canister gas mask; welder's helmet stops flying particles, reduces glare.

*Wagner
Academy
New York City*

*General Electric
at Pittsburgh*

*W. P. ...
P. ...*

2943 National Safety Council
 207 Washington Blvd. Philadelphia, Pa.

LONG before the shooting war began, the casualty lists were mounting.

American factories are America's first line of defense, and throughout the vast industrial machine soldiers with tools were dying by thousands, being maimed and disabled by more thousands, in a "blitzkrieg" led by General Carelessness. Production was mounting swiftly, but the accident toll was swelling at a higher rate.

Industrial safety experts and government men, alarmed by the loss of men and man-hours, got busy. They found that while general employment increased only two to three percent in 1940, industrial deaths jumped ten percent from 15,500 to 17,000. In 1941, fatalities may have reached above 20,000.

With millions of green

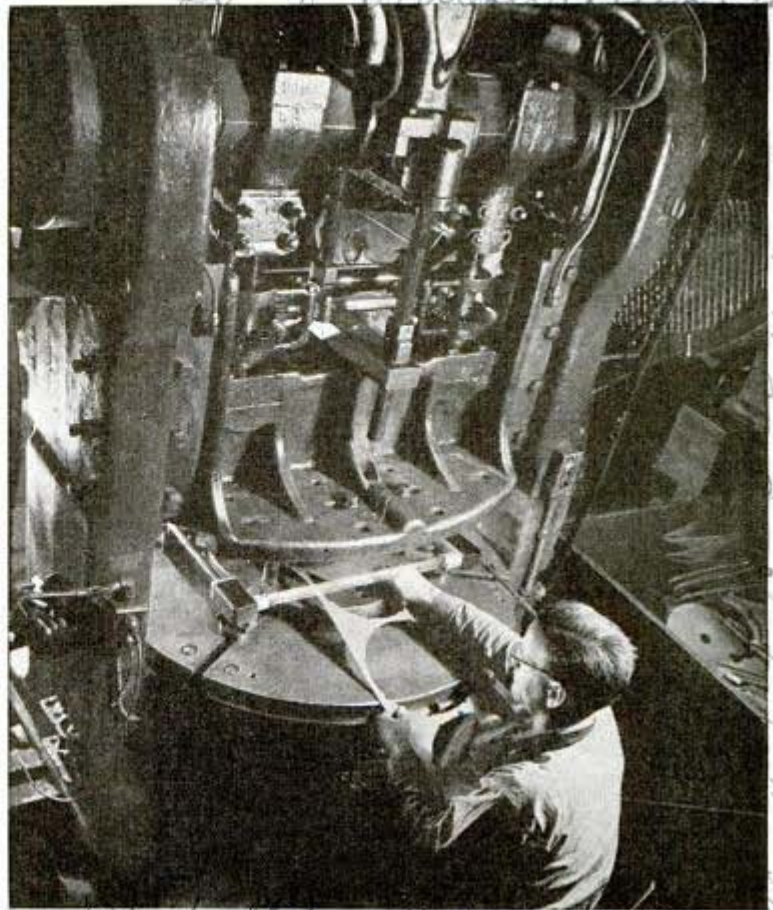

Schroeder Westinghouse
 Electric eye stops giant stamping machine as operator's hand reaches in

Flexible wire cords attached to wristlets of Bethlehem Steel worker shut off trimmer if his hands are in danger

Taking off respirator after visit to dust chamber, this man shows how well he was protected



76 & 9th, Chicago

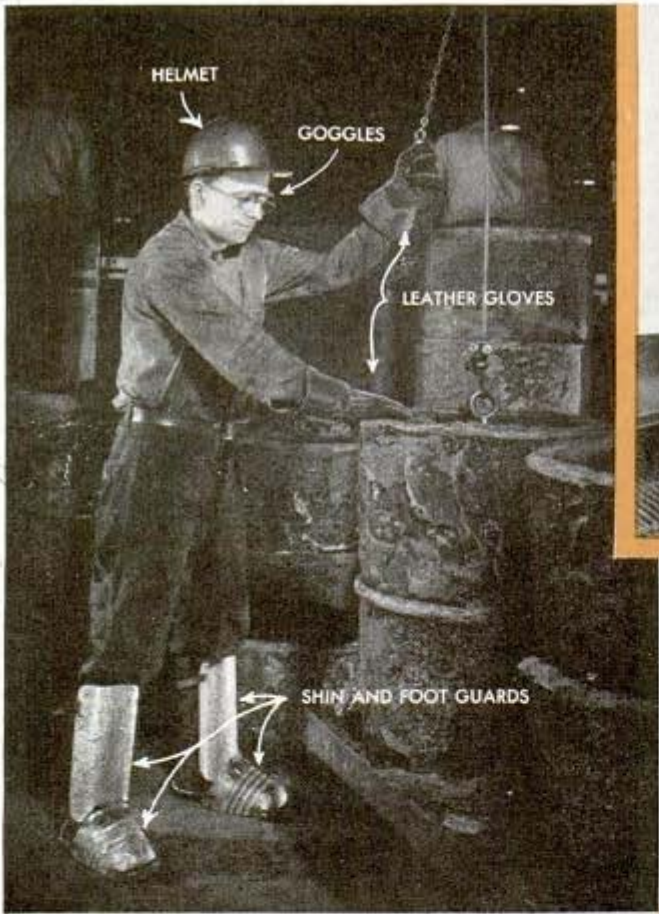

Handling hot metal is a hazardous job, but the Crane Company worker above is well protected. Below, for safety's sake a giant press in the Westinghouse plant is built so that workman must use two hands to operate it

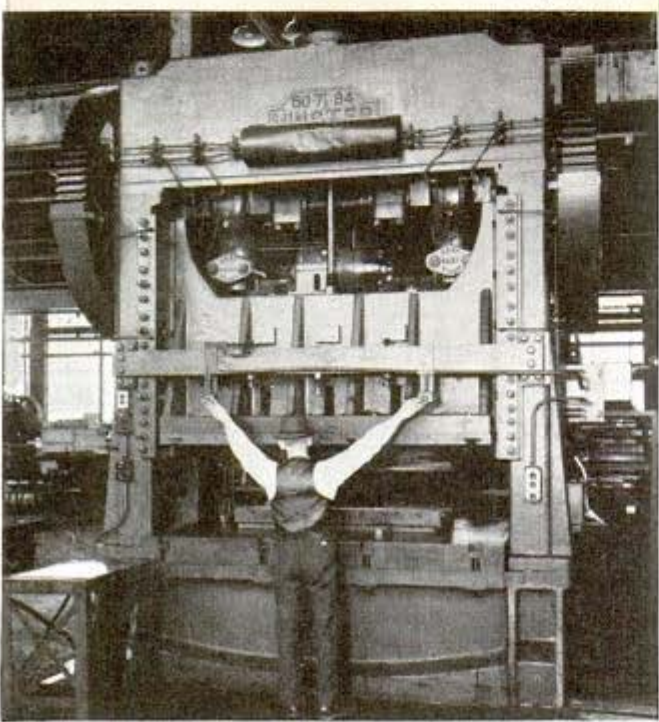

Helmet, apron, shin guards, gloves and steel-capped shoes protect a sand blaster

workers added to payrolls, all more or less unfamiliar with shop and plant routine, with manufacturing programs speeded up, with many "rusty" old hands recalled from retirement and with tiring overtime hours the rule, the accident toll has appreciably slowed the country's arming program.

But the tide of the battle for safety is believed to have been turned, thanks to the use of scientific and mechanical safety devices plus an intensive campaign of education directed at the executives of small, "mushroom" defense plants. The larger corporations are not responsible for the sharp increase in accidents. Because of never-ceasing safety drives and ingenious protective measures, their accident figures have shown a steady decrease.

The average citizen who seldom sees the interior of a factory would mistake many modern workmen for warriors from Mars, equipped as they are with masks, respirators, goggles and face shields, head guards, Neoprene clothing, rubber aprons, metal capped shoes and asbestos outfits.

Bethlehem Steel protects open hearth men with asbestos clothing; trimming machine operators have flexible cords attached to

2943

G. E. Schenckady.

Fingers are saved from mangling by this guard → on a big punch press

wristlets, and if a man's hand advances into the danger zone, the cord tightens and pulls a switch, stopping the trimmer. American Airlines has installed artificial waterfalls in its shops to eliminate dust and anti-corrosion spray. At a Westinghouse plant, electric eye mechanisms spot a welder's hand when he reaches into a giant stamping machine and stop it as the light beam is broken.

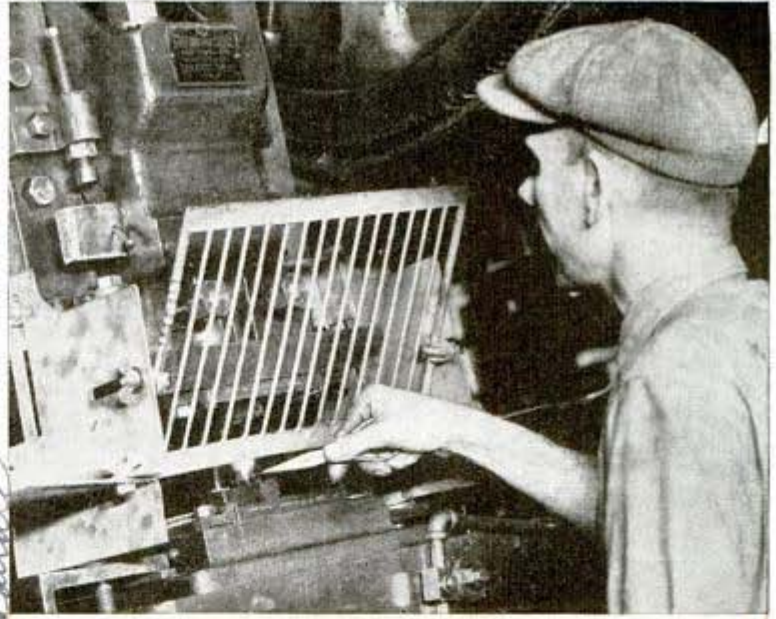

Jones and Laughlin Steel Company spent \$40,000 extra on a new building so that a 15-inch clearance could be left between overhead electric cranes and the building columns. The cranes are also provided with extra brakes on the jack shafts and miniature red and green traffic lights automatically tell whether the operator is in his cab. Caterpillar Tractor Company uses ventilated

most on market. and patents

Here is a safe device for handling heavy tanks of gas at a steel plant

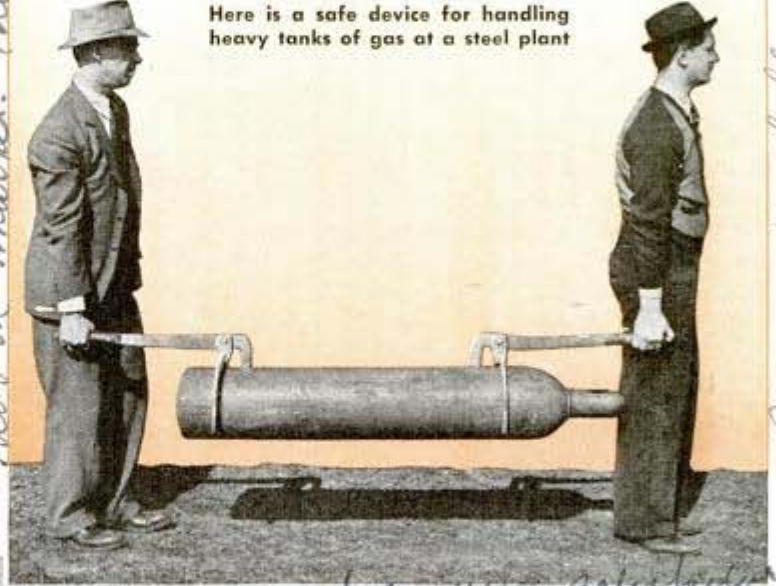

Carnegie - d. Lewis
Steel Corp. Mary, Ind

It would take 2,000 artificial eyes to replace those lost every year in accidents, mostly avoidable

Peoria, Ill.

not suitable for sale factory.
Carnegie-Illinois Steel Co. photo



work benches from which dustladen air is pulled down through a grill into filters; fire blankets are at hand to wrap around a man whose clothing is ablaze.

General Electric lost only one man by accident during 1940, despite the rising national trend. This man broke a leg falling from a ladder and died of pneumonia. Westinghouse had the lowest accident rate in the company's history. General Motors established a safety record in its 89 plants with a lost-time accident record of only 3.43 for every million hours worked, and one plant has

secret

(Continued to page 173)

21206

Portable Fluorescent Lamp Encased in Plastic Tube



Portable lamp saves time in airplane assembly line

Production of defense material is aided by the introduction of a portable fluorescent light that the workman can carry to illuminate dark corners during both day and night shifts. Enclosed in a tube of transparent Lucite, durable and light in weight, a low-wattage lamp emits a spherical light that eliminates shadows.

1224

Chess Game for Blind Requires Only a Sense of Touch

Only a sense of touch is needed to play a new chess set designed to make the lot of the blind easier. Black squares are raised, white depressed, and all men have

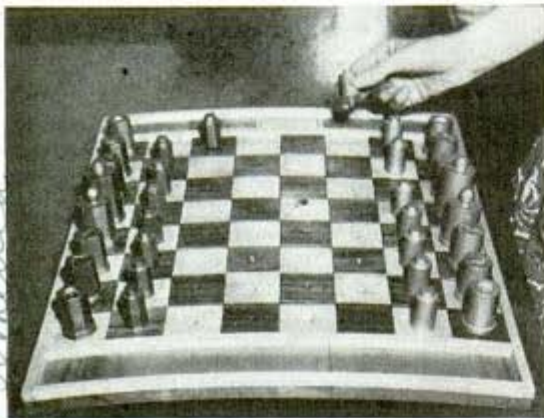

The blind recognize chessmen by distinctive shapes

distinctive tops for quick recognition. In each square there is a drilled hole, and all chessmen are fitted with pegs at the bottom so they will not topple out of position when touched. The white men are turned, while the black are octagonal. The rook has a depression at the top; the knight has an "L," right hand for the queen side and left hand for the king side; the bishop has a cross, the queen has a round ball on top, the king a beveled button, and the pawns have plain buttons. As soon as the blind players have a knowledge of the game and a tactile recognition of the men, they learn to play about as well as sighted persons, running their hands across the tops of the men constantly to familiarize themselves with relative positions.

21060

Jars Sealed End to End by Holder Help Preserve Paint Brushes

Paint brushes can be preserved in an airtight container made by joining two Mason jars with the aid of a special two-

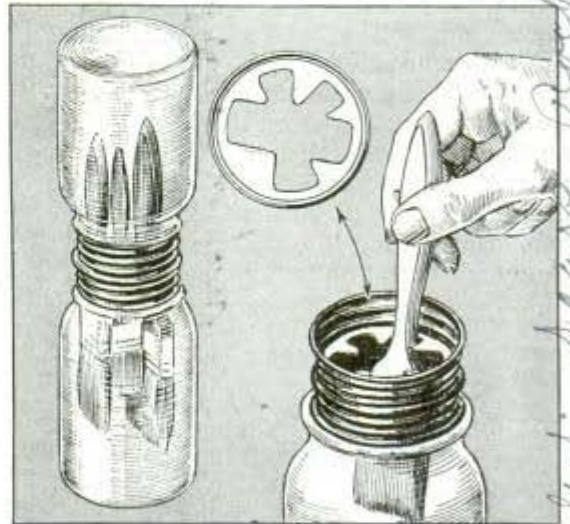

Paint brushes sealed in jars by special screw cap

way cap now on the market. At the center of the cap is a metal disk having slots through which several brushes may be suspended into the lower jar partly filled with linseed oil or other brush-preserving solution. When the second jar is inverted and screwed tightly into the upper part of the cap, the assembly makes a holder into which air cannot enter.

To learn where to buy commercial products described in these pages, see the index.

21206
 Day - Ray
 21060
 1224
 The Braille Institute
 70
 741 N. Vermont
 Los Angeles

21272.

Fighter Plane's Cockpit Is a Maze of Controls

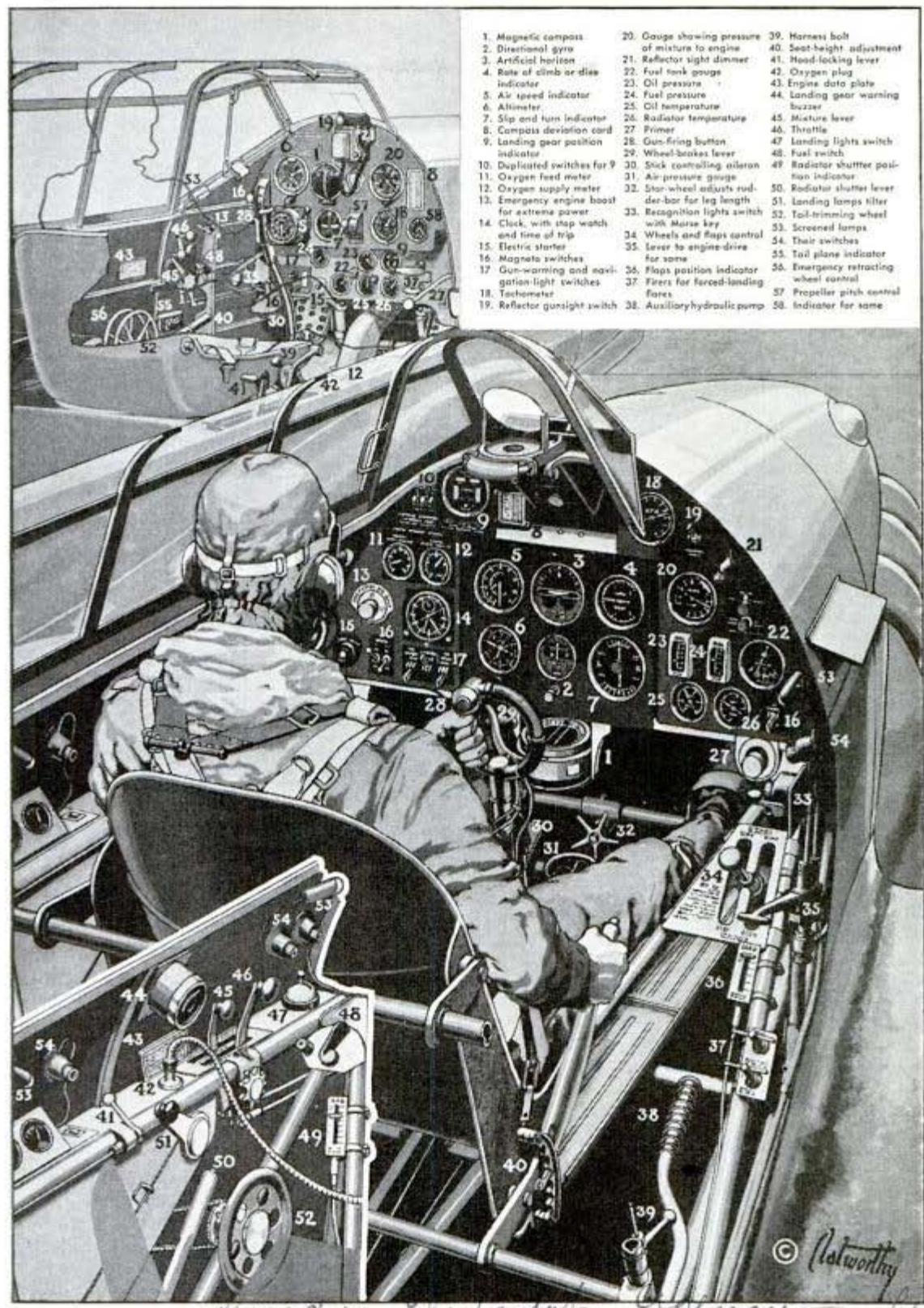

- | | | |
|---|--|---|
| 1. Magnetic compass | 20. Gauge showing pressure of mixture to engine | 39. Harness bolt |
| 2. Directional gyre | 21. Reflector sight dimmer | 40. Seat-height adjustment |
| 3. Artificial horizon | 22. Fuel tank gauge | 41. Head-locking lever |
| 4. Rate of climb or dive indicator | 23. Oil pressure | 42. Oxygen plug |
| 5. Air speed indicator | 24. Fuel pressure | 43. Engine data plate |
| 6. Altimeter | 25. Oil temperature | 44. Landing gear warning buzzer |
| 7. Slip and turn indicator | 26. Radiator temperature | 45. Mixture lever |
| 8. Compass deviation card | 27. Primer | 46. Throttle |
| 9. Landing gear position indicator | 28. Gun-firing button | 47. Landing lights switch |
| 10. Duplicated switches for 9 | 29. Wheel-brakes lever | 48. Fuel switch |
| 11. Oxygen feed meter | 30. Stick controlling aileron | 49. Radiator shutter position indicator |
| 12. Oxygen supply meter | 31. Air-pressure gauge | 50. Radiator shutter lever |
| 13. Emergency engine boost for extreme power | 32. Star-wheel adjusts radiator-bar for leg length | 51. Landing lamps filter |
| 14. Clock with stop watch and time of trip | 33. Recognition lights switch with Morse key | 52. Tail-trimming wheel |
| 15. Electric starter | 34. Wheels and flaps control | 53. Screened lamps |
| 16. Magneto switches | 35. Lever to engine-drive for same | 54. Their switches |
| 17. Gun-warning and navigation-light switches | 36. Flaps position indicator | 55. Tail plane indicator |
| 18. Tachometer | 37. Tires for forced-landing fares | 56. Emergency retracting wheel control |
| 19. Reflector gun-sight switch | 38. Auxiliary hydraulic pump | 57. Propeller pitch control |
| | | 58. Indicator for same |

To the uninitiated, the cockpit of a modern fighter plane is a bewildering maze of instruments and controls; only after months of training are the pilot's reactions so automatic that he can fight as well as fly. Here is the cockpit of a British Hurricane; above it, that of a German Messerschmitt

MARCH, 1942

© Watworth
 London Electricity Agency Ltd.
 134 Fleet St. 71
 London E.C.4. Eng

1963

Capt. Allen Warren Elliott
343rd 33rd Army

Observing the area of fire with the battery commander telescope during anti-aircraft target practice at Fort Tilden, N. Y.



The GLASS "EYES" that give

Aerial film is run through reduction printer, reproducing pictures to scale on glass plate for projection on map table
(Bausch & Lomb photo)

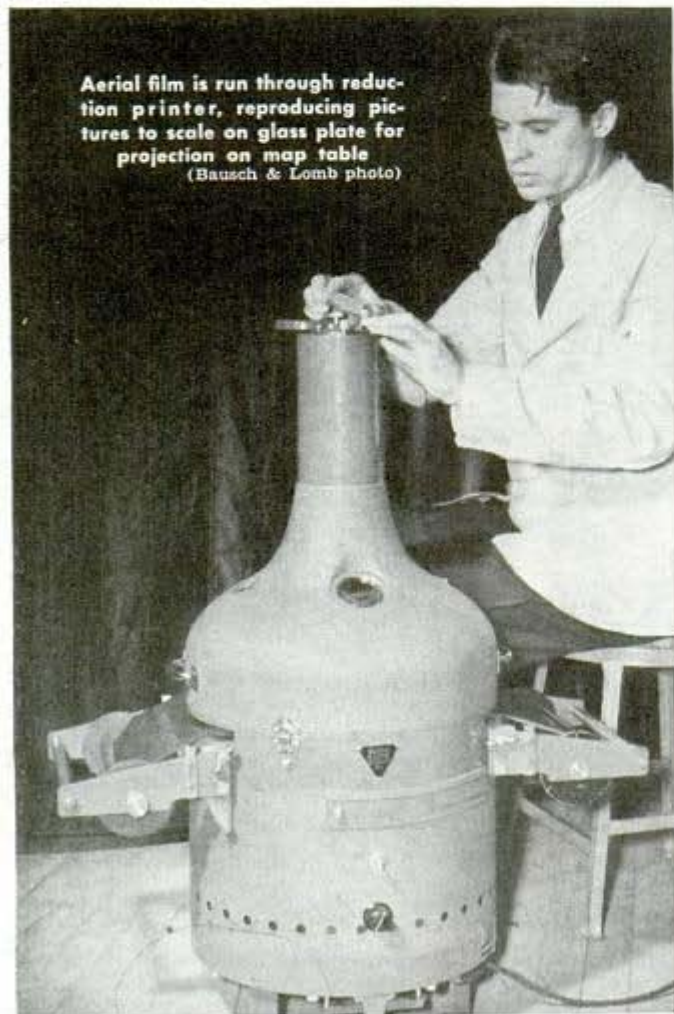

SEVEN miles above the earth aerial cameras are plotting the terrain of a military engagement. Hollywood is on the threshold of a revolution wrought by new methods of using lenses. New spectacles are freeing the color-blind motorist from danger. The greatest lens the world has ever conceived will soon be ready to reach into uncharted spaces of the universe.

Centuries ago men learned to bend light rays with glass, and few single factors have influenced the course of civilization so much as the lens. Yet men learned slowly how to put it to work. Spectacle lenses arrived about 1290, then nearly 330 years passed before a Dutch spectacle maker evolved the telescope.

In the last few generations remarkable advances have been achieved in sight, photography, motion pictures, lighting, radio, television, medicine, biology, bacteriology, metallurgy and astronomy. Today the rate of progress is phenomenal.

In New York, experimenters led by Dr. Alfred N. Goldsmith,



← "Closeup" lenses of "sculptor's glasses" are raised when they are being used for distant view

Patient with aniseikonia tilts table with white balls when told to level it; his eyes do not see alike
(American Optical Co.)



MAN SUPER-VISION

*Salembridge Mass
Dr. Charles M. Stark
Bloomfield N.J.*

known for his radio and television discoveries, have developed a new use of lenses which will revolutionize movies when Hollywood adopts the method, which is not likely to be long because it solves one of the most baffling puzzles that has confronted the moving picture industry.

One basic difference between watching a stage play and a movie is that your eye has no fixed focus and can follow a performer around the stage, keeping him always in clear view. Compared to the eye, however, the motion picture camera has been a crippled organ of vision because it has a fixed, or limited focus. For this reason, unless the camera is moved with the performer, he fades into a blur as he steps out of focus. That is the reason you have had to put up with annoying "close-ups" followed by "long shots" which break the continuity. They are merely clumsy subterfuges which hide the weakness of the camera which cannot give you both at once.

Soon you will be able to follow

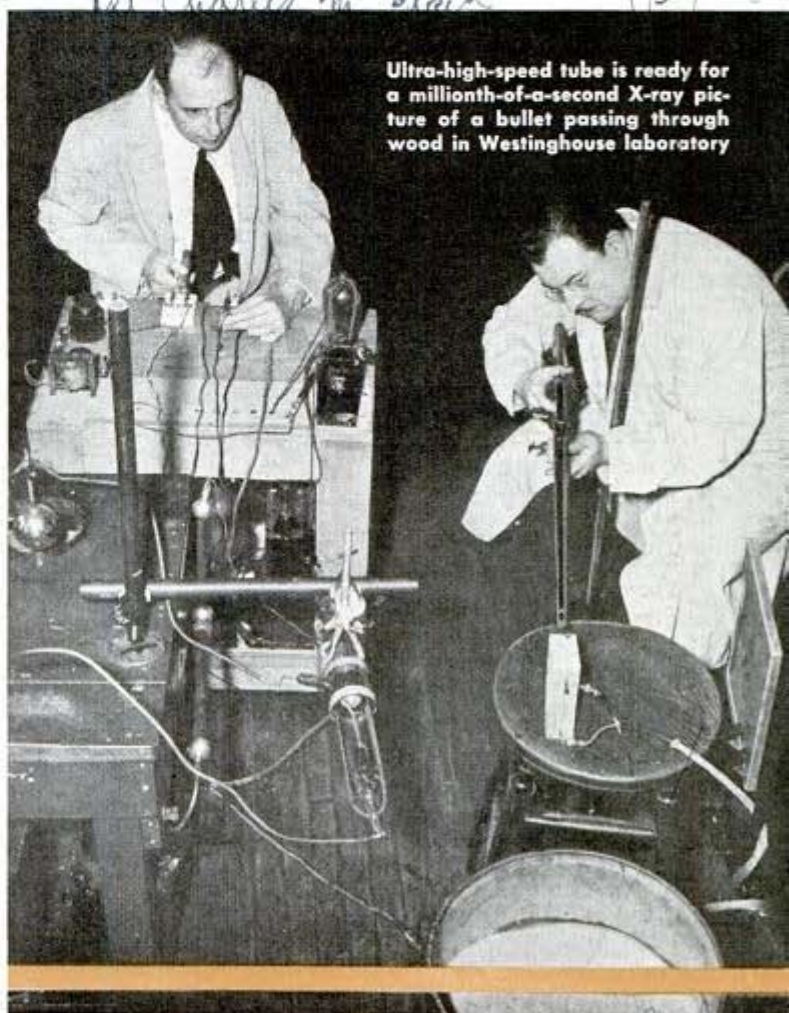

Ultra-high-speed tube is ready for a millionth-of-a-second X-ray picture of a bullet passing through wood in Westinghouse laboratory

2963



Inspecting goggle lenses used by Army and Navy air pilots

Below, lines of light are converged by double convex lens; drawings at right show how light is bent by other media

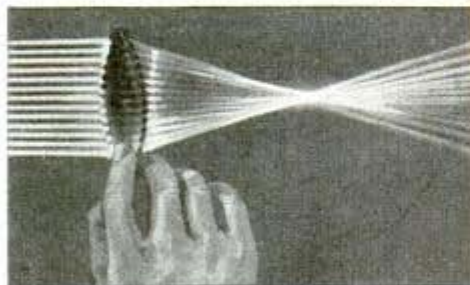

*Better Vision Institute
205 E. 42nd, New York*

Light rays passing through a cylinder in a plane perpendicular to its axis are refracted (bent)

Light rays passing through a concave lens are bent apart

Light rays passing through a prism are bent toward the base and away from the apex of the prism

all of the performers clearly wherever they move, as the result of the discovery recently patented. Movie sets are to be divided into zones, according to distance from the camera. Each zone has an independent bank of lights. These lights flash on and off 48 times a second, so fast that to the eye they seem constantly lighted.

But the camera is faster than the eye, and in front of the machine, instead of the limited single lens, whirl a number of lenses, one for each zone. As the lights flash on in a certain zone, the lens which

Star projector in Pittsburgh's Buhl Planetarium is focused by complicated electric mechanism including a special elevator

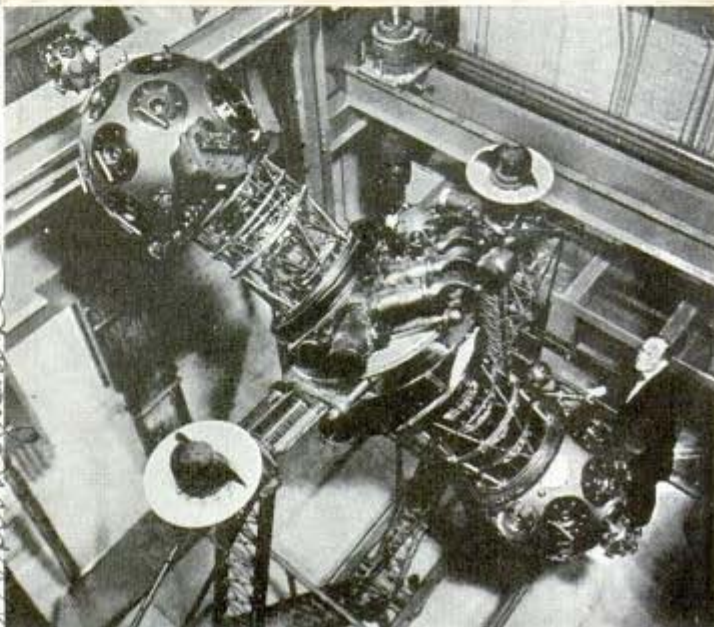

keeps that zone in focus whirls in front of the camera. Each frame of movie film is exposed several times so that whatever shows in each zone is photographed on it separately. The result is that an actor is in focus wherever he may be and his features are as sharp at 50 feet as at three.

War conditions naturally have hastened research to equip the military forces with the best "eyes" science can develop. Major George W. Goddard, chief of the army photographic laboratory at Wright Field, Ohio, predicts the ceiling for aerial photography will soon rise considerably above 40,000 feet where flying photographers would be safer from attack. Army cameramen have made pictures at 35,000 feet in temperatures 30 to 60 degrees below zero, requiring heaters on the cameras.

One important improvement to this branch originated in the laboratories of Bausch and Lomb Op-

Bausch & Lomb

Walter



↑ Case-hardened Bausch & Lomb goggles for industrial workers are tested by a barrage of steel balls from an air gun

← Inspecting molded and annealed lens blanks for fire cracks, striations and large bubbles at Eastman Kodak factory

U. S. Army Air Forces photo below shows aerial camera with telephoto lens

tical Company at Rochester, N. Y., where a new lens enables a single photograph taken straight down to show accurately three times as much area as previously possible from the same altitude. This remarkable lens will take a photograph at a height of three miles in which every detail of the landscape is clear within an area of 28 square miles. Covering a field of 90 degrees, it is also possible to photograph fortifications, plants or troop concentrations without flying over them.

With aerial light bombs, and better lenses, color photographs can be taken from military planes at night with such effectiveness that they penetrate camouflage. The flashlight bombs give billions of candlepower over a wide area. By using different colored flashes and various color films, camouflage dependent on color is exposed.

(Continued to page 178)

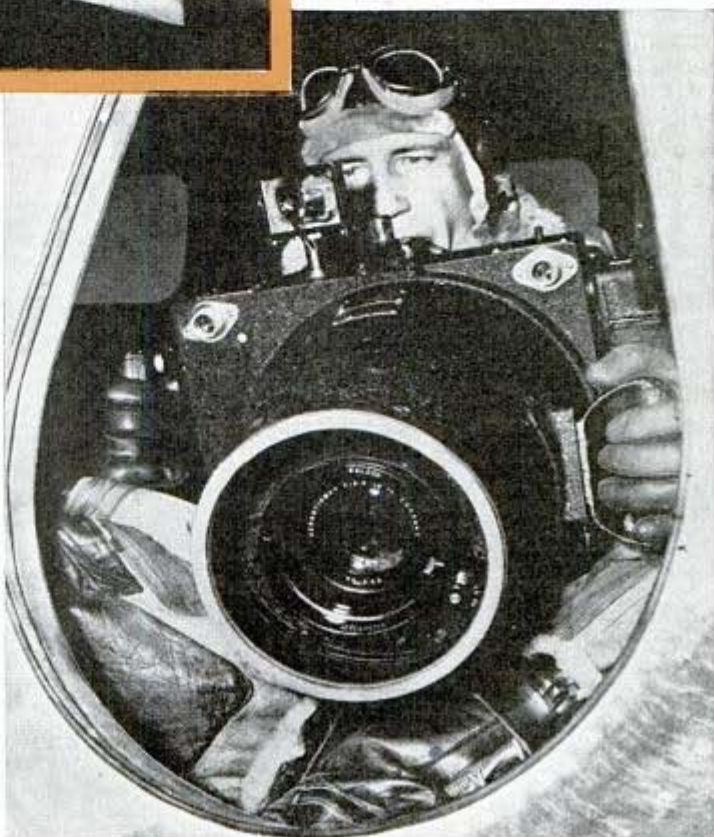

Rochester, N.Y.

21294.

Suds Fed Into Scrub Brush Clean Carpets and Floors

*Kwik Products Co. Inc.
22 W. 22nd Street
New York City*



Tank at right has pump to force suds through brush

Carpets, rugs and floors can be washed quickly with a scrub brush equipped to discharge soapsuds over the surface. Five or six strokes on the pump of an attached tank sends a stream of suds into a connecting tube, and pressing a lever releases the suds through the brush itself. There is so little moisture in the sudsy mixture that it is unnecessary to remove rugs or carpets, for after scrubbing is completed the suds, with the loosened dirt, can be wiped off the surface before moisture has penetrated.

Antiseptic Clothing Aids Health And Deodorizes Itself

*College Park
Md.*

Clothing made from specially treated fabrics which kill germs offers a new means for protecting health and avoiding body odors, declares Dr. L. H. James of the University of Maryland. The fabrics are merely self-antiseptic, keeping themselves free of germs. When such clothing is worn, infections in skin cuts are less likely to develop, people with athlete's foot are less

*Science Service
Oct. 11, 1941*

likely to reinfect themselves, and the chances of getting skin or scalp infection from hats, girdles and underwear that others may have tried on are reduced. Virtually all leather hat bands are now made of self-antiseptic material; some 15,000,000 mattresses are made of treated fabrics; more than 2,000,000 pairs of self-antiseptic canvas shoes were turned out in one year, and over 4,000,000,000 such pieces as sheets, pillowslips and night clothes were treated, Dr. James revealed in showing that the new treatment is more than a fad. Because body odors are due to bacterial growth and decomposition of organic matter in perspiration, the treated fabric remains free from offensive odors.

21280

Adjustable Glass Drawing Board Is Lighted From Beneath

Preparing drawings on mimeograph stencils, making pencil or ink tracings, and similar tasks can be accomplished easily on an illuminated glass drawing board mounted on a pedestal. The board may be tilted sharply or turned completely around on a ball joint and locked at any convenient working angle. The translucent glass top is illuminated from beneath with a cool light diffused evenly over the surface. Drawings to be traced may be clamped under the drawing paper or stencil. The light shows the lines clearly. Ruling, writing, lettering or proofreading are among other jobs aided by the lighted board.



Light under glass drawing board illuminates stencil

POPULAR MECHANICS

*A. B. Dick Co.
720 W. Jackson, Chicago*

21291

Blowing Whistle Helps Adjust "Noise" Meters

John D. Allen

Walter Mikelson

It's all part of a day's work when a tester in the General Electric engineering laboratory blows a series of blasts on a brass whistle before a sound-level meter, better known as a "noise" meter. The purpose is to make preliminary calibration of the meter. Since the whistle emits a note of known loudness, it can be used while adjusting the screw that controls the sensitivity of the meter's vacuum-tube amplifier. Final calibration takes place in a soundproof room. Sound-level meters are widely used in commerce and industry where the study of noises is essential in promoting efficiency, safety or comfort.



One blows the whistle while another adjusts sensitivity of "noise" meter

21358

Balloon Wrapped in Chains Scours Inside of Pipe Lines

Inside walls of pipe lines can be scoured clean of scale, roots and debris by an in-

flated rubber ball covered with chains, developed for use not only in water supply lines but in industrial, chemical and ore plants using pipe lines to carry various liquids. This Rotary Crawler is inserted in the pipe, then inflated. The pressure of the liquid flowing through the pipe forces the ball along, and it scours as it travels. It is made of a specially compounded rubber, and could be adapted to use in oil or gasoline pipe lines if synthetic rubber were used. Being flexible, it adapts itself to turns or irregularities in the pipe.

Corona, Wheel Metal Works, Corona, Cal. 11



This Rotary Crawler, a chain-covered inflated ball, scours pipes clean; it can be adapted to oil lines

Cheslean Science Monitor No. 3

21307

Plane Refuels Tanks by Tossing Gas in Rubber "Sausages"

"Sausages" dropped from the sky may be the means of refueling mechanized forces stranded far from supply bases. In experiments conducted by Army experts, gasoline and oil stored in sausagelike rubber bags have been tossed from planes. The containers, attached to inexpensive burlap parachutes, fell from heights of nearly 1,000 feet without bursting.

in North Carolina

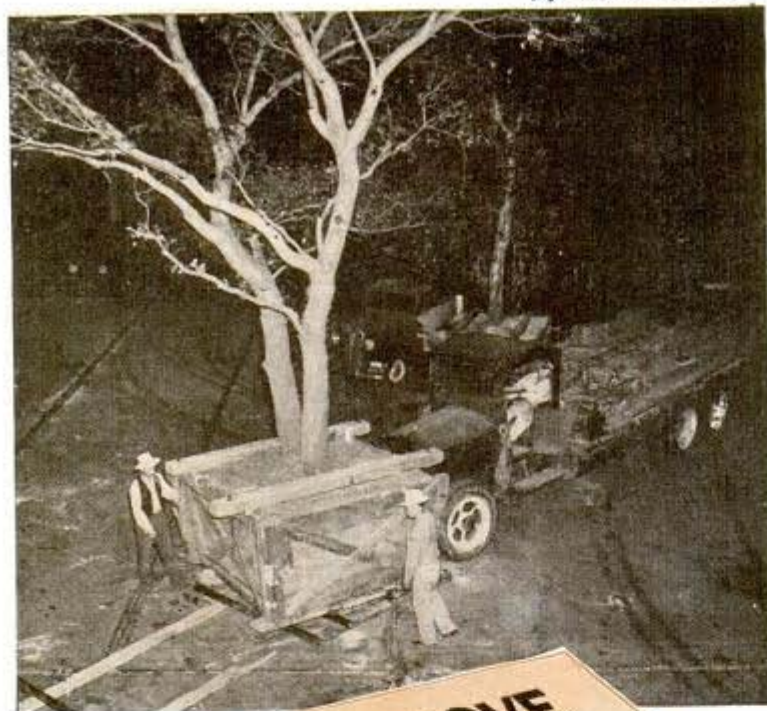

A living tree is moved to stage of the Bowl for natural scenery

vast stage is done by heavy-duty trucks with padded bumpers, winches, jacks, block and tackle. It takes but one of these trucks to shove offstage the 120-ton orchestra shell, a steel-and-wood structure rolling on steel rails set in the stage.

The Bowl is in reality "a theater on wheels." Stage directors have revolutionized backstage technique by making every unit a mobile unit. Sets are built on small rubber-tired wheels. No "flies" are used to hang the scenery, and all sets are constructed from scale models.

Real fire, smoke, and steam, of startling proportions are used in some presentations. Electrically operated flares are mounted on a sort of tri-wheel "scooter," with re-

**TRUCKS MOVE
LANDSCAPE
in the BIG BOWL**



At left, the 120-ton orchestra shell is moved offstage by truck

Stage sets are built from the ground up, as in the movie studios, from actual scale models

THOSE stage hands in the Hollywood Bowl draw assignments you'd think were business for army engineers. Moving 12 full-grown, living trees on the stage for a single act was one sample.

The Bowl itself—a "natural" theater formed by hills, with a canyon for entrance—and all its properties are on the colossal scale you'd expect in Hollywood. It has seated 26,000. Scene-shifting on its

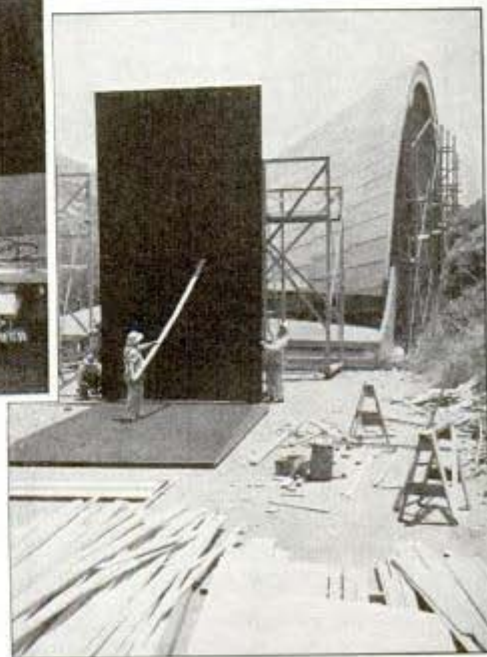

21199



flectors behind the fire and chemical pans almost five feet in diameter. When these flares were first tried at a rehearsal, the effect was so realistic that apprehensive citizens turned in a fire alarm.

Another innovation is the traveling light-control towers, two and three-deck scaffolds on wheels, carrying up to ten large heavy-duty motion-picture studio searchlights.

Stage microphones are connected to amplifying equipment in a concrete "pill box" directly behind the conductor. The "pill box" affords a view of the entire stage for the technician at the amplifier controls and his musician assistant.

Silhouetted against the Bowl, filled to capacity, is its huge shell

Sunk in ground near stage is this control board for sound amplifiers



John Ellis musician

*Berling M. Stevens
sound technician.*

21311 Conk J. Stirling
Leitchall, dno.

Long-Term License Plates Save Steel for Defense

New Center Policy - Illinois



Metal strip for 1942 covers old date on license plate

Close to 50,000 tons of steel a year, it is estimated, could be saved if all states would adopt a plan to use five-year automobile license plates. The state of California is issuing a narrow "cover strip" that extends completely across the top of the 1941 plate, as one step in that direction. The strip is painted in reverse colors to distinguish the licenses which have been renewed. In Connecticut and Delaware license plates provide a space for attachment of new "date" inserts each year.

Right Ear Doesn't Hear the Pitch Your Left Ear Hears

You may never be able to sense it, but it has been determined that your ears are a bit out of tune with each other. Tests made by Dr. S. S. Stevens and J. P. Egan of Harvard University show that persons with "normal" hearing perceive the pitch of the same tone as higher in one ear than in the other, while in defective ears this "double hearing" sometimes exists to a striking degree. The apparatus used in the

Science Service
Sept. 12

experiments delivered a separate tone to each ear. Individuals listened first with one ear and then with the other, adjusting the pitch of one tone until the two matched. Sometimes one tone had to be altered in pitch as much as two and one-half percent to make it sound the same as the tone heard by the other ear. This difference in perception between the two ears was found to be greater with faint sounds than loud ones.

21285

Hydraulic Tube Sucks Up Gold From Bottom of River

Gold-bearing sands may be worked by one man using a hydraulic dredge which allows the operator to gather material from beneath large boulders, to mine river bottoms and to draw material from 30-foot depths when extensions are used. The dredging outfit consists of a hollow tube, a moving endless chain to help material rise in the tube, a hose at the upper end leading to a suction pump, and a small gasoline engine requiring a gallon or two of fuel per day. Along with sand and other material, the dredge picks up the right quantity of water for efficient operation, and discharges the aggregate into a sluice box.



Hollow tube dredge lifts sand and gravel from river

Cambridge
Mass
76
1067

POPULAR MECHANICS
Bernhard Bros
Machine Shop

1941 & Colorado St. Pasadena Calif

21279

Lights Help Simplify Music Chart for Children

Children in an English school are learning to sing by a simplified method devised by William Willmott. With the aid of flashing lights upon a chart, it becomes easy for beginners to correlate the tone with the key on the piano and its place in the staff. The chart includes a reproduction of the piano keyboard as well as the staff, and a series of electric lights which are connected with the keyboard of a miniature piano. Striking a note on the piano turns on corresponding lights in the chart.



Watching chart, children can gain clear perception of relationship between tone, keyboard and staff when note is struck

L.E. School

English combine photos

Black Light Guides Army Trucks Under Cover of Night

With a new adaptation of black-light rays, United States Army trucks can be convoyed rapidly at night without the use of lights that might betray their presence to enemy planes overhead. Each truck has mounted at the back a greenish disk, barely

noticeable, which glimmers in eerie fluorescence. Only the driver of the truck following can see the "invisible" disk, which glows vividly before his eyes as he sights it along a black-light beam emanating from a point near the windshield of his own truck. The leader of the procession finds his way with the aid of disks of a similar type, mounted on stakes, which are stuck into the ground along the route.

7200 Black Santa Inmia Blvd.

21279

is anodes

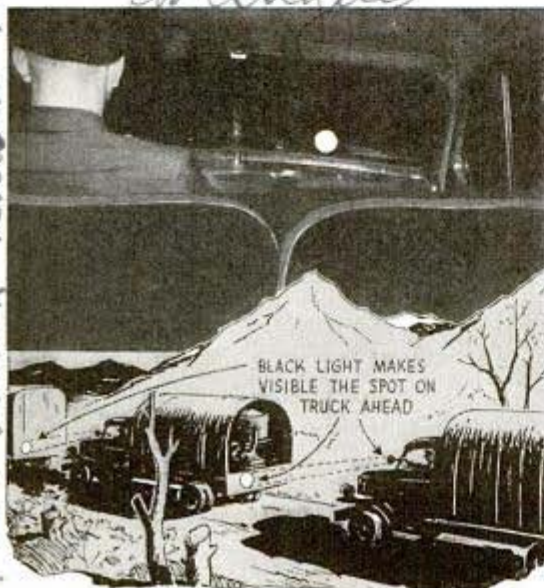

Driver sights disk in black-light beam from his truck

Steel in Discarded Razor Blades Could Build Many Tanks

Each year American men toss away 3,000 tons of high-grade steel in used razor blades which would be suitable for armament, says American Iron and Steel Institute. One company alone requires 50 tons of steel a year to make tiny staples like those at the base of match books. Paper clips account for an additional 1,200 tons of steel annually. Steel parts in men's suspenders would provide enough steel to turn out ten 25-ton tanks, and metal in women's corsets would equal 25 destroyers a year based on 1,000 tons of steel per destroyer.

21267

350 - 5th Ave New York City

MARCH, 1942

Reese Engineering Co

350 - 5th Ave New York City

2850. Leggett

The TRUTH about LIGHTNING

American Museum
of Natural History

Dr. Frederick H. Porphy, Acting
Curator of mineral and fossil



When lightning hits sand, a piece of silica glass like this is sometimes formed *fulgurite*

Three million volts of man-made lightning hits car while author sits at wheel

Big surge generator undergoing final checkup before producing a 3,000,000-volt stroke of lightning in laboratory

By Dr. Gilbert D. McCann

Westinghouse Electric & Mfg. Co.

E. Pittsburgh, Pa.
CHANCES of your being injured or killed by lightning are so slight that it's a waste of time to heed most of the popular beliefs regarding what you should and shouldn't do during a storm.

Our engineers, studying Nature's mightiest and most feared force, have found these beliefs based largely upon freakish occurrences or upon pure superstition. You undoubtedly have been warned against using the telephone during a thunderstorm. Because the Bell System employs protective devices and methods, there is very little, if any, element of danger from shock. As proof of this, many millions of calls are made each year by subscribers during storms and injuries under these circumstances are extremely rare.

Westinghouse high voltage
Laboratory, Trafford, Pa.

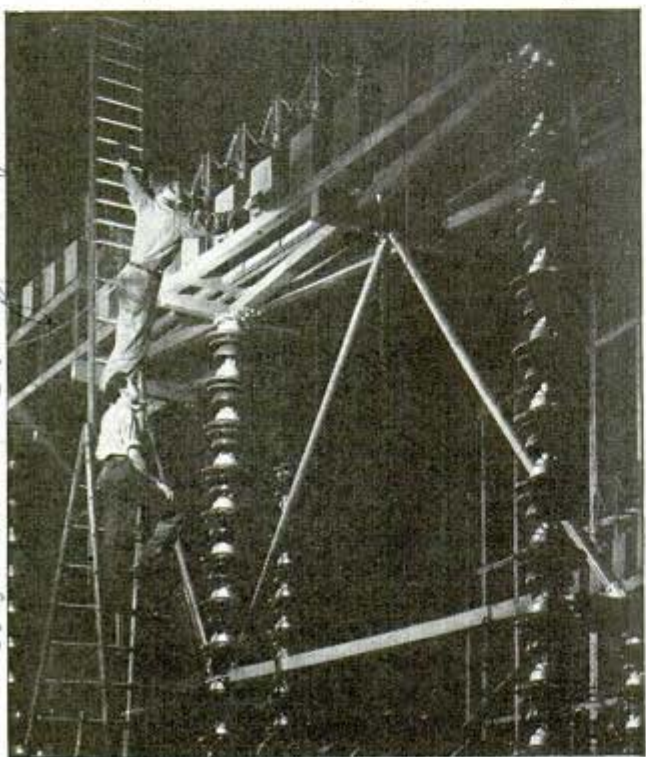

2858

Westinghouse high-voltage laboratory, Pa.

Shirt after being ripped by blast of "cold lightning," which does not last long enough to burn

Then you are told to turn off the radio when lightning begins to flash. We have found it entirely untrue that the antenna is more likely to be struck by lightning when the radio set is turned on. Of course, the antenna, if mounted very high above the ground, might be a good target for a lightning stroke, but if it is properly grounded little danger will result from its being struck. The radio set, too, will not be damaged if protected by recommended devices.

"Don't sit near an open window; close all windows and doors," someone else advises. Our studies show that there is hardly any more chance of lightning coming into a house with the windows and doors open than with them closed. We have determined that it probably is safer to be in the center of a room and safer to be on the lower floor. That's because a bolt striking the house probably will pass through the walls.

Many a mother has stern-

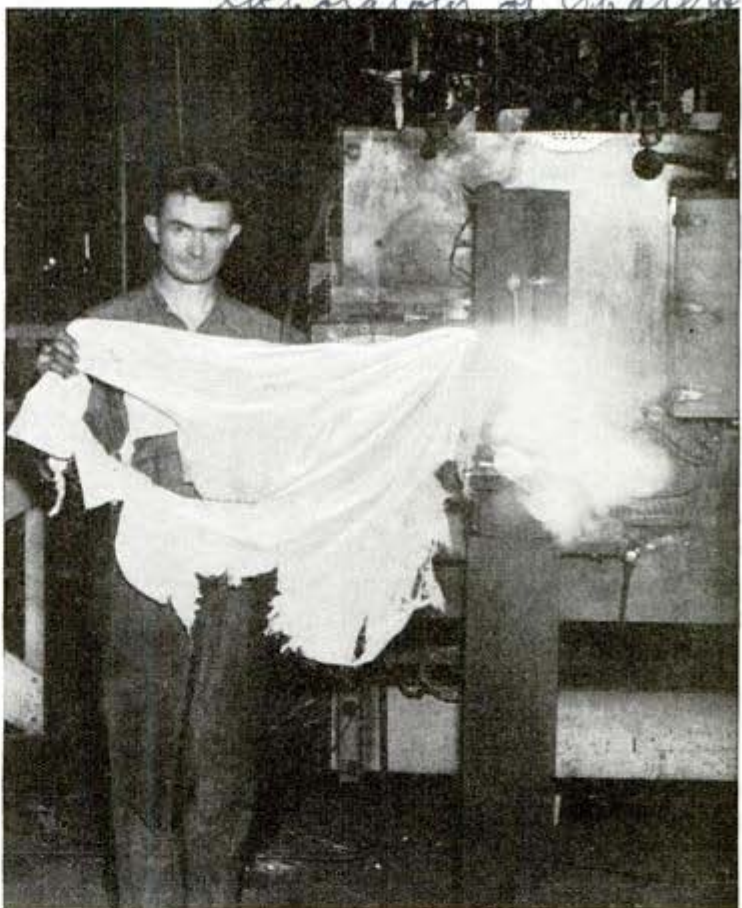

Model house protected by miniature lightning rod → withstands bolt of man-made lightning

One of the first photographic records made of direct stroke on a transmission line ↓

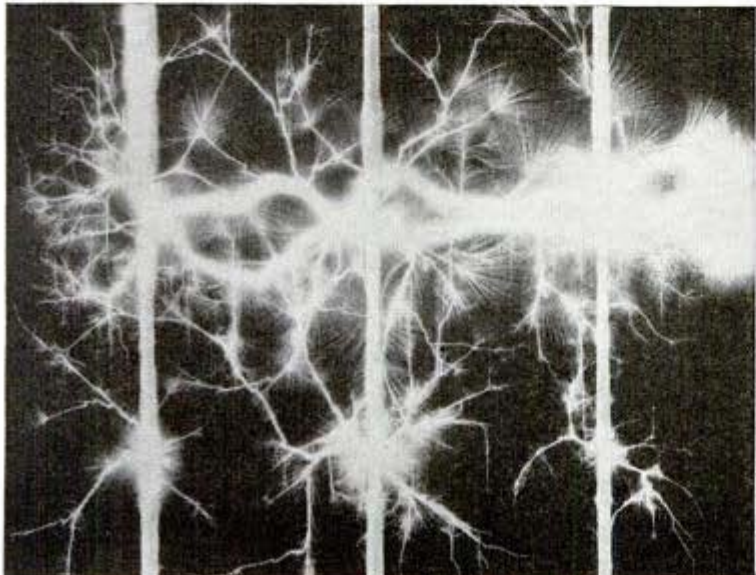

Westinghouse Laboratory, Trafford, Pa.

MARCH, 1942

made with klydenograf developed by Westinghouse

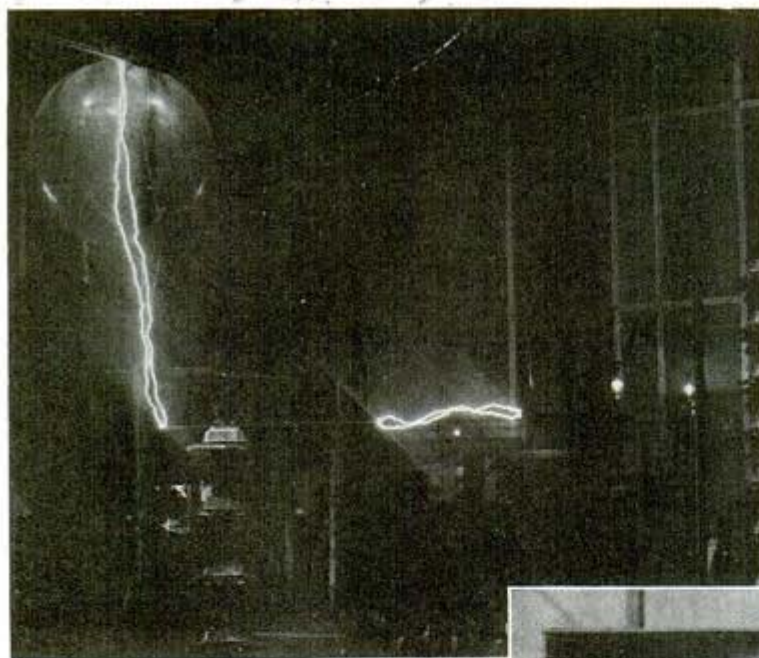

↑ *Stafford*
High voltage electricity jumps 15 feet across
spark gap in laboratory test

Result obtained by controlling 3,000,000 volts →
of electricity to form pattern

Million volt arc leaping 90 feet from insulator
to ground in Westinghouse Test

Stafford
E. Pettibone

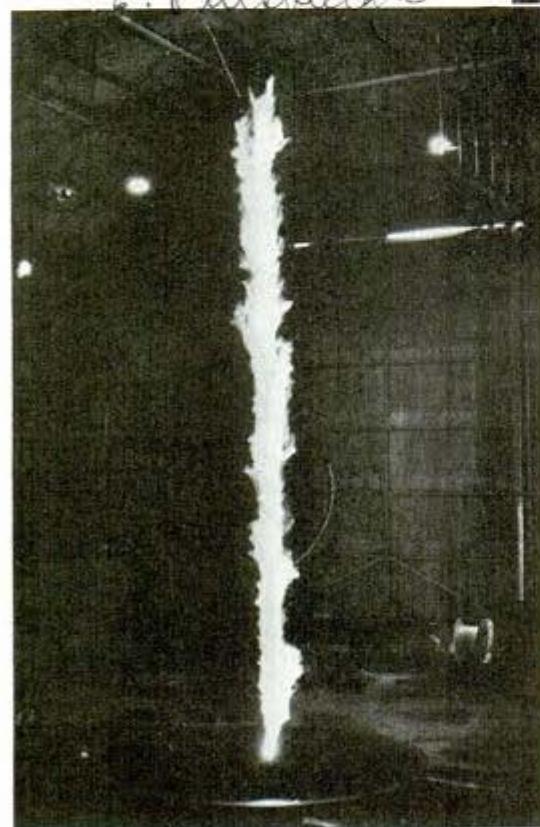
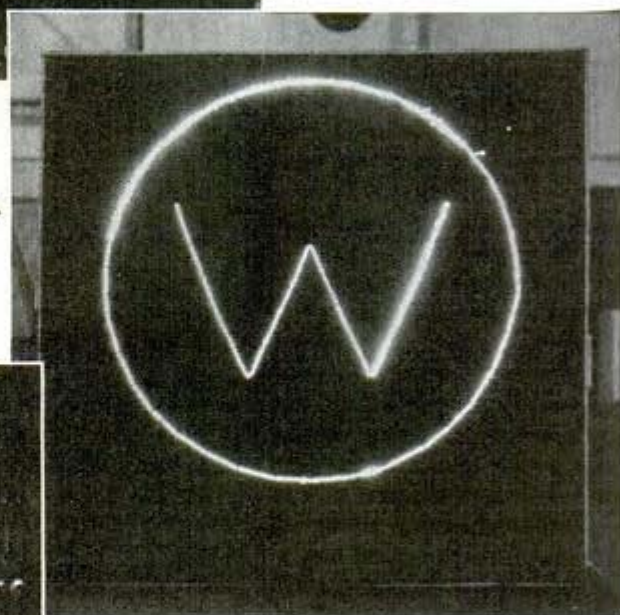

ly warned her son, "Don't go swimming during a lightning storm." As far as the risk of being struck by lightning is concerned, it probably is no greater in the water than out of it. Indeed the odds favor the water. However, if the resistivity of the water is high, a stroke to the water near a person may cause enough current to pass through the body to produce discomfort and possibly cause death through drowning — and fright probably might be given

a large share of the blame in such cases.

Farmers long have passed this one down from father to son: "Keep cattle out of barns because their warm bodies attract lightning." This is purely superstition. Warm bodies have no greater attraction for lightning than cold ones and the hot air rising from the barn is no better conductor than the hot air rising from an office building. Another bit of advice also sprung from superstition is: "Don't milk cows during a storm because it will turn the milk sour." The souring of the milk is due to specific bacillus fostered by warmth. If strict cleanliness is adhered to and the milk is chilled to the proper temperature, it will make no difference whether the milking is done during a thunderstorm or in fair weather.

2850

Many housewives wouldn't dream of using electrical appliances, such as fans and irons, during a storm because they have been warned it is dangerous. In large communities the transformer supplying each house is thoroughly grounded and the likelihood of being shocked is slight because the lightning current will be diverted to the ground. Nevertheless, if you are inclined to be nervous during a storm, it certainly is a harmless precaution to delay using the electric iron because in all probability the nervous tension is more dangerous to your health than the lightning.

Many people believe that you should avoid all metallic objects when lightning is near. Generally, that is true, but there are cases in which the presence of metal saved a life. For instance a man sleeping in an iron bed was not hurt when lightning passed through the bed. Being a good conductor, the bed was at practically the same voltage over its entire surface and the man in it had no voltage produced across his body. So it is relatively safe to be near any metallic object that is well grounded and unsafe to be near ungrounded objects.

If you get caught in the open, don't get under a tree. Engineers find that trees will attract the lightning, thus protecting the person standing under them, but that they are not good conductors of the enormous currents in lightning strokes—sometimes hundreds of thousands of amperes—and if the person is close enough to a tree trunk, sufficient voltage may be produced across it to flash over the human body and into the ground, bringing injury or death.

Almost everyone knows by this time that lightning does strike more than once in the same spot. For instance, the 40-story Cathedral of Learning at the University of Pittsburgh is struck about three times a year. On top of the 530-foot building, a 50-foot insulated mast has been placed and Westinghouse engineers studying lightning have connected to the mast special recording equipment. Lightning strokes to the mast pass through this recorder to the building grounding system. The 1,250-foot Empire State Building in New York City is struck about 20 times a year.

Steel frame buildings are doubly safe because not only do they provide a good target and conducting path for lightning strokes to ground, but their steel framework forms a Faraday cage. It was Michael

(Continued to page 176)

MARCH, 1942

Writing Pad Turns on Light When Pencil Is Removed

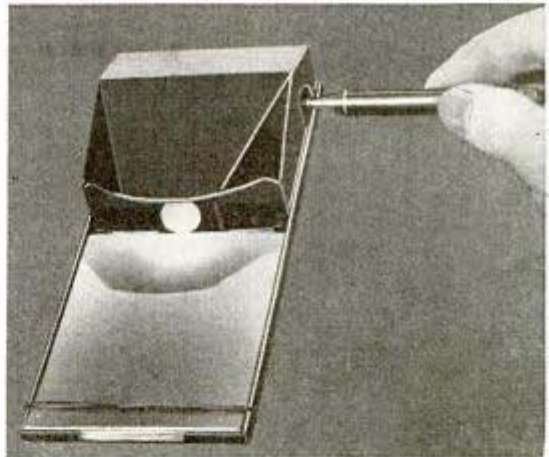

Memo pad light is turned on by removing the pencil

For convenience in making notations in the dark, a memorandum pad equipped with an electric bulb lights up as soon as the pencil is removed. Replacing the pencil turns off the light. Regular flashlight batteries, obtainable in dime stores, are used. The pad is handy in automobiles, at the telephone stand or on a night table.

Dauber Cap for Shoe-Shine Bottle Dispenses Liquid Through Top

Made of rubber, a shoe-shine dauber that fits over the bottle like a cap applies liquid through a slit at the top when pressed

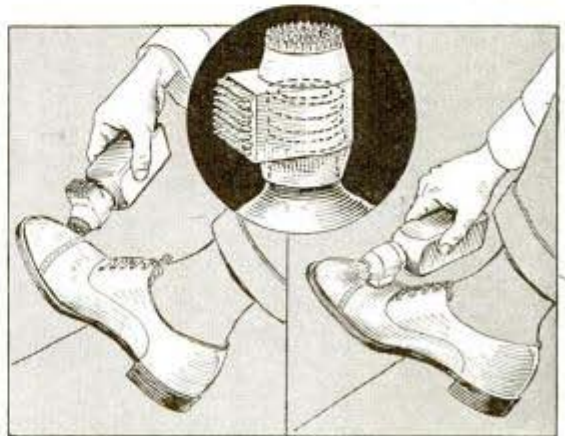

Left, applying liquid; right, rubbing it into shoe

against the shoe. Both the top and one side of the dauber have bristlelike projections of rubber, the side section being used when enough liquid has been spread over the surface of the shoe.

Pittsburgh applicator
Pittsburgh Pa.
Co. Box 7341 Oakland
Station

1230 Com. 2. H. Duck Tampa
5911 Custace Florida
Aqua Bike

Foot-Powered Water Bike Floats on Oil Drums



Treadles turn paddle-drum to propel odd fishing craft

By assembling three oil drums and some bicycle chain and sprockets, Tom Sydnor of Richmond, Va., constructed a pedal-driven water craft. Four paddles on the front drum, which is turned by the pedals, propel the aqua-bike. On land the paddles do not touch the ground, making it easy to move the unit about on the other two rollers. The craft is four and one-half feet wide, nine and one-half feet long and weighs 350 pounds. It carries two men and is especially suitable for fishing since it does not stir up water and makes no noise.

21281

Simple Gauge for Furnace Draft Checks Flue and Chamber

Handy for installing, servicing or inspecting furnaces, a draft gauge small enough to fit the vest pocket is easy to read



Gauge checking amount of draft in furnace elbow

and requires only a few seconds to operate. To take a reading it is only necessary to insert the instrument into a $\frac{3}{16}$ -inch test hole in the flue pipe, furnace door or chimney. The volume of draft in each instance is shown on a dial. Useful in coal, gas and oil-fired furnaces, the gauge is of the "dry" type, insuring long life since it lacks intricate mechanism that may get out of order. The information it gives is often indispensable for setting the draft regulator, locating basement odors caused by a faulty furnace, checking up on air leaks in the chimney, and as an aid in obtaining the best possible combustion.

21185

Tachometer "Feels" Motor Speed By Contact With Housing

Held against the housing of an enclosed motor, a vibrating-reed tachometer indicates the speed at which the motor is running. It needs no contact with the rotating element. Steel reeds within the instrument,

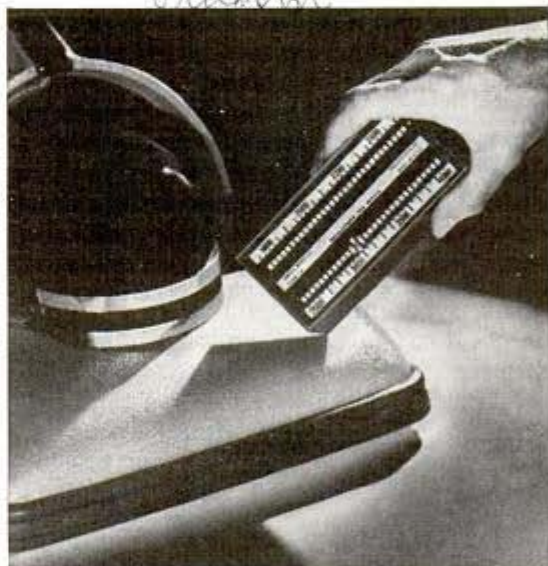

Speed of vacuum-cleaner motor found from outside

working on a principle as simple as that of the tuning fork, become energized by the vibration of the machine, which is related to its speed, and in turn there is shown on the face of the tachometer the revolutions per minute or the rate of the machine's vibrations, as the case may be. It may be applied to large machines such as turbines, generators and airplanes, as well as to electric shavers, portable electric tools, oil burners, electric refrigerators, centrifugal pumps and pneumatic drills and hammers.

no serial address needed
 Bacharach Industrial Instrument Co., 7000 Bennett St.

L1292. Capt. Paul Lersey 4483
Bevery Blvd. Los Angeles

Putting Spiders to Work for National Defense

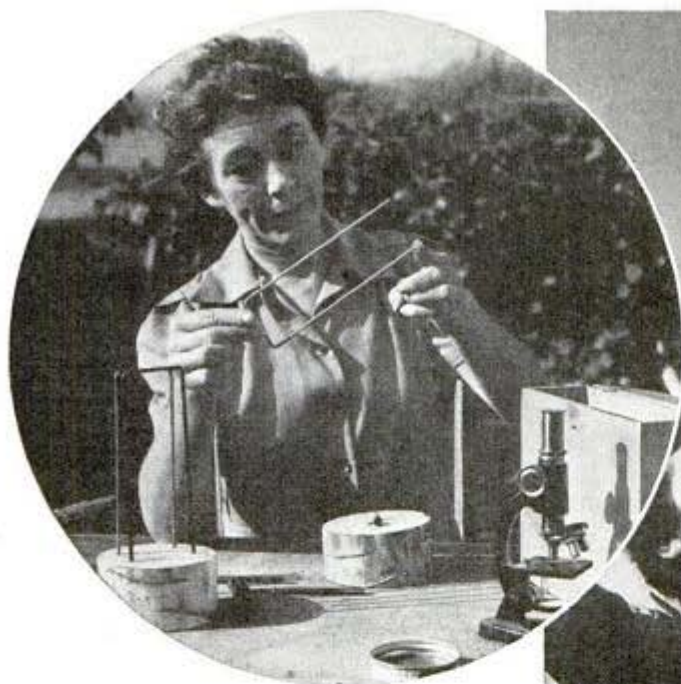

The living room of Mrs. Nan Songer's home in Yucaipa, Calif., is a spider farm. Harvesting spider silk is her business, an essential one for national defense as the silk is used for cross hairs in aiming devices of bomb sights and telescopic rifle sights. Above, she reels silk from a spider "anchored" to a section of yucca plant by a hair-pin. Twelve frames hold 100 feet of silk



Spiders are kept in glass jars (above), fed live or freshly killed flies, gnats, etc.; fast two days before being silked. Yielding 100 feet in an hour, which brings \$10, the spider is then rested two days, released after 5 "silking." Silk-wound steel frames are shipped to manufacturers in boxes (below)

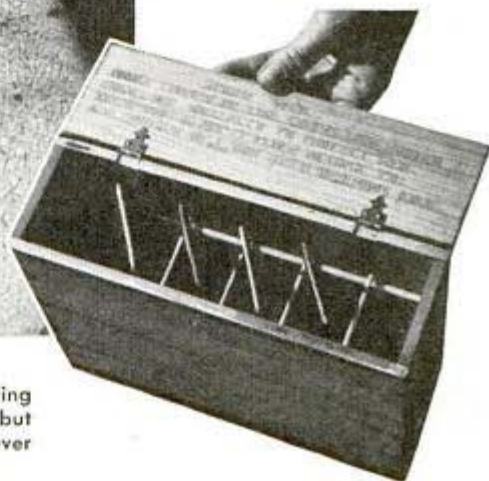

Black Widow spiders produce stronger silk used in surveying sights. Above, Mrs. Songer grips Black Widow's leg lightly but firmly with tweezers, prepares to reel out silk. She has never been bitten. The "work table" is pithy section of yucca

21279. *Emb. Mel Wharton*
1144 S. Grand Ave.
Los Angeles

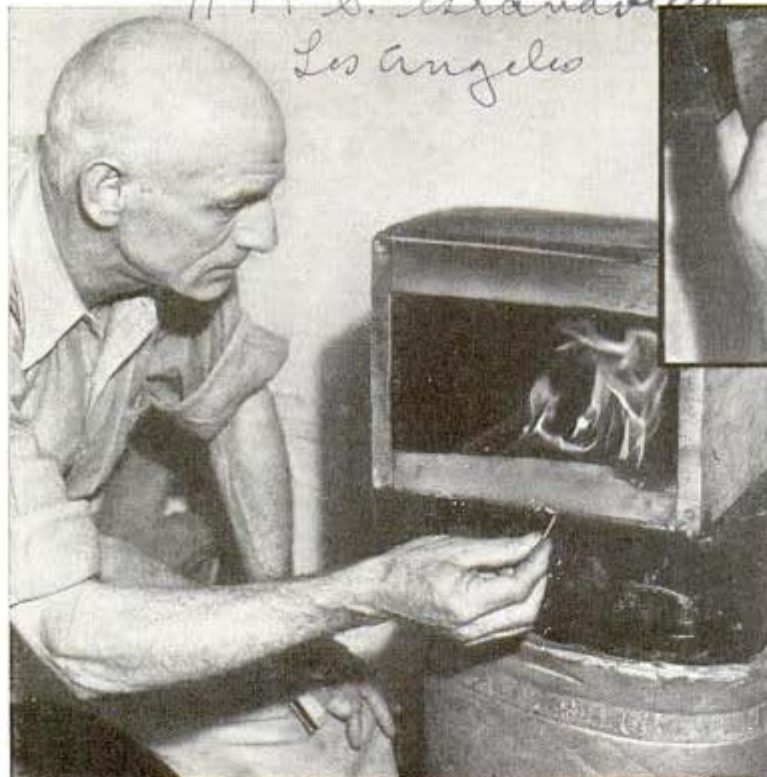

Three kinds of rubber made from milkweed are used in three layers of self-sealing aircraft fuel tank

This rubber tank, left, is still resilient after 500 fires inside it

Below, 18-pound milkweed; plants average five pounds each and produce 18 to 28 tons per acre

RUBBER *from* MILKWEED

AFTER five years of tests, an American scientist has developed from common milkweed a high-protein rubber which will not burn or melt, nor decompose in gasoline, yet will vulcanize on contact with gasoline or alcohol.

Milkweed can be harvested nine months after planting. This is in contrast with the average 15-year wait for trees to mature, as with para rubber, the only other important source of natural rubber. It is claimed that extensive planting could make the United States independent of foreign sources in two years!

The inventor is William A. Sharpe, chemist and mining engineer of Alhambra, Calif., with more than 400 inventions to his credit, including a radial gasoline engine, a submarine detector, and numerous airplane designs and accessories.

The milkweed rubber has undergone tests recently at the Douglas Aircraft plant. The rubber is jet black, odorless and tough as shoe leather. In a small section resembling an airplane's fuel tank, the inventor has built more than 500 gasoline fires, and the rubber is said to be as pliable today as before the flame tests. Countless bullets were fired through 3-layer tanks filled with gasoline, yet not a drop of gas was spilled. Only the framework of the new tanks is metal. The



no other address

21299

covering is entirely rubber, saving nearly a pound for each square foot of surface. The inner layer of tank rubber is gasoline-resistant. The center core is soft rubber which vulcanizes the instant fuel touches it, while the outer layer resembles an automobile inner tube and is reinforced by nickel alloy wire mesh.

To prevent explosions from static electricity the small amount of metal in the tanks is grounded to metal in the plane's structure. The electricity is fed back into the atmosphere by wires trailing from the wings.

Burlap sprayed with one form of the new rubber will not burn. Several chunks, immersed for a full year in gasoline, retain their elasticity and perform almost like newly rolled strips.

Milkweed grows rank and naturally throughout much of the nation. Cultivation would, it is believed, produce enough rubber in two years to furnish all domestic

(Continued to page 163)

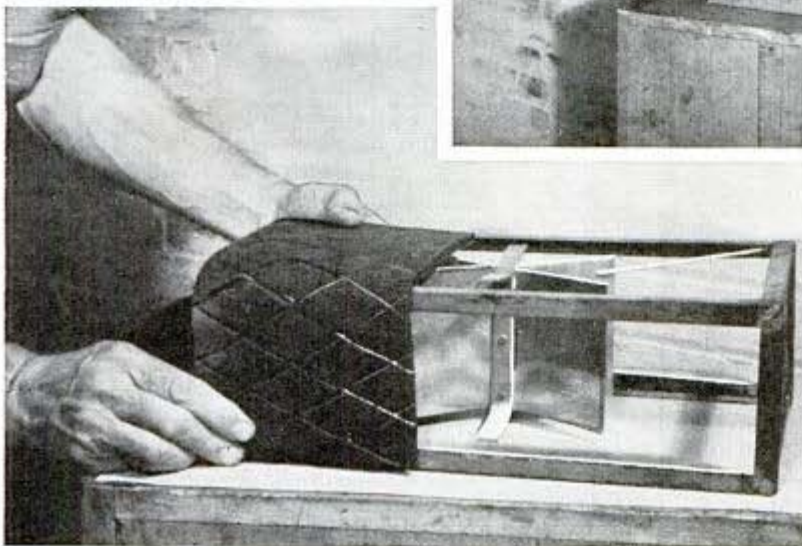
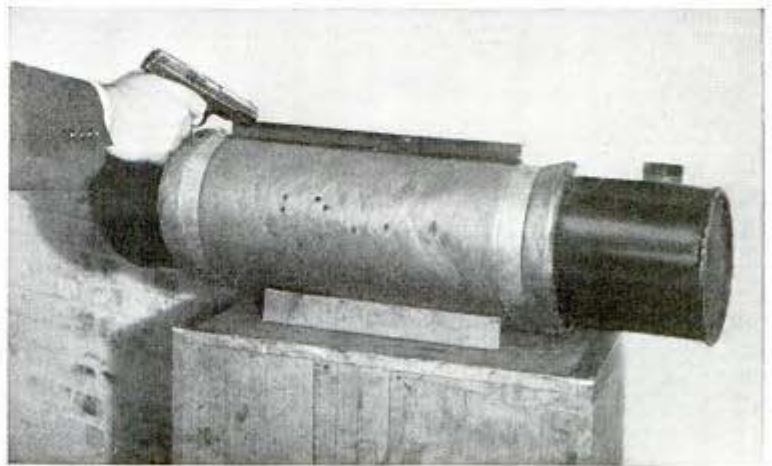
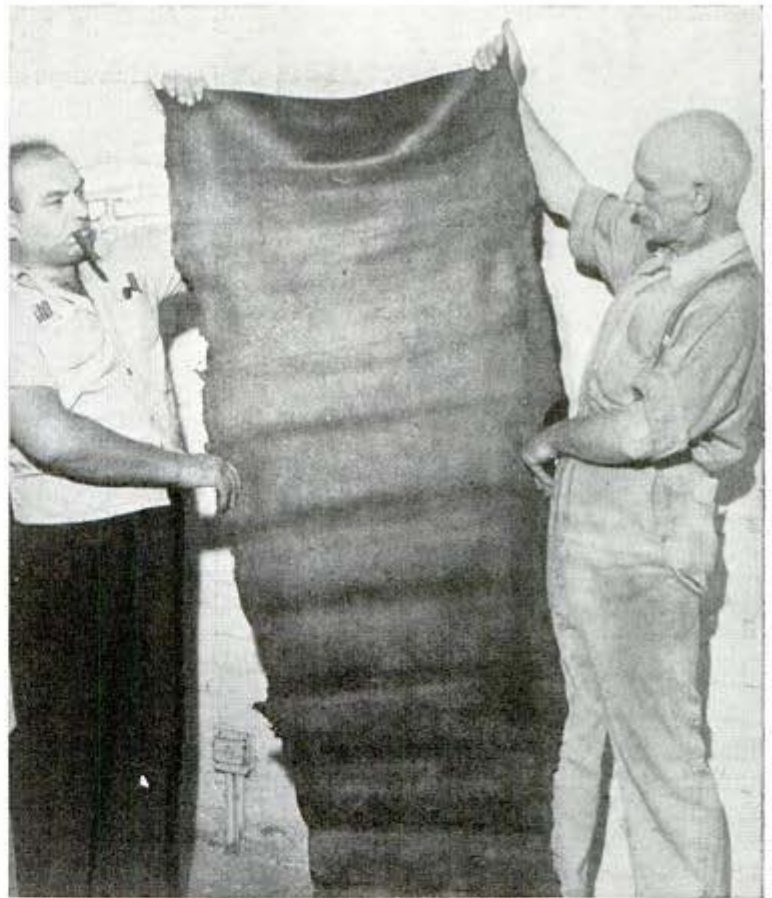

At top, a 7-foot strip of pure milkweed rubber, which was rolled into shape like ordinary para rubber. William A. Sharpe, inventor, at right

Half a dozen holes were blown through the rubber-coated gasoline tank above, yet not a drop escaped. The six bullet holes in rubber wall are plainly seen

Left, model of an airplane fuel tank showing how milkweed rubber is used in place of the usual metal sides. Using only a metal frame saves weight

21229

Mirror in Hood of Carriage Keeps Baby Amused



Baby enjoys own reflection while mother is absent

To keep the baby from crying when mother must leave him alone, a mirror attachment for the carriage provides amusement by letting the baby watch his own reflection. The mirror is built into the hood and swings down in front of the infant.

2968

Electric Outlets Easily Added With Baseboard Conduit

Electrical outlets and telephone connections in the walls may be added easily anywhere in a house furnished with a wire-

4320 Osage Ave.

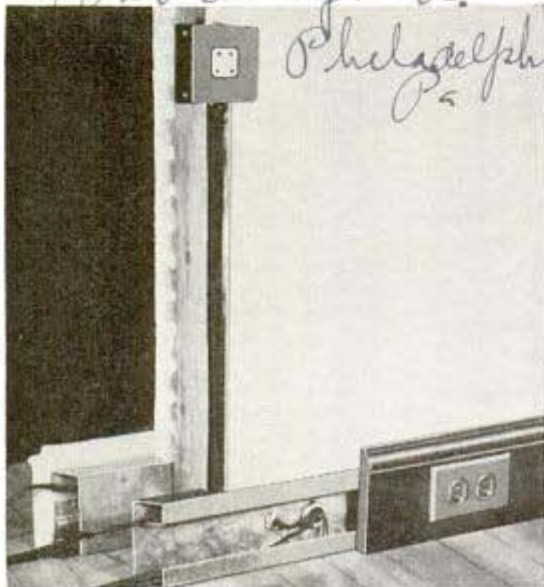

Baseboard slides off and on wire conduit set in wall

carrying conduit base now available. All the wiring is concealed by the baseboard which slips off quickly whenever you want to get at the wires. It offers an additional convenience when refinishing or repainting the walls, floor or baseboard, as the board may be removed to avoid smearing paint where it is not wanted.

21152

Scissors Blade Ruled in Inches Aids Precision Cutting

Cutting to exact measure is simplified with scissors marked with a seven-inch rule on one blade. Dressmakers, tailors,

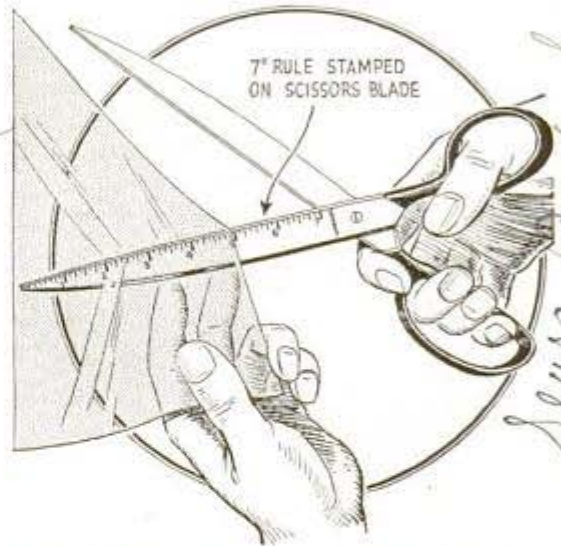

Scissors marked with 7-inch rule save time and work

artists, photographers and paperhangers may use these ruled scissors for quick precision cutting without the preliminary measuring with tape or ruler.

21275

Twin Windshield for Air Liner Eliminates Window Icing

After testing windshield wipers, fluids and application of heat to the inside surface, United Air Lines have adopted a double windshield for use on their Mainliners to prevent ice from forming and blocking forward vision. There are two panes, the front one being of quarter-inch safety plate glass and the rear of eighth-inch transparent plastic. These are mounted with a quarter-inch air space between them. Air heated to 175 degrees is passed through the air space. The air, moving at the rate of 60 cubic feet per minute, can be controlled through a valve at the captain's elbow.

Chicago
State Street

Charles E. Barnes & Son.

21218

Versatile Thresher Promotes Seed Growing

Soil conservation by owners of small farms is encouraged by a small, low-cost, portable threshing machine that makes it possible to produce economically home-grown legume seeds and small grains to meet the increasing need for livestock feed. The machine was developed by the Tennessee Valley Authority in cooperation with state agricultural agencies in the south. Having about half the capacity of large machines in common use, the thresher may be used on crops from small acreages and is adjustable for hilly and rough ground. In one hour it will thresh 50 to 90 bushels of oats, 25 to 50 bushels of wheat, 10 to 20 bushels of lespe-deza, or one-half to two bushels of other cloverseed. Flax and buckwheat also have been threshed satisfactorily. Roots and rocks will not injure the mechanism. The cylinder is of hammer-mill type construction, containing 243 swing bars spaced close enough to do effective threshing. For small grains, clovers and grasses the cylinder



Low-cost thresher being operated in hilly country for which it was designed. After grain has been brought in, three men can do all the work

speed is about 1,200 revolutions per minute. Either a seven-horsepower gasoline engine or a five-horsepower electric motor will run it. The thresher consumes about five gallons of fuel in a ten-hour day, and requires only three men for its operation after the grain or hay has been cut and brought in. This means that a single family or a few men from adjoining farms can handle the thresher, as against a crew of eight to 20 needed for larger machines.

speed is about 1,200 revolutions per minute. Either a seven-horsepower gasoline engine or a five-horsepower electric motor will run it. The thresher consumes about five gallons of fuel in a ten-hour day, and requires only three men for its operation after the grain or hay has been cut and brought in. This means that a single family or a few men from adjoining farms can handle the thresher, as against a crew of eight to 20 needed for larger machines.

Morgan mfg. Co. e. Calverville, Mo.

21078

Hospital for Modern Warfare Designed to Follow Army

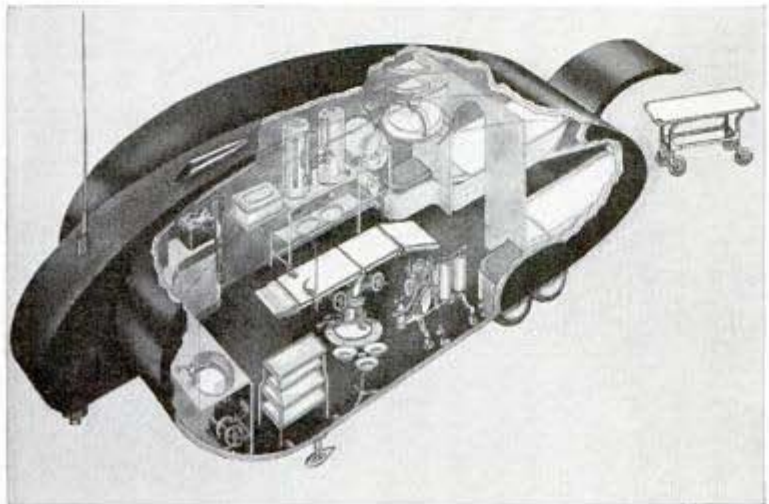

Artist's sketch of proposed mobile hospital unit shows spacious interior wherein could be carried equipment necessary to perform major operations

To provide hospitalization facilities for casualties among advance troops, a complete hospital unit within a trailer has been proposed which can be towed easily behind a truck or armored car. The trailer would be air conditioned and gas-proof, having its own two-way radio, water supply, and a gasoline-driven motor generator to operate lights and provide heat for the sterilizer. The unit would permit making major operations in the field.

Los Angeles, Calif.

MARCH, 1942

*Byrtcher Corp 5087
Huntington, W. Va., North*

2970. Comb. Thomas G. Stinson, Jr.
3872 Franklin Ave

THROWING LIGHT on the Los Angeles

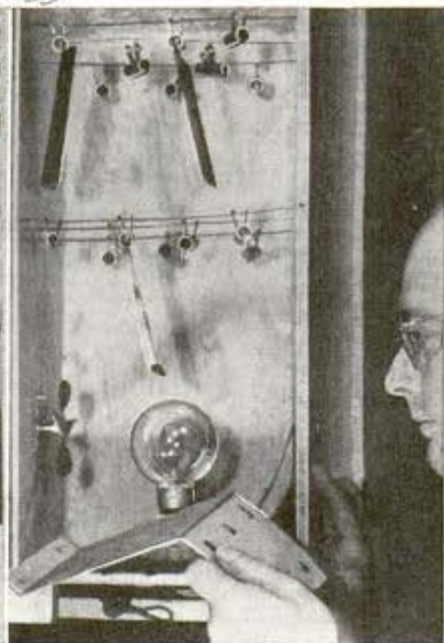
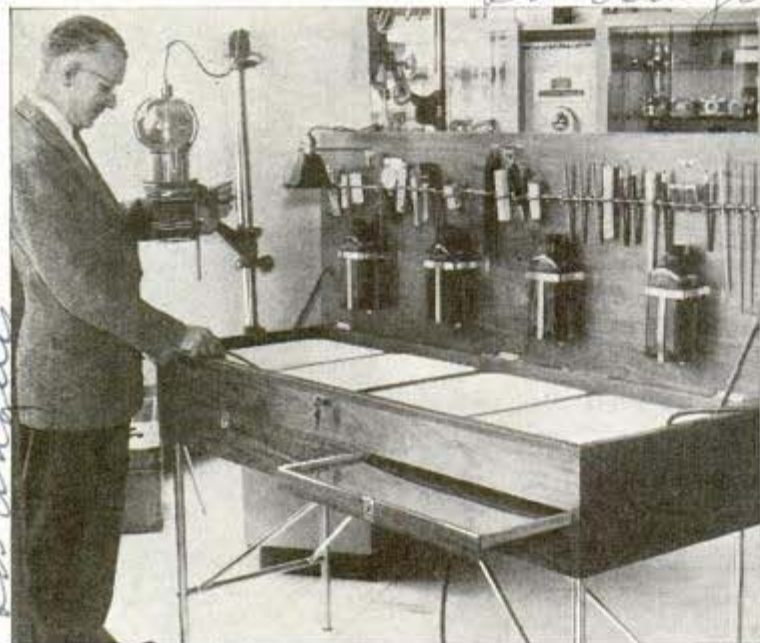

Here is an entire darkroom outfit built into a cabinet, the top of which folds down to form a table when laboratory work is finished. The sink is sprayed with an acid-resistant rubber compound

Negatives held by clips are dried by the heat of an infrared lamp in this cabinet drier; notice the tiny fan

Entrance maze, painted black inside, that admits air but not light into darkroom



Exterior of darkroom wall



Cross section of light trap, painted black inside, that prevents light from leaking into darkroom through forced-ventilation opening

YOU will enjoy photography more when you do your own developing, printing, and enlarging, for which you should have a permanent darkroom. A six-by-six closet, or space in the garage or basement is satisfactory if you can make it light-tight and connect running water to it.

You should exclude all light, and you need ventilation for comfort. Some photographers use an open entrance maze instead of a door, to stop light yet permit air to circulate. This entry is a passage that has two 180-degree turns. Paint the walls, floor, and ceiling of the maze with flat non-reflecting black paint.

In hot weather you may need forced ventilation, with a hole in the wall or ceiling

Timer operated by vacuum tube turns enlarger lamp off at correct time for making duplicate prints



Ref.: L. V. Sawyer, 5429 Wilkes Ave Los Angeles

DARKROOM

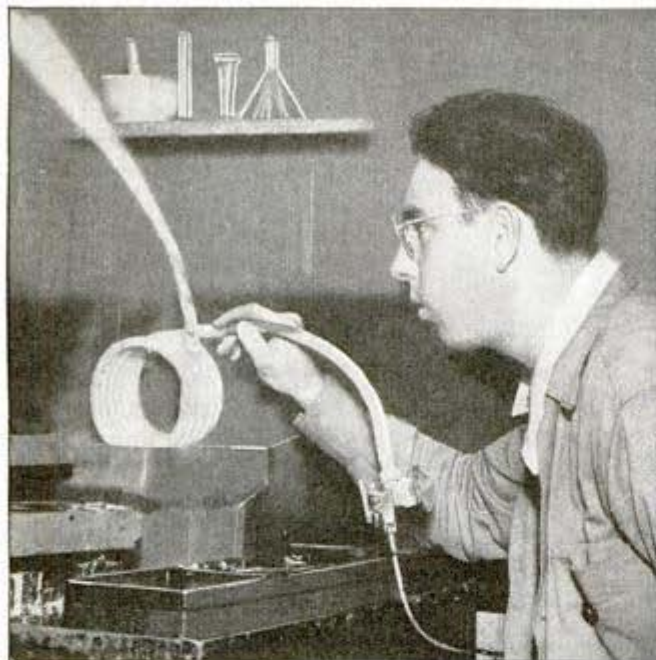

↑
Carbon-dioxide gas exhausting through coil speedily cools photo solution to right temperature



Homemade spotlight has a built-in fan to keep the powerful bulb cool and thus prolong its life

↑
Enlarger is mounted handily on stand, with plenty of room for photographer to walk around

large enough to take an electric fan at least 10 inches in diameter. The fan opening, of course, should be protected by a light trap maze that has two 180-degree turns, with all interior surfaces painted black.

Photographers once painted the interiors of darkrooms black but modern practice is to make the walls and ceilings light. Such reflecting surfaces give better visibility under safelights and since no light is stronger than its source there is no danger that the reflected light will be harmful. Use a light tint such as seafoam green and finish with a glossy coat that is easy to clean.

Arrange your shelves and working spaces according to the space available and the equipment you are going to use. It usually works out best to place a large sink, that you may get second hand, in the center of a working table that



2770



Four 100-watt bulbs inside this homemade print drier provide heat; canvas holds drying tin in place against curved metal top. Below, a film drier is sketched

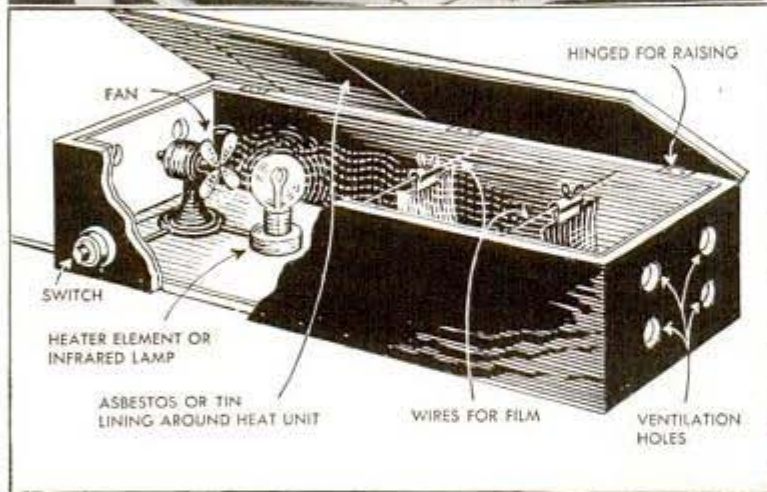

and fixing trays one above the other in a rack, each tray staggered five inches forward of the one above.

Plan your electric wiring in advance, with a safelight reflecting against the ceiling for general illumination except when developing negatives, a white light that you can switch on and off by pulling a cord stretched overhead across the room, and a photographic safelight illuminating the area at which you will develop prints. If you use one of the new plastic safelights, shield it with cardboard to keep the light out of your eyes. A shielded 7½-watt bulb in a night-light base

Metal fingers keep paper holder in position on easel board used with horizontal enlarger



should be at least two feet wide and drain toward the sink from each end. Cover the table top with several coats of black acid- and water-resisting preservative paint. A good grade of linoleum thoroughly rubbed with wax also makes a good surface. If other plumbing facilities aren't available you may run a 3/8-in. copper-tube pipe from the nearest water outlet to an ordinary faucet over your sink. A satisfactory drain from the sink consists of a length of garden hose, led outside the house, to a cesspool made by digging a six-foot hole and filling it with rocks and boulders.

You need plenty of shelf space. The shelves should be reserved for papers, dry chemicals and supplies, with storage space on the floor or under the sink for bottles of solutions. If you need to save space you may mount your developing, short stop,

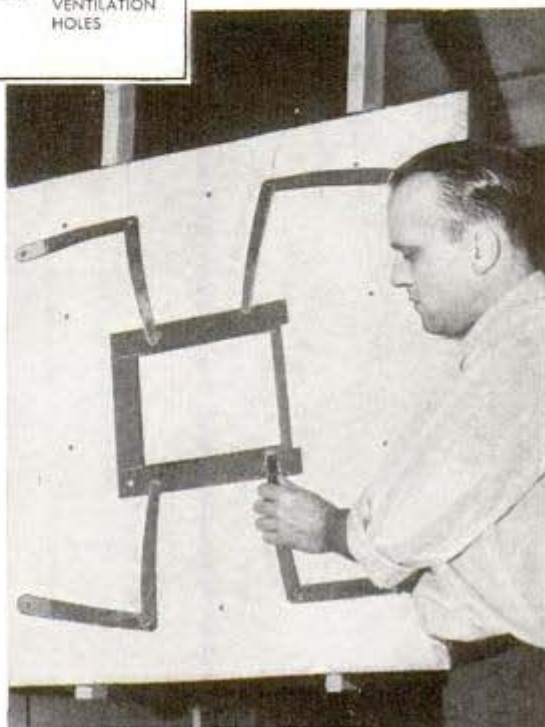

2770

makes good indirect illumination for the photo timer, which may consist of an old alarm clock.

Many pieces of needed darkroom equipment seem expensive and you can save money by buying tongs, trays, camel-hair brushes, and so forth at the five and ten cent store. Use an inexpensive window squeegee instead of a rubber roller for removing excess water from tinned prints.

Most amateur enlarging machines are mounted vertically. If you have space and if your machine can be turned on its side you may wish to mount it horizontally. The advantage is that you won't have to stoop for focusing. For horizontal projection it is best to mount the easel board on an overhead track so that it can be pushed as far away from the enlarger as desired. To avoid using one of the bulky lamp houses you may attach one of the new flat lightweight mercury argon light packs to the enlarger.

If the focal length of your enlarging lens is too long to "blow up" negatives to the size you desire, place one of the new portrait lens attachments over it. These inexpensive auxiliary lenses are made for taking close-ups with ordinary cameras, but they serve as well for enlarging.

Instead of the usual easel for holding paper flat while enlarging, try a new type that has a tacky surface to which the paper adheres. This paper holder consists of an open box slightly larger than the paper size you use. The bottom should be of plywood, with a quarter-inch-high rim around it. Slowly pour into the box enough heated hectograph compound to fill it. This is a sort of gelatin, obtainable at stationery stores. The compound when dry has a pliable and slightly sticky surface. It holds the paper flat and the paper peels off easily. Make sure the box is level, when pouring the compound, to obtain a level surface. The material may be dug out of the box, re-heated, and poured back again to renew its tacky surface after much use.

You can build your own enlarger, negative viewer, and other equipment. You should have a negative drier and a print drier. An infrared lamp mounted in front of a fan, in a box eight by eight inches in cross section and four or five feet long, makes a good negative drying outfit. Provide large ventilation holes in each end and protect the wood near the lamp with tin or

(Continued to page 162)

21159

Extension for Coal Heater Changes It to Oil Burner

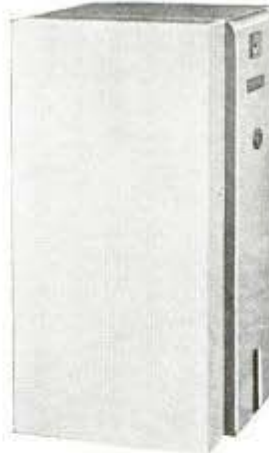

Extension unit converts coal heater into oil burner

Shortage of oil or higher prices will not worry owners of a home heating combination that can be converted readily for burning either coal or oil. Designed primarily to burn coal, the unit is provided with the usual jacket. The oil burner is purchased separately at nominal cost, and operates as an extension to the coal unit. The extension is easy to move and makes the oil burner accessible for servicing.

Miniature Jungle in Large Bottle Consists of Growing Plants

Tiny plants which give the appearance of a dense, though miniature, forest are grown in a large bottle, now on the market. Included in the bottled forest are simulated logs, a wood nymph and creeping Ficus Repens. Chinese evergreen and partridge berries also grow in the miniature jungle, which needs little care other than occasional watering. The special spun-glass bottle, capped with a cork that fits over the mouth, prevents injury to the plants from excessive light.



*Burrham Boiler Corp.
Washington, D.C.*

21263

*Stanley Hanson 95
1602 South East
Columbia, S.C.*

21259

Coat Steamed and Reshaped By Pressing Form



Fin-type heater dries coat after it is pressed

Without the use of an iron, a metal bust frame, adjustable to fit all sizes of coats, may be used for pressing and reshaping a coat in one operation. The coat is slipped on the form and fastened by means of a clamp. Then pressure on a pedal releases steam from within, restoring the garment's shape and taking out all wrinkles. Warm air from a built-in fin-type heater quickly dries the coat after pressing has been completed. The manufacturer says the presser does not produce a shine on fabrics such as serge and gabardine.

21090

Changes in Our Living Foreseen As Result of Advances

Influenced by many industrial and scientific developments already in progress, human living as we know it can hardly escape radical changes during the next few decades, in the view of Dr. Robert A. Millikan, eminent physicist at California Institute of Technology. For instance, the advance of aeronautics for war purposes will react tremendously on transportation in years succeeding the war. Industry will be modified by new metallic alloys that combine the maximum of lightness and strength. Plastics with nonscratchable surfaces will reach directly into our do-

*Christian Science
month. Sept. '27*

mestic life. Advances being made in short wave radio and in travel of radio waves through cylindrical conductors will expand communications in new directions. Health and physical well being will benefit from improved means of sterilization of drinking water, new knowledge of vitamins and their use in the fortification of foods, increased knowledge of drugs and so-called natural products gained through micro-organic biochemistry, and results of studies in immunology. Agriculture already is being revolutionized by better understanding of the mechanics of soil erosion and transport of sediments through dams. Long-range weather forecasting is having great effects on the handling of power stations, agriculture and military operations, although the science of meteorology is still in its infancy.

Soldering Iron With Pivot Head Works in Any Position

Its head pivoting so it can be adjusted to operate at any position through a 90-degree arc, a handy soldering tool is equipped with a handle comfortable to hold at all working angles. A button on the handle controls the iron for fast or slow heating.

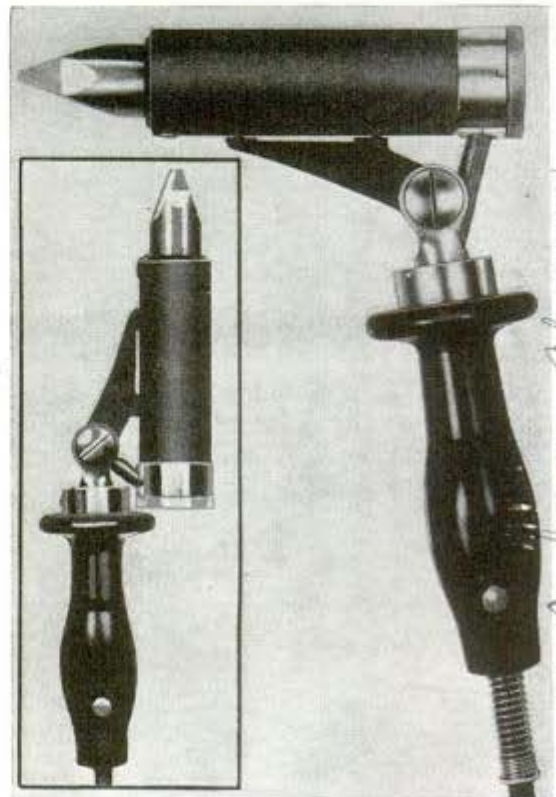

Here are two possible settings of soldering iron

*The Kintley, Meehan,
Kaufman Co.*

*U. S. Hoffman Machinery Corp.
105 South Ave.
Chicago*

*Chairman Council
Executive Council*

626 W. Jackson, Chicago



The CRAFTSMAN

"Baby-Grand" KNEEHOLE DESK has built-in chair

NO LONGER will you have to seek your pet chair when working at a desk if you build this streamlined one, which not only contains a chair, but six book niches, and four generous drawers as well. Constructed in units, then sided and topped in prefabricated fashion, it is quite simple to build. Figs. 1 and 3 show the construction of the book-niche units while Fig. 2 shows how they fit into the desk. The three shelves, top brace and sides are first nailed together after which the 1/4-in.

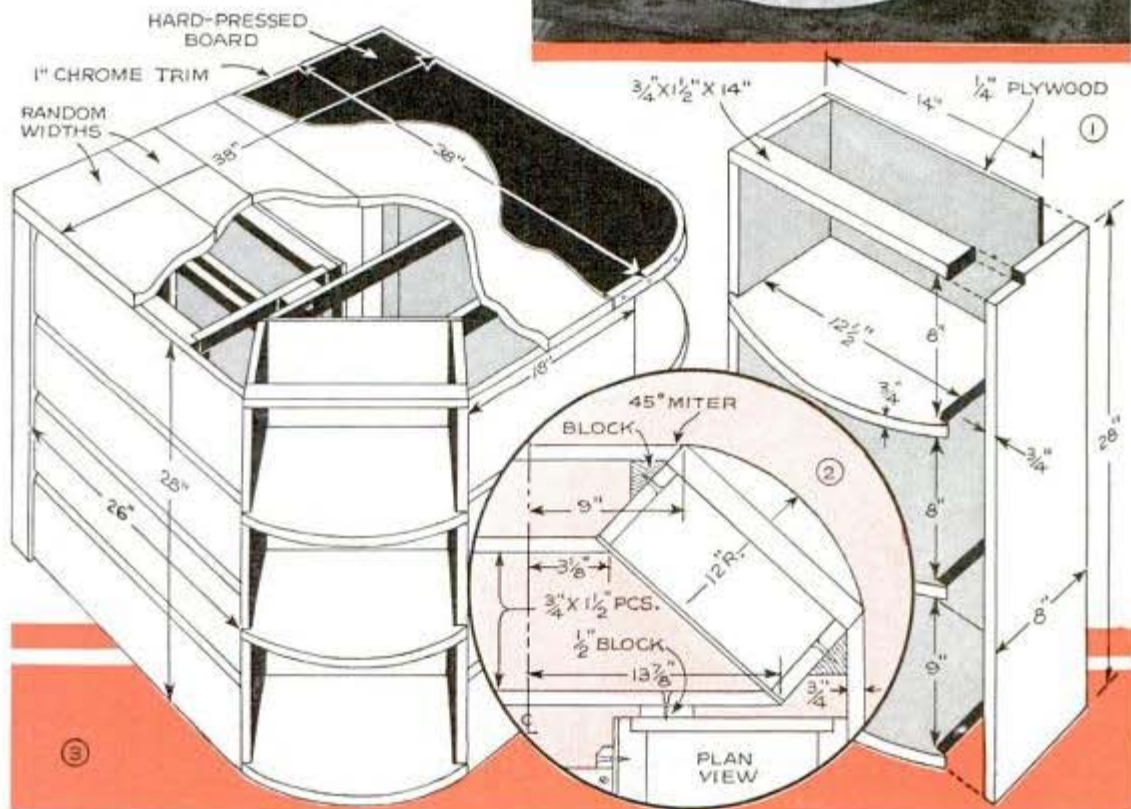

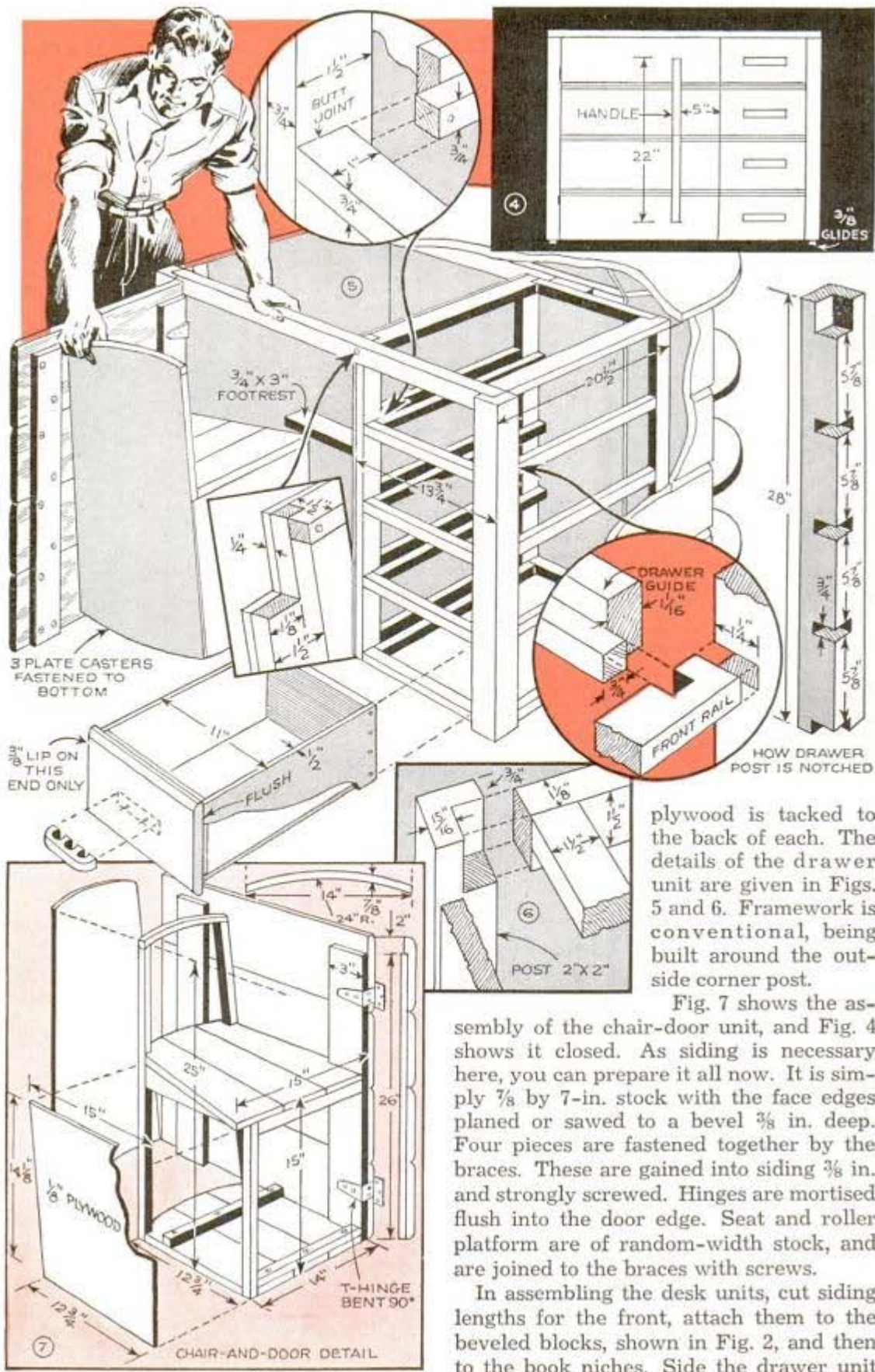

plywood is tacked to the back of each. The details of the drawer unit are given in Figs. 5 and 6. Framework is conventional, being built around the outside corner post.

Fig. 7 shows the assembly of the chair-door unit, and Fig. 4 shows it closed. As siding is necessary here, you can prepare it all now. It is simply $\frac{7}{8}$ by 7-in. stock with the face edges planed or sawed to a bevel $\frac{3}{8}$ in. deep. Four pieces are fastened together by the braces. These are gained into siding $\frac{3}{8}$ in. and strongly screwed. Hinges are mortised flush into the door edge. Seat and roller platform are of random-width stock, and are joined to the braces with screws.

In assembling the desk units, cut siding lengths for the front, attach them to the beveled blocks, shown in Fig. 2, and then to the book niches. Side the drawer unit

next. Then place the back brace in the post mortises, screw a cleat to the door post and place the other siding. Next attach the chair casters and, placing the chair door in its open position, mark intersection of hinges on the door post. Now start at one side of the top and lay $\frac{7}{8}$ -in. sheathing on it, screwing the sheathing to all braces and posts. Hard-pressed board is laid into mastic, and then the chromium trim is applied.

A slightly contrasting color in the V bevels, book niches, seat compartment, and drawers add a lot to the sleek streamlined appearance of this project. A natural wood top could be used if preferred, and by increasing the thicknesses of the fastening battens, the new hardwood veneer in panels could be placed on the sides.

Easy Way to Hold Waste Material When Cutting Floor Opening

Difficulty of preventing waste material from dropping down a wall or between floors when cutting openings in them, can be avoided by using an auger or doorstop of the types shown. Screwed into the waste material after the opening has been cut out partially, the auger or doorstop serves as a handle. Also, such a handle enables the workman to keep the material from binding the saw.

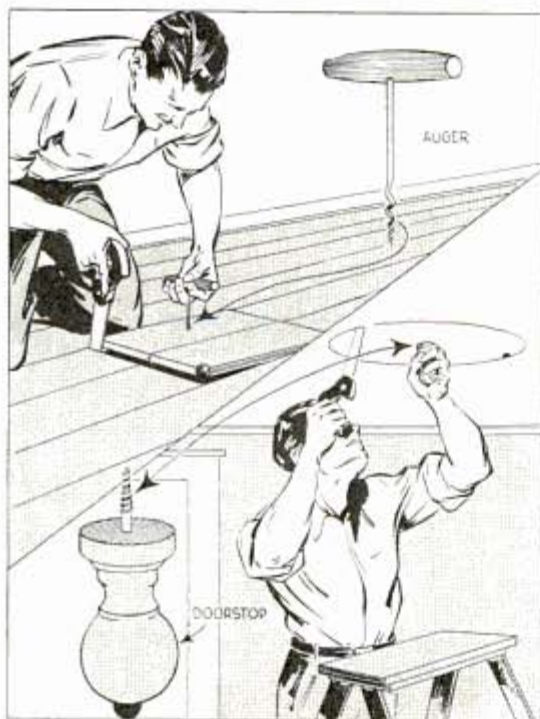

Handle on Downspout Funnel Permits Removal for Cleaning

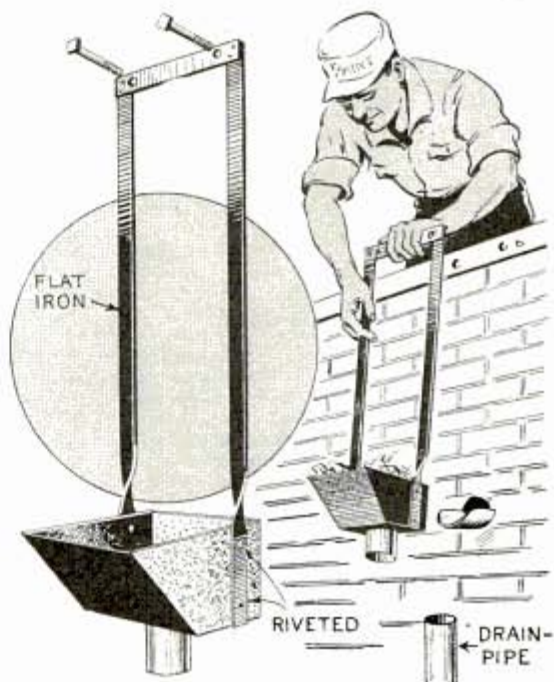

On buildings that have walls extending above the roofs, cleaning of the trash screens above the downspouts can be simplified if handles are provided for the metal funnels or receptacles at the upper ends of the spouts. Handles can be shaped from flat iron, and they can be bolted to the wall to hold the funnels in place and prevent their dislodgement by high winds.

—Andrew Vena, New York.

Ellipse Made Easily With Dividers And a Length of String

Instead of using a couple of pins and a string in drawing an ellipse, try your dividers. They are much easier than trying to push pins into a board or table top under the paper. Slip a couple of fuller balls over the legs of the dividers so that the points project slightly. The fuller balls will keep the string from slipping up too high on the legs as the pencil is moved.

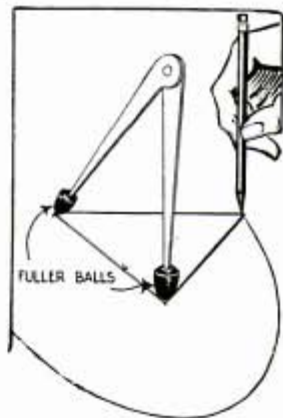

Solving HOME



1—Wagon-wheel rims provide good frames to weave round rag rugs. Two sets of crossing strips are tied to the rim. After weaving center, space strips on rim and insert extra ones as needed while weaving

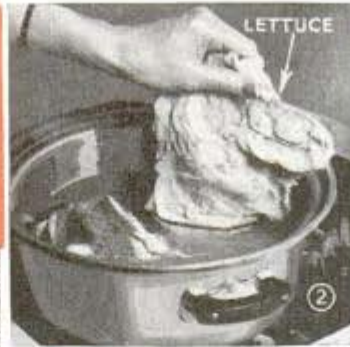

2—With a lettuce leaf, you can remove those last elusive drops of fat from a kettle of vegetable soup in a jiffy. Just hold the leaf as shown and the fat will stick to it. 3—Rust marks on sink drainboards caused by a scouring-powder can, may be prevented by dipping the bottom of the can in hot paraffin. One coat usually will protect the bottom from moisture until the can is empty

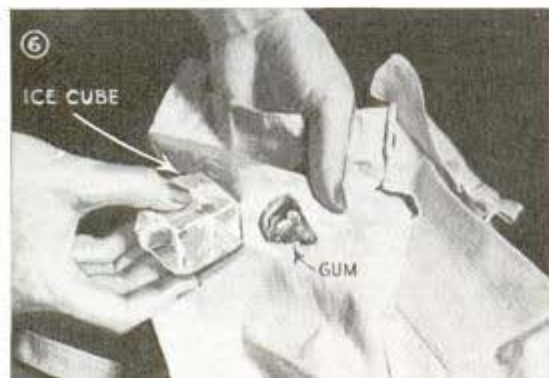

4—Liquid wax can be spread quickly over a floor by using an ordinary clothes sprinkler of the type shown, which may be purchased in most 10c stores. 5—Fastened to a piece of plywood, a cloth shoe holder is removed easily from a dark closet or wall, and as the entire edge is tacked, it will keep its shape even when completely filled. A rope handle fitted on the upper edge of the plywood panel will be found handy where considerable moving is done. 6—Chewing gum usually can be removed from cloth garments by rubbing the gum with a piece of ice. Often this method is superior to strong cleaning solutions as it does not leave spots on the material

PROBLEMS



7—As corks used in insulated bottles quickly absorb odors from the contents of the bottles, it's a good idea to wrap a piece of clean Cellophane around each cork before inserting it. This will prevent moisture from entering and keep the cork free from odors. 8—One of the simplest ways to wind a roller-spring of a window shade is to insert the flattened end in a keyhole, so that both hands will be left free to grip the roller and turn it until tight



9—If you have kitchen chairs with tubular steel legs that grind dirt into the linoleum, drill and tap the legs for glides of the machine-screw type. They make the chair easy to move and prevent floor scratches



10—Quilting patterns are transferred quickly to a number of blocks with a sewing machine. Just stack and pin several blocks under a master pattern and sew around the outline without thread in the machine. Easy-to-follow perforations will be made on each block. 11—By attaching an extra mirror on the back side of a medicine-cabinet door, you can have access to the shelves while shaving, without opening and closing the door. Four flat-iron brackets fitted with rubber cushions hold the mirror in place. 12—Instead of throwing away a celluloid powder-puff container, you can use it for a string dispenser after punching a hole in the lid



Simple Hand Press for Lapidaries Splits Stones With Ease



Splitting of stones by amateur lapidaries is made easy by use of two sturdy chisels mounted in parallel pieces of steel and driven together under pressure applied by winged nuts working on threaded bolts. The chisels should be of good quality steel and they should be much thinner than the ordinary cold chisel. The bolt threads should be 8 to 10 to the inch. Also, care should be taken to set the cutting edges of the chisels exactly opposite each other.

—Floyd McCracken, San Diego, Calif.

Improving the Hasp of a Padlock

When a hasp of the type shown is used with a padlock, any sagging of the door or settling of the frame will throw the parts out of alignment so that the lock cannot be inserted. If one part of the hasp is removed from the door, and the bolt hole

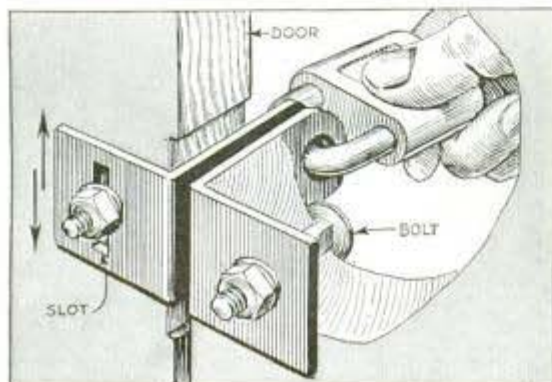

made into a slot, as indicated in the drawing, the part can then be raised or lowered to align with the other one.

Modelmaker's Anvil From Solder

The customary piece of bar solder used by modelmakers as a punching anvil, may be prevented from sliding about or tipping and spoiling a piece of work, by soldering a spring-wire clamp to the underside of the bar. This permits the anvil to be clamped to the edge of the bench.

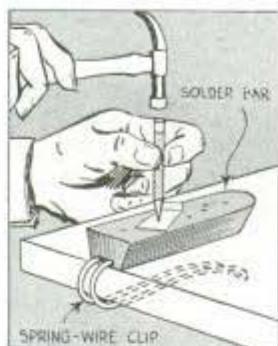

Test Tube Used as Balance Scale

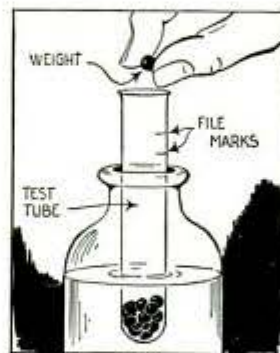

The bottle should be filled to a certain depth each time it is used, the tube should be graduated with known weights, using a file to mark the glass.

Cellulose Tape Holds Small Parts While Glue Is Drying

The next time you have to glue a small broken piece back on a chair leg or other piece of furniture, try strips of cellulose tape for holding the parts together until the glue dries. The tape is easy to remove and does not mar the wood surface.



Sheet asbestos, covered with oilcloth, makes an ideal pad for the top of your stove, which then can be used as a table.

CRICKET FOOTSTOOL

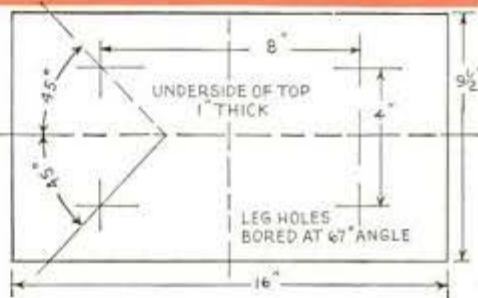
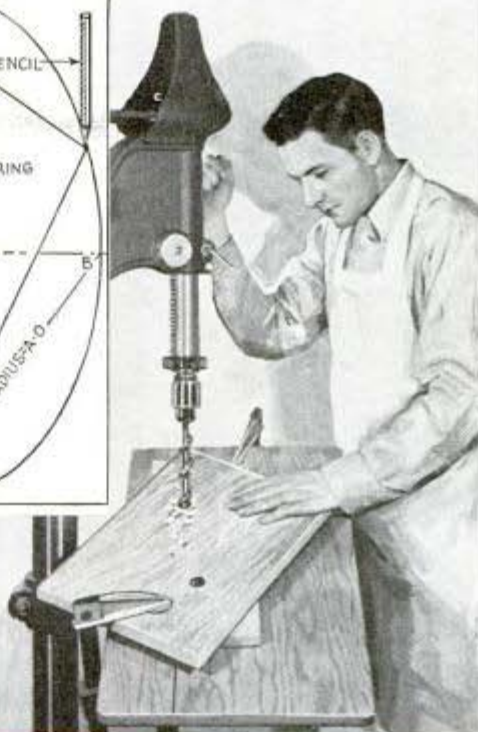
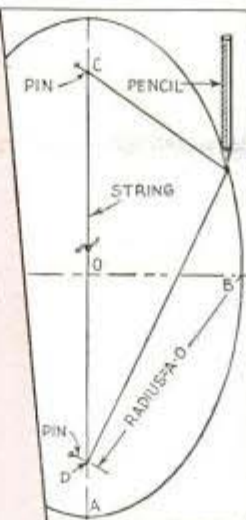
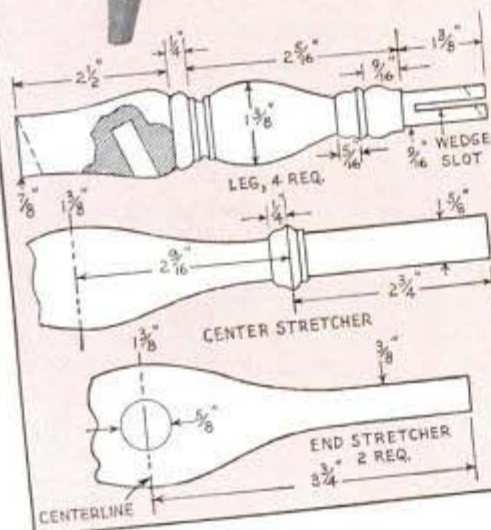
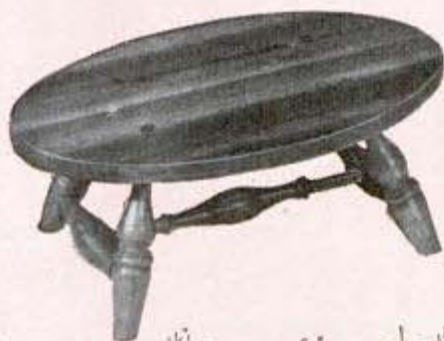

MADE of wood to match your favorite chair, this footstool is just the thing to set off your period furnishings. Construction is simple if care is taken. First, saw out the blanks for the legs and stretchers, and drill the holes in the leg blanks for the stretchers before turning them. Templates will aid in duplicating these parts. Next is the stool top, which is an ellipse. There are several ways of laying out this, one of the simplest being to use a string and two pins as shown in the upper center detail. Two lines are drawn to intersect at their centers, and then positions A and B are located, using radii equal to one half the length and one half the width respectively of the intended ellipse. Then, with a compass set to a radius equal to the distance between A and O, which in this case is 8 in. as the stool top is 9½ by 16 in., positions C and D are located by striking arcs from position B. Pins are put at these

points to take the string, which should be taut when a pencil is placed against it with the point set on position B. The ellipse is drawn by running the pencil around inside the string, keeping it taut at all times. After sawing out the top, holes for the legs are laid out as shown in the lower detail and drilled. The leg tenons are slotted for wedges, after which the stool is assembled with glue, wedges being driven into the leg slots for a tight fit. If the work has been done carefully, clamps will be unnecessary to hold the assembly while the glue dries. After a final sanding with fine abrasive paper, the stool is ready for finishing. This should be done to match the chair at which the stool is to be used.

—Wallace W. Buffmire, Evanston, Ill.

⚠ Gas flames should be turned down when foods begin to boil, as nothing is gained by rapid boiling, and much gas is wasted.

Pocket Separator Between Watch And Handkerchief

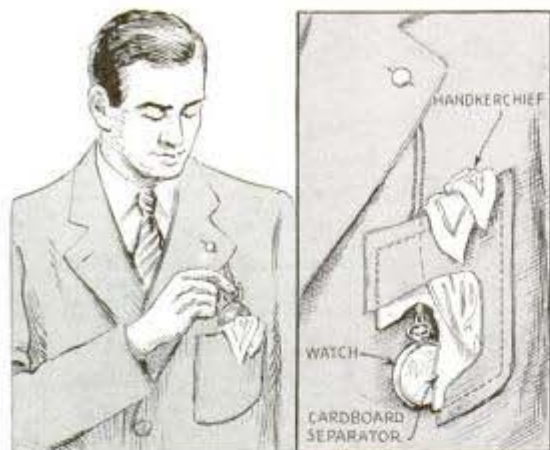

If you carry both a watch and a handkerchief in your lapel pocket, a cardboard separator in the pocket between them will enable you to pull out the watch without disturbing the handkerchief. The cardboard is cut to pocket size and short enough so that it cannot be seen.

Opening of Both Cellar Doors Avoided in This Entrance

By making one of the outside cellar doors wider than the other, one home owner made it unnecessary to open both of them



when carrying ordinary articles in or out of the cellar. However, the full width of the cellar entrance is available whenever needed by opening the smaller door.

—A. R. Hazard, Kane, Pa.

Do not set your shrubs too close together just to get an immediate effect. You should consider the size and height the plants will attain at maturity.

Remember These Points When Glazing Sash

Even in such an easy job as glazing a sash, simple but important details of correct procedure are often overlooked. The first thing that comes up is the condition of the sash frame. If it has weathered for some time and most, or all, of the putty has fallen out, look the frame over carefully for rotted wood, loose joints, and splintered or warped muntins, the latter in a multiple-pane sash. Remove the glass, clean away loose putty, tighten up the frame with bar clamps and secure the loose corners with $\frac{1}{4}$ -in. dowels. These are driven in holes bored at right angles through the tenoned joints. Repair splintered or rotted muntins by cutting away all the old wood to the bottom of the rabbets and putting in strips of white pine as in Figs. 1 and 2. Give the frame a priming coat of paint. Putty will not bond to the bare wood. If the pane, new or old, fits tightly, score it $\frac{1}{16}$ in. or so from the edges with a glass cutter and chip away the waste. The reason for this loose fit is important, as shown in the cross-section, Fig. 5. Note that the putty has been forced in between the edges of the glass and the sides of the rabbet, forming a strong bond and a waterproof joint. After the paint on the frame is thoroughly dry, replace the glass and secure each pane with glaziers' points placed as in Fig. 3. Whether you use a common putty or the new nonhardening putty it should be well worked or kneaded in the palm of the hand, Fig. 4, before being used. In puttying, start as in Fig. 6 by filling the rabbet the full length before smoothing as in Fig. 7. When you make the smoothing strokes, tilt the leading edge of the knife and apply a fairly heavy pressure to force the putty behind the edge of the glass. Allow the putty to dry before painting.

Filling Nail Holes in Tile Board

Builders who have occasion to use low density acoustical tile board on ceilings or walls ordinarily countersink the nails on each corner and then vainly attempt to fill the holes. By gathering small portions of the sawdust from the tile boards that have had to be cut, rolling it into small balls about the size of a buckshot, and gently pushing it into each hole an invisible "puttying" job can be done.

Sash Glazing

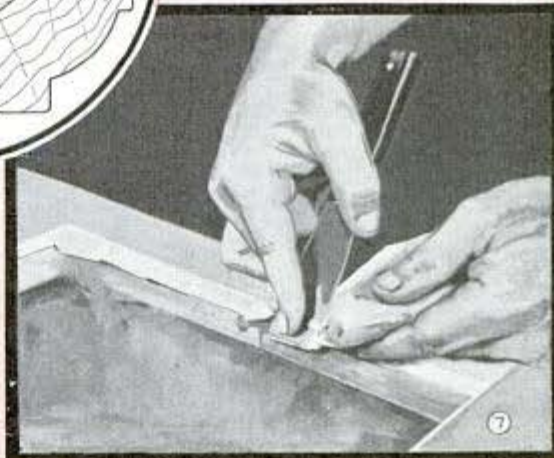
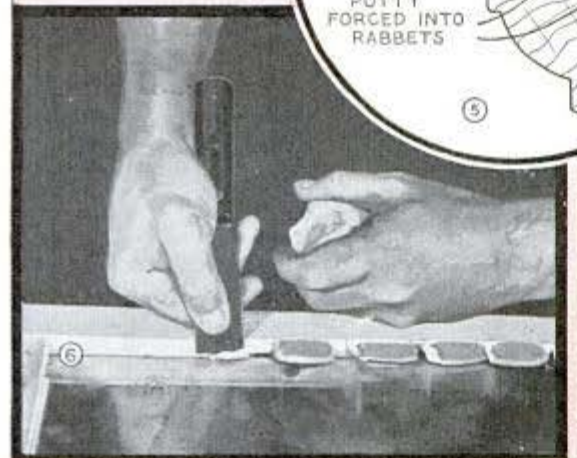
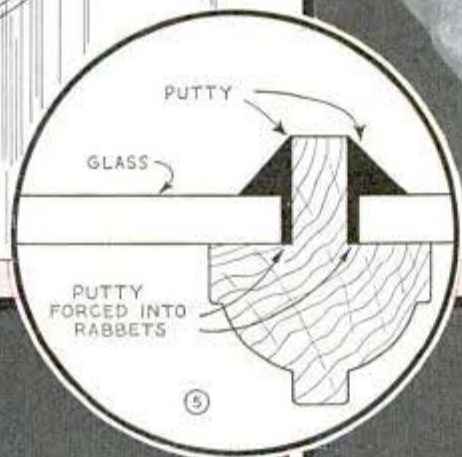
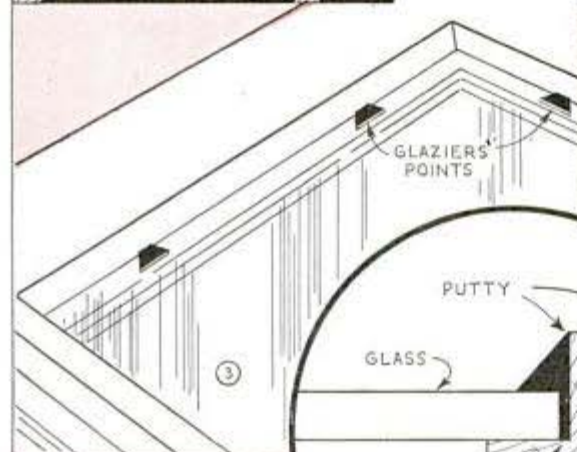
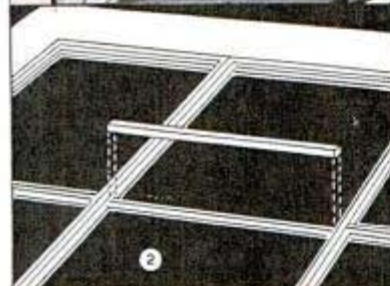
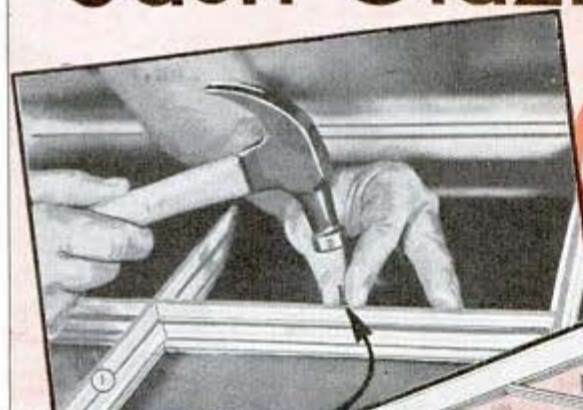

Pipe Spreader Converts Boat Oars Into Convenient Carrier



Slipped over the locks of a pair of boat oars, a short length of pipe will keep them spread so that they can be used for carrying bundles and boxes of camp equipment. When carrying the oars, a tendency to pull them together should be maintained to prevent the pipe from slipping off the locks.

Tool Handle Ledged in Place

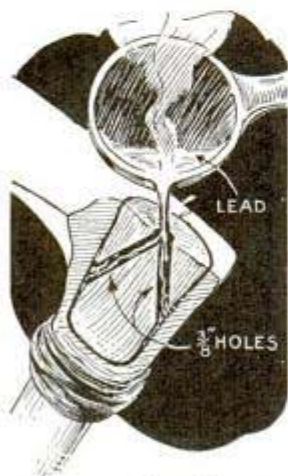

Handles that have a tendency to loosen in tools can be kept tight by this method: Drill from the center of the end of the handle diagonally to both sides, trimming the handle down so that it is a very loose fit in the tool. Then pour molten lead into the holes, wrapping a cloth or piece of rubber around the lower part of the tool head to retain the lead. Be very careful when pouring to avoid air bubbles which might cause the lead to spurt out of the hole and burn you.

—H. J. Priehs, Miami, Fla.

Easy Way to Destroy Wasps Before Painting Building

When painting houses, barns, etc., and you want to get rid of large nests of hornets, bees, wasps, etc., under the overhang

of a roof, weight a piece of cord with a large washer and then throw the cord over the building so that you can have access to each end of the cord. A piece of spiral-shaped flypaper may then be attached to the cord and hauled up alongside of the nest. If the nest is then struck with a pole or stone, the insects will rush out and stick to the flypaper. The few which do work loose will be unable to fly and will fall to the ground where they may be killed.

Stop Block Beside the Yardstick Helps Measure Short Work

You can measure short dowels, bolts, etc., without removing a yardstick or rule from its peg on the wall. Just screw a block to the wall so that its lower edge is flush with the end of the yardstick, as indicated in the drawing. In this way, all you have to do is butt the work to be measured against the stop block, after which a glance at the lower end will show you its length.



Four Doorstops Raise Chair Seat For Tots at the Table



If you have a child that has outgrown the high-chair, but is still too small to sit comfortably at the table on an ordinary chair, four rubber-tipped doorstops screwed into the chair legs will solve the problem. It's a good idea to drill pilot holes for the screws to avoid splitting the legs.

The chair is handy also, to use at the kitchen sink or work table.

—A. H. Waychoff, Phoenix, Ariz.

"ICELAND DESTROYER"

patrols the snow lanes.

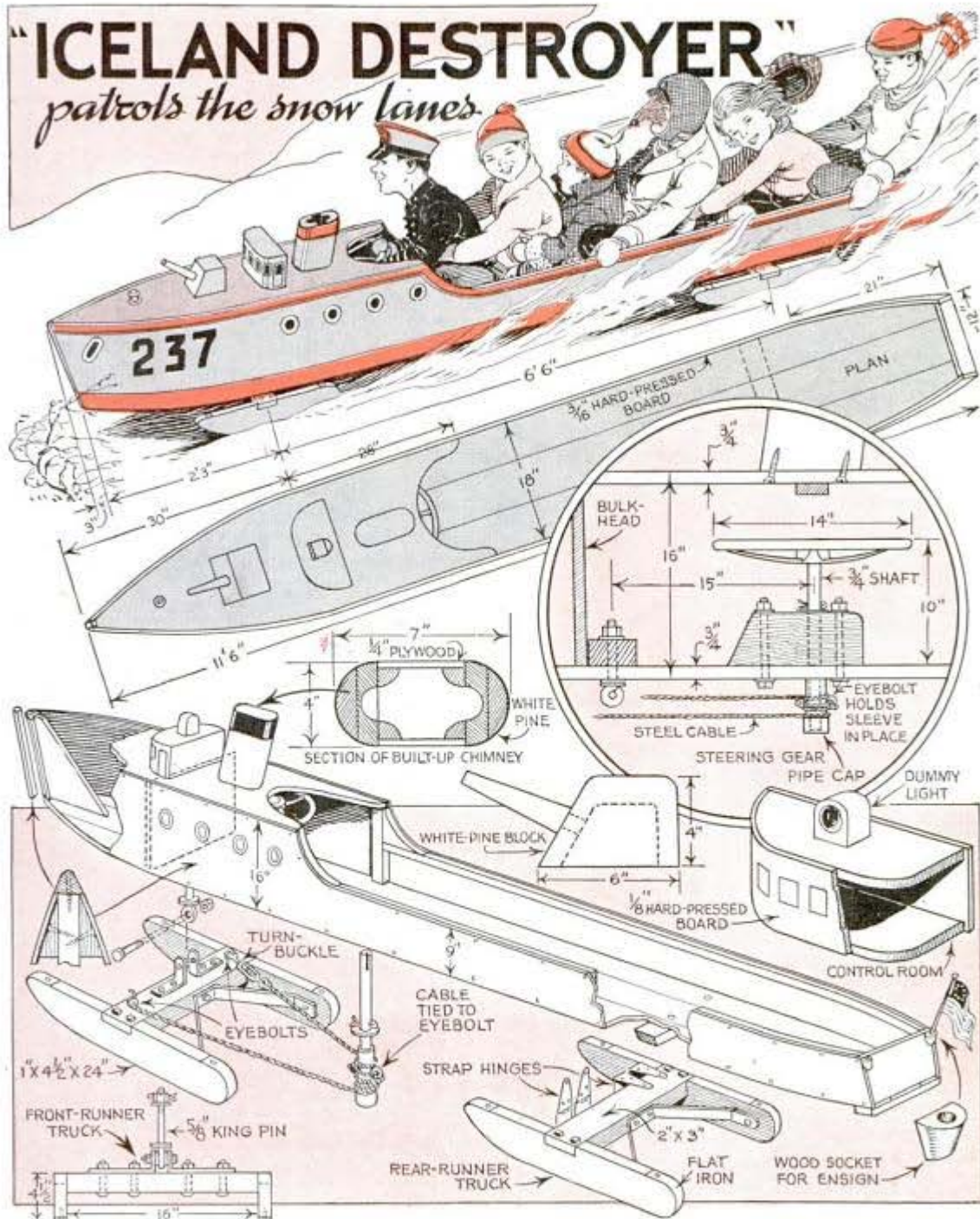

Built on a conventional bobsled chassis and having a body simulating a destroyer hull painted in gray with a red water line, this novel coaster will be a sensation on any hill. It consists mainly of thin but strong hard-pressed board, it is sturdy without excess weight, and will not splinter in case of a collision. The bottom and frame for the foredeck are made of $\frac{3}{4}$ -in. stock. Spruce strips running along the gunwales reinforce the hard-pressed board at these

points. There should be a half-round rub rail on the outside. Steering is arranged in the usual manner, and the steering wheel should be smaller than a standard auto wheel. The funnel is built up of white-pine pieces glued together and trimmed to a curve, with plywood for the sides. Control room is made as shown, and the gun turret is hollowed and trimmed from one block of white pine. Ensigns can be mounted in the twin sockets on the transom.

"Camp Stove" From Steel Rods Is Easy to Carry



Consisting of three steel rods, this utensil support is easy to carry and enables you to cook over an open fire. The rods are bent to form offsets, and are adjusted to suit large or small utensils by turning the rods in or out as indicated.

Simple Rack for Your Shoes Takes Little Space

If you want a shoe rack that takes little space and can be made inexpensively, this one is just the thing. The sides and back

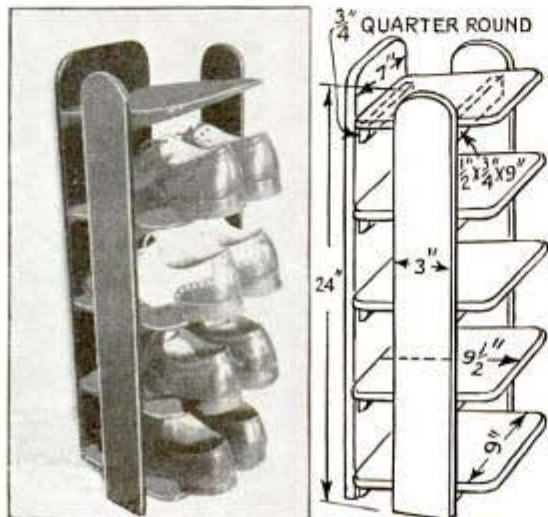

are $\frac{1}{2}$ or $\frac{3}{4}$ -in. solid stock and the shelves are $\frac{1}{4}$ -in. plywood. A couple of coats of enamel provide a good finish. If the edges of the plywood shelves have cracks or holes in them caused by faulty core in the plywood, fill them with glue and sand them smooth before painting.

—H. Skalla, Berlin, N. J.

Assembling of Small Ball Bearings Aided With Magnetized Nail

Small ball bearings or other steel parts may be handled easily for assembly work by means of a magnetized nail and a coil spring. The spring, which is of a size to just fit over the nail, is stretched so it is slightly longer than the nail. Held as shown, the nail is pushed out of the spring to pick up a bearing, which is then pushed off the nail end by releasing the spring.



Chisel Held at Angle for Honing By Grooved Blocks



To hold a chisel at the correct angle for honing on an oilstone, this simple gauge block is just the thing. It consists of a pair of blocks with grooves cut at the correct angle in which the chisel rests. The blocks are held together by means

of a bolt with a coil spring under the head. When the bolt is tightened, the blocks are pressed firmly against the edges of the chisel, holding it at the correct angle for honing.

CASH FOR UNUSUAL IDEAS

We pay cash for outstanding ideas showing simpler and better ways to do daily tasks, shortcuts in shop work, darkroom aids, household hints, auto kinks, etc. Send a good photo or sketch and a concise but full explanation of your idea to the Homecraft Editor, Popular Mechanics, 200 East Ontario Street, Chicago.

A Corner Whatnot Shelf in Maple-Leaf Design

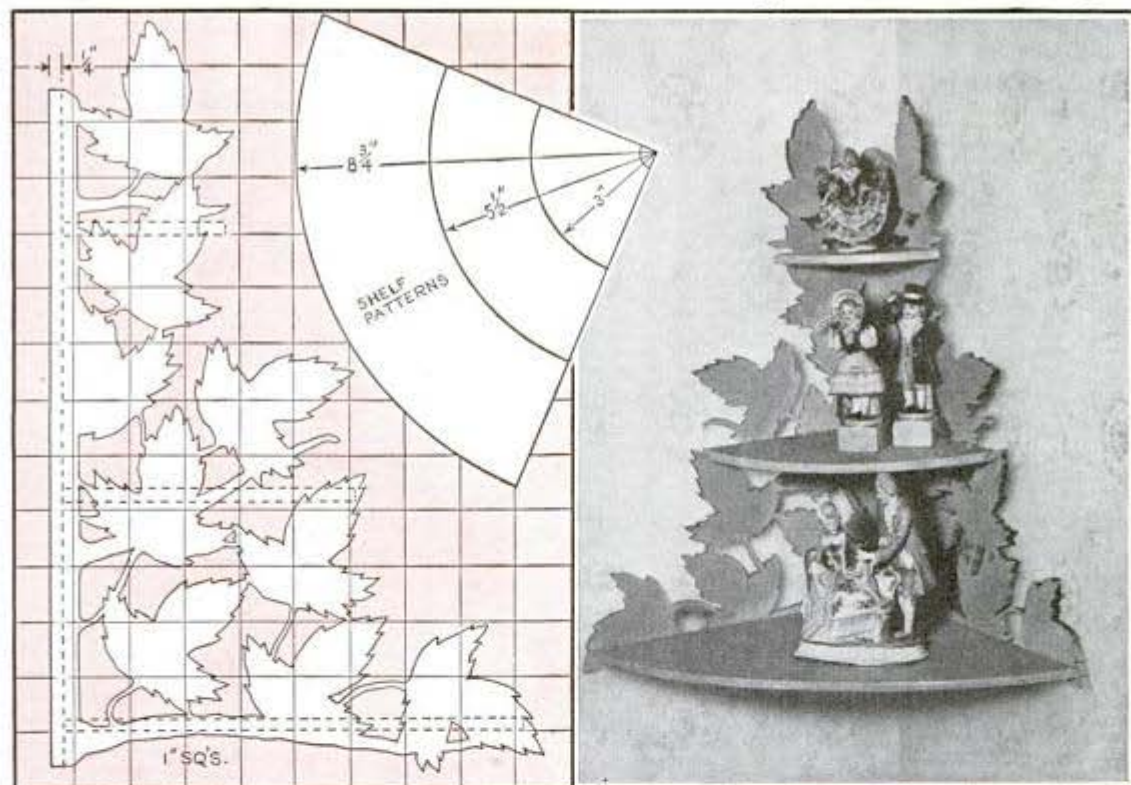

Just the thing to dress up a corner in your living room, this whatnot shelf has duplicate plywood sides that can be cut together. However, one must be $\frac{1}{4}$ in. wider than the other at the back edge. After sanding thoroughly, the sides are assembled with glue and small brads, and the

shelves are spaced as indicated on the squared drawing. Finishing the original shelf to carry out the maple effect consisted of applying maple oil stain, followed by a coat of white shellac. When the shellac was dry, the surface was sanded, dusted clean and given a coat of clear varnish.

Auto-Casing Pads Ease Strain of Carrying Heavy Packs



You can carry a heavy pack in comfort for long distances if the weight is distributed over both shoulders by a couple of pads cut from an old auto casing. These are slotted on both sides and threaded on the straps as shown. The pads fit comfortably and prevent the straps from rubbing.

Putty Can Sealed by Machine Oil

Putty will remain fresh if the can is kept sealed. This is done by merely dropping a little machine oil in the cover groove of the can before closing it.



Leather-Covered GAME

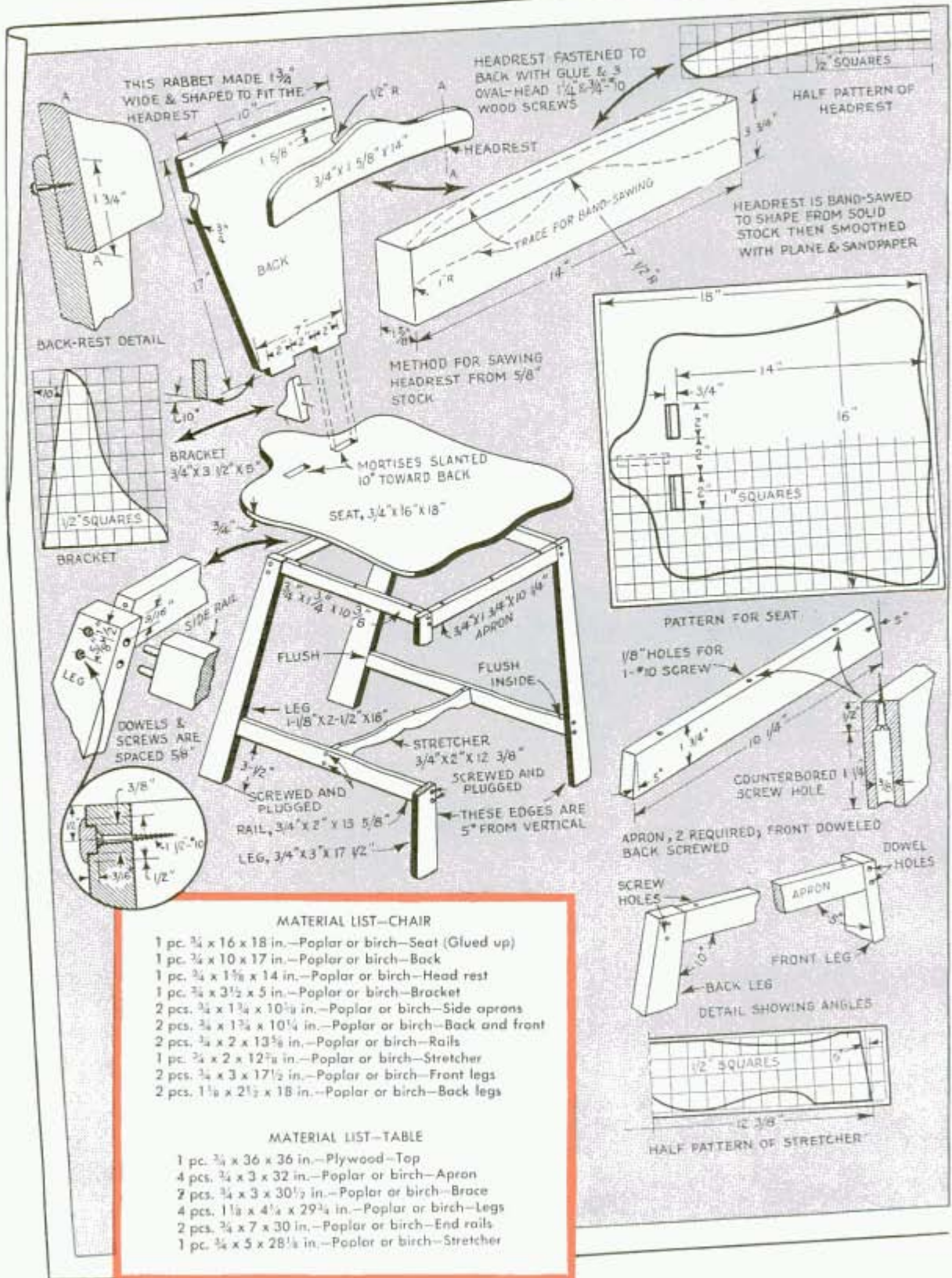

or BREAKFAST TABLE

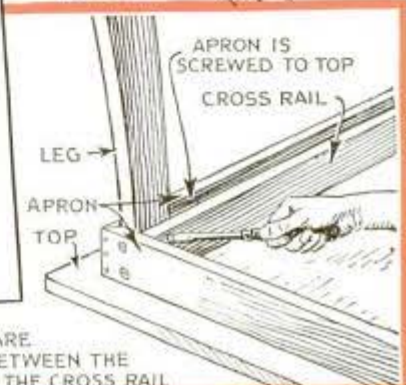
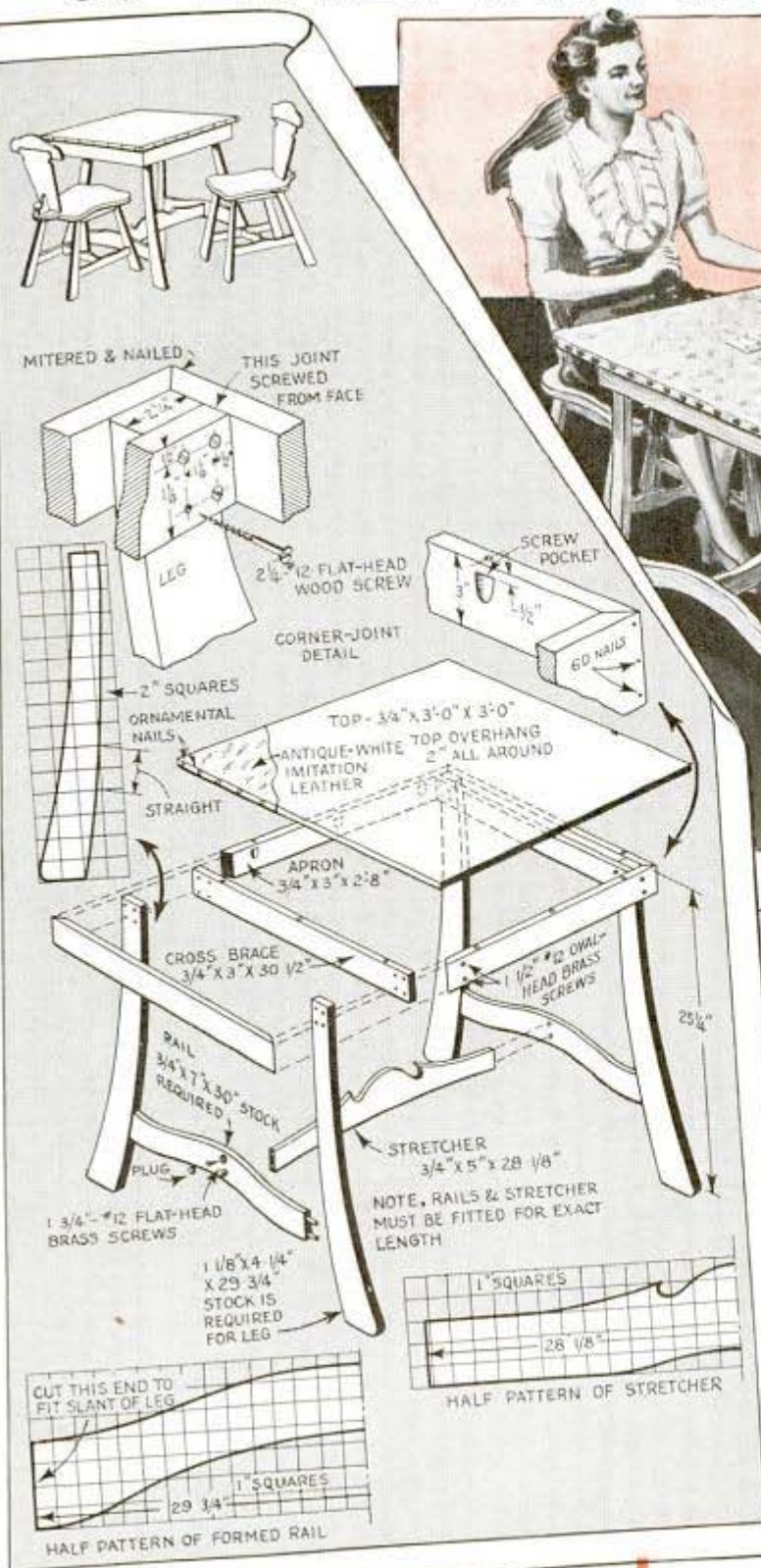
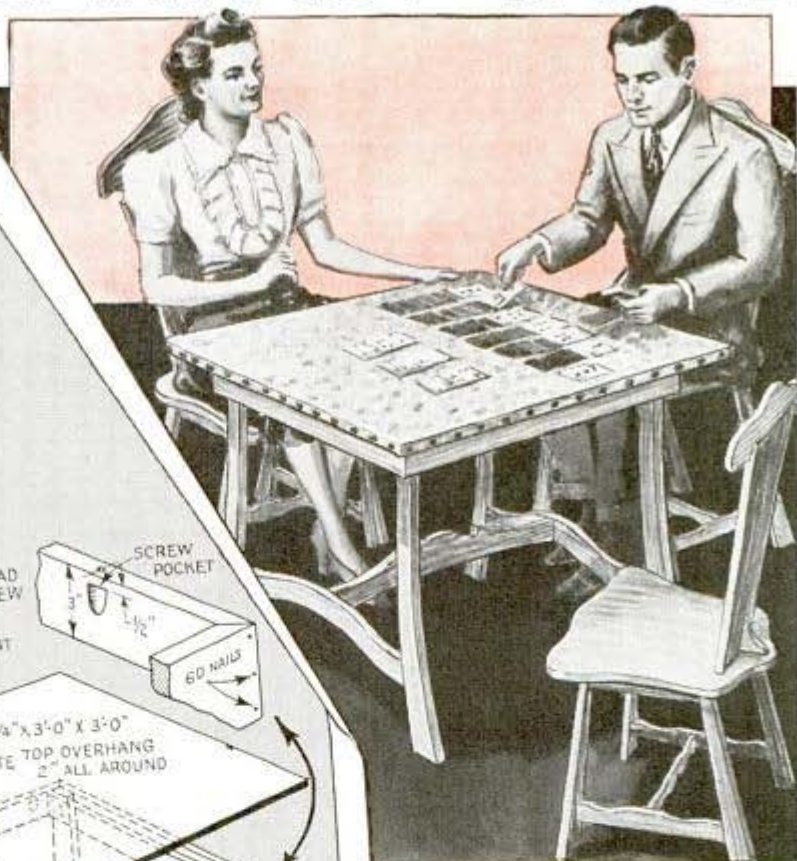

THE LEGS ARE SCREWED BETWEEN THE APRON AND THE CROSS RAIL

House Number Part of Railing Around Front Porch

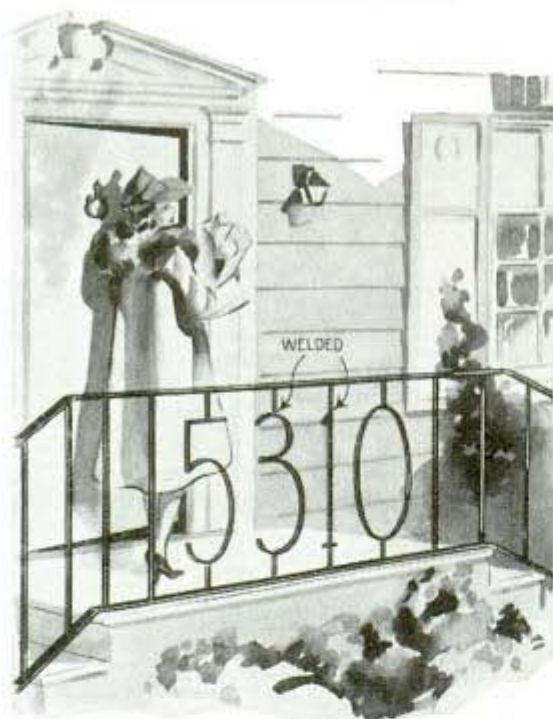

Shaped from iron and worked in as part of the railing on a porch, your house number adds a novel touch to the porch and is easy to see from a distance. The present vertical members of the railing can be sawed off and the numbers welded to them. Shape the numbers from iron of the same size as that used in the railings.

—Axel E. Ogren, Chicago.

Plastic Dish on Balance Scale Aids in Weighing Chemicals

A small plastic dish will make the weighing of chemicals easier. Just remove the pan used for chemicals and substitute the dish. Of course, the scale must be re-balanced. A dish of this kind eliminates the use of a paper cover, which most ama-



112

teurs use on their chemical pan to prevent scratches. Also, it makes possible the weighing of larger amounts of chemicals at a time.—Kenneth Kenna, Amsterdam, N. Y.

Heel of Paring Knife Sharpened To Cut Orange Skins

Orange skins can be cut so they are easy to peel, without cutting into the fruit, if the sharpened heel of a paring knife is used for the purpose as shown. To cut an orange skin, merely rotate it under the knife handle against the sharp heel of the blade.—Edward Woniger, Algiers, La.

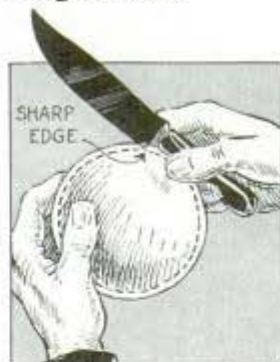

Lead Rope Is Made Adjustable By a Piece of Rubber Hose



If you have horses and other animals to lead around, a rope like the one shown will come in handy. In use, the rope is looped over the animal's neck, after which a short piece of

hose is slipped up to keep the looped portion in place. The hose should be of a size to be a snug sliding fit over the rope.

Ruling Squared Paper Quickly

It takes only a few seconds to rule a large sheet of paper into squares of equal size for enlarging patterns, if you use five short pencils in a holder of the type shown. It is merely a strip of corrugated cardboard, in which the pencils can be spaced to rule squares of different sizes.



How to Make Attractive Variegated Turnings

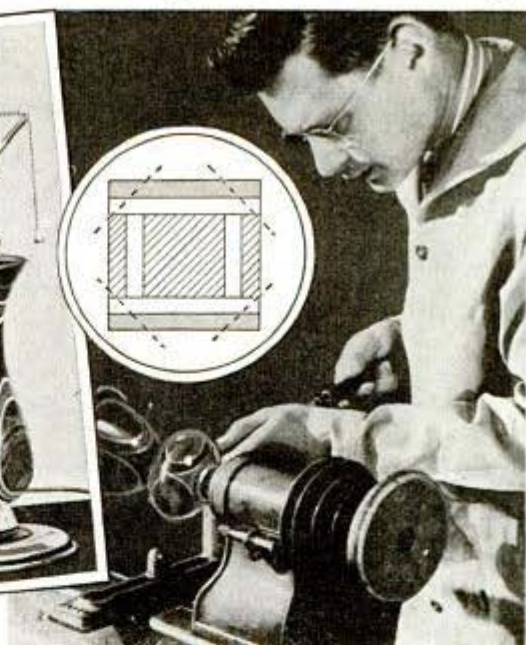
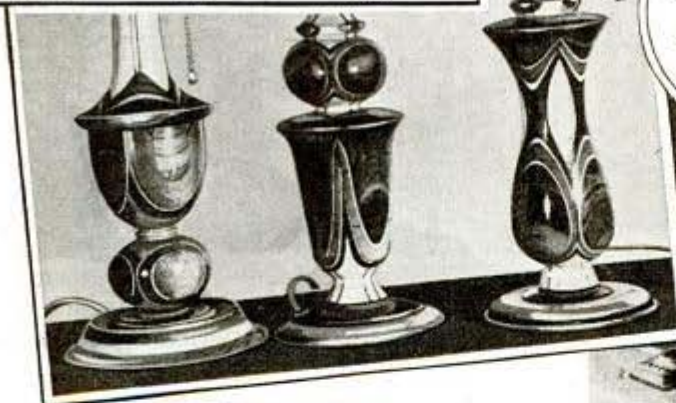
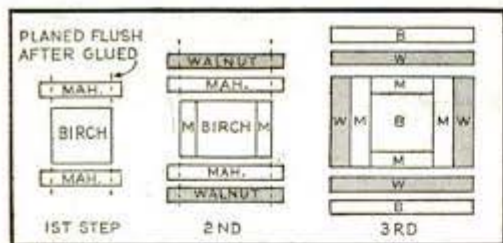

Beautiful wood turnings in various shades of color for lamps, vases, etc., can be made by gluing up turning blanks of contrasting wood blocks. To make a blank for the lamps shown, start with a 1½-in. square of birch wood and glue ¼-in. mahogany to opposite sides. After the glue has dried, square the block and add a piece of ¼-in. mahogany and ⅛-in. walnut to each of the remaining sides. Square these edges and to each of the first pieces of mahogany glue ⅛-in. walnut and ⅛-in. birch. This process is continued, varying the color and thickness of the laminations added until all sides have the same number of laminations. Only one layer can be glued the first time. After that, glue two at a time. The reason for this is that each square must be completed without a lap of different wood at the corner. Different effects are obtained by varying the number, thickness and color of the laminations.

Typewriter Silenced to Avoid Disturbing Others at Night

For those who have to type late at night or under other conditions where noise of the typewriter is likely to be disturbing, the following methods of silencing the machine will be helpful. First of all set the typewriter on sponge rubber pads to dampen vibration. Then use a piece of fabric under the paper in the machine to deaden the noise of the keys. Fabric such as 11-oz. boat-sail drill having a high thread count is preferable.—Allen Fiske, Chicago.



☛ A common clothespin, split in half lengthwise, will make two pan scrapers which will not rust or scratch aluminum.

Seedlings Transplanted Quickly With a Post-Hole Digger

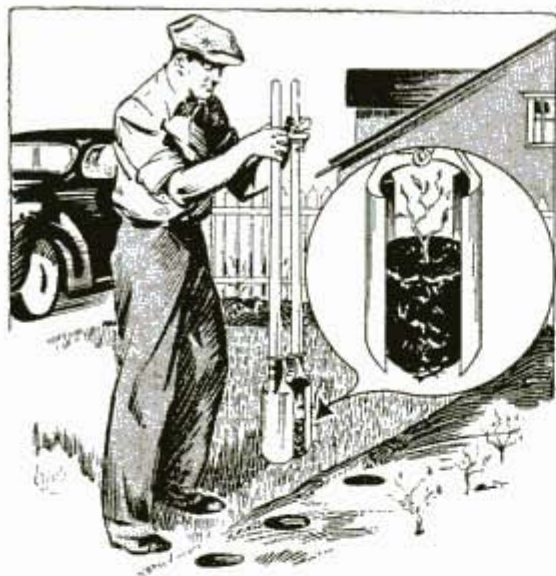

You can transplant tiny bushes and other seedlings easily with a post-hole digger of the type shown. With it, the work can be done quickly and without disturbing the plant root system any great amount. First, make the holes where the seedlings are to be transplanted. Then, with the jaws of the digger opened, set them down hard astraddle the plant and lift it out. It is a good idea to wet the soil around the seedlings to help prevent crumbling.

Jar of Oil Steadies Plumb Bob

When using a plumb bob on a long cord on a windy day it can be steadied by allowing the bob to hang suspended in a jar of

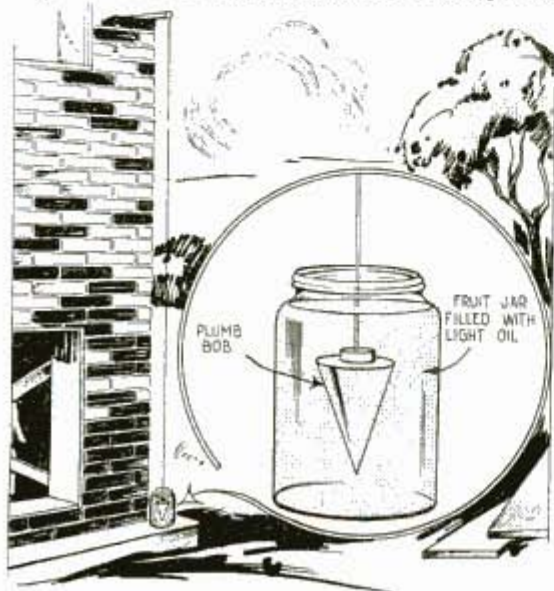

light cylinder oil. The clearest oil possible should be used so that you can see the point of the bob for marking.

Wires Spaced for Soldering To Make a Grill

Having a number of wire grills to make, one tinsmith sawed shallow slots in the sides of a cigar box to hold the wires in the desired positions while soldering them. The slots must be spaced the same distance apart as the distances between the wires in the completed grill.

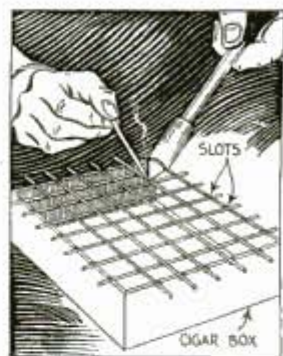

Carriage Bolt Kept From Turning By Head of Nail

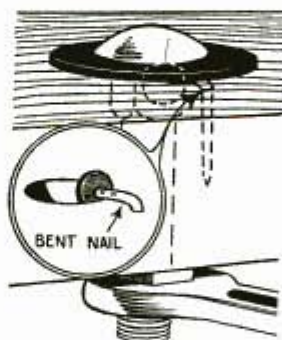

To prevent carriage bolts from turning in wood, one craftsman drives a short nail near the edge of the hole and then bends it over so that the head provides one straight side for the shoulder of the bolt to rest against. Under ordinary strain, this will keep the bolt shank from turning.

Test-Tube Envelope Moistener

In an emergency, you can make a handy envelope moistener from a test tube. Just fill it with water and bind a piece of chamois over the end with a rubber band. Be sure that the band fits tightly to avoid leaks when the tube is turned upside down in use.



Letter Board Has Pencil Guide for Blind Person

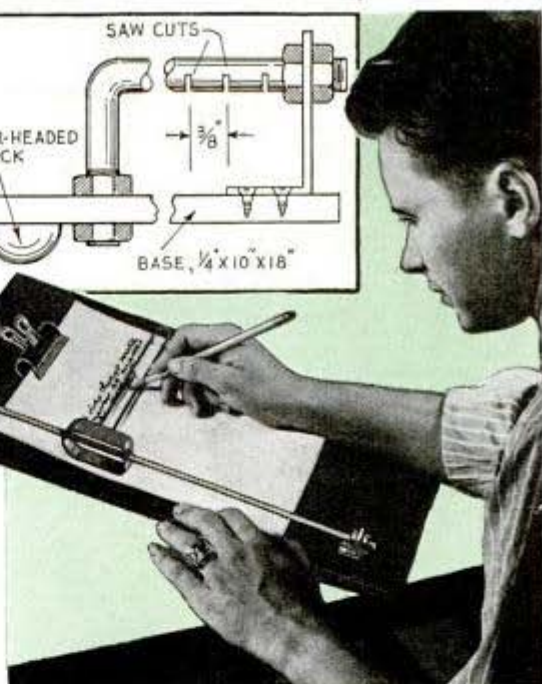
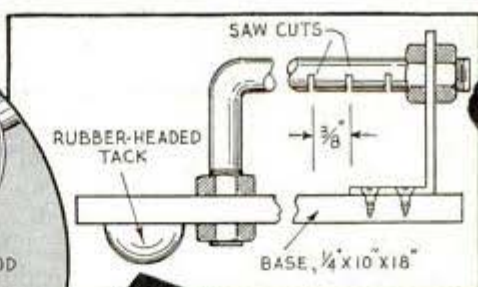
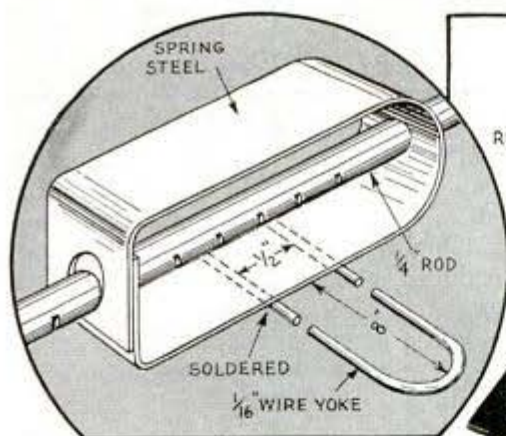

Persons who have given up letter writing on account of failing eyesight will appreciate this board as it enables them to write straight lines at uniform spacing from the edges of the sheet without any trouble. It consists of a plywood base, a notched rod along the left edge and a pencil guide, the latter being attached to a spring-steel clip which fits on the notched rod. In use, writing is done inside the pencil guide, while the left forefinger is used to mark the end of each word before lifting the pencil.

When a line is completed, the guide is moved down one notch which automatically puts it in position for the next line.

—Edwin Hicks, Indianapolis, Ind.

Simple Finishing Touches Dress Up the Backyard Swing

Instead of just bolting the top crosspiece of a swing to the uprights in the usual manner, why not give it a finishing touch



of neat workmanship and improve its appearance? This can be done by carefully pointing the ends of the crosspiece and tops of the uprights, and then half-lapping the joint so that the pointed ends will just cross each other. Two $\frac{3}{8}$ -in. bolts at each joint, one locked with an extra nut, will hold the parts together rigidly. Before assembling, apply white lead on the joints to prevent water from soaking into the wood.

"Aged" Wallpaper for Patches

After papering a room, I always save a strip of the paper and hang it in the attic to use for repair purposes. This allows the strip to "age" the same as paper in the room so that a perfect repair job can be made at any time necessary.

—Charles Latour, Jr., Albany, N. Y.

☛ Olive or vegetable oils should be stored in the refrigerator after they have been opened, as they are apt to become rancid unless they are kept chilled.

Rubber Band Over Garden Rake Used as Roofing Brush

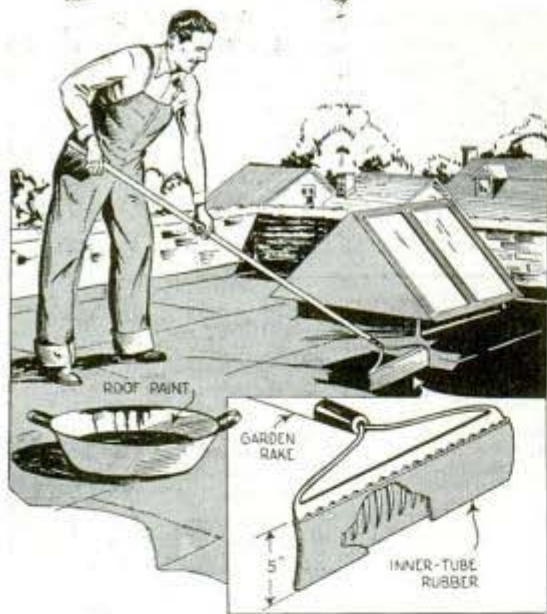

While applying paint or tar to composition roofs, one workman found that a garden rake with a wide rubber band cut from an inner tube and stretched over the teeth made a good spreader. The rubber should extend beyond the lower ends of the rake teeth so that the rake can be used as a squeegee.

Inset Borders Ruled on Showcards With Curtain Rod

To rule inset borders on showcards and price tickets, one artist uses a length of metal curtain rod. This is tacked to the top of the work table and the cards are inserted in the groove as shown, while the brush is drawn along the inside edge to paint the lines quickly and uniformly.

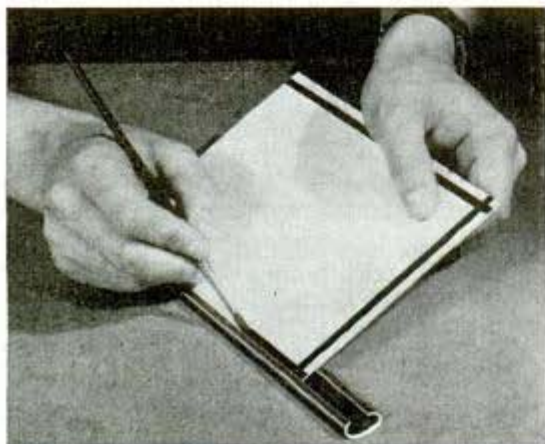

How to Build Good Fences

Much of the disappointment experienced in seeing a good fence, on which you have spent money and labor, deteriorate in a few years can be avoided if a few simple precautions are observed when building it. Posts will rot underground in a short time unless you use some method to avoid rot, such as the application of creosote. Brushing it on helps, but soaking the posts in the liquid is more effective. Setting wood posts in concrete will cause the latter to crack just as surely as water freezes. Expansion caused by moisture in the post freezing causes the trouble. For a permanent installation, wrap a layer of corrugated cardboard, smooth on one side only, around the posts, and later remove this and pour in hot asphalt. The latter provides an expansion joint between the concrete and post. When posts have to be set so that the pull of the wire will tend to lift them, rods or wooden blocks near the lower ends make good anchors. Old harrow disks screwed to the posts will prevent lifting.

Rounding or beveling the tops of the posts does more than make them attractive. It prevents water from soaking in and greatly retards checking of the wood which would cause it to rot rapidly. Dry rot of joints in wood fences can be minimized by creosoting the ends of the timbers or beams where they contact. Where pipes are used for clothesline supports, you can set them in concrete. Use a piece of stovepipe as a form, letting it project above the ground 4 or 5 in. After the concrete has set, the stovepipe is cut away above the ground. The tops of the pipes can be closed with concrete to keep out water. To do this, rags are stuffed into the pipes a few inches below the tops to retain the concrete until it hardens. Pipe set in a concrete wall makes ideal supports for woven wire. The concrete is poured into a trench in which the pipe has been placed and plumbed. Boards should be used as forms above the ground to produce a neat appearance. Nails or screws used above ground in constructing a wooden fence can be tinned by dipping them in molten solder to retard rust and to prevent rust stains on the wood. Using two staples locked together will hold barbed wire firmly in softwood posts.

Ⓛ Damp berries mold quickly so do not wash them until they are ready to be used.

Hints on building Sturdy Fences

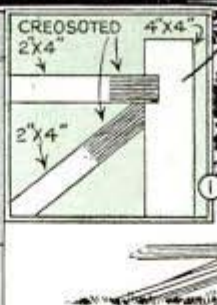
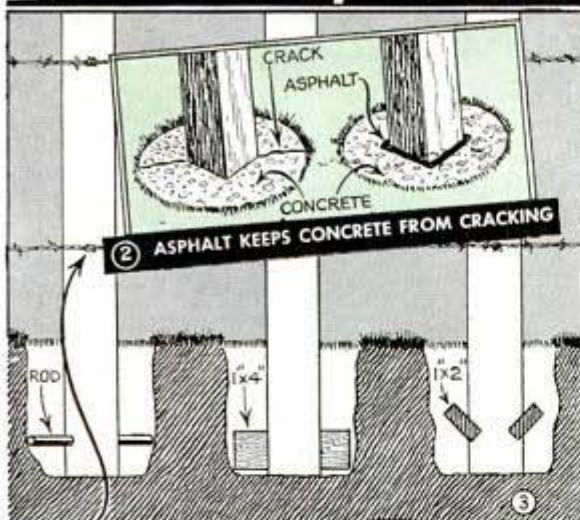

1—Creosoting wood-to-wood joints above ground retards dry rot, but if you paint over the creosote it is likely to "bleed" through the paint. 2—It's a waste of time to set wood posts in concrete unless you pour a layer of asphalt between the wood and concrete to provide an expansion joint

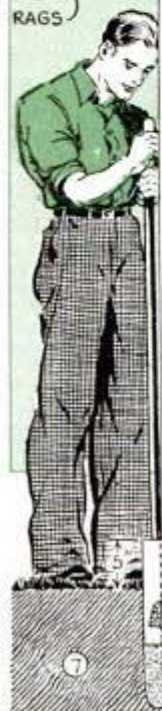
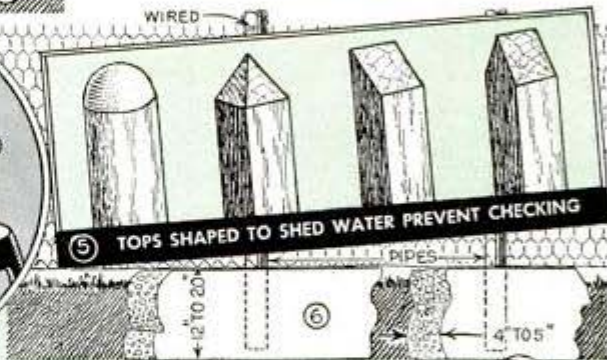
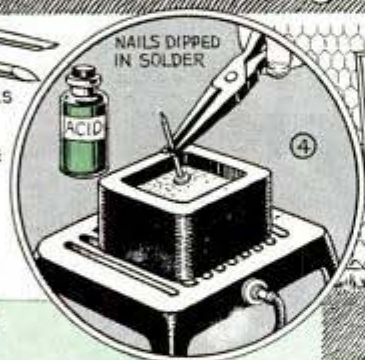
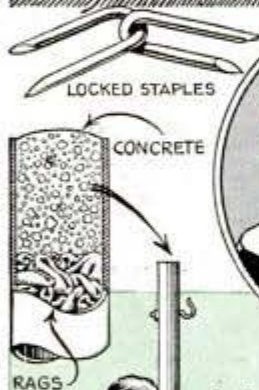

3—Posts anchored in this manner will "stay put" if the earth fill is tamped around them. 4—Tinning nails in molten solder prevents rust and its resulting stains on wooden fences. 5—Beveling or rounding post tops drains off water and helps prevent rotting. 6—Pipe set in underground concrete wall to make permanent lawn or poultry-yard fence. 7—Large pipe clothesline supports last indefinitely if set in concrete and plugged with the same material to keep water out of the tops. 8—Harrow disk used to prevent lifting of posts. 9—Many years of life are added to posts if they are protected against rotting underground by soaking them in creosote. The posts should remain in the liquid for several hours. The creosote coating should reach 5 or 6 in. above the ground

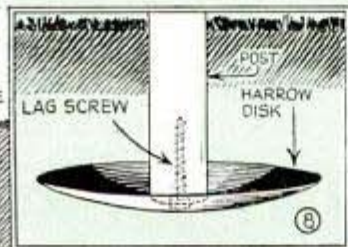

Piping for Radiator Concealed By Using Copper Tubing

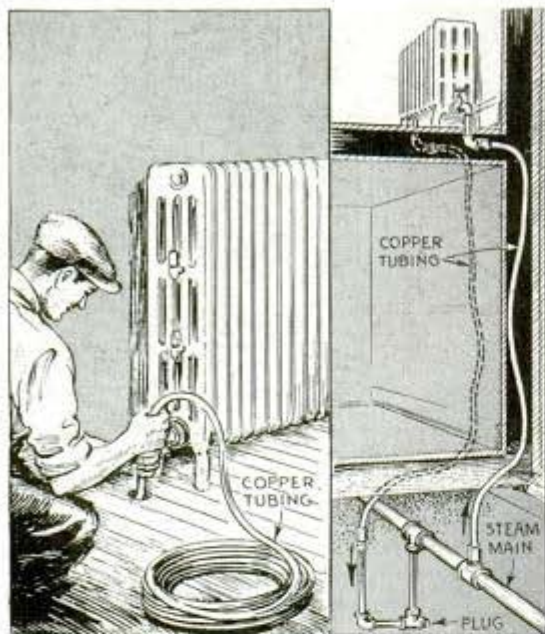

One of the disadvantages in providing steam heat for a house already built—that of concealing the piping running to the second floor—can be overcome by using copper tubing instead of pipe. In most cases, the tubing can be “fished” up between the walls with little trouble as it is bent easily. Regular pipe fittings are available for copper tubing so that it can be connected to the radiators and pipes.

Sealing Wires in Outlet Plug

Fraying and pulling of the wires from a male plug of an electric extension cord can be prevented by filling the cavity of the

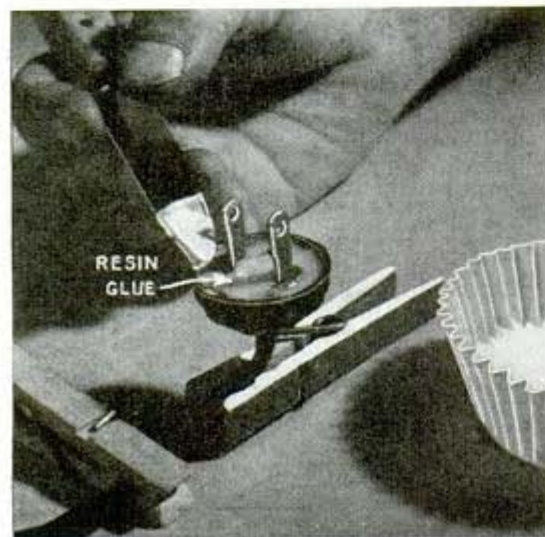

plug with plastic or resin glue. It will be necessary to plug the hole around the cord with paper to prevent the plastic from running out before it hardens.

Dishes Marked With Nail Polish When Used on a Picnic

The next time you go on a community picnic or dinner where your dishes are likely to be mixed with others so that it is difficult to identify them, mark them with fingernail polish. Dishes marked in this way can be washed without removing the identifying mark, yet the polish can be taken off with polish remover.



Crease in Felt Hat Reinforced To Prevent Excessive Wear

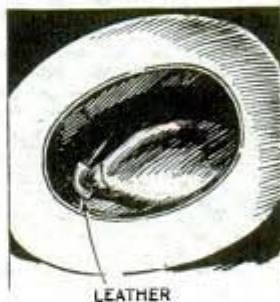

Excessive wear and cracking of the felt in a hat where the crown is creased can be avoided by reinforcing the portion to be creased with small strips or pieces of soft leather. This is attached inside the hat with rubber cement so that it can be removed for cleaning and blocking the hat.—Allen Fiske, Chicago.

Bobby Pins Make Good Clamps For Modelmakers' Use

Simple clamps for holding small parts together while gluing or fitting can be made in a few minutes from bobby pins by bending them as indicated. The clamps are opened easily by applying a little pressure to the bent side of the pin.



Turned Picture Frame Has Self-Fastening Back

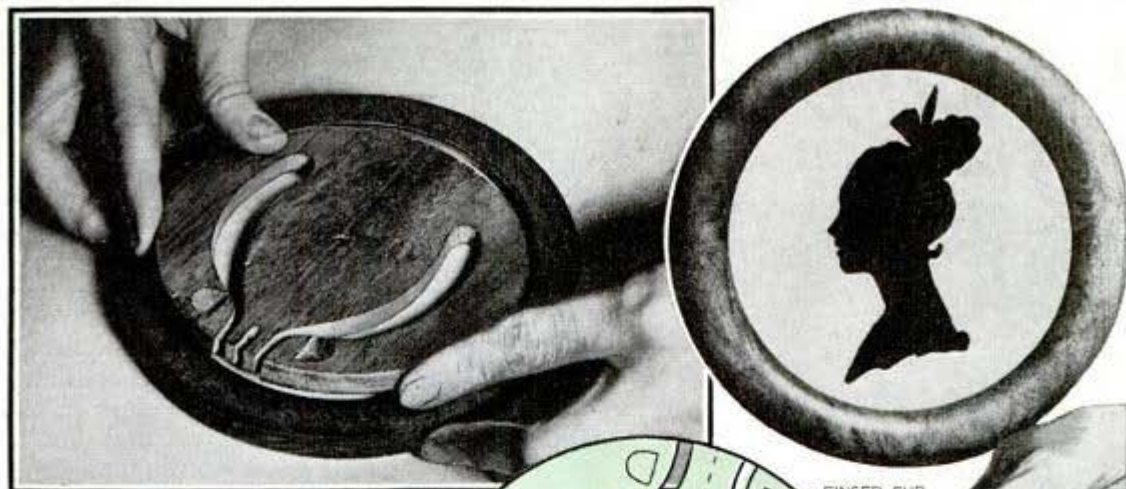

If you need a circular picture frame, here's one with a novel self-fastening back that is easy to make. The frame is first turned from a disk of $\frac{3}{4}$ -in. stock, after which the groove for the glass, picture and back is cut with a tool made by bending a file tang and sharpening the end of it. Next, the $\frac{1}{4}$ -in. plywood back is cut on the jigsaw and a chisel or knife is used for making the two finger cups. To insert the back in the frame, you merely press it in

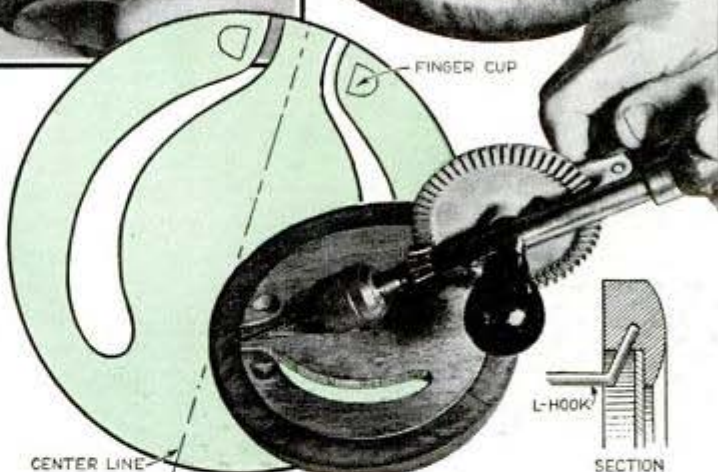

place as shown. The frame hangs on an L-hook which slips in hole drilled at an angle.

Bicycle Holder Folds Flat Against Wall When Not in Use



Instead of just leaning your bicycle against the garage wall where it might slip down, it's a good idea to provide a folding holder of the type shown. It is merely a section of old auto casing fastened to a pivoted arm that is bolted to a stud.

Weather Strips on Stepladder Hold Small Paint Cans

To prevent small cans of paint from sliding off a stepladder, one sign artist uses a couple of pieces of weather stripping to hold the cans in place. Both strips are tacked at an angle so that the cans wedge between them.



BUILDING "Starlet" - A MODEL YACHT of the Sharpie Type

By John Black

Ex-President, International Model Yacht Racing Union

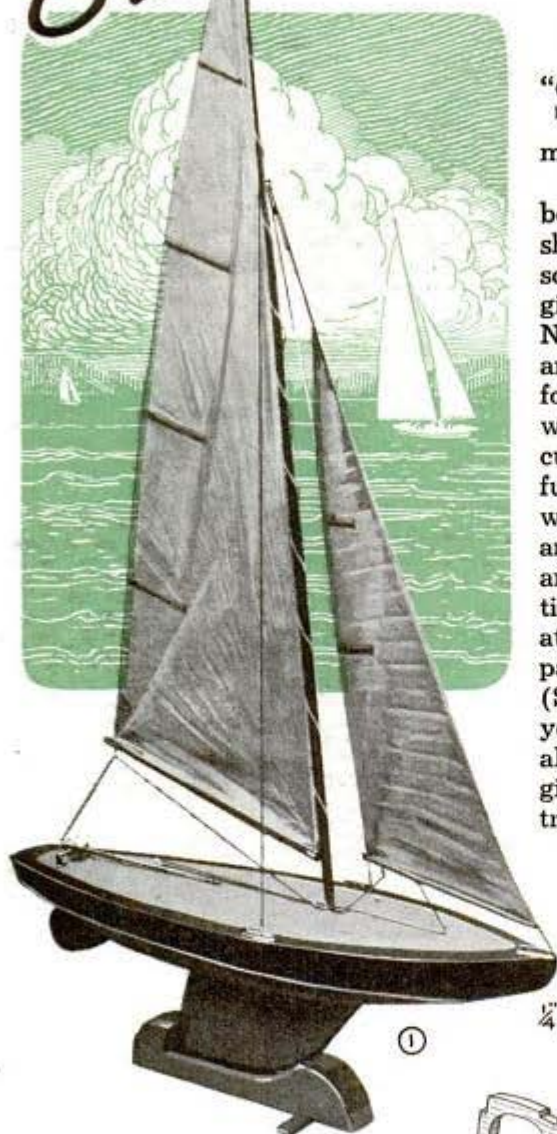

"STARLET" is a 36-in. model racing yacht that you'll find easy and inexpensive to make. The completed model is shown in Fig. 1.

You begin by making the two-piece building board as detailed in Fig. 2. One edge of this should be planed straight and true and used in squaring the station lines across the top. Fig. 3 gives the correct spacing of the seven lines. Next, 1/2-in. square cleats to which the molds are to be fastened, are glued and nailed 1/8 in. forward of the station lines so that the molds will center on the lines. All seven molds can be cut from a 1/4 by 5 by 48-in. piece. Fig. 4 gives full-size, half-breadth patterns of each mold which you can transfer through onto thin paper and then to your wood. Trace only the side and bottom outlines and mark on each respective pattern the point where the side line stops at the sheer. From the sheer point on, each pattern is drawn to extend to the base line. (See Fig. 7.) Before you can lay these out on your wood, each pattern must be reduced 1/8 in. along the side and bottom because the outlines given are to the outside of the planking. In tracing around the patterns, be careful to keep the base line even with the edge of the wood. When you get the molds cut out, mark the deck crown on each one. For this you will

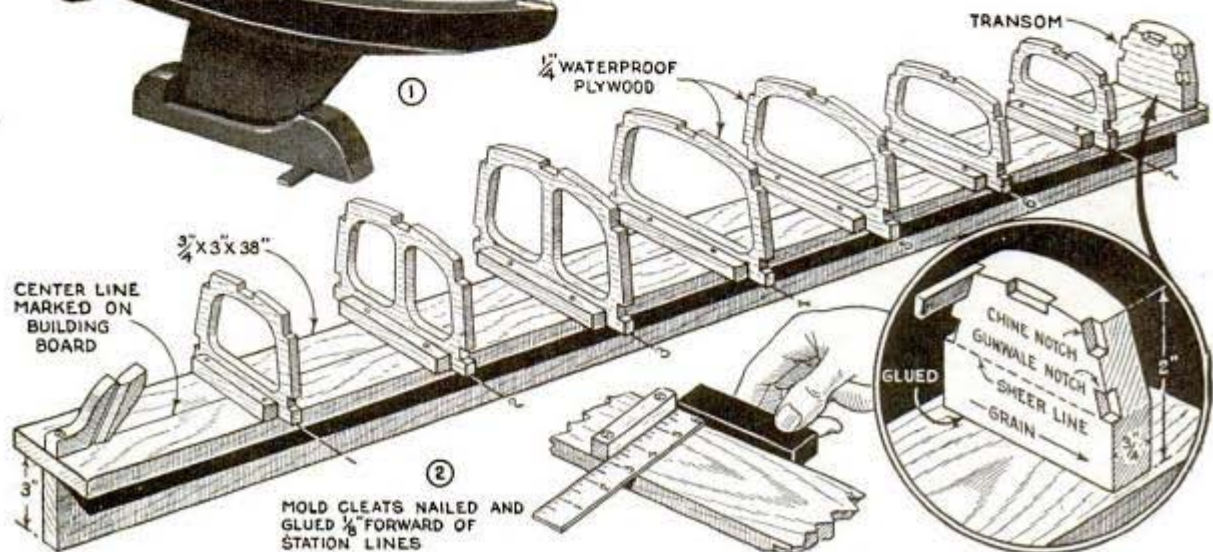

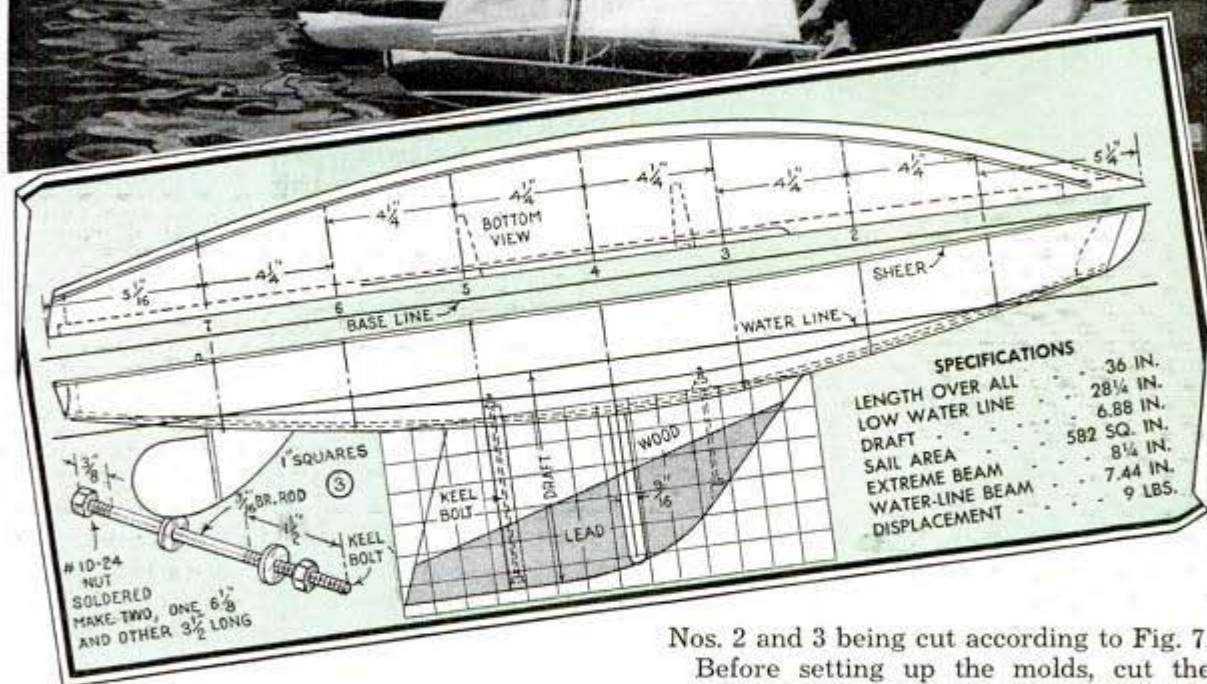
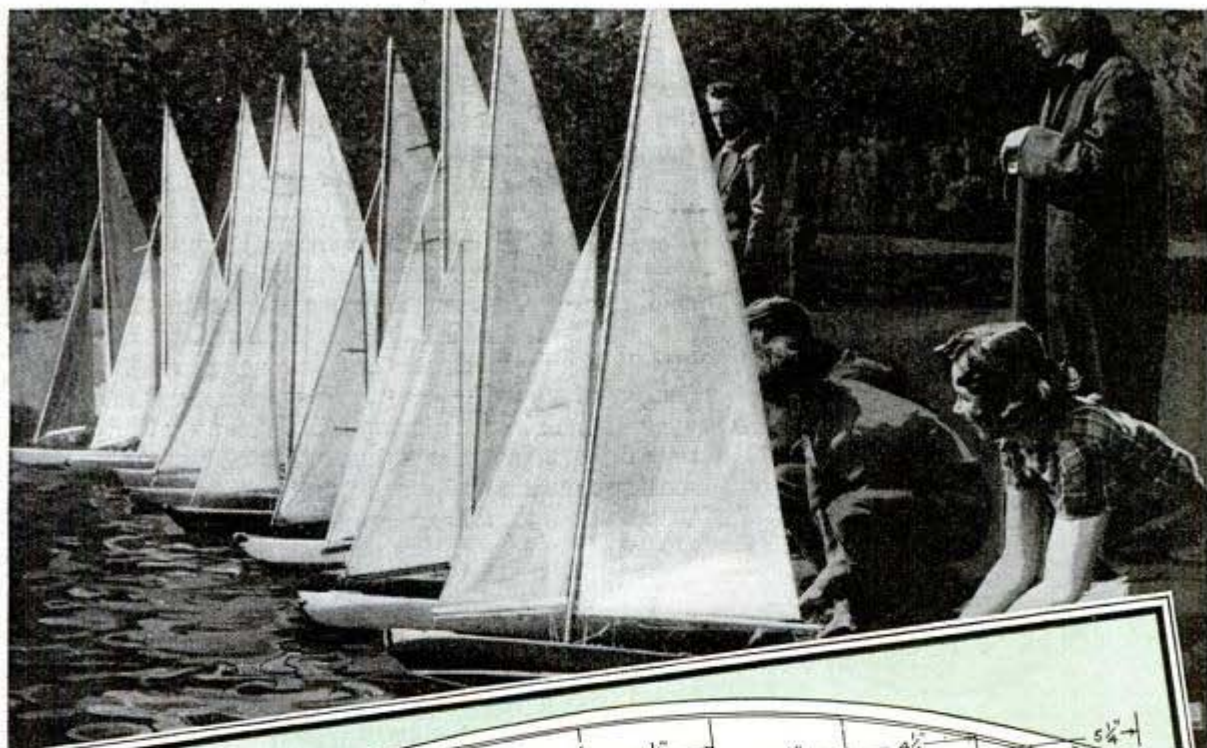

need a cardboard template like the one shown to the right of Fig. 8. This one template is used to mark all molds. Place it on the work so that the curve will be even with the sheer points when the centerlines of both mold and template coincide, and then mark the curve. As this line likewise represents the outside of the deck planking, a second line must be drawn $\frac{1}{8}$ in. in from the first. Now, referring to Fig. 7, you will see that a saw cut is made slightly above this second line and stopped about 1 in. from each side. This cut is made to simplify cutting the hull free of the building board. You will notice also that the center portion of the molds are cut out,

Nos. 2 and 3 being cut according to Fig. 7.

Before setting up the molds, cut the notches for the gunwale, chine and keelson. Make these slightly undersize so that they can be trimmed later to exact size. With a centerline marked the length of the building board, glue and brad each mold to its respective station cleat.

While these are drying, you can cut out the stem and transom. Fig. 6 gives a full-size pattern of the stem for tracing on a $\frac{5}{8}$ -in. block. The planking rabbet can be cut now, or later. In the latter case, be sure to mark the rabbet line on both sides of the block. To mark off the shape of the transom, refer to Fig. 4 and copy the full-size patterns given for the stern and top view. Follow the dotted line in sawing the stern outline, the solid line represents the

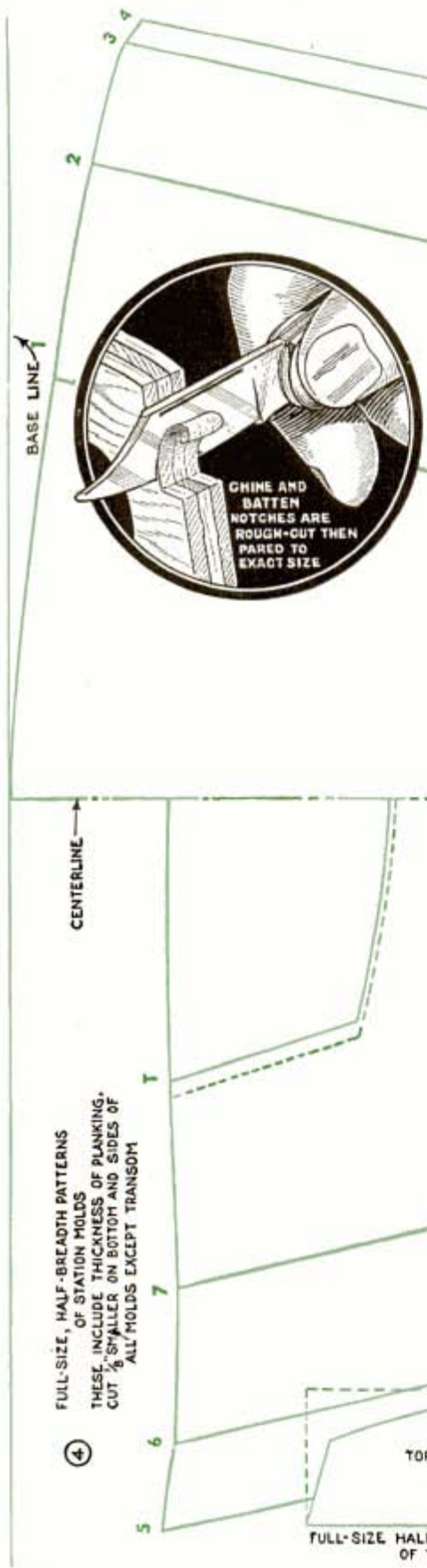

shape of the inner face. When cut, the transom should look like the one shown in the circular detail of Fig. 2. Run the notches $\frac{1}{4}$ in. in from the inner face and then center and glue it to the building board.

Commence fitting the $\frac{1}{8}$ by $\frac{3}{4}$ -in. keelson flush to mold No. 4 and fasten it with a No. 0- $\frac{3}{8}$ -in. brass screw. Hold the forward end down in the $\frac{1}{4}$ -in. stem notch and mark with a knife along each side of the keelson across each mold. Then notch and fasten. Fit the aft end the same way. The $\frac{1}{8}$ by $\frac{5}{16}$ -in. chines and gunwales are fitted similarly, trimming the notches parallel with the edge of the mold. In some cases you may find it necessary to set the chine in farther on some molds to obtain a nice sweeping curve. The forward ends of the chines and gunwales butt against the sides of the stem at the base of the rabbet, the chines coming flush with the keelson as shown in Fig. 5.

Before the planking can be applied, you'll have to fair the edges of the molds, forward and aft of No. 4, the chines and transom. A small block plane and a coarse wood file will be found best for this work. The important point here is to see that the framework is symmetrical to give a nice sweeping curve to the planking. With the hull faired, draw a line down the center of the keelson and begin fitting the two middle planks. One edge of each plank is tapered from the center to $\frac{1}{16}$ in. wide at the ends. Make this a gradual taper so that each succeeding plank will lay nicely. Place the planks over the keelson, butting the straight edges together directly over the centerline, and fasten the ends to the stem with No. 0- $\frac{3}{8}$ -in. brass screws. Then drive two screws into the keelson, between each mold, $\frac{1}{8}$ in. in from the center joint. The planking on the original model was held with tiny brass screws, but if you should find these difficult to obtain, you can use small brass escutcheon nails instead. When you are satisfied with the fit, remove the planks and re-lay them in waterproof glue. Con-

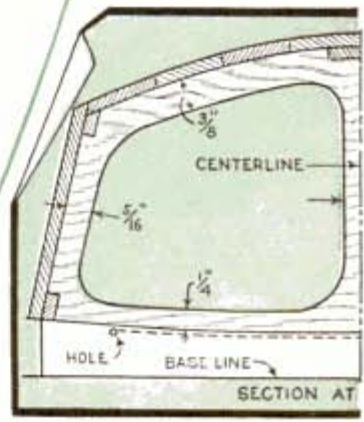

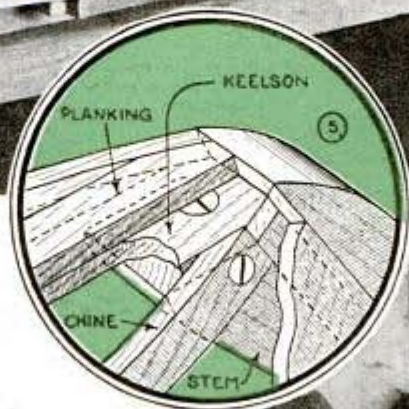
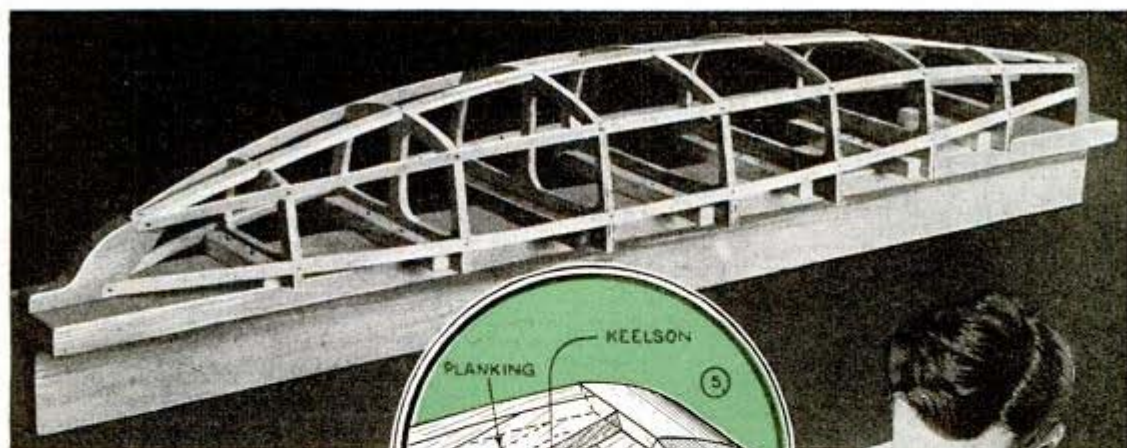

continue working from both sides of the centerline in laying the remaining bottom planks which all measure approximately $\frac{3}{4}$ in. wide. Fasten each plank to each mold with two screws, or nails, and coat the butting edges generously with glue.

To make the side planks fit properly, you will have to fair the edges of the outer planks flush with the chines. Fit the side planks to the stem rabbet first and fasten each plank with three brass screws. At the transom, use two screws, placing them be-

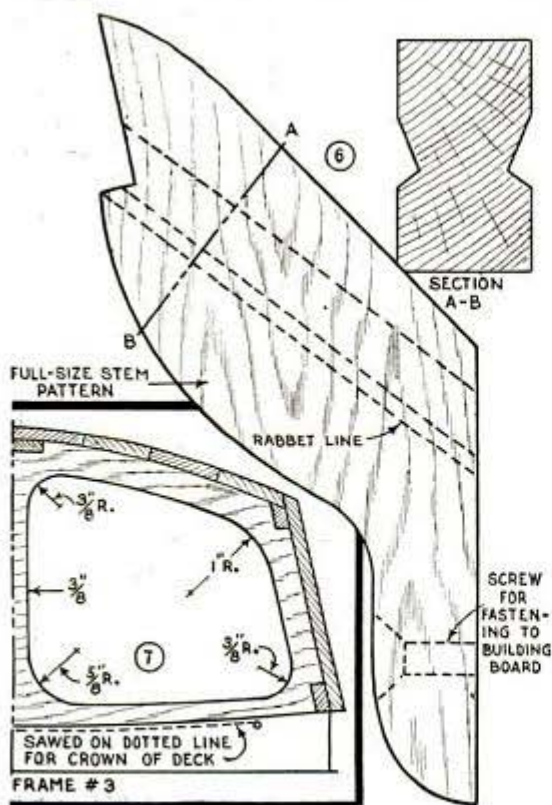
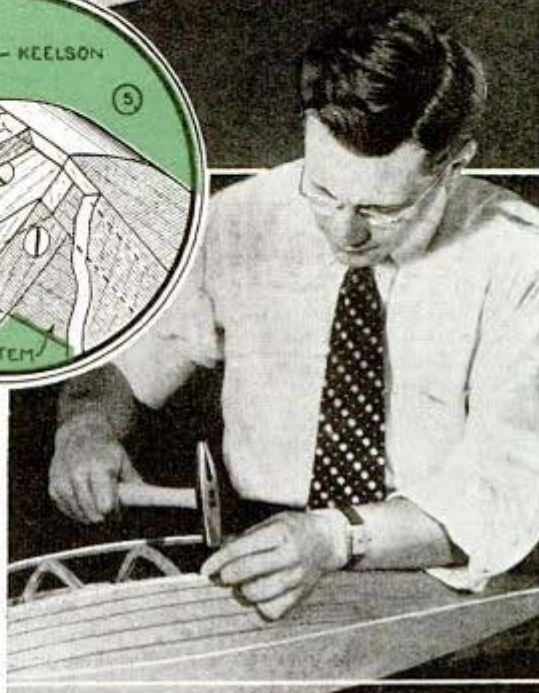

low the deck line. Along the chine and gunwale, two screws are used between each mold. When dry, remove the surplus glue and dress down the bottom planks to a smooth surface.

The shape of the two-part keel can be enlarged full size from the squares given in Fig. 3. To cast the lead part, a mold is required which you build up from three pieces of stock, the center piece being cut to the shape given in Fig. 13. When cast, the top edge is planed straight and square, after which the positions of the keel bolts are marked in the center of the top and bottom edges. (See Fig. 3.) Now center-punch and drill $\frac{3}{16}$ -in. holes, drilling from each edge to keep the hole running straight. At the bottom these are counterbored for the bolt heads. The wood half is similarly drilled and then the two are assembled as a unit for final shaping. Round the forward and bottom edges and then with the keel clamped flat, taper the aft edge to $\frac{1}{8}$ in. thick from a point 2 in. in on each side. Fit, glue and plumb the wood part of



the keel exactly over the hull centerline.

From here on the work will require the hull to be in an upright position. Start cutting it loose from the building board by sawing in from the edge to meet the saw cut previously made in each mold. Cut the transom off $\frac{1}{8}$ in. above the deck line and remove the screw in the stem. Fig. 12 details the stand which is shaped and grooved to correspond with the lower edge of the keel. Over each keel-bolt hole through the hull, you next fit a floor timber like the one shown in Fig. 10. Notice that the aft timber butts against the forward face of mold No. 5 to which it is glued. (See Fig. 3.) These timbers give a solid surface for drawing the keel firmly to the hull. When a good fit is had, apply waterproof glue and tighten the bolts.

Resuming work on the hull, you next fair off the gunwales and file down the molds to the deck lines. After this, cut a notch in the top of each mold and the stem and transom, to receive flush a $\frac{1}{8}$ by $\frac{3}{4}$ -in. backbone down the center of the

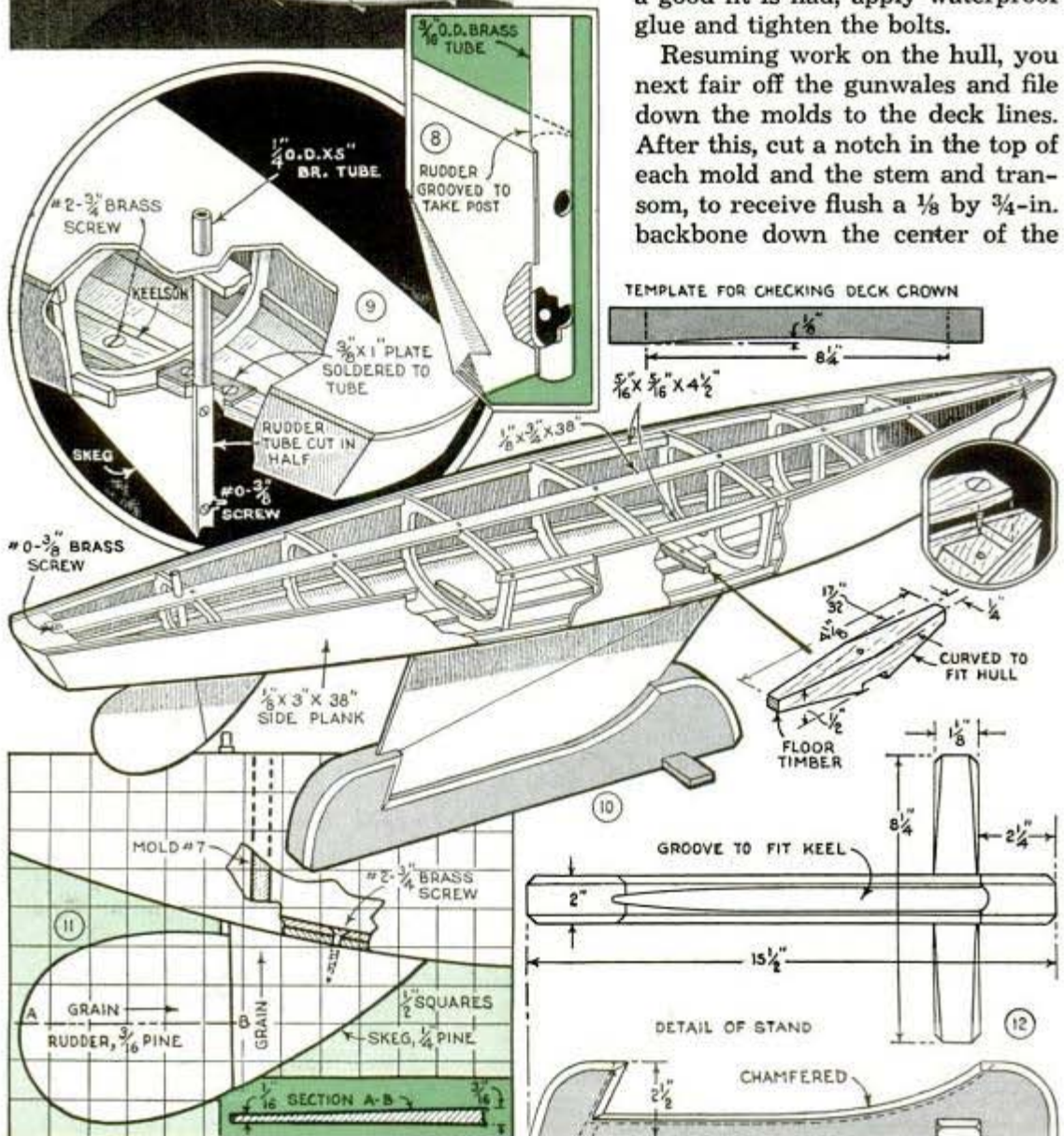

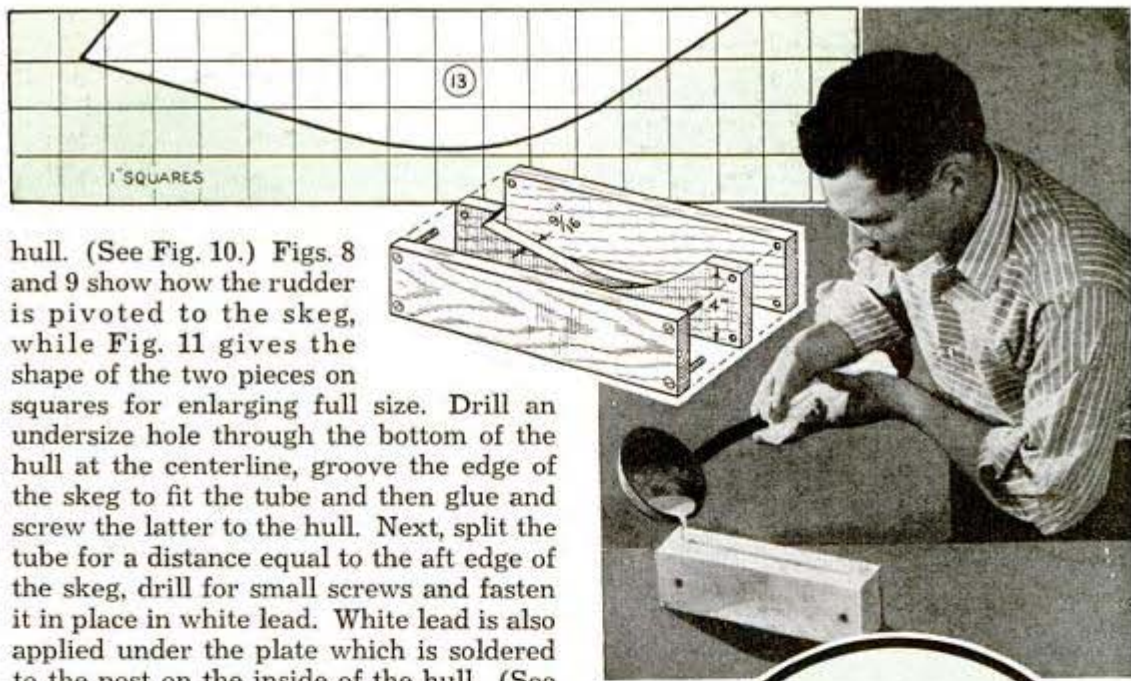

hull. (See Fig. 10.) Figs. 8 and 9 show how the rudder is pivoted to the skeg, while Fig. 11 gives the shape of the two pieces on squares for enlarging full size. Drill an undersize hole through the bottom of the hull at the centerline, groove the edge of the skeg to fit the tube and then glue and screw the latter to the hull. Next, split the tube for a distance equal to the aft edge of the skeg, drill for small screws and fasten it in place in white lead. White lead is also applied under the plate which is soldered to the post on the inside of the hull. (See

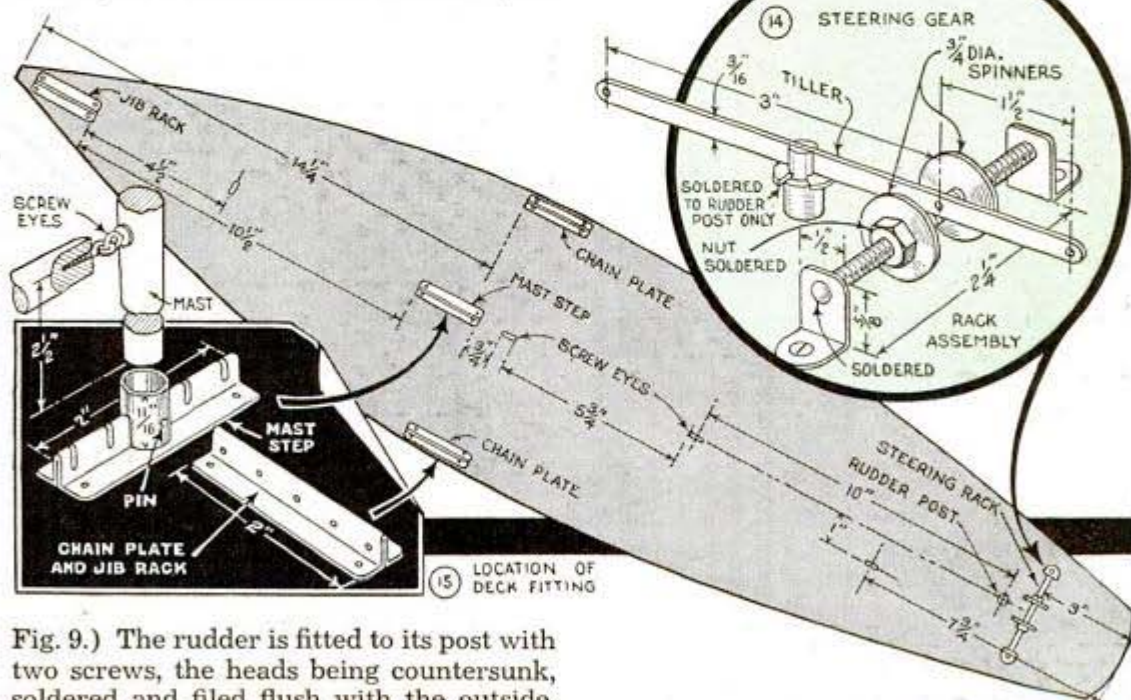
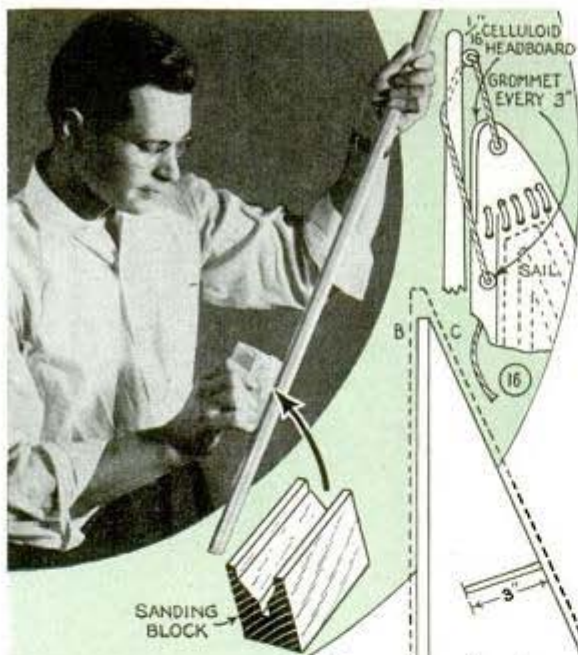

Fig. 9.) The rudder is fitted to its post with two screws, the heads being countersunk, soldered and filed flush with the outside.

To lay the one-piece deck, drill your $\frac{1}{8}$ -in. wood to fit over the projecting rudder tube and fasten it temporarily for marking. Cut the piece $\frac{1}{16}$ in. oversize so that you can later trim it flush with the sides. Prior to laying the deck in white lead, the underside of it, as well as the inside of the hull, should be given three coats of paint or varnish. Also, don't forget to add the pieces to the gunwales between molds 3 and 4. Set all screw heads just below the surface and fill with plastic

wood. Figs. 14 and 15 detail the fittings and the deck plan shows you where they go. The mast step and chain plates are bent from thin sheet brass to stand about $\frac{1}{4}$ in. high, and the tiller arm, Fig. 14, is pinned and soldered $1\frac{1}{2}$ in. from the forward end. The nut-faced spinners travel on a No. 6-32 threaded rod. Use straight-grain pine or spruce for the mast, boom and jib club shown in Fig. 19. First cut the pieces square, tapering the ends as indicated, and then form them round by planing off the



MATERIAL LIST

- 2 pcs. 3/4 x 3 x 38-in. pine, building board
- 1 pc. 1/4 x 5 x 48-in. waterproof plywood, molds
- 1 pc. 3/8 x 2 x 4-in. pine, stem
- 1 pc. 3/4 x 2 1/4 x 3 1/2-in. pine, transom
- 7 pcs. 1/2 x 1/2 x 6-in. pine, cleats for molds
- 1 pc. 1/8 x 3/8 x 38-in. pine, keel
- 2 pcs. 1/8 x 5/16 x 38-in. pine, chines
- 2 pcs. 3/8 x 5/16 x 38-in. pine, gunwales
- 2 pcs. 1/2 x 3/8 x 4-in. pine, floor timbers
- 12 pcs. 1/8 x 3/4 x 38-in. pine, bottom planking
- 2 pcs. 1/8 x 3 x 38-in. pine, side planking
- 1 pc. 1/8 x 8 1/2 x 38-in. pine, deck planking
- 3 pcs. 9/16 x 6 x 18-in. pine, lead mold
- 1 pc. 9/16 x 9/16 x 54-in. pine, mast
- 1 pc. 7/16 x 7/16 x 20-in. pine, boom
- 1 pc. 3/8 x 3/8 x 13-in. pine, jib club
- 1 pc. 2 x 3 x 15-in. pine or spruce, stand
- 1 pc. 1/4 O. D. x 5-in. brass, rudder tube
- 1 pc. 3/16 O. D. x 5-in. brass, rudder post
- 1 pc. 1/4 x 2 1/2 x 3-in. pine, rudder blade
- 1 pc. 3/16 x 10 1/2-in. brass rod, keel bolts
- 4 No. 10-24 brass nuts for keel bolts
- 2 brass washers for keel bolts
- 8 lbs. lead for two-part keel
- 3 gross 1/2-in. brass escutcheon nails
- 1 lb. waterproof resin glue
- 12 brass screw eyes
- 7 ft. 1/32-in. brass wire for shrouds
- 1 pc. No. 28-ga. x 1 x 8-in. sheet brass for mast step, jib rack and chain plates
- 1 pc. No. 22-ga. x 12-in. brass wire for hooks
- 1 pc. 1/16 x 3/16 x 6-in. brass for tiller
- 1 No. 6-32 x 2 1/2-in. brass bolt, 2 nuts, 2 washers
- 1 pc. 1/16 x 3/4 x 5-in. sheet brass for traveler angles and spinners
- 1 pc. 7/16 O. D. x 1/2-in. brass tube, mast ferrule
- 20 ft. light fish line (braided preferred)
- 18 No. 2 x 1/2-in. brass screws to fasten chines
- 10 ft. 1/4-in. linen tope
- 1 1/2 yds. oiled silk for sail

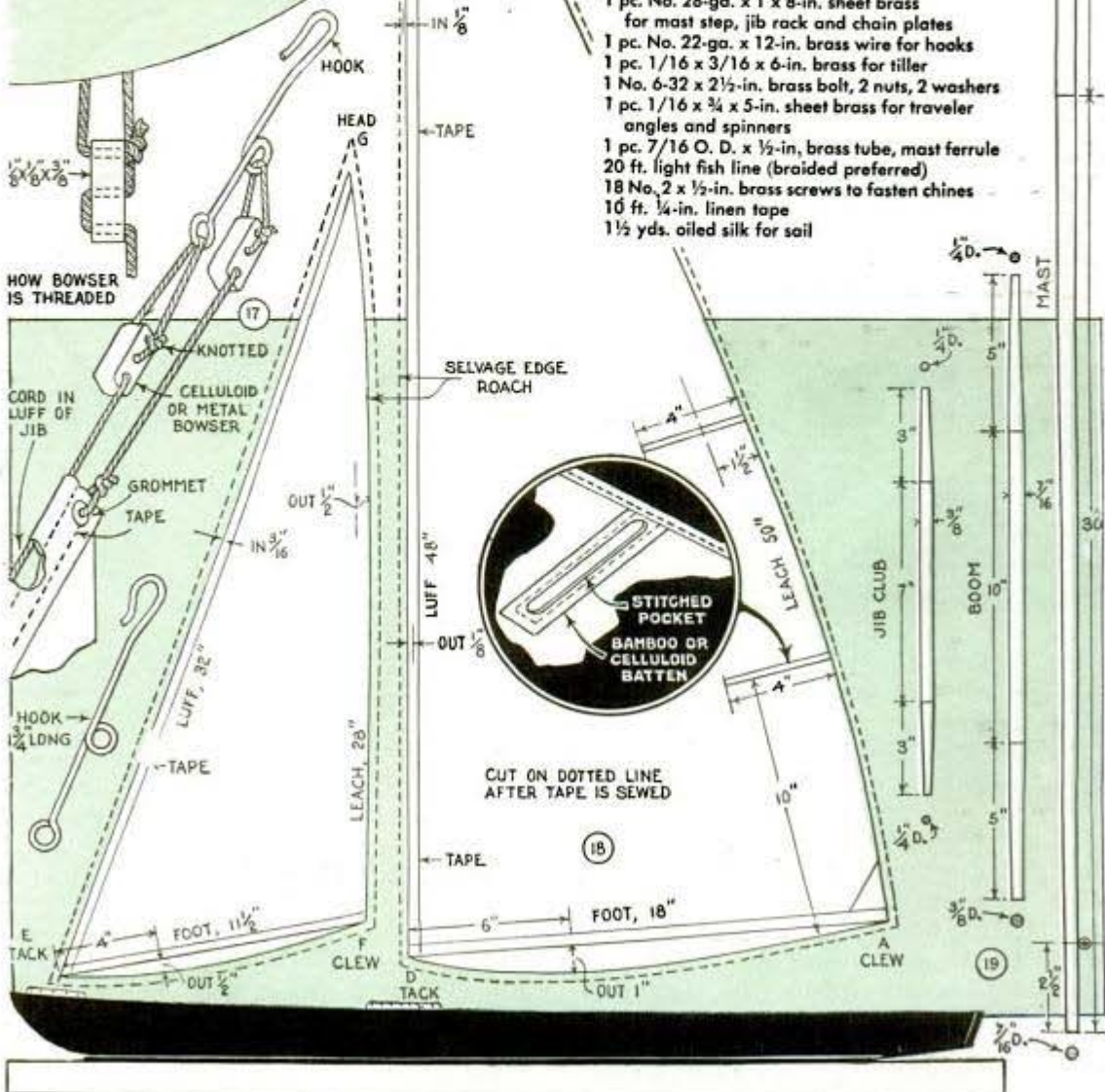

HOW BOWSER IS THREADED

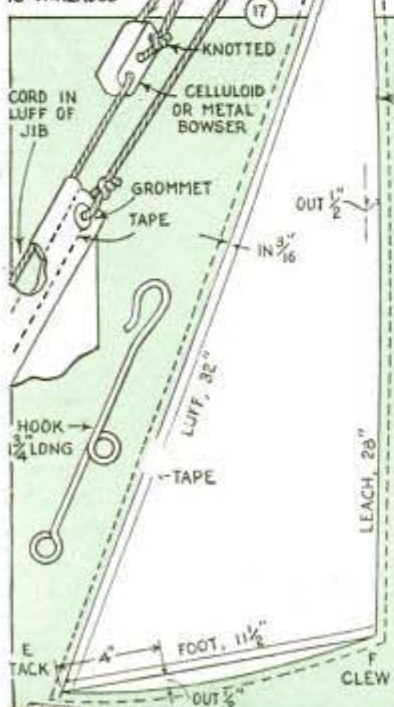

CUT ON DOTTED LINE AFTER TAPE IS SEWED

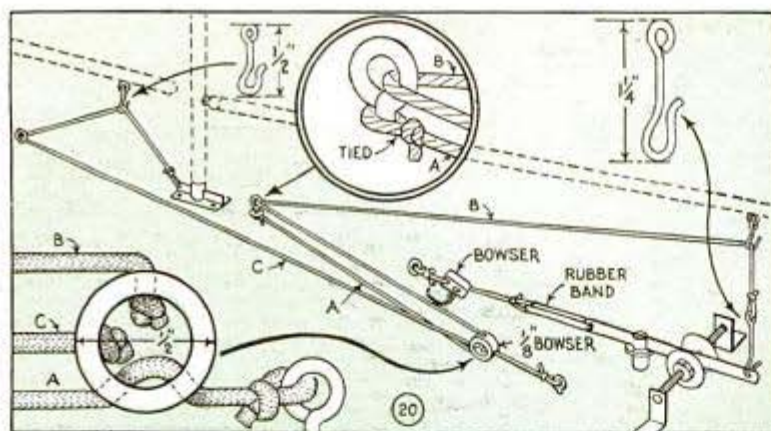

corners and finishing with sandpaper.

About $1\frac{1}{2}$ yds. of cambric or oiled silk are needed for the sails. Spread the material out flat and mark it as shown in Fig. 18. Keep the main-sail leach A-C, about 2 in. in from the selvage edge. At B-C allow $\frac{3}{4}$ in. for attaching the headboard. Draw a straight line from A-C and measure out $1\frac{1}{2}$ in. for the curved edge. Do the same at the foot. Along the luff B-D, make marks 16 and 32 in. from D. At the 16-in. mark, you measure out $\frac{1}{8}$ in., while at the 32-in. point, you measure in $\frac{1}{8}$ in. Through these points a reversed curve is drawn to give the right set to the sail. A $\frac{3}{4}$ -in. margin is allowed along B-D for hemming, while $\frac{3}{8}$ in. is sufficient along A-C and A-D. The jib sail is laid out similarly. The luff is curved through a point marked $\frac{1}{16}$ in. in, 12 in. from G, while on the leach the curve is brought out $\frac{1}{2}$ in., 14 in. from the same point. Before cutting the sails on the margin lines, sew $\frac{1}{4}$ -in. tape inside lines B-D and E-G and straight across from A-D and E-F to keep the bias edge from stretching. Fold and sew a wide hem over the tape on the luff of each sail and a narrow one on the leach and foot. Along the luff of the main-sail, shoe eyelets, or grommets, are spaced 3 in. apart through which a light cord is threaded and wound spirally around the mast as in Fig. 16. The clew and tack of the jib are tied loosely to the club in a manner similar to the mainsail, Fig. 22, while the cord in the luff, Fig. 17, runs to a hook in the deck jib rack. Figs. 20 and 21 show clearly how the main and jib sheets are rigged. The two wire shrouds

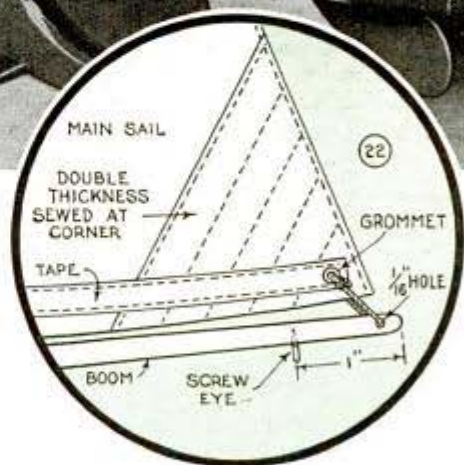

which hook to the chain plates are looped around the mast at the top of the jib screw eye and adjusted to give the mast a $1\frac{1}{2}$ -in. rake aft.

The hull, keel, rudder and deck border of "Starlet" were enameled green, while the deck, mast, boom and club were finished natural with white shellac. Before applying the first coat which should be thinned slightly with turpentine, give the wood a thorough sanding with Nos. 0 and 00 sandpaper. Between each coat rub down the enamel with No. 6-0 sandpaper or fine steel wool. The third and final coats may be left glossy, or rubbed down and waxed.

Tool Rack on Top of Stepladder Saves Many Steps



Much of the time consumed in getting off a stepladder after tools can be saved if you convert the top of the ladder into a tool rack. Holes can be drilled near the rear side to receive tools such as chisels, screwdrivers, etc., while the ends can be notched for saws, hammers, wrenches, etc. Strips of hardwood or flat iron are screwed over the open ends of the notches.

Seamed Tubing Is Spread Evenly With Wooden "Egg"

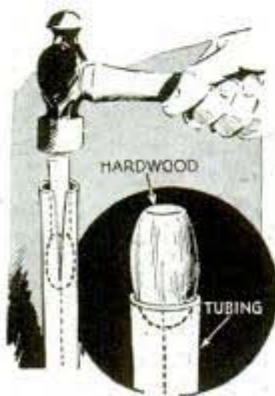

If you have to spread a piece of seamed tubing, you can do the work uniformly by using a piece of hardwood turned to the shape of an egg, making a flat surface on one end for driving. The diameter of the

egg will depend on the work at hand. After the egg has been driven in flush with the

end of the tube, a wood rod slightly smaller than the inside diameter of tube is used to drive it the rest of the way.

Light Shop Machinery Levelled With Aid of Bent Washer

Having a number of small woodworking machines to set on an uneven floor, one mechanic solved the problem of leveling them by using bent washers under the feet of each machine. Tightening of the lag screws that anchored the machines caused the washers to spread and reduce the space between the feet and the floor the required amount. The weight of the machines was not sufficient to spread the washers once the machines were leveled.



Tags on Phonograph-Record Rack Show Position of Records

Here's a simple way to identify your records so they can be selected quickly from a phonograph-record holder of the type shown. Make a tag for each slot from a strip of cardboard and attach an ordinary dress hook to each one with a paper staple. The names of the records are next printed on the tags, which are then hooked in their respective slots.

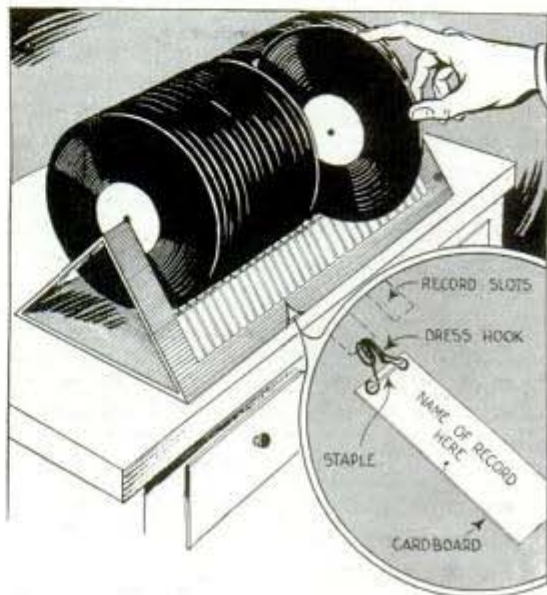

Adjustable Music Stand Is Inexpensive to Make

For use in schools or at home where stability and rigidity are more important than portability, this music stand is highly satisfactory. It can be made of any wood at hand. Begin with the base, which is triangular in shape, and has three feet screwed to it. Each foot consists of three pieces assembled with glue as shown in the lower left-hand detail. The base is mortised for the standard, which is in two parts, the upper part being made of two strips with spacer blocks at each end. This construction provides a long slot for adjustment by means of two bolts and wing nuts located in the lower part of the standard, which is a length of solid stock. The upper part of the standard is pivoted to the music rack with a long bolt, which passes through a block screwed to the rack as indicated in the circular detail. Five $\frac{1}{4}$ by $\frac{3}{4}$ -in. horizontal strips and four $\frac{1}{2}$ by $\frac{3}{4}$ -in. and one $\frac{3}{4}$ by 1-in. vertical strips make up the rack. These are half-lapped at the joints, which are glued and screwed. The heavier vertical strip is used in the center where the standard is pivoted. Two blocks, one on each side of this strip at the lower side, reinforce the rack at this point and tend to stiffen it. A strip across the bottom of the rack provides a ledge on which to rest the music. Planing the lower edge of the rack to give the ledge piece a slight downward tilt of about 2 degrees provides clearance for the pages of music so that they can be turned easily without binding.

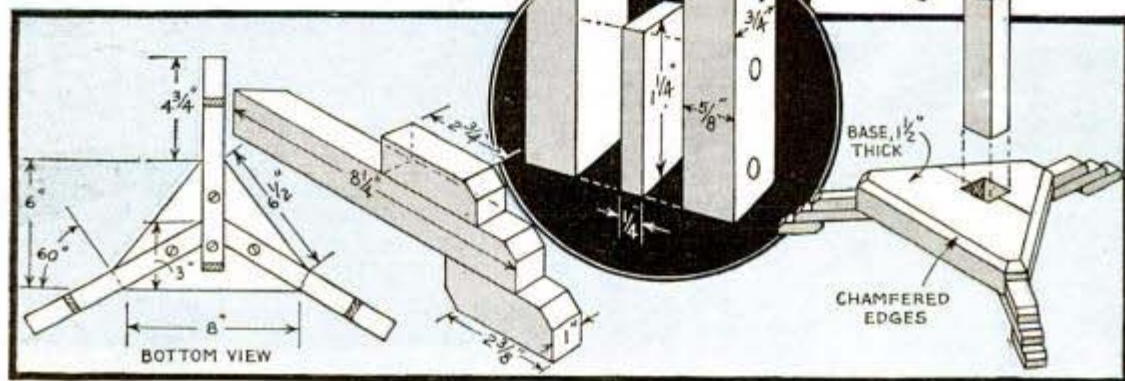
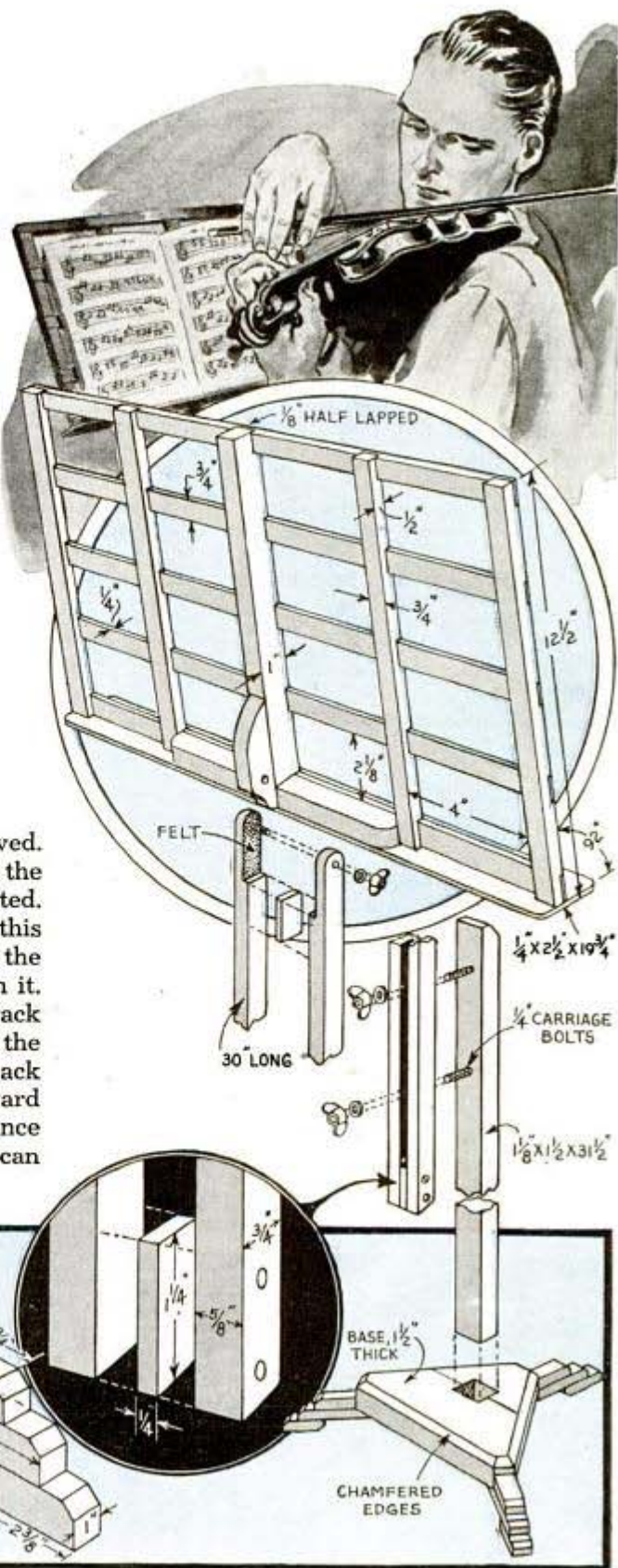

Funnel Dasher Mixes Solution Used to Spray Trees

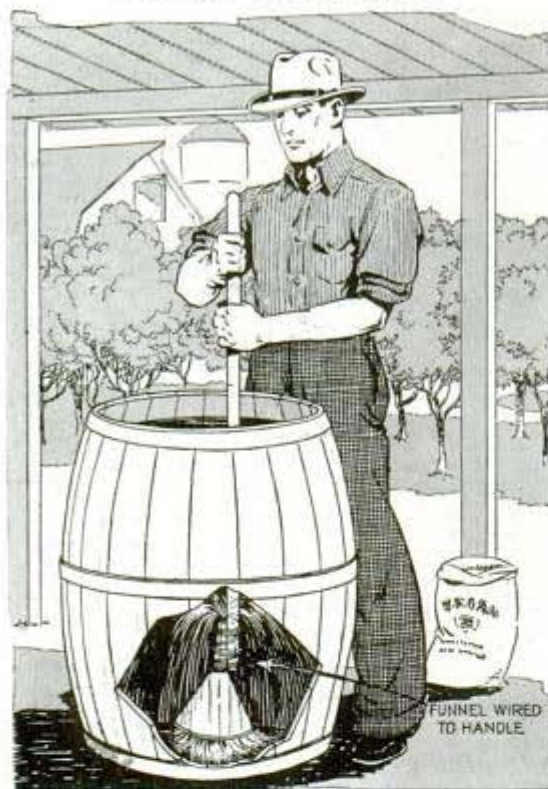

To speed up the dissolving and mixing of chemicals for his orchard spraying machine, one farmer wired a large funnel to the stirring stick. By churning this up and down in the mixing barrel, the liquid was agitated violently, and the solids were carried up through the spout instead of merely rotating around the bottom of the container, and were dissolved quickly.

Rubber-Hose Wedge Holds Saw While Filing It on Mandrel

The next time you want to touch up the teeth of your circular saw with a file, just wedge a piece of rubber hose between the saw and the ripping fence. This will pre-

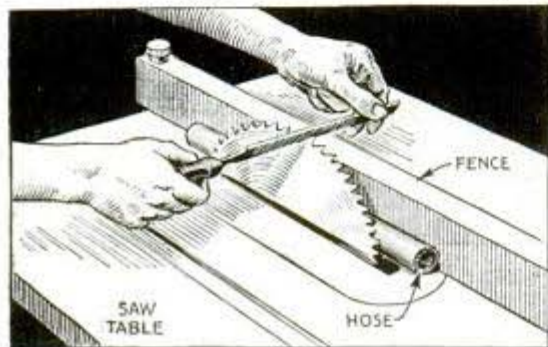

vent the saw from turning, and will also silence any tendency to screech caused by drawing the file across the teeth.

Crutch Tips From Truck Tire

I make long-wearing crutch tips from the thick, tough rubber of old truck tires. The tips are cut to shape and then forced into pipe couplings screwed onto the ends of the crutches. For use on sidewalks and hard ground, tips shaped like the one shown are ideal. If you do much walking on soft ground where the tips are likely to sink into it, the tips can be made larger to prevent this.

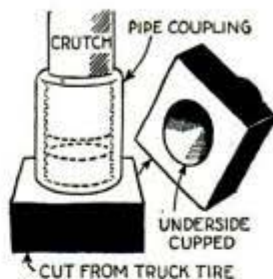

—V. A. Doty, Attleboro, Mass.

Wood Sliver Vents Glued Dowel For Easy Driving



When a dowel isn't grooved to vent it while driving, you can accomplish the same thing by using a thin sliver of wood. Just insert the sliver at the edge of the hole as shown, and drive in the dowel. After

this has been done, the sliver can be cut off flush with the surface after the joint has been completed.

Finger Ring Keeps Twine Handy When Wrapping Packages

Slip the twine through your finger ring as indicated the next time you have a number of packages to wrap. In this position, the end will always be at hand when a package is ready.



PROCESSING EQUIPMENT *for Home Movie Film*

By J. R. Bailey

AMATEUR movie-makers can save from one-third to one-half on the cost of film if they buy it in bulk and do their own processing. In using the outfit described here, the exposed film is wound on a reel mounted in a hinged frame above a round-bottom sheet-metal tank. The reel can be raised while pouring the solutions into the tank, after which it is lowered and revolved to bring all the film in contact with the solutions. Water for washing the film between and after the baths in the solutions, comes from two copper tubes, one at each side of the tank. Holes are drilled along their length.

The entire processing outfit takes little floor space. The table has a 34 by 36-in. top, which is cut out to take the tank. A convenient height for the table is 36 in., but this can be altered to suit the individual. The tank, Fig. 2, is made of three pieces of galvanized sheet metal, soldered together. The drain is fitted with a valve and can be swung around over a wide-mouth

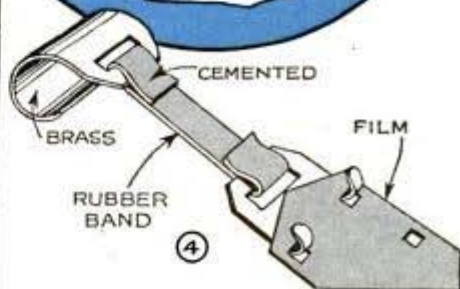
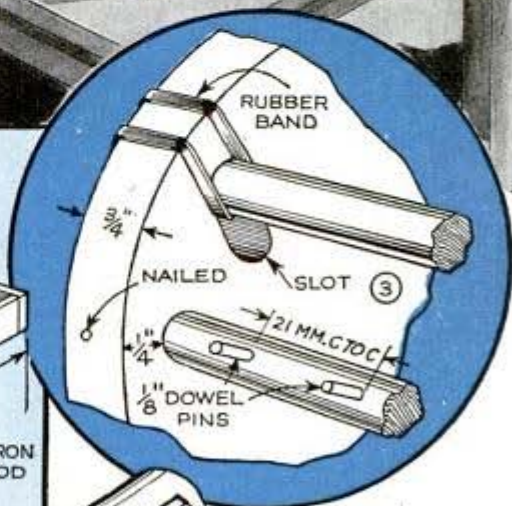
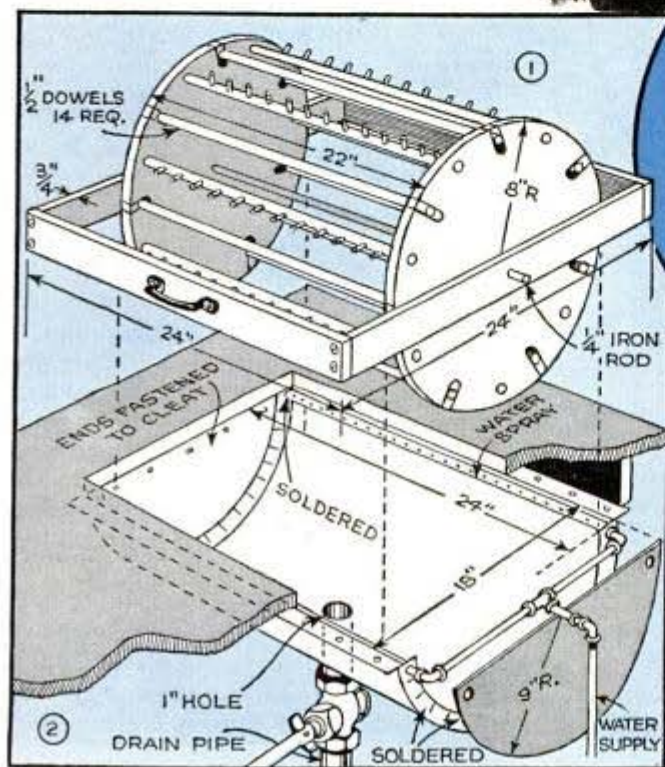

A clip like the one above is used on each end of the film to hold it on the reel. Each clip consists of two pieces of brass joined together by a strong rubber strip

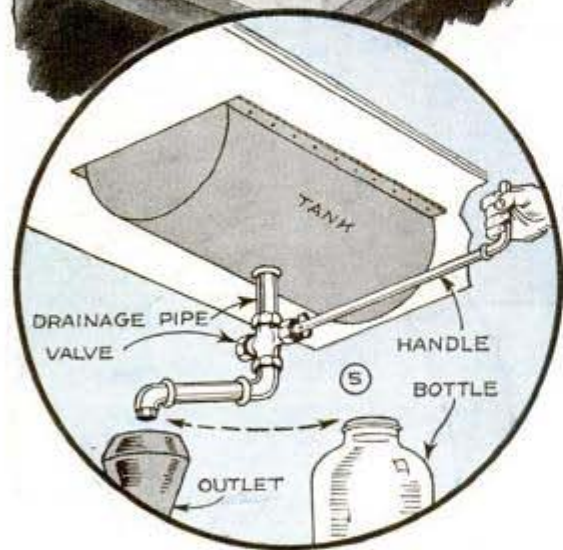
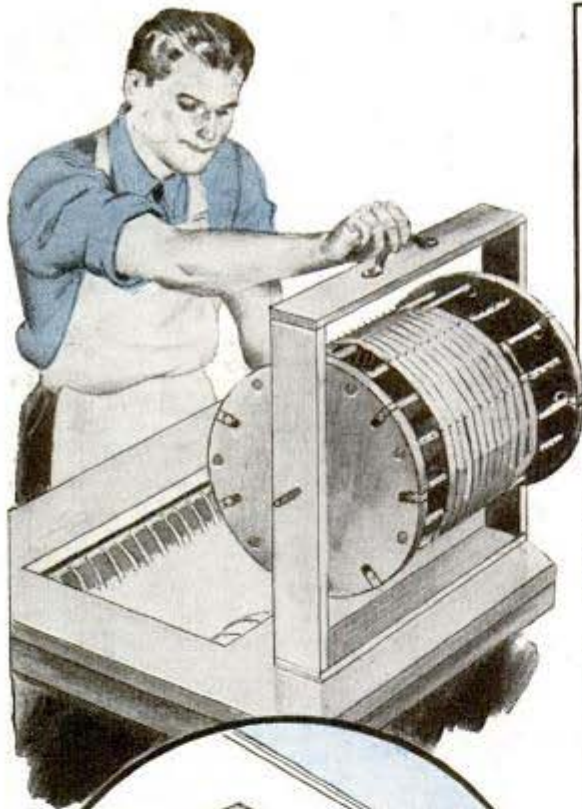

bottle to recover solutions that may be used again.

The reel, Fig. 1, is made by mounting two 16-in. wood disks on an iron-rod axle. Fourteen $\frac{1}{2}$ -in. dowels, spaced equidistantly, are mounted between the disks about $\frac{1}{4}$ in. from their edges, but only seven of the dowels are mounted solidly. The other seven are set in slots and the ends are forced toward the outer extremities of the slots by heavy rubber bands. By tying down the ends of the movable dowels before winding the film on the reel and cutting the strings after it is in place, the film will be kept taut while it is being processed.

STEPS IN PROCESSING

1. Washing and stretching . . . 5 min.
2. Developing . . . 4 min.
3. Hardening . . . 3 min.
4. Washing . . . 3 min.
5. Bleaching . . . until silver is removed
6. Washing . . . 3 min.
7. Clearing . . . 4 min.
8. Washing . . . 3 min.
9. Exposing . . . 2 min.
10. Redeholding . . . 4 min.
11. Washing . . . 5 min.
12. Drying

The film guide pegs are $\frac{1}{8}$ -in. dowel pins spaced to accommodate 16-mm. film. The pegs are mounted only in the seven stationary dowels and as the film is wound in a spiral, it is necessary to make allowance for this in the location of the pins

on each dowel. The clip by which each end of the film is fastened to the reel is detailed in Fig. 4. The frame holding the reel is $\frac{3}{4}$ -in. wood and is hinged to the table. A drawer pull on the front is convenient for moving it up and down.

FORMULAS

Developing solution

Water	1 gal.
Elon	180 grains
Hydroquinone	1 $\frac{3}{4}$ oz.
Sod. sulphite	7 oz.
Pot. bromide	$\frac{3}{4}$ oz.

Use equal amounts of solution and water. For redeveloping, add $\frac{1}{2}$ dram 26-deg. ammonia water per 16 oz. of diluted developer.

Hardener

Pot. chrome alum	$\frac{1}{2}$ oz.
Water	16 oz.

Bleaching solution

Water	58 oz.
Pot. bichromate	3 $\frac{1}{2}$ oz.
Sulphuric acid, conc.	6 $\frac{1}{2}$ oz.

Use 1 part solution to 15 parts water.

Clearing solution

Water	48 oz.
Sod. sulphite	12 oz.
Add water to make	60 oz.

Use 1 part solution to 5 $\frac{1}{2}$ parts water.

The twelve steps of processing and formulas for the solutions are shown in the boxes on this page. The film may stretch slightly after the first wetting and have to be tightened. As the tank is semicircular, very little solution is needed to contact the film as the reel is revolved. After step 2, the developer is recovered and may be used for redeveloping, step 10, by adding $\frac{1}{2}$ dram of 26-deg. ammonia water to each 16 oz. of developer. Where washing is indicated, the drain is set over the waste funnel, the water turned on and the reel revolved in the spray. The final washing should be especially thorough.

☛ If a wire is run from the metal part of your photo enlarger to a good ground, such as a cold-water pipe, static electricity will be eliminated and dust can be brushed from the enlarger easily.

Bank of Photo Lights Housed in a Vanity Case

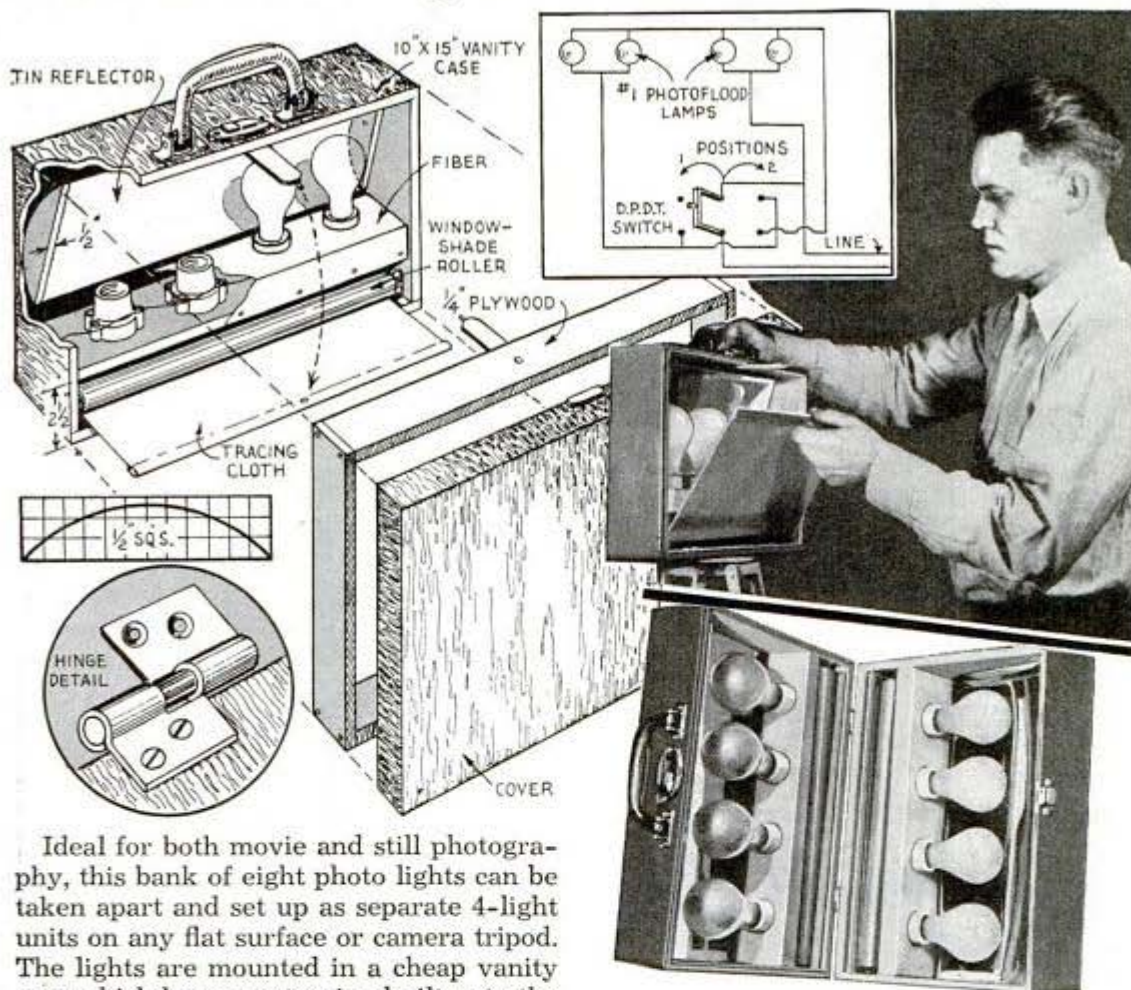

Ideal for both movie and still photography, this bank of eight photo lights can be taken apart and set up as separate 4-light units on any flat surface or camera tripod. The lights are mounted in a cheap vanity case which has an extension built onto the lid so that both parts are of equal depth. Hinges may be made from a large butt hinge by sawing it through the center and soldering a pin in two of the pieces so that the units may be separated easily. A shelf nailed in each half of the case provides a

base to which the electrical sockets are screwed. Reflectors are held in shape by curved end pieces, while strips of tracing cloth on window-shade rollers are used for diffusing the light. If desired, a dimmer switch may be installed as indicated.

Colored Tape on Holders Identifies the Film They Contain

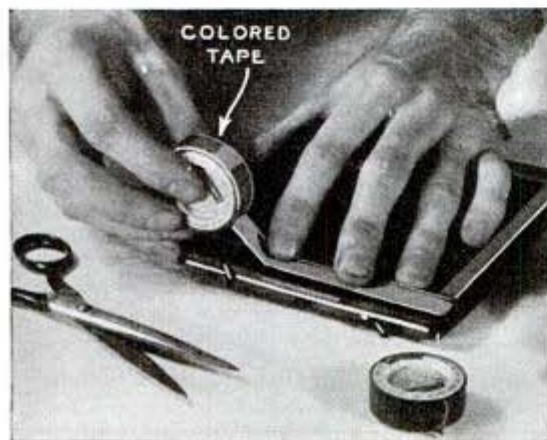

Film holders containing several different kinds of film will be easy to recognize when they become mixed in your camera case if you mark each holder with a small strip of colored cellulose tape. You can use green tape to indicate "pan" film and red for "ortho," using strips of various lengths to mark different kinds of each type.

—William Swallow, Brooklyn, N. Y.

Ⓛ In compounding formulas always mix chemicals in the order given in the instructions and be sure that each chemical is dissolved before the next one is added.

Plastic Cup Has Notch in Rim To Pour a Fine Stream



Accuracy in weighing small quantities of chemicals in the photographic darkroom can be increased by using a small plastic measuring cup with a notch filed in the rim. Dry chemicals can be poured through

the notch in a fine stream and exact balance is obtained quickly.

—Kenneth Murray, Colon, Mich.

Smoke Locates Holes in Bellows

Minute holes in camera bellows can be located as follows: With the bellows extended, remove the lens from the camera and blow some smoke in the hole from which it was removed. Place your thumb over the lens opening and push the bellows together slowly. If there are any pinholes, a fine stream of smoke will emerge from each one.



WHAT KIND OF BOAT DO YOU WANT?

Whether it's a simple rowboat, an outboard runabout or a family cruiser, you'll find something you want among our plans. Build your boat now for the coming season



"Banta," 12-Ft. Runabout—1080-1081

"Banta," 12-Ft. Plywood Runabout—1080 and 1081: Simplified construction makes this plywood runabout easy to build. Here's the boat to take along on that weekend trip. 2 prints 50c.

"Falcon"—1070-1079 Incl.: Trim, sturdy 18-ft. inboard runabout or cabin cruiser. 66 in. beam, 42 in. total depth, 7 or 8 passengers. Makes a speed of about 17 m.p.h. with a 20 h.p. motor. 10 prints, material list and procedure \$2.50.

CATALOGUE OF PLANS

If you have a home workshop and want some new ideas on things to build, just send your name and address with a 3c stamp for our new 32-pp. illustrated plan catalogue. Lists plans on workbenches, motor-driven machines, garden furniture, models of all kinds, boats, radio equipment, juvenile articles, etc.

Address—Plan Service, Popular Mechanics Magazine, 200 E. Ontario St., Chicago

"Arrowhead" Sloop—944 to 951: 21-ft. sailboat that can be built by average craftsman. Accommodates up to 10 passengers. Set of 8 prints \$2.00.

"Hi-Ho," 14-Ft. Family Runabout—840 to 845: Powered by 11 to 22 hp. outboard or light inboard motor. Beam 58 in. Set of six prints \$1.50.

"Roamer"—765 to 770: Outboard cabin cruiser. 16 ft. long, 66 in. beam. Requires outboard motor of 20 to 36 hp. Set of six prints \$1.50.

"Skipper"—1018 to 1023: Low-cost, outboard runabout. Can be built for \$30 to \$40. 14 ft. long, 54 in. beam, weighs about 275 lbs. Set of six prints \$1.50.

12-Ft. Rowboat—707: Flat bottom. Can be used with small outboard motor. 25c.

"Sea Saucer"—893: Lightweight sailboat. Length 9½ ft. Planked with 3/16-in. plywood. 25c.

16-Ft. Canoe—811 and 812: Cedar planking covered with canvas. Two prints 50c.

Canvas-Covered Kayak—928 and 929: Light framework covered with canvas. 17 ft. in length and accommodates single passenger. Two prints 50c.

7½-Ft. Plywood Rowboat—1068: Made from waterproof plywood this boat is easily transported on top of car. Complete instructions and material list included. 25c.



SHOP NOTES

LATHE DIAL *shows cutting speed*

By F. N. Schwend

TO OBTAIN the maximum efficiency of a lathe, the work should be rotated at a speed commensurate with the type of metal being turned, the kind of cut, whether lubricant is used, etc. Too high a speed will cause the cutting tool to burn, and will tend to produce chattering and overheating, while too slow a speed not only wastes time, but may result in a rough cut. However, these points are often ignored, principally because of the inconveniences in calculating the speed, which varies with the diameter of the work as well as the r.p.m. of the lathe spindle.

However, it is an easy matter to determine lathe cutting speeds on an indicator, which can be made from an automobile speedometer as shown in Figs. 2, 3 and 5. The speedometer is taken apart, the square shank of the rotor shaft is cut off and the threaded portion of the die-cast base is cut back to allow one of a pair of bevel gears to be pinned to the round part of the shaft. A bracket of heavy flat iron supports the indicator on the end cover of the lathe, the size and shape of the bracket depending on the construction of the lathe. A bearing is put in one leg of the bracket, and a drive shaft carrying the second bevel gear, is fitted into the bearing. A flanged sleeve is formed to be fixed to the other end of the drive shaft and a pin is driven into a hole

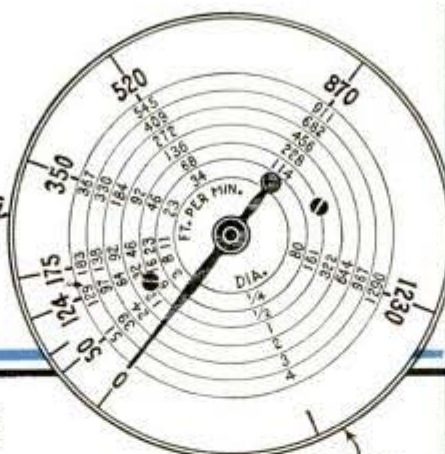

① CARDBOARD

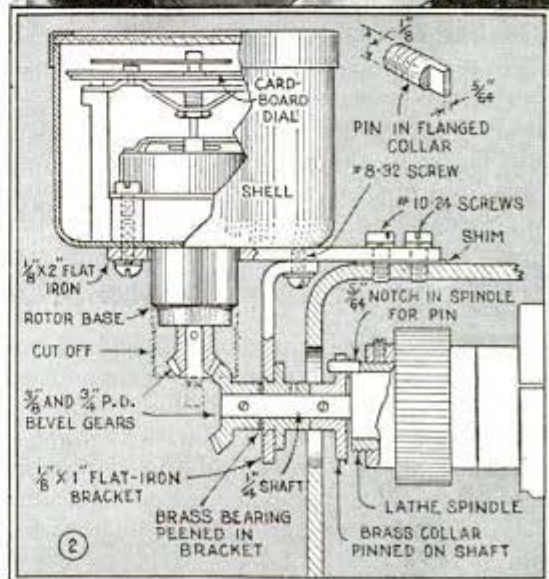

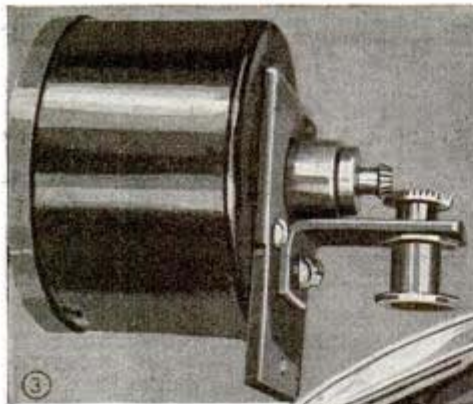

Correct Cutting Speeds	Heavy Cut	Finish Cut	Cutting Threads
Aluminum - - - -	200	300	50
Brass - - - - -	150	200	50
Bronze - - - - -	90	100	25
Cast iron - - - -	60	80	25
Steel, machine - -	90	125	35
Annealed tool steel -	50	75	20

Determining cutting speeds

Diameter in in. X 3.1416 X R. P. M. = Ft. per min.

④ $\frac{\quad}{12}$

in the flange so that it extends outwardly to engage a notch filed in the end of the lathe spindle.

This arrangement permits the indicator to be swung out of the way when a collet chuck is used or when the work is to extend through the lathe spindle. Closing the end cover and rotating the spindle to align the pin with the notch couples the indicator. The ratios of the bevel gears may vary from 1 to 1 to 2 to 1, the latter giving a full scale deflection of the needle at approximately 1,250 r.p.m. on most speedometers. The range may be varied considerably though, by adjusting the hair spring, while with a 1 to 1 ratio considerably higher speeds may be indicated. The r.p.m. of the lathe at each of its different speeds is determined either by calculating the different pulley diameters and motor speed, or by using a revolution counter. The needle positions at the different lathe speeds are marked on the regular dial. These marks are then transferred to a new dial of heavy white paper which is later secured to the face of the old dial,

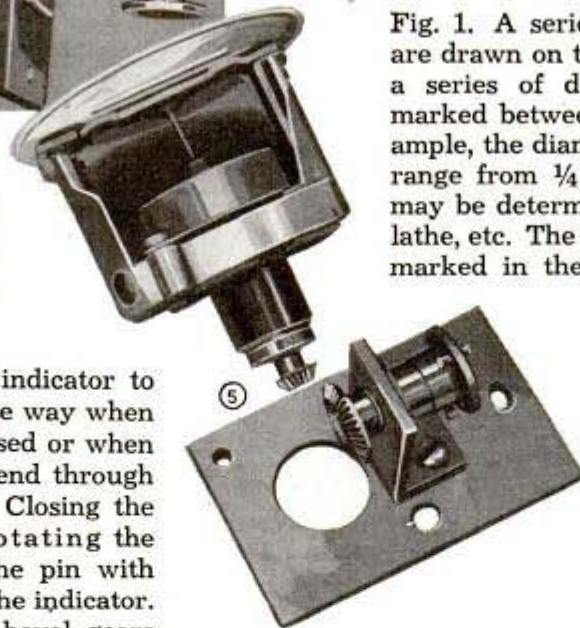

Fig. 1. A series of concentric circles are drawn on the dial, one for each of a series of diameters, which are marked between the circles. For example, the diameters may be set off to range from $\frac{1}{4}$ to 4 in. although this may be determined by the size of the lathe, etc. The r.p.m. at each speed are marked in the outside circle in line with the corresponding needle positions. The cutting speeds in ft. per min. are then calculated for each combination of lathe speed in r.p.m. and diameter.

When it is desired to check the cutting speed of a piece of work, follow the circle indicative of the nearest diameter, around to the number under the needle position, which number will indicate the actual cutting speed.

The correct cutting speeds may be found in a number of published tables. The general speeds in Fig. 4 may be used if such tables are not available. Also, the indicator may be used for selecting the correct speed of the lathe for a given diameter of the work and cutting speed in ft. per min. by following the corresponding diameter circle around until the nearest cutting speed value is found. The aligned r.p.m. value in the outside circle will then indicate the correct spindle speed.

Oil Trap Helps Locate Slight Leaks in Gas-Line Valves

To locate a slow, imperceptible leak in a safety or stop valve of gas or air lines, one engineer uses a U-shaped pipe assembly attached to the valve as indicated. Oil in the U-pipe traps escaped gas, which then builds up a slight pressure. Opening a pet cock on the pressure side of the U-pipe after a while, enables him to detect the presence of escaped gas either by odor or sound. An oil that will not absorb the particular gas, or be absorbed by it, must be used.

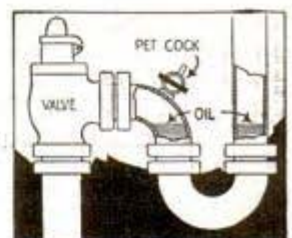

These Two Clamps Handle Wide Variety of Work

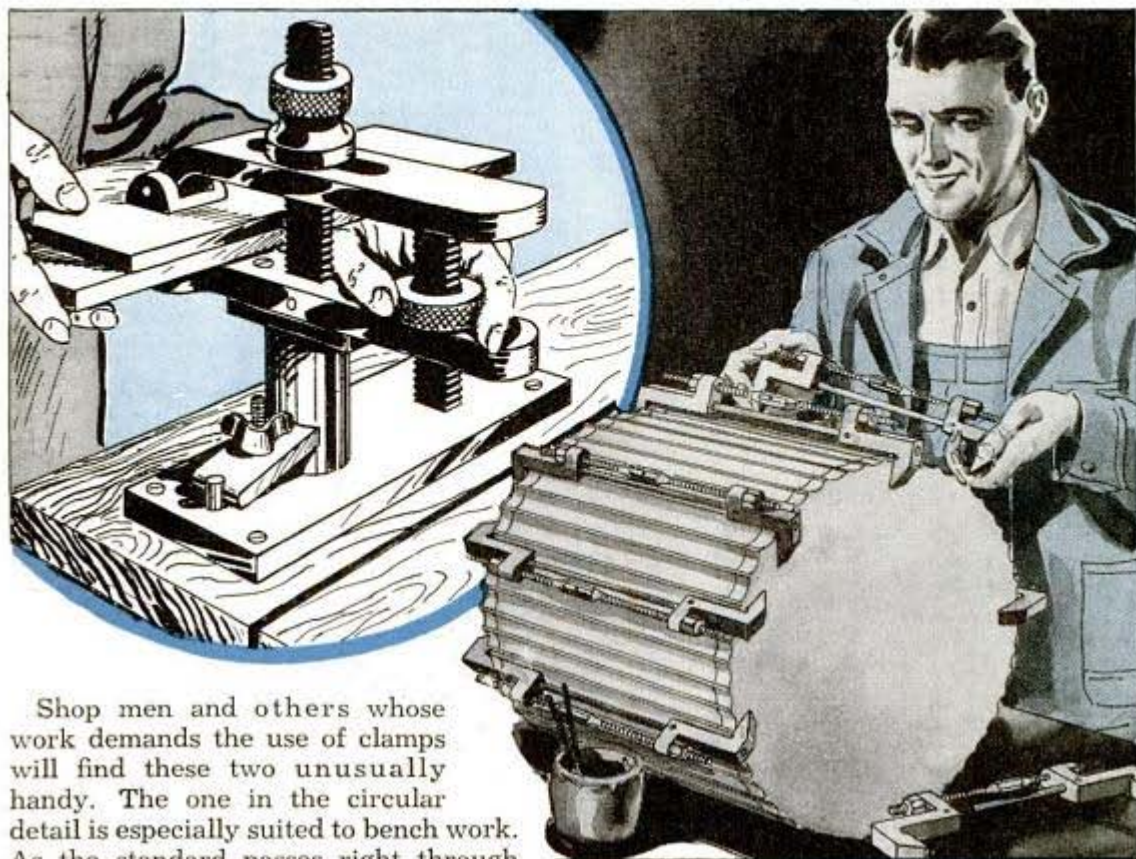

Shop men and others whose work demands the use of clamps will find these two unusually handy. The one in the circular detail is especially suited to bench work. As the standard passes right through the bench top, it can be adjusted in height or swung around by loosening the wing nut on the clamping wedge at the base. The wide upper jaw gives uniform pressure over a large area, and the slot in the jaw permits moving it back and forth. In cases where a heavy-duty clamp of the bar type is needed, the one in the lower detail is just the thing.

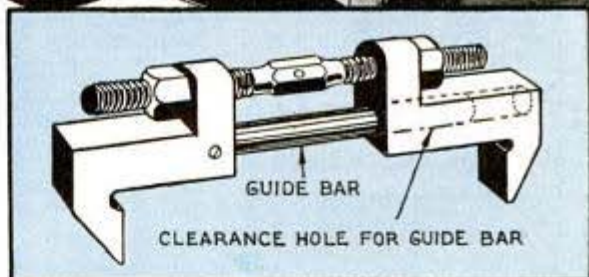

Small Coal Bins at Scales Help Get Exact Load Weights

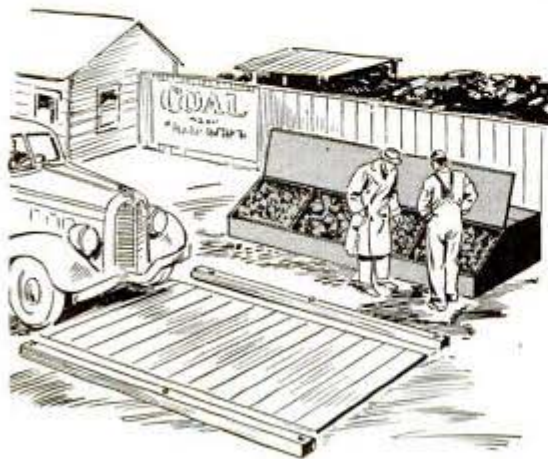

Built close to his scales, small bins make it convenient for a coal dealer to bring a load of coal to the desired weight. If a load is slightly heavy, a little coal is shoveled into one of the bins, there being a bin for each kind of coal. When a load is light, the amount needed can be taken from one of the bins. Also, they serve as a display for customers who wish to see the coal before buying.

☛ If your electric-light pull chains are broken by being jerked too hard, put a small coil spring about the size of a light screen door spring in each chain.

Pipe Stakes Pulled From Ground By Hand With a Pick



You can get good leverage for pulling pipe stakes used to anchor various farm machines solidly to the ground if a pick is used as shown. Three or four holes drilled in each stake to take the pointed end of the pick will enable you to progress from one hole to the other as the stake is raised.

Small Blocks Held on Faceplate With Center Screw and Tape

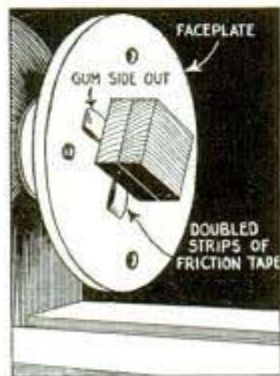

Instead of gluing a small block of wood to waste stock for attaching it to the lathe faceplate, use double strips of friction tape and place them, adhesive side out, under the block before tightening the center attaching screw. The tape provides just enough friction to hold small blocks while turning.

Flameproofing Cotton Fabric

An inexpensive method of fireproofing cotton fabric such as canvas, is to use a solution consisting of ammonium chloride, $\frac{1}{2}$ lb., dissolved in water, 1 qt. The cloth

is soaked thoroughly in the solution, then squeezed and allowed to dry. This method was helpful on canvas used to connect heating ducts.

Tape Holds Type Form Together

Before locking up a type form on a printing press, put a piece of cellulose tape around all four sides of the form. Then the type can be stored after the printing has been done without disturbing or piling the type which sometimes happens when string is used. The tape can be left in place when locking up the form.



Jewelers' Dustproof Parts Trays From Hollow Rubber Balls

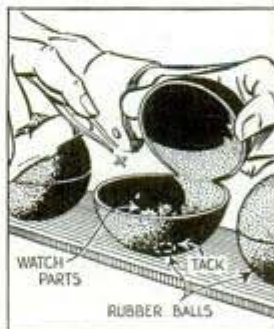

Handy dustproof trays for watch parts and other small pieces of jewelry can be made in a few minutes from hollow rubber balls. The balls are cut almost in half and fastened to the

bench top or a block of wood with thumbtacks, as indicated in the drawing.

Easy Way to Stipple Show Cards

Show-card writers who do not have an air brush can tint or stipple card stock quickly with a rubber sponge inked on a rubber-stamp pad. With the coarse or fine-grain rubber sponges available, and ink pads of different colors, almost any desired stipple effect may be obtained.

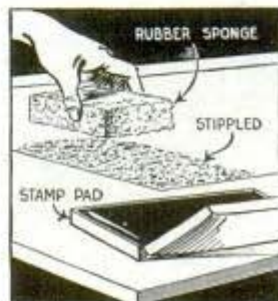

Removable Speed-Reducing Unit for Drill Press

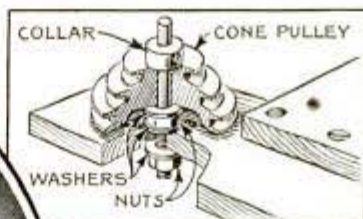
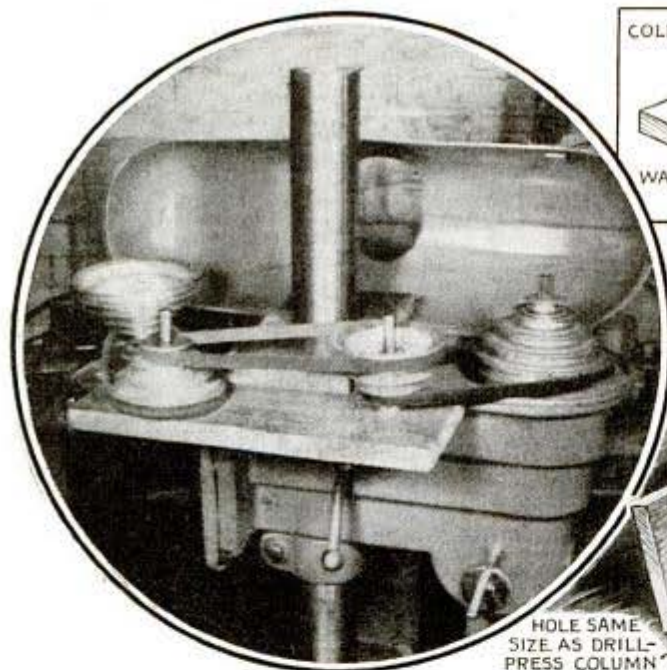

SLOTTED FOR BELT TENSION

HOLE SAME SIZE AS DRILL-PRESS COLUMN



A detachable jack shaft for adapting the speed of a drill press to such work as tapping, or boring with wood auger bits, can be made at small cost. It consists of two cone pulleys on short vertical shafts, which are mounted on a hardwood bracket that slips over the column of the drill-press standard. Three short V-belts, replacing the single long belt, transmit the power of the motor to the drill spindle. Collars with setscrews may be used above and below the hardwood bracket, or the shafts may be threaded and held in place with nuts and washers on each side of the bracket. A special chuck to fit the tapered square-shank auger bits was obtained by dismantling an old auger brace.

—N. W. Hopkins, Detroit, Mich.

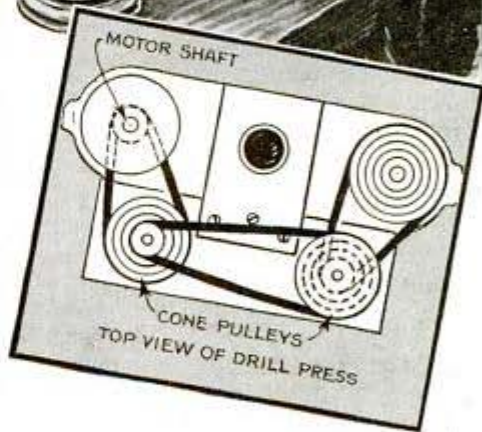

Bench Lamp on Improvised Wire Bracket Is Adjustable

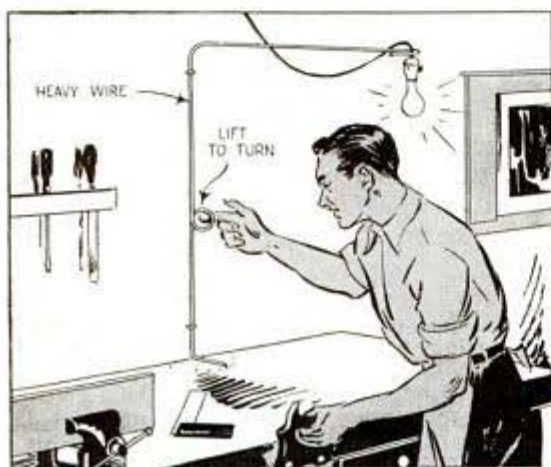

If you want an adjustable bench lamp without the trouble of making a strong permanent one, this simple lamp will be suitable. It can be made quickly as it consists merely of a length of heavy wire or small iron rod bent as shown, and mounted on a wall above the bench with staples or screw eyes. The lower end of the wire is pointed and bent over to stick into the top of the bench. A loop at the upper end is bent against the lamp cord to hold it.

☐ Before planting strawberry plants prune the roots so they are about 4 in. long, and remove most of the leaves.

Gear Wheel Under Heavy Gate Prevents Sagging at End



Sagging of a heavy lot or field gate can be avoided easily by half-burying a discarded gear wheel from an old binder under the latch end as shown. One cog is broken out of the wheel to provide a solid resting place for the gate.

Bottle Is Emergency Insulator For Electric Fence



may be added by using such insulators when regular equipment is not available.

If an insulator of an electric fence is broken and one to replace it is not available, just slip an empty bottle over the stake top and attach the wire to this as indicated. Extra lengths of fence

Cork Insulation Cut Easily

The general difficulty which mechanics have had in cutting cork insulation is in the use of the common crosscut saw. A

better way is to use a crosscut saw with extra large teeth. With it cork can be cut accurately and smoothly.

Handle and Hooks on Stencil To Letter Grain Sacks

In order to hold a stencil firmly against a filled grain sack with one hand, the operator of a grain and feed store soldered a couple of hooks at the corners of one end and a stiff, wire handle at the other.



In use, the hooks penetrate the sack cloth, holding the end firmly in place, while the other end is kept snugly against the sack by means of the handle.

Rubber Finger Stalls Speed Work Of Candling Eggs



To speed the work of candling eggs, and also to decrease the loss caused by breakage, one produce merchant provides rubber finger stalls for his workmen. These allow the eggs to

be lifted from the cases with little fumbling, automatically speeding up the output.

Loss of Small Parts Avoided By Tacky Surface on Board

In a shop where small motors, light fixtures, etc., were taken apart for repairing, loss of screws and other small parts was prevented by placing them on a board coated with belt dressing. The parts adhere to the tacky surface to prevent accidental displacement.



Servicing Car GENERATORS

By C. E. Packer

IT'S USUALLY some little thing that makes a generator stop working. Failure generally begins when the ammeter needle flickers to zero and back.

First, you want to know whether the trouble is in the generator itself or in the regulator, which controls the output. Before attempting this check, it is necessary to know if the circuit between the generator and the battery is complete, which may be determined by closing the cut-out points and noting the ammeter reading. With the engine at rest, the discharge indication will be between 15 and 20 amperes. Two simple tests are made. With the motor running at an approximate 20 m.p.h. road speed, and without having disconnected any wires, hold a screwdriver across the field terminal and the generator frame as in Fig. 1, being sure to make good electrical contact. This completes the field circuit in those generators in which the field is connected internally to a "hot" brush and has but to be grounded to give maximum output. If the ammeter shows charge when this is done the trouble is outside of the generator. If no charge is indicated the generator may be at fault, which is further checked by a second test on generators having separate field and armature terminals; these being connected together as in Fig. 2. This test completes the field circuit in generators that have a field grounded within the generator but which must be connected to the main brush to receive current. Continued

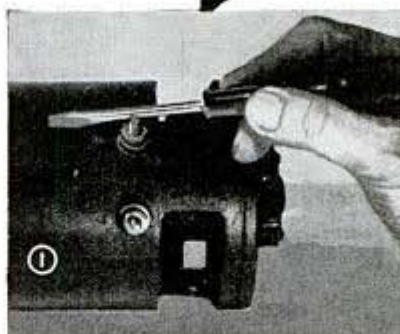

If the ammeter needle flickers from charge to zero, trouble is brewing. Perhaps the commutator must be turned down and the insulation between the bars must be undercut

To check generator, after making sure that circuit to battery is complete, start the motor. Then, without disconnecting any wires, first ground field terminal on some generators, Fig. 1; on others, hold screwdriver across terminals, Fig. 2. If ammeter does not show charge, generator is faulty

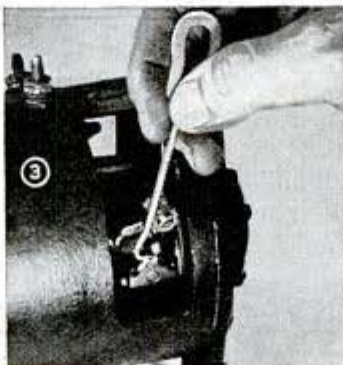

With a bent wire, you can lift out the brushes to see if they are stuck in the holders or whether they are worn down too far and should be replaced with new ones

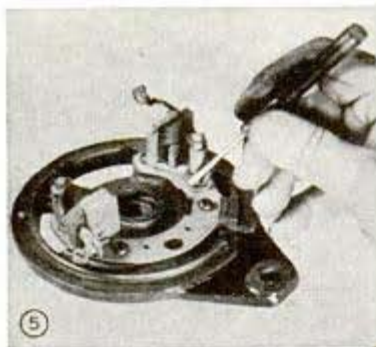

When necessary to remove the generator, the end cap to which the brush holders are attached is slipped off and the insulation of the insulated brush holder is examined as in Fig. 5 to see if there is a short circuit. Slots between commutator bars are scraped and brushed clean, Fig. 6, as carbon dust may cause a short circuit across them

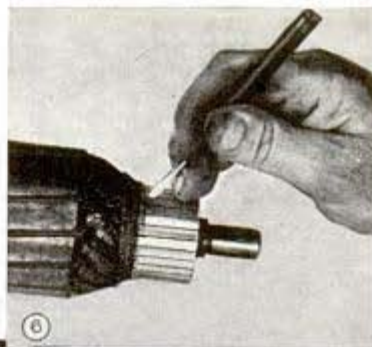

Sometimes damage to insulation on armature coils where they connect to the commutator, can be repaired satisfactorily by wrapping it with cord as shown in Fig. 8. After the wrapping is completed the cord is given a thorough soaking with shellac and allowed to dry

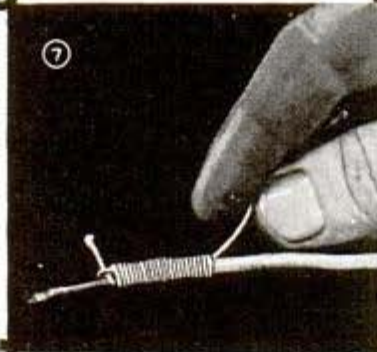

When new brushes are installed at the time a generator is dismantled, you can make the contact surfaces of the brushes conform to the curvature of the commutator by rubbing them on fine sandpaper wrapped around the commutator and held with cord as in Fig. 9



To wrap a wire having broken, double the cord, lay the doubled portion lengthwise on the wire, and while holding the end of the cord with one finger, start wrapping from this end toward the loop. When you get there, slip the loose end through the loop and pull the other end so the loop closes and grips the loose end tightly



failure to charge indicates a defective generator but if a charge is shown the trouble is elsewhere.

When it is known that the generator is defective, stop the motor and examine the brushes. Lift them up as in Fig. 3, with a wire or buttonhook bent to an L-shape at one end. Perhaps the brushes are stuck in the holders. Then lift the retaining springs and remove the brushes as in Fig. 4 to see if they are worn down too far. Usually brushes should be replaced after approximately 15,000 miles of car service. Should there still be no indication of charge after replacing the brushes, remove the generator from the car.

Now, with the brushes lifted from the commutator and held in place by side pressure of the brush springs, the wires to the brush holders are disconnected and the cap that carries the brush holders is removed from the generator. A frequent cause of failure is excessive oiling, which

soaks insulation and retains carbon dust that comes from the brushes, causing a short circuit. Examine the insulation of the insulated brush holder as in Fig. 5, to see if it has been charred. If in doubt whether this insulation is defective, make a test with a light. Short circuits between the copper bars of the commutator are common. Here again, oil holding carbon is often the prime cause. It is not enough to clean a commutator with a rag or fine sandpaper as this gives only temporary relief. You should scrape and brush all dirt out of the slits between the commutator bars as shown in Fig. 6. If the commutator is rough and looks as if it has been burned, and if the insulation between the bars comes flush with their surface or projects slightly, the commutator should be turned down in a lathe as lightly as possible, and the insulation between the bars should be undercut.

Next to brush and commutator troubles,

the most common causes of failure are short circuits, open circuits and grounded circuits. Often the trouble is due to wires rubbing on the armature. Bared wires should be re-insulated by wrapping them with cord but the wrapping should not be more than 2-in. long. Should more wrapping be necessary put it on in sections of 2 in. or less. Fig. 7 shows a wire wrapped and the accompanying caption tells how this is done. Shellac on the wrapping will stiffen the wire so that it will not sag down against the armature. Tape should not be used inside a generator as it may loosen and cause serious trouble. If you notice that the armature coils are in any way damaged where they connect to the commutator bars, you can re-wrap the wire with cord as shown in Fig. 8, after which it is thoroughly shellacked. If new brushes are installed when the armature is removed from the generator housing, the brushes are sanded down to the proper curvature on fine sandpaper wrapped around the commutator as shown in Fig. 9.

Tractor Carburetor Adjusted From Driver's Seat

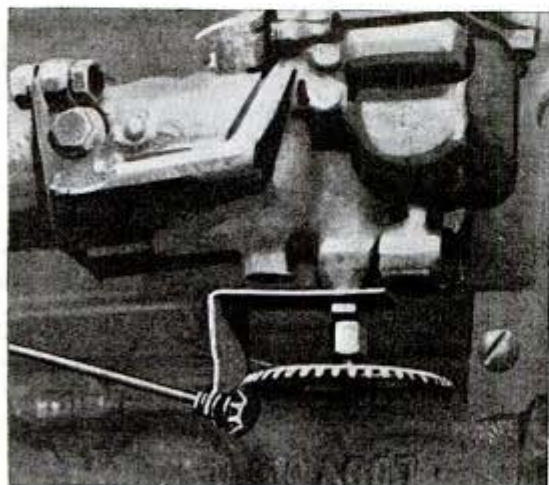

With a ten-cent egg beater and a length of steel rod, engineers of the Iowa State Agricultural College rigged up this method of adjusting a tractor carburetor from the driver's seat. They have been able to save 4 to 5 gal. of fuel a day with the tractor on heavy terracing work merely by thinning the mixture whenever the tractor motor was idling or not pulling a load. When a richer mixture is needed to provide power for heavy pulling, a slight twist of the rod does the job.—S. H. Reck, Jr., Ames, Ia.

Armatures Held for Inspection In Holes in Bench Top



By drilling holes at different angles through the top of his bench, one mechanic claims he can handle small armatures for inspection and repair more easily than when a special cradle is used for the purpose. The armature shafts are inserted in the holes to hold the armatures at any desired angle.

Scoop Shovel Aids Truck Driver When Changing Heavy Tire

One truck driver finds that heavy tires can be changed easily if a scoop shovel is employed as a lever and skid when the wheel is jacked up. One hand is used to hold the tire erect while the other operates the shovel.



Wooden Hanger Makes a Handle To Carry Several Garments



Carrying up to a dozen finished garments on hangers is a simple matter for one cleaning shop owner, who uses a wooden hanger for a handle. Six evenly spaced notches are cut along the top edge on each side to keep the hangers in place.

Cobs Replace Expensive Brushes In Scouring Dairy Floor

Finding that the concrete floors in his dairy buildings wore out expensive brushes rapidly, one dairyman saved money by substituting corn cobs for the

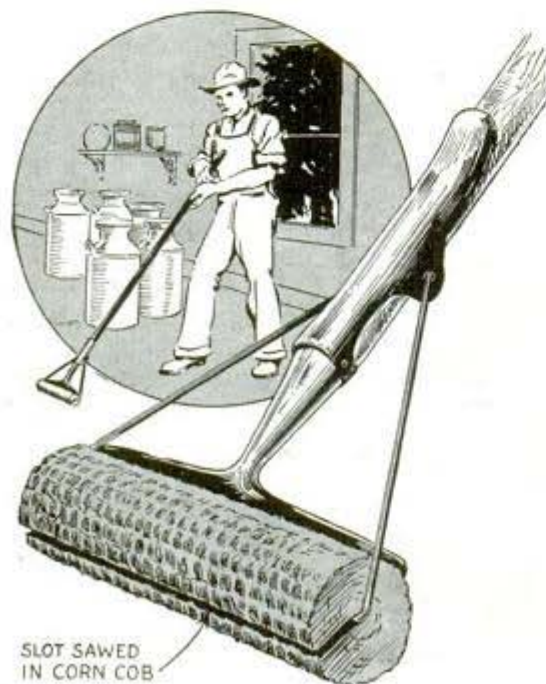

brushes. Use of the cobs enabled him to clean the floors efficiently, and they could be discarded when worn out. The cobs were sawed to fit in a mop handle.

Linotype Slugs Used as Weights In a Pressroom

Needing a number of small weights to keep stacks of paper stock from blowing around in the pressroom, one printer bent several linotype slugs as shown and used them for the purpose. Bending makes the slugs easy to pick up from flat surfaces.



Trick in Putting Nail Holes



Instead of forcing putty into nail holes with a downward pressure of the putty knife, which leaves a thin layer of putty over the area, simply use your thumb to apply pressure on the putty and force it into nail

holes or cracks. The knife is then slid under the putty, removing the surplus and leaving a clean surface.

Rubber Protector Under Phone Avoids Scratches on Counter

In one office where calls for various persons came in over a single phone, this pad was provided to avoid scratching the surface of a counter on which the receiver was laid down. The pad is made from a sheet of corrugated rubber.



Causes of Smoking Boring Bits

A smoking boring bit is evidence that it is not of suitable design for the particular job, is not properly ground at the cutting edge, or needs sharpening. After the proper bit has been selected, its rotation in the boring machine must be proportionate to the rate of feed, that is, the faster the rate of feed, the faster must be the rotations of the bit. If this proportion is not correct, the bit will not remove the chips fast enough to clear itself and will heat and choke if forced to a faster rate of feed than its speed of rotation will allow. The travel of the bit must insure it from springing one way or another as it enters the wood. Poor grinding will cause the bit to lead one way or another as it enters the wood and cause heating. If the bit has not sufficient clearance at its ends, it will fit the hole too tight and heat. To remedy this condition, heat the end of bit and swage it enough to provide the necessary clearance. Following this operation, the bit should have its temper restored by proper heat treatment to make sure it will hold its cutting edge.

—Paul H. Graham, Plainfield, Conn.

Handy Carrier for Welding Rods Made From Length of Rain Pipe

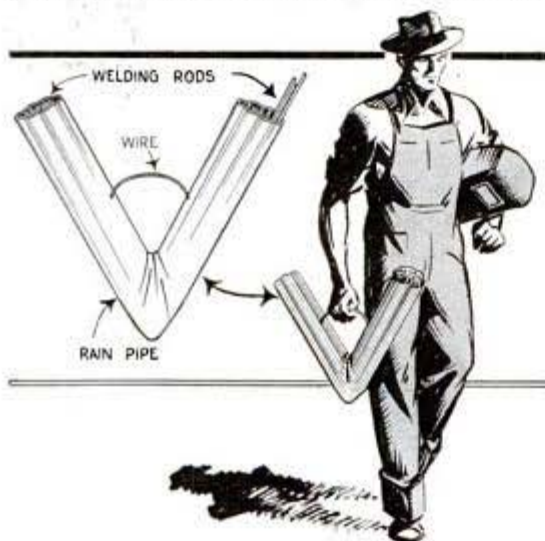

Carrying a number of welding rods about on a job or from one job to another is a simple matter with this carrier. It is made by bending a length of rain pipe to the shape shown and welding or soldering a piece of wire to it by which it is carried.

—John Krill, Youngstown, Ohio.

Holes in Grain Sacks Are Closed With Rubber Disks



To close holes in full grain sacks, one seed-store owner forces rubber disks cut from an old inner tube through the openings, using the end of a broomstick. When inside the sack, the disks flatten out and are held over the openings by pressure from the grain.

Scratch Awl Lifts Waste Pieces From Jigsawed Cutouts

Removing waste pieces from jigsawed cutouts while on the saw table is a simple matter if you use a scratch awl for the purpose. This method is especially handy when several cutouts are made at one time as all you need to do is stick the awl into the pieces and lift them out.

—Pio Panieri, Roslyn, Wash.



Wanted!

MORE MACHINE-TOOL EXPERTS

Not just machine hands, but highly paid skilled technicians! That's the crying need in U. S. defense industries to meet exacting requirements of workmanship and ever-increasing production schedules.

Do you want to be an expert in this field? Then, start today getting the basic knowledge it takes, which, plus experience, advanced studies and keeping abreast with the latest developments, will soon qualify you as an expert.

To acquaint you with the most important and generally used machine tools, Popular Mechanics Magazine herewith begins a series of articles packed full of intensely practical information on these tools and how to use them efficiently.



Above: This craftsman in the making is working at a boring mill, which often requires accuracy to .0001 in. Lower left: Men being trained to take charge of groups of operators in a large machine-gun plant

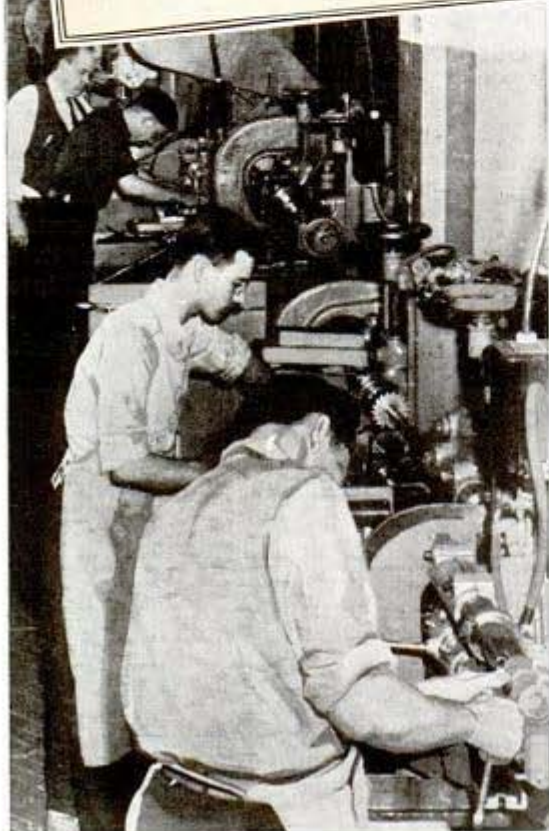

By H. J. Chamberland

BEFORE machine work is done on metal, the stock must be cut to rough size. While the hand hack saw is used in small shops on small work, in large shops the rough cutting is done with power hack saws, metal-cutting band saws, abrasive cut-off wheels and acetylene cutting torches. After rough cutting of stock, it goes through as many operations as necessary on other machines among which the drill press, lathe, shaper, milling machine and grinding machine are the most common and basic.

POWER HACK SAWS

Power hack saws, one of which is shown in Fig. 1, are used in thousands of machine shops for cutting off material up to 6 in. in thickness. These saws are either of the draw-cut or push-cut type. When draw-cutting, the blade is inserted in the saw frame so that the teeth point toward the rear of the machine, away from the operator, as in Fig. 3. With the push-cutting

Power METAL-CUTTING SAWS *and how they work*

PART
1

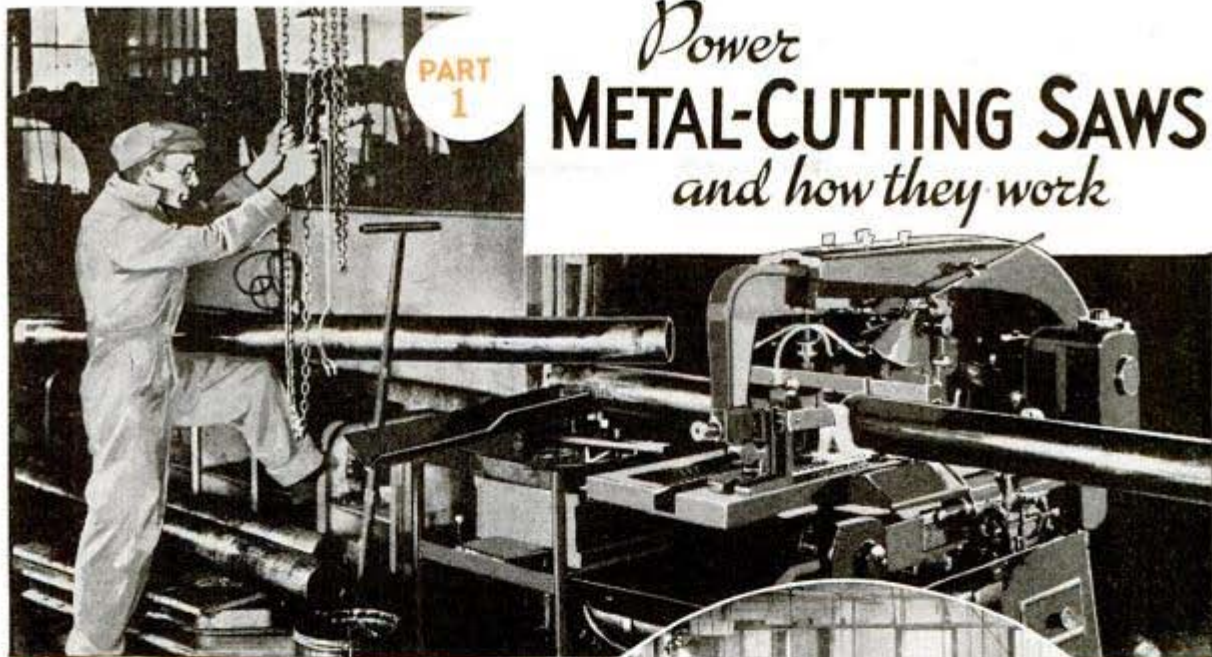

Cutting off pieces of bar stock, rods, pipe, etc., is the usual job for a power-driven hack saw, which is comparatively easy to run. Right: Here is a production line of metal-cutting band saws which are now being used to eliminate many older, slower and more complicated methods in machine-shop work



mechanism, the teeth point toward the front as shown in Fig. 4. Operation of a power hack saw is comparatively easy as you don't have to worry about guiding the saw, guess at the pressure, or lift the blade on return strokes as the machine does this automatically. The saw frame is locked in the raised position while adjusting the stock for the cut. Then the frame is gently lowered to the work. On return strokes the saw is raised by cam action so that the teeth clear the work.

Blades: Power hack-saw blades are much heavier than hand hack-saw blades, thickness of the former generally used being .049 and .065 in. Small and medium size machines take blades from 10 to 16 in. long, while blades up to 24 in. in length are used on extra heavy machines. Depending on length, the blades vary in width from 1 to 1½ in. Teeth per inch on blades most commonly used are 4, 6, 10, 14 and 18. There are blades made of molybdenum or high-

speed steel throughout, still many users prefer a welded blade such as shown in Fig. 5. A recently introduced double-edge blade is shown in Fig. 6. This one gives an extra cutting edge at 50 percent added cost. Cutting edge B has a narrower set than edge A so that by using edge A first, the set on edge B will not interfere while sawing and is used after edge A is dulled, which then gives no interference in the cut. Selection of the right blade to suit the work is of utmost importance. General rules are as follows: (1) the thinner the stock the finer the teeth should be; (2) the harder



② WHAT SAW BLADE TO SELECT FOR COMMONLY-USED MATERIALS

- 4 teeth per inch
Large, solid stock including large-diameter hard alloys and tool steel.
 - 6 teeth per inch
Medium-size solid steel stock
 - 10 teeth per inch
Cast iron; medium-diameter hard alloys; heavy angle trim, pipe and tubing, rails; soft steel; tool steel.
 - 14 teeth per inch
Hard steel; bronze; wrought iron; medium-wall pipe and tubing; light angle trim.
 - 18 teeth per inch
Thin, flat stock; light-wall tubing.
- Note: Coarse-pitch saws of high quality can be resharpened at least twice

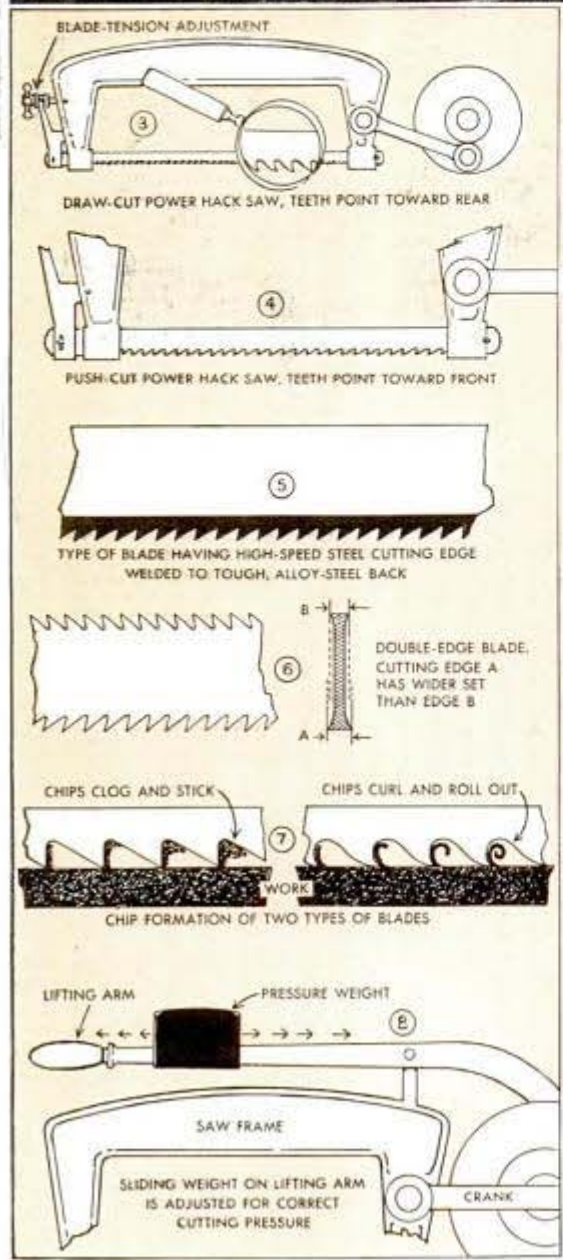

The most important things an operator of a power hack saw should know are the proper blades, the correct speeds and feed pressures on different metals

the stock, the finer the teeth; (3) no less than two or three teeth should contact the work when sawing thin stock; (4) as coarse a tooth as possible is used when not limited by restrictions 1 and 2. Other suggestions on blade selection are given in Fig. 2.

Feed pressure: Plain models of hack-saw machines have cutting speeds from 100 to 125 strokes per minute. Desired feed pressure is had by adjusting a weight back and forth on an arm positioned directly over the saw frame as in Fig. 8. A 40-lb. weight set at the extreme lifting end is equivalent to 80 lbs. of pressure on the saw. If the machine does not control pressure automatically, moderately heavy pressure is used generally. As a blade gets dull the pressure should be increased so that the teeth will not slip. It is customary to start with a pressure of 60 lbs. for hard materials and increase this to 80 lbs. maximum. For soft materials, the pressure may vary from 40 to 50 lbs. Too much pressure on soft stock causes teeth to jam and break. If a blade breaks while cutting, the work is given a quarter turn before using a new blade to avoid damaging the set by having the blade jam in the cut. After a blade has been inserted in the frame it is drawn up tightly, and after making a few cuts it is again tightened because it stretches slightly when used. The work should be set up so that the blade does not start cutting at too great an angle. All power hack-saw blades do not produce identical chips since the shape



of the tooth gullet is a governing factor as shown in Fig. 7. With a tooth shape of maximum gullet and angle as shown in the right detail, a saw having more teeth per inch (finer pitch) can be used, especially if the material to be cut is hard. On the other hand, if a saw having teeth shaped as shown in the left detail is used, it is frequently necessary to resort to coarser tooth construction to avoid chips clogging in the gullets.

Speed and cutting lubricant: Average speed for sawing with molybdenum or high-speed steel blades, using no cutting lubricant,

Three outstanding examples of what can be done on a metal-cutting band saw are shown on this page. Note how the punch and die in Fig. 10 are produced, eliminating the four time-taking steps of the older method, Fig. 11



Band saw

Grills, patterns and gaskets



New way of cutting dies



11 *Old way*



Photos courtesy Continental Machine, Inc.

varies from 75 strokes per min. for hard metals to 100 strokes for soft metals. For tungsten-alloy blades, decrease the above speed 35 to 40 percent. When using a cutting lubricant, dry-cutting speeds may be increased 25 percent, if advisable. Too fast a speed overheats blades and dulls teeth quickly. Generally the harder the stock, the slower the speed should be. Using a cutting lubricant not only permits increased speed but also aids in washing out chips. Use the lubricant whenever possible on any metals except cast iron, copper, brass and aluminum, but avoid using an excessive amount because a warm (not hot) blade cuts better than one that is cold. Slight steaming of the lubricant does not



Sharp band-saw blades produce chips of the formation shown in Fig. 13. Simple tools such as wrenches shown in Fig. 14 are cut out in record time and later hardened

indicate too high a temperature. The use of kerosene for sawing medium and large size aluminum castings and bars will lengthen saw life substantially.

METAL-CUTTING BAND SAWS

Metal cutting on a band saw is now regarded as a specialized form of machining and not only a cutting-off process. Sawing away material not needed does not involve waste in the form of chips as in turning, shaping and milling.

What can be done: Vertical accuracy of work cut on a band saw can be held to extreme limits. For instance, on the cam shown in Fig. 9, the height was 6 in., but the variation from top to bottom was only .002 in. Many other jobs are possible, such as cutting out metal grills, patterns and

gaskets. Another unusual accomplishment of the band saw is making dies and punches as in Fig. 10, which represents a considerable saving in time and labor, and also a saving of stock, over the old method which involved the four steps shown in Fig. 11. Parts that are usually forged often can be produced on a band saw, as the locomotive poppet valve shown in Fig. 12. Another possibility is the making of certain tools, especially wrenches as shown in Fig. 14. By stacking sheet or flat metal and by either soldering or bolting the pieces together, depending on the thickness of stock and the type of work, many identical parts can be sawed out in one cutting operation. See Figs. 15 and 16. This method eliminates stamping such parts with dies.

Adapting wood-cutting band saw: Cutting metals on a band saw is as easy as cutting wood or other non-metals. Chief requirements are good saws and suitable cutting speeds. You can experiment with metal cutting on a wood-cutting band saw. First thing to do is to arrange a countershaft to be able to get the lower speeds needed, and then get some metal-cutting blades. For a 12-in. band saw, the arrangement shown in Fig. 19 will give suitable speeds for metal cutting. In

this case a 1,140 r.p.m. motor fitted with a 1½-in. V-pulley was used to drive a 7½-in. V-pulley on the jackshaft. Two four-step cone pulleys fitted with a V-belt, cut down the speed still more. The jackshaft is mounted on a 2 by 6-in. base, which is hinged at the edge facing the band saw, and the motor is also hinged in a similar way with the result that both belts have an even, adequate and lasting tension. With this arrangement the average saw-blade speed for wood cutting of 2,200 feet per minute (f.p.m.), can be cut down to about 285 f.p.m. Resulting speeds of the band-saw wheels (12-in. dia.) are 91, 171, 304 and 570 r.p.m., while the saw blade speeds are 285, 536, 954 and 1,789 respectively. (The latter speed is not used for metal cutting.) For the apprentice, cutting

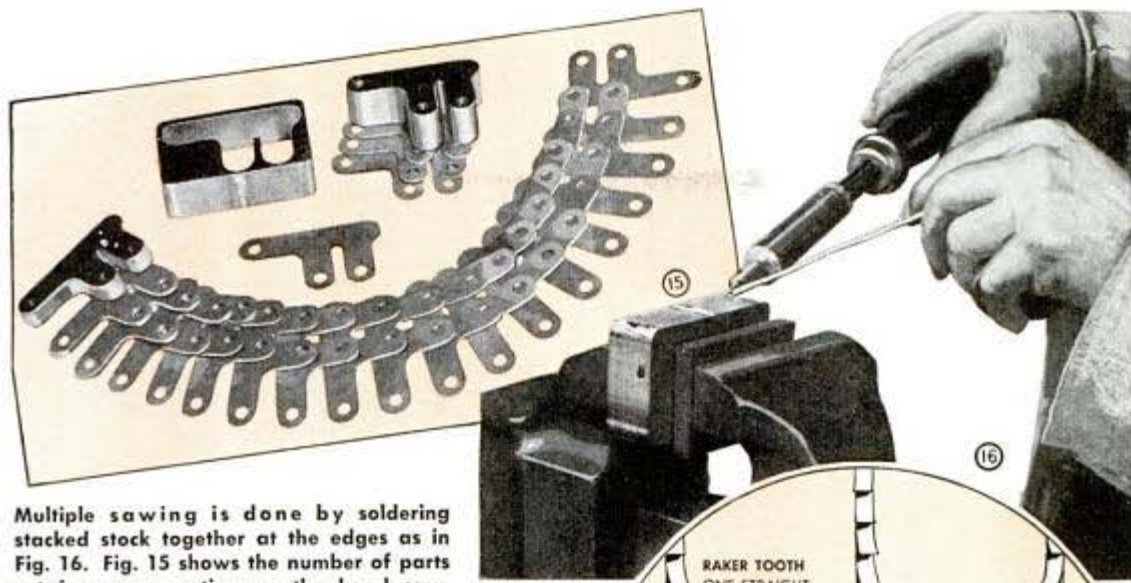

Multiple sawing is done by soldering stacked stock together at the edges as in Fig. 16. Fig. 15 shows the number of parts cut in one operation on the band saw, eliminating the need of punches and dies

should be limited to soft ferrous metals under 1 in. in thickness and nonferrous metals not exceeding 2 in. in thickness. All work should be restricted to external cuts, meaning operations that do not require cutting the saw blade, inserting it through a hole and then welding the ends of the blade together again, as is done on internal cuts.

Blades to use: Correct speeds should coordinate with suitable blades for best results. The apprentice will need three types of blades as follows: (1) $\frac{1}{2}$ -in. blade with 6 teeth per in., (2) $\frac{3}{8}$ -in. blade with 8 teeth

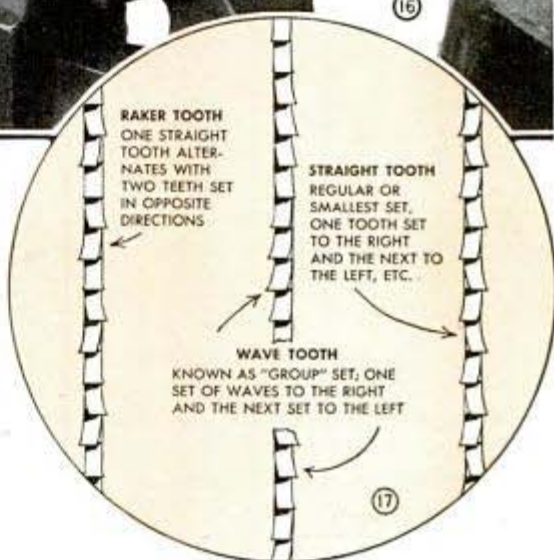

18 SAW AND SPEED SELECTIONS			
Material	Pitch (Teeth per in.)	Tooth Set	Saw Speed F.P.M. (Approx.)
Aluminum castings	6	Straight	500
Aluminum sheet and tubing	12	Straight	900
Bakelite and plastics	12	Straight	500
Brass castings	6	Straight	500
Brass sheet and tubing	12	Straight	900
Bronze castings	8	Raker	300
Copper	8	Straight	300
Cast iron	6	Raker	300
Malleable iron	12	Raker	300
Machine and mild steels	12	Raker	300
Pipe	12	Raker	300
Structural steel	6	Raker	300
Straight carbon steels	8	Raker	300

Note: Feed work easily when cutting at lower speed. These recommendations are strictly for home-workshop requirements and are not intended for regular machine-shop data or selections.

per in., and (3) $\frac{1}{4}$ -in. blade with 12 teeth per in. After some practice, one may use a $\frac{3}{16}$ -in. blade with 14 teeth per in. Fig. 17 shows three types of set on band-saw blades, available under normal conditions. The raker type is most readily obtainable. There are also two thicknesses of set, and although blades are standardized at .025 in. thick, widths of set are .032 and .042 in. The widest should be used as it gives the back of the saw more freedom. Blade selection to suit the job is similar to that on hack saws, the softer the metal, the coarser the teeth; also fine teeth for thin sections. General recommendations on blades for various types of metals are given in the table, Fig. 18.

Always use the widest blades for straight cutting. Where corners are involved, the $\frac{1}{4}$ -in. blade is of general purpose as all corners may be cleared by drilling $\frac{1}{4}$ -in. holes at these points. Work is prepared for cutting by polishing the surface, coating it with layout fluid or prussian blue and then scribing the outline on the surface from a

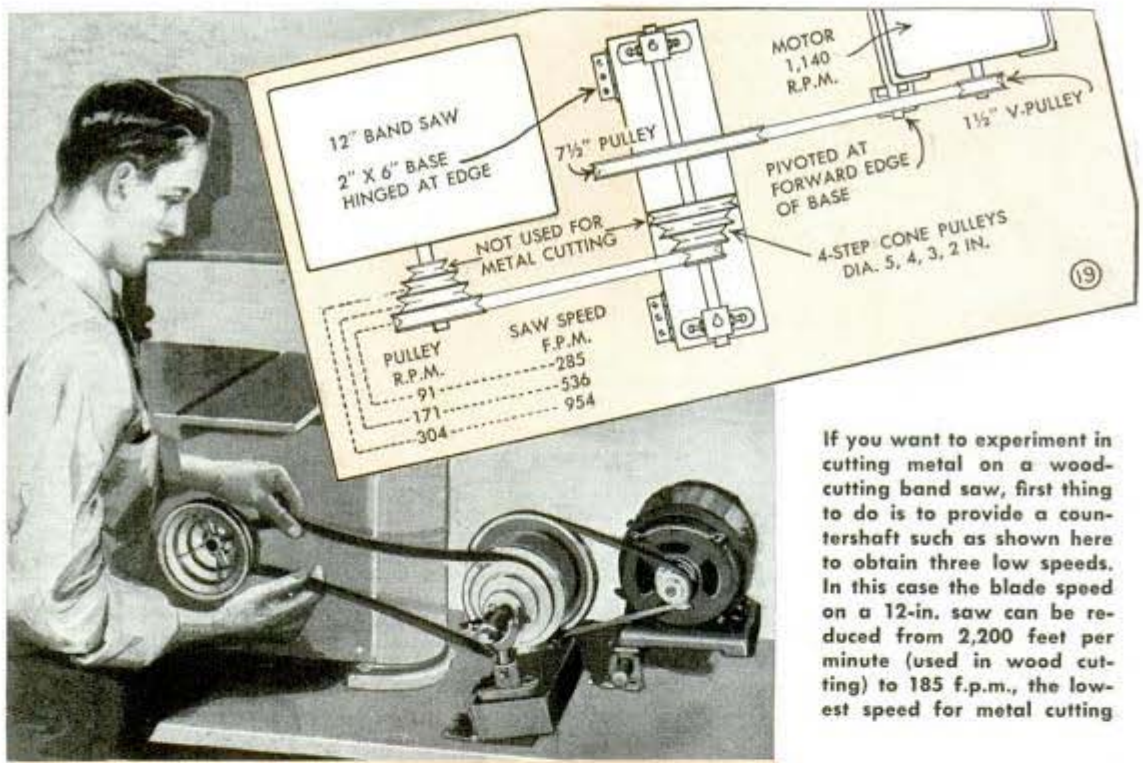

If you want to experiment in cutting metal on a wood-cutting band saw, first thing to do is to provide a countershaft such as shown here to obtain three low speeds. In this case the blade speed on a 12-in. saw can be reduced from 2,200 feet per minute (used in wood cutting) to 185 f.p.m., the lowest speed for metal cutting.

pattern or template. In actual shop work, the outline represents finished dimensions and the operator must make allowance for filing down to size later.

Blade adjustment: Adjustment of the blade is highly important, make sure that the saw runs or tracks on both wheels properly. Then adjust the upper and lower guide pins or rollers against the side of the blade so that there is a slight clearance—.001 in. is sufficient. Be sure that the blade is neither squeezed nor bent when making the adjustments. Check the alignment of the upper and lower guides frequently. Saw-blade tension should be adjusted at intervals and excessive tension, which

causes blade breakage should be avoided. Thrust wheels behind the blade must be adjusted to work freely yet give support against the back of the blade so that the cutting edge plus $\frac{3}{32}$ in. of the blade projects beyond the guide blocks or rollers. Keep the rollers well oiled and when the machine is not in use release the tension on the blade. A suitable blade run at the proper speed produces chips as in Fig. 13. Do not apply too much pressure, especially when starting a new blade. Begin slowly until the blade conforms to the cut before increasing pressure. Too much pressure causes teeth to dull quickly.

Next month: The Drillpress and How to Use It

Grooves Around Sign Letters Keep Colors From Running

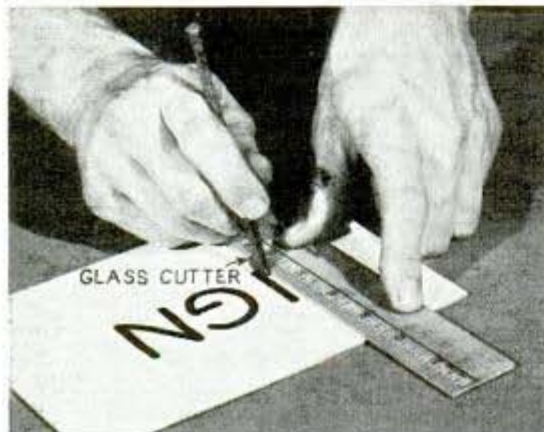

When working on wood or cardboard with contrasting showcard colors, one sign painter prevents the colors from running by outlining the letters or designs with tiny grooves by means of an ordinary ten-cent glass cutter. This compresses the surface fibers just enough to stop the colors, resulting in clean-cut edges.

Very shallow scratches can be removed from mirrors by rubbing the surface of the glass with a piece of hard felt that has been moistened in water and dipped in either red or black rouge.

Attaching Tags to Cloth Bolts



Attachment of sales or inventory tags to bolts of cloth may be done quickly with the aid of a small needle threader. The fine wire loop of the threader is pushed through the cloth easily, after which the string of the tag may be inserted through the loop

and pulled back through the cloth for fastening in the usual way.

Lumber Inventory Is Simplified By Marking Every Tenth Board

Time required for taking inventory in a lumber yard is greatly reduced when one end of every tenth board is marked by



painting it as shown. The painted ends clearly set off equal numbers of boards in a pile, making it an easy matter for the men taking inventory to estimate at a glance, the exact amount of stock on hand.

When painting windows be sure to leave both sashes opened an inch or so until the paint dries so that they will be easy to move later on in case the paint causes them to stick.

Pencil Clip Soldered to Oilcan Slips Over Edge of Pocket



To overcome the difficulty of carrying an oilcan and using other tools at the same time while working from a ladder, one mechanic soldered a pencil clip to the oilcan so it could be hung over the edge of his pocket. A heavy clip was used and the band flattened before soldering.

Sales Banners on Coat Hangers Suspended From Store Ceiling

The manager of a store sale in which much of the indoor advertising was to be done with paper banners or pennants suspended from the ceiling, cut the banners to a width suitable for folding over wire coat hangers with



which the banners were suspended. The folded corners of the paper were crossed at the back and fastened with strips of gummed paper tape as indicated in the circular detail.

Old Tire Absorbs Tractor Shock When Stretching Wire Fences

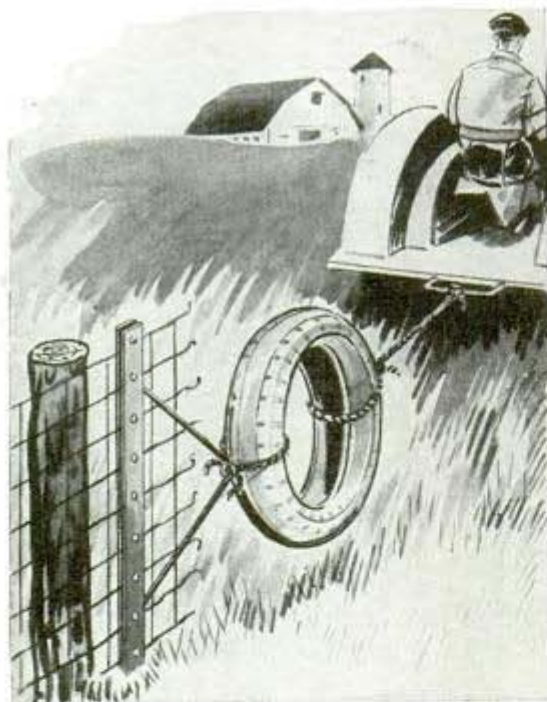

Tractors can be used to stretch woven-wire fences, without jerking the wire which might pull the corner posts or attaching

staples, if an old auto casing is used as a shock absorber. The casing is connected between the stretcher clamp and tractor draw bar. It provides just enough spring to exert an even pull on the wire.

Self-Marking Try Square

The difficulty sometimes experienced in holding both the work and a try square to mark the work while standing on a ladder or scaffold, caused one carpenter to make the square self-marking. The inside edge of the square was ground to a knife edge and then serrated with a file to form saw teeth. Held square on the work, the tool is then turned and the teeth forced into the wood to impress the cutting mark.



☞ If the threads of a saw arbor clog and bind, file a groove across them as deep as the threads themselves.

564 Things You Can Make for Fun and Profit

Third Big Book of Practical Ideas Added to What-to-Make Library

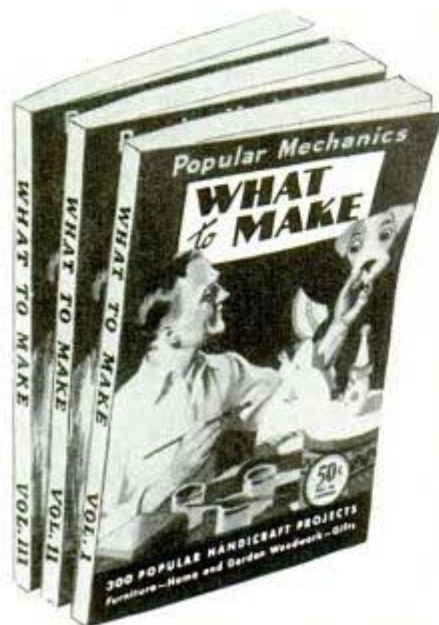

564 THINGS TO BUILD

You will never be at a loss for something to make if you have these volumes. The range of subjects covered seems limitless. You will find hundreds of ideas you can use around your home, and also things that can be made in your spare time for profit.

MORE THAN 1,500 PICTURES

You see exactly how everything is done because over half of each book is made up of pictures. Drawings and illustrations show every step in construction and also the completed project. You do not have to be an expert and your success will amaze your family and friends.

PARTIAL LIST OF CONTENTS

Lawn cutouts, basement play rooms, log cabins, attractive fences, child's room furniture, gem cutting, miniature gardens, greenhouses, lawn furniture, sundials, pier and china cabinets, clock cases, book binding, wood sculpturing, photo enlarger, projector, built-in vanities, fireplaces, glass decorations, lighting fixtures, re-caning chairs, bird and dog houses, desks, tables, trays, benches, book ends, footstools, cabinets, picture frames.

All three volumes postpaid upon receipt of \$1.47 or 50c each in U. S. A. Outside U. S. A. add 15 percent

POPULAR MECHANICS PRESS, 200 E. Ontario Street, Dept. 344, Chicago, Ill.



Radio

More Radio Operators Trained for Uncle Sam

By S. Gordon Taylor

ENLISTED men and selectees at the Navy Signal Corps Replacement Center at Fort Monmouth, New Jersey, receive training which will likely prove highly valuable on return to civilian life, but in the meantime they are helping the Navy to meet its urgent need for radio personnel.

A concentrated training program turns out qualified operators ready for active service at ship or shore stations. In 16 weeks a man is capable of copying 25 words per minute, has developed a general familiarity with Navy transmitters and receivers, and the fundamentals. One large code-practice class appears in the inset photo.

Previous to December 7, the men did not have to depend entirely on letters to keep in touch with folks at home. Uncle Sam, thoughtful of his soldiers and their



relatives, established a completely modern amateur station, W2OEC at the Center under the supervision of 1st Lieut. Preston W. Sims for handling messages to and from the men in training, without cost to them. Two operating positions are shown in the top and bottom photos. This station formed a link in a chain of civilian stations.



1942

LITTLE GIANT

By Frank M. Lund

STRIPPED of all unnecessary frills, this 1942 "Little Giant" low-cost a.c.-d.c. receiver is quite different from former models of this popular series that have appeared in the March issues of Popular Mechanics Magazine. Designed for economy and high-grade performance, it uses three dual-purpose tubes in a 4-tube superheterodyne circuit, with results equivalent to those obtained from five or six tubes on the broadcast, intermediate and short-wave bands. It includes automatic volume control, electro-dynamic speaker and a vernier tuning dial. Easier to build than some of the previous models, simple, inexpensive, open-chassis construction is employed and the chassis is insulated from the line. Six low-cost plug-in coils cover all bands; tone and volume are highly satisfactory, and the set is a real distance getter on both the domestic and foreign bands.

The dual-purpose tubes function as follows: the 70L7-GT is an output beam-power amplifier and rectifier; 12Q7-GT is an audio amplifier and duo-diode detector (2nd. detector); the 12A8-GT is the oscillator and mixer (1st. detector). Each plug-in oscillator coil has its own padder condenser built in and correctly set. The circuit is stable enough to use the 12K7-GT tube without a shield if desired, although it is common practice to use a shield on this tube.

The metal base is the same as used in the 1941 model, with one additional socket, and the 2-gang 365 mmfd. condenser is the same specified capacity, with trimmers. Complete base and panel details are shown in Fig. 1; the panel may be

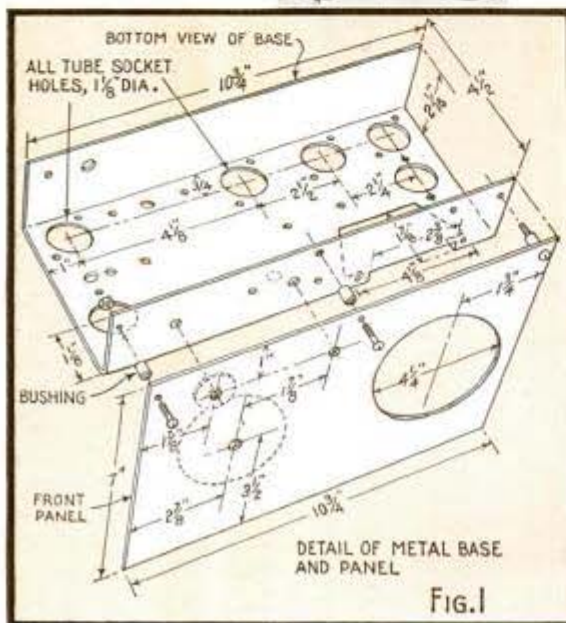
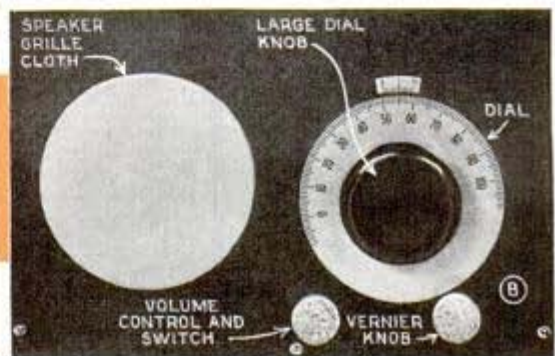

Fig. 1



A.C. D.C. THREE-BAND SUPER

ALL-WAVE TUNING RANGE

- (A) BROADCAST RANGE - 540 KC. TO 1720 KC.
- (B) INTERMEDIATE BAND - 1720 KC. TO 5.7 MC.
- (C) SHORT WAVE BAND - 5.7 MC. TO 18 MC.

made of hard pressed wood, plywood, Bakelite, or steel, offering a wide choice of materials. Please note that the panel is spaced out from the metal base by means of 3 metal bushings $\frac{1}{4}$ in. long, in order to provide room for the vernier dial drive disk just back of the panel.

A complete simplified wiring diagram, showing all connections below and above the base, appears in Fig. 2, and the schematic circuit diagram is given in Fig. 3, together with the plug-in coil chart. Photos A, B, C and D show various close-up views of the completed receiver; all parts are clearly identified in these photos. It

(Continued to page 180)

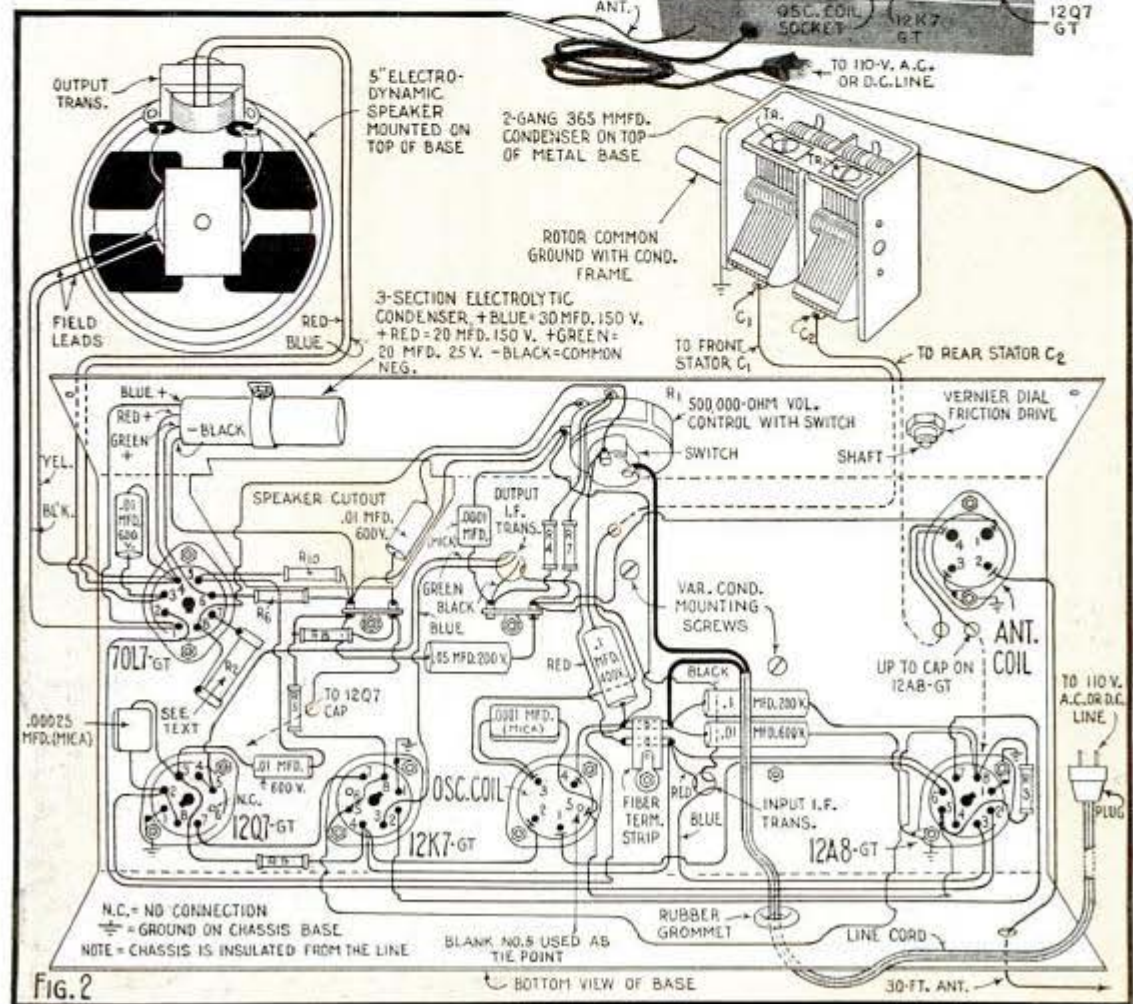



"Wireless" Record Player From the Junk Box

BY E. L. BLANCHARD

MOST of the parts for this "wireless" record player can be found in the average radio experimenter's junk box, with the exception of the small rim-drive motor, and crystal pickup, each of which costs about \$2.45. Housed in a cigar box covered with striped awning canvas, and weighing only 4 pounds, this diminutive "phantom" record player can be taken to parties for playing records through any radio.

The heart of the record player is the multi-purpose type 117L7-GT beam-power pentode tube. The pickup, instead of being permanently attached, plugs into the cabinet when the player is being used.

Construction details are quite simple as shown in Fig. 1 and photos A and B; the coil details and schematic circuit diagram are given in Figs. 2 and 2-A. The cigar box shown in Fig. 1, or a wooden box of similar dimensions, is provided with corner blocks, and a top panel which consists of a piece of 1/4-in. Masonite or similar pressed wood.

An opening large enough to accommodate the phono motor is cut in the top panel. The radio parts for the oscillator are all mounted on the L-shaped chassis cut from galvanized iron; two fiber terminal strips each with 4 insulated lugs, support all fixed

(Continued to page 183)

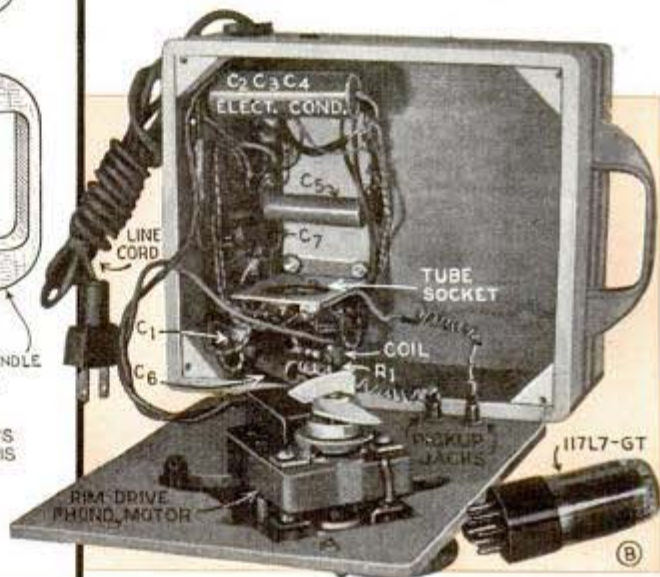
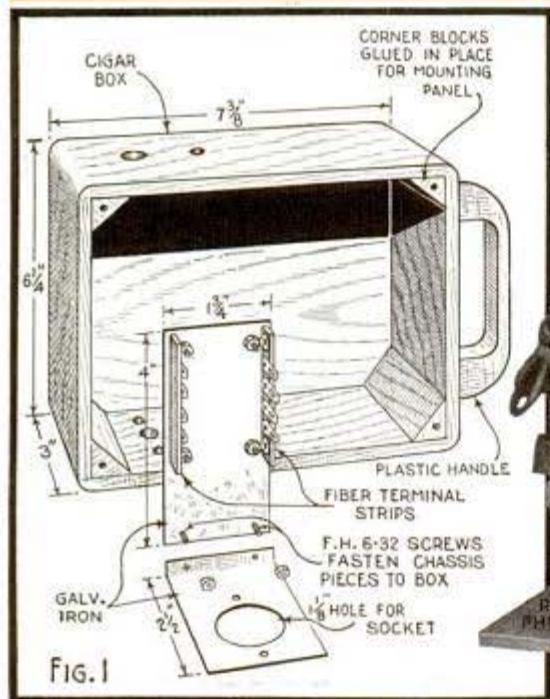

Practical RADIO SUGGESTIONS

(A) All radio experimenters and service men require some means for supporting receiver or amplifier chassis bases bottom-side-up on the bench for easy access to parts and wiring on the underside, without damaging the delicate parts and tubes mounted above. The method shown is highly efficient and costs practically nothing. Two or more 10 in. pieces of $\frac{3}{8}$ -in. steel reinforcing rod are inserted in holes drilled about 2 in. deep in the front edge of the bench. Holes 1 and 2 are spaced 8 in. apart, and the next four are 4 in. apart to accommodate bases of various sizes. All details are clearly illustrated in the diagram and sketch. The tape prevents chassis from slipping

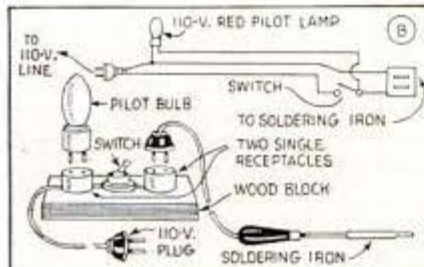

(B) This pilot lamp arrangement provides a visual reminder that the soldering iron is being heated. The sketch and circuit diagram are self explanatory. When switch is open, lamp is out and iron is cold

(D) To blueprint your charts and diagrams, make negative on architect's tracing linen. First rub fuller's earth or pumice over the glazed surface, then clean and use a sharp soft pencil. Place negative face down on printing frame glass, then lay blue side of blueprint paper on negative and clamp down

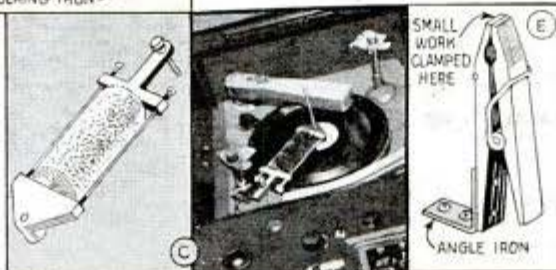

(C) Designed to fit all automatic and manual recorders, this brush keeps cuttings away from recording needle, thereby eliminating skips on record being made. (E) Spring clothespin makes handy vise for small soldering jobs. Supports work difficult to hold while soldering

(F) Armored power rheostat designed for hard use under exposed conditions; 25 watt type is available in resistance values of 1 to 5,000 ohms. (G) Screen-door hinges of the spring-return type, used to permit one-rope control of directional beam receiving antenna

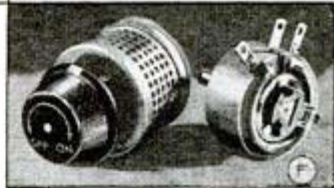

(H) Lacking a calibrated dial, a plate from an old condenser provides good substitute

(I) High-frequency iron-core coils for permeability tuning, are compact, low in cost and eliminate need for aluminum condensers and shields

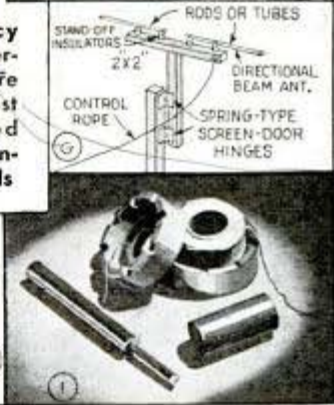
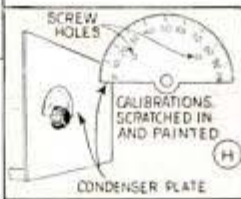

Recordit Co. 555 Bedford Ave. St. Louis, Mo.

Claremont Info Co 285 N. 1st St. Brooklyn, N.Y.
Henry S. Crawley & Co. West Chester, Ohio.

RCA Mfg Co
All-Way Loudspeaker Baffle
 Works From Single Unit



Projecting sound uniformly over a 360-degree area throughout a radius of 50 feet from 5 evenly spaced apertures, this all-way baffle is used with a single interchangeable mechanism for 5, 10, 12 or 15 watts. The baffle is 20 in. high, 20 in. deep and weighs 10 pounds.

Montgomery Ward & Co Chicago
Portable Set Has Drop Front

This 3-way, 6-tube portable is designed with a convenient telescoping drop front, and employs 325-hour self-contained bat-



*Lullaby Furniture Co
 666 Lake Shore Drive*
 teries for portable operation. It will also work on the usual 110-volt a.c. or d.c. power lines. Easy to read dial tunes from 535 to 1600 kc.; 9.0 to 18.3 mc.

Chicago
Radio-Lamp in Aviation Motif

In following the aviation motif, even the dial knob is designed to resemble a propeller blade. The shade is decorated with a pursuit plane while the light bulb protruding above the shade resembles a beacon. Set is a 4-tube a.c.-d.c. type.



Photo-Cell Counting Assembly

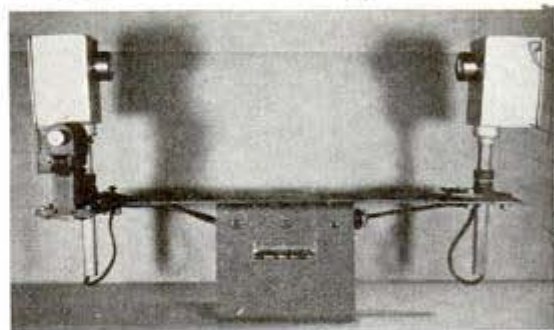

Photoelectric units have been given many important jobs in which they supervise or record production output. The portable assembly shown is a complete conveyor counting unit that can be moved and installed quickly on another conveyor when necessary. Control box contains amplifier and relays. The boxes and counters can be operated at remote locations.

Blueprints covering simplified radio construction articles in this and past issues are available for 25c each. Many popular tested circuits to choose from. Original detailed parts lists with names of supply sources, can be obtained from Popular Mechanics Radio Department upon receipt of postage.

NEXT MONTH—Two and One-Half Meter Emergency "Walkie Talkie." Fitted with pack straps, a rod-type antenna and self-contained batteries, it provides a practical and easily portable means for short distance communication in emergencies. Also—A Low-Cost Automatic Line-Voltage Regulator for Receivers.

WINTER SNAPS ARE SIMPLE...SURE

A splendid snapshot to get on a winter's day, don't you agree? We used our regular summertime film

-KODAK VERICHROME



...This shows you what good ones we're getting indoors at night. Our secret is a super-fast film

-KODAK SUPER-XX



OUTDOORS—Use Kodak Verichrome Film for your outdoor pictures this winter. It helps overcome small exposure errors, extends the "snapshot day," lets you get swell snapshots even when the weather isn't just right.

INDOORS AT NIGHT—Super-fast Kodak Super-XX Film gives outdoor excellence to indoor pictures. Use it with Photoflood bulbs and cardboard reflectors. BOOKLET FREE AT YOUR DEALER'S. Also covers flash pictures... Eastman Kodak Co., Rochester, N. Y.



OUTDOORS... INDOORS... you can always count on KODAK FILM

2970

Throwing Light on the Darkroom

(Continued from page 95)

asbestos. Roll film can be hung in the box lengthwise to dry; cut film attached to clips mounted on cross braces. A good print drier is an asbestos-lined box 18 inches deep, with a curved sheet-metal top the same dimensions as a ferrotype tin. Install four 100-watt lamps on the floor of the box.



Eccentric arm from electric motor is rigged up to rock developing and fixing trays for quick results

Heat from the lamps dries prints on the ferrotype tin that is held in contact with the top in 10 or 15 minutes.

Static electricity often causes dust and lint in the air to attach itself to the glass plates in which negatives are placed in the enlarging camera. If the camera is of metal construction, ground it with a copper wire running to a plumbing fixture. That will help. Better yet, build a negative frame that holds the film in the enlarger without any glass. The darkroom should be kept clean with a vacuum cleaner; some photographers hang large vaseline- or grease-smearred cardboard panels on the ceiling to trap dust and lint. Dust control is considered so important that at the Disney studio in Hollywood the photographers first walk along a waxed passageway and through an air blast before they enter the camera rooms. The atmosphere of these rooms is kept under a slight pressure and the air rushes out of the entrance doors, discharging any dust and lint with it, when one of the doors is opened.



Purity...
in the big big bottle
— that's **PEPSI-COLA**

Rubber From Milkweed

(Continued from page 89)

needs for both civilian and military aviation. A survey disclosed 27,000 acres of milkweed in southern California alone, an acreage that, Sharpe says, represents 100,000 tons of milkweed from which about 50,000 tons of rubber could be extracted.

The inventor planted the weeds in rows in late October, harvesting the following July. The resulting crop averaged five pounds per plant and 28 tons per acre.

The weeds are pulled up while crisp and green, washed and crushed like sugar cane. The juices extracted are allowed to stand for seven days, then the liquid is siphoned off and stored. A culture of bacteria is then added. By their magic of fermentation the microbes evolve a new kind of rubber. The "cream" or latex appears in two days and is skimmed off in a thin sheet.

"When it is recalled the part that bacteria play in the making of cheese, cider and other food products," Sharpe explains, "it is not surprising that certain strains can produce rubber when cultures are added to vegetable milk. The bacteria multiply and eat the starches, converting much of the milk into protein. The secret lies in the curing; tiny globules are developed in the mixtures which impart elasticity to the latex. Nine-tenths of the milk can be converted into various grades of rubber."

The latex is collected every two days. Then the cream is whirled in a centrifuge which removes excess moisture and foreign particles, and placed in a heated vacuum kettle. Chemicals and a deodorizer are added. After cooking an hour at 300 degrees Fahrenheit, the mass becomes smooth and plastic, about the consistency of heavy tar at the same temperature.

After cooking, the mixture is spread on metal trays and placed under infrared lights. After 60 minutes the mass is dry enough to mill, and is rolled into slabs like ordinary para rubber. The entire process of harvesting, processing and rolling requires scarcely more than three hours.

"High protein," explains Sharpe, "is very important, particularly for use in weapons of war. Whereas tree rubber contains an average of 1.5 percent protein, the bacteria protein in milkweed rubber is as high as 48 percent. This makes it resistant to freezing, acids and chemicals."



Supremacy in the air begins with Efficiency on the ground

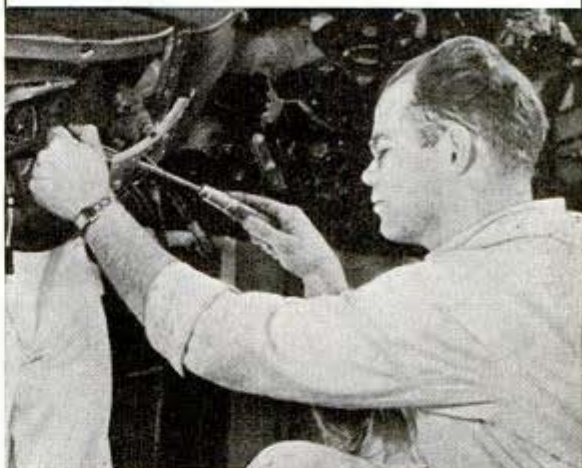

In refitting engine cowling after major overhaul, this United Air Lines mechanic makes joint a tight one with a few touches of his Nicholson File.

NEVER has American youth had a more promising field for achievements in mechanical science than is offered by the vast aviation industry. Whether on war or commercial planes—whether in building or maintaining them—the ace mechanic rates with the ace pilot in importance. For he, too, helps to "keep 'em flying."

How to choose the right tool for every job and how to use it correctly are primary requisites—necessary for the efficiency demanded by an industry which leaves nothing to chance.

Nicholson has gone far toward helping "trainees," workers and managements: (1) by making *The right file for the job*; (2) by providing free manuals on general file uses and care,* and (3) free technical bulletins on special-purpose files;† (4) and, finally, by guaranteeing *Twelve perfect files in every dozen*. At hardware and mill-supply houses.

NICHOLSON FILE CO., 22 ACORN STREET
Providence, R. I., U. S. A.
(Also Canadian Plant, Port Hope, Ont.)

NICHOLSON

FILES

FOR EVERY
PURPOSE

NICHOLSON
U.S.A.
MADE IN U. S. A.

* TO MECHANICS, "TRAINEES" AND LAYMEN—Free book, "A File for Every Purpose."

† TO INDUSTRIAL MANAGERMENTS—Free technical bulletins on Stainless Steel, Aluminum, Brass, Shear Tooth, Plastics, Foundry, Die Cast, Die-makers, and Long Angle Lathe files. State ones wanted.

21235

X-Rays in Overalls

(Continued from page 46)

X-rays is as wide as American industry itself. In a western packing house an X-ray inspection unit tells good oranges from bad as they pass beneath a fluoroscopic screen. In others, X-rays detect foreign bodies or spoiled foods in containers.

All along the line from the low voltage instruments up to the million-volt "gun," X-rays have their particular jobs to do. Most spectacular, of course, is the biggest. Big in potentialities, though not in dimensions; for the million-volt machine has been tailored by the geniuses of General Electric company into a 1,500-pound parcel only three feet in diameter, four feet long. It is relatively as easy to roll in position as the X-ray your dentist pulls up to the chair for a peek through your teeth. It draws only four kilowatts of electric power.

Small in size, modest in consumption of current, it is ravenous in appetite for work. Because of its enormous power, it can be focused on its subject from a greater distance, thus cover a wider range of vision. Result: where it took six exposures to X-ray a heavy casting for a bombing plane at the Ford Motor plant with a 400,000-volt machine, the million-volt X-ray takes in six entire castings in one exposure. Where a half-inch crack in a weld four inches deep could be detected, the new machine shows up 1/8-inch cracks in an eight-inch weld. Until two months ago it took 7 1/2 hours to make an exposure of an area 12 inches wide; the same steel 24 inches wide can now be X-rayed in 15 minutes.

In short, the big X-ray can do the work of millions of dollars worth of radium—more than is available in the world.

In the General Electric plant, where turbines for the navy and other important defense machines are built, the big X-ray is used to take stereoscopic views, two pictures made from different angles giving a three-dimensional look through the wall of a large casting. Thus the exact location of any possible defect is made apparent.

Development of this million-volt instrument was made possible by three important innovations. One was the use of Freon gas under pressure as an insulating medium. At first air was the insulator, then oil; 100 pounds of Freon performs the insulating task of 12,000 pounds of oil.

The second development was the "resonance" transformer. Ordinary transformers consist of two coils of wire wound on an iron core. In the resonance transformer the iron core is omitted; the secondary—the coils from which high voltage emanates—has several hundred thousand turns, giving it high inductance. Without the iron core, insulation problems are simplified and the transformer's tank diameter is one-third less. Furthermore, it can be operated in any position, giving the tube greater flexibility and mobility.

Third innovation is the tube itself, which consists of twelve sealed-off sections. Electrons producing the rays emanate from a heated filament at the top, and as they flow through each section they are given a fresh jolt of about 84,000 volts. By the time they hit the bottom section of the tube they have accumulated a million volts. Then they hit the tungsten target in an extension of the tube projecting from the bottom of the tank, and produce X-rays. Most of the rays pass through the target and proceed in the direction the tube is pointed, so that ordinarily the tube is aimed like a gun at its object.

Nearly 20 years ago industry first put X-rays to work, when apparatus was installed in the government's Watertown Arsenal. In the years since it has played a vital part in the onward march of aviation, helping aircraft builders adapt aluminum and other light metals to engines and structural parts requiring lightness with strength. It made possible the substitution of welding for riveting in high-pressure boilers and other heavy products by serving as the welder's "second sight," enabling him to lay down welds stronger than the parent metal.

Now the million-volt X-ray has put on its overalls in the aircraft plants of the Ford Motor company, the boiler works of Babcock & Wilcox, the Combustion Engineering company factory, and in its own home plant of General Electric at Schenectady. It is going to work soon at the American Steel Foundries and the Campbell, Wyant and Cannon Foundry works, and, focusing its appraising eye on big guns and battleship armor at the Norfolk and Philadelphia Navy Yards, will play a great part in making America's defense invincible.

All you pipe fans, Ahoy!
Here's a smoke you'll enjoy!

YO HO! AND THE FLAVOR OF RUM!



Not a trace of tongue-bite,
This new mixture is right!

YO HO! AND THE FLAVOR OF RUM!

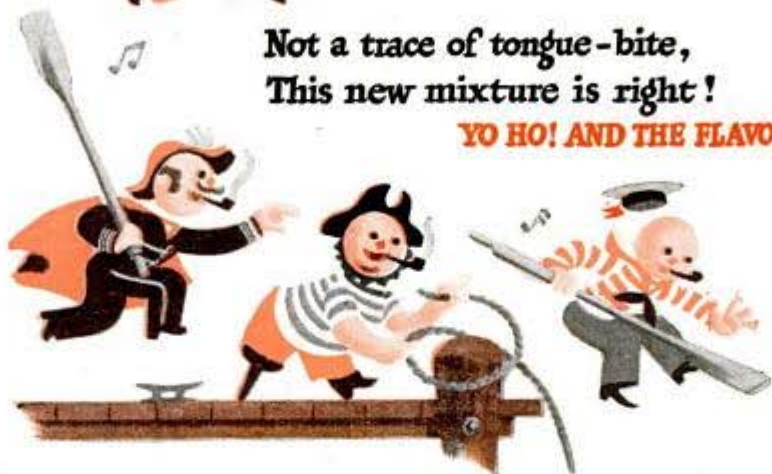

Give your pet pipe a lift —
At a dime, it's a gift!

YO HO! AND THE FLAVOR OF RUM!



Ask for FRIENDS... don't forget!
Friends, you'll like it best yet!

YO HO! AND THE FLAVOR OF RUM!



FAST!
SAFE!
LOW PRICED!

Thompson Boats

Canoes
\$75 and up
All popular models, canvas covered. Light, swift, safe, strong and durable. Many color combinations.

Rowboats
\$48 and up
Most complete line ever offered, at real money-saving prices.

Outboard Boats
\$48 and up

THOMPSON BOATS HAVE FULL LENGTH SPRAY RAILS. KEEP PASSENGERS PERFECTLY DRY AT HIGH SPEEDS

ALSO SAIL BOATS—Today's seven most popular models. Olympic, Snipe, Comet, National, Sea Gull, Lightning and Red Head. Complete with sail, mast and rigging, at low money-saving prices. Write for complete Thompson Catalog.

THOMPSON BROTHERS BOAT MFG. CO.
Two Large Factories—Write to Either Place
213 Ann St. **PESHIGO, WIS.** 113 Elm St. **CORTLAND, N. Y.**

Catalog Free
Save Money
Prompt Shipment

Thompson BEATS the World on BOATS

(115) Please state the kind of boat you are interested in

Now 14 sets of STANLEY PLANS

4 NEW sets—Five interesting things to make in each



Footstool Plan in Set No. 7

- Set No. 1 Hanging Shelves
- Set No. 2 Lamps
- Set No. 3 Trays
- Set No. 4 Tables and Stands
- Set No. 5 Book Ends and Small Articles
- Set No. 6 Flower Pot Holder, Desk Articles
- Set No. 7 Mirrors, Footstool and Table
- Set No. 8 Magazine Stands and Tables
- Set No. 9 Chests and Boxes
- Set No. 10 Smokers' Stands
- Set No. 11 Workshop Equipment, Lawn Chair
- Set No. 12 Sewing Stand, Window Cornices, etc.
- Set No. 13 Coffee Table, Book Shelf, etc.
- Set No. 14 Bird Houses, Garden Furniture

10¢

Select Sets wanted: send check, money order, or stamps to

STANLEY TOOLS DIVISION OF THE STANLEY WORKS
122 Elm Street, New Britain, Conn.

FREE! 136 PAGE BOOK ON FISHING

ALL NEW! "Fishing—What Tackle and When." Shows over 4,000 tackle items, 50 fish in color. Lists fish records, Casting instructions. Sent FREE. A postal gets it.

SOUTH BEND BAIT COMPANY
636 High St. South Bend, Indiana

NEW ASK YOUR DEALER

CONFICIENT GRIP

SOUTH BEND
A NAME FAMOUS IN FISHING

21227

How to Cut Your Heating Bill

(Continued from page 37)

the windows protected with storm glass.

Three and five-eighths inches of rock wool insulation is used in the Electric Skin House. The heat loss through this insulation is retarded to about one-sixth of what it is through any other part of the wall. Without the insulation it would cost \$65.90 a year in heat lost through the walls, thus making them the number one source of heat loss. As it is, the cost per year or heating season is \$16.00 making a saving of \$49.90 or 72.6%, the biggest saving to result from installation of any of the heat-saving devices under consideration. Only 22.2% of all the heat lost from the house is through the insulated walls.

By installation of adequate insulating protection in the ceiling and attic, the heat loss was reduced from \$26.50 to \$7.56, a saving of 71.4%, thus bringing the attic as a source of heat loss down to fourth place. Because of the insulation only 10.5% of all heat escaping is through the attic.

The balance of the heat loss is through the floor of the basement and the doors. Loss through the floor is 7.1% of all heat escaping; loss through doors is 4.8%.

What can the average person who is interested in cutting his fuel bill do?

He can start out first by making two interesting and simple tests of the heating-worthiness of his home. One is the test for blankets of heat and cold in his home. If his home is uninsulated and unprotected by weather stripping and storm sash, the difference in temperature between floors and ceilings of the rooms will be large.

On a zero day when the main inside wall thermometer of his home shows the temperature in the house to be 70, let him get an extra thermometer and hold it to the ceiling at an outside corner of his living room. After getting the reading at the ceiling, take another directly below at the outside corner of the floor. What will comparison of the two readings reveal?

In the Electric Skin House this test shows that the average "differential" between ceiling and floor in this "coldest" corner of the living room is only 4 degrees F. Mr. Wunderlich has made the same test in 50 other homes not so well insulated or protected from heat losses as his own. He has found these floor-to-ceiling tempera-

21227
ture differences to range between 12 and 18 degrees, differences three and four times greater than in his own home.

What's the answer? If any dweller finds such large differences in his home, he has not only uneconomical and wasteful, but uncomfortable and unhealthy heating.

The second test is for stairway drafts. In the average two-story home with uninsulated attic there is a large flow of warm air upward, and of cold air downward, between floors. A good part of this upward-moving heat is lost through the roof. To test for the presence of this draft, simply place two lighted candles on the steps, one on the top step and one on the bottom. Then watch the flames! Do they flicker? Lean in the direction of the strong air current? If they do, the dweller has his answer to compare with the same test made in the Electric Skin House. In the candle test there, the flames stand straight up. There are no drafts.

If a home-owner or dweller feels a good part of his heating dollar is going to heat the outside rather than the interior of his home, he can do these practical things:

If his home is unprotected by storm windows, he can put them on right away. By doing this he will save: 15 cents out of each fuel dollar if his home is not otherwise protected by insulation and weather stripping; 28 cents out of each fuel dollar if he has all other protections excepting storm windows; 63 cents out of each dollar's worth of heat lost out of his windows.

If his home is unprotected by weather stripping, it would be a good idea to plug up the cracks around his windows and doors. Installation of weather stripping will save him around: 9½ cents of each fuel dollar if this is the only safeguard against heat losses he employs; 20 cents out of each fuel dollar if his home is protected with "storms" and insulation; 46 cents out of each dollar's worth of heat escaping through all window and door cracks.

If his home is unprotected by insulation and he believes his fuel costs excessive, he should call an insulation specialist or heating engineer and talk over these points:

About ceiling and attic insulation—10 cents out of each fuel dollar can be saved by installing it if wall insulation and all other safeguards are not present; 13 cents

(Continued to page 168)

Tough

BUT OH SO GENTLE



TOUGH ON OIL-PUMPING, GENTLE ON CYLINDER WALLS

● Now, more than ever before—you can't take chances on undue engine wear. Fortunately, it's both simple and inexpensive to protect your car's engine—to insure maximum life and performance.

At the first symptom of ring wear get Hastings Steel-Vent Piston Rings. They stop oil-pumping, and check cylinder wear.

Any good mechanic can install them—quickly and economically.

Note to Used Car Buyers: Ask the dealer if it's Steel-Vent Reconditioned. It's a better buy if it is.

HASTINGS MANUFACTURING CO., HASTINGS, MICH.
Hastings Mfg. of Canada, Ltd., Toronto

HASTINGS
STEEL-VENT PISTON RINGS
Stop Oil-Pumping.
IN CARS, TRUCKS AND TRACTORS

SPEED UP SPRING REPAIRS WITH

LEPAGE'S WATERPROOF plastic resin GLUE



- ★ **IT'S WATERPROOF** ... even though submerged for months, water has no effect on glue.
- ★ **IT'S SUNPROOF** ... joints hold firm even up to temperature of 160°F.
- ★ **IT'S TIMEPROOF** ... holds for years with glue stronger than the joints it holds.

Buy a can Today!

4 HANDY SIZES
10¢ 25¢ 50¢ 85¢



New Only \$5.95

REAL ENGINE VALUE



The G. H. Q. is a miniature gasoline engine that really operates. Over 15,000 sold in the last year. Now is your chance to buy the *New Improved* 1942 model kit for \$5.95. Absolutely complete with coil, condenser, plug, instructions, etc. Only a screwdriver needed. For boats, planes, midget cars, etc. All parts guaranteed. Send only \$1.—Shipped Collect C. O. D. same day. Send for FREE circular or 6c for Jumbo catalog of hundreds of plane, boat and hobby items.

GHQ MOTORS, Dept. B, 40 East 21 St., New York, N. Y.

2 Bushels of Ripe TOMATOES from ONE VINE



2 or 3 vines will produce enough tomatoes for the average family.

New BURGESS CLIMBING TRIP-L-CROP

TOMATO rapidly grows to a height of 10 to 18 feet. Grow on trellis, side of house or barn or as a bush in garden. Beautiful crimson, solid, meaty fruits of best quality, some weighing over 2 lbs. each. The most productive of all tomatoes. Trial packet 10c—3 for 25c, postpaid.

CASH PRIZE CONTEST

Send for FREE Garden Book giving full details about CASH PRIZES to growers of this wonderful tomato.

BURGESS SEED & PLANT CO.
217 C.T., GALESBURG, MICH.

21227
saved if only the attic is insulated and "storms" and weather stripping are already in use; 20 cents if attic insulation is all that has to be added to completely safeguard the house; 71 cents out of each dollar's worth of heat lost through the attic.

About wall insulation—27 cents out of each fuel dollar can be saved if this is the only and single precaution taken; 35 cents can be saved if weather stripping and "storms" are already being used and if attic insulation is absent; 41 cents if wall insulation is all that has to be added; 72½ cents out of each dollar's worth of heat lost through the walls.

Combining the benefits to be derived by a complete insulation job, including protection of both ceiling and walls, it can be concluded that this will save nearly 49 cents out of each heating dollar if the house is already protected by "storms" and weather stripping; nearly 37 cents if the house lacks these additional protections.

The average man can cut his annual fuel bill 61.5% in an entirely unprotected home by installing the four safeguards against heat loss—storm windows, weather stripping, attic insulation and wall insulation.

Kilowatt—The New Hired Hand

(Continued from page 43)

and healthful rays. The brooder may be operated effectively on a thermostat to maintain a constant temperature.

Mr. Kilowatt, our hired hand, can play a big role in the operation of the milk house. Before the advent of "wired helpers" on one farm, three men did the milking by hand, each requiring 80 minutes, a total of 240 minutes per day; now one man operating an electric milking machine does the job in 135 minutes a day, resulting in a saving of about \$42 per month in hired help cost. In the old days 12 hours a month were used in carrying milk utensils between the barn and the house for cleaning. Today an 80-gallon electric water heater in the milk house eliminates these trips by providing 894 gallons of hot water at a cost of \$3.42 a month. The time for washing the utensils in the milk house is about the same as that formerly used in carrying utensils to and from the house.

An 80-gallon electric milk cooler chills the milk below 50 degrees Fahrenheit in

(Continued to page 171)

if you're a PIPE SMOKER

you may...like ERICSSON...

Make a Discovery



Deep in their hearts, many pipe smokers feel that they're missing something by way of fine tobacco. . . . If you're one of these many, why not do a little "discovering" on your own? Very likely, Peper's Pouch Mixture will be a real find. Mr. W. E. Anderson thinks so—he says: "It has what it takes to make a fine tobacco . . . mildness, aroma and body." At your tobacconist's for only 25¢.

LEIF ERICSSON sailed from Norway in the year 1000. Heading for Greenland, he was blown off his course and discovered an America of luxuriant fruits and grains. . . . DISCOVERING YOUR TOBACCO is so much easier!

If your dealer cannot supply you, send 25¢ for a serviceable silk pouch filled, to Pouch Mixture Division, 717 N. First St., St. Louis, Mo.



CHRISTIAN PEPER St. Louis

Fine Tobaccos Since 1852

KINKADE GARDEN TRACTOR

and Power Lawnmower

A Practical Power Plow and Cultivator for Gardeners, Suburbanites, Florists, Truckers, Nurserymen, Fruit Growers

Low Prices - Easy Terms

American Farm Machine Co.
1058 33rd Av. SE, Minneapolis, Minn.



Catalog Free

Big Money for Workers In Home or Shop



EARN MONEY as Licensed Concrete Specialist. Make lawn pottery without molds. Patented method. Cemetery products, novelties, tiles, floors, colorglazing, patching, basement waterproofing. Other projects. Workers wanted everywhere. Booklet, colorplate, details 10c.

NATIONAL POTTERIES COMPANY
Dept. A, 11 W. 26th St., Minneapolis, Minn.

TRAILED BUILDERS · BUYERS · OWNERS

TRAILER Send 25c for this Big Book Today
Over 80 pages! Beautifully Printed and Illustrated! Trailer Suggestions and Ideas! Colorful Catalog shows America's greatest line of Trailer Parts and Equipment at lowest prices. Everything from wheels to top. Rush 25c (in U.S.) today. Satisfaction guaranteed! TRAILER SUPPLY CO. Box 340-A WAUSAU, WIS.



PLANS FOR NINE NEW JIM DANDY TRAILERS Ready

Build your own trailer! Send 10c for Jim Dandy's interesting new TRAILER PLAN CATALOG which illustrates and describes NINE new models including 6 modern house trailers, plus sport, camp, and utility trailers. Rush 10c (in U.S.) for Catalog today to JIM DANDY, BOX 125-A, WAUSAU, WIS.

BURN YOUR NAME ON TOOLS WITH THE ARKOGRAF

PROTECT YOUR TOOLS FROM THEFT
Write with electricity any name or design on the hardest and finest tools and instruments, or any metal, like writing on paper with pen or pencil. Complete Outfit \$3.50—Fragile Anywhere. Interesting illustrated circular free. Write today. Agents wanted. ARKOGRAF PEN CO., 3927 S.E. Stark St., Portland, Ore.



MAKE BIG MONEY With An AMERICAN FLOOR SANDER



Get into something for yourself where your income is practically unlimited—surface new and old floors with an American floor sander. Work is easy to get and no previous experience is required. Let us tell you how to be a success and become independent. As little as \$75.00 will start you today on the road to steady profits rather than daily wages.

Be sure to sign and send in the coupon below for complete free details—no obligation.

THE AMERICAN FLOOR SURFACING MACHINE CO.
523 So. St. Clair Street • Toledo, Ohio

Gentlemen:
Send complete free details on how I can make big money with an American floor surfacing machine—no obligation.

Name.....
Street.....
City.....State.....

Can You Equal This Home for 1095

Shipped Direct from Our Mill



Save 30% to 40% on Your New Home.. **WE PAY FREIGHT**

Don't pay several hundred dollars more than necessary when you build a home! Buy it direct from our mill at our low factory price. We ship you the materials—lumber cut-to-fit, ready to erect. Paint, glass, hardware, nails, etc., all included in the price—no extra charges. We pay the freight. Plans furnished—also complete building instructions. No wonder our customers write us that we saved them 30% to 40%, compared with builders' prices. Easy terms—monthly payments.

Send for **FREE BOOK** of Liberty Homes

Handsome Big CATALOGUE FREE
Pictures wonderful homes in colors at money-saving prices. Designs to suit everyone. Write for your catalogue today.
LEWIS MANUFACTURING CO.
Dept. 1223 Bay City, Michigan

SELL FLUORESCENT LIGHTS

NEW KIND

*** FREE!**
Rush name for complete Selling Outfit, Free! NO Charge! NO Deposit!



Cuts Light Bills in HALF!

LOW PRICES & BIG PROFITS
SCREWS IN LIKE BULBS!

Amazing "Screw-In" Fluorescent—40 models, and sizes—wanted by Stores, Offices, Factories, Homes because no "installation" cost. No special wiring and positively cut light bills in Half—every month. Some as low as 4.95 retail with lamps. 1942 sales will reach QUARTER BILLION! Quick, big profits for salesmen. Rush name. We send complete selling outfit absolutely free. **SKYBEAM, 225 Fifth St., Dept. 163, Des Moines, Iowa**

BE PREPARED! LEARN TO SHOOT WITH BENJAMIN

MADE IN U. S. A.

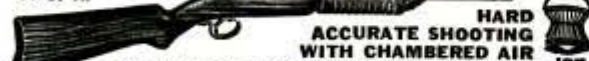

HARD ACCURATE SHOOTING WITH CHAMBERED AIR

You can use new model **BENJAMIN AIR RIFLES WITH LEVER HAND PUMP** anywhere, for practice firing or just plinking around the house or camping, fishing, hunting, etc., at lowest cost. Shooting force is adjustable with amazing maximum power and accuracy—no recoil or forward lunge to disturb your aim. **Bolt Action-Hammer Fire-Hair Trigger-Safety Lock-Hand Pump.** Single Shot RH with 1 lb. shot \$9.00! Single Shot Cal. 17 or .22 rifled—with 500 pellets \$10.50. Also a complete line of Improved **BENJAMIN GENUINE COMPRESSED AIR TARGET PISTOLS** from dealer or factory. Write for details and **FREE TARGETS.** **BENJAMIN AIR RIFLE CO., 895 Marion St., St. Louis, Mo., U. S. A.**

GERSTNER TOOL CHESTS
for economical and adequate protection of tools. Free Catalog to machinists and toolmakers.
GERSTNER TOOL CHESTS
442 Columbia St. Dayton, Ohio

WORLD'S LOWEST PRICED ADDING MACHINE Vest Pocket Size FREE TRIAL ONLY \$250
IDEAL FOR INCOME TAX GUARANTEED AC. ONLY \$250
CURATE. Not a toy. Operates with only a finger flick. Adds, subtracts, multiplies, divides. Counts up to ten million. Pays for itself over and over. **Ideal Gift—**for Business, Income Tax and School use. **MONEY BACK GUARANTEE.** Send name and address. Pay postman only \$2.50 plus postage. (Send full cash if outside U. S.) Money back in 10 days if not delighted. **AGENTS WRITE.**
CALCULATOR MACHINE COMPANY (Mrs.)
DEPT. 127, P. O. BOX 1118 CHICAGO, ILLINOIS

NEW TRAILER PARTS CATALOG

48 PAGES for TRAILER OWNERS
TRAILER OWNERS and BUILDERS
Get our new 48 page illustrated catalog! All products specially designed for trailer use—windows, combination ice and electric refrigerators, undercarriage equipment, couplers and lifting devices, metal moldings and rub rails, interior lighting fixtures, stoves, heaters, pumps. Parts you can't get locally. Catalog mailed postpaid on receipt of 10c coin. Write today.
MARVEL TRAILER PARTS CO.
19020 Celestine Ave., Detroit, Mich.

Save Your Feet

Thousands relieved from pain walk freely with **HEEFNER ARCH SUPPORTS**



Write for Free Booklet "FOOT FACTS"

HEEFNER ARCH SUPPORT CO., 668 Lewis Bldg., Salem, Virginia

GENUINE U.S. BARGAINS

O. D. WOOL BLANKETS (USED) . \$2.95
MCCLELLAN SADDLES (USED) . 5.95
U. S. ARMY PUP TENTS (USED) . 2.50
U. S. MARINE PONCHOS (USED) 1.29
Thousands of Other Bargains in Military, Outdoor & Sport Goods for Hunter, Farmer, Scout Send 10¢ for 32-page catalog returned with first order.
A and N SUPPLY CO.
4720 LESTER ST. RICHMOND, VA.

HOLD-E-ZEE AUTOMATIC GRIP SCREWDRIVERS

Hood, start and set-up screws in unhandy places. (Grippe instantly released by spring action, sliding up out of way when not in use. Finest materials thru-out, chrome vanadium blades; many have transparent, insulating unbreakable handles. (Illustrated.)
No more expensive than ordinary screw drivers. Models for re-cess-head screws. Handies over. Get one today. At auto-supply, hardware or electrical stores.
UPSON BROS., INC. 86 EXCHANGE ST. ROCHESTER, N. Y.

OWN A Printing Business

Cards, Tickets, Stationery, etc. Good profit in spare time. **PRINT YOUR OWN** greeting cards, movie titles, church work, etc. Save money. Easy rules supplied. **Junior Press \$8, Senior Out-lets \$12 up.** Have home shop. Raised printing like engraving too. Sold direct from factory only. Write for free catalog and all details.
KELSEY, INC. X-37, MERIDEN, CONN.

BUILD-ARC WELDER FROM OLD GENERATOR

For Light or Heavy Work. 30-200 amperes. Complete **PLANS 35c.** Send today and we'll include **FREE** our 1942 Catalog.
LEJAY MFG. CO., 1347 LeJay Bldg., Minneapolis, Minn.

AGENTS 300% Profit SIGN LETTERS

For Store Fronts and Office Windows. Anyone can put them on. Free Samples. Liberal Offer to general agents.
METALLIC LETTER CO., 438 N. Clark St., Chicago

PINS 30¢ up ** RINGS \$1.50 up

Class pins, club pins, rings and emblems. Finest quality. Reasonable prices from 30¢ up. Write today for our attractive, free catalog.
Dept. N, METAL ARTS CO., Inc., Rochester, N. Y.

YOU CAN HELP
SHOES, TIRES, RUBBER GOODS Last Longer.
Fix them with new plastaned "putty." **MENDS** holes and worn spots in leather, cloth, rubber. Spreads on like butter. Dries tough overnight. Flexible, non-skid, water-proof. Won't come off—guaranteed. 25¢ repairs—25 cents.
AT HARDWARE AND 10c STORES

P 1222

an hour, not only preventing loss due to milk souring, but assuring ready acceptance, even when there is a surplus of milk. In one year the milk cooler cut \$32.30 from expenses by "saving" milk and taking the place of ice. An electric sterilizer is used to rid the dairy utensils of bacteria.

Bacteria in the air of milk houses, animal pens and of places where food is prepared can be kept to a surprisingly low count by means of a tubular lamp emitting "killer" rays. This equipment is useful in the cow barn, the horse barn, pig pens, poultry house and others—because animals and poultry will be healthier in clean air.

Portable electric motors are the answer to many of the farmer's problems. On one poultry farm before electricity came, feed was ground with a large grinder run by a tractor. Two men were required to run the outfit, the operation of which meant taking the tractor out of the field, frequently at busy seasons. Today a small hammer mill, driven by a two-horsepower portable motor, does the work. The grain is fed to the grinder from overhead and the ground feed is blown into another overhead bin—semi-automatic operation. By the old method tractor fuel to grind a ton of mixed grains amounted to \$1.17; electricity to grind a ton of the same grains costs 32 cents.

The portable motor can be prepared easily by the nearest blacksmith; an electric motor of the power desired is mounted on a small wheeled truck that can be rolled from one place to another to perform dozens of jobs—grain and corn elevating, grain and seed cleaning, hay hoisting, hay baling, corn husking, shredding and shelling.

Filling the silo is one of the important activities of stock farming. On one Wisconsin farm, the silo holds about 250 tons of ensilage. At first this farmer hired a man who furnished gasoline-power equipment and a cutter; he also boarded the crew and teams and furnished the gasoline to run the engine, running the cost up to 25 to 50 cents per ton for filling the silo. Then the farmer purchased a portable 7½-horsepower electric motor and cutter. On a test run he put ensilage into the silo for only two cents per ton, a saving of at least 23 cents per ton. In addition, the motor can be employed for many other tasks.

It can well be said that the farmer's best friend is an electric motor. A one-horse-

(Continued to page 172)

MONEY MAKING OPPORTUNITIES

A New Hobby that Makes Money at Home



HOW WONDERFUL it is when we can turn our interesting hobbies into cash. And it is possible! Brush electroplating offers the opportunity. Right at home some make a good living—as much as \$30 or \$40 a week. Here's what one

home electroplater of Chicago says: "I bought my electroplater to experiment with during my spare time. In a few evenings I earned the cost of the machine by plating jewelry, silverware, headlight reflectors, etc., for friends and neighbors. Now I have all I can do. I recommend this machine to all who want a profitable business."

This man apparently finds business easily. So can you. Besides the articles he lists there are electrical appliances, surgical and dental instruments, restaurant silverware, boat hardware, musical instruments and many automotive parts.

J. J. Wilson, Slidell, La., writes: "After I received my electroplater I practiced for about an hour. I made up four samples and went out after business. One of the large chain restaurants now has me do all their silverware."

Max Hemmert, Idaho Falls, Idaho, states: "I am now spending all my time in plating work. I purchased a brush plater last summer and have worked up a very promising business."

Frank Welde, Philadelphia, goes after garage business. He writes: "I electroplated a few brass strips for samples. I then showed these strips to different people and that's how I got plenty of jobs. I have all the work from a big garage. The owner gets 10% of what is charged his customers, and the rest goes to me for my work."

MAKE BIG MONEY at HOME!
NEW INVENTION

Electroplates by Brush

Now Plates CHROMIUM Too!

FREE SAMPLE and BOOKLET EXPLAINS ALL

New, patented invention makes possible big earnings AT HOME. Replate auto-parts—worn articles in homes, stores, hotels, restaurants, etc., with durable, sparkling, new coat of metal—with stroke of brush. Easy, simple, quick. Genuine Gold, Silver, Nickel, Cadmium, etc. Everything furnished. Outfit complete, ready for use. No shop required. Clear from \$2 to \$5 an hour in lifetime business. Small investment starts you in business. Steady repeat. Machine can pay for itself in week. Send TODAY for FREE SAMPLE and illustrated BOOKLET how you can have a life income from a business of YOUR OWN built upon satisfied customers. Act at once!

WARNER ELECTRIC COMPANY
225 N. Wabash Ave., Chicago, Ill., Dept. 106

21222



Use
ROGERS
Liquid Fish Glue
The Glue with the
"Grip of a
Gorilla"

Fix your crippled furniture, chipped veneer, splintered moldings so they look like new . . . Rogers Glue stays put longer because it's stronger . . . also useful for repairing sporting goods, leather, cabinet work, wooden drawer pulls, interior building construction, and the like.

Special Offer! Sells 10 cents and up in tube, jar or can at hardware stores only or send 10 cents for full-size jar, a free project book giving new ideas, new plans on how to make useful articles, plus a free set of project sheets.
ROGERS GLUE CO.
Department L, Gloucester, Mass.



ROGERS

A TON OF STRENGTH IN EVERY DROP

EARN MORE MONEY
GRINDING LAWN MOWERS
"THE UNIVERSAL WAY"

FULL OR SPARE TIME
Build a Business of Your Own in Your basement or garage and earn \$135 a month. Mr. Felber of Ind., writes, "My UNIVERSAL GRINDER is faster and more accurate than any other grinder. Its efficiency enabled me to sharpen 450 mowers in 4 1/2 months." More than paid for itself the first month. Every customer satisfied. **Only on the UNIVERSAL** can the inside face and edge of stationary blade, as well as the edge of the reel blades, be ground to proper clearance **ALL IN ONE SET-UP** without removing any blade from the mower. Tool Grinding Rest included. "The Universal Way is the Modern Way" Write for Free Folder
Rogers Mfg. Co., Dept. 10-A, Lindsey, Ohio



FREE *Stove Catalog*



Factory Prices

106 Styles and Sizes. Coal-Wood Ranges; Combination Gas-Coal or Oil Ranges; Gas Ranges; Coal-Wood Heaters; Furnaces. 30 Days Trial. 24 hour shipments. 1,700,000 Satisfied Users.

Easy Terms. Year to pay. Factory guarantee.

KALAMAZOO STOVE & FURNACE CO., MFRS.
391 Rochester Avenue
Kalamazoo, Mich.
41 years in business

A Kalamazoo
Direct to You

power motor can do the mechanical work of eight men, yet it works all day at a cost less than that of the food one man eats at a single meal. Many machines can be driven with small—fractional horsepower—motors. These motors can be used to drive a multitude of small devices, pumps, clippers, grindstones, corn shellers, power tools in the farm workshop, etc. It is as bad to provide a motor with ten times the power required of it as to buy motors too small for their jobs. Good advice on the motors the farmer needs can be obtained from the county agent or the equipment dealer.

Not every farmer needs the amount of equipment installed on a large farm in western New York for experimental purposes, but he may get an idea of what can be accomplished with electricity and certain kinds of apparatus. Electricity had been used after a fashion to light the house and outbuildings, operate the radio and an electric iron. To existing wiring and fixtures, this equipment was added: about 5,500 feet of No. 12 or larger wire of low resistance; 80 new lamp outlets and 69 convenience outlets in the house, main barn and other farm buildings; nine motors with a total output of approximately 14 horsepower, operating silage cutter, hay chopper, hammer mill, hay hoist, wood saw, water pumps, one ventilating fan in barn, one in milk house and one in poultry house, milking machine, electric drill, paint-spraying machine, concrete mixer, cooling compressor; three bacteria-killing lamps; milk cooler; milk-house sterilizer using 3,000-watt heating unit; two 2,000-watt 80-gallon electric water heaters in milk house and home; battery charger.

In the farm house: electric refrigerator, combination sink and dish washer, cabinets and working surface for all-electric kitchen, electric roaster, 1,000-watt electric iron, electric ironing machine, electric range with double oven, mixer, toaster, fan, waffle iron, heating pad and coffee maker, three new floor lamps, three table lamps and six "pin-up" lamps.

Two years after installation, electricity had saved this farmer \$500, including the elimination of annual expenditures of \$50.35 for ice and \$96.40 for cook-stove fuel, freeing a hired man from dairy operation, replacing a part-time hired girl and increasing the farm production. And the family enjoyed life more than ever before.

2943

The Battle for Safety

(Continued from page 69)

gone three years without a lost-time accident. *at the end of Columbia*

The Bayuk Cigar plant in Philadelphia established a new American record when its employes reached 14,314,436 work hours before a lost-time accident occurred. The United States Steel Corporation and its subsidiaries has brought its accidents per million man-hours down from 79 to 6.84 since 1913. The Jones and Laughlin Steel Corporation's seamless tube department



Asbestos-clad worker taps an open hearth furnace

rolled up 28,000,000 man-hours without a fatal work accident, while in the same period, 12 employes met death by accident outside the plant.

In the front lines of the battle for safety is the National Safety Council. This organization has found the ten safest industries are tobacco, cement, laundry, steel, glass, automobile, textile, rubber, chemical, and printing and publishing, with disabling injuries ranging from 2.77 per million man-hours in tobacco to 8.81 in printing and publishing. The ten most hazardous industries are paper and pulp, tanning and leather, woodworking, marine, clay products, foundry, refrigeration, construction, mining and lumbering, ranging on the same basis, from 15.38 to 45.50.

Analysis of industrial accidents by the council showed that more than one fourth were caused by plain carelessness. Of the mechanical causes, hazardous arrangement of machinery led the list, with lack of safety guards next. Other contributors were defective machines, unsafe apparel and scanty illumination and ventilation. Improper attitude toward safety and lack of

(Continued to page 174)



EASY TO READ—easy to clean, unconditionally guaranteed for one year. The crack-proof white surface is bonded to the steel—protects it from rust. 25, 50, 75, 100 ft. lengths. Sold by hardware, building material, mill supply dealers everywhere. Write for folder. KEUFFEL & ESSER CO., Hoboken, N. J.

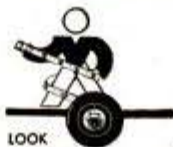

LOOK FOR THIS DISPLAY



K&E WYTEFACE
STEEL MEASURING TAPES

SAW-FILING

MAKES A GOOD LIVING

J. H. Kellogg of Michigan writes: "Mortgaged my furniture and bought a Foley Filer and one year later had all my debts paid and paid \$400.00 on a new home. I file for carpenters mostly, and many days earn as much as \$16.00."

Louis P. Wadowick says: "I have filed 764 saws in spare time."

Thor Nedribe, Iowa, says: "I have filed 559 saws, made \$350. As I'm a Carpenter, I just file saws in spare time—have more than I can take care of." With a



FOLEY AUTO MATIC SAW FILER

you can do expert work easily, quickly, without eyestrain. The Foley files hand, hand and circular saws better than the best hand filer. The new Model F-16 is the result of 40 years' experience in building saw filers, and is unequalled for accuracy, ease of adjustment and long life. Patented jointing principle brings uneven teeth back to uniform size.

FREE PLAN shows you how to start your own cash business in spare time with small investment—no canvassing. Send coupon now,—no obligation, no salesman will call.

Mail Coupon for FREE PLAN

FOLEY MFG. CO. 316-2 Foley Bldg., Minneapolis, Minn.

Send Free Plan on Saw Filing business—no obligation.

NAME:

ADDRESS:



2943



EVERY DROP WORKS
...and does a better job on all wood gluing

Franklin Glue — genuine Hide Glue in liquid form — saves you money. No waste from preparation, evaporation, souring, hardening or chilling. Makes a joint stronger than the wood it binds.

ALWAYS READY — USE IT COLD
No heating or mixing. No glue pots or heated wood with Franklin Glue. Use instantly, as is! Spreads smoothly, easily, at room temperature. Favorite of the woodworking industry, of fine craftsmen everywhere.

ASK YOUR HARDWARE DEALER
for Franklin Liquid Hide Glue or send 25c for 1/4-pint can (Regularly 30c). If from Ohio, add 1c sales tax. Only one can to a person.

THE FRANKLIN GLUE CO.
1162 Cleveland Ave., Columbus, Ohio



FRANKLIN
Liquid Hide **GLUE**
FOR ALL WOOD GLUING

PAINT STRIPING TOOL ONLY \$1.00 POST PAID

Try it! See the Added Beauty

With this NEW TOOL (not a brush) everyone can now draw lines with paint. Used on autos, models, toys, tiled walls, cabinets, furniture, linoleum floors and all home workshop projects.

As easy to use as a pencil

Send only \$1.00 for complete tool for painting a 1/16" wide stripe, including adjustable guide, operating instructions, etc. Tool uses paint, enamel, lacquer, etc. Patented interchangeable tips are available for wider or narrower stripes.

Every Painter and Craftsman Should Own One
Send for your tool today. Use it. If you are not satisfied that you have added character as well as beauty to your work, return the tool and we'll refund your money promptly.

Dealers: Write for literature, etc.
WENDELL MFG. CO.
2531 N. Ashland Ave. Chicago, Ill.



Standard RIDE OR WALK
1-2 CYLINDERS

GARDEN AND SMALL FARM Tractors

Powerful 1 and 2 Cylinder Tractors for Small Farms, Gardeners, Florists, Nurseries, Fruit and Poultrymen.

Plow Seed Cultivate Mow Hay and Lawns

FOUR MODELS
Ample Power for Field, Haying and Truck Crop Tools. Run Pumps, Saws and Belt Machines.

Steel or Rubber Tires
High Wheels—Enclosed Gears
LOW PRICES
Write for Easy Terms Plan and **Free Catalog**



STANDARD ENGINE CO.
Minneapolis, Minn. New York, N.Y. Philadelphia, Pa.
3221 Como Av. 617 West 26 St. 1914-15 Fairmount

knowledge or skill had some part in 85 per cent of tabulated accidents.

Finger injuries were 22 percent of the total. Other portions of the body in order of vulnerability are the trunk (20 percent), legs, arms, feet, hands, head, toes, and eyes (4 percent).

Leonard Cole, Safety Engineer for the Crane Company, and member of the National Safety Council, offers five "don'ts" for workingmen: don't fail to use safety appliances, don't touch a machine until you know how to use it, don't get thoughtless or indifferent while on the job, don't try short cuts when there is a safe way of doing a job and don't leave tools and machinery around the floor for someone to trip over.

The army of skilled workers forms a tremendous asset and this investment should be protected, L. S. Hawkins, Director of U. S. Vocational Training for Defense Workers, points out.

"During the past year, more than one million men and women were trained for the defense industries in vocational schools," he says. "Ten times as many already have been trained in pre-employment courses as were trained during World War I. It is apparent that a considerable investment in the training of an individual may be entirely destroyed through an accident.

"The great majority of accidents result from the failure of some individual rather than from causes which cannot be foreseen. Induction of many new workers tends to increase these hazards unless appropriate measures are taken to guard against them. Accidents can be reduced through organized training programs and safety devices not only for the good of the worker, but to protect the public's interest.

"It is much more humane and more economical to take every possible precaution to protect the worker than to prepare a replacement. Safety training and safety precautions are an indispensable part of the defense effort."

If you spent fifteen minutes reading this article during normal working hours, the chances are at least two men went to their deaths in an American plant or factory—crushed by falling metal or stone, dragged into a whirling machine, burned, mangled or fatally infected. From 160 to 180 men were injured.

HOW YOU CAN CATCH MORE FISH



Creek Chub's new 1942 catalog is a practical, fascinating, reliable guide to better fishing! Shows lures and flies in natural colors! Sent FREE upon request! Write today!

CREEK CHUB BAIT CO.
Garrett, Ind.

413 So. Randolph St.

NEW Grinding Attachment

For 8" to 16" Metal Lathes. Build it Yourself.

At last, a precision grinder within your means. You save 7/8 by finishing out semi-machine castings on your own lathe. HURON handles both internal and external grinding. Accuracies to .00025". Mirror finish easily obtained. Grinds valves, pistons, bushings, shafts, hard or soft, kales, lathe centers. Sharpens reamers, milling cutters. Does eccentric drilling; laces, polishers; scores of other uses, for home workshops, garages, machine shops. Write for FREE illustrated folder and price list of supplementary items. Mention your lathe.

Huron Machine & Tool Co., Dept. B, Yale, Mich.



Semi-Machine Castings Only \$6.45

RINGS
\$1.50

PINS
30¢

FOR YOUR CLUB

Knit your group closer together and enhance pride of membership with pins or rings. Bastian's big selection, low prices, traditional clean-cut quality work has led the field for 46 years. WRITE TODAY FOR NEW FREE CATALOG! **BASTIAN BROS. Dept. 76, Rochester, N. Y.**

PUSH BUTTON CONTROLLED GAS TANK LOCK



NO KEYS—Electrically operated from dashboard. One model fits all cars including fender door type. Greatest thing out! Sells on sight! Fully guaranteed. Distributors, dealers, here is your money making opportunity. Push name for free literature.

SNAP-UP GAS CAP CO., Dept. K, ASHLAND, KY.

OTTAWA Log Saw \$39



BIG BOOK FREE

PUTS THIS OTTAWA to work for you. MAKE MONEY! Wood is valuable. Does more than 10 men. Easily operated. Falls trees—saws limbs. Use 8 hp. engine for other work. Write for FREE Book. **OTTAWA MFG. CO.**
5327 Wood St., Ottawa, Kans.

Wonder-Tone NOISE ELIMINATOR

Just attach to your radio (long, short wave) and enjoy reception free from distracting noises. Send-No-Money Pay Postman 60¢ plus postage or send 60¢ and we'll send postpaid. Return in 5 days for refund if not delighted.

WONDER-TONE COMPANY, Dept. 13, 7078 N. Clark St., Chicago, Ill.



FREE LITERATURE FOR TRAILER BUILDERS

New up to date facts on world's most reliable parts, axles, hitches, draw bars. Used by U. S. Gov't. and largest trailer Mfrs. Easy to build in spare time. Complete working Blue Prints only \$1.00. Write for Free Literature. **HAMMER BLOW TOOL COMPANY, Dept. 103, Wausau, Wis.**



BUILD YOUR GRANDFATHER CLOCK

Send 25¢ for Simple SHOP TESTED COPYRIGHTED BLUEPRINT. The Simple Seaside Red-Kit way as thousands have. DIME brings PLANS and sixty picture "HOW" Book pricing many fine brass weight Westminster, tube chime, electric and battery movements showing nine beautiful colonial grandfather cases. Build now and save half. **KUEMPEL CHIME CLOCK CO., Bldg. 62, Guttenberg, Iowa.**



MAKE MONEY

WITH NASH CUSTOM TAILORED CLOTHES

Be your own Sales Manager, take orders; earn money with this famous make of clothes. High quality men's tailoring at popular prices.

WRITE! Write in today. Territories open.

THE A. NASH COMPANY

1913 ELM STREET • CINCINNATI, OHIO

Enjoy SANDING THIS EASY ELECTRIC WAY!

Makes sanding the job with a thrill!

SKILSAW Zephyrplane Jr.

2 1/4 IN. BELT SANDER

You'll have real fun sanding electrically with ZEPHYRPLANE JR. in your shop. It's 10 times faster and easier on every job . . . eliminates tiresome "back-and-forth" hand-sanding. Produces a finer, smoother finish, too . . . without ripples or ridges. Ideal for wood or metal. Easy to handle—weighs only 9 1/2 lbs. Link belt drive. Easy to change belt. Works from light socket.

SKILSAW, INC.
4779 Winnamac Avenue
Chicago

See it at your hardware or mill supply dealer's or write us today for full information!



BRUSH PLATING OUTFITS

• for autoparts, reflectors, faucets, bicycles. •
No tanks necessary. Free particulars.

GUNMETAL CO., AVE. M, DECATUR, ILLINOIS

AMAZING CHEAP OIL BURNER

Sweeping the Country!

COOK and HEAT Without Coal or Wood

In Your Present Stove or Furnace—No Drudgery, Dirt or Ashes—Clean Heat at SMALL COST, as much or as little as you WANT.

OVER 40,000 SOLD

Beats any cheap burner ever gotten out for low cost, efficient performance. Burns ordinary low priced free flowing oil without pre-generating. No small openings to clog. Heat regulated by Turn of Valve.

30 DAYS' TRIAL

Prove its efficiency, convenience and economical operation without risk. Write Immediately for SPECIAL OFFER TO AGENTS

AGENTS Salesmen BIG MONEY

F. Silver says: "I can dispose of 250 HEAT KINGS before this year ends." Write us now for agents' offer.

A guarantee with each burner.



who will demonstrate and take orders. Write quick, be first to learn how to make REAL MONEY right now, spare or full time—mail 1¢ postcard today.

UNITED FACTORIES, C-751, Factory Bldg., Kansas City, Mo.

Say you saw it in Popular Mechanics!

Color at Work

(Continued from Coloroto Section)

consider light at every step in their work. If dark colors are used in home or office, more lamps will be needed. The effect of artificial light on color also must be considered. Texture, too, is important. Silks and hard-surfaced paints will show highlights, while wools, velvets and flat paints diffuse the light, resulting in entirely different color ensembles.

The whole trouble in dealing with color

is not so much man's misuse of it, but his failure to use it. Most people dodge the problem of what color to use by not using it. The result has been drabness. People know few colors and are reluctant to try something different. But we may expect to see vastly more color and colors employed intelligently within the next few years. In fact we have crossed the threshold from a taupe age to an era of color.

The Truth About Lightning

(Continued from page 85)

Faraday who in the early 19th century recognized that in any space which is completely surrounded by metal, there can be no electrical effects regardless of what is done to the cage itself or outside of the cage. For this reason steel buildings, steel trains, steel buses and automobiles are safe places to be in a storm. Although a bus or an automobile may not be grounded and is usually insulated from the earth by its rubber tires, if it has a steel top, it is a Faraday cage and no harm will come to a person inside it.

People usually think of lightning in terms of voltage. Actually, it is the current which passes through his body which injures him. To produce current in any part of a person's body or through any electrical conducting material, a difference of voltage must exist across it. The current which flows through the body is proportional to this difference in voltage. If a person is sitting in an automobile and it is struck by lightning, the voltage of the car will rise to a high value, possibly 200,000 or 300,000 volts, until the current flashes over from the car across the tires to the ground. The person sitting in the car likewise will rise to a high voltage, but every part of his body will have the same voltage so that no current will flow through him—and he will not be harmed. If, however, a person were standing on the ground and touching the car when it was struck, then a difference in voltage would be produced in his body, due to the fact that his feet would be on the ground and the part of his body touching the car would be at high voltage. Under these conditions he probably would be killed. This consideration is important when live wires fall on an

automobile. You should remain in the car, not try to get out.

In the early days of lightning rods it was because the importance of providing a good ground was not realized that the rods were not effective. Today, however, there are thousands of farm buildings and homes being effectively protected by this means. The importance of adequate grounding cannot be overstressed. After lightning strikes a rod and its charges flow down it to earth, they must seek out the charges of the opposite sign on the earth's surface. These charges may be distributed over a wide area and a stroke current may have to travel over a considerable distance of the earth's surface to reach them. If an adequate path is not provided for these enormous currents into the earth by the conductor on the lightning rod, a stroke may find a better path by flashing over some part of the building, causing fire or other damage. It is very important to connect the lightning rod ground to the water system, the telephone system ground and the ground of the electric light system.

As more knowledge of the characteristics of lightning has been obtained, engineers of the Westinghouse Company have learned how to reproduce correctly lightning in the laboratory and by the use of small models of transmission lines, farm houses and the like, have determined the correct location of ground wires, lightning rods and other protective means.

Any object taller than a person, such as a church steeple, a water tank or a tower, acts as a lightning rod and will shield him from being struck, if he is close enough to it, as long as the object has a sufficiently good conducting path to earth.

CHAMPION SPARK PLUGS



*More Vital -
More Dependable
than ever!*



"Keep 'em rolling"—and Champion Spark Plugs do just that. Their many patented features include the Sillment seal which banishes troublesome leakage common to ordinary spark plugs. Leaky spark plugs overheat, pre-ignite and cause rough, wasteful engine operation.



It's a sunny "good morning" regardless of weather, when your car starts with the first touch of the starter. Champion Spark Plugs are the key to quick starts in any temperature. It's poor business to handicap your engine with any but the best in these days.



We probably won't have "tomorrow's car" for some time, but that's no reason why your present car can't be kept performing efficiently and economically. Old, worn-out, or dirty spark plugs make a car act old before its time. Have yours checked and cleaned regularly. For greatest gas economy change all spark plugs every 10,000 miles. New ones quickly save their cost.

TO SAVE GASOLINE • KEEP YOUR SPARK PLUGS CLEAN

2063

Help Yourself AND UNCLE SAM TOO!

Buy Defense Stamps! Conserve Materials! Prevent Waste!

You can add years of usefulness to home and household by keeping things in repair. Not only the everyday household repairs but also the major maintenance of the home. And many of these jobs you can do yourself with simple hand tools and the right Casco Glue.

NEW FREE CASCO BOOK Describes Modern Money-Saving Methods for Building and Remodeling



Tells how to use common lumber for strong, rigid built-up beams and girders, how to cut remodeling costs with speedy plywood panels, how to transform old worn and cracked doors into new modern flush doors, how to apply wall coverings, how to damp-proof clothes closets, refasten linoleum, make windows and drawers slide easily, make tile-cement, crack-filler, Swedish putty. Also hints for interior decorating and odd jobs. 22 pages—illustrated.

Send Coupon Below for Your Free Copy



- CASCAMITE RESIN GLUE**
For waterproof and all outdoor gluing
- CASCO CASEIN GLUE**
For heavy duty, water-resistant gluing
- CASCO FLEXIBLE CEMENT**
For odd jobs and dissimilar materials

At Hardware, Paint and Lumber Dealers

**CASEIN COMPANY OF AMERICA, Dept. PM-342
350 Madison Avenue, New York, N. Y.**

Send my free copy of "The Use of Glue in Building Construction and Remodeling."

Name _____

Address _____

City _____ State _____

Save 2¢ — stick coupon on penny post card

Glass "Eyes" Give Super-Vision

(Continued from page 75)

Also developed in the Bausch and Lomb laboratories is a stereoscopic map projector used by U. S. military forces. By the use of overlapping photographs, transferred to glass plates, one lighted green and another red and viewed through spectacles with green and red lenses, a three-dimensional effect is obtained, so realistic that it appears possible to put one's finger on a smokestack, although it has been reduced to 1/25,000 of its real proportions.

As the result of the research of this company, which was awarded the Ordnance flag and Navy "E" pennant for outstanding production of naval ordnance instruments, military commentators believe the United States navy now leads the world in development of fire control instruments on warships, with Germany second and Great Britain third. These range-finder instruments are closely guarded secrets, yet it is known they have grown so complicated and precise that a range finder may consist of 1,500 mechanical parts with almost 100 lenses, prisms and sections of optical glass. It takes half as long to build a range finder as it does a towering battleship, but when they are finished neither the shock of thundering salvos nor the vibration of engines affects their use.

Also brought up to a new standard of efficiency are the range finders for huge coast-guard guns, anti-aircraft detectors, height finders and military binoculars, which are subjected in testing rooms to man-made hurricanes to make certain weather will not cause failure.

What is termed the first major advance in optical glass since 1886 has just been developed by the Eastman Kodak Company. The entire production is being turned over to the U. S. military air service for mapping and observation purposes. The glass is made without silica, which is comparable to making steel without iron. It is characterized particularly by high light-bending ability with a minimum tendency to spread light out into a spectrum, and gives greater lens speed.

Improvements in the use of polarizing methods, in which an inserted sheet of film acts like a picket fence, excluding from lenses the rays which cause glare, have also resulted in assistance to the armed

2963

forces. Laminated Polaroid lenses have been devised which can be ground and polished to such a degree of precision they can be used in fire-control instruments. The filtered rays are so precise that a light projected through these lenses would be refracted less than a yard at a ten-mile distance.

Reduction of glare is also proving an important factor in submarine and torpedo detection, since the polarized lenses cut through the surface reflections of water and disclose what is beneath.

Nor have the discoveries been confined to movies and war, for thanks to the combined research of Dartmouth University Eye Institute and the American Optical Company, a condition which has puzzled generations of eye specialists has been remedied. Thousands of cases were encountered in which the fitting of new lenses to defective eyes failed to clear up headaches, dizziness and even upset stomachs, until it was learned that all people do not see equal images with both eyes and the difficult task of adjusting one image to the other was raising havoc with their nerves, though their sight might appear perfect. The disease was called aniseikonia. American Optical Company scientists have devised a lens that corrects the condition, modifying the image as seen by one eye.

Although Benjamin Franklin gets the honor of inventing the first bifocal lens in 1775, when he simply cut two sets of lenses in two and put the thick reading glasses in the bottom of his spectacles, it is only recently that bifocals, which correct near and distant vision in the same pair of glasses, could be manufactured without leaving a fuzzy area where the two types of glass were joined.

Dr. William Feinbloom of Optical Research, Inc., in New York City, has won a science award for combining plastic rims with glass lenses in contact lenses, which are fitted directly to the eyeball.

Another New York eye specialist, Dr. Brittain F. Payne, devised the spectacles for color-blind motorists. The upper segment of the spectacles is red. Looking down the street, the motorist sees only the red or orange light, which warns him to stop or slow down. The green signal is never visible, so when no light is seen, the motorist knows it is all right to drive on.



How Atlas SERVES THE NATION.

One in a series of messages showing how Atlas helps in the Victory Program.

Photo by Arnold, Floyd Bennett Field

BAUSCH & LOMB

Precision

SHARPENS THE



Off. U. S. Navy Photo

"EYES FOR VICTORY"



Before the mighty guns of the Army and Navy thunder into action, powerful "eyes" — telescopes, binoculars, and marvelous range finders — must spot the target. We can all be thankful that the skill of veteran instrument makers of the Bausch & Lomb Optical Company is enlisted for the duration.

Pictured below are some of the Atlas No. 73 Drill Presses on war production in the Bausch & Lomb plant. The operators are typical of those who since 1853 have carried on the B & L precision tradition. Atlas is glad to serve the nation through such firms as Bausch & Lomb.

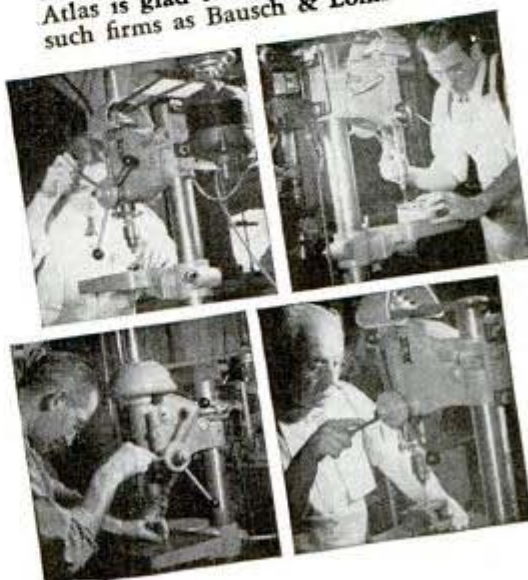

ATLAS PRESS CO.
343 NORTH PITCHER ST.
KALAMAZOO, MICHIGAN

**LATHES - DRILL PRESSES - SHAPERS
ARBOR PRESSES - MILLING MACHINES**

896 Madison.

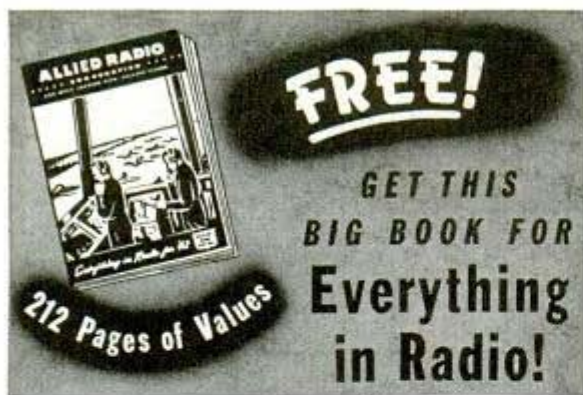

FREE!
GET THIS
BIG BOOK FOR
Everything
in Radio!



NEW 1942 RADIOS



NEW SOUND SYSTEMS



NEW BUILDERS' KITS



AMATEUR SETS

BUY NOW—SAVE MONEY

You'll want this great 1942 Radio Catalog—the biggest and best in the field! It's got Everything in Radio at prices that set the pace for value in today's market. Send the coupon today for your FREE copy of this great catalog.

New 1942 Radios—50 new models, plastic and wood table models, consoles, FM combinations, phono-radios, phono players, recorders, auto sets, farm radios, etc. Before you buy, see this great Knight line!

Sound Systems—1942's finest—full line from 7 to 60 watts—with all the new features, better tone quality, greater usable output. 15 Day Trial—Easy Time Payment Plan, too!

Build Your Own—an amazing selection of new Radio Kits, builders' diagrams—everything for the Builder and Experimenter. Learn Radio—let ALLIED help you!

Amateur Gear—all the new Communication receivers—specialized radio and electronic equipment for industrial application, defense instruction, research, etc.

15,000 Items—Everything in radio—test equipment—replacement parts—all at the lowest market prices. Also see the complete section on **Fluorescent Lighting**. Send for your FREE copy today!

MORE THAN 15,000 PARTS READY FOR PROMPT DELIVERY!



LEARN RADIO!

RADIO DICTIONARY

Nothing like it ever before—complete, authoritative, worth many times the price! Compiled by leading Radio authorities under ALLIED supervision. Gives easy-to-understand definitions of all commonly used radio terms. A "must" at only **10c**

BUILDERS' HANDBOOK

Most popular and widely sold Radio publication—ALLIED's own valuable beginner's book on Radio. Tells how to select circuits, read diagrams, build sets, etc. Fully illustrated. Easy to understand. Order by coupon. It's yours **10c** for only

ALLIED RADIO

833 W. Jackson Blvd., Dept. 5-C-2
Chicago, Illinois

Send me your FREE 1942 Radio Catalog.
 I enclose 10c for Radio Dictionary.
 I enclose 10c for Radio Builders' Handbook.

Name
Address
City State

1942 Little Giant Receiver

(Continued from page 157)

will be noted that the speaker is mounted directly on the chassis base behind the large hole cut in the front panel. This speaker opening is backed with lightweight grill cloth, cemented or glued to the back of the panel. The input and output I.F.

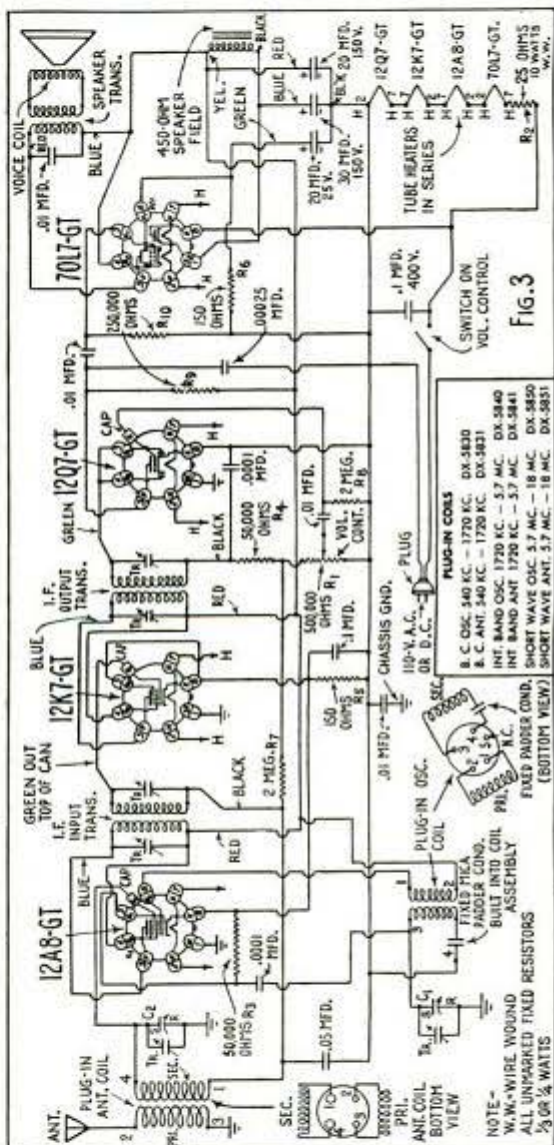

transformers are 456 kc., types DX-5826 and DX-5827 respectively, just as specified in the 1941 model.

The 5-in. electro-dynamic speaker has a 450-ohm field and requires a 2,000 ohm speaker output transformer to match the 70L7-GT tube. Fixed resistor (R₂) is a 25-ohm 10-watt wire-wound variety. The dial is a Crowe 4-in. frictional drive disk

(Continued to page 182)

EASY WAY....

Tints Hair JET BLACK



This remarkable CAKE discovery, TINTZ Jet Black Shampoo, washes out dirt, loose dandruff, grease, grime and safely gives hair a real smooth JET BLACK TINT that fairly glows with life and lustre. Don't put up with faded dull, burnt, off color hair a minute longer. TINTZ Jet Black Cake works gradual... each shampoo leaves your hair blacker, lovelier, softer, easier to manage. No dyed look, Won't hurt permanents. Full cake 50c (3 for \$1) TINTZ comes in Jet Black, light, medium and dark Brown, Tintian, and Blonde. Order today! State shade wanted.

SEND NO MONEY Just pay postman plus postage on our positive assurance of satisfaction in 7 days or your money back. Don't wait—Write today to TINTZ COMPANY, Dept. 45-B, 207 N. MICHIGAN, CHICAGO CANADIAN OFFICE: Dept 45-B, 22 COLLEGE STREET, TORONTO

ANYONE CAN DO THIS IF THEY HAVE OUR CHART

Blue Print 27"x36" shows how to find length of any rafter, find any angle in degrees, frame any polygon 3 to 16 sides, read board foot and brace tables, octagon scale, rafter tables and much other information. Can be scaled down for model work as well as full scale framing. Also Chart changing pitches to degrees for use with Radini Saws. Send 50c coin. No stamps. MASON AND PARRISH, ENGINEERS, 2103-C North Burdick St., Kalamazoo, Mich.

NEW CHEAP OIL BURNER

FOR COOKING & HEATING STOVES-FURNACES HEAT YOUR HOME, COOK YOUR MEALS WITH CHEAP FURNACE OIL

NO MORE SHOVELING COAL OR ASHES. New Fuelizer Starter Vaporizing System turns Cheap 130 Flash Furnace Oil into Oil Gas heat without chugging up. LIFE-TIME GUARANTEE against defects. \$1.00-BONUS OFFER FOR TESTING. We will let you try it in your own stove or furnace for one month. Get Yours FREE for introducing. Big profits. Be first. Send in your name today. NORTHWEST MFG. CO., 510-C 5th Ave., Mitchell, So. Dak.

DO YOU WANT A permanent business profession of your own? Then BECOME A FOOT CORRECTIONIST.

Earnings in this greatly needed profession run as high as \$50-\$100 weekly after a few weeks home training—not medical or chiropody—no further capital needed, no goods to buy. 47th year. Write for free booklet.

Stephenson System of Foot Correction
28 Back Bay, Boston, Mass.

METAL AND WOOD WORKING MACHINE TOOLS

Send for new FREE catalog of complete line of Machines, Motors and Accessories
WALKER-TURNER CO., INC. 132 Berckman St., Plainfield, N. J.

Monuments \$10.00 UP

Genuine Stone For Memorials. High Quality. Lettered. Guaranteed. Don't Delay, Write Today. Free Catalog and samples. SAVE.
U. S. MARBLE & GRANITE CO., A-18, Oneco, Fla.

New MIRACLE WALL CLEANER

AGENTS HOT SELLER!
"Erases" dirt like magic—walls, ceilings, window shades, upholstery. Saves Redecorating. Sells like wild. Write! Rush name, samples sent on trial. KRISTEL CO., 676 Bar St., Akron, Ohio

Wood workers: Here it is!

only 10c
Hunt's big No. 14 wood catalog! Latest UP-TO-DATE IDEAS for experts and amateurs: SPECIAL BARGAINS in rare woods, veneers, and ALL kinds of supplies. 148 pages—20 of rare woods in color! Get notified! Send only 10c to CRAFTSMAN WOOD SERVICE CO. 2729 S. Mary St., Dept. A-19, Chicago, Ill.

Gear YOUR Business to ESSENTIAL WORK

Priorities, shortages and increasing costs are forcing adjustments in every line of work and business. Particularly in the building industry, where lumber and steel are hard to get, even at soaring prices.

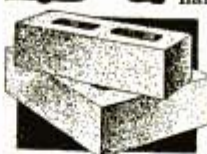

You can capitalize on these conditions by supplying the trade with Brikrete—the new scientific masonry unit. Better than brick, yet brings wall costs down to frame prices. Fireproof, termite-proof, permanent. Has beauty of color and streamlining, strength and self-contained insulation.

NO PRIORITIES—NO SCARCITIES
Brikrete is made from materials and labor that will always be plentiful and low priced. Unlimited market possibilities—now and in the future. We supply complete plant equipment for local manufacturing in protected territories. Requires but modest investment. Profits up to 150%. Write immediately for The Brikrete Book—free.

BRIKRETE ASSOCIATES, INC.
4670 Division Avenue, S., Grand Rapids, Mich.

BRIKRETE

INSTALL IT YOURSELF

CUSTOM-BUILT FLOORS—OUTLAST LINOLEUM

Distinctive designs... 15 rich-textured colors. Easily installed over wood or concrete! Ideal for home, cellar, showroom, office! Fun to install! Beautiful to look at! Long-wearing service! Tiles, Paste and Complete Instructions supplied for only 14c sq. ft. (F.O.B. New York) Send for your catalogue and samples today!
ESSEX FLOOR COVERING CO.
Dept. 5A, 100 West 42nd St. New York City

E Garden Tractors

—profitable, low-cost power
A size to fit your job. Plow, disc, cultivate, mow, haul, do belt work, for about 33c a day. Fast, safe, trouble-free. Back-saving plow lift, reverse gear. High clearance. Guaranteed. Used by hundreds of gardeners, farmers, poultrymen, florists, etc. Two weeks trial. Low factory price. FREE catalog—write today. Pioneer Mfg. Co., Dept. V-32, West Allis, Wisconsin.

New Cushman

sensationally improved with "Floating Drive"



100 Miles per Gallon

3-wheel PACKAGE-KAR
Two front wheels, one rear. Large covered, third-proof delivery box, 250-lb. load cap'y. Built for hard work.
Just Think!—500 miles on \$1 worth of gas! Cheaper than shoe leather! Beats anything you ever saw for making deliveries, getting to work, pleasure, etc. Now built with automatic "Floating Drive"—applies power of mighty Cushman engine as smooth as oil! No clutch pedal or gear shift! Hand-accelerator does it all! Flashy pick-up—swift! Safe—heavy brakes, excellent lights! Comfortable—knee-action, balloon tires! Extra rugged—all-steel welded frame. Easy to park!
WRITE If no dealer in your town handles the CUSHMAN, send for free booklet with photos, full details, very Low Price!
CUSHMAN MOTOR WORKS, Dept. 13, Lincoln, Nebr.

Power King

WOODWORKING TOOLS OF TESTED QUALITY



**NEW 15"
JIG SAW
\$17.95**

Engineered for smooth blade action on light veneers, plastics, thin metals, and boards to 2" thick. Takes 1/4 or 1/3 H.P. Motor. Full details in new catalog.

Send for **FREE** Catalog

POWER KING TOOL CORP., 308 Cleveland St., Warsaw, Ind.

Please send catalog. I am interested in Jig Saws 7", 8" Saws, Wood Lathes Drill Presses Spindle Shapers Jointer Planers Belt and Disc Sanders

Name

Address

City and State

AGENTS WANTED

GOLDENTONE .. 50% OFF



Deal Direct—Factory Prices. Over 75 models to choose from—4 to 12 tubes. Portables \$8.95 up. Table sets \$8.95 up. Car sets \$8.95 up. Foreign band sets \$8.95 up. Samples 50% off. Quantity discounts. Free 1942 Bargain outlook gives details of 10 day FREE trial, agent's proposition and discounts. No obligation. Mail postcard to GOLDENTONE RADIO CO., Dept. PM, Dearborn, Mich.



BRONZE FOUNDRY Schools and Home Workshops

Make your own castings of aluminum, copper, bronze, silver. Foundry sets are available in three sizes including 2400 Deg. F. blast Furnaces. \$17.50, \$24.00, \$34.50, f.o.b. Kansas City. Free Circular.

KANSAS CITY SPECIALTIES CO.

P. O. Box 6022, Dept. P-20

Kansas City, Mo.

FREE BOOKLET ON SHORT CUT IDEAS TO SPEED UP CAR REPAIRS

Mechanics, write for your copy, "Cures for Motor Car Ailments," today.

CHAMP-ITEMS, INC.
6189 Maple Ave., St. Louis, Mo.

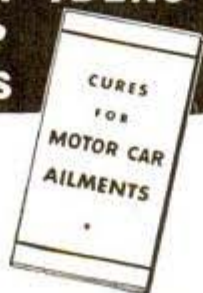

with hub, and includes a 1-in. friction drive with shaft and knob. A detailed list of the original materials used in this set is available from Popular Mechanics radio department without charge. Please note that one of the insulated terminal strips is an upright type with two insulated lugs on a fiber strip. The other two strips are the ordinary type with two insulated terminals.

Set alignment is quite simple, as the I.F. transformer trimmers are already set in most cases to about the correct setting. Merely tune in a weak signal on the broadcast band and adjust each I.F. trimmer with a small insulated screwdriver, for maximum signal strength. If you are using the receiver on a d.c. line and no signal is heard, merely reverse the plug in the wall

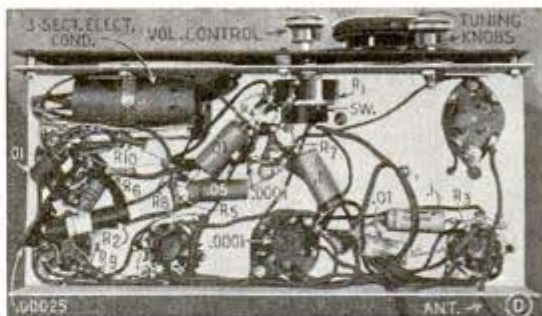

socket. To balance the set, tune the variable condenser to a minimum capacity; that is, with the condenser plates all the way out. Open the antenna coil trimmer on the rear variable condenser section (C₂) with a small screwdriver, about 1 to 1½ turns out from tight. Then open the oscillator trimmer on the front section (C₁) until police calls are heard. This will be about ½ to ¾ turns from tight. The oscillator padder condensers are adjustable for the broadcast band only, and will require a very slight adjustment, in fact scarcely any. Tune in a weak signal at about 600 kc. and make a slight adjustment of the padder, retune the dial with each adjustment to make certain that the signal strength increases each time. Continue to "rock" the variable condenser with each adjustment to be sure that the signal is at its maximum strength. No special precautions are necessary in wiring the set other than to make well soldered connections with rosin-core solder, keep all leads as short as possible, and follow the socket layout just as shown in Fig. 2. The blueprint number for this article is R-301.

"Wireless" Record Player

(Continued from page 158)

condensers and resistors rigidly. The smaller protruding portion of the chassis serves as a mounting for the 8-prong tube socket, and is attached to the larger strip of metal with the screws that mount the chassis assembly on the bottom of the box.

The oscillator coil is hand wound as in Fig. 2-A. The form can be a cardboard tube 1 in. in diameter and just long enough for

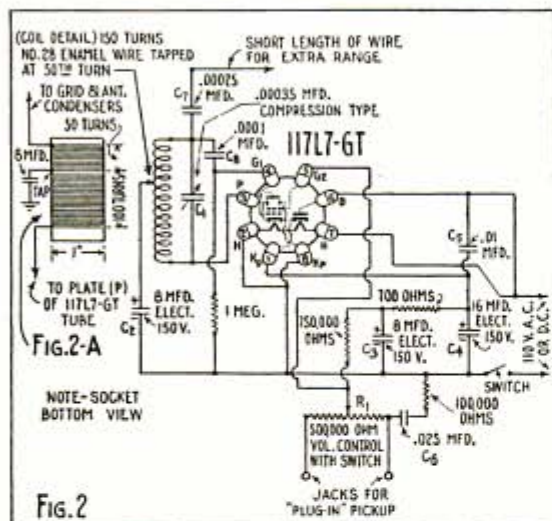

the single-layer clockwise-wound coil which can be tucked in under the tube socket. All wiring should be done on the metal chassis before it is bolted to the bottom of the box. A pair of phone-tip jacks are mounted in a corner of the motor panel for the plug-in pick-up. The pick-up swivel is mounted on a small strip of hard-pressed wood as shown in photo A; threaded phone tips are mounted on the opposite end and the pick-up connected to them.

Condensers C_5 and C_6 are 150-volt tubular paper types; C_7 and C_8 are mica types. The 700-ohm resistor is a 1-watt variety, all other fixed resistors are $\frac{1}{2}$ -watt types. One octal socket and a 500,000-ohm volume control with switch complete the list.

When operated near sensitive receivers, no external antenna is required, in most cases a short wire dropped on the floor will give best results. Set your receiver dial at any point between 1500 and 800 kc. where no station is heard. Plug in the player unit and adjust C_1 with a small screwdriver until a whistle is heard in the loudspeaker, then tune back and forth for maximum volume and best tone.

New!

**UP TO THE MINUTE
1942 EDITION**

**PRACTICAL
ARC WELDING
A TEXT BOOK**

HOBART

**WORTH HUNDREDS OF DOLLARS TO YOU,
THIS NEW 1942
"PRACTICAL
ARC
WELDING
MANUAL"**

516 Pages, 343 Illustrations

It's a combination text book, instruction manual, reference book and operator's training course on the newest types of arc welding equipment. It's needed by every engineer, welding operator, student and executive interested in arc welding and metal working.

Completely New Welding Data

This new 1942 Manual is written in plain, understandable English completely covering arc welding and how to use it. It holds a solution for every arc welding problem, with charts and diagrams to simplify explanations.

Worth Hundreds of Dollars

By introducing suggestions for extra saving and profits, this valuable book will pay for itself many times over. In construction, defense work, maintenance and repair work you can see this book to help you earn more. Practical lessons included—a complete section of lessons as used in our own trade school is a valuable part of this manual. Order this unusual book today at this special price. Only

\$2.00
POST-PAID

Everyone interested in arc welding NEEDS this new book!

**Hobart Trade School
TRAINS YOU Quickly**

Learn Arc Welding at America's
MOST MODERN TRADE SCHOOL

With this five weeks course under the supervision of veteran operators you can become eligible for the big pay arc welding jobs. Shop methods taught. Every student gets individual instruction on modern arc welding equipment. Check coupon for free booklet telling about this new arc welding school.

Packed jam full of the latest in arc welding technique, new equipment, rods and newest welding applications, including 192 pages of practical lessons.

**A BOOK YOU
CAN'T AFFORD
TO BE WITHOUT**

It's an investment that will pay you bigger dividends and increase your profit and income.

Don't delay,
send for your
copy today!

**Use the
Coupon!**

*The New Hobart
Trade School*

HOBART BROS.
TROY, OHIO

"One of the World's Largest Builders of Arc Welding Equipment"



• HOBART BROTHERS, Box M-32, Troy, Ohio, U. S. A.
Please send new 1942 Arc Welding Manual described above, at special price of \$2.00.

Check attached Money Order Send C.O.D.
 Send FREE booklet on New Hobart Trade School

I'm interested in _____ (type of welding)

Name _____

Address _____

City _____ State _____

2974

Raise Your Income \$25 a Week!

No Experience Needed

Make Big Money In Spare Time With

Ideal Lawnmower Sharpener

FREE PLANS SHOW YOU HOW TO BUILD A PROFITABLE BUSINESS OF YOUR OWN

There's big money in sharpening lawnmowers with the Ideal Sharpener. Most men earn up to \$25 a week... even in spare time. Howard Heller, Minn., grossed \$1,100 from April 15 to Sept. 15. No experience needed. It's easy. Just set mower in the Ideal, make a few simple adjustments... the machine does the rest. Ideal sharpens like magic... makes old, dull, worn blades cut like new. You get \$1.00 to \$1.50 for every job. Our FREE Plans show you how to get plenty of orders. Start in basement or garage. Work spare or full time. Easily, quickly, you build up a money-making business of your own. Today, when people have money, is a good time to start.



SIMPLE. FAST. EASY TO OPERATE. GRINDS MOWERS TO KEEN CUTTING EDGE IN ONLY 15 TO 20 MINUTES

THE FATE-ROOT-HEATH COMPANY
1342 BELL STREET - PLYMOUTH, OHIO

SEND FOR FREE 24 PAGE BOOK

NEW DESIGNS DECORATIVE NOVELTY FURNITURE OF PLYWOOD



Full size pattern Wall Shelf The Rack 25c. Magazine Basket 25c. New Catalog contains 500 Illustrations of Plywood Novelty Furniture—Lawn Ornaments—Decal Transfer Decorations and many other lines. **SPECIAL INTRODUCTORY OFFER:** Both above patterns and Catalog postpaid 25c coin.
WO-MET SHOP, Ashburn, Georgia

PIONEER NON-SINKABLE BOATS



"Relax—Go Boating!"

For 31 years, America's outstanding values in Row Boats, Hunting, Fishing, Outboard, Inboard, Sail and Play Boats! Always ready to use! Endorsed by leading summer camps! Send post card for FREE Catalog!

PIONEER MFG. CO., 413 Perry St., Middlebury, Ind.

THE DELTA POWERLite

AMERICA'S FINEST ELECTRIC LANTERN

800 FEET OF PIERCING SPOTLIGHT

Here's a powerful light for around camp or cottage—for night fishing. Its 4" front reflector shoots 800 ft. spot beam. Top reflector throws wide floodlight. Either at flip of the switch. Uses a 6-volt battery. Unbreakable lens. \$3.35 less battery at your dealers.

DELTA ELECTRIC CO.
300 W. 33rd St., Marion, Ind.



Building the "Liberty" Fleet

(Continued from page 53)

yards to minimize possible bombing damage. Building the yards themselves has been a tremendous project, one California yard alone using enough timber piles to provide poles for a telegraph line from Chicago to Los Angeles.

A year ago the United States had practically no shipbuilders nor sailors to man them. As the pace increases more than half a million men will be working in the yards. More than 15,000 sailors and engineers will be needed for the new fleet. The task of training them has been taken over by the Maritime Service. Trainees must be 18 to 23 years of age, are paid \$72.50 a month while at a training station, and must agree to serve at least one year in the merchant marine after completing their course. They may study a selection of subjects that will fit them for special duties aboard ship.

During the last war the United States experimented with concrete ships, and the chances are the same construction will be used again. The plan calls for building reinforced concrete barges of up to 8,000 tons for transportation of bulk commodities. The barges would have no motors, but would be towed by tugs or ships.

If our capacity for building ships doesn't meet the demand, a number of wooden sailing ships may be built. On some trade wind routes the old time clippers often made fast passages that are rarely beaten by cargo ships today.

Also under consideration are two luxury liners larger than the "West Point," formerly the "America." These ships are designed for rapid conversion into aircraft carriers and for this reason would carry their stacks at one side of the hull. Instead of a single large engine room the propulsion machinery would be placed in two independent compartments to avoid a complete breakdown if the hull is pierced. It may be that because of the war the ships will be built as aircraft carriers for conversion later on into passenger ships, reversing the original plan.

Today the United States is being called upon to build ships faster than they are being sunk. A year ago it seemed that this would be impossible but now it appears that the impossible is going to be accomplished.



KRW ARBOR PRESSES BENCH TYPE AND HYDRAULIC

NEEDED IN EVERY SHOP—SAVE TIME AND MONEY—DO BETTER WORK, QUICKER.

No shop is complete without a small arbor press. Pressing and squeezing operations can be done better and faster on a KRW Arbor Press. Stop using vise and sledge hammer methods—they generally deliver spoiled work in the end. KRW Factory-To-You Prices give you greater value for your money. Order today.

KRW Bench Type Arbor Presses, 3 sizes

No. 37-P 1/2 Ton, \$13.25*

No. 37-O 1 Ton, \$23.00*

No. 37-N 3 Ton, \$33.00*

*Prices F.O.B. Arcade, N. Y. Slightly higher west of Rockies. Stand illustrated extra.



KRW Hydraulic Presses are built in 25, 50 and 75 ton sizes. Prices start at \$198.00*



K. R. WILSON 17 Lock St., BUFFALO, N. Y.

Builders of Shop Equipment for Ford Dealers Since 1916

don't WORRY

Why put up with years of needless discomfort and worry? Try a Brooks Automatic Air Cushion. This marvelous appliance permits the opening to close, yet holds reducible rupture securely, comfortably—day and night. Thousands report amazing results. Light, neat-fitting. No hard pads or stiff springs to chafe or gouge. Made for men, women and children. Durable, cheap, **Sent on trial** to prove it. Never sold in stores. Beware of imitations. Write for Free Book on Rupture, no-risk trial order plan, and proof of results. All correspondence confidential. **BROOKS COMPANY, 158 State St., Marshall, Mich.**



8 Mile Range-Wide Vision BINOCULARS \$4.75

15 Days FREE TRIAL Postpaid or C. O. D.

Comes complete with case and straps. Well ground powerful lens. Easily focused for all distances and eye widths. Latest features. Ideal all-weather binoculars. Guaranteed. If not satisfied after 15 days trial, money refunded. AGENTS WANTED. Vogue Binocular Co., 8420 S. Ashland, Dept. 408, Chicago

Say you saw it in
POPULAR MECHANICS

BIG OPPORTUNITY Stucco Spraying

Present day construction needs better and faster finishing methods. Plastic COLORCRETE is waterproofed. It can be used on new or old buildings. It fuses with any masonry surface. Fills cracks and checks. Can be applied in any thickness and in 39 beautiful colors and shades.

Fully proven by over 14 years actual use under all climatic conditions. Offers big earnings. With this machine you can supply the big waiting market at amazingly low cost. Present operators report costs of 2c and up per sq. ft. and sell up to 7c. Some have paid for their equipment from first few jobs. Machine capacity up to 1,000 sq. ft. per hour.

Get the facts. Send for free book "Proven Business Opportunity." Write today.

COLORCRETE INDUSTRIES, INC.
570 Ottawa Ave., Holland, Mich.

PRESTO! ANYONE CAN MASTER GLAZE



Car Owners! Meet Master Glaze—the sensationally different luster for new and used cars! Not a wax—not an oil polish—not a paint!—nothing that “smears” over the surface.

MASTER GLAZE is a unique discovery—a creamy liquid—quick and easy to apply! Gives a hard, glass-like surface. Even gasoline cannot dull it! Lasts six months to a year! Amazing luster—beautiful, sparkling clean and brilliant! Doesn't finger-mark—doesn't smear! A match box full glazes an entire car. Seals the pores—protects! **NOTHING LIKE IT!** **FREE SAMPLE** Write now for **FREE BOOK—FREE Offer!** Let and **FREE TRIAL OFFER.** Just send your name and address: Write

MASTER GLAZE CO., 7720-276 W. Harwood Ave., Milwaukee, Wis.

WITTE DIESELECTRIC PLANTS

Your present power bill will buy a WITTE that produces power and light for 1c a K.W.H. Save up to 75%. A Size for Every Need. Write today for finance plan, literature and name of dealer.



WITTE ENGINE WORKS, 1743 Oakland Ave., Kansas City, Mo.

America's Biggest Sales Opportunity Today is



CONSOLIDATED FLUORESCENT LIGHTING . . .

SPECIAL HERE'S A LINE THAT HAS EVERY-

thing—beautiful modern fixtures for homes, stores, shops, offices, factories; the finest quality obtainable anywhere; a SENSATIONAL COOPERATIVE SALES PLAN TO HELP YOU GET THE BUSINESS! Fluorescent experience not required. No investment; we furnish everything. Liberal advance commission on every sale. Valuable Distributor's Franchise open for any salesman who can qualify. **WRITE FOR FREE SALES KIT.**

Your cost, only
\$4.10

COD—F.O.B. Chicago (Express prepaid if remittance accompanies order).

CONSOLIDATED FLUORESCENT CO., INC.
206 W. North Bank Drive, Chicago.

CASH IN NOW ON AUTO REPAIR



BOOM

Make big money servicing cars that must be kept rolling! With MoToR's 1942 Factory Shop Manual, JUST PUBLISHED, you can do any repair job on ANY American car since 1935—including all '42's! Complete collection of all Manufacturer's Official Shop Procedure Manuals. 603 big pages, size 8 1/4 x 11". Over 900 Photos, Drawings, Diagrams! 450 Charts, Tables! 200,000 Facts!

Instructors and Students—This is the book for you!

Simply fill out coupon below. Mail TODAY. MoToR's 1942 Factory Shop Manual will be sent at once. Pay postman only \$4 plus few cents C.O.D. EXAMINE ON IRON-CLAD MONEY-BACK GUARANTEE printed below. Rush coupon now to: MoToR BOOK DEPT., Room 509B, 572 Madison Ave., N. Y. C.

**30 makes, 502 Models!
603 Pages! Over 1,350
Pictures, Charts, Tables!**

Detailed Instructions on:
Engine; Electric, Fuel,
Cooling Systems; Lubri-
cation; Clutch; Trans-
mission; Universals; Rear
End; Wheels; Brakes;
Front End; Knee Action;
Shock Absorbers; Steer-
ing; Springs; Body; Free
Wheel; Overdrive; Fluid
Coupling; Main, Rod
Bearings; Starting Motor;
Pumps; Gauges; etc.

MoToR BOOK DEPT., Room 509 B, 572 Madison Ave., New York, N. Y.

Rush me MoToR's 1942 Factory Shop Manual. On delivery I will deposit with postman only \$4 (plus few cents C.O.D.) with understanding that if not delighted I may return Manual within 7 days (in original condition) and you will promptly refund my \$4.

NAME _____ YOUR JOB _____

ADDRESS _____

CITY _____ STATE _____

CHECK HERE if enclosing \$4 (check, money order) WITH coupon. We then pay postage. Same Money-Back Guarantee.

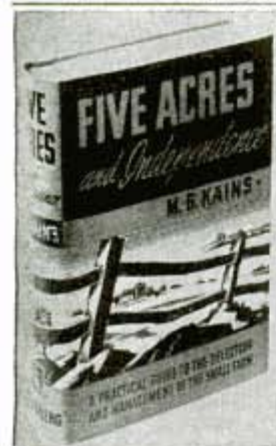

**413 Pages
Profusely Illustrated**

FIVE ACRES and Independence

**A PRACTICAL GUIDE TO
THE SELECTION AND
MANAGEMENT OF A
SMALL FARM**

By M. G. Kains

B. S., M. S., formerly Special
Crop Culturist of U. S. Dept.
of Agriculture.

ALL OF US long some day to OWN A SMALL FARM, whether it be for permanent residence or as a week-end haven where we may enjoy the relaxation of rural life. When city worries, war, inflation, depression, strikes, high rents, high cost of food get on our nerves we may find the solution in a properly operated small farm where we can eat regularly and abundantly, sleep soundly, have no money worries and live a healthy outdoor life. You don't have to own a large farm, but it is important to have practical advice from one who knows all about how to farm. There are many pitfalls which may easily be avoided. And there are many tried and proved methods which can lead to success.

We have found a practical book that starts at the beginning and takes you step by step into successful farming. This book takes nothing for granted. It tells what kind of farm to buy; how to choose its location; how to finance it; what and how to plant, choice and care of livestock, poultry, bees, etc.; especially essentials of fruit and vegetable growing, fertilizers, irrigation, spraying, cultivation, harvesting, storage, sale of products and by-products. Every page is packed with proved ways to make the small farm self-supporting and profitable. Whether you have a farm now or are planning to purchase one, get this book by Mr. Kains and prepare yourself. Don't miss "Five Acres and Independence"; it might change your whole life, it may bring you the independence and security you are now striving so hard to obtain!

Only \$2.50, Postpaid in U. S. A. (Outside U. S. \$2.75). Order Today

POPULAR MECHANICS PRESS Room 375 • 200 East
Ontario St., Chicago

Super Sailors for the Subs

(Continued from page 11)

Occasionally, however, a sailor will scream with fright, or tear off the mask and come to the top of the water gasping and choking. He simply could not stand the sensation of being cut off from the outer air. He might make a brilliant and daring aviator, but he will never qualify as an iron man for a steel fish. So it is back to general navy service for him.

In fact, the whole three months or more that a man spends in the submarine school is a test, for he is continually under observation by his instructors, who are usually veteran submarine sailors, and they are quick to spot any sign that a man is not fit for his responsibilities under the ocean's waves.

Is he flighty, or easily rattled? This is probably the final and capping test and it often comes when the candidate makes his first real dive in a submarine. Then he takes his post and handles routine orders. Perhaps he does well. Pandemonium will break loose, however, at the order of the commander. A diving order will be given. A fire alarm will also be sounded. Under each of these circumstances, every double-duty submarine sailor has one or more tasks to perform quickly and calmly. If the candidate does the wrong thing first, or the right thing too late or gets hopelessly confused, he's a marked man. He gets another chance, of course. But he will have to prove himself beyond doubt before Uncle Sam will trust him with the lives of his fellow crew members.

If he measures up physically and temperamentally, he has a number of basic lines between which he can choose—radio, sound operations, battery work, gyro operations or Diesel work—and he is sure to come out of the training competent in at least two specialties. As radio man he is likely to become also an expert in sound detection. As a battery man, learning to care for the 120 cells in each battery, each cell weighing nearly a ton, he may also be trained in gyro work and operation of the sub's controls. As Diesel man, working on the huge motors which drive a sub when it is on surface, he is sure to have another line in which he can double when the ship is below surface and the Diesels are shut off in favor of battery power.

2-238

To learn all of these things the classrooms include what is practically one or more large submarines taken apart and installed in the buildings. Huge Diesels are housed in a separate structure and there the sailors learn not only to run a Diesel almost as big as a cottage, but to take it apart and put it back together.

Substituting for the actual submarine for early training in manipulating the controls is a hooded platform which tilts up and down in response to submarine controls like a regular ship. While a petty officer gives quiet orders, the sailors are taught to submerge and resurface.

In another building which looks something like a florist's hothouse, are rows of great batteries and, like gardeners tending their plants, the future sub men pass along row by row watering and tending the cells. Even the intricate electric controls are transplanted into the building and here, as the orders are flashed in front of the novice he learns to trim ship and control speed.

A small number of lucky ones are given training in diving and this becomes one of their specialties when underwater repairs are needed on submarines.

Thus before they set foot on a real submarine, the sailors become thoroughly familiar with every part of a submersible in the various rooms of the school.

Future Sources of Power

(Continued from page 5)

barrels of petroleum per ton. The potential supply is enough to supply our motor fuel for 100 to several hundred years, depending on the grade of shale considered acceptable. If the refinery cost of gasoline should double above its present figure of five to six cents per gallon, then shale oil might begin to compete, because mining or quarrying the shale, retorting it and disposing of the waste cost effort and money. Thus we have a considerable back log of motor fuel, but we would have to pay much higher price for it. Third, there is hydrogenation of coal as a source of oil. Germany and, to a certain extent, England are making fairly satisfactory liquid fuels by reacting hydrogen gas with low grade coal at high temperature and pressure in the presence of a catalyst. But the cost of pro-

(Continued to page 189)

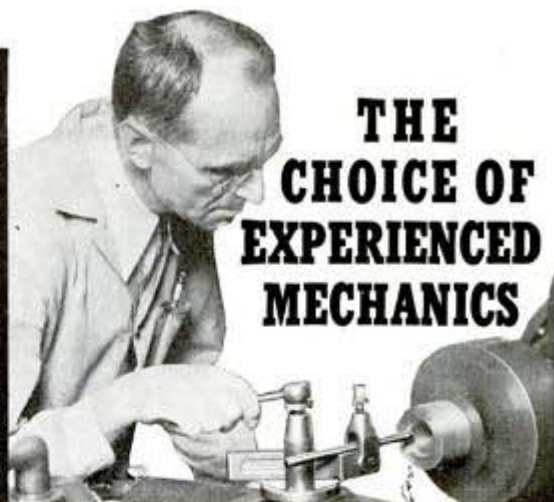

THE CHOICE OF EXPERIENCED MECHANICS

For more than half a century Williams' Shop Tools have been "first choice" with thousands of mechanics who appreciate that really fine workmanship is impossible without good tools.

Williams' line includes tool holders; lathe dogs; "C", strap, and parallel-jaw clamps in all sizes and patterns. In addition, Williams make the world's most complete line of quality wrenches — both carbon and alloy steel types. Mill Supply and Automotive jobbers everywhere sell Williams' Tools. Industrial workers and mechanics in the various trades can buy them, at a liberal discount, either direct from these suppliers or through their employer. Ask your Foreman or Superintendent.



Williams' line includes tool holders; lathe dogs; "C", strap, and parallel-jaw clamps in all sizes and patterns. In addition, Williams make the world's most complete line of quality wrenches — both carbon and alloy steel types. Mill Supply and Automotive jobbers everywhere sell Williams' Tools. Industrial workers and mechanics in the various trades can buy them, at a liberal discount, either direct from these suppliers or through their employer. Ask your Foreman or Superintendent.

FREE BOOKLETS

Interesting, informative books that every mechanic needs. The coupon brings your free copy.



J. H. Williams & Co., 227 Lafayette St., New York City. Please send "How to Select and Use Wrenches." "Machinists' Tools"

PM 342

Name.....

Address.....

City.....State.....

Two Can Play...

THE OLD TOWN WAY

Paddle the sparkling waters of a sunny lake, rest in the cool pools of a shady cove, lost in a world of peace and contentment. Let your Old Town Canoe be your guide through all the woodland waterways. Light and well balanced. Quick to respond to the softest dip of the paddle. Easy to keep and built to last for long years of use.

FREE CATALOG illustrates boats for sport, for the family, and all kinds of canoes, sailboats, dinghies and outboards. Write today. Address: Old Town Canoe Co., 833 Main Street, Old Town, Maine.

"Old Town Canoes"

ACE Drill SHARPNER

NEWEST THING IN DRILL SHARPENERS - MAKES DULL AND BROKEN DRILLS LIKE NEW IN FEW SECONDS - HANDLES FROM 1/8 TO 1/2 INCH - FOR ALL BENCH GRINDERS



Nothing like it on market
Equals work of higher priced grinders. Simple as A-B-C.
IMMEDIATE DELIVERY

Price **\$7.90** COMPLETE

Fits any grinding wheel

5-DAY FREE TRIAL. MONEY BACK GUARANTEE - Shipped prepaid upon receipt of \$7.90, or C.O.D. Money refunded if not satisfied.

NOTHING TO RISK - ASK TO SEE IT State diameter and number of threads per inch on grinder shaft when ordering.

LINDEN MFG. CO., INC. - Dept. M - 33 WEST 51st ST., NEW YORK CITY

WEATHERSTRIP YOUR WINDOWS NOW

SAVE MONEY—HAVE COMFORT

Apply All Metal Interlocking E-Z-ON yourself—without removing sash! Fits all windows. Goes on inside or outside. No special tools or skill needed. Lasts lifetime. Stops rattle and makes windows operate smoother. Amazingly small unit. Saves cost in fuel. Write today for details.

R. N. BALTZ CO., 30-U N. LaSalle St., Chicago, Ill.

WOOD WORKERS

SEND FOR MY GREAT BARGAIN BOOK

My Master Manual for every woodworking craftsman, expert or beginner contains complete instructions for making beautiful inlay pictures; finishing different woods; doing expert veneering. Gives valuable information for nearly every project. Lists many choice, rare woods and veneers not available elsewhere; the best in woodworking tools. ALL AT BARGAIN PRICES. Send 25 cents today for your copy. 25c refunded on 1st order, no Manual costs you nothing. Albert Constantine & Son, Inc., 791-C E 135th St., New York, N.Y.



New ZIPPER SHOES

ZIPPS ON
ZIPPS OFF



Sensational "Clipper" ZIPPS on and off

instantly! Leads highly profitable War-time line—hundreds fast-selling shoe styles for men and women. Build Business for Yourself—Fast. Dress, work, sport shoes. Special footwear for war plant workers. Prices from \$3.45—biggest profits for you. Complete, powerful Sales Outline Absolutely FREE. Write NOW.

VICTOR SHOE COMPANY
6805 N. Clark St., Dept. V-14, Chicago, Ill.

SALEMEN WANTED
BIG PAY
EVERY DAY



"LET'S TRADE CAMERAS!"

Generous allowance on your camera toward a new or used model of your choice. Write giving description of present camera and tell us what you want. Write for free MOVIE or STILL Bargaingram. Dept. P

Bass CAMERA CO.
179 W. MADISON ST., CHICAGO, ILL.

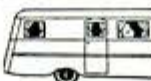

FREE TRAILER PARTS CATALOG

We'll save you money on—axles, springs, wheels, couplers, windows, sinks, water pumps, brakes, refrigerators, beds, lamps, inside and out, 6V lamps, furniture, jacks—everything. Special discount to mfrs. NATIONAL TRAILER EQUIPMENT CO. Successors to Kar-A-Van Industries, Inc. Dept. P. 714 W. Wisconsin Ave., Milwaukee, Wis.

Complete Plans and Building Instructions, 10c

SHAW and "Peppy-Pal" GARDEN TRACTORS

• Low Cost Power for home gardens, poultry and fruit ranches, estates, green houses, small farms, parks, etc. All sizes 1 H.P. to 9 H.P., plow, cultivate, spray, mow, haul, run belt machinery, etc. Write for 10 DAY TRIAL OFFER, LOW PRICES and FREE CIRCULARS.

SHAW MFG. CO., 4503 Front St., Galesburg, Kansas; 668-G N. 4th St., Columbus, O., 5812-G Magnolia Ave., Chicago, Ill.



"Peppy-Pal" with Cultivating Tools

ENGINES

A real Money Maker for farm or factory. Uses cheap fuels—pays for itself out of savings. Low factory prices—Easy Terms. Write for Engine and Log-saw Catalog.

WITTE ENGINE WORKS 4743 OAKLAND AVE. KANSAS CITY, MO.



WHOLESALE CATALOG FREE!



4000 TESTED SELLERS

For salesmen, dealers and agents. 260 pages of thrilling bargains. Over 4000 Opportunities to Make Money.

Household goods, display card items, wearing apparel, cosmetics, foods, jewelry and toys are a few of the thousands of articles shown in this exciting book for salesmen, agents and dealers. Address a postal card to address below and request a copy of this Book of Opportunity, NOW. No charge for it.

Spors Co., 142 National, Le Center, Minn.

21336

duction is about 20 cents a gallon compared to the American cost of five to six cents. We could drive our cars on motor fuel from coal, but we would have to pay dearly for it. Fourth, motor fuel might come from agricultural products, but this is not very practical because it is costly and because the supply would not be adequate. It would require nearly all the good crop land in this country to supply our motor fuel demand by this means.

In coal, we are the most happily situated country in the world. We have over half the known reserves, but less than six percent of the world's population. At present we have enough coal in sight (all grades) to last 3,000 years. That picture may change as the other 94 percent of the people of the world decide that we must divide up. Too, within the next 100 years many of the best deposits will be depleted and we will have to depend on lower grades. Expenses of recovery will go up, quality down. It will be wise to extend the life of our A-1 deposits as long as possible. Eventually, no matter how much we conserve, this sponging off past ages for fossil energy must cease—the deposits will have gone up in smoke. What then? That's a question which America will face eventually, which many groups of people in the world are facing right now.

The water power sources of the world are by no means fully developed, but even if they were, they would be quite inadequate. About 10 percent of America's energy comes from water power; full development might extend that to 20 or 25 percent. Wind power is undependable; only a small amount of power could be obtained by harnessing the tides and the waves.

About 50 times as much energy is stored up in plant life on the earth in one year as man utilizes in that year. It might appear that we could use the present growing trees, grasses and shrubs for fuel and thus solve our problem. Close investigation makes that idea discouraging. In the United States we would have to use nearly all our annual crop of vegetation (trees, grass, farm crops) to meet the energy demands. Nothing would be left to eat and the land would all be a desert in a few years. We can't push vegetation too far from its natural cycle.

Much has been said about obtaining

(Continued to page 190)



What a thrill
to
HEAR
CLEARLY AGAIN

THOUSANDS with impaired hearing find Western Electric's vacuum tube Audiphone most helpful. Freed from straining to hear, they feel younger—fit to face the future.

Created by Bell Telephone makers, the Ortho-tronic Audiphone gives living, vibrant sound—makes hearing easy in noisy places. Free audiometric test enables dealer to recommend model best suited to your needs. Send coupon.

Western Electric AUDIPHONES

by the makers of BELL TELEPHONES

GRAYBAR ELECTRIC COMPANY PM66
Graybar Building, New York, N. Y.

Please send booklet "Your Key to Hearing Happiness" and name of nearest Audiphone dealer.

Name _____
Address _____
City _____ State _____

BUILD THESE PROJECTS

For garden or lawn. Easy to build. Easy to sell. Detailed Blueprints Model B-25 Dutch Windmill 20c; Model D-1-50 Old Mill, 85c. Lawn Figure Patterns—Sunbonnet Girl, Dutch Boy, Tulip Girl, Holland Fair, 35c each, all 4—\$1.00. Catalog illustrating many models, send 10c, today.

CRAFTSMAN'S MODEL CO., Dept. P-62, 2930 N. 41st St., Milwaukee, Wis.



Amazing Military "INKMAKING" Pen

The GRAPH-O-MATIC

FILLS WITH WATER Does Away With
Makes Its Own Ink Messy Ink Bottles

Simply fill pen with water and have a pen full of fresh, lustrous, quick-drying ink. Capacity of magic-like ink battery compares to filling of ordinary pens a dozen times . . . writes for months without replacement.

Highest Quality — Guaranteed

Enjoy features no ordinary type pen can give you regardless of price: Clog-resistant, cleans as it fills. Patented Ink-O-Guard protects against leaking. Also has visible ink supply. Smooth-writing point. Sturdy military clip. Beautifully streamlined. Fully guaranteed. Marvelous pen for men in service. Enjoy a pen you can fill anywhere. Fine, Medium or Heavy point. Refill batteries 15c, 2 for 25c. Order a Graph-O-Matic "Inkmaking" Pen for only \$2.95. Specify point. Enclose money order or pay postman.

AGENTS WANTED.

Built by
Grieshaber
Craftsmen
Famous
Since 1842

Now Only
\$2.95
Post-Paid

Grieshaber Pen Co., Dept. 1, 155 N. Clark St., Chicago



No. 101

CHICAGO FLYING SCOUT
Roller Skates

This
NAME
Will Live

We're "All-Out" for Defense

For this reason "CHICAGO" Roller Skates will be difficult to get for the present. But while we are devoting our efforts to national defense and the preservation of our homes and all we cherish, the name "CHICAGO" on Roller Skates will live as a symbol of Quality and Perfect Skating.

*Sidewalk—Rink—Dancing—Trick
and Professional Roller Skates*

CHICAGO ROLLER SKATE CO.

Winner of **WORLD'S** Records for over 40 years
4414 WEST LAKE STREET CHICAGO, ILLINOIS

Sani-Flush

Cannot Injure Aluminum
Cylinder Heads or
Fittings

CLEANS OUT AUTOMOBILE RADIATORS

DURO

Super Value
**8 INCH
TABLE SAW**

A NEW SAW that has been specially designed to meet the requirements of those who need a big rugged saw to perform heavy duty work for a moderate investment.

Includes many extras which usually add many dollars to your cost. Table extensions are included to give working surface of 27"x18". The guard, splitter and anti-kickback are furnished with the machine—not as extras. All standard equipment is included such as rip fence, mitre gauge, depth gauge and tilt gauge. Includes same quality materials and same precision workmanship as our production saws. Spindle operates on New Departure Ball Bearings.

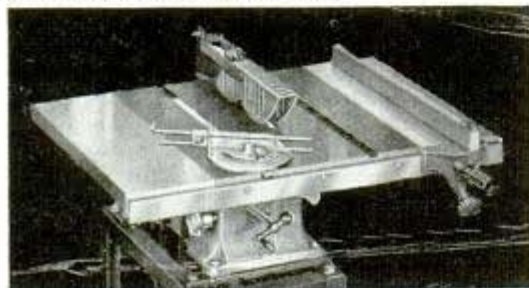

DURO METAL PRODUCTS CO
DEPT. PM-14-2653 N. KILDARE,
CHICAGO, ILLINOIS

SUPER VALUE

21336

great power by smashing atoms, but that seems a long way in the future. Radioactive materials, of which there are only minute amounts in the earth, disintegrate and slowly release large amounts of energy. If radium, for instance, were as plentiful as copper, atomic boilers using radium as fuel might be practical, but there just isn't very much radium available. One cannot say we will never be able to get energy from atomic disintegration, but we can't count on it—at least, for the present.

So we turn our faces hopefully to the sun, whence comes energy so plentiful that enough falls on about 200 square miles of an arid desert region to supply the whole United States with light, heat and power—if we can only find some way to utilize that energy efficiently.

21369

Flying Wings Are Coming

(Continued from page 15)

are hard to hold level in rough air. But such a wing has always been an intriguing goal. Any part of a plane that doesn't create lift is superfluous in theory.

Jack Northrop, among others, was irked by this inherent inefficiency of ordinary airplanes. His first experiment in 1929 had no fuselage, but it was not a true flying wing. An ordinary tail group was supported by two outriggers.

Northrop attacked the problem again three years ago, designing a true wing with the assistance of the research staff of California Institute of Technology. Models were put to months of wind-tunnel tests. Two synchronized motion-picture cameras correlated the wind tunnel data. One camera was trained on the model while the other recorded simultaneous readings of the tunnel instruments. Eventually a shape was evolved with the characteristics Northrop wanted, plus a control system that promised to make the wing as stable and maneuverable as a conventional airplane. The shape of the wing itself contributes to stability through all three axes. Both the wing and its control system have been patented. The control system consists of an arrangement of wing tip flaps.

After success in the wind tunnel the next step was to build a flying mock-up, one half or one third transport size, to see if it

(Continued to page 192)

POPULAR MECHANICS

GREAT NEW

FLASHLIGHT IDEA

GIVES FREE USE OF BOTH HANDS!



98¢
with
Batteries

REX Ristlite

Rex Ristlite snaps on like a wrist-watch! Throws 500 ft. beam. A boon to mechanics, car owners, sportsmen, housewives, Army, Navy men! G.E. pre-focused bulb. Light colorful plastic. 98c—

wherever flashlights are sold.
Flashlight Company of America
Jersey City, N. J.

ALSO STANDS ALONE AT
ANY ANGLE



DON'T DRIVE ASTRAY ON A WINTRY DAY



Know your directions with the Hull Streamline Auto Compass. Save many hazards of winter driving.



Write for Name of Nearest Dealer

HULL MFG. CO., P. O. Box 246-D3, WARREN, OHIO

SCREW-IN PLUG

ATTACH RING



New FLUORESCENT

Screws Into Socket Like Ordinary Bulb

PRICES as low as \$3.55 including Tube
—No "installation" or special wiring—
screw in and light; these LITE-KING Fea-
tures now open up fabulous sales to stores,
offices, factories, homes—of sensational
genuine FLUORESCENT Lighting. Three
Times the Light—Like daylight. Saves its own cost
in current used. Rush name for facts. All free.
NAMCO, Dept. 63, 433 E. Erie St., Chicago, Ill.

BARRON ROTARY PLANNER

TRUES UP · PLANES · PANELS · RABBETS
ROUTS · TENONS · \$7.50 COMPLETE



A WONDER TOOL

Saves hours of tedious hand planing. Parallels and surface finishes to absolute smoothness all knots and tough grained woods. Hi-speed, double edged cutter blades insure extra long wear. Unexcelled for paneling, rabbeting, routing, tenoning, grooving, beading and many other workshop uses. Safe—harmless to drill press. Thousands now in use. Money Back Guarantee Shipped prepaid on receipt of check or money order for \$7.50—or C.O.D. Full five day trial and refund guaranteed if not completely satisfied. You Risk Nothing. Barron Tool Co., 364 Architects Bldg., Detroit



FITS ANY DRILL PRESS

FREE FOLDER

TREASURE FINDER



MIDGET TRAILED



MAKE AND SAVE MONEY WITH THE HELPFUL

LITTLE LIBRARY OF Useful INFORMATION

ONLY 25c EACH
FIVE FOR \$1.00

The low cost and practical help you need. Illustrated with photos and diagrams. Order today.

1. Photo Enlargers
2. 14 Ft. Outboard Runabout
3. Electroplating
4. Woodworking Power Tools
5. Homemade Welders
6. Colored Concrete Garden Furniture
7. Bird Houses
8. Farm and Garden Tractors
9. Taxidermy
10. Automobile Kinks
11. Cleaning Formulas
12. Cosmetic Formulas
13. Treasure Finders
14. Log Cabins and Tourist Cottages
15. Food Product Formulas
16. Garden Woodwork and Furniture
17. Soldering and Brazing
18. Growing Miracle Plants
19. Home Work Opportunities
20. Telescopes
21. Metal Plating and Coloring
22. Fast Ice Yacht
23. Extra Rooms in Attic
24. Basement Playrooms
25. Photo Printer and Dryer
26. 14 Ft. Sailing Dinghy
27. Midget House and Utility Trailers
28. Metal Craft
29. Magic for Everybody
30. Building 16 Ft. Canoe
31. Lower Your Fuel Cost
32. Wood Turning
33. Trapping Small Animals
34. Motor-Driven Midget Car
35. Training Your Dog
36. Small Castings
37. Making Money With Hand Loom
38. Hanging Wallpaper
39. Backyard Gardening
40. Plain and Novelty Wood Finishing

TYPEWRITER 1/3 PRICE

STANDARD OFFICE MODELS
About 1/3 MFRS. ORIG. PRICE
Easiest Terms 70¢ A WEEK
as Low as 70¢ A WEEK



All models completely reconditioned.
FULL 2-YEAR GUARANTEE

No Money Down—10 Day Trial

FREE COURSE IN TYPING INCLUDED

Send for FREE price smashing literature in colors. Fully describes and shows all models. See our literature before you buy. SEND TODAY.

INTERNATIONAL TYPEWRITER EXCH.
Dept. 301 231 W. Monroe St., Chicago, Ill.

100¢ A DAY

GARDEN TRACTORS



SPEEDEX

6 H. P. riding type and 1 H. P. cultivator for the small tracts. Also small farm and garden tractor powered with Ford 4 cyl. motor. Low prices still in effect.

Before you buy—Write for FREE illustrated folder, covering all styles and equipments.

POND GARDEN TRACTOR CO.
Box 216D43
Ravenna, Ohio

Say you saw it in Popular Mechanics!

POPULAR MECHANICS PRESS

200 E. ONTARIO STREET • Room 370 • CHICAGO

MARCH, 1942

21369

NO OTHER RULE

offers so much

THE MASTER STEEL TAPE RULE—The small, compact, pistol-grip case makes the **MASTER** easy to handle and use for accuracy in hard-to-get measurements.

USE MASTER ALSO TO CALIPER

The square tape end, the kink-resisting blade, and the square flush edge of the case with locking lever, get and retain caliper measurements of anything from the thickness of a wood chip to a six-foot length—with ease and speed.

And it's the only rule with a spare blade for extra value of service.

GET A
MASTER RULE
+
A SPARE
BLADE

Send Coupon



\$2.65

MASTER RULES AND TAPES

Master Rule Mfg. Co., Inc., Dept. P-3, 815 East 136 St., New York, N. Y.

Send me a Master Tape Rule with Spare Blade, \$_____ is enclosed.
 Send me more information on this Master Rule.

Co. Name _____

Address _____

City _____ State _____

SANDS 10 Times Faster...



New Guild PORTABLE ELECTRIC Sander

Now, do better sanding this easy way—10 times faster! This sturdy, portable belt sander turns out expert work in minutes—instead of hours of hand-sanding drudgery.

Gives everything you make that expert finish. Works on wood, metal, stone, plastics. Sells at popular price—weighs only 9 pounds. Fully guaranteed. Try it at your hardware dealer's, or WRITE us today for full details.

SYRACUSE GUILD TOOL CO., 1742-3C No. Salina St., Syracuse, N. Y.

ACE LATHE TOOL SET

\$14.50



Be permanently toolled-up for every operation on your Metal Cutting Lathe

The ACE Set is complete—there's nothing more to buy. Drop forged by the manufacturers of rotating tools used by 98 per cent of the plants and shops in industry they are correctly designed, are of special steel, are finely finished, are stronger—will last a lifetime. You can cut easier, faster and more accurately with ACE TOOLS.

At your Hardware Store—Circular FILES.

ARMSTRONG BROS. TOOL CO.

"The Tool Holder People"

308 N. Francisco Ave., CHICAGO, U.S.A.

3 Turning
Tools, 2 Cutting
off Tools, Reaming
Tool, Boring Tool
Threading Tool, High
Speed Steel Cutters and
Blades, and 2 Wrenches
in Fitted Steel Case.

STOP Scratching Itch Fast -or Money Back

For quick relief from itching of eczema, pimples, athlete's foot, scales, scabies, rashes and other externally caused skin troubles, use world-famous, cooling, antiseptic, liquid D. D. D. Prescription. Greaseless, stainless. Soothes irritation and quickly stops the most intense itching. 35c trial bottle proves it, or money back. Ask your druggist today for **D. D. D. PRESCRIPTION**.

performed as well as the models. This wing is 28 feet from tip to tip, has considerable sweepback, and on its first flights was powered with two 60-horsepower engines later replaced by two air-cooled horizontally-opposed power plants of 120 horsepower each. The engines are completely buried in the wing and drive pusher-type propellers behind the trailing edge. Landing gear is retractable.

The first test flights were made more than a year ago and since then hundreds of others have been made. At first the wing tips were deflected downward at abrupt angles to provide instant response to the controls. Later the tips were rebuilt to study their characteristics at other angles. No matter what dip the tips have, they are permanent and not movable by the pilot.

Success of the wing and its control system was announced by Vance Breese and other test pilots who have flown it. They found the wing flies and handles just the same as a conventional airplane.

In addition to its greater aerodynamic efficiency the flying wing is lighter, cheaper, and easier to build than conventional aircraft of similar performance. Less noise enters the cabin. The greater efficiency of the wing permits carrying present loads at present speeds with much less power than is required at present, or it permits the same power to carry the same loads at much higher speeds.

Used as a passenger transport of the same capacity as present standard passenger carriers, the Northrop wing would be seven or eight feet thick. Crew, passengers, cargo, and motors would be entirely contained within the wing. A transparent leading edge as well as floor panels would permit passengers to watch the scenery. As a cargo transport, loading and unloading would be facilitated by large hatches on the upper surface of the wing. Since a few propellers are more efficient than a large number of propellers, it may be that for the huge flying wings of the future, a number of engines would be coupled to each propeller, possibly by means of an electric drive such as is used to propel some ocean-going ships.

In spite of the promise of the flying wing, engineers can't agree on what the airplane of the future will be like. Some doubt that the conventional tail group will be

21369

entirely eliminated. One compromise suggestion is the so-called "manta" design, virtually a flying wing but including a vestigial tail group about half the size of present tail surfaces. In the manta much of the lift of the true flying wing is retained while much of the ordinary tail and fuselage drag is eliminated.

Whatever the future holds, engineers agree that airplane design is now entering another cycle of refinement similar to the period that led to the development of the present cantilever monoplane.

The Emergency Patrol

(Continued from page 31)

rup pumps and sand available to extinguish incendiary bombs and to evacuate all pet dogs, which have a tendency to go mad under the excitement of a raid.

One novel suggestion for protection from air raiders was the proposal of A. F. Dickerson, head of General Electric's illuminating laboratories, for a canopy of light, rather than a blackout. Pointing out how headlight glare from automobiles renders the vehicles obscure, he suggested that thousands of small, powerful searchlights, pointed skyward, would blind enemy fliers and prevent them from spotting their targets. Similar groups of lights in fields near the city would confuse the bombers.

"Black light"—invisible ultraviolet rays focused on fluorescent surfaces—plays a big part in blackout schemes. Automobiles and buses, arm and hat bands and even warning signs glow with luminous paint at night, although invisible to aviators. Engineers found that street lights can be dimmed to a soft glow, making objects visible for 25 feet, yet furnish no light that can be observed from a bomber. This would also save current for war-time industry. Recommended for the blackout is a "black out sheet" of black paper which sticks to the inside of windows and bars escaping light. It also prevents glass from flying in the event of a nearby explosion. Another shutterlike sheet lets daylight in, but prevents light rays from escaping at night.

Power plants may be covered with huge "tortoise shells" of reinforced concrete to resist bombs. Mobile power transformers

(Continued to page 194)

★ ★ ★ ★ ★ ★ ★ ★ ★ ★ ★ ★ ★ ★ ★ ★
★ "YANKEE" TOOLS ★
★ THE SKILLED MECHANIC'S ★
★ ALLY ★
★ ★ ★ ★ ★ ★ ★ ★ ★ ★ ★ ★ ★ ★ ★ ★



No. 1993 "Yankee" Vise with detachable swivel base and V-block for round stock

For nearly half a century, "Yankee" Fine Mechanic's Tools have been the master craftsman's ally, arming him with time-saving and labor-saving ingenuity, guarding his productive hours with their absolute dependability and pre-tested quality. Today, working shoulder-to-shoulder with our armed forces for Victory, his reliance on these famous tools has been multiplied a thousandfold. All-out production is a vast job. This explains why the supply of "Yankee" Tools cannot altogether keep abreast of the present demand.

"YANKEE" TOOLS
make good mechanics better
North Bros. Mfg. Co., Phila., U. S. A.
Established 1880

Makers, also, of "Yankee-Handyman" Household Tools

KAYAKS
Easy to Build
42 MODELS Latest Designs

BOATS for Home Assembly
"U-MAK-IT"
KAYAKS, ROWBOATS, DINGHIES, INBOARDS, OUTBOARDS, RUNABOUTS
Cut-to-fit for quick assembly. Everything complete plus Illus. Instructions. No Experience Necessary. Simple as A-B-C. Thousands of Satisfied Builders. Enjoy building your own in evenings.

New AQUAMOBILE V-18
Cut-to-fit, Especially Designed for Automobile Engines. Adjustable Motorbeds. Open or with cab. Length 18 ft., width 6 ft. 7 in. Ideal for fishing and cruising. Fast VEE Bottom Hull.

Encl. 10¢ (coin). Send all Illus. Booklets at once.

Name

Address

MARINE DIVISION OF U-MAK-IT PRODUCTS
KAYAK BOAT CO., 154 P-EAST 129th ST., NEW YORK, N.Y.

Tool Makers'

Graduated
.0001"
.001"

TEST INDICATORS



Complete with holding bar, universal clamp and molded case.

A very handy Dial Indicator for general tool room and machine shop use. Two models, graduated .001" and .0001". Contact point swivels and its motion can be reversed for convenience. Dial rotates for setting zero.

Adjustable to any Position

Dovetail slide and universal clamp adjusts for any position. A high-grade instrument having highest accuracy, used by thousands of men in war industrial plants for inspecting accuracy of machine work. Good deliveries. Write to—

FEDERAL PRODUCTS CORP.
141 Edy St., Providence, R. I.

FEDERAL
PRECISION MEASURING INSTRUMENTS



PHOTO ENLARGEMENTS

Is Photography your hobby? Do you want a profitable new business at home? Make **PHOTO ENLARGEMENTS** for yourself and others. Your cost 5c each and less. The Ideal Photo Enlarger is **AUTOMATIC**. No experience required. Also **COPIES** any picture \$7.94 **COMPLETE**. Interesting circular **FREE**.

5¢ ANY SIZE

Ideal-O, 148 West 23rd St., New York City

Free Book MAKE MONEY with BEES

FREE BOOKLET tells of profitable experiences of others, also catalog with 4000 words of information. Growing demand for honey makes keeping bees profitable. Easy to get started with inexpensive Beginner's Outfit, suitable for city or country. **Write at once. Start during fruit bloom.** Send 25c for 6 months subscription "Gleanings in Bee Culture" (new readers only).

The A. I. Root Co., Dept. 12, Medina, O.

Let Bees Bring You Extra Money!

ONAN ELECTRIC PLANTS

ALTERNATING AND DIRECT CURRENT



Produce Current, same as City Power Lines, for **FARMS, SCHOOLS, THEATRES, PUBLIC BUILDINGS** . . . Operate Lights, Radios, Motors, All Appliances.

Over 40 STOCK MODELS—150 to 50,000 Watts. Any Voltage—Any Frequency. Combination A. C. - D. C. Types. Manual, Full Automatic and Self-Starting. \$99 up shipped—**COMPLETE, READY for OPERATION, THOUSANDS IN USE IN ALL PARTS OF THE WORLD.**

Write for Complete Details.
D. W. ONAN & SONS
1067 Royalston Avenue - MINNEAPOLIS, MINN.

are standing by to restore power should a regular substation be put out of operation. These four-wheel trailer units can be attached to an automobile and rushed to the scene of emergency, and provide electricity for 15,000 homes apiece.

Museums arranged to ship priceless objects to rural points. Such objects as the two-story dinosaur skeletons in the American Museum of Natural History will probably take their chances with bombs because of the difficulty of removing them.

An ingenious plan has been approved by which defense directors, using airplanes, navy blimps or vantage points atop the highest skyscrapers can direct the thousand or more radio-equipped police vehicles through the streets in an emergency. Cruising above the city in two airplanes, defense engineers testing the scheme were able to keep constantly spotted a black sedan with the word "TARGET" painted on its top, as the car moved in traffic below.

A dozen or more trailer fire pumps have been tested by the authorities. A typical unit will throw two two-and-one-half inch streams of water 75 feet high. These can be towed by hand over debris-strewn streets impassable to regular fire equipment.

Railroads are planning portable trestles by which traffic can be routed over and around bomb craters.

A suit with plastic-braced ribs which protects the firemen from the concussion of a bomb explosion has been invented. Front, back and shoulders have laminated plastic inserts and the fabric is nonflammable cotton gabardine. Also tested by defense experts is a 90 mile-an-hour motorcycle ambulance. It has a seven-foot sidecar to carry the patient and a medical attendant. A newly developed "alert" receiver turns on automatically when it catches an inaudible air raid signal from a broadcasting station, rings a bell to summon listeners and shuts itself off when the "all-clear" is sounded. The receiver can be fixed-tuned to any station. Plans have been considered for underground factories, buried under 80 to 100 feet of rock where defense work can continue under strafing.

Films from England are to be shown to New Yorkers demonstrating how to extinguish incendiary bombs. The favorite method is to drop a sand bag on the bomb, which usually smothers it in two minutes.

LET THESE GREAT BOOKS HELP YOU TO



Start Your Climb!

"the Man who KNOWS is the Man who WINS"

Easy to train yourself! These books have helped thousands—

- FORTY POWER TOOLS**
(Just Published)
Build own saw, drill, lathe, sander, etc. from scraps—save money... \$1.25
- SHOP NOTES LIBRARY**
Five big volumes including new 1942 edition (224 pages—28 in color); over 1900 articles on money-making & money-saving ideas... \$2.45
- FURNISHING HOME GROUNDS**
Build own trellises, garden furniture, etc... \$1.00
- AUTO OWNERS GUIDE**
New 192-page book describes hundreds of simple car repairs, shortcuts, how to operate car economically... \$1.25
- TIN SMITH'S HELPER**
Seams, piping, gutters, etc... \$3.00
- MODERN REFRIGERATION**
Electric, gas. Be service expert... \$5.00
- AUTO BODY AND FENDER REPAIRS**
Shows how to do professional job... \$3.00
- DYKE'S AUTO ENCYCLOPEDIA** (New Ed. includes Diesels, airplane engines)
World's greatest book for mechanics... \$6.00
- SHEET METAL WORK**
Self instruction in all phases... \$2.50
- ARMATURE WINDING**
Construction, winding, repairing AC & DC Motors, generators... \$2.00
- BLUEPRINT READING**
For building trades... \$1.25
- CIVIL SERVICE HANDBOOK**
Home study for Federal, State, City jobs... \$1.00
- FORGING PRACTICE** \$1.50
- HIGH SCHOOL SELF TAUGHT**
4 yr. course in one vol... \$1.89
- TECHNICAL BULLETINS**
Simplified data for practical men
- SMALL AC ARC WELDER CONSTRUCTION**... \$1.00
- SILVER SOLDERING AND BRAZING**... \$1.00
- REWINDING ELECTRIC MOTORS**... \$1.00
- ELECTROPLATING WITH COPPER, NICKEL & CHROMIUM**... \$1.00
- FLEXIBLE MOLDS FOR CASTING NOVELTIES**... \$1.00
- WORKING WITH PLASTICS**... \$1.00
- MIRROR SILVERING**... \$1.00
- PLAYING NON-METALLIC OBJECTS**... \$1.00
- SMALL ELECTRIC LIGHT PLANTS, CONSTRUCTING**... \$1.00

- HEAT TREATMENT OF IRON & STEEL**... \$1.00
- DESIGNING & BUILDING TRANSFORMERS**... \$1.00
- CARPENTRY & JOINERY**
Learn modern methods... \$2.00
- FOUNDRY WORK**
Standard practice... \$2.00
- WHAT TO MAKE**
3 Big Books, 588 pages of popular handicraft projects... \$1.47
- PRACTICAL WOOD FINISHING**
Shows woods in full color, describes new finishes... \$1.25
- AUTO RACING**
Constructing racer, speeding up Fords... \$1.00
- MACHINE SHOP WORK**
Excellent book on approved methods... \$2.75
- BLUEPRINT READING**
For machine trades... \$1.50
- PAINTING & DECORATING**
Getting most out of common materials... \$1.50
- PATTERN MAKING**
wood, metal... \$2.00
- TOOL MAKING**
For beginners and advanced workers... \$3.50
- WELDING ELECTRIC**
Forge, thernut, resistance, arc... \$1.25
- WELDING, OXYACETYLENE**
Welding, cutting... \$1.25
- FLUORESCENT LIGHTING AND ITS APPLICATION**
(new book)... \$3.00
- LATHE HANDBOOK** (Metal)
How to construct 6-in. lathe, shortcuts, kinks... \$1.50
- FIVE ACRES AND INDEPENDENCE**
How to make money on small farm... \$2.50
- KNOTS, TIES, SPLICES**
For everyone who uses rope... \$1.00
- PLUMBING**
Designing and installing... \$3.00
- ELECTRIC WIRING**
Includes estimating... \$2.50
- HOUSE CONSTRUCTION**
Details, Gives every step in House construction... \$2.89
- BUILD YOUR OWN BOAT**
Just published. Describes 17 popular boats — rowboats, sailboats, plywood outboard, etc. 192 pages... \$1.25
- FORD V8 CAR AND TRUCK**
Repairing, operating... \$3.00
- 1001 WAYS TO USE CONCRETE**
(New Ed.) Do work for yourself, others, save, make money... \$1.98
- STEEL SQUARE POCKET BOOK**
Best methods of using... \$1.00
- DE LUXE SMALL HOMES**
New plan book shows 210 popular designs... \$1.00

FIRST and FINEST
HANDED

TOOL OF 1001 USES

A whole toolshop in your hand. Does precision work on metals, alloys, plastics, wood, horn, bone, glass, etc. For your own hobby enjoyment or as a gift.

Uses 300 easy-to-change accessories to grind, drill, polish, cut, rout, carve, saw, sand, sharpen, engrave. 25,000 r.p.m. Wt. 12 oz. With 7 Accessories, postpaid \$18.50. Order on 10 Days' Money-Back Trial.



Plugs in Any Socket

CHICAGO WHEEL & MFG. CO.
108 S. Aberdeen St. Chicago, Ill.

FREE—64-Page Cat-logy

NEW BOAT READY!

WRITE for big Illustrated FREE Circulars!



BUILD OK-4 at Home in a Few Evenings!

Mead's sensational new 14-foot portable Outboard KI-YAK OK-4 carries 4 adults and duffel—takes motors up to 9 H.P., oars and sail. Weighs only 75 lbs. Seaworthy, dependable. Biggest, lightest, strongest of its kind! You can build yours easily, quickly, perfectly at home in a few evenings from our patented complete construction kit and save nearly HALF! Big money assembling, selling to others. (3 other paddle-sail KI-YAKS from 18 to 45 lbs. ... also OK-2 for motor, sail, oars ... weighs 50 lbs.) Double paddle or Ours now included with your Kit. Write for Free lavishly illustrated circulars, low-factory-to-you prices! MEAD GLIDERS, 15 So. Market, Dept. B-32, CHICAGO

Lower Cost BUILDING MATERIALS



MEN OF FORESIGHT realize the big possibilities today in the building industry. Big opportunity supplying locally made, low-cost, permanent, fire-safe building materials. GET READY TO SUPPLY this demand in your locality. You can build up a complete modern plant from a single machine at \$190.00. INVESTIGATE—Now is the time to get ready. Write today for our big new catalog No. 72 and easy payment plan. CONCRETE EQUIPMENT CO. 512 Ottawa Ave. Holland, Mich.

MOTORISTS Wanted!



TO MAKE THIS UNIQUE GAS SAVING TEST

Will you permit us to send you at our risk the Vacu-matic, a device which auto owners everywhere are praising? Install it on your car. Test it at our risk. Unless it trims dollars off your gas bills by saving up to 30% on gasoline consumption, gives more power, quicker pickup and faster acceleration, the test will cost you nothing.

Automatic Supercharge Principle
Vacu-matic is entirely different! It operates on the supercharge principle by automatically adding a charge of extra oxygen, drawn free from the outer air into the heart of the gas mixture. It is entirely automatic and allows the motor to "breathe" at the correct time, opening and closing as required. Saves up to 30% on gas costs, with better motor performance.

AGENTS Get Yours FREE

FOR INTRODUCING. Here's a splendid opportunity for unusual sales and profits. Every car, truck, tractor owner a prospect. Send name and address now for big money making offer and how you can get yours Free. The Vacu-matic Co., 7617-649 W. State Street, Wauwatosa, Wis.

Books sent C. O. D. anywhere in U. S.

Just check the books you want, write your name and address below, and mail this advertisement. It is your order blank. When postman hands you books, pay him the price and few cents postage. Outside U. S. A. enclose remittance and include 15% additional for shipping charges. Ask for big FREE catalog of helpful books.

Name.....
City.....
Address.....

Mail to Popular Mechanics Press
Dept. 373—200 East Ontario St., Chicago, Ill.

READY CUT HOMES

\$763.00 and up. Freight paid. Save \$500 on average. Buy direct. Modern production methods prevent waste in material and assembly time. 75 home plans to select from. Including many new features 1942 designs. All modern, practical, distinctive, complete. Simple plans for easy assembly. Includes all lumber, insulation, roofing, weather stripping, built-in features, attractive one-panel doors, latest hardware, nails, paint, varnish, etc. Also, summer cottages, etc. Information and plans for FHA Financing requirements on request. For new 1942 color catalog, with floor plans, to cover mailing, send 25 cents Dept. PM-32, International Mill and Timber Co., Bay City, Mich.



NEW COLOR CATALOG FOR ONLY 25c

FLUORESCENT Wholesale Catalog FREE!



Save up to 60% Direct from Factory

The most complete fluorescent catalog—listing fixtures, accessories, kits for every type of fluorescent lighting—including newest kitchen and bed lamps—at lowest wholesale prices direct from factory. New kit and diagram service makes it easy to assemble, install, and sell complete fluorescent set-ups for homes, stores, factories, offices and farms. Send for FREE catalog and special factory representative plan.

JACKSON FLUORESCENT SUPPLIES
427 W. Randolph St., Dept. 60, Chicago, Illinois

MOTOR DRIVEN Flexible SHAFT TOOL



WITH PENCIL-SIZE HANDPIECE for "FINGER-TIP" CONTROL at only **\$14.95**
Win real pleasure and profit by using a **FORE-DOM FLEXIBLE SHAFT TOOL**. Performs countless tasks quickly, efficiently, effortlessly in home or shop on wood, metal, glass, plastics, etc. . . . Sensitive "Finger-tip" control, easy accessibility, unobstructed view. You can grind, polish, mill, engrave, sharpen, slot, saw, carve, clean, sand, etc. Ideal for glass etching, gem-setting and finishing dies, molds, castings, etc. Complete Portable Workshop, including 50 piece accessory set, \$16.15. Order today. Send \$1.00 with C.O.D. order.

FREE, New Complete Catalog FOREDOM ELECTRIC COMPANY
Dept. 313, 27 Park Place, New York

BIGGEST \$100 PLANE IN U.S. GIANT 7-ft. GLIDER

Easily built, beautiful Class E



CLEVELAND CONDOR

Soars for hours.
● 48" Eaglet (Baby Bowler type) Glider only 50c.
● At your dealer, or direct, Catalog of "America's FIRST LINE of Model Airplanes"—all Cleveland Gas, Rubber-powered, Stick and Glider Models, 5c.
On orders less than \$1.00 add 15c for packing and postage.

CLEVELAND MODEL & SUPPLY CO. INC., 450825 Lorain Ave., Cleveland, Ohio

See 4 WOODSTOCK TYPEWRITER

A LITTLE LIBRARY of Useful Information



A Few Sample Pages

These booklets have been carefully designed to fill a long felt demand for instructions for making things and doing the everyday jobs around the home.

Only 25c Each, or 5 for \$1, 12 for \$2

- PHOTO ENLARGERS**—Shows you how to make four different enlargers.
- OUTBOARD RUNABOUT**—Fast, V-bottom boat, 14 ft. long.
- ELECTROPLATING**—Copper, nickel, chromium, gold, silver.
- POWER TOOLS**—Build your own workshop machines; saws, lathe, drill press, etc.
- WELDERS**—Details on arc and spot welders for 110 volt A.C.
- COLOR CONCRETE GARDEN FURNITURE**—Pottery, benches, bird baths, sundials, misc.
- BIRD HOUSES**—Colony houses, miniature log cabins, studio apartment houses of rustic design.
- FARM & GARDEN TRACTORS**—Two tractors you can build from old auto parts.
- TAXIDERMY**—Fun and profit in mounting fish, small animals. Expert tells how.
- AUTOMOBILE KINKS**—Money-saving shortcuts based on actual experience.
- CLEANING FORMULAS**—Preparations for woodwork, suits, brushes, paper, rugs, marble, etc. Also, soaps and bluing.
- COSMETIC FORMULAS**—Make Creams, lotions, other products for yourself and to sell.
- TREASURE FINDERS**—Build your own treasure finders and metal locator.
- LOG CABINS & TOURIST COTTAGES**—Two cabins; several inexpensive tourist cottages.
- FOOD PRODUCTS FORMULAS**—100 formulas for everyday necessities.
- GARDEN WOODWORK & FURNITURE**—Outdoor furniture, trellises, fences.
- SOLDERING & BRAZING**—Full of practical hints.
- MIRACLE PLANTS**—Grow plants without soil; mix your own B-1 solution.
- HOME WORK OPPORTUNITIES**—Handicraft projects with sales possibilities.
- TELESCOPES**—How to grind lens and make mirror for 4 in. reflecting type.
- METAL PLATING & COLORING**—Essential formulas for decorating, coloring, plating metal.
- FAST ICE YACHT**—Complete details on building and sailing Class-E ice yacht.
- EXTRA ROOMS IN ATTIC**—Add value to your home by building extra room in attic.
- BASEMENT PLAYROOMS**—Build attractive playroom in your basement.
- PHOTO PRINTERS**—For both professional and amateur photographers. No stative dryer, split second timer.
- SAILING DINGHY**—This 14-ft. boat carries 140 sq. ft. of canvas.
- TRAILERS**—Midget "tear drop" house trailer; several utility trailers.
- METAL CRAFT**—Simple instructions for making novelties, useful articles.
- MAGIC FOR EVERYBODY**—Simple tricks to puzzle your friends.
- CANDLING**—How-to-build-it details on 16-ft. Canadian type.
- LOWER YOUR FUEL COST**—Practical kinks on firing furnace, handling drafts, weather stripping.
- WOOD TURNING**—How to use lathe and chisels correctly.
- TRAPPING SMALL ANIMALS**—Luring fur bearers, preparing bait, traps; dressing skins.
- MOTOR-DRIVEN MIDGET CAR**—Complete details on boy's gas-powered car; also motor scooter.
- TRAINING YOUR DOG**—Teach your dog obedience, tricks, hunting.
- SMALL CASTINGS**—Build small 22-ft. furnace to melt brass, copper, alloys.
- MAKING MONEY WITH HAND LOOM**—Constructing hand loom for weaving rugs, scarves; leather novelties.
- HANGING WALLPAPER**—Tricks of hanging paper; also how to refinish floors, paint your home.
- BACKYARD GARDENING**—Selecting and planting.
- PLAIN & NOVELTY WOOD FINISHING**.
- GEM CUTTING**—How to cut and polish semi-precious stones.
- BOY ELECTRICIAN**—Midget motors, telephone, vest pocket lab.
- CURING LEAKY BASEMENTS**—Ways to block out water.
- 21-FT. SLOOP**—Complete constructional details.
- WORKBENCHES AND TOOL CABINETS**—Four workbenches, kits for home repairs, tool chest.
- JIGSAW FUN AND PROFIT**—Make lawn ornaments, things for child's room, doorstops, toys.

CHECK TITLES WANTED—CLIP AND MAIL

POPULAR MECHANICS PRESS, Room 374, 200 E. Ontario Street, Chicago
Send me the "Little Library" booklets checked above. I enclose remittance for \$..... Send C.O.D. (U.S.A. only) (minimum C.O.D. order \$1.00)

Name

Address

City..... State.....

Note: On orders to Canada, Mexico and all foreign, enclose remittance and add 15% for postage.

21376

Fountain Pen Produces Ink When Filled With Water



Water is turned into ink as it flows over cartridge

Only water is needed for refilling an ink-making fountain pen now on the market. Ink is generated as water flows over a capsule installed within the pen near the point. This capsule, which is easily replaceable, will last the equivalent of a dozen refillings of an ordinary pen. The pen is handy for travelers or men in service who may not always have a bottle of ink.

21395

Third-Dimension Views in Color Shown by Television Screen

Transmission of radio pictures in color and in three dimensions has been achieved by John L. Baird, English pioneer in television, as a result of applying principles of stereoscopy combined with complicated color processes. Still in the experimental stage, the present screen must be viewed from directly in front and can be seen by only one person at a time. However, the colored pictures have the qualities of depth which give viewers the illusion of seeing into an intensely real world. Pictures transmitted from a nearby studio included a bouquet of flowers and smoke curling upward from a pipe or cigarette. The inventor has now turned his efforts to developing the invention so the picture may be thrown on large theater screens.

MARCH, 1942

22 Fritth St.
London, W. 1, England

FOR OUTDOOR THRILLS!



Indian SPRING FRAME MOTORCYCLES

Only Indian offers "Spring Frame" smooth-riding comfort and safety, plus new streamlined beauty. National Defense may mean a wait for one of these great Indians, but your Indian dealer will gladly help you get more service out of your present machine.

ASK YOUR DEALER FOR THIS
NEW **FREE** BOOKLET

Jam-packed with ideas to help you get more out of any make of motorcycle. Ask your local Indian dealer for a free copy, and Indian literature.



INDIAN MOTORCYCLE CO., SPRINGFIELD, MASS.



MATCHES ALWAYS DRY!

—If you carry a Marble's water-proof match box in your pocket. Absolutely water-proof — holds supply for several days. Made of seamless brass, 3/4-inch in diameter. Only 60¢ at your dealer's, or sent postpaid. Get one today. Write for complete FREE Catalog.

Marble Arms & Mfg. Company
578 Delta Av. Gladstone, Mich. U.S.A.

★ PRODUCE the FRUITS of VICTORY ★ with BOLENS

Defense Tools for Today's
"Soldiers of the Soil"

HUSKI

Write for Catalog
BOLENS PRODUCTS CO.
Dept. PM-3
Port Washington, Wis.



GARDEN TRACTORS . . .

argus

ann arbor michigan



FREE

"CHOOSING
YOUR CAMERA"
Write for this
32 page booklet

FOR **GOOD PICTURES**

FINE AMERICAN MADE CAMERAS



A Statement of Fact

Fewer Sea-Horse outboard motors will be built in 1942. Those we do build, however, will be *genuine* Johnsons—DEPENDABLE. No material specification changes have been made which affect performance. None of the famous Sea-Horse features is missing. If you are interested in outboard motors—new or used, service or parts—see your Johnson Dealer. You'll find his name listed under "Outboard Motors" in your classified phone book.

JOHNSON MOTORS, 400 Pershing Rd., Waukegan, Ill.
Johnson Motors of Canada, Peterboro, Canada

HANDY CHART of 1942 models. Fresh from the press. Complete data and specifications. Write for your copy today.

SENT FREE!

New Improved Electric MOTO-SAW

New Blade Holder Faces Blade 4 Ways .. Multiplying Capacity

Safe as a Hand Saw JUST GUIDE IT!

More like mauls than any tool you ever saw. Imagine an electric saw only slightly heavier than a hand coping saw . . . a tool that takes no effort to run, no pressure to feed. Works at any angle—on big assembly jobs or on the tiniest piece you can hold in your fingers. Runs 7200 strokes a minute . . . so fast the blade seems to stand still. Sturdily built . . . only two moving parts . . . never needs oiling. Easily cuts intricate designs—so smooth it eliminates sanding. Novice or craftsman, a thrill awaits you when you get a Moto-Saw in your hand.

No Limit to Length of Stock It Will Cut. Saws to Center of 19" Widths. It's fast . . . cuts on an average of 1 ft. per minute up to 3/4" medium hard wood. Operates on 110-120 V., 50 or 60 cycle alternating current. If your dealer does not yet have MOTO-SAW send \$4.50 . . . we'll pay postage. Or send \$1. postman balance plus postage. MONEY BACK if not delighted after 5 days trial.

U. S. Patent 2235462
Other Patents Pending
DREMEL MFG. CO.
Dept. T-112-C
RACINE, WISCONSIN

FOR 27,000 R. P. M. INSIST ON A GENUINE

MOTO TOOL

100 Tools in One

- *Has shock-proof bakelite case.
- *Fan-cooled motor can't overheat
- *Has oil-less bearings
- *Dynamically balanced armature

Here's a guaranteed quality! The handiest tool in the shop or home. Use it daily for model making, repairing, carving wood or plastics, etching glass or metal, touching up dyes, sharpening, routing, sanding, drilling, and on a hundred other jobs. Higher speed does better work and saves cutters. Model One, wt. 6 oz., with chuck and 1/8" roller, only \$9.95. Model Two, wt. 13 oz., \$16.50. 10 DAY TRIAL—Money-Back Guarantee. If your dealer does not have Moto-Tool, order direct . . . we pay postage if you send cash. Or, send only \$1. pay postman balance plus postage. New catalog of tools and accessories FREE

KIT NO. 1 with 25 high grade accessories and Model 1 Moto-Tool in \$17.50 hardwood case

KIT NO. 2 same as above with Master Model 2 \$23.50 Moto-Tool . . .

DREMEL MFG. CO.
Dept. T-112-C
Racine, Wis.

Roosts Hung With Sash Hangers Are Removed Easily

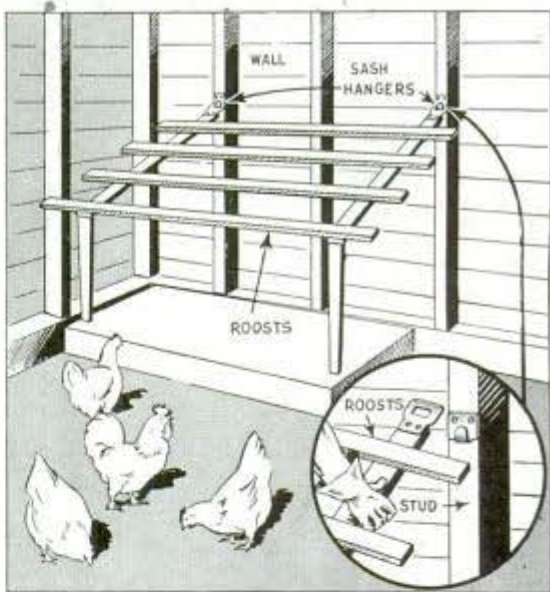

Poultry roosts made in sections can be removed easily for cleaning if they are hung with sash hangers. The hook part of the hanger is screwed to the studs of the poultry house, while the other part is screwed to the roosts as shown in the circular detail.—Everett Hanson, Argyle, Wis.

Camel's Hump Stores No Water But Plenty of Fat

Long-held theories that the camel's hump is a storage place for water have been disproved by recent investigations. Instead of being composed of cellular spaces for holding water, the hump is solid fat. Some water is "generated" from it, however, since the metabolism or burning of one pound of body fat gives rise to about a pound of water. The camel's normal reserve of liquid water is stored all over its body, as in other animals, and the camel can also store water in tissues under the skin. The water reserve in a camel depends considerably on the availability of salt. Deprived of salt, camels can actually become intoxicated when given pure water. The only recorded analysis of a camel's hump showed 80 pounds of fat. This would yield about 10 gallons of water when the fat was drawn from the hump as food.

To learn where to buy commercial products described in these pages, see the index.

NOW a DYNAMIC HEAVY DUTY INDUSTRIAL WELDER

THE BOOM IS ON IN WELDING—EARNINGS ARE SKYROCKETING

**WORKS OFF
110 VOLT
ELECTRIC
LIGHT
CIRCUIT**



Thousands of welders have already left their jobs and shops to get "war-time" pay in plants devoted to defense production, such as ship building, tanks, airplanes, munitions, etc. Also, in the erection of industrial plants, bridge construction work, etc. This creates an unusual opportunity for men everywhere to get in the welding business right in their own communities, and take over the work these men have left behind. No special training is required, for now with the new DYNAMIC Super-Charged Transformer-Type Welder that works off a 110 volt electric light circuit, men without previous experience, by following the simple, concise home instructions can quickly do finished repair jobs. In this way you may fit yourself to qualify for a big pay job in the defense industry.

WELDS BUMPERS, FENDERS, CYLINDER BLOCKS, BODIES, FRAMES, ETC. Does Farm, Factory and Home Repairs

Many welders make as much as \$15 to \$20 a day. Repair jobs that can be done in less than an hour can make as much as \$5.00. Any number of jobs can be done more efficiently with welding. The DYNAMIC Super-Charged Welder, despite its serviceability, is so easily portable it can be carried around by hand and taken right to the job. This is an added feature whose value you will appreciate once you are in welding.

**WORKS ON IRON
STEEL, TIN, BRASS, COPPER,
AND ALL OTHER METALS**

With this Welder you can work on all kinds of metal—nothing will stump you—you can tackle anything and in no time at all you will be able to do finished repair jobs that will do credit to an expert.

**DOES METALLIC AND
CARBON ARC WELDING**

Can be used efficiently on both types of welding. The cost of using the DYNAMIC Super-Charged Welder is amazingly low—costs only a few cents an hour to operate. It is built so strongly that repairs are practically unknown—you'll never have to worry about them. It cools so efficiently that you can use it continuously without ever having to stop in the midst of a job to let it cool down. **COSTS LESS THAN 6¢ A DAY.** You can buy the DYNAMIC Super-Charged Welder on easy payments. Over a year's time, it would cost you less than 6¢ a day. Once you have your DYNAMIC outfit, you are all set in a profitable welding business of your own—you boss it yourself. Send coupon for free particulars today.



These pictures show how easy it is to operate the Dynamic Super-Charged Welder.



READ WHAT USERS SAY
Electrician says: "It is the best welding outfit." I wish to tell you that I demonstrated your welding outfit to a great many people, and they all agreed with me that it did the best welding job they ever saw. A. L., Bristol, Conn.
Mechanic Praises Welder.
I have received my welder and like it very much. I am a mechanic and electrician by trade, so I can appreciate its usefulness to others. F. C., Perry, N. Y.
Repair Shop Owner Tells About Dynamic
I want to say I operate a repair garage and I am more than satisfied with the welder. It will do more than you say. C. P., Butler, Ohio.
Greatest Portable Outfit
I must say it's the greatest portable outfit any man could wish to own. You may put me on file as a booster. W. J. B., St. John, N. B., Canada.

AGENTS WANTED: Do you want something easy to sell? to garages, factories, mechanics, janitors and maintenance men the new DYNAMIC Super-Charged Welder—we'll let you try it for ten days at our risk so you can be convinced of the immense sales possibilities. Get our big profit plan and ten day trial offer. Just send attached coupon for free particulars today!

**DYNAMIC WELDER CO.
2226-TG SILVERTON ROAD CHICAGO, ILL.**

Dynamic Welder Co., 2226-TG Silverton Rd., Chicago, Ill.
Gentlemen: I want to go into the welding business. Send me free particulars on how I can learn welding at home and full details on your Dynamic Welder.

AGENTS: Just mark an "X" here and you will receive full particulars of our big profit plan and 10 day trial offer.

Name.....
Address.....
Town..... State.....

Defense Industries NEED Lathe Operators

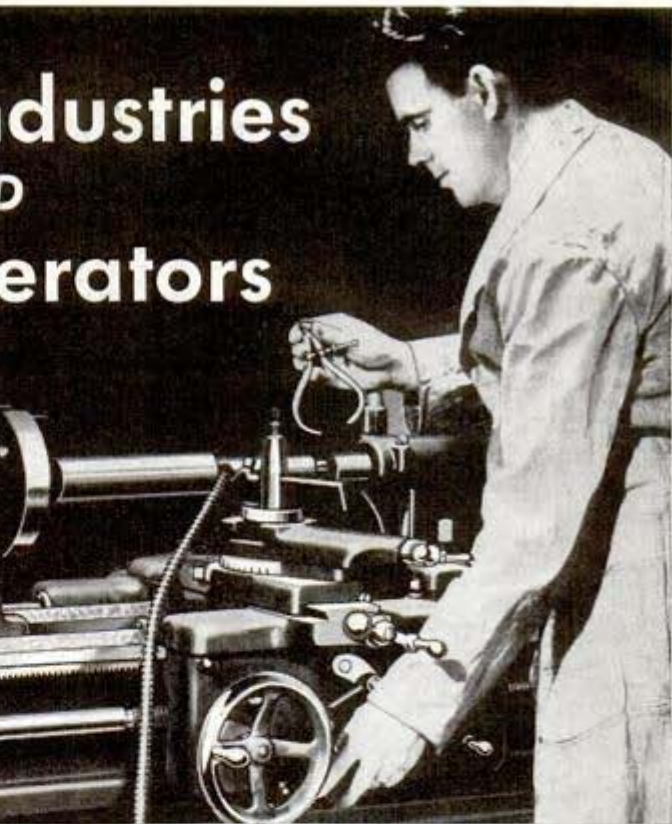
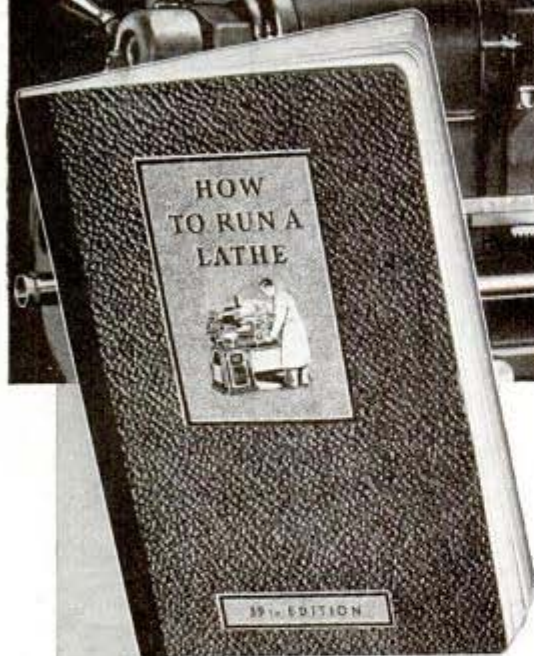

GET THIS BOOK

"HOW TO RUN A LATHE" is a complete reference book on the operation and care of a modern, screw-cutting, metal working lathe. It contains 128 pages, 5 1/8" x 8" and over 360 illustrations. Clearly written in easy-to-understand language, this is a practical handbook for the machinist, lathe operator, apprentice or shop student.

The Defense Industries need trained lathe operators—men who are skillful with their hands—know how to diagnose trouble—can suggest improvements. If you are mechanically inclined you may be able to help win the Battle of Production. Write today for your copy of "How to Run a Lathe." Price 25c postpaid. Coin or stamps of any country accepted.

PARTIAL LIST OF CONTENTS

Operation of Lathe Controls
Lathe Tools and Their Application
How to Take Accurate Measurements
Machining Work Between Centers
Chuck Work
Taper Turning and Boring
Drilling, Reaming and Tapping
Cutting Screw Threads
Erecting and Leveling the Lathe

Mail Coupon Today

SOUTH BEND LATHE WORKS

615 E. Madison St., South Bend, Indiana

Enclosed find 25c in stamps for which please mail one copy of "How to Run a Lathe."

Name _____

Address _____

City _____ State _____



SOUTH BEND LATHE WORKS

615 East Madison Street, South Bend, Indiana, U. S. A.

Lathe Builders for 35 Years

PRINTED BY POPULAR MECHANICS COMPANY, CHICAGO, ILL., U. S. A.



Keep 'Em Flying

CONSERVE VITAL GAS AND OIL WITH A HARLEY-DAVIDSON

Harley-Davidson Motorcycles do patriotic duty these days. By giving greater gas mileage and reducing oil consumption, they conserve essential products for airplanes, tanks and other motorized equipment. These same features bring unmatched economy for owners — plus faster, more convenient transportation. No time schedules or parking troubles to worry about. Come and go as you please — plenty of power for fast getaway — always ahead of the rest when the lights say "Go." Dependable, low-cost performance for everyday service—and for grand week-end trips.

Harley-Davidson Motorcycles are doing double duty these days — in defense service as well as for civilian needs. See your Harley-Davidson dealer — learn about the superior performance of these world champion motorcycles. Also look over his special values in reconditioned models.



ON AMERICA'S FRONT

LINE OF DEFENSE

HARLEY-DAVIDSON MOTORCYCLES

HARLEY-DAVIDSON MOTOR CO., Dept. P, Milwaukee, Wis.

Send FREE copy of big 24-page "Enthusiast" magazine filled with thrilling motorcycle pictures and stories. Also literature about the Harley-Davidsons. Stamp is enclosed for mailing cost.

Name

Address

Mail
COUPON
NOW!

"SET 'EM UP" — FOR CHAMPION LOWELL JACKSON

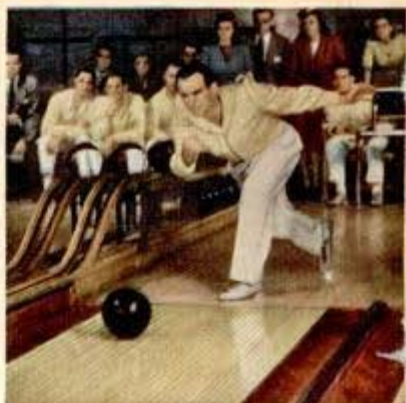

AND SET UP THE CAMELS, TOO
Whether you're bowling yourself—or just watching—nothing hits the spot like a cool, flavorful Camel

TALK ABOUT your wood-gettin' wonder! You're looking right at him—"Low" Jackson of St. Louis, 1941 All-American, captain of the world's match game champions. Light up a slower-burning Camel and watch this champion of champions in action.

THERE'S A SWIFT FLASH of the arm. The ball whirls down the alley. Take a good look at the way "Low" Jackson tossed that one—that's an All-American hook. Close to the gutter. Three-quarters down, she starts to break—straight for the slot. Watch it now—it's—



IT'S STRICTLY CAMELS WITH ME. EXTRA MILD WITH A FLAVOR THAT ALWAYS HITS THE SPOT

A PERFECT HIT! Like a homer with the bases loaded . . . like the full, rich flavor of a certain cigarette, it never fails to thrill. No matter how much you smoke, there's always a fresh, welcome taste to a Camel—for Camels are milder with less nicotine in the smoke.

THE SCORE-BOARD tells the story. More smokers prefer Camels . . . smokers like Lowell Jackson to whom mildness is so important . . . smokers who want a flavor that doesn't tire the taste. You'll never know what you've been missing until you smoke Camels.

TWENTY TIMES "Low" Jackson (above) has rolled the perfect score. Every time he lights up a Camel he smokes with the assurance of modern laboratory science that in the smoke of milder, slower-burning Camels there is less nicotine (see below, left). Get Camels next time.

The *smoke* of slower-burning Camels contains

28% LESS NICOTINE

than the average of the 4 other largest-selling brands tested—less than any of them—according to independent scientific tests of the smoke itself!

By burning 25% slower than the average of the 4 other largest-selling brands tested—slower than any of them—Camels also give you a smoking plus equal, on the average, to



5 EXTRA SMOKES PER PACK!

Camel

—the Cigarette of Costlier Tobaccos

R. J. Reynolds Tobacco Company
Winston-Salem, N. C.