

HEROES OF THE FIRE LINES

POPULAR MECHANICS

MAGAZINE

WRITTEN SO YOU CAN UNDERSTAND IT



REG'D. TRADE MARK, GREAT BRITAIN, NO. 40428

REG. U.S. PAT. OFF.

DEC.
25 CENTS



SEE PAGE 806

"GOODBYE WORLD! MY SHIP FADED INTO THE NIGHT!"

OVERBOARD IN STORM, YACHTSMAN CLINGS TO CAPSIZED DORY AS SLOOP HOLDS COURSE



① "My 40-foot sloop was footing it up Long Island Sound like a scared cat before a stiff sou'-west breeze," writes Tom Meyer

of 280 Bronxville Road, Bronxville, N. Y. "At midnight...

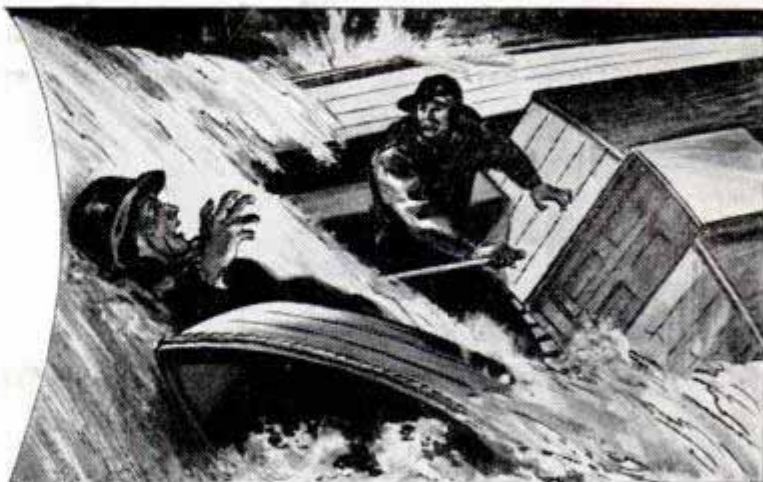

② ...off Smithtown Bay, it really began to blow. My partner, Larry Starr, was asleep below, and I gave the tiller to a friend who had done no sailing before, so I could get the dinghy in on deck before it got away from us. Then, with the darn thing half-way on board a big comber pounded over the stern, swept my feet out from under me and overboard I went, weighted down with boots and oilskins. I still clung to the dinghy, but its line had parted and my ship faded quickly into the black night!

③ "The lad at the tiller didn't know how to bring the ship about, and although he would wake Larry, they'd be too far away to ever find me in that roaring darkness.

"I was growing numb with cold. I couldn't hang on much longer. I rolled against the gunwale of the dinghy for a fresh grip on the world that was slipping away from me. Something hard dug into my side... the flashlight in my pocket! Soaked, though it was, here was a chance!



④ "I pressed the switch. A finger of light stabbed through the storm. Time dragged on as I played the light about me. I cursed my shipmates. 'Why can't the fools see my light?' and then...the beam caught the white sail! I screamed for joy. An arm waved encouragement. Minutes later, thanks to those *fresh* DATED 'Eveready' batteries that kept working under the toughest conditions imaginable, I was warm and happy in my own bunk on my own ship, our Block Island cruise resumed.

(Signed)

Tom Meyer

FRESH BATTERIES LAST LONGER... Look for the DATE-LINE



NATIONAL CARBON COMPANY, INC., 30 EAST 42nd STREET, NEW YORK, N. Y.
Unit of Union Carbide  and Carbon Corporation

SMARTER STYLING...FINER ENGINEERING...YET 1939 Plymouth is Lower Priced!

Imagine Getting all these
Great Engineering
Features—at Plymouth's
NEW LOWER PRICES!

Never Before Has a Low-Priced Car Offered So Much Value

1. Greater Size—114-in. Wheelbase.
2. New High-Torque Engine Performance with New Economy.
3. Perfected Remote Control Gear Shifting—much easier.
4. New Auto-Mesh Transmission.
5. New Amola Steel Coil Springs.
6. "Safety Signal" Speedometer.
7. New True-Steady Steering.
8. 100% Hydraulic Brakes.

ISN'T IT great news about the new 1939 Plymouth—the value is up, but the prices are down!

There's new shifting ease in Plymouth's Perfected Remote Control Shifting with All-Silent Auto-Mesh Transmission—standard on "De Luxe"... a great new ride with new Amola Steel Coil Springs!

See your Plymouth dealer today! PLYMOUTH DIVISION OF CHRYSLER CORPORATION, Detroit, Michigan.

EASY TO BUY!

CONVENIENT TERMS

"Detroit delivered prices" include front and rear bumpers and bumper guards, spare wheel, tire and tube, foot control for headlight beam with indicator on instrument panel, ash-tray front and rear, sun visor, safety glass and big trunk space (19.3 cu. ft.). Plymouth "Roadking" models start at \$645; "De Luxe" models slightly higher. Plymouth prices include all federal taxes. Transportation and state, local taxes, if any, not included. See your Plymouth dealer for local delivered prices.

MAJOR BOWES' Amateur Hour, C.B.S. Network, Thurs., 9-10 P. M., E. S. T.

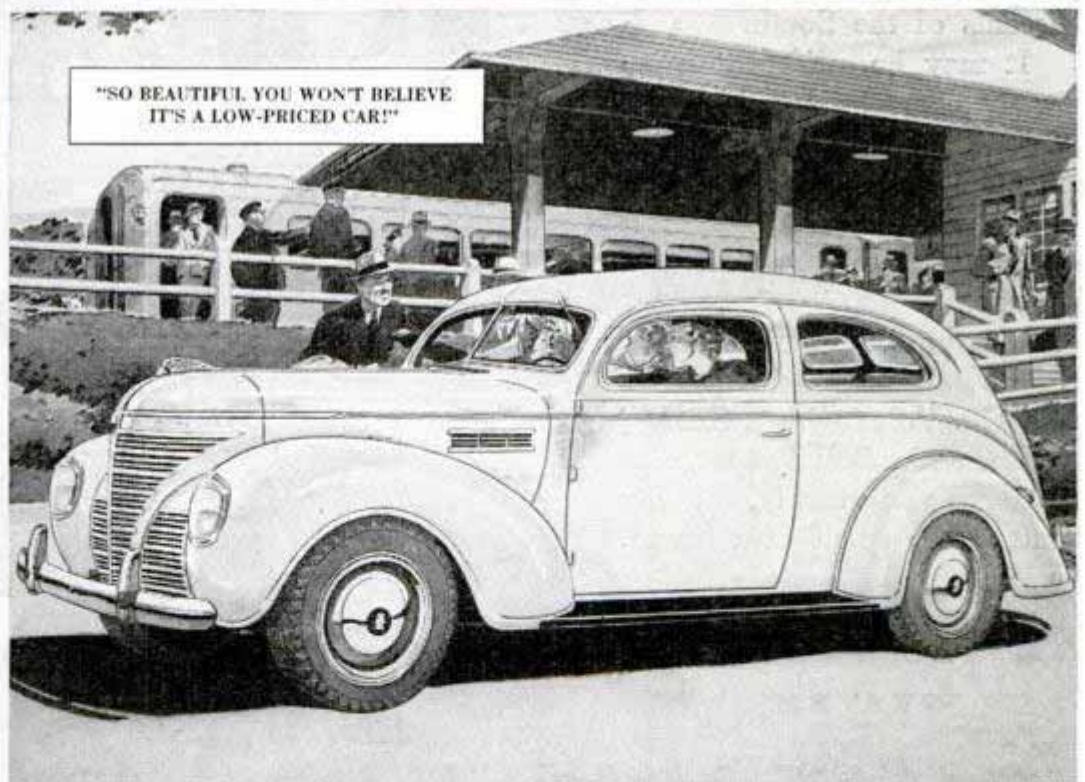

THE 1939 PLYMOUTH "ROADKING" Two-Door Touring Sedan...all-steel body completely rust-proofed.

PLYMOUTH BUILDS GREAT CARS

THE "ROADKING"
THE "DE LUXE"



THE VOICE WITH

A Smile



NORTH



SOUTH

It may carry the salty twang of New England or the soft accents of the South.

It may be swift and crisp in the New York manner or full of the pleasant rolling r's in the style of the West.

But wherever you hear it, it will be friendly, courteous, and efficient.

It's the all-American voice of the Bell Telephone operator — "The Voice with a Smile."

The entire Bell System seeks to serve you quickly, capably and in the spirit of a friend.



EAST



WEST

**BELL
TELEPHONE
SYSTEM**



Popular Mechanics Magazine

H. H. WINDSOR, Founder

H. H. WINDSOR, Jr., Editor and Publisher

December, 1938

Vol. 70, No. 6

Special Features

Goodby to the "Wobble-Stick" . . .	801
Birthplace of the Big Winds . . .	807
Behind the Scenes in Aviation - Coloroto	
Flaws Bared by High-Speed Movies	819
Ocean's Depth Measured by Radio	828
Don't Pity the Poor Eskimo, Part II	834
Lights Turn Battle Against Insects .	840
Make Your Snapshots Tell a Story .	851
Trailing the Wild Game Poachers .	858
Doing Something about the Weather	866
Off the "Platter" and into Your Home	882
Heroes of the Fire Lines	892

(Continued on next page)

Taming Wild Wells

AN ominous roar sends men scurrying away from the derrick. A gray column of gas and oil screams in its sudden release from the ground. Timbers swish into the air like toothpicks. Then a thundering detonation shakes the earth and rocketing flames a hundred feet high envelop the oil-well derrick and machinery. A call for help flashes over telephone and telegraph wires. Autos, trains and planes rush the wild-well tamers to the scene—men in asbestos suits who use nitroglycerine and complicated apparatus to battle the inferno. An exciting word-and-picture story in the January issue will tell you how these daring fire fighters go calmly about their dangerous job on which the chances are about two to one that some of them will be badly hurt or burned or blown to bits before it is finished.

Next Month

TEACHING a lion to walk a tightrope is no more difficult than teaching a seal to turn on the water in the bathtub. But watch the lion's eyes! When his pupils begin to enlarge, he's getting angry, and trouble may be brewing. An article next month, illustrated by eight pages of Coloroto pictures, tells how animals are trained for the movies.

Flight over Weather

FLIGHT at 100,000 feet? Not in our lifetime, says Capt. D. W. Tomlinson, stratosphere research pilot for TWA. But he tells you in the January issue how it will feel next summer to take a trip in the sealed, supercharged cabin of a skyliner roaring across the continent at an altitude of 20,000 feet.

Highway Trackers

JUST as Indian scouts in pioneer days "read" the footprints of the man whose trail they were following, so do modern trackers of the asphalt street and rural highway read in tire prints about the motorist they are hunting—his character and habits, the type and condition of his car. The tire sleuth may look for a fugitive driving a car with brake drums irregularly worn, or wheels out of alinement. Thus they track the modern cattle thief and highwayman. Read about this infant branch of criminology in the January issue.

Treat your new car *Safely* with **PYROIL**

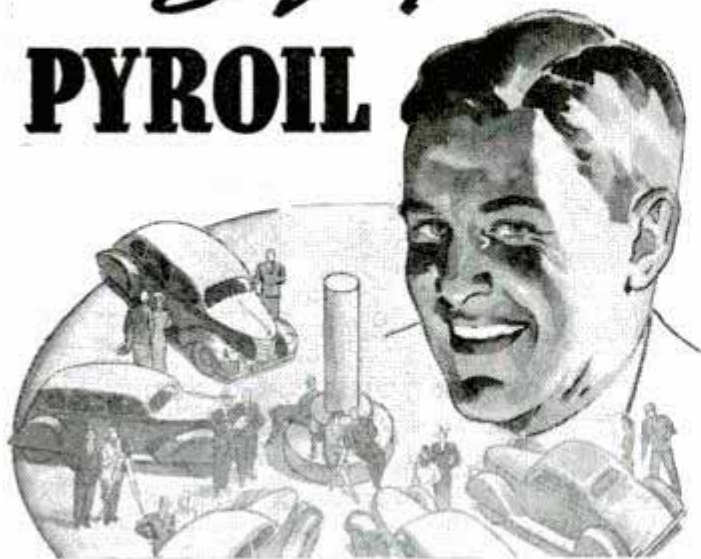

Keep Performance Up to the Manufacturer's Intended Standards

★ Mr. A. F. W., of Newton, Pennsylvania, says: "I bought a car new and used Pyroil in both gas and oil. After more than 25,000 miles I cannot get any oil in it between changes. It still has all the power and pep of a new motor."

★ And, Mr. H. J. J., of Los Angeles, California, has this to say: "I began to use Pyroil over three years ago, and since that time I have used it in both my oil and gasoline. My motor has gone 62,000 miles, runs smooth and quiet, has good compression and power. I am very well pleased with Pyroil."

Your investment in a new car is an important one. And, Pyroil is mighty good "insurance" with which to back that investment. Pyroil keeps carbon, gum, sludge and corrosion from creating early damage in your new car. These contaminations rob your engine of power, cause higher operation costs, create excessive wear.

Ask your service station or garage salesman for an inexpensive Pyroil treatment, today! Manufactured and Guaranteed by Pyroil Company, W. V. Kidder, Founder, 512 Pyroil Bldg., LaCrosse, Wisconsin, U. S. A.



NOTHING FINER FOR NON-ABRASIVE NEW CAR BREAK IN!

DISTRIBUTORS: CHECK AND MAIL COUPON FOR FRANCHISE FACTS.

SIMPLY ADD TO GAS & OIL

PYROIL COMPANY,
512 Pyroil Bldg., LaCrosse, Wis., U. S. A.

Please send me further important Pyroil facts.
 Also send details of your plan for Distributors.

Name.....

Address.....

City..... County..... State.....

(Contents—Continued)

AUTOMOTIVE

"Cat eye" mirrors guide motorists at night.....832
Tractor hauls miniature train.....857
Truss expands piston to stop oil pumping.....861
Motorcycles pull chariot of modern Ben Hur.....875
Auto bridge over a sea of sand.....128A

AVIATION

Plane climbs at forty-five degree angle.....817
Featherweight speedsters of the air lanes.....821
Expedition's flying boat steered by outboard motor.....822
Stratosphere fliers' gondola ready for trip.....822
Newest zeppelin queen goes for trial flight.....827
Plane with speed of sound proposed.....833
"Crab" tricycle gear helps takeoff in cross wind...849
Four-in-one flight instrument.....854
Pilot warned of position of landing gear.....857
Fish planted by parachute dropped from plane...861
Million-dollar flying arsenal joins the navy.....872
Airplane engines changed in twenty minutes.....873
"Big ears" listen for planes in mimic war.....873
Hurricane stirred up by ten-ton motor.....874
Aerial cameraman maps battleground.....879
Moving light on screen shows position of plane...886

BOATS

Surfboard with a motor sets speedy pace.....833
Fireproof passenger ship has latest safety aids...849
Italian speedboat wins American championship...855
"Mauretania"—Britain's new sea queen.....870
Boat sucks up oysters like vacuum cleaner.....872
On the bridge of a modern ocean liner.....876
Cargo wider than ship sails from London.....896

CONSTRUCTION

Steel house is floated across river.....823
Welded casing in deep oil well found practical...862
Big earth dams built faster with water "guns"...875
Concrete poured from bridge rolling along canal...879

FARMS

Vacuum milking process saves calcium and vitamins.832
Firecracker guns rid farm of animal pests.....847
Old tires used for cane-field sweeper.....861
Rose glasses on chickens reduce fighting.....864
Mowing machine built of odd parts.....887

HOUSEHOLD

Vacuum and spray gun preserve library books....818
Frozen bread nine months old stays palatable....826
Elastic cover protects book.....832
Coiled electric cord.....850
Self-heating iron.....878
Trigger on handle of teakettle opens spout.....891

MODELS

Fire and flood control relief map.....839
Midget air-pressure engine built like watch.....849
Model racing car runs 45 miles an hour.....880
Hobbyist strings bottle caps into useful articles...881
Relief map of U. S. A. matches earth's curvature...887

PHOTOGRAPHY

Ground-glass focuser for adapter of color film....826
Extinction type exposure meter for enlarging....827
Camera inside a football films view from air.....854
Snap frame for projecting film.....855
Focuser and view finder combined on camera.....877
Water operates agitator for developing tank.....879

RADIO AND ELECTRICITY

Radio compass proof against static.....826
Radio sends SOS after plane crash.....850
Auto wheel runs generator for a.c. or d.c. power...878
Water-cooled "Midget Sun" gives brilliant light...896
T. R. F. tuner for school P. A. system.....897
Portable battery-operated broadcast receiver.....898
Compact ten and twenty-meter transmitter.....900
Hints for radio experimenters.....901
Crystal oscillator doubler.....902
Electric-eye burglar alarm.....902
Electromechanical sound-recording film.....902
Push-button tube tester.....902

RAILWAYS

Safer wheels for streamliner gives longer service...844
Hoist swings locomotive from dock to ship.....845
120-mile iron horse hauls streamliner.....881

SCIENCE AND INDUSTRY

"Fire weather" sampled from 150-foot tower.....823
Steel mills use steel-pickling bath waste.....823

(Continued to page 6A)

**How a "Toy" Present
LED TO A
BUSINESS
CAREER**



**DAD... THIS IS REAL
ADVENTURE!... MY
CHEMCRAFT OUTFIT IS THE
BEST PRESENT I EVER HAD!**

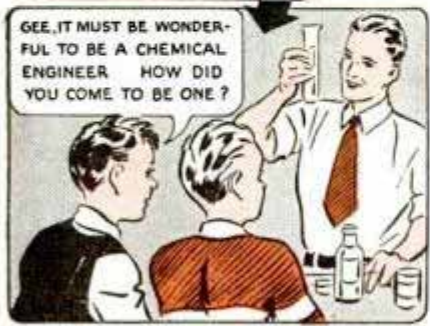

GEE, IT MUST BE WONDERFUL TO BE A CHEMICAL ENGINEER. HOW DID YOU COME TO BE ONE?



WELL JACK, WHEN I WAS YOUR AGE, FATHER GAVE ME A CHEMCRAFT OUTFIT FOR CHRISTMAS

BUT I THOUGHT CHEMCRAFT WAS JUST A TOY!



IT WAS THE BEST FUN I EVER HAD, BUT IT ALSO GAVE ME A WORKING KNOWLEDGE OF SIMPLE CHEMISTRY. THAT REALLY STARTED MY CAREER.

A FRIEND OF FATHER'S WAS WATCHING ME ONE DAY...



SEVERAL YEARS EARLIER.

YOU FIND THAT WORK VERY INTERESTING, DON'T YOU? HOW WOULD YOU LIKE TO WORK IN OUR PLANT LABORATORY WHEN SCHOOL'S OUT?



I'VE BEEN HERE SEVERAL YEARS NOW, AND THEY'VE JUST MADE ME ASSISTANT TO THE MANAGER

THAT'S WONDERFUL, I'M GOING TO ASK DAD TO GIVE ME A CHEMCRAFT OUTFIT FOR CHRISTMAS

YES, indeed, a Chemcraft Chemistry Outfit is a grand present. Fun? You bet—the greatest fun in the world—real adventure—the thrills of performing hundreds of fascinating and amazing experiments.

But with the fun you can also secure a practical knowledge of Chemistry—the marvel science that has contributed so greatly to industry, medicine and the progress of civilization. From this simple beginning many youngsters have become important figures in scientific and industrial fields.

Chemcraft Chemistry Outfits are used in schools and colleges and the Instruction Manuals contain valuable information and describe fully how to perform many interesting experiments. Chemcraft Outfits contain no dangerous substances.

See Chemcraft Chemistry Outfits at your favorite store, priced from \$1.00 to \$25.00. If they do not have them you may order direct from us.

All the thrills and wonders of a real Chemist's Laboratory are yours with

REG. U.S. PAT. OFF.
CHEMCRAFT
CHEMISTRY OUTFITS



Outfit No. 10 Big Lab Style mahogany finished cabinet containing splendid assortment of chemicals and apparatus. Instructions for 730 practical experiments in Chemistry, Electrochemistry, Glass Blowing, and Formulae & Symbols Price \$10.00



Outfit No. 4 395 fascinating chemical experiments including Chemical Magic, Plans for Home Lab, and Chemical Formulae & Symbols. Liberal quantities of chemicals and apparatus packed in convenient laboratory style wood cabinet Price \$3.95



Outfit No. 2 A big value outfit in a stand-up wood cabinet. Contains chemicals, apparatus and directions for 194 thrilling experiments including Plans for a Home Lab. Price \$2.00

You'll Enjoy this FREE BOOK. Mail Coupon

Our new book "Adventures in Science" is a real treasure house of information and entertainment for the young scientist. It is full of astonishing scientific facts, and tells about many thrilling experiments in Chemistry, Microscopy, Physics, Biology, Electricity, etc. Book also helps you to construct a home laboratory, and tells how you may become a member of the Chemcraft Science Club.



THE PORTER CHEMICAL COMPANY

452 Prospect Ave.,
Hagerstown, Md.

Company, 452 Prospect Ave., Hagerstown, Md.
our free book, "Adventures in

This One



JEZ4-84J-03A1

DON'T MISS SENDING FOR THIS
FREE BOOK
MAIL COUPON TODAY

**"DON'T GO A-WOOING
WITH A STEWING PIPE!"**

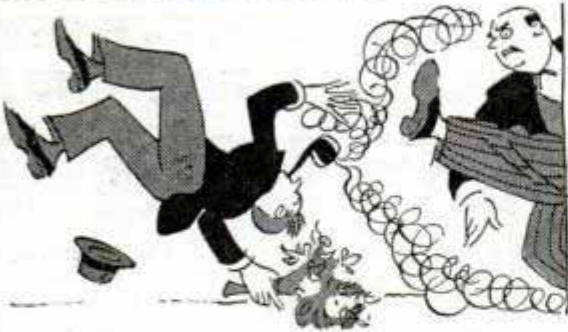

"NO DAUGHTER OF MINE can go with a young whippersnapper who smokes such rank-smelling tobacco. Clean that pipe! Switch to a mild, tasty blend like my Sir Walter!"



SMART GIRL! She swiped her father's 2-ounce tin, and now they've got the old boy's blessing—plus the world's most biteless blend of sweet 'n' fragrant burleys!



**HOW TO
TAKE CARE
of
YOUR PIPE**

FREE BOOKLET tells how to make your old pipe taste better, sweeter; how to break in a new pipe. Write for your copy today. Brown & Williamson Tobacco Corporation, Louisville, Kentucky, Dept. P-812.

TUNE IN Tommy Dorsey and his orchestra. Every Wednesday night, coast-to-coast, NBC Red Network.

(Contents—Continued)

Rust costs \$5,000,000,000 a year	826
Electric eye detects tiny flaws in steel	831
Sea scorpion wears glasses to test vision	848
Synthetic fiber stronger than silk	864
Coin machine that almost thinks	865
Long-sought boric acid crystal found	880

SPORTS

Speedboat shaped like wing of an airplane	846
Streamline rod rigging adds speed to sailboats	846
Hunter totes game home on two-wheel cart	854
"Go-back" tackling dummy trains football players ..	855
Indian's advice when you plunge through ice	856
Land lubbers go sailing on bicycles	877
Mountainside is cleared for floodlit ski slopes	890

TOOLS

Tool chest with roll-up door	862
Utility vise adapted to precise drilling	874
Screwdriver has jackknife folded in handle	132A

MISCELLANEOUS

News reporter wears gas masks at war games	818
Self-propelled street marker	818
Bracelet holds powder puff and rouge	822
Science helps carve giant faces on mountain	824
Bananas ride cradle from ship to car	831
Hand truck for moving piano	832
Carbon black in rolls and pellets	839
Philippine volcano showers ashes 125 miles	844
Bushel basket on roller stand for shopping	845
Cherry crop saved by fruit drier	845
Derrick lifts elephant after fall into moat	846
Fake locomotive fools pilots of bombing planes	847
5,000-year "time capsule"	848
Meter shows if wall is dry for painting	850
Quick-firing army rifle	850
Memorial shaft marks freeing of Texas	856
Welder's non-fog eyeshield gives wide vision	857
Bombarding foe with noises latest war weapon	862
Elastic adhesive tape	863
Keyhole door keeps big children off playground	863
Torch removes paint from wood or canvas	863
Rubber guard on trolley wire protects miner	864
Reclaiming ghost gold mines found profitable	865
Theory of exploding stars traces growth	878
Clock hands rotate once in 26,000 years	886
Magnifying glass has light to illumine work	886
The epic story of radium	888
Divers wear electric underwear in record plunge ..	891
Mushroom bed for cellar is rustproof steel	124A

(Craftsman and Shop Notes)

AUTOMOTIVE

Lightweight metal doubletree assembled easily	940
Burred valves score guides	958
Dual batteries to start car in cold weather	958
Garage stove made from two oil barrels	958
Motors must be overhauled for efficient operation ..	958
Clutch to control countershaft from auto brake	959
Guards on garage door frames protect fenders	959
Shrinking brake shoes to fit lining	959
Disks mark car spaces in parking lot	960
Eight-volt battery made from two old ones	960
Electric heater to thaw frozen brakes	960
Excess oil in air cleaner causes carburetor trouble ..	960

FARM

Preventing stock from overturning small tank	942
Tool peels logs rapidly	942
Double-loop halter tie	944
Tying grain sacks	944
Handy feed troughs for cattle	950
Tile ventilator for a cave	950
Drip pan on oil barrel prevents muss	952

FURNITURE

Bookcase folds for transportation	907
Gimp held for tacking by spring clothespin	910
Ship's wheel top on smoking stand rotates	913

HAND TOOLS

Jig for drilling equally spaced holes	910
Deflector on shears for cutting sheet metal	912
Depth gauge from saw vise	919
Removing broken tap or drill with acid	926
Sheet-metal punch improvised from hinge	930
Motorized hand plane gives smooth finish	939

(Continued to page 8A)

WHICH OF THESE MEN IS YOU?



Is This You?

OR

Is This You?



1. "My name is Stark. I'm never late mornings. I get back promptly from lunch—often work overtime cheerfully. I carefully do every single job they give me and in six years I have done each job so many times that I'm letter-perfect! Only one little raise so far, but some day I ought to get a good one. I'm probably the steadiest, most loyal employee in the whole office. One of these days the boss will realize that I'm the best man who ever worked on this job. Then I'll show these other fellows a thing or two!"

2. "My name is Baker. I've only been here a year, but the jobs they give men like Stark and me are too easy. In three months I saw I could never get far ahead on routine work like this. So I began to look for ways to increase and improve the work in my department. I'm taking home-study training that's helping me a lot. My boss heard about it and complimented me. Next month I'm going to be made Assistant Department Head at 40% more money. After that—well, we'll see. But you can bet I'm still studying!"

DON'T you recognize both these men in your office? One is a slow plodder—the other an energetic go-getter. Stark thinks of himself—Baker, of his company.

Stark runs along comfortably in a rut—*hopes* for a big raise. Baker pulls himself out of ruts—*gets* a big raise. And goes right on training for *another* one!

It's men like Baker who turn to LaSalle business training because of what it *gets* them! And they know it gets them *plenty* because the proof is plain to read in the grateful letters—and the successful lives—of thousands of LaSalle graduates.

You too can join the ranks of the "comers" like Baker if you'll "train on the

job you've got—to get the job ahead!" It all depends on you—the height of your ambition and your readiness to investigate, then study systematically and seriously.

The LaSalle Success Road is cleared and ready for earnest adults—has been traveled for thirty years. Its first sign-post has always been a man's name on a coupon like the one below.

It costs absolutely nothing to send such a coupon. But sending it may mean the turning-point in your whole life. Mail it! At least *find out* about LaSalle's road to better jobs—more money—success! There's no time like *NOW!*

LASALLE EXTENSION UNIVERSITY, A Correspondence Institution
Dept. 1264-R CHICAGO

I am ambitious like Baker. Tell me how I can prepare for larger success—and send me your free booklet on the field I have checked below:

Executive Management Law: LL.B. Degree Salesmanship
 Accounting Traffic Management

Name.....Age.....

Position.....

Address.....



LaSalle EXTENSION UNIVERSITY
A CORRESPONDENCE INSTITUTION

TAKE THE GRIEF OUT OF EMERGENCY REPAIRS

A sudden leak in the hot water heater—the hammer handle flies off—water squirts from a dent in the auto radiator—a drawer knob pulls out—screws strip from and loosen the door lock—a water pipe freezes and cracks—one caster won't stay in the table leg—your favorite pail starts to leak—a persistently loose nut puts the vacuum cleaner out of business—etc., etc.

Possibilities like these are ever present to the householder, but invite no delays, repair bills or expensive new purchases if you have a copy of the Smooth-On Home Repair Book, and a can of Smooth-On No. 1 on the shelf and like to prove yourself equal to the emergency.

Hundreds of repairs similar to the above are made quickly, easily and cheaply with Smooth-On No. 1, which stops leaks of steam, water, gas, oil, gasoline, smoke, etc., anchors loose screws, bolts, nuts, handles, machinery, etc., and holds equally well in metal, masonry, bath room tile, and wood.



Write for FREE BOOK

Smooth-On No. 1 expands in hardening and when metalized holds as tightly as the metal to which it is attached. Power plant engineers, shop foremen and professional repair men prefer Smooth-On repairs because the simple cold application avoids fire risk and extra labor and a dependable finished job is ready in a hurry.



Do it with SMOOTH-ON

SMOOTH-ON MFG. CO., Dept. 37,
574 Communipaw Ave., Jersey City, N. J.
Please send the free Smooth-On Repair Book.

Name.....

Address.....

12-38.....



Radiator



Leaky Pail



Leaky Kettle

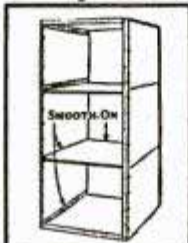

Leaky Tank



Stove Pipe



Oil Leaks

Mail the coupon for the Smooth-On Repair Book and get Smooth-On No. 1 in 7-ounce or 1 or 5-pound can from any hardware store.

(Contents—Continued)

Pocket on plumber's kit for small tools.....	942
Bushings removed from boiler with lead cone.....	945
Long-nose pliers altered to hold screws.....	951

HOME IMPROVEMENTS

Installing suction line in well.....	906
Novel weather vane.....	906
Fireplace set in wrought iron.....	908
Rainproof mounting for weather vane.....	913
Pier cabinets you can build.....	946

HOUSEHOLD

"Pin-up" vanities.....	903
Clogged drain cleaned with heat.....	924
Clothesline pulley shielded from snow and ice.....	924
Sheet-metal iron holder saves labor.....	924
Radiator improved by reflector.....	931
Solving home problems.....	936
Rubber-headed tacks in photos protect table.....	938

MODELMAKING

Tape aids in drilling small parts.....	924
Candle runs engine.....	927
Easy method of serving rigging on ship.....	930
Belt-driven tool-post grinder for modelmakers.....	941
Carbon rheostats for low-ampere current.....	945

OFFICE

T-square clamped to drawing board.....	906
Desk slide converted into drawing board.....	919
Vacuum cup serves as handle on triangle.....	938
Eraser cleaned on gummed cloth.....	950

PHOTOGRAPHY

Photo press of wood and coil spring.....	907
"Jiffy" enlargers for camera.....	911
Jig to clamp camera in vise.....	920
Miniature film printer makes positives for projection.....	921
Electric heater used as flash gun.....	923
Photo chemical scoop from shoehorn.....	924
Operating stop watch and shutter simultaneously.....	935

POWER TOOLS

Turning large disk on small lathe.....	926
Disks alined in chuck with drill pad.....	941
Micrometer attachment measures internal tapers.....	943
Saw table converted for drilling and routing.....	943

STORE AND SHOP

Spools for wire made from headlight reflectors.....	912
Weights for scale made from fishline sinkers.....	912
Shop thread stored in rubber ball.....	930
Printer's mitten for handling hot castings.....	942
Barrel spigot sealed with radiator hose.....	944
Factory steam boiler started by alarm clock.....	950

TOYS AND NOVELTIES

Dispenser for table-tennis balls.....	920
Electric target for toy artillery.....	925
Model railroad signals supported on tie.....	930

WOODWORKING

Carving wood signs.....	905
Jig to slot pegged-furniture legs.....	926
Turned bowl has novel ring handle.....	929

MISCELLANEOUS

Crucible for melting lead or brass.....	906
Protecting lantern mantles.....	907
French curve improved by calibrated edges.....	910
Red reflectors on bicycle pedals.....	910
Muffler buttoned to overcoat to prevent loss.....	912
Spray it; the modern finishing method.....	914
Glass drilled with silicon-carbide.....	919
Paint-dipping can has wiper.....	920
Small reduction gears from auto steering gear.....	920
Metal washer improves roll of tape.....	926
Applying colors to greasy surfaces.....	929
Dial carrying phone numbers permits rapid selection.....	931
Tank supply pipe supported by auto casing.....	931
Preparing your furs for market.....	932
Beam compass from curtain rod.....	935
Small containers save paint using spray gun.....	944
Shingler's seat adjustable to pitch of roof.....	951
Holder for bench-saw blades.....	952
Pad from inner tube for repairman's sawhorse.....	952
Special hinge pin aids carpenters.....	952
Making unit castings in the home shop.....	953

IMPORTANT NOTICE

It is the intention of this magazine to provide its readers with information regarding the latest developments in the mechanical arts. We take no responsibility as to whether the disclosures contained in our articles are covered by patents and advise readers to investigate this subject before making, using, or selling any of the products, machines, or processes described, in order to avoid possible liability for patent infringement.

**HOW DO
YOU JUDGE**

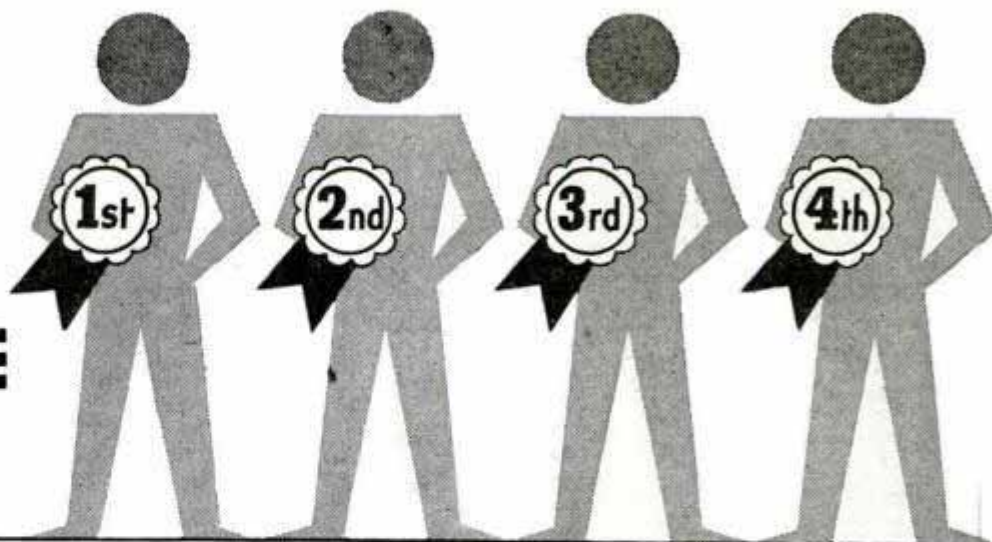

a faculty?

You judge a school's faculty by "the finished product" . . . by the character and achievements of the men and women whom the faculty has trained and educated.

Every member of the faculty of the International Correspondence Schools is thoroughly trained in the technique of home-study instruction. From Massachusetts Institute of Technology, Cornell University, Iowa State College . . . from Purdue University, Vassar College, McGill University . . . from Williams, Swarthmore, Lehigh, Columbia and a dozen other American and foreign institutions of

higher learning come the men and women whose teaching skill and human understanding supplement the specially prepared textbooks of the I.C.S.

This faculty wishes to be judged not by its advanced degrees, published works or extramural attainments, but by the thousands of leaders in every business and industry who attribute much of their success to I.C.S. training . . . and by the tens of thousands of ambitious men, now enrolled with these Schools, who are training for tomorrow's leadership and tomorrow's rewards. Mail the coupon—today.

INTERNATIONAL CORRESPONDENCE SCHOOLS

BOX 5536-J, SCRANTON, PENNA.

★ Without cost or obligation, please send me a copy of your booklet, "Who Wins and Why," and full particulars about the subject *before* which I have marked X: ★

TECHNICAL AND INDUSTRIAL COURSES

- | | | | |
|--|--|--|--|
| <input type="checkbox"/> Architect | <input type="checkbox"/> Sheet Metal Worker | <input type="checkbox"/> Commercial Refrigeration | <input type="checkbox"/> Surveying and Mapping |
| <input type="checkbox"/> Architectural Draftsman | <input type="checkbox"/> Boilermaker | <input type="checkbox"/> Plumbing <input type="checkbox"/> Steam Fitting | <input type="checkbox"/> Bridge Engineer |
| <input type="checkbox"/> Building Estimating | <input type="checkbox"/> Telegraph Engineer | <input type="checkbox"/> Heating <input type="checkbox"/> Ventilation | <input type="checkbox"/> Bridge and Building Foreman |
| <input type="checkbox"/> Contractor and Builder | <input type="checkbox"/> Telephone Work <input type="checkbox"/> Radio | <input type="checkbox"/> Air Conditioning and Cooling | <input type="checkbox"/> Chemistry <input type="checkbox"/> Pharmacy |
| <input type="checkbox"/> Structural Draftsman | <input type="checkbox"/> Mechanical Engineering | <input type="checkbox"/> Steam Engineer | <input type="checkbox"/> Coal Mining |
| <input type="checkbox"/> Structural Engineer | <input type="checkbox"/> Mechanical Draftsman | <input type="checkbox"/> Steam Electric Engineer | <input type="checkbox"/> Mine Foreman <input type="checkbox"/> Fire Bosses |
| <input type="checkbox"/> Management of Inventions | <input type="checkbox"/> Machinist <input type="checkbox"/> Toolmaker | <input type="checkbox"/> Marine Engineer | <input type="checkbox"/> Navigation |
| <input type="checkbox"/> Electrical Engineer | <input type="checkbox"/> Patternmaker | <input type="checkbox"/> R. R. Locomotives | <input type="checkbox"/> Cotton Manufacturing |
| <input type="checkbox"/> Electric Lighting | <input type="checkbox"/> Diesel Engines | <input type="checkbox"/> R. R. Section Foreman | <input type="checkbox"/> Woolen Manufacturing |
| <input type="checkbox"/> Welding, Electric and Gas | <input type="checkbox"/> Aviation Engines | <input type="checkbox"/> Air Brakes <input type="checkbox"/> R. R. Signalmen | <input type="checkbox"/> Agriculture |
| <input type="checkbox"/> Reading Shop Blueprints | <input type="checkbox"/> Auto Technician | <input type="checkbox"/> Highway Engineering | <input type="checkbox"/> Fruit Growing |
| <input type="checkbox"/> Heat Treatment of Metals | <input type="checkbox"/> Auto Electrical Technician | <input type="checkbox"/> Civil Engineering | <input type="checkbox"/> Poultry Farming |

BUSINESS TRAINING COURSES

- | | | | |
|--|---|--|--|
| <input type="checkbox"/> Business Management | <input type="checkbox"/> Bookkeeping | <input type="checkbox"/> Service Station Salesmanship | <input type="checkbox"/> Grade School Subjects |
| <input type="checkbox"/> Industrial Management | <input type="checkbox"/> Secretarial Work | <input type="checkbox"/> First Year College Subjects | <input type="checkbox"/> High School Subjects |
| <input type="checkbox"/> Traffic Management | <input type="checkbox"/> Spanish | <input type="checkbox"/> Business Correspondence | <input type="checkbox"/> College Preparatory |
| <input type="checkbox"/> Accountancy | <input type="checkbox"/> French | <input type="checkbox"/> Stenography and Typing | <input type="checkbox"/> Illustrating |
| <input type="checkbox"/> Cost Accountant | <input type="checkbox"/> Salesmanship | <input type="checkbox"/> Civil Service <input type="checkbox"/> Mail Carrier | <input type="checkbox"/> Cartooning |
| <input type="checkbox"/> C. P. Accountant | <input type="checkbox"/> Advertising | <input type="checkbox"/> Railway Mail Clerk | <input type="checkbox"/> Lettering Show Cards <input type="checkbox"/> Signs |

DOMESTIC SCIENCE COURSES

- | | | |
|---|---|--|
| <input type="checkbox"/> Home Dressmaking | <input type="checkbox"/> Advanced Dressmaking | <input type="checkbox"/> Foods and Cookery |
| <input type="checkbox"/> Professional Dressmaking and Designing | | <input type="checkbox"/> Tea Room and Cafeteria Management, Catering |

Name.....Age.....Address.....

City.....State.....Present Position.....

If you reside in Canada, send this coupon to the International Correspondence Schools Canadian, Limited, Montreal, Canada
If you reside in England, send coupon to I. C. S., 71 Kingsway, London, W. C. 2, England

You HELPED BUILD HER
Man...That's a Real Thrill



That's Only One Reward of An AIRCRAFT INDUSTRY CAREER

There's a real thrill in viewing a great plane which you have helped create. But there's a far greater thrill in playing a part in an industry so alive, and growing so swiftly, that progress depends only on you. This is a source of real satisfaction to the man who has trained for and embarked upon an aircraft industry career.

EXECUTIVE BOARD

JOHN K. NORTROP
 Formerly Pres., The Northrop Corp., and Vice-Pres. Douglas Aircraft Company, Inc.

C. A. VAN DUSEN
 Vice-Pres., Consolidated Aircraft Corporation

ROBERT E. GROSS
 President, Lockheed Aircraft Corporation



IT'S ANOTHER REAL THRILL TO START YOUR CAREER AT AERO I. T. I.

... the only aircraft training institution under the direct supervision of leading airplane builders. Devoted solely to preparing men for aircraft industry careers, Aero I. T. I. offers these courses: **Aeronautical Engineering, Design, and Drafting; Master Aircraft Mechanics; and the Combination Aircraft Mechanics Theory at Home and Shop Course.** No matter where you live you can start your training at once. For complete information on the Aero I. T. I. way to an aircraft career... send the coupon.

Aero Industries Technical Institute
 5253 W. San Fernando Rd., Los Angeles, Calif.

Please send details on Aero I. T. I. training. I am 18 years of age or over and can furnish character references.

Name _____ Age _____

Street _____

City _____ State _____ a-10-p

EASIEST to Master

This New P-A

● Such beautiful tone, and so easy to play! Just touch a key and blow normally; you can't miss. Nothing to compare with these new P-A Saxes, Clarinets, Trumpets, and other P-A instruments. Fully guaranteed; your success assured. See your music dealer or write direct for beautiful, free book. No obligation. Easy terms. 1286

PAN-AMERICAN
 1203 P-A Building Elkhart, Indiana



Regain Perfect Speech, If You STAMMER

Send today for beautifully illustrated book entitled "DON'T STAMMER," which describes the Bogue Unit Method for the scientific correction of stammering and stuttering. Method successfully used at Bogue Institute for 37 years—since 1901. Endorsed by physicians. Full information concerning correction of stammering sent free. No obligation. Benjamin N. Bogue, Dept. 197 Circle Tower, Indianapolis, Indiana.

Learn to Draw

for pleasure and profit. At home—by mail. No experience necessary. You study from photos of artist's models just as they pose in the life class.

FIRST LESSON FREE

Send name and address and only 10c to cover mailing cost to—

TOWERTOWN STUDIOS, Dept. 1236
 520 N. Michigan Ave. Chicago, Ill.



TRI-STATE COLLEGE

B. S. Degree in 2 years. World famous for technical 2-year courses in Civil, Electrical, Mechanical, Chemical, Radio, Aeronautical Engineering; Business Administration and Accounting. Those who lack high school may make up work. Low tuition. Low living costs. Located in picturesque hill and lake region. Students from every state and many foreign countries. 55th year. Enter January, March, June, September. Write for catalog. 4128 College Ave. ANGOLA, IND.



Your VOICE!

100% Improvement Guaranteed or Tuition Refunded!

You to be sole judge! Strengthen and master your voice—not with singing lessons—but by scientific silent exercises, successfully taught for over a century. *Marvelous success with DEFECTIVE Voices.* Write for Free Voice Book. Learn WHY and HOW you can now have the voice you want. If under 17, we require parent's signature. With 100% improvement guaranteed—will you faithfully follow instructions? If so, WRITE: Perfect Voice Institute, Studio 1359, 64 E. Lake St., Chicago



MAKE MONEY AT HOME

RUBBER MOLDS *Low as 6¢ EA.*

Amazing rubber mold-making outfit makes perfect flexible molds of plaques, ash trays, book-ends, etc. Molds cost from 6c to 25c each. Each mold makes hundreds of novelties and gifts to sell up to \$1.00 apiece! No experience necessary. Quick and easy. Start profitable business in your home... sell to stores, gift shops, friends, resorts, road stands, by mail. Full or spare time. "Molders Handy Book" and list of buyers FREE. Write

SO-LO WORKS
 Dept. M-827 Cincinnati, Ohio



You Ask Me What I Am Doing?



I Am Getting Ready to Earn More Money ... Preparing for a Bigger Job

I am a student of the American School, Chicago. A little more than half way through my course—already my increased knowledge has brought me promotion as a result of the hour or so a day I have been spending getting acquainted with the principles of the work I enjoy. I use only part of my spare time, so it doesn't interfere with my home and social life, and certainly helps me on the job.

I have been surprised at the practical manner in which even advanced work is explained. It is a lot easier than I had expected. I only wish I had started this plan of getting ahead a few years earlier. But when I was 18 to 20 I felt pretty sure of myself. I didn't take enough stock in what more experienced people told me about the importance of being thoroughly trained for the job I wanted.

You Can't Win If You Don't Try
American School, Dept. G945, Drexel Ave. at 58th St., Chicago

CUT ALONG THIS LINE

Try a Lesson Yourself—No Obligation

American School, Dept. G945, Drexel Ave. at 58th St., Chicago

I have checked the line of work in which I would like a good job. Please send me without expense or obligation on my part a copy of your Bulletin and an early lesson in the field I have selected.

- | | | |
|--|---|---|
| <input type="checkbox"/> Air Conditioning | <input type="checkbox"/> Electrical Engineering | <input type="checkbox"/> Law |
| <input type="checkbox"/> Architecture | <input type="checkbox"/> Diesel Engineering | <input type="checkbox"/> Liberal Arts (College) |
| <input type="checkbox"/> Automotive Engineering | <input type="checkbox"/> Drafting and Designing | <input type="checkbox"/> Mechanical Engineering |
| <input type="checkbox"/> Automobile Repairing | <input type="checkbox"/> Electric Refrigeration | <input type="checkbox"/> Merchandising |
| <input type="checkbox"/> Bookkeeping and Cost Accounting | <input type="checkbox"/> Heating, Ventilating, Plumbing | <input type="checkbox"/> Private Secretary |
| <input type="checkbox"/> Business Management | <input type="checkbox"/> Professional Accounting | <input type="checkbox"/> Radio and Television |
| <input type="checkbox"/> Civil Engineering | <input type="checkbox"/> Incl. C. P. A. Coaching | <input type="checkbox"/> Salesmanship |
| <input type="checkbox"/> Aviation | <input type="checkbox"/> High School | <input type="checkbox"/> Shop Practice |
| <input type="checkbox"/> Contracting, Building | <input type="checkbox"/> Highway Engineering | <input type="checkbox"/> Steam Engineering |

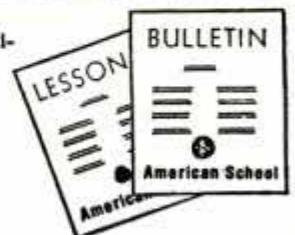

Name _____ Age _____ Occupation _____
Street _____ City _____ State _____

Engine **HEAT**, *not winter's cold,*

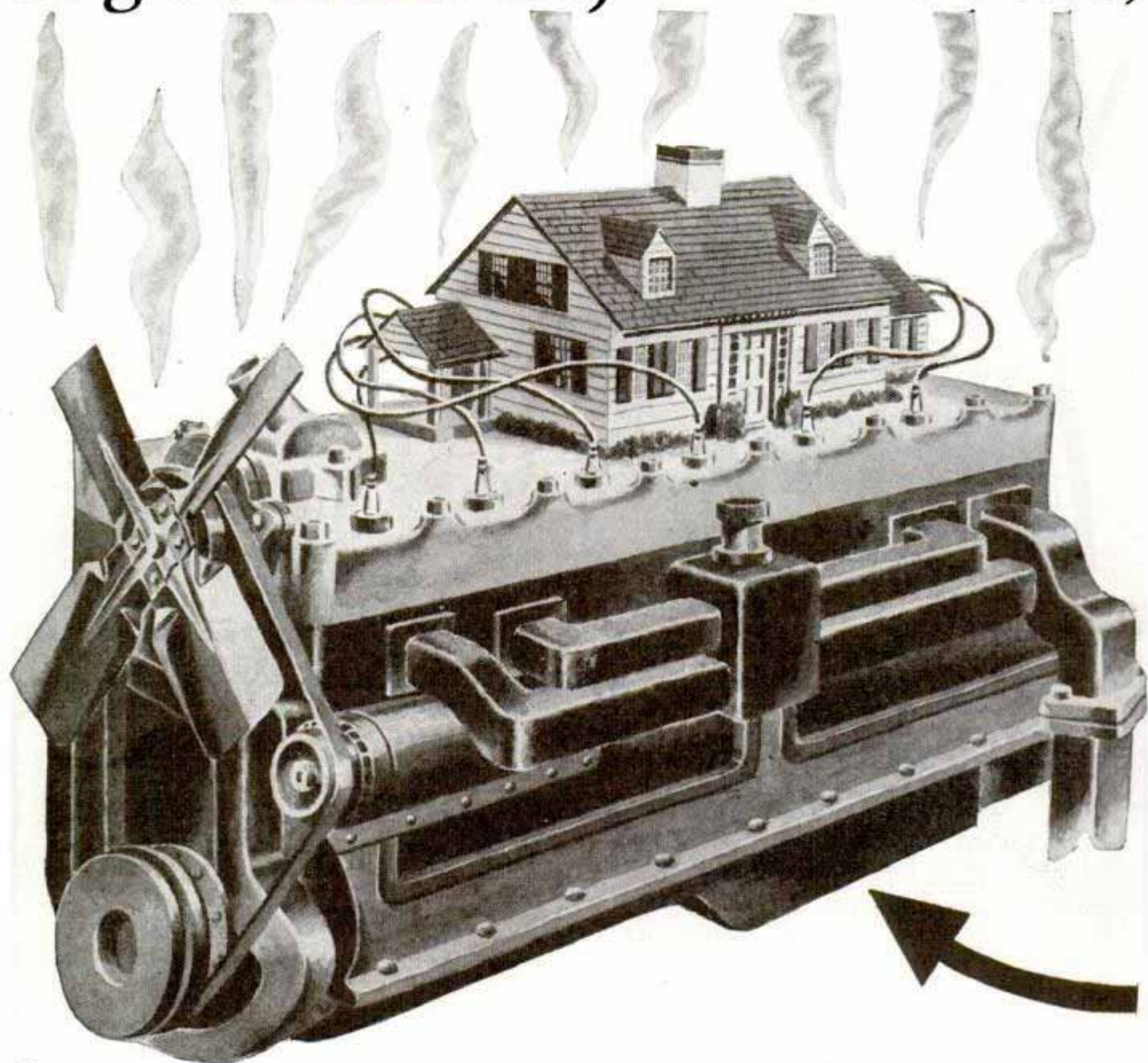

LABORATORY RESEARCH and experiments show that an automobile engine under full load and at high speed may generate sufficient heat to warm a six room house to 70 degrees on a zero day! That shows you what a big job the cooling system has to do...and why anti-freezes that can't stand heat must be replaced from time to time throughout the winter.

The boiling point of a 50 per cent solution of alcohol and water is only about 180 degrees. This is important

when you consider that modern high-compression motors operate at temperatures up to the 180 mark, *and*

is the real test of an **ANTI-FREEZE**

**THE HEAT FROM
YOUR MOTOR
WOULD WARM
A SIX ROOM HOUSE!**

even above! Further, when you shut off the engine, the heat left in the motor jumps the solution temperature as much as 20 degrees. When an alcohol solution gets hot enough to boil, steam is formed inside the engine and the pressure of this steam forces anti-freeze solution out the radiator overflow pipe onto the ground.

Even if these solution losses are small, they soon add up to a serious total loss of anti-freeze protection with the many stops a car makes in normal driving. Since the driver is rarely conscious of this *hidden boiling* that steals his anti-freeze, a freeze-up in the next cold snap is usually his first warning.

But why consider trouble that *doesn't need to happen?* Put in "Eveready" "Prestone" Anti-freeze today and be done with cooling worries for the whole winter. "Prestone" Anti-freeze contains no alcohol...will not boil off under any winter weather conditions.

The words "Prestone" and "Eveready" are trade-marks of National Carbon Company, Inc.



"EVEREADY" "PRESTONE"

TRADE-MARKS

Anti-freeze is Guaranteed in

Writing

COSTS MORE BY THE GALLON, LESS BY THE WINTER



High School Course at Home

Many Finish in 2 Years

You can complete this simplified High School Course as rapidly as your time and abilities permit. Equivalent to resident school work—prepares you for entrance to college. Standard H. S. texts supplied—Diploma. Credit for H. S. subjects already completed. Single subjects if desired. High School education is very important for advancement in business and industry and socially.

College Entrance

During the past 14 years, our High School graduates have been admitted to 531 different Universities, Colleges, Junior Colleges and Normal Schools—80% of them without entrance examination. Course also prepares for teachers' certificate and pre-professional examinations.

Business—Industry

To get and hold a good position in Business today you must be able to write clear, accurate letters and reports—do figuring involving Algebra and Geometry—talk intelligently on matters requiring a knowledge of Geography, History, and Economics.

In Industry—Mechanical and Engineering lines—you must have at least an elementary knowledge of Physics and Chemistry—be able to figure quickly and accurately—know something of Mechanical Drawing and blueprints—and be able to talk and write accurately and clearly on both your work and ordinary topics of conversation.

Our High School course meets the preparatory educational requirements for Business and Industry.

An Educational Institution

The American School was chartered in 1897 as an educational institution, not for profit—and is exempt from paying Federal income tax, like the best resident colleges and universities.

Don't Be Handicapped—Complete Your Training Now

Be a High School Graduate! Prepare yourself for promotion in Business and Industry—for the Professions, College Entrance and social success. No matter what line you may select, High School training will prove invaluable to you! Our moderate fees cover all instruction, standard textbooks and Diploma. Easy monthly terms. Get ahead in life. Start your training NOW!

20 Other Courses

Over 150 noted Educators, Engineers, and Business Men helped prepare our special instruction material, which is used by many resident schools and colleges, U. S. Navy, and Province of Manitoba, Canada. We offer you quality training at home for the best-paying lines of Industry and Business, as listed in the coupon.

tion in Business and Industry—for the Professions, College Entrance and social success. No matter what line you may select, High School training will prove invaluable to you! Our moderate fees cover all instruction, standard textbooks and Diploma. Easy monthly terms. Get ahead in life. Start your training NOW!

Mail coupon for information about line that interests you
American School, Drexel at 58th, Chicago

American School, Dept. H-445, Drexel at 58th, Chicago

Tell me how to train for success in line checked. No obligation.

- | | |
|--|--|
| <input type="checkbox"/> Accounting & Auditing | <input type="checkbox"/> Diesel Engineering |
| <input type="checkbox"/> Architecture & B'lding | <input type="checkbox"/> Drafting & Design |
| <input type="checkbox"/> Automotive Engin'ring | <input type="checkbox"/> Liberal Arts |
| <input type="checkbox"/> Business Management | <input type="checkbox"/> Private Secretary |
| <input type="checkbox"/> Commercial Aeronautics | <input type="checkbox"/> Hi'er Ac't'g (C.P.A.) |
| <input type="checkbox"/> Electrical Engineering | <input type="checkbox"/> Highway Engin'ring |
| <input type="checkbox"/> Electrical Refrigerat'n | <input type="checkbox"/> Mechanical Eng'ring |
| <input type="checkbox"/> Air Conditioning | <input type="checkbox"/> Radio & Television |
| <input type="checkbox"/> Civil Engineering | <input type="checkbox"/> Salesmanship |
| <input type="checkbox"/> Complete Law | <input type="checkbox"/> Steam Engineering |

Name.....
 Address.....

AN AVIATION CAREER



OFFERS YOU A GREAT FUTURE

MORE CURTISS-WRIGHT TECH GRADUATES ARE EMPLOYED IN THE AIRCRAFT INDUSTRY THAN THOSE OF ANY OTHER SCHOOL. Train for your future in the heart of the Aircraft Industry at Aviation's foremost and oldest school, specializing in 1 Aircraft Sheet Metal, 2 Master Mechanics and 3 Aeronautical Engineering. No flying involved. Graduates are obtaining immediate employment. Return this ad with your name, age, address and the course in which you desire full information.

Dept. PM-12

CURTISS-WRIGHT TECHNICAL INSTITUTE
 GRAND CENTRAL AIR TERMINAL
 GLENDALE (LOS ANGELES) CALIF.



CARTOONING

To those earnest students of this fascinating profession who realize the advantage of PERSONAL INSTRUCTION by a nationally known cartoonist, I offer a system of study recommended by America's foremost cartoonists. It's as near like private tutoring as is possible in a home study course. Write at once for free details.

DORMAN H. SMITH, Box C597, San Rafael, California

MAKE REAL MONEY

Get Into

ADVERTISING

LEARN AT HOME

Send for FREE Book

Field is uncrowded. Big opportunities await both men and women. Our modern home-study course trains you quickly. No special educational requirements. You learn by doing actual work, under leading Ad men. No textbooks. Low tuition fee, easy terms. Money back if not satisfied. Your 1 cent postcard brings FREE ILLUSTRATED BOOK. Send today. No obligation. Start learning at once!

ADVERTISING INSTITUTE OF AMERICA
 100-5th Av. Dept. R-2, New York City

ELECTRICAL ENGINEERING

ONE YEAR condensed course prepares for technical work in the electrical field. Thorough training in principles, with practical applications in laboratory and shop. High placement record. Modern buildings, dormitory, dining hall. Campus. 46th year. Catalog on request.



BLISS ELECTRICAL SCHOOL
 122 Takoma Ave. Wash., D.C.



Operator No. 38

FOLLOW THIS MAN

Secret Service Operator No. 38 is on the job! Running down dangerous Counterfeit Gang. Tell-tale finger prints in murdered girl's room.

Free The Confidential Report Operator No. 38 made to his chief. Write for it.

Earn a Regular Monthly Salary
 YOU can become a Finger Print Expert at home, in your spare time, at small cost. Write for confidential full report and details. Literature will be sent only to persons stating their age.

INSTITUTE OF APPLIED SCIENCE
 Dept. 1359 1920 Sunnyside Ave. Chicago, Ill.

MAIL FOR FREE INFORMATION

BROOKLYN YMCA TRADE SCHOOL

1117 Bedford Ave., Dept. PM-67
 Brooklyn, New York City, N. Y.

- | | |
|--|---|
| <input type="checkbox"/> Diesel Engines | <input type="checkbox"/> Oil Burner |
| <input type="checkbox"/> Diesel Pre Engineering | <input type="checkbox"/> Welding |
| <input type="checkbox"/> Aviation Mechanic | <input type="checkbox"/> Talking Pictures |
| <input type="checkbox"/> Aeronautical Pre Engineering | <input type="checkbox"/> Refrigeration |
| <input type="checkbox"/> Auto Mechanic | <input type="checkbox"/> Machine Shop |
| <input type="checkbox"/> Radio and Television Mechanic | <input type="checkbox"/> Air Conditioning |
| <input type="checkbox"/> Architectural-Mechanical Drafting | <input type="checkbox"/> Electrical |
| <input type="checkbox"/> Window Display | <input type="checkbox"/> Armature Winding |

Name.....

Address.....



YES- I'M CONVINCED THAT I CAN MAKE GOOD MONEY IN RADIO. I'M GOING TO START TRAINING FOR RADIO RIGHT NOW.

NO- NOT ME. I'M NOT GOING TO WASTE MY TIME. SUCCESS IS JUST A MATTER OF LUCK AND I WASN'T BORN LUCKY.

BILL SAID "YES" HE'S MAKING GOOD MONEY IN RADIO NOW

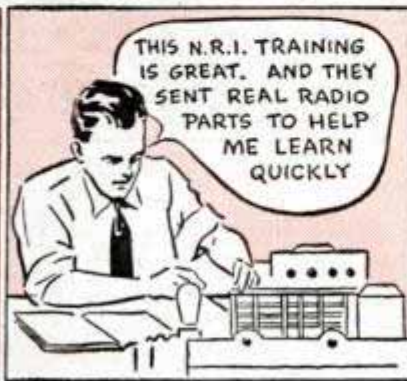

THIS N.R.I. TRAINING IS GREAT. AND THEY SENT REAL RADIO PARTS TO HELP ME LEARN QUICKLY



YOU CERTAINLY KNOW RADIO. MINE NEVER SOUNDED BETTER.

I'VE BEEN STUDYING RADIO ONLY A FEW MONTHS AND I'M ALREADY MAKING GOOD MONEY IN MY SPARE TIME

THANKS



OH BILL! I'M SO PROUD OF YOU. YOU'VE GONE AHEAD SO FAST IN RADIO

YES! I'VE GOT A GOOD JOB NOW AND A REAL FUTURE. THANKS TO N.R.I. TRAINING

TOM SAID "NO" HE'S STILL WAITING FOR LUCK



BILL'S A SAP TO WASTE HIS TIME STUDYING RADIO AT HOME



SAME OLD GRIND -- SAME SKINNY PAY ENVELOPE -- I'M JUST WHERE I WAS FIVE YEARS AGO



GUESS I'M A FAILURE. LOOKS LIKE I'LL NEVER GET ANYWHERE

YOU'LL ALWAYS BE A FAILURE, TOM, UNLESS YOU DO SOMETHING ABOUT IT. WISHING AND WAITING WON'T GET YOU ANYWHERE

I WILL TRAIN YOU AT HOME *in Spare Time* FOR A GOOD RADIO JOB



J. E. SMITH, President National Radio Institute Established 1914

Many Radio Experts Make \$30, \$50, \$75 a Week

Radio broadcasting stations employ engineers, operators, station managers and pay up to \$5,000 a year. Fixing radio sets in spare time pays many \$200 to \$500 a year—full time jobs with Radio jobbers, manufacturers and dealers as much

Many Make \$5, \$10, \$15 a Week Extra in Spare Time While Learning

The day you enroll I start sending Extra Money Job Sheets; show you how to do Radio repair jobs. Throughout your training I send plans and directions that made good spare time money—\$200 to \$500—for hundreds, while learning. I send you special Radio equipment to conduct experiments and build circuits. This 50-50 method of training makes learning at home interesting, fascinating, practical. I ALSO GIVE YOU A MODERN, PROFESSIONAL ALL-WAVE, ALL-PURPOSE RADIO SET SERVICING INSTRUMENT to help you make good money fixing Radios while learning and equip you for full time jobs after graduation.

Find Out What Radio Offers You

Act Today. Mail the coupon now for "Rich Rewards in

Radio." It's free to any fellow over 16 years old. It points out Radio's spare time and full time opportunities and those coming in Television; tells about my training in Radio and Television; shows you letters from men I trained, telling what they are doing and earning. Find out what Radio offers YOU! MAIL COUPON in an envelope, or paste on a postcard—NOW!

J. E. SMITH, PRESIDENT, DEPT. 8NP, NATIONAL RADIO INSTITUTE, WASHINGTON, D. C.

J. E. SMITH, President, Dept. 8NP, National Radio Institute, Washington, D. C. Without obligating me send "Rich Rewards in Radio," which points out spare time and full time opportunities in Radio and explains your method of training men at home to be Radio Experts. (Please Write Plainly.)



IT'S NOT TOO LATE. TAKE MY TIP AND MAIL THAT COUPON TO N.R.I. TONIGHT

NAME.....AGE.....
 ADDRESS.....
 CITY.....STATE.....



as \$30, \$50, \$75 a week. Many Radio Experts open full or part time Radio sales and repair businesses. Radio manufacturers and jobbers employ testers, inspectors, foremen, engineers, servicemen, and pay up to \$6,000 a year. Automobile, police, aviation, commercial Radio, loud-speaker systems are newer fields offering good opportunities now and for the future. Television promises to open many good jobs soon. Men I trained have good jobs in these branches of Radio. Read how they got their jobs. Mail coupon.

*What will you
be doing - ONE
YEAR FROM TODAY*



● Three hundred and sixty-five days from now — where will you be?

Still struggling along in the same old job at the same old salary—worried about the future—never able to make both ends meet? Still putting off your start to success—fiddling away precious hours that will never come again?

Don't do it, man — don't do it! There's no greater tragedy than that of the man who stays sunk in a rut all his life, when with just a little effort he could advance.

Think of the thousands of successful, prosperous men in every industry and business who owe much of their success to International Correspondence Schools training (you'd recognize hundreds of their names). They refused to be licked by lack of training! They found that the I. C. S. offered them comprehensive yet simplified texts prepared by outstanding authorities, plus personal guidance and expert, understanding instruction.

The coupon will bring you the full story of the I. C. S., and what it can mean to you.

INTERNATIONAL CORRESPONDENCE SCHOOLS

Box 5538 J, Scranton, Penna.

Without obligation, please send full particulars about the subject before which I have marked X:

TECHNICAL AND INDUSTRIAL COURSES

- | | |
|--|---|
| <input type="checkbox"/> Architect | <input type="checkbox"/> Auto Technician |
| <input type="checkbox"/> Architectural Draftsman | <input type="checkbox"/> Auto Electric Technician |
| <input type="checkbox"/> Building Estimating | <input type="checkbox"/> Plumbing <input type="checkbox"/> Heating |
| <input type="checkbox"/> Contractor and Builder | <input type="checkbox"/> Air Conditioning and Cooling |
| <input type="checkbox"/> Structural Draftsman | <input type="checkbox"/> Commercial Refrigeration |
| <input type="checkbox"/> Structural Engineer | <input type="checkbox"/> Steam Engineer |
| <input type="checkbox"/> Electrical Engineer | <input type="checkbox"/> Steam Electric Engineer |
| <input type="checkbox"/> Electric Lighting | <input type="checkbox"/> Marine Engineer |
| <input type="checkbox"/> Welding, Electric and Gas | <input type="checkbox"/> Civil Engineer <input type="checkbox"/> Highway Engineer |
| <input type="checkbox"/> Reading Shop Blueprints | <input type="checkbox"/> Bridge Engineer |
| <input type="checkbox"/> Telegraph Engineer | <input type="checkbox"/> Bridge and Building Foreman |
| <input type="checkbox"/> Telephone Work <input type="checkbox"/> Radio | <input type="checkbox"/> Surveying and Mapping |
| <input type="checkbox"/> Mechanical Engineer | <input type="checkbox"/> R. R. Locomotives <input type="checkbox"/> Air Brakes |
| <input type="checkbox"/> Mechanical Draftsman | <input type="checkbox"/> R. R. Section Foreman |
| <input type="checkbox"/> Machinist <input type="checkbox"/> Toolmaker | <input type="checkbox"/> R. R. Signalmen |
| <input type="checkbox"/> Patternmaker <input type="checkbox"/> Boilermaker | <input type="checkbox"/> Chemistry <input type="checkbox"/> Pharmacy |
| <input type="checkbox"/> Foundry Practice | <input type="checkbox"/> Coal Mining <input type="checkbox"/> Navigation |
| <input type="checkbox"/> Sheet Metal Worker | <input type="checkbox"/> Cotton Manufacturing |
| <input type="checkbox"/> Heat Treatment of Metals | <input type="checkbox"/> Woolen Manufacturing |
| <input type="checkbox"/> Management of Inventions | <input type="checkbox"/> Agriculture <input type="checkbox"/> Fruit Growing |
| <input type="checkbox"/> Diesel Engines <input type="checkbox"/> Aviation Eng. | <input type="checkbox"/> Poultry Farming |

BUSINESS TRAINING COURSES

- | | |
|--|--|
| <input type="checkbox"/> Business Management | <input type="checkbox"/> Lettering Show Cards <input type="checkbox"/> Signs |
| <input type="checkbox"/> Industrial Management | <input type="checkbox"/> Stenography and Typing |
| <input type="checkbox"/> Traffic Management | <input type="checkbox"/> Civil Service <input type="checkbox"/> Mail Carrier |
| <input type="checkbox"/> C. P. Accountancy | <input type="checkbox"/> Railway Mail Clerk |
| <input type="checkbox"/> Bookkeeping | <input type="checkbox"/> Grade School Subjects |
| <input type="checkbox"/> Secretarial Work | <input type="checkbox"/> High School Subjects |
| <input type="checkbox"/> Cost Accountant | <input type="checkbox"/> College Preparatory |
| <input type="checkbox"/> Salesmanship <input type="checkbox"/> Advertising | <input type="checkbox"/> First Year College Subjects |
| <input type="checkbox"/> Service Station Salesmanship | <input type="checkbox"/> Illustrating <input type="checkbox"/> Spanish |
| <input type="checkbox"/> Business Correspondence | <input type="checkbox"/> Cartooning <input type="checkbox"/> French |

DOMESTIC SCIENCE COURSES

- | | |
|---|--|
| <input type="checkbox"/> Professional Dressmaking and Designing | <input type="checkbox"/> Foods and Cookery |
| <input type="checkbox"/> Home Dressmaking | <input type="checkbox"/> Tea Room and Cafeteria Management, Catering |
| <input type="checkbox"/> Advanced Dressmaking | |

Name.....Age.....

Address.....

City.....State.....

Present Position.....

If you reside in Canada, send this coupon to the International Correspondence Schools Canadian, Limited, Montreal, Canada

When writing please mention Popular Mechanics

HOTEL TRAINING

—For Better Positions . . . Substantial Salaries — Classes Now Forming

Increasing opportunities for trained men and women in fascinating, nationwide hotel field. Qualify thru short, specialized, intensive courses in America's only exclusive hotel training institute. Come to Washington. Learn in four months on real hotel equipment. Study under expert instructors in \$200,000 specially designed institute. Enjoy the attractions of Washington while training. Day classes start Jan., Feb., Sept., Oct. National Placement Service FREE of extra charge.



Hundreds of graduates "making good" in Hotels, Resorts, Clubs, Apartment Hotels, Schools, Restaurants, Hospitals everywhere. Free Catalog gives full details—write for it now.
LEWIS HOTEL TRAINING SCHOOLS
Division RSZ-340 Washington, D. C.

LAW STUDY AT HOME

Legally trained men win higher positions and bigger success in business and public life. Greater opportunities now than ever before. Big corporations are headed by men with legal training.
More Ability: More Prestige: More Money
We guide you step by step. You can train at home during spare time. Degree of LL. B. Successful graduates in every section of the U. S. We furnish all text material, including 14-volume Law Library. Low cost, easy terms. Get our valuable 48-page "Law Training for Leadership" and "Evidence" books FREE. Send for them NOW.
LaSalle Extension University, Dept. 1264-L. Chicago
A Correspondence Institution



BE A RAILWAY WRITE TRAFFIC INSPECTOR TODAY

A JOB and GOOD PAY with OUR TRAINING

Ambitious Men—19 to 50—can qualify as Railway and Bus Passenger Traffic Inspectors by our simple, home-study course. We help place our graduates at up to \$135 per month, plus expenses to start, or refund tuition. Advance rapidly with experience. Get facts in Free Booklet.

STANDARD BUSINESS TRAINING INSTITUTE
Div. 212 Buffalo, N. Y.

WIN YOUR DAWN WITH THE PATROL

Unequaled advantages in location for all year flying, finest equipment, highest Government approval for obtaining license in Transport, Limited Commercial, Private Flying, Radio, Sheet Metal, Mechanical Courses. For complete illustrated catalog, write—



J. D. GREEN, Director, Dept. PM 14, TULSA, OKLAHOMA
SCHOOL OF AVIATION

MECHANICAL DENTISTRY AT HOME!

To make Crowns, Plates, Bridgework, etc., for Dentists. Easy practical way to learn mechanical dentistry at home in spare time. FULL EQUIPMENT OF TOOLS AND MATERIALS INCLUDED WITH COURSE. Low tuition. Easy terms. Write for FREE BOOK about this money making profession that is not affected by machine rage.
McCARRIE SCHOOL OF MECHANICAL DENTISTRY
207 N. Broad St., Dept. 740, Philadelphia, Pa.

**Stop Slamming Doors
AMAZING MONEY MAKER!**



Kant-Slam Door Check is an amazing invention that closes all doors silently and automatically. Closing speed easily adjusted by turning screw at top of check. Holds doors open when wanted open. Operates on hydraulic principle. Low priced. Permanent. Easily installed in ten minutes. Never needs attention.

A Real Demonstrator Furnished Every Agent
You get orders quickly demonstrating actual sample on easy to carry miniature door. Every office, factory, store, institution, and public building needs a Kant-Slam for every door. Rush name and address for details of amazing money-making opportunity.
KANT-SLAM DOOR CHECK CO.
FREE Demonstrator to Workers Dept. F-53, Bloomfield, Ind.

**MASS PRODUCTION
DIESEL
ENGINES**

Sweeps **THE COUNTRY**

★ HEMPHILL DIESEL
RESIDENT SCHOOLS

**GREATER OPPORTUNITIES THAN EVER BEFORE
NOW OPENING TO HEMPHILL DIESEL TRAINED MEN**

Millions have been poured into modern mass production plants. New type Diesels are now on the market for automotive and many uses never before considered practical. NATION-WIDE DIESELIZATION IS HERE.

Five years ago Hemphill Schools predicted leading automotive builders would enter the Diesel field. Hemphill training anticipated these history making advances. Shops, laboratories and theory offered in the Day, Night, and Combination Home Study with later Shop Training Courses, have been kept up to the minute

Never before have Hemphill Diesel Schools' students had greater opportunities before them. Eight completely equipped practical training schools are located in important marine, automotive and industrial centers—in U.S. and Canada—ready and thoroughly able to train men for this specialized field.

No matter where you live, if you are interested in training that will qualify you for this growing, fascinating industry, send for details on WHAT MASS PRODUCTION OF DIESEL ENGINES MAY MEAN TO YOU. Use coupon, no obligation.

HEMPHILL DIESEL SCHOOLS

Send Coupon Today
TO NEAREST ADDRESS

BOSTON, 114 Brookline Ave.
NEW YORK, 31-26 Queens Blvd., L.I. City
DETROIT, 2341 W. Lafayette Blvd.
CHICAGO, 2014 Larrabee St.
MEMPHIS, 417 Monroe Ave.
LOS ANGELES, 2120 San Fernando Road
SEATTLE, 501 Westlake North
VANCOUVER, B.C., 1363 Granville St.

HEMPHILL DIESEL SCHOOLS (addresses at left)

Please rush information on how I may qualify for the Diesel field, and details on your Courses. I am over 18.

NAME _____ AGE _____

STREET _____

CITY _____ STATE _____

Notwithstanding representation to the contrary, the Hemphill Diesel Schools are in no way associated with any other school of even similar name.

When writing to advertisers please mention Popular Mechanics



QUICK and easy release of ice cubes is possible if the refrigerator tray is

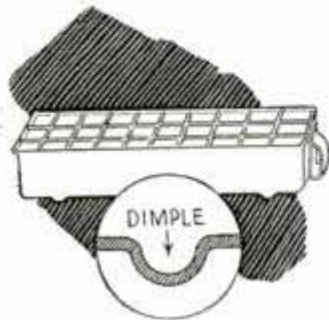

provided with "dimples" which prevent the tray from freezing to shelves of the freezing unit. The dimple is a shallow depression which can be made in any type of tray, raising

the bottom off the freezing shelf. The inventor offers to incorporate this handy feature into old ice trays at small cost. The ice tray dimple was patented recently.

FOR giving colored light-ray treatments, a curved-top reflector lamp has been patented. It is shaped to direct the rays downward and inward on the head. The reflector's lower end is large enough to receive the entire upper part of the head. Lamps and color screen produce the colored light rays desired.



CONVENIENT, fast and large enough for supplementary and emergency



trucking purposes, a new vehicle has been patented. It is a semi-trailer, designed for attachment to a motorcycle by suitable coupling. Under usual conditions, the two

wheels at the rear alone would be used, but heavy loads and disconnection from the motorcycle are problems solved by a small wheel at the front. This wheel can be retracted when not needed.

STREAMLINING of the automobile is carried to a new high point under patent issued recently to a French designer. The body is shaped somewhat

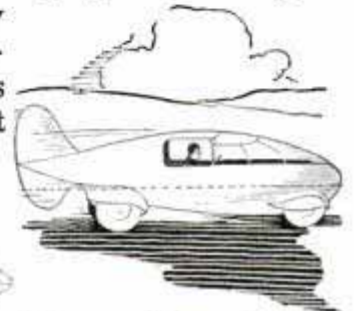
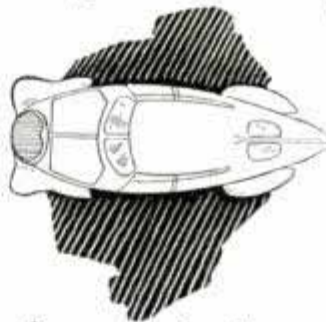

like a fish, viewed from the side, and is provided with a fin at the rear. Fairing

for each wheel permits smooth flow of air, decreasing resistance. The driver would be seated well forward, indicating that the design is intended for a rear-engine vehicle. A curved windshield permits unusually wide vision.

GREATER safety for the bicycle rider is the purpose of a stop-light switch

patented recently. The switch is actuated through the brake mechanism to turn on a warning light at the rear of the bike when the brakes are applied. Connections run from the brake mechanism to the battery case mounted beneath the seat. Any standard warning lamp may be used.



(Continued to page 33A)

KNOW ALL THE ANSWERS ON 40,000 SUBJECTS!

INCLUDING • INDUSTRY • AERONAUTICS • TELEVISION • METALLURGY • PHYSICS
 • ENGINEERING • INVENTIONS • BIOGRAPHY • MATHEMATICS • TRANSPORTATION • ASTRONOMY
 • NAVIGATION • SPORTS • MODERN HISTORY • ADVERTISING • HORTICULTURE • CHEMISTRY
 • NATURE STUDY • MYTHOLOGY • SOCIOLOGY • GEOGRAPHY • WARFARE

WORLD'S POPULAR ENCYCLOPEDIA
 With One Year's **FREE**
SUPPLEMENT
SERVICE



**NEVER BEFORE
 SUCH AN OFFER!
 All 12 Volumes Only**

\$4.89

COMPLETE!

Not \$4.89 per volume!
 BUT \$4.89 for the entire
 set, including one year's
 Free Supplement Service!

Never before—in the history of publishing—has so amazing an offer been made! Here is the entire body of the world's knowledge—yours for the taking! Here are 12 magnificent big library-size volumes that you can secure for your very own at the unbelievable price of \$4.89—not for one volume but for all twelve!

Think of it! A complete, thoroughly authentic World's Popular Encyclopedia containing concise, authoritative information on more than 40,000 essential subjects, embracing every known vital fact from the beginning of man right up to today—for less than 41c a volume!

TREASURE HOUSE OF KNOWLEDGE

Now it can be yours!—this veritable treasure house of knowledge hitherto found only in the homes of the very wealthy. Now you can know and understand thousands of facts unknown even to those with a university education... vital facts embracing every field of human endeavor... every history-making event in the news of the day!

12 MAGNIFICENT VOLUMES
 MORE THAN 40,000 SUBJECTS
 OVER 3,000,000 WORDS
 MORE THAN 3800 PAGES
 PROFUSELY ILLUSTRATED
 FREE SUPPLEMENT SERVICE
 FULL LIBRARY SIZE

Bound in Rich, Sturdy
 Midnight Blue Fabrikoid
 Handsomely Decorated Panels
 in Red and Gold
 Covers Debossed in Striking
 Modern Design
 Large Clear Type on White
 English Finish Paper
 Each Volume
 8 1/4 x 5 1/2 x 1 1/8 Inches

FREE GIFT IF YOU ACT NOW

The great World's Popular Encyclopedia is authentic, modern, up-to-the-minute! It tells you what you want to know about ROOSEVELT, MUSSOLINI, TELEVISION, DIESEL ENGINES and every other timely topic and personality. Nor will it ever grow out of date! Twice each year loose-leaf supplements prepared by trained encyclopedists keep it ever abreast with inevitable changes. If you accept this offer NOW, this vital supplement service will be yours—absolutely FREE—for an entire year!

ONCE IN A LIFETIME OPPORTUNITY

Think what this Encyclopedia can mean to you. With its help you can increase your earning power; you can win new admiration and respect from your friends; and you will make new friends, because everyone is attracted by the man or woman who KNOWS!

No wonder that in two short years this remarkable offer has been accepted by more than one and one-half MILLION people including stenographers, clerks, writers, public speakers, ministers, doctors, business men and women, teachers, students, sales people, mechanics and inventors.

You may never have such a chance again! Don't let it slip away! Open the door to knowledge and self improvement. Send today for your set of this remarkable encyclopedia!

SATISFACTION GUARANTEED—ORDER NOW!

Here's all you have to do. Simply fill out the coupon, indicating whether you prefer the regular or de luxe edition. (The de luxe edition pictured above is specially bound in rich, heavy royal blue, Morocco grain, simulated leather, beautifully decorated in black, gold, green and red.) Mail the coupon today with your dollar. When your set is delivered give the postman only 89c (plus a few cents postage). The balance—\$1 a month. This magnificent set must meet your expectations completely—or you may return it within 5 days and your money will be immediately refunded. But the edition is limited—don't risk disappointment! Mail the coupon—with your dollar—today!

**SEND
 ONLY
 \$1.00**

THE WORLD SYNDICATE PUBLISHING CO., Dept. PM, 2231 W. 110th St., Cleveland, Ohio

Send me the 12 Volume World's Popular Encyclopedia and the one year's FREE Supplement Service. I enclose \$1 and when my set is delivered, I will pay the postman only 89c plus the actual government postage. I understand that I may return the set within five days and receive a full and immediate refund. If I keep the set I will pay the balance at the rate of \$1 per month. (Please check one)
 I prefer the regular edition (\$4.89) I prefer the De Luxe Edition (\$7.29)

NAME _____

ADDRESS _____

CITY _____

STATE _____

Check here if you prefer to enclose the entire amount (\$4.89 or \$7.29) in which case WE will pay the postage charges and you save still more. The 5-day return privilege will still apply.

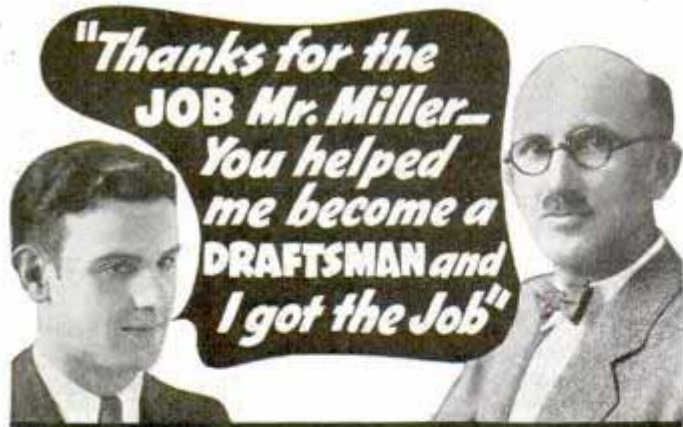

"Thanks for the JOB Mr. Miller— You helped me become a DRAFTSMAN and I got the Job"

Thousands of letters like this have been written to prove that **DRAFTING**, learned the American School way, **DOES PAY**. Here's work you will enjoy, for it's great to see some huge plant or immense building taking shape on the drawing board and the draftsman expects **STEADY WORK** for he is usually among the **first to be hired** and the last to be laid off. Why not get into drafting—have a profession instead of a trade?

Be a Draftsman—

Learn at home We train you thoroughly and expertly in the half hours you can spare from work or pleasure. No need to burn midnight oil. Go as slow or as fast as your time will permit. Lessons are so clearly written that beginners can easily understand them and our system of "practice study" adds **EXTRA VALUE** to the instruction. Use head and hands in this fascinating profession, to make **more money** and put yourself in line for promotion. Write for **FREE** bulletin—there is no obligation of any kind.

O. C. MILLER, Secretary

AMERICAN SCHOOL

Dep't. DD945 Drexel at 58th Chicago

Know! YOUR CAR

ASK TO SEE IT!



GOOD NEWS—JUST OUT

1938 AUDELS NEW AUTOMOBILE GUIDE is NEW from cover to cover. Explaining the Theory, Construction and Servicing of modern motor cars, trucks and buses; and the application of auto type Diesel Engines. . . . **PRACTICAL INFORMATION IN HANDY FORM, 1540 PAGES COVERING . . .**

AUTO REPAIRS & SERVICE HELPS

All the Parts of an Automobile—Automotive Physics—The Gas Engine—How a Gas Engine Works—Gas Engine Principles—Multi-Cylinder Engines—Horse Power—Automobile Engines—Engines: Stationary Parts—Engines: Moving Parts—Pistons—Piston Rings—Connecting Rods—Crank Shafts—The Valves—The Valve Gear—Cams and Cam Action—Valve Timing—Cooling Systems—Gasoline—Fuel Feed Systems—The Mixture—Carburetors—Automatic Choke—Super-Chargers—Transmissions—Synchro-Mesh—Clutches—Universals and Propeller Shafts—The Differential—Rear Axles—The Running Gear—Brakes—Wheel Alignment—Knee Action—Steering Gear—Tires—Lubricants and Lubrication—Automotive Electricity

—Ignition Systems—Magneto Ignition—Spark Plugs—Ignition Coils—Distributors—Automatic Spark Control—Ignition Timing—Generators—Starters—Generator and Starter Testing—Lighting Systems—Storage Batteries—Battery Charging—Battery Testing Troubles. **Automotive Diesel Engines.** Inside Views of all Automobile Parts Fully Illustrated. To Get This Assistance for Yourself Simply Fill In and Mail Coupon Today.

\$4 COMPLETE • PAY ONLY \$1. A MONTH

THEO. AUDEL & CO., 49 WEST 23rd STREET, NEW YORK
Please send me postpaid AUDELS NEW AUTOMOBILE GUIDE (\$4) for free examination. If I decide to keep it, I will send you \$1 within 7 days; then remit \$1 monthly until purchase price of \$4 is paid. Otherwise, I will return it to you promptly.

Name _____
Address _____
Occupation _____
Reference _____ PM

EASY TO PLAY — EASY TO OWN



You've always wanted to play this fascinating instrument. Now there is no reason to delay. Now you may thrill family and friends, with a chance to earn extra cash at dances, entertainments and on the radio. For now there is a genuine **DEAGAN Marimba** (including complete, easy lessons) at the lowest price in history. . . . To write for details **TODAY** may easily mean a **LIFETIME** of pleasure, profit and popularity!

J. C. DEAGAN, Inc., 2459 Deagan Building, CHICAGO

LAW

STUDY AT HOME for Personal Success and Larger Earnings. 28 years of successful student guidance assures expert instruction. **LL.B.** Degree awarded. All text material furnished. Easy payment plan. Send for **FREE BOOK**—"Law and Executive Guidance," at **ONCE**.

AMERICAN EXTENSION SCHOOL OF LAW
Dept. P, 737 N. Michigan Ave., Chicago, Ill.

FREE 25,000 BARGAINS in BOOKS CATALOG

Our 44th Annual 320-Page Bargain Catalog of new Books of all Publishers lists 25,000 titles—Fiction, Juvenile, History, Scientific, etc. Illustrated, Indexed. Used by schools, colleges, libraries, and thousands of individuals. Write today for this new 1939 catalog, "Bargains in Books."
THE BOOK SUPPLY COMPANY, Dept. 138
564-566 West Monroe Street - Chicago, Illinois

LEARN WATCHMAKING AND ENGRAVING



BY OUR PROFIT-SHARING PLAN OUR GRADUATES SUCCEED

One of our Iowa students started in a very small way—now doing over \$30,000 a year. Another in Wisconsin, over \$10,000 the first year. Day or night classes. Call or write for **FREE BOOK**.
Chicago School of Watchmaking, Dept 7001, 155 N. Clark St., CHICAGO.

CARTOONING PAYS WELL

Turn your talent into dollars

Develop your ability with personal instruction from an internationally-known cartoonist. His exclusive, successful method of drawing and creating ideas makes it easy to learn. Write for Free Booklet explaining details of this exceptional home-study course.
National School of Cartooning, 437 Penton Building, Cleveland, Ohio



Minstrels



Unique First Parts for complete show with special songs and choruses. Make-up. Catalog Free.

T. S. Denison & Co., 203 N. Wabash, Dept. 15, Chicago

MONEY-MAKING OPPORTUNITY

for men of character. Over \$1,600 per month earned by California man. Over \$400 a week by Georgia man. \$1,000 in a month by Delaware man. Exclusive franchises available for an invention expected to replace a multi-million dollar industry. Install on free trial. Sells itself. Remains. Exclusive proposition. Write **F. E. Armstrong, Dept. 1112-N, Mobile, Alabama.**

AMAZING MACHINE GROWS HAIR



"Intermittent Vacuum" stimulates deep-lying scalp blood vessels—and **GROWS HAIR** in thousands of cases of baldness. Stops falling hair. Tones up scalp. New hair often in 90 days. Easy to use this amazing machine at home. Only \$9.95 complete. Write quick for **FREE TRIAL OFFER**.
Only \$9.95 COMPLETE
FULLY GUARANTEED AFTER
RAND, DEPT. R-1662, NEWPORT, KY.



LEARN AVIATION

... Great Opportunities For Trained Men

Aviation needs trained men. Come to Roosevelt—Government approved for all classes of pilots and mechanics certificates—and let our experts prepare you for a position in this fast growing industry. Roosevelt offers career courses in Flying, Mechanics, Sheet Metal and Design. Write for full information; state age. Address Dep't. P. M.

ROOSEVELT AVIATION SCHOOL

MINEOLA, LONG ISLAND, NEW YORK

Want a Career in photography?

Wonderful opportunities to profit by the growing demand for photographs! Train at Home or in our modern studios. Commercial, News, Portrait, Advertising, Natural Color and Motion Picture photography. Famous experts will be your teachers. Free booklet.

NEW YORK INSTITUTE OF PHOTOGRAPHY

10 West 33 St. (Dept. 49) New York City

LEARN WATCH REPAIRING



AT HOME You can learn by our modern and original system of instruction every part of the Watch Repairing Trade at home. You can earn money while learning and prepare yourself for a well paying position or start in business after completing our course of instruction. Good watch repairers are in demand and generally earn very good salaries. For particulars apply to the Wisconsin School of Watch Repairing 524 E. Mason St., MILWAUKEE, WIS.

Get U.S. Gov't. Job

Men—Women, age 18 to 50. Salaries to start, \$1260 to \$2100 yearly. For list of positions, how to qualify, locations, etc., write **OZMENT INSTRUCTION SERVICE**, Dept. 111-C, St. Louis, Mo. (This service established 1907)

ENGINEERING

DEGREE IN TWO YEARS

TECHNICAL AND APPLIED COURSES. Nonesentials omitted. TIME AND MONEY SAVED. Degree 2 yrs., diploma 1 yr. Electrical, Mechanical, Architectural, Structural, Civil, Aeronautical, Highway. All courses include Air Conditioning, Electric Refrigeration and Diesel. Short intensive courses 3 and 4 months in Electricity, Power Plant, Diesel-Electric, Air Conditioning, Electric Refrigeration, Drafting. Extensive modern equipment. LOW TUITION. Part-time work for room and board. Thousands of successful graduates in U. S. and foreign lands. Approved by industry, endorsed by educators, recommended by alumni. One and two-year courses open in Sept., short courses open year round. 39th YEAR. Catalog free.

FINLAY ENGINEERING COLLEGE
1861 Indiana Avenue Kansas City, Mo.



Learn to Write

Begin Today. Write for our Free Book, "How to Become a Good Penman." It contains specimens and tells how others learned to write in spare time. Your name elegantly written on a card if you enclose stamp for postage. Write today. The Tamblin School of Penmanship, 418 Ridge Bldg., Kansas City, Mo.



WILL YOU WEAR THIS SUIT

and Make up to \$12 in a Day!

Let me send you a fine all-wool union tailored suit **FREE OF ONE PENNY COST**. Just follow my easy plan and show the suit to your friends. Make up to \$12 in a day easily. No experience—no house-to-house canvassing necessary.

Send for Samples—FREE OF COST

Write today for FREE details. ACTUAL SAMPLES and "sure-fire" money-getting plans. Send no money.

H. J. Collin, **PROGRESS TAILORING CO.**, Dept. M-216, 500 South Throop Street, Chicago, Illinois.

Now I'm Making REAL MONEY

Thanks to C.T.C.

FREE trial LESSON

IN AIR CONDITIONING and REFRIGERATION



Millions of dollars are being poured into **AIR CONDITIONING**. Thousands and thousands of jobs are opening. For the trained man this **spells opportunity . . . more jobs, better jobs, more money, a business of your own**. Let us show you how you can prepare **AT HOME** for this fast-stepping industry . . . how you can tap this rich source of income by easy, inexpensive C. T. C. **spare time training**. **FREE TRIAL LESSON** proves it. Mail post card or coupon.

Wanted . . . Trained Men

The cry goes out "Where can we get trained men to design, to build, to sell, to install, to repair and to service **AIR CONDITIONING** equipment". Get in on the ground floor **now**. C. T. C. has made it easy for you.

Learn at HOME

IN YOUR SPARE TIME LEARN AT HOME

(or at the College in Chicago) by the new, easy, inexpensive plan of Chicago Technical College, the well known 35 year old School of Engineering. Thousands of men have achieved success by our fascinating plan that anybody can master. We help you to a good job when ready. Send today for

FREE TRIAL LESSON

Prove to yourself that what we say is true . . . **YOU** can learn Air Conditioning **AT HOME** in your spare time . . . **YOU** can be a success in this field of opportunity. Fill in and mail coupon today. No charge or obligation now or later.

CHICAGO TECHNICAL COLLEGE

S302 Tech Bldg., 118 E. 26th Street, Chicago, Illinois

Please send me **FREE Trial Lesson** in **AIR CONDITIONING** and Refrigeration, and show me how I can prepare for good positions in **spare time AT HOME**.

Name Age

Address

P. O. State

I'll Train You in DRAFTING until You Get a GOOD PAY JOB



GET MY PROVEN PAY RAISING PLAN

Get practical training. Take up Drafting—because it gives you bigger, better chance to get into your favorite field—Electricity, Aviation, Diesel, Air Conditioning, Automotive, Building, Machinery, Transportation, etc. Remember, everything built has its birth on the Draftsman's Table.

Draftsmen Draw Good Pay

I have trained thousands of men aged 16 to past 50 in their spare time at home, to qualify for Bigger Jobs at Better Pay. Let me train you in a short time by same easy, low cost practical method. No experience needed. High School education not necessary.

All Working Tools Furnished

You get complete Professional Draftsman's Tools and Drawing Table—sent without extra charge at once. Mail coupon for Free Book about my PROVEN PAY RAISING PLAN. Write TODAY!



ENGINEER DOBE, Div. 3379, Libertyville, Illinois

ENGINEER DOBE, Div. 3379, Libertyville, Ill.

Send me your Free Book "SUCCESSFUL DRAFTSMANSHIP." Explain how you assist your graduates to good positions as Draftsmen.

NAME.....AGE.....
 ADDRESS.....
 TOWN.....STATE.....



DIESELS

PREPARE FOR TOMORROW'S OPPORTUNITY

This is your opportunity to qualify as a Diesel Engineer. Men with practical training are in demand for good-paying, responsible positions. You can qualify for a place in this rapidly growing industry.

TESTED TRAINING—REAL SHOP EXPERIENCE

Internal Combustion Engines—Automotive Service
 National Schools give you actual shop methods. You learn on the latest and best equipment in a million-dollar trade school. You are taught to make good and helped to make good after you graduate. It will pay you to investigate National's Master Course.

Transportation Allowed to Los Angeles

FREE!
 Coach railroad fare allowed from any point in the United States. Earn room and board while learning. Graduate employment cooperation. Mail coupon for new 40-page Book of Diesel Facts, details of training, employment opportunities.



NATIONAL SCHOOLS LOS ANGELES

Request for FREE BOOK

NATIONAL SCHOOLS
 Dept. PMA-12, 4000 Figueroa St., Los Angeles, Calif.

NAME.....AGE.....
 ADDRESS.....
 CITY.....STATE.....

EASY SOPRANI AMPLIPHONIC Simplifies Playing



Frank Pupile, N.B.C., with his Soprani

● Lighter, easier to play, less bellowsing, plus more beautiful tone and volume, — that's how Soprani's exclusive Ampliphonic feature has simplified this accordion. Assures rapid progress. Home trial. Easy terms. See your music dealer or send for beautiful free book. Write today.

SOPRANI, INC.

Dept. 1229, 630 S. Wabash Ave, CHICAGO, ILLINOIS

ANY BOOK IN PRINT!

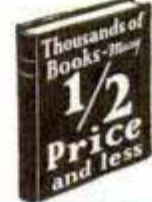

Delivered at your door. We pay postage. Standard authors, new books, popular editions, fiction, reference, medical, mechanical, children's books, etc.—all at guaranteed savings. Send card now for Clarkson's 1939 Catalog.

FREE Write for our great illustrated book catalog. A short course in literature. The buying guide of 300,000 book lovers. The answer to your Christmas gift problem. **FREE** if you write NOW—TODAY!

CLARKSON PUBLISHING COMPANY
 Dept. PM-1255 So. Wabash Ave., Chicago, Illinois

AVIATION



If you are interested in a comprehensive Technical Training Program for

APPRENTICESHIP MECHANICS PILOTS METEOROLOGISTS

Write, immediately, enclosing stamp—**MECHANIX UNIVERSAL AVIATION SERVICE CO.**

Wayne County Airport, Box 857, Dept. E, Detroit, Mich.

TRAIN FOR Radio IN 12 WEEKS

BY SHOP WORK I'll Finance Your Training
 Prepare for jobs in Broadcasting, Talking Pictures, Television, Wireless, etc., by 12 weeks practical shop training in Coyne Shops. Free Employment Service. Many earn while learning. You don't need previous experience or a lot of book learning. Write for **BIG FREE RADIO and TELEVISION BOOK**, and my "Pay-Tuition-After-Graduation" Plan.
 H. C. LEWIS, Pres., RADIO DIV., Coyne Electrical School
 500 S. Paulina Street Dept. 98-3H Chicago, Illinois

BE A CARTOONIST



AT HOME IN YOUR SPARE TIME under personal supervision of the famous cartoonist **NORMAN MARSH** creator of "DAN DUNN" appearing every day in big papers. Success—Fame—Real Money may be Yours when you learn Marsh's easy simple methods and secrets. Send name and address for free details of **MARSH'S Personal course. ACT TODAY!**
MARSH CARTOON SCHOOL

Chicago Daily News Bldg., Dept. I-L, Chicago, Ill.

ENGINEERING DEGREE IN TWO YEARS

B.S. DEGREE courses in engineering: Electrical, Civil, Chem., Mechanical, Radio and Television, or Aeronautical. 1 yr. Mech. Drafting. Intense, practical, thorough program. Prep courses without extra charge. Earn while you learn in this industrial center. Low tuition. Enter March, June, Sept., Dec. Write for Catalog.
 229 E. Washington Blvd., Fort Wayne, Ind.

INDIANA TECHNICAL COLLEGE

for
quick
action

SEND
TO-DAY

MAIL COUPON NOW

for Free Book and Record of Invention Form

CLARENCE A. O'BRIEN and HYMAN BERMAN
70-S Adams Building, Washington, D. C.

Registered Patent Attorneys Before U. S. Patent Office

Please send me at once your Big Free 48-Page Book "Patent Guide For the Inventor" and your Specially Prepared "Record of Invention" Form. This request does not obligate me.

Name.....

Address.....

City.....

State.....
(Please write or print plainly)

YOU CAN PATENT



REQUEST OUR BOOK—NOW!

Know exactly what you should do to secure a Patent—what must be done every step of the way—how the Patent Law protects you—what we, as Registered Patent Attorneys, can do for you. Mail the coupon NOW for our Big Booklet and "Record of Invention" Form.

NEW IDEAS FOR IMPROVEMENTS IN MACHINERY, ARTICLES, DESIGNS, FORMULAS, ETC.

Every year thousands of Patents are granted. Very few, however, represent the discovery of entirely new principles. Most of them provide new methods of doing some everyday thing in a better way—changes for greater efficiency, usefulness, adaptability, or beauty in some previously Patented thing. These IMPROVEMENTS are Patentable if new, and actually represent new invention. These improvement Patents offer large chances for profit if commercially useful. The business world wants improved products and services.

MODELS and FINISHED DRAWINGS UNNECESSARY

Our Big Book tells you how you can start immediately to apply for Patent Protection even if you haven't finished models or drawings available now. It will tell you how we can prepare the specifications and finished drawings necessary in the form prescribed by the Patent Office—so as to secure for you full Patent Protection. Mail Coupon for Our Big Book TODAY.

OUR SERVICES TO YOU

We are registered Patent and Trade-Mark Attorneys, serving Inventors all over the United States and abroad. Our Organization is complete. We have Draftsmen, experienced Searchers and Attorneys to serve your interests. We can act as your legal adviser in all Patent Matters. Our complete service is described in our Big Book. Mail Coupon for it NOW.

IN CASE YOU FEEL THAT YOU HAVE NOT SUFFICIENT FUNDS AVAILABLE FOR PATENT FEES

Our Big Book tells you how to legally assign an interest in your invention—before filing application—to some friend willing to aid you. Better to do this than to delay indefinitely and see another inventor develop your idea and Patent it before you do. Send Coupon NOW.

REASONABLE FEES—CONVENIENT TERMS

Don't worry about finances. Our fees are very reasonable—we can arrange convenient terms of payment. It is our custom to permit clients to pay for our services in installments as the application progresses in our office. See our Big Book for fees in obtaining Patent. It explains our arrangements clearly. Send for it NOW.

CLARENCE A. O'BRIEN & HYMAN BERMAN

70-S ADAMS BUILDING

Registered Patent Attorneys

WASHINGTON, D. C.

How E. P. WILLSON Secured a Government Position

"On June 2nd I took the examination for Storekeeper-Gauger, and on August 15th I received my returns with a grade of 93% . . . On August 25th I was appointed as Storekeeper-Gauger with my post of duty at my home here with four breweries under my supervision and entered on my new duties on August 29th. *I can't say too much for your School.*"—E. P. Willson

THIS is but one of hundreds of letters in our files from graduates of Patterson School who have been appointed to well-paid, responsible Government jobs.

Is there any *magic* in our proved ability to help men and women secure Government jobs? None whatsoever. Strictly skill, knowledge, and more than a quarter-century of experience. The Patterson School has *no connection* with the U. S. Government. But our Principal and Founder, Arthur R. Patterson, was for nearly eight years a member of a U. S. Civil Service Board of Examiners, and beginning with that experience grew his knowledge of how to train prospective citizens for Civil Service Examinations; how to prepare them individually, systematically, *successfully*, for passing their Examinations with high marks.

Why Preparation Is Necessary

The difficult part is not *passing* your Civil Service Examination. But, because there are usually more applicants than vacancies, Uncle Sam must *by law* fill the jobs from among the applicants with the *highest marks*. Therefore, you must not only pass, but pass with a high grade. And isn't it worth while, if you are interested in getting a Government position, to go about your preparation in the best way possible—to be prepared by a school whose graduates show such a high record of success?

FREE 32-Page BOOK

The Patterson School has prepared an illustrated 32-page book, "How to Secure a Government Position," which anyone interested may have for the asking. This book describes the requirements and starting salaries in Civil Service (\$1260 to \$2300 a year), and how Mr. Patterson's tested coaching method prepares you for your examinations. Send for this book without obligation; merely mail coupon below. A. C. Kehr, Managing Director, Patterson School, 812 Mercantile Building, Rochester, N. Y.

**A. C. KEHR, Managing Director, Patterson School
812 Mercantile Building, Rochester, N. Y.**

Please send me your free 32-page illustrated book, "How to Secure a Government Position." Sending for this book will not obligate me in any way.

Name _____ Age _____

Address _____

City _____ State _____

DOUBLED HIS PAY!

"I was appointed to a regular position June 22nd. I had been employed 8 years at a local factory . . . My one week of Railway Mail Service Pay is now equal to two weeks' pay that I was earning at the factory.

"I felt like a king on parade when I gave my notice at the factory . . . Everybody said I was lucky. Sure I was lucky—when I first read your advertisement and enrolled in your School!" —A. L. G.

Air Become An Conditioning Engineer

Big fast-growing field for men trained in design, estimating, insulating, installing and servicing. Offers real opportunities in Air Conditioning new buildings and remodeling worth-while old buildings. Write today for method of how you can prepare for this thriving industry. No obligation.

American School, Dept. AC-945, Drexel at 58th, Chicago



RESOLE SHOES

FOR ONLY

SO-LO mends holes, worn spots in rubber, leather, cloth. Spreads like butter. Dries tough overnight. Flexible, non-skid, waterproof. Won't come off — guaranteed! 25c (25 repairs). At all 10c and hardware stores.

4¢ EACH

Correspondence Courses in RADIO and ELECTRICAL ENGINEERING

LOW AS \$25

LES

ELECTRICAL ENGINEERING. Get good grasp of wide electrical field. Modern. Very understandable. Theory made easy. **RADIO ENGINEERING.** Extra fine course in radio, public address, photo-electric work. Trains you to be super-service man, real vacuum tube technician. Tuition ONLY \$25, either course. Deferred payment plan. Experiment kits furnished. **FREE** Write for free copies of school catalogs, student magazines, etc. **LINCOLN ENGINEERING SCHOOL, Box 531-P12, Lincoln, Nebr.**

Learn PHOTOGRAPHY at Home

Splendid opportunities. Prepare in spare time. Easy plan. No previous experience needed, common school education sufficient. Send for free booklet "Opportunities in Photography", particulars and requirements. **American School of Photography - 3601 Michigan Ave., Dept. 1359, Chicago, Ill.**

DO YOU LIKE RADIO DOES THE FUTURE OF TELEVISION INTEREST YOU?

Send for your free copy

You men anxious to make good in radio and related industries want the true facts,—you want to know about employment opportunities and requirements. National Schools,—a million-dollar trade school,—will supply you with a sincerely honest statement of facts on what you should do to get into the profitable radio industry. No exaggerations,—no mis-statements. Mail coupon today. **Send for your free copy.** Real facts on radio employment requirements. **You need real experience.** National offers complete training with modern equipment.



NATIONAL SCHOOLS Los Angeles

Request for FREE BOOK of DETAILS

NATIONAL SCHOOLS,
Dept. PMR-12 4000 S. Figueroa St., Los Angeles, Calif.

NAME _____ Age _____

ADDRESS _____

CITY _____ STATE _____



Big Pay for YOU in AVIATION

TRAIN NOW AT **LINCOLN**
GOVERNMENT APPROVED SCHOOL



MANY EARN \$200 to \$700 a MONTH as PILOTS, MECHANICS and AERONAUTICAL ENGINEERS

Exceptional employment opportunities for Lincoln Trained Pilots, Mechanics and Aeronautical Engineers. Airline and Factory expansion calls for thousands more trained men. Our Graduates regularly taking positions with leading Aviation Companies. You can soon be ready for a good position in Aviation by preparing now at this Lincoln Government Approved School. Aviation pays Airline Pilots as high as \$700 a month; Co-Pilots, \$250; Airplane Mechanics, \$200; Aeronautical Engineers, \$400 a month.

BE AN AIR PILOT—Learn to fly fast modern type airplanes. Prepare for fascinating, big-pay career as Transport or Commercial Pilot. Learn night, blind and cross-country flying. Land at different airports. 14 Training Planes . . . 6 types give you wide piloting experience. Experienced Instructors prepare you for your official Pilot Rating.

BE AN AVIATION MECHANIC—Prepare now at Lincoln to earn good pay as Licensed Airplane and Engine Mechanic. Lincoln offers you practical experience in rebuilding, overhauling, repairing modern airplanes . . . prepares you for immediate employment with Airline, Factory or at an Airport.

BE AN AERONAUTICAL ENGINEER—Lincoln Training prepares you for high-pay position as designer and builder of airplanes. Training includes experience in designing and building complete modern airplanes.



Lincoln students assist in designing and building real airplanes. They assemble, align, and rig . . . watch their test flights and make observations. It's fascinating, it's thrilling, preparing at Lincoln for a career in Aviation.

MAKE AVIATION YOUR CAREER—Training at this Lincoln Government Approved School can soon have you ready for a good position. We assist Graduates in locating positions. You should have our book "Contact." It tells how men are trained for Aviation. **MAIL COUPON TODAY** for complete information.

LINCOLN AIRPLANE & FLYING SCHOOL
DIVISION OF LINCOLN AERONAUTICAL INSTITUTE, INC.
5512 Aircraft Building Lincoln, Nebraska

WRITE TODAY for Complete Information



LINCOLN AIRPLANE & FLYING SCHOOL
5512 Aircraft Bldg., Lincoln, Nebraska.

I would like to have your book "Contact." Please send me complete information about Lincoln Training.

Name..... Age.....
Address.....
City..... State.....

IMAGINE THEIR JOY WHEN THEY FOUND THEY COULD PLAY



LEARNED QUICKLY AT HOME
I didn't dream I could actually learn to play without a teacher. Now, when I play for people they hardly believe that I learned to play so well in so short a time.
*H.C.S., Calif.



SURPRISED FRIENDS
My friends are surprised at the different pieces I can already play. I am very happy to have chosen your method of learning. *B. F., Bronx, N. Y.



PLAYS ON RADIO
I am happy to tell you that for four weeks I have been on the air over our local radio station. So thanks to your institution for such a wonderful course.*W. H. S., Alabama.

What Instrument Would You Like to Play?

JUST name your instrument and we'll show you how you can learn to play it—quickly, easily, in spare time at home. Never mind if you don't know one note of music from another—don't worry about "special talent". And forget all you've ever heard about music's being hard to learn.

The truth of the matter is that *thousands now play who never thought they could!* Yes, men and women everywhere have discovered this amazingly easy way to learn music at home. Now they are enjoying the thrilling satisfaction of playing the piano, violin, guitar, saxophone or other favorite instruments. Some of them are playing in orchestras and over the radio; others are teaching music, making money in spare or full time. And thousands are having the time of their lives playing for their own enjoyment and the entertainment of their friends.

No tedious study and practice, no tiresome exercises. You learn to play *by playing*—start right in with the melody of a simple tune! It takes only a few minutes a day; the cost is trifling. Does it sound too good to be true? Mail the coupon and get the **FREE PROOF!**

FREE DEMONSTRATION LESSON AND BOOKLET

Fascinating illustrated booklet answers all your questions; free demonstration lesson shows how method works. No cost. Just mail coupon. (Instruments supplied when needed, cash or credit.) *Actual pupils' names on request. Pictures by professional models. U. S. School of Music, 712 Brunswick Bldg. N. Y. C., N. Y.

U. S. SCHOOL OF MUSIC
712 Brunswick Bldg., New York City, N. Y.

Send me your amazing free book, "How You Can Learn Music in Your Own Home," with inspiring message by Dr. Frank Crane, also Free Demonstration Lesson and particulars of your easy payment plan.

Name.....
Address.....
Instrument..... Have you Instrument?.....

- LEARN TO PLAY BY NOTE**
Piano Guitar
Violin Saxophone
Organ Mandolin
Tenor Banjo
Hawaiian Guitar
Piano Accordion
Or Any Other Instrument

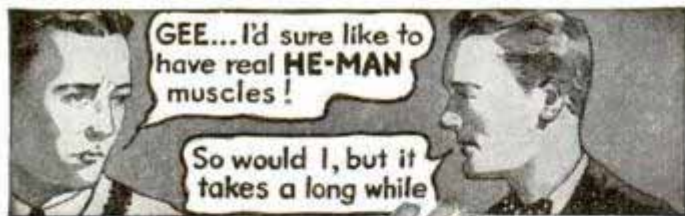

—says Charles Atlas
Holder of title, "World's
Most Perfectly Developed
Man" won in National and
International Contests.

"Bunk!"

**I'll Prove in
the first 7 days
YOU can have a
Body like Mine!"**

DON'T get the idea that it takes a lot of time and hard work for you to get smashing strength and powerful muscles! Don't think you need dumb-bells, springs or other contraptions! Both these ideas are all bunk—and I have **PROVED** it. All I need is 7 days to prove what I can do for you! And I don't need any apparatus either. In fact, I don't believe in artificial methods that may strain your vital organs for life!

NATURAL Methods Are All I Need

Here you see an actual photo of how I look today. No muscles have been "painted on." This is the camera's honest proof of what I did for MY body. Now I'm ready to prove what my secret of Dynamic Tension can do for YOURS!

A few years ago I was a physical wreck, a 97-pound weakling—flat chested, arms and legs like pipestems. I was worried. I studied myself. Then I found a new way to build myself up. A way that was simple, natural, quick and sure! "Dynamic Tension" is what I called it. In a short time I had the body that has twice won the title of "The World's Most Perfectly Developed Man."

Get My FREE Book

Thousands of others now know from their own personal experience what Dynamic Tension has done for them.

This little coupon brings you my free book, which tells all about it. No cost or obligation.

I just want to give you proof that I can do for you what I have done for so many others: give you broad, powerful shoulders, biceps that bulge with smashing strength, a chest which stands out solid and muscular, and an evenly developed body that will make others look like dwarfs next to you. Mail this coupon TODAY! CHARLES ATLAS, Dept. 812, 115 E. 23rd St., New York, N. Y.

**CHARLES ATLAS, Dept. 812,
115 East 23rd Street, New York, N. Y.**

I want the proof that your system of Dynamic Tension will make a New Man of me—give me a healthy, husky body and big muscle development. Send me your free book, "Everlasting Health and Strength" and full details of your 7-DAY TRIAL OFFER.

Name
(Please print or write plainly)

Address

City..... State.....

THIS STERLING SILVER CUP BEING GIVEN AWAY
This valuable cup stands about 14 inches high on a black mahogany base.
I will award it to my pupil who makes the most improvement in his development within the next three months.

PARKS AIR COLLEGE
PARKS AIRPORT EAST ST. LOUIS, ILL.

**Offers YOU COLLEGE and PROFESSIONAL TRAINING
Majoring in AVIATION**

Accredited by the Illinois Superintendent of Public Instruction. U.S. approved as a Commercial Ground and Flying School and Mechanics' School. Open to high school graduates.

FOUR courses lead to B.S. degrees in Professional Piloting, Aviation Operations, Maintenance Engineering, Aeronautical Engineering.

FOURTEEN TRAINING PLANES are used in professional flight training which prepares graduates for airline flight operations. 74% of graduates enter air transportation in North and South America. 69,000 hours flight training given, 650 hours being flown monthly.

FACULTY of 34 specialists in various fields of aviation. 1541 graduates. Enrollment limited to a total of 300. 100-acre airport, 14 buildings devoted to school purposes exclusively. Dormitories and dining hall at the College.

Winter Term January 4th. Send postcard for new 60-page catalog.

**12th YEAR Registrar, Dept. PM-12
PARKS AIR COLLEGE, East St. Louis, Ill.**

New Way to Improve YOUR ENGLISH



A command of effective English gives you added advantages and better opportunities. Poor English handicaps you more than you will ever realize. You can improve your English through Sherwin Cody's 100% self-correcting invention.

If you are ever embarrassed by mistakes in grammar, spelling, punctuation or pronunciation, this new free book "How You Can Master Good English in 15 Minutes a Day" will prove a revelation to you. Send for it now. It is free. Address

**SHERWIN CODY SCHOOL OF ENGLISH
512 Searle Building Rochester, N. Y.**

THERE'S MONEY IN YOUR CAMERA!

Others make good incomes selling pictures to publications. **FREE CATALOG** describes buy-study course (which may be paid for in easy installments) and tells how YOU can do it too! **Universal Photographers, Dept. 712, 30 West 53 Street, N. Y. C.**

CARTOONING

FREE TRIAL LESSON! Cash in on your sense of humor—AT HOME—BY MAIL. Have fun! Make money! No experience needed to start. Write today for **FREE LESSON**, mailed postpaid. No obligation. **MOON Gag-Cartoon School, Dept. A, Fall Creek, Wis.**

RADIO ENGINEERING, broadcasting, aviation and police radio, servicing, marine and Morse telegraphy taught thoroughly. Nine months' engineering course equivalent to three years' college radio work. School established 1874. All expenses low. Catalog free.

Dodge's Institute, Ada St., Valparaiso, Ind.

Learn ADVERTISING at Home

Greater opportunities now in advertising. Learn easily and quickly in spare time. Practical work. No text books. Old established school. Low tuition—Easy terms. Send for free booklet and requirements. **Page-Davis School of Advertising Dept. 1353, 3601 Mich. Av., Chicago**

STAMMERERS Before deciding, let us send you our free helpful leaflet "SPEECH" and Guild list of ethical, dependable schools which correct all speech defects. Most advanced methods. Personal individual instruction. Write today. No obligation. **STAMMERERS ADVISORY GUILD, 1236 Maccabees Bldg., Detroit, Michigan**

NEW YORK SCHOOL OF MECHANICAL DENTISTRY

Earn big money in a few months. We show you how. Real Laboratory Training. **GLDST school, Day, Eve. Easy terms. Ask for free Catalog P and tool offer.** **N. Y. SCHOOL of MECHANICAL DENTISTRY, 125 W. 31 St., N. Y. C.**

Yes! YOU CAN MAKE BIG MONEY WITH HOOVER UNIFORMS!

Big earnings for ambitious men and women in new uncrowded field with famous nationally-advertised Hoover line of smart, exclusive Uniforms for restaurants, fountains, hotels, taverns, stores, offices, etc. Not house-to-house. No experience—no money needed to get into this new, big-income business. Mail postcard now for beautiful new Uniform Style presentation, actual samples and money-making equipment—sent **FREE.**

HOOVER 251 W. 19th St., Dept. KH-9, New York, N. Y.

No Wonder DIESEL PAYS SO BIG!

Diesel Engines produce "LOW COST" power—the newer ones are unbelievably light in weight. High Speed trains, passenger busses; huge trucks and now airplanes have adopted **DIESEL POWER**. Think what that will mean in the way of opportunities for **DIESEL TRAINED MEN**.

Learn Diesel at Home

Get into this profitable field NOW—prepare for an ever increasing demand—know the answer to any Diesel problem. We train you at home in **SPARE TIME**. No need to waste a minute or interfere with work or pleasure. Prepare for advancement the Diesel way. Get in line for a Big Pay Job. Write for **FREE** bulletin—there is no cost or obligation.

AMERICAN SCHOOL

Dept. D945 Drexel at 58th Chicago



BE A CAMERA REPORTER

MAKE YOUR CAMERA BRING YOU A CASH INCOME. Interesting, Easy-to-Learn, Spare Time Course Prepares You For Exciting Profession. Earn Money While You Study! Camera Reporting, Picture shooting, for scores of newspapers and magazines. A high paying profession that any man or woman can enter! **YOU NEED NO EXPERIENCE.** You learn by doing. Tasope' trains you for a good job, or you can work for yourself. Most modern practices, including natural color photography! All popular cameras. Low Cost—Easy Payment Plan. Write for Beautiful Free 32-Page Photo-Illus. Book.

TASOPE' SCHOOL OF MODERN PHOTOGRAPHY, Dept. 7L8, Aurora, Mo.

DENISON'S PLAYS

Musical Comedies, Operettas, Vaudeville Acts, Minstrels, Comedy Songs, Make-up Goods.

60
YEARS
OF HITS

Catalog Free

T. S. Denison & Co., 203 N. Wabash, Dept. 9, Chicago

EARN THE DEGREE

Doctor of Psychology (Ph.D.), Philosophy, Science. General Courses—Arts, Law, Business, etc. "CHARTERED BY STATE OF MONTANA." Send for 32-page FREE Bulletin at once. No Obligation. Temple Bar College, Dept. 2-R, 213 East Main Street Missoula, Montana, U. S. A.

STATEMENT OF THE OWNERSHIP, MANAGEMENT, CIRCULATION, ETC., REQUIRED BY THE ACTS OF CONGRESS OF AUGUST 24, 1913 AND MARCH 3, 1933, of Popular Mechanics Magazine, published monthly at Chicago, Ill., for October 1, 1938.

State of Illinois, County of Cook, ss.

Before me, a notary public in and for the state and county aforesaid, personally appeared H. H. Windsor, Jr., who having been duly sworn according to law, deposes and says that he is the Editor of the Popular Mechanics Magazine and that the following is, to the best of his knowledge and belief, a true statement of the ownership, management, etc., of the aforesaid publication for the date shown in the above caption, required by the Act of August 24, 1912, as amended by the Act of March 3, 1933, embodied in section 537, Postal Laws and Regulations, printed on the reverse of this form, to wit: First. That the names and addresses of the publisher, editor, managing editor, and business manager are: Publisher, Popular Mechanics Co., 290 East Ontario St., Chicago, Ill.; Editor, H. H. Windsor, Jr., 200 East Ontario St., Chicago, Ill.; Managing Editor, L. K. Weber, 200 East Ontario St., Chicago, Ill.; Business Manager, Willis S. Brown, 200 East Ontario St., Chicago, Ill. Second. That the owner is: (If owned by a corporation, its name and address must be stated and also immediately thereunder the names and addresses of stockholders owning or holding one per cent or more of total amount of stock. If not owned by a corporation, the names and addresses of the individual owners must be given. If owned by a firm, company, or other unincorporated concern, its name and address, as well as those of each individual member, must be given.) Popular Mechanics Company, 200 East Ontario St., Chicago, Ill.; L. B. Windsor, 200 East Ontario St., Chicago, Ill.; H. H. Windsor, Jr., 200 East Ontario St., Chicago, Ill.; L. H. Windsor, 200 East Ontario St., Chicago, Ill. Third. That the known bondholders, mortgagees, and other security holders owning or holding 1 per cent or more of total amount of bonds, mortgage, or other securities are: (If there are none, so state.) None. Fourth. That the two paragraphs next above, giving the names of the owners, stockholders, and security holders, if any, contain not only the list of stockholders and security holders as they appear upon the books of the company but also, in cases where the stockholder or security holder appears upon the books of the company as trustee or in any other fiduciary relation, the name of the person or corporation for whom such trustee is acting, is given; also that the said two paragraphs contain statements embracing affiant's full knowledge and belief as to the circumstances and conditions under which stockholders and security holders who do not appear upon the books of the company as trustees, hold stock and securities in a capacity other than that of a bona fide owner; and this affiant has no reason to believe that any other person, association, or corporation has any interest direct or indirect in the said stock, bonds, or other securities than as so stated by him. H. H. Windsor, Jr., Editor, Sworn to and subscribed before me this 23rd day of September, 1938. J. GRAHAM, Notary Public. (My commission expires June 16, 1940.)



Riding gain in control room of broadcasting station

GOOD PAY! STEADY JOBS!



MIDLAND for Training .. RADIO for JOBS steady, well-paid

Here you have the success secret of ambitious young men employed at good pay in many parts of the United States. Trained radio men are needed today and always will be. And now you can get the sound, practical extension training necessary to qualify you for employment in broadcasting, police and aviation radio and many other branches of the gigantic radio industry. **DON'T LET THESE OPPORTUNITIES PASS YOU BY.**

TELEVISION

that amazing new scientific development already perfected to an astonishing degree promises to create employment for thousands in the future. Midland includes thorough, "ultra-modern" television training that can fully qualify you for this wonderful new field.

Take Your First Real Step Towards Success Right Now! Get the facts about Midland Color-Coded training that includes attractive texts, easy-to-understand home laboratory manuals, all equipment and tools to conduct 108 fascinating experiments in your own home, followed by four weeks training in our fine radio-television laboratories where you will have the friendly, expert supervision of real engineers. **We even send you a bus ticket to Kansas City for resident training.** And when you graduate you will get genuine employment service for life.

Midland Radio-Television Training may be secured on two plans: 1. Combination Extension Resident. 2. Straight Resident.



JOHN BASS, Midland trained, employed by Missouri State Hwy. Patrol



ELDON BEASLEY Midland trained, employed by Braniff Airways, Inc.



JACK COPELAND Midland trained, employed by TWA

MIDLAND TELEVISION, INC.

28, 29, 30, 31st Floors Power and Light Bldg.
KANSAS CITY, MO.

Affiliated with KMBC—a
Major Network Outlet

FREE! SEND AT ONCE FOR THIS BIG ILLUSTRATED BOOK AND A GENUINE, NOTARIZED RE-PRODUCTION OF A MIDLAND 441-Line "ELECTRONIC" TELEVISION PICTURE.



MAIL COUPON FOR FREE BOOK

Midland Television, Inc., Power & Light Bldg.
Dept. 206-M, Kansas City, Missouri

(Paste on penny postcard or mail in envelope)

Without obligating me, send your **FREE** illustrated book on Radio-Television opportunities.

Name..... Age.....

Address.....

City..... State.....

TRAIN FOR ELECTRICITY IN 12 WEEKS SHOPS

HERE IN THE COYNE PAY TUITION AFTER GRADUATION



Mail coupon today for details of my "Pay after graduation plan" and famous Coyne "Learn by Doing" method of practical shop training for your start for success in this big-pay field. Ago or lack of money need not hold you back . . . Get training first; then take 18 months to complete small monthly tuition payments starting 5 Months after you begin training.

12 WEEKS' TRAINING

Coyne Training is practical, thorough, easy to grasp . . . you learn quickly by doing actual jobs on real electrical machinery right here in my Chicago Training Shops — NOT from books or printed lessons. You don't need previous experience or a lot of book learning. Expert instructors guide you every step of the way.

EARN WHILE LEARNING—JOB HELP AFTER GRADUATION

Big things ahead in Electricity means opportunities for steady jobs, good pay, and a real future in this fascinating "live" industry. Thousands of opportunities. Rush the coupon TODAY for Big Free Book containing many photos of the great Coyne Shops in Chicago, facts about Coyne Training . . . Free Employment Service . . . many earn while learning . . . additional instruction in Diesel Engines, Electric Refrigeration and Air-Conditioning at NO EXTRA COST and amazing Pay-Tuition-After-Graduation Offer.

COYNE ELECTRICAL SCHOOL
H. C. LEWIS, President
500 S. Paulina St., Dept. 98-72, Chicago, Ill.

Learn by Doing

H. C. LEWIS, President, Coyne Electrical School
500 S. Paulina St., Dept. 98-72, Chicago, Ill.
Send me, without cost or obligation, your Big Free Book and details of Pay-Tuition-After-Graduation-Offer.

NAME _____
ADDRESS _____
CITY _____ STATE _____



AUTO

BOOKS SENT FREE

on approval. Just mail the coupon and we'll send you a set of these remarkable auto books, just off the press. Whether you are a mechanic or helper, expert or apprentice, auto owner or driver, if you're interested in knowing all about automobile mechanics, take advantage of this FREE OFFER.

GET A BETTER JOB

A better job—in the gigantic auto industry. BIGGER PAY—a chance to go into business for yourself and get a share of the huge profits, are waiting for any man who even half tries to improve himself. Learn auto engineering with these wonder books a new way—without studying or memorizing. Simply use the JIFFY INDEX to look up the answer to any auto problem. Built by eleven of America's greatest automobile engineers, and written in simple language so you can understand it. Very newest cars, all covered.

[FREE Privilege of consulting Automobile Engineers of American Technical Society for one year without cost if you mail coupon immediately]

Send NOW and we will include an EXTRA volume full of up-to-date diagrams.



CAN YOU FIX IT?

These wonder books tell step by step HOW to take out "play" in differential — to kill the shimmy in steering—to set TIMING—how to put your finger instantly on engine trouble and then the quick expert way to FIX it. Newest improvements fully covered. Equal to a complete trade course at less than a fourth the cost.

6 BIG VOLUMES
Brand New Edition
2500 pages, 2000 illustrations, wiring diagrams, etc., including Marine Engines, Aviation Motors, Diesel engines, etc. De Luxe edition, gold-stamped flexible binding.

AMERICAN TECHNICAL SOCIETY,
Drexel Ave., & 58th St., Dept. A919, Chicago, Ill.
I would like to see the new 6-volume edition of your AUTO BOOKS. I will pay the few cents delivery charges only, but if I choose to, I may return them express collect. If after 10 days use I prefer to keep them, I will send you \$2 and pay the balance at the rate of only \$3 a month, until \$24.80 is paid. Please include free membership and extra Volume 7, as per your offer above.
Name _____
Address _____
City _____ State _____
Attach letter stating age, occupation and name and address of employer and that of at least one business man as reference.



NEW! COMPLETE and Up-to-the Minute Book on HOUSE WIRING

Covers, in great detail, all phases of practical wiring for homes, garages, farm buildings, etc. Written in the simplest language; describes and illustrates fuses, circuits, switches, installation plans; also wiring diagrams; over 200 Illustrations; cloth binding \$1.50 post-paid. 5-day money-back guarantee.

FREE Complete catalog of practical books on Painting; Decorating; Commercial Art; Sheet Metal; Welding; Radio; Electricity; Engineering; Carpentry and Building; Plumbing; Heating and Ventilating. **WRITE TODAY.**

FRED'K J. DRAKE & CO., 187 N. Michigan Av., Chicago



TRIAL LESSON IN Free • DRAFTING

More good jobs now in Drafting. Learn AT HOME in spare time (or at our Chicago School). Send post card for **FREE TRIAL LESSON** and see how easy to learn and get a good job.

CHICAGO TECHNICAL COLLEGE
5-209 Tech. Bldg., 118 E. 26th St., Chicago, Ill.



The Whole Field of Practical MATHEMATICS IN ONE VOLUME

Contains more valuable mathematical information than any other book. Instant facts and formulas. Needed in every business, trade, or home workshop. Examine 5 days Free. Then pay \$2 per mo. for 3 months or return book and owe nothing.

D. Van Nostrand Co., 250A-4th Ave., New York

FREE "Air Conditioning" MAGAZINE

Write Today For Free Sample Copy
Supreme Publications, 3727 W. 13th St., Chicago, Ill.

ARTISTS MAKE MONEY

Find out your ability. Send name, age, occupation and address for Free Vocational Art Test.
Federal Schools, Inc., 12138 Federal Schools Bldg., Minneapolis, Minn.

HAWAIIAN or SPANISH GUITAR easily learned at home

Play songs almost instantly. Become an expert, modern guitarist or tuition refunded. COST LESS THAN 2c A DAY! Write NOW for free details.
HAMANN INSTITUTE, 3016 N. 24th Place, R-12, Milwaukee, Wis.

Print Your Own

Cards, Stationery, Advertising, etc. Save Money, Easy Rules Sent. Junior Outfit \$2.99, Senior \$4.25 Up. Defects Free. Write Kelsey Presses, A-37, Meriden Conn.

EXCELSIOR PROFIT PRINTING FOR OTHERS

Is Your Rupture HERE?

Why delay proper palliative treatment? If you suffer from rupture—and your doctor advises the use of a proper-fitting support—send for the facts about our perfected truss invention—the Brooks Appliance for reducible rupture—with the **AUTOMATIC AIR-CUSHION SUPPORT**. Thousands bought by doctors for themselves and patients.

Sent on Trial—Made-to-measure, individual fitting for man, woman or child. Low-priced, sanitary, durable. No obnoxious springs or hard pads; no metal girdle to rust. Safe and comfortable. Helps Nature get results. Not sold through stores—beware of imitations. Write today for full information sent free in plain sealed envelope.

BROOKS APPLIANCE CO., 457 State St. Marshall, Mich.

When writing please mention Popular Mechanics



A Simple Recipe for Inventive Success

PROBABLY the simplest recipe for inventive success would be this: First, a practical, useful invention; second, a good, strong Patent; third, a buyer or a market. The inventor needs all three to get anywhere. Lacking any one, he is likely to get nowhere. The recipe is simple. Working it out isn't so simple. That is why inventors—and others inventively inclined—have found the two books shown here so helpful. We've gone into each part of the recipe carefully. *Exactly what is an invention? We tell you. What is a strong Patent? We tell you. How can I go about finding a buyer? We tell you.*

But there's much more. For example, just how an Application for a Patent is made; how an inventor can safeguard himself with dated sketches as he goes along; how the pertinent Patent Office records are checked to see what other inventors may have done along the same line; how some successful inventors have secured financial backing; simple ways to contact manufacturers; and many other points.

40 Years in the Business of Helping Inventors

The world needs, can use and will pay for practical, useful, inventions. Manufacturers are on the alert for new articles, or improvements that will help them increase sales. Maybe you have one. Maybe not. These books will help you in deciding that. *From that standpoint alone, they are valuable.* For more than 40 years, it has been our business to help inventors. We answer your questions and supply complete information about Patent procedure, costs, steps to take, kind of sketch or model needed, and much more. Our staff is made up of experienced Registered Patent Attorneys, Draftsmen, Searchers. Fees are reasonable—deferred payments arranged. Whether your idea is large or small, finished or still in a rough stage, you should have the facts both about Patenting and Selling. The information which we give you—based on long experience with thousands of inventors—is yours for the asking. No need to delay. These two books of facts may save you time, trouble, money, even later disappointment. **Return the coupon—or write us a confidential letter—today.**

PATENT and SELL your INVENTION

Suggestions
on
WHEN
and
HOW
to Sell an
INVENTION

115 Mechanical Movements

The mechanical movements shown below are taken from 115 each movements illustrated in our book, "Patent Protection." Maybe you'll find just what you need to work out some of your own ideas. Many other interesting pictures are shown in this book. Both books and an "Evidence of Invention" form sent to you FREE the same day we hear from you.

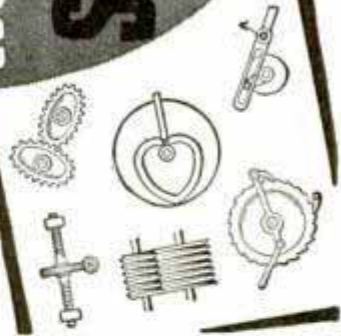

Here
TWO BOOKS
tell you how to go
about it — **Both**
SENT FREE

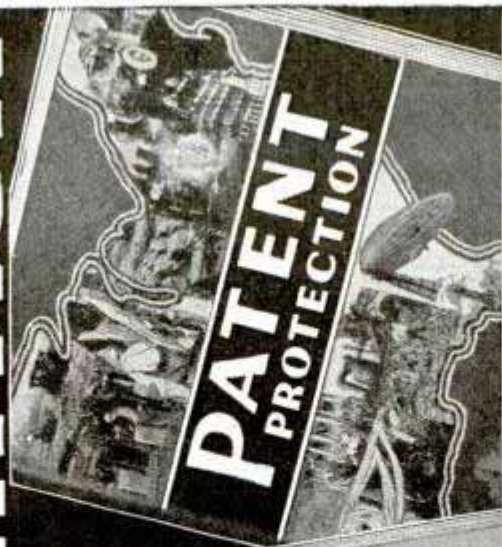

VICTOR J. EVANS & Co.

REGISTERED PATENT ATTORNEYS

Main Office: 20-P, Victor Building
Washington, D. C.

Other Offices: 514-N, Empire Bldg., Pittsburgh
405-N, Garfield Bldg., Los Angeles
1010-N, Hobart Bldg., San Francisco

Send me FREE copies of your books, "Patent Protection" and "When and How to Sell an Invention." (Note: Same books supplied by any of the other offices listed above.)

Name.....

Street and No.....

City or Town.....State.....

PATENTS

Booklet Free Highest References
 Promptness Assured Best Results

Send drawing or model.

ALL BUSINESS GIVEN PROMPT AND PROPER ATTENTION

Listed Patent Lawyer in the latest editions of the Rand-McNally Directory of Bankers and Bank-Recommended Attorneys, published by Rand-McNally & Co., Chicago, Ill.; The Baggott & Ryall Directory of Guaranteed Attorneys, published by Legal Directory Corporation, Boston, Mass.; American Lawyers Annual, Cleveland, Ohio; Bankers Service Legal Directory, published by Bankers Service Co., Boston, Mass.; Eyre's Law List, 9 Park Place, New York City; Snow-Church Directory Co. Lawyers List, published in New York City, and the Central Guarantee Co., Bankers and Lawyers Directories, 630 Fifth Avenue, New York City.

WATSON E. COLEMAN, Victor Building, 724 Ninth Street, N. W.
 REGISTERED PATENT LAWYER **WASHINGTON, D. C.**

INVENTORS PATENT YOUR IDEAS SEND FOR FREE BOOK



HOW TO OBTAIN A PATENT

Written by a Former Member of the Examining Corps (1922-24) of the U. S. Patent Office. If you want to profit by your idea, you should take steps to apply for a U. S. Patent at once. Your first step is to get this Free Book. This interesting illustrated book contains valuable information you should have. It tells you fully how to obtain a patent on your idea in the quickest way. With this Free Book you will also receive a "Record of Invention" form on which you can easily record your idea. Personal and Confidential Service: Your case will be personally handled only by a Registered Patent Attorney who is also a Former Member of the Examining Corps of the U. S. Patent Office. All communications confidential.

MAIL COUPON TODAY for FREE PATENT BOOK and RECORD OF INVENTION Form.

CARL MILLER

REGISTERED PATENT ATTORNEY
 FORMER MEMBER EXAMINING CORPS U. S. PATENT OFFICE

Woolworth Bldg., 35th Floor, Dept. 128A, New York City
 MILLER BUILDING, Dept. 128A, Washington, D. C.

Please send me your Free Book, "How to Obtain a Patent," and your "Record of Invention" form.

NAME.....

ADDRESS.....



G E A R S

In Stock — Immediate Delivery

Gears, speed reducers, sprockets, thrust bearings, flexible couplings, pulleys, etc. A complete line is carried in our Chicago stock. Can also quote on special gears of any kind. Send us your blueprints and inquiries.

Write for Catalog No. 10

CHICAGO GEAR WORKS
 763-773 W. Jackson Blvd. CHICAGO, ILL.

Inventions Wanted Patented or Unpatented

We have been successfully selling inventions, patented and unpatented, since 1924. Write for proof, and tell us what you have for sale.

Chartered Institute of American Inventors
 Dept. 4, Barrister Building, Washington, D. C.

PATENTS—TRADE MARKS

All cases submitted given personal attention
 Form "Evidence of Conception" with instructions for use and "Schedule of Government and Attorneys' Fees"—FREE!

LANCASTER, ALLWINE & ROMMEL
 Patent Law Offices

412 Bowen Bldg. Washington, D. C.

INVENTORS PROTECT & SELL

Your unpatented invention can be sold with positive safeguards under patent laws. New, low-cost procedure. Complete details, free.

AMERICAN PATENTS CORPORATION
 Dept. 4-E Washington, D. C.

INVENTORS

who derive largest profits know and heed certain simple but vital facts before applying for patents. Our book, Patent-Sense, gives those facts; sent free. Trade Marks—Copyrights.

LACEY & LACEY, Est. 1869, 635 F St., N. W., Dept. 5, WASHINGTON, D. C.

RUPTURED?

Get Up-to-Date Relief

Now you can laugh at chafing leg-straps and binding belts, yet do hard work safely with the amazing, modern Cluthe. Positively guaranteed to hold, a condition absolutely necessary for possible improvement or recovery. WATER-PROOF. Wear it in bath! Recommended by doctors. Made especially to fit each individual case, yet costs so little. Write for FREE 100-page BOOK and liberal 60-Day Trial Plan, together with endorsements from grateful patrons in your neighborhood. No obligation. Address:

CLUTHE SONS Dept. 31 Bloomfield, New Jersey



Earn Cash at Home!

We paid M. M. \$1174 for exceptional cellar crop Snow-Kick mushrooms! We furnish materials; buy all crops. Big FREE picture book tells if your cellar, shed, suitable. Est. 1908. Write today.
 United Co., 3848 Lincoln Av., Dept. 312, Chicago



BUCHSTEIN'S FIBRE LIMB

is soothing to your stump—strong, cool, neat, light. Easy payments. Braces for all deformities. Agents wanted.

D. BUCHSTEIN CO.
 610 3rd Ave., So., MINNEAPOLIS, MINN.

Send for Catalog Today

To PROTECT YOUR INVENTION—Use this coupon, NOW

Delays are dangerous and may be very costly. My personal service assures prompt action, strict confidence, and a minimum of expense. I suggest that you send me a model or drawing, or sketch and description of your invention, and \$5.00. I will make a search and report

promptly as to its patentability and send you a copy of my 72-page booklet. Or, if you prefer to read my booklet first, mail the attached coupon at once. I will also send my "Record of Invention" form. (Over 38 years experience as a Registered Patent Attorney.)

L. F. Randolph, 302-D Victor Bldg., Washington, D. C.

Please send me at once, free of charge, your 72 page booklet and "Record of Invention" form.

Name.....

Address.....

A PERSONAL CONFIDENTIAL PATENT SERVICE

*The
Lost Word*

THE KEY TO SECRET WISDOM
 "Like a bolt from the heavens, the word was spoken and from the reverberations of its sacred syllables, came the creation of the Universe"—so relates an old, old legend. Through the ages men have searched in vain for this lost word. In its stead they found keys to a secret wisdom. They learned how to unlock the hidden possibilities slumbering within everyone . . . startling, unused powers that make for a greater life.

This Sealed Book—FREE

A sealed book by the Rosicrucians, reveals the plan whereby you may obtain this wealth of knowledge leading to the greater joys and rewards of living. For free copy without obligation, write Scribe F.F.B.

The ROSICRUCIANS
 SAN JOSE [AMORC] CALIFORNIA
 NOT a religious organization

In Your Spare Time At Home
LEARN MONEY-MAKING CARTOONING

By easy Picture Chart Method. Teaches originality—the big need today. Former students include creators of "Terry & Pirates", "Out Our Way", "Winnie Winkle", etc. Don't wonder whether you have talent—rush name, address RIGHT NOW for: FREE Sample Chart to test your ability, and examples of work of former students earning \$50.-\$300. per week. Please state age.

THE LANDON SCHOOL
 1430 National Bldg. Cleveland, O.



M ECHANICS-WELDERS - COLLISION MEN

**GOOD JOBS and
Mighty GOOD PAY**

Do you want to earn big money? If so let us know which of the following trades you prefer. You learn by doing. Practical work. Expert teachers. Low tuition. Personal attention. It will pay you to investigate AT ONCE. Just check the courses you'd like to take and mail today. You will receive full information, absolutely without cost or obligation. But don't delay.

- Check the Trade You'd Like to Learn**
- | | |
|---|---|
| <input type="checkbox"/> Complete Auto Mechanics (including Diesel) | <input type="checkbox"/> Electric Arc and Acetylene Welding |
| <input type="checkbox"/> Auto Collision | <input type="checkbox"/> Spray Painting |
| <input type="checkbox"/> Metal Finishing | <input type="checkbox"/> Body and Fender Bumping |
- Ask about our "Pay After Graduation Plan"**

Name

Address

Mail the above at once to

MICHIGAN TRADE SCHOOL

3758 Woodward Ave. Detroit, Mich.

**Write for
FREE
FOLDER**

Inventors Free Books



Answer your questions!

Practical Facts You Will Want to Know About

PATENTS TRADE MARKS COPYRIGHTS

• These C. A. Snow & Co. Free Books will save you TIME and MONEY!

Now one of America's oldest firms of patent attorneys offers you important facts on how to protect and commercialize your ideas..the very facts which can save you wasted hours and unnecessary expense. These free books are based on 63 years' experience and tell you exactly what to do to protect your invention.

Find Out RIGHT NOW

Before going any further with your idea — be sure you are on the "right track". You will be able to know *before* spending more time and money the costs and procedure in obtaining a patent. In the books you will find the plain answers to questions that have long bothered inventors.

Confidential, quick service

Our years of experience in helping others should make you feel perfectly safe in dealing with this reputable firm. All inquiries are answered immediately and held in strictest confidence. Write today.

TEAR OUT and Mail Coupon Today



C. A. SNOW & CO.

Registered Patent Attorneys Since 1875

1128 SNOW BUILDING, WASHINGTON, D. C.

Gentlemen: Please send me—without cost or obligation—your FREE books, "Suggestions on How to Commercialize Your Invention" and "How We Protect You." Also Certification of Invention form.

Name

Street and No.

City or Town State

When writing please mention Popular Mechanics

NOW...YOU CAN LEARN TO DRAW AT HOME



ART TRAINING CAN INCREASE YOUR EARNINGS

USE COUPON FOR FREE BOOK

If you would like to acquire the ability to become an Artist, you can learn to draw AT HOME in your own SPARE TIME. Studying Art at home is actually fun. The new knowledge and skill you can gain this practical way should equip you to earn good money. Later you can start out "on your own"—and be your "own boss."

COMMERCIAL ART • DESIGNING • CARTOONING All in ONE Practical Course

Maybe you have never studied Art before—perhaps you have always wanted to—if so, it is not too late to start now. Washington School of Art has been established 23 years. Our intensive course of training includes all the important branches of Commercial Art. Our plan is fascinating, pleasant, and can be made profitable. We invite you to write for full details.

TWO ARTISTS' OUTFITS Included in the W. S. A. Course

Upon enrollment you will receive the first Commercial Artist's Outfit which includes everything needed to start the course. Later on, a more advanced set of Art materials will be furnished. Use Coupon Now! It brings you the details by return mail.



FREE BOOK gives details!

WASHINGTON SCHOOL OF ART
Studio 1212E, 1115—15th Street, N. W.
Washington, D. C.

I am interested. Please mail a FREE copy of your Book, "Art for Pleasure and Profit."

Name..... Age.....
Address.....
City..... State.....

When writing please mention Popular Mechanics

FREE LESSON HomeArt Crafts



Good Money for Spare Time

A new easy way. Art novelties in big demand. Get free lesson and quickly learn to decorate Gifts, Bridge Prizes, Toys, etc. No experience necessary. Almost anyone can succeed with simple "3-step" method, and you earn as you learn. Everything furnished including Novelties for you to decorate and Homecrafter's Outfit.

NO CANVASSING

Many sit at home and make up to \$50 a week spare time or full. Write today for big illustrated booklet and FIRST LESSON FREE. Absolutely not one cent to pay. Lesson is free. Opening in every locality. Write quick.

FIRESIDE INDUSTRIES
Dept. 65-W, Adrian, Mich.

Industry Needs MECHANICAL ENGINEERS

Big opportunities for men with Engineering training. Promote yourself by preparing for jobs as Engineer, Superintendent, Master Mech., Factory Eng., Chief Draftsman, Gen'l Foreman. You mechanically employed men don't have to change lines to win promotion, but do have to get ready for jobs ahead. Write today for method for preparing for this well-paying profession. No obligation.
American School, Dept. M945, Drexel at 58th, Chicago



SUCCEED IN LANDSCAPING

Send for FREE book on landscape training. Study at home, earn while learning. Profitable career; men, woman. Field uncrowded; initiative rewarded. Write today, give age, occupation.

AMERICAN LANDSCAPE SCHOOL
6015 Grand Ave., Des Moines, Ia.

Learn Public Speaking

At home—in spare time. Many overcome "stage-fright," gain self-confidence and increase earning power, this easy way. Write for free booklet, *How to Work Wonders With Words* and requirements.
North American Institute, Dept. 1359
3601 Michigan Ave., Chicago, Illinois

AUDELS Carpenters and Builders Guides 4 vols. \$6



Inside Trade Information for Carpenters, Builders, Joiners, Building Mechanics and all Woodworkers. These Guides give you the short-cut instructions that you want—including new methods, ideas, solutions, plans, systems and money saving suggestions. An easy progressive course for the apprentice and student. A practical daily helper and Quick Reference for the master worker. Carpenters everywhere are using these Guides as a Helping Hand to Easier Work, Better Work and Better Pay. To get this assistance for yourself, simply fill in and mail the FREE COUPON below.

Inside Trade Information On:

How to use the steel square—How to file and set saws—How to build furniture—How to use a mitre box—How to use the chalk line—How to use rules and scales—How to make joints—Carpenters arithmetic—Solving mensuration problems—Estimating strength of timbers—How to set girders and sills—How to frame houses and roofs—How to estimate costs—How to build houses, barns, garages, bungalows, etc.—How to read and draw plans—Drawing up specifications—How to excavate—How to use settings 12, 13 and 17 on the steel square—How to build hoists and scaffolds—skylights—How to build stairs—How to put on interior trim—How to hang doors—How to lay floors—How to paint.



THEO. AUDEL & CO., 49 W. 23rd St., New York City

Mail Audels Carpenters and Builders Guides, 4 vols., on 7 days' free trial. If O.K. I will remit \$1 in 7 days, and \$1 monthly until \$6 is paid. Otherwise I will return them. No obligation unless I am satisfied.

Name.....
Address.....
Occupation.....
Reference..... P.M.

NEW INVENTIONS

(Continued from page 18A)

DESIGNED for student and craftsman, a combination tool with numerous

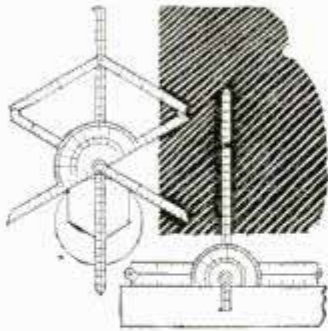

uses has been patented. It may be employed as angle and arc bisector, rafter square, compound divider, combination square, depth gauge, tee bevel, tee square, center-

ing tool, marking gauge, bevel protractor or protractor square, rule or a tool for laying out or drawing any number sided figures or objects. The tool is for students, draftsmen, architects, carpenters, cabinet-makers, sheet-metal workers, steel workers, tool and die makers and others.

HANDY for the small home or apartment is a newly patented washboard designed for use in sinks. The board has a rubbing plate mounted between two legs which extend into the sink. The frame is shaped so that metal arms grip the edge of sink to hold the board steady while it is in use. The board is particularly useful for small washings.



A COMBINED ceiling light, radio receiver and loudspeaker, which is hung like an electric lighting fixture, has been patented. The purpose of the ceiling mounted radio is to conserve room space and eliminate chance of damage. Tuning is accomplished by long, telescoping shafts with knobs on the end. The shafts hang so that all a listener need do is raise his hand from his chair to tune the receiver.

Due to the fact that many of the devices described in this department are still in the patent office stage and are not on the market, Popular Mechanics Magazine cannot undertake to supply further information regarding them.

Learn AUTO Mechanics

QUICKLY IN A FEW WEEKS

Good-Pay Jobs

Are Available!

Trained men earn top wages in these fascinating well-paying trades. This is not a correspondence school—no books—no lessons. Don't look for a job—**TRAIN FOR IT.** Read below how a McSweeney-trained man made good.

LEARN EASILY, QUICKLY:

- AUTO MECHANICS
- AVIATION MECHANICS
- DIESEL MECHANICS

Collision Repair (Complete)

Body and Fender Repair

Auto Painting

- WELDING—Arc and Gas

You Get Actual Shop Training

Work on real equipment with real tools. In a few weeks you should be trained by actual work to hold down a Good Pay Job.

**We get
many letters
like this**

1801 E. 65th St., Cleveland, O. Dear Mac—Immediately after leaving school I went to work for United Motors and am now located in Cleveland where I hold a good position. I have been able to take care of the most complicated electrical jobs. I think I have done fine considering I had no experience before coming to your school.
—Hubert Todd

LEARN NOW—PAY LATER!

We will give you complete information on how to get your training now and pay for it later out of your earnings.

FREE Write today for Big Free Book. Get the facts about jobs; and low Tuition Offers. Mailing the coupon does NOT obligate you. It obligates ME to tell YOU how you can train for Big Money in a few short weeks. Address Dept. 10-12.

McSWEENEY SCHOOLS

DETROIT, MICH. and KANSAS CITY, MO.

Write Our School Nearest You



DETROIT

In Big New McSweeney Buildings

The finest of their kind. Every modern facility for thorough instructions.



KANSAS CITY

McSWEENEY TRADE SCHOOL

Dept. 10-12, Detroit, Mich., or Kansas City, Mo.

Without cost or obligation send me your big FREE Book.

**I am interested
in the course on** _____

Name _____

Street _____

Town _____ **State** _____ **Age** _____

GOOD SALARY

FINE CAR

To the man who wants to enjoy
an **ACCOUNTANT'S** CAREER

A NICE HOME

BANK ACCOUNT

IF you're that man, here's something that will interest you.

Not a magic formula—not a get-rich-quick scheme—but something more substantial, more practical.

Of course, you need something more than just the desire to be an accountant. You've got to pay the price—be willing to study earnestly, thoroughly.

Still, wouldn't it be worth your while to sacrifice some of your leisure in favor of interesting home study—over a comparatively brief period in your life? Always provided that the rewards were good—a salary of \$2,000 to \$10,000?

An accountant's duties are interesting, varied and of real worth to his employers. He has *standing*!

Do you feel that such things aren't for you? Well, don't be too sure. Very possibly they *can* be!

Why not, like so many before you, investigate LaSalle's modern Problem Method of training for an accountancy position?

Just suppose you were permitted to work in a large accounting house under the personal supervision of an expert accountant. Suppose, with his aid, you studied accounting principles and solved problems day by day—easy ones at first—then the more difficult ones. If you could do this—and if you could turn to him for advice as the problems became complex—soon you'd master them all.

That's the training you follow in principle under the LaSalle Problem Method.

You cover accountancy from the basic Elements right up to Accountancy Systems. Later, you choose from twelve post-graduate electives, including C. P. A. coaching.

As you go along, you absorb the principles of Auditing, Cost Accounting, Business Law Organization, Management and Finance.

Your progress is as speedy as you care to make it—depending on your own eagerness to learn and the time you spend in study.

Will recognition come? The only answer, as you know, is that success *does* come to the man who is really *trained*. It's possible your employers will notice your improvement in a very few weeks or months. Indeed, many LaSalle graduates have paid for their training—with increased earnings—before they have completed it! For accountants, who are trained in organization and management, are the executives of the future.

Write For This Free Book

For your own good, don't put off investigation of *all* the facts. Write for our free 48-page book, "Accountancy, The Profession That Pays." It'll prove that accountancy offers brilliant futures to those who aren't afraid of serious home study. Send us the coupon *now*.

Over 1650 Certified
Public Accountants among
LaSalle alumni

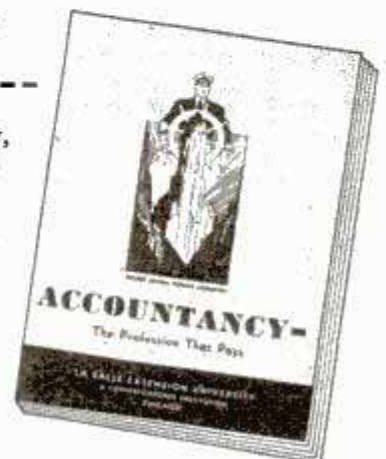

LASALLE EXTENSION UNIVERSITY, Dept. 1264-HR, Chicago, Ill.

I want to be an accountant. Send me, without cost or obligation, the 48-page book, "Accountancy, The Profession That Pays," and full information about your accountancy training program.

Name.....

Address..... City.....

Position..... Age.....

LASALLE EXTENSION UNIVERSITY
A CORRESPONDENCE INSTITUTION

When writing to advertisers please mention Popular Mechanics



CLASSIFIED

Advertisements



Advertisements in this section, 35 cents per word, each insertion, minimum 10 words, payable in advance

To be inserted under proper classification in January issue, copy should be in our office November 8th

January issue on sale December 1st

Popular Mechanics Magazine, 200 East Ontario Street, Chicago, Illinois

YOU'LL PROFIT

By reading and answering the classified ads in this section. Hundreds of opportunities to make and save money.

Mr. F. W. Johnson,
Popular Mechanics Magazine,
200 E. Ontario Street, Chicago, Illinois.

Dear Sir: Three years ago I placed a small "ad" in your classified section, every three months, for a small cost of \$3.85. At that time I was employed, earning a good salary. Today, through the results of this little "ad," I am in business for myself, employing three people, doubled my salary, and have a stock of electrical goods, valued at approximately \$9,000.00 and all paid for. One of the orders that I received last month through my "ad" in Popular Mechanics Magazine totaled \$225.00 and came all the way from CEBU, Philippine Islands. Your magazine certainly gets around.

(Original letter on file in our office)

Very truly yours,
MOTION PICTURE EXHIBITORS

1000 CLASSIFIED ADVERTISEMENTS 1000 OPPORTUNITIES FOR YOU

AUTOMOBILES

AUTOMOBILE Mechanics who want own business or earn good extra money write fully for samples and details of nationally distributed Self Locking Triplex Piston Rings. They eliminate re-boring. Guaranteed life of car. Franchises valuable. Some territories open. Triplex, 2261 South Union, Dept. P, Chicago.

MIDGET Cars, parts, plans. Catalog 20c. Derby Midget Cars, Woodstock, Ill.

MIDGET Racing book; facts for fans, builders, drivers; track sizes, regulations; pictures, specifications, working drawings. \$1.00 postpaid. \$1.15 C.O.D. Ray Kuns, Department 32, Madisonville, Cincinnati, Ohio.

NAVY Aviator helmets, calf leather, chamois lined, fur interlined, very warm, large sizes only, \$2.95. Air Transport, Garden City, N. Y.

PHOTOGRAPHS, Finest foreign, domestic automobiles. Handbook, 10c. Automobiles, Box 534, Saint Cloud, Minnesota.

ENGINES, Propellers, for sleds, midget cars. Circulars dime. Storms, 199 Broadway, Asheville, N. C.

RACE Car, Miller Eight. Winner Indianapolis 500 mile race. Raced this year. H. Kohlert, St. Charles, Illinois.

MIDGET Race cars, midget motorcycles, motorscooters, handbook catalog, parts, plans, motors, 80 illustrations, 20c coin. Midwest Midget Motors, Box 1959, Chicago.

ANTI-FREEZE! Mix your own. Gallon costs 10c. Harmless, non-inflammable, non-corrosive. Formula \$1.00. Monroe-Methods, St. Paul, Minn.

DOUBLE Any car mileage performance the easy way. Big money servicing. One dollar brings amazing, simple, exclusive guaranteed method. Edgar Holmes, 350 Acoma, Denver, Colorado.

R & R Mfg. Co., Anderson, Indiana. Racing cars and midgets. Catalogue 25c.

1938 **IGNITION** Supercharger. Quick starting, wet or cold. Mileage, pep, power, less carbon, \$1.25. E. G. Sales Co., 321 Broadway, New York.

FORD V-8's, 1934-1938; gasoline saving device. \$1. Walert Co., 3429 No. 10th St., Milwaukee, Wisconsin.

MIDGETS! Catalog—plan book, 10c. List 100 used motors, midgets, parts, 20c. Details free. Shipps Midgets, Box 543-H, Zanesville, Ohio.

AUTO TRAILERS

BUILD The famous, low-cost Jim Dandy Cabin Trailer. Complete plans and instructions 50c. Plans to build the beautiful, streamlined Jim Dandy Cabin Cruiser, \$1.00. Trailer Builders Manual and catalog of trailer parts, supplies and equipment—over 100 interesting, illustrated pages, 25c. Order today. Satisfaction guaranteed. Trailer Supply Co., 411-A Jackson St., Wausau, Wisconsin.

NEW Lightweight streamlined 2 room house trailer with 100 latest refinements only \$175; details free. Nicklin Mfg., Box 491, Newburgh, New York.

AUTO SUPPLIES AND EQUIPMENT

FREE 1938 Wholesale bargain catalogue auto supplies, equipment, tools. Lefte, 1189 Bedford Ave., Brooklyn, N. Y.

PLATING Outfits for auto parts. Connect to a battery. No tanks used. Free particulars and proofs. Gunmetal Co., Ave. J, Decatur, Ill.

RESILVER Auto headlight reflectors. Rex Kit complete, one gallon silver solution, buffing wheels, and compounds \$8.00. Rex Plating Co., Bedford, Penna.

SAVE Half! Guaranteed reconditioned truck and auto parts. All parts—all models, makes. Catalog free. General Auto, 7008-AA Cottage Grove, Chicago.

LUBRITUBE, New amazing vacuum windshield wiper lubricant 25c (coin) U.S. 483 24th Street, Oakland, California.

A HOLE In your casing? If so write Minor Tire Shop, Brookfield, Missouri.

CLEAN Spark plugs with \$2 sand blast machine. Marvelous, Box 46, Naperville, Ill.

INEXPENSIVE Guaranteed protective puncture seal. Airlock Laboratory, 1460 Hollywood, Chicago.

MOTORCYCLES, BICYCLES, MOTOR SCOOTERS AND SUPPLIES

BUILD Your own motor scooter. We furnish parts. Literature, dime. Drawings free. Comet Cycle Company, Box 3032, Madison, Wisconsin.

MOTORCYCLE Bargains, lowest prices, bargain sheets for stamp. Motorcycle accessories. Rochester Harley Davidson Corp., 129 W. Main St., Rochester, N. Y.

FRONT Drive Carycycle for pleasure and service. Carycycle Co., 2704 George St., Chicago, Ill.

MOTO-SCOOT Demonstrators, 10 1938 models. Excellent condition. A wonderful buy for interested party to enter rental business. Sold separately. Moto-Scout Mfg. Co., 205 S. Western, Chicago.

SPORT Windshield for Harleys or Indians \$2.95. Nicklin Mfg., Box 491, Newburgh, New York.

SEND 10c In stamps for illustrated bulletin of cut-rate motorcycle supplies, new and used parts. Authorized Harley distributors. Tulsa Motor & Cycle Co., 917 E. 2nd, Tulsa, Oklahoma.

ALLOY Pistons—Harley, Indian, Henderson, Excelsior, Cleveland. New and used parts for less. Cylinder grinding. Catalogue and wings pin 10c. Ballak, 1115 Chestnut, St. Louis, Mo.

INSIDE Dealer prices. Overstocked, all models, Indians and Harleys. Rebuilt, guaranteed. Dime brings latest list. Crandall-Hicks, Boston, Mass.

REBUILT Motorcycles, all makes, new and used Harley-Davidson parts. Send 10c for bulletin. Western Harley-Davidson Distributors, 914 E. 15, Kansas City, Mo.

RECONDITIONED Motorcycles. New—used parts for all makes. Authorized Harley-Davidson dealer. Whitman Motorcycle & Supply Co., 405-9 Southwest Blvd., Kansas City, Mo.

SEND 15c For illustrated used motorcycle catalog. Bargains. Largest stock genuine Indian parts and motorcycles. Indian Motorcycle Sales, Kansas City, Mo.

AVIATION

PROPELLERS For sleds, airplanes. Catalog 5c. Banks Propellers, Love Field, Dallas, Texas.

AVIATION—Train for apprenticeship, mechanic, pilot, meteorologist—Good future. Write, immediately, enclosing stamp. Wayne County Airport, Box 857, Dept. E-2, Detroit, Michigan.

PROPELLERS—All types, including latest three blade airliners. American Flea Special \$12.50 down. Universal Aircraft, Ft. Worth, Texas.

100 AIRPLANES \$40 Up. Terms. Motors, crackups, salvage. Complete catalogue 25c. Used Aircraft Directory, Athens, Ohio.

GET Into aviation—Airline pilots get up to \$700 a month; mechanics, \$200; aeronautical engineers, \$400. Prepare now at this government approved school. Write for complete information. Lincoln Airplane & Flying School, 2004 Aircraft Bldg., Lincoln, Nebraska.

PROPELLERS For airplanes, sleds. Also iced blueprints. Catalog dime. Lorenzen Propellers, Niles, Michigan.

AEROSLED Motors, 80 horsepower, air-cooled, new, weight 285, overhead valves. Price \$75. Propellers \$10. Allison Aircraft, Lawrence, Kansas.

GET Into aviation by the transport license method, which takes the drudgery out of study. For better pilots and better mechanics. Write for circular. Thompson Aviation Publishers, 8318 Woodward Ave., Detroit, Mich.

MY Experience as a wing walker and a parachute jumper with Roscoe Turner and others. How I learned to fly without money. Learn just how, I walked the wings, jumped parachutes, changed from plane to plane in mid air, from racing automobile to plane, diving a 100 ft. in water from a flying plane. The swing of death and many other death defying stunts, also my experience in moving pictures. Send \$1.00 for my big little book. Art. Starnes, Box 321, Calumet City, Illinois.

PILOTS: Quiz System covering aircraft, engines, navigation, meteorology, new civil air regulations, with questions and answers—only \$2.00. Quiz System, 1435 Flower St., Glendale, Calif.

LEARN To fly. Practical, illustrated course, \$1. Aircraft Directory, Athens, Ohio.

AIRPLANE Or engine mechanic's license questions with answers \$1.25. Both \$2.00 postpaid. Meyer Engineering, Box-8, Hempstead, N. Y.

GRADUATE Airplane mechanic. Ten weeks. \$1.00 week. Graduates with leading concerns. Free catalog. United Air School, Elgin, Ill.

AVIATION Needs men. Pilots, mechanics, draftsmen, sheet metal, positions open. Learn now. Free catalog. California Flyers School of Aviation, Dept. PMC-12, Los Angeles Airport, Inglewood, California.

AERODRIVE—Hispeed sled. Constructional blueprint 25c. Ostergaard Aircraft, Dunning, Chicago.

"SECRETS Of Aviation Success," dime. Meyer, Box 8, Hempstead, N. Y.

A. C. GENERATORS

PRACTICAL Changes for automobile generators. See our advertisement at bottom of page 141A. Autopower.

BATTERIES, GENERATORS, ETC.

EDISON Lifetime storage batteries for light and power. Eliminates acid battery diseases. Long guarantee. All kinds rebuilt generating plants, motors, and miscellaneous articles at bargain prices. Free interesting literature. T. Hawley Smith Co., Croton Falls, N. Y.

WHOLESALE Prices automobile air cooled generators for cars and trucks. New and rebuilt. Wilt Electrical Co., 7829 So. Racine Ave., Chicago.

10 HORSE Gasoline engine with magnet, like new, \$65.00. 500 watt, 110 volt, alternating generator \$22.50. 5 kilowatt, direct, 600 speed \$55.00. Electrical Surplus, 1885 Milwaukee, Chicago.

EDISON Storage batteries for light-power systems. Non-acid. Odorless. fifteen year life. Five year unconditional guarantee. Bargains in complete lighting systems. Low prices. Free illustrated literature. "See-Jay" Battery Co., 82 Sterling Ave., Yonkers, N. Y.

PLATING Generators and motor generator sets. Write for information Hobart's new line electro plating equipment. Payments low as \$12.40 monthly. Quality machines, quick delivery guaranteed. Hobart Bros., Box M-1282, Troy, Ohio.

RE-BUILD Old auto, farm light batteries. Send 25c for complete course and catalog. Tools, molds, etc. Home Occupations, St. Paul, Minn.

AIR CONDITIONING

INSTALL Your air condition system; no experience needed. Home conditioner \$19.50; office, shop conditioner \$39. Free details. Nicklin Mfg., Box 491, Newburgh, New York.

ELECTRICAL SUPPLIES—EQUIPMENT

ULTRA Violet—Infra red. Dual ray health lamp. Two separate units in one. Promotes sun tan—vitamin "D". Automatic control. AC-DC current. \$3.90 postpaid. Details. Beyer Mfg. Co., 4515-P Cottage Grove, Chicago.

ELECTRIC Pen, engraves all metals, 50c prepaid. Hudson Bros., East Syracuse, N. Y.

ELECTRICAL Arc experimental kit! Make powerful searchlight—melt glass, copper, iron—generate suntan rays, dozens others. Complete with power reducer, goggles, carbons, instructions. 110-volt. Postpaid \$1.99. Electrical Salvage Co., Box 524-P12C, Lincoln, Nebr.

ELECTRICAL Experimenter supplies, magnet wire, insulating materials, etc. Send 10c for complete catalog. Autopower, 410 So. Hoyne Avenue, Chicago.

WINDCHARGER Plan, 10c—Propeller, \$1.25 postpaid. Beacon Mfg., Benedict, N. Dak.

ELECTRO-SCRIBE: Electric pencil writes, engraves all metals. \$1.00 postpaid. Details. Beyer Mfg. Co., 4515-K Cottage Grove, Chicago.

REWINDING Electric motors! Diagrams, sketches, tables, etc., for rewinding series motors, repulsion motors, repulsion-induction motors, split-phase motors, A-C motors, D-C motors, 3-phase motors, generators, etc. Technical bulletin \$1.00. Readers Service, 800-49 North Clark, Chicago.

HEARING Aids, rechargeable batteries. Complete line, bargains. On approval. Dynamic Ear, 363 N. E. 76 St., Miami, Fla.

ELECTRIC FENCING

FENCE Controller easily converted from Ford T coil. No extra costs. Complete plans 35c. LeJay Manufacturing, 847 LeJay Building, Minneapolis, Minn.

WELDING AND SOLDERING

REBUILT a.c. d.c. Arc welders, all sizes; engine governors, idlers. Terms. Low prices. Guaranteed. Service Co., 3732 Cedar Ave., Cleveland, Ohio.

DEMONSTRATORS, Electric arc welders. Money-saving prices. Used by the government. Trial and terms guaranteed. Hobart Welders, M-1283, Troy, Ohio.

75-200 AMPERE Arc welders from Dodge generators. Complete plans 35c. 100 other generator changes. LeJay Manufacturing, 347 LeJay Building, Minneapolis, Minn.

APOLLO 110 Volt electric brazing torch. Produces 3 inch flame similar to acetylene. Welds, brazes, solders all metals including aluminum. Works on ordinary house current. Complete \$12.50. Apollo Manufacturing Company, 634 Union, Memphis, Tennessee.

AMAZING Soldering flux readily tins dirty steel or cast iron. Sample quarter. Millers, Southside, Elmira, N. Y.

ACETYLENE Welding generators, latest type. \$25.00. Johnson Generator Co., Brookfield, Missouri.

NEW Electric welder, cheap. Free literature. Holgersons Service, Canton, Kans.

SPOT Welders, small, portable, powerful. Welds always satisfactory. Child operates safely. \$40. Gale Hollinger, Glen Ellyn, Ill.

D.C. ARC-WELDER Plans \$1.00 each. (Positively no armature winding.) Delco plan: 25-200 amperes from 32 volt Delco light plant. Heavy duty plan: 25-600 amperes from d.c. truck motors. Dodge plan: 25-200 amperes from North-east (Dodge) 12 volt automobile generators. Welders Club of America, AB-3432 M-Mart, Chicago. Special: For sale; new and used d.c. truck motors.

BLUEPRINTS For powerful 110v. a.c. welder \$1.50. Marvelweld, Box 1156, San Francisco.

ACME Electric spot welder for sale. Otto Kuehl, Minonk, Ill.

ENGINES, MOTORS, DYNAMOS

BARGAIN— $\frac{1}{2}$ Hp. motors, 60 cycle, 1 phase, 110 volt, like new, guaranteed, \$7.70. Send check to Erie Electric Motor Co., 120 Church, Buffalo, N. Y.

WINDING Data, 225 motors, single and three phase. Price \$1. Motor Data Co., Box 7631, Kansas City, Mo.

$\frac{1}{2}$ H. P. General Electric motors, \$3.50, guaranteed. Larger sizes. List 10c. A. C. Motors, 3008 Bailey, Philadelphia, Penna.

SPLIT Phase $\frac{1}{3}$ h.p. motor. Guaranteed two years. Double drive shaft. Built-in starting switch. New departure ball bearings. Every part is extra strong. 110-120 volt, 60 cycle ac., 1750 rpm. Only \$8.95 plus 65c postage. Address Dept. D912, Sears-Roebuck, Chicago.

MOTORS For cars, trucks, marine, industrial. All years and models. Factory prices. Many bargains. Free booklet. Ecqua Motor Exchange, 755-57 River St., Troy, N. Y.

ALTERNATING, $\frac{1}{2}$ Horse, 110 volt, induction motors. Rebuilt, guaranteed, \$7.50. Wilmot Auto Supply, 2247 St. Paul Ave., Chicago.

MAKE Money. Rewind machine motors, auto generators. Each book \$1.00. 10c brings particulars, catalog winding materials. Ernest Knight LaSalle, Illinois.

GOVERNORS For auto engines. Candee-Smith, 445 $\frac{1}{2}$ East 3rd Street, Los Angeles.

BANKRUPT Sacrifice! New $\frac{1}{4}$ h.p. West. motors, \$1 each, cash. Acme, Claremont, N. H.

ONLY \$7.50 Postpaid. Make your automobile engine into controlled power unit for welders, sawing, etc. Our "Peppy" governor sold with money back guarantee. Write for circular. Harris Machinery, Minneapolis, Minnesota.

ALUMINUM Alloy pistons. For all makes and models of automotive, industrial, marine inboard, aviation, diesel, midget, model, motorcycle and outboard motors. Finished and semi-finished, any oversize. Catalog on request. Judson Mfg. Co., Hedge and Gillingham Sts., Philadelphia, Penna.

FOR Sale—25 small elect. motors, high speed, 1/10 h.p., 115 volt, universal. Rebuilt—\$2.00 postpaid. McConnell, 1619 Edgewood, Racine, Wis.

15 KVA Alternating generator \$235.00; other sizes. Motor-generators for magnetic chucks. Queen City Electric, 519 South California, Chicago.

ELECTRIC Shaver \$2.00; drill \$3.67; candid type camera \$2.49 postpaid. Motors, grinders, home workshop tools. Bargain pricelist free. Mailorder Electric, 713 South Dearborn, Chicago.

MACHINERY, TOOLS AND SUPPLIES

14" x 6' GREAVES Klusman cone head engine lathe, quick change. No. 0 Cincinnati miller, cheap. Write for particulars. Cincinnati Machinery & Supply Co., 221 E. Second St., Cincinnati, Ohio.

ELECTRICAL And mechanical repair parts for washers, sweepers, etc., write for free list of parts. Harper Appliance Service, Verona, Penna.

WILL Pay cash for Delta, or similar wood and metal working tools. Gerard Electric Co., 60 Pearl St., Boston, Mass.

PLASTICS, Brass, aluminum, monel, stainless steel, gears, etc. in small quantities. Catalog 10c. Hobby Supply House, Box 2014, Pittsburgh, Penna.

SOUTH-BEND 9" Lathe milling attachment, universal movement, \$9; threading dial indicator, \$3; circular free. Unique Manufacturing Co., 4807 No. 31st Ave., Omaha, Nebr.

AIR Compressors, new $1\frac{1}{2}$ x $1\frac{1}{4}$, \$6. 2x2 \$7. 2 $\frac{1}{2}$ x 2 \$8. Guaranteed. Send check or money order. National, 560 Washington, Chicago, Ill.

SEND For your free 1939 wholesale tool booklet. Machinery, tools, supplies. Homecraft Tool Supply, 236 Neptune Ave., Brooklyn, New York.

BARGAINS, Demonstrators, electric arc welders, guaranteed, 30 days trial and terms. Write Hobart Welder Exchange, Box M-1284, Troy, Ohio.

MICROMETER Bargains, complete set, \$13.95 in case. Send for details. Micro Products, 529 E. Jefferson, Detroit, Mich.

ATTENTION! Experimenters, craftsmen, inventors: You need this giant ten pound hardware kit. Big box full of screws, nuts, washers, gears, springs, rivets, brackets, etc. Experimental motor. Over 1000 parts—price \$1.49—worth \$7.50. Guaranteed satisfaction. Manufacturers Supply, 213M West Illinois, Chicago.

COMPRESSORS, Single cylinder, 100 lb. \$6.00. Edison universal double shaft motors, \$2.00. Powerful G. E. 15 volt transformers, \$2.00. All sizes Edison storage batteries. Pioneer Air Compressor, 120 Chambers St., New York City.

NEW 4 Speed $\frac{1}{2}$ " electric drill complete with chucks, drills \$19.95. Sturdy floor press for drill \$8.95. Nicklin, Box 491, Newburgh, New York.

CONCRETE Building block machines and molds. Easy payments. Catalog free. Concrete Machine Co., 5129 South Compton Ave., St. Louis, Mo.

BOATS, OUTBOARD MOTORS, ETC.

BARGAINS In rebuilt outboard motors, guaranteed. Send stamp for list. Murray Boat Shop, Traverse City, Mich.

PLANS And full-size paper patterns for cabin cruisers, sailboats, runabouts, etc. Send 10c for catalog. Melrose Boat Works, Magnolia Springs, Alabama.

FORD And Zephyr marine conversions. Send 10c coin. Lehman Engineering Co., Newark, N. J.

BOAT Blueprints, patterns, many designs, catalogue 10c. Cleveland Boat Blueprint Company, Station A-6, Cleveland, Ohio.

BUILD Your favorite boat, save on the cost. The Welch System of Boat Building makes this possible. Send 10c for 32 page catalog showing Welch designs, White Cap motors, boat equipment. The Welch System completely explained in this interesting book. Use Welch Ready Cut parts and build your boat at home. Welch Boat Company, Station K-1, Milwaukee, Wis.

12 FOOT Weldwood boat—sail, row, outboard. Complete building plans 35c. Free catalog. Rudder, 15 Murray Street, New York.

COMPLETE Your own boat with our pre-fabricated frames and materials. They're different. Save 2/3s and costly mistakes. Send requirements for quotations. Illustrated catalog 100 boats, 10c. Bay City Boats, Inc., Bay City, Mich., 1552 Adams St.

ASSEMBLE Your own boat. Our finished knock-down frames and materials save you 2/3 builder's cost. All types and sizes. Send 25c for big catalog. Brooks Boat Co., Inc., D4, Saginaw, Mich.

OUTBOARDS—Save 1/2. Good used parts, all makes and models. Bargains rebuilt motors. Crandall Hicks Co., 959 Commonwealth, Boston, Mass.

BOAT Designers are highly paid professionals. Complete course by mail. Catalog. Westlawn, Montville, N. J.

FIELD GLASSES, TELESCOPES AND MICROSCOPES

BUILD Reflecting telescopes, 6" kit, \$3.50; other kits—all abrasives, mirrors, eyepieces, diagonals, illustrated instructions, 10c. Catalogue free. Optical Development Corporation, 1560 Broadway, N. Y.

TELESCOPES, Microscopes, binoculars; 1939 bargain catalog free. Brownscope Company, 5 West 27th Street, New York.

FREE Instructions. Build powerful telescope. Jamer, Box 94, Manorville, N. Y.

TELESCOPES, Microscopes, chemistry, mineralogy. Scientific catalog free. Tracey Laboratories, Evanston, Illinois.

SPORTING GOODS, GUNS, FISHING TACKLE, ARCHERY

GUNS, Pistols, outdoor equipment, on time! 10% down, 10% monthly. Gun handbook and catalog illustrates, prices and describes hundreds most popular makes. Contains a wealth of advice by America's foremost shooting authorities. Send 25c for your copy. National Target and Supply Company, Dept. P-12, 1255 - 25th Street, Northwest, Washington, D. C.

NOVEL Woodcraft cigarette case and fancy calico handbag. \$1 for first 300 persons. Maruni Co., Hideyoshihira, Ginza, Tokyo, Japan.

FENCING Equipment. Foils, swords, masks, etc. Low prices. Free catalog. Industrial Products, Dept. 212, 48 West 48th Street, New York.

BARGAINS! Gun catalog 5c. Fishing catalog 5c. Ski catalog 5c. J. Warshal & Sons, First and Madison-PM, Seattle, Wash.

GOLF Clubs. Five club matched set \$2.50. Lincoln Surplus, 123 Galena, Freeport, Ill.

ICEBOAT Sail rig with instructions for cheap, simple chassis, \$14. Use on boat in summer. Skate sails \$7. Try-Sail Company, Patterson, N. Y.

LEARN Gunsmithing at home. Repair your own and neighborhood's firearms. Free catalog describing 20 books on firearms and gunsmithing. Samworth, Marines, North Carolina.

FLYTYING Made easy! Complete kit, tools, materials and instruction book containing 700 patterns. \$8.95 postpaid. Fly Craft Co., 108 N.W. 9th, Portland, Oregon.

"PUNCH And Speed" new training bags, at cost price. Free circulars. J. Andre, 3520 Mt. Elliott, Detroit, Mich.

ARCHERY Headquarters—617 South State, Chicago. Catalogue free. Complete instruction book 50c.

HUDSON Bay blankets, Indian pack baskets, camp stoves, knives, compasses, outdoor equipment. Free catalog. Howe Fur Co., Box P, Coopers Mills, Maine.

ANTIQUES, RELICS, INDIAN GOODS

100 GOOD, Or 60 fine, arrowheads \$3.00. George Holder, Glenwood, Ark.

SKULLS \$3.50-\$10.00. Catalog Indian relics. Bernard, Box 192, Oakland, Calif.

SWORDS, Rapiers, daggers, pistols, armor. List stamp. Abel's 860 1/2 Lexington Avenue, New York.

100 GOOD Arrowheads \$3. Catalog. 5c. H. Daniel, Hot Springs, Ark.

INDIAN Relics, beadwork, coins, curios, minerals, old glass. Catalog 6c. Indian Museum, Northbranch, Kansas.

TAXIDERMY

FREE. New 36-page 1939 catalog. New ideas. Bargains galore. Everything for every specimen. Taxidermic Manufacturers, Memphis, Tenn.

LEARN By mail to mount birds and animals, tan skins, make leather. Old reliable school teaches, easily, quickly, at low cost. Over 250,000 students. Rush postal for free 48 page book. Northwestern School of Taxidermy, 775 Elwood Bldg., Omaha, Nebr.

GLASS Eyes, taxidermists', furriers' supplies. Big catalog free. Elwood Company, 222 Smith Bldg., Omaha, Nebr.

TAXIDERMY Supplies—Quality artificial eyes, teeth, genuine Jonas head forms. Tools, materials, etc. Everything for the progressive taxidermist. Send 10c for big illustrated catalogue. Jonas Bros., 1049 Broadway, Denver, Colo.

DOGS, PETS, BIRDS

\$15.00 BUYS Trained coon hound. Opossum, fox, rabbit and bird dogs cheap. List free. Ramsey Farm Kennels, Ramsey, Illinois.

BIRDS? Get American Canary Magazine monthly. Year \$1.00. 2839-P North Halsted, Chicago.

SPORTSMEN: 200 Pointers, Setters, straight cooners, combination hunters, rabbit and fox hounds. Reasonable. List free. Ramsey Creek Kennels, Ramsey, Illinois.

SAINT Bernard puppies! Giant type and cheap! Illustrations free! Royal Kennels, Chazy, No. 8, N. Y.

FOR Sale: My beautiful 3 year old male pointer, thoroughly trained, good retriever. Price \$75. Ship C.O.D. 3 days trial, if you guarantee all express. Wire C. W. Frye, Finger, Tenn.

SAINT Bernard puppies, beauties, reasonable. Paramount Kennels, North Hatley, Quebec.

ST. BERNARDS! Strong, loveable puppies for Santa. Write us today. Lake Manitou Kennels, Watrous, Sask., Can.

BEAUTIFUL Pure white police dogs. Ansonia Kennels, Mose, N. Dak.

POULTRY AND FARM SUPPLIES

MORE Profit in your grain fed to broilers. Poultry prospects bright. Write today for catalog. Dubois County Hatchery, Box 912, Huntingburg, Indiana.

GREENSBURG Bloodtested chicks for broilers. Immediate delivery on Barred, White, Buff Rocks, Reds, also Leghorns \$4.50 up. Write for catalogue and quantity discounts. Greensburg Hatchery, Box 40, Greensburg, Ind.

40,000 CUSTOMERS In 40 different states, annually buy 10,000,000 Davis chicks for broilers and layers. 21 different breeds. Sexed chicks \$4.50—100 and up. Free catalog. Davis Poultry Farm, Route 34, Ramsey, Indiana.

CHICKS For broilers. Immediate delivery on Reds, Barred, Buff, White Rocks, Wyandottes, Orpingtons, Leghorns. Sexed chicks 90% accuracy guaranteed on pullets. Write for low prices. Salem Hatchery, Box 81, Salem, Indiana.

CHICK Raisers make extra money selling our chicks to neighbors. Write Jackson County Hatchery, Box 19, Seymour, Ind.

SEYMOUR Chicks for broilers and early layers. Our prices are always at rock bottom. Write us before you buy chicks. Seymour Hatchery, Box 36, Seymour, Ind.

MAKE Money with poultry. Read America's leading poultry magazine for latest information. Three years \$1.00; nine months 25c. Poultry Tribune, Dept. E-93, Mount Morris, Ill.

TREES, SHRUBS, ROOTS, HERBS

JUST Out! World's greatest "Herbalist Almanac." Beautifully illustrated in natural colors. Contains over 200 old-fashioned herb medicine recipes for home use. 10c postpaid. Worth dollars! Botanics, 145 W. 112th St., Chicago.

FARM MACHINERY AND SUPPLIES

ALL Purpose tractors at factory price. Shaw 2 to 5 horsepower, riding or walking types. Does plowing, discing, harrowing, cultivating; mows lawns, cuts weeds, does hauling; runs belt machinery. Air or steel tires. Three speeds forward and reverse. Thousands in use. Write for free catalog and 10 day trial offer. Shaw Mfg. Co., Dept. PM, Galesburg, Kansas.

FARMS AND FARM LANDS

THE Great Northern Railway serves an agricultural empire where rents, prices and operating costs are low in Minnesota, North Dakota, Montana, Idaho, Washington and Oregon. Write for free book. E. C. Leedy, Dept. 1257A, St. Paul, Minnesota.

GEORGIA To the fore, for farming or investment, cotton belt farms suitable for diversified farming, poultry, livestock and growing pine timber. Prices low, write stating size and type desired. Biron A. Watson, Wadley, Georgia.

BATTERY System poultry farm, 15 acres, large electrically-equipped house for broilers, big laying house, good 8-room home, electricity and furnace; barn, garage, swimming and fishing on farm; here is a bargain at \$2800, part cash; page 103 free catalog 2000 bargains. Strout Realty, 255-P 4th Ave., New York City.

40 ACRES, Near White River, unimproved; poultry land. \$175, \$5 down, \$5 monthly. Free list and literature. Hubbard, 216 Grossman Bldg., Kansas City, Kans.

GOOD Farms available. Washington, Minnesota, Idaho, western Montana, Oregon. Dependable crops, favorable climate. Write for impartial advice, literature and list of typical bargains. Specify state. J. W. Haw, 119 Northern Pacific Ry., St. Paul, Minn.

PROFITABLE OCCUPATIONS

AGENTS. Start own business. Home, office. No peddling. Little or no investment. Full particulars free. Begley Specialty, 1472 Broadway, New York.

WANTED Original poems, songs, for immediate consideration. Send poems to Columbian Music Publishers, Ltd., Dept. P66, Toronto, Can.

M. M. Earned \$267, three weeks, raising mushrooms in cellar! Exceptional, but your cellar, shed perhaps suitable. We buy crops. Book free. United, 3848 Lincoln Ave., Dept. 66, Chicago.

NICKEL Plating outfit. Complete less battery with instructions, three dollars prepaid. Florida Products, Box 51, Daytona Beach, Fla.

SAIL The high seas. Personal staffs of ocean liners require men of excellent character. Good pay, board, opportunity to see the world. Details free. Julius, Amarillo, Texas.

BUILD Lead smelter cheap. Big profits in junk batteries. Plans, information, \$1.00. Excelsior Press, Box 182, Mar Vista, California.

LEARN New, profitable profession. Wonderful opportunity. Photocolor Institute, San Francisco.

BIG Profit in fur rabbits! Beginners hints. Yearly subscription \$1. Sample 10c. American Rabbit Journal, 16 South 6th, Columbia, Missouri.

205 MONEYMAKING Plans—Opportunities to make up to \$75 weekly, today's conditions. Introductory booklet free. Stamford, 3762-a Broadway, New York.

REGROOVING Smooth tires is profitable. Your own business. Write today. U-219 N. 63rd Street, Philadelphia.

\$5, \$10 A DAY At home, sparetime. Instructions, 3c stamp. How Book Co., 557PM Mithoff St., Columbus, Ohio.

MINK Raising is fun and highly profitable. Particulars. Empire Mink, Scarsdale, N. Y.

MEN—Women, operate "Specialty Candy Factory" home, all or spare time. We furnish outfits and instruction. Opportunity to earn \$20 to \$50 weekly. (Our 29th year.) Booklet free. W. Hillyer Ragsdale, Inc., Drawer 62, East Orange, N. J.

RAISE Mink, dime for general information. Lomman's Fur Farm, Spangler, Penna.

COUNTRY Drives or movies afternoons! Work mornings home. No canvassing! Folio-H. Station D, Los Angeles.

RAISE Rabbits and cavies for us. We buy at top prices. Complete details in catalog, contract and magazine, 10 cents. Stahl, Box 1, Holmes Park, Mo.

BOOKS, PERIODICALS, PICTURES, POSTCARDS

FREE Catalog scientific, mechanical and technical books. Readers Service, 800-9 North Clark, Chicago.

SELECTED Views historic spots old Virginia, 15 cards 25c. Turbyfill, 513 W. 29th, Norfolk, Va.

EXCLUSIVE Photographs: Samples, complete list, 25c. Albert McGoldrick, Mansfield, Mass.

CHRISTMAS Boxes 21 high class folders—Sample box 25c, 5 boxes \$1.00. 100 piece package tags, seals, stamps 15c. Humorous postcards, Christmas, New Year's, flappers, views, birthdays, 20 samples, catalog 10c. 100—40c. Artform Co., 1710 Undercliff Avenue, New York City.

\$15 HEALTH Chart \$2. Saves doctor's bills. Suitable professional offices. Runyon, P. O. Box 1608, Hollywood, California.

YOUR Favorite magazines—Half price. Catalog, 10c. Magazine Exchange, Baseline, San Bernardino, Calif.

OCULT Teaching, incense, perfumes. Maha Devajata, 532 West 47th Street, Chicago.

GAMES—ENTERTAINMENT

PUZZLE Fans—Fifty problems in letter division 25c. Box 244, Corry, Penna.

PLAYS, Operettas, musical comedies, complete minstrel first-parts with song programs, blackface skits, vaudeville acts, monologs, dialogs, recitations, juvenile plays and songs, musical readings, entertainments, make-up goods. Catalog free. T. S. Denison & Co., 203 N. Wabash, Dept. 11, Chicago.

MAGIC TRICKS, PUZZLES, JOKER NOVELTIES

LOOK! Funny joke goods! Pocket tricks! Unusual novelties! Thrilling magic! Exciting puzzles! Strange curiosities! Lowest prices. Complete line. Send 25c for giant surprise catalog. Free trick included! Lawson Vick Co., Dept. P2, Queens Village, N. Y.

SPOOK Mysteries, mind reading, magic easily learned. Become a mystery man, entertainer. Complete course, 50c (coin). Details free. Victor Bagley, 6821 N. Wall, Portland, Ore.

FREE Tricks! Join Magicians' Fraternity! Monthly magazine, sample 10c. International Magicians, Mt. Morris, Illinois.

ATTENTION Magicians, new effects on magic and illusion. Send 20c for price list. Genoves, General Post Office, Box 217, New York City.

ILLUSTRATED Magic catalogue 20c. Lynn, 105 Beach, Jersey City, N. J.

SVENGALI Magic decks. Bridge size, new style. Demonstrators sell them for one dollar. Dozen \$3.25. Sample post-paid thirty-five cents. Catalog 300 jokes and magics free. Adams Company, Asbury Park, N. J.

TRICKS And magic that amaze the wisest. Booklet reveals secrets of performing—fully illustrated—not a catalog or primer—sent in U.S.A. for 25c, foreign 35c. Sawata, Ledger Bldg., Fort Worth, Texas.

WORLD'S Largest magic shop professional catalog, 25c. Holden, 220 W. 42nd St., New York.

BECOME A magician and earn extra money in your spare time. Send 25c today for your copy of our 168 page catalogue. This book is full of tricks for everyone, from the beginner to the professional performer. Established 1910. Chicago Magic Company, 2300 North Mason Avenue, Chicago, Illinois.

EARN Money in any crowd. Call names of strangers, tell unspoken questions. Professional course mind reading, spirit writing, etc., \$1. Henderson, Box 341, San Bernardino, Calif.

LEARN Ventriiloquism, 3c stamp brings particulars. Smith, 125 N. Jefferson, Peoria, Ill.

HOBBIES AND COLLECTIONS

MASTER Albums for match book covers. Hold 450, five sizes. Deluxe permanent binding. Prepaid \$2.00. Matchless Album, G.C.P.O. Box 120, New York.

RARE COINS

OLD Money wanted. Will pay \$100.00 for 1894 dime, S. mint, \$50.00 for 1913 Liberty head nickel (not buffalo). Big premiums paid for all rare coins. Send 4c for large coin folder. May mean much profit to you. Numismatic Co., Dept. 20, Fort Worth, Texas.

33 COINS, Bills, tokens, postpaid 25c. Otto Oddehon, Unionville, Mo.

RARE Coins bought and sold. 25 assorted Indian head cents for \$1.00 Gaylord Coin Co., 5316 Dorchester Ave., Chicago, Ill.

GET Profit and pleasure in collecting old coins. Send 10c for 56-page illustrated coin catalog. You'll be delighted with it. Send for it now. B. Max Mehl, 370 Mehl Bldg., Fort Worth, Texas. Largest rare coin establishment in U. S. Established 38 years.

GENUINE Roman coin 25c; flying eagle 3c. Nickel and list 25c. Maurice Gould, Box 73, Brighton, Mass.

20 NICE Coins 25c. Bishoff, 500 E. 8th, Kansas City, Mo.

50 OLD Coins, all different \$1.00; 20 dates large cents, \$2.00. Claud Denney, Box 1825, Dallas, Texas.

BIG Prices paid for certain wanted coins. 1909 cent \$10.00, some silver dollars \$4000, 1864-1865 Indian head cents \$100.00 each, dimes before 1895, \$600; liberty head nickels before 1914, \$500; encased postage stamps; some large pennies \$2000; half cents, \$275.00; paper money, gold dollars \$1500, foreign coins \$165, some worth \$6000 each. You may have coins for which we pay big premiums. Therefore send 15c today for 1939 big illustrated coin book for certain wanted coins. National Coin Corporation (80), Daytona Beach, Florida.

WILL Pay 40% premium for gold coins. A. French, Numismatist, Route 1, Troy, N. Y.

CERTAIN Large cents worth \$750.00; small cents \$12.00; nickels \$250.00; dimes \$300.00. Send 15c for latest 1938 complete 36 page illustrated buying book. American Coin Co., Box 3507-A, Cleveland, Ohio.

COMMEMORATIVE Half dollars; Columbus 65c; Lincoln \$1.25; Cleveland \$1.25. Bargain selling price list and California 50c gold token, 25c. Bob Cohen, Box 3507-G, Cleveland, Ohio.

INDIAN Head cents—25 diff. dates, \$1.00 postpaid. Lakewood Coin Co., Box 113, Lakewood, N. J.

FINE Foreign 1700 coin, 2 notes and catalog 10c. Geo. Best, Cedar Rapids, Iowa.

COMMEMORATIVE Half dollars, Lincoln, Stone Mountain, Oregon, Texas, Cleveland, Kentucky, San Diego, Long Island, \$1.50 each. Illustrated catalogue No. 14, 25c. Norman Shultz, Salt Lake, Utah.

FREE! Foreign coin, banknote, and large illustrated coin catalogue. Send 4c postage. Coin approvals sent. Tatham Coinco. Springfield-125, Mass.

\$5 TO \$500 Each paid for hundreds of old or odd coins. Keep all until posted. Many very valuable. Send 10 cents for illustrated Coin Value Book, 4x6. Guaranteed buying and selling prices. 31 years in business. Coin Exchange, Box 5, Le Roy, N. Y.

UNITED States. Large cent, 2c bronze, 3c nickel and bargain list, 25c. Eleven dates large cents, \$1. George P. Coffin Co., Augusta, Maine.

RARE U. S., foreign coins, war medals. Catalogue 10c. Mengelle, Colorado Springs, Colo.

OLD STAMPS WANTED

WILL Pay \$85.00 for 1924 1c green Franklin stamp, rotary perforated eleven (\$1,000.00 if unused). Send 6c today for large illustrated folder showing amazing prices paid. Vernon Baker, 444PM-12, Elyria, Ohio.

STAMP COLLECTING

PRODIGIOUS Gift! Fantastic Indochina, German State, savage Somalicoast, Perak, Selangor, Negri Sembilan, bicolored Banana airmail, Siberia—Absolutely free with approvals! Postage 3c. Saxon Company, 408-A Jay St., Brooklyn, N. Y.

A REAL Bargain. 200 all different foreign and 60 different U. S. stamps—our pamphlet on "How to Make a Stamp Collection Properly" and our big bargain list of sets, packets and album—all for only 18c. Queen City Stamp & Coin Company, Room 36, 604 Race Street, Cincinnati, O.

NICKEL-PLATED, Flexible steel stamp tongs, perforation gauge, rule and 20 different choice airmails and commemoratives including Zepp. All only 10c with United States and foreign approvals. Marco Stamp Co., Box 888, San Francisco, Calif.

NO Approvals: 150 different stamps 10c; 150, your choice from 200 (discontinued jumbo approval stock) for 27c. Have 50,000—Immediate refund when out. W. Booher, Lomita, California.

FREE—Tripolitania airmail, 1863 Lombardy Venetia, Alaouites, Carinthia "love" stamp, Western Samoa, etc. Everything 3c with approvals. Viking, Williamsburgh Bank Building, Dept. 9, Brooklyn, N. Y.

TWENTY Airmails, dime, with interesting approvals. Notro Stamps, 4909 North Seeley, Chicago.

USED United States approvals. References required. Donald Unger, Columbus, Indiana.

GIANT Diamond-shaped stamp! Big packet 105 all different including Alexandretta (new country), Congo, Epirus, Manchukuo, Ecuador constitution, Costa Rica triangle, air-mails commemoratives; giant diamond-shaped stamp, \$5 United States; set United States telegraphs, cataloging 30c. Packet British colonies including Burma (new country), jubilee and coronations; scarce Venezuela, cataloging 50c. Illustrated lists. Everything for only 5c to approval applicants! Write to-day! Mystic Stamp Co., Dept. 80, Camden, New York.

"DEVILS Island"—Beautiful set of five stamps from this famous French penal colony. Set portraying historic Grecian Acropolis, famous Corinth Canal. Set of 10 commemorating foundation of Rome. Plus package stamp-mounts, watermark detector, stamp-tongs, and stamp-wallet with perforation gauge. All for 10c. Approvals. Bison Stamp Company, Lackawanna, N. Y.

500 MIXED Stamps 20c. Barcus, 1631 S. Lincoln, Denver, Colorado.

RECEIVE Beautiful first day covers as issued. Seven cents over face. \$1.00 deposit. "Covers," 314 Gunter Building, San Antonio, Texas.

U. S. Price list free. M. G. Hanna, 335 Fifth Ave., Pittsburgh, Penna.

FREE—3 Diamond shaped airmails with dime purchase from bargain approvals. Vic. Grunau, Winkler, Man., Canada.

SEALED Sacks containing 1500 British Colonials from Empire Missions, \$1.00. Price, 9, Blythe Street, Liverpool, England.

FREE—20 Different Canada to approval applicants. Fort Dearborn, 5439 Aberdeen, Chicago.

FOUR Mint five colored Ecuador Constitution stamps 5c with approvals. Wright Philatelic, Box 611, Kansas City, Mo.

ILLUSTRATED Album. Spaces 4000 stamps; with penny approvals 20c. Swan Stamps, 604 Swan, Dunkirk, N. Y.

COLLECTION 2200, \$1.25 Cash. Mall Rubin, 11 Pitt St., New York City.

UNITED States stamps on approval. Ranneger's, Box 134, Pittsburg, Kansas.

ASSORTMENT U. S. and foreign stamps 25c. Richard Sander, 1421 Arch Street, Philadelphia, Penna.

WE Buy stamps. Illustrated buying list, 10c. Liberty Stamp Co., St. Louis.

DENMARK 150 Different \$1.00. Sweden 150 different \$1.00. Madsen, Tollose, Denmark.

EXCHANGE Stamps, postcards. Universe. "Exchangers," Bry 226 pres, Paris, France. Particulars free.

WHOLESALE! United States commemoratives, 50 different 38c; British Colonies, 200 different 88c; French Colonies, 200 different 88c. Fuld, Dickmann Building, St. Louis, Mo.

31 DIFFERENT Manchukuo for 25c. 60 different Colombian Republic, including Antioquia \$1.00. Approvals also sent. John Hays, South Gate, Calif.

SENSATIONAL Offer! 100 stamps including triangle, airmails, commemoratives, pictorials, colonials, only 5c with approvals. Leo, 853 North Martel, Los Angeles, California.

111 DIFFERENT Stamps 10c with approvals. Barclay & Sons, 407 S. Jackson, Kansas City, Mo.

SPECIAL. Mexican "Plan Guadalupe" commemoratives, both series complete, mint condition, and ten different Mexican used airmails: Dollar bill. Ifilatelico, Apartado 116, Morelia, Mexico.

STAMP Collectors—Get Canadian Annual—Features Canadian, United States, Newfoundland, Colonial and foreign stamps, philatelic supplies. Sixty pages, with hundreds of illustrations. Sent free. Gray Stamp Company, Dept. PM, Toronto, Canada.

1000 U. S., 15c. 30 different commemoratives, 15c. Lee, Bridgeport, N. Y.

50 DIFFERENT Chile 20c with approvals and lists. W. C. Kohl, Reading, Mass.

FREE—Coronation, airmails, commemoratives, revenues, 3c postage with approvals. Warren Pomeroy, Richfield, Minneapolis, Minn.

GOYA Nude set 20c to approval applicants. Jewells, Tamaqua, Penna.

40000 VARIETIES First quality stamps available on approvals 1/4c up. Representative selection on request. Adults only. PKEigwin Company, Vineland, N. J.

GIANT Packet 200 all different, from Africa, South America, Asia, South Sea Islands, etc. Includes world's smallest stamp, triangle and diamond-shaped stamps, animal stamps, Nicaragua Olympic "baseball" commemorative; and many others. Also packet 17 different United States (cat. 65c)—all obsolete, including \$5 denomination, commemoratives, etc. Total catalog value nearly \$5.00! All for 5c to approval applicants. Write to-day! World-Wide Stamp Co., Box 600, Camden, New York.

\$1.00 PACKET Free! Inclose postage, request approvals. Secrist, Muscatine, Iowa.

WORLDWIDE Mixture. Packet containing 1000, 25c. Plaza Stamp Co., Box 1161, Santa Fe, N. Mex.

FREE Treasure packet. 3c please. Oromoto Stamps, Kitchener, Ontario, Canada.

\$2.00 PACKET 3c To approval applicants. Quality Stamp Shop, Englewood, Colorado.

NEW Ecuador Constitution (airmail-regular) stamps and Netherlands triangle 10c with approvals. 25 different U. S. commemoratives 10c. Century Stamp Shop, 104-P Fifth, Gary, Indiana.

SPECIAL! 20 Different commemoratives to applicants for my fine foreign approvals with stamps 1c and up. Postage 3c. Dolve, 621 - 15th Ave., Southeast, Minneapolis.

DUPLICATE Book! Premiums! 5c to approval applicants. Haskins, 701 Monroe, Spokane, Washington.

PENNY Up approvals by countries. Hanslick, 180 South Ogden, Buffalo, N. Y.

BEAUTIFUL Pictorial packet 5c to approval applicants. Scheblein, Rosedale, N. Y.

BEST One cent approvals in America. Elvin Stanton, Niantic, Conn.

100 DIFFERENT U. S. commemoratives and obsolete postage stamps \$1.00. Satisfaction guaranteed. Waldo, Box 266, Dallas, Texas.

FREE, 50 Stamps, Iraq, etc. Postage 1c. Album 3c. Bullard, 268 Northampton, Boston, Mass.

PAPUA Coronations. Complete 10c with approvals. Jansen, 14, Morland Rd., Croydon, England.

AT 1/10 Cat.—U. S. and foreign. Meyrowitz, 1756Y - 70 St., Brooklyn, N. Y.

A VERY Unusual bargain. Once every 30 often we make a drive to add to our mailing list desirable collectors who appreciate the best approval service in existence. Therefore we are offering a bargain of such amazing proportions that no one can possibly pass it up: Sets:—Mexico 641-643 complete mint (all high values); New Zealand 1935, 2 values; Czechoslovakia 1919 complete mint; Mongolia 3 values; Denmark Viking ships complete; Germany Schiller complete; Roumania aviation complete; Germany Saar 2 values and Philippine 905-906. Singles:—Philippine 389 (Magellan landing); Canada 143 (scarce red parliament); Newfoundland 206 (Prince of Wales); Piume 206 (3 lire value); Ecuador 927 (Seebeck); Cape of Good Hope 24; India 64 and Netherland copper triangle. Illustrated almanac—"Famous Stamps and Their Stories." All of the above (total catalog value \$5.04) for only 10c to approval applicants. However, to prevent a loss from triflers, we reserve the right of refusal. Approval Headquarters, Globus Stamp Company, 268 Fourth Ave., New York City, Dept. 201.

1000 DIFFERENT All world, catalog \$27.00 for \$1.00. French, 241 Euclid, Cleveland, Ohio.

UNITED States commemoratives—60 different used 53c. D. M. Merrin, W528 First, Spokane, Washington.

2000 ALL Different U. S. postage. No revenues, only \$1.28. Jungkind, Box 806-8, Little Rock, Arkansas.

15 DIFFERENT United States commemoratives 5c to foreign approval applicants. Blue Grotto Stamp Co., Flint, Mich.

CANADA—47 Different, includes coronation jubilee, pictorials, commems. Only 10c to approval applicants. "Crescent Stamps," London, Canada.

FORCED To sell my stamps. \$10.00 catalog U. S. \$1. Stiles, 42 Snowden, Schenectady, N. Y.

FREE Collection 10 different Danzig for the names and addresses of three active stamp collectors if you ask for approvals. Reimers Company, 500 Flatiron Bldg., Ft. Worth, Texas.

TRIANGLES! Triangles! Triangles! Triangles! Count them. Four! With famous Rivera nude stamp. Only 3c to approval applicants. Cactus Junior, Tucson, Arizona.

3c. STAMP Sets with super bargains, lists. Scranton Stamp Service, 307 Tenth, Scranton, Penna.

UNPICKED! 100 U. S. revenues on documents—10c! (1000—60c.) Vanvoorhis, Hyndman, Pennsylvania.

GIANT Bargain package. 100 U. S. postage, 100 U. S. commemoratives, 100 foreign, 10 first day covers, etc., valuable mint stamps, big surprise premium, all for \$1.00! (Worth \$4.00.) U. S. approvals? A. Grove, 306 Blanchard, Seattle, Washington.

BRITISH Colonies included—Forty country mixture—100 stamps, 10c; 300, 25c. No approvals. Elsa, Bowling Green, Ohio.

SOUTHERN Rhodesia coronation plus 15 superb George VI commemoratives—5c with exceptional approvals. Frederick Day, 3938 Broadway, Indianapolis, Indiana.

15 ODD Surprises. 3c postage with approvals. W. Hall, 690 Marcella, Philadelphia, Penna.

MEXICAN Stamps: 50, 100, 150, all different, selected: 20c, 60c, \$2.00. Central Southamericans: 50, 100 different: 10c, 30c. Other opportunities. V. Trevino, Apdo. 79, Guadalajara, Mexico.

WANTED British jubilees and coronations. Stanley Tafilaw, 64 West 109, New York City.

FREE Stamps. No approvals. Send postage. Fanter, 5452 Robin, St. Louis.

FREE—The Stamp Finder! Our now 20 page edition, fully illustrated, which will enable you to instantly identify all difficult stamps. Also fine packet of odd and unusual stamps from Bosnia-Herzegovina, Monaco, Patiala, Cyprus, etc., including maps, ships, animals and strange scenes. All free to approval applicants inclosing 3c postage. Garcelon Stamp Co., Box 900, Calais, Maine.

1000 DIFF. Stamps 65c or 100 diff. 3c with approvals. Dura, 637 W. Brentwood, Detroit, Michigan.

FIJI Pictorial set. 8 values on registered cover \$1. Box 144, Suva, Fiji.

ILLUSTRATED U. S. list, price 50c, large complete U. S. price list free. Send postage. Stanley Gibbons, 38P Park Row, N. Y.

U. S. Constitution stamp of Ecuador, gorgeous six-color stamp showing U. S. flag in natural colors and George Washington, also Marvel packet 33 different including new Cayman Islands, Gen. Franco Spanish Morocco "war stamp" 60 yr. old Luxemburg, "bull-fight" stamp, largest diamond, tropical triangle, Chinese "mid-et" stamp, etc., all for 5c with approvals. Potomac Stamp Co., Dept. 112-D, Washington, D. C.

300 DIFFERENT Stamps 20c; 600, 50c! 1000, \$1; 2000, \$3; 3000, \$7. Fred Onken, 630 79th St., Brooklyn, N. Y.

SIX Different Czechoslovakian war commemoratives 13c. Set Hindenburg zeppelins 13c. Amazing approvals. Moulton Stamps, Elgin, Illinois.

FREE! Netherland triangle, coronation stamps, United States commemoratives, Mozambique triangle, large colonial pictorials and 25 different given free to approval applicants sending 3c postage. Sierra Stamp Co., Box 973, San Bernardino, Calif.

ESTONIA: 20 Different including scarce imperf. issues, free bargain pricelist, unexcelled approvals with profitsharing coupons. Everything only 5c. Send today! Imperial G.P.O. Box 130-E, New York.

100 STAMPS Each from a different country including coronation, jubilee, animals, ships, triangle. Ten cents to approval applicants only. A. Anderson, 367 Fulton, Brooklyn, New York.

BARGAIN Special. 25 different sets, 5 stamps to each set, beautiful French colonials, all for \$1.00. Jerome Stamp Hobby Shop, 2384 Jerome Ave., New York City.

23 UNUSED Soviet Russian beauties. Catalog 60c. Only 3c to approval applicants. Pearce, 2833 N. W. 13, Oklahoma City, Oklahoma.

U. S. Mixture, 2 pounds \$1.00. Holmes Stamp Co., New Albany, Ind.

100 U. S. Different, illustrated album pages, approvals, \$1. Brown, 470 Audubon, AA2, New York.

62 CORONATION, Jubilees, British Colonies, 10c with approvals. Sachse Stamps, London, Canada.

25 DIFFERENT U. S. 5c with approvals. Benken, 2439 South 9th Street, Milwaukee, Wisconsin.

10,000 VARIETIES 1c Each! Gordon Davison, Box a568, Manchester, N. H.

BEST U. S. approvals in America. Huber, 3 South Eighth, Minneapolis.

APPROVAL Applicants—Free stamps, 25 countries. Postage 3c. Harlan, 5307 S. Marshfield, Chicago.

TRY "Cent-Hi" penny approvals. Ransom, 1333 Pontiac, Ann Arbor, Mich.

50 DIFFERENT Foreign 3c with approvals. Siegel, 2213 North 31, Milwaukee, Wis.

1000 QUALITY Mixed United States 18c. Two pounds \$1.00. Five pounds \$2.25. Halay, 452 West 58th, New York.

U. S. Mint, Edison, Pulaski, Bay, Yorktown, Newburg, 30c, with Red Cross free. McClay, Altadena, California.

FREE! Triangle airmail! Diamond! Pictorials! British Colonies! Wonderful packet 61 different (no Europe) 5c to approval applicants. Bargain Co., Box 39P, Times Square Station, New York.

50 U. S. Used. Scott 700 through 749, \$1.00. Direct Wholesalers, Chevy Chase, Maryland.

WORLD'S Smallest airmail, free stamp magazine, \$2.00 U. S., animals, bird, Indian, airplane, commemoratives, scarce stamps 25 countries, 5c with approvals. Capital Stamps, Dept. PM, Little Rock, Arkansas.

MONTHLY Stamp and coin magazine, six months and 25 foreign stamps, 25c. American Stamp Journal, Cedar Rapids, Iowa.

SOUNDS Impossible! 120 different—Afghanistan, Azerbaijan, Zanzibar, triangle, diamond stamps; United States commemoratives, Civil War issue, \$2, \$5 high denominations; everything—5c. Abell's, 1818 St. Paul, Baltimore, Md.

FREE—Five British Colonials, 100 different from 100 different countries 25c. 200 different 20c. 300—25c. 500—50c. Charles, 506a Jones, Detroit, Michigan.

U. S., Canada, Newfoundland, Mexico: "Four Star approvals." Nothing like them! Write today. 312 mixed U. S. only 10c. Kessels, Tucson, Arizona.

EARN Cash-stamps, sell my approval books, Nickel packets. Ellison, 2841 West 37th St., Brooklyn, New York.

UNITED States approvals. Write for selection on approval. 19th century airmails, revenues. No premiums but good stamps, fast service. John Daub, Wabash Bldg., Pittsburgh, Penna.

BEAUTIFUL Irish girls. Second set of souvenir stamps issued by Irish Hospitals' Trust Limited, Dublin. Specimen sheet of 20 stamps supplied free of charge to all writing to Mr. J. O'Sheehan, Department PM, 28 Earlsfort Terrace, Dublin, Ireland.

SMALL Sheet of 4 different triangles 10c to approval applicants. Victoria Stamp Co., London 4, Canada.

UNBELIEVABLE! 62 Different, six triangles and diamonds; airmail, animal, war stamps—China, Japan, Manchukuo, insurgent Spain; Asia, Africa, South Seas. Everything, 5c! Crowder's, 127E North, Baltimore, Md.

CANNON! Set of stamps showing cannon, firing squad, cavalry charge and 200 other different stamps, only 10c to approval applicants. L. H. Reich Stamp Co., 4647 Kenmore, Chicago.

FREE! Two coronation sets. Postage 3c. Roberts, 312F Shearerblg. Bay City, Mich.

UNITED States—45 different, perforation gauge, hinges, bargain pricelist—all for 10c. Seidenberg, Baroda, Mich.

LIBERIA Snake triangle, giant Spanish triangle, 50 other stamps, 5c. Wright Co., 2527 Guilford, Baltimore, Md.

PANAMA Triangle and 50 others free to approval applicants sending 3c postage. Tatham Stampco, Springfield-30, Mass.

FREE! "United States and British North America"—our valuable, complete, illustrated, 64-page catalog quoting lowest prices. Big illustrated list of foreign stamps also included. H. E. Harris & Co., 137 Transit Building, Boston, Mass.

200 DIFFERENT 10c. Big 50% approvals. Covert Stamp, 39 State, Rochester, N. Y.

STAMPS. A superb selection sent on approval. Quality at low prices. Fred Herzberg, Box 91-P, Elmhurst, Ill.

QUEEREST Stamps packet. Receive one of world's smallest stamps; scarce Vatican City; Greek Red Cross (coiled snake in Garden of Eden!); Manchukuo; Soruth (mountain lion); Mozambique (giraffe); Palestine; many others. Also big packet 25 dif. Japan, (including earthquake stamp) and pkt. 15 dif. China. Everything for only 5c to approval applicants! R. M. Stamp Co., Box 230P, Port Chester, N. Y.

50 DIFFERENT, Fine U. S. including perforation gauge, 10c with approvals. The Stamp Shop, 809 Holland Bldg., St. Louis, Mo.

BRAZIL, 50 Different 10c with bargain approvals. Davis, Silver Lake, Ind.

ASK For our wonderful one cent approvals. Prospect Stamp Co., 225 Broadview, Toronto, Canada.

WHOLESALE Catalog for dealers. Illustrated. Postage 5c. Frank Co., 4900 Chalgrave, Baltimore, Md.

PENNY Approvals, that satisfy. Neil Gronberg, Box 5441-P, Philadelphia, Penna.

30 DIFFERENT Angola, Cape Verde, Guinea, Portugal, Mozambique, St. Thomas and Prince 5c. Approvals. Depraw, Ocean Park, Calif.

STAMP Dealers, your ad here will bring wonderful returns. Ask me for proof. F. W. Johnson, Manager, Classified Advertising, Popular Mechanics Magazine, 200 E. Ontario St., Chicago.

APPROVAL Sheets. One to three cents. Frederick B. Driver, 2009 Finance Bldg., Philadelphia, Penna.

25 UNITED States, including \$4 and \$5 stamps free to approval applicants. 3c postage. Brownie Stamp Shop, Flint, Mich.

WEEKLY Stamp magazine, thirteen weeks, 10c. Stamp Journal, Kalamazoo, Mich.

PHOTO FINISHING

TWENTY Reprints 25c. Roll developed and two prints each negative 25c. Send for free mailing envelopes, price list. Star Photos, J-109 N. Dearborn, Chicago.

FINEST Work in colored photographs. 8x10—50c, 5x7—25c. Lake Studio, 52 Ambrose St., Rochester, N. Y.

THE Best snapshot pictures in America. All size pictures one price from 12c to 127 each 3c. Enlargements contact style from smallest film to 3x4 5c, from 127 to 116, 4x6 8c. Helen Art Photo Service, Albany, N. Y.

TWO Beautiful enlargements, eight electrogloss prints with roll developed 25c. Mayfair, Dept. K, Box 261, Toledo, Ohio.

ROLL Developed, 1 print each negative, 8 by 10 enlargement 25c. Reprints 2c. Dudley Photo Service, 1701 South 11th Place, Birmingham, Alabama.

BEAUTIFUL Photographic Christmas cards, 75c dozen. Send negative and 10c for sample. Hench Studios, Harrisburg, Penna.

MAIL Your rolls to film center of the world. Any 6 or 8 exposure roll developed and printed 25c coin. DeLuxe enlargement coupon free! Photo Finishing Shop, Est. 23 yrs., 411-BB Genesee Valley Trust Bldg., Rochester, N. Y. "The Camera City."

20 REPRINTS 25c, 100 Reprints \$1. Roll developed with 16 prints 25c. Newtowne, 4, Maywood, Ill.

PHOTOGRAPHY For pleasure and profit. Prepare for profitable business or fascinating hobby at home. Previous experience unnecessary. Common school education sufficient. Write for information and requirements. American School of Photography, 3601 Michigan Ave., Dept. 3459, Chicago.

THREE Prints each good negative in roll 25c. Trial. Reprints 3c. Fred D. Eastman, Bode, Iowa.

WIN \$10 Cash for best film of the month. Rolls developed, 8 prints and enlargement offer 25c. Reprints 3c each. Geppert Studios, Dept. PM-128, Des Moines, Iowa.

ENLARGEMENT Of each picture on your roll 25c. Cut Rate Photos, Janesville, Wisconsin.

ROLL Developed, 8 prints, 3 enlargements, 25c. 35mm., 36 3/2"x5" enlargements, \$1.25. Printwell, Wyoming, Penna.

36 EXPOSURE Films fine grain developed and printed 50c. Glossy deckled edge enlargements 2 1/2"x3 1/2", \$1.25. 3 1/2"x5, \$1.50. Orco, Upper Sandusky, Ohio.

SIXTEEN Sparkling prints, 2 Hollystyle enlargements with roll developed—25c. 20 reprints 25c; 100, \$1.00. Photographic Christmas cards—10 for 49c; sample, 5c. Lifetone Studios, A-29, Des Moines, Iowa.

EXCITING Photographic pastime. Collect genuine picture stars photos with roll developed including two prints each exposure—25c. Colorcraft, Box 2510-P, Hollywood, California.

ROLL Finished, 5x7 framed enlargement 49c. Lescault Studio, Rockland, Mass.

LIFE Time photo finishing—Roll developed, 8 prints, 2 enlargements 25c. Prints 1 1/2c. Life Photos, Hutchinson, Kansas.

CHRISTMAS Cards with envelopes from your film 60c dozen. Trial 4 alike 25c. Film Capitol Service, Box 504, Rochester, N. Y.

ROLL Developed, 16 prints 25c. Eastman's Studio, 732 - 37th, Des Moines, Iowa.

ART, Your portrait painted 9x12, likeness guaranteed. Send 50c and photograph. Photoart, 857 So. 89, Wauwatosa, Wis.

35MM. Rolls fine grain developed free. 36 enlargements, 3 1/2"x5, \$1.00. Photoshop, Linton, Ind. Cartridge reloaded 35c.

PERSONAL Photographic Christmas cards, calendars. Illustrated circular free. Ideal Photos, Box 2255, Paterson, N. J.

SENSATIONAL Offer. Five 5x7 enlargements 25c. Eight candid enlargements, 3x4 1/2, 25c. Cardinal Photoers, Summit, N. J.

CANDID Special. 35mm. rolls enlarged to 3 1/4"x4 1/2, \$1.00. 18mm. rolls 60c. 3 1/4"x4 1/2 reprints 3c. Brown Photo Company, 1910-61 Emerson, Minneapolis, Minn.

ROLL Developed, two sets prints 25c. Wilkes-Barre Photo Service, Box 64, Wilkes-Barre, Penna.

IMMEDIATE Service! Better pictures. Sixteen guaranteed prints from roll, 25c. One colored or two plain enlargements and 8 guaranteed prints 25c. Sixteen reprints only 25c coin. Candid rolls developed free! Prints enlarged to 3x4, only 4c each. One day service. Details and mailers free on request. American Studios, Box B, LaCrosse, Wis.

16 PRINTS With roll 25c. 16 reprints 25c. Rex Photo, Ogden, Utah.

MILLIONS Now know "Hollytints Means Better Prints." Two professional enlargements with trial roll—25c. Fascinating premiums. Unequaled service. Hollytints, P-1350, Hollywood, California.

35MM. ROLLS Fine grain developed and each shot enlarged to 3 1/2"x5", \$1.00. Ideal Films, Birmingham, Ala.

EXPERT Photo finishing. One day service. 8 genuine expensive Velox prints, two double weight professional enlargements 25c. Expert Studios, LaCrosse, Wis.

ROLL Developed, 8 brilliant fadeproof Velox prints and two professional enlargements 25c. Embossed photo Christmas cards or calendars from your negatives, 4 for 25c, envelopes included. Overnight service. Young Photo Service, 405-C, Albany, N. Y.

BEAUTITONE Enlargement, dime and negative. Giant Snapshots, Inc., Green Bay, Wis.

GUARANTEED. Roll developed, 16 prints 25c. 20 prints 25c. Quality Photo, Hutchinson, Kansas.

QUICK Service—Rolls developed, 8 guaranteed prints; 2 enlargements; 25c coin. OK Photo Service, Ottawa, Kansas.

ROLLS Developed and printed 10c. Trial. Quality Finishers, Maywood, Ill.

PROMPT Service—Quality work; 2 beautiful double weight gloss enlargements, 8 guaranteed neverfade prints each roll, 25c. Excel Photo Service, Dubuque, Iowa.

WILLARD'S Gives your pictures a beauty treatment—they're clear, brilliant, full of life. Roll developed, 2 prints each negative 25c. Enlargement coupon. Willard's, Box 3535-A, Cleveland Heights, Ohio.

ROLL Developed, 16 guaranteed prints 25c. Smart Photo, Winona, Minnesota.

PROMPT Service, guaranteed work. Two beautiful portrait type double weight enlargements, eight neverfade gloss prints, each roll 25c. Dubuque Film Service, Dubuque, Iowa.

ROLLS Developed, 2 prints each and 2 free enlargement coupons, 25c; reprints, 2c each; 100 or more, 1c. Summer's Studio, Unionville, Mo.

ROLL Developed and 8 beautiful Velox glossy prints 25c coin or stamps. Reprints 3c each. Fotoprint Service, Box E, Roanoke, Va.

FINER Finishing. Rolls developed and printed, with one colored enlargement, or two professional enlargements. All for 25c (coin). Genuine, nationally known, Moentone superior quality. Moen Photo Service, La Crosse, Wis.

TWO Glossy enlargements, 1 colored with roll 25c. Arbor Service, 10, Joliet, Ill.

FOR The discriminating amateur, roll developed and carefully printed 25c, reprints 3c. Superior workmanship, same day service. Paramount Co., 327 E. 92nd St., New York.

CAMERAS, PHOTO SUPPLIES

CAMERAS On time! 10% down, 10% monthly. Liberal trade-in allowance on your old camera. New catalog illustrates, describes, prices, latest models, all makes. Contains expert advice on choosing your camera. Send 10 cents for your copy. National Target and Supply Company, Dept. P-37, 1255 - 25th Street, Northwest, Washington, D. C.

BASS Offers you extra value in our policy of your money back without question if you are not absolutely satisfied. Few excerpts from our great Bargaingram No. 236, 56 pages of still camera values and supplies. It's free for the asking. Zeiss Ergo detective camera, V.P. size, Carl Zeiss Tessar F:4.5 lens, right angle finder, \$32.50. 2 1/4"x3 1/4" Agfa plate and film pack camera with F:6.3 lens in shutter, precision construction, \$15.75. Midget Marvel, F:4.5 lens, 35 mm. size, \$15.75. The great Dollina II Candid, coupled range finder, Radioran F:2.9 lens, Compur Rapid shutter, \$49.75. Argus, America's own candid camera, \$12.50. But better send for this book. It is a true guide to shrewd buying. Bass Camera Company, Dept. AG, 179 W. Madison St., Chicago, Illinois.

CAMERAS, Binoculars, microscopes, drawing sets, slide rules, hundreds other scientific instruments. Bargain prices. Big illustrated catalog 10c. Cash for your old instruments. Advance Scientific Instruments, 162 Madison, Chicago.

CAMERAS And supplies. Free illustrated catalog listing everything photographic—still and movie cameras, films, lenses—at tremendous savings. Hundreds of bargains, new and used. All guaranteed. We take your old camera or equipment in trade. Write now for your free copy of our newest money-saving bargain book—just out! Limited edition. Hurry! Central Camera Co., (Photographic Headquarters Since 1899), 230 South Wabash, Dept. 12-K, Chicago.

ENLARGER \$1.59. Makes postcard size from small negatives. Fully guaranteed. Paramount Sales Company, 89 Dudley Street, Boston, Mass.

USED Cameras, tripods, equipment. Send stamp for descriptive list. H. R. Johnson, Desk M, Baltimore, Ohio.

CAMERAS, Projectors, film. Wholesale prices. Catalog. Vitagraph, Box 581, Taunton, Mass.

PHOTOGRAPHY Pays big profits. Make money with your camera. Over 200 recommended books on all branches of photography. Catalog free. Popular Mechanics Press, 200 E. Ontario St., Chicago.

300 PHOTO-KINKS—25c. Covers enlarging, lens care, developing, printing, focusing, trick effects, coloring photos, etc. 64 page book. Readers Service, 800-50 N. Clark, Chicago.

SEND For new Photographic "Bargaingram" before buying elsewhere. 1,500 live specials. Mogull's, 64 West 48th, New York.

LEARN New, profitable profession. Wonderful opportunity. Photocolor Institute, San Francisco.

BACKGROUNDS Make portraits professional. Professional backgrounds 42"x48" \$1.50 postpaid. Money back guarantee. "Girard Specialties," Long Island City, New York.

35MM. FILM Users—25 ft. Superx or Infra-Red postpaid, \$1.00. 1454 N. Gardner, Hollywood.

REVOLUTIONARY Faucet water softener improves prints. \$3.00. Watersoft, Sausalito, California.

IDEAL Gift. "Wesco" visual exposure meter guaranteed correct all films, day, night, movies, stills, moving objects. Satisfaction or money back. Send \$1.00. "Wesco" Company, 234 Sutter St., San Francisco.

IF You go to Mexico ask first for prices and pamphlets of finest German quality miniature and other cameras, binoculars, movie cameras and projectors. Foto Mantel Sucr. R. Rudiger V. Carranza 11, P. O. Box 1459, Mexico City.-105. Branch store: Tijuana, Baja California. Branch store: Tijuana, Lower California. Hotel Comercial. Branch store: Monterrey, N. L., Morelos Oriente No. 557.

MAKE Powerful telephoto camera, trifling cost. Jamer, 94D, Manorville, N. Y.

CAMERAS, Shutters repaired. Leather bellows installed in folding and view cameras. Bellows made to order. United Camera, A-1515 Belmont, Chicago.

NO More wasted film or unnecessary expense. Take pictures you can be proud of. Sell to magazines and newspapers. Make good money wherever you live. Easy, low-cost home study course shows you how! Free catalog. Universal Photographers, Dept. 104, 10 W. 33 St., New York City.

CAMERAS Films, paper 25% to 35% discount. Paramount Photo Division, 327 East 92nd St., New York.

HAVE You a camera? Send ten cents for recent number of our big magazine, showing how to make better pictures and earn money. American Photography, 116 Camera House, Boston, 17, Mass.

MOTION PICTURES AND SOUND EQUIPMENT

BASS Wants to mail you without charge our new 52-page Cine Bargaingram No. 234—sound, silent, 8 mm., 16 mm., 35 mm. equipment, of the quality we can sell on our money back guarantee. Write for this valuable book at once. Full description of the RCA 16 mm. sound on film camera. Newsreel model is only \$250.00, and Bass is exclusive distributor. Dept. A, Bass Camera Company, 179 West Madison Street, Chicago, Illinois.

HOLLYWOOD Titles made easy. Trace, artistic titling charts. \$2.00 complete. Samples, 3c. Stein Studios, Flatiron Building, New York.

16-35 MM. FILMS. List 5c. Bedner, 5300 S. Talman, Chicago.

OPERATE Movies in halls or under canvas. Pleasant cash occupation. Particulars 25c. Film catalog, samples 10c. Miller Cine Films, South Main, Elmira, N. Y.

CHRISTMAS Film, 16mm., \$1.85, 8mm., 98c complete. Free 16mm., 8mm. bargain lists. Home Movies, Box 216, Easton, Pennsylvania.

30 USED 16mm. Sound projectors—\$135. Roshon, State Theatre, Pittsburgh, Penna.

NEW Movie equipment! (Trades accepted.) Superior, 126 Fourth, Paterson, N. J.

TALKIE Programs rented, sold. Simpson, 1275 South Broadway, Dayton, Ohio.
BARGAINS 16mm., 8mm. Free lists. Camera Service, 1125 Howard St., Union, N. J.

16MM. SILENT 400 Ft. comedies \$7.50, 100 features \$50 each. Waldo Films, Cincinnati.

35MM. TALKIES At bargain prices. Free lists. Lakeshore Film Service, Michigan City, Ind.

SILENT 35mm. Films, Projectors, Cheap. Demsey, 1223 Berkley, Youngstown, Ohio.

PROFESSIONAL 35MM. camera \$20.00, projectors, Microphotography equipment, Avond, 747 6th Avenue, New York.

NEW, Novel "Bargaingram" right off press. 1,500 movie specials—sound, silent—8, 16, 35mm. Used, new. Films, cameras, projectors, screens, accessories, rental library. We trade, rent, buy, sell. Mogull's, 64 West 48th, New York.

35MM. FILMS And equipment. Lists. Kirk, 374 Driving Park, Rochester, N. Y.

35MM. SOUND Films and projectors. Oakley Film Exchange, Nelsonville, Ohio.

COMEDIES, Westerns. 500 feet 75c. Jersey Films, 2075 Richland, Lakewood, Ohio.

MOVIE Bargains galore, 16mm., 8mm. No-Watka, 151 Broadway, Paterson, N. J.

35MM. SILENTS, Bargains. Lists free. Wm. Batt, 500 Church, Monterey, Calif.

16MM. FILM, \$2.95, 100 ft., includes processing, 8mm. bargains. Photo Finishing Co., 2186 Broad St., Cranston, R. I.

DIME Brings technical bulletins, catalogs, and free equipment offer. Sample movies, 8mm., 25c; 16mm., 50c. Kearney, 1454 N. Gardner, Hollywood.

35MM. SILENT Bargains, Rented, sold. Calderara, 5119 South St. Louis, Chicago.

35MM. TALKIES, Sale or rent. Shermco, 3865 West 25th Street, Cleveland, Ohio.

SILVER Screen with floor tripod 22x30, worth \$7.50. While they last at \$2.50. Hornstein Photo Sales, 29-P East Madison St., Chicago, Illinois.

FILM For projectors, 16-8mm.; all kinds; sample 10c; lists free. Art film. Goodwill Company, Jackson, Tennessee.

MOVIE Film. Develop yourself. Univex, Eastman, etc. Chemical samples 15c. Raw film wholesale. Lake Camera Exchange, Gary, Ind.

1000 FEET 35mm. 75c. Projectors, Talkies. Savarese, Woodcliff Lake, New Jersey.

MOVIE Titles—Make them yourself quickly. Perfect lettering, with the Master Printer. Complete with supplies \$4.50. Write for illustrated catalog. The Technygraph, Master Printer Division, Techny, Illinois.

MOVIE Films, 8mm.-16mm. Reduced prices. Free list. Crown Film Corp., B-42 Melrose St., Boston, Mass.

BEST Prices 8mm.-16mm. Write. Pennsylvania Photo, Box 423-A, Williamsport, Pennsylvania.

LEARN Motion picture theatre management, advertising, projection. Free catalog. Give age. Theatre Institute, Elmira, N. Y.

8-16MM. All subjects, silent and sound, sale, rent and exchange. Films rented everywhere. Free illustrated catalogue. (With sample film 10c.) Garden Exchange, 317 West 50th, New York.

"THE World's Greatest Passion Play." Sound or silent. 8 reels, 16mm., rent and purchase. Superior than Oberammergau stage play. Write Hemenway Film Co., 37 Church St., Boston, Mass.

16-35MM. RENTED 50c Weekly; lists 3c. Hoffman Film Service, 57 Broad, Albany, N. Y.

GENERA Film, 100 feet double 8mm. \$1.75; 100 feet for Univex, \$1.00, postpaid. Sample free. Fromaders, Davenport, Iowa.

BARGAINS! 8mm., 16mm., free literature. Elder, B-739 Boylston, Boston, Mass.

15% TO 25% Discount on still or movie cameras. Free circular. Paramount Co., 327 E. 92nd St., New York City.

RADIOS, SUPPLIES, INSTRUCTION

ZENITH Radios wholesale, list free. Rademan, Box 452, Maryville, Tenn.

1939 RADIOS Only \$9.95 prepaid. Electric shavers \$7.50. Sims, Warwick, New York.

TELEVISION Transvisor kit. \$9.50. Arthur Pohl, 2123 Hubbard, Detroit, Mich.

WIRE Gauge, direct reading dial, plans and calibrated dial 35c. Trost's Radio Shop, Box 16, Concordia, Kansas.

PLANS 18 Record-breaking crystal sets, with "Radiobuilder"—year, 25c. Laboratories, 7700-C East 14th, Oakland, Calif.

LATEST Releases Vocalion, Decca, Melotone, Bluebird, \$1.00 per dozen; Victor, Brunswick, Columbia, 19c, 6 for \$1.00. Send for giant radio catalog free. United Radio Company, 58 N. Market St., Newark, N. J.

LEARN Radio—Jobs in servicing and operating for trained men. Postcard brings folder. Radio Training Institute, Box 957, Tampa, Florida.

RADIO Engineering, broadcasting, aviation and police radio, servicing, marine and Morse telegraphy taught thoroughly. All expenses low. Catalog free. Dodge's Institute, Ames St., Valparaiso, Ind.

FARM Radio (6 tube) \$9.95, 100 items. Catalog free. Marco-F, Kansas City, Mo.

FREE Information on how to obtain government license to operate your own radio transmitting station, also instructions for building transmitter. Technical Radio Co., 33 Hudson St., Yonkers, N. Y.

MUSIC AND MUSICAL INSTRUMENTS

PHONOGRAPHS, Parts, supplies. Portables \$4.95. Records 6c. Epsteins, 50 First St., New York, N. Y.

SONGWRITERS! Amazing convincing proposition. Hibbeler, C-5, 2157 N. Avers, Chicago.

MUSIC Composed to words. Rhyming pamphlet on request. Phonograph recording of completed song. Send poem. Keenan's Studios, Dept. PM, Box 2140, Bridgeport, Conn.

MELODY Composing course \$1.00. Littig, 215 Mason Theatre, Los Angeles, Calif.

SONG, Poem, melody writers. Write Studio, PM4, Guaranty Bldg., Hollywood.

SONGWRITERS—Avoid common, costly errors of amateurs. Free, instructive, authoritative booklets by famous Broadway composer, will guide you to better, more marketable manuscripts. Write today. Songwriters Institute, 1234-C Broadway, New York City.

JAZZ Piano guaranteed by mail in 20 lessons. Erskine Studios, 810 East 14th St., Oakland, California.

SONGS, Arranged, composed and printed. Satisfaction guaranteed. Modern Melodies, Box 1681, San Francisco, California.

SONGWRITERS—Agents, new sales plan. National Music-D, 532 Sixteenth, Oakland, Calif.

SONGPOEMS Wanted. Modern service—percentage basis. Newald Music Co., Kitchel, Ind.

SONGWRITERS, Verse or music. Brilliant opportunity. Write immediately. Vanburen, B78, Rockhaven, Kentucky.

SONGS, Poems bought, composed, published. Royalty contract, free advice. Metro Melody Publishers, 532A Geary, San Francisco.

PLAY Piano by ear. One dollar. Piano Shorthand Music Company, Springfield, Illinois.

DANCE Orchestration, sheet music, 15, \$1.00. Silverman, 3303 Lawrence, Chicago.

BAND Leading: Be a twirlmajor—Learn secrets of twirling and spinning baton—lead the band—it's easy—it's fun. Complete course, wood practice baton included, all for \$3.00 postpaid or sent C.O.D. in United States. Order today. Swain's Music House, Mansfield, Penna.

SONG Poem writers wanted, our 50-50 plan has aided many songwriters. Russell Duke received \$150.00 advance on his song. Burl Bogg's song won a nationwide contest. We may be able to help you. Send poems or write for free booklet today. Indiana Song Bureau, Dept. 41, Salem, Ind.

SONGWRITERS—Marketing advice, rhyming dictionary, instruction booklet, gladly mailed on request. Songwriters Institute, 1234-C Broadway, New York.

ORIGINAL Music composed to your words, \$5. 200 printed copies \$10. Reginald Belcher, Chatham, New Jersey. 30 years church organist.

WANTED Original poems, songs, for immediate consideration. Send poems to Columbian Music Publishers, Ltd., Dept. 42, Toronto, Can.

DUO-FLEX Reeds for clarinets, and saxophones eliminate your reed troubles. Write for circular. Duo-Flex Reeds, 1204 1st Ave., Evansville, Ind.

SONG Poems wanted to be set to music. Free examination. Send poems to McNeil, Bachelor of Music, 4153-PM S. Van Ness, Los Angeles, Calif.

PIANO By ear. Free booklet. Day-V-Way, Woolworth Building, Dearborn, Michigan.

MUSIC Composed to words. Wonderful proposition. Bauer Bros., Oshkosh, Wis.

WRITE Songs. Big money and reputation. Write for information, J. Gordon Pub. Co., 201 N. Hoyne Ave., Chicago.

WANTED! Lyrics, melodies for songs. We arrange, publish, sell. Superior Song Studios, Passaic, N. J.

LEARN Swing piano! Postal brings free folder. Christensen, 751 Kimball Hall, Chicago.

POEM Writers, songwriters—Send for free Rhyming Dictionary, Songwriters' Guide. Submit best poems, melodies today for bonafide, superior offer. MMM Studios, Dept. 33G, Portland, Ore.

SONGWRITERS: Send your poem today for immediate consideration. Richard Brothers, 24 Woods Building, Chicago.

SONG Writers. Send for publishing agreement. McKinley Music Publishers, 1501 E. 55th St., Chicago.

BUSINESS OPPORTUNITIES

DISTRIBUTORS - SALESMEN. Sensational new model letter sealer, automatic moisture feed, seals forty a minute. \$2.50. Kendall Company, East Jaffery, N. H.

BELTS. Men's, women's, make 'em and make money. Ideal Christmas gifts. We supply materials. Sample 25c. Art Leather, 400 Joseph Ave., Rochester, N. Y.

MAKE Money electroplating! Marvelous patented invention plates with electric brush—easy as painting. Does same beautiful, permanent electroplating—gold, silver, nickel, cadmium, etc.—as big tank outfits. No liquids—lightweight—portable. Anyone can use from battery or household current. Only \$6.85 complete. Write for details and sample of work done. Warner Electric Co., 360 N. Michigan, Dept. D-11, Chicago.

"MAKE Mirrors at home." Big profits. Little outlay. Also emboss, grind—foil, gold leaf, frost, chip and make imitation stained glass. Instruction course 50c. Bestovall, 4047-RM N. Whipple, Chicago.

MAKE Money manufacturing permanent building material. Low in cost, attractive. Big growing market. Equipment \$25.00 up. Equipment Company, Holland, Mich.

GROW Without soil—Flowers, vegetables, plants. Year round, anywhere. Only water and common chemicals used. Formula \$1.00. Clover Formulary, Niles Center, Ill.

"BINGO." New coin operated amusement game. Large income, operating "route." Small investment. Details free. Robbins, 1141P DeKalb Ave., Brooklyn, N. Y.

WHOLESALE Tires, batteries, radios. Standard makes. Mohawk Service, New Britain, Conn.

CAPITALIZE On your ideas. Send self-addressed stamped envelope for information. Allison-Items, Box 81, Bound Brook, N. J.

MAKE Money at home! Grow mushrooms in cellar or shed, with Ami U. S. Patented Mushroom Spawn and step-by-step, easy-to-follow manual of instructions. Fascinating, profitable. Booklet free—write today. Anglo-American Mushroom Industries, Dept. 27, Toronto, Ont.

SELL By mail. "The Key to Business Opportunities" shows how. Particulars for stamp. Maples, 3418 South Marshfield, Chicago, Illinois.

MAKE Artificial marble, glazed tiles, uncanny. Tabletops, plaques, floors, hones, novelties. Hard, fireproof, inexpensive, cement secrets. Brilliant tile and liquid rubber samples 3c. John A. Payn, 945 Grande Vista Avenue, Los Angeles, Calif.

FORMULAS—Fast selling products. Guaranteed. Laboratory tested. Lowest prices. Catalog free. Kemico, 55K, Park Ridge, Ill.

NEW Money-makers! \$10.00-\$20.00 daily! Details free. Samples 10c. Marquez-PBC, Apartado 1176, Mexico City.

HOME Business establishments, descriptive literature free. Byron, 82 Wadsworth Ave., New York.

STEADY Money in showcards, signs, window lettering. Easy. Amazing details free. Write Nelson Company, 2026 Manhattan Building, Chicago.

"RUBBER Molds." Make them yourself. Formulas, instructions 25c. Ideal Service, Park Ridge, Ill.

MAKE Anti-freeze, similar to Zerone, good profit, easy made. Write J. C. Hargis, Box 22, Crosstown Sta., Memphis, Tenn.

M. M. Earned \$267, three weeks, raising mushrooms in cellar! Exceptional, but your cellar, shed perhaps suitable. We buy crops. Book free. United, 3848 Lincoln Ave., Dept. 65, Chicago.

GET Into your right field. 10c brings analysis materials. Vocational Guidance Institute, Boonton, New Jersey.

EARN Money, cast liquid marble statuary, art, utility, religious. Small investment. Dime brings proof. Cole's, 348 Hayward, Rochester, N. Y.

MONEY Daily. No canvassing. Manufacturing art goods, rubber moulds. Details free. Nucraft Studio, Holten St., Danvers, Mass.

99 "TESTED" Money-making plans free for stamp. Home Industries, 89 Lehigh, Rochester, N. Y.

LIQUID Marble—anyone can make! Colorful, glazed! Moulded, brushed, sprayed. Rubberlastic moulds. Composition flooring. Big money in these! Particulars free. Marbleizing Service, Edwardsville, Ill.

WORKABLE Mail order plans. Particulars in booklet. 25 cents. J. E. Howe, Box 183, Evansville, Indiana.

WE Show you how to raise capital for your business. Write Enterprise Bureau, Syracuse, N. Y.

"RESULT Getter," magazine of money making opportunities. Copy 10c. George Fenner, 1618 Lucia, Louisville, Ky.

ATTENTION. Finest business opportunity book on market. Particulars free. Cochran, 942 Baddley Court, Salt Lake City, Utah.

YOU'LL Like resilvering mirrors, auto-parts, reflectors, making chipped glass signs. Write, Sprinkle, Plater, 127, Marion, Indiana.

FASCINATING Profitable home business. We show you how to make vanilla, auto polish, anti-freeze, laundry bleach, etc. 25c brings simplified instructions. Home Occupations, St. Paul, Minn.

PROFIT With new products. Make, sell, repeat. Analysis. Research. Guaranteed formulas. Biggest catalog free. Special prices, leads. Gibson Laboratory, Chemists, BD-1142 Sunnyside, Chicago.

HAVE Patented life saving device. Want small capital to promote it. John Abraham, 1102 N. Wells, Chicago.

HERE'S A real opportunity. If you want a business of your own that is substantial money maker right now and has unlimited future, and if you have \$500 cash to operate a business in an industry which Roger Babson predicts will, in ten years, be larger than automobile industry is today, write Department 20, Box 187, Lafayette, Indiana, for complete details.

MAILORDER And local distributors wanted. Enclose stamp. Lorrac, Albany, N. Y.

INVESTIGATE Proposition of merit. Tremendous possibilities. \$10.00 required. American, 320 Drake Building, Irvington, N. J.

INDEPENDENT Old gold buyers make quick cash profits. Work anywhere. Spare time. Full time. Start small. Grow big. Formerly cost \$20.00 up, to learn. New, confidential, copyrighted, Old Gold Buyers Manual, by expert, teaches you quickly, easily. Limited number now offered for first time, \$1.00 postpaid. No COD's. No free literature. Cunningham, Publisher, Box 591, Wilmington, N. C.

\$10 DAILY At home. \$2.50 mail order article costs only 15c for materials. Sells itself by mail, no canvassing. You make your moulds. Finart, 199 Van Rensselaer, Buffalo, N. Y.

FREE Big mail. Postal brings it! Freccarloc, 2202 Orchard, Chicago.

RUBBER Mold bargains. Stamp brings catalog. Colonial Arts, Derry, N. H.

PAYING Mailorder business for you. Write Dixie Mailers, King, North Carolina.

BUSINESS Man's information, plans, formulas. Free literature. Jamel, 2521 North Avenue, Chicago, Illinois.

BE Successful in business. Learn elementary and guiding principles from expert. Don't lose time and money experimenting; study and win. Complete course reasonable. Free booklet. Gardner & Gardner, 212-A Eighth Ave., S. W., Cedar Rapids, Iowa.

GROW Flowers, vegetables, without soil, year around. Pleasure or profit. Chemicals, formula, bibliography. \$1.00. Box 2066, Atlanta, Georgia.

MASTER Business opportunity for you. Staebler, 79-20—45th Ave., Elmhurst, N. Y.

MAIL Order business is your opportunity. Many began small, now earn thousands yearly. No personal contact. Boundless opportunities. Have had over 30 years experience; will help you succeed. Send 25c for valuable booklets, none free. B. Breniser, 257 S. 21st, Philadelphia.

CASH Daily with a route of nut and candy vendors. Small investment. Eamco, 350 Mulberry, Newark, N. J.

POPCORN Machines, caramelcrisp, crispettes, cheese coat, potato chips. Long Eakins, 2035-M High St., Springfield, Ohio.

205 MONEYMAKING Plans—Opportunities to make up to \$75 weekly, today's conditions. Introductory booklet free. Stamford, 3762-C Broadway, New York.

FOR Your car, household use, or operate electric Simonizing station. Cash in on labor-saving invention. Only \$29.50. Should net you approximately \$300-\$400 month. Write Bissell's Manufacturing, 3320-P Archer, Chicago. Dealers wanted.

FUR Farming—Profitable business. 60c book, now 25c. Fur Farms Publishing Co., Karcade, Utica, N. Y.

DOUBLED Income! Successful sidelines—mailorder, local. Write, Nu-Idea Sales, Carrollton, Illinois.

\$3000.00 TO \$5000.00 Per season running archery range. Small investment. Complete blue prints, photographs and instructions \$2.00. Photograph 50 cents. Frank Marshall, 6422 South Rockwell, Chicago, Ill.

DIME Brings copy Modern Sales News, 140 No. Gorham, Jackson, Mich.

BEST—Not cheapest! Here's guaranteed certified formulas, detailed instructions insuring absolute success for producing ultra-modern products. Stamp brings amazing information! Miller, Chemist, Tampa, Florida.

"MAIL Order Success." This book gives the ten success steps which every mail order man must know. Many dollars of information and our proposition 25c (credited.) Plan Bureau, Fillmore, N. Y.

SIX Jobs for spare time. Pay well, give satisfaction, make friends and boosters. Choose the one you like or which suits you best. I teach and help you start. Must work with hands. Information free. Custer, Box 1765-B, Fall River, Mass.

BRENISER Mail order pulling imprint 3c. Green, 15788 Parkside, Detroit, Mich.

RECEIVE Stacks of mail. Your name listed in 10,000 directories 25c. Liberty Sales Service, Sheboygan, Wisconsin.

FREE—"Big 32-page book" explaining composition novelty manufacture! Tells you how to make extra money in your spare time! Supply limited! Write today! Stewart's Studio, Dept. P12, 2927 Wilcox Chicago.

MARBELIKE Cement; mixed with water. Cast, brushed, sprayed over any concrete products, wall-board, wood, etc. Produces vitreous glossy finish. Dime brings assorted samples. Marbelike Cement Co., Grayling, Michigan.

VALUABLE Literature free describing scores of big paying mail order and home enterprises. Kessler, Box 311-MB, East St. Louis, Ill.

"DOLLARFAX" Publishes money-making mail order plans! Schemes! Formulas! Ideas! No other magazine like it. Real "eye-opener!" Three months trial 10c. Dollarfax, Plainview, Nebraska.

6 MAIL Order magazines including all you should know about mail order business 15c. Armand Cartier, 31 Cumberland St., Woonsocket, R. I.

PROFITABLE Home business! Startlingly new! Legitimate! Openings still available. No canvassing. Dr. Swearingen, 128P, Station S, Los Angeles, Calif.

SIGNS And showcards. Easily painted with letter patterns. All sizes. Sample mailed for 3c stamp. John Rahn, D1330 Central, Chicago.

\$192—K's Weekly earnings. Above average, but maybe you are too! 205 money-making plans. Introductory booklet free. Stamford, 3762-B Broadway, New York.

500 FRESH Names monthly. Yearly subscription \$1.50. Trial list 25c. Liberty Sales Service, Sheboygan, Wisconsin.

FREE—200 Big money-making ideas. Kay's, 2445 1/4 Brooklyn, Los Angeles.

107 MONEYMAKING Plans for home or office. Particulars free. Dolve, 621 - 15th Ave. S. E., Minneapolis, Minnesota.

HOW And where to obtain capital fully explained, free particulars. Star Service, Wapakoneta, Ohio.

OPERATE Profitable "route" four compartment vendors. Small investment. Penny King, 1233 Chouteau, St. Louis.

MEXICAN Feather pictures. Christmas novelty, 50c (stamps) brings \$2.00 worth samples, details. Refunded if unsatisfied. Mexicanart-M, Apartado 1593, Mexico City.

WE Help start you in business, furnishing outfits and instructions, operating "Specialty Candy Factory" home. Men and women, opportunity to earn \$20 to \$50 weekly, all or spare time. (Our 29th year.) Booklet free. W. Hillyer Ragsdale, Inc., Drawer 4, East Orange, N. J.

PROFITABLE Factory secret. Home business. McPherson Stamp Works, Middletown, Conn.

LEARN Arc welding. A growing industry with great opportunities. Consult your local school, or if there is none available write The Lincoln School of Welding, Dept. A, Box 5758, Cleveland, Ohio.

ADDED Income ideas. Mail Sales News magazine, copy 10c. Katz, 4254 No. Kimball, Chicago.

SUCCEED With your products. Make-sell them. Formulas. Processes. Accurate analyses. Catalog free. B. Thaxly Co., Washington, D. C.

COLOR Concrete with chemicals. Wishing-wells. Spin concrete pottery. Stucco-rock. Miniature castles, mills, cold glaze, marbling. Sample 10c. Hollywood Cement Craft, 8527 Wonderland, Hollywood, Calif.

MAN In each town to plate auto parts, reflectors, bicycles, fixtures, mirrors, by late method. Simple plan of manufacturing at home starts you in good paying business. Free particulars and proofs. Gunmetal Co., Ave. H, Decatur, Ill.

AFTERNOONS Free for outdoors, shows. \$340 month home. Unique plans. No canvassing. Prepare for surprise. Folio-F, Station D, Los Angeles.

MANUFACTURE From Phospholene. Cleaning fluid 1c gallon; bleach 2c gallon; hand soap 2c pound; and ten fast sellers. Sample 25c. Details free. Western, 6615 Denison Ave., Cleveland, O.

WHERE To buy at lowest wholesale prices. Information free. Yorena, Box P-312, Bayonne, N. J.

PLASTEX Industries offers industrious men an opportunity to start a business of their own, manufacturing art goods, novelties, souvenirs, etc., in Plastex and marble imitation. 5c material makes \$1 articles. Rubber moulds furnished for speed production. Small investment brings big returns. You are just in time for big wholesale season now starting. Write for interesting booklet mailed free. Plastex Industries, Dept. A, 1085 Washington Ave., New York.

SELL By mail. Books, novelties. Bargains! Big profits! Particulars free. B. Elfco, 438 N. Wells, Chicago.

PROFITABLE Home business. Legitimate. No canvassing. Maywood Publishers, P-923 Broadway, New York.

CHARTERS: Delaware; best, cheapest; free forms. Colonial Charter Co., Wilmington, Del.

DELAWARE Charters: Complete service \$35. Submitted forms. Chas. G. Guyer, Inc., Wilmington, Del.

ARTIFICIAL Marble sanitary flooring, instruction covering wood or cement flooring 1/2 inch thick, fireproof, all colors, low cost, ornamental casting, concrete, plaster, papier-mache, garden furniture, statuary, flexible molds, particulars free. Chris Mahler, Elmont, N. Y.

100 PROFITABLE Mail order and local plans. Gilbert Supply, 1107 Broadway, New York.

LIKE To draw? Earn steady income tracing and duplicating advertising cartoons. Ad-Service, Argyle, Wis.

INVENTORS—We successfully sell inventions, patented and unpatented. Write for proof, and tell us what you have for sale. Chartered Institute of American Inventors, Dept. 4-C, Washington, D. C.

I WANT To send you proof of the wonderful pulling power of Popular Mechanics Magazine's classified pages. What's your proposition? Write me today. F. W. Johnson, Manager Classified Advertising, 200 E. Ontario St., Chicago, Ill.

INCORPORATE In Delaware. Liberal laws, low costs. Corporation Registration & Trust Company, 927 Market Street, Wilmington, Delaware.

BOOKS Chock full of moneymaking ideas, formulas, plans, information. Literature free. Hicks, Box 8-A, Brooklyn, N. Y.

WANT More business? 2c daily, opens individual New York branch office requiring no room number on your stationery or advertisements. Co-operative Mail Service, 126 Lexington Avenue, New York.

MONEYMAKING OPPORTUNITIES

MAKE Money drawing for advertisers. No experience necessary. Mur-O-Graph Co., Box 4218-M, Dallas, Texas.

AUTHENTIC Proposition, literature included, brings handsome profits immediately. Details sent quickly. Direct Mail, Box 344, Summit, New Jersey.

WANTED Original poems, songs, for immediate consideration. Send poems to Columbian Music Publishers, Ltd., Dept. P65, Toronto, Can.

MAKE Money growing vegetables, fruits, flowers, plants without soil. Use only water and chemicals. Formula \$1.00. Kemixal, Park Ridge, Ill.

Your Nationwide Opportunity Pack awaits, particulars free. Swaty, Mentone, Calif.

YOU'LL Like resilvering mirrors, auto-parts, reflectors, making chipped glass signs. Write. Sprinkle, Plater, 287, Marion, Indiana.

10c BRINGS Excellent ideal article. Harry Reed, Frederick, Steelton, Penna.

MILLION Articles. Buy wholesale. Valuable directory 10c. Ideal Service, Park Ridge, Ill.

MILLIONS Jobless! Get dollars in mail for satisfying employment information. Keep dollars! We fill your orders. Details for stamp. Co-Operative Service, 77 Swan, Buffalo, New York.

FREE—100 Wonderful business, mail-order and home work moneymaking offers. Lewis Co., 828-C Carpenter, Oak, Park, Illinois.

60 PAGES 100 Money making plans, formulas 25c. Beck, 317 W. 109th, New York.

ANALYSIS. Research. Newest guaranteed formulas. Biggest catalog free. Special prices, leads. Gibson Laboratory, Chemists, CS-1142 Sunnyside, Chicago.

MAKE Money growing plants in water indoors during winter. Weighed chemicals, formula, instructions \$1.00. Gordon Laboratories, 509-E Fifth Ave., New York.

IMPRINTS! Sell by mail. Big profits. Fast sellers. Low priced. Samples, prices 10c (refunded.) Success, P-13032 Chicago St., Blue Island, Illinois.

TYPISTS Earn extra money. Send 25c (coin) for "Twenty-One Ways to Make Money With the Typewriter." H. Robbins, Box 6048, Kansas City, Missouri.

LEARN New, profitable profession. Wonderful opportunity. Photocolor Institute, San Francisco.

FREE Circular. Make money with doughnuts. Complete instructions two dollars. Muller System, Glen Moore, Penna.

HUGE Profits daily. Rush stamp for particulars. Box 423, Warren, Penna.

EMERGENCY! Need extra money. Ten ways, spare time. Anyone. No experience. 25c complete information. Swan System, 509 - 5th Avenue, New York.

"\$10.00 A DAY." Booklet 25c prep. Unity Service, 286 Wayne, Jersey City, N. J.

TODAY'S Biggest moneymaker! Few dollars starts you. 97c profit new dollar specialty. Big daily mail newest moneymakers. 10c (silver.) Fuller Publications, Drawer 1144, Kalamazoo, Michigan.

ARCHITECTURAL Modelmaking. Fascinating hobby, profitable business. Home study. Particulars. Weidler, 4589 Lexington, Hollywood, California.

XTRA Money daily. Supply information millions want. Unlimited possibilities. A. E. Jacobson, Upsala, Minnesota.

SAMPLE Reflecting skeleton face for motorists 10c. Superior Specialties, Springfield, Illinois.

1,000,000 ARTICLES Wholesale. Directory 10c. Amazing opportunities. Jelsmith, Waltham, Mass.

PROSPERITY For home workers. 52 page magazine. Sample, dime. Sizemore, 4917 N. Kostner, Chicago.

YOUR Choice of hundreds of moneymaking ideas outlined. Something entirely different. Business Service, P. O. Box 537, Muskogee, Oklahoma.

BALLGAMES. Movies afternoons. Work mornings home, your own business. Introductory booklet free. Stamford, 3762-d Broadway, New York.

TYPISTS Earn extra money. Send 25c (coin) for "Twenty-one Ways to Make Money With the Typewriter." H. Robbins, Box 6048, Kansas City, Missouri.

PENNIES In Hamilton scales produce assured income without canvassing or selling. 1910 Vermont, Toledo, Ohio.

ADDRESS Folders for us. Big profits. Malonite Corporation, Bayside, New York.

YOUR Name—5,000 mailing lists—25c. Get samples, opportunities galore from all over world. Pines, 583-A Monroe, Brooklyn, N. Y.

MAILORDER Opportunities, plans, formulas, information. Circulars free. Harvey Teeple, Decatur, Indiana.

"SCHEMER," Alliance, Ohio, (40th year) prints schemes, tips, opportunities, formulas; big producers: \$10,000 to \$25,000 reported. Year, \$1.00. Get wise! Six months trial only 30c.

"\$10.00 DAILY." Stamping names on keychecks. Sample and details 25c. Bohn Co., Box 86P, Wilkes-Barre, Penna.

STOP Squealing—Start crowing! Work mornings home—country drives or movies—afternoons! No canvassing! Folio-A, Station "D," Los Angeles.

MAN In each town to plate auto parts, reflectors, bicycles, fixtures, mirrors, by late method. Simple plan of manufacturing at home starts you in good paying business. Free particulars and proofs. Gunmetal Co., Ave. N, Decatur, Ill.

RAISE Earthworms for profit. Information free, stamp appreciated. Bureau Zoological Research, 106A Broadway, Peoria, Ill.

WHOLESALE Sources, 500,000 articles. Free directory. Maywoode, 925 Broadway, New York.

FORMULAS, PLANS, ETC.

FORMULAS, Analysis, free literature. Hertstein, 128 So Diamond Ave., Grand Rapids, Mich.

GUARANTEED Formulas—New fast sellers. None better. Lowest prices. Catalog free. Kemico, 49K, Park Ridge, Ill.

ANALYSIS. Research. Newest guaranteed formulas. Biggest catalog free. Special prices, leads. Gibson Laboratory, Chemists, BD-1142 Sunnyside, Chicago.

REFINE Used oil without cost. Particulars. F. Gerwin, Fairview, Oklahoma.

SIXTEEN Selected moneymaking formulas \$1.00. Pryor, Box 2066, Atlanta, Ga.

KILLS Moths: New. Never offered before. Money maker. Guaranteed formula. \$1.00. Chemist, 711 No. Ridgewood Pl., Hollywood, Calif.

INDUSTRIAL Chemist (established 1912) sends free catalogue latest, profitable formulas. Pierce, 412 West 90th, Los Angeles, Calif.

BEST—Not cheapest! Here's guaranteed certified formulas, detailed instructions insuring absolute success for producing ultra-modern products. Stamp brings amazing information! Miller, Chemist, Tampa, Florida.

ANY Formula \$1.00! (35 candy formulas \$2.00; C.O.D. \$2.20)! Galluzzo, Wilkingsburg, Pennsylvania.

FORMULAS—50c, Three \$1.00. Franklin-Allen Laboratories, South Paris, Maine.

ANY Formula 25c or money back. Just name it. Satisfaction guaranteed. Worl's Formulas, Tampa, Florida.

"ANYTHING In formulas." Particulars free. "Research Bureau," 100 Chelsea, Charlestown, Massachusetts.

BELIEVE It or not. The world's best 3 mirror formulas \$10.00. Gold, silver, gunmetal. 35 years in business. Nashville Mirror Co., Nashville, Tenn.

FORMULAS: Three famous money makers \$1.00 cash. Mobley, Box 3176, Hollywood, California.

FORMULAS: Ten big moneymakers 20c. R. Barnes, Cornwall-on-Hudson, N. Y.

FORMULAS. Proved successful by test and experience. Buchman, 718 E. Fayette, Syracuse, N. Y.

GUARANTEED Formulas! None better! Lowest prices! Catalog free. Hodge Laboratories, Elkhart, Ind.

THAXLY Formulas for perfect products. Accurate analysis assured. Resultful research. Catalog free. B. Thaxly Co., Washington, D. C.

ANY Formula 25c. Six for \$1.00. Satisfaction guaranteed. Clover Formulary, Niles Center, Ill.

FORMULAS: 15 Proven moneymaking formulas \$1.00. (Not stock-formula catalogue stuff), real unusual offers. List free. Marvel Laboratories, 6629 No. Maplewood, Chicago.

FORMULAS: Latest money makers. Literature free. Belfort, 4042 N. Keeler, Chicago.

CHEMISTRY

ANALYSIS. Research. Newest guaranteed formulas. Biggest catalog free. Special prices, leads. Gibson Laboratory, Chemists, CT-1142 Sunnyside, Chicago.

FREE—40 Page catalog of chemical and laboratory supplies for amateur chemists. Wollensak microscopes and supplies, scientific books at big discount. J. D. Winn, 124 West 23 Street, New York City.

JOIN American Amateur Chemists Society. Journal, particulars 10c. Haslett, Michigan.

CHEMICALS, Rare and common. Catalogue, stamp. Chemical Service, 2827 N. Rockwell, Chicago.

HANDBOOK For chemical experimenters, hundreds of experiments, illustrated, 50c. Experiment booklet, 15c. Chemical catalogue, 10c. Reading Scientific Co., Reading, Penna.

STUDY Chemistry at home, 35c complete. Jeray, 2731 Vine, Cincinnati, Ohio.

CHEMICALS, Laboratory, glassware, apparatus. Send 3c for catalog CPI. Biological Supply Company, 1176 Mt. Hope Avenue, Rochester, N. Y.

FREE Chemistry catalog. Supplies at 5c! Equip complete laboratory. Send 3c for postage. Kemkit Scientific Corp., 397P Bridge St., Brooklyn, N. Y.

TELESOPES, Microscopes, chemistry, mineralogy. Scientific catalog free. Tracey Laboratories, Evanston, Illinois.

AGENTS WANTED

NEWLY Designed patented wonder pie pan bakes bottom as thoroughly as top—up to 20% faster. Saves fuel and time. Prevents dough sweating. Pies retain freshness longer and are more nourishing, entirely digestible. Every family and bakery are prospects. Big profits for agents, salesmen, crew workers. Ideal sideline. Send 25c for full size sample and wholesale prices. Dept. 160, Bake-Right Utensil Co., Kansas City, Missouri.

GRAB This—Amazing new "Cream Making Machine" (patented) government tested. Low priced. Saves users 50%. No competition. Fastest seller in years. Exclusive territory open to livewires. Don't hesitate. Get facts now. Rudell Corp., Burnside, Penna.

SELL Finest Puerto Rican cigars, factory to consumer. Big profits. Samples free. Infanzon & Rodriguez, Mayaguez, P. R.

SOMETHING New! Sure-fire Christmas item. 100% profit on Can-O-Lites lighter. 1000 lights without refueling. 25c, 50c, \$1.00 models. Write for sample offer. Uni-Lite Mfg. Corp., Middlefield, Ohio.

80% PROFIT Selling key locks. Trial outfit \$1.00. Edjohn Company, 8 Baltimore, Middletown, Ohio.

THOUSANDS Earning big profits! So can you! Establish a spare-time subscription business, representing world's greatest magazine publishers. No experience needed. Clip this ad and mail with name and address to International Circulation Co., Inc., Dept. 452-PM, 57th St. at 8th Ave., New York, N. Y.

RAWLEIGH Men make good money. Supply everyday household necessities to Rawleigh routes of 800 family users. Ambitious men can make good earnings at start. We furnish everything but the car. Write today. Rawleigh's, Dept. L-A-PPM, Freeport, Ill.

BUSINESS Proposition: Resilvering mirrors, autoperators, reflectors, making chipped glass signs. Write, Sprinkle, Plater, 128 Marion, Indiana.

500% PROFIT With new perfected (1938) quick-action, no flint, automatic gas lighter. Retail 25c. Sample 5c. New Method Co., Box PMG-72, Bradford, Penna.

AGENTS To sell truck and auto necessity, large field, exclusive territory. Reese, 4234 Taylor St., Chicago, Ill.

MEXICAN Novelties! 100%-300% profit. Free particulars. Samples 10c stamps. Marquez-PC, Apartado 1176, Mexico City.

DEPROSTS Windshields without heat. New invention. Fits auto pocket. Defies frost, sleet, ice. Samples sent on trial. Rush name. Kristee, 108, Akron, Ohio.

NEED Money quick? Here's a genuine opportunity to make up to \$42.50 in a week. Operate grocery business from your own home. Supply friends, neighbors, others. I send complete outfit on 30-day trial; no money risk. Details free. Albert Mills, 6273 Monmouth, Cincinnati, Ohio.

SNAPPY, Flashy two colored comic Xmas cards, fast 10c sellers. Enormous profits. 20 designs with envelopes. 20 samples \$1.00; 100, \$2.50; 500, \$10.00 prepaid. Comic Shop, 2463-G Kensington Ave., Philadelphia.

COSTS 2c—Sells 25c. Fast selling necessity for agents, crews, demonstrators. Sample 10c. Linnell, Box 1963-E, Cleveland, Ohio.

NEW Discovery of ancient secret cream perfume. Sells on sight. Big profits. Persian Perfume Company, 1231 Olive, Desk 7, St. Louis.

PROFIT With new products. Make, sell, repeat. Analysis. Research. Guaranteed formulas. Biggest catalog free. Special prices, leads. Gibson Laboratory, Chemists, BD-1142 Sunnyside, Chicago.

SOCIAL Security gold bronze life time card. Sells 35c. Cost 5c in lots of 100—Engraving tool \$7.50. Hustlers get investment out plus \$15.00 profit 1st day. Information free. Machinery Sales, 192 North Clark, Chicago.

500% PROFIT. Modernistic guaranteed Stick-on letters for windows, offices, trucks. Large sizes 1c. Easily applied by agents or customers. Free samples. Modernistic, B-3000 Lincoln, Chicago.

ELGIN, Waltham watches \$3.95. Make big profits. Send for free jewelry catalog. Plymouth Jewelry Exchange, 163 Canal St., New York.

FOOT Trouble vanishes when White Bear Powder is used. Thousands get permanent relief. 15 and 35c prepaid. Agents wanted. G. D. Wiederkehr, Stryker, Ohio.

DATED Freshness, unobtainable elsewhere, clinches sale for vitamin tablets. Selling direct guarantees laboratory freshness. Dated and sealed when packed. Certified quality. Exceptional opportunity. Vitamins, P. O. Box 4510, Philadelphia, Penna.

PARING Knife. New. Peels, slices, cores, 200% profit. Sample 10c. Three other household necessities. Apex Co., 400 Dakota Bldg., St. Paul, Minn.

NEW Leather keycase gives only the right key. Samples three styles 25c, or stamps. Mercer, 101W 76, New York.

MEN, Women sell Sanasol, professionally approved first aid solution; unexcelled treatment athlete's foot, ringworm and similar skin troubles. Dignified and profitable. Request details. Schmedding Laboratories, 2343 Scarff, Los Angeles, Calif.

BIG Money for agents selling U-Te-Lite reflectors. Low priced, economical to use. For full particulars address Hodge and Blackall, Hotel Sherman, Chicago.

DON'T Wait, investigate, profits! Silver vanity cosmetics. Brindel Mfg., Muncie, Ind.

AGENTS, Sell household reminders. Big sellers and repeaters. Retail ten and fifteen cents, cost 75c dozen, \$8.50 gross. Samples 10c each. Jordan Box Co., Syracuse, N. Y.

AGENTS—Auto accessory. Brand new—no competition—good side line. Manufacturers Distributing Co., 2257 W. Madison Street, Chicago, Ill.

SALESMEN: Agents. Unlimited moneymaking possibilities selling our high-grade, guaranteed line of diamonds and watches. No investment, no competition. Cash commissions daily. Protected territories available for ambitious, alert, responsible salesmen with followings. Write today for information. R. A. Press, Inc., 812 Sansom Street, Philadelphia, Penna.

BIG Profits in fine rebuilt watches direct from wholesaler. Exceptional values. Write for free catalog. Kane Watch Co., 105M Canal St., New York, N. Y.

AUTOMOTIVE Salesmen! Distribute auto product needed by millions. Up to 500% profit. Information free. Thermo-Works, Peoria, Ill.

PROFIT 100% Selling calling cards. Bonus, prizes to workers. Outfit free. Universal, Orange, Massachusetts.

NEW Skeleton face reflector. Motorist's safety device. Sample 25c. Superior Specialties, Springfield, Illinois.

FREE Sample world's best seller. G. Mfg. Co., Washingtonville, Ohio.

PATENTED Die-stock oiling handle \$5.00. Agents sample \$1.50. Circular, Malonite, Bayside, New York.

EVERY Man needs shirts! He will gladly buy from you when you offer choice of 90 sizes for customized fit, huge selection and sensational one year guarantee backed by 45 years of shirt making experience. Half price offer creates terrific values. Repeat orders give permanent income. Simply write orders, we'll deliver prepaid and collect. World's largest concern of its kind. We paid over \$100,000 commissions past year. Get your share! Big cash commissions daily, cash bonuses regularly. Experience unnecessary. Complete self-selling outfit free. Write quick to Dept. 143, Rosecliff-Quaker Corp., 1239 Broadway, New York.

BIG Money with radiator alcohol seal—only 25c postpaid. Write quick. Midwest Sales, 1337 Monadnock Block, Chicago.

SCHOOL Graduates, sell best line graduation name cards. Wonderful commissions. Monthly bulletins. Agent prizes. Big catalogue. Write Craft-Cards, 235(A), Pittsburgh.

BALLGAMES, Movies afternoons. Work mornings home, your own business. Introductory booklet free. Stamford, 3762-F Broadway, New York.

ATTENTION Salesmen! Sell doctors, dentists, offices, homes new articles. Repeat orders come by phone without solicitation! No competition! Quick, sure-fire demonstration and sales plan. Write at once! Territories going fast! Derby Products, 19 Jackson St., Middleboro, Mass.

LARGE Profits selling Magic Fluid. Repairs instantly any fabric or rubber, heat and laundry proof. Eureka, 1911 S. Wabash, Chicago.

BLACK Walnut cracker \$8.50 prepaid. Pecan cracker \$2. Agents wanted. Money back guarantee. Clark Nut Crackers, Harrisburg, Penna.

AGENTS— Opportunity make money; book containing 107 successful business plans; home-office; send for free introductory booklet. Elite Co., 214 Grand St., New York.

AGENTS Make big profits on food products, bargain deals. Low wholesale prices. Rush name for trial outfit offer. Ho-Ro-Co, 2310-R Dodier, St. Louis, Mo.

AGENTS-DISTRIBUTORS. To mail sample herbs and literature in their territory. Establish profitable trade. Samples particulars free. Kendall Company, 155M Lake, Elmira, N. Y.

BIG Money taking orders: shirts, ties, hosiery, underwear, raincoats, pants, dresses, etc. Sales equipment free! Experience unnecessary. Write Nimrod, 4922-AN Lincoln, Chicago.

SUCCEED With your products. Make-sell them. Formulas. Processes. Accurate analyses. Catalog free. B. Thaxly Co., Washington, D. C.

STARTLING Invention—Pocket adding machine. Nationally advertised \$2.50. Whirlwind seller. Big profits. Baby Calculator Co., Box 1118, Chicago.

AGENTS: Smash go prices! Santos coffee 12c lb. 4-oz. vanilla 8 $\frac{1}{2}$ c. Razor blades 10 for 8 $\frac{1}{2}$ c. 100 sticks chewing gum 12c. Christmas cards, 21 in box 14c. 150 other bargains. Premiums. Experience unnecessary. Carnation Co., PO. St. Louis, Mo.

DO You want agents for your proposition? Your ad in this space will place your message before hundreds of men seeking fast-selling products. My folder "How to Secure Agents" is filled with proof. I'll gladly send you a copy free. F. W. Johnson, Manager Classified Advertising, Popular Mechanics Magazine, 200 E. Ontario St., Chicago.

BIG Money applying initials on automobiles. Write for particulars and free samples. American Letter Company, Dept. 40, Dunellen, New Jersey.

BIG Money applying initials on automobiles. Easiest thing today. Free samples. Also, sideline salesmen for name plates and tire cover transfers. "Ralco," 1305 Washington, Boston, Mass.

500% PROFIT! Gold and colored sign letters for windows, offices, trucks, signs. Auto monograms. Easily applied by agent or customer. Neonite, Akron, Ohio.

AGENTS—To mail our literature. Good profits. Home business. Maywood, 149 Fifth Ave., New York.

FREE Sample—Amazing cleaner; sells homes, taverns, everywhere. Big profit—fast repeater. Betco, 5007 Irving Park, Chicago.

NEW—Amazing cigarette case. Beautiful grained solid wood. Automatic ejector. Whirlwind seller. Large profits. Free sample offer. See display ad page 146A. Willott Novelty Co., Box 520, Grand Rapids, Mich.

HERE'S A "new deal" that gets the money. Agents cleaning up. Write immediately for details. Davis Specialty Co., Onamia, Minn.

AGENTS: Stamping names on pocket-key protectors. Sample check with your name, address. 25c. Stamping outfits, Emblem checks, check-fobs, name plates. Hart Mfg. Co., 303 Degraw St., Brooklyn, N. Y.

MANUFACTURE Specialties, hire agents yourself. Big money. Free literature. Gilbert Supply, 1107-P Broadway, New York.

ENGRAVED Name plates, numbers, signs, etc., easily sold, profits large. Brett Bros., Winthrop, Mass.

REVOLUTIONARY Window cleaning tool. Good Housekeeping approval. Only ten \$2.25 sales daily to housewives, factories, schools, stores will make you \$350.00 monthly. Carter Products Corp., 900 Front Ave., Cleveland, Ohio.

GUARANTEED Gold leaf letters for store and office windows. 300% profit. Free samples. Metallic Co., 438-B N. Clark, Chicago.

ATLAS Window sign letters. Large sizes, penny each. Beautiful free samples. Atlas, 7941 Halsted, Chicago.

WANTED—District purchasing agents. No experience or money required. Write Purchasing Manager, 174 N. Halsted, Chicago.

HIGH-GRADE SALESMEN

STARK Needs 1000 salesmen quick. Cash income weekly. Many make \$200.00 in month. Easy, interesting outdoor work. Spare time or full time. No cash or experience needed. Write quick for free sales making outfit and weekly income plan. If you can't sell—buy Stark trees. Largest nurseries in world. Nearly 125 years old. Highest quality trees, shrubs, roses, etc. Write for catalog. Stark Nurseries, Box C-8128, Louisiana, Mo.

SELL Mirror silhouettes! Best sellers in 35 years manufacturing advertising specialties. Also sensational calendar values. Harvest selling season starting now. Ad-Nov-Co, Newton, Iowa.

AMAZING Invention closes all doors silently, automatically. New oil principle. Easily installed. Never needs attention. Priced dollars less than other checks. Unlimited market, stores, offices, factories. Free demonstrator furnished workers. Kant-Slam, Dept. F-62, Bloomfield, Ind.

DID You make \$50 last week? Does your job offer you real future? If not, why not start a wholesale business of your own? Start with little as \$2.50. Handle line 200 nationally advertised 5c-10c products. Show merchants new plan for increasing sales and profits. Handle everything from your home at start. Chance to operate one of our Silver Fleet service trucks. Facts free. World's Products Co., Dept. 1210, Spencer, Ind.

SALESMEN Call on garages and filling stations. Sell Champion and AC spark plugs about 1/2 price. Unconditionally guaranteed. Write Fall, 1734 Lawrence, Denver, Colorado.

SALESMEN. Distributors—200 items—brushes, mops. Marvelous magnetic brush excels vacuum cleaner. Big profits. Neway Brush Company, Hartford, Conn.

BRUSH Salesmen—If you ever sold brushes write for our money making proposition. Donald Brush Co., Dept. P.M., Camden, N. J.

RAWLEIGH Men make good money. Supply everyday household necessities to Rawleigh routes of 800 family users. Ambitious men can make \$30 weekly and up. We furnish everything but the car. Write today. Rawleigh's, Dept. L-A-PMSW, Freeport, Ill.

SELL Business cards \$1.50 thousand. Business stationery. Xmas cards, calendars, book matches, advertising tape, paper towels, pencils, sales-books, rubber stamps, tags, menu covers. Free sales portfolio. 35% comm. daily. Money making specials. Willens, 2130 Gladys, Dept. BR, Chicago.

BIG Commission selling celluloid pricing tickets, metal shelf moulding, menu covers, changeable signs, celluloid advertising buttons. P. Pricing Press, 124 White St., New York.

ADVERTISING Book matches—calendars. Lowest prices. Big commission. Free matches to producers. Outfit free. Gem Match, 84 West Washington, Chicago.

CARDED Merchandise, attractive displays. Priced low. Free goods. Prepared. Aspercol Products, Oakland, Calif.

AT Home, your own manufacturing business, making popular \$1 novelties. Cost you 3c to 15c. Everything supplied. Write So-Lo Works, Dept. M-842, Cincinnati, Ohio.

SELL America's most complete line of business necessities. Regular and novelty size book matches, gummed labels, political items, pricing sets, restaurant supplies, salesbooks, embossed stationery, shipping supplies, office supplies, printed gummed tape, advertising pencils, thermometers, business stimulators, holiday novelties, sensational line of calendars and greeting cards at new low prices. Complete line printed business forms and hundreds of other fast sellers. Undersell all competition. Cash commissions advanced daily, extra bonus. Experience unnecessary. Complete sales outfit free. Federal, BA-301 South DesPlaines, Chicago.

DISTRICT Managers, field representatives, age 30 to 60 for a well established company to investigate and interview dealers for a new automatic system all cars need; method makes sensational and truly convincing demonstration; a proved dealer merchandising plan, which is covered by insurance; large earnings now and on repeat business; exclusive territory protection. Craver-Jay Corporation, Dept. 109, Kansas City, Mo.

MAKE Big daily cash profits selling Top Quality Advertising Book Matches. Low prices. Experience unnecessary. Full time profits unlimited. Free sales kit. Zipper case offer. Match Corporation of America, Dept. E-12, 3433 West 48th Place, Chicago.

UNEMPLOYED Mechanics and salesman, steady work, no competition, exclusive territory. Send postal for details. Keen Kut Machine Co., Columbus, Ohio.

SELL The Driving Master—Shows miles per gallon, when driving. Analyzes motor. Exceptional opportunity for men of ability. Driving Master Company, Sioux City, Iowa.

SALESMEN—Distributors, sell complete line automobile bulbs. Davis Lamp Co., 17 East 42nd Street, New York City.

NEW Type door knob lights key hole. Fast seller. Big profits. Jaxon, 327 N. Front, Grand Rapids, Michigan.

TIRE Accessories. Guaranteed 10,000 mile Tiger Grip Tire Patch, and complete fast-selling line auto accessories. Salesmen-distributors easily make up to \$75 weekly, and over. Protected territory. Economy Rubber Products Co., 648 Burkhardt, Dayton, Ohio.

MYSTERY Invention, carried in pocket, keeps hands, feet, ears, body warm on coldest days. Everybody buys. Low price—big profits. Kumfy Warmer, 4208 Davis Lane, Dept. R-2301, Cincinnati, Ohio.

KEY-HOLE Illuminator. Distributors, salesmen, dealers—cash in. Non-competitive, nice profits. Sample complete \$1.50 postpaid. Babco Products, Denver, Colorado; Davenport, Iowa.

\$192—K's Weekly earnings. Above average, but maybe you are too! 205 money-making plans. Introductory booklet free. Stamford, 3762-g Broadway, New York.

CHRISTMAS And calendar bargains! Catalogue free! Twenty-one piece boxes 15c; twelve pieces 8c; fifty imprint folders 25c. More profits! Easter sales! Elfko, 436 North Wells, Chicago.

EXCELLENT Opportunity selling our complete line of brushes, largest commissions. Write for sales plan. Wire Grip Sanitary Brush Company, 2300 5th Ave., New York.

BIG Money taking orders; shirts, ties, hosiery, underwear, raincoats, pants, dresses, etc. Sales equipment free! Experience unnecessary. Write Nimrod, 4922-AP Lincoln, Chicago.

SELL New Hexagon portraits. Big profits. Lowest prices portraits, frames. Catalogue free. Picture-Man Friedman, Dept. 9, 528 Cornelia, Chicago.

NEW Specialty—Sells every business and professional man. Four \$15 sales daily pay \$280 weekly. Farrell cleared over \$1,000.00 monthly. Write, F. E. Armstrong, President, Dept. PM, Mobile, Ala.

SALESMEN—Sell calendars, complete line, all sizes, including jumbos; beautiful subjects. Samples free! Fleming Calendar Co., 6539 Cottage Grove, Chicago.

GUARANTEED Gold leaf letters for store windows. Free samples. Liberal offer to car owners. Metallic Co., 438-A N. Clark, Chicago.

MAKE More money with Red Comet Automatic Fire Extinguishers. Low price. Proved seven years. Splendid sales outfit free. Some good territory open. Exclusive. Write quick. 704 Red Comet Bldg., Littleton, Colo.

HELP WANTED

WEAR Fine hose I send without cost with outfit while taking orders for amazing new hosiery. Replacement guaranteed against holes, snags, and runs. Rush name and hose size. Wilknit, Desk 37-L, Greenfield, Ohio.

LOCAL Agents wanted to wear and demonstrate suits to friends. No canvassers. Up to \$12 in a day easy. Experience unnecessary. Valuable demonstrating equipment, actual samples free. H. J. Graves, 1300 Harrison, Dept. M-817, Chicago.

MEN! Call on stores with nationally advertised counter card item—"Sure" Breath Purifier. Known to millions. Lightening seller everywhere. Big repeats. Juicy profits for retailers and you. Build route. Territories going. See our display ad page 146A. Write Sure Laboratories, 840 N. Wash, Dept. PC-1, Chicago, Ill.

INSTRUCTION—Obtaining positions, homework. Free offers. Henry, 126-B Lexington, New York.

EDUCATIONAL AND INSTRUCTION

CHICAGO Painting School. 36th year teaching painting, paperhanging, decorating, sign painting, show card writing, graining and marbling, pictorial painting. Courses from 6 to 16 weeks. Folder free. 437 N. Clark Street, Chicago, Ill.

BE An ad writer. Learn at home, taught by head of successful advertising agency. Full preparatory course, 7 lessons, supplements, 56,000-word, self-teaching manuals. \$12.50 brings all. Information free. Ad writing pays! Romer Educator System, 809-C Thirteenth St., N. W., Washington, D. C.

LEARN Watchmaking. Complete instructions \$1.90. Catalog wholesale tool, material, watches 5c. Stewart's, 721 Olive, St. Louis, Mo.

CHESS. Instructive, interesting. Particulars free. Chess Thoughts, Pearl River, N. Y.

DON'T Stammer. A permanent cure. Learn at home. A great saving. Perfect Speech, Dawson, Minn.

HOW Inventive minded become independent. Explanation free! C. Higbee, Cantil, Calif.

FOR An extremely profitable lifetime business, operate a collection-credit agency. Free folder. Cole Associates, Syracuse, N. Y.

BECOME Practical scientific investigator. Modern, illustrated course. Thorough training by former agent U. S. secret service. Particulars free. International Secret Service Institute, PM-128, Hoboken, N. J.

WORK For "Uncle Sam." \$1260-\$2100 year. Try next examinations. List jobs—particulars telling how to qualify—sample tests, free. Write today. Franklin Institute, Dept. E3, Rochester, N. Y.

WATCH Repairing is steady profitable work. Experts always in demand. You can learn watchmaking trade at home, spare time. New original instruction system. Script engraving course included. Write for free details today! Nelson Co., 2012 Manhattan Building, Chicago.

LEARN Electric arc welding at home by experienced welder. Free particulars. Roy Ankerman, Wapakoneta, Ohio.

LEARN Watchmaking at home. Book \$1.00. Carter, 1107 N. Mayfield, Chicago, Ill.

LEARN To sell in one powerful lesson from successful salesman, \$1.00. Louis D. Maynard, 156 Sandwich St., Plymouth, Mass.

CIVIL Service examinations. Customs, investigator, stenographer, no experience required. For valuable information free list opportunities write Pergande Publishers, D11, Milwaukee, Wis.

LEARN Advertising \$10. Trial lesson \$1. Cleveland's, 102 East Chestnut, Chicago.

AMAZE Your friends with this easy but baffling memory feat. Complete instructions 25 cents. E. Schieve, 1714 Wyoming, Dayton, Ohio.

LEARN Shoe dyeing, repairing. Particulars 25c. Frank Lento, Punxsutawney, Penna.

PENMANSHIP. Finest self-instructor lettering text 25c; 12 superbly written cards 25c; variety beautiful samples 10c. Courses offered. Portfolio free. L. H. Hausam, Emporia, Kansas.

BLUEPRINT Reading taught by mail. Write Blueprint Reading Institute, Dept. A. Box 5662 Metropolitan Sta., Los Angeles.

SONGWRITERS Wanted. Instruction book free. Song Bureau, Dept. 44, Salem, Indiana.

ATTAIN Mastery! Nervousness, fear, worry! Psychological instructions. Literature gladly mailed. John A. Englund, Box 335, Ironwood, Mich.

LEARN Skilled trade. Practical instruction, twelve trades. Learn by doing, in trade school not operated for profit. Request bulletin M. Ranken Trade School, St. Louis, Mo.

SECRET Investigation. Experience unnecessary. Detective particulars free. George Wagner, M-2640 Broadway, N. Y.

MAKE More money. Get a U. S. government job. Get our new plan for obtaining one—no obligations. Age 18-50. Write Ozment Instruction Service, 101, St. Louis, Mo., immediately.

LEARN Auto mechanics, body, repairing, welding, electricity, refrigeration. Diesel. Stevenson's, 2008A Main, Kansas City, Mo.

MASSAGE. Hydrotherapy, dietetics, drugless therapeutics, chiropody, taught by mail. Evans Correspondence School, Montgomery, Ala.

GOV'T Jobs start \$1260-\$2100 year. Men-women age 18-50. Former examiner's tested method helps qualify you. Particulars, list jobs free. Write today. Patter-son School, 8C Mercantile Bldg., Rochester, N. Y.

LEARN Machinist trade, tool, die making. Automatic and hand screw machines. Modern shop methods. Actual work. Jobs open for trained men. Employment help. Illustrated booklet free. Allied Screw Machine Co., 601 Lake St., Chicago.

CARTOONING COMMERCIAL ART. SHOWCARD WRITING, SIGN PAINTING

DRAW Instantly without training with the Mur-O-Graph. Make steady income drawing for advertisers. We show you how. For complete details write Mur-O-Graph Co., Box 4218-C Dallas, Texas.

CARTOONING For profit—illustrated. Contains cartoon markets, selling plans, syndication, drawing for reproduction, preparing cartoons for publication, tricks and short cuts of the trade. \$1.00 postpaid. Smith's Service, Wrentham, Wash.

LEARN To draw from large photos of artists' models. Free sample. Send name and 10c to cover mailing cost to Tower-town, Studio 6, 520 N. Michigan Ave., Chicago.

CARTOON Market guide, professional secrets 10c. Cartoon Studios, LaCrosse, Wis.

CARTOONISTS' Markets, guide, 25c (coin.) Hartman, 2438 W. Lincoln, Nebr.

CHALK Talks. Laugh producing program. \$1.00. Catalog 10c. Balda, the Cartoonist, Oshkosh, Wisconsin.

CARTOONING. Sketching, etc. 46 lessons, 600 illustrations, including drawing paper, pens, pencils, \$1.00 complete. Fraba Service, Poplar Bluff, Missouri.

PEN And ink illustrations for catalogue and general printing purposes at right prices. High grade work. Heraldic Studios, 1914 Oakdale Avenue, Chicago.

EARN cash income, copying and duplicating simple cartoons for advertisers. 3-M Service, Argyle, Wis.

PLAYS, STORIES, MANUSCRIPTS

STORIES. Books, plays, etc., read for sales possibilities. Collaboration available worthwhile manuscripts, undeveloped ideas on percentage. New York Publishing Service, Literary Agents, 246 Fifth Avenue, New York City.

STORIES Needed for sales consideration. New plan. Advance fee \$1.00. Crown Service, 916P Shreve Bldg., San Francisco.

SONGWRITERS Wanted, write for free book. Song Bureau, Dept. 42, Salem, Ind.

WRITERS: Former newspaper, magazine editor will edit, revise your manuscript. \$1. Fredericks, 944 Eighth Avenue, New York.

SHORT Stories and novels rewritten and typed for marketing. Welton Tinney, Willsboro, Texas.

SHORT Stories revised, typewritten, marketed. Hursh, Box P-1013, Harrisburg, Penna.

WANTED. Original poems, songs, for immediate consideration. Send poems to Columbian Music Publishers, Ltd., Dept. 209, Toronto, Can.

POEM Writers, songwriters. Send for free Rhyming Dictionary, Songwriters' Guide. Submit best poems, melodies today for bonafide, superior offer. MMM Studios, Dept. 33H, Portland, Ore.

ADVERTISING AGENCIES, LETTER WRITERS, FOR ADVERTISERS

LEARN Advertising quickly at home. Easy practical plan. No text books. Common school education sufficient. Interesting booklet and requirements free. Page-Davis School of Advertising, 3601 Michigan Avenue, Dept. 3432, Chicago.

ADVERTISING Placed all magazines, newspapers, radio. Lowest rates. Free service. 54 page rate book free. Baker Advertising Agency, A-189 West Madison, Chicago. Successors to Ankrum. Established 28 years.

MAIL-ORDER Ad reaching 1,500,000 families throughout United States \$15.40 inch. Newspaper, magazine, ratebook free. Chicago Union Agency, 20-P West Jackson, Chicago.

30 WORDS Printed 10,000 advertising circulars, distributed to mailorder buyers \$1.00. Particulars. Bob Lee Associates, Box 845, Little Rock, Arkansas.

INCH Display advertisement 30 magazines year \$24. Wood's Popular Services, Atlantic City, (N. J.)

ADVERTISE: 24 Words in 250 newspapers \$10. Lists free. Advertising Bureau, 4515-C Cottage Grove, Chicago.

FREE—New Advertisers Rate Guide. 44 pages. Includes everything. Lowest rates. E. H. Brown Advertising Agency, 140 S. Dearborn, Chicago.

DIRECT-MAIL Advertising services. Sales letters that sell. Mailing lists. Omaha List & Letter Co., Box 2172, South Omaha, Nebr.

ADVERTISING Placed; any publication, anywhere. Copy written. No service charge. Free rate guide. Le Grand Agency, 34 West 33rd Street, New York.

BUSINESS SERVICE

WASHINGTON, D. C., mail address; business, personal. Your mail reforwarded daily. Hawkins Mail Service, 817 Fourteenth.

RUBBER STAMPS AND OFFICE SUPPLIES

TWO Lines 25c; three lines 35c; cushioned; indexed. Rubber Stamp, Tunkhannock, Pennsylvania.

CUSHION Mounted one-two lines 25c; three 35c. Hauer Press, 1314 Ford, Youngstown, Ohio.

ORIGINAL, Cushion mounted. One, two lines 25c; three 35c; four 45c. Facsimile signature \$1.50. Stamp Works, 814 Bradley, Peoria, Illinois.

NAME. Address, 2 lines 25c; 3 lines 35c. Stamp Works, Auburn, Nebr.

2 LINES 25c, 3 Lines 35c. Stamp Works, Centertown, N. Y.

TYPEWRITERS, DUPLICATORS, OFFICE DEVICES

10% DISCOUNT. No down payment, 10c day, nationally advertised, new portable typewriters, adding machines. Booklet. Rockaway Typewriter Co., 1085-T White St., Far Rockaway, New York.

CALCULATING Board—Students, engineers, office workers. Multiplies, divides. Rapid, simple, accurate. Size eight by eleven—equivalent of six foot slide rule, \$1.00 delivered. Distributors wanted. Van Meter Calculator Co., Box 401, Detroit, Michigan.

TYPEWRITERS. Duplicators, multi-graphs. Write for free list office machine bargains. Save half. Pruitt, 518 Pruitt Bldg., Chicago.

INCREASE Business now. "Excello-graph" Rotary Stencil Printer reprints thousands everything you typewrite, hand-write, draw or trace. Colors. \$19.75 to \$44. Terms. Illustrated literature free to business or professional men. Pittsburgh Typewriter Supply, Department K-2, Pittsburgh, Penna.

NEW \$3.75 Automatic adding machine. Fully guaranteed. Bassett, Box 302-K, Altadena, California.

PRINTING, MULTIGRAPHING, MIMEOGRAPHING, GUMMED LABELS

HAMMERMILL Letterheads, 300 8½x11 any color paper and ink, \$1.48 postpaid. Free particulars. Woodruff's, 217A Lewis Duluth, Minn.

1000 GOOD Business cards \$1.00, prepaid, cash. Sullivan Printing Company, Memphis, Tenn.

QUALITY Printing. Letterheads, envelopes, cards, blotters, circulars. Low overhead prices, samples. Homer Woodruff, Sidney, Ohio.

500 LETTERS Multigraphed exactly as if typewritten \$1.70 (20 lines.) Multi-graphers, Ashland, Virginia.

125 8½x11 LETTERHEADS And 125 6¼ envelopes \$1.00 postpaid. Benneville, 907 West Roosevelt, Philadelphia.

PRINTING Prices slashed! Stamp brings latest catalog. Nixon, Stevens Point, Wis.

ENGRAVURE Printing, lowest possible prices. Samples free. Sunco, Mohawk, N. Y.

1000 BUSINESS Cards, \$1.95 postpaid. Flint, Box 3063, Chattanooga, Tenn.

PRINTED Noteheads, envelopes, 200 each, \$1 postpaid. Atlas, Argyle, Wis.

200 LETTERHEADS 5½x8½ And 100 envelopes neatly printed to your copy \$1.00 postpaid. S. O. Litzenger, Manheim, Penna.

QUALITY Printing, reasonable, 5000 circulars (envelope inserts), 3¼x5½, \$3.50 Farber Press, 740M Eighth Avenue, New York City.

200 5½x8½ LETTERHEADS, 100 Envelopes, 100 cards, \$1. Business or personal. Samples free. Western Press, Topeka, Kansas.

150 LETTERHEADS 8½x11, And 150 envelopes, \$1.00 postpaid. Eckholm, Shelby, Mich.

WEDDING Announcements, invitations, \$2.95. Samples 10c. Gruenewalders Press, St. Louis, Missouri.

500 LETTERHEADS, Envelopes, statements, \$1.75; thousand, \$2.75 postpaid. Information. Village Press, Somerset, Mass.

3"x6" CIRCULARS. 5,000, \$3.50 postpaid. Prompt. Keelerprint, 4237-W Cermak, Chicago.

LETTERS. Circulars, price lists mimeographed, 100 \$1.25, 300 \$1.45. Advertising letters written \$1.00. Mailing service. Louis D. Maynard, 156 Sandwich St., Plymouth, Mass.

GET Our prices for better printing. The Delavan Printery, 177 Freund St., Buffalo, N. Y.

PREPAID. 250 8½x11 Letterheads, 25 envelopes \$1.50. Victors Printery, Exeter, N. H.

MATCHES! 100 Match books printed your name, address, business; \$1.00 prepaid. Sanderson Match Co., Ottawa, Ill.

500 STICKERS. Four lines, 25c. Fine labels Cott's, Spickard, Mo.

PRINTING? Lowest prices, samples free. Churchill, 4316 South Salina, Syracuse, N. Y.

300 EACH 8½x11 Letterheads and 6¼ envelopes printed, \$2.00. E. Carter, Box 52, Orange, California.

FINE Printing! 1000 envelopes or letterheads, \$2.75. 1000 two-color 5x7 circulars \$3.00. Samples for stamp. Dollarfax, Plainview, Nebr.

BARGAINS! Printing! Mimeographing! Free pricelist. Gordon Co., 417-PM, Downers Grove, Ill.

STATIONERY—300 Sheets, 6x7, 150 envelopes, crisp white bond paper printed, \$1.00 postpaid. McKeever Press, Aberdeen, S. D.

ENVELOPES, Letterheads, statements, invoices, 1000, \$1.95. Samples. Marvel-sales, Davenport, Iowa.

250 NOTEHEADS, Envelopes, invoices—all three printed, postpaid \$2.85; 1000 of each \$8.85; all printing reasonable. Lonelm Printers, Paulding, Ohio.

1000 6 $\frac{3}{4}$ BOND Envelopes \$1.95. Samples. Feld, Elmwood Place, Ohio.

1938 PRICELIST, Portfolio of samples free. McCall Press, 1326 South 27th, Omaha, Nebr.

\$1.00 EACH 250 Letterheads, envelopes, statements. Postpaid. Allen, Fort Edward, N. Y.

LETTERHEADS, Envelopes, statements, order blanks, etc. Free estimates. Johnson and Lee, Fort Atkinson, Wis.

1000 6x9 CIRCULARS \$2.50. Each additional thousand \$1.00. Edward Hutter, 666 Tioga Ave., Kingston, Penna.

\$2.25—1000; LETTERHEADS, Envelopes, statements, circulars. Samples. Midwest Printing, 514P Huron, Minneapolis, Minn.

500 $\frac{3}{4}$ x2 $\frac{1}{4}$ FOUR Line gummed stickers, 25c. Moritz Printery, Saginaw, Mich.

PRINTING OUTFITS AND SUPPLIES

ROTARY Press, prints postcard notices, handbills, etc. Actual type area, 6 $\frac{1}{4}$ "x3". Type included in outfit at \$2.50. Free circular. Superior Type, 3942 Ravenswood, Chicago.

PRESSES \$5.00. Type 50c. Cuts 10c. Shops bought, sold. Complete bargain catalogs. Send stamp. Bradshaw, 3214-P Huron, Chicago.

PRESSES \$7.00 Up. Type, supplies. Lists 3c. Landis, Richland, Penna.

PRINT Your own cards, stationery, circulars, advertising. Save money. Easy rules furnished. Print for others, big profits. Junior outfit \$9.00; job presses \$11 up. Details free. Kelsey Presses, D-11, Meriden, Conn.

HAND Press, type and complete printers' supplies. Advise equipment you need and we quote prices; or send stamp for catalog. P. Peiffer, 14-C; 6 Columbia St., Newark, N. J.

BARGAINS. Four hand presses \$12-\$35; electric embosser \$30; three h.p. motor \$29. Banner Print, Statesboro, Georgia.

LINOTYPE For amateur and professional printers. Oakdale Composition, North Philadelphia, Penna.

PRINTING Presses, type, cabinets, supplies. Send stamp. Lincoln Press, Hartwell Street, Fall River, Mass.

STOCK Cuts 40c up. Catalog 10c. Gregor's, 79-N Main Street, Belleville, N. J.

BARGAINS. Presses, type. List 3c. Exchange D-15, 22 Orient, Meriden, Conn.

BARGAINS—Presses, type, supplies. Send stamp. 159 Harvard, Cambridge, Mass.

PATENT ATTORNEYS

PATENTS. Send sketch, photos or model and description of your invention for preliminary search and patentability report. Total expenses, including search fee, for preparing, filing and prosecuting your application quoted before you proceed. Rates reasonable. Prompt and efficient services. Lynwood B. James, Registered Patent Attorney, Established 1913. Suite 843-A National Press Building, Washington, D. C.

INVENTORS: Send immediately for your copies of our new free books, "Patent Protection" and "Suggestions on Selling an Invention." Sixty-eight pages of interesting facts. They tell how patent laws protect you; kind of sketch or model needed; simple steps to take without cost; how successful inventors have secured financial assistance; show interesting inventions; illustrate important mechanical movements. With books we also send free Evidence of Invention form to help establish date of disclosure. Prompt service, reasonable fees, special deferred payment plan. Strictest secrecy. Thirty-nine years experience. Highest references. Write us today. The facts in our books, are worth money to the man with a good invention. Address: Victor J. Evans & Co., Registered Patent Attorneys, 12-P Victor Building, Washington, D. C.

INVENTORS—Before disclosing your invention to anyone send for form "Evidence of Conception"; "Schedule of Government and Attorneys' Fees" and instructions. Sent free. Lancaster, Allwine & Rommel, 411 Bowen Building, Washington, D. C.

CHEMICAL Patents. Chester Tietig, M. Sc. (chemistry), L.L.B. Formerly examiner chemical division U. S. patent office. 309 Mercantile Library Bldg., Cincinnati, Ohio.

WHAT To do with your invention? Free books tell all. Patent facts clearly explained. 63 years' experience at your immediate service—on easy budget payment plan. Write today for free copies of our booklets and "Certification of Invention" form. C. A. Snow & Co., 1125 Snow Building, Washington, D. C.

PATENTS—Before too heavy an outlay of time or money is made on an invention, a search of the Patent Office records should be made to determine as nearly as possible whether or not the same idea has been patented before. The cost of this search is small, while the value of the facts it uncovers is often considerable. We offer inventors and manufacturers a thorough prompt, confidential search service—plus experienced counsel and assistance in every phase of Patent and Trade-Mark practice. Write for our new free book containing valuable information relating to patent procedure. Clarence A. O'Brien and Hyman Berman, Registered Patent Attorneys, 58-K Adams Bldg., Washington, D. C.

BEFORE You take any steps write for our 4-Points of Service for Inventors Bulletin. R. & S. Engineering Company, 17 East 42nd Street, New York, N. Y., Dept. DP-12.

INVENTOR'S Universal Educator; contains 900 mechanical movements; 50 perpetual motions; instruction on procuring and selling patents and selecting an attorney, etc. Suggests new ideas. Price \$1 postpaid in U.S.A. Address Albert E. Dietrich, 511-B Colorado Bldg., Washington, D. C.

PATENTS—Personal, confidential services at reasonable cost. Preliminary information furnished without obligation. John B. Thomas & Co., 902 F St., N. W., Washington, D. C.

PATENTS—Trade marks. Preliminary advice, book and disclosure form free. Personal service. Irving L. McCathran, 1060 International Bldg., Washington, D. C. Registered Patent Attorney.

"INVENTOR'S Guide." 100 mechanical movements, free; advises on patenting, selling inventions. Frank Ledermann, Tribune Bldg., New York.

L. F. RANDOLPH, 302-B Victor Bldg., Washington, D. C. Low cost. Book and information free.

PATENTS. Booklet free. Highest references. Best results. Promptness assured. Watson E. Coleman, Patent Lawyer, 724 Ninth St., Washington, D. C.

INVENTORS—Send for free booklet "Patent-Sense." Information based on 64 years experience. Lacey & Lacey, Dept. 5A, 635 F St., Washington, D. C.

PATENTS. Protect your idea by securing free "Proof of Invention" folder. Exceptional personal service. Established 1906. E. E. Vrooman, 871 Woodard Bldg., Washington, D. C.

FOR INVENTORS

PATENTS—Before too heavy an outlay of time or money is made on an invention, a search of the Patent Office records should be made to determine as nearly as possible whether or not the same idea has been patented before. The cost of this search is small, while the value of the facts it uncovers is often considerable. We offer inventors and manufacturers a thorough prompt, confidential search service—plus experienced counsel and assistance in every phase of Patent and Trade-Mark practice. Write for our new free book containing valuable information relating to patent procedure. Clarence A. O'Brien and Hyman Berman, Registered Patent Attorneys, 58-K Adams Bldg., Washington, D. C.

IDEAS And practical inventions developed and promoted. Protection guaranteed. Blueprint and engineering service. Write for 4-Point Service Bulletin. R. & S. Engineering Company, 17 East 42nd Street, New York, N. Y., Dept. DF-12.

HAVE You a sound, practical invention for sale, patented or unpatented? If so, write Chartered Institute of American Inventors, Dept. 4-A, Washington, D. C.

BLUEPRINT Drawing of your invention \$3.50. Write for free circular. Ormax Drafting Company, Bethesda Branch, Washington, D. C.

WE Locate buyers meritorious patented, unpatented inventions. If will sell, reply immediately. Descriptive booklet free. Invention Reporter, 5A-11236 South Fairfield, Chicago.

DEVELOP. Protect, sell your invention without patent. Valuable instructions. Guide chart 25c coin. Manual Publ., C-11, Box 458, Chicago, Ill.

HONEST Unbiased advice from experienced inventor will save you hundreds of dollars; protect you against costly or shady practices. Nothing to sell except my vast experience. Send your problem with \$1. A. B. Edwards, P. O. Box 1585, Little Rock, Arkansas.

INVENTORS Commercial Directory! From finance to underwriters! \$1. Western Press, Fort Morgan, Colorado.

LET Us develop your ideas. 20 years experience designing machinery. Strictly confidential, show us what you have. Many ideas worth money. Arthur Lonsberry, P. O. Box 914, Erie, Penna.

INVENTORS: Profit by your invention. A practical talk to inventors by an experienced manufacturer. Our 68 page booklet "Mind vs. Matter" mailed upon receipt of 25c. Rex Engineering Co., Cincinnati, Ohio, Dept. D.

INVENTIONS Bought, sold. Patented, unpatented. James Wallace, Homer, N. Y.

INVENTORS: "Making Inventions Pay," our 32-page illustrated book, mailed upon receipt of 3c postage. Crescent Tool Co., Dept. Z, Cincinnati, Ohio.

PENDING Patent applications can be brought before thousands of manufacturers, free of charge, through Invention Magazine. Write for details. Invention, Inc., 635 F Street, Washington, D. C.

INVENTORS—Send for 72-page book on patents. Reasonable terms. Conscientious treatment to inventors. L. F. Randolph, Registered Patent Attorney, 302-E Victor Bldg., Washington, D. C.

I SELL Patents. Established in 1900. Charles A. Scott, 773PM Garson Ave., Rochester, N. Y.

INVENTIONS WANTED

WANTED—New patented office specialty. Will buy or distribute on exclusive basis. Write Ranger Products Co., East Orange, N. J.

SMALL Inventions wanted by manufacturers. I'll help you sell your invention. Write for free circular. Stanley Hull, 7829-K Euclid Avenue, Cleveland, Ohio.

PRACTICAL Inventions wanted. Full protection guaranteed. Write for "4-Point Service" bulletin. R. & S. Engineering Company, 17 East 42nd Street, New York, N. Y., Dept. D-12.

SIMPLE, Practical inventions wanted by manufacturers, patented or unpatented. For information write Chartered Institute of American Inventors, Dept. 4-D, Washington, D. C.

WANTED—Meritorious patented, unpatented inventions. Booklet free. Invention Reporter, 5B-11236 South Fairfield, Chicago.

INVENTIONS Wanted for commercialization. Stamp for particulars. Arellano-Power Co., Box 1827, Dept. A, Chicago.

CASH For unpatented ideas. Stamp for particulars. Mr. Ball, 9441-A Pleasant, Chicago.

PATENTS FOR SALE

OUTRIGHT Royalty, double purpose street sign. Wilton Taylor, Pine, Colorado.

NOVEL Wire store display fitting; adjustable; low cost manufacture. Sell, offers, unpatented. W. Kilburn, 27 Foam St., Elwood, Victoria, Australia.

HAVE Several practical, simple, sound, patentable inventions. Partner or outright. F. Koellner, 5 E. Erie, Chicago.

MANUFACTURERS: For new products or profitable manufacturing opportunities, inquire, Invention Reporter, 5C-11236 Fairfield, Chicago.

ICE Creeper, automatic locking. Fits any shoe. No bolts, nuts, straps. R. M. Yarger, Morgantown, W. Va.

HOLDER For drawing ink bottles. Pat. 2,113,095. Carlos Cruz, Infanta 254, Havana, Cuba.

EASYWAY Exercise and reducing machines, build muscles, reduce fat. Patent pending. Several used machines for sale. Sell state sales rights. A fortune awaits business you can own. May sell outright. Write for territory, circular. Easyway Machine Co., 3528 Franklin, St. Louis, Mo.

SELL Your patent through a small classified ad in Popular Mechanics. Many inventors have found buyers in this way. Ask me for proof—I'll gladly send it to you. F. W. Johnson, Manager Classified Advertising, 200 E. Ontario St., Chicago.

MANUFACTURING

INVENTIONS Manufactured in any quantities. Tools, dies, metal stampings; working models built; industrial designing. Complete blueprint and engineering service. Write for "4-Point Service" bulletin. R. & S. Engineering Company, 17 East 42nd Street, New York, N. Y., Dept. DM-12.

ALUMINUM Casting at reasonable prices. H. Moore, Sutton Rd., Millbury, Mass.

ANALYSIS. Research. Newest guaranteed formulas. Biggest catalog free. Special prices, leads. Gibson Laboratory, Chemists, DS-1142 Sunnyside, Chicago.

STAMPINGS. Dies, screw machine products, specialties. Porsberg Engineering, Northfield, Ohio.

AUTOMATIC Screw machine products, special machinery, stampings, forgings machined. Send for quotation. Cogswell Corp., West Springfield, Mass.

DIES, Stampings, complete manufacturing, wire forms. Southern Products, Independence, Missouri.

INVENTIONS Manufactured by an experienced company, in any quantity at low cost. Metal specialties, novelties, stampings, dies, and models. Free estimates. Our booklet "Mind vs. Matter" sent upon receipt of 25c. Rex Engineering Co., Cincinnati, Ohio, Dept. C.

INVENTIONS Manufactured in any quantity at low cost. Stampings, dies, models, etc. Estimates and free catalog. Crescent Tool Co., Dept. X, Cincinnati, Ohio.

MODELS AND MODEL SUPPLIES

FREE Catalog, model builders supplies, save money. Ebert Model Supplies, LaGrange, Illinois.

MODEL Railroad Shop, Dept. PM, Dunellen, New Jersey. New 24 page illustrated catalog 10c postpaid.

MODEL Ship, yacht, speedboat supplies. Catalog 10c. Welcher, Fulton, N. Y.

BUILD New Queen Elizabeth—sister ship of Queen Mary. Biggest passenger ship afloat. Beautiful 30-inch scale model, complete in every detail. \$4.50 plus postage. Other models \$1.00—\$6.00. Catalog, 3c stamp. Miniature Ship Models, Dept. R, Perkasie, Penna.

CATALOG Of over 40 engines, castings, supplies 25c. Refunded. We specialize in experimental work or improve your patent as required. Howardco, A-2417 North Ashland, Chicago.

BOUCHER Ship model kits make ideal Xmas gifts. Priced \$5 to \$9.50. Free leaflet PM12. Boucher, 126 Lafayette St., New York.

AIRPLANE, Railroad, ship model kits, supplies. List 5c. New champion racer kit 35c P. P. Northern Aircraft, Manitowoc, Wis.

BUILD Miniature gasoline motors. Fascinating; educational; profitable. Details, drawing; 10c. Wright Motor Works, 3256 Lake Park Avenue, Chicago.

MODELMAKERS Catalogue of supplies and materials 20c. Buy now. Evraymesco, 28 N. Clinton, Chicago.

AIRCRAFT—Gasoline, rubber model kits, engines, supplies. Everything. Catalog 3c. Air-King, 2934 S. E. 50th, Portland, Oregon.

LARGE Assortment of model airplanes. Samples 10c. E. Schank, 1539 E. Montgomery, Philadelphia, Penna.

GASOLINE Motor for model boats, \$12.00. Circular 10c stamp. Anton Bohaboy, 2297 Price St. M. Rahway, N. J.

STEAM Locomotives! $\frac{3}{4}$ " scale. Build one by "Easy Steps." Our illustrated catalog lists all needs, 25c. Little Engines, Box 15B, Wilmington, Calif.

MODEL Airplanes, boats, radios, supplies. Catalog 10c. Imperial, 416-K McDonald, Brooklyn, N. Y.

MODELS—Practical models put over your ideas. We develop models from the crude to perfect working devices. Your idea might have large commercial value. Services confidential. Bank references. Registered graduate engineers at your service. Send 25c for our 88 page booklet "Mind vs. Matter." Rex Engineering Co., Cincinnati, Ohio, Dept. B.

SHIP And yacht model fittings; construction sets; model yacht sails; illustrated catalog 20 cents. A. J. Fisher, 1002-1 Etowah Avenue, Royal Oak, Mich.

MODEL Supplies for the inventor. Send 3c stamp for catalog. Pierce Model Works, Tinley Park, Ill.

MODELS—Your ideas developed into practical working models. 30 years' successful experience; thousands of satisfied customers. Confidential service guaranteed. Bank references. Send 3c postage for 32-page book—"Making Inventions Pay." Crescent Tool Co., Dept. Y, Cincinnati, Ohio.

RAILWAY Models. Catalog handbook 25c. Walthers, 247 E. Erie, Milwaukee.

HOME CRAFTSMEN

SQUAREKNOTTERS! Make belts, handbags, etc. Quality cord samples with catalog, free. Beginners book, catalog and samples, 10c. Special! Regular \$1 book with 50c beginners outfit, all for \$1. P. C. Herwig Co., Dept. J-12, 121 Sands St., Brooklyn, N. Y.

BUILD Shaper, lathe, jig-saw, drill from Ford parts. Drawings, instructions 50c each. Hancock, 323 Douglas, Portsmouth, Va.

15 FULL Size shelf bracket patterns. 25c coin. Albright Service, 6901 Railroad Ave., Omaha, Nebraska.

PLASTICS—How to work with this new material. Plans for 50 projects—lamps, trays, clocks, jewelry, dresser sets, etc. 232 page instruction book, \$1.00. Readers Service, 800-51 North Clark, Chicago.

20 FULL Size lawn ornament patterns 25c. Wickman, 744 Brooklyn, Dept. 10, Dayton, Ohio.

IMITATION Leather. Write your needs. Size, color, purpose. I'll send sample, price immediately. Modernize chairs, card tables, benches, etc., with beautiful washable leatherette. "Girard Leather." Long Island City, New York.

UNPAINTED Furniture saves dollars. Beds \$6.00. Dressers \$11.00. Chests \$7.00. Baby chests \$2.50. Kitchen tables \$2.50. Catalog 10c. Mayflower Manufacturing, 1551 Thomas, Chicago.

ALABASTER Works like wood. Details, stamp. Demonstrators, 1741 Harrison, Chicago.

ASSORTED Woods. 15 lbs. \$1.00 postpaid zones 1 and 2. W. Lindemann, Port Washington, Wis.

HEADQUARTERS For home craftsman machinery and equipment—bought and sold. Lathes, cutters, scroll saws, etc. If you want to sell, get our offer first; if you want to buy, send for bargain price list. Craftsman House, 315A Harding St., Avoca, Penna.

15 FULL-SIZED Lawn ornament patterns 30c. Modern Woodcraft, Saginaw, Michigan.

LEATHERCRAFTSMEN—Write for free instructions and price list of leather, tools, etc. Sample cards 5c. Wilder & Co., Dept. F, 1038 Crosby St., Chicago, Ill.

FOR THE HOME

FURNACE Regulator, automatic for hot air or steam. Complete plans including bimetal for thermostat \$1.00. Dennis Plans, Dept. 12C, 2807 Ewald Circle, Detroit, Mich.

BURN Cheaper coal; furnace blower \$3.95; thermostat \$2.50. Nicklin, Box 491, Newburgh, New York.

BEAUTIFY Your old furniture! Refinishing now made easy. Complete instructions 35c. Todd's Service, 262 Arlington, Youngstown, Ohio.

RELINE Cracked firepots easily. No taking down furnace. Inexpensive. Literature free. Furnace Repair, 3566 Milwaukee, Chicago.

OLD GOLD, WATCHES, JEWELRY, PRECIOUS STONES

BEAUTIFUL Carnelian ring set, brooch, pendant, unmounted, \$1.00 each. E. Southwick, 528 Southeast Washington, Portland, Ore.

HIGHEST Prices for old gold, teeth, watches, jewelry. Full cash value mailed day shipment received. Satisfaction guaranteed or articles cheerfully returned. Information free, or ship today. Chicago Gold Smelting Co., 300-P Champlain Bldg., Chicago.

GOLD \$35 Ounce. Ship old gold teeth, crowns, jewelry, watches—receive cash by return mail. Satisfaction guaranteed. Free information. Dr. Weisberg's Gold Refining Co., 1500-Q Hennepin, Minneapolis, Minn.

ZIRCON Diamonds from mines of far-away Siam; in exquisite mountings or unset. Inexpensive. Catalog free. Box 388-E, Wheeling, W. Va.

SILVER Filigree bracelet \$2.00. Quality guaranteed. Flores, Vallarta 1994, Guadalupe, Jal., Mexico.

HALF Carat perfect diamond set in latest style engagement ring. Guaranteed \$150.00 value. Will sacrifice for \$75.00. M. Rose, 3867 Grand Ave., Chicago, Ill.

1939 BULOVA Watches. Any quantity at wholesale prices. Pistilli, 51 Bridge St., Newark, N. J.

5000 REBUILT Elgin, Waltham, Hamilton watches. Also ladies, gents wrist watches. Make big money! 12 size, 7 jewel, Elgin or Waltham, \$4.75; 16 size, 17 jewel, \$7.50. Send for free watch and diamond catalogue. The New York Jobbers, Dept. M, 74 Bowery, New York, N. Y.

TOBACCO

GUARANTEED: Cigarette, pipe or chewing 5 lbs. \$1.00, ten \$1.75. Pay when received. Pipe and box cigars free. Rives Tobacco Co., Paducah, Ky.

CHEWING. Four pounds \$1.30. Smoking, Gold Leaf burley, Turkish tobacco, three pounds \$1.15. Postpaid. Belmont Farms, Chatham, Virginia.

RAZORS—BLADES—SHARPENING

100 DOUBLE-EDGE Blades 75c guaranteed. Olsen, 1551 Southeast Powell, Portland, Oregon.

\$1.00 PACKAGE Razor blades 69c. Samples 10c. Hardware, South Zanesville, O.

BEAUTIFUL Transparent dry electric shaver \$3.98 sent COD. Like \$15.00 machine. Year guarantee. Magnifying shaving mirror free. Monroe Sales, 520 First National Bank, Springfield, Ohio.

"KEENEREDGER" Made one blade produce 750 smooth shaves. Keeneredger, Oblong, Ill.

50 DOUBLE Edge blades postpaid 40c. Moneta Co., Box 1105, UP Sta., Des Moines, Iowa.

50 DOUBLE Edge razor blades. Beautiful gift package. Guaranteed. 75c postpaid. Economy Sales, 2145 Concord Pl., Chicago, Ill.

SURVEYING INSTRUMENTS

GUARANTEED Factory rebuilt transits and levels for rent (with purchase option) or sale (cash or terms). Order now before prices advance. We will repair, trade in, or buy your old instruments. Ship prepaid for estimate and valuation. Write for List M-312 and complete information to Warren-Knight Co., 136 N. 12th St., Philadelphia, Penna.

FOR SALE OR EXCHANGE

WATCHES Bought, sold, exchanged. List free. Wm. Janvrin, Ludlow, S. D.

FOR SALE—MISCELLANEOUS

NEW 250 Watt 110 volt bulb sunlamp, floor model, no carbons to smoke, buy, or adjust \$8.95; larger size, 500 watt \$12.95. Carbon sunlamp, reflector, carbons, and instructions \$2.95. Nicklin, Box 491, Newburgh, New York.

NORTH Eastern Quebec mink. Write Castle Mink Ranch, Belgrade, Me.

WANTED—MISCELLANEOUS

TREASURE Finders. Old radio mineral locators wanted. Will pay liberal cash regardless age or condition if suitable. Needed for historical record. We have nothing to sell. Write full details. Hidden Science Institute, 1046 South Olive St., Los Angeles, Calif.

CASH For used microscopes, binoculars, cameras, slide rules, drawing sets, surveying, mechanical, scientific, and musical instruments. Highest prices paid day shipment received. Satisfaction guaranteed or shipment promptly returned. Elman's, 2302 Van Buren, Chicago.

PERSONAL

FOOT Troubles ended. New corrective methods. Orthopedic Appliances, Box 423, Warren, Penna.

SONGS, Poems wanted now. Metro Melody Publishers, 532B Geary, San Francisco.

YOU Must have a winning personality; be in good health; radiate cheerfulness and be happy to be a real success. Free literature. Dr. H. H. Buddenberg, 2614 Jefferson Ave., Cincinnati, Ohio.

DANDRUFF! Do you suffer from dandruff and falling hair? Use "Scalpini," the latest medicine that brings marvelous results. Money refunded if not satisfied. Send \$1.00 to Scalpini Co., 317 W. 50th, New York.

LEARN The truth about yourself and friends. Know your own abilities and handicaps. Find your rightful place in business. Submit handwriting and 50c for scientific character analysis. David M. Roberts, 41-23-47th Street, Long Island City, New York.

SONG Poems wanted, 50-50 plan. Song Bureau, Dept. 43, Salem, Indiana.

NERVOUSNESS, Fear, successfully relieved! "Psychological analysis," amazingly helpful method. Literature gladly mailed. John Englund, Box 335, Ironwood, Mich.

NERVOUS? Fears? Depressed? Afflicted? Free helpful information. Norman Ferngold, Psychologist, Office 15, 22 Amherst St., Worcester, Mass.

MEXICAN Cases; no publicity. American Attorney, Box 1736, El Paso, Texas.

WANTED, Original poems, songs, for immediate consideration. Send poems to Columbian Music Publishers, Ltd., Dept. 33, Toronto, Can.

WIN Prize money: Booklet—"Successful Contesting"—shows how. 10c postpaid. Bulletin listing \$200,000.00 prizes included. World Publishers, 4515-B Cottage Grove, Chicago.

SENSATIONAL! Amazing new trick. Detect instantly every card of any pack, without preparation, partner or skill. HP, 237, 43, Chaussee Antin, Paris, France.

POEM Writers, songwriters. Send for free Rhyming Dictionary, Songwriters' Guide. Submit best poems, melodies today for bonafide, superior offer. MMM Studios, 33-J, Portland, Ore.

BOOKKEEPING. Home, personal, business. \$2.25. Popular Mechanics, 200 E. Ontario St., Chicago.

MISCELLANEOUS

HOUSEHOLD Repair kit: 3 new cements for leather, rubber, cloth, metals, etc., guaranteed. \$1.00 postpaid. Brooks-Hill Co., 711 No. Ridgewood Pl., Los Angeles, Calif.

SLIDE Rule 10" magnifying indicator 49c. Advance, 162 Madison, Chicago.

BOOKBINDING Unit that does the entire job—vocational schools, libraries, job shops, hobbyists. Practical. Low priced. Write Pratt, A-9, 4227 Euclid Ave., East Chicago, Indiana.

GOOD Eyesight without glasses. No drugs. Representatives wanted. Stamp appreciated. Arthur Jacobson, Upsala, Minnesota.

GENEALOGIES Of Vermont families traced. Howland Atwood, Hartland Four Corners, Vermont.

BUSINESS Proposition resilvering mirrors, autoparts, reflectors, making chipped glass signs. Write Sprinkle, Plater, 288, Marion, Indiana.

RAILROAD Blue-bloods. 700 of them. Can you name 100? Did you ever hear of the Plainsman, Estrella-Del-Sur, Egyptian, or the Barnacle Bill? These trains and 700 others are described in a booklet having interestingly dramatized cover. Only book of its kind. 25c coin. Trains, 1069-D Transportation Bldg., Chicago.

NEW Patented electric pencil set. Writes in all beautiful colors, gold, silver, etc. on any material—leather, wood, paper, bakelite, rubber, cellophane, etc. \$1.50 postpaid. Machinery Sales, 192 North Clark, Chicago.

GRAND Coulee dam—Jobs, cities, farms, factories, opportunities. Copyrighted book "Grand Coulee Dam—Great Pacific Northwest" ready. Chucked with information, details, etc. \$1.00 postpaid. Columbia Pacific Co., 7803 Eleven Northeast, Seattle, Washington.

SHARPEN Your own lawn mower the factory way, simple, easy, complete lifetime outfit \$2.00. Keen-Kut Sharpeners, Corpus Christi, Texas.

JUMBO Paper shell pecans, 5 lbs. \$2.00; shelled \$3.00 prepaid. Consumers Seed Co., Mt. Pleasant, Tenn.

QUALITY Christmas cards, folders, wrappings. Descriptive folder on request. Staten Island Mail Order Co., 18 Pommer Ave., Stapleton, N. Y.

IT'S Fun answering questions, birthdays, etc., blindfolded in crowd. \$100 daily. Copyrighted instructions \$2. Premier, Box 1608, Hollywood, California.

INTERESTING Gift from border. Send 50c for fancy Mexican ebony letter opener. Woodworker, 540 South Reagan, San Benito, Texas.

VIRGINIA Fairystone crosses. Samples 10c. W. E. Martin, Bassett, Va.

24 PENCILS, Your name in gold, \$1.00 postpaid. Beebe, 12317 Ohio, Detroit, Mich.

OPALIZED Wood, jasper, agates, 25 cents specimen. Box 808, Tacoma, Wash.

ORIGINAL Ala Kabozo's genuine rabbit's foot, beautifully metal mounted with ring, 25c. Ala Kabozo, Box 52, Oakland, Calif.

LAM-A-PAB, The cloth cement, acid and waterproof. Permanently repairs anything made of cloth. Sails, hunting equipment and suits, football suits and athletic equipment, rugs, canvas chairs and work clothing. S. J. Russell Co., P. O. Box 187, Peoria, Ill.

TATTOOING Outfits, supplies, illustrated list free. "Waters," 965 Put-nam, Detroit.

HOW And where to obtain capital, fully explained, free particulars. Star Service, Wapakoneta, Ohio.

COATS-OF-ARMS And crests correctly rendered in colors or black and white. Highest grade. Estimates free. Heraldic Studios, 1914 Oakdale Ave., Chicago.

AMATEUR Tattooing outfits, illustrated catalog 6c. "Tatuco," 651A S. State, Chicago.

SWAPPER'S Friend, R4, Saline, Michigan. Interests swappers, collectors. 50c year, sample 10c.

TURN Scrap into money. Convert old auto generators into A.C. generators for auto radio, camp and home lighting, power and other uses. Complete book \$1 postpaid. Popular Mechanics Press, Room (C38), 200 E. Ontario St., Chicago.



There's MONEY IN ARC WELDING!

"No more tiresome work for me. I get a real thrill out of being an arc welder—and don't forget it, I'm getting more money than I ever earned on hit or miss jobs."

You, too, can become part of this great new industry! There's almost no limit to what welders can accomplish—they cut manufacturing costs way down. Because they know the "How and Why" of Welding, Metallurgy, Drawing, Blueprint Reading, Set-Up Work and Fabrication.

No wonder manufacturers all over the country are demanding practically trained School of Engineering Welding Operators, Welding Technicians, and Welding Engineers!

Don't be content with ordinary work at low pay—when in a short time you can become a thoroughly Trained Specialist in Welding.

MILWAUKEE SCHOOL of ENGINEERING
Institute of Electrotechnics

Dept. PM-1238 Broadway and E. State, Milwaukee, Wis.

Send Free Booklet "ARC WELDING, World-Wide Dawn of a Gigantic Industry." Also tell me how I can become an

Arc Welding Operator in 2 1/2 months. . . . Gas Welding Operator (6 weeks)
Welding Technician (4 months) Welding Engineer (1 year)

Send details of Student Loan Plan. Earn Part Expense Plan.

Name. Age.

City. State.

(If interested in other courses, check here. Refrigeration and Air Conditioning Technician (3 mo.) Radio and Television Service Man (6 Mo.)

Commercial Radio Engineer (1 Yr.) Electrical Engineer B.S. Degree (4 yrs.)

PM-1238



GOOD MONEY to be made in POULTRY

Many Earn Extra Spare-Time Profits — Or You May Build a Business of Your Own

Whether you want a job at good pay or a profitable business of your own, Poultry offers you many opportunities. Poultry meat and eggs are always in demand, and at times there is a shortage of trained poultrymen. My Home Study Course shows you how to succeed—how to save money and make money, either for yourself or for an employer.

FREE Book Shows the Way to Big Pay and Big Profits

Mail coupon below TODAY —for my Big NEW FREE Book, "How to Raise Poultry for Profit." My forty years of experience are yours. The poultry industry may need you, and therefore you need my free book. Get it—and get in line for the extra money that can be made in poultry!

CASH IN SPARE TIME or FULL TIME

No matter where you live or what you do now, my proved course will show you what to do with poultry right from the start. If you choose to start a business of your own, I'll show you how to make a small investment grow, show you how to expand. Send for the facts today.

Mail NOW for FREE Book

NATIONAL POULTRY INSTITUTE, Dept. 38-D
Adams Center, N. Y., Att'n: Harry M. Lamson, Pres.

Dear Mr. Lamson: Send me your FREE Book, "How to Raise Poultry for Profit". I want to know more about my opportunity to make extra money spare or full time.

Name.

Address.

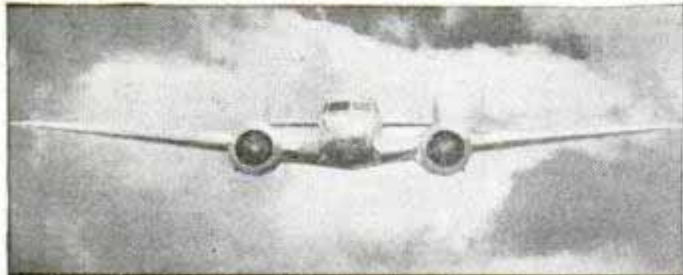

AVIATION and POLICE RADIO offer Good JOBS

The nation's airlines are rapidly expanding. This means the creation of vast radiotelephone and radiotelegraph circuits that can be operated only by men with special training. Through the cooperation of men actually connected with several major airlines, Midland has developed



an unusual plan of training that can fully qualify you for a fascinating, steady, well-paid job as an airline radio operator. All advanced instruction is under the supervision of expert operators employed by two major airlines. The many interesting subjects in addition to radio include operating procedure, weather, navigation, etc.



BILL FUHRMAN, Midland-trained radio operator employed by TWA



ARTHUR WOODS, Midland-trained radio operator, employed by Missouri State Highway Patrol



GLEN BRADY, Midland-trained radio operator employed by Braniff Airways

NATIONAL POLICE Network

Day by day the life of the criminal is becoming more uncertain because of improved local and state Police Radio facilities. Here again, radiotelephone and radiotelegraph circuits are largely used. More and more cities and towns are joining the National Police Network. Police radio operators must have special training. To prepare you for this type of employment we have gone direct to police radio operators for our information. All instruction will be supervised by men actually connected with police radio systems. Midland's HI-SPEED COMMUNICATIONS training can prepare you for airline and police operating, broadcasting and many other branches of the radio field. Your employment opportunities will be excellent—you will be given genuine employment service upon graduation, MIDLAND TRAINED MEN ARE ON THE JOB ALMOST FROM COAST TO COAST!

Midland Aviation and Police training may be secured on two plans: 1. Combination Extension Resident, 2. Straight Resident.

Complete information about this new type of training will be sent you without obligation. Simply fill out the coupon and mail to us TODAY. This may be YOUR opportunity of a lifetime. DON'T LET IT PASS YOU BY—Mail the coupon today!

AVIATION-POLICE DIVISION

MIDLAND TELEVISION, INC.

28, 29, 30, 31st Floors Power & Light Bldg., Kansas City, Mo.

Affiliated with KMBC—
a Major Network Outlet.

GET THIS **ILLUSTRATED Book** and complete information you want



Coupon Good for FREE Book!

Midland Television, Inc., Power & Light Bldg. Dept. 306-M, Kansas City, Missouri
(Paste on postcard or mail in envelope)

Without obligating me, send your FREE illustrated book on Aviation-Police Radio opportunities.

Name..... Age.....
Address.....
City..... State.....

When writing please mention Popular Mechanics

Learn to Mount BIRDS

SEND FOR FREE BOOK!

LEARN AT HOME Be a Taxidermist

Real FUN, great Hobby, sure spare-time profits. Save your hunting trophies, Mount BIRDS, ANIMALS, HEADS, FISH, TAN furs and hides. Mount common specimens into fine groups. Wild-game not needed. Easily, quickly learned. Investigate!

FREE BOOK Yes FREE. 100 pictures. Tells how YOU can be a Taxidermist, make a home museum, have fun and PROFIT from your HOBBY. Old reliable school, 250,000 successful students. Students earn BIG PROFITS mounting specimens for others. This strange FREE BOOK will interest and amaze you. Nothing like it—Send TODAY—THIS MINUTE—for YOUR Free copy. State your AGE.

N. W. School of Taxidermy, 3379 Omaha, Neb.



FARM RELIEF!

Here's farm relief no farmer can afford to be without—EN-AR-CO (Japanese style) OIL. Stimulates local circulation for the relief of pains of Neuralgia, Sprains, Sore Muscles, Fatigue and Exposure, also the discomfort of Head Colds and Bronchial Irritation. EN-AR-CO has been doing it for over 50 years. Best insurance against a crop of troubles. Get EN-AR-CO today and get your quick pain relief. Sold by all druggists.

Made in U.S.A.
NATIONAL REMEDY CO.

NEW YORK

Learn this Profitable Profession



in 90 Days at Home

Hundreds of men and women of all ages 18-50 make \$10.00 to \$20.00 in a single day giving scientific Swedish Massage and Hydro-Therapy treatments. There is a big demand from Hospitals, Sanitariums, Clubs, Doctors and private patients as well as opportunities for establishing your own office.

Learn this interesting money-making profession in your own home by mail, through our home study course. Same instructors as in our NATIONALLY KNOWN resident school. A diploma is awarded upon completion of the course. Course can be completed in 3 to 4 months. High School training is not necessary. Many earn big money while learning.

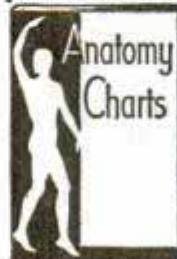

Anatomy Charts & Booklet FREE

Enroll now and we will include uniform coat, medical dictionary, patented reducing roller and Hydro-Therapy supplies without extra cost. The reducing course alone may be worth many times the modest tuition fee.

Send coupon now for Anatomy Charts and booklet containing photographs and letters from successful graduates. These will all be sent postpaid—FREE.

THE College of Swedish Massage (Successor to National College of Massage) Dept. 964—1601 Warren Boulevard, Chicago.

You may send me FREE and postpaid, Anatomy Charts, booklet containing photographs and letters from graduates, and complete details of your offer.

Name.....
Address.....
City..... State.....



What do YOU KNOW about— DIESEL JOBS?

DO YOU KNOW...

there has been an 800% increase in Diesel sales since 1932? This means jobs—selling, servicing, operating and maintaining these hundreds of units.

WHO IS GETTING THE JOBS?

There's only one answer—TRAINED MEN! Do you know that the Pacific Northwest uses more diversified Diesel power than any other Diesel center in the world?

Mr. Adcox, who has been training men in his school for 30 years says, "I believe that the Adcox school is one of the best equipped and that 80% of Diesel School graduates on Diesel jobs, in the Northwest, have been trained in my school."

Diesel—Diesel Schools—DIESEL JOBS

For the man who wants to know, who is looking ahead and planning his future in Diesel, Mr. Adcox has published a new 48-page book. It is full of interesting pictures, facts and figures about this growing industry.

FREE 48-PAGE DIESEL BOOK

Here is an easy and quick way to get a line on Diesel THAT WILL NOT COST YOU ONE PENNY! Fill out the coupon below and mail it right away.

L. L. ADCOX TRADE SCHOOL (PM-1)
237 N.E. Broadway, Portland, Oregon.

Name..... Age.....

City..... State.....

PRACTICAL SHOP TRAINING

TOOL & DIE MAKING DESIGNING MACHINIST TRADE

You can qualify in a few months for a shop job. You train on actual shop equipment under expert instructors. Skilled men, in these trades, are in demand at good pay. Learn by doing. Free Employment service. Low rates. Write today for full information without any obligation.
NATIONAL SCHOOL OF MECHANICAL TRADES
Dept. 101, 628 W. Lake St., Chicago, Illinois

LEARN AVIATION IN LOS ANGELES



Huge increases in aviation activity creating good paying positions. Rapid advancement for California Flyers graduates. Only U. S. Government approved Los Angeles school offering flying mechanics drafting and aircraft construction. Most modern equipment and strategically located school in America. Low tuition. Free transportation to L.A. Write for Catalog.

CALIFORNIA FLYERS
SCHOOL OF AVIATION—Dept. PM 12
LOS ANGELES MUNICIPAL AIRPORT, INGLEWOOD CALIF.

CARTOON YOUR WAY TO SUCCESS!



RAYE BURNS will teach you HOW to CREATE ORIGINAL CARTOONS at home that you can SELL! Course contains 25 lessons and over 600 illustrations. All for Only

\$2.85

Send name and address for free details.
RAYE BURNS SCHOOL, Dept. M, BOX 2194, Cleveland, Ohio

New York Established 1902
Electrical
Ask for free booklet **School**
44 West 17th St., N. Y. C.

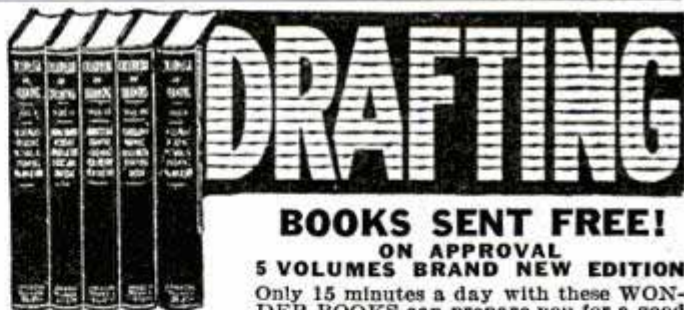

DRAFTING

BOOKS SENT FREE!

ON APPROVAL
5 VOLUMES BRAND NEW EDITION

Only 15 minutes a day with these WONDER BOOKS can prepare you for a good drafting job in less than a year. Mechanical and architectural drafting from simple straight lines to important complex plans. A step at a time! Built especially for beginners, for men with only grammar schooling. Drafting room practice, PLUS ENGINEERING, made easy and clear. Includes complete course in blueprint reading.

Big Field Big Demand Big Pay
Competent draftsmen are urgently needed right now in all building and manufacturing lines at \$30.00 to \$75.00 a week. That's just the beginning—FOR DRAFTSMEN HAVE THE BEST CHANCES FOR ADVANCEMENT. Pleasant, fascinating work, easy to learn and do. Learn quickly with these books—send coupon for a set and see for yourself.

A year's consulting membership in the American Technical Society now given to all readers of this famous cyclopedia of drafting. Many say that it is worth more than the cost of the books. Complete set of drawing instruments if you send for these drafting books NOW. These instruments are made of the finest of German silver, are absolutely accurate and are packed in velvet lined leatherette pocket case. Real \$10 value, but included with these books.

AMERICAN TECHNICAL SOCIETY
Dept. D919, Drexel at 58th St., Chicago, Ill.

American Technical Society, Dept. D919, Drexel at 58th St., Chicago, Ill. Send for 10 days' trial New 5 volume set of drafting. I will pay the few cents delivery charges. If I wish, I may return books in 10 days and owe you nothing but if I decide to keep them, I will send \$2.00 after 10 days, then only \$3.00 a month until \$24.80, the advertising price, is paid. Send latest edition and include drawing instruments and Membership Certificate.

Name.....
Address.....
Attach letter stating age, occupation, employer's name and address and that of at least one business man as a reference.

When writing please mention Popular Mechanics



START \$1260 to \$2100 YEAR

MANY 1939 APPOINTMENTS EXPECTED

Railway Postal Clerks

Railway Postal Clerks get \$1,900 the first year regular, being paid on the first and fifteenth of each month. (\$79.17 each pay day.) Their pay is automatically increased yearly to \$2,450. Advance may be had to Chief Clerk at \$2,700 a year. (\$112.50 each pay day.)

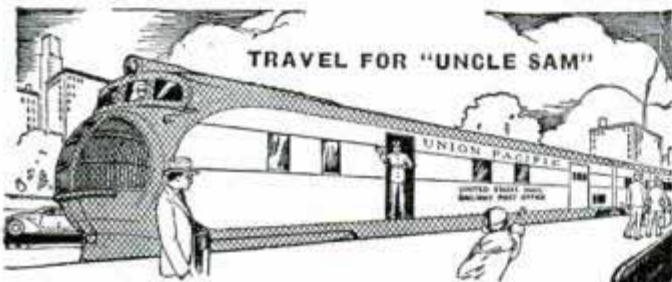

3 Days On—3 Days Off—Full Pay

Railway Postal Clerks on long runs usually work 3 days and have 3 days off duty or in the same proportion. During this off duty their pay continues just as though they were working. They travel on a pass when on business. When they grow old, they are retired with a pension.

City Mail Carriers, Post Office Clerks

Clerks and Carriers now get \$1,700 the first year on regular and automatically increase \$100 a year to \$2,100 and \$2,300.

GOVERNMENT CLERK



File Clerk—Clerk

Open to Men—women 18 to 50. Entrance salary \$1260-\$1440 Year. Appointments as File Clerks and Clerks in the Departments at Washington, D. C., are made from this examination.

Many Other Positions

Many other positions are obtainable. Those wishing these positions should qualify at once.

Get Free List of Positions

Fill out the following coupon. Tear it off and mail it today—now, at once.

This investment may result in your getting a big-paid government job.

FRANKLIN INSTITUTE, Dept. E-173, Rochester, N. Y.

Rush to me, entirely free of charge (1) a full description of U. S. Government Jobs; (2) Free copy of illustrated 32-page book, "U. S. Government Positions and How to Get Them"; (3) List of U. S. Government Jobs; (4) Tell me what to do to qualify for a U. S. Government Job.

Name.....

Address.....

Use This Coupon Before You Mislaid It. Write or Print Plainly.

Learn To **MOUNT BIRDS**

Tan SKINS, Make Up FURS

Be a Taxidermist. Double your hunting fun. We teach you at Home. Mount Birds, Animals, Pets, Heads and Fish. Save your hunting trophies; decorate home and den, MAKE MONEY. Mount and Krome-tan for others. Big sparetime profits. INVESTIGATE TODAY.

FREE BOOK with 100 game pictures, 48 pages. Hunters, get yours! It's Now Free.

Send postal card TODAY—This Minute! State your AGE

NORTHWESTERN SCHOOL OF TAXIDERMISTRY, Dept. 3379 Omaha, Nebr.

CASH IN ON YOUR SPARE TIME 300 WAYS TO MAKE MONEY

BRAND NEW BOOK—68 PAGES, 40,000 WORDS IN TEXT! "CASH IN" has ALL real money-makers—dozens of profitable tested mail-order plans, confidential business secrets, practical tested formula, successful tested schemes—actual experiences of men who started on a shoestring with less than \$10. A GOLD-MINE FOR ALERT MEN AND WOMEN.

25c a copy. Remit by coin or U. S. stamps. Sent POSTPAID. MONEY BACK if not satisfied.

NATIONAL PLANS INSTITUTE 246-M FIFTH AVENUE NEW YORK, N. Y.

MONUMENT **BIG FREE CATALOG**

Best Genuine Marble or Granite \$19.95 up. Directly Mailed. Low Prices.

U. S. MARBLE & GRANITE CO. Dept. A-18, ONECO, FLA.

Freight Paid Erected if desired. Lettered, Guaranteed. Thousands Sold. Write for Big Free Catalog and Samples

MYSTERY INVENTION KEEPS HANDS, FEET, BODY WARM

Even in Below-Zero Weather, Outdoors

KUMFY WARMER—carried in pocket, glove, sock, stocking, shoe or boot, or hung inside clothing, keeps you comfortably warm outdoors even on coldest days. Heats itself in 10 seconds—STAYS WARM 12 HOURS at a time. Lasts years. ABSOLUTELY SAFE—NO FLAME. Low-priced. GUARANTEED.

AGENTS—Make up to 200 percent profit. Everybody buys—workmen, housewives, drivers, sportsmen, spectators, farmers, others. Reserve your territory now for big winter profits. Write quick. **KUMFY WARMER, Dept. R-2300, Cincinnati, Ohio.**

FIND OUT WHAT'S HOLDING YOU BACK

Without delay . . . find out how to win success, money, friends, popularity

Research discloses that any man of average intelligence has the ability to progress much farther than his present status. Undiscovered powers worth real money lie within him, ready to push him ahead to greater success the instant they are released. Self-analysis Chart sent FREE gives you the clue to easiest, quickest way to get bigger pay, become more important in business, gain new social popularity, have perfect home life. If you are dissatisfied . . . if you are discouraged . . . if you are not making progress . . . if you want to make more money quickly in your chosen work . . . write at once for FREE Self-analysis Chart, at no cost or obligation to you. Mail coupon today.

Self-Study Foundation, Inc., 30 North Michigan Ave., Dept. A-33, Chicago, Illinois

Please send me, free of charge, instructions for analysis of my capabilities and how you can help me "Get Set for Success." I understand this places me under no obligation.

Name.....

Address.....

City.....State.....



"Air Piloting—Manual of Flight Instruction"

by Virgil Simmons, formerly Flying Instructor at Boeing School of Aeronautics and in U. S. Army and Navy Air Services. 300 pages. 75 illustrations \$3.00

This new book—just off the press—supplies a detailed system of instruction to prepare you for the official tests for a government certificate as an airplane pilot in any of the ratings, from solo to instrument, or as a flying instructor.

It completely analyzes all the flight test maneuvers required for the various certificates and special ratings. Diagrams show every detail, make correct performance easily understood. Common faults are described, their causes explained, methods for correction given. Book contains 377 questions taken from official examinations, with answers that have been accepted as correct.

5 DAYS' TRIAL—SATISFACTION GUARANTEED: Send for this book with the privilege of five days' examination. When it reaches you, pay postman \$3.00 plus a few cents for delivery. If not delighted, send it back and your payment will be refunded at once. (If you remit \$3.00 cash with order, we will pay delivery charges; same return privilege.) Write today to **THE RONALD PRESS CO., Dept. M261, 15 E. 26th St., New York**

NEW MODEL DRAW-O-MATIC DRAWING BOARD
 ATTACHED, SLIDING, SELF-ALIGNING, PARALLEL-BAR

Model B

A SELF-CONTAINED UNIT BUILT TO A STANDARD OF QUALITY. Thousands in use by Draftsmen, Students, Architects, Artists, Engineers, Designers and Executives. Hard composition board stays flat. Light weight. Bar slides accurately and easily. Patent CROSS-STRUNG bronze cable and pulley give accurate action. No thumb tacks necessary. Water, oil and acid proof. ENABLES ANYONE TO DRAW WITH ACCURACY AND SPEED. THREE SIZES: 12"x16" \$2.95, 16"x20" \$3.95, 20"x25" \$4.95 plus postage. Other models with transparent celluloid straight-edge described in FREE CIRCULAR. WRITE TODAY.

ROLLIN INSTRUMENT CO. Inc., Dept. 12-8, 216 No. Clinton St., Chicago, Ill.

STUDY ENGINEERING AT HOME

Home Study Courses leading to Degrees in Electrical, Civil, Mechanical, Drafting, Architectural, Automotive, Steam, Diesel, Aeronautical, Radio, Structural, Mining, Industrial, Highway, Petroleum, Marine, Refrigeration, Air Conditioning, Chemical Engineering; Arts; Sciences; Philosophy; Education; Public Health; Psychology; Sociology; Physics; Chemistry; Geology; Pol. Science; Theology; Law; Agriculture; Business Training; Accounting; Statistics; Adv.; Sales. Founded 1908. Chartered McKinley-Roosevelt Graduate Colleges, 4220 Clarendon Ave., Chicago

Government Jobs
 EXAMINATIONS SOON VALUABLE INFORMATION FREE
COLUMBIAN CORRESPONDENCE COLLEGE
 WASHINGTON, D. C.

3 FOR \$3.00 Make enlarging camera, perfect spot light for photo work or lantern slide projector. Two 3-inch condensing lenses and one 2-inch projection lens, unmounted, for \$3.00. Send money order to The Brisehograph Co., 24 W. Weishelmer Rd., Columbus, O. Established 1926. Ten day money back guarantee.

Best Poultry Paper 6 BIG ISSUES 10¢

Helps increase Poultry Profits. Send coin or stamps. 50 cents for 3 years or 10 cents for 6 months trial. Agents wanted. American Poultry Journal 632 So. Clark Street Chicago, Illinois

LIVE BODIES FOR SALE



Oh boy! Wouldn't that be swell—I'll tell you what I will do though, I will take that scrawny body of yours and whip it into shape just like I have done for myself and so many others. Do you want big muscles and a huge robust body? My book "Puissant Body Building" is absolutely FREE.

TOMMY LOUGHRAN
 Undefeated World Champion

TOMMY LOUGHRAN
 Dept. 73, 4 S. 15th Street, Philadelphia, Pa.

FREE
 "Puissant Body Building"
 Sign here →
 Postal card will do.

Name.....
 Street.....
 City..... State.....

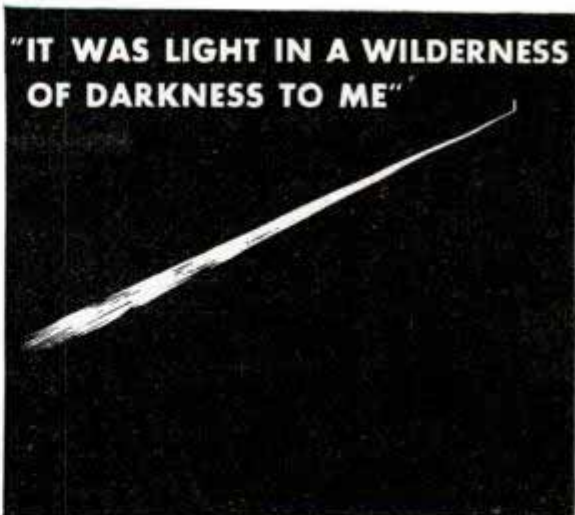

"IT WAS LIGHT IN A WILDERNESS OF DARKNESS TO ME"

● "I was stuck. A wife and three kiddies—and the same old pay envelope. I couldn't see a thing ahead except the same old grind. Then one day I read an I. C. S. ad. The coupon fascinated me. A new idea struck home—it was light in a wilderness of darkness to me! Today, because I mailed that coupon two years ago, I am a trained man—making a trained man's pay!"

Nearly fifty years ago, the International Correspondence Schools were established to provide sound educational facilities to men unable to attend resident schools. Over five million dollars has been spent in preparing textbooks and keeping them up-to-date. Today, you'll find I. C. S. graduates holding leading positions in every field of business and industry.

INTERNATIONAL CORRESPONDENCE SCHOOLS

Box 5537-J, Scranton, Penna.

Without obligation, please send full particulars about the subject before which I have marked X:

- TECHNICAL AND INDUSTRIAL COURSES**
- Architect
 - Architectural Draftsman
 - Building Estimating
 - Contractor and Builder
 - Structural Draftsman
 - Structural Engineer
 - Electrical Engineer
 - Electric Lighting
 - Welding, Electric and Gas
 - Reading Shop Blueprints
 - Telegraph Engineer
 - Telephone Work
 - Mechanical Engineer
 - Mechanical Draftsman
 - Machinist
 - Patternmaker
 - Foundry Practice
 - Sheet Metal Worker
 - Heat Treatment of Metals
 - Management of Inventions
 - Diesel Engines
 - Auto Technician
 - Auto Electric Technician
 - Plumbing
 - Air Conditioning and Cooling
 - Commercial Refrigeration
 - Steam Engineer
 - Steam Electric Engineer
 - Marine Engineer
 - Civil Engineer
 - Highway Engineer
 - Bridge Engineer
 - Bridge and Building Foreman
 - Surveying and Mapping
 - R. R. Locomotives
 - R. R. Section Foreman
 - R. R. Signalmen
 - Chemistry
 - Coal Mining
 - Cotton Manufacturing
 - Woolen Manufacturing
 - Agriculture
 - Poultry Farming
 - Heating
 - Air Brakes
 - Pharmacy
 - Navigation
 - Fruit Growing
- BUSINESS TRAINING COURSES**
- Business Management
 - Industrial Management
 - Traffic Management
 - C. P. Accountancy
 - Bookkeeping
 - Secretarial Work
 - Cost Accountant
 - Salesmanship
 - Service Station Salesmanship
 - Business Correspondence
 - Lettering Show Cards
 - Stenography and Typing
 - Civil Service
 - Railway Mail Clerk
 - Grade School Subjects
 - High School Subjects
 - College Preparatory
 - First Year College Subjects
 - Illustrating
 - Cartooning
 - Signs
 - Mail Carrier
 - Spanish
 - French
- DOMESTIC SCIENCE COURSES**
- Professional Dressmaking and Designing
 - Home Dressmaking
 - Advanced Dressmaking
 - Foods and Cookery
 - Tea Room and Cafeteria Management, Catering

Name..... Age.....
 Address.....
 City..... State.....
 Present Position.....
 If you reside in Canada, send this coupon to the International Correspondence Schools Canadian, Limited, Montreal, Canada

SENSATIONAL MIDWEST FACTORY-TO-YOU SALE

MODERNIZE YOUR OLD RADIO... PUT THIS NEW CHASSIS IN YOUR PRESENT CABINET!

15-TUBE WORLD-WIDE CHASSIS

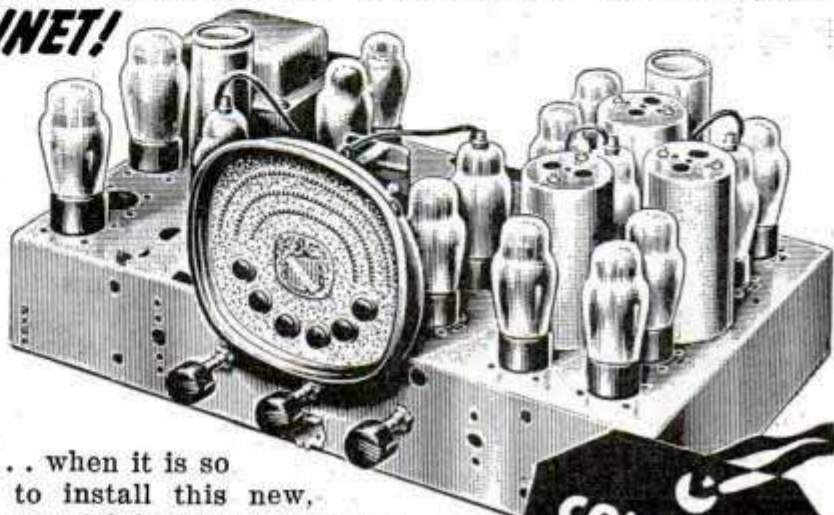

SAVE UP TO 50%

Once again Midwest scoops the radio world with the year's greatest radio value! Here it is! A big, powerful, 15-tube, world-wide Midwest. At its sensational factory-to-you price of \$29.95, this new 1939 radio is the biggest bargain in Midwest's nineteen years of pioneering! Why be content with an 8 or 10-tube

set . . . when it is so easy to install this new, big, powerful 15-tube chassis (in your present cabinet) for the same price! For a little more than the cost of new tubes, you can modernize your old radio and get exciting world-wide reception.



6-TUBE TABLE MODELS . . . TO 17-TUBE 5-BAND RADIOS

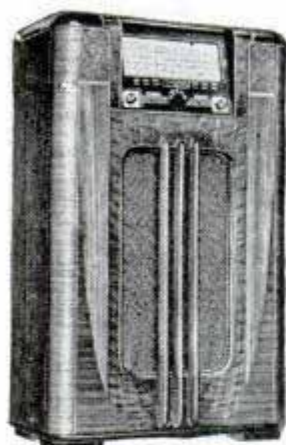

Midwest makes a radio to suit every purse . . . and prices are as low as \$10.95. Send for the new 1939 Midwest catalog and feast your eyes on a complete line of magnificent rare-wood consoles even more beautiful than the new Mid-

west 17-tube Model "D" shown at the left. Now, you can delight in 12,000-mile range on 5 bands, glorious new tone and brilliant overseas reception. Stations on the other side of the world come in like "locals." Many thrilling exclusive features.

AMAZING NEW EASY-PAY PLAN

LIBERAL TRADE-IN ALLOWANCE UP TO \$40.00 FOR YOUR OLD RADIO

The famous Midwest 30-day Trial Plan enables you to try any Midwest radio for 30 days before you make up your mind. You can trade in your old set and receive as much as \$40.00 trade-in allowance. Tell us the make and age of your present radio—so we can determine how much to allow you on it. New Easy-Pay Plan makes it easier

than ever before to own a Midwest. Absolute satisfaction guaranteed on a money-back basis. Write today for FREE catalog.

30 DAYS FREE TRIAL

NOTE — Midwest radios are sold only DIRECT from the factory by mail—never through stores or dealers!

SEND FOR FREE 1939 FACTORY CATALOG

MIDWEST *Factory-to-You* RADIOS

DEPT. 15FF MIDWEST RADIO CORPORATION...CINCINNATI, OHIO, U.S.A. *Manufacturers of Quality Radios Since 1920*

PASTE COUPON ON 1¢ POSTCARD... OR

Write Today!

MIDWEST RADIO CORPORATION
Dept. 15FF Cincinnati, Ohio

Send me your new FREE catalog, complete details of your liberal 30-day FREE Trial Offer, factory-to-you wholesale prices, and big TRADE-IN Offer.

Name.....
(PLEASE PRINT CLEARLY)

Address.....

Town..... State.....

User-Agents Make Easy Extra Money. Check Here for details

GET IN THE SWING with Slingerland . . . DRUMS GUITARS MANDOLINS



GENE KRUPA — World's Greatest Swing Drummer uses Slingerland

NOTHING CORNEY
about Slingerland Instruments

Compare the value—tone and power in Slingerland "Radio King" drums, banjos, guitars, mandolins, marimbas or bugles—before you buy. Guaranteed more for your money. Acclaimed the tops in smooth



tone, easy playing, rich power by world's leading musicians. Easy payments. 5-days free trial. See at your dealers.

Cut this ad out—good for \$1.00 credit. Free special information on how to organize drum and bugle corps. Free Catalog—mention instrument wanted.

SLINGERLAND DRUM CO.
1330 Belden Avenue Chicago, Illinois

AGENTS UP TO \$50 IN A WEEK

Big cash profits for you; full or spare time. Over 250 household necessities—things people must buy. Proven fast sellers; steady repeaters, earnings very first day.

POIND TUDOR SEDAN GIVEN YOU AS BONUS. I'll show you how to start at once; send you everything—Big Display Outfit and quick cash plans. Details FREE—no obligation. Just send name on postcard.

ALBERT MILLS
6595 Monmouth Ave. Cincinnati, Ohio

Auto-Diesel

Master a real trade. Auto Mechanics, Diesel Mechanics, Arc Welding, Acetylene Welding, etc. Let us train you to be an expert Auto-Diesel Mechanic and help you get a good job. The cost to you is reasonable. Learn on modern equipment with tools under experienced instructors. Real shop work. Steam heated buildings. Room and board in our steam heated dormitory. We pay your fare to Nashville. For free catalog write

Nashville Auto-Diesel School, Dept. 75, Nashville, Tenn.

EARN A DEGREE AT HOME

Home Study Courses leading to Degrees in Arts; Sciences; Philosophy; Education; Public Health; Psychology; Sociology; Physics; Chemistry; Geology; Pol. Science; Theology; Law; Business Training; Accounting; Statistics; Adv. Agriculture; Sales; Electrical, Civil, Mechanical, Drafting, Architectural, Automotive, Steam, Diesel, Aeronautical, Radio, Structural, Industrial, Highway, Petroleum, Mining, Marine, Refrigeration, Air Conditioning, Chemical Engineering. Founded 1908. Chartered. McKinley-Roosevelt Graduate College, 4213 Clarendon Ave., Chicago

MONEY for Talent!

Become a Professional Artist

If you have drawing talent, a large salary or a profitable business of your own can soon be yours. Learn commercial art at home through one of America's oldest and finest schools. Forty years of successful teaching proves our ability. Write today for ART YEAR BOOK and full details. No obligation.

School of Applied Art, Dept. 198, 10 E. Huron St., Chicago, Ill.

NOW YOU CAN GET A . . . HEAVY DUTY INDUSTRIAL WELDER

Works Off 110-Volt Light Socket

This marvelous DYNAMIC Power Welder will do the work of much higher priced types. It is easily portable. **WELDS** Cylinder Blocks, Bumpers, Fenders, Tanks, Farm Machinery, and etc. Will also solder and braze on the lightest material. Works on iron, steel, tin, brass, copper and all other metals. Men without previous experience can make as much as \$5.00 on a one hour repair job. Go into business—Open a Welding Shop NOW.

AGENTS—Make big profits selling to garages, factories, janitors and machine shops. Write TODAY for our 10-DAY TRIAL OFFER.

DYNAMIC WELDER COMPANY
2226-FT Silverton Road Chicago, Illinois

for Only **\$195** RETAIL



Know Electricity as Experts Know It—and Get an Expert's Pay!

Recovery has begun! The months ahead are charged with significance and expectation. What will you do to get the jump on the other fellow?

Thousands of men have used

The Croft Library of Practical Electricity

The Croft Library is a complete electrical educator. It is founded on practice—on 20 years of shirt-sleeve experience—on work as it is actually done. It is jammed from cover to cover with the kind of hard-headed facts you want. Written so that the beginner can easily understand it, yet so sound, so thorough, that it is the daily guide of 59,000 highly paid electrical workers and engineers. Croft tells you the things you need to know about motors, generators, armatures, commutators, transformers, circuits, switchboards, distribution systems—electrical machinery of every type—wiring for light and power—wiring of finished buildings—underwriters and municipal requirements—Illumination in its every phase—the most improved methods of lighting—lamps and lamp effects, etc.—how to do a complete job, from estimating it, to completion.

No money down — easy payments

Fill in and mail the coupon attached and we will send you the entire set of seven volumes for ten days' Examination. We take all the risk—you assume no obligation. If you decide to keep the books, send \$1.50 in ten days and the balance at the rate of \$2.00 a month. Send the coupon NOW and see the books for yourself.

EXAMINATION COUPON

McGRAW-HILL BOOK CO., 330 W. 42nd St., New York

Send me for ten days' examination the Croft Library of Practical Electricity. If satisfactory I will send you \$1.50 in 10 days and \$2.00 monthly until the price of \$19.50 is paid. If not wanted, I will return the books postpaid. (To insure prompt shipment write plainly and fill in all lines.)

Name.....
Home Address.....
City and State.....
Position.....
Name of Company..... PM. 12-38

Dear Tom: Thanks for the magnificent New Merriam-Webster -- it's a gift I'll appreciate a lifetime!

HERE'S the Christmas gift that is welcomed by every professional man, business man, student. A whole library of knowledge in one volume. 600,000 entries—122,000 more than in any other dictionary. 3,350 pages. 12,000 terms illustrated. At your bookdealer's; or write for free illustrated booklet to G. & C. Merriam Co., 125 B'way, Springfield, Mass.

WEBSTER'S NEW INTERNATIONAL DICTIONARY
Second Edition



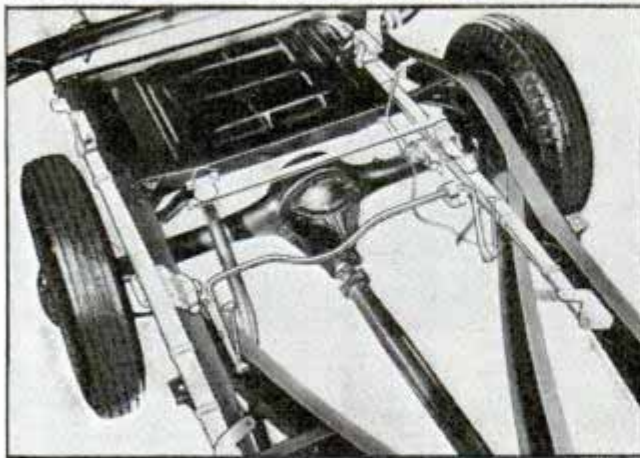
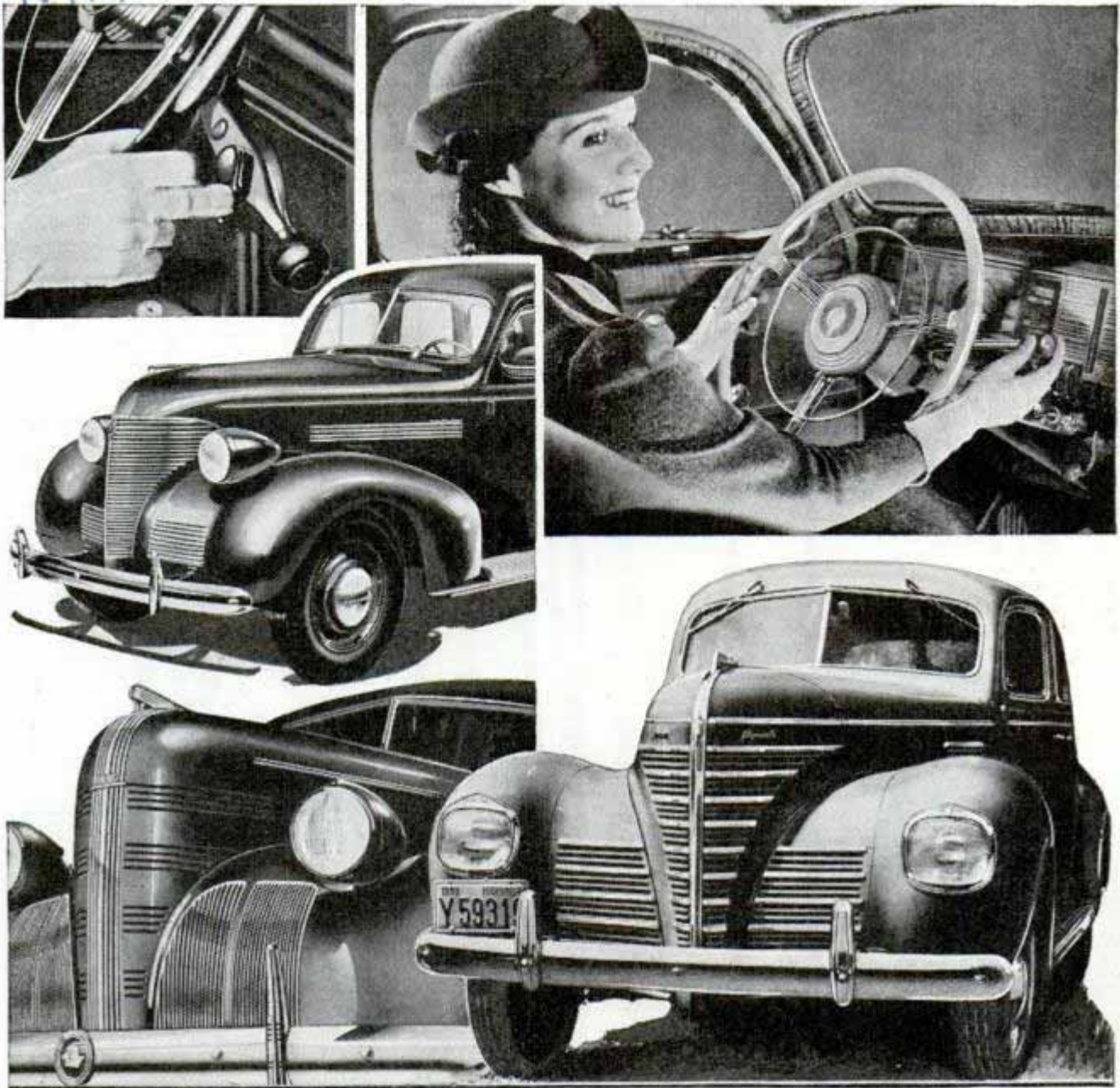

Top, left, Buick's rear signal control, located on gear lever. Right, De Soto's substitute for "wobble-stick"; Center, left, front of new Chevrolet, and (just below) new Pontiac Six; Right, "lateral airfoil" design of Plymouth's front end. Note headlamps in fenders. Bottom, Packard's rear spring suspension

doesn't have to learn how to drive all over again. It does the same job of changing gears and it does it in the same way, in conjunction with the clutch, as did the wobble-stick. From the maker's standpoint, it is so inexpensive that in most cases it can be included without increasing the price of the automobile. However, on some cars, particularly those in the lowest price field, it can be offered only as optional equipment. Chevrolet presents the shift, with a vacuum booster that takes eighty per cent of the work out of gear changing, for ten dollars extra. Deluxe models of Plymouth, and all models of DeSoto, Dodge and Chrysler have the feature as standard equipment.

Pontiac found the shifter popular as an extra-cost item last year, so all new models

H 1143

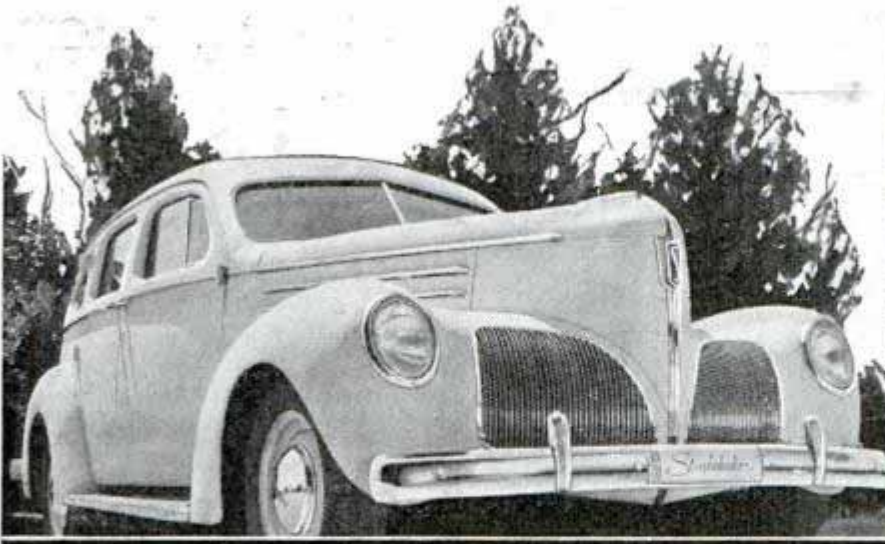

Top, left, 1939 Studebaker, with headlamps in fenders. Right, Pontiac's recessed controls. Below is new Graham combination coupe. Next to bottom, De Soto's safety-signal speedometer, with indicator illuminated. Bottom, Chevrolet's twin shock absorber that makes for better riding

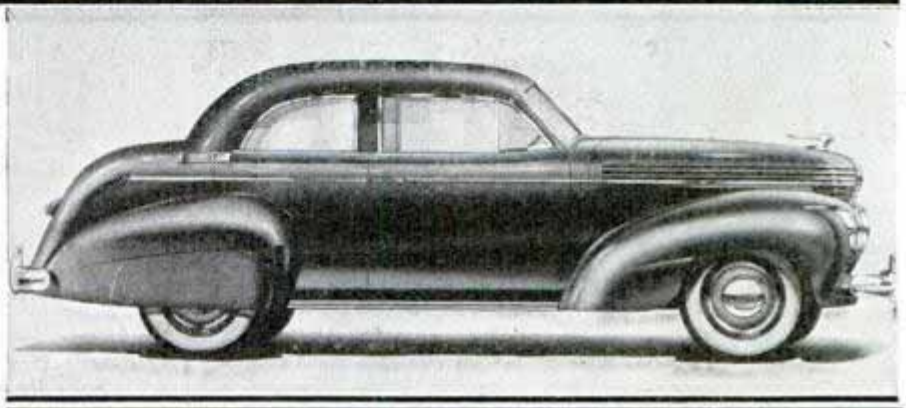

have it, plus a booster spring that does half the work, as standard equipment. Packard joins the parade by introducing the Handishift. Buick turns from the optional automatic transmission of 1938 to the steering-post shift, standard on all models in 1939.

Use of the remote-control shift permits manufacturers to redesign the transmission, making it shorter without altering gear face widths or torque transmitting capacity. Of importance to the driver is the fact that some types of the shift may be adjusted to suit the reach of the individual.

The overdrive, which permits reduction in engine speed without losing car speed, seems to be gaining ground, although it continues as an optional feature in most cases. Packard introduces the Econo-drive, which automatically disengages at speeds under thirty miles per hour.

Chrysler and De Soto introduce a new transmission with the overdrive as optional equipment on all models except the Custom Imperial Chrysler, on which it is standard. The overdrive cuts in between twenty-three and twenty-eight miles per hour. A solenoid device, actuated by press-

(Continued to page 153A)

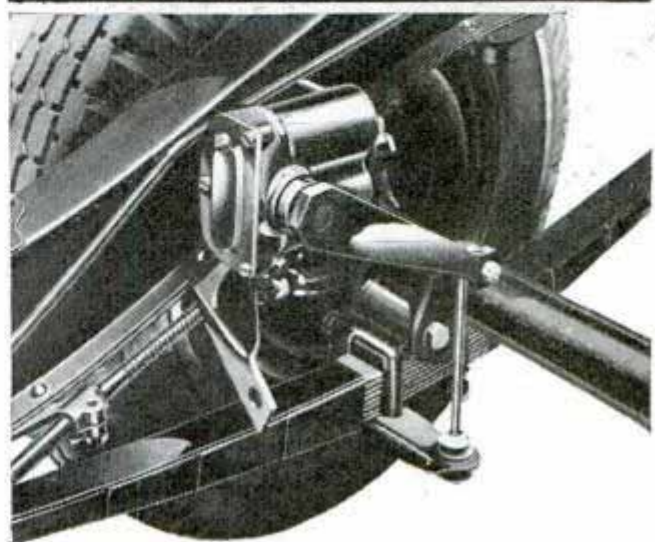
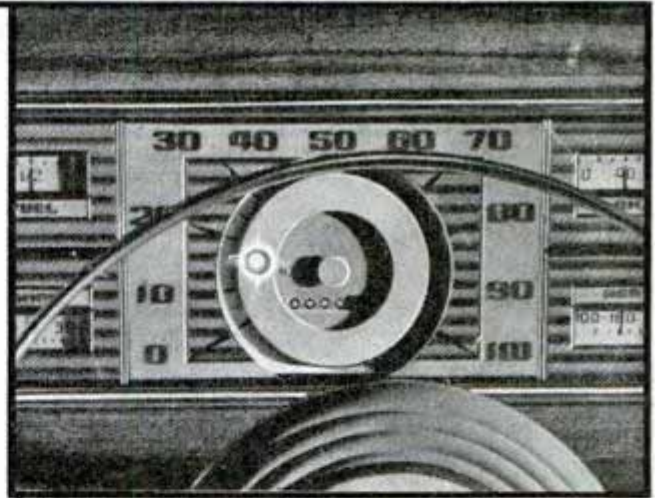

2000
 3000
 4000
 5000
 6000
 7000
 8000
 9000
 10000
 11000
 12000
 13000
 14000
 15000
 16000
 17000
 18000
 19000
 20000

Master Timekeepers Watch Clock for Nation

International News Photos



Above, granddaddy of all clocks in U. S. shows time in this country and corresponding time in other parts of world

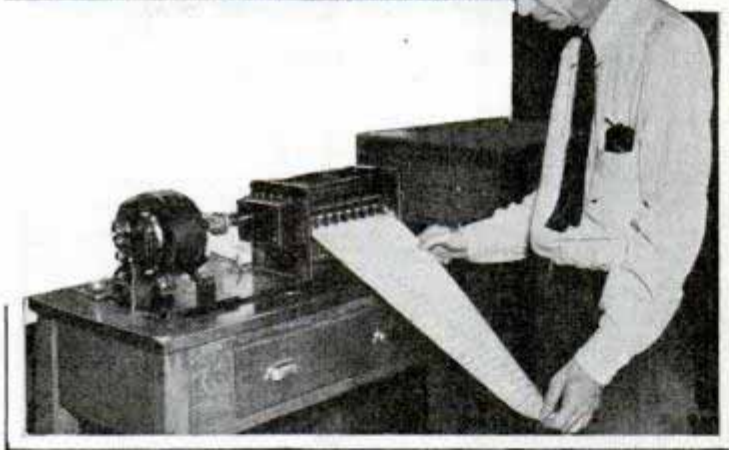

Top, tuning radio at naval observatory to receive time signal from naval radio station at Arlington. Center, reading tape from chronograph which checks synchronization of clocks in thousands of a second

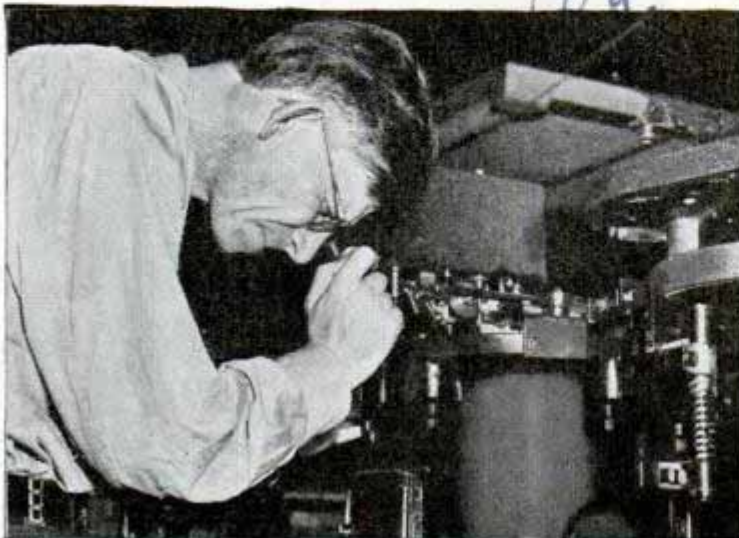

Left, astronomer at naval observatory operating "Zenith tube," which checks master clocks. It photographs stars crossing the zenith. Chronograph records time of stars' crossing. Above, master clock at observatory at exact noon, eastern standard time, but its face shows seventeen o'clock, which is Greenwich time. P. H. Tobleman points to mechanism that flashes long dash over radio to give correct time

Radio Robot Warns Pilot of Mountain Ahead

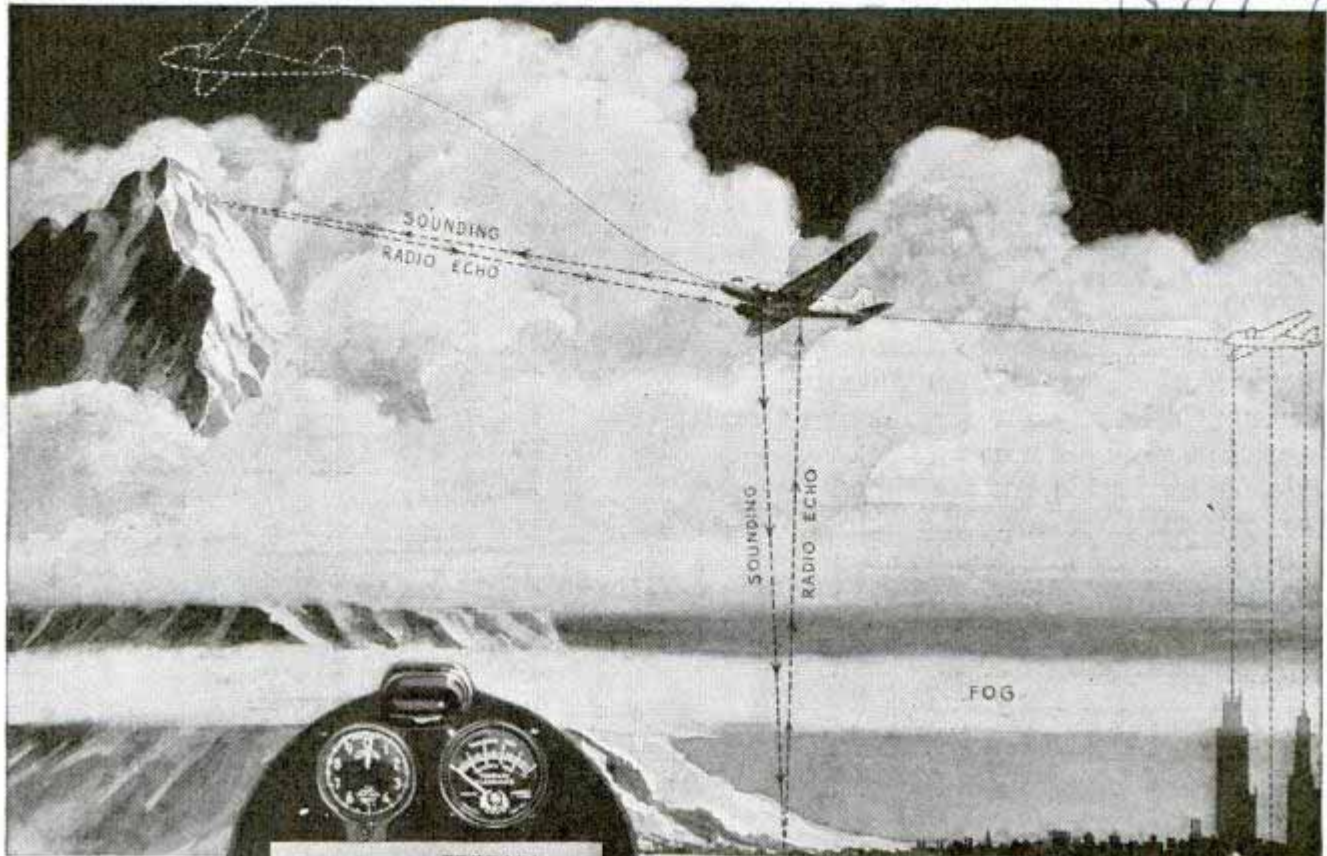

Here's how absolute altimeter protects airplane by indicating exact distance above ground, as shown by vertical lines denoting radio signal and rebound. Pointing instrument ahead enables pilot to learn whether mountain lies in his path, but instrument does not work earthward and ahead at same time. Left, standard altimeter mounted beside the new instrument in test plane

DESIGNED to meet one of aviation's greatest needs—informing the pilot how high above the ground his plane is flying—an instrument called the terrain clearance indicator has been tested successfully. The standard altimeter tells how high the plane is above sea level, but gives no indication of mountains or other obstructions beneath the ship. The instrument, developed by Bell Telephone Laboratories and United Air Lines, also warns of any obstruction ahead if the pilot points it forward. It operates by shooting a stream of radio impulses earthward. These impulses echo or rebound to the plane and an electrical device measures the time for the impulses to make the round trip. Using the speed of electricity and light, 186,000 miles per second, the instrument divides that figure by the time required for the signal's round trip and shows on a dial the plane's exact height above the ground. So

sensitive is the instrument that the indicating needle shows the height of the plane above buildings, fluctuating rapidly as the ship passes over small and then large buildings. The device uses the shortest radio wave ever employed for commercial purposes—only six-tenths of a meter long. On a blind landing in fog, the instrument, also known as the absolute altimeter, shows accurately the distance to within five feet of the ground. The entire equipment weighs twenty-five pounds. By flicking a switch the pilot can read the dial in hundreds of feet, when under 1,000 feet, or in thousands at higher altitudes. An automatic warning light can be set to flash whenever the plane goes below a fixed minimum altitude above the terrain. By signaling when the plane approaches a mountain, the device is expected to put an end to one of the most feared causes of air-transport crashes.

Anti-Aircraft Guns Aimed Automatically

Remarkable accuracy in firing at a target moving through the air at 200 miles per hour two miles away is the result of automatic aiming of anti-aircraft guns. Two instruments, the altitude finder and the director, are used. The first determines how far away is the target and does its own calculating. This range is then converted to an altitude and transmitted electrically to the director, known to the army as the "mechanical brain," which automatically computes all the data for the guns and fuses. Speed of the moving target is determined and guns are aimed by electrical impulses. The gunners simply load and fire as each gun moves slowly, like a robot, to maintain its aim. The effective dispersion range of a bursting shell is a sphere about 100 yards in diameter, so that any shell exploding within fifty yards of the target causes damage. The maximum range, up into the air, of the latest anti-aircraft guns is 9,300 yards.

Chicago Tribune. S. Wood Dept.

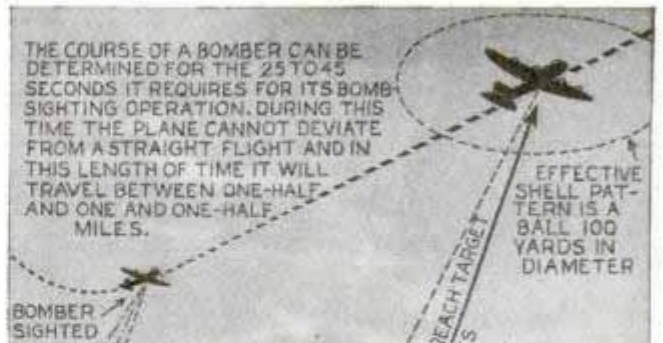

Camp Logan
Here is how anti-aircraft guns are trained on an enemy bombing plane by range finder and director. Note circle showing effective shell pattern around the plane, at upper right

202nd Anti Aircraft Artillery

BIRTHPLACE BIG WINDS

of the

*Biscayne
Bay Miami*



TWO forms of cyclonic storms—the hurricane and the tornado—wreak their destructive fury on the United States each year, exacting an enormous toll in lives and property damage.

Just recently a hurricane roared up the Atlantic and swept across six northeastern states, leaving 500 persons dead and the wreckage of property once worth millions upon millions of dollars. A few days later a tornado twisted through Charleston, S. C., killing more than twenty-five and injuring more than 300 inhabitants in sixty seconds.

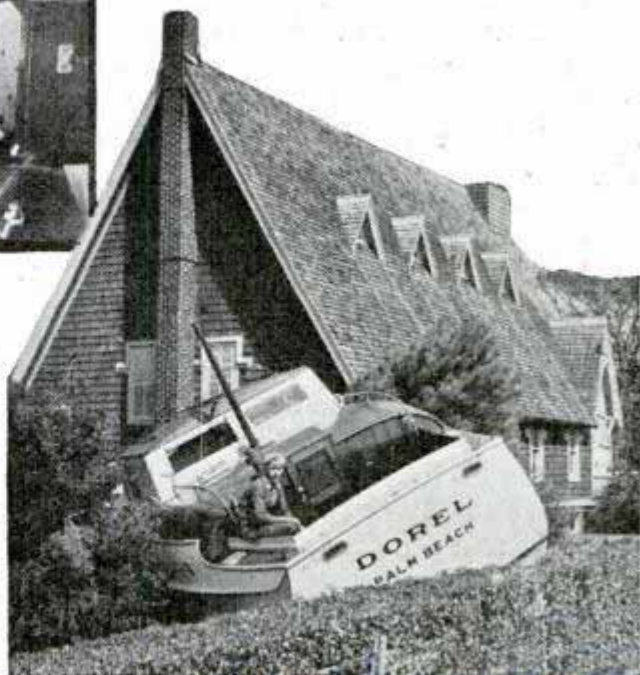

Westhampton
Top, thoroughfare strewn with debris in hurricane. Left, radio man maintains only contact between stricken village and outside world. Bottom, power cruiser hurled into churchyard by wind

*Chil Radio man
induced contact*

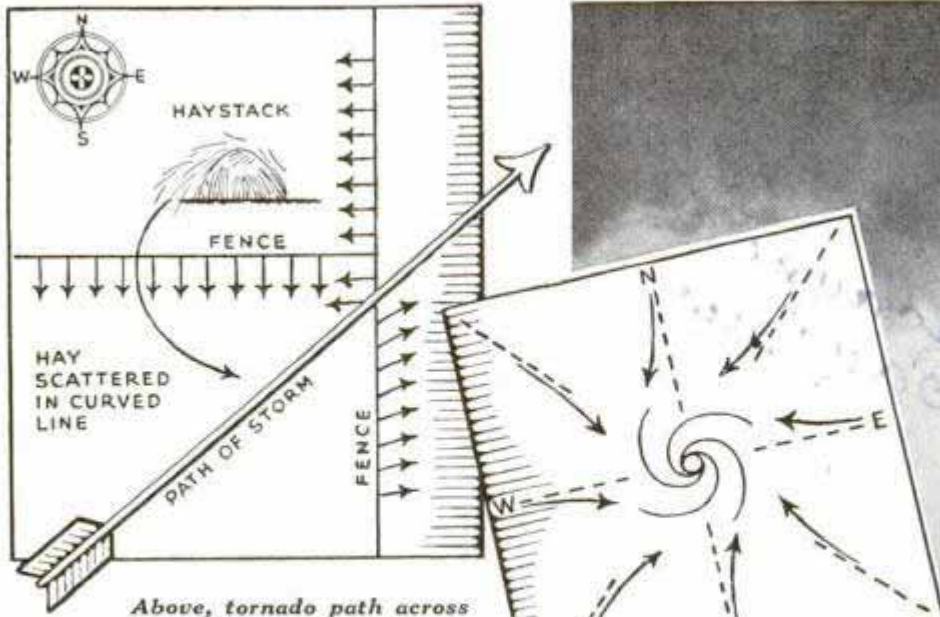

Above, tornado path across farm, showing directions in which fence posts fell and how hay was scattered in curved line. Right, air currents as tornado funnel begins to form



Above, remarkable view of tornado. Left, police emergency squad with rubber boat in which hurricane-flood victims were rescued



miles or more. The approach of a hurricane is heralded by an ominous stillness. Then follow light breezes which increase to high winds. When the storm breaks in its fury, the wind blows at seventy-five, eighty and even 100 miles per hour. Rain falls in torrents. The wind whirls in a spiral around a center of low pressure and in that center no wind is apparent

The typical hurricane begins in the warm Atlantic belt north of the equator and sweeps across the West Indies to the coast of the United States. Some turn to the northeast and are dissipated in the Atlantic while moving toward Europe, but many strike the eastern coast, usually in Florida, or pass into the Mississippi Valley by way of the Gulf of Mexico. In the beginning the diameter of the storm area is from 100 to 300 miles, but it may increase to 1,000

as the current is upward. This area of low pressure frequently is called the "eye" of the storm.

The tornado is also cyclonic in its movements, but instead of being 100 to 1,000 miles in diameter like the hurricane, it usually has a diameter of gyration of 100 to 300 yards. Its speed of rotation is so terrific that measurement of velocity is virtually impossible. Its direction is nearly

(Continued to page 149A)

Harris County Police

No. 70. Mr. Chas. G. Johnson, Jr.
100 55 Johnson Ave.
Los Angeles Calif

BEHIND *the* SCENES *in* AVIATION



MECHANIC checking the oil supply of one of the big engines of a modern transport plane before a scheduled flight.

809
American Air Lines

810



TRAILING wires, left, on United Air Lines plane used to discharge static as soon as it gathers on ship. Bottom, American Airlines transport ready for night flight. Note truck heating unit supplying warm air to cabin. Engines warm cabin in flight.

810

LITTLE by little, aviation engineers are revolutionizing the art of flying. Today's big transports are vastly improved over those of only a year or two ago although an untrained eye can hardly spot the differences. Scores of slight improvements in power plants, instruments and construction have materially increased efficiency.

Behind the scenes the engineers are working on other improvements. "Within five years we will be wondering how we ever got along without the many improvements in radio alone which are now being developed," one of them remarks. "Within that time passenger transports will be landing on schedule in zero-zero weather. Among other new in-

struments in the control room, the pilot probably will have a height indicator to tell him the exact distance down to the ground. Planes will be carrying heavier loads farther and faster due simply to numerous small improvements which are constantly being made."

Among the things looming for the near future are opposite-turning propellers for two- and four-engined airplanes. Gearing all outboard propellers to rotate inwardly at the top suggests higher speeds and greater stability. Another idea under development is to divert the flow of air used for engine cooling into the exhaust pipes, with the thought that the flow of air will have an extractor effect on the exhaust gases, contributing to engine efficiency. Vari-



ous ways of putting the exhaust gases and radiator cooling air to work by making them contribute a rearward thrust are also being studied. Greater engine efficiency is being sought in a solid fuel injection system that would eliminate the present types of carburetors.

New ways of controlling airplanes in flight are also receiving attention. Two controls instead of three, provided by coupling aileron and rudder action, seem to have possibilities. A British invention dispenses with the present ailerons completely. In this system a hollow tube crisscrosses from each leading edge of the wing to the opposite trailing edge, permitting the pilot to obtain aileron control by opening or closing the tubes to make use of the difference in pressure existing between the two edges of the wing. Localized boundary layer control at the wing tips is another suggestion for providing aileron action. If present ailerons con-

United Airt Lines
REMOVING transport plane's batteries, top, right. Center, landing flaps on Lockheed transport. Bottom, enclosed loop antenna on underside of fuselage. Diagram shows airways marker radio beacon which enables pilot to check his distance.

Dept. of Commerce

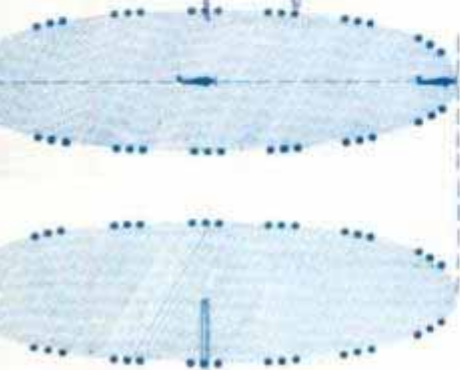



7810 812
TYPICAL night scene at a busy airport. Passengers are boarding the plane before the start of a night transcontinental flight.

tinue to be used, they may be made more effective by arranging some means of sealing the gap between the wing and the aileron surface to prevent leakage of air at that point.

Completely smooth wing and fuselage surfaces would add 273 extra horsepower to present transports, the National Advisory Committee for Aeronautics has determined. Rivet heads, overlapping joints and surface roughness resulting from working tolerances and factory workmanship offer as much as forty-two per cent more drag than perfectly smooth airfoil shapes. Manufacturers are beginning their "cleanup" campaign by using flush-type rivets but high manufacturing costs may prevent them from ever achieving perfect wings in metal construction.

Every detail counts. Even the drag of ordinary rubber boot de-icers along the leading edges of wings has been studied, and de-icer drag has been reduced from an original sixteen per cent to nine by mounting the boot in a flush position instead of lapping it over the leading edge. Engineers are studying the phenol-formaldehyde resin type of plastics as

a possible new material for airplane surfaces that can be molded into smooth and efficient airfoil shapes.

Blind landings made by instruments alone will be normal procedure within a year or two. Thousands of such landings have already been made safely, with short-wave radio signals orienting the pilot toward the field and other signals telling him when to start the "let down" glide in a safe landing attitude with flaps and landing gear extended. The new tricycle landing gear makes instrument landings easier, reducing the bounce of a hard landing, allowing more immediate braking and permitting planes to land across the wind.

Many radio possibilities are being explored. One patent provides "panoramic reception" of several radio compass signals visually and simultaneously on a cathode ray tube indicator. Static is slowly being wiped out although a moving airplane is an almost perfect static-generating machine. Shielded loop antennas have eliminated some of the static. United Air Lines is experimenting with wires with sharpened ends trailed from the tail of the plane to pro-

813
PILOT speaking over two-way radiophone of passenger transport. Below, checking instruments in nose of plane as part of the frequent regular overhauls. Diagram shows "cone of silence" over radio range beam transmitting station which enables pilot to check his position in the air.

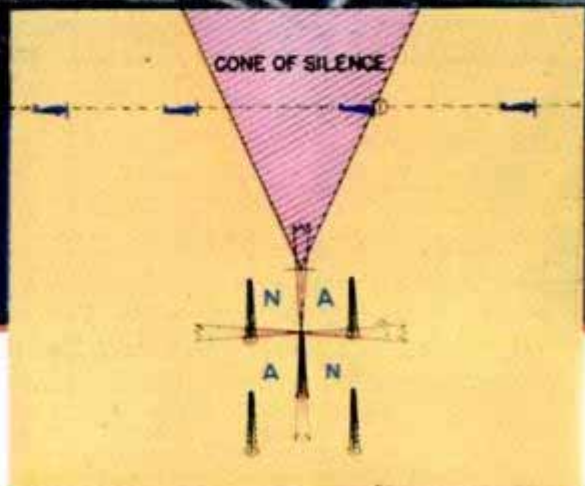

8/4

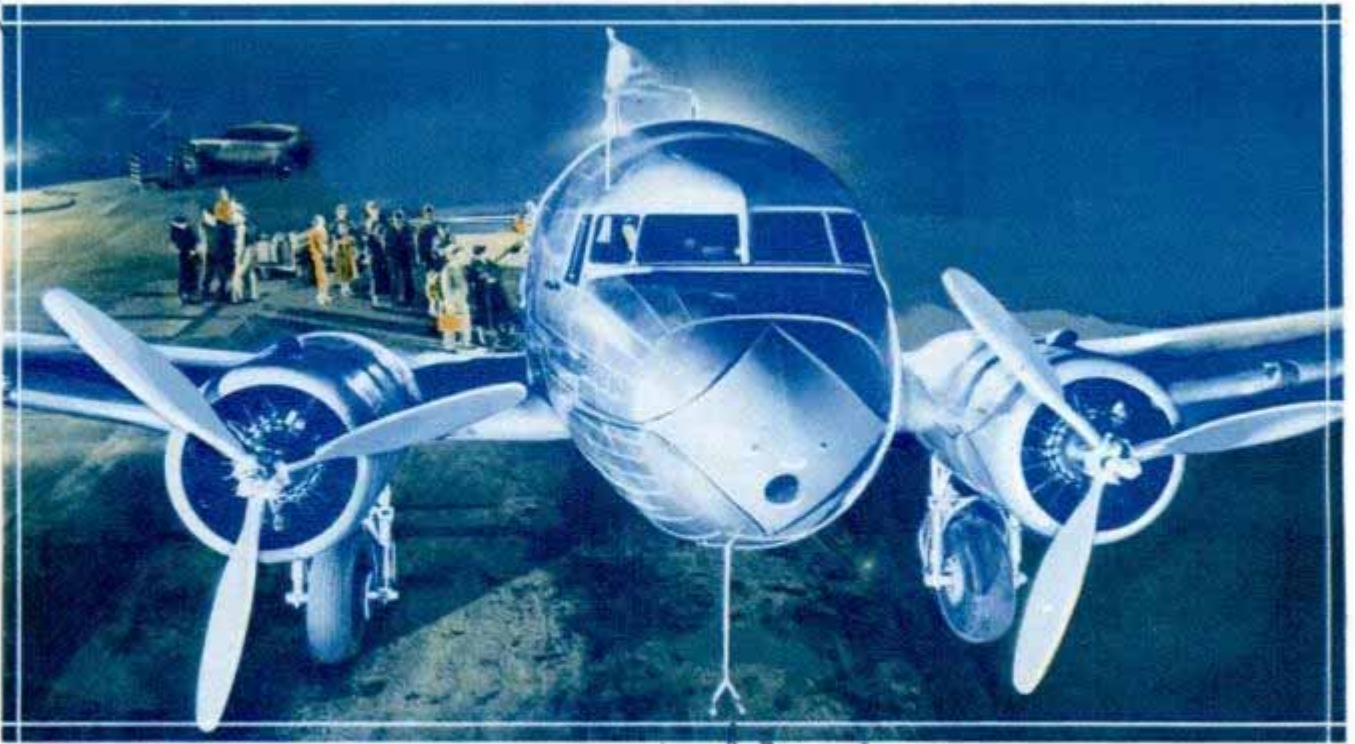

Lockheed
LOADING passengers, above, at start of night flight. Below, left, shielded radio direction-finding loop antenna mounted in glass nose of transport. Right, triple tail surfaces and passenger loading door of four-engine Douglas DC-4.

7810

vide leakage paths along which static charges may be dissipated.

Ultrashort radio waves in which static conditions are less acute are to be adapted to air line use. Beginning next year, much lower wave lengths will be used for plane-to-airport communication over short distances. Ultrashort-wave radio marker beacons will help the pilot with his navigation. Fan beacons that set up walls of short-wave warning signals will mark the edges of mountainous areas in the vicinity of airports. Auto-

matic pilots are being connected directly to the radio beam receivers so the robot actually keeps the plane on its course as well as attending to the mechanical details of flying.

Research is being conducted on various ways of providing a pilot with "fog eyes." What is wanted is an instrument that will measure the distance to the ground. Present altimeters show the height of the plane above sea level but not the ground contours beneath the plane. Short radio waves, infrared rays



and sound waves reflected from the plane to the ground and back again are being studied.

Engines are sturdier even though they are developing more power than a few years ago. Automatic oiling systems have eliminated frequent overhauls and increased engine reliability. The heavy drag of a "windmilling" propeller when an engine goes dead in the air has been reduced almost to nothing by the Hamilton hydromatic full-feathering propellers. By turning a switch the pilot can turn the blades to point directly into the wind. Propeller blades that may be rotated through 120 degrees of a pitch have been developed in France to enable flying boats to maneuver astern on the water.

Designing a transport is such a complex job that no one man can do it all. Specialists in wing construction, tail group design, and landing gear assembly work side by side. The cockpit alone needs the attention of several experts and hundreds of minor details require intensive study. The exact location of the pilot's seat, the angle of the windshield and the shapes of the control knobs are all important.

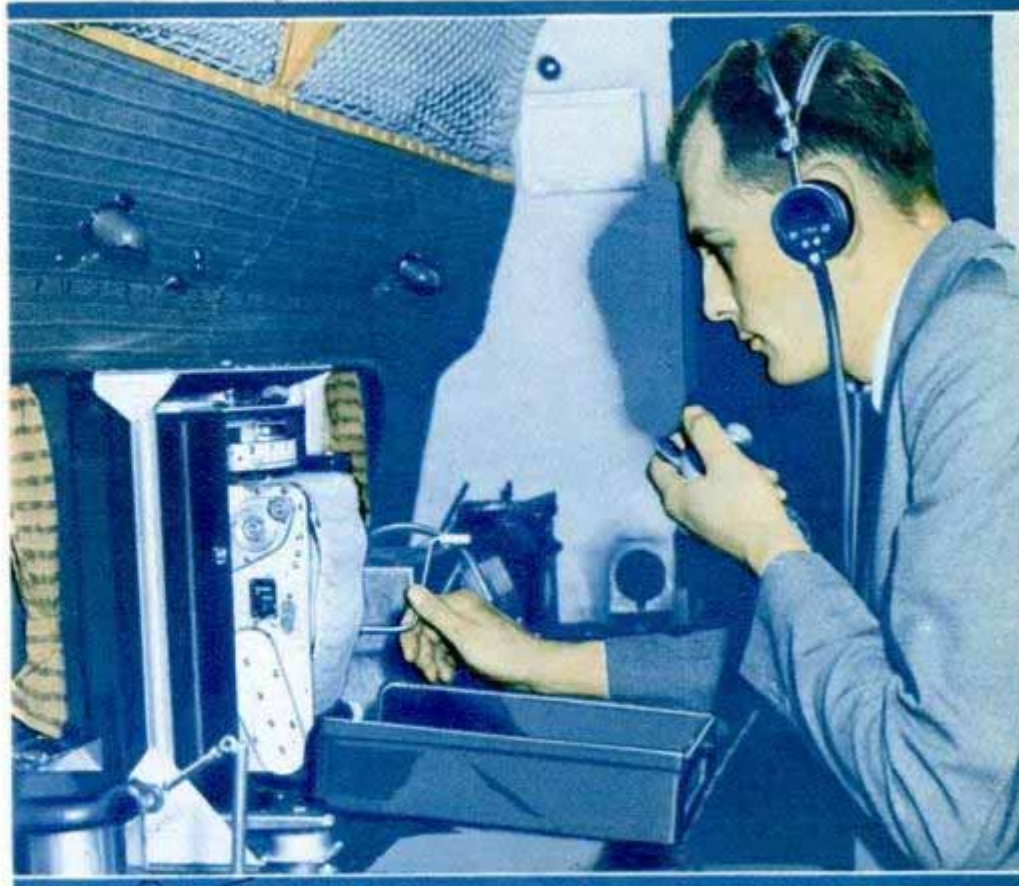

MEASURING intensity and width of radio range beam, above, while plane is in flight. Below, left, attaching "rubber boot" de-icer to leading edge of wing. Right, hydromatic propeller blades which can be turned to point into wind and reduce windmilling if engine dies.

Different control handles are given different colors and shapes so the pilot invariably can recognize the one he seeks. His seat must be close to the windshield to give him wide angle vision, yet he must be able to slide out of the seat easily without disturbing the controls. In the past, pilots were sometimes confused by lights reflected on the cockpit win-

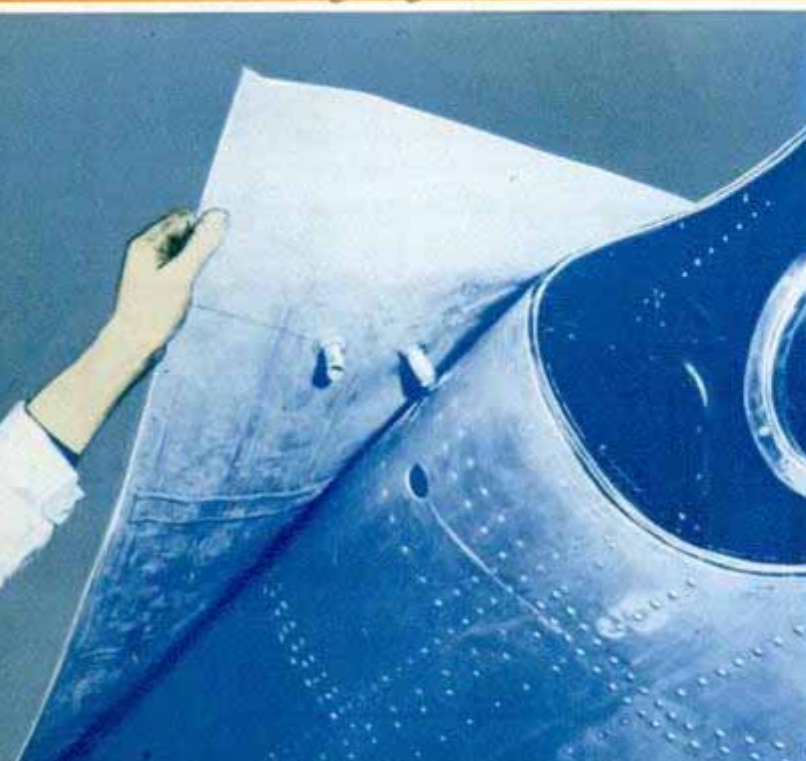



SPEED is indicated in every line of the nose of this modern transcontinental air liner.

dows. Lights on the ground behind sometimes seemed to be ahead of the plane. Placing the windows at exactly the proper angles prevents such reflections. Pilots in the past also were almost blinded by rain or snow pounding against the windshield while making night landings during storm conditions.

Designers solved that trouble in an adroit way. Instead of trying to keep the moisture out of the cockpit they let it in. Now when a pilot prepares to land

during a storm, he slides open a side window and a windshield window, allowing rain or snow to sweep in one window and out the other. Sitting behind the blast of wind, the pilot can see forward and rarely receives more than a few drops from the controlled storm that invades the cockpit. The windshield is completely waterproof when closed and can take a pressure of one pound per square inch at 200 miles per hour without leaking.

(Continued to page 128A)

Plane Climbs Sky at Forty-Five-Degree Angle

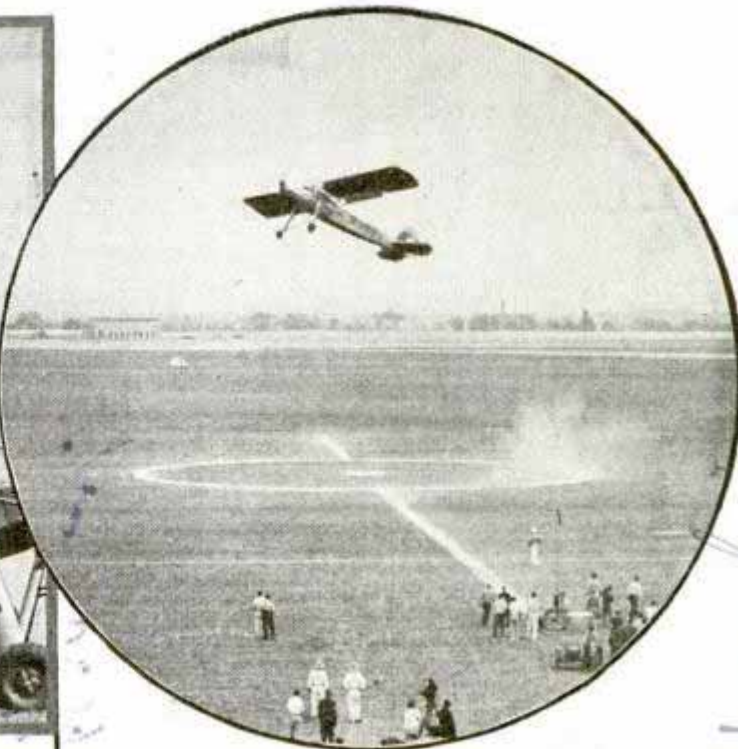

30 M.P.H.
MINIMUM FORWARD CRUISING SPEED



45° CLIMB

TAKE OFF

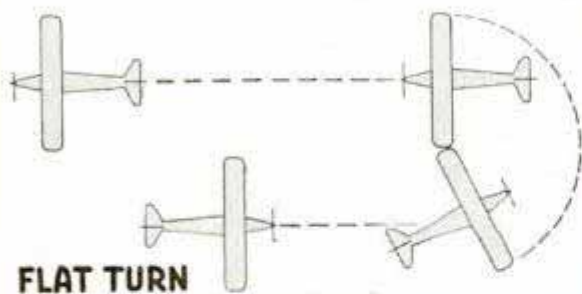

FLAT TURN

Closeup view of the "grasshopper" plane at top reveals the wing slots and flaps that make it so flexible in maneuvering. Drawings below indicate the little ship can keep aloft at a mere thirty-mile speed, take off with a twenty-three yard run and climb at forty-five degree angle, and execute flat turn with one wing tip as axis. In circle, steepness of climb is shown by dust cloud below

Spectators are not particularly impressed when a long-legged monoplane rolls across the airport runway into position for a takeoff. It boasts no great speed as modern planes go, looks rather like a grasshopper as it toes the mark. Then, with no wind blowing, it roars forward, is off the ground after a run of just twenty-three yards, and in a matter of seconds is climbing steeply, seeming to hang on its propeller as it points upward at an angle of forty-five degrees. Built in Germany, the two-passenger cabin plane is astonishing watchers at air meets in this country. With a load of 2,310 pounds it climbs at 1,141 feet a minute, lands at 23.6 miles an hour and halts within forty-nine yards, and can stay aloft at a speed as low as 30.4 miles an hour. Its ceiling is 20,340 feet, its maximum speed 130 miles an hour. Another startling feat is its ability to make a flat turn, the tip of one wing forming the axis. Wing slots and flaps enhance its maneuverability. The power plant is a 250-horsepower eight-cylinder inverted air-cooled engine. The high wings have a spread of forty-six feet nine inches. Because of its ability to climb, to get up and land in small areas, the ship has proved itself useful in Alpine regions, Brazilian jungles, Iceland and other areas where rough terrain makes air travel hazardous.

North Park Hotel, Chicago
Storch by Gerhard Feeder
Fisher
built by Gerhard Feeder

mission

Library Vacuums and Sprays to Preserve Old Books



Spraying old books on shelves of Athens library

Vacuum cleaner and spray gun are employed to save ancient books and documents in the library at Athens, Greece. The library custodians regularly go over the books and shelves carefully with a vacuum, then follow with an insecticide spray.

News Reporter in Gas Mask Covers U. S. War Games

Newspaper reporters covering the mock war maneuvers around the Fort Knox, Ky.,



Fitting gas mask on reporter covering war maneuvers

gold depository were given gas masks to make the "war" seem more real. The masks, which covered only the face and had a window for vision, were of the type with which the army plans to equip civilians in this country if the United States should be invaded.

H 1064

Self-Propelled Street Marker Cleans as It Sprays Paint

Fully controlled from its handlebars, a self-propelled marker for street traffic lanes first cleans, then sprays and finally brushes the painted line. A three-quarters horsepower motor drives the one-man



Pole extending in front of road marker helps follow guide line. All controls are at the handlebars

machine. A single-lever, motorcycle control feeds the paint, which is sprayed with a gear pump after the exhaust blower cleans the area to be painted. Immediately behind the spray box, a brush finishes the job, leaving a clean, well-defined line. The paint flows automatically during forward motion, and is shut off while the machine is in neutral or reverse.

Send return postage to our Bureau of Information to learn the name of the maker of any device described in this magazine.

Col. Benj. A. Brabankin
Chemical Warfare
103

Melvin Blumberg Corp
New Holstein, Wis.

Melvin Blumberg Corp
Chicago

Miss Katherine

Hidden Flaws Bared by HIGH SPEED MOVIES

THE "movie doctor" is not human. It is a machine that in its own line can do more than any human being. It specializes in diagnoses, because with its keen, rapid-seeing eye, it can peer at machines, watch the way they work, and point out just what is the matter with them.

This movie doctor is an exceedingly high-speed motion-picture camera, now used in conjunction with a precision clock. It is really a sort of time microscope. In it is used the ordinary sixteen-millimeter moving-picture film, which takes pictures of the object under examination and at the same time records the time of each frame. While the ordinary motion-picture camera is designed to run at a rate of around sixteen pictures per second, this high-speed camera

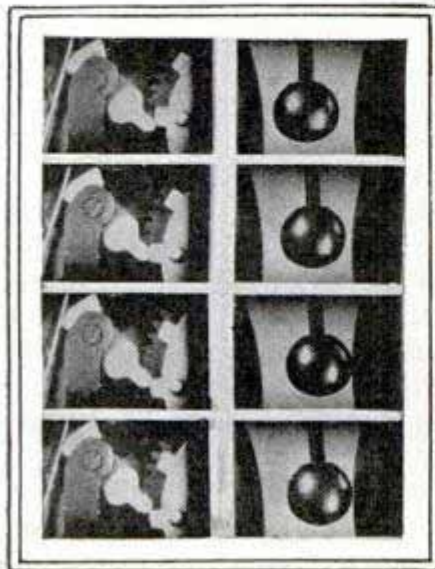
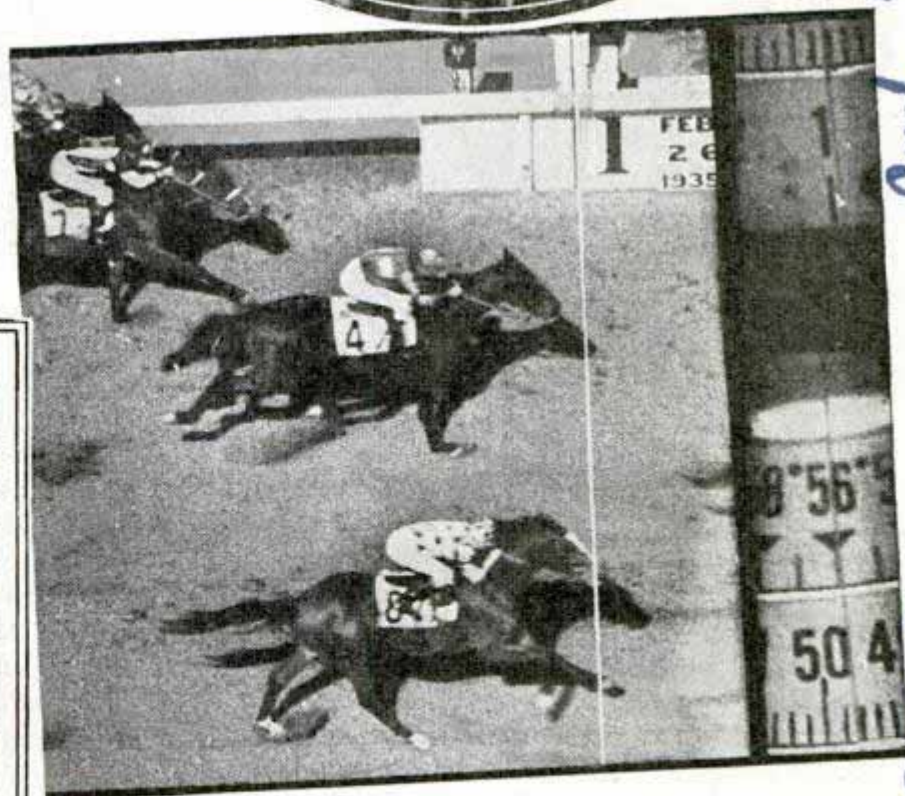
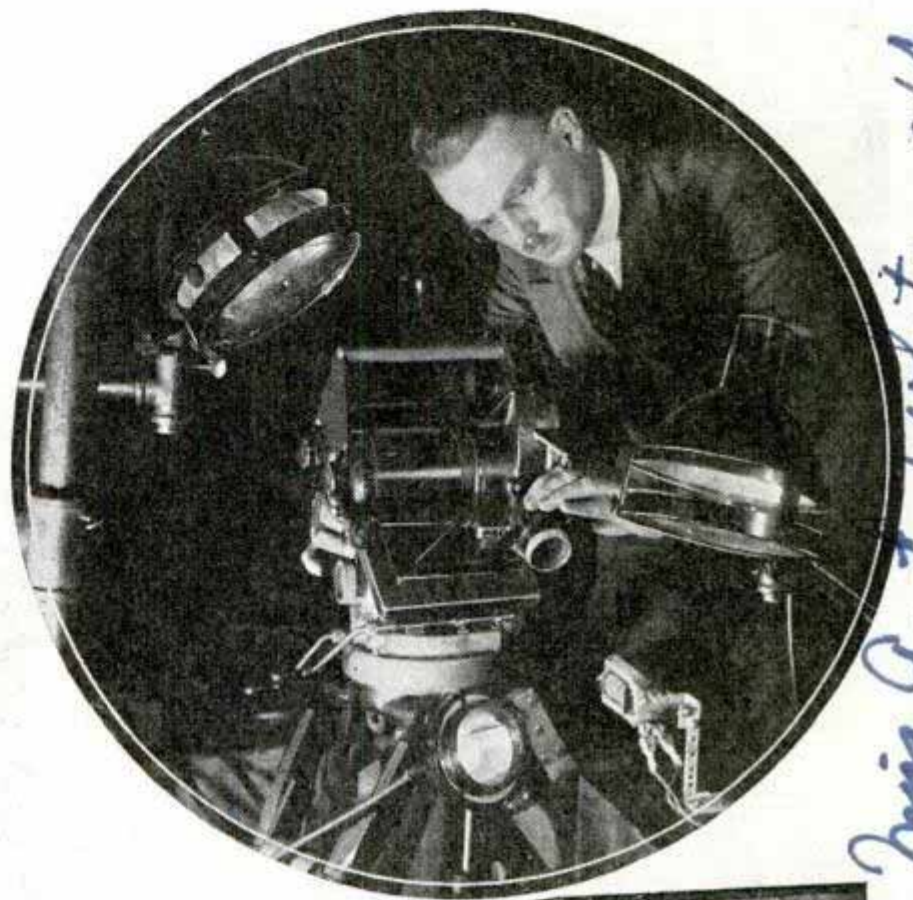

Circle, operating the "movie doctor." Below, finish of race recorded by speed camera. Left, clapper striking gong. Photos were at 2,000 per second

Western Electric 819
High Speed

Cont. Miss A. L. White Apr. 13 - 1935

195 Broadway New York

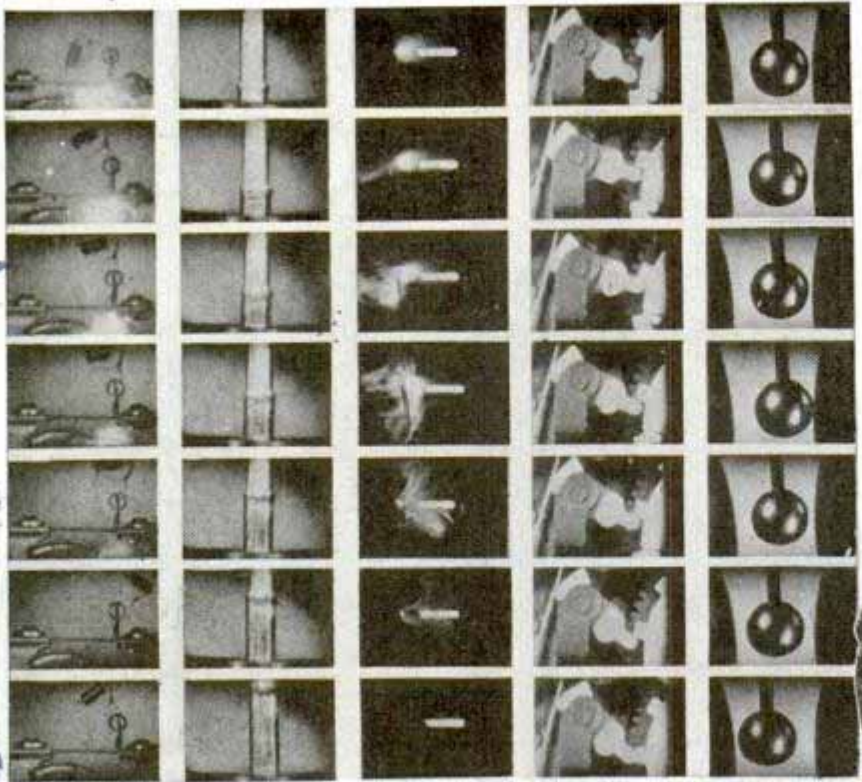

Left, speed photos in strips show (from left to right): blowing of a telephone fuse; formation of a condenser casing (similar to a collapsible toothpaste tube); burning out of straight wire fuse; gear tooth striking pawl, and clapper striking gong

Photos courtesy Bell Laboratories and Electrical Research Products, Inc.

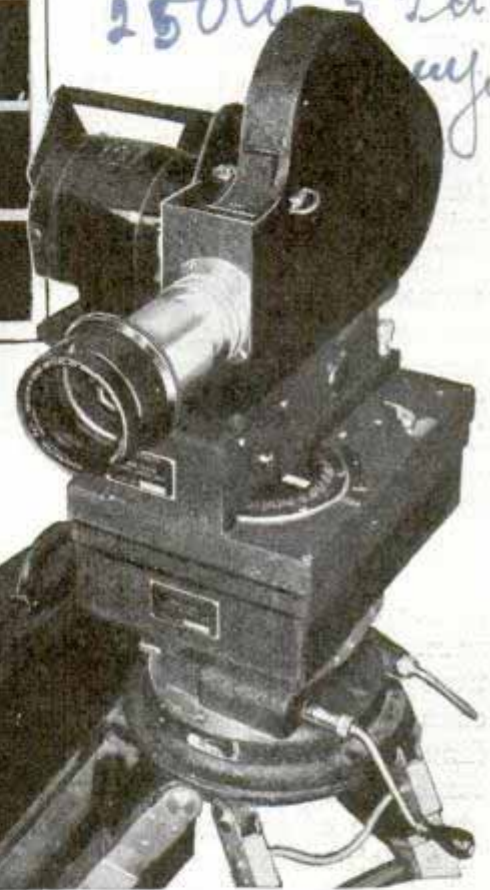

Right, Western Electric high-speed camera. Bottom, precision clock used with camera in the manner demonstrated at right

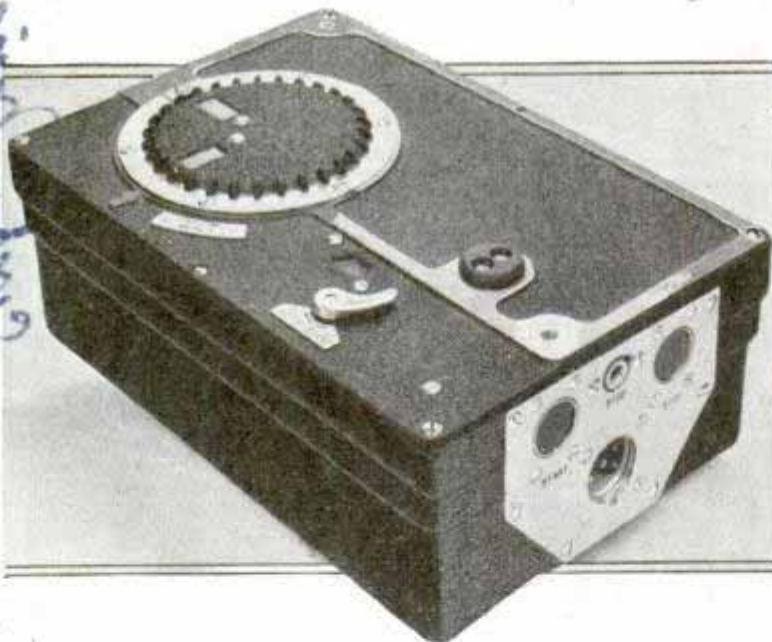

by which it is possible to read the time to a little closer than $\frac{1}{1000}$ of a second. This result is obtained by means of two dials, one with sixty divisions rotating once per minute, the other with 500 divisions rotating once per

second. With this combination camera and clock, not only panchromatic and super-panchromatic film can be used but also color film. This last is particularly useful for photographing flames and chemical processes, as by its use gases emitted may be identified by their characteristic colors. Photographs can be made in sunlight or by the light of photo-flood or spot lamps, and

can run at a speed of 2,500 pictures per second, and a specially constructed camera can run as many as 4,000 pictures per second. When the pictures taken at high speed are projected at the normal rate of sixteen pictures per second, the motion appears to be slowed down more than 150 times.

The time of each frame is photographed on one side of the film. The clock used with this camera is a precision timepiece

(Continued to page 126A)

103
 4
 9-12-30
 19-19-30
 25-8-30
 27-6
 30-12-30
 31-12-30
 32-12-30
 33-12-30
 34-12-30
 35-12-30
 36-12-30
 37-12-30
 38-12-30
 39-12-30
 40-12-30
 41-12-30
 42-12-30
 43-12-30
 44-12-30
 45-12-30
 46-12-30
 47-12-30
 48-12-30
 49-12-30
 50-12-30
 51-12-30
 52-12-30
 53-12-30
 54-12-30
 55-12-30
 56-12-30
 57-12-30
 58-12-30
 59-12-30
 60-12-30
 61-12-30
 62-12-30
 63-12-30
 64-12-30
 65-12-30
 66-12-30
 67-12-30
 68-12-30
 69-12-30
 70-12-30
 71-12-30
 72-12-30
 73-12-30
 74-12-30
 75-12-30
 76-12-30
 77-12-30
 78-12-30
 79-12-30
 80-12-30
 81-12-30
 82-12-30
 83-12-30
 84-12-30
 85-12-30
 86-12-30
 87-12-30
 88-12-30
 89-12-30
 90-12-30
 91-12-30
 92-12-30
 93-12-30
 94-12-30
 95-12-30
 96-12-30
 97-12-30
 98-12-30
 99-12-30
 100-12-30

Stratosphere Fliers' Gondola Ready for Trip

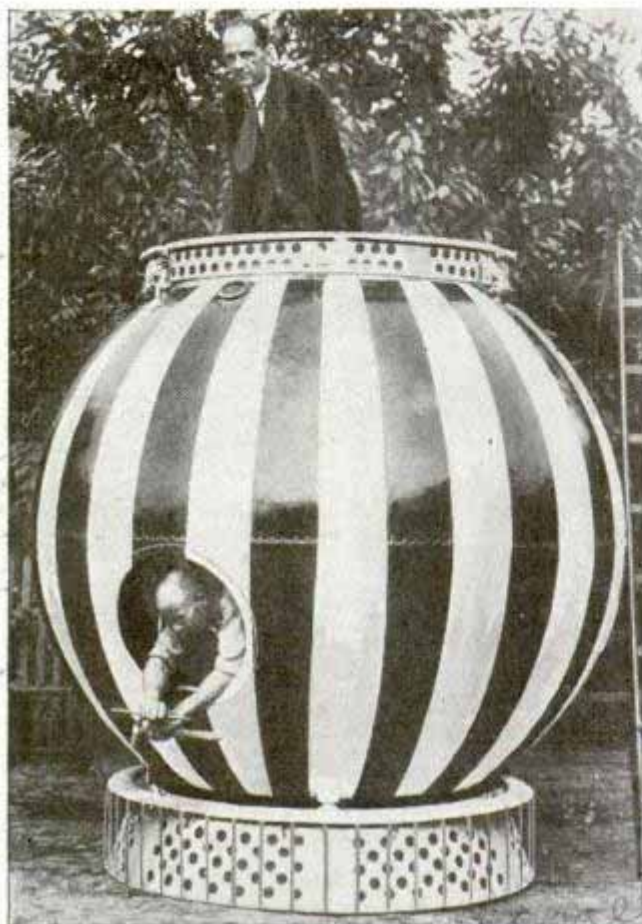

Gondola of stratosphere balloon, ready for attachment to the inflated bag

Ready for a journey into the upper air is the ball-shaped gondola which will be attached to the "Star of Poland" stratosphere balloon. Three Polish fliers will make the trip. The gondola is equipped with various instruments for making tests.

Outboard Motor Steers Plane Threading River Narrows

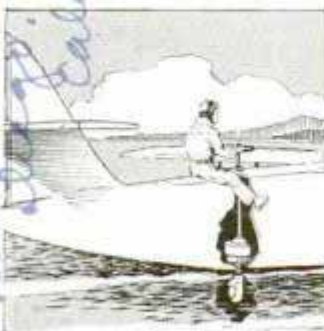

Natives of Dutch New Guinea may gape with good reason when the big flying boat of the American Museum of Natural History noses into a cove of some inland lake, the pilot astride its tail like an aerial cowboy. Sister ship of the U. S. Navy's twin-engined "PBY" patrol bombers, this aerial explor-

er can poke into snug inlets, thread narrow rivers and turn around "on a dime." An outboard motor under the aft hull does the trick. A strong propeller blast against the rudder would steer it afloat, but would also force the ship forward, making tight maneuvers difficult. Instead, the pilot of the "Guba" climbs to the "saddle" on the tail and maneuvers the ship by operating a nine-horsepower outboard motor and rudder below him. The "Guba" is a reconnaissance, supply and photographic plane owned by Richard Archbold, expedition leader. The rim of its bow turret is graduated in degrees for taking azimuth, and shadow bars show direction in relation to the sun. The rear tunnel hatch is the mount for the outboard motor, and is used also for dropping flares and supplies and for mounting a camera. The ship carries radio transmitters and receivers operating from any of eight stations in the cabin; there is a still for distilling sea water; four weeks' food supplies and a gasoline stove, a six-place raft, a collapsible boat and fourteen life jackets.

Bracelet Holds a Powder Puff, Rouge and Mirrors

All the materials for a quick cosmetic "touch-up" are concealed in a bracelet made of plastic in colors to match any



Twist this bracelet band and you find a purseful of "make-up"—mirrors, powder, rouge and puffs

Marlowe Novelty Corp. 347-5th

Vertical handwritten notes on the left margin, including "1084", "P. Kyle, III", and "Dahelito, Corp. 247 Park Ave."

Vertical handwritten notes in the center margin, including "Warsaw" and "Dahelito, Corp. 247 Park Ave."

Handwritten signature or initials at the top right of the page.

costume for sports, street or evening wear. Give the band a turn and it reveals three receptacles holding powder puff, mirror and face powder. Another turn discloses rouge, mirror and another puff. A further turn brings open a lip-rouge container.

Insulating Board Made of Waste from Steel-Pickling Bath

Steel mills used to dump into sewers and polluted streams the evil-smelling waste liquor of the steel-pickling bath. Today, by an inexpensive process, the worn-out pickle liquor is separated into pure water and a residue which is used for insulating material, wallboard, pipe covering or fertilizer. Steel is immersed in the pickling fluid to remove the "scale" or impurities. A Cleveland inventor discovered a way to redeem the worn-out fluid. The valuable residue he obtained from the waste is called ferron. At one stage it is plastic, molding into any shape and setting into a hard, tan-colored porous mass. Ferron resembles wood, is fireproof and termite-resistant, will not warp and can be sawed, cut or machined. One inch of ferron is said to be equal in insulating value to fifteen inches of brick wall.

Launch Tows a Steel House to Lot Across River

This is no rescue scene in floodtime. It is a new, eight-room steel house being towed across the Illinois river at Peoria to a home site on the opposite shore. Prefabricated at a Peoria plant, the forty-one ton house was set afloat on the river, riding evenly on its own buoyancy.



Nothing but its own buoyancy supported this forty-one ton all-steel house as it floated across the Illinois river in tow of a motorboat

"Fire Weather" Sampled from 150-Foot Tower



Weather instruments are stationed at five stages of this 150-foot tower to study "fire weather"

What influence does the weather have on forest fires? Forest research men are trying to answer that question from the steps of a 150-foot steel tower that rises eighty feet above the treetops at Priest River, Ida. The "steps" are platforms stationed at five height levels—on the ground, at thirty-five feet, seventy-five feet, 105 feet and 150 feet. On each platform are instruments recording wind velocity, temperature and relative humidity continuously, and measuring evaporation and radiation.

The annual commercial catch of fishery commodities in the world amounts to about 34,000,000,000 pounds, valued at approximately \$744,000,000.

Dept. of Commerce memo 9/16/3

*man...
Elected...
W...
Process assigned to...
See letter 14 1098
See June 1937-889*

*Les Shanas...
The emergency...
cont.*

*Le Tourneau Co.
Peoria, Ill.*

Science Helps Carve Giant Faces on Mountain



Huge models in studio are used in carving giant faces on Mt. Rushmore in South Dakota's Black Hills. One inch on the models represents one foot on the mountainside. The models aid in making measurements and taking readings



Above, director with telephone sits on side of cliff to guide the workers dangling from steel cables. Note huge face in background



Above, jackhammer driller prepares holes for dynamite in the granite. Blasting then loosens the rock. Right, Lincoln Borglum, son of the Mt. Rushmore sculptor, Gutzon Borglum, holding bundle of small dynamite charges and a bundle of caps and fuses used in blasting



Cont. H. A. Sghaderi. 2. 20. 2. Walton

By news & ...

... ..

Models Used in Shaping Mt. Rushmore Group

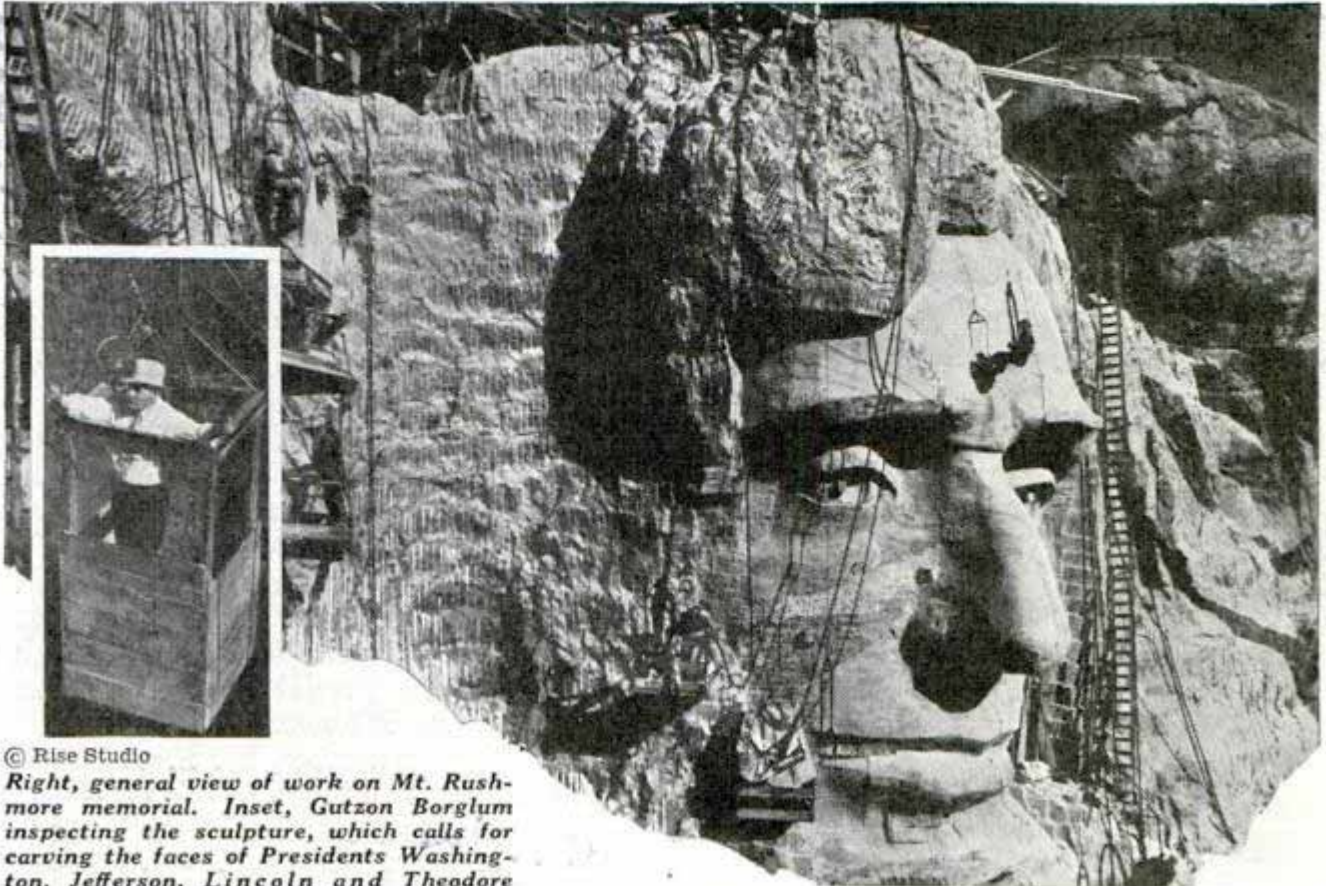

© Rise Studio

Right, general view of work on Mt. Rushmore memorial. Inset, Gutzon Borglum inspecting the sculpture, which calls for carving the faces of Presidents Washington, Jefferson, Lincoln and Theodore Roosevelt on the mountainside. Workers' tiny figures give an idea of project's size

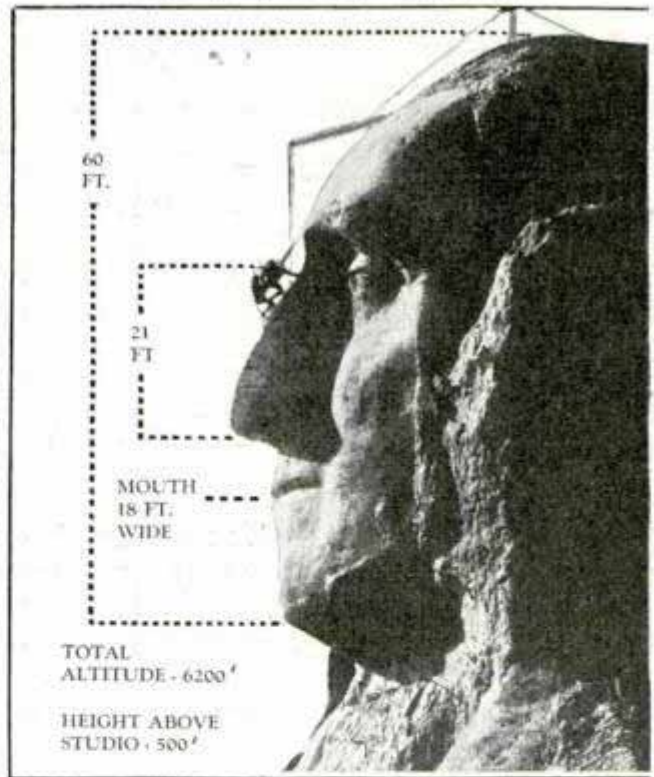

Left, measuring model in studio helps workers locate same relative spot on mountainside. Multiplying studio readings by twelve gives the correct distances. Right, giant proportions of the memorial are illustrated by measurements of this huge face

The faces of the presidents are carved into the mountain. The scale of the project is shown by the tiny figures of workers. The measurements of the face are 60 feet high, 21 feet wide, and the mouth is 18 feet wide. The total altitude of the mountain is 6200 feet, and the height above the studio is 500 feet.

Static-Proof Radio Compass Is Reliable in All Weather



Compass needle of this direction-finder points "home" to radio station regardless of static

Static troubles of the aircraft pilot are beaten by a radio direction finder just developed. Equipped with a double aerial, it is unaffected by static. When the radio is tuned to a station, the compass needle points to the direction of the station.

Adapter for Use of Color Film Has Ground-Glass Focuser



To make miniature color film available for use in some cameras not previously adapted to it, a special adapter has just been introduced. It consists of a sliding film chamber and ground-glass focusing panel mounted to fit on the back of certain film-pack cameras. The picture is focused on the small glass

panel, then the film chamber is slid down into position and the shutter snapped. The adapter can be removed from the camera when the roll of eight pictures has been only partly exposed. Photomicrography in color and "table-top" work is facilitated by this adapter.

Five-Billion-Dollar Cost of Rust Exceeds War Budgets

Wartime budgets of the nations reach sums staggering the imagination, yet the largest single cost item faced by the United States or any other country is the cost of corrosion. One automotive engineer computes the loss to the world due to corrosion of metals alone at \$5,000,000,000 a year. Each year, he says, one-fourth of all the world's iron returns to the oxides or ores from which it was derived. Although it is theoretically possible to convert iron oxide into pure commercial iron again, it is practically impossible, for most of the rust is scattered and lost.

Frozen Bread Nine Months Old Stays Fresh and Palatable

At a banquet the other day the guests were served bread thirty-two days old. It was perfectly fresh and palatable. The guests could not distinguish the month-old bread from that baked the same day. The secret lay in freezing. Immediately



It takes a hard whack with meat cleaver to break a loaf of frozen bread, but it's tasty when thawed

Dr. W. W. Warren & Co. Inc. 1073

Eastman Kodak Co. Rochester

Chrysler Corp. 341 Nassau Street

10/3/38

1119
1110

after baking, the bread had been frozen so hard that a meat cleaver was required to chop it up. Thawed out, however, it was unchanged in appearance and taste even after nine months in refrigeration. Experiments indicated it would be quite feasible in wartime to store thousands of loaves for months at a time and, if necessary, to ship bread in refrigerated boats to an army abroad.

Exposure Meter for Enlarging Gives Direct Reading

Photographic enlarging is made easier by an exposure meter of the extinction type which has no moving parts, no bulb to burn, no consumption of current. The reading is made directly, without reference to charts or calculations. There is no electric cord to interfere on the enlarging table.



Taking a direct reading with extinction type meter

*Raygram Corp.
425-4th Ave*

Newest Queen of Zeppelins Goes Aloft for Maiden Flight

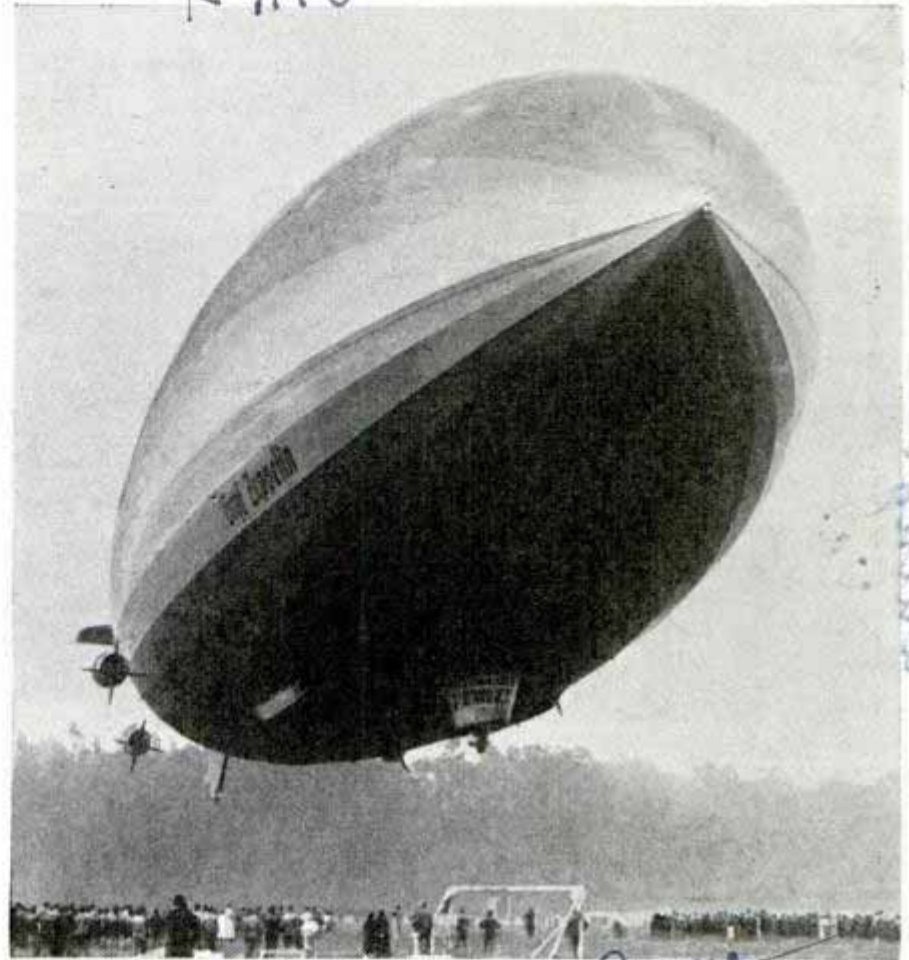

Up for its first taste of the air, Germany's newest "Graf Zeppelin" rides majestically away from the ground crew, her cells filled with hydrogen

Faith of the Zeppelin builders in their giant dirigibles, despite the tragic loss of the "Hindenburg," was expressed again when the newest of the famous line, the "Graf Zeppelin," was christened recently. The gas bags of the new sky queen were filled with hydrogen on her trial flight, as previous Zeppelins had been. Germany had been unable to obtain a supply of the non-inflammable helium gas from the United States. Helium is more costly and has only ninety-two per cent of the lifting power of hydrogen—the gas itself is twice as heavy as hydrogen—but its use eliminates the risk of explosion and fire that ended the transatlantic career of the "Hindenburg" in 1937.

☐Inquiries as to makers of articles described in Popular Mechanics, will be answered by our Bureau of Information upon receipt of return postage.

*Amesbury Institute of Reading
9 Rockefeller Plaza, New York*

1106

1110

Aeme

Handwritten notes on the right margin, including "1106" and "1110".

OCEAN'S DEPTH

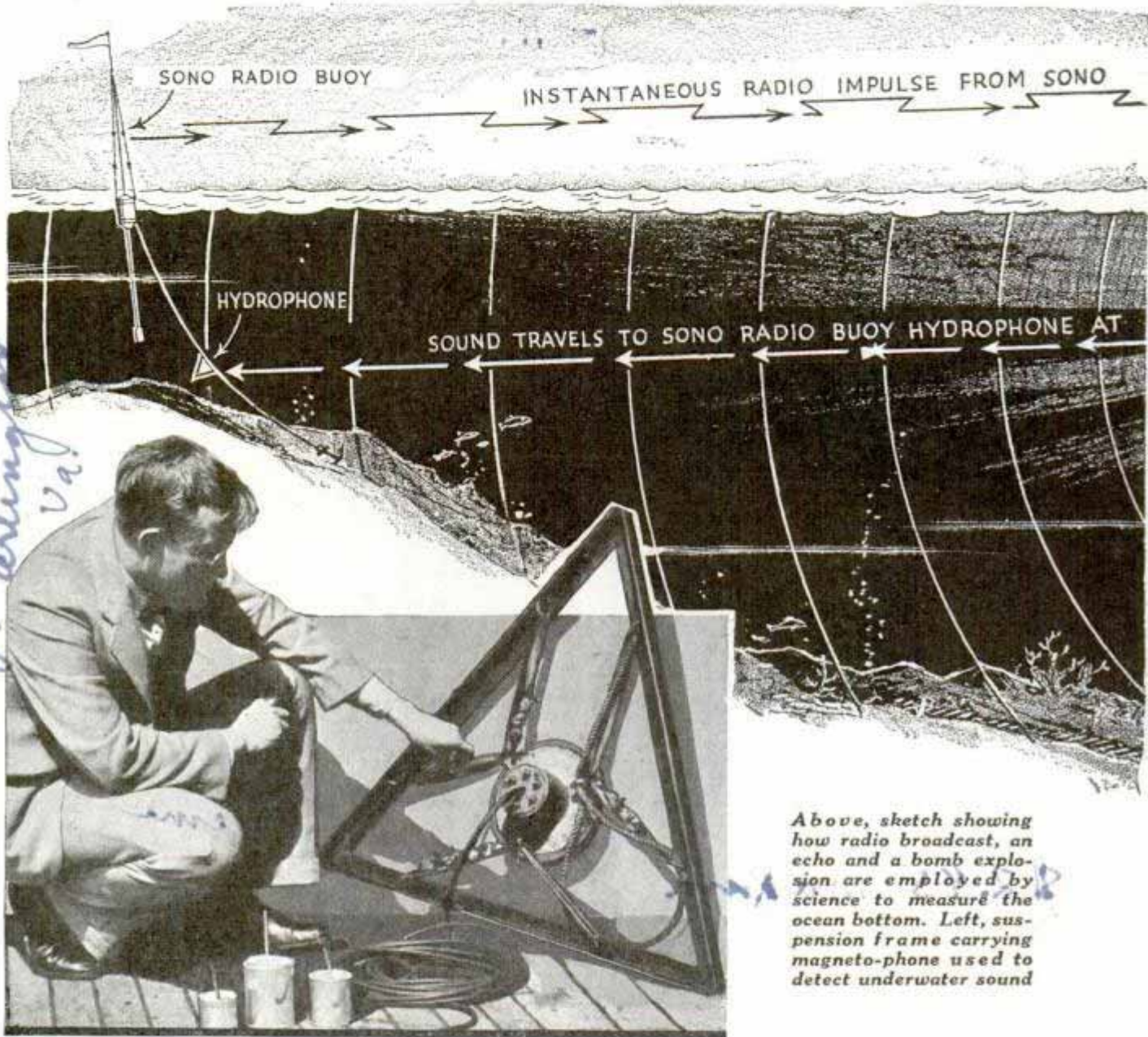

Above, sketch showing how radio broadcast, an echo and a bomb explosion are employed by science to measure the ocean bottom. Left, suspension frame carrying magneto-telephone used to detect underwater sound

Cmt. John L. Coontz, 3901-5th St. N.E., Arlington, Va.

IT'S hard to believe that a radio broadcast, an echo and a bomb full of TNT can measure the profile of the ocean's bottom.

These apparently unrelated occurrences actually work together and reveal in a few seconds' time the exact configuration of the mountains and canyons of the sea, many of which are greater than Mt. Everest and dwarf into insignificance the Grand Canyon of the Colorado.

It was accomplished the other day off the coast of New York City, giving promise of being repeated hundreds of times for years to come in stretches of the ocean off the Atlantic, Pacific and Gulf coasts.

To make the achievement seem even more weird and fantastic, the broadcast was made fifty miles out to sea by a robot sealed in an airtight container inside a buoy bobbing up and down on the waves.

It is all a part of something entirely new in the field of ocean surveying, a science which its inventors, research experts of the U. S. Coast and Geodetic Survey, with headquarters in Washington, refer to as radio acoustic ranging.

Practical importance of the feat scarcely can be exaggerated. It means the quickest and most accurate method the world has ever known of charting the ocean's floor and making it safe for navigation interests.

141036

Measured by RADIO ROBOT

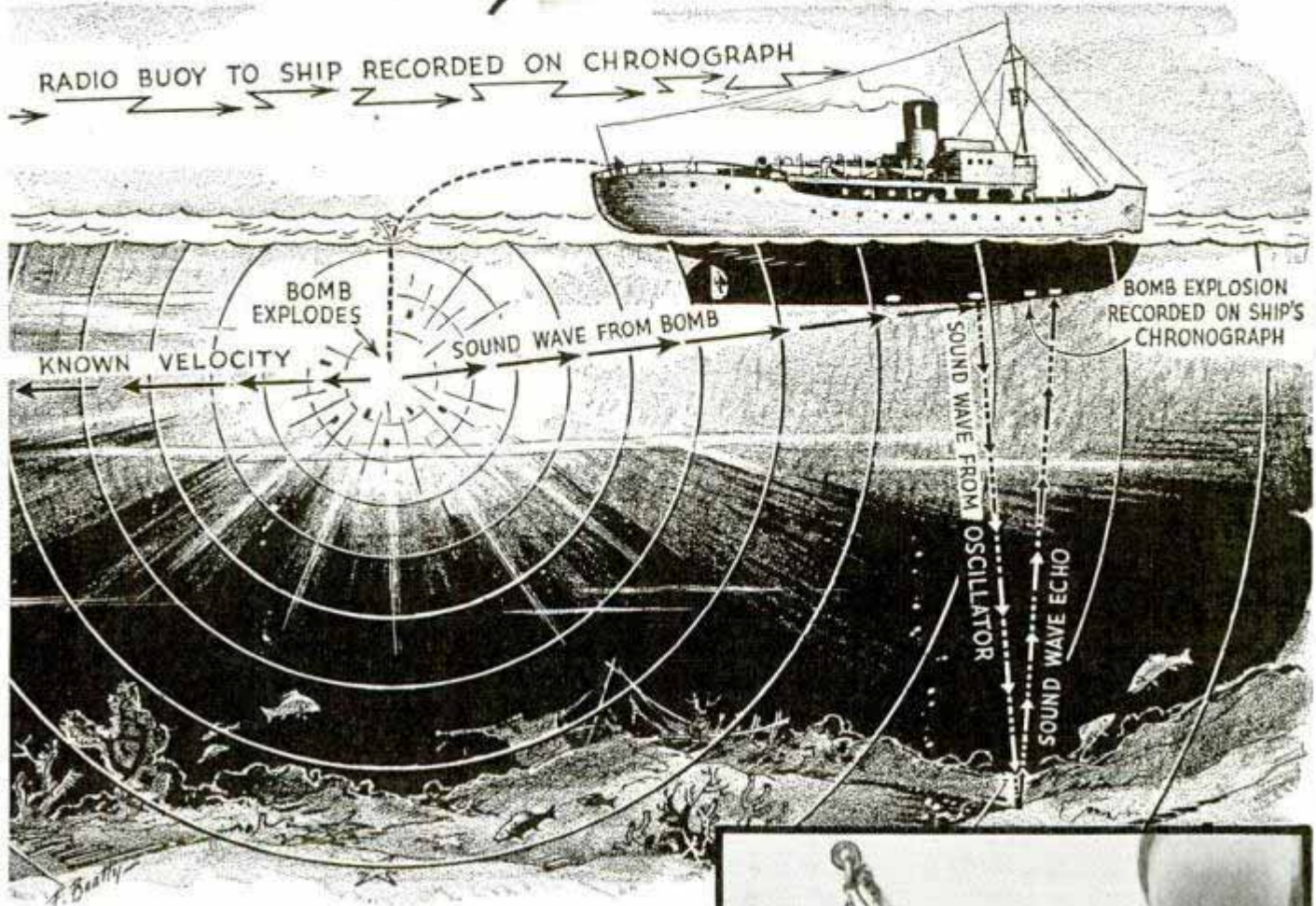

Here's an exact visualization of how the new science works, as explained by Capt. Gilbert T. Rude of the Coast and Geodetic Survey:

"Scientists have labored under serious handicaps in their efforts to explore the sea's substrata. It has been impossible to send submarines into the treacherous watery depths because the pressure would crush the craft's heavy metal as rapidly, perhaps, as an eggshell crumbles in the hand.

"The old-time procedure has been to make soundings by means of leads attached to heavy piano wire. However, to let out some six miles or more of wire and pull it to the surface again has proved to be a task, sometimes consuming at least an hour's time. Moreover, hundreds of soundings must be taken in laborious fashion in a limited area before scientists may gain anything approximating a genuine idea of the configuration of a large ocean canyon.

"Recently research workers of the Coast



Here the crew is lowering a radio buoy into the ocean. It takes only a few minutes to drop the buoy or to remove it from the water, thus speeding up the survey work

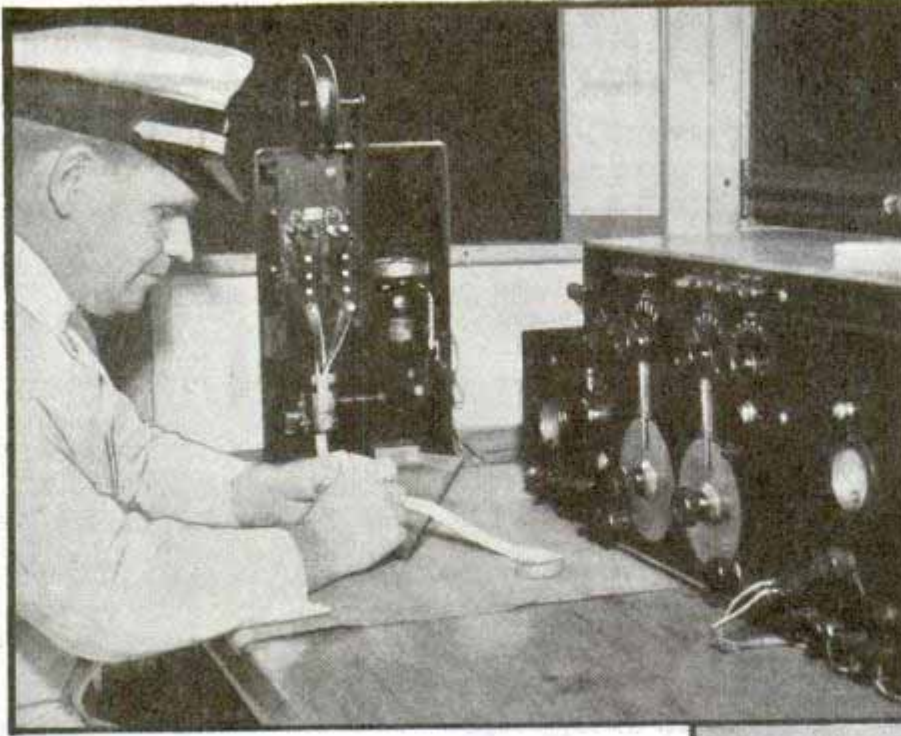

drop a buoy into the water and about the same time to pull it back into the ship. The buoy is lowered with the aid of a lightweight cargo boom with standard gear.

"Survey ships along the Atlantic and Gulf coasts are now using the new equipment regularly, chiefly because, due to generally prevalent conditions of shallow water in these regions, the sound waves would not go all the way ashore, to be measured

and Geodetic Survey developed a science, known as radio acoustic ranging which measures the ocean's floor in a quicker and more efficient way than hitherto was thought possible. It involves the use of a number of ocean-going, movable radio stations of a novel and revolutionary type.

"These stations are known as sono-radio buoys and they have proved their efficiency in working with the fathometer, used on survey ships to plot the ocean depths. The fathometer sends out a series of sharp rapping noises from the ship's bottom, catches the rap echo which resounds from the ocean bottom and by calculation of the time consumed in the emission and return of the sound, reports the exact depth of the water under the ship at the moment.

"It works at high speed, reporting the depths as frequently as four per second, even while the vessel on which it is mounted steams along at full speed.

"How does the sono-radio buoy work with the fathometer? In the first place, every time a survey ship is engaged in the task of measuring a certain section of the ocean's bottom, several new buoys are carried along and anchored at definite points close by the ship. The entire equipment for each buoy weighs 700 pounds. It is 'homemade,' devised and put together right on the survey ship. The buoy section is made from two oil drums. It takes only about five minutes for four men to

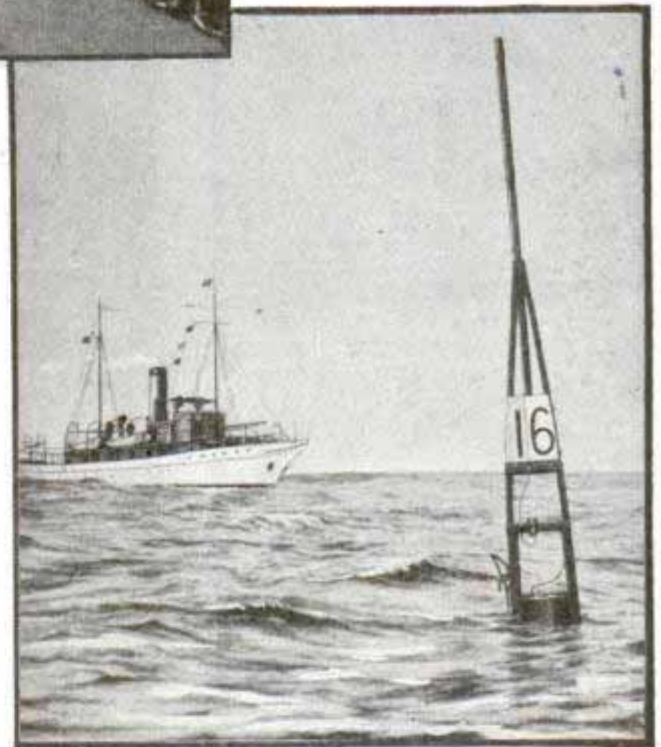

Top, officer measuring travel time of underwater sound from chronograph tape. Bottom, closeup of sono-radio buoy in position for measuring depth

by the shore stations of the Coast and Geodetic Survey. Along the Pacific where the water is considerably deeper for the most part, this difficulty is not encountered. The buoys, however, are being introduced more and more on the west coast and in Alaska. Main reason for this is that the equipment is less expensive than the previous standard procedure of setting up shore stations for such important ocean survey work.

(Continued to page 130A)

1013
**Bananas Ride Cradle
 from Steamship
 to Freight Car**

Cargoes of bananas are unloaded rapidly from fruit-carrying ships by means of large belt conveyors. The conveyors are designed so that a canvas cradle is arranged the entire length of the belt to receive the clusters of bananas. Large cargoes may be unloaded in this manner in a fraction of the time formerly required when stevedores were used in every step of the operation. The conveyors frequently carry the fruit directly from the hold of a ship to the doors of freight cars, into which the bananas are packed by hand.

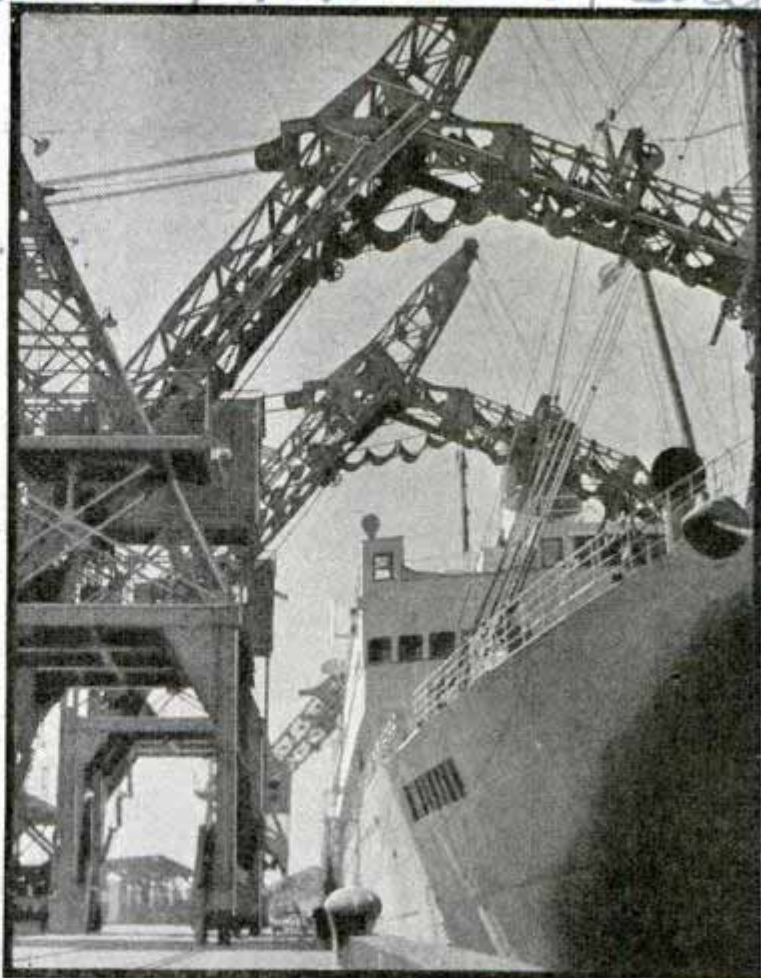

Mechanical stevedores unloading a great cargo steamer. Clusters of bananas can be seen moving in continuous stream along the belt conveyors which carry them rapidly from hold of fruit ship to the doors of freight cars, there to be packed by hand

1141
Electric 'Eye' Sees Tiny Flaws in Fast-Moving Steel Strip

Pinhole flaws in strips of steel moving through the mill at a pace of 900 feet a minute are detected by a photoelectric "inspector." Not only does the unerring "eye" see through the tiniest hole, but it operates a mechanism automatically throwing out the faulty section of steel. This electric inspector is set up at a Maryland plant of the Bethlehem Steel com-

pany. The steel strip, thirty-six inches wide, passes through a slotted scanner head; light projected upward from bulbs in the lower part of the head passes through any pinholes in the steel and operates photoelectric tubes overhead. These tubes, through an amplifier, actuate a diverter which takes the imperfect portions of the strip out of the production line.

General Electric Co. Schenectady

Hand Truck 'Walks' Piano Up or Down Stairs



One man demonstrates how easy it is to move piano, bench and girl up stairs with "walking" truck

For easy transportation of pianos up or down stairs, a hand truck has been developed. One man, using the truck, can move a piano that formerly required three men. In moving a piano upstairs, the truck literally walks up the steps, balancing first on the front wheels and then on the back wheels, which automatically proceed to the step above when the weight is taken up by the front wheels.

Milking by a Vacuum Process Saves Calcium and Vitamins

By excluding all contact of milk with air from the cow's udder to the bottle, a new vacuum milking process prevents loss of calcium and vitamins. Milk fresh from the cow contains nitrogen and carbon-dioxide gases in solution, and contact with oxygen is said to cause precipitation of calcium salts and loss of vitamins. The vacuum milker operates at one-half an atmosphere

of pressure, delivers the milk from cow to tank under partial vacuum and thence direct to bottles. Nitrogen and carbon dioxide are added to bring the milk up to atmospheric pressure, still excluding oxygen, then the bottles are capped.

H1113

Elastic Cover Protects Book

Made of a material resembling pebbled leather, an adjustable book cover will fit any size volume up to fifteen inches wide. It is held in place by four elastic bands which have at their free ends small metal hooks gripping the edges of the book.



H1114

"Cat Eye" Mirrors on Highway Guide Motorists at Night

Triple "cat eye" reflectors mounted on posts along roadsides are being installed by the Federal Bureau of Public Roads to reduce the accident toll. The three tiny mirrors reflect the headlights and lead the automobile safely around curves.



An engineer of the U. S. Bureau of Public Roads adjusts a "cat eye" on roadside post in Maryland.

Handwritten notes on the left margin:
I had Herbert Muller Hollywood
5126 Hollywood Calif
with Professor Oscar at Chic

Handwritten notes on the top and right margins:
Walden, Jr. E. O.
Walden, Jr. E. O.
near support
The Paris Calif. at 27 H
new gold

Handwritten notes at the bottom:
D. W. Lutzger
1117 12 E

Motor Surfboard Hits a Twenty-Mile Pace

Twenty miles an hour is thrilling speed when you're lying on a surfboard skimming along the surface of a lake. That's what the "skimboard" will do. Invented by a Pennsylvania automobile mechanic, it is part surfboard, part motorboat. Weighing ninety pounds, it "knocks down" into four sections for carrying, and is nine feet long when assembled. A four-horsepower outboard motor supplies the power.



Weds Walk

Top, carrying the "skimboard" from car to shore to be assembled and launched. It knocks down into four pieces, weighing ninety pounds in all. Left, idling on the water and making a turn with the outboard motor churning

Claw. Emil Hansen, Pa. media, Pa.

Plane with the Speed of Sound Is Proposed by Designer

Exhibiting the model of a plane which he claims would have the speed of sound, about 700 miles per hour, Ivan Eremeeff has drawn plans for a "flying fuselage" powered by two 1,500-horsepower engines. Its wings would be reduced to relatively small fins and its two propellers would be mounted one forward and the other in the rear. A top speed of 1,000 miles an hour and a normal speed of 600 to 700 miles an hour are claimed by the designer. His plans call for an over-all length of thirty-six feet and a span of twenty-four feet from fin-tip to fin-tip. Aeronautical engi-

neers assert that, unless he has worked out a totally new principle, such a speed with existing aviation power plants is impossible. A serious limiting factor is the fact that there is a definite ratio between top speed and landing speed; the higher the former is pushed, in general, the higher is the latter. If conventional practice were to bind Eremeeff, the 1,000-mile top speed would mean a landing speed around 150 miles an hour, a practical impossibility. One solution might be that he hopes literally to hang the plane from its forward propeller and land it vertically on its tail.

12 10 90

311 Cherry St. Phila.

Science 9/18/38

Don't Pity the

ESKIMOS of the Bering Strait region probably did not invent the pneumatic tire, but they seem to have known about its basic principle and utilized it long before the white man realized its possibilities.

These Eskimos, just emerging from the Stone Age, offer a wonderful opportunity to observe a primitive people in a primitive environment, and to compare their standard of intelligence with that of people of our modern age. Those who cherish illusions that modern man represents the acme of mental development are likely to have their illusions shattered.

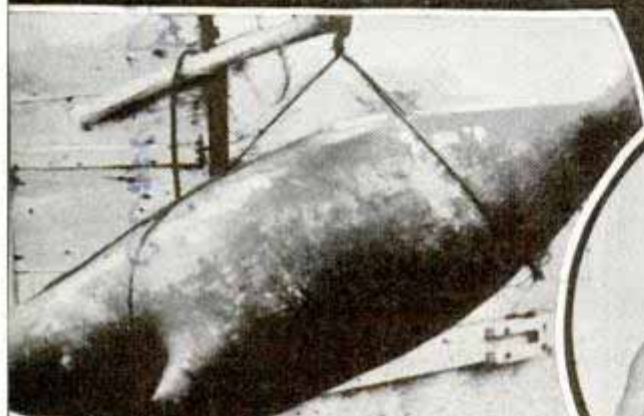

Top, Eskimo mechanic inspects outboard motor before starting walrus hunt. Circle, Eskimo girl with baby brother on back. Bottom, scene outside an igloo with inflated skin hanging from pole

Chas. William Albee,
Harry Beardley,
210 W. Harrison, Wheaton, Ill.

H1029

Box 812,
Waurenville, Ill.

POOR ESKIMO

By
Ruth and Bill Albee
PART II

For instance, many moderns think of straight-line production, precision workmanship, utilization of by-products, and streamline design as characteristics of our modern industrial age. But we found that they were old stuff to the Eskimos at Cape Prince of Wales, Alaska. In their own way, the Eskimos have practiced these principles for countless generations.

As teachers among them, working for the Bureau of Indian Affairs, we were supposed to teach their children how to cope with life. But we found them teaching us. We were amazed at their resourcefulness, efficiency, inventive genius and mechanical skill.

Modern industry can show few better examples of efficiency than that displayed by an Eskimo crew butchering a walrus. Six to ten men, working apparently without leadership or direction, will skin and cut up a 3,000-pound

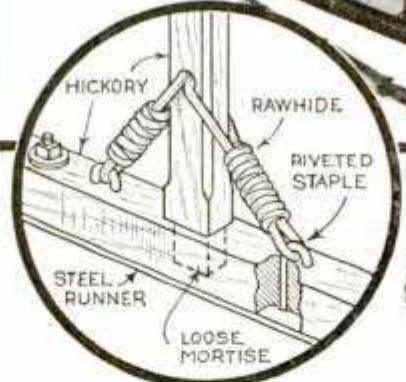
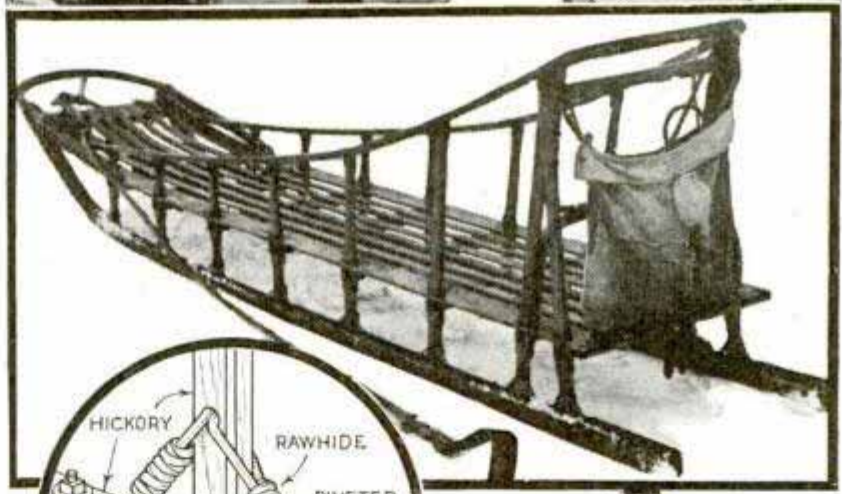

walrus in less than ten minutes. There will be no lost motion, no interference with one another.

As for utilization of by-products, the Eskimo obtains or manufactures from the hair seal alone some 500 different useful products and articles—ranging from toys

Top, natural born mechanics, these Eskimos are highly interested in movie cameras. Center, dog sled. Circle, flexible joints used in construction of sled. Bottom, sled in use

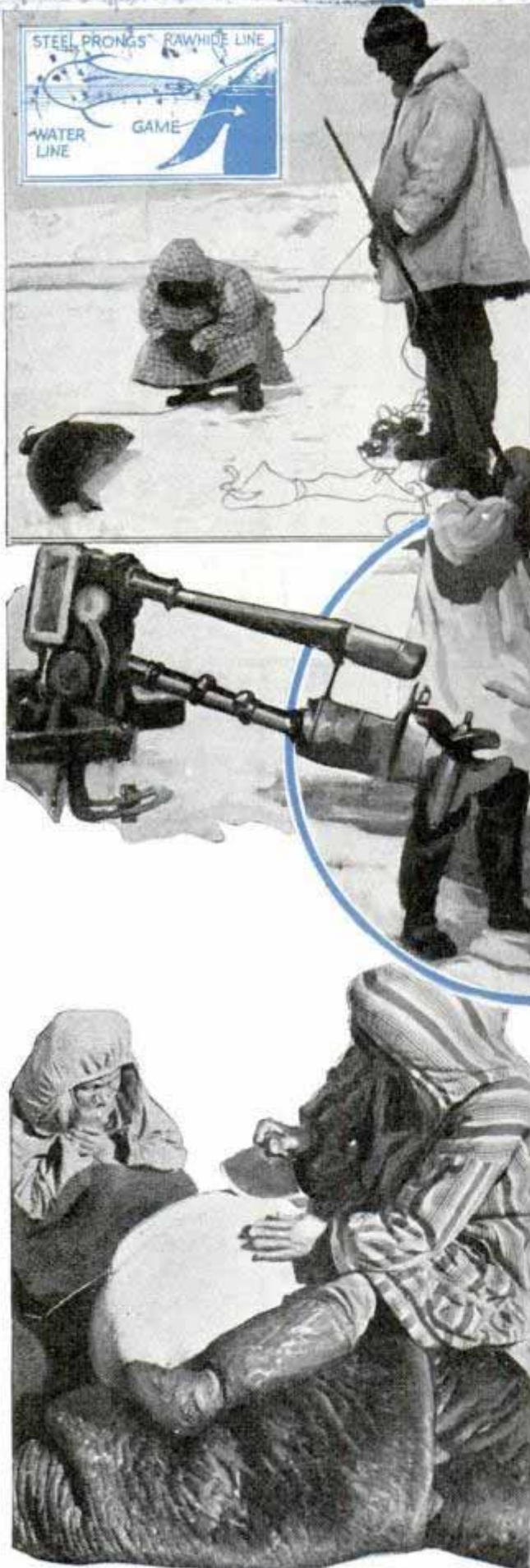

Top, seal retrieved with "ilhook," illustrated in inset. Bottom, girl learning to split walrus hide. One slip of the knife ruins the whole hide

to medicines—and food is listed as one product. Not even the Chicago packers, who boast of using every part of the pig but the squeal, can do much better.

No one who has ever seen an Eskimo woman split a walrus hide can again think of precision workmanship as being exclusively a machine-age characteristic. The walrus hide is about three-quarters of an inch thick—too thick and too heavy to be used as a covering for a skin boat or oomiak. So the women split the hides into two layers, each approximately three-eighths of an inch thick. In this operation, the women use the traditional "ooloo," a knife with a curved blade, somewhat sim-

ilar to the old-fashioned chopping knife. Holding a curved board between her knees to provide a cutting surface, she guides her ooloo strokes with her free hand and gauges the thickness of the two layers by a delicate sense of touch. It takes from six to eight hours to split a hide approximately twelve feet square. When the job is completed, the two layers will be of uniform thickness throughout. A thin spot might bring disaster to a hunt-

Circle, chopping away rotten ice before launching oomiak. Note wooden shaft housing extension (at left) on outboard motor

ing crew using the oomiak.

But the Eskimo men display even greater skill and precision in their work with rawhide. To explain their work and the Eskimo pneumatic tire, one must first explain that for some uses to which sealskin is put, the entire carcass is removed through a single opening at the neck, leaving the skin in one piece. An Eskimo man, using nothing but a hunting knife and his fingers for a gauge, will cut around the skin from neck to tail in a continuous spiral. Within an hour, he can reduce a seal hide to a rawhide thong from 500 to 800 feet long. These thongs have many uses, such as for making harpoon lines and nets

to catch seals. They are so uniform in width and thickness that the eye can detect no variation.

On feast days the men hold contests demanding even greater skill. Each contestant takes an arm's length of rawhide thong not over three-sixteenths of an inch thick, and splits it with a quick pull of his knife. The man who splits his thong into strips of the most nearly uniform dimensions, wins. Sometimes the judges ponder many hours before the victor is proclaimed.

The women cure these whole seal hides with oil to make bags or "pokes" that have many uses. Stuffed to capacity with dried meat soaked in seal oil, and with the opening sewed up airtight with sinew, the poke serves as a container to store food and preserve it for future use. Inflated with air, and attached to a harpoon line, it



serves as a buoy to support and mark the location of seals or walrus harpooned out in the open water.

But perhaps the most interesting use of a seal poke is as a pneumatic roller. Two or three half-inflated pokes, placed under the keel of a loaded oomiak, will enable a crew to pull the boat with ease over a sandy beach. Wooden rollers, or even tightly inflated pokes, are not satisfactory, as



Top, girl stretching sealskin. Center, hair-stuffed handball and "mukluks" (slippers) made from sealskin. Bottom, biting crimps to form toes and heels in mukluks

they dig into the loose sand, and pile it up in front of the roller. But the Eskimo was smart enough to discover long ago that the pneumatic wheel, or roller, overcame irregularities of terrain.

In building a dog sled for use on snow or ice, the problem was to construct a vehicle capable of transporting heavy loads over rough terrain at high speeds. Hence the sled, like the oomiak, must be strong but flexible enough to absorb shocks. Most dog sleds are made from imported hickory. One two-inch by twelve-



inch plank, twelve feet long, will be ripped by hand into more than two hundred linear feet of hickory strips varying from two inches by two inches to one-quarter inch by three inches, all the wood needed for a ten-foot sled, such as the one illustrated. The members, like those of the oomiak frame, are lashed together with taut rawhide thongs, providing strong, resilient joints that will yield

and then pull back into place without breaking. Thin steel bands, bolted to the bottom of the wooden runners, provide the sliding surface.

The Eskimo's innate mechanical sense finds many expressions in his adaptation of modern devices to his needs. Almost any Eskimo can take an outboard motor that a white man would relegate to the junk heap and make it function satisfactorily. We watched one of our Eskimo friends lengthen the shaft of an outboard motor to use on his skin boat.

He carved a "gasket" five inches thick from a piece of hardwood to insert where the bottom housing joins the shaft. In the gasket he drilled holes for bolts, water circulation, and shaft. Then he filed threads on sections of steel rods and thus made bolts to extend through the gasket. Finally he made a new long shaft from a rust-pitted drift pin resurrected from an old bit of wreckage on the beach. Cutting it to length, he filed bearings and keyways by hand, and re-

assembled shaft and housing. The motor functioned perfectly for three years to our knowledge, and is probably still in use.

Everything they can procure, even the

(Continued to page 134A)



Top, girl wearing reindeer-skin parka. Center, Eskimo being tossed from walrus hide to teach surefootedness, so necessary in hunting on the slippery ice floes. Bottom, girls using dog sled to carry water from spring to the igloo

Contour Map Helps Control Fire and Floods

Five years in the making, a detailed topographical relief map of Los Angeles county will soon be ready to aid in flood-control work, fighting forest fires, highway planning and agricultural administration. Spread over a table twenty feet square, the map—built of fiber board and plaster—weighs three tons. Every section is constructed to scale with great accuracy. Quarter-inch fiber board



Forest fire patrol stations and electric power lines are shown on relief map of Los Angeles county, now nearing completion

is cut with a jigsaw along the contour lines and built up to represent the exact shape and elevation of the foothills and mountains. Mount Baldy, highest in the area, appears four feet high on the map. When the thousands of small pieces have been arranged in layers, they appear like terraced mountains; then the plaster-of-paris covering is laid over, sanded smooth and coated with paint and shellac. Streets, roads and boundaries were laid out by miniature surveying from the U. S. geological survey maps. Forest lookout stations are indicated by an electric-light bulb adjustable to correspond to the actual height of the tower, and when lighted shows the actual ground area the lookout can observe. Transmission lines are shown in "T" pins and thread. Colored patches represent the various crop acreages of ranches.

Carbon Black in Rolls and Pellets Is Easier to Handle

Converted into small rolls the size of a pencil or into pellets the size of buckshot, carbon black is handled more easily than when it was compressed and packed into unwieldy bundles for shipment to rubber companies. The "dense black," as the new product is called, is loaded into tank cars for shipment, just as grain is loaded. The

pellets are formed by agitating carbon black, which has been blown into a funnel-shaped tank, until it has assumed the desired shape. The pencil-like rolls are formed from carbon black that has been saturated with water and then pressed through a screen. Carbon black is an important ingredient in rubber manufacture.

Cont. Miss Annice Dyer, Kenna

1019

Cont. J. Leland
Elmer
Calif

made & sold by
Monolite Co. 896
Santa Barbara
Berkeley



Left, moths caught in light-ray bait trap. Below, moths and beetles taken from ten traps in three months

a. c. covered only

LIGHTS turn BATTLE

Boyd Green



made in Berkeley

ELECTRICITY is playing a new role in agriculture. It now becomes a destroyer of insect hordes by developing light rays which lure them to their death.

Importance of the development of such death-dealing machines is apparent in a report by the United States Department of Agriculture, that insects cause an annual loss of more than \$2,000,000,000 to American farmers, and at least \$25,000,000 in California alone.

"Development of such instruments," one entomologist says, "will go far toward re-

ducing this costly destruction of crops. It will help put the farmer on a more substantial economic basis, will probably reduce the cost of fruits and vegetables to the consumer and will give the consumer a better grade of fruit and vegetables for his money."

There are two new types of traps which project a bombardment of death light rays. One is a tube which throws off certain colored light rays to attract a definite kind of insect to the source of light where it is electrocuted. The second type is a combination of light and mirrors which throws directed rays and which with the help of a odorous bait lures the insect into an oil bath from which there is no escape.

Several years of experimental work by J. K. Ellsworth, division of entomology and parasitology of the University of California, and Professor W. B. Herms of the same division, proved that insects prefer certain colors and can be lured to their death by colored light rays. The professors developed an insect electrocutor in which a

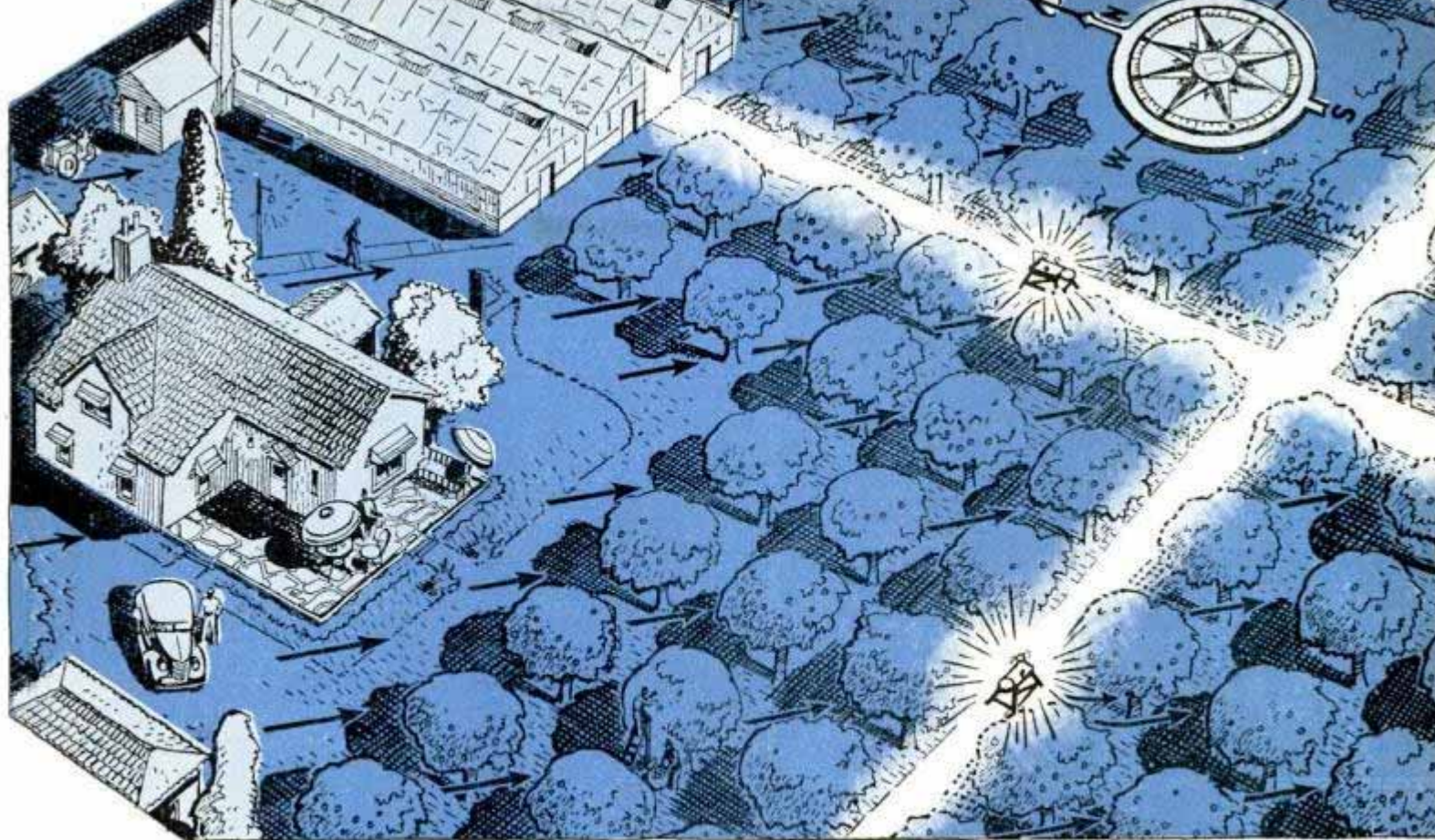

against INSECT ARMIES

Diagram of how light-bait trap works in orchard and how beams cross. Arrows show course of bait if southwest wind is blowing

helical luminescent gaseous discharge tube furnishes the light.

The combination light-bait trap, invented by Boyd Green, California orchardist, was designed on the bases that an insect is immediately excited when it flies through a ray of light and will attempt to find its source, and that insects are attracted by certain odorous baits. The bait draws the insects to the vicinity of the traps where they fly through the light rays and are lured to their death in a pan of oil.

These methods of killing insects are proving more effective on many crops than the method of partial control by the use of poison baits and expensive spray materials. They relieve the farmer of fruit-washing costs made necessary by the increasing vigor with which food and drug administrations and health authorities are

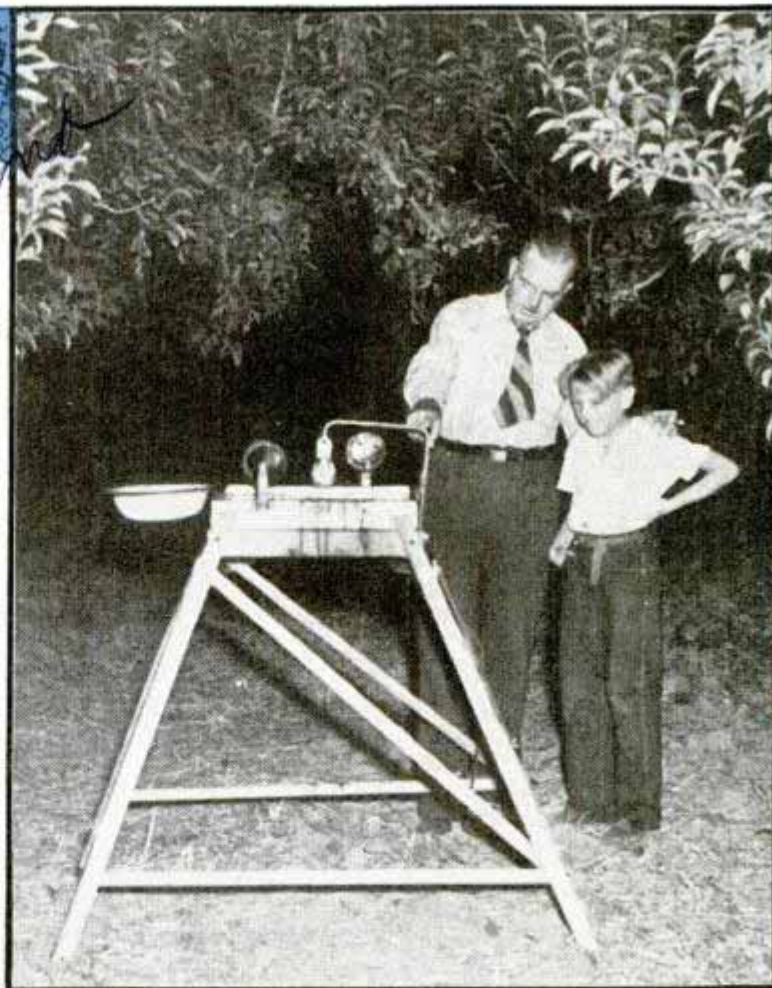

Light-ray bait trap in orchard at night. One light is used to cover an acre where trees are twenty feet apart. Beam is effective up to 800 feet if unobstructed



cage of stainless steel, the alternate wires being connected through high-tension porcelain insulation to the terminals of a transformer embedded in compound in its metal container, which supplies enough voltage to electrocute the insects as well as to furnish sufficient current for the luminescent tube. This tube projects the colored rays. It is suspended in the center of the cage so the insects attracted by the light will come in contact with the wires as they fly toward the light. These tubes are designed to burn 50,000 hours, or nightly for approximately ten years.

These electrocutors are used efficiently in the control of grape leaf hopper, artichoke plume moth, pear and apple tree codling moth, tomato insects, mushroom insects, dried-fruit insects and the lima-bean pod borer.

While the trap using light rays and bait is designed primarily to destroy the codling moth which causes thousands of dollars damage to pears and apples annually, it works as efficiently on many other insects which are attracted by light. Such insects attack walnuts, peaches, raisins, dried fruit, corn and tomatoes. Among them are the peach wig borer, hoppers, gnats, leaf-eating beetles, corn moth, and other destructive insect pests.

The trap consists of a large square pan filled with crankcase oil. Above

the pan on a swivel, and in the center, is an electric-light globe. Mounted on two sides of the pan are mirrors specially designed for the trap. These are focused on the globes to throw a beam of light between rows of trees or any other direction desired. The oil also acts as a reflector and

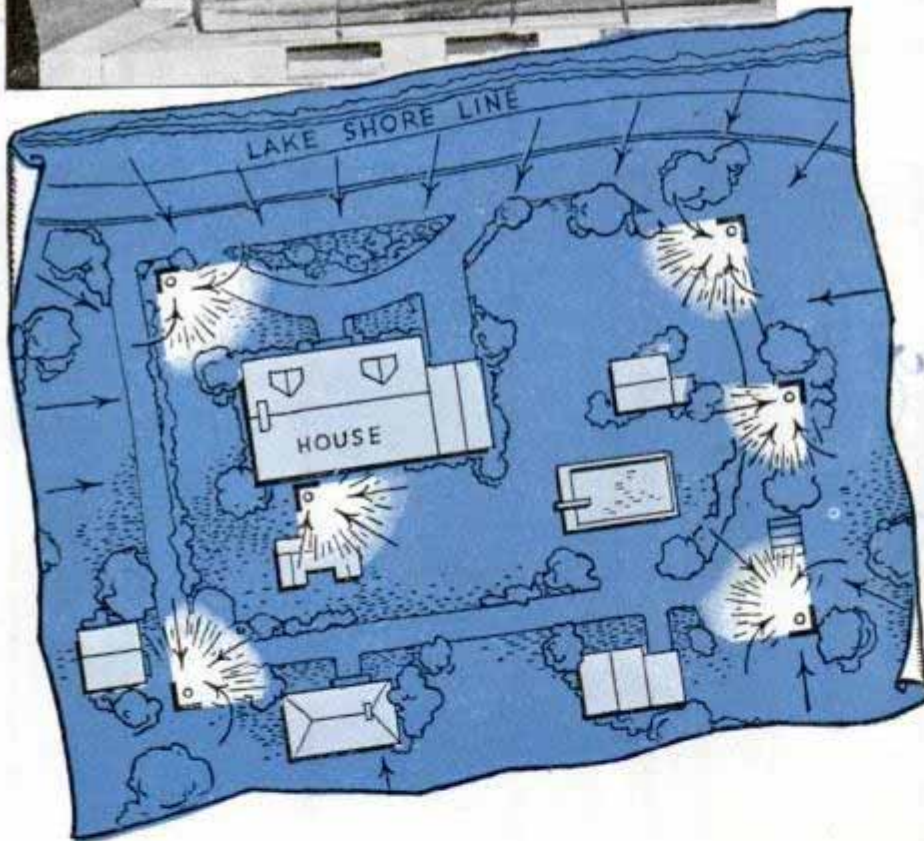

Top, cage in which moths are hatched and used in experiments to discover type of bait each species of moth prefers. Bottom, how light traps may be arranged about grounds of summer resort to attract gnats. Lights are concealed behind baffles to draw only those insects inside area

enforcing government regulations pertaining to dangerous chemical residue on fruits and vegetables resulting from the use of sprays and dusts.

The insect colored-ray electrocutors are eight inches in diameter and eighteen inches in height. They consist of a wire

University of California Entomologists

Ud Calif

Series - Von Lengerke's Automatic
Price - \$12.00 reel case - 1.00

throws a beam of light upward.

"Mounted on the oil pan is a basin of liquid bait, which is an important part of the trap," Green explains. "Perfume from the bait circulates through the orchard on the air currents. This bait draws the insects toward the traps where the odor is stronger.

"When the lights are turned on at night they reflect into the two mirrors and oil, throwing a beam from each surface which becomes at least ten feet wide, depending on the distance it goes before hitting an obstruction. Each light works efficiently as far as 800 feet."

Insects fly with such speed toward the trap, drawn both by the bait and the light, that they do not pause to fly around the light but hit the oil with a plop. As more in-



Designed by U. S. Entomologist

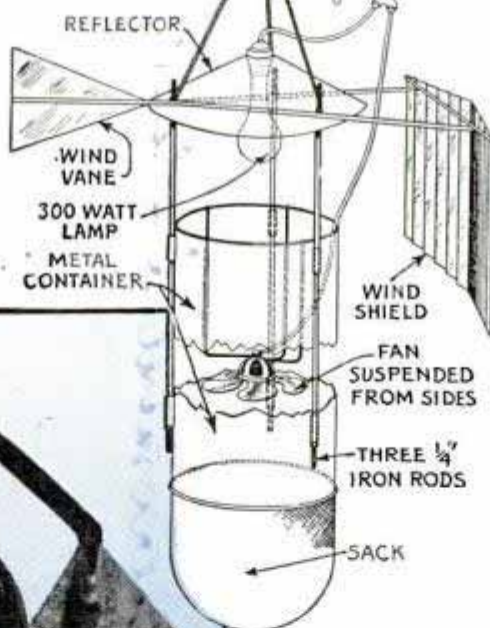

Above, latest type of electric-ray insect killer being used to rid the dog of fleas. The rays do not harm the animal. The device is called Leray

sects are trapped their weight takes them to the bottom of the pan.

A pale-blue light is used to attract the grape leaf hoppers. Population counts have shown only seventy-eight hoppers per vine in a light-trap protected vineyard with 1,280 per vine in an unprotected area.

A typical six-acre vineyard produced sixty-three tons of which fifty-eight tons were number one and sold at sixteen

dollars a ton or four dollars a ton higher than that from neighboring vineyards which received usual insecticidal treatments. No other method of control was used. The annual operating cost was fifteen dollars. In previous years the cost of treating the vineyard with oil-pyrethrum and cyanogas amounted to as much as \$100.

One pale-blue light to the acre is netting returns to the tomato grower by destroying insects, eliminating costs of insecticides and resulting in better tomatoes.

"Because of the humid, even tempera-

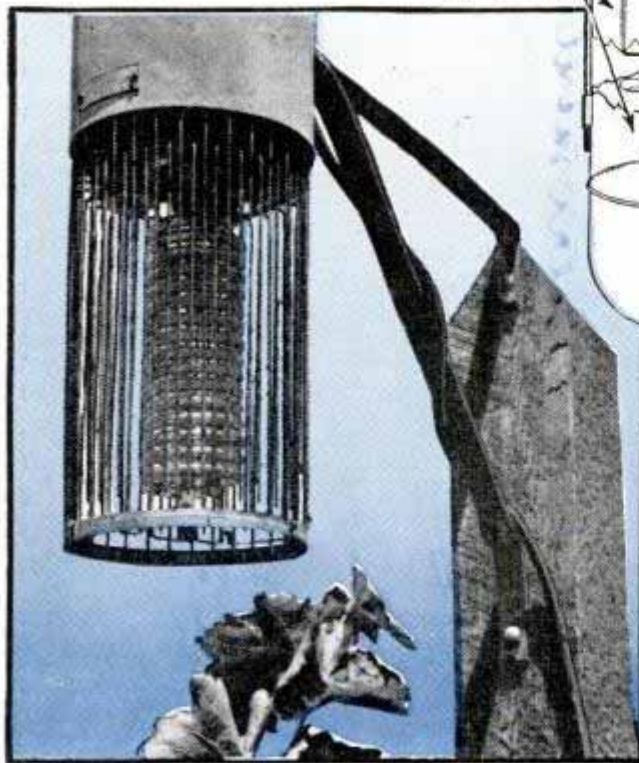

Center, combined light and suction-fan trap for gnats. Bottom, colored-light electrocutor

(Continued to page 118A)

Le Ray Corp. 2-30-30 Park Ave. New York
agent - Albert M. ...

iron streams out six feet behind the shoe. Under the heat and the strain, the car wheels change their shapes. Transverse cracks, starting so fine that a microscope is needed to detect them, also appear and grow until one-third of the wheel may drop off like a chip.

121024

Cherry Crop Saved by Fruit Drier

By drying the raindrops from cherries while they are still on the tree, one grower has been able to save a large portion of his crop which might have been lost through cracking of the fruit. This occurs during warm, sunny days immediately following heavy rains. Drying off the fruit was accomplished by means of a truck on which are mounted two airplane propellers driven by gasoline engines. The blowers are operated as the truck is driven back and forth between rows of the cherry trees.



Airplane propellers mounted on rear of truck provide blast to dry off the fruit

Clyde Harris

100-Ton Locomotive Swung from Loading Dock to Ship

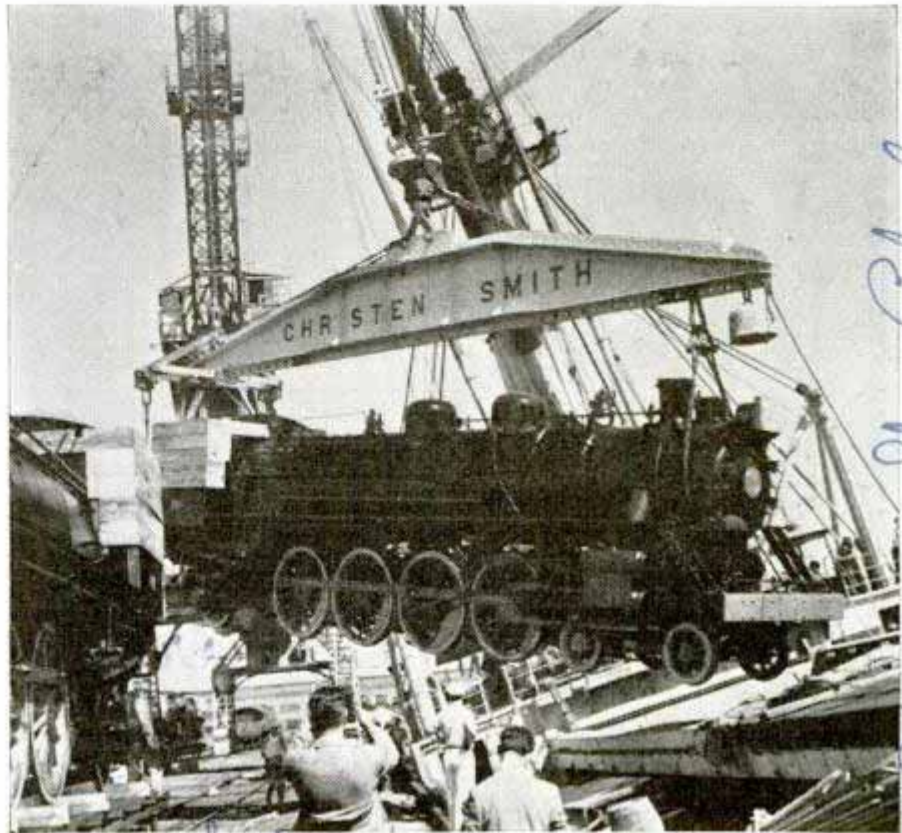

Big locomotive being swung aboard ship. Modern hoisting equipment can handle tremendous loads

Swinging a 100-ton locomotive aboard a ship is not too big a job for the loading hoists and cranes of today. At Eddystone, Pa., recently, a locomotive of this size and weight was lifted easily aboard a vessel for shipment to the Chilean state railways. It was one of seven of these big engines manufactured by the Baldwin Locomotive Works on the same order. Work on the locomotives, all of the mountain type, was rushed to completion in less than twenty weeks.

121049

Bushel Basket on Roller Stand for Self-Service Stores

Adaptable for self-service shopping or for display of merchandise, a four-wheeled "buggy" carrying a bushel basket has been put on the market. By dropping the handles it can be converted into a food display stand.



Metwood Mfg Co

123 Broad St. Chula

Rockford Ill

Speedboat Shaped Like Wing of an Airplane

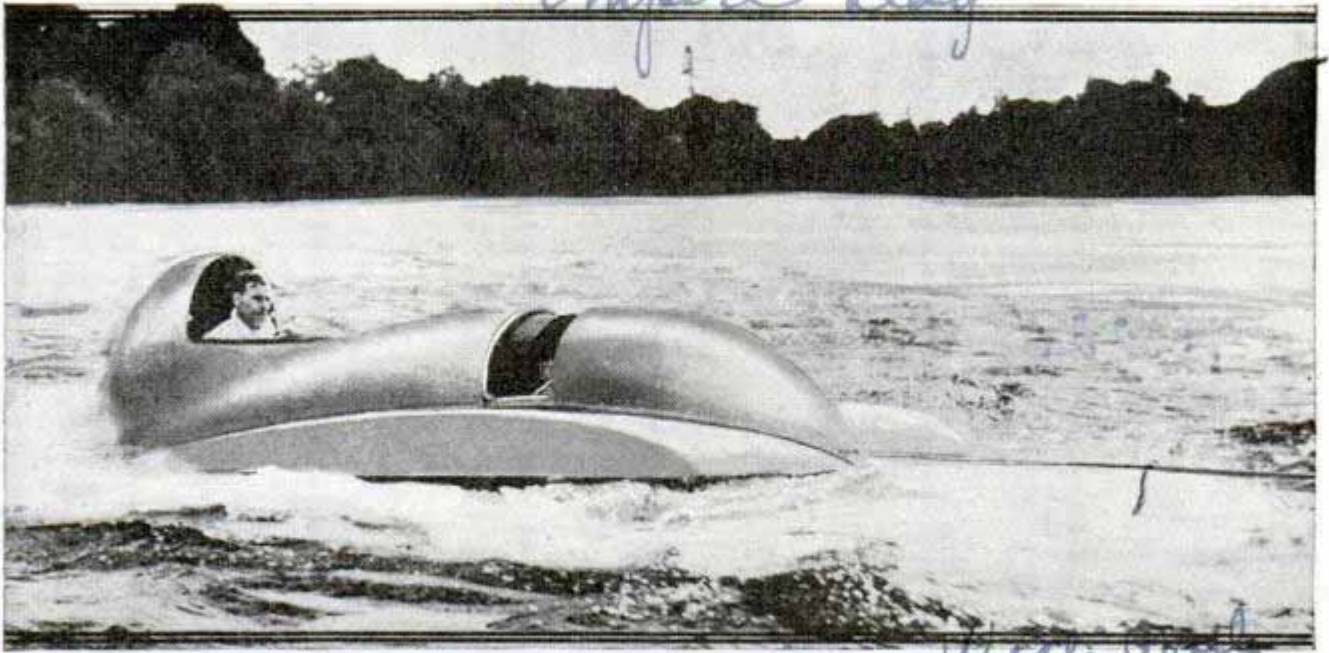

Speedboat being towed out for a test run. Note resemblance of its shape to an airplane wing. It was designed in accordance with ideas of the late "Lawrence of Arabia"

Shaped like an airplane wing, a speedboat designed by an English engineer in accordance with the ideas of the late T. E. Lawrence ("Lawrence of Arabia") has been undergoing tests on Lake Winder-

mere. The craft cost \$40,000. On its design, Lawrence had based plans for shoals of power-driven torpedo gnats which he claimed would be able to wipe out an enemy fleet completely within a week.

Crane Lifts Big Elephant Out of Twenty-Five Foot Moat

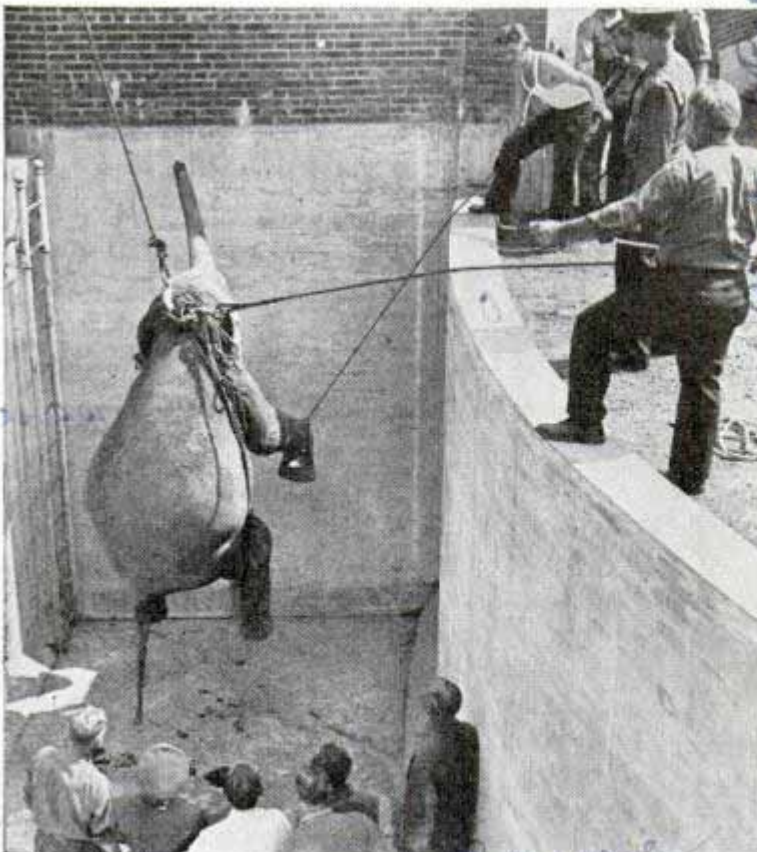

Big elephant being hoisted out of twenty-five foot moat

When a 3,000-pound elephant fell into a twenty-five foot cement-lined moat at the Brooklyn zoo recently, an emergency crew with a big crane was called. A sling was improvised and placed about the elephant, which had been unable to stand. Then the crane hoisted the animal out of the moat and back into the yard, from which it had been pushed while playing with another elephant.

Streamline Rods for Rigging Help Win Sailboat Races

Streamline rod rigging was tried out on several sailboats during the recent yachting season and racing skippers are convinced that they add speed by reducing wind resistance. Replacing the conventional steel cable, these streamline rods resemble the struts used on airplanes before internal bracing

121020

Empire Day

W. E. Wood

Edward Spurr

Bradford Guy

121020

Crane

121093

Acme

Lucius Danice

became general. They add perhaps a tenth of a knot to the sailboat's speed, and this may gain a quarter to a half mile in a race lasting several hours. There is less stretching of the rigging than when cables are used, and a single adjustment of the rod rigging may suffice for the entire sailing season. Drag of the streamline rod rigging ranges between one-eighth and one-third that of cable.

Dummy Locomotive Fools Enemy Aviators

Thousands of dollars have been wasted by Japanese pilots attempting to bomb Chinese locomotives and airplanes on the ground. Many of the bombs destroyed nothing more valuable than wood and reed decoys fashioned like railroad engines and planes. One dummy locomotive, which closely resembled a real engine, was found recently at Kiukiang, ready to fool the enemy pilots.

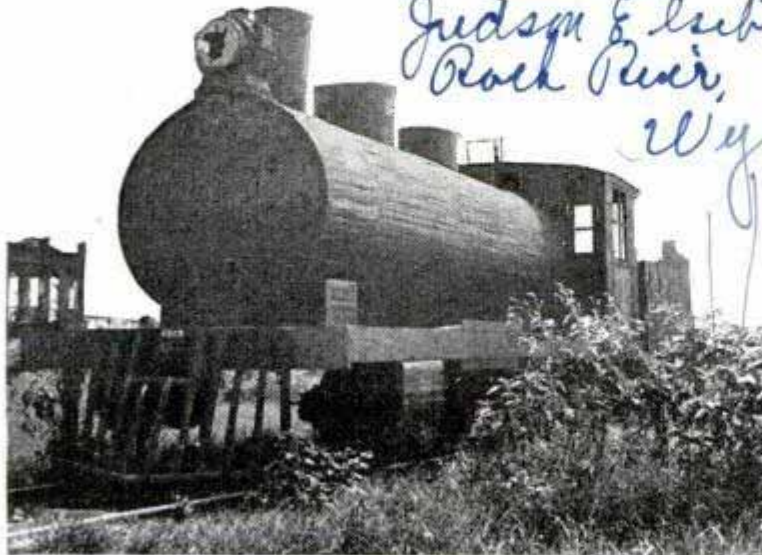

From the air this dummy locomotive looks like the real thing to enemy aviators, so they waste bombs

Firecracker Guns Rid Farm of Bird and Animal Raiders

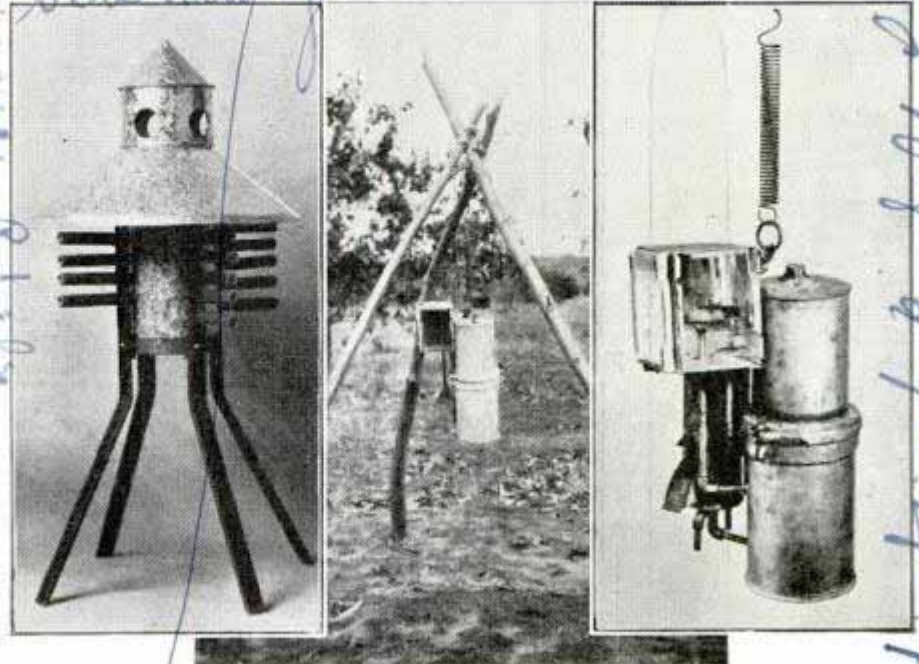

Left, "machine gun" that explodes firecrackers at regular intervals to frighten birds. Center and right, carbide lamp sets off bright flashes

Out where coyotes raid the sheep and where deer and other animals and birds make themselves nuisances in the fruit orchards, ranchers protect their crops with automatic flashers and firecracker guns. The old-fashioned scarecrow is of no use against animal pests. Something more frightening is needed. One invention, designed to chase coyotes away from the lambs, is a machine gun that explodes firecrackers at regular intervals. Radiating from its central iron cylinder are barrels housing firecrackers, each with a fuse extending into the cylinder. At the center is a "filler" made like a slow-burning roman candle, which sets off a firecracker every fifteen or twenty minutes as it burns down, and itself flashes a flare periodically. Another type, used often in orchards where deer nibble at the bark and birds attack the fruit, consists of a tank dribbling water on carbide. This generates acetylene gas to keep a pilot light burning, and at the same time fills a combustion chamber with a mixture of air and acetylene gas which is periodically exploded with a bright flash. The action is automatic and requires only a daily filling of carbide and water. The apparatus is hung from a spring and jumps violently after each explosion, adding to the frightening effect.

Handwritten notes:
 became general...
 1034
 Dummy Locomotive
 Fools Enemy
 Aviators
 Thousands of dollars
 have been wasted
 by Japanese pilots
 attempting to bomb
 Chinese locomotives
 and airplanes on the
 ground. Many of the
 bombs destroyed
 nothing more valuable
 than wood and reed
 decoys fashioned like
 railroad engines and
 planes. One dummy
 locomotive, which
 closely resembled a
 real engine, was
 found recently at
 Kiukiang, ready to
 fool the enemy pilots.

Handwritten notes:
 847
 Firecracker Guns
 Rid Farm of Bird
 and Animal Raiders
 Left, "machine gun"
 that explodes
 firecrackers at
 regular intervals
 to frighten birds.
 Center and right,
 carbide lamp sets
 off bright flashes

Handwritten notes:
 Judson & Leitch
 Rock River,
 Wyo

Handwritten notes:
 From the air this
 dummy locomotive
 looks like the real
 thing to enemy
 aviators, so they
 waste bombs

Handwritten notes:
 Patd. \$ 5.00 and

5,000-Year "Time Capsule" to Preserve Modern History

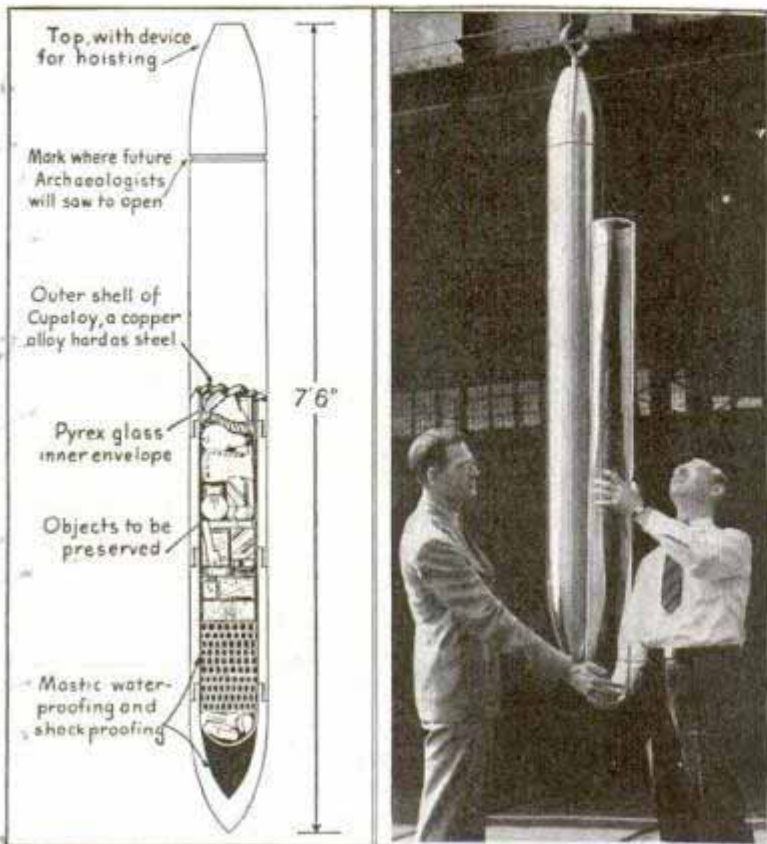

Left, diagram of the "Time Capsule." Right, the capsule and history-preserving inner tube of glass

Constructed of a special material to preserve for 5,000 years a tangible record of life of today, a "time capsule" has been deposited fifty feet in the earth beneath the Westinghouse exhibit building at the New York World's Fair of 1939. The metal envelope, weighing 800 pounds, contains the formula for Cupaloy, the copper alloy of which it is made, as well as items representing a cross-section of this age. These items were placed in a six-foot inner crypt of heat-resistant glass, the air was evacuated and replaced by an inert gas to act as a preservative. After being sealed, the glass tube was wrapped with glass tape and embedded in a waterproof compound before being placed in metal capsule, which was also sealed tightly. The alloy of which the envelope is made is the result of a five-year research by Westinghouse scientists to make copper as hard as steel. It is a heat-treatable material composed of copper, chromium and a small amount of silver. The investigators found that the silver added to copper and chromium helped to strengthen the basic metal. They believe that the completed capsule

will resist the corrosion effect of sea water seeping through the foundation soil of New York during the next 5,000 years. One pointed out that copper is quite resistant to the attack of sea-water seepage because the products of initial corrosion tend to accumulate and protect the underlying metal. Scientists think the presence of chromium in the alloy may increase the protective quality of this film.

Sea Scorpion Tests Vision with Colored Glasses

Glasses for fish? The picture is evidence that it's being done. However, it's not to help fish recognize a baited hook, nor is it from any kindness-to-animals motive that the sea scorpion was fitted with glasses. German scientists are studying the vision of animals, their reaction to colors, their lack of perspective and ability to see in darkness. Many fish react to the color of their environs by changing their own skin color. The sea scorpion was fitted with colored goggles to test the impressions made by various colors.

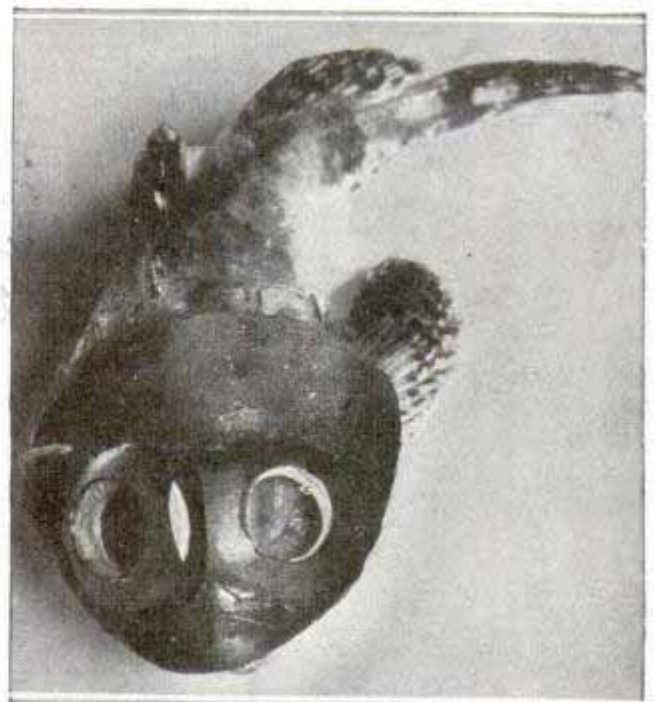

© Weltrundschau
Posing for its picture is a sea scorpion wearing glasses to test its reaction to color

*Prof. Dr. H. H. S. Müller
Hamburg*

Fireproof Liner Embodies Latest Safety Aids

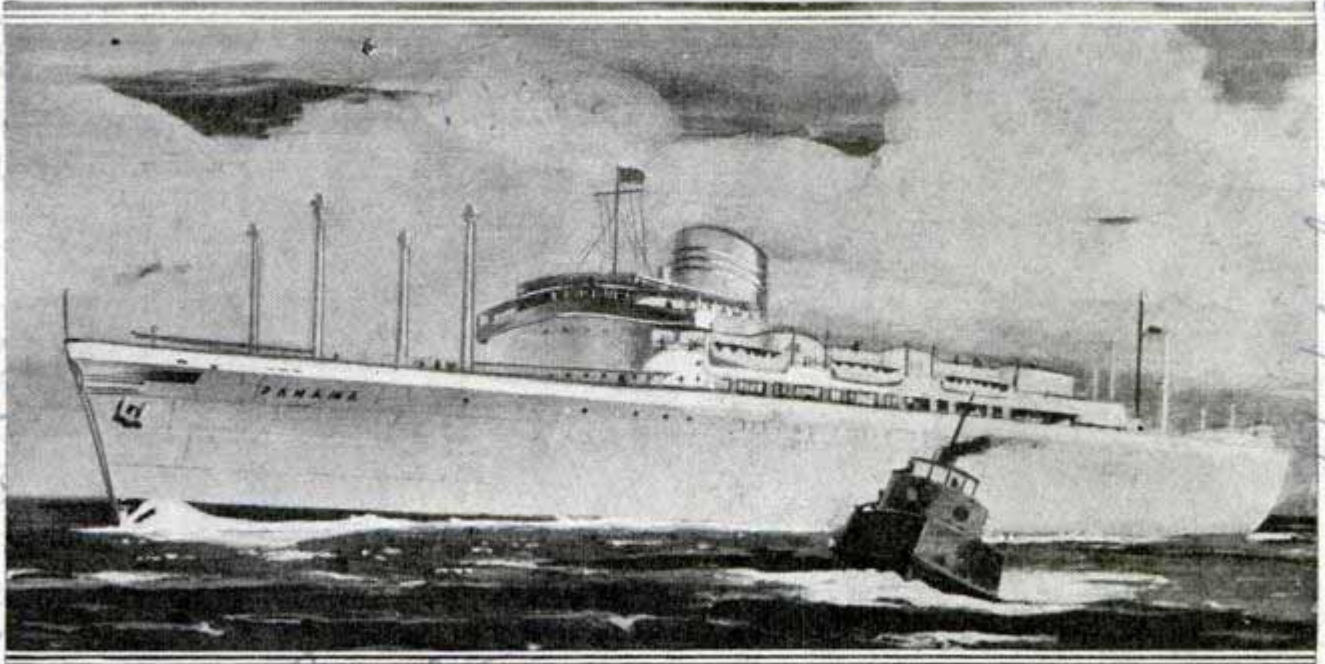

Artist's conception of the "Panama," modern cargo and passenger vessel which is the first of three ships being built for use of the government-operated Panama railroad. The "Panama" has been launched

Equipped with the most modern safety appliances, a fireproof passenger and cargo ship has been launched for use of the Panama railroad. The railroad is owned by the United States government and is operated in connection with the maintenance

and operation of the Panama Canal. A painting of the new ship, which will carry 206 first-class passengers and a crew of 130, shows how the craft will look on the high seas. The ship is the first of three being built for the Panama railroad.

Midget Air-Pressure Engine Is Built by a Watchmaker

Operating on two or three pounds of air, a midget three-cylinder engine has been built by a watchmaker. It is complete with counterbalanced crankshaft, two camshafts, pistons, connecting rods, valves,

valve springs, timing gears and other essentials of a four-cycle engine. The cylinder bore is slightly less than five millimeters. Timing gears, made from watch parts, are held to the camshafts and crankshaft by watch screws. The cylinder head is removable. Bearing caps on both main and connecting rods are removable, but it requires watchmaker's instruments.

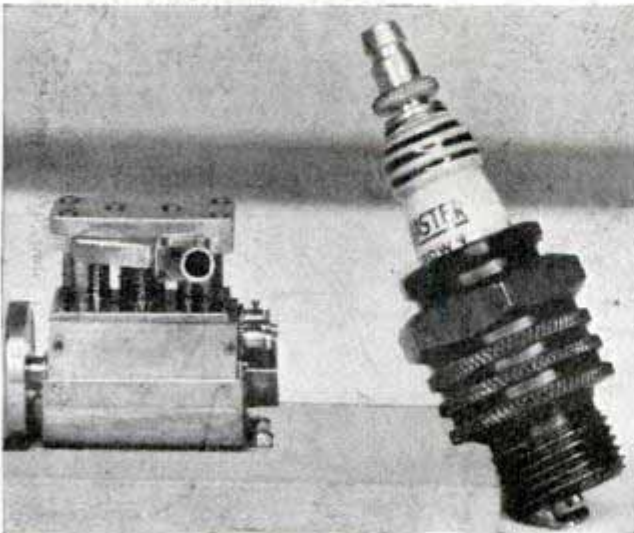

This photograph gives an idea of the diminutive size of the air-pressure engine a watchmaker built

"Crab" Tricycle Gear on Plane Helps Takeoff in Cross Wind

Tomorrow's airport may have but one long runway on which a "crab-geared" airplane will roll for a takeoff, its wheels headed straight down the lane while its nose points into the cross wind. An English designer is working on such a tricycle landing gear, with wheels that can be turned at an angle to the plane itself so that the thrust of the propeller could compensate for the side winds.

DeLichem Shipbuilding Corp.
 Quincy, Mass.
 10/30/38
 Science Service

H. S. Barnhart
 247

C. J. McGarvey

Army's Quick-Firing Rifle Has Automatic Ejector



New army rifle holds eight cartridges, gas from explosion automatically throwing out empty shell

Its automatic ejector makes the new U. S. army rifle fire five times as fast as the weapons now in use. The thirty-caliber gun holds eight cartridges. The hand-operated bolt of the old type army rifle is eliminated. Instead, the rifle is fired merely by pulling the trigger; gas from the explosion immediately ejects the empty cartridge and throws another in place.

Radio Sends SOS Automatically After Crash of Plane

Radio engineers have developed an automatic transmitter that will broadcast "SOS" continually for as long as three days after an airplane crashes, solving the problem of locating a fallen plane in a wilderness region. The two-tube transmitter is turned on by a pendulum whenever a jolt occurs strong enough to throw the pendulum forward into a position where it

locks. It would be mounted in the tail of the plane, protected by asbestos and other insulation against fire and shock. A signal light informs the pilot if the pendulum is tripped by a hard but safe landing.

Coiled Electric Appliance Cord

Coiled wire for electric appliances, just being introduced, has a spring-like recoil that keeps it always out of the way. The wire stretches to considerable length without tangling in the electric iron or other appliance.



Meter Shows If Wall Is Dry Before Paint Is Applied

Painters may determine if a newly plastered wall is sufficiently dry to retain paint by using a battery-operated meter now on the market. The device indicates surface and sub-surface moisture of the wall. It also may be used by paperhangers to find whether the wall will retain the paper.

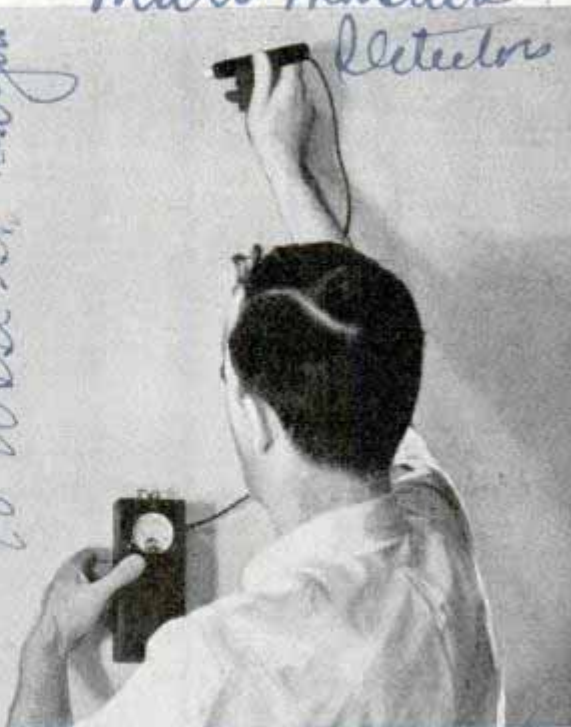

Testing freshly plastered wall with battery-operated meter to determine whether it is thoroughly dry

#1052

Argonauts... of Hull at Chicago

#1094

#1031

R. D. Colby, Beverly Hills, Calif.

Anthony Easton, English scientist

William J. DeLambert, 90 West St. N.Y.C.

Science Service 10/2/38

#1023. Casman Kodak Co
Rochester, N.Y.

Make Your **SNAPSHOTS** TELL *a* **STORY**



A BOY bends over the skeleton of his newest airplane model, fitting into place a slim, feather-light skewer of balsa wood. Light from the table lamp gleams on his curly hair; his eyes are intent and his lips pursed in concentration.

He is completely absorbed in his task—quite oblivious as his father, in the shadows of the basement workshop, focuses a miniature camera and clicks the shutter.

This will be a good picture, no matter who views it. The maker knows it will be good—although he may not know precisely why. The picture will have appeal because it “tells a story.” Not a complicated story, with an involved plot, but a simple one—really just the suggestion of a boy’s dreams, his pride in neat craftsmanship, his hope of building a better and swifter



Light, activity and figures in these story-telling pictures all are directed at center of interest



airplane than any of his friends can build.

Tomorrow, this same camera may go outdoors in search of other stories. Guided by its owner, it may snap a snowball fight, a spill from a sled, or even the tracks of birds and rabbits in fresh snow. And, if each of these subjects is approached from a "story-telling" angle, all will yield good pictures.

There is no mystery about getting good "story" pictures. It isn't a matter of finding subjects—for almost any detail of everyday life is good subject matter. The secret is in choosing a simple picture idea or theme, then taking your picture in such fashion that the theme is presented clearly.

The snapshot of the boy and his model airplane is a good example. It shows a situation concretely and effectively, and leaves out details that might confuse or obscure the central idea. The test of such a picture is: can you give it an imaginative, general title? In this case, such a title might be "Dreamer" or "Wings,"—and if the title obviously fits, the story is well told.

Telling stories in pictures is easy, and anyone can do it. Some picture-takers seem to know how instinctively, the first time they pick up a camera. Others need practice and experiment, but the more pictures they take, the more rapidly they learn.

When you take a picture, there are several factors that determine the result. One is your distance from the subject. By varying this, you can include just the material that your picture-story requires, and exclude details that are not part of the story. Composition in enlargements can

In the ski scene a story is told without even including the actual persons in the picture. At the left is a good example of a short sequence, the Christmas tree providing a background theme and holding the group together

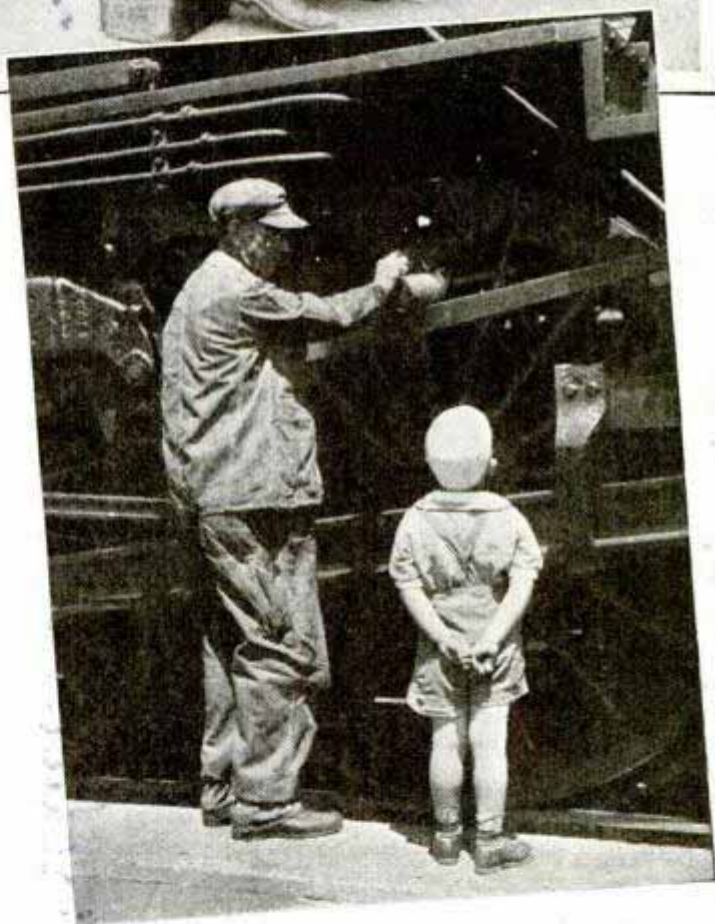

be improved by washing part of the negative.

Another factor is your viewpoint—high or low, to the left or right. By changing this, you can often bring out important details more clearly. Some stories can be told better with the camera low and tilted up; some, with the camera high and tilted down; others with the camera level. In the picture of the boy and his airplane model, the best viewpoint would probably be obtained with the camera a foot or two higher than the table level, so all the airplane skeleton shows clearly.

A third important factor is the lighting of the subject. As a rule, significant details of the story should be brightly illuminated, while unimportant details can be in shadow. This concentrates the picture interest, and it applies especially to indoor pictures, as remarkable effects can be obtained by changing the position and angle of photoflood lights.

Perhaps the most important point of all in a "story" picture is choosing the right moment. Try to catch subjects when their facial expressions are best "in key" with the story idea. If there is action of any sort, shoot when it is clearly outlined—so that anybody who looks at your snapshots

Sign on door, above, completes a tale that would be just a dog snapshot without it. You can almost hear the Gettysburg yarn being told at right. Scene below hints at boy's longing to be an engineer

can tell at a glance just what is going on.

In brief—keep the essential story simple, tell it clearly, and exclude everything that does not assist the effect you want.

Most story pictures include people doing something. Such action—real or suggested—is essential in these pictures, and the

(Continued to page 136A)

Camera Inside a Football Films View from Air



© RKO-Radio Pictures

Balsa wood container, shaped like football, is shown open to reveal camera

Wonder what the stadium looks like to the football sailing through the air? You'll soon know. For a novel sequence in a football picture filmed in the Rose Bowl by RKO-Radio Pictures, a sixteen-millimeter movie camera was fitted inside a football made of balsa wood. The lens looked out from a window in the end of the imitation ball. As the player forward-passed the football, a release spring started the camera grinding, and a panoramic view of the field and the players was recorded until the ball came to rest in the receiver's arms.

Four-in-One Flight Instrument

Aiming at simplification of the problems of flying and landing by instrument, the Sperry Gyroscope company is developing an airplane dial that combines in one the artificial horizon, directional gyro, turn indicator and altimeter. On this single dial the pilot can read all the information nec-

essary for route flying or landing. It will be adapted to use in connection with any of the ground beam systems by which the pilot is led "blind" down a glide path to the airport runway. The various readings appear in a standard pattern on the luminous screen of a cathode-ray tube.

Two-Wheel Cart for Hunters Hauls Game on Trail

Toting a full-grown buck home over a mountain trail is a backbreaking job for any hunter—but the backbreaking part can be eliminated. An Oregon sportsman has invented a knock-down cart that resembles a wheelbarrow. Dismantled and packed, it is light and easy to carry. When the hunt is over, the game can be loaded between the wheels and pushed over rough trails, for the wheels are independent of each other and the raising or lowering of either handle compensates for uneven surface.

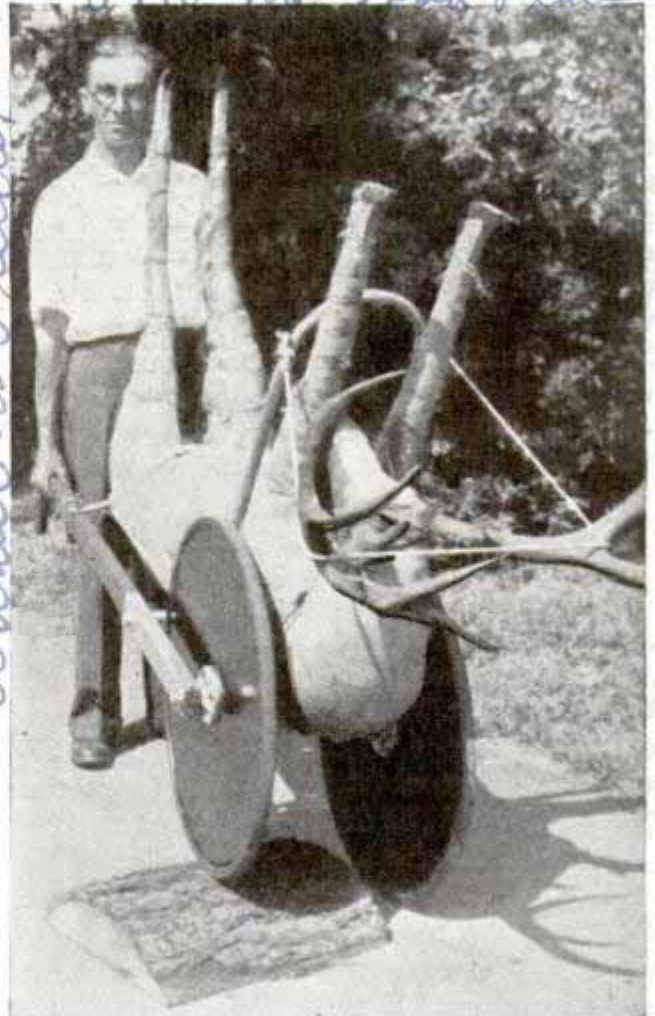

Small, lightweight cart eliminates necessity of hunter packing game long distances

*Designed by Russell Mettley
Camiciamant
RKO Picture*

*5410 N. 3rd Place
Portland*

12/11/11

Flight Day

Sperry Gyro. N.Y.

"Go-Back" Dummy Trains Football Tacklers

Football players are trained to tackle properly with the aid of a "go-back" dummy mounted on wheels. The device provides resistance to the tackle, but is not fixed rigidly to the ground, assuring the coach that none of his men will be injured while it is in use. The dummy figure is supported by a padded arm extending vertically and then horizontally.

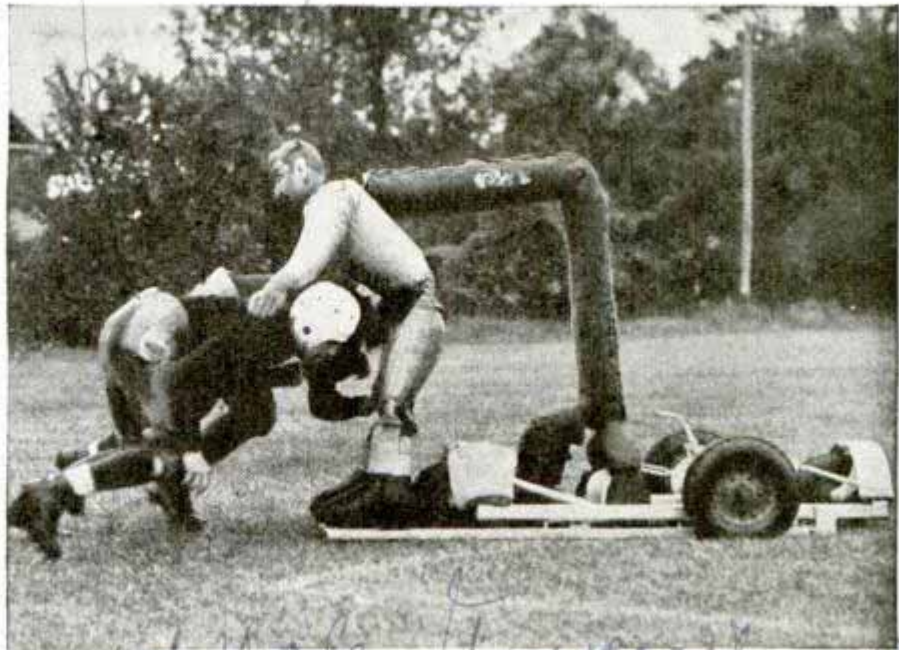

Right, player tackling the dummy. Note wheels on which the apparatus is mounted

Floating "Flatiron" Wins Title of Speedboat Champion



Here is the flatiron-shaped speedboat skimming along the surface in record-breaking Gold Cup races recently.

Resembling an animated flatiron as it skimmed over the Detroit river, the Italian hydroplane "Alagi" roared to a triple triumph in the Gold Cup race of 1938 and established itself as champion speedboat of North America. Piloted by Count Theo Rossi of Turin, the little red-and-black speedster won all three of the thirty-mile heats at better than a mile-a-minute clip.

Snap Frame for Projecting Miniature Film Does Away with Taping

Projection of miniature films on the screen is simplified by the use of a ready-made frame that holds the negative between glass. A spring arrangement holds the glass tight, and in less than a second the picture can be snapped into the frame ready to project. Binding tape is eliminated. The film can be left in the frame permanently or quickly removed to make way for another. Once snapped into the frame, the film cannot slip or twist.

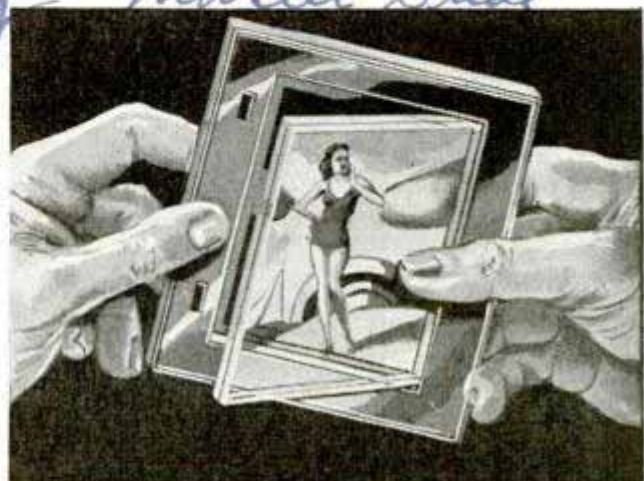

Right, frame into which two glass plates containing negative can be inserted quickly

Handwritten notes:
 at Yale University.
 De Montelera
 Kaiko Photo Products, Brooklyn
 22 West 11th St

H1043

570-Foot Memorial Shaft Marks Freeing of Texas

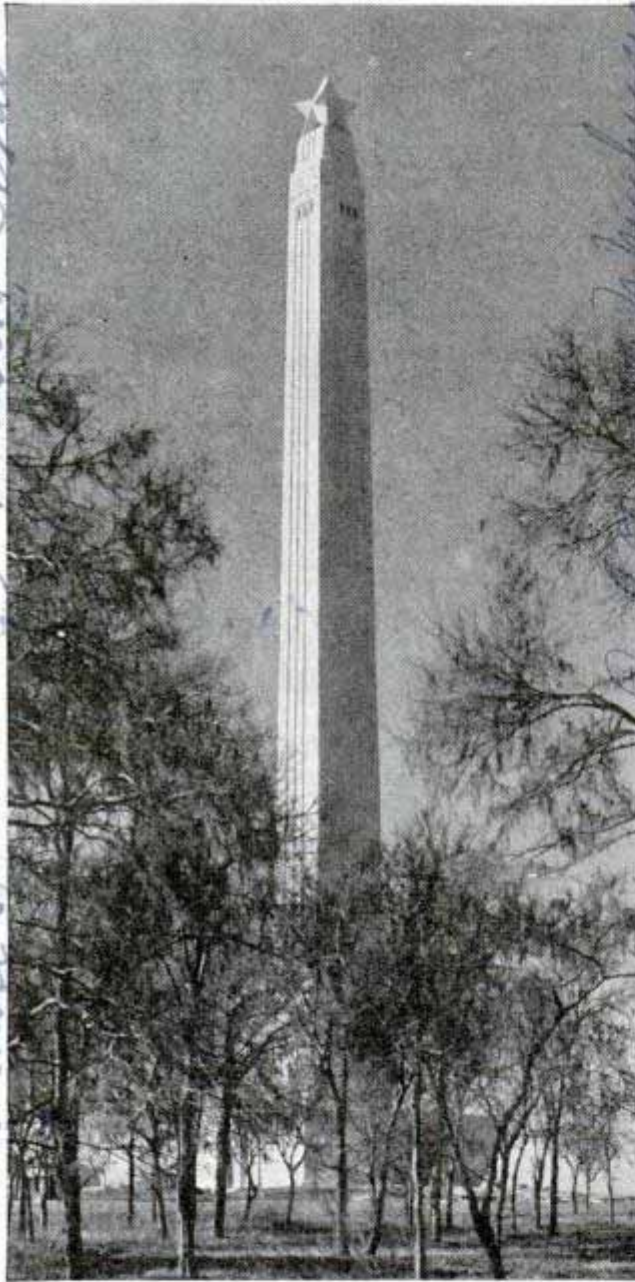

Lofty memorial shaft on historic battlefield.
Note 220-ton star at the apex

Commemorating the successful struggle of General Sam Houston and his 800 men to free Texas from Mexico, a 570-foot shaft rises from the old battlefield of San Jacinto. The memorial is reinforced concrete faced with variegated golden buff Texas limestone. Polished limestone is used for the interior, rough sawn rock for the exterior. A huge star at the shaft's apex is thirty-five feet high, thirty-five feet across and weighs 220 tons. Statues of the state's heroic men and women, historical relics and art will be housed in the base building of the memorial. Fifteen feet loftier than the

Washington monument, the shaft is forty-seven feet square at the base, tapering to thirty feet at the top. Its total weight is 70,300,000 pounds. Eight hundred and fifty steps lead from the base of the shaft to the observation tower at the top.

Take Advice from Indian Guide If You Fall through Ice

Two deer hunters were resting on the shore of a snow-covered lake in northern Wisconsin one November day. It had been a hard, gameless tramp over frozen swamps and around lakes. Homeward around this lake would mean another three and one-half mile trek. A short cut across the ice would save time and effort. They were hungry. The ice looked solid. They started across the clean expanse. A quarter mile from the home shore came an ominous crack, a sudden cry and the leader plunged into the icy water. His warning was too late, and his companion broke through the same soft ice. Searchers followed their trail the next day and read the story of the tragedy in the ice. One man, laden with heavy clothing and gun, apparently had died of shock and gone down instantly, for the ice indicated there was no struggle to get out. The other was frozen solid into the surface ice, after making futile attempts to break off the thin ice with his hunting knife and reach a strong-

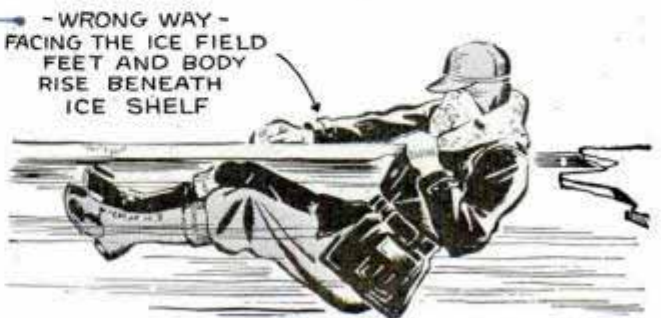

Your feet rise under ice shelf and trap you if you climb out forward. Here is right and wrong way

Comd. Jack J. Mc. Cully, Publisher, Chamber of Commerce, Houston, Texas

Com. W. S. Watson, Editor, Popular Mechanics

er surface. An Indian guide in the search party, in his comment on the unnecessary tragedy, gave a terse lesson to others who may plunge through treacherous ice in winter sports: "White man don't know how to get out of ice. Indian, he know how. White man grab ice with fingers. Feet go up under ice. It break off. Pretty soon he drown. Indian, he swim on back. His feet go up. He get head on ice. Then get shoulders on ice. If it breaks, Indian do it again and crawl up on back slow like snake. Pretty soon he get on big ice. Run, get warm, make fire. All hunky-dory." Remember that when you face the emergency. If you grasp a pier, the gunwale of a boat or an edge of ice while you face it, your feet tend to rise under the object. With your feet under the ice, you break off more and more, but remain trapped. Instead, swim to the ice edge backstroke, floating on the back, hunch head and shoulders over the edge until the supporting ice is strong enough. Then drag yourself up and get warm, as quickly as possible, with blankets, rubbing, warm drinks and dry clothing.

H 1054

Tractor in Guise of Locomotive Hauls Train of Trailers

Decked out with cowcatcher, "funnel" stack and cab to disguise it as an old-time railway locomotive, a farm tractor hauls passengers on a "scenic ride" through an Ohio summer resort park. The open passenger cars are built on standard tourist-trailer chassis. The small tractor can pull the two loaded cars at fifteen miles an hour.

Silver King tractor

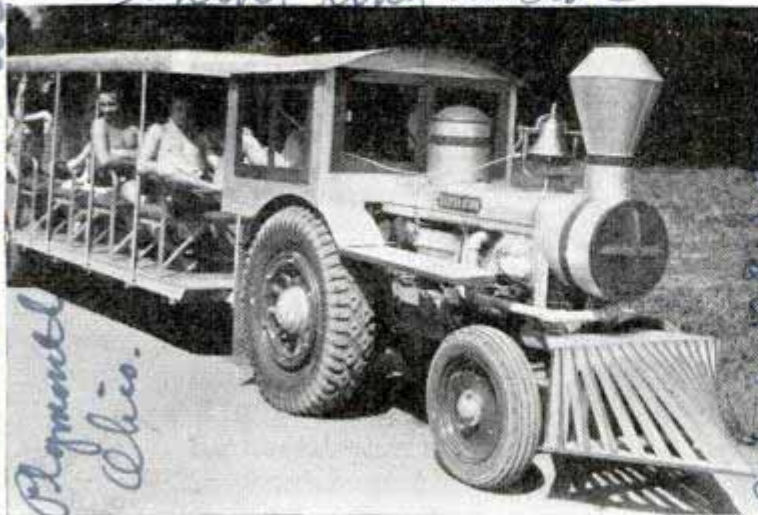

Farm tractor dressed up like an old-time iron horse attracts passengers to ride in open trailers through summer resort park

Rate - Prob. Heath
Plymouth
Ohio

cont. Ernest teifhay
211 2 4

Welder's Non-Fog Eyeshield Gives Wide Vision



Eyeshield for the welder is designed to prevent fogging. Here it is in raised position

Well ventilated to prevent fogging, a new wide vision, close-fitting eyeshield is available for blowtorch work, gas cutting, welding, overhead operations and general maintenance. A light, opaque, noninflammable Bakelite frame carries regulation welding lens of any shade and ventilated cover lens. It fits the face snugly. Fiber side shields provide further protection.

H 1033

Pilot Warned if Wheels Are Not Set to Land

Designed to prevent a pilot from landing when the wheels of his plane are not in position, a new signal automatically thumps the pilot to give warning. It consists of an auxiliary tread attached to the rudder and brake pedals. If the pilot tries to land with the wheels retracted, in flying position, an electrical circuit is closed, setting into operation a small solenoid motor that literally raps the soles of his feet.

Jackson Electro-Tool Co
 March Ave
 West Mt.
 1135
 1135
 Carpenter
 Dayton, Ohio
 and Harold
 W. Howard

W. Howard

Laurel Shuffler 1048
James Silver
Regional Director
James Silver

TRAILING *the*



Photos courtesy U. S. Bureau of Biological Survey

Federal deputy game wardens banding duck removed from trap in Chesapeake Bay. Left, illegal guns seized by wardens

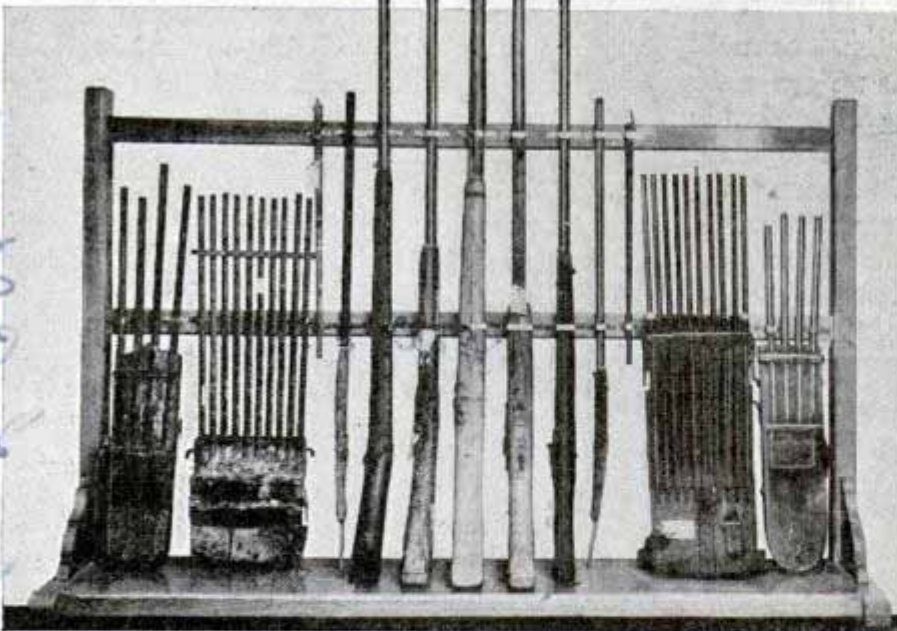

Smith Island
other stop and a second passenger left the car.

By now the first passenger in his thicket had finished his preparations. The big bundle unrolled into a sleeping bag on which he half reclined. A box at his right leaked dim rays of light as he occasionally snapped a switch. The hour hand on his watch crept round

THE moon was partly hidden and the big sedan slinking along the country road without lights, stayed in the shadow of a row of trees. It coasted to a stop beside a thicket, a passenger with a big bundle jumped out, and the car was on its way again. Fifteen minutes later there was an-

the dial and the night grew colder.

Then, so close at hand that the report startled him, a heavy gun boomed, followed half a minute later by a long fusillade as other guns joined in. The silent watcher turned to his box and picked up a mouthpiece.

Mr. Richards
Office of
Mr. Richards

2-27-54
Smith Island

Mr. Thomas S. D. Umson, Jr. 1/10/48.
10655 Hollywood Ave
Los Angeles, Calif

Wild Game POACHERS

"Hello, Biological Survey car. This is Conners. A duck drag is just starting, a quarter of a mile south of me. I'll walk in toward them and you can pick me up as you come along."

Turning off his short-wave transmitter, the federal game agent jumped up, un-snapping the holster of his revolver as he strode down the road. On this particular raid five duck bootleggers were captured. The blast of shotgun fire that had aroused the game agent had killed nearly 500 ducks which the bootleggers were gathering up just as the agents descended. Ten minutes after the firing the poachers would have been on their way and quick, silent action must be used to catch them. Sometimes pitched battles occur and officers have been killed or wounded in protecting wild game.

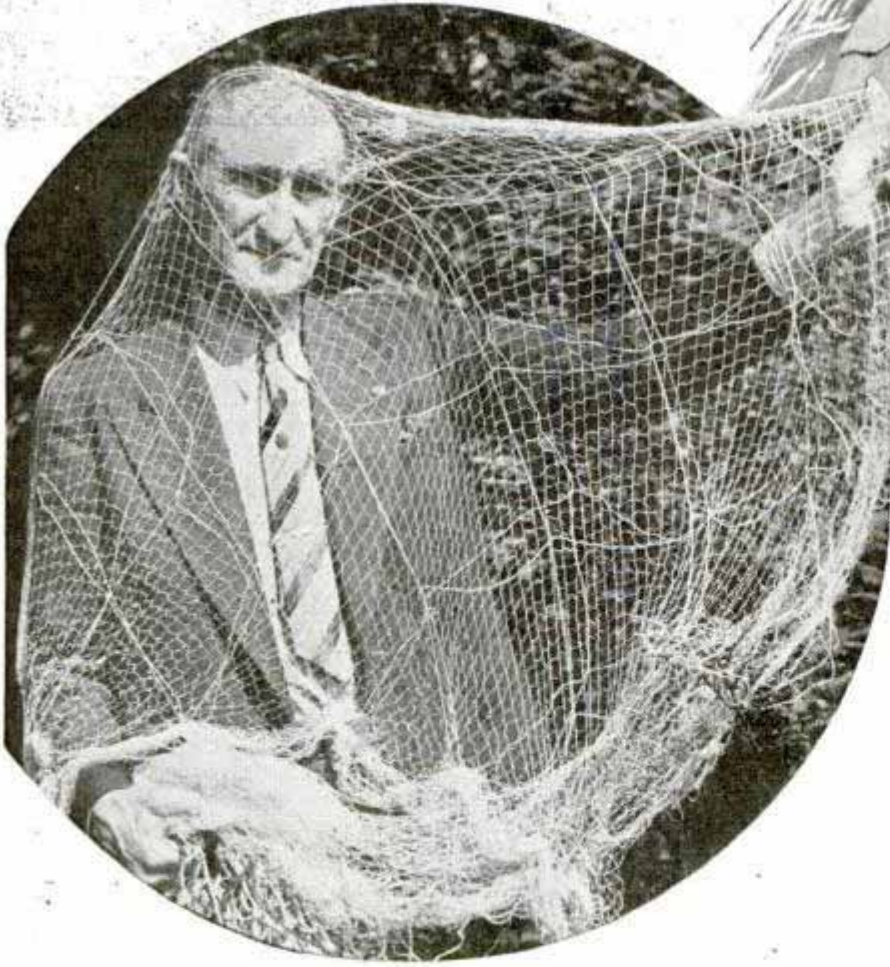

Mallards, pintails, widgeon and other ducks bring one dollar or more per bird in large cities and they are wholesaled under cover by rings that operate like bootleg liquor rings. Huge swivel guns and tremendous stationary shotguns mounted on rowboats, that kill from 150 to 500 birds per shot, were once the favorite weapons of the poachers but now automatic shotguns with extended magazines holding from eleven to twenty shells are used because they are easier to hide. Game agents may hold

Reference: W. E. Crouch, Chief, Division of Game Management, Bureau of Biological Survey

Fine linen bird net seized on its way from Europe to America. Top, game agent studying suspected poachers at long range

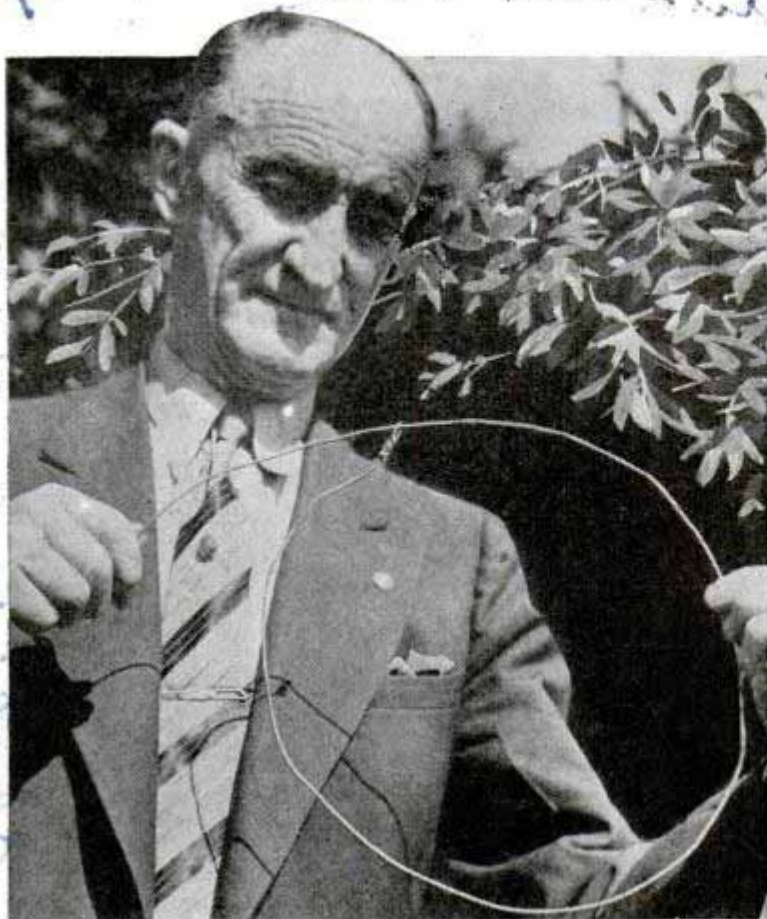

way of discouraging the poachers.

For a time duck poaching seemed on its way to becoming a big business. Now the activity has been stamped nearly out on the west coast and in the middle west and the federal agents are concentrating on the marshes of the eastern flyway where baited traps made of chicken wire capture forty or fifty birds each per night. Five hundred such traps were confiscated in a three-month period. On one week-end alone more than forty market hunters in Arkansas, Mississippi and Tennessee were rounded up, many being old offenders who sold direct to hotels and restaurants which

(Continued to page 143A)

night-long vigils for weeks without hearing a shot but ultimately they catch the poachers that are destroying the game.

Wild game of every kind, from mocking birds to mountain sheep, is the prey of the poachers. Unchecked, they could easily destroy all the wild life in the country. Moose have been killed illegally in Alaska merely for dog food. Elk have been destroyed in Washington simply for the two teeth per head that are prized as emblems. Game agents of the Biological Survey and the deputies of the fish and game commissions of the different states work hand in hand against the poaching rings. Skins have been shipped as far away as China in efforts to dodge the law and agents have trailed their men clear across the United States in making captures. Stiff fines and jail sentences seem to be the only



Lower photos courtesy U. S. Bureau of Biological Survey

Top, game deputy with heavy wire snare which had been placed in deer runway. Bottom, duck found by game wardens in steel trap. Right, releasing duck which had been trapped

Handwritten notes in blue ink:
 141048
 Clean message
 mark
 Virgin
 James
 Rubin

H 1046
 215 Market St. San Francisco, Calif.
Old Tires Sweep Up Stalks in Sugar-Cane Field

In the sugar-cane fields of Hawaii a new use has been found for old automobile tires. Split in half and given "teeth" by deep notches, the tires are mounted behind a farm tractor in such a way that they are self-rotating when dragged across the field. Thus each pair of tires, driven over the dead leaves and stalks of cane, sweeps this refuse into windrows where it is easily collected for final disposition. One man, operating the two-row "sweeper," can clean up ten acres in a day.



Right, sweeping sugar-cane refuse into windrows with the aid of old tires. This sweeper handles ten acres per day

H 1088
Fish "Planted" by Parachute Cans Dropped from Plane



Lower left, parachute and can of fish being tossed from plane in lake planting test

Thousands of young fish are being "planted" by airplane in experiments to determine whether this method may be used to stock isolated mountain lakes. The fish are placed in tin cans to which parachutes are attached. As the plane speeds over the lake or other body of water at about 1,000 feet, the cans are pushed overboard. The parachute gently lowers the cans to the water. Fish planted in this manner have not been noticeably affected by the plane and parachute ride.

H 1082
Truss Expands Auto Piston to Stop Oil Pumping

Designed to reduce piston slap and oil pumping, a new piston truss pushes against the side of the piston, causing it to expand against the cylinder wall. It is possible to expand the piston as much as .04 inch without breaking it.

A take examine Dept

Piston Truss Co.
 Pacific Idaho

Roll-Up Door of Tool Chest Is Out of Way When Open

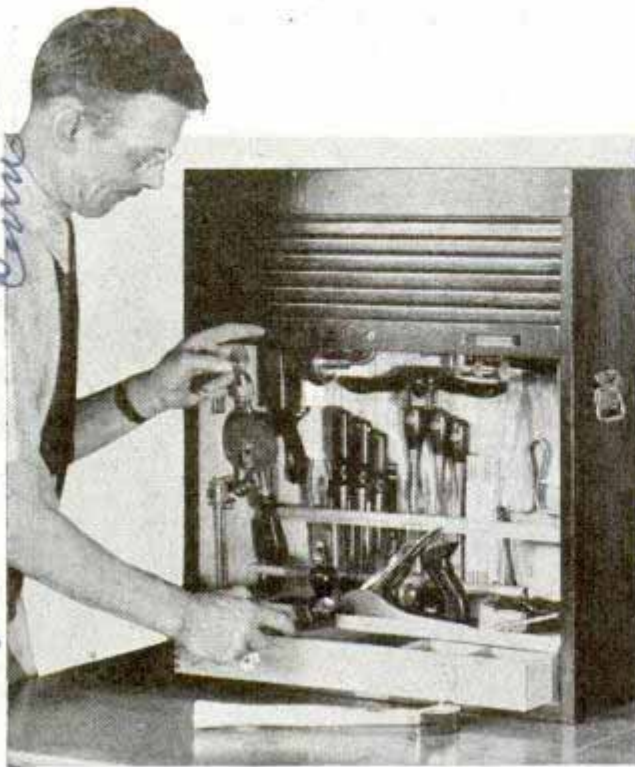

This tool chest has no swinging doors to obstruct the worktable. It is like a roll-top desk

Built with a roll-up front that operates like a roll-top desk, a tool chest with thirty-three woodworking implements is on the market. There are no doors in the way of work when the chest is open, the front sliding easily up and down, and locking.

Rubber-Tube Expansion Shield Anchors Bolt in Masonry

For anchoring bolts or screws firmly in masonry, metal or other construction materials, a rubber expansion shield has been developed. It consists of a rubber tube containing an expanding metal core. As the bolt or screw cuts its own threads in

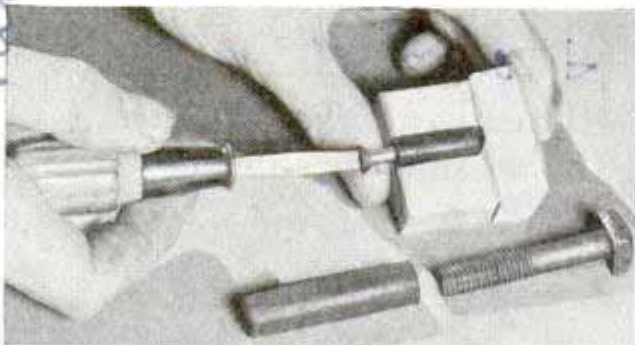

When screw is driven in, rubber tube and metal core expand and grip sides of hole

the metal, it causes both core and rubber to expand, the rubber filling all the space in the hole and gripping the sides firmly. It acts, too, as a seal against gases, water and other liquids.

Bombarding Foe with Noises Latest War Weapon

War may become a battle of sounds, as well as of bullets and bombs. A system for bombarding the ears of the enemy with all the horrible noises of the battlefield has been patented by a French citizen. It consists of playing phonograph records through a loudspeaker network to create a terrific din.

Welded Casing in Deep Oil Well Is Found Practical

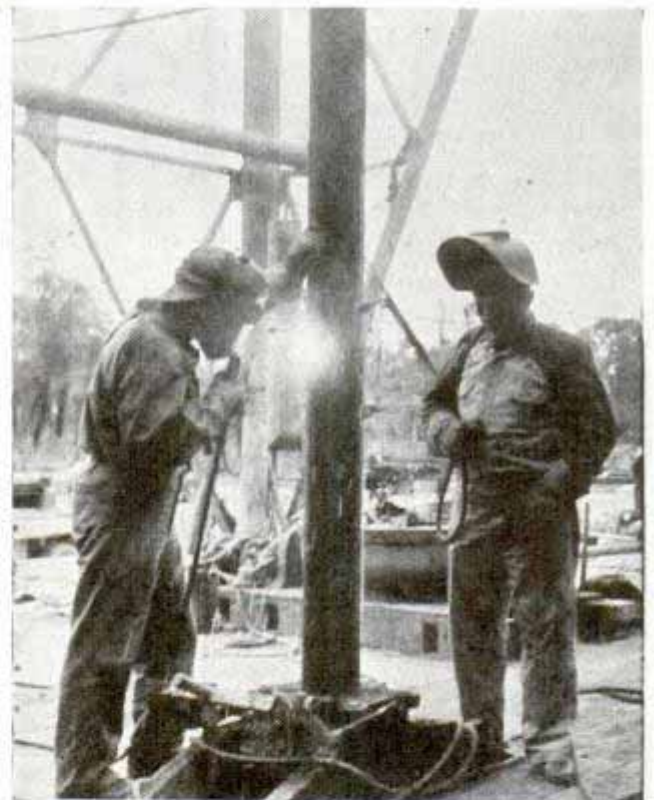

Electric arc welders at work on casing as it is sunk in deep oil well

Once considered impractical for deep oil wells, an electric arc-welded casing was used recently in place of threaded couplings, at a considerable saving in labor and first cost of material. The casing, the welds on which were made on the derrick floor as the steel pipe was sunk, was put into a 8,100-foot well in Oklahoma. The finished welds provided joints of extreme-

Stanley Tools, 19.5 Lake H. New Britain

Leland H. Adams 450 Ex 1092 Chicago

maxime wage

41014 11/3

Linnoli Electric Co 13810 East Grand

ly high strength, a fact demonstrated by building up pump pressure to 1,200 pounds and allowing it to stand for forty-five minutes. At the close of the period, the pressure had not diminished, indicating the work was a success.

H 10 30

Torch Removes the Paint from Wood or Canvas

Removal of paint from wood, metal or canvas without burning is claimed for a new air-acetylene torch. The burner works on reeds, fluted columns and flat surfaces. By changing the direction in which the torch is held, the width of the flame may be varied from one-half inch to three inches, so that paint is easily removed from grooves without scorching or injuring adjacent surfaces. The flame is of even, high temperature throughout. Holding the burner at the proper distance from the surface heats the paint evenly to the correct temperature. Boat owners find the burner handy in removing paint from wooden or metal hulls, canvas or wooden decks, cabin roofs or canopies. Paint can be taken off canvas without removing the prime coat or filling, and without melting or loosening the marine glue with which the canvas is fastened to a wooden surface.

Pres. O. Litz 0-6115 Paul Buener

Keyhole Door at Playground Keeps Out Larger Children



Unless the child is small enough to pass through the keyhole, he or she is barred from the playground

Older and larger children are kept out of a Boston, Mass., playground by a keyhole door which admits only those youngsters small enough to pass through the opening in it. The door thus restricts use of the playground to small children, for whom it was planned.

Adhesive Tape of Elastic Cloth Lets Taped Finger Bend

To permit the taped finger or other injured joint to bend naturally without stiffness, an elastic adhesive tape has just been developed. It is made of loosely



woven cloth of a color to render it inconspicuous, and is sold in a neat plastic container which could be carried in a purse.



Using acetylene torch to burn paint off boat. Inset, working on curved surface

Linde Air Product Smith and Nephew

Handwritten notes on the right margin: '5 n Wabach Chicago', 'St. Stephens Church', 'Linsplack', 'England and ...', 'H 10 40', 'E', 'Linsplack', 'Chicago'.

Rose Glasses on Chickens Reduce Fighting

Lifeguards



Here is a chicken fitted with rose-colored glasses which reduce fighting in flock

There was murder going on in a New Jersey penitentiary yard. The prison chickens were killing each other. One after another, the young White Leghorns would fight among themselves to the death. Nothing was effective in preventing the quarrels until the warden tried putting rose-colored glasses on the birds. That stopped the fighting instantly. The Leghorns, the only fighters in the poultry lot, now are all equipped with aluminum-framed spectacles, with center pieces extending in front of the bill.

Synthetic Fiber Better Than Silk in Strength and Elasticity

Finer, stronger and more elastic than natural silk or rayon, a new synthetic fiber has been developed by du Pont chemists. It is lustrous in appearance and can be drawn out to one-seventh the diameter of a real silk fiber. Because of its remarkable elasticity and recovery after being

stretched, the new fiber is expected to find use in stockings, gloves, sweaters and underwear. Larger filaments can be made into tough bristles, strings for musical instruments, fishline leaders, mohair and horsehair substitutes.

Rubber Guard on Trolley Wire Makes Mining Safer

Developed especially to protect the miner, a rubber guard for trolley wire has been introduced. It is made of cloth inserted sheet rubber which is cured in a permanent "U" shape. Placed on the trolley wire, it provides complete protection because the material flexes or bends in either direction. The feeder pole of mine vehicles slips through the guard easily. The exposed trolley wire has long been a danger to workmen. Even when the greatest care is taken to prevent body contact with the wire, there is always the possibility of serious injury or death occurring to a miner due to his touching the high-voltage cable with tools he may be carrying. Trolley guards of wood are subject to breakage and rapid deterioration.



Top, rubber guard protects miner's head. Below, trolley passes through guard easily.

1067
Illinois Laboratory
428 Meryck Boos
Synbrook, N.Y.
Western Hamina
101

deceased
1097
Devere & Evans
W. J. Woodrich Co
Apron White
North Caldwell, N.J.
101
101

E. I. du Pont de Nemours & Co.

A 1012 ... Montebello Calif

Reclaiming Ghost Gold Mines Is Profitable



Left, leaving the mine. Right, worker protected by dust mask. Bottom, at work in mine



Large quantities of gold have been taken recently from "ghost" mines reclaimed in the western part of the United States. At first reopened to provide a meager living for the workers, the once deserted mines have been found highly productive, yielding a nice profit. One of these mines is the famous old Tom Reed mine at Oatman, Ariz., where a newly discovered vein of gold is being worked. Latest methods of mining are being employed to speed up production and to safeguard the lives of the miners.

10 1069

Electric Coin Sorter Tests and Rejects Spurious Money

In a bank at Sydney, Australia, is a coin machine that does virtually everything except spend the money. Electrically driven, it sorts and counts, tests and bags the coins at the rate of \$5,000 worth an hour. Coins dumped into a tray are brushed into a hopper from which they are rapidly sorted into several receptacles, according to

their denomination, and each is tested for its worth as it passes to the bag. Registers show the total in each bag as it is filled. It takes one-fifteenth of a second to test and sort each coin. The bank has another coin machine which counts and wraps \$2,500 worth of pennies a day, a task that formerly required five men.

*Inv. R. J. Little
c/o Metal Products Ltd.*

80. Teaching ... Sydney, Australia

DOING SOMETHING

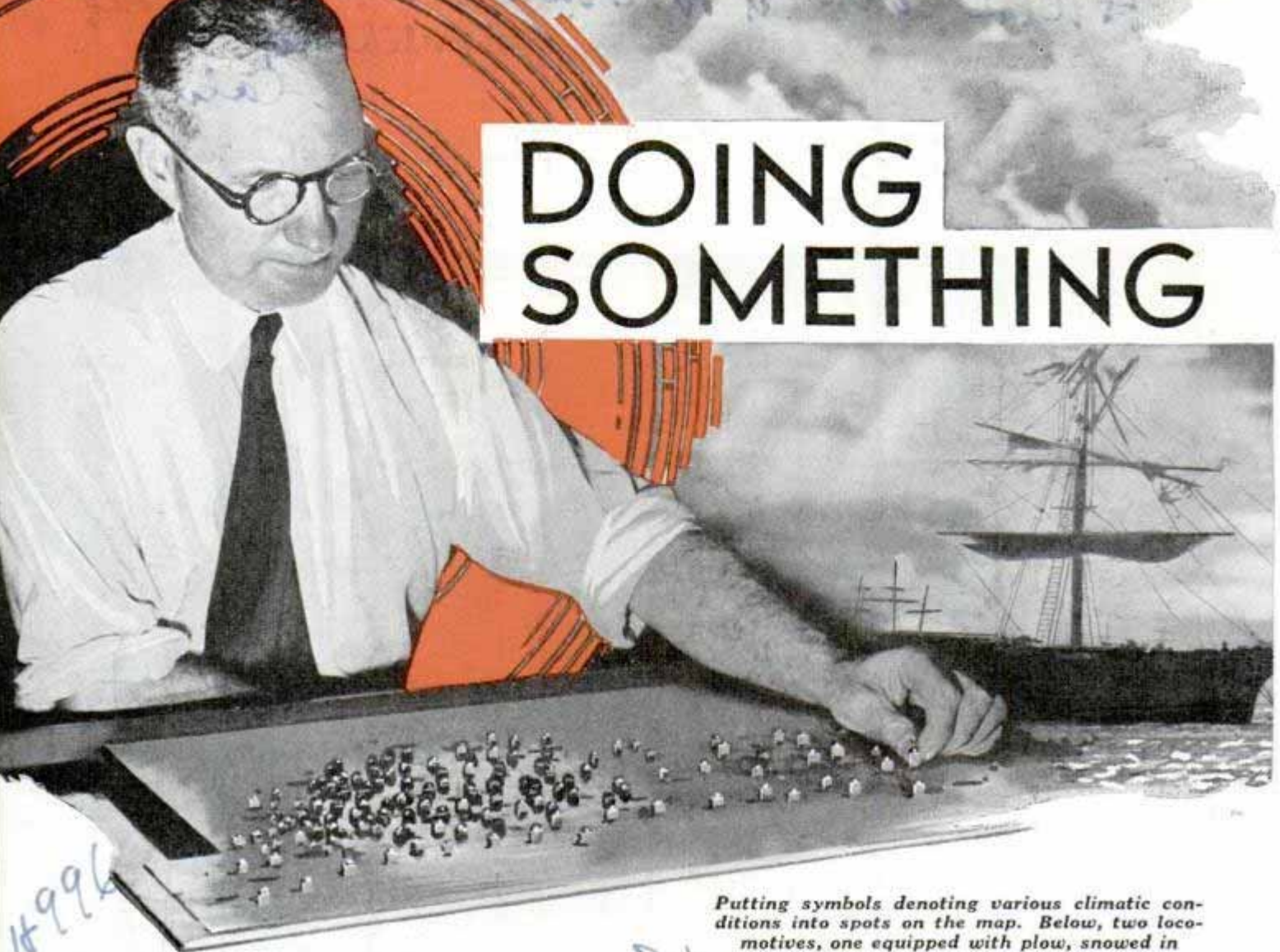

Putting symbols denoting various climatic conditions into spots on the map. Below, two locomotives, one equipped with plow, snowed in

MARK TWAIN said that everybody talks about the weather but nobody does anything about it. But back in 1931, a young meteorologist named Irving Krick decided he could do something about it. Backed by a research grant from the Rockefeller Foundation, he set out to improve methods of weather forecasting so they could be used commercially.

Despite the nation-wide service of the U. S. Weather Bureau, businessmen were not taking full advantage of it, largely because they didn't know how to apply the

forecasts in terms of their own individual needs. But since wartime, experts at the Geophysical Institute at Bergen, Norway, had been working on an "air-mass analysis" system, and here Krick went to learn details of the scheme. Then he traveled around the world visiting foreign weather observatories and gathering the best European ideas. In his laboratory at California Institute of Technology, he assembled his information and evolved a weather-forecasting system that was adopted by every major air line in the United States.

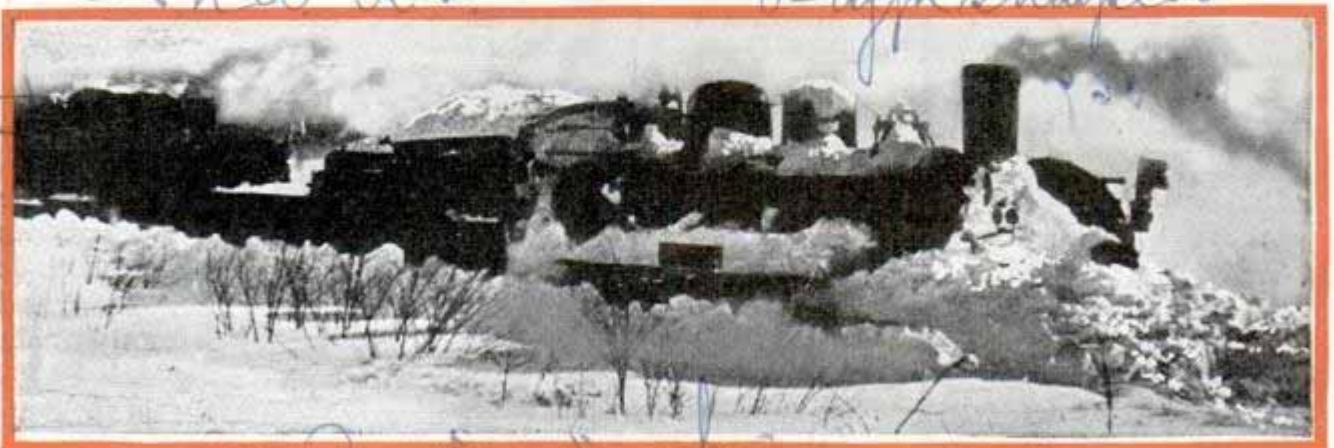

#996

Irving Krick
 meteorology Dept

Barometer

D-type snowplow

Hydro...
 ...

Capt. James M. Sweeney
481 W. 60th Terrace
Kansas City, Mo. H 9916

about the WEATHER

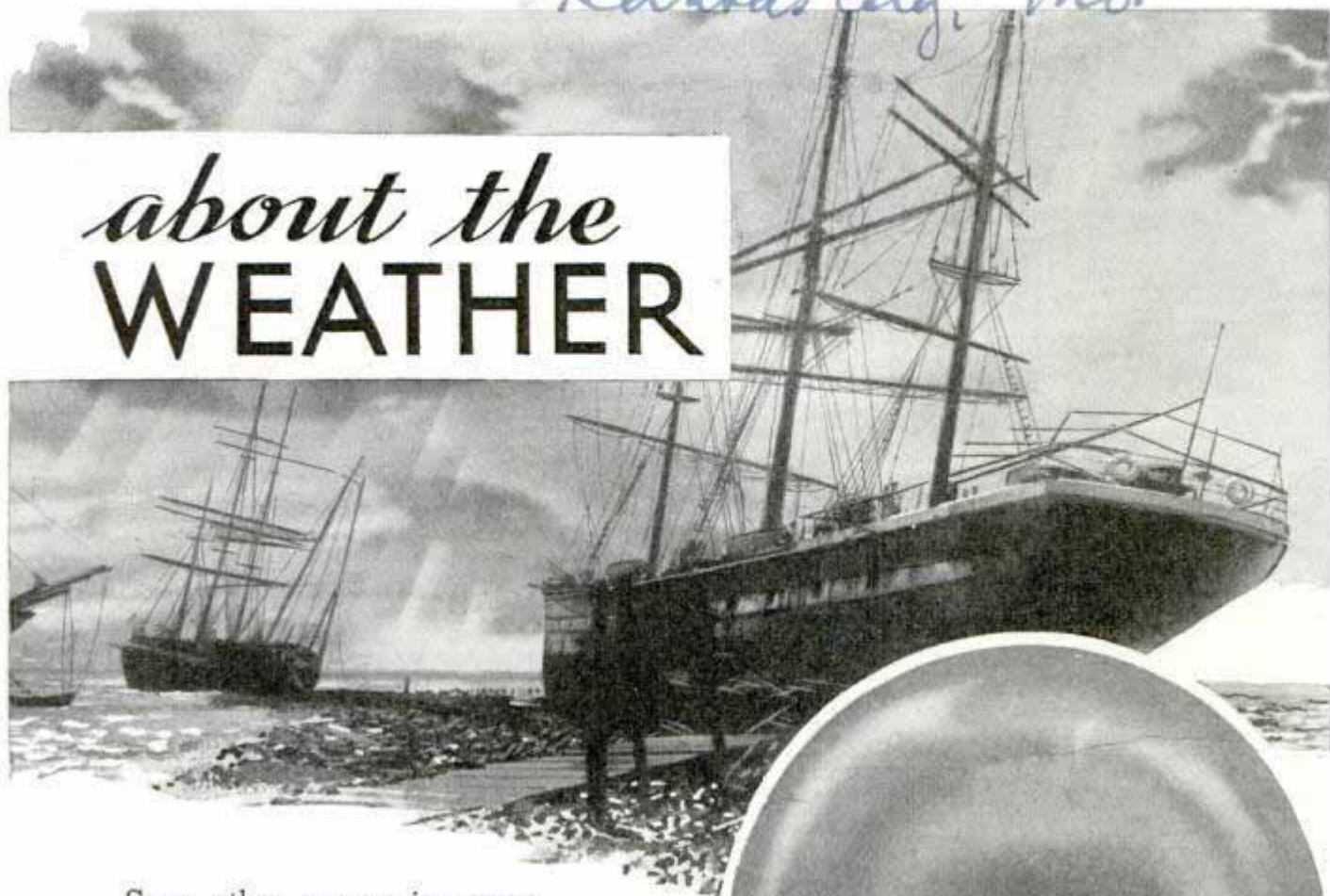

Soon other companies were wanting to know if Krick could tell them what the weather was going to be next week. Among them were the large movie studios. When it costs \$50,000 a day to set up for shooting, a run of bad weather that keeps high-salaried actors and crews idle can quickly run a picture into the red. So Krick began to issue special forecasts covering two or three days ahead. At



Top, ships blown aground by hurricane. Right, balloon and automatic radio transmitter. Left, closeup of the transmitter which flashes reports on weather conditions aloft

H 9916

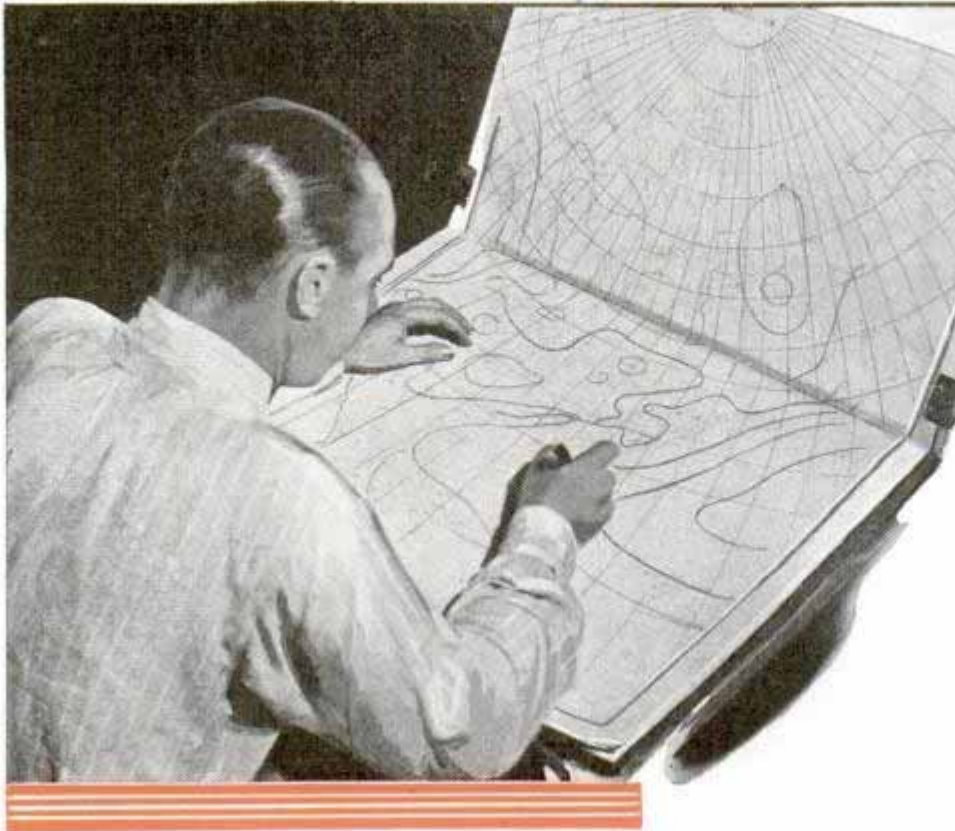

first, some conservative movie executives were skeptical, but after they had ignored warnings a few times they realized that the predictions were running up a much higher batting average than their own guesses.

For the picture, "Captains Courageous," Metro-Goldwyn-Mayer needed storm shots. A studio ship set sail with cameramen aboard, and Krick began to watch the maps for dirty weather. His radioed directions kept the skipper zigzagging from the Mexican coast to the Gulf of Alaska, chasing storms, but they led to plenty of action and saved months of aimless cruising.

By this time, dozens of commercial firms had heard about what Krick was doing and

they wanted the same service. Ordinary forecasts didn't tell them what they needed most to know: specific information as to exactly when the fog would lift at Point Loma, or how long the thermometer was going to stay above ninety degrees. Krick saw at once that he would have to learn each client's particular needs and fit the service to them.

A big soft-drink manufacturer asked how the service could help him, so Krick and his assistants carefully studied the effects of weather on the cash register. Correlating soft-drink sales with temperature changes, they determined exactly how much a given jump in the mercury would mean in thousands of bottles sold. Now the manufacturer knows in advance how many cases to ship to each territory when a hot spell is due.

Selling radiator anti-freeze compound is

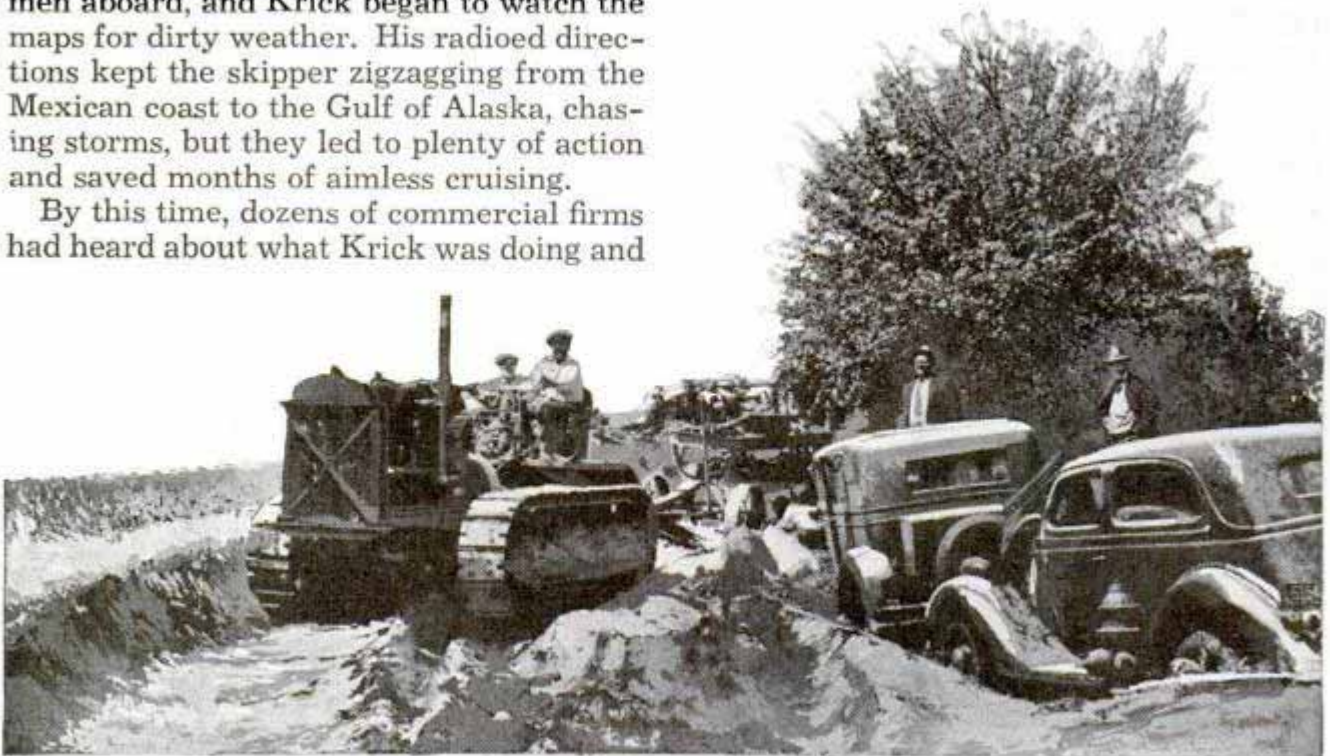

Top, making weather map at U. S. Weather Bureau. Bottom, snow-fighting equipment which was called out in midsummer to cope with drifts of hail that stalled traffic

Omaha May 1936

another temperature problem. A large chemical company gets warning of an impending cold snap far enough ahead to start shipments moving in that direction, so dealers will be well supplied when the freeze comes.

During the season when wheat from Texas to Minnesota begins to ripen and move to market, the grain market is a nervous, skittish affair, sensitive to every minor weather fluctuation. One big firm of speculators asked for regular warnings of hot spells five to seven days ahead, so as to anticipate market moves. Last summer, a rust scare boomed the grain market. Many

U.S. Weather Bureau

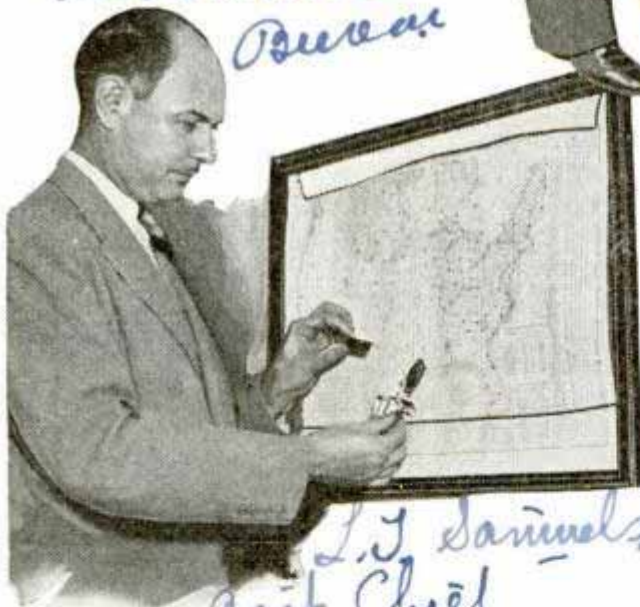

*L.J. Daniels
Asst. Chief
Aerological Div.*

experts kept advising people to buy wheat with the idea that it was going still higher. Unlike Krick, they didn't realize that long-run weather conditions were more favorable to a big crop, and that the rust scare was just a flurry. When wheat subsequently dropped fifteen cents a bushel, many speculators were wiped out—but those who had acted on Krick's warning saved their money.

In some industries, weather factors vary so that different service is needed from

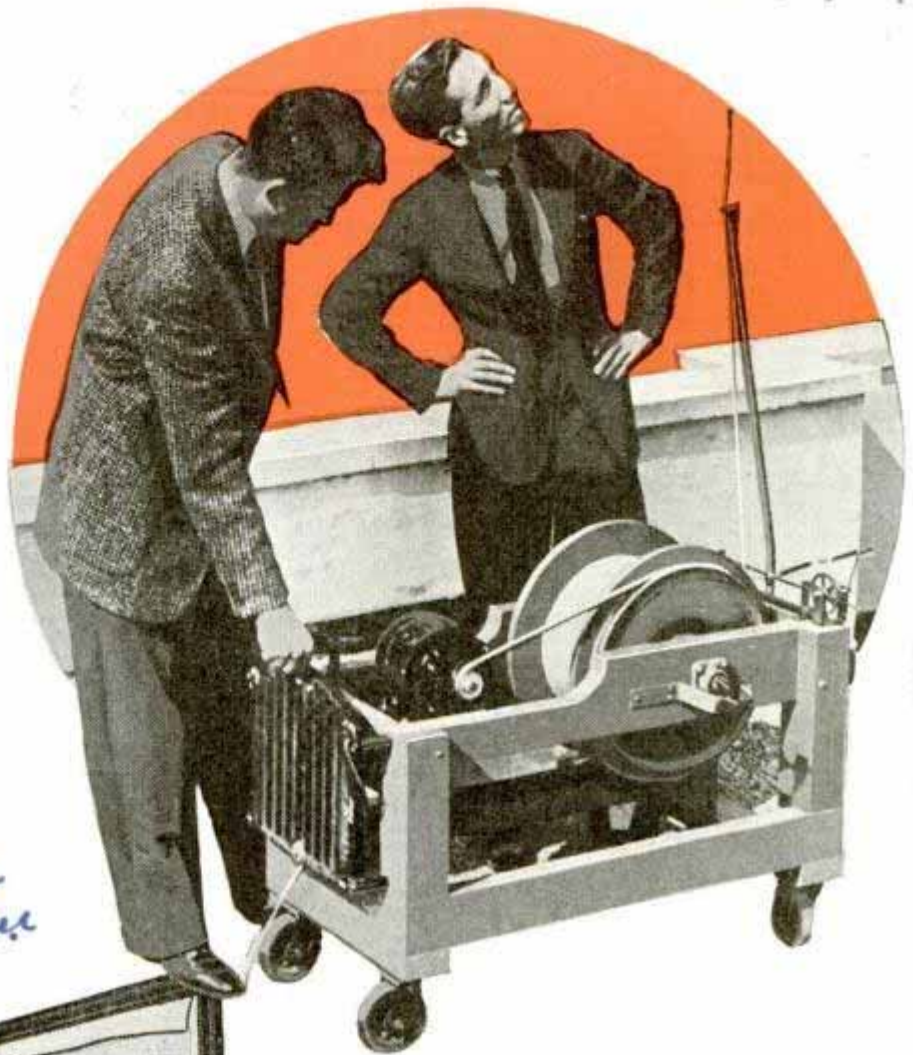

Above, motor-driven spool which controls balloon transmitter. Left, weather official holding meteorograph sent high in air to record data on violent tropical storms

month to month. In winter, orange growers need to know about minimum temperature so they can be ready to light their smudge pots when the thermometer drops to the danger level. In summer, maximum temperature and humidity are most important in governing the ripening of fruits, spraying and pest control.

Department stores find weather important in their operations. They consult the forecasts before scheduling a big sale and hiring additional help.

It's pretty hard to say exactly how much rain will fall at any given time, but air-mass analysis makes possible a close estimate of the probabilities. Recently a county fair asked for a special report advising how much rain insurance to carry. Krick's report not only foretold a favorable season, but also gave valuable clues as to how much popcorn, hot dogs, and pink lemonade would be wanted.

(Continued to page 120A)

"Mauretania"—Britain's New Ocean Queen

London: Electrotype Agency, Ltd. 23-24, Fleet St. London, E.C. 4. 1914

CROSS-SECTION OF THE NEW "MAURETANIA"
AT FRAME 76, LOOKING AFT

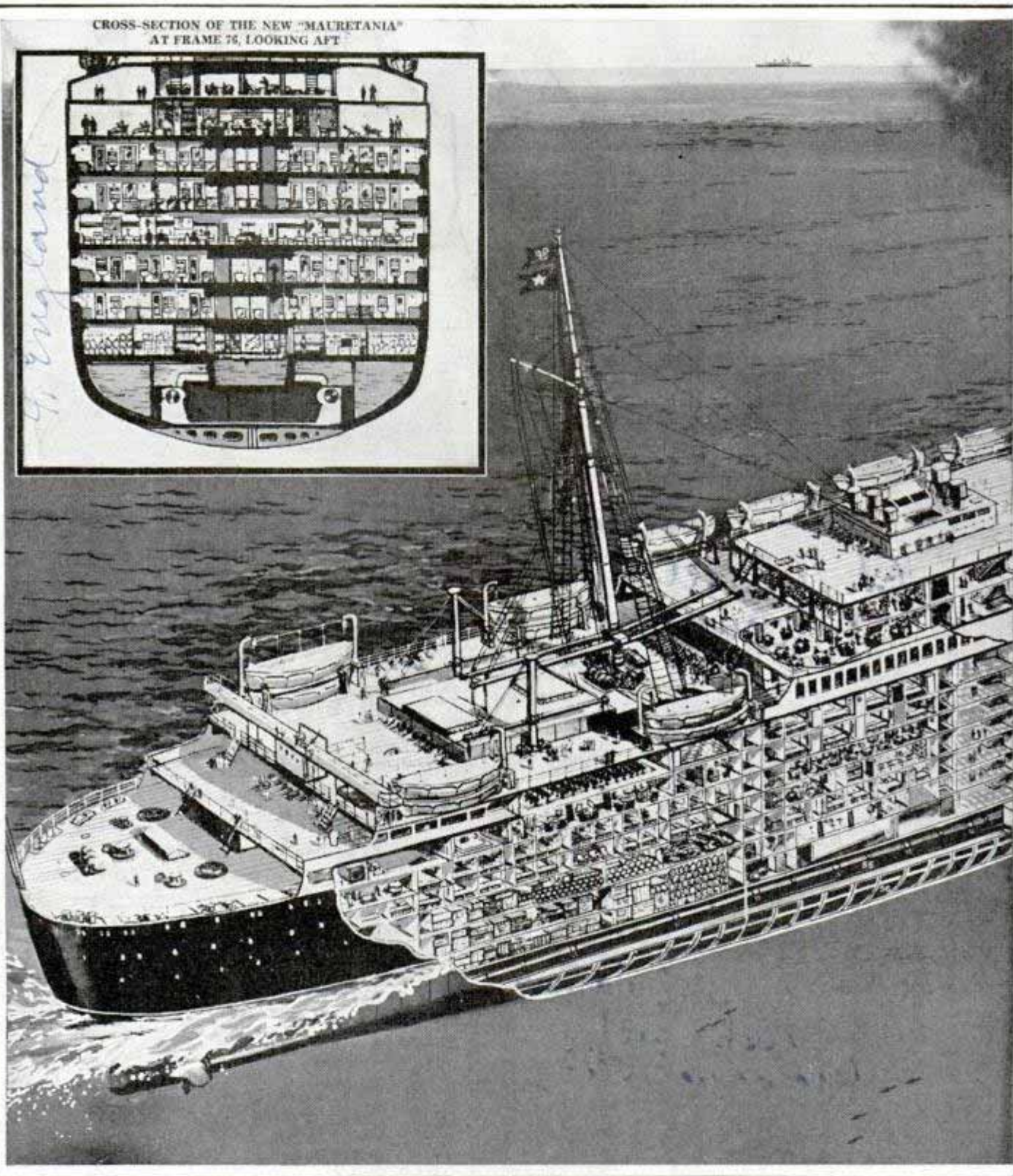
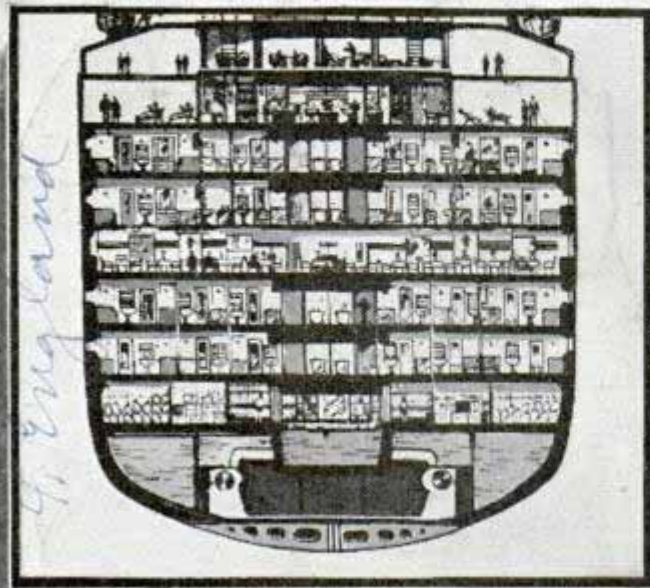

Designed to have more deck and cargo space than the old ship whose name she bears, the new "Mauretania" has been launched, the latest addition to England's fleet of ocean liners. Owing to efficiency of super-heated steam and modern boilers, which take up less than half the space that

would have been occupied by boilers had she been built in the days of the old "Mauretania," the new liner has but six boilers with super-heaters, in two stokeholds, to give her a speed of about twenty-two knots. Another feature is the provision of fans to supply air to the boiler and

H 999

Ventilators Removed to Give More Deck Space

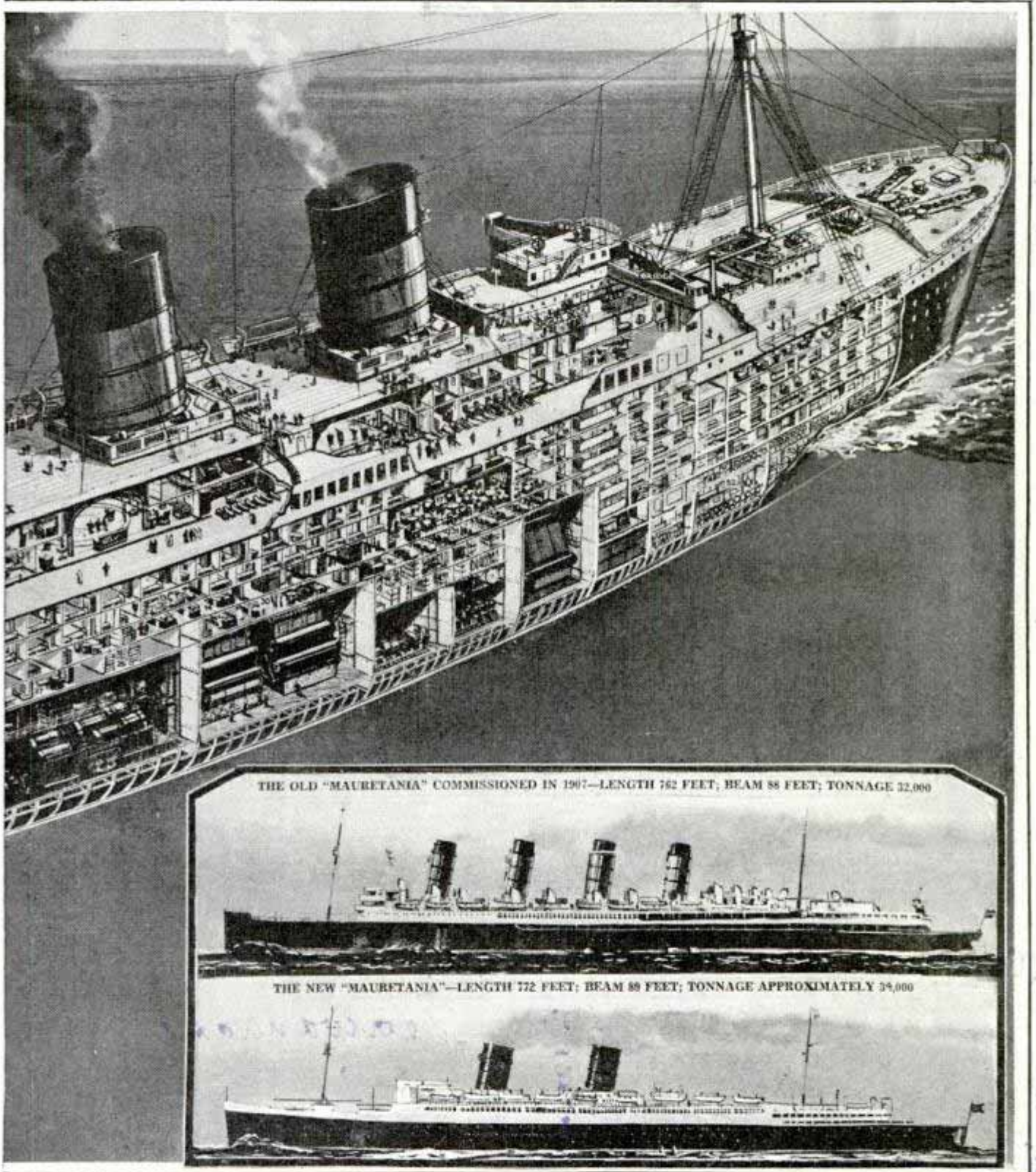

THE OLD "MAURETANIA" COMMISSIONED IN 1907—LENGTH 762 FEET; BEAM 88 FEET; TONNAGE 32,000

THE NEW "MAURETANIA"—LENGTH 772 FEET; BEAM 89 FEET; TONNAGE APPROXIMATELY 34,000

Artist's sketch showing cross-sectional view of Britain's latest sea queen, the new "Mauretania." Note absence of ventilators, giving passengers a vast area of deck space

engine rooms and to ventilate the ship, thus dispensing with the great array of huge ventilators which obstructed the deck space in the old "Mauretania." The new ship is remarkable for her amount of open deck. Because of the reduction in space

taken by the boilers and the fact that oil, which is stored in the sides and bottom, is used for fuel, the liner has an increased capacity for cargo. The old ship had four funnels, the new only two. In size, the two ships are approximately the same.

Million-Dollar 'Flying Arsenal' Joins the Navy

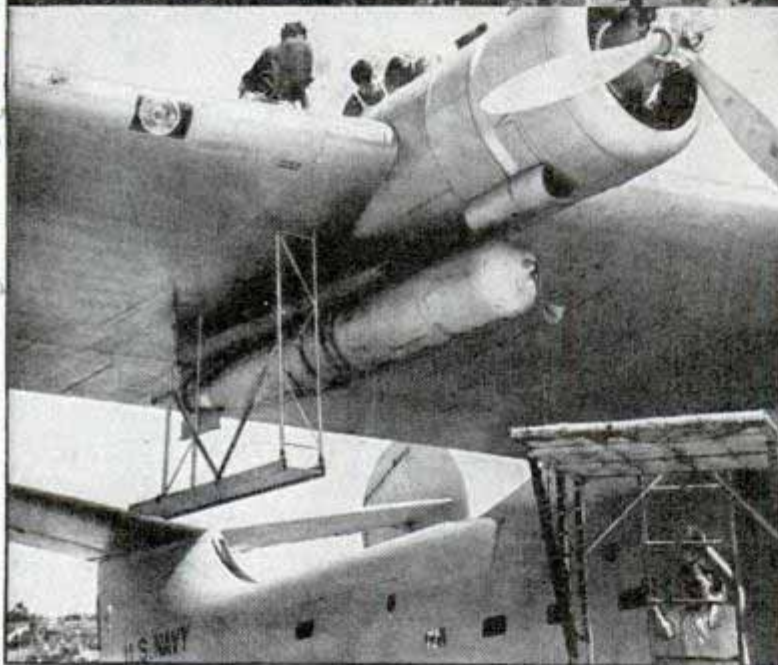

Top, the "flying arsenal" on test flight; below, one of the 2,000-pound torpedoes in its sling under a starboard engine

Under the giant wings and in the broad belly of the navy's newest air dreadnaught rides a tremendous cargo of bombs and torpedoes. In its test flights the million-dollar ship, which has been dubbed the "flying arsenal," lifted 49,000 pounds of explosives; under each wing was slung a 2,000-pound torpedo, the pair to be released simultaneously while swooping down at low altitude. Its speed unofficially rated at four miles a minute, the flying boat is powered by four 1,050-horsepower engines and has a range of about 4,000 miles.

Diesel Boat Sucks Up Oysters Like a Vacuum Cleaner

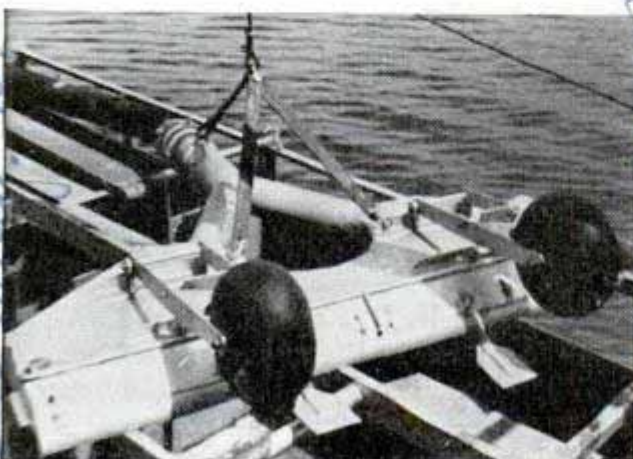

Oyster suction head has airplane wheels

Resembling the vacuum cleaner in operation, a Diesel-powered dredge sucks up oysters by a patented process that speeds up harvesting. The boat is equipped with suction heads to which is attached eight-inch flexible pipe composed of alternate sections of steel and rubber. A centrifugal dredging pump, driven by auxiliary Diesel engines, provides the suction. It is the work of but a few minutes, by manipulation of controls in the pilot house, to hoist one of the suction units, which are fitted with two airplane wheels, over the side, connect it to the suction pump and lower

Consolidated Aircraft Corp
141007
San Diego Calif

Oyster Boat
141025
San Francisco

Seawanhaka

the suction head to the oyster bed. Then, while the boat cruises at three knots, the suction heads pick up enough oysters to expel a steady stream of them onto a moving steel screen. Here water washes all mud and small refuse to the deck below, while the oysters travel with the screen and are discharged into large bins. Ordinarily oysters are harvested by means of power boats which drag chain mesh bags over the beds, each bag having a mouth formed by steel rake jaws which break the oysters loose from the bottom. The bag is hoisted aboard and emptied into bins when full. An additional duty of the boats is to drag what looks like an overgrown floor mop over the beds to pick up starfish and drills, the oyster's worst natural enemies.

"Big Ears" Listen for Airplanes in Mimic War Raid over Britain



These are sentinels who will spread alarm if warplanes approach England. Sensitive "ears" amplify sound of motors and tell path of approach

Soldiers with big ears stood guard over the British Isles during recent air maneuvers which were featured by a mock invasion by enemy planes. The "ears" were highly sensitive listening devices which the Royal Engineers pointed into the air, picking up the hum of approaching aircraft and relaying the information to the defending air force.

Changing Engines of Plane Takes Just Twenty Minutes

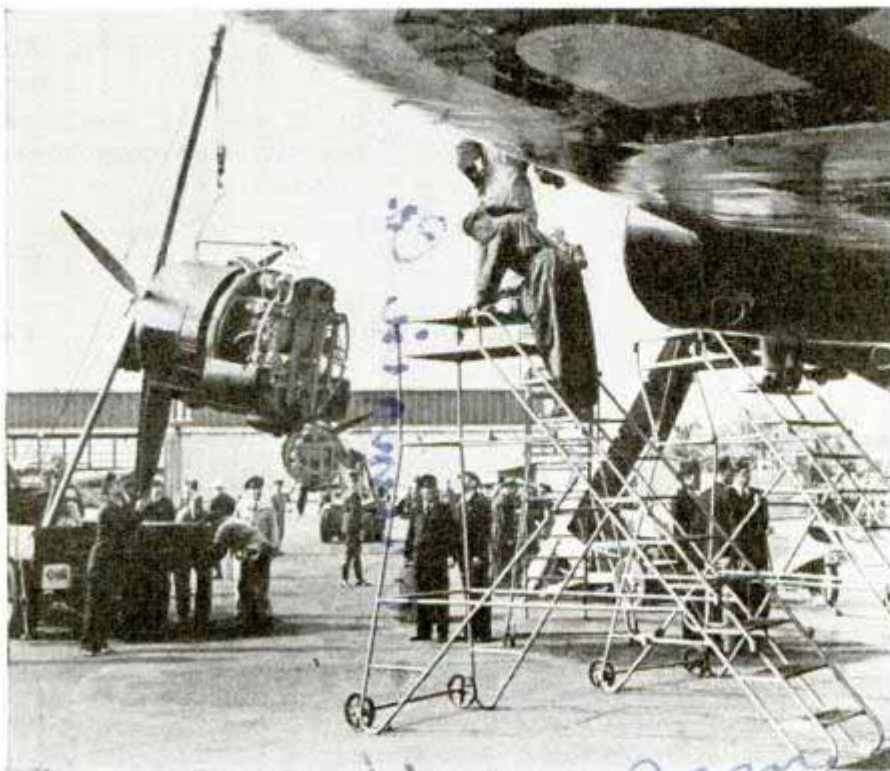

In about the time it takes to change tires on your automobile, mechanics at the Berlin airport can remove an engine from one of the giant Lufthansa transport planes and install a new one. The airport crews have developed a fast routine, making the change of motors in just twenty minutes.

When a Lufthansa air transport needs a new engine, mechanics wheel up portable ladders, tractors with tackle lower the old engine and hoist the new one into place in twenty minutes

12978.

400-Mile-an-Hour Hurricane Stirred Up by Ten-Ton Motor

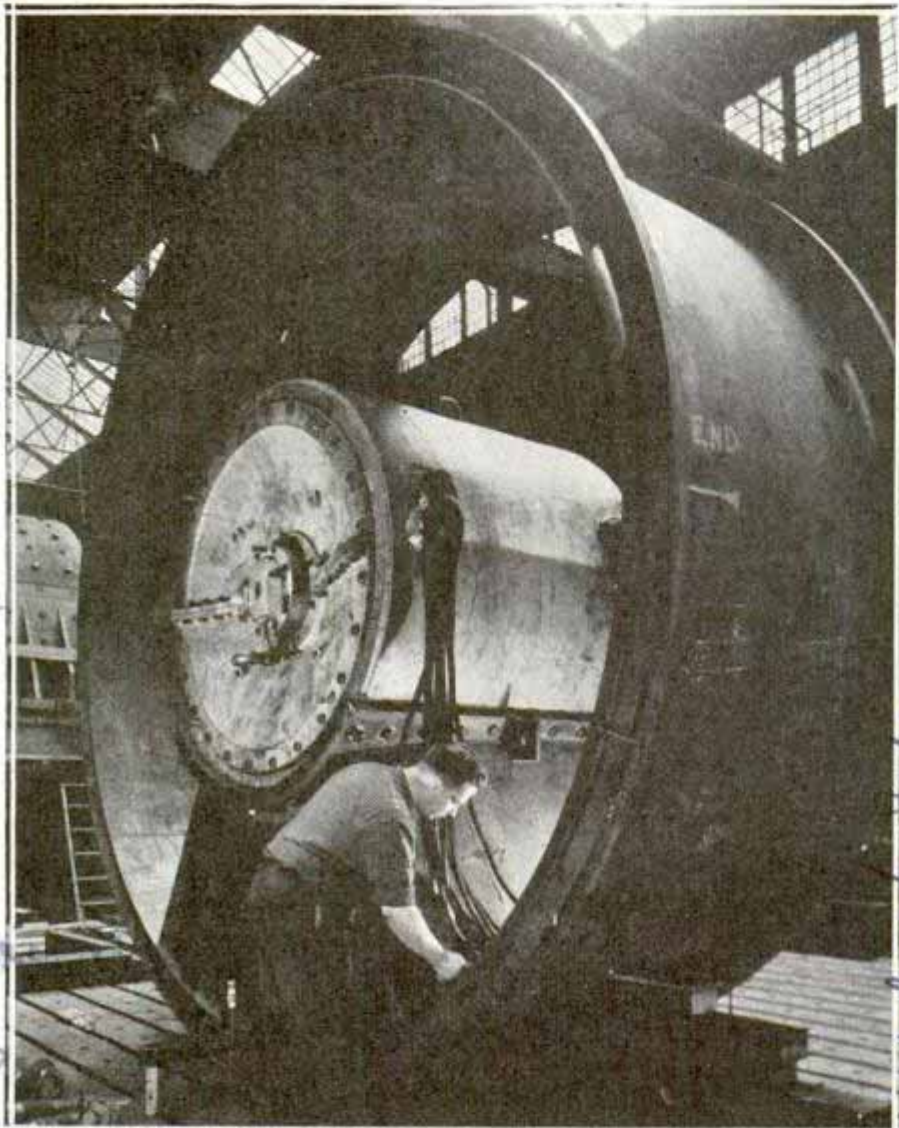

When this ten-ton, 2,000-horsepower electric motor is harnessed to its huge propeller it will fan 400-mile winds through a steel tunnel

Outdoing the violence of nature's wildest typhoons, a 2,000-horsepower motor will soon stir up 400-mile-an-hour winds in the experimental tunnel at Massachusetts Institute of Technology. While its propeller thrusts air through the tube at twice the velocity of a West Indies hurricane, aeronautical engineers can study performance of model aircraft, skin friction, turbulence and flow separation, factors important in designing fans, windmills, turbines, pumps and airships. The Westinghouse motor can run at four speeds, from 443 to 1,180 revolutions per minute. The test tunnel, six by ten feet in cross-section, will be equipped to reproduce barometric pressures up to an altitude of 35,000 feet, pressures varying from one-fourth of an atmosphere to four times sea-level atmosphere. The chamber is made of steel plates three-eighths to five-eighths inch thick, but even this is insufficient to risk maximum air-pressure testing, so the tunnel will be filled with water and the water put under

air pressure, the water reducing the punching power of the man-made tornado. The motor weighs ten tons and because temperatures up to 200 degrees Fahrenheit will develop in the tunnel it must be air conditioned to seventy-five degrees. This will be done by a separate blower driven by a forty-horsepower motor.

Utility Vise Adapted to Precise Drilling

Mounted on a swivel base which permits quick, easy adjustments, a utility vise makes itself useful at the drill press, shaper or small milling machine and as a welding jig. It is large enough to handle work up to four and three-quarters inches thick or as thin as tissue paper. Adjustable to any angle, it is handy for holding odd-shaped pieces which require precision drilling. Made of steel and cast iron, the vise has a two-piece face; the bottom is machined to receive the upper part, the vise proper, and the one-by-two inch flat steel jaws are machined to fit the secondary base so that the guide slides hold them rigid.



Cambridge Mass

Murdock

Shenquin Co

Shenquin Co
Murdock

Big Earth Dams Built Faster with Water 'Guns'

Placer gold-mining methods, calling for use of powerful water "guns," are being used in the building of great earthen dams. The streams of water are directed from the big nozzles to saturate freshly dumped earth and small rock with water under high pressure. As a result the small particles of rock and crushed stone are bound to the earth, making the entire mass pack more solidly. On some dams, the top is tamped by a big "sheepshank" roller propelled by tractor. One of the spike-studded rollers is seen below at work on the huge San Gabriel Dam No. 2 in California.

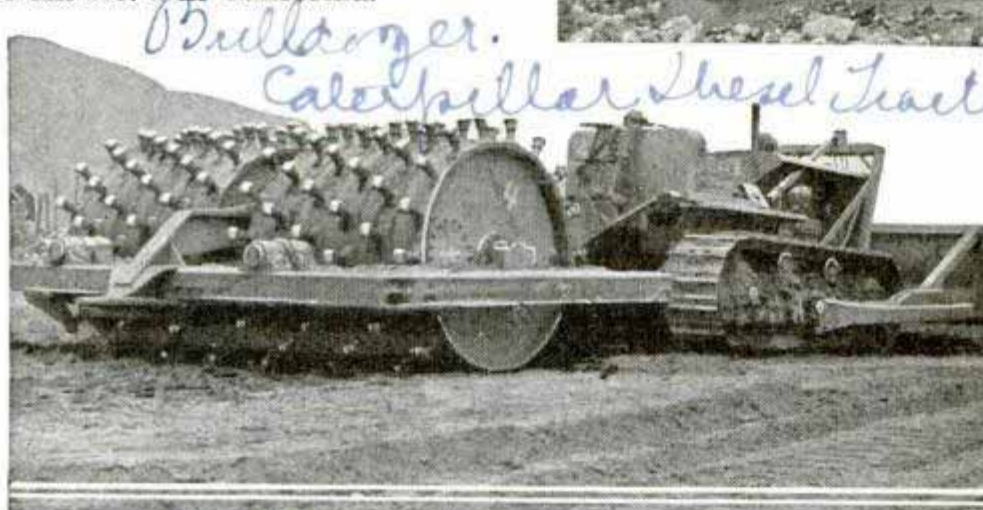
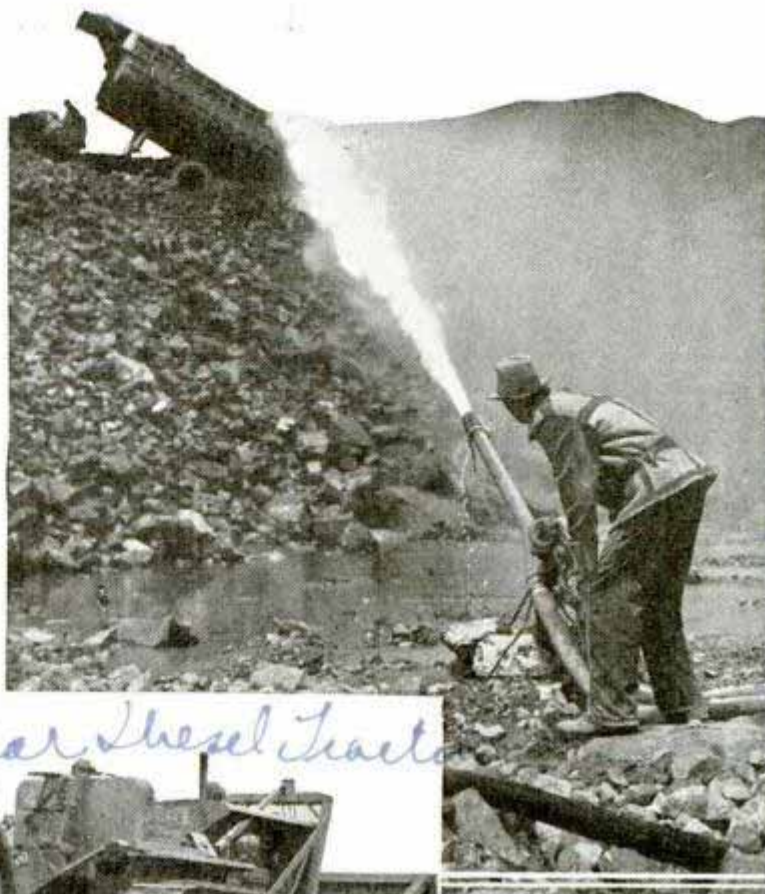

Top, hydraulic "gun" at work on dam. Left, giant roller being used to tamp top of the dam

Chariot of 1938 Ben Hur Drawn by Four Motorcycles

For the Ben Hur of the motor age, no four-horse team would do. Instead, the charioteer—stunting in a sports festival sponsored by a Potsdam regiment in Germany—rides on a rubber-tired chariot drawn by four motorcycles. "Reins" in the driver's hands lead to the handlebars of all four "bikes," which are harnessed together by three horizontal bars. The harness recalls certain farm tractors which are controlled by reins.

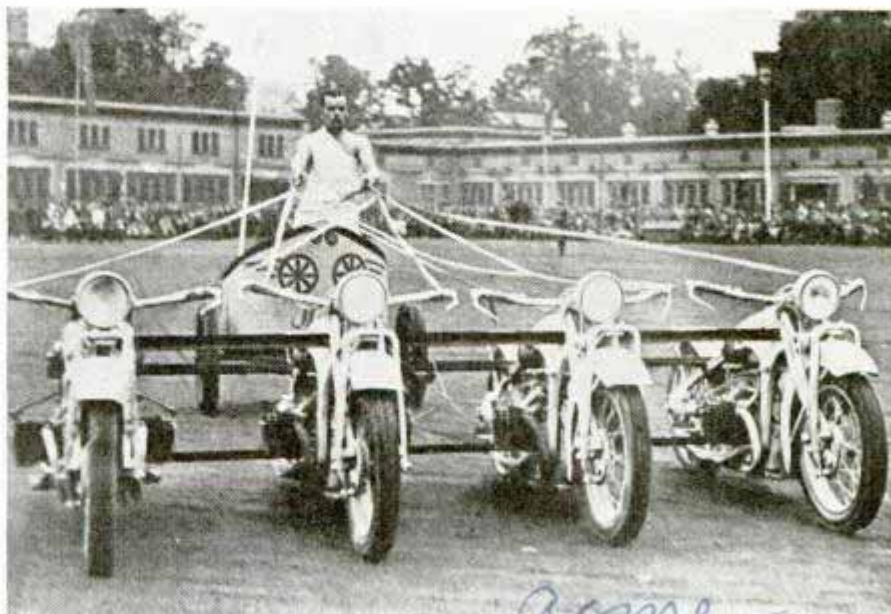

Charioteer in German sports festival drives four motorcycles with reins

Berlin

8/13/38

The Bridge—'Brain' of a Modern Ocean Liner

Admiral's Pass. Ld. 9 3rd long Acce. 10/16

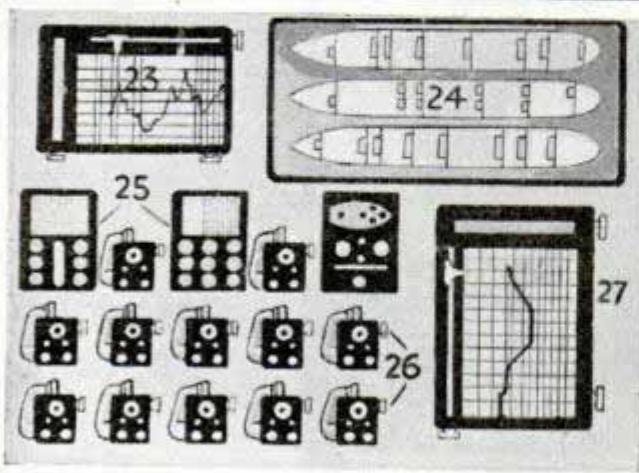
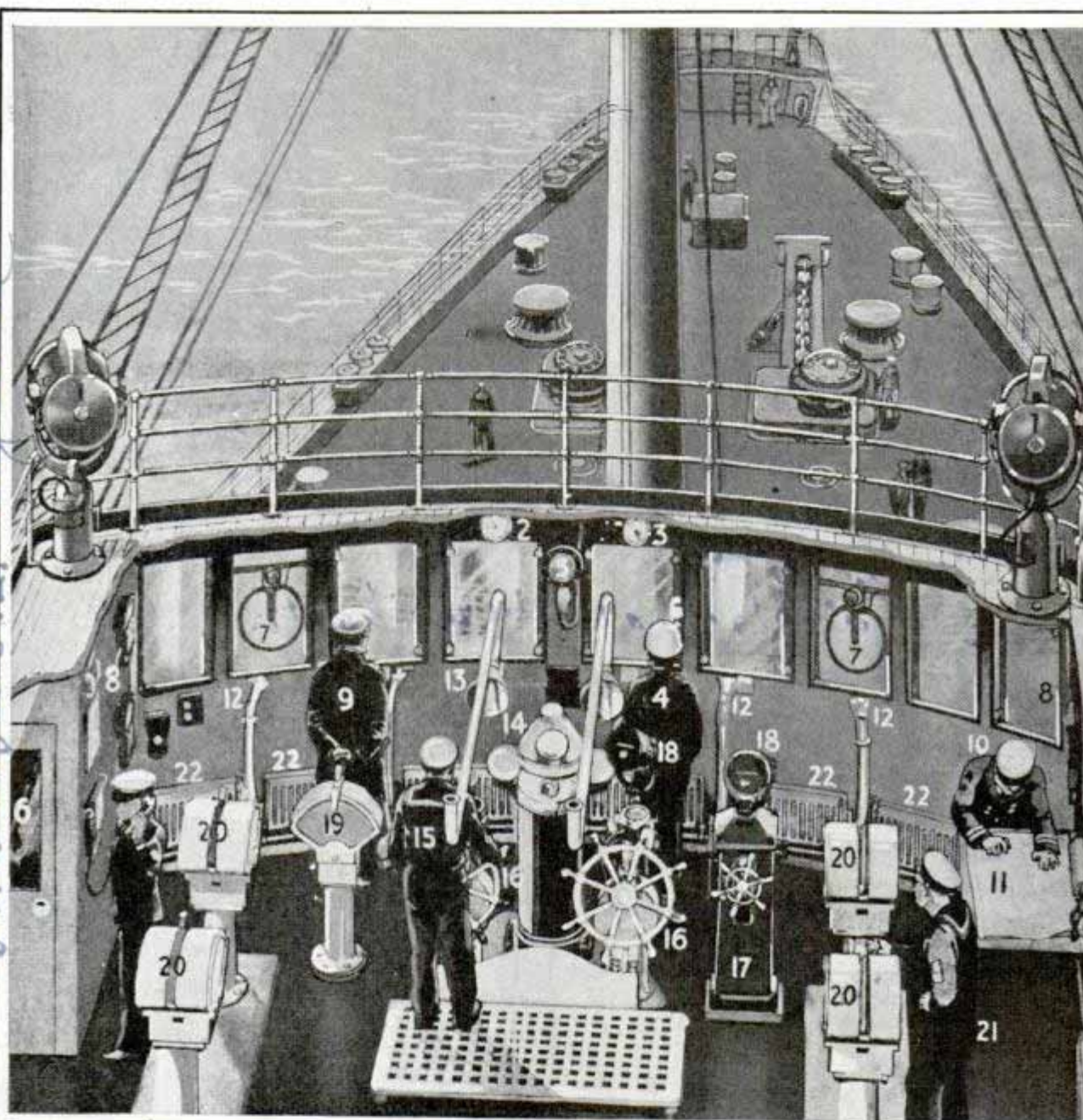

- 1. 18-inch searchlights
 - 2. New York time
 - 3. Greenwich time
 - 4. Junior officer
 - 5. Gyro instruments
 - 6. Sound-proof cabinet
 - 7. Clear view screens
 - 8. Revolution indicators
 - 9. Senior officer of the watch
 - 10. Officer of the watch
 - 11. Folding chart table with screened lamp
 - 12. Voice pipes
 - 13. Voice pipes for orders to helmsman
 - 14. Magnetic compass
 - 15. Quartermaster at wheel
 - 16. Duplicated steering wheels in case of failure
 - 17. "Iron Mike" gyro pilot
 - 18. Steering repeaters
 - 19. Steering telegraph to docking bridge (aft)
 - 20. Engine telegraphs
 - 21. Seaman on telegraph
 - 22. Wheel house heating radiators
- INSET (at Left)
- 23. Chart of depths of seabed being recorded
 - 24. Watertight doors indicator
 - 25. Fire indicators
 - 26. Loud-speaking telephones to every part of ship
 - 27. Course recorder operated electrically from gyro

Few of the thousands of passengers who cross the Atlantic or the Pacific ever see the bridge, that point from which the mighty liner on which they ride is controlled. And even if they were permitted to visit the control room they would be

H 1016
 unlikely to know what was going on unless an officer explained the function of the various instruments and controls. A visit to the control room of one big liner reveals that atop the bridge are two eighteen-inch searchlights, used for many purposes, one of which may be a dramatic rescue at sea. Inside the room are the officers of the watch at their posts, the quartermaster at the wheel and the seaman at the telegraphs, ready to transmit orders to the engineers far below. There are two clocks, one with New York time and the other with Greenwich time; duplicate steering wheels in case either fails; the "Iron Mike" gyro pilot which is capable of keeping the ship on course without human aid; revolution indicators; magnetic compass, and a host of other instruments.

H 954
Landlubbers Hoist Their Sails and Go Yachting on Bikes

Boats are nice, but not necessary for a sailing trip. Right in Miami, Fla., a city of yachtsmen, two youths who had bicycles but no boats hoisted their sails over the bikes and let the trade winds haul them down the drive.



Two dry-land sailors roll merrily along a Miami street on their two-wheeled "yachts"

H 1018
Focuser and View Finder Combined on Camera



Using focuser-view finder on camera equipped with harness and metal supports

Helping to make better pictures is the purpose of two reflex focusers for Contax lenses. Each incorporates a mirror, coupled with the shutter through a single cable release, which is automatically lifted away just before exposure and returns of itself. The reflex principle permits focusing and viewing the subject simultaneously. The focusing eyepiece incorporates a five-times magnifier. One of the focusers is for closeups only. Since it extends the lens about three inches forward of its normal position, it is usable only for large-scale reproduction at close working distances. The other focuser is for normal distances and permits accurate and rapid focusing and composition at all distances. Another new development in the photographic field is a harness for use with practically all still and movie cameras. Two metal uprights are braced across the abdomen and suspended comfortably by adjustable neck straps, and carry a tilting head to which the camera is attached with a standard tripod screw. The camera is held continually in position before the eye so that both hands are always free to arrange the subject material or to carry on the usual activities.

485-5th Ave New York
 122 S. Michigan Chicago
 Carl Davis, Inc. Los Angeles
 728 S. Hill

141063

Self-Heating Gas Flatiron Carries Its Own Tank



Pressure gas tank attached to iron makes it independent of electric source or stove

In camp or at home, away from gas stove and electric line, the housewife can do her ironing with a self-heating iron. Using gas under pressure, it has its own small tank attached, and its chromium-plated base heats evenly.

Theory of Exploding Stars Traces Their Growth

Stars grow old, Prof. George Gamow of George Washington University suggests, by gradually burning up their hydrogen and getting hotter and brighter. A source of nuclear energy within the star causes this first stage in the star's evolution. Next is a progressive contraction in which the star's radiation comes from gravitational energy alone. However, at the point between the two stages, the star's mass must redistribute itself, during which period gravitational energy is liberated which shows up, suggests the professor, as a short-time additional brightness. It is this brightness which may well be the cause of

the bright flareup of the so-called "new" stars. What happens after contraction sets in depends on its mass. For small stars, less than three and two-tenths times as large as the sun, the contraction leads to the type known as white dwarfs which have a degenerated electron gas inside and very small energy production. For larger stars, the contraction creates a central neutron core inside the star which represents a practically unlimited source of energy. The growth of such a neutron core will bring about an increase in the amount of energy liberated and probably make the star's atmosphere expand. In this state it may enter the star class known as the giants. Finally the explosion of such giant stars will lead to extremely bright novae, or exploding stars, which might be identified as the super-novae, Prof. Gamow concludes in his theory of star evolution.

141087

Auto Wheel Runs Generator for AC or DC Power

Attached to the rear end of an automobile, a new portable power unit is driven by the car's rear wheel. It consists of a generator mounted on a steel rack which is bolted to the bumper, and a welded steel driving pulley which is attached quickly to the wheel. The 110-volt AC generator is a combination unit which also provides a source of direct current at six, twelve,



Wheel of car jacked up to operate generator that powers stationary machinery

eighteen or thirty-two volts. The generator is available in various models up to 2,000-watt size. On 300 and 500-watt sizes, the direct-current capacity is about half the capacity of the alternating current winding. All terminals are brought to the

Kato Engineering Co.
530 Franklin St.

The Coleman Lamp & Stove Co.
1100
Salem, Oregon
9/20/38

outside of the generator, thus permitting use of a field rheostat for close control. Multi-wire cable is furnished to conduct power into the auto or to stationary motorized apparatus near by. The generator may be operated while the car is moving or stationary, the rear wheel being jacked up for stationary operation. The unit has a wide range of usefulness in public-address equipment, floodlights, moving pictures and all sorts of motorized outdoor machinery, being especially adapted to providing power for traveling exhibits, movies and farm apparatus.

1096

Army "Eye" Maps Terrain in Mock War

High above Kentucky's blue grass hills rides an aerial camera-man in a U. S. Air Corps photographic plane, mapping the field of battle while troops maneuver in sham war below. The area surrounding the Fort Knox gold depository was mapped as a part of the recent war games there, the photographer "shooting" through a circular window in the floor of his plane.

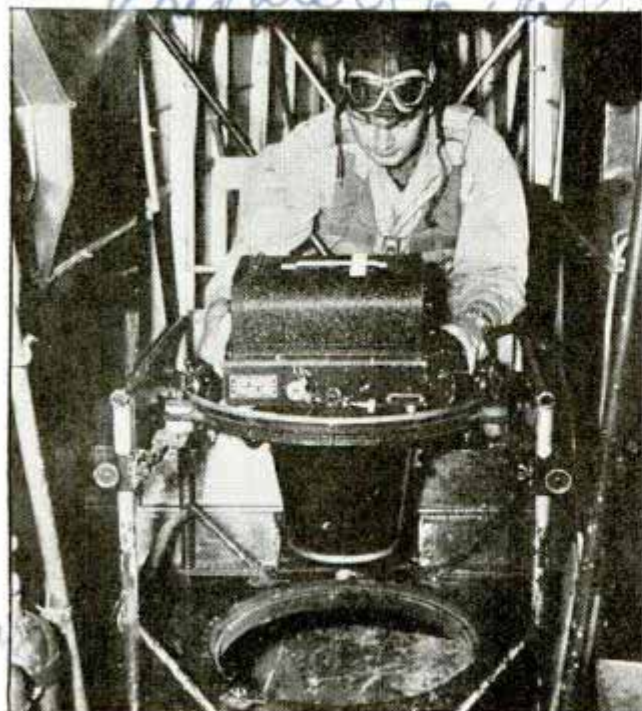

Aerial photographer sights his camera over Fort Knox, Ky., as sham war is waged below him

Concrete Poured from Bridge Rolling Along Sixty-Foot Canal



Rolling cement across bridge that moves along the canal on wheels at either end

To solve the problem of getting concrete across the sixty-foot canal of the Colorado river aqueduct, a rolling bridge was designed. Both sides of the canal were to be fenced with six-foot wire supported by steel posts set in concrete. The bridge made it possible to carry on operations on both sides of the canal at the same time. Concrete was poured directly from the end of the bridge into the holes and then the span was moved forward by a hand crank. In all, 152 miles of fences were constructed to inclose all open sections of the 392-mile aqueduct including canals and reservoirs. Two hundred and fifteen gates were included in the fence.

1098

Agitator for Developing Tank Vibrated by Running Water

Running water operates an agitator devised to speed up the finishing of negatives in a daylight developing tank. When attached to

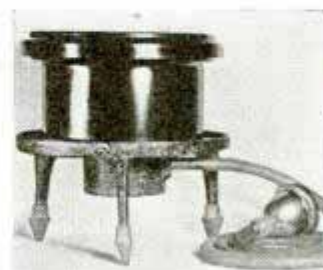

any faucet, the water causes a small turbine to set up a vibratory motion, the degree of agitation regulated by adjusting the faucet handle. Rubber feet prevent any spilling of solution.

Canaday Sound Apparatus Co.

for Pittsburgh Steel Co. 1570 Garden City Pittsburgh Pa. made by Esarlinghouse Bros. 2418 E. 16th, Los Angeles, Calif. Road Cleveland Ohio

12 1044
**Long-Sought Boric Crystal
 Discovered in a Tin Can**

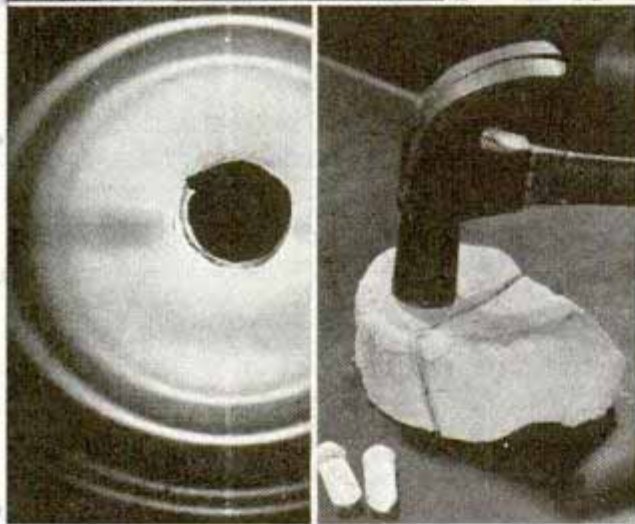

Scientist "cooks" new crystal in a tin can. Below, X-ray diffraction picture and blow showing hardness

For years scientists have hunted for some method of transforming boric oxide from a glass to a crystal. At last a chemist in the Westinghouse Research Laboratories has found the secret—in a tin can! The chemist, Leon McCulloch, was working with boric acid fused in loosely covered quart tin cans in an electric oven, heated between 225 and 250 degrees centigrade. He wanted a liquid mixture for insulating electric coils. But his mixture turned milky, then pasty, finally becoming hard as stone. He weighed it. The specific gravity of the crystal was a third greater than a similar lump of boric-oxide glass, and it was so hard that it took several blows of a hammer to shatter it. An X-ray

picture brought out sharp diffraction lines and proved the substance was the crystal for which science had been looking. In the heating process, boric acid—fundamentally the same acid used for eye washes and antiseptics—changed to the crystalline state much as sugar syrup crystallizes into fudge. Boric-oxide glass has a high resistance to heat shock and so is useful in chemical and industrial processes. The new crystal has a definite, controllable melting point and should prove valuable in commercial glass manufacture.

12 1068
**Forty-Five Mile Speed Attained
 by Model Racing Car**

Forty-five miles an hour on a fourteen-inch wheelbase is the top performance of a tiny racing automobile built in spare time by a California youth. It weighs seven pounds, and travels about two miles on its tank capacity of two ounces of gasoline. Under the hood is a one-cylinder engine of one-fifth horsepower. Built chiefly of pressed steel, with tubular steel axles, the car has wheels of wood mounted with rubber ash-tray tires.



One-fifth horsepower motor gives this model racing car plenty of speed. Its tires came from ash trays

Acma
 Ralph Richard
 Hawthorne, Calif

Research Engineer and Chemist
 Westinghouse Research Laboratories
 East Pittsburgh, Pa.
 12 1044

120-Mile Iron Horse Hauls Fintail Streamliner

Under the streamline jacket of the "iron horse" just added to the Milwaukee Railroad's "stables" is an engine packed with more than enough power to haul a loaded nine-car passenger train at a speed of two miles a minute. It may never be called on to do that, but the power is there, and those seven-foot drive wheels must pound the rails around 100 miles an hour to keep the "Hiawatha" on its schedule of 410 miles in 390 minutes between Chi-



Eighty-four inch driving wheels of this powerful steam streamliner pull nine cars at 120 miles an hour. Notice longitudinal steel ribs of train

ago and St. Paul. Replacing equipment that was new when the streamliners began service in 1935, the latest train in the fleet is new from the wheels up. The steel cars are ribbed longitudinally with semicircular bars, and structural strength is added to the slant-roofed rear observation car—slanted to reduce wind drag—by a vertical and four horizontal fins, the latter serving

also as sunshades for the rear windows. New trucks have been developed, with automobile-type hydraulic shock absorbers, coil springs and stabilizers to absorb sideway. Rubber mountings throughout trucks, couplers and buffer plates quiet vibration. A novelty in the tavern car is a station indicator; after each stop the name of the next station is illuminated.

#1062

Hobbyist Strings Bottle Caps into Many Useful Articles



Out of the ash can comes the material for a Miami modelmaker. His hobby is fashioning household articles out of old bottle caps. Small tables, flower stands for the porch, and baskets are some of his creations, made by stringing the metal caps on old wire coat hangers. One of the largest articles built of this strange material was a model airplane requiring 2,200 bottle caps.

Scientists have estimated that if all the ice in the polar regions melted it would raise the ocean level at least 100 feet, perhaps more than 200.

Bottle caps are strange material for the modelmaker. More than 2,000 were strung together to make this airplane; hundreds more made baskets

John Hanley
 Smithsonian
 1937

14 10 42

Mr. Wallace St. Morris
5902 Magnolia Ave.
Chicago

OFF the "PLATTER"



Top, control room where engineer manipulates "mixing panel" which blends volume and intensity of sound. Bottom, examining wax record under microscope

It is a big business, this offspring of radio. Every broadcasting station in the United States, without exception, uses these "platters." Many of the smaller stations depend on them for a majority of the time they are on the air each day.

As an illustration of platter adaptability, hour-long programs, such as the Ford hour, have been put on records from the actual chain broadcast, then duplicate platters have been shipped to small stations throughout the country for playing at such later time as local Ford dealers might wish.

Along about dinner time in the evening you hear your radio say: "Well, here it is 5:45 again, and Orphan Annie time." No matter whether in Maine or California, the Orphan Annie doings greet their listeners at that time. But those words were spoken, as well as the rest of the program, four or five weeks before you hear them, put on platters and shipped to the stations well in advance of schedule. Each of the country's four time belts gets its Orphan Annie, then, at 5:45. The only other way, and not a whit

more satisfactory, would be for the Orphan Annie actors to repeat each broadcast four times a night.

There is advertising psychology behind all this. Stations and certain types of products have their peak hours of listeners. The youngsters are at home by 5:45, and the sponsors of Orphan Annie know it. The same reasoning applies to other prod-

WHEN a voice from your radio says: "This is an electrical transcription," don't turn to another station, for what you are about to hear is one of the wonders of modern broadcasting. Last year the customers of one of the leading makers of electrical transcriptions for broadcasting purposes paid \$30,000,000 for the records and station time.

World Broadcasting System
7/11/54

H 1042

and into YOUR HOME

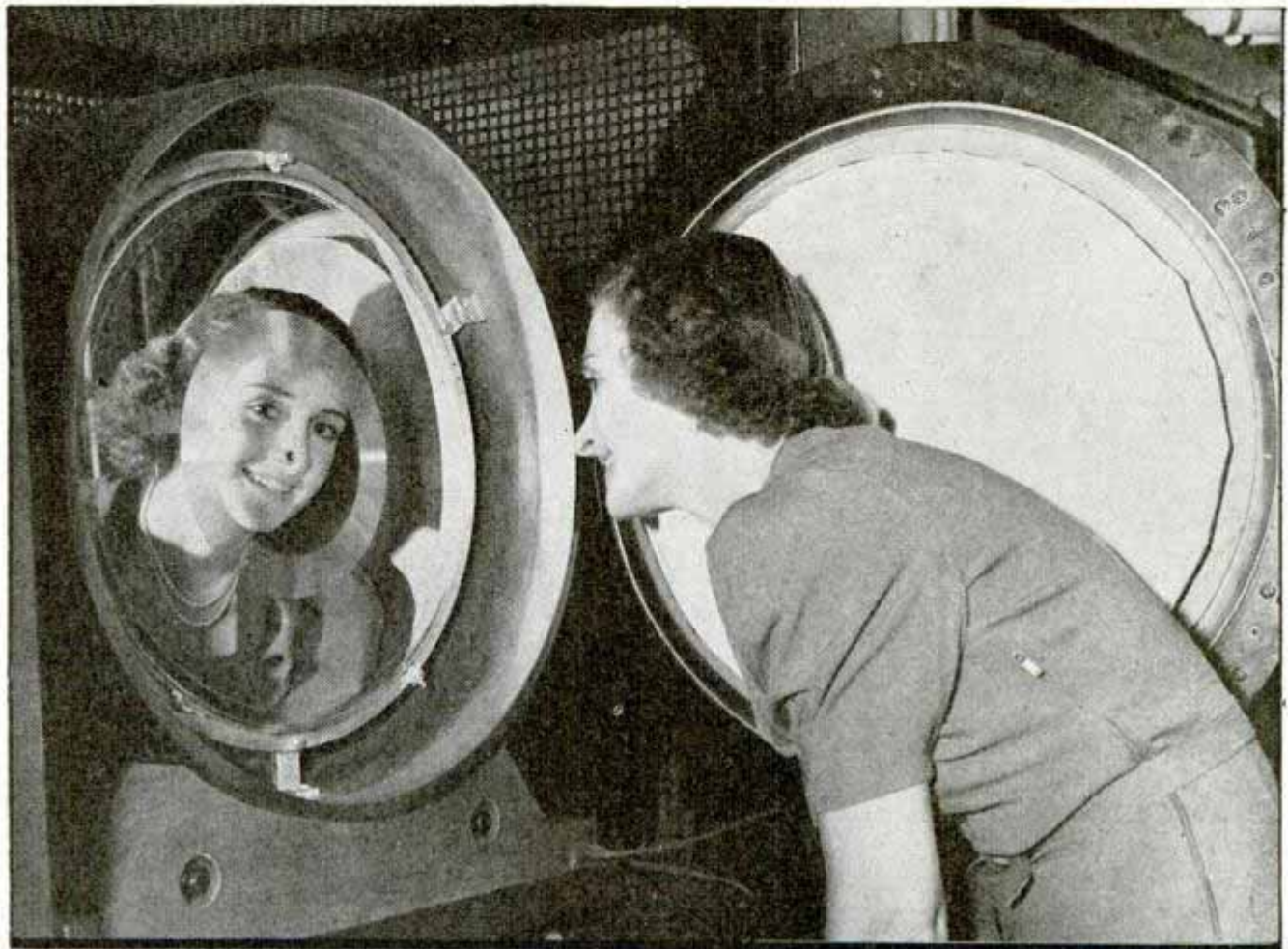

ucts sold via the air waves. Eight o'clock at night in New York may be a splendid time to sell something via radio, but that is five in the afternoon in California. And eight o'clock in California may be four o'clock during New York's daylight saving summer months. The platters supply the answer.

A regular broadcasting studio is interesting, but the plant of a modern electrical transcription company is even more so, for, in addition to the fittings of a broadcasting studio, there is an elaborate and intricate mechanical equipment devoted to the making of the original records, and of the platters after the original has been cut.

In the studio itself, where the actors, musicians and others perform, you will find the walls and ceiling broken up into a considerable number of flat surfaces, no one of which is parallel to another. Knobbed

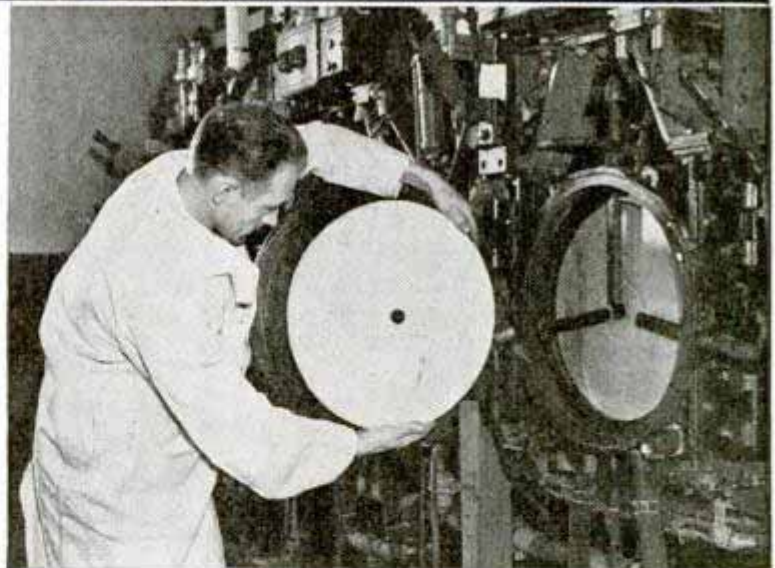

Original record goes into vacuum-sealed chamber at top to be coated with gold. Bottom, placing record in machine where it is coated with copper

projections are found in spots on the ceiling. All this is to eliminate echo and "backslap" of music and voices. A delicate microphone hangs from the ceiling—so keen in its sensitiveness that an ordinary conversation half a dozen feet away

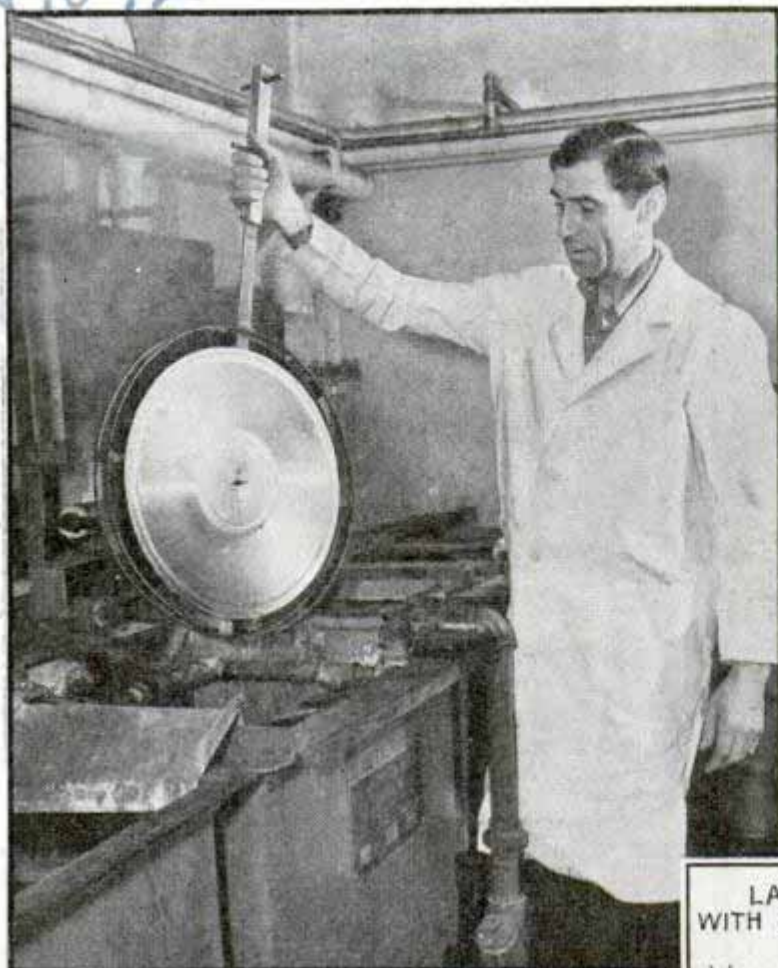

can be picked up and recorded in all its distinctness. Gone are the days when the singer or speaker had to park his vocal organs almost in contact with the old-time "mike."

Transcription studio atmosphere is pretty much the same as in a broadcasting studio. The only essential difference is that the product of the former goes on a record, while that of the latter goes directly onto the air. The only things missing from a transcription studio are seats for an audience. In this respect the business is somewhat similar to the motion-picture studios; the product of both is intended for later consumption.

However, at the transcription plants, as at broadcasting studios, you will find musicians rehearsing in various studios, and even overflowing into the halls. Actors sit waiting and watching the clock, for this business maintains a strict schedule. A platter runs fifteen minutes on the air, but there is an average of eighteen hours of writing, rehearsing, casting and producing for each quarter hour of entertainment.

Imagine a program being recorded. In a studio the action is taking place—the mu-

sic, sketch, talk or whatever is to be put on wax. As it proceeds, an engineer, seated at a "mixing panel," and watching through a glass window the activity in the studio as he listens, manipulates the knobs on his panel, so proper volume and intensity of sound are obtained.

In an adjoining room—the recording room—a stylus is cutting its continuous circular path around a blank record, the music having been passed on to that room via wire from the control room. The program finished, the record goes into a vacuum-sealed chamber. Here, for twenty minutes, it is bombarded with tiny gold particles, so that it comes out with a millionth-of-an-inch gold plating on every little groove and hollow.

Next the record, with its beau-

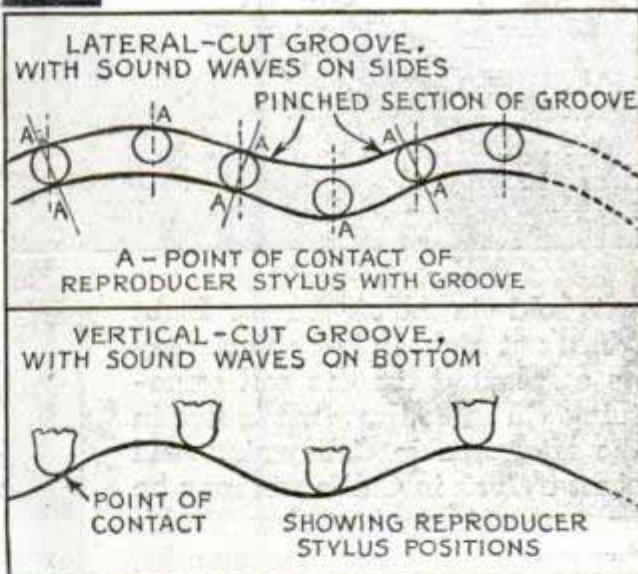

Dunking a disk in a chromium bath. Diagrams show difference in lateral-cut and vertical-cut grooves

tiful gold film, goes into a solution of copper sulphate. When it comes out it has a layer of copper on top of the gold. Another machine adds a thick layer of copper to the surface. Now, obviously, we have a negative impression of the original record, impressed on the gold, to which the copper plate is attached. The wax is then stripped off, being no longer needed, and the copper-and-gold disk is trimmed down to size. Next it goes into a chromium bath. Out of this it comes chromium-plated, goes into a drying oven, gets a final smoothing and

alining—and we have a master record from which any number of platters may be made.

Why the gold film? Because gold insures purity of the original sound, and freedom from any possibility of scratchiness. Experience and experiment have proved it the best material for the purpose, and superior to graphite, which once was the accepted finish.

Vertical, or "hill-and-dale," recording is conceded superior to lateral recording, and by far the

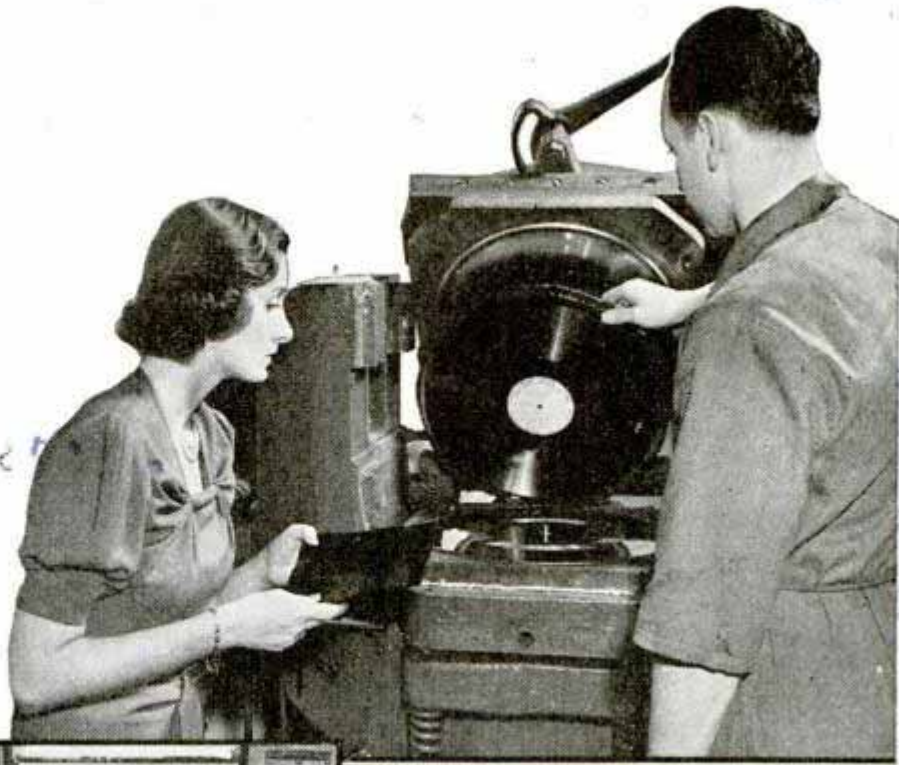

Pair of turntables enables radio station to present an endless program, one record picking up where the other leaves off. Top, hydraulic press which turns out records, using the master record as a die

greater portion of transcriptions is made by the former method. One excellence of this system lies in the fact that a vertically cut groove permits a lightweight reproducer to be used, with a very small moving part that easily and accurately follows the extremely complex waves impressed on the record. This results in low-record wear, which in turn keeps mechanical noises to a minimum.

Phonograph records are made by the lateral recording method, the sound waves being cut on the sides of the groove. When played, the needle bounces from side to

side of the groove. As a result, after about twenty playings the sound waves begin to wear from the impact of the needle, and the record loses its original sharpness and purity of tone. However, with a vertically cut transcription, the sound waves lie at the bottom of the groove, and such a record can be played from 1,800 to 2,000 times before it shows any diminution in tonal quality.

The electrical transcription makers have had to lick many problems in order to turn out their present product which often defies detection from an original broadcast. The tonal range of the human ear had to be considered, and every step taken to fulfill its

exactions. The normal ear has a range from twenty to 16,000 cycles per second. At the lower end are the slow vibrations, such as cannon fire. At the upper end the jingle of keys or the higher notes of an oboe will reach 16,000 cycles. Your telephone will transmit within the forty to 3,500-cycle range. Lateral-cut transcriptions reproduce within the forty to 6,500-cycle range. Vertically recorded transcriptions extend the limit to 8,500 cycles, and are equal in trueness to network programs put on the air at the point of origination.

(Continued to page 132A)

*Telephone Laboratories
for Western Electric
46 West Street
New York*

'Wonder Clock' Hands Turn Once in 26,000 Years

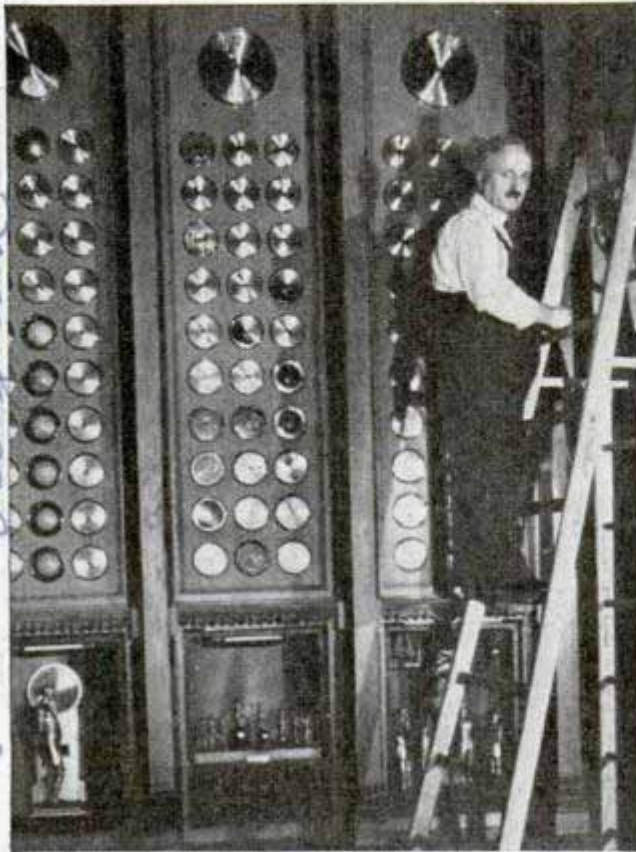

Belgian clockmaker installing the clock with ninety-three faces in a New York museum

(Pictorial Feature)

One master movement controls ninety-three different dials on the "Wonder Clock" built by a Belgian clockmaker. It was brought to this country recently for exhibition at the Museum of Science and Industry in New York. The various faces show the time divisions of the world, the location and movements of the earth, sun, moon, planets and stars, high and low tides at the principal ports and other phenomena—all synchronized by the single movement. Some of the clock hands cannot be seen moving—the slowest indicator rotates but once in 26,000 years, while the fastest revolves around its dial in one-hundredth of a second. The clockmaker, Lodewyk Zimmer of Lierre, Belgium, took three years to build the mechanism.

Built by Lodewyk Zimmer of Lierre, Belgium

tion at any moment. Even in dense fog or rainstorms the device, operated by radio waves, reveals the position of the ship and enables airport men to guide the pilot in safely by radio telephone. Any of ten wave lengths can be selected remotely for the signals. As the pilot talks, the spot of green light moves to the correct position on the circular screen of a cathode-ray tube, and compass markings around the edge of the screen enable the dispatcher to give the pilot his exact bearings.

7d 1005

Magnifying Glass Has Light to Illuminate Work

Additional illumination on close work is provided by an electric lamp built into a magnifying glass now on the market. The lamp plugs into the standard socket. The lens is of ample size, two by three and three-fourths inches, permitting vision with both eyes without strain. The lamp is ball jointed and clamps to the guide post. Adjustment of the glass is quickly made with a double-lock clamp. The fifteen-watt lamp is inclosed in the same fixture as the two-power glass. Illumination is even and covers the entire field of view. The outfit is especially useful in connection with precision-work machines.

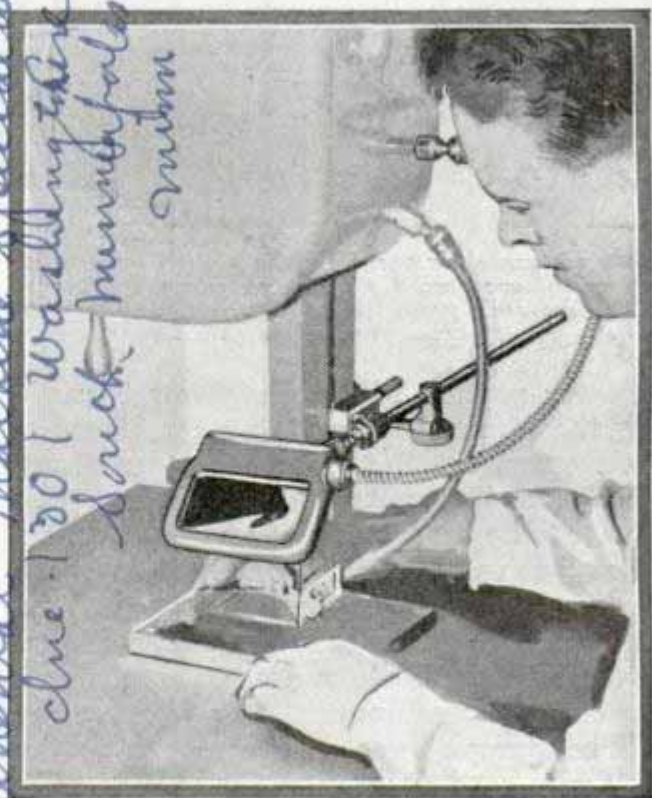

Using the new magnifying glass which has fifteen-watt electric lamp

Moving Light on Glass Screen Shows Position of Plane

Watching a tiny speck of green light moving across a frosted glass screen, airline dispatchers can follow the path of an approaching plane and tell its exact posi-

7d 1066

*controllable machine specialties
due 1201 Washington
Street
New York*

Vast Relief Map Matches Earth's Curvature



Mapmaker finds a place for a tiny segment of United States in the huge relief map, so accurately made that it conforms to curvature of earth's surface. It is built on steel frame sixty-three by forty-five feet

It will be more than a year before the huge relief map of the United States, begun at Wellesley, Mass., in 1923, is completed. The task calls for the utmost

precision, for it will reproduce in exact proportion the curvature of the earth. The states are being laid out in sections on a steel frame sixty-three by forty-five feet.

Auto Engine Drives Mower Built of Old Machine Parts



Grain mower built of odd parts is driven by automobile engine

Needing a mowing machine, a Utah farmer-blacksmith collected odd parts around the farm and built himself one. Its motor came from an old passenger automobile, its transmission from a truck; the front wheels belonged to a manure spreader, the upright guide shaft is an artillery caisson axle. The frame is of oak. The finished power mower cuts four times as much hay in a day as a team-drawn machine.

The average per capita consumption of water for all purposes in the United States is more than 100 gallons a day.

Built by Neville Jensen, Brigham

Smithsonian Institution

Adham Press. Ltd. 93 Long acre, London W.C.2



The EPIC STORY of RADIUM

Hundreds of tons of pitchblende ore mined daily must be concentrated to about two tons for removal of silver, uranium and radium



Larger pieces are removed before ore goes through crusher

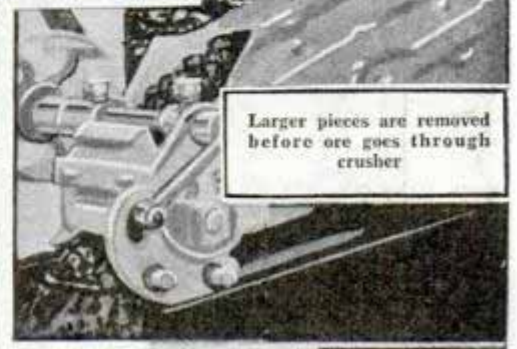

RADIUM was discovered by Madame Marie Curie, who with her husband found the secret four years after being assigned the task in 1892. Gilbert La Bine found vast fields of pitchblende, from which radium is extracted, in Canada in 1930, thus assuring the world of a steady supply of the deadly life saver at considerably lower cost than had been possible before. There radium is mined in the largest quantities known. More than 12,000 tons of pitchblende ore have to be blasted and put through various processes before a full ounce of radium can be obtained. On these pages is the story of radium, from the mines near Eldorado, Canada, through the refineries 1,500 miles away.



Packing pitchblende concentrates into 120-pound packages for easy transportation. Mask protects worker from dust

AMAZING FACTS ABOUT RADIUM

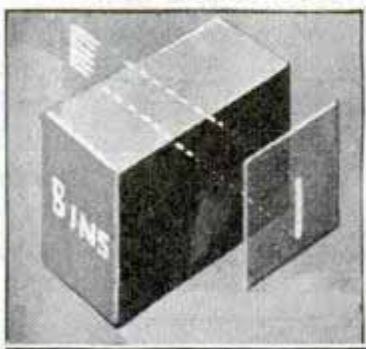

Eight-inch battleship armor cannot stop radium rays from recording on photographic plate

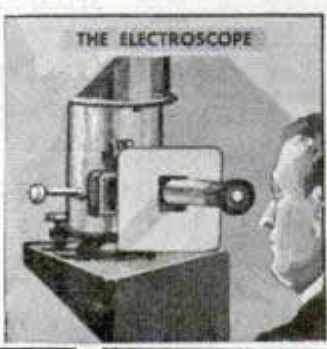

The electroscopes detects a millionth part of a milligram of radium. Only a twelve-inch lead screen upsets its sensitivity



Radium is stored in a safe with ten-inch lead walls



12688.

Mountainside Is Cleared for Floodlit Ski Slope

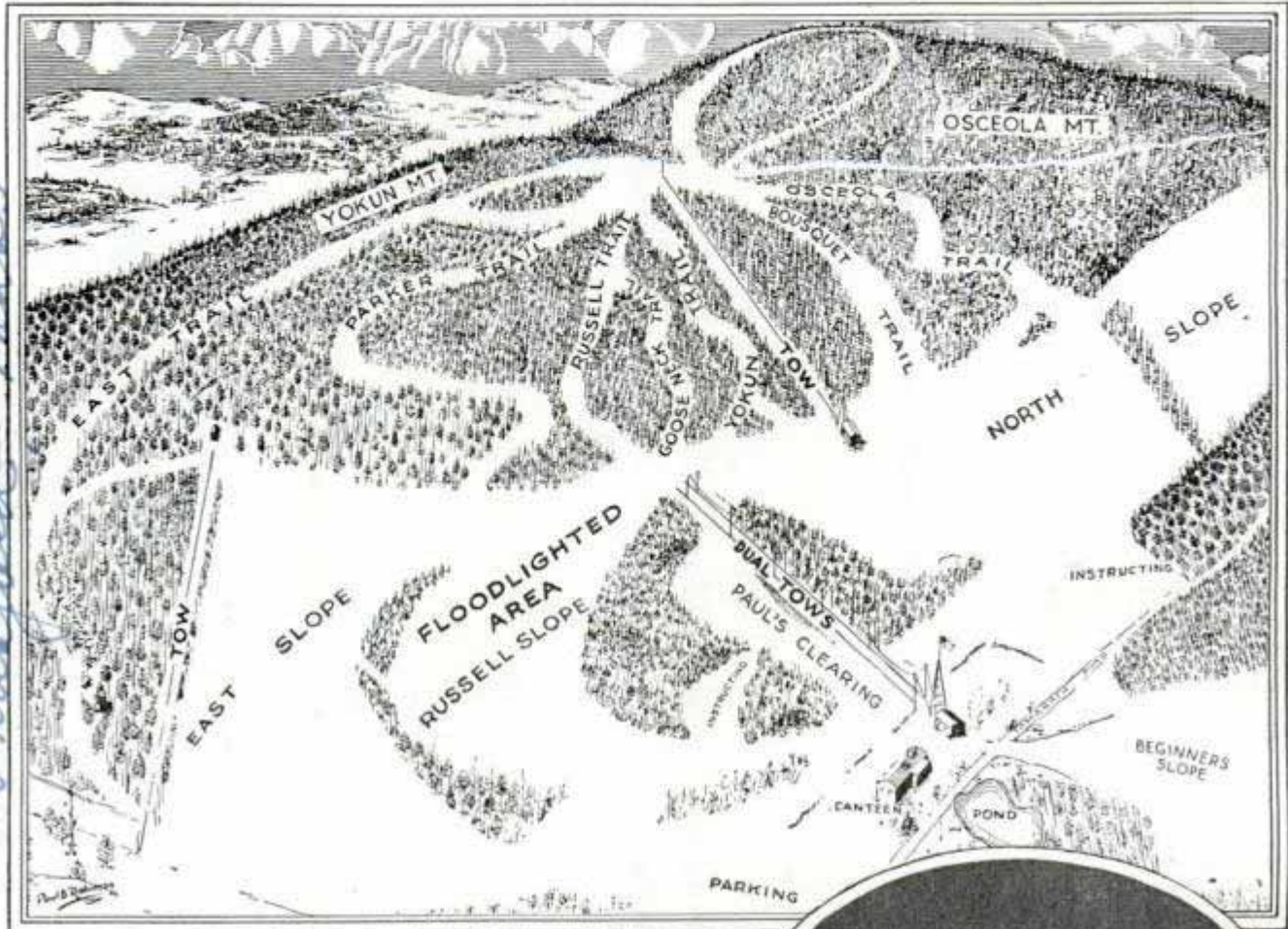

Bousquet's
 Drawing shows trails and clearings that form skiers' paradise in Berkshire Hills. Snow scooter at left can slide to any part of mountain after reaching top by tow line. Above, night view of floodlit ski center



In the heart of the Berkshire Hills near Pittsfield, Mass., ski trails and wide, open slopes have been cut from a wooded mountainside for a winter sports haven. Two to three thousand skiers come by snow train or automobile on winter week ends, ride to the top of the slope by one of the several tow ropes and then ski through the

woods on winding, slanting paths or race down the cleared hillsides. There are 200 acres of open slopes, one broad area being floodlighted at night by mercury vapor lamps. In clearing trails and slopes, windbreaks were left to prevent wind sweeping away the snow. The tow ropes, with a total capacity of 7,200 rides per hour, are

Emt. Russell Bousquet, Tamarack Road, Pittsfield Mass

1949
 10555 Holman Ave
 Los Angeles

HEROES

423
 Capt. Johnson, Fire Dept. Reserve Co. 1
 5th and Maple
 Los Angeles
 Reference:

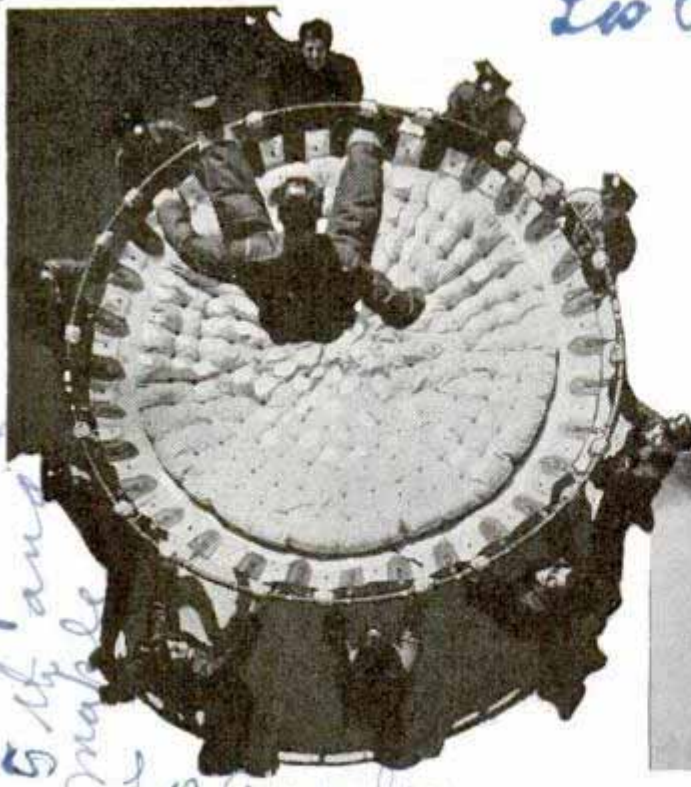

Left, fireman jumping from fourth story into safety net during drill. Below, chief ordering his men away from sheet-metal store front as it buckles. Bottom of page, rescue squad, protected by breathing apparatus, descending into hold of ship with water line to fight fire in cargo



PUTTING out fires is only a secondary job of the fire department. Saving lives comes first.

Men in every engine company are detailed to search the rooms of a burning building as soon as they respond to the alarm. A forgotten invalid in a bedroom or people trapped on an upper story may shift the generalship of fighting the fire.

In the downtown section of Los Angeles specially trained rescue squads answer each alarm with the other fire fighters. The squads have their own ambulances and rescue trucks loaded with lifesaving gear and gas masks. If every one is safely out of a building they turn to with the other firemen, dragging in water lines or running upstairs to get the ventilators open.



But when there is rescue work to be done they leave the fire fighting to the others.

Occasionally they get caught themselves and have to be rescued. Lowering incapacitated people from an upper story with the aid of a safety bag and a long rope may take so long that their exit is cut off and they have to jump. Part of their training includes the proper way to fall into a safety net that is held up by other firemen on the street.

At some fires the rescue men take over the toughest assignments in getting close to the flames while their mates stand in

of the FIRE LINES



*Top, rescue squad member dressed in gas-protective helmet.
Below, firemen fleeing from exploding gasoline tank*

the street trying to protect them with cooling streams of water. Strong ammonia fumes are frequently an accompanying hazard to fires in the business areas of large cities because quantities of ammonia are piped to many buildings and are used in refrigerating plants. When such a line breaks, unprotected firemen are often helpless because they can't see or breathe in the fumes, and the gas can cause serious burns to moist parts of the body.

When an ammonia line broke in a big ice-cream plant that was in flames the firemen were driven out to the sidewalks

by the fumes. About all they could do was wet down adjoining buildings to keep the fire from spreading. But the rescue squad got the fire out in fifteen minutes. Two of the men dressed in what amounted to dry-land deep-sea diving suits, outfits that completely covered them and inside of which they could live for two hours without replenishing the self-contained oxygen tanks. With this protection they took a water line right into the building and got the fire out.

The rubberized canvas suit completely covers the fireman. The breathing appa-



ratus, which straps on his back, weighs thirty-eight pounds. A gauge at his right shoulder tells him the pressure of the oxygen remaining in the tank so that he can escape to safety in time. Small reservoirs below the goggles of his mask contain distilled water and when the goggles fog up from his breathing he can clear the panes by shaking his head, washing the goggles off with the water.

With this outfit a fireman has complete protection against ammonia fumes and poisonous gases. He can enter gas-filled tanks, descend into the holds of ships filled with poisonous fumes, and even dive and remain under water.

Modern fire-fighting technique is to get in close to the flames before turning on the water. That way a few gallons of water may be more effective than thousands of gallons poured into a building from a distance. Fighting the flames at close quarters is sometimes pretty dangerous. Visi-

bility may be only a few feet or a few inches inside a burning building. Firemen, blinded by the thick smoke, have walked into open elevator shafts and have fallen down where staircases have burned away. If necessary, firemen stay at their posts until the floor gets soft under their feet or they can tell that a wall or ceiling is ready to collapse. Falling timbers and flying glass account for most injuries. Panes of thick skylight glass, broken loose by the heat in spite of their chicken-wire netting, have struck firemen on lower floors and injured them severely.

A big two-and-a-half inch fire hose can be a fireman's best friend inside a burning building but he must never let the hose get away from him. With plenty of water

at his finger tips he can wet down the floor as he goes in, both to keep the flames from burning the hose up behind him and to keep open a path along which he can escape. In close quarters the fumes and hot gases from the fire are suffocating and in an emergency he and his mates can place their faces down close to the water



Lowering hose down ship ventilator; demonstrating ladder rescue, and asbestos-clad fireman demonstrating use of the safety suit

stream to breathe air that has been cooled by the water. Many firemen have saved their lives that way.

It takes two men, one at the nozzle and another right behind him, to keep one of the big water lines under control. The hose is alive with energy and if one man tried to open up the water valve without the help of a companion, the kicking, writhing hose would throw him. Once the line breaks loose it is a dangerous, thrashing weapon and its thirty-seven-pound nozzle can kill a man easily. The safest thing to do, if one fireman has to let go of the nozzle, is for the other to hang on and take the bumps until he can get the water shut down. Once a line has gone on a rampage it can't be picked up until one or two men lie down on the squirming line some distance back and crawl along it until they have worked their way back up to the nozzle.



Demonstrating rescue by a ladder (left) and by breeches buoy (upper right) from dummy building

A new aid for getting in close to a fire is a combination fog and stream nozzle. With this a fireman can walk right into a hot spot behind a cool and protecting curtain of fog that sprays out in front of him like an umbrella held at the tip. With a flick of his wrist he can turn off the curtain and open up the line, hitting the fire with the usual powerful stream. If the heat becomes too intense he twists the valve again and turns on the fog curtain for a short respite.

One of the first things that young firemen are taught is that a big fire must be ventilated to get it under control. That is, skylights must be opened up or upper windows broken so that the intensely hot air and gases that are mushrooming under the roof can escape. Otherwise the fire may spread upward faster than it can be fought. But ventilating a fire can be dangerous work because the hot air and gas mixture may explode as soon as it reaches enough oxygen in the open air to become inflammable. Another thing the firemen learn is

(Continued to page 124A)



Fireman in protective suit, armed with electric lantern and wrench for shutting off ammonia and gas lines in a burning building

Water-Cooled 'Midget Sun' Gives Brilliant Light

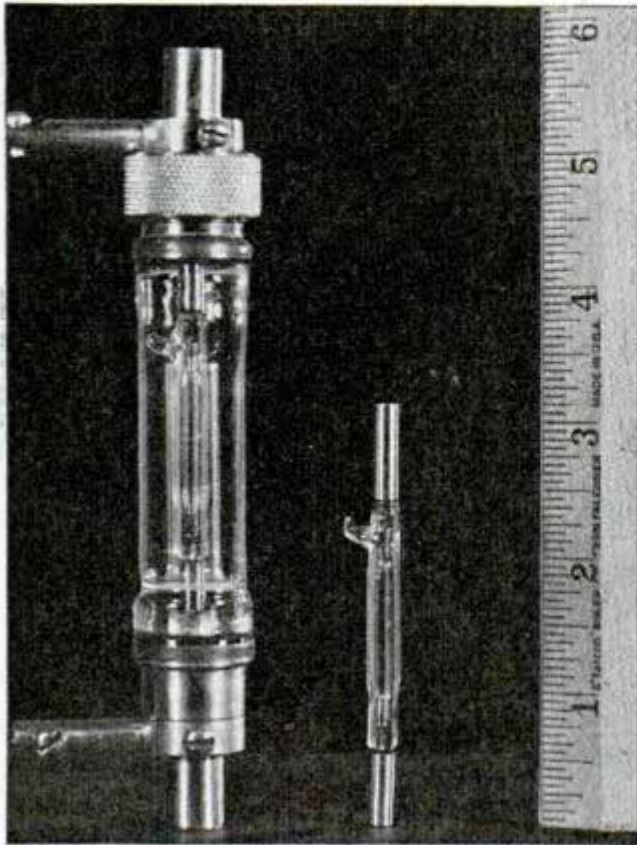

Tiny mercury lamp, center, compared in size to old-style lamp with far less brilliancy

Designed to give light with a brilliancy equivalent to about one-fifth that of the sun's surface, a new midget mercury lamp is expected to revolutionize lighting practice in many fields of light projection. Results of numerous laboratory tests indicate that the lamp can be used to great advantage in photoengraving work, blueprinting, photo-enlarging, in searchlights and for therapeutic application. The lamp consists of a quartz tube about the size of your little finger. Confined within a tiny bore inside the tube is a globule of mercury and a trace of argon gas. Each end of the tube is furnished with a brass ferrule which provides proper electrical contact. In producing so brilliant a light, the midget "sun" develops such high pressure and heat as to destroy itself unless the lamp is properly water-cooled. By developing an ingenious water-cooling jacket, permitting three quarts of water per minute to flow past the lamp, General Electric engineers at Nela Park, Cleveland, O., found a practical way to carry off the excess heat without affecting the light output. The cylindrical glass

portion of the water jacket is about the size of a shotgun shell. Rated at 1,000 watts, the lamp has an arc as its light source which is approximately twelve times as brilliant as the incandescent filament of a 1,000-watt standard projection lamp. When the water jacket is made of quartz instead of hard glass, the unit emits a wealth of ultraviolet radiation. Special glass that screens out dangerous ultraviolet rays not found in sunlight at earth levels may be used instead of quartz. The lamp is said to produce about three times as much light for the electrical energy it consumes as does the average incandescent filament type of comparable wattage.

Cargo Wider Than Freighter Sails from London to Orient

It was an unwieldy cargo that stevedores had to load at London on the S. S. "Belpamela." A shipment of oil towers 105 feet long and weighing 100 tons was destined for the Persian Gulf. Too big to be stowed away in the hold, the towers straddled the deck and overlapped about eighteen feet on each side of the ship.

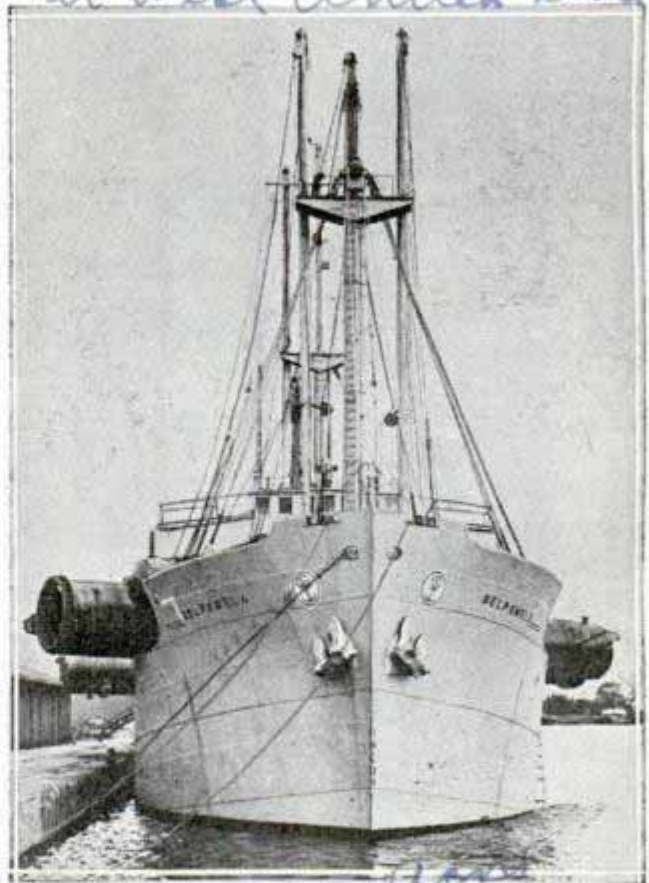

Too big to stow away in hold, 105-foot oil towers ride deck of freighter and overlap both sides

Incandescent Lamp Co see Feb 1940. 198

at West India dock

1890-7

RADIO



T.R.F. TUNER for school P.A. system

EDUCATIONAL programs from distant stations can be tuned in with this compact self-contained unit and amplified for large audiences by means of your present school public-address system.

Assembled easily from a kit of parts and diagrams, either as a classroom project or by members of the school radio club, it adds completeness to any good sound-distribution installation. Operating directly from a 110-volt 60-cycle line, the radio tuner supplies undistorted reproduction of broadcast programs to the input stage of any power amplifier system. Photo Fig. 1 shows

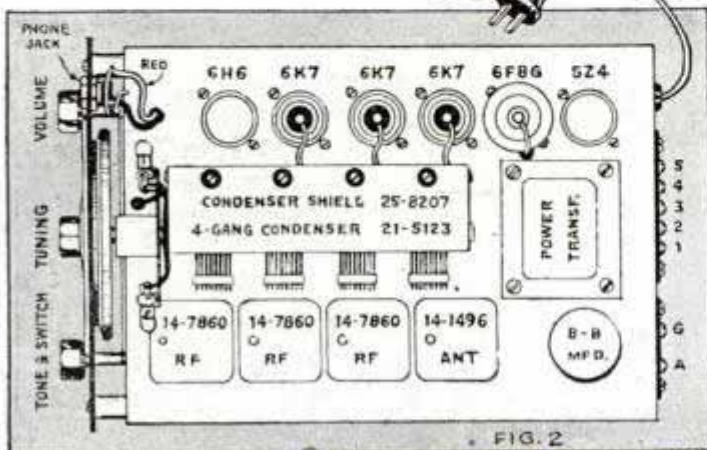
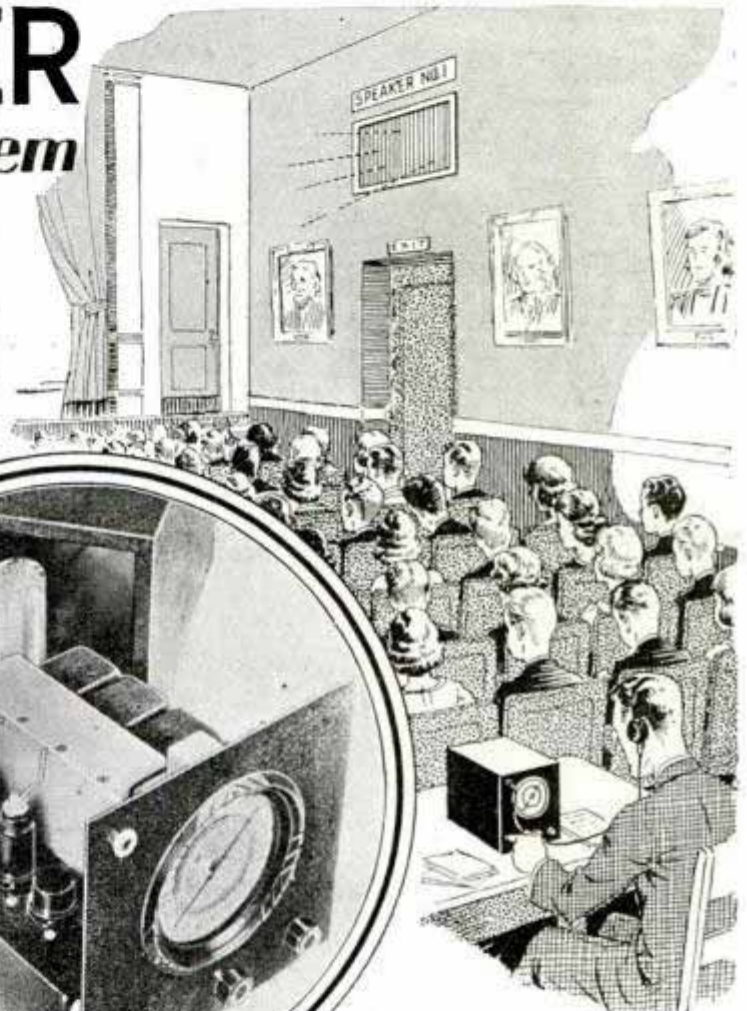
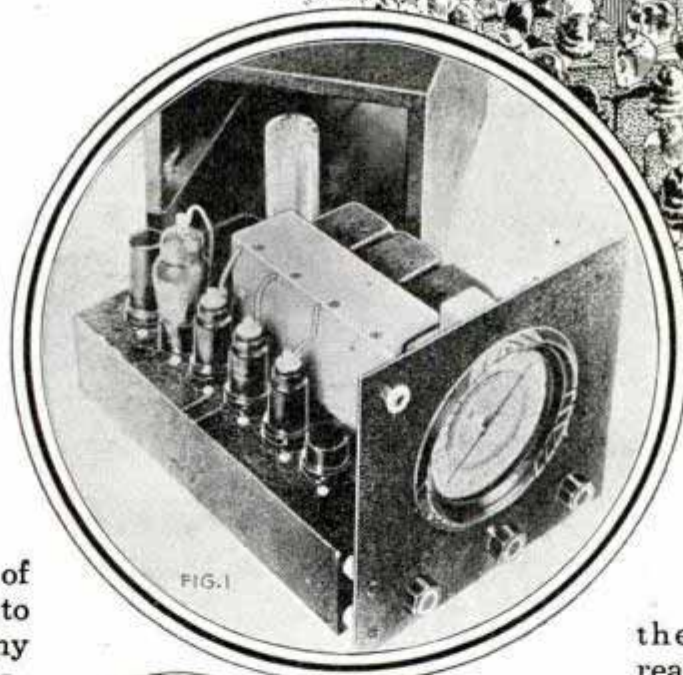

the completed chassis ready for the steel cabinet. Layout diagram Fig. 2 clearly illustrates the compact arrangement of parts on the chassis base.

Covering the full broadcast band, the tuner consists of four tuned circuits employing Meissner iron-core shielded r.f. transformers and a 4-gang tuning condenser. Special features include a convenient separate output channel that may be used for headphone monitoring purposes, frequency calibrated 4-in. airplane-type dial, high-gain coils, full automatic volume control and manual audio-gain and tone controls.

*Meissner mfg Co
not connected*

Economy BATTERY-OPERATED

By J. T. Wilcox

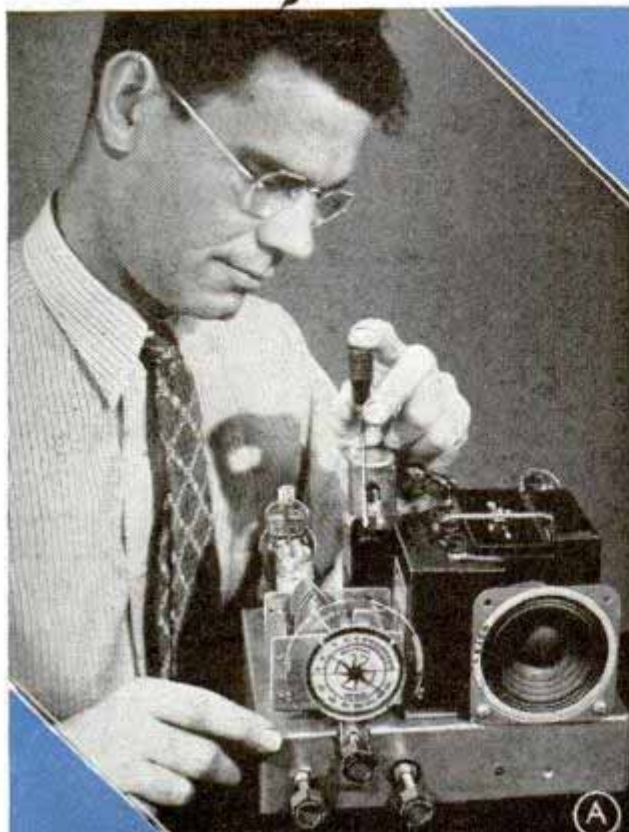

PORTABLE battery-operated radio receivers have always been popular as they are independent of any form of line supply. Many so-called portable battery sets in the past were hardly portable in the strict sense of the word, as they were much too heavy and bulky. The model to be described weighs only ten pounds complete with batteries and is capable of performance above average for portables.

Some recently developed low-drain tubes are used in the conventional super-het circuit with a few modifications. An unusually low battery drain of 7 m.a. for the B-battery, and 300 m.a. for the A-battery, makes economical operation possible. The circuit is sensitive and selective, easy to build and the parts are not expensive.

Fig. 1 shows the schematic circuit diagram, and the simplified wiring diagram appears in Fig. 2. The metal base, detailed in Fig. 3, is an underside view and all holes are clearly indicated. Photos A, B, C, D and E show various views of the completed re-

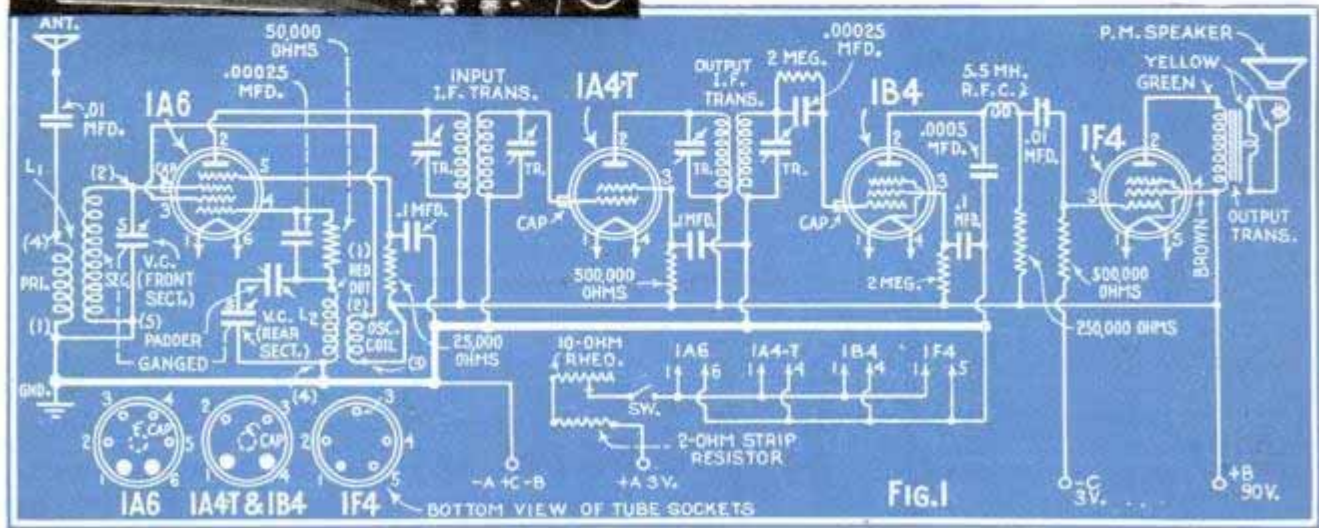
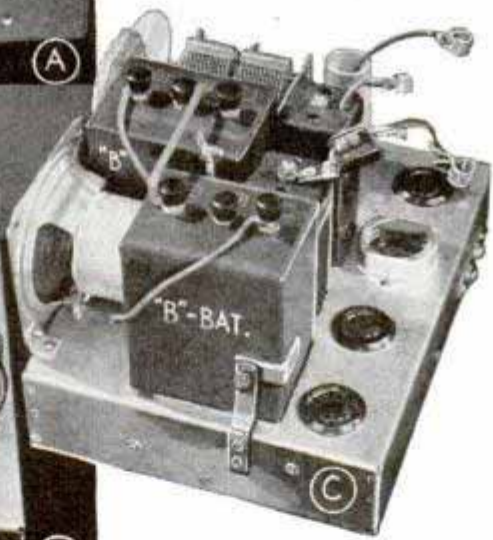
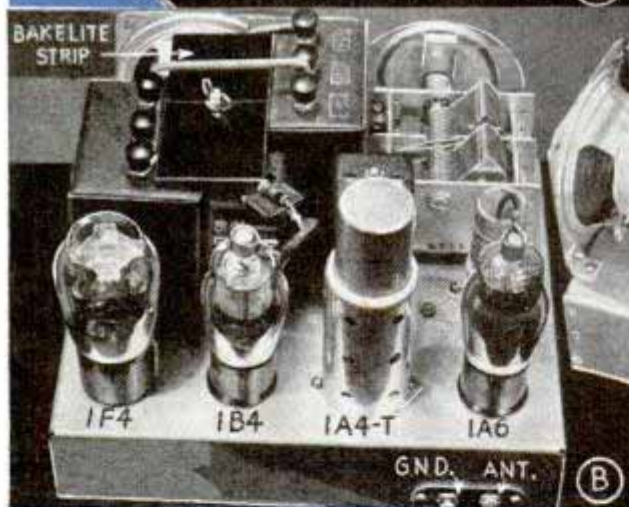

Portable BROADCAST RECEIVER

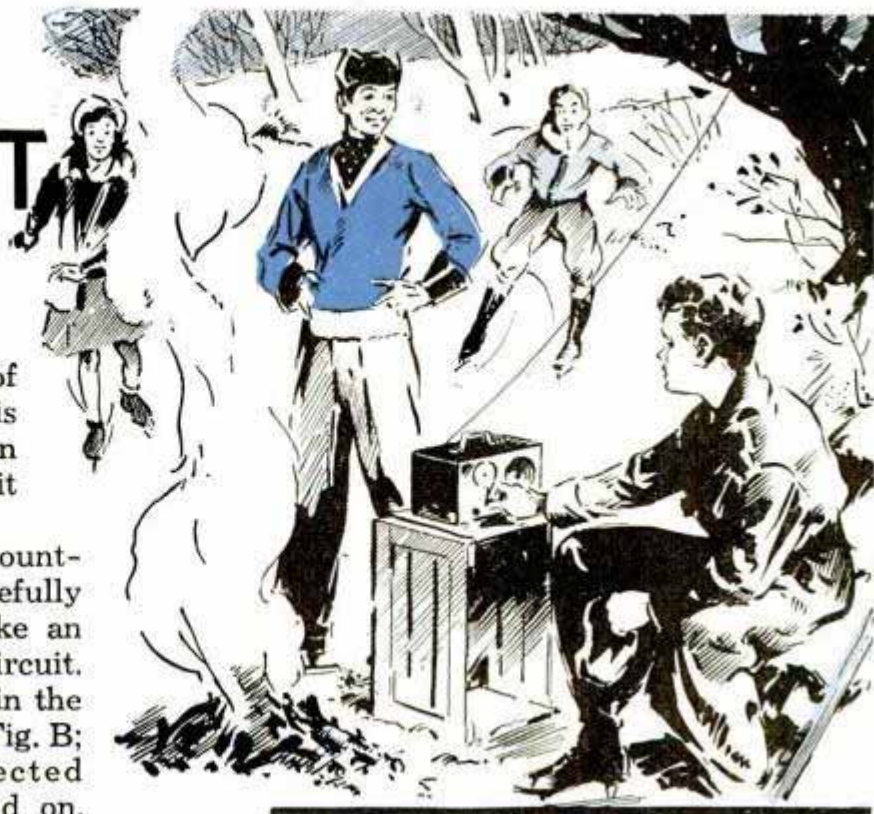

ceiver. This arrangement of parts is not critical, but it is hardly likely that any deviation from the original will make it smaller.

After all parts have been mounted on the chassis base and carefully wired, it is advisable to make an initial test of the filament circuit. All tubes should be inserted in the sockets as indicated in photo Fig. B; the A-battery is then connected and filament switch turned on. These tube filaments normally operate with a dull red glow. They are easily damaged if the incorrect battery voltage is accidentally applied. When the filament circuit is correct, the "C" and "B" batteries may be connected.

To line up the set, the trimmer condensers in the I.F. transformers should be aligned by means of an oscillator to insure maximum efficiency. If an oscillator is not available, any local radio serviceman can

(Continued to page 146A)

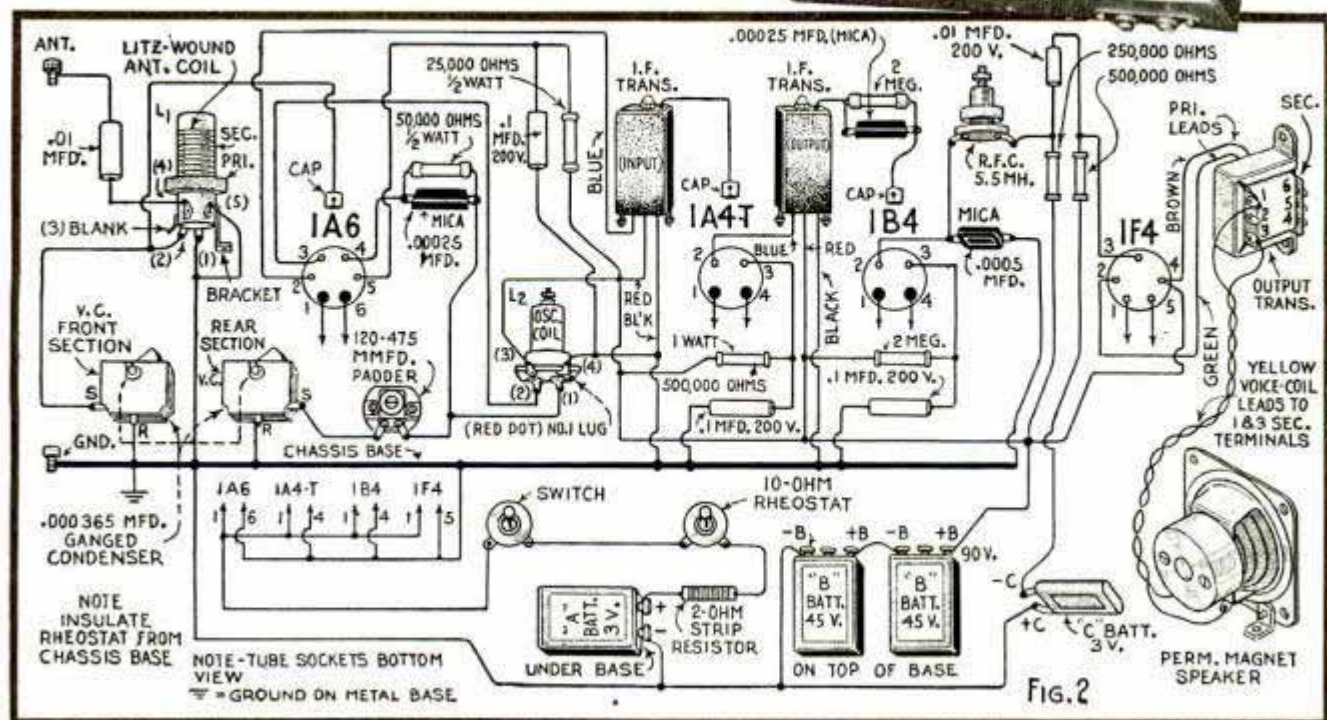
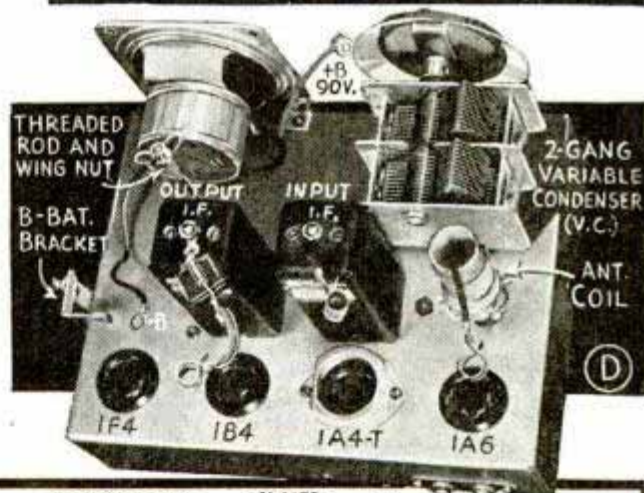
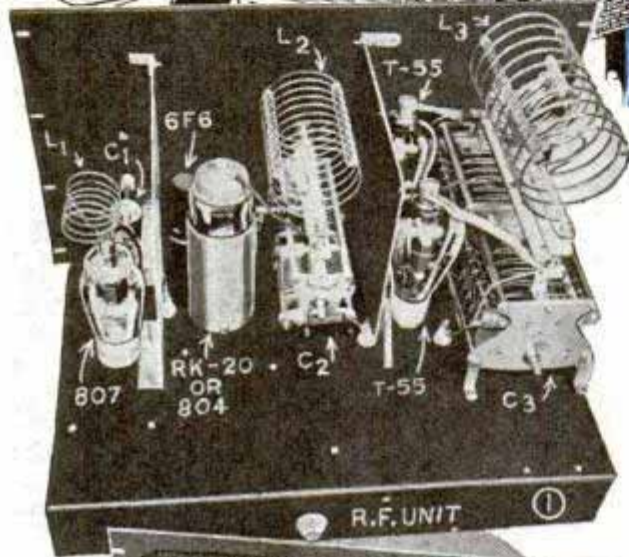

FIG. 2

Compact Ten and Twenty-Meter Transmitter

By R. E. Davy—W9GKU

F. L. Brittin—W9DCX



COMPLETE in every detail, this self-contained transmitter for the advanced amateur is designed to meet conditions where medium high power is desired and space is at a premium. Although only 58½ in. high and of standard width and depth, the power input is conservatively rated at 400 watts. An additional top panel is provided in the Bud sectional relay rack for extra equipment such as an antenna network or cathode-ray oscilloscope.

Photos 1, 2, 3 and 4 show rear views of the various units and the same numbers identify their respective positions in the front and rear photos of the rack assembly; a complete circuit diagram appears in Fig. 5. The r.f. unit panel is 12¼ in. high and the chassis base is 17 by 13 by 3 in. All panels are 19 in. wide and provided with type "A" notching for rack mounting. The chassis bases are supported directly on the panels with the exception of the high-voltage power supply. This is as-

(Continued to page 116A)

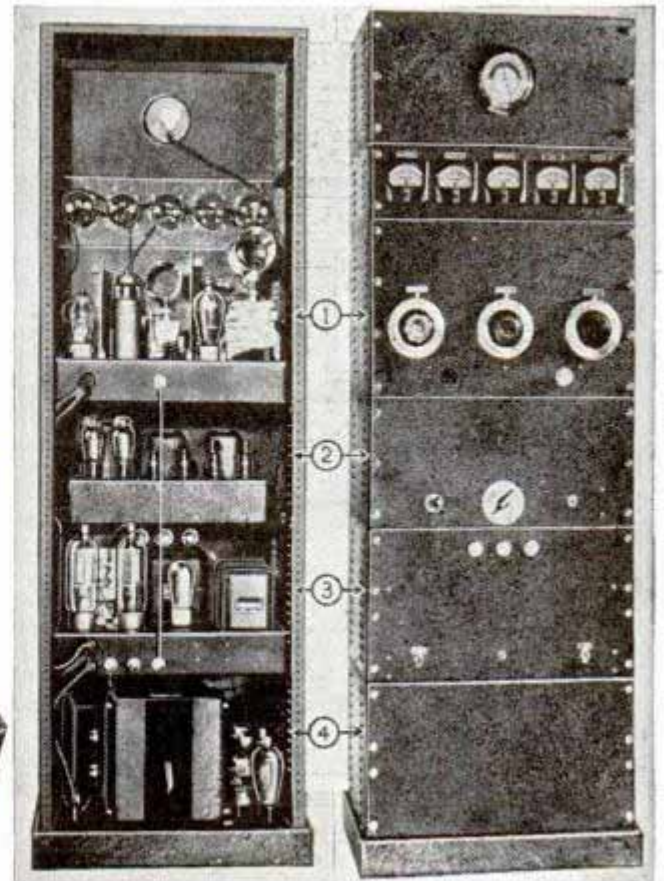

*Delmar Product Plus
Chesholm-Ryder Falls NY*

Hints for RADIO EXPERIMENTERS



Vertical receiving antenna requires no overhead wires; post and insulator assembly shown in A and B; RCA cable carries underground lead-in

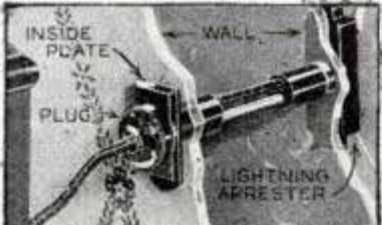

Left, compact antenna-receiver connector now available for running antenna and ground leads through building walls to inside plug and socket arrangement

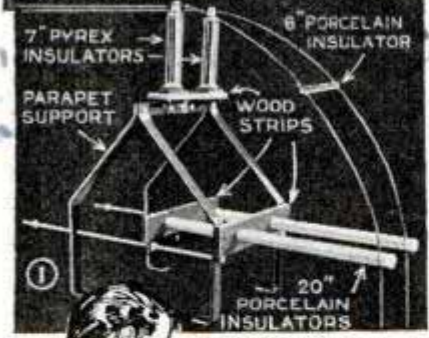

Figs. 1 and 2 show assembly and installation details of a method employed by an amateur for bringing "Zepp" transmitting feeders over the parapet of an apartment building. Wood strips are added to a Premax parapet mast support and drilled to take two 20-in. Johnson porcelain insulators which extend out over the edge of the building; these and two stand-off insulators mounted above, support the No. 12 enameled copper wires at the desired spacing

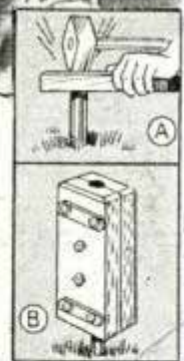

Below, handy wire clip made from spring brass; also, a panel-mounting clamp for holding small units in portable equipment. Right, variable concentric-tube neutralizing condensers mount directly on their own bus-bar leads; capacity 1 mmfd. to 20 mmfd.

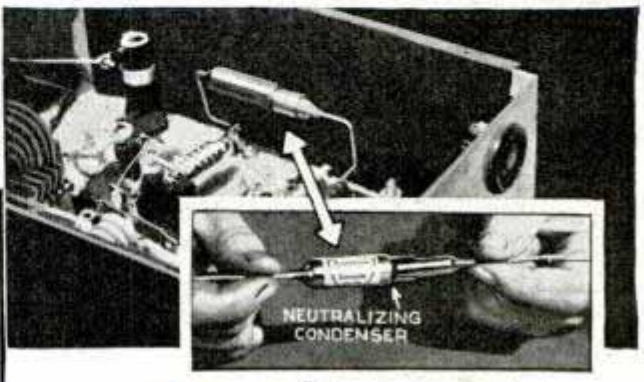
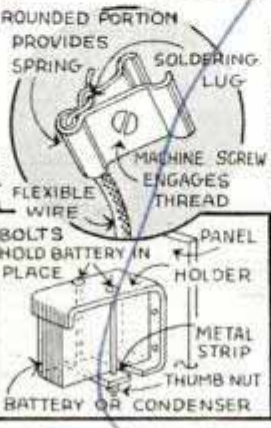

*Premax Product Plus
Chesholm-Ryder Falls NY*

*Walt G. Newell
Covinch Wale G. Church
No. 0 7. Oakland
California*

Crystal Oscillator-Doubler Foundation Unit

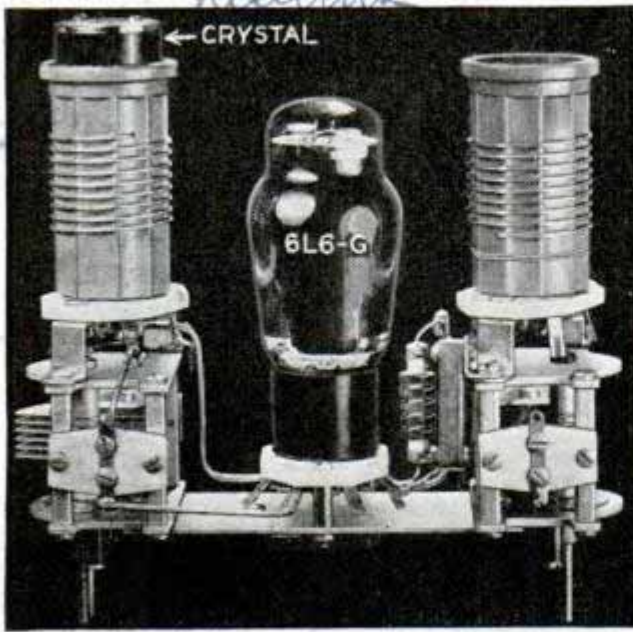

Beginners can assemble this foundation unit in a few minutes; it provides a low-power transmitter capable of up to 25 watts output on two bands with a single crystal. The entire unit is self-supporting and fastens directly to a panel by means of four mounting screws. A specially designed Hammarlund crystal socket fits into the top of the cathode coil form; both can be changed in a single operation.

Electric-Eye Burglar Alarm

No wiring is required to install this burglar alarm; it is merely plugged into an outlet and faced in the direction of a lamp.

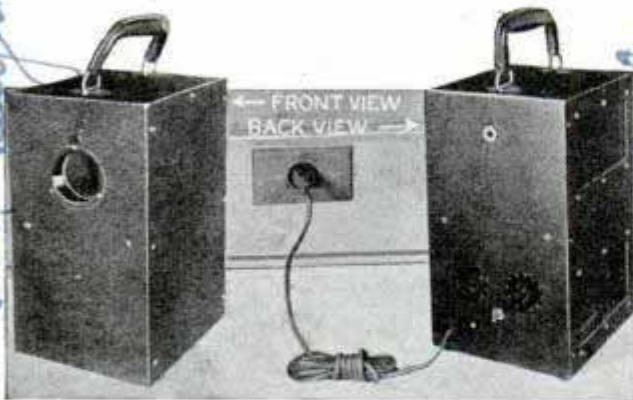

An invisible path between the lamp and unit is then fully protected from trespassers. The alarm, controlled by a secret dial combination, continues to ring if power line is cut or pulled out of socket

Push-Button Tube Tester

Equipped with automatic push buttons, this compact unit speeds up tube checking. It makes the standard R.M.A. official tests of electronic conductance, shorts, open circuits and leakage. A roller tube chart lists all tubes.



Sound Tracks Indented in Film



Used with an amplifier-speaker combination, an electromechanical device records 28 fine sound tracks on any type of developed or undeveloped 16 mm. film. No processing is required; records and plays back for dictation.

Blueprints covering radio construction articles in past issues are available for 25 cents each; original material lists and additional information can be obtained from our Radio Department without charge upon receipt of postage.

NEXT MONTH—How to Build the PM Economy Nine Superheterodyne Receiver. An excellent 9-tube a.c. super for high-quality broadcast-band reception; has 10-watt output, fine tone, full automatic volume control and phonograph pick-up jacks. Also—An Inexpensive Photo-Cell Relay, for controlling lights and bells.

Handwritten notes in blue ink:
 Hammarlund
 424 W. 33rd
 Chicago
 4019 W. Lake
 miles per hour
 \$ 5.50.00 C.F.
 37 W. 54th Street
 Tele-Touch Industries, Inc.

453 Weston Ave
Aurora, Ill.



"Pin-up" VANITIES

By
Wayne C. Leckey

FOR your guests, or for last-minute make-up, these little vanities are a pleasing addition to a hallway or dressing room, and they are very attractive when finished in painted or natural woods and backed with a crystal or blue-glass mirror. Essentially, the vanities are little cabinets attached to the bottoms of plate-glass mirrors and are hung on walls where desired. The designs presented suggest the use of both circular and rectangular mirrors, which can be purchased with plain or beveled edges at any large department store. While the beveled type gives the neatest job, you can use special shapes cut to suit, possibly from old glass on hand. For the sake of lightness, 1/4-in. plywood is perhaps the best material to use for the cabinets. You can use common fir plywood, and paint it, or you can select fancy, veneer-faced plywood which will finish beautifully. Where the edges of the stock are exposed, the plies of the wood should be concealed by painting a contrasting color, giving a pleasing two-tone finish.

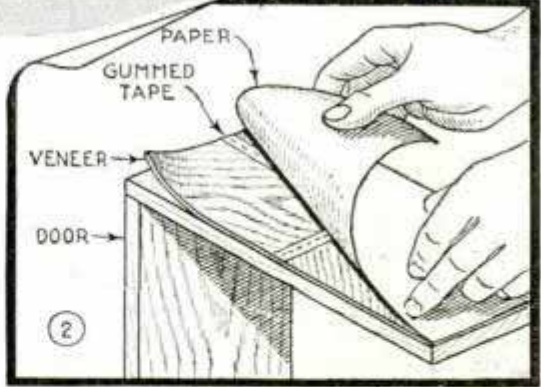

For the design shown in Fig. 1, first get a circular mirror of the size you wish. From this, the size of the cabinet is determined. The dimensions

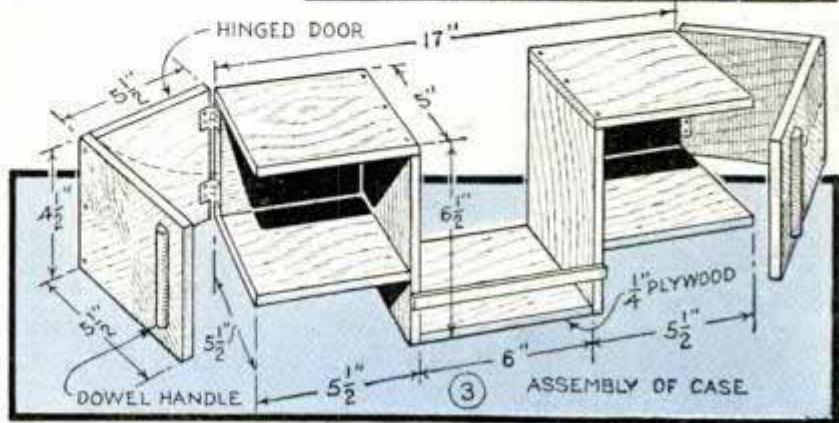

For the design shown in Fig. 1, first get a circular mirror of the size you wish. From this, the size of the cabinet is determined. The dimensions

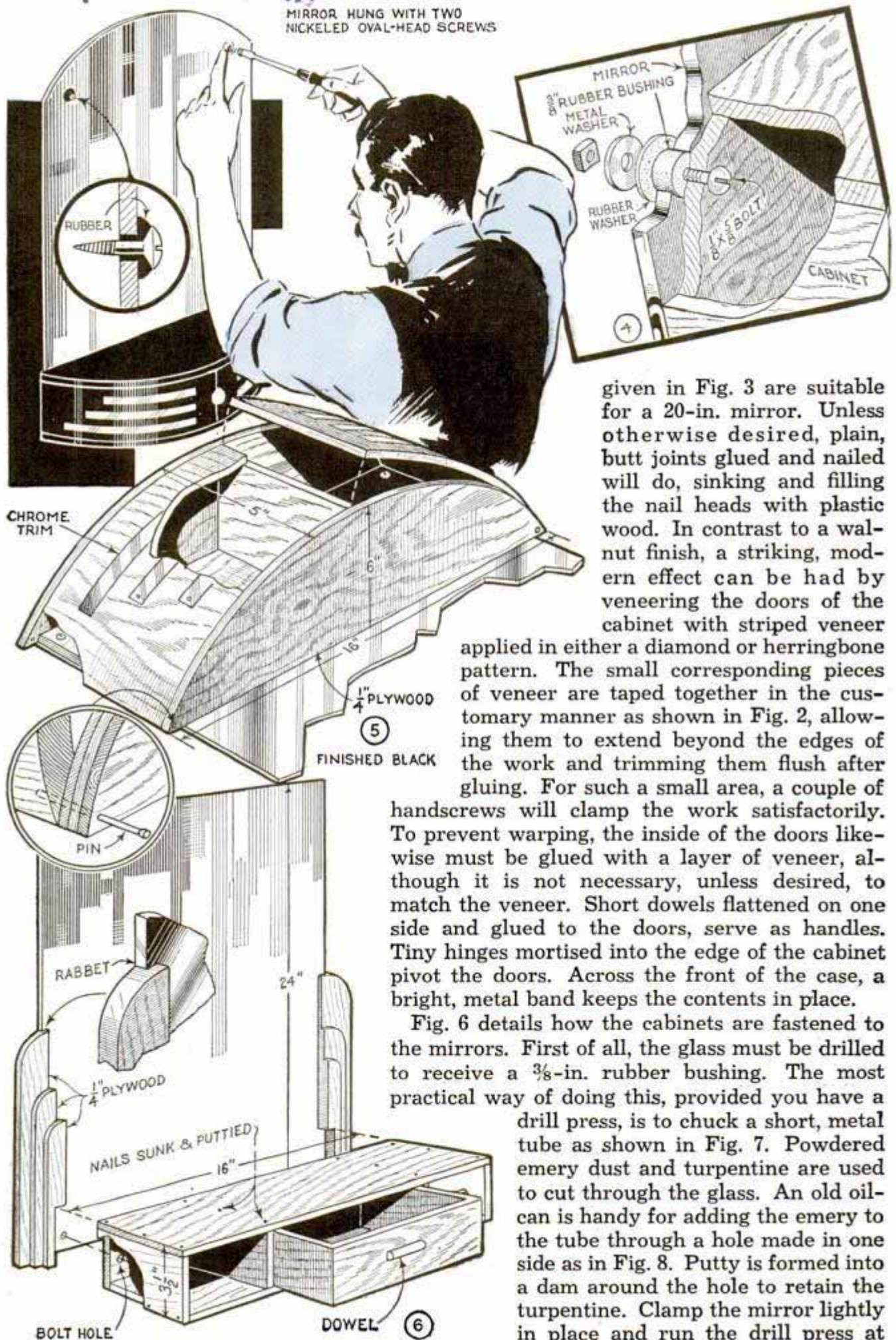

given in Fig. 3 are suitable for a 20-in. mirror. Unless otherwise desired, plain, butt joints glued and nailed will do, sinking and filling the nail heads with plastic wood. In contrast to a walnut finish, a striking, modern effect can be had by veneering the doors of the cabinet with striped veneer

applied in either a diamond or herringbone pattern. The small corresponding pieces of veneer are taped together in the customary manner as shown in Fig. 2, allowing them to extend beyond the edges of the work and trimming them flush after gluing. For such a small area, a couple of handscrews will clamp the work satisfactorily. To prevent warping, the inside of the doors likewise must be glued with a layer of veneer, although it is not necessary, unless desired, to match the veneer. Short dowels flattened on one side and glued to the doors, serve as handles. Tiny hinges mortised into the edge of the cabinet pivot the doors. Across the front of the case, a bright, metal band keeps the contents in place.

Fig. 6 details how the cabinets are fastened to the mirrors. First of all, the glass must be drilled to receive a $\frac{3}{8}$ -in. rubber bushing. The most practical way of doing this, provided you have a drill press, is to chuck a short, metal tube as shown in Fig. 7. Powdered emery dust and turpentine are used to cut through the glass. An old oil-can is handy for adding the emery to the tube through a hole made in one side as in Fig. 8. Putty is formed into a dam around the hole to retain the turpentine. Clamp the mirror lightly in place and run the drill press at

slow speed. By raising the chuck occasionally, you can keep plenty of emery under the rotating edge of the tube. Allow the tube to grind through gradually and do not press too heavily. Small bolts inserted through the back of the case and the center of the bushing are drawn up securely with a nut and washer on the back of the glass. For attaching the completed vanity to the wall, rubber grommets are likewise fitted under the screw heads as shown in Fig. 4.

The case shown in Fig. 4 is equally as simple to make. Finished a dead black, you can use soft plywood for this, trimming the doors with narrow strips of chrome metal fastened with tiny pins and providing a suitable pull at the center. The curved doors, cut to fit between the top and bottom of the cabinet, are formed to the proper contour by band-sawing from thick, solid stock and are pivoted to swing outward as shown in the detail given in Fig. 4. Finished as previously suggested, this case will contrast nicely with a crystal mirror.

A plain, rectangular mirror is used in the design shown in Fig. 5. Here a simple boxlike case is fitted with small drawers. Receding plywood pieces flanking each side of the glass are glued and nailed to the side of the cabinet which in turn is fastened to the mirror in the manner previously described. Flattened dowels, painted black, are likewise used for drawer

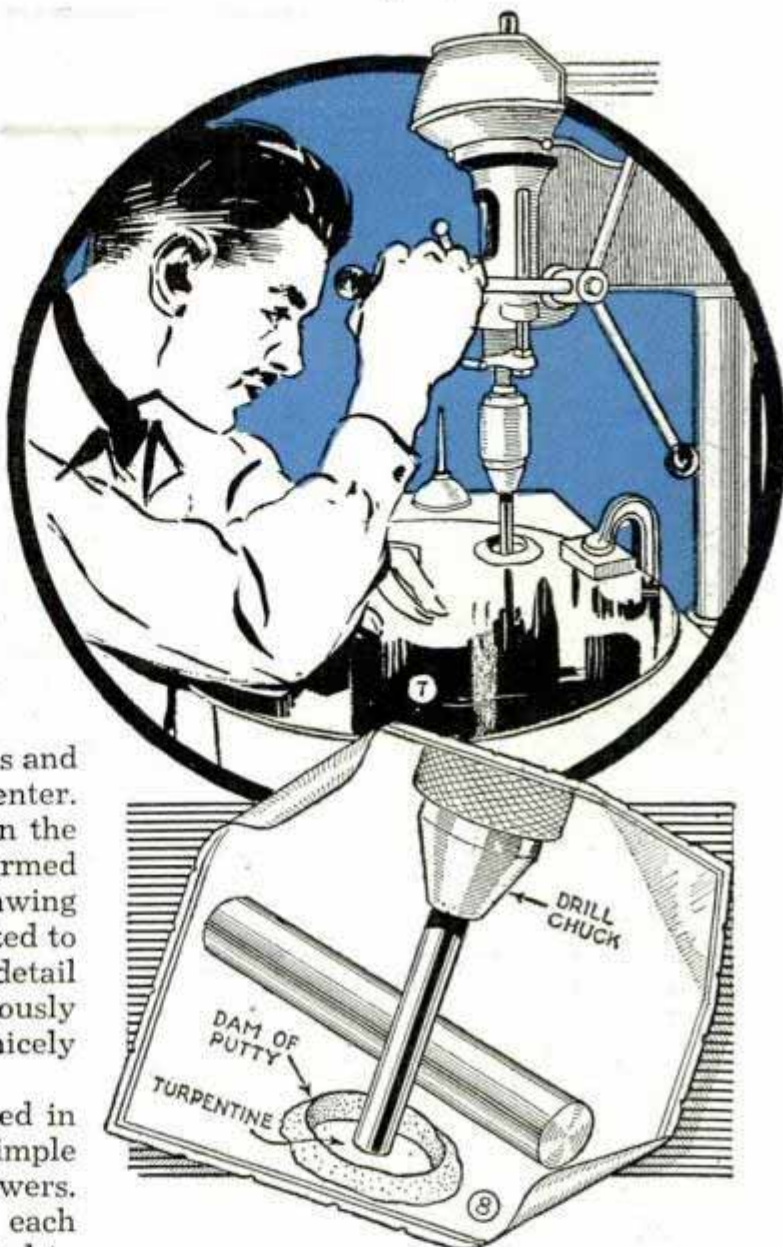

handles. Round black plastic with the ends rounded and polished is also very attractive. Small machine screws hold the plastic handles in place.

Signs with Lettering in Relief Easy for Anyone to Carve



You can carve decorative signs like the one shown by removing waste wood to bring out the design or lettering in relief. Magazines and catalogues provide a number of designs that can be enlarged and traced on the wood if you are unable to draw them. After the design has been transferred to the work, outline it with a sharp knife or carving tool, and then work away the surface of the wood to bring out the design in relief as indicated in the photo. Paint or finish the sign as desired.

—Clifford B. Paul, Moline, Ill.

T-Square Has Clamp on Head to Fasten on Drawing Board



When many lines must be drawn from a given plane with a triangle, it is a convenience to anchor the T-square firmly in place. One method of accomplishing this is to attach a large paper clip to the square. The bottom jaw is cut off to permit mounting the clip near the inside edge of the T-square head so that the top jaw projects under the board. When the clamp is squeezed, the square may be moved freely. When released, it will hold firmly in any position.

—S. J. Gancher, Richmond Hill, N. Y.

Novel Weather Vane

A Wisconsin tinsmith is responsible for this novel weather vane, which points in the opposite direction from which the wind is blowing. At the same time, the degrees that the wind flexes the standard give a rough indication of the velocity of the air current. The vane is a double arrow, cut from light tin and soldered to a length of medium-gauge spring wire. The lower

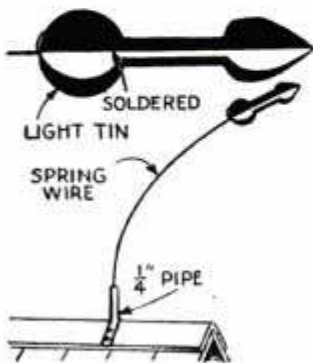

end of the wire is anchored permanently in a length of $\frac{1}{4}$ -in. pipe, which is split at one end and spread to fit over the roof gable. The tin arrows are painted in contrasting colors to make the vane easy to see.

Heater Element Serves as Crucible

An excellent crucible for melting small quantities of solder, lead or brass may be had by removing the resistance wire from an old heater element and then screwing it into a porcelain lamp socket of the type shown. The bolt and nut at the bottom of the form are retained to fill the hole in the base. In case the heat applied is so intense that the brass shell on the element or socket is melted, the space can be filled with plaster of paris or asbestos cement. It is best to use a metal plate or some other protecting layer between the crucible and the bench top.

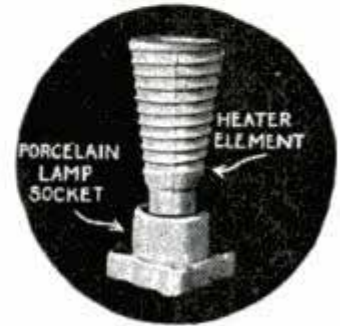

Installing Suction Line in Well

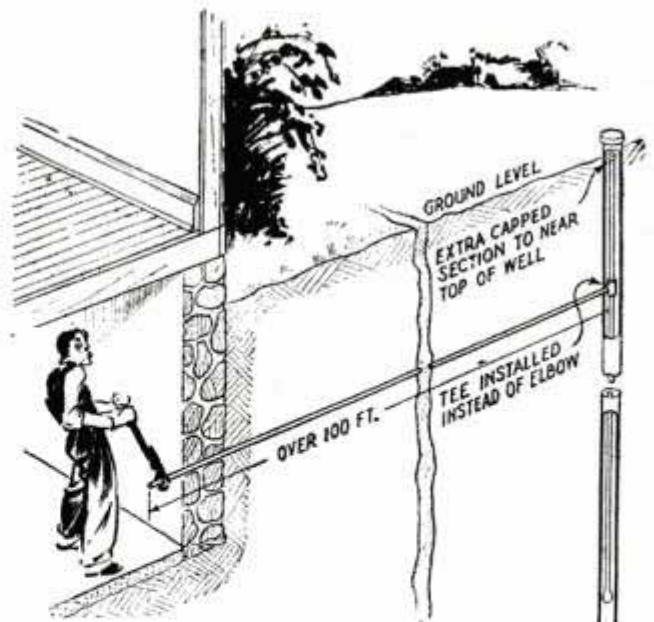

The difficult job of installing a suction pipe in a 6 to 10-in. artesian well where there is a horizontal run into the basement of a building is simplified by the following method: Instead of the usual elbow where the pipe makes its 90° turn, install a tee and add a capped section of pipe of suffi-

cient length to reach the top of the well. It is now easy to hold this combination at the proper level where the horizontal pipe can be threaded into the facing tee. Two other mechanical advantages add to the idea. First, this extra section of pipe acts as an air chamber and helps any power or hand pump to work, and should it be necessary to remove the well pipe for examination, it can be done without digging up a straight horizontal run.—Walter U. Akerman, Dover, N. H.

Photo Press Is Made of Wood and Coil Spring

Here's a simple yet efficient press that is just the thing for drying enlargements and pressing papers. A compressed spring, stapled to a plywood panel, keeps the two panels firmly together. To use it, raise the sliding panel enough to permit the insertion of the work. The panel must slide freely on the dowels.

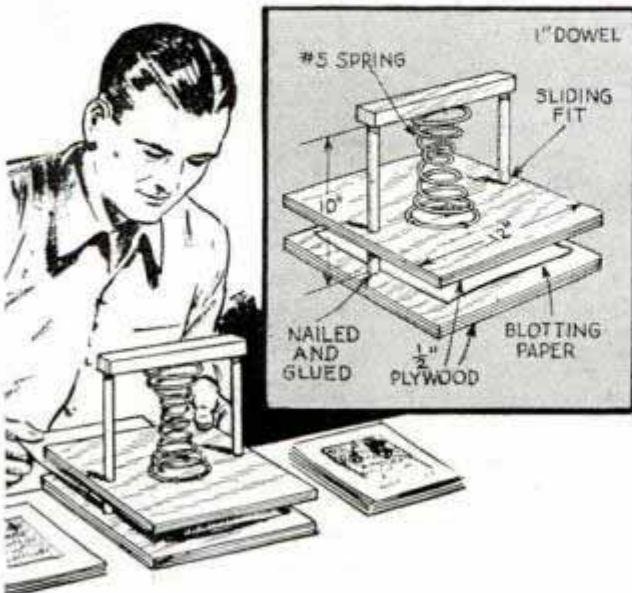

Bookcase Folds for Transportation without Taking Books from Shelves



Just tip case over on one side and fold top half against the bottom half

Students, teachers, engineers and others who take up quarters temporarily in rooms and may move from place to place frequently will find this folding bookcase just the thing. Also, it is ideal for those who live in furnished apartments and for vacations in a summer cottage. When you want to transport the case, just tip it over on one side, leaving the books on the shelves, and swing the top around against the bottom and lock them together. The two frames, which are hinged together, are made of $\frac{3}{4}$ -in. stock and are identical. The backs of the frames are covered with $\frac{1}{4}$ -in. plywood, and the shelves are cut from $\frac{1}{2}$ -in. plywood. A hasp and padlock will keep the frames from opening when folded, and two handles can be attached to one side of each frame for carrying the case like a suitcase.—Lester Lehnerr, Madison, Wis.

Protecting Lantern Mantles

You can move a gasoline lantern from place to place in a car without breaking the fragile mantles if they are impregnated with paraffin. Just melt a small amount of paraffin in a tin can, and hold it under the mantles, immersing them completely. The wax coating applied in this way hardens and stiffens the mantles. In relighting the lantern, the paraffin will melt readily when a match is applied.

in Wrought Iron

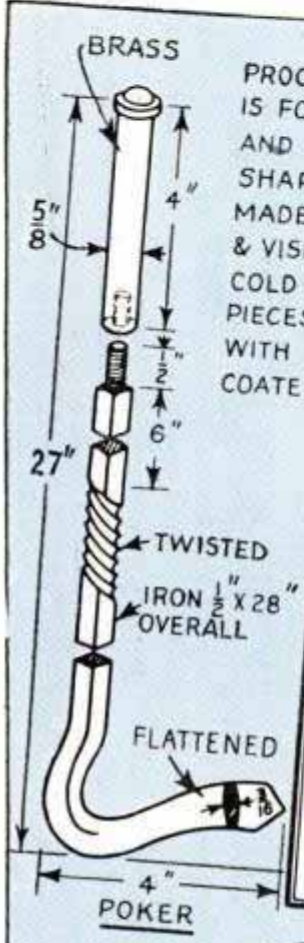

PROCEDURE: THE IRON IS FORMED BY HEATING AND HAMMERING TO SHAPE - TWISTS ARE MADE WITH WRENCH & VISE. BRASS IS BENT COLD OR MACHINED. ALL PIECES ARE POLISHED WITH EMERY CLOTH & COATED WITH LACQUER

- MATERIAL LIST**
- 6 FT OF $\frac{1}{2}$ " X $\frac{1}{2}$ " - WROUGHT IRON
 - 2 FT-3IN OF $\frac{3}{32}$ " X $\frac{3}{8}$ " - WROUGHT IRON
 - 5 FT OF $\frac{1}{8}$ " X $\frac{1}{8}$ " - WROUGHT IRON
 - 1 PIECE - $\frac{1}{4}$ " X $1\frac{1}{4}$ " X $2\frac{1}{4}$ " - IRON
 - 1 PIECE - 18 GAUGE $10\frac{1}{2}$ " X $15\frac{1}{2}$ " - IRON
 - 1 PIECE - 18 GAUGE 6 " X $7\frac{3}{4}$ " - IRON
 - 1 PIECE - $\frac{1}{16}$ " X 2 " X APPROX. 37" - BRASS
 - 1 PIECE - $\frac{3}{4}$ " X 9 " X 14 " - HARDWOOD
 - 1 PIECE - $\frac{7}{8}$ " DIAM. X 20 " - BRASS ROD
 - 1 PIECE - $\frac{1}{2}$ " X $\frac{1}{2}$ " X APPROX. 19" - BRASS

THE SHOVEL IS FORMED ON A BLOCK

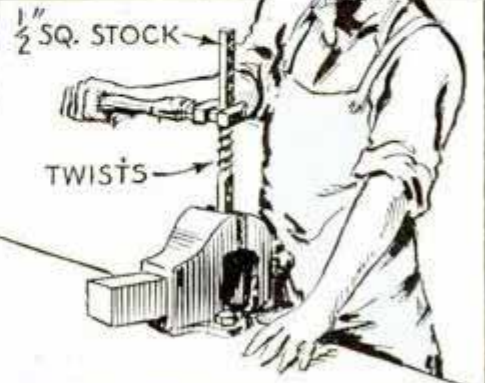
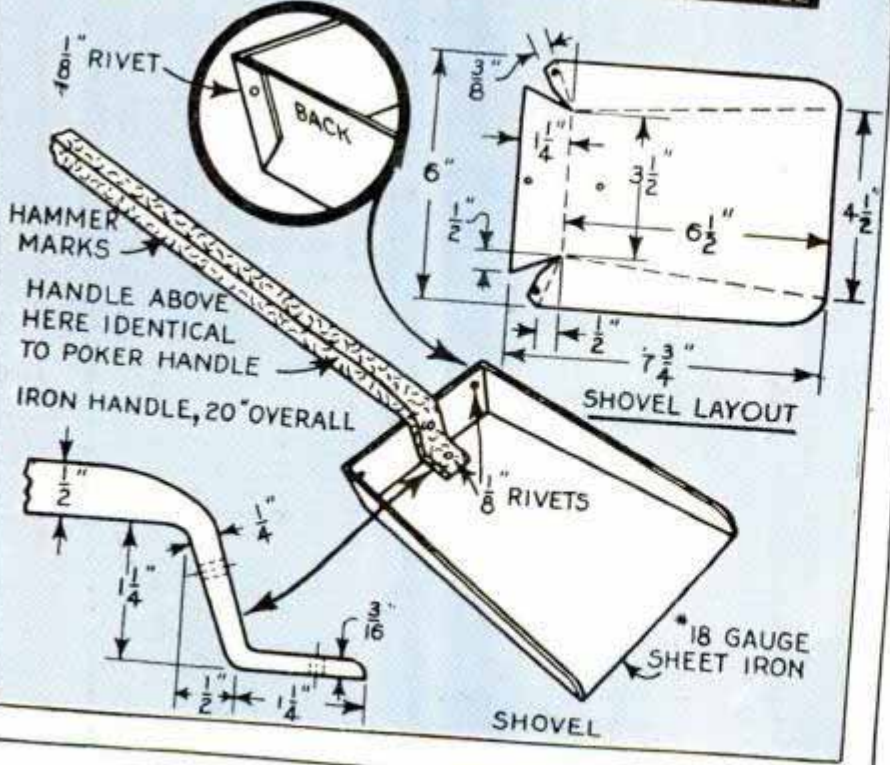

THE HEATED IRON IS HELD IN A VISE WHILE BEING TWISTED WITH WRENCH

Accurately Spaced Holes Drilled with Aid of Steel Balls

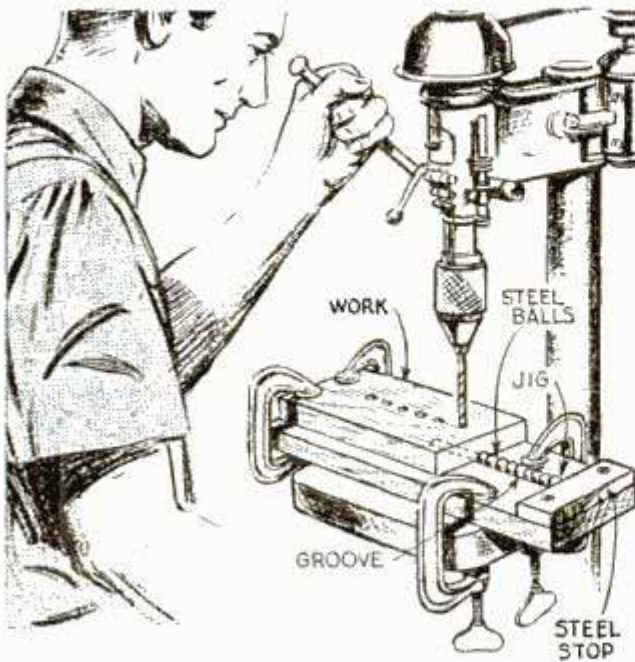

This jig will be found a timesaver when a number of equally spaced holes are to be drilled. The body of the jig is a piece of hardwood with one or two V-grooves cut in the upper surface to hold steel balls, which are used to space the holes. A stop screwed to the piece keeps the balls from rolling off at one end, while the work keeps them from rolling off at the other end. In use the jig is clamped to the drill-press table, and the work to be drilled is laid on top of it and clamped in position as indicated. After drilling the first hole, the work is loosened and moved to locate the next hole, after which balls are placed in the groove between the stop and the edge of the work. The remaining holes can be spaced by adding balls and butting the work against them.

Graduated French Curve

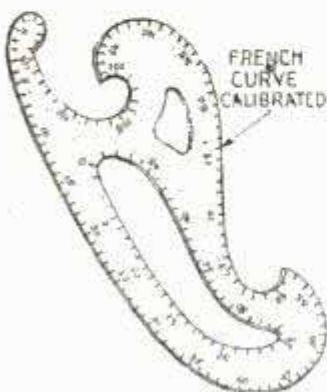

When duplicate curves of similar section are required, you will find it convenient to have the working edges of the French curve suitably graduated. The graduations are laid out with

dividers and then scratched on the surface of the celluloid with a sharp scribe. These lines can be filled with thick paint, the surplus of which is carefully wiped from the surface. An alternate method is to frost the front and back of the curve with fine sandpaper. The calibrations can then be marked on the surface with a lead pencil.

—S. J. Gancher, Richmond Hill, N. Y.

Upholstery Gimp Is Held Open by Spring Clothespin

To avoid striking his fingers while tacking leather upholstery gimp, one craftsman obtained a common spring-type clothespin to spread the gimp apart. The open end of the pin was

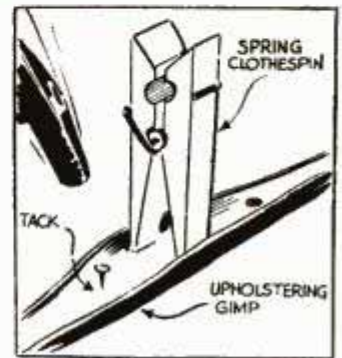

pressed together and inserted vertically between the gimp, after which it was released as shown, thus expanding the rolled edges to insert tacks. The pin is compressed and moved along the gimp as the tacking progresses.

Reflectors on Bicycle Pedals

Most bicycles have red reflectors on the fender to reflect the lights of a car approaching from the rear and warn the driver, but few riders take the precaution of warning a motorist who might approach them from the side. This can be done quite easily, however, by attaching red-glass reflectors to the ends of the pedals. The type backed by metal are easily soldered to the pedals, and are noticeable because they rotate with the pedals.

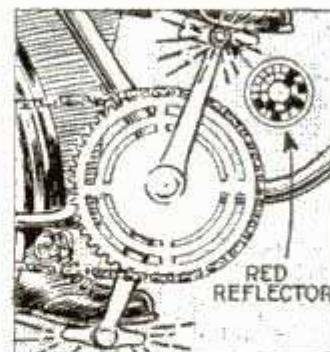

☐ Dried adhesive on gummed-paper tape can be softened so that it will stick by adding a few drops of glycerin to the water used for moistening.

Use Your Camera with These "JIFFY" ENLARGERS

Most enlargers are complete units, including lens and bellows, but these are really only lamp houses. The camera that takes the picture supplies the lens and bellows units for making the enlargement. As you see, there are two types, one using an opal glass for diffusion, Figs. 1 and 2, the other a condensing lens, Fig. 5. Both types of lamp houses are supported on a column of 1/2-in. iron pipe. The sliding arm consists of a pipe tee, with the threads reamed out to fit over the column, a 4-in. nipple and a floor flange. The vertical column is turned into a flange which is screwed to the easel or baseboard. The lower part of the lamp house is built of wood and the reflector is made from a funnel, or, can be purchased ready made

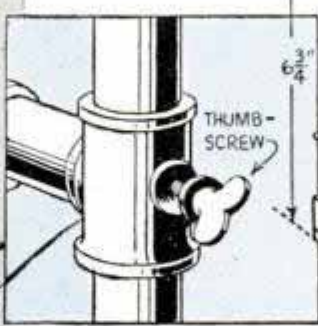
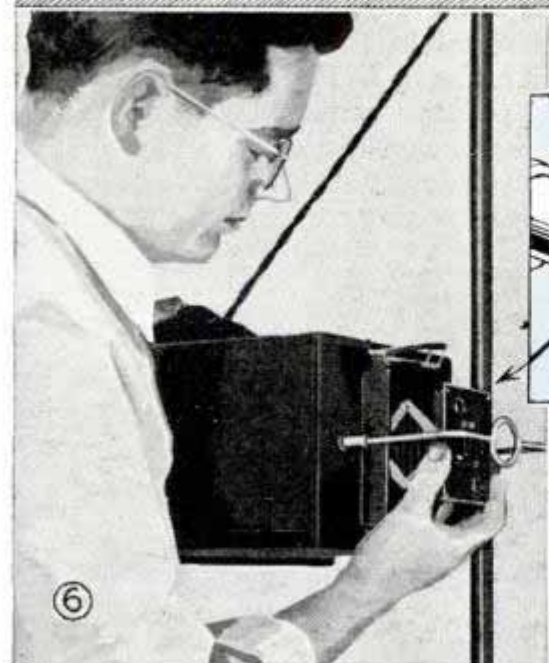
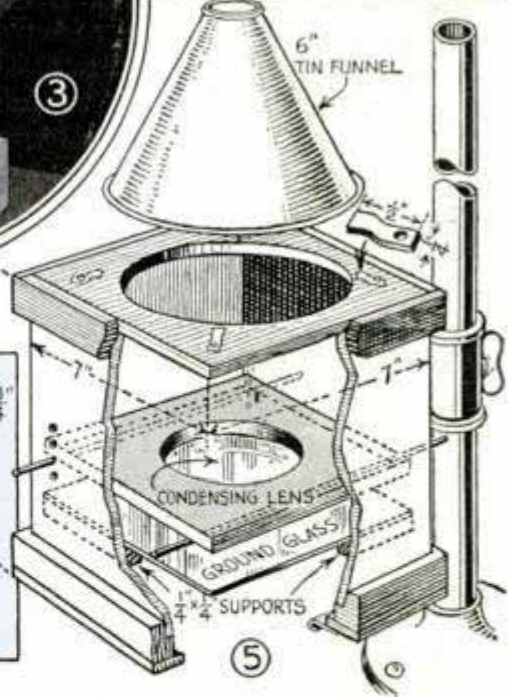
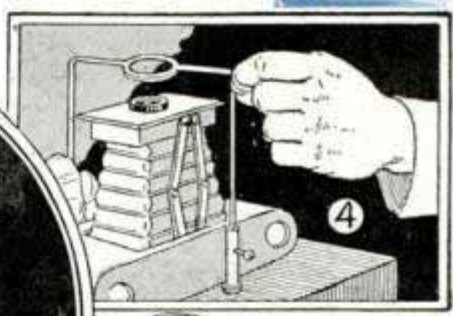
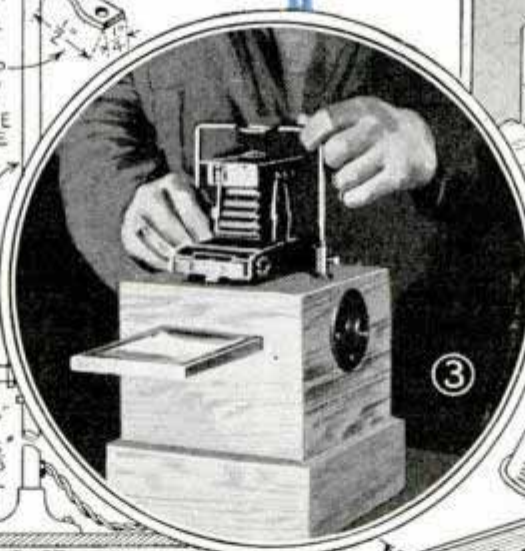
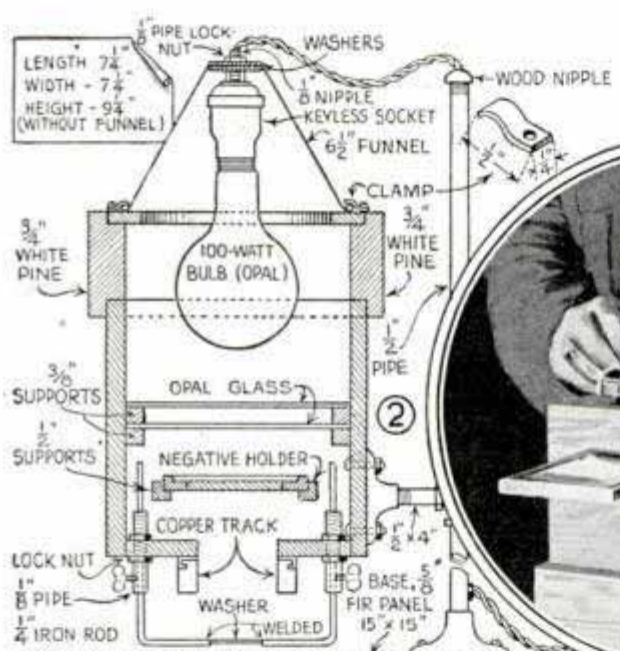
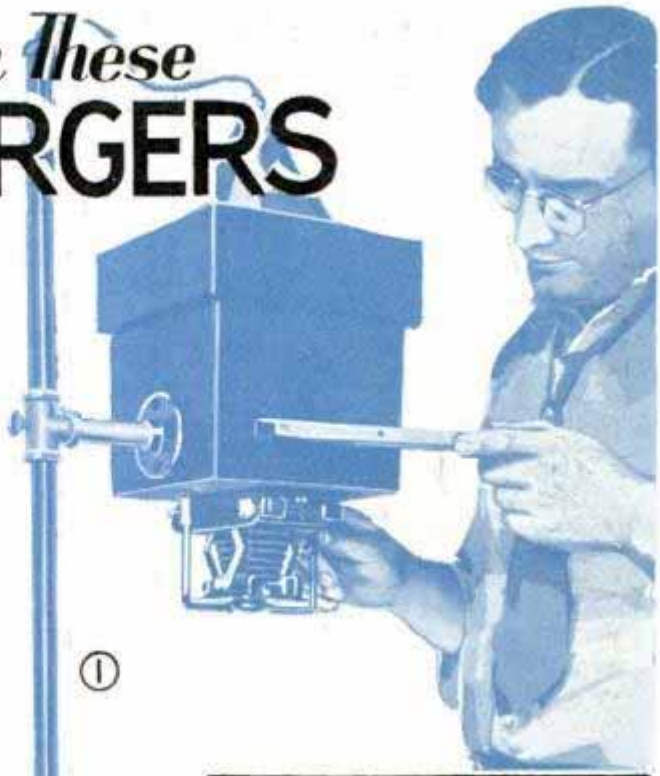

Of course, dimensions of the various parts may have to be altered to suit the camera used. In addition to the clamp for holding the camera back tightly against the light box, some types of folding cameras will require the ring support shown in Figs. 3, 4 and 6 and detailed in Fig. 2. This serves to hold the lens at exactly the position required. A negative holder can be made by hinging two pieces of plate glass with tape and then masking to the required area

Surplus Wire Wound on Spools from Headlight Reflectors

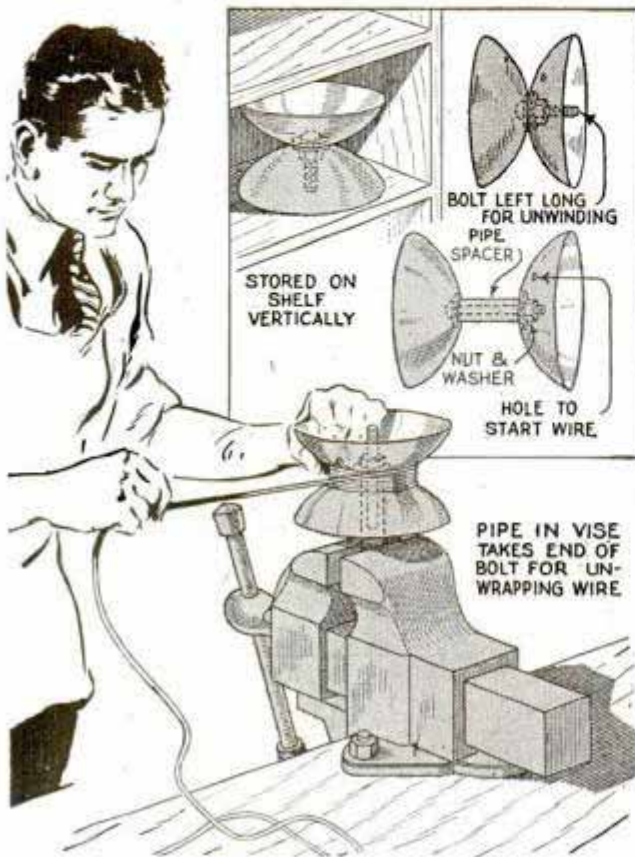

Neat, useful spools for storing odd lengths of magnet wire or single and double cord can be made if some old auto headlamp reflectors are at hand. Bolt them together as shown, leaving the end of the bolt projecting for a short distance at one end. Then, by clamping a piece of pipe vertically in the vise, the bolt end can be inserted into it and the spool will rotate while removing the wire. These spools can be made to take any amount of wire by inserting various lengths of spacers.

Muffler Buttoned to Overcoat

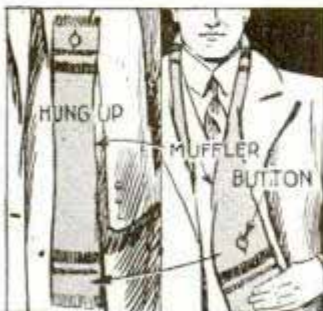

Instead of sticking your muffer in the pocket or in one of the sleeves when you take off your overcoat, why not button it to the coat so that it always will be in place when

needed? Near one end of the muffer make a buttonhole, put the muffer around your neck and then sew a button to the inside

of the overcoat in a position corresponding with the buttonhole in the muffer. Then, when you take off your coat, you can forget all about the muffer because it is buttoned in place and cannot get lost.

Metal Cam on Tinner's Shears Deflects Long Strips

Usually a long cut with tinner's shears in a piece of heavy sheet metal is hindered by interference of the waste stock, which does not bend or curl out of the way as the cut proceeds. To deflect the waste stock, attach a piece of metal under the end of the pivot bolt as shown in the photo. Be sure that the angular edge of the metal faces the direction that the cut is being made.



Fishline Sinkers Provide Weights for Small Chemical Scales

Photographers and others who mix chemicals from the same formula frequently, will find that ordinary fishline sinkers provide good weights for their balance scales. To make up a set of the weights, weigh each chemical in the formula carefully by the usual method and then take one of the sinkers and whittle it down until it just balances the chemical. Mark the name of the chemical on the sinker and then do the same thing with each chemical in the formula. The next time you make up the formula all you have to do is put the required weight on the scale and pour in the chemical until it is balanced. This saves reading the formula each time or taking care in weighing it.

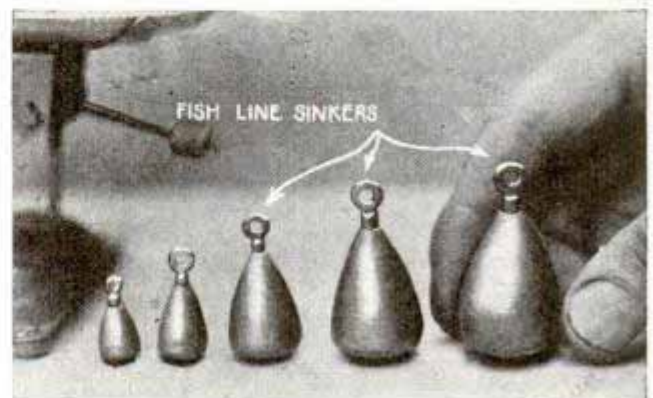

Ship's Wheel Top on Smoking Stand Rotates

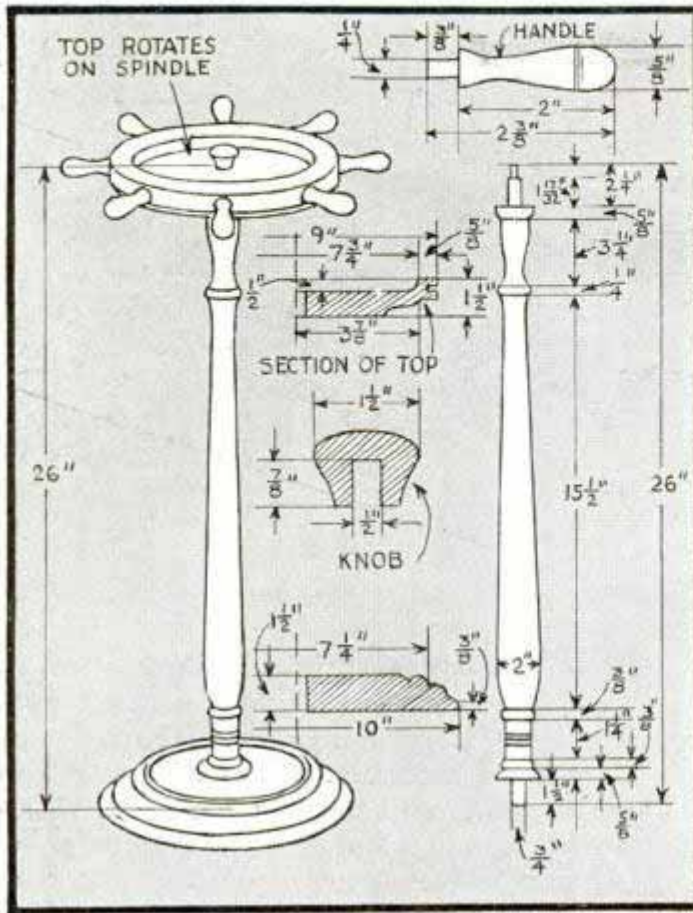

Pivoted so that it rotates for convenience in reaching articles, the helm-like top of this smoking stand gives it an unusual appearance. The entire assembly is a simple turning job, the top being deeply recessed and holes drilled in the edge to take the

eight handles. Two tenons are turned on the upper end of the standard, one on which to pivot the top, and a smaller one on the end to take a knob, which prevents the top from coming off and also serves as a finger grip for lifting the smoking stand.

Rainproof Mounting for Weather Vane Has Glass Bearing

Here's a mounting for a weather vane that reduces friction to a minimum so that the vane turns freely. The standard is pipe with a cap at the top, which is drilled in the center and a smaller pipe soldered into the hole. This pipe is reamed to take a brass rod, which carries the vane. The pointed end of the brass rod rests on a glass disk inside a cap on the lower end of the small pipe. One half a brass curtain-pole ball is soldered to the rod as shown, to keep water from entering the assembly. —Fred T. Oakes, Croton on Hudson, N. Y.

☐ Inexpensive acidproof paint used to repair storage batteries, makes a good lining for tanks or trays in which chemicals or photographic solutions are to be used.

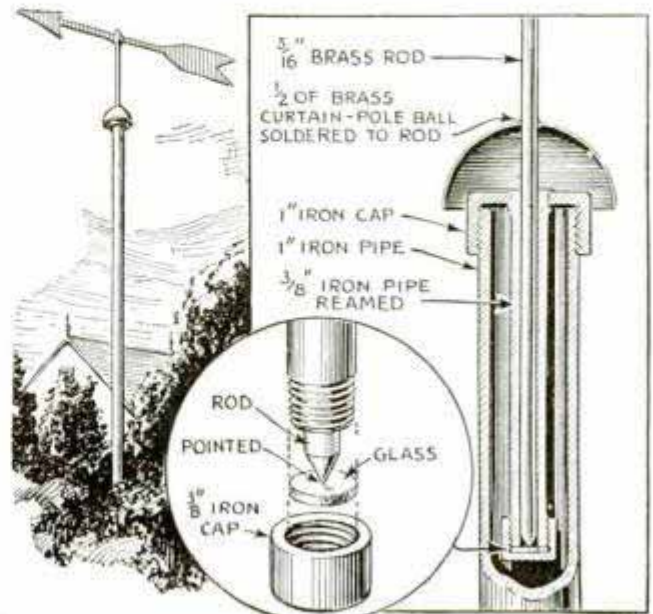

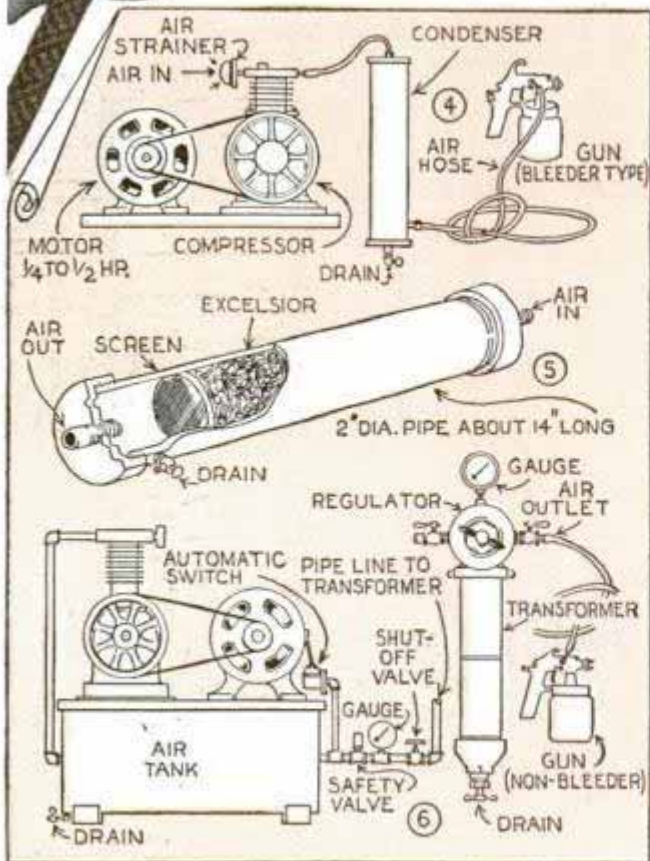
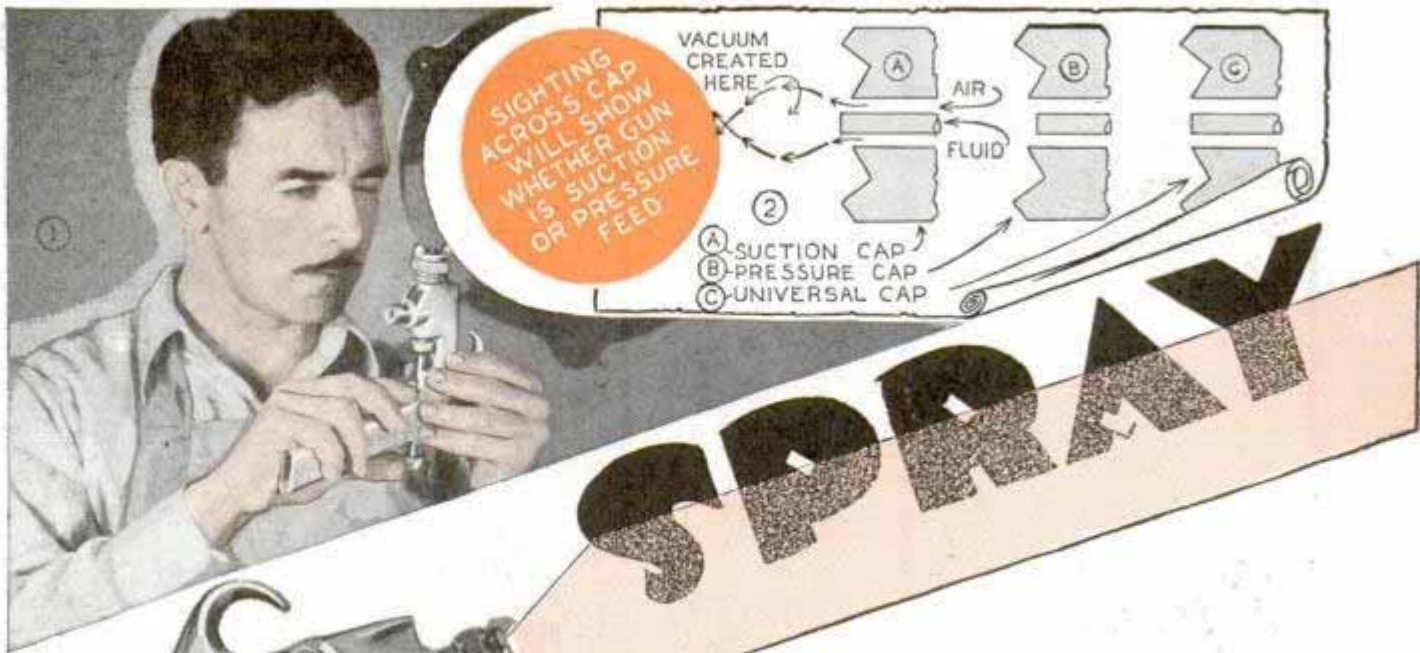

FINISHING becomes the easiest part of the job when done with a spray gun. Not only is spraying many times faster than hand brushing, but it also gives superior work and permits the use of fast-drying lacquers and synthetic enamels.

Many different arrangements are used in spray finishing. The simplest practical setup is the portable unit shown in Fig. 4. The condenser, Fig. 5, can be made from 2-in. pipe and can be arranged to drain from either the bottom or end. The condenser smooths out pulsations in the air supply, and also extracts the water and oil which form when the air is compressed. A more elaborate setup where the unit is to be stationary is shown in Fig. 6. In this arrangement, air is first pumped into a storage tank. An automatic switch on the tank turns off the motor when the pressure reaches 100 lbs., and turns it on again when the pressure drops to 80 lbs. Since the full 80 lbs. pressure is seldom needed, the main air line must be piped to a transformer. The transformer consists of two parts. The upper part is a regulator, which can be adjusted to deliver any required air pressure; the bottom part is a condenser as already described.

The spray gun for the portable installation shown in Fig. 4 must be of the bleeder type. The unit shown in Fig. 6 takes a non-bleeder gun. A bleeder gun is constructed to pass air at all times and must be used when air is taken direct from the compressor or where the compressing unit



THE MODERN FINISHING METHOD

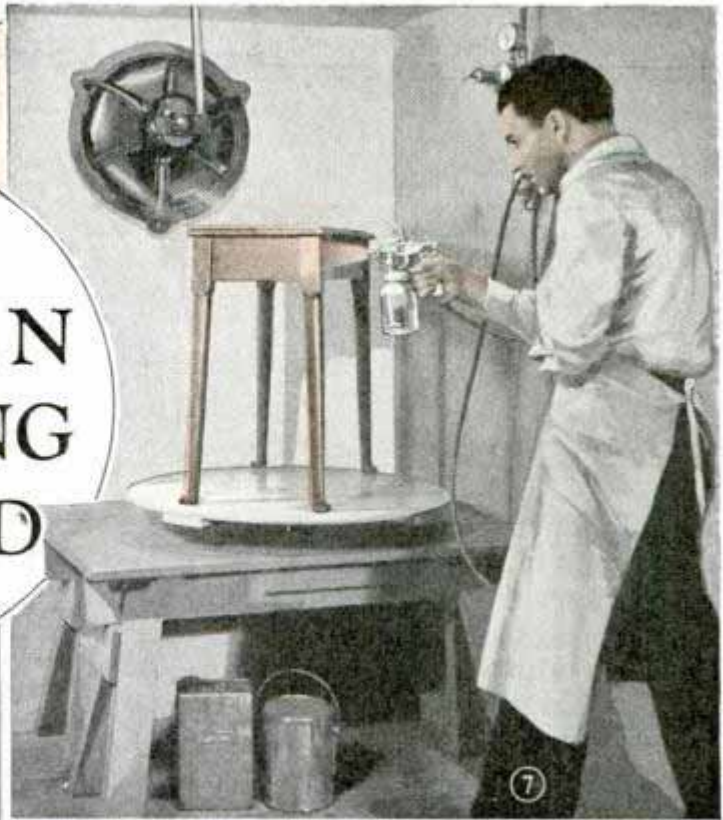

A TYPICAL HOMESHOP INSTALLATION

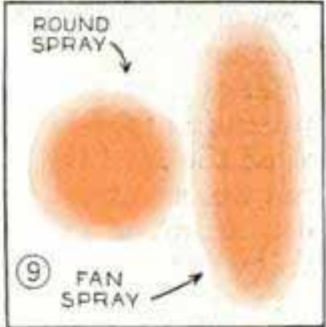

does not have some form of pressure control. A non-bleeder gun can be made a bleeder type by tying back the trigger, as shown in Fig. 10, to pass air but not pulled so far as to pass fluid. Two or three other features of gun construction must be considered. Most important of these is whether the gun shall be suction or pressure feed. In the suction feed, the fluid is pulled to the nozzle of the gun by the vacuum created by the air; in the pressure feed, air is introduced into the paint cup to force the fluid to the nozzle. Pressure feed is useful and necessary for heavy fluids; suction feed is practical for average fluids and is simpler and less expensive.



Most guns can be used with either pressure or suction feed.

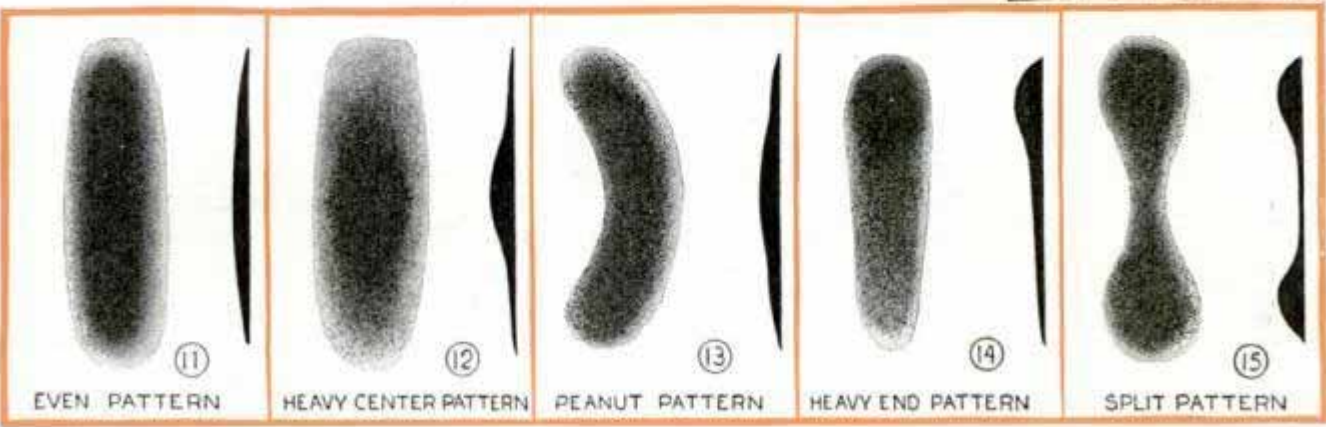

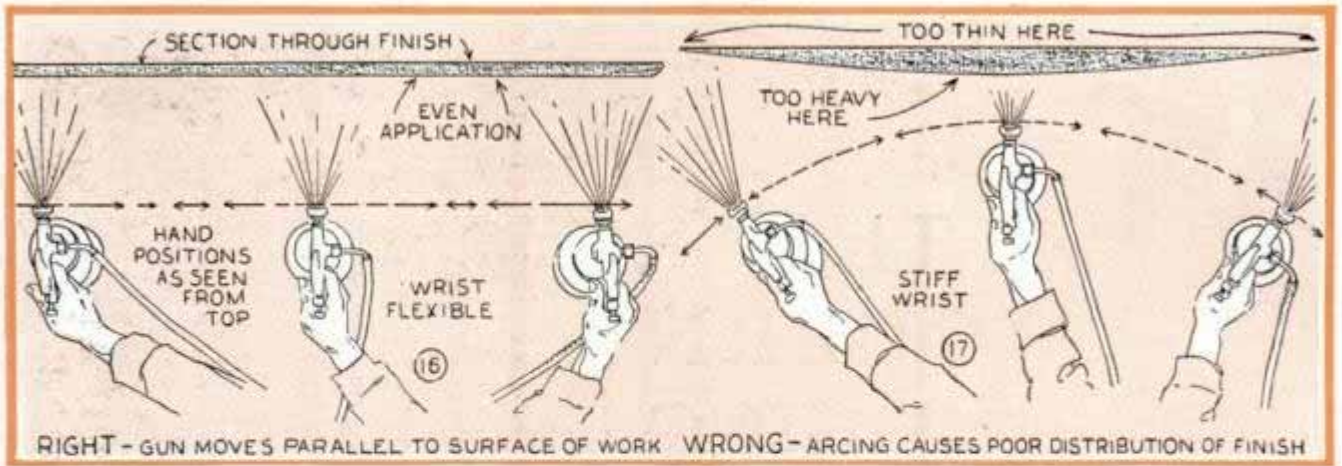
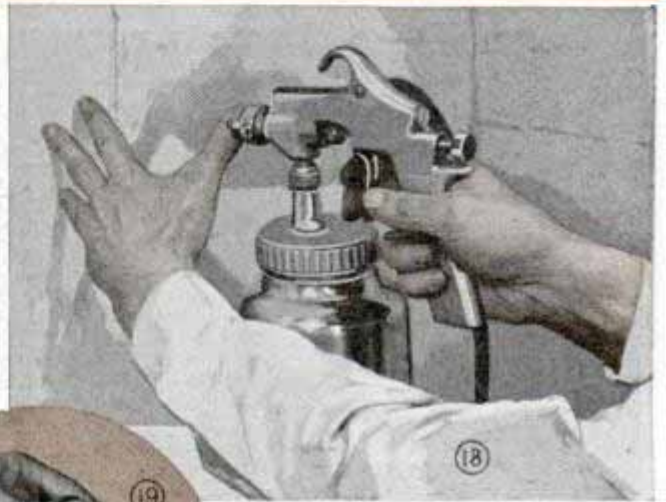

Fig. 3 shows a gun arranged for suction feed. By fitting a pressure feed cup and a different cap, the gun can be used with pressure feed. Many workers neglect the second feature—changing the cap—but it is of considerable importance. If you sight across the nozzle of a suction-feed gun, as shown in Fig. 1, you will notice that the fluid tip projects about $\frac{1}{32}$ in. beyond the air cap. This arrangement, as shown at A, Fig. 2, creates the vacuum necessary to draw the fluid to the nozzle. B shows the pressure cap, which extends beyond the fluid tip. This cap will not work with suction feed. The cap shown at A (suction feed) will work with pressure feed but gives poorer atomization of the fluid. The cap shown at C is a universal design used for either suction or pressure feed, but less effective with either than a true



8" IS A GOOD WORKING DISTANCE



suction or pressure cap.

The air cap of an external-mix gun has three holes in it. The central hole passes the air which breaks up or atomizes the fluid. The two outer or horn holes pass air which forms the atomized fluid into a definite pattern. When air passes through the center hole only, the pattern is round, as shown in Fig. 9; when air passes through all three holes, the pattern is the familiar fan spray. The longer dimension of the fan spray, Fig. 9, is called, somewhat incorrectly,

its width. This pattern can be moved to any angle by turning the air cap, the pattern being always opposite to the position of the horn holes. Thus, if the horn holes are horizontal, the long dimension of the fan pattern will be vertical. This is the

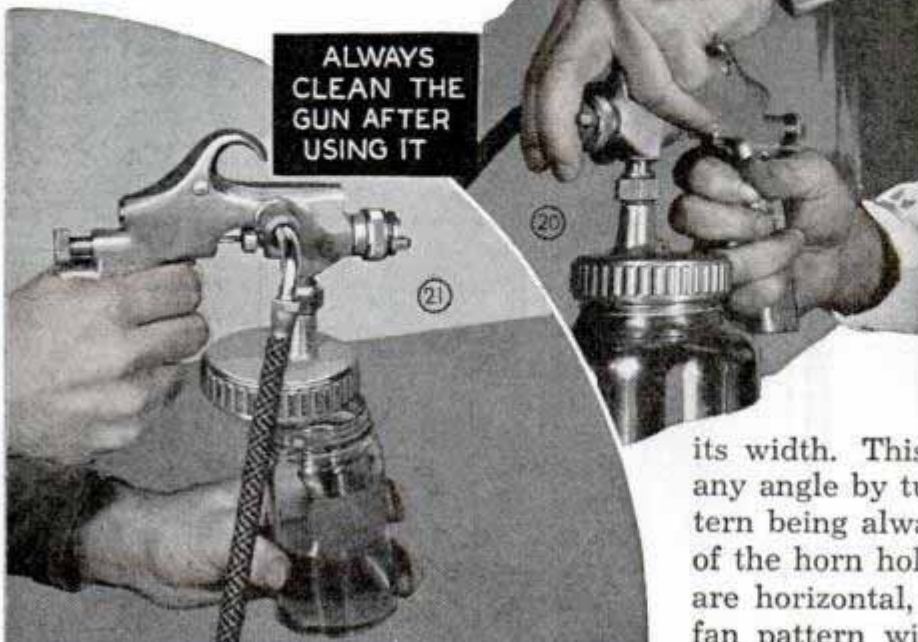

ALWAYS CLEAN THE GUN AFTER USING IT

adjustment usually used. Most guns make a fan pattern only, but better quality guns make both fan and round patterns. When the gun is of the internal-mix type, that is, the air and paint are mixed inside the cap, the air cap is slotted to give the same fan spray. Between external and internal mix guns, external mix is the most prevalent and practical.

The first operation in spray finishing calls for the making of a pattern. Hold the nozzle of the gun about 6 in. away from a sheet of cardboard or paper, as shown in Fig. 8, and pull the trigger. The resulting pattern shows whether the gun is prop-

Right, work suspended on strings for finishing. Below, construction of a simple turntable

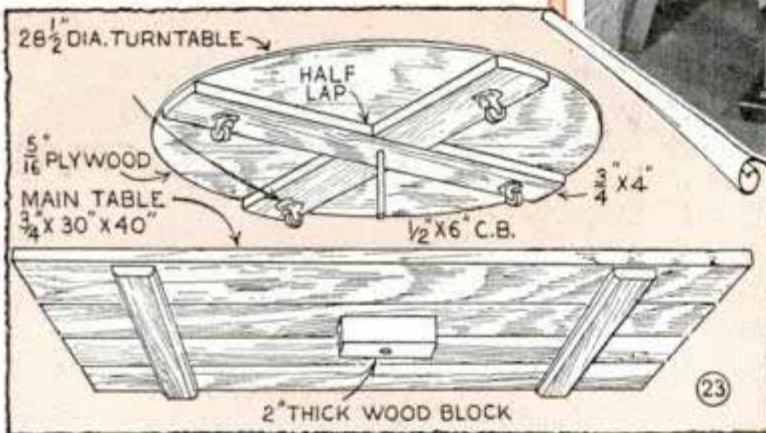

erly adjusted to go ahead with the work. Fig. 11 shows the perfect pattern—a long oval, with the paint evenly distributed and finely atomized at the edges. The heavy-center pattern, Fig. 12, is

SPRAYING RECOMMENDATIONS *

- SHELLAC** Use 3-lb. cut. Can be used either suction or pressure feed.
- VARNISH** Use spraying varnish at can consistency. Thin brushing varnish 25%. Hold nozzle 8 to 10 in. from work.
- LACQUER** Reduce 25 to 150%, depending upon type. Hold nozzle 6 to 8 in. from work. Apply full wet coats.
- SYNTHETICS** Spray mist coat, first coat. While still tacky, apply full wet coat. Average synthetic works best pressure feed, but can be thinned as required for suction feed.
- PAINT** Oil paints and enamels should be thinned as required. Hold nozzle 8 to 10 in. from work.

*With maintained air pressure between 22-28 lbs.

COMMON FAULTS

- DRY SPRAY** The sandy, "orange peel" effect encountered when spraying lacquer and synthetics is usually caused by holding nozzle too far from work so that only a dry dust is deposited on the work. Correct by working closer, increasing fluid or reducing air.
- PINHOLES** Caused by holding gun too close to work, or, excessive air pressure, or, heavy fluid; also can be caused by work improperly filled.
- BLUSHING** Blushing is a whitish cast on lacquer caused by absorption of moisture. Seldom encountered except during summer. Correct by adding retarder to lacquer.
- SAGS** Sags or curtains are caused by too much material on work. Correct by working gun faster or decreasing fluid.

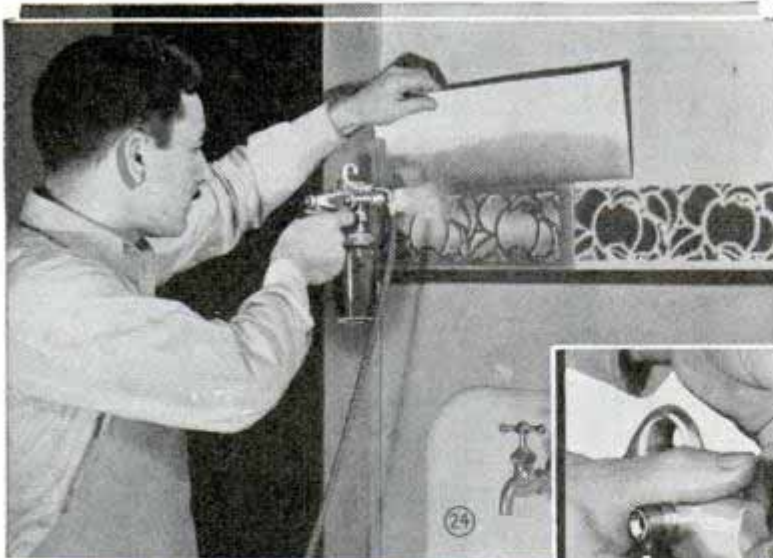

STENCILING IS DONE WITH ROUND SPRAY

poorly atomized, caused by insufficient pressure. The peanut pattern shown in Fig. 13 gives good distribution, but is poorly shaped. It is caused by the clogging of one of the horn holes. The pattern shown in Fig. 14 is usually caused by a dirty gun, resulting in a partial clogging of the fluid tip. The split pattern, Fig. 15, results when too much air pressure is used, and is corrected by reducing pressure or increasing the flow of material. Of the various patterns, the one shown in Fig. 12 will give most trouble to the home-shop owner. This fault is one of equipment—there is not enough pressure to break up the paint which is being sprayed. To some extent, this can be corrected by cutting down the amount of fluid delivered to the nozzle (your gun should have an adjustment for this), but the only true remedy is to install a larger compressor or use a smaller gun.

After obtaining a good pattern, you are all set to spray. The very first rule to remember is always to keep your gun at right angles to the surface being finished, Fig. 16. This requires a flexible wrist, and demands a little attention until the right movement becomes automatic. Fig. 17 shows the common fault of the beginner. Arcing in this manner causes poor distribution of the finishing material. Learn how to "trigger" your gun. The start and finish of a stroke on a flat-wall surface must be feathered off. If you are working on a flat surface which can be covered with one stroke, start the fluid before you hit

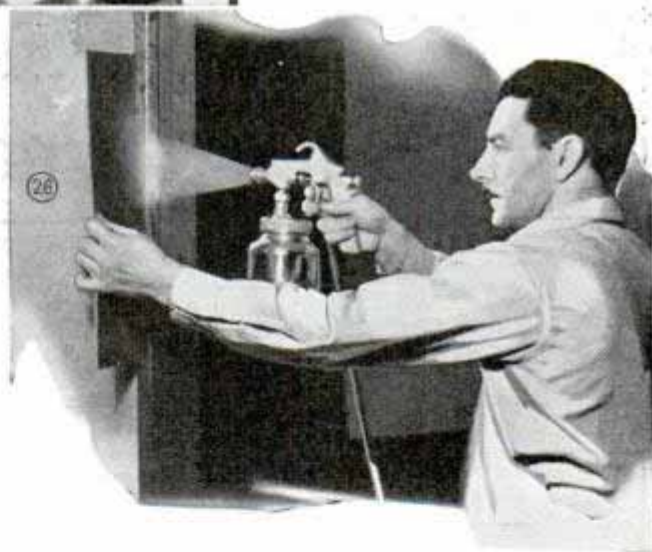

Cardboard strips can be used for a large percentage of spraying jobs where masking is necessary

strainer or cloth, Fig. 19. Always clean the gun after using it. This operation is very simple, and is done by simply placing the fluid tube in a jar of thinner and pulling the trigger, as shown in Fig. 21. Some workers also alternate this by holding two fingers lightly over the nozzle, as shown in Fig. 20. When the trigger is pulled, the thinner surges violently in the cup and exerts a powerful cleaning action.

While spray finishing can be done anywhere in the shop, it is best to reserve and equip a certain space for the work. Fig. 7

the work, and stop it immediately after running beyond the work. Overlap your strokes about one-half, that is, the edge of the second stroke should come to about the center of the first stroke. Keep the gun in motion.

A second point to be considered is the distance from the gun to the work. This varies with different materials and guns, but 8 in. is a good general average. Spraying distances for certain materials can be checked readily by spanning the fingers from the gun nozzle to the work, as shown in Fig. 18.

Cleanliness is of prime importance in spray finishing. Strain any doubtful material through a tea

shows a typical installation. Fig. 22 shows a simpler arrangement. A turntable on which work can be placed and rotated is a worth-while item, and can be made easily as shown in Fig. 23. An exhaust fan is a nice feature, but not strictly necessary in the home shop where only one piece at a time is finished. Most workers get along nicely by opening two windows of the basement, thus creating a cross current which quickly carries away fumes caused by the spraying of the finishing material. Notice that on the portable outfit shown in Fig. 22, the motor, compressor and condenser are combined in one unit. The set-up shown in Fig. 7 is a larger stationary installation using a transformer, the top of which can be seen behind the worker.

Portable equipment has a nice feature in that it can be moved to any location. Thus, if you want to stencil a border on the kitchen wall, Fig. 24, it's no trick to pick up the equipment and carry it upstairs. The stenciling operation shown here is done with the usual paper or metal stencils, holding a strip of cardboard against the wall to catch any overspray. Stencils should be worked with a round spray. If your gun does not have this adjustment, a round spray can be made by blocking off the horn holes with friction tape, as shown in Fig. 25. Fig. 26 shows how a strip of cardboard is used to catch overspray when finishing woodwork. Similar methods can be used to protect windows and other surfaces. Where clean separation is required, as in two-tone color work, masking tape should be used to cover areas which are not to be painted.

Glass Drilled with Silicon-Carbide

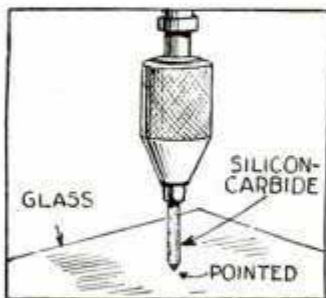

I have found that a pointed piece of silicon-carbide is superior to a steel drill for making holes in glass. When chucked in a drill press or hand drill, the silicon-carbide will penetrate the glass faster than a drill without the chances of chipping it. The pointed end of the carbide should be dipped in water occasionally.

—Nicholas Biebel, Buffalo, N. Y.

Desk Slide Instantly Converts into Drawing Board

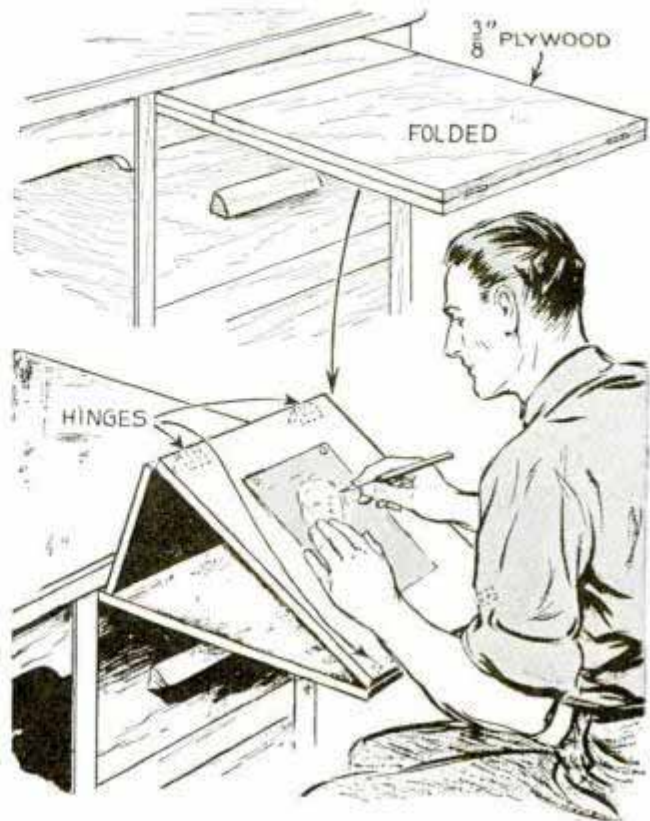

Office workers who occasionally need a sketching board will find this combined desk slide and drawing board worth-while. It is made from $\frac{3}{8}$ -in. material, doubled to fit in the slide slot of the desk. Three pieces are hinged together so that, when the slide is pulled out, one section drops down to support the outer section at any angle.

Saw Vise Serves as Depth Gauge

Fastened to a hand-saw blade to limit the depth of the cut, a small saw vise serves nicely as an emergency depth gauge. Remove the vise from its bench clamp and place the jaws on the saw blade,



making the distance from tips of teeth to the jaws equal to the depth of the cuts you wish to make. Start the cuts with the point of the saw where you can see the line easily and finish with the portion of the blade under the jaws.

Table-Tennis Balls Dispensed One at a Time

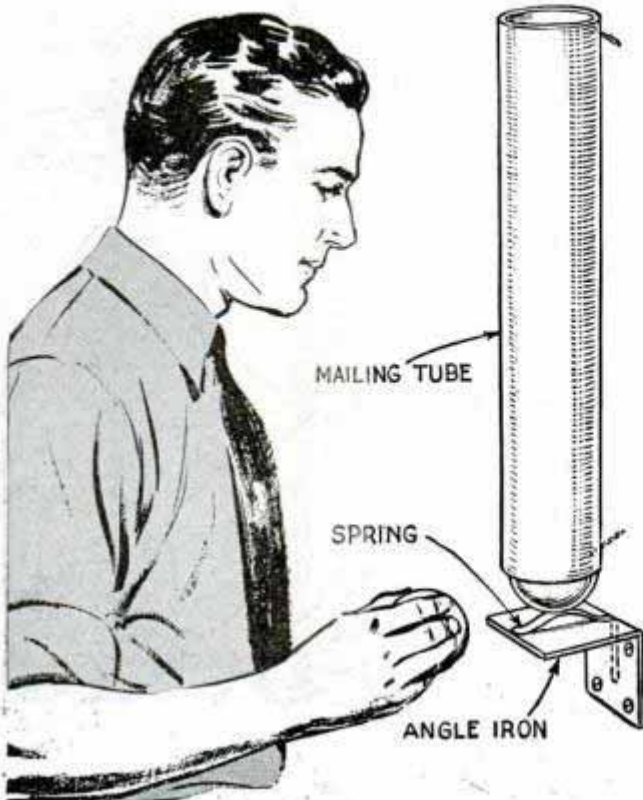

A neat holder for several table-tennis balls can be made from a 2-in. cardboard mailing tube, which is mounted on the wall near your tennis table. Just below the bottom end of the tube, screw a short piece of angle iron to the wall to serve as a shelf. Directly under the end of the tube fasten a curved spring to the shelf, letting one end extend down between the shelf and the wall to hold it in place. The spring keeps the balls from coming out. To remove them, grasp the bottom ball with the fingers and press down against the spring.

—Donald C. Stiles, Springfield, Mass.

Paint-Dipping Can Has Wiper

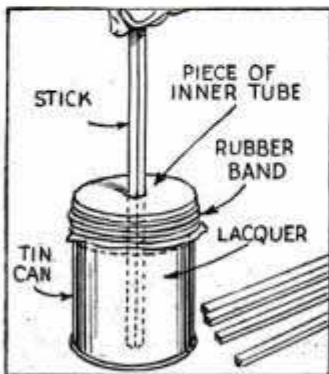

One craftsman who made up several hundred small wood novelties with handles that had to be painted near the ends, rigged up the dipping can shown. This consisted of an ordinary paint can with a piece of inner tube stretched over the top and held by a rubber band. A

small opening was made in the center of the rubber so that the handles could be inserted into the can. When they were withdrawn the rubber tended to wipe off the surplus paint.

Jig to Hold Camera in Vise Facilitates Repair Work

When repairing the bellows of your camera, or when working on other parts of it, you will find this simple jig for clamping the camera rigidly in a vise a great help. The jig is nothing more than a small wood block drilled in the center to take a standard 1/4-20 machine screw for attaching the camera to the block. The block can be clamped in the vise at any angle.

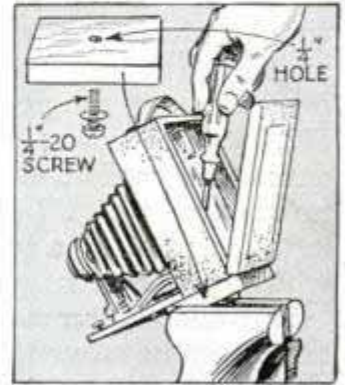

Auto Steering-Gear Mechanism Serves as Reduction Gears

For operating models, small machines around the home and other light work, the steering-gear mechanism from an old car will serve nicely as reduction gears. Also, it can be used to step up the speed by belting the motor to a pulley slipped onto the stub shaft where the steering-wheel shaft entered the housing. Many of these gears have a reduction as low as 17 to 1. If it is used to step up the speed, care must be taken, of course, to keep the gears properly lubricated.

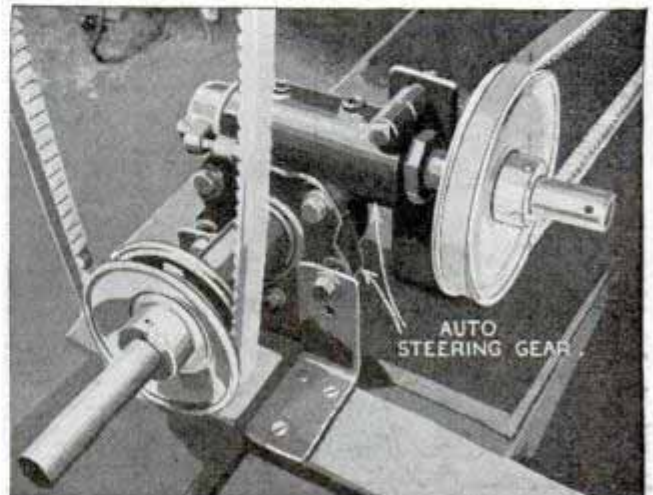

Miniature film PRINTER makes positives for projection



By R. E. BEST

YOUR choice miniature films can be shown to best advantage by projecting them on a screen like the old-fashioned lantern slides. Instead of having a large number of these films printed commercially, which would be expensive, you easily can construct a printer like that in Fig. 1, and make them yourself at a cost which is comparatively negligible. Thirty-five millimeter positive film can be purchased in 100-ft. rolls for about two cents per foot and you can print seven pictures of the standard miniature size to the foot. It is necessary to print a number of pictures at a time and then develop the whole strip at once. Of course, the film must be protected from the light during intervals between exposures, and there also must be a device to move the film the proper distance after each exposure. This should be the distance measured by nine perforations in the film.

Figs. 2 to 6 inclusive show the lightproof magazine and the arrangement for winding the film accurately. If you have access to a lathe you will find no difficulty in making a film-spacing sprocket to the dimensions given in Fig. 6. Sprocket teeth can be cut either with a milling attachment, or by turning the cutting tool sideways in the tool post and moving the carriage back and forth by hand. If no lathe is available a sprocket can be built up by hand which will be sufficiently accurate for this work. First make two disks of $\frac{1}{16}$ -in. brass or steel and carefully file in the teeth to the dimensions given in Fig. 6.

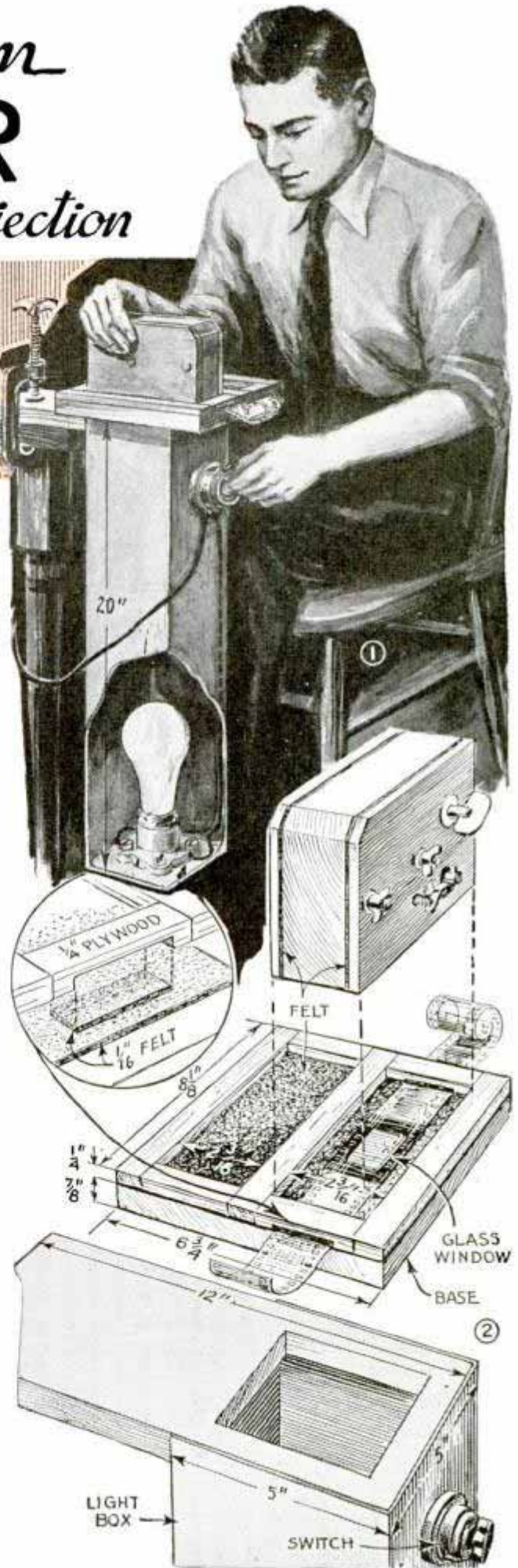

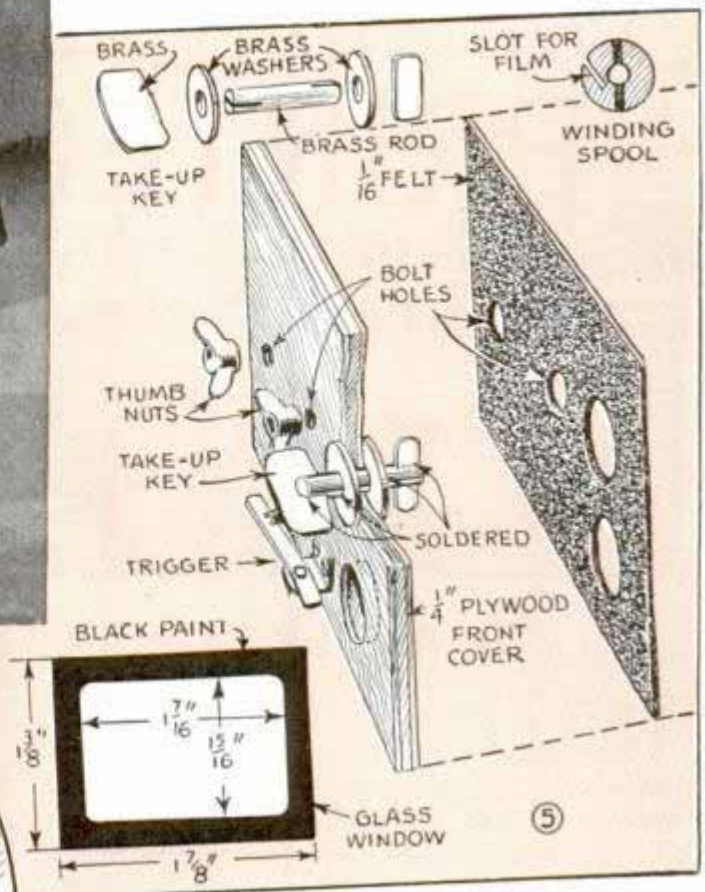
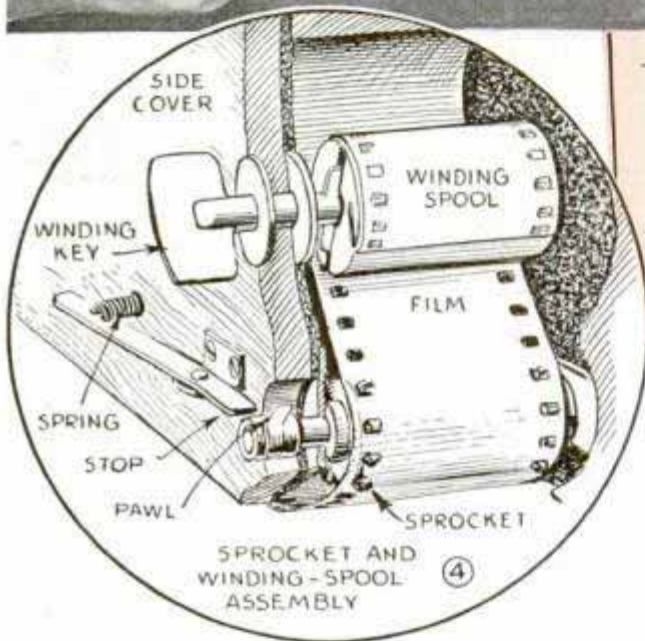
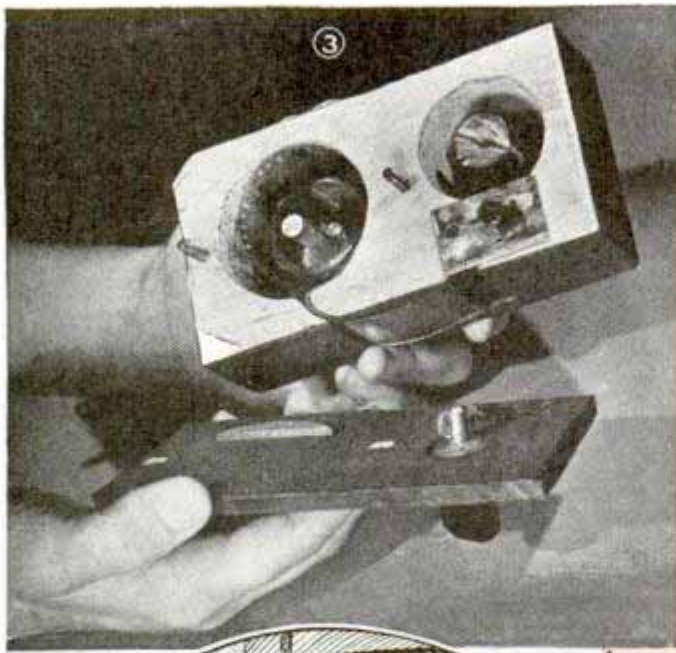

The two sprockets thus made are spaced and soldered to a $\frac{3}{16}$ -in. brass rod as shown. Solder a washer $\frac{7}{64}$ in. thick at each end making the sprocket $1\frac{3}{8}$ in. over all. Solder or pin a short piece of tubing to the shaft and to this solder a piece of No. 20-ga. sheet brass to serve as a stop or pawl to engage the trigger at the end of each revolution, as in Figs. 4 and 6.

Next, construct the film magazine of soft pine to the dimensions shown in Fig. 6. The 2 and $2\frac{5}{8}$ -in. openings in the magazine are for the unexposed and exposed portions of the film respectively. The sprocket fits into a $\frac{3}{4}$ -in. hole as indicated. Channels for passage of the film must be cut wide enough to permit it to move between strips of soft felt and narrow enough to be lightproof. Fasten a $\frac{1}{4}$ -in. plywood cover over the back with screws, using a piece

of felt for a lightproof gasket as shown. Insert and glue in place a length of $\frac{1}{4}$ -in. dowel in each magazine to hold the film supply and the take-up spool, and fit the sprocket into brass bearing plates which are fastened in place with small screws, Fig. 6. Note that the sprocket shaft must project far enough so that the pawl will strike the trigger at the end of each revolution, Fig. 4. Glue a piece of felt to the front of the block so that when the cover is fastened with bolts and wing nuts it will be light-tight.

The winding spool is center drilled and slotted along the side to engage the end of the film as shown in Fig. 5. The key for turning the winding spool consists of a $\frac{1}{4}$ -in. brass shaft, two brass washers and two cross pieces soldered into slots at each end of the shaft, one to engage the end of the winding spool and one by which the whole thing is turned. The cover is fitted with a spring-actuated trigger to engage the pawl on the sprocket shaft after each revolution and release it for the purpose of letting the film move into its new position. Strips of felt should now be glued onto the bottom and in each of the film channels so that it will be impossible for

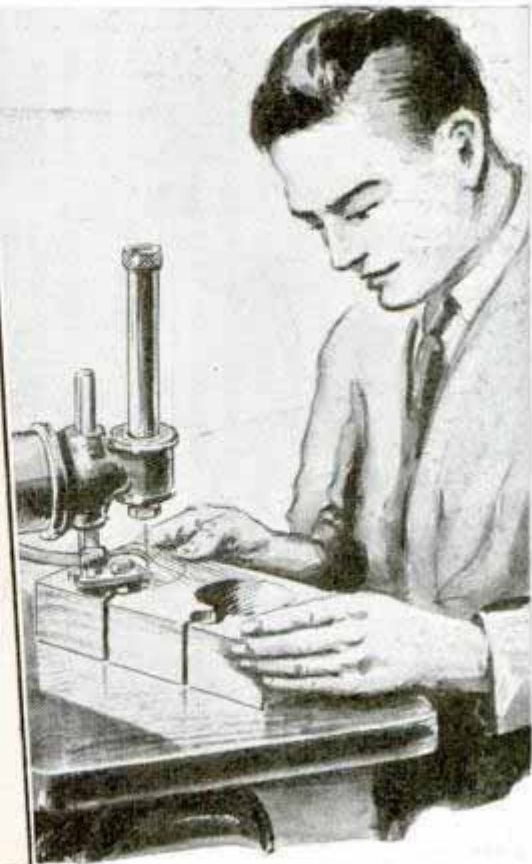
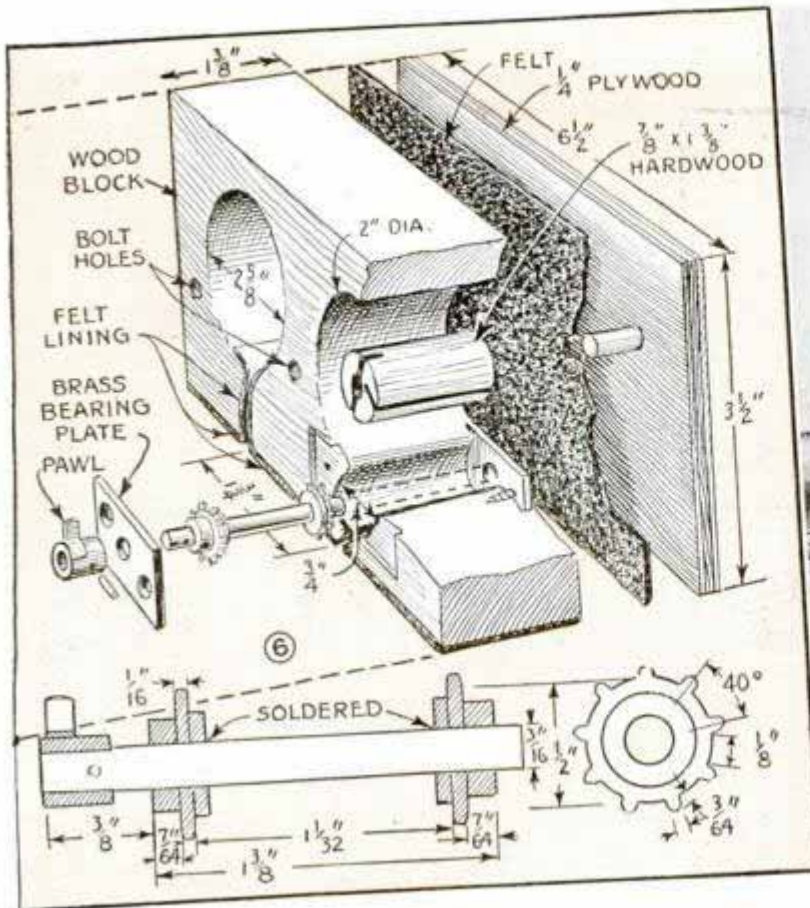

light to penetrate to the film magazines.

Next, you make a base as in Fig. 2, having two compartments $\frac{1}{4}$ in. deep into which the film magazine will fit. Line the rear compartment with felt so that when the magazine is placed there between exposures the entire film will be protected from the light. The front compartment has a glass window, Figs. 2 and 5, fitted in flush with the surface in such position that the light coming through it and the negative will strike the positive film. Paint the margins of the glass so that the unpainted portion is a rectangle with curved corners $1\frac{5}{16}$ by $1\frac{7}{16}$ in. in size. The light for exposing the film should be a ten-watt lamp placed in the bottom of a box 5 by 5 by 20 in. and fitted with a convenient switch, Figs. 1 and 2. Make the top 5 by 5 by 12 in. so that it can be clamped to the top of a table. Cut an opening 4 in. square over the light.

Now, to operate the printer, load the film magazine and place it in the rear compartment of the base. Place the latter over the light box and fit a negative strip over the glass window as shown in Fig. 2. Turn off all lights (except a ruby light) and move the magazine over to the front compartment of the base. Snap on the white light

and expose from two to fifteen seconds, depending on the density, release the trigger and turn the film into position for the next exposure, then return the magazine to the rear compartment of the base, after which you can turn on the room lights and arrange a new negative for printing. There are several inexpensive projectors on the market which will handle 35mm. film.

Electric Heater Used as Flash Gun

I find that an electric heater having a chrome reflector provides an ideal photoflash lamp. These heaters are reasonable in price and the large reflectors throw light over a wide area. A feed-through tumbler switch is a convenience, and two or three bulbs may be fired at once by using double or triple sockets.

—Arthur Trauffer, Davenport, Ia.



Clogged Drain Pipe Cleaned with Heat of Blowtorch

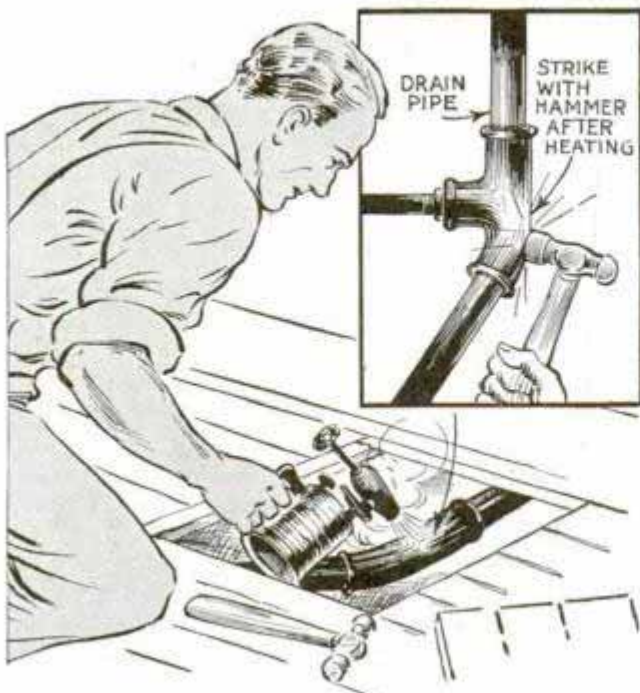

In early types of plumbing, several lines are often run into a common discharge with the result that the main line clogs at the junction. When a plumber cannot be found, the householder can often clear the lines by an old trick of the trade. Direct the flame of a blowtorch back and forth along the underside of the pipe until it becomes hot. Then follow the flame by striking the pipe sharply with a hammer. Do this at all sides of the junction. The heat will swell and even steam the clogged mass while the hammer blows will loosen it.

Scoops Made from Shoehorns

When bent as indicated, shoehorns make excellent scoops for handling photographic chemicals. Shoehorns being inexpensive, several scoops can be made and one used for each chemical. One of the features of



the scoop is that when weighing powders, they may be added slowly to the scale pan by simply pushing them with the thumb.

—Daniel Reynolds, Pontiac, Mich.

Clothesline Pulley Shielded from Snow and Ice

Pulleys supporting "traveling" clotheslines are often prevented from operating by accumulations of snow or ice which freezes within the housing. If lengths of inner tube are cut and fitted over the pulleys as shown, they will act as effective shields to prevent such difficulties.

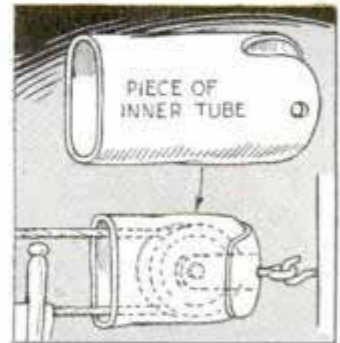

Sheet Metal on Ironing Board Reduces Arm Strain

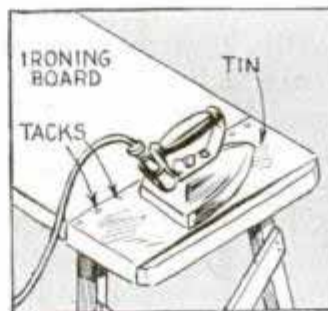

Instead of lifting the iron on and off the holder each time I set it down, I use a piece of smooth, bright sheet metal nailed flush with the ironing-board surface as a holder.

In this way I merely slide the iron off and on the metal, which also tends to help the iron retain its heat better than the regular type of holder.

—Mrs. N. C. Jensen, Chicago.

Tape Aids in Drilling Small Parts

When you have to drill a hole transversely through round wood stock, wrap the part tightly with tape before starting the hole. The tape tends to strengthen the wood so that there is less possibility of the drill splitting it.



—Fred Cornelius, El Paso, Tex.

Electric TARGET for toy artillery

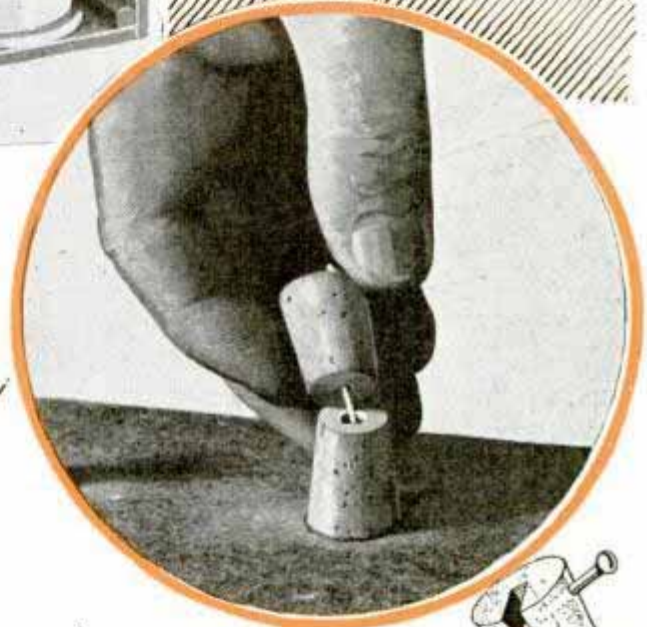
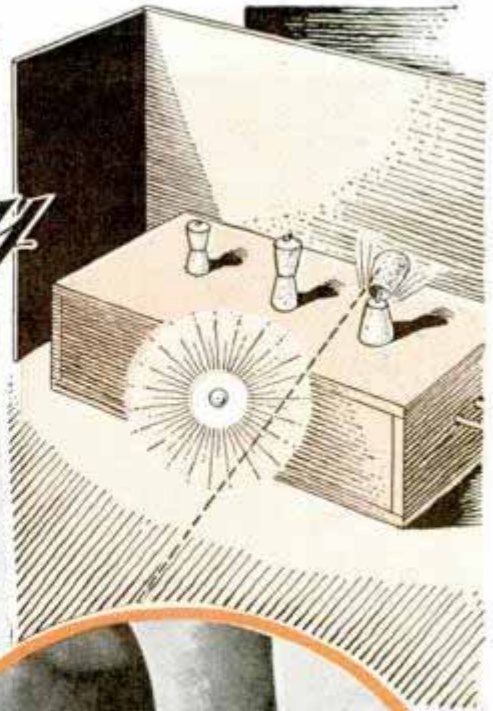
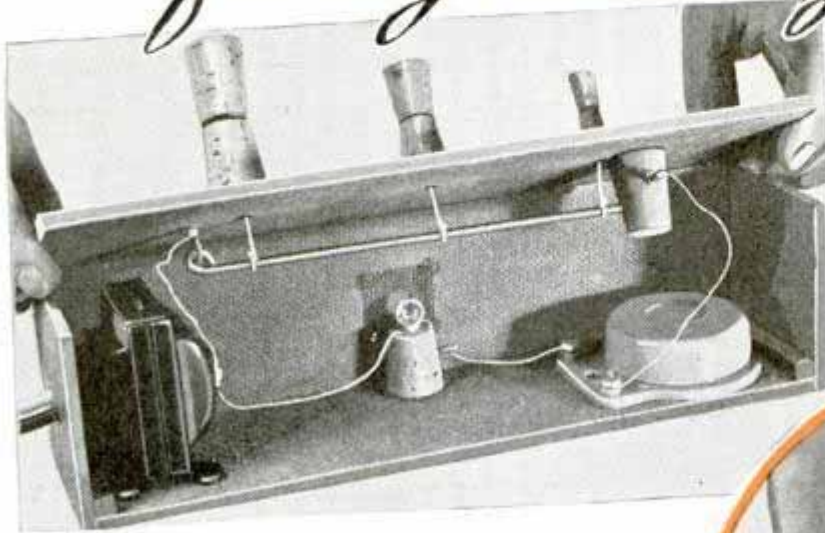

Intended for use with a pop gun or pistol, this electrically operated target sounds a buzzer and flashes a light when hit, and then automatically resets itself. If desired, it can be used as an air-rifle target by substituting rubber bottle stoppers for the regular corks. A heavy canvas back-stop will catch the lead pellets for repeated use. A peculiar feature of the target is that although the largest cork is naturally the easiest to hit, due to a leverage principle in the mechanism it is the most difficult with which to make a score. The small cork, on the other hand, is very sensitive. A direct hit is necessary in order to make the buzzer sound and the light flicker. The target case is 11 in. long and 3 in. square, and was made from $\frac{1}{4}$ -in. hard-pressed wood

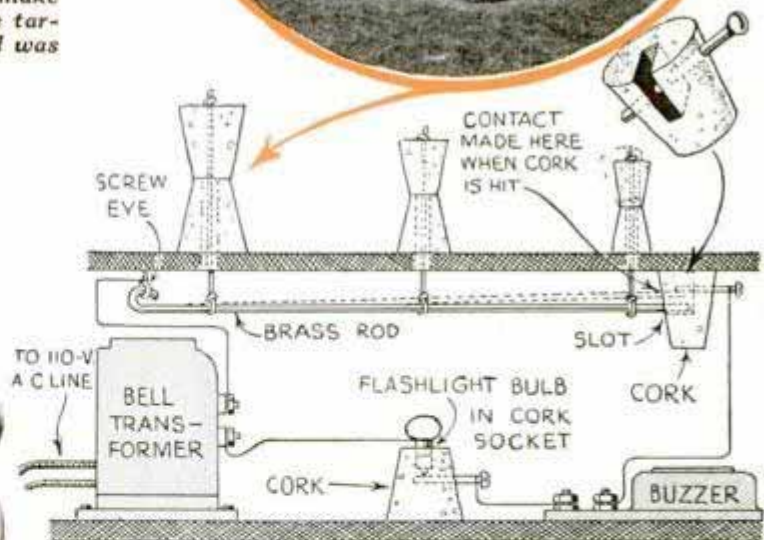
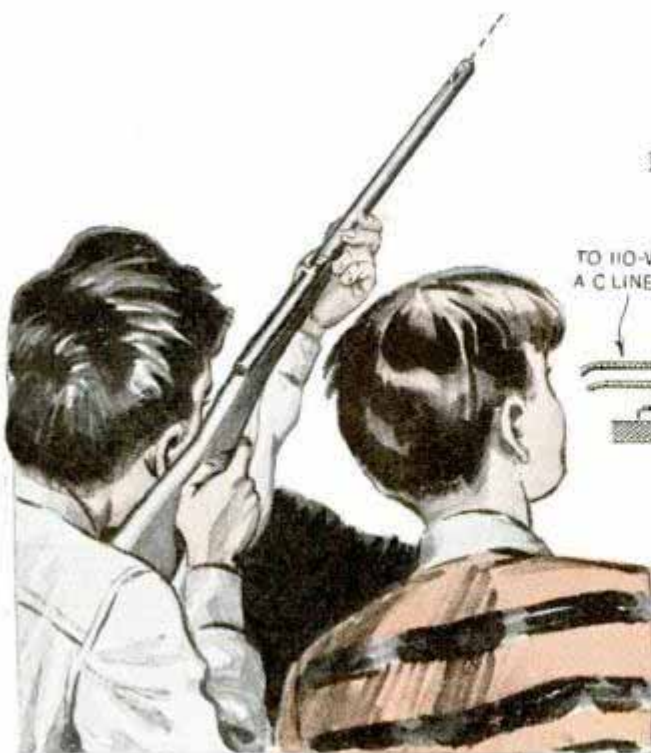

An ordinary toy or bell transformer, electric buzzer and flashlight bulb complete the electrical equipment, which is wired as indicated above. The circuit is momentarily closed when one of the three corks is hit, and, as the buzzer and light are wired in series, the light flickers instead of throwing a steady beam through a screen-covered window in the front of the case. The weight of the brass rod returns the corks to their positions after each hit

Simple Jig Aids in Slotting Legs for Pegged Construction

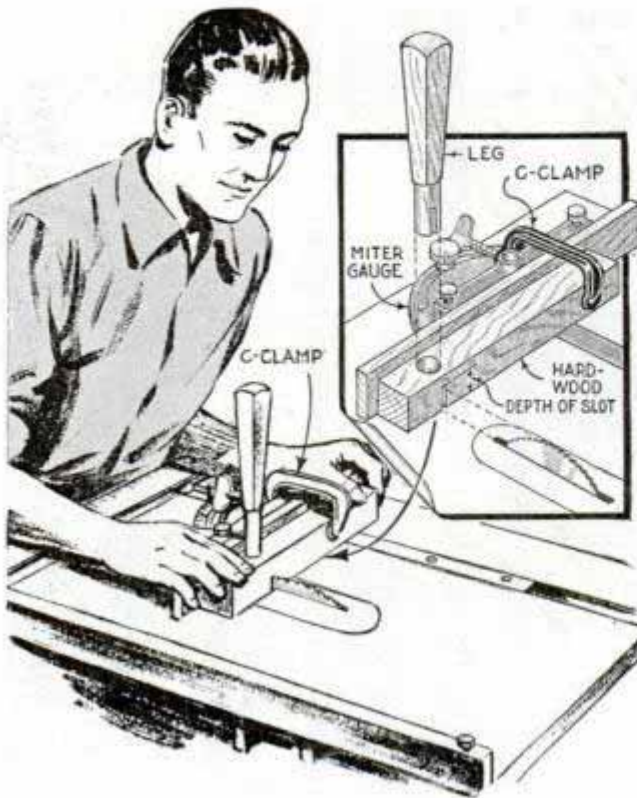

When constructing colonial furniture having "pegged" joinery, slotting of the members to receive snug-fitting wedges can be done quickly and accurately with this jig. A hardwood block, bored to take the tenon of duplicate pieces snugly, is clamped to the miter gauge of the saw in a position to allow the blade to be at exact center with the hole. The work to be slotted is inserted upright in the jig and passed over the saw. The height of the blade above the table determines the depth of the slot.

Removing Broken Taps and Drills

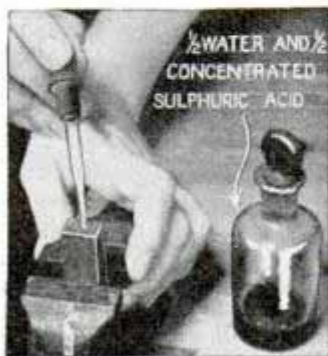

parts of water and concentrated sulphuric acid is helpful. Mix the solution by dropping the acid slowly into the water. Then

The home mechanic who has the problem of removing a broken tap or drill from a piece of work where the hole can be re-tapped oversize, will find that a solution consisting of equal

apply it directly to the broken tap or drill. While the solution will not consume the broken member entirely, it will reduce its diameter so that the piece can be removed. The solution also acts on the metal around the hole so that the latter is bound to be enlarged slightly.

—J. P. Driscoll, Buffalo, N. Y.

Tape Roll Improved with Washer

The annoying job of lifting the end from a roll of tape to tear off a piece is simplified by slipping a small metal washer under the end of the tape as indicated.



The washer will stay in place, and the uncovered portion is easy to lift with the fingernail.—Frank Bentley, Clinton, Iowa.

Turning Large Disk in Small Lathe

When I had a large disk to turn and the swing of my lathe was too small to accommodate it, I slid off the tailstock and moved the headstock to the extreme right end of the bed as indicated. This allowed the faceplate to hang over the end of the lathe bed so that I had plenty of room to handle the

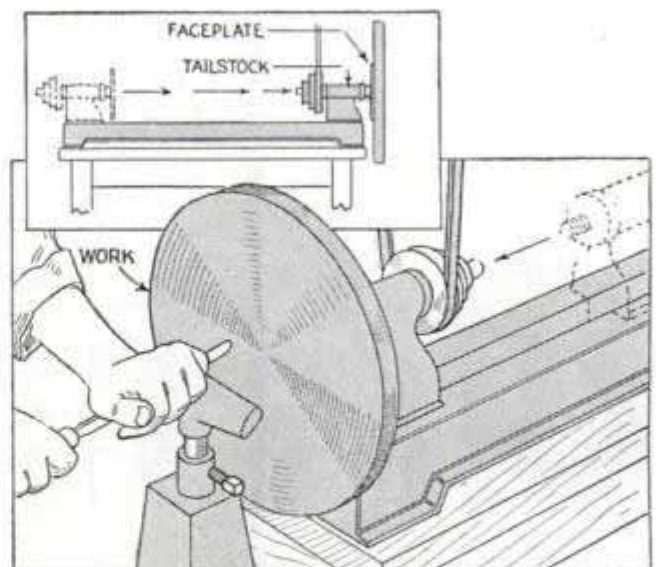

disk. An improvised post set on top of the bench top took care of the support for the turning tool. Of course, it was necessary to shift the motor to line up with the lathe pulley.—R. Rapenport, Columbus, Ohio.

A CANDLE *runs this engine*

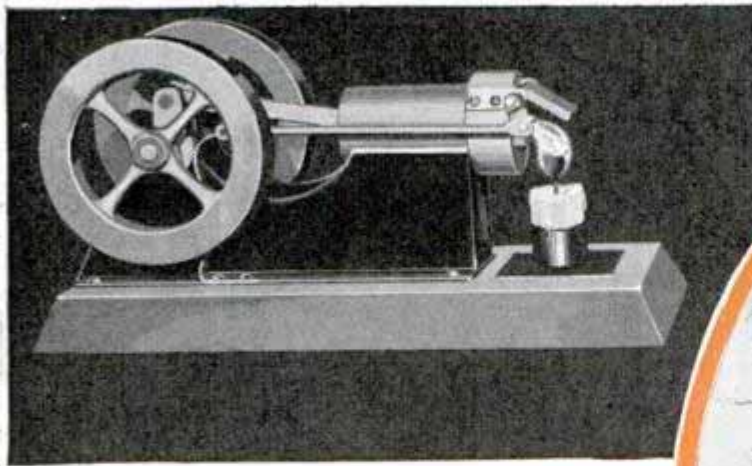

THAT'S right! The flame of a common candle is the sole source of power—no boiler, no displacement chamber, no explosion within the cylinder itself. Fig. 1 shows how it works. You will see right away that it is essentially a model of the heavy-duty, horizontal-type gasoline engine, except for the hinged valve mounted on the cylinder head. This trap-door affair fits tightly over an opening in the cylinder when closed, and is actuated by a cam on the crankshaft. The lighted candle is set with its flame adjacent to the opening. As the piston moves in one direction, the valve opens and the flame is sucked into the cylinder. At the end of the stroke the valve closes. The moment the flame is cut off a vacuum is produced in the cylinder, and the piston is drawn inward on a power stroke. When the piston reverses its direction, the cycle is repeated.

Fig. 2 details the base which is simply a matter of bending, filing and soldering sheet metal. The cylinder, Fig. 3, is a more fussy job. A 1-in. pipe nipple and cap form the body. The inside surface of the pipe must be machined smooth and bored to a diameter uniform throughout the length. Later the piston is turned to fit the bore diameter. The contact surfaces of the valve mechanism should be surface ground and then finished up on a surface plate. Soot which accumulates on the meeting surfaces tends to seal the valve. As you will see from Fig. 3 the pipe-cap cylinder head requires just a simple shoulder cut in the lathe and then some careful hand filing.

Fig. 4 shows the crankshaft, flywheels

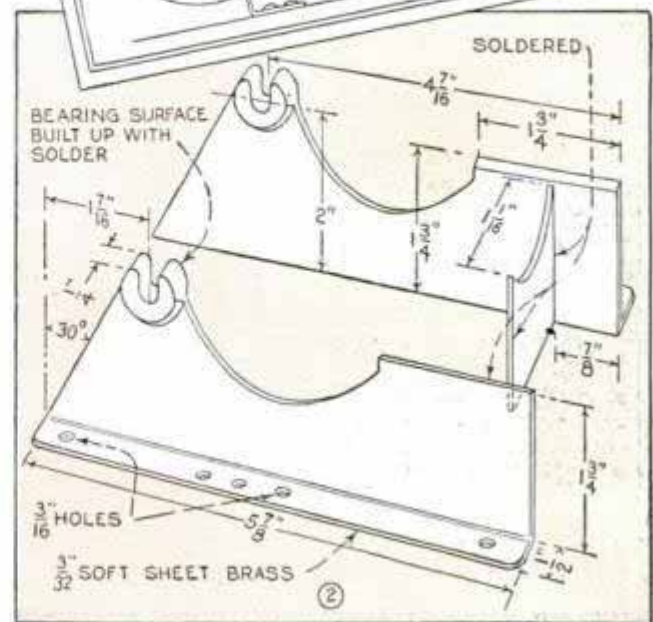
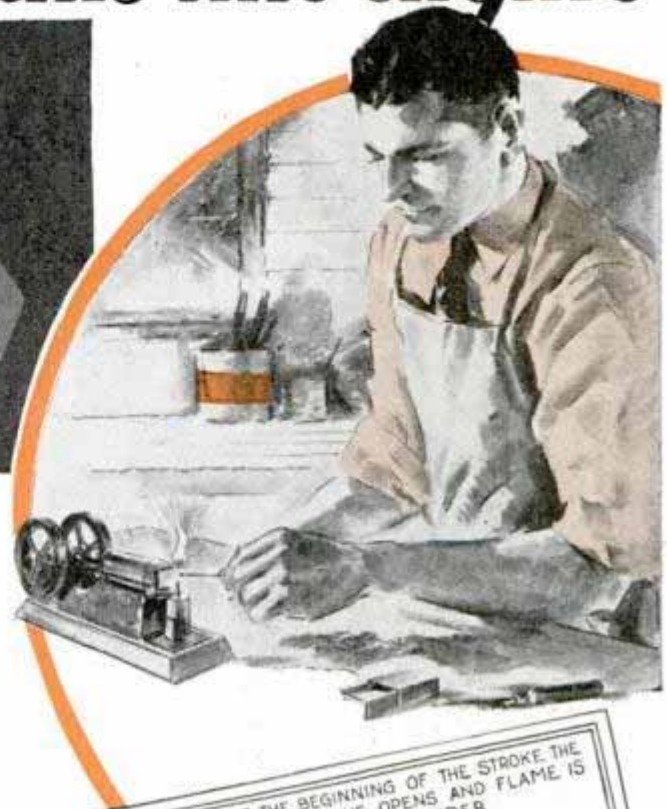

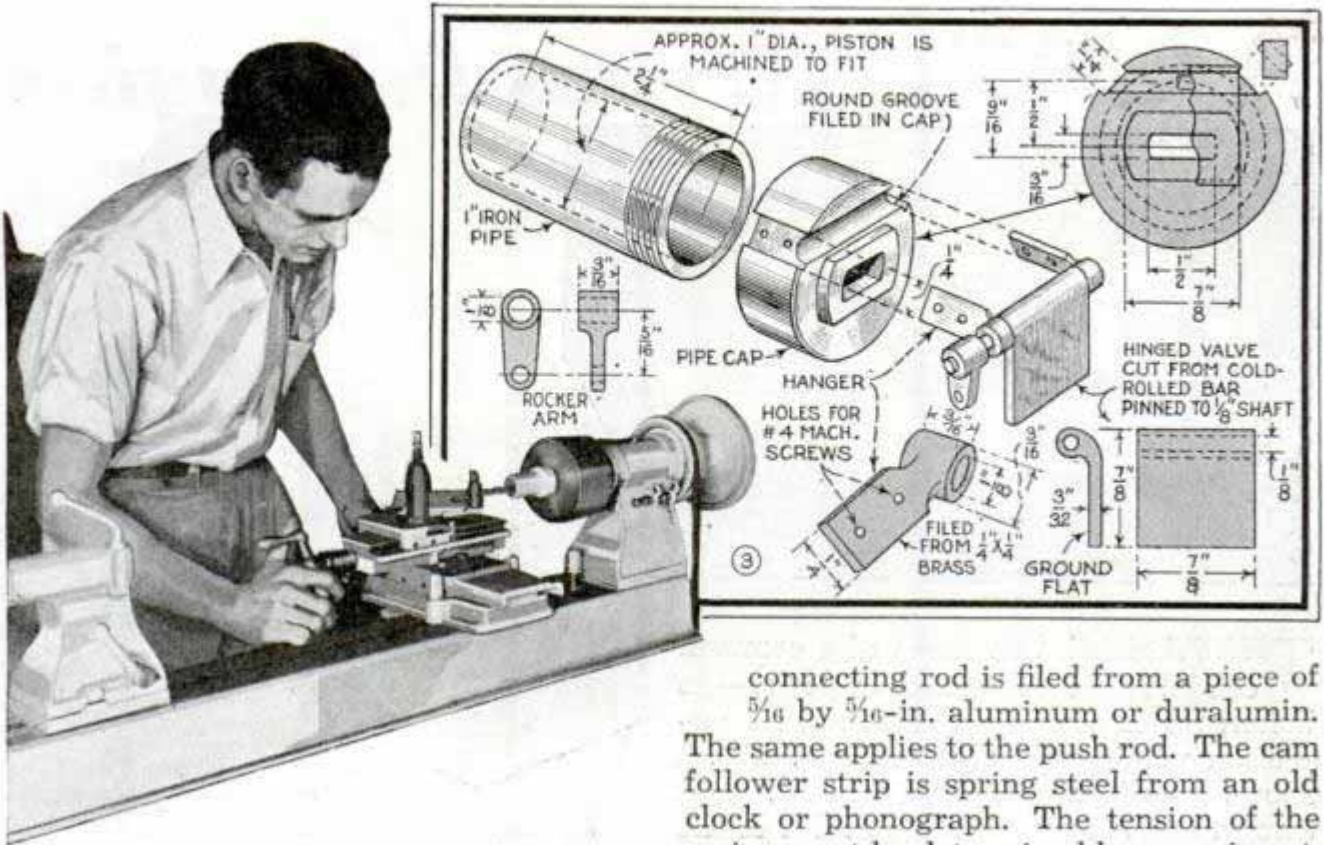

and miscellaneous parts that finish up the assembly. The crankpin is pressed into the crank throws, making the crankshaft and connecting rod a unit assembly. The flywheels can be cast of gray iron, brass, or type metal. The cam must be mounted on the shaft with its center line at 90 degrees to the center line of the crank. The piston is made from a piece of aluminum rod approximately 1 in. in diameter. The ring slot is wound with asbestos cord coated with graphite. Spacing sleeves center the connecting-rod end on the piston pin. The

connecting rod is filed from a piece of $\frac{5}{16}$ by $\frac{5}{16}$ -in. aluminum or duralumin. The same applies to the push rod. The cam follower strip is spring steel from an old clock or phonograph. The tension of the spring must be determined by experiment. It should be sufficient to close the valve quickly when the engine is running at full speed. The cylinder is lubricated by coating the piston with white vaseline each time it is taken out to clean the cylinder. If the engine is operated considerably, the cylinder must be cleaned frequently. When soot accumulation reaches a certain stage it will interfere with efficient operation. Note in Fig. 2 that there are no caps over the main bearings. This is done purposely so that the whole crank assembly can be removed easily for cleaning.

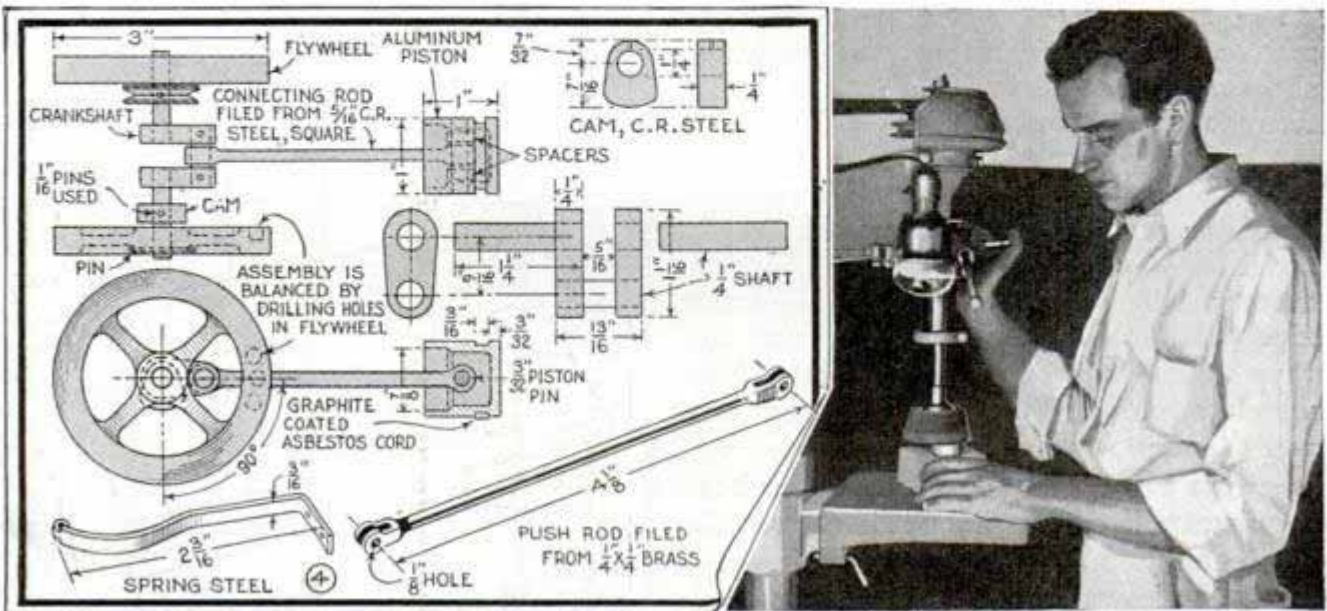

This Turned Bowl Has a Novel Ring Handle

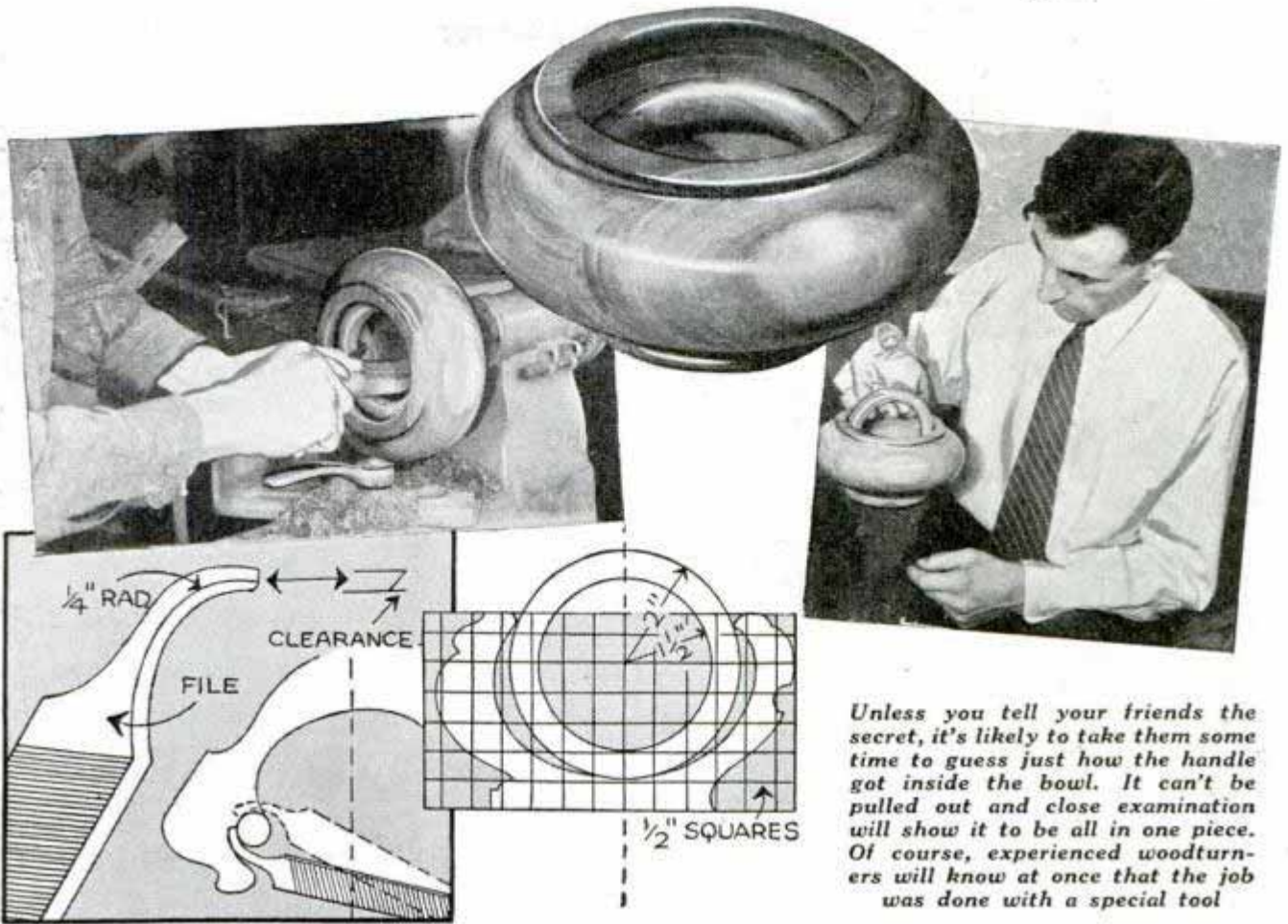

Unless you tell your friends the secret, it's likely to take them some time to guess just how the handle got inside the bowl. It can't be pulled out and close examination will show it to be all in one piece. Of course, experienced woodturners will know at once that the job was done with a special tool

You won't lose or break the handle on this turned bowl because the handle is a loose ring turned out of the waste wood in the recess. The general design of the bowl proper can be most any that suits your fancy but the contour of the inside recess must be approximately the same as that indicated in the cross-sectional view shown on $\frac{1}{2}$ -in. squares. The ring handle is turned with a tool made from an old file.

The shank is bent as shown, the end ground to a bevel and the edge sharpened. When the cut has been run in deep enough to form half the ring, the bevel on the end of the file is ground in the reverse direction and the cut completed by running the tool in from the opposite side. If you're careful, it's an easy trick to turn out the ring with a perfect circular section.

—Edwin M. Love, Monterey Park, Calif.

Soap Aids When Applying Color to Glossy Photographs

If you have trouble in making water color stick to glossy or greasy surfaces, rub each brush full of color on a bar of soap before applying. With this method you can apply color to brass or steel, as the soap dissolves the grease and makes the color take if most of the grease is wiped off first with a damp cloth.

—C. W. Woodson, East Aurora, N. Y.

☐ The lens of a vertical enlarger should be protected against dust, as this may be the cause of dull enlargements.



Punch for Light Sheet Metal from Door Hinge

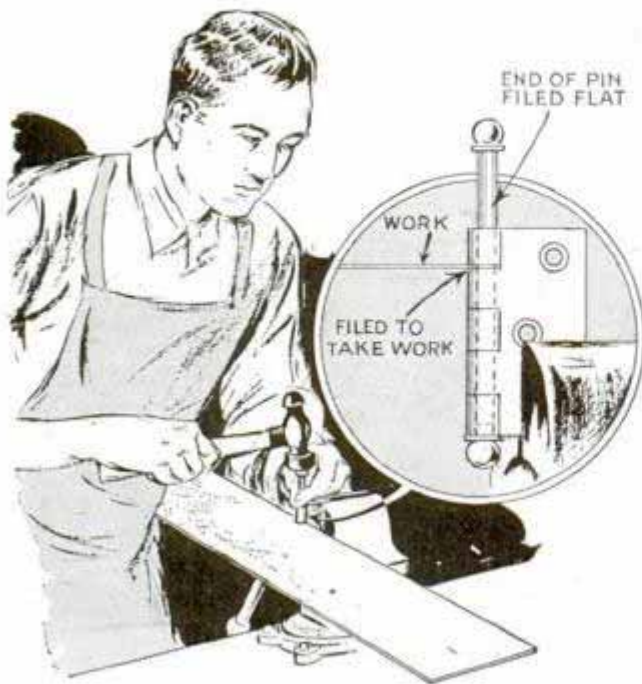

Altered as indicated, a door hinge of the removable-pin type provides a handy jig for punching holes in light sheet metal. A joint in the barrel of the hinge is filed down sufficiently to permit the insertion of the material, and the end of the pin is filed flat so that a neat hole will result when struck sharply with a hammer.

Signals of Model Railroad Supported on Tie

When it is impossible to screw model-railroad signals to the track base, which may be a rug or hardwood floor, this simple metal sub-base can be substituted for one of the ties in the track. Tin cut from a can will be found stiff enough when the sides have been bent as shown. Two holes in the end of the base projecting from the rails permit the signals to be attached with

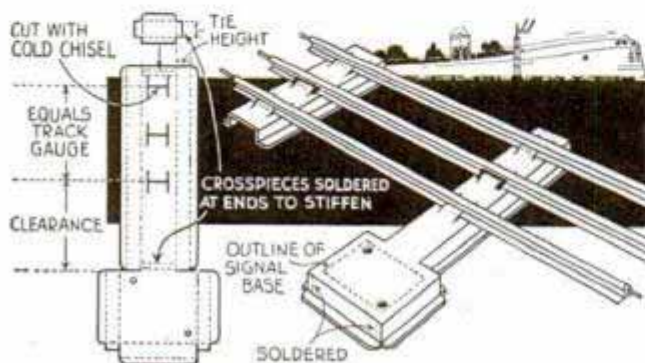

small stove bolts or machine screws. A wooden sub-base of proper thickness may be used instead of the metal, but the latter will match the factory-made equipment better.

—John L. Story, Oklahoma City, Okla.

Rubber Ball Holds Thread Spool

When a spool of heavy thread is kept in the shop drawer for various uses about the place, it often becomes entangled with tools and is more or less a nuisance in every way. If a hollow rubber ball is cut

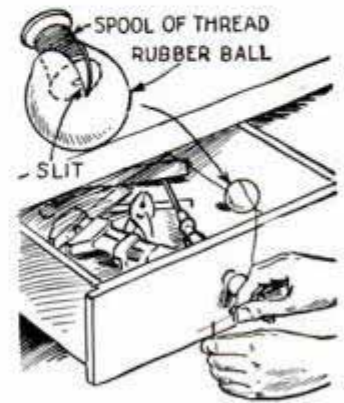

open at one side, and the spool slipped inside, this will serve as a safe container, and the thread may be dispensed by pulling through the closed slot of the rubber.

Dial Carrying Phone Numbers Permits Rapid Selection

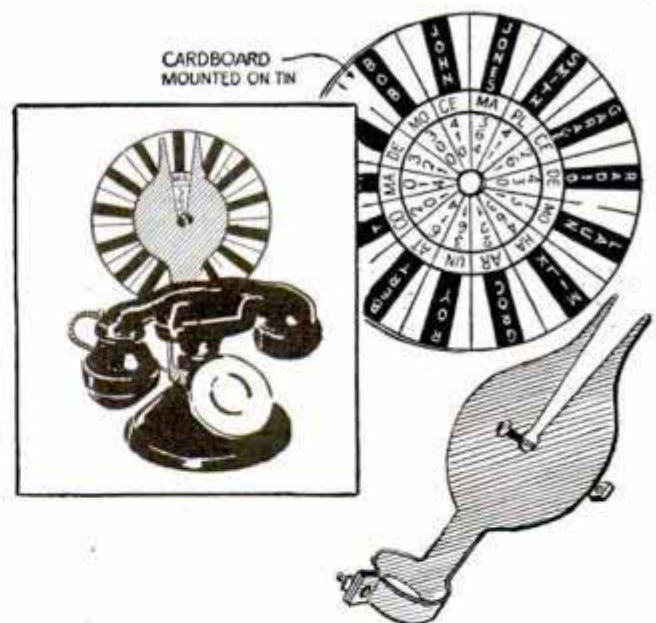

Make up this dial, write on it the telephone numbers that you use the most frequently, attach it to your telephone and it will take only a second to find the desired number when you want to call. The dial is sheet metal and is pivoted to a sheet-metal bracket, which is in turn clamped to the telephone as indicated. A paper dial

carrying the names and telephone numbers is fastened to the metal with a small stove bolt. When you turn the dial to the opening in the support, nothing but the name and telephone number of the desired person shows.

Easy Method to Serve Rigging on Fine Ship Models

The finished appearance of a ship model can be improved greatly if the rigging is served in accordance with the practice on real ships. Two quick and easy methods of doing this without expensive apparatus are shown in the drawing. In the upper detail a tin-box lid is punctured in the center to take a large pin, which is bent to form a hook to hold the rigging. Tie the rigging line to the hook, then tie the serving cord to the rigging line, pull the latter tight with the left hand, and at the same time, twist it in a counter-clockwise direction. While doing this, the left hand guides the serving cord into position. Each twist will add from 5 to 10 turns to the work. At the finish of each twist, a slight relaxation of the tautness caused by the left hand will permit the hook to spin of its own accord, thus unwinding the rigging line to its normal condition ready for the

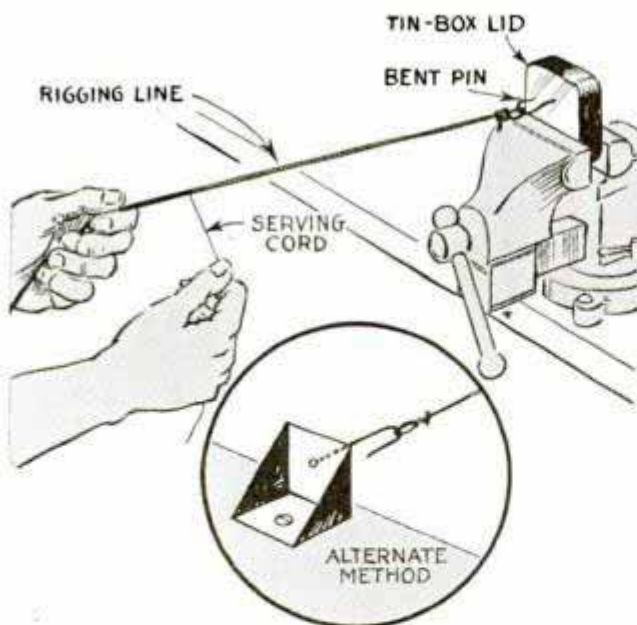

next twist. The circular detail shows another way of anchoring a hook. In this case the corner is cut from a square can, which is used instead of the lid, and is screwed to the bench top.

—A. L. Delin, Montclair, N. J.

Tank Supply Pipe Supported by Auto Casing



Attachment and removal of a tank supply pipe at a windmill may be simplified if the bail is discarded and the pipe supported with a section of auto casing, cut as indicated. A hole through the sides of the casing takes the pipe, which should be a tight fit to prevent turning or twisting. The elasticity of the rubber allows the pipe to be pushed down easily for removal from the pump spout.

Radiator Improved by Reflector

If your radiator or oil stove does not provide enough heat for a room, place a sheet of shiny tin, or a piece of paper coated with aluminum paint behind it. This will act as a reflector, and prevent the heat from being absorbed into the adjacent wall.

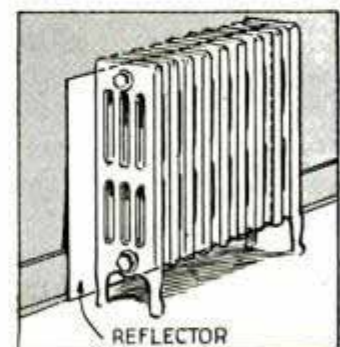

—Arthur P. Goldman, New York.

PREPARING YOUR

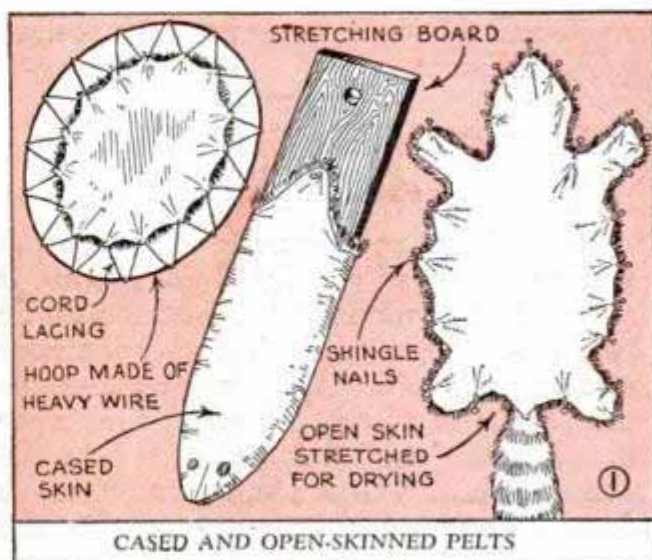
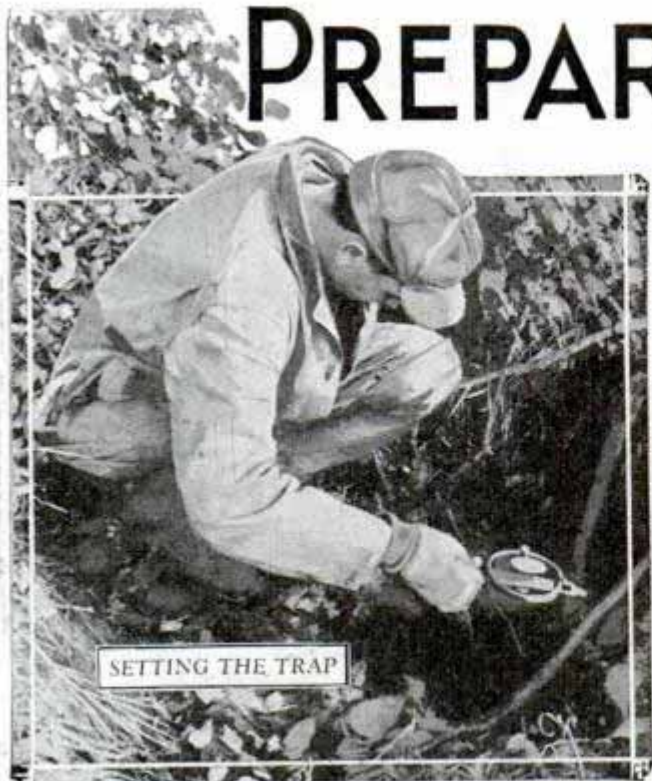

CASED AND OPEN-SKINNED PELTS

By ROYCE M. ROATH

WHILE the top figure in a raw-fur price list is the coveted prize of every trapper, fur buyers and graders know that a considerable portion of each season's catch of otherwise prime pelts must be devalued simply because of carelessness in the initial steps of skinning and curing each individual pelt to make it bring the highest market price. Care in preparing the skin begins at the time the animal is taken from the trap and continues until the pelt is packed for shipment. Many trappers with long trap lines skin each animal as soon as it is removed from the trap. Others prefer to wash and brush the fur before skinning, hence carry the catch to the fur loft where the animals are skinned and the pelts scraped and stretched all in one operation.

In many localities, weed and bramble patches are the habitat of certain fur bearers that obtain their food on dry land. In the fall burrs and seed pods get into the fur of these animals and should be combed out before skinning them. A discarded hairbrush, Fig. 4, can be used to

advantage, as it straightens the fur and leaves it sleek and shiny. Animals trapped along creeks and river banks saturate their fur with mud and sand when trying to escape. These pelts are most readily cleaned by washing in lukewarm water. Dry thoroughly and brush the fur before skinning.

The "cased" and "open" methods of removing the pelt from the carcass are accepted by fur buyers as standard with certain fur bearers. See Fig. 1. Like pulling your glove off wrong side out is a good description of the cased method. First, lay the animal on its back and with a sharp knife, Fig. 5, cut around the paw pads of the hind feet and slit down the back of the hind legs to the vent. This is the opening cut, Fig. 6. Now, suspend the carcass by

means of a skinning gambrel at a convenient working height and carefully work the pelt down over the carcass, cutting the tissues loose with your knife where necessary, Fig. 7. Cut the pelt loose at the base of the tail on muskrat, opossum, and beaver. On others the tail bone should be skinned out. A neat job can be done



FURS *for* MARKET

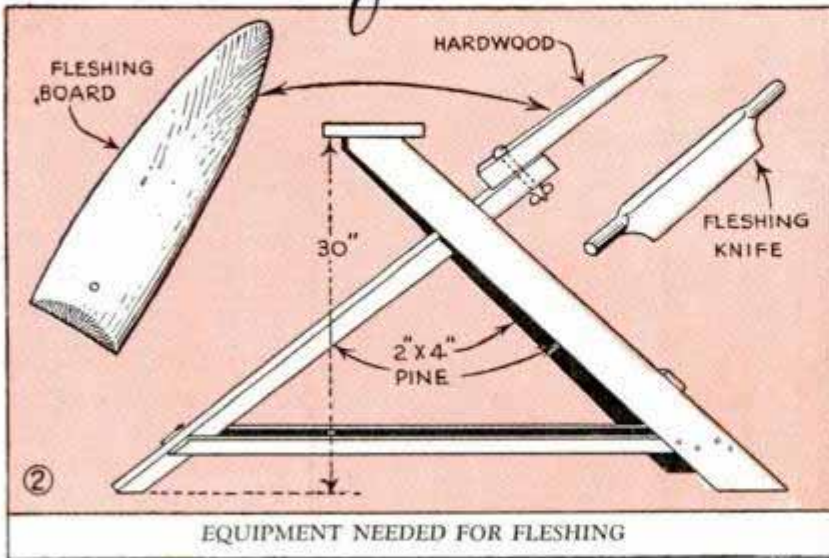

by inserting an umbrella rib or a short length of stiff wire on the underside between the skin and tailbone to serve as a guide for the point of the knife. Skin out the front legs with a direct pull as in Fig. 8. Use care in skinning out the head, working very close to the skull and cutting loose the eyes and ears, Fig. 11. The pelt is very thin at this point and tears easily so don't try to hasten the job by a vigorous pull. Skin with your knife to the tip of the nose.

Remove pelts by the cased method on the following animals: Muskrat, mink, skunk, opossum, ermine, fox, wolf, lynx, civet cat, coyote, marten, fisher, otter, lynx cat, and wolverine. Raccoon, badger, wild cat, beaver, and bear are open skinned.

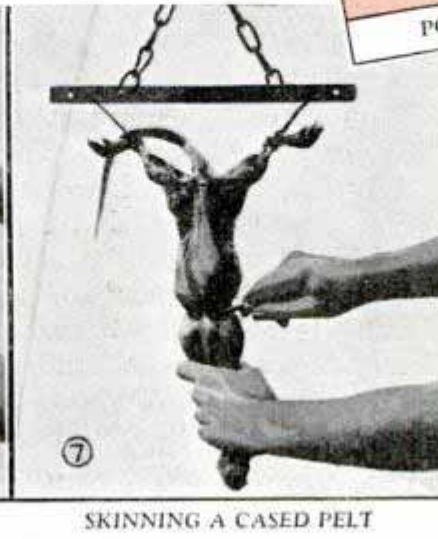
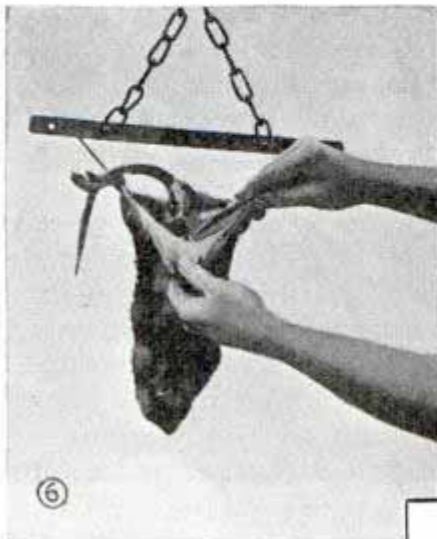

SKINNING A CASED PELT

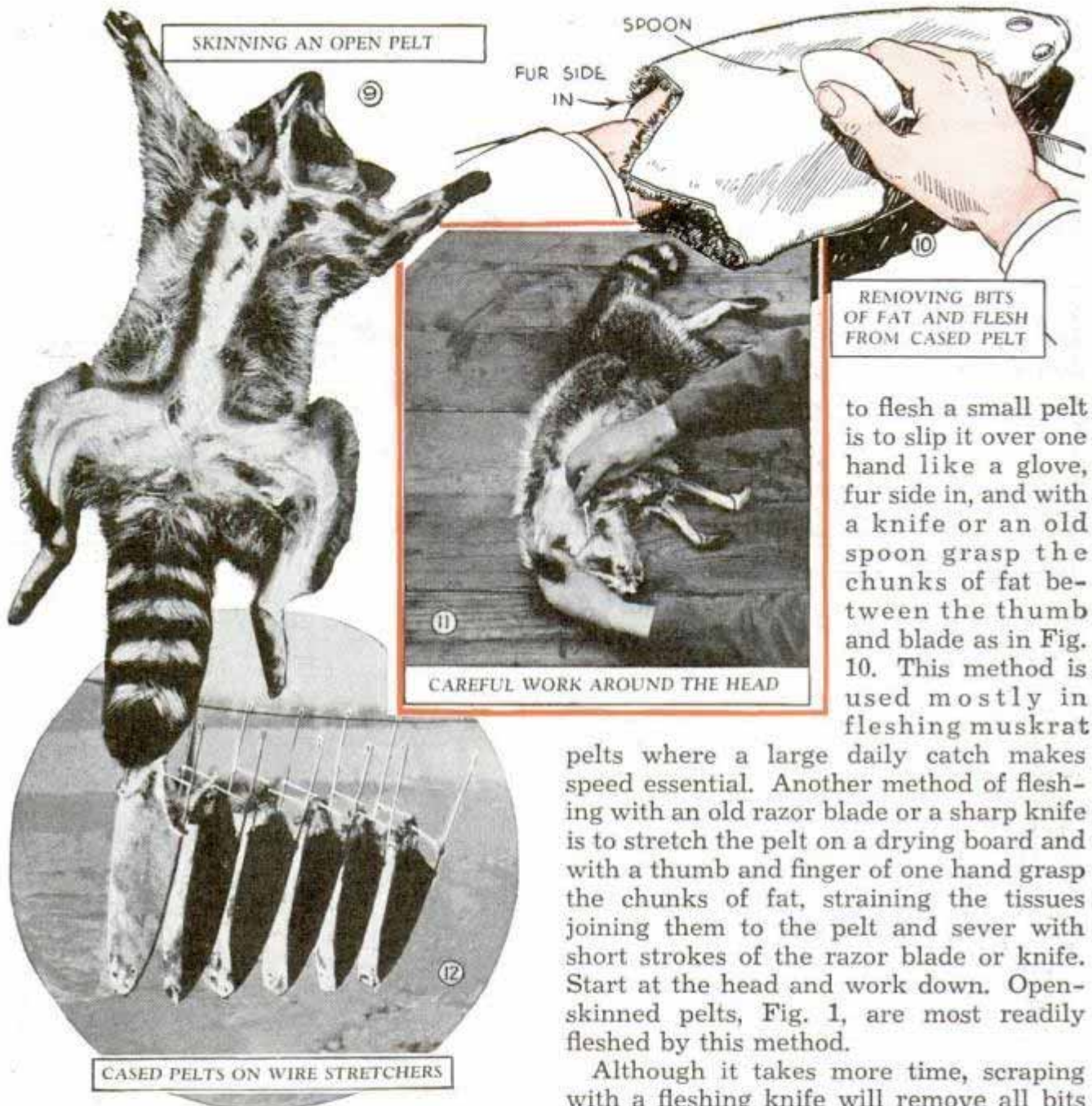

REMOVING BITS
OF FAT AND FLESH
FROM CASED PELT

CAREFUL WORK AROUND THE HEAD

CASED PELTS ON WIRE STRETCHERS

Skinning by the latter method, you slit down the back of the hind legs to the vent and cut the pelt open from the point of the chin to the end of the tail down the center of the belly as in Fig. 9. Cut around the paw pads and slit down the inside of the front legs. Then carefully skin the pelt from the carcass. Skin beaver as cleanly as possible as the pelt is very difficult to flesh.

Fleshing the pelt after skinning is always necessary as it is practically impossible to remove the pelt without some of the fat and flesh clinging to it. If this is not removed it may cause spoilage or improper curing of the skin, resulting in the hair falling out. One of the quickest ways

to flesh a small pelt is to slip it over one hand like a glove, fur side in, and with a knife or an old spoon grasp the chunks of fat between the thumb and blade as in Fig. 10. This method is used mostly in fleshing muskrat

pelts where a large daily catch makes speed essential. Another method of fleshing with an old razor blade or a sharp knife is to stretch the pelt on a drying board and with a thumb and finger of one hand grasp the chunks of fat, straining the tissues joining them to the pelt and sever with short strokes of the razor blade or knife. Start at the head and work down. Open-skinned pelts, Fig. 1, are most readily fleshed by this method.

Although it takes more time, scraping with a fleshing knife will remove all bits of fat and flesh without the danger of cutting holes in the pelt. Equipment used in this method is shown in Figs. 2 and 3. The fleshing boards are made up in various sizes, the fur bearers in your locality governing the dimensions and contour of the boards. They should be made from 2-in. stock to permit rounding the side against which the scraping is done. The working face is planed and the ridges sanded smooth. Make the hardwood fleshing knife, Fig. 2, sufficiently large to grasp firmly in both hands, and plane it to a sharp edge.

To use, pull or drape the pelt on the fleshing board, skin side out, working only against the rounded portion and turning the pelt as you scrape from the head down. Scraping too hard will loosen the hair

roots. Use just enough pressure to work the excess fat from the skin. Clean, dry sawdust sprinkled on the pelt absorbs much of the oil squeezed from the fat while scraping. Continue the scraping until all bits of fat and flesh have been removed, then wash the skin with a non-caustic soap and lukewarm water.

When the water has dried from the fur the skin should be stretched immediately. Spring-steel wire stretchers for the smaller cased pelts, Fig. 12, are generally recommended. They have a tension to properly stretch all sizes of pelts for which they are intended, and allow circulation of air for better curing. When making your own stretching boards for cased pelts, a smooth symmetrical shape is the thing. Irregular or overstretching will thin the pelt, loosening the hair roots and causing the hair to fall out. Proportion the pelt-drying boards to just take up the slack in all directions leaving the skin free of wrinkles. Several sizes will be needed.

In stretching, drape the pelt on the board with the belly on one side and the back on the other, centering the front feet openings an equal distance from each side. Tack the skin at the butt end after pulling up the slack. The following list of pelts should be stretched and dried skin side out: Muskrat, skunk, opossum, mink, civet cat, otter, ringtail cat, and weasel. To prevent sticking, which makes it almost impossible to remove the skin from the stretcher, the following should be placed first on the board skin side out and allowed to dry a few days. Reverse the pelt when it ceases to be tacky and finish curing fur side out. Wolf, coyote, fox, lynx, marten, fisher, and wolverine are preferred by the fur trade in this manner.

Stretch an open-skinned pelt by tacking to the side of a building, Fig. 1, or, if there is danger from rodents, make a panel of boards and hang it from the rafters. Get a square effect on raccoon and badger. Tack fur side in for better curing. Lace beaver skins on the inside of a wire hoop, fastening first at four points equidistant around the hoop. Gradually stretch between these points by lacing cord through the edge of the pelt and around the hoop with a sacking needle as in the upper detail in Fig. 1. Hang pelts in a cool, dry place for curing.

Beam Compass from Curtain Rod Scribes Long Arcs

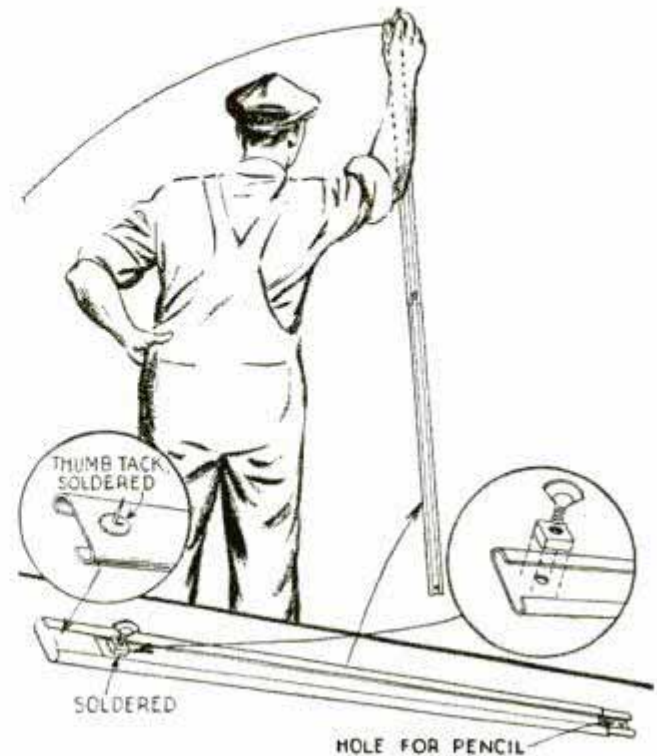

In swinging curves of a large radius, you will find a flat, telescoping curtain rod handy as a traverse compass. A flat-head thumb tack is soldered to the outer end of one member to serve as an axis, while the inner sliding rod is drilled at the extreme end to take the point of a pencil. Adjustment is made with a thumb nut soldered over a hole, which is drilled near the end of the inner rod.

Camera Shutter and Stop Watch Operate Simultaneously

Desiring to operate my camera shutter simultaneously with a stop watch, I used the arrangement indicated in the drawing. This is nothing more than a small bracket soldered to the back of the watch to take the end of the shutter release cable so that both the cable-release and the starting knob on the watch can be operated with the thumb of one hand.

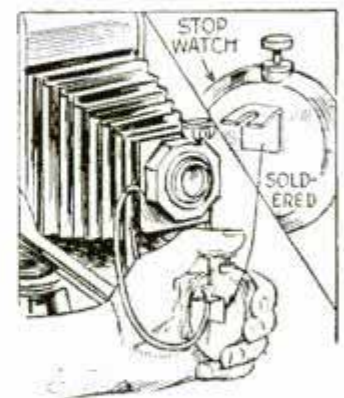

—Armand Thyot, Cohoes, N. Y.

Solving HOME



SQUARES OF TIRE PATCH OR INNER TUBE

RUBBER CEMENT

When the soles of your galoshes wear smooth, give them anti-skid surfaces by cementing squares of tire-patching material to them

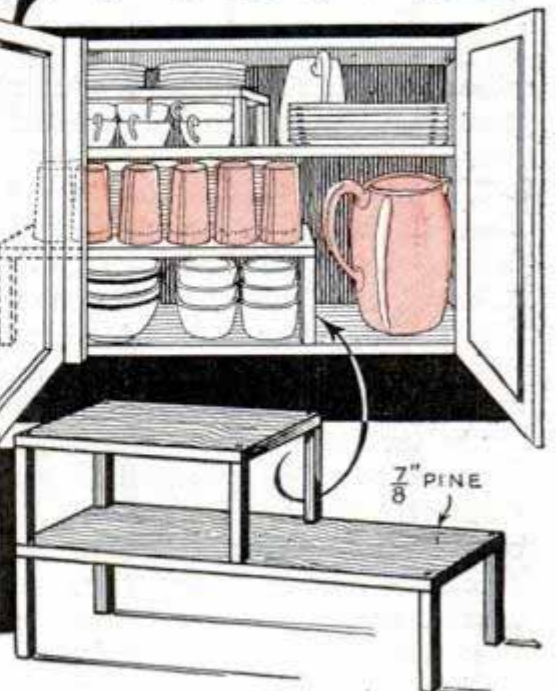

7/8" PINE

The pyramid shelf above is intended for small articles and will save space in your cupboard, while the wire handle at the left quickly converts your soap-flake box into a pitcher-like dispenser

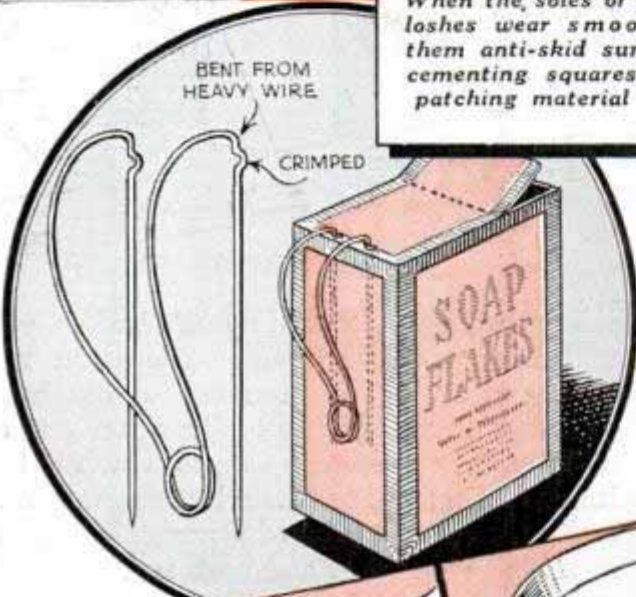

BENT FROM HEAVY WIRE

CRIMPED

SOAP FLAKES

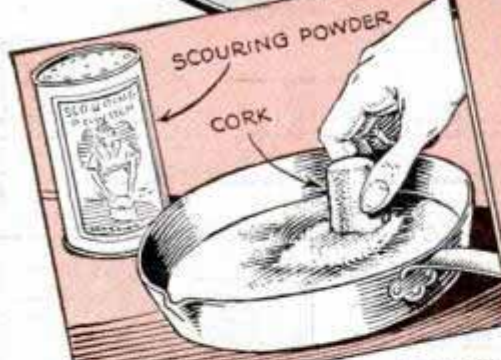

SCOURING POWDER

CORK

You can polish small surfaces on cooking utensils quickly when a cork is used as a scouring pad



REFRIGERATOR WATER BOTTLE

HEAVY WIRE

PAPER DRINKING CUPS

SOLDERED

WRAPPED WITH CORD

Store your frying fat in paper cups that you can throw away when empty

Why do without a handle on a refrigerator water bottle? You can make this one easily



NOTCHES



1" ROPE

A pail will hang on a pitcher pump if a couple of notches are filed in the spout as at the left. You can carry a heavy flowerpot easily with a rope handle like the one at the right



PROBLEMS

CUT FROM PINE 2"x4" STOCK

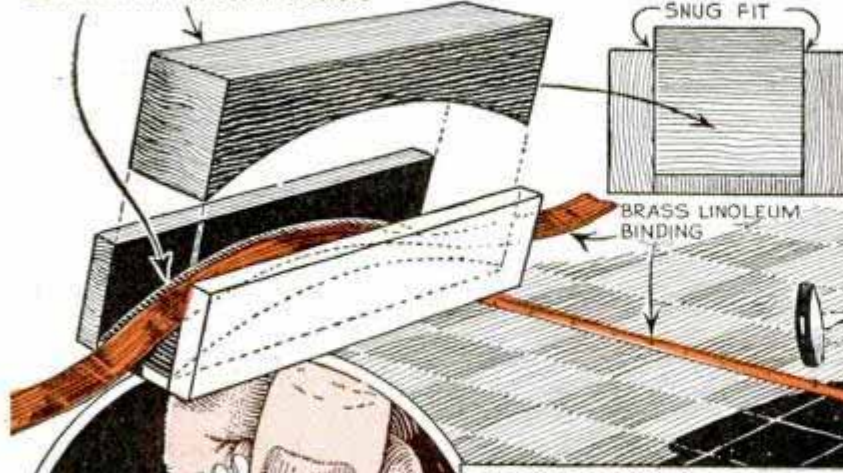

After tacking down one end of linoleum binding, you can stretch it taut with the holder above. Left, grind off one corner of a razor guard, clamp a blade in it and you have a handy cutting tool

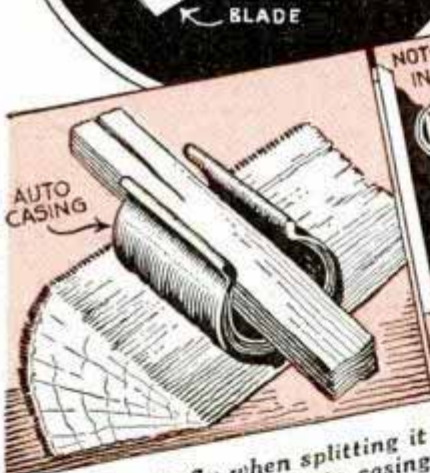
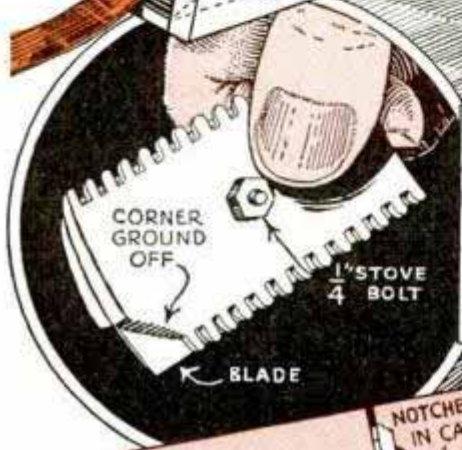

Kindling can't fly when splitting it if placed in a piece of auto casing tacked to the chopping block



Notches filed in catch on a clinker door of a heating boiler to control draft closely when starting fire

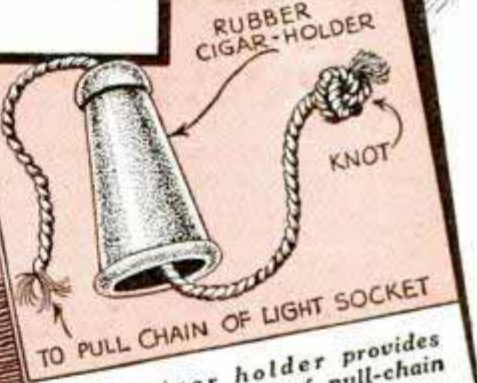

Rubber cigar holder provides handy grip on end of pull-chain cord of ceiling lamps

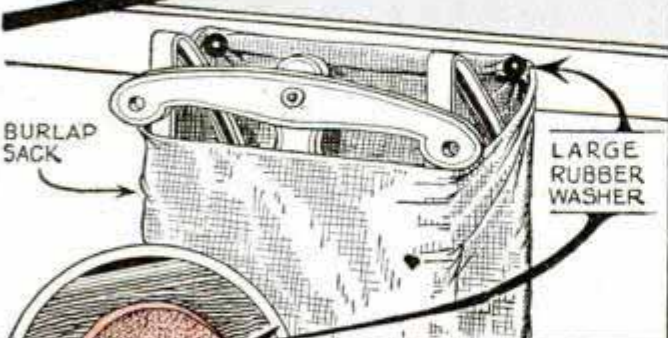

The child's sled won't be in the way if it's slipped in a burlap sack and hung on the wall of a closet, store room, basement or garage. Right, bricks stacked loosely to form a circular enclosure, provide a good outdoor incinerator

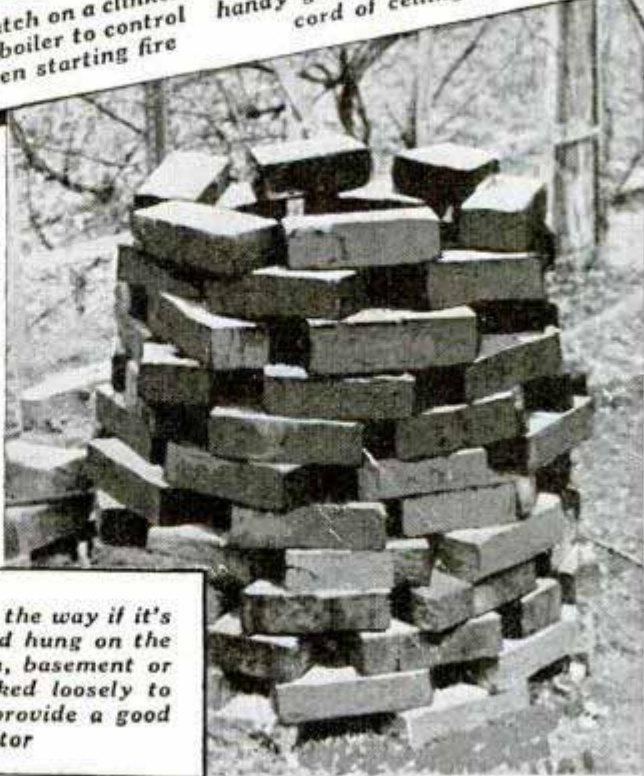

Vacuum Cup Serves as Handle for Celluloid Triangle

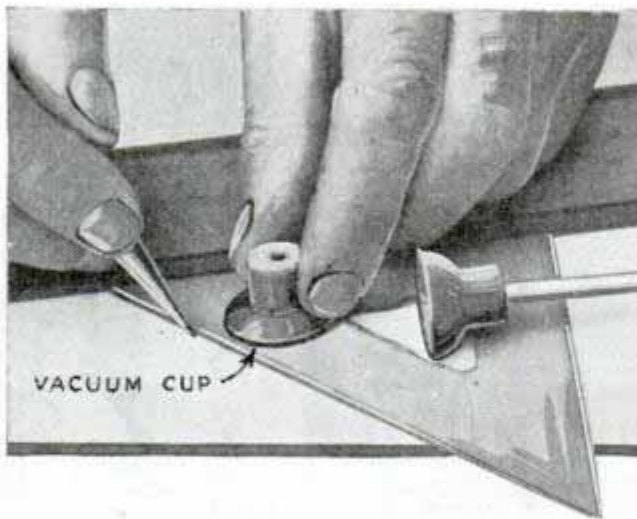

The home draftsman and student will find that one of the small soft rubber vacuum cups serves nicely as a handle on a

celluloid triangle. The cup is held comfortably with the fingers and can be used on a protractor or other drawing-board device as well as a triangle.

Rubber Feet on Framed Photo

When framed photos are kept on tables and other pieces of furniture, there is possibility of marring the highly polished surfaces unless the frames of the photos are provided with non-scratching feet. To do this easily, just insert a couple of rubber-headed tacks in the lower edge of each frame as indicated.



A Masterpiece in Ship Models

Do you want a model of one of the most outstanding warships in history? If so, build the "Sovereign of the Seas." Complete information on the construction of this ornately decorated, and highly picturesque model, 34 in. long and 26 in. high over all, is given in our blueprints 828 to 835 incl., priced at \$1.50 per set. Descriptive text in bound book, \$1.00 additional.

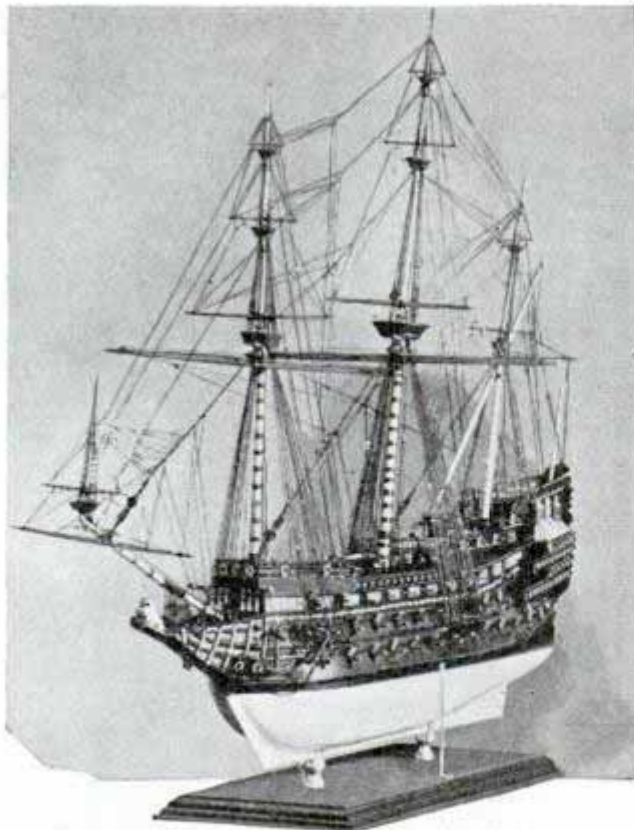

PLANS ON

OTHER WORTH-WHILE MODELS

"Flying Cloud" Clipper Ship—709-714A: No collection is complete without a clipper. Complete with full-size lift templates—\$1.25.

"Half Moon"—717-718A: Model of boat used by Dutch Seaman, Henry Hudson—\$1.00.

"Sea Bee"—965 to 968: 32 in. speed boat for circular race courses. Powered by midget gas engine—\$1.00.

Viking Ship Model—888: Used by Norsemen in early explorations. 14-in. hull—25c.

"Santa Maria"—759: Simplified design of Columbus' flagship. About 18 in. long—25c.

"U.S.S. Pensacola"—863 and 864: Midget design of 10,000-ton treaty cruiser—50c.

Prairie Schooner—728: Model is quaint reminder of covered-wagon days. Wagon without top, 8 3/4 in. long—25c.

Model Colonial Cannon—735: Perfect 10-in. miniature of guns used during days of 1776. Turned brass and wood—25c.

Blueprint Department, Popular Mechanics Magazine, 200 E. Ontario St., Chicago



Motorized HAND PLANE *gives smooth finish*

By R. G. BULLARD

JUST the thing for edging long boards, fitting doors and jointing smaller pieces of stock at the bench, this electric hand plane is made from a discarded vacuum-cleaner motor, a piece of hardwood, some sheet aluminum and a few small bolts. If you've ever had the rather disagreeable task of fitting a door with the ordinary hand plane you will appreciate this tool, as the high-speed cutter whisks away the waste wood down to the dimension line in a fraction of the time and besides, it leaves a glass-smooth surface. Or, if you need a jointer just turn the machine upside down and clamp the handle in the bench vise as in

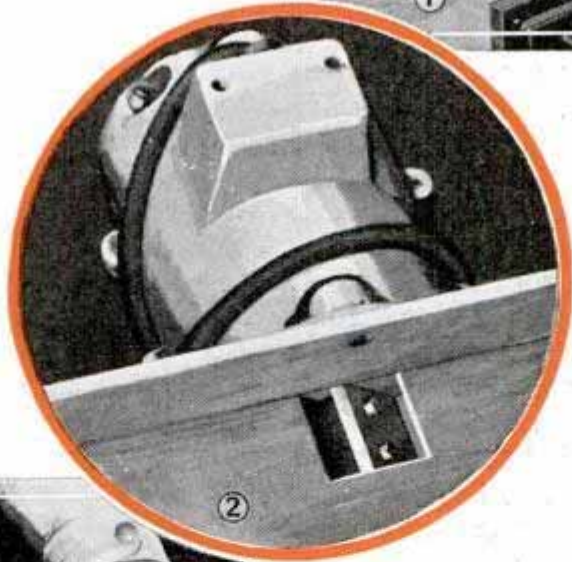
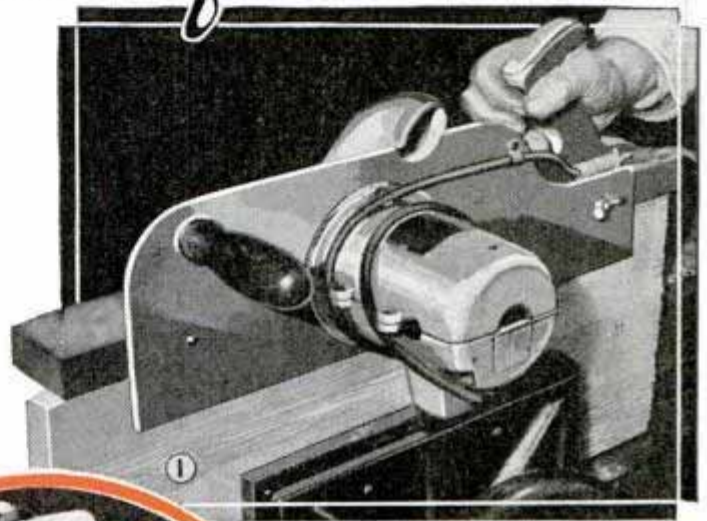
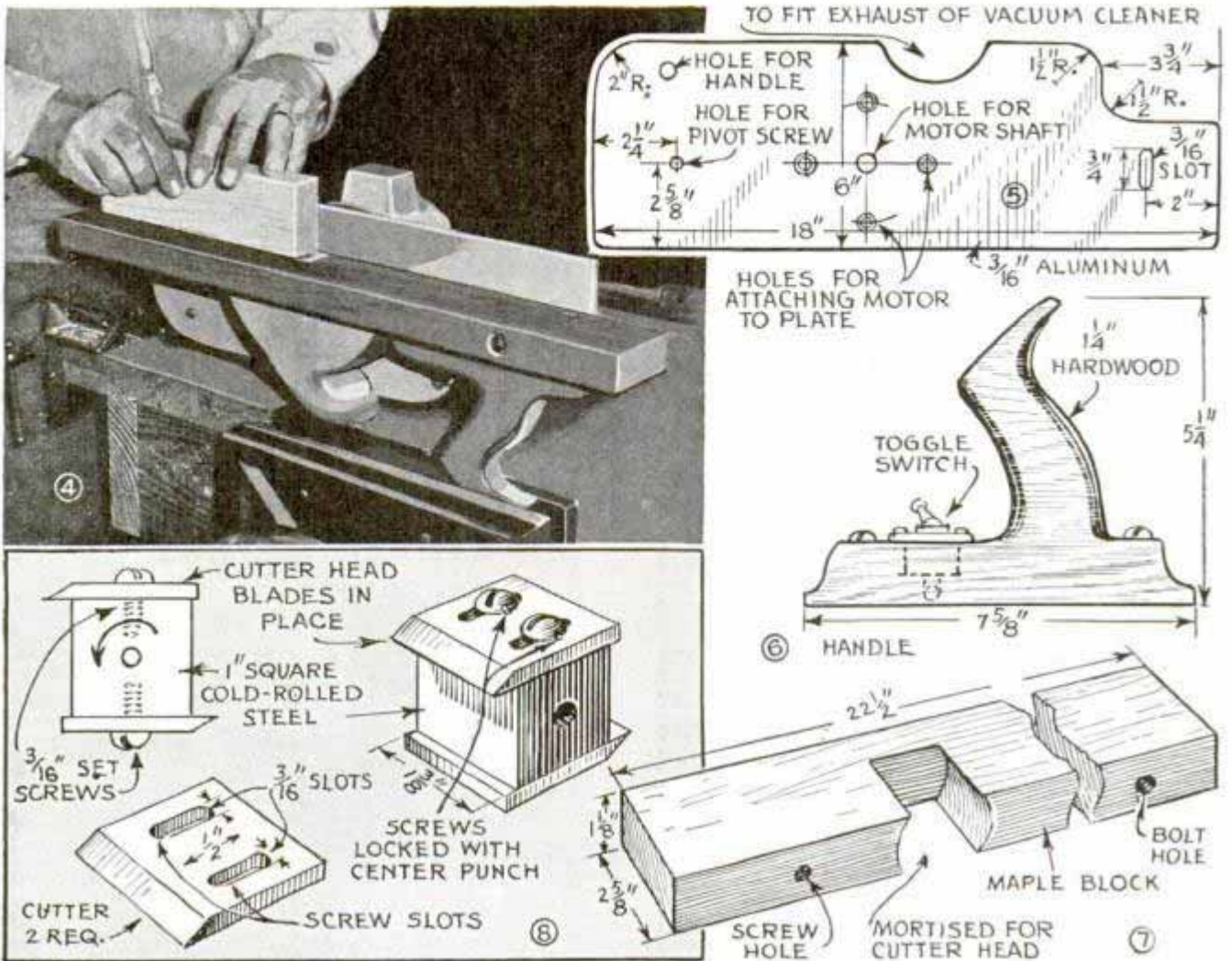

Fig. 4. In this position it's especially handy for squaring up small pieces of stock.

Figs. 1, 2, and 3 tell practically the whole story of the assembly. Of course, the arrangement of the parts shown is that suited to the characteristics of one particular motor. This

means that if another motor of somewhat different design is used minor changes in details of the assembly may be necessary. Now, referring to Figs. 5 to 8 inclusive, you'll get a good idea of how the parts are made. The guide, Fig. 5, is bolted to the motor and then to the base, Fig. 7. A slotted bolt hole, Fig. 5, provides a means of adjusting the depth of cut. You will notice from Figs. 1 and 3 that the fan housing





has been cut and fitted to the plane in such a way that it forms a combination knife guard and dust chute. The fan housings of most vacuum cleaners can be adapted in the manner shown by a bit of careful work with the hack saw and a file.

The cutter head is shown in Fig. 8. It is of the square two-knife type and is drilled to fit over the motor shaft. Perfect running balance is of the utmost importance as the head must operate without vibration at high speed. This means that the hole for the motor shaft has to be exactly centered and the cutting edges of the

knives must describe the same arc. One way to test the head for static balance is to mount it on a short length of shafting with the ends projecting equally. Then fasten two razor blades to a block of wood, level them, and place the head with the ends of the shaft resting on the edges of the blades. If the head is even slightly heavy on one side it will immediately roll until this side is down. To correct this tendency you remove metal on the heavy side of the head with a file until the head will roll on the razor-blade edges without coming to rest at any one point.

Lightweight Metal Doubletree Can Be Assembled Easily

The main leaf of an old car spring is used for the back of this metal doubletree and is braced with a piece of flat iron welded between the spring eyes. These form natural connections for the singletrees, and squares of heavy iron welded to the top and bottom of the doubletree take the tongue pin.



Tool-Post Grinder for Modelmaker's Lathe

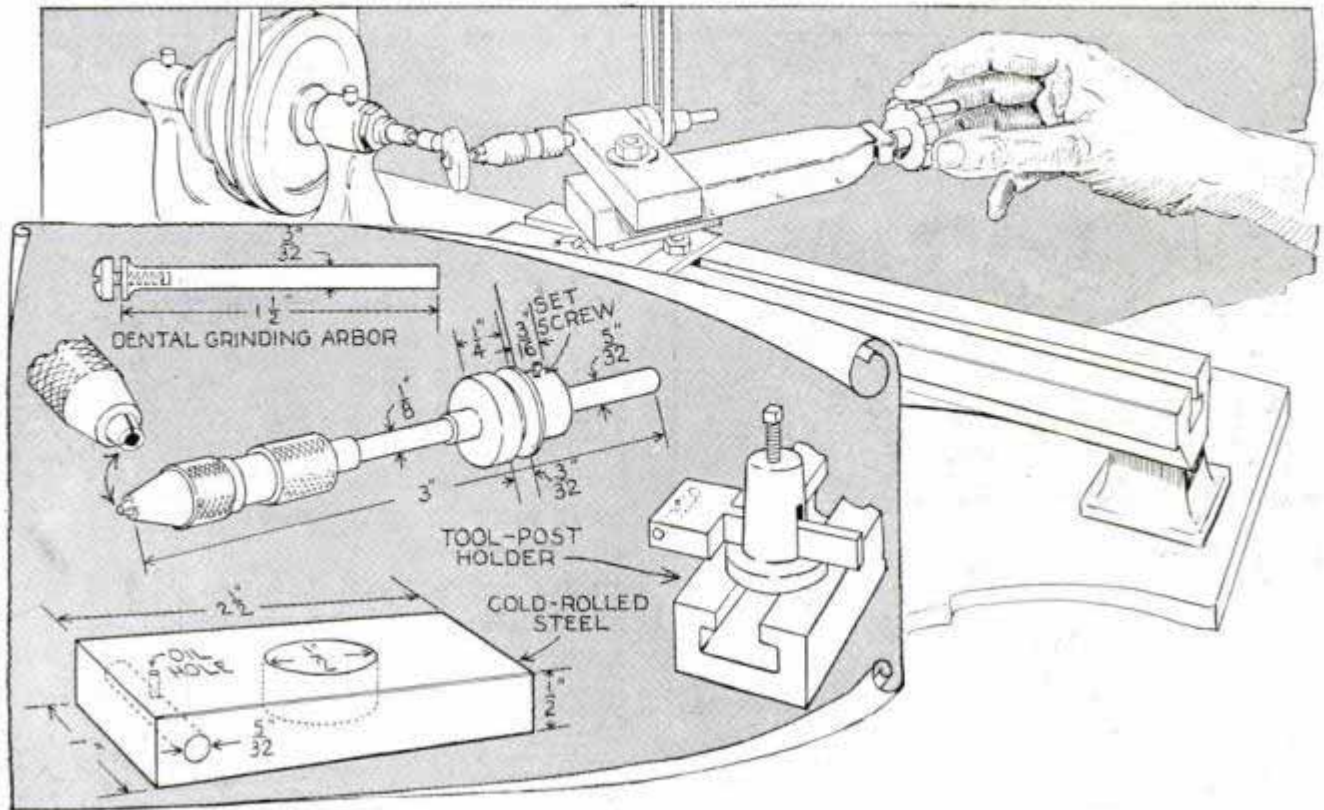

After experimenting with several types of electric tool-post grinders, I developed a belt-driven one that has proved ideal for use on small modelmaking lathes. When held in a bench vise, it is also handy for use with small drills and tools, and has saved much filing when making small model parts. It is possible to do internal grinding in holes as small as $\frac{1}{4}$ in. in diameter. As the grinder is designed to use abrasive wheels of the type employed in dental laboratories and those made for small hand electric grinders, a large variety is available. The shaft was made from a pin vise, the metal handle of which was turned to the dimensions given. It will be necessary to ream the jaws of the vise slightly with a small drill to take the dental grinding arbors, which are $\frac{3}{32}$ in. in diameter. Bearings for the grinder shaft can be ground from cold-rolled steel to fit in the lathe tool post as shown, or they can be of a rectangular shape to bolt on the compound rest or clamp in a bench vise. Be sure to provide an oil hole in the bearing. A V-pulley can be turned for the grinder shaft. A sewing machine motor is fastened to the ceiling above the lathe and belted to the grinder shaft.

—C. K. Fankhauser, Bedford, Ohio.

Thin Disks Chucked in Lathe with Aid of Drill Pad

Thin disks, which are to be faced and must project slightly beyond the chuck jaws, are chucked easily if a drill pad is placed in the tailstock. The disk is held securely against the face of the pad and the whole moved up to the chuck with the tailstock hand wheel. When in exactly the right position, the chuck jaws are tightened down on the work, which will then run absolutely true.

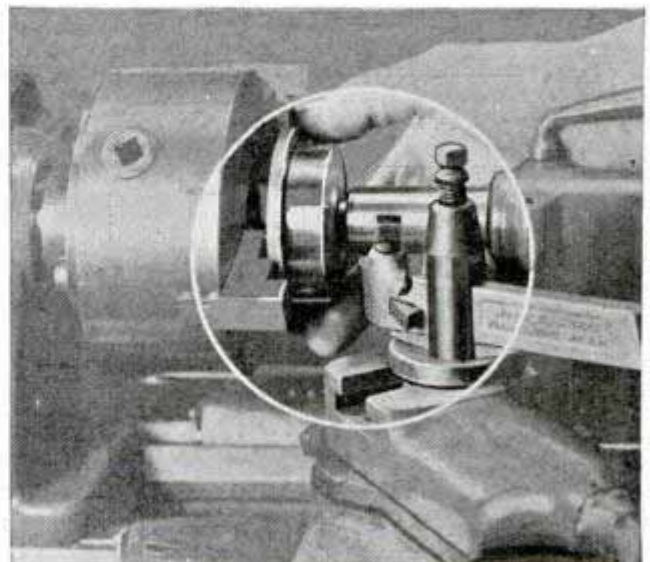

Lever-Action Tool Peels Logs with Little Effort



When peeling the bark from a number of logs for the framework of a machine shed, one farmer saved several hours of tedious labor with this tool. It consists of a length of tire-iron bent to form the handle, and a second piece of scrap metal, which was bent and sharpened to serve as the blade. In use, the bark strips are started with an ax or hatchet, after which the blade of the tool is placed in the position indicated and driven along the log by forcing the handle prongs into the wood and pushing forward.

Extra Pocket on Plumber's Kit Holds Small Tools



To avoid opening a kit for only one or two small tools, and to keep these items separate from the larger ones, a plumber made an extra pocket from a section of inner tube and attached it to one side of his tool

bag. The ends of the tube section were cut as shown to insert through slits in the side of the large bag. A slit along the upper side of the tube gives access to the contents.

Printer's Mitten Always Open for Handling Castings

Printers who employ a casting box for casting mats in their shop, will find the mitten shown useful for handling hot ladles or castings as it may be put on or removed in



an instant without the use of the other hand. The top of the mitten is stitched to a wire loop to hold it open, and the loop is provided with a hook for suspending it from the operator's belt.

Barbed-Wire Hoop Keeps Stock from Overturning Small Tank

When a small tank or tub is employed to water livestock, one farmer wraps a strand of barbed wire around it just under the



rim. While it does not prevent the safe conveyance of the tub, the barbs project sufficiently to prevent the animals from upsetting the tub with their noses.

Saw Table Converted for Drilling and Routing

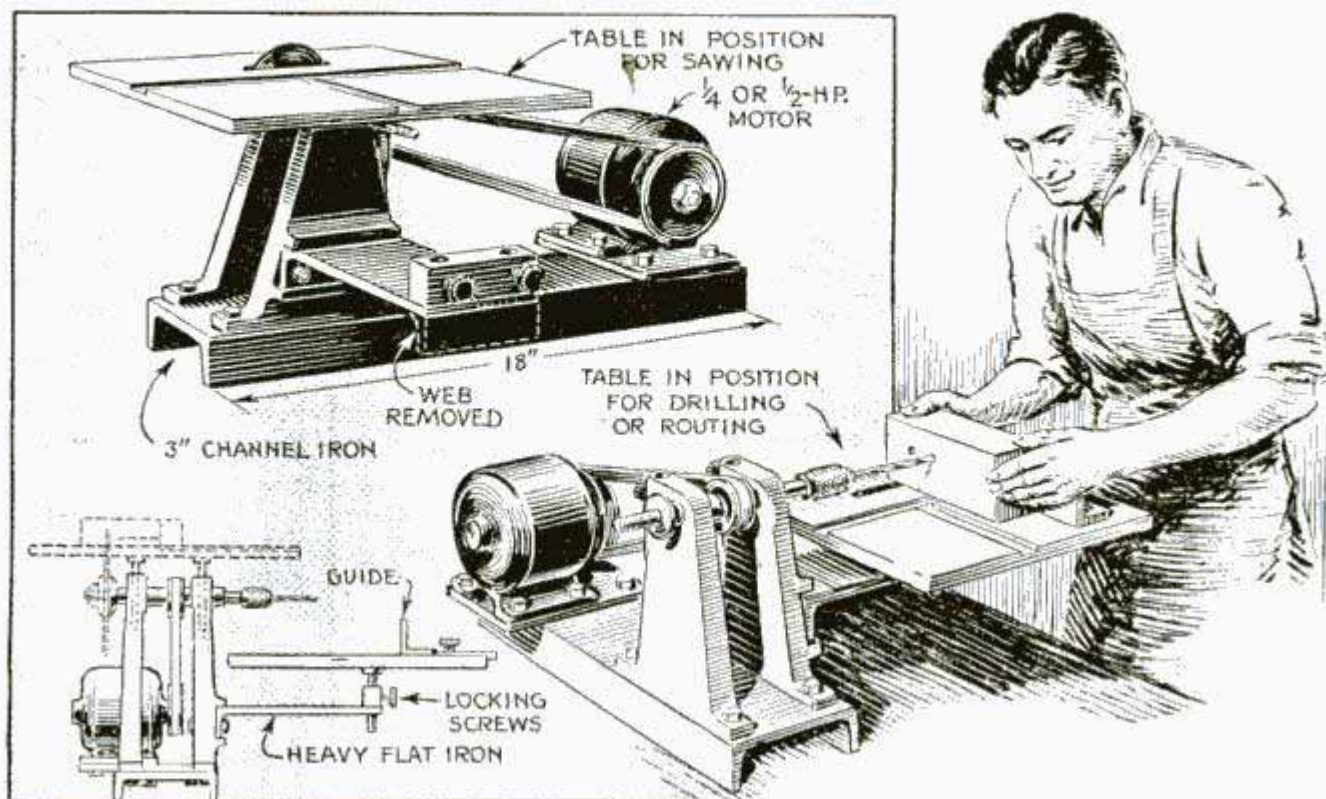

Having a small circular saw of the type that has a removable table and one end of the mandrel threaded to take a chuck for drilling, one craftsman converted the saw so that the table could be used as a drilling or routing table. To provide a support for the table when the latter is used for drilling or routing, a short length of heavy channel iron was bolted to one side of the base and leveled parallel with the table.

One web of the iron was cut off after which a piece of steel was bolted to the outer end and drilled to take the table slides. Locking screws were provided to hold the table in the desired position. The miter gauge can be used to feed the work into the drill. If both the saw base and a motor are mounted on a length of channel iron, the assembly can be moved easily wherever desired.—M. B. Birge, Hinsdale, Ill.

This Micrometer Attachment Measures Internal Tapers

Handy for quickly measuring the taper per inch of internally tapered work, this micrometer attachment is made from a steel block. The block is turned at one end for a distance of $1\frac{1}{8}$ in., and $\frac{1}{8}$ in. at the other end. Then the piece is slotted at one side to fit closely over the lock nut, and at the other side to straddle the anvil. A hole for the micrometer spindle and two holes for the U-shaped slide bar complete the work before sawing the piece in two. In use, the $1\frac{1}{8}$ -in. projections are inserted into the tapered opening and the reading is noted, after which the $\frac{1}{8}$ -in. projections are similarly inserted. The difference in the readings is the taper per inch.

—H. Moore, Leeds, England.

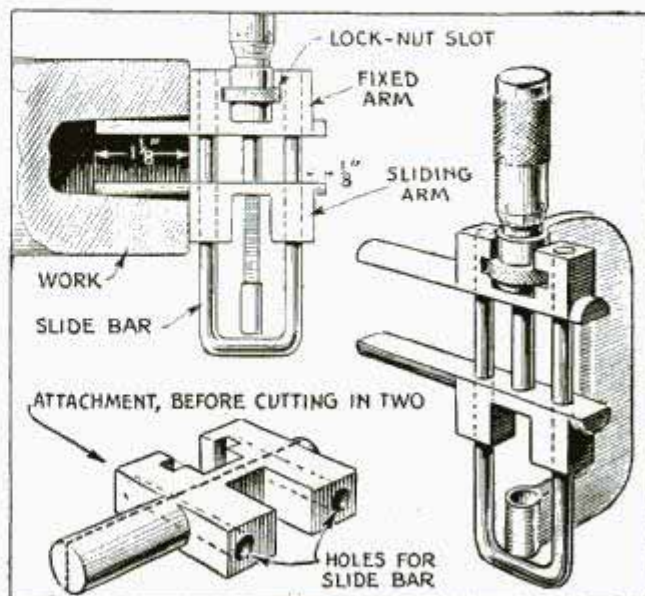

Double-Loop Halter Tie Is Better Than Knot in Rope

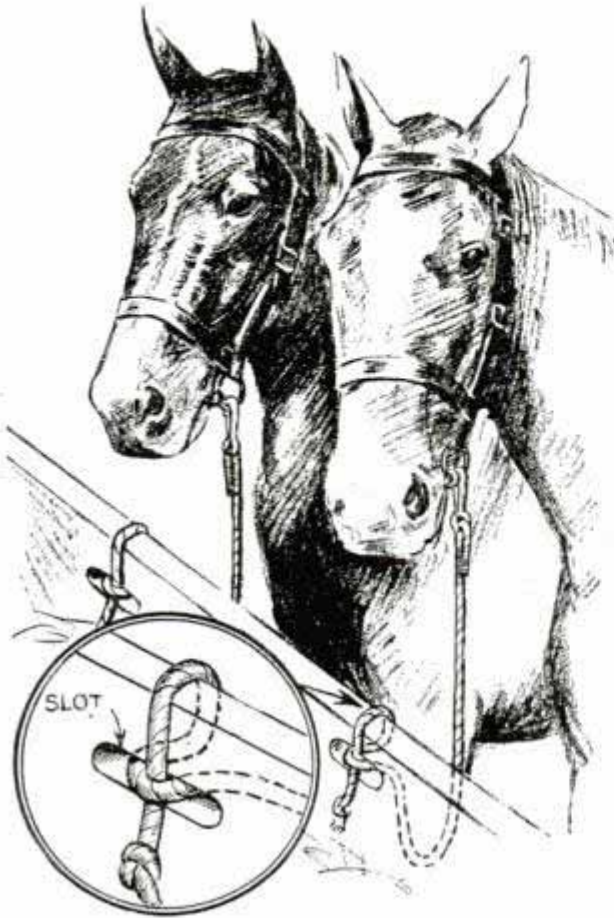

When a horse is tied to the manger hurriedly, there is a possibility that the knot employed may become so tight from the animal's pulling that it will be difficult, if not impossible, to loosen. If a long slot is sawed in the manger to receive the looped halter rope, and the end (knotted) is dropped through this, as shown, the tie will hold against all ordinary pulling, yet may be loosened and released instantly.

Small Containers Save Paint

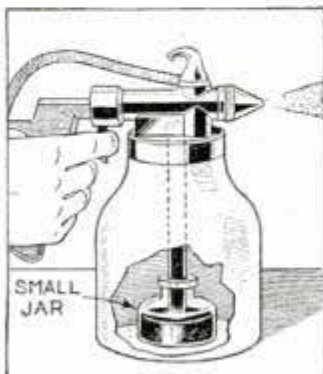

in the bottom of a regular spray gun container with a pint or quart capacity, screw-

In our business we have occasion to spray small objects with various colors of lacquer. To eliminate wasted time and material, we keep our lacquer in 2 to 4-oz. jars and insert one of these

ing the container in place. When we have finished spraying, we insert a small jar of lacquer thinner and clean the gun.

—Richard Pedersen, Chicago.

Wood Spigot Secured in Barrel with Rubber Washer

To avoid driving a spigot forcibly into a barrel for dispensing vinegar and other liquids, one merchant recommends the use of a short piece of radiator hose, which is slipped over the spigot as shown. The rubber seals the spigot snugly in place with a single tap of a hammer, and prevents it from being dislodged.

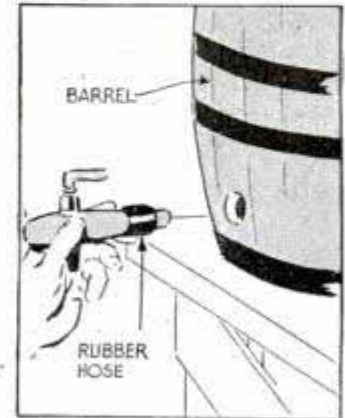

Simple Knot for Grain Sacks Is Opened Easily

Here's a knot that will hold grain sacks closed in handling, yet is easily and instantly untied by pulling on a projecting end of the string. In making the tie, the two ends of the string are doubled back on each other, the string is wrapped twice around the sack, and the loop ends are given three interlocking turns.

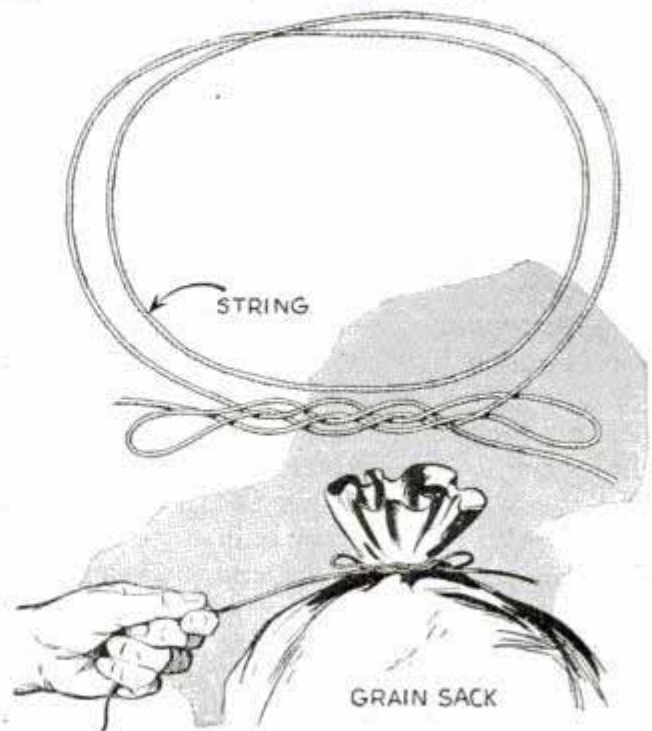

Carbon Rheostats for Low-Amperage Current

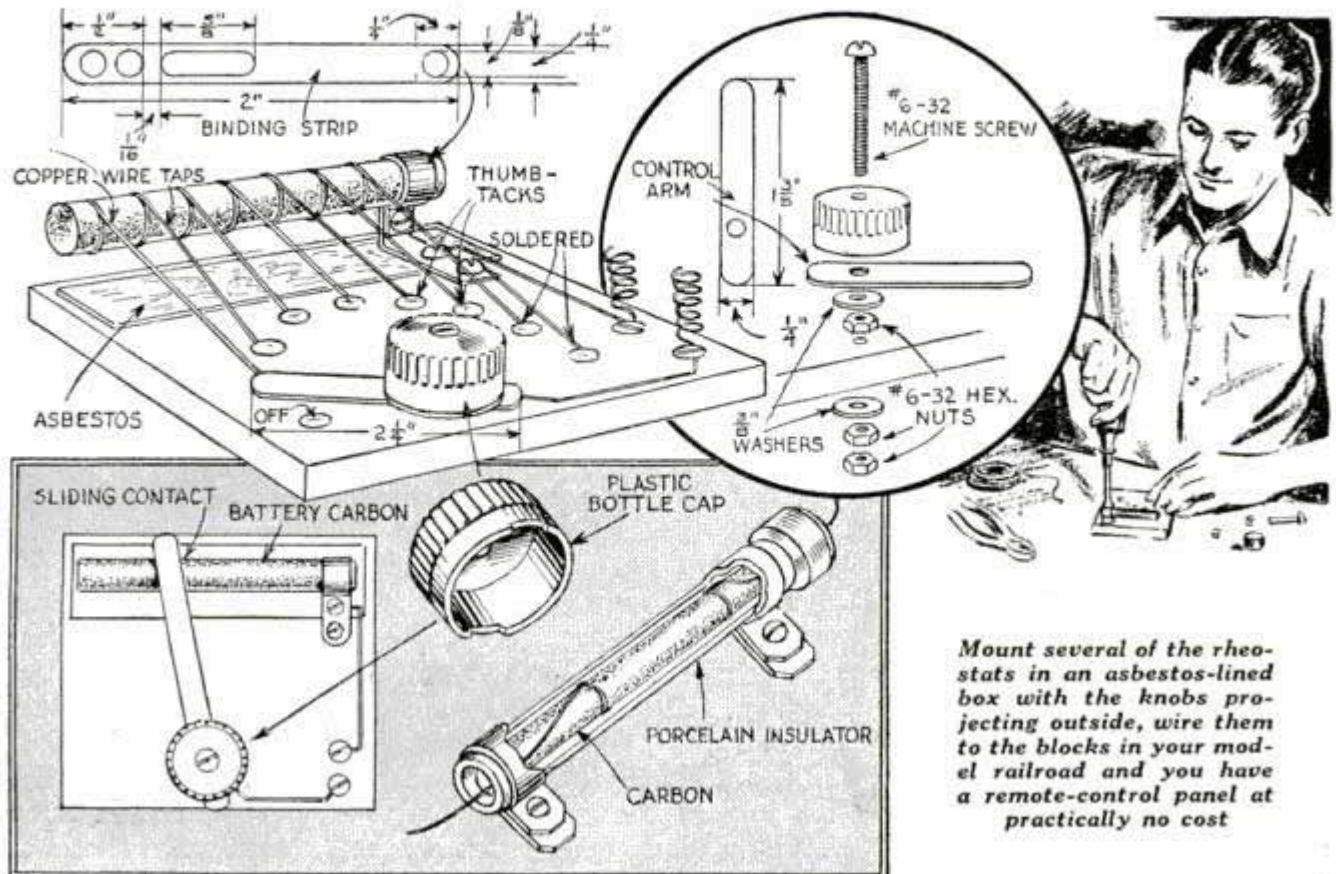

Mount several of the rheostats in an asbestos-lined box with the knobs projecting outside, wire them to the blocks in your model railroad and you have a remote-control panel at practically no cost

Model-railroad fans who would like a separate control for each block, but feel that the cost of such an installation is prohibitive, will find these rheostats just the thing. Also, they are handy for the electrical experimenter and for other uses where the current handled is of very low amperage. Of the two types shown, the one in the lower detail is simpler, and gives steadier control, but it has the disadvantage of wearing quickly if it is used where the control must be adjusted frequently. The carbons for both rheostats are taken from flashlight cells. In the lower one, the carbon is mounted on an asbestos-covered base by means of a bracket at one end. A sliding brass or copper contact brushes the carbon, and is controlled by a knob assembled as shown in the circular detail, the knob being a plastic bottle cap. The carbon in the rheostat in the upper detail is mounted in the same way, but it has several copper-wire taps leading to thumb-tacks or screws, which the control arm contacts as adjustment is made. This method avoids wear on the carbon, but control is likely to be a little jumpy unless care is taken to locate the tacks so that the arm

contacts one the instant it breaks contact with the preceding one. If the carbons are used as permanently set resistors, it's a good idea to inclose them in a porcelain tube, as they are likely to heat.

—Earle T. Orchard, North Attleboro, Mass.

Bushings Removed from Boiler with Lead Cone

Crushing of small sleeves, nipples and bushings when they are being removed with a heavy wrench, is avoided by one plumber who uses a lead cone. This is driven into the sleeves before the wrench is applied. The cone tends to keep a bushing or nipple from being crushed by the wrench when pressure is applied.

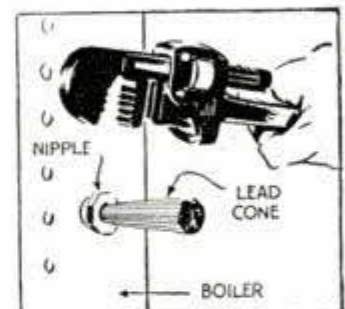

☞ To clean an empty oilcan so that it can be used for other purposes, rub the inside with a handful of sawdust.

You Can Build These

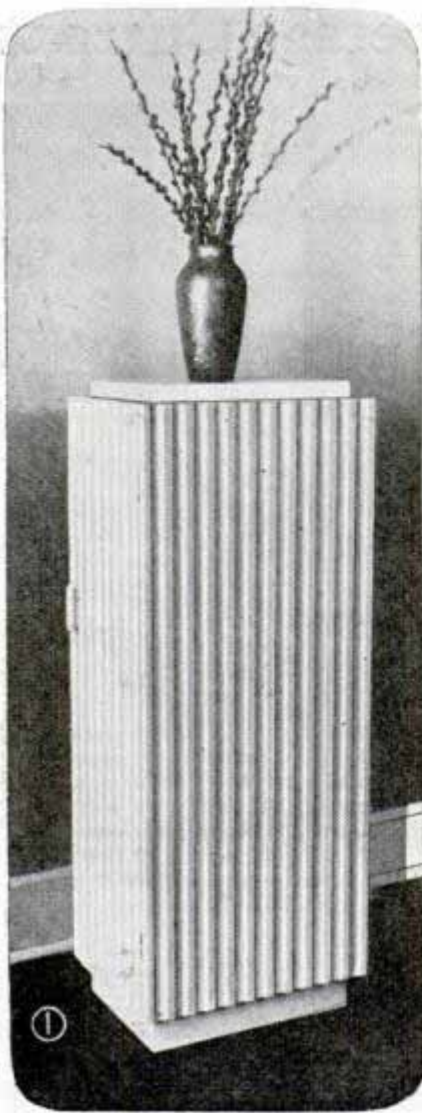

SIMPLIFIED by straight lines of modern styling, any one of these graceful pier cabinets will lend a modern touch to a bare wall or vacant corner. For a finish of bone white, any close-grained stock, hard or soft, that will take a smooth coat of enamel can be used. The cabinet in Fig. 1 is of simple design and when open, affords commodious space for numerous magazines, books, etc. Made in pairs, this cabinet offers a delightful decorative treatment at either side of a doorway or bay. The construction should be apparent readily from the cut-away drawing in Fig. 6, with full dimensions being given in Fig. 2. Simple rectangular frames fitted at top and bottom of the assembly are first made with butt joints held by corrugated nails, after which the three sides are fitted. If you use corrugated fasteners in joining the frames, keep them back from the edge of the top frame so that the top piece will hide them. The corner joints of the side pieces can be tongued-and-grooved or simply butted. The side pieces including the door, the back being left plain, are fluted before assembling them permanently. This job can be accomplished easily on a circular saw with a molding head which has been fitted with a rounded knife ground from a blank. Or, you can do the job by using a standard cutter as shown at Fig. 3. This latter method requires more time in making the repeated cuts although a $\frac{3}{4}$ -in. dado saw can be used first to remove the waste. For sake of simplicity, the fluted effect can be simulated by tacking standard half-round molding to a carcass of $\frac{1}{2}$ -in. plywood, Fig. 4. While this method produces a reeded effect, the same general appearance will result when heavily enameled. The mitered base is counterbored to take wood screws with which it is attached to the bottom frame. Cleats to support

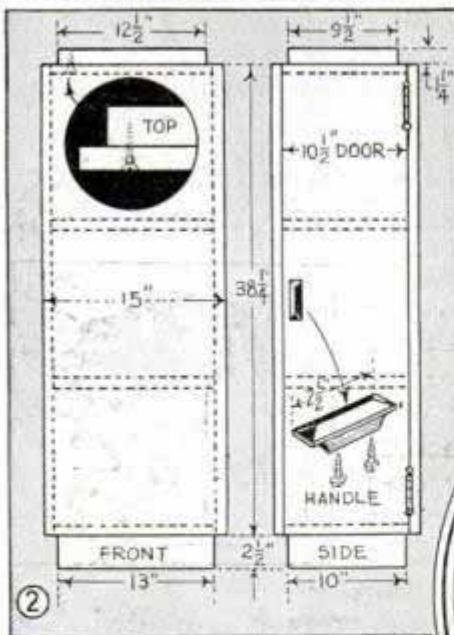

Side of cabinet opens to expose shelves on which books and magazines can be stored out of sight



PIER CABINETS

shelves of $\frac{1}{2}$ -in. plywood are fitted to the inside of the cabinet as shown. The lower frame can be covered with a piece of $\frac{1}{4}$ -in. plywood. The door is hung with two narrow butt hinges and held closed with a bullet-type friction catch.

Equally as effective for a bare corner in the living room is the cabinet shown at Fig. 5. Fully detailed in Fig. 10, the upper assembly is formed mainly from standard $\frac{3}{4}$ -in. dowels capped with 1-in. square members at the ends. The two center shelves, after being stacked and band-sawed along with the top one, are next bored, both at once, for the seven dowels. The top of the lower cabinet is cut slightly larger from $\frac{3}{4}$ -in. stock with the edge being shaped, if desired, as shown at Fig. 12. The best method of assembling the upper part, after the square-end members have been bored for the dowels, Fig. 9, is first to fit the pieces together without glue and mark the position of the square ends on the lower and upper shelves. Then remove the end from the dowels and glue these in their respective positions just

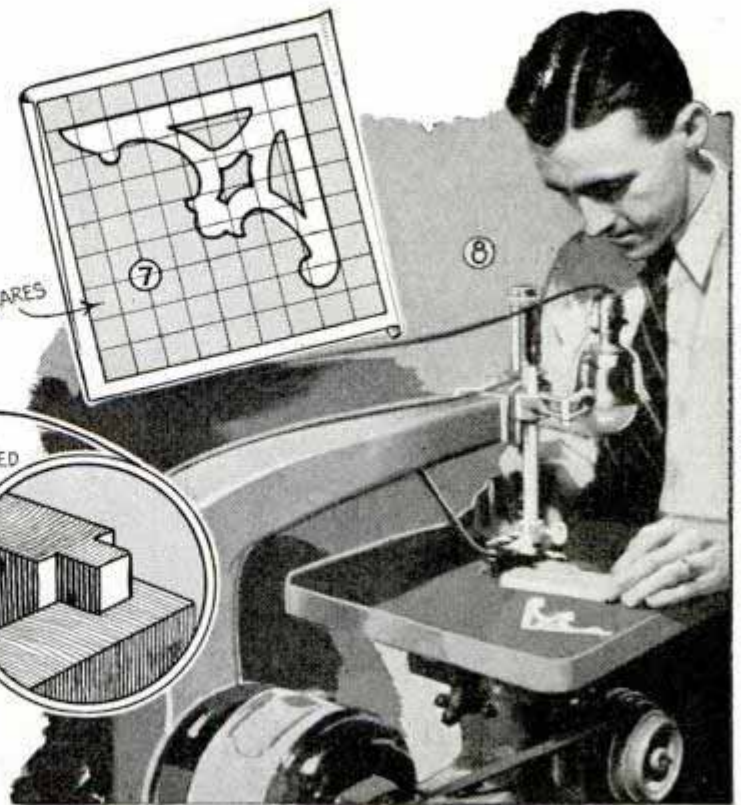
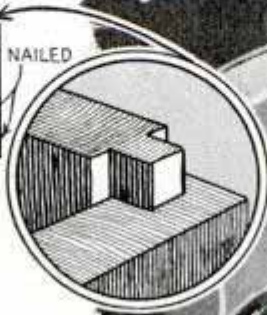
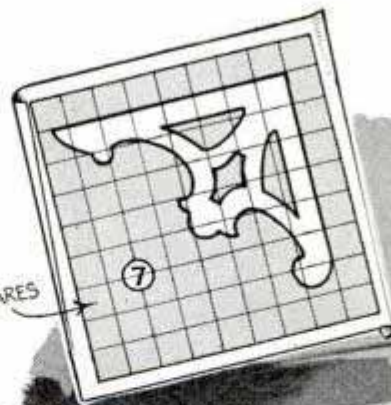
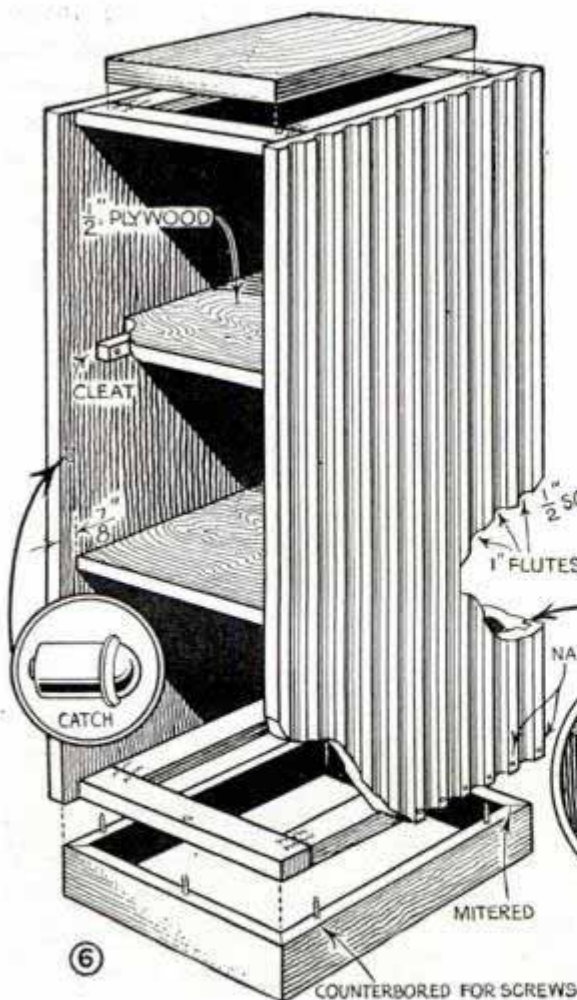



marked. When dry, they can be nailed from the top. It is then a simple task to coat the dowel end with glue and insert it in the holes. The center shelves are spaced as shown and held by nailing through the edge as at Fig. 13. Plywood sides for the lower structure are fitted to grooves run in the front and rear posts, after which the shelves are notched and nailed in place. Two jigsawed fretworks, Figs. 7 and 8, are bradded and glued to the front corners, which, when finished in walnut, will add a bit of contrast to the rest of the cabinet. The base, which can be left plain if desired, is easily formed from four angle-cut segments glued together as in Fig. 11. The ends are rabbeted to fit the plywood sides and are held with screws and glue blocks. If you flute the base, the grain of the segments should run vertical.

A distinctly novel design is shown in Fig. 14. It provides space for the installation of a small radio chassis and speaker at the top with dial mountings being made on the side of the cabinet. With the exception of the shelves and stepped-cut corners, the construction is of plywood. The sides are of 1/2-in. material, rabbeted at the back edge for a 1/4-in. back. The front facing is of 1/4-in. plywood. Fig. 15 details the layout of the corner pieces from a 2 by 6-in. block. The angle cuts are made on the circular saw set at 45° as in Fig. 15. It is best to cut the entire front facing from a single piece, jigsawing the speaker grille similar to that shown at the top and covering with a scrap of gold bronze cloth.

The location of the shelves is primarily dependent upon the size of the radio at hand which will govern the position of the remaining shelves. Provide air vents in the top compartment by drilling several large holes through the plywood back.

These pieces have been especially designed for an enamel finish and if you have used close-grained woods such as birch or

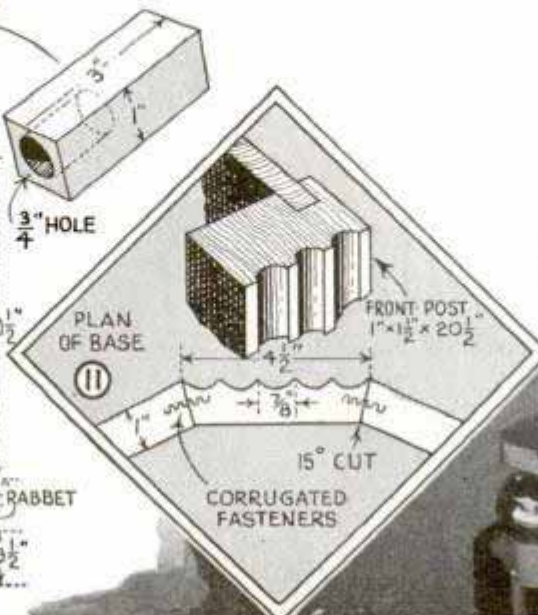
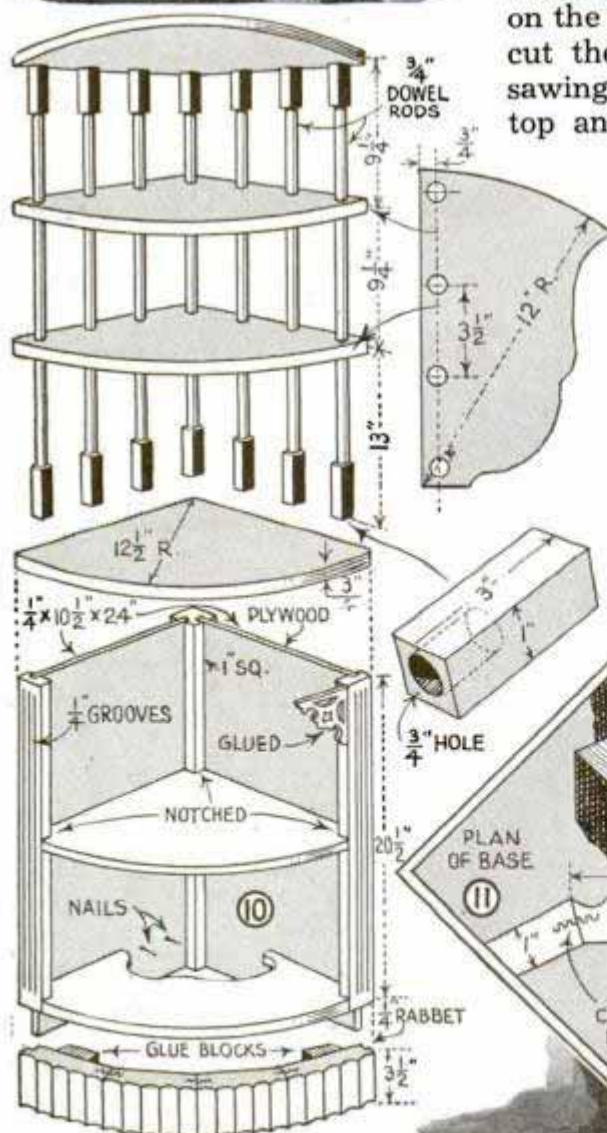



Large dowels blocked at both ends emphasize height and at the same time provide a novel means of supporting the shelves as shown at the right. The middle shelves are slipped over the dowels and held with small brads

STEPPED CORNER CUT WITH TABLE AT 45°

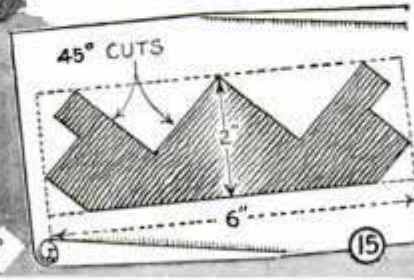

popular this is an easy job. A thorough sanding is the important thing, for enamel will not hide tool marks and rough end grain, even though several coats are applied. For sanding tool marks out of the flutes a piece of sandpaper wrapped around a short length of dowel of approximately the same radius as the fluting cutter is just the thing. Use successively finer grades of paper on both the flat and curved surfaces, being especially careful with exposed end grain. This must be perfectly smooth otherwise you will have trouble building up a level coating of enamel. After all parts have been sanded, apply a coat of enamel undercoater and let it dry thoroughly. If the undercoater absorbs on the end grain, fill the surface with a bit of paste, white lead applied and rubbed in with a piece of cloth or simply with your finger. Be sure to give this white-lead filler plenty of time to dry. Then sand all surfaces lightly with No. 6-0 paper. Then, for a first-class job, apply a second coat of undercoater, being careful to brush the coating out uniformly. After this is dry, sand again lightly with the same grade of paper. Then lay on the first coat of enamel to a uniform thickness with as little brushing as possible. When dry, sand lightly with No. 7-0 paper, and apply the second coat. When laying on both the first and second coats you have to be careful with the vertical surfaces, for if you get the enamel film a bit too heavy it will sag or run in places. This results in an unsightly blemish very difficult to remedy. When the second coat is dry, sand smooth and polish with wax.

☐ Photographers and others who often use several extension electric cords at the same time will find that they can distinguish them easily if pieces of colored paper are glued to the wires at 2-ft. intervals.



13

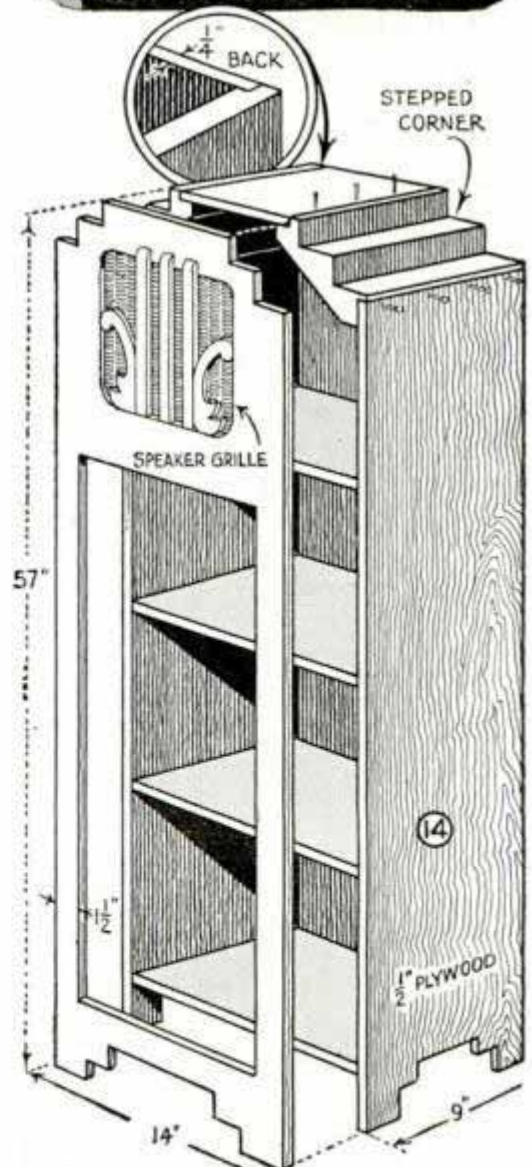

14

Boiler Plant Started in Morning by an Alarm Clock

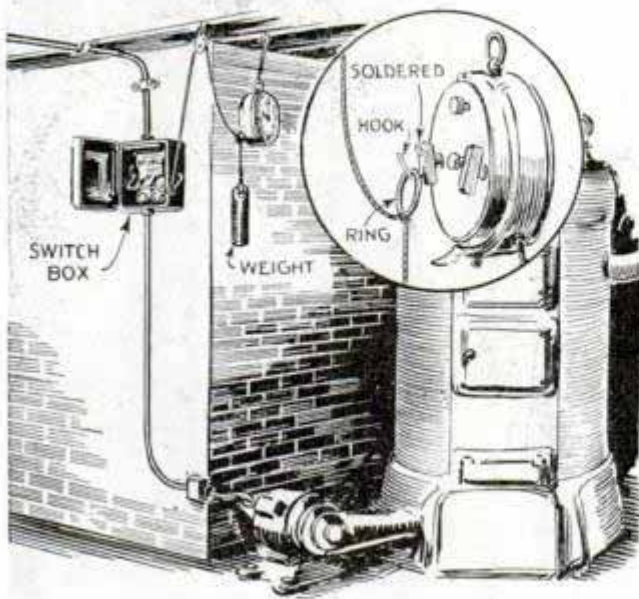

When I operated a boiler in a manufacturing plant, it was often necessary that I be down at three o'clock in the morning to start the oil burners. As this was rather unpleasant on cold mornings, I devised the time switch shown to do the job for me. As all oil burners have a wall box throw switch to shut off the power when the burner is not in use, the clock was installed so that it pulled the switch and closed the circuit at a given time. As shown, a small rope weighted at one end is tied to the handle of the switch and run over a pulley to the clock, where a ring in the chain attaches it to a hook soldered to the alarm winding key. At night, the switch is pulled and the alarm set. When it goes off the key turns, allowing the ring to slip off the hook.—W. C. Strodl, Arlington, N. J.

Cleaner for Eraser

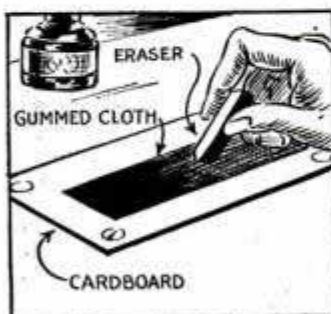

strip of cardboard or thin wood, which serves as a base. This is tacked in a convenient place where it is within an easy

Mechanics, draftsmen, artists, typists and others who often require a clean eraser, will find this cleaner just the thing. It is nothing more than a strip of gummed cloth stuck to a

reach. To clean the eraser, just draw it back and forth over the rough surface of the gummed cloth.

—M. Grossman, New York, N. Y.

Tile Ventilator for a Cave

A good ventilator for your cave is assembled easily from a clay or concrete tile. Set it bell end down in the roof of the cave, and then make a cone-shaped cap from a piece of heavy, galvanized sheet metal. Attach this to a sheet-metal band by means of three or four metal strips and clamp the band around the top of the tile.



Rounded Bottom on Feed Trough Increases Sanitation

These feed troughs or mangers, used on the University of Nebraska Experimental Farm, are worth copying because there are very few corners to accumulate small particles. The bottoms are of smooth, galvanized iron nailed to curved end pieces and patterns, which are sawed from 2 by 8-in. pieces.

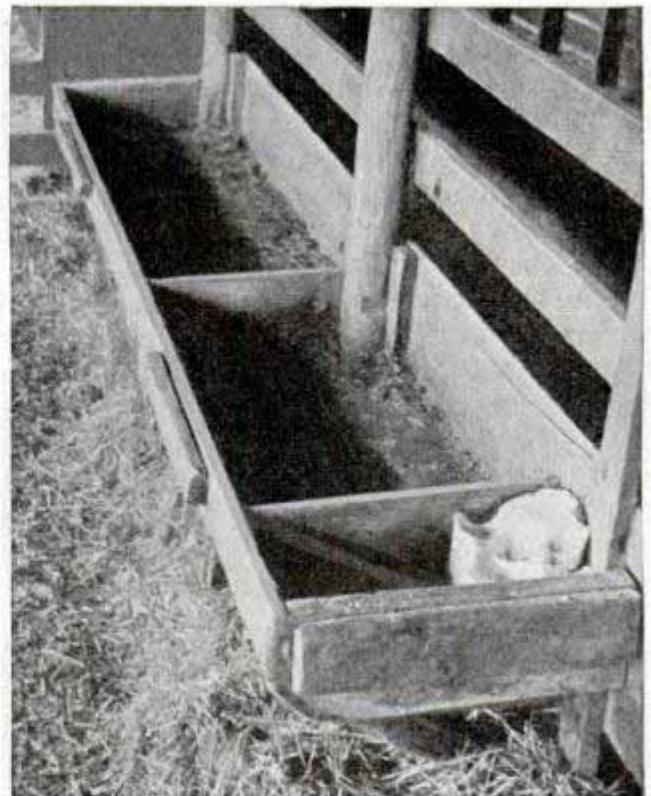

Long-Nose Pliers Are Altered to Hold Screws

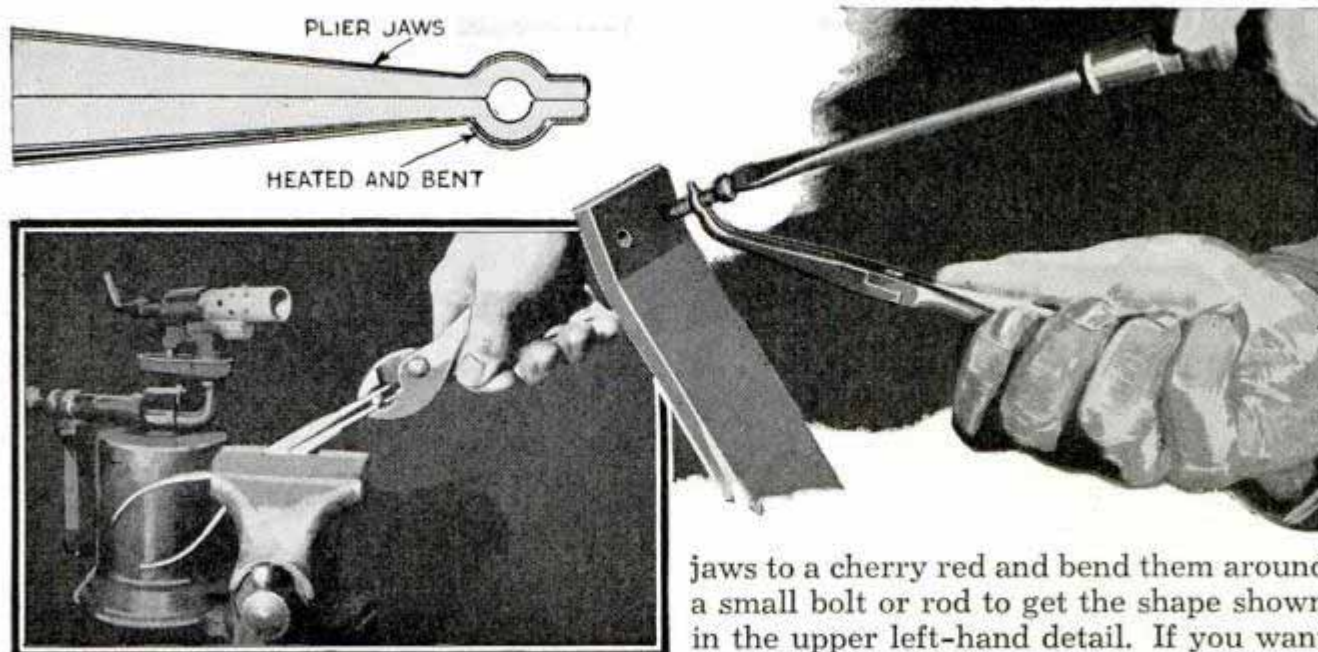

Bent to the shape indicated, you can use a pair of long-nose pliers for holding nails, screws, etc., while starting them. Also, they are handy for holding small work while grinding and similar jobs. Heat the

jaws to a cherry red and bend them around a small bolt or rod to get the shape shown in the upper left-hand detail. If you want to bend them at right angles afterward, grip them in a vise and bend them with a pair of heavy pliers. After shaping them, reharden by heating to a cherry red and then plunging into cylinder oil.

—M. W. Mutschler, Lincoln, Nebr.

Shingler's Seat Is Adjustable to Pitch of Almost Any Roof

Compact and comfortable, this shingler's seat is upholstered for comfort and is easy to adjust. Small metal spurs on the underside "bite" into the roof and prevent slipping. If used when applying composition shingles, pads of rubber should be substituted for the spurs. The seat consists of two wood blocks hinged together with a hinged spacer block between them to permit adjustment by means of a carriage bolt. Two pieces of sponge rubber provide the cushion, and they are lashed to a removable plywood slip seat.

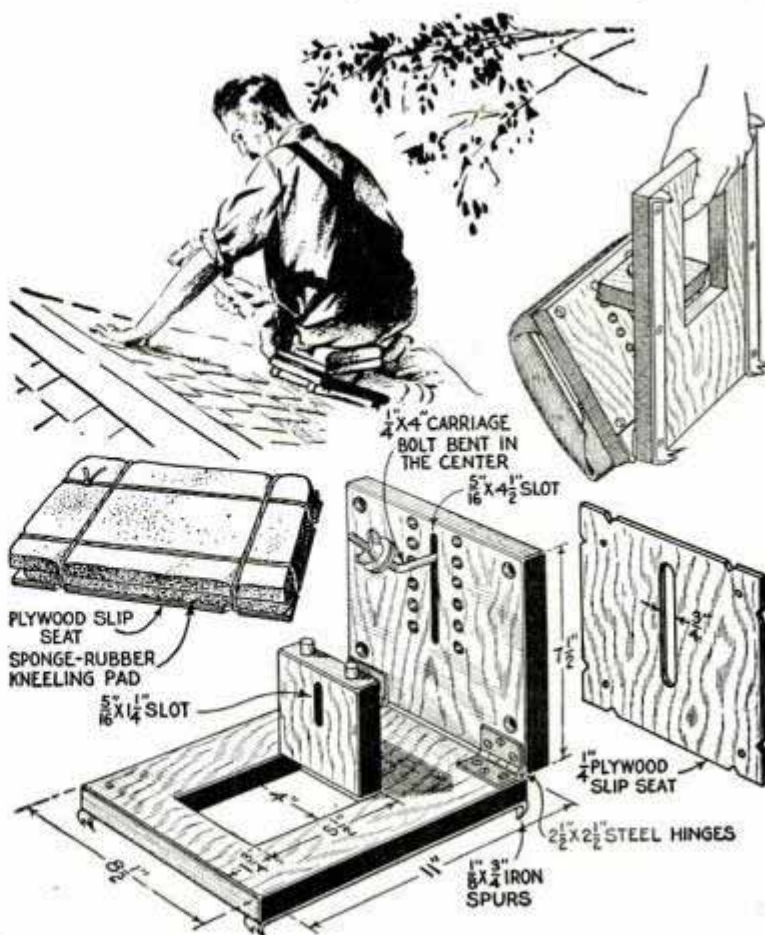

Restoring Faded Blueprints

Blueprints that have been rushed through the washing process to get them on the job quickly, often fade on contact with strong light. If this happens, store them in a dark place a few hours and their original color will return.

Pad for Repairman's Sawhorse from Inner Tube

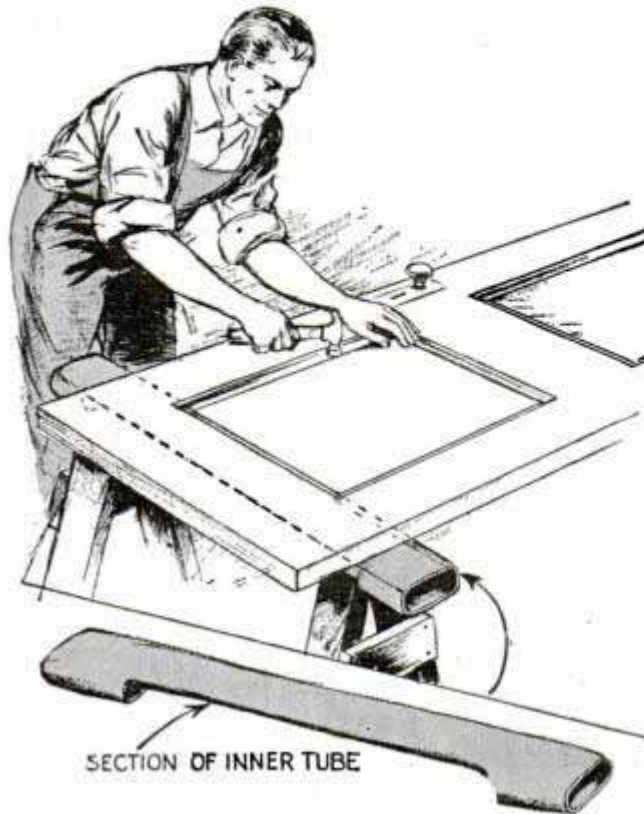

A carpenter, who frequently had to repair varnished or painted doors, windows, etc., eliminated the possibility of scratching them by carrying a removable pad for each sawhorse used on the job. The pads were made from sections of inner tube cut to the shape indicated to fit securely over the top of the horses.

—G. E. Hendrickson, Argyle, Wis.

Drip Catcher on Barrel Cock Prevents Waste

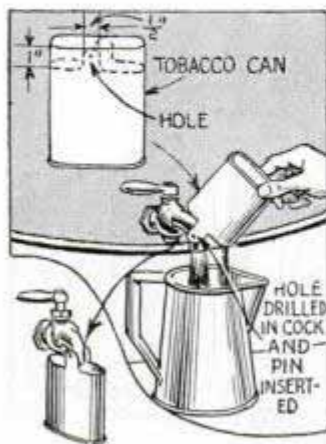

Farmers and others who keep gasoline, lubricating and fuel oil stored in barrels will find that this simple drip catcher not only tends to save oil, but also prevents the floor or ground underneath the barrels from getting oily. The catcher is nothing more than a tobacco can with the top cut away to provide two ears in the center which are

pivoted to the barrel cock so that the catcher can be swung upwards, as shown, to empty the drippings.

—A. H. Waychoff, Tempe, Ariz.

Special Hinge Pin Aids Carpenter

When hanging doors, carpenters are sometimes inconvenienced by removing and replacing the hinge pins, which may often fit so snugly that a tool must be used to loosen them. To avoid this, one carpenter suggests a set of special pins. These are made to fit the standard door hinge and are provided with a finger loop by which they may be lifted.

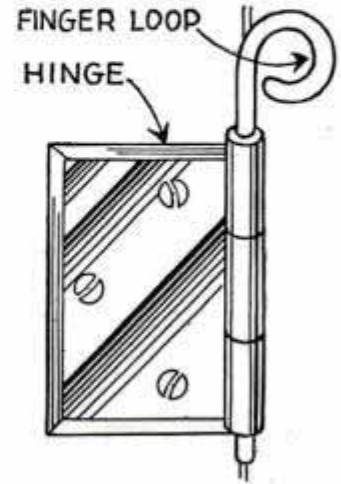

These are made to fit the standard door hinge and are provided with a finger loop by which they may be lifted.

Holder for Bench-Saw Blades from Split Lawn Hose

Several blades of your bench saw may be kept conveniently at hand in this holder, which is simply a split length of discarded lawn or garden hose, nailed to the wall as shown. The rubber will protect the teeth from damage and also allow easy selection of any blade.

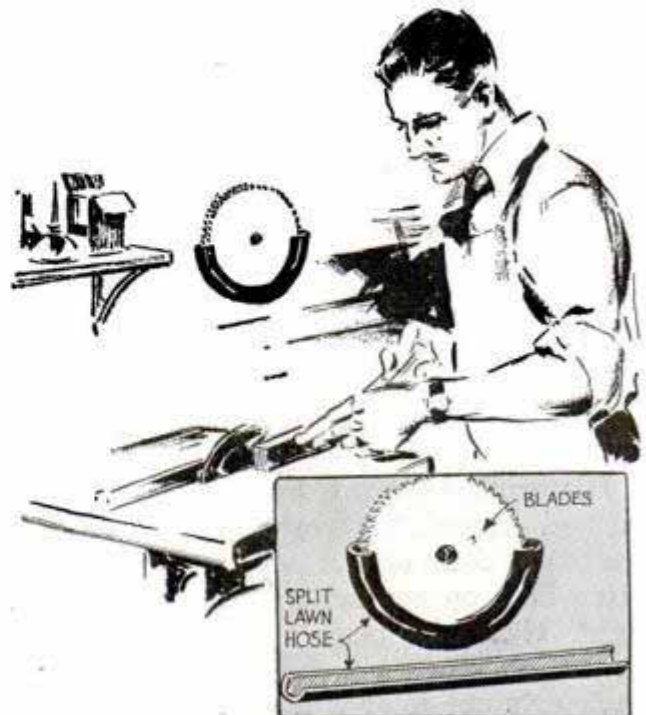

Making UNIT CASTINGS *in the home shop*

INTRICATE castings of small objects such as wheels, model parts, statues and busts can be made by this method, which employs a pattern of modeling wax. The process is such that usually it is not necessary to part the pattern. One variation of this general method makes it possible for you to purchase inexpensive novelty china statuettes and then duplicate them in every detail with soft metals such as brass, aluminum, bronze, type metal, pewter or lead. Examples are shown in Fig. 3.

Now to get into the process. The one method which is most widely applicable uses an original pattern made of wax. As an example, take the wheel shown in the center detail of Fig. 2. Making this pattern of modeling wax is really very easy as the wax can be softened and molded into most any shape, and then trimmed to the exact size wanted, as in Fig. 4. The finished pattern should be mounted on a plaster-of-paris base made as shown in the upper detail, Fig. 2. Then a form such as a tin can with the ends knocked out, is placed around it as in the lower detail. To provide for pouring the metal, rods of wax

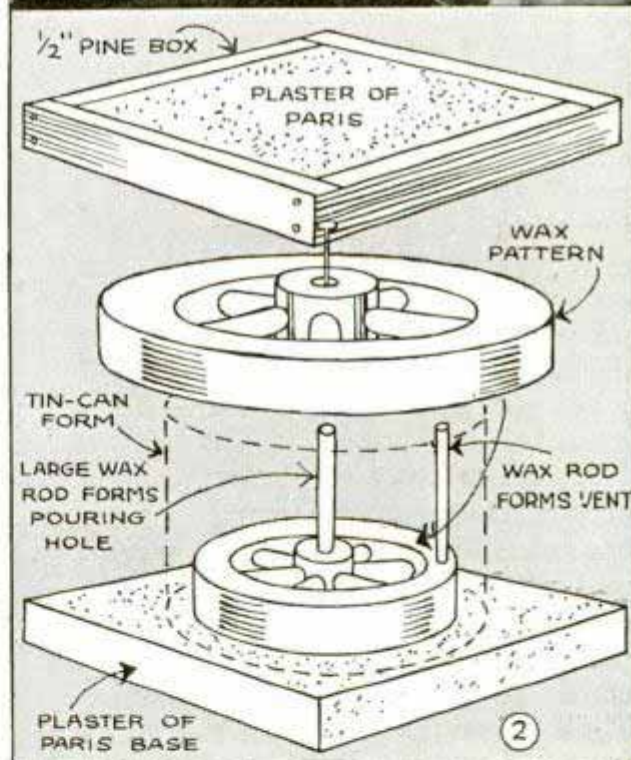

CASTINGS MADE WITHOUT PARTING



are softened and stuck on the highest part of the model, Figs. 2 and 6. These should extend higher than the metal form and one should be large enough to provide a passage for pouring the molten metal; the others serve only to let air out of the form. The wax pattern must be fastened down so that it can not move when the plaster is poured over it.

A thin mixture of plaster of paris is made by taking enough cold water in a large pail to fill the form, and slowly dropping in plaster of paris until some of the latter comes to the surface and floats, Fig. 5. Then the mixture is stirred well and poured into the form, as shown in Fig. 9. When the plaster is dry, the wax pattern is melted out as shown in Fig. 8, by standing the mold over a gas flame, with the vents down, and with a pan provided to catch the melted wax. Care must be taken that the wax does not catch fire. The mouth of the pouring hole should be enlarged so that it is funnel shaped.



ADD PLASTER UNTIL IT FLOATS

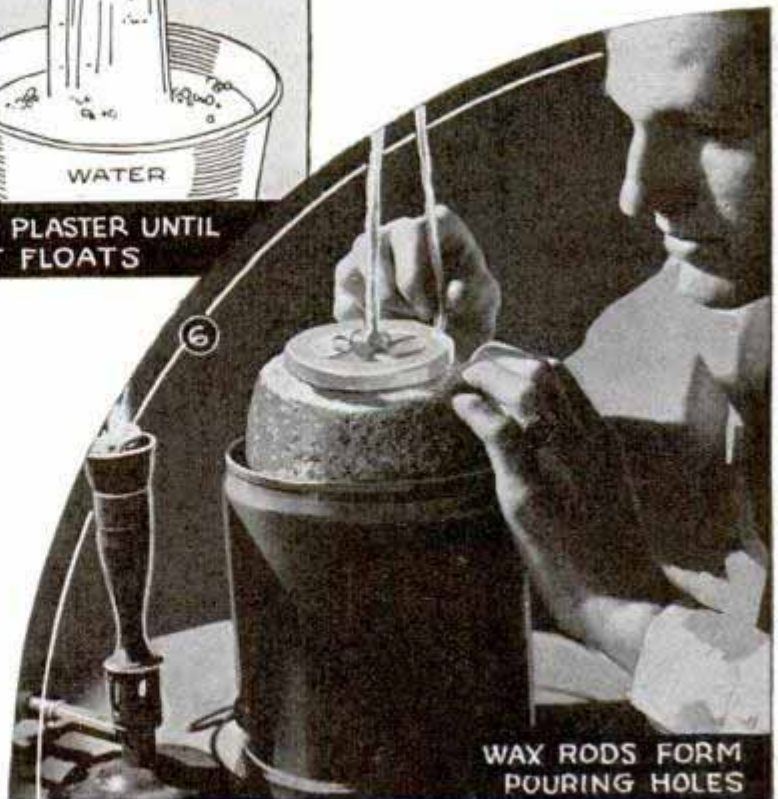

The mold must be thoroughly heated to drive out the last trace of moisture. The metal should be melted down in a crucible placed in a forge or a gas furnace. Lead, type metal, pewter, etc., may be melted in an iron pot in a forge, Fig. 16. The crucible should be handled with tongs similar to those shown in Fig. 8, and the metal poured as in Fig. 7. All pouring of molten metal should be done over dry sand. Excess metal must not be allowed to "freeze" in the crucible. After the metal has solidified in the mold, the form is removed and the plaster broken away by plunging the hot mold into a tank of cold water. With large molds, the plaster should be broken off. The pouring riser and vent prints on the casting may be sawed away and the surface dressed with a file or grinder.

Another method must be used where there is already a model to work from and where a single duplicate of any article is needed, or when a broken casting must be replaced. The broken

parts can be fastened together temporarily and used as a model for a new casting. Also duplicates of antique or unusual parts can be made from the original without in any way injuring it. The model is first set in position on a flat board, as shown in Fig. 10. In order to keep it in this position and to return it to the same place, spotting pins or small brads with their heads cut off can be driven into the base and pressed down into the model. The model next should be covered with two or three layers of wet newspaper, and then a layer of modeling clay, at least $\frac{1}{4}$ in. thick as in Fig. 11. The outside of this should be coated with paraffin oil or grease. A wood flask, spotted with pins, Fig. 12, is placed around the model to retain the plaster. The inside of the flask should be greased thoroughly. The plaster mold can be in one piece if the draft or taper of the model runs all in one direction from the base as in Fig. 14. If not, the mold will have to be parted approximately along the center line of the model by imbedding a light length of piano wire in the clay along the desired line and drawing it out when the plaster has partly set.

When the plaster has set, the mold is removed

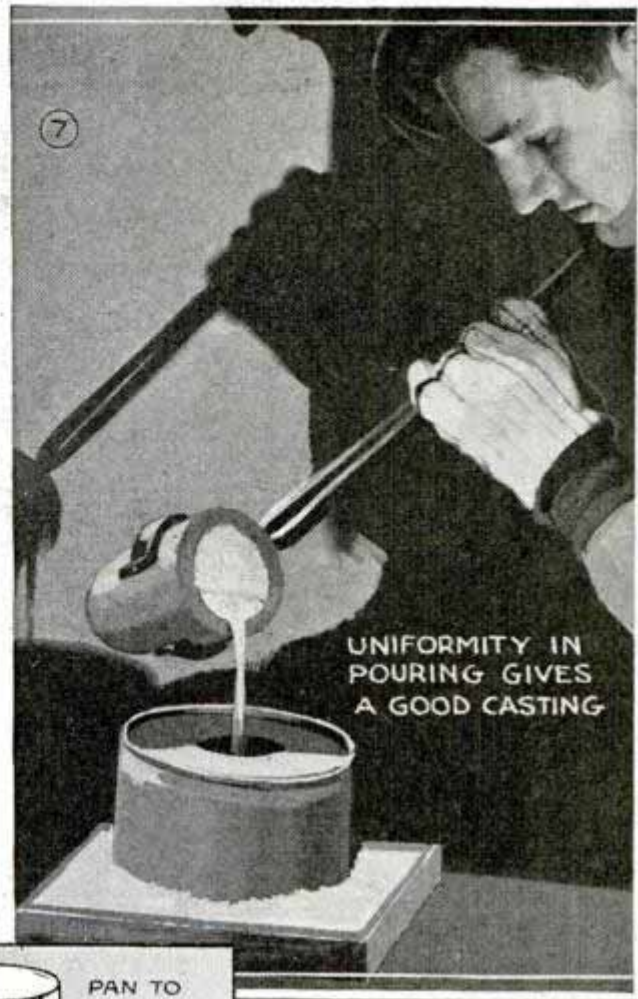

UNIFORMITY IN POURING GIVES A GOOD CASTING

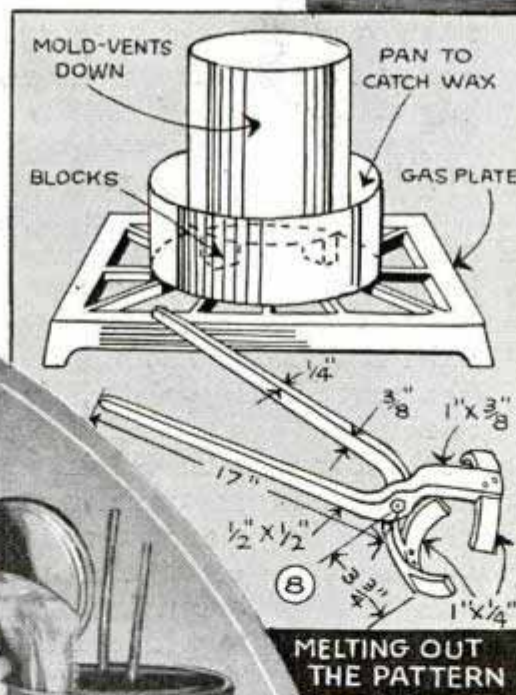

MELTING OUT THE PATTERN

carefully from the clay. All the clay and the wet newspaper are now removed from the model and plaster mold. A pouring hole is drilled through the mold at the top, using a knife and working from the inside. The mold is then set back in position around the model as shown in Fig. 15. Both the model and the plaster mold should be coated with oil. Small vent holes must be drilled any point where the air is

likely to be trapped. Next, soak cabinetmaker's white glue in sufficient cold water for fifteen minutes to swell the glue completely. Excess water is then poured off and the swollen glue is placed in a water-jacketed glue pot or a double boiler, and melted. When melted, it is poured into the mold



PLASTER IS POURED OVER THE WAX

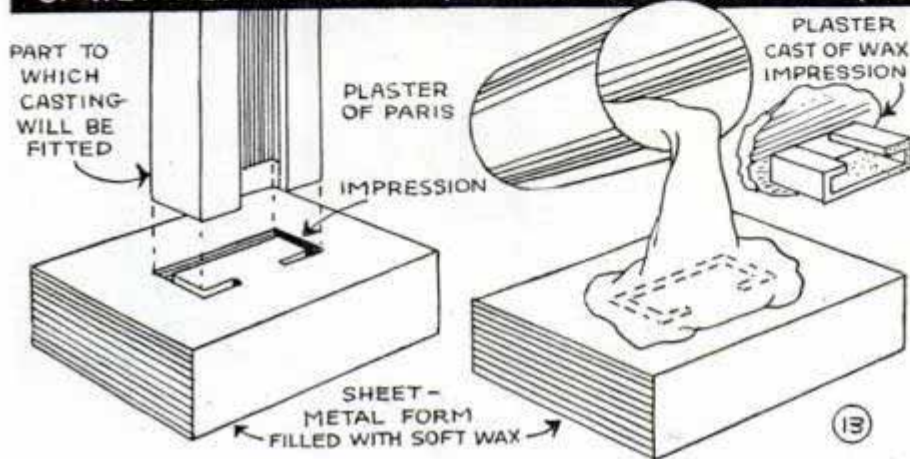
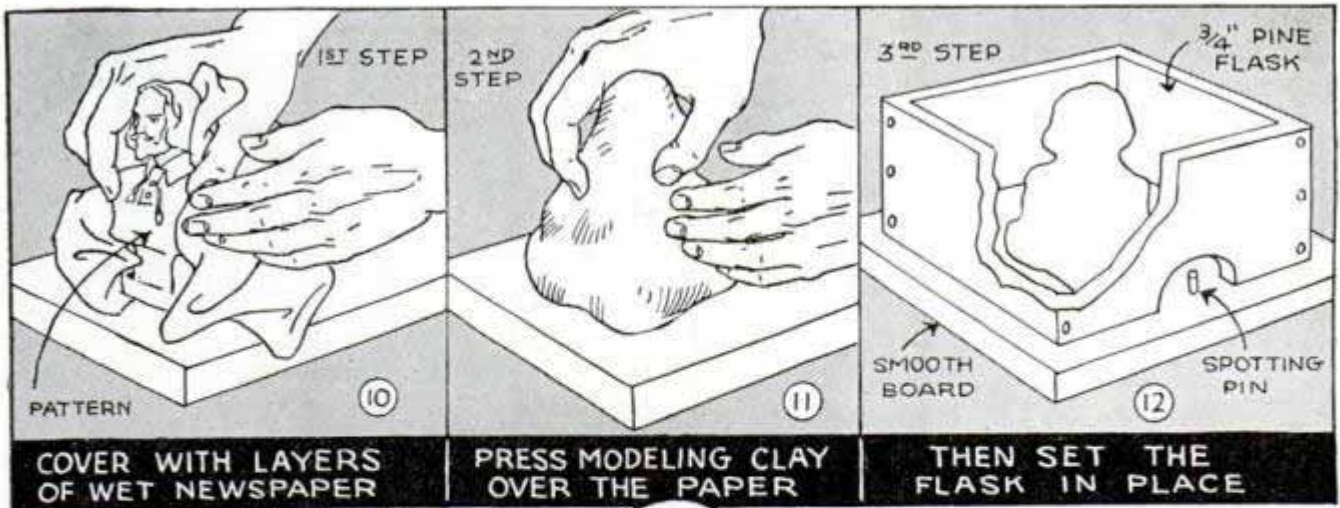

until the space between the model and the plaster is filled. Give this plenty of time to set. The plaster case is then removed and the glue mold carefully split and skinned off. The model is no longer needed. Now cut a pouring hole at the top of the glue mold, as was done with the plaster case, and put the glue mold and the plaster case together and in place on the board. Vents should be provided if necessary. If the mold is in two parts it must be clamped together. Melt modeling wax and fill the glue mold. When the wax has set, you have a wax duplicate of the original model, and the casting is made from the wax pattern as previously described.

Frequently it is desired to make a casting, one side of which shall accurately fit a contoured surface, which may be cast, stamped, or formed in some other way. Fig. 13 shows one way of doing this. This method is particularly useful when it is required to cast a mounting bracket or ornament to fit a formed section, beam, or machine part exactly. A wax impression of the contour which is to be matched is made first and then a plaster cast of this impression which gives a positive dupli-

cate of the original part. Working from this, a wax model of the desired casting can be made.

A small blast furnace which will melt a 10 or 15-lb. charge of brass, aluminum, or any other metal melting under 2000° F. can be built from a 5-gal. oil can with the top cut away, Figs. 17 and 18. Two holes are drilled

and reamed for $\frac{3}{8}$ -in. pipe nipples in opposite sides, $3\frac{5}{16}$ in. from the bottom. The heat-resistant lining is built up from ganister, a mixture of equal parts of fire clay and pulverized firebrick, moistened with water and worked up to the consistency of heavy plaster. Scraps of firebrick are added as filler and to increase the strength. The bottom of the can is covered with 1 in. of ganister, which is packed down by ramming with a stick. Four pieces of firebrick, each $4\frac{1}{2}$ in. long and $3\frac{1}{2}$ in. wide, are pressed down into the ganister, and another piece is placed in the center to support the crucible, Fig. 18. The space between these bricks is packed with ganister to within 1 in. of the top of the bricks. Two pieces of $\frac{3}{8}$ -in. gas pipe are inserted through the burner holes to form openings for the burner pipes. A smooth sheet-metal form 8 in. in diameter and free from dents is now set in the can, centered and propped in place. The space between the outside can and the center form is now filled with ganister and pieces of firebrick. When the wall has set sufficiently to support its own weight, which will be in about 12 hours, the center form and the $\frac{3}{8}$ -in.

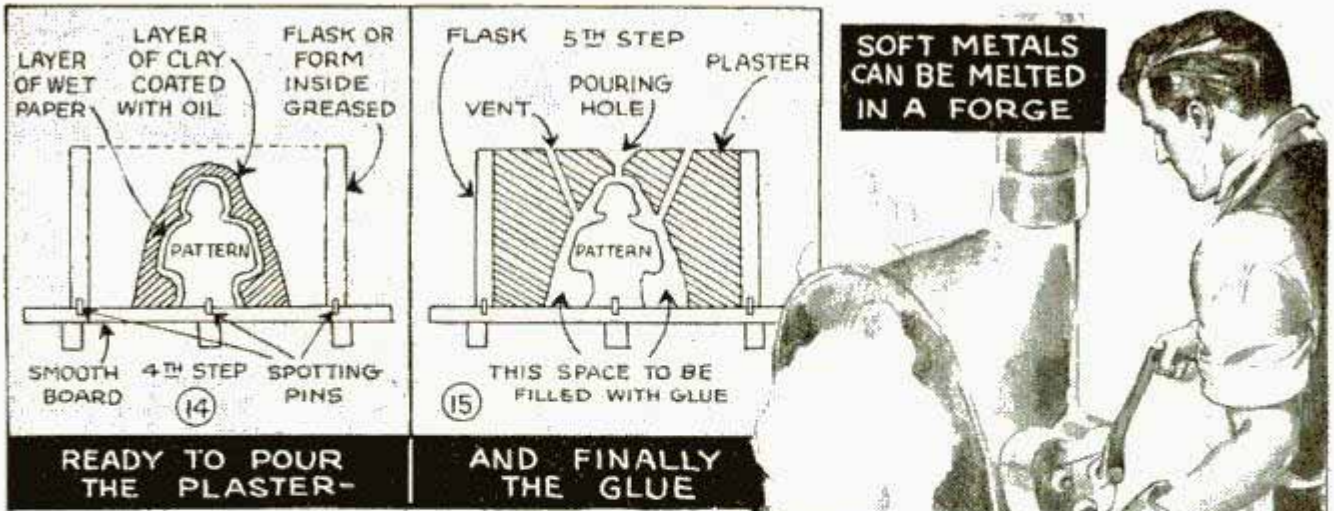

pipes should be removed and the furnace left to dry in the air for about three days. The burner assembly shown in Fig. 17 is built from $\frac{3}{8}$ -in. pipe and fittings; connections to the gas and air supplies are made with $\frac{5}{8}$ -in. garden hose, or better with pipe fittings and unions. The air can be supplied with a vacuum cleaner as shown, the adapters A and B being turned from hardwood. After testing the pipes for leaks, the final drying of the furnace is accomplished by operating it without an air blast for half an hour or more. The furnace is always lighted and adjusted according to the following sequence: (1) drop a piece of burning paper inside the furnace; (2) turn on the gas; (3) start the air blast and adjust gas flow to the minimum which will give good combustion. This is indicated by long tongues of almost colorless blue flame, forming an intense, whirling flame in the furnace. In shutting off the furnace, always turn off the air first, then the gas. Cracks that form in the refractory lining are filled with a putty made of fire clay and water. To melt a charge, start the furnace and insert the crucible of metal with tongs. Borax is added to dissolve any dross that forms. This should be skimmed off before pouring. To inspect the charge, lift the asbestos cover with tongs and observe the contents through colored goggles. The best crucibles to use are graphite. A stand for the furnace is shown in Fig. 19.

Back in Fig. 1 is shown an inexpensive gas furnace which is now on the market. In general construction it is similar to the furnace just described, but is fitted with a special mixing burner and an electric blower. It is supplied in several sizes, all suitable for home shop use.

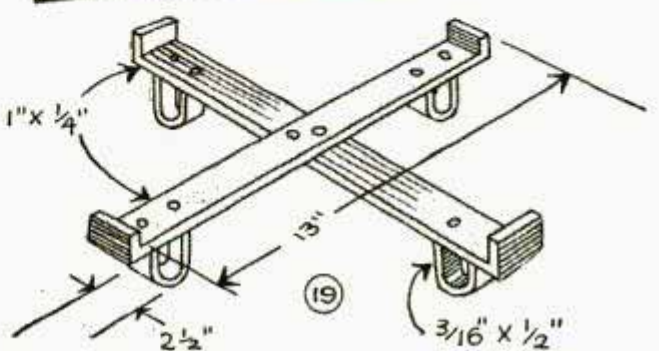
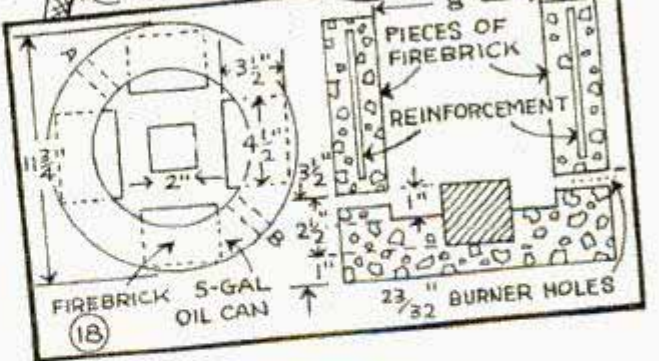
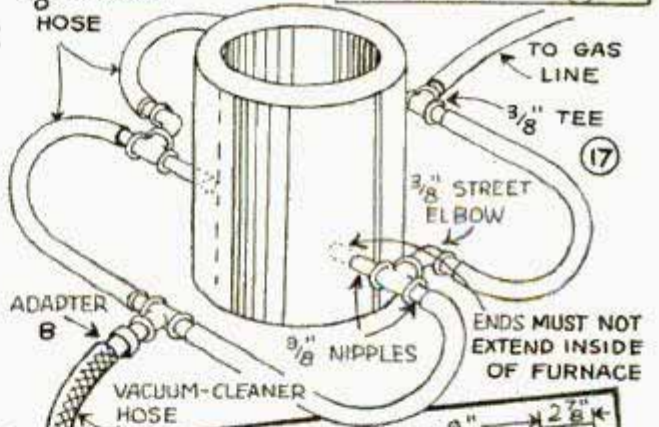
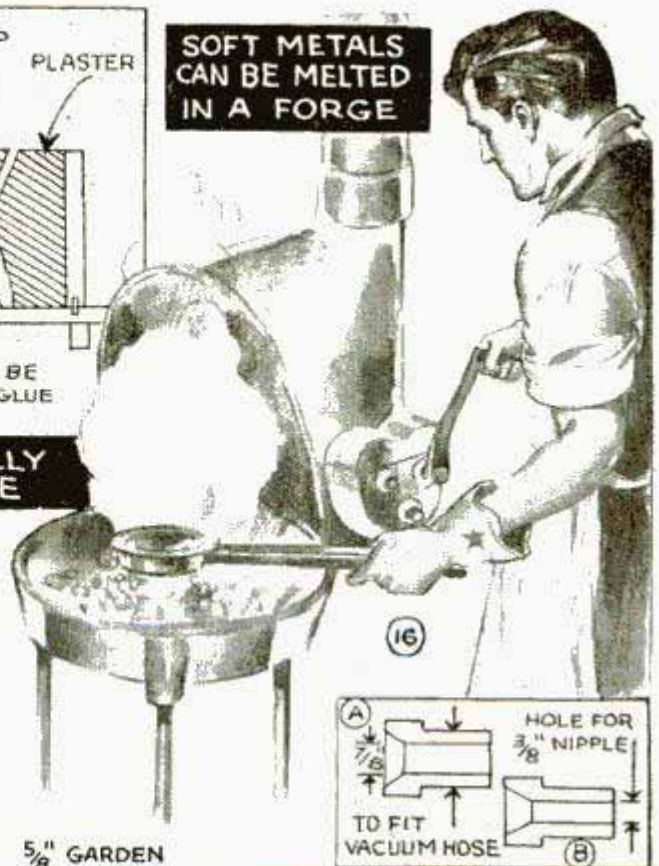

Kansas City Specialty Co City

accessories, leaving the regular battery to operate the starter only. The extra battery can be installed in the electrical circuit of the car as shown by the wiring diagram. Note that an electrical cutout is used between each battery and the generator. Also note that the output wire from the generator leads to both cutouts.

Shrinking Brake Shoes to Fit Lining

When you purchase brake lining with the holes already punched in it, don't be discouraged if they lack a little of lining up with those in the brake shoe. Just lay the shoes on the ice in your refrigerator for about 30 min. This will shrink the metal enough so that you can now lay the lining on, get the rivets in and do a neat job.

Guards on Garage Door Save Fenders

After scraping the fenders of his car on the garage-door frame, one motorist installed these guards. Two lengths of 1½-in. pipe were bent to the shape indicated. A floor flange was fitted to the end of each one and this was screwed to the frame while the other end of the pipe was set in a hole in the concrete sill. The hole was later filled with cement.

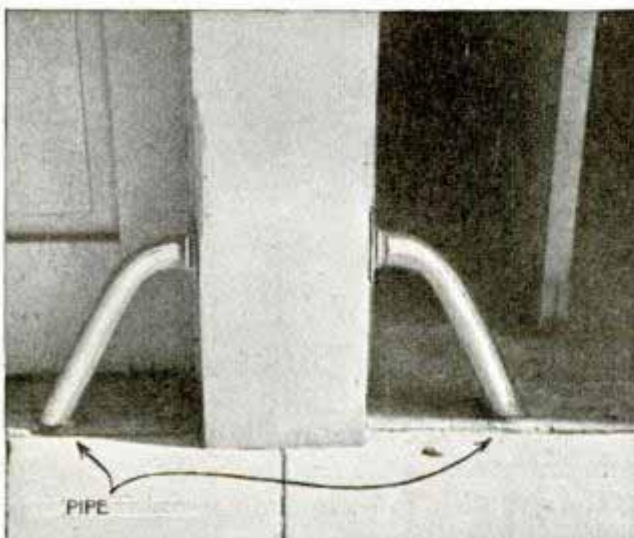

Clutch to Control Countershaft Assembled from Old Auto Brake

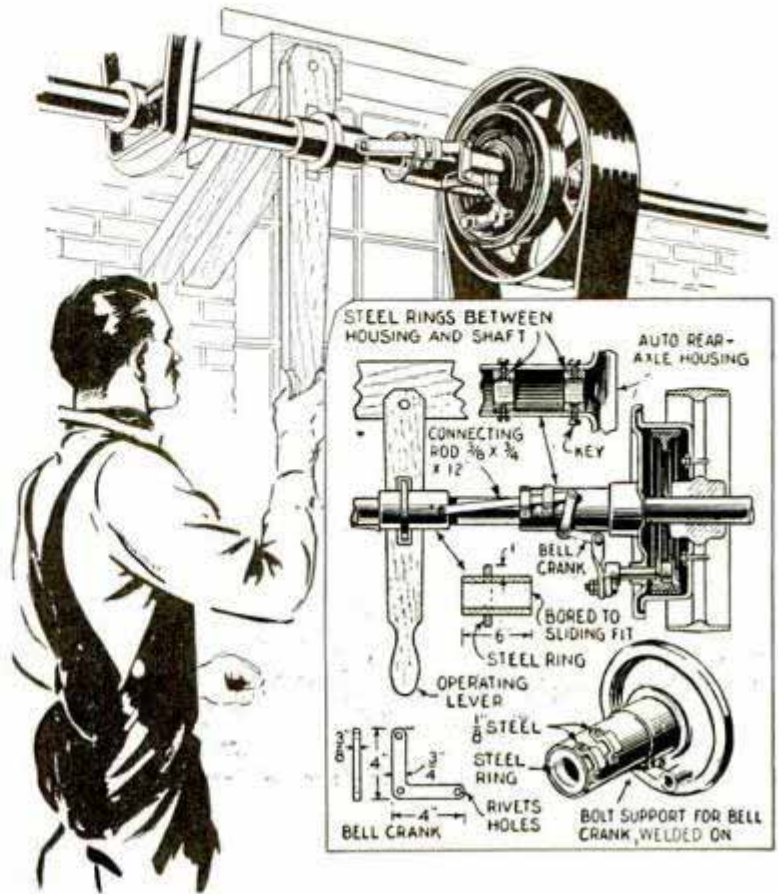

Owners of small garages who operate several tools from a countershaft, and drive the latter with a gas engine or electric motor that should be started under a light load, can rig up a clutch on the shaft by using a drum and shoe assembly from an old car brake. The drum is bolted centrally to a loose pulley on the shaft, after which a portion of the rear-axle housing carrying the brake shoes is sawed off, and steel rings are turned to center it on the shaft. These are brazed inside the housing and are locked to the shaft with keys or set screws.

The housing carries a linkage, which actuates the brake shoes as indicated. The linkage is in turn operated by a sliding sleeve, which has a steel ring welded to it to turn in a slot cut in the lever used to control the clutch. The control lever may be made of either wood or metal and is pivoted to the wall behind the shaft. The entire assembly, except the pulley, drum and lever turn with the shaft.

—W. C. Wilhite, Edelstein, Ill.

☐ The crown of an aluminum piston can be polished with a typewriter eraser, after the carbon has been removed with a strip of solder.

Heater and Headlight Reflector Thaw Frozen Brakes Quickly

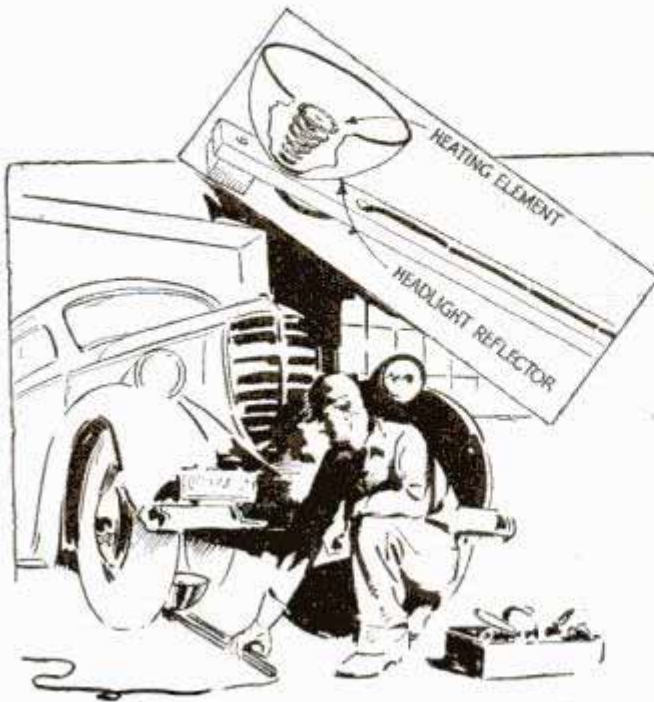

To discourage the use of a blowtorch flame for thawing frozen brakes in the garage, this simple tool was assembled to do the job electrically. It consists of a headlight reflector with an electric-heater cone in the center and a lath handle. The electric connection is made by means of wires attached along the lath. A block nailed under the reflector end of the lath elevates the heater to the height suitable for reaching the brakes on most cars.

Mechanic Carries 8-Volt Battery in Tow Car to Start Motors

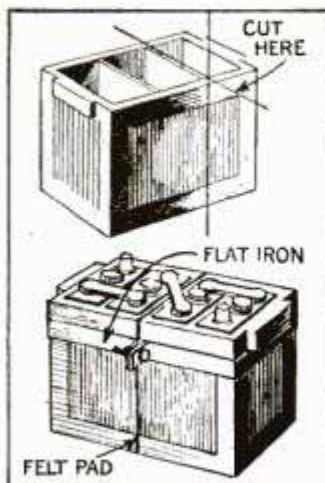

Receiving many calls during winter to start cold motors, a mechanic in one garage made an 8-volt battery to handle the jobs. This type of battery was desired because a starter, in cranking a cold, stiff motor, usually lowered the volt-

age of a three-cell battery so that there was insufficient current at the plugs to produce a hot spark. The 8-volt battery

was made by cutting a dead cell from each of two old ones and connecting the four good cells together as indicated.

—C. E. Packer, Chicago.

Too Much Oil in Air Cleaner Causes Carburetor Trouble

Oil-bath type of carburetor air cleaners often cause uneven motor idling after the oil has been renewed in the tank. This is caused by too much oil being put in the cleaner tank. If the oil touches the steel wool in the upper part of the cleaner, some air to the carburetor is cut off and a rich mixture and choking of the engine result. Choking also results in vibration of the engine which causes the carburetor to overflow, with a waste of gasoline. The proper amount of oil in the air cleaner will prevent this trouble.

—Emil J. Novak, Omaha, Nebr.

Car Spaces in Parking Lot Marked by Disks on Ground

A Nebraska country club uses markers flat on the ground to designate spaces for parking cars. The markers are disks taken from an old farm disk harrow and are held

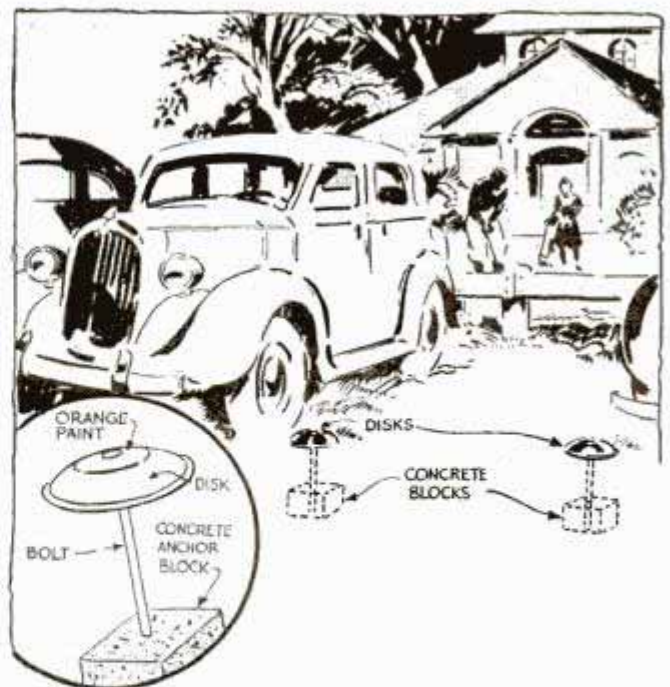

in place, convex side up, by means of long bolts extending into concrete blocks buried in the ground. A little orange paint on the disks makes them easy to see.

EASTMAN'S NEW HIGH SPEED FILM

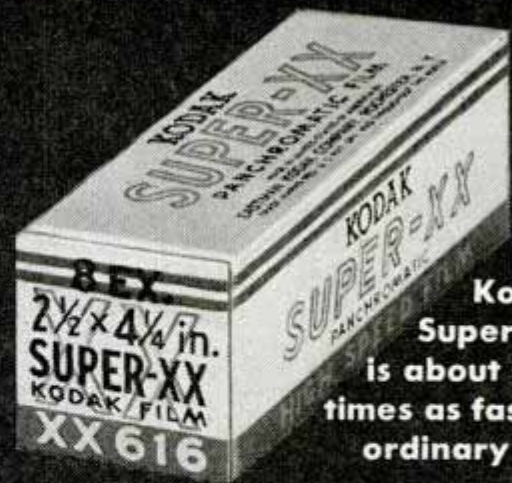

Kodak
Super-XX
is about four
times as fast as
ordinary film

MAKES NIGHT SNAPSHOTS EVERYBODY'S HOBBY



ALL YOU NEED

Your present camera loaded with
the new Kodak Super-XX Film

plus

two or three inexpensive
Photoflood lamps in
Kodak Handy Reflectors

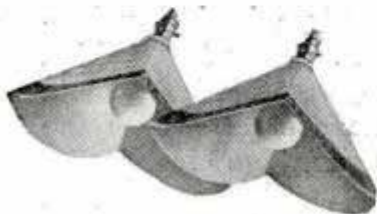

NIGHTTIME SNAPSHOTS are sure shots, now. You use any camera that takes the new high speed film, even an inexpensive Brownie—Kodak Super-XX is now available in all standard amateur sizes. You get snaps that have the spontaneous, delightfully lifelike quality of outdoor pictures. And the shooting itself is almost as simple. With Kodak Super-XX, you use two or three inexpensive Photoflood lamps in Kodak Handy Reflectors.

FREE BOOKLET . . . Condensed course in indoor snapshotting. Detailed, easy-to-understand instructions, interesting photographs, clear-cut diagrams show you how to arrange your lights and place your subjects—how to make your very first batch of indoor snapshots as good as any you'd take outdoors. Get a copy at your dealer's . . . Eastman Kodak Company, Rochester, N. Y.

Pie Has Its Face 'Washed' with a Spray Gun

Big city bakeries turn out good pies, and they bake them by the hundred thousand, but they don't bake them like your grandmother did. Imagine your grandmother hovering over the oven with a spray gun in her hand, firing an atomized mixture of egg white and water over the top crust of a delicious coconut pie! That's what the pie factories do today. The air-gun process is called "washing," and it is done to produce that golden-



Top, putting open "lattice" tops on fruit pies; left, pouring custard into shells and "washing" with air gun to brown crust



brown crust. It is just one of the machine-age methods introduced to turn out pies in quantity without losing the homemade flavor. One company in New York City bakes 100,000 pies every day, and sells them all. Pies unsold at the bakery shops the first day are picked up the next and sold to farmers to fatten hogs. The custard filling is poured into the pastry shells in a manner reminiscent of the steel mill. Kettles full of custard are shoved into the ovens on long poles and the liquid filler is ladled into one crust after another. This eliminates the sloppiness of filling each shell outside the oven and then moving it in. Americans, champion pie-eaters of the world, consume 450,000,000 pies a year.

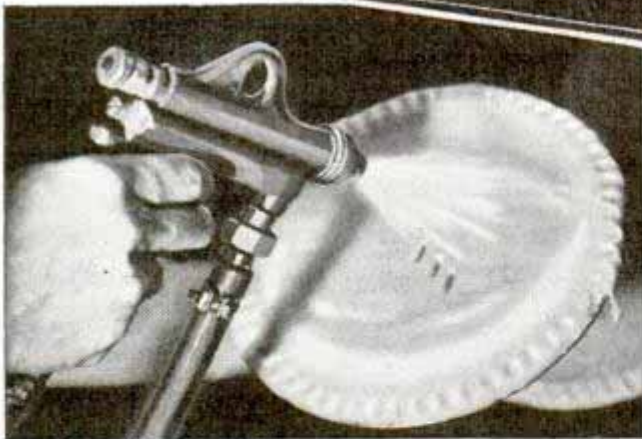

Cartridge Starter for Airplanes Saves Half the Weight

Weighing less than half as much as a conventional electric self-starter, a cartridge starter for airplane motors has been installed in a fleet of army pursuit ships. The idea of kicking over an internal combustion motor by exploding a cartridge is not new, but its application to small air-

planes to save weight is a fresh development. The pilot loads the cartridge, which resembles a twelve-gauge shotgun shell, into a breech in the cockpit, closes the breech and fires the cartridge electrically. Gas generated by the explosion moves a piston geared to turn over the engine.

New York Pie Bakery & Pastry Co. 15th St. N.Y.C.

Science Service 9/30/35

*..she couldn't
say No to that
VELVET
aroma*

Velvet
—the *MILDNESS*
of fine old
Kentucky Burley
aged in wood
—the *FLAVOR*
of pure maple
sugar for extra
good taste

*Velvet packs easy in a pipe
Rolls smooth in a cigarette
Better tobacco
for both*

*Better smoking
tobacco*

Copyright 1938, LIGGETT & MYERS TOBACCO CO.

Put this **POWER HOUSE** in your car!



A NEW BATTERY

that lasts **68% longer!**

● If you drive a '35-'36-'37 or '38 car, you need a more powerful battery than required by earlier models. You need extra power for its high-compression motor—extra power for multiple lights, twin horns, radio, defrosters and the other electrical accessories that add so much pleasure and safety to your driving.

This new Willard "H-R" Battery was built after nine years' study of how people drive and how their batteries perform. It is designed for the present-day car—designed for present-day driving.

It will deliver dependable power to every part of your car just as the substation near you delivers power to every part of your home—when you need it—and where you need it.

THE RECORDS OF 78,000 BATTERIES, DRIVEN OVER ONE BILLION MILES, PROVE THAT THE NEW "H-R" WILL KEEP ON DELIVERING THIS DEPENDABLE POWER 68% LONGER THAN THE AVERAGE OF COMPETING BATTERIES.

Expensive? No,—the "H-R" costs no more to buy than any good battery, and its extra months of life make it cost *less* to own. You'll be safer, and you'll save, if you replace your present battery with a Willard "H-R" now.

WILLARD STORAGE BATTERY CO.
Cleveland • Dallas • Los Angeles • Toronto

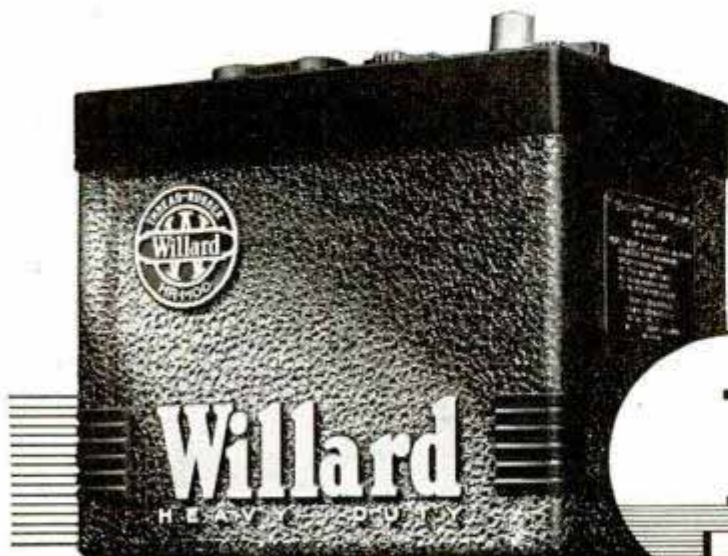

ASK FOR IT BY NAME AT YOUR WILLARD DEALER'S

SHORT CUTS FOR THE CRAFTSMAN... NO. 2

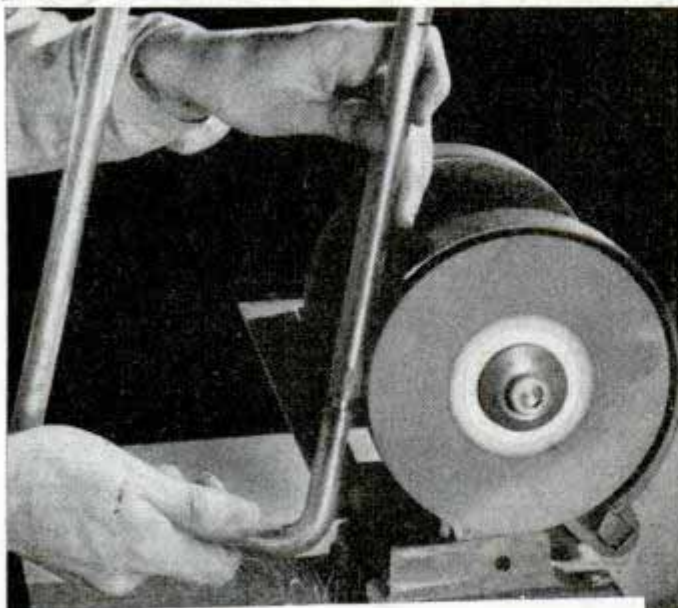

How to smooth a WELD

You can make a welded joint as smooth as can be, simply by doing these two things. Remove excess metal with an Aloxite Brand Aluminum Oxide Grinding Wheel. Then finish it off by smoothing with a Carborundum-made slip stone or Aloxite Brand Aluminum Oxide Cloth.

You can use the same Carborundum-made wheel to put a keen, sharp edge on a drill bit or to sharpen wood-working tools such as gouges, chisels and small parting tools.

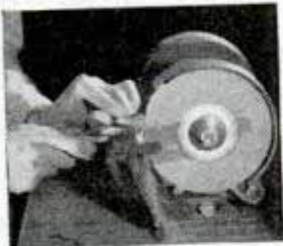

Send 20c (coin or stamps) for handy pocket sharpening stone and revised 95-page illustrated manual. It gives a hundred helpful hints on how to save time and effort by using Carborundum Brand abrasive products.

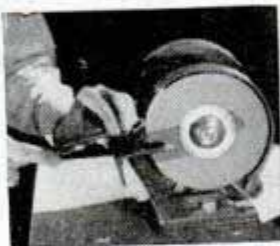

Write Department PM12-8 for Booklet and Free Stone.

THE CARBORUNDUM COMPANY, Niagara Falls, N.Y.

REG. U. S. PAT. OFF.

{Carborundum and Aloxite are registered trade-marks of The Carborundum Company}

CARBORUNDUM

REG. U. S. BRAND PAT. OFF.

ABRASIVE PRODUCTS



Lights Battle Insect Armies

(Continued from page 843)

ture and abundant food supply, mushroom houses frequently became badly infested with insects, particularly fungus gnats, house flies, mites and springtails," Dr. Herms explains. "Midnight-blue lights are allowed to burn twenty-four hours every day and are regarded as necessary for raising mushrooms."

Dark-blue light traps are now installed in dried-fruit warehouses to kill the dried-fruit moths. The manager of the 4,500-acre El Solyo Ranch, Tracy, Calif., where traps are used extensively, reports during the main flying season each of his warehouse traps average 1,000 moths a night.

The lima-bean pod borer caused a loss to beans (warehouse figures) in Ventura, Orange, and San Diego counties in California of over \$317,000 in 1935. The use of a high-intensity pale-blue light strongly attracts the female moths and is now keeping such loss to a minimum.

The artichoke plume moth reacts to a midnight-blue light. Acreage protected with such a light showed only a worminess of one and eight-tenths per cent, while a check plot without light protection showed a twenty-nine and four-tenths per cent increase in worminess.

Records of the inventor of the combination light and oil trap reveal that during a 246-hour period ten traps caught 6,696 codling moths in a pear orchard. Entomologists estimate that at least half of these, or 3,348, were female moths that had not deposited their eggs. Each female codling moth will average about 300 eggs. At least 1,004,400 potential eggs which probably would have become moths were destroyed.

"Sixty traps in this orchard cost only ten dollars to operate every night for three months," said the inventor. The cost varies, depending on the power rate."

The light-oil traps caused a general reduction of worminess in a sixty-acre pear orchard from about twenty per cent to about eight per cent. Saving in fruit paid for a major portion of the installation.

A cornfield protected by one of these traps did not produce one ear of wormy corn last year, proving it is very effective on the corn moth.

Entomologists working on the problem are conducting further experiments with

these two types of electrically lighted traps to determine the color preferences of other insects, and the effect of the directed light rays and bait.

"Thus in the near future," one entomologist says, "plagues of grasshoppers, chinch bugs, army worms, moths and beetles, and other insects may be controlled at much less cost and with greater effectiveness with light traps than they are now partly controlled with poison baits and expensive spray materials."

Entomologists have gone a step further in their use of lights which they have invented for protecting crops and have adopted them so a plain globe can be used where protection against annoying insects in general is desired.

Although some work has been done with the color reactions of mosquitoes, most species react fairly well to white light of intensities to which other annoying night-flying insects react, hence white light is generally used. Ordinarily the light used in the trap is of higher intensity than the sources of illumination.

An entirely new field for light traps has emerged in that the electrocuted insects are extensively used as food for fishes, frogs and birds on game farms.

Another electric-ray insect killer which employs the penetrating sections of an infrared ray generated by a specially designed light bulb and filament, has just been introduced. The bulb, housed in a cone-shaped container of spun steel, sheds a brilliant "spot" of light which spells sure and sudden death for fleas, ants, bedbugs, moth larvae, plant insects, animal lice and other crawling pests. Held easily in the hand by means of its non-heat-conducting handle, the device solves the insect problem without recourse to poison sprays, unpleasant powders or oily insecticides which leave stains and odors.

The light can be turned on a flea-ridden dog or cat, and without harming the animal in the least, relieve him of his unwelcome guests in an unbelievably short time. Canaries, whose delicate feathers and skins have made the application of liquid or powder insecticides impossible to use, have undergone this treatment without the slightest irritation.

Gardeners find the device efficient in dispatching flower and plant pests, including Japanese beetles and meal worms.

5 reasons why
CASCO is the
**MASTER
WORKSHOP
GLUE**



1. WEATHERPROOF BOND. A different kind of glue, CASCO sets *chemically* like concrete, forms an insoluble bond that resists both heat and moisture.

2. UNIFORM STRENGTH. Processed by laboratories with 30 years' experience in adhesives, CASCO has been proven on many of industry's toughest gluing jobs. Get this strength for *your* gluing... insist on "CASCO Powdered Casein Glue".

3. USED COLD. CASCO spreads easily, sets at full strength *without heating!* Use it outdoors, indoors, anywhere, any time.

4. EASY TO MIX. No mess. Just add water to enough CASCO for the job—no waste. Quickly forms a smooth, creamy mix.

5. ECONOMICAL. You get CASCO in powder form, *all glue...* no liquid preservatives. 1 lb. of CASCO makes $1\frac{1}{2}$ quarts of full strength glue for 65c!

10c TO 65c AT HARDWARE, PAINT AND LUMBER DEALERS

FREE—New kind of Home Workshop Handbook



Tells how and where to get free and low-cost expert advice on Tools, Free Plans, Finishes, Woods, Veneers, Sharpening Equipment, Home Workshop Clubs, etc. The *first* handbook to bring you *all* this information. Send the coupon for your copy, now.

CASEIN COMPANY OF AMERICA
350 Madison Ave., Dept. P.M.-1238
New York, N. Y.

Yes, send me your free "Home Workshop Handbook"

Name _____

Address _____

Save 2c, stick coupon on penny postcard

TO THE FINAL STEP
DELCO BATTERIES
 ARE CHECKED FOR HIGH QUALITY



On this mammoth charging floor, 25,000 Delco batteries are charged at one time.

Just before shipment, all three cells of each battery are checked for voltage and re-checked for gravity.

If you were to follow a Delco battery through its various steps of manufacture in one of the Delco-Remy battery plants, you would finally come to the mammoth charging floor. Here, thousands of batteries will be receiving a 48-hour charge before being shipped. From the charging floor, each Delco battery must pass through a final inspection test to determine that it is fully charged and functioning properly. Each cell of each battery is tested separately, as any imperfections in material or workmanship will show in a lowered voltage in the defective cell. Even a minute variation in cell voltage is sufficient to prevent the battery from being passed. This is the final factory test to assure the uniform high quality of Delco batteries.



Delco battery sales and service requirements are available at United Motors Service Stations and Delco battery dealers everywhere.

Delco-Remy
 ANDERSON, INDIANA

World's Largest Manufacturer of Automotive Electrical Equipment

Doing Something about Weather

(Continued from page 869)

U. S. Army engineers and private contractors consult Krick's service when planning time to pour concrete on big construction jobs. Last winter, an explosion in the shops of one California highway maintenance division blew up snowplow equipment. From day to day, road foremen anxiously scanned special wire predictions on snowfall, so that if a heavy storm came they could hire private equipment and have it ready to keep the mountain passes open. The Los Angeles County Flood Control regularly uses Krick's data in operating its big network of dams, reservoirs, and flood channels. When to store water, when to empty reservoirs to make room for an impending heavy rain, when to hire extra men and have them ready with truckloads of sandbags to reinforce weakened levees are a few of the problems the forecasts help the flood control to solve.

There's no secret about Krick's methods, for the air-mass analysis technique has been heralded throughout the scientific world. He has simply pioneered in interpreting the forces that make the weather, so that industry can make use of them. For rule-of-thumb predictions he has substituted quantitative measurement of the gigantic air masses that stream above the continents, forming boundaries of conflict where storms are born. Sampling these masses at many points, observers find out where the hot and cold masses are located and which way they are moving. In over the teletype of the Department of Commerce network pour reports from all parts of the country—from air fields, from ships at sea, from Weather Bureau stations.

All these observations, transformed into colored crayon marks on Krick's maps, show the movement of the gigantic air masses as they sweep across the country, and form the basis of his predictions. The more reports, the more accurate the forecast.

New methods have enabled the weatherman to make forecasts which are about eighty-five per cent correct, according to Dr. Willis R. Gregg, chief of the United States Weather Bureau. And by going to the stratosphere, the weatherman hopes to extend his forecasting period from two days to five or six days in advance.

The airplane and the radio-meteorograph have added a third dimension to the weatherman's observations, Gregg adds, as previously, only surface conditions were observable. There are approximately thirty stations in the country where airplanes or radio-meteorographs are sent to high altitudes for recording upper layers of atmosphere, and seventy additional stations are to be added as rapidly as personnel can be trained for the work.

If you can imagine a combined meteorological observatory and radio broadcasting station combined in one small mechanism weighing between one and two pounds, you have a good idea of the newest radio-meteorograph. Attached to a small hydrogen-inflated rubber balloon, it ascends to heights of from ten to fifteen miles and radios back to the earth temperature, humidity, and air pressure at various levels.

The radio-meteorograph has been placed in regular service by the United States Weather Bureau at Nashville; Fargo, N. Dak.; Omaha; Oklahoma City; Oakland, Calif.; and Sault Ste. Marie, Mich. These stations have been selected at strategic locations so that daily reports will typify upper-air conditions in the United States.

A new epoch in weather service soon may be established, Gregg believes. "When we are able," he says, "to get twice daily recordings from these instruments at stations well distributed over the world, including soundings on ships and including also reports from isolated regions and mountain summits transmitted by radio, we will be in a position to give much more precise predictions covering longer periods in advance."

No longer is the weather observer content with general forecasting. He has gone in for specialization, and every activity affected by weather demands is receiving detailed and intensive meteorological reports. More than fifty distinct services now are being offered and these probably touch directly the immediate needs of more of the people than do all the other federal agencies combined, with the possible exception of the post-office department.

Although aviation largely is responsible for this new trend, its first use was in connection with the protection of citrus and other fruits from frost.

(Continued to page 122A)

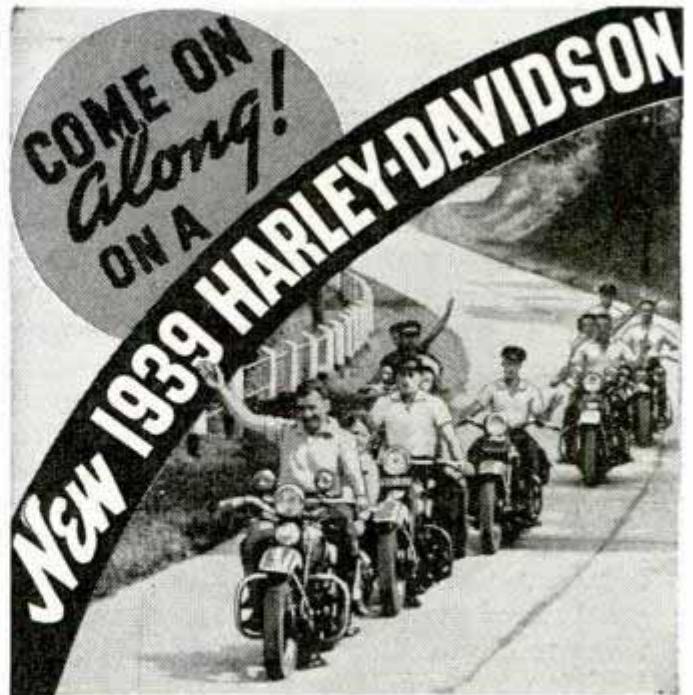

Make 1939 Your Biggest Fun Year!

You can pack the whole year with new thrills, pleasures and great adventures—when you own a new 1939 Harley-Davidson. Make more friends — enjoy the country's finest scenery and most popular fun spots with other happy riders. It's a hobby you really can ride — on a mount that's unmatched for zooming power, easy riding and smart styling.

Get into motorcycling — world's greatest outdoor sport—and ride a Harley-Davidson, World's Champion Motorcycle. See the Harley-Davidson dealer — inspect the new 1939 models with their improved performance—still lower upkeep—super-streamlined design — classy appearance and striking color combinations. Ask about his Easy Pay Plans — and mail the coupon NOW!

WINS "JACK PINE" AGAIN! For the 14th consecutive year, Harley-Davidson wins this premier National Endurance Championship!



HARLEY-DAVIDSON MOTOR COMPANY
Dept. P-1238, Milwaukee, Wis.

Send illustrated literature and FREE copy of "ENTHUSIAST," Motorcycling Magazine. Stamp is enclosed for mailing cost.

Name.....

Address.....

(Continued from page 121A)

"Several years ago," explains Doctor Gregg, "when it was found that the ordinary generalized type of forecast did not meet the needs of the fruit growers, a special service was set up so frequent observations could be made from a close network of stations in and near the fruit districts, and short-period, specific forecasts issued in the evening for the following morning.

"This enabled orchardists to take protective measures by lighting fires in the groves, thus keeping temperatures above the danger point. The value of this service was shown during a cold wave that hit southern California last winter. On the strength of the predictions, approximately three million dollars of oil was burned in the citrus groves, but as a result, almost one hundred million dollars' worth of fruit and trees were saved."

Likewise, sailings of vessels engaged in ocean and lake traffic are largely determined by storm warnings. Ships are held in port when hurricanes are predicted and in one recent instance, cargoes and vessels thus detained amounted to \$35,000,000. Of course, it is not known that all of these would have been lost had they ventured out, but the probabilities are that many would have been wrecked or damaged.

In the construction of high buildings as well as dams and bridges, it is always necessary to compromise between over-design and under-design. In all of these cases it would be possible to construct in such a way as to assure absolute safety, short of an earthquake, but such action would result in tremendous economic waste. On the other hand, under-design means definite hazard to safety of life and property. Hence the desirability of climatic statistics that will serve as a guide in reaching the compromise, which usually includes a fairly liberal factor of safety to provide against extreme conditions.

Forecasts fail at times and result in large losses. A major objective of the bureau is to reduce these failures to a minimum by furthering a broad program of research. One notable project now being undertaken in cooperation with the Massachusetts Institute of Technology is a study of conditions that give rise to the formations of immense domes of polar air over Alaska, these eventually developing into cold

waves that move southward through Canada into the United States. This investigation includes a study of the upper-air data and outgoing radiation as measured at Fairbanks, Alaska, Fort Smith, Canada, and at points along our northern border. When this study is completed it is believed the conclusions reached will result in greater accuracy of cold-wave forecasts.

If you look at a weather map you will see the lines indicating wide areas of cold and warm air that resemble vast lakes. These "lakes" remain intact from a few days to more than a week. Their "banks" are sharply held in line by the differences in weight between the cold and the warm air. These lakes of air are reservoirs that feed the "low" area, which means storms. These great cyclonic whirls are fed from one side by warm air and from the other by cold air. How long this feeding may continue, that is, how long a storm will last is contingent upon the supplies of warm and cold air in the reservoirs.

Eventually every storm is surrounded by cold air and cut off from the warm reservoir. The low then is unlikely to last much longer. By charting the air lakes on the weather maps, the forecaster can see when a storm area is about to lose its source.

Last year, the entire weather bureau consisting of 1,344 primary and secondary reporting stations covering the entire United States from Alaska to Porto Rico, and from Maine to Hawaii cost \$3,810,724 to operate. Figured out on a basis of population, the per capita cost for maintaining the far-flung weather bureau during the fiscal year of 1936 for each citizen was less than the price of a three-cent stamp.

"It's easy to get your money back," reminds A. M. Hamrick, veteran observer. "If you should heed just one cold-wave warning and drain your motorcar radiator to preclude freezing and bursting, you have saved enough to take care of your share of the cost for the rest of your life."

Our Bureau of Information keeps on file the names and addresses of makers of, and dealers in, all devices described in the pages of Popular Mechanics Magazine. We are glad to furnish this information to our readers upon request, accompanied by stamped, self-addressed envelope.

Old friends are true friends



IN 1884 . . . "This picture is out of the family album, which is fittin' in connection with Union Leader. Because it was my old Dad who told me, when Union Leader was introduced at the turn of the century, 'Son, come what may, you'll never find a finer tobacco than Union Leader!'"

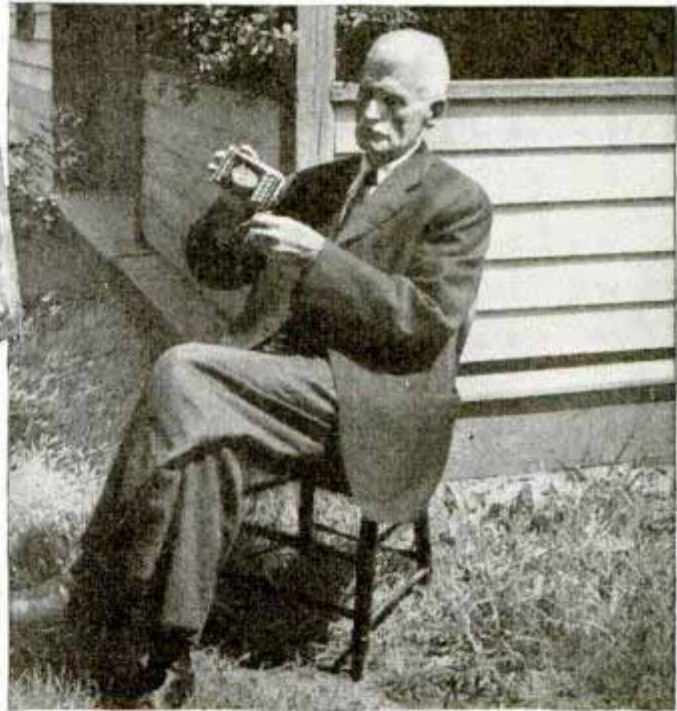

TODAY . . . "This snapshot proves how true my Dad spoke. For here I am, 84 now, and puffing on the old pipe filled with Union Leader. The mellowness and mildness of Union Leader make it a life-time pal for any man."—Thomas H. Taylor, Lake Luzerne, N. Y.

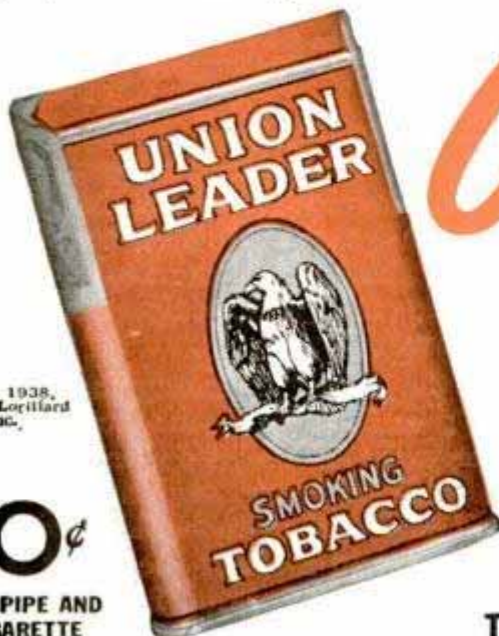

Cope, 1938,
By P. Lozillard
Co., Inc.

10¢

FOR PIPE AND
CIGARETTE

Union Leader

ALWAYS . . . UNION LEADER has won the lasting friendship of smokers through its flavor, mellowness and mildness. Flavor from rich hill-grown Kentucky Burley. Mellowness nurtured by long aging. Mildness which results from a special "bite-removing" process. No wonder smokers call Union Leader the friendliest of smokes! Try a tin today.

THE GREAT AMERICAN SMOKE



CUTTING TAPERS
A hinged jig, with thumb screw attachment for holding one end of the work the desired distance away from the fence, makes the cutting of tapers accurate and easy.

Amazing money's worth KEYSTONE made by DISSTON CIRCULAR SAWS

Very little money buys a dependable blade . . . a KEYSTONE Circular Saw—made by DISSTON! Expert sawmakers designed these saws specially for fine craftsmanship, at low cost, in your home workshop.

Keystone Saws are amazing values—\$1.70 to \$2.40 for 6" to 10" sizes. They fit your machine and suit your work. Run true, stay sharp. Ask your dealer for Keystone Home Workshop Circular Saws—made by Disston.

Cross-Cut; Rip; Combination
6" (1/2" hole) \$1.70 8" (1/2", 5/8", 3/4" hole) \$2.00
7" (1/2" hole) \$1.80 10" (5/8", 3/4" hole) . . \$2.40
Rip Saws slightly less
Also Hollow Ground, \$3.00 to \$5.00



Also KEYSTONE made by DISSTON Hand Saws. Skew-back and straight, cross-cut and rip. Prices, \$1.00 and up. K-3" Pacemaker, skew-back, 26" blade, \$1.50
Prices slightly higher in Canada

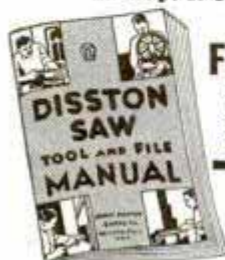

FREE BOOK SEND COUPON

For free copy of "Disston Saw, Tool and File Manual"—tells how to sharpen all kinds of saws, send this coupon to:

HENRY DISSTON & SONS, INC.
1211 Tacony, Philadelphia, U.S.A.

Name.....
Address.....

Heroes of the Fire Lines

(Continued from page 895)

never to stand in front of a door while preparing to open it in a burning house. There may be enough hot air under pressure on the other side to slam the door against them and knock them over if they are in the way. Standing alongside the door and reaching over to the knob is the safe way to do it.

Gasoline fires are dangerous even after they have been put out because severe flashbacks sometimes occur. The best thing



Fireman entering smoke-filled building to battle the flames at close quarters

to do, after a gasoline fire has been extinguished with carbon-dioxide gas, is to keep pouring on more gas from the extinguisher. Otherwise the thin inert gas blanket may dissipate before the material has cooled down to a safe temperature and a flashback will occur.

Besides the ammonia safety suits and breathing gear that the rescue trucks carry, firemen and rescue squad members are supplied with ordinary gas masks that protect against carbon-monoxide, smoke, phosgene gas, and most of the gases and fumes that are encountered in industrial

fires. A different type of portable breathing apparatus is also carried on the truck, consisting of a big oxygen tank and other gear that may be electrically or manually operated, attached to several 100-foot lengths of oilproof air lines that fire fighters equipped with small breathing masks may trail behind them as they enter gas-filled enclosures. One of the rescue companies in Los Angeles has a complete asbestos suit for use when valves have to be shut down in an oil fire. The rescue trucks carry complete sets of first-aid supplies, acetylene torches, life belts and safety belts for lowering people down to safety, and grappling and drag hooks for recovering bodies lost in lakes and reservoirs. Resuscitation aids and suction apparatus for bringing life back to people who have been overcome by water or smoke are part of the rescue squad's equipment, as is an "iron lung" respirator for infants and an oxygen tent used for emergency heart attack and pneumonia cases.

Aside from their work at the scenes of fires the rescue squads answer all sorts of other emergency calls and when an alarm rings for a rescue company the members never know whether they are to answer a fire alarm, be called in to save the life of a new-born baby, or be dispatched to the scene of a cave-in where someone has been buried under tons of dirt.

Mushroom Bed for Your Cellar Is Built of Rustproof Steel

Home growers of mushrooms can plant their crops in basement corners and under cellar stairs, using mushroom beds that are available in knockdown, kit form. Built of rustproof, light steel, these beds come in sections which can be installed in tiers, and may be erected in an evening. They are doubly insulated to hold heat and moisture.

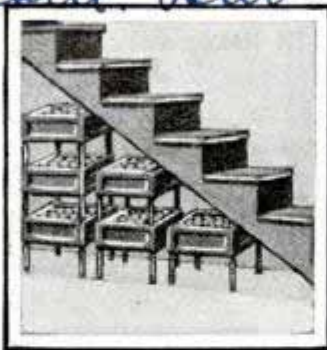

Send return postage to our Bureau of Information to learn the name of the maker of any device described in this magazine.

BUY NO ANTI-FREEZE UNTIL YOU READ THESE FACTS ABOUT

Du Pont "Zerone"*

SCIENTIFIC TESTS prove that "Zerone" would keep water from freezing solid even at 215° below zero. You'll never encounter temperatures like that, so you can be sure "Zerone" used in accordance with directions will protect your car in the coldest weather you'll ever experience.

The materials from which "Zerone" is made are so effective you need comparatively little "Zerone" to achieve protection. That's economy. Properly used, replacements of "Zerone" are little indeed—and that's economy, too.

Tests prove that the mixture of "Zerone" and water passes off engine heat better than water alone. That improves engine performance.

"Zerone" in a clean cooling system prevents formation of rust and corrosion—avoids power losses, helps save fuel and oil. Those are the facts, so ask your dealer to protect your radiator with "Zerone" today. It's only \$1.00 a gallon (\$1.20 west of Rockies). Du Pont, "Zerone" Division, Wilmington, Del.



*Reg. U. S. Pat. Off.

Only \$1.00 a gallon
Made by **DU PONT**

United Mushroom Co.
3848 Leominster Ave. Chelmsford

"G-E flash bulbs assure highest quality for fast action photography" . . .

says
GEORGE KARGER,
Staff Photographer,
Pix Publishing, Inc.



Action shot
by Karger, of
Polly Iuen
Radio City
Music Hall
Corps de Ballet



Here's why they'll help YOU get clearer shots

1. EASY TO USE . . . Flash! and you've got the picture . . . just like a news expert . . . even if you have only a simple, inexpensive camera.

2. PLENTY OF LIGHT for clearer pictures. G-E MAZDA Photoflash lamps are like a package of sunlight for your camera. For that once-in-a-lifetime shot, here's the lamp to use! Grand for color, too. Each lamp gets one good picture. Buy G-E Photoflash lamps where you buy film.

SYNCHRONIZED SHOTS? Try G-E's new No. 7 lamp.



**G-E MAZDA
PHOTOFLASH LAMPS**
No. 10 . . . 15¢ list
Get them at your camera
shop or drug store



for dozens of shots . . .
**G-E MAZDA
PHOTOFLOOD LAMPS**
No. 1 . . . 25¢ list
No. 2 . . . 50¢ list

GENERAL ELECTRIC
MAZDA PHOTO LAMPS

High Speed Movies

(Continued from page 820)

bright, self-luminous objects can be photographed without the use of additional lighting.

One of the first uses for the high-speed photographic timer was in sports events, where it proved its usefulness in revealing the exact time of runners. In this work, it is usually not necessary to have the exceedingly high-speed camera. While the machine used operates on the same principle, together with the time device, for horse races, for instance, it is gauged to take from 128 to 150 pictures per second, which is sufficient speed for photographing the action. These cameras at this speed have been found to be excellent for determining the results in closely contested races.

The value of this mechanical diagnostician, at its very high speeds, goes far beyond the realm of sports, and has made itself felt in connection with some of the most common of our modern inventions. The diagnoses of this high-speed camera are being sought in industry for analysis of manufacturing processes and the solution of problems concerning the design and performance of machinery.

The smoothness of operation of an automobile may be the result of examinations conducted in the factory by means of high-speed photography, for the automobile companies use this camera to study vibrations and the rates of combustion of fuels in motors.

In aeronautics, too, this device is used to investigate air flow around structures and as a guide in the design and performance of propellers.

The extent to which the high-speed camera is finding application to problems concerning telephone apparatus is indicated by the fact that about two thousand films have been made of various telephone operations. One group of frames taken by high-speed photography shows the action of the impulse wheel, pawl and snubbing spring in a telephone dial. One high-speed photograph disclosed the cause of a peculiar acoustical effect. This series of frames showing the action of the clapper striking one gong of an experimental ringer, revealed more strokes of the clapper per cycle than were desired.

101032
 In testing firearms, probably no other mechanism can so accurately follow and record shots and the speed of bullets; consequently the high-speed camera is frequently used in ballistic studies.

This camera, together with lighting equipment and the timing apparatus, can be moved about easily, so that it can be used in a wide variety of studies, and its use is growing in demand in industry. By the use of high-speed photography with a precision timer, not only can mechanical movements too rapid to be seen by the eye be analyzed, but these photographic records give definite space-time relationships between moving parts of the machinery. Such photographs may reveal why machines do not function exactly as designed, when parts bounce, bend or break, and where moving parts create currents in liquids or gases. The device is especially useful in studies of transient movements such as contact chatter.

This movie doctor examined a severe case of chattering in part of the mechanism of a motion-picture projector, and the resulting photograph revealed the cause of the trouble.

Sewing-machine companies and shoe companies have found uses for high-speed photography, and companies using high-speed machinery for manufacture of fragile materials such as paper, thread, and transparent cellulose, are dependent upon this device, for when there is a breakdown or any failure in such machinery, often, after the failure, it is impossible to discover just where the fault lay. A photograph of the machinery by means of a high-speed camera, even at a time when everything is operating smoothly, may often reveal some hidden flaw which must be corrected in order to avoid future failures.

One of the most recent applications of high-speed photography is in the field of biology and medicine, where it is used to study nervous and muscular reactions under controlled conditions.

Our Bureau of Information keeps on file the names and addresses of makers of, and dealers in, all devices described in the pages of Popular Mechanics Magazine. We are glad to furnish this information to our readers upon request, accompanied by stamped, self-addressed envelope.

OUTDOORS CALLS!

... CALLS FOR A SAFE AND ACCURATE RIFLE AND A FAST-STEPPING BICYCLE



Iver Johnson

Wintertime is happy gunning time—and here's just the gun for you—a safe, accurate product of expert gunsmithing—the Iver Johnson Self-Cocking .22 Bolt Action Safety Rifle. Patented Automatic Safety and Cocking device make this the fastest shooting rifle made. Price, \$5.75. Send now for Booklet A66.

And the Iver Johnson Bicycle—your pal for hundreds of happy miles! Made of costlier materials—sturdy, speedy, colorful, streamlined—latest accessories. "America's Finest Bicycle." Get all the details.

Write now for Booklet B66 of complete line.

IVER JOHNSON'S ARMS & CYCLE WORKS

21 RIVER ST., FITCHBURG, MASS.
 85 CHAMBERS ST., NEW YORK

BOOKLETS ARE FREE — A POSTCARD BRINGS 'EM!

for a *Merry Christmas* and a **HOBBY NEW YEAR**



All- **MOTO-TOOL** For Every Purpose **Craftsman**

Moto-Tool—which does all craftwork better and faster—makes an attractive, practical gift every craftsman will appreciate. No other motor-in-hand tool in its class matches Moto-Tool in speed, power, ease of handling or in exclusive construction advantages that provide long trouble-free service. These proven, demonstrable facts are important to every craftsman who wants to do in seconds jobs that require hours of hard hand work. Moto-Tool handles all accessories, does all work on all materials. Its Bakelite shock-proof housing makes it absolutely safe. Runs on A.C. or D.C. There are thousands in use.

Two Fine Models

Model 1, below, weighs 6 oz. 25,000 r.p.m., is recommended for light work. Model 2, illustrated in case above, is larger, more powerful, weighs 13 oz. about 27,000 r.p.m. \$16.50 postpaid, provides extra mechanical features shopmen want and appreciate. Either model is available in a handsome, fitted, felt-lined, highly finished hardwood case with 23 most commonly used accessories for all bench work. With Model 1 Moto-Tool, price \$17.50 postpaid; with Model 2 Moto-Tool, \$23.50 postpaid.



Price **\$985** Post-paid

Model 1

Leading dealers carry Moto-Tool—or order by mail on 10 day money back trial. Write for free illustrated booklet.

DREMEL Manufacturing Co.
2836 CT, Racine, Wis.



Universal Stand
\$4.50 postpaid



Shaping Table (stand extra)
\$2.50 postpaid

20 pc. Craftsman's Tool Set for either model
\$575 Post-paid

Send for **FREE Colorful MOTO-TOOL Booklet**

Dremel Manufacturing Co., 2836 CT, Racine, Wis.
Send on 10 day money-back trial.....
..... Here is my check , money order , or ship C.O.D.
Send me your free illustrated booklet.

Name
Address
City..... State.....

Behind the Scenes in Aviation

(Continued from Coloroto Section)

Dumping fuel in flight no longer is the hazard it was. Improved vents dump the fuel free from the body of the plane and prevent any chance of the fuel igniting from collision with tail surfaces. The flame front in a combustible mixture of gasoline and air travels only forty miles per hour, hence even if the cloud of dumped fuel happens to catch fire from a static spark the plane remains safe because it is traveling too fast for the exploding flame front to catch up.

More than 1,000,000 passengers per year are carried on domestic air lines and the number of accidents in relation to the number of miles flown is decreasing steadily, yet the aviation engineers are never satisfied. They are constantly trying to make the big transports safer and more efficient than ever.

Wooden Track for Automobiles Bridges Hatteras Dunes

Motorists visiting the Cape Hatteras region can drive on a dry land bridge. Sands are constantly shifting there, and motoring would be impossible without some hard base for traction, so a track of wooden ruts has been laid over the sand to help automobiles climb a small dune. Sand on either side has been anchored by planting grass.

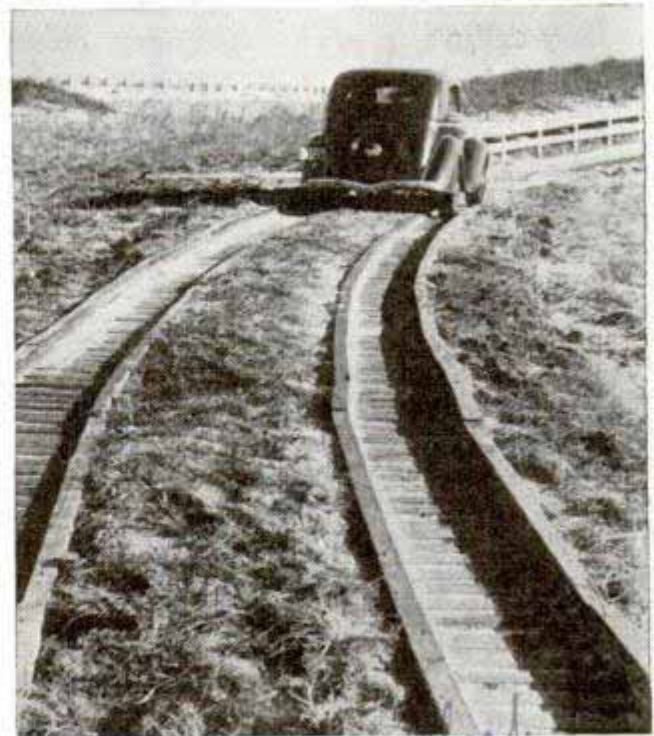

A tourist negotiates one of the shifting sand dunes of the Cape Hatteras region on a wooden track

Boys! HOW MANY OF THESE CHEMICAL SECRETS DO YOU KNOW?

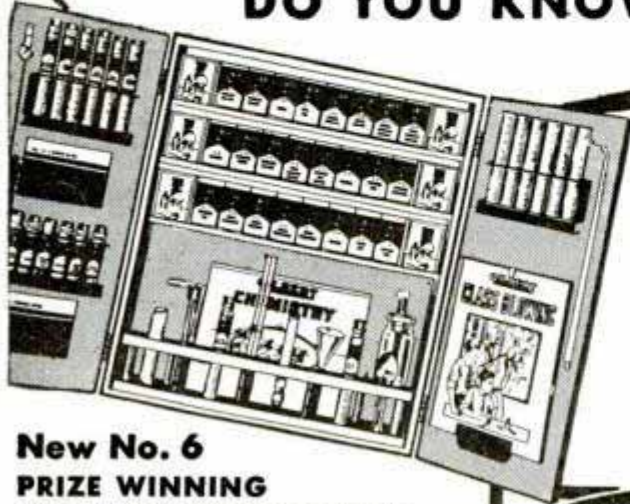

Do you know the secret of writing messages in magic ink, of making a chemical weather flag, changing the colors of flowers, making your own paints, sparklers, soda water? All these and many other thrills can be yours with a Gilbert Chemistry Set—the set that has been developed in the Gilbert Hall of Science. Also—the new, Gilbert Microscope reveals to you Nature's innermost secrets.

\$200.00 Annual Awards—To the boy doing what, in the opinion of Mr. A. C. Gilbert, is the most important research in Chemistry, Microscopy or Electricity in 1939, \$100.00 in cash will be awarded. To the ten boys doing the next most important research, \$10.00 each will be awarded. Mail coupon below for free 20-page book giving full details.

New No. 6 PRIZE WINNING CHEMISTRY LABORATORY

Big blue wooden cabinet forms Laboratory over 2 ft. long with 5 feet of test tube racks and shelf room. 63 chemicals and pieces of apparatus, including glass blowing equipment, 2 books by noted Yale professors describing over 400 exciting experiments. Price \$5.00. Other Gilbert Chemistry Sets \$1.00 to \$15.00. See them at your nearest toy store.

Free BIG BOOK "FUN WITH GILBERT TOYS"

20 pages crammed with color pictures of new Gilbert Chemistry Sets and latest developments of Gilbert Hall of Science. Mail coupon or 1¢ post card.

THE A. C. GILBERT CO., Gilbert Hall of Science, Room 107, New Haven, Conn.

Name.....
 Street.....
 City..... State.....

COMET CLIPPER GAS MODEL



\$4.95

NEW 36 PAGE CATALOG

Hundreds of models, 10¢ up. Gas model kits, motors, accessories. Send 5¢ stamps to

Prize-winning, record-breaking, 6 ft. gas model. Removable power unit; detachable wing and tail; difficult parts finished. Kit with automatic timer, \$4.95; postage 25¢, or buy from dealer.

COMET, 2509 CERMAK ROAD, CHICAGO, ILL. Dept. P12

NEW BIG STREAMLINED LATHE AT AN AMAZING BARGAIN PRICE



Swings 10 inches

Imagine! This extra heavy wood lathe, steel bed 48" long, at low prices. Heavy duty head stock, 4-step cone pulley for V-belt. No. 2 Morse Taper Centers. Sealed ball bearings. 6" face plate screws onto spindle. Tool rest 10" long. Complete line of accessories at amazing low prices. Write today for free catalog describing Blue Star full line precision woodworking machinery. Factory-to-you prices. Not sold through agents.

BLUE STAR PRODUCTS, 612 Wood Ave., Fairfield, Iowa

EARN MONEY MAKE COLOR GLAZED CONCRETE PRODUCTS



MAKE Color-glazed concrete pottery without molds or costly tools. Use only sand, cement, cheap materials. Glazed tiles, walls, gravestones, etc. **MEN (only):** Write for **FREE** colorplate, details of this new money-making business.

NATIONAL POTTERIES COMPANY
 Room 6, 13 W. 26th St., Minneapolis, Minn.

ONE-MAN SAWMILL

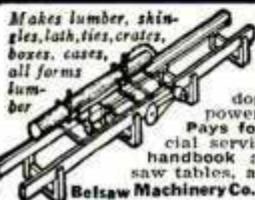

Makes lumber, shingles, lath, ties, crates, boxes, cases, all forms lumber

TURN TREES INTO MONEY WITH A BELSAW

FARM MODEL \$49.00

Three capacities: 10, 14 and 20 ft. Accurate set works positive dogs. Hand or power feed. Runs on low power—Many owners use old auto engine. Pays for itself quickly—thousands in commercial service, everywhere. Write for free lumber handbook and catalog of mills, supplies, tools, saw tables, and woodworking equipment.

Belsaw Machinery Co., 8110-T Davidson Bldg., Kansas City, Mo.

See THE BRAND NEW CORONA Zephyr

CASE AND MACHINE WEIGH ONLY 9 pounds

A real typewriter—and, at \$29.75, a sensation! Steel case, standard 84 character keyboard, backspacer, etc.—yet tucks away in desk drawer or traveling bag. You have to see it to believe it... so see it!



\$29.75

L.C. SMITH & CORONA TYPEWRITERS INC
 Desk 12,723 E. Washington St., Syracuse, N.Y. I'm thinking of buying a Corona Zephyr. Please mail free booklet.

Name.....
 Street.....
 City..... State.....

14 1036

Ocean's Depth Measured by Radio Robot

(Continued from page 830)

"The entire buoy with complete units set up, is quite cheap to make. It costs around \$150."

There are other reasons, Captain Rude goes on to explain, why the buoys are of vast importance to Uncle Sam's "ocean surveyors." The fathometer gives the depth, a special type of bomb shows the position of the depth, and the buoy is a means of charting the position of the ship.

Usually at least three sono-radio buoys are used. The scientists really are measuring the distance of the ship away from the buoys by means of the velocity of sound in sea water. The scientists know this velocity is roughly a mile a second.

Exactly how is the first buoy placed with respect to the survey vessel, assuming that the ocean surveyors are working on the profile of a section of ocean bottom off Long Island? Such a survey, which incidentally is now being conducted by the Coast and Geodetic Survey, extends from the coast line out 150 miles beyond the thousand-fathom curve. In planning this survey it was first necessary to lay down control stations consisting of sono-radio buoys, placed about five miles apart, running directly off shore about fifty miles, thence southward about fifty miles and back again to the coast line.

The precise location of these movable control stations depends on where the ship is working at any particular stage of its survey work. With the buoys set up in desired position the ship then runs parallel lines of sounding and when a certain position is desired, a bomb containing a small amount of TNT is dropped over the side about every fifteen minutes. This bomb sinks to a depth of about 100 feet and as it explodes, the sound is received by an instrument located in the bottom of the survey vessel. The time of the explosion is recorded on a chronograph tape on the ship. The sound wave also penetrates to each of three sono-radio buoys where it is received into a hydrophone attached to each buoy. The sound is amplified and it energizes a small radio apparatus inside the buoy which automatically sends a radio signal back to the ship which is also recorded on the same chronograph.

Be Wise - Alkalize

Alka-Seltzer

An Alka-Seltzer Tablet in a glass of water makes a sparkling pleasant-tasting solution. Drink it and it gives quick relief from Headaches, Sour Stomach, Distress after meals and other common ailments. It also helps overcome excess acid condition so often associated with these troubles.

WHEN YOU GO OUT TO HAVE YOUR FUN, KEEP ALKA-SELTZER HANDY. TO CHASE AN UPSET STOMACH OR A HEADACHE IT'S A DANDY.

A MERRY CHRISTMAS TO YOU ALL. GOOD HEALTH AND JOY AND PEACE. WITH ALKA-SELTZER AT YOUR CALL, MAY ALL YOUR TROUBLES CEASE.

Alkalize with Alka-Seltzer AT ALL DRUGGISTS

30¢ & 60¢ PKGS.
OR BY THE GLASS AT DRUG STORE
SODA FOUNTAINS

TUNE IN
THE NATIONAL
BARN DANCE
SATURDAY NIGHT
NBC - NETWORK

DO YOU WANT a new business profession of your own, with all the trade you can attend to? Then become a foot correctionist, and in a few weeks earn big income in service fees,—not medical nor chiropody—easy terms for home training, no further capital needed, no goods to buy, no agency. Established 1894. Address **Stephenson Laboratory, 1 Back Bay, Boston, Mass.**

Since the radio is virtually instantaneous for such short distances, the elapsed time between the receipt of the explosion of the bomb at the buoy is indicated on the chronograph tape and is scaled to within one hundredth of a second. The distance, therefore, to each of the three buoys is readily determined. The three arcs represented by these distances furnish on the survey scientist's work sheet the exact position of the ship for charting purposes. This method, furthermore, permits working in the most adverse weather conditions such as fog, storm and darkness.

151097
Model Ship Built in a Light Bulb Has Its Own Tiny Lamp

Four months in bed, ill, launched a modelmaker in the unusual hobby of building ship models inside electric-light bulbs. He finished the first job, a sailing ship, while still in bed and after recuperating kept up the work. His latest achievement is a two-funnel steamship erected inside a bulb and equipped with its own electric light—a tiny bulb in a big one.

Alfred Harris who built the steamship in a light bulb.



Twin-funneled steamship model built in the narrow confines of an ordinary electric light bulb

Treet Topics

YOU'LL NEVER MISS THE DIME ~



SO WHY MISS THE COMFORT



UMMM... NOT A SCRAPER

AND WHY MISS THE MISSES...



WHEN YOU CAN DO THIS:-

TREET BLADES!

YESSIR 4 FOR 10¢



-AND TREET YOURSELF TO A PACK OF PERFECT SHAVES!



4 FOR 10¢

Treet SINGLE EDGE BLADES

FOR GEM AND EVER-READY RAZORS

Treet Safety Razor Corporation, Newark, New Jersey

1042

COMPLETE RAILROADING
BY REMOTE CONTROL

*Uncoupling!
Loading!
Unloading!*



BUT THAT'S NOT ALL . . .
YOU CAN MAKE YOUR LOCOMOTIVE
WHISTLE, REVERSE AND SWITCH
BY REMOTE CONTROL.



UNCOUPLING

Electro-magnetic couplers
on the cars are operated
BY REMOTE CONTROL.

LOADING

Car can be loaded
from coal elevator BY
REMOTE CONTROL.

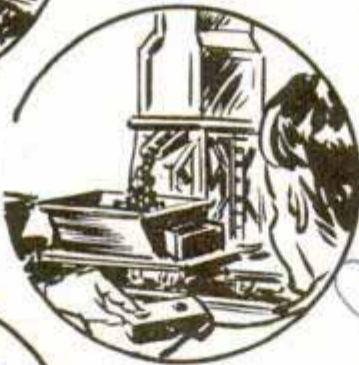

UNLOADING

Car tilts, unloading con-
tents alongside track
BY REMOTE CONTROL.

Read all about these thrilling new operating
features in the new Lionel 52-page, full
color catalog. Send for your copy at once.

Insert on **LIONEL**
FOR ALL THE THRILLS OF RAILROADING

The Lionel Corporation Dept. 11
15 East 26th Street, New York, N. Y.
Enclosed is 10 cents for a copy of the new 1938, 52-page,
full color Lionel Catalog. Send it to:
Name _____
Address _____
City _____ State _____

folded blade \$1.00 - Custom release \$2.00

Off the "Platter"

(Continued from page 885)

The commercial radio set of today re-
produces vibrations up to approximately
8,000 cycles per second without loss of true
tone. The transcription makers, whose
records capture and reproduce up to 8,500
cycles, are keeping up with the reproduc-
ing instrument in your home. As sets are
improved, transcriptions will likewise keep
step. Experimental work has already
proved that it can be done.

As a component part of the radio indus-
try, the transcription makers have proved
that they are abreast of the procession. It
all adds up to the fact that the listener who
hears such a record on his radio is ready
to credit it with being fully the equal of a
"flesh" broadcast from a conventional
studio.

17914

Screwdriver Has a Jackknife Folded into Its Handle

Really two tools in one, a screwdriver
with six-inch blade has a jackknife folded
into its handle. One model has a composi-
tion handle from which the knife is
released by pressing a button. House-
holders, electricians, motorists and shop
workers find it a handy combination.

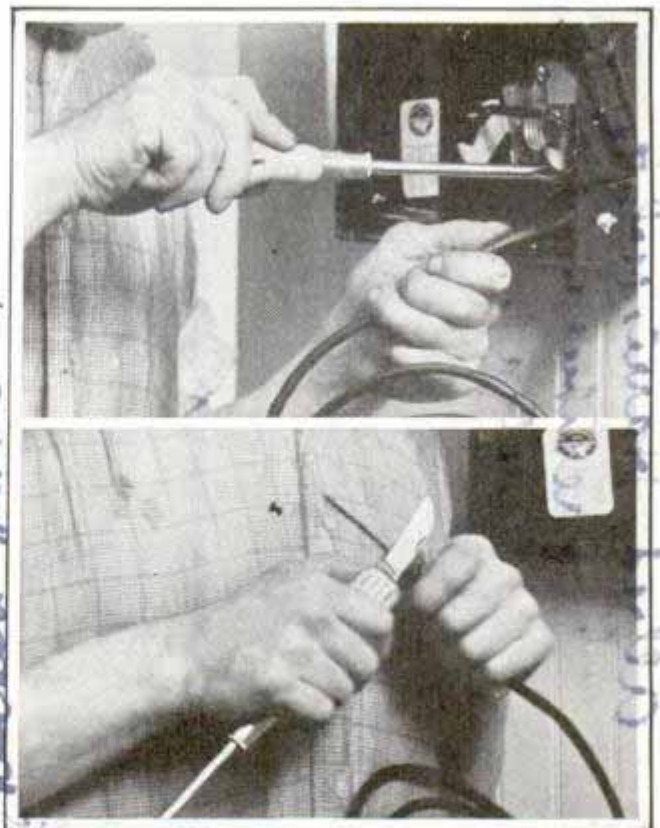

The combination tool in use as a screwdriver, top,
and as a knife, bottom

Stanley Tools

FLEXIBLE...

transparent, waterproof

● Holds permanently on china, glass, wood, metal, leather, paper, fabrics. Not affected by heat, cold, moisture. Dries quickly. Ideal for model making, as well as for mending.



DUCO CEMENT

BURN YOUR NAME ON TOOLS

WITH THE ARKOGRAF

PROTECT YOUR TOOLS FROM THEFT

Write with electricity any name or design on the hardest and finest tools and instruments, or any metal, like writing on paper with pen or pencil. Complete Outfit \$3.50—Prepaid Anywhere. Interesting illustrated circular free. Write today. Agents wanted.

ARKOGRAF PEN CO., 3927 S.E. Stark St., Portland, Ore.

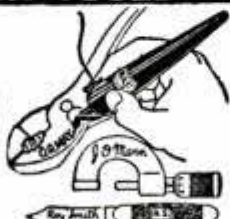

\$1.50

At Electrical Stores or Post-paid

"THE NEON LIGHT sets you RIGHT"

TEST-O-LITE

Handiest electrical tester made; quickly locates trouble in electric circuits, fuses, cut-outs, motors, radios, etc. Has 1,001 uses for electricians or home. Tests any voltage, 110 to 550; tells A.C. from D.C. Exceeds ordinary clumsy test bulb. Fountain-pen size; with pocket clip. Lifetime guarantee.

L. S. BRACH MFG. CORP.
55 Dickerson St. Newark, N. J.

CASH IN QUICK

Now Till Christmas Men and Women. Make easy money selling GENUINE LEATHER TIES

4-in-Hands and Bows, for Men and Boys. Beautiful patterns and colors. Won't wrinkle. LOOK LIKE SILK. Wear indefinitely. Cleaned with a damp cloth. Big profits; repeat orders. No sales ability needed. Big leader in necktie sales. Send 50 cents for sample kit. Information free.

Century Tie Co., Mrs. 2345-P W. Grand Blvd. Detroit, Mich. (Originators of Leather Ties)

WIND ELECTRIC PLANT

Build Your Own—We Show You How!

Easily made from old auto generator. Dime brings complete plans and 1938 catalog. 100 other generator changes to 6, 12, 32, 110 volt plants, motors, welders, elec. fence, etc. LeJay Mfg., 447 LeJay Bldg., Minneapolis, Minn.

World's Best Line of TRAILER AXLES, HITCHES and PARTS

New \$3.00 House Trailer Blue Prints Free With Axle Assembly.

WRITE FOR FREE LITERATURE

HAMMER-BLOW TOOL COMPANY, Dept. 112, Wausau, Wis.

White Seal BASS SENDS THIS Candid Midget \$19.50

Has sharp-cutting F:4.5 Huge Meyer Anastigmat lens. Vario shutter speeds to 1/100th. Time and Bulb. \$19.50. Address Dept. P. Send for Free Bass Brochure No. 236

BASS CAMERA CO.

179 W. MADISON ST. CHICAGO, ILL.

new Invention SAVES GAS!

CUTS GASOLINE COSTS up to 30%

Creates New Mileage Records It's Here! VACU-MATIC—"The Carburetor That Breathes!" AUTOMATIC CONTROL guarantees constant peak performance. More power, smoother running, quicker starting. Fits all cars; installed in a few minutes.

Don't wait! Just send name and address for details about VACU-MATIC and our FREE TRIAL OFFER. Write Today! AGENTS WANTED

VACU-MATIC CO., 7617-398 W. State St., Wauwatosa, Wis.

GET MORE HEAT

in the "Living Zone" (diagram shows improved method)

Dotted lines indicate how circulated heat rises to the ceiling, then sinks lower in the room. Arrows represent radiant heat being directed into the "living zone" and down to the floor by Comfort Control Shutters of the SUPERFEX HEAT-DIRECTOR.

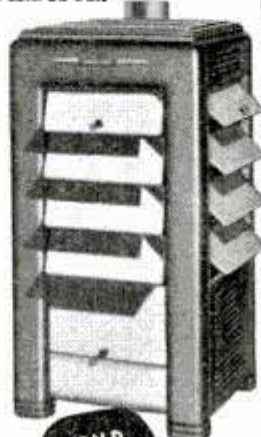

SEND FOR FREE BOOKLET

Because the SUPERFEX is the only Oil Burning Heater equipped with adjustable Comfort Control Shutters, it produces greater comfort in the "living zone"—utilizing both circulated and radiant heat. It operates hour after hour without attention. Dial regulates heat volume. Burns wide variety of inexpensive fuel oils available everywhere. Easy to own on monthly payment plan. Choice of sizes for shops and homes. Beautiful porcelain enamel finish. Radiant Heaters, too. See them at your dealer's.

PERFECTION STOVE COMPANY
7610-C Platt Avenue • Cleveland, Ohio

Duro HAND GRINDERS FOR GREATER VALUE

- POWER
- SPEED
- PRECISION

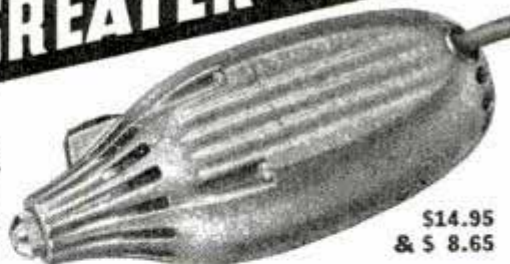

\$14.95 & \$ 8.65

ONE WELL KNOWN TOOL AND DIE MANUFACTURER WRITES—"Enclosed herewith find check for \$45.15 covering cost of three No. 3049 Hand Grinders plus postage.

"After thoroughly testing the one we purchased for trial purposes, my men have told me that it is the finest Grinder they have ever used, and we have tried them all. That it has plenty of power and speed and that it really stands up under hard work without stalling or getting hot.

"My foreman told me that if he could not replace it, he would not sell it for \$100.00."

Our Standard Duty Grinder is the same value in its price field. Write for special circular on the Duro Hand Grinders and Accessories—or let us send either model on 10-day money back trial.

SEND FOR NEW 1939 DURO WOOD WORKING CATALOG... Featuring America's Finest & most Complete line

DURO METAL PRODUCTS CO.
2657 NORTH KILDARE AVE. DEPARTMENT B2
CHICAGO, ILLINOIS

A 1029

LIE DETECTOR "TELLS ALL"

REVEALS STARTLING FACTS
ABOUT RAZOR BLADES!

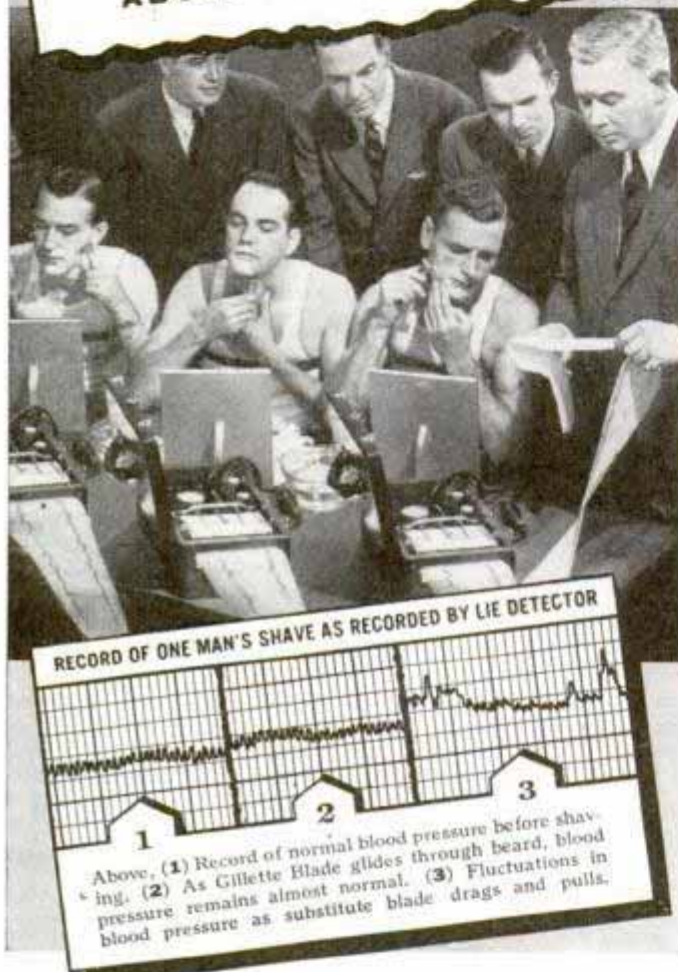

TO BARE the facts about razor blade quality, Gillette retained Dr. William M. Marston, eminent psychologist and originator of the famous Lie Detector. Strapped to the Lie Detector... the same instrument used by police... these men shave one side of the face with a Gillette Blade, the other with a blade of different make—while their involuntary emotional reactions are recorded. Dr. Marston proves the Gillette Blade is far superior in every respect to substitute blades tested. You get shaves that are: 1. Easier. 2. Faster. 3. Free from irritating disturbances that can upset you for hours. Read the graph above. Weigh the evidence. Try a Gillette Blade yourself—and learn what a big difference it makes when you shave with a blade that's precision-made to fit your Gillette Razor exactly.

MORE SHAVING COMFORT FOR YOUR MONEY

"MILLION-DOLLAR"
SHAVES FOR LESS THAN
A PENNY A DAY

Gillette Blades

PRECISION-MADE TO FIT YOUR GILLETTE RAZOR EXACTLY

Don't Pity the Poor Eskimo

(Continued from page 838)

common nail, is put to many uses by the Eskimos. One day we watched one of them rebuild a rifle in our workshop. It was an old rifle and several of the working parts had worn loose. So he made new parts from nails, heating, hammering, and filing them to shape. When finished, the old rifle worked splendidly.

Nowhere does the Eskimo display greater skill than in his ivory carving, an art handed down for countless generations. Ivory is about as hard as brass. The Eskimo now uses a hack saw to rough-shape his ivory, rasps and files for the finer details, small chisels made from saw files to work out finer lines and crevasses, bow drills for holes, and emery paper and crocus cloth for the finishing touches. Finally he rubs it well with jewelers' rouge. The high polish secured by the rouge distinguishes real Eskimo work from the Japanese carvings that constitute most of the ivory offered for sale to Alaskan tourists.

Among Eskimo implements of comparatively recent origin, perhaps the most ingenious is the ilhook, or retriever. Before introduction of the rifle, seals were harpooned and pulled ashore by the harpoon line. But with a rifle an Eskimo might kill a seal or a duck far out in the water, and then be unable to retrieve it, without launching a boat. So he invented the ilhook, consisting of a streamlined, bullet-nosed, driftwood float carved to approximately the size and shape of a 200-watt electric-light bulb. Curved metal barbs protrude from the float, and a long rawhide line is securely fastened to it. In use, the float is whirled around the head rapidly and let fly out past the seal, carrying the line with it. If the line does not fall directly across the object to be retrieved, the hunter moves along the shore line until the float is in such position that it can be pulled directly across the quarry. Thereupon the metal barbs snag the object, and hold it while it is dragged ashore.

One instance of the Eskimos' innate mechanical sense impressed us deeply. Two educated Eskimos who had visited "the States" told us that the greatest fear they experienced was not from automobiles or trains, but from swaying trees. They could never quite overcome the fear that a tree,

swaying in a stiff wind, would blow over on them!

The huge topheavy mass of branches, balanced on the small trunk, had no visible means of support. They had never seen trees growing in their native land, and while they knew that trees had roots, it didn't seem possible to them that there could be enough roots to anchor such an apparently illogical structure. To some, this concept might indicate a lack of intelligence on the part of the Eskimos. But their error was not one of logic. It was due to lack of information.

Here is where the white man enjoys perhaps his greatest advantage. He can avail himself of knowledge accumulated through the research of millions of experimenters, and the experience of millions of fellow craftsmen. Newspapers, magazines, radio, and motion pictures rapidly collect and disseminate new ideas and foster their adaptation to new uses, providing a constant source of inspiration. Perhaps it is this constant stimulus and this easy access to accumulated knowledge rather than any fancied superior intelligence that makes the white man seem to excel in mechanics and invention.

The Eskimos, in common with other peoples cut off from the rest of the world by physical barriers, have until recently enjoyed no such advantages of easy communication of ideas. They have had only their own traditions and experience, plus their native understanding of fundamental principles, to guide them.

From what we have seen of these Stone Age people, we believe that they display as much intelligence in analyzing and solving problems as do those who live thousands of miles and hundreds of years removed from them in the age of the machine.

Wood Veneer with Felt Backing Adapted to Curved Surfaces

Thin wood veneer mounted on a felt base is a sound-absorbent, flexible material for interiors, such as the inside panels of automobile doors. The veneers are available in a variety of handsome, polished woods. One especial advantage of this material is its adaptability to curved surfaces. It is waterproof, resists termites and vermin, will not support combustion and insulates against both heat and sound.

HEAT GUN

assures complete
WINTER LUBRICATION



With a Black & Decker HEAT GUN on the job, stiff, frozen oil and grease offer no handicap to the modern service station.

For complete motor protection HEAT GUN's powerful blast of concentrated heat (450°F) quickly thaws and blows out every bit of old grease, oil and sludge from transmission, differential or crankcase. It works wonders in limbering up spring shackles and other troublesome parts.

And for thawing out radiators, pumps, hose connections, sleeted windshields; or drying plugs, distributor heads and ignition wires, the Black & Decker HEAT GUN has no equal as an aid to safer, trouble-free winter motoring.

Sold through leading jobbers. Get full details today. The Black & Decker Mfg. Co., 612 Penna. Ave., Towson, Md.

BLACK & DECKER

BLACK & DECKER

World's Largest Manufacturer of
PORTABLE ELECTRIC TOOLS

"HO" GAUGE MEN

Attention!



NEW Gilbert American Flyer scale model is here!

The A. C. Gilbert Company, manufacturers of Gilbert American Flyer trains, present a new "HO" gauge two-rail train line. Built to scale from actual railroad blueprints. All rolling stock is die-cast, with bakelite wheels. All couplings are automatic. Locomotive is 4-6-4 N. Y. C. Hudson type, with remote-control reverse motor. 25-to-1 reduction gear gives tremendous pulling power. Locomotive and tender weight, 3 lbs.; freight cars and caboose, $\frac{1}{2}$ lb. each.

AND LOOK AT THE LOW PRICES!

Complete train, consisting of locomotive, tender, 3 freight cars, caboose and 16 sections of curved track (a complete 24-inch radius circle) . . . \$19.50

Train — in kit form, completely machined, to be assembled and painted . . . \$15

Locomotive and tender complete . . . \$12.50

Same—kit form, to be assembled and painted . . . \$10

Freight cars and caboose (each) complete . . . \$2

Same—kit form, to be assembled and painted. \$1.75

Write today for free catalog illustrating and describing these remarkable new trains, as well as newly designed "O" gauge Gilbert American Flyer trains and equipment.



BIG NEWS FOR "O" GAUGE MEN

Gilbert American Flyer now offers a brand-new "O" gauge six-wheel switcher. An exact scale model. Remote control. Automatic couplers. Slope-back die-cast tender with rear headlight. Read full description in free catalog. Price, \$12.50.

GILBERT

American Flyer Trains

MADE BY THE A. C. GILBERT COMPANY
505 Erector Square New Haven, Connecticut

Make Your Snapshots Tell a Story

(Continued from page 853)

subjects should be absorbed in it, apparently unaware of the camera. But it is not imperative that people be included in all story pictures. A snapshot of a gnarled, twisted tree, perched atop a windy hill tells a story of a lifelong battle with the elements—and no human figure is needed.

It is a good idea to have a title in mind before you shoot a picture. The title helps make your story idea definite—it gives you

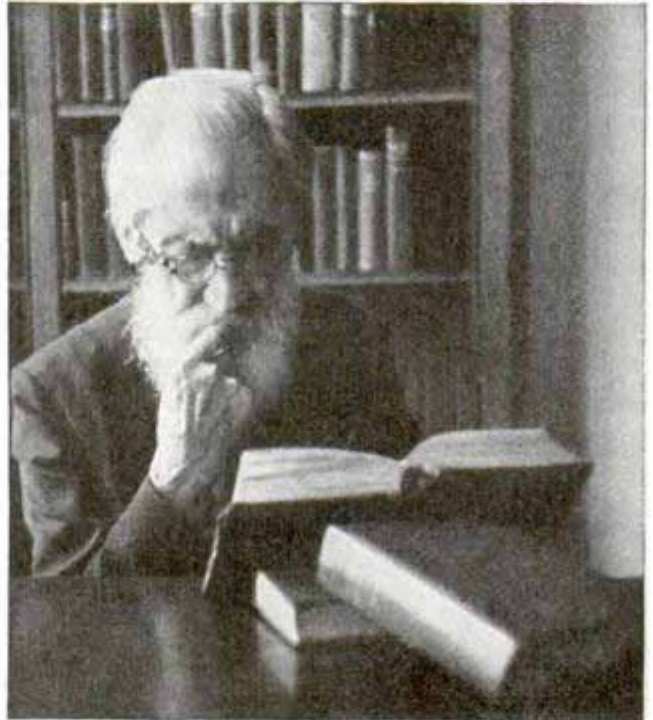

Strong light on beard, spectacles, frown, forefinger on lip give "story" quality to this library scene

a foundation or reference point to work from. Consider the twisted tree. Choose the title "Windswept" and you will automatically seek a picture angle that best shows the stretched, blown branches and the hurrying clouds beyond.

Indeed, there is no more fascinating camera pastime than choosing provocative story titles and then searching out picture subjects to illustrate them. For a snowball fight, consider the titles "Direct Hit," "Look Out Below!" and "No Quarter!" Take a general title such as "Steel," "Ripples," or "Skill," and you can find literally hundreds of pictures to fit. For "Steel," think of the gaunt frames of new buildings, railway tracks gleaming in the sunset, loading cranes and hooks, cables and chains. "Ripples" suggest snowdrifts, dunes, or the moods of wind and water,

(Continued to page 139A)



ARCADE Low Cost POWER TOOLS

Compare These Prices

Drill Press, 15" high, \$5.30; Disc Sander, 8 1/4", \$5.00; Jig Saw, 10" throat, \$5.30; Belt Sander, 4"x4" drums, \$8.00; Lathe, 8" Swing, 30" between centers, \$9.50; Band Saw, 10", \$18.00; Bench Saw, 6" blade, \$11.00; Bench Saw, 8" blade, \$25.00. Prices west of Rockies slightly higher. Also other Bench Tools, Model Makers and Accessories at very attractive prices... all quality built for long service and accurate workmanship. If dealer cannot supply, order direct. Write for

FREE CATALOG Arcade Mfg. Co., 1219 Shawnee St. Freeport, Illinois

30¢ BUYS CLASS & CLUB PIN!

SMART, up-to-the-minute designs. Pins in 2 colors with any 3 or 4 letters and year. Handsome Sterling silver rings. Oldest, largest maker; famous for quality for 44 years. Clean cut work distinguishes Bastian Pins and Rings anywhere. Write for new catalog today!

BASTIAN BROS. CO.
Dept. 70 Rochester, N.Y.

1.40

BUILD THE CUTTY SARK

2 FT. MODEL OF THE FAMOUS CLIPPER SHIP



Complete kit makes perfect building easy
2.50 plus 15¢ postage

Everything... including CARVED WOOD HULLS, Printed Balsas Decks, Cast-Metal Life-boats, Anchors, Bitts, Steering Wheel, Chains, Mast, Spars, Rigging, Cement, Colored Lacquer—Full-Size Plans and Instructions.

Send for Catalog all latest new models—10¢ IDEAL AIRPLANE & SUPPLY COMPANY, INC. 20 West 19th Street, New York

OTTAWA LOG SAW



\$39 BIG BOOK FREE PUTS THIS OTTAWA

GREATEST OFFER EVER MADE
To work for you
MAKE MONEY! Wood is valuable. Saw 15 to 20 cords a day. Does more than 10 men. Ottawa easily operated by man or boy. Falls trees—saws limbs. Use 4-hp. engine for other work. Write for **FREE** book. OTTAWA MFG. CO., 1427 Wood St., Ottawa, Ks.

EXTRA \$\$ in PRINT at HOME

Letterheads, Circulars, billheads, cards. Printing pays BIG. Easy, interesting, educational. **PRINTING PRESS BARGAINS** \$12. Types and Supplies, lowest prices. Send stamp for catalog. PEIFFER Co., 16-C, 6 Columbia St., Newark, N. J.

New Adding Machine Fits Vest Pocket!..

Adds, subtracts and multiplies up to one billion. Weighs only 4 ounces. Not a toy—strong guarantee. Absolutely accurate, very fast. Sells to offices, stores, homes—wherever figures are used. Write quick for **FREE** AGENTS sample offer and Money-Making Plan. **VE-PO-AD, Dept. 152, 303 W. Monroe St., Chicago**



CLEANS CLOTHES at Home

Saves Dry-Cleaning Bills

SELLS LIKE WILD. Never anything like it. Secret chemically treated. Used like a brush. No smelly liquids—no messy powders—no soiled hands. Keeps suits, dresses, spic and span. Also cleans hats, drapes, upholstered furniture, etc. Long lasting. Low priced. Everybody a prospect. Agents wanted everywhere. **Hustlers cleaning up big money.**

SAMPLE OFFER Samples sent on trial to first person in each locality who writes. No obligation. Get details. Be first—send in your name **TODA!**
KRISTEE CO., Dept. 682, Akron, Ohio



WITH P.W. I'LL PUT THAT ON TO STAY



RESULTS ARE AMAZING

Now if you have a broken chair—loose caster—crack or nick in woodwork, floor, plaster or tile—loose drawer pull—do a quick, expert job of repairing with wood in cans—**PLASTIC WOOD**—that handles like soft putty and hardens into wood—wood you can carve, paint and drive nails and screws into. Paint, hdwe. & 10¢ stores sell **PLASTIC WOOD** in 10¢ & 25¢ tubes and 35¢ cans.



PLASTIC WOOD

Cleans Drains without Chemicals!

Revolutionary invention, using water pressure from the faucet. Opens clogged drains. Flashes them out and leaves drain free of stoppage. Clean and sanitary, easy to use. Full instructions packed with each "Drain Flusher." Fully guaranteed. Thousands in use in homes, apartments, hotels and factories. If you are having drain trouble in your kitchen sink, washbowl, laundry tubs, etc., and want a sure cure for this condition, send your order today for a "DRAIN FLUSHER." \$1.00 postpaid, or sent C.O.D. plus a few cents extra charge.

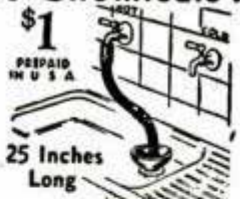

BROOKS-HILL CO.

211 N. RIDGEWOOD PLACE
LOS ANGELES, CALIF. Dept. —102

The 1939 Ranger

at new reduced prices



Now ready for Christmas! Get your Ranger now, while these special prices last. All the latest improvements, among many styles shown in 1939 catalog. You can have **2-speed gear-shift, front-wheel brakes, spring forks**—and genuine Mead quality besides!

NOW you can ride a genuine Mead bicycle 30 days without "buying for keeps." Return it at our expense if not satisfied. Write quick for **FREE** Catalog, marvelous new prices, special offers. **SAVE 1/3** buying direct from **MEAD!**

Tires—Save on lamps, wheels, tires, equipment. Drop us a postal.

Mead CYCLE COMPANY
DEPT. L-118 CHICAGO

FREE!

Great new Color Catalog sent **FREE**. Hurry!

NOW! Anyone without experience can do a thousand and one REPAIR JOBS!

WELDING BRAZING SOLDERING

QUICKLY PERFECTLY EASILY

with the

NEWLY INVENTED

3 IN 1 Electric TORCH



COMPLETE WITH POWER UNIT—WORKS OFF 110 VOLT AC OR DC LIGHT CIRCUIT

Here at last is a portable machine that does real welding, brazing and soldering, yet is priced within the reach of all. The 3 in 1 comes to you complete with goggles, carbons, various types of welding rod and all accessories needed to do various repair jobs. It is all ready to plug in a light socket—nothing extra to buy. Simple instructions make it possible for you to do first class work easily without any previous experience or mechanical skill. The 3 in 1 instantly creates a terrific flame by just touching the carbons together.



REPAIRS FENDERS, AUTO BODIES, TANKS, BICYCLES, RADIOS, ETC.

The 3 in 1 is ideal for auto body repairs and fender weld jobs—steam fitters, plumbers, sheet metal shops, engineers, maintenance men and janitors will find it indispensable. By following simple instructions, heavy work such as bumpers, tanks and industrial repairs can be done. Ideal for the countless jobs around a home or farm. **WORKS ON ALUMINUM, BRASS, COPPER, IRON, STEEL AND OTHER METALS.**

AGENTS! You will find quick easy sales waiting for you in repair shops, garages, factories, sheet metal, radio and bicycle repair shops, and many other places. Write at once for free particulars and learn how you can get your own 3 in 1 Electric Torch absolutely free for demonstration purposes by helping to introduce it to others.

ELECTRO-TORCH CO. 2613-BM MICHIGAN AVE., CHICAGO, ILL.

CAN YOU BEAT THESE POWER COSTS?

Save up to **\$293⁸⁰** Per Month on power costs

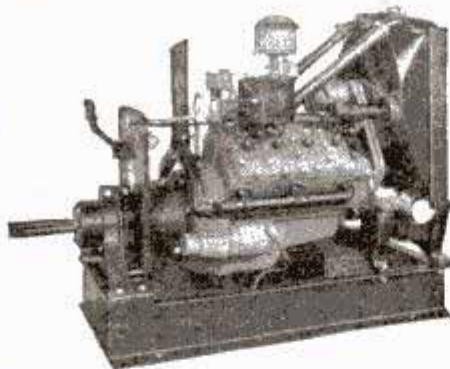

with a KRW FORD V8 Unit

50 H. P. with KRW V8 Unit using natural gas (1125 BTU) @ 30c per 1000 cu. ft. \$ 46.80 per month
 50 H. P. with KRW V8 Unit using gasoline @ 10c per gal. (no tax) \$ 140.40 per month

Above figures show primary fuel costs (lubricating oil not included) for operating a KRW V8 Unit to develop 50 H. P. for 10 hours per day—26 days per month. Compare this with electricity @ 3c per KWH which amounts to \$340.60 per month. You can pay for a KRW Unit in a few short weeks out of actual savings!

KRW V8 Units are daily saving money for operators of air conditioning and refrigeration equipment, mills, factories, shops, welders, compressors, pumps, well-drilling outfits, contractors' equipment, etc. New KRW "GUARDIAN" automatically stops engine in case of cooling or lubrication failure.

Write for new bulletin just off the press—packed with useful information, engineering data, etc. You can buy through your local Ford Dealer and benefit by local service and low-cost Ford engine replacement feature.

K. R. WILSON 17 Lock St. BUFFALO, N.Y.
 Builders of Shop Equipment for Ford Dealers Since 1916
 West Coast Branch: 722 Mateo St., Los Angeles.
 Export Office: 90 West St., New York.

When writing please mention Popular Mechanics

Spindle SHAPER \$3

less cutters (C.O.D. or outside U.S. \$3.25) Postpaid

Make tongue and groove joints; shape moldings, picture frames, plaques, etc. Limitless projects can be given a professional finish with this shaper. It has 8" x 53 1/2" steel table; stands 55 1/2" high. Uses standard 3/16" hole cutters. (Cutters 55c each). Oilless bearings. Your fractional H.P. motor runs it.

FREE CATALOG describing \$150 prize contest (1st prize, \$25; 2nd, \$15; 3rd, \$10; 46 other cash and merchandise prizes). Cat. illustr. complete power tool line; Jig Saw, \$1.50; Circ. Saw with oilless bearings, \$3; Drill Press, \$2.50; completely equipped Lathes, \$2 & \$4.90; Sander, \$1; etc. Order today or send card for Catalog.

\$150 PRIZE CONTEST

J & H Metal Products Co. 5 Commercial St. Rochester, N. Y.

BIG NEWS FOR MODELBUILDERS & HOMECRAFTSMEN

In the values and prices featured in the great new C-D Handbook Catalog—now ready! Bargains galore. Thousands of items—including 135 world-famous C-D flying model airplanes; also other makes, 10c up. Also C, CD, OO and HO gage model RR equipment, and toy trains at 20c up. Gas model airplanes, and all well known gas engines; hand tools, power machinery, ship kits—and all necessary supplies. Microscopes, etc. Nothing ever like it, before. Edition limited, act quick! Rush name, address and **10c**

Cleveland Model & Supply Co. Inc., 4508-894 Lorain Ave., Cleveland, Ohio

Sensational MONEY MAKER

WILD ELEPHANTS CAN'T TEAR IT APART

There is a flood of quick profits waiting for those first to introduce this amazing new liquid that joins all kinds of materials as if one piece. Men and women make big incomes in direct sales. Also, counter carried so you can sell in quantities to dealers and let them sell for you. **WAGON JOBBERS, CARD MEN, SPECIALTY MEN**—here's a real opportunity to add a real product to your line. **THRIFTEE-FIX** will mend almost everything imaginable without heat, soldering irons or acids. Agents cleaning up. Big repeat business—enormous profits. Write TODAY for sample proof and particulars.

INDIANA LABORATORIES
 Dept. T-1258 Elkhart, Ind.

Over 1000 Uses

(Continued from page 136A)

while with such a title as "Skill" you can illustrate hundreds of occupations—the shopworker filing a saw, the jeweler at his bench, the carpenter doing a delicate bit of fitting.

This method of choosing titles and then illustrating them is an unailing technique for finding picture subjects. Pick a good title—take a picture that fits it—and you



Here's a "direct hit"—splattering snow, screwed-up face, a snowball ready to throw. It's all told

will have a snapshot that interests everyone who views it.

There are three general classes of picture stories, and you should try them all, for each has a special application—depending on your choice of subject. The classes are:

A single picture, which suggests a complete story by presenting one aspect of it.

Series pictures—each picture covering one point of a longer story. The boy and his airplane would make an excellent series. One picture could show him examining a friend's airplane model; another would picture him poring over plans or blueprints; others would detail the progress of his construction job, and a final picture or group would cover the initial flight. Series pictures are especially good when a story needs to be told, step by step.

Sequence pictures—or movie scenes in snapshot form. It is different from a series in that the background or setting does not change. One might make a good sequence of a fisherman landing a fish, or a baby exploring a new crib. In these pictures, one concentrates on changes of expression, and slight variations of action, rather than

(Continued to page 140A)

LET THE POSTMAN
BRING YOU
THIS 188 PAGE
Catalog
FREE



Cover to cover it's brand new. New 1939 Lafayette Radios, 60 new models . . . every one a streamlined beauty and all priced within easy reach. Complete list of nationally advertised radio parts and equip-



ment. Sensational new television kit, plus the biggest selection of build-them-yourself radio kits. New photography section solid-packed with real values. 188 pages of standout buys! Send for your **FREE** copy. It's today's buying—and saving—guide.

Special Xmas Catalog

Be sure to send for our special **FREE** Christmas catalog—out now in time for thrifty Christmas shopping. This year give practical gifts. Largest selection of gifts anywhere—electric trains, cameras, modern appliances, electric shavers, radios . . . Shop at home in comfort with this greater-value gift catalog—save time and money. Check both catalogs on coupon and mail.

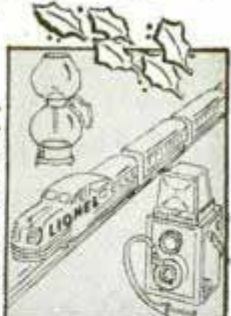

WHOLESALE RADIO SERVICE CO. INC.

NEW YORK, N. Y. • CHICAGO, ILL. • ATLANTA, GA.
100 SIXTH AVENUE • 401 W. JACKSON BLVD. • 265 PEACHTREE STREET
BOSTON, MASS. • BRONX, N. Y. • NEWARK, N. J. • JAMAICA, L. I.

WHOLESALE RADIO SERVICE CO., INC.
100 Sixth Avenue, New York, N. Y.

Rush **FREE** 1939 Gift Catalog No. 75-7M8
Rush **FREE** 1939 Radio Catalog No. 73-7M8

Name _____
Address _____
City _____



LET "VALU-BILL"
BE YOUR SANTA

PASTE COUPON ON PENNY POSTCARD

H 1023

FOR YOUR HOME WORKSHOP

Stanley Plan Book giving step-by-step instructions for building 16 useful articles. • Stanley Tool Guide shows how to use and care for all common wood-working tools. • "How To Work With Tools and Wood" is a 185 page book showing how to use tools, how to select materials, plan your work and finish it. More than 150 illustrations.



STANLEY PLAN BOOK
16 complete plans 10¢ per Copy.

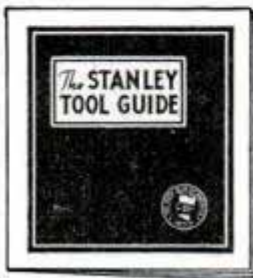

STANLEY TOOL GUIDE 32 big pages of information 25¢ per copy.

STANLEY BOOK "How To Work With Tools and Wood" 185 pages \$1.00 per copy.

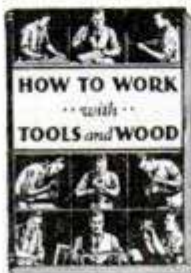

Send check, money order or stamps for your copies to

STANLEY
TRADE MARK

STANLEY TOOLS

105 Elm Street, New Britain, Conn.

At Last! **FINER SANDING**
in **HOURS LESS TIME!**

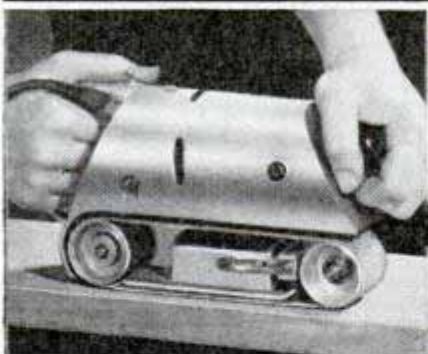

Use it for . . .
SANDING
GRINDING
SHARPENING
POLISHING
BUFFING
REMOVING PAINTS,
VARNISHES

New Guild PORTABLE ELECTRIC Sander

Just what you have been waiting for—a portable, high-precision power sander at a price you can afford. It saves time and toil on all your sanding jobs. Equals the quality of work done by sanders costing twice as much.

Straight-stroke, continuous sandpaper belt works with the grain—leaves no cross-grain marks or swirls. Handles wide variety of outside and inside curved surfaces . . . and all plain surfaces.

OUR TRIAL OFFER

will let you see for yourself the many jobs you can actually do with this tool. Write for details today.

Works on wood, metal, bone, compositions, plastics. Weighs only 9 lbs. Plugs into nearest light socket. Anyone can use it. Fully guaranteed.

Syracuse Guild Tool Company
1700-12C No. Selina St.
Syracuse, N. Y.

(Continued from page 139A)

broad shifts, and the camera viewpoint remains the same in all the shots.

"Series" and "sequence" pictures are of rather recent origin. Indeed, they were rarely seen until the development of the modern miniature cameras, built especially for rapid adjustment and quick capturing of action stories. Now, however, owners of larger cameras are adopting the miniature technique, and finding it useful for many subjects although, of course, most of the large cameras cannot rival the miniature's lens speed and simplified focusing or film-winding control.

To take sequence pictures, the amateur must learn to handle his camera quickly and efficiently. All the adjustments should become second nature to him. This calls for taking many pictures, but the results are well worth the effort. Often an especially good sequence opportunity will require that pictures be taken as rapidly as one can wind the film and snap the shutter. It is generally advisable to take more than are required, so the sequence will be of adequate length even if some of the snaps do not fit in properly.

Many clever story ideas can be worked out in series form, and there is more opportunity for humor. Stories that cannot be told at all in one snapshot can be made screamingly funny with a half-dozen snaps arranged in series. Imagine a small boy with a huge snowball on top of a hill. In one picture, show him losing his balance, and starting to roll downhill with the ball. You would pose this action, of course. At several points down the hill, picture the boy and the ball, apparently rolling—and at the bottom, get a final picture, with the boy sitting tousled and bewildered, and the ball now bigger than he is.

Creating such story sequences greatly enhances the enjoyment you get from your camera—and it costs no more than ordinary snapshooting, because when you carefully work out a picture-story, you make every film count.

If you have had difficulty making your pictures as interesting as you would like, try the "story" approach. Make each picture "say something" to those who view it. Take one snapshot when the subject is suited to single-picture treatment, and whenever you want to detail a story more fully, try a series.

Relieve Heartburn Fast This Amazing Way

YES—TUMS a remarkable discovery brings amazing quick relief from indigestion, heartburn, sour stomach, gas, and burning caused by excess acid. For **TUMS** work on the true basic principle. Act unbelievably fast to neutralize excess acid conditions. Acid pains are relieved almost at once. **TUMS** are guaranteed to contain no soda. Are not laxative. Contain no harmful drugs. Over 2 billion **TUMS** already used—proving their amazing benefit. Try **TUMS** today. Only 10c for 12 **TUMS** at all druggists. Most economical relief. Chew like candy mints. Get a handy 10c roll today.

You never know when or where



TUMS are anti-acid—not laxative. When you need a laxative get—*Nature's Remedy* NR—TABLETS—NR. This all vegetable laxative brings such gentle, dependable relief for conditions due to constipation.

BIG MONEY BUILDING MEAD'S New Portable **OUTBOARD BOAT**



IN A FEW DAYS AT HOME! Build this light, 50 lb. tough, durable, seaworthy, portable **Outboard Ki-Yak!** Take it anywhere by hand or car. Safe, leakproof, trouble-free. More speed per horsepower, more miles per gallon. MEAD'S perfected aluminum-ribbed, cut-to-fit Construction Kit guarantees successful assembly, quickly, easily, economically. New 60 lb. OK-4 uses our, sail, motors 10 h.p. or less. Also 3 "CK" paddle-sail models from 20 lbs. to 40 lbs. Rush dime for details. 50 Gift, Paddle Offer!

MEAD GLIDERS 15 S. Market St., Dept. B-128 CHICAGO, ILL., U. S. A.

TRAILER PARTS

Latest type heating stoves, window assemblies, couplers. Everything for the trailer. 40 page illustrated catalog, 10c. **MARVEL TRAILER PARTS CO.** 19020 Celestine Ave., Detroit, Mich.

The APPRECIATED GIFT

A Gerstner Tool Chest for Christmas or any other occasion. Machinists and Toolmakers may choose from Free Catalog. **GERSTNER TOOL CHESTS** 433 Columbia St. Dayton, Ohio

BUILD THESE PROJECTS

For garden or lawn. Easy to build. Easy to sell. Detailed Blueprints Model B-25 Dutch Windmill 50c; Model OM-60 Old Mill, 85c. Lawn Figure Patterns—Sunbonnet Girl, Dutch Boy, Tulip Girl, Holland Pair, 35c each, all 4—\$1.00. Catalog illustrating many models, send 10c, today.

CRAFTSMAN'S MODEL CO., Dept. P-24, 2030 N. 41st St., Milwaukee, Wis.

YOUR OWN MOVIES! 10¢ A DAY!

NATIONALLY ADVERTISED 8MM and 16MM Movie cameras, projectors. For home, business, church, school, club. **MONEY BACK 10 DAY TRIAL.** Payments as low as 10¢ A DAY. Satisfied customers throughout the world. FREE details. WRITE TODAY. Don Elder's Home Movies, Dept. A-12, 739 Baystate St., Boston, Mass.

AGENTS 300% Profit SIGN LETTERS

For Store Fronts and Office Windows. Anyone can put them on. Free Samples. Liberal Offer to general agents. **METALLIC LETTER CO., 438 N. Clark St., Chicago**

AUTOPOWER

TURN SCRAP INTO MONEY

AUTOPOWER tells you how in plain, easy, simple and illustrated instructions that anyone can follow. Change auto generators into useful, practical A C and D C generators and motors with voltage from 2 to 1,000 volts, for power, light, welding, radio, sound, etc. No previous experience nor special tools needed. Generators can be driven by wind, water, fan belt, etc. **INSTRUCTIONS FOR BUILDING AND A C WELDER THAT ACTUALLY WORKS UP TO A 3/16" ROD. ALSO COMPLETE PLANS FOR WIND AND WATER POWER PLANTS.** Send for your copy of "AUTOPOWER." Already used and endorsed by thousands. Only \$1.00 postpaid. **S. W. DUNCAN, Publisher.** 410 S. Hoyne Ave., Chicago



"STALLING ALL CARS! DON'T USE ANTI-FREEZE TILL YOU CLEAN OUT WITH **SANI-FLUSH!**"



OLD MAN WINTER has two strikes on you, if you put anti-freeze in a dirty radiator. Rust and scale choke the cooling system. Your motor overheats. You waste anti-freeze. You waste power. And you risk costly engine repairs. **SANI-FLUSH** makes it easy and inexpensive to keep radiators clean.

Just pour 10c worth of **SANI-FLUSH** in the radiator. (25c for the largest trucks and tractors.) Follow directions printed on the can. Run the motor. Drain. Flush. Refill with water and anti-freeze. Then you're all set for the winter. The delicate veins that circulate water are free and open. Motors run efficiently. **SANI-FLUSH** can't injure motor or fittings. You'll find **SANI-FLUSH** in most bathrooms for cleaning toilets. Sold by grocery, drug, hardware, and five-and-ten-cent stores. 25c and 10c sizes. The Hygienic Products Company, Canton, Ohio.

Sani-Flush

Safe NOT CAUSTIC

KEEPS RADIATORS CLEAN

(pocket size) **"DUMATIC"** (any tobacco) **Cigarette Roller**
Send Dime for sample & particulars.
A & M Sales, Box 128, Sta. V, Cincinnati, Ohio

ELECTRIC CAR LOADING

Amazing
New Feature
in 1938
**LIONEL
TRAINS**



Stop your train in front of coal elevator. Then touch a lever. By remote control, coal pours down through chute into waiting car—fills it to the brim. This year's Lionel Trains can be uncoupled and unloaded by remote control. Catalog contains all details, plus color pictures of the greatest fleet of model trains in all train history.

The Lionel Corporation Dept. LL
15 East 26th Street, New York, N. Y.
Enclosed is 10 cents for a copy of the new 1938 52-page, full color Lionel Catalog. Send it to:
Name _____
Address _____
City _____ State _____

VELVET SPRAYED FROM A GUN

Pulverized fabric (plush, cotton or wool) may now be applied to any article made of paper, cardboard, leather, cloth, plaster objects, wood, or metal, with our newly developed hand spray outfit No. 26, which includes 1 binder gun—1 fabric gun, binder and pulverized fabric for covering 15 square feet for only \$1.95 plus postage. Shipping weight 3 lbs. 10c brings attractive samples and literature.

MAGIC, SCREEN PROCESS PRINTING

Print your own Greeting Cards, favors, novelties, signs, pennants, etc., up to 200 per hour on your own kitchen table from your own designs, in snappy brilliant colors. Pulverized fabrics and tinsels can be applied while printing color is still wet. Anyone that can handle a lead pencil can make the plates, in a few minutes time. Hundreds are cleaning up in this new fascinating industry. NOT a rubber stamp or linoleum block method. Printing as sharp and accurate as regular printing. Set No. 210 includes 1 silk screen and frame—1 adjustable back bar, side support, printing base, magic film, hinges, flexible printer, pencil knife, 1 can red, 1 can green ink, and instructions for only \$3.45 plus postage. Shipping weight 7 lbs. Attractive samples 10c.

PRAIRIE STATE PRODUCTS COMPANY
DEPT. 12 1631 S. MICHIGAN AVE., CHICAGO

BUY ONE OF THESE

\$1.50
Less
Battery



**"BIG LITE"
DELTA**

\$3.35
Less
Battery



POWERAY (above) New 6-volt electric lantern with powerful 700 ft. spot beam. 80-100 hours light. 4 1/2 in. reflector. Unbreakable lens.

POWERLITE (at side) America's finest electric lantern. 6-volt, 2 reflectors—front, shoots 800 ft. beam; top, gives wide floodlight. 80-100 hours light. Unbreakable lens. At sport, hardware and electrical dealers or write direct to Delta Electric Co., Marion, Ind. Dept. 300

MEGOW'S GAS-POWERED MODEL AIRPLANE

The Cardinal

\$3.95

plus 20c post.



World's champion Bassett's new 48" gas-powered crack-up proof sensation! Finished prop., many ready-made parts, rubber wheels.

Also the famous **QUAKER FLASH, FLYING QUAKER** and others. Also rubber-powered Giant Fliers with motor-hum device \$1.00 up.

SHIPS . . . carved hulls, many ready-made parts, complete plans and materials. XEBEC (Rob. Crusoe); HISPANIOLA (Treasure Island), ARABELLA (Capt. Blood) and others, \$2.00 (15c postage).

HO-GAUGE MODEL RAILROADS. Most realistic freight cars. 50c. Send 5c postage for 100-page illustrated catalog Model Kits, ready-made parts and supplies.



XEBEC

MEGOW'S Dept. PM., Howard & Oxford Sts. Philadelphia Pa. or 217 N. Desplaines St., Chicago, Ill.

Fotoshop CARNIVAL of CAMERAS!

Our Fall CARNIVAL OF CAMERAS offers you hundreds of outstanding values in new, used and reconditioned cameras, equipment, lenses, and supplies. Prices are non-competitive. Liberal trade-in allowance; money back guarantee; 10-day FREE trial.

New "CARNIVAL OF CAMERAS" catalog ready! Send 10c to cover postage and handling. 18 E. 42nd St. Dept. G6

136 W. 32nd St. New York, N. Y.



HOLD-E-ZEE AUTOMATIC GRIP SCREWDRIVERS

Hold, start and set-up screws in unhandy places. Gripper instantly released by spring action, sliding up out of way when not in use. Finest materials throughout, chrome vanadium blades; many have transparent, insulating, unbreakable handles. (Illustrated.)



No more expensive than ordinary screw drivers. Models for recess-head screws. Handiest ever. At auto-supply, hardware or electrical stores.

UPSON BROS., INC.

86 EXCHANGE ST. ROCHESTER, N. Y.

TRAILER BUILDERS · BUYERS · OWNERS TRAILER

Send 25c for this Big Book Today

Over 100 pages! Beautifully Printed and Illustrated! Trailer Suggestions and Ideas galore! Catalog shows America's greatest line of Trailer Parts and Equipment at lowest prices. Everything from wheels to top. Rush 25c today. Satisfaction positive! guaranteed! TRAILER SUPPLY CO. Box 439-A WAUSAU, WIS.



BUILD IT YOURSELF

The Jim Dandy Cabin Cruiser

The Trailer that has everything. Classy! Roomy. Easy to build in any size with my simplified Plans and Instructions—Price \$1.00. Rush dollar bill today to JIM DANDY Box 125-A WAUSAU, WIS.

Radio-Electrical EXPERIMENT KIT

Only \$3.99

6 Books FREE

25 UNITS genuine salvage commercial apparatus with fine experimental manual! BUILD radio circuits. 110-volt AC motor, eaves-dropping phone, thief detector, powerful arc light, ultra-violet rays, arc furnace, scores more! Used world-wide! Learn at home! SEND ONLY \$3.99 for Special DeLux Kit and 6 FREE Fine Electrical Radio books. Books alone worth \$3.00! Sent C.O.D. if desired. Stamp brings Bargain Catalog! ELECTRICAL SALVAGE CO., Box 524-P12, Lincoln, Nebr.



NEW BRUSH PLATING OUTFIT For AUTO PARTS

Connects to a battery with no tanks necessary. Plates on iron, steel, brass, copper, etc. Almost as simple as painting. Hundreds of car owners waiting for this low-cost plating. Improves appearance and value of the car.

Your opportunity to make good income plating auto parts, bathroom fixtures, reflectors, mirrors, etc.

FREE PROOF

Write quick—big season here. Get FREE PROOF and particulars that put you in a paying business of your own.

GUNMETAL COMPANY

AVENUE M

DECATUR, ILL.

Trailing the Wild Game Poachers

(Continued from page 860)

served wild-duck dinners in special dining rooms. One Texas night-club operator was recently arrested in a case that required a year to complete and that involved persons from coast to coast. In season or out, the night-club operator was always able to supply illegal dinners of duck, quail or plover.

Beaver, after years of conservation, are beginning to come back and lately the traffic in illegal beaver skins has started to increase. Hundreds of pelts bought from scattered trappers in Idaho were smuggled by a fur wholesaler into Nevada and from there to New York, where agents found the shipment and started backtracking. Skins taken on the Colorado river have been captured in Philadelphia. Recently a game agent inspecting furs in a San Francisco wholesale house found five beaver skins that had no state tags certifying they had been taken legally. They had been sent to the fur house from Los Angeles, where further tracing revealed they originally came from South Dakota. It took a month to get the entire story and make the arrests.

One of the most unique smuggling rings the federal game agents have come across was put out of business early in 1938. There is a twenty-dollar bounty on wolf and coyote pelts in Alaska but no such bounty in Canada. Trappers decided there would be good money in sledding Canadian pelts into Alaska to collect the bounty and to smuggle American goods across the Canadian border on the way back to avoid the high tariffs. It had become a well-organized business by the time the agents put a stop to it by flying on a surprise visit to the depot on American soil where the smugglers gathered.

Like wild ducks, venison is widely sought by market hunters. In one very complicated case a burglar stole airplane machine-gun ammunition from a naval training station and sold some of it to a poacher who didn't know that every fifth round of the military ammunition was an incendiary bullet. On a subsequent deer hunt, one of the incendiary loads happened to strike a tree, starting a forest fire. The fire was observed from a forest service lookout

(Continued to page 144A)

*A Remington Portable
—the Gift Your Whole Family Shares*

**It's easy to do
your Christmas Shopping**

Just drop in on your nearest Remington dealer for five pleasant demonstration minutes. Or simply 'phone him and he comes to your home *at your convenience*. Or—clip the coupon and get the information by mail. You shop in your own home.

AND WHAT A GIFT IT IS! Your whole family is bound closer together by something each can use. Even those in far away places will be nearer because you'll write more often.

Remette

\$29⁷⁵

INCLUDING
CASE



Why
your family
needs a
REMINGTON

Children—Win higher school marks—have shorter home work hours—develop self-expression... greater confidence—are stimulated to new ideas with this educational tool.

Parents—Keep up with social and other correspondence easily—keep valuable family papers legibly.

**FOR THE FIRST TIME AT
SUCH A LOW PRICE...**

A real Remington—a gift you'll be proud to give your family. For so little money you now get a complete, 84 character, four-row standard keyboard machine.

Remington Deluxe Noiseless Portable

Everyone is amazed at the silent speed of this marvelous Noiseless Portable. You can work while others sleep—or travel while you work, without the slightest disturbance to anyone. It's easy to give a Remington this Xmas. (8 models to choose from.) You can pay as little as 10¢ a day.



Remington Rand Inc., Buffalo, N. Y. Dept. 152-12
Tell me, without obligation, how to get a new Remington Portable for as little as 10¢ a day. Send catalog.

Name.....
Address.....
City and State.....

READY

**THIS MONTH
NEW 1939
Atlas
CATALOG**

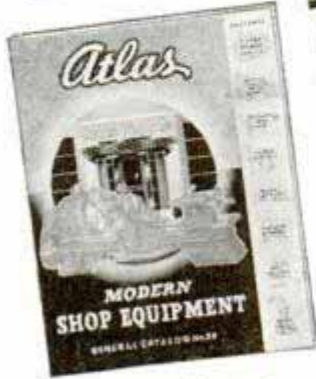

It's the biggest and most important Catalog Atlas has ever published... filled with new ideas for making your work with machine tools more interesting and profitable. Shows all the new Atlas 1939 developments and sensational machine tool values. You'll prize this book. Write for it now.

SEND THIS COUPON FOR YOUR COPY TODAY

ATLAS PRESS CO., 1243 N. Pitcher St., Kalamazoo, Mich.
Kindly send me your 1939 Catalog on: New Small Metal Lathe New 10" Metal Lathe New Metal Shaper Wood Lathes Arbor Presses Drill Presses

Name.....
Address.....
City and State.....



ATLAS PRESS CO.
1243 N. Pitcher St., Kalamazoo, Mich.

**LATHES · DRILL PRESSES
ARBOR PRESSES · SHAPERS**

DECORATIVE Decalcomania Transfers

Imported Designs of all Sizes and Types—Flowers, Figures, Marquetry, Birds, Juvenile, Borders, etc., for Furniture, Walls, Trays, and what not.

Catalog with 800 illustrations in Color sent for 25c. Deductible on first purchase of \$1.00 or more.

L. C. WELLS, Dept. PM-812, 25 East 26th Street, New York

America's Smallest Radio ... WITH BIG SET FEATURES

A real radio in every respect. Small enough to carry in one hand (6 1/4" x 5" x 4 1/2") yet powerful enough to bring in stations clear and strong. Dynamic speaker. Complete with 4 full size GENUINE RCA lic. tubes and aerial—ready to play on any 110 volt, 60 cycle current. One year guarantee. **Free Home Trial.** 1939 CATALOG FREE

\$6.94
in Walnut



IVORY...Sextra Money Back Offer! Rush \$1 deposit Balance C. O. D.

Silver Mfg. Co., Inc., Dept. P-12, 2868 Elston, Chicago

VEST POCKET ADDING MACHINE

IDEAL XMAS GIFT Adds, subtracts, multiplies, divides. Does work of more costly machine. Counts up to million, made of steel—weighs 8 ounces. Simple, accurate. Not a toy. Guaranteed 5 years.

— FREE TRIAL —
SEND NO MONEY!

\$2.50
Total Cost

Order from ad, not sold in stores. Just send name and address. On delivery pay postman \$2.50 (plus few cents postage). (If outside U. S. send cash.) 10c additional in Leatherette Case. If not satisfied after 10 days' trial you get your money back. Thousands of satisfied users. Write for Agent's proposition. **CALCULATOR MACHINE CO.** (Mfrs.) Dept. 112, P. O. Box 1118, Chicago, Illinois.

(Continued from page 143A)

tower and the fire fighters, in putting out the fire, found the dead deer, traced it to the poacher, and through him the burglar who had rifled the naval armory was caught.

Deer poachers in game refuges depend on stealth and silence. Occasionally a warden, patrolling a refuge, finds poachers are using a device adopted from the Indians. A heavy wire noose with a free-running slipknot, greased with mutton tallow for quick action, is hung in a deer runway with the end of the wire fastened to a tree. The greased loop is a deadly weapon because the deer, head down as it makes its way along the path, plunges its head and neck through the loop. Its subsequent struggles draw the wire tighter, choking it to death. The best weapon of the game wardens against this type of crime is eternal vigilance. When such a trap is found one of the agents stakes himself out and waits for the poacher. Instead of making an immediate arrest the agent waits until the man starts skinning the deer or carrying it away.

"Spotlighting" is just as effective as the snare in trapping deer and just as illegal. The deer doesn't have a chance and two or three poachers can obtain a truckload of venison in an hour or so. This type of poaching is done after dark, with a rifle equipped with a silencer and with a powerful flashlight fastened to the gun so its beam is trained along the barrel. The beam of the spotlight not only reveals the feeding deer but transfixes it with its glare so the animal appears paralyzed, allowing the poacher to pick it off at will.

Big horn mountain sheep have an attraction for some hunters who feel they ought to add a head to their collection simply because the species is rare. Some western states have short open seasons for the sheep while others do not. Patrols discourage most of the sheep hunters. What the wardens hate to hear more than anything else is news of a big mining strike in the sheep country, with an inflow of miners from all parts of the west. Some of the miners, wanting fresh meat in camp, often hide near one of the lonely water holes and pick off the sheep as they come down to water. The Boulder dam and Parker dam areas were districts that required special vigilance during the time the dams

were being built, due to the influx of people.

In some parts of Europe song birds are practically extinct because of the practice of netting them either for the market or for use as caged pets. Mocking birds, finches, larks, robins, quail, dove, pheasants and other protected species are likewise taken illegally in many parts of the United States, mostly with nets or horse-hair snares. Some of the nets, made of fine linen thread with half-inch meshes and thirty feet long, imported from southern Europe, are worth several hundred dollars. Possession of such nets alone is against the law. Hung between bushes in a baited area, the fine nets catch and hold any birds that fly into them. Coarser "jungle" nets are made of soft twine and are supported on stakes placed loosely in the ground. When large birds or rabbits run into the nets the stakes collapse and the nets fall over them.

Immigrants from some countries are apt to bring with them age-old customs in taking game, most of which are illegal here. One importation that the wardens occasionally find is "moochie," a gum-like glue that comes from the Malay jungles and which natives spread over the limbs of trees. Once trapped on the sticky surface, a bird can't release both feet at once to spring into the air and remains a prisoner until the native picks him off.

The work of the Biological Survey is not restricted to catching poachers or preventing taking wild game out of season, over the limit, or in restricted areas. The agents are charged with conducting many kinds of conservation work. One of their problems is to keep protected game from becoming a nuisance. Quail or ducks are apt to flock to cultivated fields and destroy a crop. Permits are sometimes issued to destroy the game or birds if they become too much of a pest, but first the agents try all sorts of ways to scare the game away, shooting tracer bullets through the air or igniting explosive bombs to get them out of the territory.

Names and addresses of manufacturers and dealers in articles described in this magazine will be furnished by our Bureau of Information upon request accompanied by stamped, self-addressed envelope.

Everything in RADIO

Sets • Parts • Kits
P.A. • Ham Gear • Testers
FREE! 180 Page Catalog

at
**LOWEST
PRICES!**

1939

KNIGHT SETS at New Low Prices!

See the amazing new 1939 Knight Radios in your ALLIED Catalog! New features—Push-Button Tuning, "Low-Boy" cabinets, 1½ volt tubes, etc.—at new low prices. 62 models, some as low as \$6.95, 4 to 16 tubes, in AC, AC-DC, 1½ Volt, 6 Volt and 32 Volt models. Also new "Tiny Knights," phonographs, phon-radio combinations, record players, etc. They're all in ALLIED's 1939 Catalog—the Buying Guide of Radio Buyers!

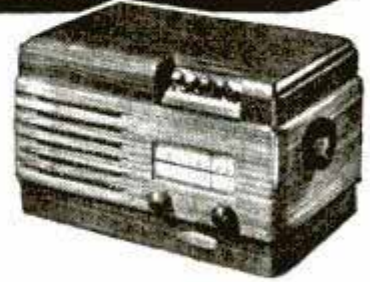

Choose
from
62 MODELS

KITS! Complete-Ready to Build! Send for FREE Parts Lists!

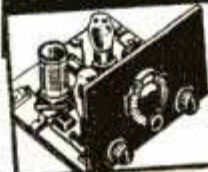

2 Tube DX'er Kit!

The favorite receiver of thousands! Low in cost, efficient, easy to build. Less coils . . . \$3.98



20 Watt X'mitter

Advanced type 6L6 Beam-Power transmitter for C. W. Tunes all bands. Complete, less tube, crystal, and key . . . \$3.60



Photo Cell Kit!

Ideal for burglar alarms, controlling lights, starting and stopping motors, etc. Complete . . . \$5.85



BEGINNERS! SEND FOR *Allied's* RADIO BUILDER'S HANDBOOK

A new and different type of book, planned especially for radio beginners. Tells how to select circuits, read diagrams, make chassis, solder, wind coils, etc. Packed with valuable data. Send coupon with 10c for your copy today! Only 10c.

FREE PARTS LISTS. We can supply Free Parts Lists covering hundreds of kits, including those above. Write!

SAVE MONEY ON ALL YOUR RADIO NEEDS

The new ALLIED Catalog also shows 14,000 radio parts, new P. A. Systems from 8-65 watts, Amateur Gear, Test Equipment, books, tools, etc. Write for your Free copy today—you'll save and profit on every order!



SEND
FOR **FREE**
CATALOG

ALLIED Radio Corp.,
Dept. 5-M-9
833 W. Jackson Blvd.,
Chicago, Ill.

- Send me your Free 1939 Catalog.
 Enclosed find 10c plus postage for Radio Builder's Book.
 Send me parts list.

Name.....

Address.....

Sensational Business WANTS MORE MEN To Make Big Money!

LOOK!

Men! Big money for you with one of the fastest growing organizations in America—a business that has already boosted scores of salesmen into big income group. National advertising to 22,000,000 men and women has created enormous demand in every community for "SURE"—the remarkable Breath Purifier that banishes offensive odors from smoking, eating, drinking. Quick, effective, lasting—"SURE" sells itself from compelling counter displays—then stays sold and repeats because it's vastly superior. "One drop does the trick."



CALL ON RETAILERS

Men wanted to cash in on this demand by calling on retailers to place Counter Displays of "SURE". Drug stores, grocers, department stores, hotels, restaurants, taverns, etc. Dealers know the product. No hard selling. No house-to-house canvassing. Yet profits to dealers and salesmen are quick and generous. Chance to build up permanent route to pay growing, lifetime income.

Send No Money—WRITE

If you are seeking the one proposition you'll stick to for life, look into this one now—while many rich territories remain open. Don't send any money. Simply say you want the details. They will be rushed on to you quickly—FREE and without obligation. Write today to

SURE LABORATORIES, 841 N. Wabash, Dept. P.M.-12, Chicago, Ill.

60 POWER TELESCOPE . . . \$219

VARIABLE EYEPIECE 20X—40X—60X

NEW! Three telescopes in one. 3 different magnifications. 20 power for ultra-bright images with 40 and 60 power for extra long range. Guaranteed to bring distant objects, people, sports, events, ships, moon, stars, etc., 60 times as close.



Most powerful made for anywhere near the money. Closes to less than a foot in length. Multiple lens system. 30 mm. objective lens, 5 sections. Directions included for using as a compound 4 lens microscope. American made. We pay the postage. Only \$2.19. Catalog of Microscopes, Binoculars, etc. FREE on request. **BROWSCOPE CO., Dept. 412, 5 W. 27th St., New York, N. Y.**



AUTO ENGINE SPEED CONTROL GOVERNORS

445 E. 3rd St. Los Angeles, Calif.



New . . . Different . . . Exclusive

Wood Cigarette Case. Beautiful Grained Solid Wood—Natural Finish—Automatic Ejector—Light Weight—Thin—Won't Crush—Separate Compartments. Fits pocket and ladies purses. Made in 4 woods: Walnut, Maple, Beech and Red Gum. \$1.00 postpaid in U. S. and Canada. Agents write for sample offer. **SPLENDID HOLIDAY GIFT AND BRIDGE PRIZE. WILLOTT NOVELTY CO., Box 520, Grand Rapids, Mich.**

NEW BENJAMIN AIR PISTOLS WITH MULTIPLE LEVER HAND PUMP FOR TARGET-SMALL GAME-CAMPING-ETC.



Guaranteed—Accurate—Practical—Economic—Safe—Clean—Quiet. Adjustable Force—Amazing Maxin um Velocity. No smoke or fumes. **WRITE TODAY!** Fire-Hair Trigger—Safety Lock—Hand Pump. Single Shot BB \$8.50; Single Shot cal. 177 or 22 with rifled barrel \$8.50; BB 8-Shot \$10.00; Bolster \$2.00. Also a complete line of Benjamin Genuine Compressed Air Rifles for BB and cal. 177 or 22. No license required from dealer or factory. Ask for complete specifications and Free Targets. **BENJAMIN AIR RIFLE CO., 890 Marion St., St. Louis, Mo., U.S.A.**

BILD-UR-OWN
COASTERS · MIDGET AUTOS · SCOOTERS ·
NEW ROADSCOUT Scooter Complete \$59
Equip your Scooter, Midget car, etc. with our Disc Wheels and Balloon tires.
GOODRICH-GOODYEAR-FIRESTONE at lowest prices. We specialize in wheel sets, scooter kits, motors, parts, etc. Send 10c to cover cost of mailing book and Free Plans.
BILD-UR-OWN DEVICES, 5237 Lake St., Dept. A-12, CHICAGO, ILL.

Portable Broadcast Receiver

(Continued from page 899)

do it for you at a very reasonable charge. The tuning condenser dial should be turned to 1,400 kc., and, with the oscillator generating the same signal, both trimmers on the tuning condenser sections should be

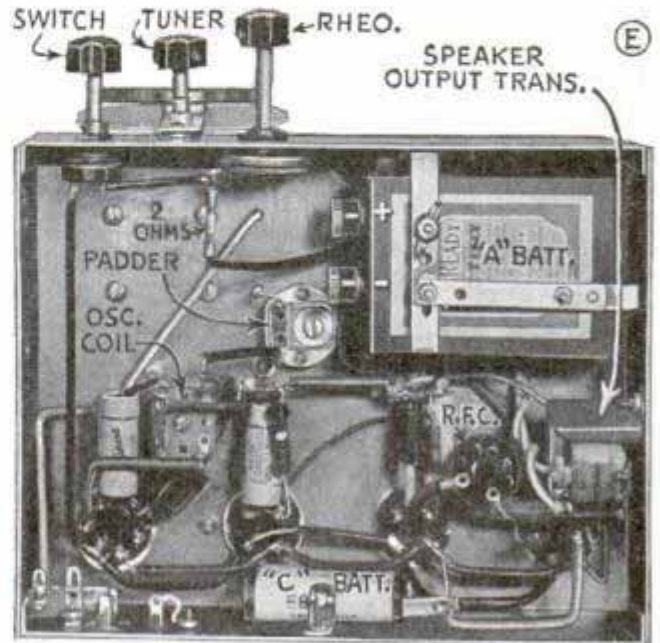

adjusted for maximum signal. Adjustment of the oscillator padder condenser for loudest signal (with tuning dial and oscillator set for 600 kc.) completes alinement.

A material list of the original parts used in the model can be obtained from Popular Mechanics radio department without charge. The blueprint number is R-260. A 25-ft. length of flexible cloth-covered antenna wire is required, and a ground should be used if possible. A carrying case has not been detailed as most builders prefer to design their own to meet individual requirements.

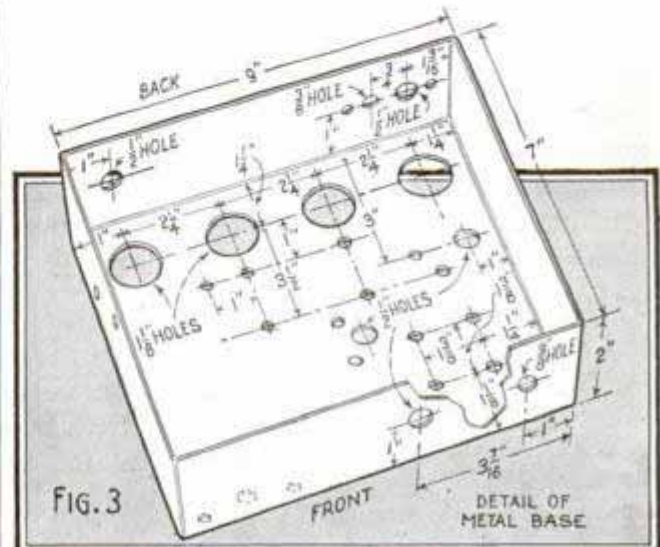

OWN A ROYAL



Believes Royal helped him get ahead!

"The day I got my Royal I started typing my reports. The boss liked it. Soon I had a larger territory. Now I have 5 men under me."

PORTABLE ON



Glad they picked a Royal

"All of us use our Royal Portable—Junior for his homework—I to work out assignments for a correspondence course which I'm taking."

YOUR OWN TERMS



Ideas typed on Royal bring raise

"Ideas count where I work. Since I got my Royal, I've typed mine out. Already I've had one raise, and I expect another."

Only a Few Cents a Day

FREE HOME TRIAL FOR EVERY

MEMBER OF THE FAMILY! A Royal Portable will help you write faster, think faster. A practical, modern necessity—it's an opportunity for a better, brighter future! A chance to do more, *be more!*

Without risking a penny prove—right in your own home—that a Royal will help you—whatever your business or profession—help you to set down your ideas and reports *legibly, impressively*. Prove too, that it will help the children with their homework... *help every member of your family with their writing!*

READ WHAT ROYAL GIVES YOU! Standard, full-sized keyboard. Easy, effortless action, Touch Control, Finger Comfort Keys, Genuine Dust Protection, Automatic Paper Lock, Touch-set Tabulator and many other office typewriter features. Tested, proved, guaranteed!

FREE! Royal's Instant Typing Chart, shows you how to type **RIGHT**. INCLUDED with every Royal Portable at no extra cost—a handsome, all-weather, triple-convertible Carrying Case.

SEE what a Royal will do! Then own it on your own terms—cash or *only a few cents a day!* Mail coupon today for full details of Royal's offer—prices, terms, Free Home Trial—everything. No obligation.



ROYAL TYPEWRITER COMPANY, Inc.,
Dept. C-84, 2 Park Ave., New York, N. Y.

Tell me how I can own—for only a few cents a day—a latest model Royal Portable—with **FREE HOME TRIAL**. (DO YOU OWN A TYPEWRITER NOW? Then make it help pay! Write Make and Serial No. on coupon margin for full trade-in value.)

NAME _____ STREET _____
CITY _____ STATE _____

WET BASEMENTS!

OFFER YOU A PROFITABLE BUSINESS

OF YOUR OWN—Ambitious men can

become waterproofing contractors with amazing Seal-Seep method anyone can use. Applied from outside to old or new masonry surfaces. No digging. Permanently effective. You can waterproof your own walls and save a lot of money. Detail's Free.

National Seal-Seep Co., Dept. 1292, Cincinnati, O.

FREE ELECTRICITY

Wind driven car generator gives free Lights and Radio reception anywhere. Homebuilt instruction plans, made to cost less than \$1.00. One wire electric fence from Ford coil. Send 25c for copyrighted booklet.

WESCO, 901 Terminal, Minneapolis, Minn.



Print Your Own

Cards, stationery, circulars, tags, labels, advertising, etc. Save money. **Print for Others; Big Profits; easy rules sent.** Will do popular Raised Printing like Engraving. Junior outfit \$9. Senior outfit \$17 and up. Send for free catalog and all details. **KELSEY PRESSES, E-37, MERIDEN, CONN.**



GRANDFATHER'S CLOCK, LOWER PRICED

Our newest Offering, at an unheard of price for a faithful reproduction of a real Grandfather's Clock. Scroll top, narrow waist, like picture. Shipped Knock Down. Cleverly designed. Easy to assemble. Others even cheaper. Plans 10c. Catalogue **FREE**.

AMERICAN CHIME CLOCK CO.
1676 Ruffner St. (Established 1877) Philadelphia, Pa.

ENGINES

A real money maker for farm or factory. Uses Cheap fuels. Pays for itself out of savings. Costs Less to Own—Less to Operate.



LOG SAWS

Make Money—Start a wood sawing business—turn spare timber into cash. Cash or Terms—Engine and Saw Catalog.

WITTE ENGINE WORKS

1749 OAKLAND AVE., KANSAS CITY, MO.

HANDEE

TOOL OF 1001 USES

This Year Give Him A HOBBY

Men and boys of all ages satisfy their inherent urge to make scores of useful articles with the famous Handee.

A WHOLE TOOL SHOP IN YOUR HAND

This amazing tool and your choice of accessories do a multitude of jobs on all materials. Set up shop wherever there is an electric outlet. De Luxe Model weighs 12 oz. 25,000 r.p.m. \$18.50 Postpaid with 6 Accessories.

200 ACCESSORIES

Quality built. Largest assortment, one for every job. See at dealers or in catalog.



- Grinds
- Drills
- Polishes
- Engraves
- Saws
- Sands
- Cuts
- Carves
- Routs
- Cleans

ULTRA DE LUXE SET

A treasure chest. De Luxe Model and 26 popular Accessories in metal case. This practical gift will be appreciated, used for years. \$25.00 postpaid. Project book included.

STANDARD MODEL

20,000 r.p.m. Weighs 16 oz. \$10.75 postpaid with 3 Accessories.

GET A DEMONSTRATION

at any store or order either model on 10-Days Money-Back Trial. Catalog Free.

Chicago Wheel & Mfg. Co., 1101 W. Monroe St., Dept. Q, Chicago, Ill.
© 1938 by Chicago Wheel & Mfg. Co.

- Send Catalog De Luxe Model Ultra De Luxe Set Standard Model Send C. O. D. PM12

Name.....
Address.....

A BARGAIN

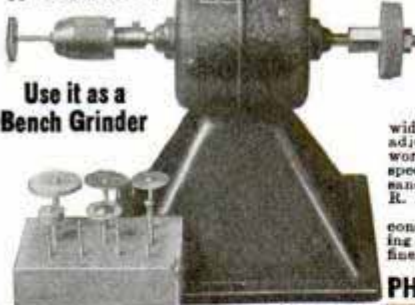

Use it as a Bench Grinder

UNIVERSAL GRINDER DELUXE Complete \$4.95

COMBINES THE CONVENIENCE OF A BENCH GRINDER WITH THE ADAPTABILITY OF A HAND TOOL. OFFERED COMPLETE WITH 30 PIECE ARBOR TOOL SET AT THIS EXCEPTIONALLY LOW PRICE. INDISPENSABLE AND CONVENIENT grinder for shop, model maker or professional man. High-speed, high-power motor develops 10,000 rev. per minute. Heavy Cast Removable Base.

wide variety of uses. Compact design, equipped with 3 jaw universal arbor chuck, adjustable to use. Real fine cutters for work on delicate jobs and to eliminate tedious work hours. **EFFICIENCY** speeds work, saves time, saves money. Arbor tool set enables you to grind, drill, rout, sand or carve. Operates on 110 volts AC or DC. **VARIABLE SPEEDS** from 10,000 R. P. M. to 500 R. P. M. can be obtained with the use of a rheostat \$2.50 additional. **INCLUDES 30 PIECE ARBOR TOOL SET** consists of 10 assorted sizes of grindstones, assorted engraving or carving burrs, polishing buffs, screw mandrels, polishing brush and assorted sanding discs, emery, garnet, fine, coarse and medium.

Rush \$1.00—Balance C. O. D. Dept. P. M. **PHILADELPHIA MACHINERY CO., 118 N. 6th St., Philadelphia, Pa.**



Used as a hand tool



50 PIECE UNIVERSAL ARBOR TOOL SET WILL FIT MOST HAND GRINDERS... 95c

Indispensable to Jeweler, Laboratory, Model Maker and Home Craftsman. The ideal outfit for fine accurate grinding, sanding, routing or carving. Includes 12 grindstones with brass centers in assorted sizes, 5 bakelite cut-off wheels, 5 assorted engraving, routing or carving burrs, 2 polishing buffs, 1 mounted point, 3 bristle polishing brushes, circular and cup shape, 3 mandrel arbors, 20 assorted sanding discs of emery, garnet, sand, fine, medium and coarse.

Send Coin or Money Order * Shipment Prepaid **Philadelphia Machinery Co. Dept. P. M., 118 N. 6th St., Phila., Pa.**

FREE Sensational OFFER 2 FENCING SWORDS FREE FENCING WORLD'S FINEST SPORT



HARMLESS-EXCITING FUN Develops strong body and alert mind. **HARMLESS.** The spring-steel 3-foot-long foils (swords) are equipped with rubber buttons. Aluminum cup-shaped hand guards. Our De Luxe foils are built for hard usage.

Complete set of two foils (swords) and free instruction booklet, only \$1.98. We pay postage. Two additional fencing swords FREE for limited time. (Regular price of these two sets of foils \$3.96.) **ORDER NOW, ALL-AMERICAN FENCERS GUILD, Dept. 12PM, 48 W. 48th St., New York**

NEW "BALANCED" TURNING TOOL

Do WOOD TURNING with complete confidence and control. Tremendous, proved advantages over Gouges. Faster, easier cutting. Steadier, smoother "forming" of any WOOD. Ideal for PLASTICS. Removable, Hi-speed CUTTERS. Tool, with 4 Cutters, \$3.25, P. P. FREE Circular. Write Lee's STEADY-CUT, 3240 3rd Ave. So., Box 2-M, MPLS., MINN.



Lee's STEADY-CUT

READY SOON! NEW & Improved BOICE-CRANE "shop tested" MACHINES

NEW 1939 Catalog - Write for Your Copy NOW

- **NEW MACHINES** More up-to-the minute BOICE-CRANE Power tools ready soon for craftsmen wanting the most modern, really quality-built equipment for their shops. See them before you buy anything.
- **NEW FEATURES** BOICE-CRANE designers have again perfected new, practical features, for easy, flawless machine operation that no others will give you. Features you'll surely want on your shop machines.
- **NEW CATALOG** In a very few weeks the New BOICE-CRANE Catalog showing the year's finest Power Tools will be ready. You'll thrill over every page. We've spared nothing to make our 1939 line the finest yet offered. Reserve a copy NOW. As soon as it's ready we'll mail you one postpaid!



USE COUPON

Include 10c for 16 page Metal Spinning Instruction Book.

BOICE-CRANE CO. Dept. 2128 Toledo, Ohio
 Catalog FREE. If Spinning Book wanted, send 10c.

Name.....
 Address.....
 City..... State.....

FUN while you LEARN and EARN!

with HOME FOUNDRY WOOD-BURNING SETS

Make Plaques, Book-Ends, Ash Trays, etc.; sell to friends and neighbors. Swell Xmas gift!

SEND FOR FREE CATALOG:

Lists Costing Sets, 85c to \$3.95; big selection of molder new **ELECTRIC Metal-Top Sets, \$1.25, \$2;** new Sand-Pen Kits, 50c to \$2.



SET NO. 1002: 12 large plaques, 1 pr. book-ends, 6-color palette and brush, sandpaper, Wonder Pen; \$2, postage 25c. Other Wood-burning sets, \$1 to \$3.



AIR-COOLED WONDER PEN

HOME FOUNDRY MFG. CO. 3122 W. Fifth Ave., Dept. P12, Chicago, Ill.

A Gift in the Right Direction



Everyone on your gift list will receive lasting enjoyment and practical use from a Hull Streamline Auto Compass—directions of travel are never a problem. Streamlined Bakelite case, built-in compensator, genuine sapphire bearing. Follow this excellent gift suggestion—only \$2.95 at your dealer. Attractive holiday package. Write for circular.

HULL MFG. CO., P. O. Box 246-D8, WARREN, OHIO

New-TYPE Cheap OIL BURNER INVENTED Sweeping the Country!

COOK and HEAT Without Coal or Wood

In Your Present Stove or Furnace—**HOTTER—No Drudgery, Dirt or Ashes—More Heat Quick at SMALL COST.**

OVER 40,000 SOLD

Beats any oil burner ever gotten out for low cost, perfect performance. Burns cheap oil a new way, without pre-generating or clogging up. Quick intense heat by Simple Turn of Valve.



30 DAYS' TRIAL

Prove its efficiency, convenience and economical operation.

Write Immediately for FREE BURNER OFFERTO AGENTS

AGENTS Salesmen BIG MONEY

F. Silver says: "I can dispose of 250 HEAT KINGS before this year ends." Sample Burner FREE to producers. Write us now for agents' offer.



Slips into Any STOVE RANGE or FURNACE

Quick HEAT At Turn of Valve!

who will demonstrate and take orders. Write quick, be first to learn how to make REAL MONEY right now, spare or full time—mail 1c postcard today. **UNITED FACTORIES, P-751, Factory Bldg., Kansas City, Mo.**

Birthplace of the Big Winds

(Continued from page 808)

always toward the northeast. The Mississippi and Ohio river valleys are the most prolific breeders of this type of windstorm.

On one day, February 9, 1884, there were sixty tornadoes in the United States, the majority being in Missouri, Illinois, Kentucky, Tennessee and Mississippi, with others in Georgia, the two Carolinas and Virginia. The aggregate loss of lives that day was 800, and 10,000 homes were destroyed.

For thirty years scientists have reserved the word cyclone for the ordinary widespread movements of air on a revolving system, while tornado applies only to the highly localized storm marked by a distinctly visible cone, or funnel, which drops down to the surface and picks up objects on land or water at sea, forming a waterspout.

A mass of warm, moist air at and near the surface, and an opposing mass of cold air above it forms the combination which may produce a tornado. The warm air



Train derailed by recent hurricane. Note rail twisted from its ties

seeks to rise above the cold and heavier air, and sooner or later finds a place to break through. The ascending air sets up a rotary motion, counterclockwise in the northern hemisphere. At the start this movement may cover a very large area, but as the movement continues the pressure in the center of the funnel-shaped mass grows less, and the outer air is pushed into this space. The gentle rotary motion may be only twenty or thirty feet a second a thousand yards from the center of the whirlpool, but as the outer particles are pushed inward their speed becomes enormous in relation to the constantly smaller path they travel.

Col. John P. Finley, U.S.A., retired, who is director of the National Storm and Avia-

(Continued to page 150A)

FREE!

THE FINEST CATALOG

Ever Published for

Radio Amateurs, Servicemen and Experimenters!



AMATEUR
EQUIPMENT

SOUND
EQUIPMENT

SERVICEMEN'S
EQUIPMENT

Lowest
Prices!

Time
Payments!

MONTGOMERY WARD

9 GREAT MAIL ORDER HOUSES • 580 RETAIL STORES

FREE!
MAIL THIS
COUPON
Now!

Montgomery Ward & Company
Dept. TM-21 Chicago, U. S. A.
Please rush me New 1939 Radio
Catalog FREE!

Name.....
Address.....
City..... State.....

FREE

CAMERA

Offers hundreds of money-saving bargains in Still and Movie Cameras, Lenses, Films, Enlargers, Exposure Meters, Dark-room Supplies — everything photographic.

BOOK!



Choose from America's most complete, varied stock—from world's leading makers: Eastman, Zeiss, Bell & Howell, Graflex, Korona, Bausch & Lomb, etc. 10 Days Trial—Satisfaction Guaranteed. (Your camera, equipment taken in trade.) Write for Free Camera Catalog NOW!

CENTRAL Camera Co. (EST. 1899)
230 S. Wabash, Dept. K-12, CHICAGO

Stoves AT FACTORY PRICES!



SALE CATALOG — FREE

Nearly 200 Styles and Sizes of Heaters, Ranges, Furnaces at FACTORY PRICES. Easy Terms. Write today for FREE CATALOG. New styles, new features—24-hour shipments.

Kalamazoo Stove & Furnace Co.,
391 Rochester Avenue
Kalamazoo Michigan
Over 1,300,000 Satisfied Users
39 Years in Business

"A Kalamazoo Direct to You"

Write for
FREE CATALOG

SpeedWay

GRINDER
\$5.95

Powerful Miniature Electric Tools! make the perfect Xmas gift.

COMPLETE KIT
\$14.95

DRILL
\$7.95

Do not judge these tools by price for they are genuine SpeedWay Tools embodying SpeedWay's 30 years of experience as manufacturers of quality electric tools for industry. Each is correctly designed, is handy, accurate, powerful. Each is operated at the correct speed for its work, has a specially built high torque SpeedWay Motor.

The No. 69 Drill Die Cast pistol grip handle and gear housing, heavy back gears, 1000 R.P.M., capacity to 3/4" in steel, equal to most drills weighing and costing twice as much.....\$7.95

The No. 129 Grinder Correct shape for work, increases accuracy and visibility. Operates at 20,000 R.P.M.—correct speed for small cutters and stones. Comes with collets for 1/4" and 3/32" arbors.....\$5.95.

The No. 250 Kit Both Drill and Grinder with 5 accessories in steel carrying case, here's a real buy.....\$14.95.

Combination Stand—with No. 69 Drill makes accurate lever drill press, with No. 129 Grinder a precision grinder or router. Stand only.....\$3.95

No. 309 Portable Shaper—with grinder makes efficient and accurate shaper.....\$3.95

Accessories Stones, brushes, cutters, sanding mandrels and arbors. Carried by leading hardware and electrical dealers and departments every where. If your dealer can't supply, order direct.

Dealers, Jobbers, Write Wire or Call

SPEEDWAY MANUFACTURING CO.
1842 S. 52nd AVE. CICERO, ILL.

NEW! **NEON SIGNS FOR TRUCKS, BUSES, TAXICABS and other motor vehicles**

—made possible by amazing new 6 volt transformer, and novel method of tube installation that protects tubing against breakage. Now used by some of the largest firms in U. S. Old Established factory wants financially responsible business executives—to handle distribution in exclusive territories. No previous sign experience necessary as we supply complete product. Signs fill long felt need. Enable any advertiser to have brilliant, colorful Neon advertising message on trucks, buses, taxicabs, etc. Also sign with word "STOP" in Neon, for use on all motor vehicles. New low prices should create large volume in any territory. Reasonable capital handles exclusive franchise contract. Get in on this new unexploited, highly profitable industry. Write or wire for free literature. Give references.

E. E. SOUTHER IRON COMPANY, (Established 1865)
1952-A-50 Kienlen Ave. St. Louis, Mo.

Responsible DISTRIBUTORS WANTED

Synco JIG SAW

Faster! Safer! Cleaner!
Real performance. Cuts with smooth, clean edges. No sanding required. Electric operation. No motor or reciprocating parts. Operates on 60 cycle, 110 volt A.C. Ideal for home craftsmen, and model makers. Two models.

Write Today for FREE LITERATURE

Export Office: 40 Worth St., New York; Western Dist.: Federated Sales Co., 2437 W. Valley Blvd., Alhambra, Cal.

7200 Strokes per minute

Only \$4.95 (East of Rockies)

SYNCO DEVICES, INC., 511 Boydell Bldg. Detroit, Mich.

(Continued from page 149A)

tion Insurance Bureau, a research organization at Ann Arbor, Mich., recently charted a typical tornado cross-section. His drawing showed the funnel path was only eighty rods wide. The region of destructive winds to the right, or southeast of the funnel path, however, was one-half mile wide, while the corresponding belt of destruction northwest of the funnel was only fifty rods wide.

The rotary motion of the funnel can be seen plainly after it has passed by studying the debris left behind. Trees, fences and other objects on the right of the storm will be blown down to the east, those nearer the funnel will lie to the northeast, some in the funnel path, on the left side, will fall pointing westward, and to the north and west of the storm, objects will be blown over to the west and south.

Destructive windstorms have always played an important part in history, so much so that in olden times dates were reckoned from them. The expression "the year of the big wind" was brought to the United States by Irish immigrants who dated their birth from in or near the year of the great storm of January 6-7, 1839.

Louisville was the first important town hit by a destructive storm in the United States. Twenty-five people were killed there on August 27, 1854, in a tornado.

Tornadoes hit seven states on the afternoon and evening of March 15, 1938, including Arkansas, Alabama, Illinois, Louisiana, Missouri, Mississippi and Tennessee.

The recent hurricane in the New England states was a high-power sea-blast. Other hurricanes have visited the northeastern seaboard in past years, but never anything like this one.

A lazy high-pressure area, moving too slowly off to sea, was the indirect cause of New England's woes, the meteorologists explained. Ordinarily, when a tropical storm center moving northward fails to make land below the Virginia Capes, it will veer off to the northeast and blow itself out at sea. But this one found itself stymied behind that loitering "high," and was forced to move straight northward and then toward the northwest—with terrible results.

The storm center traveled at a motorcar speed, weather bureau scientists say, about fifty-three miles an hour.

KILL RATS WITHOUT POISON

YOUR MONEY BACK IF RATS DON'T DIE



K-R-O won't kill Livestock, Pets or Poultry; Gets Rats Every Time. K-R-O is made from *Red Squill*, a raticide recommended by U.S. Dept. Agr. (Bu. 1533). Ready-Mixed, for homes, 35¢ and \$1.00; Powder, for farms, 75¢. All Drug and Seed Stores. Damage each rat does costs you \$2.00 a year. K-R-O Co., Springfield, O.

K-R-O KILLS RATS ONLY

SCALE MODEL TRAINS

MINI-SCALE MODELS "O" GAUGE

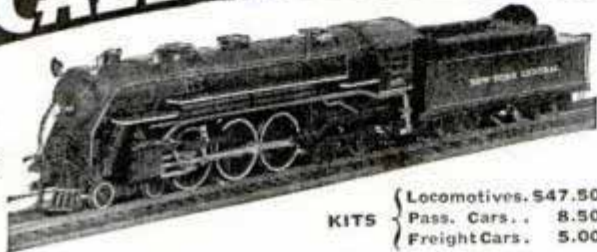

KITS { Locomotives. \$47.50
Pass. Cars. 8.50
Freight Cars. 5.00

Perfect, die cast scale models, accurate to the smallest detail. Absolute scale accuracy. Sturdy construction. Precision workmanship. All locomotives "run-in" under power. Locomotive, 25 1/2"; Pullman, Baggage and Day Coach, 22"; Box Car and Hopper, 12"; Tank, 10 1/2". Kits assembled easily without drilling or machining. Send 3¢ stamp today for full information.

CONGRESS TOOL & DIE CO.
9028 Lumpkin Ave., Detroit, Mich.

FREE FOLDER

MAKE MONEY IN PAINTING BUSINESS



Paint walls, ceilings, screens, furniture, radiators, machinery faster, better! 1/4 H. P. motor 110 Volt 60 Cycle AC, complete with Spray Gun, 15 ft. hose. Weighs only 44 lbs. Carry anywhere. **FULLY GUARANTEED.** Only \$31.15 f. o. b. Chicago. \$5 Deposit, Balance COD, or SEE YOUR DEALER. Circular FREE. Get started making money NOW!

Ideal Automatic Pump Co., Dept. PM-12, 801 Washington, Chicago **\$31.15** Complete

A AND N SUPPLY CO.
EST. 1868
Bargains—Military, Sport Goods, Firearms, Clothes, Shoes, etc. Send 10¢ for new catalog, to be redeemed on first order.
A & N Supply Co., 4772 Lester St., Richmond, Va.

ATLAS Stick-On Letters **WINDOW SIGNS**
Beautiful GOLD Colored. New Styles. 5 year Guarantee. Large Sizes—Penny each. Tremendous Demand. Amazing Profits. Write for FREE SAMPLES and Starting Equipment. HURRY!
ATLAS Sign Works, 7943 Halsted, Chicago

CLAMPS

Use more clamps as "helps" for firmer joints, for set ting-up, for accurate drilling, sawing and joining, for holding, drawing-in and lifting—you can't have too many good clamps, and "Jorgensen" and "Pony" Clamps are the very best. Those illustrated have been selected for the home work shops.

ADJUSTABLE CLAMP CO.
"The Clamp Folks"
421 N. Ashland Ave., Chicago, U.S.A.

Pony Miniatures 9 types—1" to 2 1/2" cap. Not toys but fine tools with 100 uses.

Pony "50" Fittings go on ordinary 1/2" pipe. Any length. Send \$3.00 plus postage (6 lbs.) for fittings for two "50" Clamps. Also "Pony" #52 Fittings for 3/4" pipe—2 sets for \$1.50 plus postage.

Catalog FREE!

FREE 64 PAGE Xmas Catalog

GIFT VALUE Like this PHOTO ENLARGER

Complete with "Loack Definon" f.4.5 anastigmat lens, Ruby lens filter; condenser system; unique clamping device permits adjustable framing. **Linear magnification 2 to 10 diameters.** Masking device for up to 1 1/2 x 1 1/2" negatives. Size of board 15 1/2" x 11 1/4".
SPECIAL Only \$23.95

GIVE finer gifts—and save money this Christmas! Send for our 64 page Gift Catalog jammed with a **COMPLETE** line of Cameras and Photo Supplies, Lafayette radios, electric shavers, clocks, trains... a whole toyland of children's gifts—at prices that put money back into your pocket. Mail coupon now!

WHOLESALE RADIO SERVICE CO. INC.
NEW YORK, N.Y. • CHICAGO, ILL. • ATLANTA, GA.
100 SIXTH AVENUE, 901 W. JACKSON BLVD., 285 PEACHTREE STREET
BOSTON, MASS. • BRONX, N.Y. • NEWARK, N.J. • JAMAICA, L.I.

WHOLESALE RADIO SERVICE CO., INC.
100 SIXTH AVENUE, NEW YORK, N.Y.
Rush **FREE** 64 Page Gift Catalog No. 72-7MB

Name.....
Address.....
City..... State.....



LET "VALU-BILLY" BE YOUR SANTA
PASTE COUPON ON PENNY POSTCARD

Saw-Filing PAYS BIG!

Cash for YOU in Your Spare Time—No Experience Necessary

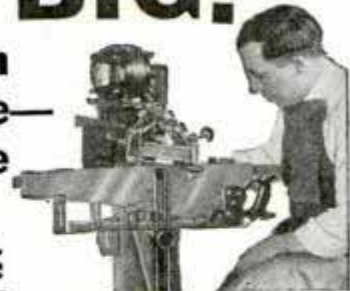

FOLEY AUTO-MATIC SAW FILER

See Exhibit New York Power Show Grand Central Palace Dec. 5 to 10th

Files hand, circular, and band saws better than the best hand filer. Cash business, no canvassing, no eye-strain.

John Joseph, California, says, "Your equipment has made a good living for me. Last year I sharpened 2,309 hand saws, for which I got \$1,154.50." J. L. Newman, Louisiana, says, "I only use my Foley Filer for a side line, and I would say that I take in from \$10.00 to \$15.00 a week now." John Fleming, Minnesota, says, "I will say that I am very well satisfied. I filed around 1600 saws last year on the Foley Filer. I judge I did about \$1000 worth of saw work last year all told."

FREE PLAN shows you how to start. Be independent! Other men are making big money, why don't you? Fill out the coupon. There is no obligation.

FOLEY MFG. CO., 1216-8 Foley Bldg., 11 Main St. N. E., Minneapolis, Minn.

Send Free Plan on Saw Filing business.
Name.....
Address.....



Stucco Spraying Machine
Renew old buildings. Make new construction more permanent and attractive. Plaster Colorcrete is waterproofed. It fuses with any masonry surface. It fills all cracks. It can be applied in any thickness and in 30 colors. Fully proven by over 12 years actual use under all conditions and every climate.

OFFERS BIG EARNINGS

Owners everywhere want to enhance present values. With this machine you can supply this big waiting market with permanent Colorcrete at amazingly low cost. Operators report cost of 2c and up per sq. ft. and sell up to 7c. Some have paid for their equipment from first few jobs. Machine capacity up to 1,000 sq. ft. per hour. Get the facts. Send for books, "Proven Business Opportunity." Write today. It offers you big extra income.

COLORCRETE INDUSTRIES, INC.
570 Ottawa Ave. HOLLAND, MICH.



WORLD'S GREATEST all around ELECTRIC TOOL

**DRILLS — GRINDS — SANDS — SAWS
POLISHES — SHARPENS — CARVES**

The new **WHIZ ELECTRIC TOOL** is the handiest power tool ever made. Not a delicate instrument but a real rugged tool, equally effective for both power and precision work. Drills through 1/4 inch iron plate in 42 seconds or engraves intricate designs on jewelry. Handles any material: Metals—Woods—Alloys—Plastics—Glass—Steel—etc. Saves time. Eliminates labor. Plug into any socket AC or DC, 110 volts. Chuck 1/4 inch capacity. Ball bearing thrust. Powerful, triple-gear motor. "Worth its weight in Gold." **STANDARD MODEL** with Normal Speed (uses 50 different accessories, instantly interchangeable.) Special Introductory Price for limited time, only \$6.95. **ONLY \$6.95 POSTPAID GUARANTEED FOR ONE YEAR**

FREE Accessory outfit (Value \$2) includes set of drills, mounted 1 1/2 inch grinding, sanding discs, cutting wheels, mounted brush, polishing wheel, carving bar, etc. **FREE** with each outfit ordered NOW. No pay postage. Will send C. O. D. if desired. **10-DAY TRIAL—MONEY BACK GUARANTEE.**

Special "3-SPEED" MODEL combines Normal Speed and High Speed in one outfit (uses 200 accessories) only \$8.95 complete, with same accessory outfit (value \$2) **FREE.**

Paramount Products Co., Dept. 12A, 48 West 48th St., New York

**POST CARD, ROTARY \$9.95
DUPLICATOR only \$9.95**

PRINT-O-PRESS Post Card Duplicator duplicates post cards by thousands—or any card 3 1/4 x 5 1/2, from stencil with true rotary principle assuring fast duplication with accurate and perfect register. Comes complete at this amazing low price of \$9.95 including supplies. User-Agents write. Details **FREE**, also samples of work.

Professional Products Corp., Dept. 1210, Silverton, Ohio



PARMAK ELECTRIC FENCE SAVES **WRITE FOR FREE BOOK** **MORE FENCE AT Exceptionally LOW COST** compared to old-type fence. Single wire on driven stakes positively holds stock safely. Over 40,000 delighted users. **PARMAK'S** amazing Flux Diverter Invention increases efficiency. Write for free book and **30 DAYS TRIAL OFFER.** **AGENT-DEALERS—Write for exclusive territory.** **Parker-McCrory Mfg. Co., 100-P, Kansas City, Mo.**

MODELS \$12.50 UP

DEALERS
Write for exclusive territory.

GOVERNS SPEED OF ANY GAS ENGINE

It's easy and economical to supply your own power for operating all types of machinery, and do more work for less money. Simply remove the engine from a used automobile or truck, set it up where you like, attach a **PIERCE UNIVERSAL GOVERNOR**, start the engine and you have constantly controlled power for the operation of electric lighting plants, are welders, refrigerating units, air compressors, feed grinders, hoists, saw mills and innumerable other applications.

The load may change but the **PIERCE UNIVERSAL GOVERNOR** will maintain a uniform engine speed. For close regulation of speed and dependable performance **PIERCE GOVERNORS** are never equalled. Installation is simple. Either V or flat belts can be used. Complete Governor outfits are also available for nearly all makes and models of industrial engines.

Write for illustrated literature and prices.
THE PIERCE GOVERNOR COMPANY
1601 Ohio Avenue, Anderson, Indiana



PIERCE GOVERNORS THE BRAINS OF ANY GAS ENGINE

New Amazing INVENTION! ELECTROPLATES

by **BRUSH PAINTING!** **EASY AS PAINTING!**

Easily..Expertly..Cheaply! **S**ensational new discovery **S**actually electroplates. *Only \$6.85* ... just brush it on. Deposits heavy, durable layer of metal by **electrolysis**. Results permanent—equal to beautiful work of costly tank outfits. **Non-liquid**—Portable—Battery or household current. Take it to the job. No dismantling... plate where and what you want. Outfit in sturdy case, complete for instant use. **Junior Battery Model: \$6.85.** **Heavy-Duty Professional Sets up to \$27.50.**

AGENTS WANTED: Write at once for Big Money Proposition. You can also make steady money plating for others.
WARNER ELECTRIC COMPANY, Dept. D-5
360 No. Michigan Avenue, CHICAGO, ILL.



Now! MOUNT SNAPSHOTS With One Single PHOTOMARK

Introductory Offer!
NEW, SMART, ALBUM . . . \$2.50
50 PHOTOMARKS40
\$2.90 Value, Now Only **\$1.95**
24 sheet, loose-leaf Album, 9"x12". Colorful, modern fabric cover. Transparent sheets between pages.
Photo mounted with **PHOTOMARK** . . . tab invisible.
PHOTOMARK tab pulled out showing title.

STUTZ PHOTO SERVICE
10858 Sheemaker Ave., Dept. PM-12
DETROIT, MICHIGAN
FREE postage if money accompanies order. 3 days inspection. Money-back guarantee.

HANDY TAPS and DIES . . .
Accurate—carefully hardened and tempered. Complete range of sizes at your local five and ten cent store
HENRY L. HANSON, WORCESTER, MASS.

CROSMAN SILENT .22 RIFLE
Adjustable peep sight

NO CLEANING ADJUSTABLE POWER LOW COST AMMUNITION
Grooves inside barrel make the Crosman a real rifle with all the hair-splitting accuracy this term implies. Shoots bullet (pell) same diameter as .22 powder rifle, but silently, powerfully, with no recoil, using the terrific force of compressed air—same force U. S. Navy uses to drive 2000 lb. torpedoes. Marvelous for target, small game. New features. Single and 20 shot repeater models. No license required.

SuperPells **FREE BOOK**
Best for all .22 cal. air rifles. Heavier, longer, more perfectly formed (secret process), thus harder hitting and more accurate. Made to American standards by American workmen. Write for folder.
Containing important target and game shooting facts; also Crosman Catalog. Write. Ask Your Dealer to Show You a Crosman.
CROSMAN ARMS CO., Inc., 401 St. Paul St., Rochester, N. Y.

Good-bye to the "Wobble-Stick"

(Continued from page 803)

ing the accelerator to the floor, causes the conventional high gear to cut in when desired, giving the car unusual pickup for climbing or passing.

The Studebaker overdrive, which has solenoid control, cuts in around thirty miles per hour, but the conventional high gear may be cut in by pressing the accelerator beyond the wide open throttle position. This actuates the solenoid control, which literally cuts off the engine for one-

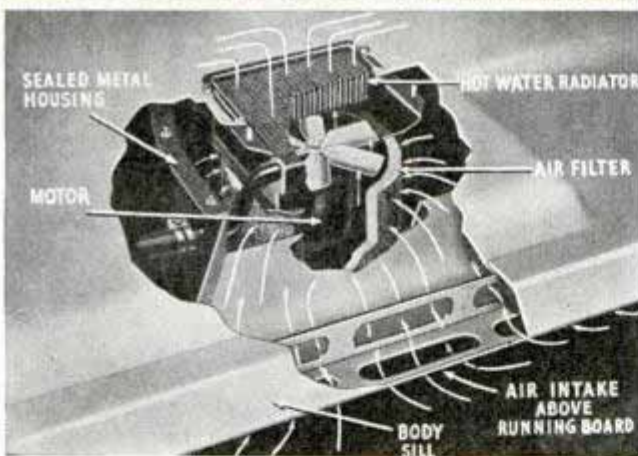
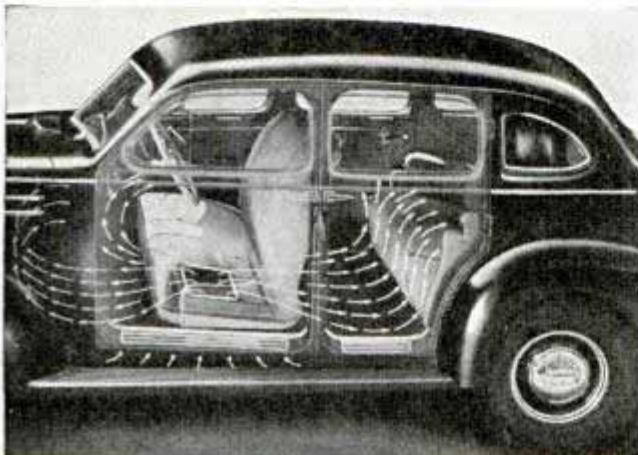

Diagram of Studebaker winter conditioning unit and manner in which air enters car

fiftieth of a second and causes conventional high gear to take hold for quick pickup or for more power to climb a hill. This feature eliminates the formerly objectional slowing down when the driver desires to get out of overdrive.

Comfort surpassing that ever offered before is claimed by several auto makers this year. The new Plymouth has front independent suspension on coil springs of Amola steel. These springs are said to give a twenty-per-cent softer ride. Chevrolet's riding system involves new short and long

(Continued to page 154A)

"MATCHED PAIR" FOR THE MAN WHO SAYS,

*"My Shop deserves
the Best!"*



10" GEARED POWER TILTING ARBOR SAW

Tired of playing with "toy" saws? Here's a big, rugged, precision-built tool! Direct Gear Drive delivers 30% to 40% more power to the blade. Makes full 3" cuts—or move the saw arbor effortlessly to any angle up to 45° and cut through 2" with the table level. No belts, no pulleys—nothing but carefully machined parts, built to give years of carefree service. See it in the new catalog!

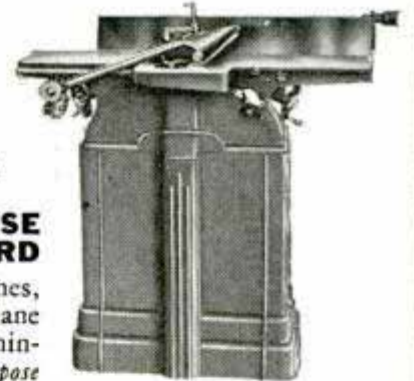

6" JOINTER WITH DUAL PURPOSE SAFETY GUARD

Clean, modern lines, triple knives that plane at 12,000 cuts per minute—and a dual purpose guard that lets you plane boards to ribbon thinness, or narrow stock down to minimum width—safely! Roomy tables, sealed ball bearings, protractor gauge that gives fine readings. Hand-finishing can never equal the work you do with this tool, whether you're planing, joining or rabbeting. See this Jointer in the new catalog!

FREE—Be one of the first to have the new Driver 1939 catalog! 48 pages of pictures, specifications, prices on Driver Tools and Accessories. Send the coupon today!

DRIVER *Engineered* POWER TOOLS

Walker-Turner Co., Inc.,
1128 South Ave., Plainfield, N. J.

Rush me free copy of new 1939 catalog, describing tools, accessories, and motors.

Name.....

Address.....

City.....



Amazing New Business

PAYS BIG DAILY PROFITS

WORK AT HOME

A SURPRISING new profit opportunity is now offered to every ambitious man and woman! A sensational new kind of food business has been invented that can be operated with no previous experience in either full or spare time—a business that pays you big daily profits selling production of one machine at wholesale only.

EVERYTHING SUPPLIED. We supply equipment and plans for making and selling a delicious new greaseless doughnut that is cooked in a remarkable electrical device. Easy to digest and more toothsome than old-style doughnuts ever were. This delicious new dainty—Brown Bobby—costs less to make and sells faster. No wonder so many people without one bit of experience are literally cleaning up "fortunes" with this new money-maker!

COSTS NOTHING

to learn all facts about this wonderful home business. Amazing details sent absolutely FREE—show exactly how you can start at home and make good profits from the very first day! Send your name on a post card for our special quick-starting offer. Do this at once, and this time next week you may actually be in a good business for yourself.

BROWN BOBBY CO.

620 N. Michigan Ave.

Dept. C-1812

Chicago, Ill.

You manufacture—get stores to do your selling for you. You may start taking in profits the very first day. We make it simple and easy for you—absolutely no experience needed. The machine manufactures electrically—every Brown Bobby a taste-delight.

(Continued from page 153A)

arm type Knee-Action embodied in a suspension system in which front and rear are scientifically balanced. There are double-acting end-to-end discharge hydraulic shock absorbers front and rear and a new ride stabilizer which prevents undue rolling and swaying on curves. Rear springs are thinner, with tapered ends, and their geometry is changed to give a smoother, softer ride.

In the LaSalle and Cadillac "61," the engineers have created a new geometry in rear-spring suspension. A principal change comes in a re-location of the ends of the leaf springs, now mounted higher and in-



Handy illuminated mirror that is a feature of new Cadillac and LaSalle

NEW ADDING MACHINE



Amazing! Sensational! Almost unbelievable! Think of it... a real adding machine for only \$4.95. All metal mechanism. Beautiful wood cabinet. Substantial. Positively accurate. Adds up to 99,999 just like \$100 machine. Merchants, manufacturers, professional men, restaurants, students, millions of individuals need this time-saver. Money-back guarantee of satisfaction. Sent postpaid upon receipt of \$4.95... or C.O.D. plus postage. (This offer good in U. S. only.) CIRCULAR FREE! KEL-SAN MFG. CO., Dept. 9, DAYTON, OHIO

only \$4.95

FLOCKING GUN Produces Suede Finish

NEW finishes applied to wood, glass, paper, leather, cloth, etc. Professional gun applies flock evenly. Choice of flock colors, can 25c. Brown, black, white, light blue, navy blue, yellow, emerald green, gray, red. Choice of binder color to match, jar 25c. FREE CATALOG. JORDAN PUMP CO., P-3, 2004 Bryant Bldg., Kansas City, Mo.



COMPLETE ELECTRIC PLANTS



Onan A.C. plants furnish same current as city lines, 110 Volt, 60 Cy. For farms, camps, construction jobs. Operate radios, water systems, all appliances. New models, 350 to 5000 watts, 6, 12, 32 and 110 volt D.C. Models \$57.50 and up. Also combination A.C.-D.C. units. Shipped complete, ready to run.

Write for details.
D. W. ONAN & SONS

1028 Royalston Ave.
Minneapolis Minnesota

side the frame. The fundamental accomplishment is a control of axle weight that prevents periodic axle "hopping," so annoying to passengers and driver. Through the use of rubber bushings at all points, the suspension requires no lubrication.

Packard, too, takes a step in the direction of rear-end suspension by presenting a fifth shock-absorber system, to stop crosswise shocks. The rear springs have rubber and special alloy inserts between the leaves to achieve easy, controlled spring resilience.

Among the engineering achievements for 1939 is Pontiac's new ride system, in which

(Continued to page 157A)

Increase Your Earning Power

Apply time and labor-saving kinks to your work. Your efficiency will soon be recognized and you will be in line for advancement.

If you do machine shop work of any kind, sheet-metal work, painting, carpentry, auto repairing, farming, concrete work, plumbing, electrical work, welding, building-glass work, general repairing, tool-making, poultry raising, masonry or home repair work, get this

LIBRARY OF 2400 TIME AND LABOR SAVING IDEAS FOR SHOPMEN AND HANDYMEN

JUST PUBLISHED

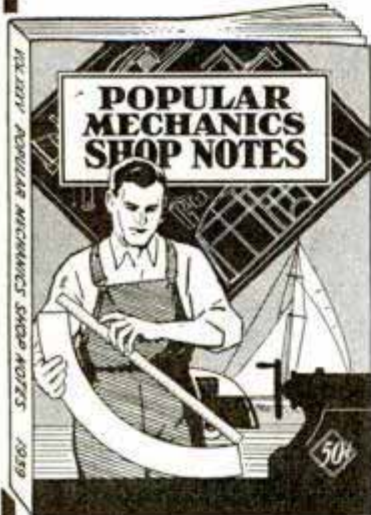

SHOP NOTES for 1939

417 Articles
806 Illustrations
224 Pages
Price 50c
See partial list of contents below

Including the new 1939 issue illustrated above, there are six volumes in the Shop Notes Library of 2400 easily understood short cuts to every-day jobs. Here are just a few of the subjects taken from the latest issue:

- | | | |
|--------------------------------|--------------------------------|---------------------------------|
| Alabaster, Turning | Grease Pit, Cover for Grinding | Printers, Hints for |
| Auto Mechanics, Short Cuts for | Lathe Kinks | Shaper, Homemade |
| Carpentry Kinks | Machinist's Helps | Sheet Metal Work |
| Drafting Room Helps | Marble, Imitation | Stainless Steel, Working |
| Electrician's Aids | Metals, Buffing and | Telescope Mount |
| Electro Engraving | Polishing | Thread Cutting |
| Farm and Garden Helps | Metals, Chemical | Trailer Kinks |
| Fluting, Spiral | Coloring of | Truck Driver, Helps for |
| Gas Engine, Midget | Motorist, Helps for | Welding |
| Generator, Wind-Driven | Paper Hanger's Helps | Window Displays, Novel |
| Charges Batteries | Pattern Sanding | Wood, Bending |
| Glass Blowing | Photographic Kinks | Wood Lathe, Homemade |
| | Poultry Appliances | Wood Turning, Complete Guide to |

Each volume contains approximately 400 articles and 600 illustrations and has 200 or more pages. This unrivaled library of shop helps may be secured for a limited time only. After the present supply of books is exhausted the offer must be withdrawn.

***Send No Money**

POPULAR MECHANICS PRESS, 200 E. Ontario St., Room 1238, Chicago, Ill.

Send me, as per your offer, the following books. I will pay postman price and small amount of postage. My money will be refunded if I am not satisfied. (Check what you want.)

- 1939 Shop Notes and Lathe Handbook (Metal Working), both for 98c.
- Shop Notes Library (6 vols.) \$2.98.

Name.....

Street and No.....

City.....State.....

*C. O. D. applies to U. S. and possessions only. If you reside elsewhere, remittance must accompany order.



"You can earn \$150 to \$300 extra profit monthly with this HOBART WELDER"

30 Days Trial in your shop on your own work to prove it SEND for complete details

Get Into Arc Welding With Dependable, Long Life HOBART 40-Volt Equipment

You can now build a big paying business of your own with a new "Simplified" Hobart Arc Welder. Prices are the lowest in arc welding history . . . low enough to allow even the smallest shops to own one of these new welders. Extra profits will pay for it in a short time. And remember, there must be a good reason why Hobart is the fastest selling arc welder on the market today. Arc welding is today's profit opportunity . . . don't miss it!

Remote Control This is an important feature you get at no extra cost with Hobart. It lets you control your welder from any working point. Saves time, temper and eliminates the need for a helper on overhead or concealed work.

Easy to Operate Hobart Welders have "Simplified" operation. This means faster welding—with the right current for every job. Hobart is simplified, so any of your men can weld easily and successfully. The mystery and uncertainty of obtaining correct welding current settings are removed.

60% Extra Capacity Over old style 25-Volt Welders . . . necessary for welding with the new coated rods. Automatic reactance lets you handle light welder work without losing the arc. Users don't understand how they got along with old style welders after trying this new Hobart. Furnished in ELECTRIC DRIVE, GASOLINE ENGINE DRIVE, or GENERATOR ONLY.

"Pays-for-Itself" Terms You have 30 days trial at our risk to prove that extra earnings and savings obtainable with this improved welder makes it easy for you to own a Hobart with practically no cash outlay.

"Build Your Own" Let us tell you how you can build your own portable electric welder by using Hobart generator and coupling to your own engine and chassis. This equipment lets you operate any place, especially on the profitable outside jobs. Check coupon for detailed information.

HOBART One of the World's largest builders of Arc Welders

HOBART BROS. CO., Box M-128, Troy, Ohio

Tell me more about—

- Building My Own Portable Welder
- Complete Gas Engine Drive
- Electric Drive Welder
- Send FREE Book on "New Profits in Arc Welding"

Name.....

Address.....

Interested in 30 DAYS TRIAL EASY TERMS

Own this PROFIT MAKER for only \$20 MONTHLY



Build Your Own Arc Welder with above Hobart unit SAVES YOU \$300 TO \$500 Use this Coupon to get FREE Arc Welding Book



Handy . . . Automatic JUSTRITE BLO-TORCH

10 3/4" LONG OVERALL

**Intense Flame . . . Easy to Handle
Operates at Less than 1c per Hour!**
Here's a torch that's "tops" in every way! Handy — easy to carry — small enough to get into tight places. Automatic — no pumps or complicated pressure controls to adjust. Single regulating valve controls flame. An ideal tool for metal craftsmen, electricians, mechanics and plumbers.
Does a real job at low cost!

**NO PUMPS—ONLY
ONE MOVING PART!**

101 USES!
Order your Justrite Blo-Torch today—you'll find hundreds of uses for it. Excellent for working and tempering metal, burning off paint, bending glass, melting glue, thawing pipes, small blacksmithing operations, most all soldering work, and a host of other jobs around shop, farm or home. 100% satisfaction guaranteed—10-day money-back trial. See it at your dealer's or order direct. Shipped either postpaid or C.O.D.

**FREE!
SOLDERING
IRON POINT**
if you order now!
Converts Blo-Torch into self-heating soldering iron—can be used anywhere—not dependent upon any other source of heat. Act today!

**Only
\$2.95
Postpaid
Order Yours
NOW!**

JUSTRITE MANUFACTURING CO.
Dept. 291, 2061-81 Southport Ave., Chicago, Ill.

**JUST OUT AGENTS
WANTED**

**\$15 TYPE ELECTRIC
DRY SHAVER.** Year Guarantee.
Retail under \$5. Make \$3 or more on every sale. Agents wanted. Territories still open. Don't wait. RUSH order today.

Sample. Each . . . \$1.75 Lots of 6. Each \$1.50
Lots of 3. Each . . . 1.65 Lots of 12. Each. 1.35
F.O.B. Chicago

RELIABLE JOBBING HOUSE
930 W. Roosevelt, Dept. C Chicago, Ill.

**AMAZING VALUE
\$17.50**

Streamlined Bicycle full size with balloon tires, guaranteed coaster brake, chromium guards. \$5.00 deposit Balance C.O.D.

PRECISION MACHINE AND TOOL CO.
Box 176, Station D., New York City, N. Y.

FREE CATALOG

PINS 30c UP **RINGS 1.50 UP**

Finest quality. Over 300 artistic designs. Write for our attractive free catalog and select a beautiful pin or ring for your class or club.
Dept. N, METAL ARTS CO., Inc., Rochester, N. Y.

XMAS MONEY FOR YOU . . .

There's a big demand for the many hand-tooled articles you can make with the Easco Leathercraft Set. Easily learn to make good money in your spare time. Complete outfit including tools, leathers, patterns, etc., and full instructions, only \$2.00—on sale at leading Department Stores or order direct and pay postman on arrival, \$2.50 outside U. S.

LEATHERCRAFT

Free When ordering direct, clip name of your Department Store to this ad, and we will include with your set, one extra free project. Illustrated catalog 10c.

E. A. SWEET CO. Dept. A-19 Binghamton, N. Y.

Amazing New Oil Heater Invented by LACO

**LOW \$23⁵⁰
AS**

**Give This
Practical Gift!**

NOW—a sensational Low Price oil heater by LACO—delivers tremendous heat with little cost! Installs like a stove—needs no basement! Easy adjustment radiates as much or little heat as wanted. Ample volume for coldest days! Only LACO has the famous "Two-Stage Double-Flue" burner which develops amazing heat from little oil—and the "Inner Heating Unit" which utilizes utmost of the heat without waste. Enclosed in beautiful lifetime steel cabinet. Quiet! Safe! Circulates, humidifies the air. 4 sizes.

Save on LACO's "Gun-Type" Burner

America's finest burner at the extremely Low Price! Simple (only 1 moving part). Quiet. Uses little fuel (often cheaper than coal). Exclusive "High Pressure Carburetor" transforms heavy oil into finest mist, produces extra rich mixture, extra hot flame. **GUARANTEED!**

WRITE Rush card for your copy of completely illustrated booklet giving complete details of my Very Low Priced LACO Heaters and Burners. L. A. COCKLIN, Pres.
LACO OIL BURNER CO., 1128 Union Ave., Griswold, Iowa

TRAILER BUILDERS

Send 10c for our latest DeLuxe Trailer plans with all the modern improvements known to trailer builders. We supply everything at bargain prices. Our new 1938 trailer supply catalog (largest and most complete) is free.

National Trailer Equipment Co., Dept. P-12, 714 W. Wisconsin Ave., Milwaukee, Wis.

BUILD YOUR GRANDFATHER CLOCK

The Simple Sensible Red-i-Kot way as thousands have. DIME brings PLANS and sixty picture "HOW" Book pricing many fine brass weight Westminster, tube chime, electric and battery movements showing nine beautiful colonial grandfather cases. **WHY WAIT LONGER?**
KUEMPEL CHIME CLOCK CO., Bldg. 23, Guttenberg, Iowa.

**YOU'LL LIKE RESILVERING MIRRORS,
REFINISHING**

Plated articles, Autoparts, Reflectors, Tableware. Making Chipped Glass Name Plates, Signs. Experience Unnecessary. Write. **SPRINKLE, Plater, 129, Marion, Indiana**

SLIDE-VALVE STEAM ENGINE

model SE-3, for small boat models. A complete power plant, ready to run, with two-cylinder engine (as illustrated), boiler, safety valve, denatured alcohol burner and propeller rig. Price \$3.00. Postage extra, shipping wt. 1 1/2 lb.

SHAWNEE ENGINE CO., Box 162, Station D, Cincinnati, O.

**FREE! WHOLESALE
CATALOG**

Has: 15 selling plans; 30 money making ideas; 4000 world wide bargains; 260 pages of big values. Also shows top-notch prizes; business stimulators. All at rock bottom wholesale prices. Salesmen-Dealers. Obtain this fascinating Book Of Opportunity FREE. Write for it today, to

SPORS CO., 10-38 Main St., LeCenter, Minn.

When writing please mention Popular Mechanics

(Continued from page 154A)

Duflex rear springs give one passenger as easy a ride as six passengers and also reduce bouncing and pitching when the car is traveling over bumps. To the conventional leaf spring, and directly below it, has been added a second but shorter auxiliary or helper spring. For light loads the car rides almost entirely on the main or upper unit which affords comfortable motion. As the passenger load increases, this upper spring comes progressively more and more into contact with the helper spring, thus building up maximum resistance to deflection. Front and rear springs have nearly the same oscillation rate, which means that pitching and kick are reduced.

Of considerable importance to the driver is the general movement to increase his range of vision. In cars with Fisher bodies,

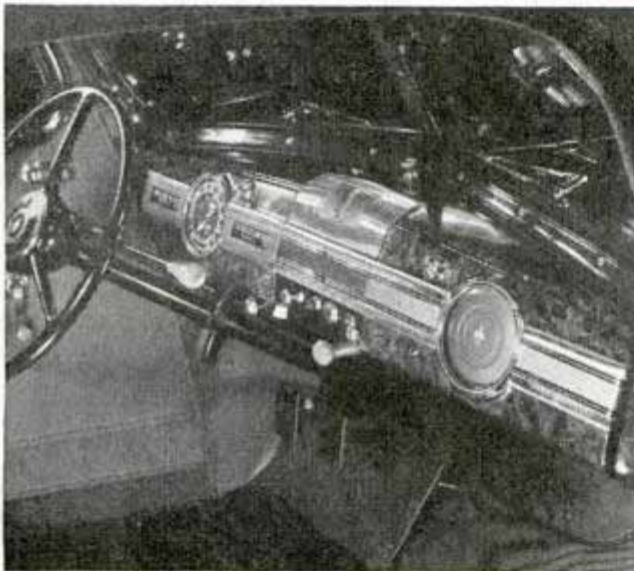

Driving compartment of Packard Six. Note Handshift beneath steering wheel

higher windowpanes and windshields, narrower body pillars and smaller corner radii add twenty-seven per cent to the glass, or visibility, area. For example, the Buick has twenty-six per cent more glass area in the 1939 windshield than in that of last year. This trend marks the manufacturers' effort to eliminate "blind spots" which have figured in many accidents. Frequently an automobile coming from one side or the other is momentarily obscured from the driver's vision by a pillar on his own car. Chrysler and other makers offer similar wide-vision windshields.

New beauty has been built into the 1939 automobiles, but the makers have con-

(Continued to page 158A)



BETTER PICTURES A FASTER WAY

JUST turn the knurled edge of this new, quick-setting calculator once with your thumb or forefinger. It's an improvement on the G-E exposure meter that makes possible *complete exposure data*—faster, more easily. Now, too, you read light values more easily on the simplified scale. These new features have been added to the G-E exposure meter for faster, smoother operation.

The new calculator has larger numerals, is faster to use, and has an extended film-speed range that covers the fastest films. Combined in the instrument with the improved calculator are other such popular General Electric features as sensitivity, sharp directional effect, and accuracy. They're *all* yours with the G-E meter. They're additional assurances of better pictures.

Your photo dealer has the improved G-E exposure meter. If you want better pictures, ask to see it today. Or write for GED-678A, which shows the new G-E meter and explains how to use it under all light conditions. General Electric Company, Schenectady, N. Y.

GENERAL ELECTRIC



FREE!

HAMMARLUND NEW '39' RADIO CATALOG

The new 1939 Hammarlund catalog contains details, illustrations, mechanical drawings and curves on a complete line of short wave parts for the experimenter. Address Dept. PM-12-38 for free copy!

HAMMARLUND MFG. CO., INC.
424-438 West 33rd Street, New York City

\$7.50 EACH POSTPAID

Most Unusual MOVIE OFFER EVER MADE

GET BOTH
CAMERA & PROJECTOR
for Only \$13.50 Complete and Postpaid



Everything to take and show real 16 mm. movies at less cost than taking snapshots.

CAMERA — Spring Motor drive — Automatic Release Button — Footage Indicator — 50 foot capacity. No adjustments necessary.



PROJECTOR—Quiet, smooth and flickerless — Motor driven — sturdily built. Uses any standard 16 mm. film.

FREE
50 FOOT PROJECTOR FILM with each \$13.50 COMBINATION.

**PARAMOUNT MFG. CO., DEPT. G-95
BOX 224, BACK BAY, BOSTON, MASS.**

H1143

New! Ideas for WOOD WORKERS



Here It Is! Craftsman's New 136 Page Catalog No. 11

This remarkable 136 page catalog is a veritable storehouse of up-to-date facts for Woodworkers. You need it.

301 Scroll and Fret Patterns, 235 of these brand new!

And—new pointers on correct processes of wood finishing! The catalog explains the new Craftsman Art Inlay Process. So easily learned.

Scores of other pointers on the "how" of woodworking! NOVEL and rare, hard-to-find, imported woods from all over the world and at astonishingly moderate prices.

Complete list of all Standard American Woods, cut to convenient sizes without waste.

Also large assortment of attractively designed legs, carved decorations, mouldings, plain and ornamental hardware of all descriptions.

Astounding Bargain deals. (A few examples in left column.)

This is but a partial list of contents, all for only 10c. Get it while the edition lasts.

136 PAGES

Only 10¢

Bargains!

For example, \$4.50, Deal No. 88:

- 4 ft. - ¼ in. West African Iroko (light brown)
- 4 ft. - ¼ in. Australian Lacewood (silky brown flaked)
- 4 ft. - ¼ in. Central African Benin (golden brown)
- 4 ft. - ¼ in. North Amer. Walnut (slate color)

All woodworkers appreciate this: 20 different kinds of American woods in neat box, each piece ¼ inch thick, 2 ½ x 5 inch, each neatly labeled, only \$1.00

Deal No. 101 only \$1.98. High quality scroll saw, one dozen saws, choice of Mahogany or Walnut for two corner pieces, 2 blue prints, all needed hardware. Total \$1.98.

(Continued from page 157A)

flicting ideas about the way tomorrow's car will appear. General Motors moves toward the knife-edge front and elimination of the familiar radiator grille, reaching the extreme point in Buick, which has a "butterfly" grille starting rather low on the front. This grille is part of the "catwalk" cooling system adopted from European racing cars. With this construction, the grille is set in rakish contour in the catwalk section of the front end, resulting in better streamlining, a narrower hood for better vision and introduction of air to the radiator at greater pressure to increase cooling efficiency.

Buick takes a step toward elimination of running boards. In the models "40" and "60," Buick offers stream boards which are not so wide as the regular running boards

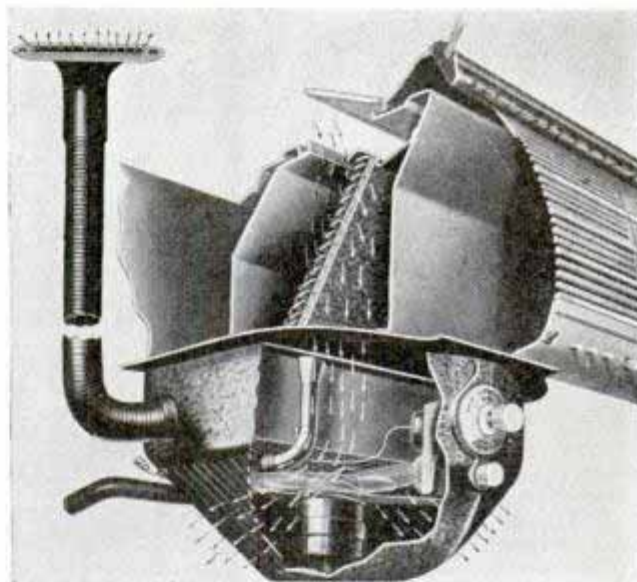

Cutaway view of Nash conditioning unit which has "Weather Eye" control dial

and which are surmounted with stainless steel moldings extending their entire length. Graham eliminates the running boards from its curb-height body, but the full-width boards may be obtained at added cost. The Cadillac "61" offers running boards as optional equipment, replacing them with the strips of stainless steel below the doors. Running boards are narrower on the Chrysler and some other cars, indicating that new models of the near future may be entirely free of step boards.

The Chrysler line has variations of the rounded nose design set off by horizontal vents protected by chrome bars. Headlamps are built into the front fenders. Rear

(Continued to page 161A)

Write for this Book

CRAFTSMAN WOOD SERVICE CO., 2739 S. Mary St., Chicago.
I enclose 10c (stamps or coin) for which please send new 136-page Bargain Catalog No. 11 for Woodworkers.

Name Age.....

Street and No.

Town State.....

If you also want to order one or more of the deals from this advertisement, state Deal No.

Enclose full amount or \$1, balance C.O.D.

Money back if not 100 per cent satisfied.

NOW I KNOW WHAT FRED MEANT WHEN HE SAID HE GOT HIS PAY BOOST OUT OF A TWO DOLLAR BOOK.



PAY RAISING EXTRA MONEY BOOKS THAT WILL HELP YOU WIN SUCCESS

You, too, will find the selected list of practical books below just what you need to help you improve your job, prepare for a better one, or add to your income through spare time earnings. Thousands give these books credit for their success.

SEND NO MONEY! Use this advertisement as an order blank. Check books wanted. Add name and address and mail. Just pay postman price plus few cents postage. (In U. S. and possessions.) Or remit with order and add 10 cents per book for postage.

POPULAR MECHANICS PRESS

Room 1238B 200 East Ontario Street Chicago

- AIR CONDITIONING**
Live Field; Great Future..... \$3.50
- ALUMINUM WORKING**
For School and Home Shops. Just Out. 295 pp., illus. \$3.00
- AUTO ENCYCLOPEDIA**
The Famous Dyke's Latest Edition..... \$6.00
- 110-V. GENERATORS**
Made From Old Auto Units..... \$1.00
- BIRD HOUSES**
Build to Sell; Easy Designs..... \$1.00
- BLUEPRINT READING**
for the Building Trades..... \$1.25
- BOAT BOOK**
Power, Sail, Rowing, Paddle Plans..... \$3.00
- BOY MECHANIC**
Hundreds Things Boys Can Make..... \$2.00
- CARPENTRY, PRACTICAL**
Complete 436 pages. Revised Edition... \$2.00
- CIVIL SERVICE**
Home Study Courses Federal, State, City Positions..... \$1.00
- CONCRETE**
1001 Ideas for Using. New Popular Mechanics Book... \$5.00
- DIESEL HANDBOOK**
New! Latest Information..... \$5.00
- ELECTROPLATING**
With Copper, Nickel and Chromium Technical bulletin..... \$1.00
- FORD V-8 CARS, TRUCKS**
New, 700 Pages. Includes Details 1937 Cars..... \$2.50
- FORMULAS**
1059 Money Making. Start a Business..... \$1.25
- A.C. POWER WIRING**
Covers all uses of a.c. for power..... \$4.00
- FURNITURE MAKING**
Tools, Materials, Design..... \$2.50
- HOUSES, SMALL**
Book of, for Home Builders..... \$2.00
- HYPNOTISM**
How to Become an Expert..... \$2.00
- LOCOMOTIVE**
Folding Chart Shows all Parts..... \$1.00

- MACHINE WOOD-WORKING**
First Complete Book on Subject..... \$3.25
- MATHEMATICS**
Easy Guide for the Practical Man..... \$1.50
- MECHANICAL DRAWING**
Learn Drafting; Good Salaries..... \$1.00
- MONEY MAKING IDEAS**
1000 Ways to Make \$1000..... \$2.50
- OFFICE MACHINES**
All Makes. Care and Operation..... \$2.50
- PAINTING AND DECORATING**
New book..... \$1.50
- PLUMBING**
500 Facts Every Homeowner Should Know..... \$1.50
- TEST GOLD—PLATINUM**
Identify—Buy—Sell. By C. M. Hoke..... \$1.00
- PROSPECTOR'S HANDBOOK**
How to Mine, Appraise, Equip..... \$3.00
- RADIO SERVICING**
Profit by Knowing Costs, Kinks, Etc!..... \$4.00
- REFRIGERATION**
Electric, Gas. Be a Service Expert... \$5.00
- REWINDING ELECTRIC MOTORS**
Fractional Sizes. Valuel..... \$2.50
- SHIP MODEL**
Entire Text, Famous "Sovereign" of 1637... \$1.00
- SHOP NOTES LIBRARY**
6 Vol. 2400 Wonderful Shop Ideas..... \$2.98
- SOIL-LESS GROWTH OF PLANTS**
Just out..... \$2.75
- STEEL SQUARE**
How to Figure Angles of Rafters, Roofs, Etc..... \$1.00
- TOYS**
For Amusement or Profit, Saleable Designs... \$1.50
- TRAILER BUILDING**
New Book..... \$1.00
- UPHOLSTERY**
Always a Big Market. Start Own Business \$2.00
- WELDING CYCLOPEDIA**
All types. New 9th ed \$5.00
- WOOD FINISHING**
Methods, Tools, Materials..... \$2.00



When writing please mention Popular Mechanics



SKIERS THRILL!

Biggest thrill in a skier's life... his first cannon-ball descent under perfect control! It's easier too, on Northland skis. Each pair is perfectly matched... uniform in grain, weight, balance and limberness. The famous Deerhead on Northland's five exclusive models guarantees you the finest skis money can buy. Write today for free booklet on How To Ski.

NORTHLAND SKI MFG. COMPANY

World's Largest Ski Manufacturers
95 Merriam Park St. Paul, Minnesota



Auto-Glide

Only \$92.45

What a value! Newest model of the original heavy-duty AUTO-GLIDE, never before sold under \$125, now only \$92.45! Most rugged machine built! Husky long-life 1 1/2 H. P. engine picks up speed quick, zips up hills, handles easily in traffic. Powerful brake stops machine on a dime! Comfortable cushion seat, big enough for two. 125 Miles to the Gallon—cheaper than shoe leather. 35 Miles per hour!

Ask about rental profits

FREE BOOKLET shows all models, and the Very Low Prices. Write NOW!

THE CUSHMAN MOTOR WORKS, Dept. N-12, Lincoln, Nebr.

MOTORITE INGENUOUS NEW MOTOR TESTER

ONLY \$1.50 Guaranteed Accurate
A remarkable new implement in the form of a fine retracting lead type pencil on one end and an accurate motor tester on the other. Fits vest pocket. Looks like a \$10.00 pen! Apply pointed end to spark plugs, cables, distributor caps, etc. Ignition condition shown instantly! Handiest item on earth for every car owner, garage and service station man. Absolutely shock proof, well made, worth twice its cost. **Ideal Xmas Gift.** Fully described on page 153A of the November, 1938, issue of Popular Mechanics. Send only \$1.50 at once. Motorite will be sent postpaid. Satisfaction Guaranteed. Agents write for unusual sales opportunity.

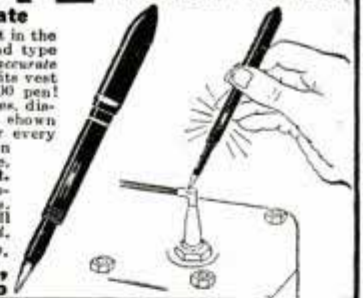

B. M. IKERT, Dept. 12, 53 West Jackson Blvd., Chicago

TYPEWRITER 1/2 Price

Yours for **10¢ a Day**
Send No Money



Sent on **10 DAY FREE TRIAL**

Money Back Guarantee

Positively the greatest bargain ever offered. A genuine full sized \$102.50 office model refinished Underwood No. 5 for only \$44.90 (cash) or on easy terms. Has up-to-date improvements including standard 4-row keyboard, back-spacer, automatic ribbon reverse. Shiftlock key, 2-color ribbon, etc. The perfect all purpose typewriter. Completely rebuilt and **FULLY GUARANTEED.**

INTERNATIONAL TYPEWRITER EXCHANGE

231 West Monroe St., Chicago, Ill., Dept. 1201
Send Underwood No. 5 (F. O. B. Chicago) at once for 10 days' trial. If I am not perfectly satisfied I can return it express collect. If I keep it I will pay \$3.00 a month until I have paid \$49.90 (term price) in full.
For quick shipment give reference and occupation.
Name..... Age.....
Address.....
Town..... State.....



YOU DON'T NEED A LESSON

Even if you can't read a note—in just a few minutes you should be playing the latest hits on this newest musical sensation! It's the life of the party, alone or with accompaniment. Music teachers recommend it. The perfect gift. At dealers—or send \$1.00 with name and address. Mailed postpaid anywhere in U. S. A. Order early!

**TONETTE COMPANY, Dept. P.M.-12/
30 East Adams Street, Chicago**

\$1.00

TONETTE

— ANYONE CAN PLAY IT —

SPRAYS Paint-Enamel-Lacquer-Wax-Etc.

NEW TOUCH-UP GUN has 1,001 uses. Used by painters, hobbyists, home craftsmen, car owners, etc. Sprays water, oil, insecticides, etc. Extra cleaning bottle included. **ORDER TODAY. JORDAN PUMP CO., P-2, 2004 Bryant Bldg., Kansas City, Mo.**

ONLY \$2.00 POSTPAID or Sent C. O. D. postal charges collect. Sent on 10-day trial either way.

Build Your Own Home Workshop

Old auto parts make wood lathe, metal lathe, jig saw, drill press, shaper, 10" circular saw. Save money. Plans, complete, for all 6 tools, only \$2.00, prepaid. Thousands satisfied. Send \$2.00 today. **B. J. MEZO CO., 8532 Vanderbilt, Dept. M, Detroit, Mich.**

A PIMPLE-FACED OUTCAST AT 17?

Read how to help protect the skin against intestinal poisons

Are you shunned and pitied because of repulsive-looking hickies? Then why not get right at a common cause of this trouble—and take steps now to help overcome it?

Between the ages of 13 and 25, final growth takes place. This is often accompanied by disturbances throughout the body. The skin may become over-sensitive. Waste poisons from the intestines often get into the blood, then ugly pimples may break out.

Many young people help solve this problem—simply by eating Fleischmann's Yeast. Each cake of this famous fresh food helps eliminate intestinal waste poisons from your body before they can get into the blood stream . . . and so gives these pimples a chance to clear up.

Don't run the risk of permanent scars by neglecting such pimples. Start eating Fleischmann's Yeast now—3 cakes daily—one cake $\frac{1}{2}$ hour before meals. Begin now!

NEW models EASIER TO PLAY

Find out about these sensational new Conn Band Instruments. Many wonderful, exclusive features! Today, more than ever, Conns are the "choice of the artists." You'll advance faster and take more pride in a genuine Conn—made by the world's largest manufacturer. See your dealer or write us for Home Trial, Easy Payment offer. Mention instrument.

C. G. CONN, LTD.
1231 Conn Bldg., Elkhart, Ind.

WRITE FOR FREE BOOK

CONN
BAND INSTRUMENTS

ACE LATHE TOOL SET for every operation

... on metal cutting lathes the ACE SET is complete—be permanently tool-up. At your hardware store!

\$14.50 Circular FREE

ARMSTRONG BROS. TOOL CO.
"The Tool Holder People"
368 N. Francisco Ave., CHICAGO, U. S. A.

3 Turning Tools, 2 Cutting-off Tools, Knurling Tool, Boring Tool, Threading Tool, High Speed Steel Cutters and Blades, and 2 Wrenches in Fitted Steel Case.

EARN BIG MONEY MAKING ELECTRIC RAZORS

We furnish all parts and instruction sheets. Easy to assemble. No tools needed. \$1.66 in Lots of 3. Sample \$1.95 ea. See our ad page 161A November 1938 issue.

Simmons Manufacturing Company
Dept. PM 12, 130 W. North Ave., Chicago, Ill.

CATCH FISH!

minnows, eels, mink, muskrat with our folding galvanized **Steel Wire Traps**. Greer Patent **Lever Hooks** are so constructed that when a fish gives the slightest pull on the bait the upper hook reaches down and gets a hold that lands him 3 for 50c. Write for descriptive catalog of Traps, Hooks, Lures, and other specialties. **Walton Supply Co., 3507B Juniata St., St. Louis, Mo.**

Earn Cash at Home!

We paid M. M. \$1174 for exceptional cellar crop Snow-King mushrooms! We furnish materials; buy all crops. Big FREE picture book tells if your cellar, shed, suitable. Est. 1908. Write today. **United Co., 3848 Lincoln Av., Dept. 300, Chicago**

ATKINS SAWS

Ask your hardware dealer about "Teeth that Bite"

MAKE MASKS!

REPRODUCTIONS, FACSIMILES OF ANY object easily made with PLASTICO mouldage. Used by police to reconstruct evidence in battling crime—by doctors to study diseases and by scientists in laboratories. Exciting, fascinating new product, makes it possible for you to make masks of your family and friends—also any object you want reproduced. Write for free illustrated folder today.

TECHNICAL SUPPLY COMPANY, Dept. No. 15, Palo Alto, Calif.

PHOTO ENLARGER Only \$4.95 COMPLETE

MAKE YOUR OWN PHOTO ENLARGEMENTS LOW AS 4¢ EACH

Enlarge your own pictures any size—earn money making enlargements for others—at home, in spare time. Also use for copying and projecting pictures on wall. Easy—automatic—no experience needed. Plugs into any light socket. Sturdy construction. Low price includes N-Larg-O complete with high-quality lens, cord, plug, and supply of print paper. Nothing else to buy. Write quick for special circular.

N-LARG-O MFG. CO., Dept. R-2353, Cincinnati, Ohio.

(Continued from page 158A)

end lines are characterized by a sweeping curve. The trunk has entirely disappeared from all Chryslers, in favor of a concealed luggage compartment, another trend in the industry. Studebaker and Nash offer new ideas of design, both with considerable appeal to the eye. The Graham retains its "Spirit of Motion" lines of 1938, giving the appearance of traveling at high speed even while it is motionless. Packard clings to its traditional styling.

Chrysler introduces a new safety speedometer, the indicator of which is illuminated when instrument lights are on. From a standstill to thirty miles per hour, the legal speed in most city driving, the light shows green. From thirty to fifty, it is amber and at fifty, it changes to a brilliant red. Thus the driver is constantly reminded of the speed at which he is traveling, and warned when he approaches a dangerous pace.

Constant-speed electric windshield wipers are another Chrysler feature. Entirely

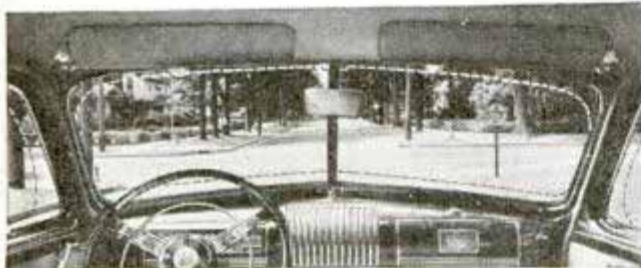

Dotted line shows area of 1938 windshield, which was much smaller than that of 1939

independent of engine action, the wipers are thus free of the vagaries of the vacuum type.

First to offer a direction signal as standard equipment is Buick. This device enables the driver to indicate to motorists in the rear that he is about to turn. The indicator lamp, located in the center of the luggage compartment door, is clearly visible from the rear at all angles. When the driver wishes to indicate a turn, he flips a switch mounted on the steering-post shift lever, without removing his hand from the wheel. This illuminates a modified arrow in the left or right end of the indicator lamp, depending upon the direction in which he expects to go. The lamp is the flashing type. Very close to the switch and visible through a small lens in the shift lever is a small green pilot light which

(Continued to page 162A)

"You've never
HEARD
anything
like it"



THE NEW
Western Electric
HEARING AID
Ortho-technic Model

Built on new principles in hearing aid design—scientifically adjusted after Audiometric tests—Western Electric's new Audiphone enables you to hear clearly in group conversation, greatly widens your hearing circle. It has greater power; longer battery life; air or bone conduction; no "cut-off" in any position. *Try it!*

GRAYBAR ELECTRIC CO., Graybar Building, New York, PM-36
Please send details on New Western Electric Audiphone (Ortho-technic Model) and name of nearest dealer.

Name.....

Address.....

City.....

State.....

NEW Grinding Attachment

For 8" to 16" Metal Lathes. Build It Yourself

At last, a precision grinder within your means. You save 2/3 by finishing our semi-machined castings, on your own lathe. HURON handles both internal and external grinding. Accuracies to .00025". Mirror finish easily obtained. Grinds valves, pistons, bushings, shafts, hard or soft, Axtels, lathe centers. Sharpens reamers, milling cutters. Does eccentric drilling; laps; polishes; scores of other uses, for home workshops, garages, machine shops. Write for FREE illustrated folder and full information.



Semi-Machined Castings Only \$5.95

HURON MACHINE & TOOL CO., Dept. B-12, Yale, Mich.



PHOTO ENLARGEMENTS

Is Photography your hobby? Do you want a profitable easy business at home? Make PHOTO ENLARGEMENTS for yourself and others. Your cost 5c each and less. The Ideal Photo Enlarger is AUTOMATIC. No experience required. Also COPIES any picture. \$5.94 COMPLETE. Interesting circular FREE.

5¢
ANY SIZE

IDEAL-O, 122 East 25th Street, New York City

QUICK CASH
IN NEW POTATO CHIPS

START AT HOME

Here's your chance—a money-making business of your own. Turn potatoes into cash by making new kind of Potato Chips with my improved outfit. Makes delicious, superior, "NON-GREASY" Chips at low cost. A few hours' practice does it. Begin anywhere—city, village, town. Potatoes cheap and plentiful. Wholesale or retail. Steady year 'round business.

Groceries, markets, restaurants, taverns, do the retailing for you. WE HELP START YOU IN BUSINESS.

Great quantities of Chips are eaten daily. Profit large—unusually so. You can start this money-making business on a "next to nothing" outlay of cash. Write for Potato Chip Booklet.



LONG-EAKINS COMPANY
1228-S High St., Springfield, Ohio



4119

(Continued from page 161A)

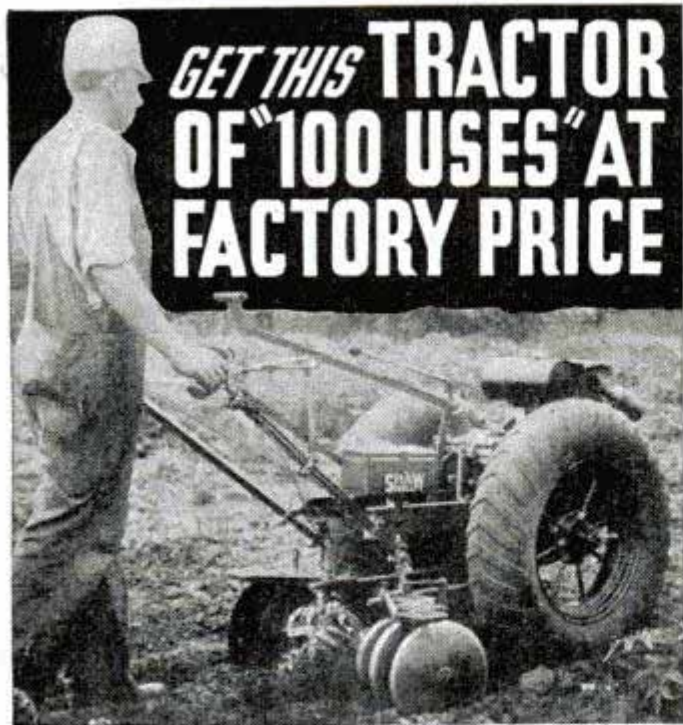

GET THIS TRACTOR OF "100 USES" AT FACTORY PRICE

DOES WORK OF MANY MEN OR 2 HORSES!

Here's untiring speed and power—that gets field and belt work done on time! Smallest size does work of many men—saving wages. Larger sizes do work of 2 horses or mules—quicker, cheaper, more efficiently—saving costly animal keep. Runs all day for 33c. Greatest time, labor and money-saver made!

"Tractor of 100 Uses"—Does all field, road, belt work. Plows, discs, harrows, furrows, seeds, cultivates, harvests, mows, rakes, cuts tall weeds, hauls. Runs washing machines, feed grinders, corn shellers, light plants, saws, concrete mixers, water pumps, lathes, other belt machinery. Does deep mold-board plowing, other heavy work. **Amazing money-maker** for farms, truck gardens, nurseries, orchards, suburban homes, golf courses, parks, etc.

SHAW GARDEN TRACTOR

New 1938 Model Has 3 Speeds Forward, and Reverse. Special to Order, 6 Speeds Forward—runs from 1/4 mile to 15 miles per hour. New Power Turn enables Shaw to turn in its tracks with no lifting or pushing. Reverse Gear makes it easy to work among rocks, roots, in close quarters. Tool Attachments for different uses. Convenient Jiffy Hitches. Improved Tool Control gives tools a wider range of movement . . . increases tractor's usefulness. Briggs & Stratton air-cooled, 4-cycle engine. 4 Models, 2 to 5 H. P., Walking and Riding Types.

Available With Air or Steel Tires. Air tires save 25% fuel. Enable Shaw to do more work in a day. Provide better traction. **LOW FACTORY PRICE!!** Mail Coupon for details of price and terms today!

10-DAY TRIAL FREE BOOK!

OFFER! Use on your own work for 10 days. Know how Shaw makes you much more money—with less work and trouble! Mail Coupon for details 10-DAY TRIAL OFFER today! Explains everything about Shaw. Tells what enthusiastic owners say. Shows photos of tractors in use. Gives LOW Factory Prices on 4 different size models—with different attachments. Mail Coupon today!



AGENTS—wanted. Liberal proposition. Mail Coupon for full information.

FREE BOOK COUPON

THE SHAW MFG. CO. (Address Nearest Office)

4512 Front St., Galesburg, Kans.; 5812-G Magnolia Street, Chicago, Ill.; 130-G West 42 St., New York, N. Y.; 608-G No. Fourth St., Columbus, Ohio.

Send me FREE information at once about the Shaw "Du-All" Garden Tractor as checked below:

- FREE Book and Low Factory Prices
- 10-Day Trial Offer
- Liberal Agent's Proposition

Name.....
 Address.....
 Town..... State.....

When writing please mention Popular Mechanics

flashes in unison with the flashing signal, when the switch is on.

Another feature is an inside lock which prevents sneak thieves from forcing open the front ventilator windows.

New efforts to make the interior of the automobile more comfortable are evident. Studebaker introduces a ventilating filtering and heating system. Positioned beneath the front floor pan, the unit draws outside air from above the running board at the left. This air is filtered, passed through the core of an efficient heater, and discharged beneath the front seat where suitable apertures distribute it between front and rear compartments to provide equal comfort to all occupants. In warm weather the hot-water supply can be shut off and the unit used to draw in fresh, cool, filtered air. Windows may be kept tightly closed, important during rain or dust storms.

Nash offers the "Weather Eye"—a device which automatically brings living-room comfort to automobile interiors during the cold months of the year. Brought in through the cowl ventilator, fresh, outside air enters the winter conditioning unit under its own pressure. Moisture is removed by "rain shedders" and the air is carried through the filter where it is cleaned of dust and soot, past the motor-driven fan, which can be used to maintain circulation when the car is moving slowly or standing still, through the heating element and into the car. A thermostat dial enables the driver to "tune in" the car comfort level desired, from "cold" through "medium" to "hot" or at intermediate points. Once the dial is set, the weather eye automatically keeps the car at this level.

A "sunshine" top, the roof panel of which slides back to provide vision upward and to let in the sun's rays, is an optional feature on certain models of Buick, LaSalle and Cadillac. The sliding roof, operated from the inside, is drip and rainproof.

Hupp enters the market with two Junior models, fitted with bodies quite similar to those on the discontinued Cord.

With the Mercury "8," Ford enters the medium-price field. The Mercury will have hydraulic brakes, an engine with more power than the Ford and other improvements. Use of hydraulic brakes on the Mercury is indicative of Ford's swing away from the mechanical brake.

GRAB HOLD OF THOSE JOBS WITH "HORSEHIDE HANDS"

THEY'LL STAY SOFT... BECAUSE THEY'RE
WOLVERINE FULL GRAIN HORSEHIDE



Style No. 569

THE thick, soft Wolverine Horsehide in these handsome work gloves will give you months of extra wear—and an exclusive tanning process makes it impossible to harden their leather! Sewed with 4-cord work-shoe thread that you just can't rip! Made by the makers of Wolverine Shell Horsehide work shoes. If your dealer can't supply you send us 75c and your dealer's name—we'll mail your gloves post-paid. Ask for No. 569. Sizes 8 to 12.

Wolverine Shoe & Tanning Corp., Dept. W50, Rockford, Mich.

DEALERS: Offer your Customers genuine Wolverine Full Grain Horsehide Work Gloves. Fast selling—nationally advertised. Write for catalog and tested sales plan for new dealers.

WOLVERINE HORSEHIDE WORK GLOVES

GROW PLANTS WITHOUT SOIL

Startling New
Development

Complete Directions for Small and Large Scale Growing

technique which everyone is talking about. Three methods described—Water Culture, Sand Culture, Sub-Irrigation. Explains all operations. Tells how to make containers and nutrient solutions from raw materials at small cost—how to grow flowers, vegetables and fruits without soil. A fine hobby and a money-saving investment for city dwellers. A source of new business for gardeners, nurserymen, etc. Only book of its kind. Order today "Soilless Growth of Plants." Sent postpaid for \$2.75.

POPULAR MECHANICS PRESS Dept. 1238 200 E. Ontario St., Chicago

NEW BOOK on WELDING EXPLAINS ALL!

Metallie and Carbon Arc, Oxy-Acetylene, Electric Spot, Butt, Flash, Resistance, Thermit Welding, Etc.



Covers All Types of Welding No Other Instruction Needed

Welding is one of outstanding trades and professions today. Big Opportunities. Brand new edition of famous WELDING ENCYCLOPEDIA is book you need to get started. Gives principles and practical methods, detailed descriptions of metals and alloys, describes joints and welds, metal spraying, cutting, hardening, etc. 638 pages. Hundreds of illustrations. Nothing else like it. Sent post-paid for \$5 or if in U. S. or possessions pay postman on delivery. Write today. Get your copy now.

POPULAR MECHANICS PRESS, Dept. 1238A, 200 E. Ontario St., Chicago

SAVE ME!

I'M COMING!

Don't live with crippled furniture, chipped veneers, splintered mouldings. It's fun "doing them over" with Rogers! Made only from cod fish skins. Stays put longer because it's stronger. 10¢ and up in tube, bottle or can at hardware stores, or send 10¢ for full size bottle and set of project plans.

ROGERS, Gloucester, Massachusetts

ROGERS

the best LIQUID FISH GLUE

TRAILER PARTS

New Catalog FREE! Also bargains. Straight, square axles for Fords, Chevrolets, etc. \$4. Drop axles, \$7 up. Undercarriage with axle, hubs, bearings, wheels, springs and fittings, \$19.50. BRAKES: Cable-controlled, \$15. Booster and car control, \$19.95. Electric brakes—prices on request.

SHAMROCK TRAILER PARTS, 12321 Turner, DETROIT, MICH.



NEW—SENSATIONAL—KEYLESS—ELECTRIC GAS TANK LOCK
Cup unlocks—SNAPS OPEN by pressing a button on your dash. **STOPS THIEVES—PROTECTS YOUR CAR—IMPROVES ITS APPEARANCE.** A money maker—every garage and filling station a potential dealer. Write immediately for exclusive distributorship proposition.

SNAP-UP GAS CAP CO. INC. ASHLAND, KY.
THE IDEAL CHRISTMAS GIFT FOR FATHER
IF DEALER CANNOT SUPPLY YOU, SEND FOR CIRCULAR



THE XMAS GIFT THAT WILL MAKE THE SHOP COMPLETE

An Ideal Present to the Craftsman Machinist and Mechanic . . .

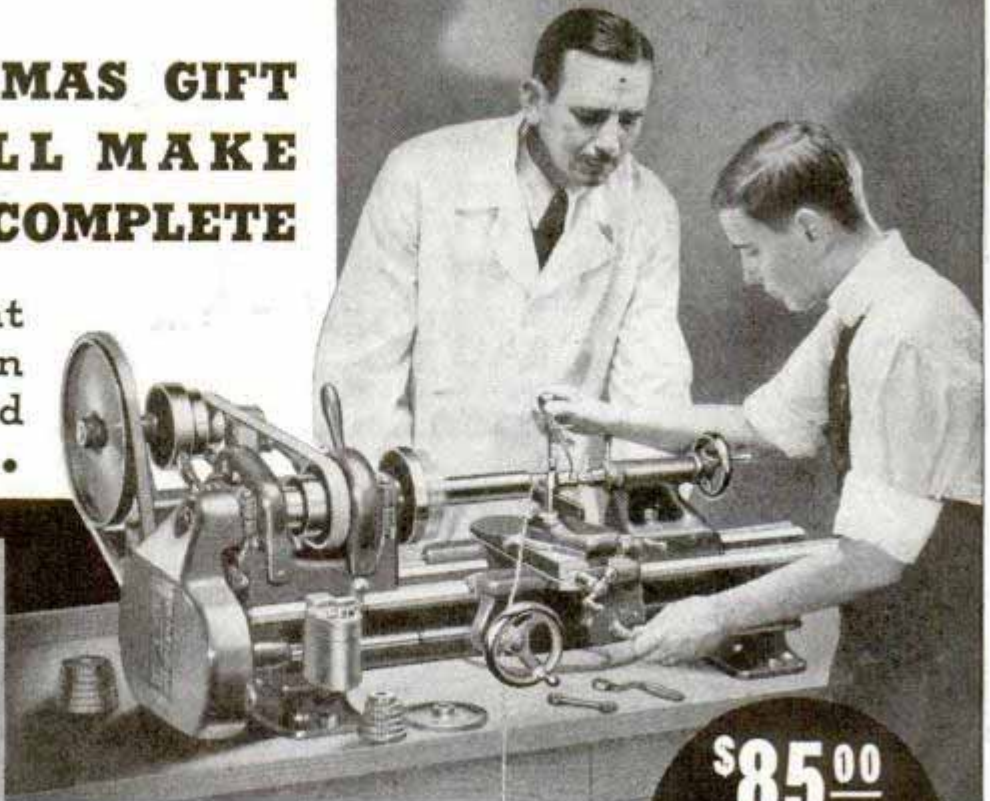

No. 415-YA, 9 1/4" swing by 3' bed Workshop Bench Lathe with Horizontal Motor Drive, 1/4 H.P. Reversing Motor, Switch, Belts, and Adjustable Belt Tension Countershaft. **\$117.00**
Wt. 320 lbs
(\$15 down—\$7 mo. for 18 mo.)

\$85.00
Less Motor Drive
Sold on Easy Payments as low as \$8.00 a month for 12 to 18 months.

THE SOUTH BEND BACK-GEARED, SCREW CUTTING METAL WORKING PRECISION LATHE

A Universal Lathe of Highest Quality and Accuracy for doing Model Work—Home Workshop Projects—Tool and Instrument Repair—Gunsmithing—Engineering Jobs—Inventive Work—Auto Repair—Electrical and Radio Service—Laboratory Work—General Shop Repair—and Metal Working Operations of All Kinds.

Send Coupon FOR THESE BOOKS

"How to Run a Lathe"—128 pages, 350 illustrations on lathe operation and valuable shop hints.

Catalog No. 46-A—illustrates, describes and prices 9" lathes in 3', 3 1/2', 4' and 4 1/2' bed lengths and 8 drives.

"The Home Workshop"—32 pages showing interesting shop views, equipment and shop instruction.



THE South Bend 9-inch Workshop Lathe is a gift to please any man or boy mechanically inclined. Besides a tool which will perform practically every metal working job in the shop, the 9" Workshop Lathe is a fine, precision machine. Accuracy—speed—and durability are designed and built into the 9" Lathe with all the skill and experience our 32 years of building fine lathes can produce.

Hundreds of different machining jobs can be handled on the 9" Workshop Lathe, such as drilling, turning, boring, reaming, cutting screw threads, facing, milling, filing and chucking in steel, iron, as well as wood, plastics, etc.

Features: Precision Lead Screw for cutting screw threads 4 to 112 per inch, Ball Thrust Bearing on Spindle, Twin Gear Reverse to Lead Screw, Automatic Longitudinal Screw Feed, 3/4" spindle hole takes collets up to 1/2".

38 attachments available for milling, grinding, draw-in collet chuck work, taper work, and other operations.

Used by well-known manufacturers in this country and abroad. The exacting requirements to which the 9" Lathe is held in doing tool and die work, production operations, etc., is proof of its accuracy and quality.

Other sizes in 9", 11", 13", 15" and 16" swing, bed lengths 3' to 12', C'shaft and Motor Drive. Priced \$85 to \$1500.

SOUTH BEND LATHE WORKS
636 East Madison St., South Bend, Ind., U.S.A.

SOUTH BEND LATHE WORKS,
636 E. Madison St., South Bend, Ind., U.S.A.

- No. 34LB, "How to Run a Lathe," 25c
- No. 46-A, 9" Workshop Catalog, Free
- No. 11W "The Home Workshop," Free
- Easy Payment Plan

Class of Work
Name
Address
City State

SOUTH BEND
Precision **LATHES**



HELLO BOYS—the sensational new ERECTORS ARE ALL LIT UP!

WOW! ERECTOR'S GONE ALL-ELECTRIC—Electric lights—4 speed Electric engine—Electro magnet



DEVELOPED AT THE GILBERT HALL OF SCIENCE

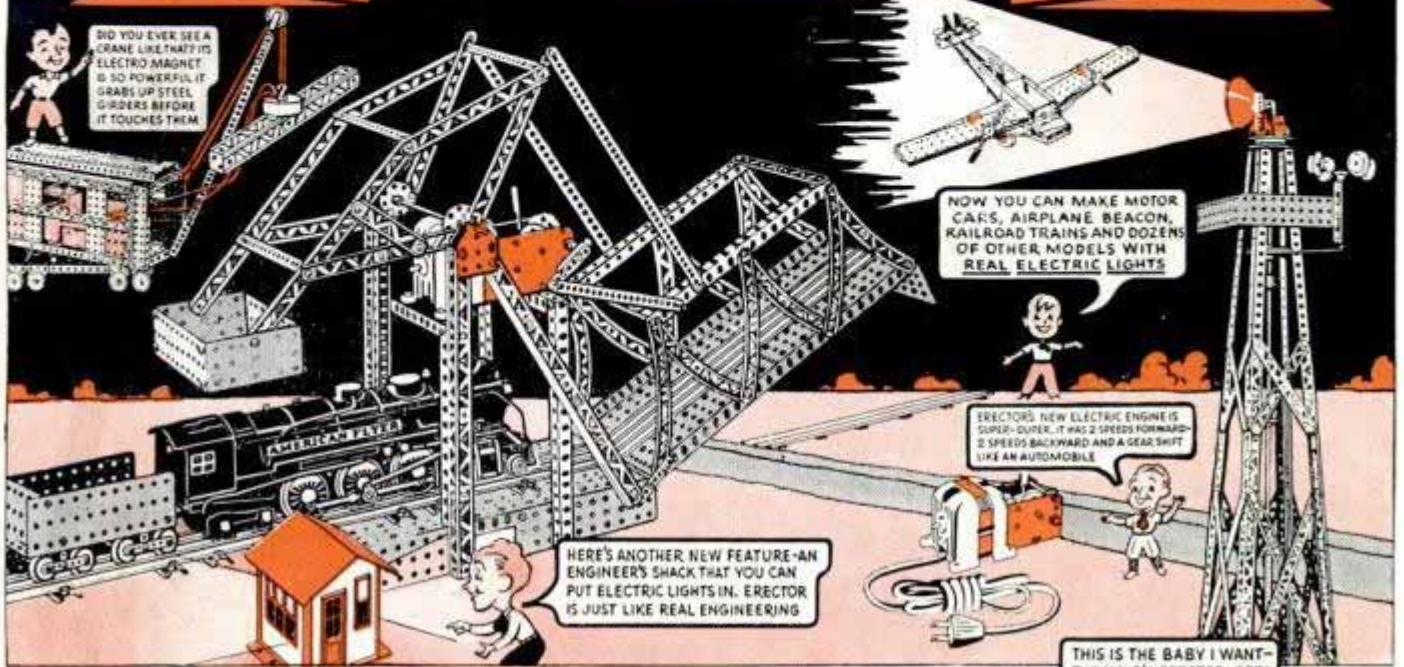

BOYS! Leading toy stores are showing a sensational new kind of Erector this year. An Erector that makes model-building more fun than the movies—more exciting than a football game. Because Erector has gone ALL-ELECTRIC.

Now, for the first time, you can build a revolving airplane beacon with real electric searchlight—construct electrically lighted railroad trains, Ferris wheel, airplanes, motor cars,—erect electric bridges that open and close—make mighty cranes that grab up steel girders by electro-magnetic power.

You can build all the engineering marvels you see on this page—and 100 more—with ONE Erector Set. Put dazzling electric lights on them. Make them buzz with action with the new 4-speed Erector electric engine. There are more blood-tingling thrills in the new All-Electric Erector than in a dozen ordinary toys. Tell Dad that Erector is your No. 1 choice of Christmas presents.



The Sensational New ALL-ELECTRIC ERECTOR

Get a load of the sensational, new No. 8 1/2 Erector. Crammed with exciting electrical and structural parts. Electric lights—110 volt electric engine with 4 speeds and automobile-type gear shift—powerful electro-magnet. Also, polished steel boiler shell—big red wheels—steel girders and structural plates—gears and pinions—a total of 18 lbs. of parts for building over 100 colossal, engine-driven, electrically lighted engineering marvels. Price \$12.95; other Erectors from \$1.00 to \$27.50.



A Christmas gift from A. C. Gilbert the inventor of Erector! The Mysterious Erectorscope. Brings you sights so amazing you can scarcely believe your own eyes. Free with catalog of New All-Electric Erectors.

THIS ERECTORSCOPE SURE IS SNAZZY



Free!

RUSH COUPON OR 1c POST CARD

Mr. A. C. Gilbert
Gilbert Hall of Science,
31 Erector Square,
New Haven, Conn.

Quick! I want one of your Mysterious Erectorscopes and advance catalog on your new All-Electric Erector. Rush both FREE.

Name.....

Street.....

City.....State.....



Chesterfields

...they double
your smoking pleasure

Good things are good because of their ingredients. Chesterfields are made from the best ingredients a cigarette can have . . . mild, ripe home-grown and aromatic Turkish tobaccos, cut into long even shreds, rolled in pure cigarette paper, and made just right for smoking.

Millions of smokers say, "Chesterfield's milder, better taste gives me more pleasure."

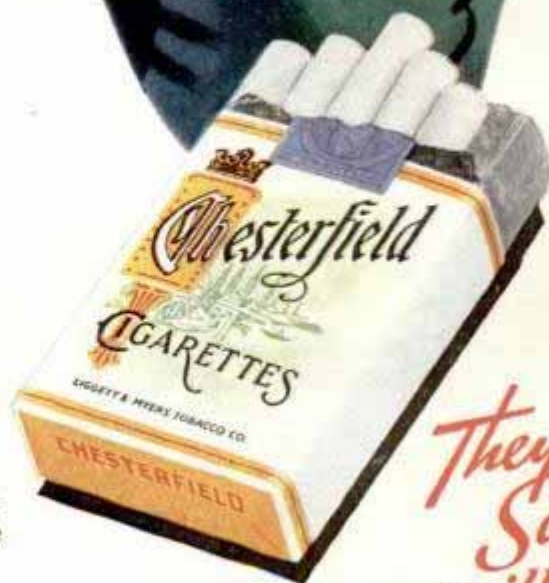

*They Satisfy
..millions*