

CHEMISTRY SOLVES NATURE'S SECRETS

POPULAR MECHANICS

MAGAZINE



WRITTEN SO YOU CAN UNDERSTAND IT

40426

REG. U.S. PAT. OFF.



JUNE
25 CENTS

MALROSE

SEE PAGE 888



HE WAS HEADING FOR "HOME SWEET HOME" WHEN -BANG! A BLOW-OUT!

TRAFFIC was heavy that blistering hot Summer afternoon as Mr. E. P. Keenan of Chicago, returning from a business trip, sped along Waukegan Road. His passenger did most of the talking. Mr. Keenan was too busy keeping one eye glued on the oncoming traffic in the other lane.

"We're making pretty good time," Keenan's pal said. He couldn't reach "Home Sweet Home" quickly enough.

A Close Shave

Bang! Like a thunderbolt the staccato crack of a blow-out rose above the roar of the motor. In desperation he gave the steering wheel one final, frenzied tug. The car bolted—lurched to the right—and came to a stop at the brink of a deep ditch. They were safe—yes. But after that close call no wonder Mr. E. P. Keenan will tell you that he now "believes in miracles."

It took Goodrich engineers to fight this driving hazard for American motorists and provide them with a real defense against high-speed blow-outs. They invented

Read TED HUSING'S account of the terror-crowded moments experienced by a Chicago motorist

the now famous Life-Saver Golden Ply which is found only in Goodrich Silvertown Tires. This remarkable Golden Ply is a layer of special rubber and full-floating cords, scientifically treated to resist internal tire heat. By resisting this heat, I am told, the Golden Ply keeps rubber and fabric from separating—keeps blisters from forming. Thus the blow-out that might have been, never gets a start.

Are Your Tires Safe?

You can bet your bottom dollar that Mr. E. P. Keenan of Chicago, is now riding on Silvertowns. My advice to every motorist who has his own and his family's safety at heart is to see these life-saving tires at any Goodrich Silvertown Store or Goodrich Dealer's. The sooner the safer.



FREE! Millions have joined the Silvertown Safety League—pledged to drive safely. See your Goodrich dealer and join now. Nothing to buy. He'll get for you FREE a handsome emblem with red crystal reflector to protect you if your tail light fails.

Goodrich SAFETY Silvertown

With Life-Saver Golden Ply Blow-Out Protection

**Re-
Vitalize**

**YOUR
ENGINE**



WITH NEW

**CHAMPION SPARK
PLUGS**

Spark Plug Change Week is Champion's annual reminder to millions of motorists that Spring is engine tune-up time. Champion dealers everywhere are at your service to show you why all spark plugs, including even Champions, should be retired from active service after 10,000 miles. The habit of changing spark plugs has grown enormously be-

cause new Champion Spark Plugs have proved in service that they re-vitalize engine performance and actually save their cost in renewed gasoline economy. See your Champion Spark Plug dealer this week. Have him check and clean your spark plugs, and replace with new Champions, if necessary. You can depend on Champion Spark Plugs.



CHECK AND CLEAN SPARK PLUGS WHEN YOU CHANGE OIL

When writing to advertisers please mention Popular Mechanics

1927

1937

TEN YEARS AGO THIS OCTOBER

It is interesting to turn back the pages of the years and read the record of a business. . . . For time has a way of testing purposes and policies. Good years and lean reveal the character of men and organizations. . . . The fundamental policy of the Bell System is not of recent birth—it has been the corner-stone of the institution for many years. On October 20, 1927, it was reaffirmed in these words by Walter S. Gifford, President, American Telephone and Telegraph Company.

“The business of the American Telephone and Telegraph Company and its Associated Bell Telephone Companies is to furnish telephone service to the nation.

“The fact that the responsibility for such a large part of the telephone service of the country rests solely upon this Company and its Associated Companies also imposes on the management an unusual obligation to the public to see to it that the service shall at all times be adequate, dependable and satisfactory.

“Obviously, the only sound policy that will meet these obligations is to continue to furnish the best possible telephone service at the lowest cost consistent with financial safety. This policy is bound to succeed in the long run and there is no reason for acting otherwise than for the long run.



“Earnings must be sufficient to assure the best possible telephone service at all times and to assure the continued financial integrity of the business. Earnings that are less than adequate must result in telephone service that is something less than the best possible.

“Earnings in excess of these requirements must either be spent for the enlargement and improvement of the service furnished or the rates charged for the service must be reduced. This is fundamental in the policy of the management.

“With your sympathetic understanding we shall continue to go forward, providing a telephone service for the nation more and more free from imperfections, errors or delays, and always at a cost as low as is consistent with financial safety.”



**BELL
TELEPHONE
SYSTEM**

Popular Mechanics Magazine

H. H. WINDSOR, Founder

H. H. WINDSOR, Jr., Editor and Publisher

June, 1937

Vol. 67, No. 6

Special Features

The Mud That Runs the World	-	801
Things Are Not What They Seem	-	809
Grim Jokes of the Fire Demon	- -	820
Summer Comfort at Low Cost	- -	826
You Can't Believe Your Ears	- -	834
Oilier Oils for Your Car	- - -	840
Searching for New Wood Ideas	- -	850
The Electric Age in Food	- - -	858
"Wigwagging on the Diamond"	-	866
Sea Lore Kept Alive by Films	- -	874
Dispatchers of the Sky Lines	- -	882
Rhythm in the Making	- - -	890

(Continued on next page)

You Drive Four Cars at Once

IF YOU'RE a safe driver, you really pilot four cars instead of one when you breeze down the highway—your own, the one behind you, the car ahead and the car you can't see, around the next turn. So says "Cannonball" Baker who has driven more than 3,000,000 record-smashing miles and learned a lot about keeping out of trouble on the road in the process. It takes thought, care and ability—real brains—to drive safely and in giving you the benefit of his experiences during years at the wheel, the "Cannonball" points out some of the common mistakes which land drivers in hospitals and morgues. Watch for this sermon on safe driving in the July issue. You will find good driving habits not only keep you out of accidents but save you fuel, oil and repair bills as well.

Next Month

FLOWERS and coal—a strange pair. Yet, curiously enough, coal has enabled man to duplicate not only the fragrance of the flowers but the hues of the rainbow as well. Watch next month for the conclusion of "Things Are Not What They Seem," illustrated with eight pages of Coloroto pictures.

Shooting History

HOW VALUABLE to us today would be a talking picture of Lincoln or of Washington. Important events of today—the history of tomorrow—are being preserved by the movies for our children's children. A century hence a child will learn from a strip of film what President Roosevelt looked like and how he talked. Recording history on film is exciting business as you'll find by reading "Shooting Modern History" next month.

Super-Streamlining

A STREAMLINE transport plane could fly twenty or thirty miles an hour faster on the same or less power if it were super-streamlined. And the difference between ordinary streamlining and super-streamlining usually is so slight that an untrained observer cannot tell one from the other. An article next month explains how airplane speeds are being increased by seemingly minor changes in shape.

Published monthly by POPULAR MECHANICS CO., 200 East Ontario Street, Chicago, U. S. A. Single copy in United States, 25 cents; \$2.50 a year, \$4.00 for two years, \$5.00 for three years in United States and possessions, Canada, Newfoundland, Labrador and countries of the Americas and Spain. To all other countries add \$1.00 a year extra for overseas postage. Changes in address must be reported to us immediately to eliminate delay. Entered as Second Class Matter, Sept. 15, 1903, at the Post Office at Chicago, Illinois, under Act of March 3, 1879. Entered as Second Class Matter at the Post Office Department, Canada. Copyright 1937, by Popular Mechanics Co. in the United States, Australia and France.

This One



POPULAR MECHANICS

**EVERY TIME
YOU BUY
GASOLINE &
OIL...ADD
PYROIL**

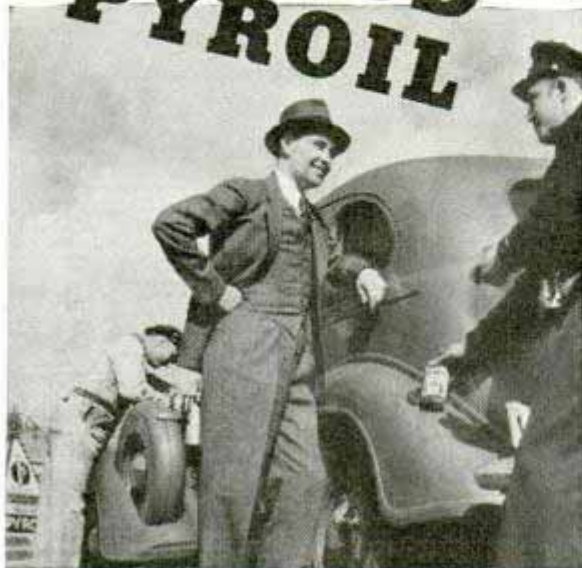

WHAT IS PYROIL?

Pyroil is a concentrated SUPER lubricant. You simply add one or two ounces to each filling of gas and oil.

WHAT DOES PYROIL DO?

It makes valves work better and increases power . . . It also stops corrosion which damages pistons, rings and bearings. It reduces wear and offsets repairs.

You need Pyroil for many emergencies; when your oil level drops; when you undergo hard driving; when you use high test gas; when you drive through storms, quick weather changes, over dusty roads. Pyroil establishes its own (extra powerful) sheath of protection—a glossy, slippery film—upon every vital and delicate moving part. This film takes the punishment—keeps the metal from clashing wear and damage that otherwise does occur. And Pyroil does not corrode. It prevents corrosion!

Ask for an ounce or two of Pyroil every time you buy gasoline and oil. Costs but a few cents. Saves you many dollars. Sold the world over. Mail coupon below. Manufactured and Guaranteed by Pyroil Company, W. V. Kidder, Founder, 56 Pyroil Bldg., La Crosse, Wisconsin, U. S. A.

PYROIL HAS BEEN TESTED BY POPULAR MECHANICS AND IS USED BY POPULAR MECHANICS' PRESSES AND EQUIPMENT.

DISTRIBUTORS:

Check and mail coupon for facts of our unusual Sales Opportunity for you. Big season starting now.



**SIMPLY
ADD TO
GAS & OIL**

This 12-ounce can treats 7 Quarts of Lubricating Oil.

**PYROIL COMPANY,
56 Pyroil Bldg., LaCrosse, Wis., U. S. A.**

- Please send Free facts on Pyroil's money saving and protection features.
 Send details of Premium Plan and Business Opportunity for me.

Name.....

Address.....

City.....County.....State.....

(Contents—Continued)

AUTOMOTIVE

Gauge measures thickness of paint on car	824
Vulcanizing set heated by storage battery	824
Motorcycle has streamline design for speed	825
Speed limit is painted on pavement	832
Three-wheel tank truck refuels airplanes	847
Switch engine runs on rails or highway	849
Tractor conquers snow at work or play	849
Automatic transmission tried thirty years	862
Motorists drive into bank to make deposits	871
Glass body shows steel frame of auto	873
Tougher tires of rayon resist heavy wear	880
"Blacking detector" checks headlight bulbs	887
Truck has movable floor for loading	894

AVIATION

Forty-passenger plane to have four engines	819
Plane grows wings as student learns to fly	823
Tiny Diesel aircraft motor	830
Radio loop practice set on movable platform	831
Assembling giant air liner	839
Radio trailer guides planes to blind landings	845
Red light warns of drop in gas pressure	847
Latest weapons in aerial fights	856
Pelorus helps navigate round-the-world plane	862
Radio signpost marks airport for planes	871
Tire cleats and "wraps" aid winter flying	879
Wings for superplanes riveted by experts	880
Coast-guard planes refueled at sea	881
Wind tunnel to test planes	881
Balloon "dog team" to explore stratosphere	887
Plane engine has cannon bore in prop shaft	889
Man-power plane pedaled like bike	894
Test stand tips plane engine to imitate dive	162A

BOATS

Latest U. S. submarine ready for trial runs	825
Ocean liner gains speed by adding to length	831
Two forty-five ton Diesels drive yacht	864
Streamline speedboat resembles airplane	888

CONSTRUCTION

Window in garage door adds to attractiveness	818
Church steeple toppled by tractor-drawn cable	824
Highways of tin cans, molasses and aluminum	824
Waterproof bond for cement	830
Streetcar fleet becomes a bungalow court	833
Giant arches on Germany's super-road	844
Huge tamper pounds road surface hard	844
Quick drying of concrete to speed building	865
Machine makes bricks for low-cost homes	878
Non-skid street surfacing material reduces cost	878
Factory-built steel house towed to site	889

FARMS

Cotton picker covers half acre per hour	818
Water jacket for cooling milk can	848
"Hundred acre" tractor serves small farm	872
Cutter for corn makes canning easy	880

MODELS

Relief map of plywood cut with jigsaw	832
Ten-foot streamline rail car built at school	855
Skillful illumination of a model	870

MOVIES AND PHOTOGRAPHY

Lenses molded from plastic superior to glass	819
Television camera sharpens its eye for detail	846
Range finder for focusing in the dark	896

RADIO AND ELECTRICITY

Radio detects illegal tapping of pipe line	844
Wind charger runs ship's radio	847
Portable unit generates alternating current	854
Oil station floodlit from outside	855
World at fingertips of radio executive	861
Electric robot with a memory	864
Miniature cathode-ray tube in portable oscilloscope	897
Amplifier built into portable case	898
Five-meter transceiver mounted on bicycle	900
Practical radio hints	901
Automatic tuner for radio and television	902
Piezo-electric phonograph record pickup	902
Portable power unit for radio and lights	902

(Continued to page 6A)

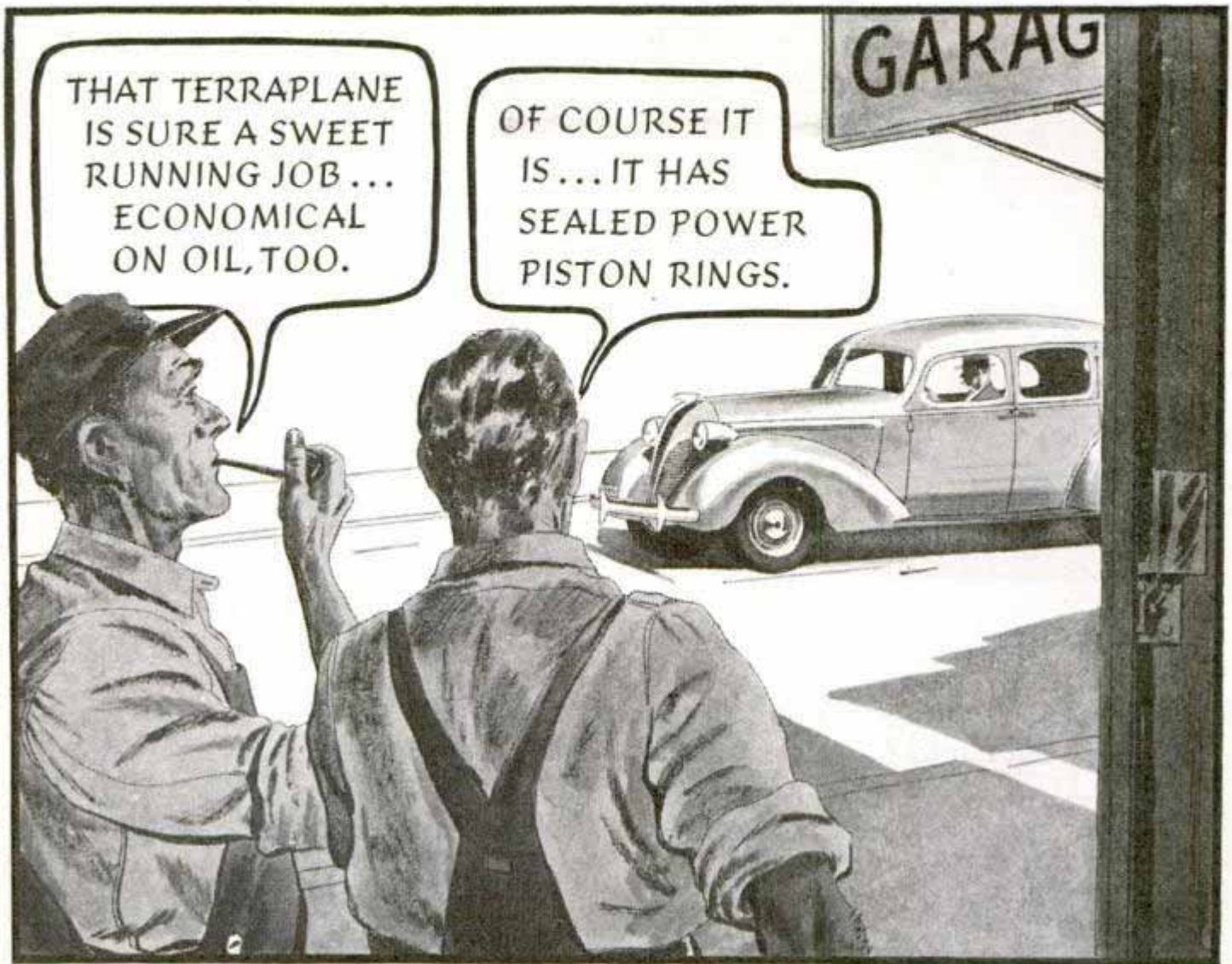

SEALED POWER PISTON RINGS

Best in New Cars! Best in Old Cars!



SEALED POWER LO-EX* PISTONS

give top notch performance

Engineers everywhere agree that Sealed Power LO-EX Pistons are the finest pistons ever built. They're light yet sturdy. Leading cars feature them as standard equipment. If your car needs new pistons, specify Sealed Power LO-EX. Remarkable performance will make you glad you did!

*LO-EX is a trade mark registered for pistons cast and alloys produced exclusively by Aluminum Co. of America.

Terraplane has a reputation to uphold—as a sweet running, economical car. So, Terraplane engineers specify Sealed Power Rings—because they know as do the engineers of Buick, Cord, Hudson, Nash LaFayette, Oldsmobile, Pontiac, Willys and other cars—that these famous rings *seal* power properly.

Sealed Power now offers you a remarkable new-type ring—already proved in millions of cars—featuring an inner spring of imported steel which without excess tension creates a perfect seal against blowby—ending "between meal oil hunger," restoring new car pep, speed, power.

But if your car needs new valve guides, new bearings or new Sealed Power Lo-Ex Pistons, even these great rings can't bring back 100% oil economy. Your Sealed Power ace mechanic will tell you what your car needs. Also, get our valuable new booklet, "New Low Cost Way to Save Oil and Gas and Increase Pep." It's free!

SEALED POWER CORPORATION
Dept. 276 Muskegon, Michigan

Canadian Factory at Walkerville, Ont.

Manufacturers of Piston Rings, Pistons, Piston Expanders, Piston Pins, Valves and Cylinder Sleeves



When writing to advertisers please mention Popular Mechanics



Shaves Are Kinder To Your Face

when razor and blade match

FOR clean, comfortable shaves men everywhere agree that a Gillette Blade in the Gillette Razor is the perfect shaving combination. These two are *made for each other*. Designed as a unit — produced in the same factory — they give a measure of shaving comfort that is matchless.

So why experiment when you *know* that the Gillette Blade is the ideal teammate for your Gillette Razor. Buy a package from your dealer today. Use one in your Gillette Razor tomorrow morning and enjoy a wonderful new kind of shaving thrill!

Reputable merchants never offer substitutes for Gillette Blades. Always ask for them by name.

Tune in Gillette's "Original Community Sing" with Milton Berle and other stars Sundays 10 P.M., E. S.T., CBS Network, Coast to Coast.

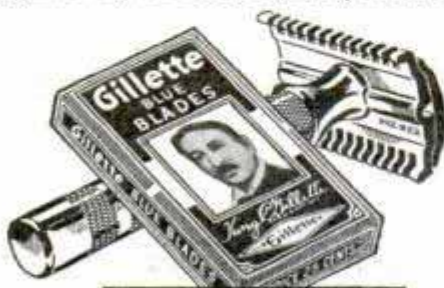

Gillette Blades

Precision-made for the Gillette Razor

(Contents—Continued)

RAILROADS

Mile-long rails smooth out train ride	848
Locomotive goes for ride on flat car	853
Modern locomotives save fuel	865
Sand polishes streamliners on desert trips	124A

SCIENCE AND INDUSTRY

Freezing in can keeps fruit juice nutritious	817
Salmon's memory discredited	817
Sun bright in midnight sky of stratosphere	833
Germ-killing chemicals found in onions and garlic	849
Observers to ride inside giant telescope	853
Radium "bombs" carried safely in pneumatic tube	854
Asiaties discovered America in Ice Age	863
"Solid" oil mined by squeezing it from sand	872
Smell is measured by freezing it	873
Acid blowgun restores ink in tampered documents	879
Germ-killing rays fight disease and decay	894
Magnet lifts twenty times its own weight	120A
Odor added to gas helps detect leaks	138A

SPORTS

Fourteen-pound boat motor for outings	830
"Outrigger bikes" ride rails on flanged wheels	861
Sponge cushion on bike seat adds comfort	863
Dressing room mounted beside automobile	895

TOOLS

Suction-cup tool lifts lens off headlamps	838
Tool dresses ignition quickly	887
Dustless floor edger	896

MISCELLANEOUS

Robot speeds up wire service	818
Fire hose seeps water to keep from burning	819
Curtains of light mark speed of artillery shells	823
Acid water reveals murder many years old	825
Automatic dial stock ticker	830
Burglar or fire detector phones for help	832
Unthreaded pipes joined with leakproof fittings	845
Ventilator used to pipe water into tanks	848
Identification by "eye prints" studied by scientists	854
Replicas of mission bells made in workshop	855
Shoe shop moved outdoors under canvas shelter	862
Hands of clock taken down for inspection	863
"Water sweep" attached to hose cleans lawn	864
Welders working on tunnel create own fireworks	872
Groceries sold by electricity	873
Variable spacing typewriter makes margins even	879
Log carrier made of cloth is handy	887
Ash tray in table unscrews for cleaning	889
Fishways built for migrating salmon	895
Glass fibers strong as steel	896
Nickel coin contains more copper than nickel	896
Police use old photo-flash bulbs as targets	116A
Flexible grip pulls pilings without breakage	120A

Craftsman and Shop Notes

AUTOMOTIVE

Auto with home comforts offers travel luxury	938
Car motor performance shown by vacuum gauge	958
Filling gasoline tanks safely	958
Truck wheels removed with one-wheel dolly	958
Driving your car safely	959
Easy carburetor adjustment	960

BOATS AND BOATING

Tilted boat seat eases body strain	912
Midget model of the "Mayflower"	914
Canoe carries its own wheeled cradle	929
"Airstream" sail rig steps up speed	947

CAMPING, FISHING, HUNTING

Spool holder helps in wrapping fish poles	908
Camp stove uses canned heat	913
Collapsible garment hook on tent pole	918
To cast a fly	920
Weighted fish stringer	929
Spring-wound fish-line drier	934
Fishhook vise from safety pin	936

(Continued to page 8A)

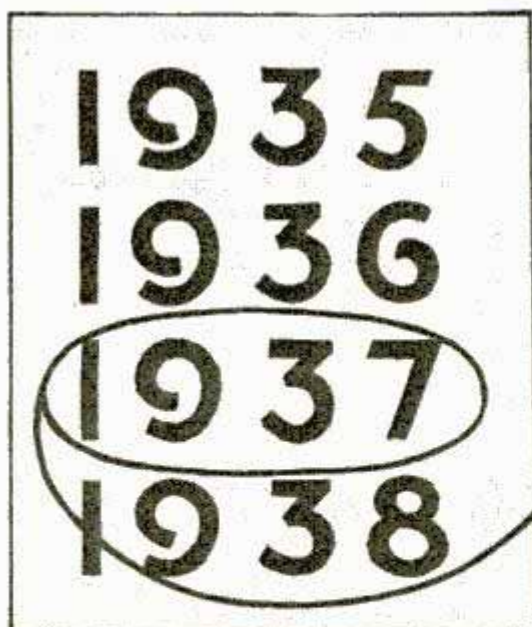

Now

is the time!

Business is Searching for YOU, if

RIGHT now, in many lines, there is a search for really *good* men—managers, leaders—men who can take charge of departments, businesses, branch offices, and get things humming.

As always, there are not enough ordinary jobs to go 'round—but rarely before, in the history of American business, has there been so much room at the *top!* New jobs are being created by the business pick-up in almost all lines—jobs that pay splendidly and that open the way to lifetime success.

Ordinarily, there would be plenty of men to fill these jobs—men in junior positions who had been studying in spare time. But most men have been letting their training slide during these dark years of depression . . . “What’s the use?”—You have heard them say. Perhaps there has been some excuse for sticking to any old kind of a job one could get the past few years—but the door is wide open for the man with ambition and ability *NOW!*

And don’t let anyone tell you that “Opportunity Only Knocks Once”—that’s one of the most untruthful sayings ever circulated. Op-

portunities flourish for *every* American every day of his life.

Far more to the point is to be ready—to be *prepared*—to make yourself *interesting* to the big-time employer—and LaSalle offers you a short-cut method of qualifying for opportunity jobs in accounting, law, traffic, executive management, and kindred occupations.

LaSalle Extension University is 28 years old—averages 40,000 enrollments a year—60 American firms each employ 500 or more LaSalle-trained men—surveys show that LaSalle students attain 40% average salary increase after graduation—10% of all C. P. A.’s in the U. S. A. are LaSalle-trained.

Why not find out what LaSalle has done and is doing for men in *your* position? Send and get the facts; see what LaSalle can do for you, personally!

There’s no question about it—business is picking up—jobs are looking for *men*—the time has come for you to *qualify* for prosperity. Mail this coupon today!

LA SALLE EXTENSION UNIVERSITY, Dept. 664-R, Chicago

I am in earnest about my success and I would like to have your special booklet—without any cost or obligation to me—about my opportunities and your success training in the business field I have checked.

- | | |
|--|--|
| <input type="checkbox"/> Business Management | <input type="checkbox"/> Industrial Management |
| <input type="checkbox"/> Higher Accountancy | <input type="checkbox"/> Modern Foremanship |
| <input type="checkbox"/> Traffic Management | <input type="checkbox"/> Business Correspondence |
| <input type="checkbox"/> Modern Salesmanship | <input type="checkbox"/> Business English |
| <input type="checkbox"/> Commercial Law | <input type="checkbox"/> Effective Speaking |
| <input type="checkbox"/> Law: Degree of LL. B. | <input type="checkbox"/> Office Management |
| <input type="checkbox"/> Expert Bookkeeping | <input type="checkbox"/> Stenotypy |
| <input type="checkbox"/> C. P. A.’s Coaching | |

Name _____ Age _____

Position _____ Address _____

LaSalle Extension University

Ask for one of these booklets—or a similar one on your own field of business. They are free!

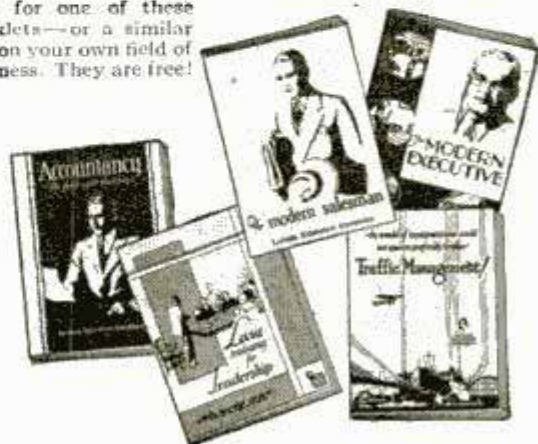

DID YOUR BATTERY COME FROM A GOOD PIG?



● "Did you ever hear of a pig-dust collector?"

"That's what I am. They say 'pigs is pigs' but that's not true when it comes to pig lead for storage batteries. Just a shade of impurity may upset the chemical balance inside a battery and shorten its life.

"So here at Willard we saw apart sample pigs of lead from every shipment—collect the lead sawdust and analyze it in laboratories *before* the shipment is unloaded. Result: none but the purest of materials get into a Willard Battery."

* * *

This is typical of the 74 tests and inspections which control every operation in the building of Willard Batteries. Because only the best of materials and the finest of skill go into them, *Willards last longer—crank faster—don't let you down.* And owners' records prove that Willards Cost Less To Own.

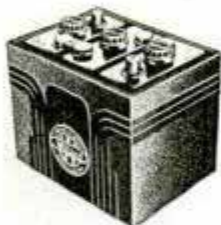

You'll find today's prices for a Willard much lower than you might expect.

Willard Storage Battery Co.
Cleveland • Los Angeles
Toronto, Canada

Willards

COST LESS TO OWN!

Because they last longer . . .
crank faster . . . don't let you down

(Contents—Continued)

FARM

Tom Thumb greenhouses grow plants early	919
Chicken wire attached for easy removal	937
Hog trough anchored with metal stakes	946
Keeping lines from getting under cultivator tongue	950

FURNITURE

Dining set for the garden	907
Folding refreshment stand	910
Breakfast set in old Spanish style	931
Sheet-metal umbrella holder on chair back	946

HAND TOOLS

Shovel has pry block to remove roofing	908
Flooring butted together tightly with simple tool	909
Plane serves as handle for sanding block	926
Rubber grips for coarse rasps	936
Coil spring on drill relieves arm strain	940
Tool traces profile of turning	946

HOUSEHOLD

Solution to clean painted surfaces	906
Cement to repair crockery	918
Renewing luster of window glass	919
Removing water spots from silk cloth	934
Removing mildew stains	937
Easy way to solve your home problems	938

LAWN AND GARDEN

Ridding the lawn of gophers	912
Flagpole from bamboo	918
Plant stakes from coat hangers	930

OFFICE

Pencil pointer and cleaner in match book	906
Vacuum paperweight is handy	926
Window envelopes aid in typing small cards	928
Feeding mimeograph machine by hand	934

PHOTOGRAPHY

Washing photo films in lavatory	906
Photoprinter fits on bath tub	917
Fun with shadow pictures	927
Filter for your photo enlarger	930
Changing photoflash bulbs quickly	936
Heated photoprint drier saves time	951

POWER TOOLS

Supporting long rods in lathe	918
Wooden grinder head has babbitted bearings	928
Twin lathe arbor saves time	950
The mechanics of drills, Part II	953
Spur gear cutter improvised from lathe tool	960

MISCELLANEOUS

Midget steam engine develops high speed	903
Dressing room improvised from umbrella	906
Truck tire provides safe sandbox	908
Shaper depth collar to prevent scored work	908
Nested dish set for picnics	909
Fork removes burrs from dog's hair	912
Matchbox presents drills for instant selection	912
Signal lights from flashlight and toy balloon	913
Marking live-center turnings	917
Non-skid checkers for playing on train	918
Keeping bottle corks at hand	926
Tool to remove bulbs from high fixtures	926
Cement for modeling	928
Relay saves fuses on electrical test bench	930
Sharpening lawnmower safely	930
Painting underside of porch floors	934
New solarium gives comfort	935
Electrician's tape strengthens sandpaper strips	936
Venting fuel-oil tanks correctly	936
Automatic control for toy-train crossovers	937
High-temperature electric furnace	941
"Cellophane" speeds press feeding	945
Concrete worker's straightedge fitted with handle	945
Tailor wears tape measure on finger	946
Raising pressure in ammonia drum	950
Rubber carrier for hot cans	950
Cool handle for rivet-bucking bar	951
Collapsible display stands for show windows	952
Fence wire pinned to post easily removed	952
Spring thumbtacks loosen drawing quickly	952
Trapping rodents for game survey	952

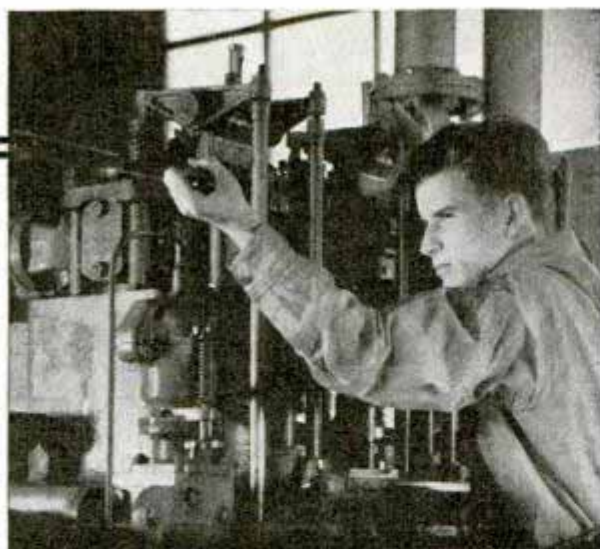

HERE'S THE WAY TO
BECOME AN EXPERT
ON
**DIESEL
ENGINES**



● If you work in industrial power and lighting plants; in small community power and light plants; in municipal pumping stations for water supply; in construction work, including trucks, tractors, hoists, graders and power shovels; in transportation, with special reference to buses, rail buses, locomotives; in marine service, including ocean liners, freighters, river and lake vessels, yachts and small cabin cruisers—

You should become an expert on Diesel Engines!

Your future depends on it. And the time to insure your future is—to-day. In your spare time, by study of the I.C.S. Diesel Power Course, you can become an expert. Mail the coupon for free information.

INTERNATIONAL CORRESPONDENCE SCHOOLS

BOX 5676-H, SCRANTON, PENNA.

★ Without cost or obligation, please send me a copy of your booklet, "Who Wins and Why," and full particulars about the subject *before* which I have marked X: ★

TECHNICAL AND INDUSTRIAL COURSES

DIESEL POWER

- | | | | |
|--|--|--|---|
| <input type="checkbox"/> Architect | <input type="checkbox"/> Boilermaker | <input type="checkbox"/> Refrigeration | <input type="checkbox"/> Civil Engineering |
| <input type="checkbox"/> Architectural Draftsman | <input type="checkbox"/> Heat Treatment of Metals | <input type="checkbox"/> Plumbing <input type="checkbox"/> Steam Fitting | <input type="checkbox"/> Surveying and Mapping |
| <input type="checkbox"/> Building Estimating | <input type="checkbox"/> Sheet Metal Worker | <input type="checkbox"/> Heating <input type="checkbox"/> Ventilation | <input type="checkbox"/> Bridge Engineer |
| <input type="checkbox"/> Contractor and Builder | <input type="checkbox"/> Telegraph Engineer | <input type="checkbox"/> Air Conditioning | <input type="checkbox"/> Bridge and Building Foreman |
| <input type="checkbox"/> Structural Draftsman | <input type="checkbox"/> Telephone Work <input type="checkbox"/> Radio | <input type="checkbox"/> Steam Engineer | <input type="checkbox"/> Chemistry <input type="checkbox"/> Pharmacy |
| <input type="checkbox"/> Structural Engineer | <input type="checkbox"/> Mechanical Engineering | <input type="checkbox"/> Steam Electric Engineer | <input type="checkbox"/> Coal Mining |
| <input type="checkbox"/> Management of Inventions | <input type="checkbox"/> Mechanical Draftsman | <input type="checkbox"/> Marine Engineer | <input type="checkbox"/> Mine Foreman <input type="checkbox"/> Navigation |
| <input type="checkbox"/> Electrical Engineer | <input type="checkbox"/> Machinist <input type="checkbox"/> Toolmaker | <input type="checkbox"/> R. R. Locomotives | <input type="checkbox"/> Cotton Manufacturing |
| <input type="checkbox"/> Electric Lighting | <input type="checkbox"/> Patternmaker | <input type="checkbox"/> R. R. Section Foreman | <input type="checkbox"/> Woolen Manufacturing |
| <input type="checkbox"/> Welding, Electric and Gas | <input type="checkbox"/> Aviation Engines | <input type="checkbox"/> Air Brakes <input type="checkbox"/> R. R. Signalmen | <input type="checkbox"/> Agriculture <input type="checkbox"/> Fruit Growing |
| <input type="checkbox"/> Reading Shop Blueprints | <input type="checkbox"/> Automobile Mechanic | <input type="checkbox"/> Highway Engineering | <input type="checkbox"/> Poultry Farming |

BUSINESS TRAINING COURSES

- | | | | |
|--|--|--|--|
| <input type="checkbox"/> Business Management | <input type="checkbox"/> C. P. Accountant | <input type="checkbox"/> First Year College | <input type="checkbox"/> Grade School Subjects |
| <input type="checkbox"/> Office Management | <input type="checkbox"/> Bookkeeping | <input type="checkbox"/> Business Correspondence | <input type="checkbox"/> High School Subjects |
| <input type="checkbox"/> Industrial Management | <input type="checkbox"/> Secretarial Work | <input type="checkbox"/> Stenography and Typing | <input type="checkbox"/> College Preparatory |
| <input type="checkbox"/> Traffic Management | <input type="checkbox"/> Spanish <input type="checkbox"/> French | <input type="checkbox"/> Civil Service | <input type="checkbox"/> Illustrating <input type="checkbox"/> Cartooning |
| <input type="checkbox"/> Accountancy | <input type="checkbox"/> Salesmanship <input type="checkbox"/> Advertising | <input type="checkbox"/> Mail Carrier | <input type="checkbox"/> Lettering Show Cards <input type="checkbox"/> Signs |
| <input type="checkbox"/> Cost Accountant | <input type="checkbox"/> Service Station Salesmanship | <input type="checkbox"/> Railway Mail Clerk | <input type="checkbox"/> Apartment House Management |

Name.....Age.....Address.....

City.....State.....Present Position.....

If you reside in Canada, send this coupon to the International Correspondence Schools Canadian, Limited, Montreal, Canada

When writing to advertisers please mention Popular Mechanics

Are You TIED TO YOUR JOB?

Are you in a rut, tied to a factory job, with little or no prospect for advancement? Will you be doing the same thing 20 years from now?

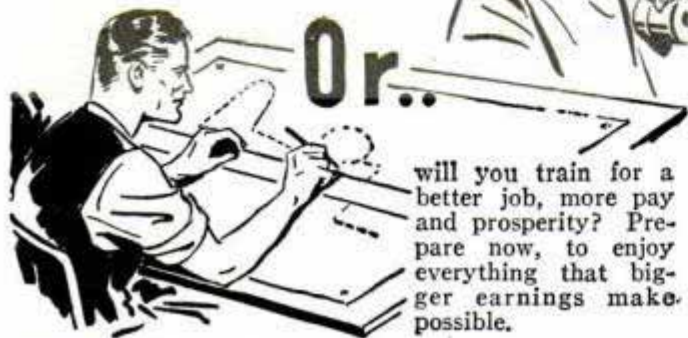

Or.. will you train for a better job, more pay and prosperity? Prepare now, to enjoy everything that bigger earnings make possible.

The Road to Advancement DRAFTING

In every walk of life practical training in DRAFTSMANSHIP will prove valuable. Even if you don't accept a job as a DRAFTSMAN, you will be money ahead by taking Engineer Dobe's Course. You will be amazed at the speed with which you can learn in your own home in your spare time by Engineer Dobe's PRACTICAL METHOD.

JOBS NOW OPEN

In all industries, Drafting leads the way. In Aviation, Electricity, Building, Machinery, Automobile, Draftsmen must be used, and their work comes first. Recovery in industry and building is definitely on the way. Many trained Draftsmen will be needed on better jobs at better pay and shorter hours. Prepare NOW!

Learn at Home From an Engineer

I will teach you my practical method that has been successful with thousands since 1900. I will furnish you with all tools and a drawing table. I will teach you in a very short time by mail in your spare time until you actually have a desirable Draftsman's job, or prepare you for better pay in the job you now have. No High School or previous experience needed. You must be entirely satisfied with my personal training UNTIL COMPETENT and until assisted to a position. OR YOU GET ALL YOUR MONEY BACK. Start NOW and get the training. Prepare for more pay and a better job. Send the coupon below TODAY! Time is money! Don't delay! No obligations!

Complete Outfit
Size 20 x 25 inches
FURNISHED

Free Book!

ENGINEER DOBE, Div. A337, Libertyville, Ill.

Send me your free book, "Successful Draftsmanship" and explain how you will assist me to a good position as a draftsman.

Name..... Age.....

Address.....

Post Office..... State.....

To EARN MORE MONEY in AVIATION

Aviation needs newly trained men. But Aviation executives who pay \$200 to \$700 a month for Pilots and Mechanics demand men with thorough, expert training... the kind of Approved training LINCOLN offers you.

LINCOLN is Government Approved! Flight courses give you required training for Government Pilot's License. Government Approved Mechanic's course gives you required training for Government Mechanic's License. Exceptional training facilities. Spacious, modernly lighted airport. Fleet of modern-to-the-minute training planes. Biplanes, high and low wing monoplanes, transport cabin planes for complete experience. Modernly equipped Mechanics School where factory methods combined with shop and laboratory practice make learning easy and thorough. Both Flight and Mechanics School under Government Licensed Instructors. School now in 27th year; 17th year teaching aviation. Now is the time and Lincoln the place to prepare for YOUR big job in aviation. Write for complete information. Please state age.

Lincoln Airplane & Flying School, 209-G Aircraft Building, Lincoln, Nebr.

Train
at
LINCOLN

Be A Journalistic or NEWS PHOTOGRAPHER

Learn at Home—in Spare Time

how to make money with your camera, selling pictures to magazines, newspapers, trade journals. We teach you at low cost. No special camera or previous experience needed. Write for FREE BOOKLET. Universal Photographers, Inc., Dept. 76, 10 West 33 Street, New York City.

GAG-CARTOON!



AND MAKE BIG MONEY—AT HOME—BY MAIL! Magazines pay up to \$200.00 per cartoon. Get in this NEW FIELD and be your own boss! My 50 lesson—1000 illustration course shows you how. FREE CARTOON MARKETS INCLUDED—only \$2.80 course of its kind. All for.....

Free Drawing Set if you act at once. WRITE TODAY—Stamp brings FREE details. MOON GAG-CARTOON SCHOOL. Paramount Bldg. Dept. A-1, Fall Creek, Wis.

RADIO ENGINEERING



RCA Institutes offer an intensive course of high standard embracing all phases of Radio. Practical training with modern equipment at New York and Chicago schools. Also specialized courses and Home Study Courses under "No obligation" plan. Catalog Dept. PC-37.

RCA INSTITUTES, Inc.

75 Varick St., New York 1154 Merchandise Mart, Chicago
Recognized Standard in Radio Instruction Since 1909.

You Can Regain Perfect Speech, if you

STAMMER

Send today for beautifully illustrated book entitled "DON'T STAMMER," which describes the Bogue Unit Method for the scientific correction of stammering and stuttering. Method successfully used at Bogue Institute for 36 years—since 1901. Endorsed by physicians. Full information concerning correction of stammering sent free. No obligation. Benjamin N. Bogue, Dept. 179, Circle Tower, Indianapolis, Indiana.

PLAY GUITAR

You'll enjoy learning for less than 2c a day. Full particulars FREE.

Write today

HAMANN INSTITUTE, 3019 N. 24th Place, MILWAUKEE, WIS.

LEARN WATCH REPAIRING



AT HOME You can learn by our modern and original system of instruction every part of the Watch Repairing Trade at home. You can earn money while learning and prepare yourself for a well paying position or start in business after completing our course of instruction. Good watch repairers are in demand and generally earn very good salaries. For particulars apply to the Wisconsin School of Watch Repairing 524 E. Mason St., MILWAUKEE, WIS.

When writing please mention Popular Mechanics

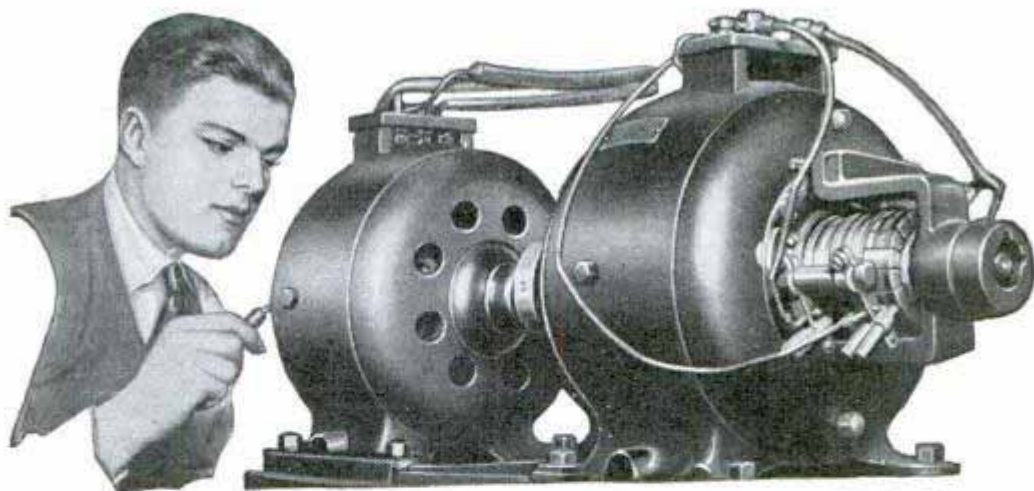

Amazingly Easy Way to train for **ELECTRICITY**

PAY FOR YOUR TRAINING IN EASY MONTHLY PAYMENTS

Don't spend your lifetime waiting for small raises in a dull hopeless job, or in some work that thousands of others can do. LET ME SHOW YOU HOW TO GET YOUR START IN A MONEY MAKING FIELD. THOUSANDS OF TRAINED MEN MAKE SALARIES OF \$30—\$40—\$50 WEEKLY, and MORE, IN ELECTRICITY—NOT by Book Study but by an amazing way taught RIGHT HERE IN THE COYNE SHOPS IN CHICAGO. Coyne gives you a Practical training in 90 days that should give you a real start to a better paying job in this Big Field. Getting started in Electricity is far easier than you imagine . . . For here at COYNE you can GET TRAINING FIRST, THEN PAY FOR IT IN EASY MONTHLY PAYMENTS. Send Coupon NOW for information.

"Learn By Doing" in 90 Days

Lack of advanced education or previous experience bars no one. I don't care if you don't know an armature from an air brake . . . I don't expect you to! The COYNE method of practical training teaches you on actual, full sized electrical equipment, in our own Five Story Modern Building. When you have finished a job you KNOW HOW . . . Because you did it yourself.

MANY EARN WHILE LEARNING

If you need part time work to help pay your living expenses, my Employment Department will give you this service. I will also tell you about my Low Cost Room and Board Plan. You can get, here at COYNE, the KIND of TRAINING many hundreds of Coyne Graduates have turned into actual CASH. Here at COYNE, every effort is made to make you happy and contented during your training.



PREPARE FOR JOBS LIKE THESE

Thousands of positions in the Electrical Field pay Trained Men \$30 - \$40 - \$50 weekly, and more. Get ready now for your start in this fascinating field. Our Employment Bureau for graduates gives FREE lifetime employment service.

Armature Winder
Sub-Station Operator
Auto & Aviation Ignition
Maintenance Engineer
Service Station Owner
And many others

HERE'S PROOF

" . . . On . . . 1936, I was made meter superintendent for this company. I do not forget that it was COYNE TRAINING that gave me the start in this large, interesting and ever growing field", writes Earl F. Ott of Ohio. . . . and "I'm still Chief Electrician and getting along almost perfectly. . . . I know that I can take up almost any job that might show up, because if and when I need help, the school will help me. . . . The Coyne School has sure put me where I am today", says Pete Duzenack, in a recent letter from his job in Colorado—and I could go on quoting from hundreds of letters from successful Coyne Trained Men.



COYNE H. C. LEWIS, PRESIDENT FOUNDED 1899
ELECTRICAL SCHOOL
500 S. Paulina St., Dept. A7-72, Chicago, Ill.

TRAIN

on Actual Equipment

No dull Books, no baffling Charts, No Reciting. At COYNE you get individual training. All real actual work. You build real batteries, wind real armatures, operate real motors, dynamos and generators. You learn house wiring, electric welding, trouble shooting and many other practical phases of the industry.

Now I am including

DIESEL ENGINE, ELECTRIC REFRIGERATION AND AIR CONDITIONING

Instruction in these new, rapidly expanding branches of Electricity are now included without extra cost. It is all fully described in the Big FREE COYNE Illustrated Book. Send the Coupon for it Today.

Get the Facts

COYNE Training can be the foundation to the better pay jobs in Electricity. Founded in 1899, Coyne methods have been developed for 38 years. You can have complete information for the asking. Just mail coupon and let me send you the big FREE COYNE BOOK. It is filled with facts and actual pictures of the COYNE Shops in Chicago. Learn about my New Low Cost Room and Board Plan . . . Part-time Employment . . . Easy Monthly Tuition Payments Plan . . . Free Lifetime Employment Service for graduates . . . Lifetime Consulting Service, etc. Act at once . . . Mail the COUPON.

Get this
**FREE
Book**



H. C. LEWIS, Pres.,
COYNE ELECTRICAL
SCHOOL

500 S. Paulina Street,
Dept. A7-72, Chicago, Ill.

Send me your Big FREE Book and full information on how I can get Practical Training in Electricity.

Name Age

Address

City State

When writing to advertisers please mention Popular Mechanics

Play a Tune in One Lesson!



Easy as A-B-C by this Amazing Method

JUST think of it! You actually play the melody of a famous tune in your very first lesson! No long, tedious study and practice. You learn to play by **playing!** And you can choose any instrument you please—piano, violin, saxophone, guitar or other favorite.

No wonder over 700,000 men and women all over the world have taken advantage of this remarkable way to learn music at home! You need no private teacher, no special talent or previous knowledge of music. At last the way has been found to make music so easy to learn that even a child can grasp it! Every step is made crystal clear in words and pictures.

Yet this is no "trick" method. You play by note, just as the best musicians do. You can soon gain the ability to read music at sight. Think of the pleasure and good times in store for you!

Which Instrument Do You Want to Play?

Simply mention the instrument you would like to play in the coupon below and by return mail you'll get startling proof that you CAN master it, easily and quickly in a few minutes a day. You'll receive a FREE Demonstration Lesson showing how this wonderful method actually works, together with an interesting illustrated booklet. No cost or obligation. Mail the coupon or write today. Instruments supplied when needed, cash or credit. U. S. School of Music, 76 Brunswick Bldg., N. Y. C., N. Y.

**LEARN TO PLAY
BY NOTE**
Piano Guitar
Violin Saxophone
Organ Mandolin
Tenor Banjo
Hawaiian Guitar
Piano Accordion
Or Any Other
Instrument

U. S. School of Music, 76 Brunswick Bldg., N. Y. C., N. Y.
Please send me FREE your Demonstration Lesson and Illustrated Booklet showing how I can learn to play the.....
(mention instrument).

Have you Instr.?
Name.....
Address.....
City..... State.....

ENGINEERING

**DEGREE
IN TWO
YEARS**

TECHNICAL AND APPLIED COURSES. Nonessentials omitted. TIME AND MONEY SAVED. DEGREE 2 YRS., DIPLOMA 1 YR. Electrical, Mechanical, Architectural, Structural, Civil, Aeronautical, Highway. All courses include Air Conditioning, Electric Refrigeration and Diesel. Short intensive courses 3 and 4 months in Electricity, Power Plant, Diesel, Air Conditioning, Electric Refrigeration, Drafting. Extensive modern equipment. LOW TUITION. Part-time work for room and board. Thousands of successful graduates in U. S. and foreign lands. Approved by Industry, endorsed by educators, recommended by graduates. One and two year courses open in Sept., short courses open year round. 38TH YEAR. Catalog free.

FINLAY ENGINEERING COLLEGE
1001 Indiana Avenue Kansas City, Mo.

AVIATION



APPRENTICES

Ambitious, air-minded young men, interested in entering the well paid field of Aviation, write immediately, enclosing stamp, to

Mechanix Universal Aviation Service, Incorporated
Strathmoor Station Dept. E Detroit, Mich.

CARTOONING PAYS WELL

Turn your talent into dollars. Develop your ability with personal instruction from an internationally-known cartoonist. His exclusive, successful method of drawing and creating ideas makes it easy to attain success. Write for details of this exceptional home-study course. No salesman will call.

National School of Cartooning, 437 Penton Building, Cleveland, Ohio

INVESTIGATE WORK FOR U.S. GOVERNMENT

Thousands of openings yearly. Many Social Security jobs. Men-Women, age 18-50. Start \$105-\$175 month. Get ready now for next entrance test. Details Free. Write OZMENT INSTRUCTION SERVICE, Dept. 111, St. Louis, Mo.

LEARN WATCHMAKING AND ENGRAVING
BY OUR PROFIT-SHARING PLAN
OUR GRADUATES SUCCEED

One of our Iowa students started in a very small way—now doing over \$30,000 a year. Another in Wisconsin, over \$10,000 the first year. Day or night classes. Call or write for FREE BOOK.
Chicago School of Watchmaking, Dept. 5201, 155 N. Clark St., CHICAGO.

MEN GET THEIR MAN!

So do the Mounties, all are Jiu Jitsu Experts, get illustrated course on **13 KNOCKOUT BLOWS** above the waist line **15c** By the world's foremost Police Jiu Jitsu Instructor. Get Your Man! S. J. JORGENSEN, 793 Maritime Building, Seattle, Washington

MAIL FOR FREE INFORMATION

**BEDFORD
YMCA
TRADE
SCHOOL**

1117 Bedford Ave., Dept. PM-49
Brooklyn, New York City, N. Y.

- Diesel Engines
 Diesel Engineering Oil Burner
 Aviation Mechanic Welding
 Aeronautical Engineering
 Auto Mechanic Talking Pictures
 Refrigeration Machine Shop
 Radio and Television Mechanic
 Air Conditioning Sign Painting
 Architectural-Mechanical Drafting
 Electrical Window Display
 Armature Winding

Name.....

Address.....

When writing please mention Popular Mechanics



DIESELS *for*

the PRACTICAL EQUIPMENT

of the Hemphill Diesel Schools includes practically every make and type of Diesel engine built in America — from small 5 hp farm service engines to mammoth marine types. Also complete laboratories for fuel injection system repair and testing. ALL for one purpose: to provide the most thorough Diesel training possible for its students.

If you can meet the entrance requirements of the Hemphill Schools you are thus assured of a practical and thorough training in Diesel operation, installation, service, and maintenance. Upon graduation you will be qualified for this fast growing field of employment because your training will be on engines of the world's largest group of Diesels for instruction purposes.

the "MARCH OF DIESEL"

A free copy of this interesting 32 page book is ready for you. Contains 112 illustrations. Read what manufacturers and graduates say about Hemphill training. One says "My first pay check was \$350 more than my tuition." Get the facts about America's oldest exclusive Diesel training institution, and about the opportunities being created in this vast field.



HEMPHILL DIESEL SCHOOLS

are located only in the cities and at the addresses listed below—

BOSTON, 114 Brookline Avenue
 NEW YORK, 31-26 Queen's Blvd., L.I. City
 DETROIT, 2341 W. Lafayette Blvd.
 CHICAGO, 2014 Larrabee Street
 MEMPHIS, 417 Monroe Avenue
 LOS ANGELES, 2120 San Fernando Road
 SEATTLE, 501 Westlake North
 VANCOUVER, B.C., 1363 Granville Street

HEMPHILL DIESEL SCHOOLS (addresses at left)
 • A NATION-WIDE INSTITUTION •

Please send me the "March of Diesel" and data on your Diesel courses.

Name.....Age.....

Street.....

City.....State..... m-21-p

TRAINS
 CARS
 TRACTORS
 BUSES
 PLANES
 SHIPS
 TRUCKS
 FARMS
 YACHTS
 PUMPING
 MINING
 GENERATING
 UTILITIES
 TUGS
 OIL FIELDS
 DREDGES

Persons interested in the PURCHASE of Diesel engines to serve any of these fields will be given the names of such manufacturers by the Hemphill Diesel Schools. Use your business stationery in mailing inquiry and state type of service contemplated.

NEW ELECTRIC LIBRARY

\$ 1.50 A VOLUME

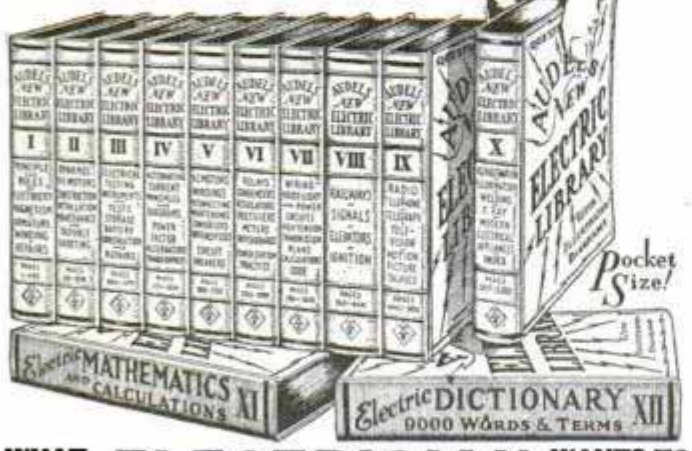

WHAT EVERY ELECTRICIAN WANTS TO KNOW!

Is easily found in AUDEL'S NEW ELECTRIC LIBRARY. Electricity made simple as ABC. Up-to-date, trade dope for the expert and ALL electrical workers. Questions, answers, diagrams, calculations, underwriter's codes, design, construction, operation and maintenance of modern electrical machines and appliances FULLY COVERED. All available at small cost, easy terms. BOOK-A-MONTH service puts this NEW information in your hands for 6c a day. You can start your subscription with any volume. Write TODAY for electric folder and FREE TRIAL offer.

THEO. AUDEL & CO., 49 W. 23rd St., New York City

Mail Vol. I, Electric Library on 7 days' free trial. If O. K. I will remit \$1.50, otherwise I will return it. I also request you to mail one book each month on same terms. No obligation unless I am satisfied.

Name.....
 Address.....
 Occupation.....PM

ELECTRICAL ENGINEERING

THE FIELD with a FUTURE

For those who cannot afford the expense of 4-year college training, Bliss offers a CONDENSED ONE-YEAR residence course, approved by educators/endorsed by industry. 44 years experience. Modern laboratory and shop equipment, suburban campus. Excellent faculty; wholesome, friendly atmosphere. 45th year begins September 29th. CATALOG!

BLISS ELECTRICAL SCHOOL
 116 Takoma Ave., Washington, D. C.

Be a DENTICIAN



Learn at home to make Crowns, Plates, Bridgework, etc., for Dentists. Easy, practical way to learn mechanical dentistry at home in spare time. Full Equipment of Tools and Materials included with Course. Low tuition. Easy terms. Write for FREE BOOK about this money-making profession that is not affected by "machine age."

McCARRIE SCHOOL OF MECHANICAL DENTISTRY
 207 N. Broad St., Dept. 722, Philadelphia, Pa.

IF YOU WANT

a new easy-to-learn business-profession and all the business you can take care of... BE A NEW KIND OF FOOT SPECIALIST! Good money after few weeks of spare time reading at home. New system. No Medicine or surgery. No expensive equipment needed. Low cost training on easy terms. Earn while you learn. Chartered 1915 by State of Illinois. Write D. N. Higbe, AMERICAN COLLEGE, Dept. C-6, 54 W. Illinois St., Chicago



Operator No. 38

FOLLOW THIS MAN

Secret Service Operator No. 38 is on the job! Running down dangerous Counterfeit Gang. Tell-tale finger prints in murdered girl's room.

Free The Confidential Report Operator No. 38 made to his chief. Write for it.

Earn a Regular Monthly Salary YOU can become a Finger Print Expert at home, in your spare time, at small cost. Write for confidential full report and details. Write! Literature will be sent only to persons stating their age.

INSTITUTE OF APPLIED SCIENCE
 1920 Sunnyside Ave.
 Dept. A-135 Chicago, Ill.



High School at Home

Many Finish in 2 Years

Go as rapidly as your time and abilities permit. Course equivalent to resident school work. During the past 14 years, our graduates have been admitted to 531 different Universities, Colleges, Junior Colleges and Normal Schools—80% of them without entrance examination. Also prepares for teacher's certificate and pre-professional examinations. Meets all preparatory educational requirements for Business and Industry. Standard H.S. texts supplied. Diplomas. Credit for H. S. subjects already completed. Single subjects if desired. Tuition low as \$5 monthly. Be a High School graduate. Send for details NOW.

20 Other Courses

Specialized training is absolutely essential to Success today. Over 150 noted Educators, Engineers and Business Men helped prepare our special instruction material, used by many resident schools and colleges, U. S. Navy and Province of Manitoba, Can. Train at home for best-paying lines of Business and Industry, as listed in coupon below. No interference with present earnings while preparing for better job.

American School, Drexel at 58th, Chicago

Mail Coupon for Information—No Obligation

American School, Dept. HA-45, Drexel at 58th, Chicago
 Tell me how to train for success in line checked.

High School Course in 2 Years

<input type="checkbox"/> Air Conditioning	<input type="checkbox"/> Electrical Refrigeration
<input type="checkbox"/> Architecture and Building	<input type="checkbox"/> Highway Engineering
<input type="checkbox"/> Automotive Engineering	<input type="checkbox"/> Liberal Arts (College)
<input type="checkbox"/> Aviation	<input type="checkbox"/> Mechanical Engineering
<input type="checkbox"/> Business Management	<input type="checkbox"/> Private Secretary
<input type="checkbox"/> Civil Engineering	<input type="checkbox"/> Professional Accounting
<input type="checkbox"/> Complete Law	<input type="checkbox"/> Incl. C, P. A. Coaching
<input type="checkbox"/> Diesel Engineering	<input type="checkbox"/> Radio and Television
<input type="checkbox"/> Drafting and Design	<input type="checkbox"/> Salesmanship
<input type="checkbox"/> Electrical Engineering	<input type="checkbox"/> Steam Engineering

Name.....
 Address.....

Learn to Write

Begin Today. Write for our Free Book, "How to Become a Good Penman." It contains specimens and tells how others learned to write in spare time. Your name elegantly written on a card if you enclose stamp for postage. Write today. F. W. TAMBLYN, 418 Ridge Bldg., Kansas City, Mo.

STAMMERER S

Write for our Free List of ethical schools that correct stammering.

STAMMERERS' GUILD
 Maccabees Bldg., Suite 1236, DETROIT, MICH.

WHY NOT spend spring, summer, fall, gathering butterflies and moths. I buy hundreds of kinds for collections. Some worth \$1 to \$7 each. Simple work with my low cost Instructions, pictures, price list. Profit—Pleasure. Send 10c for Illustrated Prospectus, terms, before sending any butterflies.

Mr. Sinclair, Dept. 6, Box 1424, San Diego, California

BE A PASSENGER TRAFFIC INSPECTOR

WE HEAR OF GOOD OPENINGS CONSTANTLY—YOU CAN QUALIFY

Men—19 to 50—trained as Railway and Bus Passenger Traffic Inspectors are in constant demand. Simple home-study course trains you; upon completion we help place you at up to \$135 per month, plus expenses, to start, or refund tuition. Splendid opportunities for the ambitious. Free Booklet.

STANDARD BUSINESS TRAINING INSTITUTE
 Div. 206 Buffalo, N. Y.

When writing please mention Popular Mechanics

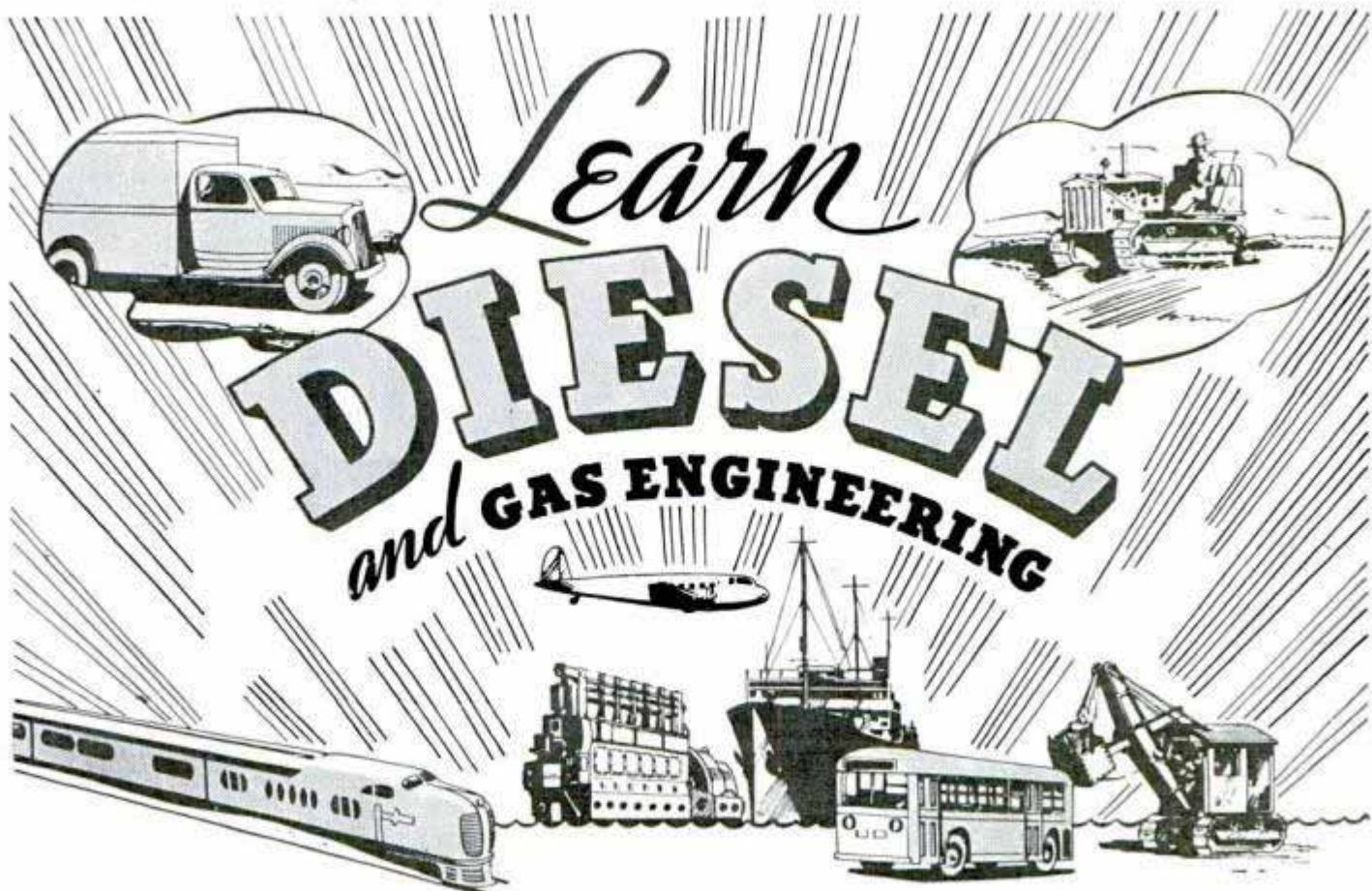

TESTED SYSTEM OF DIESEL AND GAS ENGINE TRAINING

To qualify for a good Diesel job you must receive training in an institution that can offer you **practical** instruction. At National Schools you actually work on the latest equipment, including practically every approved make of Diesel engine. You get the kind of instruction that serves your every day needs in the Diesel field after you have graduated. It's the type of training you can "cash in" on. You are trained under the direct, personal supervision of licensed Diesel Engineers. You learn Diesel and gas engine operation, repair, trouble-shooting, theory.

Easy-to-Learn Master Training

National Schools' training is complete in every respect. It includes all phases of Diesel engines, fuel injection, gasoline, butane, propane and natural gas engines, also Auto-Diesel electrics, machine shop practice, batteries and other essentials that must be learned in order to give you well rounded-out training.

Learn in Los Angeles

The most delightful place to learn—Los Angeles—the playground of America. Fascinating surroundings. Your coach railroad fare will be allowed to Los Angeles from any point in the U. S.

Earn Room and Board

We help students obtain part-time jobs to earn room and board while learning. This service only for residents of U. S.



Partial Room, Diesel Engine Dept.

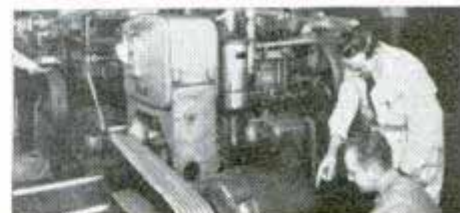

Student Servicing Diesel Electric Unit



Diesel Generating Unit. Diesel Converted Ford Auto

NATIONAL SCHOOLS

Special Added Feature
DIESEL ELECTRIC POWER GENERATION

A new feature essential to the complete training of Diesel experts. Completely covers power generation. This extra course is now presented to all Diesel students without extra tuition.

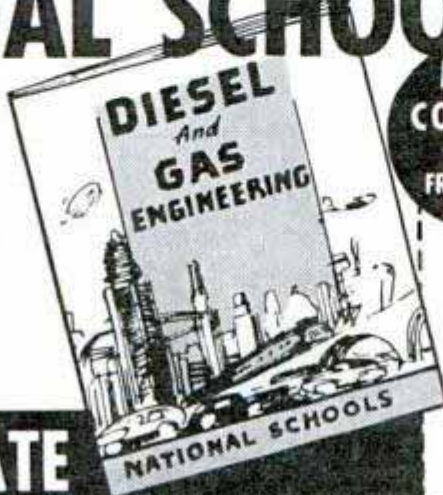

MAIL COUPON
 for
FREE BOOK

National Schools, Dept. 6-PMA
 4000 So. Figueroa St., Los Angeles
 Send Free Diesel Book of Details.

Name.....Age.....

Address.....

City.....State.....

INVESTIGATE

AUDELS Carpenters and Builders Guides 4 vols. \$6



Inside Trade Information for Carpenters, Builders, Joiners, Building Mechanics and all Woodworkers. These Guides give you the short-cut instructions that you want—including new methods, ideas, solutions, plans, systems and money saving suggestions. An easy progressive course for the apprentice and student. A practical daily helper and Quick Reference for the master worker. Carpenters everywhere are using these Guides as a Helping Hand to Easier Work, Better Work and Better Pay. To get this assistance for yourself, simply fill in and mail the FREE COUPON below.

Inside Trade Information On:

How to use the steel square—How to file and set saws—How to build furniture—How to use a mitre box—How to use the chalk line—How to use rules and scales—How to make joints—Carpenters arithmetic—Solving mensuration problems—Estimating strength of timbers—How to set girders and sills—How to frame houses and roofs—How to estimate costs—How to build houses, barns, garages, bungalows, etc.—How to read and draw plans—Drawing up specifications—How to excavate—How to use settings 12, 13 and 17 on the steel square—How to build hoists and scaffolds—skylights—How to build stairs—How to put on interior trim—How to hang doors—How to lath—lay floors—How to paint.



THEO. AUDEL & CO., 49 W. 23rd St., New York City

Mail Audels Carpenters and Builders Guides, 4 vols., on 7 days' free trial. If O.K. I will remit \$1 in 7 days, and \$1 monthly until \$6 is paid. Otherwise I will return them. No obligation unless I am satisfied.

Name.....

Address.....

Occupation.....

Reference..... P.M.



DRAFTING

BOOKS SENT FREE!

ON APPROVAL
5 VOLUMES BRAND NEW EDITION
 Only 15 minutes a day with these WONDER BOOKS can prepare you for a good drafting job in less than a year. Mechanical and architectural drafting from simple straight lines to important complex plans. *A step at a time!* Built especially for beginners, for men with only grammar schooling. Drafting room practice, PLUS ENGINEERING, made easy and clear. Includes complete course in blue-print reading.

Big Field Big Demand Big Pay
 Competent draftsmen are urgently needed right now in all building and manufacturing lines at \$30.00 to \$75.00 a week. That's just the beginning—FOR DRAFTSMEN HAVE THE BEST CHANCES FOR ADVANCEMENT. Pleasant, fascinating work, easy to learn and do. Learn quickly with these books—send coupon for a set and see for yourself.

A year's consulting membership in the American Technical Society now gives to all readers of this famous cyclopedia of drafting. Many say that it is worth more than the cost of the books.

Complete set of drawing instruments if you send for these drafting books NOW. These instruments are made of the finest of German silver, are absolutely accurate and are packed in velvet lined leatherette pocket case. Real \$10 value, but included with these books.

AMERICAN TECHNICAL SOCIETY
 Dept. DA19, Drexel at 58th St., Chicago, Ill.

American Technical Society, Dept. DA19, Drexel at 58th St., Chicago, Ill. Send for 10 days' trial New 5 volume set of drafting. I will pay the few cents delivery charges. If I wish, I may return books in 10 days and owe you nothing but if I decide to keep them, I will send \$2.00 after 10 days, then only \$3.00 a month until \$24.80, the advertising price, is paid. Send latest edition and include drawing instruments and Membership Certificate.

Name.....
 Address.....
 Attach letter stating age, occupation, employer's name and address and that of at least one business man as a reference.

SECRETARIES, STENOGRAPHERS and TYPISTS—Become An Expert STENOTYPIST



Stenotypists win today's preferred jobs and better pay. Stenotype's machine speed, accuracy and ease make your work faster, better, easier—and you get the credit. Executives welcome this machine way of taking dictation—faster than any man can talk. Stenotypy is easy to learn—easy to write—easy to read. We train you thoroughly at home in your spare time—at low cost and on easy terms. Write for interesting, free booklet, "Stenotypy, the New Profession," describing the many opportunities in Stenotypy and telling how you may master it successfully.

THE STENOTYPE COMPANY
 Dept. 664-ST, 4101 S. Michigan Ave., Chicago, Ill.

WE CAN TEACH YOU TO MOUNT BIRDS

ANIMALS, HEADS, FISH

Also to tan skins and FURS. Easily learned AT HOME BY MAIL. Wild game growing scarce—big demand. Be a taxidermist. Mount for others. Big Fun, Real Hobby. Mount common specimens—no wild game needed. REAL PROFITS IN SPARE TIME.

FREE BOOK Men, Boys, get wonderful FREE BOOK—tells how YOU can learn this fine art quickly. Investigate. Send this minute. State AGE. N.W. School of Taxidermy, Dept. A337-OMAHA, NEB.

ENGINEERING

Get a Bachelor of Science Degree! Complete courses and fully accredited degrees in Aeronautical, Architectural, Chemical, Electrical, Industrial and Mechanical engineering. Modern equipment. All college activities. Low tuition. Write Registrar today for full information and catalog.

LAWRENCE INSTITUTE OF TECHNOLOGY
 15102 Woodward, Detroit, Mich.

A NON-PROFIT COLLEGE CATALOG ON REQUEST

BE AN ARTIST

WE CAN TEACH YOU DRAWING in your own home during your spare time. Thirty-five years of successful teaching proves our ability. Artists receive large salaries.

Write today for Art Year Book **SCHOOL OF APPLIED ART**
 Dept. 167, 10 E. Huron St., Chicago, Ill.

VOICE

100% Improvement Guaranteed

We build, strengthen the vocal organs—not with stinging lessons—but by fundamentally sound and scientifically correct silent exercises... and absolutely guarantee to improve any singing or speaking voice at least 100%... Write for wonderful voice book—sent free. Learn WHY you can now have the voice you want. No literature sent to anyone under 17 years unless signed by parent.

PERFECT VOICE INSTITUTE, Studio A-135
 64 E. Lake St., Chicago

REFINISHES AUTOS Like NEW!

PAYS UP TO \$7.00 AN HOUR!

KAR-NU refinishes any color automobile easily, quickly and economically without polishing, waxing, rubbing or painting. JUST WIPE IT ON WITH A CLOTH! Magic-like fluid covers old paint with tough, elastic coat. Absolutely transparent, self-leveling, self-polishing. Guaranteed. Lasts 8 to 12 months. Equal in beauty to repaint job costing \$10 to \$35. Write for Free Sample to prove our claims and Territory offer.

KAR-NU CO. Dept. S-30, Oakley Sta. Cincinnati, O.

IF MEN WORE PRICE TAGS



HOW WOULD YOU FEEL?

WELL, your boss thinks of you in terms of so much a week! You are worth this or that to him. How much you are worth depends upon—YOU! You decide the amount chiefly by your ability—by your

training. Why not increase the amount by increasing your training? Thousands of men have done it by spare-time study of I. C. S. Courses. You are invited to earn more money. Mail this coupon.

INTERNATIONAL CORRESPONDENCE SCHOOLS

BOX 5675-H, SCRANTON, PENNA.

★ Without cost or obligation, please send me a copy of your booklet, "Who Wins and Why," and full particulars about the subject *before* which I have marked X: ★

- | | | | | |
|---|---|--|--|--|
| <input type="checkbox"/> Architect | <input type="checkbox"/> Sheet Metal Worker | <input type="checkbox"/> Plumbing | <input type="checkbox"/> Steam Fitting | <input type="checkbox"/> Bridge Engineer |
| <input type="checkbox"/> Architectural Draftsman | <input type="checkbox"/> Boilermaker | <input type="checkbox"/> Heating | <input type="checkbox"/> Ventilation | <input type="checkbox"/> Bridge and Building Foreman |
| <input type="checkbox"/> Building Estimating | <input type="checkbox"/> Telegraph Engineer | <input type="checkbox"/> Air Conditioning | <input type="checkbox"/> Steam Engineer | <input type="checkbox"/> Chemistry |
| <input type="checkbox"/> Contractor and Builder | <input type="checkbox"/> Telephone Work | <input type="checkbox"/> Steam Engine | <input type="checkbox"/> Steam Electric Engineer | <input type="checkbox"/> Pharmacy |
| <input type="checkbox"/> Structural Draftsman | <input type="checkbox"/> Mechanical Engineering | <input type="checkbox"/> Marine Engineer | <input type="checkbox"/> R. R. Locomotives | <input type="checkbox"/> Coal Mining |
| <input type="checkbox"/> Structural Engineer | <input type="checkbox"/> Mechanical Draftsman | <input type="checkbox"/> R. R. Section Foreman | <input type="checkbox"/> R. R. Signalmen | <input type="checkbox"/> Mine Foreman |
| <input type="checkbox"/> Management of Inventions | <input type="checkbox"/> Machinist | <input type="checkbox"/> Highway Engineering | <input type="checkbox"/> Civil Engineering | <input type="checkbox"/> Navigation |
| <input type="checkbox"/> Electrical Engineer | <input type="checkbox"/> Patternmaker | <input type="checkbox"/> Civil Engineering | <input type="checkbox"/> Surveying and Mapping | <input type="checkbox"/> Cotton Manufacturing |
| <input type="checkbox"/> Electric Lighting | <input type="checkbox"/> Diesel Engines | <input type="checkbox"/> Air Brakes | | <input type="checkbox"/> Woolen Manufacturing |
| <input type="checkbox"/> Welding, Electric and Gas | <input type="checkbox"/> Aviation Engines | <input type="checkbox"/> Highway Engineering | | <input type="checkbox"/> Agriculture |
| <input type="checkbox"/> Reading Shop Blueprints | <input type="checkbox"/> Automobile Mechanic | <input type="checkbox"/> Civil Engineering | | <input type="checkbox"/> Fruit Growing |
| <input type="checkbox"/> Heat Treatment of Metals | <input type="checkbox"/> Refrigeration | <input type="checkbox"/> Surveying and Mapping | | <input type="checkbox"/> Poultry Farming |
| | | | | |
| <input type="checkbox"/> Business Management | <input type="checkbox"/> Bookkeeping | <input type="checkbox"/> Service Station Salesmanship | <input type="checkbox"/> Grade School Subjects | |
| <input type="checkbox"/> Industrial Management | <input type="checkbox"/> Secretarial Work | <input type="checkbox"/> First Year College Subjects | <input type="checkbox"/> High School Subjects | |
| <input type="checkbox"/> Traffic Management | <input type="checkbox"/> Spanish | <input type="checkbox"/> Business Correspondence | <input type="checkbox"/> College Preparatory | |
| <input type="checkbox"/> Accountancy | <input type="checkbox"/> French | <input type="checkbox"/> Stenography and Typing | <input type="checkbox"/> Illustrating | |
| <input type="checkbox"/> Cost Accountant | <input type="checkbox"/> Salesmanship | <input type="checkbox"/> Civil Service | <input type="checkbox"/> Cartooning | |
| <input type="checkbox"/> C. P. Accountant | <input type="checkbox"/> Advertising | <input type="checkbox"/> Railway Mail Clerk | <input type="checkbox"/> Lettering Show Cards | <input type="checkbox"/> Signs |
| | | | | |
| <input type="checkbox"/> Home Dressmaking | <input type="checkbox"/> Advanced Dressmaking | <input type="checkbox"/> Millinery | <input type="checkbox"/> Foods and Cookery | |
| <input type="checkbox"/> Professional Dressmaking and Designing | | <input type="checkbox"/> Tea Room and Cafeteria Management, Catering | | |

Name.....Age.....Address.....

City.....State.....Present Position.....

If you reside in Canada, send this coupon to the International Correspondence Schools Canadian, Limited, Montreal, Canada

When writing to advertisers please mention Popular Mechanics



STAMPS



..... and Collecting

By Richard McP. Cabeen

R-900.

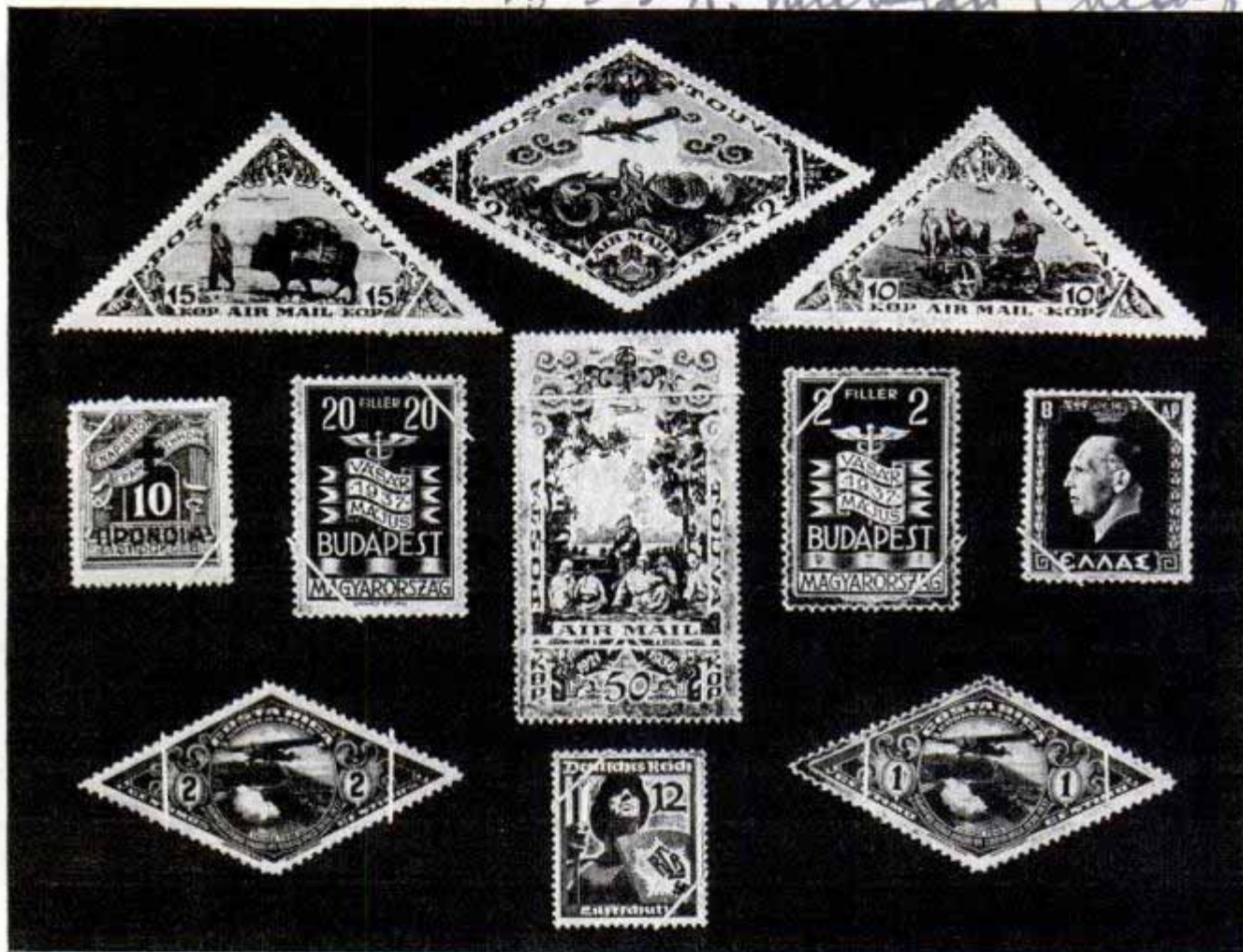

Courtesy De Soto Stamp and Coin Co., and Garden City Stamp Agency, Chicago

Here are some air-mail stamps of picturesque design and odd shapes likely to appeal to the collector who is looking for the unusual to add to his album

THE big question with beginners is how to classify stamps. This involves more than determination of the country for you must also know the year of issue, or at least the order in which the stamps of a country were issued, to arrange them in an album. But so many stamps have been issued that it is no longer possible to give directions which will enable the young collector to sort his stamps properly. It is not always possible to give printed directions which can be depended upon in naming the country of origin, to say nothing

of the sequence of the various issues. There are only two courses open to the collector, and unfortunately both involve spending money which could be used in buying stamps. The first is to buy a standard catalogue of the postage stamps of the world. This illustrates all the types of adhesive foreign stamps ever issued for postal purposes. But it does not illustrate the revenue or fiscal stamps, or the various telegraph and local stamps. Its more than 1,100 pages, each with three columns of

(Continued to page 24A)

SO SKINNY
..HE WAS ASHAMED
TO GO
SWIMMING!

But He Gained 30 Lbs.
Quickly On Kelpamalt
Now Feels Great!

Read This Actual Letter

The Kelpamalt Co.

Gentlemen:

I had been skinny since childhood. Last September was my 19th birthday, so you see how long I had been skinny. Most every Sunday the kids in the neighborhood would go swimming. I did not go with them. I suppose they knew why. I was ashamed of my skinny body. I was nervous too. Even when I went to town or to picnics in summer I was ashamed to have my sleeves rolled up like the other fellows did. A few months ago when I was uptown I stepped on a pair of scales. I weighed about 120 lbs. and me a young man going on twenty. I thought of the future—would I always be skinny? I had seen Kelpamalt advertised in the papers and magazines so I bought a bottle. I was sure amazed at how much I gained and how much better I felt. I bought 4 more bottles. Over two months have passed. I have gained better than 30 pounds. You don't know how much better I feel and look and how thankful I am for what Kelpamalt has done for me. I would not take a hundred dollars for what Kelpamalt has done for me, if I could not get any more. So I am going to thank Kelpamalt and the Kelpamalt Company for what their sea minerals have done for me.

Yours very truly, Lester D. Curlless, Astoria, Ill.

Hosts of Men and Women Report This Amazing Concentrate from the Sea—Rich in Naturally Occurring Minerals and Iodine—Has Added Flattering Extra Pounds, New Strength and Energy

Don't be discouraged if you are weak, skinny, tired-out, sickly—unable to gain an ounce of flesh or strength, no matter what you eat. Doctors now know that the fault often is not with the amount of food you eat. Your daily diet may contain enough potential nourishment of many kinds, but unless it contains certain essential minerals, your system is unable to extract full nourishment from the food you eat. The result is you may be eating enough good food to satisfy your appetite, and still not be able to gain weight or strength.

In Kelpamalt, the new mineral concentrate from the sea, minerals so essential to the normal chemical processes of the body are available in their naturally occurring form, such as assimilable iron, copper, manganese, calcium, phosphorus, potassium and magnesium. All contribute to the supply of vital minerals needed for digestion and assimilation, the body's weight and strength building process. Most important, however, is Kelpamalt's natural iodine (not to be confused with ordinary liquid chemical iodine). Iodine, scientists say, is found in the blood, liver and glands, and is vitally important to their normal functioning.



Posed by professional model

Try Seedol Kelpamalt for 1 week. See if, like thousands of others, you don't feel better, sleep better, eat better, and add at least 3 to 5 husky new pounds the first week. If you don't, the trial is free. It costs you nothing! Your own Doctor will approve this way. Get Seedol Kelpamalt today. It costs but a few cents a day to use and is sold at all good drug stores. If your dealer has not yet received his supply, send \$1.00 for special introductory size bottle of 65 tablets to the address below.

SPECIAL FREE OFFER

Write today for fascinating instructive 50-page booklet on How Thousands Have Built Strength, Energy, and Added Lbs. Quickly. Mineral contents of Food and their effect on the human body. New facts about NATURAL IODINE. Standard weight and measurement charts. Daily menus for weight building. Absolutely free. No obligation. Kelpamalt Co., Dept. 1210, 27 West 20th St., N. Y. C.

NAME.....

STREET.....

CITY.....

SEEDOL
Kelpamalt Tablets



There's Quicker, Bigger MONEY for YOU-in POULTRY

Earn \$1,000 to \$2,500 a Year or Have a Business of Your Own!

Whether you want a job at good pay or a highly profitable business of your own—the Poultry Industry offers you more than any other. There's a shortage of poultry meat and eggs — a shortage of trained poultrymen. I'll train you quickly at home—to fill a good job in Poultry—and our FREE Students' Employment Dept. will help you get one!

FREE Book Shows the Way to Big Pay and BIG Profits

Mail coupon below TODAY—for my Big NEW FREE Book, "How to Raise Poultry for Profit." My forty years of experience are yours. The Poultry Industry needs YOU. You need my book. Get it—and get in line for the BIG Money that's waiting for you in POULTRY.

Spare Time or Full Time YOU CAN Cash-in BIG No matter where you live—city, town or country—or what you do now, my proved methods will assure your success right from the start. I'll help you make from \$1,000 to \$2,500 a year and UP! And, if you choose to start your own business, I'll show you how to make your tiny investment multiply itself automatically. What I've done for thousands of others—I can do for you.

Mail NOW for FREE Book

NATIONAL POULTRY INSTITUTE, Dept. 30-C
Adams Center N.Y., Att'n: Harry M. Lamon, Pres.

Dear Mr. Lamon: Send me your FREE Book, "How to Raise Poultry for Profit." I want to know more about my opportunity to make \$1,000 to \$2,500 a year, spare or full time.

Name

Address



Know Electricity as Experts Know It—and Get an Expert's Pay!

Recovery has begun! The months ahead are charged with significance and expectation. What will you do to get the jump on the other fellow?

Thousands of men have used

The Croft Library of Practical Electricity

The Croft Library is a complete electrical educator. It is founded on practice—on 20 years of shirt-sleeve experience—on work as it is actually done. It is jammed from cover to cover with the kind of hard-headed facts you want. Written so that the beginner can easily understand it, yet so sound, so thorough, that it is the daily guide of 59,000 highly paid electrical workers and engineers. Croft tells you the things you need to know about motors, generators, armatures, commutators, transformers, circuits, switchboards, distribution systems—electrical machinery of every type—wiring for light and power—wiring of finished buildings—underwriters' and municipal requirements—illumination in its every phase—the most improved methods of lighting—lamps and lamp effects, etc.—how to do a complete job, from estimating it, to completion.

No money down—easy payments

Fill in and mail the coupon attached and we will send you the entire set of seven volumes for ten days' Free Examination. We take all the risk—you assume no obligation. If you decide to keep the books, send \$1.50 in ten days and the balance at the rate of \$2.00 a month. Send the coupon NOW and see the books for yourself.

FREE EXAMINATION COUPON

McGraw-Hill Book Co., 330 W. 42nd St., New York

Send me for ten days' free examination the Croft Library of Practical Electricity. If satisfactory I will send you \$1.50 in 10 days and \$2.00 monthly until the price of \$19.50 is paid. If not wanted, I will return the books postpaid. (To insure prompt shipment write plainly and fill in all lines.)

Name

Home Address

City and State

Position

Name of Company

PM-6-37

ENGINEERING DEGREE IN TWO YEARS

B.S. DEGREE courses in engineering: Electrical, Civil, Chem., Mechanical, Mech. Drafting, Radio and Television or Aeronautical. Intense, practical, thorough program. No extras for prep. or review. Earn while you learn in this industrial center. Low tuition. Enter March, June, Sept., Dec. Write for catalog. 229 E. Washington Blvd., Fort Wayne, Ind.

INDIANA TECHNICAL COLLEGE

AUTOMOBILE RACING New Book

(FOURTH EDITION)

Nine Chapters—66 illustrations of dirt, midget and championship cars and drivers. How to build cars and bodies—14 plates working drawings. Converting stock cars to 135 m.p.h. racers. Answers all questions on speeding up cars, balance, speed, revs., rules, specifications, track records, etc. Postpaid \$1.00, C.O.D. \$1.12. Order NOW. Ray Kuns, Dept. B-6, Madisonville, Cincinnati, Ohio.



REAL JOBS OPEN

AUTO, DIESEL, AVIATION, WELDING

Step into big pay. Earn \$35.00 to \$75.00 a week. Learn in eight weeks. Practical Shop Work. Use real tools on real equipment. Write our school nearest you for big Free Book and special low tuition offer. Guaranteed training.

McSWEENEY SCHOOLS, Dept. 10-42
Detroit, Mich., or Kansas City, Mo.

FREE BOOK



EARN WHILE LEARNING AT HOME!

Television, Photo Electric Cells, Public Address

Many R-T-I Trained Men make up to \$75 a week and more in full-time radio jobs—\$8-\$15 in spare time alone. More trained men are needed. Learn at home by quick, easy, R-T-I-WAY. Endorsed by 50 big concerns. Write for big Opportunity Book FREE.

RADIO and TELEVISION INSTITUTE, Inc.
2130 LAWRENCE AVE., Dept. I-A, CHICAGO, ILL.

PHILCO GROSLEY ZENITH GRUNOW and 46 other mfrs. endorse R-T-I

NEW YORK SCHOOL OF MECHANICAL DENTISTRY

★ ★

Make more money as a DENTICIAN. We show you how! Oldest school. Real Laboratory Training. Day, Eve. Easy terms. Tools FREE. Ask for Catalog P. N. Y. SCHOOL of MECHANICAL DENTISTRY, 125 W. 31 St., N. Y. C.

NEON

Prepare yourself quickly for today's biggest opportunity—design, build, sell and service NEON or "gaseous tube" lighting—for lighted displays. Future's greatest source of illumination. Most complete, practical, low-cost, home-study course. FREE book gives full details, student letters, Low Price! WRITE! COMMERCIALITE LABORATORIES Box 47-P OMAHA, NEBR.

Learn Public Speaking

At home—in spare time. Many overcome "stage-fright," gain self-confidence and increase earning power, this easy way. Write for free booklet, *How to Work Wonders With Words* and requirements. North American Institute, Dept. 135-A 3601 Michigan Ave. Chicago, Illinois

LOOK! Baby Chicks

THOUSANDS WEEKLY ALL YEAR

Finest quality & Layers in 40 breeds. Hybrid Baby Pullets and Cockerels, B. W. D. Tested. 25 lbs. feed FREE with each 100 chicks. Ducklings, Goslings, Baby Turkeys, Guinea. Mature Breeders priced right! In business 27 years, Catalog free, Nabob Hatcheries, Box M. Gambier, Ohio.

Write for 1937 picture book, "How to Breed Squabs," to Elmer Rice, Box 632, Melrose, Mass. Thousands wanted weekly at profitable prices.

Make Money at Home

GROW MUSHROOMS in cellar or shed, with AMI selected-spore spawn and step-by-step, easy-to-follow MANUAL OF INSTRUCTIONS. Book Free. Anglo-American Mushroom Industries, Dept. 112, Toronto, Ont.



When writing please mention Popular Mechanics

AMAZING "TYPEWRITER-AGENT" PLAN...COINS MONEY FOR ALL

WHO SAY

"I'm from Remington-Rand"



You Offer this Remington Portable for only 10c a Day ... and Your Average Profit is Over \$10.00 per Sale

A brand new Remington Portable Typewriter for only 10¢ a day! Priced so low that it's the greatest typewriter bargain in ten years! Guaranteed by REMINGTON RAND INC.—the largest manufacturers of portables in the world!

There is still room for a few more ambitious men and women on our sales force. You can share in the big weekly incomes that are being handed out. Simply show

the demonstrating portable we supply. Receive regular weekly commission checks for your work.

No wonder these modern, stream-lined portables sell fast! Teachers approve their use for students; housewives, business men, doctors, lawyers, dentists, writers, find them invaluable. Local stores, garages, clubs, restaurants; the field is as big as you want to make it. And when your customers find that they can buy on the easiest terms we have ever offered—only ten cents a day—you'll be amazed at the profits you pile up!

EVERY PORTABLE IS BRAND NEW!

These are not rebuilt machines, but BRAND NEW—latest stream-lined or noiseless models with all the latest features—Automatic Ribbon Reverse, Stencil Cut-out, Standard Easy-type Keyboard, Paragraph Self-starter, etc. All for only \$3.00 a month—equal to 10¢ a day! We pay all shipping charges, give liberal trade-in allowances on old machines, plus everything you need to get started.

Now FREE!

Your Own Remington Portable!

Yes, you can get a REMINGTON PORTABLE absolutely FREE, and complete with FREE CARRYING CASE and FREE Touch Typing Course. Use your Remington for demonstrating and personal typing needs. Send coupon for details.

Prestige and Dignity...plus PROFITS... as a Remington Rand Representative!

Your average profit per sale is more than \$10.00! Five sales a week would pay you over \$50.00 clear profit—and our "TYPEWRITER AGENT" Plan makes that a cinch! Bonnell, New Jersey, made 177 sales in one month—Boland, New York, hit \$2,000 in less than four weeks. Remember—you do no collecting, you make no deliveries. You don't risk a single penny to get started. If you want to get into the "big money" class; to enjoy the prestige that comes when you say "I'M FROM REMINGTON RAND", then clip and mail the application coupon below.

Use Your Remington for 90 days—FREE

You don't need any experience—you don't even have to know anything about typewriters. These easy-writing, trouble-free REMINGTON PORTABLES almost sell themselves. You have a full 90 days to test our special THREE MONTH NO-RISK PLAN. Don't wait for another announcement... mail coupon for full particulars.

REMINGTON RAND INC.
315 FOURTH AVE. DEPT. F-15, NEW YORK, N. Y.

APPLICATION COUPON

Mr. M. N. Rand,
REMINGTON RAND Inc., Dept. F-15
315 Fourth Avenue, New York, N. Y.

I'm interested in making money. Send me all the facts about your "Typewriter-Agent" and FREE TYPEWRITER PLANS. This does not obligate me in any way.

Name _____

Address _____

Town _____ State _____

INVENTORS

TO be successful as an inventor, you don't need to be an Edison who took out 1099 Patents before he died, or a C. F. Kettering, who helped develop the Self-Starter, Duco, Ethyl Gas and other outstanding inventions, and is today the famous head of the Research Division of the General Motors Corporation. In fact, you don't need to be known as an inventor at all, if you have a practical, useful, salable invention—or an idea for one—and go about it right.

Remember that for every Edison or Kettering, for every McCormick, DeForest or Atwater Kent—there have been thousands of unknown men whose inventions helped along the wheels of progress and helped the inventors financially at the same time.

MANY LITTLE IDEAS HAVE BIG COMMERCIAL POSSIBILITIES

For example, who knows the name of the inventor of the wooden golf tee, the ordinary crinkly hair pin, or the metal ball or disc that the average housewife uses for scouring pots and pans? Who knows the inventors of the thousands of gadgets that you will find in the ten-cent stores, in the modern drug and department stores? Some day, stop and look at some of the simple articles you'll find on the counters of a ten-cent store. Notice how many of them are marked "Patented or Patent Applied For." It is an interesting educational experiment. These inventors, most of them, weren't of the genius class. They simply got an idea for doing something in a better, easier, faster, or more economical way—AND THEN DID SOMETHING ABOUT IT.

Interesting Points

Who is today's "champion inventor"?

Ans.: John F. O'Connor, of Chicago, Ill., holds 949 Patents, more than any other living man.

Who is "Lady Edison"?

Ans.: Miss Beulah Louise Henry of New York City leads all women inventors, holds fifty patents; is known as "Lady Edison."

What is an improvement?

Ans.: Nearly all inventions today are improvements over earlier inventions. Often the improvement proves more profitable than the earlier invention.

Is a model necessary?

Ans.: Today, most inventions are patented without models. A subject fully explained in our book.

What is the preliminary search?

Ans.: The preliminary search is ordinarily the first step to help an inventor. Also fully explained in our book. Send for a copy today.

A New Book about Selling Inventions

There are two sides to every inventive success: The inventive side and the commercial side. A good invention poorly handled, can prove a failure commercially. An ordinary invention, properly handled, can be made a money-maker. In the special booklet, shown here, we give you some suggestions on "When and How to Sell an Invention"; practical hints on the commercial side of inventing. We'll send this new booklet along with the big 48-page book, "Patent Protection" illustrated on the next page. Use the convenient coupon to request your copies.

You may be able to do as well as others who have been successful. That only time can tell. But there is one thing you can do, and do now, without waiting on time. You can find out easily and quickly **exactly what to do to protect yourself.** In the 48-page book, "Patent Protection" shown on the opposite page, which will be sent to you FREE, we tell you what many other inventors have done, just what you yourself must do to make Application for a Patent, give you interesting facts about inventive history, show you 115 mechanical movements that inventors have used in working out ideas, and **much more.** Decide now to get a copy of this interesting book. Its facts can be worth much—yet they cost you nothing.



We Cordially Invite You to . . .

NOTE ★ ★

You may not be an Edison or a Kettering but still you may have a good idea

YOUR QUESTIONS ANSWERED! There are a lot of questions that the average man with an invention, or an idea for one, wants answered before he goes ahead. Here are a few of them that most inventors put up to us: How do the Patent Laws protect me? What easy steps can I take, without cost, to put myself in position to support my belief that I am the **first** man to think of **my invention**? Is a Patent worth the cost? Should I try to sell my invention before I have it Patented? Is there any

safe, business-like way to secure financial help? If I do apply for a Patent how shall I reach people who can market my invention? Can I protect and sell an improvement on some invention that has already been patented? These are but a few of the questions which usually confront the average man. **You need the answers! YOU CAN HAVE THEM,** without cost, trouble, or delay.

Our Business Is to Help You Write Us Today

For more than thirty-seven years, this firm has been helping men with an inventive turn of mind. We maintain a large staff of trained, experienced specialists—**Registered Patent Attorneys, Draftsmen, and Searchers** to help our clients secure all the protection to which they are entitled. Fees are reasonable. Deferred payments frequently arranged. Questions promptly answered. Write us frankly with absolute assurance that what you say will be treated with strictest secrecy. **But first send for the FREE BOOKS shown on these two pages.** They are filled with facts, pictures and suggestions. They tell you things about Patents, Inventions and Selling Inventions that we have learned in our long experience. **They may save you time, expense, EVEN LATER DISAPPOINTMENT.** Simply fill in the coupon or write us a confidential letter. No charge, no obligation. **Mail the coupon today.**

VICTOR J. EVANS & Co. **REGISTERED PATENT ATTORNEYS**

Main Office: 200-G, Victor Building,
Washington, D. C.

Other Offices: 1007-N, Woolworth Bldg., New York
1445-N, Monadnock Bldg., Chicago
514-N, Empire Bldg., Pittsburgh
1010-N, Hobart Bldg., San Francisco
736-N, Security Bldg., Los Angeles

Send me FREE copies of your books, "Patent Protection" and "When and How to Sell an Invention." (Note: Same books supplied by any of branch offices listed above.)

Name.....

Street and No.....

City or Town.....

.....

.....

**MAIL THIS
COUPON TODAY**

Turn JUNK IN TO Cash! TIRES START AT HOME

The Most Sensational Business Opportunity Since 1929

Like turning lead into gold, here is a business with gigantic possibilities. Factories, Clubs, Stores, Schools, Homes, spend millions every year for rubber mats. Think of your profit when a



HAND MACHINE and

5¢ TIRE MAKES \$2.00 MAT

Brand new. Fully patented. Few men already started report unprecedented success. Wm. Eagle writes: "Can't make mats fast enough. First week brought over 200 orders for \$1.00 to \$10.00 each." Flash from Harris says: "Orders enough to keep 15 men busy all the time." Gunter got big order from County Commissioners and now reports: "Just signed up order for all Grade Schools and High Schools." No wonder responsible men are throwing everything else aside to establish local FABRIX factories.

COSTS NOTHING to get complete facts. Just send name and address. We'll send description of simple hand machine that quickly slices old tire into strips; show you how patented method forms strips into thick, springy, long-wearing FABRIX Mats—how five cents worth of Junk Tires makes a \$2.00 Mat; how you can start on a reasonable investment and build a business so big, so fast, that it will take your breath away. Don't delay a minute. Write or wire today. All information is free.

FABRIX, Inc., 325 W. Huron St., Dept. 76, Chicago, Ill

AUTO-MECHANICS & WELDERS

GOOD JOBS and MIGHTY GOOD PAY

Do you want to earn big money? If so let us know which of the following trades you prefer. You learn by doing. Practical work. Expert teachers. Low tuition. Personal attention. It will pay you to investigate **AT ONCE**. Just check the courses you'd like to take and mail today. You will receive full information, absolutely without cost or obligation. But don't delay.

Check the Trade You'd Like to Learn

- Auto Mechanics
- Auto Collision
- Metal Finishing
- Welding
- Spray Painting
- Torch Soldering

Ask about our "Pay After Graduation Plan"

Name

Address

Mail the above to

MICHIGAN TRADE SCHOOL

Write for **FREE CIRCULAR**

3758 Woodward Avenue DETROIT, MICH.

(Continued from page 18A)

text and illustrations, are restricted to postage stamps, postage due, and special-delivery stamps, official stamps, air-mail stamps and semipostal stamps, or those having a surtax for a charitable purpose.

It is not necessary for the beginner to buy a new catalogue each year, although that is about his only way of classifying current stamps, for the text changes very little from year to year. There are price changes but these are usually unimportant in the foreign section of any two consecutive catalogues. Catalogues are printed at the beginning of the fall season each year, and at this time it is possible to buy the catalogue which has been superseded, at one-half, or one-third the original price.

The second course open to a collector is to buy a printed album which contains illustrations of various issues. This album may be a set of four volumes with spaces for all of the stamps listed in the standard catalogue, or it may be a single volume junior album, with spaces for all of the stamps within a moderate price range. In these albums the countries are arranged alphabetically and the spaces which have been outlined are in regular chronological sequence, and all new designs are illustrated in the proper order.

When you obtain your first catalogue or album, you should go through it carefully to become acquainted with the various designs and inscriptions which appear on the stamps, noting particularly those countries whose stamps seem hopelessly barbaric, without anything which the collector can recognize as a name or a value. For some time it will be necessary to depend on the memory to find these, or to search through the catalogue each time a stamp is to be classified. Most stamps bear inscriptions in English, French, German, Spanish or Portuguese or Italian. It is generally easy to classify such stamps. Those whose inscriptions are in Cyrillic characters are more difficult. This peculiar alphabet of about forty-six characters, depending upon the country, is easily identified by its mixture of Roman and Greek letters to which have been added a liberal assortment of upside-down and reversed letters. Fortunately for the collector, many countries which have subscribed to the conventions of the Universal Postal

(Continued to page 27A)

Law!

LEARN AT HOME

Are you adult, alert, ambitious, willing to study? Investigate LAW! We guide you step by step—furnish all texts, including 14-volume Law Library. Training prepared by leading law professors and given by members of bar. Degree of LL. B. conferred. Low cost, easy terms. Send NOW for Free, 64-page "Law Training for Leadership." LaSalle Extension University, Dept. 664-L, Chicago

Aviation Career OFFERS YOU GREAT FUTURE

Demand for trained aircraftsmen in Southern California plants is increasing and already exceeds supply. Curtiss-Wright Technical Institute, Aviation's foremost and oldest school, is located in heart of this activity and specializes in Sheet Metal, Master Mechanics and Aero Engineering. (No flying involved.) Graduates are obtaining immediate employment. Write for details NOW. Curtiss-Wright Technical Institute, Glendale, Los Angeles, Cal. Dept. PM-6.

BE A CARTOONIST



AT HOME IN YOUR SPARE TIME under personal supervision of the famous cartoonist NORMAN MARSH creator of "DAN DUNN" appearing every day in big papers. Success—Fame—Real Money may be Yours when you learn Marsh's easy simple methods and secrets. Send name and address for free details of MARSH'S Personal course. ACT TODAY! MARSH CARTOON SCHOOL Chicago Daily News Bldg., Dept. F-1. Chicago, Ill.



TRAILER ENGINEERING

(Second Edition)

BRAND NEW BOOK

To Help You Buy or Build. 14 chapters, 130 illustrations.

Proven plans for 10, 14, 17, and 21-foot trailers. Tells you about bob, roll, weave, snaking, nose diving, rear vision, Ackerman steering, tandem wheels, tow car balance, trailer balance, all State laws, American coaches, English coaches, plumbing, wiring, brakes, step action, chassis, parking packs, weights, furniture, ironing the low car, every engineering detail. Get unvarnished trailer engineering facts before you buy or build. Order NOW. \$1.00 postpaid, \$1.15 C. O. D.

RAY KUNS, Dept. 6, 6 Eastwood Circle, Cincinnati, Ohio

Learn ADVERTISING at Home

Greater opportunities now in advertising. Learn easily and quickly in spare time. Practical work. No text books. Old established school. Low tuition—Easy terms. Send for free booklet and requirements. Page-Davis School of Advertising Dept. 135-A, 3601 Mich. Av., Chicago

PENNY EACH !!

Large sizes! Beautiful Gold Reflecting Window Sign Letters. Finest Quality. 5 Year Guaranteed. New Styles. Tremendous Demand. Amazing Profits. Easily applied. Write for FREE SAMPLES and starting equipment. HURRY!

Atlas Sign Works, 7943 Halsted, Chicago, Ill.



BECOME A VENDING MACHINE OPERATOR!

Own a "chain" of 10 peanut and chewing gum vending machines. Large, steady profits, as people eat peanuts and chew gum daily. Start with \$100. Write for details today!

D. ROBBINS & CO.

1141P DeKalb Ave. BROOKLYN, N. Y.

Print Your Own

Cards, stationery, circulars, tags, labels, advertising, etc. Save money. Print for Others; Big Profits; easy rules sent. Will do popular Raised Printing like Engraving. Junior press \$5.99, job presses. \$11 up, power \$149. Send for free catalog and all details. THE KELSEY COMPANY, R-37, MERIDEN, CONN.



BUCHSTEIN'S FIBRE LIMB

is soothing to your stump—strong, cool, neat, light. Easy payments. Braces for all deformities. Agents wanted.

D. BUCHSTEIN CO.

610 3rd Ave., So., MINNEAPOLIS, MINN.

Send for Catalog Today

MAKE ME PROVE that I can train you at home for a GOOD JOB in RADIO



MAIL COUPON FOR FREE SAMPLE LESSON



\$80 Monthly in Spare Time

"I work on Radio part time, still holding my regular job. Since enrolling five years ago, I have averaged around \$80 every month." — JOHN B. MORISSETTE, 773 Silver St., Manchester, N. H.

Operates Public Address System



"I have a position with the Los Angeles Civil Service, operating the Public Address System in the City Hall Council. My salary is \$153 a month." — R. H. ROOD, R. 136, City Hall, Los Angeles, Calif.



Makes \$50 to \$60 a Week

"I am making between \$50 and \$60 a week after all expenses are paid, and I am getting all the Radio work I can take care of, thanks to N.R.I." — H. W. SPANGLER, 308 Walnut St., Knoxville, Tenn.

Do you want to make more money? Make me prove that I can train you at home in your spare time for a good Radio job. Mail the coupon. I will send you my first lesson FREE. Examine it; read it, see for yourself how practical and easy I make learning Radio at home—even if you've never had Radio or electrical experience.

Many Radio Experts Make \$30, \$50, \$75 a Week

Radio broadcasting stations employ engineers, operators, station managers and pay up to \$5,000 a year. Spare time Radio set servicing pays as much as \$200 to \$500 a year—full time Radio servicing jobs pay as much as \$30, \$50, \$75 a week. Many Radio Experts own their own full time or part time Radio businesses. Radio manufacturers and jobbers employ testers, inspectors, foremen, engineers, servicemen, paying up to \$6,000 a year. Automobile, police, aviation, commercial Radio, and loud speaker systems offer good opportunities now and for the future. Television promises to open many good jobs soon. Men I have trained at home are holding good jobs in all these branches of Radio.

Many Make \$5, \$10, \$15 a Week Extra in Spare Time While Learning

Almost all neighborhoods need a good spare time serviceman. The day you enroll I start sending you Extra Money Job Sheets. They show you how to do Radio repair jobs that you can cash in on quickly. Throughout your training I send you plans and ideas that have made good spare time money for hundreds of fellows. I send you special Radio equipment and show you how to conduct experiments and build circuits which illustrate important Radio principles. My Course gives you practical Radio experience.

Get My Lesson and 64 Page Book FREE. Mail Coupon

In addition to my Free Sample Lesson, I will send you my 64 page book "Rich Rewards in Radio," FREE to anyone over 16 years old. My book describes Radio's spare time and full time opportunities and those coming in television; describes my Training in Radio and television; shows you actual letters from men I have trained, telling what they are doing and earning; tells about my Money Back Agreement. MAIL THE COUPON in an envelope, or paste it on a penny postcard—NOW!

J. E. SMITH, President National Radio Institute, Dept. 7FP, Washington, D. C.

MAIL NOW for FREE PROOF

J. E. SMITH, President National Radio Institute Dept. 7FP, Washington, D. C.

Dear Mr. Smith: Without obligation, send me the Sample Lesson and your free book about the spare time and full time Radio opportunities, and how I can train for them at home in spare time. (Please write plainly.)

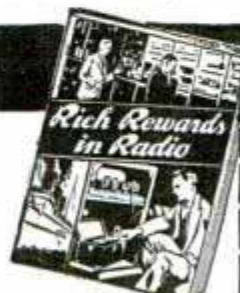

Name..... Age.....
Address.....
City..... State..... 2FR

To help you answer these 3 questions:



- 1—What are today's opportunities in Drafting?
- 2—Will I like the work?
- 3—Can I learn Drafting readily?

2 Beginning Lessons in Drafting Free

Before anything can be made or built, the Draftsman first must draw it. Building trades, transportation, manufacturing—ALL depend on him. That is why any pick-up means first call for the Draftsman! Experience not necessary. You can master Drafting readily by home study because you learn and advance exactly as professional Draftsmen work—with T-square, dividers and drawing board. Actual working conditions duplicated. Thousands of successful graduates enthusiastically endorse our methods.

Prove That You Can Qualify

The 2 lessons will be sent without obligation. Look them over. See how simply you start—how you can pass from a raw beginning to complete mastery of Drafting—able to hold a pleasant, profitable job. Such a future is worth looking into; so, write Today!

American School • Dept. DDA-45 • Drexel Avenue at 58th Street • Chicago, Illinois

TRI-STATE COLLEGE

ENGINEERING DEGREE IN 2 YEARS



Courses in Civil, Electrical, Mechanical, Chemical, Aeronautical, Radio Engineering. Essentials of engineering training included and non-essentials eliminated. B. S. Degree granted upon completion of course. Also short diploma courses in Surveying (36 weeks), Drafting (36 weeks). For ambitious, earnest students. Those who lack high school training may make up required work. Graduates compete successfully with those of 4-year schools. Technical in-

struction at lowest cost and in least time consistent with thorough training. Intensive instruction in accord with individual ability. Courses also in Business Administration and Accounting. Students from all parts of the world. Tri-State graduates make good. Located in picturesque hill and lake region. Tuition, living expenses low. 54th year. Enter September, January, March, June. Write for catalog. 467 College Ave., Angola, Ind.

AMATEUR CARTOONISTS WIN \$25.00

Wanted—Amateurs with humorous ideas. No drawing ability necessary. The amateurs of today are the professional cartoonists of tomorrow. Ideas judged and prizes awarded by Applause-O-Meter test before movie audiences. Everyone has an equal chance. 26 cash prizes in all. Rush name on penny post card for "Valuable Tips on How to Make Money With Simple Cartoons and Humorous Ideas". Cash Prize Entry Blank and Rules—SEND NO MONEY.

CARTOONISTS' EXCHANGE, Dept. 96, Pleasant Hill, Ohio

BECOME A SUCCESSFUL FINGER PRINT EXPERT

Prepare for a Thrilling Career with a splendid, steady income. Write for Free Publication and Particulars. NATIONAL INSTITUTE, Dept. G, Fremont, Nebraska.

I WANT MEN

TEA AND COFFEE ROUTES PAYING UP TO \$60.00 IN A WEEK

National company needs more men at once to make regular calls on local routes. No experience needed. Operate on our capital. I give producers brand-new Ford cars as bonus. Rush name on postcard for FREE Facts.



ALBERT MILLS
3985 Monmouth Cincinnati, Ohio

RAISE GIANT FROGS

MUFOND GIANTS WEIGH UP TO 3 LBS. EACH



EASY TO START!

Markets Waiting! Frog legs in big demand at good prices the year 'round. Millions used yearly!

WE BUY

We have one of the largest frog markets in the world. Sell to us in addition to other markets. Easy to ship. Men and Women starting in every state and Canada. See what others already doing. Small pond starts you. FREE FROG BOOK explains our unusual offer to beginners! Now's the time to begin! Write today sure!

AMERICAN FROG CANNING CO.
(Dept. 133-H) New Orleans, Louisiana

FREE BOOK



(Continued from page 24A)

362

Union, design their stamps so one set of inscriptions and values is in a recognizable language, usually French or English, while the other is in the native characters.

Following is a list of the more common stamp-issuing countries showing the country name as it now appears upon its stamps:—Austria, Osterreich; Belgium, Belgique and Belgie; Czechoslovakia, Ceskoslovensko; Denmark, Danmark; Estonia, Eesti; France, Republique Francais or R.F.; Germany, Deutsches Reich; Hungary, Magyar; Iceland, Island; Irish Free State, Eire; Jugoslavia, Jugoslavija; Latvia, Latvija; Lithuania, Lietuva; Netherlands, Nederland; Norway, Norge; Persia, Persanes; Poland, Polska; Russia, C.C.C.P.; Spain, Republica Espanola; Sweden, Sverige and Switzerland, Helvetia. The stamps of Great Britain have never shown the name of the country.

While specialists in modern United States stamps were busy looking for flaws and minor varieties in the Washington Bicentennial issue, they allowed a second die of the current two-cent stamp to escape unnoticed. This die was cut and new plates were made for sheet stamps, and stamps were printed and issued. After three or four years, the existence of a new die was discovered. By this time the stamps were nearly all gone and it has not been possible to find enough to satisfy collectors. The most prominent difference between this die and the regular die, which had been used for ten years before the new die was discovered and which is again in use, lies in the lines which indicate the hair at the top of Washington's head. In the new die there are three coarse lines outlining locks of hair while in the regular die all of the lines in this part of the portrait are uniformly faint and delicate. There are also other minor differences. Existing prices make these stamps worth finding and collectors should examine all two-cent stamps, used as well as unused, which were issued after 1929.

New Stamp Issues

The illustration includes a few air-mail stamps of picturesque design likely to appeal to the collector of unusual stamps.

(Continued to page 31A)

BIG MUSCLES - SMASHING STRENGTH GLOWING HEALTH!

I'll Prove in the first 7 days - that I can Make You a New Man!

DO YOU want big, smashing, sledge-hammer muscles all over your body? Husky, broad shoulders? Deep, powerful chest? All the pep and vigor of a "hard as nails" athlete? Give me just 7 days—one short week. I'll give you the PROOF that I can make you a *new man*—with a real he-man build, glowing health that resists sickness, ends pimples, skin blemishes, constipation, other troubles.

Read the reports below. That's the kind of RESULTS you can get with my discovery—*Dynamic Tension*. My free book, "Everlasting Health and Strength," tells how I can give YOU a body women admire and men envy.

The 97-lb. Weakling Who Became "The World's Most Perfectly Developed Man"

This new photo is *exactly* how I look today. Yet once I was a 97-lb. weakling! Timid, self-conscious—never had good times. Then I discovered the secret of my *Dynamic Tension* method of body building. It changed my entire life. It has twice won me the title, "The World's Most Perfectly Developed Man!" And what my amazing system did for me—what it has done for hundreds of other fellows like yourself—it can now do for YOU, too!

I back up that promise with quick RESULTS. You begin to SEE and FEEL the difference at once. What's more, it's actual fun to build a husky body my *Dynamic Tension* way, at home, in just a few minutes daily. And you don't have to buy any contraptions that might strain your heart or other organs.

Mail Coupon for My Big 48-Page Book - FREE!

Make me prove in just 7 days that I CAN give you the big, smashing muscles — powerful shoulders — deep chest — all round health you have always wanted. Mail coupon for FREE copy of my big Book, "Everlasting Health and Strength." Address me personally. I'll send it by return mail. Show me you're a man of action. Do it NOW!

CHARLES ATLAS,
Dept. 8 V, 115 East 23rd Street, New York, N. Y.

**CHARLES ATLAS, Dept. 8 V,
115 East 23rd Street, New York, N. Y.**

I want the proof that your system of *Dynamic Tension* will make a New Man of me—give me a healthy, husky body and big muscle development. Send me your free book, "Everlasting Health and Strength."

Name.....
(Please print or write plainly)

Address.....

City..... State.....



Puts FIVE INCHES on Chest!

"Chest gained five inches; arms two inches. Nervous troubles, constipation gone. Feel like new man." — George Tobias Finkbone, West Middletown, Ohio.

Gains 20 lbs.!

"Gained 20 lbs. Biceps 1 3/4 inches and large powerful shoulders. Rest of my body well proportioned, hard as rock." — Howard Sibley, Wichita, Kans.

Results in ONE WEEK!

"Just a week ago I started. What a difference already! Before, my chest was 32 in. normal. Now it's 35 1/2 in. normal, 38 1/2 in. expanded!" — Frank Segretto, Yonkers, N. Y.

Actual photo showing how CHARLES ATLAS looks TODAY



STEP NO. ONE

Make a rough pencil sketch of your invention, describe it fully, and send it to us for preliminary search through United States Patents in the U. S. Patent Office.



STEP NO. TWO

Our trained searchers will then make a preliminary search of the pertinent U. S. patents to determine if your invention is probably patentable.



STEP NO. THREE

Our complete report of search and opinion on patentability will be mailed to you with copies of U. S. Patents that we consider nearest to your invention.



STEP NO. FOUR

If you decide to make patent application, for customary fees explained in our booklet, our draftsmen will make drawings and proper papers will be prepared for presentation of your invention to the Patent Examiner in U. S. Patent Office.

INVENTORS

KNOW HOW TO START KNOW EACH STEP TO TAKE *Before Going Too Far With Your Inventions*

Very often, the patent procedure is what we call a "simple" one—as illustrated here. Our FREE BOOK, "Patent Guide for the Inventor," describes what to do and how to go about it. Send for it by all means—let us urge, however, that you take the first step (Step No. 1 to left) without further delay. It will prevent wasted work, mis-steps, and going ahead "in the dark"—your whole patent procedure depends upon the first step.

If you have an invention that is patentable—and want to secure for yourself your inventor's sole right to profit from the invention—you can't afford to lose time in securing the protection of a U. S. Patent. Other inventors may be working on the same thing right now. Should they develop this invention and file patent application before you do—the burden of establishing priority will be upon you. Our Big Book—"Patent Guide for the Inventor"—will tell you the quickest possible way to secure Patent Protection for your invention. SEND FOR IT TODAY!

Immediate Search Necessary

A search at the U. S. Patent Office will disclose one of three things: That you have hit upon an entirely original invention—that you have suggested patentable improvements upon an existing invention—or that your invention has been anticipated throughout, and you should drop it. You should have this information at once. The next steps (the whole procedure of obtaining a patent) will be thoroughly explained to you in our FREE BOOK.

Our FREE BOOK tells everything you need to know about patents. We will mail this book upon receipt of your letter requesting search—or if you want to read it before having search made, simply fill out the coupon on opposite page.

FREE RECORD OF INVENTION

This FREE Record of Invention Form enables you to make in convenient form a sketch of your invention and have it witnessed in a manner of value to you should the occasion for evidence arise. MAIL THE COUPON TODAY and obtain our FREE BOOK and Record of Invention Form.

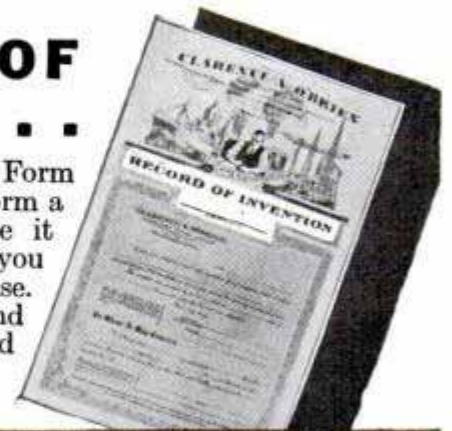

CLARENCE A. O'BRIEN & HYMAN BERMAN

705 Adams Bldg.

Washington, D. C.

Registered Patent Attorneys Before U. S. Patent Office

PATENT YOUR INVENTIONS *Act Now!*

DELAYS ARE DANGEROUS IN PATENT MATTERS

The Free Book shown here was prepared for inventors, to show them exactly what steps they must take to secure a PATENT. If you have an invention, you should send for this book AT ONCE. It will tell you exactly how an application for a Patent is made, what information you must furnish your attorney, and what steps he must take in order to protect your interests. Remember, inventing an article is one thing—securing the exclusive right to manufacture it, use it, or sell it is another. Without a U. S. Patent, you cannot expect to reap the profits that your invention may make possible. Send at once for this book. After you get that, you'll know exactly what to do to protect yourself.

WHAT A PATENT DOES FOR YOU

Every year thousands of Patents are granted. Very few, however, represent the discovery of entirely new principles. Most of them provide new methods of doing some everyday thing in a better way—changes for greater efficiency, usefulness, adaptability, or beauty in some previously Patented thing. These IMPROVEMENTS are Patentable if new, and actually represent new inventions. These improvement Patents offer large chances for profit if commercially useful. The business world wants improved products and services.

WE SERVE YOU QUICKLY AND SECRETLY

Anything you write us or send us is strictly confidential between us. All letters and drawings are kept in strong, steel, fireproof files, which are open only to ourselves or authorized members of our staff. We have secured patents for inventors located in every state in the Union. Our organization is a large and efficient one. Our practice is confined entirely to Patents, Trade-Marks, and Copyrights. We have had years of experience in Patent Matters. When you place your invention in our hands, we are in position to proceed at once to secure protection for you. Our fees are reasonable, and, if you desire, we can arrange convenient terms of payment.

IMPORTANT!

Please understand that you are not under the slightest obligation in sending for this book. We will mail it, together with the Record of Invention Form, the same day we receive your request. Use the coupon to save yourself time and trouble. After that, you will be in position to proceed or not as you choose, to make your application for a patent.

THIS FREE BOOK ... Tells How!

How your Patent Application is made; what kind of sketches or drawings are necessary; what other papers must be made out; how the Patent Laws protect you; why it is important to avoid loss of time in getting your application filed; and many other important points. Even a very simple invention, if new and useful, may prove very valuable. You may have much to gain and nothing to lose by sending for this book TODAY.

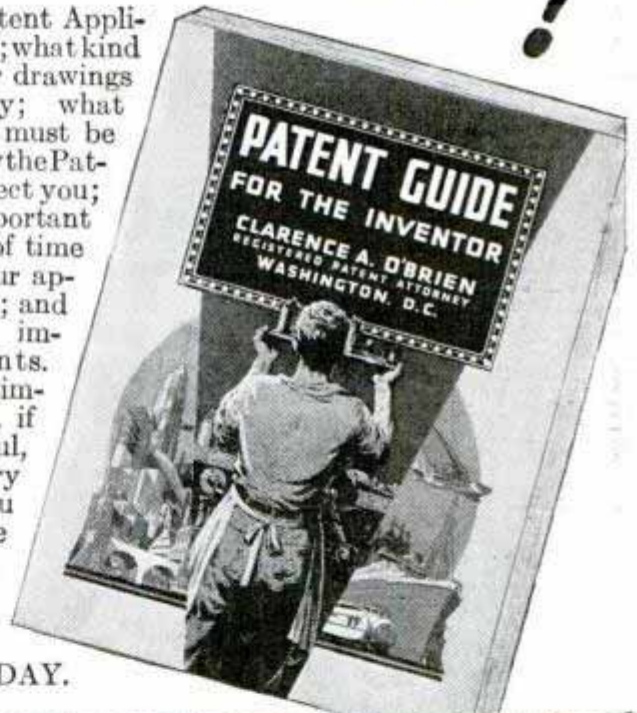

CLARENCE A. O'BRIEN & HYMAN BERMAN

705 Adams Building

WASHINGTON, D.C.

REGISTERED PATENT ATTORNEYS
BEFORE U.S. PATENT OFFICE

Please send me at once your Big Free 48-Page Book, "Patent Guide for the Inventor" and your Specially Prepared "Record of Invention" form. This request does not obligate me.

NAME.....

ADDRESS.....

(Please write or print plainly.)

PATENTS

Booklet Free Highest References
Promptness Assured Best Results

Send drawing or model.

ALL BUSINESS GIVEN PROMPT AND PROPER ATTENTION

Listed Patent Lawyer in the latest editions of the Rand-McNally Directory of Bankers and Bank-Recommended Attorneys, published by Rand-McNally & Co., Chicago, Ill.; The Baggott & Ryall Directory of Guaranteed Attorneys, published by Legal Directory Corporation, Boston, Mass.; American Lawyers Annual, Cleveland, Ohio; Bankers Service Legal Directory, published by Bankers Service Co., Boston, Mass.; Eyre's Law List, 9 Park Place, New York City; Snow-Church Directory Co. Lawyers List, published in New York City, and the Central Guarantee Co., Bankers and Lawyers Directories, 630 Fifth Avenue, New York City.

WATSON E. COLEMAN,
REGISTERED PATENT LAWYER

Victor Building, 724 Ninth Street, N. W.
WASHINGTON, D. C.

INVENTORS PATENT YOUR IDEAS SEND FOR FREE BOOK



HOW TO OBTAIN A PATENT

Written by a Former Member of the Examining Corps (1922-24) of the U. S. Patent Office. If you want to profit by your idea, you should take steps to apply for a U. S. Patent at once. Your first step is to get this Free Book. This interesting illustrated book contains valuable information you should have. It tells you fully how to obtain a patent on your idea in the quickest way. With this Free Book you will also receive a "Record of Invention" form on which you can easily record your idea. Personal and Confidential Service: Your case will be personally handled only by a Registered Patent Attorney who is also a Former Member of the Examining Corps of the U. S. Patent Office. All communications confidential.

MAIL COUPON TODAY for FREE PATENT BOOK and RECORD OF INVENTION Form.

CARL MILLER

REGISTERED PATENT ATTORNEY
FORMER MEMBER EXAMINING CORPS U. S. PATENT OFFICE

1638 Woolworth Bldg., Dept. 67A, New York City
MILLER BUILDING, Dept. 67A, WASHINGTON, D. C.

Please send me your Free Book, "How to Obtain a Patent," and your "Record of Invention" form.

NAME.....

ADDRESS.....

DEAF ?

AMAZING NEWS!

You may hear like normal again!
Amazing new instrument releases deaf
from misery and embarrassment

The Godsend, new Scientific, Electrical Hearing Aid, is guaranteed to give you same strain-free power to hear as instruments selling for \$85.00 to \$175.00, and more. PRICED AT ONLY \$19.75! Backed by \$1000.00 Money-Back Guarantee. Now you may enjoy sermons from back of church, lectures, conversation, radio, movies. Complete with Microphone, Batteries, and TWO Appliances for BONE or AIR CONDUCTION, both for less than the usual price of only ONE. Music and words heard distinctly from all directions, at close range or from distances. No distortion—no head noises. Instrument is lightweight, easily concealed in clothing, no more noticeable than pair of glasses. Write quick for FREE DETAILS, sent in plain envelope.

GODSEND COMPANY, Dept. W-488,
4204 Davis Lane, CINCINNATI, OHIO

PATENTS

TO THE MAN WITH AN IDEA

Personal service, reasonable charges. Preliminary advice, book and disclosure form free. Registered Patent Attorney.

IRVING L. McCATHRAN, PATENT LAWYER

Formerly with and successor to RICHARD B. OWEN
1020 International Bldg., Washington, D. C.

TRADE-MARKS

PATENTS—TRADE MARKS

All inventions submitted held confidential and given personal attention by members of the firm.

Form, "Evidence of Conception" and instructions, "How to Establish Your Rights"—FREE!

LANCASTER, ALLWINE & ROMMEL

Patent Law Offices

412 Bowen Bldg.

Washington, D. C.

Inventions Wanted Patented or Unpatented

We have been successfully selling inventions, patented and unpatented, since 1924. Write for proof, and tell us what you have for sale.

Chartered Institute of American Inventors
Dept. 4, Barrister Building, Washington, D. C.

INVENTORS

who derive largest profits know and heed certain simple but vital facts before applying for patents. Our book, Patent-Sense, gives those facts; sent free. Trade Marks—Copyrights.

LACEY & LACEY, Est. 1869, 635 F St., N. W., Dept. 5, WASHINGTON, D. C.

PATENTS Protect Your Idea: By securing FREE my "PROOF OF INVENTION" folder. Exceptional Personal Service Excellent References. Established 1906.
E. E. VROOMAN, 871 Woodward Bldg., WASH., D. C.

ALBERT E. DIETERICH
REGISTERED PATENT ATTORNEY
512 B Colorado Building, WASHINGTON, D. C.
Booklet on Patents sent free

In answering advertisements always write name and full address clearly.

To PROTECT YOUR INVENTION—Use this coupon, NOW

Delays are dangerous and may be very costly. My personal service assures prompt action, strict confidence, and a minimum of expense. I suggest that you send me a model or drawing, or sketch and description of your invention, and \$5.00. I will make a search and report

promptly as to its patentability and send you a copy of my 72-page booklet. Or, if you prefer to read my booklet first, mail the attached coupon at once. I will also send my "Record of Invention" form. (Over 38 years experience as a Registered Patent Attorney.)

L. F. Randolph, 302-D Victor Bldg., Washington, D. C.

Please send me at once, free of charge, your 72-page booklet and "Record of Invention" form.

Name.....

Address.....

A PERSONAL CONFIDENTIAL PATENT SERVICE

(Continued from page 27A)

The triangular and diamond shaped stamps at the top and the large stamp in the center are the latest output of the soviet state of Tanna Touva where the printing presses are never idle. Several previous issues from this state have been refused catalogue recognition as no proof has been offered that the stamps were valid for postage purposes.

At either side of the center are examples of a recent Hungarian set issued to advertise the International Fair at Budapest. At the ends of the middle row are two Greek stamps, at the left being one of two semipostal issues, and that at the right a new portrait stamp showing King George II. The diamond-shaped stamps in the lower row are from the new air-mail set of Costa Rica, and appear to have been regularly issued. At the center of the bottom row is one value of the recent set of three German stamps which were issued to mark the fourth anniversary of the German Air Protection league.

Silver Three-Cent Pieces

The silver three-cent piece, midget coin of the United States, is an excellent item for those who wish to form a complete collection of dates. This coin was authorized in 1851 and was coined in Philadelphia each year from that date until 1873. In addition it was coined at New Orleans in 1851. Altogether there are twenty-four pieces in a complete set, with three varieties of the same design used throughout the entire period. The face of this coin presents a large six-pointed star with a shield in the center and the inscription "United States of America," around the edge with the date below.

The reverse shows a large ornamental "C" inclosing the Roman numeral "III," and surrounded by a circle of thirteen stars near the edge. The edge of the coin is plain. The first variety without lines around the star was in use from 1851 until 1853. From 1854 until 1857 there were three lines around the star, and from 1858 until coinage ceased, only two. The scarcest date is 1864, when only 470 pieces were minted. In the final year, 1873, 600 pieces were coined. All dates after 1862 are moderately scarce as is the 1851 coin with the mint mark of New Orleans.

More GOOD JOBS in BUILDING NOW!



The building industry is up against a shortage of TRAINED men. 600,000 homes a year must be built . . . scores and scores of industrial plants, public buildings, etc. "Give us trained builders," they say . . . "Men who can read blue prints—lay out and run jobs—estimate costs—draw plans!"

Make MONEY in BUILDING

"TRAINING" is the magic word that will let you cash in on this great building upswing. You can't learn on the job—it takes too long. Nowadays it takes "headwork" training—quick, interesting, practical training as offered by Chicago Tech, the 34 year old School for Builders. Mark your choice on coupon below.

Learn BUILDING, DRAFTING, AIR CONDITIONING, LUMBER YARD WORK AT HOME—or in Chicago

In only 6 to 12 months in your spare time—at home, you can learn by the approved C. T. C. plan. If employed now, or if funds are limited—mark subject **and Plan 1** on Coupon. If finances permit you to go away to College mark subject desired **and Plan 2**. Full information sent FREE—no obligation.

Free TRIAL LESSON

Send coupon or post card for Free Trial Lesson if interested in home-study (Plan 1). Prove to yourself how easy to learn by C. T. C. step-by-step method right in your own home. Get the Coupon in the mail today!



CHICAGO TECHNICAL COLLEGE

G146 Tech Bldg., 118 E. 26th St., Chicago, Ill.

Please send FREE BOOK as checked below:

- BUILDING. Plan Reading, Estimating, etc.
- DRAFTING. How to Draw Plans.
- AIR CONDITIONING and Refrigeration.
- LUMBER YARD COURSE for Yard Men.

Plan 1. At Home. **Plan 2.** At Chicago Tech.

Name

Address

P. O. State.....

Age..... Occupation.....

DON'T BUY

Until you have seen and tried out these wonderful instruments at your dealer



Don't buy Guitar, Mandolin, Banjo, Electric Guitars, Ukuleles, or Drums, until you have tried the Slingerland May-Bells, Guaranteed More for your Money. Wonderful, snappy, powerful, pleasing tone. No equal in price. Sold on easy payments and 5 days free trial by all leading music dealers.

Send for free catalog. Mention instrument wanted.

Write today:

Slingerland Musical Instrument Mfg. Co.,
1325 Belden Ave., Chicago, Illinois



Cut This Adv. Out — Good for \$1.00 Credit

Learn this Profitable Profession



in 90 Days at Home

Hundreds of men and women of all ages 18-50 make \$10.00 to \$20.00 in a single day giving scientific Swedish Massage and Hydro-Therapy treatments. There is a big demand from Hospitals, Sanitariums, Clubs, Doctors and private patients as well as opportunities for establishing your own office.

Learn this interesting money-making profession in your own home by mail through our college extension course. Same instructors as in our NATIONALLY KNOWN resident school. A diploma is awarded upon completion of the course. Course can be completed in 3 to 4 months. High School training is not necessary. Many earn big money while learning.



Anatomy Charts & Sample Lessons FREE

Enroll now and we will include uniform coat, medical dictionary, patented reducing roller and Hydro-Therapy supplies without extra cost. The reducing course alone may be worth many times the modest tuition fee.

Send coupon now for booklet containing photographs and letters from successful graduates, illustrated sample lesson sheets and Anatomy Charts. These will all be sent postpaid—FREE.

National College of Massage & Physio-Therapy
Dept. A64—20 N. Ashland Boulevard, Chicago

You may send me FREE and postpaid, Anatomy Charts, illustrated sample lesson sheets and booklet containing photographs and letters from graduates.

Name.....
Address.....
City..... State.....

BE A

TELEVISION ENGINEER

Get ready for the big opportunities for trained men in this coming industry. Home study course with professors of leading scientific universities, plus resident laboratory work for 2 or 3 months. Prepares you to specialize in television with sound fundamental basis of radio and electricity. Build your own television receiver from parts which we send you. High school graduates or those who pass test accepted. Also resident day courses.

Write now for free catalog.

Massachusetts Television Institute
Dept. B, 108 Massachusetts Ave.
Boston, Mass.

CARTOON YOUR WAY TO SUCCESS!



DON'T COPY — LEARN TO ORIGINATE!

RAYE BURNS will teach you HOW to CREATE ORIGINAL CARTOONS at home that you can SELL! Course contains 26 lessons and over 600 illustrations. All for Only . . .

\$2.85

Send name and address for free details.

RAYE BURNS SCHOOL, Dept. M-X, BOX 2194, Cleveland, Ohio

AERONAUTICAL UNIVERSITY



ENGINEERING - LICENSED MECHANIC
ADMINISTRATION - RADIO - SHEET
METAL - WELDING

A real technical university education in less time at less cost. B.S. Degree. Graduates with all leading aviation companies and air lines. Day and eve. classes. State Accredited. Government approved. Write for "Aviation as a Career." Address Curtiss Wright Bldg. Dept. A, 1342 S. Michigan Ave., CHICAGO, ILL.

Learn PHOTOGRAPHY at Home

Splendid opportunities. Prepare in spare time. Easy plan. No previous experience needed, common school education sufficient. Send for free booklet "Opportunities in Photography", particulars and requirements.

American School of Photography
3601 Michigan Ave., Dept. 135-A, Chicago, Ill.

RADIO

ENGINEERING, broadcasting, aviation and police radio, servicing, marine and Morse telegraphy taught thoroughly. Nine months' engineering course equivalent to three years' college radio work. School established 1874. All expenses low. Catalog free.

Dodge's Institute, Ada St., Valparaiso, Ind.

Save Your Feet

When all else fails end your suffering with the flexible "no metal"

Heefner ARCH SUPPORT

Write for Free Booklet



HEEFNER ARCH SUPPORT CO., 658 Commercial Bldg., LOUISVILLE, KY.

ITCH

.. STOPPED IN A HURRY BY D.D.D. ..

Are you tormented with the itching tortures of eczema, rashes, athlete's foot, eruptions, or other externally caused skin afflictions? For quick and happy relief, use cooling, antiseptic, liquid **D. D. D. PRESCRIPTION**. Greaseless and stainless. Soothes the irritation and swiftly stops the most intense itching. A 35c trial bottle, at all drug stores, proves it—or your money back.

When writing please mention Popular Mechanics

The Diesel Engineer

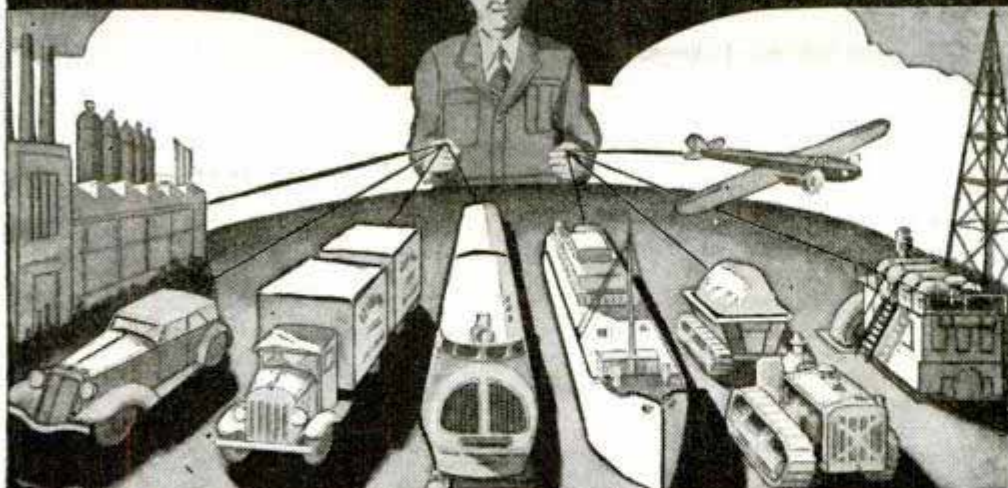

Is Your Job Safe?

Just as the gasoline engine changed or wiped out the jobs of thousands who depended on horse-drawn vehicles for their living—just as electricity changed the entire set-up in the fields of light and power—so now the Diesel engine is fast invading both the power and transportation fields, and threatening the present jobs of thousands of workers.

If jobs in your line are steadily growing scarcer, you owe it to yourself to investigate this new, progressive, uncrowded line, that in our opinion will offer good openings for the next 25 years.

2 Beginning Lessons in Diesel Engineering Free

Diesel—The New, Fast-Growing Power

Diesel engines—because of their high efficiency, dependability, and economy of operation—are fast replacing steam and gasoline engines in power plants, motor trucks and busses, locomotives and ships, aircraft, dredges, drills, pumps, etc.—opening up an increasing number of well-paid jobs for Diesel-trained men. The field of Diesel Engineering is on the upgrade and continually expanding. It will provide steady employment, advancement and good pay for those properly trained in this new industry.

What This New Field Offers You

Now is your chance to get into a big new industry and grow up with it to an important position. Today there is practically no competition in the Diesel field, but the increasing use of Diesel engines will result in keen competition for jobs in the near future. By starting your training now, you can keep ahead of such competition.

American School, Dept. DA-45, Drexel at 58th Street, Chicago, Illinois

You get complete information on all the latest Diesel developments—two- and four-stroke cycles; low- and high-speed and heavy duty types; Diesel-electric generating systems, etc.—in our course. Includes all text material—with special diagrams for quick understanding of this new power.

Get 2 Lessons FREE to Prove Your Own Possibilities in Diesel

Can you learn Diesel? We want to give the opportunity of finding out. So, *without cost or obligation on your part*, we will send you 2 beginning lessons. In the quiet of your own home, look them over. See how clearly all is explained—how thoroughly you grasp every point—how definitely you progress step by step—so that your knowledge of Diesel grows constantly. Making this simple trial may be the turning point in your life—so write to us **TODAY!**

Turn Your Spare Time into Dollars

LEARN CARTOONING

by the method that has developed hundreds successfully. Send name, address and age for free chart to test your ability.

THE LANDON SCHOOL, 1404 E. 9th Street, Cleveland, Ohio.

LES Correspondence Courses in **RADIO and ELECTRICAL ENGINEERING** SPECIAL Only \$25

ELECTRICAL ENGINEERING. Get good grasp of wide electrical field. Modern. Very understandable.

RADIO ENGINEERING. Extra fine course in radio, public address, photo-electric work. Trains you to be super-service man, real vacuum tube technician. Tuition ONLY \$25, either course. Deferred payment plan. Exper. kits furnished.

WRITE TODAY for free copies of school catalogs, student magazines, etc.

LINCOLN ENGINEERING SCHOOL Box 931-25 Lincoln, Nebr.

JOBS for PHOTO-ENGRAVERS!!

EARN WHILE LEARNING PHOTO-ENGRAVING IN SPARE TIME—Photo-Engravers are needed to operate Tasope' Photo-Engraving Equipment we sell to publishers everywhere . . . Start training at home in spare time. We furnish all equipment including photo-engraving camera with lamps, lens and screen. Earn while learning by making engravings for local advertisers, newspapers, printers, etc. Copper plate for picture shown here, size 8x10 inches sells for \$15.87. SEND TODAY for job plan details and catalog illustrated with pictures engraved by equipment we furnish. No cost! No obligation.

THE AURORA SCHOOL OF PHOTO-ENGRAVING
Dept. 167 Aurora, Missouri



PARKS AIR COLLEGE

Offers COLLEGE AND PROFESSIONAL TRAINING Majoring in Aviation

FOUR two-year courses (96 weeks) lead to Bachelor of Science degrees in Professional Piloting, Aviation Operations, Aviation Mechanics and Aeronautical Engineering.

THIRTEEN TRAINING PLANES are on the flight line. They range from the Kinner Sportster to the high speed twin-engined Monocoach equipped with retractable landing gear, air brakes, two-way radio, radio direction finder, and blind flight instruments.

58,000 hours flight instruction have been given, 650 hours now being flown monthly. THE FACULTY of 33 is composed of specialists in the various fields of aviation. AN ENROLLMENT of 254 resident students for the 1937 Spring term.

On its 100-acre airport, Parks has 14 buildings with a total floor area of 2 3/4 acres, devoted to school purposes exclusively.

Accredited by the Illinois Superintendent of Public Instruction. Government approved as a Transport Ground and Flying School and Mechanics' School.

DORMITORIES AND DINING HALL ON THE FIELD.

1434 graduates.

Graduates are being placed prior to graduation.

74 per cent of graduates enter air transport operations in North and South America.

At Parks you train for aviation in aviation. Parks is recognized as the training division of the industry. Ask any one who is in aviation. You can expect more at Parks and still be agreeably surprised when you come.

The 60-page catalog gives complete information. Send for it. It is FREE. It is packed full of valuable information. A letter or post card will bring it to you.



PARKS AIR COLLEGE

637-M Cahokia Rd.

East St. Louis, Illinois

This MACHINISTS' Home-Study Course



helps men get ahead

Newly assembled—specially priced—these five recent books give you the practical facts on modern machines, up-to-date methods, you need to advance in machine shop work. Take advantage of the other man's experience as found in books, to solve your problems, increase your efficiency, with the new

Library of MODERN MACHINE SHOP PRACTICE

5 volumes—2000 pages—1600 Illustrations
(A combined home-study course and reference library)

This library of machine shop practice was written for practical men. It gives you the best methods for every kind of machine shop work. It fully explains lathes, drills, and other machine tools and their operation, automatic screw machines, speeds and feeds, gear design and production, punch and die work, metal finishing, etc., etc. Plainly written—completely illustrated—the best kind of help to the machine-shop man who wants to advance himself.

No money down—special price—easy payments.

FREE EXAMINATION COUPON

McGraw-Hill Book Co., 330 W. 42nd St., New York

Send me for ten days' free examination the Library of Modern Machine Shop Practice. If satisfactory I will send you \$1.50 in 10 days and \$3.00 monthly until the price of \$16.50 is paid. If not wanted, I will return the books postpaid. (To insure prompt shipment write plainly and fill in all lines.)

Name

Home Address.....

City and State.....

Position

Name of Company..... PM-6-37

WORK FOR THE



GOVERNMENT START

\$1260 TO \$2100 YEAR

OVER 42,000 APPOINTMENTS LAST GOVERNMENT YEAR MEN — WOMEN

- File Clerks
- Postoffice Clerks-Carriers
- Railway Postal Clerks
- Customs Inspectors
- Stenographers-Clerks
- Many Other Jobs

GET READY IMMEDIATELY
Common Education Usually Sufficient

Mail Coupon TODAY—SURE

Name

Address

Franklin Institute
Dept. D-173
ROCHESTER, N. Y.

Gentlemen: Rush to me, FREE of charge, list of U. S. Government big pay jobs. Send FREE 32-page book describing salaries, vacations, hours, work, etc. Tell me how to get one of these jobs.

When writing please mention Popular Mechanics

FREE BOOK

Tells How to Earn Up to \$30-\$50 WEEKLY

ELECTRIC REFRIGERATION and AIR CONDITIONING



U.E.I. HELPS MEN GET JOBS

RIGHT NOW there are jobs for thousands in Electric Refrigeration and Air Conditioning. Prepare for your opportunity at home in spare time by U.E.I.'s low-cost, easy-pay plan. Learn Engineering, Estimating, Installation, Servicing under a system that has brought outstanding results for TEN years. Get practical experience in our large, completely equipped Laboratories. We'll help you get Big Pay Job. Hundreds of U.E.I. trained men now employed by leading manufacturers, distributors and service organizations. Employment Service offered FREE of extra cost. Get Book of Facts.

UTILITIES ENGINEERING INST., Est. 1927
400-410 N. Wells St., Dept. 167, Chicago, Ill.

New York Established 1902

Electrical School

Ask for free booklet

44 West 17th St., N. Y. C.



Electric Guitar Only \$49.95 Cash

This is the most outstanding Electrical Guitar offer. Amplifier and speaker housed in black case with handle, fine grade Guitar; plugs into any 110 volt A.C. source. Plenty of volume; Ideal for beginners. Be the first in your neighborhood to have one. ORDER TODAY to avoid delayed shipment, due to demand! 1/2 cash, balance C.O.D. (Terms if desired.) Special Offer—Complete Guitar Chord Chart, 50c.

Stephens Sales & Service Co., 1601 E. 79th St., Cleveland, O.



AMAZING NEW BUSINESS Sell to Stores

Get Set for Life!

Handle Big Pay Store Route. Place nationally-known Line 5c-10c Counter Goods, 200 products. Included is Laymon's Aspirin—advertised in Saturday Evening Post. All sold from Self-Help Counter Displays. Up to 112% profit. Earn up to \$65 weekly. No experience needed to start. Facts free.

WORLD'S PRODUCTS COMPANY
Dept. 6810 Spencer, Indiana

HOME STUDY COURSES

Home-Study Courses, leading to Degrees in Arts and Sciences; Education; Writing; psychology; Chemistry; Business and Commerce; Law; Theology; Agriculture; Engineering; also courses in Business Training; Accounting; Advertising; Sales Management; Public Speaking; Radio. Many others. Low Cost, Easy Terms.

McKinley-Roosevelt College of Arts and Sciences, 4247 Clarendon Ave., Chicago

ENGINEERING COURSES

Home Study Engineering Courses leading to degrees Electrical; Mechanical; Diesel; Civil; Aeronautical; Automotive; Chemical; Radio and Television; and other Engineering Courses. Low Cost Easy Terms

McKINLEY COLLEGE OF ENGINEERING, affiliated with McKINLEY-ROOSEVELT COLLEGE OF ARTS AND SCIENCES, FOUNDED 1908, 4242 Clarendon Ave., Chicago, U.S.A.



Learn CHALK TALKING

Entertain for all occasions. Send \$1.00 for Laugh Producing Program of 23 Trick Drawings with Instructions. Catalog of Chalk Talk Supplies 10c.

BALDA ART SERVICE, Dept. K, Oshkosh, Wis.

BIG PAY DIESEL JOBS OPEN

Northwest, home of Adcox School is hot spot of Diesel employment. Finest training. Established 27 years. Successful graduates everywhere. Earn room and board while learning. Send for FREE big, 40-page, Diesel School Catalog.

L. L. ADCOX TRADE SCHOOL
Dept. 18 Portland, Oregon

No JOKE TO BE DEAF

—Every deaf person knows that—
Mr. Way made himself hear his watch tick after being deaf for twenty-five years, with his Artificial Ear Drums. He wore them day and night. They stopped his head noises. They are invisible and comfortable, no wires or batteries. Write for TRUE STORY. Also booklet on Deafness.



THE WAY COMPANY
729 McCreedy Bldg. Detroit, Michigan

KNOWLEDGE
THAT HAS
ENDURED WITH
THE PYRAMIDS

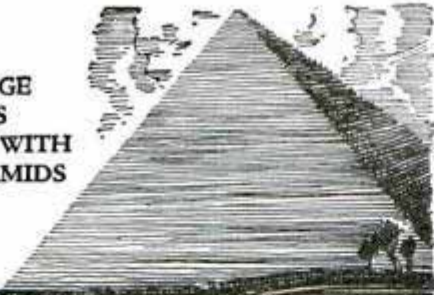

A SECRET METHOD FOR THE MASTERY OF LIFE

WHENCE came the knowledge that built the Pyramids? Where did the first builders in the Nile Valley acquire their astounding wisdom that started man on his upward climb? Did their knowledge come from a race now submerged beneath the sea? From what concealed source came the wisdom that produced such characters as Amenhotep IV, Leonardo da Vinci, Isaac Newton, and a host of others?

Today it is known that they discovered and used certain *Secret Methods* for the development of their inner power of mind. They truly learned to master life. This secret art of living has been preserved and handed down throughout the ages and today is extended to those who dare use its profound principles to meet and solve the problems of life in these complex times.

This Sealed Book — FREE

The Rosicrucians (not a religious organization) have prepared an unusual book, which will be sent free to sincere inquirers, in which the method of receiving these principles and natural laws is explained.

Write today for your copy of this sealed book. Possibly it will be the first step whereby you can accomplish many of your secret ambitions and the building of personal achievements. Address your inquiry to: Scribe D. F. X.

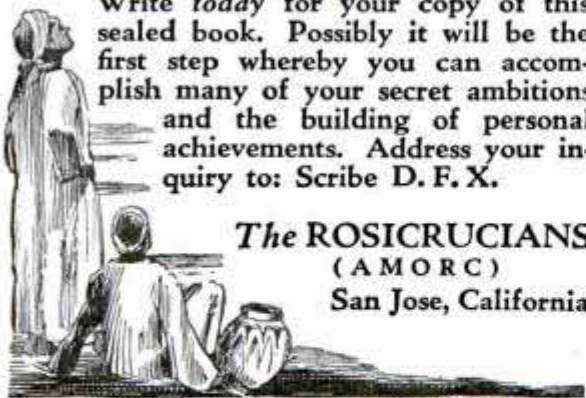

The ROSICRUCIANS
(AMORC)
San Jose, California

In answering advertisements always write name and full address clearly.

NEW SCIENTIFIC WONDER

"X-RAY" CURIO

10c
3 for
25c



"Silver Only"
BOYS BIG FUN. You apparently see thru cloth, Wood, Stone, any object. See Bones in Flesh. FREE PACKAGE radio picture films, take pictures without camera. "You'll like 'em." 1 package with each 25c order.
MARVEL MFG. CO., Dept. 80 — NEW HAVEN, CONN.

Get the FREE Book of opportunity

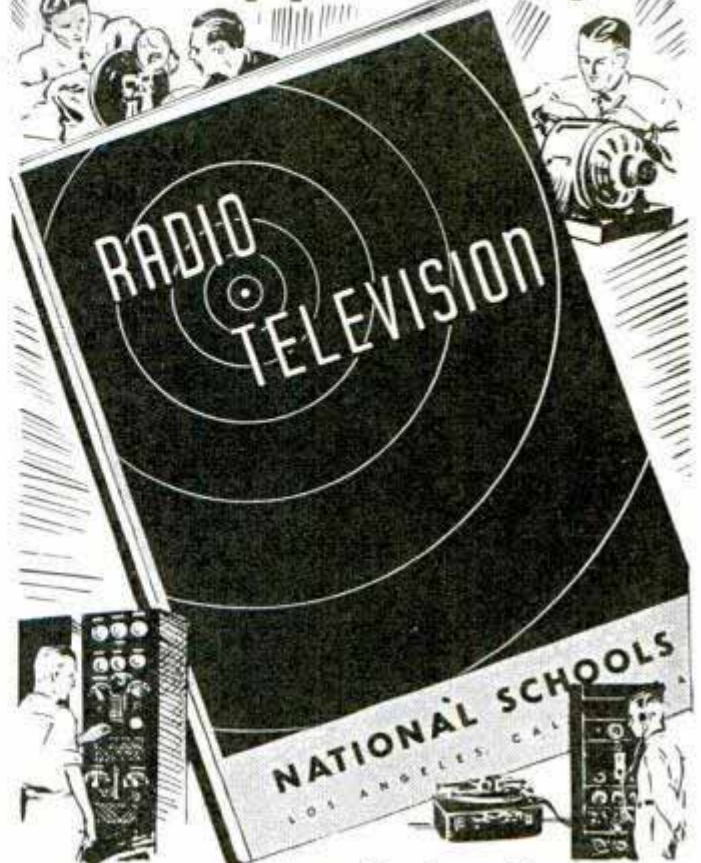

Brimful of terse instructive facts about TELEVISION RADIO SOUND RECORDING ELECTRICITY

Note These Intefesting Contents

Written in plain, understandable language, this free Book gives facts you want to know about the best-paying trades and opportunities. 95 illustrations. Major subjects include Television Theory and Construction, Pick-up Systems, Amplifiers, Transmitters, Receivers, Cathode Tubes; Radio in all its branches, Receiving, Broadcasting, Trouble-shooting, Construction and Theory; Sound-recording on Disc; Loud Speakers, Talking Picture Projection, Radio Communication, Laws, etc. This book also tells how you can qualify for these good pay trades by training at NATIONAL SCHOOLS. Send coupon now for free book.

National Schools is the oldest trade Institution in the West. Est. 1905. More than 30,000 graduates. You can earn room and board while learning. Coachrailroad fare allowed to Los Angeles. This service only for residents of U.S.

NATIONAL SCHOOLS LOS ANGELES



NATIONAL SCHOOLS, Dept. 6-PMR,
4000 So. Figueroa St., Los Angeles, Calif.
Without obligation send your free book.

Name..... Age.....
Address.....
City..... State.....

Why Trained Accountants Command High Salaries

—and how ambitious men are qualifying by the LaSalle Problem Method

GET this straight.

By "accountancy" we do not mean "bookkeeping." For accountancy begins where bookkeeping leaves off.

The skilled accountant takes the figures handed him by the bookkeeper, and *analyzes* and *interprets* them.

He knows how much the costs in the various departments should amount to, how they may be lowered.

He knows what profits should be expected from a given enterprise, how they may be increased.

He knows, in a given business, what per cent of one's working capital can safely be tied up in merchandise on hand, what per cent is safe and adequate for sales promotion. And these, by the way, are but two of *scores* of percentage-figures where-with he points the way to successful operation.

He knows the intricacies of government taxation.

He knows how to *survey* the transactions of a business over a given period; how to show in cold, hard figures the progress it has made and where it is going. He knows how to *use* these findings as a basis for constructive policies.

In short, the trained accountant is the *controlling engineer* of business—one man business cannot do without.

Small wonder that he commands a salary two to ten times as great as that of the bookkeeper. Indeed, as an independent operator (head of his own accounting firm) he may earn as much as the president of the big and influential bank in his community, or the operating manager of a great railroad.

Some Examples

Small wonder that accountancy offers the trained man such fine opportunities—opportunities well illustrated by the success of thousands of

LaSalle accountancy students.* For example—one man was a plumber, 32 years old, with only an eleventh grade education. Today he is auditor for a large bank and his income is 325 per cent larger.

Another was a drug clerk at \$30 a week. Now he heads his own very successful accounting firm with an income many times as large.

A woman bookkeeper—buried in details of a small job—is now auditor of an apartment hotel, and her salary mounted in proportion to her work.

A credit manager—earning \$200 a month—moved up quickly to \$3000, to \$5000, and then to a highly profitable accounting business of his own which nets him better than \$10,000 a year.

And What It Means to You

Why let the other fellow walk away with the better job, when right in your own home you can equip yourself for a splendid future in this profitable profession?

Are you really *determined* to get ahead? If so, you can start at once to acquire—by the LaSalle Problem Method—a thorough understanding of Higher Accountancy, master its fundamental principles, become expert in the practical application of those principles—this without losing an hour from work or a dollar of pay.

Preliminary knowledge of bookkeeping is unnecessary. You will be given whatever training, instruction or review on the subject of bookkeeping you may personally need—and without any extra expense to you.

If you are dissatisfied with your present equipment—if you recognize the opportunities that lie ahead of you through home-study training—you will do well to send at once for full particulars. The coupon will bring them to you without any obligation, also details of LaSalle's convenient payment plan.

Check, sign and mail the coupon NOW.

Business Control Through Accountancy



LaSalle Extension University

DEPT. 664-HR CHICAGO

Opportunities in Accountancy—Check below and we will send you a copy of "Accountancy, the Profession that Pays," without obligation.

Higher Accountancy:

Other LaSalle Opportunities: If more interested in one of the other fields of business indicated below, check here:

- | | |
|---|---|
| <input type="checkbox"/> Business Management | <input type="checkbox"/> Modern Foremanship |
| <input type="checkbox"/> Modern Salesmanship | <input type="checkbox"/> Personnel Management |
| <input type="checkbox"/> Traffic Management | <input type="checkbox"/> Expert Bookkeeping |
| <input type="checkbox"/> Law: Degree of LL. B. | <input type="checkbox"/> C. P. A. Coaching |
| <input type="checkbox"/> Commercial Law | <input type="checkbox"/> Business English |
| <input type="checkbox"/> Industrial Management | <input type="checkbox"/> Stenotypy |
| <input type="checkbox"/> Business Correspondence | <input type="checkbox"/> Effective Speaking |
| <input type="checkbox"/> Credit and Collection Correspondence | <input type="checkbox"/> Railway Accounting |

Name

Present Position

Address

*Names available on request.

When writing to advertisers please mention Popular Mechanics

**WORLD'S
BEST
WANT AD
MEDIUM**

CLASSIFIED Advertisements



Advertisements in this section, 35 cents per word, each insertion, minimum 10 words, payable in advance

To be inserted under proper classification in July issue, copy should be in our office May 8th

July issue on sale June 1st

Popular Mechanics Magazine, 200 East Ontario Street, Chicago, Illinois

YOU'LL PROFIT

By reading and answering the classified ads in this section. Hundreds of opportunities to make and save money.

F. W. Johnson, Manager, Classified Advertising,
Popular Mechanics Magazine,
200 East Ontario Street, Chicago, Ill.

Dear Mr. Johnson: I had read so much about your claims for the pulling power of classified advertisements in Popular Mechanics I really thought you were overestimating it a little bit, but I find from my own experience that they pull even better than you claim. I tried my first classified ad in Popular Mechanics last October (1936) and I am still getting many replies from that ad. I am wondering just how long that first ad is going to continue to pull. Believe me, your classified columns sure give advertisers results.

(Original letter on file in our office)

Very truly yours,
SMITH-DAWE COMPANY.

AUTOMOBILES

FORD V-8's, 1935-37; ~~gas~~ saves gas, oil. \$1.00. Walert Co., 3429 No. 10th St., Milwaukee, Wis.

MIDGET Car plans, parts, engines. Circulars dime. Storms, 199 Broadway, Asheville, N. C.

MIDGET Cars, plans, parts. Catalog dime. Derby Midget Car, Woodstock, Ill.

REBUILD Ford T or A motor into fast pumping air compressor. Instructions \$1.00. Tuck Garage, 73 Shirley, Pontiac, Michigan.

DIESEL Engine Hi-Lites. Informative. Illustrated. 25c. Scheall Research, Duluth, Minn.

ATTRACTIVE Money made putting owners' initials on automobiles. Full or part time. Easy to do. Transfer Letter Co., Maplewood, New Jersey.

R & R MFG. CO., Anderson, Ind. Racing cars and midgets catalogue 25c.

SPECIAL Semi-Diesel, diagrams, instructions, 25c. Sovereign's Sales, Toronto, Canada.

FORD V-8s—5 to 8 more miles per gallon with "Automatic Gasaver." uses the fumes from crank-case. Automatic Gasaver Co., 126 W. Wood St., Youngstown, Ohio.

ECONOMY! Performance! Mileage! Semi-diesel conversions for all gasoline motors. \$5.00 up. Deal direct with the manufacturers. Unconditional written guarantee. Special complete units for Ford and Chevrolet. Learn basic facts, illustrated literature free. Des-A-Gas, 1719 Addison, Berkeley, California.

AUTO SUPPLIES AND EQUIPMENT

NEW Brush plating outfits for automobile parts. Connect to battery. No tanks used. Free particulars and proofs. Gunmetal Co., Ave. J, Decatur, Ill.

COMMUTATORS—Delco Remy, mica re-insulated; \$1.18—17 exchange. Used commutators bought. Auto Specialty Co., 3711 East 18th, Kansas City, Mo.

1937 IGNITION Supercharger. Quick starting, wet or cold. Mileage, pep, power, less carbon. \$1.25. E. G. Sales Co., 321 Broadway, New York.

MICROMETER (Calliper) one inch, adjustable for accuracy. Precision tool. \$1.05 prepaid. Schaap, Laurelton, New York.

DEMONSTRATORS. Compressor, test bench, 8-hour battery charger—are welder. Guaranteed. Trial and terms. Ken's Equipment Exchange, Box M-671, Troy, Ohio.

CHAMPION Automobile air cooled radio generators. Distributors wanted. List and literature. Wilt Electric Co., 7829 South Racine Avenue, Chicago.

USED Auto parts at half price for all cars. Century Parts Co., 1712 Lafayette Ave., St. Louis, Mo.

FOR FORD OWNERS

NEW Ford repair book for all Ford V-8 models from 1932 to 1937 inclusive, and Lincoln Zephyr cars. Includes data taught in Ford training schools. Answers hundreds of mechanical and electrical questions in non-technical language. Used in thousands of Ford garages. Over 100 pages, many charts and diagrams. Sold on moneyback guarantee. Price \$1.00, postage prepaid. Trade Press Publishing Co., Montgomery Building, Milwaukee, Wisconsin.

A. C. GENERATORS

PRACTICAL Changes for automobile generators. See our advertisement at bottom of page 155A. Autopower, Inc.

AUTO TRAILERS

HOUSE-TRAILERS: Build fourteen, sixteen foot or de luxe model in spare time. Detailed blue-prints and instructions, per model \$1.85. Parts for sale. Box 1654, Wichita, Kansas.

EARN As you travel by trailer. Experienced business man suggests 125 practical ways to use your trailer to make money in legitimate businesses and professions. For men or women, to operate in part or full time, in temporary or permanent locations. Other valuable information. All postpaid for only \$1.00. Send today. Dept. A., L. and A. Publishing Co., 313 N. Center, Bloomington, Illinois.

BEST Cushions, beds, dinettes made. J. Edgar Noonan, Streator, Ill.

BEFORE You build that trailer, write for prices on steel chassis, electrically welded. Monarch Trailers, 377 W. 7th St., Winona, Minn.

EVERYTHING For the trailer builder at bargain prices. Free catalog. Building plans 25c, formerly \$1.00. National Trailer Equipment Co., Welsh Bldg., Milwaukee, Wis.

NEW Trailer Manual—Just off the press. Big 68 page book in color. Tells all about trailers. How to plan and build them. Latest modern designs. Complete instructions—how to select and where to get dependable material and supplies. Over 350 illustrations—shows the latest improved accessories, parts and plans used in 1937 factory made trailers. Every phase of trailer construction is covered. Send 25c in coins or stamps today for this valuable book. A. J. Stephens & Company, 2809 E. 14th St., Kansas City, Mo.

THE New 1937 Fold-A-Way Rambler. "V" front, de luxe windows, vestibule entrance, double walls and air cell insulation throughout. And it folds away. Fold-A-Way Trailer Co., Box 642, Davenport, Iowa.

HOUSE Trailer, light weight, 16 foot, blueprint and specification. \$1.00. Box 174, Cary, Ill.

PARTS For the Popular Mechanics "Family Trailer" featured in the February, March and April, 1936 issues. Everything you need—Axle, hitch, wheel housings, water tank, pump, toilet, sink, stove, wood parts, windows, screens, lights, cushions, etc. Send for price list. Include 25c for our big catalog and Trailer Builders' Manual. Trailer Supply Co., 411 Jackson St., Wausau, Wis.

BUILD The famous Jim Dandy cabin trailer—thousands on the road! A roomy, good looking trailer easy to build at low cost by anyone handy with tools. Complete plans and instructions—only 50c—give every detail of chassis, body, top, beds, cabinets, refrigerator, electric light and water systems and where to buy all parts. Can be built in any size to accommodate 2 to 4 people. Send 50c for these practical plans. Rush your order today to Jim Dandy, Box 1125, Wausau, Wis.

POPULAR Mechanics "Family Trailer," complete illustrated plans for building in Shop Notes for 1937 only 50 cents postpaid. Popular Mechanics Press, Dept. (C37), 200 E. Ontario St., Chicago.

MOTORCYCLES, BICYCLES AND SUPPLIES

POWER Your bike with low priced Speedbike motor. Attach in one hour. Eighty miles to gallon. Thirty miles an hour. Free folder. Guaranteed. Evinrude Motors, 4050 N. 28th St., Milwaukee, Wis.

MOTORCYCLE Tires \$3.00; motor bicycles \$45.00; magnetoes \$5.00; belts, chains, fenders, parts, tandem bicycles. Send 12c. Deninger, Rochester, N. Y.

SEND 10c For new 1937 Handbook of Information, listing new and used parts, for Indian, Harley, Excelsior, Henderson; accessories, batteries. Bootz, 622 East Grand, Des Moines, Iowa.

MOTORCYCLES—Direct to you at rock-bottom wholesale prices. Rebuilt, roadtested and guaranteed Indians, Harleys, etc. Send 10c today for "Bargain Bulletin 43." Crandall Hicks Co., 780 Commonwealth Avenue, Boston, Mass.

ALLOY Pistons—Harley, Indian, Henderson, Excelsior, new or used parts, cylinder grinding. Catalogue and wings pln 10c. Ballak, 1115 Chestnut, St. Louis, Mo.

SEND 15c For illustrated used motorcycle catalog. Bargains. Largest stock genuine Indian parts and motorcycles. Indian Motorcycle Sales, Kansas City, Mo.

GENUINE Harley Davidson parts, accessories, repairs. Prompt service. Send 10c for used motorcycle bulletin. Bill Knuth, 2491 Fondulac Ave., Milwaukee, Wis.

RECONDITIONED Motorcycles. New—used parts for all makes. Authorized Harley-Davidson dealer. Whitman Motorcycle & Supply Co., 405-9 Southwest Blvd., Kansas City, Mo.

MOTORCYCLE Bargains, lowest prices, bargain sheets for stamp. Motorcycle accessories. Rochester Harley Davidson Corp., 129 West Main St., Rochester, N. Y.

REBUILT Motorcycles, all makes, new and used. Harley Davidson parts. Send 10c for bulletin. Western, 914 E. 15th, Kansas City, Mo.

AVIATION

GLIDER Motor. Complete propeller mounting and etc. Like new, \$60.00. Glider Motors, 1507 Scott, Covington, Ky.

MAKE Money in aviation. Special mechanics training course—Finest instructors and equipment—Located at aviation center. Write Robertson Aviation School, Department D, Lambert-St. Louis Municipal Airport, Robertson, Missouri.

DON'T Buy anything until you get Ort's Aviation Material Catalogue. Prices are lower. Send thin dime today. (Canada 20c.) Karl Ort, 634 W. Poplar, York, Pa.

PROPELLERS For airplanes, fans, sleds. Catalog dime. Lorenzen Propellers, Niles, Michigan.

ALTIMETERS, 28,000 Feet \$4.95; same reading meters, \$2.95; Jaeger tachometers, 9-2400 r.p.m., \$7.50; airplane seats, \$1.50. Air Transport, Garden City, N. Y.

A CAREER in Aviation. New book on aviation employment, 35 cents (coin). Aviation Personnel Service, 72 Monroe, Williams-ville, New York.

AVIATION. Rapid advancement for intelligent young men; write immediately, enclose stamp. Meyer Engineering, Box-8, Hempstead, N. Y.

YOUNG Men interested in entering aviation under apprentice plan see ad on page 12A.

GET Into aviation. Air transport pilots get up to \$7,000 per year; mechanics, \$2,500. Learn at this government approved school. Write for complete information. State age. Lincoln Flying School, 2004 Aircraft Building, Lincoln, Nebr.

NEW Airplanes, \$98.00. Terms. Motors, propellers, air-wheels. Send 25c for information. Hibbs, Fort Worth, Texas.

BATTERIES, GENERATORS, ETC.

ZENITH Light plants. Johnson $\frac{1}{2}$ h.p. Iron Horse engine directly coupled to Delco generator. List \$59.95. In original factory crates \$39.95. Lindgren Radio Corp., 1316 East 63rd Street, Chicago.

BUILD Wind light plant from automobile generator. Complete plans and catalog 10c. 50 other generator changes. LeJay Manufacturing, 1647 Lake, Minneapolis, Minnesota.

BALL Bearing, 750 watt, 32 volt generators, \$18.00. M. Solon, 636 East Third St., Duluth, Minn.

ELECTRIC Light plants, 350 watts and up. AC or DC. For use with or without batteries. Priced as low as \$95. Ideal for cottages, camps, trailers, etc. Write for bulletin "G." Universal Motor Company, Oshkosh, Wisconsin.

EDISON Storage batteries for light-power plants. Non-acid, non-sulphating. Long life. Fully guaranteed. Low priced. Also attractive bargains in power-light plants, generators, motors, etc. T. Hawley Smith Company, Croton Falls, N. Y.

GENERATOR Propellers, expertly designed at factory prices. Hibbs, Ft. Worth, Texas.

ELECTRICAL SUPPLIES, EQUIPMENT

HUNDREDS Of new and rare items, replacement parts and supplies. Send 10c for new, 60-page wholesale catalog. Autopower, 410-Q S. Hoyne Avenue, Chicago.

ELECTRICALLY Minded? Build dignified business manufacturing lamp annunciators. Big field, profits. Kirkland Company, Morristown, New Jersey.

MAGNET Lifts 50 times own weight. Recover lost articles, \$1.00 postpaid. Particulars stamp. Amfadco, 861 Minneapolis, Minn.

BURGLAR Alarms from closed banks. Eighteen inch gongs, housings, instruments complete. Safety, Defiance, Gamewell. Suitable wholesale houses, garages, department stores. Supplies, diagrams. Midnight Alarm System, Fenton, Michigan.

NEW Washing machine and oil burner marketed soon. Inquire. Farris, Valley Junction, Iowa.

DEALERS—Sell motors, grinders, flex shafts, saws, blowers, exhaust fans, vacuum cleaners, parts. Wholesale catalog stamp. Cmco, 1111 Washington Blvd., Chicago.

WELDING AND SOLDERING

ARC-WELDING Outfit, heavy duty, \$2.00. Weld fenders, braze, solder. Lavrow, 4368-W. Warren, Detroit. Stamp appreciated.

ECONOMICAL Arc-welder from Dodge generator. No rewinding. Plans dollar. Pulls, Booker, Texas.

BUILD Your own arc welders. Transformers, supplies furnished at low cost. 100 ampere welder complete, \$27.95. Literature. Laboratories, 1936 Lyndale, South Minneapolis, Minnesota.

ARC Welder only \$39.25. Professional type—110-220 volt. Delivers 110 amperes. Easy to use. Details free. Commonwealth, Dept. W-55, Cincinnati, Ohio.

SPECIAL Bargains on new and used welding equipment. Circulars 10c. Adastik Bros., Grand Rapids, Mich.

SEND 50c For complete easy to read instructions "Building your own 6 volt arc welder." Welds! Brazes! Solders! Dicksons, Beaconsfield, Iowa.

60 AMPERE 110-Volt arc welding transformer \$10.00. 100 ampere 110-220 volt \$20.00. Welding supplies. Literature. Aremaster, 4115 Ravenswood, Chicago.

ELECTRIC Soldering, braze and weld from auto battery. Write for particulars. 1456 West North Avenue, Chicago, Ill.

DODGE Arc-welder. 25-200 amperes, 40 volts, direct current. Single generator uses $\frac{1}{2}$ inch rod, welds 5/16 inch sheet. Dual generator, $\frac{3}{8}$ inch sheet weld. Build it yourself from old North-East 12 volt Dodge automobile generators. Low cost and unkept. Results guaranteed. Certified instructive plans \$1.00, COD. \$1.12. Welders' Club of America, Box 3432-A, Merchandise Mart, Chicago.

DEMONSTRATORS, Electric arc welders. Money-saving prices. Used by the government. Trial and terms guaranteed. Hobart Welders, M-672, Troy, Ohio.

ACETYLENE And electric welding equipment. Box 331, Hamilton, Ohio.

REBUILT Electric arc welders, all sizes, a.c.—d.c. Service Co., 3732 Cedar Ave., Cleveland, Ohio.

300 AMPERE Welding generator. Fine condition \$150.00. Wilnot Auto Supply, 1970 Wilnot St., Chicago.

MACHINERY, TOOLS AND SUPPLIES

BARGAIN, 10" Centrifugal pump, never used. 32 volt generator, Ralph Golden, Angola, Indiana.

KELLOGG Air compressors, \$6.00. Electric refrigerators \$25.00. Taylor, 105 East 192nd Street, New York.

LATHE, Bench type, \$39.50. Screw cutting, new. Burk Machine, 1314 Prospect Ave., Toledo, Ohio.

LAWN Mower sharpening made easy, plenty business everywhere. Engle & Wirt, West Burlington, Iowa.

BARGAINS, Demonstrators, electric arc welders, guaranteed, 30 days trial and terms. Write Ken's Equipment, Box M-672, Troy, Ohio.

SPECIAL! Child foot switch for controlling power tools, same as latest model except iron cases instead of aluminum. Capacity $\frac{1}{2}$ horsepower. While they last \$1.50. Limited quantity, buy now and save. Child Manufacturing Co., Richmond, Calif.

TREMENDOUS Surplus of factory tools selling out. Drills, taps, files, hacksaws, etc. Send for free lists. Include six cents postage. Travers Tool Co., 264 Jackson Ave., Long Island City, N. Y.

FREE Catalog all shapes brass, copper, steel, aluminum, Downmetal, monel, stainless steel, gears. Hobby Supply House, Box 2014, Pittsburgh, Penna.

SPRING Winder, best on the market. Circular 10c. John Blauer, Box 163, Sharon, Pa.

$\frac{1}{2}$ HORSE, 110 Volt, Universal motors with 14 to 1 gear reduction \$3.50. Wilnot Auto Supply, 1970 Wilnot St., Chicago.

15" x 6' SOUTH Bend screw cutting engine lathe, \$175.00. 14" Steptoe crank shaper \$125.00. All sizes of machine tools. Cincinnati Machinery & Supply Company, 27 West Second St., Cincinnati, Ohio.

EVERY Tractor owner needs Irving's 84 page 1937 tractor replacement parts catalog. Absolutely free. Thousands parts, all makes; tremendous price savings. Irving's Tractor Lug Co., 134 Knoxville Road, Galesburg, Illinois.

ENGINES, MOTORS, DYNAMOS

BARGAIN— $\frac{1}{2}$ HP. a.c. motors, 60 cycle, 1 phase, 110 volt, like new, guaranteed, \$9.50. Send check to Erie Electric Motor Co., 120 Church St., Buffalo, N. Y.

ELECTRIC Motors, well built, quiet running, 1/20 h.p., series wound fan motor and three speed controls. Make your own air conditioner and rice coal burners. Motors \$3.50, control \$1.50. Pure Air Sales, 20 Glendale Place, Buffalo, N. Y.

"PEPY" Gasoline engine governor \$7.50 postpaid. Automobile engines made into controlled power plants. Guaranteed. Agents wanted. Harris Machinery, Minneapolis, Minn.

GOVERNORS Control speed of any make of auto engine, regardless of load changes, when used for stationary or portable power production. Read our ad on page 134A. Man'gs Candee-Smith Governor.

MOTORS—Alternating, direct current. New, rebuilt. Tell us your needs. Bargain price list free. Mailorder Electric Co., 1718 So. Michigan, Chicago.

THREE To ten KVA alternating generators. Motors, converters. Queen City Electric, 1736 Grand Avenue, Chicago.

TO Close out. Slightly used $\frac{1}{2}$ horse, 110 volt, alternating motors \$8.50. Wilnot Auto Supply, 1970 Wilnot St., Chicago.

WINDING Data, 225 motors, single and three phase. Price \$1.00. Motor Data Co., Box 7631, Kansas City, Mo.

BOATS, OUTBOARD MOTORS, ETC.

BUILD A Boat—Everything for building, equipping or repairing a boat. Build a boat by the Welch system. Use Welch ready cut parts. Inexpensive; interesting and profitable. Send 10c for catalog showing boats of many types; boat materials; boat hardware; marine motors; propellers. Damaged propellers repaired. Welch Boat & Supply Company, Station K-1, Milwaukee, Wisconsin.

NEW Nationally advertised outboard motors. Delivered at bargain prices. Catalogue free. Marine Store, Sac City, Iowa.

ATTENTION Boatmen—Our fabricated boat frames save $\frac{2}{3}$ s and costly mistakes. Send requirements for quotation. Illustrated catalog 100 boats, 10c. Bay City Boats, Inc., 1552 Adams St., Bay City, Michigan.

ALUMINUM Canoes, Kyaks. Lightest and toughest made. Robert Little, Trenton, New Jersey.

MARINE Inboard engines, all sizes. 1 cylinder to 8 cylinders. Featuring our 1 cylinder, 8 hp. engine for \$140. Featuring our 4 cylinder 25 hp. engine complete with electric starter for \$287. Write for catalog "Department G." Universal Motor Company, Oshkosh, Wisconsin.

KAYAKS, Kits. Sensationally new designs. Five remarkable major improvements. Outstanding values. Catalogue dime. Dedham Kayaks, Dedham, Mass.

ASSEMBLE Your own boat. Our finished knock-down frames save you $\frac{2}{3}$ s builder's cost. All types and sizes. Send 25c for big catalog. Brooks Boat Company, Inc., D4, Saginaw, Michigan.

15 FT. Canoe \$32.50. Ready to ride. Catalogue free. Jamestown Specialty Company, 377PX, Titusville, Pa.

12-FOOT Flat bottom rowboat—complete plans 25c. Free boatbuilding catalog. The Rudder, 15 Murray Street, New York.

FORD Marine conversion parts and kits. Models A, B, V8 (domestic or foreign). Catalogue 25c (coin). Osmithson, 3101 C St., Philadelphia, Pa.

BOAT Designers are highly paid professionals. Complete course by mail. Catalog. Westlawn, Montville, N. J.

OUTBOARDS—Save $\frac{1}{2}$. Good used parts, all makes and models. Bargains rebuilt motors. Crandall Hicks Co., 780 Commonwealth, Boston, Mass.

KAYAK Construction kits \$9.45 up. Catalogue free. Jamestown Specialty Company, 377P, Titusville, Pa.

SAIL Your rowboat! Complete equipment including detachable keel, \$24.75. Try-Sail Company, Patterson, New York.

SPORTING GOODS, GUNS, FISHING TACKLE, ARCHERY

FENCING Equipment. Folds, swords, masks, etc. Low prices. Free catalog. Industrial Products, 274 Madison Ave. New York.

FISHERMAN: Sinker molds, \$1.25 up postpaid. Free folder. Box 313-C, East Liverpool, Ohio.

PERFECT-GUIDE, Flashlight compass. Free pamphlet. Box 2346, Cleveland, Ohio.

ARCHERY, Raw materials. Geo. Brommers, 9708 So. Hoover St., Los Angeles, Calif.

FATALLY Attractive to game, fish, night or day. Electric lighted lure. Postpaid \$1.00. Seigle's, Hinton, Oklahoma.

FISHERMEN—Send for free interesting circular, patented fish bag holder. McConnell, 1619 Edgewood, Racine, Wis.

FISHERMEN—Twenty assorted spinners, one dollar. Guaranteed. E. J. Knechtges, Grafton, Ohio.

FISHERMEN! Finest stock of hooks. Spanish sut, leaders, tools and materials in America. Send 4c in stamps for list and 1937 catalog. Paul H. Young, 8065-3 Grand River Ave., Detroit, Mich.

TENTS: Factory to you. Catalog free. Willis Co., Everett, Mass.

BUCKTAILS. Flytied material. Hofmann Studio, 992 Gates Avenue, Brooklyn, N. Y.

HUDSON Bay blankets, Indian pack baskets, camp stoves, knives, compasses, outdoor equipment. Free catalog. Howe Fur Co., Box P, Coopers Mills, Maine.

FIELD GLASSES, TELESCOPES AND MICROSCOPES

FREE Catalog listing microscopes, telescopes, field glasses, chemical and scientific supplies. Send 10c (rebatable) for postage and handling. Kemkit, 397M Bridge Street, Brooklyn, New York City.

POWERFUL Astronomical telescope easily made at low cost. Free details. Jamer, Box 4, Bayside, N. Y.

TELESCOPES, Microscopes, binoculars. Lowest prices. Optical catalog free. Brownscope Company, 234 Fifth Avenue, New York.

INTERESTING Free literature. Amateur Telescope Makers Supply Co., Box 213, Flushing, N. Y.

TELESCOPES, Microscopes, binoculars, chemistry, mineralogy. Catalog free. Teeko, Evanston, Illinois.

BUILD Reflecting telescopes; catalog free. Instructions 10c. Optical Laboratories, Larchmont, N. Y.

ANTIQUES, RELICS, INDIAN GOODS

WANTED To buy fine gem points and arrowheads from Ore., Wash., Colo. G. Pilquist, Dardanelle, Ark.

13 ARROWHEADS, Spearheads, lancehead, wampum, 99c. 120,000 bargains. Photolist 10c. Museum, Rutland, Illinois.

5 ARROWHEADS 20c. 3 Birdpoints 18c. Knife, birdpoint, scraper, spearhead 45c. Catalogue, Coins, Minerals, Curios. Lemley Curio Store, Northbranch, Kansas.

100 GOOD Arrowheads \$3.00. Catalog 5c. H. Daniel, Dardanelle, Ark.

TAXIDERMISTRY

MOUNTED Specimens. Glass eyes, supplies. Hofmann Studio, 992 Gates Avenue, Brooklyn, N. Y.

TAXIDERMISTRY Supplies—Quality artificial eyes, teeth, genuine Jonas head forms. Tools, materials, etc. Everything for the progressive taxidermist. Send 10c for big illustrated catalogue. Jonas Bros., 1049 Broadway, Denver, Colorado.

GLASS Eyes. Taxidermists', furriers' supplies. Lowest prices. Forty page catalog, free. Write today. Elwood Supply Co., 222 Smith Building, Omaha, Nebraska.

FREE—Official catalogue. Big values. Eyes. Head forms. Everything, direct from manufacturer. Taxidermic Manufacturers, Memphis, Tenn.

DOGS, BIRDS, PETS

TEACH Your pet tricks, obedience, commands; simple, easy manner. Book \$1. Royal Kennels, Naperville, Que.

PAYMENTS, Monthly! Boston! Circulars, dime. 405P Gardenia, Royal Oak, Michigan.

BABY Saint Bernards—reasonable! Dime brings interesting photographic particulars. Royal Kennels, Naperville, Que.

STANDARD Rabbit Journal, Milton, Pa. Year 50c, sample dime; propositions.

BEAUTIFUL Pure white police dogs. Ansonia Kennels, Mose, N. Dak.

POULTRY AND SUPPLIES

BABY Chicks \$3.00—100, light breed cockerels. 22 different breeds, all priced low. Write for complete price list. Davis Poultry Farm, Rt. 34, Ramsey, Indiana.

POULTRY Tribune—America's leading poultry magazine. Five years \$1.00; one year trial 25c. Poultry Tribune, Dept. 93-C, Mount Morris, Illinois.

BUY Salem's tested chicks. Hatching all popular breeds weekly. Write for our prices on sexed chicks, and catalog. Salem Hatchery, Box 19, Salem, Indiana.

FARMS AND FARM LANDS

PRODUCING Farm, fine bay team, 5 cows and heifers, hens, implements, crops included; 151 acres, 2 orchards, tidy 6-room home, basement barn, tenant house, only 400 yds. to macadam; \$3000, terms; pg. 65, free catalog 1000 bargains. Strout Ag'y, 255-P 4th Ave., New York City.

CANADIAN Tax sale lands in parcels at one dollar an acre up. Small monthly payments. Farms, timber, hunting and fishing camps, minerals. Limited number of properties. Write at once for free illustrated booklet. Tax Sale Service, Room 613, 72 Queen St., W. Toronto, Canada.

THE Great Northern serves an agricultural empire where rents, prices and operating costs are low in Minnesota, North Dakota, Montana, Oregon, Idaho and Washington. Write for free book. E. C. Leedy, Dept. 657, St. Paul, Minn.

40 ACRES, Near White River, unimproved; poultry land. \$175, \$5 down, \$5 monthly. Free list and literature. Hubbard, 216 Grossman Bldg., Kansas City, Kansas.

NEW Farm opportunities! Washington, Idaho, Montana, North Dakota, Oregon, Minnesota. Farm income is up. Good land still at rock bottom prices. Literature. Specify state. J. W. Haw, 119 Northern Pacific Bldg., St. Paul, Minn.

TREES, SHRUBS, ROOTS, HERBS

JUST Out! World's greatest "Herbalist Almanac." Beautifully illustrated in natural colors. Contains over 200 old-fashioned herb medicine recipes for home use. 10c postpaid. Worth dollars! Botanic, 145 West 112th Street, Chicago.

BOOKS Covering hundreds of subjects. Big catalog for 3c postage. Popular Mechanics Press, Room (C37), 200 E. Ontario St., Chicago.

PROFITABLE OCCUPATIONS

"RAISE Earthworms for Profit," practical culture methods, \$1.00. Bureau Zoological Research, 106 Broadway, Peoria, Illinois.

"RAISE Giant frogs!" Free book. Small pond starts you. We buy. American Frog Canning, (153-H), New Orleans, Louisiana.

MAKE Money at home—No canvassing. J. Russell, Box 335, San Diego, Calif.

AGENTS—To mail our literature. Good profits. Home business. Maywood, 149 Fifth Ave., New York.

RAISE Giant mushrooms! We buy! Start cellar, shed. Book, pictures free. United, 3848 Lincoln Ave., Dept. 66, Chicago.

RAISE Ginseng, ginsol, frogs, particulates free. Specialty Farm, Rockford, Minn.

RAISE Love birds (Parrakeets) easy and profitable, we supply breeding stock at reasonable prices and marketing plan for young you raise. Particulars stamp. J. Sheehan, Box 104, Lemoyne, Pa.

MAKE Architectural models. Profitable, dignified business. Particulars free. Weidler, 4589 Lexington, Hollywood, California.

FREE Circular describes 107 successful business enterprises. Home City Specialties, Box P1273M, Springfield, Massachusetts.

FREE Booklet describes 107 plans for making \$20-\$100 weekly, in home or office, business of your own. Elite Co., 214 Grand St., New York.

RAISING Jumbo frogs. Interesting. Big future. Females lay 10,000 eggs. Free literature. American Frog Industries, Box 336, Rayne, Louisiana.

OLD BOOKS WANTED

WE Pay up to \$5000 each for old books, also high cash prices for old magazines, letters, newspapers. A single story book, school book, old Bible, travel book, almanac, etc., that looks worthless may bring you \$50, \$100 or \$500 in cash. Thousands wanted! Send 10c now for latest price list. American Book Mart, 140 S. Dearborn, Dept. 1713, Chicago.

WE Pay \$5.00 to \$6,000.00 for old books, magazines, newspapers. Send one dollar for our buying catalog, listing over 1100 wants with prices paid for each. The Bibliophile, 126 Lexington Avenue, New York.

BOOKS, PERIODICALS, PICTURES, POSTCARDS

NEED Help in technical or business problems? McGraw-Hill books bring you the experience of experts in your field. The latest complete McGraw-Hill catalogue is a guide to up-to-date books that give the facts and experience you need. Describes more than 1500 volumes, by leading minds in business, industry and research. Explains free examination and budget book-buying plans. Send name, address, and occupation for your free copy today. G. A. Wiley, McGraw-Hill Book Co., Inc., 330 W. 42nd St., New York City.

FREE! Profusely illustrated booklet, "Scientific Wonders." Contains drawings, photographs and diagrams showing marvels of movies, power, television, nature, ingenious inventions, etc. Also many fascinating articles on mechanics, astronomy, biology, chemistry, engineering, etc. Metro, Dept. 2206, 70 Fifth Ave., New York.

FREE—Send for list of new technical books at sensational discounts. V. Winn, 124 West 23 St., New York.

YOUR Favorite magazines—Half price. Catalog, 10c. Magazine Exchange, Baseline, San Bernardino, Calif.

THOUSANDS Of old magazines. List 10c. Seeley Service, Jennings, La.

SAVE Money on magazine subscriptions. Catalog free. Wilbur Erickson, Box 141, Englishtown, N. J.

CASH Prize contests everyone can enter—interesting stories, articles and features always in every issue of The Little Chronicle. "America's fastest growing magazine." 10c brings sample copy. Little Chronicle Corp., Oak Park, Ill.

GAMES—ENTERTAINMENT

PLAYS, Operettas, musical comedies, complete minstrel first-parts with song programs, blackface skits, vaudeville acts, monologs, dialogs, recitations, juvenile plays and songs, musical readings, entertainments, make-up goods. Catalog free. T. S. Denison & Co., 623 So. Wabash, Dept. 11, Chicago.

MAGIC TRICKS, PUZZLES, JOKER NOVELTIES

LARGE Magic catalogue 20c. Lynn, Midland Ave., Paramus, N. J.

NOVELTIES, 12 Assorted samples only 10c. Hoover's, 1525 Grove St., Lafayette, Ind.

LEARN Professional fire eating, safe. Manly, 1315 S. Ferris, Los Angeles.

WHOOPIE! Comic "business" cards, 25c packet. David Sanderson, Ottawa, Illinois.

5 CARD Tricks outfit, opportunity guide (48 pages), all 10c. Hub Publishers, Box 138, Omaha.

CATALOG Exclusive magic 10c. Grant's Studio, 327 West 42nd, New York City.

VENTRILOQUISM; Complete course, dialog and history \$1.00. Illustrated puppet catalog 25c. Frank Marshall, 5518 So. Loomis, Chicago.

36 DOLLAR Secrets 25c. Circular free. (Dealers 21c profit). "Aemie," 326 South-eastern, Los Angeles.

BE A magician. Send 20c mailing fee for our large catalog. Chicago Magic Co., 2300 N. Mason Ave., Chicago.

STARTLING! Mysterious Hindu money vanisher. Amazes everybody. Send 3c for trick and illustrated catalog jokers, novelties, tricks, etc. Special! Included free—age guessing trick and directions for staging complete magic show. National Magicians, 220 S. State, Dept. 350, Chicago.

FREE Tricks! Join Magicians' Fraternity! Monthly magazine, sample, 10c. International Magicians, Mt. Morris, Ill.

AMAZE And mystify! Hundreds of tricks for home or stage require no skill. You can perform them—be popular entertainer. Learn fifty good ones by sending 10c for "50 Magic Mysteries," and receive free "Book of 1000 Wonders," America's most complete catalog of low-priced magic. Lyle Douglas, Station A-5, Dallas, Texas.

MAGICAL Apparatus, illusions, catalog 3c. McKwade, 600 Martinique, Dallas, Tex.

EARN Money in any crowd. Call names of strangers, tell unspoken questions. Professional course mind reading, spirit writing, etc., \$1. Henderson, Box 341, San Bernardino, Calif.

LARGE Professional magic catalogue, 25c. Holden, 220 W. 42nd St., New York.

LEARN Ventriloquism, 3c stamp brings particulars, Smith, 125 North Jefferson, Peoria, Ill.

RARE COINS

OLD Money wanted. Will pay \$100.00 for 1894 dime, S. mint, \$50.00 for 1913 Liberty head nickel (not buffalo). I pay big premiums for rare coins. Send 4c for large coin folder. May mean much profit to you. B. Max Mehl, H. Mehl Bldg., Fort Worth, Texas.

LINCOLN Cents 1922D 25c, 10 different S mint 25c, California jubilee, bay bridge \$2.50 each, coin book 50c, lists 4c. Coin-shop, 2510 Chester, Alameda, California.

COIN Catalogue listing all countries. Send stamp for copy. Ray Willard, Monett, Missouri.

1909 CENT \$10—We buy certain coins, common and rare—Others worth to \$6000; 1864-1865 Indian head cents \$100 each; dimes before 1895, \$450; Liberty head nickels before 1914, \$300; large pennies, \$2000; encased postage stamps, \$13; half cents, \$275; half dimes, \$175; quarters, \$300; fractional currencies; paper money; gold dollars \$1,500; colonial coins, \$300; silver dollars, \$4,000; 1933, 50c, \$4.00; foreign coins \$165, etc. Send 15c today for illustrated 1937 coin book, before sending coins. National Coin Corporation (82), Springfield, Massachusetts.

OLD Coin and price list—10c. Maurice Gould, 11 Hillside, Worcester, Mass.

1879 DIMES, Proof, \$1.10 each insured. George Ball, Barre, Vt.

SOMETHING New. Your opportunity to sell or buy coins at your own prices. Send 25c and receive our bulletins for one year. Ohio Coin Brokerage Exchange, Box 3507-H, Cleveland, Ohio.

LINCOLN Cents, complete set fine to un-circulated condition, including album, \$4.75 postpaid. S. M. Koepfel, 406 Merritt Bldg., Los Angeles, California.

OLD Coins, all kinds bought, \$15.00 each guaranteed for certain Indianhead pennies. Send dime for list of these wanted. Coin-shop, "D," Springfield, Missouri.

COMMEMORATIVE \$1/4s, Illinois, Stone Mountain, Oregon, Texas, Long Island, \$1.50 each. California gold quarter size and illustrated catalogue 25c. Auction catalogue 50c. Norman Shultz, Salt Lake, Utah.

NEW Illustrated coin book 15c. Auction catalogue free. Entire collections wanted. Ira S. Reed, Sellersville, Penna.

U.S. TWO Cent piece in 1860's with lists 20c. Acorn Stamp & Coin Co., South Norwalk, Conn.

WE Pay \$3.00 each for 1914 Lincoln cents D or S mint in un-circulated condition. We purchase all kinds of coins and paper money. Send 15c for new and interesting 28 page buying catalog before sending coins. (No other book purchases requested.) American Coin Company, Box 3507-A, Cleveland, Ohio.

UNITED States. Large cent, 2c bronze, 3c nickel and bargain list, 25c. Eleven dates large cents, \$1.00. George P. Coffin Company, Augusta, Maine.

\$5.00 TO \$500.00 Each paid for old coins. Keep all old money. Send 10 cents for illustrated coin value book, 4x6. Guaranteed prices. Buying and selling. Coin Exchange, Box 5, Le Roy, N. Y.

FREE! Foreign coin, banknote, and large illustrated coin catalogue. Send 4c postage. Coin approvals sent. Tatham Coinco, Springfield-125, Mass.

RARE United States, foreign coins, war medals. Catalogue 10c. Mengelle, Colorado Springs, Colorado.

U. S. COIN Book—Guide to values, just issued. Many special features. Order Burt's, the leader among American coin books, only 50 cents postpaid. Popular Mechanics Press, Room (C37), 200 E. Ontario St., Chicago.

STAMP COLLECTING

LIBERIA And new India triangles; large diamond; Egypt and Lebanon airmails; packet Congo; San Marino; Charkhari; China; Mexico; Brazil; many British Colonies; rare Borneo, etc. 6c to approval applicants. Eureka Stamp Co., Dept. Burbank, California.

200 DIFFERENT 18c; 1000, \$1.10; 2000, \$3.00. Lists, Elite, Charlevoix, Mich.

BRAZIL, 50 Different 10c with bargain approvals. Davis, Silver Lake, Ind.

KING Edward souvenir, stamps attached 50c. Quessenberry, Box 3641 Georgetown, Washington, D. C.

APPROVALS—United States, airmails, foreign selections sent general collectors. Lincoln Stamp Mart, Shelbyville, Illinois.

FREE Dollar packet. Inclose postage, request bargain approvals. C. Secrist, Muscatine, Iowa.

UNPIKED: 100 U. S. revenues on documents—10c! Vanvoorhis, Hyndman, Pennsylvania.

25 DIFFERENT Nyasaland, etc., free to approval applicants. Frank Ewing, 2096 East 89, Cleveland, Ohio.

CORONATION Stamps 10c. As fast as ships and airplanes can bring them here we will have all British Coronation stamps to be issued May 12, not only the 45 Crown colonies but all other colonies and dominions as well. For 10c we will send one Coronation stamp each from Bahamas, Falkland, Gibraltar and Trinidad, and then keep on sending on approval single stamps and complete sets of the entire issue of Coronation stamps at lowest prices. This astounding Coronation service is extended only to regular approval buyers on our mailing list. No deposits required. Write today for your Coronation reservation and our unsurpassed approval service. Play safe, get on our mailing list now. Approval Headquarters, Dept. 50, Globus Stamp Co., 268-4 Avenue, New York City, N. Y.

FREE! Scarce triangle airmail! Extraordinary packet 115 different from strange countries, British and French Colonies, Haiti, unique jubilee, pictorials, etc. 5c to approval applicants only. Bargain Co., Box 39P, Station H, New York.

FREE—20 Different Canada to approval applicants. Fort Dearborn, 5439 Aberdeen, Chicago.

CANNON! Set of stamps showing cannon, firing squad, cavalry charge and 200 other different stamps, only 10c to approval applicants. L. H. Reich Stamp Co., 4225 Broadway, Chicago.

GREATEST Historical set! Fascinating packet! Illustrated price lists! 3c to approval applicants! Conklin's, Osage, Iowa.

FREE—Surprise packet, approvals. Postage 3c. Hunt, 184-U, Lambertville, N. J.

EXTRAORDINARY Free offer—Turks Caicos, \$5 U. S., Caymans, Western Samoa (native girl), genuine Baden. Everything free to approval applicants enclosing 3c postage. Viking Stamp Company, 1-Z Hanson Place, Brooklyn, N. Y.

ASSASSINATION Set, 7 Australian, 200 different 15c with approvals, 25c without. Ralph Tanner, Red Creek, N. Y.

CORONATION Sets on approval. Deposit required. Write Scott, 22 Strathearn Blvd., Toronto, Canada.

FREE! Austria pictorial set to approval applicants only. Gem Stampco, Box 194, Chicopee, Mass.

WORLDWIDE Penny approvals. Bargains. L. D. Gibson, Bandana, North Carolina.

DEALERS: Sell beautiful, profitable side line. Particulars free. Arthur Kelley, 24 Church, Montclair, N. J.

U. S. Commemoratives, unused—mint, 25 different 75c (stamps). Steger, Box 154, Crown Point, Ind.

THE World in a packet—100 different stamps from 100 different countries, including Abyssinia, Afghanistan, Brunei, Falkland, Zanzibar, and others from Africa, Asia, South America, West Indies, etc. Our pamphlet which tells "How to Make a Stamp Collection Properly," together with our large bargain list of albums, packets, sets, etc., all for only 20c. Queen City Stamp Co., Room 36, 694 Race St., Cincinnati, Ohio.

U. S. Entire post cards, uncancelled, 12 different 25c. Steger, Box 154, Crown Point, Ind.

EXCELLENT Foreign approvals. Send 6c postage and receive free premium. Howard Wilcox, Box 142, Torrington, Conn.

GORGEOUS Packet including Spanish airmail, King Edward, triangle, United States, ships, maps, only 5c to approval applicants. Imperial Stamp Company, Fontana, California.

POSTAGE Dues, army, navy's, foreign mixture 10c. With approvals. Summers Stamp Service, Unionville, Mo.

FOUR Superb Belgium. New Queen Astrid with Prince on cover, to approval applicants sending 10c. Above complete set of eight 60c. Henry Loufs, (Dept. 21), Wetteren, (Belgium).

EXCHANGE Stamps with collectors all over the world. Information free. Big list of collectors in Australia, New Zealand, South Africa, etc., for 10c. Carmichael, Seaforth, Ontario, Canada.

23 RUSSIA Catalogued \$1.06, only 25c. Gene's Stamps, 2155 Broadview, Cleveland, Ohio.

U. S. Commemoratives, used, 30 different 20c. Steger, Box 332, Crown Point, Ind.

100 DIFFERENT 5c To approval applicants, Samuel Spanner, 100 Forsyth, New York.

SOMETHING Really good. Three dimes or a dollar will bring you beautiful introductory lot stamps worth ten times more. Lists free. Bileski, Station B, Winnipeg, Canada.

EXCHANGE Stamps with foreign members! Particulars for stamp. Monda Ligo Club, Box No. 3, Ennis, Montana.

FOREIGN Airmails will be sent to approval applicants. Save by investing at our prices. Wunsch, 4420 Sycamore, Dallas, Texas.

GIANT Spain triangle and bi-colored Persia airmail (both illus.); big packet 25 diff. Russia (cat. nearly \$1); pkt. British Colonies including Egypt, Travancore, Ireland, Malay, Silver Jubilee, etc. All for only 5c to approval applicants. Fidelity Stamp Co., Dept. 20, Barrister Bldg., Washington, D. C. Free: Large U. S. list.

DIAMOND-SHAPED Airmail! Big packet 105 all different including airmail, commemoratives, Congo, Epirus, Manchukuo, etc.; set of two ex-King Edwards and Costa Rica diamond-shaped airmail; scarce U. S. telegraph, cat. 30c; pkt. British colonies—Gwalior, Hyderabad, Silver Jubilee; big lists. Everything for 5c to approval applicants! Send today! Mystic Stamp Co., Dept. 80, Camden, New York.

MIDGET Stamp, 22 British Colonials, 50 different worldwide, 5c with approvals. Shultes, Box 13P, Berne, New York.

FORTY Different American Christmas seals 50c, American and foreign seals on approval. Ben Morris, Bellaire, Ohio.

CHOOSE Your premiums! Jungle stamps! Animal! Bird! Airmail! Triangle and map stamps. Pick any ten from our big approval selection. Absolutely free. Stamp Importers, Akron, Ohio.

500 CANADIANS—Pictorials, airmails, high values, many varieties, with George VI issues. Remarkable mixture \$1.00. Marigold Stamp Co., 77 Victoria, Toronto, Canada.

FREE—Beautiful Minerva triangle and airmails to approval applicants enclosing postage. Green & Company, Norwood, Ohio.

100 DIFFERENT For this ad and 3c to approval applicants. Evanston Stamp Shop, Box 200, Evanston, Illinois.

SMALLEST Airmail only 1/2 inch high, free stamp magazine, \$2.00 U. S. stamp, bird, animals, train, Indian, airplane, commemoratives, special issues, with many scarce stamps from 25 different countries. 5c with approvals. Capital Stamps, 413M Roosevelt, Little Rock, Arkansas.

10 DIFFERENT Brazil and 15 different Chile only 3c to approval applicants. Maynard Sundman, M6, Bristol, Conn.

CANADA Coronation packet free. 3c postage please. Oromocto Stamps, Kitchener, Ontario, Canada.

DIFFERENT: 1000 Stamps, unpicked mixture. 25c a packet. G. E. Pigeon, Meriden, Conn.

FREE—15 Different Peru to approval applicants enclosing postage. Hanson, 3555 Fullerton, Chicago.

WANT Lists filled United States, foreign premiums with approvals. References. Lewis Kelsey, South Bristol, Maine.

50 BRITISH including George VI; Edward, jubilees, Newfoundland. 10c with approvals. Mantle Stamp Company, London, Canada.

UNITED States approvals! Reasonable! Serious collectors only! Box 822, Minneapolis, Minn.

MAMMOTH Mystery packet rare stamps only 10c to serious approval applicants, also valuable free premiums with every selection afterwards. Our stamps are better, our service is different. Fair-Play Stamp Service, 1215 Browning Blvd., Los Angeles, Calif.

WHOLESALE Pricelists. Stamp appreciated. No approvals. Prince Warren, Grant Hotel-5, Chicago.

PRODIGIOUS Gift! Scarce Perak, Negri Sembilan, bicolored almost, cheery French Colonies, picturesque Trinidad, Siberia, Selangor. Absolutely free with approvals! Postage 3c. Saxon Stamp Co., Dept. 65, Albee Bldg., Brooklyn, N. Y.

U. S.—57 Different (commemorative, airmail, etc.) with approvals 9c. Moseley, 4332 Forestpark, St. Louis, Mo.

FREE—\$2.00 And 15 other United States. Foreign approvals. Postage 3c. Wm. Clatworthy, Unland, Calif.

WONDER Packet! United States \$1.00, \$2.00, \$4.00, \$5.00, Spanish ship, Kookaburra, Lyre, Fantail, Kiwi birds, cruiser, Madonna, Dhow, slave god, aviator, 5c with approvals. Extra! India jubilee set. Plymouth, Dept. A5, Bell, California.

50 NEW Zealand 10c. M. Mantell, 227 Collins, Miami Beach, Florida.

300 DIFFERENT Stamps 10c to approval buyers. R. McKinney, Elsie, Michigan.

GENERAL Collectors bargain bulletin free. Gage, Arcade Building, Pasadena, California.

FREE—40 Different to approval applicants. Arrow, 5228 South Paulina, Chicago.

WORLD-WIDE Assortment 5c-10c packets. 15 Africa, 5c. 25 Italy, 5c. Elsea, Bowling Green, Ohio.

107 STAMPS, including St. Helena, Swaziland! Dime to approval applicants. Hutter, Cumberland, Maryland.

20 DIFFERENT Silver jubilees 25c (scarce.) Nugents, Lakeand, South Dakota.

WORLDWIDE Packet. Pictorials. Comems. Jubilees, 3 cents. Approvals. James Stamps, Stone Street, New Bedford, Mass.

SIX Different scarce jubilees plus mint Astrid mourning stamp 5c—to approval applicants. Sylvan Stamps, Box 22, Sta. H, Brooklyn, N. Y.

ONE And two dollar United States revenues given to approval applicants. Wendt, 10413 Calumet, Chicago, Ill.

100 STAMPS From 100 countries, exceptional value at 20c. Approvals. Illing, 6711 Sheridan, Chicago.

NEW Rivera nude stamp! World's largest triangle! Congo, Sudan, South Seas, bicolored, pictorials, and many others. Only 3c with approvals. Cactus Junior Approvals, Box 1870, Tucson, Arizona.

1000 **WORLDWIDE** Stamp mixture 25c. Monjar, 1542 Waverly, Cincinnati, Ohio.

"**GOYA** Nude" stamp, 5c to approval applicants. "Jewell's," Tamaqua, Penna.

50 DIFFERENT, including airs, commemoratives, Ethiopia, French-British Colonies, with approvals 12c. Star Supply Company, Lima, Ohio.

50 **CZECHOSLOVAKIA**, 30 Portugal, 10 cents each. Price list free. Graf, 1874 Loring Place, New York.

BEAUTIFUL Naru ship stamp, triangle and 56 others for nickel. Lists, approvals included. Black Star, Evanston, Ill.

INVESTORS—1000 United States commemoratives, 45 varieties, \$2.00. Maumee Stamp Co., Maumee, Ohio.

ABSOLUTELY Free! Sensational packet five different triangle stamps (alone worth 20c retail) plus remarkable collection Cayman Islands, (large map stamp); Sudan, Epirus, (sharpshooter), other thrilling stamps, big lists, valuable coupons and surprise souvenir—all free to approval applicants sending 5c for mailing and advertising expenses! Write today for this sensational offer. Midwood Stamp Company, Department P3, Midwood Station, Brooklyn, New York.

CORONATION Souvenir stamps, 60 beautifully coloured stamps, all different, comprising crownings from King Harold (1066) royal family portraits and historical events. Secure this unique collection as a Coronation memento. Send 25c (postal notes only) for complete set, postpaid. P. P. Co., 10 Station Road, London, N. 4, England.

STAMP Annual free:—Describes and illustrates albums, supplies, United States, British Colonial and foreign stamps, sets, collections. This 36-page catalogue free. Gray Stamp Company, Dept. P.M., Toronto, Canada.

15 **BEAUTIFUL** Airmails 7c. Airmail approvals. George Davis, Webster, Mass.

FREE!! New King George VI set. Postage 3c. Roberts, 901F Fourth, Baycity, Michigan.

LARGE Spanish ship stamp, Azerbaijan, Cameroons, Chad, Dahomey, Gabon, Ubangi in packet of 57 stamps. All for 5 cts. with approvals. Swedell, 3129 Garfield Ave., Minneapolis, Minn.

50 **STAMPS** Free—Manchukuo, etc. Postage 1c. Album (500 illustrations) 3c. 1450 U. S. bargains. Bullard, 268R Northampton, Boston, Mass.

25 **DIFF.** South America 6c. Approvals. Charles Sweetser, Dover, Foxcroft, Maine.

UNITED States and foreign approvals. Huber, Three South Eighth, Minneapolis.

FREE—U. S. \$1, \$2, \$4 and \$5 stamps. Unbeatable U. S. approvals. Nelson, 658 Laurel, St. Paul, Minn.

FREE! "United States, British Colonies and Better-Grade Foreign Stamps"—our valuable illustrated 96-page catalog. Money-saving prices! Send today. H. E. Harris & Co., 137 Transit Building, Boston, Mass.

NEW Copyrighted loose leaf stamp collection system. Most economical yet. Most beautiful sheets ever printed. Samples 5c postpaid. S. J. Jorgensen, 90 Maritime Bldg., Seattle, Wash.

200 **DIFFERENT** 10c. Big 50% approvals. Covert Stamp, 39 State, Rochester, N. Y.

FREE Set to approval applicants. August Fischer, 235 Citizens Bldg., Louisville, Ky.

ACE Penny approvals for satisfaction. Bent, 1739-A N. Wells, Chicago.

OBsolete. Scarce \$1.00 Abyssinia elephant and thirty other rare stamps totaling \$1.25 sent approval applicants for 3c. Kummer, King, Lancaster, Ohio.

SUPERIOR Approval selections foreign stamps. U. S. list free. Aldrich, Box 744, St. Joseph, Mo.

STAMPS. Prices we pay you. Catalogue 25c. Traffic Station, Box 161, Minneapolis.

MIXTURES—United States 50c lb., 5 lbs. \$2.00; Canada 75c; Belgium \$1.10; France \$1.00; Netherlands \$1.25; foreign \$1.00; Japan \$2.00; postpaid. Mission, 4512 North Racine, Chicago.

LIBERIA Snake triangle, giant Spanish triangle, 50 other stamps, 5c. Wright Company, 2527 Guilford, Baltimore, Md.

4½ **TRIANGLES!** Guatemala bisect (diagonal half-stamp), beautiful Liberia, three additional triangles, 27 other stamps, 5c. Abell Company, 1818 St. Paul, Baltimore, Md.

UNITED States—45 different 10c; 125 different arranged on card, each with catalog number, \$1.00; 25 different free to foreign approval applicants, enclosing 3c. Seidenberg, Baroda, Mich.

MONTHLY Stamp and coin magazine, six months and 25 foreign stamps, 25c. American Stamp Journal, Cedar Rapids, Iowa.

BARGAIN! 50 Different British Empire including jubilee, Edwards, 50 different new, recent and pictorial world issues, 15 different airmails, 500 hinges, perforation gauge—all for 25c. Approvals sent. Lists free. Victoria Stamp Co., London 4, Canada.

UNITED States, 75 different commemoratives, etc., 20c. Steger, Box 154, Crown Point, Ind.

FROM Earth's far corners, 25 Republics, Dominions, 40 U.S. commemoratives, airs, etc., 10c with approvals. Stamp Shop, 809 Holland Bldg., St. Louis, Mo.

300 **DIFFERENT** 20c; 1,000, \$1; 2,000, \$3.00; 3,000, \$7.00; 5,000, \$17.00. Fred Onken, 630 79th St., Brooklyn.

500 **MIXED** 18c. Animals, birds, boats, rulers, scenes. Approvals sent. Elmer's, 196A Washington St., Boston.

FREE!! Edward stamp, packet Canada 3c, approvals. Hazett Stamp Shop, 701P Fourth, Baycity, Mich.

FREE—\$1.00 U. S. stamp with request for 52 page list of United States and foreign stamps. Stamps on approval. References necessary. 1000 U. S. no current \$1.46. New Hussman Stamp Co., 1122 Pine St., St. Louis, Mo.

QUEEREST Stamp packet. Receive world's smallest stamp; Vatican City; scarce Liberia triangle (value 15c); 1935 Greek Red Cross picturing coiled snake in Garden of Eden; Australian Bushman; new Spanish Morocco; Japan "quake" stamp; Manchukuo; many others. Only 5c to approval applicants. R. M. Stamp Co., P. O. Box 230P, Port Chester, N. Y.

ILLUSTRATED Album. Spaces 4000 stamps; to approval applicants 20c. Swan Stamps, 604 Swan, Dunkirk, N. Y.

WHOLESALE Approvals. References. Fuld, 3155 So. Grand, St. Louis, Missouri.

AMAZING Offer! Army and navy commemoratives, imperforate Chicago, packet of 25 North American stamps from U. S., Canada, Mexico, Newfoundland. Catalogue value over 65c—all for 5c to approval applicants. Illustrated pricelist free. Curhan Stamp Co., Dept. P, Gloucester, Mass.

NEWFOUNDLAND, 15 Different 5c with approvals. Frederick Brown, Plainfield, N. J.

FREE—Dollar packet to approval applicants. Harlan, 5307 S. Marshfield, Chicago.

SCARCE New giant sized, diamond-shaped Russian "sports" stamp; Nyassaland "leopard"; Morocco; Tanganyika, and other scarce countries included in our big packet of new and recent issues—stamps most collectors have never seen! Get this valuable packet today. 5c to approval applicants. Reimers, 115 Flatiron, Fort Worth, Texas.

\$5.00 U. S. Postage due, No. 2284, fine copy 5c with general approvals. Hudson Company, 116 Nassau St., New York City.

ILLUSTRATED U. S. list, price 50c, large complete U. S. price list free. Send postage. Stanley Gibbons, 38P Park Row, N. Y.

PENNY Approvals that please. Haywood, 395 Adams St., Pomona, Calif.

AIRMAIL Triangles from Liberia and Mozambique, 3 British silver jubilees, new King Edward stamp and packet 25 different stamps from Azerbaijan, China, Ukraine, etc. All for 5c to approval applicants. Clipper Stamp Co., Dept. 7, Gloucester, Mass.

ASK For our wonderful one cent approvals. Prospect Stamp Co., 225 Broadview, Toronto, Canada.

MIDGET Airmail (½ in. tall), Szechuen, Kouang-Tcheou, Mozambique, etc., 30 stamps—5c Depraw, Ocean Park, California.

STAMPS: A splendid selection sent on approval. Quality at low prices. Scarce and high value stamps are included in our approval books. Fred Herzberg, Box 91-P, Elmhurst, Ill.

STAMP Dealers, your ad here will bring wonderful returns. Ask me for proof. F. W. Johnson, Manager, Classified Advertising, Popular Mechanics Magazine, 200 E. Ontario St., Chicago.

GIANT-SIZED Russian Zeppelin stamp (cat. val. 20c!) and beautiful Lithuania airmail triangle; also big packet of 53 diff. stamps including Azerbaijan, Epirus, new Martinique, etc. and illustrated lists—all for 5c to approval applicants! World-Wide Stamp Co., Box 600, Camden, New York.

WEEKLY Stamp magazine, thirteen weeks, 10c. Stamp Journal, Kalamazoo, Mich.

PENNY Approvals, that satisfy. Neil Gronberg, Box 5441-P, Philadelphia, Pa.

44 **DIFFERENT** United States including \$5 stamp, or complete set United States bi-centennials, or 30 different obsolete Canada, 13c postpaid with approvals. C. A. Lennan Co., Box 322, City Hall Annex, New York, N. Y.

\$5.00 U. S. Red and blue liberty, present postage value. Scott No. 573 cat. \$1.25 (retails as high as \$1.00 net by some dealers) only 5c to approval applicants. Giant U. S. pricelist free! Tatham Stamp Company, Springfield-5, Mass.

25 **UNITED** States, including \$4 and \$5 stamps free to approval applicants. 3c postage. Brownie Stamp Shop, Flint, Michigan.

DIAMOND-SHAPED Stamp, Liberia gunboat triangle, two other triangles, silver jubilee, 27 others, 5c. Crowder Company, 127E North, Baltimore, Md.

BARGAIN! Bosnia numbers 11 to 24. Catalogue \$20.45. Only 25c. Approval applicants only. National Stamps, 1140 Gower, Hollywood, California.

NEW Issue service, 100% complete. You are advised of new issues by mail. Have your name placed on my mailing list. Frederick A. Newman, 109 Shoreland Arcade, Miami, Florida.

PHOTO FINISHING

20 **REPRINTS** 25c—Films developed, 16 prints 25c. Enlargements 8x10—25c; 5x7—10c. Low Photo, M2657 Nava, Chicago.

TWO Beautiful Masterprint enlargements included with roll developed, printed 25c. Reprints 3c each. Beautiful "oilcolored" professional enlargement included with each 25c reprint order. Guaranteed highest quality. Brown Photo Company, 2209-12 Lowry, Minneapolis, Minnesota.

ROLL Developed, two sets dated Velox prints 25c. Hench Studios, 1814 Chestnut, Harrisburg, Penna.

IMMEDIATE Service! No delay! Roll developed, carefully printed and two beautiful 5x7 double weight professional enlargements or one tinted enlargement or six reprints—all for 25c coin. The expert's choice. Reprints 3c each. The Photo Mill, Box 629-Z, Minneapolis, Minn.

DEVELOP And print your own pictures. Save time, money with our complete \$1.49 outfit postpaid, or pay postman \$1.55 COD. Includes electric ruby lamp, printing frame, photo paper, chemicals and equipment. One of hundreds of amazing bargains in our free, newest, money-saving bargain book. Send for it today! Central Camera Co., 230 So. Wabash, Dept. A-935, Chicago.

ROLL Film developed and printed, including two beautiful double weight olive tone enlargements free. 25c coin. Nu-Art Photo Shop, LaCrosse, Wis.

MAIL Your rolls to film center of the world. 8 guaranteed glossy Velox deckle-edged prints, 25c coin. Professional enlargement coupon free! Photo Finishing Shop, Est. 22 yrs., 411-J Genesee Valley Trust Bldg., Rochester, N. Y. "The Camera City."

FILMS Developed 2 prints of each 25c; 20 reprints 25c. Pine Photo, M-5134 Nevada, Chicago.

SAME Day service. Films developed, eight Velox prints in de luxe album, two enlargement coupons. Complete 25c. Paramount, General Post Office Box 48, New York.

"HOLLYTINTS Mean better prints." Two Hollywood professional enlargements with trial roll—25c. Valuable premium coupons free. Unequaled service. Hollytints, P-1350, Hollywood, California.

ROLL Developed and printed. Two enlargements, one of them in colors, all for 25c coin. The Photo Finisher, Station E, Box 42, Columbus, Ohio.

GUARANTEED. Film developed, 16 prints 25c. 20 reprints 25c. Quality Photo, Hutchinson, Kansas.

YOUR Negatives (films) enlarged, size 5x7 1/2, 3 for 25c; size 8x10, 20c. 3 for 50c. Guaranteed fadeless. Roll developed and printed only 25c. Paris Photo Service, Dept. PM, 121 West 42nd, New York.

ROLLS Developed. Two professional double weight, enlargements, 8 Nu Tone prints 25c. Herman Studio, Ft. Wayne, Ind., 105 Main.

FILMS Developed, printed, 25c. Fadeless Velox reprints 3c. Western mountain scene free. Denco, Box 781, Denver, Colo.

YOUR Photo on name cards, book plates, labels. From your film or photo. Acme Color Studio, 225 Republic Building, Miami, Florida.

RADIO Film Company, LaCrosse, Wisconsin. Latest in photo finishing. Eight guaranteed prints—two enlargements 25c.

TWO Beautiful portrait type double weight enlargements, eight guaranteed never-fade prints each roll 25c. Dubuque Film Service, Dubuque, Iowa.

ROLLS Developed, 2 prints each, 25c. Hitone, P. O. 134, Hagerstown, Maryland.

ROLLS Developed—Two new Beautitone Dubluate professional enlargements, 8 guaranteed fadeless Beautitone prints, 25c. Giant Snapshots, Inc., 667A, Green Bay, Wisconsin.

KODAK Roll finished 25c. Univex 15c. Anselmo Tellez, B-623-PM, Pecos, Texas.

SOMETHING New! We carefully develop and print your film and send you a new roll (127 to 116 size) of a nationally known brand, all for 50c. Economy Photo Service, Box 157-B, Greensburg, Pa.

FOR The discriminating amateur—roll developed and carefully printed 25c, reprints 3c. Superior workmanship, same day service. Paramount Co., 327 E. 92nd Street, New York.

BEAUTIFUL Colored Enlargement with each film, 25c. LaCrosse Film Company, LaCrosse, Wis.

ROLL Developed, eight prints that will not fade, and two enlargements, 25c (coin). California Film Service, Box 379, Department 16, Pasadena, California.

22 REPRINTS 25c. Rolls developed, 16 prints, two enlargements—25c. Four 5x7 enlargements 25c; 17—\$1. Truefoto, Des Moines, Iowa.

IMMEDIATE Service! No delay! Roll developed, carefully printed and two beautiful 5x7 double weight professional enlargements or one tinted enlargement or six reprints—all for 25c coin. The expert's choice. Reprints 3c each. The Photo Mill, Box 629-12, Minneapolis, Minn.

TRIAL Order, developing and eight Velox prints 15c. Tinted enlargement 10c. Kodokraft, Highland Station, Minneapolis, Minn.

ROLLS Developed, 8 prints, two beautiful glossy enlargements 25c coin. 6 hour service. The Picture Folks, Box 911, Lincoln, Nebraska, Dept. X.

ROLL Developed with 16 prints and two professional enlargements 30c. 100 reprints \$1.00. 16 reprints and 2 enlargements 30c. Dependable, RiverGrove, Illinois.

HAND Colored enlargement with each roll 25c. 40 reprints 50c. Colorgraph, Dunning Station, Chicago.

PHOTO Mirrors. Make, sell. Samples. 30c. Printercross, Perrinton, Mich.

ROLL Developed, 8 fadeproof Velox prints and a photo-file 25c. Reprints 3c. Professional 8x10 enlargement 25c. Beautiful premiums. Young Photo Service, 405-B, Albany, N. Y.

CASH For snapshots! Earn extra money. Thousands wanted immediately. Stamp brings information. Division 155, International Photos, Hohm Building, Sixth & Western, Hollywood, California.

ENLARGEMENTS Our specialty. 4x6 or smaller, 5 for 25c. 5x7, 3 for 25c. 8x10, 3 for 35c. Roll developed 10 prints 25c. 25 reprints 25c. Enlargers, Dunning Station, Chicago.

PROFESSIONAL Quality service. Rolls developed, 8 prints and 2 enlargements 25c. The Film Capital Service, Box 504, Rochester, N. Y.

20 REPRINTS 25c. 100 Reprints \$1.00. Rolls developed with 16 prints 25c. Nordskog, 4, Maywood, Ill.

20 REPRINTS 25c. Films developed, two prints each negative, 25c. Skrudland, 6970-8 George, Chicago.

IDEAL Finishing. Your roll developed and printed 25c. Snapshot folder and enlargement coupon with each order. Ideal Photo Service, Box 2255, Paterson, N. J.

CLEAR, Brilliant prints; prompt service. Roll developed, 2 prints each negative 25c. Enlargement coupon. Photo Finishers, Dept. 5, Cleveland Heights, Ohio.

QUICKER Service, sparkling double-clear never-fade prints. Roll developed, two prints each negative, enlargement coupon 25c. Willard's, Box 3535-A, Cleveland Heights, Ohio.

ROLL Developed, 2 prints each negative, 25c. Reprints 2c. Photoshop, Ogden, Utah.

FILMS Developed and printed, also two double weight enlargements 25c, 8 reprints and one enlargement 25c. Photoart Shop, Box 3406 P, St. Paul, Minnesota.

ROLL Developed, two prints each, two enlargement coupons 25c. Summers' Studio, Unionville, Mo.

ROLLS Developed, 16 guaranteed prints, two coupons on plain or colored enlargement 25c. Smart Photo, Winona, Minnesota.

LABJAGRAPH Reprints (5x7), five 25c. Cardinal Photographs, Berkeley Heights, N. J.

TWO Glossy enlargements, 1 colored, with roll 25c. Arbor Service, 10 Joliet, Ill.

FINER Finishing. Rolls developed and printed, with one colored enlargement, or two professional enlargements. All for 25c (coin). Genuine, nationally known. Moentone superior quality. Moen Photo Service, La Crosse, Wis.

ROLLS Developed. Two beautiful double-weight professional enlargements and 8 guaranteed Never Fade Perfect Tone prints. 25c coin. Rays Photo Service, LaCrosse, Wisconsin.

ROLL Developed and 8 beautiful Velox glossy prints 25c coin or stamps. Reprints 3c each. Fotoprint Service, Box E, Roanoke, Virginia.

24-HOUR Service, roll Filmachine developed and your choice (1) 8 Finerfotos and 2 professional bromide enlargements; (2) 16 guaranteed Velox Finerfotos or (3) 8 Finerfotos and one beautiful colored (in oil) enlargement, all for 25c coin. Order by number. Finerfotos, Box D-898, Minneapolis, Minn.

CAMERAS, PHOTO SUPPLIES

MAKE Money in photography. Learn quickly at home. Spare no full time. Easy plan. Previous experience unnecessary. Common school education sufficient. Write for full information and requirements. American School of Photography, 3601 Michigan Avenue, Dept. 3431, Chicago.

INTERESTING Sample copy of 25c photographic magazine for 10c. Special, 6 months trial subscription for \$1.00. Photographic Digest, 1666 Linden Street, Brooklyn, New York.

BASS Is the camera cross roads of the world. Saves you money on the highest-grade cameras. Goldi candid camera F:2.9 lens, Rapid Compur shutter, only \$34.50. Voigtlander streamlined convertible miniature takes 16 V. P. or 8 2 1/4 x 3 1/4. F:4.5 Anastigmat, only \$24.75. Voigtlander Superb Reflex, twin lens, Skopar F:3.5 Anastigmat, only \$67.50. Brilliant Reflex F:7.7 lens. A knockout at \$7.50. The famous Argus candid camera, F:4.5 lens, postpaid \$12.50. The above just a few from the hundreds of items from the latest and greatest Bass Bargaingram No. 231. Write for your copy or order direct from the ad. Money-back guarantee. Department A-G, Bass Camera Company, 179 West Madison Street, Chicago.

CAMERAS And supplies. Free illustrated catalog listing everything photographic—still and movie cameras, films, lenses—at tremendous savings. Hundreds of bargains, new and used. All guaranteed. We take your old camera or equipment in trade. Write now for your free copy of our newest money-saving bargain book—just out! Limited edition. Hurry! Central Camera Co. (Photographic Headquarters since 1899), 230 So. Wabash, Dept. A-135, Chicago.

MAKE At home; simple, practical vest pocket exposure meter. Illustrated instructions 25c. R. Horn, Box 8, San Francisco, California.

KODAK Snapshot steamship Queen Mary, 10c. Forman, 882 Lorimer, Brooklyn.

FREE! Sample copy sixty page photographic magazine—interesting, instructive. Pocket Photo Monthly, Canton, Ohio.

GET Inside! Fire lines; parade lanes; courts. Photographer's Press Card (like reporters) 25c each. Emery Service, Adam St., Pittsfield, Mass.

ARGUS Or Voflenda. World's finest black or tan cowhide Eveready cases. \$3.75 postpaid. Quentin Products Co., West Salem, Illinois.

PHOTOMURALS. Giant enlargements. Easily and economically made. Complete illustrated instructions \$1.00. Information free. Fogarty, 1689 Capitol, Bridgeport, Conn.

PRICES Are lower in Mexico: Leica, Contax, Rolleiflex, Voigtlander, etc., at Mexico's camera specialist. Foto Mantel Sucr. Rudolf Rudiger, Apdo. 1459, Mexico, D.F. 105. Branch No. 3, Tijuana, Baja, California. Calle la, 169-1/2.

MAKE Money selling snapshots. Complete instructions, 1800 markets, 10c. Photo Markets, 201-P Barrister Bldg., Washington, D. C.

35% DISCOUNT On films. Write Paramount Photo Division, 327 E. 92nd St., New York.

HAVE You a camera? Send ten cents for recent number of our big magazine, showing how to make better pictures and earn money. American Photography, 116 Camera House, Boston, 17, Mass.

INCOME From your camera instead of expense. Low cost home course teaches you to make photographs for magazines, newspapers, advertisers. Tremendous demand. Earn good money wherever you live. Free book. Universal Photographers, Dept. 104, 10 West 33rd St., New York.

MOTION PICTURES AND SOUND EQUIPMENT

CENTRAL'S Free, new, money-saving bargain book explains latest movie developments, offers money-saving bargains in cameras, lenses, projectors, films. Used equipment taken in trade. Write for free copy. Central Camera Company, (Photographic Headquarters since 1899), 230 So. Wabash, Dept. A-835, Chicago.

230 IS READY. Cine edition of the Bass Bargaingram. Don't buy without this guide to Cine value. No questionable merchandise. Guarantee values only. 100 watt, 400 ft. Keystone motor drive projector \$13.75. 100 ft. De Vry 16 mm. camera F:3.5 lens \$16.75. Cine Kodak Model B, F:3.5 lens, \$24.75. Film 70A Cooke F:3.5 lens with case \$35.00. RCA latest model 750 watt sound on film projector \$245.00. Whatever you want in movie apparatus, write to the camera cross roads of the world. Bass Camera Company, Department A, 179 West Madison Street, Chicago.

16MM EXCEL Motor driven projector, 100-ft. reel, \$3.95. 8 and 16mm. Pop-Eye, Betty Boop, "Our Gang" comedies and others, 3c stamp for catalogue. Excel Home Movies, 622 Madison, Toledo, Ohio.

WESTERNS. Comedies, 500 feet 75c. Jersey Films, 2075 Richland, Lakewood, O.

35MM. FILMS Rented, 50c weekly. Lists 3c. Hoffman Film Service, 57 Broad, Albany, N. Y.

BARGAINS: Film humidors, Argus cases. Screens. Catalog free. Mirotext, 6241 Southwood, St. Louis, Mo.

CLOSE-OUTS. Cameras, projectors, arts. Listings. Cine, 151 Broadway, Paterson, N. J.

BARGAINS! 8mm, 16mm. Literature free. Elder, Dept. B-36, Chelsea, Massachusetts.

1001 **BARGAIN** List. Trades accepted. BL-Camex, 1451-P Broadway, New York.

16MM. 25 FT. Exchanged, 2-15c, 4-25c, postpaid. State preferences. Warren Darling, 1115 - 16th No., Seattle, Wash.

16MM CAMERAS, Projectors, all makes and models, new and used, big discounts, trades accepted, films for rent, sale and exchange. Free illustrated catalogue (with sample film 10c). Parkway Exchange, 1040 Eastern Parkway, Brooklyn, N. Y.

8-16MM. TITLES 2c Word. Catalogue. Cineshop, 1560 Jackson, Charleston, West Virginia.

8MM-16MM MOVIE Cameras \$9.95. Film 54c up. Projectors \$9.95. Screens. Free circular. Bytown, Dept. C, Park Ridge, Ill.

15% TO 25% Discount on still or movie cameras. Free circular. Paramount Co., 327 E. 92nd Street, New York City.

16MM CAMERAS, Projectors, all makes and models, new and used, big discounts, trades accepted, films for rent, sale and exchange. Free catalogue. Fulton Camera Exchange, 381 Fulton Street, Brooklyn, N. Y.

8MM TITLER—For Univex cameras—\$3.75. Camera, projector, accessories. 8mm-16mm films. Send stamp for catalogues. Hollywood Cine Film Distributors, Dept. C, 1431-33 No. Highland, Hollywood, Calif.

MAKE Your own black-and-white and Kodachrome movie titles with new Stamp-O-Title outfit. Eradicator removes lettering enabling permanent use of backgrounds. Complete with type, patented chemicals, indestructible cards, accessories only \$5.75. Stamp-O-Title Co., Dep't P-6, 318 East 116th Street, New York.

FILMS—8-16MM. List 10c. Spring Films, Westboro, Mass.

16MM PROJECTORS, Victors, Ampro bargains. Guaranteed. Soundfilms bought, traded, rented. DeVry 35mm camera \$50, projector \$40. Acme sound projector \$225. Howard Hill, Piedmont, California.

LEARN Motion picture theatre business. Home-study training; management, advertising, projection. Tenth year. Free catalog. Theatre Institute, Elmira, N. Y.

TENTH Anniversary. 35mm, complete \$1.00. Savarese, Woodcliff Lake, New Jersey.

POPULAR Star films, 16mm-8mm, 25c up. Free bargain lists. Home Movies, Box 32, Easton, Pennsylvania.

ROAD Show exhibitors. Complete, late 9 reel, 16mm, sound programs, \$20.00 week. Tremendous selection. Eastin Pictures, Davenport, Iowa.

RADIOS, SUPPLIES, INSTRUCTION

MILLIONS New radios obsolete without instant magic tuning. Radio Wise stick favorite call letters on any dial, 200 gummed, \$1.00. Free, world wide chief station finder. "Radiograph," 1111-A, 538 South Dearborn, Chicago.

SAVE Money on radios and parts. Send for our money saving catalog. United Radio Company, N-Newark, N. J.

RADIO Experimenters and set builders; parts and kits of parts for improved Little Giant R235, six tube R233, Pre-amplifier R228, Portable battery R223, Little Giant R220 and 205 and 6 volt R238, described by Popular Mechanics. Guaranteed specified parts. Lund Manufacturing Co., 43 East Ohio, Chicago.

BLUEPRINT, Distance record crystal set, 17 others, with "Radiobuilder" year—25c. Laboratories, 151-C Liberty, San Francisco.

RADIO Engineering, broadcasting, aviation and police radio, servicing, marine and Morse telegraphy taught thoroughly. All expenses low. Catalog free. Dodge's Institute, Ames St., Valparaiso, Ind.

BOOKS Covering hundreds of subjects. Big catalog for 3c postage. Popular Mechanics Press, Room (C37), 200 E. Ontario St., Chicago.

MUSIC AND MUSICAL INSTRUMENTS

NEW Melodeons ("parlor" reed organ). Only \$16.25, f.o.b. New York. Three octaves, tremendous controlled volume, marvelous tone. Light, portable. Bench included. Return if dissatisfied. Ask for folder. Sun Technical Supply Company, 505 Professional Bldg., Pittsburgh, Pa.

ATTENTION Concertina players! Revolutionary, new, amazing. Write, circular free. Glass Bros., 7150 S. Morgan, Chicago, Ill.

LEARN "Swing" piano playing with new self-instruction book. Descriptive folder sent free. Axel Christensen, 751 Kimball Hall, Chicago, Ill.

REBUILT Band and orchestra instruments. Honestly rebuilt—fully guaranteed. Catalog of new instruments on request. Weymann Company, Dept. M-6, 1613 Chestnut St., Philadelphia.

PIANISTS—Free booklet reveals remarkable method improving playing, sight reading, technic, memorizing—Quick results. Write Broadwell Studios, Dept. 422F, Bendix Building, Los Angeles, California.

CATCHY Melodies, snappy arrangements, for song-poems, orchestrations. (Twenty years experience). Frank Wildt, Music Arranger, Lancaster, Pennsylvania.

PIANO In a nutshell—theory \$1. Fairview Music, Houston, Texas.

SONGWRITERS! Amazing opportunity. Investigate. Hibbeler, C5, 2157 N. Avers, Chicago.

SONGWRITERS: Send for free Rhyming Dictionary and Writers' Guide. MMM Publishers, 637 Studio Bldg., Portland, Ore.

SONGWRITERS—Fifty-Fifty Magazine, copy free. Lee Ice, Marietta, Ohio.

FREE Booklet "Giving Your Songs the Right Start" by famous Broadway composer. Songwriters Institute, 1234-C Broadway, New York.

SONG Writers—a genuine new service. Write Globe Song Service, 605 Parliament St., Toronto, Canada.

ORCHESTRATIONS Or harmony. Learn at home. 2344 Foothill, Oakland, California.

SONGS—Words or music immediately. Brilliant opportunity. Vanburen, 1013 McClurg Bldg., Chicago.

BIG Money in popular music. Details free. National Music Distributors, San Francisco.

SONG Poets—Free instruction book, 50-50 plan. Write Song Bureau, Salem, Indiana.

SONGWRITERS' Manual, disclosing important information, sent free. Standard Song Service, 1412 Great Northern Bldg., Chicago.

CHORDS, Scales, keys, signatures, transpositions, instrumentations formed instantly. Paper musical slide rule. Send \$1.00. Paper Co., 2 Elwood St., New York City.

SONGS Published, arranged and composed. Royalty basis. West Coast Music Publishing Company, 942 Market Street, San Francisco, California.

SONG Writers. Send for our "Publishing Agreement and Arranging Plan." McKinley Music Publishers, 1501 E. 55th St., Chicago.

SONGPOEMS Set to music. Modern marketing plan. Newald Music Co., Kitchel, Ind.

POEMS Wanted. Work guaranteed. We publish. Great Eastern, Thomaston, Maine.

SONGWRITERS!! Songs arranged, prepared for publication by the arranger of "Carolina Moon," "Melancholy Baby," "Gypsy Tearoom," "Treasure Island," "Bamboo Bridge," etc. Send for details. Harold Potter, 1619(P) Broadway, New York.

PIANO Jazz guaranteed by mail in 20 lessons. Erskine Studios, 810 East 14th St., Oakland, Calif.

SONGPOETS, Royalty publishing. Poem lessons 50c. Songland, "PM," Thomaston, Maine.

WANTED! Lyrics, melodies for songs. We arrange, publish, sell. Superior Song Studios, Passaic, N. J.

DUO-FLEX Reeds for clarinets, and saxophones eliminate your reed troubles. Write for circular. Duo-Flex Reeds, 1204 1st Ave., Evansville, Ind.

SONG Poems wanted—Home, love, sacred, any subject. Send best poem today for offer. Richard Bros., 24 Woods Bldg., Chicago.

SONG Poems set to music. Get our phonograph recording plan. Zerse Bros., 210 Olive, St. Louis, Mo.

VIOLINS—Handmade. Best since Stradivarius days. (Curious don't bother.) John Lehto, San Pedro, Cal.

EARN Your own musical instrument. Get free details and free attractive savings bank at your music store, or write Fred Gretsch Mfg. Co., 521½ So. Wabash, Chicago.

MUSIC Composed to words. Wonderful proposition. Bauer Bros., Oshkosh, Wis.

WRITE Songs. Big money and reputation. Write for information. J. Gordon Pub. Co., 201 N. Hoyne Ave., Chicago.

HAVE Phonograph record made your song. Rainbow Recording Studios, 210 Olive, St. Louis, Mo.

BUSINESS OPPORTUNITIES

MAKE Up to \$50 weekly. New invention makes toughest meat tender. Money back guarantee. Rose Co., 4803 So. Sixth, Louisville, Ky.

SMALL Inventions wanted by manufacturers. I'll help you sell your invention. Stanley Hull, M-7829 Euclid Avenue, Cleveland, Ohio.

FINANCIALLY Independent collecting amusement and vending machines. Investment required. Box 1591, Rockford, Ill.

START An exclusive, independent business of your own in the booming building field. Experience not necessary. Investment one hundred dollars, easy terms. Secured by materials and exclusive franchise. Get complete information. P. O. Box 2606, Memphis, Tenn.

MAKE Artificial marble, glossy tiles, uncanny. Tabletops, plaques, floors, whetstones, novelties. Cement secrets, hard, fire-proof, inexpensive. Brilliant tile and liquid rubber samples 3c. John A. Payn, 945 Grande Vista Avenue, Los Angeles, Calif.

FORMULAS—Fast selling products. Guaranteed. Laboratory tested. Lowest prices. Catalog free. Kemico, 55F, Park Ridge, Ill.

BIG Opportunity mail free. R. V. Lundquist, Redfield, So. Dak.

WANTED! 100 Inexperienced newspaper correspondents. Stamp appreciated. Publisher, Albion, Maine.

BIG Paying mail business. Write, Sawyer, 9301 Interlake Ave., Seattle, Washington.

AUTOMATIC Merchandising! Explained thoroughly. Plans, \$1.00. Service Malls, Grand Marais, Mich.

"MONEYMAKER"—Book filled with formulas, plans, etc. 66 pages—25c. Box 102, Okmulgee, Okla.

EIGHTY Page wholesale supply source directory and copy of "Mail Order Selling" magazine, 25c postpaid. Pruitt Press, Elburn, Ill.

AMAZING Opportunities. Literature free. Publishing Service, Box 101, Aurora, Ill.

WORK With plastics. Easy, interesting, profitable. Send dime today for samples, kit catalogue. Plaskit, 2369 Rosewood, Toledo, Ohio.

1937 COMBINATION Outfit starts home business resilvering mirrors, spoons, reflectors. Making chipped glass name plates, signs. Small investment. Write, Sprinkle, Plater, 127, Marion, Indiana.

HAVE A dignified, profitable business-profession of your own. Outstanding opportunity. Write, Cole Associates, Syracuse, New York.

COLOR Concrete surface with chemical solutions. Inexpensive. Beautiful, permanent results. Formulas, directions \$1. Sample 10c. Hollywood Cementcraft, 8527 Wonderland, Hollywood, California.

INVENTORS—Small ideas may have large commercial possibilities. Write us for free book, "Patent Guide for the Inventor" and "Record of Invention" form. Delays are dangerous in patent matters. Free information on how to proceed. Clarence A. O'Brien & Hyman Berman, 58-Z Adams Building, Washington, D. C.

STOP Squealing—Start crowing!! Work mornings home—drive to country—"movies"—afternoons!! Unusual "plans." No canvassing! Prepare for surprise! National Folio-A, Station "D," Los Angeles.

START Mail! Home businesses! Steady income. Write, Service Malls, Grand Marais, Mich.

MAKE Your own products. We sell formulas for highest quality toilet preparations, extracts and household specialties. Catalog free. Scientific Laboratories, 1950-W Broad, Richmond, Va.

NU-SHINE Startling new polish. Formula, 10c. Box 319, Canton, Kansas.

\$30 WEEKLY Opportunity. Operate new advancing business. Experience unnecessary. Iron-So-Ezee, Mt. Washington, Ohio.

START A distributing business. Have others work for you. Make splendid profits. Plan 50c. Billings, Box 145, Middletown, New York.

MAKE Money at home! Grow mushrooms in cellar or shed, with Ami Selected Spore Mushroom Spawn and step-by-step, easy-to-follow manual of instructions. Very interesting. Booklet free—write today. Anglo-American Mushroom Industries, Dept. 116, Toronto, Ont.

"OPPORTUNITY Offerings"—Copyrighted money-making dollar folio filled with ideas, tips, formulas—dime. Publishers, Twin Peaks, Calif.

MEN, Women, Regular income, no canvassing. Unique; world-wide. McArthur, Drawer 339-5, Butte, Montana.

RAISE Giant mushrooms! We buy! Start cellar, shed. Book, pictures free. United, 3848 Lincoln Ave., Dept. 63, Chicago.

WE Buy from you. Product easily obtained everywhere. Write Superior Supply Service, Springfield, Illinois.

"FREE Particulars"—mailorder, local business plans. Charles Dutz, 626 Wichita, Lincoln, Illinois.

ZERPID. Amazing new plant fertilizer. 25c. Sanquist Co., Pomeroy, Iowa.

FREE—Wholesale directory; opportunities. Todd, 325 East Fourth, Cincinnati, Ohio.

UNUSUAL Opportunities for business of your own. Stamp appreciated. Roche, 34 Connecticut, Somerville, Mass.

OPERATE Your own business. No investment or selling. Good pay. Unlimited possibilities. Particulars—dime. Tricity Service, Box 151, Davenport, Iowa.

CARICA Papaya, Powerpex-Zonxontite, Benzolene crystals, Hand Lithoprint, Disolvolene, Hypower magnets. Stamp gets details. Waldo Press, Box 266, Dallas, Texas.

500 NEWLY Classified names \$1.00. Edw. Johnston, 257 North Washington St., Tiffin, Ohio.

GENUINE Sales opportunity. Particulars, mammoth mail, quarter. Jay Towers, Federalburg, Maryland.

SILVERING Mirrors, artificial coal formula, others—25c. Gilbert P. Supply, 1107 Broadway, New York.

BOOKS, Chock full of money-making ideas, plans. Particulars for dime. Strom, 302 Boyden Ave., Maplewood, New Jersey.

START Spare time business. Home or office. Details free. Stewart Company, 189 Poplar Circle, Atlanta, Georgia.

CASH Every week clipping and preparing news items for publishers. Simple, fascinating work. Experience unnecessary. Stamp brings information. Division 55, National Press, 3923 West Sixth, Los Angeles, California.

BURGLAR Proof window lock. Locks windows open any height. Sample \$1.00. Big discount, exclusive territory. Burglalink, Box 1, Edmonton, Canada.

PROFITABLE Moneymaking business, buying, selling old books. Fairmont, 9 Hester, New York.

ROACHES And bed bugs. Our formula kills them. Instructions and formula \$1.00. Stewart, 18 St. George Ave., Linden, New Jersey.

MONEY Making chances offered in the Key to Business Opportunities. Free. F. Spindler, 4628 McPherson, St. Louis, Mo.

PROFITABLE Novelty business! Write! Stewart's Industries, 2162 West 10th, Chicago.

"FOOD Concentrates" offer quick mail success. Vegetable powders, tablets, vitamins (millions vitamin E already sold). Your brands labels. Samples, dime. Gardena, 128B, Station "S," Los Angeles, California.

BEDBUGS 100% To 300% profit have your own business secret formula sales pointers \$1. Particulars free. Bentons Buckley, Liberty, N. Y.

WHERE To buy at lowest wholesale prices. Information free. Yorena, (Box P312), Bayonne, N. J.

WE Start you in business, furnishing outfits and instructions, operating "Specialty Candy Factory" home. Men and women, earn \$25.00 up to \$60.00 weekly, all or spare time. Hundreds successful. (Our 29th year). Booklet free. W. Hillyer Ragsdale, Inc., Drawer 4, East Orange, N. J.

YOUR Own magazine! Three different propositions, samples, 10c. Janetize, Brentwood, New York.

AMAZING Profits in stamp hunting. Information free. Box 1043, Erie, Penna.

BEST 1937 Opportunity. Be a distributor for Grafo products, selling to automotive and industrial trades. Large commissions. A business of your own. Write today for complete information. Grafo Lubricants Corporation, Grafo Building, Sharon, Pa.

BARGAINS—Paint spray outfit, gasoline engine drive. Terms—trial. Helmick Paint Spray Exchange, M-674, Troy, Ohio.

PROFIT With new products. Make, sell, repeat. Analysis. Research. Guaranteed formulas. Biggest catalog free. Special prices, leads. Gibson Laboratory, Chemists, RD-1142 Sunnyside, Chicago.

CONDUCT A paying mail order business from home or office. Particulars free. Thomasson's Service, Minneapolis, Minn.

\$5 STARTS Profitable home business, everything furnished. Fuller, Newport, Ark.

REAL Money, steady business, manufacturing modern raise sign letters. Sells 1c and up. J-H-M Company, 12844 Omaha St., Detroit, Mich.

PRACTICAL Profitable mailorder plan—Dime. F. Rothe, 3949 Ontario, Chicago.

POPCORN, Crispette, carmelcrisp, potato chip, salted nut machines. Long Eakins, 1960 High St., Springfield, Ohio.

LIQUID Marble—anyone can make! Colorful, glazed! Moulded, brushed, sprayed. Rubberlastic moulds. Composition flooring. Big money in these! Particulars free. Marbleizing Service, Edwardsville, Illinois.

500 NEW Names of opportunity seekers, compiled Feb. 9th, 1937, 25c. Carl Edquist, Odessa, Minn.

NEW Ways to make money. Western Reserve Laboratories, 6615 Denison, Cleveland.

LEARN The mail order business, before losing money. Illustrated lessons \$1.00. Scheall Research, Duluth, Minn.

AMAZING New money making plans. Get details quick! Murray, Whitewater, Wisconsin.

MARBLEIZING; Porcelain enamel finish. Cement prepared, mix with water, applied to wood, wall-board, concrete, etc. Flintlike hardness, brilliant. See our 85c liquid rubber for mold making. Sets solid in four hours. Any thickness. Send dime for assorted samples, both rubber and porcelain. Cowell Institute, Grayling, Mich.

"SCHEMER," Monthly Magazine, Alliance, Ohio, prints schemes, tips, ideas, formulas—big winners—\$10,000 to \$25,000 reported. 39th year; \$1.00. Special: Trial six months only 30c.

MANUFACTURE Newest profit-making specialties from guaranteed formulas, trade secrets, analyses. Complete chemical service. Charges most reasonable. Interesting literature free! Miller, Manufacturers' Chemist, Tampa, Florida.

INVENTION Finance Magazine, 80-G Wall Street, New York. Year subscription 60c entered upon promise to pay on receipt of first copy.

START Your own circulating library. We furnish and exchange your books. Fireside Rental Library, 210 Crosby Bldg., Buffalo, N. Y.

SUCCEED With your products. Make-sell them. Formulas. Processes. Accurate analyses. Catalog free. B. Thaxly Company, Washington, D. C.

PLASTEX Industries offer industrious men an opportunity to start a business of their own, manufacturing art goods, novelties and utility products in Plastex and marble imitation. $\frac{1}{2}$ c material makes regular 10c store sellers. Rubber moulds furnished for speed production. Small investment brings big returns. Since the crash, low priced goods are needed and this line meets the demand. Interesting booklet mailed free. Plastex Industries, Dept. A, 1085 Washington Avenue, New York.

SELL By mail. Books, novelties. Bargains! Big profits! Particulars free. B. Eifco, 438 North Wells, Chicago.

CHARTERS: Delaware; best, cheapest; free forms. Colonial Charter Co., Wilmington, Del.

DOLLARS Daily. No canvassing. Details, dime. Fitzallen, 295 W. 150th, New York.

MANUFACTURE Polishpuffs. Amazing proposition 10c. Particulars free. Hickorydell, Glenbeulah, Wisconsin.

ARTIFICIAL Marble sanitary flooring, instructions covering wood or cement flooring $\frac{1}{2}$ inch thick, fireproof, all colors, low cost, ornamental casting, concrete, plaster, papier-mache, garden furniture, statuary, flexible molds, particulars free. Chris Mahler, Elmont, N. Y.

FREE Booklet describes 107 plans for making \$20-\$100 weekly, in home or office, business of your own. Elite Co., 214 Grand St., New York.

MAIL Order business is your opportunity. Many began small, now earn thousands yearly. No personal contact. Boundless opportunities. Have had over 30 years experience; will help you succeed. Send 25c for valuable booklets, none free. B. Breniser, 257 South 21st, Philadelphia.

I WANT To send you proof of the wonderful pulling power of Popular Mechanics Magazine's classified pages. What's your proposition? Write me today. F. W. Johnson, Manager Classified Advertising, 200 E. Ontario St., Chicago, Ill.

MONEYMAKING OPPORTUNITIES

500 MONEYMAKING Opportunities—10c. 96 guaranteed moneymaking secrets—25c. Schumacher, P1502, Monticello, Chicago.

WHEAT, Rice, corn, puffing machines \$300.00. David Haffner, Hynes, California.

START A factory at home. Particulars free. Draper's, Culver City, Calif.

NEW Brush plating outfits for auto parts, reflectors, etc., connect to a battery, no tanks used. Almost as simple as painting. Good income plating and silvering mirrors, low cost. Free proof. Gunmetal Co., Ave. N, Decatur, Ill.

AMATEUR Cartoonists—Win \$25.00. No drawing ability necessary to win. 26 prizes in all. Rush name on postcard for valuable tips on "How to Make Money With Simple Cartoons," cash prize entry blank and rules. Send no money. Cartoonists' Exchange, Dept. C-96-B, Pleasant Hill, Ohio.

1000 MONEYMAKING Ideas, book 50c; literature free. Harvey Teeple, Decatur, Ind.

GIVE Away \$10.00 Clipshave electric razors free. Make \$5.00 profit each transaction. Novel, new, self starting proposition. Big money for live wires. Send 10c for salescard and details. American Novelty Company, 1841 Broadway, New York City.

MONEY Galore! Unique—don't miss this! Superior Services, Hesston, Kansas.

QUICK Cash! Spare or full time. No canvassing. National, B239, Neodesha, Kansas.

\$30.00 PER Week with a typewriter! Earn comfortable income at home. Information mailed for 25c (coin). Ace, TPM-1, 322 Empire Bldg., Birmingham, Ala.

"17 WAYS To Make Money With Pigeons," 15c postpaid. Mrs. Johnnie Jeffers, Okaloosa, Iowa.

1,000,000 ARTICLES Wholesale. Latest directory, 10c. Jelsmith, 163 Myrtle, Waltham, Mass.

JUST Out. 50 sure fire money making plans. Guaranteed. Folio 50c. Peak Specialty, Colorado Springs, Colo.

MAKE Liquid wax at home. Supplies locally cost 14c gallon. Retail \$4.00. Original formula \$1.00. Crane, 3340 Englewood, Philadelphia, Pa.

WANTED: Men who use their brains. Send dime to cover mailing. Miller Enterprises, Port Monmouth, N. J.

OPERATE Profitable home business, details 3c. Demonstrators, 1743W Harrison, Chicago.

30c STARTS Money getter plan. Big malls, cash galore. Churchill, 319 Marengo, Pasadena, Calif.

COMPLETE All profit moneymaking mail-order business 10c. Gibson, 5413 Calumet, Chicago.

"PROFITABLE Ideas" Magazine, 6-M North Dearborn, Chicago. Sample copy 10c.

COPYRIGHT Plan, make Tidysop cabinets, \$1.00 hour business at home. Dime brings it. Page Mfg. Co., Liverpool, New York.

FIFTY-ONE Easy ways to make money. Ideas for the whole family. 35c. R. Bishop, Cohasset, Mass.

PROFITABLE Business, buying, selling old books. Fairmont, 9 Hester, New York.

START Mail business. Stamp brings big envelope of latest money making opportunities. A. Brittin, 1719 St. Charles, New Orleans, La.

MAGIC Vacuum pipe cleaner yields magic profits. Inquire Stern Mfg., Wurliitzer Building, Cleveland, Ohio.

PRIZES, \$1 To \$15,000, listed; WC Mag. 10c. 6551 Jones, Seattle, Wash.

WHOLESALE Sources, 500,000 articles. Free directory. Maywoode, 925 Broadway, New York.

FOOD Clerks (employed) raise your pay. If idle, get good job. Sales secrets revealed by successful operator, 25 years experience. Everything \$1. Money back guarantee. Beight-Zimmerman, Youngstown, Ohio.

INVESTIGATE Money-making opportunity; builds income on small investment; pays us, will pay you. Seneca Specialties, Geneva, N. Y.

MAKE Toys for Christmas. Book of "Easy-to-Make Toys" gives 67 popular designs. \$1.50. Popular Mechanics Press, Dept. 637, 200 E. Ontario St., Chicago.

MAKE Money with a business in your own home. We start you. Smith-Dawe Co., Atmore, Ala.

PROFIT With new products. Make, sell, repeat. Analysis. Research. Guaranteed formulas. Biggest catalog free. Special prices, leads. Gibson Laboratory, Chemists, 1112 Sunnyside, Chicago.

SPEEDWAY Patterns for handsome sign lettering. Perfect letters. Unique process. Extremely low prices. Numerous modern styles. Send dime complete 3-in. alphabet. Free samples, literature. Display Letters, Station G-235, New York City.

MAILORDER Opportunities. Send name—postal. Acme, 328 Southeastern, Los Angeles, Calif.

TWO Big money making plans. Full or parttime. 25c. Don't miss this. Chas. Hyde, 537 Ritter St., Reading, Pa.

ADDRESS Postcards. Liberal commissions. Stamp brings details. Box 85, Winona, Minn.

10c BRINGS Copy National Mail Order News, Box 1773PM15, Roanoke, Virginia.

NEW Mailorder and local opportunities. Merchants Sales, 617M North Second, Milwaukee, Wis.

107 PLANS For making \$20-\$100 weekly in home or office business of your own. Descriptive booklet free. Elite Co., 214 Grand Street, New York.

TO Win success you must do something different; particulars free. Publishers Sales Company, Box A-76, Nelson, Georgia.

MILLIONS Jobless! Get dollars in mail daily, like we do, for amazing employment information (got man 76 jobs). Keep money; we fill your orders free. Stamp brings details. Co-Operative Service, 77 Swan, Buffalo.

FORMULAS, PLANS, ETC.

NEW Amazing sauce—Makes toughest meats nice and tender. Simple, just dip meat in sauce and then cook in usual manner. Big seller to hotels, restaurants, homes. Easy to make. Pays big profit. Complete formula 25c. Carlin Chemical Co., Alexander, N. Y.

REFINISH Your furniture. It will look new. Instructions 25 cents. C. Alexander, 512 Mitchell St., Orange, N. J.

GUARANTEED Formulas—New fast sellers. None better. Lowest prices. Catalog free. Kemco, 49F, Park Ridge, Ill.

STAGE Curtain track lubricant formulae \$1.00. Albert R. Clayton, 2923 W. Girard Avenue, Philadelphia, Penna.

FREE Supply catalog, and book containing over 2000 money making formulas \$1.98 plus 20c postage. Kemkit, 397P Bridge Street, Brooklyn, New York City.

500 MONEYMAKING Formulas 25c. Descriptive literature free. Harvey Teeple, Decatur, Indiana.

NO More ice bills. Ice Ola keeps food cool. Formula 25c. George, 285 East Queen, Philadelphia, Pa.

HOLLYWOOD'S Confidential cosmetic, perfume formulas—2 cts. each. Make your own. Stamp brings information. Lo-Shon, Box 413, Hollywood, California.

MAKE Your own products. We sell formulas for highest quality toilet preparations, extracts and household specialties. Catalog free. Scientific Laboratories, 1950-W Broad, Richmond, Va.

ICELESS Ice! Colder! Cleaner! Cheaper! Instructions, 25c. Duffy, Covington, Ky.

REFINISH Furniture, resilver mirrors, three other formulas. \$2.50. Bateman, Fredonia, Kansas.

FORMULA—Cooling antiseptic foot powder recommended by an advisory board of physicians, \$2.00. Sample 50c. Sheephead Pharmaceutical Manufacturing Chemists, 2362 East 23 St., Brooklyn, New York.

MONEY Making formulas 2c each. Send for list. Ben Buller, P. O. Box 211, Henderson, N. C.

PROFIT With new products. Make, sell, repeat. Analysis. Research. Guaranteed formulas. Biggest catalog free. Special prices, leads. Gibson Laboratory, Chemists, 1112 Sunnyside, Chicago.

ANY Formula 50c!! ("Fifty Cosmetic Formulas," \$1.00!) Thomas Galluzzo, Wilkensburg, Pennsylvania.

CERTIFIED Formulas, best science can produce for making popular, biggest-selling specialties. All lines. Before buying formulas, get my valuable "Eye-Opening" literature, including free subscription to Miller's Monthly Messenger. Miller, Chemist, 1706-A, Tampa, Fla.

SUCCEED With your products. Make-sell them. Formulas. Processes. Accurate analyses. Catalog free. B. Thaxly Company, Washington, D. C.

FORMULAS—Latest money makers. Literature free. Belfort, 4042 N. Keeler, Chicago.

CHEMISTRY

SEND 25c For new illustrated chemical experiment book with over 300 formulas and tests. Also receive 32 page illustrated catalog of apparatus, microscopes, telescopes and chemicals free. W. Winn, 124 West 23 St., New York.

CHEMICALS—5c—Apparatus. Free magazine, price lists. Nawoj Syndicate, 2124 Iowa, Chicago.

FREE Chemistry catalog. Supplies at 5c! Equip complete laboratory. Send 10c (refundable) for postage and handling. Kemkit Scientific Corp., 397P Bridge Street, Brooklyn, New York.

MAGIC Chemical submarine 10c. Book 20 experiments, 6 chemicals, 2 test tubes, 50c. Prompt orders receive chemistry magazine, chemicals price list free. Clinton Chemical, Swedesboro, New Jersey.

CHEMICALS From waste materials! Details, sample experiments, 10c. Oklahoma Technical, Box 742, Oklahoma City.

PROFIT With new products. Make, sell, repeat. Analysis. Research. Guaranteed formulas. Biggest catalog free. Special prices, leads. Gibson Laboratory, Chemists, 1112 Sunnyside, Chicago.

CHEMISTRY, Mineralogy, microscopes, telescopes, binoculars. Catalog free. B. Teeko, Evanston, Illinois.

NEW Chemistry supplies catalogue, lowest prices, 10c. Handbook for chemical experimenters, hundreds of experiments, 50c. Reading Scientific Company, Reading, Penna.

CHEMICALS In 5c quantities. Catalog 5c. Fleischer's Laboratories, Everett, Massachusetts.

CHEMICALS, Laboratory glassware, apparatus. Send 3c for catalog CP. Biological Supply Company, 1176 Mt. Hope Avenue, Rochester, New York.

AGENTS WANTED

EARN Extra money or a steady income selling Fine-Art all-season greeting cards; 100% profit. Descriptive folder free. Fine-Art Card Co., Inc., Dept. 120, Buffalo, N. Y.

AMAZINGLY Easy seller. Cedarized moth-proof bags. Profits tremendous. Every home a prospect. Get details at once. Besco Sales Co., 125 Franklin Ave., Hartford, Conn.

"CALIFORNIA Flowers Sachet" perfume 10c. Sells fast. Sidella, Pottsville, Penna.

300% PROFIT In new perfected (1937) quick action self-starting cigar lighter. No flint or friction. What makes it light? No wind can blow it out. Retail 50c. Costs you \$2 a dozen. Sample and sales plan 25c. New Method Co., New Method Bldg., Box PM-54, Bradford, Pa.

I'LL Send you complete outfit to run home-operated coffee agency. Make up to \$45 first week. No money risk. Details sent free. Write Albert Mills, 2368 Monmouth, Cincinnati, Ohio.

500% PROFIT! Gold and colored sign letters for windows, offices, trucks, signs. Monograms. Easily applied. Neonite, Akron, Ohio.

RAZOR Blades, neckties, shoe laces, etc., all big sellers. New bargain list. Heil Premium Co., 111, Gaylord, Minn.

STOP Squealing—Start crowing!! Drive to country—"movies"—afternoons. Work mornings—home. No canvassing! National Folio-F. Station "D." Los Angeles.

AGENTS! Dresses 33c, men's suits \$1.50-\$2.00, shirts 46c, ties 6 1/2c, chifon hose 42c. Amazing prices. Big profits. Catalogue free. Acme, AB-1219 So. Jefferson, Chicago

NEW Ironing invention. Pocket size. Save electricity. End scorching. No lifting. Abolishes kinks from cord. Telephones also. 135% profit. Samples furnished. Neverknot, Dept. 6-A, 4525 Ravenswood, Chicago.

MEN! Women! Tremendous market untouched. Germicidal deodorant needed everywhere. Steady repeater. Surefire demonstration. Act quick! No'Der Laboratories, Kewanee, Illinois.

PORTRAIT Agents get new Hexagon portraits, frames. Lowest prices. Catalog free. Picture-Man Friedman, Dept. 9, 528 Cornelia, Chicago, Ill.

5c WILL Make you \$1 profit. Free sample product, literature. Stanley Products, Lansing, Mich.

NO Boss! Sure cash! Silvering mirrors, autoparts, reflectors. Combination outfit. Write Sprinkle, Plater, 128, Marion, Ind.

UP To \$6.00 an hour. Amazing Karnu refinishes autos like new without rubbing, polishing, waxing or painting. Inexpensive—costs little. Wipes on with cloth. Lasts 8 to 12 months. Free sample. Karnu, Dept. 8-8, Cincinnati, Ohio.

NEW Brush plating outfits for auto parts, reflectors, etc. connect to a battery, no tanks used. Almost as simple as painting. Good income plating and silvering mirrors, low cost. Free proof. Gunmetal Co., Ave. H, Decatur, Ill.

NO Competition. Money saving device. Usually saves customer investment in ninety days. 100% profit. White Electric, 632 Clifford, Lansing, Michigan.

BIGGER Profits selling your own products. Supply agents, stores. Free sample. Cee-Tee Products, 608 Evergreen Ave., Brooklyn, N. Y.

MANUFACTURE Products yourself. Chemicals, labels supplied. Quality Company, E-20030 Russell, Detroit, Mich.

450% PROFIT in perfected (1937) quick action automatic gas lighter. No flint or flame. Lights gas instantly. Retail 25c. Costs you \$1.00 for dozen or \$8 for 12 dozen postpaid. Sample 10c. New Method Co., Box PMG-54, Bradford, Pa.

HOW To obtain capital, fully explained, particulars free. Star Service, Wapakoneta, Ohio. Established 1934.

CANVASSERS Buy household products cheaper. Your own literature. Latest deals. Paty Co., Dept. B, Somerville, Mass.

MONOGRAMMING Automobiles biggest money maker today. New type requiring no varnish to apply. Write for samples. International Monogram & Transfer Co., Box 9360, Philadelphia, Pa.

TRANSPARENT Neon-like signs, 4c—retails 25c. Celluloid pricing sets, 50% commission. Sample free! Lowy, Department 716, 8 W. Broadway, N. Y.

PERFECT Cleaner for windows, mirrors, auto glass, etc. Complete kit only \$1.00 post-paid. Reyburn Company, 246 Pearl Street, New York City.

WE Finance agents anywhere. Easy selling foot comfort tablets everybody wants. Full; part time. Good income, repeat business. Details for stamp, sample 25c. Leslie Laboratories, 3287 North Fourteenth, Milwaukee, Wis.

SELL Novelty fun cards, novelties, etc. Samples 10c. National, Box 500M, Cincinnati.

CLEAN-E-ZE Polishing cloth sells on sight. 12x12 sample 25c. Para-Sweet Co., Pleasantville, N. J.

MEN, Women, children, deliver circulars for me. Honest, faithful service brings dollars for you. Rundell, Coshocton, Ohio.

WANTED—Men in shops and offices to sell technical books. Liberal commission. For plan write F. Dickman, 330 W. 42 Street, New York.

NEW Kind heat boils water instantly. Pocket size, 218% profit—\$20 daily. Magic minute demonstration. Big demand now! Free sample offer. Nuway, 502 - 10th, Des Moines, Iowa.

AGENTS: Make money selling account collecting system. The Friendly Letter Service. Commercial Station, Box 925, Springfield, Missouri.

AGENTS—Sensational new first-aid kits; every factory, garage, auto-owner, home needs one. Retail 35c and 50c. 100% profit. Sample of both—46c, or write for details. Guardian Products, 41 Union Square, New York City.

AMAZING Auto refinisher makes old cars look new. Easily applied with ordinary cloth. No painting, no polishing, no waxing. Inexpensive and long lasting. Big profits. Particulars free. Bee-Nu Products, Dept. H-3, New Hartford, New York.

WANTED—Experienced leather belt man to sell leather belting on commission basis to factory trade. Side line no objection. Bridgeport Leather Specialty Co., Bridgeport, Conn.

BE Sure to read the Hillyer Ragsdale, Inc., advertisement under "Business Opportunities."

OPPORTUNITY Calling manager store demonstrators. Ramo Laboratories, Brighton Station, Rochester, N. Y.

SELL Rainbow palmetto whiskbrooms. Beautiful colors, longwearing fiber. Five sizes. Sample 25c. Write Root & Son, Okechohee, Florida.

SELL Something to be proud of. Sur-Po Sanitary Products are fast sellers, repeaters. Possibilities unlimited. Also in bulk, or under your own private label. Surpass Lab., Upper Darby, Pa.

20 INCH Propeller fan, guard, stand, \$6.50. Pullite Co., 815 S. 20, Omaha, Nebraska.

GLAS-GLOS—Magic cleaner for glass, white metals, porcelain and enamel. Quick seller to homes and stores. Large profits. Sample 10c. Startling order, \$1.00. Write today! Pioneer Sales Co., Commerce Bldg., Erie, Penna.

500% PROFIT! Gold reflecting letters for store windows. Large sizes 1c. Free samples. Modernistic Sign, B-3004 Lincoln Ave., Chicago.

MONEY In butterflies, moths. See Sinclair Display Advertisement on page 14A.

PROFIT With new products. Make, sell, repeat. Analysis. Research. Guaranteed formulas. Biggest catalog free. Special prices, leads. Gibson Laboratory, Chemists, BD-1142 Sunnyside, Chicago.

AGENTS Wanted. Distributors handle our new built-in bathroom scales. Exclusive territories. This new concealed scale brings big profits. Every home needs one. Wallweigh, 101 Park Ave., New York City.

NEW Meat block cleaner and evener. Big profits. Write Butch's Friend, 2855 Norwood, St. Louis, Mo.

DRI-TOP. One hole, air conditioned salt server. Market test shows demand for millions. Thousands now used, hotels, restaurants, United States government, colleges, institutions, homes, hospitals. Best season now. Sample 25c. Humaldis and other Drirock products. Dry Products Company, Clermont, Florida.

\$2.00 OR More an hour. Men, women. Sell home necessities. Big demand. Samples free. Horner Manufacturing, Established 1885, 578 Jefferson, Pittsburgh, Pa.

FRECO Ends battery troubles. Amazing. 25c for sample. Distributors wanted. Werbelow Mfg. Co., Box 198, Alameda, Calif.

MEXICAN Finest feather pictures, blankets, curios. Free particulars, samples, 10c stamps. Jumbo assortment, \$1.00 postpaid. Marquez, Apartado 1176-P, Mexico City, Mexico.

SELL Elgin watches, rebuilt and guaranteed, for \$3.95. Make 25%. No investment. Write for catalogue. Greenberg, 3352-A Polk Street, Chicago.

MEXICAN Feather pictures. Unusual novelty, 50c (stamps) bring \$2.00 worth samples, details. Refunded if unsatisfied. Mexican Art, Apartado 1593, Mexico City.

100 PROFITABLE Mail order and local plans. Gilbert Supply, 1107 Broadway, New York.

ENGRAVED Nameplates, signs, initial plates, Enamel finish, five colors, big profit. Hilton Specialty, 29 Portland, Providence, R. I.

SELL The Driving Master. Shows miles per gallon when driving. Analyzes motor. Described page 369 September Popular Mechanics. Driving Master Co., Sioux City, Iowa.

AGENTS—Make \$25-\$75 weekly. No peddling. Free outline of 107 plans. C. Murray, Whitewater, Wisconsin.

MAKE More money taking orders: Shirts, ties, hosiery, raincoats, uniforms, dresses. Sales kit free! Experience unnecessary. Nimrod Company, Department 8, 4922-28 Lincoln Avenue, Chicago.

NEW Cleaner—Amazes everybody. Cleans everything. Washes clothes snow-white quickly. Spots, stains removed like magic. Startling demonstrator. Free samples make fast sales. Quick repeater. Immense profit. Write quick for "free sample." Super-X Cleaner Co., 11, Berwyn, Illinois.

BIG Money applying gold initials on automobiles. Easiest thing today. Free samples. Also, sideline salesmen for name plates and tire cover transfers. "Ralco," 1084 Washington, Boston, Mass.

MAKE Your own products. We sell formulas for highest quality toilet preparations, extracts and household specialties. Catalog free. Scientific Laboratories, 1950-W Broad, Richmond, Va.

GOLD Reflecting window sign letters. Penny each. Large sizes. Easily applied. New styles. Absolutely beautiful. Free samples. Atlas Sign Works, 7941 Halsted, Chicago, Ill.

SALESBOARD Men—New put and take jars. Details, samples free. Tom Thumb, Dept. PM, Navroo, Ill.

BIG Money and fast sales. Every owner buys gold initials for his auto. You charge \$1.50, make \$1.45. Ten orders daily easy. Write for particulars and free sample. American Monogram Company, Dept. 40, Dunellen, N. J.

AGENTS: Smash go prices. Santos coffee 12c lb. 4-oz. vanilla 8½c. Razor blades 10 for 8½c. 100 sticks chewing gum 12c. 150 other bargains. Premiums. Experience unnecessary. Carnation Co., PO, St. Louis, Mo.

SUCCEED With your products. Make—sell them. Formulas. Processes. Accurate analyses. Catalog free. B. Thaxly Company, Washington, D. C.

ENGRAVED Name plates, numbers, signs, etc., easily sold, profits large. Brett Bros., Winthrop, Mass.

FREE Sample—Amazing cleaner; sells homes, taverns, everywhere. Big profit—fast repeater. Beto, 5007 Irving Park, Chicago.

GENUINE Gold letters for store windows. Easily applied. Free samples. Liberal offer to general agents. Metallic Letter Co., 438-B North Clark, Chicago.

AGENTS: Stamping names on pocket-key protectors. Sample check with your name, address, 25c. Stamping outfits. Emblem checks, check-fobs, name plates. Hart Mfg. Co., 303 Degraw St., Brooklyn, N. Y.

AGENTS—Opportunity to make money; book containing 107 successful business plans; home or office; send for free introductory booklet. Elite Co., 214 Grand St., New York.

WANTED—District purchasing agents. No experience or money required. Write Purchasing Manager, 174 N. Halsted, Chicago.

DO You want agents for your proposition? Your ad in this space will place your message before hundreds of men seeking fast-selling products. My folder "How to Secure Agents" is filled with proof. I'll gladly send you a copy free. F. W. Johnson, Manager Classified Advertising, Popular Mechanics Magazine, 200 E. Ontario St., Chicago.

PROFITABLE Home business. Legitimate. No canvassing. Maywood Publishers, P-923 Broadway, New York.

HIGH-GRADE SALESMEN

SANFORIZED Summer suits \$4.95 up! Biggest commissions. Newest patterns, summer fabrics. Also complete line pants, as low as 2 pairs \$2.97—raincoats, shirts, jackets, uniforms, etc. Earn free garments, extra cash bonuses. Illustrated selling outfit free with samples. Send name, address. Dunlap Pants Co., PM-67, Cincinnati, Ohio.

SALESMEN Wanted to sell the new patented 100% Nail-less Air Cushion Shoes direct to the weaver. Fast money maker. Bronson Shoe Company, 776 West Lake Street, Minneapolis, Minn.

EARN Big commissions daily; cash bonuses regularly. Sell genuine Trubenzed Starchless-Collar Shirts guaranteed one full year. All season's newest styles. Ties, socks, underwear, also. Expensive new sample outfit free. Write today. Dept. P6, Quaker, Broadway at 31st Street, New York.

SALESMEN Wanted to sell key cases, etc., to garages, dealers, service stations, etc. Bridgeport Leather Specialty Co., Inc., Bridgeport, Conn.

SELL Celluloid and cardboard pricing tickets, steel shelf moulding, changeable signs, menu covers. Every store prospect. P. Pricing Press, 124 White St., New York.

AT Last a new idea in shirts. Rosecliff shirts are worn and endorsed by famous movie stars assuring latest, fastest selling styles. You can make big cash daily. Complete sample outfit free. Write today. Dept. P6, Rosecliff, 1259 Broadway, New York.

NEW Burglar proof lock. Fast seller. Salesmen, distributors wanted. Stewart Safety Window Lock, St. Clair Shores, Mich.

SELL: Leo's new, adjustable handmade, leather-link belts. Belts and details 35c. Leo Thomas, Hot Springs, S. D.

ADVERTISING Salesmen for new utility sign. Sell only to large concerns. Orders \$500.00 up. Must give complete information; age, experience, ability. Ad-Novelty-Co., Newton, Iowa.

EARN Quick cash selling new game. Sample 10c. Word Game Co., Peoria, Illinois.

SELL Nothing! \$95.00 weekly. \$500,000 punchboard firm announces new, no investment plan. Season starting. K&S, Dept. C126, 4329 Ravenswood, Chicago.

YOU Get paid first. Take orders for 200 home necessities. Pay after you collect. Big profits. Write Ho-Ro-Co, 2765-R Dodder St., St. Louis, Mo.

NEW Punchboard assortments. Free 32 page full color catalog. Nothing to carry. Larger cash commissions daily. Season now! Lea-Moore Co., 189 Adams, Chicago.

DON'T Be a job hunter. Start your own business on our capital. No hard times; no lay-offs; always your own boss. Hundreds average \$3,000 to \$5,000 annual sales year after year. We supply stocks, equipment on credit. 200 home necessities. Selling experience unnecessary. Wonderful opportunity to own pleasant, dignified, profitable business backed by world wide industry. Write Rawleigh, Dept. F-U-PPM, Freeport, Ill.

GIVE Away free 1937 short wave and home radios, also full electric automobile radios, with our unique "Punch Sales Card Plan." 2 sales daily pay \$203.88 weekly profit. Write for our free starting orders. DeLuxe Mfg. Co., Dept. 323, 173 W. Madison, Chicago.

LONG Needed invention—proved success. Ready for national distribution. Powerful demonstration. Every home, store, office, school, factory a prospect. Low price—long profit. Exclusive. Get facts quick. Write Barker, Box 804, Littleton, Colorado.

IRRESISTIBLE—Every lady a sale. Nu-Mirror Co., Bridgeport, Conn.

"KEENEREDGER" Puts "Keener-n-new" edge on razor blades or money refunded. Jobber-salesman sample \$1.00. Keeneredger, Ohlong, Ill.

THERMOCAST Electric water heaters for trailer, shop, home. Safe, rugged, practical. Details. Parkideas, Box 1168, Los Angeles, Calif.

PATENTED Combination radiator faucet, high velocity autowash nozzle and lawn sprinkler. Trigger controlled automatic shutoff. Every commercial and home autowasher a prospect. Sample postpaid receipt \$1.50. Molded Specialties Co., 4707 Chester, Cleveland, Ohio.

BUILD Exclusive, profitable, large business with attractive multicolor advertising book match line. Represent factory direct. Spot cash commission. Bonus. Quick reorders. Full-part time. Plan, sample kit free. Match Corp. of America, Dept. E-6, 6041 Grand, Chicago.

SALESMEN: Sell complete line Hammermill bond business stationery, book matches, advertising pencils, shelf moulding, tear-off business cards, labels, salesbooks, garage forms, etc. Free deals, premiums, 35% comm. daily. Free sales portfolio. Willens, 2130 Gladys, Dept. SP, Chicago.

BLADES, Factory prices. Free delivery. National Blade, D-5, Rochester, N. Y.

SALESMAN: Fine line soaps, cleaners, polishes, disinfectants. Old established manufacturer. Liberal commission. Baum's Castorine Company, Rome, N. Y.

TIRE Accessories. Guaranteed 10,000 mile Tiger Grip Tire Patch, and complete fast-selling line auto accessories. Salesmen-distributors easily make up to \$75.00 weekly, and over. Protected territory. Economy Rubber Products Co., 825 Burkhardt, Dayton, Ohio.

PROFIT 100% Supplying service stations guaranteed auto necessities. Attractively boxed, carded. Products, Box 352, Grand Rapids, Mich.

"BLUMER" Lengthens costly flowers life! Sample 10c. Pomoco, Sparkill, New York.

JAY-WAY Door holder. New. Sensational. Money-making. Jay-Way, One East 42nd, New York.

MAKE More money taking orders: Shirts, ties, hosiery, raincoats, uniforms, dresses. Sales kit free! Experience unnecessary. Nimrod Company, Department 65, 4922-28 Lincoln Avenue, Chicago.

SALESMEN—Four \$15 sales to stores net you \$40 daily. Sayers Systems, Est. 1895, 2801-123 Sheffield Ave., Chicago, Ill.

SALESMEN: Sell advertising novelties, calendars, fans, thermometers, etc., for nationally known firm. Liberal commissions. Stanwood Hillson Corp., 21 Station St., Brookline, Mass.

NEW Specialty—Sells every business and professional man. Four \$15 sales daily pay \$280 weekly. Ferrell cleared over \$1,000.00 monthly. Write, F. E. Armstrong, President, Dept. PM, Mobile, Ala.

BE Your own boss. Make the largest commissions selling our complete line of brushes. Write for sales plan. Wire Grip Sanitary Brush Corp., 220 Southern Boulevard, N. Y.

BRUSH Salesman—If you ever sold brushes write for our money making proposition. Donald Brush Co., Camden, New Jersey.

FREE Booklet describes 107 plans for making \$20-\$100 weekly, in home or office, business of your own. Elite Co., 214 Grand St., New York.

HELP WANTED

MAN Wanted—Manufacturer established 46 years will finance responsible man with complete stock of guaranteed food, farm and household necessities—you pay when sold. Mighty attractive proposition. Good living right from start with steady increase for industrious man. Big value combination deals, premiums and fast-selling specials now in effect. Jacob Van Dyke of Michigan sold \$441.21; Maurice Vander Haar of Michigan sold \$376.15; and B. M. Anderson of Utah sold \$530.55 in one week. Pleasant outdoor work. Experience not necessary. No slack seasons or layoffs. Write today for "No Investment" offer. McConnon and Company, Room 66FS, Winona, Minn.

MONEY in butterflies, moths. See Sinclair Display Advertisement on Page 14A.

WANTED—Local buyers to purchase used office machines for us. Positively no selling. Send stamp for details! Pruitt Co., 1104 Pruitt Bldg., Chicago.

WONDERFUL Opportunity to make up to \$240 in a month, \$45 first week. Be a grocery route dealer. I send everything complete on trial; no money risk. Details free. Albert Mills, 2362 Monmouth, Cincinnati, Ohio.

STEADY Work—Good pay. Reliable man wanted to call on farmers. No experience or capital required. Pleasant work. Home every night. Make up to \$12 a day. Wonderful new proposition. Particulars free. Write McNess Co., Dept. 5, Freeport, Illinois.

NEW Ways to make money. Western Reserve Laboratories, 6615 Denison, Cleveland.

USE \$500.00 Raise canaries for us. Free particulars. Crummins, 3741-B 60th Street, Woodside, New York.

EDUCATIONAL AND INSTRUCTION

AMBITIOUS Young men trained, for air conditioning and refrigeration jobs, in our service department shops. Practical experience under our engineers. Write Training Division P, Western Trades Association, 2024 W. 6th, Los Angeles, Calif.

MEN Wanted willing to learn landscape designing and fill big paying position as landscape architects. Free test of your natural ability and chance to win in \$750 contest. No experience needed to start. Earn while you learn. Write today for free test blank. American Landscape School, 837 Plymouth Bldg., Des Moines, Iowa.

AIR Conditioning and refrigeration industries demand more trained men than can be supplied. Our graduates advance rapidly because of their complete technical and practical training. Write to Detroit School of Refrigeration and Air Conditioning, 4125 Grand River, Detroit, Mich.

TIMESTUDY. New practical home training. Rapidly growing field for conscientious workers, with mechanical experience, ambitious for advancement into executive positions. Dix-Staunton School of Timestudy, Rochester, N. Y.

PHOTO-COLOR—Learn at home—Easy method. Make money. Complete course only \$1.00. W. Greener, St. Johns, Michigan.

"SPANISH"—Everyday phrases easily learned with pronunciation, authoritative, copyrighted wonderbook, mail 25 cents. Prishmann, Box 1792, El Paso, Texas.

WELDING. Bumping, metal finishing torch soldering taught. Days, nights. Jobs open. Men from this school getting good jobs right now. Free employment service. Licensed by state. Factory Trade School, 8807 Harper, Detroit, Michigan.

BECOME An investigator—Secret service agent. New "Test Problem Method." Develops your ability. Particulars free. International Secret Service Institute, (PM67), Hoboken, N. J.

DOUBLE Entry bookkeeping, 60 hours with keys. (Diplomas.) International Bookkeeping Institute, S. Springfield, Mo.

FREE! Profusely illustrated booklet, "Scientific Wonders." Contains drawings, photographs and diagrams showing marvels of movies, power, television, nature, ingenious inventions, etc. Also many fascinating articles on mechanics, astronomy, biology, chemistry, engineering, etc. Metro, Dept. 2300, 70 Fifth Ave., New York.

RADIO Course in 14 lessons. \$1.00 per lesson. Thiele's Radio Institute, Amityville, New York.

BLUE-PRINT Reading taught by short, easy home course. Get bigger wages. Write today for details. Blueprint Reading Institute, Box 5602, Metropolitan Sta., Los Angeles.

HOMESTUDY. Trimester doctor course. Earn while learning. Collegium, 8-Whitley, Ind.

SUMMER, Winter, hotel positions. Instructions. Lee Institute, Drawer 1706, Boston.

HOME Study engineering courses leading to degrees. Mechanical; electrical; Diesel; civil; aeronautical; automotive; chemical; radio and others. McKinley College of Engineering, Chicago.

"UNCLE Sam" jobs. Start \$105-\$175 month. Prepare now for next examinations. Experience usually unnecessary. Full particulars—list positions, free. Write today sure. Franklin Institute, Dept. D3, Rochester, N. Y.

CRIME: Be a high paid investigator. Learn fingerprinting. Former famed metropolitan police lieutenant's home course on fingerprinting complete \$1. Satisfaction guaranteed. Empire Identification School, Dent. PM, Memphis, Tenn.

LEARN Massage, physiotherapy. Free literature. Dept. Crandalls Institute, York, Pa.

KNOCK 'Em cold. Learn police Jiu Jitsu. 13 secret knockout blows without fists. Illustrated course by world famous instructor. Price 15 cents. S. J. Jorgensen, 405 Maritime Bldg., Seattle, Wash.

FREE—Valuable 120-p. Health-Diet-Prosperity guide for two 3c stamps. Box 97, Lake Placid, Florida.

LEARN Advertising layout. New high pay profession. Design advertisements, billboards, booklet, etc. Art talent helpful, not necessary. Special trial course \$2.00. Send name, address. Pay postman on delivery. School of Advertising Layout, 430 Boyd Street, Los Angeles.

TAKIGRAFY—Simplest, scientific shorthand. Free lesson. Simmons, Rocky Hill, Conn.

MATHEMATICS, Arithmetic, algebra, geometry, trigonometry, calculus, drafting, airplane, Diesel, mechanical, electrical, naval architecture, structural, surveying, blueprint reading, building estimating, engineers license, civil service engineering examinations tutored by licensed professional engineers. Mondell, 112 Wst 42nd, New York.

STAMMERING Successfully treated at School for Speech Handicaps, Fremont, Nebraska.

ADVERTISING Business. Operated by telephone. Paid me \$30 to \$100 weekly. No personal canvassing. Start at home. Booklet. Nameyer, Utica, N. Y.

LEARN To be a tree surgeon. Interesting healthy outdoor work. Good pay. Write National School of Tree Surgery, 409 Willow St. Lombard, Ill.

GET \$50 To \$87.50 every pay day on Uncle Sam's payroll. Many appointments expected soon. Our coaching helps qualify you for Social Security, liquor gauger, meat inspector, office clerk, stenographer, typist, customs, postal and many other positions. Write today for free book, list of positions, etc. Patterson School, (Arthur R. Patterson, former Government examiner, Principal), 8 Case Bldg., Rochester, N. Y.

GOVERNMENT Social security jobs. For men and women, age 18-50. Are you interested in obtaining one? Write immediately for full information and how to pass entrance test, etc. Instruction Service, 101, St. Louis, Mo.

BECOME Business investigator. Earn \$1.00 hourly, upwards—spare time. Experience unnecessary; we teach you. Details free. Business Detective System, 1009 Oak, Elmira, N. Y.

SECRET Service. Particulars free. Write immediately. George Wagner, M-2640 Broadway, New York.

BIG Bargain catalogue educational matter 10c. Handling, Y-709 Broadway, New York.

MASSAGE, Hydrotherapy, dietetics, drugless therapeutics, chiropody, taught by mail. Evans Correspondence School, Montgomery, Ala.

LEARN Machinist trade, tool, die making. Automatic and hand screw machines. Modern shop methods. Actual work. Jobs open for trained men. Employment help. Illustrated booklet free. Allied Screw Machine Company, 601 Lake Street, Chicago.

LEARN Auto mechanics, body, repairing, welding, electricity, refrigeration, Diesel. Sterinson's, 2008A Main, Kansas City, Mo.

LEARN Latest methods solving arithmetical problems quickly. Frederick A. Smith, 2410 Smalley Court, Chicago.

TIME Study engineers are in great demand. A practical home study course will qualify you for increased pay. Employment service. National Time Study Institute, 612 N. Michigan Ave., Chicago, Ill.

PLAYS—STORIES—MANUSCRIPTS

"BELL" Series of musical comedies, operettas, sacred songs, juvenile plays, minstrel songs, quartets, flag pageants. Particulars from Author Reginald Belcher, Chatham, New Jersey. 30 years church organist, play-wright.

SCREEN Writers—Movie plot digest supplies, story ideas. Sample 25c (coin). Friedman, 1146 Ogden, New York.

WANTED—Unusual manuscripts for publication. Fortuny's Publishers, 45 West 45, New York.

STORIES Needed for sales department. Commission basis. New sales plan. Crown Service, 917 Shreve Bldg., San Francisco.

CARTOONING, COMMERCIAL ART, SHOWCARD WRITING, SIGN PAINTING

SIGN Painting letter patterns ready to use for quick layout. Illustrations postpaid. Thompson School, 872-2, Pontiac, Michigan.

CARTOONING, Sketching, etc., by Alexander Murray. 46 lessons, 600 illustrations, including practice sheets, pens, pencils, drawings criticized, \$1.00 complete. Singer Service, 1782 E. 100th, Cleveland, Ohio.

AMATEUR Cartoonists—Win \$25.00. No drawing ability necessary to win. 26 prizes in all. Rush name on postcard for valuable tips on "How to Make Money With Simple Cartoons," cash prize entry blank and rules. Send no money. Cartoonists' Exchange, Dept. C-96-A, Pleasant Hill, Ohio.

CARTOONING Course: 30 illustrated lessons, over 500 drawings, pens and pencils, \$1.00 complete, postpaid. Scovell Studios, Box 748-P, Hollywood, Calif.

AMATEUR Cartoonists, earn up to \$35.00 weekly, copying cartoons for advertisers. 3-M Service, Argyle, Wisconsin.

LEARN Cartooning and earn over \$25 weekly while learning with my two amazing plans. Complete illustrated course, plans—\$2.00. Jenkins, 43 E. Ohio, Chicago.

CHALK Talks. Laugh producing program, \$1.00. Catalog 10c. Balda, the Cartoonist, Oshkosh, Wisconsin.

CARTOONING, Sketching, etc.—46 lessons, 600 illustrations, including drawing paper, pens, pencils, \$1.00 complete. Fraba Service, Cashton, Wisconsin.

LEARN Lettering, complete course. Northeastern School of Lettering, Bangor, Maine.

AMATEUR Cartoonists—Sell your work. Write Smith's Service, Wenatchee, Wash.

SELL Drawings. Read Art Advisor Monthly, Parkville, Missouri. Samples 20c.

ADVERTISING AGENCIES

LEARN Advertising quickly at home. Easy practical plan. No text books. Common school education sufficient. Interesting booklet and requirements free. Page-Davis School of Advertising, 3601 Michigan Avenue, Dept. 3431, Chicago.

ADVERTISE: 5 Lines in 100 national mail order publications \$4.00. Lists free. Advertising Bureau, 4258-C, Drexel, Chicago.

INCH Display advertisement 30 magazines year \$24. Wood's Popular Services, Atlantic City, (N. J.)

PUERTO Rico (1,500,000 American citizens) purchased nearly \$100,000,000 from U.S. alone in 1936. Advertise in Employment Service Bulletin, 25 words, \$1.00; 7x4 1/2" page, \$15.00; 7x2" column, \$8.00; 50,000 readers. Circulars reaching homes, merchants, etc., distributed daily—3x6" \$1 thousand, 6x9" \$2 thousand, 9x12" \$3 thousand. Box 1518, San Juan, Puerto Rico.

ADVERTISING Placed anywhere. Helpful, free service. Rate guide book free. Baker Advertising Agency, 189 W. Madison, Chicago. Successors to Ankrum Advertising Agency. Established 27 years.

ADVERTISE Profitably: \$15 reaches 6,000,000 Sunday newspaper readers with 24 word ad. Newspaper, magazine rate-guide, free. Chicago Union Agency, 20 West Jackson, Chicago.

FREE—New Advertisers Rate Guide, 44 pages. Includes everything. Lowest rates. E. H. Brown Advertising Agency, 140 S. Dearborn, Chicago.

FOR ADVERTISERS

ADVERTISE: Inch display \$5.46; Bonomo International Messenger; circulation 100,000. Sample 10c. Box 84, Sta. A, Brooklyn, N. Y.

NAMES—Your prospects, 200—\$1.00. Joy E. Schreiner, Dunbar, Nebraska.

24 WORDS, 40 Newspapers, \$2.00. Goodall Agency, 742 Market, San Francisco.

25 WORDS "Word's Advertiser," three months \$1.50. Empire, Shawano, Wisconsin.

24 PENCILS. Your advertising \$1.00. Samples 5c. Ad-Crafters, Lacrosse, Wis.

BOOKS Covering hundreds of subjects. Big catalog for 3c postage. Popular Mechanics Press, Room (C37), 200 E. Ontario St., Chicago.

BUSINESS SERVICE

TRADE Marks, patents procured; low cost; consider exchange services. Saunders, 6430 Evans, Chicago.

WE Specialize in obtaining hard to get articles. Try us. Universal Salesman Research Department, Box 3, North Tarrytown, N. Y.

DELAWARE Charters: Complete service \$35. Submitted forms. Chas. G. Guyer, Inc., Wilmington, Delaware.

CHICAGO: Our business is minding yours? Small, large business or personal. Investigate, write for folder. 24 hour service. Telephone Mail Secretariat, Pittsfield Building, Chicago.

INFORMATION Where to buy anything! Correct addresses of reliable manufacturers, wholesalers. \$1.00 per item. King Buyers' Service, 60 Day's Park, Buffalo, N. Y.

WASHINGTON, D. C., a "capital" mail address. Letters, messages, government transactions received-forwarded daily; \$2.00 monthly. Hawkins Mail Service, 309 Burchell, 817 Fourteenth.

CHICAGO: Business-personal mail address, representation, forwarding; \$1.00 month. Established 1919. General Business Service, 56 West Washington.

ALASKA Information, practically everything. Illustrated. \$1.00. Scheall Research, Duluth, Minn.

RUBBER STAMPS AND OFFICE SUPPLIES

CUSHION Mounted, one-two lines 25c; three 35c; signatures \$1.50. Changeable rubber type printing outfits. Stamp Works, 814 Bradley, Peoria, Illinois.

TWO Line quality cushion mounted 35c. Frank Landis, Auburn, Nebr.

FREE Catalog! Office supplies! Rubber stamps! Sylco, Downers Grove, Ill.

NAME, Address, 2 lines 25c; 3 lines 35c. Stamp Works, Auburn, Nebr.

2-LINES 25c, 3 Lines 35c. Stamprite, FP43, Springfield, Mass.

2 LINES 25c, 3 Lines 35c. Stamp Works, Centerport, N. Y.

TYPEWRITERS, DUPLICATORS, OFFICE DEVICES

TYPEWRITER Ribbons! Three, \$1.10; six, \$2.00! Guaranteed! Galluzzo, Wilkesburg, Pennsylvania.

INCREASE Business now. "Excellograph" Rotary Stencil Printer reprints thousands everything you typewrite, handwrite, draw or trace. Colors. \$19.75 to \$44.00. Terms. Illustrated literature free to business or professional men. Pittsburgh Typewriter Supply, Department K-2, Pittsburgh, Pa.

OFFICE Machines, typewriters, adding machines, duplicators, etc., 29 different makes, care and operation of. Only book on subject. 384 pp. illus. \$2.50 postpaid. Popular Mechanics Press, Dept. (C37), 200 E. Ontario St., Chicago.

NEW \$4.75 Automatic adding machine. Fully guaranteed. Bassett, Box 302A, Altadena, California.

TYPEWRITERS, Duplicators, multi-graphs. Write for free list office machine bargains. Save half. Pruitt, 518 Pruitt Bldg., Chicago.

PRINTING, MULTIGRAPHING, MIMEOGRAPHING, GUMMED LABELS

QUALITY Printing, 1000 envelopes, cards, billheads \$2.90. Mayflower, 227C Brookline Street, Cambridge, Massachusetts.

LETTERHEADS, Statements, envelopes, 1000—\$2.95, 5000—\$9.95. Samples. Becker Bros., Portchester, N. Y.

6x9 CIRCULARS, Letterheads, envelopes, postcards, \$2.95 1000, 5000, \$8.99. Booklets, folders, low prices. Goodprint, Harrisonburg, Va.

WEDDING Invitations, modernistic letterheads, personal stationery, 200 noteheads, 100 envelopes \$1.00. Harwill, Phelps, N. Y.

RAISED Letter. Letterheads, envelopes; 100 of each \$1.00. Printer, Albion, Maine.

100 EACH 8 1/2 x 11 Letterheads, 6 1/2 envelopes, \$1.00 postpaid. Tucker, Box 63, Indianapolis, Ind.

SEND Dollar for mimeograph lessons, headlines, layouts. Wooding, Salmon Arm, B. C.

250 3x5 GUMMED Shipping labels \$1.00. Millington Press, Millington, Mich.

AMERICA'S Finest—Large sample portfolios free. Sanderson's Printing, Ottawa, Illinois.

A PRINTING Price list, request it. Box 6003, Cleveland, Ohio.

200 PERSONAL Cards 50c. Correia's Press, 305 Elm Street, Cambridge, Mass.

50c PER 100 Letterheads, envelopes, cards. Windy City Printers, 3301 Carroll, Chicago.

1000 GUMMED Labels printed to order, two colors. \$1.00. Horack, Weissport, Pa.

100—50c HAMMERMILL Letterheads, envelopes, cards. Lit, 11720 Imperial, Cleveland, Ohio.

TAPE Sealing machine, ten rolls one inch printed gummed tape. Ten dollars cash with order. Avon Gummed Tape Co., 515 Melish Ave., Cincinnati, Ohio.

100 EACH, Letterheads, business cards, envelopes, all \$1.00; 250 each—\$2.00. Lowe's, Box 255, Oakland, Calif.

LETTERHEADS, Envelopes, statements, tickets, \$2.50 per 1000 delivered. Edward Johnson, West Creek, N. J.

250 LETTERHEADS, 250 Envelopes \$1.50. Benneville, 907 West Roosevelt, Philadelphia.

100—50c HAMMERMILL Letterheads, envelopes, cards. Lit, 11720 Imperial, Cleveland, Ohio.

LET A mail order expert do your printing. Low overhead, automatic high speed presses, quantity production offer you amazingly low prices. Two-color broadsides, folders, letterheads, envelopes, forms, etc. Let us quote you prices. Prompt delivery anywhere. Ray's Printing Service, Dept. 66, Pleasant Hill, Ohio.

MIMEOGRAPHING, 1,000, \$2.85. Samples. Bur-Wil Enterprises, 24 Louisa, Binghamton, N. Y.

1000 BUSINESS Cards \$1.50. Jones, Box 342, Mineola, N. Y.

QUALITY \$1 Special! Postpaid—125 20-lb. letterheads, 100 envelopes, 1000 of each \$5. Samples. Almo, 10728 116th, Richmondhill, New York.

2000 BUSINESS Cards \$1.50. Neat work. Quick service. Free samples. Bell Printing Co., 2915 Aramingo Ave., Philadelphia, Pa.

1000 BOND Letterheads, 8 1/2 x 11, \$2.95. Best Printing Company, Salamanca, N. Y.

1500 NEAT Business cards \$1.00. World, 2710-A Clara, St. Louis, Mo.

DESIGNED Labels in small quantities. 2 1/2 x 1 1/2, three colors, 100 for \$2.00. Acme Color Studio, 225 Republic Building, Miami, Florida.

FREE Samples! Printing! Mimeographing! Bargains! Premiums! Sylco, Downers Grove, Ill.

GET Acquainted bargain offer! 500 quality letterheads and envelopes \$2.95! Samples. Thrift Printers, 730-W Madison, Milwaukee, Wisconsin.

1000 BUSINESS Cards \$1.00. Cycle Press, Box 325, Lawndale, Calif.

PRINTING—1000 Billheads, letterheads and envelopes—\$5.75. Highland Print Shop, Highland Place, Fall River, Massachusetts.

LABELS—All kinds. Write, samples. JBSCO, Box 93, Holyoke, Mass.

CIRCULARS—5 1/2 x 8 1/2, \$2.95 thousand; 3x6, \$1.00. Howard Weaver, Mechanicsburg, Pa.

PRINTING Exchanged for anything, 500 envelopes \$1.10. Printers, Mansfield, Ark.

TRIAL—150, 8 1/2 x 11, 20-lb. Bond letterheads, 150 envelopes \$2.00 postpaid. Race Printery, Hudson, N. Y.

ENVELOPES, Any size, quantity, reasonably priced. Samples, estimates. Universal Envelope Supply, Orange, Mass.

SEND Dollar bill for 300 pieces fine printed noteheads and envelopes. Springer Press, Miami, Oklahoma.

250 LETTERHEADS And 250 envelopes, \$2.49. Postpaid. Webpress, Farmland, Indiana.

PHILATELIC Printing, samples, prices. Dehler, 324 Boyden, Syracuse, N. Y.

ENGRAVURE Printing. Lowest possible prices. Samples free. Sunko, Mohawk, N. Y.

BETTER Printing. Reasonable prices. Valuable premiums. Write Angel, Drawer 837PM, Charleston, South Carolina.

BUSINESS Cards, 1,000, \$1.00, post free. McBride Printery, 648 McBride Avenue, Los Angeles, Calif. Agents wanted.

500 3/4 x 2 1/4 FOUR Line gummed stickers, 25c. Moritz Printery, Saginaw, Mich.

2000 BUSINESS Cards neatly printed \$1.50. Quick service. Free samples. Atlas Distributing Co., 1814 Bedford Ave., Pittsburgh, Pa.

1000 BUSINESS Cards, card case, \$1.50. Miller, Printer, Ambler, Pa.

CUTS 2x3, \$1.10, from drawings and photos. Joe Reik, 118 Gazette Ave., Lexington, Ky.

PRINTING OUTFITS AND SUPPLIES

MAKE Stereotype caster for \$1. Mateco, 150 West Larned, Detroit.

ZINC Cuts mounted 2x3, \$1.00; 3x4, \$1.75. Cozatt, Danville, Ill.

ROTARY Typeless printers \$9.95 complete. Color printing in one operation. Delmaco, Wilmington, Del.

MAKE Cuts—Cheap, easy process. Half-tones, zinc etchings. Andercamco, 1248 West 102nd Place, Chicago, Ill.

PRINTING Presses, supplies. Long established. Lists 3c. Landis, Richland, Pa.

HAND Press, type and complete printers' supplies. Advise equipment you need and we quote prices; or send stamp for catalog. P. Peiffer, 14-B; 6 Columbia St., Newark, N. J.

FOLDER, 28" Electric, \$11-\$15, easy built; for complete blueprints send \$2.00. Meyer Eng., Box-8, Hempstead, N. Y.

PRINT Your own cards, stationery, circulars, advertising, etc. Save money. Easy rules furnished. Print for others, big profits. Junior press, \$5.90; job presses, \$11, power \$149. Write for details. Kelsey Co., A-11, Meriden, Conn.

BARGAINS—Presses, type, supplies. Send stamp. 159 Harvard, Cambridge, Mass.

PRINTING Outfits—Presses, type, supplies, type novelties. Send 20c for card case samples. Catalog free. Model Press, York, Pa.

BARGAINS, Presses, type. List 3c. Exchange D-15, 22 Orient, Meriden, Conn.

PATENT ATTORNEYS

INVENTORS: Send immediately for your copies of our new free books, "Patent Protection" and "Suggestions on Selling an Invention." Sixty-eight pages of interesting facts. They tell how patent laws protect you; kind of sketch or model needed; simple steps to take without cost; how successful inventors have secured financial assistance; show interesting inventions; illustrate important mechanical movements. With books we also send free Evidence of Invention form to help establish date of disclosure. Prompt service, reasonable fees, special deferred payment plan. Strictest secrecy. Thirty-six years' experience. Highest references. Write us today. The facts in our books are worth money to the man with a good invention. Address: Victor J. Evans & Co., Registered Patent Attorneys, 900-G Victor Building, Washington, D. C.

INVENTORS—Small ideas may have large commercial possibilities. Write us for free book, "Patent Guide for the Inventor" and "Record of Invention" form. Delays are dangerous in patent matters. Free information on how to proceed. Clarence A. O'Brien & Hyman Berman, 58-Z Adams Building, Washington, D. C.

"INVENTOR'S Guide," 100 mechanical movements, free; advises on patenting, selling inventions. Frank Ledermann, Tribune Bldg., New York.

SELL Your unpatented ideas. We tell you how; help you make the sale. Particulars free. Write W. T. Greene, 976 Barrister Bldg., Washington, D. C.

PRACTICAL Inventions now salable before patenting. What have you? Write Chartered Institute of American Inventors, Dept. 4B, Washington, D. C.

PATENTS—Proper service for manufacturers and individual inventors. Established 1895. Reasonable charges. Consult Chandiee & Chandiee, Patent Attorneys, 902 F. Street, Washington, D. C.

INVENTORS—Send for free booklet "Patent-Sense." Information based on 64 years experience. Lacey & Lacey, Dept. 5A, 635 F. St., Washington, D. C.

PATENTS—Personal, confidential services for protection of your invention at reasonable cost. Preliminary information and approximate cost of patent furnished without obligation. John B. Thomas & Co., 902 F. Street, N. W., Washington, D. C.

L. F. RANDOLPH, 302-B Victor Building, Washington, D. C. Low cost. Book and information free.

PATENTS. Protect your idea by securing free "Proof of Invention" folder. Exceptional personal service. Established 1908. E. E. Vrooman, 871 Woodward Building, Washington, D. C.

PATENTS. Instructions "How to Establish Your Rights" and form, "Evidence of Conception"—sent free! Lancaster, Allwine & Rommel, 411 Bowen Building, Washington, D. C.

PATENTS. Booklet free. Highest references. Best results. Promptness assured. Watson E. Coleman, Patent Lawyer, 724 Ninth St., Washington, D. C.

BOOKS Covering hundreds of subjects. Big catalog for 3c postage. Popular Mechanics Press, Room (C37), 200 E. Ontario St., Chicago.

FOR INVENTORS

INVENTORS: Send immediately for your copies of our new free books, "Patent Protection" and "Suggestions on Selling an Invention." Sixty-eight pages of interesting facts: They tell how patent laws protect you; kind of sketch or model needed; simple steps to take without cost; how successful inventors have secured financial assistance; show interesting inventions; illustrate important mechanical movements. With books we also send free Evidence of Invention form to help establish date of disclosure. Prompt service, reasonable fees, special deferred payment plan. Strictest secrecy. Thirty-six years experience. Highest references. Write us today. The facts in our books are worth money to the man with a good invention. Address: Victor J. Evans & Co., Registered Patent Attorneys, 901-G Victor Building, Washington, D. C.

INVENTORS—Small ideas may have large commercial possibilities. Write us for free book, "Patent Guide for the Inventor" and "Record of Invention" form. Delays are dangerous in patent matters. Free information on how to proceed. Clarence A. O'Brien & Hyman Berman, 58-Z Adams Building, Washington, D. C.

GET Copies of patents similar to your ideas. L. A. Summers, 5229 7th Street, N. W., Washington, D. C.

UNPATENTED Ideas can be sold. I tell you how and help you make the sale. Particulars, with list of manufacturers and wanted inventions sent free on request. Write W. T. Greene, 944 Barrister Building, Washington, D. C.

PATTERNS For castings, models. Confidential service. Michigan Pattern Works, 1148 Godfrey, Grand Rapids, Michigan.

"HOW To Sell an Invention." Booklet of practical information, compiled by Registered Patent Attorney. Postpaid \$1. C. L. Drew, Hobart Bldg., San Francisco, California.

BOOKS Covering hundreds of subjects. Big catalog for 3c postage. Popular Mechanics Press, Room (C37), 200 E. Ontario St., Chicago.

UNPATENTED Ideas can be sold. I tell you how and help you make the sale. Particulars, with list of manufacturers and wanted inventions, sent free on request. Write W. T. Greene, 944 Barrister Building, Washington, D. C.

YOUR Pending patents and good unpatented ideas listed free as news items for manufacturers in our semi-monthly magazine. Send descriptions. "Successful Inventions," Dept. 84, Barrister Building, Washington, D. C.

KILLING Time wasting dollars? Market invention differently! Tabor, 2210 South Marshall Blvd., Chicago.

INVENTORS. Manufacturers, distributors, patent attorneys and model makers are invited to attend four-day meeting and exhibit of the National Inventors Congress, June 7th to 10th. For details write Roy C. Burns, Hotel Edison, New York City.

INVENTORS—Why not profit from your unpatented and patented inventions? International Inventors Service, Leon Building, 501 F. Street, Washington, D. C.

HAVE You invention problems? Financing, patenting, selling? Get information that offers your chance to cash in. Inventors' Counselor, Cantil, Calif.

WE Successfully sell inventions, patented and unpatented. Write for proof, and tell us what you have for sale. Chartered Institute of American Inventors, Dept. 4-C, Washington, D. C.

TO Inventors: We are in the market to purchase a good patent, preferably a small item made of metal. Will purchase outright or royalty. Purchasing Agent, 241 Front St., New York, N. Y.

INVENTORS: "Making Inventions Pay." Our 32-page illustrated book, mailed upon receipt of 3c postage. Crescent Tool Company, Dept. Z, Cincinnati, Ohio.

INVENTORS—Send for 72-page book on patents. Reasonable terms. Conscientious treatment to inventors. L. F. Randolph, Registered Patent Attorney, 302-E Victor Bldg., Washington, D. C.

I SELL Patents. Established in 1900. Charles A. Scott, 773PM Garson Ave., Rochester, N. Y.

SELL Your patent through a small classified ad in Popular Mechanics. Many inventors have found buyers in this way. Ask me for proof—I'll gladly send it to you. F. W. Johnson, Manager, Classified Advertising, 200 E. Ontario St., Chicago.

INVENTOR'S Universal Educator; contains 900 mechanical movements; 50 perpetual motions; instruction on procuring and selling patents and selecting an attorney, etc. Suggests new ideas. Price \$1.00 postpaid in U.S.A. Address Albert E. Dietrich, 511-B Colorado Bldg., Washington, D. C.

INVENTIONS WANTED

SMALL Inventions wanted by manufacturers. I'll help you sell your invention. Stanley Hull, K-7829 Euclid Avenue, Cleveland, Ohio.

WILL Buy interest or outright, finance, manufacture and sell sound invention. References exchanged. Roy Hoppie, 1132 Spruce, St. Louis, Missouri.

CASH For unpatented inventions. Mr. Ball, 9441 Pleasant Avenue, Chicago.

HAVE You a sound, practical invention for sale, patented or unpatented? If so, write Chartered Institute of American Inventors, Dept. 4A, Washington, D. C.

INVENTIONS Wanted—Patented, unpatented. If you have an idea for sale, write Hartley's, Inc., Box 928-E, Bangor, Maine.

PATENTS FOR SALE

METAL Pocket dispenser for tablet or candy ring. A. Pearson, 5012 Tioga Street, Duluth, Minnesota.

PATENTED Gas heater. Fan forced heat. Modern design. E. L. Snyder, 1511 - 17 St. N. W., Canton, Ohio.

MACHINE Corrects crosseyes. Cost \$50. Sells \$200. Optimotor, Hoodsport, Washington.

NEW Patented household necessity, nothing like it on the market. Sell outright or half interest. Heiman, 20 Stephenson Bld., New Rochelle, N. Y.

\$50,000 PATENTABLE Invention, sell, or partner. Harold Motlow, Lynchburg, Tenn.

TOOTHPICK Dispenser—Single delivery, simple. 822 N. Fourth, Allentown, Penna.

CLOTHES Closet bracket, No. 1,707,921. Olson, 237 Jessie, Pontiac, Mich.

SAFETY Device for the prevention of overloading cranes and the like. Patent No. 2,015,957. J. O. Neal, Rte. 2, Box 401, Bremerton, Wash.

NAIL Clipper and sharpening feature combined—require capital for material and advertising. C. P. Murphy, 637 Loraine St., Ardmore, Pa.

PATENT Applied for: Novelty toy—practical, neat, attractive, inexpensive to manufacture. Very different. Walter Lindeman, Box 534, Beloit, Wis.

PRACTICAL. Economical, single prong appliance plug. Earl Allabach, Treviso, Pa.

SELL Your patent through a small classified ad in Popular Mechanics. Many inventors have found buyers in this way. Ask me for proof—I'll gladly send it to you. F. W. Johnson, Manager, Classified Advertising, 200 E. Ontario St., Chicago.

MANUFACTURING

METAL Stamping, drop hammer work, dies, tinning, spot welding, small die castings. Inquiries solicited. Write, Warren, 34 Hubert St., New York City.

DIES. Tools, stampings, manufacturing, screw machine work. Porsberg, Northfield, Ohio.

PROFIT With new products. Make, sell, repeat. Analysis. Research. Guaranteed formulas. Biggest catalog free. Special prices, leads. Gibson Laboratory, Chemists, DS-1142 Sunnyside, Chicago.

INVENTIONS Developed, manufactured. Write, Robey Manufacturing Company, East Lansing, Michigan.

MANUFACTURING. Dies, machinery, models, brasswork, white metal casting moulds. Catalog 3c. Baum's Metal Specialties, Kansas City.

INVENTIONS Manufactured in any quantity at low cost. Stampings, dies, models, etc. Estimates and free catalog. Crescent Tool Co., Dept. N, Cincinnati, Ohio.

15,000 PROFIT Making formulas. Following and many others: Accidents and emergencies, agriculture, alloys and amalgams, artist's materials, beverages, cements, glues, pastes, mucilages, bleaching, renovating, coloring metals, dyeing glass, heat treatment of metals, household formulas, ice cream, confectionery, chewing gum, lapidary work, exterminating vermin, lubricants, paints, varnishes, photography, condiments, canning formulas, rubber, soap, candles, soldering, toilet preparations, perfumes, waterproofing, fireproofing, writing materials. \$5.50 postpaid. Popular Mechanics Press, Room (C37), 200 E. Ontario St., Chicago.

MODELS AND MODEL SUPPLIES

FULLY Illustrated circular. Listing 40 engines. Locomotive castings. Supplies. Stamp required. Howardo, A-2417 N. Ashland, Chicago.

SENSATIONAL Bargain lists. Machines, tools, etc. Howard Machine, H-2417 No. Ashland, Chicago.

INVENTIONS—Small ideas may have large commercial possibilities. Write us for free book, "Patent Guide for the Inventor," and "Record of Invention" form. Delays are dangerous in patent matters. Free information on how to proceed. Clarence A. O'Brien & Hyman Berman, 58-Z Adams Building, Washington, D. C.

MODEL Airplane supply bundle! Gifts, catalog, 25c pp. Models, 4802P Clarendon, Brooklyn, New York.

BUILD 39" "Miss America." Plans, instructions \$1.00. Power Model Boat Co., 4022 N. 39th, Milwaukee, Wis.

BUILD Queen Mary. 27 in. long, all wooden model. Fully finished hull, cut to fit parts, and plans. \$2.50 complete, plus postage. Send 3c stamp for catalog. Miniature Ship Models, Perkasie, Pa.

RAILWAY Models. Catalog handbook 25c. Walthers, 247 East Erie, Milwaukee.

3/4" SCALE Steam locomotive easily built by "Step" method. Latest catalog of castings, boiler fittings, track materials, etc. 25c coin (returned on first order). Little Engines, Box B15, Wilmington, Calif.

HEADQUARTERS For yacht fittings—Marblehead (50-800) and Class A. List free. Illustrated catalog of ship fittings and construction sets 15c. A. J. Fisher, 1002-1 Etowah Ave., Royal Oak, Mich.

POWER Modelers—Read Modelmaker Magazine. Current sample 15c. Special big buy, 25 assorted back issues. \$1.00. Model steam locomotives, gas engines, power boats, stationary engines. Box 196-P, Wauwatosa, Wis.

BIG 96-Page model engine catalog, post-paid 20c. Particulars free. Evraymesco, 28 No. Clinton, Chicago.

MODELS, Stampings, and special machinery. Send for catalog of brass gears and model supplies. The Pierce Model Works, Tinley Park, Ill.

MODELS—Your ideas developed into practical working models. 30 years' successful experience; thousands of satisfied customers. Confidential service guaranteed. Bank references. Send 3c postage for 32-page book—"Making Inventions Pay." Crescent Tool Company, Dept. Y, Cincinnati, Ohio.

MECHANICAL Models, new and novel. Popular Mechanics has developed accurate models in the mechanical field. Those now ready are Wright "Whirlwind" Airplane Engine, Ocean Liner "Europa" and Modern Passenger Locomotive. Every part clearly shown and the name given. Invaluable to students and all who are mechanically inclined. \$1.00 each postpaid. Popular Mechanics Press, Room (C37), 200 E. Ontario St., Chicago.

BLUEPRINTS AND PLANS

20 FULL-SIZED Lawn ornament patterns, 30c. **200 full-sized silhouette patterns** 30c. Modern Woodcraft, Saginaw, Michigan.

BUILD Unit air conditioners with salvage parts—plans \$5.00. Air Engineers, 3239 Division, Chicago, Ill.

HOME CRAFTSMEN

LAWN Ornaments, ready cut and sanded. 25c brings two and price list of other designs. A. Barker, Mount Kisco, New York.

12 MODERN Bird house plans 50c. Suburban Arts, 1309 South 62nd Ave., Cicero, Illinois.

KEROSENE Lamps made from glass jars with Century Lamp Jar Caps; 10c each postpaid. Handy Gadget Co., 8th and John Sts., St. Paul, Minn.

ROCK-GARDEN, Lawn ornaments, beautiful cave crystals, 10 pounds postpaid \$2.00; 100 lbs. Black Hills collection, crystals, gold ores, colored rocks, \$5.00; not prepaid. Prospector, Box 338, Deadwood, South Dakota.

"MODERN Wood sculpture." Complete instruction book on carving statues \$1.00. Lee, Wood Art Studio, Centerville, Ia.

LEATHERCRAFTSMEN—Write for free instructions and price list of leather, tools and beginners' kits. Send 5c for sample cards. Address Wilder & Company, Dept. F, 1038 Crosby St., Chicago, Ill.

MAKE IT Yourself. Hundreds of practical and useful devices described in our big book. Plain instructions and illustrations show you how to make them. Save money on things for yourself or make profit selling to others. 900 articles of great variety. 480 pages. 823 illustrations. \$3 postpaid. Popular Mechanics Press, Room (C37), 200 E. Ontario St., Chicago.

OLD GOLD, WATCHES, JEWELRY, PRECIOUS STONES

ANY Watch repaired \$1.00 (plus parts). Holmes Watch Co., Washington, Kansas.

BRILLIANT Zircons, aquamarines, topaz. Arthur Kelley, 28 Church, Montclair, New Jersey.

OPAL Bracelets, dozen stones, very beautiful, \$17.00. Catalogue free. Norman Seward, Melbourne, Australia.

5000 REBUILT Hunting Waltham, Elgin watches. New chromium engraved open face cases. Make big money! 16 size, 7 jewel, \$3.75; 16 size, 17 jewel, \$6.25. Send 3c stamp for free catalog. New plan. The New York Jobbers, Dept. M, 74 Bowery, New York, N. Y.

DIAMONDS, Wedding rings, 25% to 50% discount. Free catalogue. Sweeney, Manufacturing Jeweler, Park Ridge, Ill.

SAVE Half on watch repairing and parts. Paul Jewelry Co., LaCrosse, Wis.

CASH For old gold, teeth, watches, jewelry, 100% full cash value mailed day shipment received. Satisfaction guaranteed or articles cheerfully returned. Information free, or ship today. Chicago Gold Smelting Company, 300P Champlain Building, Chicago.

HOW To identify and determine value of old precious metals. Where to buy. To whom to sell. Reliable and up-to-date information. Complete instructions only \$1.00 postpaid. Popular Mechanics Press, Room (C37), 200 E. Ontario St., Chicago.

WATCHES, Diamonds, radios, typewriters, unredeemed pledges at savings of 2/3 list free. Pawnbrokers Exchange, 1218 - 7th, Washington, D. C.

GOLD \$35.00 Ounce. Ship old gold teeth, crowns, jewelry, watches—receive cash by return mail. Satisfaction guaranteed. Free information. Dr. Weisberg's Gold Refining Company, 1393 Hennepin, Minneapolis, Minn.

TOBACCO

LOOK! Higher quality! Golden yellow smoking or rich ripe chewing, four pounds, guaranteed and postpaid, \$1.00. Riverside Ranch, Hazel, Kentucky.

POSTPAID, 2 Years old, high grade Red-leaf chewing, 10 pounds \$2.00. Smoking \$1.50. Guaranteed. Curtis Rogers, Dresden, Tenn.

RAZORS—BLADES—SHARPENING

100 FINEST Steel new double-edge blades \$1.00 postpaid. Samples free. Ames, 181 Mystic, Arlington, Mass.

SURVEYING INSTRUMENTS

GUARANTEED Factory rebuilt transits and levels for rent (with purchase option) or sale (cash or terms). Order now before prices advance. We will repair, trade in, or buy your old instruments. Ship prepaid for estimate and valuation. Write for List M-26 and complete information to Warren-Knight Co., 136 N. 12th St., Philadelphia, Pa.

AUTOMATIC Ink filling device for ruling pens. Free circular. Paramount Co., 327 E. 92nd Street, New York.

WANTED—MISCELLANEOUS

WILL Buy outright, tools, dies, etc., for the manufacture of any small useful article—something that can be sold on display cards preferable. State price and give full description in first letter. Houston Maupin, P. O. Box 418, Gainesville, Texas.

MINIATURE Period, furniture, hardware, lighting fixtures, etc. (Approximately one-sixth actual size). For fine model construction. Furnish full particulars, John C. C. Mayo, Ashland, Kentucky.

CASH For used microscopes, binoculars, slide rules, drawing sets, cameras, surveying, medical and scientific instruments, tools, marine equipment. Highest prices paid day shipment received. Satisfaction guaranteed or shipment promptly returned. Elman's, 2302 Van Buren, Chicago.

WILL Pay \$250.00 Colt revolver, factory dated 1847. Other firearms wanted. Selling list 20c. Hobby Shop, 406 Clement, San Francisco.

PERSONAL

WHO Owes you money? Mail them one of our collection forms. Quick results, 4 forms 50c, 10 forms \$1.00. Davis Oil Co., Ridgeway, Wis.

'TIS Said, famous tribesmen originated Har-O-Uth! Lin-O-Uth!! formulas. Invigorating! "Unique!" Money-making! Both \$1.00. Particulars, stamp. Davis, Box 1484-4, Clarksburg, W. Va.

AMAZING 65 Page book exposing crooked financial advertising schemers. Postpaid 25c. Ford Research, Gibsonia, Penna.

VENTRILOQUISM—Complete \$2.50 course 25c. Lonk Institute, D-1613, Palatine, Ill.

WANTED—Original poems, songs, for immediate consideration. Send poems to Columbian Music Publishers, Dept. 33, Toronto, Can.

HAIR Getting thin? Then investigate my "No Hair—No Pay" offer. No obligation. Paul Downing, 625 Swetland Bldg., Portland, Oregon.

CASH'S Woven names. For marking men's, women's, children's clothing. Free sample. Oulmette's, 1007A Water, New Bedford, Mass.

STUTTERING And stammering corrected at home. Descriptive booklet free. Paul J. Wolfe, Box 52, Pittsburgh, Penna.

200 TRICKS You can do—Mystify your friends; have loads of fun. This collection of tricks has been selected by Thurston for the average person. Neither unusual skill nor elaborate apparatus required. 200-page illustrated book, \$1 postpaid. Popular Mechanics Press, Room (C37), 200 E. Ontario St., Chicago.

MISCELLANEOUS

"BEAUTIFUL" Weird cactus from Arizona deserts. 6 varieties postpaid \$1.00. H. Wiener, 118 N. Stone, Tucson, Arizona.

RAZOR Blade watch-chain knife, Durable. Artistic. 25c. Vital Products-P, Hoboken, N. J.

NAMEPLATES Engraved, brass, mailbox or bell fitted, 35c. Peterell, 60 James, Quincy, Mass.

MONUMENTS \$9 Up delivered, erected, guaranteed. Thousands sold. Catalog free. Marble Granite Factory, A-17, Oneco, Fla.

JAPANESE Sundries and novelties. Catalog sent free. Samples \$10. Seicho Trading Co., Tairamachi, Meguroku, Tokio, Japan.

TATTOOING Outfits, supplies, 1937 illustrated list. "Waters," 965 Put-nam, Detroit.

NO Boss! Sure cash! Silvering mirrors, autographs, reflectors. Combination outfit. Write Sprinkle, Plater, 288, Marion, Ind.

MEN—One dollar buys a secretary. A genuine leather pocket case for your personal papers. Separate pockets for letters, cards, bills, identification, etc., and large size memorandum pad. It fits inside coat pocket. Bridgeport Leather Specialty Co., Inc., Bridgeport, Conn.

IT Pays, in every community to demonstrate successful production of "Sollife" earthworms. Send 10c for information. California Earthworm Farms, LaCanada, California.

PROFITABLE—Bind favorite magazines into attractive books. New, easy way. Thoroughly illustrated instructions \$1.00. Henry Estberg, Waupaca, Wis.

AVAILABLE: Domestic servants earning from \$10 monthly, commercial employees from \$10 weekly, knowing English and/or Spanish. Box 1518, San Juan, Puerto Rico.

COLLECTORS, Swappers, investigate free trading service. Exchange, Box 425, Chicago.

STAGE, Auditorium, amateur or professional lighting questions answered by mail \$1.00, or in person. Landow, 106 Beachway, Keansburg, N. J.

CUSTOM Made riding boots from \$10.50, made to your measure by hand also, pairs \$9.50. Make your own moccasins. We find everything for making. Price \$1.50. Catalog free. H. W. Clark, 534-536 Forest, Ann Arbor, Mich.

INDIAN Teepee incense burner. A new novelty. Selenite Sylrite rock crystals. Wheeler, Roswell, New Mexico.

ELECTRIC Lamp kills insects indoors, outdoors. \$2.00 up. Literature free. Sauer Bros., 14820-C Foothill Blvd., Oakland, Calif.

HOW Keen is your mind? Try the army "Alpha" tests for a searching analysis. Personal Guidance Institute, 70 Chapel Street, Albany, New York.

MONEY In butterflies, moths. See Singular Display Advertisement on page 114.

ANALYZE Handwriting, read characters. Instructions 25 cents. Culturals, 419 Maple, Manchester, New Hampshire.

FEATHER Pictures, 12 different samples, \$1.00 postpaid. Marquez, Apartado 1176-P, Mexico City, Mexico.

BULL Flight playing cards. Richest collection of oils painted by Ruano Llopiz. Limited number. Send one dollar. Anything from Mexico. Fernando Montes de Oca, Apartado 2686, Mexico City, Mexico.

SWAP Or sell articles you don't need. Get those you want. Send dime for Swapper's Guide, listing articles from all over United States. Dept. PM., Swapper's Guide, Delphos, Ohio.

AMATEUR Cartoonists. Sell your work. Write Smith's Service, Wenatchee, Wash.

AMATEUR Tattooing outfits, illustrated catalog 6c. "Tatuco," 651A South State, Chicago.

BOOKS Covering hundreds of subjects. Big catalog for 3c postage. Popular Mechanics Press, Room (C37), 200 E. Ontario St., Chicago.

CUTS Anybody can make. Zinc etching process. Specimens, particulars, testimonials for stamp. J. C. Day, Windfall, Ind.

SWAPPER'S Friend, R4, Saline, Michigan. Interests swappers, collectors, sportsmen. 50c year, sample 10c.

COCOONS, Butterflies, collectors' supplies, butterfly art materials. Free lists. Maynard, 1192 Lewiston, Rochester, New York.

AUDELS MATHEMATICS AND CALCULATIONS FOR Mechanics



\$2
A
HANDY
BOOK

Good News!

MATHEMATICS AND CALCULATIONS FOR HOME STUDY AND REFERENCE

PRACTICAL MATHEMATICS ILLUSTRATED. How to figure correctly. EVERY MECHANIC can use the new, correct, easy methods, covering a complete review of practical arithmetic—with examples including mensuration—plane and solid geometry—trigonometry—algebra—calculus—ELECTRICAL and MECHANICAL SHOP CALCULATIONS—practical tests—reference tables and data—how to use the slide rule—700 pages—550 illustrations—pocket size.

Highly endorsed. Let us mail you copy for free trial. Price \$2, postpaid.



FREE EXAMINATION COUPON

THEO. AUDEL & CO.
49 W. 23rd St., N. Y. C.
Mail Audel's Mathematics on 7 days' free trial. If O. K. I will remit \$2, otherwise I will return it.

Name

Address

Occupation P. M.

Free AIR CONDITIONING AND REFRIGERATION TRIAL LESSON



Get into this great industry. Trained men needed. Good pay. Real opportunity. Learn easily AT HOME in your spare time. Send for FREE TRIAL LESSON. No charge now or later. Write today.

CHICAGO TECH COLLEGE

G301 Tech Bldg., 118 E. 26th St., Chicago, Ill.

Sign Painting. This large 27 lesson Sign and Show Card Course gives you the complete training for this well-paid profession. No experience necessary. (\$15.00 value.) Money Back Guarantee!

\$1

Stewart Sign School, Dept. P6, 3555 Aberdeen, Alton, Ill.

INVENTING Now Taught for the First Time!

Home study course. Send 3c stamp for free catalog TODAY.

TROFIMOV SCHOOL OF INVENTIVE PRACTICE, INC.
3859 Northampton Rd., Cleveland, Ohio

MANY TRAINED MEN EARN \$30 TO \$60 A WEEK in RADIO



\$5 to \$25 in SPARE TIME

My latest free book tells how you can quickly learn Radio and make good money in spare time—big money full time. My system of training is unusual because I not only teach you Radio—but teach you on a FULL SET OF REAL PROFESSIONAL RADIO EQUIPMENT, right in your own home. Furthermore, I show you how to get the business and make the money.

Earn While You Learn

My training is designed to help average, intelligent men earn \$5 to \$25 weekly while learning—\$25 to \$60 in good jobs thereafter. Also, my training and equipment sets you up in business for yourself. Learn Aviation Radio, Electronics, Public Address Systems, Police Radio, etc. Get into the real money. Send for my FREE BOOK OF FACTS—Today!—F. L. Sprayberry, Pres., Sprayberry Academy of Radio, Office No. 10-G, University Place, N. W., Washington, D. C.

BIG OUTFIT!

Learn on—and earn with—my real professional Radio outfit which includes genuine tester, complete manuals, complete tools, replacement parts, new "Electric Eye"—everything you need to understand Radio and work in Radio. Get full details in my

FREE BOOK

Earn Money at Home



BIG FREE book in colors tells new easy way. You don't need experience. We show you how to decorate beautiful Art Novelties right in your own home by simple "3-step" method. No tedious study. Everything furnished including supply of Novelties for you to decorate and Homecrafters Outfit. Big profit per piece for decorating. Many sit at home, and make up to \$25 to \$50 a week—full time or spare time.

First Lesson Now Free!

Prizes, Toys, etc. More like fun than work and you earn as you learn. Hundreds making big money this fascinating way.

NO CANVASSING You risk nothing in sending for Free Lesson. So sure are you to succeed we give an absolute Warranty backed by \$1,000 Bond. Costs nothing to find out. Openings for new workers now in every locality. Mail coupon immediately for Free Book and Free Lesson. Get started making money at once.



MAIL THIS!

FIRESIDE INDUSTRIES
Dept. 66-G, Adrian, Mich.

Please send big Free Book and FREE LESSON. This does not obligate me in any way.

Name

Address

GIVEN YOU TO DECORATE

U. S. GOVERNMENT JOBS

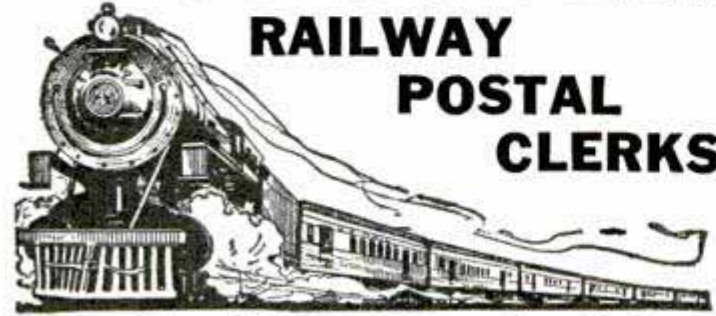

RAILWAY POSTAL CLERKS

\$1260 to \$2100 First Year
Mail Coupon Before You Lose It

FRANKLIN INSTITUTE, Dept. D 196, Rochester, N. Y.
Sirs: Rush to me, without charge, copy of 32-page book, "How to get a U. S. Government Job," list of positions, and full particulars telling how to get them.

Name.....

Address.....

City and Rural Carriers—Postoffice Clerks—
File Clerks—Accountants—Stenographers—
Typists—Many other Government Jobs.
Common Education Usually Sufficient



TELEVISION AND RADIO ARE YOUR OPPORTUNITY

BIG MONEY and READY JOBS AWAIT EXPERTS

Unlimited opportunities in this new expanding field await alert, aggressive, trained men...men who LEARN NOW...men with vision to get in on the ground floor when the profession is young and uncrowded. TELEVISION is already a reality awaiting development of man-power to sweep the nation.

LEARN FASTER, BETTER—"ON THE JOB"
Television Broadcasting Station W9XAL and Radio Station KXBY, owned and operated by First National Television, Inc., are your practical laboratories...your "proving ground". YOU LEARN BY DOING! Think what this means to you! Elaborate, complete broadcasting stations give you practical experience absolutely vital to rapid progress and to thorough, advanced knowledge necessary for SUCCESS.

ONLY 6 MONTHS FOR U.S. GOVT. LICENSE
Our "training on the job" qualifies you in 6 months for U.S. Govt. License (First Class). Our new, illustrated, FREE book, "Pictures on the Air" gives full facts. You owe it to yourself to investigate! Don't wake up a year from now and find your friends making big money in fascinating Radio-Television careers...while you stood still! ACT NOW! Send coupon today!

FIRST NATIONAL TELEVISION, INC.
Training Division, Kansas City, Mo.

MAIL COUPON NOW!

S. O. MOEL, Pres. First National Television, Inc.
Dept. A.A.G., Training Division, Kansas City, Mo.
Rush me "Pictures on the Air" Free!

Name _____ Age _____
Street _____
Town _____ State _____

FREE

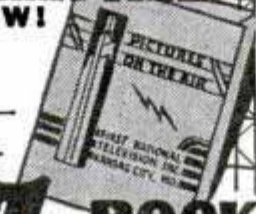

GET THE INSIDE STORY BOOK



AUTO BOOKS SENT FREE

on approval. Just mail the coupon and we'll send you a set of these remarkable auto books, just off the press. Whether you are a mechanic or helper, expert or apprentice, auto owner or driver, if you're interested in knowing all about automobile mechanics, take advantage of this FREE OFFER.



CAN YOU FIX IT?

These wonder books tell step by step HOW to take out "play" in differential—to kill the shimmy in steering—to set TIMING—how to put your finger instantly on engine trouble and then the quick expert way to FIX it. Newest improvements fully covered. Equal to a complete trade course at less than a fourth the cost.

6 Big Volumes Brand New Edition
2500 pages, 2000 illustrations, wiring diagrams, etc., including Marine Engines, Aviation Motors, Diesel engines, etc. DeLuxe edition, gold-stamped flexible binding.

FREE! Send NOW and we will include FREE an extra loose-leaf volume No. 7 with newest cars and diagrams and also that famous book "Automobile Service Shop Management."

AMERICAN TECHNICAL SOCIETY
Drexel Avenue & 58th St., Dept. AA19, Chicago, Ill.

AMERICAN TECHNICAL SOCIETY,
Drexel Ave. & 58th St., Dept. AA19, Chicago, Ill.
I would like to see the new 6-volume edition of your AUTO BOOKS. I will pay the few cents delivery charges only, but if I choose to, I may return them express collect. If after 10 days use I prefer to keep them, I will send you \$2 and pay the balance at the rate of only \$3 a month, until \$24.80 is paid. Please include free consulting membership and the two extra books as per your offer above.

Name.....
Address.....
City..... State.....
Attach letter stating age, occupation and name and address of employer and that of at least one business man as reference.

When writing please mention Popular Mechanics

SAVE 25% in Fuel Cost with LACO Oil-Burning Heater



Now, your home (even without a basement) can have clean, automatic, "No-Work" OIL HEAT—at sensational saving! Two great features—new and exclusive in the oil-burner field—give LACO Tremendous Heating with Very Little Fuel Cost.

1. Famous LACO Burner. Most efficient. Same principle used in LACO's 11 years—now, improved!
2. Inner Heating Unit. Adds 30% extra heating surface! Actually delivers 20% to 40% More Heat!

More heat from less, low-cost oil! All delivered into the rooms, none wasted up the chimney! Humidifies and circulates the air. Extra durably built. 4 sizes. Largest delivers 120,000 B.T.U. of heat!

Free Book Send Now!

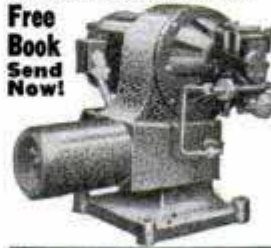

NOW—Save About \$100!

This very newest "Gun-Type" LACO equals high-priced burners in heating efficiency, yet saves you \$75 to \$100! Only 1 moving part. Almost noiseless. Uses less low-priced oil. Amazing new patented device makes heavy oil highly combustible. Factory-tested. Guaranteed. 3 sizes. WRITE Send postcard for big free book with photos, details, money-saving prices!

DEALERS Get Spl. Offer on world's lowest priced, easy-to-sell oil burner!
LACO OIL BURNER CO.
167 Union St. Griswold, Iowa

ARTISTS MAKE MONEY

Find out your ability. Send name, age, occupation and address for Free Vocational Art Test.
Federal Schools, Inc., 6137 Federal Schools Bldg., Minneapolis, Minn.

LAW HIGH-GRADE INSTRUCTION BY CORRESPONDENCE

College, Post, Grad. and Bar Ex. Rev. Courses. Law has attracted more keen, brainy men than any other calling. Send today for catalog. Low cost, easy terms. Text books loaned free.
Chicago School of Law Dept. 801, Reaper Block CHICAGO, ILL.

Men & Women Earn Cash at Home!

Raise giant Patented Mushrooms! We supply materials, instruct with pictures, & our 25 branches buy all crops. Big FREE book, photos, tell if your cellar, shed, barn, etc., suitable. Write today.
Est. 1908 UNITED CO., 3848 Lincoln Ave., Dept. 311, CHICAGO



U.S. Manufacturers desire men to learn Electric Arc Welding and get practical experience under actual production conditions in the laboratories of the School of Engineering. Moderate training Fee. Accepted applicants will be fully trained until ready to pass rigid test and assisted in securing employment.

ARC WELDING

presents one of the outstanding opportunities for steady income and future success. Welding is growing rapidly, replacing large and intricate castings, rivets, nuts, bolts, screws. It is commonly used in assembling cranes, hoists, bridges, structural steel work, etc. No limit to the application of welding to industry, increasing durability and reducing manufacturing costs. There is a decided shortage of properly trained Welding Operators, Technicians, and Welding Engineers. Why be content with ordinary work, hit and miss jobs and low pay when in a short time you can become a trained Specialist in Welding?

MILWAUKEE SCHOOL of ENGINEERING

Institute of Electrotechnics

Dept. PM-6-A. Broadway & E. State, Milwaukee, Wis.

Without obligation send Free Booklet "The Dawn of a Gigantic Industry and Its Outstanding Opportunity." Also tell me How to Become a

Welding Operator (3 mo.).....	Refrigeration and Air
Welding Technician (6 mo.).....	Conditioning Technician (3 mo.)...
Welding Engineer (1 yr.).....	Radio and Television
Electrical Engineer	Service Man (6 mo.).....
B.S. Degree (4 yrs.).....	Commercial Radio Engineer (1 yr.)...
Student Loan Plan.....	Earn Part Expense Plan.....

Name..... Age.....
City..... State..... (PM-6-A)

PATENT

your INVENTION through this RESPONSIBLE FIRM

... and Get PROMPT EXPERIENCED ACTION

We offer you the experience and proven responsibility of 61 years. Since 1875 we have rendered expert service and counsel to tens of thousands of inventors. Every member of C. A. Snow & Co. who works on your case is a Registered Patent Attorney. This is important, for only Registered Patent Attorneys may plead your case before the Patent Office.

The home of C. A. Snow & Co. is the largest building in Washington occupied exclusively by one Patent Attorney firm. We offer you thorough, competent work.

DEFERRED PAYMENTS ON REQUEST

Write today for our FREE "Certification of Invention", which is of real value to you RIGHT NOW! Also two new guides, "How We Protect You" and "Suggestions On How To Commercialize Your Invention".

C. A. SNOW & CO.
Patent Attorneys Since 1875
SNOW BLDG. Dept. WASH., D. C.



NOW-IT'S

SCIENTIFIC CRIME DETECTION that Pays BIG REWARDS

The nation's cry is for SCIENTIFICALLY trained investigators. This new training not difficult. Advanced education or previous experience not necessary. Study at home during spare time. Easy terms policy. Course includes Finger Prints, Handwriting, Photography, Investigation and Defense and Attack. Big regulation outfit free to students. Instructors nationally known experts in Scientific Crime Detection. Get into SCIENTIFIC Crime Detection and prepare for BIG EARNINGS. Send for thrilling book containing full particulars. It's FREE to any young man 17 or over.

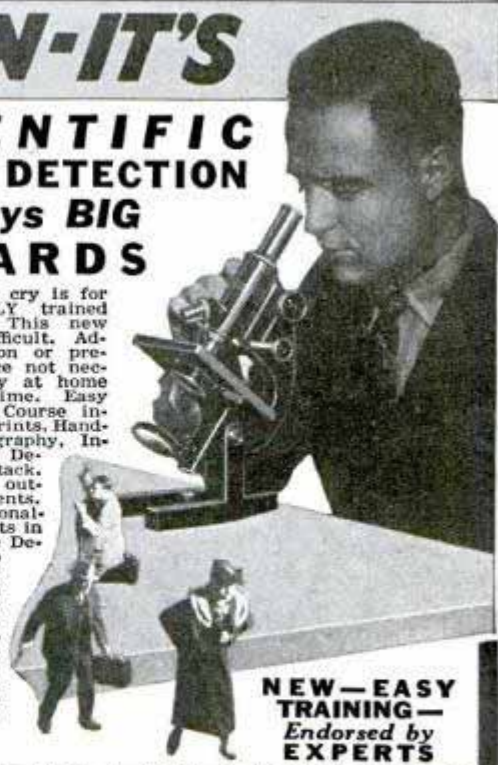

NEW - EASY TRAINING - Endorsed by EXPERTS

SCIENTIFIC CRIME DETECTION INSTITUTE OF AMERICA, INC. Dept. 2F7
Chesapeake & Ohio Bldg. J. T. Burdette, Pres.
Huntington, West Virginia

Gentlemen: Without obligation, send big book including 14 famous cases, telling how I can get it to Scientific Crime Detection.

NAME
ADDRESS..... AGE.....

The World's Biggest

Get Shop Notes for 1937! Only 50 cents. May easily be best investment of your entire lifetime. Contains 357 money-making, time-saving ideas, kinks, short cuts for mechanics farmers, home workshop fans, handymen - for everyone who uses tools. 224 pages, 357 articles, 703 illustrations. Get 1936 Shop Notes too. Only 50c. POPULAR MECHANICS PRESS Room 436 C, 200 E. Ontario St., Chicago

50¢ WORTH

SHOP NOTES FOR 1937



NEW - UNIQUE - ENTERTAINING
Saves Money. Adds to Home Comfort.
Ideal Wedding or Anniversary Gift.

Manual Press, Stockton, California:
Send me "657 Short Cuts". Here is my dollar (money order or currency).

Name
Address
Agents Wanted: Send dollar for MANUAL and BIG MONEY-MAKING Plan. (or dime for literature and plan)

\$1 POST PAID

BARBERING OR BEAUTY CULTURE OLDEST, LARGEST SCHOOLS. Est. 1893. EARN while LEARNING. Day, Night classes. Free National employment bureau. Prize winning teachers. Big pay. Professions. Low rates. Easy terms. Free booklet "B." **MOLER SYSTEM, NEW YORK, N. Y., 303 Fourth Ave.**

THIS AD IS WORTH \$2.50 TO YOU

10-FT. SUPER RADIO CHARGER

Write for information. Also learn how you can buy a DUN-CHARGER and easily EARN MORE THAN ENOUGH to pay for it. Supplies 6-volt radio and house light-current, operating at less than one cent a week.

Mail Postcard Today for FREE Literature!

PARRIS-DUNN CORP., DEPT. A10, Clarinda, Iowa



Men-Women (Age 18-50)

1937 GOVERNMENT JOBS

PAYING \$1260-\$2100 A YEAR TO START

Send for FREE LIST Telling About

Jobs, Salaries, Automatic Raises, Vacations, Pensions

SOCIAL SECURITY EMPLOYEES TO BE HIRED THROUGH EXAMINATION

MAIL COUPON FOR FREE LIST

"We will advise you where your examination will be held, and how to pass it with a high rating for early appointment."

Arthur R. Patterson (former Govt. Examiner), Principal PATTERSON SCHOOL, 86 Case Bldg., Rochester, N. Y. Rush absolutely free, list of Govt. jobs, salaries paid, etc. Send your 48 page book telling how I am to qualify.

Name
Address..... City..... State.....

THE WORLD PAYS FOR LAUGHTER!

Making people laugh is a sure way of making big money! Former unknown Artists are today famous and wealthy because their illustrations and cartoons have caused enjoyment for millions attending the movies and reading magazines and newspapers.

YOU CAN LEARN TO DRAW

—AT HOME IN YOUR SPARE TIME! We teach you COMMERCIAL ART, CARTOONING AND DESIGNING all in ONE COMPLETE course. A few pleasant hours of study and drawing a week should give you the ability to earn good money as thousands of other graduates have done during our 23 years. Necessary Artists' outfit given with first lesson.

FREE BOOK shows how

"Extra Income Paid for Course" — Says D. Peckham of Nevada



Washington School of Art, Studio 126A, 1115—15th St., N. W., Washington, D. C.
Please send me without obligation your Free Book, "Art for Pleasure and Profit."

Name..... Age.....
Address.....
City..... State.....

JUST OUT!

AUDEL'S DIESEL ENGINE MANUAL

QUESTIONS AND ANSWERS

DIESEL ENGINE MANUAL

\$2

If you are interested in the construction, operation and maintenance of modern Diesel engines, you will want this new timely book of practical, useful information.

"AUDEL'S DIESEL ENGINE MANUAL" with Questions and Answers explains in simple, concise language the Fundamental Diesel Principles—Operating Principles—Engine Starting—Air Starting Valves—Fuel Spray Valves—Inlet and Exhaust Valves—Valve Timing—Fuel Pumps—Fuel Injection Compressors—Starting Air Compressors—Scavenging Air Compressors—Pistons and Piston Rings—Cylinders—Lubrication—Cooling Systems—Fuel Oil—The Engine Indicator—Governors—Engine Reversing—Semi-Diesel Engines—High Speed Diesel Engines—Answers on Operation—Horse Power Calculations.

The illustrations and texts are clear and easy to understand. All details are plainly brought out. This book is of extreme value to engineers, operators, students and all who desire a knowledge of the Diesel engine. A handsome book, flexible, with gilt edges. 300 pages—illustrated.

Send for free Diesel folder today.

FREE EXAMINATION COUPON

THEO. AUDEL & CO., 49 W. 23rd St., New York

Please mail a copy of AUDEL'S DIESEL ENGINE MANUAL. If satisfactory, I will remit \$2 on its safe arrival, otherwise I will return the book.

\$2

Name.....
Address.....
Occupation.....PM

AMAZING NEW ELECTRIC ARC WELDER

COMET

RETAILS Only \$1.95 Complete

HOOK UP TO ANY BATTERY!

Just invented! Amazing new Comet ELECTRIC ARC WELDER—hooks up to any storage battery—generates tremendous heat to weld all metals. PRICE, ONLY \$1.95, complete. Repairs fenders, auto bodies, galvanized cans, radiators, brass castings, machinery parts, etc. Low power consumption. Take the Comet anywhere to the job, operate from auto battery. Sturdily built of finest materials to last years. FULLY GUARANTEED BY BIG MANUFACTURER.

SEND NO MONEY! You'll find a thousand uses for the Comet around your home, garage, and work shop. Thousands of garages need the Comet Welder. Also factories, repair shops, mechanics, farmers, inventors, tin shops, plumbers, etc. Order a Comet now. Send no money. We'll rush one to you, complete with rods. Pay postman only \$1.95 plus few cents postage. If not delighted, return Comet in 5 days from receipt and money you paid for it will be refunded instantly. Rush your order NOW. Comet Welders, Dept. W-155, Cincinnati, Ohio



MAKE \$10 DAILY WITH YOUR CAMERA

COMPLETE INSTRUCTIONS 50¢

EDUCATIONAL PUBLICATIONS, DEPT. 61, P. O. BOX 995, BALTIMORE, MD.

Amazing SIGHT-CORRECTING ART COURSE

Teaches you QUICKLY to draw for Profit or Pleasure. 150 \$ easy lessons. Simple, Practical. Nothing like it! Complete with drawing paper \$1 Postpaid or sent C.O.D. Satisfaction Guaranteed. Artists & Models Studio, Dept. PM-81, Memphis, Tenn.



NEW TYPE CHEAP OIL BURNER

COOK and BAKE Without Coal, Ashes, Dirt — Twice the Heat, at SMALLER COST.

COOKS A MEAL for LESS

Slips into Any Old Stove, Range or Cooking Stove. No Ashes, Dirt — Twice the Heat, at SMALLER COST.

Beats any oil burner ever gotten out for low cost, perfect performance. Slips into any old stove, range or furnace; burns cheap oil a new way without pre-generating or clogging up. Intense heat quickly by Simple Turn of Valve.

Quick Heat at TURN OF VALVE



AGENTS Salesmen BIG MONEY

IT'S SWEEPING THE COUNTRY. GET YOUR OWN BURNER FREE AND MAKE REAL MONEY. Write quick.

COOLER KITCHEN IN SUMMER

Prove it ends drudgery and dirt of coal or wood; cuts fuel bills in half, pays for itself quickly by what IT SAVES.

FREE SAMPLE FOR AGENTS

offered to one energetic man or woman in each locality who will demonstrate and take orders. Write quick, be first to learn how to make REAL MONEY—mail 1c postcard today.

UNITED FACTORIES, G-751, Factory Bldg., Kansas City, Mo.

GET THIS GORGEOUS RING ON APPROVAL

We challenge you to tell it from rings costing up to \$300. Wear at our risk. Your friends will envy its sparkling beauty. Mail 10c to cover shipping costs and we'll send on this exquisite full Carat facsimile Diamond, in newest style. Pay only \$2.25 monthly until balance of \$4.50 is paid. Money back if not satisfied. Send strip of paper showing finger size. State if man's or lady's. Ring sent postpaid to your door by return mail. Rush 10c, stamps or coin to:

Raymor, 203 N. Wabash, Dept. 24, Chicago, Ill.





New Profession *Air-Conditioning*

offers amazing opportunities to trained men right now. Here is a growing industry which is bound to provide thousands of good jobs with **BIG PAY**.

Learn at Home

Train yourself **NOW** through our Home Study Method without interfering with your present work. All instruction is under the direction of the staff of this great school. Information is free. Write now.
American School, Drexel at 58th, Dept. ACA-45, Chicago, Illinois

1937 COMBINATION OUTFIT STARTS HOME BUSINESS

Resilvering mirrors, spoons, reflectors. Making chipped glass name plates, signs. Small investment. Write,
SPRINKLE, Plater, 129, Marion, Indiana

A Billion Ideas

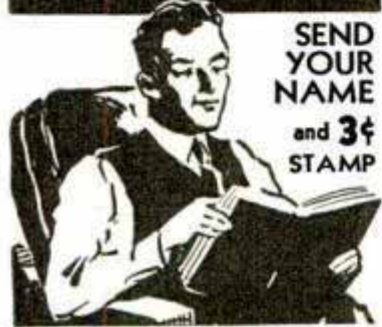

SEND
YOUR
NAME
and 3¢
STAMP

in POPULAR MECHANICS BOOK CATALOG

Every man who reads Popular Mechanics will want this new big illustrated catalogue of practical, helpful and money making books. It describes over 5,000 informative and authoritative books, alphabetically arranged under a thousand subjects—everything from ACCIDENT PREVENTION to X-RAYS. It's an amazing guide to the world's BEST practical books. You must see it to appreciate its value. Only limited edition printed. Send your name and address and three cent stamp to cover postage on your copy. Do it today.
**Popular Mechanics Press
200 E. Ontario St., Chicago**

Extra Money From Books

SEND NO MONEY • Books Sent C.O.D. Anywhere in U.S. These famous Pay-Raising, Extra Money Books have helped thousands of others. Let them help you too. Check this list and mail with your name and address. Pay postman on delivery plus few cents postage. Send 3c stamp to cover postage and ask for catalog of other books.



SELECT FROM THIS LIST

- ARMATURE WINDING**
For A.C. and D.C. Machines..... \$2.00
- AUTO REFINISHING**
Duco With Spray Gun... \$1.50
- BLUEPRINT READING**
For Machine Trades... \$1.50
- BRICKLAYING**
Plain and Fancy..... \$1.50
- CARBURETORS (All Makes)**
New, Revised Edition... \$2.50
- CHEVROLET SIX**
Car, Truck, Operation
Repair..... \$2.50
- COLONIAL FURNITURE**
Making, 95 Pieces..... \$3.50
- DANCE**
Learn at Home Without
Music or a Partner... \$2.00
- DIE CASTING**
Machines, Dies, Alloys... \$3.00
- ELEMENTS DIESEL**
Engineering Questions
and Answers..... \$4.00
- FOUNDRY WORK**
Molding, Casting, etc. \$2.00
- FURNITURE REPAIRING**
Finishing and Decoration..... \$3.00
- HEATING, VENTILATING**
Homes and Buildings... \$2.50

- HIGH-SPEED DIESELS**
New, practical, non-technical..... \$2.50
- INVENTIONS**
1500 Needed... \$2.50
- LEATHER MAKING**
and Home Tanning... \$1.00
- MACHINE SHOP WORK**
Tools and Methods... \$2.50
- MAGICIAN'S MANUAL**
New, 100 Tricks for
Amateurs..... \$1.39
- METAL SPINNING**
Practical New Book... \$1.00
- MONEY MAKING FORMULAS**
10,000 Practical..... \$4.00
- MOTOR VEHICLE**
'Trouble Shooters'
Handbook..... \$2.00
- PLASTERING**
Best Instruction Manual..... \$1.25
- RADIO PHYSICS COURSE**
New edition. Everything about Radio... \$4.00
- SHEET METAL**
Construction Work... \$2.00
- STEAM ENGINEER'S LICENSE**
How to Obtain..... \$2.00
- STEEL SQUARE**
Hodgson, 500 pp.
300 illustrations... \$2.00
- TAXIDERMY, HOME**
Mount Trophies
Profit, Pleasure... \$1.50
- WROUGHT IRON WORK**
Practical..... \$1.35

POPULAR MECHANICS PRESS

Room 637A 200 E. Ontario St., Chicago

MIDWEST.

FACTORY TO YOU
SAVES 50%



18 TUBES For the Price of 10

Why be content with an ordinary 6, 8, 10, or 12-tube set when you can buy an 18-tube deluxe Midwest for the same money... direct from the factory, at half the cost! Not a cut-price set, but a more powerful super-performing radio in a big, exquisitely designed cabinet.

Only
\$39.95
AND UP
(LESS TUBES)

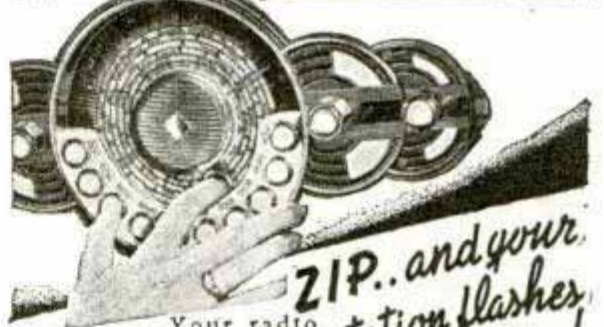

ZIP.. and your station flashes in!

Your radio enjoyment is doubled with Dial-A-Matic Tuning* (*optional) the amazing new Midwest feature that makes this radio practically tune itself. Zip!... Zip!... Zip!... stations come in instantly, automatically, perfectly... as fast as you can push buttons.

30 DAYS FREE TRIAL

You have a year to pay... terms as low as 10c a day... you secure privilege of 30 days free trial in your own home. Other Midwest radios complete with tubes and console, \$29.95 and up! (*Base price, less tubes and console).



SEND FOR FREE
40-PAGE CATALOG

... and see why Midwest gives you so much more radio for so little money! You are triply protected with Foreign Reception Guarantee, One-Year Warranty and Money-Back Guarantee.

Dept. P-15, Midwest Radio Corp., Cin'ti, O.

MIDWEST RADIO CORPORATION
DEPT. P-15 CINCINNATI, OHIO

Send me your new FREE 40-page catalog.

Name.....

Address.....

Town..... State.....

User-Agents Make Easy Extra Money. Check Here for details.

When writing please mention Popular Mechanics

FOL' JUDGE ROBBINS

THE JUDGE TAKES A TRIP - HE IS WITH CHUBBINS SEEING THE SIGHTS OF NEW YORK



OH, DADDY - WHERE SHALL WE START OUR SIGHT-SEEING?

WELL, 'SPOSE WE FOLLOW THE METHODS YOUR GRANDFATHER WOULD HAVE USED



EXCUSE ME, SIR - BUT I'M CURIOUS TO KNOW HOW YOU CAN SMOKE A PIPE IN THIS GALE

SURELY YOU KNOW THAT YOU CAN SMOKE PRINCE ALBERT ANYWHERE. IT STAYS PUT



YOU SEEM TO HAVE REACHED A NEW HEIGHT OF ENTHUSIASM FOR PRINCE ALBERT, DADDY

WELL, I SURE APPRECIATE BEING ABLE TO SMOKE AND ENJOY THIS VIEW AT THE SAME TIME



HOW DO YOU MEAN - LIKE GRANDFATHER?

HE WAS A FRONTIERSMAN. WHEN HE WAS IN STRANGE TERRITORY, HE WOULD CLIMB THE HIGHEST TREE AND RECONNOITER. SO WE'LL GO UP IN THE TALLEST BUILDING THE EMPIRE STATE, AND LOOK AROUND



I'LL BET GRANDFATHER NEVER-IMAGINED A BUILDING LIKE THAT

NO - NOR A PIPE TOBACCO AS CHOICE AND MILD AS THIS MODERN SMOKE - P.A.

Copyright, 1937, R. J. Reynolds Tobacco Company

"THAT PRINCE ALBERT 'CRIMP CUT' CERTAINLY PACKS AND DRAWS TO PERFECTION"

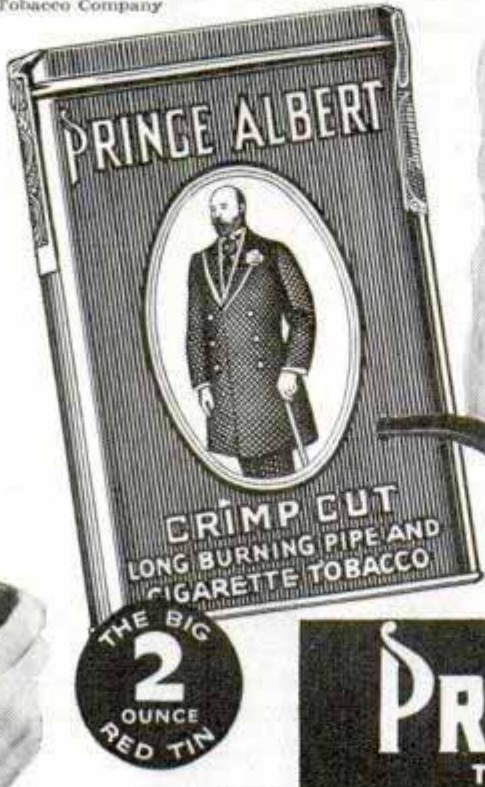

TRY P.A. ON THIS MONEY-BACK GUARANTEE!

SMOKE 20 FRAGRANT PIPEFULS OF PRINCE ALBERT. IF YOU DON'T FIND IT THE MELLOWEST, TASTIEST PIPE TOBACCO YOU EVER SMOKED, RETURN THE POCKET TIN WITH THE REST OF THE TOBACCO IN IT TO US AT ANY TIME WITHIN A MONTH FROM THIS DATE, AND WE WILL REFUND FULL PURCHASE PRICE, PLUS POSTAGE.

(Signed) R. J. Reynolds Tob. Co., Winston-Salem, N. C.



ALSO TRY ROLLING YOUR OWN WITH P.A.

PRINCE ALBERT
THE NATIONAL JOY SMOKE

When writing to advertisers please mention Popular Mechanics

Popular Mechanics Magazine

REGISTERED IN U. S. PATENT OFFICE AND CANADA

WRITTEN SO YOU CAN UNDERSTAND IT

Vol. 67

JUNE, 1937

No. 6

The MUD that RUNS the WORLD

Flames shooting 100 feet high from burning well in Texas field. Note wreckage of derrick. Below, gas escaping from well after failure of mud circulation has caused it to blow drill equipment out of the hole



MUD, to the average mother, is just something the children track in on her rugs after a hard rain, but to the oil-fields worker it's a life-saving substance that enables him to drill deep wells with less danger of fire.

Beside every modern well in the process of drilling is the mud pit. The mud is a concoction of dirt, water and commercial drilling fluid which is pumped into the hole through the inside of the drill stem. Properly compounded, it is heavy enough to hold back gas pressures up to 3,000 pounds per square inch and to prevent the gas from blowing the drill right out of the hole.

When the mud reaches the bottom, it picks up material which the bit has cut

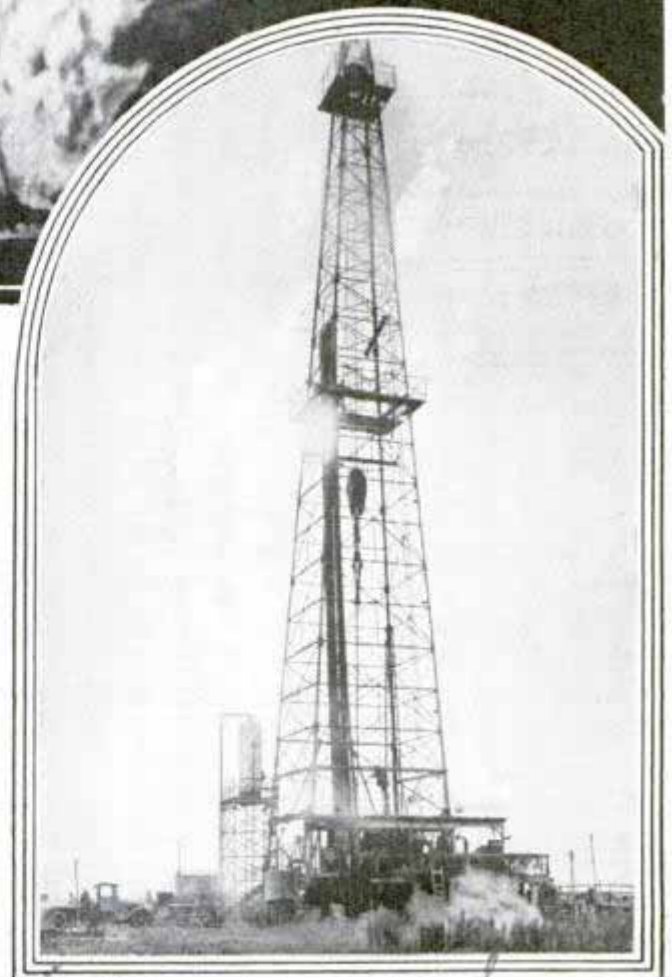

Oil Well with Miller, 457 ft

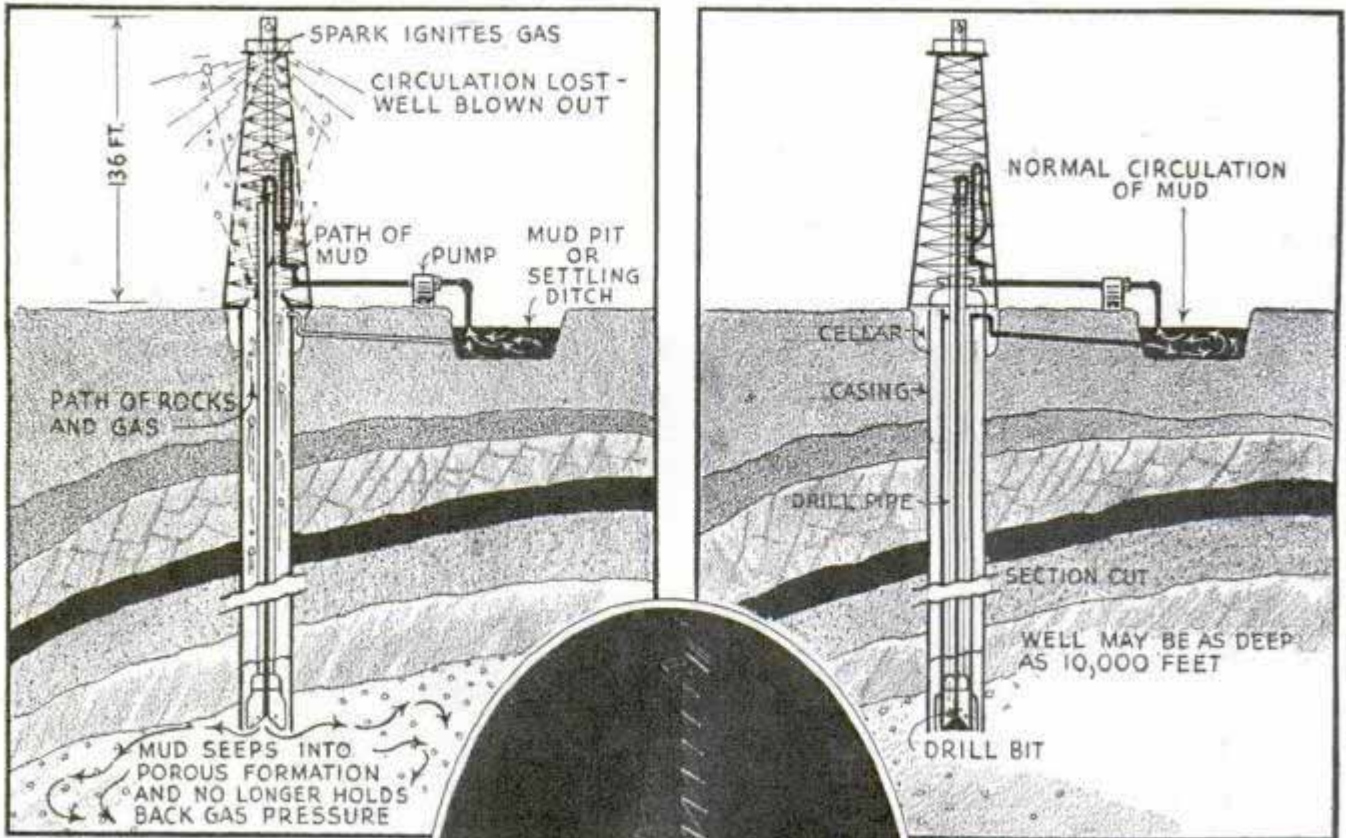

loose and travels back up the hole outside the drill stem, thence into its pit. On its return trip it also serves to seal the lower part of the hole into which the permanent casing has not been driven.

In the early days when oil wells were comparatively shallow holes the gas pressure was controlled by pumping water down the bore. But water, as a drilling fluid, left much to be desired.

Frequently its weight was reduced so much when it mixed with gas that it could not hold back the gas and the well "blew out." Anyone who has seen the flaming horror of a blown-out well after that gas catches fire can understand the dread with which drillers regard its possibility.

Then came the rotary drill with which deeper wells could be bored, intensifying the need for a drilling fluid more efficient than water because the deeper the well the greater the gas pressure. Then someone hit upon the idea of using mud and later commercial drilling fluids were developed to mix with it.

But not all danger is eliminated by the

mud. Sometimes a bit will encounter a formation so porous that the mud is unable to seal it. Then the mud leaks into surrounding strata and is lost. No drilling fluid returns to the surface and "circulation is lost," meaning that drill cuttings accumulate in the hole and gas pressure may blow out the bit and drill stem. Added to this is the danger that the escaping gas will be ignited

and that roaring flames will turn the derrick into a mass of twisted steel, perhaps spreading to other wells.

There is only one way to get back circulation and that is to plug the holes in the underground formation by stuffing fibrous substances down the well. So a member of the drill crew, known in the fields as a "tool pusher," hurries over to the nearest farmer and shouts:

"I want your haystack to put down an oil well!"

Usually the farmer stares in amazement until the tool pusher grabs him by the arm and explains:

"See that? That's an oil well we're try-

Left, what happens when mud circulation is lost. Note gas and rocks rushing upward. Right, normal circulation, with mud holding back gas pressure. Below, California well catches fire after blowing out

ing to drill. We've hit a formation with more holes in it than a sieve. If we don't get your haystack to plug those holes, we might as well quit. How much do you want for the stack?"

When the farmer names his price, most likely a good one, the tool pusher pulls out his money and pays. Other members of the crew quickly load the hay on a truck and within ten minutes are forking it into the mud pit from which it can be pumped into the well casing.

Slowly the haystack disappears. More than a mile below the surface of the ground it begins to do its work, the strands of hay filling the pores and cracks in the formation. As the gaps are plugged, the precious mud is directed back into its proper channel, instead of seeping away into the formation.

"Circulation" is again established and the well saved.

The story of this fight to keep the mud circulating during the drilling of deep wells is one of the most thrilling chapters in the history of modern engineering. It is a story sometimes humorous, sometimes tragic. Shirts off the workers'

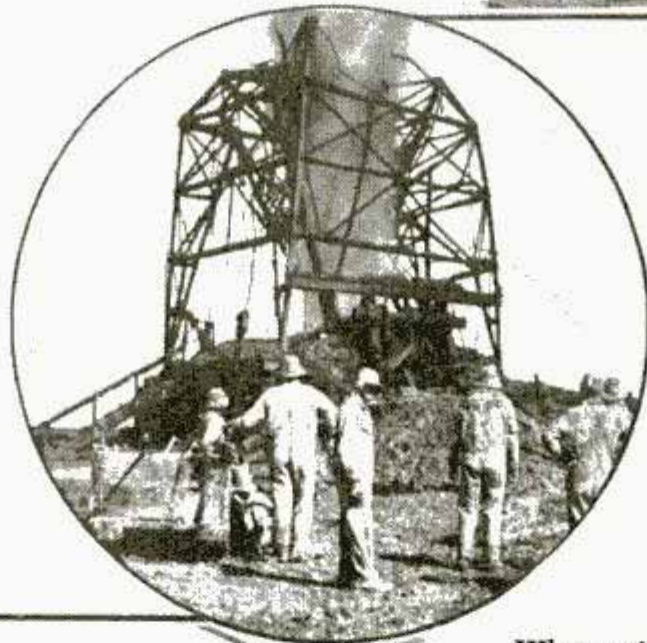

Top, machinery on derrick floor. Center, derrick crumples as well blows out. Bottom, oil-fire wreckage

backs have sometimes been used to help plug holes in porous formations. Old straw hats, worn-out automobile tires, discarded upholstery, and similar rubbish are salvaged from city dumps and shoved into the well. Sweepings from barber shops make excellent material for this purpose.

When circulation is lost, the chief tool pusher seldom stands on ceremony. Articles are often taken—and paid for afterwards, at whatever price the owner demands. Clothes have been jerked from lines. Straw and hay have been confiscated. Excelsior, beet pulp, and cottonseed hulls are used when these can be procured in time. Wood fiber and pieces of rope are also used. Commercial cement, specially designed for this purpose, often saves the day—when there is time to get it.

There is a famous case of a well in Texas. The bit bored into an

(Continued to page 126A)

Handwritten signature

Camera Peers into Secret 'Brain' of Warship

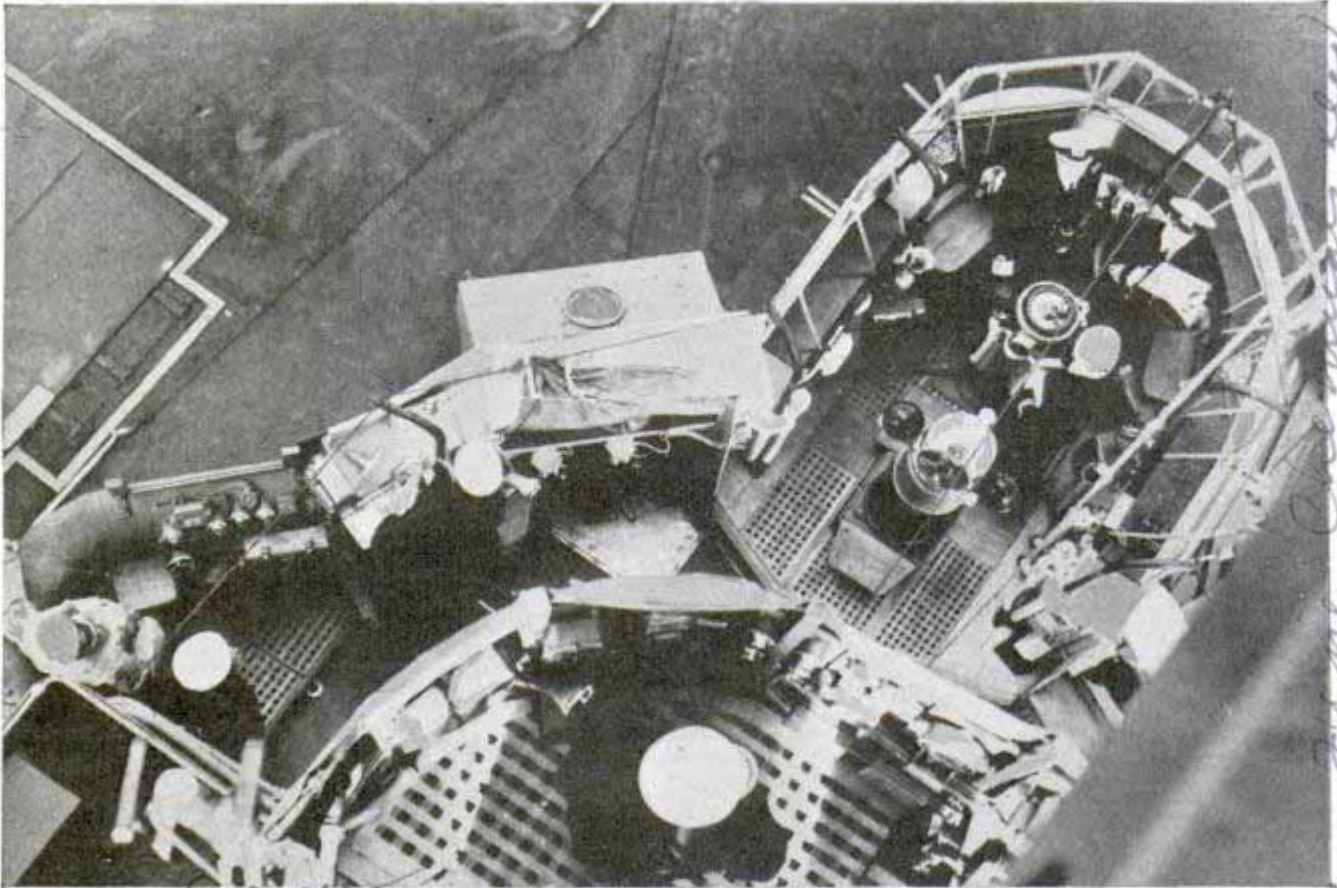

This "war bird's-eye view" of admiral's bridge and captain's bridge of H.M.S. "Courageous," a spot usually forbidden to visitors, was caught by cameraman during British fleet maneuvers

Looking down on the secret "nerve center" of the British aircraft carrier "Courageous," a cameraman snapped his shutter while the commanding officers were at their posts. His picture showed a war bird's-eye view of the admiral's

bridge, in the foreground, and beyond it the captain's bridge with its binnacle and speakers and battery of telephones reaching every part of the ship. The photograph was taken during maneuvers of the British fleet in the south Atlantic.

Three-Power Shaving Light Has Socket for Electric Razor



Handy lamp with three light intensities has convenient socket for electric razor

Equipped with an outlet for electric razor or vibrator, a new three-power lamp is handy for bathroom or dressing room. For normal use the switch provides forty or sixty watts. When an especially strong light is desired, for applying make-up or shaving, the switch produces 100 watts.

Clothes Given "Fresh Air" Odor by Ozone Perfume

Intended for use in laundries, an ozone perfume gives a "fresh air" smell to clothes. It carries the odor of fresh air, giving clothes dried in steam chambers and other devices a smell of freshness like that they would have if dried outdoors.

Geolite Corp; Trenton, N.J.

Vertical handwritten notes on the right margin, including "Remanish" and "H. J. du Pont de Nemours & Co."

H. J. du Pont de Nemours & Co.

Giant 'Floating' Sphere to Be Wonder of Fair

Wonders at the New York World's Fair in 1939 will be a white sphere 200 feet high and a 700-foot triangular obelisk. The sphere apparently will float on a cluster of fountains, being supported by eight glass-incased columns set in the center of a giant pool. The columns will be sheathed in jets of water to simulate fountains. Glass-inclosed escalators will carry visitors over the pool to an entrance in the side of the sphere where they will step on a moving platform to be carried around the edges of the giant ball. Below the platform will be a great panorama of human progress. Weighing 5,760,000 pounds, the sphere will be of articulated steel-frame construction with an inner and an outer shell. The obelisk will be the "Voice of the Fair" from which announcements will be broadcast.

located near Flushing Meadows.

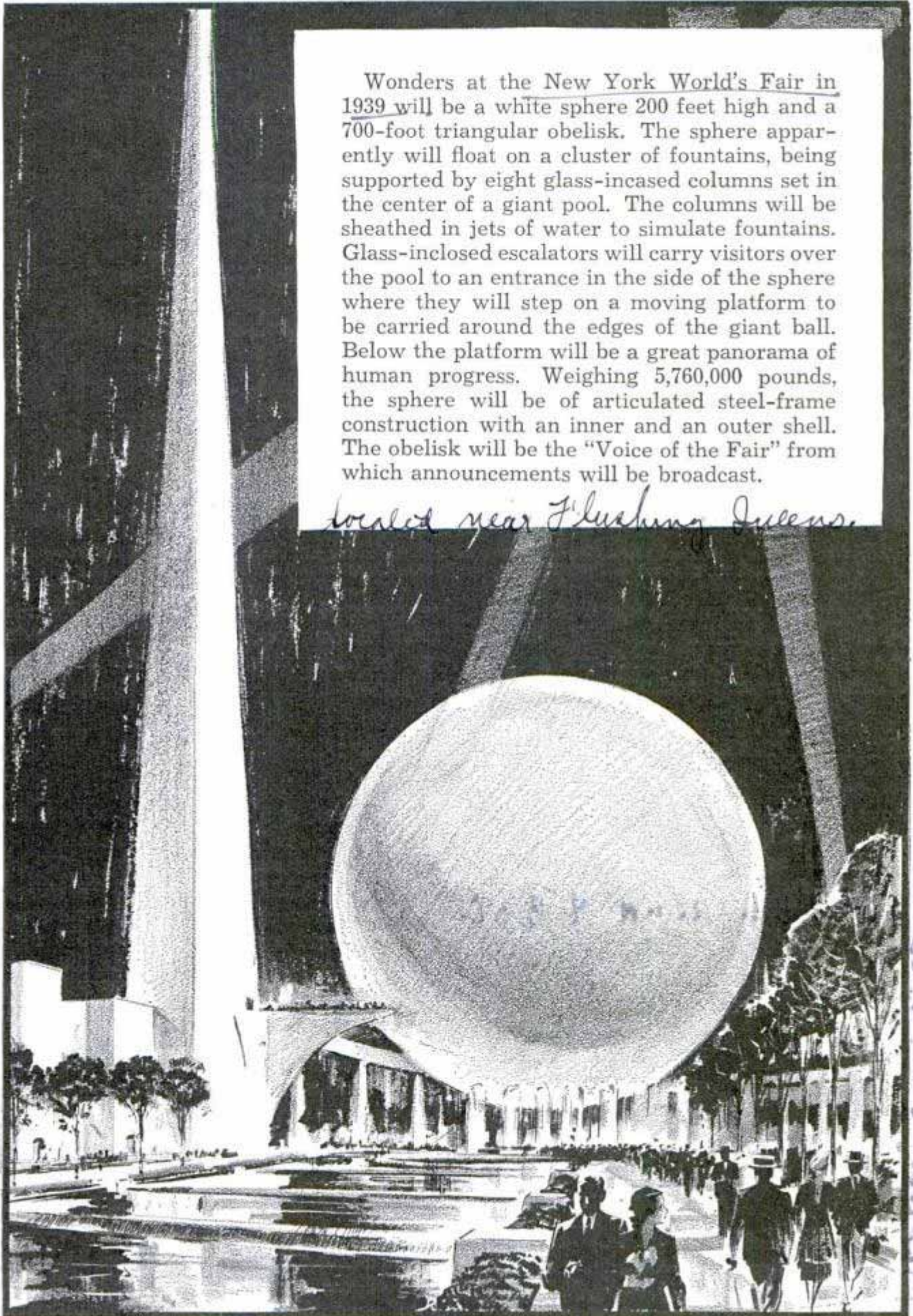

*New York Times
10/10/39*

*Unisphere
Flushing Meadows
1939*

Quarter Million Tons of Ships Side by Side

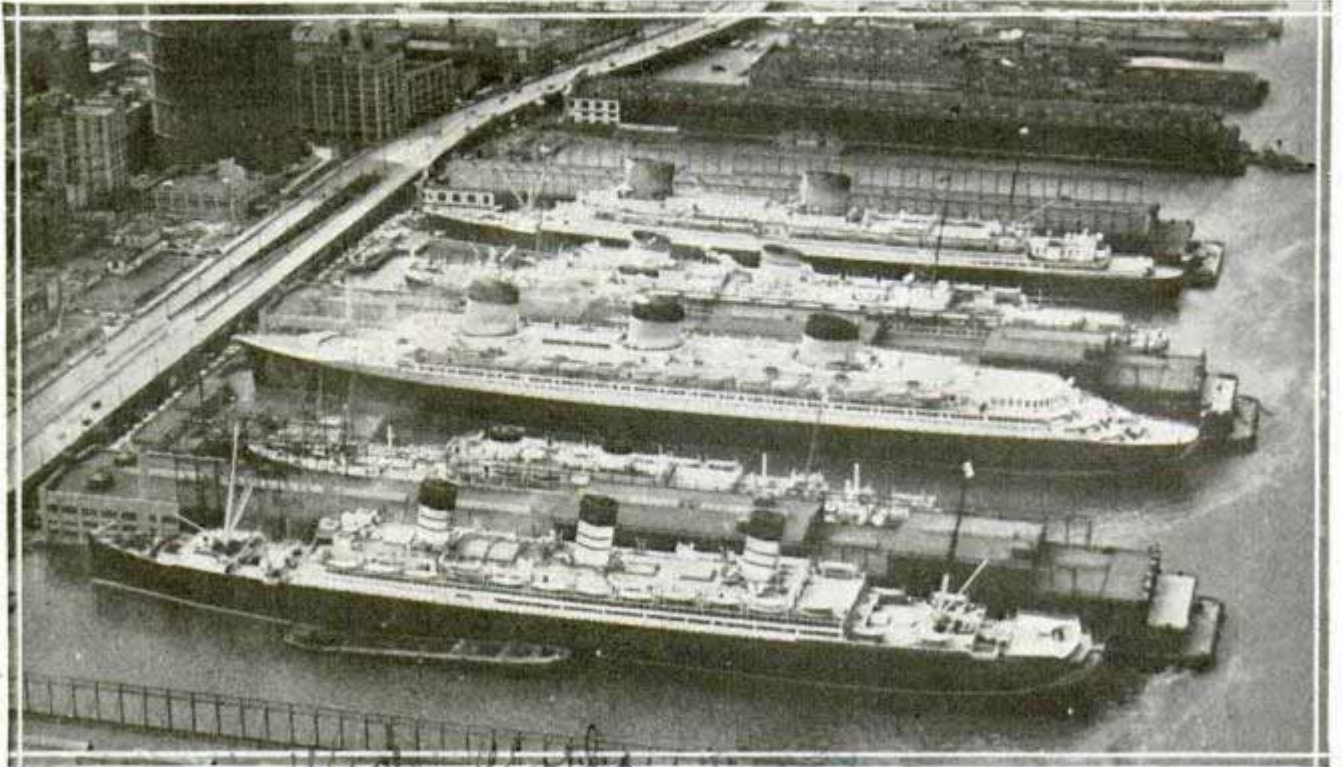

Lined up at their New York piers, from front to rear in the photograph, are the Berengaria, the Georgic, the Normandie, the Rex and the Europa, rarely seen together in such neighborly grouping

Five great ocean liners at rest in adjoining berths in the New York harbor were caught by a photographer in an unusual view from the air. Together they

represented 250,000 tons. The French liner "Normandie," largest of the quintet, can be easily recognized at the center of the group.

Night Driving Glasses Stop Glare but Give Clear View

Glare from the lights of approaching cars is eliminated without interfering with vision directly ahead by night driving glasses of unusual design. The lens of dark-colored plastic composition rests in

front of and above the eyes like a shade, being placed at a sufficient distance from the eyes to cast a shadow from the oncoming lights across each pupil. When properly adjusted to the eyes of the wearer, the portion of the lens above the eyes protects from headlights 400 or 500 feet distant. As the car comes nearer, the eyes are protected by the portion of the lens to the left of each eye. Due to the angle from which the light from headlights reaches the shield, the glasses stop the glare without obstructing vision straight ahead. In other words, the left side of the road is "dimmed" for the wearer, but the right side is left clear. This effect is produced without the wearer moving his head down or sidewise if the glasses are correctly adjusted. The wearer has good vision, unobstructed by the glasses, on his own side of the road and there is no "blind spot" accompanying oncoming headlights.

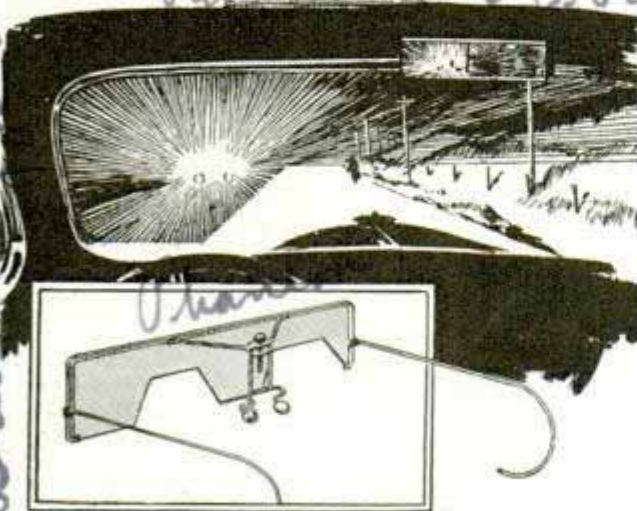

These night driving glasses shade the eyes from glare without affecting vision straight ahead

Lawrence Lawrence
c/o Brewer & Co

es 236.

Pak Rena 8 3.50

1617 University

Tug Gets a Lift over Unfinished Lock at Dam

River traffic goes on while work on the ship locks of the great Bonneville dam is being completed, and a powerful crane stands by to help Columbia river boats over the hurdle. When finished, the locks will permit ocean-going vessels to pass the dam, forty miles above Portland, Ore. Meanwhile, the crane lifts small craft past the temporary bulkhead.

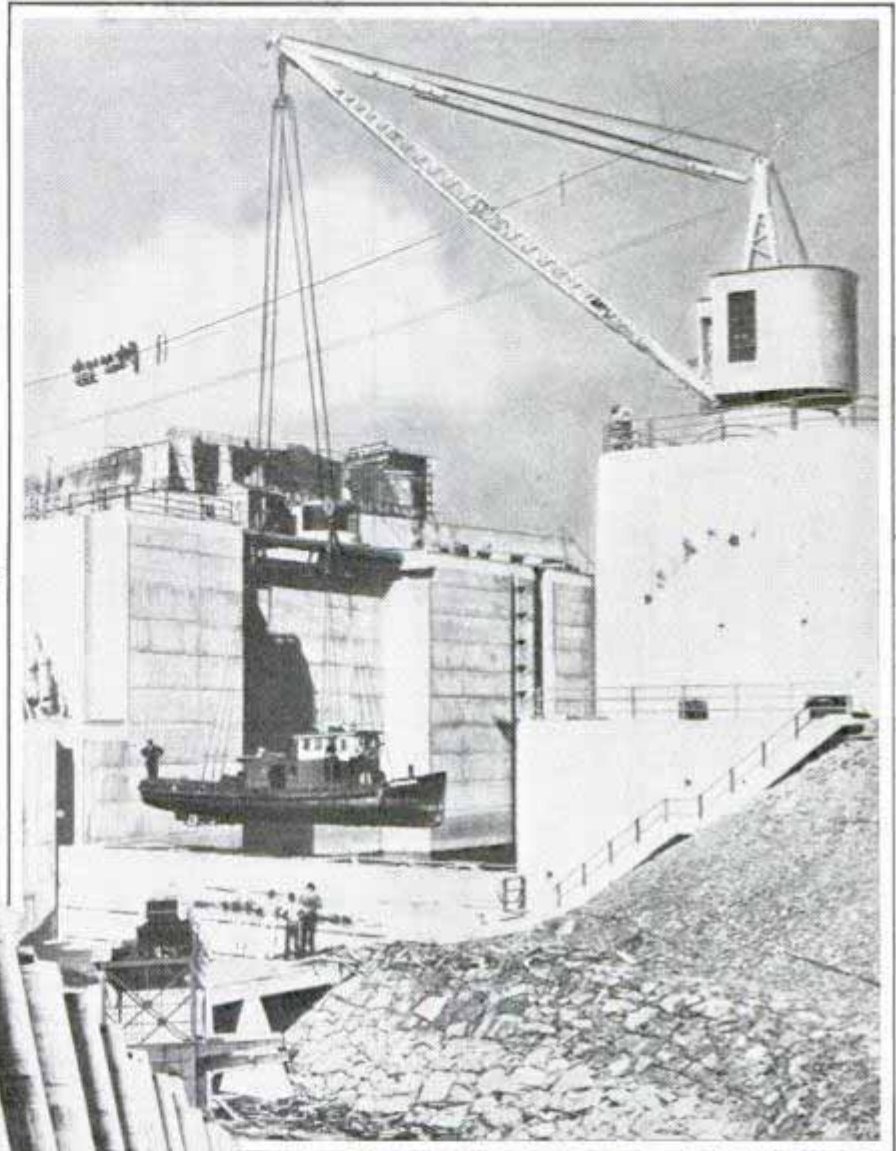

acme

Above, Columbia river boat is being lifted bodily by powerful crane over temporary bulkhead in Bonneville dam, forty miles upriver from Portland, Ore. When lock is completed, it will permit passage of ocean vessels. At left, standing ninety-two feet above ground, are the piers forming powerhouse substructure



es 363

Heavy Water May Prolong Life by Slowing Bodily Wear

Ten years or more may be added to man's life by drinking heavy water, predicts Dr. James E. Kendall, head of the chemistry department at Edinburgh University, in Scotland. Heavy water, containing the heavy hydrogen atom, has the same effect on the body as lowering its

temperature, but it does not actually reduce the temperature. It would slow functional processes, reducing bodily wear and tear without appreciably impairing man's faculties. Dr. Kendall believes persons over sixty soon will drink heavy water to slow the pace of life and prolong it.

American Chemical Society

Clippers Pioneer Air Trail to New Zealand

*Pan American Airways?
135 E 42nd Street New York City*

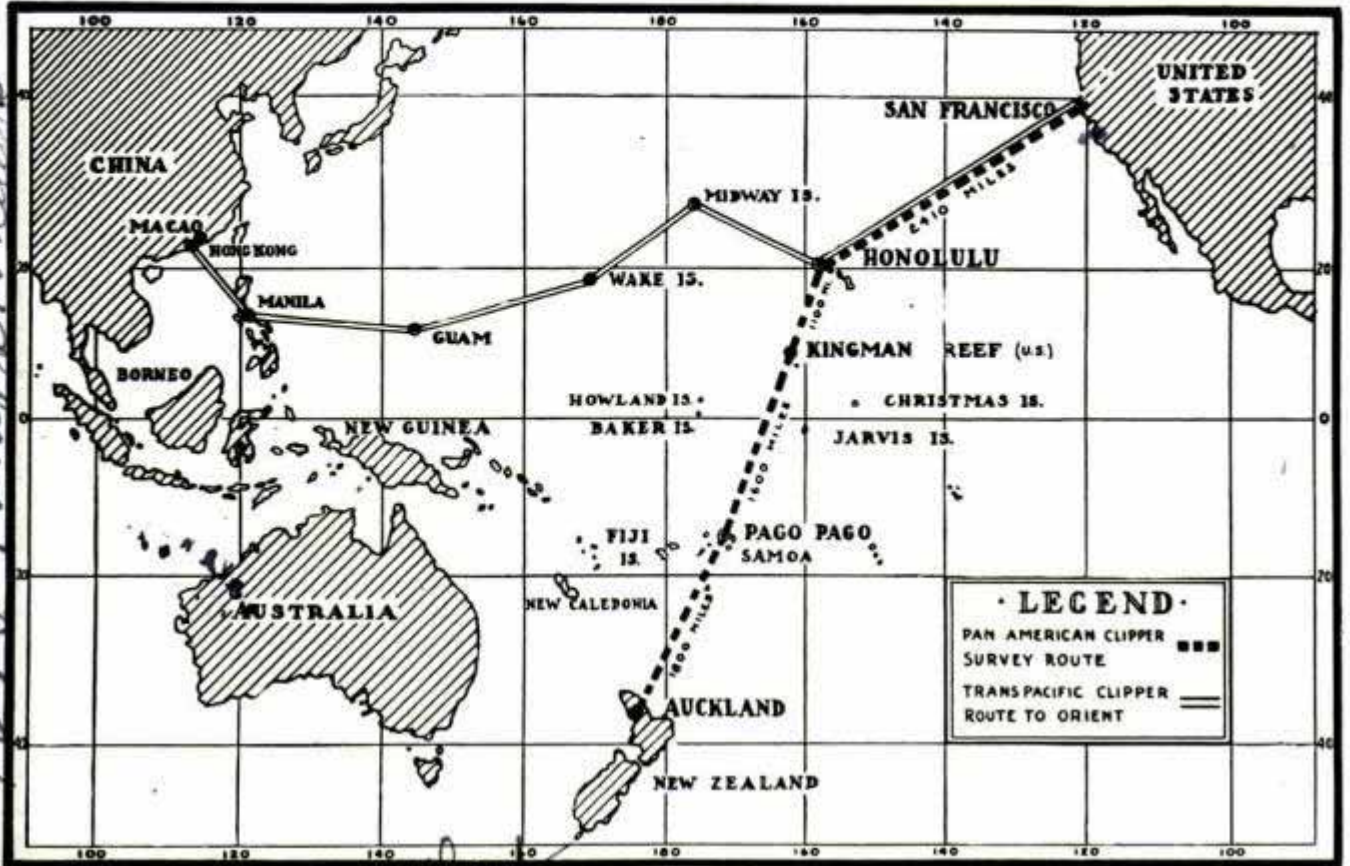

Dotted line traces projected Pan-American Airways route between San Francisco and Auckland, New Zealand, blazed by clipper ship on pioneer flight. Stops are planned at Kingman Reef and Pago Pago

Pan-American clipper ships are blazing a new trade route through the air between the United States and New Zealand. The first "hop" of this 7,000-mile route is already a part of the trans-Pacific lane, the

2,410-mile flight from San Francisco to Honolulu. Thence the clippers would fly 1,100 miles to Kingman Reef, another 1,600 miles to Pago Pago, and a final 1,800-mile lap to Auckland, New Zealand.

Big Model of Sleeper Plane Opens Roof to Show Cabins

*Douglas Aircraft Co
Santa Monica
Calif*



Cabin roof of model sky liner is lifted to show appearance during night flight, some passengers in lounges and others asleep in their berths

Furnished in miniature exactly like a giant sleeper plane, a model of the latest Douglas sky liner opens its roof to reveal its accommodations. Tiny figures represent the passengers and crew, some of them in their berths, some in lounge seats and others at a card table.

To rid steamships of rats and vermin, Dry Ice is mixed with ethylene oxide and the resultant gas, harmless to man if properly handled, is circulated through the hold.

*24th Nov 1935
W. W. Walker*

W. W. Walker

THINGS ARE NOT WHAT THEY SEEM

PART I

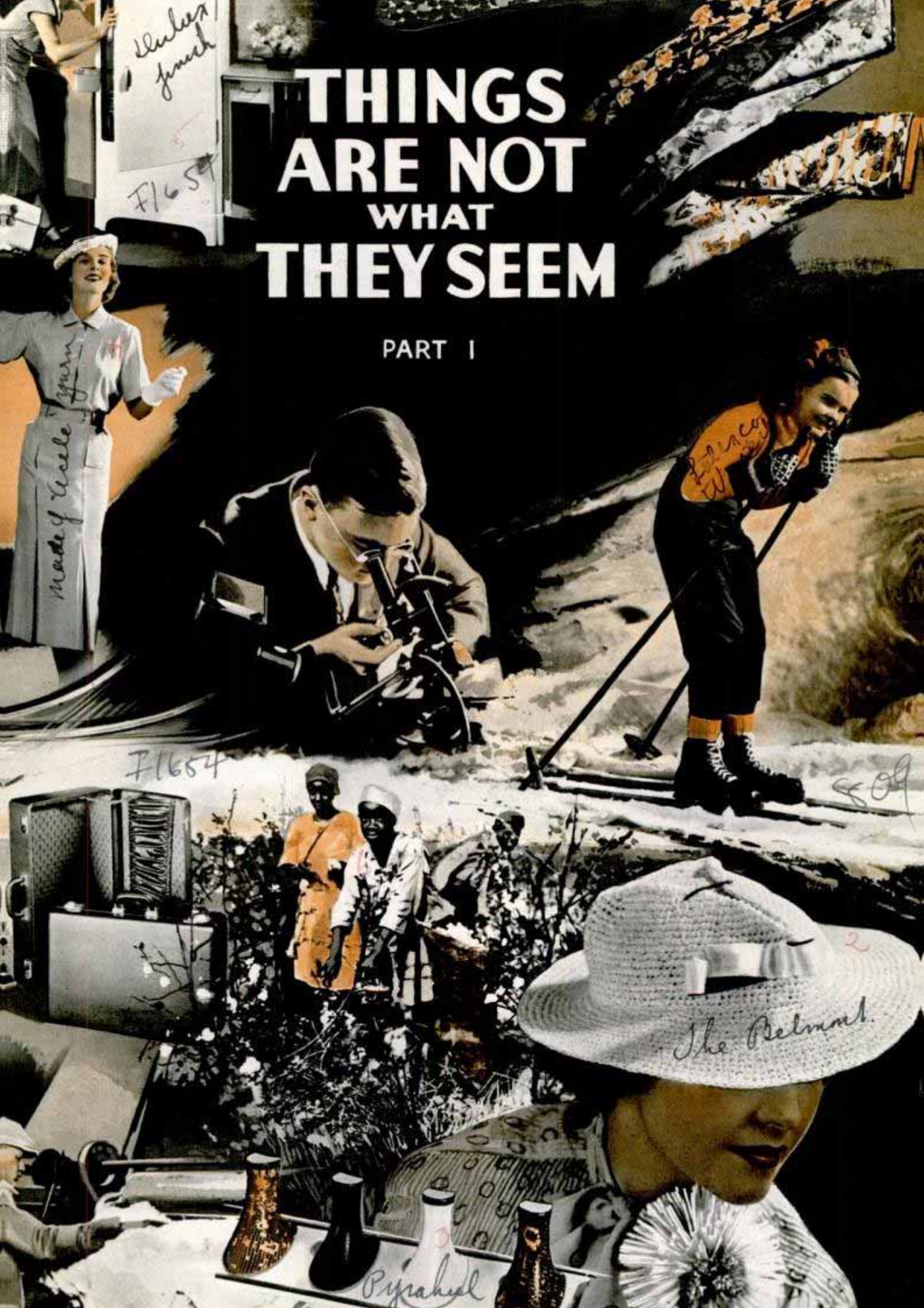

Ladies lunch
F1654

Made of Laclede's yarn

71654

The Belmont

Pyrexial

G. O.

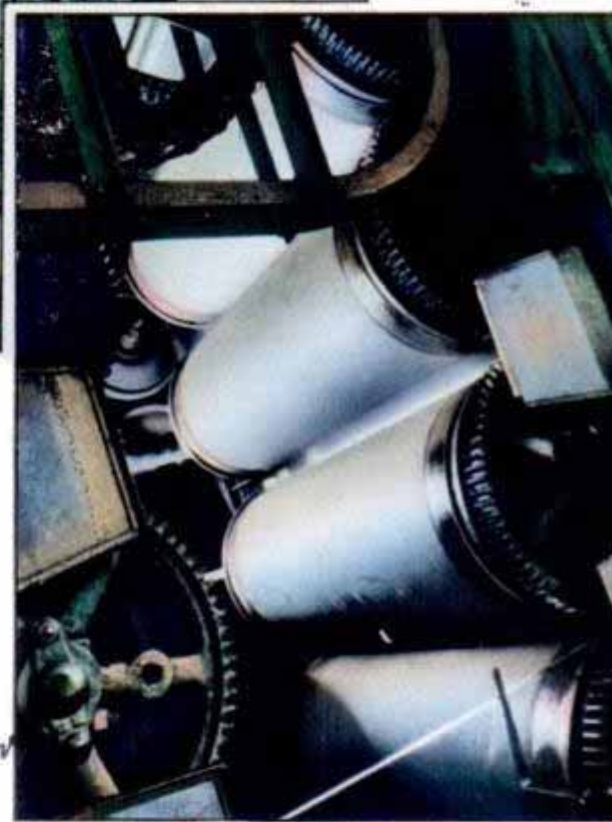
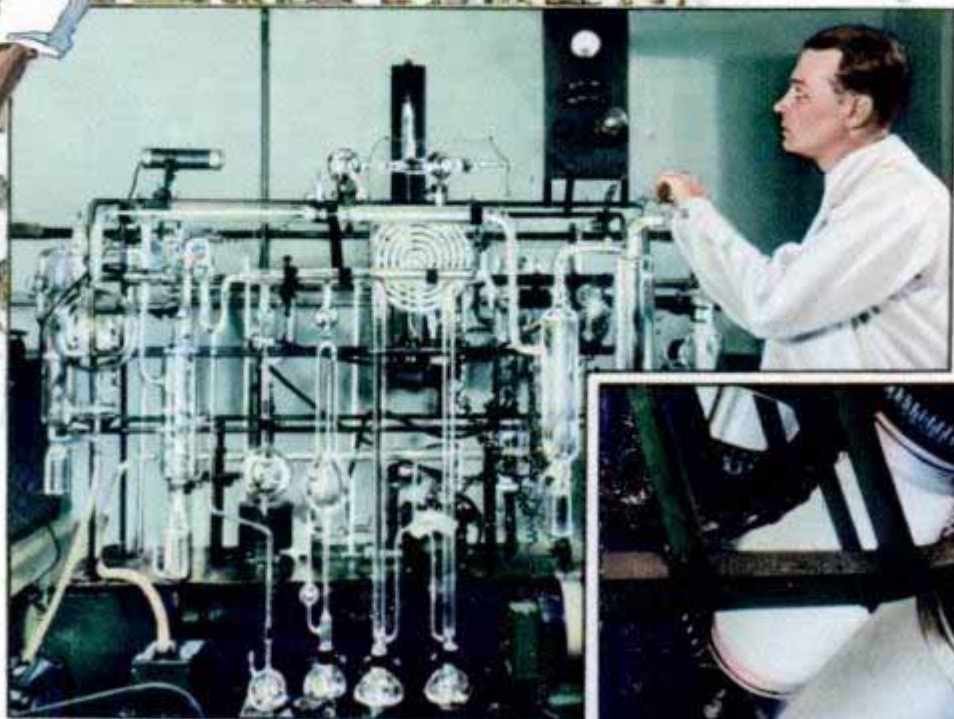
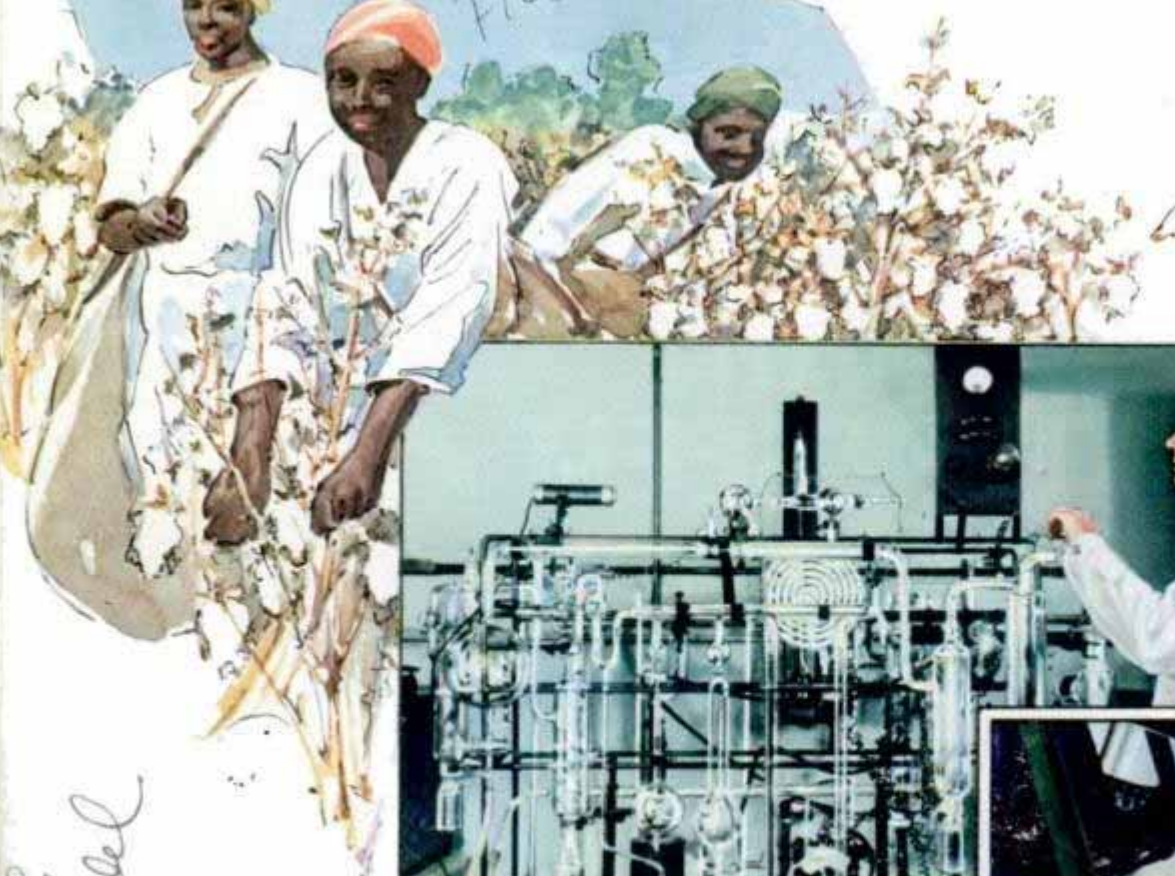

RESEARCH chemist at work in experimental station of the du Pont company. Right, cellulose solution, dyed the desired color, is coated on a cotton textile base, the surface is embossed to give the grain or finish desired—and the result is an endless sheet of "Fabrikoid."

Photographs courtesy E. I. du Pont de Nemours and Company

*W. I. du Pont de Nemours & Co.
Wilmington, Del.
S/O
Zalmond
Liv., Wilmington
Del*

By H. W. MAGEE

MOTHER NATURE had a rare sense of humor. She provided man with the materials to produce virtually anything his mind could conceive—but she omitted the labels.

She scrambled, concealed and disguised her gifts with diabolical cunning. In a lump of coal, for instance, she hid the materials for beautiful dyes and rare perfumes. In a spruce tree and the cotton boll she secreted the substance of a shimmering fabric, a lacquer for your car or a handle for your toothbrush. She placed all her treasures in three great storehouses—the earth, the sea and the

air—and challenged man to fit together the jumbled pieces of the colossal jigsaw puzzle she had created.

In the beginning, man took the raw materials provided by nature and clumsily adapted them to his needs virtually in their original form. To him, wood was wood and stone was stone. He knew of no way to change them into something else, so he made the best of the basic substances nature offered. Then man made one of his greatest discoveries. He found how to make a fire. And heat, he learned, changed the form of some of nature's products.

Thus was born the era of chemistry.

*E. I. du Pont de Nemours & Co.
Wilmington, Del.
S/O
Zalmond
Liv., Wilmington
Del
Magee*

Man began taking apart some of the simpler materials which were his heritage from nature. And, as the centuries passed, he began putting some of these parts together in a different pattern than he had found them. He learned, for instance, how to remove iron from ore with heat. Then he added carbon to the resulting product and obtained steel. He began to identify more and more of the pieces of nature's jigsaw puzzle and fit them together.

And, strangely enough, man solved some of nature's more complex puzzles

before he began to realize what a marvelous chemical storehouse nature had provided in the simple and abundant materials everywhere about him—such common things as wood, air, water, salt, coal and growing plants. He isolated and identified rare elements, then discovered the possibilities hidden in a cornstalk. But, having finally learned the potentialities of these everyday substances, industrial chemists in the past two decades have been making over the world. Products of the farm, the mine, the forest, even the sea and the air have been going to the chemical manufacturer by the millions of pounds and he has transformed these basic materials into new, man-made things of beauty and utility which have added comfort and happiness to our daily lives.

Today, give one of these modern chemists a lump of coal and he will do some re-

WINDING machine in rayon plant. Below, furniture and wearing apparel are products of the chemical laboratory, including the draperies, the upholstery on the chairs, the lamp shade, wall covering, and the gown.



see slip

811



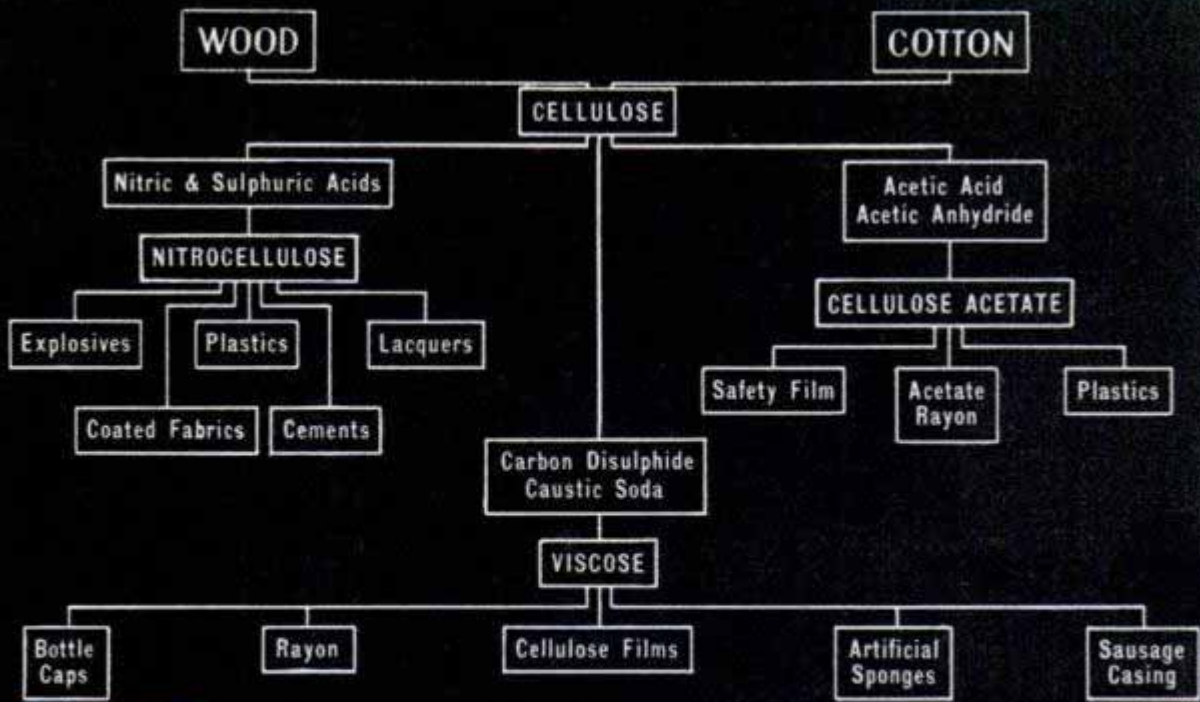

*Centaurich
Mfg Co
579. 8th St
Wilmington*

*Rider - du Pont Fine Chemical
Wilmington*

GIRL dressed in water-repellent fabric snow suit which got its start in the chemist's laboratory. Top, the family tree represented by the union of wood and cotton. The first "child" was cellulose and all the other products represented are derived from cellulose in combination with other simple materials.

markable things with it. Or present him with a Christmas tree and he will perform miracles that put Santa Claus to shame. Let's visit the headquarters of the E. I. du Pont de Nemours and Company at Wilmington, Del., one of the world's great chemical manufacturers, and learn how the magic of chemistry converts spruce or cotton into a soft fabric, a flexible lacquer or a durable plastic at the will of the scientist, and how, in like manner, a lump of coal becomes a dye or a perfume.

The secret of scores of modern, man-made substances can be told in one word—cellulose. Cellulose, the fibrous or woody structure of plants, is one of the most plentiful materials produced by nature. Cotton, trees, straws, grasses, cornstalks, sugar cane, flax and hemp all contain cellulose in the form of fibers but for chemical purposes, cellulose is obtained principally from spruce and cotton. The du Pont company alone annually converts about 52,000,000 pounds of cotton and 74,000,000 pounds of wood pulp into cellulose products.

Once the chemist has isolated the cellulose in spruce or cotton with sulfite liquor, made from lime and sulphur, or caustic soda—salt plus electricity plus water—he becomes a modern miracle man. If he treats this



cellulose with nitric and sulphuric acids—nitric acid is ammonia plus air while ammonia is coke plus water plus air, and sulphuric acid is sulphur plus air plus water—he gets nitrocellulose which originally attracted attention as the basic ingredient of smokeless powder. Nitrocellulose dissolves in many solvents to give viscous solutions or “dopes.” Spread this dope in a thin layer on a smooth surface and allow the solvent to evaporate and a transparent, flexible film remains.

And that thin, transparent, flexible film revolutionized the automobile industry by making possible today's mass production of cars. A few years ago cars were finished with coat upon coat of slow-drying paints, enamels and varnishes. When the car reached the paint shop, there it stayed for days and weeks as men brushed and rubbed, rubbed and brushed. Chemistry changed all that by producing from nitrocellulose—cellulose, water, air, coke and sulphur—

BRIDAL gown of rayon velvet and spools of the man-made fabric called rayon. Top, dressing table with chip-proof finish made on synthetic resin base. Pearl "Pyralin" covers tops of side chests and seat of matching chair.

Lord and Taylor, 5th Ave

Lord and Taylor - \$48.50 - called rayon

Lord and Taylor

F/654

a quick-drying, long-lasting lacquer which reduced the finishing time from days to hours.

Out of the same substance that covers, beautifies and protects your car, the chemist produces a host of other useful materials by adding softeners and plasticizers to control flexibility, softness, rigidity, suppleness and other characteristics. For coating compositions, he also adds dyes and pigments to lend color. By coating cloth with lacquer, du Pont produces an impervious fabric which can be made to simulate the hide of any animal or the skins of reptiles. Or it can be produced to give an almost unlimited range of decorative effects through the use of artistic designs and color combinations.

This material, known as "Fabrikoid," is used for book bindings and you will find it made into traveling

Saks Fifth Ave
Cellophane film
Cellulose film

9/14
18



all-Saks Fifth Ave.

BLOUSE with colored plastic fastener and, top, smart "Cellophane" boa. Center, battery of mixers used in making the coated textile, "Fabrikoid."

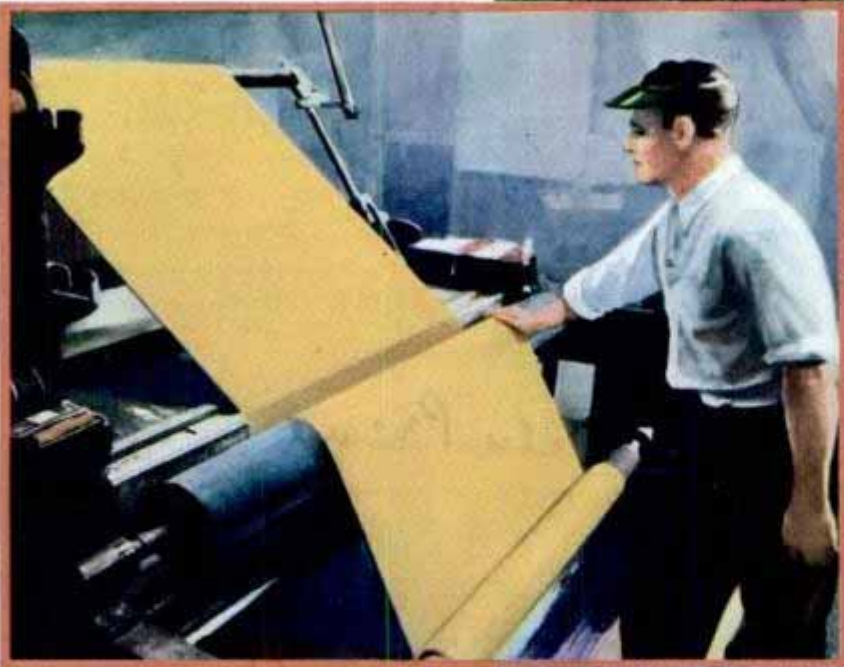

INSPECTING "Fabrikoid" to insure uniformity of grain and color. This material is virtually all cotton, being composed of a cotton textile coated with a solution made from cotton cellulose. Right, the spruce forest and the cotton field supply the raw materials for cellulose products.

Photo at right copyright Asahel Curtis Photo Co.



815
Olympia Forest Reserve

bags, brief cases, a tablecloth that looks like damask but is soilproof, durable wall coverings, furniture upholstery, coated fabrics for automobiles, window shades which can be washed with soap and water, men's belts, parts for shoes and scores of other products.

Blend camphor with nitrocellulose and you get another material of a thousand uses, not a lacquer but a plastic—"Pyralin." When heated, this plastic can be worked like bread dough and it is produced in rods, sheets and tubes and in all the hues of the rainbow. It forms the "sandwich" between two sheets of shatterproof glass, it is made into toilet articles of beauty and durability, toothbrush handles, advertising novelties, bath fixtures, fountain-pen barrels, toys, automobile trim and articles of office equipment. The elephant and the tortoise should be grateful to the chemist because this inexpensive plastic in its myriad

hues gives the beauty, durability and lasting loveliness of ivory tusks and tortoise shells. "Pyralin" is tough, hard, solid, almost unbreakable and can be cut, sawed, filed, blown, rolled, planed, hammered, drilled and turned in lathes without cracking or splintering. Its surface can be made smooth and lustrous, rough or dull. It can be made transparent or opaque, it can be given any color or mottled effect. It lends itself to the exact simulation of mother-of-pearl, ivory, ebony and other natural substances. Its uses are legion in our everyday life.

Now let's return to our old friend, cellulose, the base of all these products. Instead of treating it with nitric and sulphuric acids to produce nitrocellulose, let's add salt to the water, air, coke and sulphur composing the two acids, but let's obtain the ingredients from a different source—lye and carbon disulphide, for example. Caustic soda—lye to you—

71659 Plastic

Manufacture of Cellulose

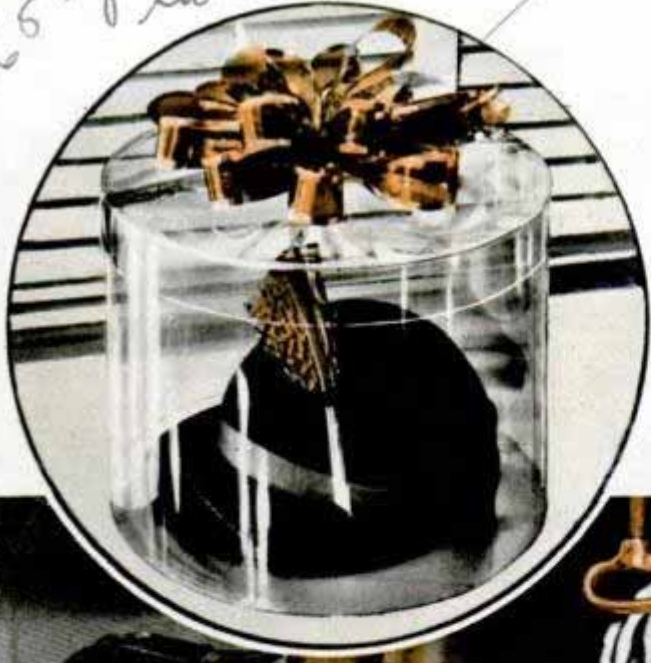

TRANSPARENT hat box made of a cellulose acetate plastic. Center, synthetic rubber in an intermediate stage of processing. Bottom, polishing silver with a man-made sponge. This sponge, like rayon and "Cellophane" and "Fabrikoid," is also a cellulose product, another material produced from cotton and spruce.

du Prene

816

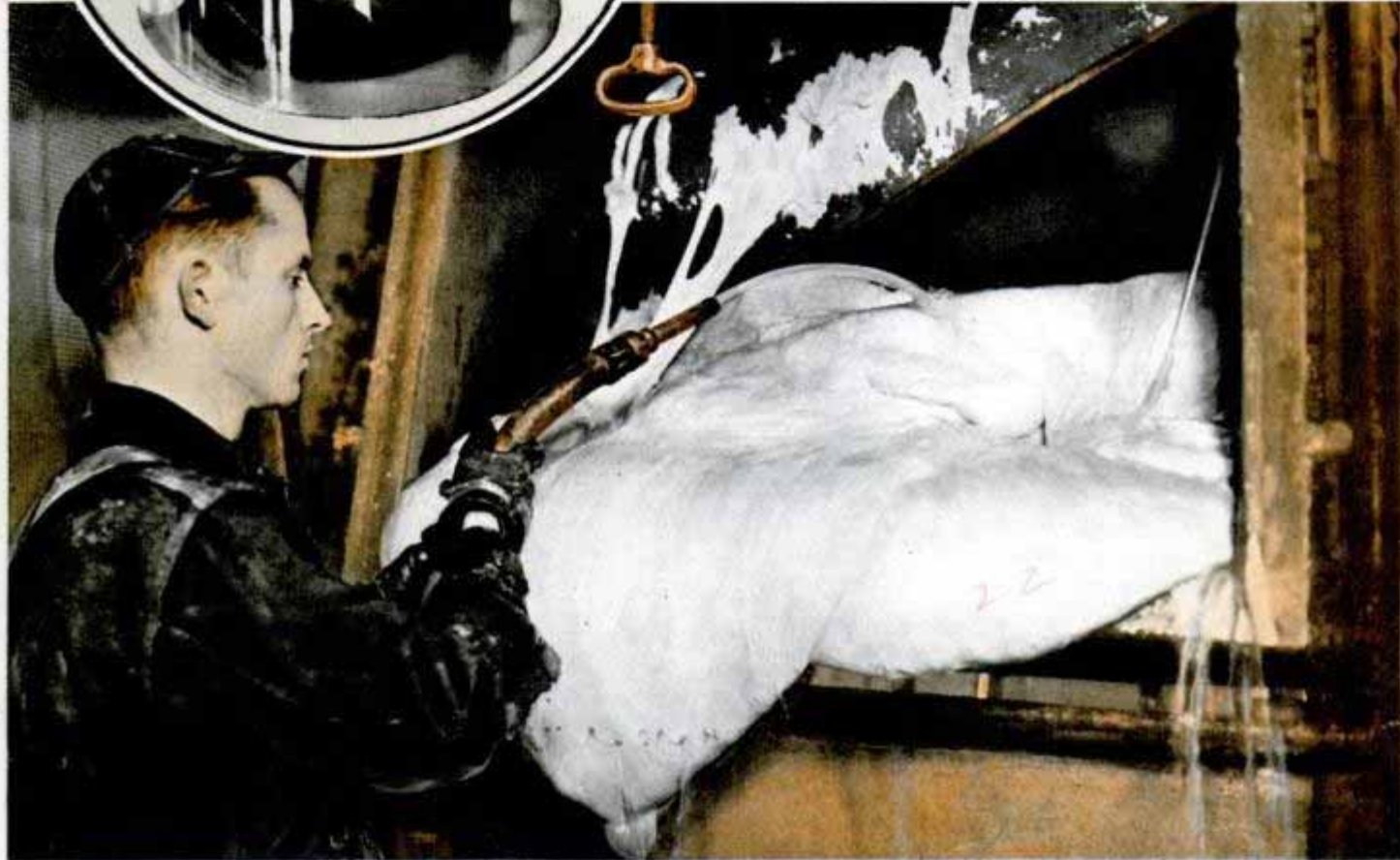

is salt plus water plus electricity, and carbon disulphide is coke plus sulphur plus heat.

Treat wood pulp with these materials and you obtain, not nitrocellulose, but a sirupy solution known as viscose. Now extrude this sirup through a narrow slit and into a bath of sulphuric acid—sulphur plus water plus air—and you get, not a viscous solution, but a solid—a cellulose film. You know this film as "Cellophane"—the transparent, shimmery, flexible, moistureproof wrapper which protects nearly everything you buy. Even new-born babies are wrapped in this protective covering today. At least one hospital encases the new-born in

(Continued on page 128A)



Cellulose sponge - du Prene

Calif. - California Consumer Corp
230 W. Jefferson Blvd
Los Angeles, Calif
Freezing in Can Keeps Fruit Juice Nutritious

Quick-freezing of citrus fruit juices in the can at a temperature of fifty degrees below zero Fahrenheit has been adopted by a California packing concern as a means of keeping the juice fresh and nutritious. The halved oranges, grapefruit or lemons are placed in split rubber cups on continuous metal chains and carried into contact

Top, feeding fruit to juicer; below, right, placing can in quick-freeze tube; left, removing from tube for packing

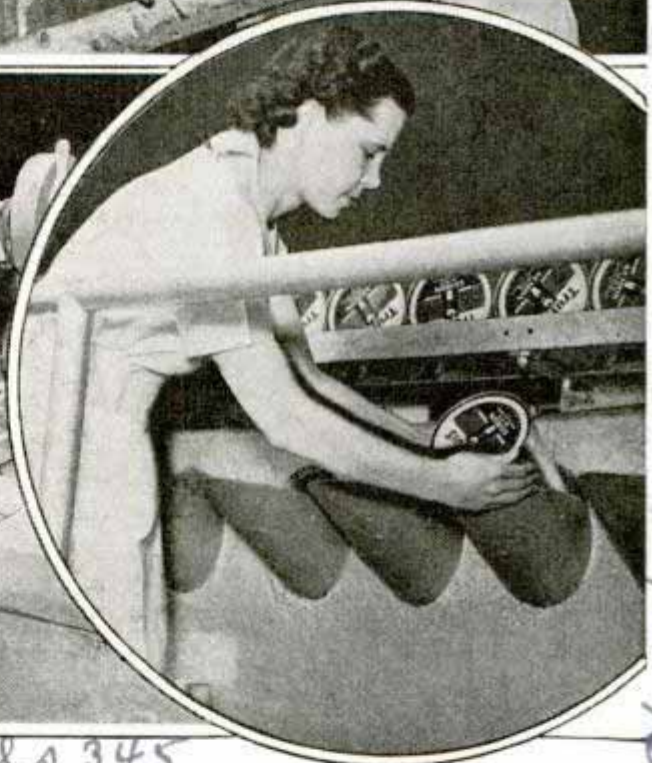
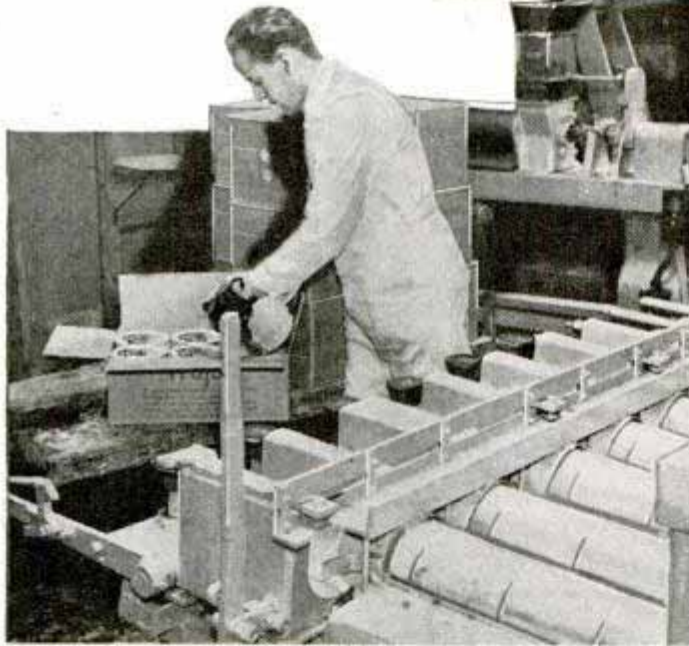
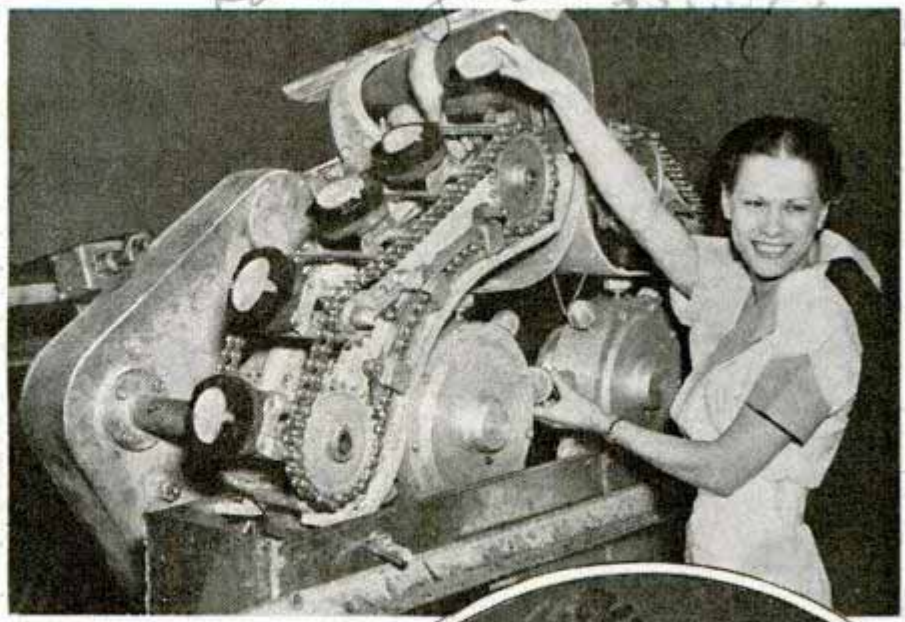

with rapidly revolving juicer heads on stainless steel drums, thus extracting juice at sixty gallons an hour. The juice is strained, de-aerated and vacuum-sealed in tins, which are dropped into a battery of chutes in a quick-freezing system using alcohol brine for cooling. Fifteen minutes later the hard-frozen product is removed from the cooling tubes by a lever-controlled "harvester" which expels one can at a time. The entire process takes forty-five minutes. The packer's theory is that fast, intense freezing keeps the vital, nutritious properties of the juice in suspension until the can is opened. The sealed tins must be kept in refrigeration.

20345
Salmon Forgets the Way Home After 1,000-Mile Swim

Salmon may not have so remarkable a memory, after all. The belief that salmon return unerringly to spawn in the stream where they were born is discredited by Prof. A. G. Huntsman of the University of Toronto, after a study of Atlantic salmon. While the homing instinct may persist if the fish stays near the river mouth, the scientist found no instance of salmon returning from a distance. One salmon tagged in its natal river was picked up 1,000 miles from home, and five were found 900 miles away.

Toronto, Canada

25/37

Cotton Picker Covers Half an Acre per Hour

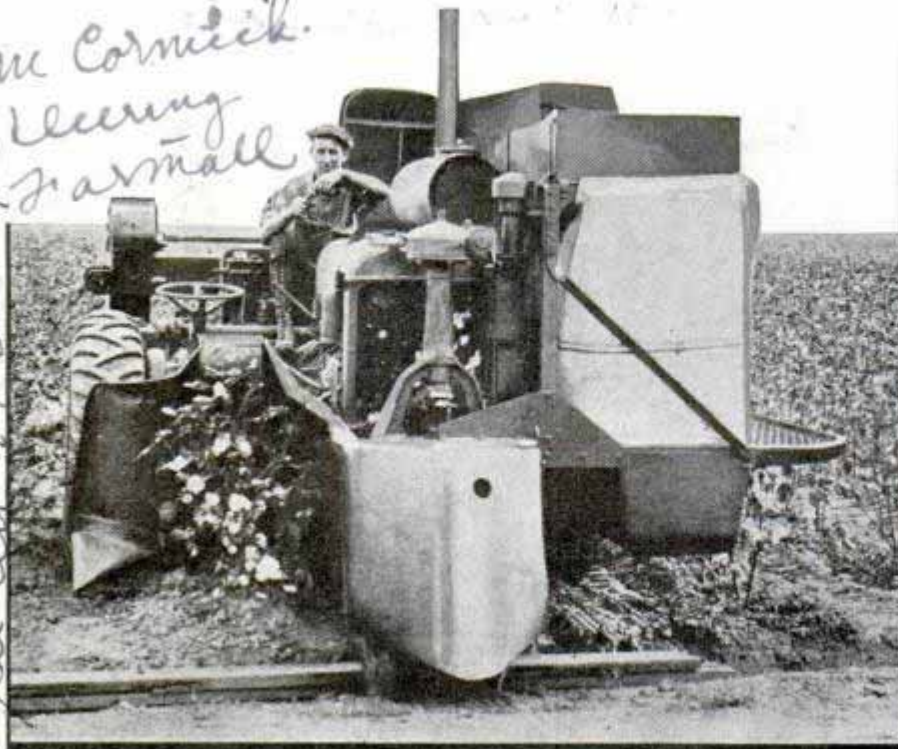

Here is the single-row cotton picker, undergoing tests in field. Its capacity is about one-half acre per hour, much faster than human workers

Capable of covering one-half an acre in an hour, a mechanical cotton picker mounted on a farm tractor has been developed by E. A. Johnston of the International Harvester company. Known as the single-row picker, the machine is provided with revolving cylinders between which the cotton plants pass as the picker moves along the rows. From each cylinder protrude 240 spindles, 480 in all, each of which has numerous tiny hooks or barbs that catch the lint. The cotton is removed from the spindles and passed to the cleaning equipment placed to the

Window Built in Garage Door Makes Bungalow Attractive

Rather than present a wide, blank garage door at the front of his bungalow, a California man built a cottage window in the door. Curtained and shuttered, it relieved the expanse of white clapboards and added to the attractiveness of the home, besides admitting light to the interior of the garage.

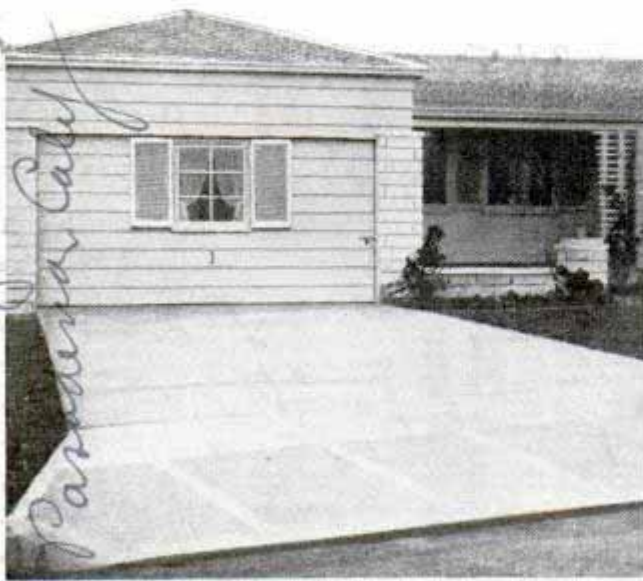

Shuttered and curtained window in door of garage improves appearance of bungalow and lets in light

left of the operator driving the tractor. Another operator tends to the bags which receive the cotton as it comes from the cleaner. The picker, which can be made to cover two rows at a time, will undergo further tests before being placed on the market. The single-row machine does as much work as twenty to twenty-five human workers on land yielding one-half bale per acre and as much as 100 workers on land producing two bales per acre.

Robot Speeds Up Wire Service and Reduces Costs

Faster and cheaper communication is made possible by a telegraphic robot which takes words from several teletypewriters, counts and records them and then sends them in scrambled order over main trunk lines. At the other end is a receiver which sorts the words into their respective messages and speeds them to their separate destinations. The object is to use, at all times, the full multi-channelled telegraph lines and so permit lower costs to subscribers. The users pay for their telegraph tolls by metering the volume of business they have. Where many subscribers are using the channels together,

See ad pg 38-53
Mc Cormick
clearing
small

Blenda

Emb Roy Earl
243 St. Crevier
Pasadena Calif

Scene Service
7/29/41 4/4/37

the charge for the total carrying capacity of the circuit is split between them. The system, developed by Western Union, is the answer to those larger businesses which carry on much of their vital transactions by linking teleprinters in their offices in widely separated cities and asking and answering questions back and forth almost instantaneously.

Forty-Passenger Airliner Powered by Four Engines

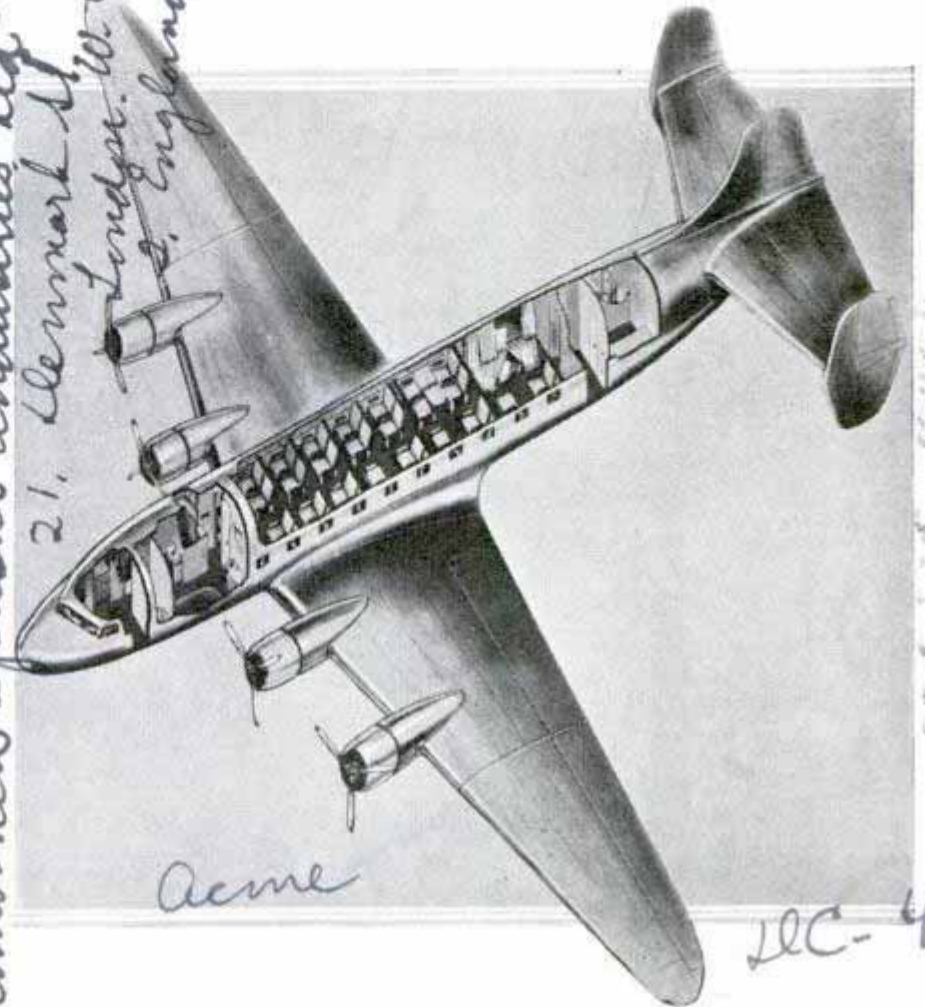

This sketch in cross-section shows how new forty-passenger plane will look. Note the four motors comprising the power plant

Lenses Molded from Plastic Materials

Lenses ready for mounting in cameras, telescopes, spectacles, television apparatus and similar optical equipment can be molded from a new plastic material resembling glass. Only half the weight of glass, the lenses are said to have certain optical properties superior to those of glass. A machine delivers the lenses already polished, eliminating the costly process of grinding and polishing which glass requires.

Fireproof Hose Oozes Water When Expanded by Heat

So long as it is carrying water, a newly developed fire hose is safe from damage by flames. Heat expands its fibers enough to let water seep through and keep the jacket cool and moist. When the hose is removed from the fire, the fibers resume their original position and become watertight again. It weighs only half as much as conventional fire hose and can be packed wet.



Powered by four 1,250-horsepower engines, a super-airliner soon will be ready for tests. Its capacity is forty passengers and crew of five and its speed 237 miles per hour. The giant plane's wing span is 138 feet, its length ninety-seven feet and its height slightly more than twenty-four feet. Planned to be used by five American airlines, the ship will have a landing speed of only sixty-eight and one-half miles per hour. Cruising range will be 2,200 miles. It is being constructed at the Douglas Aircraft company's plant at Santa Monica, Calif. Weighing thirty tons and boasting a useful load capacity of ten tons, the airliner will be equipped with several new safety devices, including a "level landing" feature developed to eliminate bumps from landing. This feature is said to be a retractable landing wheel located in the nose of the plane.

From industries of Dulans 37

newspaper
21. Denmark St. W.C.
London, W.C.
England

ES 325

Combined Optical Industries Ltd

Acme

DC-4

American Fire Hose

20/80.

GRIM JOKES of the

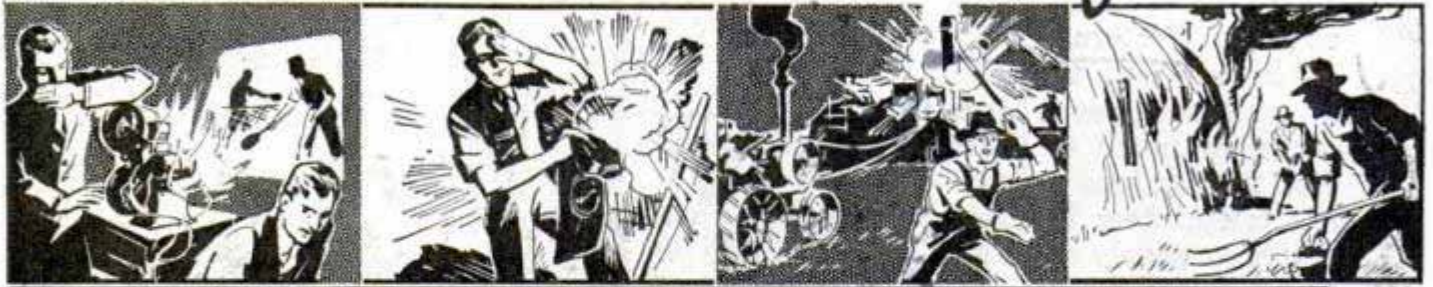

Top, experimental dust explosion shows how vents prevent destruction by permitting force of blast to escape. Bottom, ready to set off explosion in experimental building

SUCH a grim and costly jokester has the fire demon become that government chemical engineers are on his trail. They have discovered that for years he has been using water to cause fires, while most people had thought that water was the worst enemy of flame.

A sinister alliance between the prankster and a band of invisible bacteria also has been revealed. For generations the bacteria which normally cause decay have been setting fire to hay barns, igniting railroad cars loaded with fertilizer or feed and starting other mysterious conflagrations in which losses have been staggering.

Recently, the fire demon has had fun causing dust from vac-

Arlington, Va.

Cmd. Walter E. B. Wilson 1032 Florida Ave
Akron Ohio

...is ...

Virginia Williams
Training School,
Richmond, Va
Mr. Price

FIRE DEMON

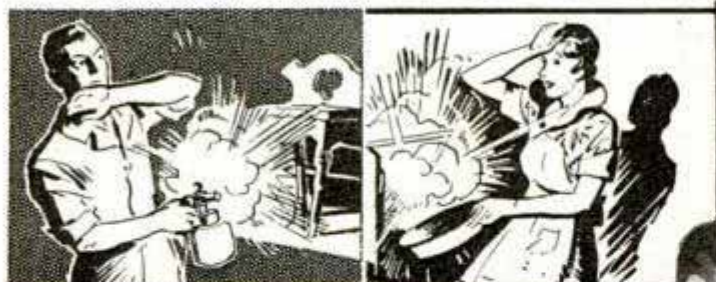

uum-cleaner bags to explode as housewives emptied them into incinerators.

But such a stunt is tame compared with the hundreds of big factory explosions caused by peculiar combinations of air, water and finely powdered solids; explosions resulting in the loss of 308 lives and \$35,000,000 worth of property in eighteen months.

The man leading the battle is Dr. David J. Price, principal engineer in charge, Chemical Engineering Research Division, Bureau of Chemistry and Soils, U. S. Department of Agriculture. This work is done by the department of agriculture because most disastrous dust explosions and fires of mysterious origin occur on farms or involve farm products. Doctor Price began his work when threshing machines were exploding at a rate of 300 per season in Idaho. This particular season happened to be one in which temperatures were above 100 degrees by day, down to forty at night, and the humidity very low—ideal for production of static electric charges. When the wheat straw rubbed the threshing machine cylinder, the cylinder became charged and, eventually, a spark would leap to one of the concaves. There was a fairly high percentage of smut spores,



Top, demonstrating explosive characteristics of dust. Center, apparatus used by government engineers in studying heating of hay. Bottom, ruins of plant in which malt dust exploded at Buffalo, N. Y.

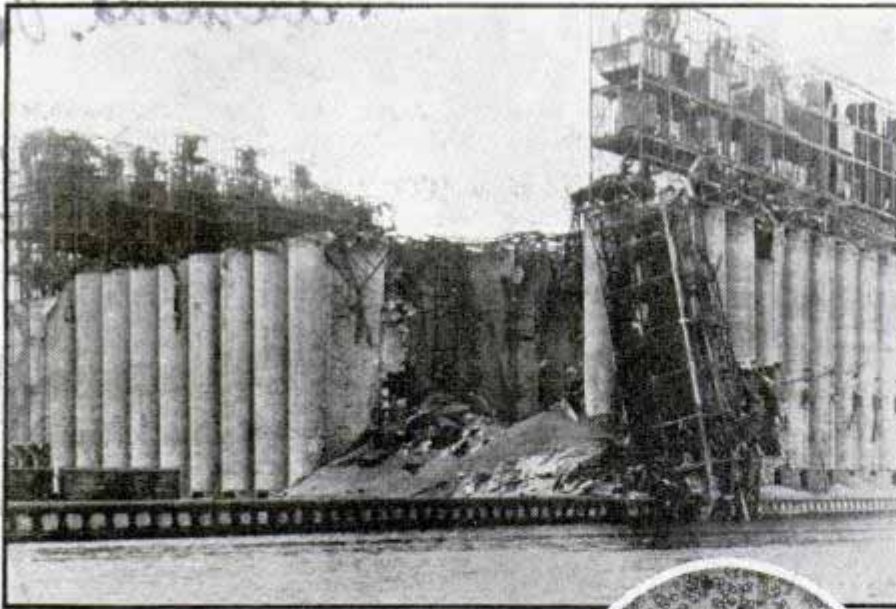

something like 240,000,000 tiny particles per head of smutty wheat, which formed an explosive mixture. So when the spark jumped, the machine exploded. Measurements of the static charge indicated that a potential of more than 52,000 volts was produced. The trouble was solved by grounding the machine cylinders, and installing fans to blow out the smut spores before they could collect in quantities.

Because of high winds in the Texas Panhandle, farmers developed the practice of weighting down stacks of sorghum hay by throwing strands of barbed wire over them and tying weights to the wire ends, the weights dangling above the ground. During dust storms the sorghum stacks burst into flames in a mysterious manner. It was discovered that the fire had been started by discharge of static electricity between the hold-down wires and the ground. The static charge was built up on the wires by friction of dust particles carried by the wind. Voltages as great as 68,000 were measured. Grounding all the wires solved the problem.

The chemical engineering research division has been called upon to solve dust problems not strictly connected with fire hazard.

Public health mosquito eradicators working in a southern camp not long ago

were traveling about in a boat, blowing powdered insecticide mixture into the air. On some days the poison powder would spread beautifully, but on other days the powder simply plunked into the water and refused to rise in even a tiny cloud. The answer was found to be electrical rather than chemical. Under certain atmospheric conditions, static charges collect on dust particles. Some dusts collect positive charges, while others prefer negative charges. The mosquito-killing preparation was a mixture of several dusts, some of which be-

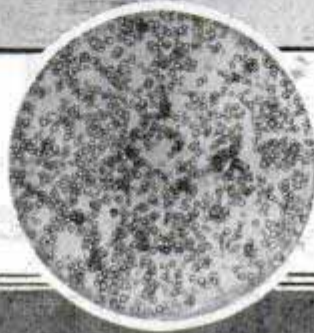

Top, wreckage of big grain elevator after dust blast. Center, microscopic photo of explosive corn dust. Bottom, remains of barn destroyed by spontaneous combustion of hay after flood

came positively charged while others were negative. Positive and negative charges attracted each other, so that the dust, the instant it became charged, gathered in clusters too heavy to float in the air.

Several cases that came recently to the attention of government experts have suggested that there may be a real dust risk in the home.

A woman living in an apartment build-

(Continued to page 132A)

Plane Grows Wings as Student Learns to Fly

see April 1937. 561

Kronfeld Ltd, London Air Park Feltham Middlesex Engla

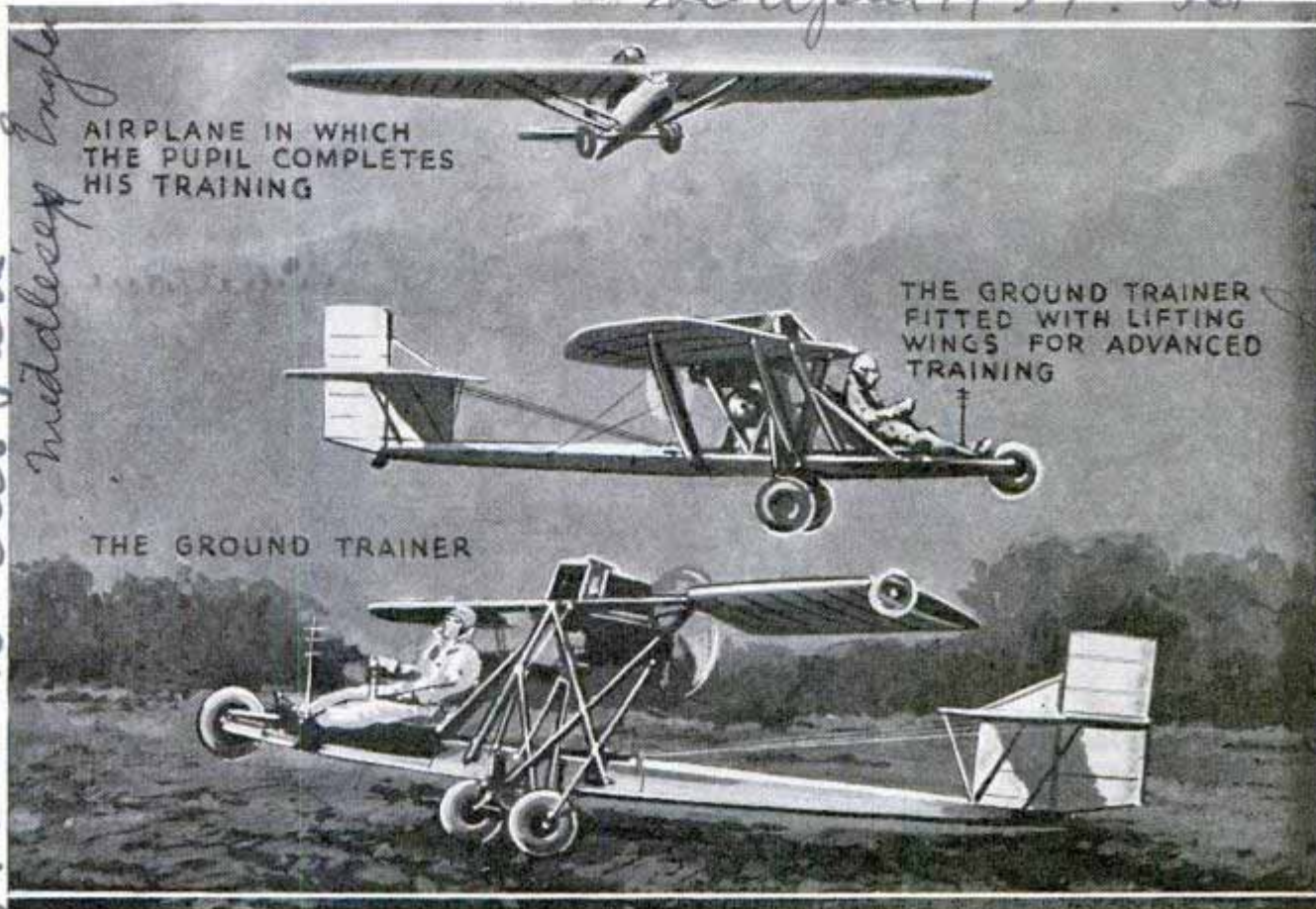

AIRPLANE IN WHICH THE PUPIL COMPLETES HIS TRAINING

THE GROUND TRAINER FITTED WITH LIFTING WINGS FOR ADVANCED TRAINING

THE GROUND TRAINER

After learning to maneuver ground trainer about airport, pilot is allowed to add wings, shown at center, for short hops above field. These wings are finally installed on standard plane to finish training

Student aviators solo at the very start in a flightless plane developed in England, which grows wings as the young pilot learns to fly. At first the pupil learns to handle the ship on the ground, the plane having at this stage two large ailerons in place of wings. When he can maneuver skillfully on solid earth, a pair of wings is substituted and the student takes the ship for short hops three or four feet above ground, rising to twenty feet as he becomes expert in maneuvering and masters gliding and landing. When he is able to fly around the airport and land properly the wings are removed and installed on a standard type airplane for final training and license tests. The preliminary training craft has a nose wheel, a forward open seat and wheels on the wing tips to prevent the ailerons from touching ground.

Curtains of Light Mark Speed of Artillery Shell

Artillery shells are fired through invisible curtains of light to determine their speed by a method developed at the National Research Laboratories in Canada. The equipment is portable, lending itself to use in the field. Light beams, mirrors, photoelectric cells and sensitive recording apparatus make the speed tests. In effect the shell passes down a narrow tunnel. Every fifty feet it intersects a beam of light falling on a photocell, resulting in a permanent record on photographic film. The curtains of light are created by metal frames whose upper and lower surfaces consist of mirrors. A light beam started from the bottom is reflected back and forth until its ray finally touches the photocell concealed in a small box at the top of the frame. Thus the entire space is filled with a light beam so that the shell cannot pass through the frame without interrupting the flow of light.

Passengers who want to catch an early morning train in certain towns along the Chicago & Northwestern railway can have the station call them by telephone.

from ... 2/20/37 P. 288

Science Service 3/29/37

Div. of Physics and Metallurgy

Railway Age 3/6/37

Dr. C. Rose, physicist

and

*Van Dyke, Secular
of highway Phila*

Church Steeple Is Toppled by Tractor Pulling Cable



Hundred-foot steeple toppling into ruins of church as tractor pulls down supporting columns

When fire razed the First Baptist church at Ypsilanti, Mich., its hundred-foot steeple remained erect, a menace to traffic at the intersection of two main streets, and engineers had to find a way to topple it into the ruined auditorium. A tractor tugged at a steel cable until a brick wall collapsed but still the steeple stayed upright, trembling and swaying. Then the tractor was hooked to another cable attached to three supporting columns, and as it hauled away the steeple crashed down exactly where it was intended to fall.

Highways Paved with Tin Cans Molasses and Aluminum

Cotton sandwiches and tin cans, rubber and molasses are among the odd paving materials used on highways around the world. Cotton is laid between crushed stone and asphalt. Paris is trying streets of iron. Georgia has a road built of old

tin cans, crushed flat with a steam roller and overlaid with sand and soil. Surface oil is mixed with molasses on highways in India. Australia has rubber streets. German engineers mix powdered aluminum with tar or asphalt to form a pavement.

Vulcanizer Run by Car Battery for Roadside Tube Repairs

Roadside repairs can be made with a tube vulcanizing set which draws power for the heating element from the automobile storage battery. Round and oval patches are furnished with the outfit and are attached without using gasoline.

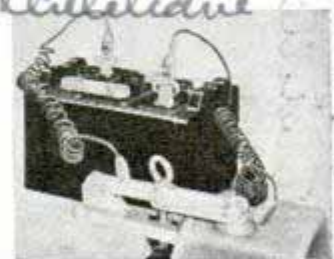

Paint Thickness Is Measured After Application

Paint thickness on automobiles can be determined at the factory by an electrical gauge now being used by the Studebaker company. A dial on the gauge registers the difference in resistance between an established thickness of paint and that on the surface of the car. The tests show



Inspector tests thickness of auto paint at factory with electrical gauge

*Emb. Cyril E. Lamb
Ypsilanti, Mich.*

sell Mt. Walden

es 305

South Bend Ind.

es 344

Aluminum new letter

whether the proper number of coats of paint have been applied and whether the paint is of proper consistency to produce a long-wearing finish.

ls 281
**Nation's Latest Submarine
Is Ready for Its Trial Runs**

ls 284
**Motorcycle Built
for Attack on
Speed Mark**

Constructed for the purpose of breaking world speed records, a specially built Harley-Davidson motorcycle has been undergoing tests. It has vital parts of streamline design to reduce wind resistance. The existing record on straight-away is 132 miles per hour. The motorcycle prepared for an assault on the present mark is said to have attained 125 miles an hour in trials.

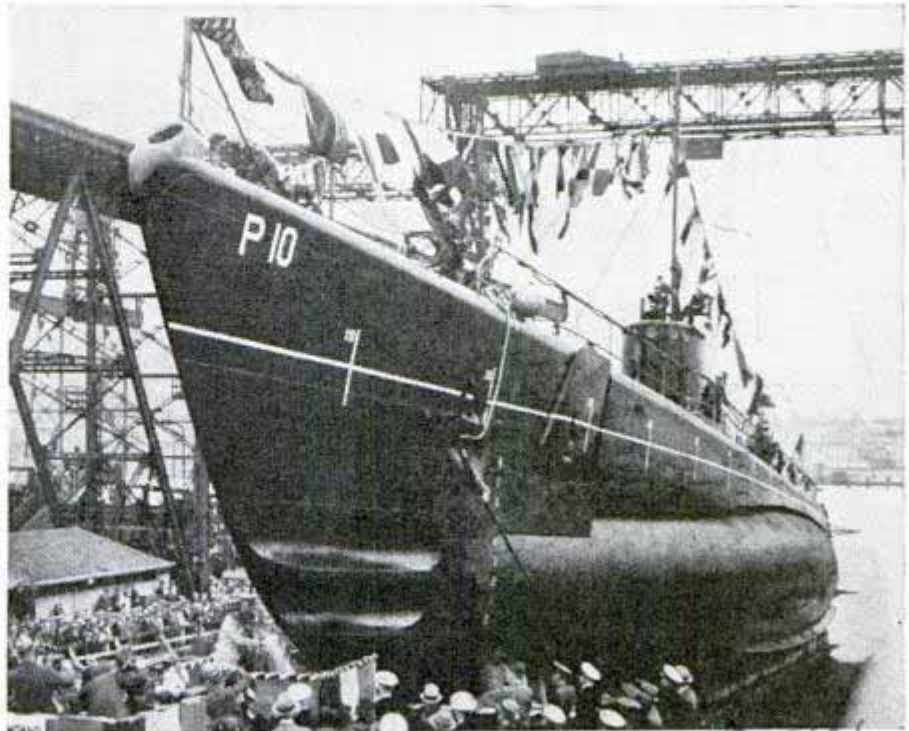

Wade Wala
Here is the "Pompano," at the moment of its christening, as it slid into the water at Mare Island navy yard recently

Recently launched at the Mare Island navy yard, the latest American submarine is ready for its trial runs. Named U.S.S. "Pompano," its equipment includes powerful motors for underwater and surface operation and the latest weapons for that type of fighting craft.

ls 349
**Acid Water Reveals Murder
Six Hundred Years Old**

Acidity of the water into which the victim's body was placed has helped to reveal a murder at least six hundred years old. The water preserved the wool in the clothing so well that tailors were able to reassemble the parts. One piece was a poncho-like overcloak with V-shaped opening for the head, a principal garment consisted of a tunic with close-fitting waist and loose knee-length skirt, while a third article was a caped cowl with long streamer trailing back of its point. The leather shoes and weapon sheath had decayed until they were soft as butter. The blade of the dagger with which the man had been stabbed had rusted away. The body was found recently near Gotteborg, Sweden.

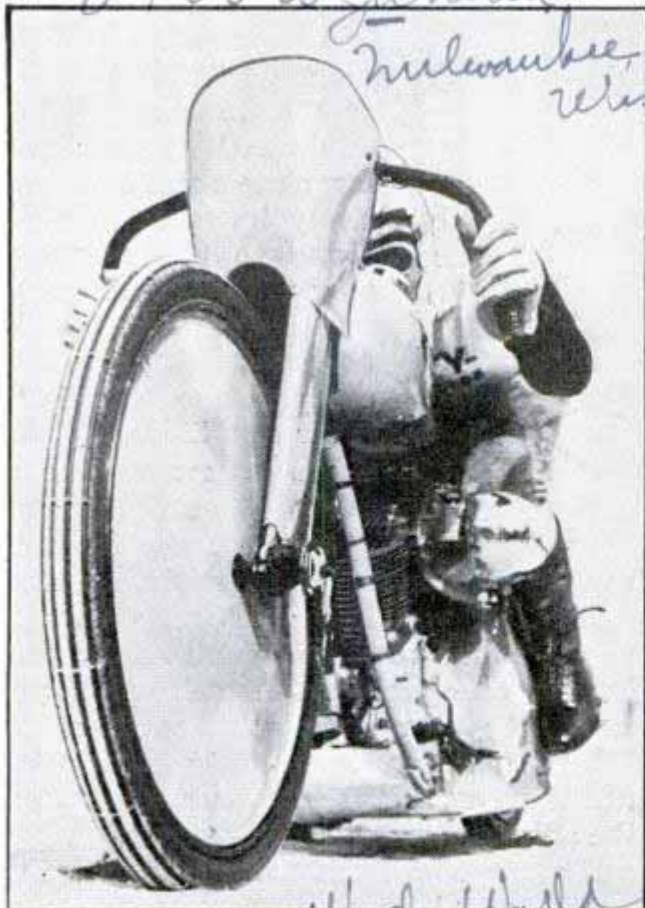

Wade Wala
Complete to protective shield for driver's face, this motorcycle is ready for speed run

Science Service

es 250
 10555 Dolman Ave
 Los Angeles Calif.

SUMMER

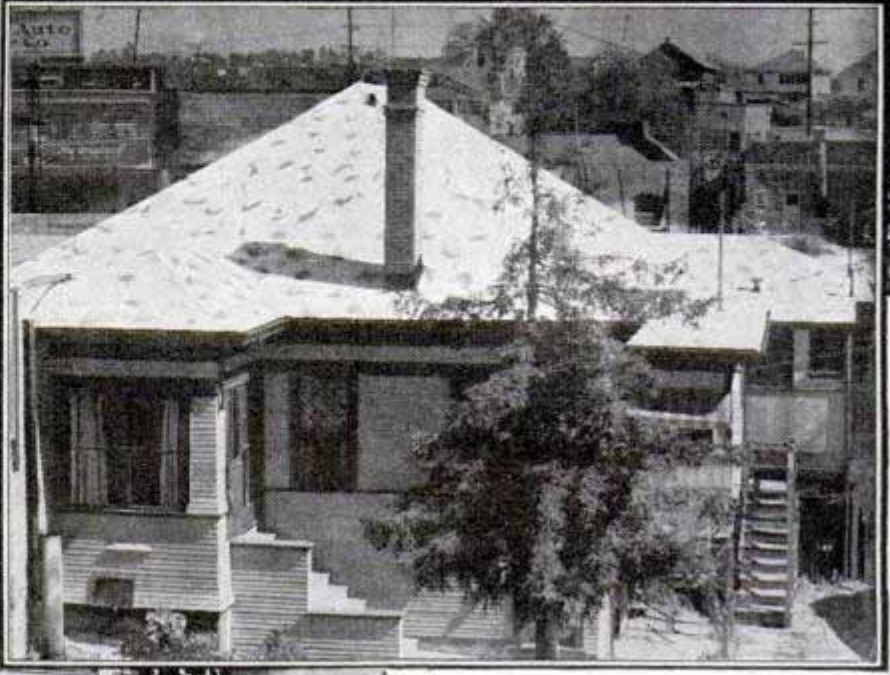
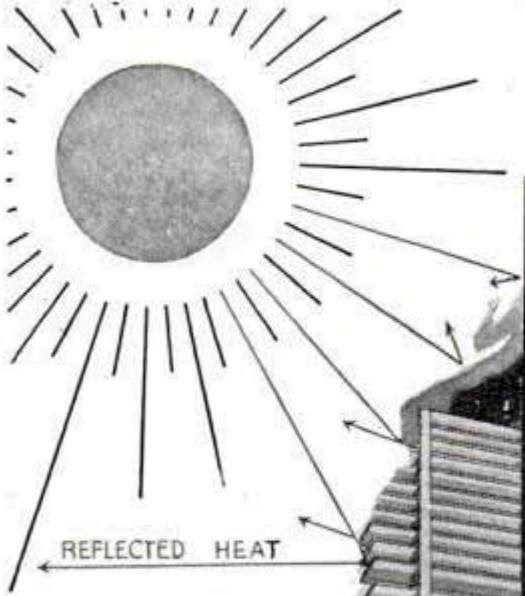

Blinds coated on outside with aluminum paint reflect the heat and help keep house cool, as does a light-colored roof

iced lemonade and electric fans. Much of the discomfort of hot weather can be eliminated or minimized by making a few simple and comparatively inexpensive additions to the average house. And here's how:

The ideal solution of both the cooling and heating problems, of course, is air conditioning which offers you air free of dust, odors and gases and gives you simultaneous

MARK TWAIN complained that "everybody talks about the weather, but nobody does anything about it." His remark applies particularly to hot weather. Let the mercury begin flirting with the century mark, and most of us confine our weather tinkering to inspecting the thermometer and sagely observing that "it ain't the heat; it's the humidity."

And yet, if you know how, you can combat sizzling days and sweltering nights with weapons much more effective than

control of air motion, temperature and humidity. If you have \$1,000 or more to spend to air condition your home, your hot-weather problems are solved and you need not waste time reading further.

Unfortunately, however, complete air conditioning still is beyond the means of the average family. But don't resign yourself to a perspiring summer if yours is just an average family. You can make your home fairly comfortable in hot weather without cooling, filtering and dehumidi-

1133 Venice Blvd.
 Los Angeles Calif.

COMFORT at LOW COST

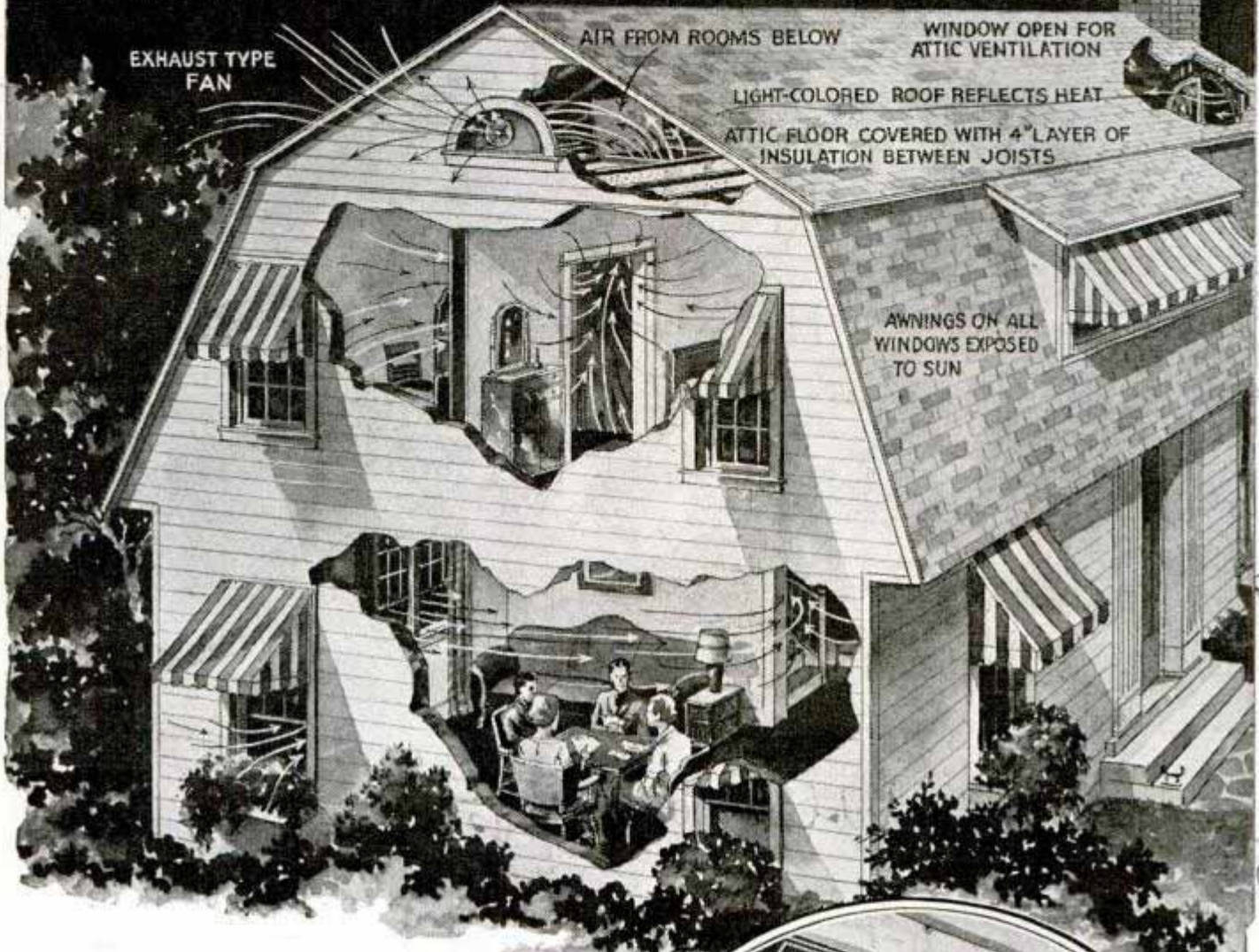

fyng the air you breathe—and at a fraction of the cost of complete air conditioning.

If you can't afford air conditioning, how about awnings? Research and experimentation have proved that you can scarcely make a better investment for summer comfort. A. P. Kratz, research professor of the Engineering Experiment Station at the University of Illinois, found that awnings on the research residence at Urbana, Ill., reduced the summer cooling requirements of this air-conditioned home by more than thirty per cent.

This does not mean that awnings alone will make your home thirty per cent cooler, but it does mean that awnings over your



Awnings, an attic fan, an insulated attic floor and a light-colored roof all add to summer comfort

Shuster-Corning Corp. 700 W. DuSoy Chicago

Maturiano Inc. Los Angeles
POPULAR MECHANICS

1325 Maple Ave
Calif

Shuman Architects
Architects
Blody, et al
Frederic J. Blody, et al
Frederic J. Blody, et al

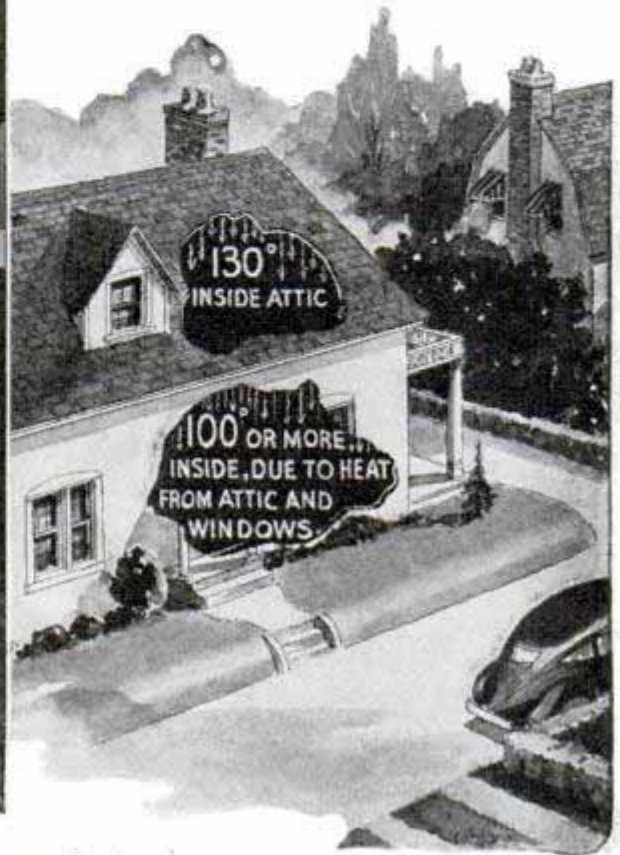
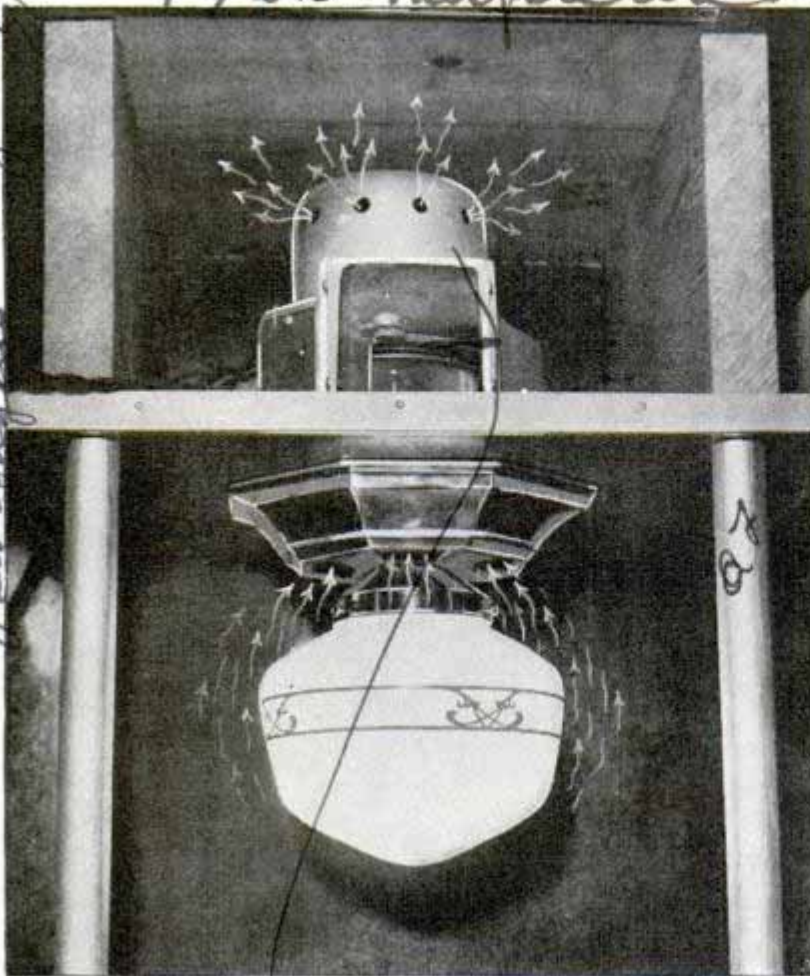

Kitchen unit consisting of overhead light and overhead fan to draw out hot, humid air

Air comes out blower discharge
not caps

windows keep out some of the heat and pay for themselves by decreasing the cost of cooling if you are employing artificial cooling aids. The reason is obvious. About ninety per cent of the radiated heat from the sun passes right through your windows and is trapped in your house. If you can keep out the direct heat coming through the windows, you have gone far toward maintaining a more comfortable temperature inside the house. So, by all means, install awnings over all south, east and west windows as your No. 1 step in defeating heat.

Because most of the heat striking a windowpane passes through it, an ordinary shade or even a Venetian blind is not very effective in keeping out heat. The blind keeps out light but does not retard the heat rays much unless it is outside the window instead of inside. Weatherproof blinds which can be hung outside the window are available, but only duplicate the work of awnings. Shades or Venetian blinds coated with aluminum foil or paint, however, really help you to keep cool be-

cause aluminum reflects the heat instead of absorbing it.

Since your first task in defeating heat is to keep it from getting into your home, you have gone a long way when you are equipped with awnings or aluminum-coated shades. Lower the awnings and pull the shades on the sunny side, keep doors and windows closed unless there is a breeze, isolate the sun porch by closing doors and drawing blinds. And remember that storm windows keep heat out as well as in. Don't remove your storm sash in summer on the windows not opened for ventilation.

Perhaps the largest port of entry for summer heat is your roof. The sun strikes one particular side of your house only a few hours out of the day, but it beats down on your roof all day long. And you need only make a trip to your attic some hot summer day to prove to yourself that the heat comes through the roof. It not only comes through, but is imprisoned there. Just as an aluminum-shade surface reflects the heat, so will an aluminum-

Reynolds Corp
Aluminum Foil



coated roof reflect it. If you find it impractical or too costly to paint your roof with aluminum paint, even a coat of whitewash will help because light colors do not absorb heat like dark shades. But you need more than a white roof to keep heat out of an attic which naturally is the hottest part of the house and, if kept closed, may be twenty or thirty degrees warmer than outside ground temperatures. This "super-heated" air penetrates to ceilings of rooms below and transforms them into large-area radiators. So the thing to do is to remove this "heat load" from

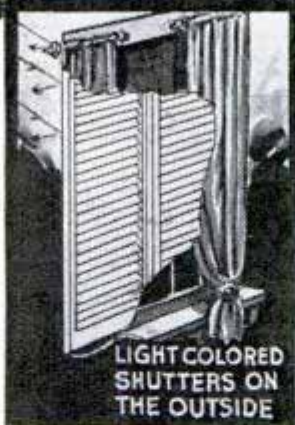

Light-colored shutters help keep house cool. With an outside temperature of ninety-five, the house with attic fan, awnings, light roof and insulated attic floor may be eighty-five or even less inside, while one at left without these aids to comfort may have inside temperature of 100 degrees or more

your attic and prevent its penetration to your living and sleeping quarters.

The first step, which costs nothing, is to open your attic windows, create a draft and allow the hot air to escape. The next step is to insulate the attic floor—not the roof, but the floor, because you need ventilation above your insulation. Three or four inches of mineral wool or its equivalent will hold back the heat from ceilings below the attic for three or four days. Note that this insulation only retards the heat, it does not stop it. But it

(Continued to page 156A)

Lightweight Boat Motor Handy for Outings

The Pal.
\$34.50



This outboard motor, weighing only fourteen pounds, fits any small boat

Weighing only fourteen pounds, the latest outboard motor propels small boats economically, operating one and one-half hours on one quart of fuel. The price of the engine is low. It develops nine-tenths horsepower at 3,500 revolutions per minute. Provided with automatic tilt-up and pivot steering features, the engine has a new two-stage centrifugal pump that keeps it cool at lowest trolling speed. The engine's light weight makes it easy to handle on outings. It fits rowboats, resort boats, skiffs, dinghies and canoes, driving them at speeds up to five and one-half miles per hour.

Broker Dials to Get Quotation Quickly on Stock Ticker



telephone. By dialing the code number of the stock on which he wishes the quota-

When a broker desires quotations from the new Toronto stock exchange, he may get a particular one quickly by using a device operated like a dial

tion and then pressing a button, he sets in motion equipment which prints the quotation on his ticker tape within seven seconds. The dial ticker supplements the regular ticker service.

Moistureproof Bond for Cement Closes Pores of Wall

Masonry surfaces can be bonded together permanently with a waterproof bond just patented. It penetrates the pores of the masonry and becomes an insoluble crystal, proof against further disintegration and a permanent seal against moisture. It permits the bonding of a cove or apron of processed concrete where wall and floor join, the point where seepage usually threatens. On large structures such as retaining walls and dams, fresh pourings of concrete can be bonded to the old without danger of seepage along the crack. The waterproofing can be applied to the inner surface of walls, new or old.

Midget Diesel Aircraft Engine Weighs Eighteen Pounds

Weighing only three pounds per horsepower, a tiny Diesel aircraft engine built by a Los Angeles inventor develops six and one-third horsepower at 2,000 revolu-



Model for larger aircraft engines, this tiny Diesel develops six and one-third horsepower

Wounded Motors. 5171 E. 27th Milwaukee, Wis

5170 Harbour Blvd. Toronto, Ont. Canada

deal deep service

es 346

es 294

Charles Keene

2419 Chadaby Los Angeles printing Co

with signers from Delaware State Corp. Inc.

Specially developed by

1% Kempbell Diesel School 2120

Radio Loop for Training Pilot Is Mounted on Mobile Board

tions per minute. Despite its minute size it operates successfully on crude oil, without carburetor or spark plugs, at a com-

ension of 460 pounds per inch, a ratio of six to one. It is a three-cylinder, two-cycle, water-air-cooled model with three-ounce pistons and a stroke of one and one-eighths inches. Too small for actual airplane use, the midget engine will be the pattern for small motors.

Strengthening Bow Helps Speed Up Big Liner

In order to gain speed, the British liner "Arundel Castle" has undergone a radical operation in the shipyards at Belfast. The hull was stripped open and twenty-five feet were added to the length of the ship. This re-design, together with new engines, increased the vessel's speed so that ten days have been cut from the trip from Britain to Cape Town.



Pilot tunes practice set to receive directional signals from air line transmitter while helper maneuvers platform to find direction of station

To familiarize themselves with the directional radio loops being installed on passenger transport planes, American Airlines pilots practice with a radio set mounted on a movable platform. While the pilot tunes in on an airway transmitter, he directs a helper to push the truck about so that he can tune to the peak volume, giving him the direction of the station. Once pointed toward the station, a dial on the instrument board shows any deviation from the course. The loop aerial is inside a streamline housing.

When you telephone from New York to Los Angeles your words ride on 3,000,000 pounds of copper wire.

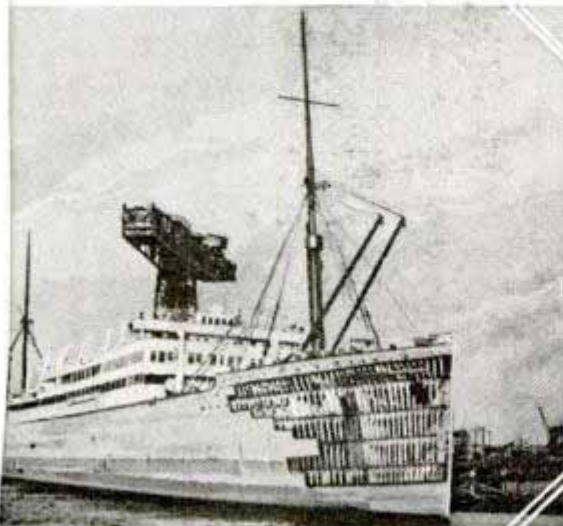

Adding twenty-five feet to bow of the "Arundel Castle" in shipyards at Belfast helped increase her speed

Telegraphs engineering office at Toronto in conjunction with engineers
60 Hudson St.

Comb. Thomas & Stegman Dr. 1055 E. Holman Ave. Los Angeles Calif

Referene. Barb Cor. Flight Supp. American Airlines Central Air Terminal. Orlando

Illustrated London News 3/1/27

Compressed Air Magazine Feb Philadelphia

Jigsaw Cuts Out Relief Map from Layers of Plywood



Building up a relief map with layers of plywood, cut out by jigsaw along lines traced from government contour map

Relief maps are made inexpensively at the Philadelphia Academy of Natural Sciences by cutting out plywood layers with a jigsaw. The contour lines of each elevation shown on a government map are traced on plywood with carbon paper, cut out with the jigsaw, and each level is built up by gluing it on the one below, starting from sea level. The rough edges are smoothed with a chisel and the map painted to indicate rivers and wooded or farm land.

Burglar or Fire Detector Phones for Help

So sensitive that it reacts to heat not much greater than that from a star, a new trap detects burglars or fire and then puts in a phone call for help. The device also can tell the location where help is needed. In demonstrations the trap reacted to heat from a capped thirty-two candlepower auto headlamp nearly half a mile away. When it was pointed directly at one window in a



Lettered in white, the word "Speed" in each traffic lane catches eye of motorist and a few feet farther white figures tell him the speed limit

distant building, a lamp in that window lighted, its switch operated by the invisible heat ray from the tiny bulb. Heat from the human body actuated the system, causing it to say over the phone: "This alarm originates from the fourth floor of the General Electric building. Police wanted." The voice comes from a prepared phonograph record.

Speed Limit Painted on Street Catches Motorist's Eye

Instead of posting speed limits at the curb, warning signs are being painted in white on the pavement of Los Angeles streets so that motorists cannot escape seeing them. First the word "Speed" appears in the traffic lane, then, a few feet farther on, the speed limit at that point. Wavy lines are used to indicate caution.

Chicago Tribune 3/24/37

Philadelphia. Schematics. 2435

4117 Georgia St
San Diego, Calif

Streetcar Fleet Becomes a Bungalow Court

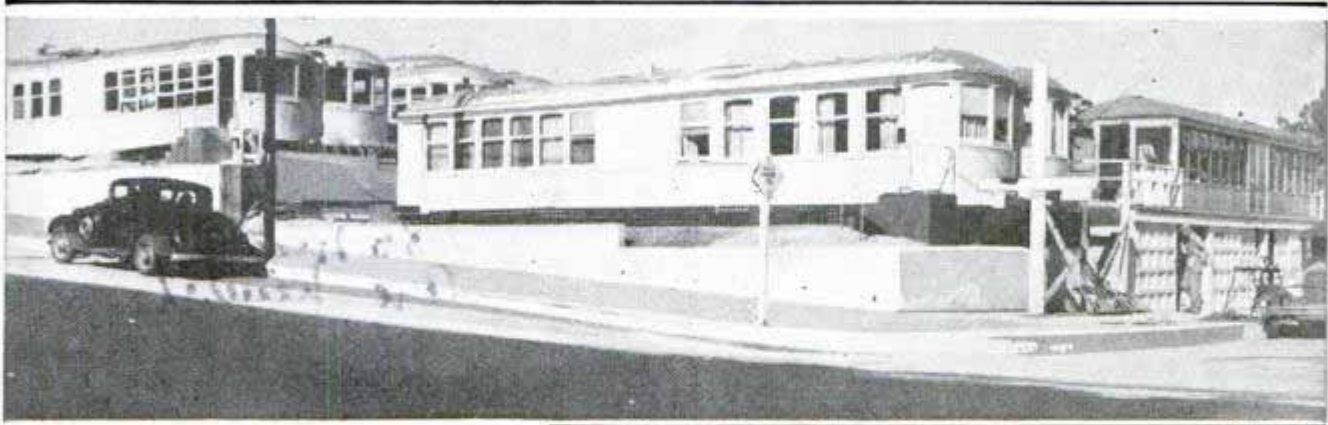

Twin streetcars set up side by side in terraced residential block form court of duplex bungalows. Right, the compact kitchenette and living room with built-in bookcases

Retired from use on San Diego streets, a fleet of streetcars has been converted into a "bungalow court" arranged on a terraced lot facing the ocean. With the running gear removed, the cars were placed in pairs, side by side, on cement foundations and partitions built across the middle so that each end became an apartment two cars wide, comprising three rooms and bath. Interiors were plastered, bookshelves were built in and modern furnishings and equipment installed. Aluminum paint was used on the roofs.

250.

Bright Sun in Stratosphere Shines in Dark Sky

Although the sky is "midnight blue" when seen from a gondola hanging fourteen miles above the earth, the sun is glaringly brilliant—within two per cent of the brightness it sheds constantly upon the outer boundary of the earth's atmosphere. Measurements with photocell units installed in the "Explorer II" stratosphere balloon, which reached an altitude of 72,395 feet on Nov. 11, 1935, showed that the sky darkened with increasing altitude until at 72,000 feet it was only five per cent as bright as it appears from the ground. The decrease in brightness of sky paralleled decrease in barometric pressure,

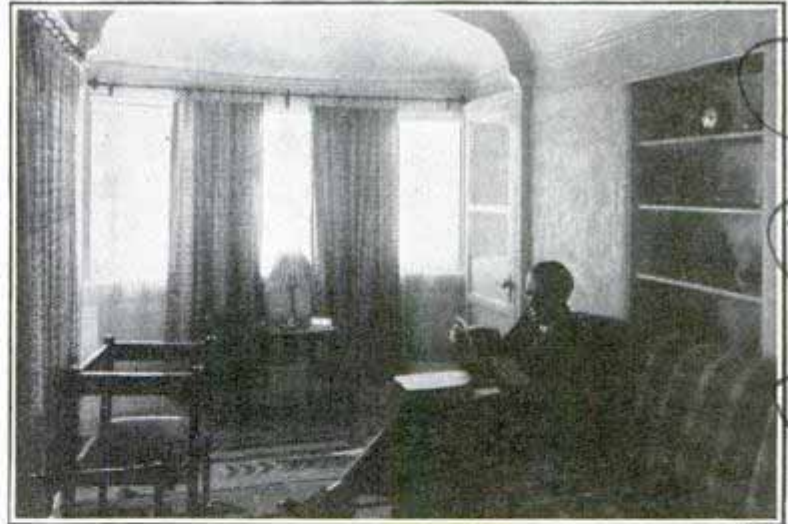
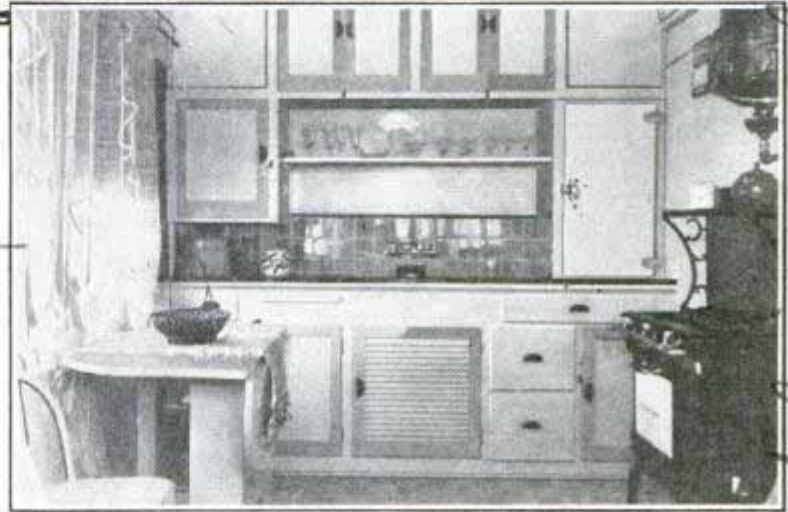

confirming the theory that sky light is produced by the scattering of light rays by air molecules. The total visible solar radiation outside the earth's atmosphere was found to average 12,000 foot-candles, indicating brightness of the sun's disk is 190,000 candles per square centimeter.

Soap can be made from coal; by a new process, paraffin obtained in distilling brown-coal tar is made to yield a fatty acid useful in soap manufacture.

R. B. Puschinger, Licensed Contractor
521. San Diego, Calif.

Walter, Hermann
Koschke
Herman

Ray P. Teale

W. H. House

YOU CAN'T

By Urban Johnson

Sound Effects Expert
Columbia Broadcasting System

*485 made you
are newyork*

*Columbia Broadcasting System
sound effects crew producing
storm. Man at left is operating
rain machine. Wind machine is
on stool, thunder sheet at right*



WHEN your radio receiver quivers with drama, a silent chap whose voice you rarely hear over the air provides many of the thrills. He's the fellow who fools your ears.

To illustrate, let's assume you are listening to the climax of a melodramatic episode, the scene of which is a lonely cabin during a storm. Besides the voices of the actors, you hear, perhaps, the sighing of the wind, the patter of rain, the distant rumble of thunder. Then possibly there's the clatter of a horse's feet—the villain approaches. A door opens. The noise of the storm increases. The door closes. The sound of the storm abates. There's the crack of a pistol, a shriek, then silence.

"Who fired that shot?" asks the announcer. "Was it the villain? Tune in next week for the answer."

But you don't need to wait until next week. That shot wasn't fired by the villain, regardless of what the next episode reveals. The real gunman was the silent fellow you didn't even know was there—the sound effects man.

He smacked a leather cushion with a pine board—that was your gunshot. But that's not all he did. In that final bit of action, the actors contributed a few words and one shriek. The sound effects man supplied everything else you thought you heard—the moaning wind, the driving rain, the crashing thunder, the galloping

BELIEVE *Your* EARS



Making sound of dancing chorus and, at right, horse and wagon. Note horse's "feet"

horse, the opening door. All but one of these sounds were "synthetic." The door was real. It was a half-size door in a frame which was pulled close to a microphone and opened as the sound man increased the volume of his rain. Then he shut it and turned off part of the rain. And the rain itself? Just birdseed pouring out of a hopper onto a sheet of "Cellophane" backed with cardboard. The wind was the whirring of motor-driven wires. Pounding a cowhide stretched taut on a wooden frame made the thunder. A couple of cocoanut shells produced the clickety-clack of the galloping horse.

Radio sound effects date from about the time the movies became articulate.

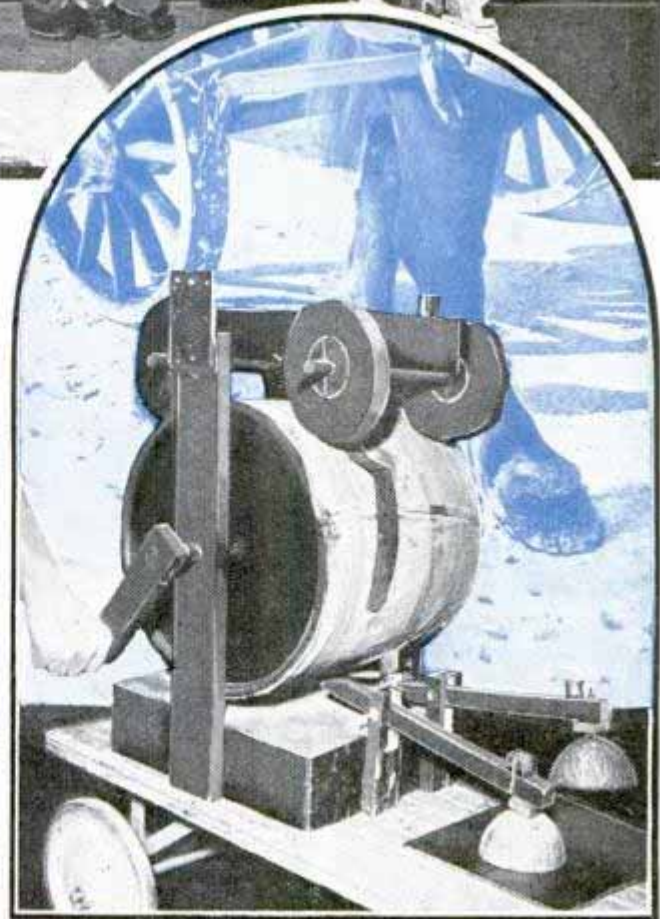

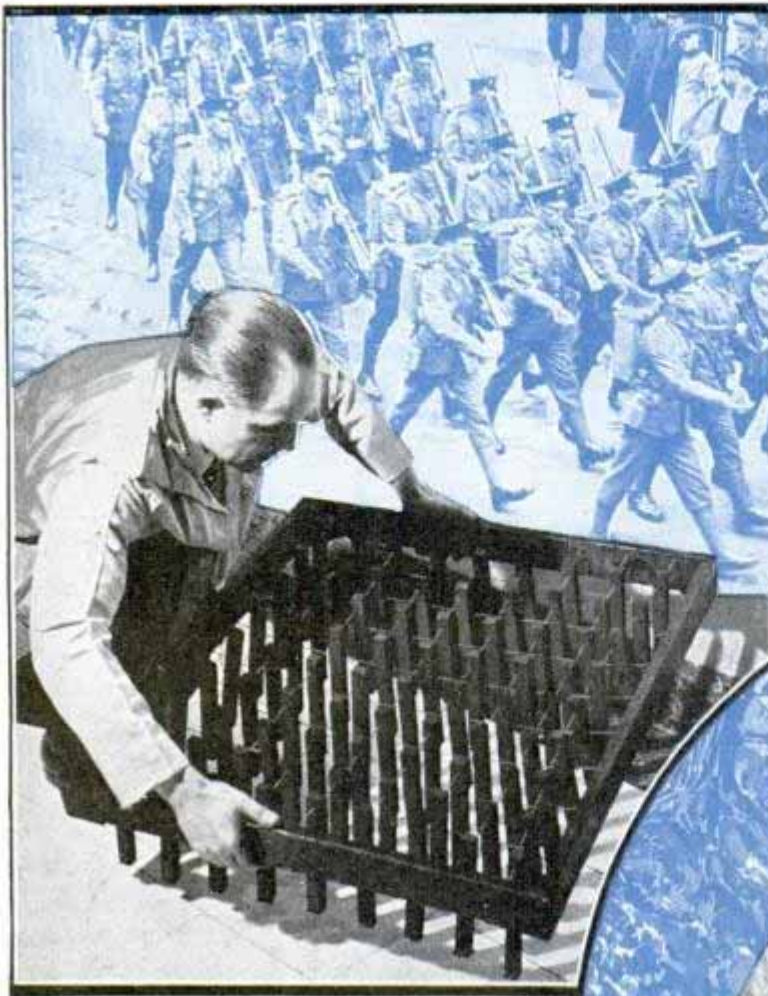

Until then, broadcasting stations confined themselves to transmitting words and music. Then script writers, blissfully ignorant of the difficulties, began turning out pieces interspersed with "sound of marching feet," "blowing of boat whistle" and "sound of approaching train." Radio engineers thought of their sensitive "mikes" and got the jitters. Fire a pistol or blow a locomotive whistle in front of a "mike" and it would all but explode in your face, they declared. All right, said the program arrangers, busily putting in more noises, get somebody to imitate a pistol shot or a locomotive.

The radio people meditated awhile about all the sounds involved in imitating a train—the whistle, the bell, the hiss of steam, the chug-chug of the engine, the click of wheels on rails, the rumble of the coaches. They decided they needed help. Then someone remembered the snare drummers of silent pictures who cued scenes with the aid of drums, cymbals,

bells, whistles and a few noise-makers of their own construction, such as a can of buckshot which, when revolved, they fondly believed, sounded like rain. So radio began taking on drummer boys to imitate everything from the crunch of wagon wheels on gravel to the twinkling feet of a Follies chorus. And this piece might well be called "Drummer Boys Make Good" for many radio sound effects men today were former drummers.



Imitating sound of automobile and, at top, the author creating illusion of marching feet

The drummers had one great asset. They possessed a sense of timing and rhythm. But most of their cherished noise-makers were useless before the "mike." In the theater the drummer tried for a good loud noise. But the "mike" couldn't take it, so many an ex-drummer found himself blowing a boat whistle out on a fire escape instead of into a microphone as he had orig-

inally planned. Those early sound men were ingenious inventors. They had to be. They found, for instance, that such an ordinary sound as the ringing of a doorbell or telephone could not be produced for the radio merely by ringing a bell. Why? Because early "mikes" were not true to pitch and picked up the "beat" of the bell rather than the jingle. One sound man solved this by drumming on a xylophone bar. To you, it was the telephone ringing.

As microphones improved, the sound effects men were forced to change their technique. They could use real doorbells and telephone bells, for instance, but they had to discard their storm effects. At first, they used ordinary backstage storm apparatus. They shook a sheet of tin to make thunder or revolved buckshot in a tin can to make rain. Sensitive "mikes" picked up the "tinny" noises and made them sound just like someone shaking buckshot in a tin can or rattling a tin sheet.

Each sound effects man had to solve the problems he faced in his own way. There were no precedents. It was mostly a case of try something and use it if it worked. If it didn't, try something else. As a result, the sound men each have their own jealously guarded trade secrets—special apparatus they have devised for imitating particular sounds. The average sound effects storeroom looks like a junk shop, a litter of rattles, wires, boards, whistles, bells, horns, gongs, wheels, springs and other odds and ends, all neatly stored on shelves and in bins. Each piece of "junk" makes a noise which sounds like something else. A glance at the bells makes us realize how all of us are "bellhops" to some extent. There are alarm clocks, doorbells, telephone bells, squad car bells, am-

(Continued to page 122A)

Above, sound man producing effect of boat pounding to pieces on rocks. Below, imitating crash of two cars

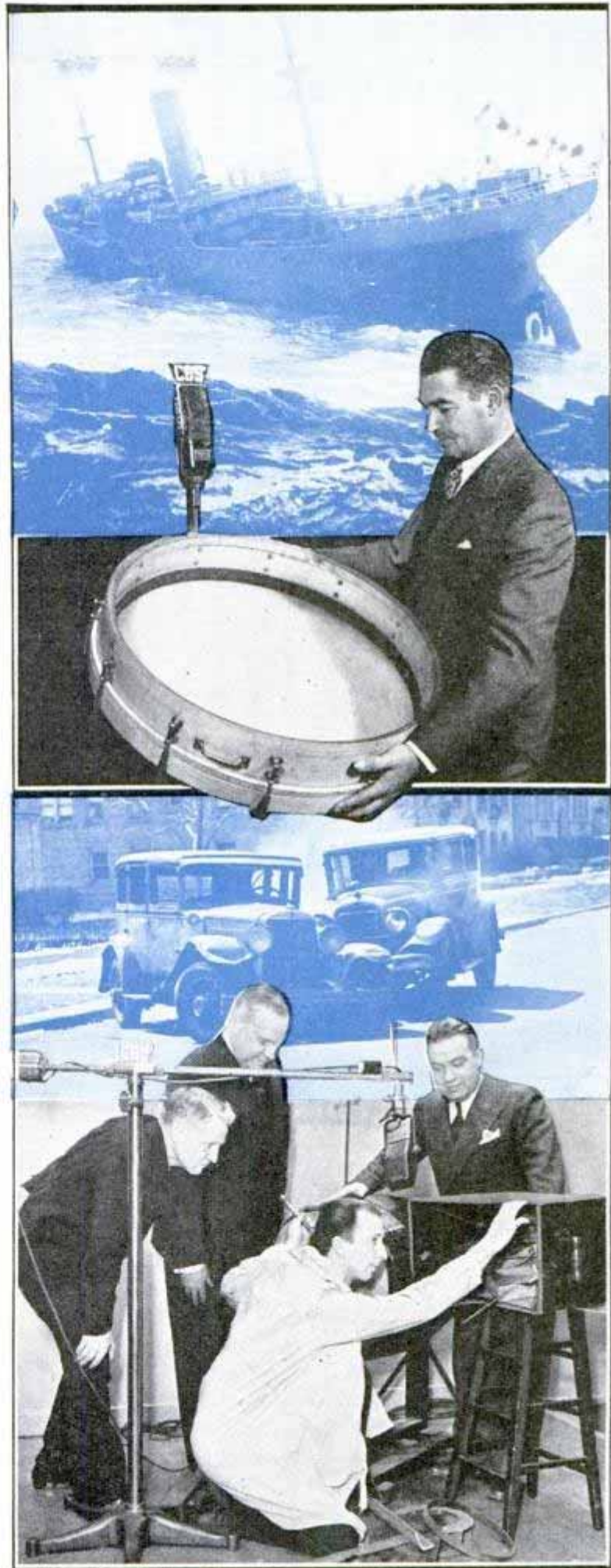

Conveniences of Home in Car Provide Real Travel Luxury



Top, elaborate beverage service compartments. Bottom, left, eating snack from food storage drawer. Right, writing desk in use

Magnificent fittings for serving food and beverages, for writing, smoking, making a hasty toilet and even for shaving, are features of an automobile built by Chrysler corporation for a customer. The twenty-foot car offers conveniences of home and office. A radio console is built into the division between front and rear compartments. At the top center of the console is an instrument grouping that includes barometer, clock, compass and altimeter. Above these are two humidors, a cigar lighter and ash tray, all covered by ornamental metal covers. On each side are compartments holding beverages and glasses. Directly below the instruments is a collapsible serving table lined with amber mirrors and equipped with indirect lighting. At the bottom of the serving compartment is a stainless steel drawer, in the center of which is a thermal compartment for storage of ice cubes and

beverages. On the other side is a compartment for fruit and other food. The rear seat is constructed like a divan. In the right-hand armrest are the radio controls, ash receiver and buttons for operating an electrically driven glass partition between front and rear seats. The partition is rolled up or lowered by pushing a button. Behind a folding armrest in the center of the rear seat is a writing desk with stationery and pen and pencil sets. The desk has a cover which folds down and may be used as a serving tray. Recessed behind the armrest are a Thermos bottle and a toilet compartment containing electric razor and plug for attaching it, a brush and a comb. The footrest is hollow and serves as storage place for walking stick and umbrella. There are two folding auxiliary seats with backs and armrests.

Suction-Cup Tool Lifts Lens Off Car Headlamps

Lenses from frameless automobile headlamps may be removed safely by using a new suction-cup tool designed for garages and service stations. Four suction cups grip the lens and two handles on the tool provide leverage necessary for removal from the headlamp. Even a lens which has become corroded can be worked loose and lifted off in this manner.

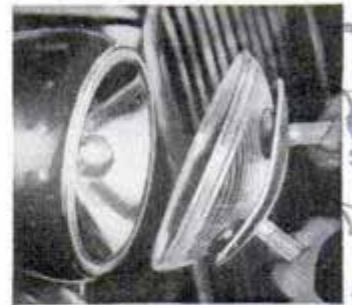

Steam power plants burn about the same tonnage of coal in the United States today as they burned in 1920, but they generate twice as much electricity with it.

341 Massachusetts Ave. Detroit, Mich.

Chrysler
airflow

es: 24
es + 54
ms

maris Edward

General Electric 1937

Assembling Giant Air Liner Is Job for Experts

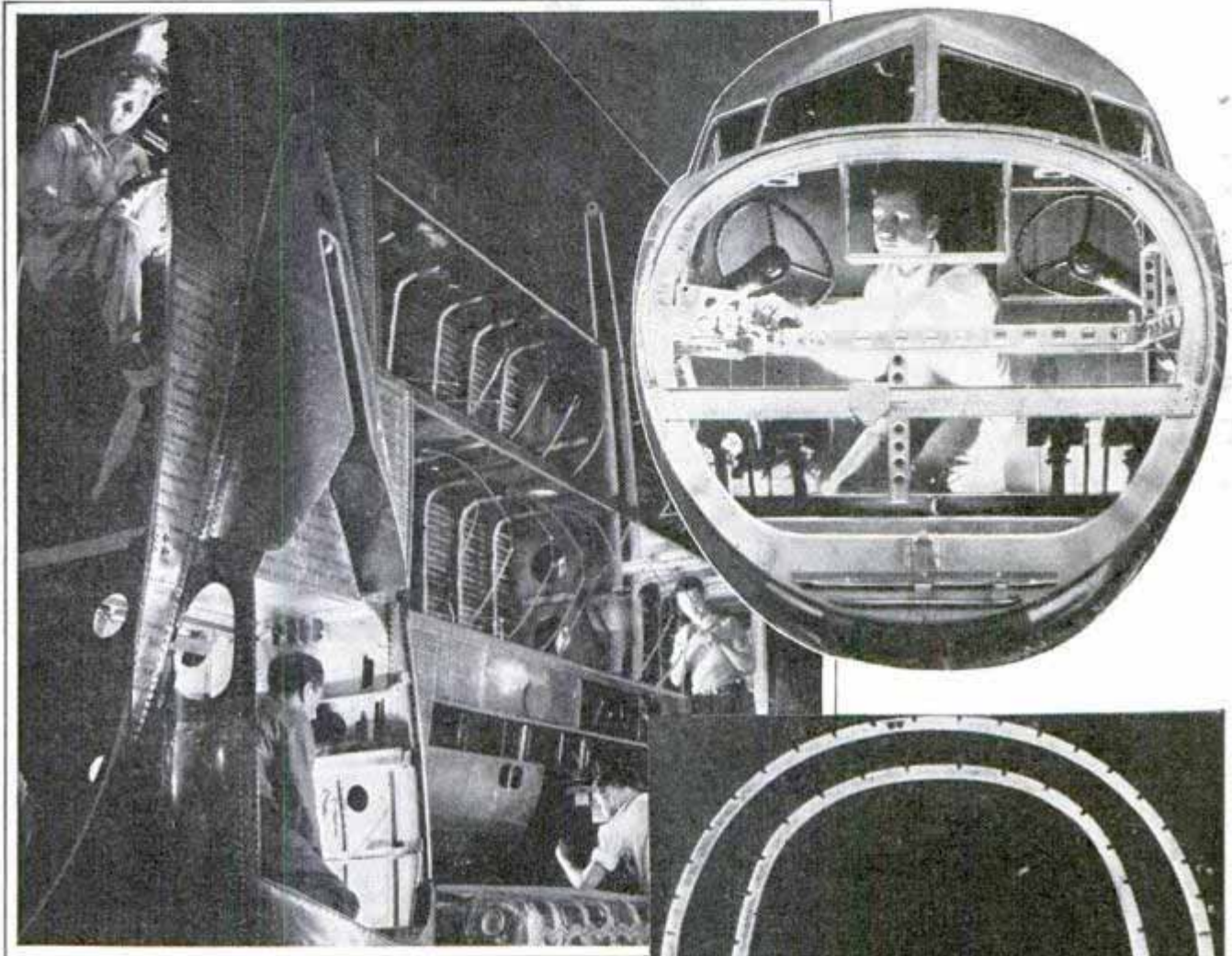

Left, finishing wing panel. Right, inspecting control compartment. Bottom, fuselage frame

Since the safety of many passengers depends on the way each does his part, expert workmen are charged with the assembly of giant transport planes. Huge wing panels must be put together so they will stay together when subjected to the severe strains encountered in flying; fuselage frames must be constructed and assembled with component parts in a manner that will give the greatest safety under all conditions, and controls must be fitted into place so that they will respond instantly to the pilot's touch. These, and many other construction and inspection jobs, call for the services of experts. One of the important tasks is the installation of the controls and instruments. In the Douglas transport now being used by several air lines there are 115 control, flight, navigation, radio and electrical instruments in the control compartment. All these are fitted carefully with their con-

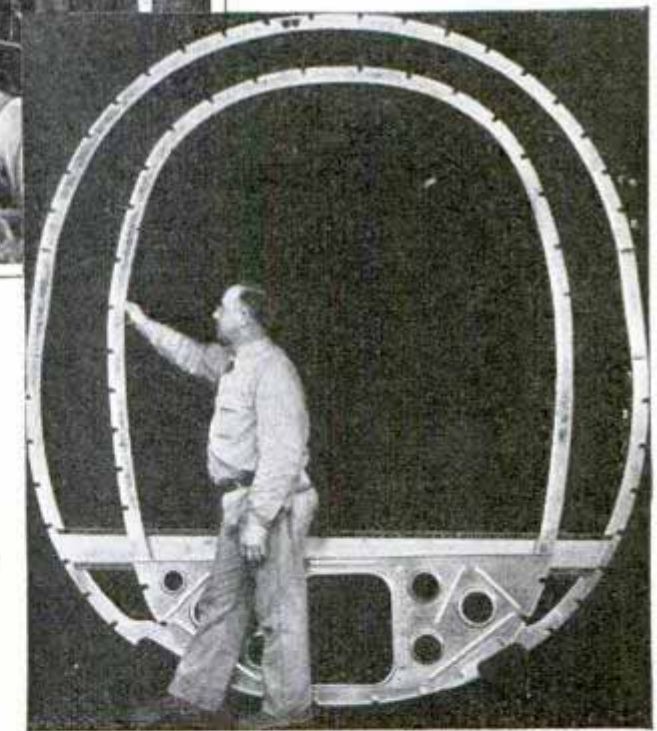

nections into the streamline nose of the big ship, then tested and retested before the ship ever leaves the ground. Inspectors watch the assembly of controls, as well as of every other part of the plane. Then, when the transport is completed, comes the big test—that of actual flight. Only after the ship has been put through all its paces is it turned over to the transport company to carry thousands of passengers millions of miles, in safety.

Douglas Aircraft Co. Memphis, Calif.

219

OILIER OILS for

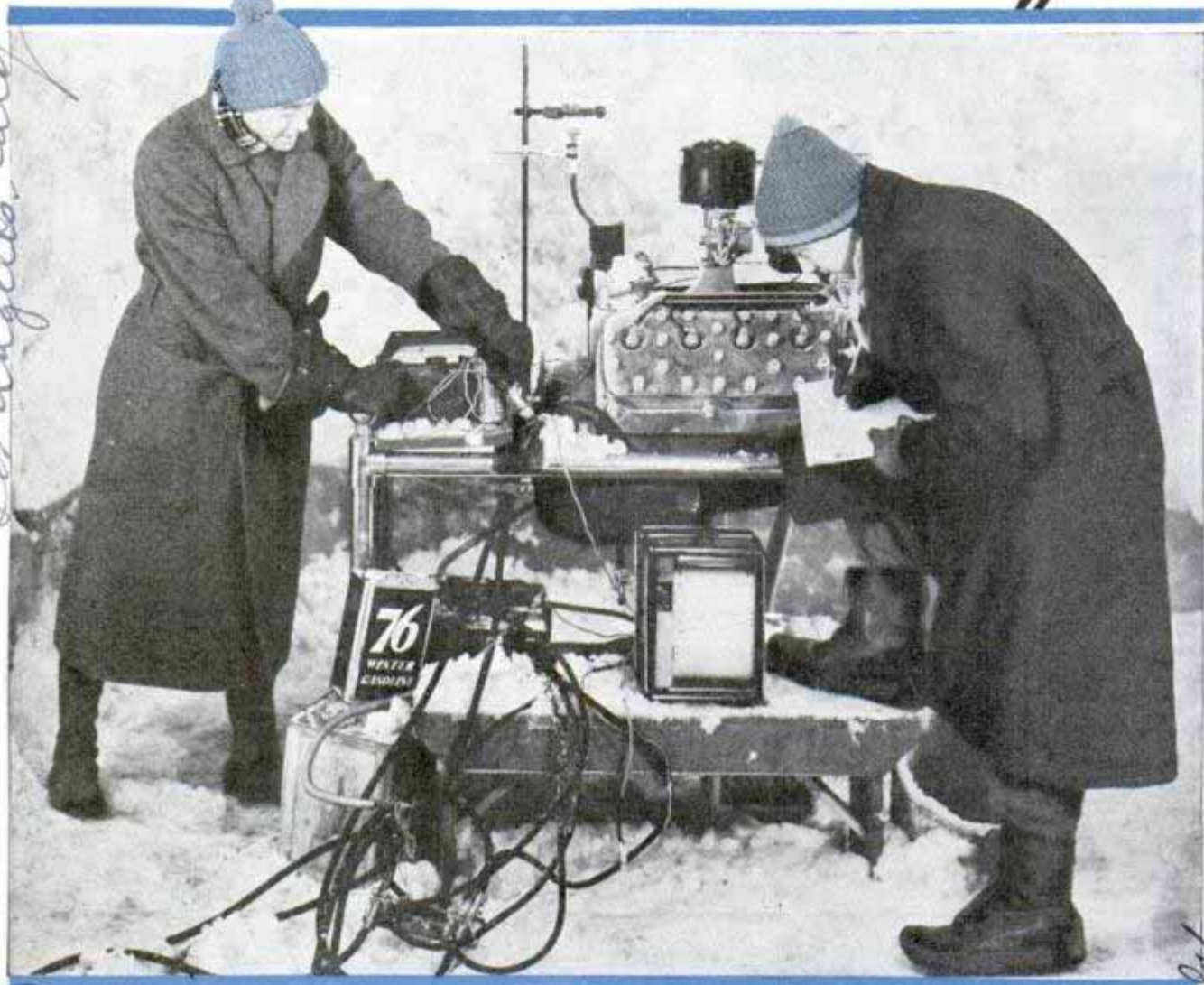

Union
 Engineers testing oil and fuels in sub-zero temperatures of a cold-weather laboratory. These tests show how lubricants will act in motor on severest winter days
 Courtesy Union Oil Co.

By Thomas E. Stimson, Jr.

Stimson
Propane solvent →
JUST think of putting an oil in your automobile crankcase that automatically reduces carbon, increases power and mileage, and saves repair bills! You have heard claims like that before and doubted them. But today some major oil companies will practically guarantee that their new "slippery" oils will do all these things. Oils much oilier than ever before are on the market at regular prices.

These oils, petroleum chemists state, will reduce friction between moving parts, reduce wear on cylinder walls and rings, free the rings of carbon and gum and thus restore them to full service, and help keep carbon deposits out of the combustion

chambers. The oils cut down on oil pumping, reduce chances of burned-out bearings at high speed, and step up acceleration, power and mileage.

"Switching to one of the new oils amounts to giving an engine a free motor tune-up," a test engineer says. "In one case an engine that was quite rough was tested for compression. In good shape the engine should have shown 120 pounds compression on each cylinder. Five cylinders were down around ninety or ninety-five pounds and one was building up to 135 pounds pressure. That meant that rings on the weak cylinders were stuck, allowing some of the gas to blow by. The

Union Oil Co. Union Oil Bldg Los Angeles Calif

Los Angeles Calif

Dr. J. S. Hamilton

YOUR CAR

Right, camera records effect of new oil in combustion chambers. After several hours of running, engine head is removed and new pictures made. Below, comparative results of operation with old and new oils. Bottom, note reduction in amount of carbon

Richfield

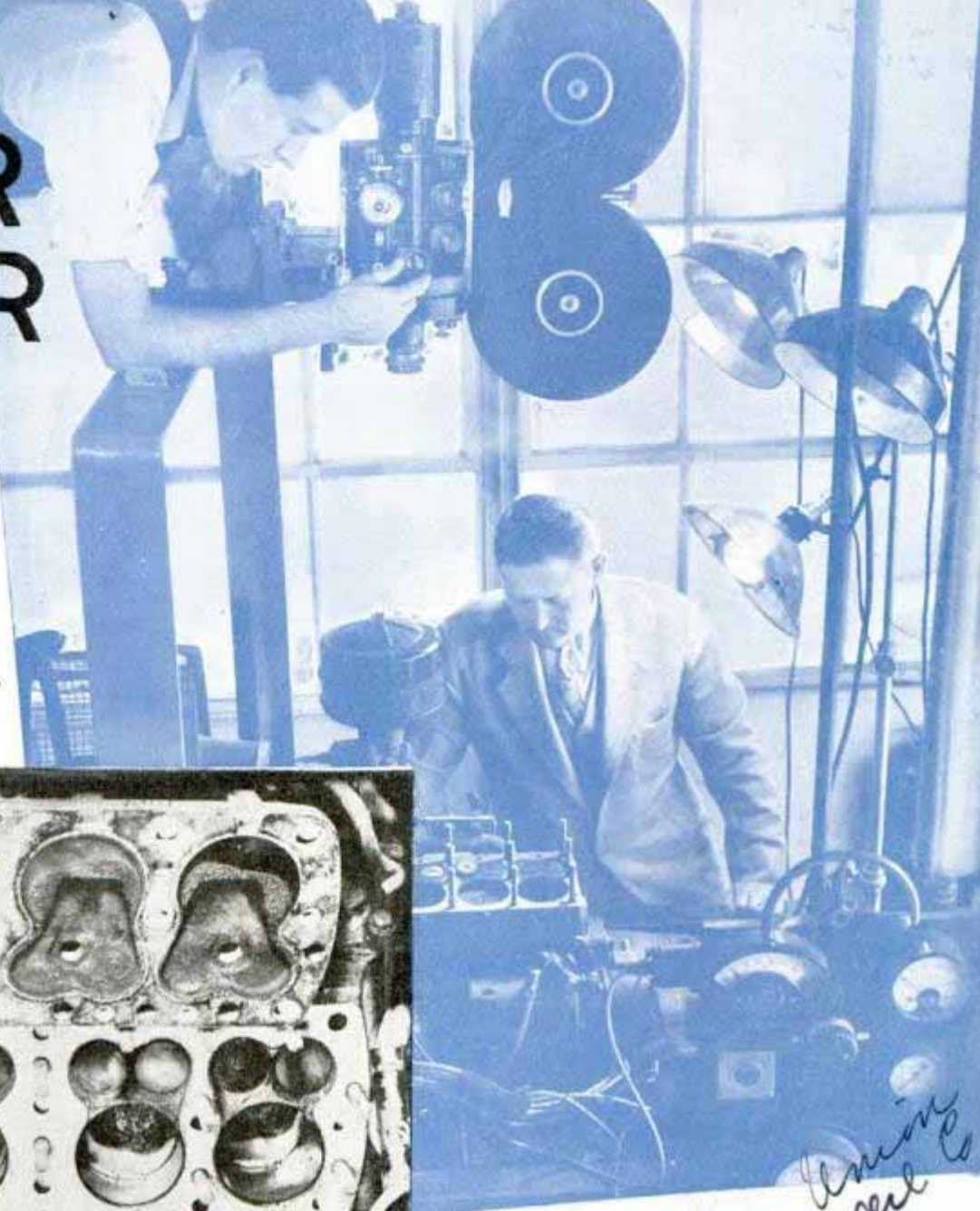

Richfield Oil Co

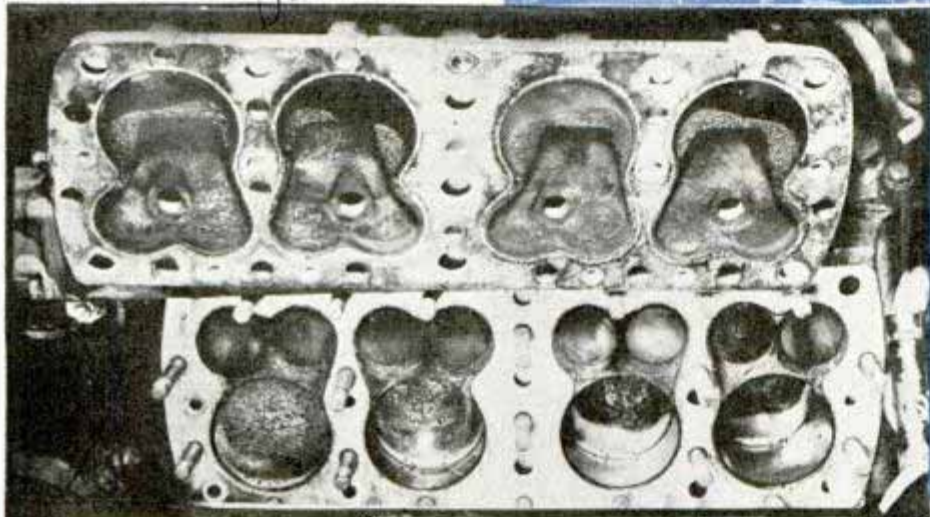

1934 CAR *Penna* ENGINE NO. 18-1040890

Had run 25,914 miles on ordinary motor oil. Carbon out and valves ground at 8000 miles. Note wet cylinders. Using considerable oil. Heavy deposits on heads, pistons and valves. Detonated on Hi-Octane.

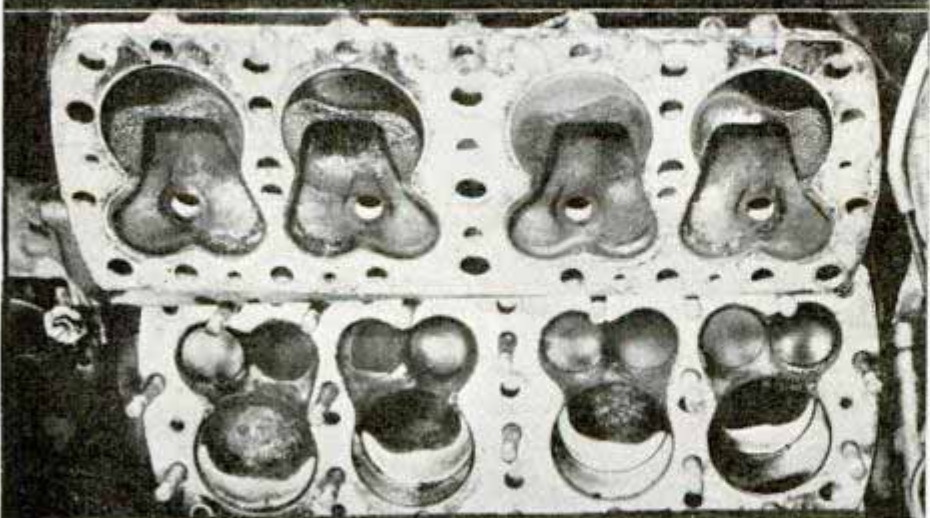

1934 CAR *ford V-8* RUN 1000 MILES WITH NEW OIL

Original mileage 25,914 on ordinary motor oil, making 26,917 miles total. Note dryness of carbon. Valves decidedly cleaned up. Combustion chambers now have soft, sooty carbon. Pistons cleaner and not such sharp deposits.

high pressure in one cylinder resulted from good rings plus a heavy carbon deposit. The engine was detonating on that cylinder.

"A change to one of the new oils brought about a miracle in a few hundred miles. The new oil freed the rings and loosened the carbon, increasing the compression in the weak cylinders and reducing it in the cylinder that had too high a pressure. Before the new oil was used there was a difference of forty-five pounds pressure between the low and the high cylinders. After the oil had gone to work, all the cylinders registered within six pounds of each other."

Richfield Oil Co



ly high film strength and will not form excessive carbon in the combustion chambers. There are a lot of other requirements, too, but these are the most important. To get these qualities the oils today are being compounded in the same way a druggist stirs up a prescription. Starting with some high-grade oil as a base, the petroleum chemist adds a few ingredients in the right quantities and turns out a product that does a lot

Courtesy Union Oil Co.

Top, measuring engine bearing temperature on desert speed run. Bottom, engineers prepare fuel of known octane rating to measure carbon-removing effect of oil in tests with fleet of cars



None of the new oils is able to increase performance above the original ability of an engine. All they are able to do is to restore the engine more closely to its new condition so that it runs better. Used in a new engine, the new oils retard deposits of gum and carbon and keep the motor in better shape. Five years ago, oils were judged simply by flash and fire points, gravity, viscosity and freedom from gum and impurities. But they aren't slippery enough for modern engines. Higher compression ratios, higher engine speeds, decreased working clearances between moving parts, and heavier bearing loads are conditions that put severe strains upon ordinary lubricants. After 10,000 miles, many owners of new cars began to complain about fouled plugs, knocking, and sticking valves where they had expected care-free operation.

To meet these conditions there has been a secret race in the oil industry. The demand today is for oil that has exceptional-

of things no oil was ever able to do before. Many chemicals will give a higher film strength to oil, but not all of them are desirable. Carbon tetrachloride, for instance, tremendously increases film strength when it is added to an oil but the combination creates hydrochloric acid, a liquid that has no place in an engine.

Starting with many facts such as this, chemists investigated hundreds of fats and fatty acids derived from animal and vegetable oils. Castor oil, palm oil, olive oil, tallow, lard, and dozens of derivatives were studied. Many were tough and slippery, but they broke down in service and formed corrosive acids that attack metal. The problem was all the more acute be-

Archfield Oil Co. Los Angeles

cause engine manufacturers are abandoning soft babbitt bearings and turning to harder alloy bearings that are quite susceptible to corrosion. The goal was to find compounds that were extremely slippery and that still remain stable and inhibit corrosion. One group of chemists emerged from their secret sessions with a liquid that they called dichloromethyl stearate. The compound is an ester derived from animal fat that is treated with wood alcohol and chlorine. It is so oily that if you pour some of it on a metal surface you can't wipe it off. The film strength is so great that you can polish the metal for half a day and it is still slippery. The only way to remove the last trace is to wash



Top, burning an oil to test its flash and fire points. Left, two pistons, one after 10,650 miles operation and the other after 25,914 miles. Below, same two pistons after 1,000 miles running with oilier oil. Note how rings are cleaning up and carbon softening



10,650 MILES
Oil control rings clogged with a hard tenacious carbon and binder. Compression rings sticking slightly. Carbon on head

25,914 MILES
Oil control ring openings clear, but rings tight in grooves. Rings weak. Considerable carbon on head of piston



1000 MILES WITH NEW OIL
Oil control rings cleaning up. Top rings free in grooves. Carbon on piston head being removed

1000 MILES WITH NEW OIL
All rings free in grooves. Carbon decidedly being removed on piston head

it off with a solvent. Added in amounts of one or two per cent to an ordinary high-grade oil that has a film strength of about 5,000 pounds per square inch, the compound increases the film strength to 15,000 pounds per square inch.

Another oil company developed a substance that is called hexachlorodiphenyl oxide, which is a coal-tar product derived from benzol. This stuff is also "slipperier than greased lightning."

(Continued to page 135A)

Handwritten notes at the bottom of the page, including '1936 Plymouth' and '1934 Ford V-8'.

Giant Arches Bridge Valley on Super-Road

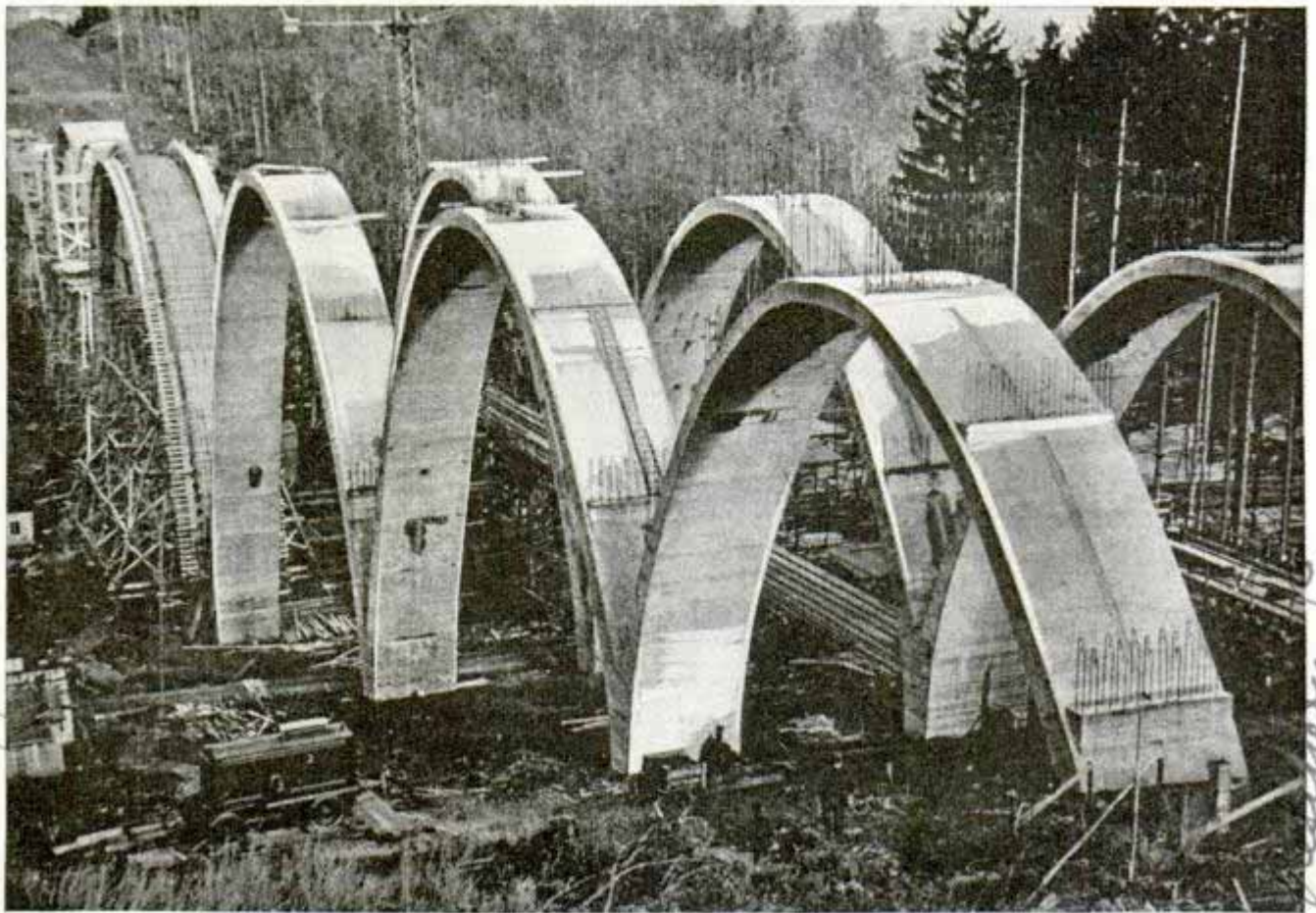

These great arches will support super-highway in Germany. Note arches still in process of construction at left. Considered masterpieces of engineering, the arches are concrete

More than 200 feet high, great concrete arches support the floor of the bridge over which traffic will flow at the point where Germany's super-highway crosses Rohrbach valley. A masterpiece of engineering

skill, the big bridge is more than 1,180 feet long. It is located on the Stuttgart section of the auto road. Graceful and eye-appealing, the arches serve to make the bridge ornamental as well as useful.

Road Surface Is Pounded Hard by Giant Paving Tamper



Workman guiding the heavy tamper which maneuvers over gravel road pounding its surface smooth

Instead of smoothing a road surface with the old-style steam roller, the top soil is pounded hard and smooth by a giant tamping machine developed in Germany. Resembling somewhat an inverted mushroom, it breaks up heavy gravel and compresses the surface.

Illegal Tapping of Pipe Lines Detected by Radio Hum

Bootleggers who tap oil pipe lines are now being fought with a radio detector. When illegal tapping is suspected, electrical oscillations are set up in a section of pipe as long as 1,500 feet. The electrical field about the pipe retains a characteristic

Germany
Ludwigshafen
Ludwigshafen
Ludwigshafen

Patent applied to Phillips
200 10 road

demonstrated at

*Science Service
May 15, 1937*

Mentor and
William Beecher

pattern if the line is untapped. An inspector travels over the buried pipe listening to the signals in earphones, and if he passes a buried tap he is warned by a hum.

— 256

Unthreaded Pipe Connected with Special Fitting

Eliminating the necessity for threading, grooving and flaring pipe, leak-proof fittings are available for making connections with no tools except a wrench. After inserting plain-end pipe into the fitting it is necessary only to tighten two threaded follower nuts with the wrench. As this is done, gaskets at each end of the fitting are compressed tightly around the pipe to form a positive seal. The resulting joint is not only permanently tight, but absorbs normal vibration, expansion and contraction movement and permits deflections of the pipe in the joint. If the pipe is already threaded it can be used in the same way. The fittings simplify joint-making and repair on both inside and outside piping, for oil, gas, water, air or special industrial lines.

Radio Trailer Guides Planes to Blind Landing in Safety



© Harris & Ewing
Top, signals transmitted from trailer to plane guide pilot. Bottom, plane in air about to pass over the radio-signaling trailer

at Washington D.C.

Mounted on wheels, a radio-equipped trailer designed to guide planes to the ground when the weather is murky may be transported easily to any position on the airfield. Shifting the trailer as the wind changes makes it possible to direct the pilot into the wind for the landing. A radio beam transmitted from the trailer actuates an indicator on the instrument panel of the plane. By watching the indicator the pilot can follow the curved beam to the ground. The instrument shows whether the plane is to the right or left and above or below the beam. The pilot also remains in communication with the control tower to receive information which may aid in landing.

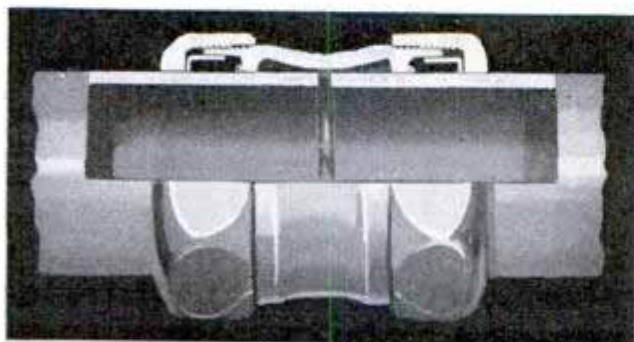

Showing how unthreaded pipes may be fitted together with special coupling

S. R. Dresser Mfg. Co. - Portland, Pa.

Television Camera Sharpens Its Eye for Detail

Charles Deery Olds
3781 N Broad St

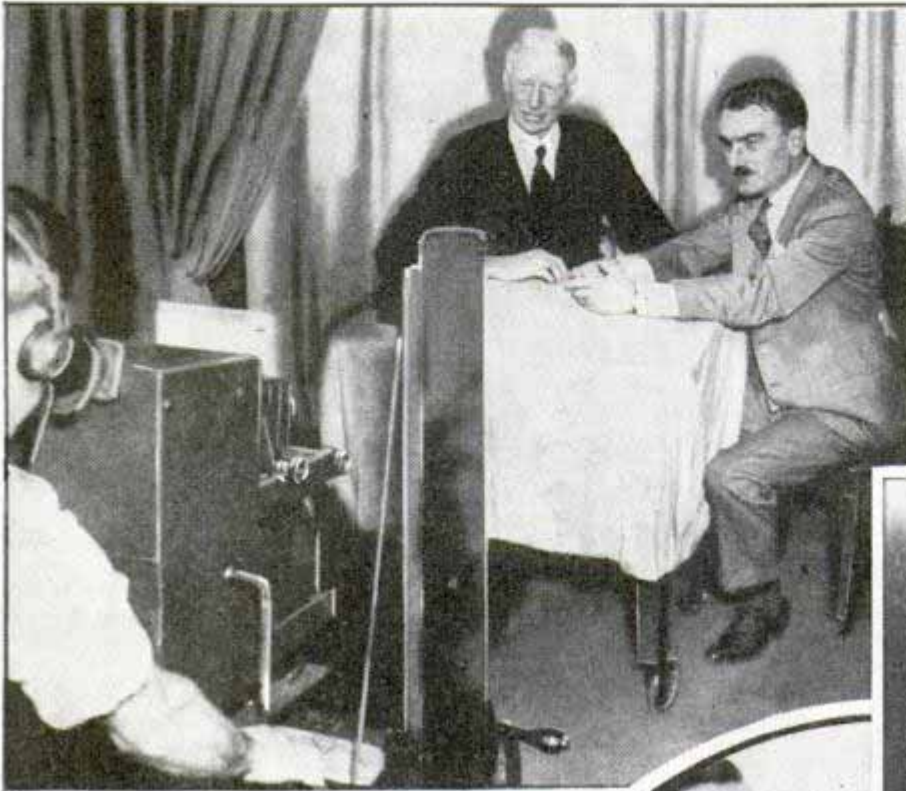

Top, Boake Carter (right) interviews Connie Mack, baseball manager, before the sharp eyes of television camera. Observe compactness of the camera, below. Camera tube is shown in photograph below and diagram at left. With this instrument a Philadelphia studio broadcasts high-definition television program

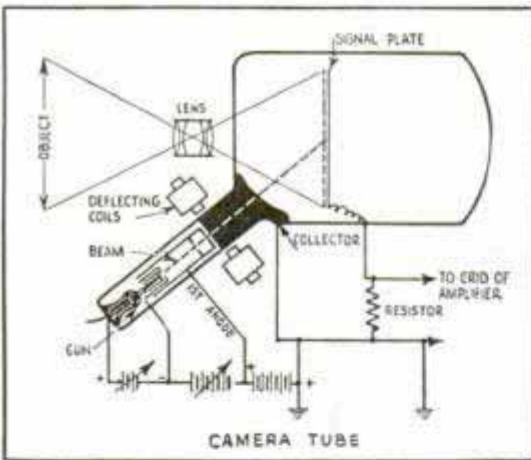

Richard

Television pictures clear-cut in detail and so smooth that the scanning lines are invisible from the ordinary viewing distance are going on the air from a Philadelphia studio. A television camera as compact and portable as a movie outfit picks up the image and transmits it instantly. By stepping up the scanning lines from 345 to 441, the engineers have produced a picture of pleasing sharpness, and, using a wide communication channel, broadcast experimentally a program of music, news interview, fashion show and vocal numbers that was received three miles away with

faithful reproduction on a seven and one-half by ten inch tube area. So highly defined was the picture that the audience could read the serial numbers on a dollar bill placed before the camera. By switching from 345 lines to 441 lines during transmission, the engineers demonstrated the surprising improvement in clarity gained by the thirty per cent increase in

scanning lines. The transmitter range was about ten miles. Both sound and television antennas were powered by coaxial transmission lines.

Three-Wheel Gasoline Truck Refuels Two Planes at Once

ls 259

Wind Charger Runs Ship's Radio

Among the new uses being found for wind-powered generating outfits is that of supplying current for radios aboard ships and houseboats. When the captain of the lake steamer, "Chief Watam," encountered trouble with his direct-current radio on the 350-foot craft, he installed a farm-type battery set and a wind-driven six-volt generator to keep the batteries charged. As the steamer plows along, the wind charger's propeller builds up the batteries so rapidly that operation is necessary only a few hours a week.



Shell *Aemie*
Gasoline truck built for maneuvering among planes at airport. It can refuel two ships at once, and is easily steered with single front wheel

Airplanes at Croydon airdrome, London, are refueled by a specially designed tank truck with three wheels. The single front wheel enables the operator to maneuver it easily, and it can be driven between the big passenger planes when two are to be refueled simultaneously.

ls 240

Red Light Warns Pilot of Drop in Oil or Gas Pressure

Flashing a red light in front of the airplane pilot, a pressure indicator gives ample warning when oil or fuel pressure begins to drop. The oil indicator, with an adjustable control unit installed at the oil pump body, tells instantly when oil drops to a predetermined safety level, becomes dangerously thin or if the line breaks or the pump fails. The gasoline pressure unit gives the pilot time to switch to another tank.

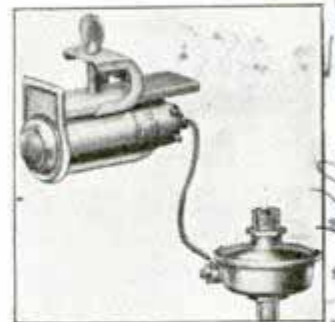

Indians in four communities in New York state still put on false-face masks to drive away disease.

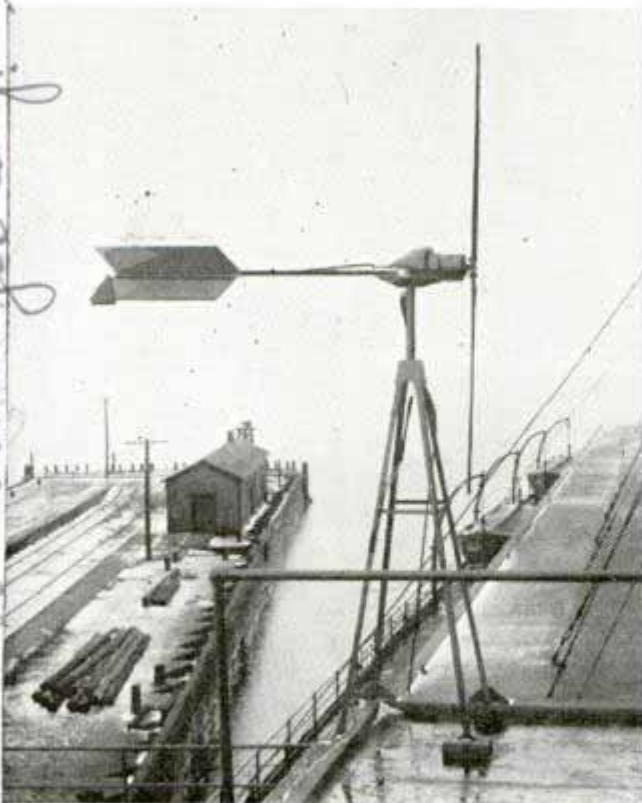

Windmill mounted on ship generates power to operate farm-type battery radio

Wind charger carf. down City down

Klemm & S 33 N. Chicago
Standard Central
Journal

Scientific Monthly

Julesburg, Colo

Water Jacket for Milk Can Cools It During Shipment



Jacket made of felt and burlap is soaked with water to keep milk can cool during shipment to creamery

To keep milk and cream cool while in transit from dairy farm to creamery, a water-cooled jacket has been developed. In actual experiments the jacket kept cans of cream at sixty-eight degrees while the room temperature was ninety-four. The jacket consists of inner and outer layers of burlap separated by diagonal strips of absorbent felt which act as a reservoir for water, keeping the burlap moist for several hours.

expansion and contraction. Experiments with a one-half mile rail disclosed that instead of contracting an estimated twenty-two inches in winter, it contracted only three-fourths of one inch. Use of the long rails eliminates the clickety-clack of the train wheels passing the short-rail joints, thus reducing noise and vibration.

es 223

Ship Rigs Ventilators to Pipe Fresh Water into Tanks

When a ship in Arctic waters began to run low on fresh water recently, small boats were sent ashore and filled from snow-fed streams, then towed back. Lacking a pump, the crew hoisted the boats on the davits and rigged a makeshift pipe by fitting together the ventilators gathered from various parts of the ship. The first was placed so that water would drain into it when the plug was removed from one of the boats, then the others were connected until the last was over the tanks. This arrangement permitted the fresh water to pass from boat to tank by gravity.

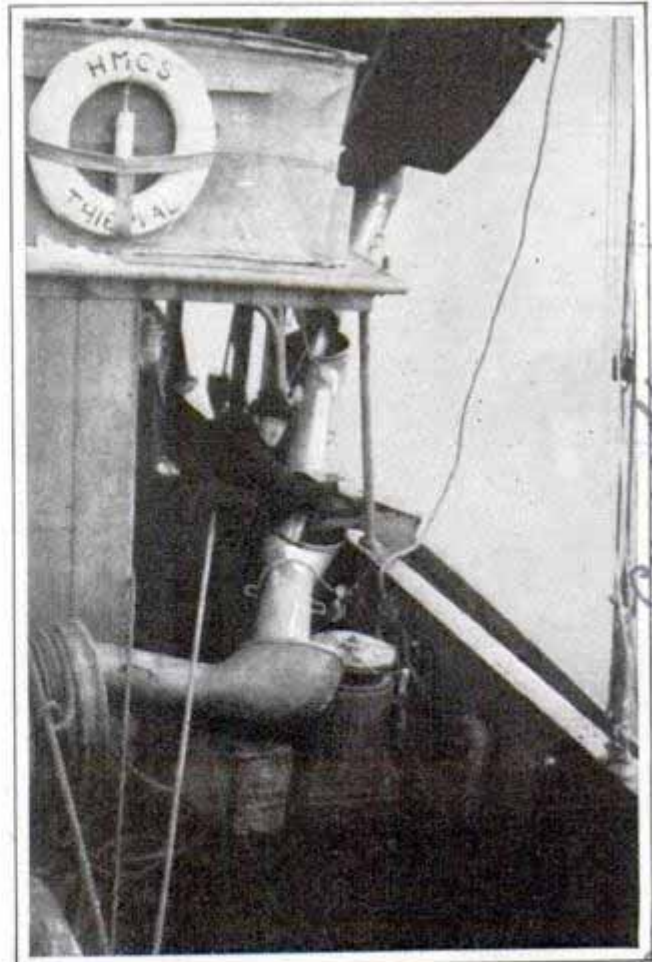

Ventilators fitted together to drain water from small boat into ship's tanks

Rails More Than Mile Long Smooth Out Train Ride

Rails more than a mile long are being used by some American railroads to give smoother riding, lower costs of maintenance and reduce wear on tracks and rolling stock. Four rails, each 8,000 feet long, have been laid in Pennsylvania, while others, each one mile 700 feet long, are in use in New York. They are made by welding ordinary rails together, either on the track or in the shops. Strings of flat cars are used in laying the "endless" rails. Tests seem to upset the 100-year old belief that rails had to be short to allow for

es 286

Chicago Tribune 3/14/37

Ottawa, Canada

Capt. Res. H. Valiquette

Tractor Conquers Snow at Work or Play

Capable of a speed of twenty-five miles per hour, a tractor for operating on snow has power to pull two sleds loaded with eighteen persons each or four tons of supplies. Dubbed the "snow cat," the tractor can negotiate forty-five per cent grades. It is of all-steel construction and has its own moving track on which it rides over the snow. Only three-and-one-half feet wide, the tractor provides transportation where there is slight clearance.

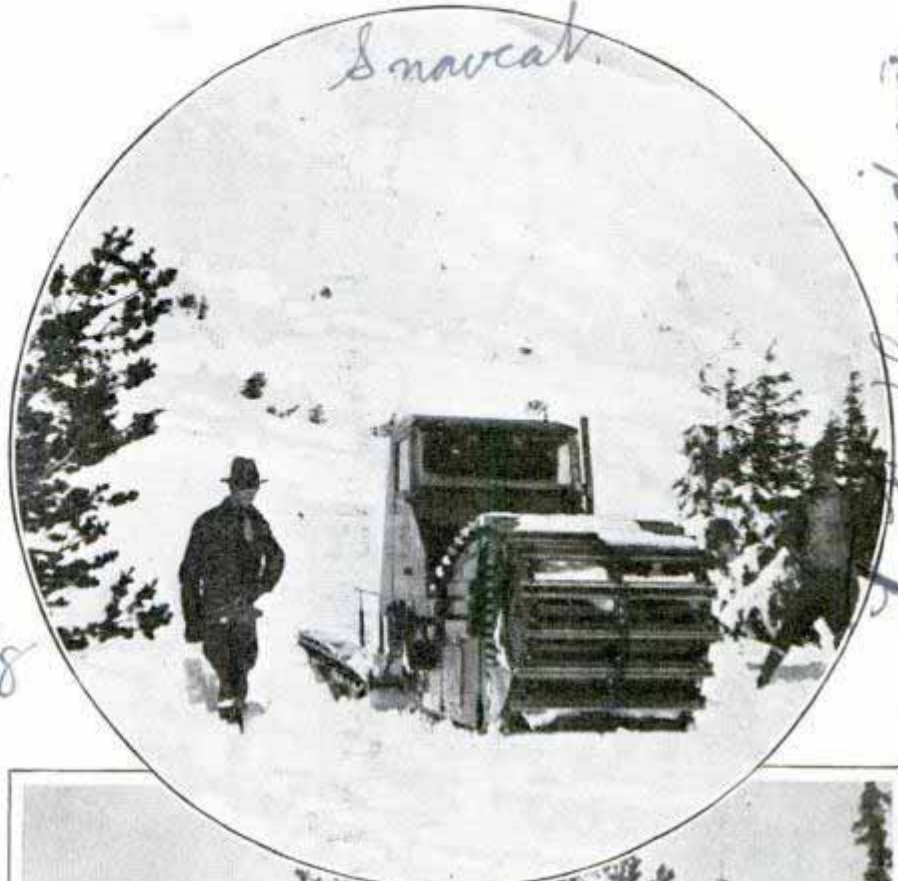

Two views of tractor and big sled on which may be transported several persons or a large quantity of supplies

Road-or-Rail Car Is Designed as Switch Engine

Adapted to either paved roads or railway tracks, the latest switch engine resembles a streamline motor coach. It is driven by automobile engine. Designed by a woman, Rachel De Wolf Raseman of Detroit, Mich., the engine bears little resemblance to the puffing, grimy switch engines in use for many years.



Rail-or-road switch engine which closely resembles automobile. Note retracted wheels which permit operation on rails

Germ-Killing Power Found in Onions and Garlic

Onions and garlic are germ killers. The chemicals that bring tears to the eyes of the cook as she prepares onions and garlic for dinner have been isolated by scientists at the University of Southern California, who say this bactericidal property may prove useful in fighting disease. Onions contain the germ killer allyl aldehyde, and garlic the less potent crotonic aldehyde.

Dr. Richard E. Vollrath
Prof. of Physics.

Rev. Sept. 1936 357

Auto Trailer Locomotive

Auto Trailer

*J. J. Standen
2611 S. 5th Ave
Portland, Ore*

Bacteriology Dept.

Chairman

*Auto Evans Products Co
H. J. Esquard*

1032 Florida Av Akron Ohio



SEARCHING *the* WORLD



Top, new ideas about wood often originate in far places, reached by difficult roads like this one. Bottom, strips of Chinese "Pau-hoi" wood which experts traced to its source

WHEN an American businessman wants the answer to any question about wood a vast army of fact-finders and wood experts in all parts of the world is called into service by telegraph, telephone, radio and mail.

Perhaps a method of treating soft wood to wear like iron is developed in Germany or a parquet flooring made of bamboo is placed on the Japanese market. If the businessman wants to know how it is done

and whether he may be able to sell the same thing in this country, Phillips A. Hayward, chief of the Forest Products Division of the U. S. Department of Commerce, starts the wheels turning to obtain the information desired.

As a result the forest products division has become a clearing house for ideas concerning wood, providing new information about an old material and working constantly to create new markets for American forest products and to introduce foreign products which seem desirable. Many products familiar to everyone, such as wood-flour crack fillers, were suggested by these wood experts and many ideas have grown into mil-

lion-dollar industries. How the division works is illustrated by a case concerning a peculiar wood product.

The story starts with a telegram from a middle western businessman:

Department of Commerce
Washington D C

There is a tree bark about the thickness of wrapping paper that is being marketed here under its real or trade name of Rus-

sian Kura bark that is supposed to come from a district of Russia close to Roumania. If your records disclose such an import can you tell me if it is handled through the X— company or individual importers and if such bark comes from any place other than Russia. Will you kindly refer this to proper department with suggestion that they phone or wire me collect Monday if possible.

Richard E Noman
Flatfoot Ind

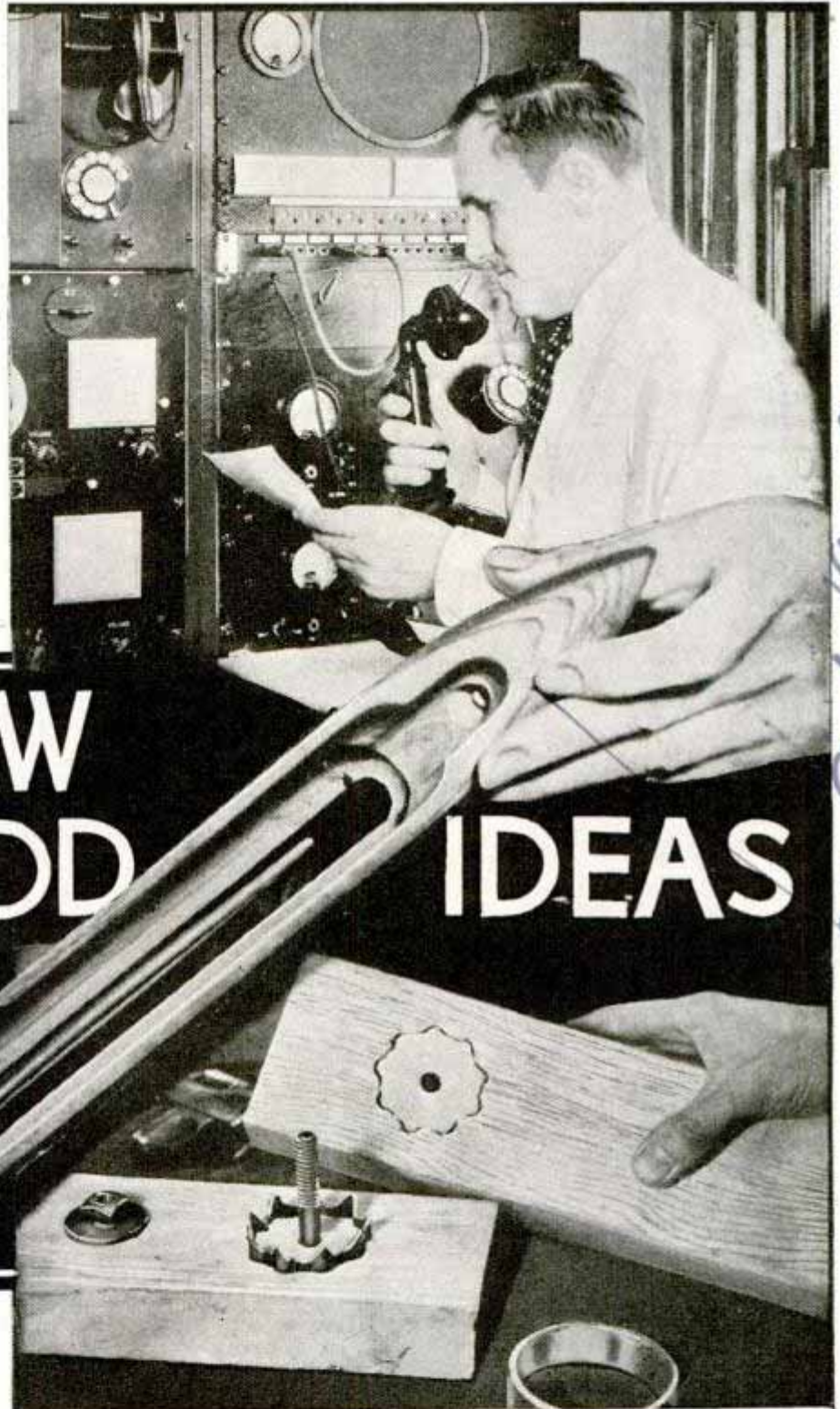

for **NEW WOOD IDEAS**

Top, department of commerce uses all forms of communication in tracing strange woods. Center, left, laminated wood shuttle made hard as iron by synthetic resin treatment. Right, connectors for timber joints make possible wooden structures strong as steel. Department of commerce introduced these connectors to American industry. Bottom, wooden "corks" from Germany

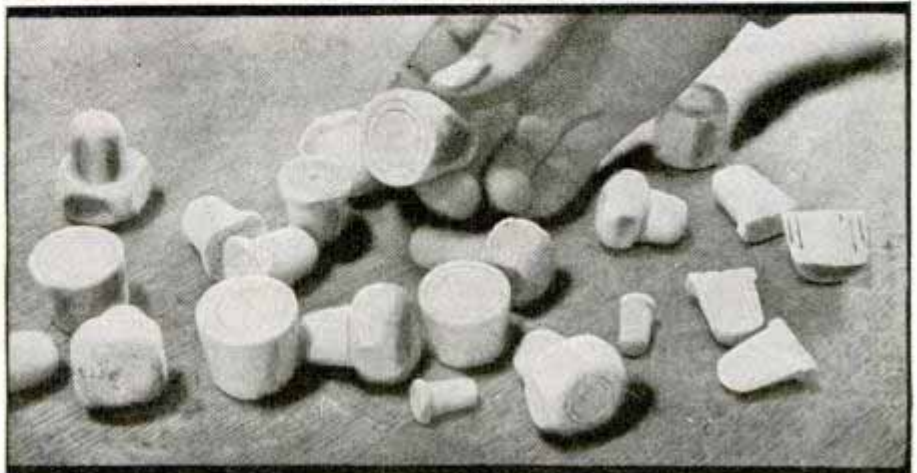

*Seco
Lumber Engineering Co. 1337*

es 165

see book 1938

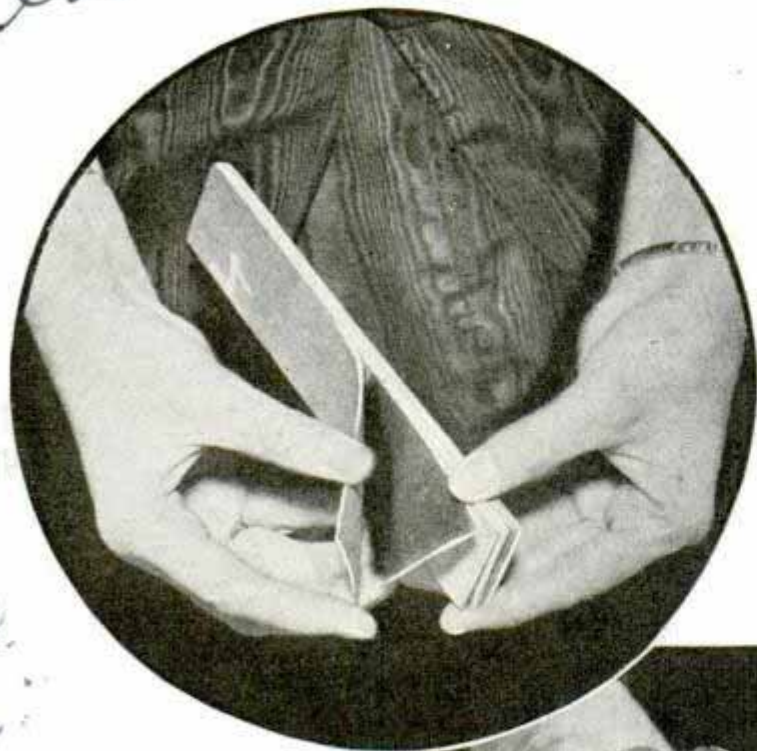

The two wood experts soon reported that the bark was not a bark at all, but shavinglike veneer made from "Pau-hoi" wood from China.

Certain that his Russian bark really was Chinese wood shavings Noman wanted to learn where he could buy it in quantities, so he wrote to the Chinese ambassador and the X—— importing company for aid. No help was obtained from these sources, so the department got in touch with its Shanghai office, which reported that Pau-hoi wood comes from several

Chinese provinces, and is used in the making of Chinese paper, toilet preparations and hair pomade. The name of an exporting firm was supplied. Washington passed this information on to Noman, who now had all the information he required. Thus the department of commerce, through its wood-sleuthing efforts, had opened the way for another industry based on wood.

(Continued to page 144A)

In reply, the department wired:

Mr Richard E Noman
Flatfoot Indiana

Unable to identify article in reference books but X—— has special department with monopoly on imports of medicinal and similar plant products.

Chemical Division
U S Dept of Commerce

Noman mailed a sample of the material to Washington so the wood sleuths could examine it. This sample consisted of several thin, crinkly ribbons of barklike substance, slightly yellowish in color.

The forest products division, to which the case had been transferred, surmised that the stuff might be the cambium layer from a Russian birch tree used to make baskets, postcards and wooden novelties. It sent samples to two well-known wood experts, one a scientist at the Smithsonian Institution, and the other a Yale University professor. It also asked Noman what the ribbonlike material was used for. Kura bark, he explained, when soaked and kneaded in water produces a jellylike substance used as a base for hair-setting fluid employed in hairdressing parlors.

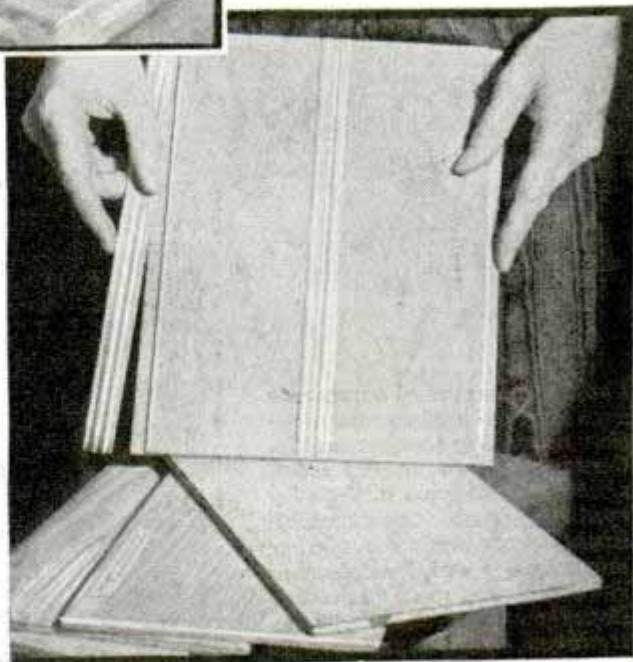
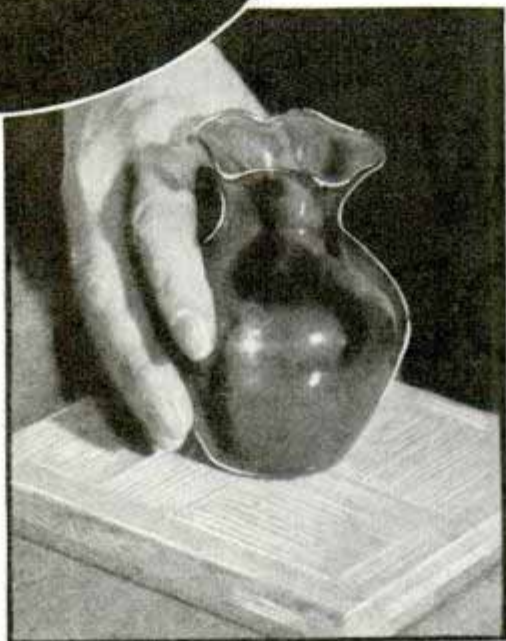

Top, waterproof plywood introduced in Germany and now used in this country. Center, laminated plywood with bamboo surface from Japan. Bottom, molded strips conceal joints in plywood

Technology Pasadena Calif

Observers to Ride Inside Giant Telescope

So large will be the structure of the Palomar mountain telescope, located in California, that observers will ride within. They will work in special rooms which will remain right side up no matter how the telescope is turned. A photo-diagram of the giant telescope, now complete only in model form, shows where each observer will be stationed and where the light from heavenly bodies will enter. The model is used by scientists of California Institute of Technology to work out intricate problems concerning the telescope's construction. A 200-inch mirror, which required many months to cast, cool and polish, will give the telescope vast power to explore distant regions of the sky.

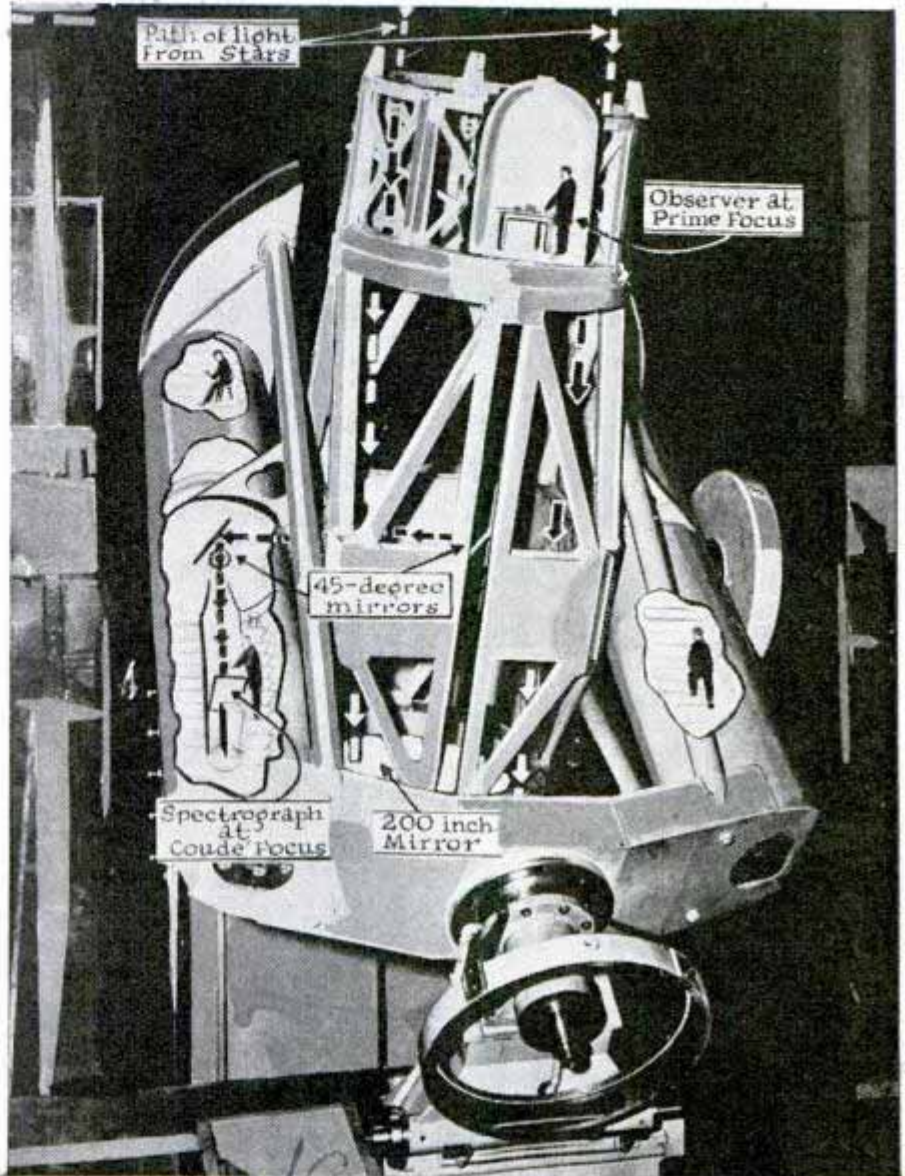

Right, diagrammatic view of model shows how observers will ride inside giant telescope

Es 275

Locomotive Travels by Train without Touching the Rails

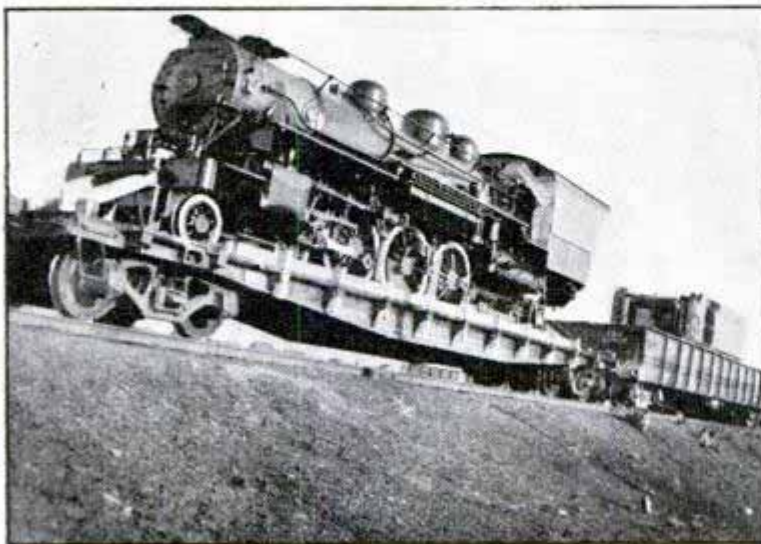

Bound for work in South America, this locomotive rode a flat car from Kansas City to New York, its tender in car behind

Locomotives usually do the hard work in railway transportation, but occasionally they go for a ride themselves. One big engine was loaded on a flat car at Kansas City, its tender riding in a gondola just behind, and was hauled to New York to be placed on a freighter for Rio de Janeiro.

Eleven elements make up ninety-nine and one-half per cent of the earth's surface; in order of abundance they are: oxygen, silicon, aluminum, iron, calcium, sodium, potassium, magnesium, titanium, phosphorus and hydrogen.

*Cont. Joseph Buchter
 Brand
 central
 Seventy-ninth
 March 1937*

Small Gas Engine Yields Alternating Current

43 Royalston Ave. Minneapolis
110 volt
60 cycle

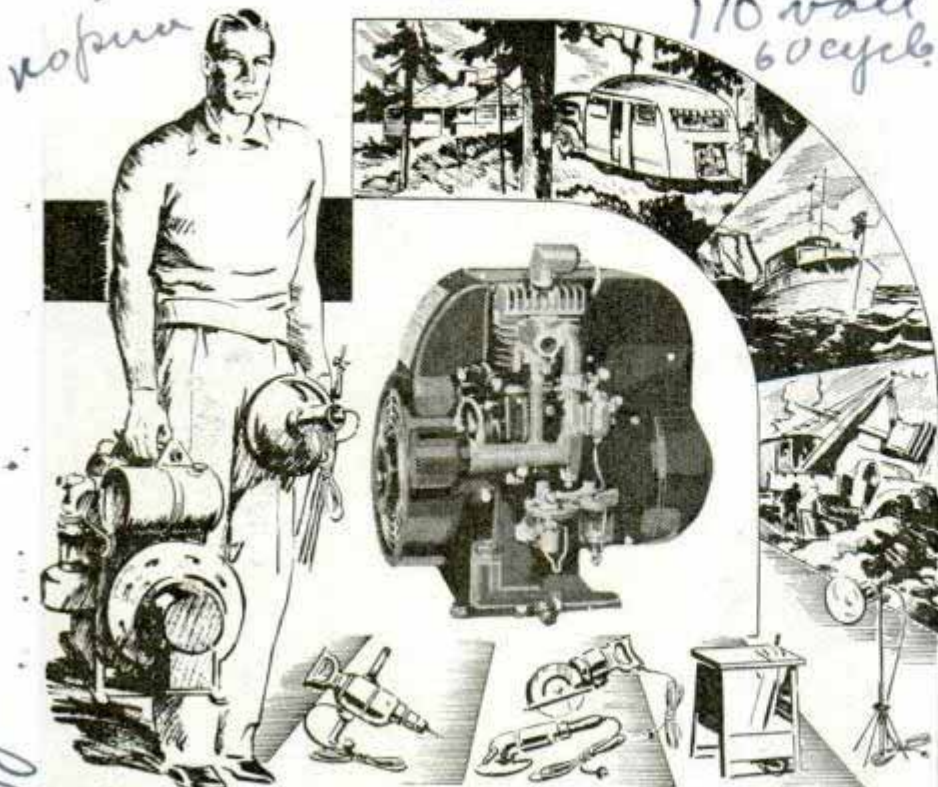

Alternating current for radio transmission, X-ray and sound apparatus where city power lines are unavailable, can be furnished by a portable "a.c." generator now available. It is a small, compact gasoline-powered unit developing from 350 to 1,000 watts, rubber-mounted to absorb vibration and noise. Installed in automobile, trailer, boat or plane, it makes possible the use of electrical appliances and public-address systems.

Gasoline-powered portable generator and some of its uses—furnishing alternating current in camp, in trailer and yacht

City Physician's Office

Identification by "Eye Prints" Investigated by Scientists

That the tiny veins in the eye may be a positive means of identification is being studied by scientists. Dr. Samuel J. Rubley, Detroit specialist, points out that "eye print" identification is not intended to replace fingerprinting, but to supplement it. He adds that there is no way to tamper with eye identification, unless the criminal is prepared to remove his eye. Study thus far indicates, Dr. Rubley says,

that no vein markings on the retinas are ever duplicated and that they never vary from birth to death. A special optical camera is used to photograph, through the pupil, the optic nerve and the network of the retina, or background, of the eye. After a picture is made a transparent screen is placed over the negative. Called a retinal protractor, the screen has a counterclockwise scale of two concentric circles divided into "centigrees." This is placed over the negative, or photograph, to measure the location and angles of the veins and from this reading the eyes are classified. The principal disadvantages of the system, according to Dr. Rubley, are that criminals leave no telltale evidence at the scene of the crime and that some diseases prevent photographing the blood-vessel network. But he believes the system will be a definite asset to criminology.



Photo courtesy Detroit Free Press
Photographing the eye to show veins by which individual may be identified

Radium "Bombs" Carried Safely in Flexible Pneumatic Tube

To safeguard the hospital staff, radium "bombs" at the London Radium Institute are "blown" through a flexible pneumatic

City Physician's Office

London, Eng

Radium Beam
The Radio Research

3/16/39

tube from storage safe to treatment table. Use of large radium units for treating malignant diseases entails extreme caution on the part of the handlers. Monel metal tubes containing 200 milligrams of the element are placed in a steel bobbin and blown from the thick-walled safe to the treatment mechanism by air pressure provided by a simple vacuum-cleaner blower.

Es 296

Replicas of Old Mission Bells Made in Woman's Workshop



California woman makes exact copies of mission bells all around the world. Her workshop is filled with bells of every shape and kind.

Ten-Foot Streamline Rail Car Is Built by Schoolboys

Running on narrow-gauge track in a California schoolyard is a streamline rail car built by the young railroaders themselves after the pattern of the big streamliners. It has an air whistle and bell, brakes, steel steps, grip irons and even "exit" signs. The ten-foot car is propelled by levers geared to steel wheels running on a crankshaft. The rails were obtained from an abandoned mine near the school.

Miss. A. C. Forbes 335-4-31-37

Wido Wald

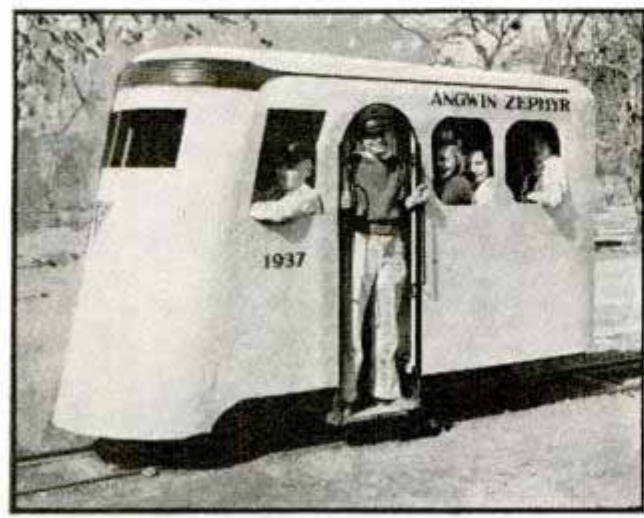

Ten feet long but built like a big streamliner, this car is fun by youngsters on narrow-gauge track

Capt. W. D. Baldwin, Pres. P. U. C. Training

Mission bells from around the world are reproduced in replica by a Los Angeles woman who has operated her own workshop for twenty-three years. She not only copies old mission bells but will "tailor to measure" bell of any size and shape.

Es 333

Oil Station Floodlit from Outside to Eliminate Fire Hazard

In order to reduce the fire risk at a pumping station, an oil pipe-line company in Oklahoma lights the interior of the station with floodlights outside the building. The light is installed at the window, with all wiring and fixtures outdoors.

Capt. Harold A. Board, Edin. Dept

California City Okla

Trailing Wire Latest Weapon in Aerial Fights

*Cmd. Esq. H. Davis "Gimmers" Holland
Royal Naval Air Station, Culterwell, Surrey, England*

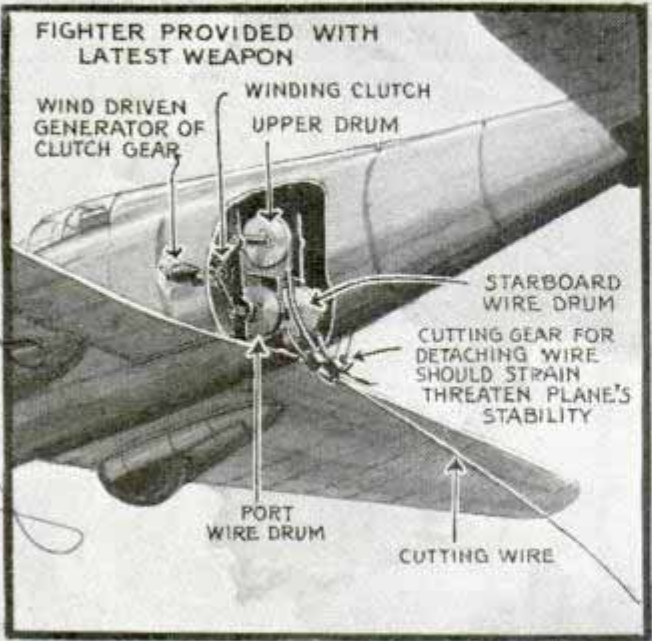

AT TERRIFIC PASSING SPEEDS OF MODERN FIGHTING AIRCRAFT THIN PIANO WIRE HAS ENORMOUS CUTTING FORCE

FIGHTER'S DIVING SPEED OVER 300 MILES PER HOUR

PASSING SPEED OF CUTTING WIRE OVER 500 MILES PER HOUR

BOMBER'S SPEED 200 MILES PER HOUR

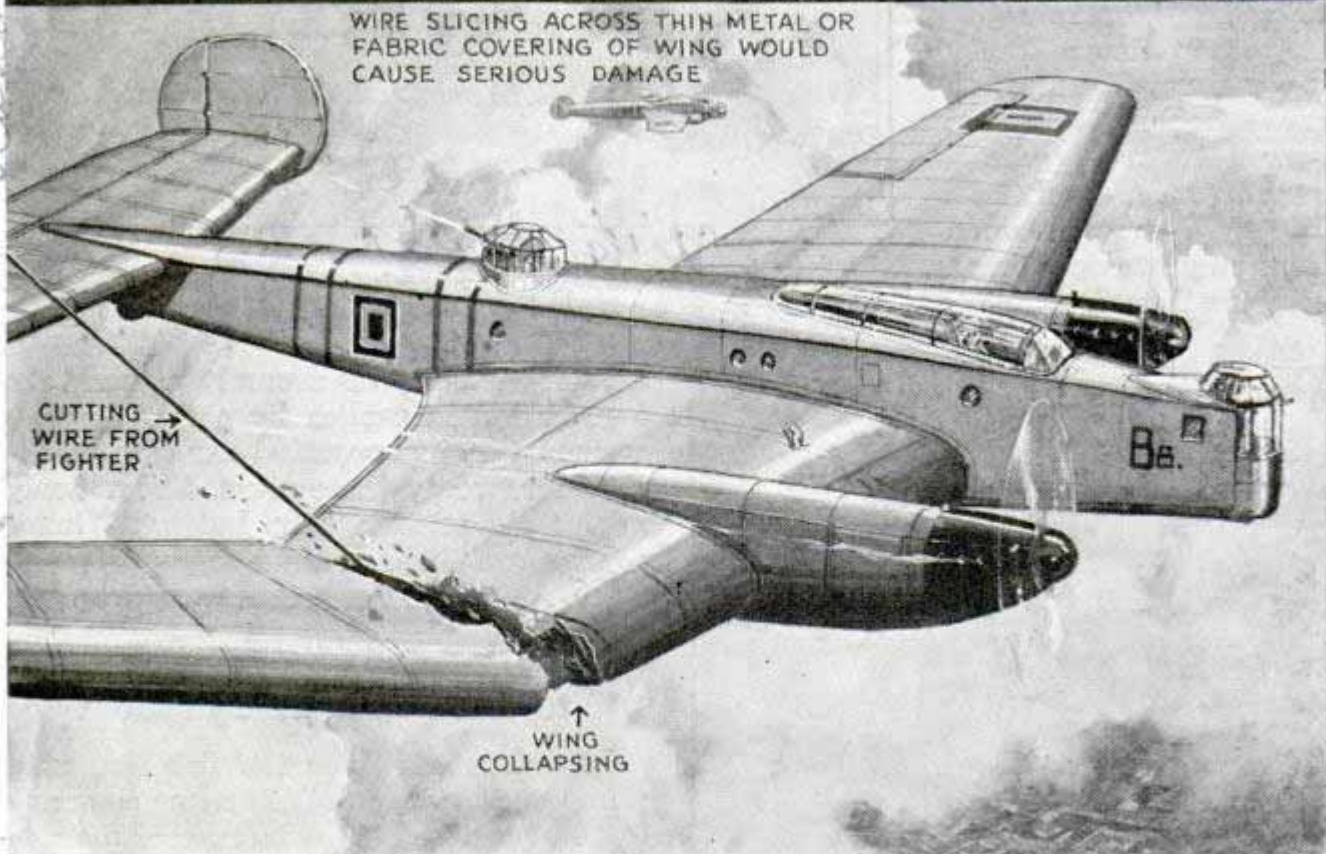

Tough steel wire trailing from a plane is the latest weapon of attack in aerial battles. The plane dives on enemy ship and sweeps wire across wing or fouls propeller. Combined speeds of the two planes give wire sufficient force to slice through wing. Automatic release frees wire upon contact with enemy craft

Balloon Nets to Guard City Against Air Raids

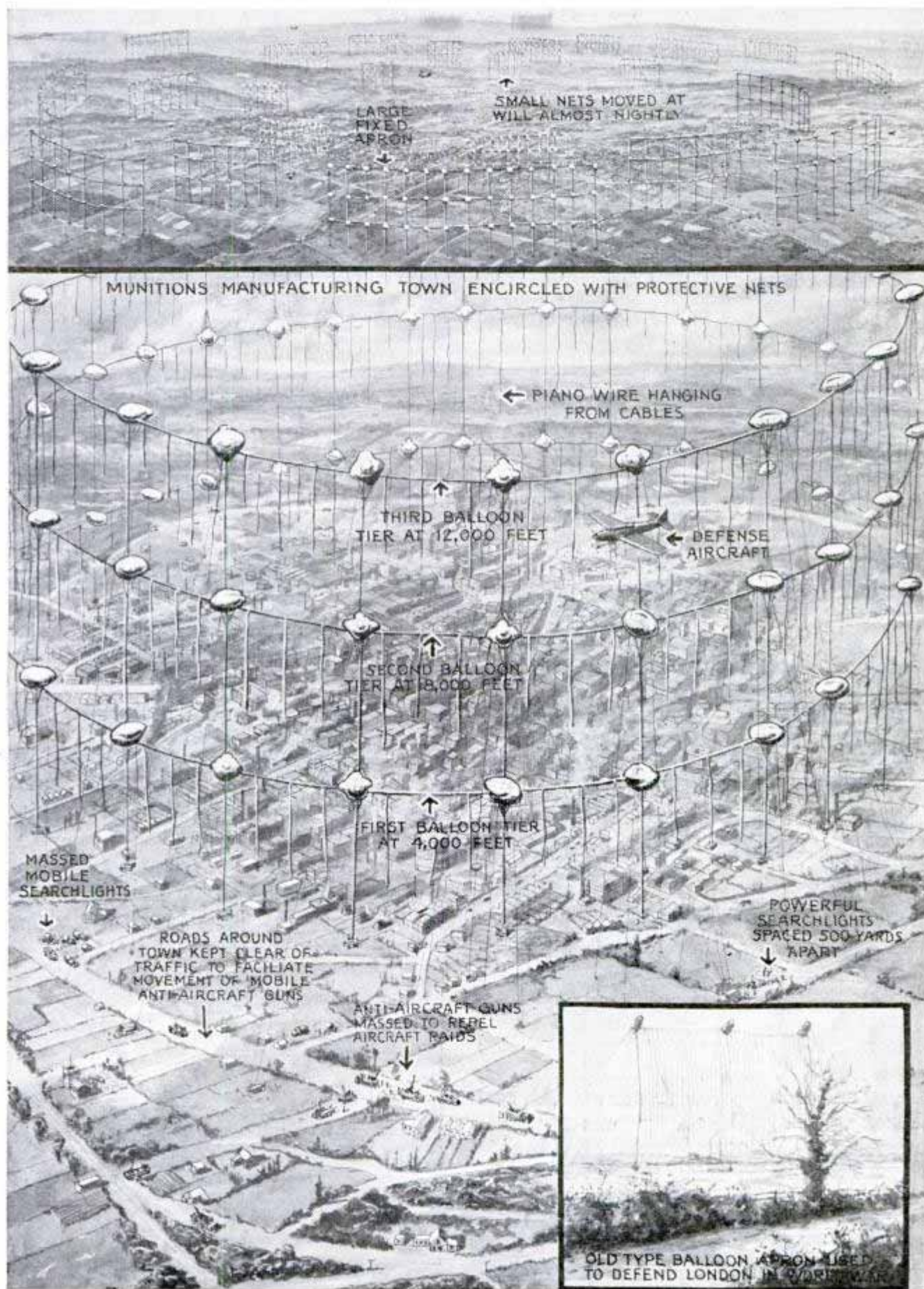

These drawings show how England plans to protect cities and munitions manufacturing towns against enemy planes in war. Nets made of wire and supported by a number of captive balloons would prevent aircraft from flying low. Defense planes would fight off ships attempting to enter at top

in FOOD

than they are today, will provide a better living to farmer and merchant, and will give the housewife assurance that when she buys a pound of foodstuff she will have a pound of edibles, free of wastes in fat, bone, hulls, stems, or pits. Work of preparing food will be cut to a small fraction of what it is today. More foods will be eaten raw and, in the case of vegetables and fruits, cooking time will be reduced from a half to two-thirds. Butchering, drawing, and other preparations which now require expert labor in the store will be done at central packing points, which means that better and

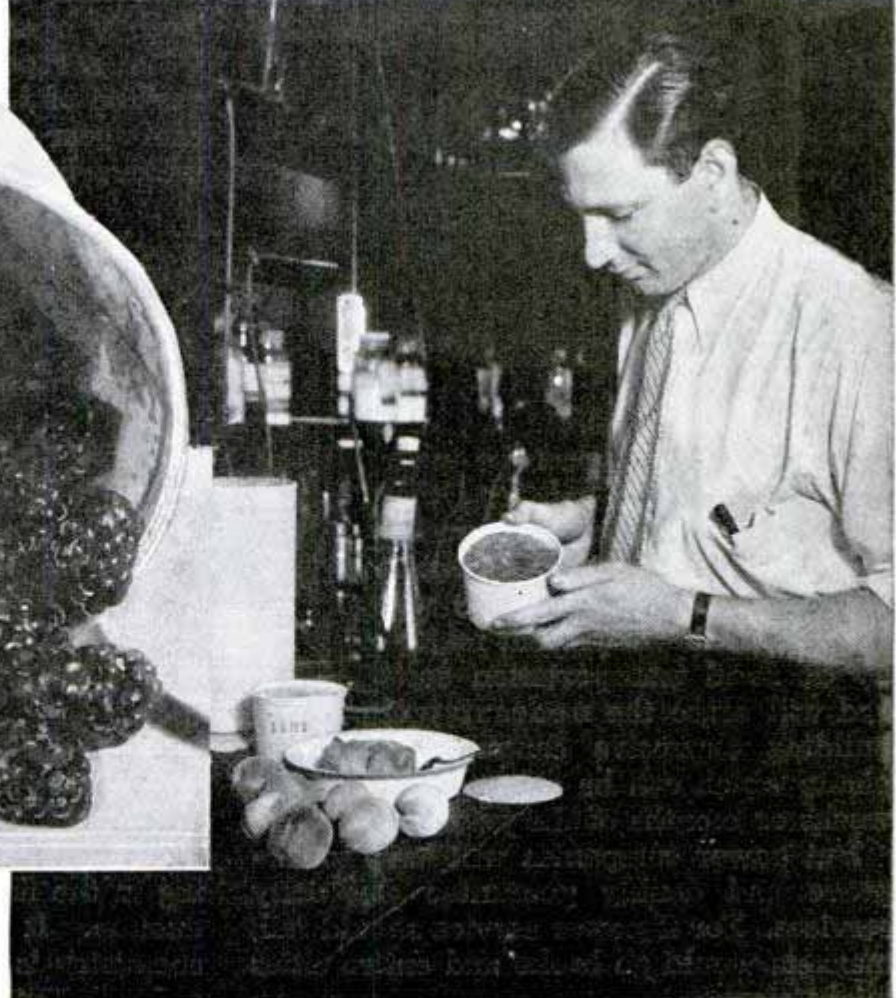

Top, packaging machine for frozen berries. Bottom, left, after opening. Right, opening frozen pack peaches for testing

J. M. Lutz, plant physiologist U. of Calif.



This grocery store picture is more than possible. It is highly probable. Even today food freezing is climbing into a multi-million-dollar industry and gains on every front.

Freezing is nature's oldest way of preserving foods. It is man's newest. Not long ago, Vilhjalmur Stefansson, famous explorer, gave a dinner party and served as feature course a cut of meat taken from the frozen carcass which had been

incased in tundra ice of North Siberia probably for hundreds of thousands of years. The meat was well flavored, edible, and digestible. But in the modern sense quick freezing of food is another forward step in the great science of refrigeration, already a life necessity to the industry of meat packing, film manufacture, textile making, candy, ice cream, dairy, oil and lubricant industries.

Back in 1907 the American Chemical Society heard Richardson and Scherubel make a report upon rapid freezing as a method of food preservation. During the same year the U. S. Department of Agriculture began its first research upon the

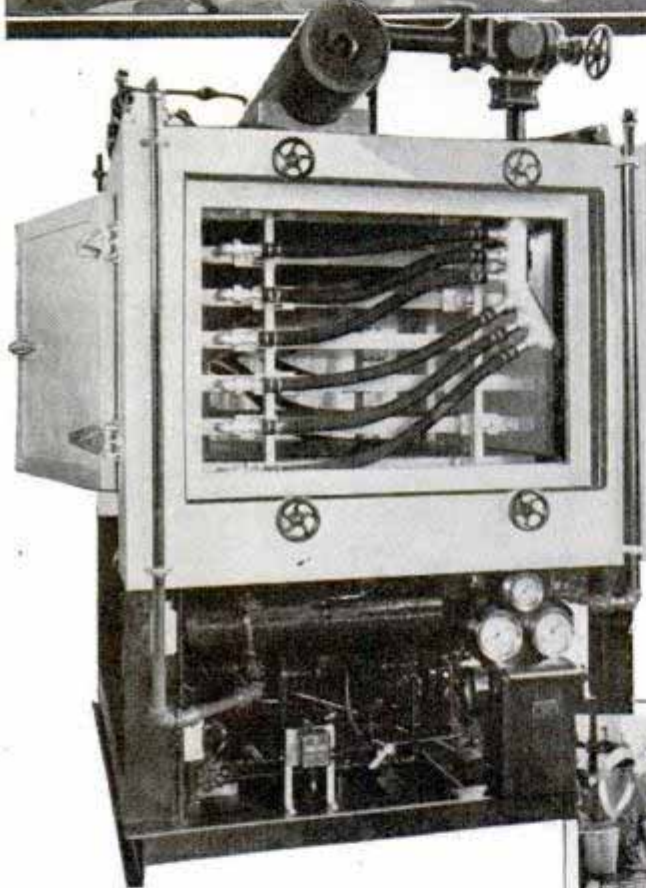

more profitable use can be made of scraps and food wastes. Other great savings will result from the fact that freezing equipment is compact and portable. This will do away with the present majority of food transportation costs and will erase the necessity of building expensive canning or packing plants which can be operated only a few weeks or months of the year.

But power companies will have to improve and doubly guarantee electricity services. For if power service should fail, markets would go broke and entire cities might starve.



Top, examining frozen pack peaches. Center, rear view of froster. Bottom, rigid inspection of green peas before freezing

subject. By 1920 such scientists as Harden F. Taylor and Clarence Birdseye, for whom the commercial brand of frosted foods was named, and others were working in the field of quick freezing by conduction. It soon became evident that chemistry is a vital factor in progress of

(Continued to page 148A)

Whole World at Fingertips of Radio Executive

By twisting a dial, pushing a button, or tapping a key, all conveniently located in his desk, David Sarnoff, president of Radio Corporation of America, may contact the whole world by radio. A small chromium panel in the executive's desk slides in and out like any desk shelf. On it is mounted a telephone dial, a sending key, push buttons and an etched map of the world showing the location of stations in the vast RCA radio network. It also shows most foreign stations. By operating the dial, President Sarnoff may flood the room with music. This is made possible by a selector system which connects with any of a score of radio receivers in operation in the National Broadcasting company's plant in the same building. Each receiver is tuned to a different station. Another twist of the dial brings in any of many NBC programs, just as they come from the studio and before they go on the air. If Mr. Sarnoff desires to contact various commercial stations, he taps out a few code signals on the telegraph key. This puts him into instant communication with the central operating



David Sarnoff, president of RCA, shown tapping out code at his desk. Note dial mounted on same panel

offices of the RCA communications in downtown New York. Dots and dashes from as many as thirty different countries can be brought into the office. Music, voice and key signals all are heard over loudspeakers concealed in wall panels.

Mr. George H. Eckhardt
 20 47 W Park Ave Phila

260

"Outrigger Bikes" Ride Rails on Four Flanged Wheels



Russian bicyclists at conclusion of long tour, part of which was by rail with flanged rims and "outrigger" wheels fitted on track

Five soviet Russian bicyclists made a tour of their country on "outrigger" bikes fitted with flanged wheel rims for traveling on rails. The bicycle wheels themselves were of standard size, while two smaller outrigger wheels rode the opposite rail. One of the tourists had a rear-view mirror fitted to the handlebar to watch for trains.

Pressure at the core of the earth is computed at 3,200,000 atmospheres.

Sovfoto. 723 Several scientific family

shelter which he erected over the driveway to his garage. The equipment is mounted on casters, making it easy to roll in or out of the garage where it is kept at night.

Sweden service 3/15/37

295
Asiatics in Ice Age Found America While on Hunt

Ten thousand years before Columbus discovered America, Asiatics hunting food discovered this continent by crossing the Bering strait. This is the theory of Prof. Ernst Antevs, Swedish geologist studying prehistoric America. He believes hunters from Asia followed the mammoth north as the Ice Age closed, and that the oldest records of man in North America are still hidden in Alaska.

293
Sponge Cushion on Bike Seat Adds Comfort

Made of sponge rubber, a handy pad for the bicycle seat improves riding comfort. No alterations of the standard bicycle are necessary. The pad is slipped over the seat like a cover.

Hands of Big Clock Rest After a Twenty-Year Run

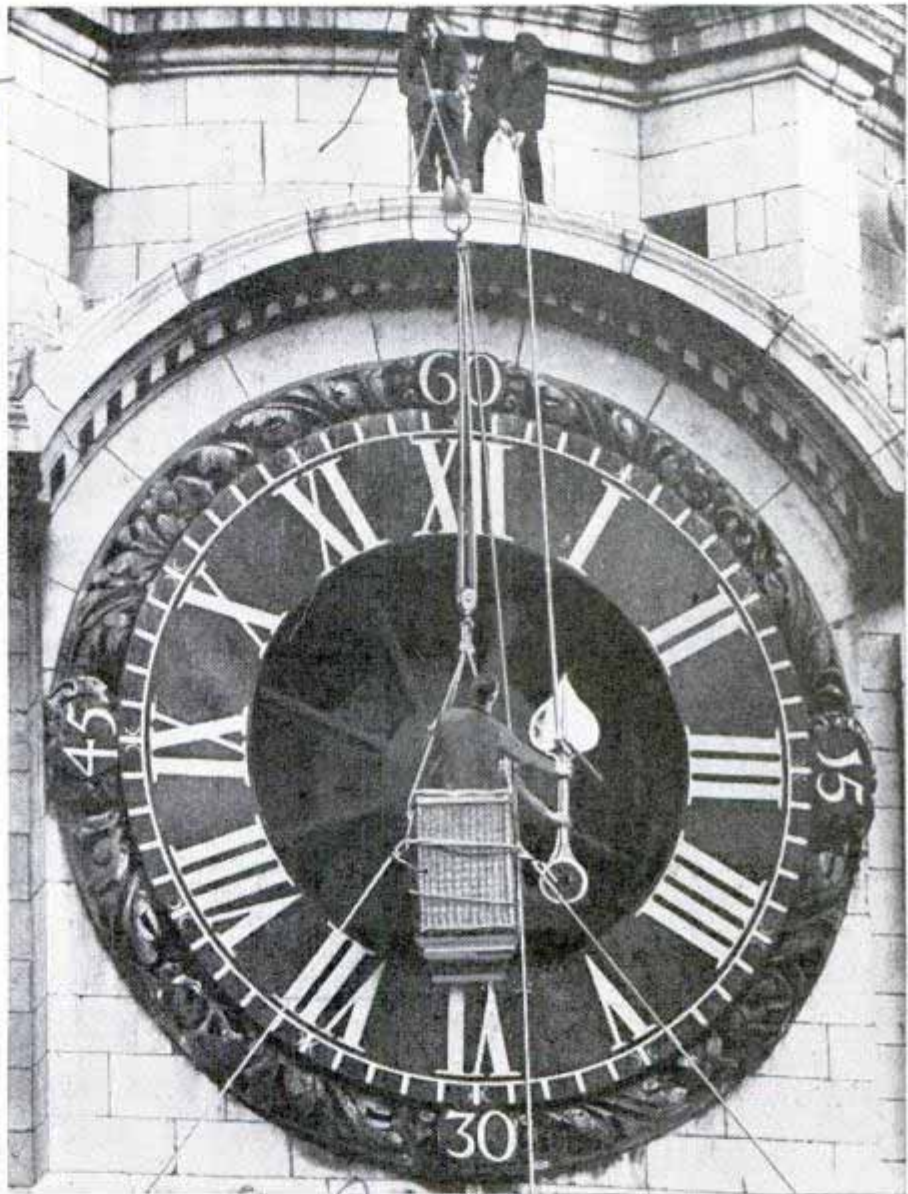

© Planet News, Ltd.

Workmen lowered in basket disconnect hands of St. Paul's cathedral clock to inspect dial mechanism and clean gold leaf on face and hands

For the first time in twenty years, the giant hands of St. Paul's cathedral clock in London have been taken down for inspection. Repairmen were let down in a basket to disconnect the hands, which were then lowered to the ground with a rope. The clock, which strikes the hours on the "Big Tom" bell, stopped January 5, and after preliminary repairs it was decided to examine the dial mechanism and clean the gold leaf on face and hands.

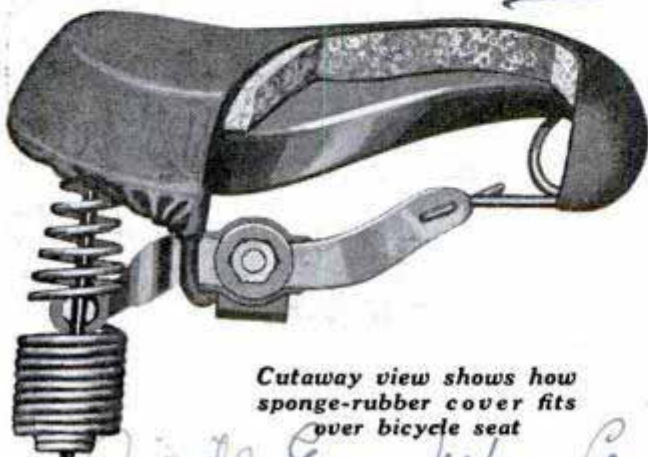

Cutaway view shows how sponge-rubber cover fits over bicycle seat

Whenever you find that you wish to know more about any article in this magazine, write our Bureau of Information, inclosing return postage.

*Wade Eye-hy Co
5713 Euclid Ave*

9/29/37

Two Forty-Five Ton Diesels Will Propel Luxury Yacht



Here is one of the two Diesel engines. Weighing forty-five tons, it is being handled by special floating crane

Propulsion of T. O. M. Sopwith's new luxury yacht, "Philante," is accomplished by two forty-five ton Diesel engines recently installed at Southampton, England. So heavy were the huge motors that each had to be hoisted aboard the yacht by a 150-ton floating crane. The "Philante" was outfitted to act as tender to Sopwith's America's cup challenger "Endeavour II," on its trip across the Atlantic from England.

Electric Robot with a Memory Stores Image in Aluminum

Its "gray matter" a bit of aluminum foil in a copper wedge, a robot with an electrical memory has been developed. It stores away an electrical image which can be recalled in its original likeness. Called a "memnoscope," this robot is used to prove that an electrical charge can assume a specific shape and hold it; and to test the theory that human memory is electric. The memnoscope remembers pulsations

of electricity occurring when alternating current is converted into direct current by an ignitron, a new type of vacuum tube. The "eye" of the memnoscope, an induction circuit, picks up the pulsations and telegraphs them to the "brain," a rapidly revolving copper roller like an ordinary commutator. The brain has 147 cells, each a copper segment of the commutator containing aluminum foil which stores the electrical charge, which is an image of the pulsation being watched. The segment carries the image through one revolution and then it is drawn off by a brush. The robot thus remembers the image of trouble in the ignitron by tripping the-shutter of a camera.

Handy "Water Sweep" Clears Off Lawn

Cleaning the lawn, walks and yard of papers, leaves and other debris is made easy by a device called the "water sweep." It consists of a length of brass pipe with a reducer nozzle or spout at one end. It is attached to the water hose, enabling the operator to play a forceful stream of water over the surface to be cleaned.



"Water sweep" in action. It quickly clears leaves and trash off the lawn

Drs. B. E. Marshall and W. E. Sakala, Westinghouse Earl Pilsbrough Jr Research Laboratories

12/21/37

Letter returned

Zalov Nijal

VACUUM CONCRETE CORPORATION
30 ROCKEFELLER PLAZA
NEW YORK CITY

Karl P. Billner
PULAR MECHANICS

865

March 1936-38
of Concrete to Speed Building

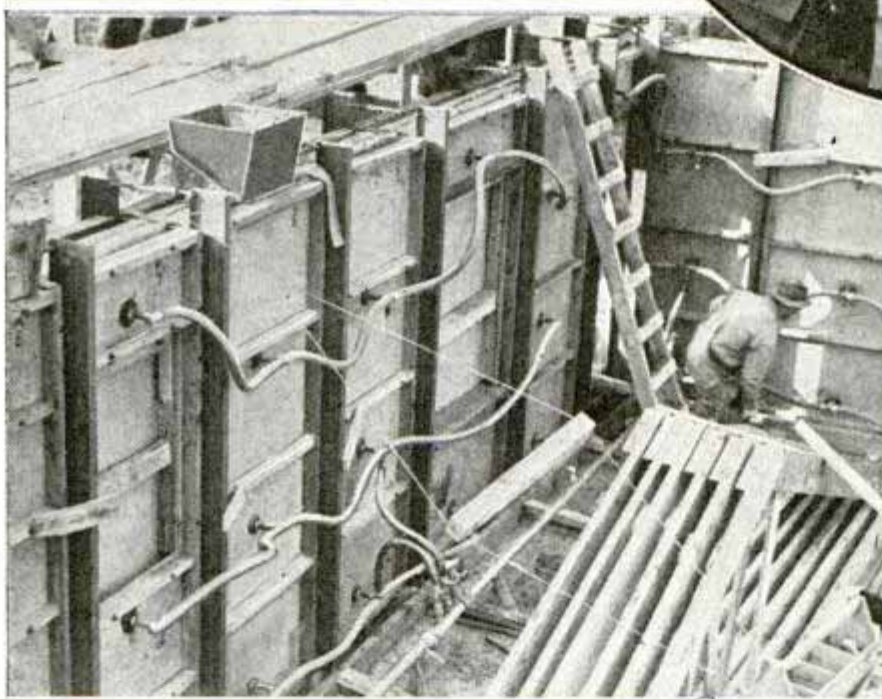
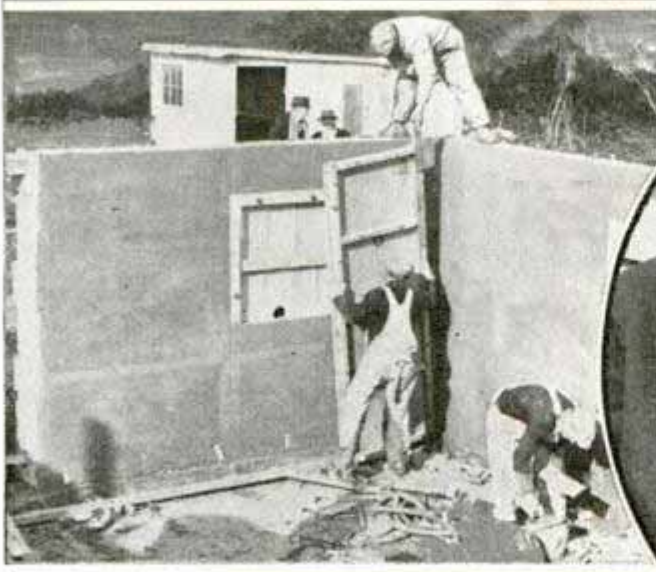

Top, removing forms from concrete wall. Bottom, forms in place with vacuum cups applying pressure which dries out the wet cement. Circle, one of the vacuum heads

Excess moisture may be forced out of concrete by using a vacuum mold process introduced recently, offering a means of speeding up construction of small homes with this material. Complete resistance and cohesion are attained within an hour, permitting removal of molds and making possible the erection of concrete buildings at the rate of one story per day. Quick drying results from pressure created by the vacuum molds.

Vacuum Concrete Corp. 30 Rockefeller Plaza, New York City
Karl P. Billner, Pat. 2,000,000

248
Modern Locomotives Save Fuel by Increasing Efficiency

Refinements of steam-locomotive design in the last fifteen years have lowered fuel consumption to the point where it now takes fifteen pounds of coal to haul a passenger train one mile, while in 1922 it took eighteen pounds of coal. The principal improvements have been higher superheating temperatures and better use of waste heat. Railway engines have an over-all efficiency of only about nine per cent compared with thirty per cent effi-

ciency of steam power stations. Fuel accounts for more than one-fourth of railroad operating costs. The Diesel-electric "Comet" of the New Haven road travels one and six-tenths miles on a gallon of oil. Seeking more efficient power, the Union Pacific railroad is building a steam turbine-electric locomotive with two 2,500-horsepower units capable of pulling a load of 1,000 tons at 110 miles an hour when the two units are synchronized.

Technology Review 1937

20 194

Cent. James Mc
Queeny. 31. W. 6. O. H.
Tenn. Carascito, Md.

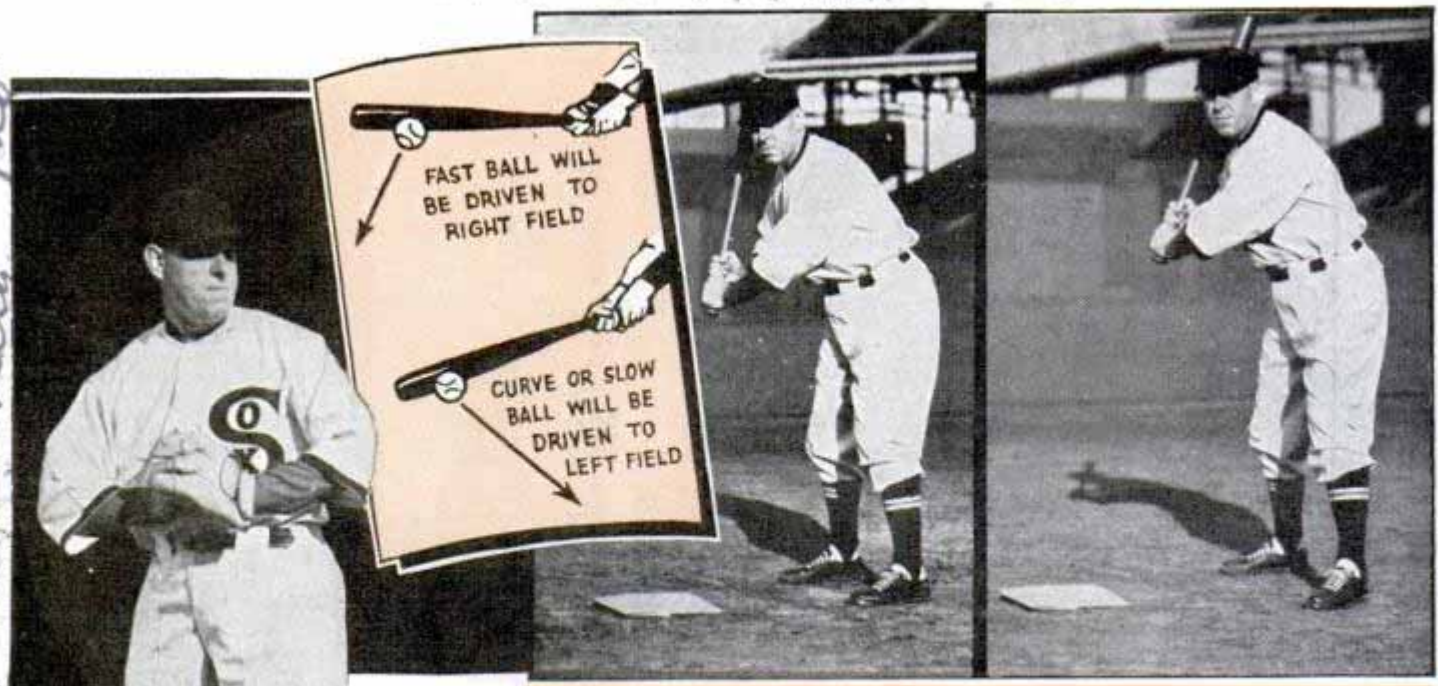

“WIGWAGGING

By Lew Fonseca

(Promotional Director, American League)

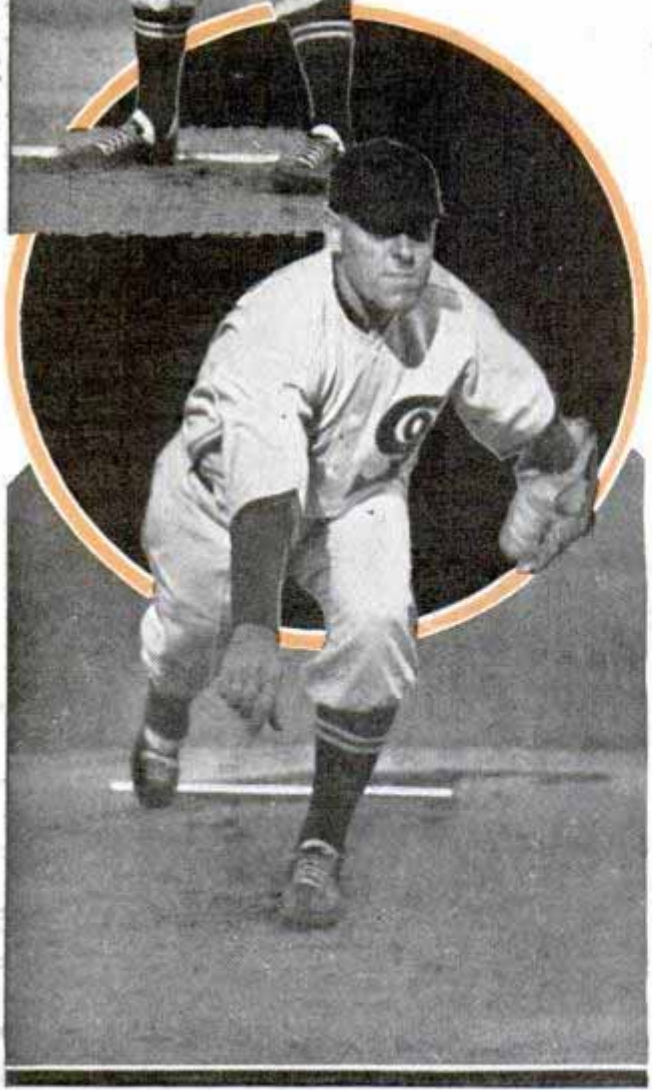

TO GET the most enjoyment out of a baseball game, you should know something of the subtleties and stratagems of baseball. It is one thing to watch a play, and another to watch and understand it.

Signaling, for example, is one of the most interesting phases of inside baseball. It is not confined to a few motions between the pitcher and catcher, as many fans suppose, but frequently extends to every player on the diamond.

One of the first things a sandlot catcher learns is a set of signs to signal the pitcher the ball he wants pitched in accordance with his knowledge of the batter's habits. Squatted down low with his hand hidden by his mitt so only the pitcher, the second baseman, and the shortstop can see, he employs a signal for each ball. Commonly he extends one finger for a fast ball, two for a curve, the fist for a pitch-out, and the wave of all the fingers for a change of pace.

Such signs are used in every class of baseball, but in the major leagues they become somewhat complicated and intricate. Big league signs are given in series, and the observers on the opposing team

Top, stance for pitcher with men on base and correct hitting stance. Below, pitcher's follow through

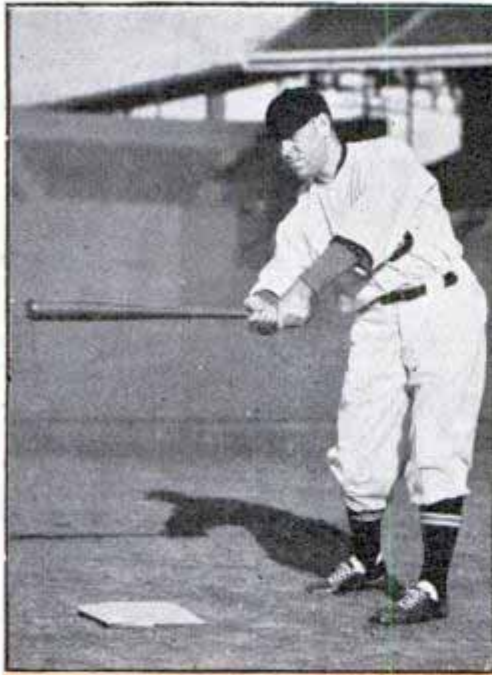

on the DIAMOND"

must figure out which signal goes. The signs are changed frequently, and in addition, a host of deceptions are used. By simple, unobtrusive actions, the signals may be reversed, changed, or checked.

Some clubs make a systematic effort to learn the signals of their opponents starting with the opening game of the season. Runners who reach second base observe closely the signals given by the man behind the plate, then report the signals for the balls delivered. To offset this, some teams automatically switch signals when a runner reaches second. In this way the runner can be confused. On his first trip to second, the first sign in a series may be the correct one, while later in the game, it may be the second or the third. Or an



Above, left, follow through of batter. Above, right, the correct bunting stance. The bat is gripped loosely and kept well out in front



Photos courtesy Western Athletic Goods Co.

Left, proper position for catcher when giving signals. Right, the catcher in correct position to receive the pitch

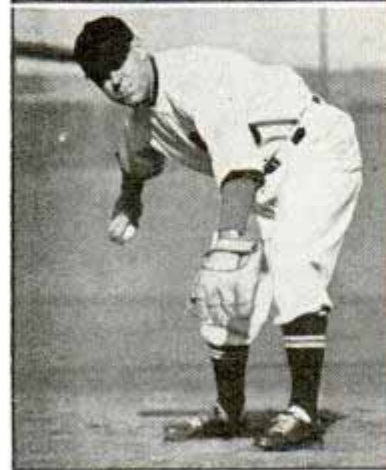
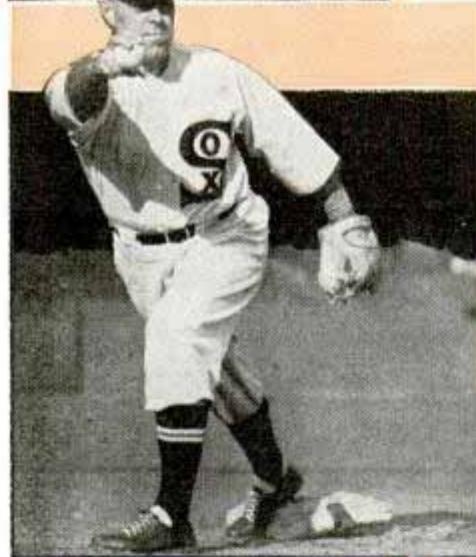
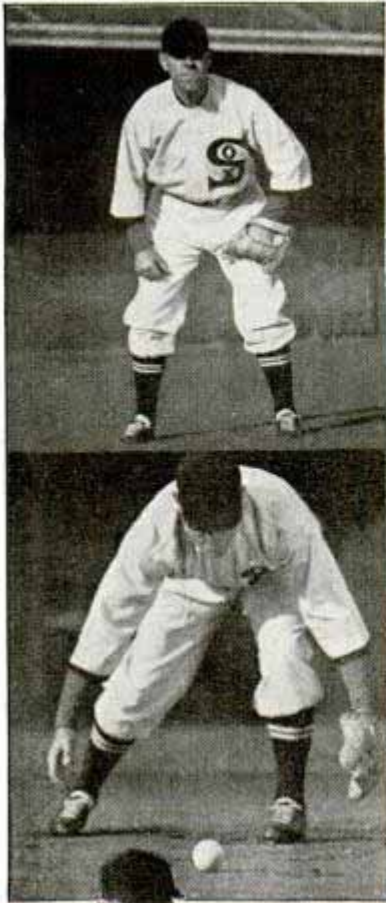

*Player making snap throw.
Above, pivoting to complete double play after touching bag*

entirely new set of signals may be introduced or the finger movements may become a ruse, the actual signal being given by the catcher placing his glove against his knee, touching his cap or some part of his uniform.

When he had a runner on second and there was danger of the batter being tipped off, Jimmy Ring, right-hand pitcher for the Philadelphia Nationals, would take the sign from the catcher, nod in approval, and go to the mound. When he would drag his hand across his pants, the catcher would be informed the signal previously given was to be reversed. If he did not touch his clothing, the signal stood. Similar ruses are used by other hurlers.

When men were sent down to the base line in the early days, there was no thought of using them for giving signals or directing play. Their job was to heckle the opposition. Today, many coaches on the third base line have become very clever in interpreting the mannerisms of pitchers on the mound. They have found, for instance, that some assume different facial expressions for each ball pitched.

To inform the first or third baseman what the next pitch is likely to be, the second baseman or shortstop who catches the signal uses key words. If the shortstop wants to say the next ball is to be a curve, he will usually shout

*Upper left, alert outfield stance and coming in fast for ground ball.
Above, reaching for throw and catcher blocking plate*

something like, "Come on, Charlie," the "c" meaning curve. If a fast ball is on tap, his remark may be "The old fight in there." To relay information to the batter the most common system is to call the hitter by his first name to indicate a curve and his last to signify a fast ball. When a batter has been crossed up a few times, however, he is reluctant to take any more tips. If he is tipped off that a curve is coming and then has a fast ball dished up to him, he is apt to be carried from the field on a stretcher because he waited for the curve to break.

Normally, everyone on the field is informed of the catcher's signal. One method is to have the shortstop take the signal from the catcher and pass it along to the out-

fielders by holding his hand behind his back. The value of a properly interpreted signal is obvious. Normally a right-handed batter will hit a curve to left field and a fast ball to right, but if a curved ball is thrown to a left-handed batter it will generally end up in right field and a fast ball in left. With this information at hand, the outfielders can be "leaning" in the direction the ball is likely to be hit and at the crack of the bat can be in a position to field it.

As a supplement to this on-the-spot information, the batting habits of an opposing lineup are studied throughout a season and discussed in detail in the clubhouse before each game or series. Tentative decisions are made to pitch to each player according to his batting weakness. Thus, when

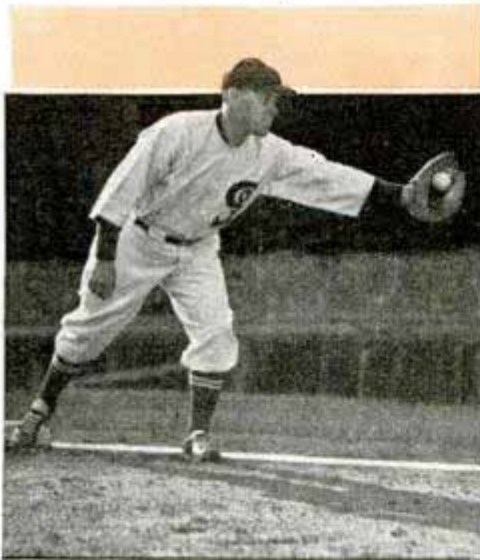
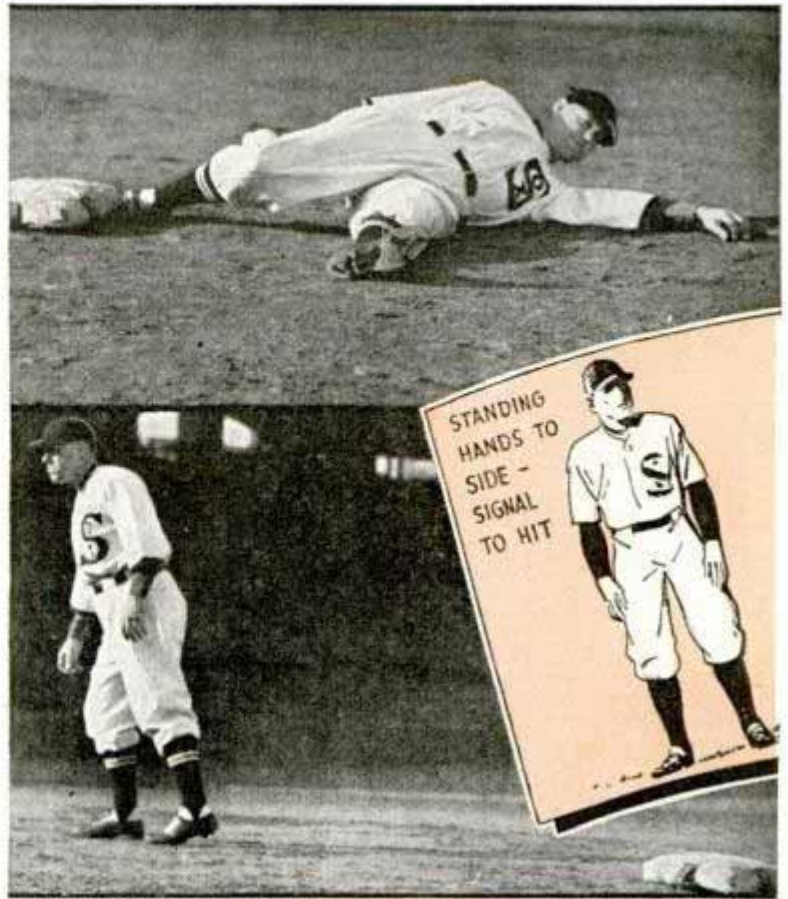

Reaching for catch and making snap throw from fielding position

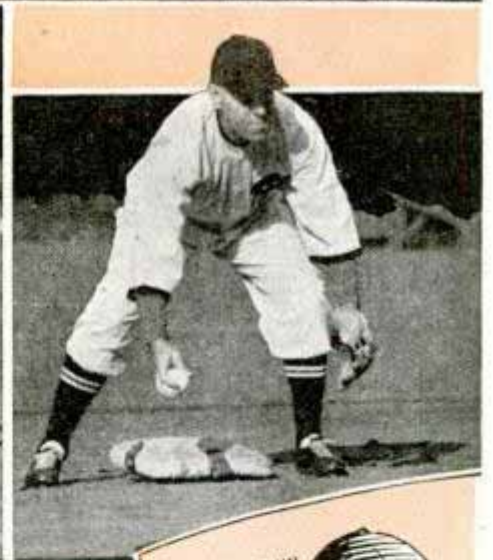

a team takes the field, both infielders and outfielders have some idea as to how to play the batter in accordance with the particular brand of pitching he is to receive.

With the advent of the lively ball, teams have abandoned the idea of playing for one run, and instead have adopted the "big inning" attack. As a result, the sacrifice play is not used as much as formerly. It still finds favor,
(Continued to page 146A)



Top, executing hook slide and correct position in taking lead from base. Below, ready to tag runner and illustration of walking lead

es 200

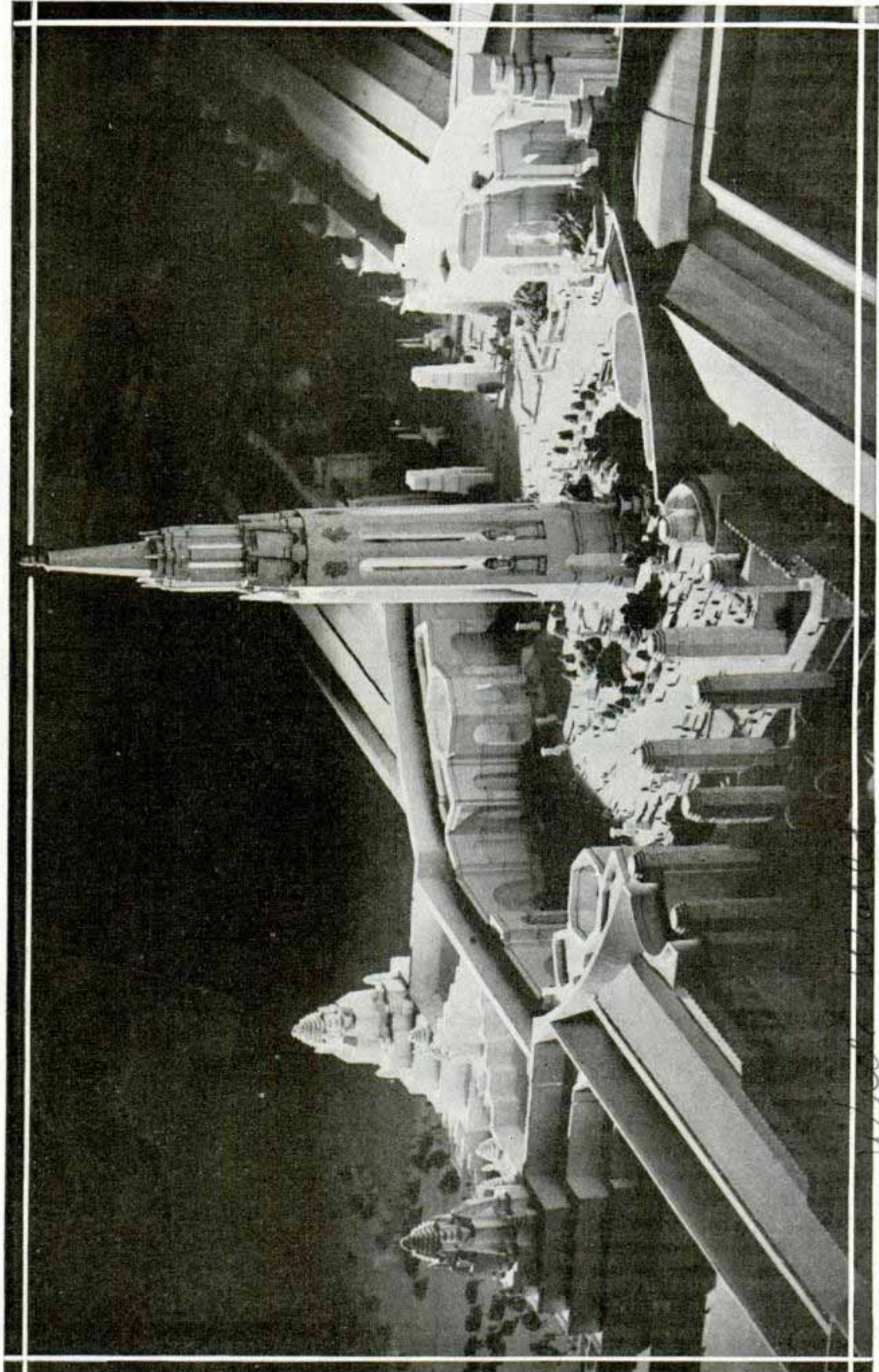

Skillful illumination of a model resulted in what appears to be an aerial view of the Golden Gate Exposition, scheduled to open in 1939. Note how the lighting enhances the general effect by throwing the main tower into prominence. Main gate is at left

P.O. J. J. J. J.

Radio "Signpost" Beckons Planes to Airport

58 E. 42nd St New York

Umbrella-type antenna erected on the landing field now acts as a radio "signpost" showing aircraft the way to port. Developed by United Air Lines engineers, the triangular antenna sends a directional localizer beam which can be focused in any direction from the airport. Pilots follow the path of radio signals until they are right above the field. The triangular shape is said to prevent any distortion of the directional beam by weather conditions. It is possible to install the beam transmitter directly on the airport because a "suppressor" keeps it from interfering with voice communication between planes and airport radiotelephones.

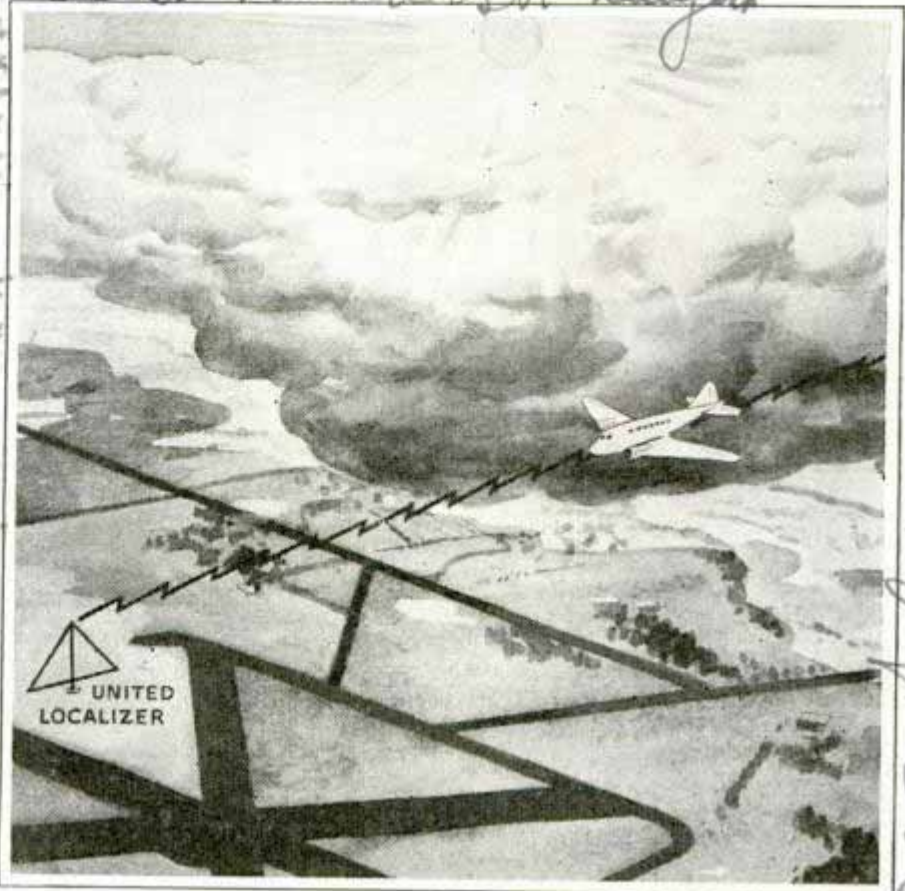

Drawing shows how a radio beam focused from triangular antenna at airport can lead the sky liner directly to the field, regardless of weather

25 1937

Motorists Drive Up to Bank Window and Make Deposits

see Sept 31 1937

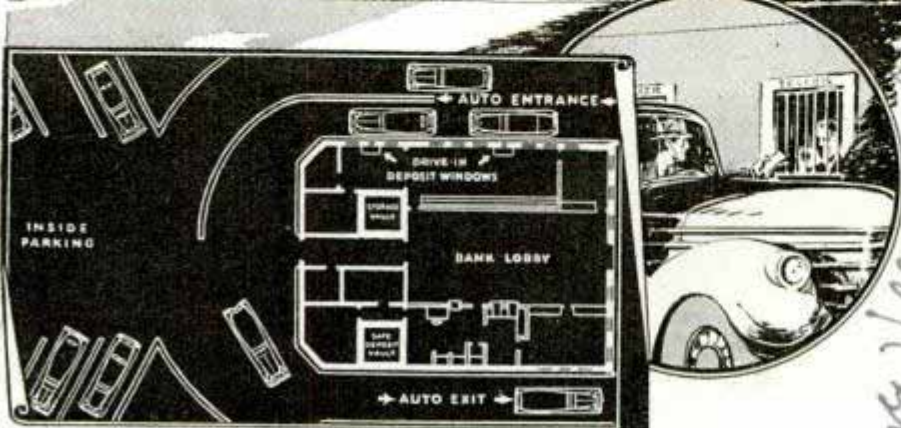
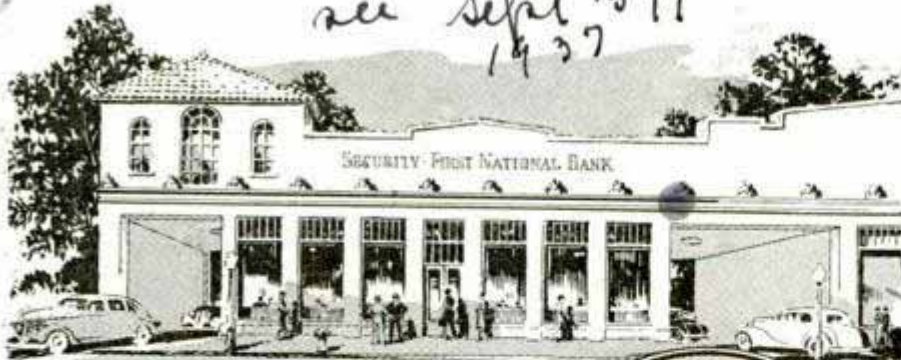

Diagram shows how auto is driven into bank entrance, then to handy deposit window and finally out to the street again

Customers of a Los Angeles bank may drive right up to the cashier's window, if they wish, by using a special driveway incorporated into the building. Turning into the building from the street, the motorist stops his car at one of several glass-enclosed cages. Here he may make a deposit, or conduct other business without leaving the car, then drive out. A ventilating system keeps the drive-in area free from exhaust gases.

Automobiles, buses and railroads carried the people of the United States about 1,840 miles per capita in 1936.

*825 S. Granada
Monte, Calif
Emb. Brady
see Vernon*

Security-First National Compressed Air

Welders Working in Tunnel Create Their Own Fireworks



This spectacular photograph shows two welders at work in tunnel. Note (in foreground) the white streaks produced by flying sparks

As welding crews on the mid-town Hudson tunnel project in New York go about their work they create their own fireworks. Showers of sparks around any particular spot of the tunnel mark the activity of at least one welder. The tunnel, a \$37,500,000 job, will provide a vehicular thoroughfare under the Hudson river, connecting Manhattan and Weehawken.

"Solid" Oil Is Mined in Canada by Squeezing It from Sand

Petroleum so hard that it will not flow has been found in northwest Canada and is to be "mined" by squeezing it from the sand. The hard oil sands are ground to a pulp, mixed with water and naphtha, and the oil flows off the top of the water ready

for refining. After the top sands have been wrung free of oil, shafts may be sunk 800 to 1,200 feet deep. The hard petroleum deposit covers an area estimated from 10,000 to 50,000 square miles in northern Alberta, and contains reserves estimated by various authorities from 100 to 250 billion barrels of oil, perhaps four times the total of other known oil reserves in the world.

Low-Cost Tractor Serves Needs of Small Farm

Intended to meet the varied needs of the small farmer, a "hundred-acre" tractor has been designed by a college professor. Instead of the low speeds of the ordinary tractor, the latest version cruises at twenty-five miles per hour between barn and fields. It weighs only 1,650 pounds, but can be loaded to give better traction when pulling is hard. A tractor of this type can

be sold for less than \$500, according to the inventor. It has a variable speed governor, friction drive, battery ignition, starter and lights for night work and is equipped with hand, foot or power brakes on either

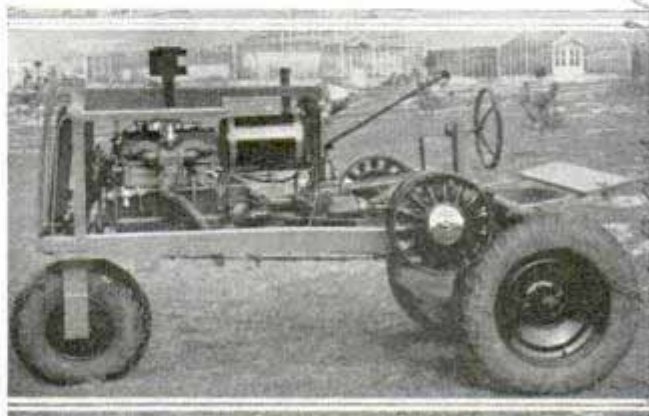

Here is how a college professor would build the farm tractor. Note friction drive

es 208
2/19/37
cheap Tribune

W. Ball, Edmonton.
for refining. After the top sands have been wrung free of oil, shafts may be sunk 800 to 1,200 feet deep. The hard petroleum deposit covers an area estimated from 10,000 to 50,000 square miles in northern Alberta, and contains reserves estimated by various authorities from 100 to 250 billion barrels of oil, perhaps four times the total of other known oil reserves in the world.
es 222
Low-Cost Tractor Serves Needs of Small Farm
Intended to meet the varied needs of the small farmer, a "hundred-acre" tractor has been designed by a college professor. Instead of the low speeds of the ordinary tractor, the latest version cruises at twenty-five miles per hour between barn and fields. It weighs only 1,650 pounds, but can be loaded to give better traction when pulling is hard. A tractor of this type can be sold for less than \$500, according to the inventor. It has a variable speed governor, friction drive, battery ignition, starter and lights for night work and is equipped with hand, foot or power brakes on either
es 200
"Solid" Oil Is Mined in Canada by Squeezing It from Sand
Petroleum so hard that it will not flow has been found in northwest Canada and is to be "mined" by squeezing it from the sand. The hard oil sands are ground to a pulp, mixed with water and naphtha, and the oil flows off the top of the water ready
Here is how a college professor would build the farm tractor. Note friction drive
es 208

Medical School Chicago
 H. H. Shaw, Research Scientist Pullman Co

Groceries Sold by Electricity
 at Contact with Master Key

or both rear wheels. Implement wheels are used. The seat, a big departure from cast-iron molds in common use, is a board with a cushion on it, resting on spring steel at either end.

From America-Chemical

es 217.
Scientists Freeze a Smell to Measure It

Seeking a way to filter odors from the circulation in air-conditioned railway cars, research scientists measured the smells by freezing them. The conditioned air was one-fourth fresh and three-fourths recirculated. To measure the odors, air from the car was filtered through Dry Ice and then placed in a wide-mouthed bottle with a cork collar through which an osmoscope was inserted. This instrument measures smells by measuring the concentration of fresh air at the moment the smell becomes apparent to the operator.

es 231
'X-Ray' View of Steel Auto Given by Glass Body

To demonstrate its steel construction, an automobile with a body of glass was exhibited at the Berlin automobile show. The standard steel frame was used, and the glass body gave an "X-ray" view of the structure.



Acme
 Top, clerk inserts key to release grocery purchases. Bottom, customers making selections and using electric key

Keedoogle store
 Operated by electricity, a novel grocery, opened recently in the South, dispenses goods when a master key is plugged into various sockets. This key is handed to the customer as he enters. Merchandise is displayed behind glass. When the purchaser makes his selection he inserts the key into the socket beside that particular case, releasing the food on a conveyor belt. Taken to the cashier when the shopping is completed, the key is plugged into another socket which causes the conveyor belt to transport all the articles purchased to the wrapping clerk. While the packages are being wrapped, the cashier totals the purchases and collects the money.

Clarence Sanders Memphis Tenn.



Apel Germany
 Prospective automobile buyers look through glass body of this car and see its sturdy steel frame

Russell Chem & Man

Adam Opel
the wellschaff

SEA LORE Kept Alive

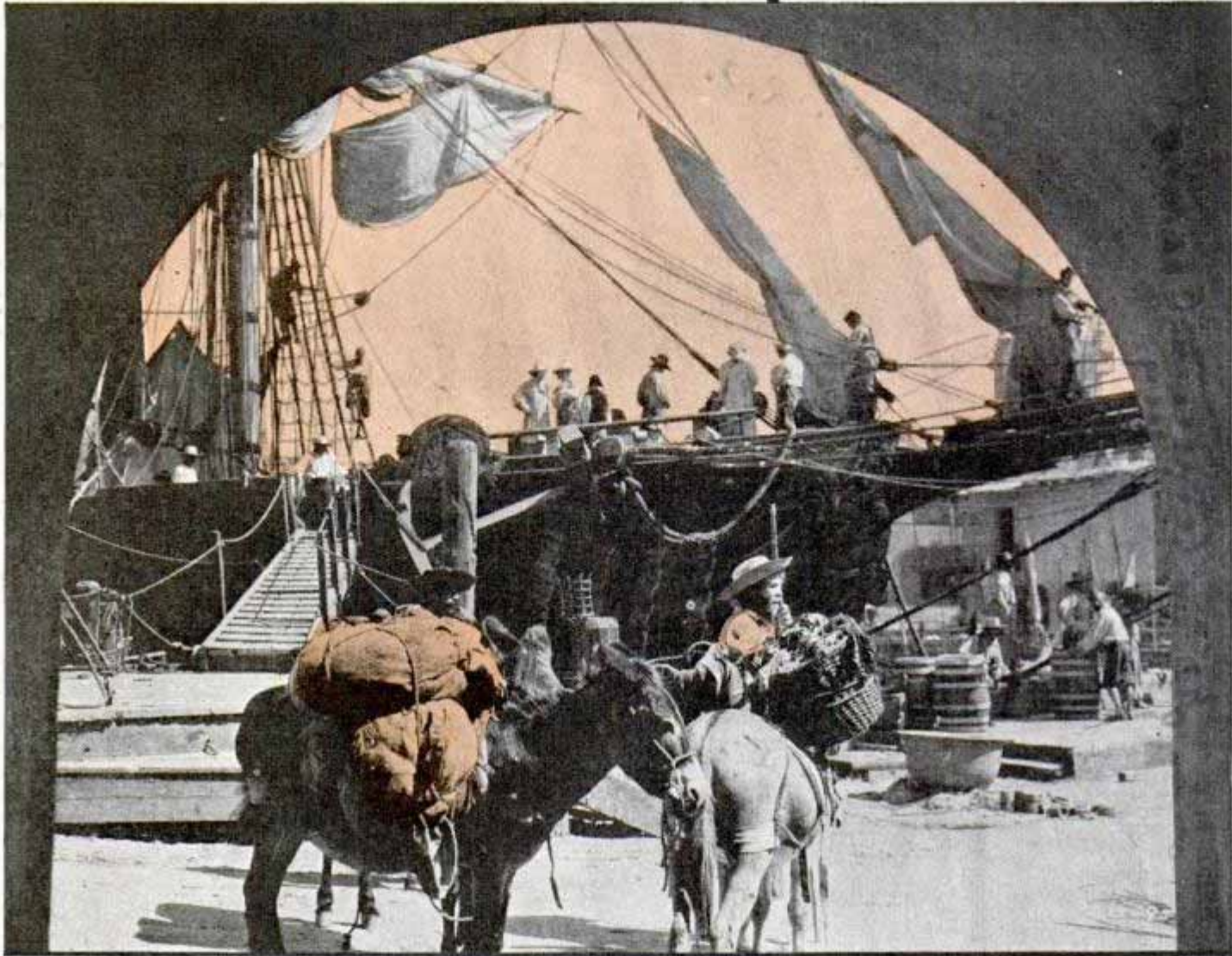

Old bark reconstructed into pirate ship is shown in Warner Brothers' film, "Captain Blood." This dock scene built at San Pedro, Calif., resembles South American harbor of pirate days

AROUSED by a shrill blast from a sea-going tug pulling into Los Angeles harbor, seamen along the water front stared in amazement at the ghostlike ship it had in tow.

It was the old three-masted windjammer "Star of Finland," once queen of the famous Alaska packers' fleet. Old mariners remembered when the "Finland" was built in 1889 for the king of Hawaii and named the "Kainlani." A few years later she was sold, rechristened "Star of Finland," and spent twenty-five years bucking storms in the Alaska trade.

Last of her fleet of twenty-three ships, the "Finland" dozed on the mud in the San Francisco harbor for ten years before a Paramount studio scout discovered her. She was chartered to sail once more for

the sea sequences of "Souls at Sea," the film adaptation of an actual case of shipwreck gleaned from U. S. Circuit Court records in 1843.

Today, the greatest collection of old sailing vessels in the world is gathered in Los Angeles harbor for use in motion pictures.

While the "Finland" was being moored, another camera crew was busy near the Coronado islands shooting scenes on board the 110-foot, two-masted schooner, "We're Here," once known as the heavy-weather boat of the Atlantic coast, for M-G-M's picturization of Rudyard Kipling's saga of the Gloucester fishermen, "Captains Courageous."

A year ago a motion-picture camera crew, with James Havens, Hollywood's

1221 Fifth Ave
Los Angeles, Calif.

by FILMS

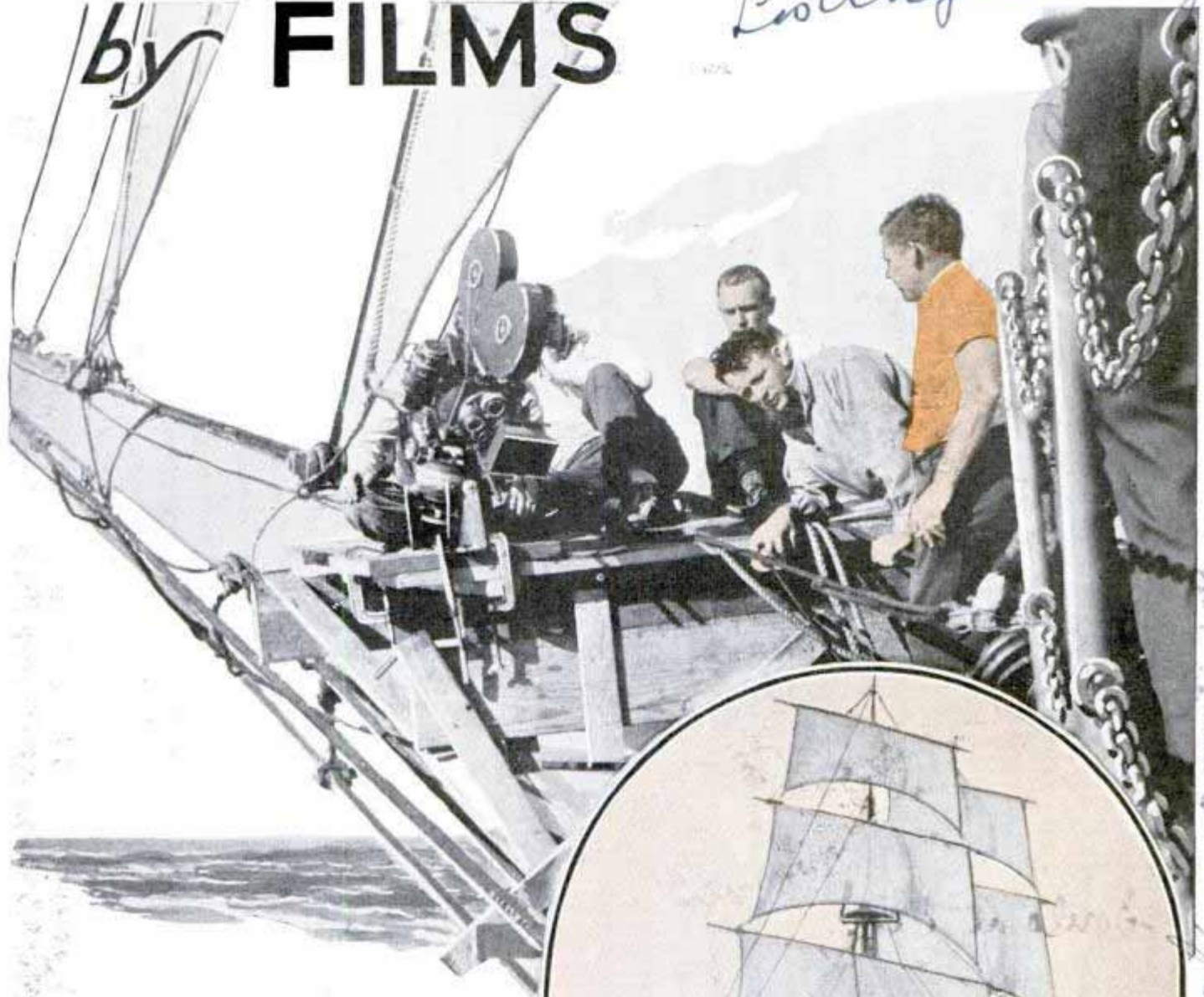

authority on sailing ships, in charge, started from Gloucester, Mass., on what developed into the longest and most adventurous ocean location trip on record. They sailed 20,000 miles on the "We're Here." Capt. J. M. Hersey, old-time New England skipper, was at the wheel. Originally known as "Oretha F. Spinney," "We're Here" was built fifteen years ago for the Newfoundland Banks cod fishing.

In winter fogs, sleet and snow, the camera and sound equipment crews recorded conditions under which men of the old fishing fleet lived their robust lives. From Gloucester the "We're Here" sailed to Norfolk, Charleston, the West Indies, and the Cuba Keys to shoot other marine details. Thence it proceeded through the



Paramount camera crew on bowsprit of "Star of Finland." Below, full-size model of H.M.S. "Bounty" built for M-G-M film

Harry Cooper, George Ray

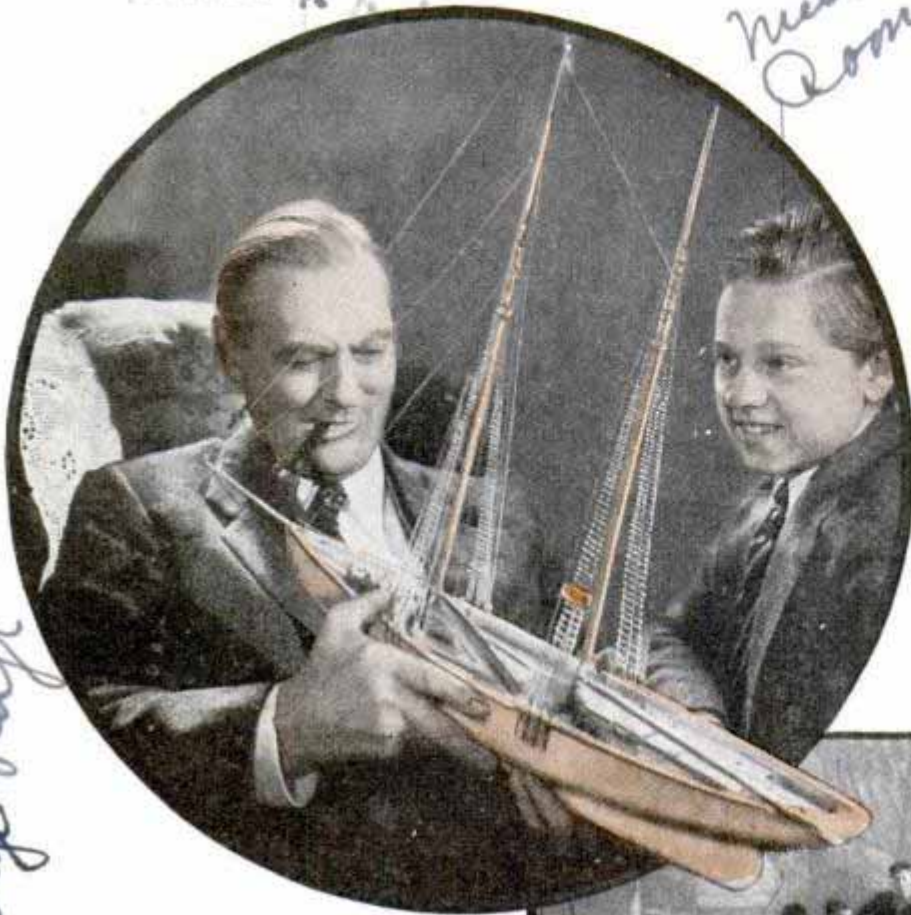

Top, scale model of schooner "We're Here" used by M-G-M in planning action shots in "Captains Courageous." Bottom, schooner "Lottie Carson" after being remodeled as slave ship of 1850 for Fox movie

Souls at Sea
Panama Canal and up to San Pedro. There she joined her sister ship, the "Jennie Cushman," and was completely reconditioned.

Thousands of feet of film were shot, picturing the sea in all its savagery and a cod fishing fleet under every possible condition. Of course, you see only a small percentage of the more colorful action views on the screen, but the complete footage is carefully stored away in studio vaults.

Interest in sea movies has created a new occupation in Hollywood—that of marine technical adviser. Every major studio has at least one. Some, like Mr. Havens, are deeply versed on ancient sailing boats; others are authorities on modern naval and commercial craft.

Take Mr. Havens for example. He graduated from Columbia University and started his career as a draftsman in M-G-M's art department. Because everything nau-

Mutiny on the Bounty
Treasure Island
tical had always been his hobby he soon acquired a reputation as the studio's expert on sailing ships. Thus when Director Frank Lloyd started the epic, "Mutiny on the Bounty," he was made marine director. He was again assigned to work on "Treasure Island."

He'll take any sailing vessel anywhere the script demands. And the more dangerous the job, the better Havens likes it. Before he finished one assignment he had to deliberately wreck a schooner

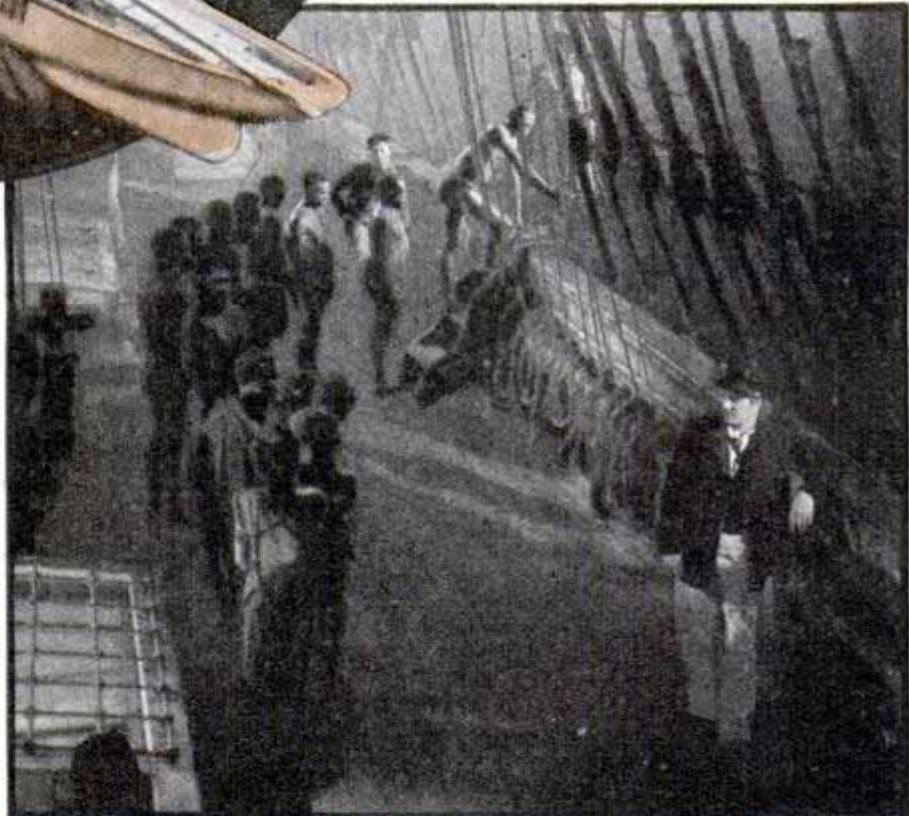

during a heavy storm off the Mexican coast. The camera, on board, recorded the wreck. He said his biggest job was sailing up and down the coast, from Seattle to Mazatlan, Mexico, for weeks, searching for a storm.

When the script for "Souls at Sea," called for a clipper ship, plus two barkentines, the studio property department struck a snag. They found there is only one clipper ship still in existence—the famous "Cutty Sark." It's being used as a training vessel by the British government.

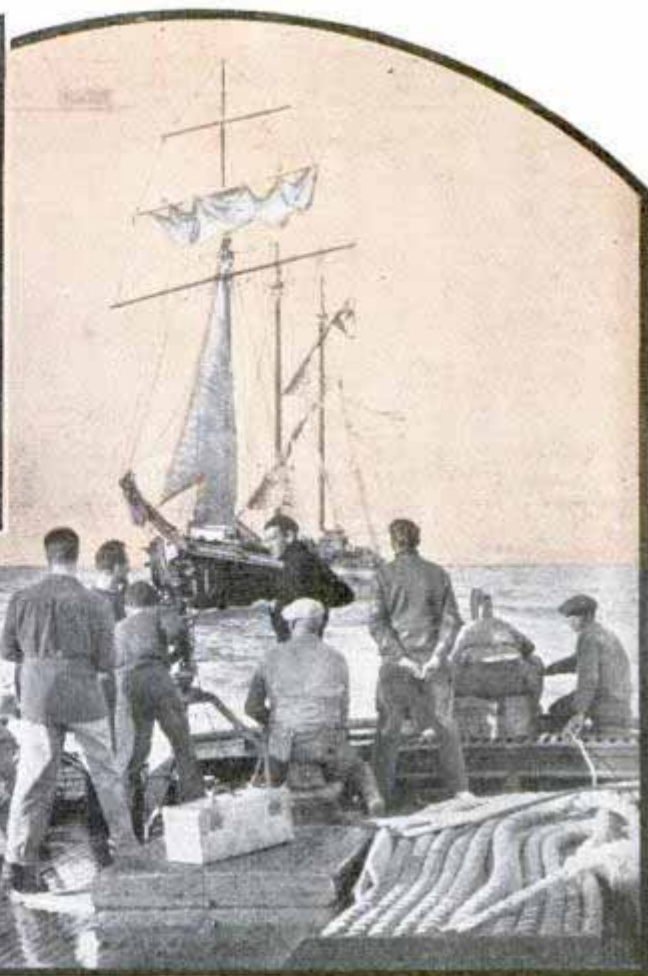

But they had the barkentine, "Star of Finland." So the barkentine sequences were made first, then she was returned to the shipyards and completely re-rigged as a clipper. Her black hull was painted white and she was given a great spread of white canvas. Another movie schooner, "Lottie Carson," was re-rigged for the other bark.

Probably if it weren't for the screen presentations and the research that is done for sea stories, much of the knowledge of sailing vessels would fade out. No doubt soon the only active

Top, left, Paramount's "Star of Finland" after being altered to resemble clipper. Right, "Lottie Carson" being filmed in Paramount's "Souls at Sea." Bottom of page, scene from "Captain Blood"

fleet of large sailing vessels in existence will call Los Angeles harbor their home port and the movies their owners. Steam and Diesel powered boats have replaced nearly all the sailing ships used for fishing throughout the world—likewise commercial passenger ships.

"Mariner," another sister ship of the re-named schooner, "We're Here," was converted into a racing yacht years ago. In 1928 it set a racing record from the mainland to Honolulu. It was changed once more into a fishing brigantine for "Captains Courageous."

The "Pandora," another famous movie ship used in "Mutiny on the Bounty," is also anchored in the harbor. Recently it was re-rigged as an antique Puritan brig for a few oceanic scenes in Frank Lloyd's "Maid of Salem." Originally it

(Continued to page 116A)



es 242.
878

W. & L. Dunn Mfg. Co.
POPULAR MECHANICS
Holland Mich

Machine Makes Bricks for Low-Cost Homes

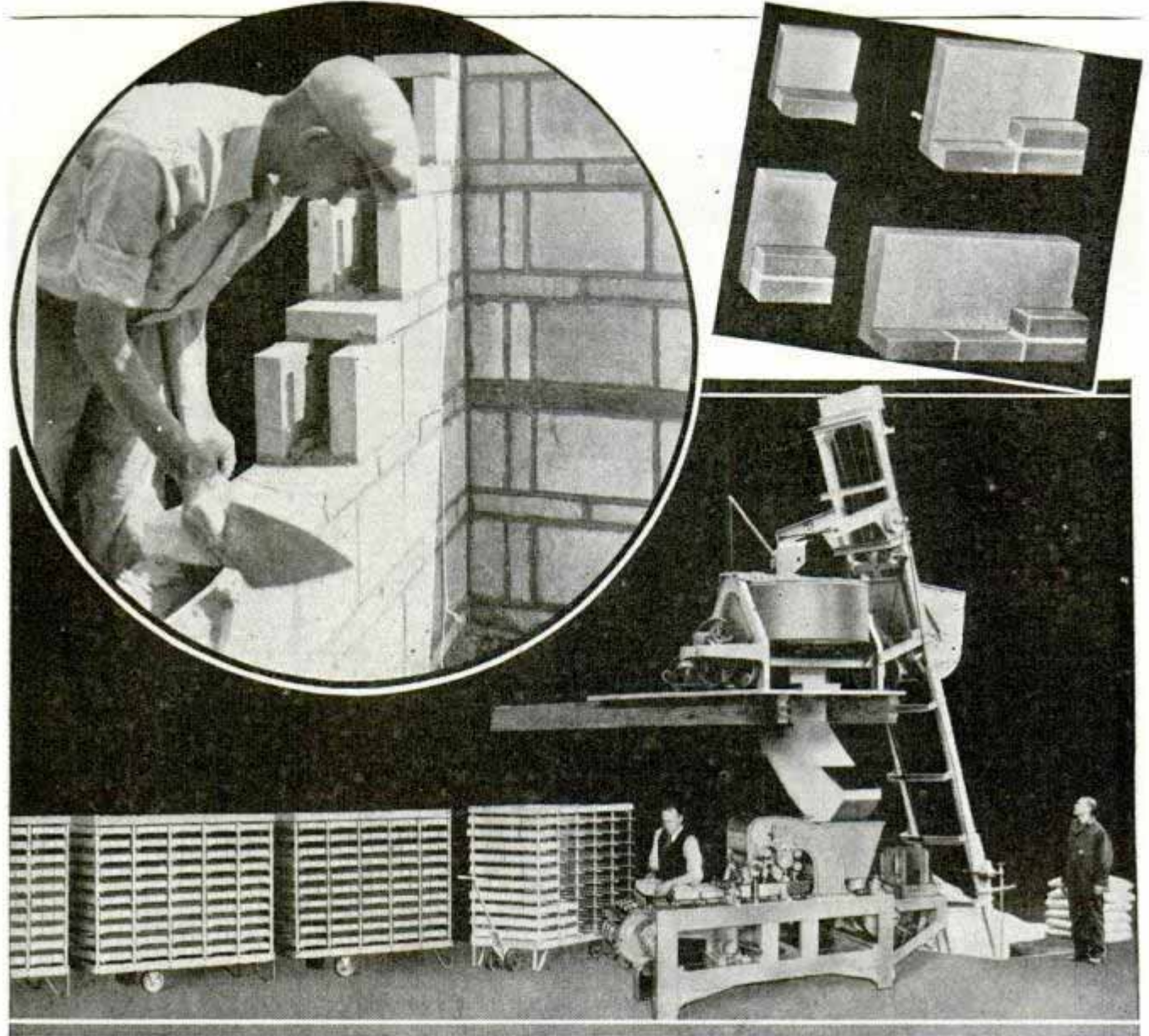

Brick-making machine in action, with only one man busy taking bricks from production table. Circle, constructing wall. Top, right, some forms of building material which the machine is capable of making

Meeting the demand for low-cost materials with which permanent small homes may be built, a brick-making machine turns out thirty-two bricks per minute. It uses materials easy to obtain locally, such as cement and sand, in producing fireproof, termiteproof, permanent bricks in standard and several additional sizes and in colors. The plant consists of an overhead mixer and automatic hoist, with a bucket that lowers to floor level where it is filled easily, then raised and discharged. From the mixer the material passes into the hopper of the machine. The plant is entirely automatic and requires only one man to remove the finished product. In test localities the machine has

demonstrated that its products may be used in building permanent masonry homes at costs comparable to good frame construction. The product, called Dunbrik, has one partially hollow side. One method of coloring is by means of a machine which pneumatically applies a facing material before or after construction. Applied after the house is completed, the facing material gives it a permanent, waterproof, colorful finish and seals all mortar joints.

es 262

Anti-Skid Street-Paving Material Costs Little and Stops Glare

St. Louis has developed a non-skid resurfacing material for streets, a hot bitu-

Tire Cleats and "Wraps" Aid Plane in Winter Takeoff

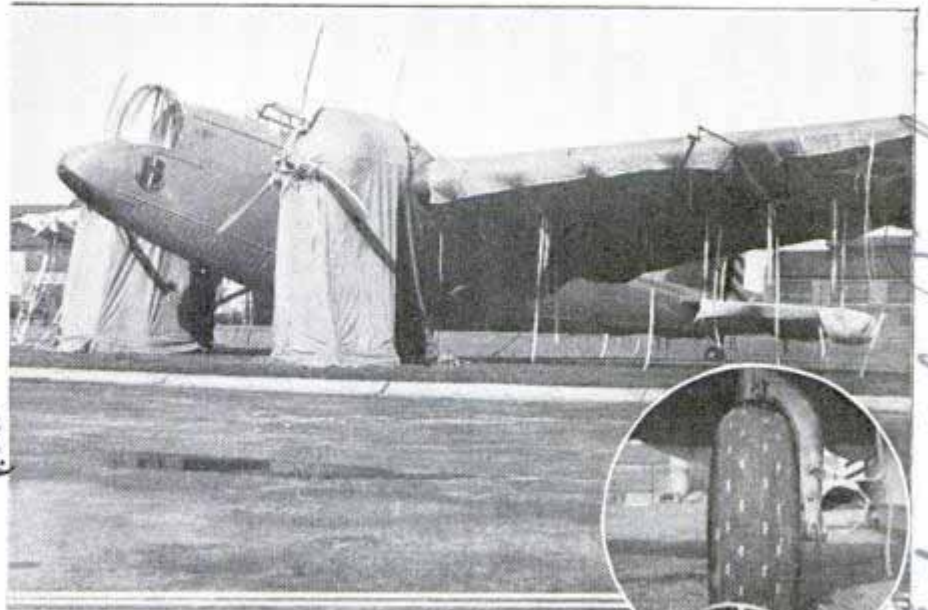

Stove under tent warms engine for quick takeoff.
Steel cleats in tires at right aid traction

When schedules call for split-second departures, fliers cannot let winter stop them. At Selfridge Field, Michigan, the big army bombers are kept "under wraps," ready for instant takeoff. Pup tents of light tarpaulin are draped over the cowling and staked to the ground. In the center of the tent a gasoline stove is placed; its heat warms the engine in a few minutes, avoiding the wear in starting a cold engine. Wings and tail surfaces are also covered until time for flight, saving hours of work in cleaning off snow and ice. Steel cleats are imbedded in the rubber tires to make safer traction on icy runways.

Variable Spacing Typewriter Evens Up Both Margins

You can type a letter now with the right-hand margin lined up as evenly as the left. A typewriter has been developed

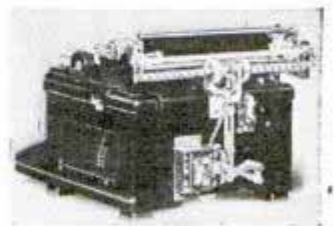

which does for the typed page what the type-setting machine does for the printed page. By turning a knob on the back, it is adjustable for three spacings—ten, eleven or twelve characters to the inch.

*Summary of Dept. of Street
Frank J. Mc Cleath*

minous mixture which reduces both the original and the maintenance cost. It has a rough surface that provides friction and stops glare. Costing not more than fifty cents a square yard to install, the material is five per cent asphaltic cement and ninety-five per cent crushed Dolomite. Applied at 275 degrees Fahrenheit, it is compacted with a roller and is ready for traffic immediately.

Acid Gun Restores Ink on Tampered Document

Latest tool of the crime detection laboratory is an acid blowgun designed to restore handwriting on documents where forgery or tampering is suspected. Invented by Dr. Edwin O'Neill of Northwestern University, the blowgun applies the vapor of sulphocyanic acid to the paper, bringing out any of the commonly used blue or blue-black inks.

*Crim. Detection Laboratory
469 E. Ohio*

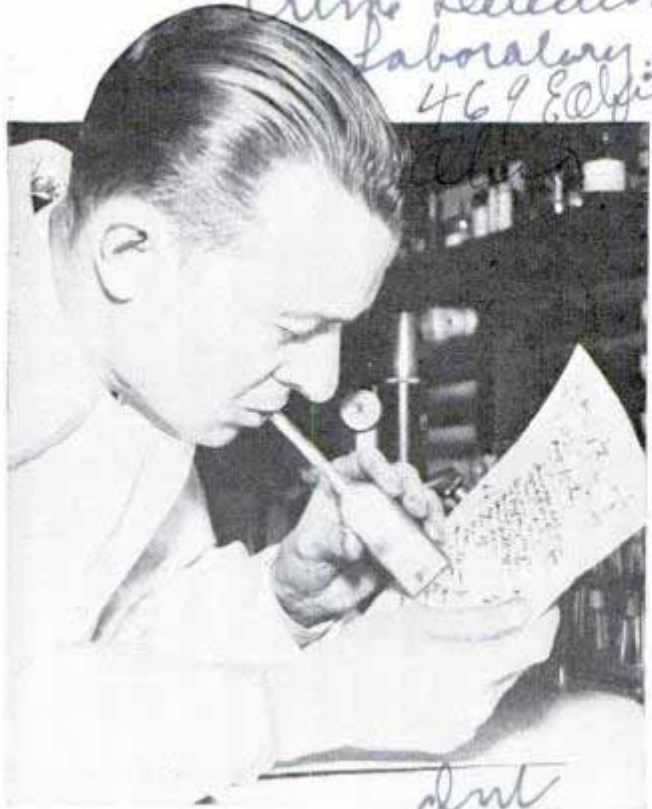

Blowing acid vapor on paper to restore ink where tampering or forgery is suspected

*Cmd. Private Edward J. Richards
Air Base, Selfridge
Chicago*

Hoover Sales. Inc.

Riveters Co. Akron, Ohio

Experts Rivet Giant Wings in Sections for Superplanes

Douglas Aircraft Corp. Santa Monica Calif.

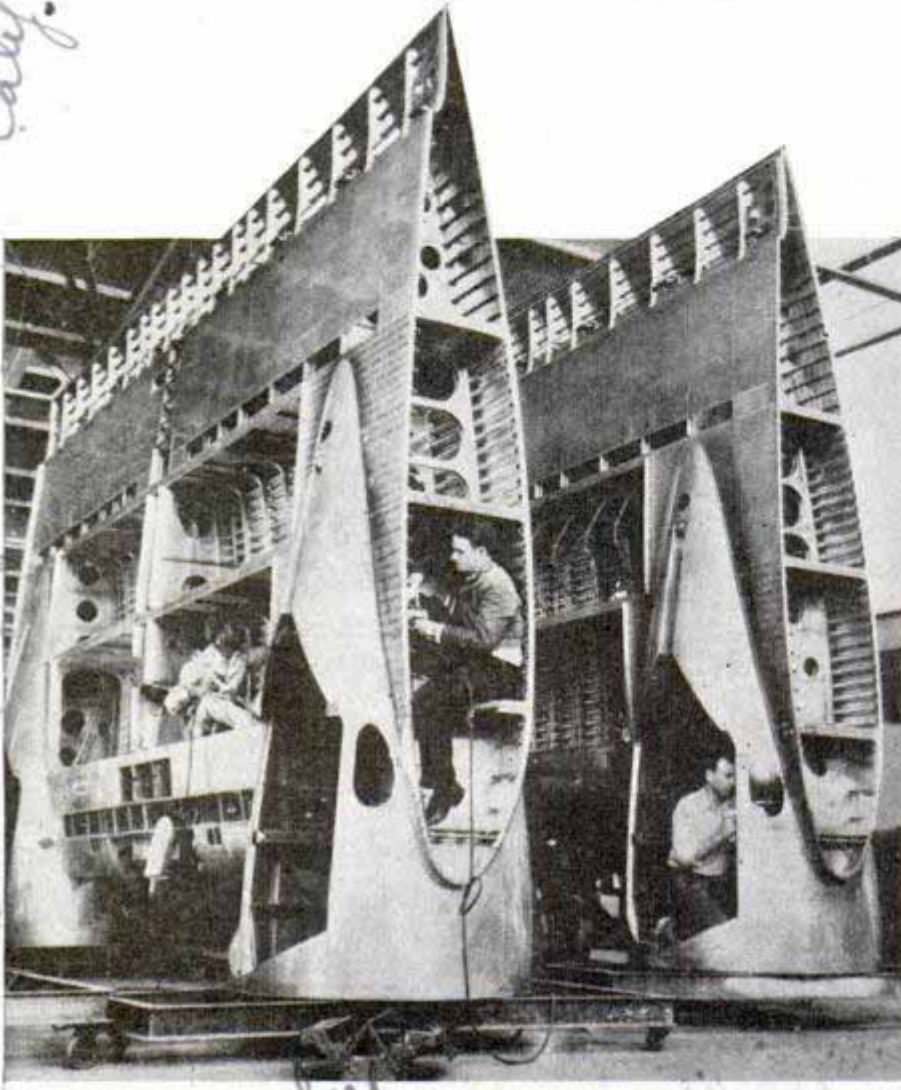

Crew of riveters is shown at work on wing sections of big air liner. Note size of wing in comparison with that of a workman

Wing sections for superplanes being manufactured for major air lines of the United States are assembled in a California factory by expert riveters. Ten of the great air liners are under construction for addition to the flagship fleet of one transport company. Thirty twenty-one passenger ships will be built under the same contract.

lo 267

Tougher Tires of Rayon Resist Wear Longer

Designed to withstand damaging strains of high-speed, heavy-load runs, a super-tire made of a new rayon material gives exceptional mileage on bus or truck. The rayon is spun into tough, strong cords and bound to rubber compound in a way which

helps to resist internal heat generated by constant flexing of the cords. Sustained high speeds and heavy loads increase flexing to such an extent that ordinary tires cannot withstand the extreme temperatures. Before development of the new tire by Goodyear, truck and bus companies reported maximum performance of tires on fast, heavy-duty runs at less than 5,000 miles. Tests indicate that mileages ten to fifteen times greater may be the average for the new rayon tires. In one case a record of 84,000 miles was rolled up by a tire tested on a truck.

Cutter for Corn Makes Canning Easier

Whole kernels of corn can be cut off the cob quickly by a device which speeds up canning. Fifteen to twenty quarts of corn per hour may be separated from the cob, according to manufacturers of the tool. The ear is held in the machine by a four-prong chuck and a sliding tail center. When the knife is placed on the track and held down, it travels along the cob when the crank is turned, cutting off the kernels.



Turning the crank while knife is held on ear strips corn off the cob

Paulmer machine

Coast-Guard Cutters Refuel Planes at Sea

Cooperation between the sea and air arms of the Coast Guard is enabling the planes to extend their range of operations on emergency flights. Coast-guard cutters communicate with the amphibion pilots by radio and arrange a meeting at sea to refuel. Heretofore, the plane was limited by its fuel capacity to five hours of flying, and had to return to its shore base for gasoline. Now the plane drops to the ocean alongside a coast-guard ship



Top, commander of coast-guard cutter "Nemesis" and amphibion pilot confer on refueling plan. Left, plane alights alongside cutter and fuel hose is passed to crew



which carries drums of gasoline equipped with pumps. The hose is passed to a mechanic on the nose of the amphibion, thence back to the fuselage and the fuel is pumped into the wing tanks. The entire refueling process takes but a few moments. First tests of this method were made under simulated emergency conditions in Tampa bay off St. Petersburg, Fla., with the coast-guard cutter "Nemesis" servicing a twin-motored amphibion.

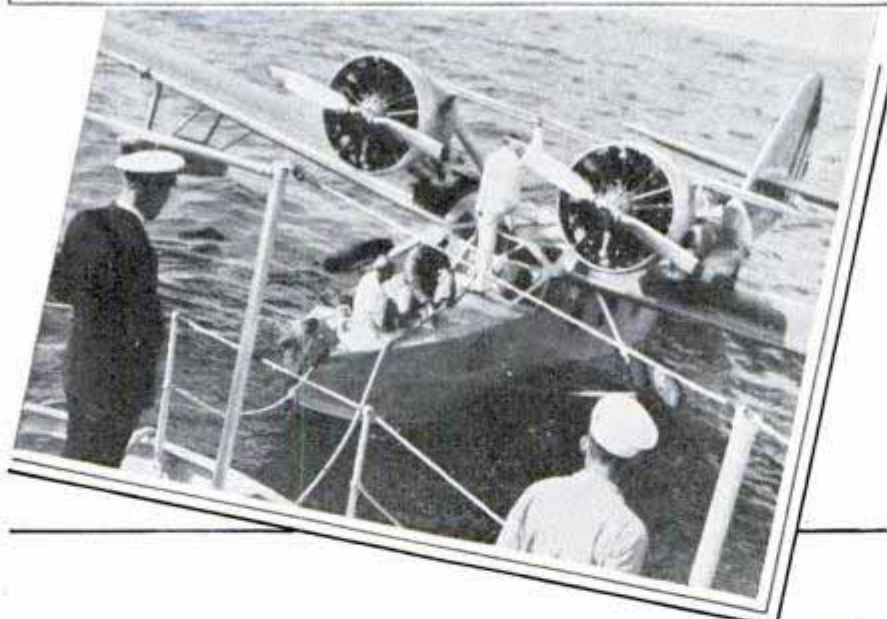

Four-Hundred-Mile Wind Speed in Tunnel Tests Planes

Wind velocities up to 400 miles per hour will be employed in testing model aircraft in a wind tunnel designed for the Massachusetts Institute of Technology. Ten feet in diameter the tunnel will permit testing of models with eight-foot wing spans. A 2,000-horsepower steam turbine will operate the giant fan. Variations in air pressure to duplicate those at altitudes up to

35,000 feet will be possible. The body of the tunnel will be constructed of welded ship steel to withstand strains of the super-gales and unusual pressures which scientists will employ in their search for data which will aid in construction of faster transport planes. Conditions encountered in sub-stratosphere flying will be duplicated in testing the models.

Cambridge, Mass

42512
Cmnd, Edward Litchheim
St. Petersburg, Fla.
Cmnd. Arthur M. York
10 Jay St. Boston.

DISPATCHERS *of the*

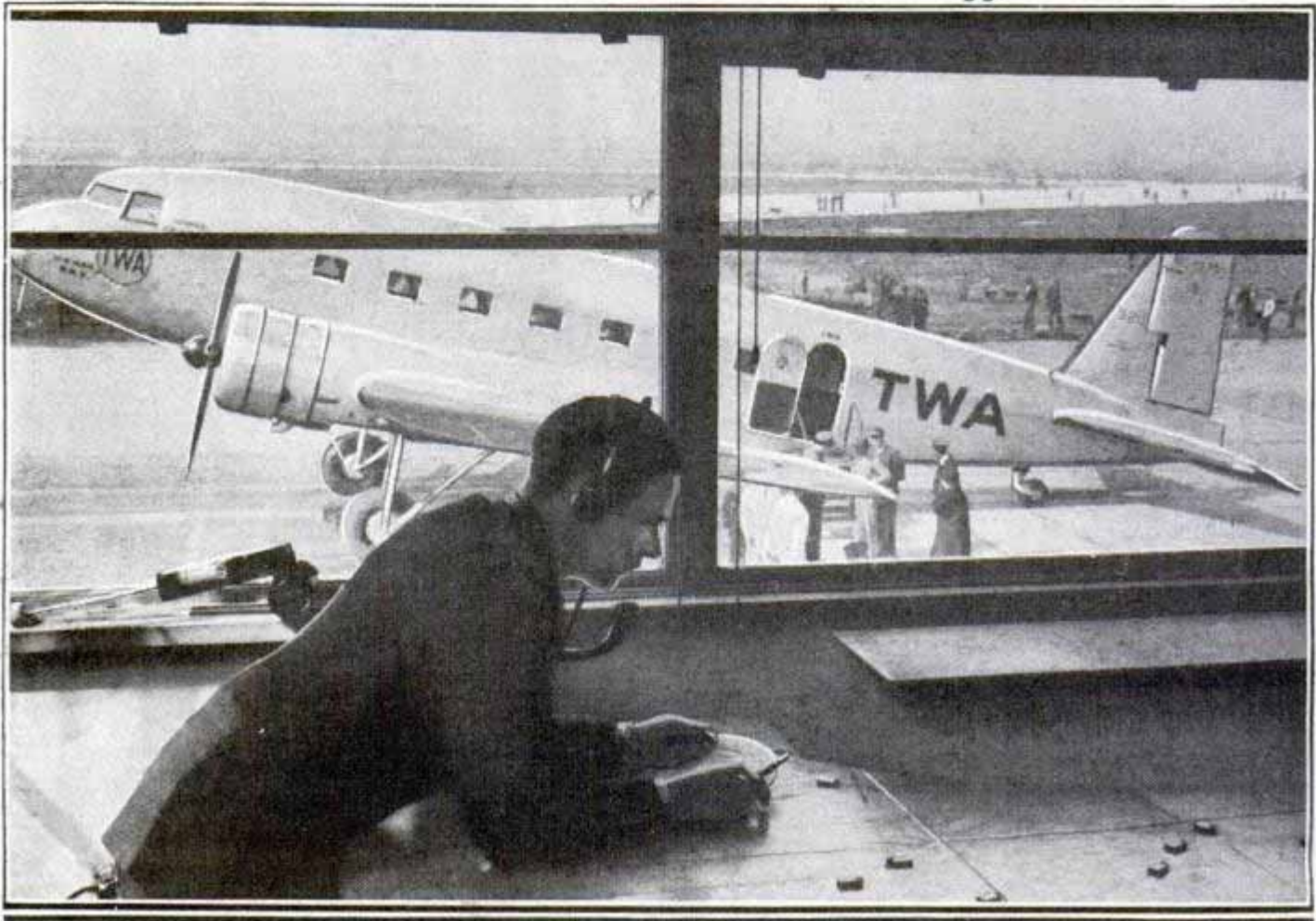

Air traffic officer studies map in "Airways" control room as transcontinental passenger ship prepares to depart from Chicago municipal airport

TWAIN motors drumming against a back-board of slate-gray cloud, tail fin knifing the low ceiling, a giant sky liner hurdles the invisible air-lane crossing and heads into the main line westbound.

Radio signals momentarily black out. The ship is over a cone of silence. Capt. Don Terry notes the time, calls his home station, reports position and altitude. A few seconds later in the traffic-control room of the Chicago airport an officer jots down the sky liner's position in a log, scribbles an entry on a blackboard, then picks up a tiny wooden block and moves it to the point marked "Goshen" on a huge table map.

Intently the control officer studies the map. Over there in Michigan is another little wooden block, its pointed end toward Chicago. It is a private plane, loafing along from Detroit at 100 miles an hour according to its flight plan. It will strike the

transcontinental airway at South Bend, and the chances are that Capt. Don Terry's "Sun Racer" will overtake it this side of Chicago. The little biplane has no radio. No way to check its exact position now.

The control man consults his log book, examines flight plans of the two planes. With circular slide rule and compass he rechecks their progress, then flicks a key and calls into the mouthpiece of his telephone headset:

"Airways, TWA!"

Loudspeakers carry his voice into the radio room of every air line at the Chicago airport. In the Transcontinental and Western Air radio office a dispatcher lifts the receiver and responds.

"Advise Flight 21 there's a private ship inbound from Detroit, estimated arrival here 1:10," the Airways control man notifies TWA. "It is a biplane, at 4,000 feet according to flight plan, and we estimate

02-2011 2p 13000000 608 42nd

SKY LINES

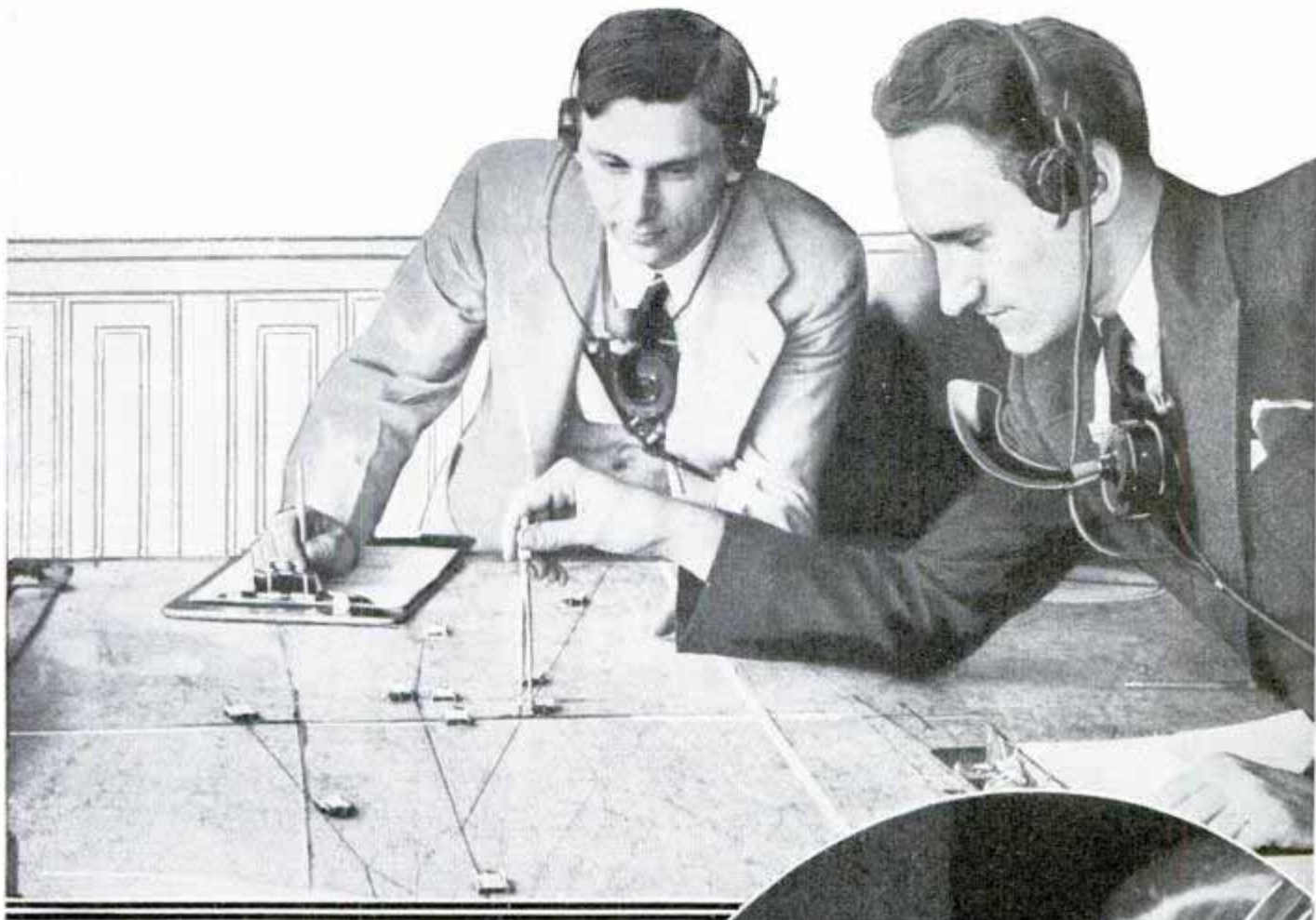

Flight 21 will overtake it fifteen miles west of South Bend. Advise Trip 21 to fly at 6,000 feet as far as McCool."

One chance in millions, perhaps, that the big transport and the little sport plane might ride the same air groove and meet. But one chance in millions is too many. It is the business of Airways to foresee and forestall traffic tangles in the sky, to watch the air trails as the railroad dispatcher and switch tower man watch the main lines and sidings; to follow every aircraft—passenger liner, flying boxcar and fence-jumping private coupe—from takeoff to journey's end.

A few years ago you would have laughed at the suggestion that the skyways were becoming dangerously crowded. Today ships buzz like flies around the metropolitan



Adjusting compass span according to plane's speed. Position of ship is plotted on map every quarter hour. Land speed is computed with circular slide rule, shown below

Halton calculator

I 14
Capt. Jerry



er notifies Airways of a departure for St. Louis, and a control man chalks trip number and time on the blackboard, marks a wooden tab to identify it as the departing craft and sets it on the map at Chicago, pointed for St. Louis. Whenever the pilot reports his position by radio to company headquarters, the latter relays the information over the interline telephone to Airways and the wooden block is shoved along the table map.

Across the table flows the "Px" ribbon—the department of commerce

fields; sky "traffic cops" direct landings and departures from control towers, and the department of commerce has taken over the regional control room which was started as a joint safety measure by the air lines. Regional traffic controls are operating or being established at Chicago, Newark, Cleveland, Detroit, Washington, Pittsburgh, San Francisco and other centers.

Around the table in Airways office on the second floor of the Chicago municipal airport stand operators, telephone headsets and mouthpieces strapped on, pencil or chalk in hand, closely scrutinizing the map. On it can be seen the airports, emergency fields, beacons and commercial routes. Along these routes are twenty or thirty wooden blocks representing aircraft in flight. Glancing out the window, the operators observe a slim gray liner streak across a runway and climb away. At the same instant the loudspeak-



Weather information and advice to pilot from Airways control officer are relayed by air line radio. All conversation over Airways interline communication system is recorded on wax cylinders and kept on file

teletype. Along with weather reports, it brings word of the departure of a private monoplane from Des Moines for Cleveland. Without a radio, the Des Moines flier cannot report his position. Nevertheless, the Airways man marks a wooden block and sets it down over Iowa. He makes his own estimate of the plane's speed, taking the pilot's flight plan, winds, temperature and type of plane into con-

Chicago Municipal Airport

sideration and tosses these data together in his slide rule. This gives him the probable net speed. Then the control officer spreads the points of an engineer's compass on a chart bearing parallel lines of graduated lengths; these lines represent distance traveled on the table map in five minutes at given speeds from sixty to 300 miles an hour. Using the line representing the

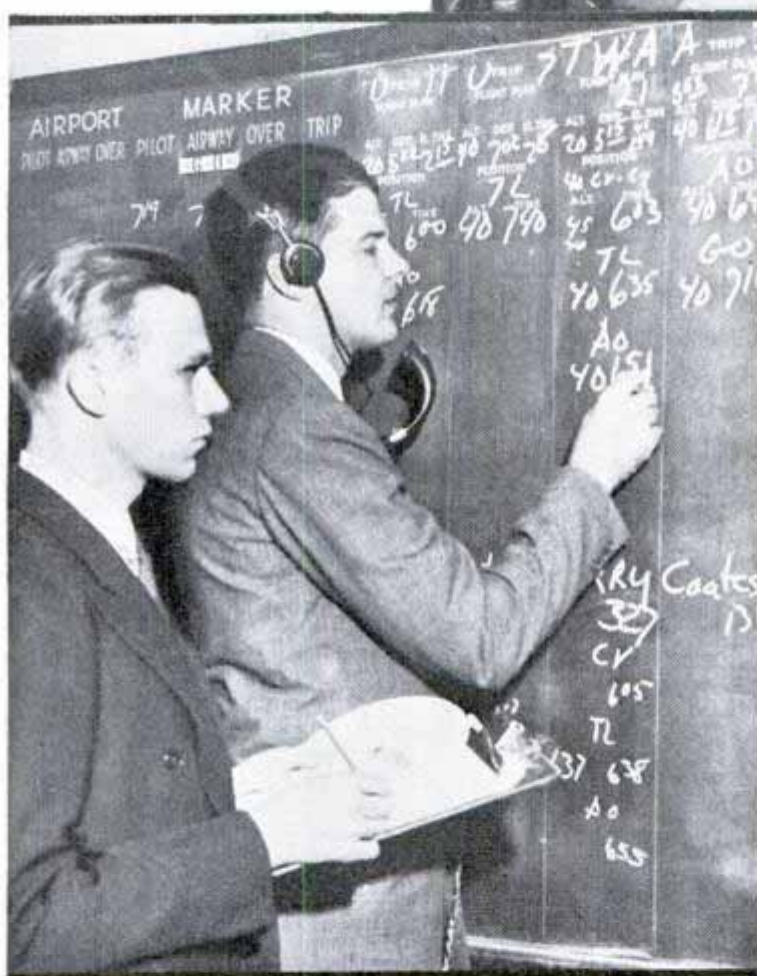

Top, air line radio man is link between pilot and Airways. Below, chalking up movement of liner on Airways blackboard

speed estimated for the Iowa flier, he marks off the probable progress of the plane every quarter hour and advances the wooden tab accordingly. Whenever one plane approaches or crosses the path of another, Airways telephones the airline dispatcher a warning, gives directions to slow down, take another altitude, or even circle or land if real danger exists.

The nine-by-five foot map at Chicago

covers the region from Pittsburgh to Omaha and Louisville to Minneapolis. Every plane flying a charted route in this area is expected to furnish its flight plan before the takeoff. Let's trail one of the big passenger liners across the table. From the far eastern edge of the Chicago control office's jurisdiction comes by radio a flight plan of the TWA "Sun Racer" as it lifts its wings westward from Pittsburgh. The flight plan comprises Capt. Don Terry's estimates of fuel consumption, speed and altitude, and departure time on the Pittsburgh-Chicago leg of this New York-Los Angeles flight. In it are incorporated estimated arrival times over various towns and check points and finally at Chicago. In the Chicago radio room of TWA an operator takes down the plan and relays it over the interline phone to the Airways control. There the es-

timated arrival times and proposed altitude are chalked up on the blackboard and entered on the log, while a wooden block is placed on the map at Pittsburgh.

Then the traffic-control officer makes his own calculations, which are also entered on the blackboard and the log. Picking up his "speed calculator," the circular slide rule calibrated for figuring speeds

(Continued to page 118A)

Balloon "Dog Team" to Explore Stratosphere

Info. from J. D. Oberman, head Aeronautical Dept. University of Minnesota, Minneapolis, Minn.

RUSSIAN SOUNDING BALLOON REPORTED AT 25 MILES

RISING TEMPERATURE

TOP OF STRATOSPHERE

ALTITUDE 20 MILES JEAN PICCARD'S PROJECTED RECORD

STEVENS-ANDERSON 72,395 FEET

SETTLE-FORDNEY 61,237 FEET

A-PICCARD 53,152 FEET

CAPT. GRAY 42,470 FT.

COXWELL-GLAISHER 7 MILES

BOTTOM OF STRATOSPHERE

MT. EVEREST 29,141 FT.

WAR-TIME "ZEPP" 28,000 FEET

MT. WHITNEY 14,496 FEET

BALLOON

GLASS STOPPER

RUBBER SLEEVE

GLASS PLUG

CORD TO LOAD RING

DYNAMITE CAP

WIRE TO GONDOLA

TAPE

CORD

DETONATION OF DYNAMITE CAP TO BREAK CORD TO RELEASE BALLOON CLUSTERS

GONDOLA

LOAD RING

2000 COLORLESS SOUNDING BALLOONS AS ASSEMBLED TO LIFT JEAN PICCARD TO A NEW HIGH ALTITUDE RECORD. BALLOONS REACH AN EXPANSION OF 15 FEET

ONLY BY RELEASING CLUSTERS OF BALLOONS CAN THE TOO RAPID RISE OF THE ENTIRE ASSEMBLY BE PREVENTED. RELEASING CLUSTERS, ALSO, BRINGS THE GONDOLA BACK TO EARTH

ESCAPING BALLOONS EVENTUALLY EXPLODE

TO CUT DOWN WEIGHT, CORDS OF COTTON OR LINEN TO BE USED

BALLOON SIZE COMPARED TO EMPIRE STATE BUILDING

Drawing demonstrates immensity of balloon "dog team" Prof. Jean Piccard plans to harness to gondola in attempt to rise twenty miles above earth. Instead of valving gas, balloon clusters would be released by dynamite caps. Records of previous stratosphere expeditions are shown at left

new York Times

Gondola Cuts Gas Bags Loose with Dynamite Caps

Prof. Jean Piccard plans a record-seeking expedition into the stratosphere in a gondola lifted by a balloon "dog team." Two thousand small balloons would be harnessed together, linked to the gondola by lightweight cords of linen or cotton, and blasted loose with dynamite caps to control the rate of rise or descent. Each balloon, of the type used in making aerial weather observations, has a lifting power of about five pounds and for a preliminary test flight Dr. Piccard will attempt to ascend 10,000 feet with a dog team of eighty balloons tied to his basket. The dynamite caps are of the safety type which would not explode the hydrogen gas. Glass stoppers seal the balloons. The scientist hopes to reach his "ceiling" of twenty miles above the earth within three hours and then drift while making observations.

Log Carrier Made of Cloth Is Handy for the Home



Illustrating the ease of handling small logs by using this handy cloth bag

"Blackening Detector" Warns of Light Bulb Burning Out

To check automobile headlight bulbs before they burn out on the road, the General Electric company laboratories have developed a "blackening detector." It is a small white receptacle of molded material

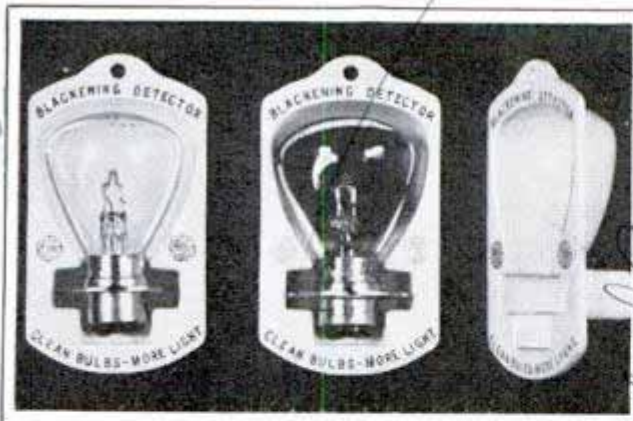

Bulb at center shows up black against white receptacle, indicating bulb is worn and needs replacing

in which the bulb is rotated, showing up by contrast any blackened part of the lamp. Severe blackening indicates the bulb is soon to burn out.

An activated-carbon paint for coating metals, suitable for primary or finishing coat and containing no lead pigment, has been developed in Germany.

Carrying small logs from the basement or woodshed to the fireplace is made easy by a cloth bag with metal handles devised recently by Hollywood designers. When not in use the carrier bag folds into a small bundle. Use of the carrier in the home saves the floor from dirt and bark.

Tool Dresses Ignition Points Quickly and Accurately

Designed to dress ignition points quickly and accurately without removing them from the automobile, a new tool for mechanics is available. Attached to the edge of the ignition housing the dresser is operated by turning a crank. The abrasive wheel grinds both points at once, leaving clean, smooth contact surfaces.



Baume & Mercier Chemical Co

Curie 5. Kerzhaw's 200 Ang. cal. 7/18 J. S. Flower

Weaver mfg. Co. Springfield, Ill.

Chandelent Lamp

Streamline Speedboat Resembles an Airplane

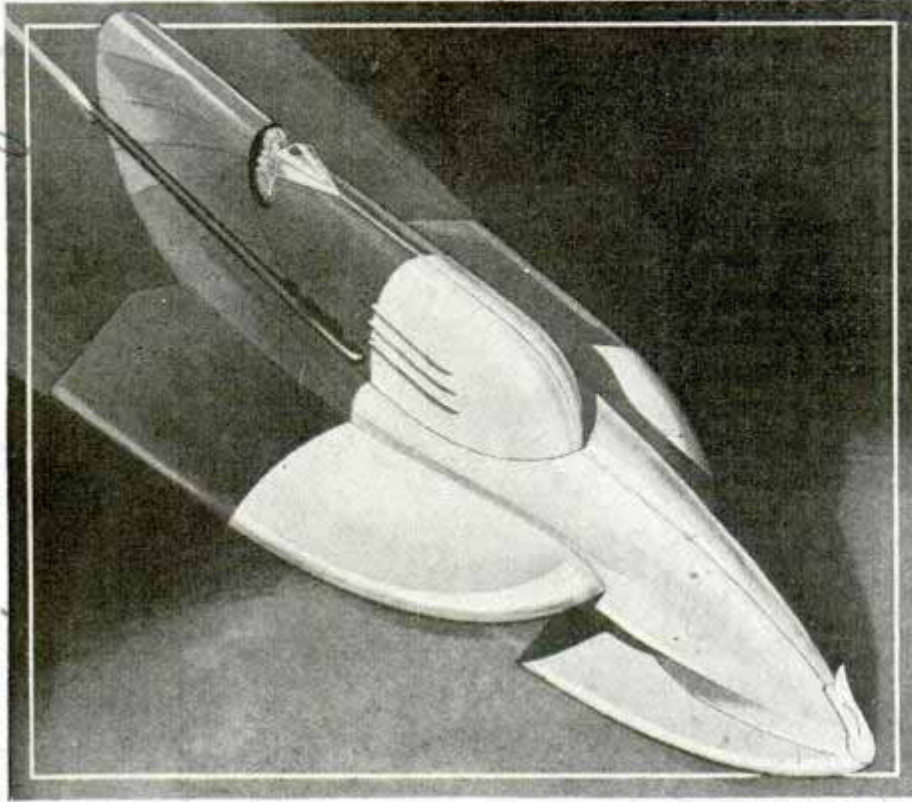

These sketches and drawings show how latest speedboat will resemble an airplane. Left, artist's conception of finished craft. Center, cutaway sketch showing placement of motor and controls. Note the protective fire wall. At bottom are profile and top views of the speedboat. Light construction is a feature of this streamliner

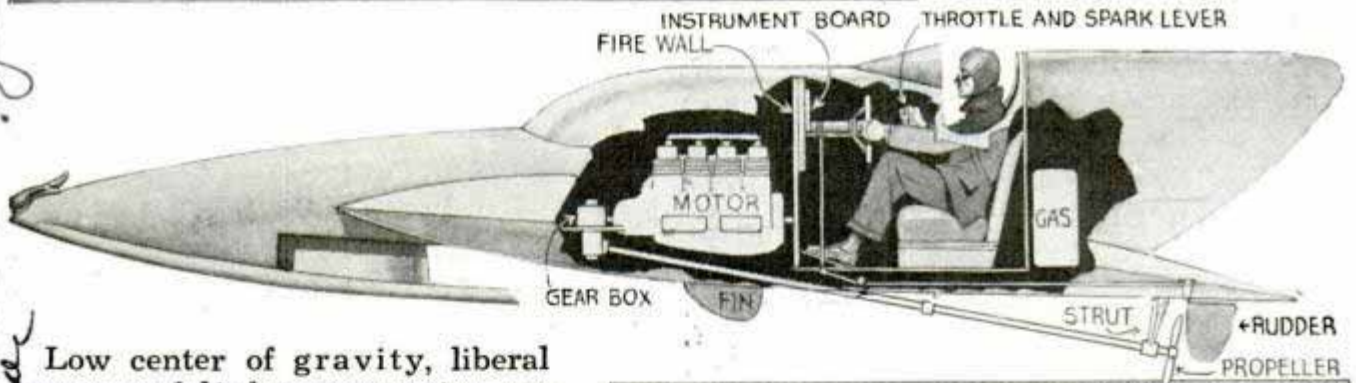
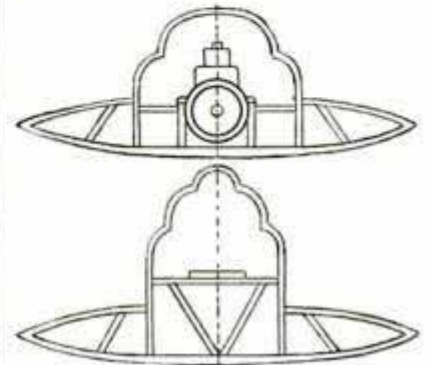

Low center of gravity, liberal beam and light construction are features of the latest streamline speedboat which bears a close resemblance to an airplane. It has two planes on each side, which look like wings, and the driver sits in a narrow cockpit, much in the manner of the pilot operating an open cockpit plane. The motor is located forward, with exhaust pipe extending along the side to the rear. At high speed, motor and driver are in the center of suspension balance. The cockpit is padded. The length is eighteen feet six inches, the beam five feet six inches, the forward plane six feet long and four feet wide and the rear plane twelve feet long and five and one-half feet wide. The hull is built of white oak, cedar and pine, the keel of oak and the frame of cedar. The super-structure

is plywood covered with cedar frames and stringers of white oak. The motor is mounted on tapered oak beams which make up the backbone of the entire craft. No reverse gear or clutch is used. Directly behind the motor is a metal fire wall,

434 W. Armington Chicago Ill. 540 N. Michigan. Chicago
 es 59
 no answer to letters.

all as
 no plans
 540 N. Michigan Chicago

and airplane
Co. Farmingdale, 20159
 protecting the driver, and the motor cowl is made of pounded aluminum with vents. Cushioned seat, instrument panel, steering wheel and airplane throttle are among the fittings of the cockpit.

Factory-Built House of Steel Towed to Its Site by Tractor

210

'Prop' Shaft Is Bore of Cannon in Giant Airplane Motor

Its propeller shaft hollowed for the firing of a cannon, a twenty-four cylinder airplane engine is being built in a Long Island factory to deliver 1,000 horsepower. Instead of being a radial type, this motor consists of four air-cooled banks of six cylinders in line, with low air resistance because of its small frontal area. It is designed exclusively for military use. The need for synchronizing a machine gun is eliminated, for instead of firing through the whirling propeller, small cannon shells are fired through the propeller shaft.

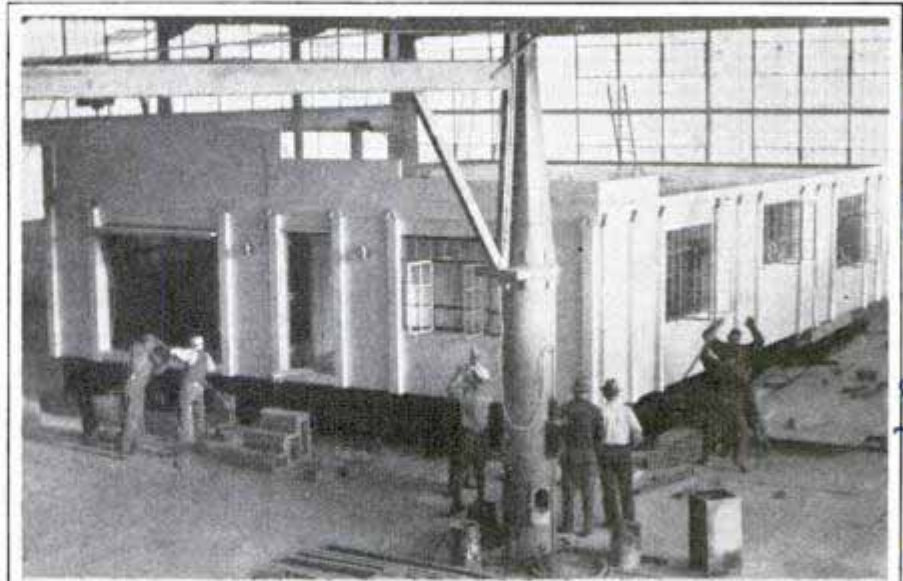

Five-room welded steel home being completed in factory and moved to site, where a crane lifted it from sixteen-wheel trailer and set it down

195

Ash Tray Built into Table Top Is Unscrewed for Cleaning

Easy to keep clean and orderly, an ash tray now manufactured is built into the table top. It can be made a permanent part of the card table, reading desk or soda-fountain table. When installed, its curved upper surface projects slightly above the table, and the receptacle can be unscrewed for emptying. Of stainless steel with a glass receiver, it is not damaged by spilled liquids or by burning cigarettes.

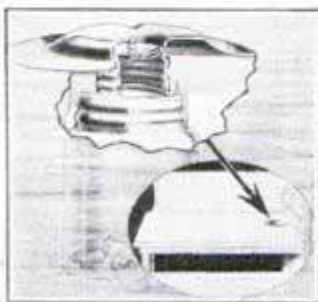

With its furnace going and the house comfortably warm, a five-room electrically welded steel house built in a Peoria factory was hoisted on a sixteen-wheel trailer and rolled to its site, ready for the family to move in. It had been built complete, with a garage incorporated in the plan, and was fully decorated when taken from the factory. The forty-one ton load was set down gently by a tractor crane which lifted the house by three steel rings in the roof and let the trailer creep out from under. A few hours later all water, sewer and electric connections were made, drapes were up, floors carpeted, each room appropriately furnished, and the house was ready for occupancy. The factory is building houses entirely of steel except for plumbing fixtures and insulation.

see p 20 Dec 1938

W. K. ...

Es. 126

Instrument to
rehab. club.

RHYTHM



Left, few people fail to thrill to the stirring music of a college band marching down the street. Below, lacquering saxophone to preserve its luster

Buecher

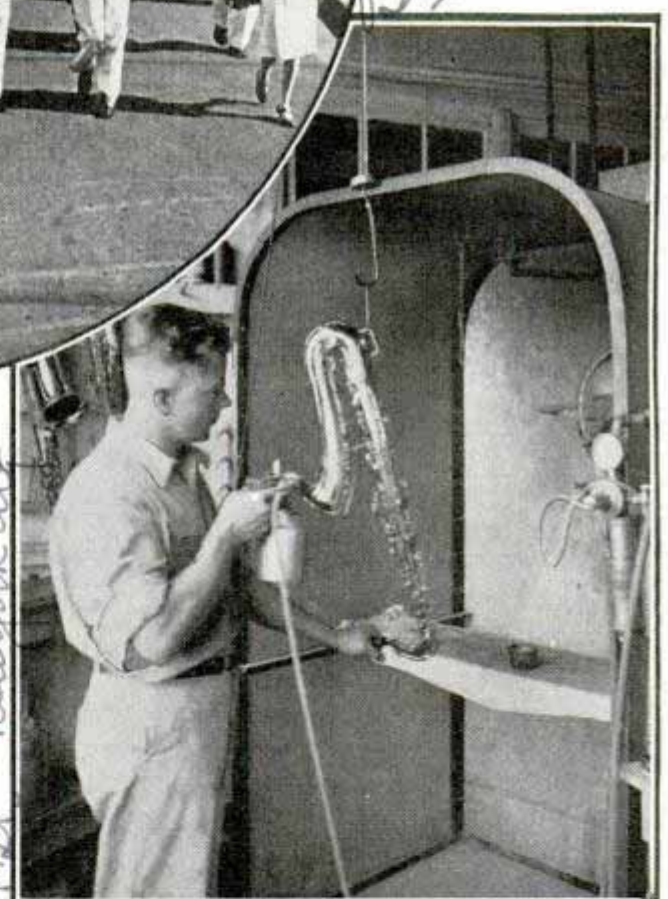

AMERICA is clamoring as never before for music and, as a result, is spending in the neighborhood of \$100,000,000 for musical instruments this year.

Almost a revolution has occurred in the business. Back in 1932 orders for pianos dwindled close to the vanishing point, due to scarcity of money and high prices of the bulky instruments then on the market. Piano men evolved an idea that threw old theories into the discard and they introduced a product once considered only a dream. It was a piano retailing for less than one hundred dollars, easily within the reach of thousands of families hitherto unable to own a piano.

When talking motion pictures swept the country the organ industry seemed doomed. But by redesigning the mighty organ to fit into the average home and by pricing it at a fraction of the previous cost, organ manufacturers resurrected the industry. Advanced thinking and modern design are the two factors responsible for

remarkable comeback of the piano and organ makers, as well as of manufacturers of other musical instruments.

The sixty-six key Pianette made by Winter and Company of New York and selling at \$99.50 is emblematic of the new day. Even more radical in design and slightly higher in price is Hardman and Peck's Minipiano, which fits into a convenient corner like a large radio. Weigh-

B. B. W. 57 H.

in the MAKING



Osaka - Japan

ing one-fourth as much as the old-style piano, it can be pushed around easily or transported by auto trailer. Minipiano dispenses with huge sounding boards, confining its soundboard below the keys. It is thirty-four inches high, fifty-one inches wide and fifteen and one-quarter inches deep. Its performance excels that of pianos much larger.

Ready to play when plugged into a convenient electrical outlet, the Hammond organ is another instrument introduced during the musical revolution. It looks like a writing desk and fits into a space four feet square. Since its tones originate from electrical impulses, it has no pipes. The organ is priced at \$1,250, less than the down payment on the old-type organs used in churches and theaters.

Nine out of ten musicians haven't the slightest idea why their instruments give

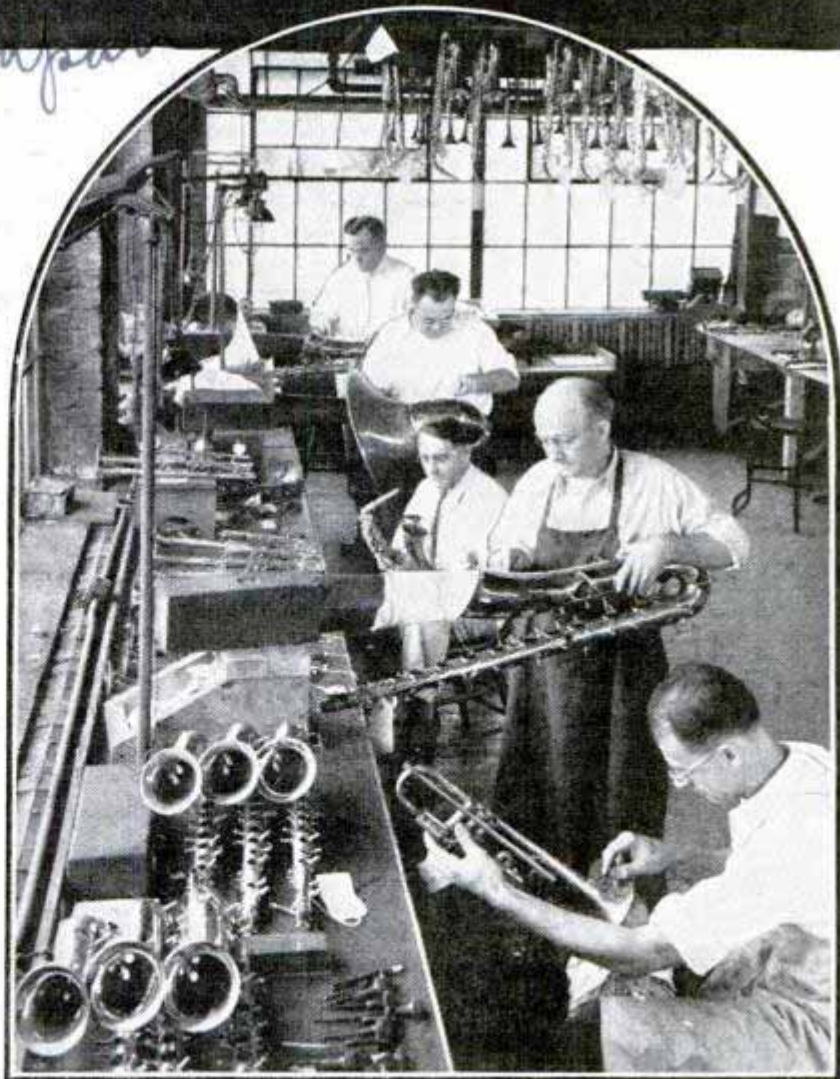

Music-makers in distant lands use American instruments. Top, an all-girls band from Japan. Bottom, scene in factory as expert engravers etch designs on instrument bells

Hammond Clock Co.
2915 4th St. Grand Rapids, Mich.
Band of Osnescher 891

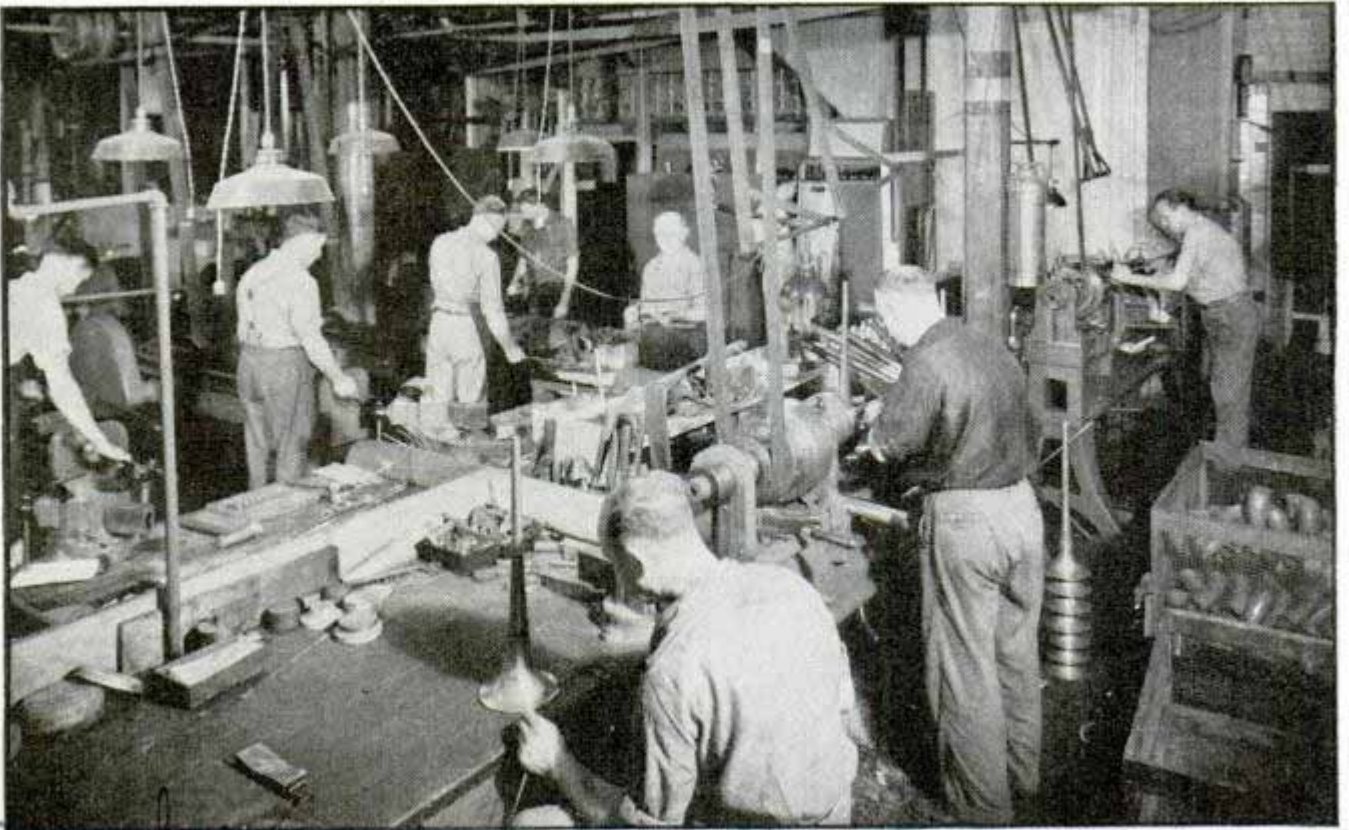

Briescher
Here is another step in the manufacture of musical instruments. In this department the workers are shown forming bells for trombones.

C-sharp when they press down the first valve. On the other hand sound engineers know the answer but they can't play a note. They point out that it is the result of careful manufacture and of obeying the law of the tone wave at every step in the making of the instrument. Tone waves are invisible but they have strange and freakish powers. A tone wave has a given number of vibrations per second, whether the sound issues from a violin string or an automobile tire on wet pavement. The faster the vibrations the higher the pitch of the tone. In a piano the range from lowest to highest note is from twenty-eight to 4,185 vibrations per second. A tone vibrating 20,000 times per second is inaudible to the human ear and a tone with less than sixteen vibrations per second ceases to be a tone and separates into distinct beats.

The tone wave also has length. There is a definite mathematical proportion between the length and diameter of an instrument's tubing and the sound wave it accommodates. The thirty-two foot pipe of an organ which gives a note of sixteen vibrations per second accommodates a tone wave seventy feet long, and a tiny pipe one-quarter of an inch long, vibrat-

ing 16,000 times per second, has a wave length of half an inch. These basic natural laws the manufacturer obeys implicitly. A B-flat trombone is built for a basic wave about 235 inches long. If inaccurate construction produces the instrument with a 234-inch wave length it will be off key. So the business of manufacturing musical instruments is done with hairline, scientific precision.

The most popular instrument is the saxophone, which not so long ago was likely to produce sour notes at crucial moments. Today the saxophone is sturdy and dependable, the result of rare craftsmanship and precise manufacture. A case in point is one saxophone which is made of nine different metals, has more than 500 parts and requires two months for its transition from raw materials to a thing of beauty.

There is sorcery in the way these craftsmen take flat sheet brass and transform it into the multicurved tube that is a saxophone. It is done by blanking the four parts—mouthpipe, body, bow and bell—from flat stock, then skillfully hand-shaping them over mandrels and brazing the seams that make them tubular.

The bow and body are then set in steel dies and subjected to a mighty process

Briescher

that demonstrates what industrial machinery can do even in so delicate a field as music making. The parts are made to conform with the die by hydraulic pressure of 3,000 pounds to the square inch which forces lead lugs through the tubing and makes the interior glassy-smooth. No hand-work could hope to achieve that perfection of finish.

The manufacturers of fine instruments spend much time and money in making the dies that determine the size and

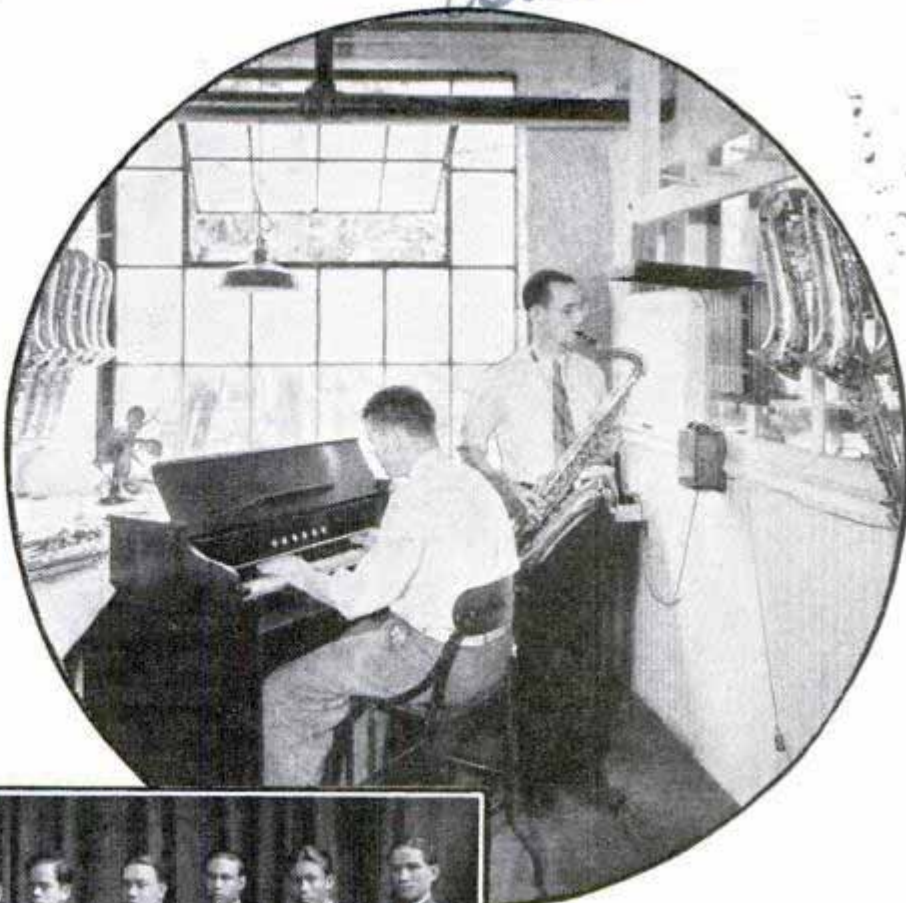

Top, tone sleuths testing instruments. If they find a false note the instrument goes back to factory. Center, Manila band. Bottom, Amedee Dieudonne, France's famous violin maker, in his shop. Only on the violin have manufacturers failed to improve on construction methods used centuries ago

shape of instrument tubing. It takes an expert from twenty to thirty days to make a set of such dies. Every dimension, like every important step in manufacture, is double-checked with micrometers and calipers corrected with world-famed Johanson blocks.

For years saxophonists groaned because the particular weakness of their instrument was in the tone hole sockets. The solder which held these sockets to the body was prone to spring pin-point leaks due to acid formed by breath moisture; and a pin-point leak is enough to make a saxophone virtually unplayable. Music engineers developed an entirely new process. By means of steel balls inserted in

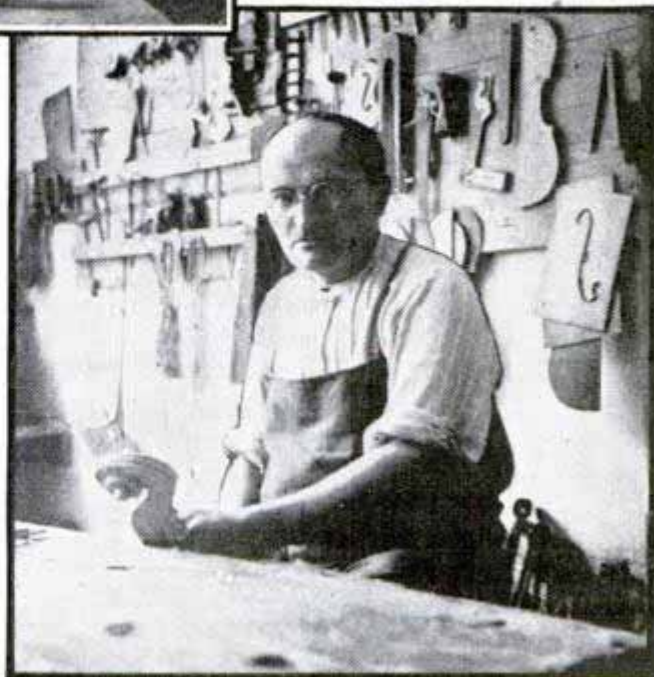

(Continued to page 120A)

Man-Power Plane Is Pedaled Like a Bicycle

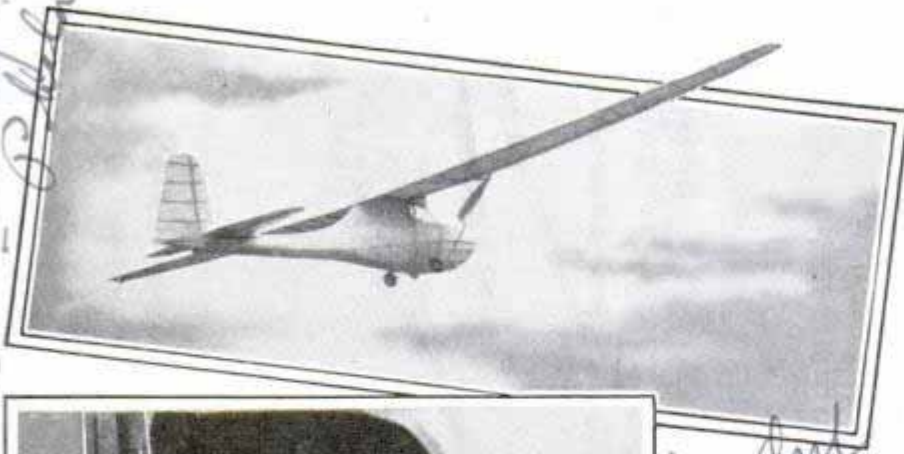

Top, pedal-drive glider-plane in flight. Bottom, view of the pilot's compartment, showing pedals and chain drive for turning the propeller and keeping the lightweight craft in the air. Pilot makes own job easier by following technique of glider operation

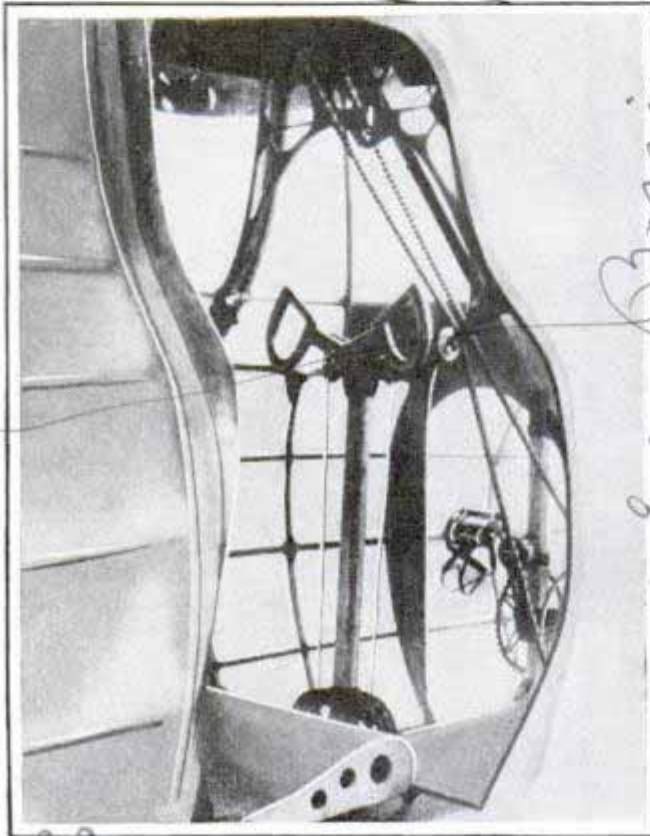

Said to be the first "man-power" plane ever flown successfully, a lightweight aircraft resembling a glider has a bicycle mechanism for keeping it in the air. The pilot operates the pedals to keep the propeller turning. It is the invention of a Philadelphia engineer and its first flight was made at Milan, Italy. The craft, said to have cost only \$500, weighs 200 pounds. It will be entered in the "human flight" contest scheduled to be held in Rome by the Italian Aero Club.

Truck Driver Rolls up Floor to Unload the Cargo

Loading and unloading a non-tilting truck body is simplified by a movable floor introduced recently. The truck floor is a single sheet of tough cord rubber belting supported by tiers of steel rollers. The operator can roll the floor the full length of the cargo section by turning a hand crank which requires little effort. A cargo of sand, coal, bags, or heavy machinery can be loaded or dumped in a few seconds.

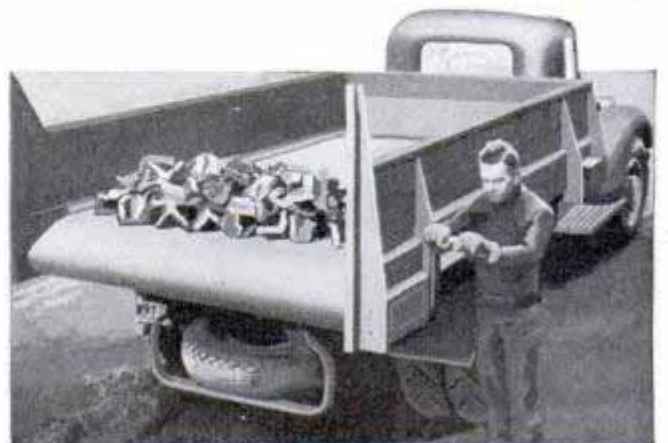

Driver dumps load by turning hand crank which winds up movable floor, made of tough rubber

Germ-Killing Sun Rays Enlisted to Fight Disease and Decay

Man is arming himself with the sun's rays in his eternal fight against disease and decay, and even the air he breathes may some day be purged of germs by a sterilizing ray. Sunlight, even with its ultraviolet and infrared rays filtered out, can kill microorganisms. Rays of short wave lengths emanated by a lamp are now being used to destroy the germs of skin infections. Sterilizing lamps mounted over surgical operating tables purify the air and prevent infections. Meat and bakery products are kept from mold growth by the rays from a tubular lamp of special glass, and efforts are being made to develop a ray that will sterilize milk.

Sterilizing lamp

*25th and 1st Street Park Co
Westinghouse Lamp Co
Blanchfield N.C.*

idea based on

Lo 201

Laylor

Easton Car & Instruction

Fishways Built for Salmon to Pass over Dam

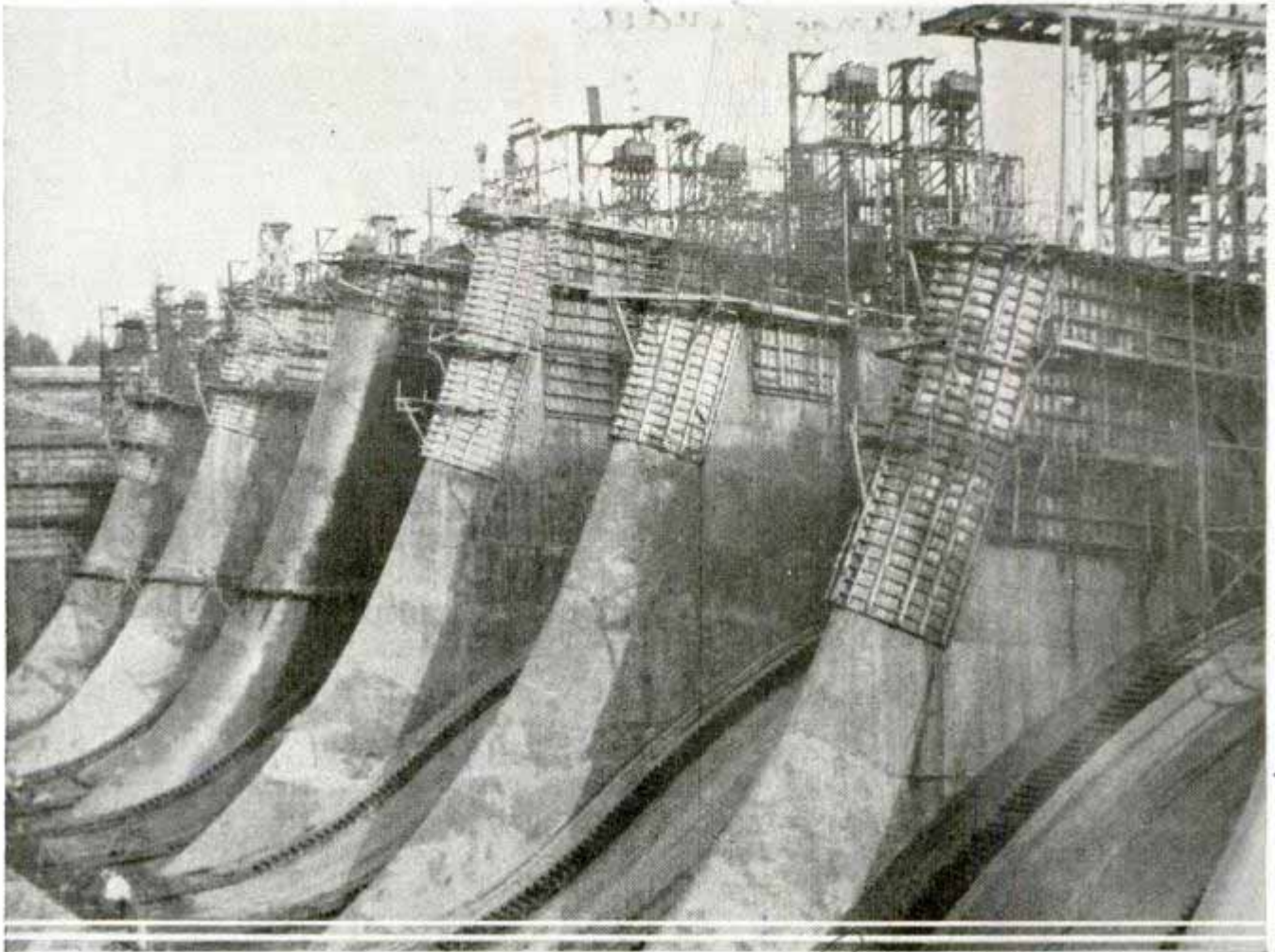

Here is the latest view of Bonneville dam, Pacific coast project which will produce vast power when it is completed. Fishways are built into the dam so salmon may move upstream at spawning season

Bonneville dam, the great power project under construction on the Pacific coast, is designed so that salmon may pass over the spillways on the way upstream at spawning season. The fishways providing

this passage are built into the dam. Fisheries experts in Oregon and Washington claim that the fishways are inadequate, however, and that the salmon are stopped in their migration.

Dressing Room for Auto Tour Attaches to Side of Car

Convenient for the beach or automobile tour, a light canvas tent which is attached to the side of the car for a dressing room has been put on the market. Side walls, top and front are mounted over a collapsible frame which is clamped to the two open doors on one side of the sedan. A flap extends over the car and curtains the opposite windows. It is mounted or taken down in a few minutes, and folds into a bundle thirty-six by eight inches.



Canvas tent is quickly mounted on collapsible frame beside car for dressing room at roadside or beach

☐ Farm crops from 6,500,000 acres find use in the automobile industry in manufacturing parts for one million cars.

same
 Mrs. A. Schindler
 12/14

SAE Journal

Spot of Light Helps in Focusing for Camera Shot in the Dark



Before shooting flashlight, photographer throws light beam with electric range finder to aid focusing

Attached to the side of the camera, an electric range finder for focusing in the dark throws a tiny beam of light upon the object to be photographed. The cameraman follows the beam and racks the camera lens in or out until a sharp image is obtained. A voltage control regulates brilliance of the beam.

Glass Fibers Strong as Steel Hold Vast Possibilities

Now used as insulation for buildings and industrial equipment, glass fibers with a tensile strength even greater than that of steel hold vast possibilities. Such glass is fire resistant, vermin and moisture proof, possesses dielectric properties and is lightweight. In tape form fibrous glass can be used to insulate small wires and cables. Theater drapes, hotel tapestries, awnings and many other applications may be found for glass textiles. Colors can be produced readily. Formerly produced by heating glass rods and pulling them into fibers, fibrous glass is manufactured by an American firm by drawing the fibers at a

speed exceeding the muzzle velocity of a Springfield rifle bullet. Glass in rods has a tensile strength of about 20,000 pounds per square inch, while commercial fibrous glass has a strength as high as 2,000,000 pounds per square inch. Under present processes the fibers are about thirty inches long, varying from .02 to .0002 inch in diameter, the smaller being even finer than a human hair. Some fibers for special purposes are only .00005 inch. Yet the individual strength of these fibers averages 250,000 pounds per square inch. Making it ideal for insulation on air-conditioning installations, the glass is extremely lightweight. A floor area of 800 square feet can be covered four inches thick with 400 pounds of glass fibers, yet the increase in floor weight will be only one-half pound per square foot.

Dustless Floor Edger Saves Time and Hand Labor

Designed to speed up finishing and re-finishing of floors, a dustless edger developed recently saves tedious hand labor and gives a better matched job. Circular scratches are eliminated by operating the edger at constant high speed. A heavy duty one and one-half horsepower motor drives the machine. A specially designed dust intake opening extends around seventy-five per cent of the sanding disk, resulting in unusual cleanliness on the job. Protection of the machine from contact with baseboards and stair risers is afforded by a hardened steel guard around the disk.



Nickel Coin Is Mostly Copper and Penny Is Bronze

You may call it a nickel, but your five-cent coin has three times as much copper in it as nickel. And your penny is nick-named a "copper," but strictly it is bronze, for it contains ninety-five per cent copper and five per cent tin and zinc.

James. Slayter, Research Dept. Cleveland Edison Brass Co. remark this

Speedac Range Finder

Wag. St. of Yuma
Carler, Cable Machine Co. 100

es 237
Copper and Brass
420 des ingtm at

R A D I O . . .



MINIATURE CATHODE-RAY TUBE *in Portable Oscilloscope*

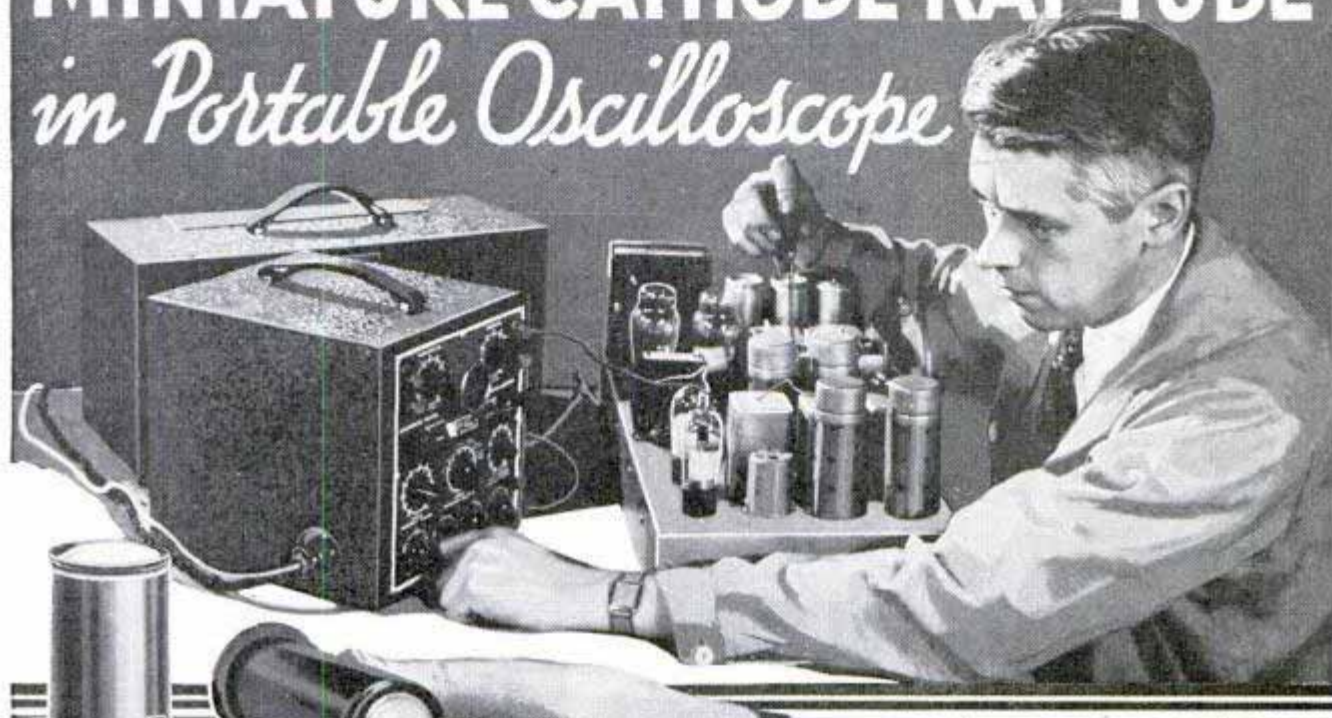

THIS compact and easily portable oscilloscope has been made possible by the recent introduction of a type-913 miniature low-voltage cathode-ray tube of all-metal construction having a fluorescent screen about 1 in. in diameter. Service men and radio experimenters are thus provided with an accurate means for visibly checking the performance of various circuits in receivers. Students will find this low-cost oscilloscope complete in every detail; it includes a built-in linear sweep with a type-885 Thyatron tube. This sweep has a fundamental range of 7 to 30,000 cycles, permitting its use for viewing frequencies as high as 300,000 cycles per second. Horizontal and vertical input amplifiers complete the self-powered assembly shown in the photo at lower left. The unit is said to afford satisfactory operation even on the 5-meter band.

Clough - Bringle Co.
2815 W 19th St

General Purpose



ALTHOUGH only four metal tubes and a type-83 rectifier are used in this portable general-purpose amplifier, the output is sufficient for the average school auditorium. Among other useful applications it makes an excellent hum-free amplifier for stringed instruments, small orchestras, window demonstrations and call systems.

The layout is quite simple and has been designed to fit into a standard portable speaker case, thus making a self-contained unit that weighs only 27 pounds complete.

All parts for the amplifier unit proper are available for about twelve dollars.

A schematic circuit diagram is given in Fig. 1, and the speaker-plug connections are shown in Fig. 1-A. Details for the metal base appear in Fig. 2 and the case dimensions in Fig. 2-A. Beginners can follow the simplified wiring diagram given in Fig. 3; this shows an underside view of the base and all parts in their relative positions as they appear in photos 3-A, 3-B and 3-C. Shielded leads must be used where indicated, the metal shielding being grounded directly to the metal base at the points shown. If the wiring is carefully done, a surprisingly flat frequency response will result,

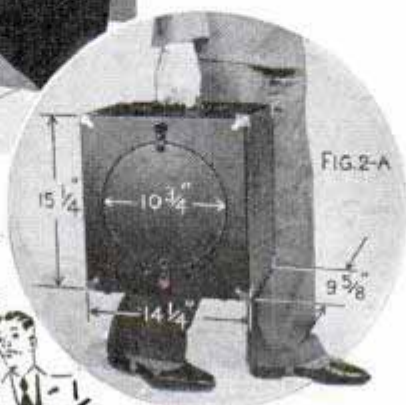

WINDOW DEMONSTRATIONS

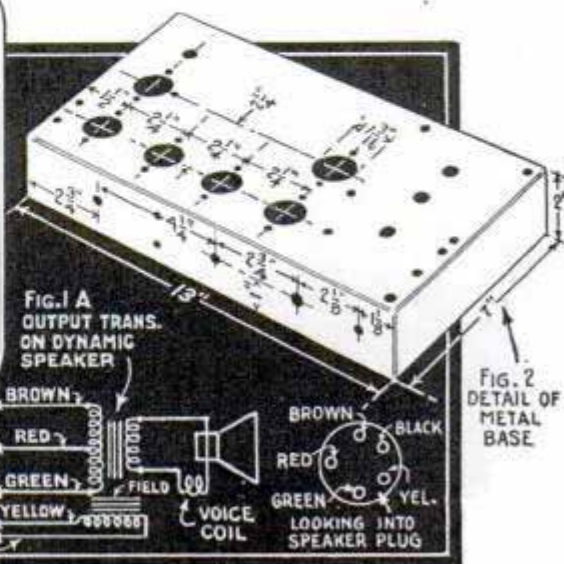
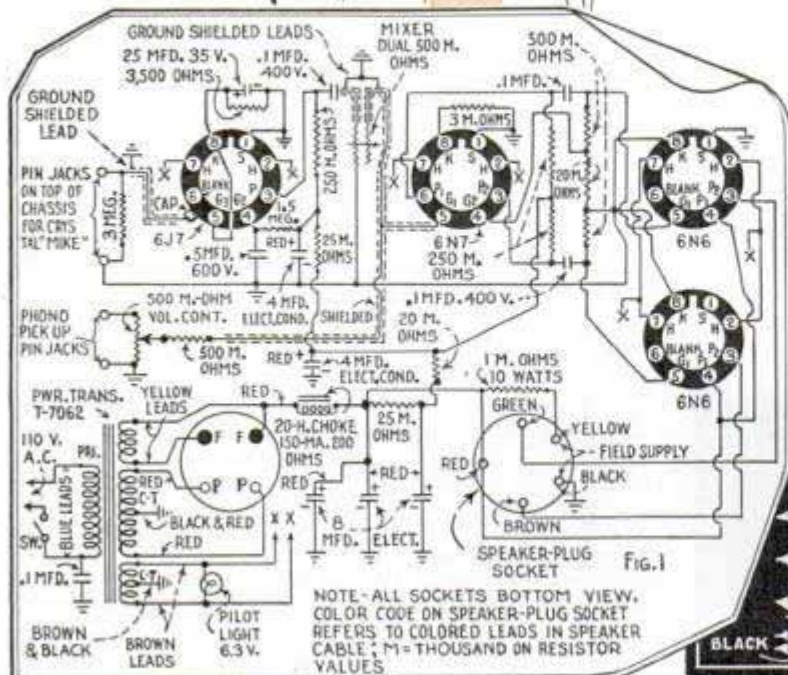

AMPLIFIER built into portable speaker case

owing to the use of resistance coupling throughout. The low tones are also good due to the use of large coupling and cathode bypass condensers. A simple mixer circuit enables the operator to control the microphone and phonograph inputs as desired.

Note that eight of the small fixed resistors are grouped together on a fiber, or Bakelite, strip which is mounted on $\frac{3}{4}$ -in. angle

(Continued to
page 142A)

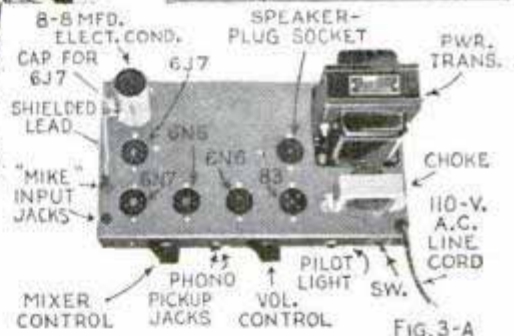

FIG. 3-A

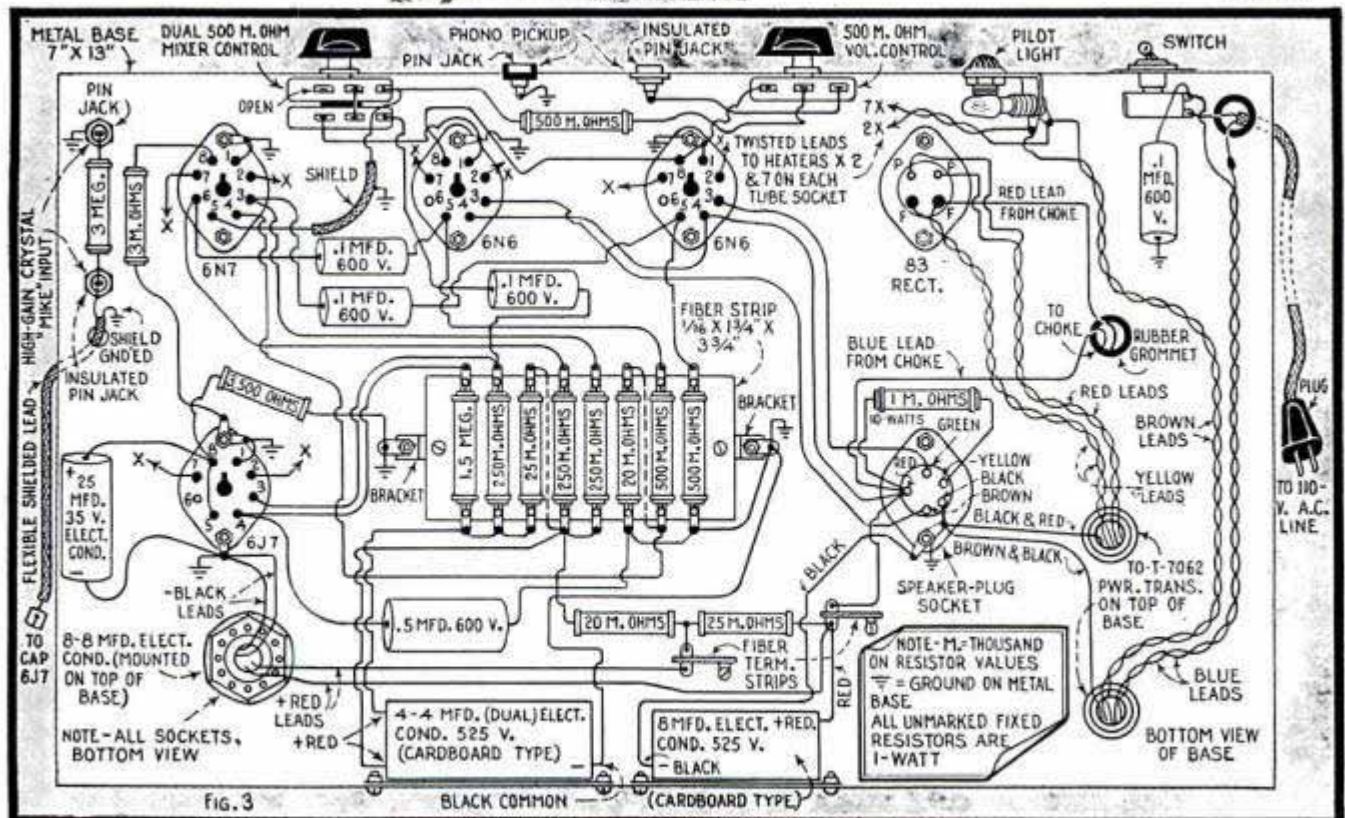

FIG. 3

BLACK COMMON (CARDBOARD TYPE)

Five-Meter Transceiver Mounted on a Bicycle



TWO-WAY 5-meter phone contacts over distances of from one to five miles are quite common between amateurs operating inexpensive stationary or portable "transceivers" which are merely combination transmitters and receivers operated with dry batteries. Now that mobile radio-phone operation in the ultrahigh frequencies is permitted, licensed amateurs are using 5-meter transmitters in automobiles and airplanes. By keeping down bulk and weight, a bicycle installation is practical.

The accompanying photos and diagrams show layout and construction details for a transceiver of this description; circuit Fig. 1 is standard practice in every respect.

All parts for the transceiver proper are mounted on a wood baseboard, $\frac{1}{2}$ by $4\frac{1}{4}$ by $6\frac{3}{4}$ in., and a Bakelite front panel. When assembling the parts on the baseboard arrange the tube socket and coil-supporting bracket directly behind, and as close to the tuning condenser on the panel as possible, to insure short leads. The plate and grid-coil details are all shown in Fig. 2. Note that a notch is filed in the copper tubing, which forms the plate coil, so that the grid coil winding inside, can be center tapped. Be sure that this soldered connection is well insulated

(Continued to page 152A)

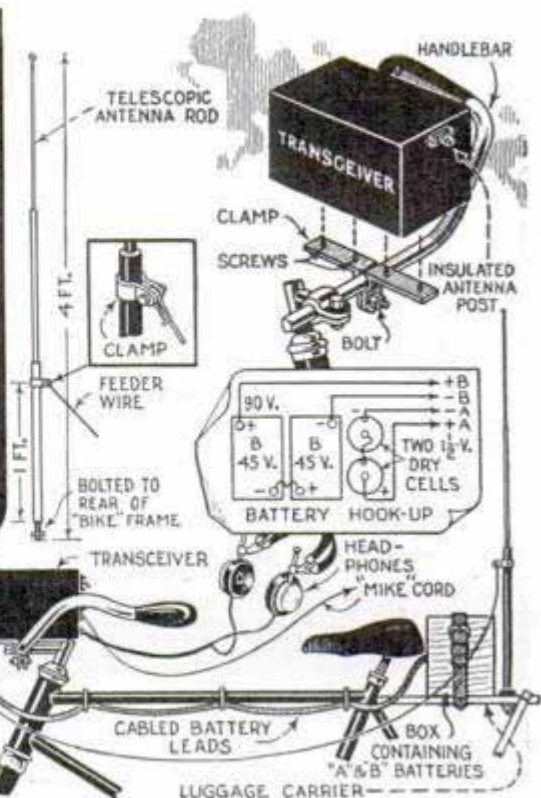
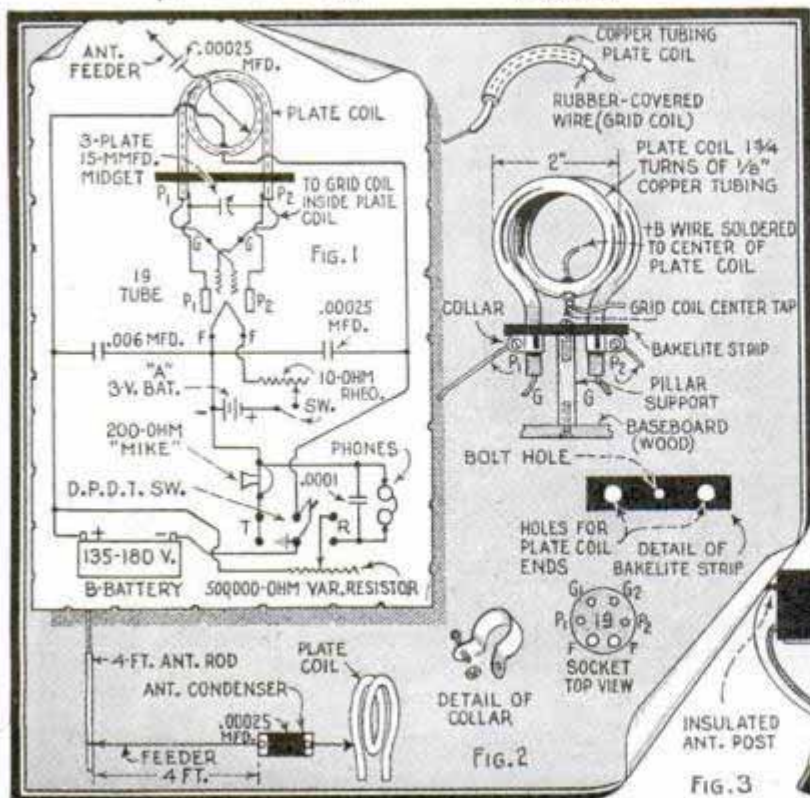
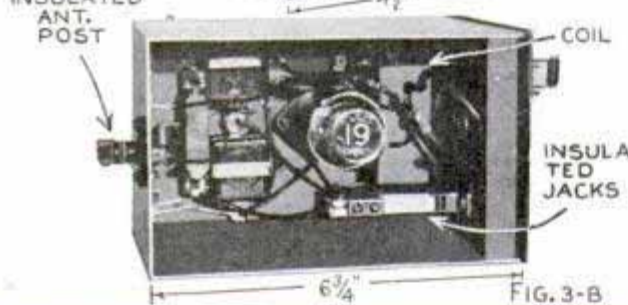
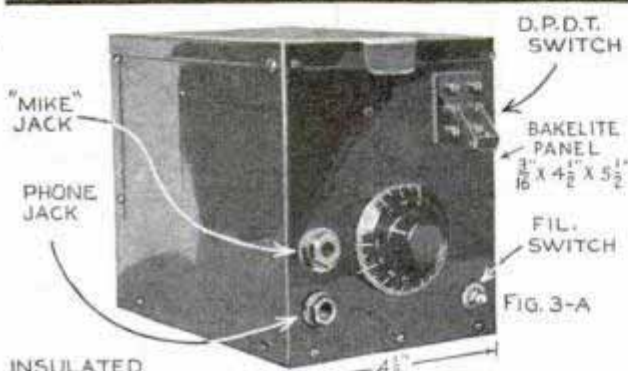

Trimin Radio Rep. Co. 1970 Berkeley Ave

Practical RADIO HINTS

Anyone can have quiet radio reception now on late programs or foreign short waves without disturbing others. This headset attachment left is designed to be connected to the loudspeaker voice-coil circuit as shown in the diagram below the sketch at right. It enables the user to have the headset or loud-speaker alone, or both together if desired for hard-of-hearing applications

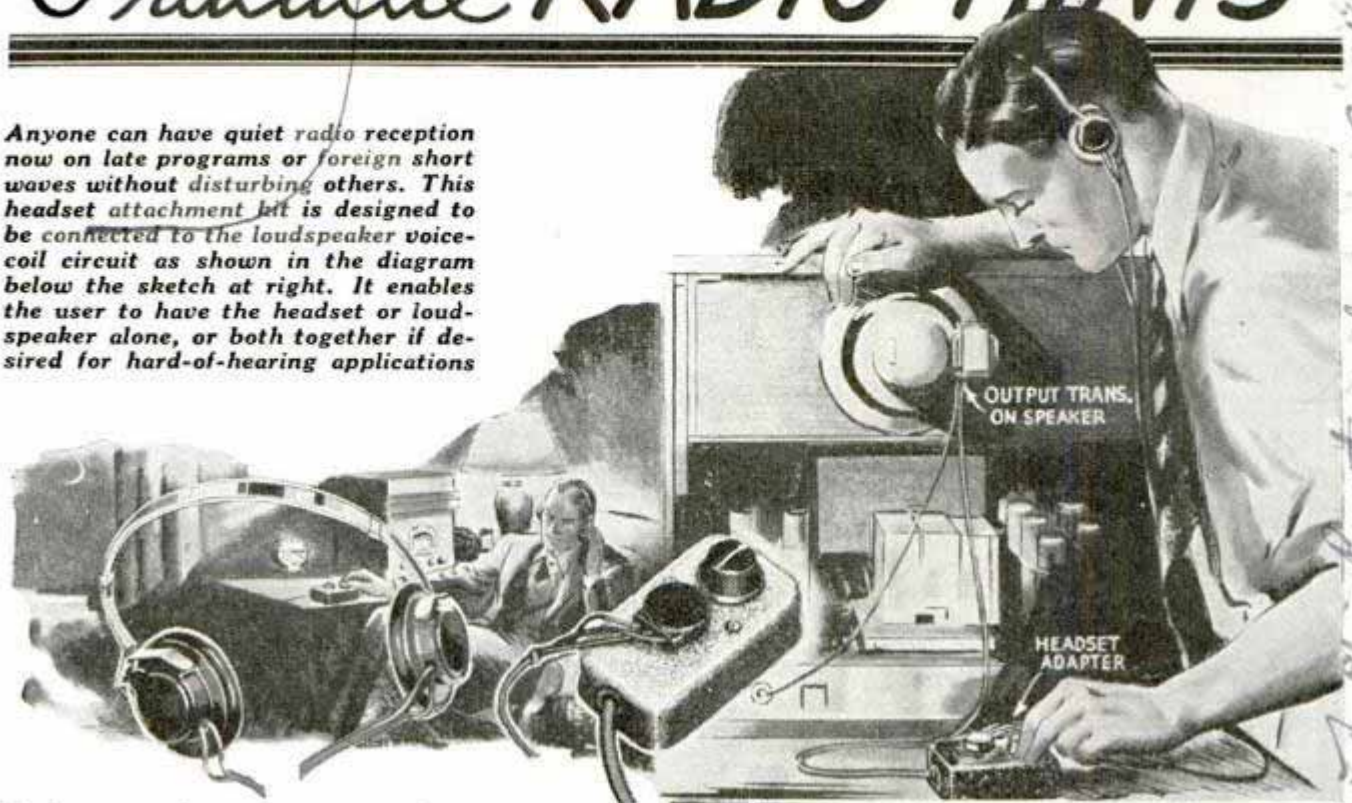

Wafer-type tube sockets commonly employed for sub-panel mounting may also be used above the baseboard in experimental breadboard layouts. Three suggested methods are illustrated. Short lengths of fiber or metal tubing can be used for bushings through which wood screws are inserted. Brass binding-post nuts from old dry cells will also solve the problem. If no hollow material is at hand, a U-shaped bracket may be bent as shown and drilled to take short machine screws; the mounting strip is then fastened to the baseboard

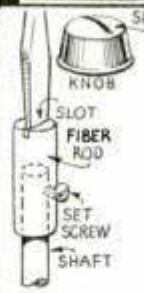
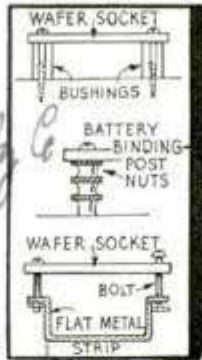
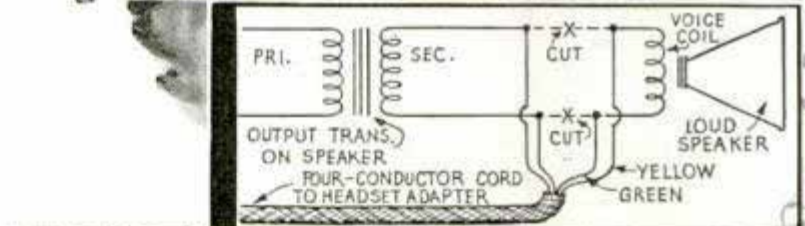

Left, easily made shaft insulators for screwdriver adjustment of trimming condensers; hacksaw slot permits the use of an ordinary screwdriver without troublesome hand-capacity effects. Lower right, flat shoestring used for wide spacing short-wave coil windings; string is then removed and winding shellacked



Left, low-loss plug-in coil form used for a stationary inductance by means of mounting brackets; tapped leads will go direct to prongs

Below, six-volt storage battery converted to a long-life 2-volt A-battery by cutting series connecting straps and wiring all three cells in parallel as shown

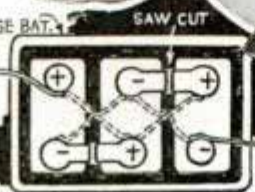

Left, metal clip over Bakelite stem of glass-type octal-base tube grounds shield

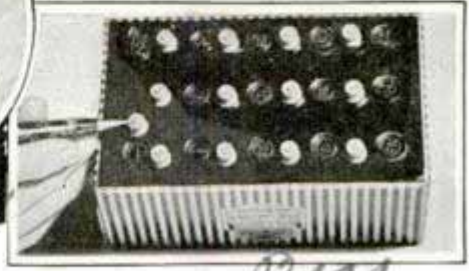

Heavy-duty multi-tapped C-battery offers a wide choice of voltage values

Burgess Battery Co. 901

Tube parts cluc. 3 14. Cleanly. Brooklyn. N.Y.

Television Tuner Is Automatic

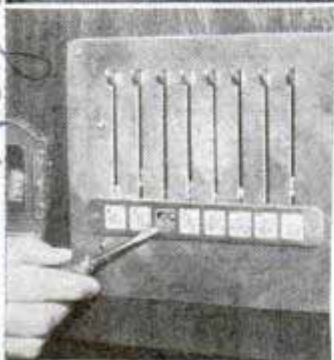
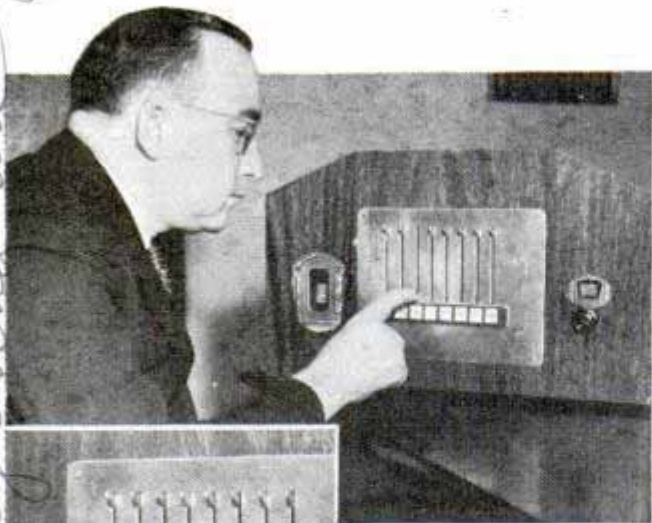

Levers select television and sound frequencies automatically; dials used only for adjusting levers. Left, set screws, under station name plates, for locking in desired frequencies

Tuning in any two desired frequencies with a single operation, this lever-operated device synchronizes the tuning of television bands and their accompanying sound, thus doing away with the need for a special sound receiver, ordinary broadcasting channels being used for voice and music. It may be employed also for automatically tuning ordinary broadcast sets.

Piezo-Electric Record Pickup

With wide-range frequency response and sufficient output to operate through the audio system of a modern radio re-

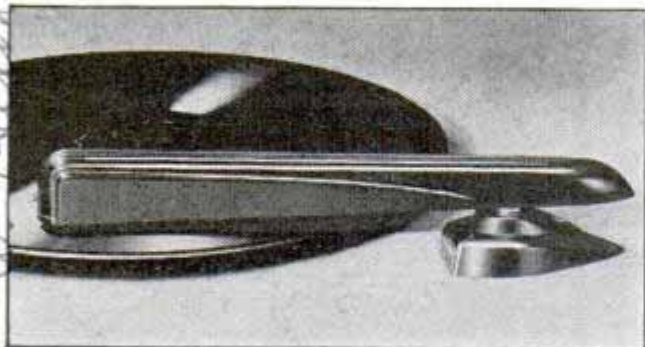

ceiver, this "streamline" phonograph-record pickup arm employs a Rochelle salt crystal of the type now used in microphones, headphones and vibration pickup devices. An additional feature is a built-in "needle tilt" principle for improving reproduction and increasing record life.

Portable Gas-Operated Unit for Radio and Lights

One gallon of gasoline is said to operate this portable power plant from 18 to 20 hours. The 6-volt unit lights up to fourteen 15-watt electric lamps and will charge your 6-volt radio battery at the same

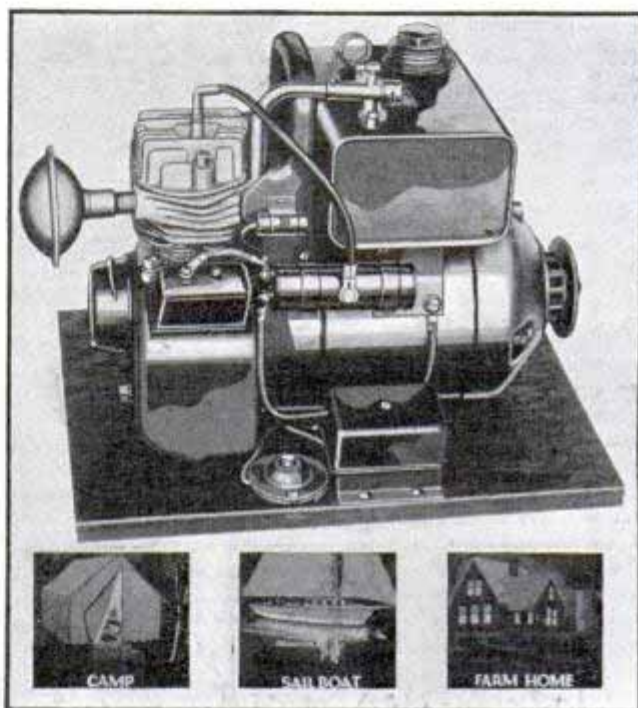

time. It weighs only 57 pounds and is provided with a handle for portable use in boat or camp. Semi-automatic in operation, the battery is protected from overcharge.

Blueprints covering radio construction articles in past issues are available for 25 cents each; original material lists and additional information can be obtained from our Radio Department without charge upon receipt of postage.

NEXT MONTH—How to Build a Three-Tube Little Giant "Pup" Broadcast Receiver. An ultracompact simple T.R.F. portable a.c.-d.c. set, with dynamic speaker and a new dual-purpose output tube. Assembled on a 6¾ by 4 by 1½-in. metal base. Other features include a page of **Radio Symbols for Beginners.**

Shure
 225
 Chester
 1256
 L. J. Leishman, Los Angeles
 12801 Jefferson Blvd.



Small STEAM ENGINE

develops high speed



This one, with its rotary valve, is very simple to build and is suitable for driving model speedboats

THERE are only three parts of this steam engine that require lathe work: the flywheel, crankshaft and piston. The rest of the work is done with a file, drill and soldering iron. The sectional detail, Fig. 3, shows all parts in proper relation. Cylinder, crankshaft bearing and connecting rod are of brass, the steam pipes copper, and the other parts of steel, Fig. 2. Operating diagrams are shown in Fig. 1. The crankshaft serves as a rotary valve. On the power stroke a recess admits steam to the cylinder; at the end of the stroke the valve closes and at the beginning of

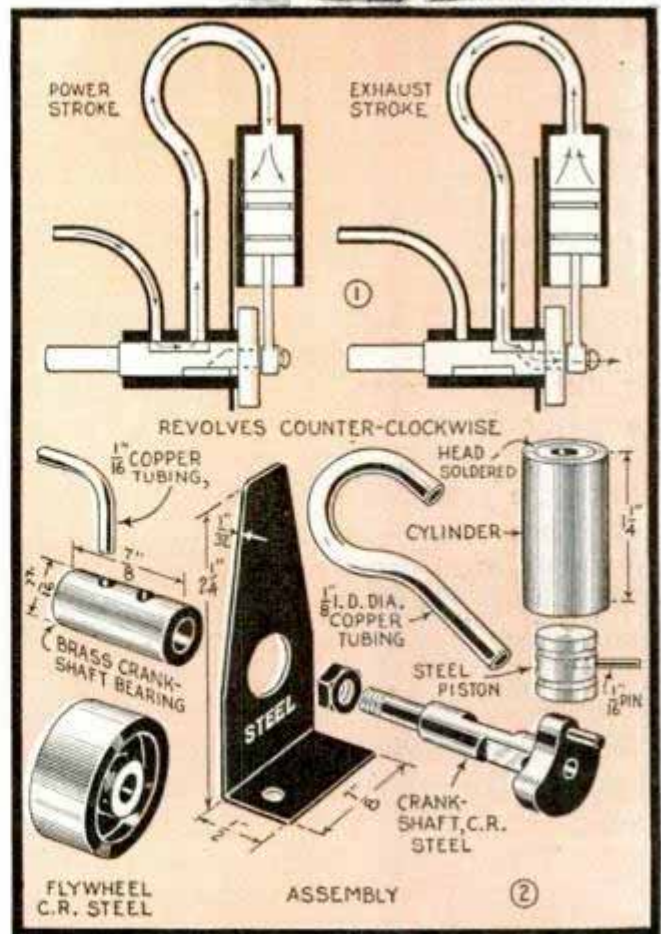

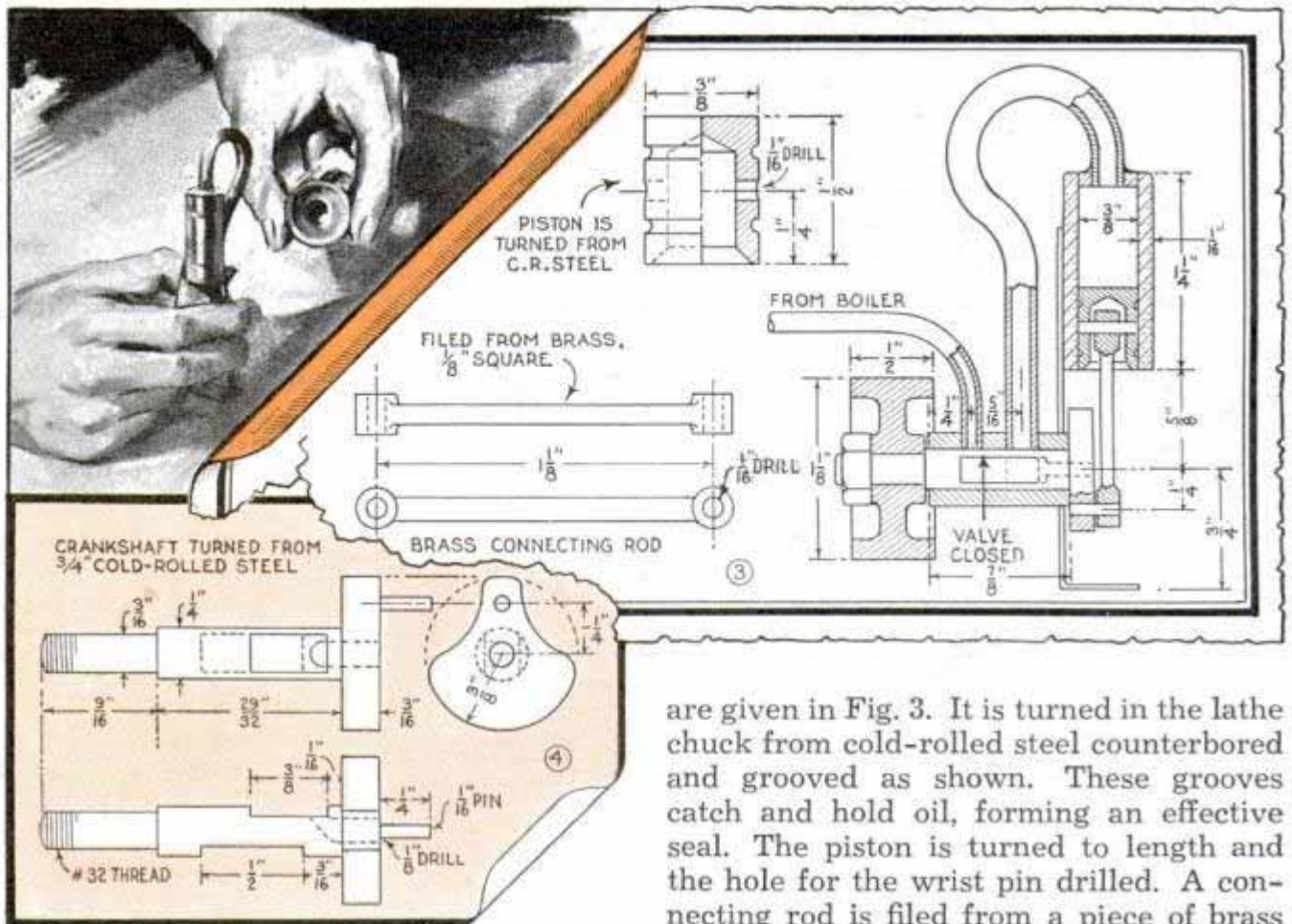

the up-stroke another recess registers with the inlet tube and allows the exhaust steam to pass out through a hole drilled in the end of the crankshaft, as in Fig. 1.

Simplicity of construction is illustrated by the few parts required, Fig. 2. The crankshaft, detailed in Fig. 4, is fitted into a bushing which has been reamed $\frac{1}{4}$ in. Then the bushing is soldered to the frame, after which the piston, with wrist pin and connecting rod assembled, is inserted into the cylinder. The latter is then soldered to the frame. A drop of solder on the crankpin will serve as a nut, although if properly fitted the connecting rod is not likely to slip off. Next, the copper steam tubes are soldered in place and a small nut is screwed on the crankshaft over the flywheel hub to complete the job.

Detailed drawings of the crankshaft show that it must be turned down from $\frac{3}{4}$ -in. cold-rolled steel, the shaft being finished to exactly $\frac{1}{4}$ -in. diameter, with recesses filed away. Portions of the crank disk are removed with hacksaw and file until the proper balance with the piston and rod is attained. The crankpin must be a press fit. Dimensions of the tiny piston

are given in Fig. 3. It is turned in the lathe chuck from cold-rolled steel counterbored and grooved as shown. These grooves catch and hold oil, forming an effective seal. The piston is turned to length and the hole for the wrist pin drilled. A connecting rod is filed from a piece of brass or bronze, and drilled as indicated. It should be assembled with the piston for lapping the latter to the cylinder. Chuck the cylinder in the lathe, coat the piston with polishing rouge, then slide it back and forth while the lathe is running.

Although the engine will run on compressed air, it operates better with steam. Figs. 5 to 9 detail the construction of an efficient boiler of the marine type with a coiled water tube directly over the burner, which circulates the water. It is also equipped with a safety valve, set in the filler cap, and the form of stack and fire-box directs a large portion of the heat to best advantage. The engine and a boiler of this type make a good power plant for a model speedboat.

To make the coil, a hardwood stick is trimmed down to oval section as shown in Fig. 8, and seven turns of copper tubing are wrapped around it. The coils are removed from the form and partly flattened as shown. Opposite ends of the coils are then silver-soldered to the boiler as in Fig. 9. Note that the copper coil has one end soldered at the bottom of the boiler, the other end just below the center of the boiler head, this to promote circulation of

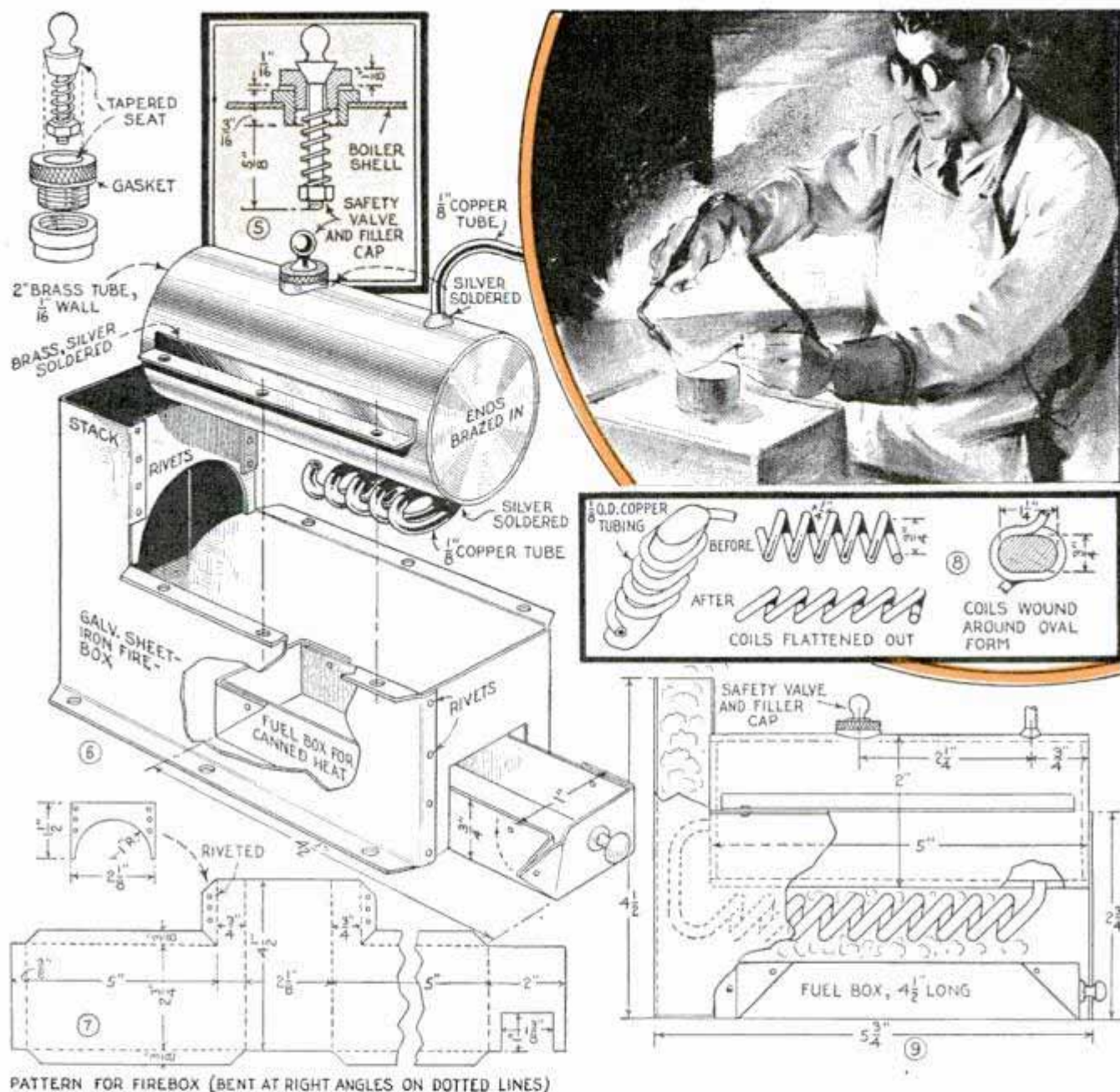

PATTERN FOR FIREBOX (BENT AT RIGHT ANGLES ON DOTTED LINES)

the water. The filler cap, with the safety valve, is made of brass. Note that the flange for the filler cap is silver-soldered to the boiler shell. The important point to bear in mind is that the diameter of the valve seat must not be much over $\frac{3}{16}$ in. unless a fairly heavy spring is used. The valve seat also serves as a filler cap. The boiler is supported in the firebox by brass angles silver-soldered to the boiler shell as in Fig. 6. With the exception of the inner side of the stack, the firebox is cut from a single sheet of galvanized iron as in Fig. 7. The joints must be riveted, as ordinary solder would melt. Small nails cut off and peened over are used for rivets. The fuel box is simply bent in shape from a single piece of galvanized iron and is intended for the use of "canned" fuel.

To run the engine, fill the boiler three-fifths full of hot water and add a few drops of auto-engine oil. Whether mounted on a board or in a boat, both boiler and engine should be screwed down to a base.

Rust Stains Easily Removed

Stubborn rust stains may be removed by covering the moistened spot with a mixture consisting of tartaric acid, 1 oz., and potash alum, 1 oz. After the damp powder has stood on the spot for a few minutes, it may be removed by rinsing. If the spot has not been entirely removed, the process may be repeated. For a new stain, the mixture may be dissolved in water to make 16 oz. of solution. After filtering, the solution is applied to the spot.

Portable Beach Dressing Room by Curtaining Umbrella



Substitute mosquito netting for the canvas and you have an insect-proof enclosure

By simply cutting buttonholes around the edge of a beach umbrella so that a drop curtain of light canvas can be buttoned to it as shown, you have a portable dressing room. Or, you can substitute mosquito netting for the canvas and provide an insect-proof enclosure for use on either the beach or lawn. It will be necessary to reinforce the netting with a cloth band where the buttons are sewed.

Pencil Pointer and Cleaner in a Match Book

Artists, reporters and others whose work requires pointing a pencil, will find that a small piece of sandpaper, glued inside of an empty match book, provides a handy sharpener to carry in the pocket. As an additional convenience, a pipe cleaner is glued under the cover of the book to serve as a wiper for the pencil point after sharpening. An-



other convenient sharpener, employed by a reporter in a court-reporting case, consisted of a small piece of sandpaper glued to the instep of his shoe. While entirely out of the way, it was at hand when needed.

other convenient sharpener, employed by a reporter in a court-reporting case, consisted of a small piece of sandpaper glued to the instep of his shoe. While entirely out of the way, it was at hand when needed.

Cleaning Painted Surfaces

This cleaner quickly removes dirt from painted surfaces when applied with a cloth, and when rubbed, the cleaned surface acquires a natural luster. To make the cleaner, melt diglycol stearate, 1 lb., in kerosene, $\frac{1}{2}$ gal., over a water bath. In a separate container, dissolve trisodium phosphate, $4\frac{1}{2}$ oz., in water, $\frac{3}{4}$ gal., and heat to 150° Fahr. Then add the hot-water solution to the hot-kerosene solution while stirring at high speed. Continue stirring until the mixture has cooled to 85° Fahr.

Washing Photo Films in Lavatory

Set over a lavatory as shown, this film-washing rack accommodates about a dozen negatives. It can be made quickly by stringing short lengths of twine loosely across a picture frame. The twine should sag sufficiently to dip below the surface of the water when weighted down by the films, which are suspended by paper clips. With the bottom drain closed, the water may be kept running as fast as it will pass through the upper drain, causing constant circulation of fresh water around the film.

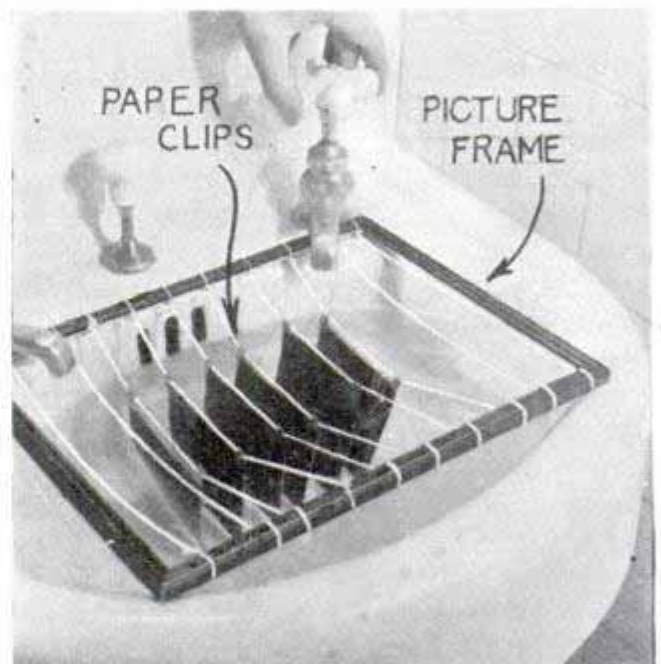

If you have to improvise a darkroom in your bathroom, here is a simple rack to wash films

Weatherproof DINING SET for the Garden

Durability—that's what you want in an outdoor refreshment set. It must be attractive and novel, too. This one consists of a half-dozen chairs designed to fit neatly between the six legs of a hexagonal table with a "grille" top, simply a series of parallel strips with spacers between and inclosed in a six-sided frame. Made of the proper materials and joined substantially, you can leave the set out during the summer season. There's no need to carry table and chairs back and forth each time you use them

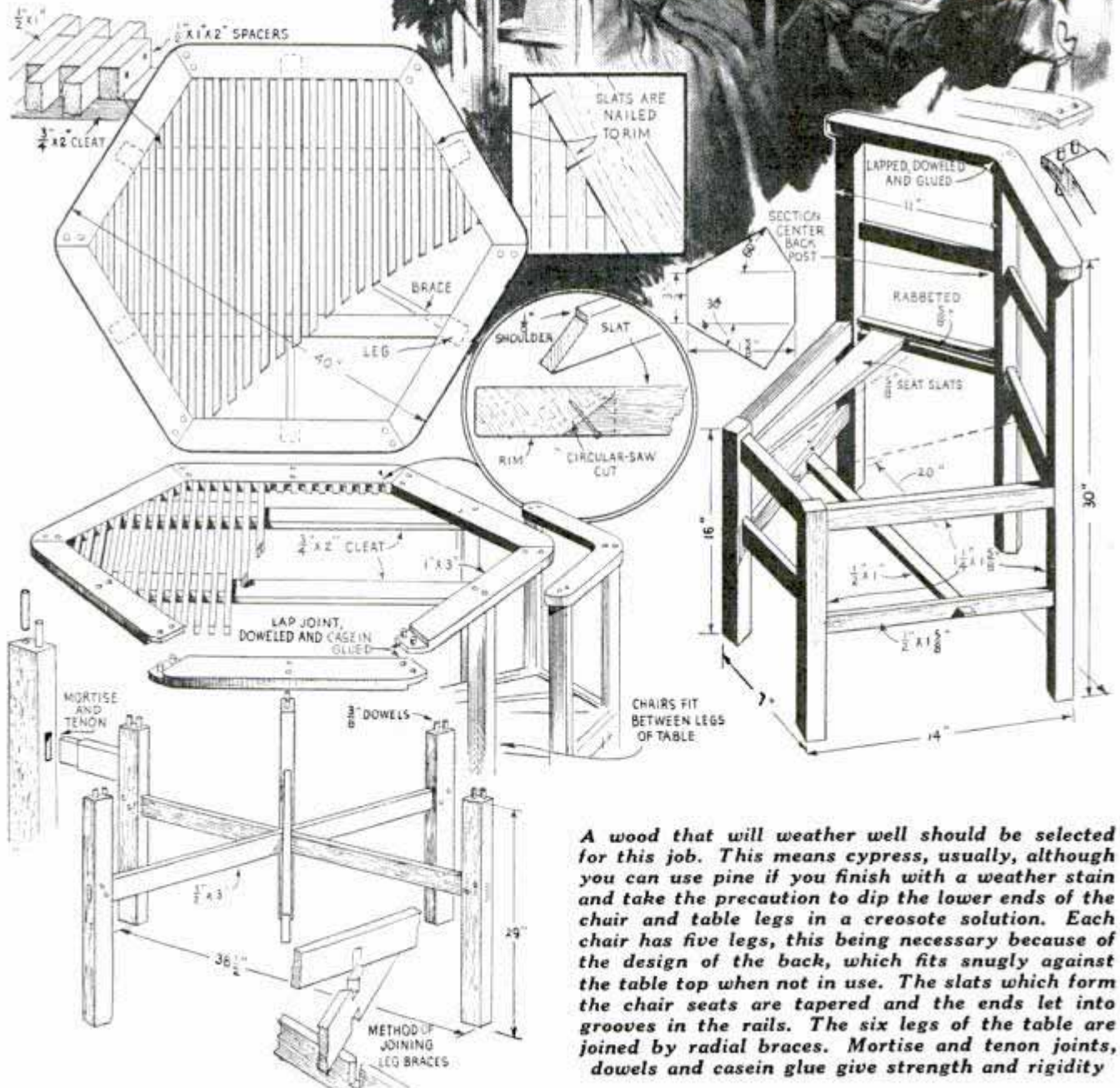

A wood that will weather well should be selected for this job. This means cypress, usually, although you can use pine if you finish with a weather stain and take the precaution to dip the lower ends of the chair and table legs in a creosote solution. Each chair has five legs, this being necessary because of the design of the back, which fits snugly against the table top when not in use. The slats which form the chair seats are tapered and the ends let into grooves in the rails. The six legs of the table are joined by radial braces. Mortise and tenon joints, dowels and casein glue give strength and rigidity

Spool Holder to Wrap Fish Poles Keeps Thread under Tension

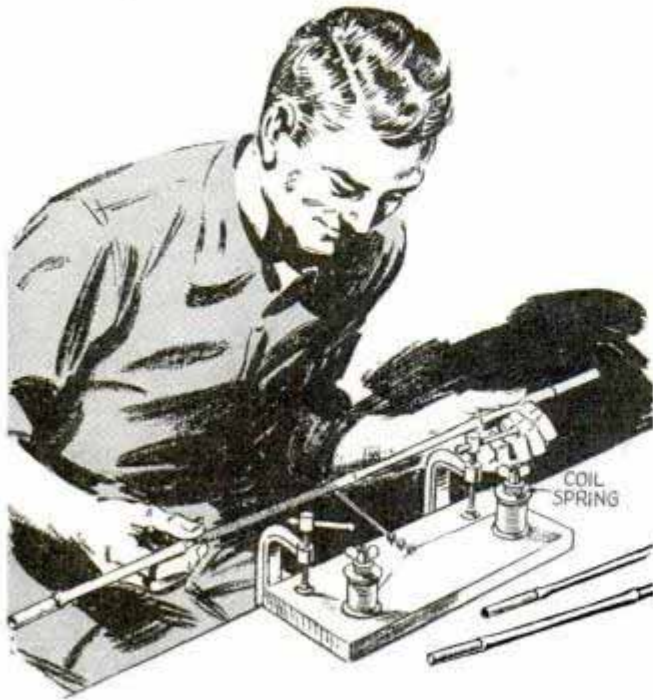

You can wrap a fish pole with any number of colored threads at one time with this spool holder

The next time you want to wrap a fish pole, here's a holder that will accommodate as many spools of colored thread as you want to put on it, and the spools are put under a tension by coil springs which enable you to do a tight wrapping job easily. The holder consists of a wood block drilled to take bolts over which the spools fit. The bolts are fitted with wing nuts and short coil springs are slipped over the bolts on top of the spools to provide the desired tension.

—J. P. Knipp, Long Beach, Calif.

Bearing Depth Collar for Shaper Prevents Scored Work

When shaping irregular work, a common ball bearing substituted for the standard solid depth collar will effectually prevent the work from being scored or scorched due to friction of the spinning collar. The bearing allows the work to "roll" with the free outer race. In the shaping of plastics, this method is especially desirable where the bearing of the



work against a solid collar would have a tendency to burn the edges. Various sizes of bearings will allow cutting of the most common depths.

Roll Roofing Easily Removed with Old Shovel

When using an old shovel to remove roll roofing, a wood block wired to the underside of the shovel will serve as a fulcrum in prying out the nails. You will be surprised how rapidly the work

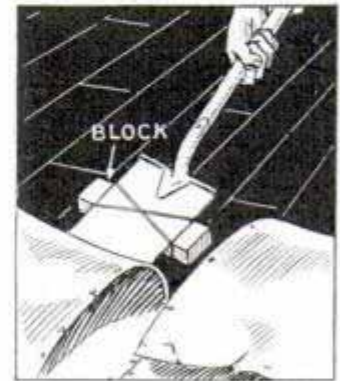

can be done by just pushing the shovel along under the roofing while the handle is worked up and down.

Truck Tire Makes Safe Sandbox for Small Tots

Turned inside out and laid on the ground, an old truck tire provides a lasting sandbox that will neither rot nor rust. And, being slightly pliable, even the smallest child can fall against it without injuring itself. Slits may be cut in the tire to take sticks to support a sunshade.

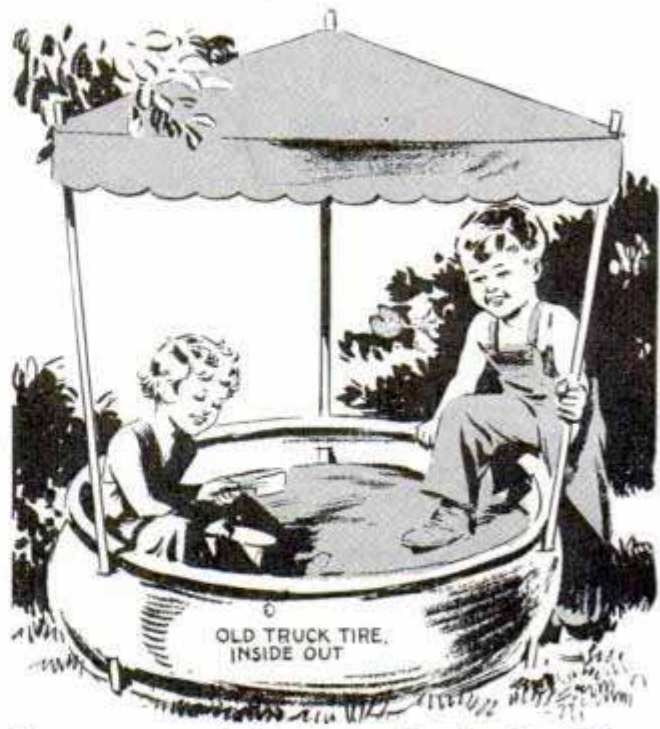

If you want a safe, lasting sandbox for the children, just get an old truck tire and turn it inside out

This Nested Picnic Dish Set Stacks Compactly

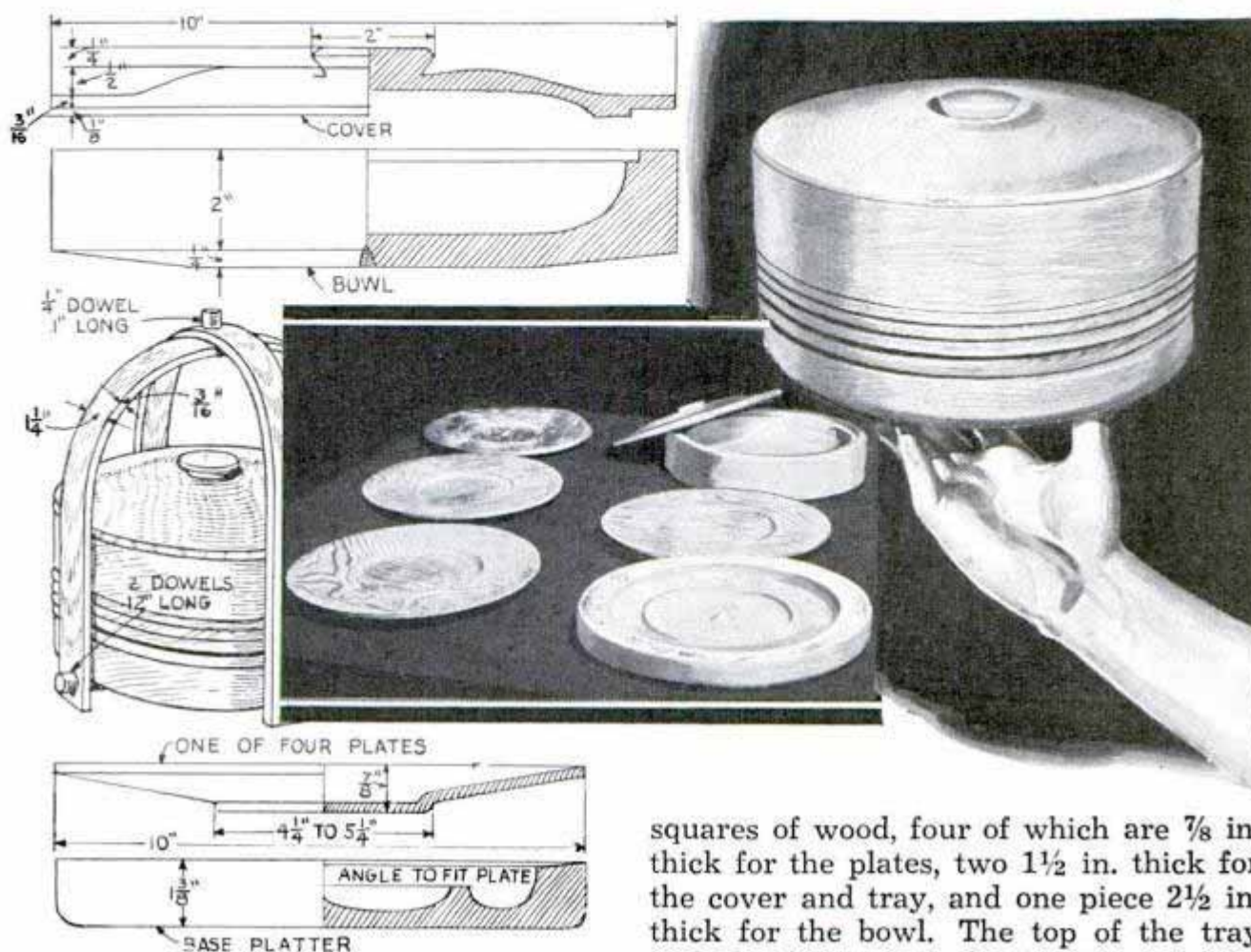

Nesting into a compact stack that takes little space, this wood dish set consists of a deep bowl with cover, four plates and a serving tray, partitioned for olives, pickles, sliced cold meats or nuts and candy. If desired, two strips can be steamed and bent as indicated to form a carrying cradle. All pieces are turned from 10½-in.

squares of wood, four of which are 7/8 in. thick for the plates, two 1½ in. thick for the cover and tray, and one piece 2½ in. thick for the bowl. The top of the tray and the bottom of the bowl should be turned at the same bevel as the plates so that they nest snugly. As the dishes are not intended for liquids or hot, moist foods, they can be finished with a mixture of equal parts of rosin and beeswax rubbed in thoroughly. Or, a more permanent finish of lacquer can be used if desired.

—Dale R. Van Horn, Lincoln, Nebr.

Flooring Butted Together Tightly with This Simple Tool

By riveting three strips of flat iron to a T-hinge so that the assembly fits the tongue edge of flooring, you will have an effective tool to force the flooring boards together tightly. After the free end of the hinge is bent over slightly, teeth are filed in it to grip the sub floor. In using the tool, first push the teeth against the sub floor and slip the other end against the flooring, allowing the tool to be raised slightly. Then, by pushing it down with your hand or foot, the flooring is forced home snugly after which it is nailed in the usual way.—A. H. Waychoff, Tempe, Ariz.

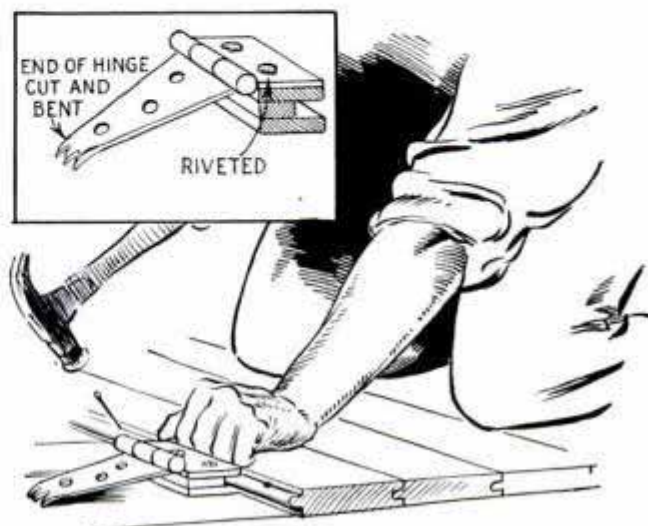

Folding REFRESHMENT

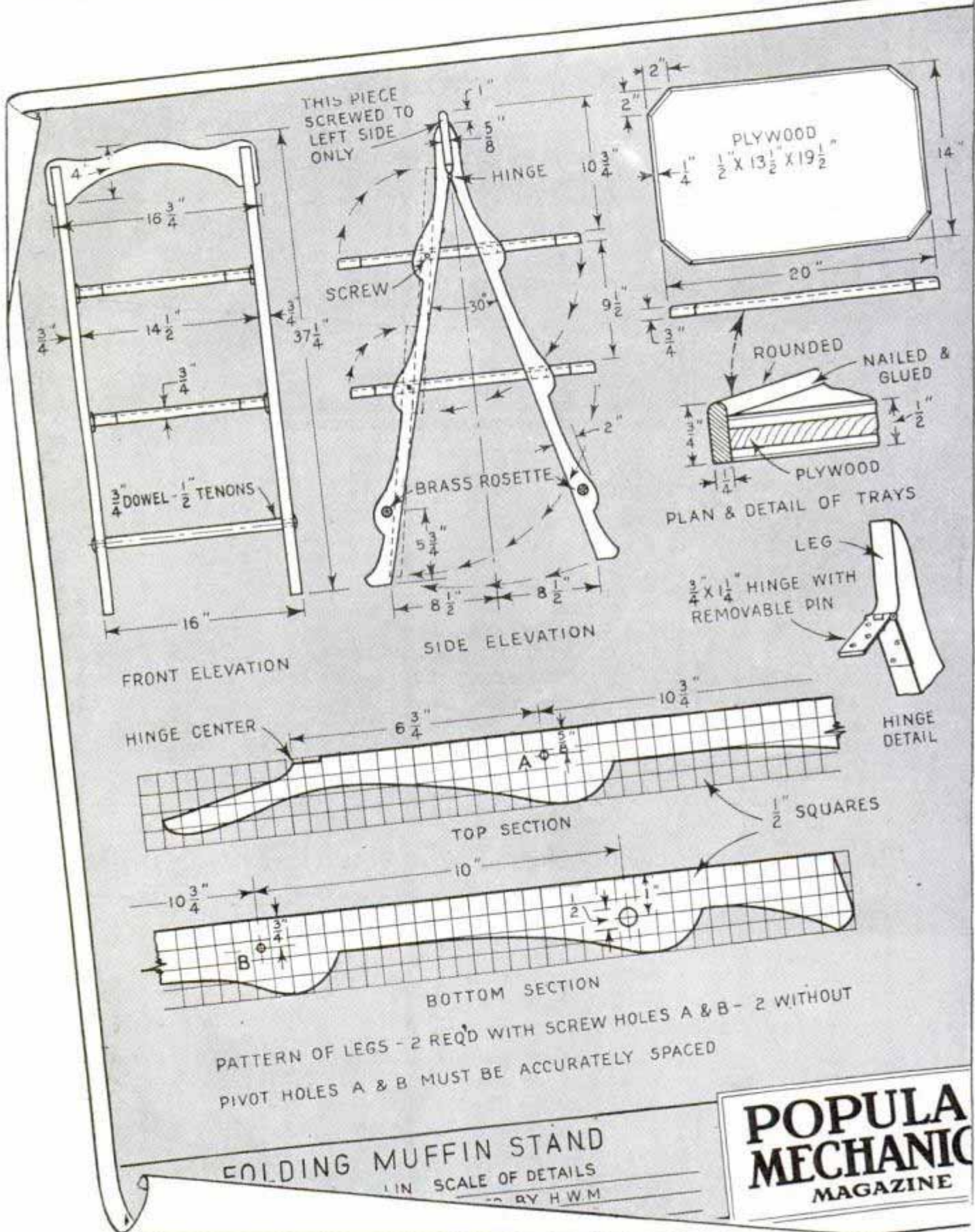

STAND

for
Bridge
Lunches

ANY CLOSE GRAINED
HARDWOOD - FINISHED
IN JADE GREEN OR
CHINESE RED

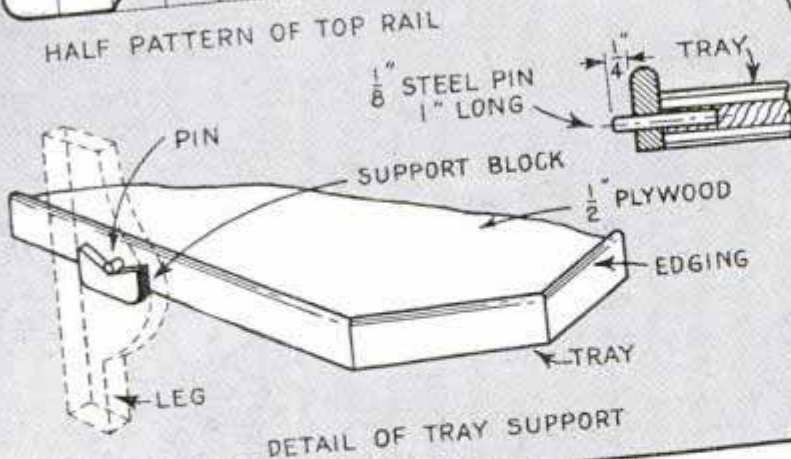
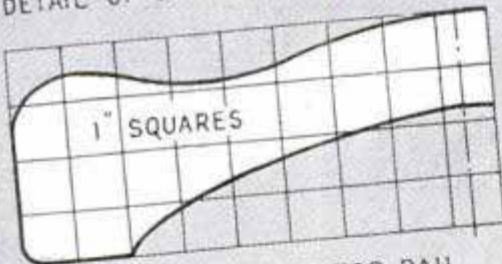
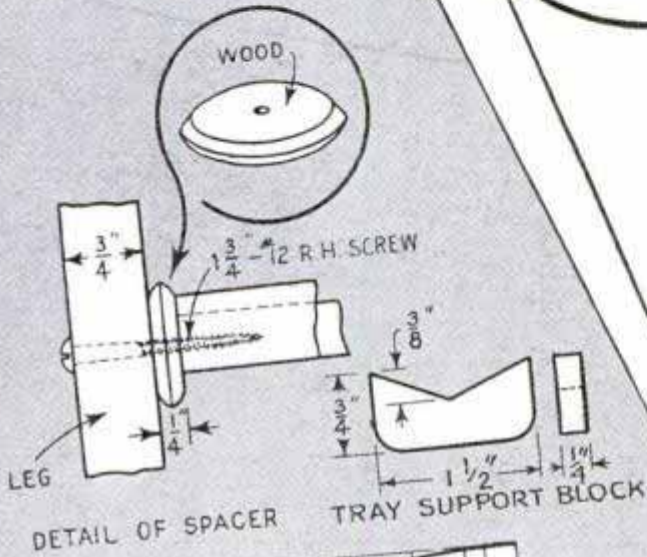

TRAY EDGING IS
APPLIED WITH
LIQUID GLUE
AND BRADS

TRAY
EDGING

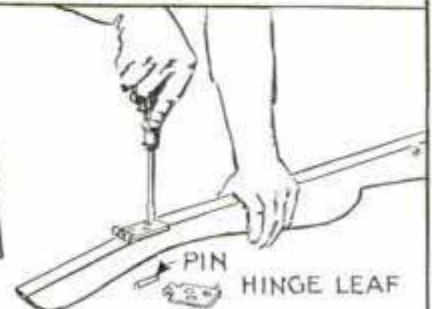
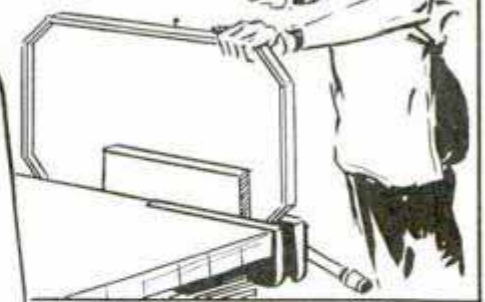

HINGE LEAVES MUST BE SEPARATED
TO GIVE SPACE FOR SCREWS

Every craftsman will be especially taken with this stand—a real spacesaver because it folds flat when not in use. As you will see from the details, there's really no joinery at all. Just make four legs, a top rail and two trays, then apply your choice of enamel—and that's all

GAZINE
GO
SN

Gophers in Lawn Exterminated with Naphthalene Flakes



If you have gophers in your lawn, blow some naphthalene flakes into the burrows and they will leave

If you have tried to exterminate gophers in your lawn unsuccessfully here is a method that has been used effectively. Take your vacuum cleaner, remove the dust bag and suction nozzle, and put the attachment hose on the outlet side. Then insert the nozzle in a gopher hole, turn on the cleaner and feed naphthalene flakes slowly into the fan. This lines the burrows with the flakes, which are highly irritating to the rodents. Treat all the burrows in this manner and seal the openings tightly with dirt to retain the naphthalene fumes.—Carl M. Page, Long Beach, Calif.

Matchbox Presents Pin Drills for Instant Selection

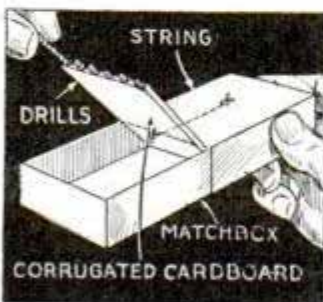

By fitting a small matchbox with a false bottom of corrugated cardboard, several pin drills can be kept at hand ready for instant selection without danger of loss or misplacement.

The cardboard is cut the same width as the inside of the box, but somewhat shorter, and is attached to the cover by

means of a cord. When the box is closed the cardboard rests on the bottom of the box, but when the box is opened the cord pulls the holder up at an angle.

Table Fork Removes Burrs from Dog's Hair

An old table fork, with the tines bent back, makes a handy comb for removing burrs from a dog's hair. The tines are strong and the handle makes it more useful for the purpose than a common comb as each burr may be singled out and removed.

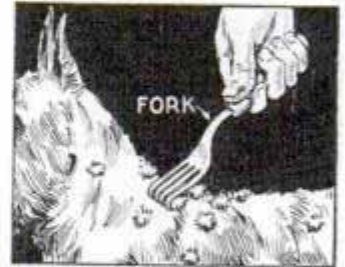

Pivoted Seat in Small Boat Makes Rowing Easy

If the muscles in your body get tired when rowing, try pivoting the seat as indicated. The pivot point is near the front edge, and stout springs mounted on short blocks support the back, allowing it to rise or lower with the swing of the rower's body. When the spring motion is not desired, screen-door hooks at either end are used to hold the seat firmly in place.

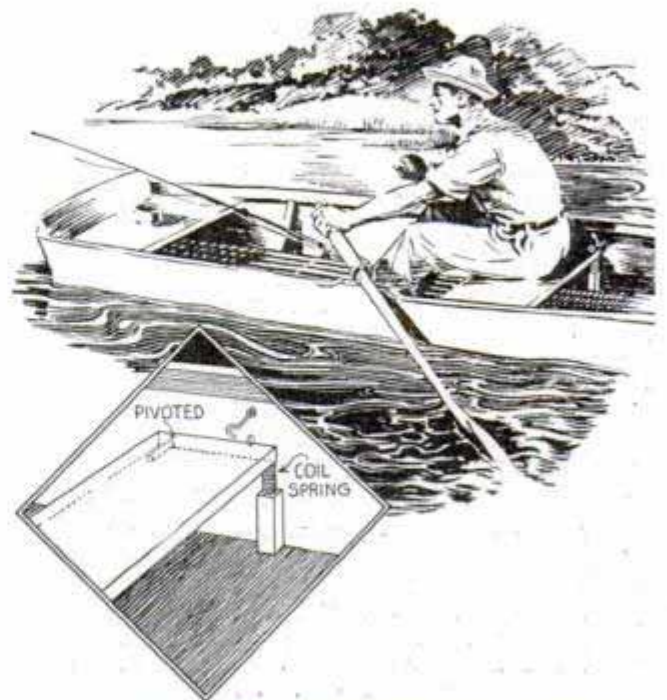

The rear edge of this boat seat rises and lowers with the motion of the rower's body, thus reducing strain

Folding Camp Stove Fired by 'Canned Heat'

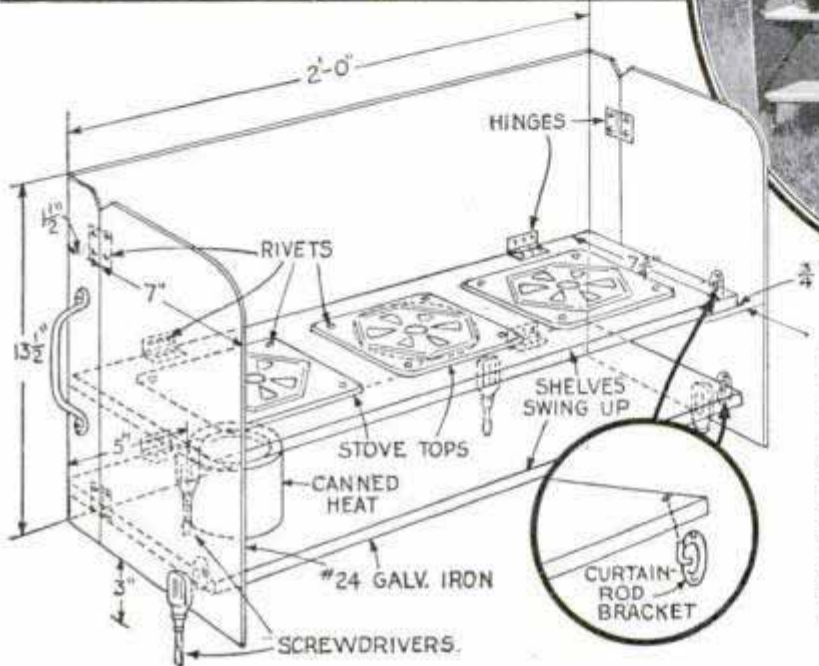
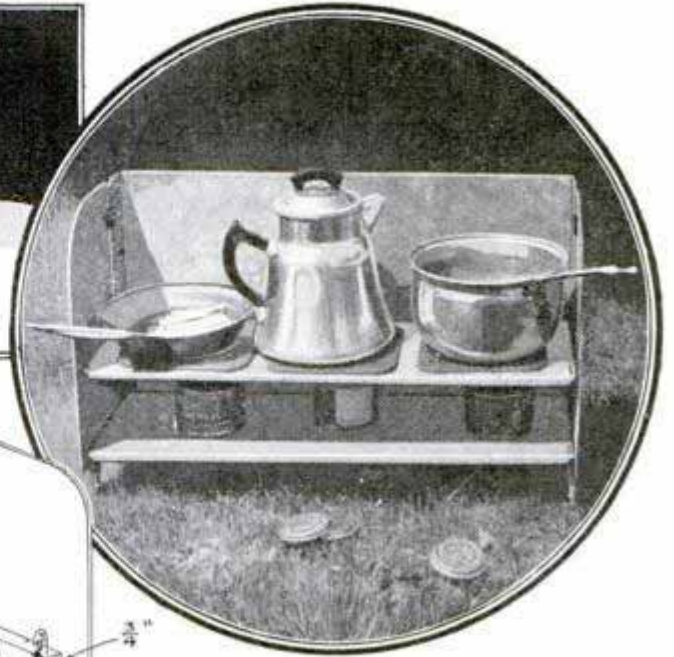

Folding into a small unit, this camp stove is clean and sootless. And, as it uses Canned Heat for fuel, there are no burners, generators or pressure tanks to get out of order. The top, bottom and sides are hinged to the back, curtain-rod brackets being riveted to the sides to fit into holes in the top and bottom, to support them and make the stove rigid. Ten-cent screwdrivers provide legs, which are stuck into the ground when the stove is set up

Signal Light Improvised from Flashlight and Toy Balloon

Needing colored lights to signal their comrades, the members of a searching party used inflated toy balloons on the lens ends of their flashlights. After coating the inside surface of the lens cap with shellac or melted paraffin to make the end of the flashlight airtight, the balloon was slipped over it. A short length of small rubber tubing was then inserted into the mouth of the balloon and the assembly was tied to the flashlight with a string. The balloon was inflated by loosening the string slightly and blowing into the rubber tube. When the balloon was 8 or 10 in. in diameter, the string was tightened.

☞ Lime encrusted inside a teakettle can be loosened by boiling a strong solution of vinegar inside the kettle and then rinsing it thoroughly before putting in water for cooking purposes.

—A. W. Scheib, Arlington, Mass.



Signal light for hikers, searching parties and boys' clubs quickly improvised by slipping toy colored balloons over the ends of their flashlights and inflating them to 8 or 10 in. diameter

MIDGET MODEL *of the*

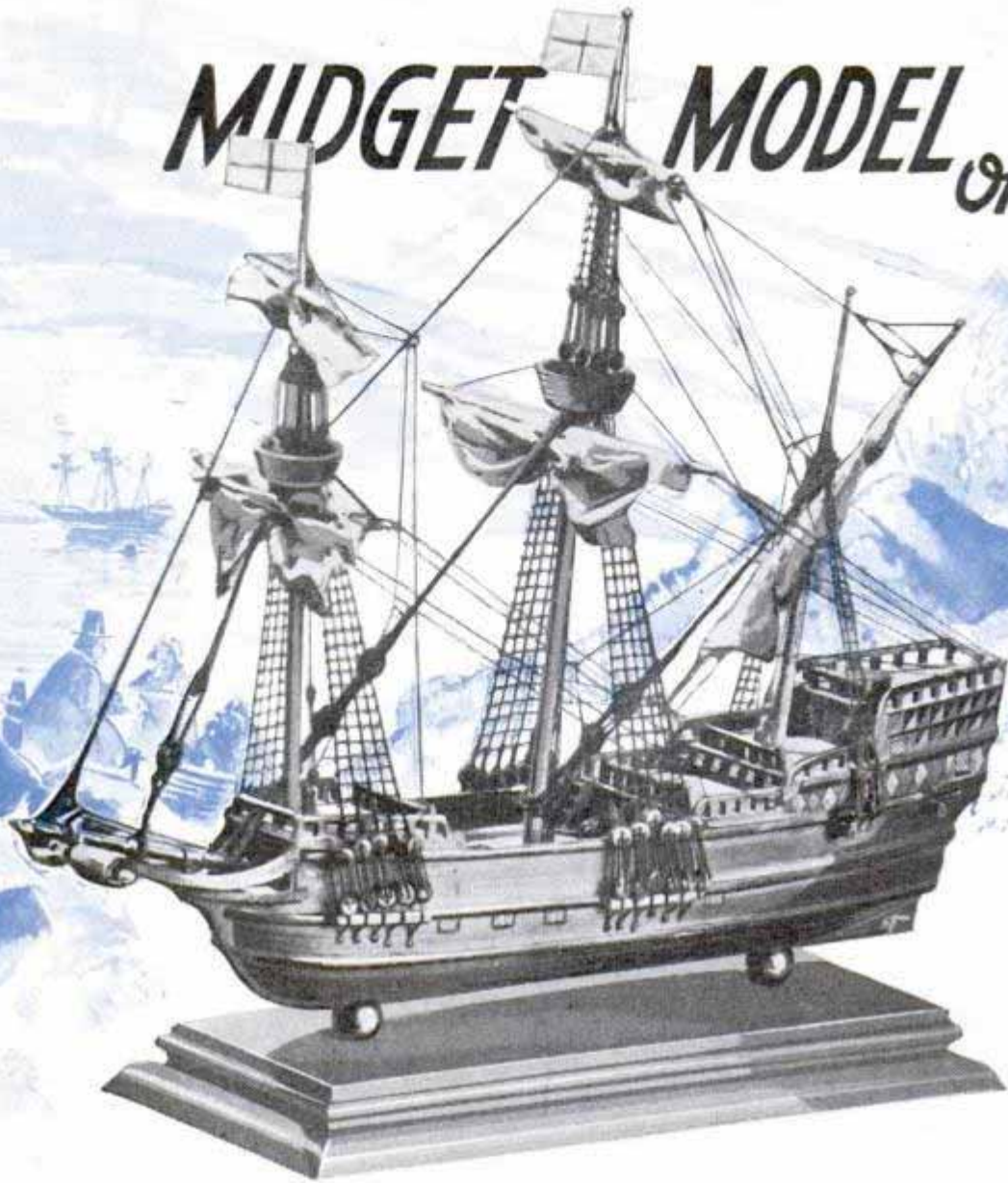

A tiny, yet authentic miniature replica of a famous ship, recalling vividly to mind a most stirring period of American history

DUE to its small size, the building of this model has been simplified greatly without loss of authentic details of construction. As a mantelpiece it stands alone in both decorative and historical interest.

The hull consists of three parts: A centerboard, which forms the stem, keel, sternpost and rudder in a single piece and a hull block, initially formed as a single piece and later sawed apart along the centerline. These split blocks are then glued on each side of the centerboard to make the hull. White pine stock is suitable. The centerboard depth is from the spar deck, Fig. 3, to the keel. Dotted lines show the contour of the hull blocks. The dotted

lines, Figs. 2 and 3, are transferred to a solid pine block, on the top and one side. Using the stern view, Fig. 3, as a guide, but cutting to the full width of $1\frac{1}{4}$ in. from the centerline, a cardboard template is made to the curve of the hull at midships. Beginning forward, a spokeshave is used to carve the hull in smooth rounded sections at all points, the finished curves flowing smoothly into the section represented by the template. Avoid pointing the bow, which should be blunt and "apple-shaped" as typical of this period. This done, the block is sawed apart down the centerline and the two halves glued to the centerboard. The curve of the spar

MAYFLOWER



deck is indicated by the centerboard and the blocks are shaved down flush to this, the full length. Now, scratches representing the planking lines are cut into the hull, making sure that these match up when viewed from the bow or stern. V-cuts identify the rudder and keel outlines.

A small block represents the forecandle; another forms the upper decks at the stern. These must be cut wide enough to cover the hull at the spar deck. Fig. 2 shows that the deck widths on the upper surfaces are less than the blocks as now cut. This is to provide for the "tumblehome," or inward slant, of the ship's sides. Drill a small hole directly in line with the rudder, to receive the round post. Then the tumblehome is carved to conform approximately with the stern view, Fig. 3. Seen from all angles, the hull and upper works should join smoothly. Scratches for deck planking are now carefully put in, the rectangular hole of the main hatch sunk to about $\frac{1}{4}$ in. depth and mast holes drilled to sizes given in the chart, Fig. 3. Pine wales, Fig. 1, are glued and pinned in place and, when dry, thin wooden bulwarks are fitted and glued at the waist, these units being sanded for finishing. The two after gunports are sunken slightly into the wood and drilled to take dummy guns about $\frac{3}{16}$ in. in diameter. Other gunports and windows are painted on after the hull is finished. A block forming the helmsman's shelter

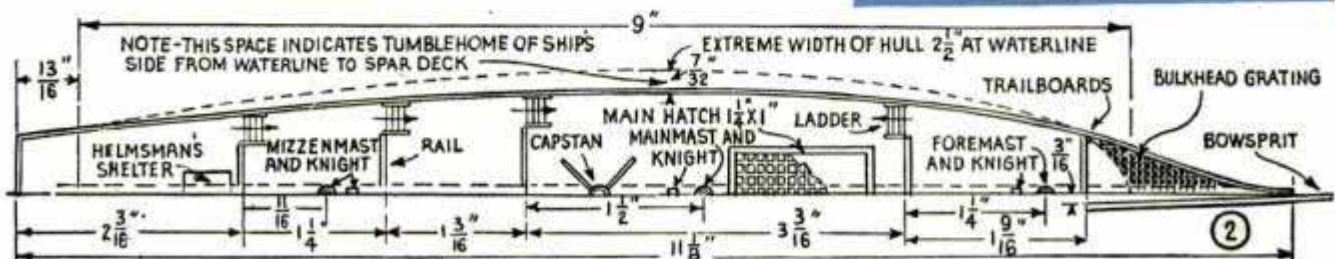

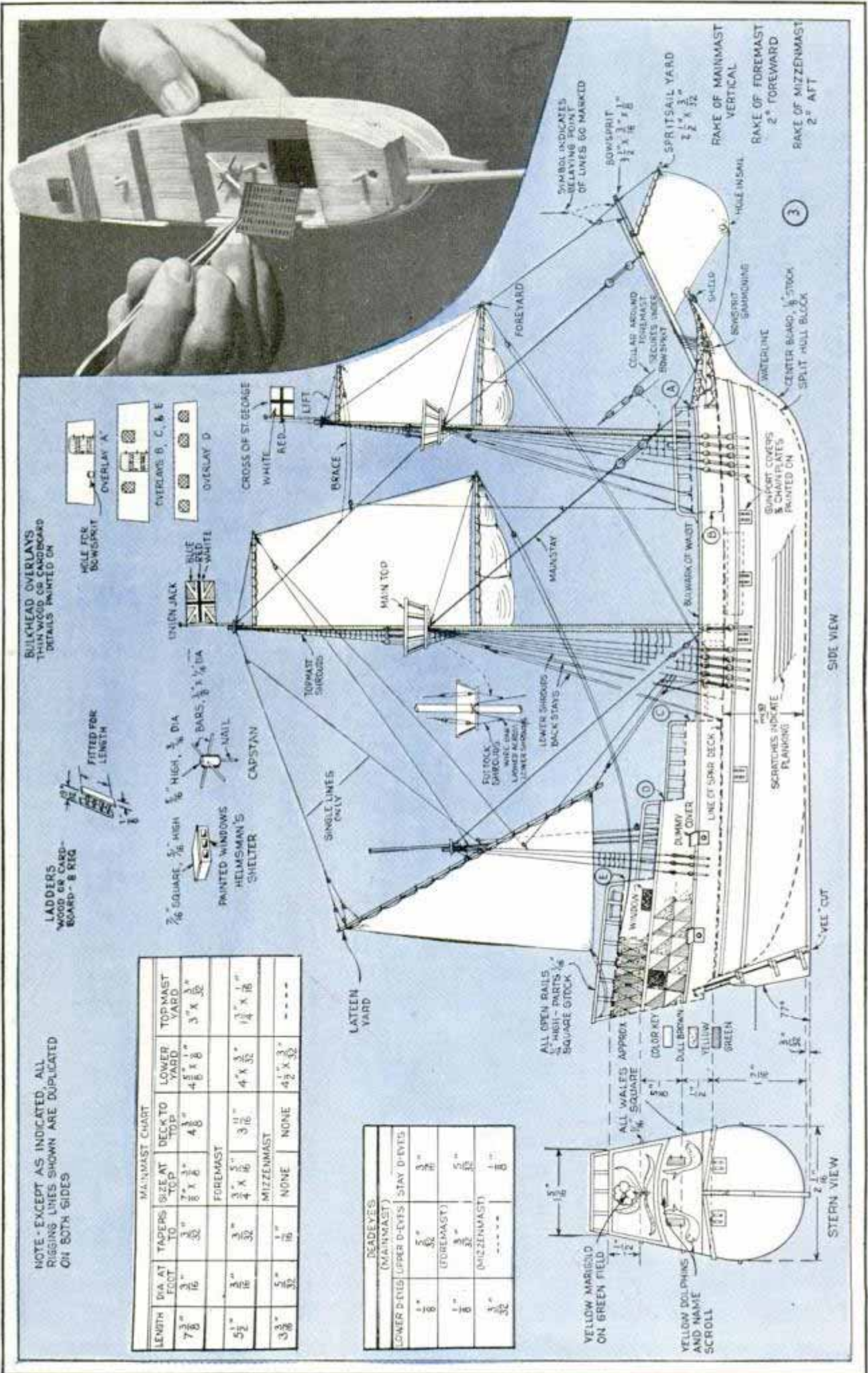

BULKHEAD OVERLAYS
THIN WOOD OR CARDBOARD
DETAILS PAINTED ON

LADDERS
WOOD OR CARD-
BOARD - 8 REQ

NOTE - EXCEPT AS INDICATED, ALL
RIGGING LINES SHOWN ARE DUPLICATED
ON BOTH SIDES



LENGTH	DIA AT FOOT	TAPERS	SIZE AT TOP	DECK TO TOP	LOWER YARD	TOPMAST TO YARD
7 3/8	3/16	3/32	7/8 x 3/8	4 3/8	4 5/8 x 8	3" x 3/32
5 1/2	3/16	3/32	3/4 x 5/16	3 1/2	4 3/32	1 1/4 x 1/16
3 3/8	5/32	1/16	NONE	NONE	4 1/2 x 3/32	----

LOWER D-EYES (UPPER D-EYES)	STAY D-EYES
1/8	3/16
1/8	5/16
1/8	1/8

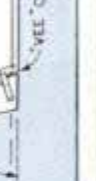
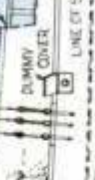
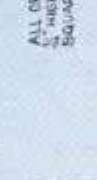
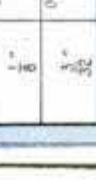
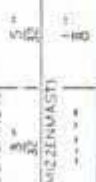
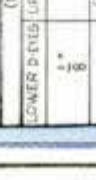
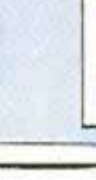
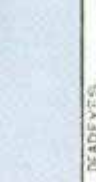
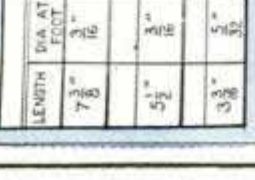
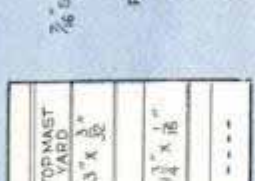
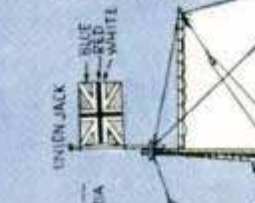
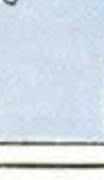
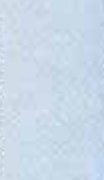
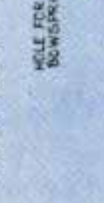

is made as detailed, Fig. 3. Except for light-blue windows, it is painted brown and glued to the poop deck. The main hatch hole is painted dull black inside, after which a wooden grating of $\frac{1}{16}$ -in. squares is glued over the opening. After fitting the trailboards, a similar grating is fitted at the beakhead, as in Fig. 2.

Cardboard bulkhead overlays are painted with doors and windows, then glued in places indicated. All rail parts are of $\frac{1}{16}$ -in. square stock, glued to the decks and, with a fine pin drill, holes are driven vertically through every second stanchion to take lill pins. Knights are $\frac{1}{8}$ in. square by $\frac{5}{16}$ in. high. Decks are given a coat of orange shellac and the hull an all-over coat of dull brown. Decorative painting is specified in Fig. 3. The imitation carved work on the trailboards is represented with gilt paint. Windows and gunports are also painted on. Hull fittings are completed by placing the ladders and capstan. Masts and yards are dull shellacked.

Sizes of the masts and their parts are given in the mast chart. The mast lengths must provide allowance to set into the holes in the decks. The main mast is vertical but the foremast rakes 2° forward and the mizzenmast, 2° aft. Parts of the standing rigging are indicated on the main mast and running rigging on the foremast. Locate the start, or belaying point of each line, then trace to the opposite end.

Yards are attached to the masts with simple thread slings or bindings. Sails are optional. The standing rigging is No. 30 black linen thread, the stays being the same, but twisted to triple diameter. Running rigging is No. 50 or 60 black linen thread. For uniformity, all blocks are $\frac{1}{16}$ in. size. Deadeye sizes are given in the mast chart. The deadeyes at the lower ends of the shrouds are secured by a fine wire passed around them, twisted a couple turns underneath and the wire ends passed through vertical holes in the wales made with a pin drill. These wires are $\frac{1}{2}$ in. below the channels and their free ends pinned to the hull. Ratlines across the shrouds are No. 50 black linen thread. Gammoning (lashing) holding the bowsprit down at the beakhead passes through small holes in the centerboard. It is No. 30 black linen thread. The illustrations will suggest the type of base to be used.

Photoprinter Fits on Bath Tub

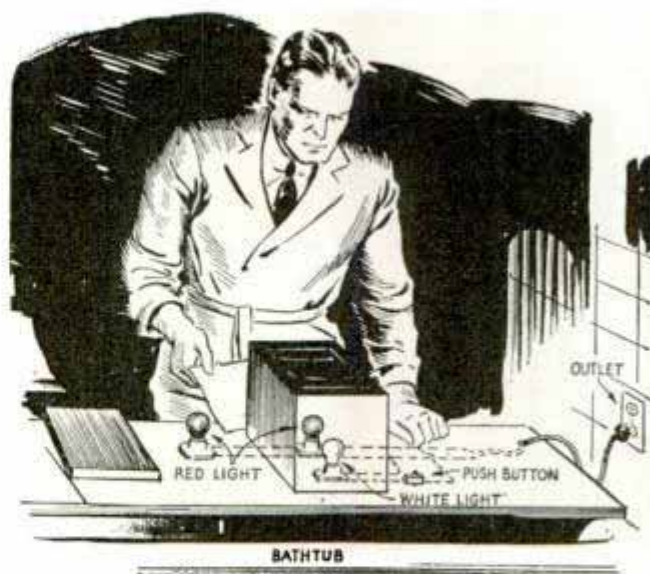

If you are crowded for space, here's a photoprinter that fits on top of your bath tub

If you are crowded for space and have to use your bathroom for a darkroom, here is a photoprinter that sets on the bath tub. It consists of a 1 by 12-in. white-pine board long enough to reach lengthwise across the tub and a light-tight box on top of which is fitted a commercial printing frame. There is a white bulb and a red one under the box and a red one outside. The red bulbs burn constantly when the socket is plugged into a wall receptacle, while the white one is controlled by a push-button switch. The wiring should be waterproof.

—Wm. A. Kimber, Kansas City, Mo.

Marking Live-Center Turnings

When spindle work is taken out of a lathe and replaced before the job is done, the finished turning usually shows a little off center unless it is put back on the spur center in exactly

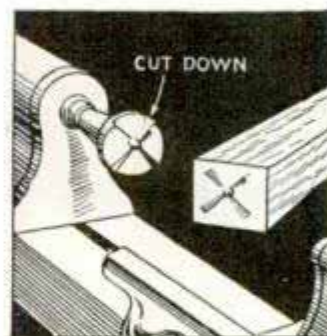

the same position it was in at first. As a guide in replacing the work, grind $\frac{1}{16}$ in. from one of the spurs, which will then make a depression in the end of the work that is more shallow than the other three. This shows at a glance just where to put the work.

Non-Skid Checkers for Playing on Train or Trailer



Swaying of a train or trailer will not cause these checkers to skid around on the board

The annoyance of having your checkers slip around on the board or even fall off when playing on a train or trailer, is avoided by making them non-skid. To do this, small holes are drilled through the squares on the board to take screw heads projecting from each checker.

Supporting Long Rods in Lathe



When a long, slender rod is set up in a lathe, and one end projects through the headstock, the tendency of this end to whip can be reduced by running it through a cork which fits the hollow spindle snugly. The cork can be drilled for the rod with a short length of tubing which has been beveled to a sharp edge at one end.

Repairing Crockery and China

Broken chinaware and crockery can be repaired by cementing the parts together with a hot, molten mixture consisting of

bleached shellac flakes, 10 parts, and gutta percha, 1 part, cautiously melted together with constant stirring in a double boiler. The parts to be cemented should be cleaned and heated after which the hot cement is applied to the broken edges. Then the parts are quickly pressed firmly together and bound until the cement has hardened. Unused cement may be poured into small bars and remelted whenever needed. If the work to be repaired must stand heat after repairing, another type of cement made by rapidly mixing dry casein, 1 part, and water glass, 10 parts, is very effective if made quickly and applied without delay. The casein and water glass are mixed by shaking them together in a bottle. In preparing this cement only pure casein should be used. Casein glue will not serve the purpose.

Collapsible Garment Hook on Tent Pole

Instead of driving nails or garment hooks into a tent pole, try this collapsible hook, which is made from two pieces of stout wire. In use, the short arm of the hook is pulled

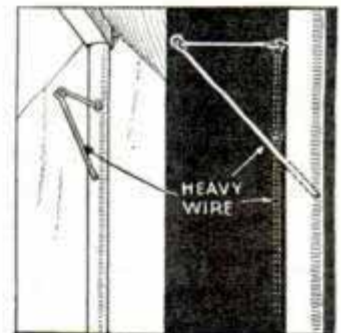

up to horizontal position where it is retained by inserting the longer arm into a hole drilled in the pole.

Lawn Flag Holder from Bamboo



In parks and on lawns where a small flag is to be displayed temporarily, a bamboo tripod of the kind shown is convenient, as the flag may be removed or replaced instantly. The tripod is made by splitting

one end of a bamboo stick and sharpening the legs so formed, which are forced into the ground. One section is left intact to serve as a socket for the flagstaff.

Tom Thumb Greenhouses Grow Plants Early

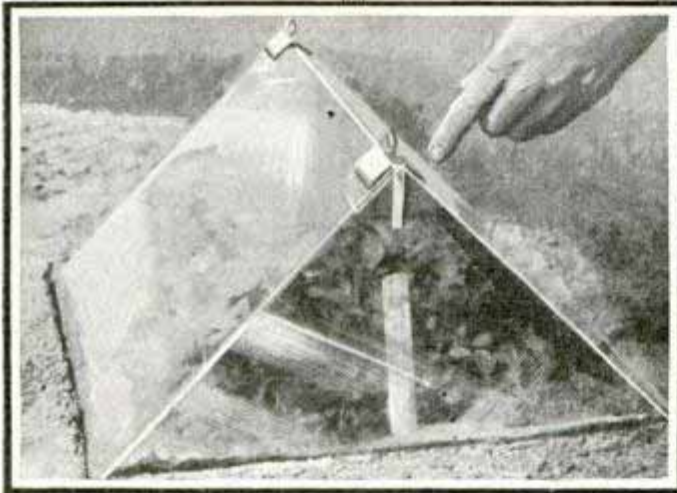
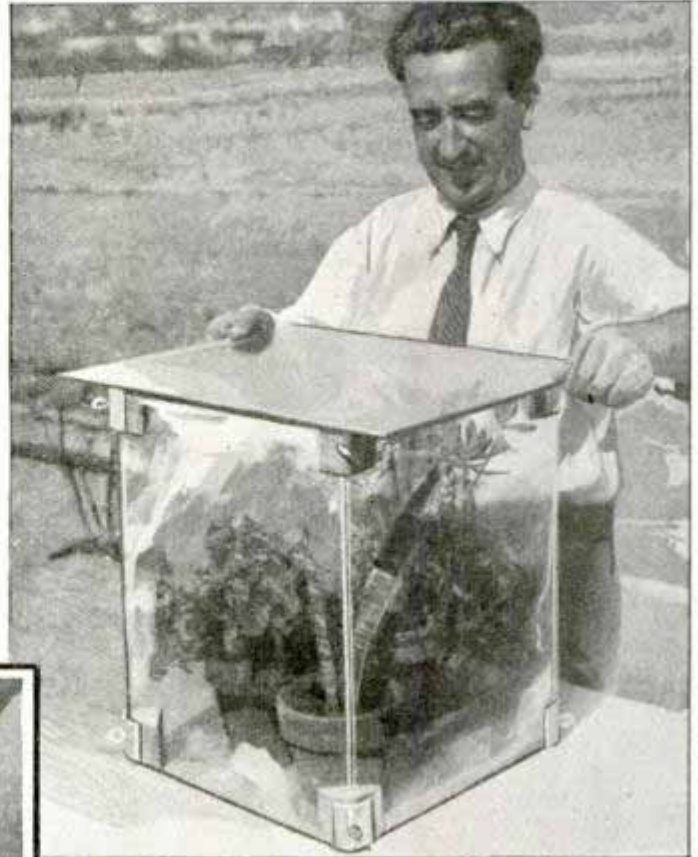
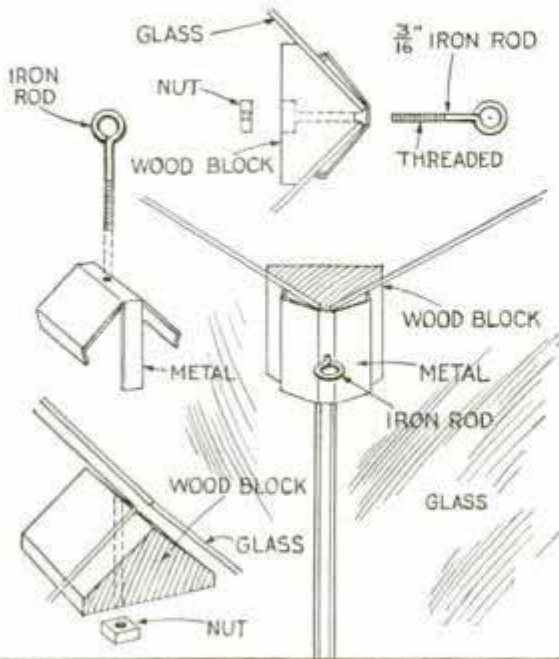

Vegetable and flower seeds germinated right in the beds or garden under these greenhouses get an early start as they are not "set back" by transplanting

By using a number of these miniature greenhouses, you can propagate flower and vegetable seeds right in the bed or garden where they are to grow without having to reset the seedlings when danger of frost is past. Also, the houses are ideal to set over potted plants when sunning them on cool days. Consisting of glass

panels held together by the corner clamps shown in the detail, the houses are assembled or dismantled in a few minutes. They can be set up either in the shape of a rectangle or they can be laid out "pup-tent" fashion. In putting up the houses, the clamps should be adjusted to allow $\frac{1}{4}$ -in. spaces between the panels for ventilation.

Solution to Renew Luster of Weathered Window Glass

After long exposure to the elements, window glass becomes dull and opaque due to decomposition, and it cannot be polished by ordinary methods. To renew the original brilliance, the glass should be washed first with water and then with a solution made by pouring hydrochloric acid, 2 oz., into water, 1 pt. It is best to use rubber gloves while washing the glass with this acid solution. After washing

away the acid with water, the glass may be polished with a paste made from precipitated chalk and water. A better polishing paste is made by mixing precipitated chalk, 1 lb., with ammonia, 1 pt., and denatured alcohol, 1 pt. Either of these pastes is rubbed onto the glass with a cloth and allowed to dry, after which it is wiped off with a soft, clean cloth, leaving the glass clean and bright.



to CAST

How to select a fly rod for action and balance. Level and tapered lines. Good casting depends on wrist movement

AMONG all the varied forms of offering artificial lures to fish, fly fishing stands alone. There is no other method quite like it. Yet it has no rules. Obviously, the angler whipping a fly over rough, fast water must vary his methods when compared with the man fishing the fly on a meandering meadow brook. The tactics must be continually altered to suit the conditions. And then, too, there's the fish to be considered. Trout have been taken with a \$50 rod and accessories of comparable cost; and trout have also responded, in certain seasons, to the lowly earthworm fished beneath the surface of the water on a bent pin. Hence, no hard-and-fast rules can apply.

However, the fly fisherman has a technique all his own, and it has to do with casting the fly. If you've ever watched a skilled fly fisherman in action you have noticed that his manner of casting is very different from that used in throwing a plug. His rod weighs next to nothing, a mere 5 or 6 oz., and yet it is from 8 to 10 ft. long. The reel seat is





A FLY

By W. Clyde Lammey

below the cork grip, Fig. 1, and the reel is either of the single-action or the automatic type as shown in Fig. 8. The line is tied to a leader, and this in turn is tied to the fly, Fig. 3 A, B and C. The knots shown in Figs. 2 and 3 are only typical of a number of knots used. The same is true of the flies shown at the right, as a fly fisherman's kit may contain several times this number.

Most experienced fly fishermen possess more than one rod, but the average size used for both wet and dry fly fishing is 9½ ft. long and weighs 5 or 5½ oz. Personal preference will vary this weight and length, of course. The best fly rods are made from triangular strips of selected bamboo glued together to form a hexagonal cross section. Fly rods are also made of tempered steel tubing. In any case the big thing is the temper, or "backbone." This refers to the reaction or response of the rod to movement of the wrist. When held properly it should respond instantly, without being soft or sluggish of action. If a rod is soft and whippy it will lack line-driving power. If it feels light at the grip it will be difficult to manipulate delicately and will tire the wrist. In a sense, the resiliency should be proportional to the decrease in size from butt to tip, the latter section particularly must have a fair



Knots and Flies

		PARMACHEENE BELLE	
	BLACK GNAT		
			MONTREAL
	GRAY HACKLE		
		SCARLET IBIS	
	ROYAL COACHMAN		
			BROWN HACKLE
	PARMACHEENE BEAU		
			SILVER DOCTOR



The horizontal cast

amount of spring without being too light and pliant, otherwise it will be slow in lifting the line off the water. There are ways of testing a rod right at the counter, before you buy. Have it fitted with a reel to give the natural balance, then hold it out in front of you elevated about 30° , with your hand on the cork grip and the thumb extended on top to give leverage to the wrist. Keep your elbow close to the body and give the rod several moderately hard upward swings, using solely a wrist movement. Watch the tip closely and note how much it dips under a smart, upward swing. If the rod has a loose, rather flabby feel and the tip is slow in coming up or if there is the sensation of "bend without spring" then you had best try another. Another critical test is to hold the rod straight out from you with your eye sighting along its length and revolve it slowly. If properly tensioned, it will bend slightly of its own weight, the curve will shorten somewhat toward the tip, and will remain uniform throughout the complete revolution. But should there be a point where the rod stiffens or the tip tends to rise, it should be discarded. However, if a rod passes this test, it is likely to be a good one. Many reputable makers furnish rods with two interchangeable tips of different tension, the aim being, among other things, to furnish as nearly as possible, an "all-around" fly rod. And too, this feature is a help, for temperament and physical build have something to do with your choice of a fly rod. If you are larger than average in stature and habitually quick and decisive of movement, you will work your rod harder than a smaller man whose wrist would tire quickly when using one of the same weight, length and tension. As to reels, the single-action type seems to have the preference, although the automatic reel is coming into widespread use. In any case, it should hold at least 30 yds. of line.

In order to cast well, a fly line must have weight and flexibility plus a certain amount of stiffness so that it can be stripped and coiled loosely without fouling. The best fly lines are made of the finest solid-braided silk, "vacuum finished" or enameled, and hand dressed to a satiny

smoothness. Lines are supplied in both single and double taper and level, the latter term signifying that the line is the same diameter throughout its length. Single and double-tapered lines are made in considerable variation as in Fig. 12, the drawings being purposely exaggerated. The single-tapered line grows progressively finer from the center toward one end only, while the double taper may fine down each way from a central point or in both directions from a level section near one end. Many fly fishermen still prefer the level line, but it is generally agreed that the tapered line, with its combination of terminal fineness and concentration of weight in the "swell," has a distinct advantage when distance and accuracy are essential. It is more easily controlled under varying conditions, particularly in the wind, and is especially well suited to use with a floating fly. Sizes of the lines are generally designated by letter, as HDH, repetition of the letter usually meaning the line is double tapered. Some makers, however, use numbers in indicating sizes.

Now the leader, one purpose of which is to make the connection between the fly and the line as nearly invisible as possible; it also aids in dropping and "cocking" the floating fly at the end of a cast. You can buy level or tapered leaders of practically any length, with or without dropper loops, a good average length being about 7 ft. Some fly casters use a leader as long as the rod, and others one as short as 4 ft. Much depends on the individual and local conditions. A leader longer than 6 or 7 ft. is rather difficult to handle on a windy day.

Both the overhead and the horizontal or side casts are commonly used, the latter method when trees and bushes overhang the stream. However, in either maneuver there is considerable variation simply because no two casters can be exactly alike. Assuming that you are ready to make the overhead cast and that the leader has been properly softened by soaking in water to make it pliable, a look at Figs. 9 and 10 will give you the idea of how to proceed. The diagrams in Fig. 9 have been exaggerated purposely for the sake of clarity—the line is shown somewhat higher in B and C than it is in the actual cast, and the arm is shown more extended than in common practice. Make trial casts downstream as the current will aid in straightening out the line. Stand facing the spot at which you intend to cast, strip the line off the reel until you have out about 15 feet of free line with two or three coils held in your left hand as in

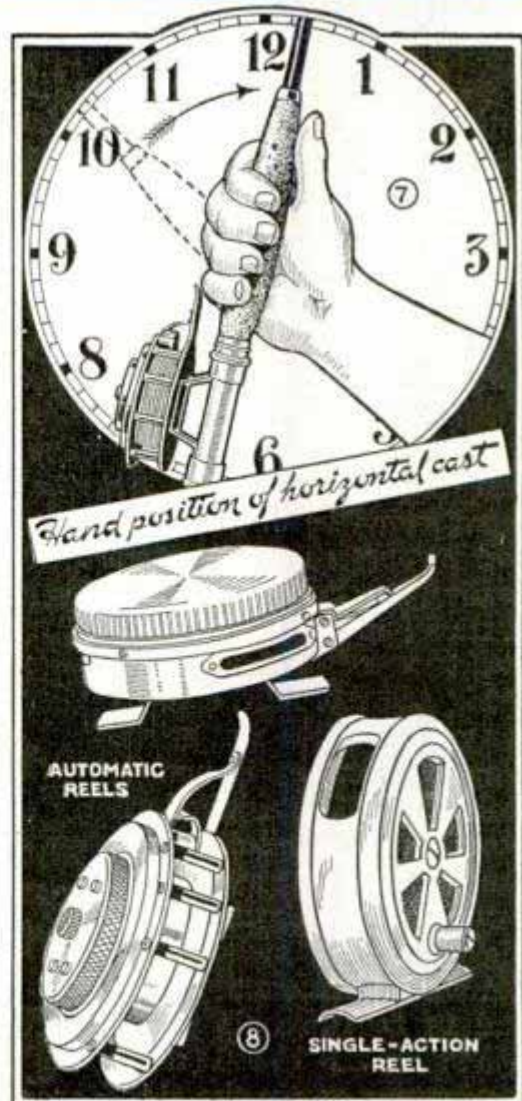
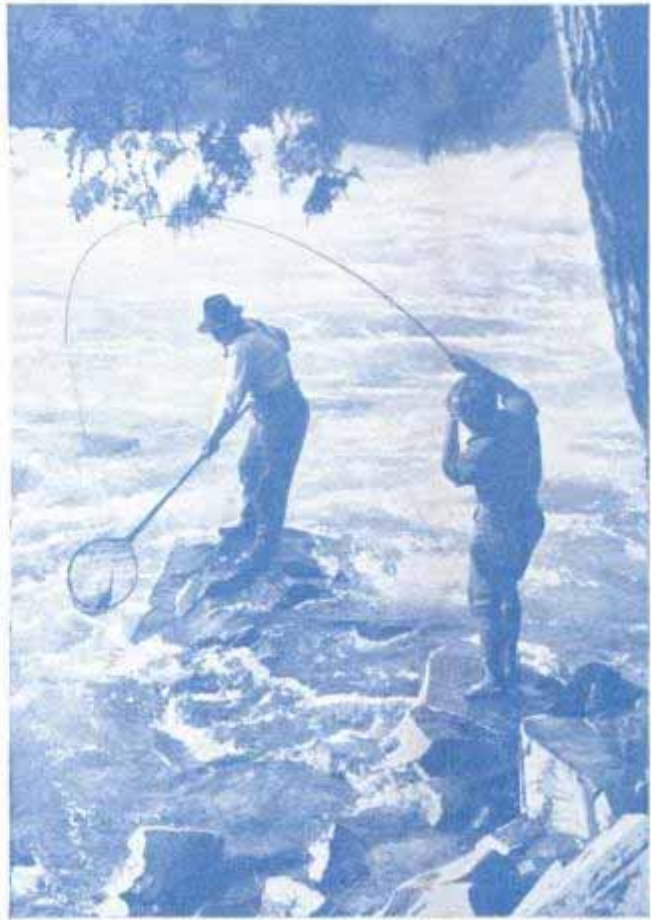

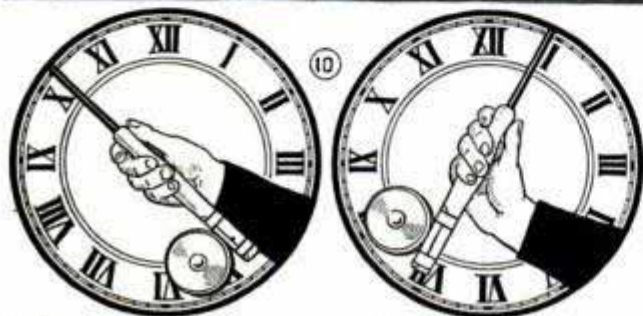
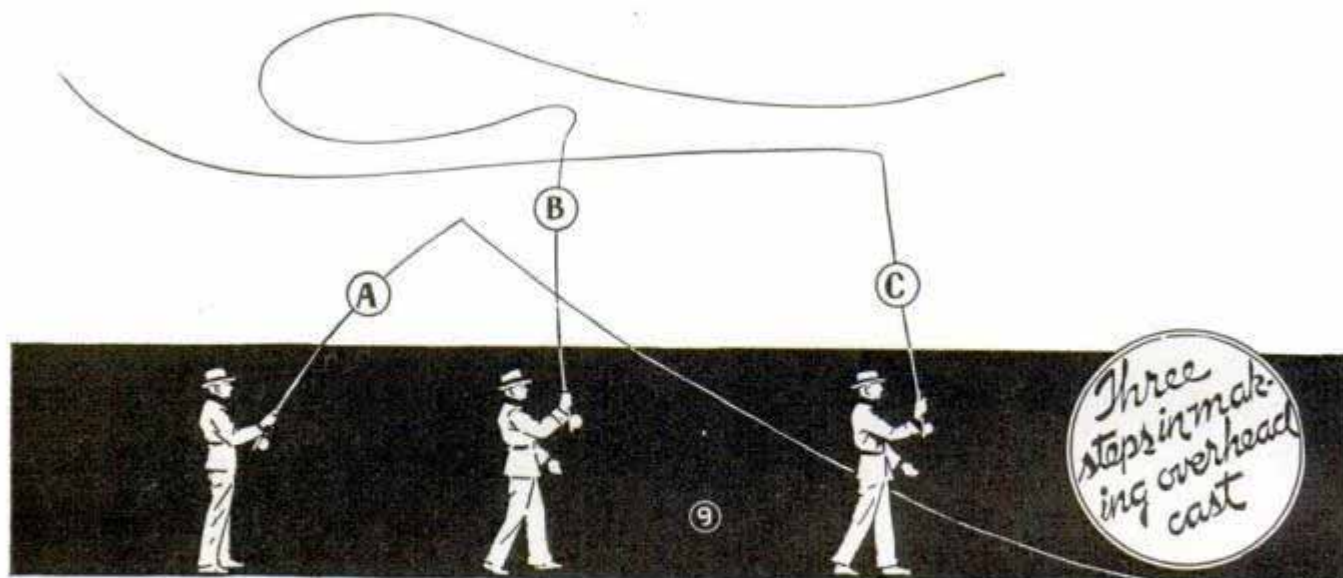

Hand positions in an overhead cast

Figs. 4 and 5. Now note the positions of the rod on the clock faces in Fig. 10 and those corresponding in Fig. 9. To start the back cast you grip the rod with the thumb extending along the cork grip, and give it a smart, upward swing, the whole movement pivoting at the wrist. The trick here is to get the line off the water and into the air without coils or kinks, and to do this the movement must be swift but at the same time it must be done without a sudden jerk. Once the line is started, the upward swing is increased in speed and the rod swung slightly outward to prevent fouling the line. By increasing the speed of travel on both the back and forward strokes you bring the full line-driving power of the rod into play. Now comes the critical stage of the whole business—the matter of timing the start of the forward cast at just the right instant, otherwise the whole maneuver will end in failure. If you wait until the line straightens out in the air

behind you it will lose momentum and begin to fall. If you start the forward cast with a falling line it will loop and is almost sure to become fouled and drop to the water. The trick is to start the forward stroke of the rod just before the line straightens out. The start is made with an easy reversal of motion, not a sudden jerk which might snap the fly off the leader. A bit of persistent practice will give you the "feel" of the line when it's in the air and the rest is easy. Some casters keep a light tension on the line throughout the back and forward casts, releasing tension or "feeding" slack into the line, just as it begins to level out over the water at the end of the forward cast, Fig. 6. Others slacken the line slightly just before starting the forward cast, the idea being to "cushion" the snap of the fly as it changes direction. Still others omit this procedure entirely, keeping the line coiled and the left hand in the same relative position throughout the maneuver. The latter method is probably less complicated.

After all, the whole procedure depends for success on wrist action, not arm movement. When the arm is kept well in to the body, your wrist will move only a certain distance up and back. With the thumb on the top of the grip, as mentioned before, the natural limitations in the wrist movement will automatically stop the back cast at ap-





proximately 1 o'clock, Fig. 10, and leave the arm and wrist in a natural position to start the forward stroke. The same thing is true of the horizontal or side cast. The rod is held just above the horizontal in approximately the position shown by the dotted lines in Fig. 7. Here you are looking down on the clock face. Otherwise the procedure is essentially the same as that used in making the overhead cast, the line being whipped backward and returned over the rod, which swings in a horizontal arc. Many experienced fly fishermen hold that the side cast is the better method of the two under average conditions. Although the beginner will likely find the side cast somewhat more tricky due to the difficulty in keeping slack out of the line, it is true that the side cast has advantages on a windy day and the position of the rod and line at the finish of the cast is a definite aid in aiming and cocking the surface fly. The method is perhaps less tiring as it is easier to make the continuous "false" casts necessary to dry the fly. But when fishing an open stream, or where necessary to get into deep water, the overhead cast is probably the handiest.

A method commonly used to get the fly under overhanging bushes is that of "shooting the line," Fig. 11. To do this you simply release the coils held in the left hand at the instant the line straightens out above the water at the end of the forward cast. The rod is lowered slightly just as the coils are released. It's a neat trick, that will send the fly into otherwise inaccessible places. Many use this method at all times because less free line has to

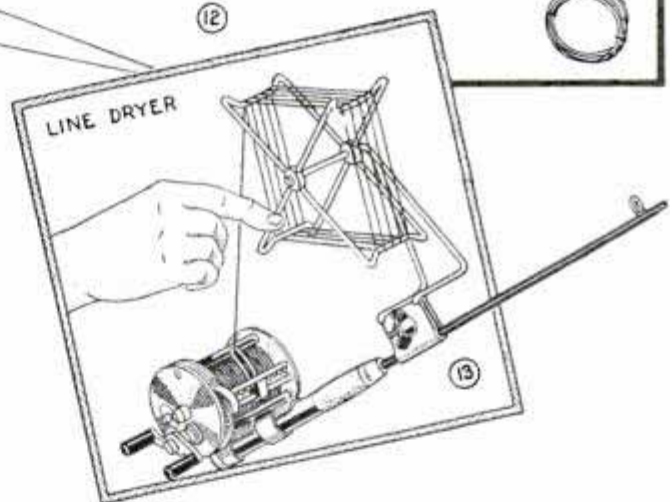
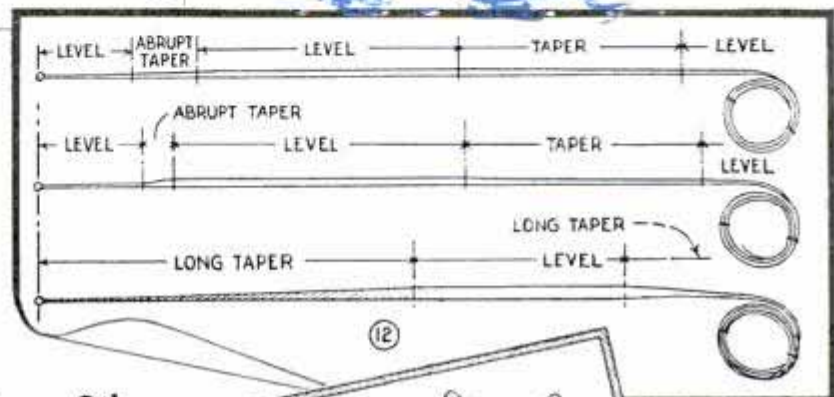

be whipped through the back and forward cast. It saves the wrist and, under most conditions, will land the fly more naturally. Another one often used is that of extending the right arm at the finish of the forward cast, at the same time slacking off on the line with the left hand without releasing the coils. This shoots the fly forward another foot or two and drops it easily.

Lastly, when you're through with the tackle, don't forget to run the line off the reel onto a line dryer as in Fig. 13, which shows a simple type used for bait-casting lines. This handy and inexpensive dryer can also be used on your fly rod. Take the rod apart and keep it in a protecting case when not in use. A fly rod should never be left standing, as in a corner, for any length of time.

Sanding Block Attached to Plane Is Easy to Use



When finishing large surfaces, your hand plane provides both weight and a handle for the sanding block

Taking advantage of the weight and convenient grip on a hand plane, one craftsman uses it as a handle on a large sanding block. The plane is attached to the block by means of a couple of metal drawer pulls as indicated, and is taken off by simply removing a screw from one of the pulls so that the latter can be swung around.—Wayne C. Leckey, Aurora, Ill.

Cork for Bottle of Cleaning Fluid Is Always at Hand

When bottles of cleaning or other volatile fluids are used frequently, and it is rather troublesome to cork and uncork them constantly to prevent evaporation, insert a rubber band through the cork and fasten the ends of the band under a strip of adhesive tape wrapped around the neck of the bottle. With this arrangement, the cork may be reversed to rest on the top of the bottle, closing it against evapora-



tion, yet allowing it to be used conveniently when pouring out the contents. Loss of the cork is also prevented.

Vacuum Cup and Spring Wire Replace Paperweight

Instead of using a paperweight for holding papers conveniently at hand, try the vacuum-cup and spring-wire assembly shown. The cup sticks tightly to the smooth top of a desk, and the wire holds a stack of papers so that one sheet or the whole pile can be removed instantly by merely lifting it with one finger.

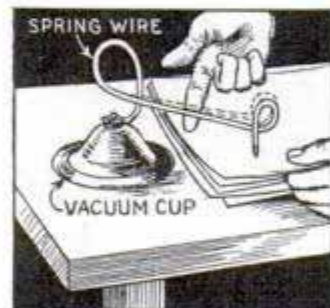

Bulbs in Ceiling Fixture Removed with Funnel on Broomstick

Here's a simple tool to remove electric bulbs from ceiling fixtures. Just slip a small funnel over the end of a stick and cement three or four strips of sponge rubber inside the funnel as indicated. When the funnel is pushed over a bulb and turned, friction between the glass and the rubber strips will unscrew the bulb.



A ten-cent funnel, a few strips of sponge rubber and a stick are all you need to make a bulb remover

FUN *with* SHADOW PICTURES

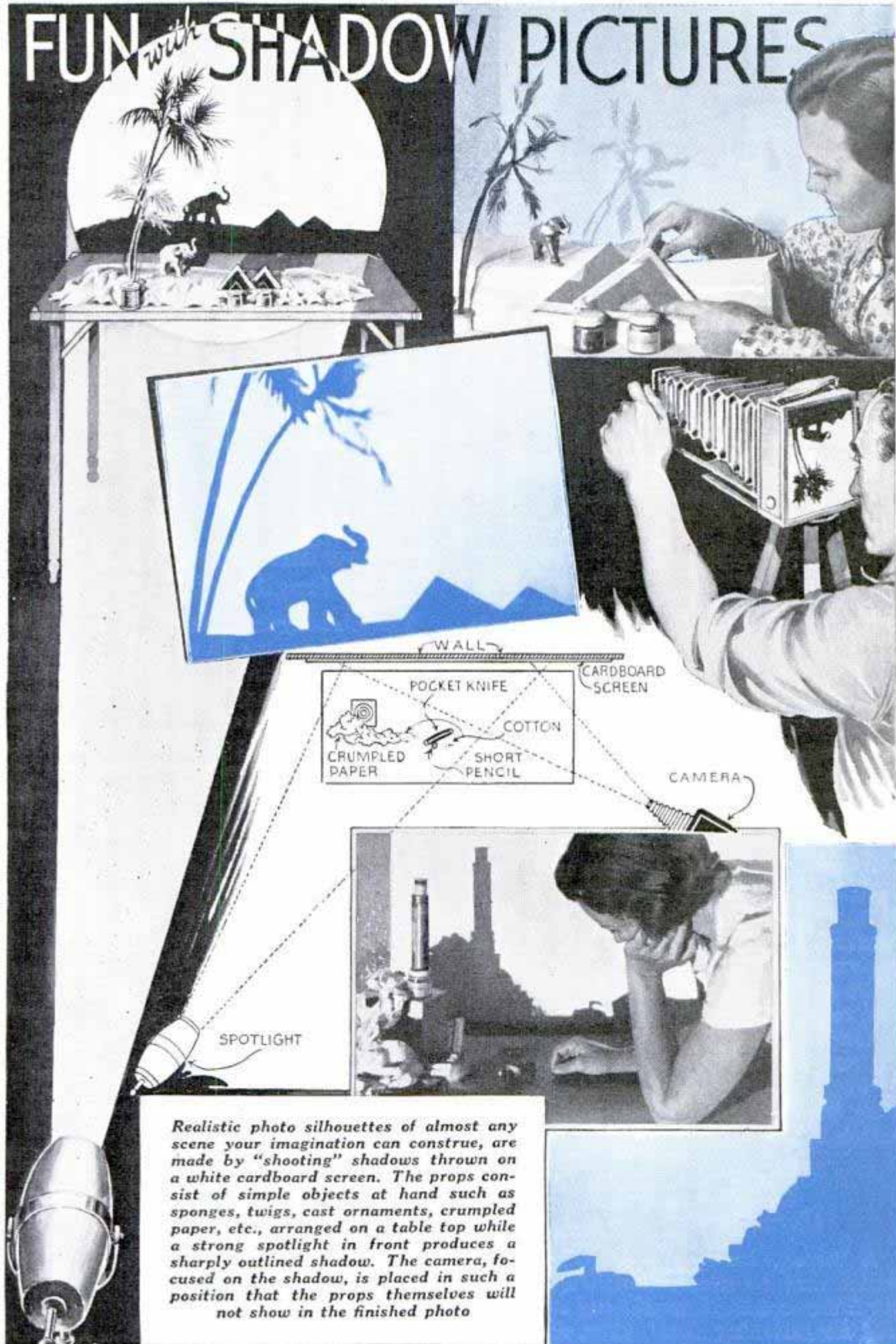

Realistic photo silhouettes of almost any scene your imagination can construe, are made by "shooting" shadows thrown on a white cardboard screen. The props consist of simple objects at hand such as sponges, twigs, cast ornaments, crumpled paper, etc., arranged on a table top while a strong spotlight in front produces a sharply outlined shadow. The camera, focused on the shadow, is placed in such a position that the props themselves will not show in the finished photo

Wooden Grinder or Buffer Head Has Lasting Bearings of Babbitt

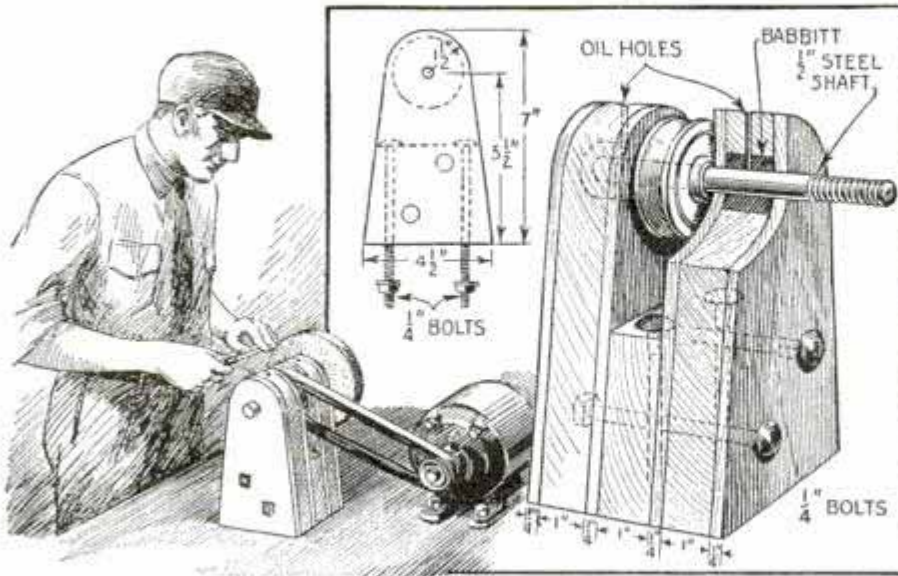

Costing practically nothing to make, this grinder head is strong and will serve nicely where the work is not too heavy

If you are looking for a low-cost bench-grinder or buffer head, here's a rigid one, which has babbitted bearings and is made of wood. It consists of two built-up side members, which are bolted together with a 1-in. spacer block between them, a 1/2-in. steel shaft threaded at one end and a V-pulley. The sides are sawed from 1-in. hardwood stock and are faced with 1/4-in. plywood glued and bradded in place. To provide a mold for pouring the shaft bearings, the shaft holes in the cores of the sides are 1 in., while those in the facings are only 1/2 in. Thus, when the head is assembled and the shaft is inserted, there is 1/4 in. clearance all around between the shaft and the cores for the babbitt, which is poured through the 1/4-in. oil holes. The shaft should be greased heavily to keep the molten babbitt from sticking to it. When the babbitt cools, the shaft should be removed and the oil holes extended through the metal. Two long bolts running vertically through the spacer block attach the grinder head to the bench.

—Ray Barry, Chicago.

Cement for Modeling

A strong, hard and durable cement, which may be used for molding objects, for filling cracks in marble and stoneware and for fastening metal, glass, and wood parts together, is made by mixing thor-

oughly powdered zinc oxide, 12 oz., and finely powdered calcined magnesia, 1/4 oz. The mixed powders will keep indefinitely if stored in a tightly stoppered bottle. To use the cement, take the amount of powder required and work it to a stiff paste with sirupy phosphoric acid. A spatula or pocketknife and a piece of plate glass are handy for the mixing. When the paste is of uniform consistency, it is packed into place and allowed to set. The hardened cement is waterproof and can be polished.

Window Envelope Aids in Typing Small Stiff Cards

The job of typing on small cards can be simplified by using an envelope, having a large open window in it, as a mask to feed the cards into the typewriter. If a window envelope is not at hand, one can be improvised by cutting a rectangular hole in the side of a regular one.

—G. E. Hendrickson, Argyle, Wis.



Cards inserted into a window envelope are easily fed into a typewriter

Pneumatic-Wheeled Cradle Carried in Canoe

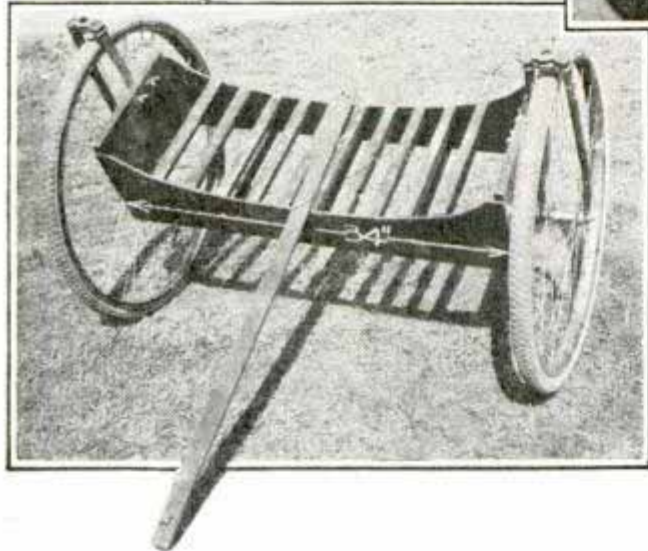
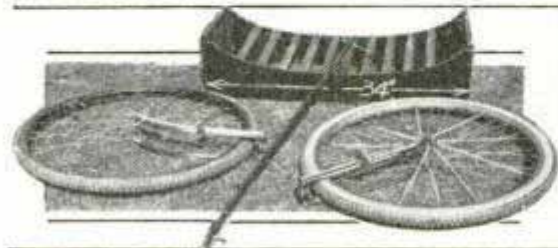
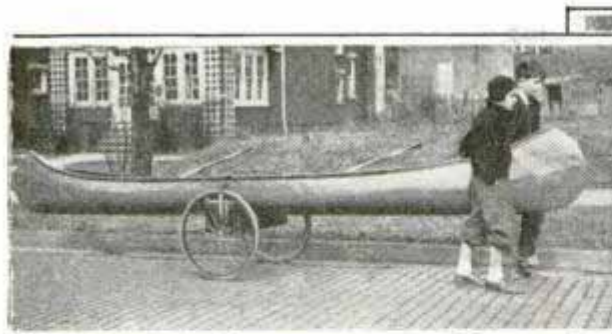

Adding to your canoe equipment this wheeled cradle, small enough to be stowed in it, solves the problem of transporting the canoe to and from the water, moving it to storage and making portages. The cart weighs 25 lbs., and can be carried in the canoe while assembled, or it can be taken apart into four units, which consist of a wooden cradle, 34 in. long, two 28-in. bicycle wheels with forks having four $\frac{3}{16}$ -in. bolts attached, and a wood lath fitted with three $\frac{1}{4}$ -in. bronze hook bolts and wing nuts to serve either as the cross bar across the top of the canoe or as a tongue when the cart is wheeled. The cradle sides are made of $\frac{1}{4}$ -in. fir plywood, but the thirteen $\frac{3}{4}$ by $\frac{3}{4}$ by $11\frac{1}{2}$ -in. crosspieces and the two $\frac{3}{4}$ by 9 by $11\frac{1}{2}$ -in. ends are of maple. The front forks of the bicycles are cut off at the top. To the inside prong of each fork are brazed steel straps having bolts that project through holes in the ends of the cradle

Fish-Stringer Weight Slips Off Easily to Remove the Catch

Here is a weighted fish stringer that not only keeps the fish under water, but it has a quick-release attachment for removing the string so that the fish can be slipped off easily. The weight consists of a short length of brass rod having four small holes drilled through it; two near the upper end and two near the lower end. A short brass pin in one of the lower holes helps anchor the lead weight, which is molded in place, and a longer pin in the other hole keeps the fish from slipping off the stringer. The two upper holes take a small hook bolt, which clamps the string to the weight as indicated.—Axel L. Johnson, Chicago.

☐ Pine or cedar sawdust placed in a shallow pan and set under a circulating heater imparts a delightful aroma to the house.



Just loosen the wing nut on the hook bolt and the string slips out to remove the fish

Lawnmower Blades Held Steady While Sharpening Them

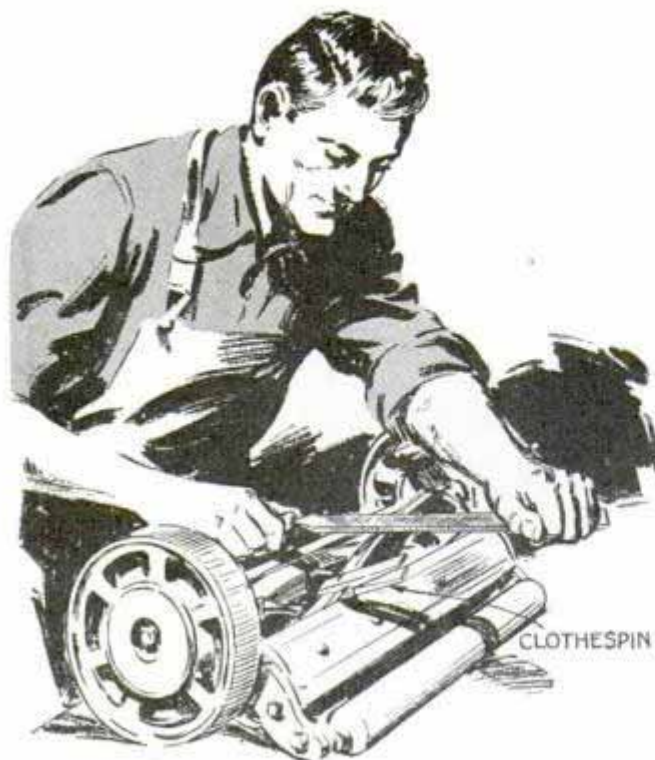

Don't take a chance of cutting your finger when sharpening a lawnmower. Slip a clothespin over one of the blades so they can't turn

If you are in the habit of sharpening your lawnmower blades with a file, here is an idea that may save you an injured finger. When you get the mower in position for filing, just clip a spring-type clothespin over the blade you are working on and let the clothespin rest against the knife bar. This will keep the blades from turning toward the bar.

Simple Filter on Photo Enlarger Helps Place Paper on Easel

Pivoted to the lens board of your photo enlarger, this filter or light shield is swung over the lens instantly before placing the printing paper on the easel, and it allows enough light to filter from the lens to provide safe illumination for the job. The filter is merely

one half of a tortoise-shell spectacle frame with the glass removed and the opening



covered with red paper, the temple being cut off at the point where the curved section starts and inserted into a hole drilled in the lens board. The temple should be a fairly tight fit in the hole so that friction will hold the filter at any desired angle.

—Joseph Prince, Dorchester, Mass.

Plant Stakes from Coat Hangers

If you have a surplus of wire coat hangers lying around, they make good plant and shrub stakes. Just untwist the hangers, straighten them out, and bend them to shape. The wire is given a sufficient offset to clear the roots.



Protective Relay for Test Bench Saves Electrical Fuses

For testing electrical appliances and experimental work, a relay in the line to the test bench is much better than fuses, as it does not have to be replaced every time the line is overloaded. Such a relay can be picked up from almost any refrigerator repair shop. They open on various currents from 2½ to 9 amps. As these relays must work perfectly on refrigerators, you can obtain a slightly defective one, which can be used on the test bench.



If the line is overloaded, the relay breaks the circuit —all you have to do is close the relay.

BREAKFAST SET

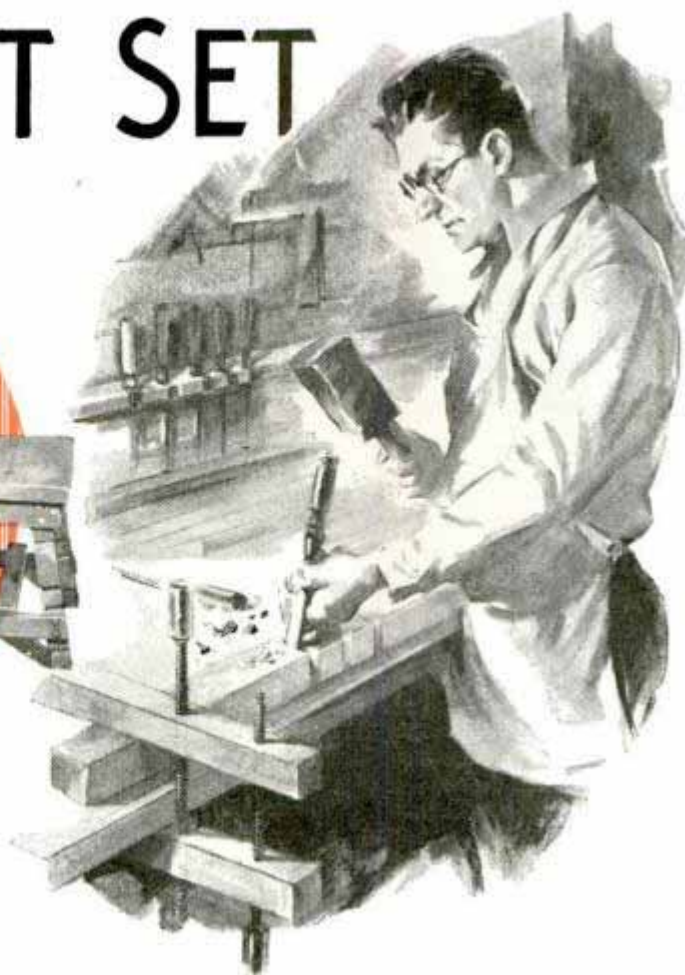
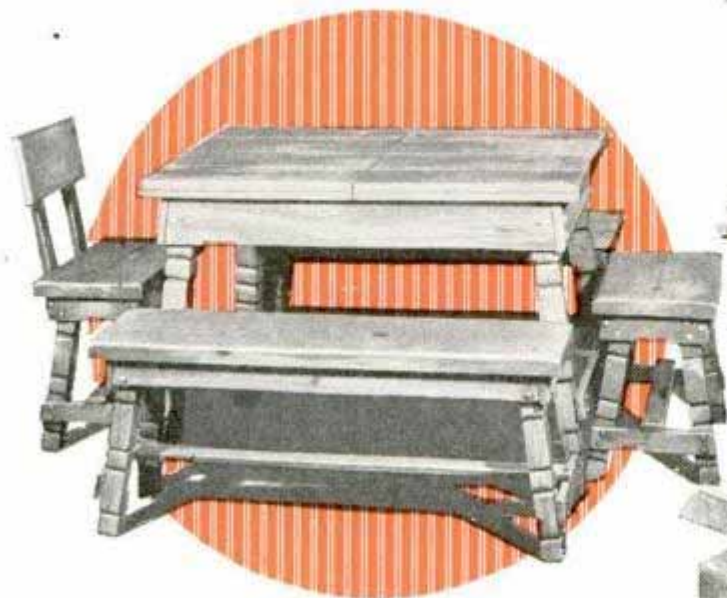

Here is good furniture construction and authentic styling reduced to the utmost in simplicity

in old Spanish style

By EDWIN M. LOVE

DESIGNED for the man with only a few hand tools, this type of furniture involves very little ripping and planing to get odd thicknesses and widths of materials, for almost all parts are cut directly from stock sizes of knotty pine lumber. Only butt joints are used. The aprons and stretchers lap past the legs, and the boards in the table top are glued together without dowels, corrugated nails driven in the underside taking their places. To simulate pegged joints you use screws driven in counterbored holes, with false dowels glued in to hide the screw heads.

When making up the table top, Fig. 4, the boards are arranged edge to edge in such a way as to make a pattern of the knots. The edges are jointed slightly concave, so that the ends will be under extra strain when the joints are drawn together, thus compensating for variations in shrinkage. Upper corners of the jointed boards are chamfered to give a grooved effect to the finished top.

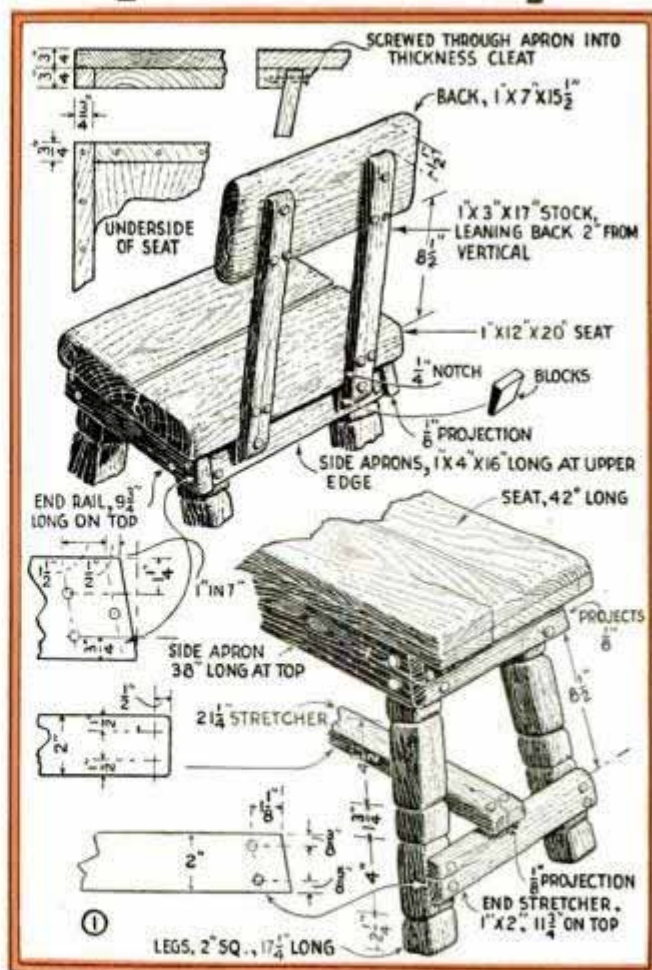

The buffet, Figs. 2 and 3, is built in the same manner, with butt joints and lapping aprons. The legs and the shelf posts are shaped as are those for the table. The sides, lower shelf, and countershelf are glued up in the same way as the table top. Since the plywood lower back and the 3/4-in. upper back rest in the countershelf notch, a double rabbet is made, or else a notch is cut and a cleat nailed underneath to take the end of the plywood. Cleats also may be screwed to the sides, to avoid the trouble of cutting rabbets. To assemble, join the sides with the countershelf and the lower shelf. As these parts all shrink in the same direction, they can be screwed solidly together. However, the cleats under the ends must be cut into short lengths and

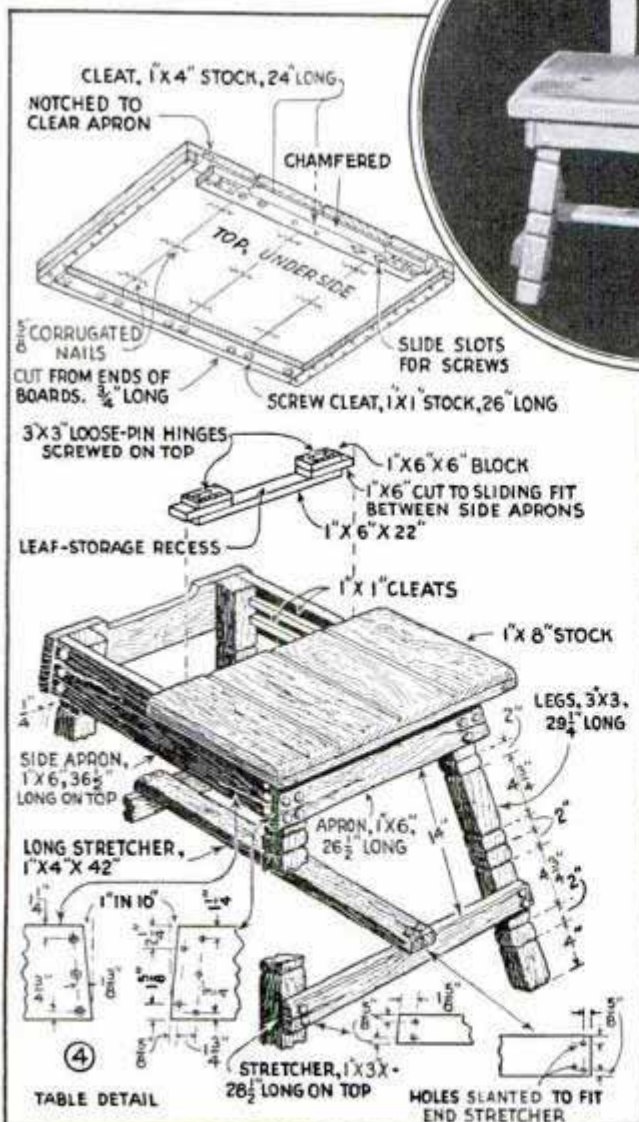
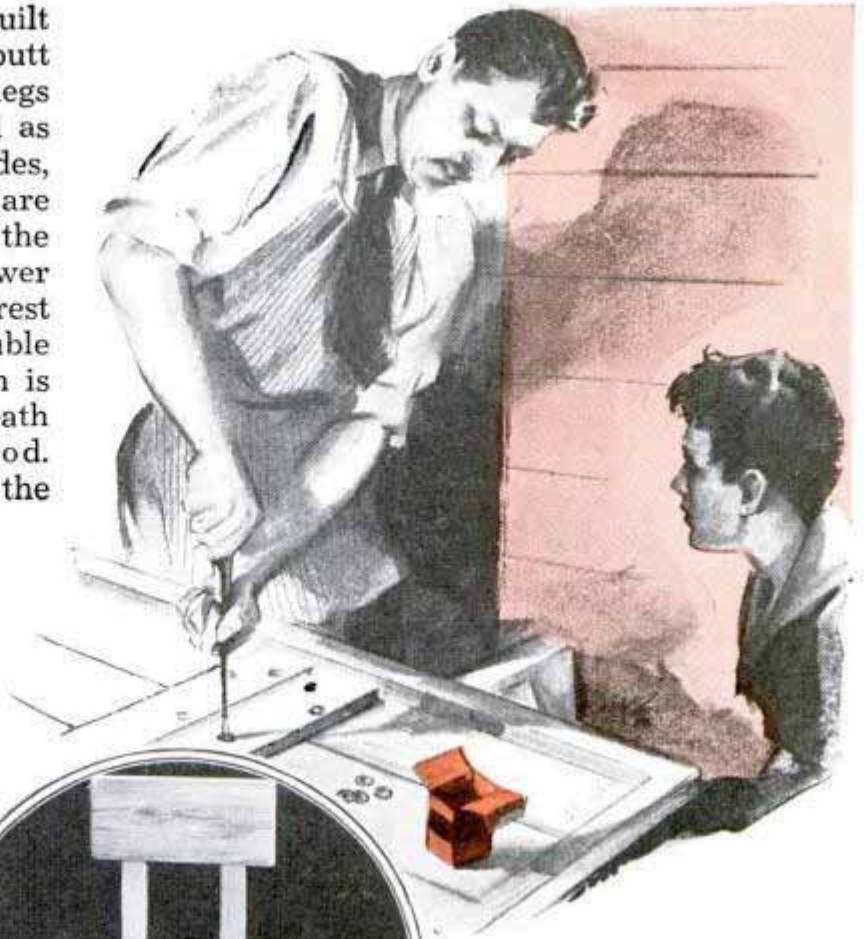

spaced so that they can move with the wood. After attaching stiles, the rails are nailed between, then aprons and bases are added. Rear screw holes in the aprons and bases should be slightly oblong so that the screws can

slide when the wood in the case shrinks.

Finish the set by applying a coat of flat white paint, wiping it off the knots. When dry, rub down lightly with fine sandpaper and give a coat of antique glaze, which is wiped off with a cloth when it becomes tacky, leaving worn spots quite white, with smudges on areas less worn and in cracks and angles where wear could not occur. Should you desire the effect of natural checking of the wood this is easily simulated by scratching the surface here and there with a sharp-pointed awl. A coat of medium flat varnish gives the finish wearing quality.

☛ A cherry pitter can be made by inserting the ends of a wire hairpin in a cork. The seed is hooked through the end without mashing the cherry.

Spring-Wound Fish-Line Drier from Old Phonograph



If you have an old portable phonograph, it makes a dandy reel for drying fish line

Have you an old portable phonograph? If so, it's easily converted into an automatic reel on which to wind your fish line to dry it. Just substitute a disk of $\frac{3}{4}$ -in. soft wood for the turntable and drill it for six or eight pegs to take the line. In use, tie the line to one of the pegs, start the phonograph and feed the line on the reel. When rewinding the line on your fishing reel, the spring motor provides just enough tension to lay the line properly, while the operation rewinds the motor, which is then ready for the next time.

—R. M. Munroe, Coral Gables, Fla.

Removing Water Spots from Silk



a lighted electric bulb and brushing it with a dry, fine-bristle brush. In such

Water spots on certain silks like crepe de Chene, which give the cloth a soiled appearance even when there is no dust or dirt present in the garment, often can be removed by stretching the fabric over

cases, the spots are usually caused by the water washing the stiffening of the fabric to the edge of the circular area, where it becomes visible as soon as the water has evaporated. Brushing the cloth loosens and removes the excess stiffening material.

Paint Underside of Porch Floors

Porch floors should be painted on the underside as well as on top to protect them against moisture. This is especially true where the space between the floor and the ground is insufficiently ventilated. If the boards absorb moisture from underneath, the paint on the top surface is likely to blister and peel.

Operating Mimeograph Machine Without Automatic Feed

If you operate a mimeograph machine that is not equipped with an automatic feeding device, here's a way to speed up the work. Just crease two strips of sandpaper near one edge and place them on the sides of the feed table as shown. Then use the eraser end of a lead pencil to push each succeeding top sheet of paper into the machine. The sandpaper tends to hold the stack of papers so that only the top one slips into the machine. If a more permanent improvement is desired, glue strips of $\frac{1}{4}$ -in. sponge rubber to the paper guides in place of the sandpaper.

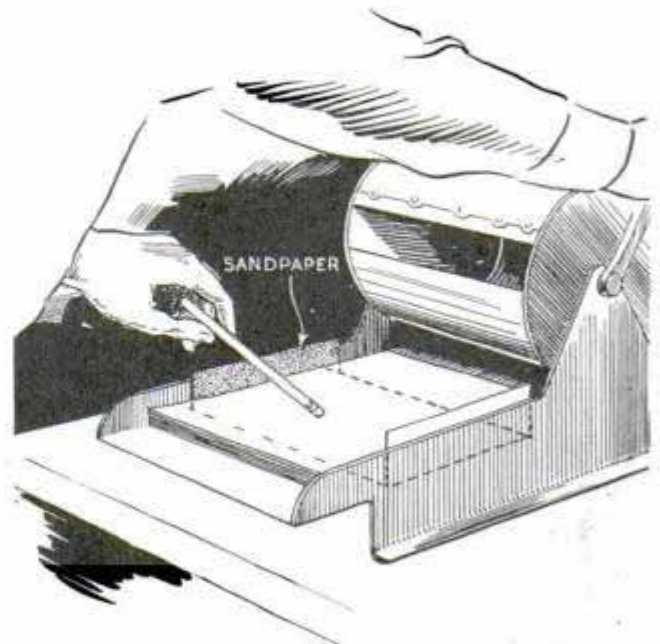

You'll be surprised how fast you can feed a mimeograph machine with this arrangement

NEW SOLARIUM

gives comfort and privacy

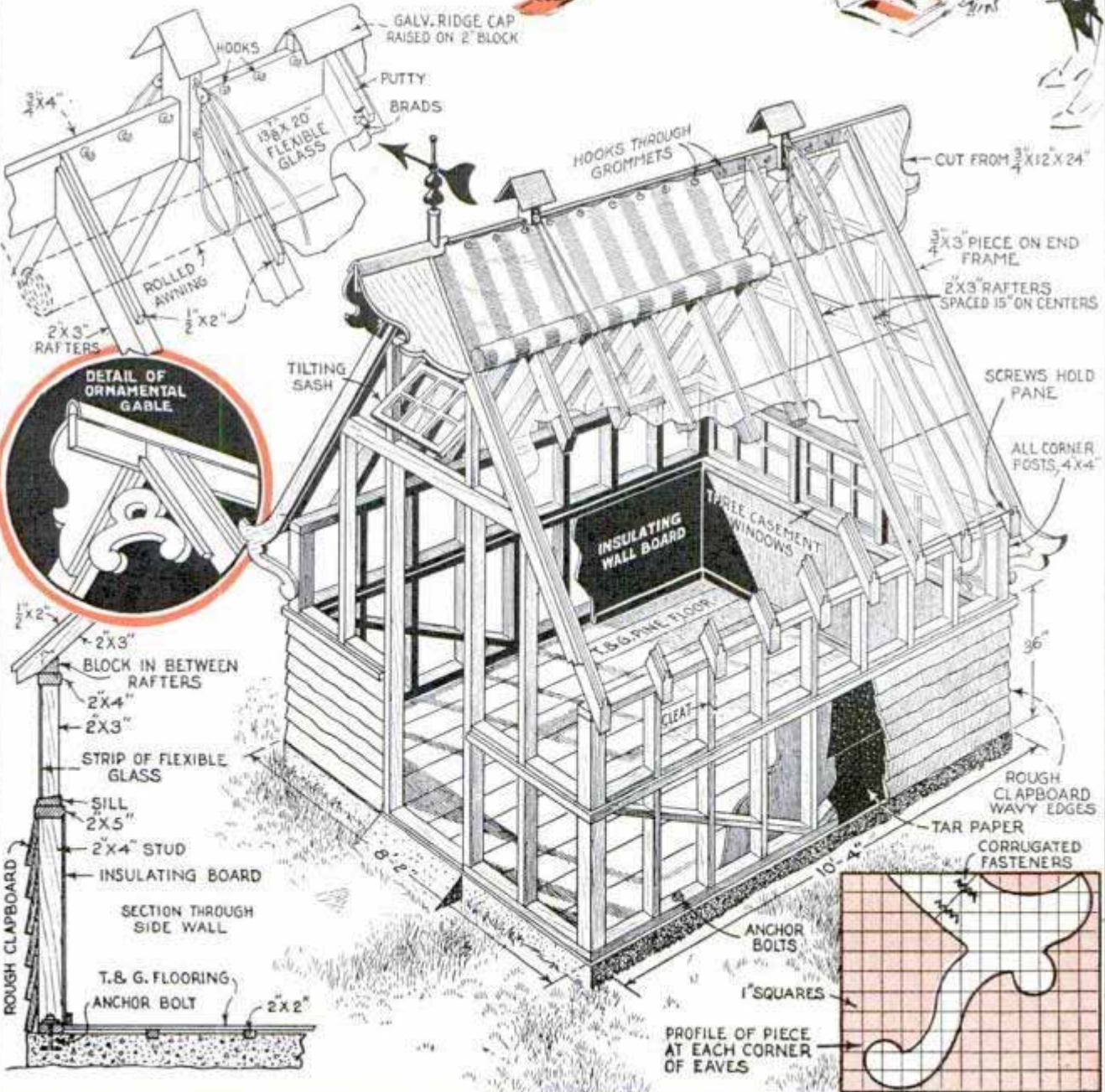
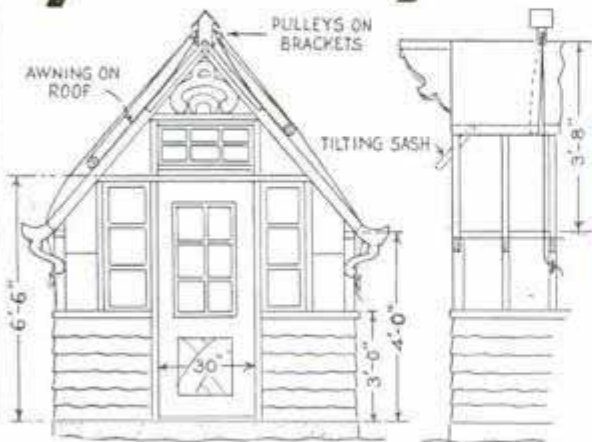

Rubber Heels Slipped on Rasp Make Good Hand Grips



These rubber hand grips are resilient and will last the life of the wood rasp

Rubber shoe heels slit to fit on the ends of a wood rasp will provide comfortable hand grips. The slits, which should pass entirely through the heels, can be cut while the heels are held in a vise, using either a wood chisel or a knife. Dipping the blade in water will make cutting easy as it reduces friction. Strips of light tin are folded over the ends of the rasp to cover the teeth. Then a length of wire is run through the folded ends of each strip and passed through the slit in the heel so that, after the heel has been pushed in place, you can pull out the strips. When these have been removed, the teeth of the rasp will hold the grips in place.

Changing Flash Bulbs Quickly

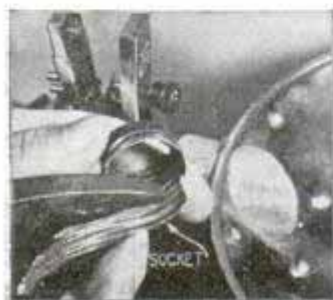

When speed is a factor in shooting pictures at night with photoflash bulbs, time can be saved in changing the bulbs by slightly altering the socket in the

reflector. Just remove the threaded brass lining from the socket and, with a pair of tin snips, cut off enough of the lining to leave three or four threads. Then replace the remainder of the lining in the socket. A single twist then will be enough to insert or remove the bulbs, requiring only a second or two for each operation.

—Kenneth Murray, Sturgis, Mich.

Electricians' Tape Strengthens Sandpaper Strips

By cutting strips of sandpaper slightly wider than equal lengths of electricians' tape and joining the two together, intricate lathe turnings may be sanded efficiently. In this way the sanding strip is made more flexible to fit into grooves without tearing.

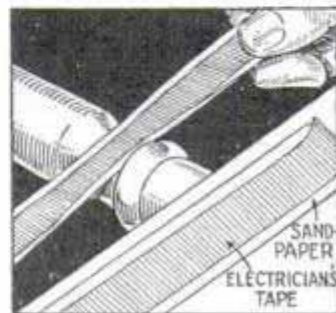

Vise to Hold Fishhooks Made from Large Safety Pin

Fishermen who repair or manufacture their own flies will find that a small vise

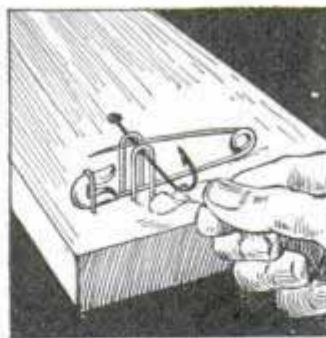

to hold the hooks can be made easily from a large safety pin. It is attached to a bench, table or block of wood by means of a staple driven over the head, and a staple is driven into the wood on each side of the

pin. In use, the hook is slipped under these two staples, and the pin is opened to hold it tightly in place.

Venting Fuel-Oil Tanks Correctly

On page 588 of our April issue, a short article described how a basement fuel-oil tank could be filled and vented through one pipe. It is now expressly called to the readers' attention that such an installation is not approved. Regulations governing

fuel-oil tanks specify that the fill and vent pipes must be separate pipes and they must not be cross-connected. Vent pipes must be arranged to drain to the tank, must terminate outside of buildings at a point not less than 2 ft., measured vertically or horizontally from any window or other building opening, and the outer ends must be protected by a weatherproof hood. Fill pipes on storage tanks, other than outside aboveground tanks, must terminate outside of buildings at a point at least 5 ft. from any building opening at the same or lower level. Fill terminals should be closed tightly when not in use by a metal cover designed to prevent tampering.

Attaching Chicken Wire for Easy Removal

When you put up a temporary chicken pen, fasten the wire netting to each post or stake with a length of straight wire over which the staples are driven as indicated. When you want to remove the pen, just give one end of the straight wire a jerk and the staples will come out of the post. This method also offers protection for the netting, which may be damaged when removing the staples if they are driven over the stay wires.



You can take down a temporary fence in a jiffy without damaging the wire if you use this method of fastening it to the posts

Relay Control for Toy Trains Avoids Wrecks at Crossover

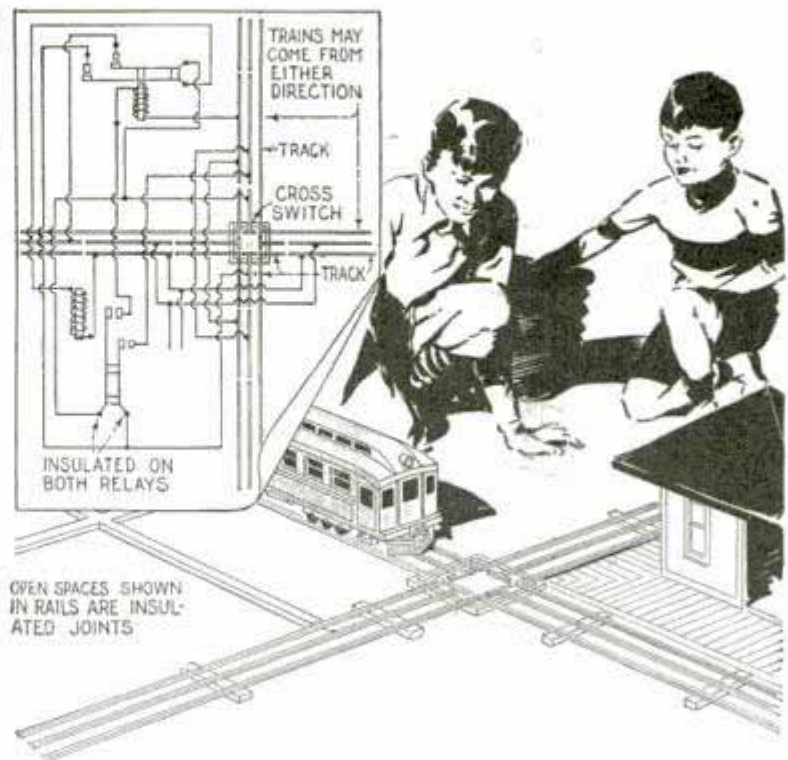

When two trains approach the crossing at the same time, the relays automatically stop one train until the other passes

In laying out the tracks realistically for a toy electric train, they often cross at some point where wrecks will occur unless some means is provided to control trains approaching the intersection. Two relays wired to the tracks as shown in the diagram will do the job automatically. When two trains approach the crossing at the same time, the one farthest away is automatically stopped until the one nearest the intersection has crossed, after which the other one will proceed. The relays should be of the double-pole, single-throw type to handle 15 volts, and they can be purchased reasonably from most electrical stores. The open spaces shown in the tracks signify insulated joints.

—Earl Snader, Jr., Waynesboro, Pa.

Removing Mildew Stains

Mildew stains may be removed from cloth after washing in the usual manner, and while still damp, by immersing in hydrogen peroxide, or in a solution of chlorinated lime. While the spot is damp, expose it to the sun's rays. If the material is colored, test a scrap piece to determine whether or not the dye will be affected.



Easy Ways to

No need to have chairs marking the walls if $\frac{1}{2}$ -in. strips of hardwood are nailed to the floor about 5 in. from the walls. Finished to match the floor, the strips are scarcely noticeable. Right, tall, slender vases kept from tipping by small lead weights, which can be cast in a soup spoon or any other object of a suitable size

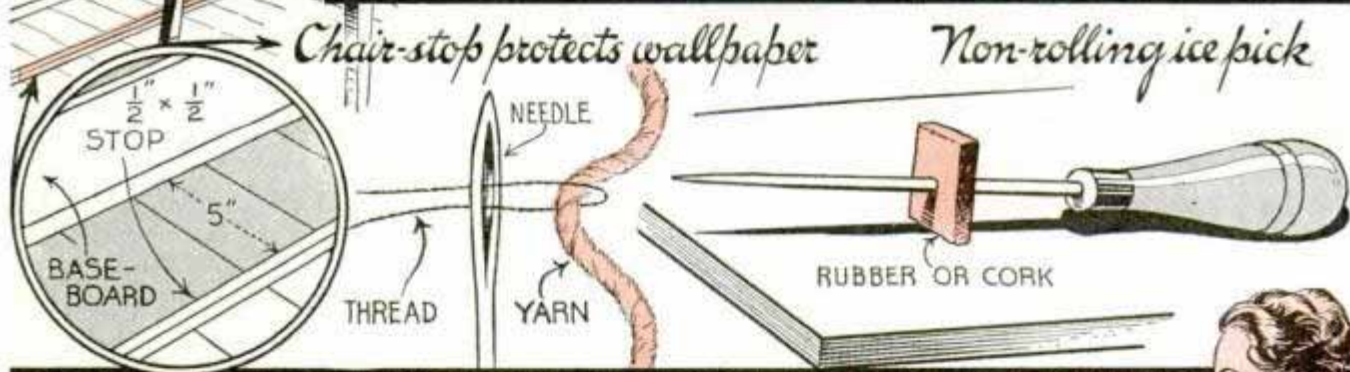

If you have trouble threading a darning needle, just run a doubled thread through the eye, slip the yarn into the looped end and pull it through the needle. A square piece of flat rubber or cork will keep your ice pick from rolling off the table when laid down. Below, by sharpening one tine of your kitchen fork, it can be used for slicing and still serve for its regular uses. Right, using a string and a couple of corks to take comparative measurements when moving furniture

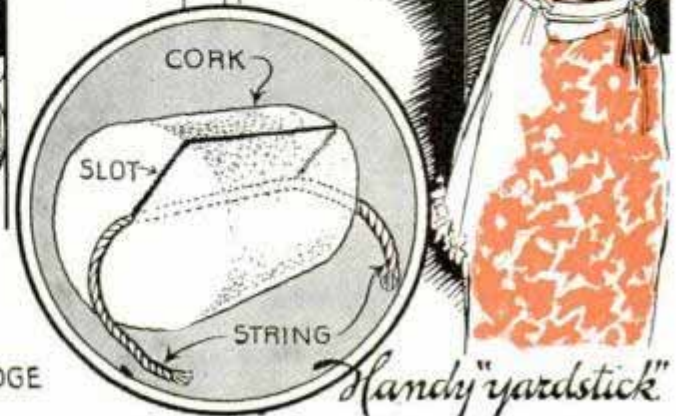

Space-saving trouser hanger

Right, this sliding trouser hanger fits through screw eyes under the edge of your dresser and is out of sight when not in use. Below, tacks driven on each side of a window-screen turnbutton keep it from turning if changing weather causes it to loosen



ROUND-HEAD TACKS

HEAVY WIRE

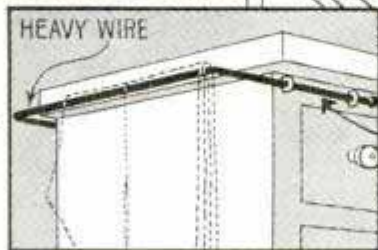
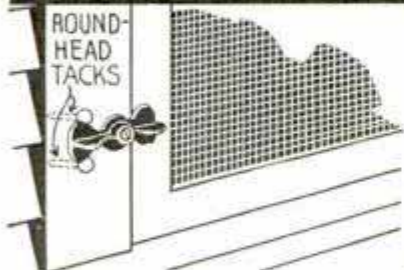

Solve Your

HOME PROBLEMS



PIPE

Long-handled lawnmower



THIN SHEET BRASS

CRACK IN GLASS

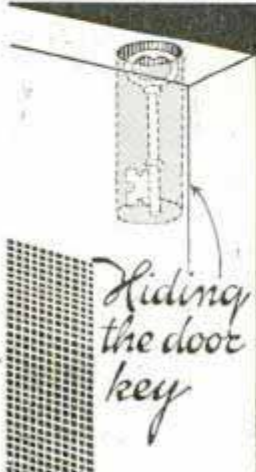

Hiding the door key

A long, extension handle of pipe and fittings for your lawnmower will save many steps when mowing a terraced lawn. Brass shim stock serrated along both sides and slipped through the crack of a broken window pane will hold the glass until it can be replaced. Instead of hiding the door key under a mat or in a mailbox, where any intruder would be likely to look for it, drop it into a hole drilled into the top of the screen or storm door as shown. Right, paste soldering flux kept in the center of spool on which wire solder is wound by tightly closing one end of the spool with a plug and inserting a small cork in the other end

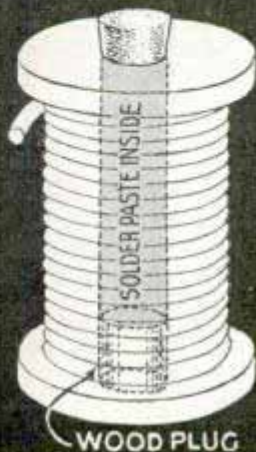

WOOD PLUG

Coil Spring on Small Star Drill Eases Arm Strain

The next time you use a small star drill, slip a coil spring over the lower end, where it is held by a pin, and see how much it relieves the strain on your arm. The spring, which rests against the work, lifts the drill a trifle after each blow. Three or four holes through the drill shank will enable you to adjust the pin to get the desired spring pressure.

—A. H. Waychoff, Tempe, Ariz.

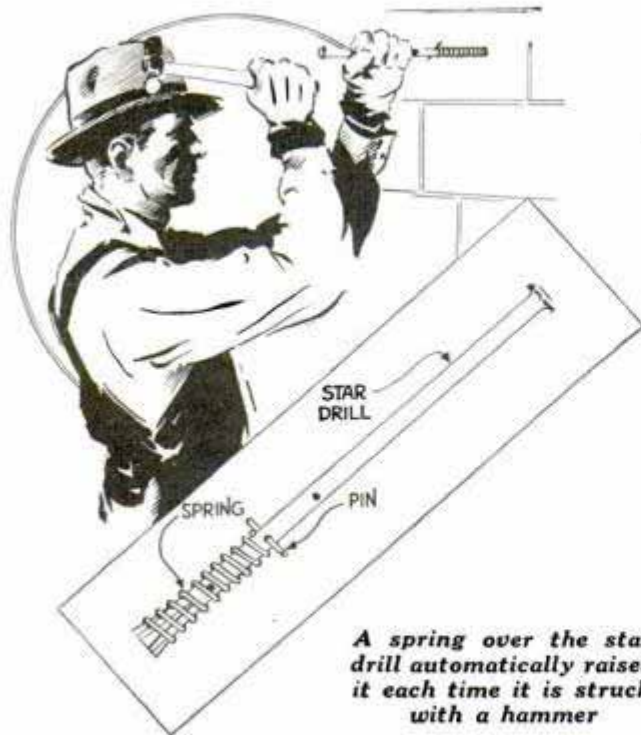

Red anti-halation backing on photo films is a good indicator as to the freshness of the fixing bath. If the coloring matter has not entirely disappeared by the time the film has cleared, the fixing bath is probably exhausted.

Lawn Table, Barrow Chairs, Trellises - - -



Bent-Iron Tables—568

arched gateways, ornamental wood fences, Dutch windmills and many other easy-to-make items which will help beautify your garden, are included in Popular Mechanics' blueprint service. You can order from this list, or send 15c in U. S. stamps for our 96-page "What to Make" booklet describing hundreds of other projects.

TWO BENT-IRON TABLES—568: Smart designs in bent iron. 17 and 30 in. high. 25c.
BARROW CHAIRS—924: Two styles. Built for comfort. Simple construction. 25c.

TRELLIS SUGGESTIONS—639: Six types that will help make your home more attractive. 25c.

LAWN AND GARDEN FURNITURE—920 to 922: Arbor-and-seat combinations and swings. (3 prints) 75c.

ORNAMENTAL WOOD FENCES—640: Shows five designs which can be made from standard wood stock. 25c.

DUTCH WINDMILL AND WATER WHEEL FOR ROCK GARDENS—911: Mill, 40 in. high. Small water wheel. 25c.

CIRCULAR ARBOR AND GATE—637: Popular style anyone can build. Alternate gate designs. 25c.

METAL WEATHER VANES—520: Scroll-sawed from sheet aluminum. Complete assembly details. 25c.

Any six of these blueprints will be sent postpaid upon receipt of \$1.00

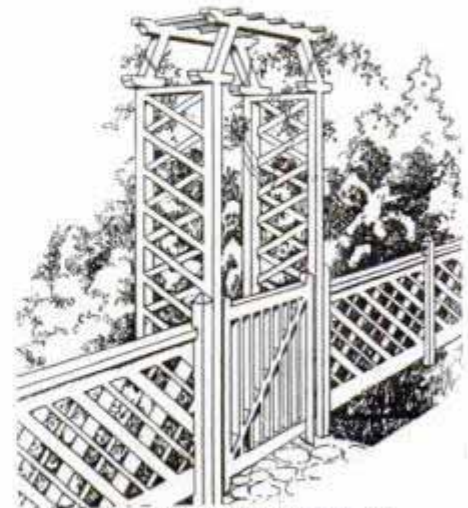

Ornamental Wood Fences—640

Blueprint Department, Popular Mechanics Magazine, 200 E. Ontario St., Chicago



SHOP NOTES

*muffle. 255. 203 - \$6.15 net. for Worcester
Norman Co. Worcester Mass*

Electric FURNACE

DEVELOPS TEMPERATURE OF 1650° F. FOR ENAMELING, ANNEALING, HEAT-TREATING, ETC.

By C. A. CROWLEY

IN designing an electric muffle furnace, first decide the size of muffle, or heating compartment. Fig. 1 gives dimensions for eight standard sizes. After selecting one of these for size, you note its capacity and then refer to the curve in Fig. 6 to find the required wattage of the heating element and size of Nichrome V-wire with which it is to be wound. Thus, for size F, Fig. 1, which has a capacity of 236 cu. in., you find by following the dotted line that a heating element between 2,000 and 2,100

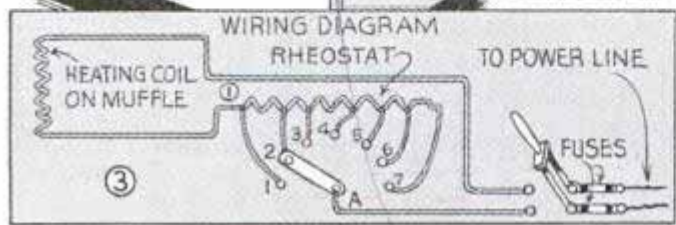
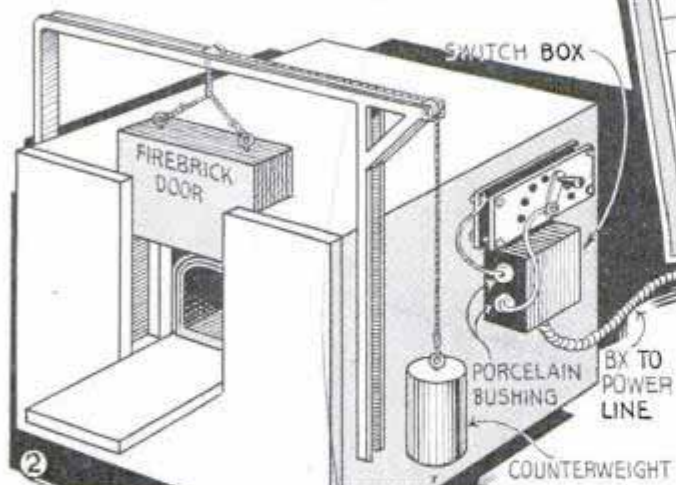
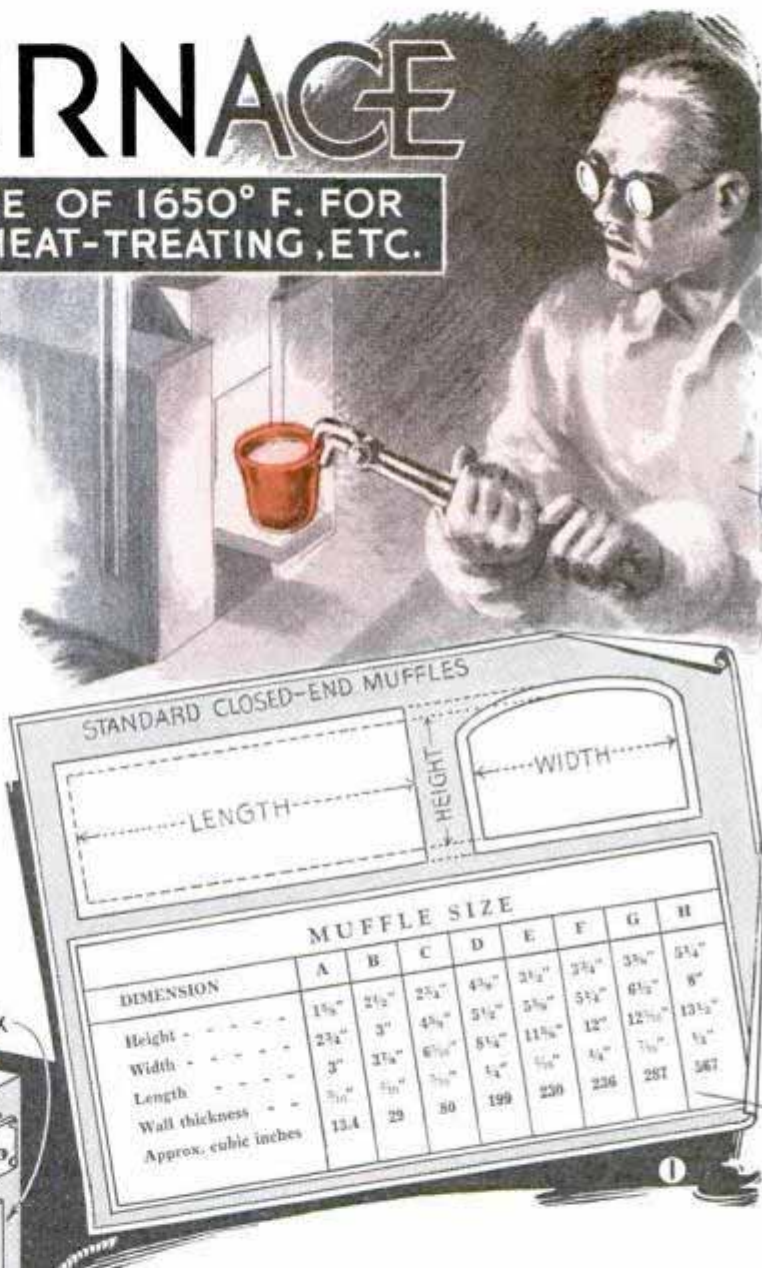

watts will be required. Always select the one on the high side, in this case 2,100 watts. By continuing down, we find that for 110 volts, you must use No. 12 Nichrome wire, and for 220 volts you will need No. 16 Nichrome wire. Next, from Fig. 4, you find that the amperes in the heating element will be equal to watts divided by the volts, or in this case, 2,100 divided by 110 which equals 19.09 amperes, necessitating 25 or 30-watt fuses

1,150 feet - \$6.00



DESIGNING HEATING ELEMENT **DESIGNING RHEOSTAT**

- (1) Amperes = watts ÷ volts
 (2) Ohms = volts ÷ amperes
 (3) Feet of wire = ohms ÷ ohms per foot
- (1) Use same size of wire as for heating element
 (2) Feet of wire = $\frac{\text{feet used in heating element}}{4}$
 (3) Inches between taps = $\frac{(\text{feet needed}) \times 12}{6}$

RESISTANCE OF NICHROME WIRE

Size B&S Gauge	Diam. in Inches	Feet per Pound	Ohms per Ft. at Maximum Furnace Temperature
No. 10	.102	34.7	.0655
No. 12	.081	55.0	.104
No. 14	.064	88.0	.167
No. 16	.051	139.0	.262
No. 18	.040	226	.427
No. 21	.0285	446	.84
No. 22	.0253	565	1.07
No. 24	.0201	893	1.71
No. 26	.0159	1,429	2.70
No. 30	.0100	3,623	6.85

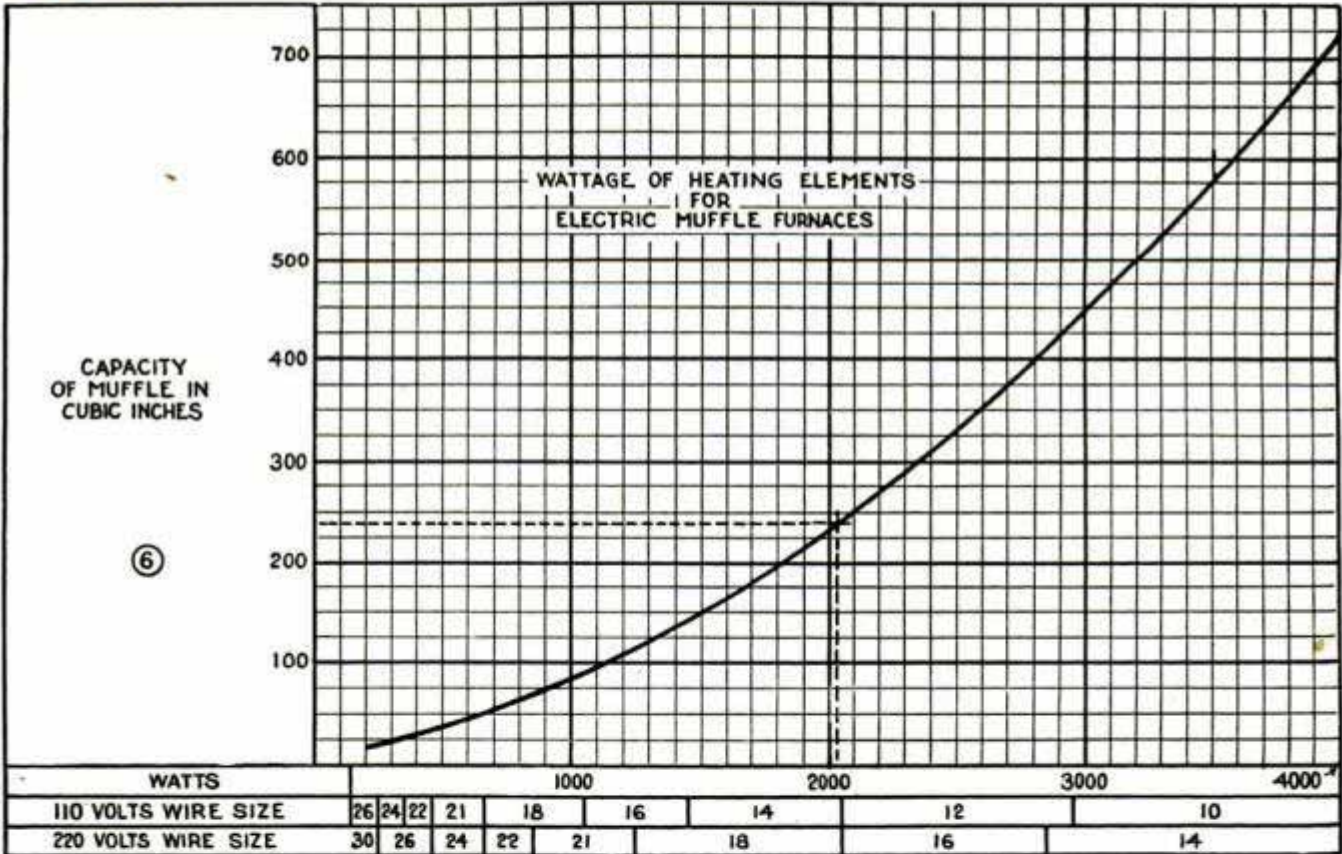

in the power line feeding the furnace. The resistance of the coil in ohms is next found by dividing the voltage, or 110, by the amperes, or 19.09, as above calculated, which gives 5.76 ohms. Then, to determine the number of feet of Nichrome wire required you divide the ohms by ohms per foot of the wire to be used. From table, Fig. 5, you find that No. 12 Nichrome wire has a resistance of .104 ohm per foot. Using the formula given in Fig. 4, you divide

the ohms required, or 5.76, by .104 and get as an answer approximately 55½ ft. of wire required. Next, you figure the length of wire needed for the rheostat to regulate the temperature of the furnace. Fig. 4 shows the method of computing the amount of wire required for the rheostat. The same size of wire is used on the rheostat as is used for the heating element. The number of feet of wire required for the rheostat is equal to the feet used in

Hurtm Co. Worcester Mass

the heating element divided by four or 13.9 feet for the size being followed.

Then the wire is wound around the muffle. The turns must be equally spaced and the ends fixed in small holes drilled in the muffle, leaving an unwound space of about 3 in. at each end for connections. A doubled length of No. 12 Nichrome wire 3 or 4 ft. long is attached securely to each of the leads from the coil with iron machine screws and washers. Solder or spelter should not be used. A thin layer of cement such as refractory cement RA-162 is now applied to hold the element permanently in place. This cement, which comes in dry-powder form, is mixed with water to a consistency of a thick paste. This is troweled on as in Fig. 7, until the wires have been covered, and allowed to

THE HEATING ELEMENT IS HELD IN PLACE WITH REFRACTORY CEMENT

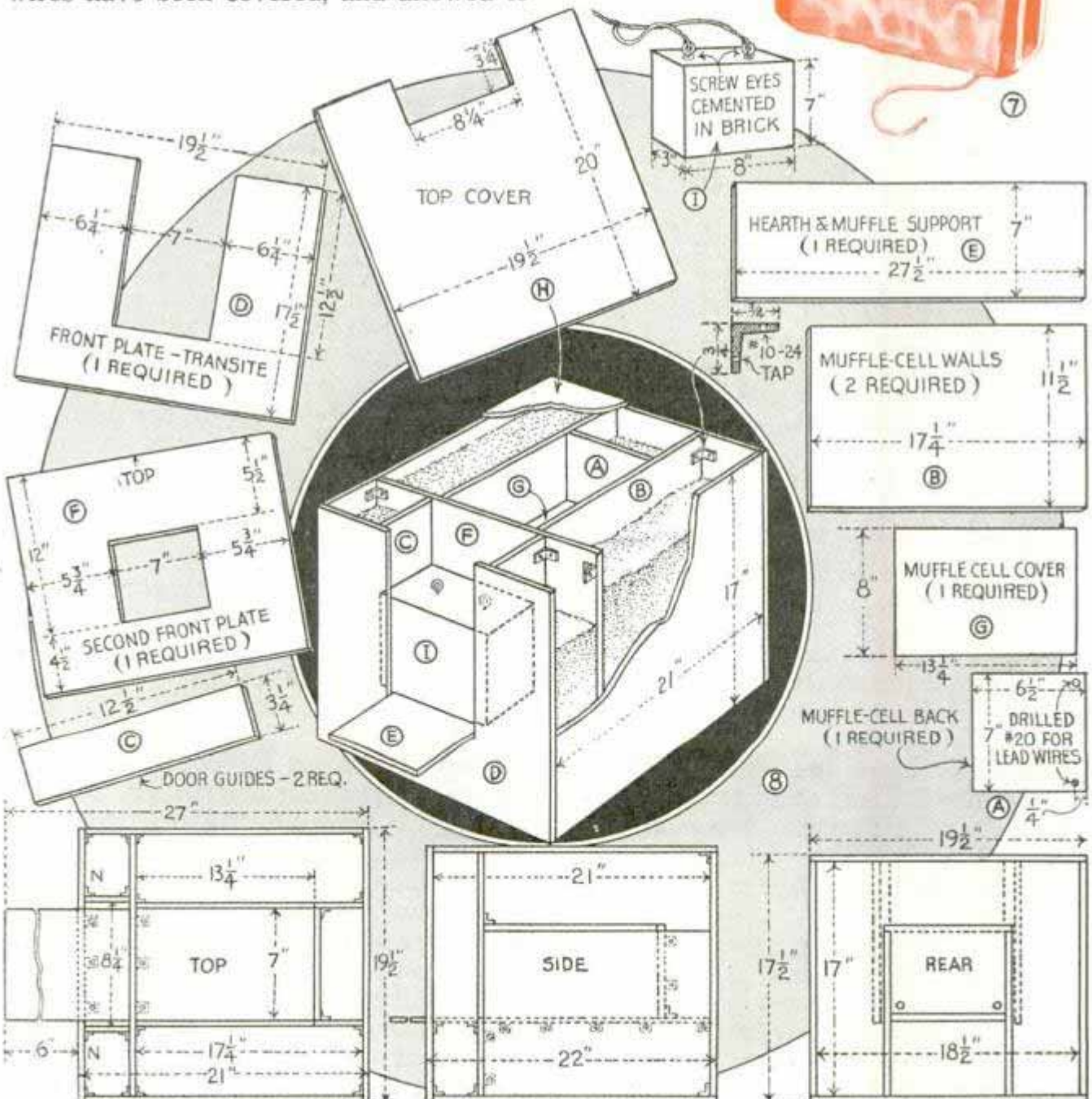
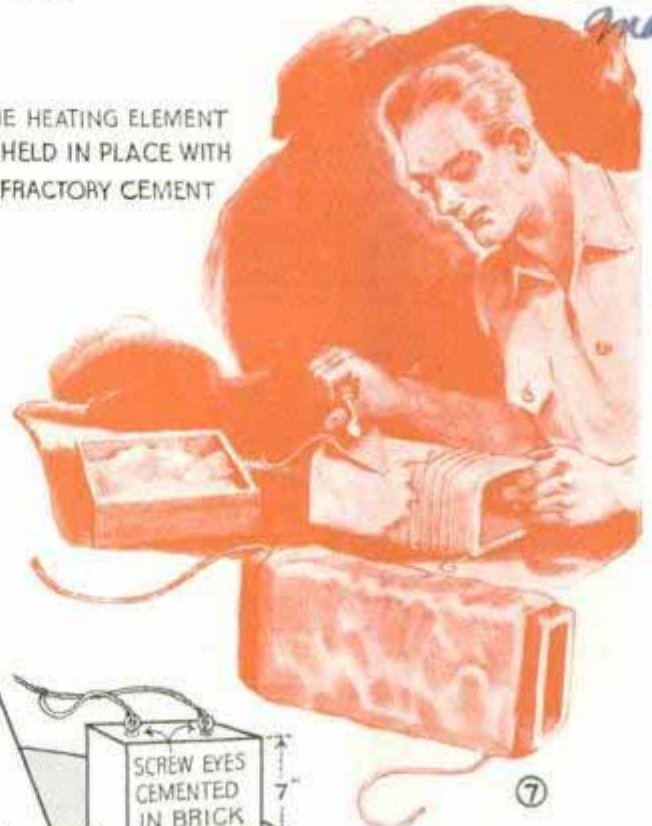

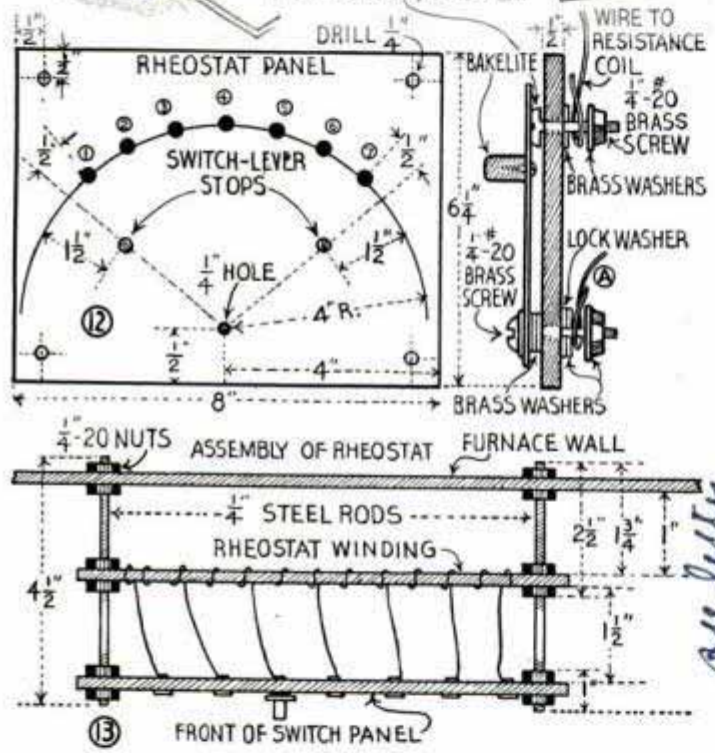
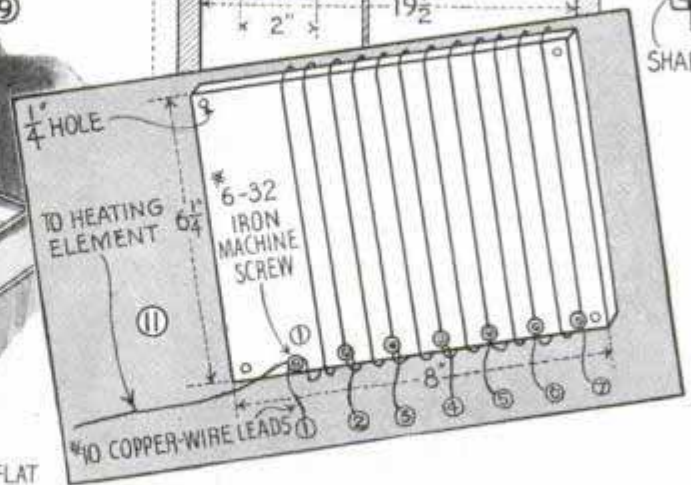
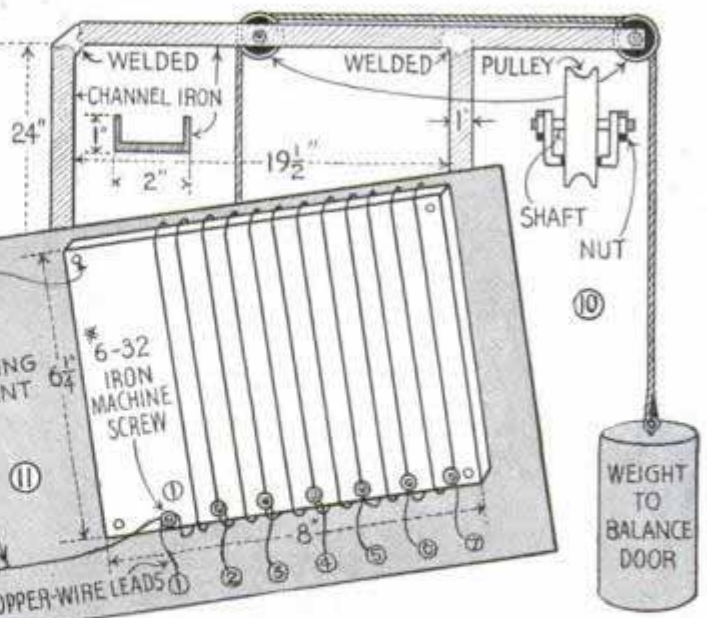
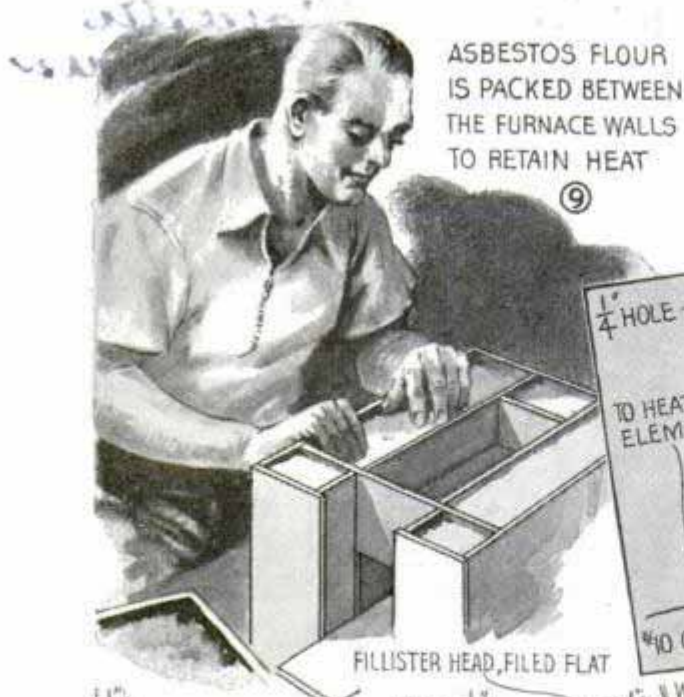

placed immediately over the wire are also secured 2-ft. lengths of No. 10 copper wire to serve as connection leads to the rheostat switch. Then the wound portion should be covered with the same cement as was used on the muffle. Fig. 12 shows the switch panel of the rheostat. The side view shows the method of mounting contact posts and a switch arm, which should be of heavy spring brass. The numbers on the front view of the panel correspond with those in Fig. 11. Fig. 13 shows the method of assembling the rheostat panel and winding with 4½-in. iron rods as studs. Fig. 2 shows the location of the rheostat on the side of the furnace. The electrical connections are shown in Fig. 3.

see letter

dry thoroughly. The muffle will have to be handled with extra care to prevent damage until the cement has been heated to 1,000° Fahr., when the furnace is first used. After heating, this cement is easy to flake off when it becomes necessary to rewind the heating coil. Most users of electric muffle furnaces keep on hand enough Nichrome wire of the proper size, so that rewinding is only a matter of a few moments.

The Nichrome wire required for the rheostat should be wound in twelve turns on a piece of ½-in. hard asbestos board (Transite) as in Fig. 11, with six taps to machine screws. The screws are placed over the wire and between two washers

The furnace itself is next, Fig. 8. The walls are cut from Transite and when assembled, form several compartments, which are filled with asbestos flour for insulation. Transite is very hard and accordingly it should not be expected that saws used for its shaping will last very long between periods of sharpening and setting. A fire brick, detail 1 of Fig. 8, serves as a door for the furnace. Into the top of this brick are anchored a pair of heavy screw eyes to hold the supporting cable. The ends of the screw eyes should be bent and the holes filled with a cement consisting of a viscous paste of litharge and glycerin. Assembly of the sections is done by the use of angle plates spaced 6 in. apart along all joints. No plates should be located inside the muffle compartment. Cracks through which the asbestos flour

can be lost, should be filled with cement. The asbestos flour is packed lightly. In this way all sides, top and bottom of the muffle are insulated with thick layers of asbestos flour. The lead wires from the winding to the rheostat are protected with short lengths of porcelain tubing. It is not advisable to connect furnaces which draw in excess of 10 amperes to the line with a detachable plug. Accordingly, it is recommended that the furnace be connected direct to the power supply with conduit or flexible BX. The final assembly consists in the construction and mounting of a bracket to support the door and its counterweight as in Fig. 10. Welded construction is recommended. The counterweight may be a pail of bricks or a container filled with lead to the requisite weight. Fig. 2 shows the supporting bracket mounted on the furnace with large machine screws and the arrangement of the fire brick door ready for use.

Having completed the muffle furnace, it is next necessary to give it a trial run at a low temperature to cure the cement on the element. The rheostat switch arm is set on point 7 which gives the lowest heat, and the switch is closed, leaving the muffle door open for about 10 or 15 minutes. The door may then be closed and the muffler allowed to come to full temperature. If the furnace has been well insulated and properly built it is probable that the switch will never need to be set on point 1 to develop the maximum temperature. If the temperature is allowed to rise above 1,650° Fahr. the element is likely to be burned out. Long life of the element will be had if the furnace is operated at 1,500° Fahr. A rheostat setting of 3 or 4 usually gives the maximum temperature which the furnace will develop without rapid destruction of the element. It is important that when a new element is installed or a new furnace started, some means be used to determine the approximate temperatures for which a thermocouple is ideal. Construction of thermocouples has been described in a previous issue of Popular Mechanics.

Feb 1937-310.

☐ Before starting to braze a large piece of metal with a light torch, preheat the metal to a cherry red color over a stove or furnace and save on oxygen bills.

Concrete Worker's Straightedge Has Shovel Handle



Handle on straightedge enables worker to test newly poured concrete surfaces without kneeling

To provide his 10-ft. straightedge with a convenient handle by which it could be readily manipulated, one contractor attached a broken shovel handle. This allowed the worker to lift the straightedge from a standing position, which eased the usual task of kneeling to test the work. Low spots in the concrete could be detected easily from a standing position simply by noting the marks left in the soft cement.—Wayne C. Leckey, Aurora, Ill.

'Cellophane' Speeds Press Feeding

In order to speed the printing of cards, envelopes, letterheads and other small jobs, it is necessary that they drop onto the gauge pins quickly and with the least possible friction. To accomplish this, as soon as the make-ready is completed on the press, glue a sheet of Cellophane over the tympan sheet

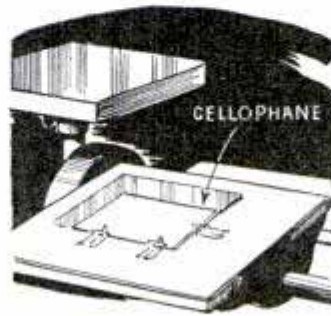

to include the area within the limits of the gauge pins. Upon this glassy surface the stock will slip into position instantly.

Tool Traces Profile of Turning to Make Template

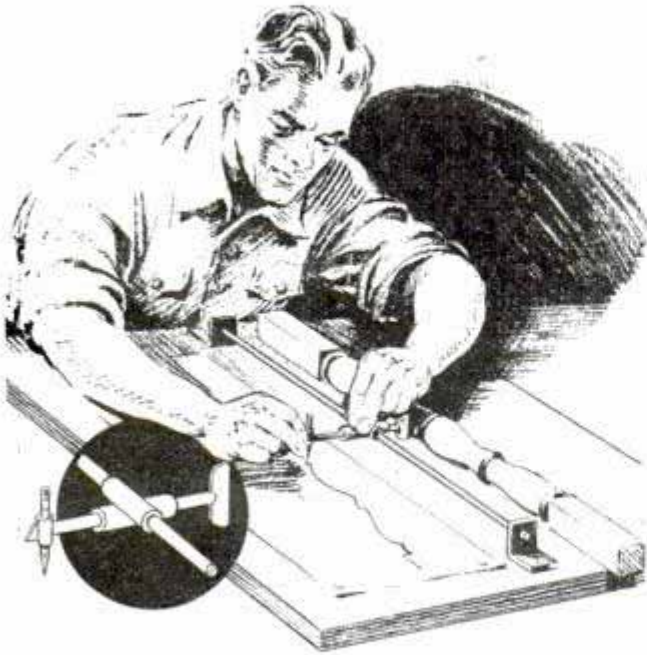

You can trace the profile of a turning on a piece of cardboard in a jiffy with this simple tool

Those who have occasion to duplicate a turning will find this tracing tool handy in making a profile template of the original turning. To make the tool, a cross of pipe or tubing is soldered together at right angles. One tube slides on a rod attached to a base or board by angle brackets, and the other tube takes a short rod which carries a scribe on one end and a guide on the other. In use, the turning is laid on the base alongside the tool, after which the profile is traced by pulling the cross along the rod, keeping the guide against the work and holding the scribe or tracing pencil on the template material.

—John R. Metzger, Maplewood, N. J.

Trough Anchored with Stakes Will Stay in Place

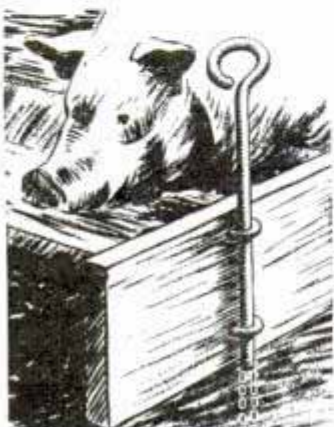

This hog trough cannot be upset easily. Stakes having large eyes at the upper ends to serve as handles, are slid through large staples or screw eyes driven into the ends of the trough. They should be

made long enough to allow one end of the trough to be raised for the insertion of small blocks when leveling it.

Tape Measure Worn on Finger

A tailor who uses a tape measure frequently finds that he can wear the measure on his finger where it is ready for instant use, yet not inconvenient. To wear the tape



measure in this fashion, it is only necessary to solder a cheap, brass ring to one side of the tape reel as indicated.

Sheet-Metal Umbrella Holder Attached to Chair Back

To prevent customers' umbrellas from being misplaced, one restaurant owner fitted the back of a chair, at each table, with a sheet-metal holder, as shown in the sketch. The holders, approximately 3 in. in diameter and 8 in. long, were made by a local tinsmith, for a small amount. Painted to match the chairs, they were hardly noticed when not in use.

—Opie Read, Jr., Chicago.



Here's an idea for the restaurant owner who has trouble with customers losing their umbrellas

'AIRSTREAM' SAIL RIG

steps up speed

This rig has won the international canoe sailing championships for the past five years. Can be used on either canoes or boats carrying up to 100 sq. ft. of sail

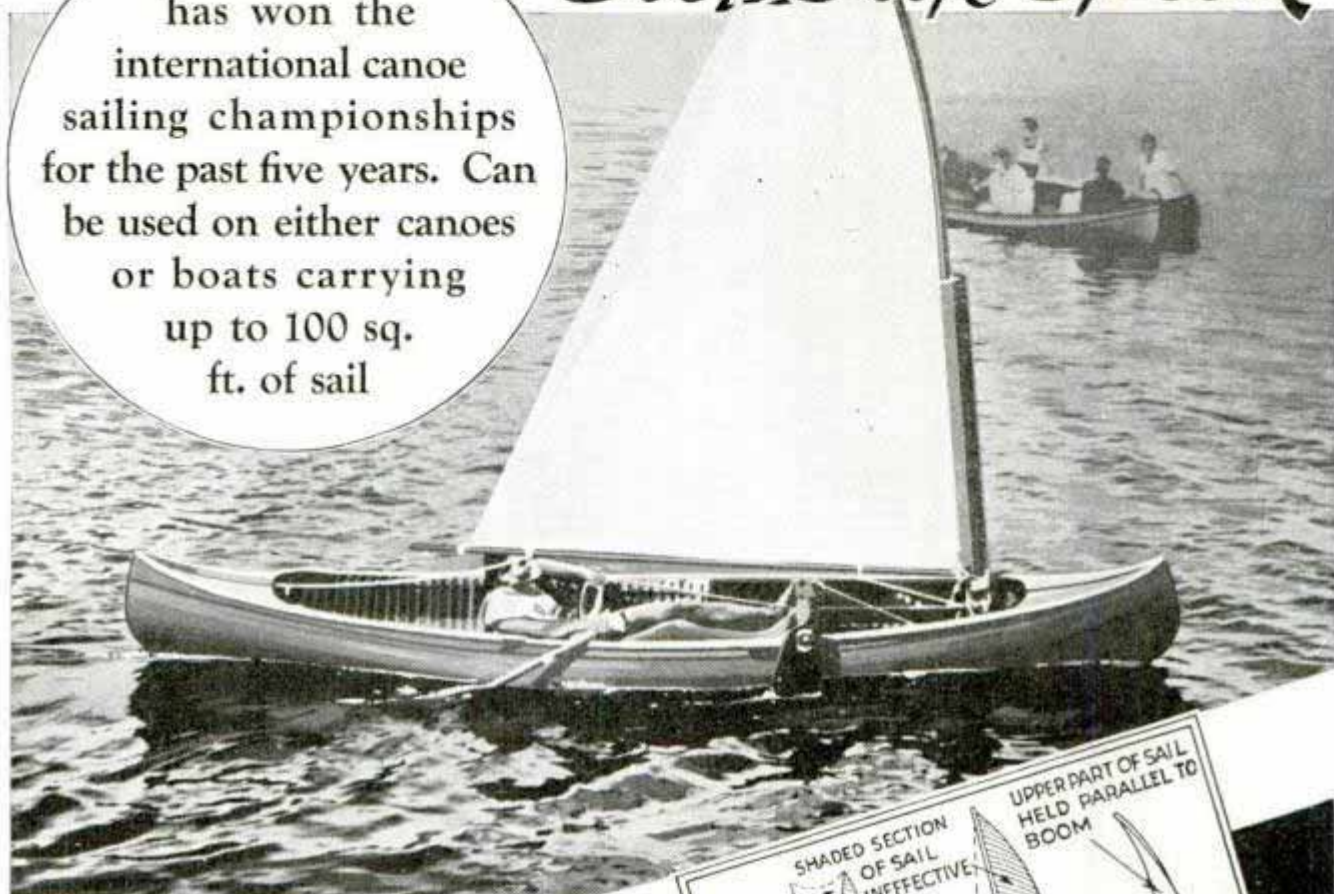

By H. G. La BRANT

DEVELOPED for canoes, this sail rig is adaptable to any boat carrying up to about 100 sq. ft. sail area and may be used with a jib. The plans given here are for a 48-sq.-ft. sail. For a larger sail, the height of the mast in the straight part is increased and the boom is lengthened. Height along the mast is added sparingly as this raises the center of effort. An increase ratio of 2 to 3 in. along the boom to 1 in. in the mast is about right.

Fig. 1, A and B, shows older sail types bellied out so that the upper shaded part is ineffective. The curved mast, Fig. 1, C, prevents this by holding the upper part of the sail parallel to the boom. The curved mast is four ply laminated, 1 by 2-in. stock to the beginning of the curve and three ply in the curve. The plies are glued with casein glue, bent dry as in Figs. 2 and 3 and clamped. After the glue has set, trim

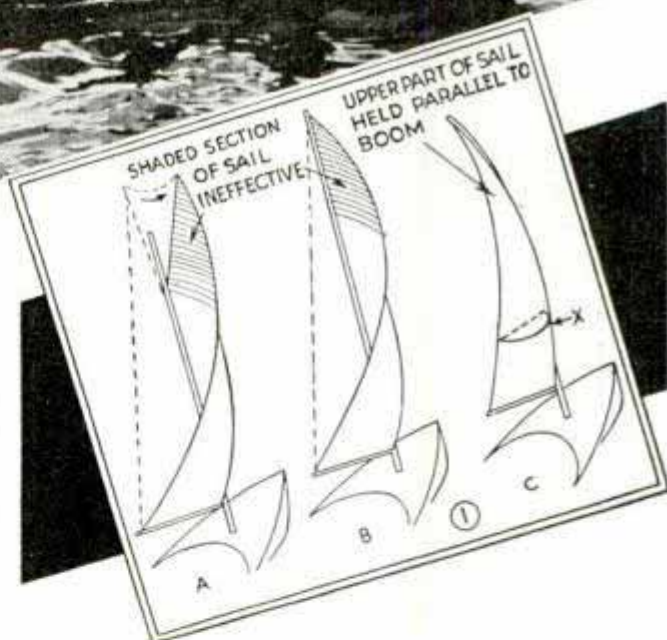

the mast to the sectional sizes given in Fig. 4, then varnish. The "board" boom, Figs. 7, 8 and 10, allows the sail to be changed quickly to suit varying conditions by shifting the mounting wire from the runners to the screw eyes. Hinge the boom to the mast by bolting through both to a heavy brass band as in Fig. 4.

Close-woven muslin is satisfactory for the sail. Purchase a piece wide enough to run from the free edge of the sail (the leech) to the hinged point, and as long as

at the boom hinge, turn a small brass screw eye into the mast every 9 in. Lay the mast and boom assembly along the edges of the sail and notch the tape to coincide with the screw eyes and wire runners. Then slide a 1/8-in. brass wire through the tape loop and screw eyes and wire runners on the mast and boom. Fasten these sail-mounting wires as in Fig. 9. Drill 1/4-in. "tie" holes through the mast and boom close to the ends, and turn a heavy screw eye into the mast at the boom hinge for the sail cords.

The mast is supported by means of a mast thwart and step as in Figs. 4 and 5, the step being made of hardwood securely fastened to the bottom of the boat. The thwart should be 1 1/4 by 6-in. hardwood long enough to reach across the boat. It may be bolted permanently to the gunwales. Double leeboards have been generally discarded in favor of a single longer board. The edges of the single leeboard, Fig. 6, should be quite sharp, and the board tapered from the waterline to the bottom. Length of the leeboard thwart or crossbar depends upon the width of the canoe. It should be ruggedly constructed and securely fastened as shown in Fig. 6. The mast should be stepped about 42 in. behind the extreme end of a 16-ft. canoe, and the leeboard should be placed just forward of the center of effort of the sail, as indicated in Fig. 4.

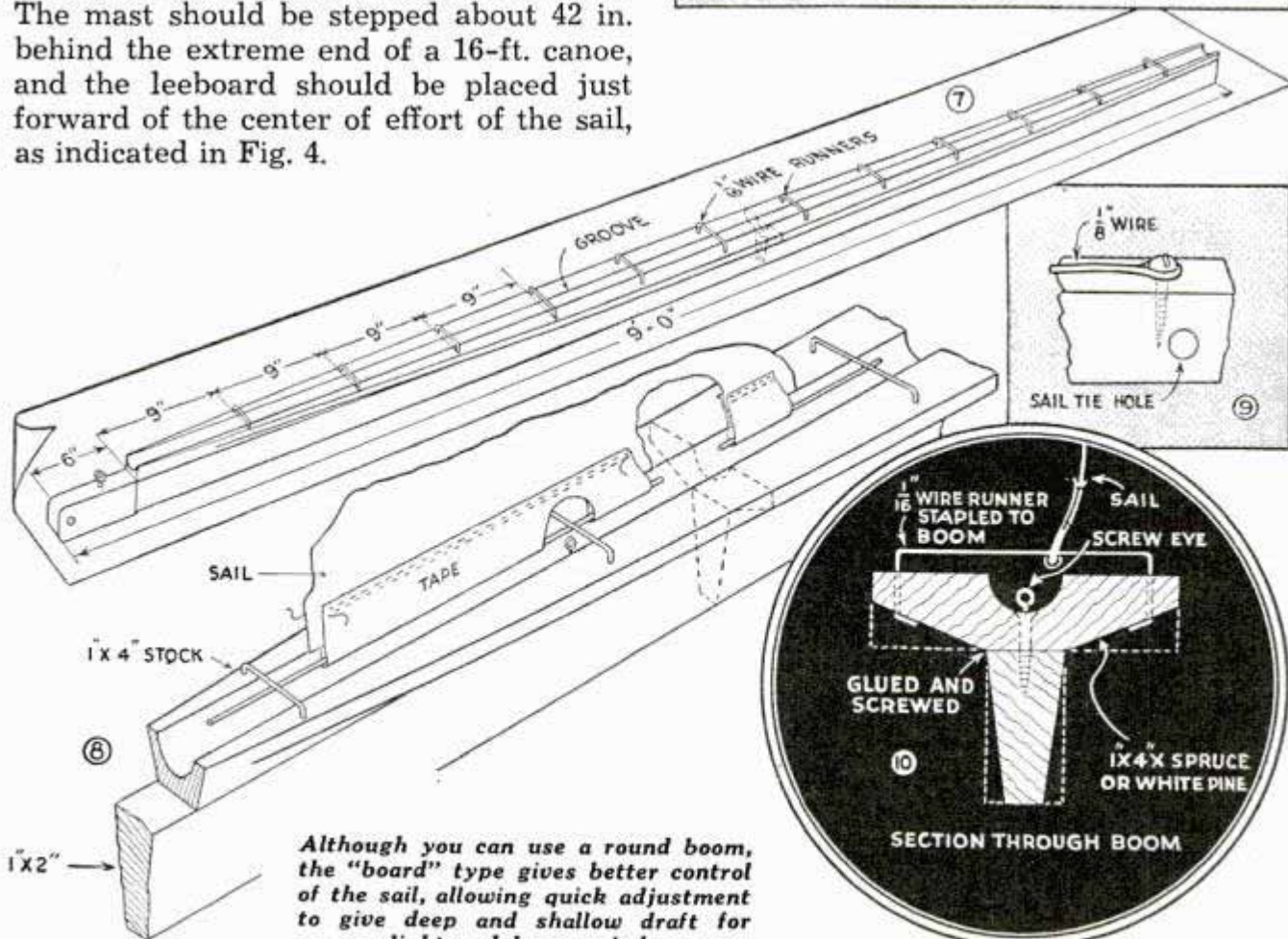
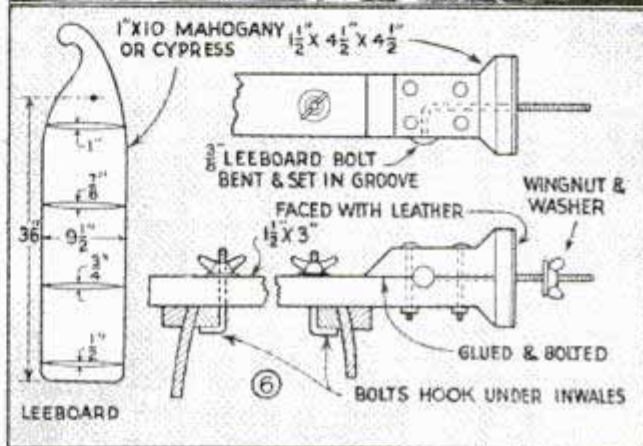
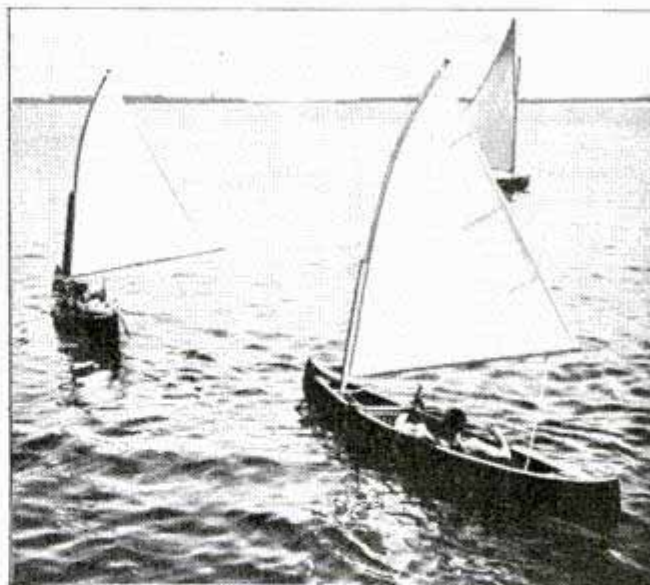

Although you can use a round boom, the "board" type gives better control of the sail, allowing quick adjustment to give deep and shallow draft for light and heavy winds

Hot Cans Carried in a Holder to Protect the Hands

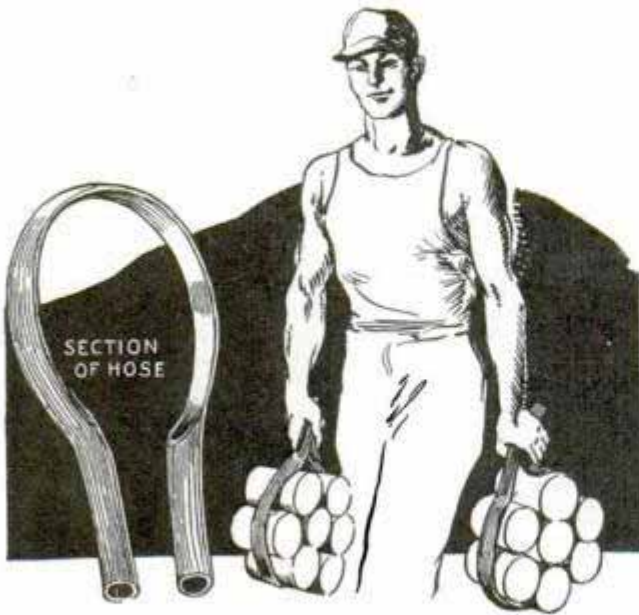

Workmen transfer hot cans from cooker to draining crates quickly with these rubber-hose carriers

In a canning plant where hot cans of fruit and vegetables had to be carried by hand from the cookers to draining crates and conveyors, the workmen were provided with lengths of rubber hose to handle the hot cans. One side of each hose was cut away from the center toward the ends as shown to make it more flexible. Accommodating six or eight cans each, the carriers permitted the men to do more work without burning their hands.

Twin Lathe Arbor Saves Time

On a job of making a number of collars, which had to be turned on an arbor, the novel lathe center shown was used to avoid driving the work on the arbor twice.

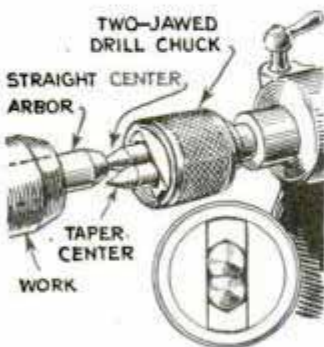

As there was a straight and tapered portion to be turned on the collars, the distance the tailstock would have to be set over was first determined. Then this distance was used as the meas-

urement between two centers made of $\frac{1}{2}$ -in. drill rod, which was flattened on one side to get the proper distance between the points, after which both centers were locked in a 2-jaw drill chuck. The arbor

was also tapered at the end so that it cleared one center point when it was running on the other one. The tailstock was then set over to bring the straight center in line. When the arbor was placed on the straight center, the work was turned straight, and when it was shifted it was turned to a taper.

—H. Moore, Hamilton, Ont., Can.

Raising Pressure in Drums of Ammonia

On a job of recharging an absorption system of refrigeration with ammonia, I found that the pressure was exactly equal to the pressure in the ammonia drum, which, of course, prevented a flow of gas. As very little heat will expand the ammonia gas, we poured hot water over the drum which raised the drum pressure sufficiently to proceed with the recharging job.—W. F. Schaphorst, Newark, N. J.

Chain on Cultivator Tongue Prevents Tangled Lines

To keep his team from getting the lines caught under the cultivator tongue, one farmer suspended a short length of chain from the end of the tongue. This does not interfere with hitching the team and it is heavy enough to deflect a line.

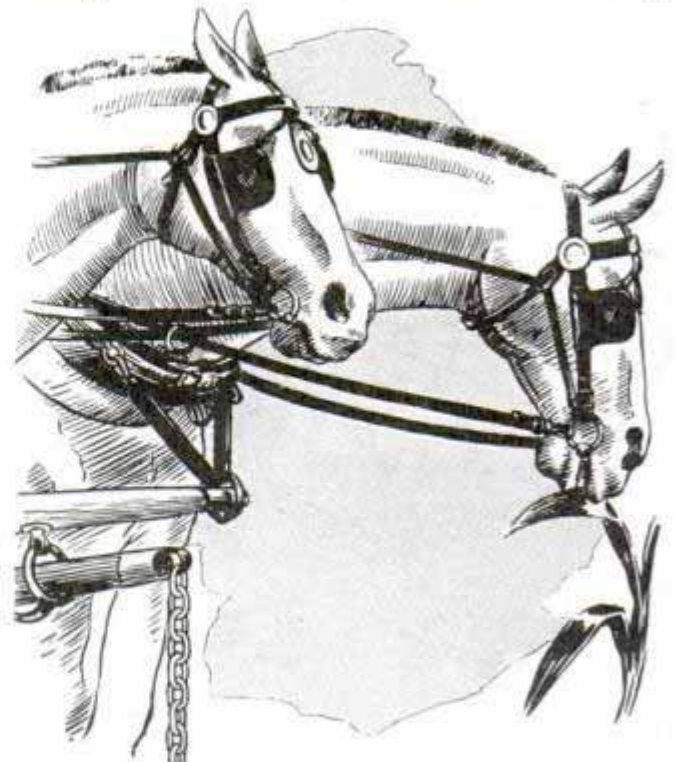

If a short chain is suspended from the end of a cultivator tongue, lines won't get under it

Heated Photoprint Drier Saves Time in Studio

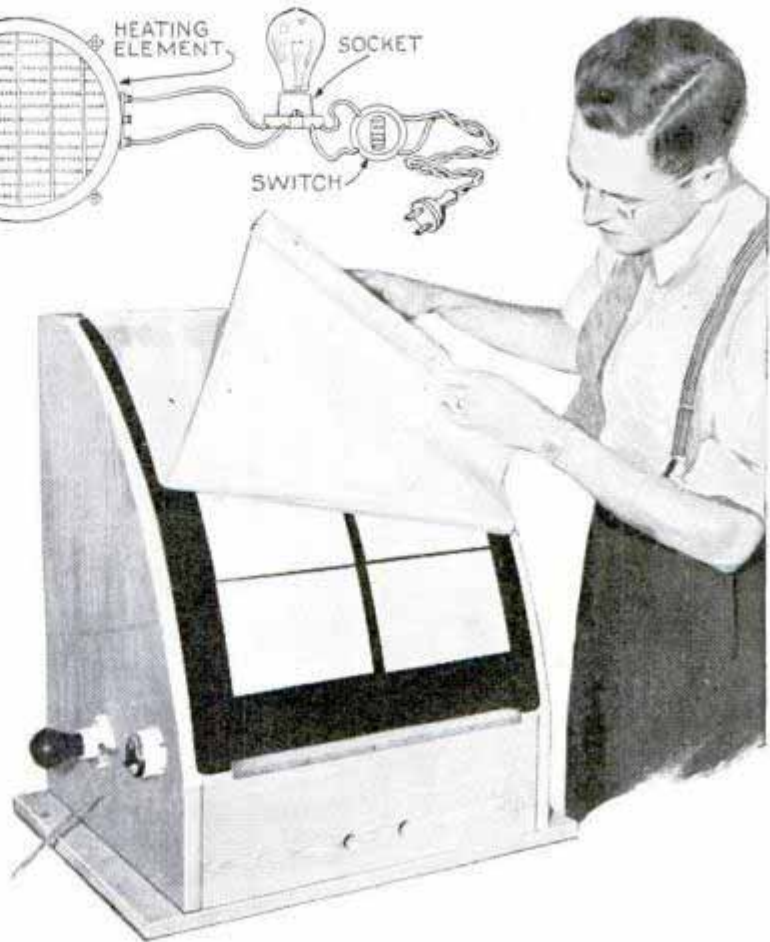
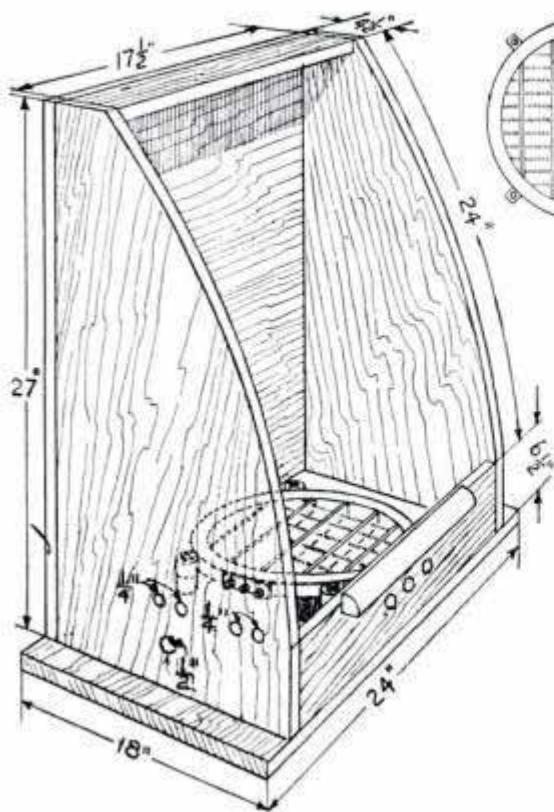

With this heated drier, which will handle several prints every 15 or 20 min., you can get out a photo job in less than half the time it usually takes. Consisting of a wood box of the shape shown, with a curved, open front over which a ferrotyp plate is placed, the drier is heated by an electric element. It can be built to accommodate the ferrotyp plate you already have, or it may be made to the size given which will take one 18 by 24 in. The element should be about 1,000 or 1,500 watts although an electric grill of about 650 watts was found satisfactory and was easy to install. A switch to control the element and a 10-watt red bulb to serve as a pilot light, are mounted on the side of the drier. Large holes drilled in the front near the bottom and in the back near the top permit circulation of air to heat the ferrotyp plate uniformly. The plate is slipped under narrow wood strips at the top and bottom of the opening to hold it in place. When drying prints that have velvet surfaces, a muslin curtain is hung over them to hold them and prevent curling. The curtain has a rod at the bottom to serve as a weight. In drying glossy prints, the curtain can be laid over them to help absorb moisture.

—E. W. Minty, Rapid City, S. D.

Asbestos on Rivet-Bucking Bar Protects Worker's Hand

If the end of a bucking bar becomes too hot to hold comfortably, when used continually, try wrapping the handle end with a few layers of asbestos cloth. This not only protects the hand against heat conducted through the tool, but also helps to absorb shocks.

—Philip Chandler, Nashville, Tenn.



Spring Thumbtacks on Board Loosen Drawing Quickly



Thumbtacks on spring arm attach or release drawing paper from board quickly

When a number of drawings are to be made on sheets of approximately the same size, thumbtacks soldered to short strips of spring steel and screwed to the drawing board will be found a convenience and a timesaver. When the tacks are arranged in this way, a flip of the finger loosens each one and a slight downward pressure of the thumb attaches the drawing paper.

Trapping Field Rodents Alive for Game Survey

At the University of Wisconsin, a trap similar to the one shown is used to catch field rodents alive for the purpose of tag-

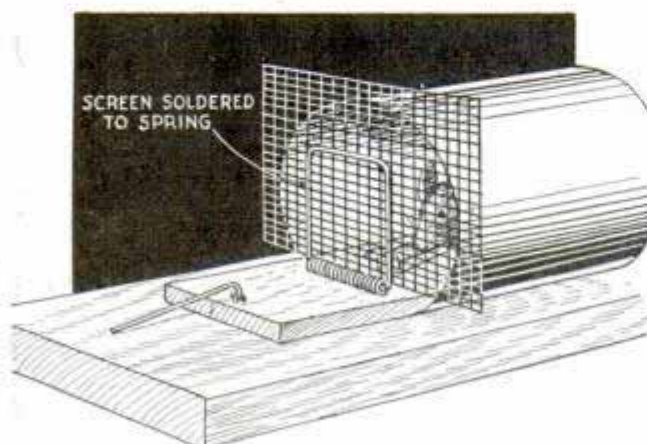

This trap not only keeps the rodent confined, but actually pushes it inside when it gets close enough

ging them as an aid in determining the populations of the various species. As most rodents are suspicious of ordinary traps, and will not enter them, this one pushes them inside when they get close. It consists of a tin can mounted on a base with a mouse trap set in the open end, the latter being screwed to the base. A piece of screen wire soldered to the jaw of the trap pushes the rodent inside and closes the opening when the trap is tripped. In setting it, the trigger wire is run through one of the meshes of the wire.

Fence Wire Pinned to Post Easily Taken Down

When it is impractical to place a gate between fields for the passage of machinery or livestock, loosen the wire on two or three posts and drive a pair of staples at each point of attachment.

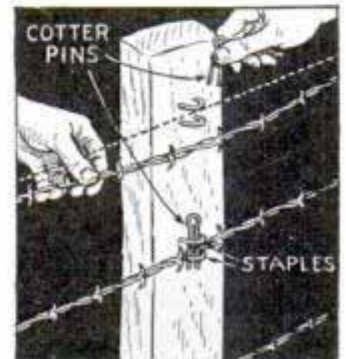

Then the fence wire placed between the staples may be locked securely in place by means of an improvised cotter key, made of medium-gauge wire.

Collapsible Display Stands Folded Flat in Storage

Merchants who do not have enough display stands to handle their stocks during special sales, can make them in quantities from heavy cardboard. Cut to any shape desired and assembled as shown, the stands can be decorated in bright colors with show-card ink, or they may be covered with tissue paper. When not in use they can be taken apart quickly and stored flat, requiring very little space.

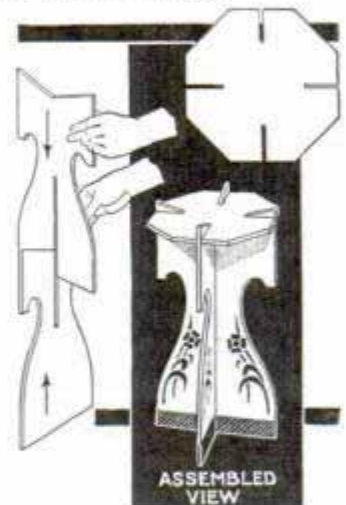

The Mechanics of DRILLS

PART II

Useful information for the shop on setting up work, avoiding drill breakage, drilling hard rubber and plastics and a table of tap and body-drill sizes

A MAJORITY of drilling operations are carried out with drills which have been ground a number of times. As the web, or central section tapers, repeated grinding causes it to grow thicker as in Fig. 19. There comes a time when the web section at the point is so thick that the drill will no longer operate properly, Fig. 20. To correct this condition the regular grinding procedure should be followed by thinning the web as in Fig. 19. The drill is applied to the wheel as shown, first on one side and then the other. The resultant thinning brings the web back to normal thickness.

Drilling Large Holes: Large drills have thick webs and therefore require considerable power. For many purposes it is more practical to drill a lead or pilot hole as shown in Fig. 21. The pilot hole should be of the same diameter as the thickness of the web. The hole should not be made larger than the thickness

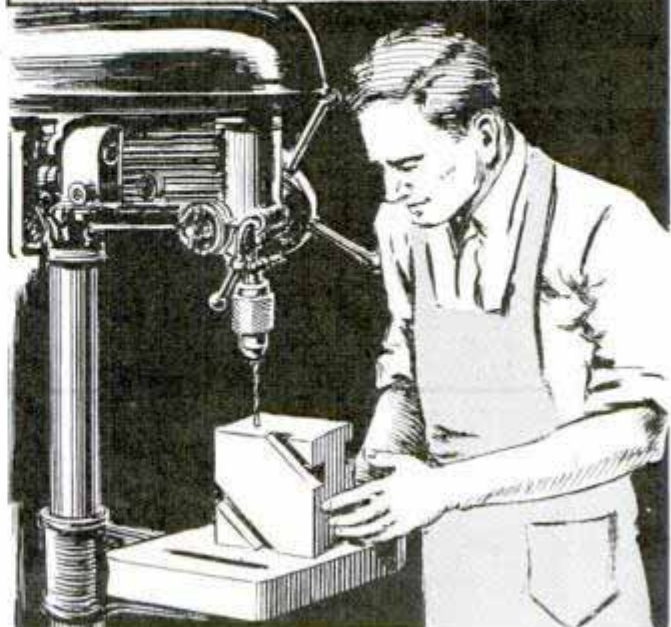
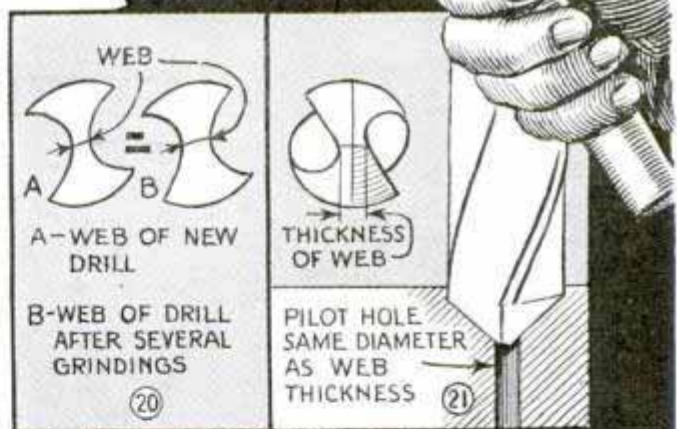

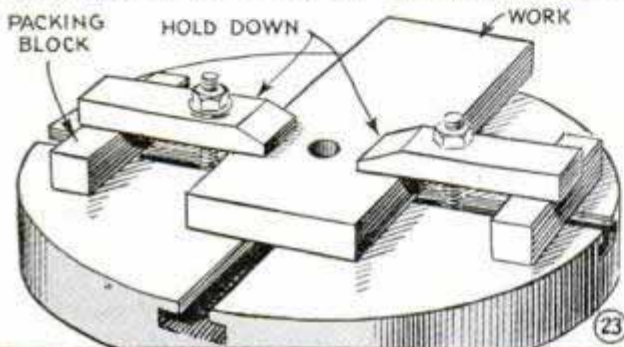
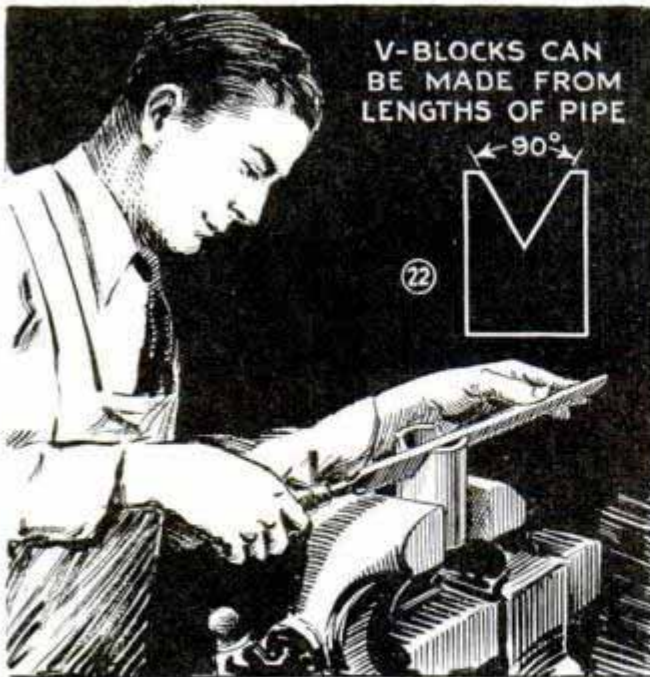

CLAMPING FLAT STOCK FOR DRILLING

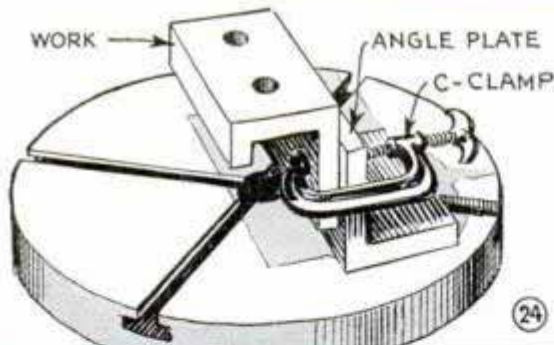

IRREGULAR WORK CLAMPED TO ANGLE PLATE

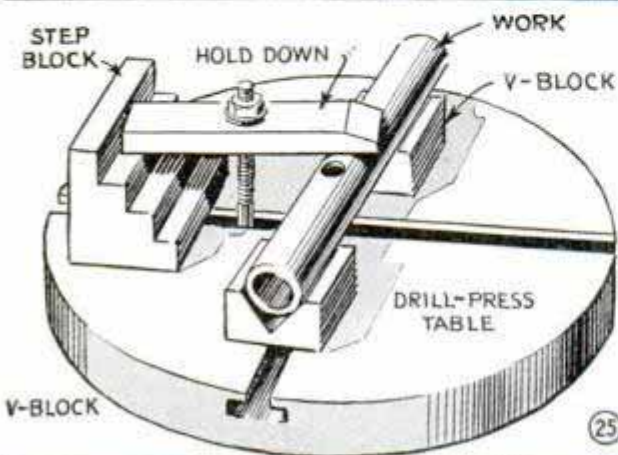

ROUND WORK SET UP FOR DRILLING

of the web as this would result in chattering and possible drifting.

Drilling Deep Holes: If the depth of a hole exceeds the flute length of the drill, Fig. 28, there will be no means for the escape of chips. In this case, it is, of course, advisable to use a longer drill. If this is impossible, then the next best thing is to lift the drill every few seconds and clear the flutes and the hole of chips, continuing this precaution until the hole has been finished to the required depth.

Drilling Out Threads: The enlarging of threaded holes presents a problem which can be overcome most readily by the use of left-handed drills. If an ordinary right-handed drill is used to enlarge a hole which has right-hand threads, it will be drawn into the hole more rapidly than it should, jam, and probably break the drill. Left-hand drills must be revolved in the reverse direction by crossing the belt between the motor and the drill press.

Fixtures and Accessories for Drilling: Although drills will perform fairly well even when improperly used, they can be made to do many apparently impossible jobs if a little time is spent in preparing a number of simple accessories and fixtures. The most useful items are "V" blocks. These can be purchased at little cost or can be made as needed. A form of V block is easily made from a length of pipe as in Fig. 22. The pipe is marked with a scribe and the vee cut out with a hack saw. The base and "veed" surfaces are then filed smooth and true. Fig. 23 illustrates a simple method of securing a piece of stock to the table of the drill press. The hold-down clamps are simply flat pieces of steel with the outer ends supported on packing blocks, holes being drilled through the centers to facilitate bolting down. Fig. 27 shows a common error in supporting work while drilling. Here the drill has been started at a considerable distance from the supporting blocks. Under pressure of drilling the work will spring. The result is almost invariably a broken drill bit. When drilling small holes in solid stock that rests squarely on the drill table, the work can be held safely in the hand but when drilling larger holes in irregular-shaped stock the practice is dangerous, as the drill may "bite" unexpectedly and jerk the piece out of the hands. Better to set

up the job as in Figs. 24 and 25 using an angle plate or a step block, both these supporting members being bolted or clamped to the drill table. Another frequent source of trouble and sometimes breakage, is the tendency to undue tightening of a precision drill chuck, Fig. 26. Drawing the chuck unduly tight, particularly on a small drill, will eventually cause the chuck jaws to be inaccurate. Release of the drill is also difficult. Another accessory which is easily made up as needed, is the drill stop, Fig. 33. This is particularly useful when a number of holes must be drilled to the same depth with a drill press which has no scale or adjustable stop.

Drilling Holes in Round Stock: Difficulties in drilling holes through round bars and rods may be overcome easily if the method shown in Fig. 29 is used. A short length of round stock of the size which is to be drilled transversely is drilled longitudinally as in Fig. 29. This section of drilled stock may then be used as a collet to guide the drill. For this purpose it is essential that a drill-press vise be used. A drill block of width slightly less than the diameter of the round stock is placed in the bottom of the vise and on top of this the shaft to be drilled. Next, the collet is set on top of this section at the exact location where the hole is to be drilled.

Making Slots in Shafts: Another problem is that of making slots in shafting. This job is easy if a drill collet of the type just described is set up in the drill-press vise just as shown in Fig. 26. After drilling the first hole, the collet is shifted to the next position and the second, third and other holes as required are drilled. Following the drilling of the required number of holes the excess metal is removed.

Drilling Small Parts: Small parts such as machine screws, rods, etc., present drilling problems which can be handled easily by the application of a few tricks. For example, a small machine screw which must have a tiny hole drilled through it as shown at the left in Fig. 31. The only item needed for this job is a bar of steel dressed true and square. First, lay out scribe marks and center punch for drilling a hole of exactly the size which is to be drilled through the screw. Next, you consult the table of tap-drill sizes, Fig. 30,

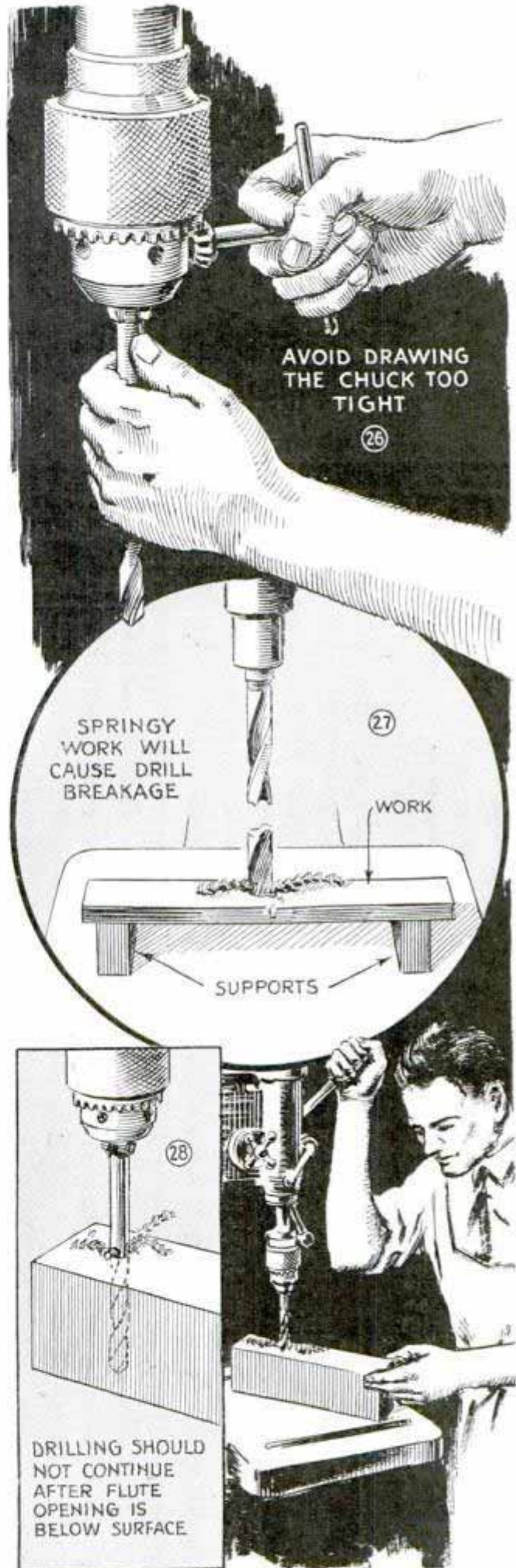

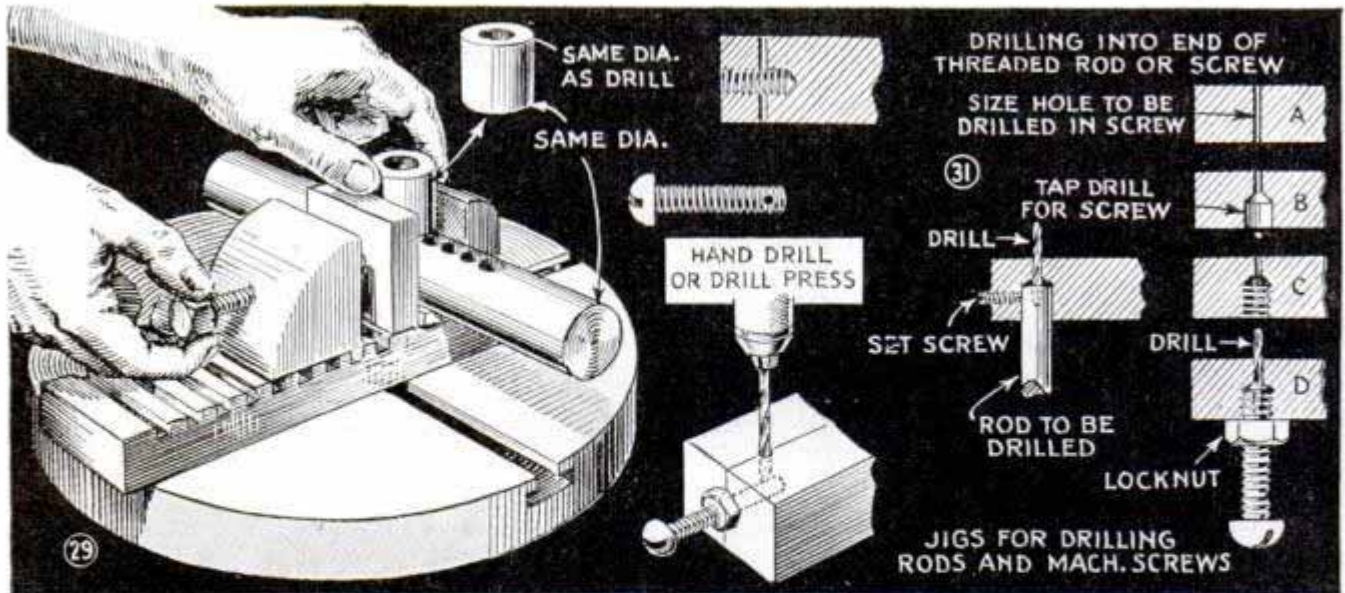
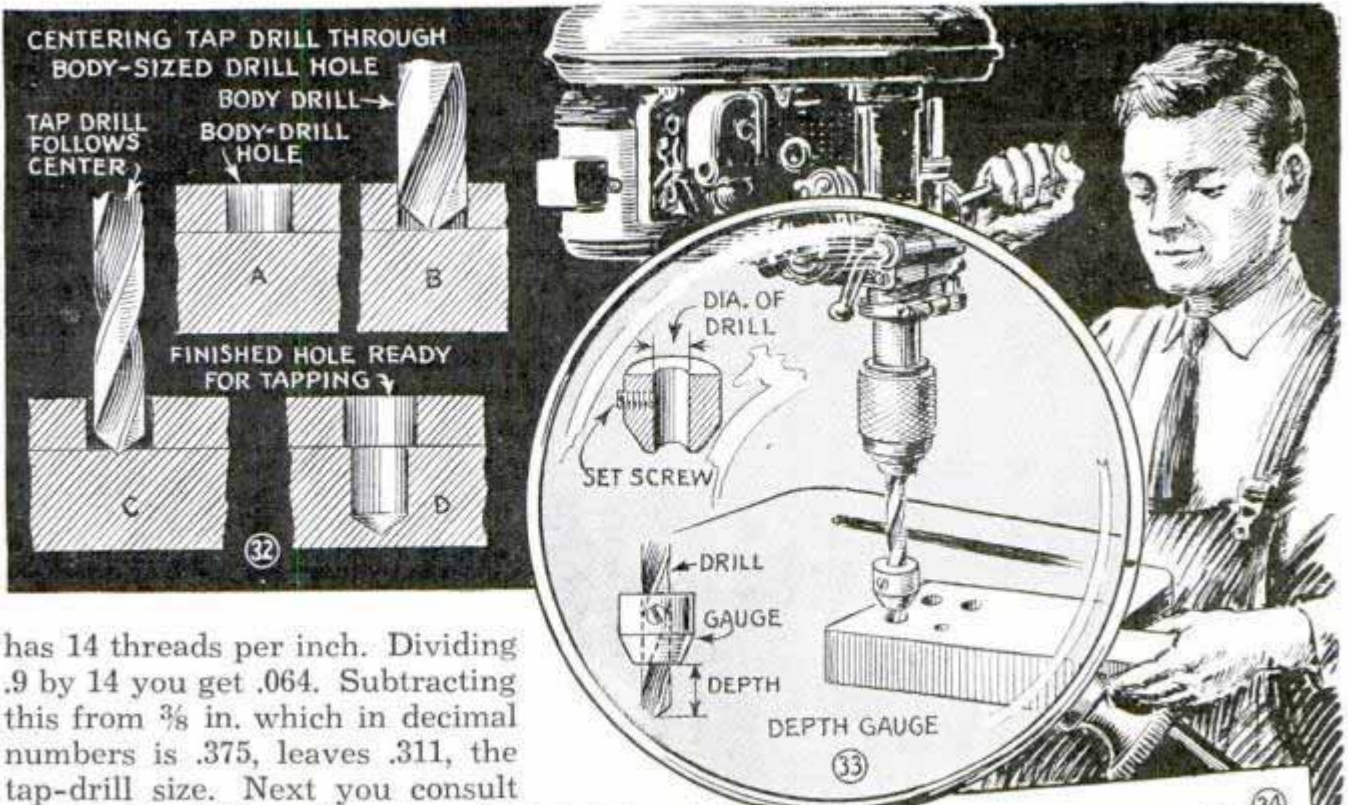

FIG. 30—TAP AND BODY DRILL SIZES FOR MACHINE SCREWS INCLUDING NUMBER SIZES, A.S.M.E., U.S.S. AND S.A.E. STANDARD SCREWS

Body Drill Size	Screw Number or Size	Threads per Inch and (Tap Drill Sizes) (Number in parenthesis is tap drill size for preceding number of threads per inch)
No. 52	0	80 (56)
No. 49	1	56 (54), 64 (53), 72 (53)
No. 44	2	48 (52), 56 (51), 64 (50)
No. 39	3	40 (49), 48 (48), 56 (45)
No. 33	4	32 (45), 36 (45), 40 (44), 48 (42)
No. 30 or 1/8"	5	30 (42), 32 (42), 36 (40), 40 (39), 44 (37)
No. 28	6	30 (36), 32 (36), 36 (34), 40 (33)
No. 24	7	28 (32), 30 (31), 32 (31), 36 (31 or 1/4")
No. 19	8	24 (31 or 1/4"), 30 (30), 32 (29), 36 (29)
No. 16	9	24 (29), 28 (27), 30 (27), 32 (26)
No. 11	10	24 (25), 30 (21), 32 (20)
No. 6	11	24 (19), 28 (18), 30 (18)
7/32"	12	20 (18), 22 (17), 24 (16), 28 (14)
15/64"	13	20 (14), 22 (13), 24 (11)
D	14	18 (11), 20 (9), 22 (7), 24 (6)
F	15	18 (6), 20 (4), 22 (3), 24 (3)
I	16	16 (3), 18 (3), 20 (2), 22 (1)
L	17	16 (2), 18 (1), 20 (15/64")
19/64"	18	16 (15/64"), 18 (C), 20 (D)
5/16"	19	16 (1/4"), 18 (F), 20 (G)
P	20	16 (17/64"), 18 (17/64"), 20 (I)
S	22	16 (L), 18 (19/64")
3/8"	24	14 (N), 16 (5/16"), 18 (P)
13/32"	26	14 (Q), 16 (11/32")
7/16"	28	14 (23/64"), 16 (U)
29/64"	30	14 (W), 16 (X)
1/16"	1/16"	64 (3/64"), 72 (3/64")
5/64"	5/64"	60 (1/16"), 72 (52)
3/32"	3/32"	48 (49), 50 (49)
7/64"	7/64"	48 (43)
1/8"	1/8"	32 (3/32"), 40 (38)
9/64"	9/64"	40 (32)
5/32"	5/32"	32 (3/8"), 36 (30)
11/64"	11/64"	32 (9/64")
3/16"	3/16"	24 (26), 32 (22)
13/64"	13/64"	24 (20)
7/32"	7/32"	24 (16), 32 (12)
15/64"	15/64"	24 (10)
1/4"	1/4"	20 (6), 24 (4), 27 (3), 28 (1), 32 (7/32")
5/16"	5/16"	18 (G), 20 (17/64"), 24 (I), 17 (J), 32 (9/32")
3/8"	3/8"	16 (5/16"), 20 (21/64"), 24 (Q), 27 (R)
7/16"	7/16"	14 (U), 20 (25/64"), 24 (X), 27 (Y)
1/2"	1/2"	12 (27/64"), 13 (27/64"), 20 (29/64"), 24 (29/64")
9/16"	9/16"	12 (31/64"), 18 (1/2")
5/8"	5/8"	11 (17/32"), 18 (9/16")
11/16"	11/16"	16 (5/8")
3/4"	3/4"	10 (21/32"), 16 (11/16")
7/8"	7/8"	9 (49/64"), 14 (13/16")
1"	1"	8 (3/4"), 14 (15/16")

and drill another hole at right angles which can be tapped to a depth sufficient to allow the screw to be inserted far enough to properly locate the transverse hole. Having tapped the hole, the screw is run in over a nut which can be used to lock it in place. Then you drill through the screw, the first hole acting as a guide. This fixture can be used repeatedly. Details at the right in Fig. 31 show another easy method of solving a common problem. In this case it is required to drill a hole into the end of a machine screw or tapped rod. When it is necessary to drill the hole into the end of an unthreaded rod a set screw is provided in the working plate. Holes which are to be threaded should be drilled undersized so that the tap will cut a thread deep enough to hold securely. Although the table presented in Fig. 30 is rather more complete than usual, it is handy to have a rule which can be applied for finding tap-drill sizes for odd screws. The simplest method of doing this is to first divide the number of threads per inch on the screw into .9 and subtract the quotient from the body size of the screw. To illustrate the method, suppose you have a 3/8-in. screw which



has 14 threads per inch. Dividing .9 by 14 you get .064. Subtracting this from $\frac{3}{8}$ in. which in decimal numbers is .375, leaves .311, the tap-drill size. Next you consult a drill-size table such as was included in Part I of this series of articles and find that the nearest drill less than this diameter is $\frac{19}{64}$ in. The "N"-sized drill is also close enough so we may use either of these which is at hand. In the case of screws over $\frac{1}{4}$ in. in diameter, select the nearest smaller size of tap drill as figured above. For screws smaller than $\frac{1}{4}$ in., the nearest drill larger than the required size is selected. Centering a tap drill through a larger-sized body drill hole is a job which frequently causes difficulties. A simple method of accomplishing this is illustrated in Fig. 32. First a drill of the same size as the large hole is inserted to locate the center. After this the smaller tap drill will easily follow the start made by the larger drill. Countersinks and counterbores are so much used in connection with drilling operations that Fig. 35 has been included to make clear their application in this work.

Drilling Hard Rubber and Plastics: If standard high-speed drills are used those smaller than $\frac{1}{4}$ in. should be ground to an angle of 45° rather than the standard 59° angle. Drills larger than $\frac{1}{4}$ in. should be ground as usual. Fig. 34 contains the values of speeds and feeds which have been found satisfactory for drilling these types of material. The drill should be backed out frequently to insure the removal of chips and prevent overheating.

34

SPEEDS AND FEEDS FOR DRILLING RUBBER AND PLASTIC MATERIALS

SIZE OF DRILL (DIAMETER)	SPEED (R.P.M.)	FEED IN INCHES PER REV. OF DRILL
$\frac{3}{16}$ " AND SMALLER	4000	.005
$\frac{1}{4}$ "	3000	.006
$\frac{3}{8}$ "	2000	.008
$\frac{1}{2}$ "	1550	.010
$\frac{5}{8}$ "	1200	.011
$\frac{3}{4}$ "	1000	.012
1" OR LARGER	750	.014

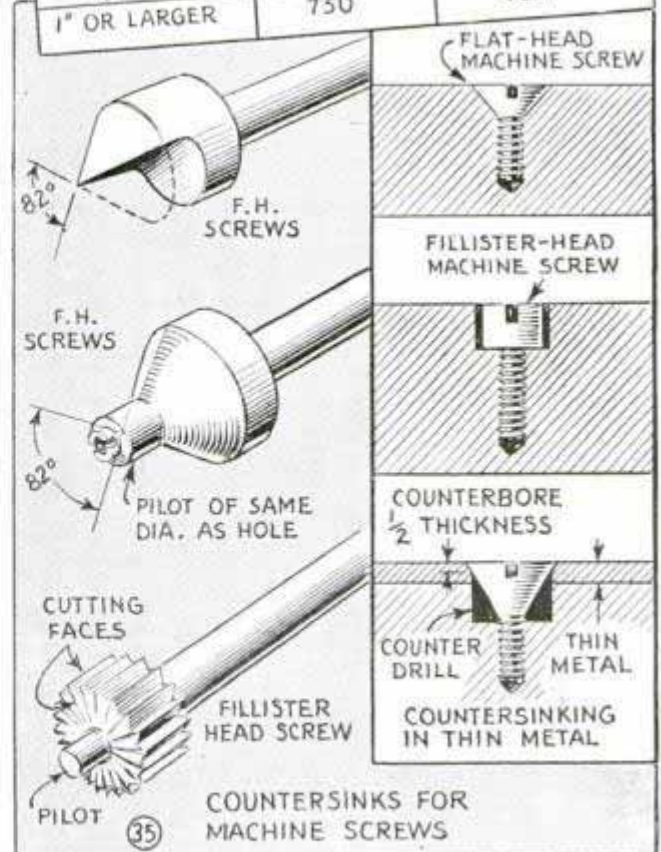

Truck Wheels Removed Easily with One-Wheel Dolly

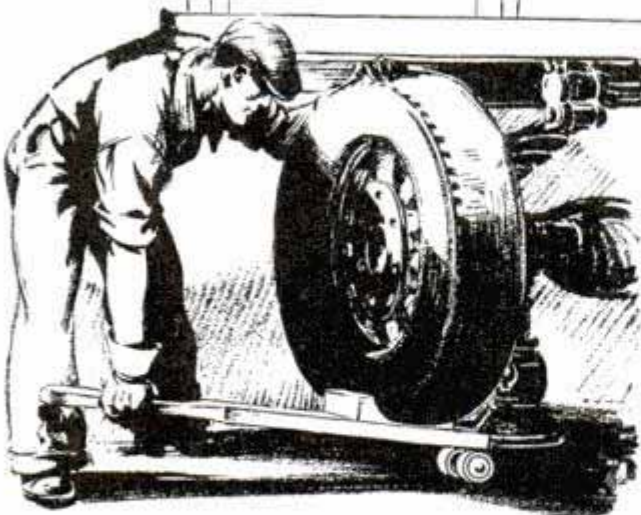

This simple dolly will save lifting a heavy truck wheel or tire to remove it

Heavy truck wheels are readily removed or put on single-handed with the aid of this one-wheel dolly. It is merely a length of 2 by 4-in. stock having a heavy trunk caster screwed near one end. The other end is shaped to form a handle. A 2 by 6-in. block with the top carved concave forms a cradle to hold the wheel.

Performance of Car Motor Shown by Vacuum Gauge

Actuated by the vacuum in the intake manifold of your car, an ordinary 0 to 30-in. vacuum gauge, such as is used on heating plants, will show at a glance the approximate operating condition of your

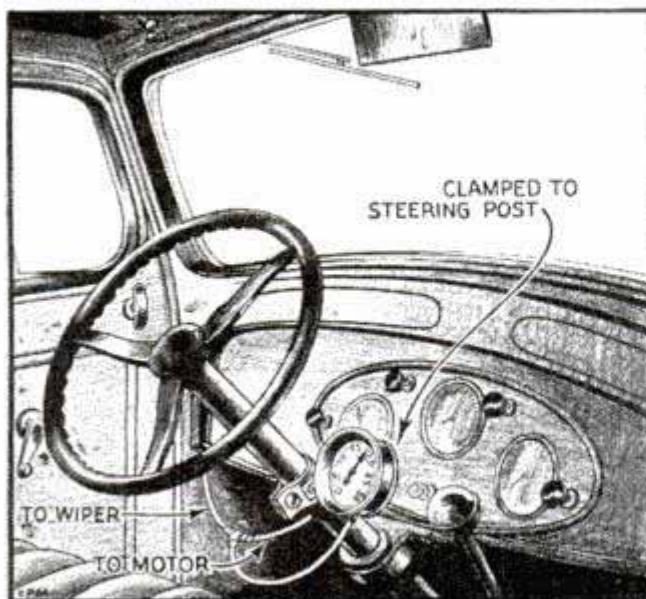

Mechanical deficiencies of the motor affect the vacuum, which gives various readings on the gauge

motor. The gauge is mounted on the instrument panel or on the steering column and is connected into the windshield-wiper hose by means of a Y-fitting, the wiper being turned off. As any inefficiency of the valves and valve springs, spark plugs, motor gaskets, piston and piston rings, carburetor, etc., will affect the vacuum in the manifold, this will, of course, affect the reading of the gauge. On the average new motor in good condition, the reading will be about 18 at idling speed with the spark retarded. If the hand shows a reading of less than 5, check up on the intake gaskets for leaks. With the spark advanced, the normal reading should be about 20. Then drive the car at about 45 m.p.h. and the hand will drop to about 18. At this point you take your foot off the accelerator so that the car will be coasting against motor compression. The reading should be 23 to 25 if the piston rings are in good condition. Of course, bad oil would allow the compression to leak past the rings and it should be inspected before passing judgment on the rings. If a valve sticks, the hand will drop occasionally about 4 points. If the reading fluctuates from 14 to 19, look at the carburetor, spark-plug gaps or tappets. Weak valve springs will show large and rapid fluctuations. If the valves are timed late, the hand will vary from 5 to 10 points from normal. Altitude and climate have a bearing on the readings of a vacuum gauge, the figures above being given for an altitude of about 2,000 ft. above sea level. The gauge is effective only on cars having the wiper hose tapped directly into the intake manifold. On cars having dual intake manifolds, the readings would apply only to those cylinders reached by the manifold into which the wiper hose was connected.—M. L. Harmon, South Bend, Ind.

Filling Gasoline Tanks

As a safety precaution against serious accidents from explosions, always keep the nozzle of a gasoline-pump hose in close contact with the side of the filler hole when filling the gasoline tank of a car or motorboat. This precaution helps prevent a spark of static electricity from jumping from one metal part to another, which might ignite gasoline vapors.

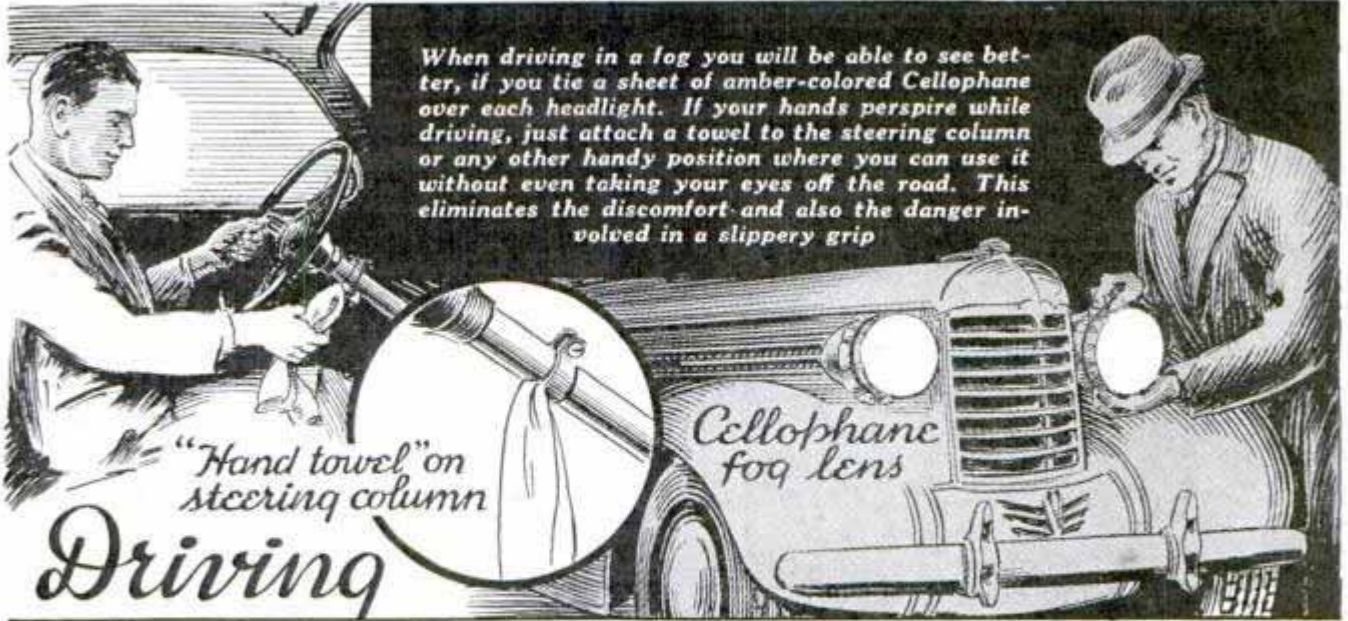

YOUR CAR SAFELY



By drilling a 1/32-in. hole in the thin metal plug of a non-adjustable steering knuckle, you prevent high pressure being built up by a grease gun, which sometimes swells the plug and causes looseness in the steering assembly. Where non-glare shields attached to the windshield often obstruct vision during the day, one motorist prefers wearing a colored celluloid visor. All that's necessary is to tip the head forward to look through the visor when approaching a car with bright lights. Below, chattering of Ford brakes, often caused by uneven wear on the sides of the wedge, can sometimes be reduced by removing the anchor bolt and wedge, and turning the latter around to reverse the position of the sides

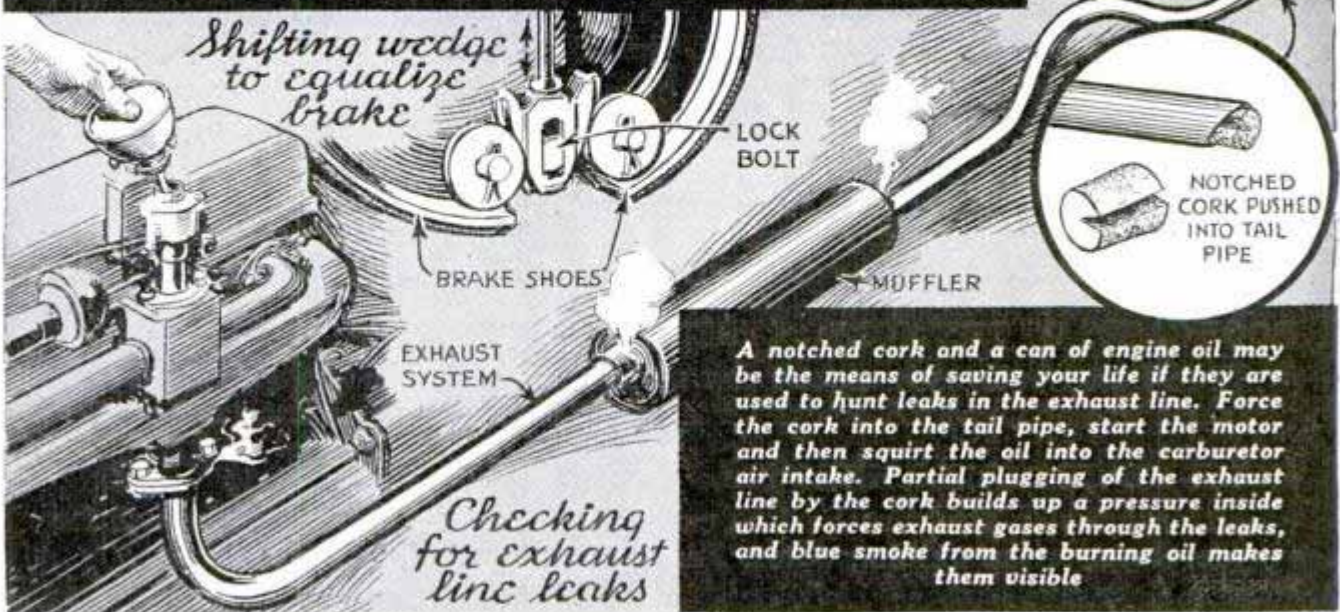

Spur Gear Cutter Improvised from Lathe Tool

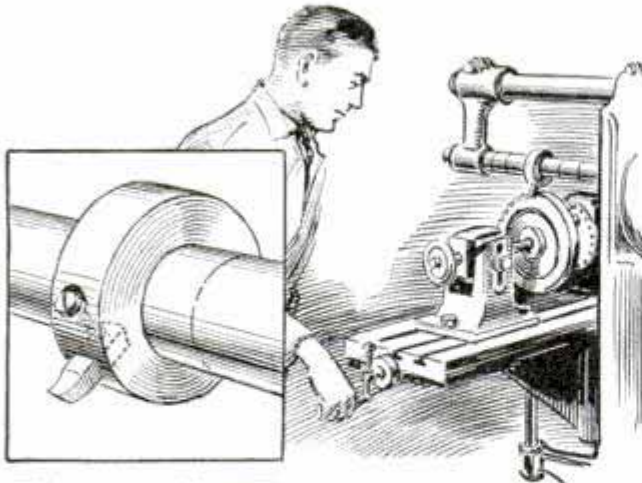

When a suitable milling cutter is not at hand, this improvised one can be made to do the job

On a job of making a gear where a suitable milling cutter was not at hand, and the gear was needed at once, we improvised a cutter that handled the work satisfactorily. I set up the gear blank in the milling machine and turned up a steel collar about $2\frac{1}{2}$ in. in diameter and $\frac{3}{4}$ in. thick. This was bored to slip over the milling-machine arbor. A hole was drilled

in the edge of the collar and filed square to take a lathe turning tool, which was held with a set screw, the tool being ground to the shape necessary to cut the gear teeth.—R. S. Cutlan, Minneapolis, Minn.

Easy Carburetor Adjustment

Due to efficient muffling and smooth operation of the modern car, the owner is often led to believe that the car is operating at peak performance when, in reality, the carburetor may be set quite inefficiently, causing a loss of power and a waste of fuel. A good way to check the motor for smooth operation, however, is to jack up one rear wheel, put the transmission in high gear and run the motor at idling speed. If there is any unevenness in the running of the motor, the slight amount of backlash in the gears will cause the spinning wheel to jerk.

☞ To make a polishing cloth for wiping the windshield to prevent mist from forming on the inside, soak a soft cloth in heavy soapsuds and dry it without rinsing.

The Next Issue

BUILD YOUR PRIVATE DRIVEWAY TO LAST

If you want a driveway of concrete—ribbon or solid type—stone, gravel, brick or even tar surfaced, this story tells how to make a lasting one. Covers mixing of the aggregates and suggests the best thicknesses to lay the different types as well as the most suitable bases and methods of providing drainage.

RIDING THE BREAKERS ON HOLLOW SURFBOARDS

A light, graceful surfboard designed by a Hawaiian surfboard paddling champion. Easy to build, the board has a narrow, shallow hull resembling a boat.

UNPOSED PHOTOS WITH A BOX CAMERA

How to get those candid "shots" you have always wanted by silencing the shutter and concealing the camera from view of the unsuspecting subject.

BOOKCASES OF THE MODERN TREND

Two fluted bookcases anyone can make inexpensively. Includes the open-shelf type and a round, rotating one, which also serves as a lamp table.

HOME-MOVIE DEVELOPING REEL

A large, motor-driven reel, which carries your exposed movie film through the developer or the washing water. Easily made to take any length of film.

Vacation Days!

ALL HIGHWAYS
LEAD TO



when you own a HARLEY-DAVIDSON

The most thrilling way to get ALL the fun out of vacation days is the Harley-Davidson way. Cover more than double the territory you could cover in most any other way! That's like doubling your vacation time. What's more — you stretch vacation days all through the year with glorious evening rides, Saturday afternoon jaunts, and week-end trips!

Own a new 1937 Harley-Davidson! Thrill to its flashing style—gliding ride—surging power—zooming speed—and most important of all, its *low-cost mileage* because of many advanced motor and other improvements. Don't wait—ask your Harley-Davidson dealer for a *free ride*—he'll gladly explain his Easy Pay Plans. And send in the coupon—*now!*

HARLEY-DAVIDSON MOTOR CO.
Department P Milwaukee, Wisconsin

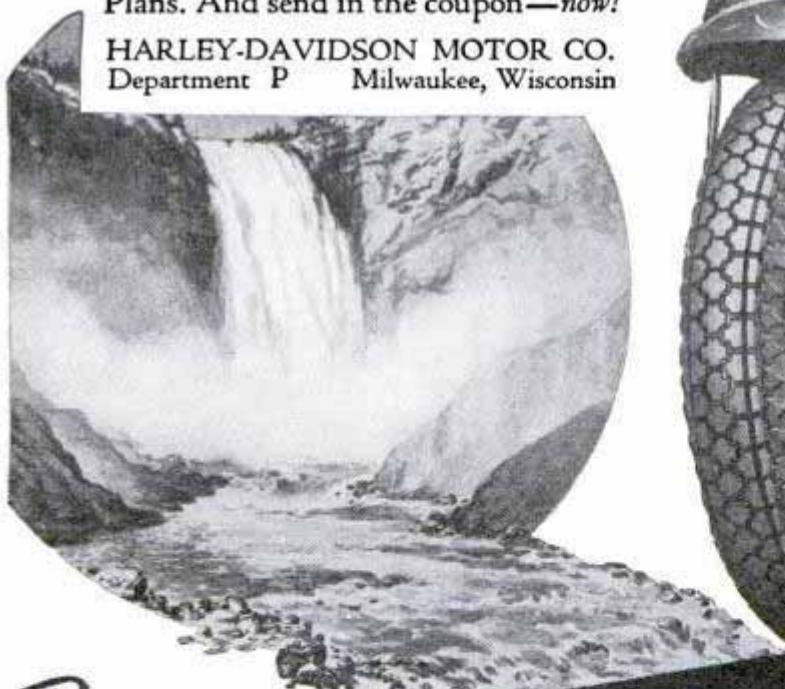

MAIL THIS COUPON

HARLEY-DAVIDSON MOTOR CO.,
Department P, Milwaukee, Wis.

Interested in motorcycling. Send illustrated literature. Postage stamp is enclosed to cover mailing cost.

Name.....

Address.....

My age is 16-19 years, 20-30 years,
 31 years and up, under 16 years.
Check your age group.

Ride a

HARLEY- DAVIDSON

Ran 2 Record-Smashing



RAY ELLINWOOD, sensational track star of the University of Chicago, clipped .3 second off the world's indoor 440-yard dash record in his first college meet.



HE DUPLICATED the feat 20 minutes later as anchor man on the relay team. Ray's start enables him to jump into the lead at the crack of the gun.



OPERATES steam-hammer. Charlie Kimball (*left*) says: "Camels always give me a welcome 'lift' in energy when I need it most."



ATTRACTIVE Claire Huntington (*right*), public stenographer, says: "No matter how tired I get, a Camel puts new pep in me. Although I smoke a lot, Camels never jangle my nerves."



SURVEYOR William Barrett (*left*) speaking: "When I begin to feel below par, it's me for a Camel and that invigorating 'lift' in energy."

Mrs. John W. Rockefeller, Jr. (*right*), of New York, says: "It's wonderful when you're tired to get a 'lift' with a Camel."



"JACK OAKIE'S COLLEGE"

A gala show with Jack Oakie running the "college"! Hollywood comedians and singing stars! Join Jack Oakie's College. Tuesdays—8:30 pm E.S.T. (9:30 pm E.D.S.T.), 7:30 pm C.S.T., 6:30 pm M.S.T., 5:30 pm P.S.T., over WABC-CBS.

440 Yd. Dashes in One Day!



IN THE FIRST few strides, Ray unleashes almost explosive power. And keeps driving!

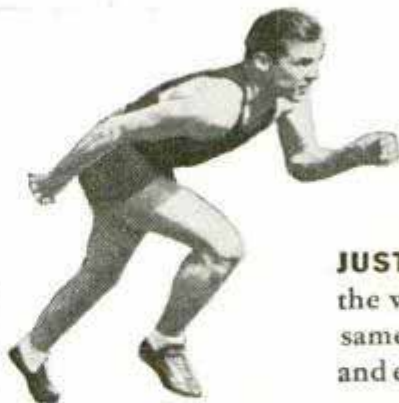

JUST IMAGINE breaking the world's record twice the same day! That takes stamina and endurance of high order.

"Please add me to the athletes who get a 'lift' with a Camel"—Ray Ellinwood

I NEVER fully realized just how much 'Get a "lift" with a Camel' meant to me until I ran two world record-breaking quarters in one afternoon," Ray continues. "That night I ate heartily and digested my meal as well as ever."

In every line of endeavor—men and women light up Camels to renew their vim and add enjoyment to mealtimes.



For Digestion's
sake... smoke
CAMELS

Copyright, 1937, R. J. Reynolds Tobacco Company, Winston-Salem, N. C.

COSTLIER TOBACCOS — Camels are made from finer, **MORE EXPENSIVE TOBACCOS... Turkish and Domestic...** than any other popular brand.

When writing to advertisers please mention Popular Mechanics

Sea Lore Kept Alive by Films

(Continued from page 877)

was the whaling ship, "Nanook" and was sailed to the Arctic by Director W. S. Van Dyke for the screening of "Eskimo."

A full-size model of H.M.S. "Bounty," copied from the original, sailed to Tahiti and back for M-G-M's "Mutiny on the

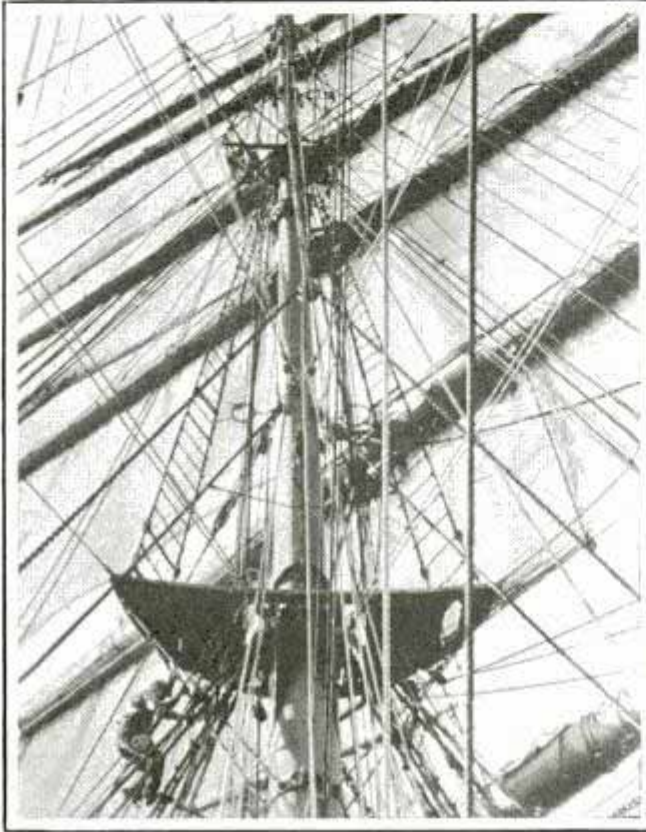

Sailors aloft to furl sails of "Star of Finland" on location off Catalina Island, Calif.

"Bounty." It now lies in San Pedro's back harbor waiting for a call to sea again.

Producer Sam Goldwyn recently sent representatives down to Tahiti to make arrangements to procure ships for his production of the Nordhoff-Hall story, "Hurricane."

After much scouting around for an obsolete slave ship, Twentieth Century-Fox finally chartered the "Lottie Carson," an aged schooner that another studio had just finished using. It is being used for their production, "Slave Ship," and has been reconstructed to resemble the once hated slave ships of 1850. This was done because the marine department at the studio found it impossible to find a real slave ship anywhere.

A studio's marine research crew must always know how to construct a prop ship on the studio lot. Often it's impossible or

too costly to procure a seaworthy ship. Occasionally the deck and a portion of a ship are constructed at the studio to serve as a nautical set. Sometimes these sets are built on the inclosed sound stages. This is done to assure silence, while taking dramatic scenes.

Most of the major studios have tanks where shallowly constructed craft can be floated. At Twentieth Century-Fox such an arrangement was used to take many of the old-time naval shots for "Lloyds of London." Their tank is located on high ground to assure a clear skyline. It covers an acre of ground. The side and prow of an old English frigate were reproduced and rolled across, while property men made artificial waves with huge paddles.

Expert ship model builders often can find highly paid positions in Hollywood. Sometimes shipwrecks and sea battles are filmed in miniature, with model ships being the victims. In every oceanic movie production at least one scale model of a real movie ship is made. The director and his staff use this in their nightly studio conferences to plan the shooting for the next day.

Pirate ships are another type of ancient vessels that tax studio researchers' ability. Several re-constructed pirate ships are anchored at San Pedro, too. One of these Warner Bros. used for the exciting "Captain Blood." This same company is planning another buccaneer film, "The Sea Hawk." Often it takes over a year of research to gather the facts about constructing such an historic ship.

Old Photo-Flash Bulbs Used as Targets by Police

Burned-out photographic flashlight bulbs, which usually are thrown away, are being used in Philadelphia as targets on the police pistol range. News photographers now save the old bulbs, instead of discarding them after completing assignments, and they are turned over to the police department.

Our Bureau of Information will answer questions regarding articles in this magazine, if accompanied by return postage.

Picture Story

of Eastman's Finest Miniature

KODAK BANTAM SPECIAL



LENS . . . Super-speed, super-corrected Kodak Anastigmat EKTAR $f.2.0$. Shoot early or late, in sun or rain; go after lightning-swift action; snap away indoors at night—your negatives will be needle-sharp; they'll yield big, detailed enlargements. (Standard, low-cost enlarged print size is $2\frac{3}{4} \times 4$ inches.)



COMPUR-RAPID SHUTTER

Nine speeds (1 to 1/500) capitalize to the full the Kodak Bantam Special's ability to cope with swift action, or difficult light conditions.

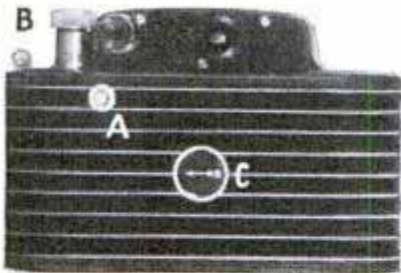

AUTOMATIC FILM CENTERING DEVICE

. . . Press button "A" while turning winding knob "B" about a half turn, then release the button and continue winding until knob locks. Film is then in position for the next exposure. You uncover film window "C" only to check the number of exposures made.

CONVENIENT LOADING

. . . Pull-out lock opens the hinged back. As the illustration shows, the winding knob can be extended beyond the housing of the camera for easier winding of the film.



RANGE FINDER . . . Split-field, military-type; coupled with focusing mechanism; adjustable to user's vision. Range is found by moving focusing knob. When the split image is brought into a straight line, camera is in focus.



As image will appear when range finder is set for a distance shorter than the correct one.



As image will appear when range finder is set for a distance greater than the correct one.



As image will appear when the range finder and focus have been simultaneously adjusted.



For superb enlargements, for wonderfully rich contact prints in any size, load with Kodak Panatomic Film.

For snapshots very early or late in the day, fast action shots, and indoor work with Kodak Bantam Special, use Super X Film.



Loaded with Kodachrome Film, Kodak Bantam Special gives you full-color transparencies to be viewed as they are or mounted in slides for large-size home projection.

KODAK BANTAM SPECIAL, '110 . . . AT YOUR DEALER'S . . .

Eastman Kodak Company, Rochester, N. Y.

When writing to advertisers please mention Popular Mechanics

Dispatchers of the Sky Lines

(Continued from page 885)

and distances, he studies weather maps, considers the type of ship, a Douglas twin-motored liner, and examines the speed reported by similar planes in recent hours. Using these facts, he moves the slides of his calculator and arrives at his own estimate of when the plane will cross various check points and reach Chicago.

As "TWA Flight 21" rockets over Pennsylvania at 6,000 feet it passes the first check point 126 miles out of Pittsburgh. This is the northeast segment of the Columbus, Ohio, radio beam, a signal extending spotlight fashion from Columbus.

As he crosses the beam, Captain Terry picks up his short-wave microphone and calls the company station, WAEO in Chicago: "TWA Trip 21 calling WAEO." Back comes the answer: "Okay, Terry. Go ahead." The Chicago operator listens as Captain Terry reports "TWA Trip 21 over the northeast leg of Columbus beam, 6,000 feet at 11:51. Estimated arrival south leg Detroit 12:14½." Chicago cuts in with a laconic "Okay," enters the report in the log and picks up the interline phone.

"TWA, Airways," he calls, and passes the information on to the traffic-control room. The block representing TWA Trip 21 is moved to the spot on the map where its course crosses the northwest leg of the Columbus radio beam. One hour and fourteen minutes out of Pittsburgh, Captain Terry passes over the south leg of the Detroit beam, notes the time and calls Chicago. Again the report is relayed to Airways, along with the estimate that he would be over Goshen, Ind., one hour and fifty-six and a half minutes after his Pittsburgh takeoff. The Airways operator carefully notes the position of all planes converging on this point. At Goshen the TWA ship will cross over the heavily traveled Chicago-Cleveland airway. Airways calls over the loudspeaker: "Airways TWA!" The TWA operator responds.

"United Air Lines westbound Trip 1 is estimated over Goshen 12:55 at 8,000 feet," says the Airways man. "American Airlines eastbound Trip 22 is estimated over Goshen 12:50 at 11,000." Station WAEO radios this advice to Captain Terry. Airways itself does not talk directly to planes.

As he nears Goshen, Captain Terry

climbs from 6,000 to 6,500 feet and swings about to cross the Chicago-Cleveland route at not less than a forty-five degree angle. Across the airway, he swings into the westbound lane and glides back to 6,000 feet. The time of crossing is radioed to WAEO and relayed to Airways.

The procedure of climbing to 6,500 feet is required by the department of commerce to avoid any chance of collision of two planes flying intersecting routes. The forty-five degree angle gets the ship across the lane quickly. Eastbound planes fly at odd altitudes—3,000, 5,000 feet, etc.—westbound at even altitudes.

At Goshen, Trip 21 receives traffic clearance to McCool, Ind., the inner marker thirty-five miles southeast of Chicago. Again, at McCool, the Airways control issues clearance into Chicago and in good weather, if traffic is not congested, Airways relinquishes control to the municipal control tower whose radio "traffic cops" bring the ship in. In heavy weather, however, Airways may retain control until the plane is over the airport.

Captain Terry reports good visibility over McCool two hours and sixteen and one half minutes from Pittsburgh, and a few minutes later, fifteen miles southeast of Chicago's depot, tunes in on the municipal traffic tower, Station WGEH.

"TWA Trip 21 to WGEH," Terry calls.

"Go ahead, Trip 21," comes the answer.

"TWA Trip 21 is twelve miles southeast of the airport. What are landing instructions, surface winds?"

"WGEH to TWA Trip 21: Surface winds east southeast, landing east. There is a private ship south of the field at 1,000 feet. All clear to the airport. Okay to come right in and land."

As the big bird swoops down across the runway, the Airways traffic control man enters arrival time in his permanent log, wipes "Trip 21" from the blackboard and picks up the little wooden tab from the map. Then he turns, always alert, to check those ships still in the air. There is no relaxing in vigilance. Airways is responsible for lives. And Airways cannot dodge responsibility, for every word spoken over that interline communication system is recorded on a wax cylinder and filed away.

HERE'S ALL IT TAKES *to get full engine power as you stop wasteful "knock"*

Just two easy steps bring you all the economy and performance offered by modern high compression cars...

1. (Below) Practically all modern high compression cars have an adjustable spark for the octane (anti-knock) quality of the fuel used. "Knock" can be eliminated by retarding the spark, but the result is loss of power, sluggishness, danger of overheating and waste of gas and oil. To take full advantage of your high compression engine, have your car dealer adjust the spark for *maximum* performance. It takes only a minute or two, and then...



2. (Above) Use Ethyl! Your high compression engine, with its spark properly adjusted for maximum performance and with Ethyl in the tank, will give you the fast acceleration and the generous reserve of power it was meant to give. Ethyl is at least six octane numbers higher in anti-knock value than any regular-grade gasoline—and what a difference that extra anti-knock value makes in the engines of modern high compression cars!

Here's the EXTRA value you get at the ETHYL pump:

1. You get more anti-knock fluid (containing lead tetraethyl) at pumps marked "Ethyl" than you get in the best regular-grade gasoline.
2. You get the all-round quality (including quick starting) that is *double-tested* by the oil company and by the Ethyl Gasoline Corporation.
3. You get 100% performance from your high compression engine.
4. You save on oil as well as gas by preventing overheating.

**NEXT TIME GET ETHYL...
A BETTER RUN FOR YOUR MONEY**



es 126

Rhythm in the Making

(Continued from page 893)

the body, rotated at high speed and pulled outward, the tone hole sockets are drawn from the body itself. There are no joints to spring leaks.

After its four parts are silver-soldered together, the instrument is dangled in huge electroplating vats. There, in the larger-size horns, as much as \$300 worth of pure yellow gold covers its exterior. Instruments are offered also in burnished brass, nickel or silver.

Before going to the shipping room the instrument must pass a long line of mechanical testers, and finally an expert player inspector. This man, a connoisseur



Drawing tone hole sockets, an exclusive process which makes them part of the saxophone

of pitch and tone, spends his entire day putting instruments through their paces. Often the tone-sleuth detects a false note, stiff spring, or some other flaw, and he immediately sends the misfit back to the factory for re-adjustment.

Popular Mechanics Magazine does not publish the name of the maker of, or dealer in, any device described in its pages, but this information is kept on file and will be furnished by our Bureau of Information upon request, accompanied by stamped, self-addressed envelope.

es 245

Powerful Magnet Lifts Weight Twenty Times Its Own



Block of metal twenty times its own weight is not too much for this small but powerful magnet to lift

Engineers in the Westinghouse laboratories have developed a magnet so powerful it can lift twenty times its own weight. It is so highly magnetized that it does not require the metal keeper which is used to help prevent loss of strength from small magnets.

East Pittsburgh Pa

Flexible Grip Pulls Pilings

es 308 - Without Breakage

Made of improved plow steel rope, a flexible grip with a tensile strength of over 200,000 pounds is available for pulling

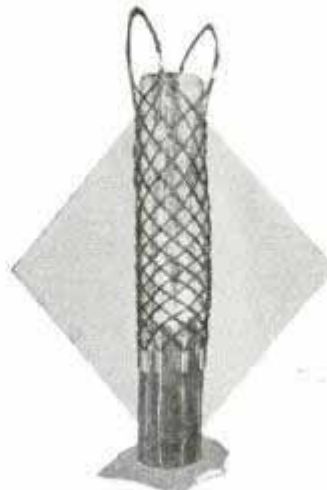

pilings fourteen to eighteen inches in diameter. Being flexible, the grip will conform to uneven surfaces of the piling. The present method is to throw a chain around the piling, but if the wood is decayed the chain frequently cuts the piling in two. The steel rope fits around the piling

and secures traction on a minimum of four feet, extracting it without breakage.

Kelleys Products, Inc
1911 Park Ave

Half & Half Makes
ONE Swell Smoke!



Get a pipe and get aboard with Half & Half. Cool as the thought that you've missed your train. Smooth as discovering it's ten minutes late. Fragrant, friendly, full-bodied tobacco that won't bite the tongue—in a tin that won't bite the fingers. Made by our exclusive modern process including patent No. 1,770,920. Cool and smooth. Smells good. Makes your pipe welcome anywhere. Tastes good. Your password to pleasure!

Copyright 1937, The American Tobacco Co.

No Bite!

No Bite!

Still no Bite!

Not a bit of bite in the tobacco or the Telescope Tin, which gets smaller and smaller as you use-up the tobacco. No bitten fingers as you reach for a load, even the last one.

HALF ^{AND} HALF
The Safe Pipe-Tobacco
FOR PIPE OR CIGARETTE

You Can't Believe Your Ears

(Continued from page 837)

balance bells, fire-truck bells, burglar-alarm bells, schoolhouse bells, church bells, ship's clock bells, sleigh bells, table hand bells, bicycle bells, cow bells, train bells, prize-fight gongs. Some of the "bells" are not bells at all. A section of a circular saw, for instance, may sound like a train bell when struck with a mallet. It's the sound produced, not the contrivance that produces it, that is important.

As sound effects became more important in radio programs, broadcasting stations, and particularly the big networks, began to rely on phonograph records for sound effects of certain kinds. Today every big



Sound man producing noise of feet climbing stairs and a closing door

studio has its own record library containing hundreds or perhaps thousands of recorded sounds, each one carefully catalogued. Such records are the foundation for sound effects today but sound men must still be relied on for special effects or for momentary sounds like the blowing of a whistle, the ringing of a bell or a pistol shot.

A record of the noise of a speeding train, for instance, supplies an effect which would require four or five sound men—one to ring the bell, one to supply the click of the wheels, one to rub a brush across a drum head to furnish the chug-

chug of the engine and another to work the whistle and hiss of steam with an air tank and a hose. The momentary ringing of the bell, however, as the train is about to start, is still a job for the sound man and not for a phonograph record.

Often both recorded and studio-produced sounds are combined as, for instance, in the noise of a cheering crowd. The record supplies the background, voices in the studio lend reality. Bells and doors are the two most common sounds heard over the air. One of the newer noises which caused sound men some trouble was the air whistle of a streamline train. One sound man solved the difficulty by retuning an old train whistle.

One of the most difficult sounds to imitate is a gunshot. Slapping a leather cushion with a stick is one way. Other sound men use a fiber box which gives resonance and depth when struck. The box and a pair of drumsticks make a noise like a machine gun. In the studios of the Columbia Broadcasting System we also use real blank cartridges but do not fire them from a pistol because the concussion might damage the diaphragm of the microphone. We place the blanks in a frame and hit a firing pin with a hammer. You hear the noise but the concussion is absorbed in a baffle beneath the frame.

There is a trick even to such a simple thing as opening and closing a door. The sound man must visualize the action. If he opens and immediately slams the door, it appears that the person entering popped into the room rather than strolled in. And when you hear the door open at the wrong time, don't blame the sound man. Ten to one, he hasn't missed a cue at all. He followed instructions in the script, hoping to get a laugh out of you.

Microphones and radio technique have improved today to a point where sound effects men, with certain exceptions, can use the exact article called for to make the sound of that article unless it is too big or too heavy to get into a studio. Nearly every sound effects man knows the Morse and wireless codes and sends real dots and dashes when the script calls for such messages.

(Continued to page 124A)

200,000 H.P. UNDER HER HOOD.

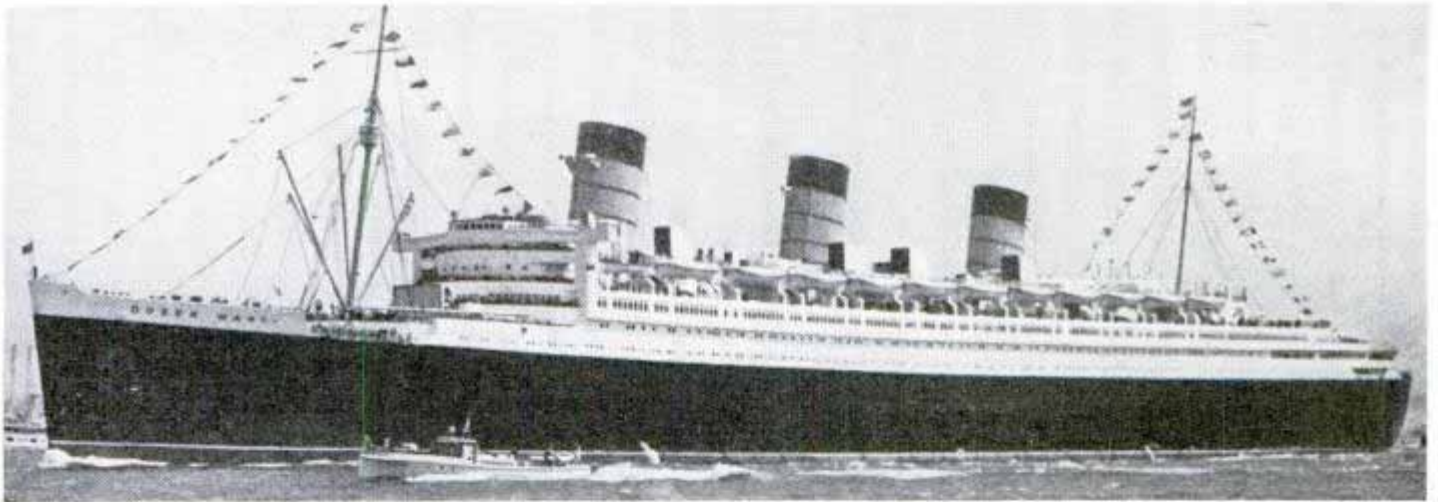

**AND SHE RELIES ON THE MAKERS OF MOBIL OIL
FOR VITAL ENGINE PROTECTION!**

WHAT has the "Queen Mary" to do with your car?
Just this: In winning the right to the coveted Blue
Ribbon, she used oil refined by the makers of Mobiloil! Every
North Atlantic record-breaker has! That just about makes
Mobiloil the world's Blue Ribbon oil, doesn't it?

It does! Use Mobiloil . . . and you'll have the best.



MOBIL OIL AND MOBIL GAS

SOCONY-VACUUM OIL COMPANY, INC.



When writing to advertisers please mention Popular Mechanics

You Can't Believe Your Ears

(Continued from page 122A)

Devices for creating specific sound effects are both ingenious and simple. In addition to those already mentioned, here are some others you hear on CBS programs. Put a chamois skin over a length of rain spout, hold it so rubber slappers driven by a small motor strike the chamois—and you have an automobile. Speed up the motor and you speed up the car. Lengthen the rain spout and you get the roar of an airplane. A real automobile door set in a frame makes the sound of the opening and closing car door. Nails in a board scraped over a metal plate im-



This is a desperate battle between two gunmen taking place on a gravel driveway

itate the squeal of brakes, and a collection of auto horns completes the car effects.

Three sound effects men, each armed with half a dozen slippers imitate a whole stage full of tap dancers. Rows of pegs with padded ends attached with fishline to a square frame make the sound of a thousand men on the march when the frame is raised or lowered rhythmically. A little wagon atop a revolving drum sounds like a big wagon in front of the microphone. Cleats in the drum cause coconut shells to move up and down to make the sound of the horses' feet.

A paddle wheel revolved in a tub of

water imitates everything from a side-wheel boat to a torpedo, depending on the manner in which it is turned. A cord stretched between two squeaky pulleys sounds like the curtain rising in an old-time theater and an assembly of loose gears turned with a crank can be used for a dozen machinery effects.

A voice over the telephone is imitated by having the actor speak into an apparatus which cuts out either the high or low frequencies to give the sepulchral or echo effect. The same apparatus is employed to imitate the hollow voices of miners working underground and for many other voice effects.

Problems of the sound effects men are illustrated by the evolution of the rain machine used on CBS programs. This is a rain-maker that works—at least so far as making a noise like rain is concerned. A can of buckshot revolved before today's sensitive microphone would sound like a dozen Niagaras in action at once. We tried wax-paper cylinders containing rice, but the "mikes" became too sensitive for this effect. Before we determined that birdseed dropping on a sheet of Cellophane made a noise like rain, we experimented with salt, wheat, oats, bran and half a dozen breakfast foods.

Modern radio sound effects men pride themselves on the ability to imitate any noise you ever heard, and do it so well that the "synthetic" sound will fool your ears. Only once have I ever heard of a sound man giving up. He was asked to make a noise like a bicycle coasting on a concrete sidewalk. He finally convinced the inspired script writer that a coasting bicycle doesn't make much of a noise.

Sand Polishes Streamliners on Fast Desert Runs

When streamline trains made of stainless steel speed through the western deserts, the sand carried against the coaches by the rush of air has a blasting effect. This keeps the trains polished and shining, even brighter than when they came from the manufacturer's shops. The peculiar air currents which cause this sandblasting are set up by the streamline construction.

*Budd Mfg Co
25th and Huntington*



Just one whiff...

will tell you it's better

FIVE REASONS WHY YOU'LL LIKE VELVET

1. *Fine old Kentucky Burley aged-in-wood.*
2. *Flavored with pure maple sugar for extra good taste.*
3. *An altogether different fragrance.*
4. *Cut to pack easy in a pipe — cut to roll smooth in a cigarette.*
5. *Every tin contains 2 full ounces.*

There's an altogether different fragrance to Velvet... the milder, sweeter aroma of sun-ripened Kentucky Burley . . . cured and aged the right way for good smoking.

And another thing... a dash of pure maple sugar adds just the right flavor for extra good taste. For a new smoking enjoyment . . . try *Velvet*.

Velvet

better Smoking tobacco

for pipe or cigarette

The Mud that Runs the World

(Continued from page 803)

underground crevice. Circulation was completely lost. Things began to be shoved down the well. First, 100,000 barrels of water were poured down in an effort to control the pressure. These were followed by additional mud. Then 200 feet of wire, cut into three-foot lengths, were dumped in, but the crevice ate them all and asked for more. Down went 600 feet of scrap iron, followed by 1,800 sacks of ordinary cement. Still the crevice was not plugged.

Finally engineers rushed to the scene and concocted a mixture of cottonseed hulls, cement, and a special bentonite clay from California. Large quantities of this finally saved the well.

One of the first things to determine when circulation is lost is exactly what sort of formation is causing the trouble. To discover this, a special "core bit" is sent down and a drill core brought up. This is simply a circular bit of earth the size of the core bit. If there is time, and the gas pressure doesn't threaten to blow everything away, this core is sent to a laboratory for analysis. Here it is put under conditions identical to those which prevail at the bottom of the well. Terrific pressure is applied. Then various fibrous substances and types of cement are shoved through the core, until one is discovered which will plug the holes in the formation. This mixture is then shipped to the well and shoved down the casing.

Of course, when the drill crew is unfortunate enough to bore into a crevice or underground fissure, the coring method of analysis is useless. You can't take a core out of an open space. Heroic methods are then called for, with everybody guessing what will plug the gap.

When these holes aren't filled and a roaring inferno of flaming gas shoots out of the well the story of stuffing the cracks with workers' shirts loses its touch of humor. The record of wells that blew out prematurely is marked too often by lost lives.

☐Inquiries as to makers of articles described in Popular Mechanics, will be answered by our Bureau of Information upon receipt of return postage.

Gas Mask Guards Cameraman in War Games at Sea



Cameraman in grotesque mask tries out aerial camera during British fleet movement

When the British fleet conducted maneuvers in the south Atlantic ocean recently, all the latest weapons and defensive equipment were tested. The war games called for use of gas masks and even the cameraman trying out a new aerial camera wore one as he snapped pictures from his position aboard the aircraft carrier "Courageous."

Safety Matches on Rotary Pad Are Lit by Pulling Out "Ad"

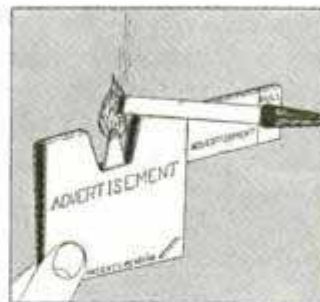

Advertisers are given an extra "break" by a rotary safety-match pad recently invented. The matches revolve on an axis, only one at a time being exposed for

use. When a light is desired, you pull a slide bar which turns the rotor, scratching the match against a built-in abrasive and producing a light in the opening at the top of the pad. This slide bar has additional advertising space, which commands attention each time a match is struck.

☐The temperature of the earth's core has been estimated by scientists at about 3,000 degrees centigrade.

Harry L. Klassen, 1101 Pratt Street

Science Monthly
March 1927

CHEVROLET TRUCK

breaks all known economy and
dependability records

Here's proof!



Through blazing heat... through blasting cold...
across high mountains . . . across
level plains . . . this Chevrolet
half-ton truck rolled up
amazing new records



10,244 MILES
with 1000-pound load

\$101 TOTAL COST
OF GAS

TOTAL COST
OF REPAIR
PARTS **73¢**

Study this unequaled record—then
buy CHEVROLET TRUCKS

Location of Test	'Round the Nation
Gasoline Used	493.8 Gallons
Oil Consumed	7.5 Quarts
Water Used	1 Quart
Gasoline Mileage	20.74 Miles per Gallon
Average Speed	31.18 Miles per Hour
Running Time	328 Hours, 31 Minutes
Cost per Vehicle Mile	\$.0098
Average Oil Mileage	1,365.9 Miles per Qt.

These records have been certified by the A.A.A. Contest Board as being officially correct.
*General Motors Installment Plan—monthly payments to suit
your purse.*

CHEVROLET MOTOR DIVISION
General Motors Sales Corporation
DETROIT, MICHIGAN

"MORE POWER per gallon  **LOWER COST per load"**

When writing to advertisers please mention Popular Mechanics

Things Are Not What They Seem

(Continued from Coloroto Section)

"Cellophane" for protection during handling immediately after birth. But this product of the stately spruce tree is more than a wrapper. It is used for decorative purposes in the arts and crafts, it is made into rain capes and used in colors on hats, shoes and belts and for printing purposes.

Now watch closely while the chemist performs another sleight-of-hand trick. Instead of extruding the sirup through a slit and into an acid bath, he merely squirts it through tiny holes, called spinnerets, and into the acid. And it emerges not as a film but as a filament—microscopic threads finer than human hairs, finer even than the silk of the silkworm. Here you see the birth of rayon, the first man-made fabric. So fine are the tiny strands that one pound of them would reach from the Atlantic to the Pacific but, when woven into yarn, it can be converted into a fabric of chalky crepe or transparent velvet, dull or lustrous, in solid colors or printed designs. Man at last has succeeded in doing mechanically what the silkworm does—making a filament from a plant. The difference is that man uses spruce wood or cotton and works under scientifically controlled conditions; the silkworm takes the mulberry leaves as they come. Moreover, the natural silk filament is a protein material, not cellulose.

New and revolutionary things are being done with rayon today and so widespread have become its applications that the United States alone used more than 250,000,000 pounds of this man-made fabric in 1935, four times the consumption of natural silk. In many minds rayon is associated only with cheap and inferior goods but such is not the case today. Nearly every type of dress fabric today is produced in rayon or by combining rayon with other materials. This is partly due to the fact that the production of rayon can be controlled scientifically to impart any desired quality whereas so-called natural yarns possess certain inherent qualities which the manufacturer must take or leave, he cannot change them.

Rayon, for instance, originally was made highly lustrous. Styles changed and later rayon appeared with chalky and even frosty surfaces. With other yarns such a

change would be impossible. The strength and uniformity of rayon yarn have been improved to a point where it is claimed that rayon as irregular as the most regular natural yarns available would be unsalable today. It is also true that more brilliant color effects can be achieved with rayon than with other fabrics because its luster in itself gives added brilliance.

More than 700,000,000 yards of woven fabric were loomed from rayon in 1935, varying from sheer cloths of fine filaments to heavy ones of the wool type, delicate transparent and crushproof velvets, sturdy plushes, smooth sheers, durable rough crepes, satins with a bright glitter and others which were lusterless. Many fabrics are created today which could not be produced at all with other textile fibers and the list is growing. Spun rayon, composed of threads made from cut-up filaments, also has opened up a completely new set of fabrics since it blends with natural fibers to make novelty wools, men's tropical suitings and many other materials.

And still more fabrics are bound to come from cellulose. E. H. Killheffer, executive vice-president of the Institute of Textile Research and an official of the du Pont company, suggests that perhaps some day a method will be found, with the aid of proper buffers, to introduce wool into viscose just before it is extruded into threads or sheets, thus producing a textile fabric after the fashion paper is made. Only time and research will tell.

Various other products besides rayon and "Cellophane" are produced from viscose. Put the sirup into a vat with chemical solids, stir it up and then dump it into the acid bath and it "freezes." Treat the coagulated product to remove the chemicals, thus creating holes where the chemicals were—and you have a sponge. Saw up this product and you obtain a sponge of regular shape in any size desired. Sausage casings and bottle caps also are made from the same sirup.

Now, let's return once more to our starting point—cellulose. Treat this cellulose with acetic acid—which gives vinegar its taste—and you obtain, not nitrocellulose and not viscose, but cellulose acetate and

(Continued to page 130A)

Their Tiny Light Kept Life Aglow



Entombed 12 Days in Moose River Mine, Scadding Now Tells How Pair Survived



"Our miner's lamp went out when the mine crashed around us on Sunday night," writes C. A. Scadding, one of the two survivors of Moose River, the most famous mine rescue in history, in telling of critical moments that dragged into 12 despairing days in the crumbling underground blackness, 142 feet below the surface.

"From then until other flashlights, candles and matches were lowered to us through the drill hole on the following Sunday, our only source of light was the 'Eveready' Boy Scout flashlight I had brought for an emergency. It was just as wet as we were at all times, and without its light I would never have been able to even locate the drill hole, much less to get to it for the food and medicine that kept the doctor and myself alive. The hole broke through 40 feet away from us and to get to it required a dangerous crawl through broken rocks and

timbers and down the shaft about 18 feet. If that flashlight had failed us during that horrible week, the

doctor and I would not be alive today. But for those *fresh* DATED 'Eveready' batteries the heroic work of the rescue crew would have been in vain. (Signed)

C. A. Scadding

**"EVEREADY"
BATTERIES
ARE FRESH
BATTERIES**

**The Date-Line
Guarantees Freshness**

NATIONAL CARBON CO., Inc.,
30 E. 42nd St., New York, N.Y.

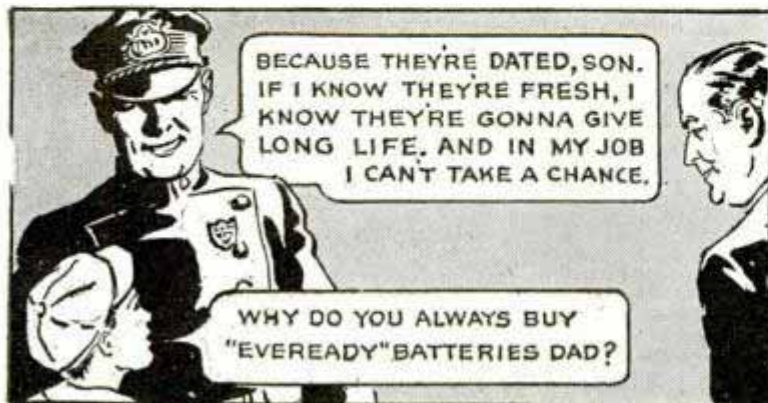

(Continued from page 128A)



A new sponge made (like rayon) of Cellulose. Soft, durable, sanitary, absorbent.

Get this AMAZING SPONGE FREE

*with every
pint can of*
**No. 7
POLISH**



WE make this generous offer so that new thousands of car owners will try No. 7 Duco Polish immediately, and see how greatly it improves the appearance of the car. You should use No. 7 Polish on new cars as well as old. It keeps new cars beautiful and restores the color and lustre of old finishes dulled by grime and Traffic Film.

Now we offer a Du Pont Cellulose Sponge (25c size) FREE to everyone who buys a pint can of No. 7 Polish. (Offer good in U. S. only.) This sponge, created by du Pont chemists, is ideal for bath and household cleaning, as well as for the car. See your dealer WHILE THEY LAST!

**GRIME DOES NOT PAY
... USE No. 7**

the starting point for a new array of products. Like nitrocellulose, it dissolves in solvents to form viscous solutions, but its solubility characteristics are different. One of its characteristics is that it is slow-burning and hard to ignite so it can be used to make products employed where fire would be a hazard. It goes into photographic film and safety film for movies and as a thin plastic sheet reenforced with wire mesh it is used instead of glass in poultry houses because it admits ultra-violet light.

It is worked into a plastic somewhat like "Pyralin" and it is made into a fabric, acetate rayon, and converted into high-style women's wear. Acetate rayon is more "immune" to stains of various kinds, perspiration, grease, ink and fruit juices, it absorbs less moisture, it dries quickly after laundering, does not wrinkle easily, resists water spotting, does not yellow with age or exposure to light and will not mildew in the tropics. What natural fabric can boast as many advantages?

Thus has chemistry taken the fibers of growing plants and converted them into useful products seemingly as unrelated as the lacquer on your car, the lining of your coat, the barrel of your fountain pen and the wrapper around your cigar. All are brothers under the skin—their parent was cellulose. The elimination of cellulose products from our civilization today would send us backward toward the Stone Age.

Yet, many of the potentialities of this field admittedly are unexplored. Cellulose may be combined with many acids other than nitric and acetic and it seems probable that patient research in the chemist's laboratory may some day produce a whole new series of cellulose derivatives just as important as the cellulose products we enjoy today.

Truly, the story of cellulose must demonstrate that "things are not what they seem." But this description applies to more than cellulose. What about the rainbow hues of rayons and of the beautiful plastics we use today? That's where the lowly lump of coal enters the picture.

(Concluded next month)

Our Bureau of Information will answer questions regarding articles in this magazine, if accompanied by return postage.



**Complete
your camp
with an
outboard
boat**

THE lake is your playground . . . each point and each pool . . . each shady cove and creek. An Old Town Boat is your passage to pleasure. A boon to the fisherman . . . a thrill to the kids.

There's an Old Town Outboard Boat for every vacation need. Open-deck boats for sport. Large, fast, all-wood boats for family use. Each is a masterpiece—steady and safe. Rugged and ready for use. No calking or soaking, and no big expense. Write for a free catalog showing many models. Also rowboats, dinghies and a fleet of canoes. Address: Old Town Canoe Company, 336 Main Street, Old Town, Maine.

"Old Town Boats"



New HULL AUTO COMPASS

Saves miles of travel in wrong direction. This handsome, STREAMLINE Airplane Type Compass keeps you on the right road. Easily installed. 3 1/2 inches high. Bakelite case, sapphire bearing. Built-in compensator. Only \$2.95 POSTPAID. SATISFACTION GUARANTEED.

MODEL A

Airplane Type. 1 3/4-inch diameter. Sticks to windshield. Guaranteed. With separate compensator, only \$1.95 POSTPAID.

If your dealer cannot supply you, order direct.



HULL MFG. CO., Box 246-D, WARREN, OHIO

POPULAR MECHANICS FAMILY TRAILER PARTS

Available from Hammerblow Tool Company — the original.

Don't build until you get Hammerblow facts. Save money, time, wasted labor. Hammerblow guarantees a rugged, non-sway, perfect trailer! BLUEPRINTS FREE WITH PARTS. Hammerblow parts are world's best. Used by nationally known firms and engineers who know. Send only 50c for 64-page Trailer Builder's Guide and Free 40 page supplement. Immense value. Or write for Free Literature. HAMMERBLOW TOOL COMPANY, Dept. 106, Wausau, Wis.



CATALOG AND COUPON

Return coupon with order for Fireworks and get big 35c box of SALUTES FREE

SPENCER FIREWORKS CO., Box PM 150, POLK, OHIO

INTRODUCING! MASONITE INSULATION SHEATHING BOARD

(A NEW MASONITE PRODUCT)

"Mr. Sellers, MASONITE has a new product that's going to reduce that estimate on your new home. I'll drop in and tell you about it."



ARCHITECT: "Here's the new material—MASONITE INSULATION SHEATHING BOARD. 25/32 of an inch thick. You see, it's thicker than their former insulation and 50% stronger. That adds 50% more strength

to every wall. And 50% more insulation value. Now, you'll notice that BOTH sides are smooth, so we can use either one, or both, for exposed surfaces.

MR. SELLERS: "That sounds fine, but how will this new board save us any money?"

ARCHITECT: "First, it's just the right thickness to use with standard door and window frames. Second, it's going to give us extra strength and extra insulation that, otherwise, we'd have to pay a lot for. Third, in some rooms we can eliminate any further wall and ceiling treatment. And fourth, it's going to cost less to install."



MR. SELLERS: "Just what we want! Let's have MASONITE INSULATION SHEATHING BOARD on EVERY wall."

• Masonite Corporation also announces a new cane insulation board of high quality and efficiency for use where light-colored board is specified. Ask for MASONITE CANEC INSULATION.

MAIL THIS COUPON FOR FREE SAMPLES OF TWO BRAND-NEW MASONITE PRODUCTS

MASONITE CORPORATION, Dept. PM-6
111 W. Washington St., Chicago, Ill.

Without cost or obligation, please send me FREE samples and complete information about the two new MASONITE Products—MASONITE INSULATION SHEATHING BOARD and MASONITE CANEC INSULATION.

Name _____

Address _____

City _____ State _____

When writing please mention Popular Mechanics

**NEVER BEFORE . . . A
MOVIE CAMERA LIKE THIS!**



ONLY \$9.95

Today more UniveX Movie Cameras and Projectors are being sold than those of *any other make!* There must be a good reason for such a record. And there is! UniveX Cine "8" is the first fine, precision-built, lifetime movie camera ever offered for only \$9.95! And the first movie camera to take movies *at less cost than snapshots!* Thousands couldn't believe their ears when they heard these sensational prices. And could hardly believe their eyes when they saw the brilliant, theatre-quality movies taken with UniveX.

FEATURES: Backed by written guarantee. Sturdily built. So compact it can easily be "shot" with one hand. No complicated gadgets! Simple to operate—easy to load. Produces sharp, clear, brilliant movies that can be screened up to 34" x 24". Interchangeable lens equipment. Quiet operation.

USES 60c FILM! The UniveX Cine "8" is the only movie camera in the world that uses the 30-ft. UniveX Cine Film that costs only 60c and takes as many scenes as 60 feet of 16 mm. film. Just think! Movies for only 6c a scene. Ask your dealer for demonstration today!

FREE BOOKLET may be secured by writing Dept. 28, Universal Camera Corp., New York City.

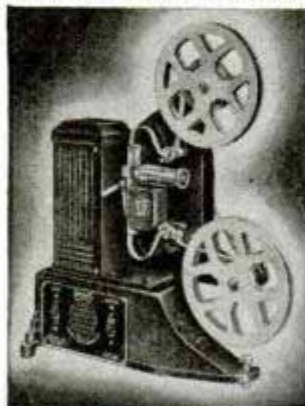

**Only 8 MM. Projector
For Less Than \$26**

Projects all 8 mm. film including professionally-made movies. 15 minute continuous projection capacity, flickerless movies, and 15 other important features heretofore found only in the highest priced movie projectors. **\$14.95**

*Prices Subject to Change
Without Notice*

UniveX CINE "8"

Grim Jokes of the Fire Demon

(Continued from page 822)

ing started to bake a cake. She mixed sugar and flour, then noticed the flour contained worms. So she poured the mixture down the incinerator chute. Instantly there was an explosion.

At another time a man was emptying a vacuum-cleaner bag into the incinerator flue of his apartment house. The dusty contents exploded. Dust dumped into an incinerator might be ignited by fire or by static charges generated by friction.

The rapid growth of the soybean industry has resulted in a number of serious explosions in soybean processing plants. Inflammable, volatile solvents used to extract oil from the beans, or dust created by converting beans into flour become ignited by static or other means, and the fire or explosion follows. Sometimes there is no fire, but only a blast like one in Chicago which caused \$600,000 damage, killed eleven men and injured forty-five others. Government experts are working on this problem.

When a farmer discovers that his hay-mow is heating, the best thing for him to do is to push a pipe down into the hot hay and let a thermometer down into it. If the thermometer shows a temperature of about 200 degrees Fahrenheit, it is time to call the fire department. When the firemen have run their hose lines into the barn, the farmer can then proceed safely with the task of removing the hay. The reason for calling the department is that the "hot spots" in the hay, when uncovered so that air gets to them, frequently burst into flame. Such firing of hay is known as spontaneous combustion.

An ice building, insulated with sawdust, contained 10,000 tons of ice. The roof developed a leak during a storm, and the sawdust began drying out. Then the ice house burst into flames and burned to the ground!

Take the recent case in New England where floods covered a farm region with roof-high water. The water, after reaching its highest stage, began to recede rapidly. But when it still had six feet to go, a large barn caught fire and burned.

Long research by Dr. E. J. Hoffman and Max A. Bradshaw into the chemistry of the spontaneous combustion that sets fire

to water-logged haymows has revealed the startling fact that the water actually is responsible for the fire. Briefly, what happens is something like this: The wetting of the hay starts billions of decay organisms, tiny bacteria which break vegetable matter down into simpler compounds, to growing. As they grow, they produce inflammable gas. They also generate heat. This heat continues to collect until, at about 400 degrees Fahrenheit, the hay, sawdust, fertilizer, or cattle feed bursts into flame.

There are several puzzling angles still to be solved before methods of preventing it can be worked out. The bacteria cannot stand 400 degrees of temperature. At about 170 degrees they disappear. But what happens after the tiny fire bugs leave? That is what Doctor Price and his men are hoping to discover. When they know that, they hope to discover some chemical which, when added to the hay or other material, will prevent spontaneous combustion by killing off the bacteria.

Finely powdered aluminum, such as that handled in many industrial plants, will burn vigorously when ignited. To throw water on it only makes matters worse because the water and aluminum react to produce hydrogen gas which is violently inflammable and explosive. A recommended way of fighting aluminum dust fires is to isolate them with dry sand and then let them burn themselves out.

Another peculiar fact discovered about water used in fighting fires is that there are several kinds of it. A common hazard, which firemen try to avoid, results from directing a hose stream on an electric wire or machine carrying a current. The current may travel back down the water stream, and may cause injury to the firemen. Studies at Purdue University have revealed that the electrical resistance of water may vary widely. In general, that from deep wells has from 1,000 to 2,000 ohms per cubic centimeter; that from lakes and reservoirs, 2,000 to 4,000 ohms, while filtered water may have still greater resistance. The greater the resistance in ohms, the less likely a short circuit. Future fire fighters may use one kind of water on one fire, and another on a second, because of such differences.

In order to learn about fires and explo-

(Continued to page 134A)



Only
\$39²⁵
COMPLETE
WITH DELUXE
EQUIPMENT

Complete Full-Size
Professional Machine

What savings! Now you can get this full-size, heavy duty Electric Arc Welder—only \$39.25 complete with De Luxe accessories—less than one-third the cost of any other kind! equipment of its kind! Now for the first time

every inventor, laboratory, home work shop, repair and machine shop, garage, and factory, dairy, farm, etc., can own a powerful, efficient Electric Arc Welder that handles all kinds of welding—everything from fenders and light sheet metal to motor blocks and heavy castings. Big opportunity for PROFITS in starting your own Welding Shop.

Works from 110 or 220 Volt A. C. Socket

Just plug the Aladdin into a 110 or 220-Volt 50 or 60-cycle A. C. socket and do practically any welding job right on the spot. Ideal for all kinds of maintenance, production and experimental welding jobs. Leading companies have purchased the Aladdin—United States Government, Johns-Manville, Eastman Kodak, Ford Motor, etc. Costs only few cents an hour to use. Usually pays for itself on first few jobs. Portable, on casters, easily taken to outside jobs in auto, truck, or sidecar.

Big Practical Machine—

The Aladdin is a big, 100-lb., sturdily-built tool that welds iron, steel, cast iron, cast steel, and alloys of these, or any other weldable metals. Also does electric soldering and brazing. Uses standard welding rods. Current controls instantly adjustable. No experience or training needed to operate. Simple, complete instructions for doing all kinds welding jobs included.



FREE! Manufacturers — Garages — Repair Shops — Inventors — you can save money with Aladdin. Find out how. Send no money! Mail post-card or coupon for complete FREE details, today! You are not obligated.

COMMONWEALTH MFG. CORPORATION
4208 Davis Lane, Dept. W-51, Cincinnati, Ohio

Commonwealth Mfg. Corp., Dept. W-51,
4208 Davis Lane, Cincinnati, Ohio
Please rush me at once, FREE, all facts and details about
Aladdin Electric Arc Welder at only \$39.25 with De Luxe
Accessories.

Name

Address

Town

State



You can save repair bills and add to the enjoyment of summer driving if you clean out the rust and scale in your radiator. Sani-Flush does it, for ten cents, in a few minutes.

Just pour some Sani-Flush in the radiator. (Directions on the can.) Run the motor. Drain. Flush. Refill with clean water. A cool-running car has more power, more snap. It doesn't depreciate so fast. Sani-Flush cannot hurt aluminum cylinder heads or motor fittings.

You'll find Sani-Flush in most bathrooms for cleaning toilet bowls. Sold by grocery, drug, hardware, and five-and-ten-cent stores—25 and 10 cent sizes. The Hygienic Products Company, Canton, Ohio.

Sani-Flush **Safe NOT CAUSTIC**
KEEPS RADIATORS CLEAN

NEW BENJAMIN AIR PISTOLS

Powerful—Accurate—Economical—Practical—Adjustable Shooting Force—Amazing Maximum Velocity—ent. 177 or 22 and BB—For Target and Small Game—the only Genuine Compressed Air Pistol on the market—Single Shot with Bolt Action—Hammer Fire—Hair Trigger—Safety. Price \$7.50. Also 177 and 22 Single Shot Air Rifles \$7.50—Single Shot BB Air Rifle \$6.00—25 Shot BB Repeater Air Rifle \$7.50—at Dealer or Direct—No license required—Safe for indoor use. FULL DETAILS—TARGETS—FREE—WRITE TODAY. Benjamin Air Rifle Co., 691 N. Broadway, St. Louis, Mo.



\$7.50



AUTO ENGINE SPEED CONTROL GOVERNORS

To control speed of any make of auto or truck engine, regardless of load changes, when used as a stationary or portable power plant. Fully guaranteed. No cash down. Governor speed range from 400 to 3000 R.P.M. Fine opportunity for established agencies. Send for free circulars. Mfrs. Candee-Smith Gov., Dept. 112-F 215 No. L. A. St., Los Angeles, California.

(Continued from page 132A)

sions so they can take steps to control them, government scientists manufacture conflagrations by the hundreds. Much of the investigation has consisted of non-spectacular experiments in the laboratories of the bureau of chemistry and soils, research such as that on the action of decay bacteria in causing haymow fires.

On the department of agriculture's experimental farm at Arlington, Va., is a special building in which Hylton R. Brown and Richard L. Hanson make dust explosions to order. The primary purpose of the building is to study venting methods—the use of swinging windows and the like to relieve explosion pressure.

Powdered starch is the most common explosive used in test blasts.

Use of windows that swing outward under pressure from within is relatively easy in new buildings, but protection for older buildings, without extensive alteration, is not easy by this method. A series of studies revealed that windowpanes can be scored so that they blow out like safety plugs, yet normally perform all the functions expected of a window. An ordinary window will withstand a pressure of about 300 pounds per square foot. But if the panes are scored with a glass cutter on the outside, the window will break at pressures of eighty-eight to 143 pounds.

There is evidence that the explosive dust can be broken to harness and put to work—evidence that dust engines, running on starch and what not, are feasible. Already the coal-dust engine has been developed, and is being used in Europe.

Great possibilities can be visualized for such engines. Many factories, particularly those handling grain, starch, and the like, could run on their own waste dust. Farmers may operate their tractors and other machines on starch produced from their acres. Sweet potatoes, for example, can be dried and pulverized to give an excellent grade of fuel starch. An acre of ground will grow enough potatoes to produce about three and one-half tons of such starch; and that amount of starch would, in a properly designed engine, be equivalent to many gallons of gasoline.

At any rate, Doctor Price is beginning research on harnessing explosive dust. Later, he hopes to build experimental engines designed to run on dust.

Oilier Oils for Your Car ²¹⁹

(Continued from page 843)

Added in small amounts to a base oil having a film strength of around 5,000 pounds per square inch, it increases the film strength to as much as 18,000 pounds per square inch. Another company who produces a compound for addition to oils, uses methyl esters of Poly-Keto-Hydroxy compounds manufactured from petroleum itself. These substances produce high oiliness and inhibit bearing corrosion.

These are only a few of a number of ingredients that oil companies have added to their oils. Some of the compounds have both the high film strength and carbon softening characteristics. Others merely increase the film strength, while some materially improve the oiliness and remove carbon. Most of them stick to metal surfaces and decrease the usual "starting wear" that takes place when a cold motor is started up.

One advantage of the new oils is that a motorist can usually switch to a lighter grade than he has been using. Due to the chances of heat breaking down the oil film this was not always recommended in the past. Switching to a lighter grade is safer now and a lighter oil may increase gasoline mileage as much as one or two miles per gallon. Since the rings are freed, oil pumping is not as serious as with the old-type oils. One prediction is that within ten years all motorists will use SAE 10-W oil all through the year as within that time additional improvements will make oils even more oily than those of today. The reason why slight improvements in oil are reflected directly in better mileage and power is that any decrease in friction losses is added directly to the power delivered to the rear wheels. Only twenty-six per cent of the power developed by an automobile engine performs mechanical work. The rest is lost in radiation and in the exhaust gases. Of the twenty-six per cent that works, more than eight per cent is lost in friction. Four per cent is lost in the differential, a little more than seven per cent goes toward overcoming wind resistance, leaving not much more than five per cent that actually goes to work at the rear tires.

High film strength is even more impor-

(Continued to page 136A)

DROP THAT SHOVEL!



The Sensational New WILLIAMS OIL BURNER

MADE BY

WILLIAMS
OIL-O-MATIC
HEATING

If you are still wielding a coal shovel, evidently you haven't heard the sensational news! That Williams is now offering a remarkable new oil burner at a sensational new low price!

A few of the many marvelous features of this new Williams Oil Burner are listed below. Study them! They prove what a truly exceptional bargain this great oil burner is!

Orders are pouring in! Prices are advancing! See your Williams Oil-O-Matic dealer . . . *today!*

BUILDERS ATTENTION! Investigate this new Williams Oil Burner! It is what you have been looking for!

STUDY THESE FEATURES!

- ★ Fully Automatic
- ★ High Pressure continuous spark—no radio interference
- ★ Two-stage pump with automatic safety shut-off—uniform pressure—constant flame
- ★ Exclusive anti-carbon nozzle
- ★ 1-10 h.p. motor—very low current consumption
- ★ Burns low cost No. 3 fuel oil
- ★ Silent as a whisper
- ★ Williams engineered throughout
- ★ Easy payments—12 to 36 months to pay

WILLIAMS OIL-O-MATIC HEATING CORP.
Dept. 396, Bloomington, Ill.

Please send me full facts about your amazingly low-priced Williams Oil Burner.

Name.....

Address.....

City.....State.....

BETTER COOKED MEALS

Hunting · Fishing · Touring · Anywhere

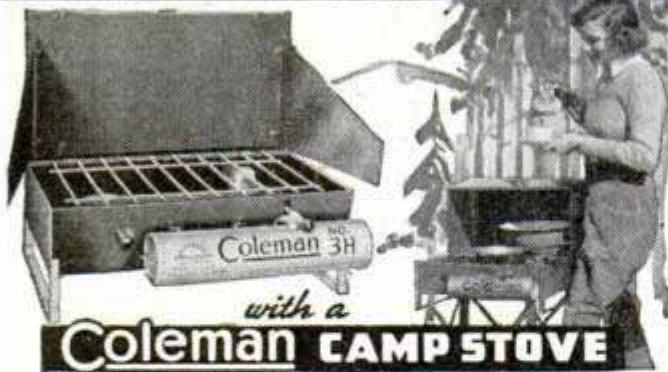

MAKES and BURNS OWN GAS • LIGHTS INSTANTLY

You'll be happier...have more fun...enjoy meals that satisfy big outdoor appetites...if you take a Coleman Camp Stove along on your outing. It makes and burns its own gas from regular gasoline. Speedy, wind-proof burners light instantly. No wood to cut, no smoke. Sturdily built to give years of service. Everdur Metal Fuel Tank won't rust; easily removed for filling. Folds up like a suitcase for easy carrying. Six models, all moderately priced.

The FINEST OUTDOOR LIGHT—A COLEMAN. A real light for fishing, hunting, workshop, all kinds of uses. Lights instantly. Provides high candlepower pure white light. Sturdily built. Pyrex glass globe protects mantles from wind and insects. No storm can put it out. Gasoline and kerosene models to fit every lighting need.



FREE! Write for Free Folders illustrating and describing Coleman Camp Stoves and Lanterns. **THE COLEMAN LAMP AND STOVE COMPANY** Dept. PM531, Wichita, Kans.; Chicago, Ill.; Philadelphia, Pa.; Los Angeles, Calif.; Toronto, Ont., Canada (7531)

2 DOG WORM CAPSULES

Now Combined
in

ONE TREATMENT

NO LONGER need you guess which kind of worms afflict your dog—or guess which type capsule to use. Pulvex Worm Capsules expel "all three": Tape and Round, and Hook worms. Now you can be sure of worming your dog correctly. Easily given. No gassing, gagging or harmful effects. Guaranteed. At pet, drug, department stores, 75c.

Expels
HOOK, TAPE
and ROUND
WORMS



PULVEX WORM CAPSULES



APPLY AND DRY—NO RUBBING

KEENIZER PRODUCTS,

FOSTORIA, OHIO

Cleans, Polishes,
Restores Color.
Other Cleaners
Unnecessary!
Dust free, hard.

Permanent,
quick, easy to
use. For new
and old cars.
Results guar-
anteed when di-
rections are fol-
lowed. Specify
color—red,
green, blue,
brown, gray,
black. Mailed
for 75c.

(Continued from page 135A)

tant in greases used for lubricating gears than it is in a motor oil, and all extreme-pressure lubricants are now improved with some kind of substance that imparts high film strength.

The best way to test an oil is to actually use it in an engine. One oil concern installed six identical automobile engines in its laboratory and lubricated the first, third, and fifth with its best grade of SAE 20 oil. The alternate motors were supplied with the same oil, to which small amounts of a new super-slippery ingredient had been added. Then the battery of engines was started up and operated long enough to equal 15,000 miles of driving. At times the engines were stopped and cooled below ordinary temperatures so that a full range of driving conditions could be approximated. At the end of the test, all the engines were torn down and carefully micrometered. The results were surprising. The three engines that had used the new "alloyed" oil were found to have thirty-three per cent less wear on the cylinder walls than the others and forty per cent less wear on the rings.

Another oil firm wanted to test its new oil under actual operating conditions. A car that had already been driven 15,000 miles without much overhaul work was selected. With a high-grade oil in the crankcase the driver started for another city 400 miles away. All the way along, he reported afterward, "carbon knock" was noticeable in spite of the fact that he was using a high grade of gasoline. At the end of the 400 miles the oil was flushed out and replaced with the new treated oil. By the time the return trip was over the carbon knock had disappeared. In that short distance the oil had loosened enough carbon to end detonation.

Unless they understand what is going on inside their engines some motorists are apt to be disappointed soon after they change to one of the new oils. Instead of immediately sweeping out the carbon and decreasing the knock, an oil is apt to make some engines "bang" more loudly than ever for a short time. The reason is that if the rings are frozen in their slots the oil will loosen them before going to work on the carbon. This prevents the blow-by of gases and naturally increases

(Continued to page 138A)

Governs Speed

OF ANY GAS ENGINE

Take any car motor out of the chassis, equip it with a Pierce Universal Governor, and you have a stationary power unit that runs steadily enough to operate even an electric welder. And that's some test for close speed regulation.

Pierce Universal Governors are standard controls on gasoline engines for commercial purposes—for electric lighting plants, refrigerating units, air compressors, feed grinders, hoists, saw mills, welders, etc.

Pierce Universal Governors are the time-tested flyball type and respond instantly to each change in engine load, maintaining uniform speed. Belt driven, either V or flat. Easily installed and never equalled for close regulation of speed and for dependable performance.

Write for illustrated literature and prices, whether you want to equip one used motor or a thousand new ones.

The Pierce Governor Company
1600 Ohio Avenue, Anderson, Indiana

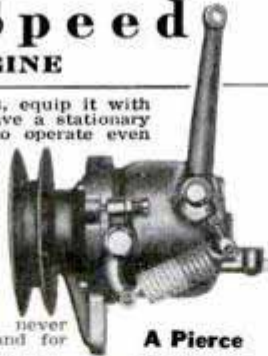

A Pierce Governor puts "brains" into any gas motor.



CORONA 1937 SPEED MODEL

We've made close to two million Corona Portables—but these new 1937 machines are the finest yet! Amazingly complete, professionally fast and easy to operate, and made to last for years. Dollar for dollar they give you unmatched value. Ask any dealer to show you their many exclusive features—the effortless "Floating Shift," the Touch Selector, Piano Key Action, All-around Frame, etc., etc. And then ask about the new easy-payment plan—as low as \$1.00 a week! Lets you pay for it as you use it. Free booklet on request.

..... MAIL COUPON TODAY

L C Smith & Corona Typewriters, Desk 6
723 E. Washington St., Syracuse, N. Y.

I'm thinking of buying a Corona. Please send free booklet showing models and prices.

Name

Street

City State

PLEASE PRINT PLAINLY

Thompson BEATS the World on BOATS



Better Built Lower Prices

Canoes \$54 and up

Rowboats \$42 and up

Outboards \$42 and up

Very fast utility model

Only Boats With Full Length Spray Rails
Keep passengers perfectly dry—even at high speeds. Catalog also shows today's five most popular models of sailboats. Two big factories. Prompt shipment.

CATALOG FREE
Write for your copy. State kind of boat in which you are interested.

THOMPSON BROS. BOAT MFG. CO. (79)
213 Ann St., PESHIGO, WIS. (Write to either place) 113 Elm St., CORTLAND, N. Y.



BUILD WITH DOENUTS

Build with the original patented low pressure Musselman Doenut cord tires and wheels. They absorb surface obstructions, eliminate jolts and reduce pushing and pulling effort approximately 50%. Tire requires only 12 to 15 lbs. air pressure for loads up to 200 lbs. per wheel. Size 10" x 2 1/2". Cadmium plated steel disc wheel with adjustable ball bearings. Doenuts are ideal for building hand trucks, midsize autos, wheelbarrows, lawn mowers, lawn furniture, portable painting, spraying and greasing equipment or any portable unit under 850 lbs. Boys: send 50¢ for full set blue prints for building wagons, wheelbarrows, bicycle trailers, scooters and midsize autos, with free literature.

MUSSELMAN PRODUCTS CO.
6247 ST. CLAIR AVE. CLEVELAND, OHIO

BURN YOUR NAME ON TOOLS WITH THE ARKOGRAF

PROTECT YOUR TOOLS FROM THEFT
Write with electricity any name or design on the hardest and finest tools and instruments, or any metal, like writing on paper with pen or pencil. Complete outfit \$3.50—Prepaid Anywhere. Interesting illustrated circular free. Write today. Agents wanted.

ARKOGRAF PEN CO., 3927 S.E. Stark St., Portland, Ore.

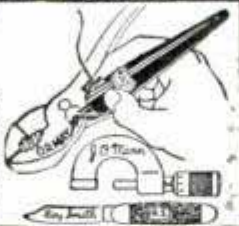

STANDARD GARDEN TRACTORS

Plow Seed Cultivate Mow Hay and Lawns
Powerful Gas Tractors for Small Farms. Gardeners. Florists. Nurseries. Fruit Growers & Poultrymen.
1 & 2 Cylinders
Walk or Ride-Do Belt Work High Wheels--Free Catalog

STANDARD ENGINE CO.
Minneapolis, Minn. Philadelphia, Pa. New York, N. Y.
3221 Como Ave 2546 Market St. 290 Cedar St.



HANDEE TOOL OF 1001 USES

Grinds - Drills - Cuts - Polishes
Carves - Routs - Saws - Sands
Sharpens - Engraves

A whole shop full of tools in one for work on all metals, alloys, bone, resins, glass, stone, wood, etc. Uses 200 accessories. Saves hours of tedious work. 13,000 r.p.m. A C or DC, 110 volts. \$10.75 and up, postpaid. 3 Accessories Free.



Plug in any Socket

DE LUXE MODEL

For constant service, nothing compares with this easy-to-handle production tool. Saves time and labor. Fastest, smoothest, most powerful tool for its type and weight. 25,000 r.p.m. \$18.50 postpaid, 6 Accessories Free.

Get a Demonstration at Your Dealer's or Order Either Model on 10-Days Money-Back Trial. Catalog Free.

CRAFTSMAN'S PROJECT BOOK
"Pleasure and Profit with a Handee"
Easy working plans for making many interesting and unusual projects, 25¢ stamps or coin.

CHICAGO WHEEL & MFG. CO., 1101 W. Monroe, Dept. Q, CHICAGO

Send Catalog Project Book
 \$10.75 Model De Luxe Send C. O. D. PM-6

Name

Address

FREE TO EVERYONE interested in doing better shop work — new 48-page 1937 catalog describing and illustrating latest Driver Engineered Power Tools and accessories. Write to-day to Walker-Turner Co., Inc., 167 South Ave., Plainfield, N. J.

DRIVER Engineered POWER TOOLS

When writing please mention Popular Mechanics

GET FREE PLANS

To build these and 21 other
FREE CASCO PROJECTS



Twin End Tables— one for magazines, the other for radio—two of a group of 8 associated modern living-room pieces by Gilbert Robde, internationally famous furniture designer.

Modernistic clock, Colonial corner cabinet, typewriter desk, table and floor lamp, portable boat, wood jewelry . . . are only a few of the amazing variety of projects CASCO offers for 1937. Every one a worthwhile project . . . fun to build . . . a pleasure to possess. New and exclusive designs never before available in any project service . . . at any cost.

How to Get Free Plans

Every 25c (or larger) package of CASCO contains a green ticket listing all 24 projects. Check project you want and complete plans will be sent you Free, postpaid. If you want to see pictures of projects, ask your Dealer for new 1937 Free Project Folder . . . or use coupon below.



Kayak—this new Eskimo canoe can be built for one or two persons— with provisions for a sail.



**FIXES THINGS
PERMANENTLY**

*Sold by Hardware,
Paint and Lumber
Dealers Everywhere*

**SEND
FOR
FREE
FOLDER**

CASEIN COMPANY OF AMERICA, Inc.
350 Madison Ave., Dept. PM837, New York, N. Y.
Please send folder about FREE Project Service.

Name.....

Street.....

City..... State.....

BUILD YOUR OWN

Wind Driven Light Plant

from old auto generator. We show you how. Make money building for others. Light your buildings, play radio, operate washing machine and other motors. Dime brings complete plans and 1937 catalog. Over 50 other changes for 6-12-32 and 110 volt plants.
LEJAY MFG. CO., 1447 W. Lake St., Minneapolis, Minn.

FREE
Lights

20 FILTER TIP CIGARETTES 6¢

MAKES 20 IN 5 MINUTES. Loose or tight as you prefer. Use your favorite tobacco—granulated—mentholated—pipe—Turkish or Domestic.

ALL METAL EASY MAKER \$1.00
EASY MAKER with sufficient supply of best tobacco and tubes to make 100 cigarettes sent Postpaid for \$1.30. Enough to make 200 cigarettes \$1.60. Send money order or cash.

Distributors—Crew Managers—Salesmen—Sells on sight to men and women in Homes, Offices, Stores and Shops, also to stores for re-sale. Highly profitable, permanent repeat business on Filter-Tip Tubes. Write for Distributors' confidential prices and money-making sales plan.

Easy Cigarette Maker Co.
Box 31 Sullivan, Ill.



100 FILTER TIP
TUBES 10¢



(Continued from page 136A)

compression pressures, bringing on detonation. But as soon as the carbon is loosened in the chambers the pressures are restored to normal.

There is one definite danger that you must guard against in changing to one of the new oils. If the oil turns dirty during the first few hundred miles, as it probably will, drain, flush, and replace it at once, at the same time replacing the oil filter element. After that you will be safe. This precaution is necessary because, if the engine contains a lot of carbon and gum, the new oil will start to wash these away and carry them around with it. The sludge and gritty particles discolor the oil, warning of its condition.

At the same time that gasoline engines are getting better lubricants, Diesel engines are also being provided with better oils. Ordinary oil is not satisfactory in compression-ignition engines as the higher heats aggravate carbon formation and the carbon usually has to be scraped out every 500 hours or so. This period between overhauls is being increased four or five times by using special compounds in the oil, one of which is called aluminum naphthenate, a wax-like compound of aluminum that helps dissolve the gums formed by Diesel fuels.

Odor Is Added to Natural Gas to Help Detect Leaks

Risks of explosion from natural gas leaks can be greatly reduced by adding an evil-smelling odorant to the gas so that the leak can be detected. It would cost only fifty cents to treat a million cubic feet of gas. Some odorants are so pungent they would awaken a sleeping person, yet they do not affect the odor of gas when burned. Natural gas, which was blamed for the tragic schoolhouse explosion at New London, Tex., in March, is odorless. In 1929 the nation's natural gas consumption totaled eighteen billion cubic feet and this entire amount could have been given a recognizable odor for \$9,000.

Whenever you find that you wish to know more about any article in this magazine, write our Bureau of Information, inclosing return postage.

PUT SOME FLESH ON YOUR BONES

IF YOU WANT TO MAKE
A HIT WITH GIRLS

HERE'S HOW THOUSANDS
HAVE GAINED 10 TO 25 LBS.
—QUICK!

*Posed by
professional model*



WOMEN have always admired, and always WILL admire well-built, well developed men. And, according to physicians, there's no excuse today for thousands remaining skinny, scrawny and unable to win friends.

Because, thanks to these new "7-power" Ironized Yeast tablets, hosts of thin, rundown people have changed to different persons—in 30 days or less! They've put on 10 to 25 pounds of solid flesh—normal, good-looking heftiness. Their skin has cleared to natural smoothness. They have new pep that brings new friends and new popularity.

Why it builds up so quick

Scientists recently discovered that thousands of people are thin and rundown for the single reason that they do not get enough Vitamin B and iron in their food. Without these you may lack appetite and not get the most good out of the body-building foods that are essential.

Now one of the richest known sources of Vitamin B is cultured ale yeast. By a new process the finest imported cultured ale yeast is now concentrated 7 times, making it 7 times more powerful. Then it is combined with 3 kinds of iron, pasteurized whole yeast and other valuable ingredients in little tablets known as Ironized Yeast tablets.

If you, too, need these vital elements to aid in building you up, get these new "7-power" Ironized Yeast tablets from your druggist today. Note how quickly they increase your pep and energy. Then watch flat chest develop, skinny limbs round out to natural attractiveness, skin clear to normal beauty. Soon you feel like a different person.

Money-back guarantee

No matter how skinny and rundown you may be from lack of sufficient Vitamin B and iron, try these new Ironized Yeast tablets just a short time and note the marvelous change. See if they don't aid in building you up in just a few weeks, as they have helped thousands. If not delighted with the benefits of the very first package, your money back instantly.

Only be sure you get the original Ironized Yeast tablets. Don't accept any substitute. Insist on Ironized Yeast.

Special FREE offer

To start thousands building up their health right away, we make this FREE offer. Purchase a package of Ironized Yeast tablets at once, cut out seal on box and mail it to us with a clipping of this paragraph. We will send you a fascinating new book on health, "New Facts About Your Body." Remember, results with the very first package—or money refunded. At all druggists. Ironized Yeast Co., Inc., Dept. 536, Atlanta, Ga.

When writing to advertisers please mention Popular Mechanics

Atlas

LOOK FOR THE RED STARS IN THE CATALOG

METAL WORKING LATHES
\$45.50 to \$124.50

FREE
write

Red Stars in the Atlas Catalog lathe descriptions show exclusive Atlas features provided as regular equipment at no extra cost—savings of over \$35. on back geared models. Before you buy any lathe get an Atlas catalog and make your own comparison. Write today to—



ATLAS PRESS CO.
643 N. Pitcher St., Kalamazoo, Mich.
Factory Displays at
Chicago—35 E. Wacker at Wabash
New York—130 W. 42nd St.
Philadelphia—113 N. 3rd St.

FREE ELECTRICITY From Wind Power

For Lights, Power, Radio, from Auto Generators. New Copyright Book with over 100 Facts about Wind Chargers. Wind-Propellers—Generators—Plants—Batteries. Answers all questions you should know. Including plans for 6 or 32 V. Plant. Send 25c for plans, facts and catalog.

CURRIER MFG. CO.
421 Terminal Minneapolis, Minn.

EARN MONEY Stringing TENNIS RACKETS

An opportunity to earn as much as \$3.50 for a few minutes of your spare time. String your own racket and save money. Tennis players need restringing frequently. Every restringing means profit for you. No experience needed—we teach you how. TOMGUT Equipment makes it easy. Costs practically nothing to start. Easy work. Begin NOW!

FREE Write today and we will send you Free our new low prices of TOMGUT "Court-Tested" Tennis and Badminton Strings, Restringing Equipment and a complete line of Racket Frames.

THOMPSON MANUFACTURING CO.
4535 Packers Ave., Chicago, U. S. A.
TOMGUT "Court-Tested" Tennis & Badminton Strings

Please send, without charge or obligation, the new price list of TOMGUT Tennis and Badminton Strings, Racket Frames, and Restringing Equipment.

Name.....
Address.....
City..... State.....

MAIL THIS COUPON

IVER JOHNSON

This boy knows what it means to ride

AMERICA'S FINEST BICYCLE

Send for color folder 66B describing all models and sizes for Boys, Girls, Men and Women

\$27.50 UP

IVER JOHNSON'S ARMS & CYCLE WORKS
21 River Street, Fitchburg, Mass.
New York San Francisco Montreal
85 Chambers St. 731 Market St. Coristine Bldg.

COLUMBIAN METAL BOATS

Light weight, durable, carefully built of toughest galvanized copper bearing steel; low prices. Wood gunwales. Heavy transoms for out-board motors. Two or more built-in air chambers for extra buoyancy in case of upset. Easy to handle. Never leak or warp. Write for Free Boat Booklet and prices of complete metal boat line—knockabouts for fishermen, light weight lively boats for resorts, heavy duty craft for out-board motors.
(Dealers wanted—who can develop volume sales.)

Columbian Steel Tank Co. 1509 W. 12th St. Kansas City, Mo.

BIG 1937 LEADER

For greater profits, steady income and repeat business, sell Century.

GENUINE LEATHER TIES

NO SALES EXPERIENCE NEEDED. Beautiful 4-in-Hands for Men and Boys, sell on sight, everybody buys. LOOK LIKE SILK; cleaned with a damp cloth. Famous Century Bows sell to uniform men, such as policemen, firemen, letter carriers, etc. Write today for our new FREE DEAL OFFER, or send 50c for samples, 4-in-Hand and Bow.

CENTURY TIE CO., 2345-L, W. Grand Blvd., Detroit, Mich.

INVENTORS Be Sure to See Page 23A

DO YOU

WANT a new business profession of your own, with all the trade you can attend to? Then become a foot correctionist, and in a few weeks earn big income in service fees,—not medical nor chiropody—easy terms for home training, no further capital needed, no goods to buy, no agency. Established 1894. Address Stephenson Laboratory, 1 Back Bay, Boston, Mass.

15% OFF ON ALL FIREWORKS

FREE

BIG ROTOGRAVURE CATALOG. PLENTY OF PICTURES AND BARGAINS GALORE. WRITE DEPT. 112.

PARAMOUNT FIREWORKS CO.
34 PARK PLACE NEW YORK CITY.

ALL-PURPOSE MOTO-TOOL



Does many jobs speedily, easily—grinds, drills, engraves, sharpens, routs, carves, polishes, etc. Universal motor—about 20,000 R.P.M.—plugs in any light socket A. C. or D. C. Handles as lightly as a pencil. Weighs 6 oz. and is amazingly powerful. Oilless—self aligning—ball thrust bearings.

TEN DAY TRIAL, satisfaction guaranteed or money back. 20 pc. general utility tool set \$5.75 extra. Send for **Free Booklet**.

DREMEL MFG. CO., 2818-Cl, Racine, Wis.

only \$9.85

ONE-MAN SAWMILL



TURN TREES INTO MONEY WITH A BELSAW **FARM MODEL \$49.00**

Three capacities: 10, 14 and 20 ft. Accurate set works positive dogs. Full or one way type power feed runs on low power—Many owners use old auto engine. Pays for itself quickly—thousands in commercial service, everywhere. Write for free lumber handbook and catalog of mills, supplies, tools, saw tables, and woodworking equipment.

Belsaw Machinery Co., 611-E Davidson Bldg., Kansas City, Mo.

RADIO-ELECTRICAL EXPERIMENTAL KIT



Complete! Greatest value! Fascinating! Educational! Instruction manuals make experiments easy. Wire up thief detector, extension phone, elec-welder, electro-plating, arc-furnace, AC to DC rectifier, 110-volt motor. Make powerful arc light, generate ultra-violet and infra-red rays, make electric stove, elec. door lock, etc. Build radio circuits, crystal set, 2-tube circuit, AC-DC set, code practice set, 110-volt rectifier, radio transmitter, screws more. If bought separately, \$18.50. NOW **\$3.99**

FREE! 6 Books, value \$5.50, with kit. Elec-Radio Short Courses, Fun with Elec., Electrical-Arc, Motor-transformer, Exper. Lab. Plans. 3c stamp brings Elec-Radio-Tool bargain catalog. SEND! **ELECTRICAL SALVAGE CO., Box 524-A41, Lincoln, Nebr.**

FOR MODERN SHAVING

Barbasol

**NO BRUSH
NO LATHER
NO RUB IN**

PHOTO ENLARGEMENTS



Is Photography your hobby? Do you want a profitable easy business at home? Make **PHOTO ENLARGEMENTS** for yourself and others. Your cost 5c each and less. The Ideal Photo Enlarger is **AUTOMATIC**. No experience required. Also **COPIES** any picture. **\$5.94 COMPLETE**. Interesting circular **FREE**.

IDEAL-O, 122 East 25th Street, New York City

5¢

ANY SIZE

GET YOUR TRACTOR AT FACTORY PRICE



3 Speeds Forward and Reverse. Runs 4 to 8 hours per gal.

Amazing money maker for farms, truck gardens, orchards, nurseries, poultry ranches, country homes, etc. Plows, discs, harrows, cultivates, mows lawns, cuts weeds. Runs belt machinery. 2 to 5 H.P. riding or walking types. Write for **FREE CATALOG, Low Factory Prices and 10 day Trial Plan**. Address **Nearest Office**.

SHAW MFG. CO., 4508 Front St., Gatesburg, Kans.
130 G West 42nd St., New York, N.Y., 5812 G Magnolia Ave., Chicago, Ill., 868 G North 4th St., Columbus, O.

SHAW DU-ALL TRACTOR

Air Tires or Steel Wheels

Make Glazed Concrete Products NEW MONEY MAKING BUSINESS



Make beautiful, colored glaze finishes on concrete pottery, tiles, walls, novelties. New, perfected, low cost method. Make 2,500 designs of vases, jars, birdbaths, etc., without molds, power or costly tools. Use only sand and cement. No experience needed. Learn glazing, decorative waterproofing, pottery making, statuary casting. Earn money in your own business. Send 10c **TODAY** for booklet, color plates and complete information.

NATIONAL POTTERIES COMPANY
 13 West 26th Street, Room 21
 Minneapolis, Minnesota

TAKE THE GRIEF OUT OF EMERGENCY REPAIRS

A sudden leak in the hot water heater—the hammer handle flies off—water squirts from a dent in the auto radiator—a drawer knob pulls out—screws strip from and loosen the door lock—a water pipe freezes and cracks—one caster won't stay in the table leg—your favorite pail starts to leak—a persistently loose nut puts the vacuum cleaner out of business—etc., etc.

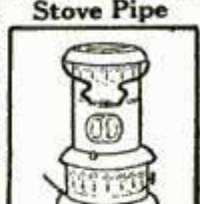
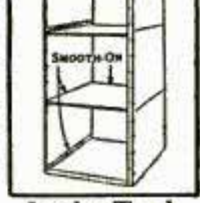

Possibilities like these are ever present to the householder, but invite no delays, repair bills or expensive new purchases if you have a copy of the Smooth-On Home Repair Book, and a can of Smooth-On No. 1 on the shelf and like to prove yourself equal to the emergency.

Hundreds of repairs similar to the above are made quickly, easily and cheaply with Smooth-On No. 1, which stops leaks of steam, water, gas, oil, gasoline, smoke, etc., anchors loose screws, bolts, nuts, handles, machinery, etc., and holds equally well in metal, masonry, bath room tile, and wood.



Write for FREE BOOK

Smooth-On No. 1 expands in hardening and when metalized holds as tightly as the metal to which it is attached. Power plant engineers, shop foremen and professional repair men prefer Smooth-On repairs because the simple cold application avoids fire risk and extra labor and a dependable finished job is ready in a hurry.



Mail the coupon for the Smooth-On Repair Book and get Smooth-On No. 1 in 7-ounce or 1 or 3-pound can from any hardware store.

Do it with SMOOTH-ON

SMOOTH-ON MFG. CO., Dept. 37,
 574 Communipaw Ave., Jersey City, N. J.
 Please send the free Smooth-On Repair Book.

Name.....
 Address.....
 6-37.....



When summer driving's
Increased speeds
Step up your
Lubrication needs,
Use Pennzoil—

A fresh crankcase full
Will give your motor
Snap and pull
And, with a heat-proof
Film that's stronger,
Summer Pennzoil
Lasts much longer.



Learn BRASS TAPPING

FUN and PROFIT! Get this big new outfit. Learn "raised metal" work. Sell gift and art wares. **Complete Outfit \$2.00** Make Bookends, What-Not Racks, Twin Plaques. Equipment includes non-tarnishable jewelers' metals, handcraft hammer, plywood backing-board, noiseless tapping tools, special nails and design patterns. Send \$2.00 money order for outfit complete. State choice Brass or Copper. ("Silver" or "Gold" \$2.50.) **FREE CATALOG** with outfit or send 3c stamps. Write today. **RAPAPORT BROS., 703 W. Ohio St., Chicago**

BILD-UR-OWN

COASTERS • MIDGET AUTOS • SCOOTERS •

DISC WHEELS equipped with 10"x2 3/4" (GOODRICH-GOODYEAR-FIRESTONE)
Balloon Tires offered at **LOWEST PRICES**
Also larger tires and wheels—Motors, etc.

BILD-UR-OWN DEVICES

SOAP BOX DERBY WHEELS
BIKE TRAILERS, ETC.

WRITE TODAY FOR PRICES

5237 Lake St. Dept. MJ Chicago, Ill.

General-Purpose Amplifier

(Continued from page 899)

brackets. A detailed list of all materials used in the original model can be obtained upon application to Popular Mechanics radio department, without charge. The blueprint number is R-239.

The phono channel has sufficient gain to realize full power output when using any

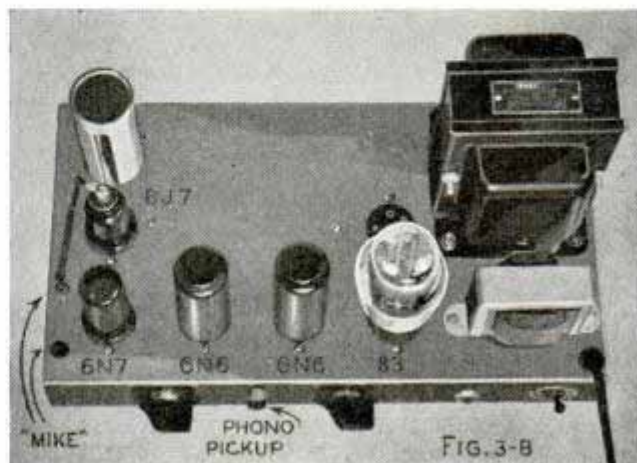

high-impedance pickup. If a low-impedance pickup of from 200 to 400 ohms is used, a 200 or 400-ohm line to grid transformer should be employed, or, if the "mike" and phono pickup are not to be used together, the low-impedance pickup can be plugged into the high-gain channel without using the transformer. A good

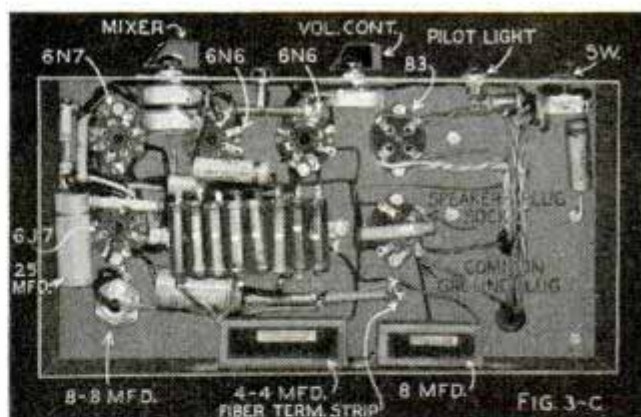

ground should be connected to the metal base to make the shielding most effective. Reversing the a.c. line plug in the wall socket will also often aid in eliminating hum pickup and other noises. The dynamic speaker used is a 10-in. high-fidelity type with output transformer for push-pull 6N6 tubes and a 4,000-ohm field. For 6-volt storage-battery operation, a 300-volt gen-e-motor and a 3-pole double-throw switch are all that is required.

"MISTER, CAN YOU SPARE A DIME?"



• 10¢ buys 4 super-sharp Treet Blades—so keen they slide through your whiskers without a pull or pang.

More shaves for your money—try Treet today!

Treet Safety Razor Corp., Newark, N. J.

Treet BLADES
FIT GEM AND EVER-READY RAZORS

4 FOR 10¢

BALL JOINT \$1.95
AUTO TRAILER COUPLER
Rocky Mt. States West, \$2.25. Postpaid

ADJUSTABLE \$1.35
BUMPER HITCH

This hitch can be put on, taken off, or adjusted to 6 different positions with a wrench. Postpaid, \$1.35 without ball. (Rocky Mt. States West \$1.50.) Write for catalog on trailer hardware and camping trailers.
ZAGELMEYER AUTO CAMP CO.
1476 S. Henry St. Bay City, Mich.

ALADDIN READI-CUT SUMMER COTTAGES

\$230 AND UP

WE PAY FREIGHT

BUILD IT YOURSELF



Buy direct from manufacturer and save money with the Aladdin readi-cut system.

Save 18% material waste, save 30% on labor and own a fine, substantial cottage! You can build it yourself. Easy to follow instructions.

CATALOG FREE Send today for new catalog showing amazing values in Aladdin 4 to 10 room homes and Summer cottages. Ask for Catalog 275, Mail a postcard TODAY! Address office nearest you.

ALADDIN CO. BAY CITY, MICH. PORTLAND, ORE.

MICROMETERS

Six piece set, in velvet lined leather case. Special price, only \$11.95. Precision machined in one thousandths, up to 4" outside and 3 3/4" inside measurements. Guaranteed accurate, easy to read and adjust. Satisfaction guaranteed or money back.

This is your opportunity to get one at a Bargain Price if you act now. Shipped prepaid on receipt of remittance. On C.O.D. shipments, send deposit of \$2.00.

FREE FOLDER

MICRO PRODUCTS, 529 E. Jefferson Ave., Detroit, Mich.

Synco JIG SAW

FASTER—SAFER—CLEANER

Astounding performance! Cuts up to 1" or more, with smooth, clean edges. No sanding required. Accurate, sturdy, efficient—a revelation to skilled craftsmen in handling both intricate designs and heavy work. Ideal for cutting light metals, veneers and plastics. Operates on 60 cycle, 110 volt AC, without motor or any reciprocating parts. Requires no oiling. 10" square table; 13 1/2" throat; adjustable guide; variable stroke. Complete with underwriters approved cable and rubber plug. Built for years of continuous service.

Electric Operation 7200 Strokes per Minute



No Motor Required

GET FREE LITERATURE TODAY

Ask your dealer to show you the models now available. Or send your name for full information and illustrated literature, FREE.

SYNCO DEVICES, INC.

511 Boydell Building Detroit, Mich.

FREE FOLDER

OTTAWA LOG SAW



Make Money! Wood is valuable. Saw 15 to 20 cords a day. Does more than 10 men. Ottawa easily operated by man or boy. Falls trees—saws limbs. Use 4-hp. engine for other work. Write today for **FREE** book.

OTTAWA MFG. CO., 613 Wood St., Ottawa, Kansas

When writing please mention Popular Mechanics

Searching for New Wood Ideas

(Continued from page 852)

Piled on a bookcase in the office of the chief of the forest products division is a queer assortment of things made from wood—one that represents, as if in cross section, some of the work the division is doing.

There is a square of bamboo plywood which an assistant trade commissioner in Japan sent in. A Japanese manufacturer of bamboo fishing-rod and golf-club handles developed it. The plywood consists of a bottom ply of parallel strips of mahogany, a center layer of red cedar, and a top layer of rectangular bamboo pieces arranged to form a pattern. A high-gloss lacquer protects the surface. This plywood, suitable for use on walls, floors, and in furniture, is being studied for possible large-scale marketing in America.

From Germany came a substitute for dogwood and persimmon-wood shuttles used in fabric looms. It is a laminated wood almost as dense and tough as iron, and is made by saturating layers of beech wood with a synthetic resin and pressing them together to form a solid mass.

Another idea that originated in Germany and which is now the basis for a thriving American industry is the use of resinous adhesives to bind together plywood layers. Phenol-formaldehyde resin is formed into a thin, paperlike sheet. A plywood panel is built up by arranging alternate layers of wood veneer and the resin film; and the sandwich is placed in a hot-plate hydraulic press, which forces the layers together and melts the resin. Wood-to-wood contact is obtained, the resin penetrating the surfaces and becoming a water and chemical proof binder. Veneer-making jobs difficult or impossible with water-mixed adhesives are easy with this method.

Uncle Sam's wood wizards developed, not long ago, a synthetic plastic material made from wood waste at a very low cost. It is easy to cut, and takes a high polish. The latest wrinkle is to use this material as a core or base for panels surfaced with thin layers of costly wood such as mahogany burl. The plastic impregnates the veneer, producing a wear-resisting surface.

In the collection are several plywood panels which look like quartered oak but

which really are made of Douglas fir. The effect is produced by a machine that makes a series of tiny incisions in the outer veneer layer, producing the flaky-grained effect of quarter-sawed oak.

Another promising development is the use of molded strips to join edges of plywood panels and to break the panels up into parallel "boards." The molding, thinner than the plywood and an inch or so wide, is set in rabbeted grooves. It prevents open cracks at joints, and makes it easy to use ordinary plywood for producing attractive walls which look as if they were paneled with real boards.

The department of commerce recently uncorked in Germany an idea that may revolutionize the technique of sealing champagne and other bottles. A German inventor has produced a wooden "cork" by making concentric, ring-shaped cuts in wooden plugs. These cuts, usually two in number, begin at the outer end and extend about two-thirds the length of the plug, parallel to the grain. This makes the stopper elastic, so that the bottle neck compresses it. The wooden stoppers can be made cheaply in various shapes and colors. They are said to be more durable and hygienic than ordinary corks. Undoubtedly they will come into use in America.

Just now the forest products division is searching the world for something new from which cedar chests can be made. A manufacturer, fearful that his domestic cedar supply would run out some day, inquired about a foreign substitute. The odor given off by red cedar heartwood actually kills young moth larvae, department of agriculture investigators have found. So the department of commerce's wood sleuths are trying to locate another wood that has similar larvae-gassing properties. The wood sleuths thought they had reached their goal when an East African outpost reported that in its neighborhood was a wood related to American red cedar. But the territory was so undeveloped that the wood could not be logged in commercial quantities. So the search continues. If there is a foreign tree anywhere in the world that might play on the American red cedar sub team, Uncle Sam's wood scouts will find it.



Left AT THE LIGHT!

... because of worn-out spark plug wires

Nothing you can do to your car will restore its full pep and power if you are driving with worn and leaking spark plug wires. Instead of a fat, hot spark in the combustion chamber, you get one that is weak and lean. This not only robs you of the smooth power which makes driving a pleasure, but robs you of money as well. The car uses more gas; spark plugs foul; and timing needs re-setting. Yet all this can be corrected in a few minutes by replacing old, leaking wires with a complete set of Packard FOUR-FORTY.

Why Spark Plug Wires Wear Out

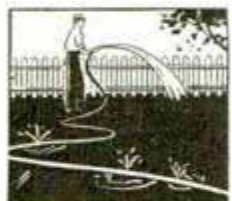

It is no wonder that spark plug wires wear out in the "torture chamber" under the hood of your car. They are ravaged by heat and cold, rotted by water and oil, worn by abrasion, oxidized by age, and eaten by corona. The insulation becomes porous, the vital electric current escapes like water out of a leaky hose, the spark is too weak to fire the gas properly in the cylinders, and — you are "left at the light."

Why Packard FOUR-FORTY is Better
Packard, not content with the ordinary cable covering of cotton braid and lacquer — both of which are of vegetable origin and therefore readily susceptible to heat, cold, oil, abrasion and corona — utilized a *new* discovery of science — an *inorganic*, man-made "rubber" derived from coal, water and salt. This new, secret-formula composition is now applied as an outer sheath to Packard FOUR-FORTY — making it a *better*, more resistant and therefore a longer-lasting cable. Check your spark plug wires today. After 10,000 miles they should be replaced with a complete set of Packard FOUR-FORTY Ignition Cables. Packard Electric Division, General Motors Corp., Warren, Ohio.

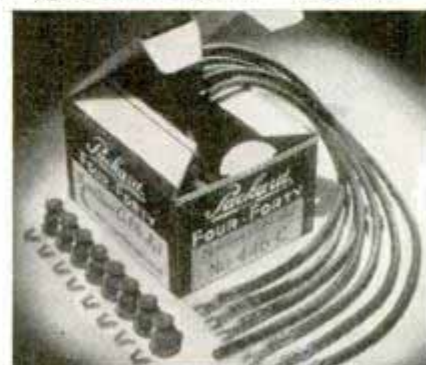

Packard

REG. U.S. PAT. OFF.
TRADE MARK

STANDARD WIRING EQUIPMENT OF THE AUTOMOTIVE INDUSTRY

20194

“Wigwagging on the Diamond”

(Continued from page 869)

however, when a game is close and has gone beyond the sixth inning. Also, in some instances teams with exceptional pitchers frequently use this play in the earlier innings with considerable success.

When a hitter gets on first with no out or there are runners on first and second with no out, the stage is set for the sacrifice play. The batter wants to know as he approaches the box whether the manager wants him to bunt or sacrifice. The answer is given in a sign, of which there are

The stage is set. There is a runner on first and no outs. The hitter signifies to the runner that the hit-and-run is to be tried on the next pitch. As the pitcher starts his motion, the runner dashes for second; the batter swings, striving to hit the ball between first and second back of the runner. No matter where the ball is, the man at the plate has to swing at it—get a “piece” of it if he can. By virtue of the signal the runner is enabled to take a long lead and can advance an extra base. Or, by having the start, he avoids the possibility of a double play, reaching second safely even though the hitter may be out at first. Of course, in the hit-and-run one infielder is pulled out of position, as either the shortstop or the second baseman must cover the bag, and the player who can hit the reverse of his natural batting tendency will send the ball into territory left unprotected.



Baseman reaching out as far as possible for short throw. Note foot touches sack

hundreds. For example, if the manager stands with his arms at his sides, he may indicate to the batter that he is to hit. If, however, he touches hands together, it is a sign to bunt.

Perhaps the greatest offensive play in baseball is the hit-and-run. It is generally used when the batter has the pitcher in the hole and runners are on first, on first and second, or first and third with less than two outs. A team usually does not use the hit-and-run unless it is in the lead or not more than two runs behind.

Managers allow certain batters to put on this play and prohibit others from using it. A player is considered a good hit-and-run performer if he can hit behind the runner. This means that if there is a man on first a batter who might normally hit the ball into left field must clout it into right field. The pitcher strives to keep him from doing this by throwing him balls he would normally hit into left field.

There are many signs for the hit-and-run. One player's favorite is to tip his hand upward after touching his cap. Other players rub the pants leg opposite the side on which the bat is resting, tug at their belts, or touch skin to skin.

Another thrill-packed bit of diamond strategy seldom understood by spectators is the squeeze play. It is rarely used except with a runner on third and one out when the hits have been scarce and the tying or winning run is on third.

In the squeeze play, the batter, after giving the runner the pre-arranged signal, lays down a bunt and the latter starts for home. This maneuver may be divided into two classes, the safety and the suicide squeeze. In the safety type, the opposing infield is usually playing back a little and the runner takes a big lead off the bag but doesn't start home until he sees the ball actually bunted. In the other classification, when the infield is playing up close the runner breaks for home at the start of the pitch. If the ball is bunted down the first or third base line—a roller too far for the catcher to get and too close to the base line for the pitcher—it is virtually impossible to catch the man at the plate.

The signal for this is generally given by the manager or coach to the batter who in turn communicates with the man on base.

The world's most accurate gages insure the precision of **GENUINE FORD PARTS**

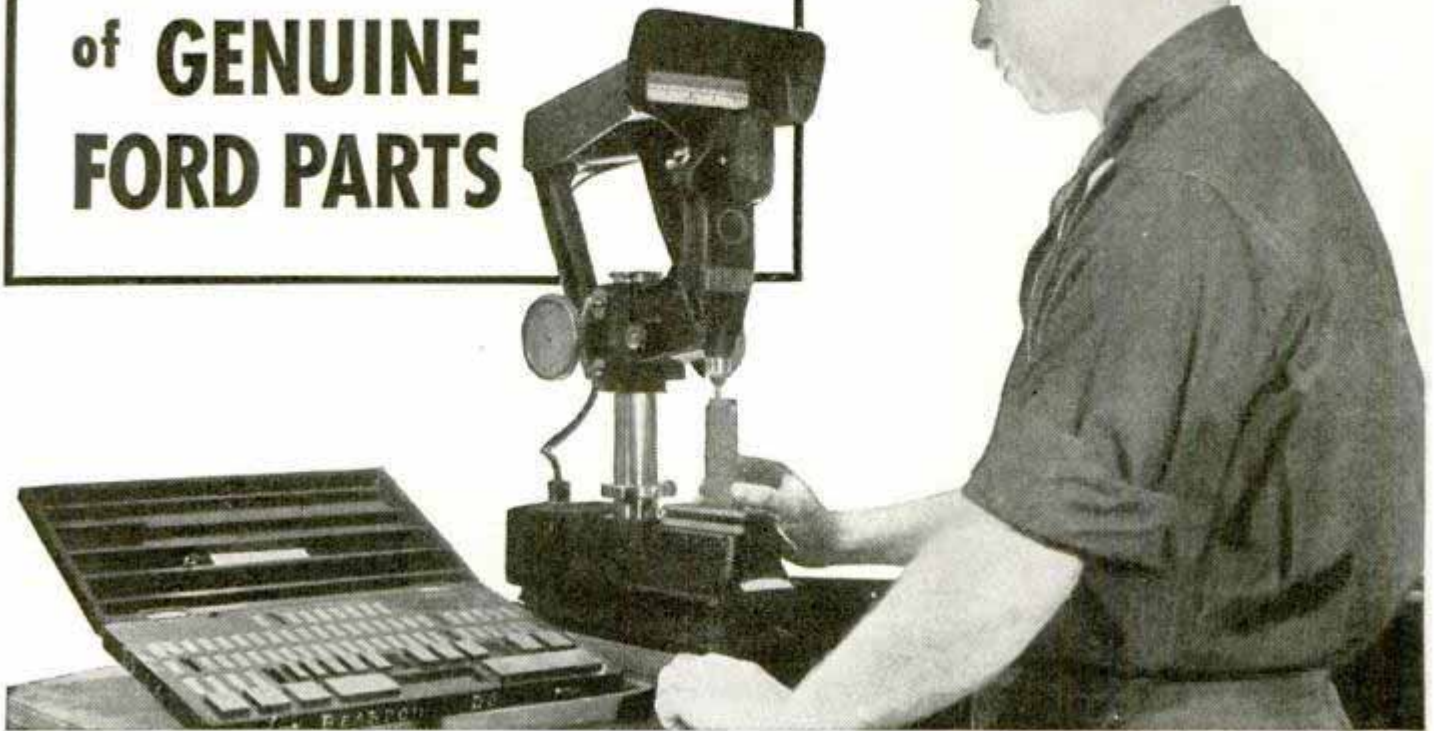

Inspection gages of all types are set accurately by means of Johansson Gage Blocks at the Ford Plant in Dearborn, Michigan.

Precision manufacturing is one reason why you can depend upon Genuine Ford Parts to fit properly — to last longer. For example, you can depend upon camshaft bearings and push rods to measure within five ten-thousandths of an inch (.0005") of specified size, and valve stem diameters to vary not more than one one-thousandth of an inch (.001").

In making Genuine Ford Parts, extreme precision is maintained by the use of Johansson Gages — gages made by Ford Motor Company in the United States and so accurate

that they have been accepted as the world's standard of linear measurement. These gages are accurate within two millionths of an inch (.000002") of specified sizes.

And quality is just as outstanding as precision manufacturing. Genuine Ford Parts are made of the highest quality materials. 36 kinds of steel are used — each steel of a special type to meet a specific need.

When replacement parts are needed, remember that you can get the same precision and quality



All prices subject to change without notice.

Genuine Ford Oil Pan Gaskets are made of a treated cork fiber material that has high tensile strength to insure resistance to tearing. They pass rigid absorption, compressibility and weight tests. 10c each.

When writing to advertisers please mention Popular Mechanics



Even texture, correct hardness, uniform resistance and long life are features of Genuine Ford Generator Brushes. Per set of three, 18c.

that was built into your Ford car or truck at the factory only by using Genuine Ford Parts. Get them from any Ford dealer or from any garage that displays the sign "Genuine Ford Parts."

FORD MOTOR COMPANY
Dearborn Michigan

Genuine Ford Starter Springs are made of special high-carbon steel. Close tolerances insure alignment between screws, shaft and drive-head. 55c each.



THIS MUCH MORE
Exclusively
IN A
SHELVADOR



★

★

★

**MORE BEAUTY
ECONOMY
CONVENIENCE
USABLE SPACE
ACCESSIBILITY**

★

EXCLUSIVELY IN
CROSLEY
ELECTRIC REFRIGERATORS

**WISE
GRIP**



THE BIGGEST LITTLE TOOL EVER BUILT. A wrench of tremendous gripping power that LOCKS to the work with a grip that never slips. Holds anything, round, square or otherwise. Works in close quarters at any angle. Adjustable to ratchet like action. Quick, positive, no lost motion. Capable of exerting more than a ton of pressure yet light and handy as a pair of pliers. ABSOLUTELY LIMITLESS IN ITS USES. Wise-Grip is engineered to a perfection that makes it the CLASSIC IN HAND TOOLS. No tool user can afford to be without it. Send \$1.95 for 10" size, \$1.65 for 7" size. \$3.50 for set. Wonderful agent's proposition.

PETERSEN MANUFACTURING CO., DE WITT, NEBR.

NEW Light Weight Paint Sprayer—Only \$31.15

1/4 H.P. Motor AC110 Volts. 60 Cycles— COMPLETE



Quick, easy way to paint screens, furniture, radiators, machinery—anything—in homes, factories, stores, schools, hospitals, office buildings, etc. Small, compact. Carry anywhere. Weight 44 lbs. Complete with Spray Gun; 15 ft. Hose. FULLY GUARANTEED. Only \$31.15 f.o.b. Chicago. \$5.00 Deposit, Balance C.O.D., or see your dealer. Free

Circular. Ideal Pump Co., Dept. P-6, 801 Washington St., Chicago, Ill.

GIVE AWAY FREE ^{RCA}LIC. RADIOS

MAKE \$15.00 ON EVERY DEAL
Send 10c for sample salescard and plan.
Many making up to \$150 weekly.

BUY at FACTORY PRICES
Resell at 100% profit

Get into radio business. 1937 catalog
FREE. 25 new models for farms, homes
and autos, 5 to 15 tubes. **FOREIGN**
Reception. New "MAGIC-EYE" tuning.
ONE YEAR guaranteed. **FREE** home trial.
MONEY-BACK if not 100% satisfied.
SILVER MFG. CO.
606 N. Michigan Ave., Chicago, Ill.



Write for
FREE CATALOG

**MEN
MAKE
MONEY**

Exclusive "huge profits" business of your own, providing income practically unlimited. New, amazing waterproofing process. Patented. Applied to **INSIDE** of basement walls, etc.—no digging. Permanent. Guaranteed. Jobs easy to get. No experience or special tools necessary. Small investment starts you. Sole rights granted. Write quick for free details.

The Seal-Seep Service, Desk 692
Montgomery & Plainfield, Cincinnati, Ohio

The Electric Age in Food

(Continued from page 860)

freezing, particularly the law that when solutions are allowed to crystallize the size of the crystal is in proportion to the amount of time in which it forms. In the case of ordinary or slow freezing, ice crystals in meats usually grow to many times the size of the individual flesh cells. Such crystals pierce the tissues, tear the delicate cell walls and upon defrosting this causes excessive leakage, which means loss of flavor and firmness. But quick freezing at low temperatures keeps the ice crystals



Packages of frozen berries brought from cold storage for examination

small, and in fruits and vegetables causes stiffening of the semi-fluid content of the cell, which preserves the original flavor and appearance.

Freezing between the temperatures of thirty-one and twenty degrees is the zone of maximum crystal formation. When products are damaged during freezing, most of the damage occurs in this temperature zone. The real purpose of quick freezing is to pass the product through this temperature range so quickly that injury to tissues may be reduced to absolute minimum. Thus temperatures of minus fifty-four to minus fifty are used to bring

(Continued to page 151A)



SHEDS WATER LIKE A DUCK!

AZTEC Cold Liquid ASPHALT makes ALL roofs 100% WATERPROOF whether paper, metal or wood shingles. Anyone can easily apply—no skill or equipment necessary! Costs less than other methods yet does not crack or weather away—Guaranteed! Use direct from container without heating—avoids danger of fire, etc.

MANY OTHER PROTECTIVE USES
Excellent as non-skid deck coating for boats. Also for basements, floors, tanks, etc. Contains no oils or solvent thus eliminating possibility of it softening or peeling.

SEND NO MONEY
AZTEC ROOFING KIT comes ready to use, nothing else to buy—sent C.O.D. on receipt of your order. Enough material for waterproofing 400-500 sq. ft. wood shingles or 600-800 sq. ft. of roofing paper, etc. Kit consists of 1 brush, 2 gallon can AZTEC TACK COAT and 2 gallon can AZTEC ROOF MASTIC—Black \$4.75, Green \$5.45, Red \$4.95, F.O.B. Chicago. Particulars sent on request.

AZTEC ASPHALT CO.
404 N. Wells St. DEPT. C Chicago, Illinois

HIGH SCORES EASIER With Xpert .22's!



You'll get a big thrill out of the **GREATER ACCURACY** of XPERT Long Rifle .22's! They're **WINNERS** for target marksmanship and all-around shooting, even at 100 yards and more! The .22 Short and .22 Long have comparable accuracy. Smokeless! Non-Corrosive! Lead lubricated bullets. Yet they **COST NO MORE** THAN ORDINARY .22's! Send for the **FREE**, new **HANDBOOK!**

Western Cartridge Company,
Dept. F-46, East Alton, Illinois

Send, **FREE**, the new **WESTERN AMMUNITION HANDBOOK**, a complete shooting guide. Tells all about the new XPERT .22's and the complete Western line.

Name.....
Address.....
Post Office..... State.....



HANDY Taps and Dies

Electrically heat treated for long, accurate service. Every tool guaranteed to give complete satisfaction. When you need 'em you'll realize why they're named Handy.



Made by **HENRY L. HANSON**
Worcester, Massachusetts
At Your Local 5 and 10 Cent Store

The Barking Dog AUTO HORN

2575 BEVERLY BLVD. LOS ANGELES, CALIF.

\$2.85

WHIZ Electric Tool

DRILLS, GRINDS, POLISHES, SHARPENS, SANDS, SAWS, CARVES — easily, quickly

Saves TIME and MONEY

A whole shopful of tools in one. Most sensational value of 1937. A sturdy power tool needed by all *homecraftsmen, mechanics and carpenters.*

POWERFUL — SPEEDY — DEPENDABLE
110 volt A.C.-D.C. Motor. Triple geared for extra power. Drills steel, wood, all materials. Universal chuck, 1/4" capacity. Ball-bearing thrust. Self-enclosed fan. Highest quality workmanship and materials. Uses 50 different accessories, instantly interchangeable. **10-DAY money-back TRIAL.**

FREE Accessory outfit, including set of 3 drills, mounted grinder, sanding disc, mandrel, mounted brush, etc., sent free with each WHIZ tool ordered now. Most amazing value of 1937. Complete outfit for only \$8.95 postpaid.

PARAMOUNT PROD. CO., Dept. 7A, 245 Broadway, New York

ONLY \$6.95 POSTPAID

NEW WELDER with 1000 USES



LEJAY ELECTRIC ARC WELDER \$2.50

Welds any metal quickly. So simple anybody can repair broken fenders, tanks, radiators, brazes castings, etc. **Postpaid** Operates from regular auto battery. Intense heat with special LeJay carbon makes repairs in few seconds on brass, copper, iron, steel, tin, etc. \$2.50 includes welder, welding rods, brazing rods, solder rods and carbon tips. Backed by LeJay's famous guarantee, "Satisfaction or money refunded." We also ship C. O. D.

LEJAY MFG. CO., 347 LeJay Bldg., Minneapolis, Minn.

In answering advertisements always write name and full address clearly.

OUTDOOR PLYWOOD

Make your own...
Trailers • Truck Bodies
Boats • Summer Homes
Garages • Greenhouses

The world is on the move and this new weatherproof plywood is on the job with modern mechanics and build-it-yourselfers. No rain—snow—sun or wind can harm

SUPER-Harbord

It is made with a resinoid bond absolutely insoluble in water and not to be confused with ordinary plywood. It is also proof against termites, molds—all forms of rot. Strong, durable—easy to saw and handle. Your lumber dealer can obtain from nearby warehouse stocks. Mail coupon today for folder 8 for full information.

GUARANTEED WEATHER PROOF

Harbor Plywood Corp., Port Dock Hoquiam, Washington

Gentlemen: Please tell me how Super-Harbord will give me better and cheaper outdoor construction.

Name.....
Address.....
Lumber Dealer.....

MAIL THIS COUPON TODAY

When writing to advertisers please mention Popular Mechanics

DON'T MISS JUNE

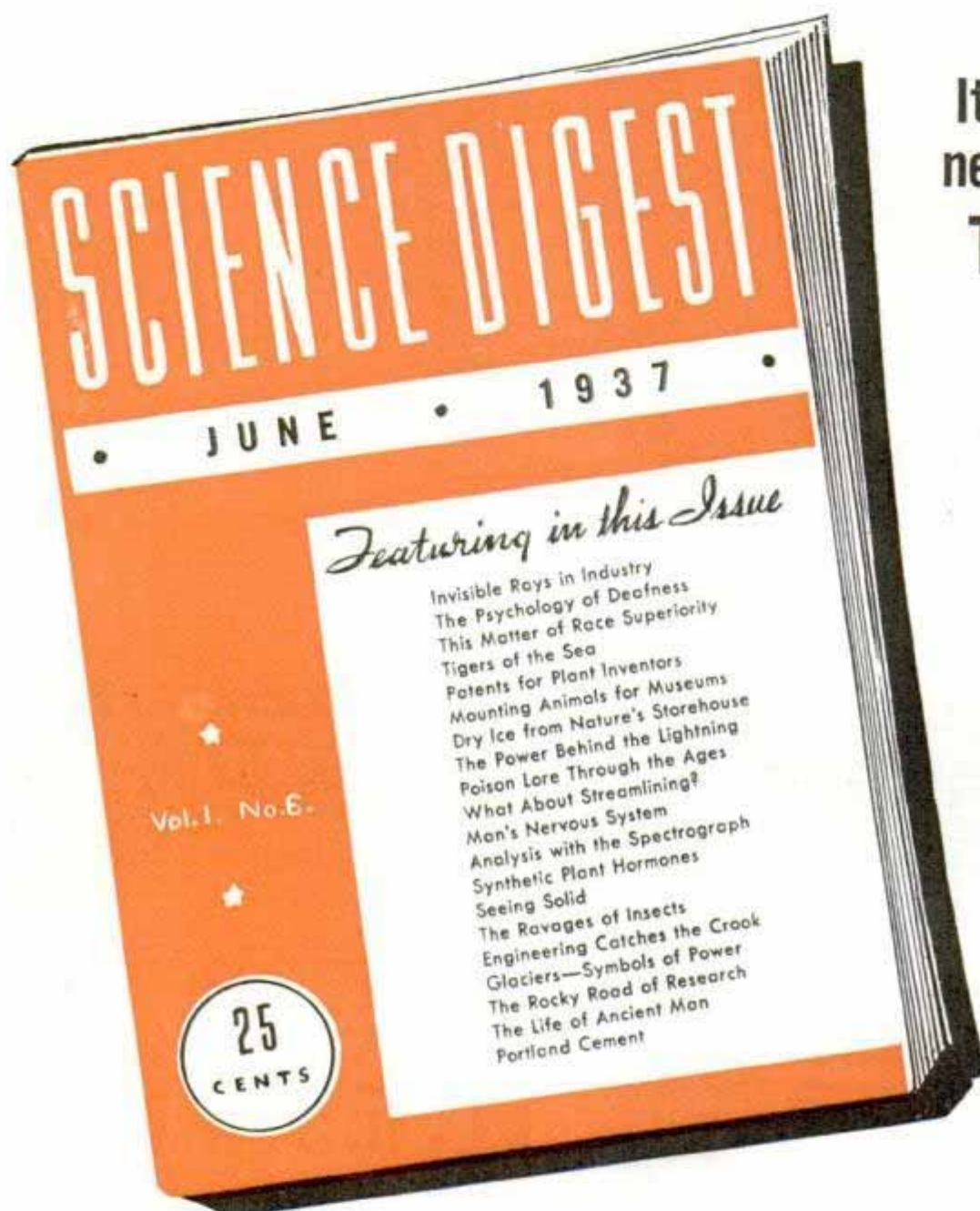

It's on the
newsstands
TODAY
25¢

THAT list of titles assures you ninety-six pages of absorbing reading—condensed from the scientific journals of the world. If you are interested in anything—in manufacturing or research, in man or plant life, in the future or past—you will read Science Digest with interest, perhaps

with profit. Busy men keep informed in all branches of science by subscribing for Science Digest. You can make sure of getting every issue by subscribing now. In the Americas and Spain, a year's subscription is \$2.50. Elsewhere 50 cents more, to cover overseas postage. Start with June.

SCIENCE DIGEST, INC.

631-643 St. Clair Street

Chicago, Illinois

When writing to advertisers please mention Popular Mechanics

(Continued from page 148A)

the product to zero or slightly above, which produces only a microscopic formation of crystals. Today there are four basic methods of quick freezing: direct immersion, by which the product is immersed in sodium chloride brine which freezes at about minus five; the can methods, whereby materials are placed in open cans and sprayed or immersed in calcium chloride brine which freezes at about minus fifty-seven; the single-plate methods by which the material to be frozen is

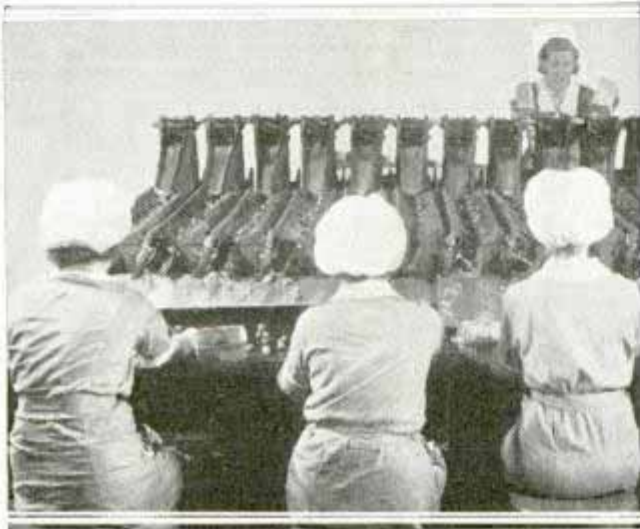

Here is modern machine for hulling strawberries preparatory to freezing

placed on a metal plate, the under side of which is in contact with calcium chloride brine; and, finally, the newest method of freezing under controlled pressure between two metal surfaces—usually by direct expansion of ammonia.

The newest commercial food-freezing machine is called the multiple-plate froster. It consists of a series of refrigerated metal plates placed one above the other in such a way that they may be moved apart to receive products between them and then closed upon the product with any degree of evenly distributed pressure. The plates are made of aluminum alloy and contain passages through which the refrigerant is circulated. In operation, the lower plate, and its load, is raised by hydraulic piston until it picks up the next plate with its load and so on until all the plates are raised. Plates are inclosed in an insulated cabinet so the apparatus may be operated at ordinary room temperature. Plates are also adjustable so that thick-

(Continued to page 154A)

WIN
\$
PART
OF
200
CASH

• ENTER THIS BIG
• CONTEST TODAY

- It's easy. Simply write an advertising slogan in 10 words or less about the greatest coaster brake ever made. Here's a sample slogan, "The coaster brake that wins all world coasting records." Prizes will be awarded as follows: 1st prize \$100.00; 2nd prize \$35.00; 3rd prize \$15.00 and 25 prizes of \$2.00 each. Your slogan must refer to the

• M U S S E L M A N
• CARTRIDGE
• COASTER BRAKE

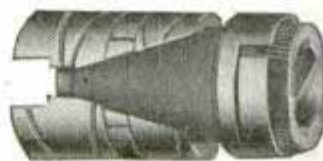

• CARTRIDGE UNIT

- See this great, 1937 model at your department store, hardware, or independent bicycle dealer today. You will get ideas for your slogan and you will see an outstanding masterpiece of coaster brake engineering and design.
- This 1937 model is so much better, so unusually efficient that it makes all old style brakes obsolete. There is nothing like it on the market. Built for quick stopping, it is absolutely the latest in mechanical simplicity. It is the only brake that can be reconditioned as easily as changing a safety razor blade, simply by changing the
- AZ cartridge; the only brake that uses only 3 moving parts while pedaling and no moving parts while coasting (except ball bearings). It is self lubricating and pedals much easier than other brakes. Outcoasts any and all others. Rugged, sturdy, durable and the only coaster brake to stand the grueling one mile drop down the 25 mile Pikes Peak road.
- Demand the Musselman Coaster Brake with your bicycle. Get the best. Don't buy an obsolete out-of-date model. All manufacturers will give you this wonderful coaster brake at no extra cost.
- Address your slogan, post card or letter, to



• THE MUSSELMAN HUB BRAKE CO.
• 6220 St. Clair Avenue Cleveland, Ohio

- Musselman patented brakes are used today on leading airplanes because they are safe.



Everything in
RADIO
SEE ALLIED'S NEW CATALOG

Send for ALLIED'S new Spring 1937 Radio Catalog—156 pages include 10,000 exact duplicate and replacement parts; Set-Builders' kits; Amateur transmitting and receiving gear; 53 new Knight Radios; Public Address systems; test instruments; books, tools, etc. Everything in Radio at lowest prices!

BUILD "POPULAR MECHANICS" RADIO CIRCUITS

Write to us for Free parts lists covering any Popular Mechanics circuit: 1 Tube Portable (R209); 2 Tube AC-DC (R211); "Hurricane" set (R234); Improved Little Giant (R235); 1 Tube S-W Set (R236); "Beam" Tube X-mitter (R237); 6 Volt Farm Set (R238), etc. ALLIED approved parts assure best results!



FREE

ALLIED RADIO

833 W. JACKSON BLVD.,
CHICAGO, ILL.

Dept. 5-F

Send me your new Spring Radio Catalog.

Send me parts list No

Name.....

Address.....

City..... State.....

Send for
CATALOG



**Folding
Puncture Proof
Canvas Boats**

Light, easy to handle, no leaks or repairs; carry by hand and on auto; safe for family; all sizes; non-sinkable, stronger than wood; used by U. S. and foreign governments. Awarded First Prize at Chicago and St. Louis World's Fair. Catalog.

KALAMAZOO CANVAS BOAT CO.
450 Harrison Street Kalamazoo, Michigan



FINE PILOT-LIGHT UNITS

"A high grade electrical panel deserves a quality Pilot-Light. Thousands used on products of most prominent electrical manufacturers. Lamp removed from front of panel; One hole mounting; For lamps up to 120 V.; 180 degrees visibility; Screw terminals; All colors; \$1.60 delivered (without lamp). Free data, International Signal Devices Co., Morristown, N. J.

**100 Mi. per Gallon
30 Miles per Hour**

Auto-Glide

\$125

f. o. b.
factory

It's easy to own the year's greatest sensation in low-priced transportation! Actually 1/10th the operating cost of an auto—much easier to park. Save money getting to office, factory, school. Wonderful for pleasure. For light deliveries, get Kari-Pac model with big rear parcel carrier, 1 H.P. Cushman engine (1½ H.P. optional, \$7 additional). 12x3¼ in. balloon air tires. Extra strong frame. Ignition lock, real clutch, starts like an auto. Hand throttle. Drum brake. Big comfortable cushion seat.

FREE Send today for free book, photos, full details. **DEALERS:** Here's your big opportunity! Send!

The Cushman Motor Works

Dept. 54
Lincoln Nebr.



Transceiver Mounted on Bicycle

(Continued from page 900)

from the copper tubing. The legs of the plate coil are 1½ in. long.

The flexible-wire antenna feeder clips to the plate coil about 1 in. from the B-positive center tap and is taken out to the rod antenna by means of the insulated antenna post mounted on the sheet-copper cover, as shown in photos 3-A and 3-B; this metal cover should be grounded to B-negative with a short flexible wire.

It is important when connecting the ends of the grid coil to the tube-socket terminals, to fasten the G lead that comes out of the P₁ end of the plate coil, to the G₂ terminal on the socket, and the other G lead to the G₁ socket terminal. If these grid leads are not crossed over, the tube will not oscillate properly.

If an ordinary telephone transmitter is used instead of the 200-ohm "mike," connect a 500-ohm fixed resistor across the two switch points of the d.p.d.t. switch on the mike side instead of the jumper wire. When mounting the transceiver on the strap-iron handlebar clamps, connect one of the mounting bolts that go through the baseboard to B-negative to ground it to the bicycle frame, otherwise do not permit the clamp screws to come in contact with any other part of the circuit. Pack the A and B-batteries in a suitable weatherproof box and strap it on the luggage carrier. The 4-conductor battery cable and feeder lead are then run to the transceiver as shown in Fig. 3; the battery leads enter the metal cover through a small hole and are connected to Fahnestock clips screwed to the wood baseboard. Fasten the vertical rod antenna to the rear of the metal luggage carrier so that it makes a good electrical contact with it.

No blueprint is available for this layout. However, the circuit diagram and specifications are similar in many details to those of the beginner's two-way 5-meter transceiver described in the November, 1934, issue; this is blueprint number R-203.

In operation, a hissing noise will be heard in the headphones; this hiss disappears when a station is tuned in. Make tests with another 5-meter station if possible. If you are below the band in frequency, separate the plate coil turns slightly; if above, squeeze the turns closer together.

New Invention WITH SUPERCHARGE PRINCIPLE SAVES GAS

NEW MOTOR LIFE MORE POWER MORE PEP UP TO 30% GAS SAVINGS QUICKER STARTING

AT LAST! Automotive engineers have smashed down the barriers to perfected combustion! The new VACU-MATIC solves the secret of greater power! With almost magical action, this amazing invention instantly puts new life and pep in any motor. It adds mileage to every gallon of gasoline... produces split-second pick-up, sensitive accelerator response, quicker starting, greater speed and smoother running.

Automatic - Nothing Like It!

The self-starter — four wheel brakes — knee action — streamlining... and now VACU-MATIC! The sensational money-saving invention! With it, engineers have achieved a practical means of balancing air and gasoline automatically for all speeds.

VACU-MATIC is *entirely different!* It operates on the supercharge principle by automatically adding a charge of extra oxygen, drawn free from the outer air, into the heart of the gas mixture. It is entirely AUTOMATIC and allows the motor to "breathe" at the correct time, opening and closing automatically as required. No idling troubles—no carburetor adjustments necessary. It is so simple it will amaze you—so practical it will save you many dollars on gas costs.

USERS REPORT
3 to 7 MILES MORE PER GALLON
MOTORIST SAVES \$180.00 a YEAR

"On my V-8 Ford it works miracles. Its added power, acceleration and top speed has sold me. The results are unbelievable."—Ralph Field, Mass.

"Very glad to say, the Buick showed an increase of 5 miles more per gallon."—A. V. Gross, Washington.

"On my Plymouth, I obtained an average of 22 miles per gallon, an increase of 7 miles. This means a saving of \$15 a month or \$180 a year."—F. S. Park, Calif.

"It saves me one gallon a day. I had to buy 5 gallons each day—now only 4 gal. less."—L. V. Sweet, Pa.

"I have twelve VACUMATICS on cars now, and they all show an increase in mileage. The car owners are very well pleased."—Fred Taylor, Okla.

"I have been placing VACU-MATICS on expert mechanics cars. All are well pleased."—J. W. Donahoe, W. Va.

Guaranteed Gas Savings
 VACU-MATIC proves itself on every car. It is guaranteed to give worthwhile gas savings, quicker pick-up, and more power or it costs you nothing. You can instantly tell the difference in added power and motor performance — you quickly notice the cash savings on gasoline.

Fits All Cars

VACU-MATIC is constructed of six parts, assembled and fused into one unit, correctly adjusted and sealed at the factory. Nothing to regulate. Any motorist can attach VACU-MATIC in ten minutes. Once in, its only reminder is the surge of instant power and speed it gives to the motor and the savings it affords your pocketbook.

AGENTS & SALESMEN

VACU-MATIC offers a splendid opportunity for unusual sales and profits. Valuable territories now being assigned. Check and mail coupon.

Free Details

You owe it to yourself to know all about this remarkable discovery. Mail the coupon below. Start saving gas with VACU-MATIC and enjoy a new driving thrill! There's no obligation—so get the facts now! Write today!

The VACU-MATIC Co. Wauwatosa, Wis.

FREE OFFER COUPON

THE VACU-MATIC COMPANY
 7617-312 W. State St., Wauwatosa, Wis.

Gentlemen: Please send me full particulars concerning the VACU-MATIC and details of your Free Offer. This of course does not obligate me in any way.

Name

Address

City State

Check here if interested in selling proposition



NEW INVENTION MAKES \$34.50 IN 5 HOURS • YOU WILL DO IT!

With The "BIASCOPE-NICKEL-PLATED-CAMERA." Loads with 200, FILMLESS-POSITIVES in DAYLIGHT, Snaps, Develops on the Spot. Automatically Discharges TWO-NEGATIVES-SIMULTANEOUSLY in One Minute. NO PHOTO-EXPER. NEEDED. Men, Women—CASH IN with this FAST MONEY MAKER. WRITE FOR FREE ILLUSTRATED BOOKLET RIGHT NOW.

PACIFIC BIASCOPIES
 Rm. 515-D, Cotton Exchange Building,
 LOS ANGELES, Calif.

MAKE BIG MONEY WITH THIS PROFITABLE LINE



SENSATIONAL NEW PLUNGER PEN
 High Quality—Low Price. This is the pen that is setting the money. Write today for FREE Money Making Sales Plan or send 25c for Sample prepaid.

BENSON PEN CO. 348-A Plymouth Bldg. MINNEAPOLIS, MINN.

ROTARY TYPELESS PRINTER

Sensational PRINT-O-PRESS Stencil Duplicator. Prints post cards and up to 8 1/2 x 11 letters, circulars. Many advance features. Details free. Fully Warranted.



Professional Products
 Dept. 610, Silverton, Ohio

Does work of \$150 Machines
\$9.95 COMPLETE
 ORDER DIRECT

"GREASELESS" POTATO CHIPS

Here's your chance—a money-making business of your own. Turn potatoes into cash by making potato chips with my improved outfit. Makes delicious, superior, "NON-GREASY" chips at low cost. A few hours' practice does it. Begin anywhere—city, village, town. Wholesale or retail. Steady year 'round business. Groceries, markets, restaurants, taverns do the retailing for you.

WE HELP START YOU IN BUSINESS

Great quantities of chips are eaten daily. Profit large—unusually so. You can start this money-making business on a "next to nothing" outlay of cash. Write for Potato Chip Booklet. **LONG-EAKINS COMPANY, 628-S High St., Springfield, Ohio.**

AMBITIOUS MEN READ THIS

If you are looking for something permanent, congenial and profitable. Our proposition is one of the sturdiest in the U. S. A., not easy but genuine. Manufacture Lamps, Art Goods & Novelties in imitation marble in our guaranteed rubber moulds. Experience unnecessary. Small investment brings big returns. You have a chance to become one of our successful branch manufacturers. Interesting booklet mailed FREE. **Plastex Industries, Dept. 4, 1085 Washington Ave., New York.**

MANUFACTURING OPPORTUNITIES



IN BUILDING INDUSTRY—with machine and process producing permanent construction with savings of 1/3 labor, 1/2 mortar, and 1/3 material costs—ashlar, hollow, veneer or solid walls—plain or 40 colors.

WE EQUIP YOU with Automatic Machinery—large production only one or two men. Equipment costs but fraction of other processes with equal capacity.

INVESTIGATE—let us show you why building today offers you the greatest opportunity for growth, expansion and profit in a business of your own, using raw materials available in your territory. Write today.

W. E. DUNN MFG. CO.
 600 West 24th St. Holland, Michigan

Largest Assortment of Kayaks—Built & designed by America's oldest Kayak factory. 20 Models, 6-20 ft., 1-4 persons; for Touring, Racing, Sailing & Fishing. Cedar Kayaks—Folding Kayaks—Kayak Assembling Kits—Canoes—Children's Playboats—Rowboats—Racing Sculls—Ice Yachts—Aquaplanes—Accessories.

New Reduced Prices.

KAYAK BOAT CO.
 NEW HEADQUARTERS
 152 EAST 129th ST.
 NEW YORK, N. Y.

Complete Cut-to-Fit Assembling Kits

SEND 10¢ for BIG CATALOG



**TROUSERS
PRESSED**
for **1/4¢**

**New Pocket Size
ELECTRIC PRESSER!**
Saves Scores of Pressing Bills!
Works Like Magic!

Just plug into any light socket—AND PRESS!
New patented POCKET SIZE ELECTRIC
PRESSER PUTS RAZOR EDGE CREASES
IN TROUSERS IN A JIFFY! Made of
beautifully plated steel—complete with 6
ft. cord and plug—weighs less than 10 ozs.
Backed by a full year's guarantee. SELLS
AT A SENSATIONALLY LOW PRICE!
Pays for itself on the savings from just
a few pressing bills.

A New "Goldmine" For Agents!

Robinson sold 51 in one office—Leaberry
made \$365.00 in one month. Agents the
country over reporting phenomenal
profits. Quick, easy WHIRLWIND
DEMONSTRATION MAKES
MANY MEN BUY ON SIGHT.
SEND NO MONEY! Your name
and address on a postcard brings
you all the magic money-making
details ABSOLUTELY
FREE! COMPLETE
DEMONSTRATING
OUTFIT EASILY
CARRIED IN COAT
POCKET. WRITE
TODAY!

The Empire Electric Co.
Dept. P-8, Cincinnati, O.

RIDE AN AUTO-SCOOT!
"The Mightiest Midget of Them All"

Loads of fun and designed for practical use.
Powered by the famous Briggs & Stratton
Motor with engine starter, clutch-mission and
real brakes. An honest to goodness vehicle.
Can be ridden by anyone that can ride a
bicycle including women and small girls. Can
be used instead of a bicycle for pleasure,
rental service or commercial.

Extremely high gas mileage. Speeds up to
25 M.P.H. Safety controls. Meas-
ures only 57 inches over all and
33 inches high. Weighs only

\$98.50

F.O.B. Chicago

WRITE FOR FULL PARTICULARS

RENMOR MFG. CO., NOT INC.
Dept. A-6, 4877 Armitage Ave., Chicago



COLLETS FOR YOUR LATHES AND MILLERS

Bulletin
No. 36D
Gives
Information
Dimensions
Prices



Ask for
Free
Bulletin
No. 36D

ACCURACY - DURABILITY - ATTRACTIVE PRICES
Collets in stock for South Bend, Atlas, Sheldon, Burke,
Sundstrand and all other Lathes and Millers.

HARDINGE BROTHERS, INC. ELMIRA, N. Y.



HOME AUTOMATIC CIGARETTE MACHINE

Have YOUR OWN Monogrammed Cigarettes
Put tobacco and block of papers on machine, TURN THE CRANK
—PRESTO—CIGARETTES. Easy—simple. All metal construction.
Guaranteed. No cloth ribbons; no special tube or gummed
papers required. **ASK FOR FREE ILLUSTRATED FOLDER.**

A. C. MACHINE WKS., PM-6, 1055-57 Devon Ave., Chicago, Ill.



SAVE \$75⁰⁰ A YEAR

On Oil and Repair Bills
With "RECLAIMO" the Super Filter-Refiner

Much more than a mere oil filter. Removes Dirt, PLUS Water,
Gasoline Dilution, Acid; maintains permanent PURITY, BODY
and OILINESS.

Eliminates All Oil Changes!

Easily attached to old and new motors. Skeptical?—O. K.—
Just read our "OIL FACTS," they'll tell you plenty (much more
than the oil interests would have you know) and may save you
hundreds of dollars. Yours for a penny postcard. Don't DELAY!
P. SCHWALGE CO., 2306 N. Western Ave., CHICAGO, ILL.

(Continued from page 151A)

ness of the freezing layer or package may range from less than an inch to as much as six inches. The front and the rear of the cabinet have sliding doors for quick loading. Pressure between the plates is automatically maintained at about 150 pounds.

This pressure gives a temperature of minus twenty-five at the surface of the plates, sufficient to freeze most packaged products in about twenty minutes, or from five to fifteen minutes without packages. The great bulk of commercial foods is frosted ready packed. The froster is a small machine. Commercial models occupy floor space of about five by seven feet, with a freezing capacity of about 930 pounds per hour, and therefore can be moved from place to place—in packing houses, canneries, storage sheds or private homes. Compactness and portability are important. Storage of frosted foods is merely a matter of efficient electrical refrigerators, or cold-storage lockers capable of holding temperatures from zero to fifteen degrees. Safe transportation demands an accurate and reliable type of refrigerator car or truck.

Wrapping and packaging materials vary a great deal. Some of the fruits and berries which are subject to color deterioration are packed in vacuum-sealed or the ordinary airtight tin cans. But metal cans are usually painted inside with stainproof lacquer. Commercial frosted foods are usually paper-packed, but commercial manufacturers are perfecting an improved material known as "Moisture-proof Cellophane" which protects the foods as well as displaying the goods to the best possible advantage. Quick freezing of foods has already grown into an industry measurable in terms of millions of dollars and hundreds of millions of pounds. But it is still an infant industry.

Beginning with cranberries, probably the easiest of all foods to quick-freeze, the principles of frosting have been applied successfully to 133 different food products. In Washington and Oregon, which deserve to be mentioned as the real homeland of the idea, farmers and gardeners are beginning to quick-freeze their own products at home and to keep the goods in home refrigeration plants or rented space in commercial cold storage.

DIESELECTRIC PLANTS

UNBELIEVABLE ECONOMY

Produce **ELECTRIC LIGHT & POWER**
for **LESS than ONE CENT per KILOWATT**

Simple in design and construction, the WITTE is the most important development in the small engine field. Thoroughly modern in every respect, incorporates every worth-while advance in Diesel Engine design. The 1600 watt Dieselectric Plants are small, compact and radiator cooled. Installation is simple—upkeep low—unusual flexibility for power applications. 110 volt A.C. and D.C. plants for direct lighting. 32 volt plants for low cost battery charging.

3000-6000
WATTS

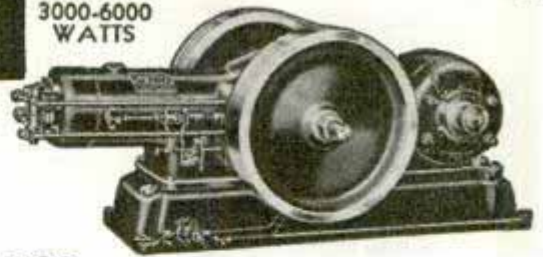

110 Volt D.C.

\$565

F.O.B.
Kansas
City,
Mo.



1600
WATTS

Make your own electric light and power—be independent of the power companies. Cut your power bills 75% with a WITTE Dieselectric Plant 1600 to 6000 watts. Smooth, flickerless current—close voltage regulation. Alternating or direct current. Uses non-explosive fuel. WITTE Diesel Engines offer the small power user the same important features, operating characteristics and startling economy of the large Diesel. Quality assured by more than 67 years of manufacturing experience.

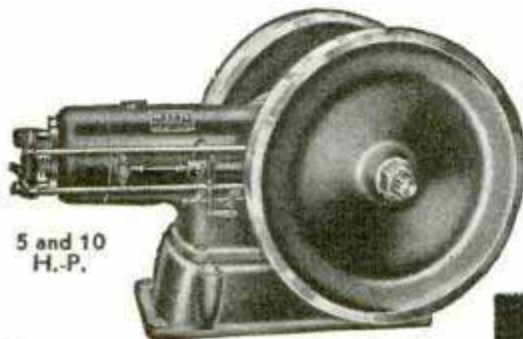

5 and 10
H.-P.

CHOOSE A DIESEL FOR POWER ECONOMY

WITTE Stationary Diesel Engines are offered in 3, 5 and 10 H.-P. sizes. Install a WITTE Diesel and **watch it pay for itself.**

RESPONSIBLE DIESEL DEALERS WANTED

174-A Oakland Ave.

Kansas City, Mo.

WITTE ENGINE WORKS

DEAFNESS IS MISERY



Many people with defective hearing and Head Noises enjoy Conversation, Movies, Church and Radio, because they use Leonard Invisible Ear Drums which resemble Tiny Megaphones fitting in the Ear entirely out of sight. No wires, batteries, or head piece. They are inexpensive. Write for booklet and sworn statement of



the inventor who himself has been benefited by the use of the drums.

A. O. LEONARD, Inc., Suite 699, 70 5th Ave., New York

GENERAL UTILITY PRECISION \$18.50 FLEXIBLE SHAFT MACHINE

Quantity production makes this price possible

Powerful air-cooled 110 volt Universal motor—Self-aligning semi-oilless bearings—All metal chromium sheath—New style pencil type handpiece chuck. Wt. 2 ozs.—Six speed foot control rheostat—Total weight 4 lbs.—Fully Guaranteed. 10 day money back trial.

Send for free catalog No. 350M showing many other machines and over 800 quick change Grinders, Burs, Reamers, Polishers, Routers, Sanders, Saws, Drills, etc., for almost any mechanical operation on all materials.

LINICK, GREEN & REED, Inc.
29 E. Madison St., Chicago, Ill.





Sell Improved Leather Ties

DON'T waste effort on second raters. Sell fast and repeat on handsomest improved ties. Rich colors, embossed like silk. Fullest cut; long wear; wrinkle-free. Wipe clean like new with damp cloth. Send 50c for sample tie (65c value) and Big Free Sales Kit of new season's smartest patterns. Money back plan. Free premiums.

NU-MODE TIE CO., Dept. 203
1333 N. 12th Street Milwaukee, Wis.



BUILD YOUR OWN ELECTRIC OUTBOARD MOTOR

from old auto generator. We show you how. Variable Speed. Light weight and Silent. Operates from 8 to 12 hours on ordinary storage battery. Dime brings complete plans and catalog. Wind Driven Cottage Light Plants, Motors, etc.

LEJAY MFG. CO. 1547 W. LAKE ST. MINNEAPOLIS, MINN.



BUILD THESE PROJECTS

For garden or lawn. Easy to build. Easy to sell. Detailed Blueprints Model B-25 Dutch Windmill, 50c; Model OM-60, Old MRL, \$1.00. Lawn Figure Patterns—Sunbonnet Girl, Dutch Boy, Tulip Girl, Holland Girl, 35c each, 4—\$1.00. Catalog illustrating over 25 models, send 10c today.

CRAFTSMAN'S MODEL CO., Dept. P-6, 2030 N. 41st St., Milwaukee, Wis.





Printing Offers BIG PROFITS

Cards, stationery, circulars, etc. Easy rules sent. Does raised printing like engraving. Do your own printing. Save money. Junior press \$5.90; job press \$11; power, \$147. Sold direct from factory only. Send for free catalog and all details.

THE KELSEY CO., P-37 MERIDEN, CONN.

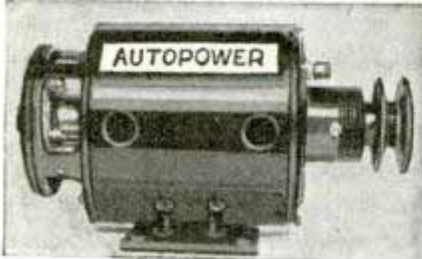

TURN SCRAP INTO MONEY

AUTOPOWER tells you how in plain, easy, simple, and illustrated instructions that anyone can follow. Change auto generators into useful, practical A C and D C generators and motors with voltage from 2 to 1,000 volts, for power, light, welding, radio, sound, etc. No previous experience nor special tools needed. Generators can be driven by wind, water, fan belt, etc. Already used and endorsed by thousands. Send today for your copy, and also receive **FREE** a copy of **PRACTICAL ELECTRIX**, the new publication for the man who wants to **KNOW, BUILD, REPAIR and READ** about electrical apparatus and machinery. Book and magazine postpaid only \$1.00.

AUTOPOWER, Dept. Q 410 S. Hoyne Ave., Chicago



When writing to advertisers please mention Popular Mechanics

... MAKE YOURS a TRAILER VACATION



A Covered Wagon is the best investment you can make in rare vacation pleasure. Travel and see the country—live like a king—go farther and stay longer—do it as thousands are doing it today for far less than staying at home. These modern, low cost homes are complete with living room, dining room, kitchen, bedroom and bath. As originators and world's largest builders, Covered Wagon assures you outstanding values plus real dependability. New low time payment plan. On display at your nearest dealer—or send 10c postage for Trailer Book with Plans.

COVERED WAGON COMPANY
566 Cass Avenue, Mt. Clemens, Michigan
FREE—Illustrated literature

\$395
AND UP
F.O.B. FACTORY
EQUIPMENT
EXTRA



COVERED WAGON TRAILER HOMES

BUILD CLOCKS
for
PLEASURE
—**PROFIT**



Wall clocks are high priced in stores—you can make good money building them or electrifying spring clocks. Dime brings drawing of easily built Grandfather Case with "HOW" Book pricing banjo, desk, mantel, RADIO, spring, ELECTRIC, chime, BATTERY from \$1.40. Brass weight movements from \$16.95. Start now.
KUMPEL CHIME CLOCK CO., Bldg. 5, Guttenberg, Iowa

PRISMATIC HAND LEVEL



\$100
Post-paid

A compact, accurate and useful instrument size 5"x1" for landscaping, grading, surveying, camping. Excellent for camp and boat construction. Made for U. S. Army at approximate cost of \$7.50.
F. C. Meichsner Co., 93 Federal St., Boston, Mass.

NEW Moto Scoot
READY!

Pay While You Ride
with the
Money
You Earn!



6 Miles
for
1 Cent!

ONLY
\$99.75

F. O. B.
Chicago

EASY
TERMS

Here it is—at last!—a MOTO SCOOT so simple, so safe a child can run it YET strong enough for a heavy man! Go anywhere—at 30 miles per hour—120 miles to gallon. No other like it! Easy Terms—pay as you ride with the money you can earn from it! Shipped ready to ride. WRITE QUICK for color folder while this Special LOW PRICE. Special TERMS Offer lasts! (DEALERS! Write for available territories!)

Mead CYCLE COMPANY Write us today
DEPT FM-116 CHICAGO for free folder

Summer Comfort at Low Cost

(Continued from page 829)

makes a big difference during a hot spell extending over only three or four days, and it helps even during a protracted heat wave.

Aluminum foil also is available today with a sort of building-paper backing and can be used to cover the attic floor, or even inexpensive insulating board will help. Of course, new houses being constructed today should be completely heat insulated, and the better the walls of an old house are insulated, the less heat will come through them. But if you have only a limited amount of money to use for insulation, cover the attic floor first.

Now that you've stopped some of the heat from entering, you're ready to do something about what gets in despite awnings, light roofs and attic insulation and ventilation. Removing the excess heat from the air is one way but this involves some air-conditioning equipment. A less expensive way is to replace the warm air in your house with cooler outside air at night. And the way to do this is to install an attic fan—the machine era's priceless gift to a perspiring populace.

"I wouldn't mind hot weather at all," people say, "if I could only sleep at night." An efficient attic fan big enough for the job not only makes the night more comfortable during hot weather, but also the following day. Here's what happens. By midafternoon of a hot day it may be ninety-five outside and only a few degrees cooler inside. Soon after sundown, however, the outside temperature may be ten degrees cooler and during the night it may be fifteen or twenty degrees cooler outside.

But the inside temperature of your house does not drop correspondingly. Furniture, walls and ceilings hold the heat which in turn warms the air. By bedtime, it may be quite comfortable on the front porch but stifling in the bedroom. Under such a condition, an attic fan does the trick. You turn it on about the time outdoor and indoor temperatures are equal. First, it clears the attic of warm air. Then, since you have opened the attic door and downstairs windows, it exhausts the rising warm air from these rooms. This air is replaced by cooler outside air, the process

(Continued to page 160A)



Renew old buildings. Make new construction more permanent and attractive. Plastic Colorcrete is waterproofed. It fuses with any masonry surface. It fills all cracks. It can be applied in any thickness and in 30 colors. Fully proven by over 12 years actual use under all conditions and every climate.

OFFERS BIG EARNINGS

Owners everywhere want to enhance present values. With this machine you can supply this big waiting market with permanent Colorcrete at amazingly low cost. Operators report cost of 2c and up per sq. ft. and sell up to 7c. Some have paid for their equipment from first few jobs. Machine capacity up to 1,000 sq. ft. per hour. Get the facts. Send for books, "Proven Business Opportunity." Write today. It offers you big extra income.



COLORCRETE INDUSTRIES, INC.
570 Ottawa Ave. HOLLAND, MICH.

RE-STRING RACKETS AT HOME



EARN MONEY

It's easy, pleasant, profitable work. No experience required. Learn in a FEW MINUTES. I supply everything needed. Earn \$50 to \$100 cash in your spare time. Act QUICK—write for details FREE.

W. A. BICKEL, Dept. A-6, 809 W. Madison St., Chicago, Ill.

25 POWER TELESCOPE \$1
THE NEW SUPER-POWER 25X "SPOTTER"

Most powerful made for anywhere near the money. All five sections are brass bound. Opens to approx. 3 feet long. This amazing telescope is guaranteed to bring distant objects, people, moon, stars, etc., 25 times as close.



Large 30 mm. objective lens. Directions included for using as a powerful 4 lens compound microscope. Try it for 5 days. Satisfaction or your money refunded. Order now at the amazing price of only \$1. By mail, add 20c for shipping.
BROWSCOPE CO., Dept. 46, 234 Fifth Ave., NEW YORK, N. Y.

VENETIAN BLIND MATERIALS

You can make fine blinds for your own home at low cost, also go into the business. All parts supplied. Send 10c for circular and samples of ladder tape, cord, slats and rails.
Venetian Blind Mfg. & Supply Co., Dept. 2, 1760 Lunt Ave., Chicago, Ill.

NEW BIG TRAILER PARTS CATALOG

Shows 320 valuable trailer items. Build your own trailer or recondition the one you have. Wholesale prices for quality merchandise. Send 10c for this money saving catalog today.
C. M. Hoof Company, 1736 S. Michigan Ave., Dept. P-6, Chicago, Ill.

TOMBSTONES \$9 UP FREIGHT PAID or ERECTED

BEST MARBLE AND GRANITE. Thousands sold. Lettering Free. Satisfaction Guaranteed. Reasonable Prices. Write for Big Free catalog.
U. S. MARBLE & GRANITE CO., Dept. A-18, Oneco, Florida

VEST POCKET ADDING MACHINE

IDEAL For Business or Personal Use. Adds, subtracts, multiplies, divides. Does work of more costly machine. Counts up to million, made of steel—weighs 8 ounces. Simple, accurate. Not a toy. Guaranteed 5 years.

— FREE TRIAL —
SEND NO MONEY! \$2.50 Total Cost

Order from ad, not sold in stores. Just send name and address. On delivery pay postman \$2.50 (plus few cents postage). (If outside U. S. send cash.) 10c additional in Leatherette Case. If not satisfied after 10 days' trial you get your money back. Thousands of satisfied users. Write for Agents' proposition. **CALCULATOR MACHINE CO. (Mfrs.) Dept. 314, P. O. Box 1118, Chicago, Illinois.**



LET ME TELL YOU HOW TO EARN \$150 TO \$300 MONTHLY

Do Electric Welding... New big-profit jobs... low investment... pay as you earn... with the Guaranteed FlexArc. Do as hundreds of other shops are doing. Cash in on the new profits of the Welding Age! Be welding headquarters for your community. But, plan wisely. Get a full-range, high-capacity welder that will do all kinds of work. Common-sense says your best guide in picking a machine is the advice of operators who have used all makes. Here's what they said about the New FlexArc in a recent nation-wide poll: 89% said it welds FASTER; 91% said BETTER; 74% said it EARNs MORE MONEY; 96% liked its SAFETY!



It's the only d-c. welder sold with a written guarantee. Backed by Westinghouse, 50-year veteran electrical pioneer.

Build Your Own—With a second-hand auto engine and chassis, all you need is the FlexArc generator. Save \$300 to \$500.

Electric Driven FlexArc—If you have electric power, your most profitable buy is the FlexArc motor-driven set.

Gas Engine Driven—Big Dodge truck engine drive, electric starter, complete!

Easy to Buy—Easy installations. No red tape. Pay out of monthly profits. Act now while offer lasts. Mail coupon.

30-Day Trial
Easy Payments
Priced Right

Westinghouse Electric, Room 5N2, East Pittsburgh, Pa. Without obligation, send your new "1937 Catalog of Popular FlexArc Models." I am especially interested in:

Building my own Electric Driven Gas Engine Driven 30-Day Trial Easy Payment Plan.
Name.....
Address..... J 20249

Westinghouse Flexarc Welder
FASTEST SELLING WELDER ON THE MARKET TODAY



Spray gun \$6.96—Wet grinder with 10 x 1 1/2" sand stone and jack shaft \$7.45—Back gear Power Hack Saw with vise \$7.95—1/4" Elec. Drill \$8.95—Spray Unit Comp. with 110 V. A.C. Motor (1/2 H.P.) and gun \$14.95. Compressor only \$3.75. Many other tools at popular prices. **FREE CATALOG.**

BALKO ELECTRIC MOTOR & SUPPLY COMPANY
Dept. A16 10 S. Clinton St. Chicago, Ill.

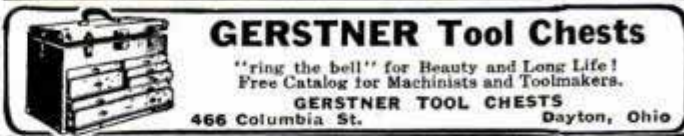

GERSTNER Tool Chests
"ring the bell" for Beauty and Long Life!
Free Catalog for Machinists and Toolmakers.
GERSTNER TOOL CHESTS
466 Columbia St. Dayton, Ohio



POWERlite
ELECTRIC LANTERN

The most powerful, serviceable hand electric lantern for all needs—home, work, fishing, camping.

80 to 100 Hours Light
On One 6-Volt Dry Battery

2 lights on a double action switch. 800 ft. spot beam from the front reflector; broad floodlight from top. Handle reverses. Unbreakable lens. 6 1/2 inches high. At sport, hardware, electrical dealers or write

DELTA ELECTRIC COMPANY
Marion, Indiana Dept. 300 **\$3.35** Less Battery

Get only a GENUINE DELTA

MAKE EACH PROJECT A STEP AHEAD

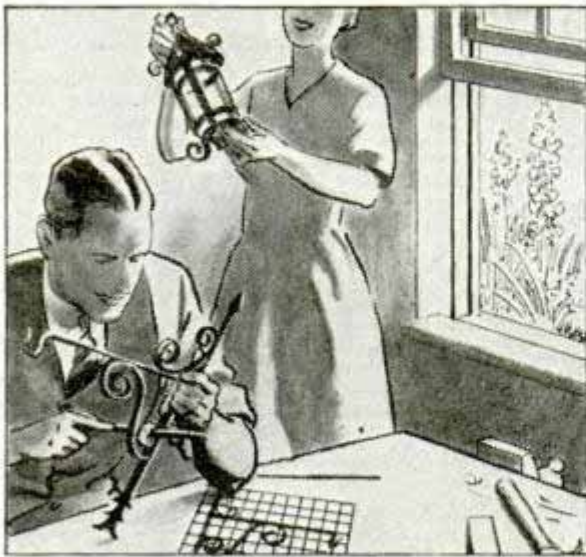

NICHOLSON FILES WILL HELP YOU

You are one of the modern home craftsmen who always looks forward to making something more difficult, more beautiful, more useful. . . .

The new Nicholson Files will help you take each step ahead more quickly, surely and easily.

Tests prove these modern files, made on a new and different principle of tooth construction, remove far more stock, stay closer to the line of work, file faster and cost less to use.

Try Nicholson Files now. Let them help you with your summer projects. These files are first choice among expert home craftsmen and experienced filers in the industrial field.

Your hardware store can supply you. Nicholson File Company, Providence, R. I., U. S. A.

FILES FOR SMALL,
ACCURATE WORK . . .

Ask us about Nicholson X.F. SWISS PATTERN FILES—Set of 1 dozen assorted $6\frac{1}{4}$ " knurled handle needle files in a wooden box which, with top removed, serves as a convenient holder on the work bench.

Patents
Pending



A FILE FOR EVERY PURPOSE

LOW COST POWER

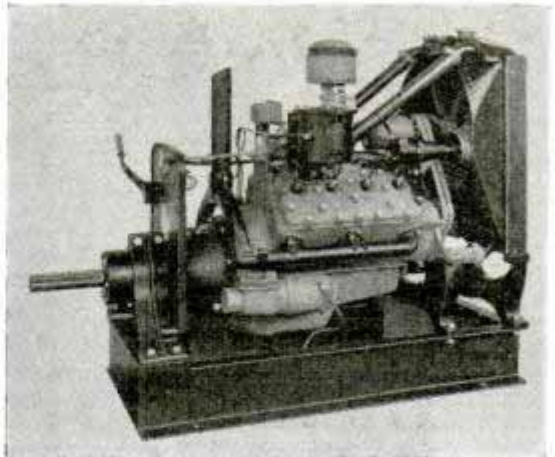

with this KRW-FORD V-8 unit

Here's dependable, low-cost power up to 60 H.P.—complete, compact, portable. Ideal for line shafts, welders, compressors, hoists, pumps, amusement devices, well drillers, agricultural, oil field and contractors' equipment, etc., etc. The most complete industrial power plant built. Uses gasoline or natural gas.

Assembled with brand new heavy duty Ford V8 Truck engine. Large capacity radiator protected by heavy screen. Engine rubber mounted—outfit complete with governor, gas tank, 17-plate battery, instruments, etc. Available also completely enclosed with sheet steel housing.

Write for complete information, price, and data showing how this unit will pay for itself out of savings in a few weeks, whether operated on gasoline or natural gas. You can buy thru your Ford Dealer and benefit by local service and low-cost Ford engine replacement feature.

K. R. WILSON 17 Lock St. BUFFALO, N. Y.
EXCLUSIVE BUILDER OF APPROVED FORD SHOP EQUIPMENT SINCE 1916

Send for CATALOG of Motor-Driven Tools

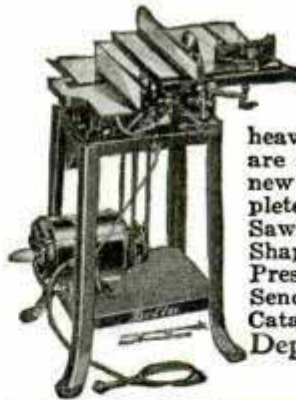

Thousands of home workshops, factories, builders, farms are using these new compact portable, rugged and efficient motor-driven tools. They stand the heavy grind of continuous use—yet are astonishingly low priced. Many new features and improvements. Complete DELTA line includes: Circular Saws, Scroll Saws, Lathes, Jointers, Shapers, Band Saws, Grinders, Drill Presses—and full line of accessories. Send today for big 48 page FREE Catalog.

Dept. A637, DELTA MFG. CO.
600-634 E. Vienna Ave.
Milwaukee, Wis.

NEW $\frac{1}{4}$ -inch
JUNIOR DRILL \$19.95

Write for Details
BLACK & DECKER
606 Penna. Ave., Towson, Maryland

Catch Fish!

Eels, Mink, Muskrats, with our new folding galvanized STEEL WIRE TRAP. Write for our FREE TRAP OFFER and Bargain Catalog. 51 Box of our famous Fish Bait FREE to introduce our traps. WALTON SUPPLY CO., 3501 JUNIATA AVE., ST. LOUIS, MO.



TRAILER DESIGNERS TRAVELERS TRAILER PLANS

SEND 25c TODAY FOR this big 68 page Trailer Manual printed in color. It is chock full of builders' information—Over 350 illustrations, 500 exclusive Trailer supplies, equipment and accessories needed to build the most modern Trailer. BUILDERS GUIDE with complete plans, instructions, designs, specifications, listing practical material. Trailer cabinets, stoves, refrigerators, sinks water tanks, cushions, table, drawers, bathtubs, toilet etc. Also a complete Trailer shell built into 10 sections ready to set up and bolt together. Takes low freight rate. Send 25c, coins or stamps today.
A. J. Stephens & Co., 1403 Chestnut St., Kansas City, Mo



DeLuxe
Alternate
Firing
Twin

**Packed
WITH
PERFORMANCE
FEATURES**

THE GREATEST outboard motors in Johnson history! Packed with performance features including perfected alternate firing, patented exhaust, combined with 360° intake, underwater pilot, synchro-control, dual steering and reverse! You've never seen anything like them! Ask your Johnson dealer for a demonstration. Nine great models, priced as low as \$59.50. (F. o. b. factory. Subject to change.)

FREE Write for special illustrated literature including 1937 Sea-Horse Handy Chart of sizes and specifications. **JOHNSON MOTORS, 400 Pershing Rd. WAUKEGAN, ILLINOIS** Johnson Motors of Canada, Peterboro, Can.

JOHNSON ALL-STAR
Sea-Horse
OUTBOARD MOTORS

Home Craftsmen, Schools, Hobbyists

METAL CASTINGS



produced in your own workshop allow you to design and build your own GASOLINE ENGINES, STEAM ENGINES, STATUARY, ART OBJECTS, SPECIAL TOOLS, NEW INVENTIONS, ETC. You can also make forgings and case harden steel. Your shop is not complete without a FOUNDRYETTE. Three sizes are available capable of making bronze castings of 1½, 3, and 6 pounds weight, aluminum, copper, brass, etc., in proportion to specific gravity. Clean scrap metal suitable for use. Each outfit includes a complete Blast furnace, Domestic gas supply and 110 volt Electric energy required for operation.

Size	Capacity	Wt.	Price
351	6 cu. in.	25 lbs.	1½ lbs. \$13.50
352	12 cu. in.	40 lbs.	3 lbs. \$19.00
353	24 cu. in.	65 lbs.	6 lbs. \$27.50

Above price includes Universal high speed blower. For low speed blower good on 110 volt 60 cycle only, deduct \$4.00. Prices f. o. b. K. C. Check or money order acceptable, express charges C. O. D. Write for circular.

KANSAS CITY SPECIALTIES CO.

P. O. Box 6022

Kansas City, Mo.

PORTABLE ELECTRO-PLATING OUTFIT

Retails for

\$3.75

DOES SAME HIGH QUALITY PLATING AS BIG TANK OUTFITS

New patented invention. **GUARANTEED** to PERMANENTLY electroplate Silver, Brass, Nickel, Copper, Zinc or Cadmium WITH A BRUSH—as easy to apply as a coat of paint.

A NON-LIQUID process, always ready for use, quickly applied, and equal to any commercial electroplating. Used in factories, hospitals, work shops, garages, stores, jewelers, etc. Operates from dry cells, automobile battery or battery charger—nothing else needed. Retails \$3.75 (Silver \$7.25). Specify metal finish wanted when ordering or write for full particulars. **Money back guarantee.**

RAPID ELECTROPLATING PROCESS
2135 N. Cicero, Dept. 25, Chicago, Ill.

I'VE GOT RURAL ELECTRIFICATION WITHOUT WAITING FOR THE HIGH LINE!

32-VOLT

Plenty of Current for
**LIGHTS—RADIO—
WASHER—PUMP—
IRON—SWEEPER**
AT 50¢ A YEAR

Power Operating Cost!

CHEAPER THAN THE HIGH LINE

32-VOLT 650-WATT GIANT

WINCHARGER
REG. U. S. PAT. OFF.

\$69⁹⁵

NOW ONLY \$15 DOWN 10 MONTHS TO PAY

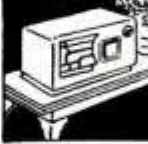
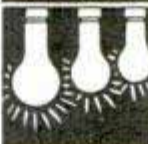

"At the present time we are using about 20 lights, electric washer, pump, iron, and radio from our Wincharger and have plenty of power to spare." *Geo. Barlow, Simms, Mont.*

Put The Wind to Work on Your Farm And Have Rural Electrification NOW!

Let the amazing new 32-Volt Giant Wincharger use your free wind power to make all the electricity you want on your farm right now! Get away from the drudgery of oil lamps—washboards—brooms—and hand pumping! Wincharger is far cheaper than the high line, both in first cost and operating cost! There's no electric meter ticking your dollars away! Wincharger's power operating cost is only 50¢ a year!

**No Electric Bills!
No Gasoline Bills!**

Most users of the 32-Volt Giant Wincharger report 100 kilowatt-hours of current per month or more. That's \$5 worth of electricity, according to average high line rates, that they get FREE from the wind with Wincharger! If you have a gasoline operated electric plant, Wincharger will save you \$30 to \$60 a year on gas and oil! There's no tax on the wind—it's FREE!

World's Largest Makers of Wind-Driven Generators

Wincharger is made by the world's largest makers of wind-driven generating equipment, in the largest factory devoted exclusively to this product. More than 500,000 farm folks are now enjoying free electricity from Winchargers.

Sold Direct—Fully Guaranteed

Wincharger is sold direct from factory to you at a rock bottom price. You save up to \$100 by doing business this way. Every Wincharger is sold under an iron-clad guarantee, "Satisfaction or your money back." Get all the facts NOW!

MAIL THE COUPON TODAY

WINCHARGER CORPORATION

World's Largest Makers of Wind-Driven Generating Equipment

Dept. PM6-37, Sioux City, Iowa

Please tell me all about how I can have electricity on my farm at a power cost of 50¢ a year.

Name.....

P. O..... Route.....

County..... State.....

If you now own an electric plant, what make?.....

Save Postage: Paste coupon on penny postal card

PLASTER FOR PATCHING THAT ANYONE CAN USE



Holes in walls are easy to repair with Rutland Patching Plaster. Makes a perfect, lasting patch.

FLAME-GUN Destroys Weeds Does Work of 4 Men !



Hauck Kerosene Flame-Gun—2000°F. controlled heat—quickly, easily, economically destroys weeds (seeds and all), brush, other objectionable growths. Keeps roadways, fences, irrigation ditches, orchards, etc., clean. Hundred and one uses. Inexpensive—Safe—Easy to use. Pays for itself in time and money saved, 10 day Free Trial. Write for Free booklet and special introductory price.

Hauck Mfg. Co.,
130 Tenth St., Brooklyn, N.Y.

"Handy" HAND PUMPS

for shop, garage or home—pump oils, gas, paints, etc., from drums and barrels. Easy turning—no priming—capacities up to 20 gallons per minute . . . **LOW PRICED.** FREE BULLETIN shows 14 Different Models by a nationally known builder of rotary pumps.



BLACKMER PUMP CO. 1801 CENTURY AVE.
GRAND RAPIDS, MICH.

SAXOPHONISTS YOUR MOUTHPIECE WORRIES ARE OVER

With our new double tone chamber saxophone mouthpiece. Two separate tone chambers instead of one. (See Cut.) What a wonderful difference this makes, none other like it. Beautifully made from finest hard rubber rod. Velvet smooth precision machine facings.

**PRICED SO LOW ALL CAN PLAY THIS
NEW MARVELOUS MOUTHPIECE**

Alto Sax. \$3.00. Tenor Sax. \$3.50. Wonderful clarinet mouthpieces \$3.00. End your worries, order now, shipped C.O.D. anywhere plus postage. Give make of Inst., close, medium or open lay. (90% play open facings.)

MONEY BACK GUARANTEE

Play it for three days, if not the most marvelous mouthpiece you ever put a reed on, gives you a bigger and more beautiful tone from top to bottom, return it, we'll refund.

HARRY E. O'BRIEN & SON

Dept. P6, P. O. Box 5924, Indianapolis, Ind.
A maker of over 100,000 mpcs. 25th Year.

(Continued from page 156A)

being continued over and over, possibly twenty or thirty times an hour.

When you go to bed, perhaps you close downstairs windows and open those upstairs and the air movement continues through the night. In the morning, you turn off the fan, close the windows and hold the cool night air inside the house until the sun begins to do its worst.

Theoretically, it would seem possible to reduce inside temperatures at night to those prevailing outside. Because of the residual heat in the house and its furnishings, you can't do this, but you can bring the inside mercury reading down to within three or four degrees of the outside temperature, in all probability, thereby getting rid of several degrees of inside heat under certain conditions.

Prof. Kratz and his associates have concluded that you must have nine or ten air changes per hour at the very minimum to lower temperatures appreciably in this manner. If you have a warm-air heating system, it is quite likely that the fan in your furnace will deliver such a volume of air. But you must bring this air from outside, not merely recirculate air in the house. To bring inside temperatures to within three degrees or so of those outside at night, you probably will need an attic fan capable of changing the air twenty or thirty times per hour. If you employ a fan which will exhaust the air fifty or sixty times an hour, you will obtain an artificial breeze which will have some cooling effect on the body, but the actual reduction in the temperature of the house and its contents will not be much more than if the air were changed only thirty times per hour.

If you live on the top floor of an apartment building without attic space, a high-speed fan which changes the air fifty or sixty times an hour will give you a breeze, but it won't cool your apartment nearly as much as if you had that attic above you through which to draw the air. In any event, be sure you get a fan big enough to do the work. The cubic contents of your living quarters multiplied by thirty gives you the number of cubic feet of air to be moved per hour if you want thirty changes hourly. And the better insulated your house is, the longer you will enjoy the cooling effect the following day. Even if

you are doing artificial cooling in the daytime, an attic fan is a good investment. It reduced the cooling requirements for the research house at Urbana by more than twenty per cent.

If you have available enough water to permit you to use as much as 5,000 gallons each twenty-four hours and if this water is below sixty degrees in temperature in hot weather, you are in a position to do some real air cooling by using a fan to blow the air over water coils and then conveying the cooled air from the basement to your living quarters. The job is simplified if you have a warm-air heating system and can use the ducts to carry the cooled air.

But before considering this, look well to your water supply and remember the water must be below sixty degrees. You may need 200 gallons or more of water per hour for forty or fifty days during the summer. The ordinary cistern is unlikely to supply this, and it is unlikely that you can return the water to the cistern because eventually the water which has run through your cooling system will warm up all the water in the cistern to a point where it will be useless for cooling. If you use city water, be sure you will be permitted to employ it in such quantities and for such a purpose and inquire into the cost. If you happen to have a deep well of large capacity, plus a warm-air heating plant, you may be "sitting pretty" for this system of cooling. Don't forget, however, that you've got to get rid of about 200 gallons of used water per hour. Can your sewer system take it?

Watering the lawn and grounds as soon as the sun goes down helps to reduce the amount of heat being reflected at the house. In some sections water is sprayed on the roof to get evaporative cooling but this practice is not general—and it's likely to be hard on your roof, too.

While hot-weather discomfort results from both high temperature and high humidity, and one probably is to blame about as much as the other, there is, unfortunately, no very practical way to lower the humidity of the air without installing air-conditioning equipment. It can be done by chilling the air to a point where the atmosphere gives up its moisture and then

(Continued to page 162A)

Steps up the FORD V-8 to 124 H.P.



You'll find a whole new world of motoring pleasure, when you equip your Ford V-8 with the *Mighty McCulloch Supercharger*. Here's vast reserve power that levels off the steepest hills. Here's a new pick-up and "punch" that masters any traffic jam. No one can pass you, or push you around, without your consent. Your engine is stepped up to 124 H.P.—Gas is saved—Engine life prolonged. McCulloch Engineering Co., Dept. "B," 1327 S. 70th Street, Milwaukee, Wisconsin.

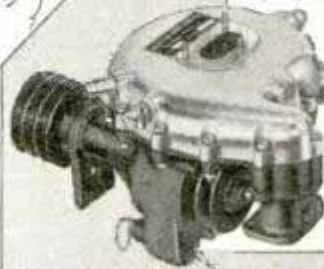

**THE MIGHTY
McCULLOCH
Supercharger**
FOR FORD
V-8 ENGINES

WRITE FOR LITERATURE

**Earned \$3000 Last Year
with FOLEY Machines**

Mr. Stilwell of Illinois

has established his own business with a FOLEY SAW FILER and a FOLEY LAWN MOWER SHARPENER. He says, "Last year I filed 3086 saws which brought in \$1800. I also sharpened 860 lawn mowers, earning \$1290, or a total income of \$3090 from my two FOLEY machines."

FOLEY AUTO MATIC SAW FILER

Files all types of hand, band, or circular saws better and quicker than the most expert hand filer. Makes all teeth uniform in size, height, spacing, so the saw cuts true and stays sharp longer.

FOLEY LAWN MOWER SHARPENER

sharpens all sizes and types of mowers in 15 to 20 minutes. You can get \$1.00 or more for each job. No canvassing necessary to start a profitable business. Write for our Free Plan and information on Saw Filer or Lawn Mower Sharpener.

FOLEY MFG. CO.
11 Main St. N. E.,

616-7 Foley Bldg.
Minneapolis, Minn.



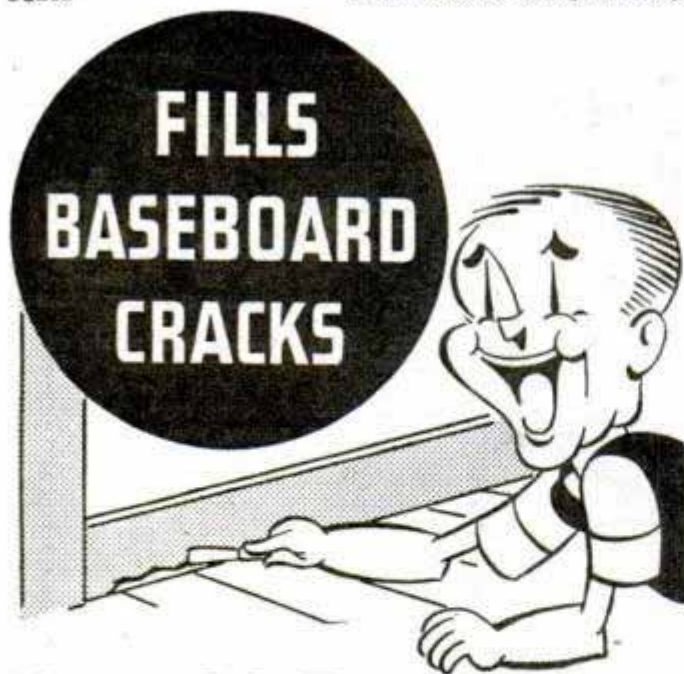

Now...It's Easy To Make 1001 Repairs!

Fix...once and for all time...those pesky things around the house that are always needing attention—

Cracks in baseboards, floors
Loose bathroom fixtures
Loose drawer pulls, casters
Broken furniture
Loose tiles
Old nail and screw holes,
Etc., Etc.

Plastic Wood—the marvelous preparation that handles like putty and hardens into lasting, waterproof wood—will end these and other troubles forever. It adheres to wood, metal, tile, stone, porcelain—holds nails and screws without splitting and can be finished just like real wood. You can get handy Plastic Wood in cans and tubes—in 9 colors including white—at all paint, hardware and variety stores. Try it—you'll say it's great!

Use Genuine
**PLASTIC
WOOD**



A AND N SUPPLY CO.

Bargains—Military, Sport Goods, Firearms,
Clothes, Shoes, etc. Send 10¢ for new cata-
log, to be redeemed on first order.

ESTD
1868

A & N Supply Co., 4772 Lester St., Richmond, Va.

FACTORY TO YOU

NEW REMINGTON NOISELESS PORTABLE

AT LAST! The famous Remington NOISELESS Portable is yours for only ten cents a day. Brand new. Not rebuilt. Standard keyboard and every modern feature. Free carrying case and typing course. 10-Day free trial. You don't risk a penny. WE PAY ALL SHIPPING CHARGES. Act now! Write Remington Rand Inc., Dept. 152-6, 315 Fourth Ave., New York, N.Y.



10c A DAY

reheating it, and it can be done with chemicals, but you must have control of your air to do this, something impossible without air conditioning.

Don't forget, when considering how to keep cool, that there are plenty of commercial room coolers available which will keep one room at a comfortable temperature twenty-four hours a day, and even help to lower the temperature of two or three small rooms. If you live in a small apartment, a good room cooler may solve your problem.

And now, if you've read this far and are all steamed up about keeping cool, just one word of warning. Awnings and white roofs and attic fans do not constitute air conditioning. All of them together may not bring you absolute comfort during a protracted hot spell. But if you'll install some or all of these aids to keeping cool, you'll find that they will increase the comfort of your home on average hot days and nights—and besides, you'll really be doing something about the weather.

Test Stand Tips Plane Engine to Imitate Dive or Climb

For testing airplane engines at an English factory, a stand permits tipping the engine up or down to imitate climbing or diving conditions. Held by strong supports the engine may be revolved through an arc of 180 degrees by manipulating controls in the test cabin.

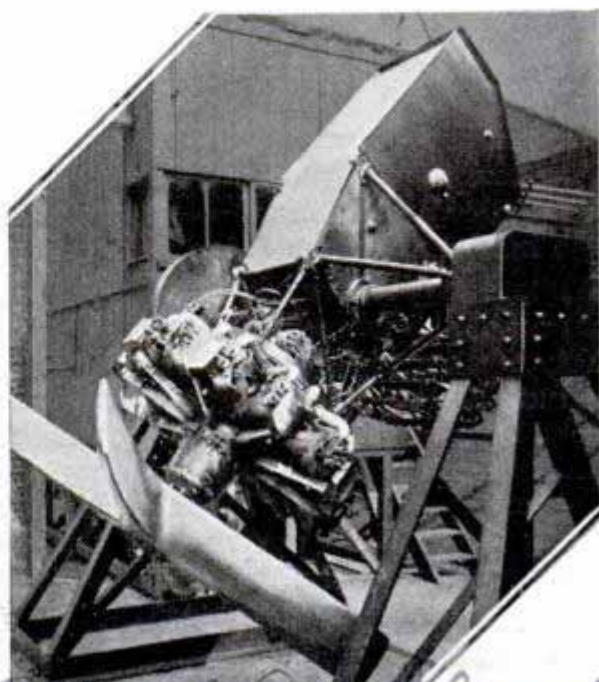

Cristal Aeroplane Co

MANUFACTURING OPPORTUNITIES



THE BUILDING INDUSTRY TODAY demands fire-safe, colorful roofs. Your market is big. Every building, whether old or new, is a prospect. WE EQUIP YOU with machine and process enabling you to dominate your market. You use low-cost materials obtained locally. Your product is unequalled in value, permanence, beauty & fire safety. INVESTIGATE the profit possibilities for your locality. Learn about this wonderful machine—Manufacturing costs low—Investment moderate. Send for free book "DUNTEX Manual." Write today.

602 W. 24th St. W. E. DUNN MFG. CO. Holland, Mich.

TYPEWRITER Bargains

Send No Money—

Genuine Underwoods, Royals, etc., refinished \$100 office models greatly reduced to about 1/3 mfg.'s org'l price. 10 day trial—fully guaranteed—easy terms—10c a day. Free catalog, limited supply. International Typewriter Exch., 231 W. Monroe St. Dept. 601, Chicago

ALL STEEL TRAILER KIT

SAFE—STRONG—EASILY ASSEMBLED—COST UNDER \$300

All steel chassis and body in knock-down kit. Complete with springs, wheels, and tires, hitch, doors and windows. Furnish to suit yourself, and you will have a custom built coach which will last a lifetime. Low freight rates throughout the U. S. Send for free illustrated circular giving specifications and prices.

STEFCO STEEL COMPANY . . MICHIGAN CITY, IND.
"Largest Exclusive Manufacturer of Sectional Steel Buildings"

INVENTORS Be Sure to See Page 23A

In answering advertisements always write name and full address clearly.

Get this new CONCRETE BOOK Just Published!

Now Ready! A new and practical book on the amazing new art of concrete work. Things are being done with concrete that will amaze and thrill you. And "1001 Ideas for Using Concrete," by Harold Hayes, covers it all with the exception of big engineering projects. Nothing like it ever published before. It covers every known use of concrete for the home, farm, building, business and industry, plus newer uses in decoration and arts, including new quick-setting type and recent developments in glorious colored concrete that you can make.

It's the book of the hour for contractors, handymen, hobby seekers, farmers, home builders, factories, shops and home work shop owners. It is filled with plans, methods and formulae. Shows how to make money, build your own business and improve your property. Gives 146 "Concrete Kinks", alone, easily worth cost of entire book. See chapter headings and description. Order your copy today. Sent postpaid for \$5.00 with order, or pay the postman.

Tells how to make concrete pools, statuary, garden walks, walls, buildings, etc. 146 Concrete Kinks in one section alone.



POPULAR MECHANICS PRESS • Dept. 537 • 200 East Ontario Street • CHICAGO

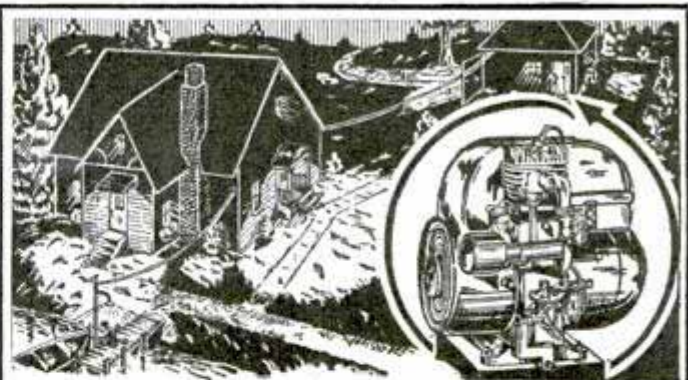

ONAN A. C. ELECTRIC PLANTS

FOR THOSE WHO MUST PROVIDE THEIR OWN ELECTRICITY

ONAN ELECTRIC PLANTS furnish the same current as supplied by power lines—110 volt, 60 cycle, ALTERNATING CURRENT. Operate Radio, Water System, Washing Machine, Electric Iron and all Electric Appliances.

Run from gasoline or gas and generate electricity for Farms, Lake Cottages, Oil Stations, Commercial Places. A woman or child can operate it.

SIZES 350 WATTS AND UP

Each ONAN PLANT is a complete Unit, ready to run. No battery used except to start the engine. Easy to install. Available from stock. 32 volt, Direct Current Models also available. Write for details.

D. W. ONAN & SONS

1005 Royalston Ave.

MINNEAPOLIS, MINN.



Balance as above with 1-50; 1-20; 2-10; 1-5 and 2-2 gram weights base 6 3/4" x 3 1/4" - \$4.75. Catalog with 3000 illustrations of laboratory apparatus sent for 50c. Catalog listing 10,000 chemicals, drugs, flavors, etc. and 1700 scientific books sent for 25c; Wholesale Price List 1000 Ill. 10c.

Laboratory Materials Company, 639 E. 71st St., Chicago, Ill.

Gives Money-Making Plans Describes Interesting Hobby Covers New Concrete Arts Facts on Colored Concrete Applications and Methods

"1001 IDEAS FOR USING Concrete" BY HAROLD A. HAYES

Size 7 x 10 Inches. About 250 Pages. 16 Colored Plates and Hundreds of Beautiful Half-tone Illustrations and Working Drawings. Cloth Binding. \$5.00

SOME CHAPTER HEADS

Concrete About the Home
Concrete in the Garden
Concrete About the Farm
Concrete Homes and Buildings
Recreation
Concrete in the Workshop
Concrete Products for Plant Manufacture
Concrete in Business and Industry
Concrete Kinks
Varied Uses of Concrete

BUY... NOW



SAVE
on a
SEA GULL
OUTBOARD MOTOR

At the record-breaking price of \$39.50 you simply can't afford not to own a SEA GULL Outboard. You SAVE - because you BUY DIRECT! These new 1937 SEA GULLS have everything you want - easy starting, plenty of power, rugged durability, economical operation - in addition to such ultra-modern features as:

- Automotive type float-feed carburetor
- Underwater exhaust
- Monel metal shafts
- Carburetor control in steering handle
- New type sensational magnetol

STEEL BOATS - \$24.50 UP

Also a complete line of steel boats for rowing or outboard motor use - the smartest, sturdiest, safest on the market. Investigate our "2-in-1" Offer - any one of our steel boats and a SEA GULL motor of the size you require - at a money-saving combination price!

WRITE FOR FREE ILLUSTRATED LITERATURE!

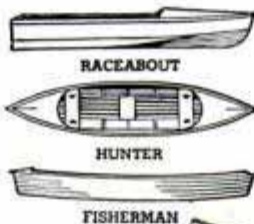

RACEABOUT

HUNTER

FISHERMAN

NATIONAL OUTBOARD MOTOR CO.
DEPT. PM MARSHALL, MICHIGAN



BONNEY TOOLS

are the finest
money can buy

No. 19 TUTYPE
WRENCH SET
Contains 4 Zenel
Chrome-plated
TuType Wrenches
—combination
open-end and box
wrenches—with
 $\frac{1}{16}$ " to $\frac{5}{8}$ " open-
ings, for automot-
ive and general use. Ask your Jobber,
or send post-card for Catalog "M."

Bonney Forge & Tool Works
Allentown, Penna.



**BONNEY
TOOLS**

FOR Real FUN Play. A Soprani



AMPLIPHONIC ACCORDION

- Music, popularity, and romance surround you when you play your Soprani Ampliphonic accordion, a complete band in itself. Easier playing, reduced size and weight, more beautiful tone, greater volume with a third less bellowsing. Exclusive ampliphonic feature assures rapid progress. Home trial. Easy terms. See your music dealer or send postal for beautiful free book. No obligation. Act now. Write today. 158

Easy
TO PLAY

SOPRANI, INC. DEPT. 629
630 South Wabash Avenue, Chicago, Illinois

FIREWORKS

1¢ POSTCARD will Save YOU many DOLLARS

FREE!
100 "Fort McHenry"
SALUTES
with every order
of \$1.00
or more!

FREE!
CATALOG
Full of LOWEST
PRICES on America's
Best Fireworks!

GUARANTEED SAVINGS ON EVERY ITEM AT

BALTIMORE FIREWORKS CO., INC.
6900 EASTERN AVE. BALTIMORE, MARYLAND

TRAILER BUILDERS · BUYERS · OWNERS

TRAILER Send 25c for this Big Book Today

Over 100 pages! Beautifully Printed and Illustrated! Trailer Suggestions and Ideas galore! Catalog shows America's greatest line of Trailer Parts and Equipment at lowest prices. Everything from wheels to top. Rush 25c today. Satisfaction positively guaranteed!

TRAILER SUPPLY CO. Box 438-A WAUSAU, WIS.



BUILD IT YOURSELF

The Jim Dandy Cabin Cruiser

The Trailer that has everything. Classy! Roomy! Easy to build in any size with my simplified Plans and Instructions—Price \$1.00. Rush dollar bill today to JIM DANDY Box 125-A WAUSAU, WIS.



PARTS for the POPULAR MECHANICS

FAMILY TRAILER

Everything you need! Axle, Tongue, Hitch, Wheel Housings, Wood Parts, Tank, Sink, etc. Send for price list. Include 25c (coin) for our big Catalog and Trailer Builders' Manual. Satisfaction guaranteed!

TRAILER SUPPLY CO., Box A, Wausau, Wis.



SEE WITHOUT GLASSES.

The NATURAL EYESIGHT SYSTEM Gives Your Eyes a New Deal

If you wear glasses, or think you should, our FOUR MONTHS' TRIAL OFFER—containing the inspiring story of glasses discarded for Nearsight, Farsight, Astigmatism, Old Age Sight, Eyestrain, Weak Eyes, Eye Muscle Trouble, Etc., as told by USERS AT HOME of this Revolutionary System—will be mailed FREE upon request.

NATURAL EYESIGHT INSTITUTE, INC.
Dept. 75-C Los Angeles, Calif.



SPEED UP Your .22 Rifle With THESE

AT 100 yards the bullet of the Winchester Super Speed .22 Long Rifle rim fire cartridge beats a regular .22 Long Rifle bullet fully 20 yards. Beats that wily duck, jump or dive made by your woodchuck, jackrabbit, crow or snapping turtle just as you press trigger. And power! At 150 yards your Super Speed has as much as a regular bullet has at 77 yards. Staynless priming, which means no rust in the bore. Choice of regular lead greased or wax coated Kopperklad bullets—solid point for practice shooting, hollow point for hunting. And they cost you no more than regular .22 cartridges in same popular Short, Long and Long Rifle sizes. Get them at your dealer's. For free folder, giving comparative ballistics, please write Dept. 46-C, Winchester Repeating Arms Co., New Haven, Conn., U. S. A.



be right in any argument

● If you want to know what's going on today—inside stories of the war in Spain, what's happening in Russia, capital chat at Washington, read the short, snappy reviews in the Review of Reviews every month. Read what Review of Reviews has to say, then speak with authority. Only twenty-five cents at your favorite newsstand, or, on this

Special Offer

Send only one dollar for eight months trial. The whole family will benefit. Pick up the clues to up-to-date news in

REVIEW OF REVIEWS

Dept. A15, 233 Fourth Avenue New York, N. Y.

ARE YOUR KEYS THE ONLY KEYS

to your shop, home, office, store, garage, etc.? Why be in doubt? Don't take chances. Learn how to reset your own cylinders so that keys that may be in the hands of old tenants and landlords or perhaps



burglars will not work. Our locksmith manual for resetting cylinders sent for \$1. After several minutes with our manual you will be able to reset cylinders very easily.

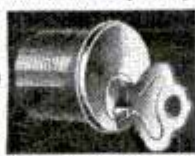

SEND NOW!

Midwest Locksmiths, 3711-H-W. Chicago Ave., Chicago, Ill.

PAINT SPRAY OUTFITS

National Paint Spray Units suitable for all purposes. 5 Sizes, \$14.50, \$22.50, \$32.50, \$47.50 and \$98.50. Best value money can buy. Send for free folder. NATIONAL ELECTRIC TOOL CO., Dept. 06, 560 W. Washington Blvd., Chicago, Ill.

GET "NEW CAR" PEP AND POWER

save oil, gas, money, with amazing, low-cost Ramco Overhaul and Ramco Spring Piston Rings. Marvellous economy and performance proved in millions of cars. Many imitators. So insist on genuine Ramco for Ramco results. Send for Ramco booklet—FREE!

RAMSEY ACCESSORIES MFG. CORP., St. Louis, Mo.

EXTRA \$5 in SPARE TIME PRINT at HOME

Letterheads, Circulars, billheads, cards. Printing pays BIG. Easy, interesting, educational. PRINTING PRESS BARGAINS \$12. Types and Supplies, lowest prices. Send stamp for catalog.

PEIFFER Co., 13-B, 6 Columbia St., Newark, N. J.

When writing please mention Popular Mechanics

PIPE MAKES MUMMY CRY "MAMMY!"

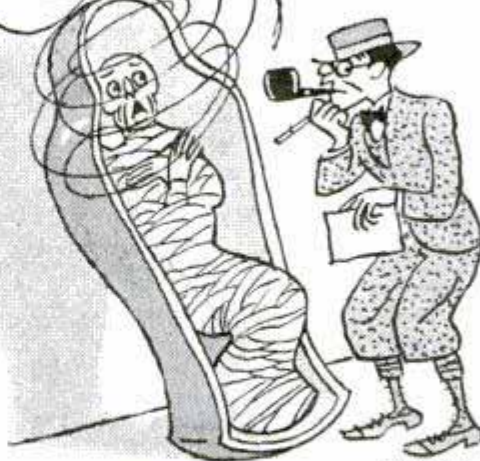

..then Doc switched to the
brand of grand aroma



WE add our own "tut tut" to poor King Tut's. Professor—bury that weedy briar and reform! Smoke when you please—but for your pipe's sake—keep it *clean*. And for the sake of those around you, smoke a *mild* and fragrant brand of tobacco. Sir Walter Raleigh is mild because it's blended from the mildest burley tobaccos that Kentucky grows. It burns slowly and evenly, won't nip your tongue, and wins fast friends with its superb aroma. Try a tin.

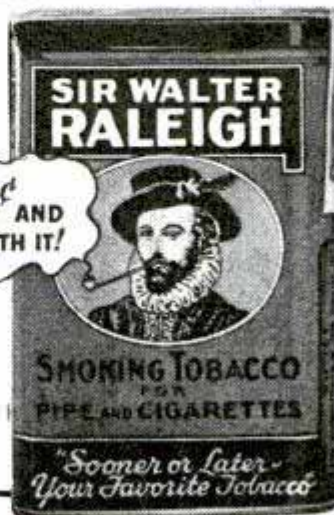

UNION
MADE

15¢
AND
WORTH IT!

FREE booklet tells how to make your old pipe taste better, sweeter; how to break in a new pipe. Write for copy today. Brown & Williamson Tobacco Corporation, Louisville, Kentucky, Dept. P-76.

HOW TO
TAKE CARE
of
YOUR PIPE

TUNE IN JACK PEARL (BARON MUNCHAUSEN)
NBC BLUE NETWORK, FRIDAYS 10:00 P. M., E.D.T.

Master

... the strongest
PADLOCK
ever built!

Sold by Dealers Everywhere
Master Lock Co., Milwaukee
916 W. Juneau Ave.
World's Largest Exclusive Padlock
Manufacturers
OVER 52,800,000 IN USE

For..BIG Money-Making..Doing ALL Work Use The EISEL-GEARED PIERRENCH KITS

● It's 10-to-1, 1-TON, Power-Gear gives your hands 1-Ounce to 1-TON Gripping Pressures and amazing working power and skill. ● With the Universal Gear-jaw, No. 1, it is a Super Parallel Pliers, Lock-& Ratchet Wrench, Hand-Vise . . . with 4-Way V-Grips, Wire-Cutter, Screwdriver, etc., etc.

● With PIPE Gear-jaw, No. 2, holds and Turns Pipe tight to a wall, nearly flush sink nipples; basin nuts and chewed nuts in tight places . . . Hard wrist pins, shafting, etc.!

● With WIRE Gear-jaw, No. 3, Cuts up to 1/4" wire; makes Springs; Holds Washers, Ends of Tubing and Pipe, and does 101 'odd' and amazing things.

● You Get ALL 3 . . . a \$50 Tool Service . . . at the Price of ONE Good tool in the 8 1/2" (20-Oz.) KIT; or, in the 7" (12-Oz.) KIT; and the 2 KITS give you 9 Different Super-2-Tool Combinations!

● WHAT'S MORE. These "Miracle KITS" are making \$30 to \$85 WEEKLY for AGENTS and DISTRIBUTORS, and we Need More . . .

● MAIL this Part of Ad TODAY with your Address (on a Postcard will do), Get FREE—this 7-Edge-End-6-Angle SCREWDRIVER (It Turns Screws in ALL Positions and does many useful things) . . . and 101-PICTURE MANUAL OF MECHANICS, with . . . User Offers; or, With . . . DISTRIBUTOR, Territory and Free Kit Offers!

AMERICAN PIERRENCH CORP'N **FPM-4809N, Ashland Ave. CHICAGO, ILL.**

FREE

NEW BRUSH PLATING OUTFIT For AUTO PARTS

Connects to a battery with no tanks necessary. Plates on iron, steel, brass, copper, etc. Almost as simple as painting. Hundreds of car owners waiting for this low-cost plating. Improves appearance and value of the car.

Your opportunity to make good income plating auto parts, bathroom fixtures, reflectors, mirrors, etc.

FREE PROOF

Write quick—big season here. Get FREE PROOF and particulars that put you in a paying business of your own.

GUNMETAL COMPANY
AVENUE M **DECATUR, ILL.**

WEIGHS ONLY 15 LBS.

Now EVINRUDE SCOUT \$45

F. O. B. FACTORY
SUBJECT TO CHANGE WITHOUT NOTICE

WRITE FOR CATALOG

EVINRUDE

Now, an Evinrude for only \$45 . . . and what an Evinrude! Weighs little more than a pair of oars . . . drives good sized boats up to 5 1/2 miles an hour . . . uses only a single quart of fuel in 1 1/2 hours! Famed Evinrude Hooded Power construction, water-sealed silencing and finger-tip controls. Smooth, quiet, dependable power for row-boats, fishing craft, canoes, dinghies.

Write today for complete catalog on the Scout and other Evinrude models. Address, EVINRUDE MOTORS, 5171 N. 27th Street, Milwaukee, Wis.

BUILD THIS RADIO ONLY AMAZING \$1.55

(Or buy it Laboratory Wired) **POST-PAID**

A sensational Radio! Thousands now in use. Can actually bring in foreign stations, police calls, aeroplanes, amateurs, etc., as well as local broadcast! Short and Long Wave. Ace Radio give guaranteed results!

For only \$1.55 we send you the complete kit containing an attractive metal chassis panel and every part needed to build a powerful one-tube receiver, AMAZING VALUE! Works for months on two inexpensive dry batteries. Our clear diagrams make it simple to hook up. Not a feeble crystal set!

TWO TUBE KIT (More volume)—\$2.00.
ALL-ELECTRIC two tube house current set. No batteries! Complete kit \$3.00.
(Sets laboratory assembled and wired 75c extra.)
Enjoy NEW thrill! Send for your ACE Radio today!

ACE RADIO LABORATORIES, 227 Greenwich St., Dept. P-6, New York City

WHOLESALE CATALOG of 4000 FAST SELLERS

FREE

SPURS WHOLESALE CATALOG

Hot off the press. Opportunity to make up to \$15 a day. Shows fast sellers of every description from many parts of the world, at rock bottom wholesale prices. 256 pages chock full of the biggest bargains you ever saw, many new items just being introduced, articles for every member of the family, office necessities, etc. One of the most complete lines in America.—The 15 proven money making plans are fully explained in the catalog and may increase your earnings a hundred fold. This catalog is FREE—Send for it, today.

SPURS CO.
4-37 Main St. Le Center, Minn.

WHOLESALE IMPORTERS and MANUFACTURERS
LE CENTER, MINNESOTA

When writing please mention Popular Mechanics

WINCHESTER

TRADE MARK

New!



SUPER SPEED .219 ZIPPER

3420 Feet per Second at Muzzle . . . Supremely Accurate . . . Lever Action . . . Easy to use . . . Handy . . . Moderate Cost.

SHOOT Woodchucks, Jackrabbits, Crows at any range up to 100 yards with no change in your sights. For 150 to 200 yards—say for Woodchucks or Coyotes—just aim a trifle high, or else turn the peep-sight screw up 3 to 5 clicks. And plenty of power. New super speed does it! Famous Winchester Model 64 improved design with shotgun stock, solid frame, short magazine. Barrel, 26 inches. Six shots. New quick adjusting peep sight, mounted on breech bolt, gives extra long sighting radius. Gold bead front sight with steel cover. Adapted for telescope sight. Choice of two cartridges, 46-grain and 56-grain hollow point. Ask your dealer. For Free folder please address Dept. 46-C, Winchester Repeating Arms Co., New Haven, Conn., U. S. A.



TENNIS SAVE on our NEW LOW PRICES!

● Gut Tennis Strings direct from factory to you. ● Silk Tennis Strings ● Vises and Frames ● Tennis Equipment. Write for Free Catalog! **H. E. WILLS CO.** 1047 W. 47 St. Dept. A-135 Chicago

TENNIS CATALOG FREE!



\$1.00 A WEEK Buys The RANGER!

Pay while you ride this glittering new Ranger—as low as \$4.00 down and only \$1.00 a week.

30 Days' Trial We ship on approval. If not satisfied after trial return the bicycle. lamps, wheels, equipment at half usual prices. Write for marvelous new prices and terms.

Mead CYCLE COMPANY DEPT F-116 CHICAGO



Write us today for free catalog

You can't just "rinse" rust out of a radiator...IT TAKES A PROFESSIONAL JOB!



NEW "EVEREADY" CLEANER

- ✓ Cuts all grease and sludge!
- ✓ Removes even hard rust scale!
- ✓ Leaves inside of radiator bright and shiny!
- ✓ It's harmless—less corrosive to radiator metals than water!

If you want your old car to run as cool as "new" this summer, ask your service man for an "Eveready" cooling system cleaning job. This new "Eveready" cleaner was developed exclusively for automobile radiators. It is an entirely new product, using a special combination of rust and grease solvents developed just for this job. There's nothing else like it—so don't fool with cleaners that don't clean and which might do damage. Get a professional job—an "Eveready" job.

"EVEREADY"

3-STEP

COOLING SYSTEM PROCESS



The Professional Cleaning Job

Manheim POCKET SLIDE RULE

With A-B-C-D Scales. Multiplies, divides, squares, takes square root, finds circumference and area of circles. 6 inches long—thin construction. NO WOOD OR CELLULOSE. Fits in vest pocket. Send \$1 in cash, money order or check (\$1.25 Canada & foreign countries) and receive slide rule with genuine leather case and instructions. Box M-8. M. MANHEIM COMPANY, Inc. 15 E. 26th St. New York, N. Y.



Easy

YOU'LL advance faster with an easy playing Conn. Choice of world's greatest artists. Many exclusive features yet they cost no more. Home trial. Easy payments. See your dealer or write for free book. Mention instrument. C. G. CONN, Ltd. 631 Conn Bldg. ELKHART, IND.



CONN

BAND INSTRUMENTS

New 6-Volt TRINDL Electric ARC WELDER

Works Off Any Storage Battery or With Converter Off Ordinary Light Socket

This new electric arc welder is made possible by the invention of a low voltage carbon. Auto batteries may be used without removing from car. Uses about the same current as four headlight bulbs. Can be used on electric light socket by using a Trindl converter in place of battery. Produces about 7,000 degrees heat.



HOTTEST FLAME KNOWN

Melts iron and steel instantly. Welds fenders, repairs radiators, holes in bodies, milk cans, small tanks, brazes broken castings. Works on anything—iron, steel, brass, copper, tin, or galvanized metal. Permanent repairs made almost for nothing. Used by factories in many operations. Positive money-back guarantee by a responsible firm. Act now!



AGENTS Men with cars to sell mechanics, repairmen, farmers, radio and battery shops, factories. Five-minute demonstration makes sales. **UP TO 150% PROFIT!** Write Today!

TRINDL PRODUCTS, 2229-PC CALUMET AVE., CHICAGO, ILLINOIS



BELL ALL PURPOSE TRAILER

CONVENIENT — ECONOMICAL — STURDY — SAFE
Used by Contractors, Campers, Farmers, Gardeners, Home owners, Hardware dealers, Package deliveries, Retail stores, Sportsmen, Service Men, Tourists and many others. **GUARANTEED, WE SELL PARTS FOR BUILDING YOUR OWN TRAILER.** Send for free circular.

BELL TRAILER MFG. CO., Dept PM 6, 2452 S. Michigan Ave., Chicago, Ill.

BUILD YOUR OWN FANS. 20-inch aluminum propellers for aeroplane fans, \$3.50. For 1/2-inch shafts. Shipped collect. Michael Electric Co. Fort Worth, Texas



NEW PROFITS IN 40 VOLT ARC WELDING \$150 to \$300 Extra Profit Monthly

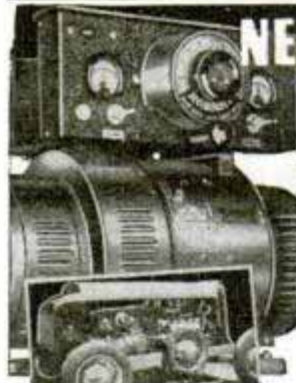

"BUILD YOUR OWN WELDER!"

New low prices make this profitable welding service available to everyone. Opens doors to big pay jobs that carry real profit. Hobart Welders are easier to operate, faster, guaranteed to bring you quality welding business... extra profits will pay for welder without expense to you. Special "Build-Your-Own" generator mounted on trailer with auto engine lets you operate any place. Saves \$300 to \$500 over factory built units.



No Investment Terms Profits Pay for It
Extra earnings and savings possible with Hobart Welders make it easy to own without expense. You can even rent a new Hobart and later purchase it without loss. Coupon brings details.

HOBART BROTHERS, Box M-67 TROY, OHIO

Gentlemen: Send me information on () Build Your Own Welder () Electric Drive Welder () 30 Days' Trial, Easy Terms () Rental Plan. Also send me free books I've checked.

Name.....
Address.....

Free!
VALUABLE WELDING BOOKS—CHECK THEM

30 DAYS TRIAL AT OUR RISK

Pays for itself Terms



HOBART
THE FASTEST SELLING WELDER ON THE MARKET TODAY

RAISE GIANT FROGS

MUFOND GIANTS WEIGH UP TO 3 LBS. EACH



EASY TO START!

Markets Waiting! Frog legs in big demand at good prices the year 'round. Millions used yearly!

WE BUY We have one of the largest frog markets in the world. Sell to us in addition to other markets. Easy to ship. Men and Women starting in every state and Canada. See what others already doing. Small pond starts you. **FREE FROG BOOK** explains our unusual offer to beginners! Now's the time to begin! Write today sure!

FREE BOOK



AMERICAN FROG CANNING CO.
(Dept. 133-HH) New Orleans, Louisiana

EASY TO START
Dependable Operation
LOW COST!



\$49.50 UP

Buy a NEPTUNE Outboard Motor - the **greatest value on the market!** No blistered hands - no loss of temper at the end of a hard day - you can depend on a NEPTUNE to bring you home in the worst weather! Not only are they easy to start - they deliver a smooth, dependable performance at high or trolling speeds.

Only \$49.50 buys the NEPTUNE 2 H.P. Single. For a little more you can purchase the famous 4 H.P. Junior Twin, the 6 H.P. Improved Twin, or the heavy duty 16 H.P. NEPTUNE Master Twin at \$149.50.

- ALL NEPTUNES HAVE:**
- New type sensational magneto.
 - Automotive float-feed carburetor.
 - Monel metal shafts.
 - Underwater silencing.
 - Carburetor control in steering handle.



WRITE FOR FREE ILLUSTRATED LITERATURE

MUNCIE GEAR WORKS Inc.
 DEPT. PM MUNCIE, INDIANA

S AGENTS 500% Profit GOLD LETTERS

For Store Fronts and Office Windows. Anyone can put them on. Free samples. Liberal Offer to general agents. METALLIC LETTER CO., 438 N. Clark St., Chicago

JUNGE FOLD BOAT A RUBBER KAYAK

Cheaper than a home made boat and it folds up. Easily carried or transported with your luggage. Stores in the corner of a closet. JUNGE FOLD BOAT WORKS, 209-30th St., Brooklyn, N. Y.

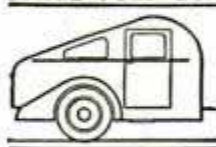

A TRAILER UNDER \$100.00
 The Ideal Trailer For Week-end and Vacation Trips Contains Fully Equipped Kitchen, Dinette and Berth For Two
 With only a few hand tools you can assemble this sturdy compact trailer in a few days' time; we furnish necessary parts at exceptionally low prices.
 MAIL \$1.00 TODAY FOR COMPLETE PLANS
 TRAILERCOACH, 3219 N. 15TH ST., PHILA., PA.



BUILD CLOCKS with our help
 Cash in on the demand for Mantel, Banjo, GRANDFATHER'S CLOCKS. Ask about our new, low-priced! Hall Clock and Special Blue Print Offer. Send dime for illustrated working drawing of Hall Clock; 25c for plans of 18 Mantel & Banjo Clocks. Catalogue FREE.
AMERICAN CHIME CLOCK CO.
 1677 Ruffner St. (Established 1877) Philadelphia, Pa.



Earn Cash at Home!
 Raise giant Patented Mushrooms! We supply materials, instruct with pictures, & our 25 branches buy all crops. Big FREE book, photos, tell if your cellar, shed, barn, etc., suitable. Write today.
 Eu. 1208 UNITED CO., 3848 Lincoln Ave., Dept. 312, CHICAGO

When writing please mention Popular Mechanics

for **VACATION**
 or **PROFITS NOW!**

4 Evenings
 TO BUILD
new PORTABLE BOAT!

OK-2→
 is Strong
 as a
 Giant
 YET
 Weighs
 only
 50 Lbs.

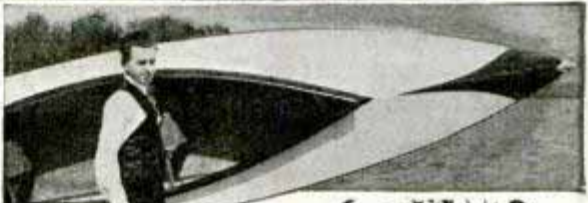

OK-2 takes any motor 4 1/2 HP or less—also uses oars and sail rig.

PRICED LOW!

Yes! Only 4 evenings to build this sensational 50 Lb. tough, durable, seaworthy, portable Outboard Ki-Yak, for vacation fun or big money! Then it's always ready to go anywhere by hand or car. Safe. Leakproof. More speed per horsepower. More miles per gallon! Mead's patented, perfected, aluminum-ribbed, Cut-to-Fit Construction Kit guarantees successful assembly, easily, quickly—and profitably (if you build to sell to others). OK-2 is really 3 boats "for the price of one."
 Use with any motor 4 1/2 h.p. or less—with oars—or with sail. Mead's "CK" Sportaman's series offer 20 Lb. boats up to only 40 Lb.—and take either paddle or 5-minute Convertible Sail Rig. "Home Assembly" saves you nearly half factory-built cost! Most sensational boat development in years! Thousands in use! Don't buy any boat until you've seen our circular! Remember, our special Progressive Group Payment Plan makes it easy for anyone to own a genuine Mead Ki-Yak.

\$6 PADDLE GIVEN
 with your CK Ki-Yak—if you hurry!



Write!

RUSH dime (covering handling, postage) for new Colored Circulars showing 57 untouched photographs of Mead's new portable Ki-Yaks—Low Introductory Prices, \$6.00 Gift Paddle Offer. Hurry!

MEAD GLIDERS
 15 So. Market, Dept. B-67, Chicago, U.S.A.

10c A DAY BUYS ANY Movie Camera

- EASTMAN
- KEYSTONE
- UNIVEX

Don't put off for another day the thrill of owning a fine movie camera! Now you can get all your movie equipment—including film—on easy payment terms. Do business with the largest retailer dealing exclusively in home movie equipment. We sell nothing else! Most important of all—we sell either for cash—or on easy payment terms. Terms as low as 10c a day. Mail coupon for free illustrated literature.

MAIL COUPON TODAY

Modern Camera Exchange, Inc.
1270—6th Ave., Dept. 3, New York City

**NOT AN
ORDER**

Send me free literature describing the items checked, together with complete details of your liberal 10c a day plan.

UniveX 8 mm. Keystone 16 mm. Eastman 8 mm.

Name

Address

City State

FLASHLIGHT GIVEN



worth
75¢

AND FULL SIZE PACKAGE
Amazing New Product for You

**WRITE
QUICK**

Greatest way to make money easy you ever saw. No experience needed. Clyde Collins' "Marvel Offer" going out by carload. Start now. We give you this flashlight—and package of "7" and make you a lot of easy money. Write Clyde Collins, Dept. JMP-5, Memphis, Tenn.

**SEND
NO
MONEY**

BARGAINS IN USED ARC WELDERS

All models, sizes and makes. Rebuilt and guaranteed. Also unconditioned welders at enormous savings. Ask for free listing. **THE LINCOLN ELECTRIC CO., Room 11, Cleveland, Ohio.**

SWEEPING the CAMPS!

Thousands of boys and girls are crazy about the new EASCO LEATHERCRAFT SETS. Buy them for your camp educational projects. EASCO contains everything—tools, leathers, patterns, dyes, etc. Each set, \$2.00 complete, at Sporting Goods and Department Stores, or order direct and pay postman on arrival.

LEATHERCRAFT

Free Clip name of your department store to this ad. Send in with order for valuable leathercraft project free with your set.

E. A. SWEET CO. Dept. A-3 Binghamton, N. Y.

Do You Want a WATCH or DIAMOND?



Thousands have found it easy to own America's finest diamond rings, watches, silverware or jewelry by the Santa Fe Plan. Bulova, Hamilton, or Elgin watches—brilliant blue-white diamonds—silverware from world-famous companies, and the great Santa Fe Specials—offered to you at startling cash prices on confidential liberal credit terms.

A Few Cents a Day is the Santa Fe Way

That watch or diamond you've always wanted, longed for—you needn't wait any longer for it. The Santa Fe will trust you—let you wear the watch or diamond you want while you pay only a few cents a day.

TURN PIN MONEY INTO DIAMONDS

Gifts for Every Occasion

Don't Pay Extra For Credit!

No honest person should pay extra to have someone trust him. The Santa Fe trusts you the way you want to be trusted—straight from the shoulder without any extra charges, extra fees, or taxes. You pay only the low advertised cash price in small monthly payments. Send for 1937 Catalog NOW!

FREE to Adults—Send for this beautiful book today. Sent ABSOLUTELY FREE to adults. Send your name and address, and the beautiful catalog will come to you by return mail. Do it now while you think of it.

SANTA FE WATCH COMPANY
Dept. 66, Thomas Bldg., Topeka, Kans.



"Jewel" Electric Fountain

3 Sales a Day Pay You \$46.50
Fast Selling Humidifier makes beautiful illuminated table decoration for homes, clubs, hotels, stores. Also Jewel Hamburger Rotogrill and Electric Pie Oven—\$90 profit every sale! Causing a sensation. Send 6c for Photo Print proposition on fast selling Jewel Specialties. Dept. P-5, Jewel Electric & Mfg. Co., 4313 Ravenswood Ave., Chicago, Ill.



Rheumatism

Relieve Pain In Few Minutes

To relieve the torturing pain of Neuritis, Rheumatism, Neuralgia, Lumbago in few minutes, get **NURITO**, the Doctor's formula. No opiates, no narcotics. Does the work quickly—must relieve worst pain to your satisfaction in few minutes—or money back at Druggist's. Don't suffer. Get trustworthy **NURITO** on this guarantee. Don't wait.

At Least! A WIRELESS Pocket TUBELESS BATTERYLESS Radio

World's Smallest Real Performing Radio
Amazing Midget radio weighs only 3 ozs. complete. Receives all stations with clear beautiful tone. Very little static and interference. Nothing to adjust or cause trouble—should last for years. **USES PATENTED FIXED CRYSTAL DETECTOR, ENTIRELY NEW DESIGN!** Not to be confused with cheaply made imitations. Music and programs come DIRECTLY FROM FRONT OF RADIO—NOT FROM REAR! New patented "Speakophone" gives more volume and stations! NOT A TOY. Tunes broadcast band. The Newest radio sensation of the year. Absolutely complete with picture instructions for use in hotels, offices, boats, autos, bed, etc. **TAKES ONLY A SECOND TO CONNECT**—no messy hookups to any current or extra wires. **SATISFIED OWNERS report wonderful service in ALL PARTS OF THE WORLD. THESE ARE FACTS!** Beautiful two color cabinets in six colors. **SEND NO MONEY.** Pay postman only \$2.99 plus charges or send \$2.99 (check, M.O., cash) and yours will be sent postpaid. **GUARANTEED.** Can be used by anyone. **ORDER NOW! DEALERS.**
TINYTONE RADIO CO., Dept. P-6, KEARNEY, NEBR.

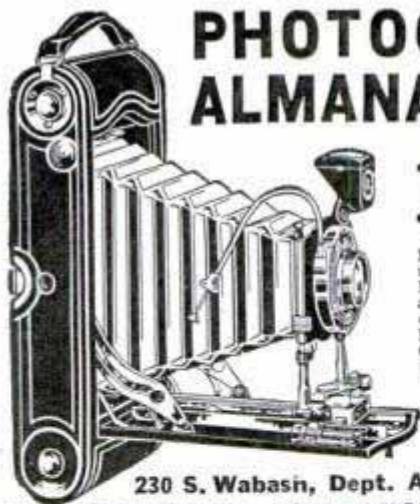

PHOTOGRAPHIC ALMANAC AND 148 PAGE BARGAINBOOK

FREE

Explains latest inventions, methods in Photography and Home Movie Making, for fun and profits. Offers hundreds of amazing, money-saving Bargains in still and movie Cameras, Lenses, Films, etc. Used equipment accepted in trade. Satisfaction guaranteed! WRITE!

CENTRAL CAMERA CO.

230 S. Wabash, Dept. A-735, Chicago, U. S. A.

PHOTOGRAPHIC HEADQUARTERS SINCE 1899

MAKE YOUR OWN VENETIANS

at 1/3 Store Prices

Your wife will be thrilled with these beautiful blinds—you will enjoy privacy and the open window breezes and shade. **Pleasant Home Work**—make one window an evening—only small saw, hammer, chisel and screwdriver necessary. **ALL MATERIAL**—Hardware, tapes, slats and cords furnished. Nothing to buy but a little paint. Full instructions.



100 Page Book No. 8

ONLY 10c Full of beautiful things easily made—14 pages of lumber—hard to find foreign woods—lovely crotch, butt, burl, fiddle back, etc. Veneers, panels and Solid Woods—Hard to find Hardware. Lists and illustrates 76 Blue Print Designs for Scroll Patterns, Inlay Table Tops, etc.

CRAFTSMAN WOOD SERVICE CO.
We Ship All Over the World 2722 MARY STREET CHICAGO



NEW TRAILER CATALOG PARTS

New catalog of trailer parts at bargain prices. Drop center axle undercarriage, \$25, complete less tires. Utility trailer plans, 50c. Cabin trailer parts, \$1. Send for **FREE** Catalog today.

SHAMROCK TRAILER PARTS, 12321 Turner, DETROIT, MICH.

STRIPE YOUR OWN CAR

Anyone can stripe a car with a **ROLL-A-STRIPE**. You can save the price of your striping job and earn money doing others. Specially knurled roller and dependable gauge. Paint, lacquer, enamel or varnish may be used. Stripes signs, furniture, models, etc. See any **Ducro Dealer** today or send direct. Postpaid \$1.50.



MODCRAFT INDUSTRIES, Dept. P26, 2908 N. Nordica Ave., CHICAGO, ILL.

Famous Boat Book Shows How

Detailed instructions, plans, materials, methods for building 15 most popular power, sail and row boats. Get **Popular Mechanics BOAT BOOK** and build your own at low cost. Prepared for those with limited skill and few tools. Includes also—"What a boat enthusiast should know." Only \$3.00. Pay postman on delivery or write for descriptive circular.

Popular Mechanics Press
Room 637-D,
200 E. Ontario St.
Chicago

Now BOAT BUILDING MADE EASY



FREE 116 PAGE CATALOG
MAIL COUPON NOW!

Save Money. Spring catalog lists thousands of items—Radio Sets, P.A., Tubes, Parts, Kits, etc., at lowest "wholesale" prices.
WHOLESALE RADIO SERVICE CO., Inc.
105 Sixth Avenue, New York, N. Y.

Name.....
Address.....

When writing please mention *Popular Mechanics*



JUST PUSH-

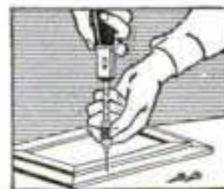

"YANKEE" Handyman



You have always needed a "Yankee" Spiral Ratchet Screw-Driver for work around the home. Now, for the first time in history, you can buy a genuine "Yankee" for \$1.00!

AMAZING VALUE! The new "Handyman" size—for shop, home, garage. "Yankee" Quality! Same as the famous "Yankee" Tools that add skill, speed, save labor and help "Make Better Mechanics."

See it on display at your dealer's. "Yankee" No. 33H. Price \$1.00. For boring small holes for screws or other purposes, buy also "Yankee" Chuck and 3 Drills. They fit Driver in place of blade. Price, 39¢ for "Yankee" Drill Set, as shown below.

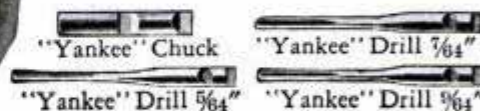

"Yankee" Chuck "Yankee" Drill 5/64"
"Yankee" Drill 3/64" "Yankee" Drill 1/8"



COUPON
NORTH BROS. MFG. CO.
PHILADELPHIA, U. S. A.

If this new tool is not displayed by dealer, mail us \$1 with coupon. Receive postpaid, "Yankee" Handyman Screw-Driver. "Yankee" Tool Book, sent **FREE**.

Name.....
Address.....(PM6)

New 9" x 3'

Genuine SOUTH BEND WORKSHOP LATHE

ON
NEW LOW
TERMS

Lathe may be
operated from any
ordinary lamp
socket

\$85⁰⁰

Less Motor Drive

Terms as Low as

\$6⁰⁰

A Month

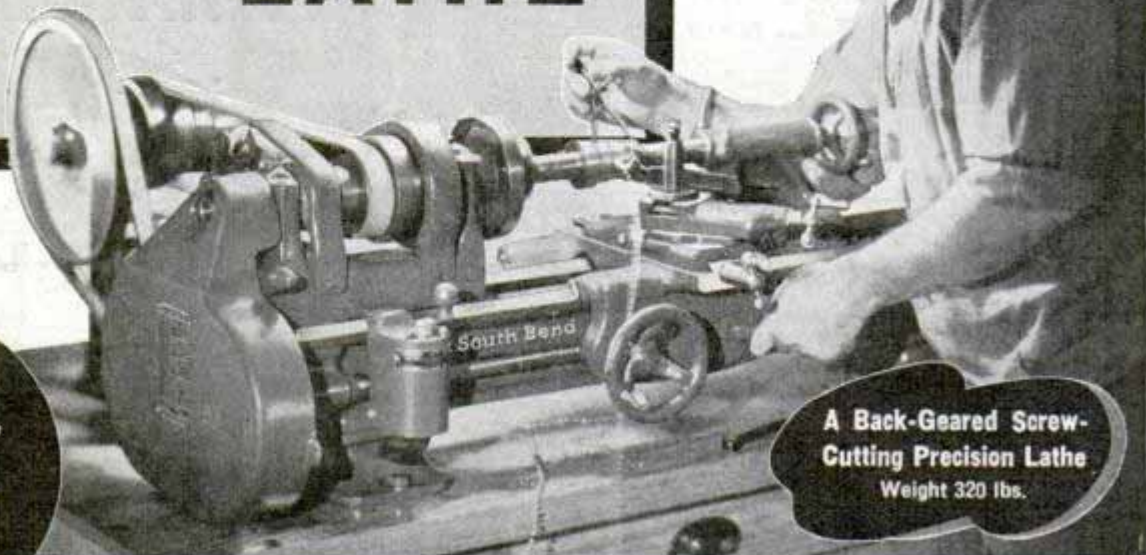

A Back-Geared Screw-
Cutting Precision Lathe
Weight 320 lbs.

No. 415-YA 9 1/4" swing by 3' bed Workshop Bench Lathe with Horizontal Motor Drive, 1/4 h.p. Reversing Motor, Switch and belt tension countershaft as shown above. **\$116⁰⁰**
(*\$15.00 Down, \$6.00 a month for 18 months*)

THE new 1937 model 9-inch Workshop Precision Lathe is a back-geared Screw Cutting Lathe and is recommended for the finest, most accurate jobs in manufacturing—in the tool room, in home workshops and automotive machine shops. Workmanship and materials used are exactly the same as used in more expensive models of larger size, making it represent the greatest value we have ever offered in 31 years of fine lathe building.

Features include Twin Gear Reverse to lead screw, Ball Thrust Bearing on Spindle, Longitudinal Screw Feed to Carriage, Precision Lead Screw for Cutting screw threads—and scores of other important features. Takes 38 practical attachments for milling, grinding, draw-in collet chuck work, and many other manufacturing jobs.

South Bend Lathe Works

618 E. Madison St., South Bend, Ind., U.S.A.

5 OTHER SIZES: 9", 11", 13",
15" and 16" SWING IN ALL BED
LENGTHS
PRICED \$97 to \$1200

Lathe shown below is No. 117-C 16" x 6' Quick Change Gear Underneath Belt Motor Driven Lathe with 1 h.p. motor. Complete as shown. **\$869**
(*\$87.00 Down, \$38.50 Monthly for 22 Months*)



Write FOR NEW CATALOG 15-K

New catalog illustrates and describes in detail this new Workshop Lathe in 8 different drives, 4 bed lengths. Shows the 38 attachments for use with this lathe. A valuable book for all interested in metal working lathes. This catalog sent free, postpaid. Use the coupon shown below.

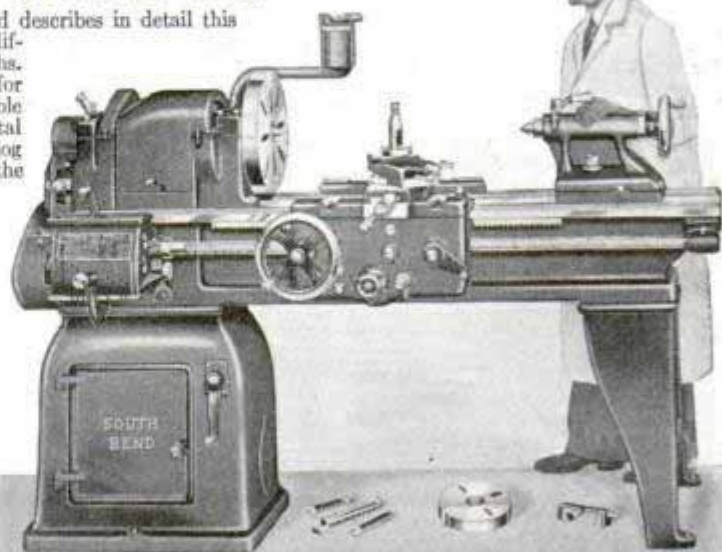

South Bend Lathe Works,
618 E. Madison St.,
South Bend, Ind., U.S.A.

Please send the following free, postpaid:

- () 9" Workshop Lathe Catalog No. 15-K.
() General Catalog No. 96.

Class of work

Name

Address

City State

SOUTH BEND Precision LATHES



White Heat Means a Cooler Kitchen

WORKING with searing heat at 5400 degrees Fahrenheit, G-E scientists have evolved more durable, more efficient heating units. These CALROD units, used in General Electric and in Hotpoint electric ranges, provide quick, clean, even heat—localized just where it is needed. This means a cooler kitchen. In thousands of plants, CALROD units are being used for industrial heating because they provide heat at a remarkable saving in cost.

But the CALROD unit is only one achievement of the ceramics experts in the G-E Research Laboratory. New and unusual kinds of glass serve as vital parts in sodium

lamps that light miles of American highways—light them for greater safety for drivers and pedestrians. Large insulators support the wires that bring electric power from the generators to your home; tiny insulating blocks help to maintain the high quality of reception in your radio tubes. To these, too, General Electric scientists, in Schenectady, have brought important improvements.

These examples are but a few of the contributions of research which has stimulated industry, increased employment, made available more things for more people at less cost.

G-E research has saved the public from ten to one hundred dollars for every dollar it has earned for General Electric

GENERAL  **ELECTRIC**

*Your cigarette line
reads...
They Satisfy*



*And there's a wealth of
good taste in store for you*