

WITH THE AMATEUR SKY PATROL

POPULAR MECHANICS

★

MAGAZINE

WRITTEN SO YOU CAN UNDERSTAND IT

REG'D. TRADE MARK, GREAT BRITAIN No. 410428

NOV.
25 CENTS



SEE PAGE 649

**PREFERRED AT HOME
PREFERRED ABROAD**



Harry McQuinn, Ronnie Householder and Bob Swanson, three of the leading, most consistent winners in midget car racing, use Champions.



MONTLHERY, FRANCE—Trevoux and Maclure in their Champion-equipped Riley, won in Group 1 in the French Grand Prix.



BARCELONA, SPAIN—Nuvolari, in a Champion-equipped Alfa-Romeo, won the Pena Rhyn race through the streets of Barcelona.



GOSHEN, N. Y.—Rex Mays, 1935 Pacific Coast AAA champion, won the 100-mile national championship race here using Champions.

As an exacting car owner you undoubtedly know that there is a gradual deterioration in spark plugs resulting in loss of power, speed, acceleration and economy as mileage accumulates. If you are no longer satisfied with your car's performance and want a smoother, more economical and more dependable engine, do as most automotive engineers recommend—install new Champions. You'll be surprised at the new snap, the easier starting, faster acceleration and, above all, the greater economy that only Cham-

**Choose the
Spark Plugs
Champions
Use**

pions insure. That's why Champions are chosen and recommended by most automotive engineers and why practically every race throughout the world in the last thirteen years was won by engines equipped with Champion Spark Plugs.

TO RID YOUR CAR OF MOTOR "BUGS" INSTALL A SET OF CHAMPION PLUGS



**Want More
Economical
Engine
Performance?**



Mom's wise now!

Mom used to tell me to bring home some 60-watt bulbs. Now she always says, "Be sure to get 60-watt General Electric MAZDA lamps." She's wise now! She has learned that good lamps like these STAY BRIGHTER LONGER and don't waste electricity. So now when I go to the store for lamp bulbs, I always look for the trademark  on the end of each bulb.



THEY STAY BRIGHTER
LONGER

General Electric makes a 10 cent lamp, too! It is the best lamp you can buy at the price. 7½, 15, 30 and 60-watt sizes. Each dime lamp is marked like this . . . 

GENERAL  ELECTRIC
MAZDA LAMPS

When writing to advertisers please mention Popular Mechanics

"How I Tamed a Ferocious Pipe" by LIONEL HUNTER Famous Big Game Trapper

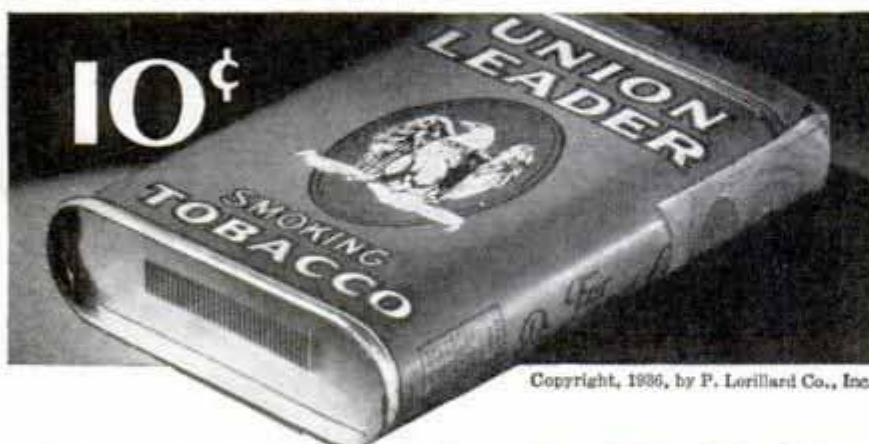

Copyright, 1936, by P. Lorillard Co., Inc.

You too, can be a Pipe-Tamer

THIS EASY, INEXPENSIVE WAY!

Now you can make a *pet* of your pipe, once you've taught it to eat out of a tin of Union Leader! That vicious biting of your tongue is only a sign that it's hungry for the real fully-ripened Kentucky Burley that gives Union Leader such a blissful blend of rich flavor and cool smoothness. Even wild *young* pipes can be tamed with a ten-cent tin of this soothing tobacco, *aged-in-wood* to banish bite! (Swell for rolling cigarettes, too!)

UNION LEADER
THE GREAT AMERICAN SMOKE

FOR PIPE
AND
CIGARETTE

Popular Mechanics Magazine

H. H. WINDSOR, Founder

H. H. WINDSOR, Jr., Editor and Publisher

November, 1936

Vol. 66, No. 5

Special Features

Modern Fire Walkers	641
The Gasoline Dope Racket	645
The New Era of Railroading	Coloroto
Learning to Fly the Clippers	660
The Spin Shots of Table Tennis	668
"Courts" Offer Luxury for Motorists	674
Building a River in the Desert	682
With the Sea-Going Engineers	690
Uncle Sam's Forest Fire Fighters	696
Man-Made Weather for the Movies	706
Why Gamble with Death?	714
The Amateur Sky Patrol	722
The Latest for the Hunter	732

(Continued on next page)

Hitch Your Wagon to a Car

THE canvas-topped prairie schooner, first home on wheels, carried the pioneers across the plains and helped push our frontiers westward to the Pacific. Today America is returning to the covered wagon era, and the modern rolling home again is extending our boundaries by releasing us from permanent abodes and giving travel a new value. Today's prairie schooner is a streamlined, luxury-crammed "cottage" on rubber-tired wheels and it is hitched to a 100-horsepower car instead of to a team of oxen. Thousands of families are living permanently or part time in trailers and trailer manufacturers are swamped with orders. Watch next month for the first of two trailer articles, illustrated with eight pages of Coloroto pictures.

Next Month

VISUALIZE a flying boat weighing 1,500 tons with 200,000 horsepower in its engines and accommodations for 500 passengers in its hull. It seems a Jules Verne dream but flying boat designers think you may be buying a one-day ride to Europe in such a giant within twenty years. Read "Future Titans of the Skies" next month.

Training a T-Man

EVERYONE knows of the exploits of the G-Men, but have you ever heard of the T-Men, the trigger squad of the Treasury Department? There are more than 5,000 of these T-Men affiliated with the Secret Service, White House police, Customs service, or employed as guards in other departments. A story next month tells of the rigorous training it takes to make a T-Man.

Flying Caterpillars

THE Caterpillar Club is one of the most exclusive in the world, but no one seeks membership in it. To join it, you jump. You leap from an airplane to save your life and trust your neck to a parachute. If you survive, you automatically become a Caterpillar. The Club has more than 800 members and the leaps which landed them in it are woven into an absorbing adventure article in the December issue.

Published monthly by POPULAR MECHANICS CO., 200 East Ontario Street, Chicago, U. S. A. Single copy in United States, 25 cents; \$2.50 a year, \$4.00 for two years, \$5.00 for three years in United States and possessions, Canada, Newfoundland, Labrador and countries of the Americas and Spain. To all other countries add \$1.00 a year extra for overseas postage. Changes in address must be reported to us immediately to eliminate delay. Entered as Second Class Matter, Sept. 15, 1903, at the Post Office at Chicago, Illinois, under Act of March 3, 1879. Entered as Second Class Matter at the Post Office Department, Canada. Copyright 1936, by Popular Mechanics Co. in the United States, Australia and France.

This One



All New Cars Need SIMONIZ



The Sooner You Simoniz Your Car, the Better

No matter what car you have or buy, it should be Simonized. As experience proves, sun, weather and dirt quickly dull the lustre—soon ruin the finish itself. Simoniz stops this destruction. The weather-proof protection which it gives makes any finish last longer. So, Simoniz your car now! If it's dull, first use Simoniz Kleener to quickly and easily restore sparkling beauty. Remember, nothing else is like Simoniz and Simoniz Kleener. Always insist on them!

Motorists Wise

SIMONIZ

(Contents—Continued)

AUTOMOTIVE

Compartment bus driven by twin motors.....	657
Car lighting system guards against road trouble...	664
Auto makers turn to easy control	665
Super-steam in welded pipes used by auto makers...	666
Flexible taillight bracket for trucks	667
Automatic windshield washer	672
No-roll-back brake for auto works automatically...	678
Washable cotton cover for steering wheel.....	679
Auto battery guaranteed for life of car	680
Streamline auto in movies offers tip to industry...	681
Gear shifting eliminated in latest transmission.....	686
Curved rear-view mirror on auto fender	687
Vacuum-operated gear shift for autos	700
Racing car has air intake like a gun	703
Two-faced glareproof rear view mirror	703
Air from tire jacks up car in ten seconds	713
Low wheel motorcycle goes twenty miles on a pint.	725
Folding one-wheel trailer has beds for four.....	726
Short-measure gas costs autoists millions	728
Tips on how to get all the gasoline you order.....	729

AVIATION

Baby antelopes cross country in flying boxcar.....	659
War plane flies five miles a minute	666
"Flying flea" in big wind tunnel undergoes test....	672
Oxygen mask protects pilot in high-flying ship....	731
Shielded loop antenna helps pilot keep on course...	736

CONSTRUCTION

Ships without portholes in air-conditioned world...	672
Window with double glass aids air conditioning....	680
Moisture eliminator stops chimney corrosion	710
Gravel roads made dustless by adding salt	726

FARMS AND GARDENS

Acetylene treatment speeds ripening of pineapples..	657
Hydraulic auto jack pulls up fence posts	664
Floral windmill made of 12,000 plants	704
Windbreak of trees saves farmhouse fuel	704
Mower cuts and cleans lawn like vacuum cleaner...	705
Iodized paper wrapper keeps fruit from decay.....	736

HOUSEHOLD

Garbage can holder	658
Carpet sweeper with elbow handle	688
Lighted shelf for bathroom or kitchen	694
Six curtains accommodated on pinless stretcher....	694
Lock in cork seals bottle	700
Gas-vapor heating plant uses fuel efficiently	702
Handy wrenches for kitchen have rubber teeth....	719
Home knitter makes hard stitches easy	732

MODELS

Stamp collection pasted on auto	658
Model engine driven by remote control	679
Sculpturing with sponges	688
Famous trains in miniature run on model line	721

MOVIES AND PHOTOGRAPHY

Photo enlarged by air brush guided by scanner....	679
Speed camera stops flight of humming birds.....	680
Television movie camera transmits Olympic pictures.	681
Photo enlarger protects negative from light source.	695
Photo enlarger with timing switch	700
Camera on auto hood takes pictures of accident....	701
Smashup on race track caught by camera	710
Synchronizer fires battery of speed flash bulbs ...	711
Mural photos printed by spray gun and enlarger...	712
Adjustable film developing tank for amateurs....	720
Camera "sees" lightning as bolt hits monument...	730
Sound film traps criminals	730

RADIO AND ELECTRICITY

"Umbrella" loud-speakers free from echo	678
"Walking transmitter" sends programs one mile...	711
Latest clock has a "voice" to announce time	719
Midjet radio for policeman is carried in pocket...	725
Portable television transmitter	727
Electric robot tells time every three seconds.....	736
Four-tube transceiver for five meters	737
Six-tube amplifier for theatrical sound effects....	738

(Continued to page 6A)

STRANGE BUT TRUE



540,000

AUTOMOBILES FROZE UP LAST WINTER

(OFFICIAL STATISTICS)

THOUSANDS OF THESE CARS FROZE UP AFTER THEIR OWNERS HAD PUT IN ALCOHOL ANTI-FREEZE. THIS WAS POSSIBLE BECAUSE ALCOHOL, OR ANTI-FREEZE BASED ON ALCOHOL, BOILED AWAY WHEN THE WEATHER TURNED WARM BETWEEN COLD SNAPS



THERE ARE APPROXIMATELY **50 BRANDS** OF ANTI-FREEZE ON THE MARKET WITH AN ALCOHOL BASE, BUT CALLED SOMETHING ELSE!

ANTI-FREEZES OF THIS CLASS MUST BE CHECKED FREQUENTLY FOR BOIL-AWAY, AND MORE ADDED FROM TIME TO TIME, TO AVOID DANGER OF COSTLY FREEZE-UP

EVEREADY PRESTONE

PUT IN YOUR CAR ONCE PROTECTS IT AGAINST BOTH FREEZE-UP AND RUST

ALL WINTER LONG



THOUSANDS, DISAPPOINTED BY OTHER ANTI-FREEZES BOUGHT EVEREADY PRESTONE AFTER JANUARY FIRST LAST SEASON. THEY WILL SAVE MONEY THIS SEASON BY BUYING EVEREADY PRESTONE BEFORE COLD WEATHER COMES AND SO WILL YOU!

The words "Eveready Prestone" are the trade mark of National Carbon Co., Inc.

GUARANTEED — CONTAINS NO ALCOHOL — ONLY \$2.70 A GALLON



NOW IN A NEW 12-OUNCE SIZE Tamper-Proof, Sealed Container

This new 12-ounce size of Genuine Improved Pyroil is sufficient for 5-quart, 6-quart and 7-quart crankcases. And it costs you less! A triple value: an improved product in an improved container for less money. Sealed at the factory, you can be assured of Genuine Pyroil when you ask for this new size.

Improved Pyroil is a matchless product. It definitely saves you money. Its regular use safeguards all frictionized parts of your car against excessive wear and other damages. It saves common repairs. It frees away sludges, gums and carbon. Improved Pyroil gives your car new power and "pep."

The coupon below will bring you many surprising and important facts about the money you can save when you use Improved Pyroil regularly. Sold throughout the civilized world at service stations, garages and other dealers. Manufactured and Guaranteed by Pyroil Company, W. V. Kidder, Founder, 511 Pyroil Bldg., LaCrosse, Wis., U. S. A.

PYROIL HAS BEEN TESTED BY POPULAR MECHANICS AND IS USED BY POPULAR MECHANICS' PRESSES AND EQUIPMENT.

DISTRIBUTORS: NEW PYROIL PREMIUM PLAN NOW IN EFFECT GIVES NATIONALLY ADVERTISED MERCHANDISE OF HIGH VALUE, ABSOLUTELY FREE. CHECK COUPON FOR FULL DETAILS, AND FACTS OF BUSINESS OPPORTUNITY.

Genuine Pyroil bears this signature on every can

W. V. Kidder
Founder

**PYROIL COMPANY,
511 Pyroil Bldg.,
LaCrosse, Wis., U. S. A.**

Please send Free important facts on Pyroil's money saving features.

Please send details of New Premium Plan and Business Opportunity for me.

Name.....

Address.....

City.....County.....

State.....

Genuine
PYROIL
LUBRICATION PROCESS

(Contents—Continued)

How to build a 150-watt all-band transmitter.....	740
Easy solutions for everyday radio problems.....	741
Desk microphone for call systems.....	742
Modern easy chair has built-in receiver.....	742
Radio noise filter for car heater.....	742
Windcharger for camp trailers and trucks.....	742

SCIENCE AND INDUSTRY

Stainless steel railway car tested under water spray.....	667
Sun's rays harnessed to steam engine.....	673
Pre-shrunk oil for paint is discovered by accident.....	688
Coal "dry cleaned" in portable air-sand plant.....	695
Motor boats lift river water over dam.....	700
Instinct organ of animals found at center of brain.....	702
Rain gauge read once a year shows 451 inches fell.....	703
Midget and giant aluminum pistons.....	704
Gas extracted from clover by inexpensive process.....	720
Census taker counts bacteria in grain of soil.....	731

SPORTS

Cyclists ride side by side on double bicycle.....	694
Motorcycle's dive into canal is crowd thriller.....	701
Sinker mold for fishermen.....	730

TOOLS

Special punch for starting hinge screws at center.....	659
Jointed rule measures angles.....	666
Tool for cutting sheet metal leaves edges smooth.....	688
Silent gasoline road drill tested in war on noise.....	713
Solder applied with spray gun.....	726

MISCELLANEOUS

High power sound projectors.....	658
Pump to fit outboard motor supplies camp water.....	659
Secrets of earth's interior told in mineral hall.....	664
Miniature organ has three-octave span.....	667
Floating fire-hose monitor guided like a hose.....	686
Periscope on tee gives golfers view of green.....	687
Insect farmers reap a fortune in butterflies.....	689
Figure of Christ dominates odd design for church.....	693
Tape binder for edges of paper.....	693
Money bag leaves smoke trail to trace thief.....	694
Pretzel bending machine solves problem.....	705
Rubber coating keeps soap water and weather proof.....	711
Sunlight cast into dark rooms by reflector.....	720
Electric unit sterilizes dirt and eliminates weeding.....	721
Fruit trees fed from bottles to speed up growth.....	725
Portable hammock and stand handy for outings.....	727
Pumps aerate water and save fish.....	731
Liner's anchor chain tested to destruction.....	732
Poison found for locusts.....	732

Craftsman and Shop Notes

AUTOMOTIVE

Cushioned boot in tire lasts longer.....	798
Dashlight illuminates glove compartment.....	798
Retrieving small parts from gasoline pan.....	798
Roller on luggage compartment saves lifting.....	798
Adjustable rear-view mirror.....	799
Protecting storage battery against cracking.....	799
Rattan cover weighted to keep it in place.....	799
Squeaky springs silenced by screen wire.....	799
Trailer-hitch pin locks itself.....	799

FURNITURE

Spool bed you can make.....	748
Upholstered den couch has storage space.....	755
Chest of drawers hides lavatory.....	769
Lamp table with matched veneer top.....	771
Sliding table on book shelf saves steps.....	786

HAND TOOLS

Utility pliers slotted to cut wire.....	747
Profile gauge checks lathe turning tools.....	752
Teeth on one side of file filled to protect work.....	754
Twist tamper doesn't stick.....	762
Depth gauge carried in pocket.....	762

(Continued to page 8A)

How Can I—a Business Man—Really Learn Law at Home?



YOU are not alone in asking that. Practically every man has seen where knowing law would have helped his success. The structure of business is held together by legal relations—and the man who knows law has a distinct advantage—for himself and his firm.

Again, countless occasions arise outside of the office—leases, insurance, inheritance questions, domestic affairs, taxes and trust agreements are but a few—on each of which you may lose unless you know something of law.

Again, legal training gives you what the business world prizes highly and rewards liberally—a keen, analytical mind, the ability to judge shrewdly and to act with surety.

But whether you want law for personal and business values, or intend to prepare for a bar examination, the same problem confronts you. How can you acquire that knowledge?

You can't go back to school or spend years in a law office. But there is one road open to you—*home study*—a road that some of the greatest leaders have traveled—men like Lincoln, Grant, Disraeli, John Marshall, Coolidge—who mastered this important subject in hours that otherwise would have been wasted.

It *can* be done, of course—thousands have done it—yet what you want to know is—can *you* reasonably hope to do it? Will it hold your interest, or will you find it drudgery? And—most important of all—will you really benefit by it?

You are quite wise in asking these questions—in holding your decision until they are answered.

And these paragraphs are written to help answer your questions so far as LaSalle law training is concerned. Let's get right down to facts.

80,000 Others Have Proved It for You

First: LaSalle has been successfully training men and women in law for twenty-five years—more than 80,000 individuals. Some of these are now successful lawyers and judges—others are owners of business, presidents and general managers, department managers, etc. Their names and addresses are readily available for your direct investigation.

Second: Out of this experience in training so many, LaSalle naturally has perfected the material and methods of teaching law by home study. No matter what your situation, your handicap, your education, your needs and desires, etc.—we have already trained some man in similar circumstances.

A Most Remarkable Law Library

Third: Since text books are of such importance in any study of law, the LaSalle Law Library was prepared by more than twenty law professors—leading teachers in our greatest resident law schools—and three lawyers. Five of these professors—including the editor-in-chief—have been deans of their schools. One of the editors is now president of a great state university. Also, among the writers of the special lectures are two U. S. Senators, a former U. S. attorney-general, and a Supreme Court Justice of the State of New York.

More, these men—in preparing this Library—kept in mind always that it was to be used for home study. They knew it was for men like you—busy men who would study it at night, on trains, in spare moments in offices or stores—men who must find it clear and engaging, yet complete and reliable. So they wrote directly, simply, interestingly.

Problem Method Interesting and Practical

Fourth: This training is *personally* applied to you under lawyer-instructors, members of the bar who give *full time*.

These men check your work, guide you, and instruct you at every step according to your individual needs. You study under a definite, clear-cut plan involving continual use of the Problem Method. Thus you learn by actually handling legal problems, analyzing cases, and making legal decisions—not by merely memorizing rules.

Fifth: In certain permitted states, each year, LaSalle-trained men pass the bar examination with honor. And if you are interested in Law for your business success—as most of our members are—we would like you to read a booklet called "Evidence." In it hundreds of business men and lawyers tell you exactly what this training has meant to them in more money and advancement. There is no charge for this book. It is yours simply for the asking. Just fill out and mail the coupon below.

We Have Answered Your Questions— Now Answer Ours

You have our answers to your questions. Now, let us ask you a question—the real question—about the size of your ambition, and the quality of your determination.

For legal training, with all its fascination and values, is no magic wand for the lazy or the fearful or the quitter—it offers success only to the alert adult who has the courage to face the facts and the will to carry on. No other should consider law training—or even write us for further information.

But if you ARE that man, let us assure you that whatever your circumstances, your handicaps—we will successfully teach you Law at home, and help, in every possible way, to turn your study into higher pay and advancement.

This may be the opportunity you have been waiting for. Fill out and mail the coupon today—for the information that can open up to you the success of which you have dreamed.

No cost or obligation to your request. So why not?—NOW.

These books are
FREE—
ask for them

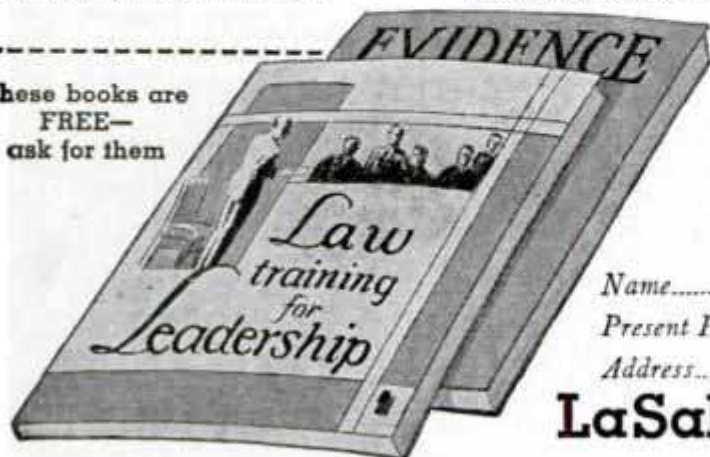

LA SALLE EXTENSION UNIVERSITY
Dept. 1164-LR, Chicago

Kindly send me free copies of your two booklets, "Law Training for Leadership" and "Evidence" together with full information about your Law Training for business men—without obligation to me.

Name.....

Present Position.....

Address.....

LaSalle Extension University

When writing to advertisers please mention Popular Mechanics



Where the Canaries Sing Bass

—and we manicure our nails in cigar cutters

By "Bugs" Baer

Famous Author and Humorist

AN UNGRATEFUL child is sharper than a serpent's tooth. But it is dull compared with a Gillette Blade, which is so keen that a lightning bug couldn't find its edge even if he had two tails.

I am Mayor of Rufftown, which is so tough the canary birds sing bass and we manicure our nails in cigar cutters. Nobody in our town ever shaved until the Gillette Blade was invented, but now we all shave twice a day, including the children, Aunt Ella and the iron deer on the front lawn.

We all want nice, smooth, enjoyable shaves and we've all got a right to them. The Constitution of the United States guarantees that in the paragraph about the pursuit of happiness.

To get the lowdown on this shaving thing, I took a cruise through the Gillette factory in Boston recently and watched a blade go through 248 minor operations so that a shave would not be a major operation. I discovered there isn't any microscope powerful enough to see the shaving edges of a Gillette Blade.

I have been using Gillette Blades for twenty-five years, man and boy, so I ought to know what I'm talking about when I say that the Gillette Blade gives the world's cleanest, smoothest shaves.

Like Frank Buck, Grantland Rice, Graham McNamee and many other famous men, "Bugs" Baer agrees that the Gillette Blade is the finest that science can produce. If you have strayed away from Gillette Blades, may we suggest that you now buy a package, and get ready for a new thrill in shaving! You will be surprised how easily and quickly it whisks off stubborn bristles without pull or irritation. Buy a package today. Slip one into your razor tomorrow morning and see for yourself why millions of men will use no other blade.

With these important facts before you, why let anyone deprive you of shaving comfort by selling you a substitute! Ask for Gillette Blades and be sure to get them.

GILLETTE SAFETY RAZOR CO., BOSTON, MASS.

(Contents—Continued)

Filing work square	779
Swirl machine finish on metal by hand	779
Roll-up tool kit is handy	785
Auger bits shielded to protect points	786
Drawing longitudinal lines on round stock	786
Pliers lock on work	786

HOME IMPROVEMENTS

Dark room brightened by reflected light	753
Storm windows sealed with adhesive tape	757
Draining off water above a storm door	770
Getting good draft in chimney	773
Screened storm windows keep out insects	773
Small window in storm door saves heat	774

HOUSEHOLD

Portable strainer has rubber feet	750
Wheeled ash can is easy to move	750
Hat rack on closet door	752
Runners on refrigerator trays make removal easy ..	752
Cutter on spool of heavy thread is timesaver	754
Stove poker has cool, sliding handle	754
Buttonholes made with table knife	757
Meat pressed into food chopper with spoon	757
Small garments dried on radiator	757
Oven rack has guard on edge	763
Kerosene stove heats water	769
Sewing kit from poker-chip rack	770
Shaving brush suspended from shelf	770
Hot-dish mat of wood	775
Sweeper with pivoted handle gets under furniture ..	779
Removing glass stoppers	779
Cleaning piano keys	780

MACHINE TOOLS

Angle sawing for economy	751
Lead faceplate weights save time	786
Disk and drum sanders fit your drill press	795
Drill-press vises with skids easily moved	796
Lathe kick-off spring saves time	796

PHOTOGRAPHY

Tray development of roll film with aid of guide ..	753
Reflector for photo-flash bulbs	763
Photo enlargements vignettted with cardboard	775
Favorite photos in novel mountings	776

STORE AND SHOP

Workshop plans held with trouser hanger	752
"Stellite" tipped tools for working cast iron	794
Improvised shear quickly cuts wire	796

MISCELLANEOUS

Air-propelled railplane	743
Concrete-form anchor wires tightened quickly	747
Mono-scooter is speedy	750
Sanding block for rounded surfaces	750
Dangers in diving helmet to be avoided	754
Nicked nails easily broken off	757
Safe fun for Halloween	758
Articles in gratings retrieved with long "finger" ..	762
Stiffened broom sweeps snow	762
Upholsterers' tape applied with aid of steel ball ..	762
How to put up signs on windy days	763
Pipe insulation protected by sheet metal	763
Selecting your shotgun	764
Lubricating metal-spinning work	770
Putting several papers into a typewriter	774
Sewing machine improved by extension shelf	774
Slotting wood without splitting it	774
Taped shoes for icy walks	779
Composition board cut with tracing wheel	780
Friction electroplating	781
Bolts coated with cement to prevent rusting	785
Cutter on job press is aid to operator	785
Rings in harness lines ease hand strains	785
Midget gas engine—Part II	787
Mirror used as protractor	793
Self-heating roller imbeds gravel in tar roofs	793
Paint gun with strap eases strain on wrist	794
Pockets in carpenter's apron kept open with wire ..	794
Rubber-tipped putty knife taps glass into place ..	794
Tool kit has self-locking handles	794
Ream of paper divided into equal parts with ruler ..	796
Broken band saw brazed with aid of jig	800
Soldering terminal lugs	800

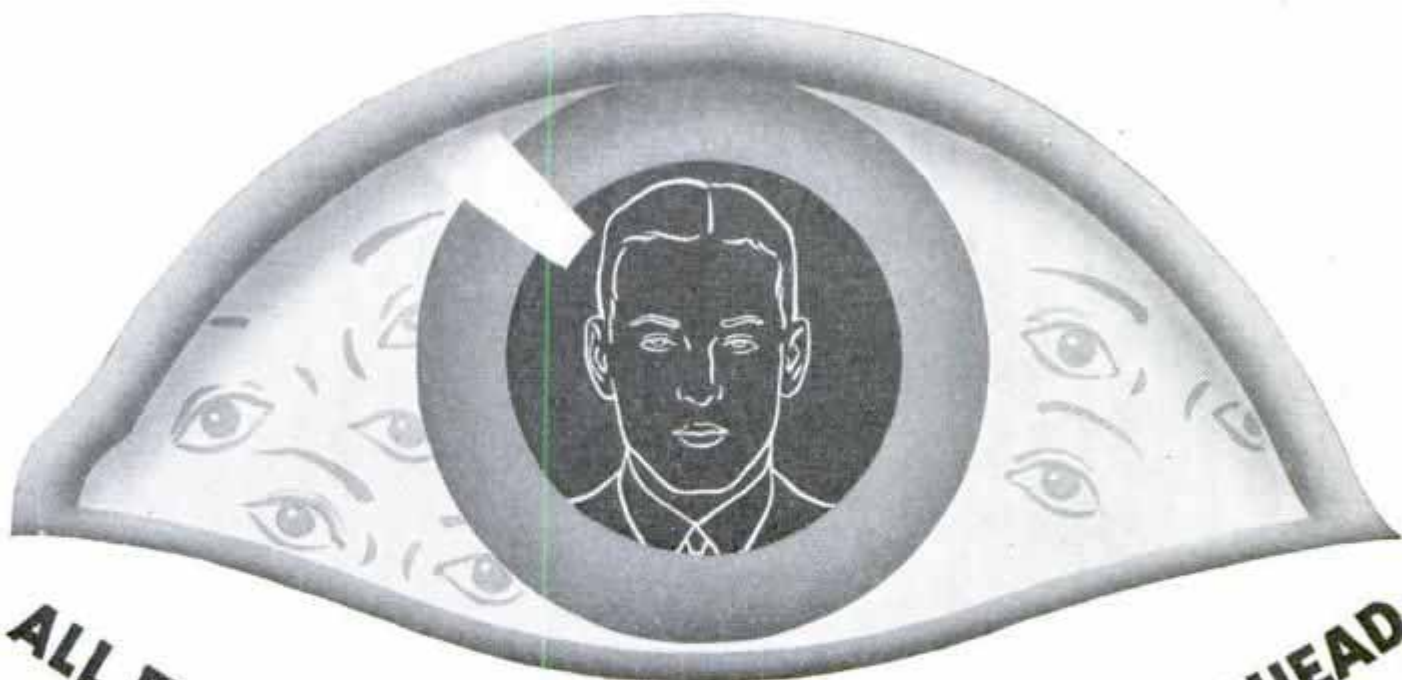

ALL EYES ARE ON THE MAN WHO LOOKS AHEAD

A MAN cannot conceal ability. And the man who is determined to go some place and is doing something about it cannot conceal that either. His associates feel it and his superiors recognize it. The man

who looks ahead knows the importance of training, and other men who have looked ahead and gone some place know that I. C. S. offers the right kind of training. Look ahead — mail this coupon!

INTERNATIONAL CORRESPONDENCE SCHOOLS

BOX 5639-H, SCRANTON, PENNA.

★ Without cost or obligation, please send me a copy of your booklet, "Who Wins and Why," and full particulars about the subject *before* which I have marked X: ★

- | | | |
|---|---|--|
| TECHNICAL AND INDUSTRIAL COURSES | | |
| <input type="checkbox"/> Architect | <input type="checkbox"/> Sheet Metal Worker | <input type="checkbox"/> Plumbing |
| <input type="checkbox"/> Architectural Draftsman | <input type="checkbox"/> Boilermaker | <input type="checkbox"/> Steam Fitting |
| <input type="checkbox"/> Building Estimating | <input type="checkbox"/> Telegraph Engineer | <input type="checkbox"/> Heating |
| <input type="checkbox"/> Contractor and Builder | <input type="checkbox"/> Telephone Work | <input type="checkbox"/> Ventilation |
| <input type="checkbox"/> Structural Draftsman | <input type="checkbox"/> Mechanical Engineering | <input type="checkbox"/> Air Conditioning |
| <input type="checkbox"/> Structural Engineer | <input type="checkbox"/> Mechanical Draftsman | <input type="checkbox"/> Steam Engineer |
| <input type="checkbox"/> Management of Inventions | <input type="checkbox"/> Machinist | <input type="checkbox"/> Steam Electric Engineer |
| <input type="checkbox"/> Electrical Engineer | <input type="checkbox"/> Patternmaker | <input type="checkbox"/> Marine Engineer |
| <input type="checkbox"/> Electric Lighting | <input type="checkbox"/> Diesel Engines | <input type="checkbox"/> R. R. Locomotives |
| <input type="checkbox"/> Welding, Electric and Gas | <input type="checkbox"/> Aviation Engines | <input type="checkbox"/> R. R. Section Foreman |
| <input type="checkbox"/> Reading Shop Blueprints | <input type="checkbox"/> Automobile Mechanic | <input type="checkbox"/> Air Brakes |
| <input type="checkbox"/> Heat Treatment of Metals | <input type="checkbox"/> Refrigeration | <input type="checkbox"/> R.-R. Signalmen |
| | | <input type="checkbox"/> Highway Engineering |
| | | <input type="checkbox"/> Civil Engineering |
| | | <input type="checkbox"/> Surveying and Mapping |
| | | <input type="checkbox"/> Bridge Engineer |
| | | <input type="checkbox"/> Bridge and Building Foreman |
| | | <input type="checkbox"/> Chemistry |
| | | <input type="checkbox"/> Pharmacy |
| | | <input type="checkbox"/> Coal Mining |
| | | <input type="checkbox"/> Mine Foreman |
| | | <input type="checkbox"/> Fire Bosses |
| | | <input type="checkbox"/> Navigation |
| | | <input type="checkbox"/> Cotton Manufacturing |
| | | <input type="checkbox"/> Woolen Manufacturing |
| | | <input type="checkbox"/> Agriculture |
| | | <input type="checkbox"/> Fruit Growing |
| | | <input type="checkbox"/> Poultry Farming |
| BUSINESS TRAINING COURSES | | |
| <input type="checkbox"/> Business Management | <input type="checkbox"/> Bookkeeping | <input type="checkbox"/> Service Station Salesmanship |
| <input type="checkbox"/> Industrial Management | <input type="checkbox"/> Secretarial Work | <input type="checkbox"/> First Year College Subjects |
| <input type="checkbox"/> Traffic Management | <input type="checkbox"/> Spanish | <input type="checkbox"/> Business Correspondence |
| <input type="checkbox"/> Accountancy | <input type="checkbox"/> French | <input type="checkbox"/> Stenography and Typing |
| <input type="checkbox"/> Cost Accountant | <input type="checkbox"/> Salesmanship | <input type="checkbox"/> Civil Service |
| <input type="checkbox"/> C. P. Accountant | <input type="checkbox"/> Advertising | <input type="checkbox"/> Mail Carrier |
| | | <input type="checkbox"/> Railway Mail Clerk |
| | | <input type="checkbox"/> Grade School Subjects |
| | | <input type="checkbox"/> High School Subjects |
| | | <input type="checkbox"/> College Preparatory |
| | | <input type="checkbox"/> Illustrating |
| | | <input type="checkbox"/> Cartooning |
| | | <input type="checkbox"/> Lettering Show Cards |
| | | <input type="checkbox"/> Signs |
| DOMESTIC SCIENCE COURSES | | |
| <input type="checkbox"/> Home Dressmaking | <input type="checkbox"/> Advanced Dressmaking | <input type="checkbox"/> Millinery |
| <input type="checkbox"/> Professional Dressmaking and Designing | | <input type="checkbox"/> Tea Room and Cafeteria Management, Catering |
| | | <input type="checkbox"/> Foods and Cookery |

Name.....Age.....Address.....

City.....State.....Present Position.....

If you reside in Canada, send this coupon to the International Correspondence Schools Canadian, Limited, Montreal, Canada

When writing to advertisers please mention Popular Mechanics



**Which One
OF THESE TWO MEN
ARE
You?**

This man has routine job in shop. Would like to earn more money, advance to better job, but does nothing about it. Will be doing same work 20 years from now.

This man had job in shop. Wanted more pay and better job. Learned Practical Drafting at home from Engineer Dobe. Advanced steadily, increased his earnings considerably, became full-time draftsman.

Better JOBS Now



ENGINEER DOBE has taught drafting by mail to thousands of successful students, aged 16 to 18 to past 50. Established since 1900.

As industry revives, who is always needed first of all? The **DRAFTSMAN** who draws the plans. **AFTER** that the steel mills, lumber mills, brickyards and others start getting busy. Recovery in business and most industries now seems well on the way.

Government efforts to help are making things hum. In some factory towns a shortage of draftsmen appears at times. Many trained draftsmen will be needed on better jobs—at better pay and shorter hours. Who'll get those good jobs? Of course, the men who have prepared—so, prepare now!

Drafting Leads Most Industries

Ahead of most any other work is Drafting and Planning for mechanics, builders and factory to produce. It leads them all!

Here Is Your Opportunity!

Yes, here is an opportunity that's open to those who know how to grasp it:—At a few dollars a month, students get complete training in drafting by mail in surprisingly few months—Engineer Dobe teaches his students until thoroughly trained and until holding a good paying job. Trained Draftsmen enjoy good salaries. Unless you get a satisfactory job:—all your money back. That's Engineer Dobe's guarantee.

No Experience Required

With Engineer Dobe's method no previous experience is necessary. High School education not needed. Everything made plain. Practical work from the start until you're in position.

Time is money. Learn drafting in your spare time. It's high time now to prepare. Don't wait another day. Send coupon for Dobe's free book.

ENGINEER DOBE Div. 3378 Libertyville, Ill.

Start NOW

Win PROMOTION—DRAFTING

If you're a mechanic, a knowledge of draftsmanship may make you a foreman or superintendent in short order. Get out of overalls and draw the pay of a boss. If you **are** a boss, learn draftsmanship, a foundation stone of many a line of business.

In every walk of life, practical training in draftsmanship will prove valuable. Even if you never accept a job as a draftsman, will you not be **money ahead** by taking Engineer Dobe's course?

You'll be amazed at the speed with which you can learn in your spare time by Engineer Dobe's Practical Method. Send coupon TODAY for free book entitled "Success in Draftsmanship".

All Working Tools Furnished

Here's a valuable set of tools—sent at once (also a drawing table)—all without extra charge the day you enroll.

Complete Outfit, size 20x25 in., furnished to you.



These **TOOLS** and Other **EQUIPMENT** Given When You Start

Free Book!

ENGINEER DOBE, Div. 3378, Libertyville, Ill.

Send me your free book "Successful Draftsmanship". Please explain how you assist your graduates to good positions as draftsmen.

Name

Address

Town

State..... Age

When writing to advertisers please mention Popular Mechanics

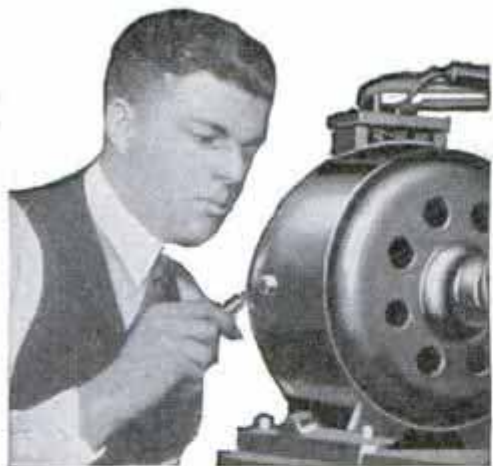

EASIER WAY TO SUCCESS *in* ELECTRICITY

LEARN THE GREATEST INDUSTRY OF THE AGE—TRAIN NOW FOR A REAL FUTURE

Finance Your Training!

Are you dissatisfied with your job? Are you out of a job because you lack specialized training for a live industry? Is your future uncertain? Then let me show you an amazing, easy way to get your start in Electricity, where thousands of TRAINED MEN earn good pay. Where hundreds of Coyne Graduates are drawing Good Pay every week. Coyne has been training ambitious fellows for the Electrical Industry since 1899. Whether you are 16 or 40 years old, Electricity thru Coyne training offers you your start for a real future—and you can start training any time.



H. C. Lewis

Opportunities for a good job, or a business of your own

Here is YOUR opportunity. Every day brings news of new developments in this fascinating, big-pay field, with new jobs and a greater future for the trained man than ever before. If you are ambitious to get ahead, I want to help you. MAIL THE COUPON BELOW and I'll tell you about my finance plan, which has enabled thousands to get Coyne Training with very little money. Get training first, then take 18 months to complete small monthly tuition payments starting FIVE MONTHS after you begin your training. NOT a Home study course.

Learn By Doing In 90 Days

The great Coyne Shops are famous the world over for their unusual Learn-by-Doing method of practical, individual instruction. There is no book study, no reciting—you learn quickly and thoroughly by doing actual jobs under the personal guidance of trained instructors, on a great outlay of machinery and equipment assembled strictly for training purposes. That is why, in 12 short weeks, we are able to take fellows without previous experience or a lot of book learning, and train them for their start to a real future.

MANY EARN

WHILE LEARNING

If you need part-time work to help pay living expenses while at school, tell us your problems and we may be able to help you as we have hundreds of other students. Then, after you graduate, our Free Employment Department will give you life-time employment service. Every Coyne graduate also receives a Life Scholarship, with free technical and business service and privilege of review at any time without additional tuition charge.



COYNE

**DIESEL OPERATOR
ARMATURE WINDER
AND TESTER
SUBSTATION OPERATOR
AUTO ELECTRICIAN
INVENTOR
MAINTENANCE ELECTRICIAN
SERVICE STATION OWNER**

and many other money-making opportunities in the Electrical field. Learn by actual work on real dynamos, engines, power machinery, autos, switchboards—equipment ranging from door bells to large power motors, controls and generators, in full operation every day.

**DIESEL ENGINES
REFRIGERATION
AIR CONDITIONING**

These two fast growing industries offer opportunities to the trained man. Right now I'm including instruction in Diesel Engines, Electric Refrigeration and Air Conditioning at no extra cost.

HOME OF COYNE SHOPS

This is our fireproof modern home wherein is installed thousands of dollars worth of Electrical equipment. Every comfort and convenience has been arranged to make you happy and contented during your training.

H. C. LEWIS, PRESIDENT **FOUNDED 1899**
ELECTRICAL SCHOOL
500 S. Paulina St., Dept. 86-72, Chicago, Ill.

PROOF That Coyne Training Gets QUICK RESULTS

"I owe my electrical success to your 12-week shop course," says R. B. Umbarger of Tennessee. "Two weeks after leaving school I took a wiring job," reports E. O. Berndt of Illinois, "and the profits from this one job alone more than paid for the entire course." A. C. Hoehnle of Ohio says "Received several raises in pay, due to the training I received at Coyne." And I could quote from hundreds of similar letters from successful Coyne-trained men. What they have done, you should be able to do!

GET THE FACTS... NOW

Coyne is your great chance to get into this big-pay field. This school is 37 years old... Coyne training is tested. And it costs you nothing to find out about this amazingly easy, practical way to learn Electricity. Simply mail the coupon below and I'll send you the big, free Coyne book, with photographs... facts... opportunities. There's no obligation... so act at once.



Send Today for this FREE Book!

H. C. LEWIS, President
Coyne Electrical School,
500 S. Paulina St., Dept. 86-72, Chicago, Ill.

Without obligating me, send full details of your "Pay-Tuition-After-Graduation" Plan and Big Free Illustrated Catalog.

Name.....

Address.....

City.....State.....

Mail in envelope or paste on a postcard.

Okmulgee, Okla.
Hazelton, Pa.

Des Moines, Iowa
Sioux City, Iowa

Look Men!

Here's a Partial List of States, Cities and Institutions in which **GRADUATES** of I. A. S. were placed in positions as **Finger Print Experts!**



Be A Secret Service and Identification Expert!

State of Wash.
State of Michigan
State of Utah
State of Ohio
Duluth, Minn.
Detroit, Mich.
Pueblo, Colo.
Idaho Falls, Idaho
Ogden, Utah
Lorain Co., Ohio
St. Paul, Minn.
Pittsburgh, Pa.
Lincoln, Nebr.
Birmingham, Ala.
Columbus, Ohio
Havana, Cuba
New Haven, Conn.
Great Falls, Mont.
Galveston, Texas
Pensacola, Fla.
Stillwater, Okla.

Calgary, Alta., Can.
Houston, Texas
Waterloo, Iowa
Victoria, B. C.
Baton Rouge, La.
Atlantic City, N. J.
E. Lansing, Mich.
Globe, Arizona
London, Ont., Can.
Henryetta, Okla.
Seattle, Wash.
Ferndale, Mich.
McAlester, Okla.
Negaunee, Mich.
Lawton, Okla.
Crown Point, Ind.
Bay City, Mich.
Roanoke, Va.
Glendale, Calif.
Hawaiian Islands
Drumright, Okla.

Miami, Florida
Orlando, Florida
York, Pa.
El Paso, Texas
Everett, Wash.
Schenectady, N. Y.
Alhambra, Calif.
Livingston, Mont.
Saginaw, Mich.
Fort Collins, Colo.
Bedford, Ohio
Huntington, W. Va.
Salt Lake City, U.
Taft, California
Jamestown, N. Y.
Phoenixville, Pa.
Rochester, N. Y.
Media, Pa.
Dayton, Ohio
East Chicago, Ind.
Green Bay, Wis.
Nocona, Texas
Neerah, Wis.
Kingfisher, Okla.
Centralia, Wash.
Bismarck, N. D.
Bloomington, Ind.
Cuyahoga Falls, O.
Rock Island, Ill.
Philadelphia, Pa.
Astoria, Oregon
Pendleton, Ind.
St. Joseph, Mo.
State of Illinois
State of Iowa
State of Idaho
State of Colorado
Lima, Ohio
Selma, N. C.

Want a Regular Monthly Salary?

Investigate this opportunity to earn a regular monthly salary and share in Rewards—the *same opportunity* which appealed to those hundreds of Institute of Applied Science Graduates now holding positions in the partial list of States, Cities and Institutions shown here. And one to fifteen I. A. S. Graduates are employed on regular monthly salaries by each bureau listed. Be a Finger Print and Secret Service Operator! Write for Free details how you can train at home in spare time to enter this young, swiftly-growing profession.

FREE The Confidential Reports Operator No. 38 Made to his Chief!

Write or send coupon for Free Reports and Illustrated Finger Print Book . . . the same information requested by *hundreds* of I. A. S. graduates now earning a monthly salary!

**Institute of Applied Science, Dept. 1358
1920 Sunnyside Ave., Chicago, Ill.**

Gentlemen:— Without any obligation on my part whatever, send me the Reports of Operator No. 38, also your Illustrated Free Book on Finger Prints and your low prices and Easy Terms Offer. Literature will NOT be sent to boys under 17 years of age.

Name _____
Address _____ Age _____

When writing please mention Popular Mechanics

DON'T BUY

guitars, mandolins, banjos, drums, or Electric Hawaiian guitars until you have tried the Slingerland May-Bell Violin Craft. Guaranteed more for your money. A wonderful snappy, powerful, and pleasing tone. Over 100 styles at surprisingly low prices and sold on easy payments by all leading music dealers.



Send for Free Catalog. Mention instrument wanted and nearest music dealer.

Cut This Adv. Out — Good for \$1.00 Credit

Write today:

**Slingerland Musical Instrument Mfg. Co.,
1325 Belden Ave., Chicago, Illinois**

ENGINEERING



TECHNICAL AND APPLIED COURSES. Nonesentials omitted. TIME AND MONEY SAVED. Degree in 2 yrs., diploma in 1 yr. Electrical, Mechanical, Architectural, Structural, Aeronautical, Civil, Highway. Short intensive courses in Diesel-Electric, Electricity, Power Plant, Drafting. All courses include Refrigeration, Diesel, and Air-Conditioning. Low tuition. Extensive modern equipment. Part-time work for room and board. 37th year. Thousands of successful graduates in U. S. and foreign lands. Approved by Industry, endorsed by educators and alumni. One and two-year courses begin in Sept. Short courses open the year round. Catalogue free.

FINLAY ENGINEERING COLLEGE
1001 Indiana Avenue Kansas City, Mo.



Make this your life-time career

Wonderful, money-making opportunities. Men, women. Growing field. Become a Commercial Photographer; a News, Advertising, Portrait or Motion Picture Photographer. Personal Attendance or Home Study training. 26th year. Free Booklet.

NEW YORK INSTITUTE OF PHOTOGRAPHY
10 West 33 Street (Dept. 49) New York

CARTOONING PAYS WELL

Develop your ability with personal instruction from an internationally-known cartoonist. His exclusive, successful method of drawing and creating ideas makes it easy to attain success. Write for details of this exceptional home-study course.

National School of Cartooning, 437 Penton Building, Cleveland, Ohio



VOICE

100% Improvement Guaranteed

We build, strengthen the vocal organs—not with singing lessons—but by fundamentally sound and scientifically correct *student exercises* . . . and absolutely guarantee to improve any singing or speaking voice at least 100% . . . Write for wonderful voice book—sent free. Learn WHY you can now have the voice you want. No literature sent to anyone under 17 years unless signed by parent.

**PERFECT VOICE INSTITUTE, Studio 1358
64 E. Lake St., Chicago**

Did You Miss High School?

"I was always held back because I didn't go through High School. But now this amazing new, easy book has helped me make up for it—RIGHT AT HOME!"

IS YOUR advancement being hindered by lack of more schooling? Do "circumstances" seem to keep you in a rut—side-tracked from jobs and opportunities you know you have the brains and ability to handle?

If YOU have been handicapped because you missed High School — or had to quit before graduating—this fascinating new book will help you make it up—in just a few minutes a day of pleasant reading! In a very short time you can have a surprising command of English, Mathematics, Psychology, History, Literature, and other important subjects every successful person is able to discuss.

Takes Up TWENTY Different High School Subjects

Up to now, no single volume has ever put the very backbone of a High School education into such brief yet effective form. All unnecessary words are cut. You read quickly, easily—you remember what you read. Useless repetition has

- These 20 High School Subjects Now Made Easy**
- Good English
 - Civics and Government
 - Short History of United States
 - English Literature
 - Biology
 - Geography
 - Psychology
 - Classics of World Literature
 - Chemistry
 - Ancient History
 - Medieval History
 - Modern History
 - Elementary Algebra
 - French
 - Astronomy
 - Physics
 - Plane Geometry
 - Spanish
 - Physiology
 - The Arts
- 16 Full Pages of Modern Maps in Color

been eliminated. Everything is in simple, everyday language.

Only thus can all these twenty subjects be included in one amazing volume — a book that is actually fun to read! Not like your past ideas of a "schoolbook"! More like a wise, helpful friend telling you facts you want and need!

Yet this book, "High School Self-Taught," is specially arranged so you do not have to ask for help from anyone else. And fascinating Self-Tests following each section help you check your newly-gained knowledge.

IT'S MISSING HIGH SCHOOL THAT KEEPS YOU FROM GETTING AHEAD, JIM!



The Big Question Today

It is more vital NOW than ever to have the essentials of a High School training. The first question today is, "Have you a High School Education?" Without it, you are regarded as poorly equipped for positions that offer real salaries and futures.

And everyone can tell by the way you talk—and from the subjects that puzzle you—whether you have a high school background. They "grade" you accordingly. They may be sorry you missed this schooling. But you don't want pity! You want to be on an equal footing; admired as an individual, welcomed as a friend or business associate.

WHAT FUTURE WOULD I HAVE MARRYING A FELLOW WHO NEVER EVEN FINISHED HIGH SCHOOL?

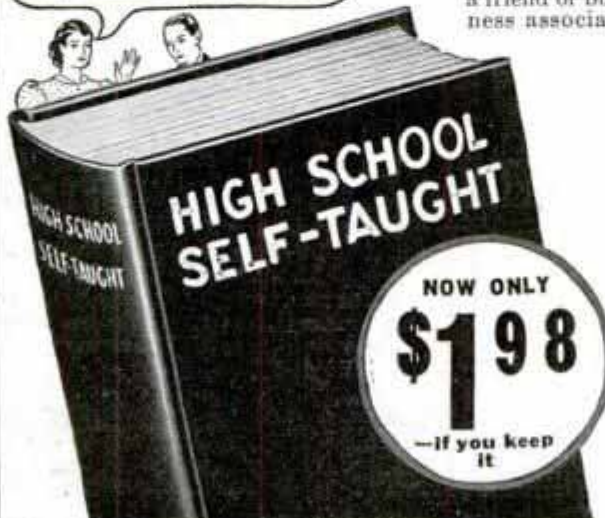

And now you can be! In fact—your new high school training will actually be fresher in your mind than it is today for many who graduated years ago!

SEND NO MONEY

This remarkable volume will be sent with a guarantee of complete satisfaction. Unless it proves it will give you the training we promise, we do not want you to spend one cent for it.

Send no money with the 5-DAY EXAMINATION COUPON below. When postman delivers book to you, deposit with him only \$1.98, plus few cents postage. Then read it. See exactly what it can do for you, how much it will help you. If not convinced that here, at last, is the help you need to get ahead—simply return book to us within 5 days, and its cost will be refunded immediately. Mail coupon NOW to: HOME-EDUCATION BUREAU, Dept. 211, 386 Fourth Ave., New York, N. Y.

HOME-EDUCATION BUREAU, Dept. 211, 386 4th Ave., New York, N. Y.

Please send "High School Self-Taught." When postman delivers it, in plain wrapper, I will deposit with him only \$1.98 plus few cents postage. I will examine it for five days. If I am not completely satisfied, I will return it and you will refund my \$1.98.

Name.....

Address

City..... State.....

Check here if enclosing \$1.98 WITH this coupon, in which case we will pay the postage—you save. Same return and refund privilege applies, of course.



BEARADIO

**MANY MAKE
\$30 \$50 \$75 A WEEK**

**I Will Train You at Home—
mail coupon for FREE Book**

J. E. SMITH
Pres., N. R. I.
The man who
has directed the
home study
training of more
men for the
Radio Industry
than any other
man in America.

**HERE'S PROOF
THAT MY TRAINING PAYS**

Do you want to make more money? Radio offers you many opportunities for well-paying spare time and full time jobs. And you don't have to give up your present job or leave home and spend a lot of money to become a Radio Expert.

**Chief Operator Broadcasting
Station**



"When I completed 20 lessons, I obtained my Radio Broadcast Operator's license and immediately joined Station WMPC, where I am now Chief Operator."—**HOLLIS F. HAYES**, 85 Madison St., Lapeer, Mich.

**Many Radio Experts Make
\$30, \$50, \$75 a Week**

Radio broadcasting stations employ engineers, operators, station managers and pay up to \$5,000 a year. Spare time Radio set servicing pays as much as \$200 to \$500 a year—full time jobs with Radio jobbers, manufacturers and dealers as much as \$30, \$50, \$75 a week. Many Radio Experts operate their own full time or part time Radio sales and service businesses. Radio manufacturers and jobbers employ testers, inspectors, foremen, engineers, servicemen, paying up to \$6,000 a year. Radio operators on ships get good pay and see the world besides. Automobile, police, aviation, commercial Radio, and loud speaker systems are newer fields offering good opportunities now and for the future. Television promises to open many good jobs soon. Men I have trained are holding good jobs in these branches of Radio. Read their statements. Mail the coupon.

\$10 a Week in Spare Time

"My work has consisted of Radio set servicing, with some Public Address Systems work—all in my spare time. My earnings in Radio amount to about \$10 a week."—**WILLIAM MEYER**, 705 Ridge Road, Hobart, Ind.



**There's a Real Future in Radio
for Well-Trained Men**

Radio already gives jobs to more than 300,000 people. In 1935 over \$300,000,000 worth of sets, tubes and parts were sold—an increase of 20% over 1934! Over 1,100,000 auto Radios were sold in 1935, 25% more than in 1934! 22,000,000 homes are today equipped with Radios, and every year millions of these sets go out of date and are replaced with newer models. Millions more need servicing, new tubes, repairs, etc. Broadcasting stations pay their employees (exclusive of artists) more than \$23,000,000 a year! And Radio is a new industry, still growing fast! A few hundred \$30 \$50, \$75-a-week jobs have grown to thousands in less than 20 years!

Service Manager for Four Stores



"I was working in a garage when I enrolled with N. R. I. In a few months I made enough to pay for the course three or four times. I am now Radio service manager for the M—Furniture Co., for their four stores."—**JAMES E. RYAN**, 1535 Slade St., Fall River, Mass.

**Many Make \$5, \$10, \$15 a Week
Extra in Spare Time
While Learning**

Practically every neighborhood needs a good spare time serviceman. The day you enroll I start sending you Extra Money Job Sheets. They show you how to do Radio repair jobs that you can cash in on quickly! Throughout your training I send you plans that make good spare time money—\$200 to \$500 a year—for hundreds of fellows. My training is famous as "the Course that pays for itself."

Own Business Pays \$300 a Month

"I now have my own Radio business which shows three hundred dollars a month profit—thanks again to National Radio."—**FRANK T. REESE**, 39 N. Felton St., Philadelphia, Penna.



**Earned \$50 First Month
in Spare Time**

"I knew nothing about Radio. After four lessons I began servicing Radios, earning \$50 the first month. Last winter I made as high as \$100 a month in spare time."—**G. F. WALTON**, 808 West Olney Road, Norfolk, Va.



THE TESTED WAY TO

EXPERT



I Give You Practical Experience

My Course is not all book training. I send you special Radio equipment and show you how to conduct experiments and build circuits which illustrate important principles used in modern Radio receivers, broadcast stations and loud speaker installations. I show you how to build testing apparatus for use in spare time work from this equipment. This 50-50 method of training makes learning at home interesting, fascinating, practical.

You Get a Money-Back Agreement

I am so sure that I can train you successfully that I agree in writing to refund every penny you pay me if you are not satisfied with my Lessons and Instruction Service when you finish. I'll send you a copy of this agreement with my Free Book.

Find Out What Radio Offers You

Act Today. Mail the coupon now for "Rich Rewards in Radio." It's free to any fellow over 16 years old. It describes Radio's spare time and full time opportunities and those coming in Television; tells about my training in Radio and Television; shows you actual letters from men I have trained, telling what they are doing and earning. Find out what Radio offers YOU! MAIL THE COUPON in an envelope, or paste on a postcard—NOW!

J. E. SMITH, Pres., National Radio Institute
Dept. 6MP
Washington,
D. C.

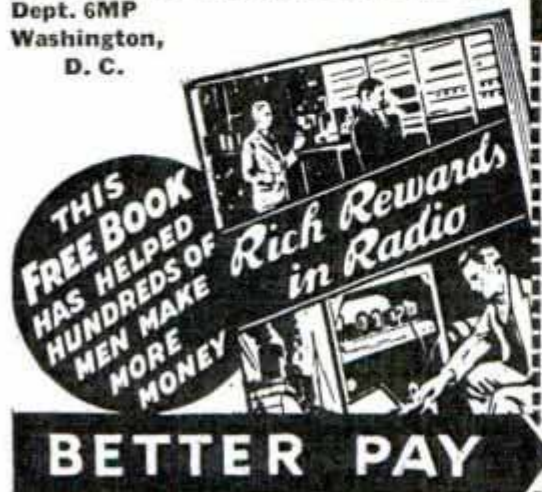

SET SERVICING. Spare time set servicing pays many \$5, \$10, \$15 a week extra while learning. Full time servicing pays as much as \$30, \$50, \$75 a week.

BROADCASTING STATIONS.

Employ managers, engineers, operators, installation and maintenance men for fascinating jobs and pay up to \$5,000 a year.



LOUD SPEAKER SYSTEMS. Building, installing, servicing and operating public address systems is another growing field for men well trained in Radio.



AUTOMOBILE RADIO. Another new Radio field—selling, installing, servicing. One million or more auto owners will install radio sets within a year.

Mail this to get 64 page Book FREE

J. E. SMITH, President, Dept. 6MP
National Radio Institute, Washington, D. C.

Dear Mr. Smith: Without obligating me, send "Rich Rewards in Radio," which points out the spare time and full time opportunities in Radio and explains your 50-50 method of training men at home in spare time to become Radio Experts. (Please Write Plainly.)

NAME.....AGE.....

ADDRESS.....

CITY.....STATE.....

The Diesel Engineer

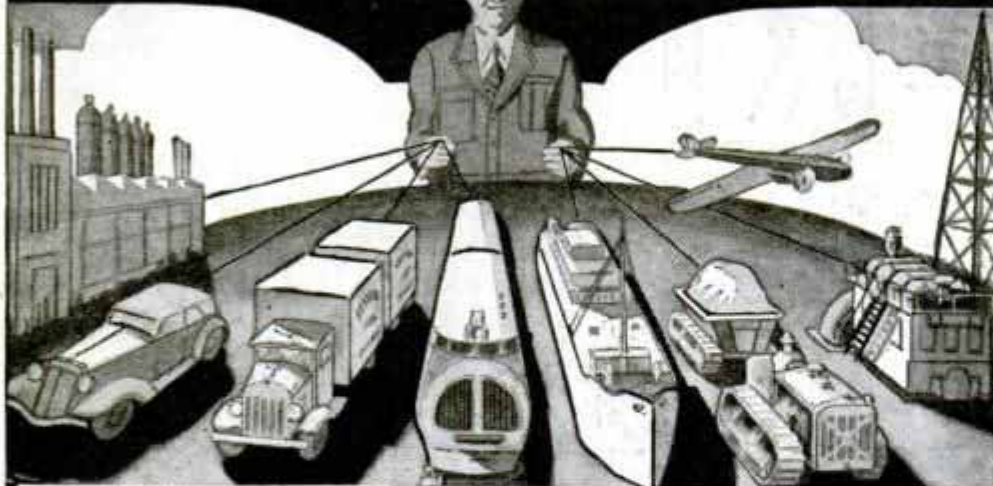

Diesel—The Newest, Fastest-Growing Power

Diesel engines—because of their high efficiency, dependability, and economy of operation—are fast replacing steam and gasoline engines in power plants, motor trucks and busses, locomotives and ships, aircraft, tractors, dredges, drills, pumps, etc.—opening up an increasing number of well-paid jobs for Diesel-trained men. The field of Diesel Engineering is on the upgrade and continually expanding. It will provide steady employment and advancement for those properly trained in this new industry—as long as they need to work.

You get complete information on all the latest Diesel developments—two- and four-stroke cycles; low- and high-speed and heavy-duty types; Diesel-electric generating systems, etc.—in our course. Includes all text material—with special diagrams for quick understanding of this new power.

American School, Dept. D-845, Drexel Avenue at 58th Street, Chicago, Illinois

Turn Your Spare Time into Dollars

Now is your chance to get into a big new industry and grow up with it to an important position. Today there is practically no competition in the Diesel field, but the increasing use of Diesel engines will result in keen competition for jobs in the near future. By starting your training now, you can keep ahead of such competition.

What This New Field Offers You

Get our Free Diesel Booklet and learn all about this newest, fastest-growing line—its opportunities and requirements. Find out what the Diesel field offers you—how rapidly the Diesel industry has developed during the last three years—the large number of Diesel engines and accessories being manufactured today—how quickly you can obtain a complete understanding of Diesel engine principles and operation by home study during your spare time—without interfering with your regular work.

Asking for information involves no obligation—but it may mark the turning point in your life. Write TODAY for full information.

AUDELS Carpenters and Builders Guides 4 vols. \$6



Inside Trade Information for Carpenters, Builders, Joiners, Building Mechanics and all Woodworkers. These Guides give you the short-cut instructions that you want—including new methods, ideas, solutions, plans, systems and money saving suggestions. An easy progressive course for the apprentice and student. A practical daily helper and Quick Reference for the master worker. Carpenters everywhere are using these Guides as a Helping Hand to Easier Work, Better Work and Better Pay. To get this assistance for yourself, simply fill in and mail the FREE COUPON below.

Inside Trade Information On:

How to use the steel square—How to file and set saws—How to build furniture—How to use a mitre box—How to use the chalk line—How to use rules and scales—How to make joints—Carpenters arithmetic—Solving mensuration problems—Estimating strength of timbers—How to set girders and sills—How to frame houses and roofs—How to estimate costs—How to build houses, barns, garages, bungalows, etc.—How to read and draw plans—Drawing up specifications—How to excavate—How to use settings 12, 13 and 17 on the steel square—How to build hoists and scaffolds—skylights—How to build stairs—How to put on interior trim—How to hang doors—How to lay floors—How to paint.



THEO. AUDEL & CO., 49 W. 23rd St., New York City

Mail Audels Carpenters and Builders Guides, 4 vols., on 7 days' free trial. If O.K. I will remit \$1 in 7 days, and \$1 monthly until \$6 is paid. Otherwise I will return them. No obligation unless I am satisfied.

Name.....

Address.....

Occupation.....

Reference..... P.M.

When writing please mention Popular Mechanics

Is Your Job Safe

Just as the gasoline engine changed or wiped out the jobs of thousands who depended on horse-drawn vehicles for their living—just as electricity changed the entire set-up in the fields of light and power—so now the Diesel engine is fast invading both the power and transportation fields, and threatening the present jobs of thousands of workers.

If jobs in your line are steadily growing scarcer, you owe it to yourself to investigate this new, progressive, uncrowded line, that will offer good openings for many years to come.

LEARN MECHANICAL DENTISTRY

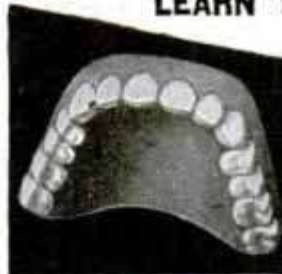

A profession offering unlimited opportunities. Most modern and complete course embracing every branch from Plate to Porcelain Work, which prepares you to work for Dentists or start your own business. Individual instruction—practical training in day or night school. No books—no classes. Catalog upon request.

Dept. 715

McCARRIE SCHOOL OF MECHANICAL DENTISTRY
207 N. Broad St. Phila., Pa.

AUTOMOBILE RACING New Book

(FOURTH EDITION)

Nine Chapters—66 illustrations of dirt, midget and championship cars and drivers. How to build cars and bodies—14 plates working drawings. Converting stock cars to 135 m.p.h. racers. Answers all questions on speeding up cars, balance, speed, revs., rules, specifications, track records, etc. Postpaid \$1.00, C.O.D. \$1.12. Order NOW. Ray Kuns, Dept. B, Madisonville, Cincinnati, Ohio.



ENGINEERING DEGREE IN TWO YEARS

B.S. Degree in Electrical, Civil, Chemical, Radio, Mechanical or Aeronautical Engineering in two years. Located in an industrial center with that Engineering atmosphere. Earn board. Low tuition. Preparatory Department. Enter Dec., Mar., June, Sept. Catalog.

INDIANA TECHNICAL COLLEGE

229 East Washington St., Fort Wayne, Indiana

LEARN JIU-JITSU

from AMERICA'S LEADING INSTRUCTORS

Become a qualified Jiu-Jitsu Instructor in 90 days. Excellent social and financial benefits afforded graduates of this school. For free booklet, write

The American School of Jiu-Jitsu

P. O. 382 Dept. 6 Toronto, Ont.



BE A RADIO EXPERT



LEARN at HOME
From
REAL RADIO ENGINEERS

RAY D. SMITH, Pres. R-T-I

If you're dissatisfied with small pay—lay-offs and an uncertain future—here's an opportunity that's too good to miss. At the cost of only the time it takes you to mail the coupon, you can get my big FREE book, "RADIO'S FUTURE AND YOUR OPPORTUNITY." This book tells how you can learn at home under the supervision of factory engineers, to make more money almost at once in Radio—whether you want to make Radio your life's work, or use it to pick up an extra \$5 to \$20 a week in your spare time.



TRAIN NOW FOR GOOD PAY FULL-TIME AND SPARE-TIME JOBS THAT PAY UP TO \$75 A WEEK (and more)

Now is the time to get into Radio. 1935 was its biggest year. Over 5 million new sets sold. Over 30 million dollars paid for service alone in 1935. Where only a few hundred men were employed a short time ago, thousands are employed today. And where a hundred jobs paid up to \$75 a week—there are thousands of such jobs today—many paying even more. And new jobs are being created all the time—full time jobs and spare time jobs. Get my book and see how easy it is to learn at home for this good-pay work.

"Shop Training" for the Home

R-T-I Training is different than any training you ever heard about. It comes to you right from the heart of the Radio Industry—right out of the factories where Radio sets and other vacuum-tube devices are made. It was planned and prepared and is supervised by big radio engineers IN these factories—by men appointed for the purpose. This means that trained the R-T-I way, you'll be trained as the Radio Industry wants you trained—just as the Radio Industry, itself, would train you if it was doing the job.

Television, Photo Electric Cells, Public Address Systems Included

Radio service work is only the starting point in R-T-I Training. From there it will take you through the whole field of Radio and Electronics. You will learn about every new development, including Television, so you'll be ready when Television breaks. You'll also learn the big money subjects such as Aviation and Auto Radio; Public Address Systems; how to handle Photo Cells; Sound Picture Recording, Etc.

4 Working Outfits Furnished

Start almost at once doing part time radio work. I furnish 4 outfits of apparatus that you build into test equipment with which you can do actual jobs and earn extra money. My Training pays its own way and you get your money back if not satisfied.

Age or Lack of Experience No Handicap

You don't have to be a high school graduate, nor even have finished the grades. My Training is so simple, easy, and practical, that the average man, regardless of age, education, or previous experience can master it. It offers the chance you have wanted to get out of a small-pay, no-future job, into good pay work with a future, in Radio and all its branches.

Get My Big New Free Book

INVESTIGATE! Learn why R-T-I Training is different. Find out why R-T-I Trained men get "Quick Results" and "Big Results." Send for your copy of "Radio's Future and Your Opportunity" today. It tells you about Radio's amazing opportunities. It describes my approved training. It tells what R-T-I students are doing and making. It gives the history of my Advisory Board and 50 endorsing manufacturers. It's FREE. Clip, sign and mail coupon RIGHT NOW!

RAY D. SMITH, President



RADIO AND TELEVISION INSTITUTE

Dept. 18

2130 Lawrence Ave.

CHICAGO

Let these Engineers, RIGHT FROM THE HEART OF THE GREAT RADIO INDUSTRY TRAIN YOU IN SPARE TIME FOR A *Good Pay Job!*

HERE THEY ARE:

Kendall Clough
Chief Engineer,
Clough-Brengle Co.

E. E. Gramer
Chief Engineer,
Standard
Transformer
Corporation.

Karl E. Hassel
Chief Engineer,
Zenith Radio
Corporation.

H. C. Tittle
Chief Radio Engineer,
General Household
Utilities (Grunow).

Dr. C. M. Blackburn
Asst. Factory Manager
P. R. Malloy & Company,
Mfrs. of Radio Apparatus.

F. L. Howard
Chief Engineer,
Radio and Television
Institute.

HAS MADE \$250 IN RADIO IN ONE WEEK



Wm. T. Ridd, Verdun, P. Q., Canada, formerly an \$18 a week car washer, averages more than \$75

a week as an R-T-I Trained man. He says: "Have made \$250 in single week. R-T-I is entirely responsible for my success."



STARTING SALARY HIGHEST HE EVER EARNED

Harold Apley, 2658 Brookside Ave., Indianapolis, made as high as \$30 a week in spare time while getting his R.T.I. training. Starting on a regular job, obtained because of his training he said: "This job is starting me in at better pay than I ever got on any job before."

MAIL COUPON FOR FREE BOOK

RAY D. SMITH, President,
Radio & Television Institute (R-T-I)
2130 Lawrence Ave., Dept. 18,
Chicago, Ill.

Without obligating me, send me your book that explains your Engineer-Directed and Industry-Endorsed method of training men quickly and inexpensively at home in their spare time to be Radio Experts.

Name

Address..... Age.....

City..... State.....



Know Electricity as Experts Know It!

— and get an expert's pay

Recovery has begun! The months ahead are charged with significance and expectation. What will you do to get the jump on the other fellow? Thousands of men have used

The Croft Library of Practical Electricity

A combined home-study course and reference library of master electrical practice.

7 VOLUMES, 3000 PAGES, 2100 ILLUSTRATIONS

THE Croft Library is a complete electrical educator. It is founded on practice—on 20 years of shirt-sleeve experience—on work as it is actually done. It is jammed from cover to cover with the kind of hard-headed facts you want. Written so that the beginner can easily understand it yet so sound, so thorough, that it is the daily guide of 59,000 highly paid electrical workers and engineers. Croft tells you the things you need to know about motors, generators, armatures, commutators, transformers, circuits, switchboards, distribution systems—electrical machinery of every type—wiring for light and power—wiring of finished buildings—underwriters' and municipal requirements—illumination in its every phase—the most improved methods of lighting—lamps and lamp effects, etc.—how to do a complete job, from estimating it, to completion.

FREE—if you act now

Kushlan's HANDBOOK OF INDUSTRIAL ELECTRICITY

As soon as you decide to accept the Croft Library, we will give you absolutely free, a copy of this handy manual. Kushlan's Handbook is a regular 500-page McGraw-Hill book, compact enough to fit in your tool kit or pocket, that gives a wealth of practical, how-to-do-it information for those engaged in electrical construction, maintenance, testing, inspection and contracting.

No money down — easy payments

Fill in and mail the coupon attached and we will send you the entire set of seven volumes for 10 days' Free Examination. We take all the risk—you assume no obligation. If you decide to keep the books, send \$1.50 in 10 days and the balance at the rate of \$2.00 a month, and get Kushlan's useful Handbook free, in addition. Send the coupon NOW and see the books for yourself.

FREE EXAMINATION COUPON

McGraw-Hill Book Co., 330 W. 42nd St., New York. Send for 10 days' free examination the Croft Library of Practical Electricity. If satisfactory I will send you \$1.50 in 10 days and \$2.00 monthly until the price of \$19.50 is paid. If not wanted, I will return the books postpaid. Upon receipt of my first payment of \$1.50 you are to send me a copy of Kushlan's Handbook of Industrial Electricity, absolutely free. (To insure prompt shipment, write plainly and fill in all lines.)

Name.....
 Address.....
 City and State.....
 Position.....
 Company..... PM—11-36

When writing please mention Popular Mechanics

Questions

about every

Hobby and Special Interest

quickly answered by the NEW MERRIAM-WEBSTER



DO YOU LIKE sailing? Or building ship-models? Can you name butterflies, birds? Are you acquainted with the wonders of the microscope? These and all other hobbies are fully described in Webster, with hundreds of detailed illustrations, half tones, and color plates. Every science, art, and profession is covered in the New Merriam-Webster with the same unprecedented thoroughness. 600,000 entries—122,000 more than in any other dictionary. 3,350 pages. Edited by 207 authorities. See it at your bookdealer's.

Write for illustrated new booklet, "Through Wonderland with Webster"

G. & C. MERRIAM CO. Dept. 680 Springfield, Mass.

The Supreme Authority—A New Creation WEBSTER'S NEW INTERNATIONAL DICTIONARY Second Edition

CARTOON YOUR WAY TO SUCCESS!



DON'T COPY—LEARN TO ORIGINATE!

RAYE BURNS will teach you HOW to CREATE ORIGINAL CARTOONS at home that you can SELL! Course contains 26 lessons and over 600 illustrations. All for Only...

\$2.85

Send name and address for free details. RAYE BURNS SCHOOL, Dept. M-X, BOX 2194, Cleveland, Ohio



Learn to Write

Begin Today. Write for my Free Book, "How to Become a Good Penman." It contains specimens and tells how others learned to write in spare time. Your name elegantly written on a card if you enclose stamp for postage. Write today. F. W. TAMBLYN, 418 Ridge Bldg., Kansas City, Mo.

Learn PHOTOGRAPHY at Home

Splendid opportunities. Prepare in spare time. Easy plan. No previous experience needed, common school education sufficient. Send for free booklet "Opportunities in Photography", particulars and requirements. American School of Photography 3601 Michigan Ave., Dept. 1358, Chicago, Ill.

GOV'T. JOBS

SALARY TO START \$90 to \$175 MONTHLY MEN.. WOMEN Age Range 18 to 50

- () Railway Mail Clk.
- () P. O. Laborer
- () R. F. D. Carrier
- () Special Agent
- () Customs Inspector
- () City Mail Carrier
- () P. O. Clerk
- () Elevator Conductor
- () Special Investigator
- () Typist
- () POSTMASTER
- () Stock Clerk
- () Auditor
- () Stenographer
- () U.S. Border Patrol
- () Telephone Opr.
- () Watchman
- () Meat Inspector
- () Secret Service Opr.
- () File Clerk

OZMENT INSTRUCTION SERVICE Dept. 111 St. Louis, Mo.

Send me FREE particulars "How to Qualify for Government Positions" marked "X". Salaries, locations, opportunities, etc. ALL SENT FREE.

Name.....
 Address.....

THE TRUTH ABOUT DIESEL

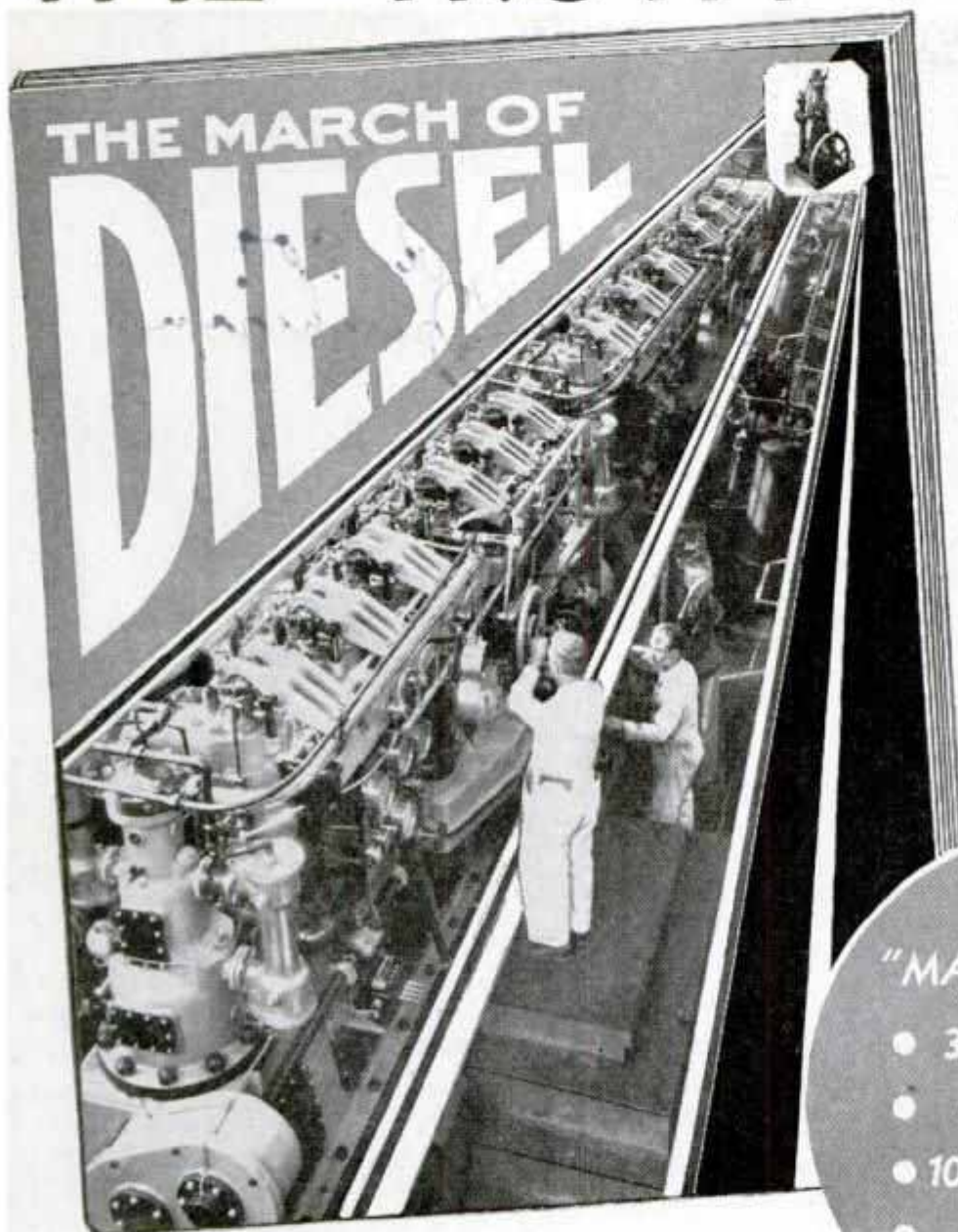

- Clearly Told.
- Profusely Illustrated.
- Authoritatively Written.
- A Standard by which **YOU CAN JUDGE** the importance and significance of this field to the world today. . .

THE "MARCH of DIESEL"

- 32 Pages
- 2 Colors throughout
- 104 Illustrations
- 8 Graphs

A FREE COPY

of the "March of Diesel" will be sent without cost or obligation (while supply lasts) to those men who are interested in the history, the growth, the magnitude and the future of the Diesel.

Send Coupon
for your copy
TODAY

USE NEAREST ADDRESS

BOSTON, 114 Brookline Avenue
 NEW YORK, 31-26 Queens Blvd, L.I. City
 DETROIT, 2341 West Lafayette Blvd.
 CHICAGO, 2014 Larrabee Street
 MEMPHIS, 417 Monroe Avenue
 LOS ANGELES, 2120 San Fernando Road
 SEATTLE, 501 Westlake North
 VANCOUVER, B.C., 1363 Granville St.

HEMPHILL DIESEL SCHOOLS

(Addresses at left)

I am interested in Diesel. Please send me free copy of "March of Diesel", and information on your training.

Name _____ Age _____

Street _____ City _____ State _____



STAMPS



..... *and* **Collecting**

By Richard McP. Cabeen, *Chic. 900.*



Interesting naval cover from Shanghai. These covers bear postal markings of foreign men-of-war on stamps of their countries and naval cancellation on U. S. stamp

WHILE stamp collections are started in many ways, a large percentage grow without plan or guidance. In the early stages a stamp is a stamp even though torn and smudged. The beginner will not believe one stamp of the same variety can be worth more simply because it is cleaner and undamaged, or has better centering or a fairer cancellation.

Later when comparisons are made with other collections or with exhibits, the beginner notices some are better than others, and that this comes about through the selection of nicer copies of stamps, and through the care used in arranging the album, rather than through any difference in money spent. For the first time "condition" is noticed, and it should teach the collector to select his stamps when buying them. Years ago young collectors

looked upon unused stamps as fakes or counterfeits, but following the world war, and the changes in value of monetary units in many countries, millions of left-over stamps were sold to dealers for packets. These may be mixed with the used stamps in an album without detracting from its appearance.

The beginner's first lesson should be on preparing stamps. They should never be "skinned" off the paper for this almost always damages them. They should be soaked in lukewarm water just long enough to dissolve the gum. Now scatter them over a newspaper and when partly dry transfer them to a book with soft paper pages for complete drying. A weight placed on the book will increase the crisp flatness, but may delay the dry-

(Continued to page 34A)

Learn **DIESEL** and **GAS ENGINEERING**

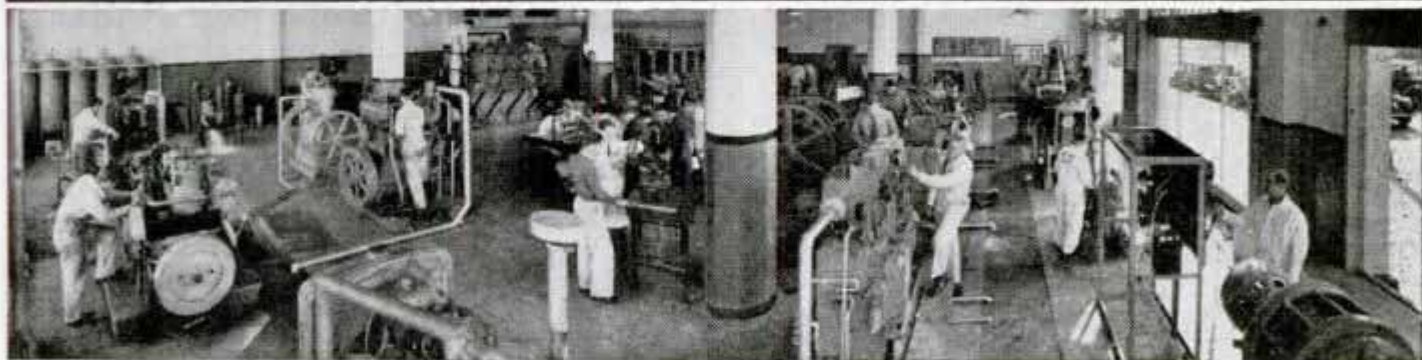

Partial view of Diesel-engine operating room—one of the important Departments at National Schools.



Students servicing Fairbanks-Morse Diesel power generating unit.

YOU WORK ON FINEST and LATEST EQUIPMENT AVAILABLE IN AMERICA

National Schools' course of Diesel Training is the outgrowth of years of successful development. The instruction is **PROVEN**. Over 30,000 graduates have received National Training. Now, National offers the most comprehensive training—actually three complete courses for the price of one—Gas and Diesel Engineering, and Electric Power Generation—all of which are absolutely essential to qualify for best jobs.

Easy, Fascinating "Shop-Practice" Method

The day you begin your training at National you start right in with a practical job on the most modern Gas and Diesel equipment, including Caterpillar, Cummins, McCormick-Deering, Hercules, Venn-Severin, Fairbanks-Morse, Enterprise, and many others. The work is actually a pleasure for students—easy to understand—ever fascinating. You learn in a few months what would ordinarily take far longer.

Complete, Modern Equipment Actually Used by Students

The vast installation of modern Gas and Diesel equipment here is all used by you in learning your trade. You learn to assemble and disassemble all parts, learn trouble-shooting; operating and all essentials to qualify you for big-pay Gas and Diesel opportunities. Your instruction is personalized under direct supervision of a large staff of experts.

LEARN IN LOS ANGELES, Playground of America RAILROAD FARE ALLOWED EARN ROOM AND BOARD

For a limited time, coach R. R. fare allowed to L. A. from any part of the U. S.

We help students obtain part-time jobs to earn room and board while learning.

NATIONAL SCHOOLS, LOS ANGELES

ESTABLISHED 1905



Electrical trouble-shooting in gas engine department.

QUALIFY FOR GOOD PAY JOBS

NATIONAL'S

Master Training
Includes

All Phases of
Diesel Engines
Fuel Injection

Gas Engines
Butane Engines

Propane
Natural Gas

Auto-Diesel Electrics
Also Diesel Power

Generation
Machine Shop
Batteries

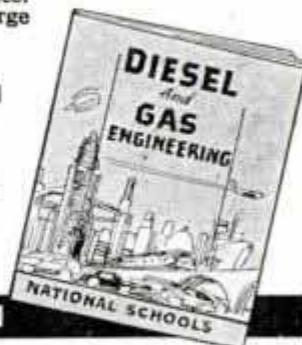

MAIL THIS COUPON

NATIONAL SCHOOLS, Los Angeles, Calif.
Dept. PMA-11, 4000 So. Figueroa St.
Please send Catalog

NAME.....AGE.....

ADDRESS.....

CITY.....STATE.....

Special Added Feature!

DIESEL ELECTRIC POWER GENERATION

In keeping with National Schools' progressive policy of offering the most complete Course, we announce this added feature, made available to you by an investment on our part of thousands of dollars. Full instruction includes:

Alternating and Direct Current Power Stations

Switchboards and Instruments

Station and Motor Wiring
Motors and Controls

Distribution Lines, Transformers, etc.

This specialized training enables our graduates to expertly handle Diesel equipment in power plants, mines, public buildings and utilities, boats, trains, etc. Knowledge of Diesel Electrics is just as essential as the fundamentals of Diesels. This school is the only one in the U. S., to our knowledge, offering this extra, yet necessary, specialized training.

INVENTORS

TO be successful as an inventor, you don't need to be an Edison who took out 1099 Patents before he died, or a C. F. Kettering, who helped develop the Self-Starter, Duco, Ethyl Gas and other outstanding inventions, and is today the famous head of the Research Division of the General Motors Corporation. In fact, you don't need to be known as an inventor at all, if you have a practical, useful, salable invention—or an idea for one—and go about it right.

Remember that for every Edison or Kettering, for every McCormick, DeForest or Atwater Kent—there have been thousands of unknown men whose inventions helped along the wheels of progress and helped the inventors financially at the same time.

MANY LITTLE IDEAS HAVE BIG COMMERCIAL POSSIBILITIES

For example, who knows the name of the inventor of the wooden golf tee, the ordinary crinkly hair pin, or the metal ball or disc that the average housewife uses for scouring pots and pans? Who knows the inventors of the thousands of gadgets that you will find in the ten-cent stores, in the modern drug and department stores? Some day, stop and look at some of the simple articles you'll find on the counters of a ten-cent store. Notice how many of them are marked "Patented or Patent Applied For." It is an interesting educational experiment. These inventors, most of them, weren't of the genius class. They simply got an idea for doing something in a better, easier, faster, or more economical way—AND THEN DID SOMETHING ABOUT IT.

Interesting Points

Who is today's "champion inventor"?

Ans: John F. O'Connor, of Chicago, Ill., holds 949 Patents, more than any other living man.

Who is "Lady Edison"?

Ans: Miss Beulah Louise Henry of New York City leads all women inventors, holds fifty patents; is known as "Lady Edison."

What is an improvement?

Ans: Nearly all inventions today are improvements over earlier inventions. Often the improvement proves more profitable than the earlier invention.

Is a model necessary?

Ans: Today, most inventions are patented without models. A subject fully explained in our book.

What is the preliminary search?

Ans: The preliminary search is ordinarily the first step to help an inventor. Also fully explained in our book. Send for a copy today.

You may be able to do as well as others who have been successful. That only time can tell. But there is one thing you can do, and do now, without waiting on time. You can find out easily and quickly exactly what to do to protect yourself. In the 48-page book, "Patent Protection" shown on the opposite page, which will be sent to you FREE, we tell you what many other inventors have done, just what you yourself must do to make Application for a Patent, give you interesting facts about inventive history, show you 115 mechanical movements that inventors have used in working out ideas, and much more. Decide now to get a copy of this interesting book. Its facts can be worth much—yet they cost you nothing.

A New Book about Selling Inventions

There are two sides to every inventive success: The inventive side and the commercial side. A good invention poorly handled, can prove a failure commercially. An ordinary invention, properly handled, can be made a money-maker. In the special booklet, shown here, we give you some suggestions on "When and How to Sell an Invention"; practical hints on the commercial side of inventing. We'll send this new booklet along with the big 48-page book, "Patent Protection" illustrated on the next page. Use the convenient coupon to request your copies.



We Cordially Invite You to . . .

NOTE ★ ★

You may not be an Edison or a Kettering but still you may have a good idea

YOUR QUESTIONS ANSWERED! There are a lot of questions that the average man with an invention, or an idea for one, wants answered before he goes ahead. Here are a few of them that most inventors put up to us: How do the Patent Laws protect me? What easy steps can I take, without cost, to put myself in position to support my belief that I am the **first** man to think of **my invention**? Is a Patent worth the cost? Should I try to sell my invention before I have it Patented? Is there any

safe, business-like way to secure financial help? If I do apply for a Patent how shall I reach people who can market my invention? Can I protect and sell an improvement on some invention that has already been patented? These are but a few of the questions which usually confront the average man. **You need the answers! YOU CAN HAVE THEM, without cost, trouble, or delay.**

Our Business Is to Help You Write Us Today

For more than thirty-seven years, this firm has been helping men with an inventive turn of mind. We maintain a large staff of trained, experienced specialists — **Registered Patent Attorneys, Draftsmen, and Searchers** to help our clients secure all the protection to which they are entitled. Fees are reasonable. Deferred payments frequently arranged. Questions promptly answered. Write us frankly with absolute assurance that what you say will be treated with strictest secrecy. **But first send for the FREE BOOKS shown on these two pages.** They are filled with facts, pictures and suggestions. They tell you things about Patents, Inventions and Selling Inventions that we have learned in our long experience. **They may save you time, expense, EVEN LATER DISAPPOINTMENT.** Simply fill in the coupon or write us a confidential letter. No charge, no obligation. **Mail the coupon today.**

VICTOR J. EVANS & Co.

REGISTERED PATENT ATTORNEYS

Main Office: 700-M, Victor Building,
Washington, D. C.

Other Offices: 1007-N, Woolworth Bldg., New York
1445-N, Monadnock Bldg., Chicago
514-N, Empire Bldg., Pittsburgh
1010-N, Hobart Bldg., San Francisco
736-N, Security Bldg., Los Angeles

Send me FREE copies of your books, "Patent Protection" and "When and How to Sell an Invention." (Note: Same books supplied by any of branch offices listed above.)

Name.....

Street and No.....

City or Town.....

.....

.....



LEARN AUTO MECHANICS

in 8 weeks!

Earn \$35 to \$75 a week as an Auto Mechanic. Never in the history of the automotive business has there been such a demand for TRAINED men. 8 weeks training fits you for a job that's waiting for you or to open your own repair shop. Read what two McSweeney trained men have done. Hundreds of others can tell you facts equally interesting. Don't look for a job! TRAIN for it!

Farrell, Pa.

Dear Mac: Please forward me your catalog. I want it to add to my traveling souvenirs. I am working in a modern garage although I have been out of school only four weeks, thanks to McSweeney Training. My best regards to all. M. Klushauk

Rector, Ark.

Dear Mac: Just a few lines which might interest you. I left your school two years ago last May. Since I left I have not seen a day I could call "hard times." I have been working ever since I left and have averaged in my earnings \$173.00 a month, in spite of the hard times. Many thanks. Thos. J. Sharp

EIGHT WEEKS of Actual Shop Training

No books or lessons the McSweeney way. First you learn the "why" of everything you do; then under competent instructors, you DO the job. You work on real equipment and machines, with the real tools of the auto expert. In eight short weeks you are TRAINED to hold down a permanent BIG PAY job. Any man 16 to 50 can learn. Write today for New Low Tuition Offer.

Diesel Engines and Aviation Ground Course!

Diesel and Aviation coming fast! Prepare now for the wonderful opportunities of the future.

MONEY BACK GUARANTEE!

Eight weeks of intensive training, actual shop work with real tools on real equipment, qualifies you for a Big Pay Job. If not satisfied, your tuition will be refunded.

FREE Write today for Big Free Book on AUTOS. Get the facts about jobs; and Low Tuition Offers. Mailing the coupon does NOT obligate you. It obligates ME to tell YOU how you can train for Big Money in eight short weeks. Address Dept. 10-35,

McSWEENEY SCHOOLS

AUTOMOBILE—DIESEL—AVIATION

DETROIT, MICH. or KANSAS CITY, MO.

Write Our School Nearest You

McSweeney Auto and Aviation School,
Dept. 10-35, Detroit, Mich., or Kansas City, Mo.

Without cost or obligation, send me your Big FREE Book on Autos; also full information about your Low Tuition Offer.

Name.....

Street.....

Town..... State..... Age.....

When writing please mention Popular Mechanics

HOME-STUDY BUSINESS TRAINING

Your opportunity can never be bigger than your preparation. Prepare now and reap the rewards in earlier and larger success. Free 64-Page Books Tell How. Write now for book you want, or mail coupon with your name and address in margin today.

- | | |
|--|--|
| <ul style="list-style-type: none"> O Higher Accountancy O Mod. Salesmanship O Traffic Management O Law: Degree of LL.B. O Commercial Law O Industrial Mgm't O Banking and Finance O Stenotypy O Rail. Station Mgm't O Paper Salesmanship | <ul style="list-style-type: none"> O Business Mgm't O Business Corres. O Credit and Collection Correspondence O Modern Foremanship O Personnel Mgm't O Expert Bookkeeping O C. P. A. Coaching O Business English O Effective Speaking |
|--|--|

LA SALLE EXTENSION UNIVERSITY
Dept. 1164-R Chicago

BE A PASSENGER TRAFFIC INSPECTOR



We Hear of Good Openings Constantly
—You Can Qualify

Men—16 to 50—trained as Railway and Bus Passenger Traffic Inspectors are in constant demand. Simple, home-study course trains you; upon completion we help place you at up to \$134 per month, plus expenses, to start, or refund tuition. Splendid opportunities for the ambitious. Free Booklet. Standard Business Training Institute, Div. 211, Buffalo, N. Y.

ELECTRICAL ENGINEERING

A BROAD, basic, intensive course complete in one school year. Includes fundamentals of Refrigeration, Air-conditioning, Electronics. Approved by educators, endorsed by industry. 44th year. Catalog.



BLISS ELECTRICAL SCHOOL
121 TAKOMA AVE., WASHINGTON, D. C.

Be an ARTIST



MAKE \$50 TO \$100 A WEEK!

Many of our successful students are now making big money. Our simple methods make it fun to learn Commercial Art, Cartooning and Designing at home, in spare time. New low tuition rate. Write for big free book, "ART for Pleasure and Profit," today. State age.

STUDIO 1211, WASHINGTON SCHOOL OF ART
1115—15th ST., WASHINGTON, D. C.



Correspondence Courses in
RADIO and ELECTRICAL ENGINEERING

SPECIAL
Only
\$25

ELECTRICAL ENGINEERING covers complete electrical field. Most modern course. Very understandable. RADIO ENGINEERING. Ultra-modern course in radio, public address, photo-electric work. Trains you to be super-service man, real vacuum tube technician. Tuition ONLY \$25, either course. Deferred payment plan. WRITE TODAY for free copies of school catalog, student magazines, etc. LINCOLN ENGINEERING SCHOOL 805-Y So. 37th St., Lincoln, Nebr.

LEARN MECHANICAL DENTISTRY

SEND FOR
FREE BOOK



Special Tool Offer—Now!

Don't waste the best years of your life. Learn this money-making business in a few months, Day or Evening, and become independent. Big demand. Highly endorsed—oldest school. Practical training. Individual instruction. Easy terms. Employment Service. Write TODAY for FREE Catalog P → New York School of Mechanical Dentistry, 125 W. 31 St., New York



LEARN WATCH REPAIRING



AT HOME You can learn by our modern and original system of instruction every part of the Watch Repairing Trade at home. You can earn money while learning and prepare yourself for a well paying position or start in business after completing our course of instruction. Good watch repairers are in demand and generally earn very good salaries. For particulars apply to the Wisconsin School of Watch Repairing 524 E. Mason St., MILWAUKEE, WIS.

TELEVISION AND RADIO -- ARE YOUR OPPORTUNITY



...if you *ACT NOW*

Bigger opportunities than ever before are open to trained men in new fields of radio. Television broadcasting is now a reality and leaders of industry predict immediate commercialization will put thousands of sets in homes; thousands of new jobs for trained men will be created as Television sweeps the nation.

"Get in
on the
ground
floor"

Learn TELEVISION WITH RADIO

in "First National's" huge laboratories and studios, where young engineers are trained on the job—to fit the job—graduates qualify for First Class Government License—which is the "ticket" it takes to get a job—and are First National graduates getting the jobs? I'll tell the world they are.

only 6 months Training required

to qualify for your Government License. Then you are assigned to active duty in broadcasting, immediately getting valuable experience "on the job". You actually handle the control and transmitter of High-Fidelity Station W9XBY and Television Station W9XAL while training—

CONTROL ROOM
TRANSMITTER
TELEVISION
BROADCASTING
CAMERA-ACTION
STATION OPERATION

WRITE FOR FREE BOOK OF FACTS—Telling of big, genuine opportunities for First National Trained men—

FIRST NATIONAL TELEVISION
INCORPORATED
TRAINING DIVISION . . . KANSAS CITY, MO.

FREE
NEW BOOK
ON
TELEVISION



FILL OUT AND MAIL THIS COUPON TODAY

S. Q. NOEL, Pres., First National Television, Inc.
Dept. A-11, Power & Light Bldg., Kansas City, Mo.

Please send me immediately, without charge or obligation, your big, new book on Television—"Pictures On the Air"—completely illustrating Television methods, and giving full facts about big, new money-making opportunities in this career. I am ___ yrs. old.

NAME _____

STREET _____

TOWN _____

STATE _____

When writing to advertisers please mention Popular Mechanics

NOW FIX ANY MAKE OF

AUTO**SIX BIG AUTO BOOKS ALL SHIPPED FREE**

on approval; whether you want to qualify as garage owner, auto repair expert or merely wish to know how to keep your own car 100% efficient, look at these books—they are sent to you for free examination. This brand new edition has been prepared by a large group of America's greatest automotive engineers. Anybody who can read will understand them, for this great automobile encyclopedia is a veritable

gold mine of valuable facts. Take advantage of this offer now; send in the coupon for FREE examination. You don't pay us a penny, you don't obligate yourself to pay anything unless you decide to keep the books. Just tell us you want to see them and the full set of 6 great volumes, just off the press, will be sent to you! Read them, look them over and prove to your own satisfaction that one fact alone, which you will find in them, may save you an expensive repair, or help you to a better job.

**DIESEL ENGINES
AVIATION MOTORS
MOTORCYCLES
OUTBOARD MOTORS
MARINE ENGINES
TRACTORS
AUTOMOBILE RADIOS
ALL COVERED**

Very Latest Edition

Imagine books which are so new that every page is right up to date—wiring diagrams, construction details, service problems—are all right up to the minute. Nowhere else can you get as complete and timely information. Over a million dollars of resources have enabled us to give you the most authoritative books on the subject ever published. Everybody interested in automobiles in any way will welcome these books published by the world's largest publishers of Technical Cyclopedias (est. 1897) with agencies all over the world.

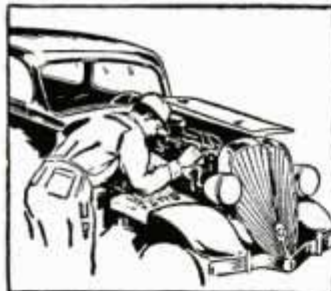
**Can You Fix It?**

Can you take out "play" in differentials? Can you kill the "shimmy" in steering? Can you reset TIMING? Can you put your finger on engine trouble without guessing or tinkering? Can you pull the starter off and fix it? Can you adjust and repair transmission, engine, rear axle, bearings?

These Books Tell How and tell you how to do any and every auto job right, the first time.

6 Big Volumes

Nearly 3,000 pages, over 2,000 illustrations, wiring diagrams, equipment charts, etc. De Luxe edition with gold-stamped flexible binding. Sent FREE for 10 days' use. If not wanted return express collect. If kept, send only \$2.00 after 10 days, then \$3.00 a month until special advertising price, \$24.80, is paid.

A Year's Consulting Membership FREE!

Privilege of consulting engineers of million-dollar American Technical Society for one year if you mail coupon immediately. We also include 2 extra books, "Service Shop Management" and loose leaf book of new diagrams.

SEND NO MONEY

AMERICAN TECHNICAL SOCIETY,
Drexel Ave. at 58th St., Dept. A819, Chicago, Illinois.

I would like to see the brand new 6-volume edition of your automobile books but without any obligation to buy. I will pay the few cents delivery charges only and will examine the books and return them at your expense in 10 days unless I like them, in which case I will send you \$2.00 then and only \$3.00 per month until the special price of only \$24.80 is paid. You are to include free, consulting membership certificate in the American Technical Society and the two extra volumes.

Name

Street

City State

Employer's Name

Employer's Address

Please give us, in addition, the name and address of one business man as reference.

When writing please mention Popular Mechanics

HOTEL TRAINING

—For Better Positions... Substantial Salaries—Classes Now Forming
Increasing opportunities for trained men and women in fascinating, nationwide hotel field. Qualify thru short, specialized, intensive courses in America's only exclusive hotel training institute. Come to Washington. Learn in four months on real hotel equipment. Study under expert instructors in \$200,000 specially designed institute. Enjoy the attractions of Washington while training. Day classes start Jan., Feb. National Placement Service



FREE of extra charge. Hundreds of graduates "making good" in Hotels, Resorts, Clubs, Apartment Hotels, Schools, Restaurants, Hospitals everywhere. Free Catalog gives full details—write for it now.
LEWIS HOTEL TRAINING SCHOOLS
Division RMT-340 Washington, D.C.

New JOBS for THOUSANDS in AIR CONDITIONING and REFRIGERATION

33rd Year
Get Free
"Prosperity
Booklet"

If you want steady work—all year 'round—good pay, or a business of your own, prepare NOW. Such ground-floor opportunities are rare. Learn at low cost right in your own home (or at our school in Chicago). Write for FREE "Prosperity Booklet."

CHICAGO TECHNICAL COLLEGE
P 300 Tech Bldg., 118 E. 26th St., Chicago

**BE A CARTOONIST**

AT HOME IN YOUR SPARE TIME under personal supervision of the famous cartoonist NORMAN MARSH creator of "DAN DUNN" appearing every day in big papers. Success—Fame—Real Money may be Yours when you learn Marsh's easy simple methods and secrets. Send name and six cents—stamps or coin—for details of MARSH'S Personal course. **ACT TODAY! MARSH CARTOON SCHOOL**
Chicago Daily News Bldg., Dept. 111, Chicago, Ill.

LEARN WATCHMAKING AND ENGRAVING BY OUR PROFIT-SHARING PLAN OUR GRADUATES SUCCEED

One of our Iowa students started in a very small way—now doing over \$30,000 a year. Another in Wisconsin, over \$10,000 the first year. Day or night classes. Call or write for FREE BOOK. Chicago School of Watchmaking, Dept. 4501, 155 N. Clark St., CHICAGO.

CRIME DETECTION SECRET SERVICE AND FINGER PRINTS

SECRET SERVICE BOOK FREE

For 30 Days Reading
No Money Down—Actual Crime Cases—
If You Act Quick!—We will send you this stirring book on Crime Detection, Secret Service and Identification Work for 30 days free reading. Send no money. If you decide to keep it, then send only \$1.00. If not, return it. **WRITE TODAY. Not sent to boys under 17 years of age.**
T. G. Cooke, Dept. 1358, 1920 Sunnyside Ave., Chicago

Learn Radio - 12 Weeks SHOP TRAINING FINANCE YOUR TUITION GET DETAILS of MY AMAZING OFFER!

Prepare for jobs in Radio Broadcast, Talking Pictures, Television, by twelve weeks of practical shop work in the great Coyne Radio Shops, on real machinery and equipment. You don't need advanced education or experience. Free Employment Service for life. Many earn while learning. Mail coupon today for free book which tells you how hundreds have become successful Radio men after taking my training and all details of my "Pay Tuition After Graduation" Plan.

H. C. LEWIS, Pres., COYNE RADIO SCHOOL
500 S. Paulina Street., Dept. 86-3H, Chicago, Ill.

Send Free Radio Book and facts. Tell how I can pay for my course on easy payment plan after I graduate.

Name

Address

Town State

Stop Throwing Away PROFITS!

DO YOUR OWN
Welding



Only
\$39.25
WITH DELUXE
ACCESSORIES

Now You Can Own
**FULL-SIZE
PROFESSIONAL
ELECTRIC
ARC
WELDER**

For Personal Or Shop Use— Or Go Into Welding Business For Yourself

Why throw away profits by sending welding jobs out? Now with the new, sensationally, low-priced Aladdin Electric Arc Welder at only \$39.25 with De Luxe Accessories, you can do your own welding and make money doing outside work besides! Now for the first time, inventors, laboratories, experimental and home work shops, repair and machine shops, garages, factories, etc. can own a powerful, efficient Electric Arc Welder that handles all kinds of welding—everything from fenders and light sheet metal to motor blocks and heavy castings—for less than one-fifth the price of any other equipment of its kind! Imagine! You just plug the Aladdin into any 110 or 220-Volt A. C. socket and do practically any welding job, right on the spot, often without removing the part to be welded. Ideal for all kinds of maintenance, production and experimental welding jobs.

BIG PRACTICAL MACHINE The Aladdin is not a toy or an experiment. It is a big, 100-pound, sturdily-built tool that welds iron, steel, aluminum, bronze and their alloys and does electric soldering and brazing. Uses standard welding rods. Controllable current—instantly adjusted. Costs only a few pennies an hour to use. New Principle makes amazing low price possible. Often returns its cost on first two or three jobs. Can be easily put in auto, truck or side-car and taken to outside jobs. Equipped with casters for moving around in shop. No experience or training needed to operate. Simple, complete instructions for doing all kinds welding jobs included. Aladdin is used by U. S. Government, Anaconda Wire and Cable Co., Eastman Kodak, Johns-Manville and hundreds of big companies.



**Finest Quality
DE LUXE
ACCESSORIES
With Every Welder**
Professional Helmet
Protects operator from sparks and welder's "sunburn."
ELECTRO-TITAN' ELECTRODE HOLDER
Specially designed for holding any size welding rods.
LEAD CABLES, CORD
Finest flexible quality—generous length, also carbon for soldering, brazing.
WELDING RODS
Generous Quantity
Special Shielded Welding Rods.

is used by U. S. Government, Anaconda Wire and Cable Co., Eastman Kodak, Johns-Manville and hundreds of big companies.

Get Amazing Details—FREE!

Send today for amazing details about Aladdin Electric Arc Welder at \$39.25 with De Luxe Accessories. Now you can own this highly efficient, high-power, PROFIT-MAKING, welding machine—factory tested and fully guaranteed—at a fraction of the price asked for others. Send now for full facts.

COMMONWEALTH MFG. CORP.
3785 Beechmont, Dept. L-12
Cincinnati, Ohio

MAIL THIS COUPON NOW!

Commonwealth Mfg. Corp., Dept. L-12.
3785 Beechmont, Cincinnati, Ohio
Please rush me at once all facts and details about Aladdin Electric Arc Welder at only \$39.25 with De Luxe Accessories.

Name.....
Address.....
Town.....State.....

When writing to advertisers please mention Popular Mechanics

INVENT

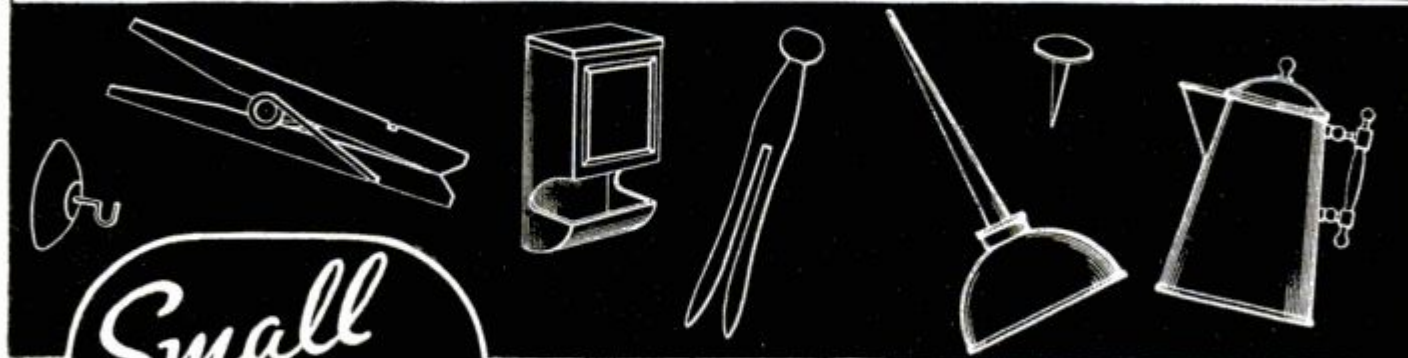

Small Ideas

**THAT HAVE
BUILT BIG
BUSINESSES**

IDEAS do not have to be complicated to be profitable when Patented. The 5c and 10c stores flourish on simple Patented products which are commercially successful. The zipper, safety pin, thumb tack, paper clip, collar button—all simple, yet familiar inventions—brought their inventors rich rewards. If you have a Patentable idea—act to protect it. Many of the most useful, widely popular, greatly profitable, and extremely successful inventions have been very simple ones. You have only to look at the devices we have pictured here to realize how a simple idea may become a utility bought by a hundred thousand or a million people soon after it is produced. Don't be afraid that the simplicity of your idea makes it valueless. The thing that you find so simple that you wonder why a thousand other people haven't already done it is often the invention worthwhile.

HOW OTHER INVENTORS GOT STARTED

The list of men who succeeded in invention with only a poor boy's start is a very long and noble one. Poverty, hardships, lack of friends, distance from the market—these could not hold back Bell, Edison, Eastman, McCormick, Whitney and others. Everyone cannot succeed. But every man can try. Courage, sacrifice, and hard work may bring you a measure of the success these men had. Lack of mechanical ability is not a serious draw-back. You can always get someone able to build a model, draw a detailed design, or otherwise materialize your idea for you. The big draw-back is discouragement.

Your idea for a practical article or an improvement upon an old one should be patented NOW. Frequently many of the thousands of applications filed in the U. S. Patent Office each year are for the same or almost the same idea. In such a case, the burden of proof rests with the last application filed. Sometimes a delay of even a few days in filing the application means the total loss of the patent. **LOSE NO TIME.**

The entire time of this large and experienced organization is devoted exclusively to patent and trade-mark cases. We know the rules and requirements of the Patent Office. We understand the technicalities of Patent Law. We can proceed in the quickest and safest ways in preparing an application for a patent covering your idea.

FREE

**The Biography of
George Eastman**

Views of the man who used Patent Protection to amass millions and give perfection to a new art—*Photography*—itself one of the greatest inventions.



CLARENCE A. O'BRIEN & HYMAN BERMAN

REGISTERED PATENT ATTORNEYS BEFORE U. S. PATENT OFFICE

70-X ADAMS BLDG.

WASHINGTON, D. C.

When writing to advertisers please mention Popular Mechanics

T O R S

Act Now TO PROTECT YOUR
IDEAS
WITH A U.S. PATENT

Send For **FREE BOOK**

If you have a new idea that is patentable—and want to secure for yourself your inventor's sole right to profit from the idea—you can't afford to lose time in securing the protection of a U. S. Patent. Other inventors may be working on the same idea right now. Should they develop this idea and file patent application before you do—the burden of establishing priority will be upon you. Our Big Book—"Patent Guide for the Inventor"—will tell you the quickest possible way to secure Patent Protection for your idea. SEND FOR IT TODAY!

The FIRST IMPORTANT STEP in SECURING A PATENT

—is to obtain the services of a Registered Patent Attorney. The U. S. Patent Office advises that you secure the aid of an experienced Registered Patent Attorney to prepare your statements. Establish the date of your invention as explained in our book and disclose your idea to him in correct form. He then makes a SEARCH of the Patent Office Records and reports to you on existing U. S. Patents which might bear on your invention, giving his opinion on the advisability of proceeding and filing formal application.

REASONABLE FEES—CONVENIENT TERMS.

Don't worry about finances. Our fees are very reasonable—we can arrange convenient terms of payment. It is our custom to permit clients to pay for our services in installments as the application progresses in our office. See our Big Book for fees in obtaining Patent. It explains our arrangements clearly. Send for it NOW!

Free Record of Invention Form

Use our FREE "Record of Invention" form to assist you in recording the descriptive outline of your ideas and to establish the date of your invention. With it you can make a rough sketch of your idea and have it witnessed in a manner of value to you as evidence should occasion arise.

**TEAR OFF
AND
MAIL
NOW!**

COUPON

NAME _____

ADDRESS _____

(Please write or print plainly)

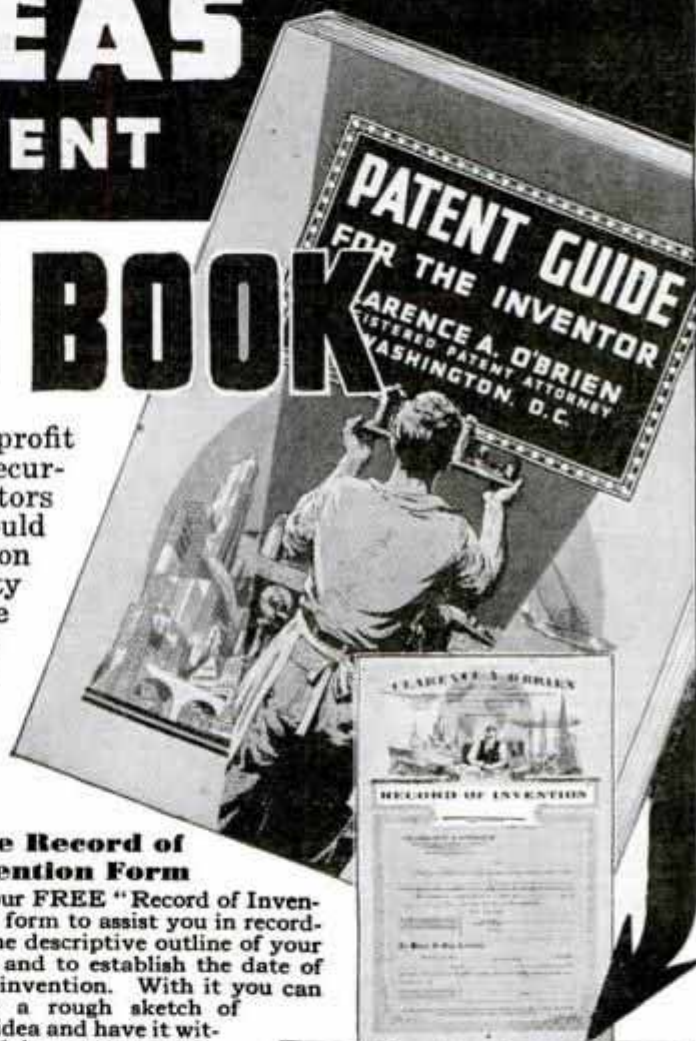

**CLARENCE A. O'BRIEN
and HYMAN BERMAN**

Registered Patent Attorneys

70-X Adams Bldg.

WASHINGTON, D. C.

Please send me at once your Big Free 48-Page Book, "Patent Guide for the Inventor" and your Specially Prepared "Record of Invention" form. Also George Eastman Biography, "Inventor and Business Man." This request does not obligate me.

PATENTS

Booklet Free Highest References
Promptness Assured Best Results

Send drawing or model.

ALL BUSINESS GIVEN PROMPT AND PROPER ATTENTION

Listed Patent Lawyer in the latest editions of the Rand-McNally Directory of Bankers and Bank-Recommended Attorneys, published by Rand-McNally & Co., Chicago, Ill.; The Baggott & Ryall Directory of Guaranteed Attorneys, published by Legal Directory Corporation, Boston, Mass.; Flugel's Law List, published by Legal Directory Publishing Co., St. Louis, Mo.; American Lawyers Annual, Cleveland, Ohio; Bankers Service Legal Directory, Bankers Service Co., Boston, Mass.; Eyre's Law List, 9 Park Place, New York City, and the Central Guarantee Co., Bankers and Lawyers Directories, Empire State Bldg., New York City.

WATSON E. COLEMAN,
REGISTERED PATENT LAWYER

Victor Building, 724 Ninth Street, N. W.,
WASHINGTON, D. C.

INVENTORS PATENT YOUR IDEAS SEND FOR FREE BOOK



HOW TO OBTAIN A PATENT

Written by a Former Member of the Examining Corps (1922-24) of the U. S. Patent Office. If you want to profit by your idea, you should take steps to apply for a U. S. Patent at once. Your first step is to get this Free Book. This interesting illustrated book contains valuable information you should have. It tells you fully how to obtain a patent on your idea in the quickest way. With this Free Book you will also receive a "Record of Invention" form on which you can easily record your idea. Personal and Confidential Service: Your case will be personally handled only by a Registered Patent Attorney who is also a Former Member of the Examining Corps of the U. S. Patent Office. All communications confidential.

MAIL COUPON TODAY for FREE PATENT BOOK and RECORD OF INVENTION Form.

CARL MILLER
REGISTERED PATENT ATTORNEY
FORMER MEMBER EXAMINING CORPS U. S. PATENT OFFICE

1638 Woolworth Bldg., Dept. 116A, New York City
MILLER BUILDING, Dept. 116A, WASHINGTON, D. C.
Please send me your Free Book, "How to Obtain a Patent," and your "Record of Invention" form.

NAME.....

ADDRESS.....

PATENTS—TRADE MARKS

All inventions submitted held confidential and given personal attention by members of the firm.
Form, "Evidence of Conception" and instructions,
"How to Establish Your Rights"—FREE!

LANCASTER, ALLWINE & ROMMEL
Patent Law Offices

412 Bowen Bldg. Washington, D. C.

NEURITIS

Relieve
Pain In 9
Minutes

To relieve the torturing pain of Neuritis, Rheumatism, Neuralgia or Lumbago in 9 minutes, get the Doctor's Prescription **NURITO**. Absolutely safe. No opiates, no narcotics. Does the work quickly—must relieve your worst pain in nine minutes or your money back at Druggist's. Don't suffer. Use guaranteed **NURITO** today.

INVENTORS PATENT YOUR IDEAS

Get this FREE Book

Protect the future profits from your idea by securing a U. S. Patent. Delays are often dangerous. I give prompt and personal attention to your case—nothing is entrusted to unskilled assistants. The Patent Office itself urges you to select a Competent Registered Patent Attorney in order to protect your interests properly. Therefore, before doing anything else, send for my NEW FREEBOOK and get the full facts, and with it I will send you my FREE "Record of Invention" form. All correspondence strictly confidential. Mail Coupon TODAY



L. EDWARD FLAHERTY
REGISTERED PATENT ATTORNEY

707 International Building WASHINGTON, D. C.

Please send immediately your FREE book and Record of Invention Form.

Name.....

Address.....

City..... State.....

New Ideas now Salable Before Patenting

Practical, useful inventions may now be safely marketed without patenting expense. Write for proof that we successfully sell both patented and unpatented inventions.

Chartered Institute of American Inventors
Dept. 4, Barrister Building, Washington, D. C.

INVENTORS who derive largest profits know and heed certain simple but vital facts before applying for patents. Our book, Patent-Sense, gives those facts; sent free. Trade Marks—Copyrights.
LACEY & LACEY, Est. 1869, 635 F St., N. W., Dept. 5, WASHINGTON, D. C.

ALBERT E. DIETERICH
REGISTERED PATENT ATTORNEY
512 B Colorado Building, WASHINGTON, D. C.
Booklet on Patents sent free

To PROTECT YOUR INVENTION—Use this coupon, NOW

Delays are dangerous and may be very costly. My personal service assures prompt action, strict confidence, and a minimum of expense. I suggest that you send me a model or drawing, or sketch and description of your invention, and \$5.00. I will make a search and report

promptly as to its patentability and send you a copy of my 72-page booklet. Or, if you prefer to read my booklet first, mail the attached coupon at once. I will also send my "Record of Invention" form. (Over 38 years experience as a Registered Patent Attorney.)

L. F. Randolph, 302-D Victor Bldg., Washington, D. C.

Please send me at once, free of charge, your 72-page booklet and "Record of Invention" form.

Name.....

Address.....

A PERSONAL CONFIDENTIAL PATENT SERVICE—



FREE!

New Kind of MOVIE Shows CHARLES ATLAS in ACTION

It's a real inspiration to watch the magnificent body of Charles Atlas in action. As the pages flick over—like magic—the "movie" comes to life! 60 pages of clear, unretouched "moving" pictures. Be the first to have one! Mail coupon NOW!

See the Giant Muscles Ripple Over His Amazing Body!

NOW you can WATCH "The World's Most Perfectly Developed Man" go through his paces. See him flex those mighty muscles on his 17-inch biceps! Look at that enormous 47-inch chest expand. Boy! What a build! Find out, with your own eyes, what Dynamic Tension has done for him—what it can do for you. Get this fascinating "new kind of movie" of Charles Atlas in action. Mail coupon below. Act promptly, as supply is limited and this offer may be withdrawn at any time.



STERLING SILVER CUP GIVEN AWAY

Stands 14 inches high on black mahogany base. Engraved with winner's name. I will give it to pupil who makes most improvement in development in next 3 months. Therefore, **everyone** has an equal chance!

I'll Prove—in Even the First Seven Days—I Can Make YOU a New Man!

I used to weigh only 97 pounds; a sickly scare-crow. Then I discovered Dynamic Tension — my famous method of body-building. It changed my life — gave me the body you see here—twice won for me the title, "The World's Most Perfectly Developed Man"! What it did for me—

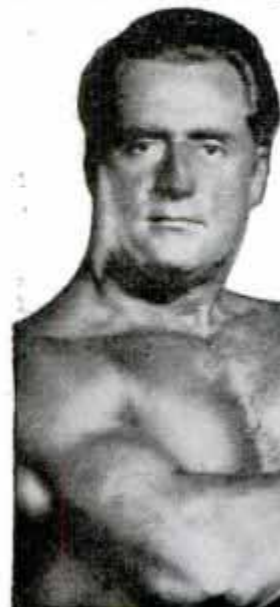

and for hundreds of other fellows—it can now do for YOU, too. You'll see, in even the first 7 days, why I can make you a NEW MAN—with big muscles, smashing strength, the glowing health that resists sickness, ends pimples, constipation and other troubles. It's fun to build a husky body my Dynamic Tension way—at home, in spare time, in the privacy of your room. And I haven't any need for contraptions that might strain your heart or other vital organs. I don't dose you or doctor you. Dynamic Tension is all I need. It's the natural, tested method for developing real men inside and out. It distributes added

CHARLES ATLAS

Holder of the title: "The World's Most Perfectly Developed Man" won in open competition in the only National and International Contest held during the past fifteen years.

pounds of powerful muscles over your body, gets rid of surplus fat, and gives you the vitality, strength and pep that win you the admiration of every woman and the respect of any man.

Get This FREE Book

Mail coupon for your "movie" of me in action. There is no charge for the "movie" itself. Merely enclose with the coupon 10c (postage stamps accepted) to cover my actual expense of postage, packing and shipping. That is all. And there is no obligation of any kind. I will also send you FREE my book, "Everlasting Health and Strength." It tells all about my Dynamic Tension method and how it has made big-muscled men out of run-down specimens. See, from actual photos, how I have developed my pupils to my perfectly balanced proportions. Don't be only half the man you CAN be. Find out what I can do for you. Show me you're a man of action. Address me personally. Mail coupon (or letter) TODAY! CHARLES ATLAS, Dept. 8L, 115 East 23rd Street, New York, N. Y.



CHARLES ATLAS, Dept. 8L, 115 East 23rd Street, New York, N. Y.

I want the proof that your system of Dynamic Tension will make a New Man of me. Send me your FREE Book, "Everlasting Health and Strength."

I enclose 10c merely for postage and packing (postage stamps accepted). So also send me FREE your "new kind of movie," 60 "moving" pictures showing you in action.

Name.....

Address.....

City..... State.....

YOU CAN REPEAT ALMOST EVERY EXPERIENCE IN LIFE

—EXCEPT

Life - itself



TODAY is life. Tomorrow is a hope. Yesterday is a dream. Nothing is so dead as a day that has passed. Only the trailing clouds of memory remain.

One *today* upon another *today*—how quickly a decade is built! Youth approaches manhood in high heart, embraces maturity as the period of his conquest, then “remembers with a sigh the days that are no more.”

So life goes—like that. NOW is the only opportunity. NOW is the moment of success. NOW men decide—NOW men win or fail.

Are you one of the men who are wondering today what will happen to them tomorrow? Then remember this: *If you take care of today, tomorrow will take care of itself.* And one of the most important safeguards you can take is to be certain your *training* is modern . . . that you are adequately equipped to master the problems of 1937. Today, in almost every line of human endeavor, ambitious men are modernizing their training by spare-time study of International Correspondence Schools Courses. Their action is a guide to you—and NOW is the time to act! Complete information on any subject in which you are interested will be sent without cost or obligation. The coupon is for your convenience. Return it today.

INTERNATIONAL CORRESPONDENCE SCHOOLS

Box 5640-H, Scranton, Penna.

Without obligation, please send full particulars about the subject before which I have marked X:

TECHNICAL AND INDUSTRIAL COURSES

- | | |
|--|---|
| <input type="checkbox"/> Architect | <input type="checkbox"/> Diesel Engines |
| <input type="checkbox"/> Architectural Draftsman | <input type="checkbox"/> Aviation Eng. <input type="checkbox"/> Auto Mechanic |
| <input type="checkbox"/> Building Estimating | <input type="checkbox"/> Plumbing <input type="checkbox"/> Heating |
| <input type="checkbox"/> Contractor and Builder | <input type="checkbox"/> Air Conditioning <input type="checkbox"/> Refrigeration |
| <input type="checkbox"/> Structural Draftsman | <input type="checkbox"/> Steam Engineer |
| <input type="checkbox"/> Structural Engineer | <input type="checkbox"/> Steam Electric Engineer |
| <input type="checkbox"/> Electrical Engineer | <input type="checkbox"/> Marine Engineer |
| <input type="checkbox"/> Electric Lighting | <input type="checkbox"/> Civil Engineer <input type="checkbox"/> Highway Engineer |
| <input type="checkbox"/> Welding, Electric and Gas | <input type="checkbox"/> Bridge Engineer |
| <input type="checkbox"/> Reading Shop Blueprints | <input type="checkbox"/> Bridge and Building Foreman |
| <input type="checkbox"/> Telegraph Engineer | <input type="checkbox"/> Surveying and Mapping |
| <input type="checkbox"/> Telephone Work <input type="checkbox"/> Radio | <input type="checkbox"/> R. R. Locomotives <input type="checkbox"/> Air Brakes |
| <input type="checkbox"/> Mechanical Engineer | <input type="checkbox"/> R. R. Section Foreman |
| <input type="checkbox"/> Mechanical Draftsman | <input type="checkbox"/> R. R. Signalmen |
| <input type="checkbox"/> Machinist <input type="checkbox"/> Toolmaker | <input type="checkbox"/> Chemistry <input type="checkbox"/> Pharmacy |
| <input type="checkbox"/> Patternmaker | <input type="checkbox"/> Coal Mining |
| <input type="checkbox"/> Foundry Practice | <input type="checkbox"/> Navigation |
| <input type="checkbox"/> Sheet Metal Worker | <input type="checkbox"/> Cotton Manufacturing |
| <input type="checkbox"/> Boilermaker | <input type="checkbox"/> Woolen Manufacturing |
| <input type="checkbox"/> Heat Treatment of Metals | <input type="checkbox"/> Agriculture <input type="checkbox"/> Fruit Growing |
| <input type="checkbox"/> Management of Inventions | <input type="checkbox"/> Poultry Farming |

BUSINESS TRAINING COURSES

- | | |
|--|--|
| <input type="checkbox"/> Business Management | <input type="checkbox"/> Lettering Show Cards <input type="checkbox"/> Signs |
| <input type="checkbox"/> Industrial Management | <input type="checkbox"/> Stenography and Typing |
| <input type="checkbox"/> Traffic Management | <input type="checkbox"/> Civil Service <input type="checkbox"/> Mail Carrier |
| <input type="checkbox"/> C.P. Accountancy | <input type="checkbox"/> Railway Mail Clerk |
| <input type="checkbox"/> Bookkeeping | <input type="checkbox"/> Grade School Subjects |
| <input type="checkbox"/> Secretarial Work | <input type="checkbox"/> High School Subjects |
| <input type="checkbox"/> Cost Accountant | <input type="checkbox"/> College Preparatory |
| <input type="checkbox"/> Salesmanship <input type="checkbox"/> Advertising | <input type="checkbox"/> First Year College Subjects |
| <input type="checkbox"/> Service Station Salesmanship | <input type="checkbox"/> Illustrating <input type="checkbox"/> Spanish |
| <input type="checkbox"/> Business Correspondence | <input type="checkbox"/> Cartooning <input type="checkbox"/> French |

DOMESTIC SCIENCE COURSES

- | | |
|---|--|
| <input type="checkbox"/> Professional Dressmaking and Designing | <input type="checkbox"/> Millinery |
| <input type="checkbox"/> Home Dressmaking | <input type="checkbox"/> Foods and Cookery |
| <input type="checkbox"/> Advanced Dressmaking | <input type="checkbox"/> Ten Room and Cafeteria Management, Catering |

Name..... Age.....
 Address.....
 City..... State.....
 Present Position.....

If you reside in Canada, send this coupon to the International Correspondence Schools Canadian, Limited, Montreal, Canada

When writing please mention Popular Mechanics

Cheaper HEAT Without COAL



EARN \$60 A WEEK! Write for FREE Burner of brand protected territory

New Invention Fits Any Stove or Range — 30 Days Free Trial
 Remarkable invention burns 96% air, 4% of a cheap variety of oil obtainable everywhere. Does away with coal, wood, ashes, dirt and drudgery. Clean, silent, quick, like gas heat. 3 times hotter than coal and cheaper. Temperature controlled. No more getting up on bitter cold, wintry mornings. Many automatic features. No gas or electricity needed. Safe as any ordinary kitchen range. Easy to install—no damage to stove—simply sits in firebox of any stove, range, heater or furnace. Costs just a few cents a day to operate. TRY 30 DAYS AT OUR RISK. Low introductory price and 30-day trial. Write for FREE CATALOG. AGENTS and spare time workers: Oil heat saves money this year; people buy to save. Write for free burner offer that starts you in business for yourself. Act NOW! Listed as approved by Nat'l. Board of Fire Underwriters. BRIGHAM OIL BURNER CO., 2927-M Clark Ave., St. Louis, Mo.

BE A TRAINED AUTO-DIESEL EXPERT *Learn AT HOME*

PREPARE NOW for rich new fields of opportunity in this fast-growing industry. Diesel-Trained Men needed for trucks, buses, tractors, farm power and lighting plants. Practical, easy, spare-time training plan offers quick way to good jobs at good pay, or a profitable auto repair business of your own. Learn from the pioneer automotive home-study school. Write today for Free AUTO - DIESEL Book and pay-as-you-learn offer.

EARN BIG MONEY SEND FOR FREE BOOK!

MOTOR INSTITUTE of AMERICA 4554 Broadway, Dept. L-11, Chicago, Ill.

Be an ELECTRICAL EXPERT *Learn to Boss Big Jobs*

No "hard times" in Electricity—the Big Pay Field. Thousands of new Experts needed for present and future activity. Boulder Dam—"TVA"—other government electrical projects soon ready. Start Now. Earn while learning at home. Easy. Low Cost. 100,000 men successfully trained. Write for FREE BOOK. Learn to earn \$35 to \$75 a week.



L. L. Cooke School of Electricity, Dept. 18, 2150 Lawrence Ave., Chicago



Learn Public Speaking

At home—In spare time. Many overcome "stage-fright," gain self-confidence, and increase their earning power, through ability to sway others by effective speech. Write for free booklet, *How to Work Wonders With Words* and requirements.

NORTH AMERICAN INSTITUTE, Dept. 1358 3601 Michigan Avenue Chicago, Illinois



If you act quick!—we will send postpaid—for 30 days free reading—new 89 page Voice Book disclosing startling VOICEFACTS that may save hundreds of dollars to every man or woman seeking a strong, rich voice for either singing or speaking. 30 days free reading—then send \$1.00. Otherwise, return it—that's all! Prof. E. Feuchinger Studio 1358 64 E. Lake St., Chicago

MAIL FOR FREE INFORMATION

BEDFORD YMCA TRADE SCHOOL

1117 Bedford Ave., Dept. PM-42 Brooklyn, New York City, N. Y.

- | | |
|--|--|
| <input type="checkbox"/> Auto Mechanic | <input type="checkbox"/> Talking Pictures |
| <input type="checkbox"/> Aviation Mechanic | <input type="checkbox"/> Welding |
| <input type="checkbox"/> Aeronautical Engineering | <input type="checkbox"/> Machine Shop |
| <input type="checkbox"/> Refrigeration | <input type="checkbox"/> Diesel Engineering |
| <input type="checkbox"/> Oil Burner | <input type="checkbox"/> Sign Painting |
| <input type="checkbox"/> Air Conditioning | <input type="checkbox"/> Window Display |
| <input type="checkbox"/> Electrical | <input type="checkbox"/> Radio and Television Mechanic |
| <input type="checkbox"/> Architectural-Mechanical Drafting | <input type="checkbox"/> Armature Winding |
| <input type="checkbox"/> Diesel Engines | |

Name.....
 Address.....



Give Me 5 Hours and I'LL GUARANTEE to make you a GOOD DANCER!

Good dancers "fit in" with any crowd. They are in demand, popular, interesting, sought after. Their manner is charming, their assurance winning.

By **ARTHUR MURRAY**
World-Famous Dance Authority

GOOD dancers have great fun, healthful, invigorating exercise that thousands of doctors recommend. They make friends readily, make valuable contacts.

You can easily become a smart, accomplished dancer, do the latest steps gracefully, confidently, with all the swing and pep of youth! For the amazing method I have perfected of teaching you by mail is so simple, yet thorough, that you can learn any of the latest steps in one evening right in your own home, with or without music or a partner!

Learn Quickly, Easily, AT HOME

You start at the very beginning with my remarkably simple lessons and master every step and variation from the waltz to the very newest smart steps now so socially popular.

And you do it in the privacy of your own home, where there's no one to detract your attention, to keep you from concentrating on learning. You practice whenever you want to, at regular intervals or in spare time. No expensive private teacher to pay. Almost before you realize it, you will be a fine

Introductory Course Now Only \$1⁰⁰

—Teaches Whole Family

How to Lead—Correct Common Faults—Overcome Stiffness and Heaviness Through Balance Control—Gain Confidence, Self-Assurance—Develop Grace Through Dance Exercises. Correct Dancing Position. Secret of Following Any Partner. Special Instructions for Beginners. Basic Steps for Men and Women. Ballroom Etiquette. Easy Popular Steps of Fox Trot and Waltz—and many other pointers on how to become a popular partner and fun to dance with.

dancer, holding your own anywhere, dancing with all the grace, poise, and assurance of an experienced dancer!

INTRODUCTORY COURSE NOW ONLY \$1.00

Through my amazingly simple method I have taught many thousands how to become smart, up-to-date dancers. They don't stay at home now, but go out and have great fun dancing with other finished dancers, making friends, knowing what it means to be genuinely popular.

You, too, can become a good dancer through my easy method. I'm so sure you can that I have decided to offer you my *Introductory learn-at-home course for only \$1.00!*

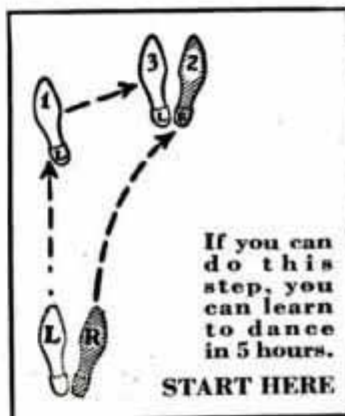

5 DAYS' TRIAL

Just mail the coupon with \$1.00. My Introductory course will be mailed at once. Use it 5 days. Practice the steps. Note how easily and quickly you can become a finished popular dancer the Arthur Murray way.

Do it today! If, at the end of 5 days, you are not absolutely delighted with results, return the course and your money will be promptly refunded.

That's how sure I am you can become a good dancer through my simple, thorough course. Clip and mail coupon NOW: Arthur Murray, Studio 233, 7 East 43rd St., New York City, N. Y.

**ARTHUR MURRAY, Studio 233
7 East 43rd Street, New York City, N. Y.**

To prove that I can learn to dance at home, you may send me your Introductory course for only \$1.00 enclosed. I understand that if not delighted I may return the course within 5 days and my money will be refunded.

Name

Address

City State

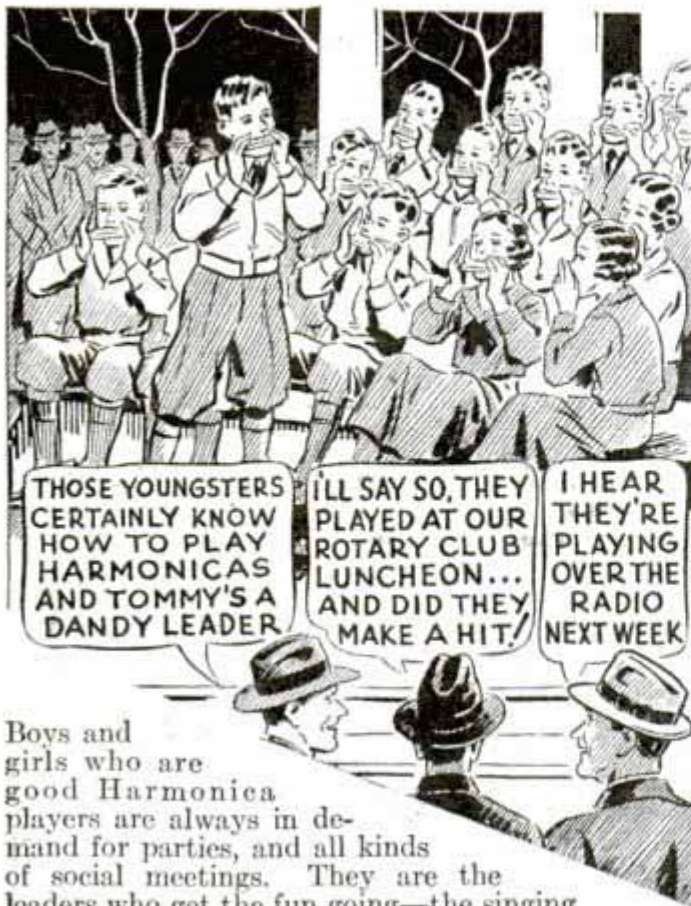

Boys and girls who are good Harmonica players are always in demand for parties, and all kinds of social meetings. They are the leaders who get the fun going—the singing and dancing that make the party “peppy”—the ones that form Harmonica Bands that play at school functions and community meetings. More and more boys and girls are realizing how much fun they miss if they are left out of these groups because they don't play the Harmonica.

NEW INSTRUCTION BOOK MAKES LEARNING TO PLAY THE HARMONICA EASIER THAN EVER

The New Hohner Instruction Book, “Harmonica Playing Made Easy,” is the simplest and easiest Instruction Book ever prepared for the Harmonica. It takes you step by step from the correct way to blow each single note, right up to where you play complete selections. A number of old time popular songs arranged for the Harmonica are included in the book. Also tells how to form a Harmonica Band. Just send in the coupon below for a Free Copy.

ALL FINE PLAYERS USE HOHNER HARMONICAS

Practically all the expert players you hear on the stage or over the radio use Hohner Harmonicas, because they are true in pitch, accurate in tone, and sturdy in construction. So be sure to ask your dealer for a Hohner Harmonica—“the world's best.”

M. HOHNER, Inc., 351 Fourth Ave., New York

HOHNER HARMONICAS

M. HOHNER, Inc., Dept. 990L,
351 Fourth Ave., New York City.
Please send me your new Instruction
Book.

Mail Coupon for

FREE

Illustrated
Harmonica
Instruction Book

Name

Address

City State

Address Canadian inquiries to Hough & Kohler, Ltd., 468 King
St. W., Toronto.

STAMPS and COLLECTING

(Continued from page 20A)

ing process. There will be a few mishaps when soaking the first lots, for some ink is soluble in water, some changes color when wet, and some gum will not dissolve. A little salt added to the soaking water will tend to set the color in some red stamps which “bleed,” and a little vinegar will loosen the gum.

Stamps printed in fugitive and changeable colors may be freed of paper by placing them face up on wet blotters. A difficult combination occurs in some British colonial stamps printed in soluble colors upon a chalk-surfaced paper, and which are provided with an almost insoluble gum. These cannot be soaked without losing the design, and paper must be removed by moistening from the back. To prevent curling, place the stamps face up on a sheet of celluloid and dry under pressure. Many stamps may be soaked in hot water but it is best to use cool water when handling unknown varieties.

Recent articles about rotary intaglio stamps, such as the current low values of Great Britain, call attention to size variations which occur from time to time. Since the process by which the stamp design is transferred from the die to the copper printing cylinder is photographic, it is difficult to set the step and repeat camera so a duplicate plate made later will not show a variation in the stamp size.

Similar results were found in the rotary offset United States stamps issued in 1918 and 1920. In the first two plates made for the three-cent value, the stamp designs measured nineteen by twenty-two millimeters, which closely approximated the size of the regular flat-plate engraved stamps, but in later plates the size was progressively reduced until the stamps finally measured about eighteen and one-half by twenty-one and one-half millimeters. The size variations in the rotary press line engraved United States stamps are due to other causes.

Recent Issues and Discoveries

The new stamps made available to collectors recently include many interesting and beautiful designs. The sale of stamps

(Continued to page 70A)

Only MIDWEST GIVES YOU PUSH BUTTON TUNING

plus Exclusive New
ELECTRIK-SAVER
for 1937

*Doubles
World-Wide
Radio Enjoyment
and Slashes
Radio Current Bills
in Half!*



PUSH BUTTON TUNING
Finger tip tuning is made possible with the Midwest Automatic Push Button Tuning System. Doubles radio enjoyment.



ELECTRIK-SAVER

This exclusive feature cuts radio wattage consumption 50%... enables 18 and 16-tube Midwests to consume no more current than ordinary 7-tube radios and to operate on voltages as low as 50 volts.

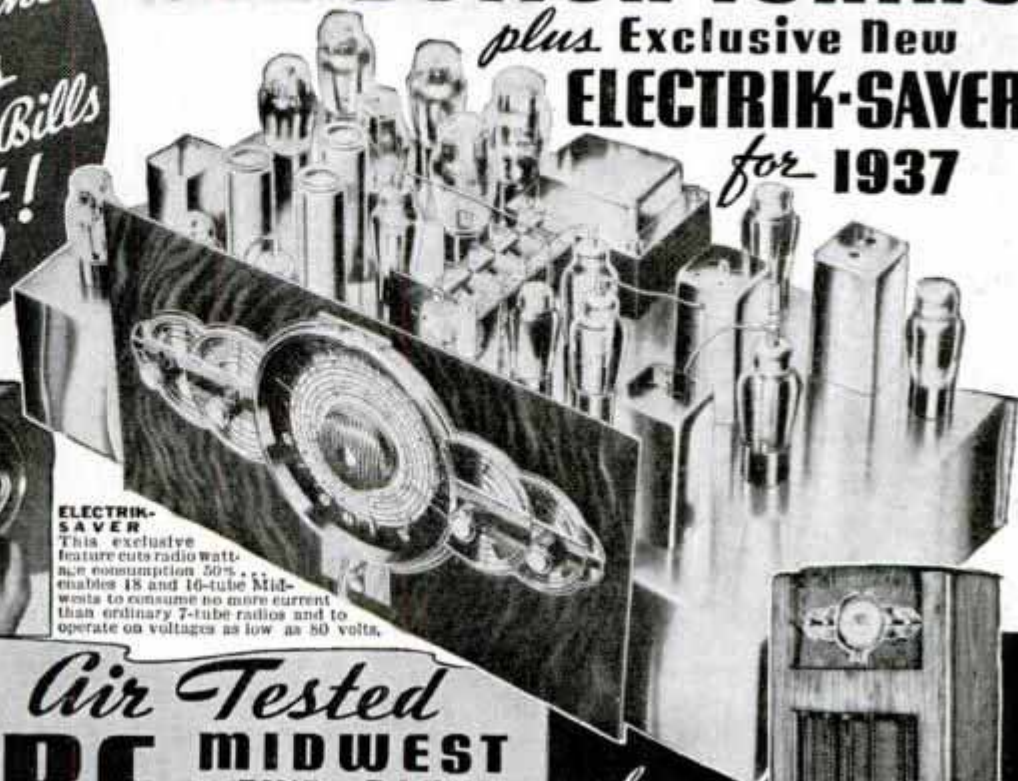

NEW 1937 Air Tested 16-TUBE MIDWEST FIVE-BAND RADIO

SAVE UP TO 50% DIRECT FROM FACTORY

NO middlemen's profits to pay! See for yourself that Midwest offers you greater radio values—enables you to buy the more economical factory-to-you way that scores of thousands of radio purchasers have preferred since 1920. Never before so much radio for so little money! Why pay more? The broad Midwest Foreign Reception and Money-Back Guarantees insure your satisfaction. You get 30 days FREE trial in your own home!

Once again, Midwest demonstrates its leadership by offering the world's most powerful and most beautiful ALL-WAVE 16-tube, 5-Band Radio. A startling achievement, it makes the whole world your playground. Powerful Triple-Twin tubes (two tubes in one!) give 18-tube results. This advanced radio is a master achievement, a highly perfected, precisely built, radio-musical instrument that will thrill you with its marvelous super performance...glorious crystal-clear "concert" realism...and magnificent foreign reception. The Dual Audio Program Expander gives a living, vital realistic quality to voice and musical reproduction.

74 ADVANCED 1937 FEATURES

This Super Deluxe Midwest is so powerful, so amazingly selective, so delicately sensitive that it brings in distant foreign stations with full loud speaker volume on channels adjacent to powerful locals. Scores of marvelous Midwest features, many of them exclusive, make it easy to parade the nations of the world before you. You can switch instantly from American programs... to Canadian, police, amateur, commercial, airplane and ship broadcasts... to the finest and most fascinating foreign programs.

With a Midwest, the finest entertainment the world has to offer is at your command. It is preferred by famous orchestra leaders, musicians, movie stars and discriminating radio purchasers everywhere. You can order your Midwest "Air-Tested" radio from the new 40-page catalog with as much certainty of satisfaction as if you were to come yourself to our great factory. (It pictures the beautiful 1937 radios... in their actual colors!) You pay as little as \$5.00 down! Three iron-clad guarantees protect you: (1) A Foreign Reception Guarantee — (2) Absolute Guarantee of Satisfaction — (3) One-Year Warranty.



**MIDWEST USES LESS
CURRENT THAN AN
ORDINARY LIGHT BULB**

Fill in coupon
NOW, and mail
T O D A Y!



MY MIDWEST
NOT ONLY MEETS
BUT SURPASSES MY
MOST CRITICAL
STANDARDS.
Bing Crosby



NO SET THAT I HAVE EVER
OWNED HAS BROUGHT
IN FOREIGN RECEPTION
SO CONSISTENTLY AND
SATISFACTORILY.
Gloria Stuart



only
\$49.95



WITH
GIANT THEATRE-SONIC SPEAKER
(LESS TUBES)

TERMS AS LOW AS \$5.00 DOWN

Only **MIDWEST** Gives You
16 TUBES • 5 WAVE BANDS
9 TO 2200 METERS • ELECTRIK SAVER

• PUSH BUTTON TUNING •
• AUTOMATIC AERIAL ADAPTION •
**DOUBLE
PUSH-PULL AUDIO**

30 DAYS FREE TRIAL!

MAIL COUPON TODAY for
Free 30-DAY TRIAL OFFER
and **40-PAGE FOUR-COLOR Free CATALOG**

MIDWEST RADIO CORPORATION
Dept. E-15, Cincinnati, Ohio
Without obligation on my part, send me your new FREE catalog and complete details of your liberal 30-day FREE trial offer. This is NOT an order.

Special offer and prices prevail only when dealing direct with factory/retail.

Name _____
Address _____
Town _____ State _____

MIDWEST RADIO CORP.

DEPT. E-15
Established 1920

CINCINNATI, OHIO, U.S.A.
Cable Address MIRACO...All Codes

When writing to advertisers please mention Popular Mechanics



There's Quicker, Bigger MONEY for YOU-in POULTRY

Earn \$1,000 to \$2,500 a Year or Have a Business of Your Own!

Whether you want a job at good pay or a highly profitable business of your own—the Poultry Industry offers you more than any other. There's a shortage of poultry meat and eggs—a shortage of trained poultrymen. I'll train you quickly at home—to fill a good job in Poultry—and our FREE Students' Employment Dept. will help you get one!

Spare Time or Full Time YOU CAN Cash-in BIG
No matter where you live—city, town or country—or what you do now, my proved methods will assure your success right from the start. I'll help you make from \$1,000 to \$2,500 a year and UP! And, if you choose to start your own business, I'll show you how to make your tiny investment multiply itself automatically. What I've done for thousands of others—I can do for you.

FREE Book Shows the Way to Big Pay and BIG Profits

Mail coupon below TODAY—for my Big NEW FREE Book, "How to Raise Poultry for Profit." My forty years of experience are yours. The Poultry Industry needs YOU. You need my book. Get it—and get in line for the BIG Money that's waiting for you in POULTRY.



Learn to EARN MORE

IT'S EASY WITH THE RIGHT BOOKS TO HELP YOU

To help you on your job; to prepare for a better job; to develop a spare-time extra money income—make use of these books. Thousands have profited by them.

Send No Money!

BOOKS SENT C. O. D., ANYWHERE IN U. S.

Order by post card or letter. Send name and address and list of books wanted. Pay postman on delivery, plus few cents postage. Outside U. S. and possessions remit with order. Add 10 cents per book for postage.

POPULAR MECHANICS PRESS

Room 1136C 200 East Ontario Street Chicago

SELECT FROM THIS LIST

- AIR CONDITIONING**
Live Field; Great Future..... \$3.50
- AUTO ENCYCLOPEDIA**
The Famous Dyke's Latest Edition..... \$6.00
- 110-V. GENERATORS**
Made From Old Auto Units..... \$1.00
- BIRD HOUSES**
Build to Sell; Easy Designs..... \$1.00
- BOAT BOOK**
Power, Sail, Rowing, Paddle Plans..... \$3.00
- BOY MECHANIC**
Hundreds Things Boys Can Make..... \$2.00
- BUILT-IN FURNITURE**
Take Orders, Make Money!..... \$2.50
- CARPENTRY**
Practical. Complete. 436 Pages. 1936 Edition..... \$2.00
- CHEMISTRY, PRACTICAL**
Make Hundreds Things Daily Use..... \$2.00
- CONCRETE WORK**
173 Uses Described, Pictured..... \$1.00
- DIESEL HANDBOOK**
New! Latest Information..... \$5.00
- DOG TRAINING**
Home, Stage, Movies, Etc..... \$1.50
- ELECTROPLATING**
Modern Practice Including Nickel, Zinc, Cadmium and Chromium..... \$2.25
- FURNACE HEATING**
Warm-Air. Every essential covered. 568 pages \$3.00
- FORDS (V-8)**
Also "A" and "B" Models. All New!.. \$2.50
- FROG INDUSTRY**
New! Raise and Sell. Profits!..... \$2.00
- FURNITURE MAKING**
Tools, Materials, Designs. \$2.50
- HYPNOTISM**
How to Become an Expert..... \$2.00
- LATHE WORK**
(Metal) Drilling, Threading.. \$1.00
- LOCOMOTIVE**
Folding Chart Shows all Parts..... \$1.00
- LOG CABINS**
Easy Plans; Build for Profit. Value!..... \$2.50
- MATHEMATICS**
Easy Guide for the Practical Man..... \$1.50
- MECHANICAL DRAWING**
Learn Drafting; Good Salaries..... \$1.00
- METAL PRODUCTS, FINISHING**
Just Out..... \$3.50
- MONEY MAKING IDEAS**
1000 Ways to Make \$1000..... \$2.50
- OIL HEATING HANDBOOK**
Just Out..... \$3.50
- PLUMBING**
500 Facts Every Homeowner Should Know..... \$1.50
- POULTRY**
Breeding, Management. Protect Your Profits! \$2.00
- TEST GOLD—PLATINUM**
Identify—Buy—Sell. By C. M. Hoke..... \$1.00
- PROSPECTORS' HANDBOOK**
How to Mine. Appraise, Equip..... \$3.00
- RADIO SERVICING**
Profit by Knowing Costs, Kinks, Etc., \$4.00
- REFRIGERATION**
Electric. Gas. Be a Service Expert..... \$4.00
- REWINDING ELECTRIC MOTORS**
Fractional Sizes. Value! \$2.50
- SHIP MODEL**
Entire Text, Famous "Sovereign" of 1637 \$1.00
- SHOP NOTES LIBRARY**
5 Vol. 2000 Wonderful Shop Ideas..... \$2.50
- STAMP ALBUM**
Modern. 400 Pages..... \$1.00
- STEEL SQUARE**
How to Figure Angles of Rafters, Roofs, Etc., \$1.00
- TELEVISION**
New! Book of the Hour.. \$2.50



Send 3c stamp for "A Billion Ideas"

Nothing Else Like It Anywhere

Mail NOW for FREE Book

NATIONAL POULTRY INSTITUTE, Dept. 33-B, Adams Center, N.Y., Att'n: Harry N. Lamon, Pres.

Dear Mr. Lamon: Send me your FREE Book, "How to Raise Poultry for Profit." I want to know more about my opportunity to make \$1,000 to \$2,500 a year, spare or full time.

Name.....
Address.....

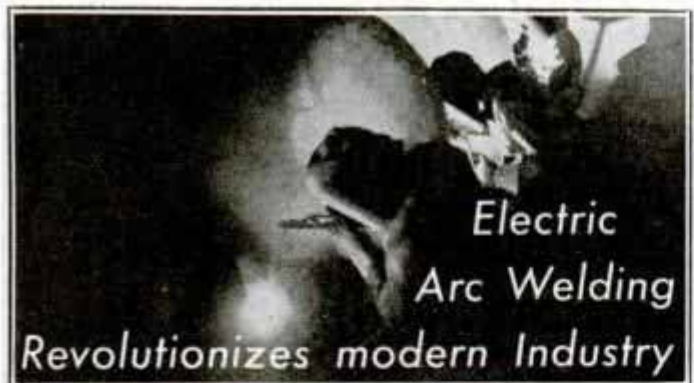

Electric Arc Welding Revolutionizes modern Industry

U.S. Manufacturers desire men to learn Electric Arc Welding and get practical experience under actual production conditions in the laboratories of the School of Engineering. Moderate training Fee. Accepted applicants will be fully trained until ready to pass rigid test and assisted in securing employment.

ARC WELDING presents one of the outstanding opportunities for steady income and future success. Welding is growing rapidly, replacing large and intricate castings, rivets, nuts, bolts, screws. It is commonly used in assembling cranes, hoists, bridges, structural steel work, etc. No limit to the application of welding to industry, increasing durability and reducing manufacturing costs. There is a decided shortage of properly trained Welding Operators, Technicians, and Welding Engineers. Why be content with ordinary work, hit and miss jobs and low pay when in a short time you can become a trained Specialist in Welding?

MILWAUKEE SCHOOL of ENGINEERING Institute of Electrotechnics

Dept. PM-11A. Broadway & E. State, Milwaukee, Wis.

- Welding Operator (3 mo.).....
- Welding Technician (6 mo.).....
- Welding Engineer (1 yr.).....
- Electrical Engineer B.S. Degree (4 yrs.).....
- Student Loan Plan.....
- Radio and Television Service Man (6 mo.).....
- Refrigeration and Air Conditioning Technician (3 mo.).....
- Self Help.....

Name..... Age.....
City..... State..... (PM-11A)

Skinny, Weak, Nervous, Rundown..!

Feed Strength-Building
NATURAL IODINE to
Glands for *Rich, Red
Nourishing Blood!*

**How Amazing New Sea Plant from Pacific
Ocean Feeds IODINE-STARVED GLANDS,
Quickly Renews ENERGY, Builds Glorious
NEW STRENGTH, and ADDS 5 Lbs. in 1
Week or No Cost!**

Here's new hope and encouragement for thousands of tired, weak, worn out, haggard-looking men and women whose energy and strength have been sapped by overwork and worry, who are nervous, irritable, always half-sick and ailing. Science has at last placed its finger on one of the principal causes of this dangerous rundown condition, and provides the way for building up and renewing a rich supply of red, nourishing, strength-building blood. "In most cases," agree many leading scientists and health authorities, "the cause of weakness, nervousness, skinniness and poor blood may be traced directly and indirectly to MINERAL and IODINE-STARVED GLANDS. When these glands don't work properly, all the food in the world can't help you. It just isn't turned into solid flesh, husky tireless strength, vibrant energy and the red blood supply that keeps you strong and well. The inevitable result is, you stay skinny, rundown, nervous, weak and ailing."

The most important gland—the one which actually controls body weight and strength, and assures the utilization of nourishment—needs a definite ration of iodine all the time—**NATURAL ASSIMILABLE IODINE**—not to be confused with chemical iodides which often prove toxic. Only when the system gets an adequate supply of iodine can you regulate metabolism—the body's process of converting digested food into firm flesh, new strength and energy.

To get this vital mineral in convenient, concentrated and assimilable form, take Seedol Kelpamalt—now recognized as the world's richest source of this precious substance. It contains 1,300 times more iodine than oysters, once considered the best source. 6 tablets alone contain more NATURAL IODINE than 486 lbs. of spinach or 1,387 lbs. of lettuce.

Try Seedol Kelpamalt for a single week and notice the difference. See flattering extra pounds appear in place of scrawny hollows.

**Accept This Startling No Risk Offer!
Your Money Back If Kelpamalt Does Not**

- | | |
|---|---|
| 1. Improve appetite. | 5. Banish Ordinary Stomach Trouble. |
| 2. Add at least 5 lbs. of Good Solid Flesh. | 6. Give You New Strength, Energy and Endurance. |
| 3. Strengthen Nerves. | 7. Clear Up Skin. |
| 4. Make You Sleep Sounder. | |

**SEEDOL
Kelpamalt Tablets**

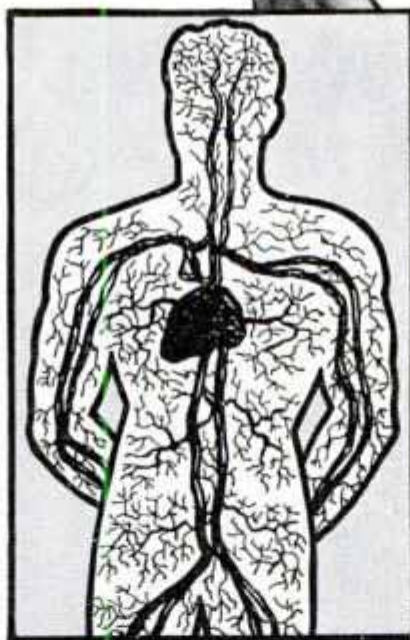

Every minute hundreds of arteries all over your body carry blood to the muscles and nerves. This blood must be rich in Natural Iodine and in minerals to nourish Starved Glands.

Notice how much better you feel, and if you don't gain at least 5 lbs. in one week, the trial is free. Your own doctor will approve this way. 100 jumbo size Seedol Kelpamalt tablets—four to five times the size of ordinary tablets—cost but a few cents a day to use. Get Seedol Kelpamalt today. Seedol Kelpamalt is sold at all good drug stores. If your dealer has not yet received his supply, send \$1.00 for special introductory size bottle of 65 tablets to the address below.

• **Manufacturer's Note:**—Inferior products sold as kelp and malt preparations—in imitation of the genuine Seedol Kelpamalt are being offered as substitutes. The Kelpamalt Company will reward for information covering any case where an imitation product has been represented as the original Seedol Kelpamalt. Don't be fooled. Demand genuine Seedol Kelpamalt Tablets. They are easily assimilated, do not upset stomach nor injure teeth. Results guaranteed or money back.

SPECIAL FREE OFFER

Write today for fascinating instructive 50-page booklet on How to Build strength, energy, cool, calm nerves and Add lbs. Quickly. Mineral contents of Food and their effects on the human body. New facts about NATURAL IODINE. Standard weight and measurement charts. Daily menus for weight building. Absolutely free. No obligation. Kelpamalt Co., Dept. 994, 27-33 West 20th St., New York City.

Name

St.

City



Magic Box!

TURN SPARE HOURS INTO CASH!

UP to \$40 Weekly
In Your Own Home

No soliciting! No canvassing! We show you how to make big money decorating fast-selling Giftwares. We start you with the big \$10 Artist's Outfit shown above. We supply you with \$150 worth of Giftwares free of extra charge and show you how to dispose of them without leaving your home. We give you 29 Tested Plans for making money. One Fireside Member says, "I made \$100 on furniture in one week." Another writes, "My sales were \$500 for 5 weeks. This is my first year." R. M. P., of Ill., says, "I did \$3,500 worth of business last year and over \$12,000 this year." D. W., New Mexico, reports, "I would not take \$1,000 for my course."

No Experience Needed

You too may have a guaranteed income opportunity with Fireside. No tiresome study. You learn by doing. No artistic ability necessary. Our easy 3-Step Method makes the work easy to learn and easy to do and fits you to make good money practically from the start.

Quick Sales in Your Home

No need to leave the house to dispose of everything you make. Our new automatic salesman does all the selling for you. Designed to quickly find cash buyers for all the Giftwares you can turn out.

No Cost Plan

Send coupon for details of new plan that pays for your Fireside Course besides putting big cash profits in your pocket. Mail coupon now while openings for new members are still being offered.

FIRESIDE INDUSTRIES
 Dept. 66-S

Adrian, Mich.

Fireside Industries
 Dept. 66-S, Adrian, Mich.
 Send me FREE Book on Home Decorating for a big steady income. Also details of plan that will pay for my Course and give me big profits besides.

FREE!
 Book on decorating at home for big money. Tells how to get big assortment of beautiful Giftwares free of extra charge.

NAME
 ADDRESS
 CITY STATE

When writing please mention Popular Mechanics

New Way to Improve YOUR ENGLISH



A command of effective English gives you added advantages and better opportunities. Poor English handicaps you more than you will ever realize. You can improve your English through Sherwin Cody's 100% self-correcting invention. If you are ever embarrassed by mistakes in grammar, spelling, punctuation, or pronunciation this new free book "How You Can Master Good English in 15 Minutes a Day" will prove a revelation to you. Send for it now. It is free. Address

SHERWIN CODY SCHOOL OF ENGLISH
 511 Searle Building Rochester, N. Y.



TRI-STATE COLLEGE

B. S. Degree in 2 years. World famous for technical 2-year courses in Civil, Electrical, Mechanical, Chemical, Radio, Aeronautical Engineering; Business Administration and Accounting. Equivalent in technical hours to 4-year course. Those who lack

high school may make up work. Low tuition. Low living costs. Located in picturesque hill and lake region. Students from every state and many foreign countries. 53rd year. Enter Sept., Jan., March and June. Write for catalog.

4116 COLLEGE AVE.,

ANGOLA, IND.

PARKS AIR COLLEGE

PARKS AIRPORT EAST ST. LOUIS, ILL.

Offers you college education majoring in aviation

Three 2-year courses leading to B.S. Degrees in Aeronautical Engineering, Aviation Administration, Aviation Mechanics. 100 acre airport. 14 buildings. 26 in faculty. 5,000,000 miles flight training. 1510 planes. 470 motors repaired and rebuilt in shops. Graduates with all leading aviation companies. Dormitories, cafeteria on Field. Winter term Jan. 4. Catalog. Write

10th YEAR REGISTRAR, DEPT. PM-11
PARKS AIRPORT, EAST ST. LOUIS, ILL.

Be a GUNSMITH

Learn this fascinating, big pay, profession right at home. Start now to learn gun mechanics, how to repair, restock, blue, check, refinish, make new parts, etc.

WRITE FOR PROSPECTUS

GUILD SCHOOL OF GUNSMITHING
 Dept. 19 NEWARK, OHIO



DRAFTING

BOOKS SENT FREE!

ON APPROVAL

5 VOLUMES BRAND NEW EDITION

Only 15 minutes a day with these WONDER BOOKS will prepare you for a good drafting job in less than a year. Mechanical and architectural drafting from simple straight lines to important complex plans. A step at a time! Built especially for beginners, for men with only grammar schooling. Drafting room practice, PLUS ENGINEERING, made easy and clear. Includes complete course in blue-print reading.

Big Field Big Demand Big Pay

Competent draftsmen are urgently needed right now in all building and manufacturing lines at \$30.00 to \$75.00 a week. That's just the beginning—FOR DRAFTSMEN HAVE THE BEST CHANCES FOR ADVANCEMENT. Pleasant, fascinating work, easy to learn and do. Learn quickly with these books—send coupon for a set FREE and see for yourself.

A year's consulting membership in the American Technical Society now given free to all readers of this famous cyclopedia of drafting. Many say that it is worth more than the cost of the books.

Complete set of drawing instruments if you send for these drafting books NOW. These instruments are made of the finest of German silver, are absolutely accurate and are packed in velvet lined leatherette pocket case. Real \$10 value, but free to you with these books.

AMERICAN TECHNICAL SOCIETY
 Dept. D819, Drexel at 58th St., Chicago, Ill.

American Technical Society, Dept. D819, Drexel at 58th St., Chicago, Ill.
 Send for 10 days' free use New 5 volume set of drafting. I will pay the few cents delivery charges. If I wish, I may return books in 10 days and owe you nothing but if I decide to keep them, I will send \$2.00 after 10 days, then only \$3.00 a month until \$24.80, the special introductory price, is paid. Send latest edition and include drawing instruments.

Name.....
 Address.....
 Attach letter stating age, occupation, employer's name and address and that of at least one business man as a reference.



Stop Slamming Doors AMAZING MONEY MAKER!



Kant-Slam Door Check is an amazing new invention that closes all doors silently and automatically. Closing speed easily adjusted by turning screw at top of check. Holds doors open when wanted open. Operates on new oil principle. Low priced. Everlasting. Easily installed in ten minutes. Never needs attention.

A Real Demonstrator Furnished Every Agent door. Every office, factory, store, institution, and public building needs a Kant-Slam for every door. Rush name and address for details of amazing money-making opportunity.
KANT-SLAM DOOR CHECK CO.
Dept. K-53, Bloomfield, Ind.

You get orders quickly demonstrating actual sample on easy to carry miniature door. Every office, factory, store, institution, and public building needs a Kant-Slam for every door. Rush name and address for details of amazing money-making opportunity.
FREE Demonstrator to Workers

STARTLING DISCOVERY Gives Amazing RESULTS



**SAVES GAS & OIL in AUTOS TRUCKS
CUTS REPAIR BILLS**

New Scientific Discovery Takes Country by Storm. More than 30 Million Prospects for Product that Saves Millions of Dollars for Auto and Truck Owners. One Truck Fleet Saves \$768 a Year.

AGENTS—"I Made Profits Up to \$34 Per Day

Sold 21 Truck Lines in 3 Weeks"—says B. J. Balmer, Tenn. Make Big Money Fast. Build Steady Business with Big Monthly Repeat Sales. Product Sells Itself. Have Exclusive Territory with Agents, Dealers working for YOU. Make up to 185% Profit. Territories Going Fast. You Can Test This New Discovery FREE of Risk. Write Today.

K-W CORPORATION, 3200 Holmes St., Kansas City, Mo.

WANTED MAN

OPERATE POTATO CHIP STORES

We furnish everything—help finance and locate you. No experience needed. Tremendous profits. Sensational introductory starting plan. No house-to-house canvassing. Wonderful opportunity. Rush name for free book of Profit Facts—today!

LONG-EAKINS COMPANY

1128-S High Street, Springfield, Ohio



Build YOUR OWN Slow Speed Wind Charger

from old auto generator. We show you how. Make money building for others. Light your buildings and play radio. Dime brings complete plans and catalog. 36 other changes, 6, 12, 22 and 110 volt motors; engine drive and wind generators; welders; electric fence controls; electric onboard motors; etc.

LEJAY MANUFACTURING CO.

1447 W. Lake Street Minneapolis, Minn.



FREE Lights

Best Poultry Paper 6 BIG ISSUES 10¢

Helps increase Poultry Profits. Send coin or stamps, 50 cents for 3 years or 10 cents for 6 months trial. Agents wanted. American Poultry Journal 632 So. Clark Street Chicago, Illinois



Make Money at Home!

GROW MUSHROOMS in your cellar or shed. Exclusive new process. Bigger, better, quicker crops. More money for you! Enormous new demand. We buy Mushrooms. Write for Free Book.



American Mushroom Industries Ltd., Dept. 746, Toronto, Ont.

Forms to cast Lead Soldiers, Indians, Trappers, Hunters, Wild and Farm Animals. 239 different forms to select from. Every form guaranteed to cast perfect figures. Send 5c stamp for illustrated catalogue.

HENRY C. SCHIERCKE Spencer Rd. GHENT, N.Y.



ARMY AND NAVY SUPPLY CO.

Bargains—Army, Sport Goods, Firearms, Clothes, Shoes, etc. Send 10c for new catalog, to be redeemed on first order
Army & Navy Supply Co., 4772 Lester St., Richmond, Va.



START

\$1260 to \$2100 YEAR Men--Women

**Common Education Usually Sufficient
Influence Not Needed**



City Mail Carriers, City Post Office Clerks

Clerks and carriers now get \$1,700 the first year regular and automatically increase \$100 a year to \$2,100 and \$2,300. Open to men—women, 18 to 45.

Railway Postal Clerks

Railway Postal Clerks get \$1,900 the first year regular, being paid on the first and fifteenth of each month. (\$79.17 each pay day.) Their pay is automatically increased yearly to \$2,450. Advance may be had to Chief Clerk at \$2,700 a year. (\$112.50—each pay day.) Open to men, 18 to 35.

Customs Inspector

Salary \$2,100 to start. Men 23 to 45. Work connected with examining baggage and merchandise entering the country from foreign parts covering boats, trains, roads, automobiles, etc.

File Clerk—Clerk

Open to Men—Women 18 to 50. Entrance salary \$1260 — \$1440 Year. Appointments as File Clerks and Clerks in the Departments at Washington, D. C., are made from this examination.



Men—Women at Washington, D. C.

Get Ready At Once

Many other positions. Experience is usually unnecessary and political influence is not permitted. Let us show you how to get a government job.

Free List of Positions

Fill out the following coupon. Tear it off and mail it today—now, at once.
This investment may result in you getting a big-paid government job.

FRANKLIN INSTITUTE, Dept. R173, Rochester, N. Y.

Gentlemen: Rush to me, FREE of charge, list of U. S. Government big pay jobs obtainable. Send me FREE 32-page book describing salaries, vacations, hours, work, and full particulars telling how to get one of these jobs.

Name.....
Address.....



High School Course at Home

Many Finish in 2 Years

You can complete this simplified High School Course as rapidly as your time and abilities permit. Equivalent to resident school work—prepares you for entrance to college. Standard H. S. texts supplied—Diploma. Credit for H. S. subjects already completed. Single subjects if desired. High School education is very important for advancement in business and industry and socially.

College Entrance

During the past 14 years, our High School graduates have been admitted to 531 different Universities, Colleges, Junior Colleges and Normal Schools—80% of them without entrance examination. Course also prepares for teachers' certificate and pre-professional examinations.

Business—Industry

To get and hold a good position in Business today you must be able to write clear, accurate letters and reports—do figuring involving Algebra and Geometry—talk intelligently on matters requiring a knowledge of Geography, History, and Economics.

In Industry—Mechanical and Engineering lines—you must have at least an elementary knowledge of Physics and Chemistry—be able to figure quickly and accurately—know something of Mechanical Drawing and blueprints—and be able to talk and write accurately and clearly on both your work and ordinary topics of conversation.

Our High School course meets the preparatory educational requirements for Business and Industry.

An Educational Institution

The American School was chartered in 1897 as an educational institution, not for profit—and is exempt from paying Federal income tax, like the best resident colleges and universities.

Don't Be Handicapped— Complete Your Training Now

Be a High School Graduate! Prepare yourself for promotion in Business and Industry—for the Professions, College Entrance and social success. No matter what line you may select, High School training will prove invaluable to you! Our moderate fees cover all instruction, standard textbooks and Diploma. Easy monthly terms. Get ahead in life. Start your training NOW!

20 Other Courses

Over 150 noted Educators, Engineers, and Business Men helped prepare our special instruction material, which is used by many resident schools and colleges, U. S. Navy, and Province of Manitoba, Canada. We offer you quality training at home for the best-paying lines of Industry and Business, as listed in the coupon.

Prepare yourself for promotion in Business and Industry—for the Professions, College Entrance and social success. No matter what line you may select, High School training will prove invaluable to you! Our moderate fees cover all instruction, standard textbooks and Diploma. Easy monthly terms. Get ahead in life. Start your training NOW!

Mail coupon for information about line that interests you
American School, Drexel at 58th, Chicago

American School, Dept. H-845, Drexel at 58th, Chicago

Tell me how to train for success in line checked. No obligation.

- | | |
|--|--|
| <input type="checkbox"/> Accounting & Auditing | <input type="checkbox"/> Diesel Engineering |
| <input type="checkbox"/> Architecture & B'ldg | <input type="checkbox"/> Drafting & Design |
| <input type="checkbox"/> Automotive Engin'ring | <input type="checkbox"/> Liberal Arts |
| <input type="checkbox"/> Business Management | <input type="checkbox"/> Private Secretary |
| <input type="checkbox"/> Com'rcial Aeronautics | <input type="checkbox"/> H'ier Ac't'g (C.P.A.) |
| <input type="checkbox"/> Electrical Engineering | <input type="checkbox"/> Highway Engin'ring |
| <input type="checkbox"/> Electrical Refrigerat'n | <input type="checkbox"/> Mechanical Eng'ring |
| <input type="checkbox"/> Air Conditioning | <input type="checkbox"/> Radio & Television |
| <input type="checkbox"/> Civil Engineering | <input type="checkbox"/> Salesmanship |
| <input type="checkbox"/> Complete Law | <input type="checkbox"/> Steam Engineering |

Name.....

Address.....

When writing please mention Popular Mechanics

EASY to play

With an easy playing Conn band instrument, you can be ready for band or orchestra in 4 to 6 weeks. A sure road to popularity if you start on a Conn. Choice of the world's greatest artists. Magnificent tone. Many exclusive features—yet they cost no more.

Ask to see the marvelous new models now being displayed by Conn dealers.

WRITE FOR THIS NEW FREE BOOK

Home trial. Easy payments. Write us for free book on whichever instrument interests you most. Mention instrument.

C. G. CONN, LTD., 1131 CONN BLDG., ELKHART, IND.

CONN
BAND INSTRUMENTS

New York Established 1902

Electrical

Ask for free booklet

School

44 West 17th St., N. Y. C.

Hand Out **FREE CIGARETTES**

EARN UP TO \$95 WEEKLY

Introducing NEW WAY TO SMOKE. We furnish you Free Cigarettes. Ask any man to have a Free Smoke. Hand him LIGHTED Cigarette from beautiful pocket-size "Magic Case." Just touch button. Presto! Out comes Lighted Cigarette automatically. No batteries or electricity. Get Magic Case for 15 days' trial at our risk. State favorite brand cigarettes.

MAGIC CASE MFRS., Dept. 5-371
4234 Cozens Ave. St. Louis Mo.

Make up to **\$150** Weekly
GIVING AWAY

FREE  **RADIOS**
RCA LICENSED

We offer this and other money making plans to all salesmen, distributors, cardmen, punch board men and agents with our new full 1937 line consisting of 30 beautiful and exclusive Radio Models for home, auto, and farm use. Make up to \$150 cash in a week for yourself. Every dealer and sub-agent, home, car owner, store, office, factory, lodge, club or individual wants these marvelous new plans for giving away FREE WORLD FAMOUS RCA LICENSED DELUXE RADIOS. WRITE TODAY FOR OUR NEW STARTING OFFERS. Start at once making money with our unique sales plans. Write for full information how you can secure any or all of these plans FREE.

DELUXE MFG. CO., Dept. 277, 173 W. Madison St., Chicago, Ill.

QUICK WAY TO LEARN MUSIC

Thousands have learned to play at but a fraction of the old way costs. Simplified method brings amazing results . . . 700,000 Students

HAVE you ever dreamed of the fun you'd have playing some musical instrument? Pictured yourself doing all the popular hits—even classical numbers?

Then here's grand news for you! It's news of a quick, easy method whereby anyone can learn to play real music by notes right at home. You won't need a private teacher. No tiresome exercises or long hours of practice. You start right in playing little tunes. Sooner than you ever expected you'll find yourself entertaining your friends—playing at parties—having the time of your life. And the cost is but a fraction of the expense required by old-fashioned methods. The success of the U. S. School of Music system is due to the fact that it makes everything so simple. First it tells you how to do a thing. Then it shows you in pictures how to do it. Then you do it yourself and hear it. What could be simpler?

LEARN TO PLAY BY NOTE

- Piano
- Violin
- Organ
- Guitar
- Saxophone
- Mandolin
- Tenor Banjo
- Hawaiian Guitar
- Piano Accordion
- Or Any Other Instrument



FREE BOOK AND DEMONSTRATION LESSON

Prove to yourself without cost how easily and quickly you can learn to play. Send today for Free Demonstration Lesson and Explanatory Booklet. See the simple principles around which this remarkable method is built. If you really want to learn music—enjoy good times—mail the coupon below. Don't delay—act NOW. Instrument supplied when needed, cash or credit.

U. S. School of Music, 711 Brunswick Bldg., New York City

U. S. SCHOOL OF MUSIC,
711 Brunswick Bldg., New York City.

Send me your amazing free book, "How You Can Master Music in your Own Home," with inspiring message by Dr. Frank Crane; also Free Demonstration Lesson and particulars of your easy payment plan (mention instrument).

Name

Address

Instrument..... Have You Instrument?

Extra Money From Books

SEND NO MONEY • Books Sent C.O.D. Anywhere in U. S.

These famous Pay-Raising, Extra Money Books have helped thousands of others. Let them help you too. Check this list and mail with your

name and address. Pay postman on delivery plus few cents postage. Send 3c stamp to cover postage and ask for catalog of other books.



SELECT FROM THIS LIST

- AIR CONDITIONING SERVICE MANUAL**
Small Unit Apparatus... \$5.00
- ARMATURE WINDING**
and Motor Repair... \$3.00
- AUTO RACING**
How to Build Racers... \$1.00
- AUTO REFINISHING**
Duo With Spray Gun... \$1.50
- BRICKLAYING**
Plain and Fancy... \$1.50
- CAMPS AND LOG**
Cabins (Building)... \$2.00
- CARBURETORS (All Makes)**
New, Revised Edition... \$2.50
- DANCE**
Learn at Home Without Music or a Partner... \$2.00
- DRAWING**
Freehand and perspective... \$1.50
- DRY CLEANING (Practical)**
and Dyer... \$3.00
- ELECTRICAL TROUBLE SHOOTING**
Motor Car and Airplanes \$4.00
- FURNITURE REPAIRING**
Finishing and Decoration... \$3.00
- INVENTIONS**
1500 Needed... \$2.50

- LANDSCAPE GARDENING**
Practical... \$2.50
- LEATHER MAKING**
and Home Tanning... \$1.00
- MONEY MAKING FORMULAS**
15,000 Practical... \$5.50
- MUSHROOMS**
Raise for Market... \$1.75
- NEON SIGNS**
Only book on, New... \$3.00
- PATTERN MAKING**
Excellent New Book... \$1.50
- PLASTERING**
Best Instruction Manual... \$1.25
- PLASTIC MOLDING**
Production Basis... \$3.00
- RADIO PHYSICS COURSE**
New edition. Everything about Radio... \$4.00
- REFRIGERATION SERVICE**
Manual... \$5.00
- RUBBER ARTICLES**
How to Make... \$2.00
- SHEET METAL**
Construction Work... \$2.00
- Steam Engineer's License**
How to Obtain... \$2.00
- TAXIDERMY, HOME**
Mount Trophies Profit. Pleasure... \$1.50
- WROUGHT IRON WORK**
Practical... \$1.35

POPULAR MECHANICS PRESS
Room 1136A 200 E. Ontario St., Chicago

When writing to advertisers please mention Popular Mechanics



LEARN PROFITABLE PROFESSION IN 90 DAYS AT HOME

If you are looking for a NEW and BETTER way to make a living, take up Swedish Massage, for now you Can Learn at Home. This interesting, big pay profession was for years available only to a few. Its secrets were guarded jealously and fabulous prices were paid for instruction. This same instruction is now available to you at a mere fraction of the former price and you need not leave your present work until you have qualified as an expert and can command an expert's pay.

Hundreds of men and women of all ages 18 to 50 are making \$10.00 to \$20.00 a day giving scientific Swedish Massage and Hydro-Therapy treatments. There is a big demand from Hospitals, Sanitariums, Clubs, Doctors and private patients. Enroll now and we will include anatomy charts, medical dictionary, patented reducing roller and Hydro-Therapy supplies without extra cost. The reducing course alone may be worth many times the modest tuition fee. Send coupon for reduced price offer. Complete details and booklet containing list and photographs of successful graduates will be sent FREE.

National College of Massage & Physio-Therapy
Dept. 864—20 N. Ashland Boulevard, Chicago

You may send me FREE and postpaid, your illustrated catalog and details of your special offer, also booklet containing names and photographs of successful graduates.

Name.....

Address.....

City..... State.....

Learn in Los Angeles TALKING PICTURE PROJECTION



Talking pictures offer excellent opportunities to trained experts. Complete course at National Schools qualifies you to accept positions in theaters. Newest equipment to learn with.

SOUND RECORDING



Radio Transcription Recording is a fascinating profession. The field of opportunity for trained men is unlimited. At National Schools you receive the most complete instruction on newest equipment. Experienced instructors. Students learn on same equipment used in largest transcription studios.

TELEVISION-RADIO



All of the science of sound is based on RADIO. National Schools' course of training embodies all divisions of Radio, including Television in its latest development. Graduates are qualified for Radio engineering, home, auto and commercial radio repairing, and Broadcasting. Easy "shop-and-studio" practice methods. No dry text books. Students actually operate our own Radio and Television equipment. You don't need advanced education. National's training methods teach you the practical way.

QUALIFY FOR GOOD JOBS IN FEW MONTHS

National training is thorough. Finest equipment in America. Proven methods. When you graduate you can command jobs that assure future success.

EARN ROOM AND BOARD WHILE LEARNING

We assist students to obtain part-time jobs while learning. For limited time we will allow coach railroad fare to L.A. Send coupon for Catalog.

NATIONAL SCHOOLS

LOS ANGELES

More than 30,000 Graduates.
Established 1905



REQUEST FOR BOOK

NATIONAL SCHOOLS
Dept. PMR-11, 4000 S. Figueroa St., Los Angeles, Calif.

Name..... Age.....

Address

City..... State.....

New-TYPE Cheap OIL BURNER INVENTED Sweeping the Country!

COOK and HEAT Without Coal or Wood
In Your Present Stove or Furnace—**HOTTER—CHEAPER—No Dirt or Ashes—Twice the Heat Quick at HALF THE COST.**

COOKS A MEAL for LESS

Beats any oil burner ever gotten out for low cost, perfect performance. Burns cheap oil a new way, without pre-generating or clogging up. Quick intense heat by Simple Turn of Valve.

Try At Our Risk 30 DAYS' TRIAL

Prove it ends drudgery and dirt of coal or wood; cuts fuel bills in half, pays for itself quickly by what IT SAVES.

FREE SAMPLE FOR AGENTS

offered to one energetic man or woman in each locality who will demonstrate and take orders. Write quick, be first to learn how to make REAL MONEY right now, spare or full time—mail 1c postcard today.

AGENTS Salesmen BIG MONEY
Drop Everything for this Quick Seller. Clark of Ind., sold 35 in 20 days. Get YOUR OWN oil burner FREE and make REAL Money. Write now.



Slips Into Any STOVE RANGE or FURNACE
Quick HEAT at Turn of Valve!

AMATEUR CARTOONISTS WIN \$25.00

Wanted—Amateurs with humorous ideas. No drawing ability necessary. The amateurs of today are the professional cartoonists of tomorrow. Ideas judged and prizes awarded by Applause-O-Meter test before movie audiences. Everyone has an equal chance. 26 cash prizes in all. Rush name on post card for "Valuable Tips on How to Make Money With Simple Cartoons and Humorous Ideas," Cash Prize Entry Blank and Rules—Send No Money.

CARTOONISTS' EXCHANGE, Dept. C-911, Pleasant Hill, Ohio

AMAZING-NEW INVENTION! BIG EARNINGS QUICK! WITH THIS NEW MONEY MAKER

No Experience Needed. Sells easy to amazing big market. Combination **BLOW TORCH AND SOLDERING IRON**. No pressure system. No pumps. No stove. No charcoal. Operates with 100% satisfaction. Neat, complete, compact. Guaranteed by 30 year old company. Write quick for New Agents' Plan and Exclusive territory offer. Hurry!

JUSTRITE MFG. CO.
Dept. 511, 2061 Southport, Chicago



CANS, JARS and BOTTLES Fly Open! TOUGH! NEW KITCHEN DEVICE

Amazing discovery! Let us send it to you on trial and show you how to make big profits. Works like magic. Cans, Jars, Bottles—any size, shape—opened instantly. Amazingly low priced. Startling demonstration makes housewives buy instantly.

AGENTS Make up to \$9 in a Day

FREE SAMPLE OFFER Two magic selling plans pour profits into your pockets. Wonderful spare time money maker. Send name, address, for Free Sample Offer.

MAGIC PRODUCTS CO.
1418 Pendleton Ave., Dept. CS-371, St. Louis, Mo.

When writing please mention Popular Mechanics

BE AN ARTIST

WE CAN TEACH YOU DRAWING in your own home during your spare time. Thirty-five years of successful teaching proves our ability. Artists receive large salaries.

Write today for Art Year Book

SCHOOL OF APPLIED ART

Dept. 186, 10 E. Huron St., Chicago, Ill.



You Can Regain Perfect Speech, if you

STAMMER

Send today for beautifully illustrated book entitled "DON'T STAMMER," which describes the Bogue Unit Method for the scientific correction of stammering and stuttering. Method successfully used at Bogue Institute for 35 years—since 1901. Endorsed by physicians. Full information concerning correction of stammering sent free. No obligation. Benjamin N. Bogue, Dept. 172, Circle Tower, Indianapolis, Indiana.

RADIO ENGINEERING

RCA Institutes offers an intensive course of high standard embracing all phases of Radio. Practical training with modern equipment at New York and Chicago schools. Also specialized courses and Home Study Courses under "No obligation" plan. Illustrated Catalog on request



RCA INSTITUTES, Inc. Dept. PC-36

75 Varick Street, New York, N. Y.
1154 Merchandise Mart, Chicago

Recognized Standard in Radio Instruction Since 1909

GOVERNMENT APPROVED



STATE ACCREDITED

Jobs in AVIATION

Get training now

Get into America's fastest growing, most active industry. Huge government and commercial orders mean plenty of good high paying jobs. Get your training NOW in AERONAUTICAL ENGINEERING, LICENSED MECHANIC, ADMINISTRATION. Also special short courses. Low tuition. Easy terms. Day and Evening classes. Write for booklet "Aviation As A Career."

AERONAUTICAL UNIVERSITY, Dept. A,
Curtiss-Wright Bldg., 1342 S. Michigan Blvd., Chicago



Build a BOAT FOR PLEASURE OR PROFIT



Shows EXACTLY HOW TO BUILD 15 DIFFERENT BOATS

This is the new edition with 42 added pages, 6 new boats, and conversion of Ford motor for marine use. Full directions and details for cabin cruiser, racing, hydroplane, outboard runabout, sail boats, kayak, sled type—15 boats in all. Also sectional boat to carry on car.

SEND NO MONEY

Write for new edition of Boat Book today! Sent anywhere. Pay postman \$3.00 plus few cents postage. Outside U. S. and possessions remit with order. Money refunded if not satisfied.

POPULAR MECHANICS PRESS—Room 1136A
200 East Ontario St., Chicago

EASY—LOW COST with POPULAR MECHANICS BOAT BOOK

Build a boat at home! You can do it. Just the kind you've wanted—power, sail, or row boat. The "Boat Book" shows you how in simple step-by-step directions. Specially prepared for those with limited tools, little skill and money. Build boats to sell for profit too. Book tells how.

GIVES PLANS, METHODS AND MATERIALS

Actual working plans and photos of real boats under construction makes building easy. Shows materials needed and rock-bottom costs. Hundreds of pictures. No chance for mistake. Includes also, navigation and pilot rules, handling sailing craft, boat knots, boating terms. Everything a boat enthusiast should know. Size 7x10 inches. 312 pages. Fine cloth binding.



Free DRAWING TEST

If you like to draw, test your sense of design, color, proportion, etc., with our simple Art Ability Test. An opportunity to get a frank opinion, free, as to whether your talent is worth developing.

Magazines, newspapers, publishers and advertisers spend millions yearly for illustrations. Design and color influence the sale of most things we buy. Artists have become important to industry. Machines can not displace them. If you have talent, train it. Drawing may be your surest road to success.

The Federal Schools, affiliated with a large art, engraving and printing institution, has trained many young men and women now serving industry as designers or illustrators, capable of earning from \$1,000 to \$5,000 yearly. Its Home Study courses in Commercial Art, Illustrating and Cartooning, contain exclusive illustrated lessons by many famous artists. Practical instruction by experienced men is the reason for its many years' outstanding success. Courses sold on easy payments.

Send today for Art Test and Free Book explaining present opportunities in art. Just fill out and mail coupon below.

FEDERAL SCHOOLS, Inc.

11136 Federal Schools Bldg.
Minneapolis, Minn.

Send me, without obligation, your Art Test and Free Book.

Name.....

Address.....

Age..... Occupation.....

FREE BOOK Tells How to Earn Up to \$50 and MORE WEEKLY



ELECTRIC REFRIGERATION and AIR CONDITIONING

Young man — here's the easiest, quickest way to big pay and a real future. Get into Air Conditioning and Electric Refrigeration NOW. World's fastest-growing industries. New, uncrowded field.

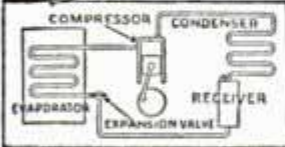

Quick Way to Big Pay!

Easy to train in spare time at home as expert in Installing and Servicing, Planning and Estimating, all kinds of Air Conditioning and Electric Refrigeration equipment. Take your choice of office and shop positions. Quick low-cost method of home study approved by leading manufacturers. Practical work in large laboratories and Employment Service free. Low easy to pay fee.

U. E. I. Qualifies Men for Jobs

"Had no trouble locating job paying better than expected, thanks to U. E. I. for training, and opportunity you extended." O. I. B., Okla.

"Well satisfied with U. E. I. Training; earnings average \$54 a week." W. S., New York.

"Secured employment with C. & S., one of firms to which you referred me... taking full charge of Service Department." R. R. W., Ill.

"I am sending in my last lesson. My rise in the refrigeration industry has been rapid, having received about 100% increase in earnings and I am just getting started." E. D., Wash.

"Enjoy my lessons. Have obtained position as engineer in a new cold storage plant. I have charge of refrigeration." G. C. C., Canada.

Get Facts Now!

Get free book telling the TRUTH about big opportunities in Electric Refrigeration and Air Conditioning and how U. E. I. Training GETS MEN JOBS. Write giving age and present occupation, stating which industry interests you most.

Utilities Engineering Institute

Established 1927

400-410 N. Wells St., Dept. 1116, Chicago, Ill.

Utilities Engineering Institute, Dept. 1116, 400-410 N. Wells St., Chicago, Ill.

Please send me your Free Book telling how I can qualify for the big opportunities offered in Air Conditioning and Electric Refrigeration. I have marked which interests me most.

- Air Conditioning Electric Refrigeration

Name.....

Address.....

City..... State.....

DIESEL POWER



Courtesy DIESEL PROGRESS

A Coming American Industry

The internal-combustion engine represents man's supreme triumph of machine power. Diesel operators are in demand. Here is real opportunity for mechanics, draftsmen, owners of shops, motormen, farmers and all others employed where Diesel replacements will be made. Get necessary knowledge through study of the modern I. C. S. Course on Diesel engines. Free booklet!

INTERNATIONAL CORRESPONDENCE SCHOOLS

BOX 5643-H, SCRANTON, PENNA.

Please send information on course checked.

- DIESEL POWER ELECTRICAL ENGINEERING
 Mechanical Engineering Automobile Course
 Aviation Engines Air Conditioning

Name..... Age.....

Address.....

When writing please mention Popular Mechanics

Start Your Own NOVELTY MAKING BUSINESS At Home



We Teach You How To Make Your Own Molds with Liquid Live Rubber and Cast Beautiful Novelties From Plaster, Cement, Liquid Marble, etc.

There's fun, fascination and a steady income ahead for you making Garden Furniture, Book Ends, Ash Trays, Flower Holders, Plaques and hundreds of useful artistic novelties — with LIQUID LIVE RUBBER. It's new—different—the finest development for the flexible mold maker. Our complete instructions tell you each step-by-step procedure in the fascinating use of this marvelous discovery. You quickly build your own business with hundreds of customers for your novelty creations.



FREE STARTING OFFER! Write quick for full details of our FREE COURSE in Flexible Mold Making. For quick starting action, send \$1 for 1/2 pint Can of LIQUID LIVE RUBBER, postage with FREE MODERNISTIC HEAD MODEL (value \$1) included. Money refunded if not delighted. STEWART'S STUDIO 2102 West 19th Street, Dept. P-116, Chicago, Ill.

MOUNT BIRDS HOME COURSE \$1



ANIMALS • FISH • TAN HIDES • MAKE NOVELTIES
 Make your OWN trophies! FUN, INEXPENSIVE! Decorate your home, office! My amazing NEW easy methods have taught THOUSANDS to MOUNT BIRDS, ANIMALS, FISH, TAN HIDES and MAKE NOVELTIES! Simple diagrams and plain words take you step by step from start to finish — EVERYTHING told... MODERN professional secrets revealed... shows mistakes... hundreds of NEW pointers. Interesting hobby... MONEY MAKING Profession. Complete HOME course of 7 books, life membership, diploma ALL \$1 postpaid ANYWHERE. Satisfaction GUARANTEED! Send \$1 with order or pay postman \$1 plus postage.

SCHMIDT SCHOOL OF TAXIDERMY Dept. G-14-11, Memphis, Tenn.

LEARN FROM A FORMER G-MAN

Learn the most fascinating of professions. Prepare yourself for a job with a future. Study under the personal direction of a man who was previously one of the famous G-Men. Take advantage of the many opportunities for the trained man. Write for particulars.

INTERNATIONAL INVESTIGATIVE INSTITUTE
 1-A Maryland Title Building WASHINGTON, D. C.

BE A PILOT — FLY A SHIP

If you are stumped at the high cost of training to qualify for a license and a good future in the field of Aviation, write immediately, enclosing stamp for information on opportunities now available under our Transport Pilot and Mechanic's

TRAINING PLAN
 MechaniX Universal Aviation Service, Inc.
 Strathmoor Sta. Dept. E Detroit, Mich.

ITALIAN ACCORDIONS

OF ALL TYPES. Hand-made, best quality. Buy direct from our factory and save 1/2. Satisfaction guaranteed. Used musical instruments taken in trade. FREE accordion lessons. ITALIAN ACCORDION CO. 323 W. Polk St., Dept. P-1, Chicago

BRING YOUR RADIO UP TO DATE



ADD-A-TUBE

Get Rid of Static, Distortion, Strong Local Interference, A "New Radio" For Only..... Tune out strong local stations... tune in Los Angeles, Canada, Mexico! Increase selectivity—cut out static, distortion, interference, with amazing new ADD-A-TUBE. Uses no extra current, fits any radio, electric or battery, works on inside or outside aerial, all waves. GUARANTEED! Use 5 days. If not delighted, return within 10 days from date shipped and your money will be refunded instantly!



Send No Money! Pay nothing now. Just send name and address on postcard. Pay postman only \$1.00 plus few cents postage on delivery. Send your order today!

R-E ENGINEERS, Dept. H-511, Marburg Ave., & B & O. R.R. Cincinnati, O.

Turn JUNK TIRES
IN TO Cash! START AT HOME

The Most Sensational Business Opportunity Since 1929

Like turning lead into gold, here is a business with gigantic possibilities. Factories, Clubs, Stores, Schools, Homes, spend millions every year for rubber mats. Think of your profit when a



HAND MACHINE and

5¢ TIRE MAKES \$2.00 MAT

Brand new. Fully patented. Few men already started report unprecedented success. Wm. Eagle writes: "Can't make mats fast enough. First week brought over 200 orders for \$1.00 to \$10.00 each." Flash from Harris says: "Orders enough to keep 15 men busy all the time." Gunter got big order from County Commissioners and now reports: "Just signed up order for all Grade Schools and High Schools." No wonder responsible men are throwing everything else aside to establish local FABRIX factories.

COSTS NOTHING to get complete facts. Just send name and address. We'll send description of simple hand machine that quickly slices old tire into strips; show you how patented method forms strips into thick, springy, long-wearing FABRIX Mats—how five cents worth of Junk Tires makes a \$2.00 Mat; how you can start on a reasonable investment and build a business so big, so fast, that it will take your breath away. Don't delay a minute. Write or wire today. All information is free.

FABRIX, Inc., 325 W. Huron St., Dept. 711, Chicago, Ill.

Make Glazed Concrete Products



Pottery, tiles, novelties. Wall Glazing, water-proofing. Make jars, vases, bird baths out of sand and cement without molds or costly tools and glaze them like clayware. We show you how. Earn money in your own business. Send 10c for booklet, color plate, details.

NATIONAL POTTERIES COMPANY

13 West 26th St., Room 21. Minneapolis, Minn.

The Lost Word

THE KEY TO SECRET WISDOM

"Like a bolt from the heavens, the word was spoken and from the reverberations of its sacred syllables, came the creation of the Universe"—so relates an old, old legend. Through the ages men have searched in vain for this lost word. In its stead they found keys to a secret wisdom. They learned how to unlock the hidden possibilities slumbering within everyone... startling, unused powers that make for a greater life.

This Sealed Book - FREE

A sealed book by the Rosicrucians, reveals the plan whereby you may obtain this wealth of knowledge leading to the greater joys and rewards of living. For free copy without obligation, write Scribe R.R.M.

The ROSICRUCIANS
SAN JOSE [AMORC] CALIFORNIA
NOT a religious organization

No machine can ever take a DRAFTSMAN'S JOB

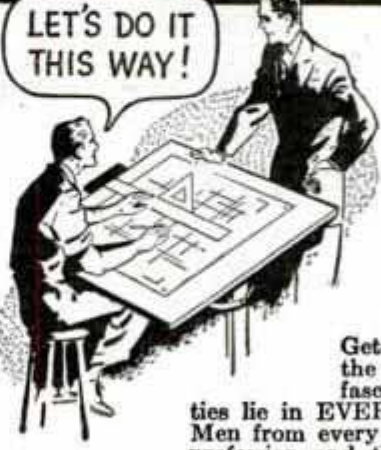

● The draftsman is one man who doesn't have to worry about being replaced by a machine. His HEAD and his HANDS are needed — always. Even the smallest improvements must be laid out by the draftsman so he is usually the first man to be hired, and among the last to go in a lay-off.

Get into drafting, where the pay is big, the work is fascinating and opportunities lie in EVERY branch of industry. Men from every walk of life enter this profession and thus start their careers toward success and independence. We can help YOU. Let us send you our plan, there is no cost or obligation.

Learn at Home

Unlike many other professions, drafting is easily learned at home. It requires no previous training, no college education. Just an hour or two a day right in your own home can do wonders towards making you a draftsman and fitting you for this interesting, profitable, inspiring profession. The American School is proud of the success of its students, for American School graduates are found everywhere in positions of responsibility and power.



The American School Building, Drexel Ave. at 58th Street.

BIG OPPORTUNITIES NOW

Right now is the time to get into drafting, for new machines, replacements, buildings, bridges, roads, and all other new ventures must be planned on the drafting board before the actual work can begin. The classified sections of most daily newspapers carry advertisements of jobs open for draftsmen NOW. Under our plan of instruction you can often qualify for a good job long before you have completed the course. This is important for it enables you to get into this fascinating work within a comparatively short time. Business is building fast, every month more draftsmen will be called for. Join this profession NOW.

Text Material All Furnished

When you enroll for a course in drafting with the American School you will be impressed with the low cost of this instruction and the easy terms of payment. There are no books to buy, for these are all supplied as a part of the course without one penny of extra cost. Send the coupon for information, there is no cost or obligation.

AMERICAN SCHOOL

Drexel at 58th St. Dept. DD-845 Chicago, Ill.

American School
Drexel at 58th St., Dept. DD-845
Chicago, Illinois

You may send me, without cost and fully prepaid, details of your course in **Drafting** and tell me why such wonderful opportunities exist now.

Name.....
Address.....
City.....State.....

When writing please mention Popular Mechanics



DIESEL the NEW POWER

The whole world gasped at the amazing performance of the Diesel Powered Burlington St. R. Zephyr train. It opens a new era of power efficiency. Aeroplanes, automobiles, great industrial plants may soon be using these marvelously efficient engines. It means a new profession, a new trade for thousands and thousands of men. Learn Diesel operation, construction and repair NOW. Use our magical quick reference method. Find out all you need to know through these books, "Diesel and Other Internal Combustion Engines"—"Diesel Engines, Operation and Maintenance"—"Diesel Electric Plants," which we send free for examination. This combination offer brings you the latest and most authoritative information obtainable. Over 300 illustrations.

3 BOOKS ALL SHIPPED FREE

for examination. There are no strings to this offer, if you really want to get into the most promising new field of the century—the livest—most up-to-date—most talked of profession, send for these books on our amazing free shipment offer. Read them, examine them, test them in any way and then if you are not sold 100% send them back at our expense and you won't owe one cent.

American Technical Society, Dept. 0819
Drexel at 58th Street, Chicago, Illinois.
Send me the 3 Volumes on Diesel Engines, listed above for 10 days FREE examination. I will pay the few cents express but don't owe you a cent unless I keep the books, in which case I agree to send \$2.00 in 10 days and \$3.00 a month until the introductory price of only \$9.80 is paid.

Note: If you prefer you may send only \$8.80, cash or money order (you save \$1.00) in full payment, and we will send the 3 books prepaid. We agree to return your money if you are not satisfied and return them in 10 days.

Name

Address

City State

Please attach a letter giving age, occupation and the name and address of your employer and that of at least one business man as reference.

Electricity at your finger ends

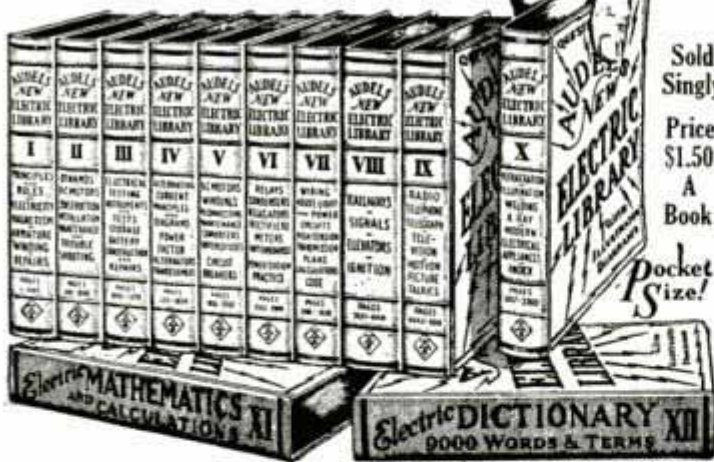

Sold Singly
Price \$1.50
A Book
Pocket Size!

AUDEL'S NEW ELECTRIC LIBRARY—A progressive Home Study and Reference Course in applied electricity. Easy to understand. Questions and answers plainly written for a complete working knowledge of modern electrical practice, necessary to every electrician, engineer, mechanic and student.

LEARN THE AUDEL WAY! You ask the question—Audel's New Electric Library gives the answer—9500 simplified outlines, graphic illustrations and precise explanations covering Construction, Operation and Machine Maintenance.

BOOK A MONTH PLAN—Order the volume that interests you—today! We will send that volume on 7 days' free trial. If the book helps you, send us \$1.50. If it does not help you, mail book back to us. On receipt of your first payment, we will send your second book. We allow 30 days to pay for this and for each following book until you complete the Series.

If you are not satisfied, you may cancel your subscription at any time.

FREE EXAMINATION COUPON

Theo. Audel & Co., 49 W. 23rd St., New York City
Mail Vol. I, Electric Library on 7 days' free trial. If O. K. I will remit \$1.50, otherwise I will return it. I also request you to mail one book each month on same terms. No obligation unless I am satisfied.

Name

Address

OccupationPM

FOR Real FUN Play. A Soprani ACCORDION



● If you want to be really popular, have all the fun, the center of attraction everywhere, just learn to play this thrilling instrument from Italy. A complete band or orchestra in itself, and so easy to learn to play. You'll master this easier Soprani in no time, and you'll have real fun from the start. Don't delay. Big future. Send postal for beautifully illustrated literature. No obligation. Easy terms. Write today sure. 41

SOPRANI, INC., DEPT. 1129
630 S. WABASH AVE. CHICAGO, ILL.

MAKE MONEY AT HOME

RUBBER MOLDS

Low as
6¢ EA.



Start big profit business at home. Make your own flexible rubber molds with amazing SO-LO GO-MA Molding Rubber. Turn out hundreds reproductions. **BUSTS OF PRESIDENTIAL CANDIDATES**, ornaments, ash trays, book-ends, etc.—in plaster, concrete, artificial marble. Costs you little as 3c each, sell for up to \$5.00 to friends, stores, by mail. Easy, quick—experience unnecessary. We supply all materials and instructions. Write today for free details and proved plans.

SO-LO WORKS, Dept. H-827, Cincinnati, Ohio

\$ MONEY-MAKING \$ OPPORTUNITIES

For those who need larger incomes or must seek new occupations. The following workable, tested plans are adaptable both to the needs of the country or city dweller either for part time development or principal income source.

Every idea set forth in these books has been used by others for profit. They are well worth your consideration.

Plan No. 1—1000 Ways to Make \$1,000. Practical new book of tried, tested methods that work that you too, can use. Price \$2.05.

Plan No. 2—Radio Servicing. Let an expert teach you how to engage in this money making business. Price \$4.15.

Plan No. 3—Refrigeration Service. Official manual covers all makes. Good service men are needed. Price \$5.00.

Plan No. 4—Automobile Refinishing. Start a lucrative business of your own. Fine possibilities here. Excellent new instruction book. Price \$1.50.

Plan No. 5—Outdoor Opportunities. The raising of small animals, birds and plants for profit. Price \$2.00.

Plan No. 6—10,000 Money-Making Formulas. Complete instructions for the making of commodities at small cost that may be sold at a handsome profit. Price \$4.00.

Plan No. 7—1000 Spare Time Money Making Ideas. A job for everybody. 146 page book tells how. Price \$1.00.

Plan No. 8—100 Civil Service Examinations. Covering steady Government jobs. All types of positions. Better business means thousands of new jobs. Prepare now by studying this new book. Price \$2.50.

Plan No. 9—Making Poultry Pay. The proper breeding and management of fowls for higher egg production. Price \$2.00.

Plan No. 10—Fur Farming for Profit. Complete instructions that enable the beginner to succeed from the start. Price \$4.00.

Plan No. 11—Rabbits for Food and Fur. A complete guide to the successful rearing and breeding of rabbits. Price \$2.00.

Plan No. 12—The Frog Industry. Should be considered more as a side line than as a major means of income. Price \$2.00.

Plan No. 13—How to Live on a Subsistence Homestead. Facts and figures on how one family fled from the city and found security and independence. Price \$2.50.

Plan No. 14—Auto Service Shop Management. Money-saving and business-producing ideas by two men who know just what is essential to a profitable service shop business. Price \$1.50.

Any of the above mailed postpaid upon receipt of price or sent C.O.D. anywhere in U. S. Pay postman price and few cents postage.

POPULAR MECHANICS PRESS
Room 1136 200 E. Ontario St. Chicago, Illinois

Carry this Shirt Factory in Your Pocket!



WE WANT MEN!
Big Steady Earnings

Yes, here's a real proposition where you can make real money with a real future.

Have you ever investigated the Packard Line which offers you Big Daily Commissions, Steady Employment and Regular Cash Bonuses? New complete up-to-date line is now ready and consists of a large variety of the latest Shirtings, Neckwear, Men's Hosiery, Dress and Work pants. No experience necessary; work full or part time. Without question the greatest and fastest money-making line ever offered a direct selling representative. \$5.00, \$10.00 and up can be made every day and a big monthly cash bonus besides. Write for Free Complete Sample Line.

PACKARD SHIRT MANUFACTURING CORPORATION
Terre Haute Dept. P-328 Indiana

Trailer Travel Magazine

Keep abreast of trailer travel and trailer life!

If interested in trailer lore as owner, builder, buyer or prospect, you want the only magazine devoted exclusively to—

- News, articles and stories on all phases of trailer life.
- Current events in the trailer world.
- Official announcements of all trailer conclaves.
- Trailer tours and trailer camp information.
- Lists of national, state and local trailer parks.
- Developments in the trailer industry.
- New features in trailer construction and equipment.
- Helps for the trailer home-builder.
- Federal, state and local laws and regulations.
- Hunting, fishing and other sports via trailer.
- Housekeeping on wheels by the trailer wife.
- Advertisements—a directory in themselves of the field.

For 1 year monthly mail, \$1, or for sample copy.....10c
TRAILER TRAVEL Magazine, PM11, 180 N. Michigan Ave., Chicago

BULL DOG Trailer HITCH

CHEAPEST TRAILER INSURANCE in the world. **DROP FORGED Bull Dog Hitch NEVER LETS LOOSE! GUARANTEED AGAINST BREAKAGE.** Certified tensile strength up to 52,400 lbs. Unfastens easily at any angle BUT ONLY when desired. Wear compensator prevents back lash, lost motion, noise. A type for every trailer. Used EXCLUSIVELY by Biggest Trailer Manufacturers. WRITE TODAY for FREE details. (Include only 50c for latest Guaranteed Trailer Builder's Guide.)
HAMMER BLOW TOOL CO. Dept. BD-11 WAUSAU, WIS., U. S. A.

We Take Your Camera and Equipment in trade!

Free WRITE US if you have a Camera or equipment you want to exchange for some other outfit. A reasonable sum offered for any saleable apparatus.

BARGAIN BOOK of Cameras & SUPPLIES
Central's Newest Bargain Book offers hundreds of bargains in new and used movie and still cameras, lenses, films, etc. All GUARANTEED. Write for your FREE copy!
CENTRAL CAMERA CO., (Est. 1899) 230 S. Wabash, Dept. K-11, CHICAGO

AGENTS 500% Profit GOLD LETTERS

For Store Fronts and Office Windows. Anyone can put them on. Free samples. Liberal Offer to general agents.
METALLIC LETTER CO., 438 N. Clark St., Chicago

NEW SCIENTIFIC WONDER

"X-RAY" CURIO



10c
3 for 25c

Reg. U.S. Pat. Off.

BOYS BIG FUN. You apparently see thru clothes. Wood, Stone, any object. See Bones in Flesh. **FREE PACKAGE** radio picture films, take pictures without camera. "You'll like 'em." 1 package with each 25c order.
MARVEL MFG. CO., Dept. 80 — NEW HAVEN, CONN.

When writing please mention Popular Mechanics

Here is my gift to mother! Made in three evenings. We had the lamp. Taxidermy material cost me 85¢.



For tired business men; for the older boys, too!

Boys with hobbies are better boys; and become better men.

This case is invented & illustrated an interesting fact.

A wonderful hobby for old and young

Tired Business Men NEED a hobby!

Learn this Art:

Learn Taxidermy (also tanning and fur work) at home; direction sheets will be **mailed** to you. After 4 or 5 evenings of practice in spare time you should successfully mount the simpler specimens of birds and fish. Thereafter practice makes perfect. **Very inexpensive** — Taxidermy supplies, such as glass eyes, etc., cost **so little**. Booklet free.

And Profits, too

Malcolm Greany made a squirrel lamp. Now he writes us that he has 15 orders for squirrel lamps. **Figure his profit!**

Beautiful Decorations

for your own home or to sell to others

Work out your own ideas for lamps, book ends, clocks, etc., etc., decorated with stuffed specimens of squirrels, rabbits, white mice, pigeons, frogs, etc., etc. Also comical things:— squirrels boxing, frogs playing fiddles, chipmunks fighting, etc., etc.

Mr. Sportsman:

With wild game scarcer and scarcer, you'll get more pleasure out of one specimen you personally mount than out of your former big bag. Prepare yourself **now**. Practice up on Taxidermy before the season!

Free Book

To J. W. Elwood (Est. 1908) 3378 Elwood Bldg., Omaha, Neb.

Without any obligation send me (free) your illustrated book telling me how I can quickly learn the knack of Taxidermy. Tanning and Fur-work from direction sheets sent me by mail.

Name.....
Address.....
Age.....
State your age!

Train Now at LINCOLN for Good Pay Jobs in AVIATION

Thousands of new jobs being created in aviation as a result of the greatest growth the industry has ever known. Factories are working night and day building new airplanes. Airlines are adding millions of miles to their flight schedules. Thousands of newly trained men are needed. There is a place for you... if you have the proper training... the complete training Lincoln offers you.

Lincoln Government Approved Training gives you the accurate technical knowledge and practical experience which qualify you for these better pay jobs in aviation: Airline Pilots get up to \$700 a month. Co-Pilots get \$250 a month. Licensed Mechanics get up to \$200 a month.

We train you for Government License as Transport, Limited Commercial, Private or Amateur Pilots. Also every requirement for Government License as Airplane and Engine Mechanic. Sheet Metal Training.

Start training now at this Government Approved School. Now in the 26th year. 16 years teaching aviation.
LINCOLN AIRPLANE & FLYING SCHOOL
Mail Coupon Now 202G Aircraft Bldg., Lincoln, Nebraska

LINCOLN AIRPLANE & FLYING SCHOOL
202G Aircraft Bldg., Lincoln, Nebraska

YES! I want further facts about LINCOLN'S complete training and the big-pay opportunities ahead in Aviation.

NAME..... AGE.....

CITY..... STATE.....



JUST OUT!

\$2



If you are interested in the construction, operation and maintenance of modern Diesel engines, you will want this new timely book of practical, useful information.

"AUDEL'S DIESEL ENGINE MANUAL" with Questions and Answers explains in simple, concise language the Fundamental Diesel Principles—Operating Principles—Engine Starting—Air Starting—Valves—Fuel Spray Valves—Inlet and Exhaust Valves—Valve Timing—Fuel Pumps—Fuel Injection Compressors—Starting Air Compressors—Scavenging Air Compressors—Pistons and Piston Rings—Cylinders—Lubrication—Cooling Systems—Fuel Oil—The Engine Indicator—Governors—Engine Reversing—Semi-Diesel Engines—High Speed Diesel Engines—Answers on Operation—Horse Power Calculations.

The illustrations and texts are clear and easy to understand. All details are plainly brought out. This book is of extreme value to engineers, operators, students and all who desire a knowledge of the Diesel engine. A handsome book, flexible, with gilt edges. 300 pages—illustrated.

Send for free Diesel folder today.

FREE EXAMINATION COUPON

THEO. AUDEL & CO., 49 W. 23rd St., New York
Please mail a copy of AUDEL'S DIESEL ENGINE MANUAL. If satisfactory, I will remit \$2 on its safe arrival, otherwise I will return the book. **\$2**

Name

Address

Occupation PM

**SWEET OR SWING
BUESCHER'S THE THING**

Hal Kemp
leader, and many players in his popular Radio Band, use Buescher True-Tones.

Easy to Play
**FOR FUN
OR PROFIT**

Quickly, easily, you'll learn to play a Buescher True-Tone saxophone, cornet, trombone—any band instrument. Exclusive Buescher features mean faster progress—you join a band or orchestra in a few weeks—win pleasure and profit.
FREE TRIAL: Easy Payments. Send now for details, no obligation. Mention instrument which interests you.
Buescher Band Instrument Company
1100 Buescher Bldg., Elkhart, Ind.

BUESCHER
True Tone

LAW HIGH-GRADE INSTRUCTION BY CORRESPONDENCE

College, Post Grad, and Bar Ex. Rev. Courses. Law has attracted more keen, brainy men than any other calling. Send today for catalog. Low cost, easy terms. Standard text. Degrees.

Chicago School of Law Dept. 301, Reaper Block CHICAGO, ILL.

Learn ADVERTISING at Home

Greater opportunities now in advertising. Learn easily and quickly in spare time. Practical work. No text books. Old established school. Low tuition—Easy terms. Send for free booklet of interesting information.

Page-Davis School of Advertising
Dept. 1358, 3601 Mich. Av., Chicago

REPAIR MOTORS

YOURSELF—A complete knowledge of electricity isn't necessary to enter this profitable field. Our New Illustrated course on Practical Winding of A. C. Motors tells YOU how to wind, test, and repair all types. The Course includes a TROUBLE CHART that enables anyone to trace motor troubles to their source. Both Complete for \$2.00.

EDUCATIONAL ADVANCEMENT CO.
Box 252 Lakewood, N. Y.

CIVIL SERVICE

VALUABLE INFORMATION
COLUMBIAN CORRESPONDENCE COLLEGE
WASHINGTON, D. C.

BECOME A VENDING MACHINE OPERATOR!

Own a "chain" of 10 peanut and chewing gum vending machines. Large, steady profits, as people eat peanuts and chew gum daily. Start with \$100. Write for details today!

D. ROBBINS & CO.
1141P DeKalb Ave. BROOKLYN, N. Y.

NO BOSS! SURE CASH!

SILVERING MIRRORS

Autoparts, Reflectors. Combination outfit. Write
SPRINKLE, Plater, 129, Marion, Indiana

PENNY EACH !

Beautiful Window Sign Letters. Lowest Price in America. Finest Quality. 5 Year Guaranteed. New styles. Tremendous Demand. Big Profits. Easily Applied. Record Breaking Offer. FREE Samples and Working Equipment. Hurry!

Atlas Sign Works, 7943 Halsted, Chicago, Ill.

SHIP MODELS

Get this dandy catalog of true-scale models of Flying Cloud, Viking, Blue Nose, Tally-ho Coach, deluxe fittings. Send 15c (in coin) for your copy.

ROY HANCOCK, 323 Douglas Ave., Portsmouth, Virginia

AERO SOCKET LIMBS

Are made to be comfortable. Chafing, sore spots, blisters are unknown to wearers of Aero Socket limbs.

Write for circular today.
Aero Socket Artificial Limb Co.
La Crosse Wis.

Men & Women Earn Cash at Home!

Mrs. M. M. earned \$267 in 3 weeks (sworn statement) raising mushrooms for us in her cellar! Exceptional? Yes, but your cellar, shed, barn may be suitable to bring moderate income. Book, pictures, sample free. Est. 1908.

UNITED CO. 3848 Lincoln Ave. Dept. 67 CHICAGO

When writing please mention Popular Mechanics

**WORLD'S
BEST
WANT AD
MEDIUM**

CLASSIFIED Advertisements



Advertisements in this section, 35 cents per word, each insertion, minimum 10 words, payable in advance. To be inserted under proper classification in December issue, copy should be in our office October 10th Popular Mechanics Magazine, 200 East Ontario Street, Chicago, Illinois

YOU'LL PROFIT

By reading and answering the classified ads in this section. Hundreds of opportunities to make and save money.

Popular Mechanics Magazine,
200 East Ontario, Street, Chicago, Illinois

Gentlemen: We wish to compliment you on the wonderful results that your National Magazine has produced for us. We have placed advertising in your magazine each month consecutively and have checked on the results. At this writing we wish to say that your magazine has produced as many results as any other two magazines combined. If we were to advise our fellow advertisers as to a good medium for advertising their products, we would recommend your fine publication among the first to try. If it can be sold, "Popular Mechanics" will sell it. We hope that future advertising will prove as advantageous to us as in the past.

(Original letter on
file in our office)

Very sincerely yours,
THE FRIEMARK PRINTING COMPANY.

AUTOMOBILES

NOW! A money-back guaranteed Diesel converter for automobiles, trucks, tractors, boat engines; complete with fittings only \$7.75. (V type engine \$10.00.) 5 days trial. Saves up to 70% fuel cost. Easy to install. Send \$7.75 money order or \$2.00 and pay balance when delivered. Great Diesel Co., Dept. C, 516 Morgan Bldg., Portland, Oregon.

CONVERT Your automobile to burn Diesel oil—average cost five dollars. Save hundreds. Complete instructions for one dollar. Dual Mfg. Co., 1139 Broadway, Seattle, Wash.

DIESELIZE! Pre-combustion chambers \$2. Screw in spark plug holes; spark plugs in top. Burn Diesel or gasoline completely. Eliminate fouling, dilution, smoke, pingz. High turbulence combustion. Outstanding mileage, performance. Diesel conversion's missing link. Proven. Pre-combustion conversion data \$1. Perry, Diesel Engineer, Washougal, Washington.

REBUILD "T" motor into fast pumping air compressor. Plans \$1.00. Tuck, 73 South Shirley, Pontiac, Mich.

GUARANTEED Fuel conversion plans 25c. Technical Supply, 1457 Broadway, New York.

DIESELIZE Gasoline engines—Simple installation low as \$3.00. No special parts. Use cheap fuel. Information free. Dieselizer, Box 5202, Los Angeles, Calif.

SEMI-DIESEL Conversions for gasoline motors, \$12.00. Enclose 5c. (stamps or coin)—for illustrated literature. Desogas, 1719 Addison, Berkeley, California.

R & R MFG. Co., Anderson, Indiana. Speed equipment for Fords and Chevrolets 25c for catalogue, midgits included. Camshafts reground.

INCREASED Mileage; lower cost. Oldest and original conversion blueprints to burn stove distillate in any car. Get parts in junk yard. Complete detailed information and blueprint 50c (coin). Thousands of successful conversions. Maydwell Mfg. Co., Box 492, Glendale, Calif.

"SEMI-DIESELIZING With Controlled Heat." Continuous peak performance, most mileage. Copyrighted plans 50c. Crippen-Deming Labs., Norwood Rd., Jackson, Mich.

MIDGET Racing book; facts for fans, builders, drivers; track sizes, regulations; pictures, specifications, working drawings. Also stock car conversions for fastest cars. \$1.00 postpaid. \$1.12 C.O.D. Ray Kuns, Dept. 20, Cincinnati, Ohio.

MIDGET Car plans, parts, engines. Circulars dime. Storms, 13 Southside, Asheville, N. C.

BOOKS Covering hundreds of subjects. Big catalog for 3c postage. Popular Mechanics Press, Room (C36), 200 E. Ontario St., Chicago.

AUTO SUPPLIES AND EQUIPMENT

USED Auto parts at half price for all cars. Century Parts Co., 1712 Lafayette Ave., St. Louis, Mo.

PLATING Outfits for automobile parts. Connect to battery. No tanks used. Free particulars and proofs. Gunmetal Co., Ave. J. Decatur, Ill.

DEMONSTRATORS. Compressor, test bench, 8-hour battery charger—are welder. Guaranteed. Trial and terms. Ken's Equipment Exchange, Box M-1161, Troy, Ohio.

SAF-T-LITE Tire deflation signal flashes light (on steering post) if any tire deflates, even slightly. Prevents accidents. Saves tires. Positive. Easily installed. Autos, trucks. Low priced. Write Splith Mfg. Co., Dept. P, Omaha, Nebr.

SAVE Money with Thydro-X. Complete details free. Agents wanted. Robert Kephart, Georgetown, Delaware.

"SPARK Plugs." Sell genuine Tungsten hot and cold spark plugs, give sand-blast cleaner and eight piece wrench set free, with each 50 plugs. Four easy orders daily pay you \$120 weekly. Tungsten Factory, 1402 So. Michigan, Chicago.

IGNITION Supercharger — Fast-starting wet or cold. More mileage, pep, less carbon \$1.25. Order now, one free. Agents wanted. E. G. Sales Co., 321 Broadway, New York City.

WINDING Data automobile armatures \$1.50. Supreme Elect., 24 W. 20th St., New York City.

A. C. GENERATORS

PRACTICAL Changes for automobile generators. See our advertisement at bottom of page 161A. Autopower, Inc.

AUTO TRAILERS

BUILD Trailer—Use auto parts. Plans 20c. Century, Box 127, Racine, Wisconsin.

PARTS For the Popular Mechanics "Family Trailer" featured in the February, March and April issues. Everything you need—Axle, hitch, wheel housings, water tank, pump, toilet, sink, stove, wood parts, windows, screens lights, cushions, etc. Send for price list. Include 25c for our big catalog and Trailer Builders' Manual. Trailer Supply Co., 410 Grand Ave., Wausau, Wis.

TRAILER-ITES! See advertisement of Trailer Travel Magazine on page 47A.

MOTORCYCLES, BICYCLES AND SUPPLIES

POWER Your bike with low priced Speed-bike motor. Attach in one hour. Eighty miles to gallon. Thirty miles an hour. Free folder. Guaranteed. Outboard Motor Corp., 4043 N. 28th St., Milwaukee, Wis.

"LET Me supply your motorcycle needs." Genuine Harley Davidson parts, accessories, oil. Motorcycle tires, cylinders and pistons re-honed and fitted. Expert repairing, frames and forks straightened. Prompt service. Send 50c for complete parts and accessory catalogue. Bill Knuth, 2491 W. Fondulac Ave., Milwaukee. Exclusive Harley Davidson dealer.

DIME Secures sample Speedway Racing Magazine, catalog English motorcycles, crash helmets, speed books, supplies. Clymer, 434 W. Pico, Los Angeles, Calif.

SEND 10c For Handbook of Information listing new and used parts, for Indian, Harley, Excelsior, Henderson; accessories, tires, batteries. Bootz, 622 East Grand, Des Moines, Iowa.

MOTORCYCLE Bargains, lowest prices, bargain sheets for stamp. Motorcycle accessories. Rochester Harley Davidson Corp., 129 West Main St., Rochester, N. Y.

HENDERSON, Excelsior, Harley, Indian, used parts, alloy pistons, catalogue and wings pin 10c. Ballak, 1115 Chestnut Street, St. Louis, Mo.

SEND 15c For illustrated used motorcycle catalog. Bargains. Largest stock genuine Indian parts and motorcycles. Indian Motorcycle Sales, Kansas City, Mo.

MOTORCYCLES—Direct to you at rock-bottom wholesale prices. Rebuilt, roadtested and guaranteed Indians, Harleys, etc. Send 10c today for "Bargain Bulletin 43." Crandall Hicks Co., 780 Commonwealth Avenue, Boston, Mass.

RECONDITIONED Motorcycles. New and used parts for all makes. Complete service. Whitman Motorcycle & Supply Co., 405-9 Southwest Blvd., Kansas City, Mo.

REBUILT Motorcycles, all makes, new and used. Harley Davidson parts. Send 10c for bulletin. Western, 914 E. 15th, Kansas City, Mo.

MOTORCYCLE Tires \$4.00. Motor bicycle \$45. Chains, wheels \$1. Parts at low prices. Send 12c. Bicycle \$12.50. Price Cutter Deninger, Rochester, N. Y.

AVIATION

WANT To get into aviation? Train at home in spare time. Complete, practical up-to-the-minute home study course trains you to fill many different types of ground jobs. Write for free book. Aviation Institute of America, Dept. A-10A, 1115 Connecticut Ave., Washington, D. C.

NEW Heath airplane bulletin. Photos, description, specifications 1936 factory welded "Parasol." Build it yourself. Send dime today for Bulletin "P". Heath Aviation Company, Benton Harbor, Michigan.

YOUNG Men interested in entering aviation under transport pilot and mechanics training plan. Write immediately enclosing stamp. Mechanix Universal Aviation Service, Strathmore Station, Dept. D, Detroit, Michigan.

FREE Full size wing curve of the famous flying Flea Airplane. Send 10 cents for postage. Box 30, Schertz, Texas.

PROPELLERS, Literature 6c. Woodcraft Propeller Co., Hillside Station, Wichita, Kans.

PROPELLERS For airplanes, icesleds, snowsleds. Catalog dime. Lorenzen Propellers, Niles, Michigan.

BECOME Junior student. Start your flying course now with home studies. For particulars write Freeland Flying School, Pine Brook Airport, Pine Brook, N. J.

WE Train sea and air navigators. Former pupils: Gatty, Lindbergh, Ellsworth. Correspondence courses, equipment, charts, etc. Latest contribution to star-minded—Ilyne's Star Chart with booklet, 50 cents. Write, Weems System of Navigation, Annapolis, Md.

GET Into aviation. Air transport pilots get up to \$7,000 per year; mechanics, \$2,500. Learn at this government approved school. Write for complete information. State age. Lincoln Flying School, 2004 Aircraft Building, Lincoln, Nebr.

NEW Airplanes, \$98.00. Terms. Motors, propellers, air-wheels. Send 25c for information. Hibbs, Fort Worth, Texas.

HUNDREDS Airplanes \$75 up. Terms. Complete directory, 25c, postpaid. Aircraft Directory, Athens, Ohio.

BATTERIES, GENERATORS, ETC.

BUILD Windcharger from auto generator. Dime brings complete plans and catalog. 6, 32, 110 volt motors, generators; welders; electric fence. LeJay Mfg., 1647 Lake, Minneapolis, Minn.

GUARANTEED Windcharger parts—Powerful propeller \$1.40. Information 10c. Beacon Mfg., Bismarck, N. Dak.

HARNESS Wind. Simplest wind plant, direct drive. No turntable, gears, belt, cut-out or rewinding. Charges below 100 r.p.m. AC-DC, 6/32 volts. Complete plans 75c. Main Electric, Hollis, Kansas.

ELECTRIC Lights—Wind driven—You build them. Write Wind Motor Electric, Brainerd, Minnesota.

EDISON Storage batteries for light-power plants. Non-acid, non-sulphating. Long life. Fully guaranteed. Low priced. Also attractive bargains in power-light plants, generators, motors, etc. T. Hawley Smith Company, Croton Falls, N. Y.

GENERATOR Propellers, expertly designed at factory prices. Hibbs, Ft. Worth, Texas.

EDISON Storage batteries will save you money. Replace your lead with the Edison. Non-acid. Odorless. Fifteen year life. Liberal unconditional guarantee. Bargains in complete generating plants, motor, etc. Free illustrated literature. "See Jay Battery Company," 82 Sterling Avenue, Yonkers, New York.

ELECTRICAL SUPPLIES—EQUIPMENT

HUNDREDS Of new and rare items, replacement parts and supplies. Send 10c for new, 60-page wholesale catalog. Autopower, 410-G S. Hoyne Avenue, Chicago.

REVIVE Scorched windings. Practical. Economical. Instructions \$1. Farris, Valley Junction, Iowa.

NICHROME Heating coils, wire, ribbon. Stamp for list. Heatercolleo, Edgerton, Wis.

ELECTRIC Engraver, designs metal beautifully. \$1.00 prepaid. Hudson Bros., East Syracuse, N. Y.

DESIGNING And building solenoids and electromagnets and 358 other valuable electrical and shop kinks in Shop Notes for 1936, only 50c postpaid. Popular Mechanics Press, 200 E. Ontario St., Chicago.

WELDING AND SOLDERING

80 AMPERE, 110 Volt welder, handles 3/4th electrodes. Air cooled multi-heat, sturdy transformer. With cables and tongs, \$27.50. Welding supplies. Dealers wanted. Armstrong, 1936 Lyndale, South, Minneapolis, Minnesota.

DEMONSTRATORS, Electric arc welders. Money-saving prices. Used by the government. Trial and terms guaranteed. Hobart Welders, M-1162, Troy, Ohio

ECONOMICAL Arc-welder from Dodge generator. No rewinding. Plans dollar. Particulars dime. Pulis, Booker, Texas.

MAKE Cast iron filler for cast iron welding. Formula \$.50. Weissert, Morris Ave., Union, N. J.

DODGE Arc-Welder, 25-200 amperes. Build your own from old North-East automobile generators. Certified plans, instructions; in United States \$1.00, COD's \$1.12. Foreign orders appreciated. Welders' Club of America, 3432 Drake, Chicago, Illinois.

CR. ARC Welder. Sensational performance and price. The positive, safe, Flex-Amp control gives you any welding current to a fraction of an ampere. Welds 1/16 to 3/16 coated rod using 110 or 220 volt ac. Overhead or sheetmetal welding a cinch. Low price. Welder, 615 N. Commerce, Stockton, Calif.

ATTENTION All Dodge arc-welded builders. Install new heavy duty brushes designed for welding. Set of four brushes \$2.00. Welders' Club, 3432 Drake, Chicago.

REBUILT Electric arc welders, all sizes, a.c.—d.c. Service Co., 3732 Cedar Ave., Cleveland, Ohio.

OXY-ACETYLENE Welding outfits on easy payment plan. Box 331, Hamilton, O

ARC-WELDING Outfit \$1.25. Weld fenders, braze, solder. Lavrow, 4368-W, Warren, Detroit. Stamp appreciated.

300 AMPERE Welding generator. Fine condition \$150.00. Wilmot Auto Supply, 1970 Wilmot St., Chicago.

ENGINES, MOTORS, DYNAMOS

GOVERNORS Control speed of any make of auto engine, regardless of load changes, when used for stationary or portable power production. Read our ad on page 139A. Man'g's Candee-Smith Governor.

WINDING Data 180 motors, test transformers, generators, growlers, \$1.00. Atlas Data, 24 West 20th St., New York.

SEVEN—1/2 Horsepower General Electric motors, 60 cycle, 1 phase, 110 volts, like new, \$9.50. Send check to Erie Electric, 120 Church, Buffalo, N. Y.

ALTERNATING Current, new and rebuilt, motors, grinders, electric clocks. Exceptional bargains. Pricelist free. Mailorder Electric Co., 1718 So. Michigan, Chicago.

12 VOLT Dodge generators \$5.00. N.P.&M.Wks., 1367 Niagara St., Buffalo, N. Y.

SMALL Elect. motors, high speed, 1/10 horsepower, 110 volts, universal. Reworked, \$1.50 postpaid. L. McConnell, 1619 Edgewood Ave., Racine, Wis.

THREE To ten KVA alternating generators. Motors, converters. Queen City Electric, 1736 Grand Avenue, Chicago.

WINDING Data, 1000 a.c. motors, eight leading manufacturers, \$1.00. Chas. Chittenden, Jr., Box 7631, Kansas City, Missouri.

SMALL Electric motors, high speed, 1/10 h.p., 110 volts, universal rebuilt, like new. \$2.00 postpaid. L. McConnell, 1619 Edgewood Ave., Racine, Wis.

25 SLIGHTLY Used 1/2 horse alternating motors \$9.85. 3/4 horse new General Electric \$5.90. Wilmot Auto Supply, 1970 Wilmot St., Chicago.

MACHINERY, TOOLS AND SUPPLIES

1/2" MICROMETERS—65c. Measures to .001". Limited quantity. Postpaid. Sandry, 74 DeSoto, West Roxbury, Mass.

SPRING Winders \$3.00. Or drawing and make it yourself, \$1.25. Myers Spring Winder Co., 111 Washington St., Burlington, Iowa.

WOODWORKING Machinery, clamps. Dealers write. John Redin Company, Rockford, Illinois.

KELLOGG Air compressors, \$6.00. Refrigerator parts. Taylor, 105 East 102nd Street, New York.

MACHINISTS, Tool makers chests at bargain. Circular free. Cepader, 3602 Wesley, Berwyn, Ill.

BARGAINS, Demonstrators, electric arc welders, guaranteed, 30 days trial and terms. Write Ken's Equipment, Box M-1163, Troy, Ohio.

POWER Hack saw, bench type, \$11.95 new. Burk Machine Co., 1314 Prospect Ave., Toledo, Ohio.

CONCRETE Building block machines and molds. Easy payments. Catalog free. Concrete Machine Co., 5 North Main St., St. Louis, Mo.

1/2" HEAVYDUTY Precision bench drill presses \$6.95 complete. Lacquer spray guns \$2.00. Machinery lists, stamp. Universal Electric Company, Indianapolis.

FREE Price list all shapes brass, copper, steel and aluminum. All orders postpaid. Hobby Supply House, Box 2014, Pittsburgh, Pa.

15" x 6" SOUTH Bend screw cutting engine lathe, \$175.00. 14" Steptoe crank shaper \$125.00. All sizes of machine tools. Cincinnati Machinery & Supply Company, 27 West Second St., Cincinnati, Ohio.

TREMENDOUS Surplus of factory tools selling out. Drills, taps, files, hacksaws, etc. Send for free lists, include six cents postage. Travers Tool Co., 264 Jackson Ave., Long Island City, N. Y.

50-1/2 HORSE, 110 Volt, Universal motors equipped with 14 to 1 gear reduction \$3.50. Wilmot Auto Supply, 1970 Wilmot St., Chicago.

BOATS, OUTBOARD MOTORS, ETC.

12-FOOT Flat bottom rowboat—complete plans 25c. Free boatbuilding catalog. The Rudder, 15 Murray Street, New York.

WANTED—Outboard motors and parts. We pay cash. Outboard Headquarters, 305 Atlantic Avenue, Boston, Mass.

BUILD A boat. You can build a better boat by the Welch System. 32 page catalog 25c. Welch Boat & Company, Station K-1, Milwaukee, Wisconsin.

BOAT Designers are highly paid professionals. Complete course by mail. Catalog. Westlawn, Montville, N. J.

CARRY Amazing folding boat like luggage. Light, strong, seaworthy, 5 models. Porto Boats, Box 304, Glen Cove, N. Y.

BUILD Your own boat. Save two thirds, use our ready cut semi-assembled materials. Send 25c for catalog. Brooks Boat Co., Inc., P. 20, Saginaw, Michigan.

OUTBOARD Parts—New or used—All makes—What do you need? Crandall-Hicks Company, 782 Commonwealth Avenue, Boston, Mass.

BOAT Blue prints, paper patterns. Send postage. Box 1007, Station A, Cleveland, O.

SPORTING GOODS, GUNS, FISHING TACKLE, ARCHERY

BOYS! Thrills galore, hunting and target shooting with bow and arrow. Kill rabbits, possum, coyotes, etc. Shoot 100 yds. 5 foot bow and three arrows \$2.95 postpaid. Arrowhead Archery Co., Dept. J, South Bend, Indiana.

TENTS: Factory to you, Catalog free. Willis Co., Everett, Mass.

TRAPPERS! Killum traps 68c doz! Circular free. Grant Sportgoods, B51-K, Detroit, Mich.

GUNSMITHS Secrets. Bluing, checkering, engraving. Instructions 25c. Duffy, Covington, Ky.

ARCHERY. Become expert! Send 25c for instruction book. Illustrated catalogue free. Largest stock. Archery Sales Co., 439 South Wabash Avenue, Chicago.

TRAPPERS—Three size 0 Kiefflock steel animal snares, 50c. Per doz., \$1.60, postpaid. For catching fox, coon, lynx, woodchuck, rabbit. Kieffman Lock Snare Co., Dept. P, Hibbing, Minn.

COLLAPSIBLE Canvas decoys. Light, durable, lasting, lifelike. \$2.95 doz., delivered. Send money order to C. A. Frakes, Port Arthur, Texas.

FISHERMEN. Free new 1936 catalog showing many new and improved items for fly and leader makers, all that is new in tackle. Paul H. Young, 8065-3 Grand River Ave., Detroit, Mich.

HUDSON Bay blankets, Indian pack baskets, camp stoves, knives, compasses, outdoor equipment. Free catalog. Howe Fur Co., Box P, Coopers Mills, Maine.

FISHERMAN! Sinker molds. Only \$1.25 postpaid in United States. Free folder. Box 313-C, East Liverpool, Ohio

FIELD GLASSES, TELESCOPES AND MICROSCOPES

GET Our lowest prices on telescopes, microscopes, movie cameras and hundreds of other items. Catalog free. RR. Winn, 124 W. 23 St., New York

TELESCOPES, Opera glasses—\$.50. Field glasses—\$1.00. Microscopes—\$1.50. Postpaid. Box 66, Sta. W, Brooklyn, N. Y.

BUILD 6" Reflecting telescope. All parts ready to assemble including silvered mirror \$25. Lutts, Norwalk, Ohio.

FREE Literature—Amateur Telescope Makers Supply Company, 24 West 20 Street, New York.

TELESCOPES. Microscopes, binoculars. Lowest prices. Optical catalog free. Brown-cope Company, 234 Fifth Avenue, New York.

BUILD Reflecting telescopes; catalog free. Instructions 10c. Optical Laboratories, Larchmont, N. Y.

TELESCOPES. Microscopes, binoculars, movie cameras. Cut prices. Easy time payments. Illustrated catalog 10c (refunded). Teeko Optical, 515NE, Evanston, Illinois.

USED Microscopes, binoculars, astronomical telescopes, surveying instruments—Bought, sold, repaired. Send 10c for list. Rasmussen, P. O. Box 294, Amsterdam, N. Y.

ANTIQUES, RELICS, INDIAN GOODS

MODEL Indian teepees. For information inclose stamped, self-addressed envelope. Wallace Larkey, Crow Agency, Mont.

500 GOOD Arrowheads \$13.00 prepaid. Also other relics. Flint knife 40c. A. Mayes, Pelham, Tenn.

15 ARROWHEADS, Spearhead, pottery, lancehead \$99. Firearms, 120,000 bargains. Photolist 10c. Museum, Rutland, Illinois.

WORLD War relics, for club house or den. Vickers aircraft machine guns, rendered unserviceable without marring, \$7.75 each. Marlin aircraft machine guns, rendered unserviceable, \$7.75 each. Send money order, check or draft. \$1.00 deposit on C.O.D. orders. Fiala Outfits, 10-C Warren St., New York.

5 ARROWHEADS 20c. 3 Birdpoints 18c. Knife, birdpoint, scraper, spearhead 45c. Catalogue. Coins. Minerals. Curios. Lemley Curio Store, Northbranch, Kansas.

100 GOOD Arrowheads \$3.00. Catalog 5c. H. Daniel, Dardanelle, Ark.

DOGS, BIRDS, PETS

SAINT Bernards—Giant type puppies priced right! Dime brings photographic prospectus promptly! Royal Kennels, Napierville, Que.

COONHOUND Puppies. Registered. \$10.00 up. Nightsong Kennels, High Street, Bridgton, Maine.

BEAGLE Puppies. AKC litter. Registered, reasonable. Leo Hoffman, Lapeer, Mich.

QUALITY Puppies. Chows, cockers, Scotties \$20. Scholls Kennels, Sterling, Ohio.

SAINT Bernard puppies, rare beauties, reasonable. Dime brings photos. Paramount Kennels, North Hatley, Quebec.

SPORTSMEN: 200 Pointers, Setters, Straight Cooners, Combination Hunters, Rabbit and Fox Hounds. Cheap. Lists free. Ramsey Creek Kennels, Ramsey, Ill.

COON, Fox, Beagle, Rabbit and combination hounds. Pointers, Setters. Cheap. Trial. Literature free. Dixie Kennels, B68, Herrick, Ill.

BEAUTIFUL Pure white police dogs. Ansonia Kennels, Mose, N. Dak.

TAXIDERMY

TAXIDERMY Supplies—Quality artificial eyes, teeth, genuine Jonas head forms. Tools, materials, etc. Everything for the progressive taxidermist. Send 10c for big illustrated catalog. Jonas Bros., 1049 Broadway, Denver, Colorado.

FREE—Official catalogue. Big values. Eyes. Head forms. Everything, direct from manufacturer. Taxidermic Manufacturers, Memphis, Tenn.

LEARN Taxidermy complete \$1.00. Glass eye catalog free. Schoepper Eyes, 134 West 32 St., New York.

GLASS Eyes. Taxidermists', furriers' supplies. Lowest prices. Forty page catalog, free. Write today. Elwood Supply Co., 222 Smith Building, Omaha, Nebraska.

UNCLAIMED Specimens, eyes, scalps, supplies. Hofmann Studio, 992 Gates Ave., Buffalo, N. Y.

FARMS AND FARM LANDS

FARMS, Groves, ranches, auto camps, gas stations—Coast-to-coast—Money-saving bargain sales catalog mailed free. Mention state. Strout Ag'y, 7-MT So. Dearborn, Chicago, 255-P 4th Ave., New York or 453-AG So. Spring, Los Angeles.

40 ACRES, Near White River, unimproved, poultry land, \$100, \$5 down, \$5 monthly. Free list and literature. Hubbard, 216 Grossman Bldg., Kansas City, Kansas.

FARMS That pay in the Great Northern Railway agricultural empire—Minnesota, North Dakota, Montana, Idaho, Washington, Oregon—Fertile black soil, high producing crops, grain, fruit, vegetables, feed and livestock. Many kinds of farms for selection. Write for lists and Zone of Plenty book. E. C. Leedy, Dept. 1157, Great Northern Railway, St. Paul, Minnesota.

GOOD Land still at rock bottom prices. Washington, Oregon, Minnesota, Idaho, North Dakota. Ask about new northwest developments. Literature. Specify state. J. W. Haw, 119 Northern Pacific Ry., St. Paul, Min.

TREES, SHRUBS, ROOTS, HERBS

FREE! Send for this amazing new "Herbalist Almanac." Interesting! Instructive! Educational! Contains over 200 valuable herb medicine recipes and Indian secrets for home use. Beautifully illustrated in natural colors. Needed every home. Dime covers postage and handling. Write today! Botanics, 145 West 112th Street, Chicago.

PROFITABLE OCCUPATIONS

MONEY In mushrooms! Start now, in cellar or shed, get highest prices. Exclusive new process. Bigger, better, quicker crops. We buy. Books free. American Mushroom Industries, Dept. 771, Toronto, Ont.

"RAISE Giant frogs!" Start backyard. We buy! Breeder lays 10,000 eggs yearly. Frogs sell up to \$5 dozen. Free book. American Frog Canning Company, (153-W), New Orleans, Louisiana.

MAKE 100 Gal. penetrating oil, \$15.00—Sell 25c pint. Formula and full information \$2.00. Product guaranteed. A. L. Hess, Box 245, Janesville, Wis.

FREE: Opportunities galore! Home City Specialties, Box PM1273, Springfield, Massachusetts.

MRS. M. Earned \$267, three weeks, raising mushrooms in cellar! Exceptional, but your cellar, shed perhaps suitable. We buy crops. Book free. United, 3848-A250 Lincoln Ave., Chicago.

MAKE Architectural models; profitable, dignified business. Particulars free Weidler, 4589 Lexington, Hollywood, California.

MAKE Superfine statuettes, easy, profitable, illustrated instructions. \$1.00. P. O. Box 415, Seattle, Wash.

OLD BOOKS WANTED

WE Pay up to \$5,000 each for old books; also high cash prices for old magazines, letters, newspapers. A single story book, school book, old Bible, travel book, almanac, etc., that looks worthless may bring you \$50, \$100, \$500 or more cash. Thousands wanted! A small town barber discovered a valuable edition of "Pilgrim's Progress" and sold it for \$4000. Two boys playing in an old barn found a valuable edition of "Venus and Adonis" for which we pay \$5000. Send 10c now for big price list. American Book Mart, 140 S. Dearborn, Dept. 1013, Chicago.

BOOKS, PERIODICALS, PICTURES, POSTCARDS

FREE—Send for list of new technical books at sensational discounts. OO. Winn, 124 West 23 St., New York.

25 WORLD'S Fair cards 25c. Rettig, 3763 Barnes Ave., Bronx, N. Y.

FREE! Big catalog describing hundreds of books on various subjects. Franklin Publishing Company, 800 North Clark Street, Dept. 2109, Chicago.

PICTURE Collecting—Makes a fascinating, profitable hobby. Complete information and samples 10c. Mulligan, 255 W. 92, New York.

30,000 CIRCULATION—30 Word ad—\$1.80. Meriden Magazine, Des Moines, Iowa.

HOW To live 150 years. Particulars free. 800 Cowles, Joliet, Ill.

SINGLE Motion, still picture solid vision mirror \$3.00. Nu-Mirror Co., Bridgeport, Conn.

INFORMATION: Where to buy books, magazines, correspondence courses, about textiles, sent for 50c. Joseph Kisiolek, Billerica Road, Chelmsford, Mass.

THOUSANDS Of old magazines. List 10c. Seeley Service, Jennings, La.

FREE—Send name for beautiful 8x10 art print. Herbert Crowl, Route Four, Canton, Ohio.

GAMES AND ENTERTAINMENT

PLAYS, Operettas, musical comedies, complete minstrel first-parts with song programs, blackface skits, vaudeville acts, monologs, dialogues, recitations, juvenile plays and songs, musical readings, entertainments, make-up goods. Catalog free. T. S. Denison & Co., 623 So. Wabash, Dept. 11, Chicago.

MAGIC TRICKS, PUZZLES, JOKER NOVELTIES

MYSTIFY Your friends—Be a mind reader! Amazingly clever trick and catalog sent for 10c. National Magicians, 5710-a Woodlawn, Chicago.

SENSATIONAL Trick—10c coin. Box 66, Sta. W., Brooklyn, N. Y.

250 MAGIC Tricks with cards, coins, etc. Complete simple instructions, 10c. Zodiaco, 717 Washington, Evanston, Ill.

ASTOUNDING, Bewildering, unusual card tricks. Defy solution. Illustrated book 50c. Foster, Box 222, Swarthmore, Pa.

JOIN Magicians' fraternity! Monthly magazine, sample 10c (contains many tricks). International Magicians, Mount Morris, Ill.

MAGIC Tricks, joke novelties, puzzles, at lower prices. South's largest line. My famous catalogue, "Book 1000 Wonders" and "50 Mysteries Magic" posted 10c. Write today. You will be surprised! Lyle Douglas, Station A-5, Dallas, Texas.

LARGE Professional magic catalogue, 25c. Holden, 220 W. 42nd St., New York.

LEARN Ventriloquism, 3c stamp brings particulars. Smith, 125 North Jefferson, Peoria, Ill.

BE A magician. Large professional magic catalogue of latest tricks 25c. Cash paid for complete Tarbell magic courses. Write. Ireland, 804 Wesley, Oak Park, Ill.

RARE COINS

COMMEMORATIVES: Columbians 70c, California jubilee \$3.50, Vancouver \$7.50, 1926 Oregon \$1.75, Illinois, San Diego \$1.40 each, Spanish Trail \$7.75, Hudson \$11.00, California gold tokens 25c and 50c size with large coin book \$1.00, Isabella quarter \$2.75. Coinshop, 2510 Chester, Alameda, California.

OLD Money wanted. Do you know coin collectors pay up to \$100.00 for certain U. S. cents? High premiums for all rare coins? I buy all kinds. Send 4c for large coin folder. May mean much profit to you. B. Max Mehl, H. Mehl Bldg., Fort Worth, Texas.

UNITED States commemorative half dollars, Columbian 85c, Lincoln \$1.19, Lexington \$1.69, Texas \$1.69. Bargain selling price list and California 50c gold token 25c. Arcy, Muskogee, Okla.

3c STAMP Brings new price list, commemorative coins, large and small cents. Schultz, 419 First National Bank Building, Cincinnati, Ohio.

NEW And old coins wanted. List 10c. Walter Allgeyer, Box 192, Newark, N. J.

1909 CENT \$10. We buy certain coins, rare and common. Some worth to \$6000; 1864-1865 Indian head cents, \$100 each; dimes before 1895, \$450; Liberty head nickels before 1914, \$300; large pennies, \$2,000; encased postage stamps, \$13; half cents, \$275; half dimes, \$175; quarters, \$300; fractional currencies; paper money; gold dollars \$1,500; colonial coins \$300; silver dollars, \$4,000; 1933, 50c, \$4.00; foreign coins, \$165, etc. Send 15c today for illustrated informative coin book before sending coins. National Coin Corporation (81), Springfield, Massachusetts.

GOOD 3c Silver, 4 notes and catalog, 15c. E. Roberts, Box 329, Cedar Rapids, Iowa.

THREE Foreign coins and rare coin price lists 10c. Joseph Coffin, 1182 Broadway, New York.

6 DIFFERENT Coins 10c. 60 different \$1.00. Otto Oddehon, Springfield, Missouri.

\$5.00 FOR Missouri half dollar. Coins wanted. Karl Stecher, 312 Armory Place, Louisville, Ky.

2 COINS, 4 Notes—different—big bargain list, all 10c. Hubert Carcaba, St. Augustine, Fla.

UP To \$1,000 each for U. S. coins and stamps over 10 years old. New buying list, 10c. Coin-Stamp Shop, Box 37-P, Ottawa, Ill.

\$5.00 TO \$500.00 Each paid for old coins. Keep all old money. Send 10 cents for illustrated coin value book. 4x6. Guaranteed prices. Buying and selling. Coin Exchange, Box 5, Le Roy, N. Y.

FREE! Foreign coin, banknote, and large illustrated coin catalogue. Send 4c postage. Coin approvals sent. Tatham Coinco, Springfield-125, Mass.

\$3.00 EACH For certain Lincoln pennies dated between 1911 and 1923. Keep posted. Send 15c for complete 28 page buying book. American Coin Company, Dept. 128, Muskogee, Okla.

RARE United States, foreign coins, war medals. Catalogue 10c. Mengelle, Colorado Springs, Colorado.

COMMEMORATIVE $\frac{1}{2}$ Illinois, Monroe, Oregon, San Diego, Texas \$1.50 each. Illustrated catalogue 25c. Norman Shultz, Salt Lake, Utah.

UNITED STATES. Large cent, 2c bronze, 3c nickel and bargain list. 25c. Thirteen dates large cents, \$1.00. George P. Coffin Company, Augusta, Maine.

STAMP COLLECTING

FREE—Dominican Republic triangle stamp to approval applicants. Paul's Stamps, 2119 N. Lamon, Chicago.

APPROVAL Selections made to order. Fine stamps, reasonably priced. Choose your own premium. Telehmann, 1685 Fillmore, Philadelphia, Pa.

RARE Mint Newfoundland commemorative, 23 different Russia. Poland's astronomical commemorative, Yugoslavian war horror, Denmark 1921 issue, United States telegraph set, all complete; 42 stamps cataloging \$2.93 only 25c. Friendly Philatelists, 3615 N. Sydenham, Philadelphia, Penna.

A SNAP—200 Different foreign and 60 different U. S. stamps, including \$1 value, for only 30c. Free with each order, our pamphlet telling "How To Make A Stamp Collection Properly," together with our price lists of albums, supplies and hundreds of bargains in sets, packets, etc. Queen City Stamp Co., Room 36, 604 Race St., Cincinnati, Ohio.

UNUSUAL Penny approvals. H. Moore, Jr., Box 37, Lansdowne, Pa.

100 DIFFERENT Foreign, three nickel packets, one dime packet, regular 35c value, only 10c. Skillman, Titusville, N. J.

SCARCE Iceland airmail triangle and fine packet including Ubangi, Chad, Gabon, Inini, St. Pierre, Togo, Senegal, British Colonies—Savages, ships and animal stamps. Only 5c to approval applicants. Potomac Stamp Co., Dept. 111, Washington, D. C.

Old Stamps and envelopes wanted. Will pay \$85.00 for 1924 1c green Franklin rotary perforated eleven stamp. Write before sending. Large illustrated folder 10c. P.M. Box 444, Elyria, Ohio.

AIRMAIL Or general approvals. Fine, priced right. Clark, 1612 Dial, Springfield, Illinois.

\$1.30 CATALOG Value free! Scarce interesting jungle birds, beasts, high values. Totals \$1.30 or over. 3c with outstanding approvals. Kumler, King, Lancaster, Ohio.

IGUANA, Galapagos, strange animal stamps, 3c with approvals. Simmons Stampco, Elsie, Mich.

SPECIAL! 60 Ships, scenery stamps 10c. Sachse Stampco, London, Canada.

FREE, 25 Foreign cataloging \$1.25 with approvals. 5c postage. Wille Stampco, Box No. 285E, Brooklyn, N. Y.

QUEEN Astrid! Short set (2) 5c; (4) 10c; complete 50c. Approvals. Burke, Marshfield, Vermont.

FINLAND—25 Different, 8c (stamps accepted). Elsea, Bowling Green, Ohio.

10 ITALY Commem. gauge, 3c with approvals. Corn Belt, Marion, Iowa.

COMPLETE Spanish Goya Nude set only 88c to serious approval applicants. References please. Lambert M. Gerber, Tamaqua, Penna.

25 BRITISH Colonies with premiums and approvals, 5c. Harold Bowen, Dept. D, Fort Dodge, Iowa.

GOOD Foreign approvals $\frac{1}{2}$ c each. W. Seward, South Bellingham, Wash.

CUBA Packet \$1.00. Guarantee no trash. Golcochea, Apartado 2213, Habana.

CANADA Treasure packet free. 3c postage please. Oromocto Stampco, Kitchener, Ontario, Canada.

UNITED STATES. 100 nineteenth century \$1.50. 270 State, Flushing, N. Y.

FREE—15 Different Mexico with approvals. Lincoln, 5335 May, Chicago.

SILVER Jubilees 50 varieties mint \$2.50; 100 different British Colonies 20c; 200—70c; 500—\$3.00. Lists free. Approvals. Westminster Stamps, 5060, London, Canada.

A TO Z, 53 countries 15c; 25 Japan 10c; 20 Turkey 10c. All 25c. Approvals. Edgard, 100 Maple, Windsor, Ontario.

U. S. Seconds at $\frac{1}{8}$ th cat. in dollar lots wanted. Park Stamp Co., 589 Beacon St., Boston.

FREE Packet cataloging 50c to approval applicants. Send postage. Frank Ewing, 2096 East 89, Cleveland, Ohio.

AGENTS Wanted!! Any age. Capital unnecessary. Dunlap, 1023 Forest, Ann Arbor, Michigan.

SCARCE Zanzibar! New Ceylon, mint, Senegal, Eritrea camel, British Colonies and others. Over 50 stamps! Only 10c to approval applicants. Jamaica Stamp Co., P. O. Box 52, Dept. A, Jamaica Plain, Massachusetts.

1000 DIFF. \$1.25. Catalogs nearly \$30.00. Dr. A. Browne, Ferriday, La.

FREE! Curious set Azerbaijan with bargain list, airmails, commemoratives, colonials. 3c postage. Riedell, Greensburg, Pa.

UNPICKED: 100 U. S. revenues on original documents, 10c! 1,000 Canada—35c! Vanvoorbis, Hyndman, Pennsylvania.

WHOLESALE—Send 3c for large wholesale catalogue. Stamp Importers, Palms Station, Los Angeles, Calif.

FREE, Free, penny approvals. For every 5 purchased 1 free. Extra premiums, pictorials, airmails, triangles. M. G. Strang, 3820 Waldo Ave., New York.

APPROVALS—Books of 100 stamps priced 1c each. Mounted by country. Sent upon receipt of reference. F. H. Schultze, Box 55PM, Woodhaven, N. Y.

WORLD'S Best penny approvals. Giger, 576 S. Roys, Columbus, Ohio.

BOYS, Girls—Free—Dollar packets. Rodermond, Box 666, Miami, Florida.

STAMPS Sent on approval at 70% discount. Reference required. Emory Renoll, Hanover, Penna.

FREE—15 Different Peru to approval applicants enclosing postage. Ranson, 3555 Fullerton, Chicago.

SURPRISE Collection—Airmails, commemoratives, pictorials, Eritrea, Tunis, Ubangi, South America, many others. 10c with approvals. Clatworthy, Upland, California.

DISGUSTED? Try my approvals. Bargains galore. Viscusi, Route 4, Scotia, N. Y.

CASH For your collection, accumulations, etc. Write me or send to State Savings Bank for offer. Phil McKinney, Elsie, Michigan.

GIVEN—Prize set 10c value with packet 50 different 10c. Approvals. Stampercraft, Box 126, Kansas City, Kansas.

25 DIFFERENT South American for only 10c, no approvals. Burkhart Stamps, Sandwich, Ill.

BETTER Quality penny approvals. G. E. Davis, 1205 Glenhurst, Rock Island, Illinois.

85 ERITREA, Nyassa, Manchucko, etc., 10 cents. Lufbery, Middletown, Connecticut.

100 STAMPS 25c. \$1.00 value. Liggett's, 824 Passmore, Philadelphia, Pa.

SPECIALS. All face different. 100 Netherlands 50c; 100 Greece 50c; with approvals. LC Trading Company, Box 38A, Bellerose, New York.

BARGAIN Approvals—United States, foreign selections. Lincoln Stampco, Shelbyville, Illinois.

200 DIFFERENT Stamps 25c; 1000, \$1.00. Arnold Croll, Manitowoc, Wis.

ATTENTION. Set North Borneo, set jubilee, triangle, set Epirus, set mourning stamps, Armenia, Syria, money stamp, etc. Everything 10c to approval applicants. Brownell, 1608 Tenth St., Niagara Falls, N. Y.

LUCKY Collectors, get Trinidad 79, 80, 81; \$4.40 worth for 53 cents, cash with order. Guaranteed satisfactory. Special offer Canadians 15c with approvals. Colonial Stamp, P. O. Box 554, Montreal, Canada.

WORLD'S Smallest air mail, \$2.00 U. S. stamp, animals, bird, train, Indian, airplane, commemoratives, special issues with scarce stamps from 25 different countries only 5 cents with approvals. Capital Stamps, 413D Roosevelt Road, Little Rock, Arkansas.

50 STAMPS, Manchukuo, etc., 1c. Album 3c. Bullard, 268 Northampton, Boston, Mass.

\$10.00 FOR \$1.00. Over 50 varieties North and South America. (No U. S.) Approvals sent. Elmer's, 196A Washington Street, Boston, Mass.

HIGH Grade approvals. References. Outmette's, 907 Brock D20, New Bedford, Mass.

EARN Cash selling approvals. Crystal, 259 W. 30, New York.

PRIVATE Collection. Canada, Newfoundland, Sacrifice. George Laird, Leaside, Ontario, Canada.

CANADA 50 Different 10c. H. Staples, 1106 Robin, Montreal, Canada.

MAMMOTH Mystery packet rare stamps only 10c to serious approval applicants, also valuable free premiums with every selection afterwards. Our stamps are better, our service is different. Fair-Play Stamp Service, 1215 Browning Blvd., Los Angeles, Calif.

PENNY Approvals—Try our South American specials. Kokomo Stamp Exchange, Kokomo, Indiana.

SEASON Opener, packet containing triangle airmails, jubilees, commemoratives, 10c to new approval applicants. Belnat, 1976 Lafontaine Ave., New York City.

200 DIFFERENT Foreign, 15c; 300 different, 25c. Approvals. Methuen Stamp Shop, Methuen, Mass.

ONE Hundred one different 5c to approval applicants. Ward, 116-31 146 St., Jamaica, N. Y.

BRITISH Turkislands—Also Congo's, Montecarlo, Nicercoast, Uganda, Djibouti, Ecuadorian, Ivorycoast, Ubangi, countries collectors need. Free for 5c postage. Empire Stamp Shop, Dept. PM, Toronto, Canada.

"TREASURE Collection"—Something different—Featuring rare Pirate Island map commemorative, containing exclusively Golden stamps. Only 10c providing you desire our double premium approvals. Progress Stamp Service, 532 Fremont, Los Angeles, Calif.

TANNOUTOUVA Triangle, Manchukuo, Charkhari, Mongolia, Malay, 40 Asia, 5c. Ferguson, Ridley Park, Penna.

FREE! Illustrated album scarce Jamaica jubilee, \$2.00. United States, two sets cataloging \$1.00. Only 10c mailing charges! Choice approvals. Clifton English Co., Nashua, New Hampshire.

MARVELOUS Packet Azerbaijan stamps, 5c. Approvals sent. Stampco, Kaufman, Texas.

500 MIXED, including 50 different American, 10c! Approvals. Fort Stampco, DeFiance, Ohio.

THE Most historic issue in existence, "The Bosnian Assassination, the Spark That Set the World Afire." We include this complete set; also a complete Denmark ancient-ship set; 2 complete Russian sets; 3 stamps over 50 years old; and Italy's Mussolini stamp, all for 10c. Pearson Bros., 68 Nassau St., Dept. 19, New York.

10 UNUSUAL Jubilees 25c. Halay, 452 West 58th, New York.

SORUTH Stamps of Sir Rasue Khanji and the Kathi Horse (2); Grecian war nurse (2); King Michael, Roumanian boy ruler (4); Bahamas war charity; Turks and Caicos Islands cactus; Cook Island commemorative; and 50 other interesting stamps together with unusual approvals—10 cents. International Stamp Corp., Dept. 20, Newport, R. I.

\$5.00 U. S. Stamp No. 573 perf. initials only 10c with general approvals. Hudson Company, 116 Nassau St., New York City.

COMPLETE Mint set Italian occupation Ethiopia 10c to approval applicants. Scott, 22 Strathearn Blvd., Toronto, Canada.

NYASSA 94-105 Mint, 25c. Complete set of twelve beauties, picturing Nyassaland animals. Traders Club, 16152 Snowden, Detroit, Michigan.

UNITED STATES, foreign stamps, premiums to approval applicants. Lewis Kelsey, South Bristol, Maine.

CANADA—Fine packet of 25 different, also large ship stamp and beautiful airmail from Spain, only 5c to approval applicants. Clarence Yuchartz, 435 Sycamore St., Dept. A, Wyandotte, Michigan.

LARGE Spanish ship stamp, Azerbaijan, Camerouns, Chad, Dahomey, Gabon, Ubangi in packet of 57 stamps. All for 5 cts. with approvals. Swedell, 3129 Garfield Ave., Minneapolis, Minn.

12 DIFFERENT British Guiana (ship) stamps only 8c to approval applicants. Douglas, Hawkesbury, Ontario.

LOW Prices. Invite comparison. Approvals on request. Vincent Hoof, 4415 N. Sawyer Ave., Chicago, Ill.

DEAD Countries. Stamps of dead countries always increase in value. Through an extremely fortunate purchase we are enabled to offer an amazing bargain in same. 11 stamps from Eastern Roumelia, Transcaucasian Republic, Azerbaijan, Armenia, Georgia, which already catalogue 77c, besides number 304 Upper Silesia, so scarce that since 15 years it catalogued without any price, all these together with the latest issue of "Stamp Lore," most interesting of all stamp magazines for only 10c to approval applicants. Globus Stamp Company, 268-4th Ave., New York, N. Y., Dept. 50.

WORLD'S Largest map stamp, scarce triangle, pictorials—10c including double premium approvals. Tru-Value Stamps, Box P1412, Hartford, Connecticut.

U. S. MIXTURE 25c, 1000, with approvals. Schiffermuller, Bellerose, L. I.

\$1.00 MONTHLY, Maintains New York office. Co-Operative Mail Service, 126-H Lexington Avenue.

BRITISH Solomon Islands! Bicolored Columbian airport, gigantic stock stamp, beautiful complete Costa Rican set, Siberia (first stamp), weird Far Eastern Republic. Everything 5c with approvals! "Saxon," Albee Bldg., Brooklyn, N. Y.

BADEN, (Scarce German state), Mongolia, Georgia, \$5 U. S., Azerbaijan, Caymans, Transcaucasian Federated Republic—everything absolutely free to approval applicants enclosing 3c. Viking Stamp Co., 1-Z Hanson Place, Brooklyn, N. Y.

6 DIFFERENT Silver jubilees, including magnificent jubilees of India, are in our big packet of 57 different stamps. Only 5c to approval applicants. Berg, Linwood Station, Detroit, Mich.

SCARCE Airmail and triangle. Beautiful Uruguay "flying horse" airmail and scarce Guatemala triangle (smallest in the world) are included in our big packet of 60 different stamps from Alouites, Grand Liban, Venezuela, British and French Colonies, etc. All for 5c to approval applicants. Big illustrated lists free with each order. Write today! Mystic Stamp Co., (Dept. 80), Camden, New York.

UNITED States mixtures 50c lb. Canada 75c. Foreign \$1.00. Japan \$2.50. Mission, 4512 North Racine, Chicago.

SILVER Jubilees—15 different 25c. World specials—500 different 35c, 1000 different \$1.00, 2000 different \$3.00. These offers to approval applicants only. List free. Victoria Stamp Co., London 4, Canada.

FREE—Beautiful airmails, 5 countries, including new Mozambique, to approval applicants. Green & Co., Norwood, Ohio.

STAMPS: A splendid selection sent on approval. Quality at low prices. Scarce and high value stamps are included in our approval books. Fred Herzberg, Box 91-P, Elmhurst, Ill.

20 BEAUTIFUL New issues, including Newfoundland commems., Guatemala Quetzal, Ecuador bean, Denmark Andersen set, 10c to approval applicants. Premier Stamps, 1709 Second Ave., New York.

FREE! New illustrated 56-page catalog "United States, British Colonies & Foreign Stamps"—at real money-saving prices. Includes details of amazing free stamp offer. Send postcard for copy. H. E. Harris & Co., 137 Transit Building, Boston, Mass.

FREE—20 Different Canada to approval applicants. Fort Dearborn, 5439 Aberdeen, Chicago.

200 DIFFERENT 10c. Big 50% approvals. Covert Stamp, 39 State, Rochester, N. Y.

UNITED States—Elaborate pricelist free. 45 different 10c, 75 different 30c. Seidenberg, Baroda, Mich.

STAMP Dealers, your ad here will bring wonderful returns. Ask me for proof. F. W. Johnson, Manager, Classified Advertising, Popular Mechanics Magazine, 200 E. Ontario St., Chicago.

GIANT-SIZED Russian Zepelin stamp (cat. val. 20c!) and beautiful Lithuania airmail triangle; also big packet of 53 dif. stamps including Azerbaijan, Epirus, new Martinique, etc. and illustrated lists—all for 5c to approval applicants! World-Wide Stamp Co., Box 600, Camden, New York.

FREE—\$1.00 U. S. stamp, our choice, with request for 52 page price list of United States and foreign stamps. Stamps on approval. References necessary. 1000 U. S. no current \$1.50. New Hussman Stamp Co., 1122 Pine Street, St. Louis, Mo.

FREE! Rare airmail! Jubilee! Pictorials! Extraordinary packet 65 different stamps from strange countries (no Europe), 5c postage to approval applicants. Bargain Co., Box 39P, Station H, New York.

UNITED States approvals only. Write for selection. Positively no foreign. Jack Daub, Wabash Bldg., Pittsburgh, Pa.

SCARCE "New issues" packet! New giant sized, diamond-shaped Russian "sports" stamp; Nyassaland "leopard"; Morocco; Tanganyika, and other scarce countries are included in our big packet of new and recent issues—stamps most collectors have never seen! Get this valuable packet today. Only 5c to approval applicants. Reimers, 115 Flatiron, Fort Worth, Texas.

40 UNITED States, commemoratives, airmails, etc., 10c with approvals. Stamp Shop, Mabel Hoehn, Holland Bldg., St. Louis, Mo.

FREE!! Scarce airmail triangle and fascinating Cayman Islands map stamp; also large Silver Jubilee commemorative (a future rarity!), fine packet hard-to-get countries, including Sudan (desert scene), Epirus (sharpshooter), etc., and, finally, a set of U. S. stamps more than 50 years old. This valuable collection absolutely free to new approval applicants sending 3c postage! Midwood Stampco, Dept. P6, Midwood Station, Brooklyn, N. Y.

300 DIFFERENT 20c; 1,000, \$1; 2,000, \$3.00. Fred Onken, 630 79th St., Brooklyn.

107 DIFFERENT; Algeria, Gabon, New Zealand, Guinea, Congo, etc., 5c to approval applicants. Extra—Airmail packet free!! Hunziker, Box 225H, Minneapolis, Minnesota.

44 DIFFERENT United States including \$5 stamp, or complete set United States bicentennials, or 30 different obsolete Canada, 13c postage with approvals. C. A. Lennan Co., Box 322, City Hall Annex, New York, N. Y.

FREE! Philatelic parade. Beautiful Queen Astrid, New Brunswick, Commemoratives, jubilees, air mails. Postage 3c. Approvals. Grandstamps, 619 1/2 South Spring, Los Angeles, California.

MAKE Extra money. Sell stamps in your spare time. Write for free illustrated wholesale catalogue. Fordham Co., 152 W. 42 St., New York.

AIRMAILS (15) 5c To approval applicants. Wollaston Stampco, Wollaston, Mass.

NEWFOUNDLAND, 15 Different 5c with approvals. Hudson Company, Plainfield, N. J.

\$5.00 U. S. Red and blue liberty, present postage value, Scott No. 573 cat. \$1.25 (retails as high as \$1.00 net by some dealers) only 5c to approval applicants. Giant U. S. pricelist free! Tatham Stamp Company, Springfield-5, Mass.

ANNUAL Wholesale catalogue—illustrated and enlarged. Free upon application. Empire Stamp, Department 5, Toronto, Canada.

25 UNITED States, including \$4 and \$5 stamps free to approval applicants. 3c postage. Brownie Stamp Shop, Flint, Michigan.

FREE Dollar packet to penny approval applicants. Harlan, 5307 S. Marshfield, Chicago.

MIDGET Airmail (1/2-in. tall), Szechuen, Kouang-Techeou, Mozambique, etc.—5c. Depraw, Ocean Park, Calif.

DIAMOND-SHAPED Stamp, Liberia gunboat triangle, two other triangles, silver jubilee, 27 others, 5c. Crowder Company, 127E North, Baltimore, Md.

CANNON! Set of stamps showing cannon, firing squad, cavalry charge and 200 other different stamps only 10c to approval applicants. Paramount Stamp Co., 4225 Broadway, Chicago, Ill.

FREE!!! King George memorial packet, 15 varieties. Postage 3c. Roberts 901F Fourth, Baycity, Michigan.

ILLUSTRATED U. S. list, price 50c, large complete U. S. price list free. Send postage. Stanley Gibbons, 38P Park Row, N. Y.

LIBERIA Snake triangle, giant Spanish ship triangle, 50 other stamps, 5c. Abell Company, 2527 Guilford, Baltimore, Md.

PENNY Approvals that please. Haywood, 395 Adams St., Pomona, Calif.

UNBELIEVABLE—Suriname, Panama, British Honduras, Jubilee, airmail, triangle. Complete collection every country from Straits Magellan to Arctic. 10c. Approval applicants only. Mutual Stamp Service, Box 666PD, Ventura, Calif.

QUEEREST Stamp packet. Receive world's smallest stamp; Vatican City; scarce Liberia triangle (value 15c); 1935 Greek Red Cross picturing coiled snake in Garden of Eden; Australian Bushman; new Spanish Morocco; Japan 'quake stamp; Manchukuo; many others. Only 5c to approval applicants. R. M. Stamp Co., P. O. Box 230P, Port Chester, N. Y.

SCOTT'S 1937 Catalogue mailed with imperforates, \$2.00. Superior approvals. Kattau, 10315 - 108th Street, Richmond Hill, N. Y.

SCARCE Triangular Mozambique commemorative airmail and packet of 33 U. S., including imperforate 3c Chicago; early issues; high values; commemoratives; envelopes; revenues, etc., cataloging more than 75c—only 5c to approval applicants. Illustrated pricelist free. Curhan Stamp Co., Dept. P. Gloucester, Mass.

UNITED States, Canada, Newfoundland. Where? Our "Four Star" approvals. Nothing like them! 300 mixed U. S. 10c to applicants. Kessels, Tucson, Arizona.

BRITISH Silver Jubilees from 3 different countries, imperforate 3c Tipex commemorative—all included in Clipper packet containing 25 different stamps from Azerbaijan, China, Ukraina, etc. All for only 5c to approval applicants. Clipper Stamp Co., Dept. 7, Gloucester, Mass.

WEEKLY Stamp magazine, thirteen weeks, 10c. Stamp Journal, Kalamazoo, Mich.

WHOLESALE Catalog for dealers. Illustrated. Postage 5c. Frank Co., 4900 Chalgrove, Baltimore, Md.

PENNY Approvals, that satisfy. Neil Gronberg, Box 5441-P, Philadelphia, Pa.

SUPERIOR "New Issues" collection, airmails, commemoratives, jubilees, pictorials, triangle, etc., only 10c providing you desire bargain approvals. Superior Stamp Service, Box 866, Sacramento, Calif.

WORLD'S Largest triangle! Giant Spain triangle and bi-colored Persia airmail; big packet 25 different Russia (catalog value nearly \$1.00); packet British Colonies including Egypt, Travancore, Ireland, Malay, etc. Big United States list. All for only 5c to approval applicants. Richfield Stamp Company, Dept. 20, McLean, Virginia.

JUST Published—New 1936 edition Popular Mechanics Book Catalog. "A Billion Ideas." Thousands of books on practical subjects. 3c stamp to cover postage brings you this valuable catalog. Popular Mechanics Press, 200 E. Ontario St., Chicago.

PHOTO FINISHING

12 PHOTOGRAPHIC Christmas cards and beautiful gift calendar from your photo for \$1.00. Send negative and dime for sample. Ideal Photo Service, Box 2255, Pater-son, N. J.

FINER Finishing. Rolls developed and printed, with one colored enlargement, or two professional enlargements. All for 25c (coin). Genuine, nationally known, Moentone superior quality. Moen Photo Service, La Crosse, Wis.

MAIL Your rolls to The Kodak City. 8 guaranteed glossy Velox deckle-edged prints, 25c coin. Two professional enlargement coupons free! Photo Finishing Shop, Est. 22 yrs., 411-B Genesee Valley Trust Bldg., Rochester, N. Y. "The Kodak City."

ROLL Films developed eight enlargements 25c, or eight regular size prints and two enlargements 25c (coin). Reprints or enlargements 3c each from rolls 116 size or smaller Leica and all 35mm cameras. California Film Service, Dept. 48, Box 379, Pasadena, Calif.

TRIAL Roll developed and 8 prints 25c. Reprints 3c. Hand colored, embossed photo Christmas cards or photo greeting calendars from your negatives 10c each, 12 for \$1.00 with envelopes. 8x10 enlargement 25c. Young Photo Service, 405 Bertha St., Albany, N. Y.

FINER Photos guaranteed! Rolls developed professionally—8 Velox prints, 2 bromide enlargements—25c coin. Finerfotos, Box D-898, Minneapolis, Minnesota.

SPECIAL—Roll developed, two sets dated prints 25c. Hench Studio, 1814 Chestnut, Harrisburg, Penna.

FILMS Developed, 2 prints of each 25c; 20 reprints 25c. Pine Photo, M-5134 Nevada, Chicago.

20 REPRINTS 25c—Films developed, 16 prints 25c. Enlargements 8x10—25c; 5x7 10c. Low Photo, M-2657 Neva, Chicago.

TWO Glossy enlargements, 1 colored, with roll 25c. Arbor Service, 10 Joliet, Ill.

TWO Beautiful double weight professional enlargements, 8 guaranteed Never Fade prints, 25c coin. Century Photo Service, LaCrosse, Wis.

ENLARGEMENTS—4x6, Glossy, 7c; six 30c. Send negative. Alberts, Box 76, Easton, Penna.

21 EXCELLOTONE Reprints 25c; 42, 50c. Film finished, 16 prints 25c. Two 5x7 enlargements 15c. Excelofotos, Albany, Wis.

DEVELOPED And 8 beautiful double deckle Velox prints, 5x7 enlargement, 25c. 3x4 Argus, bantam, Univex prints 5c. Elkhart Photo Service, Elkhart, Ind.

SPECIAL—4x6 Enlargement, colored, golden oak frame. Send negative. 50c coin. Fotofram, Riverhead, N. Y.

HAND Colored print with each roll developed and printed, 25c. Insist on "Photocraft" for quality work. Photocraft, Box 110, Oak Park, Illinois.

ROLLS Developed, two beautiful Nu-border enlargements, eight Nu-border prints, guaranteed fadeless, 25c coin. Giant Snapshots, Inc., Dept. A, Greenbay, Wis.

ROLL Developed and printed, one photo calendar, one Christmas card, all for 25c coin. Photo Finisher, 1129 E. Main St., Columbus, Ohio.

DAY Service! 2 projections, 8 Velox prints, 25c. Griffin Studios, Winona, Minn.

DEVELOP And print your own pictures. Save time, money with our complete \$1.49 outfit postpaid, or pay postman \$1.55 COD. Includes electric ruby lamp, printing frame, photo paper, chemicals and equipment. One of hundreds of amazing bargains in our free, newest, money-saving bargain book. Send for it today! Central Camera Co., 230 So. Wabash, Dept. K-411, Chicago.

IMMEDIATE Service! No delay! Roll fully developed, carefully printed and two beautiful, full-size 5 x 7 double weight professional enlargements (or one tinted enlargement)—all for 25c coin. The experts' choice! Reprints 3c each. The Photo Mill, Box 629Z, Minneapolis, Minn.

FRAMED 5x7 Professional enlargements 15c. 8 reprints and two 4x6 enlargements 25c. Newton, Maywood, Ill.

ROLL Developed and 8 guaranteed prints including two enlargements, 25c coin. Super Snapshot, Winona, Minn.

TWO Professional enlargements with each roll developed and printed 25c. Eight reprints, two enlargements 25c. Hygloss, River Grove, Ill.

ROLL Developed. Two double-clear prints each negative 25c. Reprints 2 1/2c. Enlargement coupon. Willard's, Box 3535-A, Cleveland Heights, Ohio.

ROLLS Developed. Two beautiful double-weight professional enlargements and 8 guaranteed Never Fade Perfect Tone prints, 25c coin. Rays Photo Service, LaCrosse, Wisconsin.

HAND Colored enlargement with each roll 25c. 40 reprints 50c. Colorgraph, Dunning Station, Chicago.

BEAUTIFUL Glistening prints, roll developed, 8 guaranteed glistening prints, 2 enlargements, 25c. American Photo Ser., 2946-C Nicolet, Minneapolis, Minn.

ROLL Developed, two prints each, two enlargement coupons 25c. Christmas cards 60c dozen. Summers' Studio, Unionville, Missouri.

PHOTOGRAPHIC Christmas cards, 20 for \$1.00. Send your negative. Sample 10c. Seascout Service, Box 52, Chelsea, Mass.

BEAUTIFUL Colored enlargement with each film 25c. Speedy service. Satisfaction guaranteed or money refunded. LaCrosse Film Company, LaCrosse, Wis.

QUALITY Counts—Two double weight gloss enlargements and eight prints guaranteed not to fade from each roll. 25c. Prompt service. Excel Photo, Box D, Dubuque, Iowa.

ROLLS Rushed! Developed and printed with two supertone enlargements 25c. Four 4x6 enlargements 25c. Newton, Maywood, Illinois.

20 REPRINTS 25c. 100 Reprints \$1.00. Rolls developed with 16 prints 25c. Nordskog, 4, Maywood, Ill.

ROLL Developed and 8 beautiful Velox glossy prints 25c coin or stamps. Reprints 3c each. Fotoprint Service, Box E, Roanoke, Virginia.

20 REPRINTS 25c. Films developed, two prints each negative, 25c. Skrudland, 6970-8 George, Chicago.

ROLL Developed and 16 prints 25c. Smart Photo, Winona, Minn.

ROLL Developed with 16 prints and two professional enlargements 30c. 100 reprints \$1.00. 16 reprints and 2 enlargements 30c. Dependable, River Grove, Illinois.

THREE 5x7 Enlargements 25c, tinted 50c, coin. Send negatives. Midwest Studio, Humboldt, Iowa.

DAILY Service—Roll developed, 16 guaranteed prints, 25c. Valuable enlargement coupon; 16 reprints 25c. Modern Finishers, Box 3537-L, St. Paul, Minnesota.

FINEST Super gloss Velox prints, roll developed and printed 25c, reprints 2c. Films 35% discount. Paramount Studio Division, 403 E. 92nd St., New York.

COMPARE The difference! Roll developed, two professional double weight enlargements, 8 guaranteed prints, 25c coin. Excellent service. Nationwide Photo Service, Box 3333, St. Paul, Minnesota.

GET The best. Roll developed, beautiful hand colored enlargement, 8 neverfade border prints, 25c coin. Prompt service. Sun Photo Service, Drawer T, St. Paul, Minn.

TWO Prints each with every roll developed, 25c. Very finest quality. Reprints 2c each. Brown Photo Company, 2209-34 Lowry, Minneapolis, Minnesota.

PHOTOGRAPHIC Christmas cards from your own kodak negatives. Mail negative and five cents for sample and quantity prices. Send something different this Christmas—a card nobody else can duplicate. The Photo Mill, Box 629-12, Minneapolis, Minnesota.

BOOKS Covering hundreds of subjects. Big catalog for 3c postage. Popular Mechanics Press, Room (C36), 200 E. Ontario St., Chicago.

CAMERAS, PHOTO SUPPLIES

BASS Will postpay to you the new Argus candid camera with f:4.5 lens at \$12.50. Daylight film, 36 shots at 85c. Welti candid camera with Carl Zeiss Tessar f:2.8 lens in Compur shutter at \$48.50. Voigtlander Duo Bessa, 2 1/4 x 3 1/4, or 16 V. P., f:4.5 Anastigmat in speed shutter, \$29.00. Unequalled values. Write for free Bargaingrams. Bass Camera Company, Dept. AG, 179 W. Madison St., Chicago, Illinois.

SENSITIZED Paper, 116 size, 35 sheets 25c. Harry Rubin, 1565 St. Marks Ave., Brooklyn, N. Y.

BARGAINS In new cameras. Special discount on kodak films. Catalogue free. Camera Store, Sac City, Iowa.

CAMERA, Movie bargains, bought, sold. Bi-Cam-Ex, 1451-P Broadway, New York.

CAMERAS And supplies. Free illustrated catalog listing everything photographic—still and movie cameras, films, lenses—at tremendous savings. Hundreds of bargains, new and used. All guaranteed. We take your old camera or equipment in trade. Write now for your free copy of our newest money-saving bargain book—just out! Limited edition. Hurry! Central Camera Co., (Photographic Headquarters since 1899), 230 So. Wabash, Dept. K-311, Chicago.

INCOME From your camera instead of expense. Low cost home course teaches you to make photographs for magazines, newspapers, advertisers. Tremendous demand. Earn good money wherever you live. Free book. Universal Photographers, Dept. 104, 10 West 33rd St., New York.

MAKE Money in photography. Learn quickly at home. Spare or full time. Easy plan. Previous experience unnecessary. For full information and requirements. Common school education sufficient. Write for full information and requirements. American School of Photography, 3601 Michigan Avenue, Dent, 343-A, Chicago.

HAVE You a camera? Send ten cents for recent number of our big magazine, showing how to make better pictures and earn money. American Photography, 116 Camera House, Boston, 17, Mass.

35% DISCOUNT On films. Write Paramount Photo Division, 403 E. 92nd St., New York.

MOTION PICTURES AND SOUND EQUIPMENT

READY For you—No. 224—the latest and greatest Bass Bargaingram of Cine apparatus. Acknowledged leadership in the cinema field. A few of the fine values: Cine Kodak Model B, f:1.9 lens and case, \$54.50. 8 mm. Stewart-Warner camera with f:3.5 lens, \$15.00. 100 ft. DeVry 16 mm. camera, f:3.5 lens, \$22.50. RCA sound on film projector complete, \$85.00. Willo Cinemeter with case, \$3.75. Write today to Cine Headquarters and start to save now. Bass Camera Co., Dept. A, 179 W. Madison St., Chicago, Ill.

16MM—8MM ART Films. New Hollywood art featurettes now available in 8mm. or 16mm. Send 50c for 10 ft. 8mm. Art Screen test or \$1.00 for 20 ft. 16mm. test. Eight Art film samples, 25c. Stamp brings Illustrated Art catalogues. Hollywood Cine Film Distributors, 1431-33 No. Highland, Hollywood, Calif.

DE VRY Sound film 35 projector, amplifier, speaker, complete, 500 watt \$185.00. 1,000 watt \$215. 35mm silent 1,000 ft. films shorts complete \$1. Features \$5. 16mm F 1.9 Kodak camera \$45.00, like new. 16mm silent films \$1.00 per 100 ft., \$2.85 per 400 ft. Sound odd \$2.00, 400 ft. \$8.00. Collapsible screen 22"x30" spring roller, map case with adjustable tripod \$4.50 complete, the biggest bargain ever offered. Leica camera F 3.5 perfect \$45.00. New Zeiss Contaflex camera F 1.5 \$372.50. Send for film lists, 8mm, 9 1/2, 16-35 silent, soundisc, soundfilm, one of America's largest film libraries, rentals sent anywhere. Just issued Fall Bargaingram full with used, new equipment, parts. Trades accepted, bought. Mogull's, 1944-J Boston Road, New York.

35MM COMPLETE Stories. Stamp for lists. Calderara, 5119 South St. Louis, Chicago.

UTILITY 16mm. Film printers, \$19.50 each. Write. Frommader, Davenport, Iowa.

16MM. ART Films \$1.00. Sample, list, 10c. Moorfield-Shannon, Nutley, New Jersey.

DEVELOP Your own movies, reversal and negative-positive instructions, 50c. Milio, 622 Myrtle Ave., Brooklyn, N. Y.

FAMOUS 16mm. Silents (new). "Great Train Robbery" (1903), 330', \$12.00. "Christmas Miracle" (1905), 112', \$4.90. 1900—Auto Parade, 33', \$1.69. Pickford Comedy (1910), 155', \$6.99. "Jewels of Yesteryear" catalog 10c. Chicago Film Dealers, 6801 Carpenter, Chicago.

SPECIAL! "Motion Picture Projection," published price \$5.00, now 98c. Loads of bargains, new, used 16 and 35 mm. sound film equipment. Lists free. S.O.S., 1600-G Broadway, New York.

35 MM. \$1.75 REEL. Stamp list. Bedner, 5300 S. Talman, Chicago.

CENTRAL'S Free, new, money-saving bargain book explains latest movie developments, offers money-saving bargains in cameras, lenses, projectors, films. Used equipment taken in trade. Write for free copy. Central Camera Company, (Photographic Headquarters since 1899), 230 So. Wabash, Dept. K-211, Chicago.

TALKIES \$15.00, Silents \$5.00. Simpson, 1275 South Broadway, Dayton, Ohio.

LEARN Motion picture theatre management, advertising, projection. Big opportunities for men trained for the theatre. Free catalog. Theatre Institute, Elmira, N. Y.

8—16 MM. Sound-silent films. One reel 16 mm. rents 50c. New Bell-Howell 16 mm. projector, \$112. Address: Pictures, Westport, Conn.

16MM. SOUND-SILENT Film rental library. Lowest rates by day or week. Home and toy films, also. Eastin Pictures, Davenport, Iowa.

BARGAINS! 8mm. 16mm. Catalogue free. Elder, Dept. B-29, Chelsea, Mass.

WESTERN Thrillers, 500 feet 75c. Jersey Filmes, 2075 Richland, Lakewood, Ohio.

35MM. FILMS \$1.00 reel. Projectors \$10.00. List 10c coin. Box No. 6, Rosedale, Kansas.

16MM. BELL Movie camera \$6.95. Projectors \$6.95 up. 16mm. film including processing \$1.89. Free circular. Bytom, Dept. A, Park Ridge, Ill.

35MM. ODD Reels \$1.00. Projectors. Bergen, Woodliff Lake, New Jersey.

16MM-35MM TALKIE And silent rented anywhere. Silent dollar reel. Talkie \$1.50 reel. Weekly rates. Projectors dollar up. Thousand feet 35mm dollar. Waldo Films, Suite 6, Waldo Bldg., Cincinnati.

8-MM-16 CAMERAS, Projectors, films. Free catalog. Taylor, Bx-234, Corning, N. Y.

LOOK! "The World's Greatest Passion Play." Seven reels, (new) 16 mm. Superior than the Oberammergau stage play. Rent or purchase. Write Hemenway Film Co., 37 Church St., Boston, Mass.

35MM. FILMS. Bargain lists 3c. Hoffman Film Service, 57 Broad, Albany, N. Y.

8MM. COLOR. Panchromatic. Economical titling film. Film slitter, titling lens, instructions. Reversible data. Film Specialties, 111P, El Monte, California.

BASS Now exclusive distributor for Radio Corp. of America 16mm. R.C.A. Sound on Film Cameras. Anyone can record sound pictures. New low price. News reporter model was \$350.00, now \$210. Send for complete details. Bass Camera Co., Dept. AK, 179 W. Madison St., Chicago, Ill.

8MM FILMS: Cartoons, travel. List. Lincoln Film Service, Box 293-A, Saginaw, Mich.

THREE Cameras in one. Takes snapshots, moviebooks, 16mm movies. Springmotor driven. \$5.95 brand new. Films \$1.00. Send no money. Pay postman. Projectors \$1.00 up. Tarzan, Buck-Rogers, Joe-Palooka films 35c up. Free lists. Home Movies, Box 32, Easton, Pennsylvania.

16MM EXCEL Motor driven projector, 100-ft. reel \$3.95. Pop-Eye, Betty Boop, Hal Roach, "Our Gang" comedies and others. 3c stamp for catalogue. Excel Home Movies, 622 Madison, Toledo, Ohio.

16MM BARGAIN Bulletin free! Acme Cine, Box 794, Lima, Ohio.

RADIOS, SUPPLIES, INSTRUCTION

PROFESSIONAL Antenna for all-wave sets. Same type used on receivers in licensed stations in South Africa and South America. Greatly increases DX performance, cuts down static, eliminates local interference, doubles short wave reception. Complete set includes: double aerial, double lead-in wires, high-tension porcelain support and lead-in insulators, dual lightning arrestors, variable ratio matching transformer, complete instructions and installation diagram. Ask us for statements of performance from world-wide users. \$3.75 C.O.D. or \$3.50 check with order. Write today for your all-wave antenna kit to Porcelain Products, Inc., Dept. 35, Findlay, Ohio.

FARM And city radios, \$6.95 up; save over 60 per cent; amazingly new farm radio; operates from free windpower; new farm power or battery. Lowest cost electric lights. Agents—clean up; catalog; free offer. Marco Company, 242 E. 14th, Kansas City, Mo.

RADIO Experimenters and set builders; parts and kits of parts for portable Superhet Battery, Improved Little Giant four and five tube, Economy three, 32 volt, and Pre-Amplifier described by Popular Mechanics, Lund Manufacturing Co., 43 East Ohio, Chicago.

7-TUBE Worldwide radios \$27.45. Wind-charger bargains. Agents wanted. Propeller Man, Kindred, N. D.

SW CRYSTAL Set—4250 mile record. Instructions 18 distance models; "Radio-builder" year; 25c. Laboratories, 151-C Liberty, San Francisco.

YE Radio fans. Blueprints and unusual suggestions for the crystal radio experimenter 25c postpaid. Wm. Maurice Clifton, Great Falls, Mont.

RADIO Engineering, broadcasting, aviation and police radio, servicing, marine and Morse telegraphy taught thoroughly. All expenses low. Catalog free. Dodge's Institute, Ames St., Valparaiso, Ind.

MUSIC AND MUSICAL INSTRUMENTS

PIANISTS Send for free booklet that reveals remarkable method to improve your accuracy, sight reading, memorizing, technique and playing through mental-muscular coordination. Quick results. Practice effort minimized. Used by famous pianists and students of classical and popular music. Broadwell Studios, Dept. 421-L, Bendix Bldg., Los Angeles.

REBUILT Band and orchestra instruments. Honestly rebuilt—fully guaranteed. Catalog of new instruments on request. Weymann Company, Dept. M-11, 1613 Chestnut St., Philadelphia.

VIOLINS—Handmade. Best since Stradivarius days. (Curious don't bother.) John Lehto, San Pedro, Cal.

ORCHESTRATIONS: Make them yourself. Write for free particulars. 1944 Crosby, Oakland, Calif.

WRITE A song; mother, love, patriotic, sacred, comic or any subject. Send poem today. Richard Bros., 24 Woods Bldg., Chicago.

SONG Composers; piano arrangement and phonograph recording of your songs. Write Mus-O-Matic Recordings, 4 East 53rd Street, New York.

SONGWRITERS! Collaboration outstanding! Inquire. Hibbeler, D1, 2157 No. Avers, Chicago.

USED—Rebuilt nationally known instruments—bargain prices. Supply limited. Write at once for information. Tom Brown Music Company, 315 South Wabash, Chicago.

SONGWRITERS! Poems—melodies. Special offer. Studio PM, Guaranty Bldg., Hollywood.

SONGS Published, arranged and composed, royalty basis. W. Coast Music Pub., 942 Market, San Francisco.

SONG Poems wanted to be set to music. Free examination. Send for offer. McNeil, Bachelor of Music, 1582-PM W. 27th St., Los Angeles, Calif.

SEND 10c And get two songs free with song catalog. Dewey, Music Publisher, 9825 Ave. M, Chicago.

MUSIC Arranged for songs. Orchestration. Frank S. Wildt, Lancaster, Penna.

EARN Your own musical instrument. Get free details and free attractive savings bank at your music store, or write Fred Gretsch Mfg. Co., 521½ So. Wabash, Chicago.

MUSIC Composed, arranged. Reliable. Sample 25c. A. Halgerson, Whitewater, Wis.

POPULAR Orchestration, 10—\$1.00. Sheet music, 25—\$1.00. Orchestra Service, 3303 Lawrence, Chicago.

SONG-WRITERS. Professional phonograph record of your song. Musical arrangements. Free information. Paramount Song-Recording Studio, J-8, Box 190, Hollywood, California.

SONGWRITERS—Send for free copy of booklet revealing Secrets of Successful Songwriting, free rhyming dictionary and market information. If you write poems or melodies, send for our offer today. MMM Publishers, Dept. E1, Studio Bldg., Portland, Ore.

Duo-FLEX Reeds for clarinets, and saxophones eliminate your reed troubles. Write for circular. Duo-Flex Reeds, 1204 1st Ave., Evansville, Ind.

SONG Poems wanted, 50-50 plan, instruction book sent free. Song Bureau, Salem, Indiana.

SONGWRITERS—Get all inside facts. Free booklet by famous Broadway composer. Songwriters Institute, 1234C Broadway, New York.

MUSIC Composed to words. Wonderful proposition. Bauer Bros., Oshkosh, Wis.

MUSIC Composed to song poems. Our published songs endorsed and featured by stage, radio, screen celebrities. Adelman Bros. Music House, Dept. 601, Washington, D. C.

POEMS Wanted. Work guaranteed. We publish. Great Eastern Song Bureau, Dept. 27, Thomaston, Me.

WRITE Songs. Big money and reputation. Write for information, J. Gordon Pub. Co., 201 N. Hayne Ave., Chicago.

SONGS! We compose, arrange, publish, sell. Superior Song Studios, 211 Hope Ave., Passaic, N. J.

SONGPOEMS Wanted. Your song published. National Songland, "PM," Thomaston, Maine.

ORIGINAL Music composed to your words \$5. Reginald Belcher, Chatham, New Jersey. 25 years church organist, musical director.

SONG Writers. Send for our "Publishing Agreement." McKinley Music Printers, 1501 E. 55th St., Chicago.

BUSINESS OPPORTUNITIES

BIG Profits for distributors, salesmen—Startling discovery. Flushes sticky carbon, gum from motors in 30 minutes. Amazing test shows 58.9% gas mileage gain, 86.4% oil mileage gain, compression up 186 lbs. Millions of prospects. Product sells itself. Make up to 185% profit. Territories going fast. Guaranteed profit plan. Test product free of risk. Write today. K-W Corporation, 3253 Holmes Street, Kansas City, Mo.

WE Start you in business, furnishing outfits and instructions, operating "Specialty Candy Factory" home. Men and women, earn \$25.00 up to \$75.00 weekly, all or spare time. Booklet free. W. Hillyer Ragsdale, Inc., Drawer 4, East Orange, N. J.

COLOR Any concrete article with chemical solutions. Ten color formulas. Full instruction. \$15.00. Hollywood Cement Craft, 8527 Wonderland Ave., Hollywood, Calif.

"DIRECT-BY-MAIL Salesmanship." A booklet of forceful facts and thoughts helpful to every advertiser. Postpaid, 10c. Hays Graphic Arts Shop, Box 311, McComb, Mississippi.

NEW Or old businesses financed, reorganized. Prospectuses prepared. Incorporating and organizing service free. Johanson, 512 Sherman, Chicago.

MONEY In mushrooms! Start now, in cellar or shed, get highest prices. Exclusive new process. Bigger, better, quicker crops. We buy. Books free. American Mushroom Industries, Dept. 772, Toronto, Ont.

OPERATE Amazing new vending machine business. Big profits. Wonderful opportunity. Propell-O-Lite Company, Mt. Washington, Ohio.

FORMULAS—Fast selling products. Guaranteed. Laboratory tested. Lowest prices. Catalog free. Kemico, 55, Park Ridge, Ill.

19 SPARE-TIME Profitable ideas; local, mail order. Free literature. Charlton, Box 6310 West Market St., Philadelphia, Pa.

VEGETABLE Concentrates, powders, tablets, vitamins making fortunes. Mail order, local. Samples 12c. Gardena Laboratories, Drawer 1310B, Hollywood, Calif.

WRITING Stories simply training. Easy, fascinating study. Rich rewards. Complete study, only \$5.00. Ideal Xmas gift. "Myers' System," Box 354, Spokane, Wash.

FREE Literature on 101 business ideas. Pruitt Press "2", Elburn, Ill.

MAIL Business. Start small. Everything furnished. Free details. Metromails, P-11, Cincinnati.

BARGAINS—Paint spray outfit, gasoline engine drive. Terms—trial. Helmick Paint Spray Exchange, M-1164, Troy, Ohio.

LEARN Retail shoe salesmanship quickly, \$3.98. Profitable. Boyde, Eureka, Minn.

1,000,000 ARTICLES Wholesale. Latest directory. 10c. Jelsmith, 163 Myrtle, Waltham, Mass.

THE Mail promotion bureau. Best plan, yet. Circular free. George Walker, School St., Brunswick, Maine.

WANTED—Thirty co-partners to operate branches of profitable mail selling business. Proven sales literature furnished. Write, Morrison, Pontotoc, Miss.

100 CIRCULARS Mailed and a big mail sent you, all for a dime. Carl Edquist, Odessa, Minn.

NEW Discovery—Possibilities unlimited, operate your own business in protected territory. Send three cent stamp for full particulars. K-B Chemical Co., Brazil, Ind.

WE Buy and sell business propositions of all kinds. No books, nothing to pay in advance. Let us aid you in selling or buying. Send us your problems. Cole Syndicate, Bryant Pond, Maine.

CHARTERS: Delaware; best, cheapest; free forms. Colonial Charter Co., Wilmington, Del.

OPERATE Route penny peanut and gum machines. Steady cash income. Park Place Supply Co., Box 1983, Houston, Texas.

EARN Easy extra money without selling. Boyd, Eureka, Minn.

MAILING And advertising business. Start at home. Make good income spare time to grow to bigger things. Practical, modern, profitable. Good for man and woman or two men. Free information. Lewis P. Blair, 1229 Park Row Bldg., New York City.

SELL Photographs to advertisers. People. Scenes. Goods. Big pay. All or part time. Trifle starts you. Free circular. Lenox, 115 Prospect, East Orange, N. J.

TRISODIUM Metasilicate—Amazing chemical powder, thousands of uses, dissolves paint, grease, grime, 10c gets formulas and supply sources. Waldo, Box 266, Dallas, Texas.

BIG Profits operating "route" penny peanut and gum vending machines. Start with \$100. Robbing Co., 1141P DeKalb Ave., Brooklyn, N. Y.

OPERATE Your own business. No capital required. Good pay. No selling. Literature free. Tri-City Service, Box 151, Davennort, Iowa.

MAKE Artificial marble, glossy tiles, uncanny. Tabletops, plaques, sanitary floss, whetstones. Inexpensive, hard. Cement secrets. Brilliantly colored tile and liquid rubber samples 3c. John A. Payn, 945 Grande Vista Avenue, Los Angeles, Calif.

STOP Squealing—Start crowing! Work mornings home—drive to country—"movies"—afternoons! Unusual "plans." No canvassing! Prepare for surprise! National Folio-A, Station "D," Los Angeles.

"TURN Ideas into cash." Free details. Martinez-PM, San Bernardino, Calif.

SELL. Install, or build modern oil burners. Oil Burner Company, 1304 Washington, Chicago.

GO Into business for yourself in cooperation with us. Use newly patented Spongmetal to make useful articles. Send 25c for sample and proposition. B & B Service, Box 712, Pittsburgh, Pa.

\$1.00 MONTHLY, Maintains New York office. Co-operative Mail Service, 126-B Lexington Avenue.

TALKING Santa Claus. Mysterious, magic, works like phonograph. \$3 per dozen. Sample 30c. Talkie Toy Company, 4451 Irving Park, Chicago.

500-1936 NAMES Of opportunity seekers—50c. Trial hundred 10c. Carl Edquist, Odessa, Minn.

FREE Particulars over 400 business opportunities. Larner Service, 214 Court Street, Brooklyn, N. Y.

MAGAZINE Catalog, 6x9, 36 pages, 10c. Home Industries, Irvington, Nebr.

WHERE To buy thousands of items at lowest wholesale prices; information free. Yorena, Box 312, Bayonne, N. J.

REAL Business Ideas at less than 1/2 cent each. 120 first class suggestions sent for 50c. D-Co Service, Box 256 E. A. Sta., Akron, O.

LIVE Salesmen make big money selling showcard sets. Every merchant a prospect. Glenn W. Pope Sales Co., Grand Rapids, Michigan.

DUPLICATE Or surpass nationally advertised products. Easy with my formulas. Guaranteed. Big list free. Terrone, 22F Station S, Brooklyn, New York.

CORRESPOND For newspapers. Profitable, interesting. Easily learned. Write Publishers' Service Bureau, 4258-F Drexel, Chicago, Ill.

PROFIT With new products. Make, sell, repeat. Analysis. Research. Guaranteed formulas. Biggest catalog free. Special prices, leads. Gibson Laboratory Chemists, BD-1142 Sunnyside, Chicago.

SUCCEED With your products. Make-sell them. Formulas. Processes. Accurate, detailed analysis. Catalog free. B. Thaxly Company, Washington, D. C.

WE Teach you new business, then buy your product. Write Superior Specialties, Springfield, Illinois.

MAKE World's newest, strongest, cheapest building material without machinery. Tomon, Mishawaka, Ind.

FINANCE Your own proposition! Raise necessary funds by proven method. Used everywhere. Plans 25c. Radex, 3948 South Western, Chicago.

HAVE Your own profitable business-profession. Many opportunities everywhere. Write Enterprise Bureau, Syracuse, N. Y.

MANUFACTURE Polishpuffs. Amazing proposition 10c. Particulars free. Hickory-dell, Glenbeulah, Wisconsin.

INCOME Monthly! \$10.00 commences fortune! Salable wherever people congregate. Prepaid outfit—\$1.10. Vapator, 6249 St. Lawrence, Chicago.

UNEMPLOYED? Dollars in profit working my plan. Details 3c. Mancini, P. O. Box 154, Chicago Heights, Ill.

START Small mailorder business. Complete plan, 25c. Duffy, Covington, Ky.

DREAMING of your own profitable business? Why dream? Why not investigate the importing business? Only small capital necessary to start. At last complete and authentic information available. Write for particulars. R. G. Business Research Bureau, Ellwood City, Pa.

RECHARGE Discarded batteries, easily, cheaply. Enormous profits. Particulars stamp. Ralph Brooks, Arkansas, Wis.

FREE Homework suggestions for stamp. Healy, 48 Washington Bridge Station, New York.

IF You want to make real money, we will help to establish you in the retail oil burner business. Free details. Webster Oil Burner Co., Barrington, N. J.

MRS. M. earned \$267, three weeks, raising mushrooms in cellar! Exceptional, but your cellar, shed perhaps suitable. We buy crops. Book free. United, 3848-A39 Lincoln Ave., Chicago.

ARTIFICIAL Marble sanitary flooring. Instructions covering wood or cement flooring 1/2 inch thick, fireproof, all colors, low cost, ornamental casting, concrete, plaster, papier-mache, garden furniture, statuary, flexible molds, particulars free. Chris Mahler, Elmwood, N. Y.

NO Boss! Sure cash! Silvering mirrors, autographs, reflectors. Combination outfit, Write Sprinkle, Plater, 127, Marlon, Ind.

MAIL Order business is your opportunity. Many began small, now earn thousands yearly. No personal contact. Boundless opportunities. Have had over 30 years experience; will help you succeed. Send 25c for valuable booklets, none free. B. Breniser, 257 South 21st, Philadelphia.

PLASTEX Industries offers industrious men an opportunity to start a business of their own, manufacturing art goods, novelties, souvenirs, etc., in Plastex and marble imitation. 5c material makes \$1 articles. Rubber moulds furnished for speed production. Small investment brings big returns. You are just in time for the big X-mas business. Write for interesting booklet mailed free. Plastex Industries, Dept. A, 1085 Washington Ave., New York.

HOW And where to obtain capital fully explained, particulars free. Star Service, Wapakoneta, Ohio.

BIG Mail 10c. Milton Boss, 2007M 34th St., Rock Island, Ill.

SELL By mail. Books, novelties. Bargains! Big profits! Particulars free. B. Elfeo, 525 S. Dearborn, Chicago.

I WANT to send you proof of the wonderful pulling power of Popular Mechanics Magazine's classified pages. What's your proposition? Write me today. F. W. Johnson, Manager Classified Advertising, 200 E. Ontario St., Chicago, Ill.

GET Lots of mail. Money making offers, etc. Your name in 10,000 directories. 35c. Roscoe, 4627 Glenshade, Cincinnati.

FREE Booklet describes 107 plans for making \$20-\$100 weekly, in home or office, business of your own. Elite Co., 214 Grand St., New York.

COMPLETE Chemical service, analysis, formulas, processes, trade secrets. Particulars free. W. L. Cummings, 228 Gordon Avenue, Syracuse, N. Y.

POPCORN, Crispette, caramels, crisp, potato chip, salted nut machines. Long Eakins, 1960 High St., Springfield, Ohio.

MILLIONS Jobs! Get dollars in mail daily for satisfying employment information (got man 76 jobs). Keep money; we fill your orders free. Stamp brings details. Co-Operative Service, 77 Swan, Buffalo.

DOLLARS \$40,000—"Moore Made" it. Plan 10c. "Moore Made," Lapeer, Michigan.

OPERATE Chain world's finest money making vending machines. Sells four products—same time. Instant success! Small capital—profits immediately. No curiosity seekers. Penny King, 1233 Chouteau, St. Louis.

MAIL Order and local business. All office. No canvassing; no stock; no shipping. Part of national chain. All instructions given. Shoestring capital. Circular free. Harrigan, P.O. Box 97, Drexel Hill, Pa.

MONEY-MAKING Ideas, plans, formulas, information. Literature free. J. Korngay, 1621 County St., Portsmouth, Va.

"**SCHEMER** Magazine." Alliance, Ohio, prints schemes, ideas, business starters, formulas—big winners; \$10,000 to \$50,000 reported. 38th year; \$1.00. Trial special: six months only 30c.

START Little business anywhere. Everything furnished. No canvassing. Maywood, PM-923 Broadway, New York.

LEARN Marbleizing with our new formula. Flintlike hardness. Imitates marble over wood, concrete, anything. Free samples. See our new rubber composition samples. Stands all required tests. Cowell Institute, Grayling, Michigan.

MONEYMAKING OPPORTUNITIES

BIG Money at home plating auto parts, reflectors, mirrors, chandeliers, by late method. Experience unnecessary. Free particulars. Gunmetal Co., Ave. N, Decatur, Ill.

EXTRA Dollars! Interested? Free particulars. Trable, 528 Garfield Avenue, Chicago.

BIG Money exterminating pests. Benton, 183 Chestnut, Liberty, N. Y.

BIG Profits from ordinary ashes! Finished product in great demand. Raw material found everywhere. Write for details of money-making secret. Adolph Ringle, 12524 Moran, Detroit, Mich.

PULL In the dollars with the "Money by Mail" system. Particulars free. R. Bowen Company, American Bank Building, Portland, Oregon.

FORTUNES In home manufacturing. Booklet free. Ogg Laboratories, Tampa, Florida.

1000 MONEYMAKING Ideas, book 50c; literature free. Harvey Teeple, Decatur, Ind.

MAKE Superior bath salts 5c pound. Sell 35c pound. Formula, only \$25.00. Fancy quart jar \$1.00. Other formulae \$1.00 up. Circulars free. Multichrome Co., Box 3014, Kansas City, Mo.

RAZODRY, New big profit invention for shavers. No sharpener. Christmas bonanza. Sample 25c. Razodry, 332 Van Nuys Bldg., Los Angeles, Calif.

ZIGZAG, Scientific whirling toy; \$1.00 sales outfit starts earning; inquirers inclose stamp. Newton J. Darden, 922 Grant Place, Washington, D. C.

FREE Mail-selling literature! New beauty parlor products! Henkle Mfg., Norwich, Conn.

10 DOLLARS Per day. 3c stamp brings details. A. Lane, Post Office Box 50, Muskegon, Mich.

10c WILL. Bring you plan for profitable home business. Smith-Dawe Co., Atmore, Ala.

TO Win success you must do something different; particulars free. Publishers Sales Company, Box A-76, Nelson, Georgia.

QUARTERS In your mail. All profit. Mailing postcards. Orders filled free. Plan 25c. Details free. Stamp brings our other money-making opportunities. Hampton, Beechwood, Rochester, N. Y.

DOZENS Nationwide profitable offerings. Homework, etc. Listing 10c. Evers, Box 66PM, Elmhurst, N. Y.

EMPLOY Yourself profitably at home. Free information. Western Publishers, Minneapolis, Minn.

DANDY Home business plan 10c. Brinkley Press, Washington, N. Car.

WHEAT, Rice, corn puffing business. General information \$1.00. William Haffner, Clearwater, California.

BEAUTIFUL Pocket handkerchief, handy-memo and identification card. 25c coin. Free—List of 13 firms that furnish homework. Also 300,000 article wholesale directory. Box 5724, Olney, Philadelphia.

WISE Home worker and spare time money makers will send immediately for free details of new "Silent System" business. No canvassing. Harry Julius, Amarillo, Texas.

FREE Booklet describes 107 plans for making \$20-\$100 weekly, in home or office, business of your own. Elite Co., 214 Grand St., New York.

SEE "Millions Jobs!" ad under Business Opportunities. Nothing like it!

"**HOME** Factory." Start in business for yourself. Details. Elyte Supply, Linden, N. J.

BE A perfumer—at home, retail, or mail order. Hardly any capital. Free instructive booklet gives plans of operation. Call-Blossom Perfume Syndicate, Alhambra, Calif.

WEALTH Quickly and honestly made! Dime brings "Key to Business Opportunities." Valuable gift, also complete proposition. Cutler Publisher, Ephrata, Penna.

PROSPERITY For home workers, 52 page magazine. Sample, dime. Sizemore, 4917 N. Kostner, Chicago.

10c BRINGS Copy National Mail Order News, Box 1773-PM9, Roanoke, Virginia.

SCORES Of tested money making ideas for home, shop, farm. Send for list. It's free. Popular Mechanics Press, Room (C36), 200 E. Ontario St., Chicago.

FORMULAS, PLANS, ETC.

FERTILIZER For potted plants, 6 formulas, \$1.00. Balc, 1150 Leonard, St. Louis, Mo.

ANALYSIS, Consultation, Research. Mail sample to Dobin Laboratory, 1746 Roscoe, Chicago.

GUARANTEED Formulas—New fast sellers. None better. Lowest prices. Catalog free. Kemico, 49, Park Ridge, Ill.

ANALYZE Fast sellers. Duplication guaranteed. Write. Associated Chemists, Indianapolis, Indiana.

GUARANTEED Formulas 30c each. Supply sources. National Research Bureau, Pleasantville, N. J.

500 MONEYMAKING Formulas 25c. Descriptive literature free. Harvey Teeple, Decatur, Indiana.

ANY Formula \$.50, three \$1.00. Cole Laboratories, Bryant Pond, Maine.

SELECT Your products—Get formulas, mfg. process from us. Pawn Laboratory, 2362 N. Leavitt St., Chicago, Ill.

ANALYSIS, Research. Newest guaranteed formulas. Biggest catalog free. Special prices, leads. Gibson Laboratory Chemists, BD-1142 Sunnyside, Chicago.

SUCCEED With your products. Make-sell them. Formulas, Processes. Accurate, detailed analysis. Catalog free. B. Thaxly Company, Washington, D. C.

FREE Book—1,000 plans—Formulas, business ideas. Meriden Magazine, Des Moines, Iowa.

USE 40% Less coal. Common ingredients obtained cheaply. Formula 50 cents. Backus Laboratory, Waterloo, Iowa.

FORMULAS—Latest money makers. Literature free. Belfort, 4042 N. Keeler, Chicago.

FREE Gift with 12 moneymaking formulas for 25c. Martex, Princeton, Minnesota.

CHEMISTRY

SUPPLIES For chemistry students. Catalogue 5c. Book catalogue free. Handbook for chemical experimenters, hundreds of instructive experiments, 50c. Reading Scientific Company, Reading, Penna.

CHEMICALS, Laboratory glassware and apparatus. Catalog CP. Biological Supply Co., 1176 Mt. Hope Ave., Rochester, N. Y.

DIME Brings 6 chemicals, moneymaking invention. Electro-Lac System, 3216 Olive, Chicago.

SEND 25c For new illustrated chemical experiment book with over 300 formulas and tests. Also receive 32 page illustrated catalog of apparatus, microscopes, telescopes and chemicals free. PP. Winn, 124 West 23 St., New York.

ANALYSIS. Research. Newest guaranteed formulas. Biggest catalog free. Special prices, leads. Gibson Laboratory, Chemists, CT-1142 Sunnyside, Chicago.

25 CHEMICALS With experiments, 50c. Kayare Chemical, 5522P Ft. Hamilton Parkway, Brooklyn, N. Y.

FREE Chemistry catalogs. Supplies at 5c! Equip complete laboratory. Send 10c for postage and handling. Kemkit Scientific Corp., 135P Johnson Street, Brooklyn, New York.

HELP WANTED

GO Into wholesale business without investment. Call on stores with biggest line self-selling counter displays: Aspirin, razor blades, handkerchiefs, breathlets, household cement, 79 different items. Up to 125% profit for you. Experience unnecessary. Write for catalog and plans. Procopax, Dept. 36-E, 1956 S. Troy, Chicago.

CLERKS. Assistants, bookkeepers—Make your services big paying. Particulars free. Write Business Service, Rockville Centre, N. Y.

BECOME A business detective. Make money in your spare time. Pleasant work. Good fees. Details free. Business Detective System, 1009 Oak Street, Elmira, N. Y.

MRS. M. earned \$267, three weeks, raising mushrooms in cellar! Exceptional, but your cellar, shed perhaps suitable. We buy crops. Book free. United, 3848-A60 Lincoln Ave., Chicago.

I'LL Give you groceries at wholesale besides splendid opportunity to make up to \$45.00 in a week. Brand new Ford sedan given as bonus. Details free. Albert Mills, 2907 Monmouth, Cincinnati, Ohio.

MAN Wanted—Manufacturer established 46 years will finance responsible man with complete stock of guaranteed food, farm and household necessities—you pay when sold. Mighty attractive proposition. Good living right from start with steady increase for industrious man. Big value combination deals, premiums and fast-selling specials now in effect. Jacob Van Dyke of Michigan sold \$441.21; Maurice Vander Haar of Michigan sold \$378.15; and B. M. Anderson of Utah sold \$530.55 in one recent week. Pleasant outdoor work. Experience not necessary. No slack seasons or layoffs. Write today for "No-Investment" offer. McCannon and Company, Room 66LS, Winona, Minn.

AGENTS WANTED

SAVE Gas! Miracle invention of the age—Typhoon super charger. Motorists astounded! More power! More life and pep! More miles per gallon of gas! Unbelievable economy! Split-second pick-up, smoother operation—brings new thrill to motoring. Operates automatically, drives gases uniformly under pressure to all cylinders. Owners everywhere report gas savings up to 33% and more. Requires no servicing—ever! Saves money the instant you step on the starter. Coin money demonstrating to car owners and fleet operators. Typhoon Manufacturing Company, 321-7 Equitable Building, Baltimore, Maryland.

NEW 3-Way profit plan on Christmas greetings includes box containing 16 fine French-fold greetings, 16 envelopes, and 48 new NipApart Christmas seals, 80 pieces costing you 25c. Also personal greetings and individual cards at prices making sales easy. You double your money. Be first. Get sample set on approval. American Card Co., Dept. A-95, Lancaster, Pa.

ASTOUNDING New electric water heater. Plugs in light socket. Tremendously fast seller. \$2.25 brings sample. Industrial Laboratories, Des Moines, Iowa.

UP To \$32 in a week. Sell great line of hosiery backed by definite replacement guarantee, covering holes, snags, runs. Write for samples quick. Wilknit Hosiery, Desk 37-L, Greenfield, Ohio.

MEN! Women! No dull times selling guaranteed food products. Regular customers. Steady income. Experience unnecessary. Free sample. Write today. Federal Pure Food Co., G-2944 Lake St., Chicago.

BIG Money selling to stores. Thanksgiving; Xmas signs. Retail 25c, cost 5½c. Also wreaths, gift wrappings, etc. Samples free. Variety, 41 W. 17th, New York.

300% PROFIT In new self-starting no-flint cigar lighter. Retail 50c. Sample 25c. Get details quick on wonder seller. New Method Co., Box PM-47, Bradford, Pa.

MAN In each town to plate auto parts, reflectors, bathroom fixtures, refinish beds, mirrors, chandeliers, by late method; experience unnecessary. Simple plan of manufacturing at home starts you in big money making business. Free particulars and proofs. Gunmetal Co., Ave. H, Decatur, Ill.

NEW Cleaner—Amazes everybody. Cleans everything. Washes clothes snow-white quickly. Spots, stains removed like magic. Startling demonstrator. Free samples make fast sales. Quick repeater. Immense profit. Write quick for "free sample." Super-X Cleaner Co., 11, Berwyn, Illinois.

WANTED—Men for good paying work with a large shoe company. Good pay every day. Free shoes as bonuses to "go-getters." No experience needed. Complete sales outfit sent free. Write Consolidated Shoe System, Dept. F2, Chippewa Falls, Wis.

MAKE More money selling shirts, ties, underwear, dresses, hosiery, raincoats, jackets, pants, uniforms. Sales outfit free. Nimrod Company, Department 8, 4922-28 Lincoln Avenue, Chicago.

AGENTS! Dresses 33c, men's suits \$1.50-\$2.00, shirts 46c, ties 6½c, chiffon hose 42c. Amazing prices. Big profits. Catalogue free. Liquidation, AB-550 East 43rd, Chicago.

GENUINE Gold letters for store windows. Easily applied. Free samples. Liberal offer to general agents. Metallic Letter Co., 438-B North Clark, Chicago.

MEN—Women \$3 to \$6 daily. Selling 25c household necessity that repeats. Three to ten sold in every home. Free sample. Write Puro Company, 3107 Pine St., Dept. R-2046, St. Louis, Mo.

MAKE Up to \$12 day with sensational extract deal. Everybody buys. Particulars free. Wyatt, Box 2322, Houston, Texas.

STRANGE Ironing cord. Saves electricity. Abolishes scorching and kinking. For telephones also. 150% profit. Sales guaranteed. Big free offer. Neverknot, Dept. 11A, 4525 Ravenswood, Chicago.

MAN Wanted, by shoe manufacturer established 33 years, for sales work. Ready cash daily and extra bonuses to producers. No experience needed. Your own shoes at factory prices. Sales outfit sent free. Write Mason Shoe Manufacturing Co., Dept. A7, Chippewa Falls, Wis.

MONOGRAMMING Automobiles biggest money maker today. New type requiring no varnish to apply. Write for samples. International Monogram & Transfer Co., Box 6365, Philadelphia, Pa.

EASIEST 25c Seller. Has thousand uses. Simple demonstration gets the money. Sample 25c. Dozen \$1.50. Don't pass this up. Parmer, 645 West 66th St., Chicago.

MEXICAN Feather pictures. Christmas novelty. 50c (stamps) brings \$2.00 worth samples, details. Refunded if unsatisfied. Mexican Art, Apartado 1593, Mexico City.

450% PROFIT In new automatic gas lighter. No flint or flame. Lights gas instantly. Retail 25c. Costs you \$1.00 a dozen or 15 dozen for \$8.00 postpaid. Sample 10c. New Method Co., Box PMG-47, Bradford, Pa.

BUY Wholesale 1000 bargains. Catalog free. Products Company, Gary, Indiana.

BIG Money. Commissions daily. Free clothing. Sell quality raincoats, jackets, overcoats. New styles—Lowest prices. Sales kit free. Goodwear, 712-A Roosevelt, Chicago.

BIG Money applying gold initials on automobiles. Easiest thing today. No experience needed. Free samples. "Ralco," 1084 Washington, Boston, Mass.

SELL Made to measure raincoats. Outfit free. Goodyear Rainwear, 126 West 22nd, New York.

SELL Popular cosmetics. Liberal commission. Samples 50c. Cienet Mfg. Co., Box 222, Kansas City, Kansas.

500% PROFIT Selling new "20-in-1" kitchen utensil. Retail 25c. Costs you \$1.00 a dozen. \$7.20 a gross. Sample 10c. New Method Co., PMM-47, Bradford, Pa.

FREE Sample—Amazing cleaner; sells homes, taverns, everywhere. Big profit—fast repeater. Betco, 5007 Irving Park, Chicago.

MAKE Daily profits with fastest selling line of men's ties in America! Priced \$1 to \$9.60 dozen. Over 100% profit! Unbeatable guarantee backs you up. We pay postage. Write for catalog and free samples swatches. Boulevard Cravats, 22 West 21st St., Dept. M-24, New York.

AMAZING Light discovery. Patented Amplifiers reduce electric bills 25% to 50%. Needed by every store, factory, office. Huge profits for distributors—salesmen. Wonderful demonstrator. Write today for convincing proof and no risk initial stock offer. Apex Lamp Works, 150-PO West 25th, New York.

AGENTS! Make \$5 daily selling quality household necessities. Over 250 guaranteed positive repeat sellers. Atlas Products, 2129 S. Broadway, St. Louis, Mo.

STOP Squealing—Start crowing!! Drive to country—"movies"—afternoons. Work mornings—home. No canvassing! National Folio-A, Station "D," Los Angeles.

CAMPAIGN Ties—Pictures of Roosevelt, Landon, Lemke on rayon ties. 2 samples 25c. \$7-100. Legion Tie, 703 Broadway, New York.

SELL Made to measure raincoats. Outfit free. Goodyear Rainwear, 126 West 22nd, New York.

WHOLESALE Catalog free, 500 best sellers. Paty Co., 1167 Broadway, Somerville, Massachusetts.

YOUR Favorite cigarettes free! Selling tinselled Thanksgiving-Christmas signs! 11"x14" costs 5½c—retails 25c. Sample free. 21 boxed Christmas cards 35c—retails 85c. Lowy, Department 669, 8 West Broadway, N. Y.

BE Your own boss! Operate used-new clothing business from store, home, auto. 200%-300% profit. Everything furnished. Catalogue free. Portnoy, 566-G Roosevelt, Chicago.

SANTA Claus that talks. Magic, mysterious. Works like phonograph. \$3 per dozen. Sample 30c. Talkie Toy Company, 4151 Irving Park, Chicago.

MAGAZINES. Sell new and renewal subscriptions. All publications. Full or spare time. Highest commissions. Pay daily. Mission Circulation Company, Box 802, Santa Barbara, California.

PROFIT With new products. Make, sell, repeat. Analysis. Research. Guaranteed formulas. Biggest catalog free. Special prices, leads. Gibson Laboratory Chemists, BD-1142 Sunnyside, Chicago.

GOLD Reflecting letters for store windows. Large sizes penny each. Free samples. Modernistic Sign, B-3004 Lincoln Ave., Chicago.

500% PROFIT! Gold and colored sign letters for windows, offices, trucks, signs. Monograms. Easily applied. Neonite, Akron, Ohio.

SUCCEED With your products. Make-sell them. Formulas. Processes. Accurate, detailed analyses. Catalog free. B. Thaxly Company, Washington, D. C.

SELL Novelty fun cards, novelties, etc. Samples 10c. National, Box 500M, Cincinnati.

UNIQUE Printed specialties. Money-getters. McPherson Stamp Works, Middletown, Connecticut.

SELL Neon tubes 65c foot, neon signs, neon plants complete \$395.00. Marcella's, 742 Strong, Schenectady, N. Y.

AGENTS—Men-women. Big profits supplying perfumes to families. Laffer & Co., 741-PM, St. Louis, Mo.

NEW Item—New plan—No selling. Free samples. Quick cash returns. Werth Bros., 825 S. Wabash, Chicago.

AGENTS—Route men: Here's a fast selling, big profit item. New scientific cleanser and specially designed brush for false teeth. Nothing else like it. Needed by one out of three persons over forty and many younger. Easy to demonstrate and sell. Nelson Products Co., 31 N. Garfield Ave., Alhambra, Calif.

500,000 ARTICLES At lowest prices. Lists 10c. Duffy, Covington, Ky.

I WANT Men for local tea and coffee routes. Make up to \$42.50 first week. No experience needed but must give prompt service to families on your route. I send everything; no money risk. Write Albert Mills, 2911 Monmouth, Cincinnati, Ohio.

AMAZING Finish, thousand uses. Sells itself. 150% profit. Dime brings sample. King, 612 North Michigan, Chicago.

EXCELLENT Trouserpresser, stretcher, creaser, hanger \$1.00. \$7.00 doz. Perfect pants hanger stretcher 10c. 60c doz. Get circulars. Widness, 208 Van Buren St., Brooklyn, N. Y.

CHRISTMAS Cards—50 beautiful folders, name imprinted, cost 65c, sell for \$1.00. Samples free. New England Art, North Abington, 206, Mass.

SELL North American oil burners. No experience needed. Write for free particulars. Wrenn Burner Service, Nashua, New Hampshire.

AGENTS: Stamping names on pocket-key protectors. Sample check with your name, address, 25c. Stamping outfits. Emblem checks, check-fobs, name plates. Hart Mfg. Co., 303 Degraw St., Brooklyn, N. Y.

BIG Money and fast sales. Every owner buys gold initials for his auto. You charge \$1.50, make \$1.45. Ten orders daily easy. Write for particulars and free sample. American Monogram Company, Dept. 40, East Orange, N. J.

AGENTS—Opportunity to make money; book containing 107 successful business plans; home or office; send for free introductory booklet. Elite Co., 214 Grand St., New York.

AGENTS Mosco corn and callous remover will build you a steady repeat business. Send today for pocket-size trial outfits. The Moss Company, 64 Searle Bldg., Rochester, N. Y.

MAKE And sell your own products. Employ agents yourself. We supply formulas and full instructions for making toilet preparations, perfume, flavoring extracts, soap, household specialties. Valuable booklet free. National Scientific Laboratories, 1950W Broad, Richmond, Va.

COSTS 1c—Sells 25c. Make non-explosive cleaner from benzene crystals. 1c gallon. Sample 10c. Literature free. Western Reserve Laboratories, 6615 Denison Ave., Cleveland, Ohio.

AGENTS: Smash go prices! Santos coffee 12c lb. 100 sticks chewing gum 12c. Christmas cards, 21 in box, 14c. 150 other bargains. Premiums. Carnation Co., PO, St. Louis, Mo.

NO Boss! Sure cash! Silvering mirrors, autopaarts, reflectors, combination outfit. Write Sprinkle, Plater, 128, Marion, Ind.

BOOKS Covering hundreds of subjects. Big catalog for 3c postage. Popular Mechanics Press, Room (C36), 200 E. Ontario St., Chicago.

WANTED—District purchasing agents. No experience or money required. Write Purchasing Manager, 174 N. Halsted, Chicago.

DO You want agents for your proposition? Your ad in this space will place your message before hundreds of men seeking fast-selling products. My folder "How to Secure Agents" is filled with proof. I'll gladly send you a copy free. F. W. Johnson, Manager Classified Advertising, Popular Mechanics Magazine, 200 E. Ontario St., Chicago.

SALESBOARD Men—New put and take jars. Details, samples free. Tom Thumb, Dept. PM, Nauvoo, Ill.

GUARANTEED Double-edged blades 50c hundred up. If there's anything else you want, write us; we have it. Samples sent. Steven Spencer, 412 E. 51, Brooklyn, N. Y.

PROFITABLE Home business. Legitimate. No canvassing. Maywood Publishers, P-923 Broadway, New York.

BIG Profits eyeglass necessity. Cleans, polishes, prevents steaming. Sample ten cents. Shurberg Chemical, Hartford, Conn.

GOLD Reflecting letters for store windows. Easily applied. Large sizes, penny each, free samples! Atlas Sign Works, 7941 Halsted, Chicago.

HIGH-GRADE SALESMEN

BIG Money maker! Amazing invention closes all doors silently, automatically. New oil principle. Easily installed. Never needs attention. Priced dollars less than other checks. Unlimited market stores, offices, factories. Free demonstration furnished workers. Kant-Slam, Dept. K-62, Bloomfield, Ind.

BIG Money makers: Large line work uniforms, raincoats, pants, shirts, etc. Advertising embroidered. Low prices. Every business, individual prospect. Free outfit. Dove Garment Co., 1733 Milwaukee Ave., Dept. 904, Chicago.

GIVE Away free 1936 short wave and home radios, also full electric automobile radios with our unique "Punch Sales Card Plan." 2 sales daily pays \$203.88 weekly profits. Write for our free starting offers. DeLuxe Mfg. Co., Dept. 278, 173 W. Madison, Chicago.

MAKE Jobber's profit on fastest selling truck and window signs. Send \$3 for dozen 4-color "100% Locally Owned" decalcomanias. Sell \$1.00 each. 1427 Welton, Denver, Colorado.

BRAND New grab-bag deal. Going big everywhere—big profits—swift sales—fast repeats. No restrictions. All dealers buy. Act! K&S, 4347-C Ravenswood, Chicago.

NEW Punchboard line. Free 32 page full color catalog. Nothing to carry. Larger cash commissions daily. Season now! Lea-Moore Co., 180 Adams, Chicago.

WANTED County dealer: Man with car to demonstrate and service for large manufacturer. First class job. 248 Fyr-Pyter Company, Dayton, Ohio.

MAKE More money selling shirts, ties, underwear, dresses, hosiery, raincoats, jackets, pants, uniforms. Sales outfit free. Nimrod Company, Department 65, 4922-28 Lincoln Avenue, Chicago.

EARN \$5000 Annually distributing astounding new product. Industrial Laboratories, Des Moines, Iowa.

IF You are ambitious you can make good money with a Rawleigh route. We help you get started. No capital or experience needed. Steady work for right man. Rawleigh's, Box K-2-PPM, Freeport, Ill.

SALESMEN—Sell 2000 business cards \$1.50; 1000 watermarked letterheads \$3.00; 1000 20 lb. envelopes \$3.00. Your commission 33%. Free sales kit. Dept. P, Star Publishing Company, Corsicana, Texas.

NEW Drycleaning clothes brush. Revolutionary invention. Cleans clothes like magic. Homes, offices buy instantly. Phenomenal profits. Outfit free. Kristee, Dept. 260, Akron, Ohio.

SPECIALTY Salesmen—Glider skates; new invention for youngsters; sell toy, hardware, sporting goods, jobbers, dept. stores, etc.; 79c retailer; big comm.; write Glider Skate Co., 3129 W. 49th Place, Chicago.

LUCKY Star sales stimulator sells on sight! Pays to \$4.50 commission on \$7.95 sale. Free sales kit. Repeat Sales Co., Univ. Bldg., Denver, Colo.

SALESMEN—Sell calendars. Complete line, all sizes, including jumbos; beautiful subjects. Samples free! Flemming Calendar Co., 6543 Cottage Grove, Chicago.

BRUSH Salesman—If you ever sold brushes write for our money making proposition. Donald Brush Co., Camden, New Jersey.

NEW Specialty—Sells every business and professional man. Four \$15 sales daily pay \$280 weekly. Ferrell cleared over \$1,000.00 monthly. Write, F. E. Armstrong, President, Dept. PM, Mobile, Ala.

FREE Booklet describes 107 plans for making \$20-\$100 weekly, in home or office, business of your own. Elite Co., 214 Grand St., New York.

SALESMEN—New deal guarantees stores \$10 for one. Two \$15 sales net you \$20 daily. Sayers, 2801-123 Sheffield, Chicago.

WANTED: Reliable, energetic salesman who knows farming, to sell Martin poultry buildings and corn cribs direct to farmers on easy terms. Big profits—permanent income. Martin Steel Products Co., Dept. 8, Mansfield, Ohio.

BE Your own boss. Make the largest commissions selling our complete line of brushes. Write for sales plan. Wire Grip Sanitary Brush Corp., 220 Southern Boulevard, N. Y.

SOMETHING New in fire extinguishers—Red Comet Automatics. Proved in west five years. Exclusive territory. Low price opens pocketbooks. Write, Red Comet, 404 Comet Building, Littleton, Colorado.

MAN—Handle regular store route. Place nationally advertised 5c-10c counter card mdse. New aspirin deal—6 tablets 5c. 85 other fast sellers. 100% profit. No investment. Samples free. World's Products Co., Dept. 11810, Spencer, Ind.

TIRE Accessories—Tiger-Grip tire patches, guaranteed 10,000 miles, and complete fast-selling line auto accessories. Salesmen-distributors easily make up to \$60.00 weekly, and much over. Exclusive territory. Economy Rubber Products, 812 Burkhardt, Dayton, Ohio.

REPRESENT Auto tool manufacturer, selling only automatic tool of kind, fully patented, moneyback guarantee. First time sold direct. Garagemen want it on sight. Hurry! MacGregor Tool Co., 1316 Folsom Street, San Francisco, California.

SALESMEN: Sell complete line book matches, labels, salesbooks, pricing sets, garage forms, calendars, business stationery, etc. Free deals. Comm. daily. Free sales portfolio. David Lionel Press, 312-MP So. Hamilton, Chicago.

BE Independent. Own your business; experience unnecessary, selling \$10,000 accidental death, \$50 accident; \$25 sick weekly benefits—\$10.00 yearly. Other amounts proportionate. Guaranteed steady renewal income. \$726,415.63 securities deposited. Universal Policy, 716-A Lefcourt Bldg., Newark, New Jersey.

EDUCATIONAL AND INSTRUCTION

PLEASANT Profitable years with a hobby. Stamp brings this descriptive folder. Byron, 82 Wadsworth Ave., New York.

MEN—Women. Get government jobs. Start \$105 to \$175 month. Prepare now for next announced examination. Short hours. Influence unnecessary. Common education usually sufficient. Full particulars, list positions and sample coaching tests free. Write today. Hurry. Franklin Institute, Dept. R3, Rochester, N. Y.

HOME Study courses. Earn degrees: arts, literature, sciences, chemistry, engineering, psychology, philosophy, theology, English, education, languages law, business and commerce. Numerous others. Low cost; easy terms. Catalog on request. Thomas Jefferson University, 749 Independence Boulevard, Chicago.

LEARN Spanish. Everyday phrases easy with pronunciation English, Spanish. Copyrighted authoritative wonderbook, mail 25 cts. Prischmann, Box 1792, El Paso, Texas.

"SHORTHAND Simplified" (complete) \$1.00. Free lesson. Erskine Simmons, Cromwell, Conn.

JIU Jitsu now simplified, shows everybody self-protection. 5 samples for dime. Wandekirk, Suite 5PK, 2504 West Seventh, Los Angeles.

SECRET Service. Particulars free. Write immediately. George Wagner, M-2640 Broadway, New York.

BECOME An investigator—Secret service agent. New "Test Problem Method." Develops your ability. Particulars free. International Secret Service Institute, (PM-116), Hoboken, N. J.

GET A government clerk job. File clerk, P.O. clerk, statistical clerk—all good jobs. Men-women, age 18-50. Want to qualify for next entrance test? Details free. Write, Instruction Service, Dept. 101, St. Louis, Mo.

LINGUAPHONE—Unique language method brings voices of native masters into your own home. 23 languages. Write for free booklet. Linguaphone Institute, 32 Rockefeller Center, New York City.

DO You like to draw? Learn illustrating, designing or cartooning in spare time. Write today for talent test (no fee). Give age and occupation. Federal Schools, Inc., Dept. 116, Minneapolis, Minn.

REPAIR Upholstered furniture. Illustrated course of instruction, including a full set of upholsterer's tools \$7.50. Money returned if not satisfied. M. Swider, 260 19th St., Brooklyn, N. Y.

ACCOUNTING, Leading to C.P.A. \$100.00. Earn tuition. Graduates placed. 25 cents first lesson. National School of Commerce, Chattanooga, Tenn.

LEARN Shoe dyeing, course \$1.25. Frank Lento, 36K12, Punxsutawney, Penna.

SALESMANSHIP! Ten lesson course in aggressive selling complete for dollar. Ruth Publishers, 729 S. 6 St., LaCrosse, Wis.

BE An investigator. Earn big money—Travel. Crime detection newspaper and particulars free. National System, 425-G, Fremont, Nebraska.

BE A super salesman. Learn how to use your mental powers. Our course is the answer. 3c stamp brings particulars. Super Salesman Institute, 402 North Warren, Saginaw, Michigan.

SHORTHAND In 30 days. Wonderful Boyd system. Free catalog. Chicago Home Study Schools, 801 Reaper Block, Chicago.

SHORTCUT Business training. New, complete, simplified shortcut "Business Tech" course trains you at home, for promotion and more pay. 1/2 the usual cost and in a fraction of the time. Get out of the rut—and on the road to success—quickly, easily. Postcard brings free book which tells how. Write Institute of Business Technology, Dept. AT-313, Chattanooga, Tenn.

MEN Wanted willing to learn landscape designing and fill big paying position as landscape architects. Free test of your natural ability and chance to win in \$750 contest. No experience needed to start. Earn while you learn. Write today for free test blank. American Landscape School, 400 Plymouth Bldg., Des Moines, Iowa.

LEARN Machinist trade, tool, die making. Automatic and hand screw machines. Modern shop methods. Actual work. Jobs open for trained men. Employment help. Illustrated booklet free. Allied Screw Machine Company, 601 Lake Street, Chicago.

LEARN Auto mechanics, body, repairing, welding, electricity, refrigeration, Diesel. Stevenson's, 2098A Main, Kansas City, Mo.

LEARN Latest methods solving arithmetical problems quickly. Frederick A. Smith, 2410 Smalley Court, Chicago.

STAMMERING. Stuttering corrected. Write Lewis Institute, 12052 Woodward, Detroit, Michigan.

HOME Study courses leading to degrees: Arts and sciences, philosophy, education, law, letters, theology, psychology, engineering, chemistry, business and commerce. Many others. McKinley-Roosevelt University, Chicago.

U. S. GOVERNMENT Positions. \$1700-\$1900 and up a year. Let our expert (former government examiner) prepare you for a position in the railway mail service, rural carrier, post office, customs and other branches. Write today for free booklet. Dept. S, Patterson School, Rochester, N. Y.

BIG Bargain catalogue education matter 10c. Hanfling, Y-799 Broadway, New York.

CHIROPODY Taught by correspondence. Evans School of Chiropody, Montgomery, Alabama.

ZEJAY. Remarkably simple secret language. Correspondence, detective work, etc. Instructions 1c. Zendu, Burbank, Calif.

AUTHORS' SERVICE

SHORT Stories marketed. Write, Hursh Service, Box 1013, Harrisburg, Penna.

CARTOONING—COMMERCIAL ART

CARTOONING Course:—30 lessons, over 500 illustrations, drawing pens and pencils, \$1.00 complete. Scovell Studios, Box 748-P, Hollywood, Calif.

CARTOONING, Sketching, etc.—46 lessons, 600 illustrations, including practice sheets, pens, pencils, \$1.00 complete. Fraba Service, Cashton, Wisconsin.

CHALK Talks. Laugh producing program, \$1.00. Catalog free. Balda, The Cartoonist, Oshkosh, Wis.

COMIC Strips written. Gags for free lance cartoons supplied. Welton Tinney, Wlmsboro, Texas.

SIGN Painting taught by successful sign painter. Dime brings literature. James Meagher, 71 Dunham St., Norwich, Conn.

CARTOONISTS! Markets, rates, requirements—25c. Mueller, Phillips, Glen Ellyn, Illinois.

MAKE \$25.00 Weekly duplicating advertising cartoons. Write, Palsley-K, Kinloch Bldg., St. Louis, Mo.

ADVERTISING AGENCIES

LEARN Advertising quickly at home. Easy practical plan. No text books. Common school education sufficient. Interesting booklet and requirements free. Page-Davis School of Advertising, 3601 Michigan Avenue, Dept. 3432, Chicago.

INCH Display advertisement 30 magazines year \$24. Wood's Popular Service, Atlantic City, N. J.

ADVERTISING Placed anywhere. Helpful, free service. Rate guide book free. Baker Advertising Agency, 189 W. Madison, Chicago.

ADVERTISE Profitably: \$15 reaches 6,000,000 Sunday newspaper readers with 24 word ad. Newspaper, magazine rate-guide, free. Chicago Union Agency, 20 West Jackson, Chicago.

FREE—New Advertisers Rate Guide, 44 pages. Includes everything. Lowest rates. E. H. Brown Advertising Agency, 140 S. Dearborn, Chicago.

FOR ADVERTISERS

NEW Live salesman's and inspirational magazine. 15,000 circulation. Classified rate 4c per word. Send a trial ad now. Sample copy free. Mutual Crusader, Berwyn, Ill.

SPECIALIZE Writing sales letters, advertisements and folders on approval. Thompson Advertising Agency, Youngstown, Ohio.

DRAWINGS For all types of advertising. Reasonable. Armin Reinke—Artist, Oshkosh, Wisconsin.

50 CO-PUBLICATIONS: 4c Word. Bryant, Box 4684-E, Kansas City, Mo.

ADVERTISE: 24 Words in 250 newspapers \$10. Lists free. Advertising Service Bureau, 4258-C Drexel, Chicago.

BUSINESS SERVICE

ESTABLISH New York offices at Times Square! Ideal personal, business mailing address. Builds sales; adds prestige. Room number unnecessary. Mail forwarded daily. Only \$1.00 monthly! Paramount Office Service-G, 140 West 42nd, New York.

CHICAGO! Business-personal mail address, representation, forwarding; \$1.00 month. Established 1919. General Business Service, 56 West Washington.

DELAWARE Charters: Complete incorporating and organizing service \$35. Submitted forms. Chas. G. Guyer, Inc., Wilmington, Delaware.

ALL International legal matters. Lic. Victor Prieto, Mexican Attorney at Law, P. O. Box 122 M. Jurez, Mexico.

\$1.00 MONTHLY Maintains Chicago office. King, 612 North Michigan Avenue.

RUBBER STAMPS AND OFFICE SUPPLIES

\$1.00 METAL Pocket case self-inking address stamp 60c. Fehlbeg, Lacrosse, Wis.

SPECIAL! 3 Lines 25c. Knob handle. Owl, 6452 Kenwood, Chicago.

WRITE For free catalog. McKechnie Brothers, 11E36 Calvin, N. Dak.

NAME Address, 2 lines 25c; 3 lines 35c. Stamp Works, Auburn, Nebr.

2 LINES 25c, 3 Lines 35c. Stamprite, PP43, Springfield, Mass.

2 LINES 25c, 3 Lines 35c. Stamp Works, Centerport, N. Y.

CUSHION Mounted, one-two lines, 25c; three, 35c. All kinds. Stamp Works, 814 Bradley, Peoria, Illinois.

TYPEWRITERS, DUPLICATORS, OFFICE DEVICES

GUARANTEED Letter-size hectograph duplicator \$1.00 cash or C.O.D. Send for circular. MultiPrinter Company, 5710 Woodlawn, Chicago.

REBUILT Standard size and new portable typewriters at bargain prices. Write for prices. Hoyt's Store, Sac City, Iowa.

TYPEWRITERS, Duplicators, multi-graphs. Write for free list office machine bargains. Save half. Pruitt, 518 Pruitt Bldg., Chicago.

INCREASE Business. "Excellograph" rotary stencil, clay and film duplicators \$3.85 to \$37.50. Prints anything. Typewritten, penned, drawn, traced. Colors. Folder free. Pittsburgh Typewriter Supply, Suite 518, Pittsburgh, Pa.

PRINTING, MULTIGRAPHING, MIMEOGRAPHING, GUMMED LABELS

SUCCESS! Prestige! Distinctive stationery!! Samples. Write, Hall's Printing, Dalton, Massachusetts.

MODERNISTIC Two color gummed labels, 7/8 x 2 1/2. 250—three lines—25c. Ad-Man, 301-N, New Jersey, Indianapolis, Indiana.

QUALITY Printing. 500 envelopes, \$2.00 postpaid. Raymond Whitney, Johnson, Vermont.

1000 HI-QUAL-I-T Business cards—Special—\$1.19. Shinn, 1038FL, Bellflower, California.

500 TWO-COLOR Letterheads \$1.75. Samples free. Colorpress, 333-P State, Detroit.

PRINT Your own. Bargains, presses, type. List 3c. Exchange D-14, 22 Orient, Meriden, Conn.

ENGRAVURE Printing. Lowest possible prices. Samples free. Sunko, Mohawk, N. Y.

PRINTING That satisfies, complete samples, prices. Jobey Press, 3932 Madison Street, Chicago.

LETTERHEADS, Envelopes, etc. Samples, prices, for stamp. Wilsonprint, 707 Cherry, Long Beach, Calif.

AGENTS Wanted—\$2.35 line of letterheads—envelopes. 4719 Wisconsin, Milwaukee.

2000 CAMPAIGN Or business cards \$1.00. Postage extra. Kalata, Ironwood, Michigan.

LABEL Value headquarters. Specimens free. Labelers, 6618D Quimby, Cleveland, Ohio.

250 BOND Letterheads or envelopes \$1.00. Woods Press, Bedford, Penna.

MATCHES—1,000 Books \$4.50. Finest quality book matches printed with your advertisement. Send \$1.00 with order. VanDorn Company, Ottawa, Ill.

250 BOND Letterheads or envelopes, \$1.00. Moverco, B-241-P, Milton, Pa.

\$1.85—1,000; ENVELOPES, Letterheads, statements, circulars. Midwest Printing, Northfield, Minn.

500 ENVELOPES And 550 whitebond letterheads, \$3.50. Webpress, Farmland, Ind.

GUMMED Labels. All kinds; write, samples. JBSCO., Box 93, Holyoke, Mass.

COUPON Books—For gasoline stations, ice dealers, dairies, etc. Lowest prices! Discounts! Sample assortment 10c. Sander's Coupon Books, Ottawa, Illinois.

LETTERHEADS, Envelopes, business cards—250 each kind neatly printed, postpaid, \$2.65. Lonelm Printers, Paulding, Ohio.

PHOTO Engravings—Zinc line cuts made, 10 square inches, \$1.00 up; half tones; electros; artist; speedy; free price list. Riteway Engraving, 1457P Broadway, New York.

125 LETTERHEADS 8 1/2 x 11, 100 Envelopes \$1.00; 200 printed personal sheets, 100 envelopes, \$1.00. Croydon Press, 100 Fourth Avenue, New York.

LETTERHEADS, Envelopes, postcards, labels, 2 1/4 x 4 blotters, \$2.95 thousand prepaid. Complete list free. Press, Box 103, Station W, Brooklyn, New York.

COLORFUL Labels, cards, 3c for samples. Paga Press, Shippensburg, Pa.

NEARGRAVURE Processed business stationery. Distinctive. Reasonable. Samples. Soliday's, Knox, Indiana.

\$1.00 PRINTING. 1000 Cards, letterheads, etc. United Printing, Pottstown, Pa.

200 PERSONAL Post cards, \$1.00. Printing samples free. Riggs, Vevay, Indiana.

GOOD, Inexpensive printing. Send for catalog. Springer Printery, Miami, Oklahoma.

5000 3 1/4 x 6 CIRCULARS \$3.25; 250 noteheads, 100 envelopes \$1.00. Abbott Press, Oswego, Kansas.

2000 3 1/4 x 5 1/2 COLORED Envelope slips, \$2.00. 5000 letterheads, envelopes, cards, \$7.49-\$8.95. Samples. Goodprint, Harrisonburg, Va.

PRINTING? Lowest prices, samples free. Churchill, 704 Montgomery, Syracuse, N. Y.

ATTRACTIVE Printing, envelopes, statements, stationery, etc. Octagon Press, Belleville, Ill.

1000 BUSINESS Cards \$1.00. Charles Harmon, Chester, W. Va.

PERSONAL Printed stationery. 100 sheets and 100 envelopes \$1.00. 100 name cards 50 cents. Frank O. Wrob, 3974 E. 66 Str., Cleveland, Ohio.

300 20-LB. 8 1/2 x 11 Letterheads and 300 6 1/2 envelopes printed \$2.00. Carten, Box 52, Orange, Calif.

QUALITY Printing, minimum prices, samples. Paul James Press, 140 Ralph Ave., Brooklyn, N. Y.

1000 6 1/2 ENVELOPES Printed \$2.50. Zone 4. Fry Printing Co., Rothsville, Pa.

1000 BUSINESS Cards, card case, \$1.50. Miller, Printer, Ambler, Pa.

BETTER Business cards, 500 postpaid \$1.00. Artisan Press, Riverdale, Maryland.

BETTER Grade printing, reasonable priced. Free samples. Economic Press, Leonia, N. J.

CUTS 2x3, \$1.10, from drawings and photos. Joe Rek, 118 Gazette Ave., Lexington, Ky.

GOOD Printing, reasonable prices. Samples free. Harmon Company, 318 So. 19th Street, Philadelphia, Penna. Established 1885.

PRINTING OUTFITS AND SUPPLIES

PRINT Your own cards, stationery, circulars, advertising, etc. Save money. Easy rules furnished. Print for others, big profits. Junior press, \$5.90; job presses, \$11, power \$149. Write for details. Kelsey Co., A-11, Meriden, Conn.

BARGAINS, Presses, type. List 3c. Exchange D-15, 22 Orient, Meriden, Conn.

STEREOTYPE Caster \$5.00. 50 mats free. Green, 531 Broadway, Lawrence, Mass.

HAND Press, type and complete printers' supplies. Advise equipment you need and we quote prices; or send stamp for catalog. P. Peiffer, 90-A; 6 Columbia St., Newark, N. J.

PAPER—Wholesale prices 3c. Samples 10c. VanDorn Paperstocks, Ottawa, Illinois.

PRINT Your own circulars, envelopes, with home made press costing less than \$1.00. Illustrated instructions 10c. Carl Edquist, Odessa, Minn.

BARGAINS—Presses, type, supplies. Send stamp. 159 Harvard, Cambridge, Mass.

PRINTING Presses and printers needs. Lists 3c. Landis, Richland, Pa.

PRINTING Outfits—Presses, type, supplies, type novelties. Send 20c for card case samples. Catalog free. Model Press, York, Pa.

PATENT ATTORNEYS

INVENTORS: Send immediately for your copies of our new free books, "Patent Protection" and "Suggestions on Selling an Invention." Sixty-eight pages of interesting facts. They tell how patent laws protect you; kind of sketch or model needed; simple steps to take without cost; how successful inventors have secured financial assistance; show interesting inventions; illustrate important mechanical movements. With books we also send free Evidence of Invention form to help establish date of disclosure. Prompt service, reasonable fees, special deferred payment plan. Strictest secrecy. Thirty-six years' experience. Highest references. Write us today. The facts in our books are worth money to the man with a good invention. Address: Victor J. Evans & Co., Registered Patent Attorneys, 801-M Victor Building, Washington, D. C.

INVENTORS—Small ideas may have large commercial possibilities. Write us for free book, "Patent Guide for the Inventor" and "Record of Invention" form. Delays are dangerous in patent matters. Free information on how to proceed. Clarence A. O'Brien & Hyman Berman, 58-M Adams Building, Washington, D. C.

JUST Published roster names, addresses patent attorneys United States and Canada. \$2. Schack Service, 15 West 44th Street, New York.

PATENTS—Trade marks—Personal service, reasonable charges. Preliminary advice, book and disclosure form free. Irving L. McCathran, 1060 International Bldg., Washington, D. C. Registered Patent Attorney.

PATENTS—Personal, confidential services for protection of your invention at reasonable cost. Preliminary information and approximate cost of patent furnished without obligation. John B. Thomas & Co., 902 F Street, N. W., Washington, D. C.

INVENTORS—Send for free booklet "Patent-Sense." Information based on 64 years experience. Lacey & Lacey, Dept. 5A, 635 F St., Washington, D. C.

L. F. RANDOLPH, 302-B Victor Building, Washington, D. C. Low cost. Book and information free.

PATENTS. Protect your idea by securing free "Proof of Invention" folder. Exceptional personal service. Established 1906. E. E. Vrooman, 871 Woodward Building, Washington, D. C.

PATENTS. Instructions "How to Establish Your Rights" and form, "Evidence of Conception"—sent free! Lancaster, Allwine & Rommel, 411 Bowen Building, Washington, D. C.

PATENTS. Booklet free. Highest references. Best results. Promptness assured. Watson E. Coleman, Patent Lawyer, 724 Ninth St., Washington, D. C.

WHAT To invent. List of wanted inventions sent free on request. Use our legal form for recording evidence of ownership. Write W. T. Greene, 946 Barrister Bldg., Washington, D. C.

"INVENTOR'S Guide," 100 mechanical movements, free; advises on patenting, selling inventions. Frank Ledermann, Tribune Bldg., New York.

THEODORE H. Rutley, Registered Patent Attorney, 512 Colorado Bldg., Washington, D. C.

FOR INVENTORS

INVENTORS—Small ideas may have large commercial possibilities. Write us for free book, "Patent Guide for the Inventor" and "Record of Invention" form. Delays are dangerous in patent matters. Free information on how to proceed. Clarence A. O'Brien & Hyman Berman, 58-M Adams Building, Washington, D. C.

INVENTORS: Send immediately for your copies of our new free books, "Patent Protection" and "Suggestions on Selling an Invention." Sixty-eight pages of interesting facts. They tell how patent laws protect you; kind of sketch or model needed; simple steps to take without cost; how successful inventors have secured financial assistance; show interesting inventions; illustrate important mechanical movements. With books we also send free Evidence of Invention form to help establish date of disclosure. Prompt service, reasonable fees, special deferred payment plan. Strictest secrecy. Thirty-six years' experience. Highest references. Write us today. The facts in our books are worth money to the man with a good invention. Address: Victor J. Evans & Co., Registered Patent Attorneys, 801-M Victor Building, Washington, D. C.

IDEAS. Let us try selling yours. Allied Engineering Enterprises, 455 Paul Brown Building, St. Louis, Mo.

INVENTORS: "Making Inventions Pay," our 32-page illustrated book, mailed upon receipt of 3c postage. Crescent Tool Company, Dept. Z, Cincinnati, Ohio.

INVENTORS—Send for 72-page book on patents. Reasonable terms. Conscientious treatment to inventors. L. F. Randolph, Registered Patent Attorney, 302-E Victor Bldg., Washington, D. C.

UNPATENTED Ideas can be sold. We tell you how and help you make the sale. Particulars, with list of manufacturers and wanted inventions sent free on request. Write W. T. Greene, 946 Barrister Building, Washington, D. C.

I SELL Patents. Established in 1900. Charles A. Scott, 773PM Garson Ave., Rochester, N. Y.

WE Make models and manufacture inventions. Send 3 cents stamps for catalog. Pierce Model Works, Tinley Park, Ill.

SELL Your patent through a small classified ad in Popular Mechanics. Many inventors have found buyers in this way. Ask me for proof—I'll gladly send it to you. F. W. Johnson, Manager, Classified Advertising, 200 E. Ontario St., Chicago.

FREE Information about new magazines for inventors who want more profit from their ideas. Write "Successful Inventions," 800 Barrister Bldg., Washington, D. C.

HAVE You a sound, practical invention for sale, patented or unpatented? If so, write Chartered Institute of American Inventors, Dept. 4A, Washington, D. C.

INVENTOR'S Universal Educator; contains 900 mechanical movements; 50 perpetual motions; instruction on procuring and selling patents and selecting an attorney, etc. Suggests new ideas. Price \$1.00 postpaid in U.S.A. Address Albert E. Dietrich, 511-B Colorado Bldg., Washington, D. C.

INVENTORS—Ideas developed into practical inventions. Working models built. Low prices. Confidential service. Reo-Paul Engineering Co., 722 N. Gay St., Baltimore, Maryland.

INVENTIONS WANTED

INVENTORS—Small ideas may have large commercial possibilities. Write us for free book, "Patent Guide for the Inventor" and "Record of Invention" form. Delays are dangerous in patent matters. Free information on how to proceed. Clarence A. O'Brien & Hyman Berman, 58-M Adams Building, Washington, D. C.

SMALL Inventions wanted by manufacturers. I'll help you sell your invention. Stanley Hull, 7829 Euclid Ave., Cleveland, Ohio.

SKILL And science: Have you an idea for a new game of skill or science for either public or home use? We will buy outright or finance marketing of meritorious presentation. No gambling devices. Will H. Wade & Co., (Investment Bankers), 134 S. LaSalle, Chicago.

WANTED—Ideas, products—Sales director, prominent contacts. Rogers, 12 East 41st, New York.

INVENTIONS Wanted—Patented, unpatented. If you have an idea for sale, write Hartley's, Inc., Box 928-E, Bangor, Maine.

WE Successfully sell inventions, patented and unpatented. Write for proof, and tell us what you have for sale. Chartered Institute of American Inventors, Dept. 4-C, Washington, D. C.

PATENTS FOR SALE

AUTOMATIC Fluid strainer; outright, royalty or organize. Box 15, Boldman, Ky.

PATENTED (Ornamental), (stage) and (toy) building blocks. Direct from inventor. A. Malm, 48 Thomas St., West Hartford, Conn.

FOR Sale—Improved vehicle wheel hub cap. Patented. Write John Vicherilla, 108 Danforth Ave., Paterson, N. J.

IDEA For non-chatter hack-saw blade and direct reading latitude finder for sale. Write Kenneth B. Morris, Belmar, N. J.

REINFORCED Shopping bag. Jan. 1, 1935. Number 1,986,743. Original or modified. No reasonable offer refused. Write Harry F. Musick, 3337 Opal St., Los Angeles, Calif.

PATENT Number 2,036,641. Sash holder for sale. Bldg demand. Or will consider partner, or factory to manufacture it for me. Worth investigation. Write Neil Monaster, McKenzie Island, Ont., Canada.

PRACTICAL Inventions now salable before patenting. What have you? Write Chartered Institute of American Inventors, Dept. 4B, Washington, D. C.

ELECTRIC Appliance. William Baresch, 1108 131 St., College Point, N. Y.

MANUFACTURING

DIES, Stampings, light manufacturing, development engineering. Hagstrom Model & Tool Works, Kansas City, Mo.

MANUFACTURING, Dies, machinery, models, brasswork, white metal casting moulds. Catalog 3c. Baum's Metal Specialties, Kansas City.

INVENTIONS Manufactured in any quantity at low cost. Stampings, dies, models, etc. Estimates and free catalog. Crescent Tool Co., Dept. X, Cincinnati, Ohio.

TWO Profitable shop books—Lathe and Drilling and Thread Cutting—filled with hundreds of valuable "kinks" discovered by successful mechanics all over the world. To do regular jobs more quickly, easier and better send for these low cost books. Both postpaid for \$1.15. Popular Mechanics Press, Room (C36), 200 E. Ontario St., Chicago.

MODELS AND MODEL SUPPLIES

3/4" SCALE Steam locomotive easily built by "Step" method. Latest catalog of castings, boiler fittings, track material, etc. 25c (returned on first order). Little Engines, Box B15, Wilmington, Calif.

POWER Models, locomotives, steam, gasoline engines, accessories. 80 page catalog 35c. Chas. Cole, Ventura, Calif.

INVENTIONS—Small ideas may have large commercial possibilities. Write us for free book, "Patent Guide for the Inventor," and "Record of Invention" form. Delays are dangerous in patent matters. Free information on how to proceed. Clarence A. O'Brien & Hyman Berman, 58-M Adams Building, Washington, D. C.

MODEL Makers—Brass, copper, fibre, steel and aluminum in all shapes. Also castings, gears, screws, fittings. Catalog 10c. Experimenters Supply House, Dept. P, Box 10, Station Y, New York.

UNIQUE Injection engine, blueprints one dollar. Art Egoal, Westville, Indiana.

FREE: Illustrated circular. Listing 40 engines. Locomotive castings. Supplies. Stamp required. Howardeco, 2417 N. Ashland, Chicago.

3 NEW Catalogs: No. 36—Engines, castings, small shop machinery. No. 37—Modelmakers, experimenters and mechanics materials and supplies. No. 38—Model power engines, locomotives, boats and airplanes, supplies, etc. Either postpaid in U.S.A. for 20c silver or stamps, or all 3 for 50c. Canada 75c. Refunded first order. Evray Mechanics Supply Co., PM-28 North Clinton, Chicago.

RAILWAY Models. Catalog handbook 25c. Walthers, 1564 West Pierce, Milwaukee.

YACHT Model fittings, for Zip, Vanja and others. Send for illustrated list. A. J. Fisher, 1002-1 Etowah Ave., Royal Oak, Mich.

MAGAZINES. Books for modelmakers. Write for free list. 25c brings sample Modelmaker and Model Railroad. Modelmaker Corp., Wauwatosa, Wis.

MODELS—Your ideas developed into practical working models. 30 years' successful experience; thousands of satisfied customers. Confidential service guaranteed. Bank references. Send 3c postage for 32-page book—"Making Inventions Pay." Crescent Tool Company, Dept. Y, Cincinnati, Ohio.

BRASS Gears, models and model supplies. Send 3 cents stamps for catalog. Pierce Model Works, Tinley Park, Ill.

POPULAR Priced model gasoline engine, ready to run, \$14.00. Circular 5c. Anton Bohaboy, 212 Price St., Rahway, N. J.

MODEL Ship, yacht, speedboat supplies and fittings. Catalogs dime. Welcher, 7th St., Fulton, N. Y.

MECHANICAL Models, new and novel. Popular Mechanics has developed accurate models in the mechanical field. Those now ready are Wright "Whirlwind" Airplane Engine, Ocean Liner "Europa" and Modern Passenger Locomotive. Every part clearly shown and the name given. Invaluable to students and all who are mechanically inclined. \$1.00 each postpaid. Popular Mechanics Press, Room (C36), 200 E. Ontario St., Chicago.

HOME CRAFTSMEN

VICES—Best made. Ideal for home craftsmen. Used the world over. Reasonably priced. Write now for circular describing entire line of "World Famous Abernathy Vises." Dept. P.M. 11, Abernathy Vise & Tool Co., 2828 W. 26th St., Chicago.

BUY Direct from manufacturer. You save money. Fancy native, beautiful foreign wood veneers. Walnut burl crotches, stump wood, etc. Taped veneered faces to your specifications. Also plywood and veneered panels. Free catalogue. Special homecrafters' service. Write Nickey Brothers, Dept. H, Memphis, Tenn.

MAKE Your own furniture designs. Our complete "Easy to Understand" course explains all. Invaluable for home craftsmen. Write now for descriptive folder. Klok Institute, 430 Lyon, Grand Rapids, Mich.

HOW To make profitable lawn ornaments with 24 full-sized prints (14"x21") \$1.00. Satisfaction guaranteed. "Rork's," 3739 Fulton, Saginaw, Mich.

20 FULL-SIZE Lawn ornament prints 25c. Modern Woodcraft, 1343 Wadsworth St., Dept. B, Saginaw, Michigan.

CUTOUTS For all seasons. Ornaments, toys. Patterns 3 for 25c. Catalog, big variety, 10c (refunded first order). Lea, Box 6030, Kansas City, Mo.

"MODERN Wood sculpture." Complete instruction book on carving statues \$1.00. Lee, Wood Art Studio, Centerville, Ia.

LEATHERCRAFTSMEN—Write for free instructions and price list of leather, tools and beginners' kits. Send 5c for sample cards. Address Wilder & Company, Dept. F, 1638 Crosby St., Chicago, Ill.

BOY Mechanic—Famous library of 4 volumes covers the building of almost everything a boy might want to make. A great boon to parents and teachers. Actually covers 4,000 different articles. Each volume 460 pages, fully illustrated. Cloth. Price \$2.00 each or set of 4 vols.—\$7.00 postpaid. Popular Mechanics Press, Room (C36), 200 E. Ontario St., Chicago.

OLD GOLD, WATCHES, JEWELRY, PRECIOUS STONES

BEAUTIFUL Australian opals. Sample \$1.00. Interesting catalogue post free. Norman Seward, Melbourne, Australia.

GEMSTONES: I buy, sell, exchange; wholesale, retail. Cut, uncut. McCampbell, Calexico, Calif.

5000 HUNTING Waltham, Elgin watches! New chromium, engraved, open-face cases. Make big money! 12 size, 7 jewel, \$3.25, 16 size, 7 jewel, \$2.75. Ask for free catalogue, new plan. The New York Jobbers, 74 Bowery, New York.

MAIL Order repair service on watches and clocks. Mainsprings 50c. Crystals 15c. Send to Paul Jewelry Company, LaCrosse, Wis.

FOR THE HOME

OIL Burners—\$5.00. Guaranteed for 5 years. Fits into any stove. Burns crank case drainings or fuel oil. Made since 1919. Staples Oil Burner Co., Dept. P, Mount Vernon, Indiana.

PEPPERMINTOIL—Finest, double distilled, healthful. Sample bottle 10c. Particulars free. Minto, Baroda, Michigan.

LOWEST Price oil burner—Gravity type. Will fit any coal stove or heater. Burns any oil. Price \$7.95. Renmor Mfg. Co., Not Inc., 2548 S. Wabash, Chicago.

DUPLICATE Plans of \$35.00 oil burner for stoves and furnaces 25c. Easily made for \$2. Reddex, 3948 South Western, Chicago.

REFRIGERATE With chemicals! Convert your ice box. No mechanical parts; complete plans 50c. Technical Supply, 1457 Broadway, New York.

INSTANTANEOUS Faucet water softener \$3.50. Amazing economies. Alkatrap, Sausalito, California.

CLOCKS: Build your own grandfather's, banjo, shelf. Thousands built successfully. Some with beautiful chimes. Directions 10c. Particulars free. Clock Company, 1671 Ruffner Street, Philadelphia.

TOBACCO

FREE—Box cigars and pipe with 5 pounds Goldleaf cigarette, pipe or chewing tobacco \$1.00, ten \$1.75. Guaranteed. Pay when received. Co-Operative Dealers, Sedalia, Ky.

BUY At wholesale prices by mail—Cigarettes, cigars, tobaccos. All brands. Postal stating your favorite brands brings low postpaid prices. Moberly, Box 1016, Owensboro, Kentucky.

TATTOOING

(TATTOO Outfits). Learn to be artistic with them. Circular. Sergt. Bonzey, 367 So. Main, Providence, Rhode Island.

AMATEUR Tattooing outfits, free folder, illustrated catalog 6c. "Tatoco," 651A South State, Chicago.

SURVEYING INSTRUMENTS

GUARANTEED Factory rebuilt transits and levels for rent (with purchase option) or sale (cash or terms). Order now before prices advance. We will repair, trade in, or buy your old instruments. Ship prepaid for estimate and valuation. Write for List M-111 and complete information to Warren-Knight Co., 136 N. 12th St., Philadelphia, Pa.

WANTED—MISCELLANEOUS

WANTED—Used firearms, microscopes, binoculars, surveying and scientific instruments, etc. Send what you have. Satisfaction or shipment returned. Orr, 2035 North Main Avenue, Scranton, Pa.

CASH For used microscopes, binoculars, slide rules, drawing sets, cameras, surveying, scientific instruments, tools, marine equipment, typewriters, calculators. Highest prices paid day shipment received. Satisfaction guaranteed or shipment promptly returned. Elman's, 2302 Van Buren, Chicago.

PERSONAL

PERPETUAL Motion machines! Book, 10c. Information free. Zanco, 3351 Wall St., Chicago.

HAIRGRO Grows hair. Formula 10c coin. Healthway, 60 Weldon, Rochester, N. Y.

THINNING Hair, dandruff; guaranteed treatment formula, \$1.00. Allied Laboratories, 2903 Waverly Ave., Detroit, Mich.

MONEY From crossword puzzles. Rules dime. Box 35, Riverside, Illinois.

HAIR Getting thinner? Rosekrantz Natural Oil Restorer has helped many. Eight ounces \$1.00. Highland Park Laboratories, 73 East Buena Vista, Detroit, Michigan.

STUTTERING And stammering corrected at home. Descriptive booklet free. Paul J. Wolfe, Box 52, Pittsburgh, Penna.

MISCELLANEOUS

INTRODUCTORY Offer—Send \$1.00 for \$5.00 Sackless Vacuum Fountain Pen and 55c package of powder. Visible ink supply. Holds 200% more. Durium pen point. Lifetime guarantee. Money returnable. Lois Cosmetics, 1514 Prospect, Cleveland.

MEXICAN Curios. Wonderful for Christmas. Write for free sample. Apartado 1176, Mexico City.

"STA-KREAS" Gives knife-edged lasting crease to trousers, pleated skirts, etc. Price 25c coin. Dodd, 3493 W. 118 St., Cleveland, Ohio.

CHEAP Heat for all purposes. Make it yourself. Convert distillate oil into pure gas. \$1.00 buys parts. Send 50c for instructions. Lawrence Carter, 3449 East First St., Los Angeles, Cal.

TYPEWRITERS, Duplicators, encyclopedias, watches. Bargain lists free. Dee's Exchange, 436 N. 9th, Manitowish, Wis.

SENSITIZE Your own blueprint paper. Instructions 25c. American Blueprint Company, 121 Nicholson Ave., Knoxville, Tenn.

WINDOW Sundial. \$1.25. Translucent Sundials 1243 Webster Ave., New York.

500 PENCILS With your advertising \$10.50. Samples 10c. Ad-Craft, LaCrosse, Wis.

NEW Radio treasure locator. Distinguishes between iron and gold or silver. Descriptive literature 10c. Radio Metal Locating Co., Dept. 54, Box 5693, Cleveland, Ohio.

LEARN To cut and polish semiprecious stones. Complete plans, details. Book \$1.00. Home Lapidary Shop, Malibu, Calif.

PRACTICAL Everyday chemistry—How to make what you use. 2342 practical workable formulas of widely used products. Save 45%. Start a paying business of your own. \$2.00 postpaid. Popular Mechanics Press, Room (C36), 200 E. Ontario St., Chicago.

SEA Shell collections. Start this new fascinating hobby, sweeping country. Special offer—four shells, chart, only dime. Direct Supply Service, 2619-A No. Ashland, Chicago.

YOU Can correct your eye defects through proven scientific principles. No medicine—no glasses. Send today for free valuable booklet, "Eye Weaknesses." Better Eyesight Institute, Alexandria, Minnesota.

MARK Your belongings in gold. Tricky pencils. Sample 25c. Stamp Works, Centerport, N. Y.

SWAP Or sell articles you don't need. Get those you want. Send dime for Swapper's Guide, listing articles from all over United States. Swapper's Guide, Dept. PM, Delphos, Ohio.

NAVIGATION, Sun, stars, illustrated, 50c. Candlerco, 1810 - 34th, Seattle, Wash.

COLLECTORS, Hobbyist, model builders, pen pals, swappers, world wide. The Pen Pal Club, Drawer 692, San Marcos, Texas.

WHO Said you can't make \$75.00 monthly at home. Write us. We'll tell you how. E. J. Peroutka Adv. Agency, Whitelaw, Wisconsin.

SENSATIONAL Offer! Hand-engraved name plates. Free circular. Acme Engraving Shoppe, 211 Roby Avenue, East Syracuse, N. Y.

BOOKS Covering hundreds of subjects. Big catalog for 3c postage. Popular Mechanics Press, Room (C36), 200 E. Ontario St., Chicago.

NO Boss! Sure cash! Silvering mirrors, autoparts, reflectors, combination outfit. Write, Sprinkle, Plater, 288, Marion, Ind.

MONUMENTS \$9 Up delivered, erected, guaranteed. Thousands sold. Catalog free. Marble Granite Factory, A-17, Oneco, Fla.

WANTED—Hear from parties interested gold or silver ores, buried or hidden treasures. Bergman's instrument \$5.00. Particulars free. Henry Bergman, Box 398P, Springfield, Missouri.

TREASURE Seekers—Make your own gold finders. Wyss, 104½ Frances, St. Joseph, Missouri.

CUTS Anybody can make. Zinc etching process. Specimens, particulars, testimonials for stamp. J. C. Day, Windfall, Ind.

TURN Scrap into money. Convert old auto generators into A.C. generators for auto radio, camp and home lighting, power and other uses. Complete instructions \$1.00 postpaid. Popular Mechanics Press, Room (C36), 200 E. Ontario St., Chicago.

BRONZE Tablets, desk plates, wall plates, memorials, grave markers. Bronze, brass and aluminum casting. Wandkey Pattern & Foundry Co., Anderson, Ind.

AMATEUR Cartoonists can earn \$35.00 weekly, spare time, duplicating cartoon advertisements. 3-M Syndicate, Argyle, Wis.

SWAPPER'S Friend, R4, Sallie, Michigan. Interests swappers, collectors, sportsmen. 50c year, sample 10c.

\$1.00 MONTHLY Maintains New York office. Co-operative Mail Service, 126-F Lexington Ave.

MECHANICAL ENGINEERING

—A Field with a Future



This course has meant advancement to hundreds of ambitious men, mechanics, draftsmen, blacksmiths, foundrymen, patternmakers, apprentices, and mechanical engineers — men who wanted to get ahead and to earn more money. You will find, as they have found, that enrolling for an I. C. S. Course is an investment in a Bigger Future. Use the coupon!

ELECTRICAL ENGINEERING

—A Great Industry with a Great Future

The new course in Electrical Engineering covers this fascinating field thoroughly. If you are just starting or are partly on the way to a real paying position in this industry, this new course brings the broader knowledge necessary for advancement. The coupon brings complete information.



DIESEL POWER

A Coming American Industry



The internal-combustion engine represents man's supreme triumph of machine power. Diesel engineers are in great demand. Many are acquiring necessary knowledge through spare-time study of this modern I. C. S. Course on Diesel engines. Free booklet!

AUTOMOBILE EXPERTS

are always in demand

The rapid progress in manufacture and service of the modern automobile brings new opportunities to thousands of ambitious and forward-looking men. There's always a demand for trained men. The new I. C. S. Automobile Course will make you a trained man! The time to act is now. Use the coupon.



INTERNATIONAL CORRESPONDENCE SCHOOLS

Box 5642-H, Scranton, Penna.

Without obligation, send me full information on subject checked below:

- | | |
|--|--|
| <input type="checkbox"/> MECHANICAL ENGINEERING | <input type="checkbox"/> ACCOUNTING |
| <input type="checkbox"/> ELECTRICAL ENGINEERING | <input type="checkbox"/> GOOD ENGLISH |
| <input type="checkbox"/> DIESEL POWER | <input type="checkbox"/> SALESMANSHIP |
| <input type="checkbox"/> AUTOMOBILE COURSE | <input type="checkbox"/> ADVERTISING |
| <input type="checkbox"/> ARCHITECTURE | <input type="checkbox"/> SHOW CARD LETTERING |
| <input type="checkbox"/> CONCRETE CONSTRUCTION | <input type="checkbox"/> CIVIL SERVICE |
| <input type="checkbox"/> READING SHOP BLUEPRINTS | <input type="checkbox"/> HIGH SCHOOL SUBJECTS |
| <input type="checkbox"/> CIVIL ENGINEERING | <input type="checkbox"/> AIR CONDITIONING |
| <input type="checkbox"/> DIESEL ENGINES | <input type="checkbox"/> INVENTING AND PATENTING |
| <input type="checkbox"/> GAS ENGINE OPERATING | <input type="checkbox"/> AVIATION ENGINES |
| <input type="checkbox"/> REFRIGERATION | |
| <input type="checkbox"/> CHEMISTRY | |
| <input type="checkbox"/> HIGHWAY ENGINEERING | |
| <input type="checkbox"/> POULTRY FARMING | |

Name _____

Address _____

When writing please mention Popular Mechanics

NEW AUTHORIZED TELEVISION BOOK

*Strips the Mystery from the World's Newest Science.
Gives Money-Making Facts.*

**MATERIAL NEVER
BEFORE IN PRINT**

ELECTRONIC TELEVISION

By **GEORGE H. ECKHARDT**

Just published. Covers Electronic Television in simplified non-technical way. Gives all information about methods, apparatus, wiring diagrams, etc., including cathode ray, iconoscope, kinescope and other recent inventions. Authorized by R. C. A. and Farnsworth, the two leaders in Electronic Television development. Positively authentic. Order **ELECTRONIC TELEVISION** today. Be an expert in enormous coming industry. 182 pages, cloth bound. Illustrated throughout. Postpaid \$2.50. Money back if not satisfied. Send 3 cents postage for catalog of other money-making books.

POPULAR MECHANICS PRESS
Room 1136 200 E. Ontario St. Chicago



The World's Biggest

Get Shop Notes for 1936! Only 50 cents. May easily be best investment of your entire lifetime. Contains 360 money-making, time-saving ideas, kinks, short cuts, for mechanics, farmers, home workshop fans, handymen — for everyone who uses tools. 224 pages 260 articles, 793 illustrations. Get 1935 Shop Notes too. Only 50c.

POPULAR MECHANICS PRESS
Room 1136 C 200 E. Ontario St. Chicago

50¢ WORTH

SHOP NOTES FOR 1936

TECHNICAL BULLETINS

Technical Data Simplified for the Practical Man

A New and Valuable Popular Mechanics Service • \$1.00 Each

Here is a valuable, inexpensive service for mechanics, inventors, technical specialists and practical craftsmen of all kinds. Popular Mechanics Technical Bulletins give the needed basic and practical information on a wide variety of subjects — briefly, concisely and simply presented — yet complete in every detail. No advanced mathematics, chemistry or physics needed to understand them. Material never before in print, now specially prepared in bulletin form. Postpaid \$1 each or sent C.O.D. in United States. Ask for list of complete bulletin service.

- D-101—Using Nichrome Resistance Wire.—Features electrical appliance repairs.
- D-102—Cleaning Products for all Purposes.—Includes ten formulae for making.
- D-103—Automobile Specialty Chemical Products.—Complete instructions for making wide-selling products.
- D-104 — Silver Soldering and Brazing. — Includes data, methods and materials needed.
- D-105—Latest Gas-Welding Practice.
- D-106—Rewinding Electric Motors.—A difficult subject made simple and easy.
- D-107 — Electro-Plating with Copper, Nickel and Chromium.
- D-108—Electro-Plating with Gold and Silver.
- D-109—Electro-Plating with Zinc and Cadmium.
- D-110—Electro-Plating Non-Metallic Objects and Electro-Forming.
- D-111—Designing and Building Transformers.
- D-112—Designing Electro-Magnets.
- D-113—How to Design Solenoids and Plunger Magnets.
- D-114—Designing Thermostats for Air Conditioning and Heat Control Purposes.
- D-115—Flexible Molds for Casting Small Objects.
- D-116—Printing Photos on Cloth, Paper, Etc.
- D-117—The A B C of Air Conditioning.

POPULAR MECHANICS PRESS
Room 1136B 200 East Ontario Street Chicago

PHOTO-ENGRAVING LEARN IT AT HOME



We Furnish all equipment and materials including large photo-engraving camera complete with lamps, lens and screen. When you have finished the course you can establish a good paying independent business with the equipment furnished or work for others at a big salary. Photo-Engraving offers greater opportunities today than any other industry. Every picture in this issue of Popular Mechanics was engraved by the process we teach you. Earn good money while learning. Write today for our new illustrated catalog which was engraved on equipment such as we furnish. You will not be obligated in any way by writing Aurora School of Photo-Engraving, Dept. 1116, Aurora, Mo.

A copper plate to print above picture size 8 by 10 inches sells for \$15.37

FREE! **LABORATORY APPARATUS**
BIOLOGICAL SUPPLIES
MICROSCOPES
TELESCOPES
CHEMICALS



New complete 32 page catalog lists hundreds of items of interest to amateur and professional experimenters. Save Money—Buy Direct. Send now! It's FREE and crammed full of bargains and valuable information.

J. H. WINN MFG. CO., Dept. 411, 124 W. 23 St., New York

LEARN CARTOONING

by the method that has developed hundreds successfully. Send name, address and age for free chart to test your ability.

The Landon School, 1738 National Bldg., Cleveland, Ohio

HOME STUDY COURSES

Home-Study Courses, leading to Degrees in Arts and Sciences; Education; Writing; Psychology; Chemistry; Business and Commerce; Law; Theology; Agriculture; Engineering; also courses in Business Training; Accounting; Advertising; Sales Management; Public Speaking; Radio. Many others. Low Cost; Easy Terms.

McKinley-Roosevelt University, 4247 Clarendon Ave., Chicago

Men Wanted

We pay your railroad fare to Nashville. Let us train you to be an expert automobile mechanic and help you get a good job. The cost to you is small. No negroes taken. For free booklet write Nashville Auto College, Dept. 75, Nashville, Tenn.

Be a Civil Engineer!
Learn—Quick Reference Way



It's Paying Big Right NOW

Cyclopedia of Civil Engineering
7 great volumes.
2,800 pages.
1,600 illustrations.
New revised edition by twelve of America's greatest engineers.

Earn \$3000

with these books

a Year—and Up!

"Civil engineers are wanted NOW. Enormous amounts are being spent in all kinds of public works and not a dime is spent until the Engineer has prepared plans. Then He must direct the work. It's a big job and there are not enough men to go around. Everywhere you go, you see road work going on—water and sewer systems being built—vast projects of all kinds. Here is Your Opportunity to get the necessary training right at home. These books are complete and simply written so anyone can understand them. Start now on our FREE examination plan. Mail the coupon without obligation.

American Technical Society
Dept. C819, Drexel at 58th St., Chicago

American Technical Society
Drexel at 58th St., Dept. C819, Chicago
I want to examine the CIVIL ENGINEERING Cyclopedia for 10 days FREE. I will gladly pay the few cents express, but I am to pay nothing for the 7 big volumes if I return them within 10 days. If I wish to keep them I will send you \$2 after the 10 days, then \$3 a month until special advertising price \$29.80 is paid. Send latest Edition and Slide Rule.
Name

Address
(Attach letter stating age, occupation, employer's name and address and that of at least one business man as reference.)

Shipped Free **Slide Rule**

Be prompt and we will include a brand new, circular slide rule to carry in coat pocket. Invaluable in solving all kinds of problems.

"How I Boosted MY INCOME 300%!"



An interesting true story of J. N. Dixon... and how he quickly became more capable and more successful

"JUST after I returned from the war, one of your representatives found me plugging away at a bookkeeper's job in Marietta, Ohio," writes J. N. Dixon, now of Columbus, Ohio. "He performed a real service in explaining to me the need of further training and induced me to take the LaSalle Training in Higher Accountancy. After a few months of study, I secured a position with the Trust Department of a National Bank. This was the stepping stone I needed to various responsible positions, including handling of receiverships and other important duties that quickly boosted my income several hundred per cent. Two years ago, I leased from the Pure Oil Company a super station in downtown Columbus. In six months time, the business of this station increased 300%."

"I can trace my success and progress to the foundation laid in my LaSalle training. I heartily endorse a similar program to any young person who is sincere in his desire and determination to get ahead. LaSalle will help him build the bridge from what he is to what he wants to be; will enable him, through study to become a progressive factor in the business world."

Yes... LaSalle training can help you! It will enable you to emulate the thrilling climb towards success that Mr. Dixon had if you, too, will seize the opportunity and enroll in LaSalle's Higher Accountancy Course. This course has trained over 1,350 C.P.A.'s—as well as more than 500,000 other business people.

Why not learn more about this great training? To get full information costs you only the price of a postage stamp. And from this 3c investment may come a position which will pay you much more than you're earning now. Send coupon below today.

LaSalle Extension University

Dept. 1164-HR Chicago
The school that has trained over 1,350 C.P.A.'s

Please send me full information about your training in Higher Accountancy and your free booklet, "Accountancy, the Profession That Pays."



Name.....Age.....

Address.....

When writing please mention Popular Mechanics

A GREAT CHRISTMAS GIFT

FOREST FIRE RADIO LAMP



Forest fire in full colors seems to really burn. Smoke and flames rise through the trees—reflect on the lake. This striking effect is created by an automatic revolving cylinder inside. Amazes and delights everyone. A novel and beautiful lamp. Picture is a handsome reproduction of oil painting on parchment. Artistic metal top and base. Full size. Complete, ready to plug in.

Now Only **\$1.00**
(Foreign and Canada, \$1.50
Duty and Postage Paid)

Send \$1.00 bill or money order for prompt shipment, postage paid. PRINT your name and address plainly. No lamps shipped C. O. D. or on approval.

GIFT SPECIAL

Special discount to those who order several. Dozen lots, \$10. Six, \$5.50. Shipped postpaid to you or to separate addresses.

NIAGARA FALLS LAMP

Beautiful new picture. Falls really seems to flow. Price same as above.

IGNITION CO.

52 Tompsett Ave.

Omaha, Nebraska

HOW IT WORKS—A striped cylinder revolves about a striped electric lamp, casting an ever changing pattern of light and shadow through the translucent outer shade. This creates action in the picture real as a colored movie. An interesting, unusual and beautiful lamp for any home. Heat is the only motive power.

MIDGET *Electric* RADIO



World's Smallest Loudspeaker Radios

Just a handful. Weight only 1½ lbs. Size 3½x5x2½, either model. Uses two Multi-purpose high gain tubes—built-in aerial. Needs no ground. Midget BUILT-IN speaker reproduces all programs with unusual tone and clarity. Tunes broadcast band and SHORT WAVE. Ideal personal radio. Operates on 110 volt A.C. D.C. current any cycle. Kit of parts with set of tubes and diagram for only \$6.49. COMPLETELY WIRED ready to listen for only 50c extra or \$6.99. Send only \$2.00—pay postman balance. GUARANTEED. Comes in beautiful colors: White, Black, Brown, Blue and Green. State color and if upright or oblong model is wanted. ORDER NOW!

TINYTONE RADIO CO.

Dept. P-11
Kearney, Nebraska

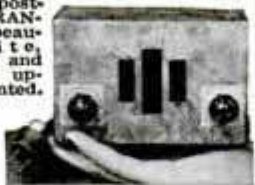

SEND ONLY
\$2.00

STOP Your Rupture Worries!



C.E. Brooks, Inventor

Why worry and suffer any longer? Learn about our perfected invention for all forms of reducible rupture. Automatic air cushion acting as an agent to assist Nature has brought happiness to thousands. *Permits natural strengthening of the weakened muscles.* Weighs but a few ounces, is inconspicuous and sanitary. No obnoxious springs or hard pads. No salves or plasters. Durable, cheap. **Sent on trial** to prove it. Beware of imitations. Never sold in stores or by agents. Write today for full information sent free in plain envelope. All correspondence confidential.

BROOKS COMPANY, 111F State St., Marshall, Mich.

Raise
GIANT

FROGS



"Nufond Giants"
weigh up to 3 lbs. each!

START BACKYARD—GOOD POSSIBILITIES

Pair of breeders lays 10,000 eggs yearly! Frogs sell up to \$5.00 per dozen! Compare with other livestock!

We Buy Frogs! As originators of "canned frog legs" we are developing one of the world's largest frog markets. Canned frog legs now on sale in most large cities.

Attractive Future! We believe frog raising is one of America's most promising new industries. Get the facts today! See what others are actually doing already! Our big, free illustrated book "A Future in Frogs" explains everything in detail. Send for it TODAY!

AMERICAN FROG CANNING CO. Dept. 133 W New Orleans, La.

**FREE
BOOK**



New! Greatly Improved OIL BURNING LACO Heater

PRICED 'WAY BELOW OTHERS

Beautiful!
Extra Durable!
MORE HEAT!
No Basement Needed

Wonderful for homes, stores, etc. Entirely automatic—requires no attention — temperature never varies. No dirt, no ashes. New "Inner Heating Unit" has 20% extra heating surface—develops amazing volume of heat. Pours up through top grill, walls remain cool. Humidifies and circulates the air. Built of copper-bearing steel—heavier than usually used—more durable. Electrically welded into a solid unit. Handsome as finest furniture. 4 sizes—for small homes up to large stores, etc. Uses low-priced oil. One filling of tank heats average home up to 4 days in below-freezing weather.



LACO

FREE BOOK!

Amazing Low Price!
Write today for free booklet, many photos, full details, and the Very Low Price. **SEND NOW!**
DEALERS! Many dealers making big money selling LACOs. Ask about Special Dealer Offer. **WRITE!**

Complete Line Oil Burners!

LACO's famous "Mineral-Wick" model burns oil new way, hotter flame with less oil. LACO's new pressure-type burner greatest value known. Prices \$100 under others—saves 25% in fuel cost. **WRITE!**

LACO OIL BURNER CO.
1116 Union St. Griswold, Iowa

NEW FREE BOOK ABOUT BETTER JOBS IN TELEVISION, RADIO, SOUND PICTURES

Write for your copy of "THE KEY TO SUCCESS" today. Learn exactly what the engineering field of **SOUND PICTURES, RADIO, TELEVISION** offers you. Well known engineers will discuss your future with you, in this book, and explain how you may find actual employment. "THE KEY TO SUCCESS" is full of vital, factual information every young man of mechanical or electrical inclination and sincere determination wants to know. Be among the men who obtain "THE KEY TO SUCCESS" . . . and if you qualify, it will open the door to a brighter future for you. Write today.
DeForest's Training, Inc., 1109 Center, Dept. 11, Chicago

GUARANTEED FOR LIFE
MONEY BACK GUARANTEE
WITH EACH PEN SET
SAMPLE 30¢
DOZ.
\$3.00

Suggested selling price 60¢. No. R61. Vacuum pen set without box. Consists of: fountain pen fitted with the latest type, size 4, stainless durium point, vacuum filler and transparent barrel. Mechanical pencil to match. Comes in attractive mottled colors. (Send for FREE Wholesale Catalog of 3000 fast sellers.)
SPORS CO. 9-36 MAIN ST., Le Center, Minn.

STUDY SYSTEMS 1819 B'WAY, N.Y.C.

Please send free booklet about how I can train for a career in one of today's big industries checked below for the total sum of \$30.

<input type="checkbox"/> Diesel Engines	<input type="checkbox"/> Air Conditioning	<input type="checkbox"/> Applied Electricity
<input type="checkbox"/> Oil Burners	<input type="checkbox"/> Refrigeration	<input type="checkbox"/> Radio
<input type="checkbox"/> Television	<input type="checkbox"/> Aviation	<input type="checkbox"/> Neon Signs

Name

Address

Ask me for my BIG FREE BOOK

...and I'll tell you page by page, how to get a steady

GOV'T JOB

Through this book I've shown thousands of fellows how to get the well-paid, permanent classified civil service jobs they now hold. Let me send it to you, FREE. I'll tell you how to say good-bye to lay-offs and "hard times" FOREVER. Here are some of the pointers I'll give you:

- Page 4** tells **What Uncle Sam Pays**—Squarest boss in the world. No more worry about layoffs, and you average \$200 more a year than in other jobs.
- Page 9** **How You Pick Your Job**—You choose it; I help you get it. Travel, or work in Washington or at home. Government has many openings.
- Page 12** **How I Prepare You Quickly**—For 8 years I was Civil Service Examiner. I help you to get High rating; FIRST jobs open.
- Page 18** **About Raises Every Year**—Don't live on promises; Uncle Sam increases your pay regularly, and you get it, every week.
- Page 18** **About Vacations With Pay**—Up to 30 days' vacation and 30 days' sick-leave with pay. Your boss is generous as well as steady.

Mail Coupon for Free Booklet

If you're an American, 18 to 50, you may be a Railway Mail Clerk, Postmaster, Customs Service Man, Post Office Clerk, or get any one of the well-paid jobs which I tell you about in my FREE BOOK. "How to Secure a Government Position." Let me "talk" to you about it; tell you how my coaching helps you to get the job you want, or your money back. Stop worrying about "hard times" and losing your job. Just ask me for this book. Mail coupon today.

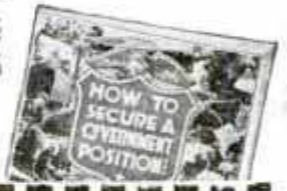

A. R. PATTERSON
PATTERSON SCHOOL
811 Case Bldg., Rochester, N. Y.

ARTHUR R. PATTERSON, Civil Service Expert
PATTERSON SCHOOL,
811 Case Bldg., Rochester, N. Y.

Send me your big FREE BOOK telling how I may secure a position with the U. S. Government paying from \$1,850 to \$3,300 a year, with excellent chances for advancement. This doesn't obligate me in any way.

NAME.....

ADDRESS.....

CITY..... STATE.....

When writing please mention Popular Mechanics

INVENTORS

WE OFFER YOU 61 YEARS OF
PATENT EXPERIENCE

FREE THESE VALUABLE GUIDES FOR INVENTORS

C. A. Snow & Co., Registered Patent Attorneys, are specialists in obtaining all classes of patents, trademarks and copyrights. We have served tens of thousands of inventors. Our clients include many large National Corporations as well as individuals. Yet our fees are standard.

We invite you to take advantage of our long years of experience in patent matters and we offer you absolutely free our "Certification Of Invention", a document originated by us. In addition we will give you our complete handbook on patent procedure, "How We Protect You" and "Suggestions On How To Commercialize Your Invention".

Fill out and clip the coupon below. Send it to us today. Remember... delay can mean loss in patent matters.

-----Cut Coupon On Dotted Line-----

DEPT. A-11, SNOW BLDG., WASH., D. C.

Gentlemen: Please send me absolutely free and without obligation on my part, your original document, "Certification of Invention", together with your two guides for inventors, "How We Protect You" and "Suggestions On How To Commercialize Your Invention."

NAME _____

ADDRESS _____

(PLEASE PRINT NAME CLEARLY)

C. A. SNOW & CO.

Registered Patent Attorneys Since 1875



Get Popular Mechanics Famous BOY MECHANIC Library

This is it Fellows! Here's what you want! You know it's the fellow who can do things—make things that "work" and "go"—that's the kingpin in every school and neighborhood. Get the "Boy Mechanic" and enjoy that popularity yourself. These famous books give thousands of plans, kinks, and articles on everything the average boy wants to do and make for himself.

4 Big Books — 7x10½ Inches

A total of 4,000 wonderful ideas you can use at the workbench; in camp; on land or water; winter or summer. Something for every place—every time. Each book is different—has about 460 pages, hundreds of pictures. Anyone can understand and use them. Send \$2 for Book 1, 2, 3 or 4. Whole set for \$7.00. Sent C.O.D. if you live in U. S. or possessions. Just pay postman. Give yourself a thrill—Order at least one book—any one—today.

POPULAR MECHANICS PRESS, Room 1136A
200 East Ontario St. Chicago

4000 Ideas, Plans, Thrills, Including

Scoters
Push-Mobiles
Real Autos with
Motorcycle
Engines
Wind Wagons
Ferris Wheels
Roller Coasters
Merry-Go-Rounds
Swings
Gliders
Model Airplanes
Model Ships
Model Railways
Water Wheels
Pile Drivers
Cableways
Boats
Shop Machinery
Movie Cameras
Ice Boats
Toboggans
Bob Sleds
Snow Speedsters
Etc. Etc. Etc.



900 WORKSHOP IDEAS!

How to Make Articles of Beauty and Utility that Sell

Get the most out of your hobby. Turn your Work Shop hours into profit. The "Make It Yourself" book shows you what to make and how to make it, with that "professional touch"—models—toys—useful decorative articles of all kinds. Newest edition—480 pages, 823 pictures, 7 x 10 inches. Sent postpaid for \$3.00 or in U. S. and possessions C.O.D.—you pay postman. Order Now.

POPULAR
MECHANICS
PRESS,

Room 1136B
200 East Ontario
Street, CHICAGO

"MAKE IT YOURSELF" INCLUDES:

Toys — Models — Furniture — Garden Equipment — Home Repairs — Sports Equipment — Auto Kinks — Radio Equipment — Workshop Tools and Machinery. Articles on Working: Wood, Metal, Leather, Glass, Etc., Etc., Etc.



A Billion Ideas

POPULAR MECHANICS NEW BOOK CATALOG

SEND
YOUR
NAME

and 3¢
STAMP

Every man who reads Popular Mechanics will want this new 1936 illustrated catalogue of practical, helpful and money making books.

It describes over 5,000 informative and authoritative books, alphabetically arranged under a thousand subjects—everything from ACCIDENT PREVENTION to X-RAYS. It's an amazing guide to the world's BEST practical books. You must see it to appreciate its value. Only limited edition printed. Send your name and address and three cent stamp to cover postage on your copy. Do it today.

POPULAR MECHANICS PRESS
200 E. Ontario St., Chicago



BUILDING BOOKS sent FREE for examination



5 BIG VOLUMES

Don't send us a cent—just your name and address and we ship all of these books to you for ten days free examination.

Look them over carefully, see how easy it is to find out the things you want to know, and then decide whether or not you want to keep them. The price and terms are so low that everyone should have them on hand for ready reference. Billions of dollars are being used to make jobs and the Home Modernization Program offers the biggest chance to make money carpenters have ever known. Are YOU Ready? Can you remodel etc.? Here's your chance to get these facts—quickly—easily—without study or work—just put your finger on what you want to know instantly.

Carpenters, Architects, Contractors, Home Builders

A gold mine of facts can often be converted into a gold mine of dollars, for builders save money and learn how to make more money with the five big books on architecture, carpentry and building. Carpenters make themselves contractors by learning how to estimate correctly; contractors are able to handle bigger and more profitable jobs by learning how the big fellows do it. Men who want to build homes can save money by learning how it should be done. The new Jiffy Index puts before your eyes without wasted time, the things you want to know. Nothing overlooked. Use of tools, building construction, heating, lighting, plumbing, architectural drawing all covered.

These Drawing Instruments \$10.00 Value Included



Complete set of drawing instruments if you send for these building books NOW. These instruments are made of the finest German silver, are absolutely accurate and are packed in velvet lined leatherette pocket case. Real \$10 value, but free to you with these books.

American Technical Society,
Drexel Ave. at 58th St., Dept. G819, Chicago, Ill.
I would like to look at the five books described above. Send them on your free offer. I will pay the few cents delivery charges only and will examine them thoroughly and return them in ten days unless I like them, in which case I will send you \$2.00 and after that \$3.00 per month until the total price of only \$19.50 is paid. You are also to send me the drafting instruments and consulting membership certificate of the American Technical Society, without extra charge.

Name _____

Address _____

Please attach letter stating age, employer's name and address and that of at least one business man as a reference.

CONSTIPATION MADE HUSBAND DRAGGY



HE just didn't feel like work or play. Always draggy and worn out—often cross and irritable. But like so many women, his wife knew about Nature's Remedy (NR Tablets). She put him wise. He found out what an astonishing difference there was in this purely vegetable laxative. Not merely partial relief. Instead thorough, cleansing action that aided in ridding his system of poisonous waste, refreshed him, made him feel like a "million." Try NR Tablets yourself. Note how gentle they are and non-habit forming. 25 tablets —25 cents at any drugstore.



FREE: Beautiful Six-color 1937 Calendar-Thermometer. Also samples of NR and Tums. Send stamp for packing and postage to A. H. Lewis Co., Desk 1138-18, St. Louis, Mo.

ITCH

...STOPPED IN ONE MINUTE...
Are you tormented with the itching tortures of eczema, rashes, athlete's foot, eruptions, or other skin afflictions? For quick and happy relief, use Dr. Dennis' cooling, antiseptic, liquid **D. D. D. PRESCRIPTION**. Its gentle oils soothe the irritated skin. Clear, greaseless and stainless—dries fast. Stops itching instantly. A 35c trial bottle, at any drug stores, proves it—or money back.

No JOKE TO BE DEAF

—Every deaf person knows that—
Mr. Way made himself hear his watch tick after being deaf for twenty-five years, with his Artificial Ear Drums. He wore them day and night. They stopped his head noises. They are invisible and comfortable, no wires or batteries. Write for **TRUE STORY**. Also booklet on Deafness.



Artificial Ear Drum
THE WAY COMPANY
720 Hofmann Bldg. Detroit, Michigan

BUCHSTEIN'S FIBRE LIMB



is soothing to your stump—strong, cool, neat, light. Easy payments. Braces for all deformities. Agents wanted.
D. BUCHSTEIN CO.
610 3rd Ave., So., MINNEAPOLIS, MINN.
Send for Catalog Today



CASH for you every week raising **ROYAL** squab baby birds. Orders waiting for hundreds of thousands. Easy to raise. You get your money for them when only **25 days** old. Send 3-ct. U. S. stamp for particulars and picture book. Write **PR COMPANY**, 635 Howard St., Melrose, Massachusetts. Refer any bank.

RAISE RABBITS FOR US

WE PAY YOU UP TO \$5.00 EACH. ALSO PUT YOU IN TOUCH WITH MARKETS EVERYWHERE. Large illustrated book and catalog, also copy of the **AMERICAN RABBIT FARMER** and monthly market bulletin showing names of buyers in various parts of America who continuously buy all rabbits offered them. All for 10 cents. Address **OUTDOOR ENTERPRISE CO.**, 101 Main St., Holmes Park, Mo.

When writing please mention Popular Mechanics

Have that healthy **TAN** ... that Men and Women Admire! **FREE TRIAL!**



IMPROVES YOUR APPEARANCE 100%
DON'T lose that rugged "outdoor" appearance ... that healthy out-in-the-sun-and-wind color, just because you can no longer get out in the sunshine in a bathing suit! You can keep that tan and get even more if you wish it, right in the privacy of your own room! Just a few minutes a day under a Health Ray Sun Lamp and your friends will think you spend your week-ends in Palm Beach!

LOOK SUCCESSFUL — BE SUCCESSFUL!

■ A good, healthy coat of tan has a surprising effect on your business success. You look healthy and virile and instantly command attention. Your prosperous appearance makes people want to do business with you. Salesmen find their sales actually increase after they have acquired a real bronze tan! And you will find yourself more popular, for both men and women are attracted by that healthy outdoor look!

IMPROVES HEALTH AS WELL AS APPEARANCE!

■ The appearance of health is based on actual fact—for frequent exposure to the ultra-violet rays of the sun tones up the entire system, stimulates the body into energy and vitality, increases gland activity, builds up resistance to colds . . . and aids in clearing up many skin diseases.

4 TIMES AS POWERFUL AS THE SUMMER SUN!

■ Now Health Ray has made a really high quality, genuine carbon-arc sun lamp available at a price within the reach of all—\$7.95. In 15 minutes with your Health Ray lamp you can get the equivalent ultra-violet radiation of an hour in summer sunshine. Compact, convenient, easy to operate, approved by many of the finest testing laboratories in the country, this lamp will be the greatest investment you ever made! But don't take our word for it—test it for 7 days at our expense. You can't lose, and you can gain so much . . . mail the coupon for complete information today... NOW!

IF YOU WANT SUN-LAMP AT ONCE WITHOUT WAITING FOR LITERATURE

Send \$1 and lamp will be shipped at once—try it for 7 days—pay \$6.95 balance or get your dollar back. Or send \$7.95 with order, and we will include one box of ten carbons and bottle of Sun Tan Oil FREE, 7-day money back guarantee protects you fully!

HEALTH RAY MFG. CO., INC., 342 WEST 14TH ST. N. Y. C.



FOR EVERY MEMBER OF THE FAMILY
\$1.00 DEPOSIT BUYS IT!

TEST IT AT OUR EXPENSE — SEND FOR FREE TRIAL OFFER!

HEALTH RAY MFG. CO., INC.,
342 W. 14th Street, Dept. 1411, New York City
Send me full details of your special **FREE TRIAL OFFER** on the Health Ray Sun Lamp.

Name
Please write Mr., Mrs., or Miss

Address

City.....State

Learn to *really* sell

... be a

MASTER SALESMAN!

The man who brings in the orders is the man who gets the big money. Business can't EXIST without salesmen for there is no profit without sales. Almost anybody can sell but to be a REAL salesman, to join the big money class, to be at the top of the payroll and in line for executive positions, you must know "the tricks of the trade," the seemingly simple things that star salesmen use to get the name on the dotted line. There are opportunities galore for this type of men, for competition is keen and industry wants men who know how to meet buyers, to get their confidence and a big batch of orders.

Home Training Fits You for

a place in the small army of successful men who know the ropes, who command BIG PAY in the form of salary or commission. Our method of instruction is based on the experience of thousands of men. Many of them spent years in learning what you may get in a few short months. Learn the RIGHT way to sell. Eliminate mistakes and you should be able to qualify for a big pay job.

FREE It costs nothing to learn about the method which has helped hundreds and hundreds of men. Just send your name and address and we will forward promptly, complete details of our plan and an amazing book "THE KEY TO MASTER SALESMANSHIP" without one penny of cost obligation. SEND THE COUPON NOW.



National Salesmen's Training Association, Dept. 3-408
21 W. Elm Street, Chicago, Illinois.

You may send me free and postpaid, details of your Salesmen's Training Plan and a copy of your book "THE KEY TO MASTER SALESMANSHIP." This does not obligate me in any way.

Name.....

Address.....

City..... State.....

STEP INTO THE Spotlight



FREE LESSONS... A YEAR TO PAY

Banish Boredom ... Earn Extra Money START TO PLAY VERY FIRST DAY

Picture the joy of playing a snappy foxtrot, dreamy waltz or mellow old favorite on the Xylorimba. No reason why you shouldn't! Xylorimba is **easiest** of instruments to play and yet the most spectacular. In constant demand by orchestras, radio stations, at lodge meetings and parties. Marvelous opportunity to increase popularity, make big spare-time money. No bothersome practice or exercises. With Free easy lessons you actually **Start to Play Very First Day.**

BIG FREE BOOK tells all about Deagan line, liberal trial offer and easy payments. Send coupon today for your free copy.

J. C. Deagan, Inc., Dept. 9458, 1770 Berteau Ave., Chicago

Send me, without obligation, full details of Free Trial offer and easy-payment plan on the Deagan Xylorimba.

Name.....

Address.....

When writing please mention Popular Mechanics

\$1.00 a month

is all you need to pay for
LIFE INSURANCE

\$1194.00 of insurance at age 21; \$813.00 at 35. Other ages in proportion in this Old Line Legal Reserve Company that sells without agents and gives the saving to its policy holders. Postal has paid out \$42,000,000 in 31 successful years. It has millions in assets and reserves. Just write a card today with your name, address and exact date of birth and you will get full details and rates for your age by return mail. Insurance is vital! Act promptly while rates are low.

Postal Life Insurance Company
Dept. RD-177, 511 Fifth Ave., New York

PRINT YOUR OWN 10¢ a Thousand!

World's Lowest Priced
Rotary Letter Printer

COMPLETE OUTFIT
\$7.95



Print-O-Press—amazing new necessity! Prints up to full 8½x11" Letters, Ads, Menus, Price-Lists—everything! Typeless—Anyone can use! Fast reliable Rotary action. Portable. Cleanly. Prints colors. Work equal to \$200 equipment. Details of four-way profits on request. Rush \$7.95 today for yours POSTPAID. Satisfaction guaranteed.
PROFESSIONAL PRODUCTS, Dept. 1110, Silverton, Ohio

OWN AN
AGENTS
SUPPLY
FACTORY

MAKE PRODUCTS AT HOME—Toilet preparations, flavoring extracts and household necessities. Chemicals, bottles, and labels furnished. Just add water. No experience needed. Up to 900% profit. Sell yourself or hire agents. Send name for free sample and all facts.

STANDARD CHEMICAL CO.
121 E. Second St., Dept. C-116, Dayton, Ohio



PLAY A SAW!

Produce wonderful music in 5 days ... quickly play popular and classical numbers. No notes to read, no dreary practice—success guaranteed. Since 1924 thousands of my students have amazed friends, starred in shows and broadcasting orchestras. Without obligation, write for 5 DAY TRIAL OFFER now.

MUSSEHL & WESTPHAL
100 Water St., Fort Atkinson, Wis.

AUTO-MECHANICS & WELDERS

GOOD JOBS and Mighty GOOD PAY

Do you want to earn big money? If so let us know which of the following trades you prefer. You learn by doing. Practical work. Expert teachers. Low tuition. Personal attention. It will pay you to investigate AT ONCE. Just check the courses you'd like to take and mail today. You will receive full information, absolutely without cost or obligation. But don't delay.

Check the Trade You'd Like to Learn

- | | |
|--|--|
| <input type="checkbox"/> Auto Mechanics | <input type="checkbox"/> Welding |
| <input type="checkbox"/> Auto Collision | <input type="checkbox"/> Spray Painting |
| <input type="checkbox"/> Metal Finishing | <input type="checkbox"/> Torch Soldering |

Name

Address

Mail the above to

MICHIGAN TRADE SCHOOL

Write
for
FREE
CIRCULAR

3758 Woodward Avenue

DETROIT, MICH.

ANY BOOK IN PRINT!

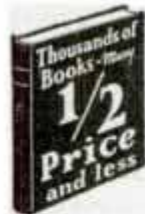

delivered at your door. We pay postage. Standard authors, new books, popular editions, fiction, reference, medical, mechanical, children's books, etc.—all at **guaranteed savings**. Send card now for Clarkson's 1936 Catalog. **FREE** Write for our great illustrated book catalog. A short course in literature. The buying guide of 300,000 book lovers. The answer to your Christmas gift problem. **FREE** if you write **NOW—TODAY!**

CLARKSON PUBLISHING COMPANY
1259 S. Wabash Ave. CHICAGO, ILLINOIS

STAMMERERS

Write for our Free List of ethical schools that correct stammering. **STAMMERERS' GUILD**
260 Tremont St.—Suite 821, BOSTON, MASS.

Learn CHALK TALKING

Entertain for all occasions. Send \$1.00 for Laugh Producing Program of 23 Trick Drawings with Instructions. Catalog of Chalk Talk Supplies Free. **BALDA ART SERVICE, Dept. K, Oshkosh, Wis.**

PLAY GUITAR

We Guarantee to teach you for 9½¢ per week. Full particulars **FREE**. Write today.

HAMANN INSTITUTE, 3019 N. 24 Place, Dept. PM-11, Milwaukee, Wis.

BIG PAY DIESEL JOBS OPEN

Northwest, home of Adcox School is hot spot of Diesel employment. Finest training. Established 27 years. Successful graduates everywhere. Earn room and board while learning. Send for **FREE** big, 40-page, Diesel School Catalog.

L. L. ADCOX TRADE SCHOOL
Dept. 18 Portland, Oregon

RADIO ENGINEERING

broadcasting, aviation and police radio, servicing, marine and Morse telegraphy taught thoroughly. Nine months' engineering course equivalent to three years' college radio work. School established 1874. All expenses low. Catalog free.

Dodge's Institute, Ada St., Valparaiso, Ind.



START \$1260 to \$2100 YEAR MEN—WOMEN

Many appointments being made. Common education usually sufficient. **Mail Coupon immediately. Hurry.**

Franklin Institute
Dept. R182
Rochester, N. Y.

Gentlemen: Rush to me, **FREE** of charge, list of U. S. Government big pay jobs obtainable. Send **FREE** 32-page book describing salaries, vacations, hours, work, etc. Tell me how to get one of these jobs.

COUPON

Name.....
Address.....

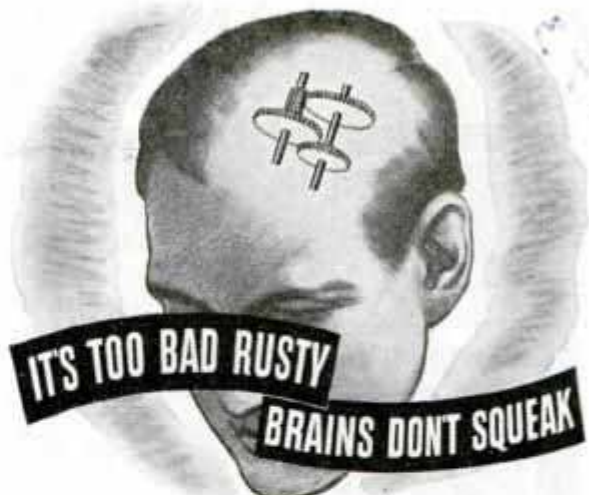

IF RUSTY brains did squeak, no one would have to warn you against trying to get ahead in a modern world with antiquated training! Keeping your brain modern is just as important as keeping plant equipment modern. The best way to keep your brain up to date is to keep your training up to date. The business of modernizing men's training is the business of the International Correspondence Schools. If your pay envelope is too thin, this coupon can be the first step towards changing the whole course of your life.



INTERNATIONAL CORRESPONDENCE SCHOOLS

Box 5641-H, Scranton, Penna.

Without obligation, please send full particulars about the subject before which I have marked X:

- TECHNICAL AND INDUSTRIAL COURSES**
- Architect
 - Architectural Draftsman
 - Building Estimating
 - Contractor and Builder
 - Structural Draftsman
 - Structural Engineer
 - Electrical Engineer
 - Electric Lighting
 - Welding, Electric and Gas
 - Reading Shop Blueprints
 - Telegraph Engineer
 - Telephone Work
 - Mechanical Engineer
 - Mechanical Draftsman
 - Machinist
 - Patternmaker
 - Foundry Practice
 - Sheet Metal Worker
 - Boilermaker
 - Heat Treatment of Metals
 - Management of Inventions
 - Diesel Engines
 - Aviation Eng.
 - Plumbing
 - Air Conditioning
 - Steam Engineer
 - Steam Electric Engineer
 - Marine Engineer
 - Civil Engineer
 - Highway Engineer
 - Bridge Engineer
 - Bridge and Building Foreman
 - Surveying and Mapping
 - R. R. Locomotives
 - R. R. Section Foreman
 - R. R. Signalmen
 - Chemistry
 - Coal Mining
 - Navigation
 - Cotton Manufacturing
 - Woolen Manufacturing
 - Agriculture
 - Poultry Farming
 - Auto Mechanic
 - Heating
 - Refrigeration
 - Pharmacy
 - Fruit Growing
- BUSINESS TRAINING COURSES**
- Business Management
 - Industrial Management
 - Traffic Management
 - C.P. Accountancy
 - Bookkeeping
 - Secretarial Work
 - Cost Accountant
 - Salesmanship
 - Service Station Salesmanship
 - Business Correspondence
 - Lettering Show Cards
 - Stenography and Typing
 - Civil Service
 - Railway Mail Clerk
 - Grade School Subjects
 - High School Subjects
 - College Preparatory
 - First Year College Subjects
 - Illustrating
 - Cartooning
 - Signs
 - Mail Carrier
 - Spanish
 - French
- DOMESTIC SCIENCE COURSES**
- Professional Dressmaking and Designing
 - Home Dressmaking
 - Advanced Dressmaking
 - Millinery
 - Foods and Cookery
 - Tea Room and Cafeteria Management, Catering

Name..... Age.....
Address.....
City..... State.....
Present Position.....
If you reside in Canada, send this coupon to the International Correspondence Schools Canadian, Limited, Montreal, Canada

When writing please mention Popular Mechanics

STAMPS and COLLECTING

(Continued from page 34A)



Some of the new stamps which have been made available to collectors recently and which include many interesting and beautiful designs

to collectors plays an important part in the postal program of most countries.

France has issued stamps to honor the centenary of Rouget de Lisle, author of the Marseillaise, and for the one hundred and fiftieth anniversary of the death of Pilatre de Rozier, pioneer balloonist. Her most recent issues honor the famous French socialist, Jean Jaures, and the Canadian monument at Vimy Ridge. Germany has issued two values for the International Health congress at Hamburg. Brazil has a symbolic design to honor the Eucharistic congress.

A bicolored set of four values in very large size has been issued by the Dominican Republic. These show a view of the ocean drive known as George Washington avenue in Ciudad Trujillo, and have an inset portrait of President Trujillo at the upper right. Italy has stamps inscribed "Etiopia," in Italian and Amharic, showing the portrait of Victor Emmanuel of

Italy, and bearing the inscription of "Poste Coloniali Italiane." A new stamp from Yugoslavia shows a portrait of Nikola Telsa.

A novel set has been issued by Netherlands for the three hundredth anniversary of the Utrecht University Foundation. The six-cent stamp shows a profile of Pallas Athene, and a twelve and one-half cent shows the portrait of Gysbertus Voetius. Danzig has a series of stamps to mark the one hundred twenty-fifth anniversary of the foundation of the city of Brosen, and Cuba honors Gomez with two stamps.

The stamp mistake of the year will be found in the Bermuda stamp pictured in this column last month. The yacht upon that stamp was to be the "Viking," owned in Bermuda, but a mixup occurred and the stamp shows the "Lucie," owned by an American.

The Cover Collector

Interesting covers from Shanghai with the postal markings of all foreign men-of-war in the harbor on stamps of their respective countries, and with a United States stamp and naval cancellation may be obtained through J. N. Lawrence, Regimental Hospital, 4th Reg't., U. S. Marines, Shanghai, China, c/o Postmaster, San Francisco. Send twenty cents in coin to cover everything.

Coin Notes

An interesting commemorative half dollar will be issued in connection with the one hundredth anniversary of the establishment of Bridgeport, Conn. It will bear the portrait of P. T. Barnum.

THIS COMPLETE, SIMPLE, PRACTICAL COURSE FOR SELF-INSTRUCTION WILL QUICKLY GIVE YOU

A Complete Mastery of MATHEMATICS



Prepare now to advance yourself to an important job by *Mathematics Training*. Mathematics is the foundation of all mechanical and scientific work, and of all business or industry based on science. Without this essential knowledge even the most capable man is left behind while others forge ahead to better jobs, bigger contracts, more money. You need mathematics to solve technical problems and to improve, speed up and check on your work and the work of others.

Now you can learn mathematics by an easy, inexpensive and time-saving method. A very simple and extremely interesting course in book form has been prepared for you by an expert who has devoted a lifetime to teaching practical men the fundamentals of this important subject.

MATHEMATICS FOR SELF-STUDY

By **J. E. Thompson, B.S., A.M.,**
Dept. of Mathematics,
Pratt Institute

These books start right from the beginning with a review of arithmetic that gives you all special short-cuts and trick methods that save countless hours of your time. Then they go right into higher mathematics and show you how simple it is when an expert explains it for you. In no time at all you will be tackling with ease the most difficult questions on this subject.

An Expert's Simplified Methods

Mr. Thompson, the author of these books, has had many years' experience in mathematical training. He presents each practical method and problem in the clearest, simplest way. He gets right down to the kind of information that you need in your daily work.

Send No Money—Mail This Coupon for FREE EXAMINATION

D. Van Nostrand Co., Inc., 250 Fourth Ave., New York
Send me **MATHEMATICS FOR SELF-STUDY** in 5 volumes. Within 10 days I will either return the books or send you \$2.95 as first payment and \$2.00 per month for 3 months—total \$8.95 (5% discount for cash).

Name.....
Address.....
City and State.....
Reference.....
Address.....

FOR FREE CATALOG of best books of practical instruction and technical information check here P.M. 11-36

Every Needed Fact, Figure, Formula, Every Shortcut and Special Method in the

WHOLE FIELD of MATHEMATICS

Now in ONE Handy Volume

For the first time you can have this wealth of practical mathematical information, covering every trade and business, condensed into one handy book for quick reference. This volume puts right at your finger tips instant facts and formulas for making every kind of mathematical calculation. From hundreds of different sources, this priceless information has been gathered together, boiled down into brief, simple language, and applied to actual problems. Every man in business, every man in the mathematical trades, every man who ever uses a tool or has to make calculations or estimates in office, shop, or home, will find here a treasury of money-making, money-saving ideas.



THE HANDBOOK OF APPLIED MATHEMATICS

No previous knowledge of mathematics is needed. No study is required. The specific information you want is easy to find, by looking it up in the index. The book takes up every trade and gives you practical methods, easily-worked formulas for solving every problem. Thousands of specific examples show you just how to make your calculations. If your work involves mathematics in any way this complete reference handbook is an indispensable part of your equipment. It is an amazing time saver for any one concerned with engineering, architecture, electricity, mechanics, construction, automobiles, machinery, printing, or any other industrial work; or with accounting, auditing, manufacturing, costs, taxes, or any other

Entirely NEW Greatly ENLARGED

Revised throughout, greatly extended in scope, with a wealth of NEW MATERIAL in all sections. The subjects of pulleys, gears, the use of the slide rule, and weights and measures have been greatly lengthened. Valuable new sections deal with the topics of strength of materials, papering, glazing, and radio. Ample new material has been furnished on machine shop practice and sheet metal work. Finally, an entirely new treatment covers exhaustively the great field of business mathematics. In its new form, more than ever before, this book will simplify your most important and puzzling problems.

No Increase in Price
754 Pages. Lavishly illustrated. Strong Cloth Binding. Page Size 5 1/2 x 8 inches.

business mathematics. No practical man, no house owner who makes an occasional repair, no one who has a home work-shop can afford to be without the valuable information quickly found in this book. A few of the subjects covered:

- | | | | |
|-----------------------------------|-----------------------------|--------------------|-----------------------------|
| Arithmetic (including Slide Rule) | Excavations and Foundations | Mechanics Painting | Sheet Metal Work |
| Algebra | Concrete | Plumbing | Radio |
| Geometry | Brickwork | Glazing | Electricity (D.C. and A.C.) |
| Trigonometry | Carpentry and Building | Paper Hanging | Print Shop |
| Weights and Measures | Lathing and Plastering | Heating | Business |
| | | Machine Shop | Mathematics |
| | | Automotive Shop | Accounting |

EXAMINE THIS BOOK FREE

Send No Money—Mail This Coupon

D. VAN NOSTRAND CO., 250 Fourth Ave., New York
Send me on approval *The Handbook of Applied Mathematics*. Within 5 days after I receive the book, I can return it and owe nothing. If I keep it, I will send you \$2.00 as first payment and I will pay \$2.00 monthly thereafter for 2 months—\$6.00 in all. (5% discount for cash.)

Name.....
Address.....
City..... State.....
Reference.....
Address.....

FOR FREE CATALOG of best books of practical instruction and technical information check here P.M. 11-36



Copyright, 1936, R. J. Reynolds Tobacco Co.



COOL, MILD, TASTY SMOKING

Right on the back of the Prince Albert tin it says: "Prince Albert is prepared under the process discovered in making experiments to produce the *most delightful and wholesome tobacco.*" Prince Albert is "crimp cut," with the "bite" removed, made of choice tobaccos. Make Prince Albert your tobacco! P. A. is swell "makin's" for roll-your-own cigarettes too.

PRINCE ALBERT GUARANTEES SATISFACTION

Smoke 20 fragrant pipefuls of Prince Albert. If you don't find it the mellowest, tastiest pipe tobacco you ever smoked, return the pocket tin with the rest of the tobacco in it to us at any time within a month from this date, and we will refund full purchase price, plus postage. (Signed)

R. J. Reynolds Tobacco Co., Winston-Salem, N. C.

PRINCE ALBERT THE NATIONAL JOY SMOKE!

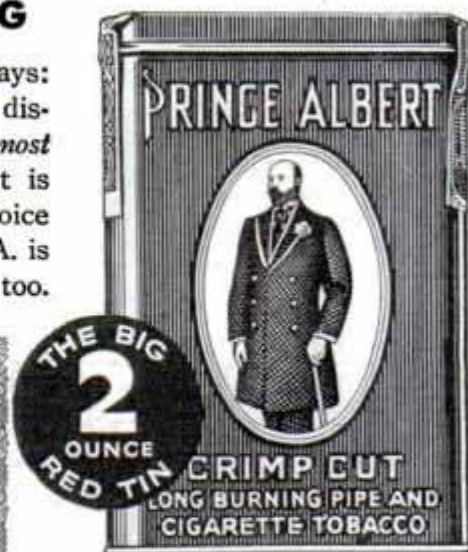

50 pipefuls of fragrant tobacco in every 2-oz. tin of Prince Albert

When writing to advertisers please mention Popular Mechanics

Popular Mechanics Magazine

REGISTERED IN U. S. PATENT OFFICE AND CANADA

WRITTEN SO YOU CAN UNDERSTAND IT

Vol. 66

NOVEMBER, 1936

No. 5

#1029

The MODERN FIREWALKERS



Fire walkers clothed in asbestos leaving burning plane

IN a large field an airplane rests with tail pointing upward, nose buried in the ground. A group of men are gathered about the ship and to passersby this seems to be the scene of a serious accident. A closer inspection, however, reveals something unusual about everybody and everything in this field.

A man is emptying cans of gasoline into a deep tray beneath the wreck, and combustible materials heaped about the fuselage are also soaked with it. While puzzled spectators gasp, another man deliberately applies a match to the pile. Then, with the exception of two men dressed in what appear to be diving suits, everybody runs for safety. In a moment the entire wreck is bathed in flames that leap twenty-five to thirty feet high.

Suddenly a movement is seen in the midst of the flames. Inside the cockpit a helmeted figure appears to be struggling feebly for freedom. An excited onlooker points a shaking finger.

"There's a man inside," he screams, "trapped in the pilot's seat!"

His words go unheeded. Several seconds pass, then the two shrouded figures near the burning pile move closer to the flames and pass inside them. The helmeted man in the cockpit rises calmly from the roaring inferno, and is lifted out by his two assistants. They walk unconcernedly toward a man holding a stopwatch.

"Two minutes!" says the timekeeper. "Everything O.K.?"

"Absolutely," replies the man from the blazing cockpit.

Con. Stephen Swift and associates

see Sept 1937 - 344

see Nov 1936

Bedwell, Strong, Saprat, Griso, ...

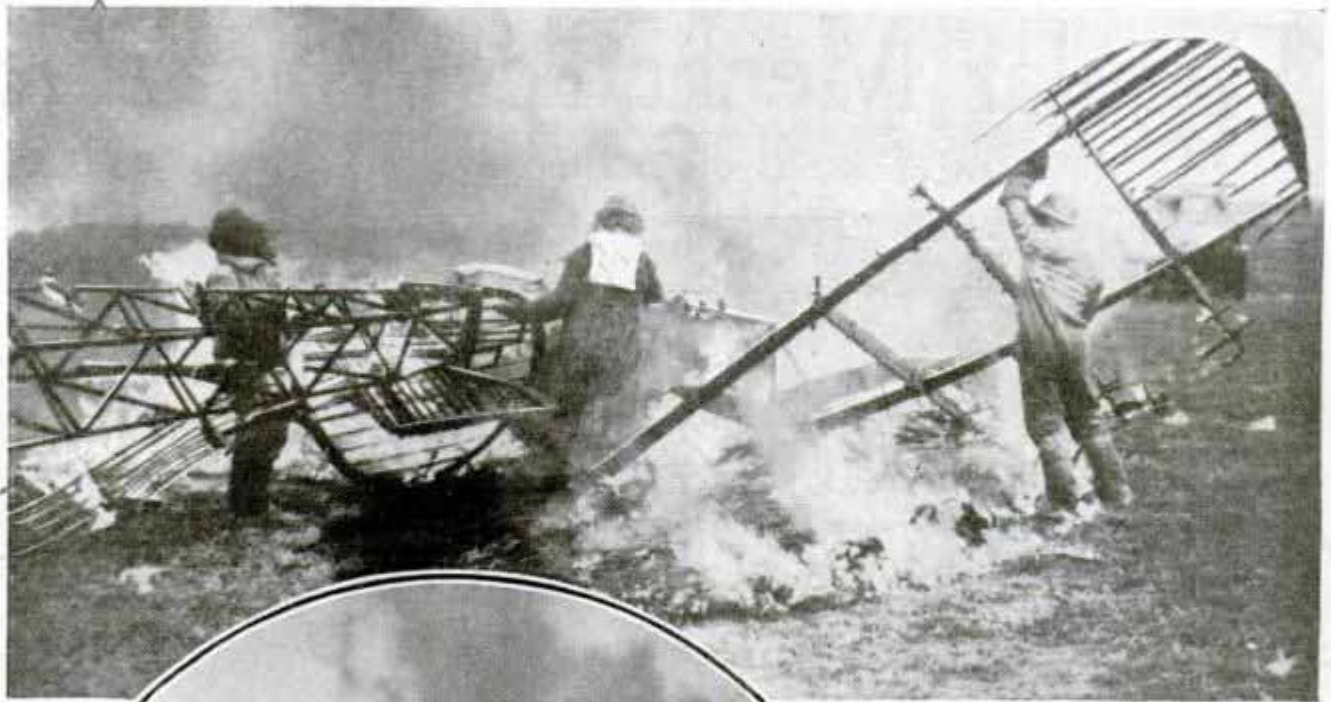

Photos by Authenticated News
 Fire fighters clothed in asbestos suits standing amid flames of blazing ship and, below, man in asbestos leaving plane after sitting in blazing cockpit for five minutes

only after a long series of dangerous experiments. Although asbestos was in use more than 2,000 years ago, it was regarded as merely a curiosity until the middle of the nineteenth century. With the advent of steam and electric engines and the daily use of inflammable materials in factories and households, however, men began to take a serious interest in the queer fire-resisting substance discovered by the Greeks. For the last fifty years asbestos has proved an indispensable material to engineers, and now scientists realize we are only beginning to appreciate its real possibilities.

During the last five years experiments have been conducted at Slough, in England, under the direction of T. G. Bedwell, and here a suit has at last been evolved which makes firemen fireproof and enables the wearer to sit in a furnace heated to 1,700 degrees, Fahrenheit, and come out unharmed. At Slough they will place a glove on your hand which enables you to grasp a white-hot bar of iron and hold it

(Continued to page 152A)

Slough Laboratories

Journal of the American Society of Mechanical Engineers

Copyright 1918 by the American Society of Mechanical Engineers

The Berlin Laboratory

Flat Cathode Tube Sharpens Television Image

Cmd W. E. Schrage, 230 W. 97 St. New York

Distortion of the television picture has been solved in Germany by development of a flat-screened cathode-ray tube, ground with the accuracy of an optical lens. Reception tubes previously had a convex reproduction surface which resulted in vague definition and distortion. To design a flat-faced vacuum tube strong enough to withstand outside pressure when evacuated, American glass four-tenths inch thick was used. For large projection—hitherto the spectators had to sit close to the small receiver to see the picture—high voltage is used, electrons in the tube bombarding the screen at 12,000 miles per second and projecting a brilliant image three by four feet in area

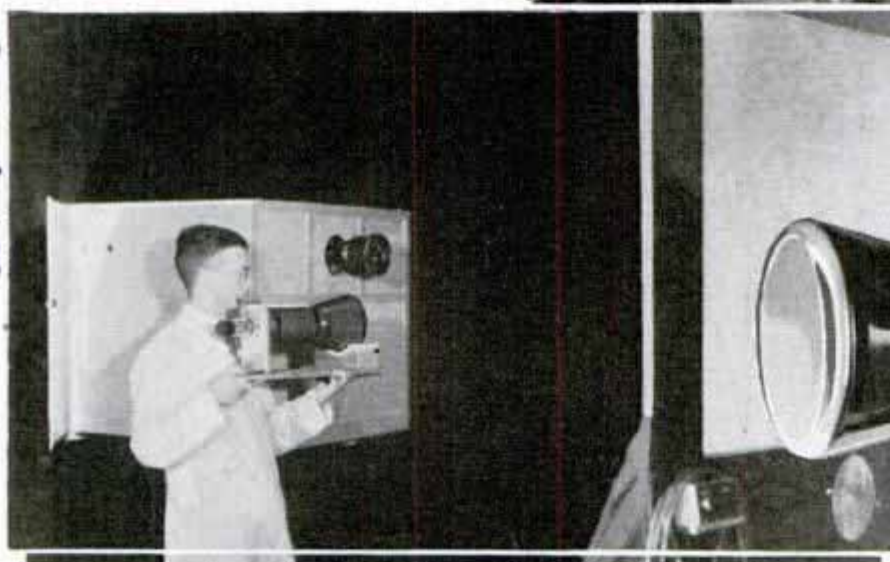
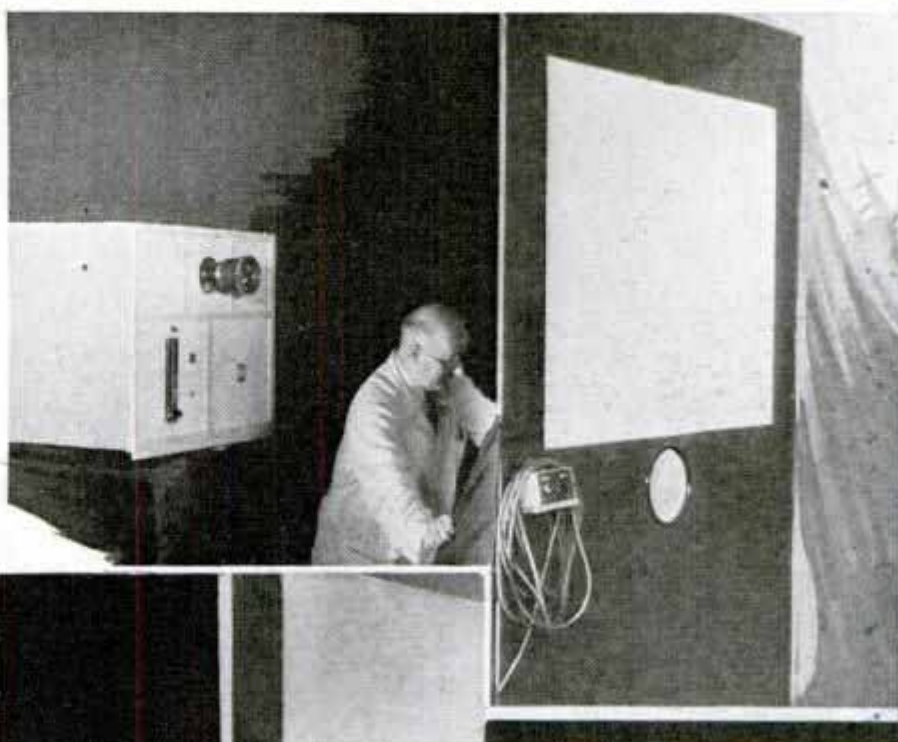

Focusing the television tube on a three by four foot screen and projecting a brilliant image by high voltage. Observe the flat cathode-ray tube

2.2.2. Conf. New York

F-119

Fast Midget Racing Plane Has Fifteen-Foot Wing Spread

Capable of a top speed of around 300 miles per hour, a tiny racing plane with a wing spread of only fifteen feet was completed recently. The midget ship is only nineteen and one-half feet long. It has a fuel capacity of forty gallons and a cruising range of 250 miles at high speed. Radio receiving equipment is among its features. The plane's power plant is a six-cylinder engine with a displacement of 550 cubic inches.

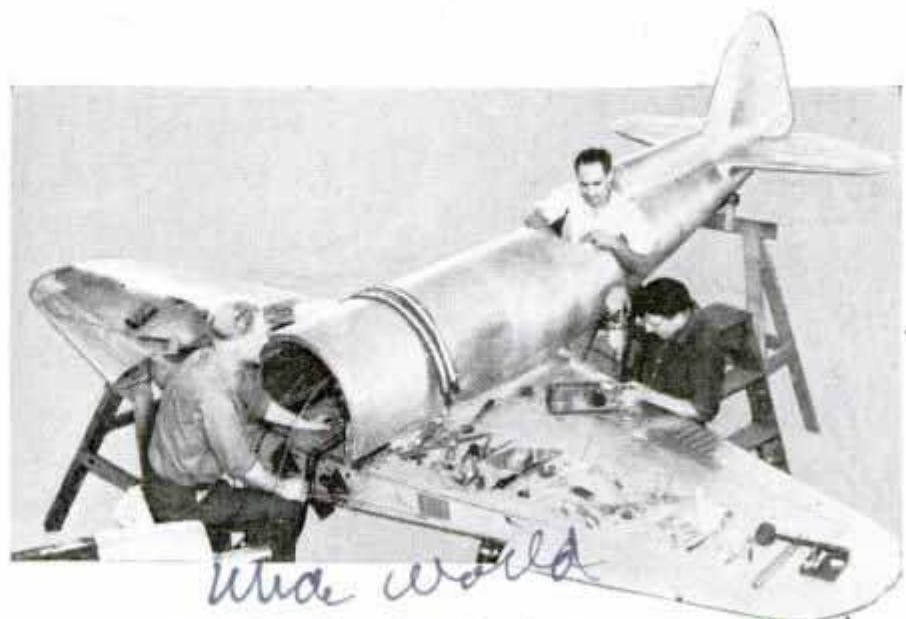

Assembling the midget plane for its speed trials

What would
Being built by Harry B...

BEWARE The

ed fuel had exactly the same characteristics as the original gasoline.

This racket started many years ago, a gasoline authority recalls, when someone discovered fuel knocks seemed to be reduced when ordinary moth balls were dissolved

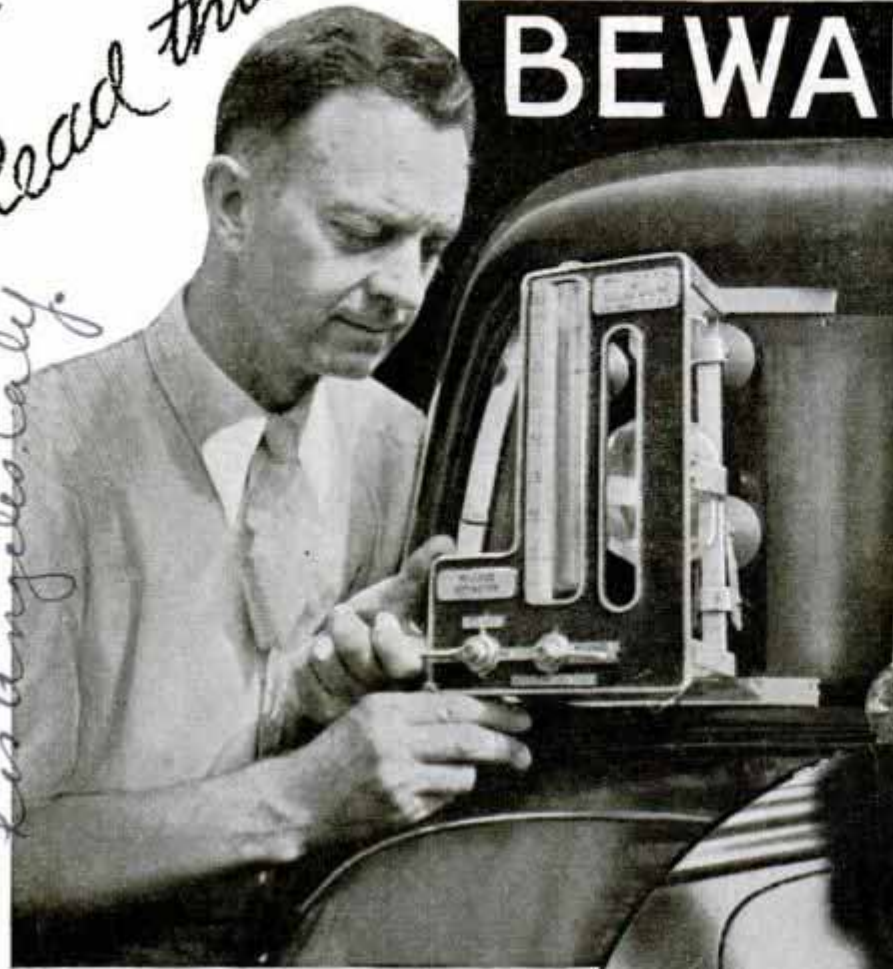

"FIVE More Miles per Gallon!"
"Removes Carbon!" "Stops Oil Pumping!" "More Power with Pep Tablets!"

When you see signs like these, stop, look and beware! Magic fuel elixirs and cure-all compounds that are sold in tablet, powder, pill or capsule form to motorists comprise a wide-spread highway racket. There are hundreds of such preparations on the market that you can buy for a dime or a dollar, but few of them are any good. Some are actually harmful to motors.

Recently a liquid "vegetable compound" said to be distilled from a rare desert plant was investigated. The usual claims of increased mileage and decreased carbon were made for it and to prove it was harmless the salesman would drink one of the tiny bottles that sold for a quarter right before your eyes. It was useless, too, laboratory men decided after they had followed directions on the label and stirred half an ounce into a gallon of gasoline. The treat-

Top, measuring tank used to determine accurate mileage of gasoline. Below, putting moth balls in your gasoline tank has same effect as many dopes and increases carbon

in the gasoline. The next step was to give the moth balls a fancy name and sell them at a good price. Ever since then naphthalene, the basic ingredient of moth balls, has been peddled in powder, liquid, and pellet form as a carbon remover and fuel economizer. Naphthalene and other coal tar products really have some effect in suppressing detonation, but unfortunately

71061
Read this
Cmt. Thomas E. Skinson Jr.
10565
Bobman Ice
Los Angeles, Calif.

any 10565 is from the
Cmt. 10565 is from the

Gasoline DOPE Racket

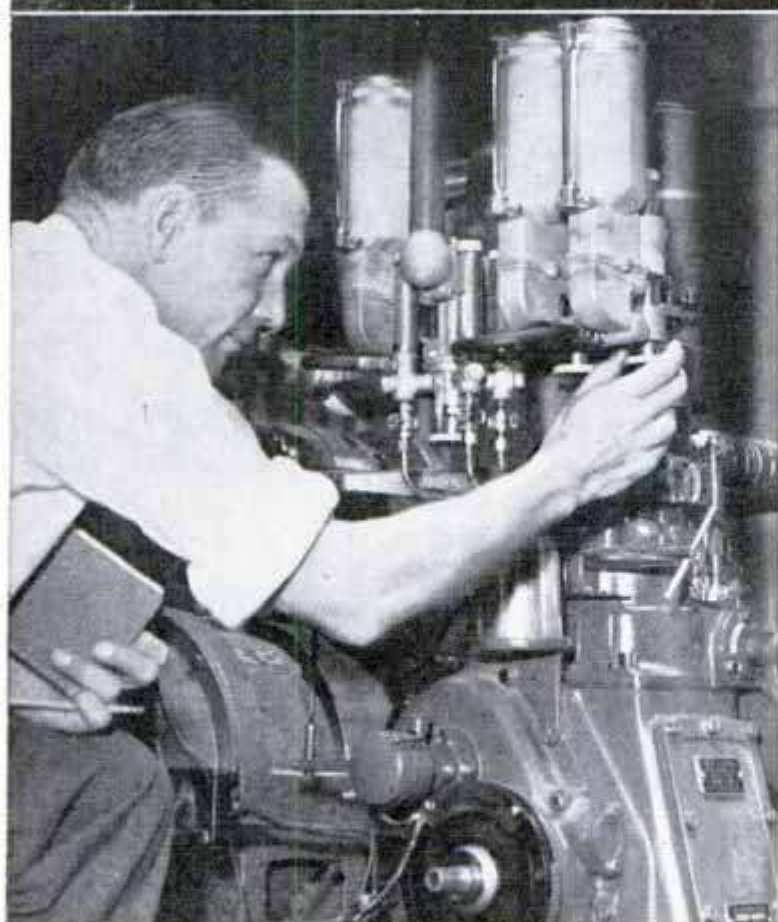

Top, fuel being tested for sulphur content by California Testing Laboratory and, below, adjusting "knock engine" to get exact anti-knock quality of fuel

they create excessive carbon deposits in the combustion chambers, leaving the motor in worse shape than it was before.

A typical "magic gas" powder about which startling claims were made was investigated by the Milwaukee Better Business Bureau. After its tests the bureau issued a warning that the powder neither increases the power nor the octane rating of a fuel, hence it has no effect on economy.

The Bureau of Standards, after testing hundreds of such compounds, declared that "in no case has the treatment of gasoline with one per cent or less of such dope been found to have any significant effect, beneficial or otherwise, unless the dope affects the tendency of the fuel to knock or detonate." A publication of the American Automobile Association reported after similar tests that not a sin-

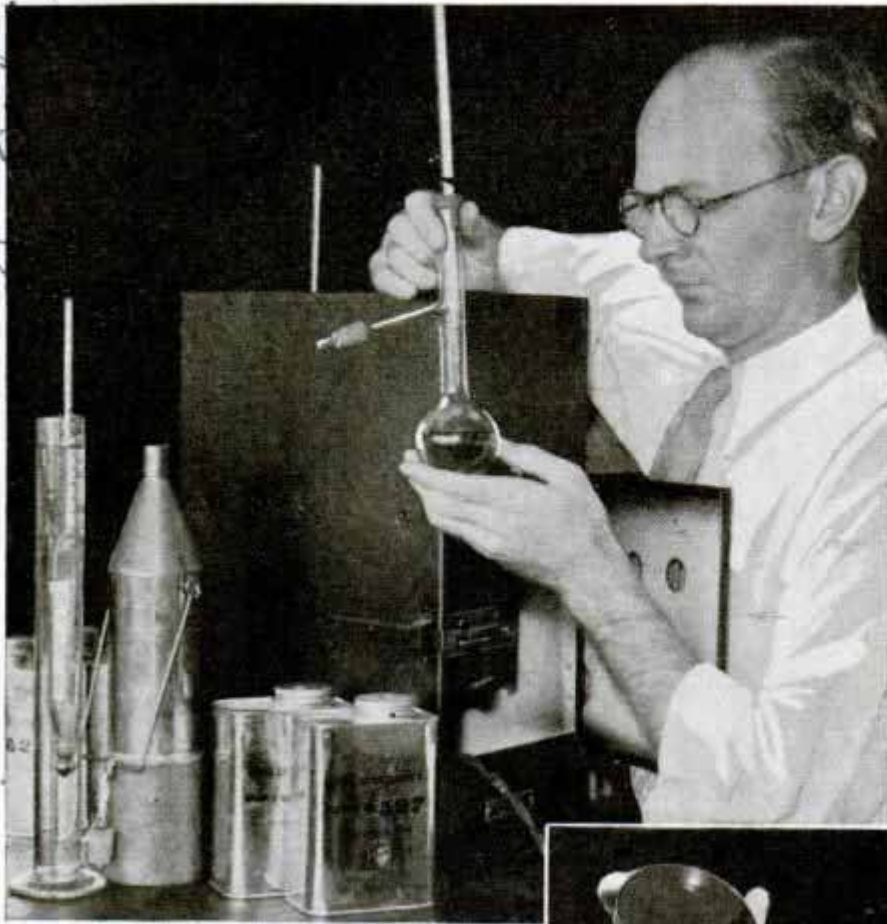

splendid mileage improver because it was highly radioactive. The laboratory test staff rejected it too after tests showed that no matter what else it might be good for, it was useless as a fuel ingredient.

In another case a laboratory tested a dope and found it did all the inventor claimed. The liquid had splendid anti-knock qualities but a complete analysis showed the material contained



Testing volatility of fuel to which dope has been added and, below, discoloration of upper dish shows excessive gum formed in a doped gasoline

gle instance had been found in which fuel dope decreased carbon deposits, knocks, or caused any improvement in the general operation of the automobile to an extent that could be measured.

Don't let a money-back guarantee fool you. One company offered to refund the purchase price of ten bottles if they failed to reduce the carbon. The company will do exactly that, if and when a disgruntled customer comes in with the empty bottles and definite proof that carbon was not reduced. The point is that few customers will use that many bottles, and only a few of those who do will bother to claim the guarantee if dissatisfied. This is known as the "one tenth of one per cent racket," which is just about the percentage of dissatisfied customers who actually ask for their money.

One man who had a "more miles" compound claimed he extracted it with kerosene from a rare mineral deposit. Perhaps he did, a laboratory staff for an oil company admitted after they tested it, but they couldn't find it improved gasoline. Another had a dope he declared was a

tetraethyl lead, a recognized anti-knock compound, which the "inventor" had secretly added to his mixture. In another instance an aromatic compound extracted from Indian tea looked good until it was learned that copious quantities of benzol were required in the extraction process. This was a case in which the discoverer was unaware that benzol alone is a very effective knock suppressor. But benzol, at about forty cents per gallon, is too expensive to use as a knock inhibitor in the quantities necessary.

The oil companies are not interested in testing compounds of lead, iron, nickel, aniline, benzene, or xylene. The anti-

(Continued to page 154A)

California Testing Laboratory, 1429 1/2 Santa Fe Ave. Los Angeles, Cal.

Thousands of Tiny Things in Odd Collection

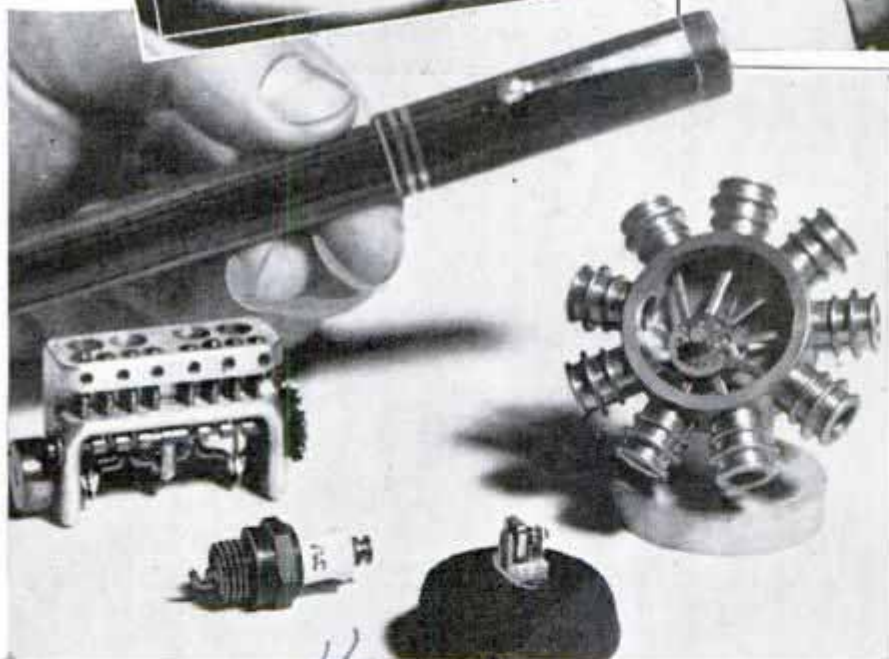
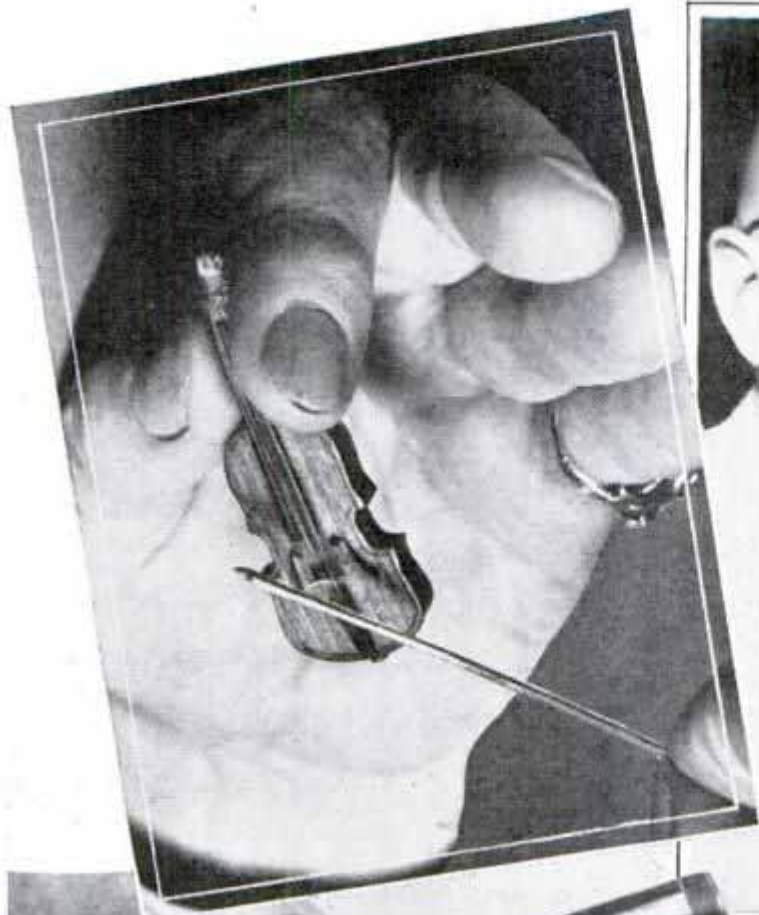

Top, left, perfect little violin. Right, reading prayer on pinhead. Bottom, comparing fountain pen with midget Ford motor, spark plug, tiny electric motor and miniature Lindbergh engine (right)

that time he went blind. Also in the museum is a Chinese junk with sails set, sixteen men on deck and eight portholes behind each of which stand two men, with 257 Chinese characters on the bottom of the junk. This object was carved from the pit of an olive. Then

Three thousand silver spoons that fit into a hazel-nut shell, ivory camels small enough to pass through the eye of a needle and 25,000 other objects in miniature are in an odd collection of tiny things assembled by Jules Charbneau of Spokane, Wash. The collection also includes a pin on the head of which is engraved the Lord's prayer, a feat which occupied an artist for twenty-five years. At the end of

there is a tiny electric toaster, one-half inch wide and three-quarters of an inch long. The smallest Ford motor, a four-cylinder model which will run, is one and one-half inches wide. It is only a fraction smaller than an operating model of the Lindbergh transatlantic plane motor. Also there is a Bible verse written on a glass plate and framed by the eye of a small needle, but invisible to the human eye.

1750 Palm Ave.
Seattle.

Keystone

Vertical handwritten text on the right margin, possibly a date or page number.

Twin Unit Starts "Installation Plan" Train



and by adding similar cars or articulated units an entire light-weight streamline train can be built up. The twin unit weighs about the same as a standard steel sleeping car. The forward car has sleeping rooms on two decks, the uppers reached by three steps. Rooms are air-conditioned and have individual regulators for heating and cooling. In the upper room there is a luggage locker, and a folding aluminum table in each room can be used for writing or serving meals. The observation car contains a compartment, double bedrooms, buffet and lounge. The body of the cars is of alloy steel, and their interior and furniture finished

One car a double-decked sleeper and the other an observation-lounge, a two-car articulated unit has been built as the first section of an "installation plan" streamline train. It can be used as the rear unit of a train of old type cars today,

with aluminum alloy. Outside, the finish is gun-metal shade accented by black and gold striping. A streamline skirt along the sides conceals the batteries and tanks under the car, but leaves the trucks exposed for servicing.

Genl. George A. Kelly U.P. The Pullman Co. 79 St. Adams Chicago

... ..

F1824



The **NEW ERA**
of **RAILROADING**

LINES of light illumine the aisles of the "City of Los Angeles," and corner lamps in each berth focus bullets of light over your shoulder.



LUNCHEON on the transcontinental streamliners is served on a tray that folds into the seat ahead.

PART II

IT took ninety years to start the revolution that set the streamline train on its time-shattering career. You knew that revolution had come when you read that the fiery old iron horse had been stabled and in its place, trailing a string of coaches straight and smooth as an arrow's shaft, was no grimy black engine but a strange new power car of "cobalt and sarasota blue, golden olive and pimpernel scarlet." Like an arrow the streamliner shot across the country, caught the public imagination, beckoned a new generation that thought the railways outmoded and slow to come for a thrilling hundred-mile-an-hour ride in this aluminum bullet.

A new era in railroading was beginning, yet its seeds were buried ninety years ago. For the streamline train was first prophetically suggested in a British patent granted in 1846 to Sir Henry Bessemer, inventor of the Bessemer steel process. He proposed a "wedge form" for the piston carriage of "atmospheric railways," to "diminish atmospheric resistance and allow the carriage to move at higher velocities with less power. The wedge



7814

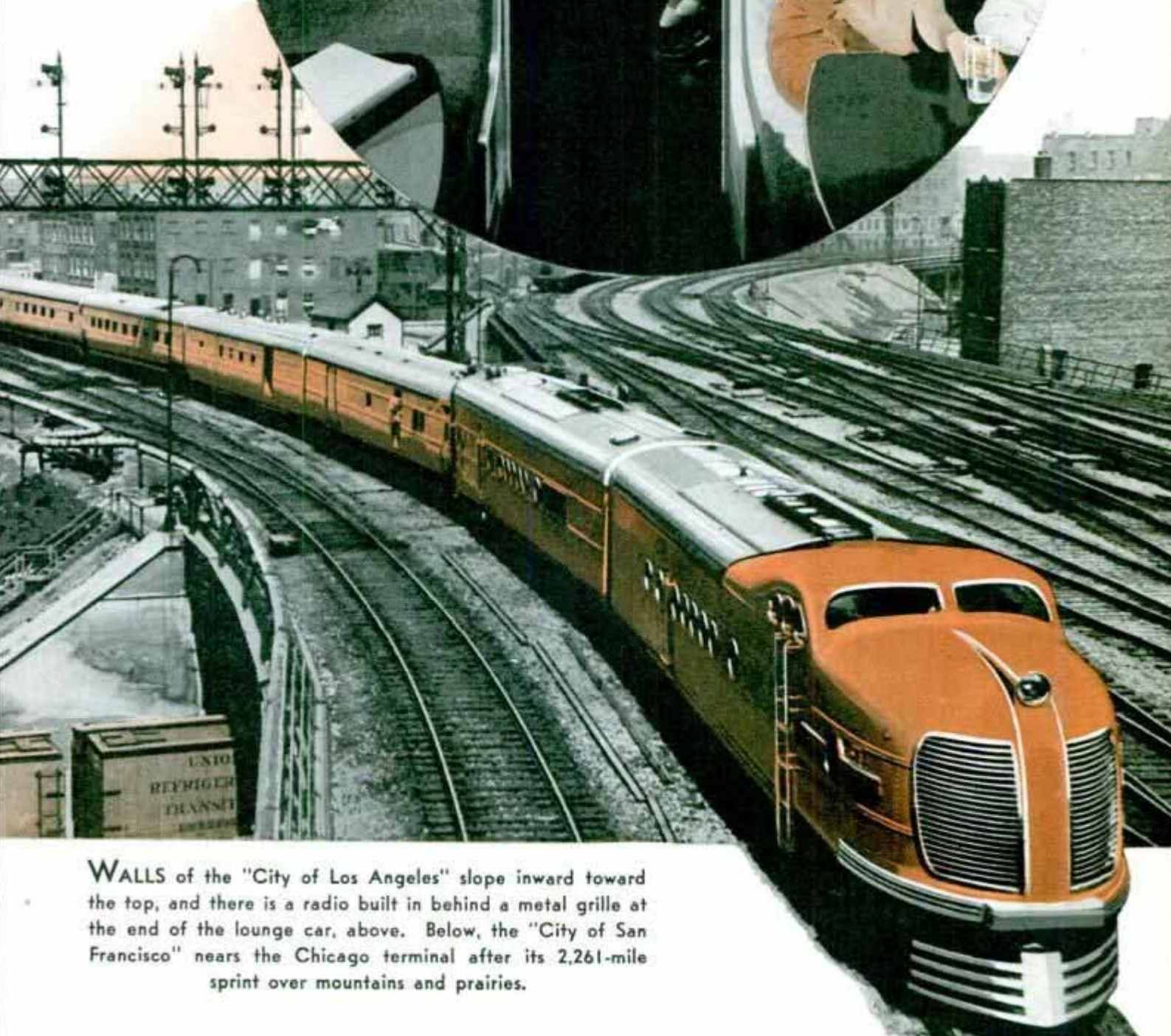

WALLS of the "City of Los Angeles" slope inward toward the top, and there is a radio built in behind a metal grille at the end of the lounge car, above. Below, the "City of San Francisco" nears the Chicago terminal after its 2,261-mile sprint over mountains and prairies.



MORE like an intimate club room than a railway car, the rear end of the Alton railroad's "Abraham Lincoln" is an air-conditioned solarium.

form may be used both in the fore and hind parts of carriages or of trains, in addition to the closing of the intermediate spaces." In 1865, as the American Civil War closed, U. S. patent No. 49,227 was issued to S. R. Calthrop for a train designed to diminish wind resistance, but the train was never developed. At the turn of the century the "Windsplitter," America's first streamline train, was given trial on the Baltimore & Ohio tracks in Maryland. It was designed by F. U. Adams of Chicago, a newspaper man. It never was placed in scheduled service, and the streamline idea slumbered on.

The epoch of the streamliner was born, at last, of necessity. In 1920 the railroads carried a peak-year load of 1,235,-

000,000 passengers. In 1933 only 433,000,000 passengers chose the rails for their thoroughfare. Passenger-miles dwindled from forty-seven billion in 1920 to a little more than sixteen billion in 1933. What drastic, dramatic gesture could lure back the lost passengers to the railways?

The streamliner was the answer. Dramatic "packaging" for the traveler. Mighty power plants wrapped in color—"sarasota blue and pimperl scarlet," for one—that would draw thousands every day to watch them roar by, and would pile up a waiting list of passengers.

The railroads borrowed style from giant air transports and from streamline automobiles. But speed called for more



LUNCH counter service is an innovation on the "Abraham Lincoln." Here the Chicago-St. Louis passenger is served quickly at reasonable prices.

than mere styling, and the railroads went to the automotive manufacturers for an engine that would haul million-pound trains—built at a cost of a dollar a pound—across the continent day after day at eighty and ninety mile speeds without breakdown. Speed was nothing new to the old iron horse, for a record of 127.1 miles per hour marked up by the Pennsylvania's Broadway Limited in 1905 has yet to be challenged by today's fast trains. Even today the Chicago and North Western's conventional steam "400" matches the better than mile-a-minute pace of the streamline steam "Hiawatha" and the Diesel-electric "Zephyr" between Chicago and St. Paul. But sustained speed, a thousand miles nightly from Chicago to Denver,

two-thousand-mile sprints from Lake Michigan to the Pacific, called for an engine with long-distance stamina, and the Diesel was given the assignment.

Climb into the massive yellow power car of the "City of San Francisco," one of the newest and most powerful of the growing fleet, and watch the engineer start his eleven-car streamliner on its journey of two nights and a day to the bay city from Chicago. Half-way across Nebraska this speedster will overtake the steam train that left Chicago eight hours in advance.

The Diesel-electric engineer is half automobilist, half electric motorman. His "fireman"—an obsolete term—climbs down into the grey power room that resembles the engine room of a great ship,

WINDOWS make upper berths of the California-Chicago streamliners attractive, and there are folding steps instead of ladders. Below, the chef on a speed train mixes a salad bowl.



starts the Diesels as you would start an automobile engine, and rejoins the engineer in the cab. Three auxiliary motors have already been running, furnishing power for lights, air-conditioner, brake lines. Given the "highball," the engineer releases his brakes, sets the motor in "series" and advances the controller to "Speed 2." The mighty locomotive starts forward almost imperceptibly—a jolt is all but impossible with articulated, shockproof coupling—the controller is advanced again and the purr of the Diesels becomes a roar as



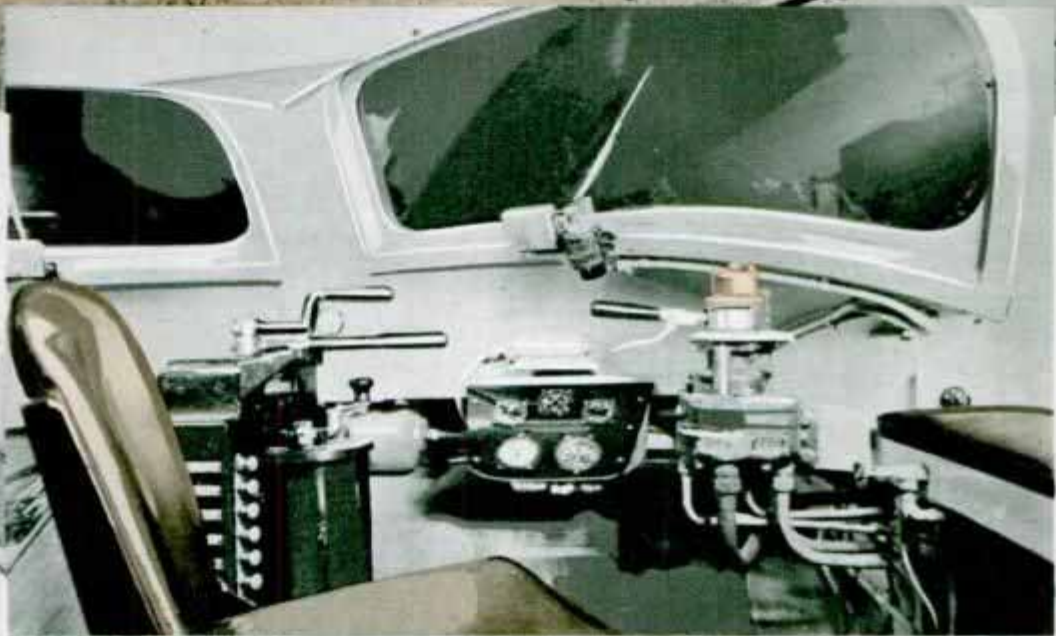

CANADA'S first streamline engine, top, a giant steam locomotive hauling crack passenger trains of the Canadian National railroad. Center, a view of the controls in the cab of a Diesel-electric power car, and below, the Milwaukee road's "Hiawatha" putting on its spectacular daily show between Chicago and St. Paul.





FRONTIER days are remembered in this unique room on the "City of Denver." With its pine walls decorated with old photographs and posters, it is reminiscent of the pioneer west.

the electric drive draws more and more power. When the train reaches a speed of thirty miles an hour the controller is thrown back, as if to shift gears; the motor is switched from "series" to "parallel" and again the controller moves forward. There are eight speeds on the controller. At sixty miles an hour the engineer switches beyond "parallel" into the high cruising range, and the streamliner hits its stride.

Like an automobile, the Diesel is watercooled and the crew must keep its

temperature around 160 degrees. Dials in the cab show the engine temperature, train speed, and air-brake pressure. There are warning lights to indicate overheated motor and low lubricating oil. Instead of semaphore signals, the automatic train control flashes a light in front of the engineer if the track ahead is obstructed, and if he fails to reduce speed in acknowledgment of the warning, the train is automatically brought to a stop. Temperature of the motors can

(Continued to page 132A)

Twin Motors with Single Clutch Drive Big Bus

Two eight-cylinder motors set at forty-five-degree angles to the transmission shaft, with a single clutch, give remarkable smoothness and flexibility to a sleeper bus just built in California. Accelerating swiftly like a steam-powered vehicle, it cruises at fifty-five miles an hour yet travels smoothly in high gear as slowly as ten miles an hour. The twin engines are at right angles to each other, connected into a single bevel-gear drive unit that provides sixteen-cylinder synchronized performance. If one motor fails, the bus can travel on the remaining engine. Being interchangeable, a new motor can be installed with little loss of time at the re-



Latest sleeper bus and interior view of compartments during day travel. Diagram illustrates how its twin engines are connected to single drive shaft

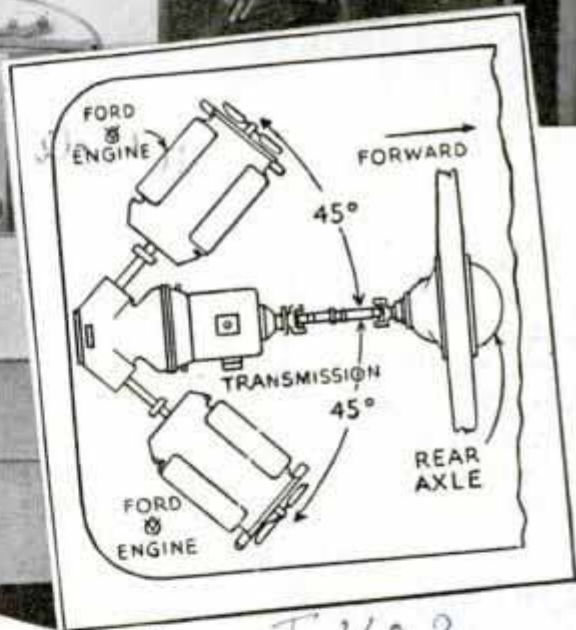

pair depot. Designed for the utmost passenger comfort, the bus is air-conditioned and is of the "sleeping car" type with eight compartments, accommodating thirty passengers as a day coach and twenty in berths at night. There are four reclining chairs in a glass-enclosed front observation compartment. Each compartment contains three single berths and a lavatory. The motors are mounted at the rear of the bus, which is built of aluminum.

Our Bureau of Information will answer questions regarding articles in this magazine, if accompanied by return postage.

Pineapples Ripen Much Faster When Treated with Acetylene

Gas a pineapple with acetylene—the gas used in welding torches and once used in automobile headlights—and your pineapple will blossom and bear fruit four times as fast as if left to nature. A patent granted to a Hawaiian pineapple grower describes his method of treating the plants with acetylene before their normal flowering period. The pineapple plant is either gassed in a sealed chamber or sprayed with acetylene-saturated water. Five treatments of twelve to eighteen hours are enough to speed up the ripening process.

granted to K. O. ... Hawaii

Mrs. Stanley Meagher 4322 Century Blvd. Los Angeles, Calif.

Photo - Wm. R. Haas
Cine Opera Aldy
Chicago

30 1936
F 1103

1936

Stamp Collection on Wheels

T-1110 Covers Every Inch of Auto

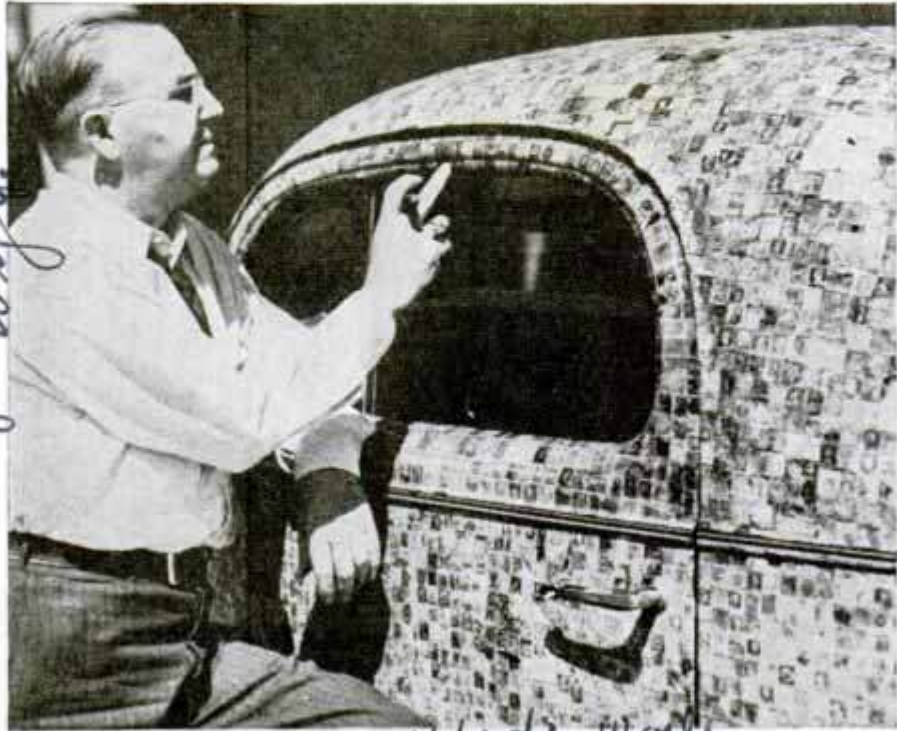

Automobile covered with more than 10,000 stamps. Five girls worked for six weeks pasting the collection on the car

One stamp collector has evolved a novel way of displaying his collection of more than 10,000 stamps. He set five girls to work pasting them on his automobile. When they finished after six weeks of labor, every inch of his car was covered with stamps, thus transforming his automobile into a rolling stamp exhibit.

Garbage Can Kept Off Ground by Adjustable Holder

Adjustable to any size of container, a garbage-can holder keeps the can off the ground at a convenient height to reach but away from cats, dogs and other animals. It consists of a metal standard supporting an adjustable holder. The standard is screwed into the ground and provides a substantial support for

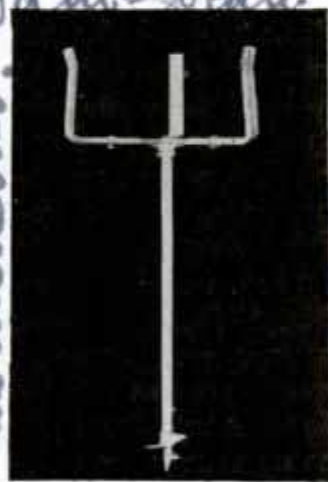

the can. The holder permits free circulation of air and sunlight about the can and also prolongs its life since it retards rusting by keeping it off the ground.

Sound Projectors on Tower Give Race Results

Atop a tower 100 feet high, super-power projectors will announce race results at the pretzel-shaped Roosevelt Raceway at Westbury, Long Island. In addition to announcements, transcriptions and radio broadcasts also will issue from the projectors, into which may be fed a total of 20,000 electrical watts from a bank of audio amplifiers. This energy is converted into 10,000 acoustic watts. Grouping the long-range projectors at one

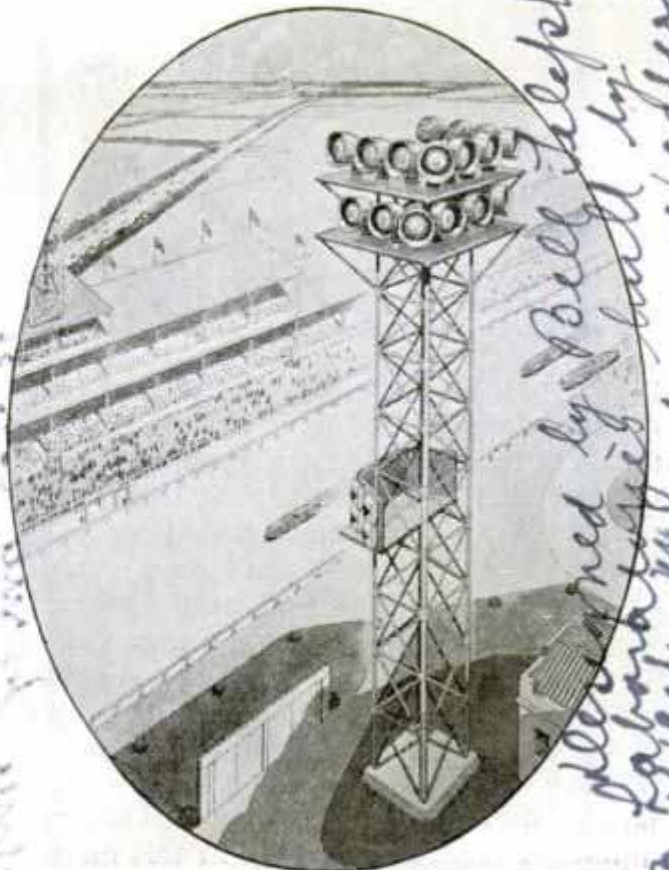

Sound projectors for race course atop 100-foot tower

Ed Hadley, Casper, Wyo.

Wide world

T-1104

Vertical handwritten notes on the right side of the page.

T-109

Western products

Designed by Bell Telephone Laboratories, built by Westinghouse Electric Corp., West. N.Y.

463

point instead of placing smaller loud-speakers at different points accomplishes clear and distinct reproduction, free from confusing echo effects, it is claimed. The search-light-shaped speakers atop the tower have their sound beams trained so as to cover remote portions of the course where spectators park their cars.

709.2
Baby Antelopes Ride to Zoo in Rancher's Flying Boxcar



Wide World
Bar J.
Wyoming rancher unloads one of his sky-riding antelopes from the plane in which he took twenty-three animals to eastern zoos

Fill 3
Outboard Motor Drives Small Water Pump

Attached in place of the propeller, a compact centrifugal pump for use with an outboard motor supplies cottage or camp with an adequate water supply. The smallest single-cylinder outboard will deliver a full stream through a hose 250 feet long, while small twin motors will handle two streams. An old barrel, elevated for a gravity supply system, can be filled rapidly for fire protection. In

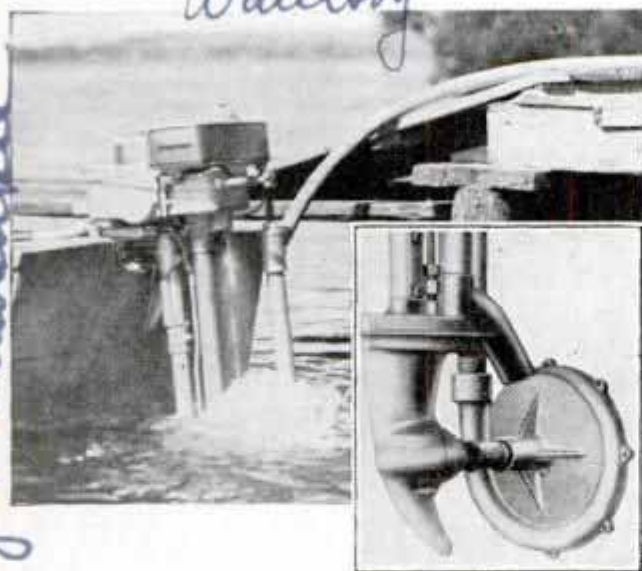

Outboard motor operating water pump. Inset, the pump attached to motor

tests the pump delivers thirty-five gallons per minute with a two and one-half horsepower motor running full speed. The pump works on motors from one and four-tenths horsepower to five horsepower.

Twenty-three baby antelopes from the plains of Wyoming rode the skyways in style on their way to eastern zoos. Rounded up by Charles J. Belden at his Pitchfork, Wyo., ranch, they were loaded aboard his flying boxcar and flown east. Several were delivered to zoos in American cities and two were consigned to Germany aboard the Zeppelin "Hindenburg."

Fill 6
Hinge Screws Started at Center by Using Special Punch

Screws can be started accurately at the center of hinge holes by using a simple tubular steel punch. Through the middle of the punch moves a sharp pointed pin which is driven into the wood to start the hole for the wood screw. The lower, beveled end of the punch is inserted in the screw hole in the hinge, the beveled part centering it exactly. Then the protruding end of the pin is struck with a hammer.



A. W. Iserström Co.
634 - 8th Ave. N.Y.C.

817.50 job Milwaukee

Outboard Motors
Car. 4143-91

Vertical text on the right edge of the page, possibly a page number or reference.

7896

4 W. K. S. S. H.
New York

LEARNING to FLY

Pan. American Airways, 135 E. 42nd St., New York

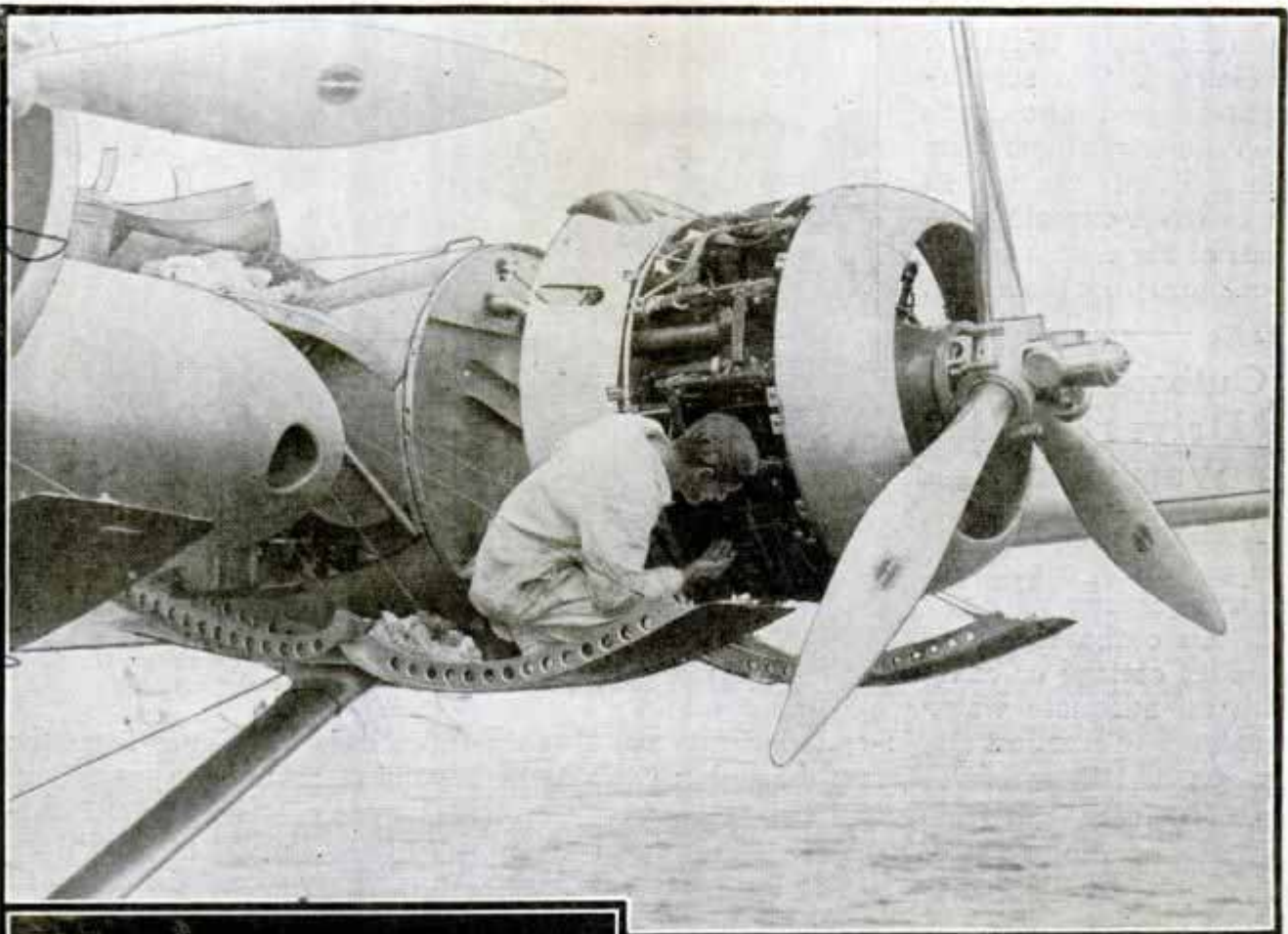

SUPREMACY on the ocean airways lies in the hands of a small band of airmen, the most skillful transport officers in the world.

Flying crews for Pan American clippers pass through the most intensive training ever given to men in charge of land, sea or air craft. Now five years old, the first ocean-flyers' school was organized by Col. Charles A. Lindbergh and other ranking officers of P.A.A. The school began in the Caribbean area, but now its operations have been extended to the Pacific, and soon they may include the Atlantic.

Anticipating a boom in transoceanic passenger, express and mail service, the company is training enough officers to handle the clipper ships when they are ready to go. More than 100 men already have taken their final examinations for responsible posts. They are the nucleus of a small army of expert pilots, engineers, radio operators, mechanics and navigators who will be in charge of America's destiny on

and maintained by P.A.A.

Junior officer, top, working on one of the clipper engines and, below, a student studying the mechanics of a clipper power plant

7895

the CLIPPERS

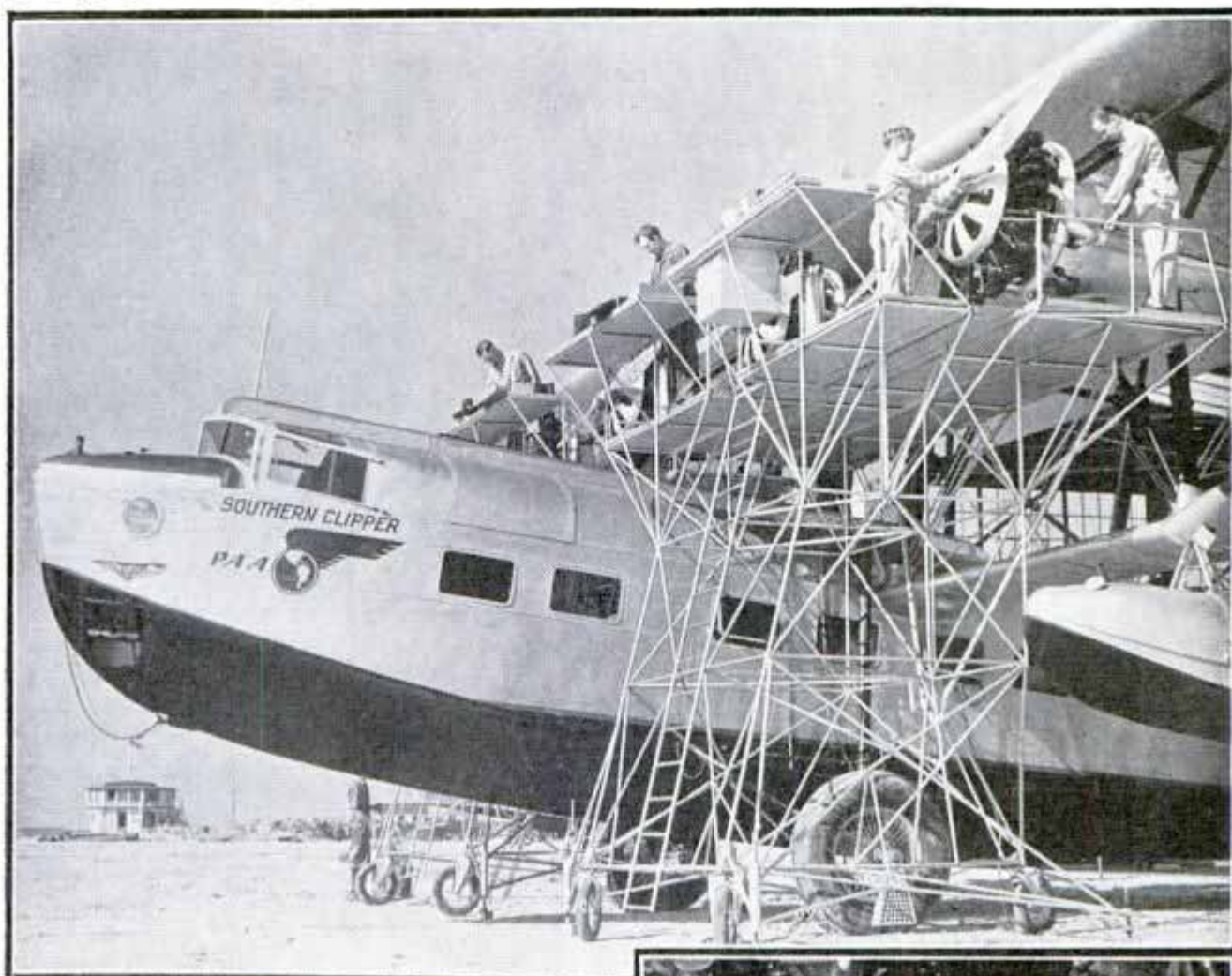

the ocean airways. Five years ago, engineers of this international air line were convinced that long-distance ocean flying was not only practicable, but that it would become an accepted fact within a relatively short period. That was when Col. Lindbergh and his associates mapped out a course of training for ocean flyers. They worked out the first conception of a flying boat crew as it is known today: captain, co-pilot, navigator, radio officer and flight engineer. All must be specialists in their chosen field, but in addition, they must be interchangeable. At a moment's notice, one officer must be able to assume complete responsibility for another's duties.

This is like having a train conductor who can drive an engine, and an engineer who can pinch hit as a conductor. To train men so exhaustively, schools were set up at divisional headquarters. Pilots, no matter how extensive their experience; passed

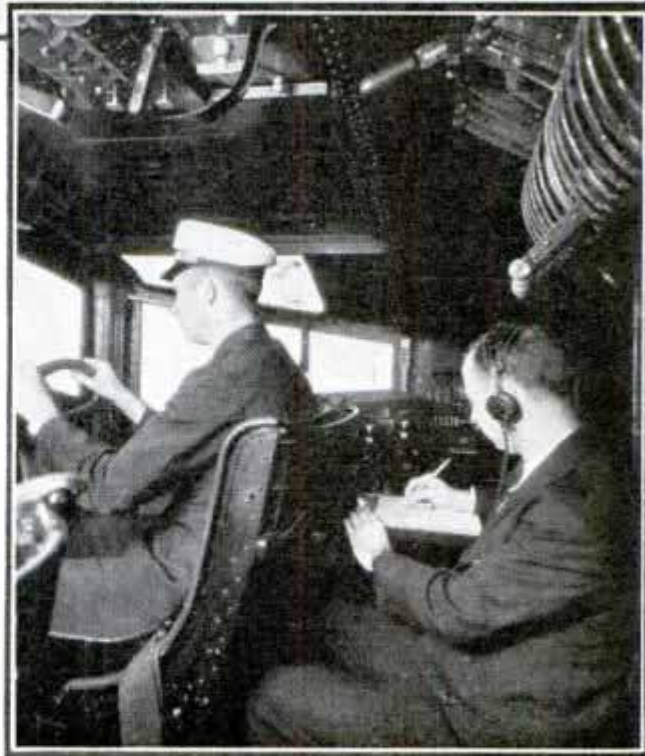

Crew servicing a clipper ship with the aid of a portable scaffold and, below, pilot and radio operator in cabin of clipper

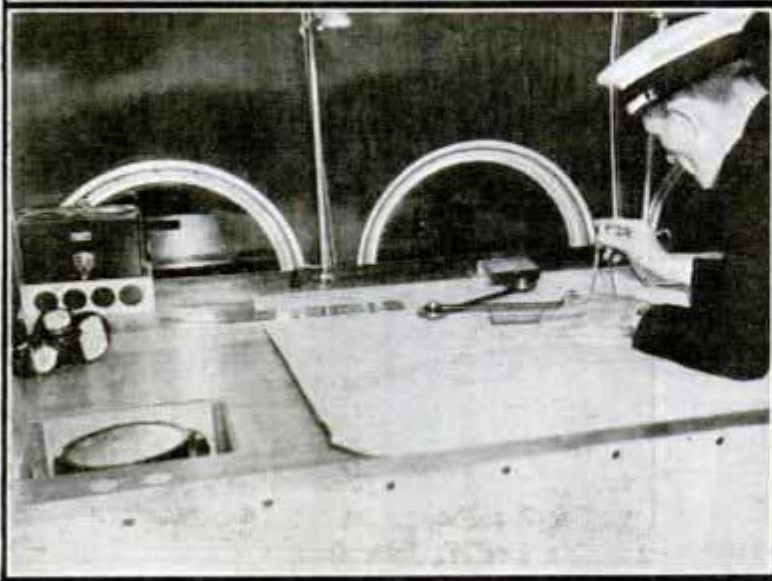
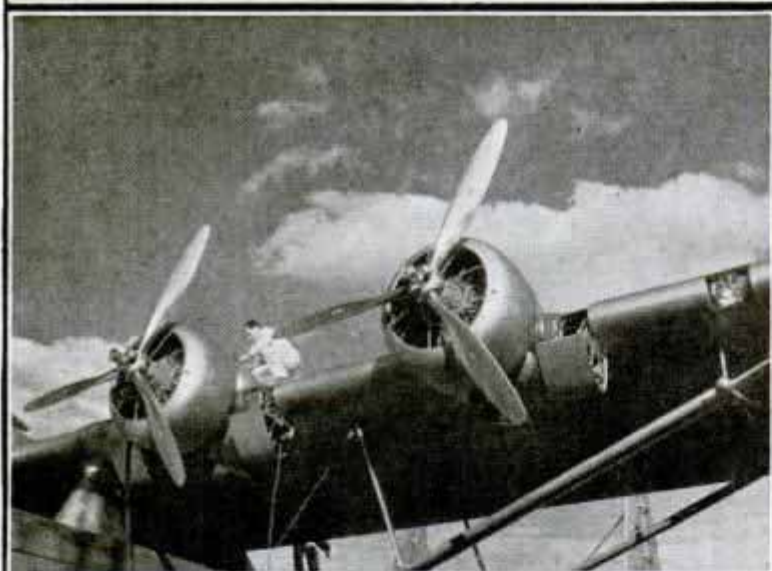
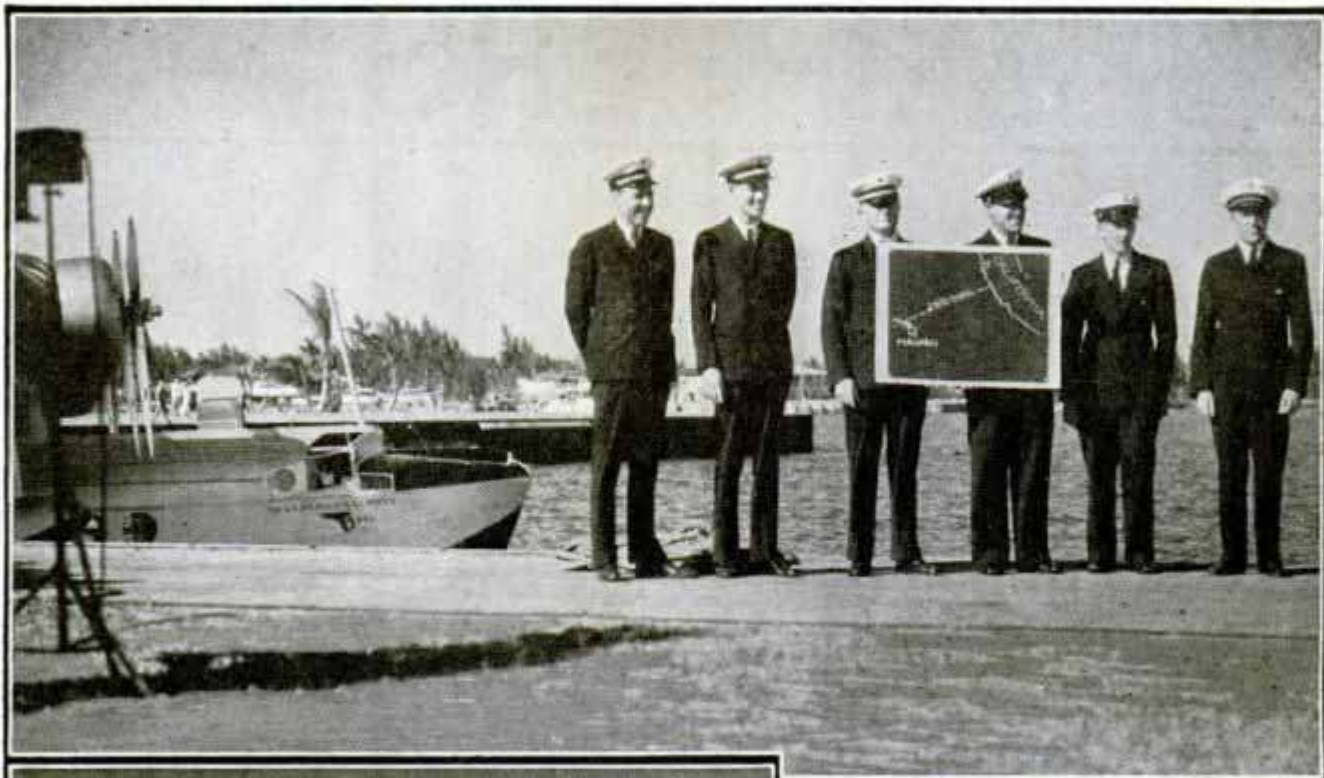

Trim clipper ship crew, at top, ready for a flight. Center, two of the engines of a clipper. Bottom, officer in navigation room of clipper ship

through instruction in blind flying, and were given a chance at the controls of all the common types of aircraft. All flying personnel took courses in meteorology, navigation, and radio. New pilots were given long training periods in engine shop work. For years after joining the line, they served as assistant pilots, as junior officers, and clerks in charge of every detail of clearing cargoes and caring for passengers.

The requirements for becoming an apprentice pilot in the ocean-flying school are unusually high. To qualify for training, a candidate must be a graduate aeronautical engineer, the holder of a transport pilot's license, and not over twenty-four years old. If he passes the preliminaries, he receives a thorough education in the international transport business. This takes in a lot of ground. It begins with traffic handling and clearances, then leads to radio construction, radio operation, engine mechanics, airplane mechanics, and piloting.

To become a finished clipper-ship officer, he is also schooled in foreign languages, international

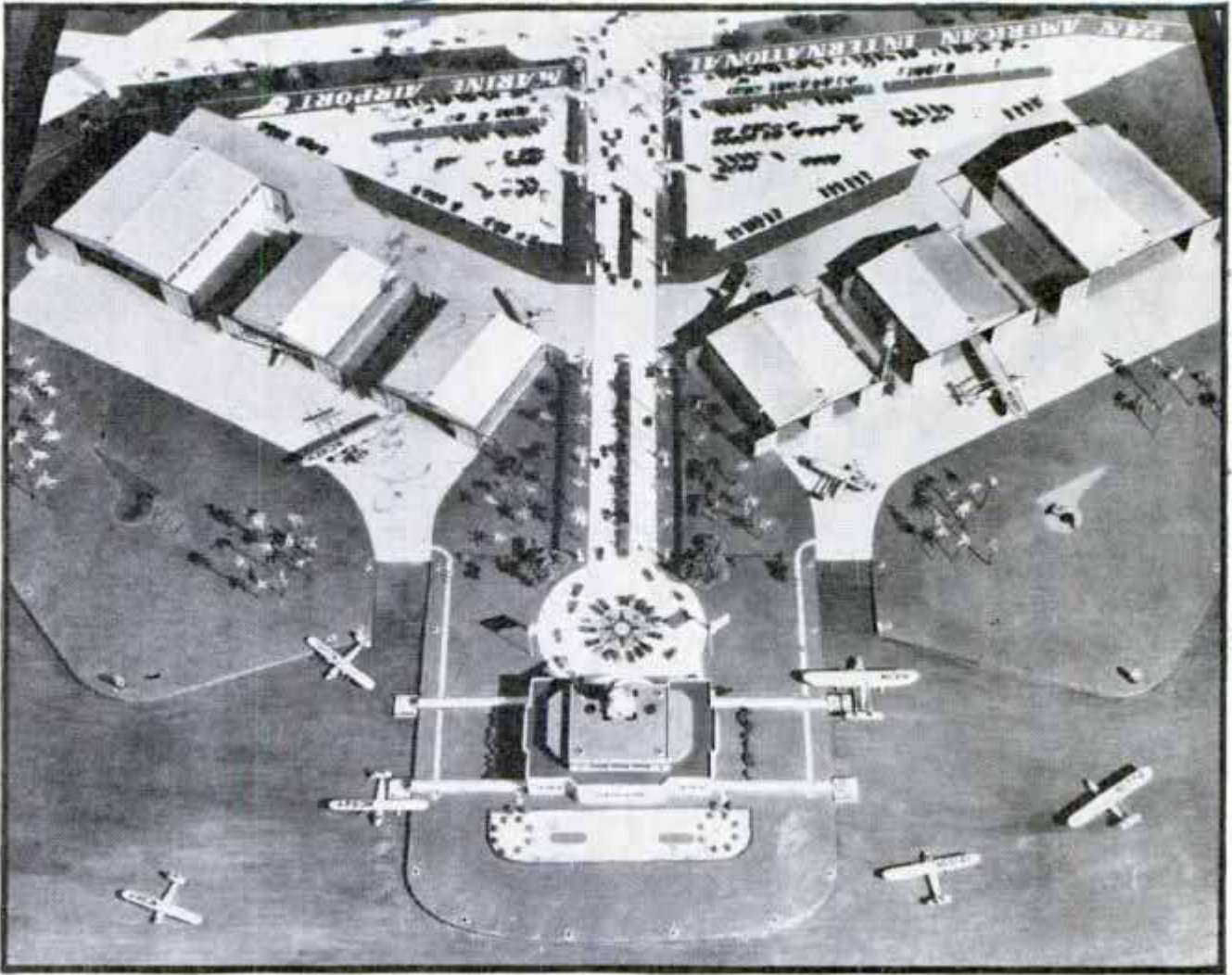

law, international maritime law, seamanship and kindred subjects. If these courses are passed, the candidate is in line for a rating as junior pilot. This rating implies he is a qualified traffic man, a licensed engine mechanic, a radio operator, a licensed mariner and a master seaman.

The next rating is flight engineer, for which the requirements are still higher. To become a first officer on an ocean clipper, you need at least 5,000 hours of transport flying and at least three years of service with the company. You must also have a supervisory knowledge of engines, airplane mechanics and radio operation, besides being a graduate navigator. The next highest rating, captain, requires 7,000 hours of experience in transport flying and four or five years with the company.

Officers who give evidence of superior judgment and ability, and who have all the foregoing qualifications, are in line for the highest rating—master of ocean flying boats. This title implies the holder knows how to man every post on an ocean clip-

(Continued to page 139A)



An international airport where clipper ships land and depart and, below, signal light for an approaching clipper.

I 1093.

Secret, Mech

Secrets of Earth's Interior Revealed in Mineral Hall

And. Lester L. Pelton

headlamps carries sufficient current to dimly light the lamps and has a capacity sufficient to prevent fire when the circuit is shorted. In addition, the system has a thermostatic switch in parallel with the resistance which periodically bridges the resistance and causes the lamps to light up brightly. Another system has a thermostatically controlled switch which causes the headlamps to flash on and off when there is a short circuit.

F 1116

Hydraulic Car Jack Pulls Fence Post Up with Chain

Fence posts and even small stumps can be pulled up with an all-purpose hydraulic jack designed for use in automobile, garage, farm or shop. Twenty inches high at its low point, it has a lift of fifteen inches and can hoist 3,000 pounds. The chain and hook employed to haul up posts are detachable, and the base is demountable. A pin-point release valve allows automatic and positive control in lowering the load.

Cont. George Eckhardt. 2047 1/2 Park Ave. Chicago

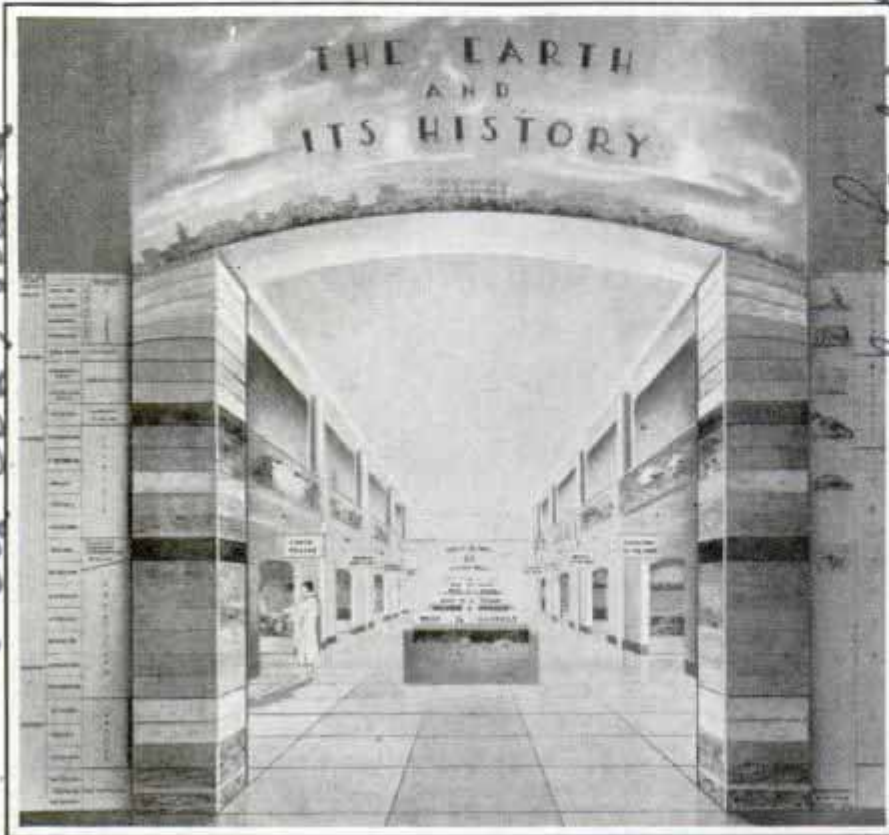

Design of mineral hall, showing its wall of rock strata. Inside are numerous exhibits which help to tell history of earth's interior

With its walls constructed of rock strata found under Philadelphia, a mineral hall at the Academy of Natural Sciences reveals the secrets of the earth's interior. The mineralogical age of each strata in the walls is shown, with the strata drawn to scale. The entrance is like entering a cross section of the earth. On one side of the door are figures of animals which occupied the earth during the various ages. These figures are reconstructed from fossils. In the hall are exhibits showing details of the earth's interior.

at its low point, it has a lift of fifteen inches and can hoist 3,000 pounds. The chain and hook employed to haul up posts are detachable, and the base is demountable. A pin-point release valve allows automatic and positive control in lowering the load.

Car Lighting System Guards Against Road Trouble

Designed to warn the motorist of trouble in the circuit, and at the same time to keep the lights burning sufficiently to reach a garage, a new automobile lighting system has been introduced. When a fuse blows out, or other trouble occurs, the system gives a noticeable signal. A heavy resistance connected in circuit with the



Jerking a fence post out of the ground is a simple job with a hydraulic auto jack and chain

F 1117

Pat. # 2,037,058

Assigned to Packard Motor Car Co. 1580

American Esunder

712 st 2nd Milwaukee, Wis

Auto Makers Turn to Easy Control, Economy

That the automobile industry is turning from its former goal of more speed to simplified control, quietness of operation, longer life and economy is indicated by the 1937 Studebaker. Outstanding in this new model are the overdrive transmission which may be cut in or out at any speed above thirty-five miles per hour by operating the accelerator; the hypoid rear axle which permits lowering the body floor without using a tunnel or sacrificing road clearance; direct-acting shock absorbers built into the chassis; the twin lever steering for easier parking and improved control at road speeds; rubber-insulated universal joint for smoothness and quietness at



Length

Studebaker 1937

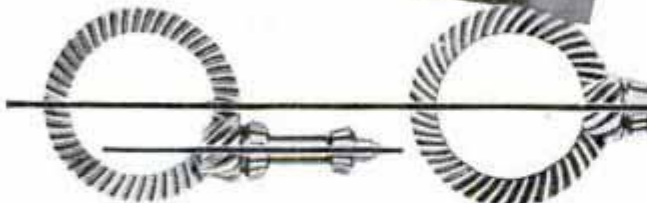
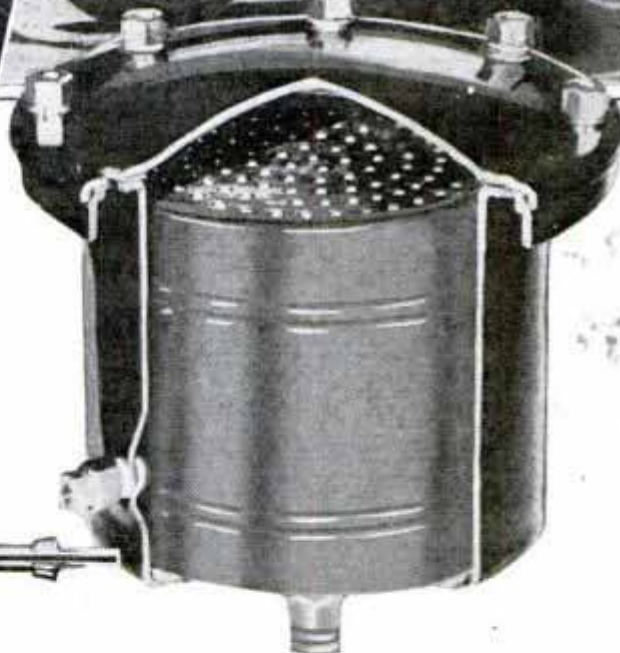

Top, right, the new Studebaker. Left, photo-diagram of built-in defroster. Bottom, left, sketch showing how hypoid axle permits lowering body floor. Bottom, right, oil and motor cleaner

high speed; improved shifting which permits the amateur to change gears without clashing, and an oil and motor cleaner which eliminates frequent changing of oil. Except for seasonal changes in winter or summer, the oil need not be changed. Instead, a new filtering element is installed in the cleaner when the oil becomes dirty. Instructions on the crankcase dip-stick

show when the oil is regarded as dirty. Another innovation is the built-in defrosting equipment which is used with the heater. Two air ducts opening just below the rear of the windshield at the top of the instrument panel carry warm air upward and against the windshield when connected to the heater. This warm air clears the windshield of frost.

Studebaker 1937

All-Metal Plane Makes Five Miles a Minute

Developed by Chance-Vought
The Northrop Corp
Inglewood, Calif
described

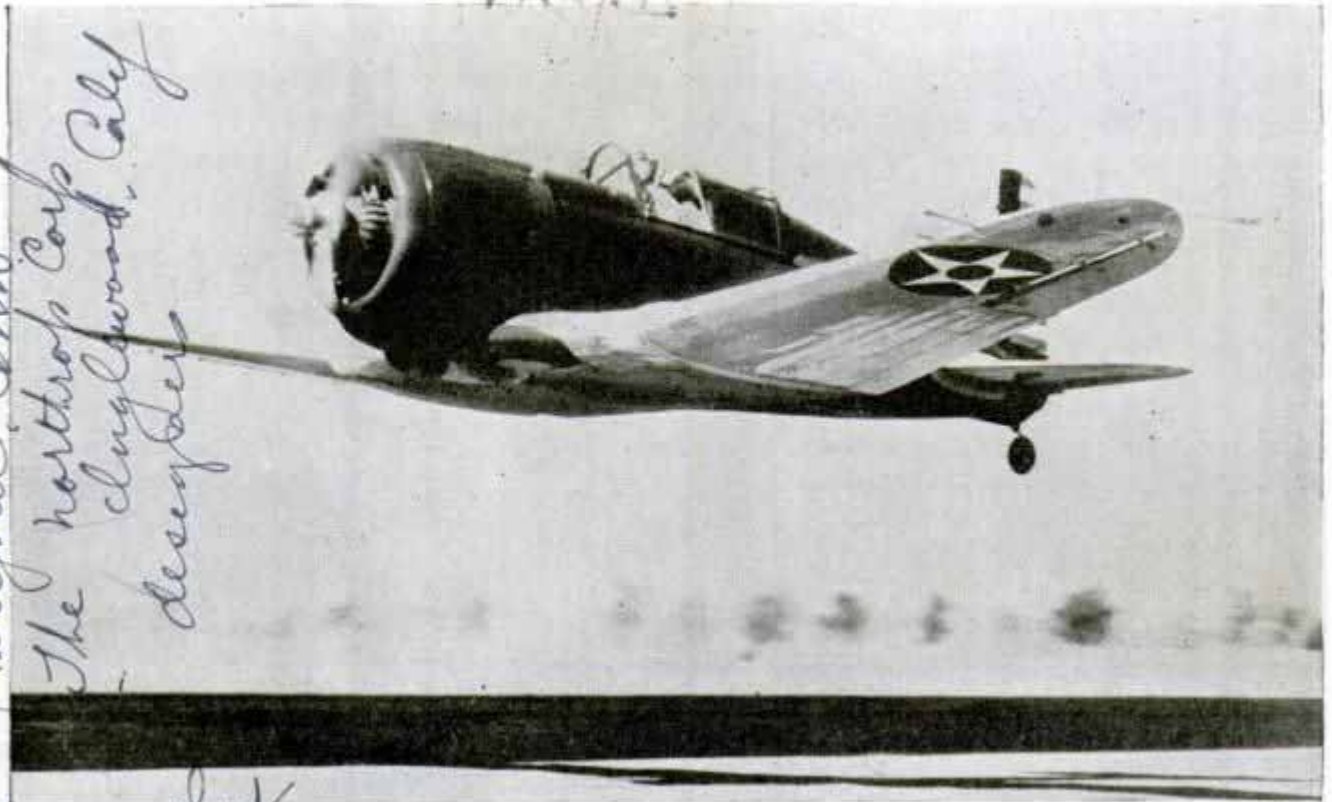

This fighting ship is an all-metal, single-seater, low-wing monoplane equipped with a 750-horsepower engine and capable of a speed of 300 miles per hour

Capable of a speed of 300 miles per hour, an all-metal war plane recently underwent successful test flights in the east. The fighting ship is a single-seater, low-wing monoplane equipped with a 750-

horsepower engine. Among its features are completely retractable landing gear, wing flaps, and cowl flaps to control engine cooling. The pilot sits far forward where he has virtually unlimited visibility.

Jointed Foot Rule Measures Angles with Aid of Dividers

With the help of an ordinary pair of dividers, a jointed two-foot steel rule can be set at any desired angle and the rule

line of chords until the two points exactly span the distance from zero to forty-five degrees. With the dividers locked in this position, the rule is spread until the divider points exactly span two center dots on the rule. Then the rule is opened at a forty-five degree angle. To measure an angle the rule is opened to agree with the angle and the procedure is reversed.

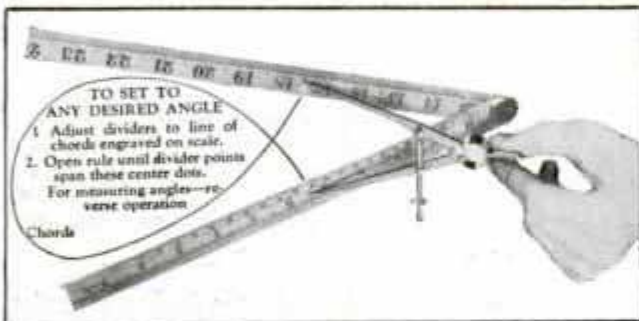

Rule is set at angle by opening divider to proper span on chords then spotting it on center dots

itself can be used to measure an angle. On one arm of the jointed rule a line of chords from zero to 120 degrees is engraved. To set the rule at forty-five degrees, for example, the dividers are opened along the

Super-Steam in Welded Pipes Used by Auto Makers

Carried in a welded pipe system, super-steam is used in making automobiles. Steam heated to 900 degrees Fahrenheit flows from the powerhouse of the Ford plant to various parts of the vast factory, so hot that the pipes carrying it glow cherry red. This heat, and a pressure of

George Scher Co
125 Lafayette

Detroit Free Press

Orange plan. #1087

Mfg. Co.

25th and Bernting Park Ave. Phila

more than 1,200 pounds to the square inch, made it necessary to find a better way of connecting the pipes than by flanged and bolted or threaded joints. So the entire installation was welded, a total of 1,600 joints. To complete the job a "stress relieving machine," to take the stresses out of the freshly welded joints, was built.

Stainless Steel Railroad Car Tested under Water Spray

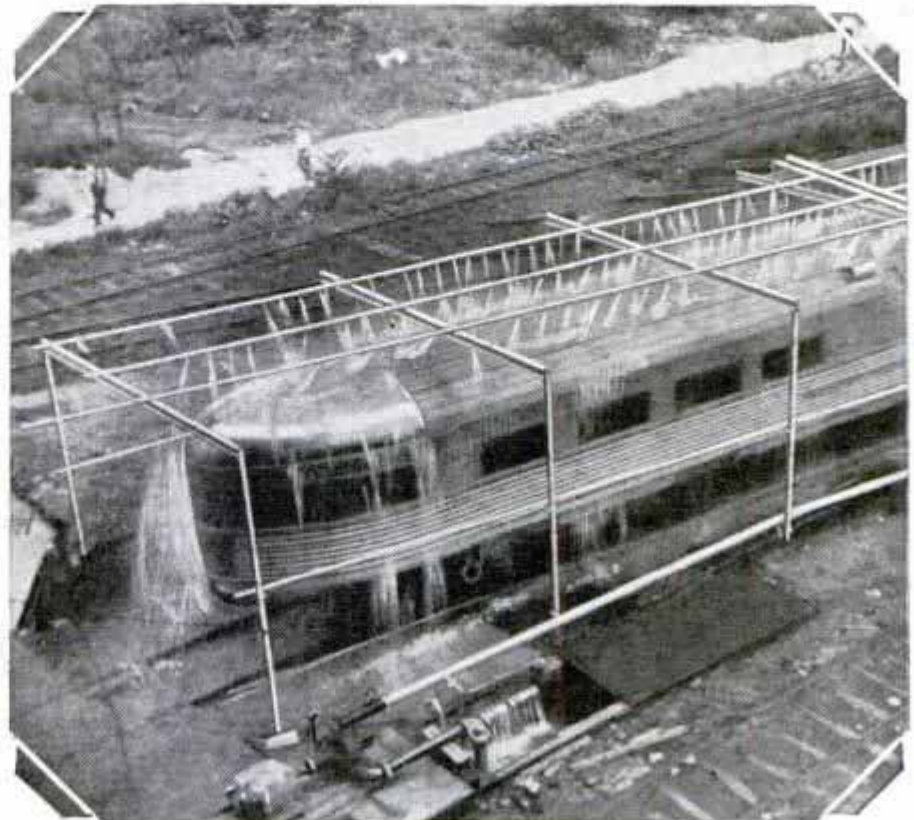

Streamline rear car of stainless steel train is given shower bath on track at factory to determine whether there are any leaks in its armor

#1056
Reed-Toned Organ of Three Octaves for Children

Learning to play an organ is more fun than work when the tiny instrument has the reed tones and action characteristic of the full-sized organ. A miniature organ developed for children has a span of three octaves, and there are two pedals. The "works" are concentrated in the smallest possible space.

Stainless steel cars being built at Philadelphia for a streamline train are given a thorough baptism under water sprays to test them for leakage. Although the stainless steel is as thin as a dime, it is four times stronger than ordinary steel and being shot-welded, no rivets are necessary.

F1098
Taillight Bracket That Bends Prevents Breaking

Eliminating the principal cause of breakage of brackets, lamps and lenses on trucks and trailers, a flexible lamp bracket of heavy canvas webbing bends when the vehicle is backed into an obstruction. It is made of heavy fabric belting suspended from an angle iron attached to the truck. The light is fastened to this flexible hanger which "gives" if an obstruction is encountered.



Midget organ for children has only three octaves but possesses tone and action of real reed organ

Estey Organ Corp.

Trailer Company, Baltimore, B. Island, Baltimore, America's Best

Feb 10-14

The SPIN SHOTS

100 W. Monroe St. Chicago

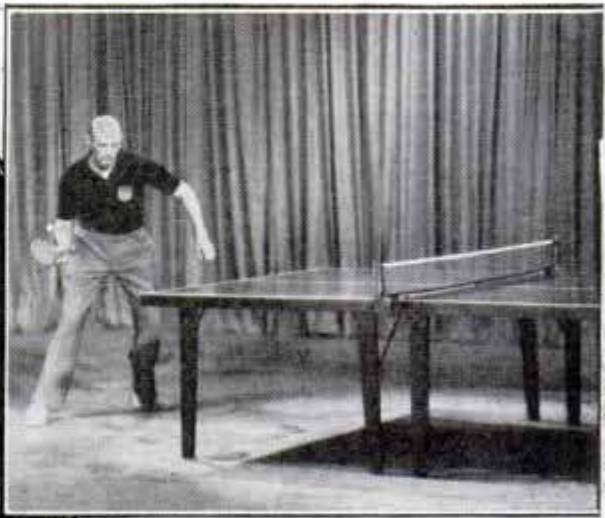
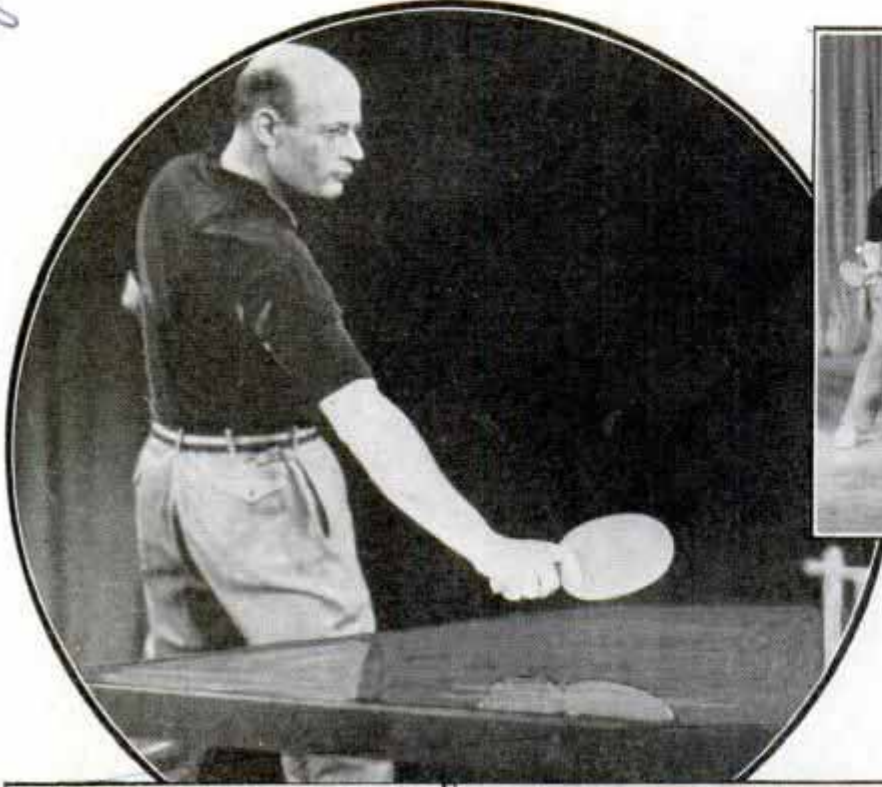

Left, finish of backhand chop. Above, chopping ball which has just left racket

By Coleman Clark
Former National Champion

OF ALL the games in which a ball is used, table tennis by all odds is the "spinniest."

Willie Hoppe, the billiard wizard, puts plenty of "English" on the cue ball and Dizzy Dean flicks his wrist and manipulates his fingers as he whizzes the revolving ball through the air to get his "upshoots," "outs," "ins" and "drops." Every golfer knows one sort of spin makes his ball slice and a different one brings about a hook. Smart lawn tennis players consciously impart certain spins or twists to the ball to force their opponents into errors. Even top-notch bowlers get more strikes if they roll "hooks" by a simple twist of the wrist as the ball leaves their fingers.

In all these sports the ball revolves in the course



START OF RIGHT-TO-LEFT SIDE SPIN SERVICE

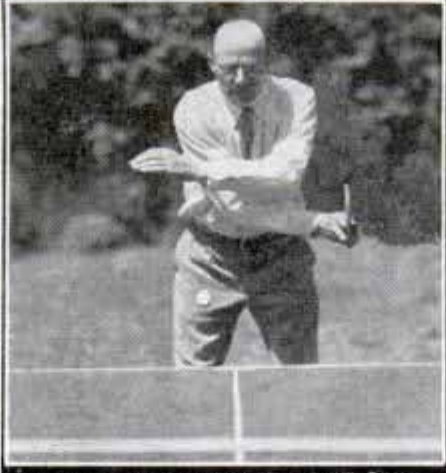

FINISH OF RIGHT-TO-LEFT SIDE SPIN SERVICE, NOTE VERTICAL POSITION OF RACKET

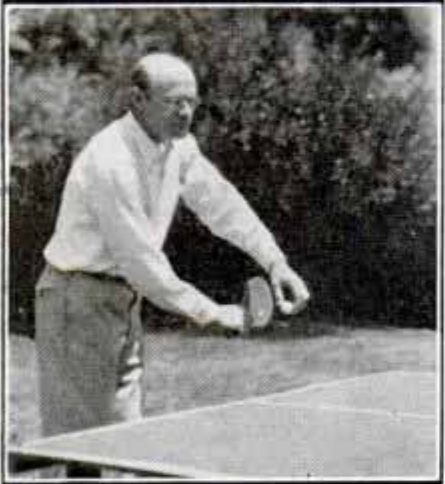

START OF LEFT-TO-RIGHT SIDE SPIN SERVICE

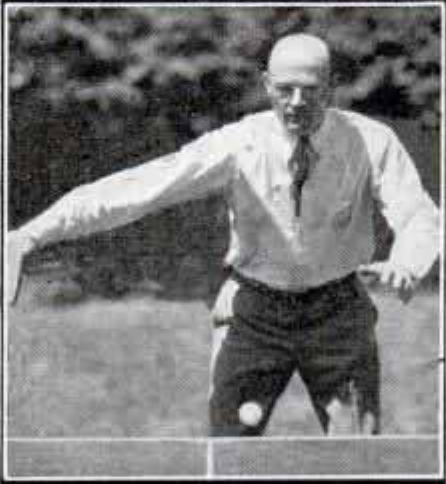

FINISH OF LEFT-TO-RIGHT OR BACK HAND SIDE SPIN SERVICE

see page 19 3 6 8 3 4

see May

Walter Brennan Corp.

Commonwealth

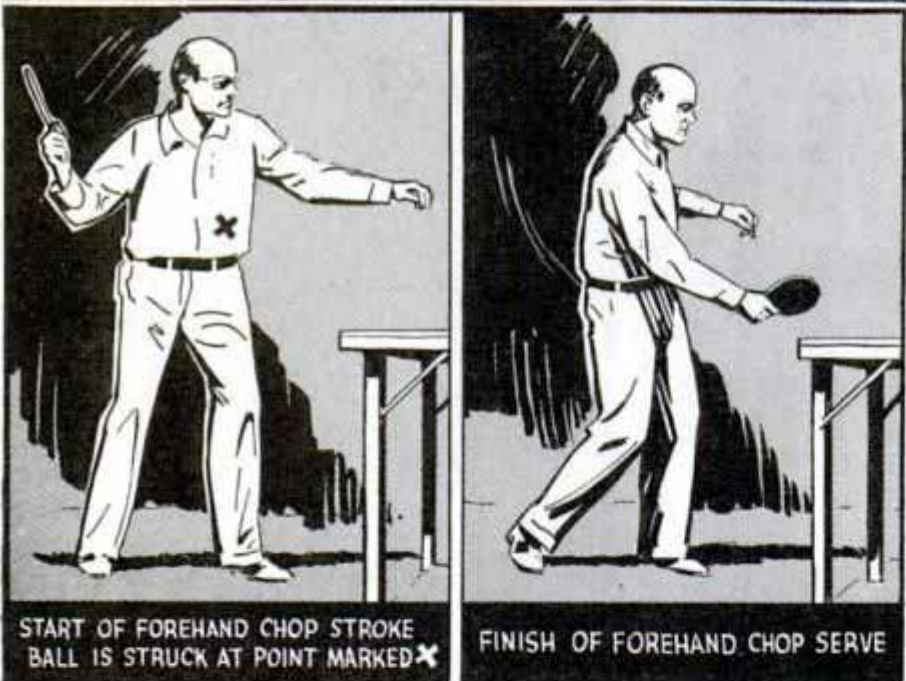

The author, top, left, illustrating the tennis grip. Note position of index finger on blade and that hand presses against the throat

Before telling you how to make spin and trick shots, I want to urge you to adopt the so-called "tennis" grip, the most natural and effective way to hold the racket. The winning shots and most of the trick shots are learned quicker and can be executed more effectively if this grip is used rather than the old-fashioned "penholder" method, still seen frequently among novice players. Also, use a racket surfaced with pebbled rubber which will give you better control and provide the means of imparting added English to the ball. Wooden and sandpaper rackets, of course, are still available.

We are now ready to deliver some fancy spin serves to make your receiver sit up and take notice. Let us first try the right-to-left sidespin service, so named because the stroke starts from the right side of the body and winds up on the left. Take a position a foot or two behind the table. The ball is held in the fingers of the left hand approximately waist high. The racket is held outstretched in the right hand and to the right side and the blade of the

will fool the other fellow and enable you to return safely spin shots directed at you. All this may give you the impression that such shots are difficult to learn. Such is not the case. Many of them are very easy to master and it will surprise you how simply you can outwit your unsuspecting adversary and win point after point. Spin is part and parcel of the modern game and one of its greatest fascinations. Besides no one can become proficient without understanding the underlying principles.

racket must be at right angles to the table. Now quickly draw racket and ball together, releasing the ball when the racket reaches the center of the body. As the hands cross one another in delivering the stroke the left should be in front of the right. Get plenty of zip into the shot and keep the blade of the racket upright through the entire sweep of the stroke. This serve will impart violent sidespin on the ball and unless the receiver realizes what you are doing the chances are he will return

the ball clear off the table to your left side. This will score a point for you and should give you a kick if you enjoy outsmarting your opponent in any game.

The twin to this is the left-to-right sidespin serve. In this instance, deliver a backhand sidespin serve which starts on the left side and finishes on the right. The ball is held in the fingers of the left hand well out in front of the body. The racket hand lies across the

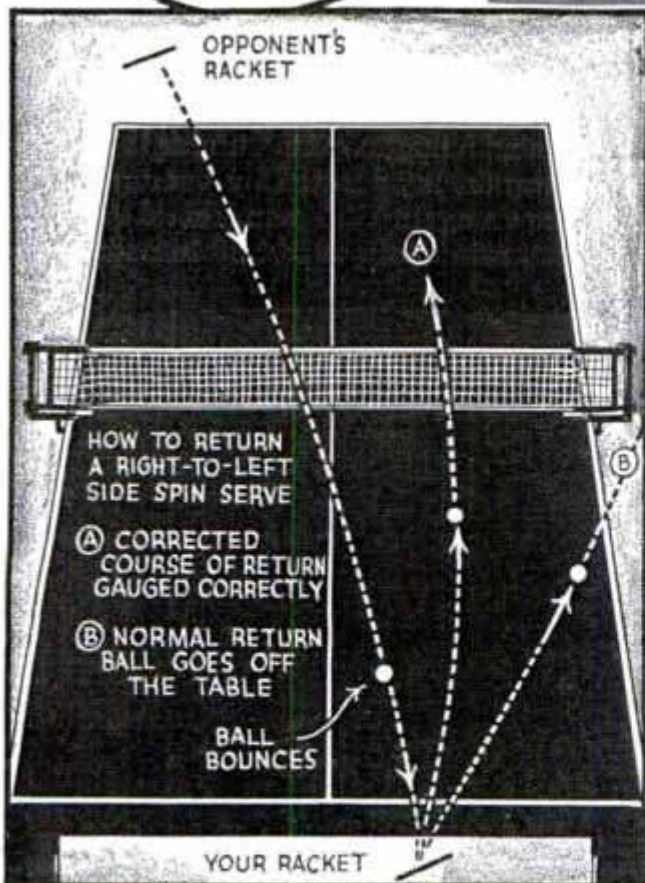
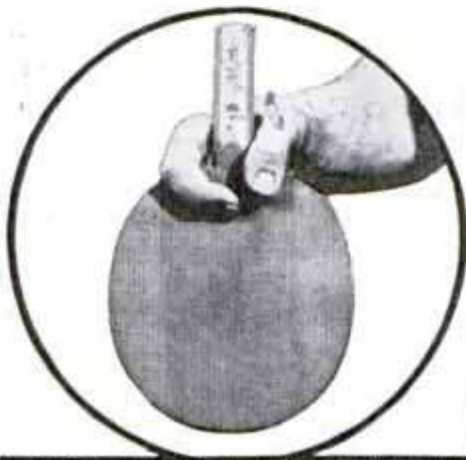

Top, the old-fashioned "penholder" grip, left, as compared with the modern tennis grip

body with the racket about opposite the left hip. Draw the right arm quickly to the right and release the ball just as the racket crosses the middle of the body. This action will give you a powerful sidespin which your opponent most likely will return off the table, this time to your right side. Practice these two sidespin serves until you can put them on the table every time and at the same time put a lot of stuff on the ball. Then spring them on your friends and watch their faces.

But suppose your opponent springs these spiny sidespin serves on you. Are you going to be caught napping? Not if you follow this simple rule. Be sure to aim your opponent's service to the side of the table from whence the serve started. In other words, push the ball back in the direction opposite to that which your adversary's racket moved in slicing the ball. If it started from his left side, aim your

(Continued to page 148A)

Wind Tunnel Blows a Storm to Try Wings of 'Flying Flea'

see no. 1935-648

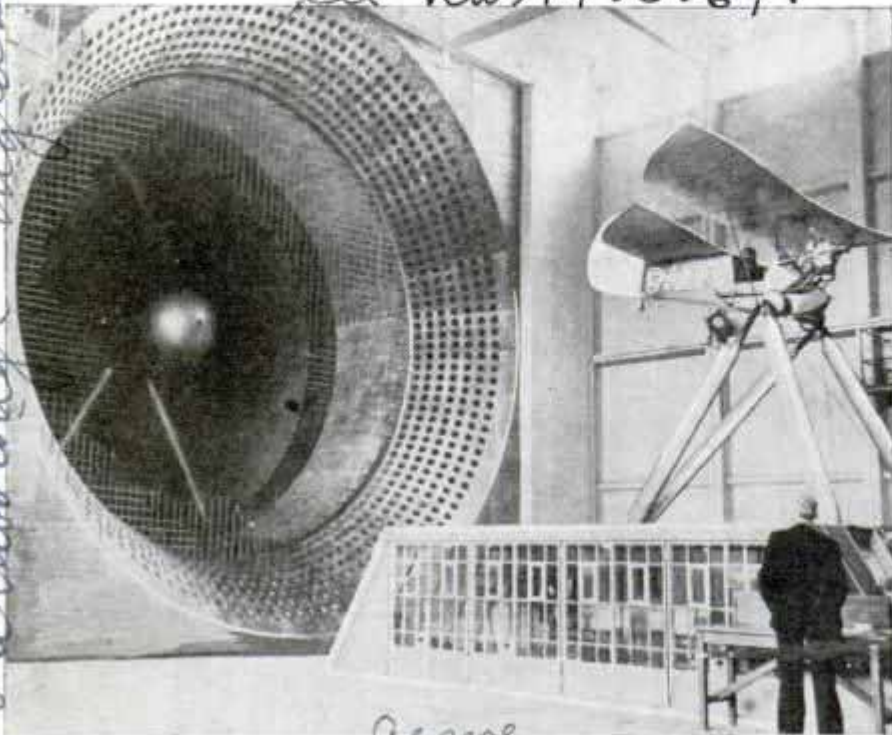

Pilot puts tiny "flying flea" through paces under buffeting of stiff winds from air tunnel to test its airworthiness

So small that it was completely dwarfed by the giant wind tunnel, a plane called the "flying flea" recently was subjected to severe tests to prove its airworthiness. The ship, with a pilot in the cockpit, was mounted in the center of the air channel. Then the velocity of the wind stream was increased steadily until the little ship rocked and quivered, as though in a storm. In comparison with the wind tunnel, the plane appeared almost a toy.

will be a basic factor in future stratosphere flying, he predicts. While air cooling is important for hot weather, the greatest benefit from air conditioning, he asserts, comes in winter through proper humidification of the air. Dining rooms on some modern steamers already are air conditioned, and Mr. Carrier believes that entire vessels some day will be thus treated. Then portholes may be replaced with false windows decorated with artificial light, he hazards.

Windshield Cleaned by Jets of Water While Driving

Controlled by a button on the dashboard, an automatic windshield washer will keep the glass clean while driving. Two small chromium-plated nozzles mounted on the cowl just in front of the windshield wipers are the only external parts, the glass jar used as a reservoir for clear water being mounted under the hood. The fountain is operated by vacuum, two jets thrown against the windshield removing dust, rain spots, mud and insects.



Spray of clear water from jar under hood cleans windshield at touch of button on dashboard

Ships Without Portholes Seen in Air-Conditioned World

Office buildings without windows in the lower floors and ships without portholes are predicted for the air-conditioned world of the future by Willis H. Carrier, known as the "father of air conditioning." Double windows or a special type of double glass will replace ordinary windows as air conditioning becomes general, and the industry will bring comfort to hospital patients and to sufferers from hay fever and pollen asthma, believes Mr. Carrier. The cabins of airplanes already are air conditioned for comfort and such conditioning

at Royal Aircraft Establishment Farnborough England

F1139

Carrier Corp. Newgreen

Price Products Corp. 817 Washington

7 1050.

Washington, D.C.

Sun's Rays Harnessed to Run Steam Engine

One of man's great ambitions—to harness the sun to a steam engine—has been achieved. Dr. C. G. Abbot, secretary of the Smithsonian Institution, has developed a solar heater and demonstrated that it would operate a one-half horsepower steam engine with sufficient efficiency for commercial purposes. The sun's rays are his fuel. Caught in three parabolic cylindrical mirrors of sheet aluminum, the rays are reflected in high concentration upon tubes of Pyrex glass. Passing through two concentric tubes of glass respectively one and one-fourth and seven-eighths inch in diam-

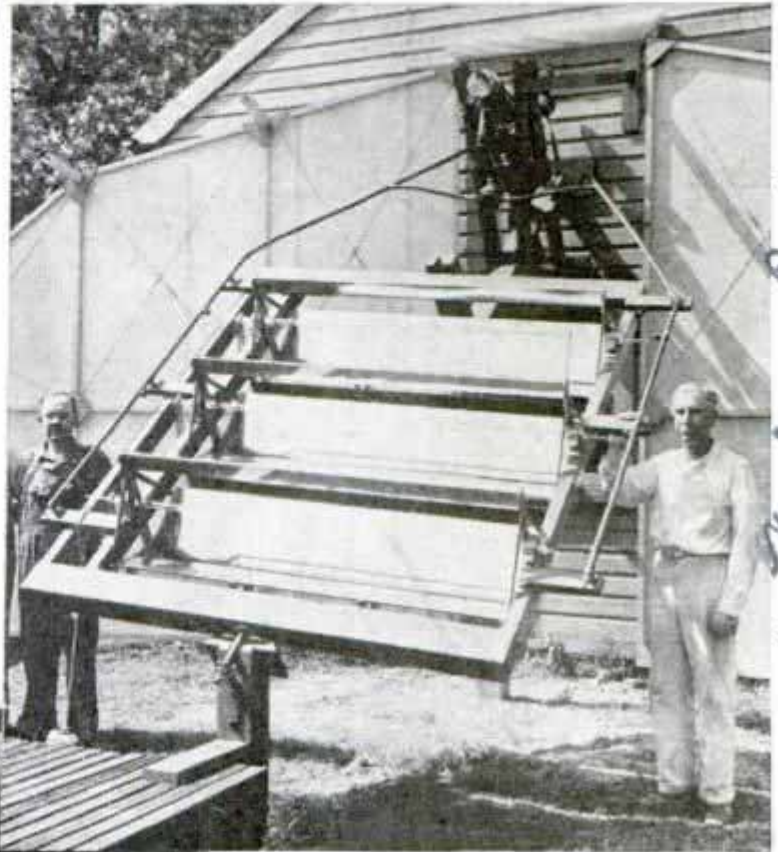

Top, aluminum mirrors focus sun's rays on tubes containing liquid which absorbs heat, flowing through pipes at side to boiler where steam is generated. Left, Dr. Abbot and aides with solar heater

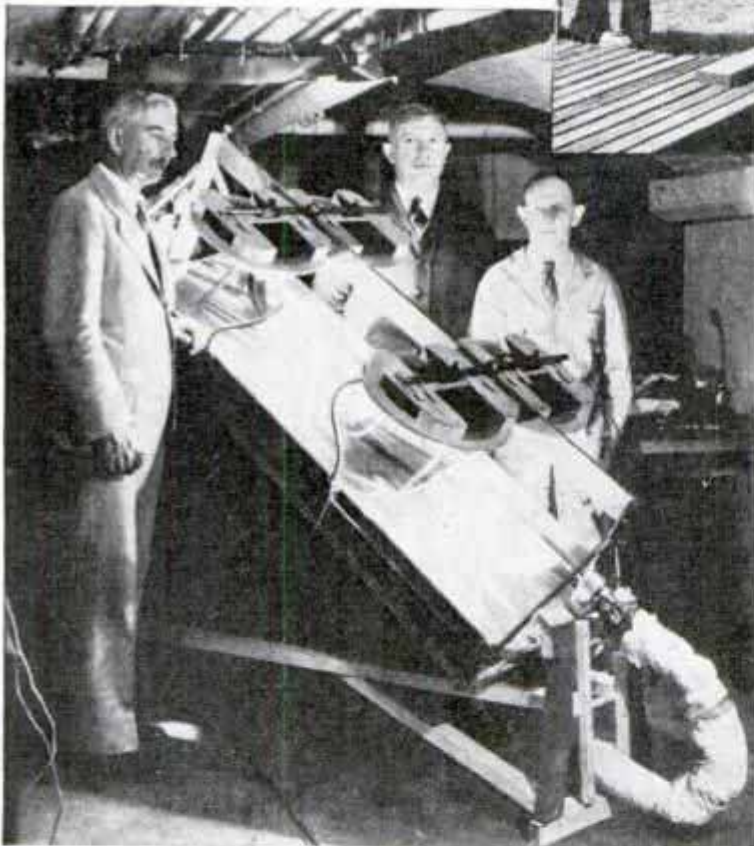

concentric tubes a vacuum is maintained so that the heat of the liquid is retained. Superheated, this chemical is circulated through pipes to a boiler where it generates steam. Experimentally, this solar heat engine had an over-all efficiency of fifteen per cent in producing steam power. Dr. Abbot believes the time may come when, with coal and oil supplies dwindling, sun power may become essential. Even with the apparatus available today, he says, the sun can be harnessed for cooking, refrigeration, evap-

eter, the rays reach a central one-half inch Pyrex tube which is metal plated on top and contains a black chemical, a chlorinated diphenyl compound to which a small amount of lampblack is added so that the liquid absorbs virtually all the sun's rays. Although liquid at ordinary temperatures, it still does not boil or flash at 662 degrees Fahrenheit. Between the

oration and small power plants. Ranches and communities in cloudless regions are manifesting interest in development of sun power.

☐Inquiries as to makers of articles described in Popular Mechanics, will be answered by our Bureau of Information upon receipt of return postage.

Photo from Kaufmann & Fabry Co. 425 W. Washington Chicago.

Handwritten notes at the bottom of the page, including "Photo from Kaufmann & Fabry Co. 425 W. Washington Chicago."

"COURTS"

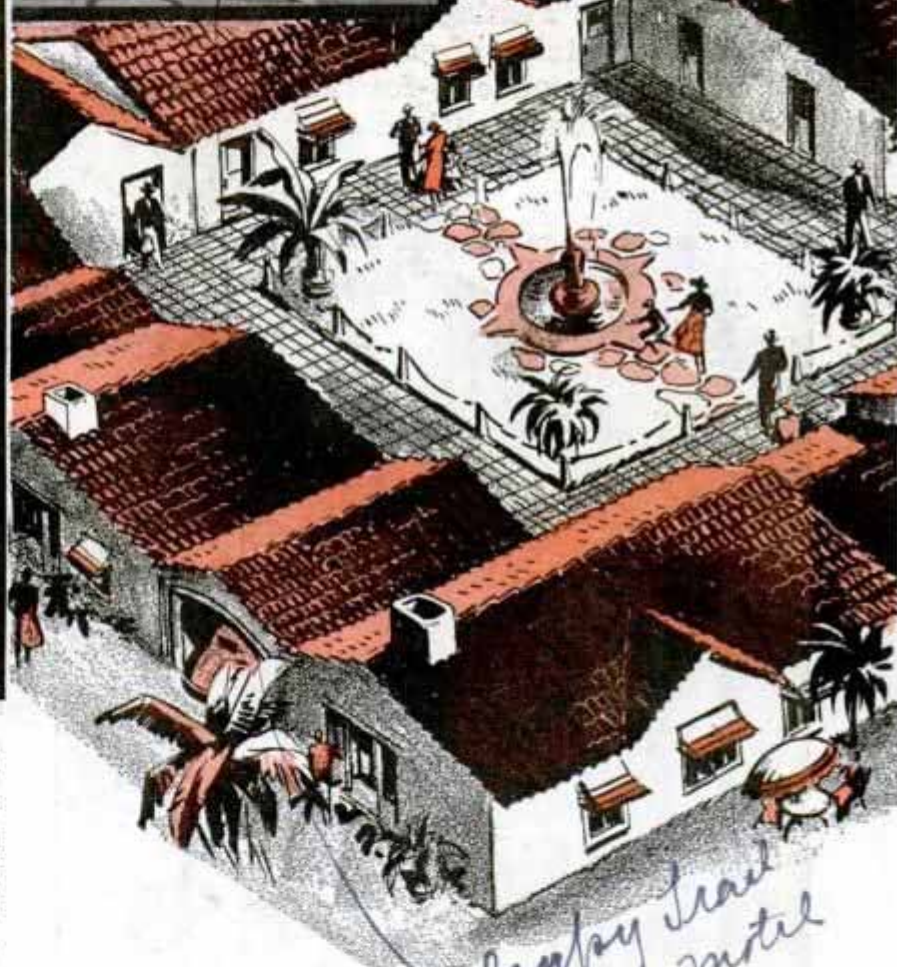
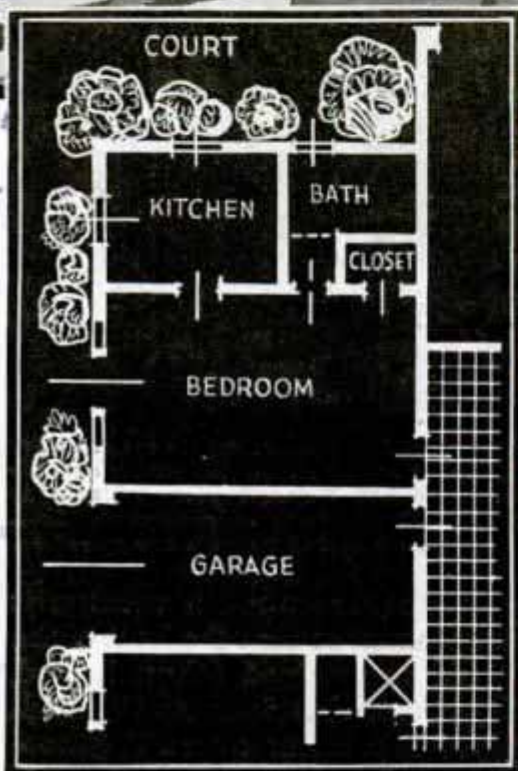

Drawing showing ideal arrangement for motor court and layout of one unit. Above, lobby of a Pasadena court

YOU can see the world through a windshield today and live in your own private home each night while you're doing it. Not the dwelling you started from, of course, but one offering similar comforts, luxuries and privacy.

You'll find these overnight homes in motor courts, and if you've never spent a night in a court cottage, a pleasant surprise awaits you. The motor court is a recent development of the motor age, an individual type of accommodation designed specifically for motorists, entirely unlike any form of "night lodging" heretofore available.

It's not a tourist park, it's not an auto camp and it's not a hotel, although it in-

cludes some features of each. It's a collection of miniature homes clustered around a central service and administration building and combines the natural beauty of a park setting, the freedom and informality of an auto camp and the comforts and luxuries of an up-to-date hotel.

You'll find them today in or near the larger cities and towns west of the Mis-

*United Motor Courts 3230
Hollywood Ave. Santa Barbara, Calif*

*2896
James Campbell*

Esperanza Motel

offer **Luxury for MOTORISTS**

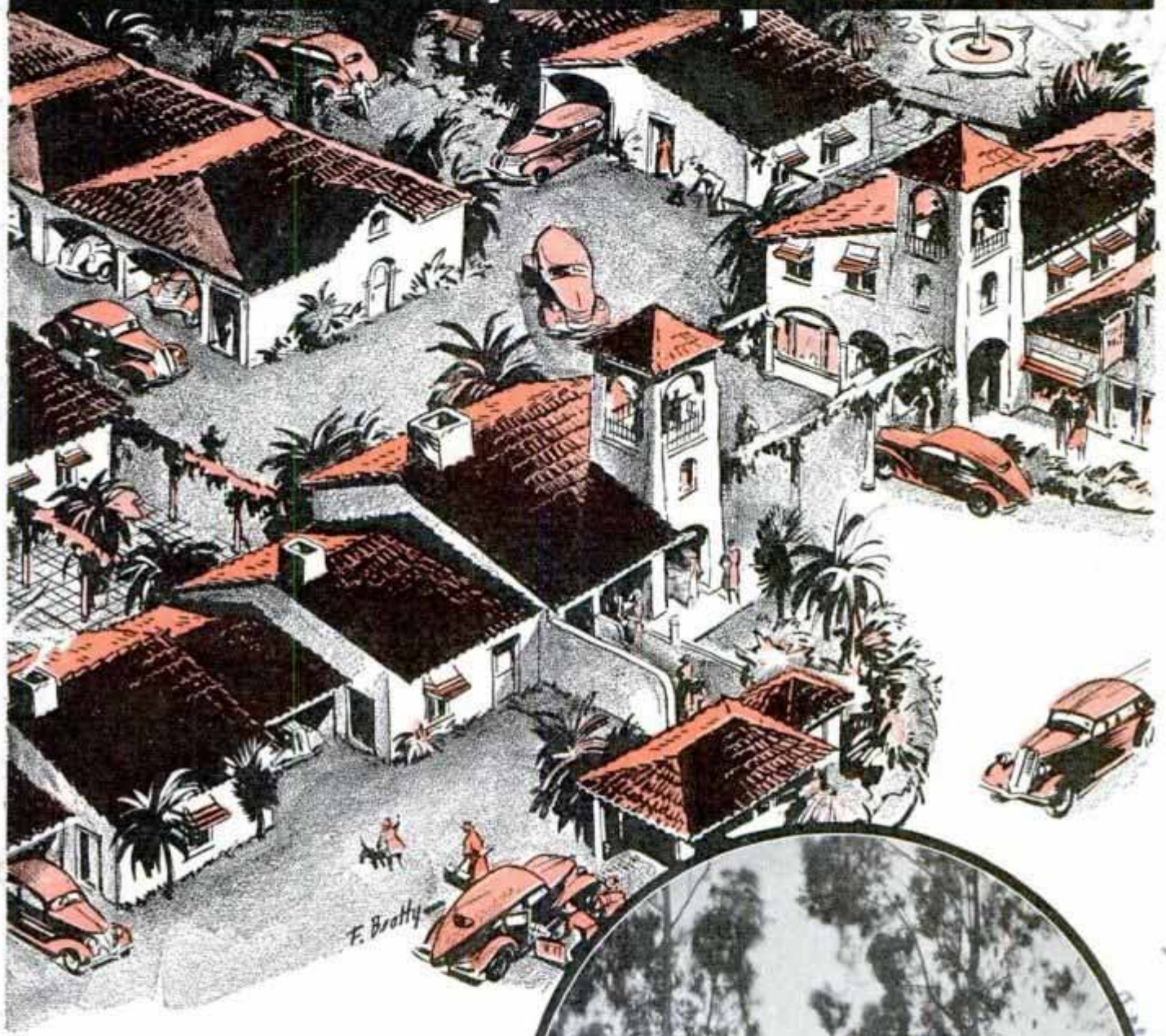

issippi and through the southwest. Tomorrow you are likely to find them dotting the highways throughout the country for the idea is rapidly spreading eastward.

They are solving a problem that motorists have wrestled with ever since the first adventurous driver sallied forth in a horseless buggy, a pair of goggles, a long linen coat and a cloud of dust to conquer strange trails. This driver had only two choices. If he could afford it and could find one, he headed for a hotel and hoped for the best. If he couldn't, he camped out, cooked his meals in the open



Motor court in Santa Monica, Calif. Note the U-shaped court and the substantial construction of the individual cottages in this lodge

Proctor Motor 675

Vertical handwritten text on the right side of the page, possibly a date or reference number.

Real north eye
Real pass eye

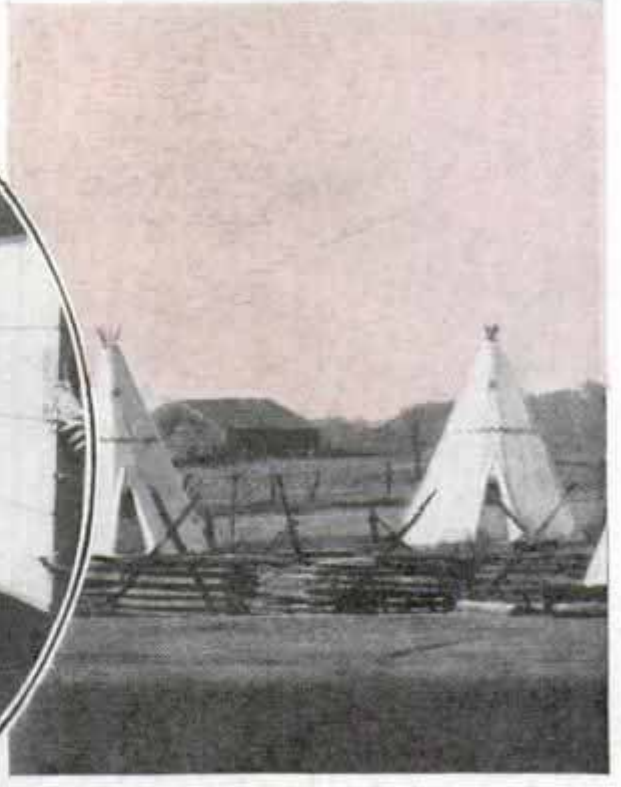

Registering in a motor court, a Denver court and bedroom of a court cottage



and slept in a tent or possibly in his car.

But despite the discomforts, more and more motorists persisted in "making trips." It got so more travelers were arriving by auto in some sections than by train. So cities and towns began laying out camp grounds equipped with water hydrants, outdoor ovens and crude comfort stations. They proved a boon to the camper, but didn't aid the chap who wanted shelter of a more permanent kind. Later home owners along traveled highways saw dollars rolling past their doors and "rooms for tourists" signs began to appear. Then some astute service station owners built a few wooden shacks, installed beds, tables and chairs and the first cabin camps vied with the other forms of accommodation.

Each had its own particular advantages and disadvantages for motorists. Hotels offered more comforts and luxuries, but usually were located in congested, noisy sections and were the most expensive type of lodgings. Camp grounds were least expensive and



Denver, Col
El Royale Motor Court
Denver, Ariz

Denver, Ariz

*Wigwam camp
3 mi. East of Horse Cave Ky.*

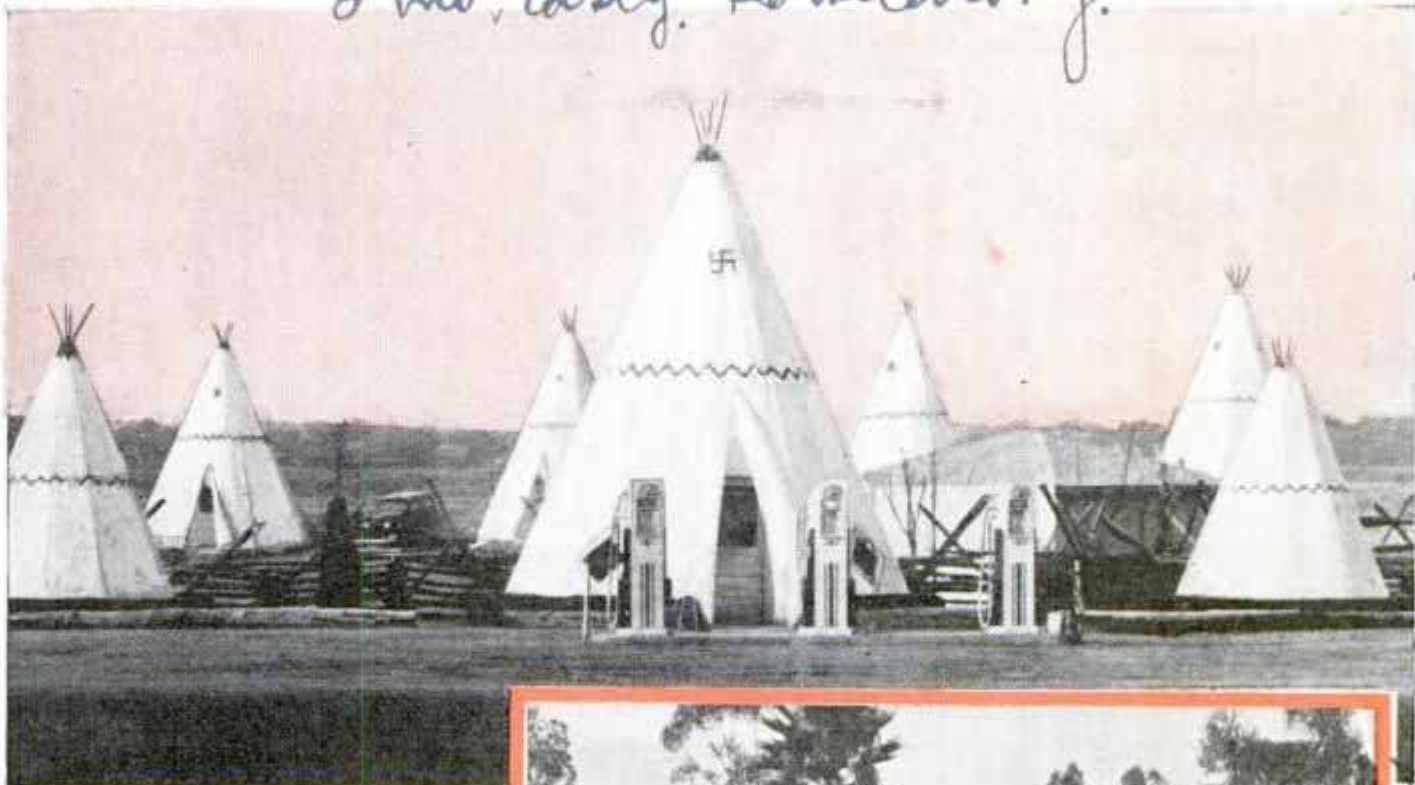

*Indians Trading Post
Highway Travel*



Motor court in Pasadena, Calif., and a Kentucky camp modeled after Indian wigwams. Each wigwam has hot and cold running water

sometimes free, but comfort facilities were limited. Some cabin camps attracted undesirable customers and the motorist lured by a "rooms for tourists" sign had no way of knowing in advance the accommodations offered in such a private home.

The motor court combines most of the advantages of the above types of accommodation and eliminates the disadvantages. It is a collection of individual homes, each particular home intended to meet the needs of some particular motorist. Let's drive in and inspect a typical court in California.

You'll find it set back from the highway among shade trees. You drive into a U-shaped court with a crushed stone or concrete driveway and stop at the office building. The owner-manager greets you and you walk along paths lined with trees, shrubs and flowers to one of the thirty or more cottages, each separated from its neighbor by a garage. The construction of the group in this particular state is likely to be stucco of Spanish or Mission architecture with tile roofs.

You enter a large living room with thick

carpet covering the entire floor. There's an overstuffed divan, two or three easy chairs, a desk, occasional tables, reading lamps, pictures on the wall, possibly a telephone and built-in radio. It's as comfortable and luxurious as any room in a good hotel. But this is only the living room. Adjoining it is a bedroom with comfortable twin beds, dresser, chairs, dressing table and a large closet. You note steam radiators in living room and bedroom, supplied from an underground central heating plant. The bedroom is carpeted too. Then there's a kitchen, completely equipped with table, gas range, electric refrigerator and you may find dishes and silverware in their places in the cupboard. Perhaps there's also a dinette with a folding bed tucked away in a closet to pro-

(Continued to page 118A)

'Umbrella' Loud-Speakers Are Free from Echo

Emb. W. & Schrage, 510 W. Calhoun St. Pasadena, Calif.

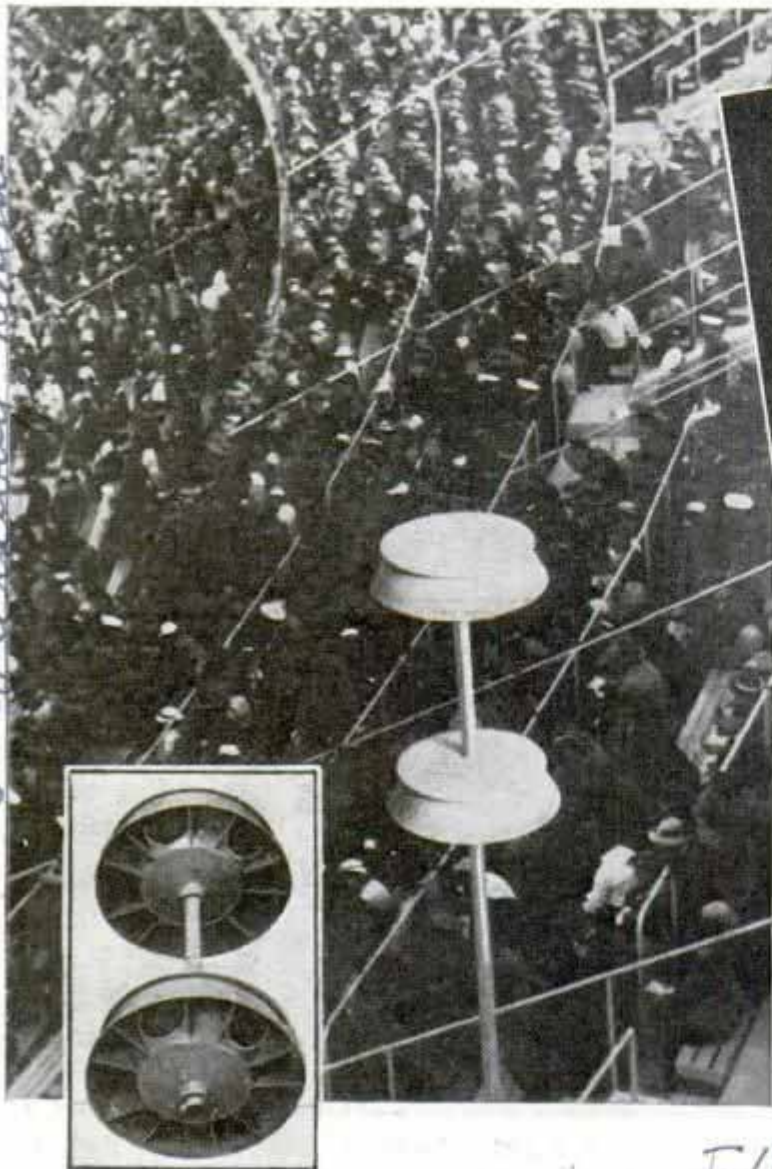

Left, view of Olympic stands with "umbrella" speaker installed. Inset, underside view of the speaker. Right, microphone wrapped in sponge rubber to reduce noise during broadcast of regatta

Free from echo effects and double sounds, a new type of loud-speaker was introduced at the Olympic games in Germany. The speaker somewhat resembles a double umbrella and its secret of eliminating echo lies in the wings and deflectors arranged inside the "umbrellas" so that the sound is radiated downward only. Five medium size speakers are installed in each of the two umbrellas, with each loud-speaker unit located to cover a certain sector of the grandstands. Another method of reducing noise in the public address system used at the Olympics was by means of a crystal microphone mounted with the pre-amplifier in a tube and wrapped in sponge rubber to exclude unwanted noise. This device was used by the announcer in the motor launch which followed the crews in the regatta.

F1017

No-Roll-Back Brake for Auto Works Automatically

Offered as a simple means of preventing the car from rolling backward on an incline, a new safety brake is designed for installation on the transmission main shaft behind the rear main bearing and in front of the universal joint. When the car is brought to a stop on a hill

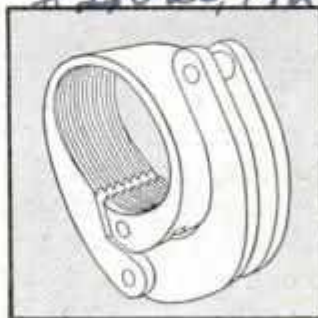

the brake keeps it at that point without any operation by the driver. A clamping ring locks the shaft, holding the car on any incline. The device is handy for start-

Pine St. Melinda Alexander, Va.

P. R. Wheeler, Cranif
P. R. Wheeler, Cranif

ing upgrade, since the driver is free from brake operation. The car is placed in gear, as usual, and started forward when the driver removes his foot from the clutch. Shifting into reverse is accomplished as usual, the brake releasing automatically. The brake is enclosed in a housing which is a part of the transmission housing or which is secured to it. It runs in a bath of oil.

301 Richmond Road

Steering wheel cover Co

F1037
Auto-Wheel Cover Prevents Hands from Slipping

Another contribution to motoring comfort is the cotton jacket for the steering wheel. Not only does it take the chill off the wheel in winter, but it is cooler in summer driving, absorbing perspiration and preventing the hands from slipping. The steering wheel cover is made of a durable, washable cotton fabric.



White gloves are kept clean when the steering wheel is covered with a washable cotton jacket

Robot Engine Built in Japan Is Driven by Remote Control



Acme
Model streamline electric locomotive built by Japanese is understood to have an automatic braking mechanism and remote-control drive

Automatic train control is understood to be a feature of a mysterious robot locomotive model built in Japan. Streamlined, but of a design unlike any conventional locomotive, the details of its mechanism have not been revealed. It is believed, however, that it will be operated electrically by remote control and will be equipped with a braking mechanism which will stop it automatically if the rails ahead become dangerous.

F1064
Photo Enlarged with Air Brush Guided by Electric Scanner

Photographic enlargements are made in watercolor or ink by "remote control" under a method just devised in England. The original photograph is placed on the surface of a revolving cylinder while a photoelectric "eye" scans it, transmitting electrical impulses which control air pressure operating a brush that paints the image on paper or canvas wrapped around a synchronous cylinder. No sensitized photographic paper is needed for reception. The photograph can also be copied or enlarged on any flat surface. This method may be adapted to long-distance transmission of pictures by telegraph or radio.

Developed by Jiro Aoyama
London, E. England
53 New Broad St. London, E. England

Keep Kloss 75c

Camera Aug. 19 16 1910

Photo Electrograph

Hummingbirds' Swift Wings Stopped by Speed Camera

#1043

Method of Photography developed at Massachusetts Institute of Technology Cambridge Mass

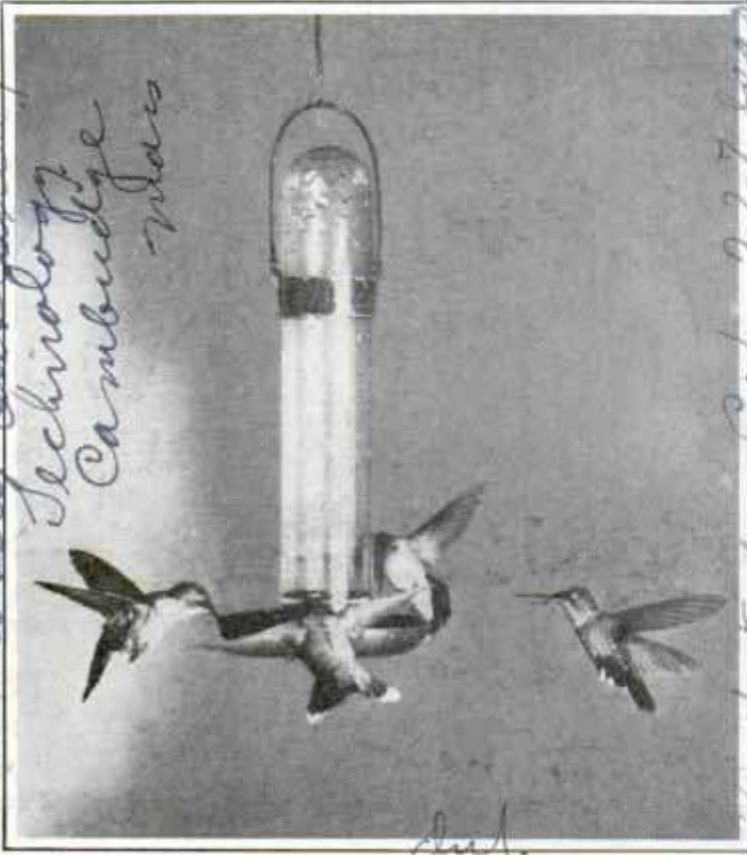

Hummingbirds hovering around vial of sweet liquid stand still as camera shutter opens for one hundred-thousandth second

Only the ultrafast eye of the speed camera can stop the throbbing wings of the hummingbird as if motionless in air. An exposure of one hundred-thousandth of a second resulted in a remarkable photograph of four ruby throated hummingbirds hovering around a vial of sweetened fluid. Although the wings of the tiny birds were beating nearly sixty times per second, the speed camera stopped the action.

Albright, etc. Grand Island 22508

Window with Double Glass Aids Air Conditioning

#1034



Designed for use in homes equipped with air-conditioning apparatus, a double-glass window with a three-fourths inch dead air space is now on the market. Heat losses through windows

are said to be reduced more than fifty per cent and condensation and frosting are eliminated, under normal conditions. The window may be removed to permit cleaning of the inner glass surface.

Battery That Outlasts Auto Protected by Spun Glass

#1042

Carrying the guarantee that it will last as long as you own your car, a "lifetime" automobile battery is being introduced this fall. The secret of its claim to long life is a mat of spun glass that protects each positive plate. Adopting a principle that has been used in giant electric power plants of submarines, locomotives, dreadnaughts, traction motors and industrial plants for fifteen years, the flexible web of porous glass sheaths the plate and prevents tiny particles of lead from dropping away. In the ordinary battery, continual vibration and wear attack the active lead, breaking it down, weakening the power of the battery and shortening its

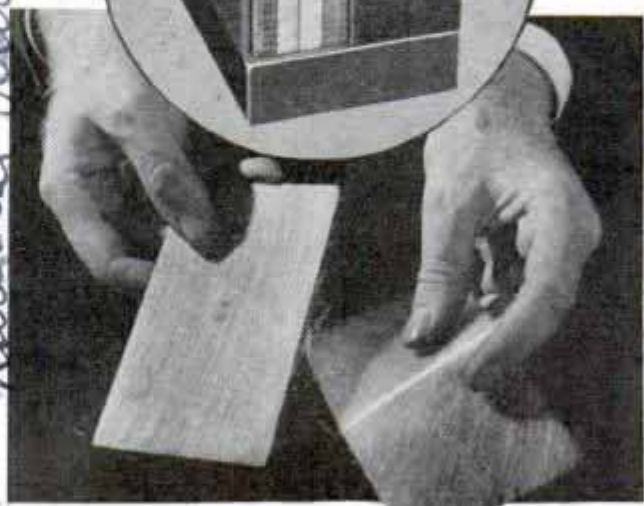
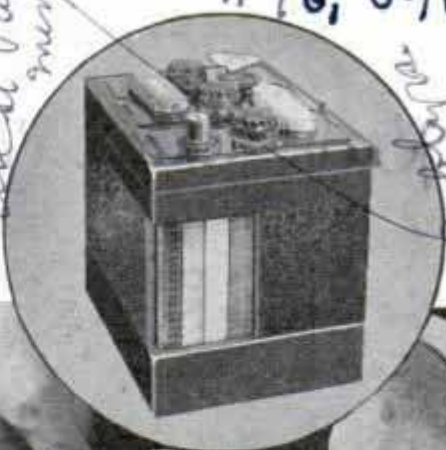

Cutaway view of battery with positive plates wrapped in spun-glass mats, shown below

17 28 Parkway National Battery Co. Lowell Mass

#16,548

1936 29th Street New York City

life. In the new type the glass permits the electrolyte to reach the positive plate freely, in fact, aiding in its equal circulation to all parts of the plate, and offering no resistance to the current. Since less space is required for deposit of sediment at the base of the battery, there is more room for plates, and the plate area is twenty-two per cent larger than a comparable battery of the usual type. The lifetime battery will sell for one or two dollars more than the ordinary battery.

1968
**Auto in Movies
 Offers Tips
 to Industry**

Containing many features which might be considered and possibly adopted by the automobile industry for incorporation into future models, a streamline car appears in one of the latest motion pictures. Its flowing lines result in a body with low wind resistance without sacrificing eye appeal.

47063.
**Television Turret Camera
 Sends Movies of Olympics**



Wide World
 Focusing its big eye on Olympic sports events, television camera transmits moving picture of international games to spectators miles away

Bleacherites ten miles away from the Olympic stadium saw the sports events by television. Mounted on a movable pedestal like a turret gun, a television movie camera trained

its giant eye on the international games and transmitted the action pictures to distant bleachers and to a projection room in the German post-office headquarters. Done experimentally, the reception was not always clearly defined.

Commercial use of explosives in the United States totaled 30,349,819 more pounds in the first half of 1936 than during the same period of 1935.

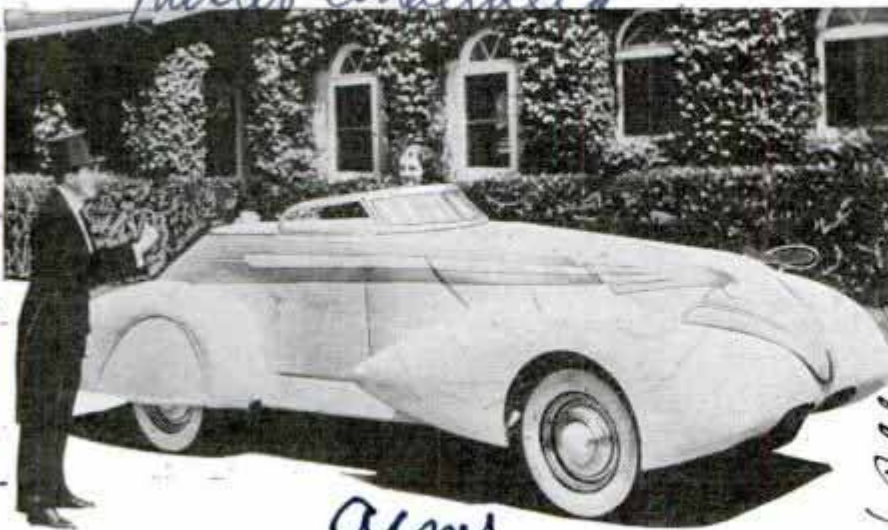

Acme
 Hollywood's ideas about how an automobile should look are incorporated into this car which was constructed for a recent movie

see...
103 Park Ave New York
 Jack Haley. Betty Furness

1881

1144 S. Grandview St.
Los Angeles, Calif.

BUILDING a RIVER

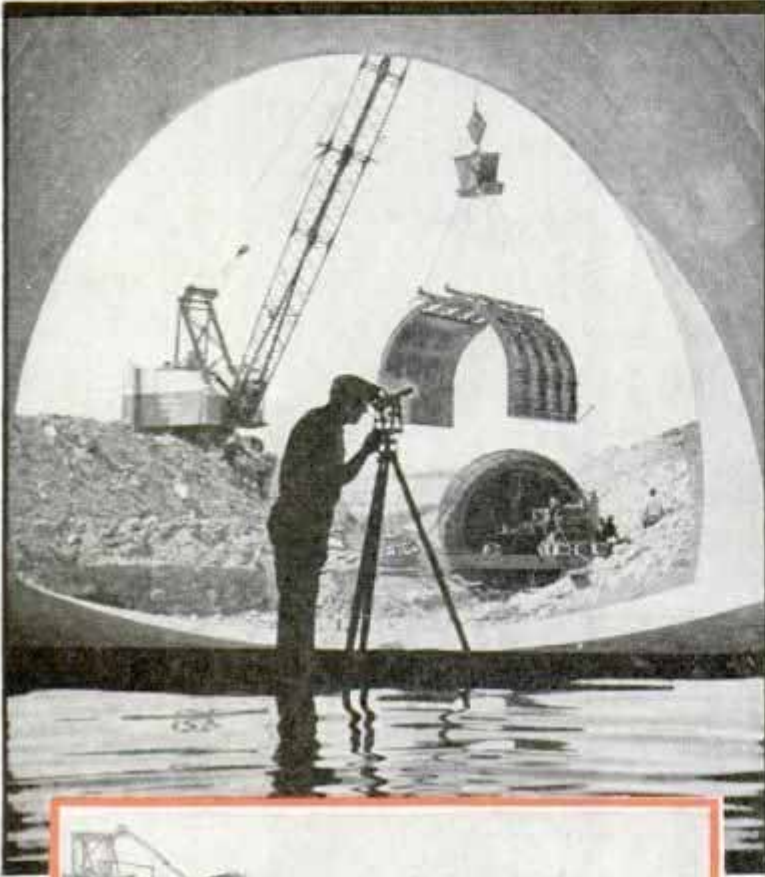

WATER, in southern California, means life. Its absence means parched vegetation, barren, thirsty soil, eventual death.

For years the area has waged a grim, incessant war against an encroaching desert with precious water transported more than 200 miles from the Sierras. That seemed a long distance to carry water, but the region contented itself with the thought that the Sierras offered an inexhaustible supply of the life-giving substance.

But a few years ago startled citizens of the south coast awoke to the fact that the area was outgrowing its water supply. Unless more water was found, the desert eventually would win, after all.

So southern California set out to find more water. A survey revealed plenty of it—in the snow-capped Rocky mountains. The Rockies are a long way from California, but nevertheless the snow of the Rockies will be running through Los Angeles faucets in a few years. The situation was met

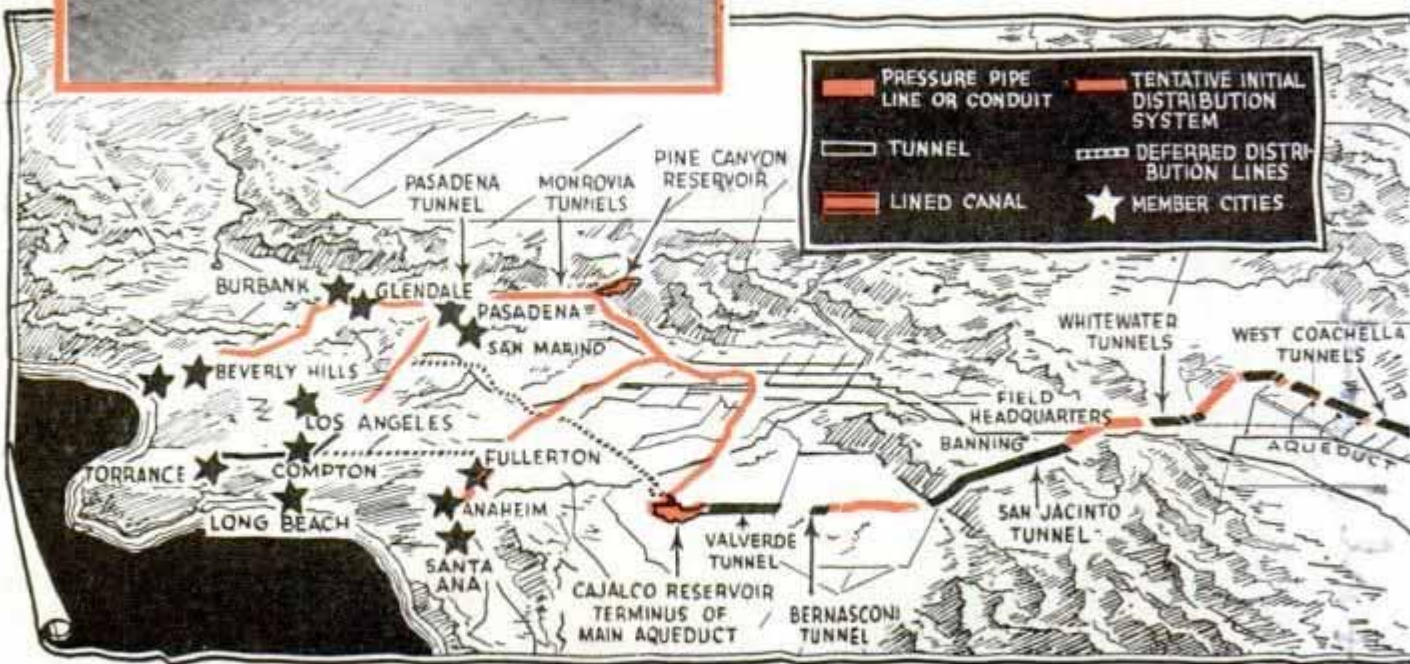

Top, engineer peering through level from interior of huge aqueduct conduit. Center, giant paving machine lining floors and walls of open canal. Bottom, map of the aqueduct route from Colorado river to coastal plain of southern California

7887

in the DESERT



by putting 9,000 men to work on the world's biggest aqueduct project, creating an artificial river that will connect the Colorado river with Los Angeles 300 miles away. Stretching across a land of rattlesnakes and cactus, over desolate desert wastes, piercing mountains, and tunneling un-

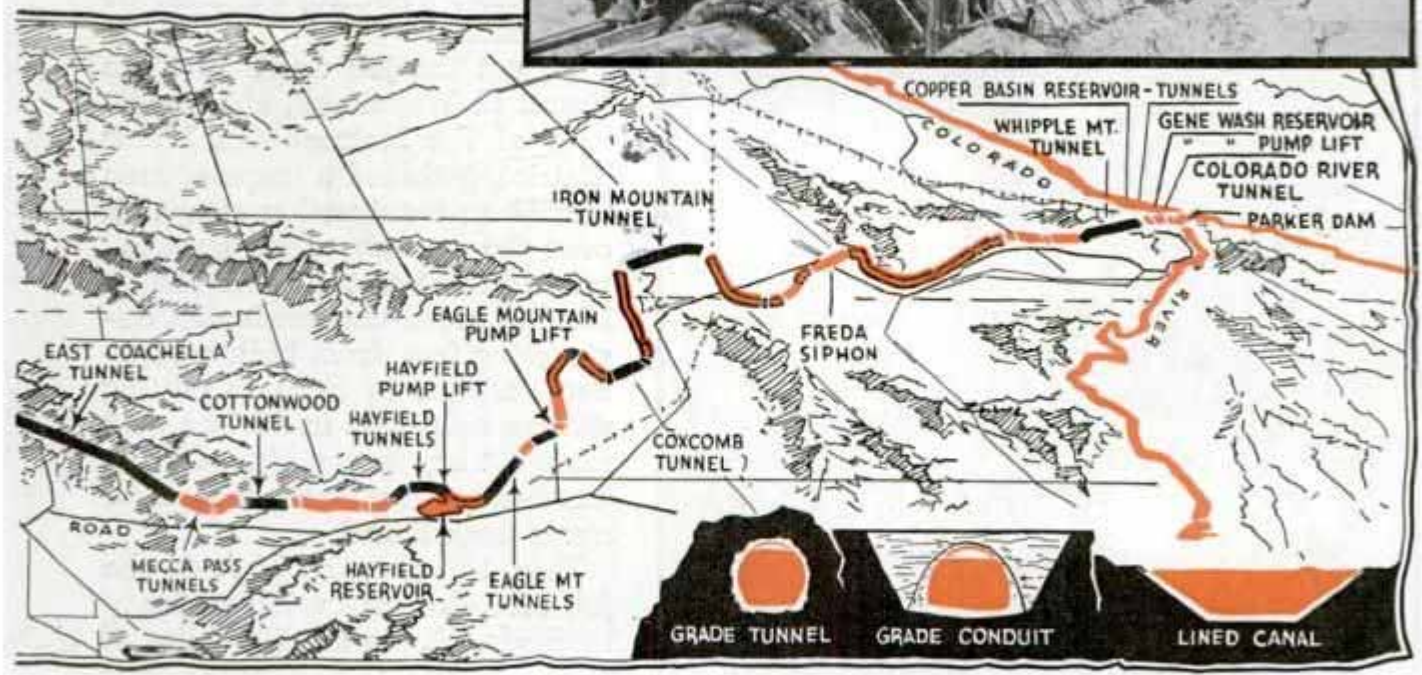
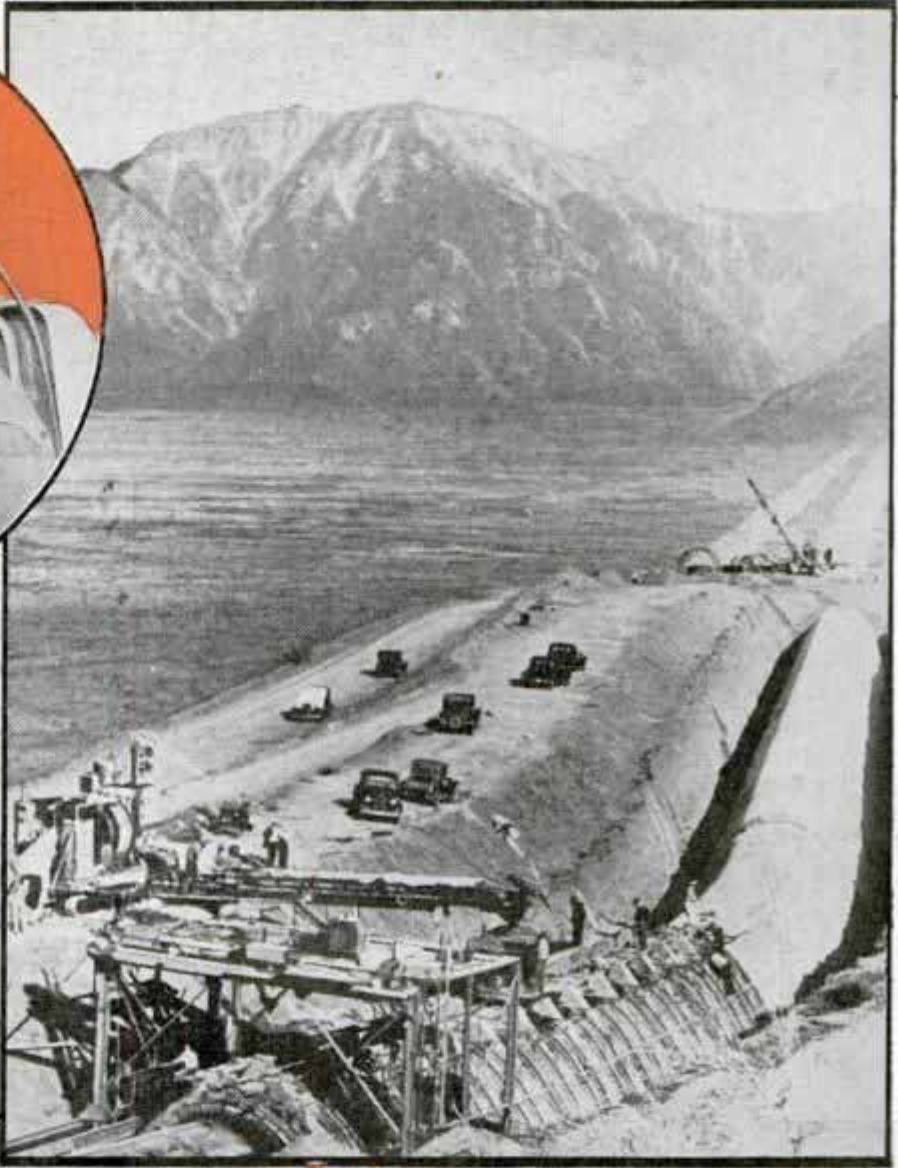

Top, left, member of tunnel rescue squad and his equipment. Right, like a great snake, the concrete conduit and the parallel road stretch out into the desert as thousands of men push forward with the greatest water-supply program in history

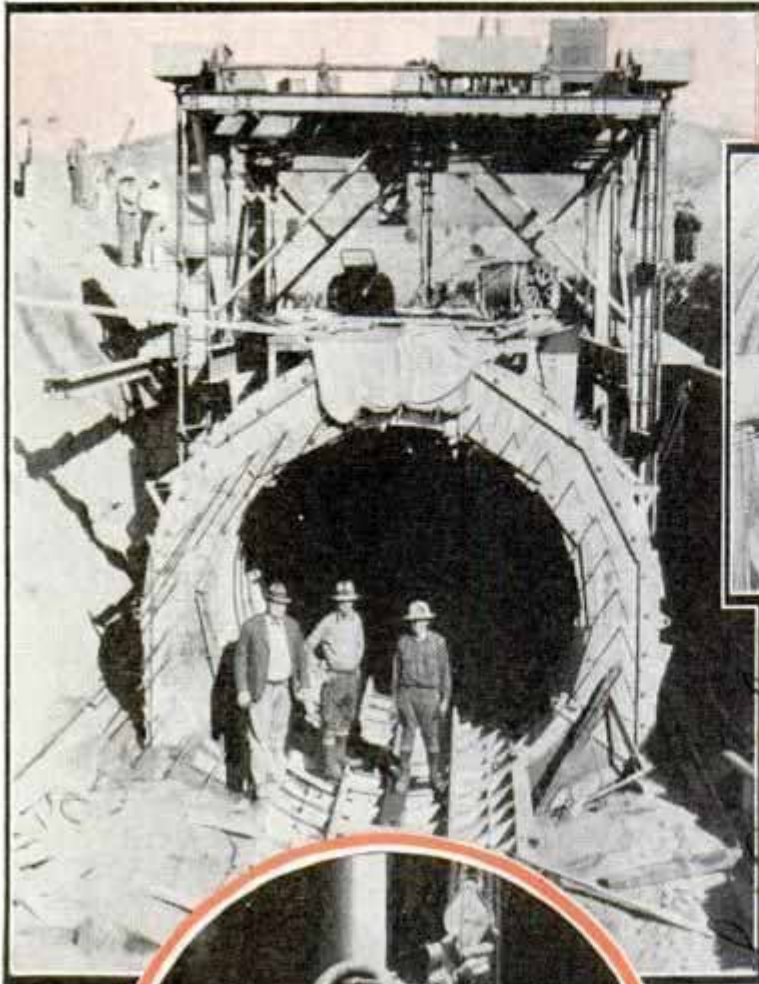

Left, end of siphon section. Right, "cherry picker" which enables cars to pass. Below, mechanical hands which pat concrete and wheeled concrete hopper

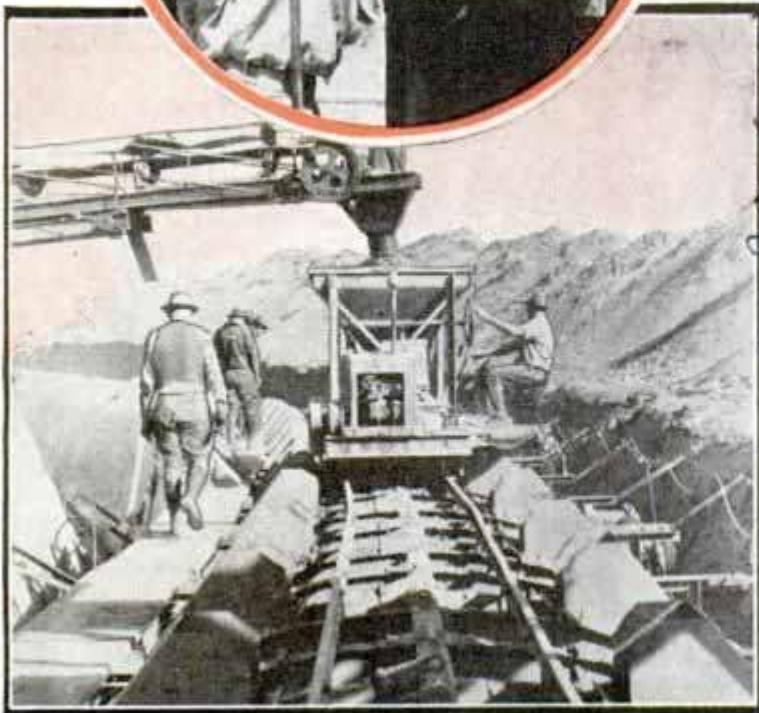
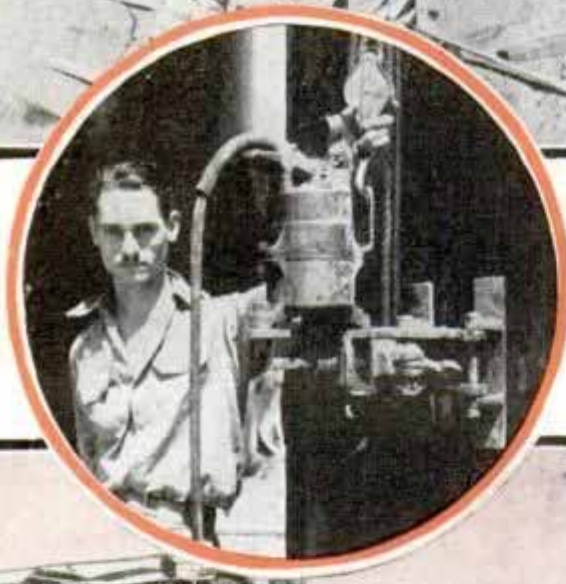

der small streams, the aqueduct will have a capacity of more than one billion gallons per day.

Ordinarily, a job like this would take a generation. Los Angeles wants the water three years from now, six years from the time work was started. Keeping up with this high-pressure schedule means breaking construction records. Unexpected difficulties must be handled without losing stride. Underground rivers that flood tunnels, sand that pours through the cracks in sheet piling like water, excessive temperatures above and below ground, all must be anticipated.

To get the job done in time Frank E. Weymouth, chief engineer of the Metropolitan Water District, gathered a corps of men famous in construction camps all over the country. Each superintendent can boast of having had a hand in some unprecedented engineering feat, from building spidery bridges in Peru to cutting shafts a mile deep in African gold mines. They are a tight-lipped, hard-working crew who have never been licked.

Even this gang couldn't do the job on schedule with ordinary methods. There are 108 miles of tunnels in the project and most of them will be large enough to handle a train. In the longer tunnels

J. G. W. Shud. Los Angeles

such as an eighteen-mile bore that follows the backbone of the Coachella range, the engineers are pushing the work from as many as ten faces at the same time by means of elevator shafts leading from the surface to the grade of the bore.

Machinery takes the place of hand labor in modern tunneling. Drilling machines and dynamite break down the face of the rock, traveling belts and electric shovels load the broken material on cars, and tiny electric



Welder on aqueduct project and lowering form into place prior to pouring concrete

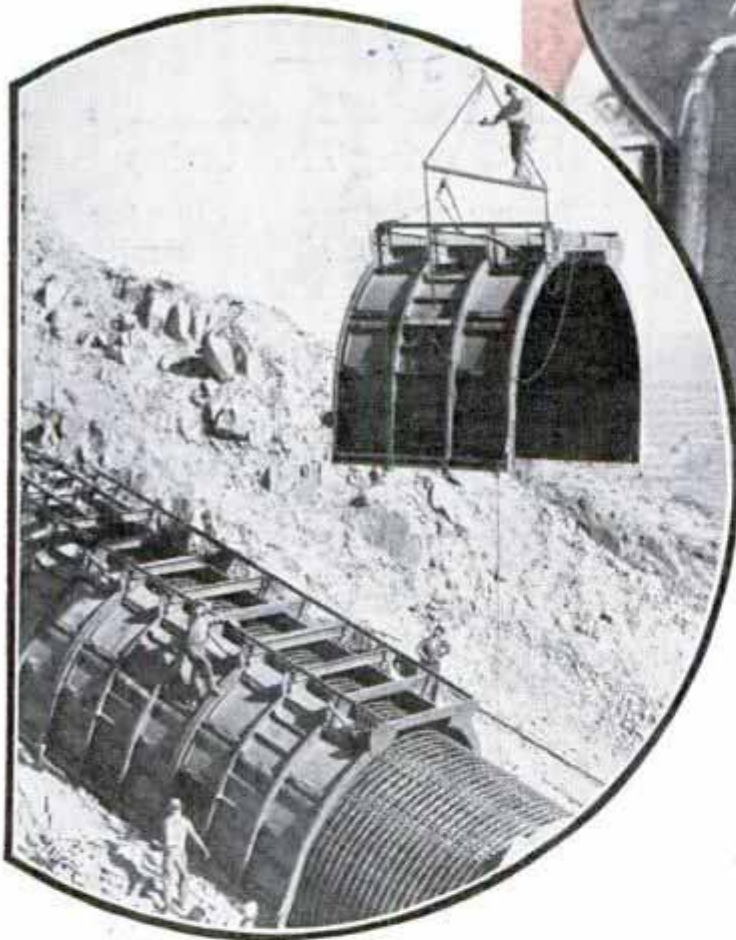

structure that closely resembles a caisson.

When ordinary machines won't do the work the engineers invent something new. One is the "grasshopper," an elevated track from which empties are dropped for loading. Another is a huge ungainly structure that looks like a bridge turned upside down, a traveling "paver" that places a smooth concrete lining on the floor and walls of the open canals used for crossing parts of the desert. The paver lines 1,000 feet of canal a day. A canal trimmer something like the paver cuts and smooths the canal walls.

On other sections the water is to be carried in long reinforced concrete conduits. Ordinarily, conduit is precast in sections, then assembled on the spot. On this job, it is manufactured at its perma-

(Continued to page 120A)

locomotives snake the cars out to the dumps. In one tunnel a battery of pumps is sucking up 15,000 gallons of water a minute to keep up with the inflow of ground water while the miners, clad in oilskins, seal up the tunnel walls with fast-hardening cement. In another tunnel leading through saturated strata of sand and clay the miners are working inside a

Floating Fire-Hose Monitor Is Controlled Like a Horse

Seattle Wash Fire Dept



Here is the monitor, creeping over the water while its operator ashore guides it with reins like a horse

Controlled with reins like a horse, a new fire-hose monitor creeps on the surface of the water to fight the flames under docks and near water-front buildings. It is propelled by the force of the water pumped through the hose. The device is expected to find wide use in port cities, since it provides a new means of reaching sources of fires which have been inaccessible to other apparatus.

turbine pump which transmits light oil to a turbine motor which delivers its torque to the drive shaft. The mechanism is contained in a compact housing which replaces the flywheel. After moving the control lever from neutral to high-speed forward position, the driver steps on the accelerator and the transmission automatically takes care of the gear movement. Acceleration at twenty miles per hour is double that of the conventional transmission, the rate gradually tapering off until at forty-four miles per hour engine and propeller shaft speeds are about equal. There is no mechanical connection between engine and rear wheels, so the car runs much more smoothly.

F1058

Bust Modeled from Sponge by Carving Thin Strips

Sponge is a strange medium for the sculptor, yet striking results can be obtained with it. Slicing sponges into wafer-thin strips and then overlaying the strips to form the contours, a Filipino sculptor modeled the bust shown in the accompanying photograph. It was shaped with only a photograph for a guide.



This bust was sculptured by cutting strips of sponge and laying one over another to form the contours

F1096 Gear Shifting Is Eliminated in Latest Transmission

Gear shifting and operation of the clutch are eliminated in an automotive transmission announced by Bendix. The device consists of an engine-driven hydraulic

*Bendix Products Corp
Bendix Division of Chrysler Corp*

*and I vor affordabl.
60 Fireboat's no-horner*

*Student
Clark Chicago
15-8 n.
speech*

Golfer Sights Green in Thirty-Foot Periscope

When hazards are mountain-high, a golfer really needs a periscope. There is one hole on the Aberdovey course in North Wales where the green, only 165 yards away, is quite out of sight and it's not safe to drive until you have peeked in the periscope to learn whether the foursome ahead has putted down and moved out of the way. The periscope is thirty feet high. Sand hills form the natural hazard that obscures the view from the tee.

Before teeing off on one 165-yard hole on a golf course in Wales you must look through this thirty-foot periscope to see whether the players ahead are still on the green, obscured by high sand hills. Right, a close-up of the view-finder

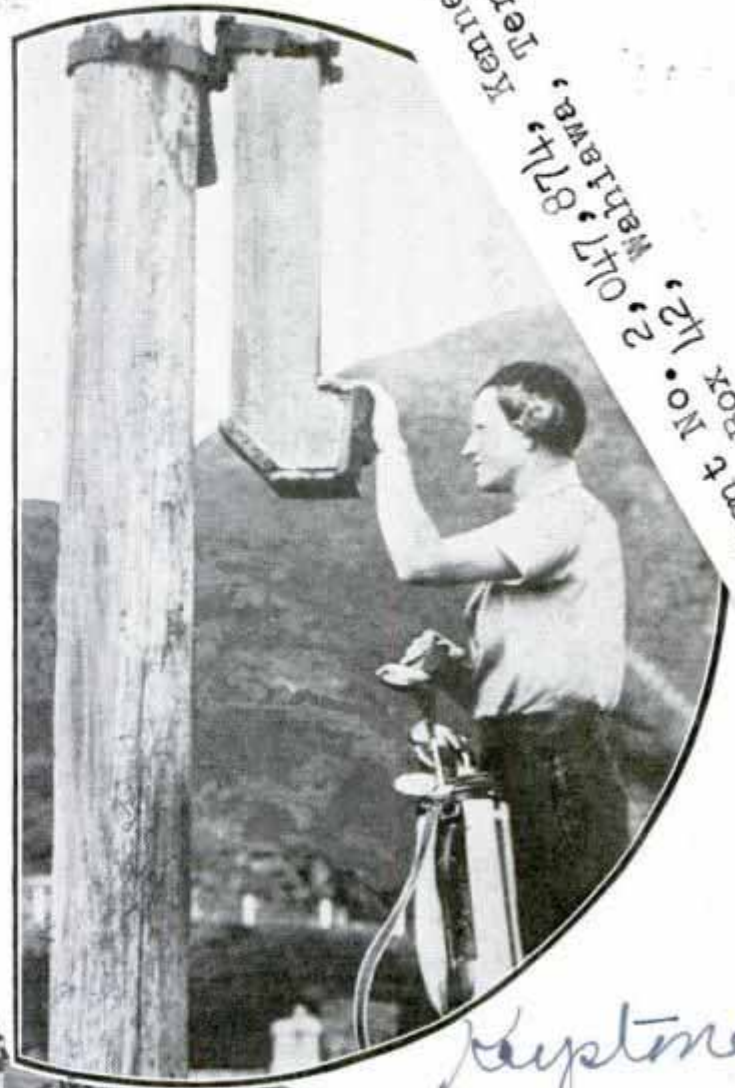

Patent No. 2,017,874, Kenneth R. Kerr
 Patent No. 1,201,787, Kenneth R. Kerr
 Patent No. 1,201,787, Kenneth R. Kerr
 Patent No. 1,201,787, Kenneth R. Kerr

Keystone

J 106 C

Curved Mirror on Auto Fender Gives Wide Rear View

Instead of the usual small, flat mirror inside the car, a deaf motorist at Washington has mounted a convex curved mirror on his automobile fender to obtain a wider circle of vision toward the rear. To the deaf driver, the unheard warnings of other cars, sirens and bells of ambulances and fire trucks are added hazards. The curved mirror on the left front fender gives him a clear view of the rear and eliminates the "blind spot."



No data

Mounted on left front fender of his automobile, this curved mirror gives deaf motorist a broad view of traffic to rear

Our Bureau of Information will answer questions regarding articles in this magazine, if accompanied by return postage.

Cond. Deal. L. Horse

Elbow-Handled Sweeper Dusts under Furniture

F1072



Elbow handle of this carpet sweeper drops almost to floor without making operator stoop

Without stooping, a housewife can tidy up floors beneath the furniture with an elbow-handled carpet sweeper. Its hinged handle automatically opens and closes according to the distance of the sweeper box from the operator, and the sweeper hugs the floor without extra pressure. The grip is curved, and rubber bumpers all around protect polished furniture. At its lowest position the elbow handle is almost parallel with the floor.

Pre-Shrunk Oil to Make Paint Is Discovered by Accident

Purely by accident, industrial chemists have discovered a way to "pre-shrink" oil used as a vehicle for paint. Raw oil shrinks in weathering, and if it can be pre-shrunk the paint should have longer life. The use of tung nut oil in paint has been limited by its tendency to solidify suddenly under high-temperature treatment. In trying to find a formula to prevent solidification, chemists hit upon a mixture of forty-five

per cent soy-bean oil with fifty-five per cent tung oil. During one trial 100 gallons of the mixture weighing 775 pounds were heated, then found to have shrunk to ninety-seven gallons still weighing 775 pounds. Accidentally, the research men had found a formula for pre-shrinking oil.

Tool for Cutting Sheet Metal Leaves Edges Smooth

Designed to cut sheet metal without distorting or stretching the edges, a new tool handles work up to sixteen gauge. It is used with a hammer. Holes of any shape and size down to two-inch radius in eighteen-gauge iron can be cut and the tool will cut smaller holes in lighter metal.

\$ 2.50 on market

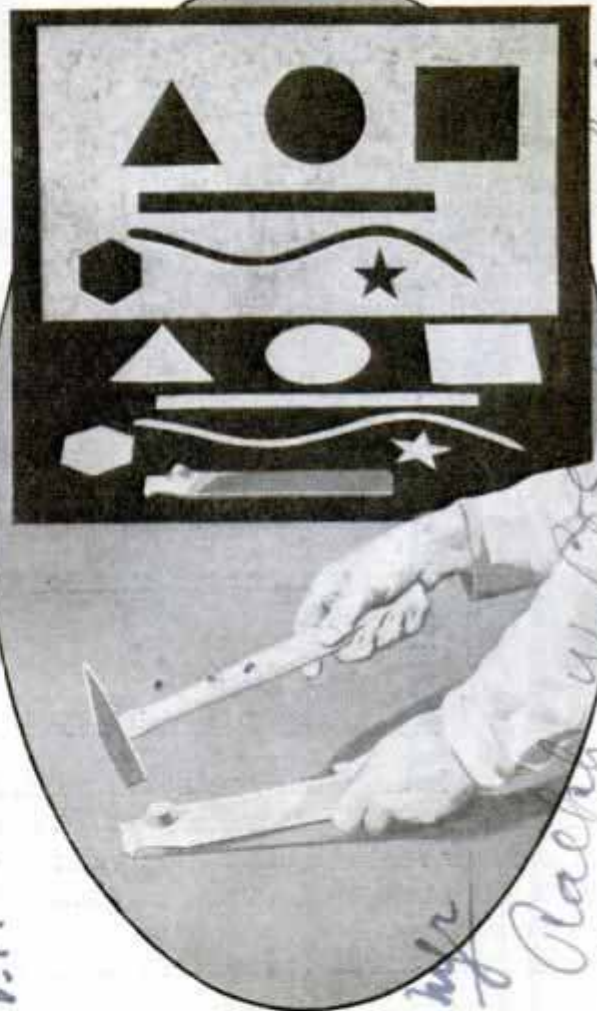

Top, some of the shapes which may be cut in metal with tool shown in use at bottom

either flat or formed sheets. Small pieces are clamped in a vise for cutting but larger pieces having sufficient weight do not require such handling. The tool is useful in shops working on auto bodies.

Science Service
20/365

F1102

Soy. paint

M. J. Jaggard and J. M. Gage. O'Brien Carmel Co.

White Carb.
Capt. A. H. Canton.

M. J. Jaggard

Insect Farmers Reap a Fortune in Butterflies

Ten thousand dollars for a butterfly! An English collector paid that for one rare tropical fly, the "Charaxes Fournierai," of which there are but two known specimens—and that is why butterfly farming is a profitable, yet little-known industry. Among the loveliest things in nature are their flashing, fluttering, brightly pigmented wings. They are coveted by private collectors, natural-



© London Daily Herald
Covering trees and shrubs to protect caterpillars while they feed and enter the chrysalis

flowers, herbs, vegetables, mulberry trees, scented rosemary, bayrose, beech, sycamore, even nettles and dandelions—whatever will please the fastidious palate of the caterpillar. At the proper time this "fodder" is collected in sacks and the caterpillars that thrive best on that particular diet are put in with the leaves. Twelve thousand swallow-tail butterflies are bred at one time, bringing enough income to pay the "farm hands" good wages. When the caterpillar starts weaving its chrysalis the farmer isolates it in a small "pen" to prevent spread of infectious disease. Another species is given a bit of bark, a matchbox or tin in which to await transformation. Others are

left in treetops which are completely swathed in huge bags to protect them from birds. A brilliant blue butterfly from the Dutch East Indies may bring \$300, and a gorgeous "morpho" from the Amazon tropics would bring a fortune if it could be raised in captivity. Instead, the only way they can be captured is by

nets in Brazilian treetops.

L. Neuman (owner)

*Colombene 29 Dec 1909
 (death, Mr. London England
 Wilkins, Esq.
 Bexley Kent
 David, Bexley*

With the SEA-GOING

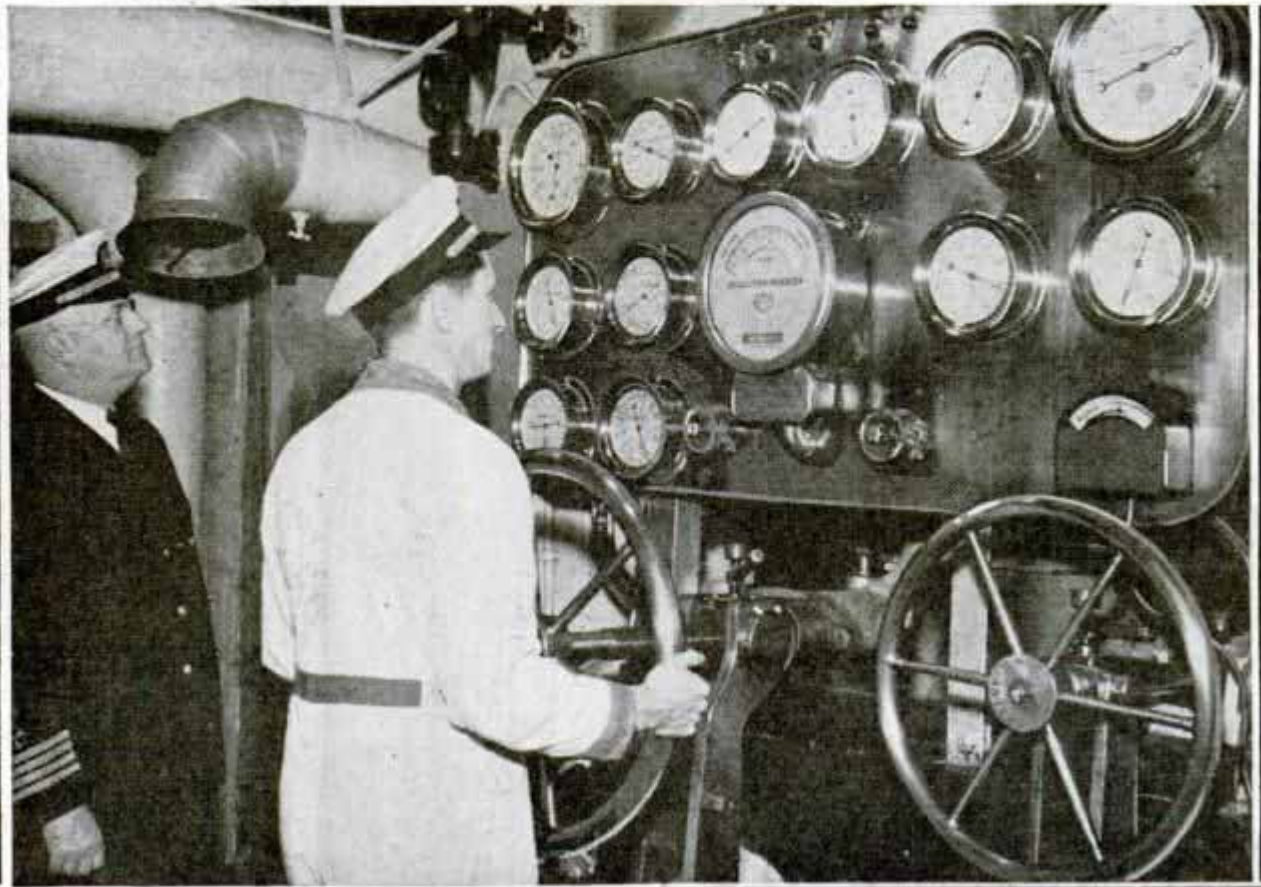

GETTING a big liner to sea looks easy. With the tugs alongside and the shore lines cast off, a junior officer on the bridge swings the handles of the engine room telegraphs over to "Slow Speed Ahead."

Down on the operating platform of the engine room a horn blares and the pointers on the telegraph dials turn to the command. Engineers at the port and starboard engines wind their throttle wheels out and steam begins to hiss into the high-pressure turbines. Shafts spin, the propellers turn over slowly, and the ship begins to move. It takes only three men to start a 26,000-ton liner.

But it's not as easy as that. For the last five or six hours the engine room gang had been preparing for the command. Raising steam takes time. Ponderous as the engines are, they are almost as delicate as fine watches. A 25,000-horsepower plant gets more care than the sensitive engine of a race car.

Aboard the S.S. "Monterey," one of the fast Matson liners on the California-Australia run, Chief Engineer H. T. Keene calls his officers together half a day before

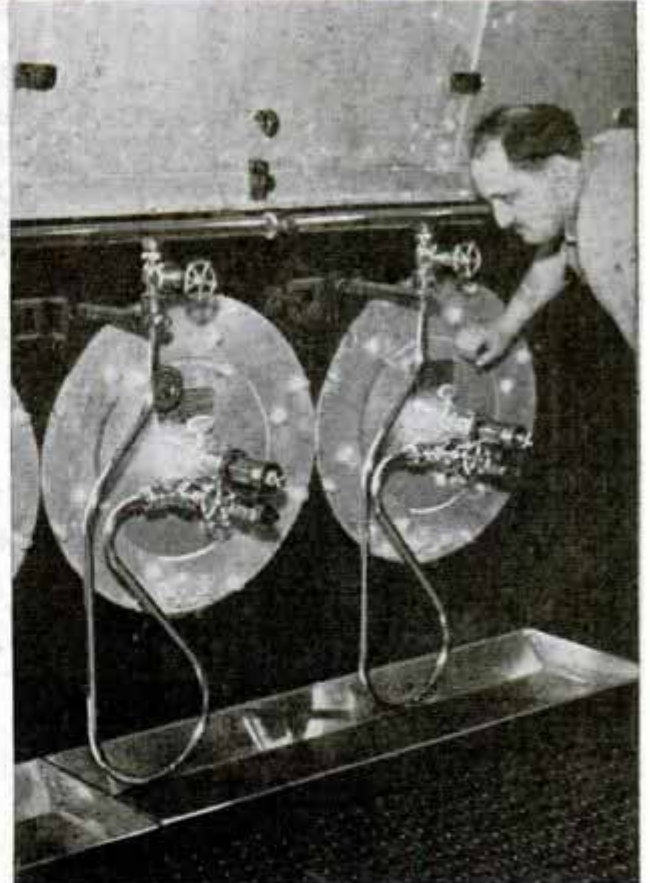

Engineer, top, at main throttle of port engine of the "Monterey." Note the many dials to show engine performance. Below, fireman, regulating flow of fuel oil on a modern vessel

215 Harbor St. San Francisco, Calif.

21961

ENGINEERS

sailing time and lays out a schedule. Fires must be started up under eight or ten boilers, steam must be raised to a superheated temperature, and the big engines must be slowly and evenly heated up. Even in an emergency it would not do to hurry the warming process. To blow steam at 750 degrees into a turbine while it is still cold would warp and twist the rotor, thus damaging the fine blades and seriously crippling the ship. When a liner docks for only a few hours or



Top, baby steering wheel attached to "metal mike" on bridge with which liner may be steered. Below, opening main steam line leading to turbines. Getting up steam requires several hours on a modern ship

when it might have to maneuver on short notice, the engineers keep steam up and the engines warm so they are always ready.

One of the first steps in warming is to start a series of pumps. One of them circulates cooling water through the condensers, another pumps barrels of lubricating oil through the engine bearings. Other pumps begin to lift water out of the feed tanks and boost it on its way to the boilers where it passes through first and second stage heaters. After evaporation in the boilers, it passes through a series of superheaters from which it emerges as superheated steam. Meanwhile partial vacuums are created inside the turbines and condensers by means of steam ejectors that

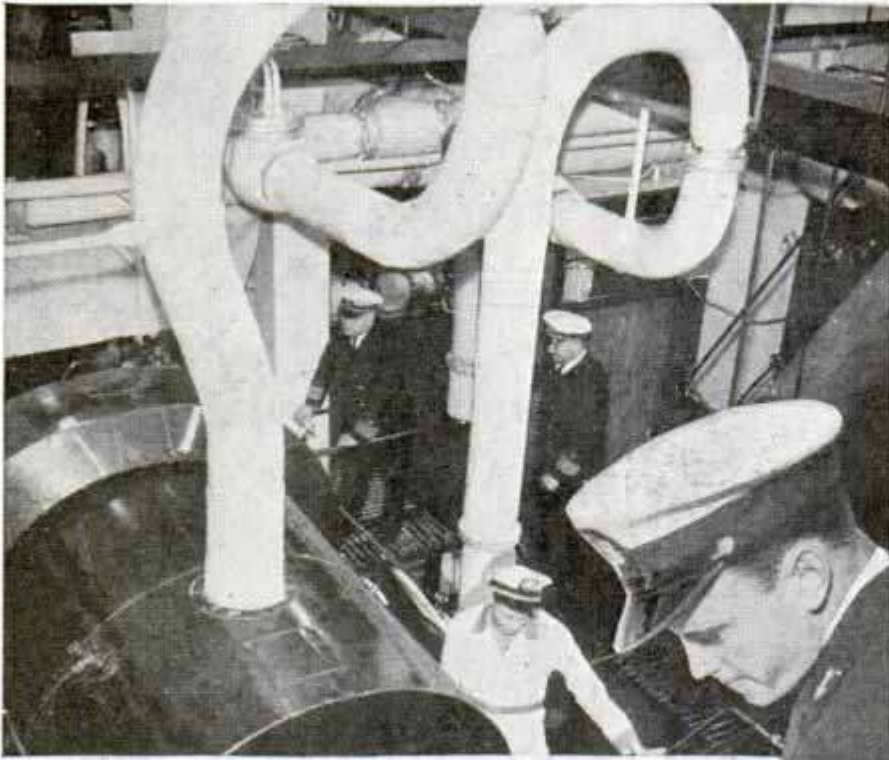

draw off water vapor and air.

Finally, the engines are ready for warming up. Each throttle is "cracked" to release a little steam that rushes through the high, intermediate, and low pressure turbines of the engines. Little by little, the vacuum inside the turbines is increased and more steam is admitted until the engines begin to turn. With the engines partly warmed up, they are operated ahead slowly and then astern for twenty-five minutes so all parts of the rotating units can come up to an even temperature. From then until sailing time, each engine is turned over for a few revolutions every few minutes to prevent it from cooling.

At sea the engine room is the hot spot of the ship, much hotter than the fire rooms in these days of fuel-oil furnaces and forced draft. Away from the small "islands" of cool air coming down the ventilators, thermometers in the moist atmosphere usually read around 100 degrees. Every minute the big ship is at sea, an engi-

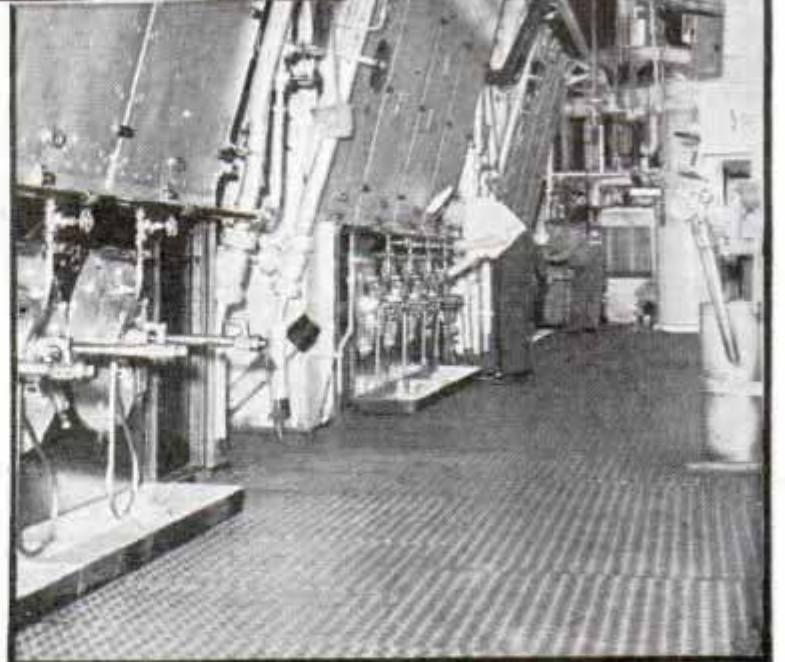

neer stands close by the throttle of each engine. No one below knows when an order is coming down from the bridge, or whether the next order will be an emergency command. As a result, every order is treated as an emergency and executed with split-second speed. An engine room log records everything that happens during a voyage. The yeoman in charge writes down each command transmitted from the bridge, together with the hour and minute. He also reads the faces of forty or fifty instruments that show the condition of every part of the power plant and keeps records of the readings.

(Continued to page 140A)

Top, insulated steam lines leading to turbines. Center, officer on bridge signaling to engine room. Bottom, furnaces in fire room which superheat steam before it is admitted to the turbines

Vancouver, B.C. Canada

Giant Figure of Christ in Odd Church Design

378 859 4



Designer's sketch of new plan for church. Giant figure of Christ at Gethsemane would be made of copper. At night special floodlights would provide a halo and illuminate the entire structure

Patents have been issued for an odd architectural design for churches. The plan calls for a giant figure of Christ, to be constructed of burnished copper, which would dominate the church building made of cement in natural stone color. The de-

sign has Christ seated on a rock at Gethsemane, with the church entrance in the rock, beneath the flowing robes of the figure. A halo for the figure and illumination for the entire structure would be provided by a system of floodlights.

Edges of Paper Strengthened with Tough Tape Binder

F1095

Due to frequent handling, the edges of drawings and other valuable papers are

often mutilated. To overcome this difficulty, a small taping machine binds the edges of any sheet or flat material with a protective border which won't tear, lays flat, handles easily and files smoothly. The tape is applied without heat or moisture, the user merely turning a crank on the binder with one hand and guiding the sheet with the other. Rollers form and press the tape on the edge of the sheet. By binding a piece of cardboard and a piece of Cellophane of equal size on three sides, a convenient transparent folder is formed to keep on the desk for sketches, notes and data sheets.



Taping machine which binds edges of sheet of paper with border which prevents mutilation from handling

Code Wall, 378 E 59th Ave
Vancouver, B.C. Canada

56 York St. Vancouver 9 B.C.

\$18.50 complete

Vertex Co. 5 local

Coal 'Dry Cleaned' in Portable Air-Sand Plant

*Stephens-Adams Mfg Co.
36 Ridgway Aurora Ill*

Operated without water, a "dry cleaner" for coal has been mounted on a truck for use anywhere. It employs air-sand, an artificial dry liquid, for separating the coal from slate and for similar specific gravity separations. The air-sand liquid is formed by bubbling air continuously through a mass of fine, dry sand. This makes a quicksand on which the pure coal floats through the cleaning box and into the chute while slate and sulphurous impurities sink and are discharged through gates in the bottom. A simple arrangement recycles and recirculates the sand. The plant is made in units up to 100-tons capacity. Costs of dry cleaning the coal are said to be small.

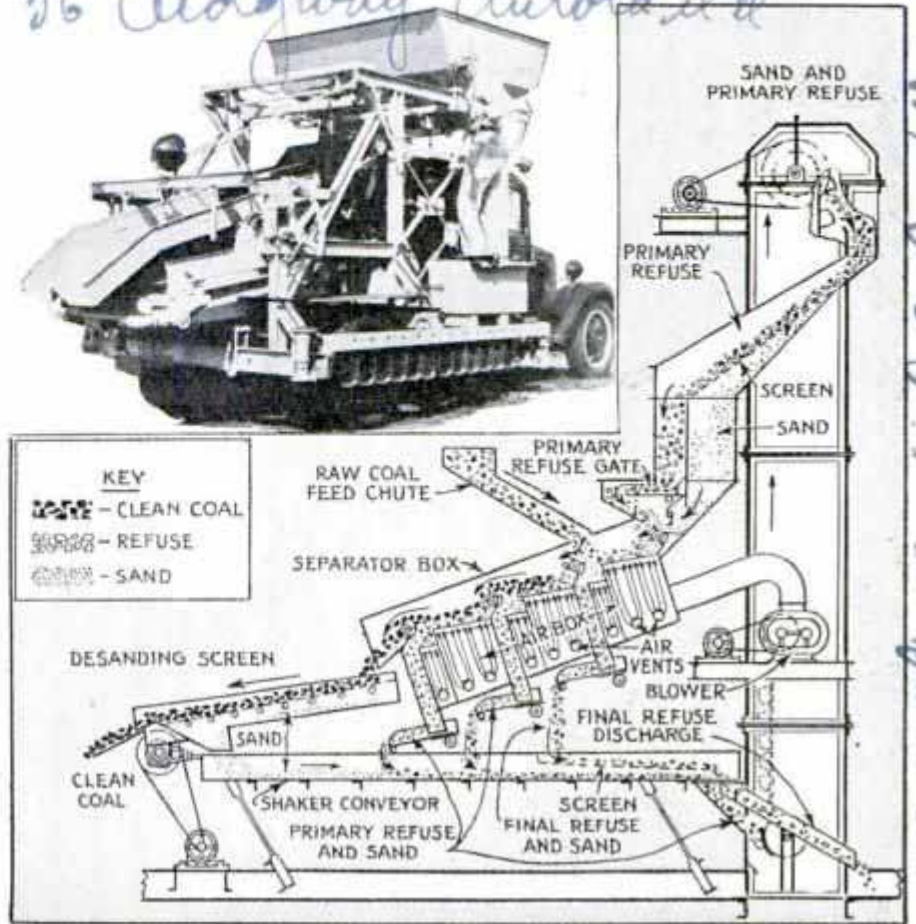

Top, coal-cleaning plant mounted on truck chassis. Bottom, diagram showing how the coal is cleaned by separating from other substances

Photo Enlarger Reflects Light Protecting Film from Heat

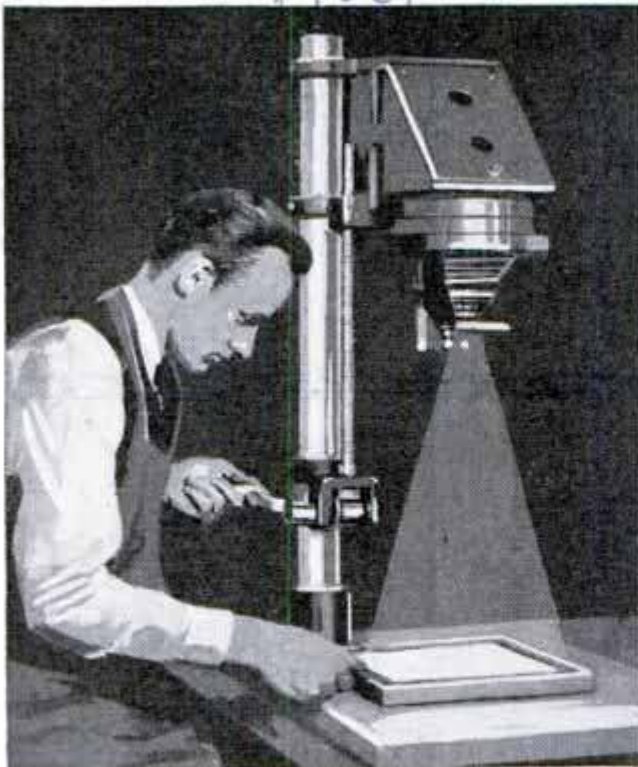

Turning the hand crank of this photo-enlarging outfit adjusts the projector to desired print size

By using a series of condensers, reflectors and a ground-glass shield, a photo-enlarging outfit attains positive control of light values and screens out heat that might damage the negative. Any lamp up to 1,000 watts can be used, the light proceeding from a back reflector through the ground-glass shield, which can be raised; through a condenser lens to a mirror that throws the light down at right angle through two more condensers to the negative, the lens and the paper. The machine head is readily adjusted up and down for print size by turning a hand crank, and the focus is similarly adjusted by turning a screw. The castings are of machined aluminum.

Names and addresses of manufacturers and dealers in articles described in this magazine will be furnished by our Bureau of Information upon request accompanied by stamped, self-addressed envelope.

Barhead Box 194

Chicago 20 N. Wacker

Uncle Sam's FOREST

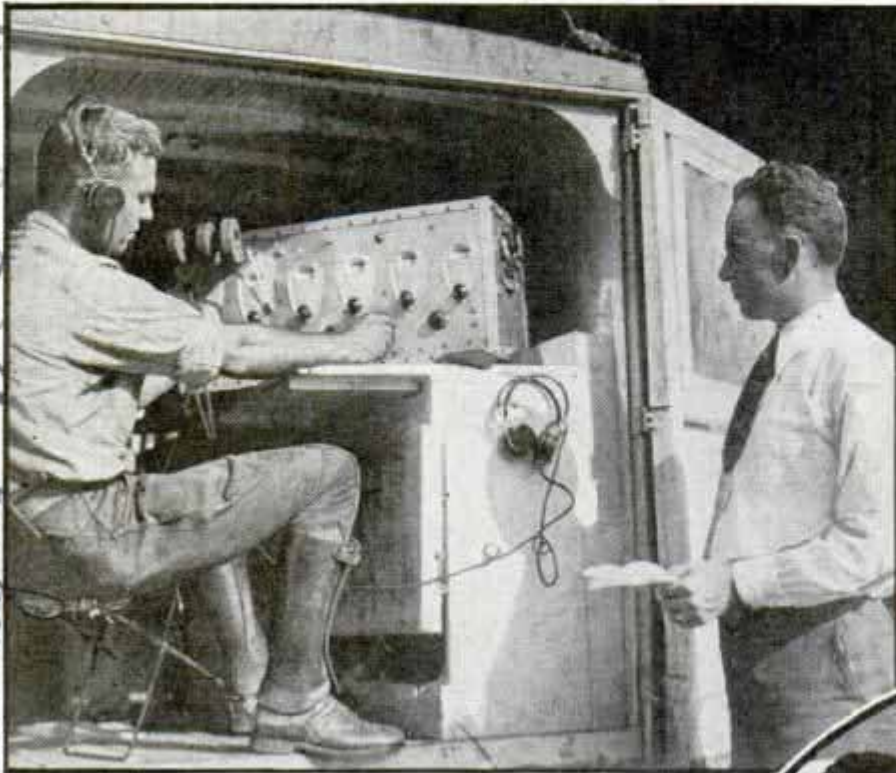

plane in metal shockproof containers. A motor pump, with 2,000 feet of hose is loaded into a lightweight steel box with parachute attached. Other strange-looking containers are hustled aboard and the plane zooms aloft with its load.

The boss of the ground crew assigns a number of men to start trenching in order to "pinch" the fire, then begins talking to the radio observer in the



Forest ranger reporting fire and, at top, sending radio weather reports to fire crews from truck

"FIRE starting on degree 372 approximately twelve miles southwest from station three."

The supervisor in the main ranger station of a huge western national forest hangs up the telephone receiver and stretches a cord across a map from station three on the 372-degree mark in the required direction. He doesn't do anything more—yet. In a moment the phone rings again.

"Fire starting at degree 171 about nine miles northeast from station two."

That's what the supervisor has been waiting for. On the map he stretches a second string from station two, and where the two cords meet is the exact location of the blaze.

"All right, boys, let's go," he orders. "Can't use the trucks—no roads. Tell the airport to drop a fifty-man equipment outfit and one centrifugal pump; there's a stream near."

The men set out, some on foot, some on horseback. All portable equipment is packed and ready at the station. Each man takes what he can comfortably carry and proceeds to the fire. Meanwhile, at the nearest National Forest landing field, fifty fire-fighting units are packed in the

plane now circling overhead. "Drop the pump near the stream!" he orders.

A black object comes hurtling from the plane and is suddenly checked by a mushrooming parachute. It is a pump, capable of shooting twenty-two gallons a minute at 200 pounds pressure. Other smaller objects come plummeting down. They are pack units composed of a five-gallon can of water, hose and lever pump.

*Cmh C. d. van der...
1424 - N. W. N. W.
The Champlain, Aft. 23-9
Washington, D. C.*

78730

FIRE FIGHTERS



Here we have a picture of Uncle Sam's newest forest-fire fighting equipment in action. A combination of expert scientific detection, transportation facilities stepped up to the maximum of efficiency, and a system of "cafeteria delivery" of any equipment needed by air, has become so effective that, according to recent reports from the National Forest Service, less than one-tenth of one per cent of the total national forest acreage was destroyed by fire last year. After five years of exhaustive laboratory research, resulting in the large-scale inventing of machinery peculiar to the needs of forest-fire fighting, the official guardians of over 200,000,000 acres of forest lands have at their command almost every known kind of fire-fighting equipment that can possibly be brought into play. Ultramodern methods of synchronizing old and new equipment, accurate and speedy methods of locating the tiniest incipient fire, new mechanical devices for automatically digging firebreaks and a ground-to-air-to-main-ranger-station ra-

Photos by U. S. Forest Service

Fire truck ready to start for a forest blaze and, at top, digging a fire trench



ly different. Cutting through heavy brush while digging through to earth is a slow process, and the fire often catches up with the spade wielder. So our engineers have developed the automatic brush cutter, a power-driven circular saw arrangement that cuts through tough underbrush, leaving the way open for the shovel man. The brush cutter does the work of several men in far less time—and time is most important in fighting forest fires.

dio communication system are but a few of the latest advancements made by the engineering and research staff of the Forest Service.

"Within the past three years," says David Godwin, associate chief of the fire-fighting division of the service, "the service has built fifty-five landing fields at strategic sections, mostly in the far west. No matter where a fire breaks out, it can be reached in a short time by plane. Furthermore, thousands of miles of roads have been built, closed to public traffic, but used exclusively by forest rangers and CCC boys in fire fighting.

"Until recently, the main method of fighting a fire was to line up a number of men, arm them with picks and shovels and have them dig trenches parallel to the line of fire and thus attempt to pinch it out. In connection with this, upon favorable conditions, with the wind not too strong, backfiring was attempted, the uprushing current of air caused by the approaching conflagration drawing the backfires to it, despite the adverse wind.

"Today, trenching is still the major means of fighting fires, but the methods involved are entire-



Top, ranger reporting fire by radio. Center, transporting fire boxes in a section where the only roads are trails. Bottom, plane used for patrol work

"For the first time we have reached maximum efficiency in spotting fires. For years the army air corps cooperated with us by keeping forty planes constantly in the air to report fires. This system served as an excellent primary stage of the present method of detection. However, accurate location directions cannot be given from a fast-moving plane and the territory was not covered 100 per cent. Our present system of fire towers, manned day and night, keeps every square inch of national forest lands under constant observation. In almost every instance, fires are reported by two or more rangers at these stations, and by simple geometry applied on a chart map, the superintendent can deter-



Ranger using fire finder to spot a blaze and, below, Forest Service truck used to fight fire

mine the exact location of the fire down to the acre.

"Many times, of course, there are roads near the fire, which are not open to the public, but built for just such emergencies. Then the mobile ground units get into action. Tractors with plowlike arrangements for digging fire trenches, trucks, carrying men equipped with 'pack extinguishers,' picks, axes and shovels form the vanguard. Airplanes report progress

to the ground boss. Automatic brush-cutters zip into action. A unit of our very latest equipment, a counterpart of a city fire truck, is capable of shooting powerful streams of water, and if no supply is available in near-by stream or lake, it carries a huge tank which can be refilled at headquarters.

"The whole battle is carried on as efficiently as any wartime maneuver. Planes and ground crews keep in constant contact by radio, and if equipment is needed in a hurry, it is dropped from the air by parachute, or 'free-dropped' in specially constructed nonbreakable containers. If the blaze is a large one and men must stay on duty for several days, the planes drop food as well as supplies.

"For the past three years the service has been building a system of reservoirs, pipelines and dams in small streams for a permanent water supply. At first the notion of men walking around with five gal-

(Continued to page 128A)

2706 8 59 44
St Louis Mo

Timing Switch for Enlarger Insures Right Exposure



Automatic timer, on table, turns off photo enlarger at expiration of interval set on its dial

Inserting an automatic timing switch between the electric outlet and the photograph enlarger assures accurate exposure of the print. The switch is calibrated in seconds from zero to sixty, and turns off the enlarger at the expiration of the interval set beforehand on the dial. It has a ruby light which illuminates the dial and also serves as darkroom light.

Motorboats Hoist River Uphill to Supply Power for Refinery

So low was the Mississippi river this year that motorboats were employed to "lift" river water into a channel supplying power for a large oil refinery at Wood River, Ill. The river, at a record low stage, had fallen below the level of the intake channel and the refinery, 4,000 feet from the inlet, was threatened with a shutdown. Pumps being unavailable in the emergency, a river man suggested building a low

dam of wood stakes and planks across the mouth of the intake channel. Six small motorboats were then placed seven feet from the dam and securely fastened, stern ends to the dam. Pipes twelve inches in diameter and about eight feet long were arranged to take the wash from the propeller and lift it over the dam into the channel. When the engines were started each propeller thrust about 1,500 gallons of water a minute up and over the dam.

Lock in Cork Seals Bottle Tight Preventing Use of Poisons

To safeguard against mistaken use of poison, a cork containing a lock which seals the bottle has been invented. Twist the key in the lock and two metal balls are pressed against the neck of the bottle.



Vacuum Gear Selector for Autos Shifts Quietly at Finger Tip

At the touch of a finger tip you can shift gears silently with a vacuum-operated gear selector which has just gone into production. Built as a unit in the transmis-

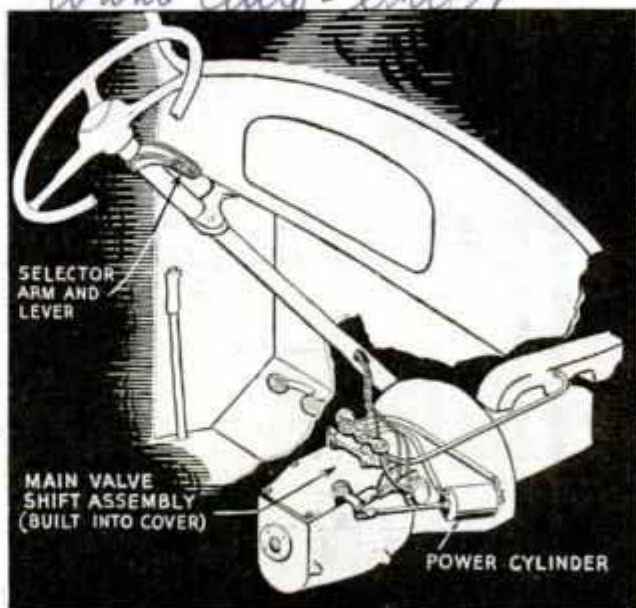

Vacuum gear-shift unit built into transmission cover is controlled by lever on steering post

J. A. D. Instrument Co.
216 N. Vermont St.
St. Louis, Mo.

Evans Auto-Shift
Evans Products Co.
St. Louis, Mo.

F1086

William Dougherty
10 and Pine St. St. L.

Evans Auto-Shift
Evans Products Co.
St. Louis, Mo.

vacuum gear selector unit

sion cover, it can be installed in any conventional automobile transmission. Both construction and operation have been made quite simple. Gears are controlled from a lever at the top of the steering post. In shifting, you can either depress the clutch in the usual way and then move the selector lever, or first set the lever at the desired gear and then press down the clutch. The mechanism is operated by a vacuum suspended cylinder, in which vacuum is maintained at all times.

1065

Camera on Radiator Cap Photographs Accident

Just to advertise his trade, a Washington photographer mounted an inexpensive miniature camera on the hood of his automobile—and accidentally it became an expert witness to an accident. Unintentionally the motorist had left a film in the camera, which was set for an exposure. A minor collision jarred the shutter, and when the film was developed the photographer was surprised to find a perfect picture of the collision. Now the photographer always loads the camera and has the shutter release set so that a bump would expose the film.



Camera on hood is ready to snap picture of wreck

Motorcycle's Dive into Canal Is Latest in Crowd-Thrillers



Daring motorcyclist photographed as he dived his machine into canal in a new crowd-thrilling stunt

Latest in stunts devised for thrilling sport-show crowds is the dive of motorcycle and rider from a height of eighteen feet into a canal at Vienna. An Austrian soldier, wearing uniform complete to steel helmet, performs the stunt, which is a feature of the Vienna police department's water-sports show on the Danube canal.

Popular Mechanics Magazine does not publish the name of the maker of, or dealer in, any device described in its pages, but this information is kept on file and will be furnished by our Bureau of Information upon request, accompanied by stamped, self-addressed envelope.

Carl Best, L. J. Lane,
142 31st St. W.

F1097

Hot Gas Mixed with Steam Cuts Heating Cost

Saf. J. Neak



both the steam and the products of combustion carrying their heat through the radiators. A one-sixth horsepower motor regulates air supply, circulation and exhaust. Because of the method of collecting condensate and returning it to the generator, there is a minimum of corrosion and tests established that corrosion would be less than in an ordinary steam heating system. The plant heats up rapidly because only a small amount of water is needed in the jacket and because the hot gases reach the radiator quickly. The heater, applicable wherever gas is available, is designed for a five to seven room house, and in larger buildings extra units

C.A. DuBois Co. 450 E. Ohio, Chicago, Ill. 2/42

Steam mingles with the burned gases in the radiators of a home heating plant which, in laboratory tests, has attained an efficiency of ninety-seven per cent in fuel use. The gas-vapor heater has just been placed on the market. Because its air supply is controlled, a large amount of gas can be burned in a small combustion chamber and the heating plant is therefore quite compact. Around the combustion chamber is a water jacket. Exhaust vents lead the products of combustion into a space above the water where the steam and the spent gases are thoroughly mixed. This gas-vapor mixture flows through the piping to the radiators, where the moisture condenses and the gas cools. The condensate flows back to the water jacket and is reheated and circulated again, while the cooled gases are separated and, under pressure, discharged through a flue to the outside. In a new home equipped with this heater, a chimney would be unnecessary. A vent pipe only two and one-half or three inches in diameter is sufficient to exhaust the gas through the roof. There is practically no loss of heat in this system,

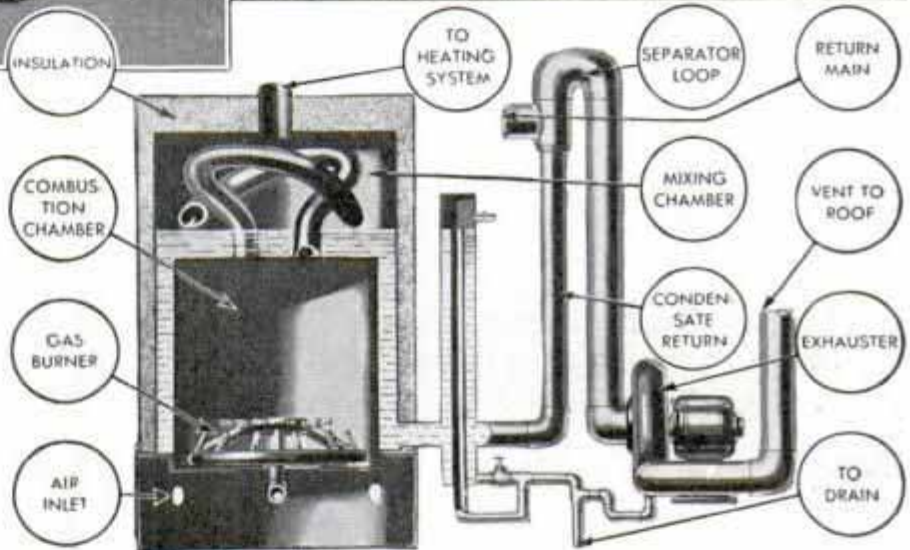

Heating unit for five to seven room house and diagram showing how burned gases mix with steam and circulate through radiators

are added. Where steam or hot-water systems are already in use, they can be converted to connect with the gas-vapor heater. It is thermostatically controlled.

Instinct Center of Animal Found at Middle of Brain

Instinctive actions of animals are controlled from the middle of the brain. Prof. E. Grunthal of Wurzburg University found the instinct center by searching for structural details more highly developed in the animal brain than in man's. He believed that man is superior to the animals in intellectual ability but inferior in instinctive actions. In the animal mid-brain, Professor Grunthal found what he believed were

Science News 8/26/12

Wurzburg Germany

the organs of instinct, containing nerve centers more numerous and highly differentiated than in the human brain. These nerve centers or nuclei were numerous in the brains of bats, rabbits and mice; less plentiful in carnivorous animals and fewest in brains of gorillas and orangs. In man and chimpanzees, the nuclei are about the same type and number.

Air Intake Built Like Gun Supercharges Racing Car



Acme
It looks like a cannon mounted on an armored car, but it is really the air intake duct for the supercharger of a racing automobile

Two-Faced Mirror for Day or Night Motoring

One side of a reversible rear-view mirror for automobiles has a crystal-clear face for daytime driving, and the other side is a jet black glareproof mirror that kills the blinding reflections during night driving. Either side provides clear vision



Twist the mirror and you have a vanity, a daytime glass or a glareproof mirror for night driving

of the road to the rear. The mirror is turned and locked in position either way by a simple twist of the wrist, and it can also be held in a vertical position for use as a vanity glass.

What appears to be a weapon of war on Capt. Woolf Barnato's racing car is really only part of a forced-induction system. The gunlike projection sucks in more air as the automobile gathers speed, supercharging the motor. Oliver Bertram, British racing driver, is seeking new speed records with Barnato's car, a Barnato-Hassan special.

Rain Gauge Read Once a Year Shows 451 Inches Rainfall

In one of the wettest spots on the globe, the rain gauge is read just once a year and the annual average precipitation is 451 inches. The gauge is at the top of Mt. Waialeale on Kauai, westernmost of the larger islands of Hawaii. In unusually wet years the rainfall sometimes reaches 600 inches. Because of the difficulty of reaching the peak through dense forest, undergrowth vegetation and sticky mud, a huge gauge which need be read only once annually was installed. It is of copper and will hold 900 inches. Tests of evaporation showed practically no loss, so the scientists assume evaporation at zero. Mile-high Mt. Waialeale is a moisture trap for rain-laden subtropical winds.

☐ Rambler roses planted along the right of way of the New York, New Haven and Hartford railroad not only beautified the line but their roots reduced soil erosion.

Handwritten notes on the right margin:
Hassan special
Barnato
Acme
F112
F112 4
demonstrated 8/25/36
reduced soil erosion

Handwritten note at bottom left:
Sands Mfg Co

Handwritten note at bottom right:
Roadways Age 8/1/36

Floral Windmill Is "Grown" from Thousands of Plants



This windmill in a park at Buffalo, N. Y., is made of twelve thousand plants. It is lighted at night

More than 12,000 plants of the Echeveria and Alternanthera species were "grown" into a decorative windmill in a park at Buffalo, N. Y. Delaware Park greenhouse gardeners constructed the windmill and arranged its floral designs. Lighted at night, it attracts thousands of admirers.

Trees Used as Windbreak Save Fuel in Farmhouse

Trees planted around a farmhouse are not only a source of fuel but actually save fuel when they grow into an effective windbreak. Tests by the U. S. Forest Service showed that winter temperatures are two to six degrees higher in winter on the leeward

side of a windbreak than on the windward side, and that heating requirements of a house unprotected by trees are tripled when cold winds exceed twenty miles an hour. Three or four rows of trees eight to twelve feet apart should be planted 100 to 150 feet from the house.

Midget and Giant Pistons Both Made of Aluminum

Aluminum pistons such as are being employed in modern high-speed automobiles also are being adapted to many other types of engines, both large and small. A striking contrast in size is offered by the aluminum-alloy piston produced for the engine of a fifty-seven pound portable lighting plant and that turned out for a 450-horsepower Diesel engine. The lighting-plant piston weighs three ounces, while the one for the Diesel is nine and one-half inches in diameter, nineteen inches long and the casting before it is machined weighs sixty-four pounds. Tests have been made with such pistons for Diesels fifteen to thirty inches in diameter. These pistons in iron weigh up to 300 pounds while the same size in aluminum would weigh one-third that much.

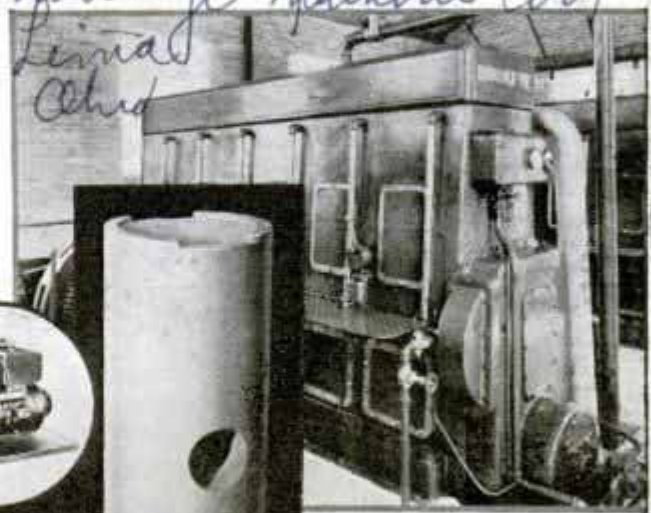

Tom Thumb and giant aluminum pistons used in portable lighting plant, in circle, and in big Diesel engine

Edwin S. Weinheimer, Supel.
U. S. Dept. of Agr.
no. 647
W. R. Williams

12802
Motor
F1085
Beaumont, Alameda
am 2 shells. 12802

Buckeye Machine Co.
Leina
Alred

W. R. Williams

Pretzel Bending Machine Solves Problem

Chas. H. E. Farmer, 37 Labernia Ave. Lanes Point, Md.

Chas. H. E. Farmer, 37 Labernia Ave. Lanes Point, Md.

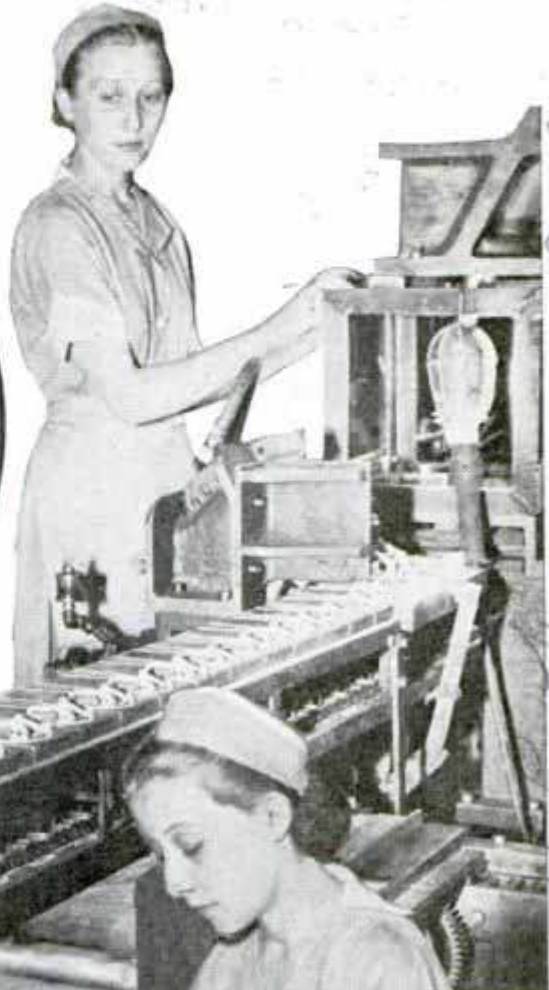
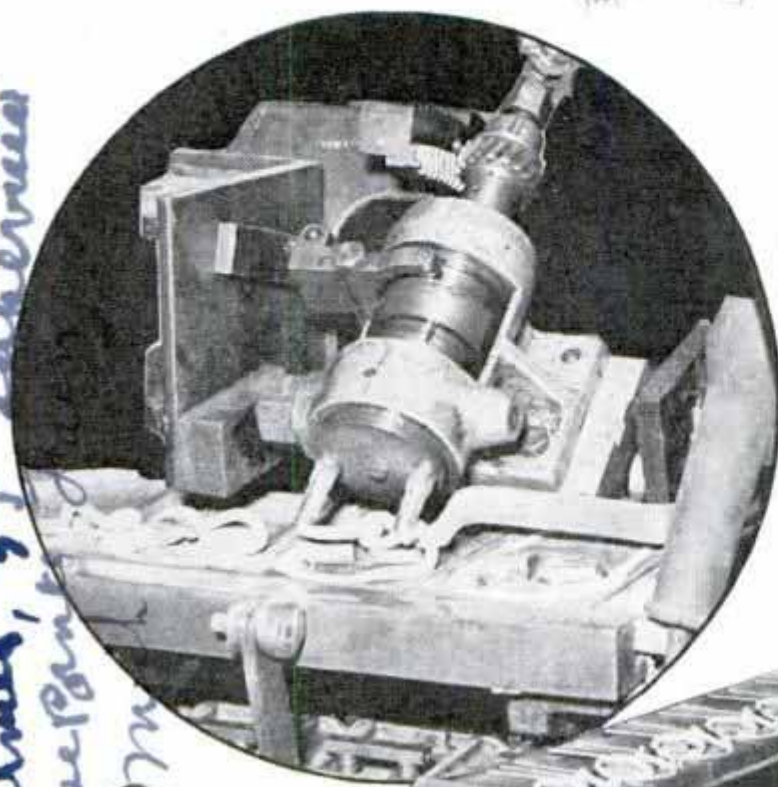

Accomplishing what once was considered as impossible for a machine, a new pretzel bender turns out 900 completely twisted pretzels per minute. It more than equals the work of fifteen expert pretzel-bending girls. The machine is an odd assembly of wheels, endless belts, air hose and electric motors, yet it handles pretzels with far more skill and speed than the best worker. Circle, top, machine at work. Center, pretzels ready for cooking. Bottom, expert worker bending pretzels by hand

FIG 41

Mower Cuts and Cleans Lawn Like a Vacuum Sweeper

Resembling a vacuum cleaner both in form and action, the latest lawn mower cuts the grass and then sucks the cuttings, leaves, twigs and other small rubbish into a container. Thus it does a thorough job of cleaning as it goes. Cutting is done by scythe-like rotary blades which are turned by direct drive from a gasoline

engine. The cutting blades of the mower are adjustable and can be set to cut the grass to any height desired. The blades are hollow-ground, and it is their rapid revolving that creates the suction which draws the mowed grass and rubbish into the large container located at the back of the machine.



Mess Power Speculators, Hds, Parks

F 582.

8649 Lookout Mountain
Hollywood, Calif

WEATHER *Made-to-Order*



NATURE cannot be relied on to provide a thunderstorm or a cloud bank on the particular day a movie director desires to shoot such an effect, so Hollywood studio technicians use mechanical equipment to produce these and many other natural phenomena.

There are machines for making noiseless rain, sleet, or snowstorms, while other paraphernalia set fires and control the extent of the destruction, or produce fire which can be projected, artificial sun rays, dust, fog, and wind effects. These tools are as much a part of motion-picture making as the camera itself and in most instances the artificial effects photograph better than the real and are more con-



Top, scene from "Mary of Scotland" as ship is sighted. Below, camera cabin used in rain sequences during filming of "Anthony Adverse" by Warner Brothers. The rain was produced by man and not by nature

for the MOVIES



Camera and technical crew ready to film a blizzard. Marble dust and artificial snow are used in creating the illusion of a howling winter storm

vincing on the screen. Rainstorms of many kinds can be produced at a moment's notice with devices made by Harry Redmond, head of the R.K.O. special effects department. Misty rain is made by compressing water to about 150 pounds pressure and then releasing it through a fine jet. The jet has a half-inch thick wall around an elongated cavity the thickness of a pencil lead in which is a V-shape cut. The water strikes the cut, and is sprayed into a mist almost dry because of its fineness. Each jet covers an area of about fifty feet, and about 100 are used at once.

For rain effects around street lamps at night, Redmond uses a special jet eight inches long, with a one-half inch interior

cavity tapering toward the end. Arranged spirally around the jet are V-cuts which bite into the water stream because of the taper. At the end of the jet is a spray attachment. The large drops from the spray "catch" the light for movie rain drops while the V-cuts add the needed mistiness for proper photographic effect. Only a small portion of a set is made wet with this device.

When rain is seen pouring down outside movie windows, the part you don't see is a "rain tube" consisting of a one and one-quarter-inch iron pipe made into a rectangular form. Into the pipe are drilled holes the size of a pencil lead. Low-pressure water gives the rain-drop effect. A

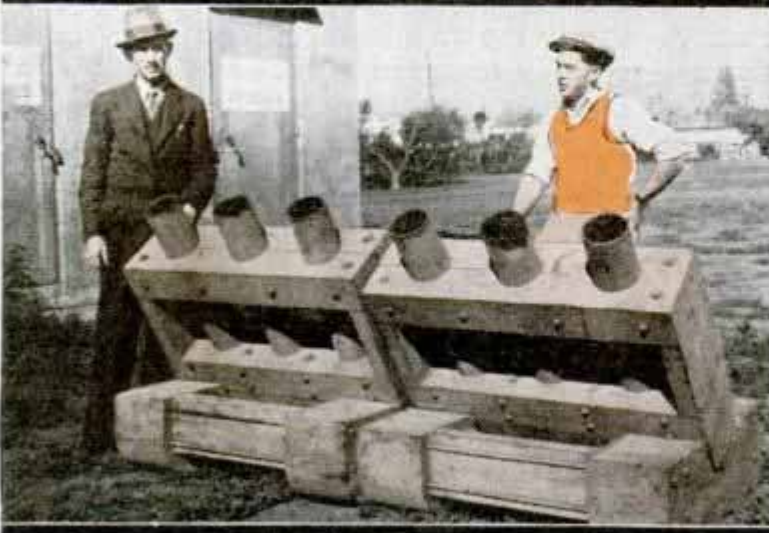
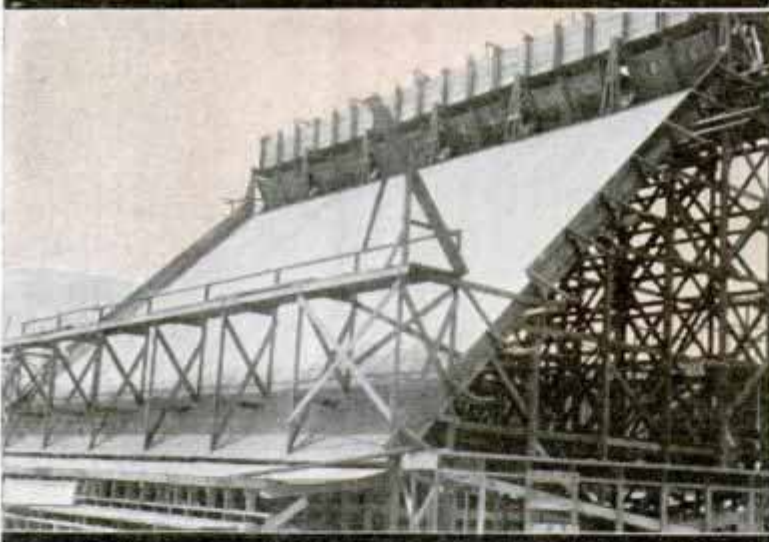
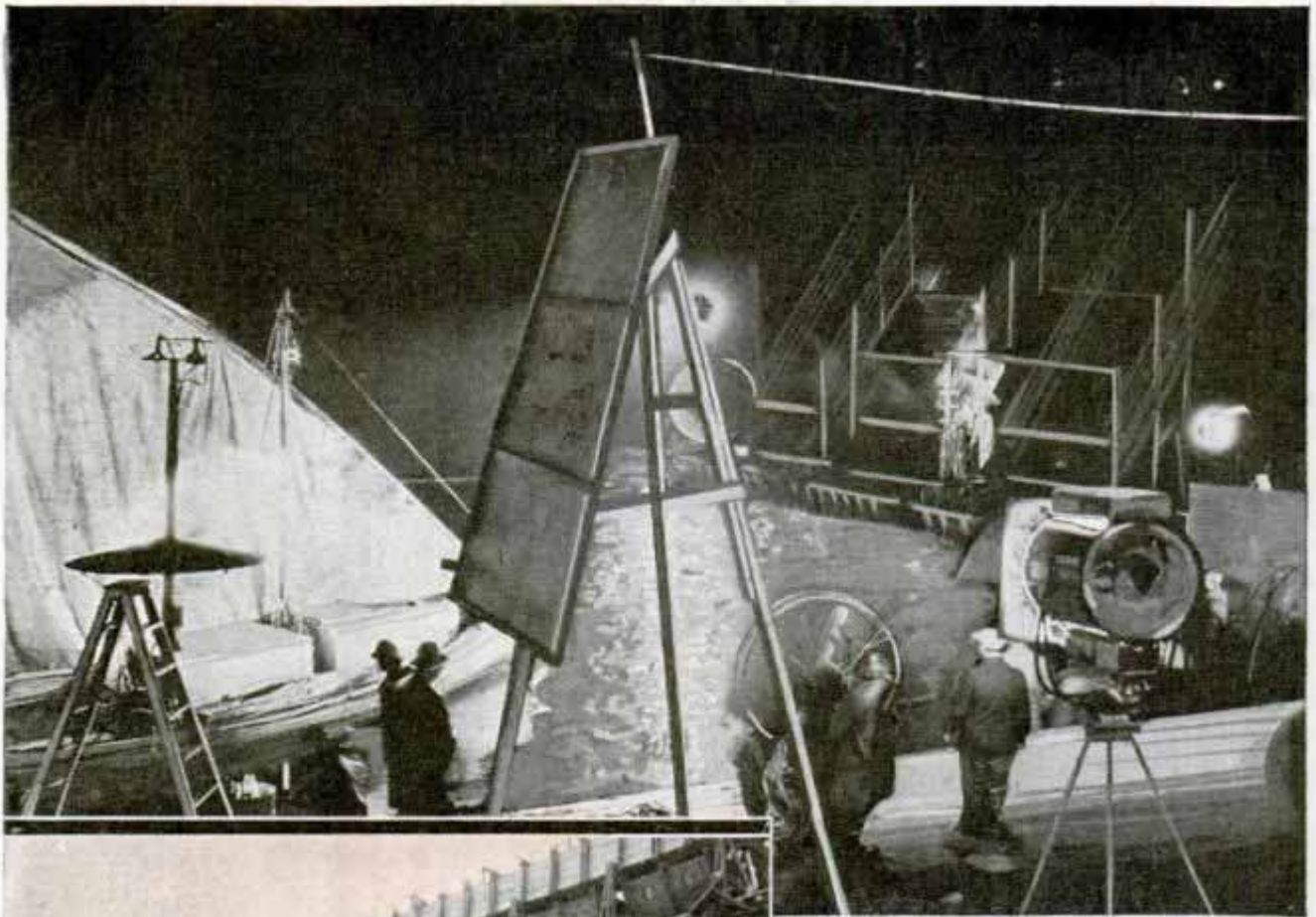

Sound stage tank in which boat scenes are made, outdoor set, and apparatus for making artificial clouds and overhead fire effects for the movies

pan below the window out of camera lines catches the water.

For more elaborate rainstorms sprays known as "acorn jets" are screwed into pipes. The spray jet is shaped like an acorn with fine holes drilled into the "nut" portion. The pipes are suspended above the setting and are attached to a three-stage pump of 750-gallons-a-minute capacity. From 1,000 to 3,000 feet of pipe and hose are required for the usual rain scene. Increasing the pressure of the water adds to the fogginess of the rain.

When rain is to be "silenced" so it won't interfere with the sound recording, excelsior is laid about the set to absorb the noise. If artificial rainstorms are needed on location, tank trucks transport the water to the outdoor setting and pumps build up pressure to 125 pounds in the pipes to get the storm effect from the jets.

In the R.K.O. film "Mary of Scotland," a cloudburst effect was gained by shooting water from a

fire hose into four-bladed propellers turned by 400-horsepower airplane motors. Wind machines are used to create the "blown effect" of slanting rain. By ejecting fuller's earth into the wind machines the effect of wind tugging at the clothes of the actors is produced. Without the fuller's earth, the illusion would not be so realistic.

Several new fog machines using chemicals are being used. The old-time "fog-bucket" from

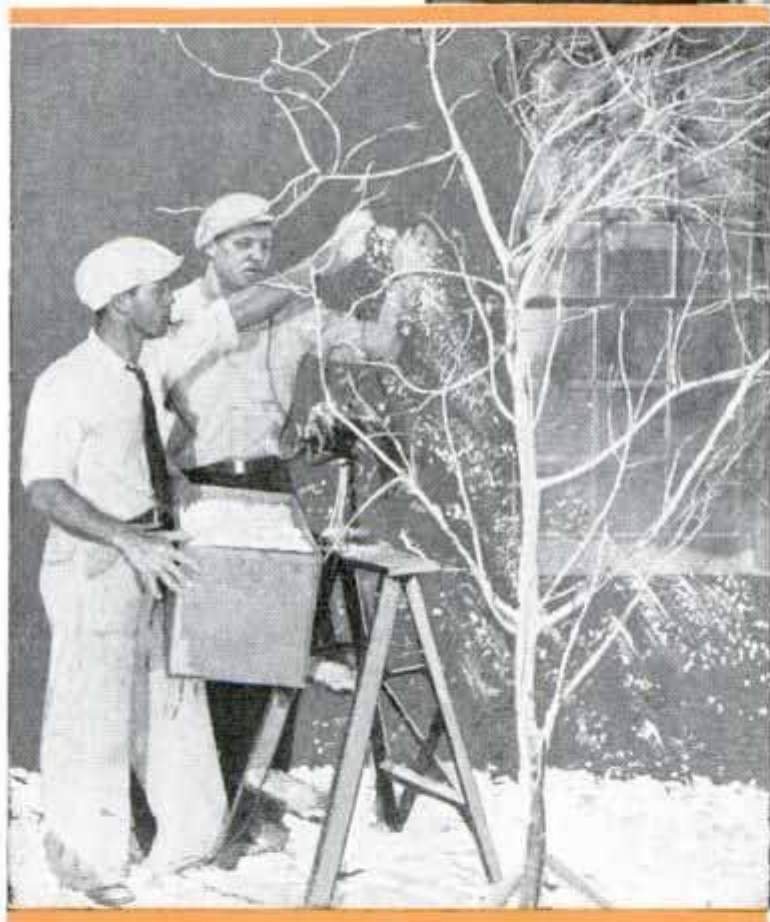
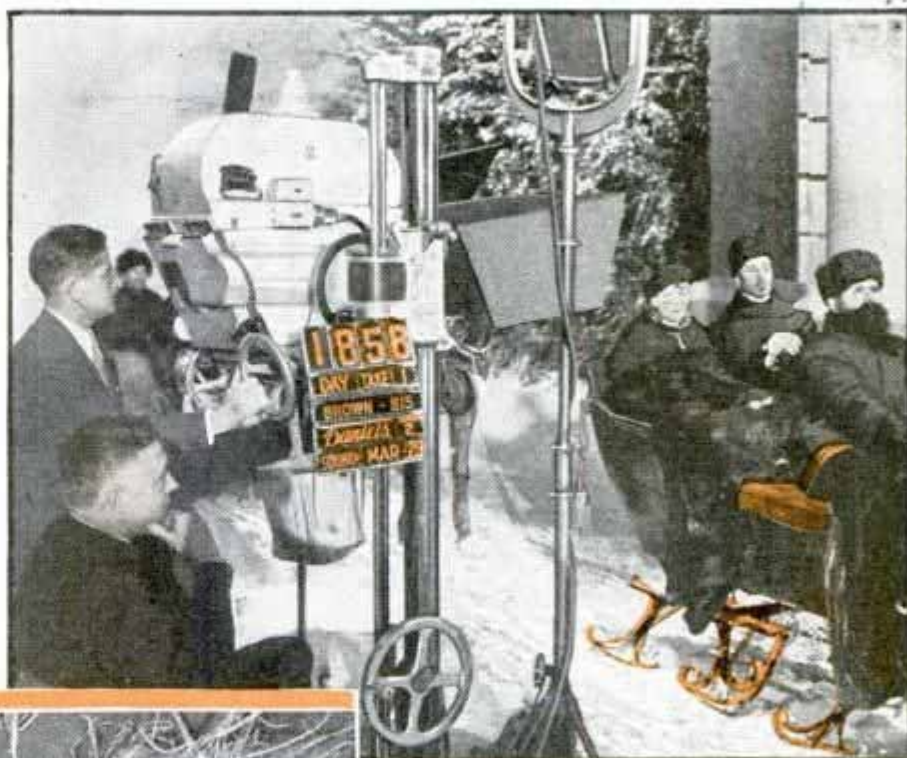

Top, filming winter scene in M-G-M picture, "Anna Karenina."
Below, creating winter scene on sound stage

which an air jet sprayed lubricating or mineral oil is not extensively used because of the effects of the oil-laden atmosphere on the actors and their costumes. Instead, complicated machines manufacture fog according to the demands of the director. For "Mary of Scotland" Director John Ford asked Redmond for a special fog which would hang with clear spaces be-

tween layers of fog. The first layer was to cover the ground with a four-foot blanket, and over this was needed six feet of clear air. Above the clear air was required another layer of fog. A special machine was used that electrically carbonized oil and then, by a muffled-air arrangement, laid it as microscopic particles in a vaporous air mixture. By controlling the carbonization the height at which the particles floated could be ascertained. A small blower in the fog machine gave the drifting movement characteristic of fog.

Spray arrangements made after the principle of the paint spray gun are used when an impenetrable fog bank is needed. The chemical, silicate tetrachloride, is put in the spray gun and instead of air pressure, compressed ammonia gas operates the spray which lays a dense low-hanging fog through which the camera cannot photograph. The chemical is also used for making artificial clouds in miniature settings. Titanium tetrachloride is used for smoke effects.

Another very light and almost colorless fog is made chemically by a machine which

(Continued to page 130A)

Smashup on Race Track Caught by Camera

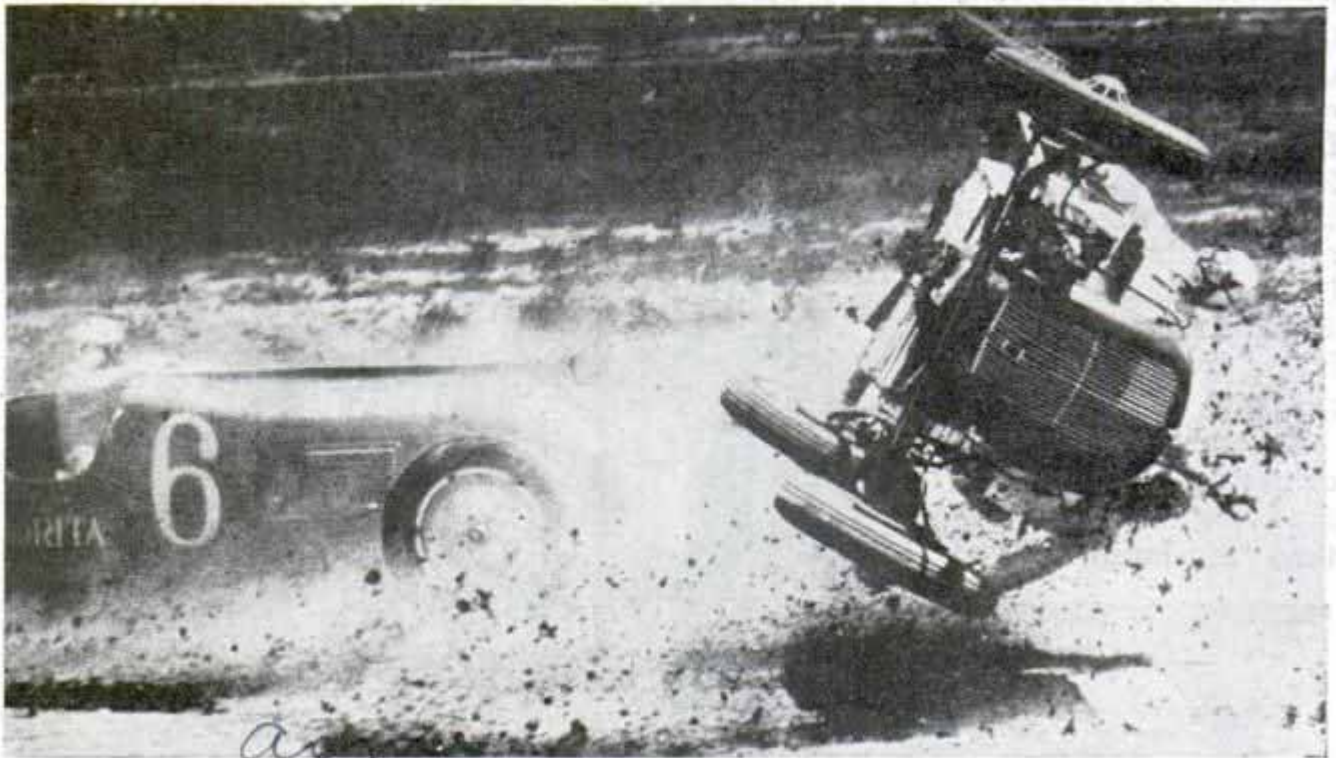

This remarkable photograph shows one racing car turning over, all four wheels off the ground, right in the path of a second speeding car. None of the men in the two cars was seriously hurt

Just as one speeding car turned over in the path of another during an all-Japanese championship race, an alert photographer pressed the bulb of his camera. The resulting picture was full of smashing action, a rare shot of automobile racing. The over-

turning car is shown in the air with the second car swiftly bearing down, its driver unable to avoid a smashup. Judging from the picture, it seems impossible that the drivers could have escaped death, but they were only slightly injured.

Condensation Engineering Corp.
 335 S. Western Ave.
 #1044
 #1840628

Moisture Eliminator Prevents Chimney from Corroding

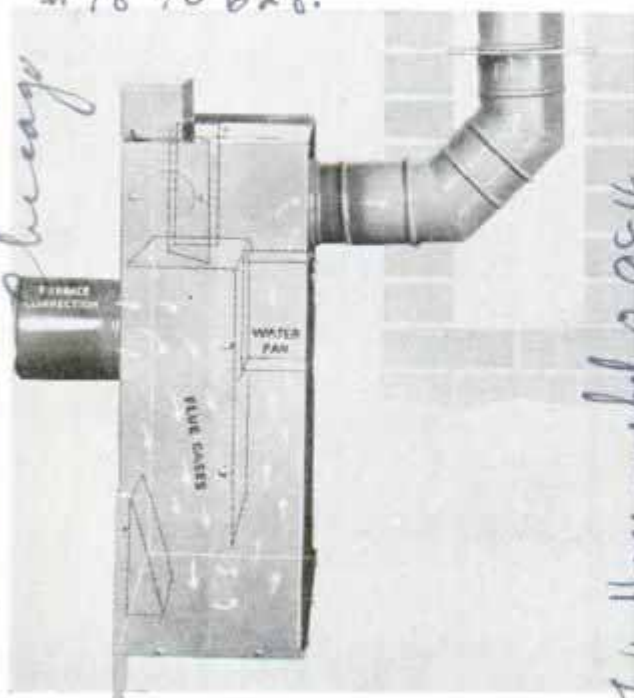

Cutaway drawing shows how condensed moisture is collected in water pan to be re-evaporated

Condensation of vapor in the chimney, a cause of constant disintegration of the bricks, mortar and flue lining, can be controlled by installing a condensation eliminator developed recently. In the efficient furnace there is little waste of heat up the chimney, but as a result there is heavy condensation of moisture with a slightly acid content which attacks the chimney. In a gas furnace, from six to twelve gallons of water are generated in vapor form for each thousand cubic feet of gas burned. The condensation eliminator, installed at the base of the chimney, controls up-draft and down-draft. It collects the condensed moisture during the warming-up period and when the furnace is hot, the water is re-evaporated and carried out of the chimney as vapor. An acidproof flue lining protects the porous brick and mortar, and leaves a dead air space between it and

Tel. Haymarket 0984

the chimney, tending to prevent absorption of heat by the bricks and to maintain a stack temperature high enough to evaporate the moisture and carry it away.

F1018

Battery of Photo Flash Bulbs Synchronized by Control Box

"Walking" Radio Station Sends One Mile

Operating on low power and ultra-high frequency, a new "walking transmitter" introduced recently by one of the larger broadcast companies has a working range of one mile. It consists of antenna and radio-frequency oscillator concealed in a cane, a microphone on a wrist strap, batteries in a money belt and audio amplifier and modulator in a binocular case. Its first use was for roving interviews at a political convention, the voice of the speaker being transmitted to a central station nearby and rebroadcast.

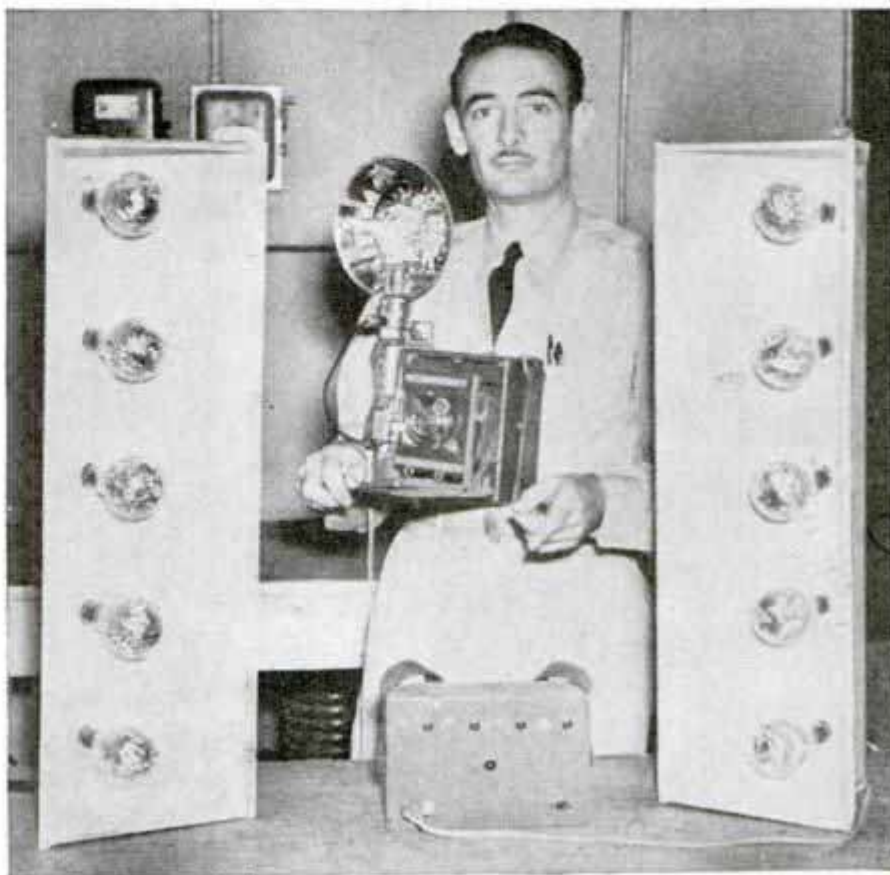

Portable multiple control box on table in center fires ten flashlight bulbs simultaneously with bulb attached to camera

Firing an entire battery of flashlight bulbs simultaneously with the click of the speed camera shutter has been accomplished by the development of a multiple control box. The ordinary synchronizer opens the camera shutter at the peak of the flashlight. With the multiple control, as many as ten photoflash bulbs arranged at strategic points within a radius of 100 feet can be touched off in unison, literally flooding with light the area being photographed. The control box is a compact case containing bulbs and switches, supplying its own current.

Rubber Wrapper Keeps Soap Water and Weather Proof

Applied to 'cakes' of soap by a special quick-vulcanizing process, a rubber coating water and weatherproof has been developed for wrapping soap. To unwrap, the coating is stripped off by pulling a small tab on the side. The wrappers may be colored. The coating is impermeable to the perfume of the soap.



Patent No. 2,042,104, John P. Kane, 16 Park Avenue, New York, N.Y.

...is the "walking transmitter." Note the microphone strapped to announcer's wrist

John P. Kane
16 Park Avenue
NY
Penney Radio Camera
Japan
Central

Exhibit Ave.

Spray Gun and Enlarger Print Photo on Wall

511-5th Ave N Y C

Photographie & spraying Ltd. 15 Elizabeth St. d. d. London England. had igel on market in U.S. 12/19/36



Top, projecting negative on sensitized wall and fixing it with spray gun. Mask, shown at lower left, is worn for protection while spraying sensitive emulsion. Right, the finished mural photograph

One evening you walk past a tall office building whose brick wall on one side is bare and windowless. The next morning you are amazed to discover a huge mural photograph printed on those bricks. With a spray gun, sensitive emulsions and an ordinary enlarger, photographic artists today are actually printing pictures on interior walls of plaster or canvas, exterior walls of brick or wood. They can even project an imperishable photograph on a cement sidewalk, on metal—on virtually any solid surface. The process takes but a few hours. First a patented emulsion is spread over the entire surface with spray guns; the photograph is projected with an ordinary enlarger, and is developed and fixed again with the spray guns. The pic-

Cont. Paul Lambert. Photographie & spraying Ltd. 47 St. St. London

71045

ture dries quite rapidly, the speed of the entire process depending upon the roughness of the surface. Since the image penetrates as far as light carries it, the photograph becomes a part of the surface and is impervious to weather. Homes, offices and stores are being decorated in this manner. Outdoor advertising finds the mural photograph a new and attractive medium, for a lasting picture or poster or design can be printed overnight on a billboard or wall. Theater scenery can be printed with utmost realism. On plywood and plaster the mural photograph has a soft luminous effect quite attractive for decorative purposes. In spreading emulsion on the wall, the spray-gun operator wears a mask to protect himself from inhaling fumes.

Air from Tire Jacks Up Car in Ten Seconds

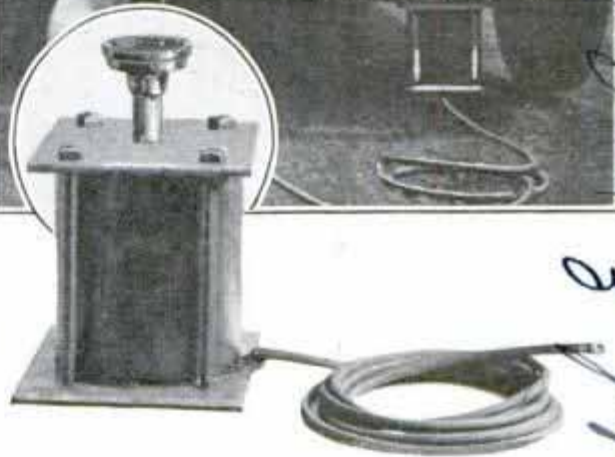

Top, jacking up wheel with air from spare tire. Bottom, the air-operated jack

Silent Gasoline Road Drill Tested in War on Noise

Self-contained and operated by gasoline, a silent road drill has been tested as a means of reducing noise in England. The drill lacks the familiar clatter of drills now in use on highways and streets. Hardly more than a steady hum can be heard as the drill pounds to pieces various kinds of pavement or breaks up rock.



Official trying out the noiseless road drill which is operated by gasoline engine

Demonstrated by Isaac Kight & Co

Mar 28 1942

London

Milton Chamberlain, Milton M. Nottingham, England

Entirely automatic and requiring no manual operation by the car owner, the latest jack is raised by air from one of the tires. Five pounds of air elevate the car sufficiently to permit changing a tire or wheel. Loss of five pounds from normal operating pressure will not interfere with travel to the next service station where the tire may be inflated to full pressure. The jack is easy to use. Its air hose is screwed onto the tire valve after the jack has been placed to raise the car. When the air hose is connected properly, the jack immediately starts lifting the car and the complete operation occupies only ten seconds. The car is lowered by unscrewing the hose from the tire.

Glass fishing line made of braided fibrous glass threads has been found stronger than linen or silk line of equal diameter.

Messrs. Warsop, Patent

Experiment made by C. C. Ashaway

3876 W. Warren Ave

Mc Cabe, 2071 & 21st, Eastmont, Mich.

Mr. Ralph E

C. C. Ashaway

F809.

Why GAMBLE

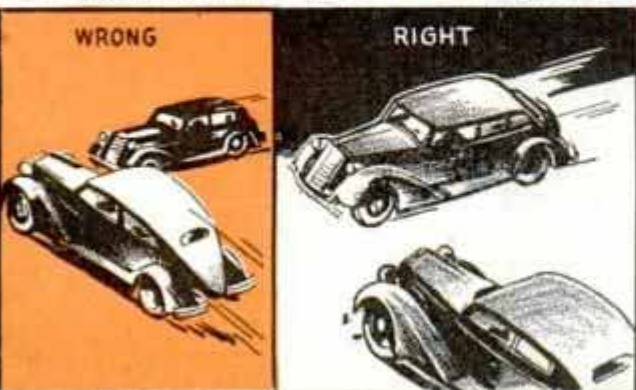
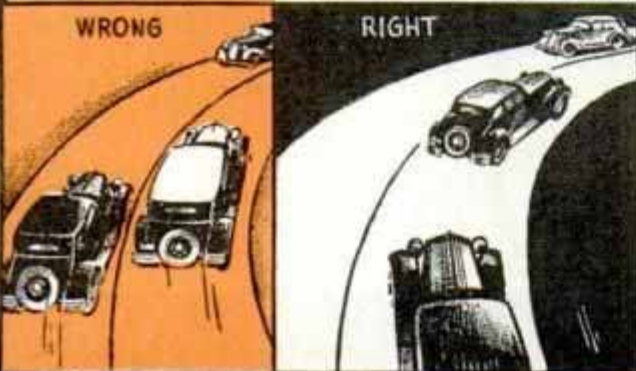

Acme
By H. W. Magee

THERE'S one law which, sooner or later, is going to stop every reckless or careless driver. That's the law of averages. And when this law of averages is applied to traffic accidents today, the rows of cold figures scream a grim warning which every sane motorist should heed because you can't break this law without eventually breaking your neck.

From 1922 through 1935 automobile accidents snuffed out the lives of 380,000 persons in this country. That's more than twice the total of those killed in action or who died of wounds in all the wars in which we ever participated. It's more than the combined population of Wyoming and Nevada, and about the same as wiping out the population of Vermont or Indianapolis. And deaths continue to mount.

Last year 40,000,000 motorists burned up 16,250,000,000 gallons of gasoline driving 26,250,000 cars over our 3,250,000 miles of roads. Statistics of the National Safety Council show this traffic resulted in 37,000 deaths—an all time high—105,000 persons permanently disabled, 1,180,000 others temporarily disabled and 6,500,000 accidents causing damage to property. And that's one death for each eighty-eight miles of highway, one permanent disabil-

Right and wrong driving practices and, at top, one New York company teaches its drivers caution with the aid of this dummy which rolls out unexpectedly

Spray Gun and Enlarger Print Photo on Wall

712
I 10 53

Exhibit Ave.
511-5th Ave NYC

Photographers & Praying Ltd. 15 Elizabeth St. d.W.
London England.
had igel as market in U.S.
12/19/30



Top, projecting negative on sensitized wall and fixing it with spray gun. Mask, shown at lower left, is worn for protection while spraying sensitive emulsion. Right, the finished mural photograph

One evening you walk past a tall office building whose brick wall on one side is bare and windowless. The next morning you are amazed to discover a huge mural photograph printed on those bricks. With a spray gun, sensitive emulsions and an ordinary enlarger, photographic artists today are actually printing pictures on interior walls of plaster or canvas, exterior

walls of brick or wood. They can even project an imperishable photograph on a cement sidewalk, on metal—on virtually any solid surface. The process takes but a few hours. First a patented emulsion is spread over the entire surface with spray guns; the photograph is projected with an ordinary enlarger, and is developed and fixed again with the spray guns. The pic-

Cont. Paul Samboit Photographers

the chimney, tending to prevent absorption of heat by the bricks and to maintain a stack temperature high enough to evaporate the moisture and carry it away.

F1018

"Walking" Radio Station Sends One Mile

Operating on low power and ultra-high frequency, a new "walking transmitter" introduced recently by one of the larger broadcast companies has a working range of one mile. It consists of antenna and radio-frequency oscillator concealed in a cane, a microphone on a wrist strap, batteries in a money belt and audio amplifier and modulator in a binocular case. Its first use was for roving interviews at a political convention, the voice of the speaker being transmitted to a central station nearby and rebroadcast.



Here is the "walking transmitter." Note the microphone strapped to announcer's wrist

Battery of Photo Flash Bulbs Synchronized by Control Box

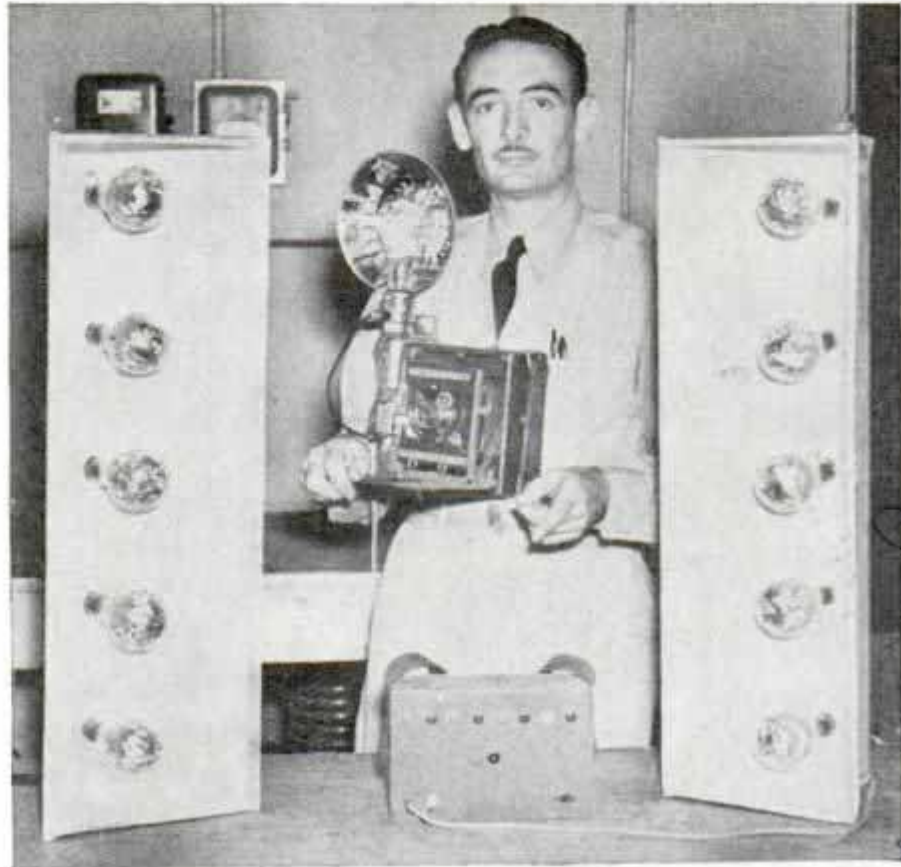

Portable multiple control box on table in center fires ten flashlight bulbs simultaneously with bulb attached to camera

Firing an entire battery of flashlight bulbs simultaneously with the click of the speed camera shutter has been accomplished by the development of a multiple control box. The ordinary synchronizer opens the camera shutter at the peak of the flashlight. With the multiple control, as many as ten photoflash bulbs arranged at strategic points within a radius of 100 feet can be touched off in unison, literally flooding with light the area being photographed. The control box is a compact case containing bulbs and switches, supplying its own current.

#991

Rubber Wrapper Keeps Soap Water and Weather Proof

Applied to cakes of soap by a special quick-vulcanizing process, a rubber coating that is water and weatherproof has been patented for wrapping soap. To unwrap a cake, the coating is stripped off by tugging at a small tab on the side. The wrappers may be colored. The coating is permeable to the perfume of the soap.

John Parlane wife
1/16 Parlane wife
d.w.

Handwritten notes on the right side of the page, including "Perry Leidy's Camera" and "Lester's Camera".

Handwritten notes at the bottom of the page, including "Columbia Broadcasting" and "Lester's Camera".

7809

with DEATH ?



ity for each thirty-one miles, one temporary disability for every three miles and a property damage accident for each half mile. Truly death and destruction stalk our highways.

There's just one message in all these figures—be careful or be killed. But how do these statistics concern you directly? You consider yourself a careful driver, you've never killed anyone, never injured anyone, perhaps never dented a fender. Well, that's where the law of averages comes in. If the present traffic accident rate continues, one out of every twenty persons in this country will be injured or killed in an automobile accident within five years. And that includes you!

Just jot down your name, then add the names of nineteen relatives and friends. One of you will be killed or injured in a traffic smash-up by 1941 by the law of averages. Here's another way of looking at it. Write down the

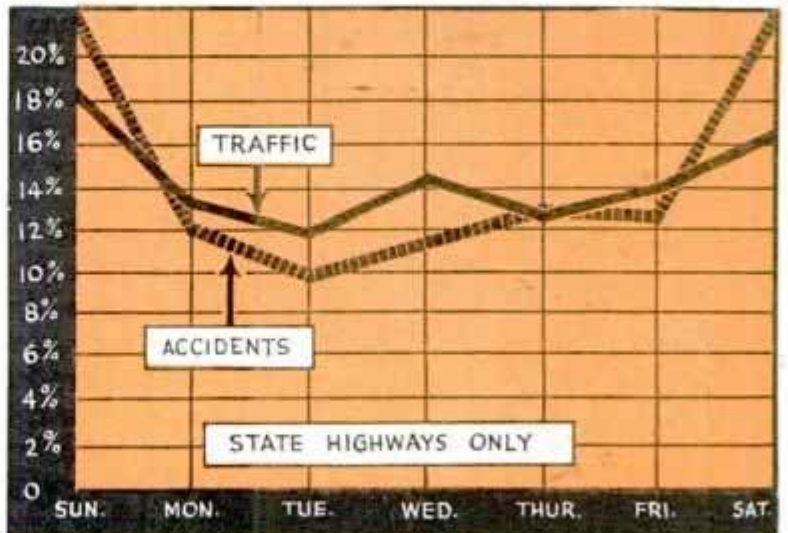
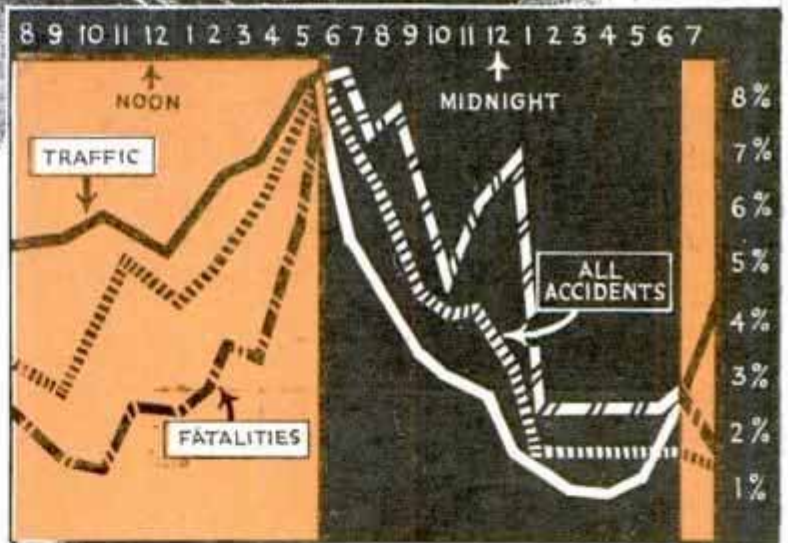

Top chart shows traffic accidents around the clock and bottom one shows accidents through the week. The two charts indicate that safest time to drive is about 3 a.m. on Tuesdays

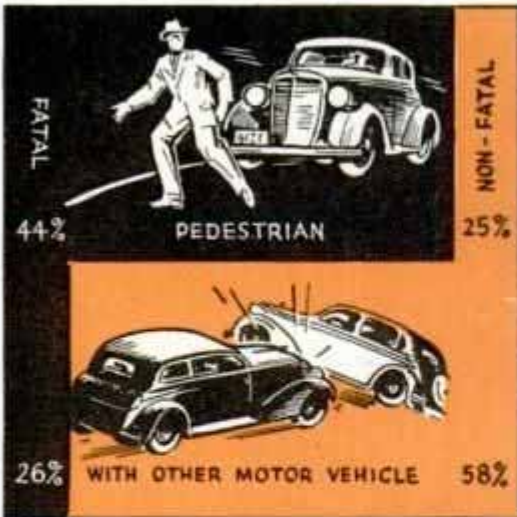

names of three children in your neighborhood. Two of the three are sure—not likely, but sure—to be injured in auto accidents during their lifetimes if the present rate continues. Or perhaps you have a sixteen-year-old boy. If he looks forward to a lifetime of driving and is exposed both to driving and pedestrian hazards, your son also is certain, by the law of averages, to be hurt in a traffic accident unless the present rate is reduced.

Not a very cheerful outlook, is it? Now let's compute the economic loss in addition to human lives wasted. Last year we spent about \$2,638,000,000 for new cars and trucks. During the same



Road illuminated with 400-candlepower incandescent lamps and reflectors. Left, types of fatal and non-fatal accidents



period accidents cost us more than \$1,600,000,000 in wage losses, doctor and hospital bills, insurance overhead and property damage. Thus for each \$1,000 spent for new cars in 1935, another \$600 went for accidents. Most of that was money wasted. Some of it was your money—paid in high insurance rates if for nothing else. Project this loss over the next ten years and you have a figure approximating half the national debt.

So there you are. Automobile accidents are costing you money whether you have accidents or not, and by the law of averages you or someone close to you will be killed or injured in one within five years if present conditions continue.

"So what?" you say. "I'm a very careful driver. A lot of other fellows are causing all this. They ought to be ruled off the highways. But why pick on me?"

Well, you'll be just as dead if the "other fellow" kills you as if you do the job yourself. And are

you careful every minute you're behind the wheel, or do you think you are? For every accident last year which went to pile up the grim total of death and destruction, there were literally hundreds of near accidents—situations when something almost happened but didn't. Every driver has had these narrow escapes—some call them "lucky breaks." Now accidents don't just happen; someone causes them. It's human to blame the "other fellow" but the other chap can't always be in the wrong. You've got to accept part of the responsibility, at least part of the time.

Who had all those thousands of accidents last year? Some were physically defective, some didn't know how to drive. But the great majority were competent drivers who had acquired careless habits. They went too fast, passed on hills and curves, sped through intersections, jumped the lights and did a thousand and one other foolish things until the law of averages caught up with them. They didn't actually want to have an accident, but neither did they want sufficiently not to have one.

And that's the secret of staying out of trouble on the highways today. You've got to prevent the accident before it happens. And the best way to do that is to check up im-

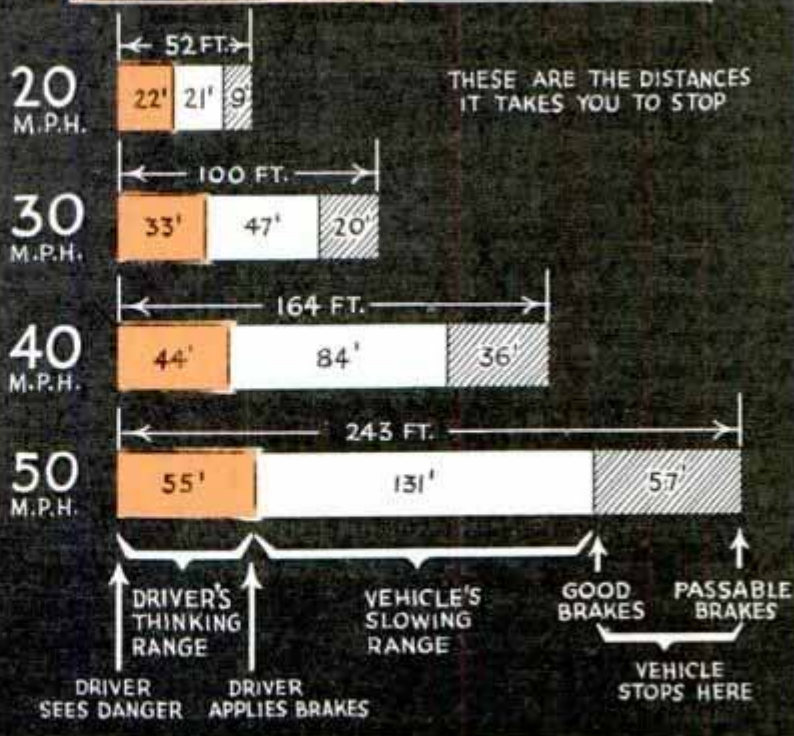
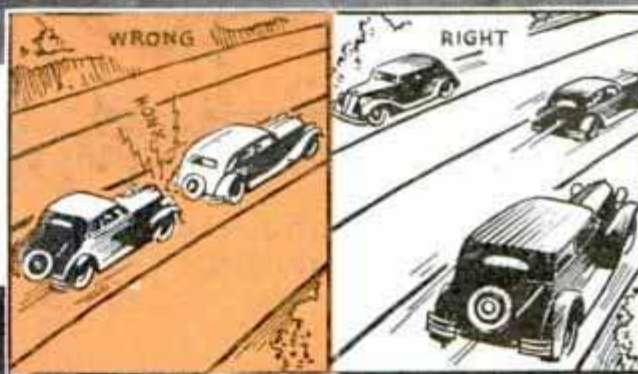
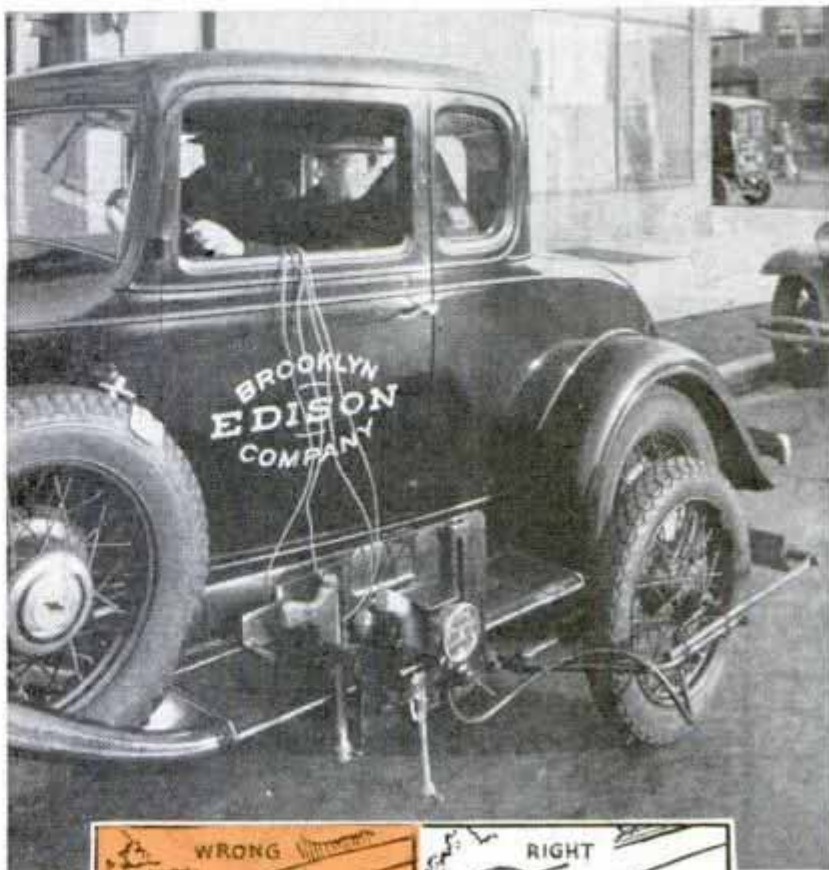

Distances required to stop with good and fair brakes. Top, machine for measuring reaction time and distance required to stop after driver applies brakes

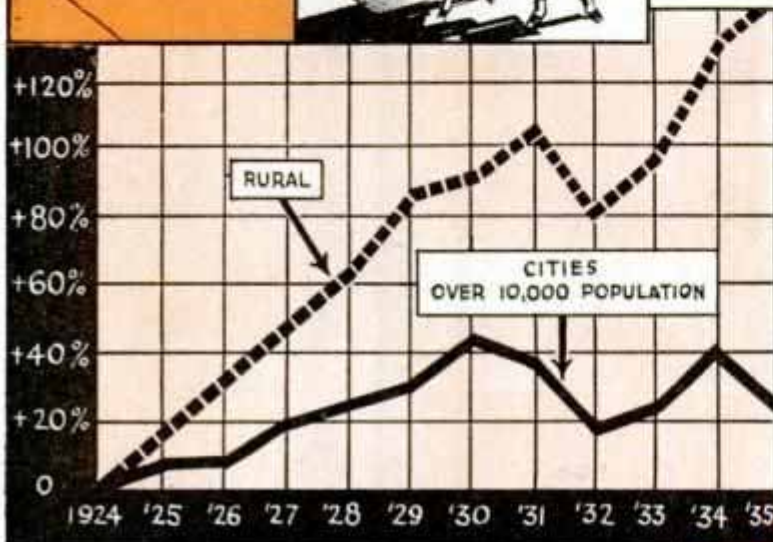
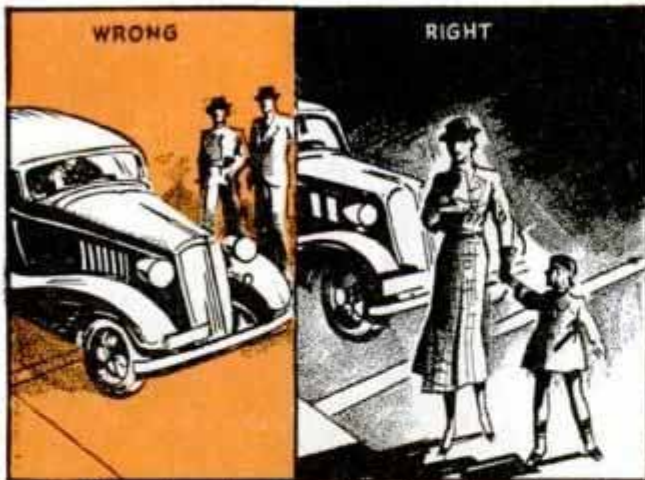

mediately on your driving habits. If every one of 40,000,000 drivers discarded all careless and dangerous practices today, the deaths, injuries, property damage—and insurance rates—would drop tomorrow. If you'll overhaul your own driving practices, you'll go far toward avoiding an accident.

First, let's consider speed. Modern cars do seventy, eighty or even ninety miles an hour with ease. But can your brain go ninety miles an hour, or even sixty? Cars and highways are faster, but your reaction time isn't. And it still takes time to think. It takes about three-fourths of a second on an average. So from the time you see the heifer until the time you do something about it, your car travels about fifty-five feet if you're doing fifty miles an hour. Then after you get your foot on the brake, you need nearly 200 feet more to stop—unless you have poor brakes.

Did you ever do sixty at night on a good stretch? The chances are you were driving "blind" and didn't even know it. With good brakes and good road conditions, you need about 330 feet to stop at sixty miles per hour. Now if your lights enable you

to see only 200 feet, your stopping point at any moment is almost 150 feet beyond the distance you can see ahead. You would even be out-driving 300-foot head lamps at that speed.

Here's another startling conception of sixty miles an hour. At that speed your car has enough momentum to travel 120 feet straight up if it could "take off." So when you do sixty you might as well be 120 feet in the air if you hit something.

Just another way of saying that hitting a stationary object at sixty creates the same impact force as though the car were to drop from the top of a twelve-story building.

The higher the speed, the worse the accident. One accident in eleven is fatal at fifty miles per hour and above. At speeds of twenty and under, only one accident in sixty-one is fatal. But just driving under fifty isn't any insurance against accidents. Most of them occur at speeds under

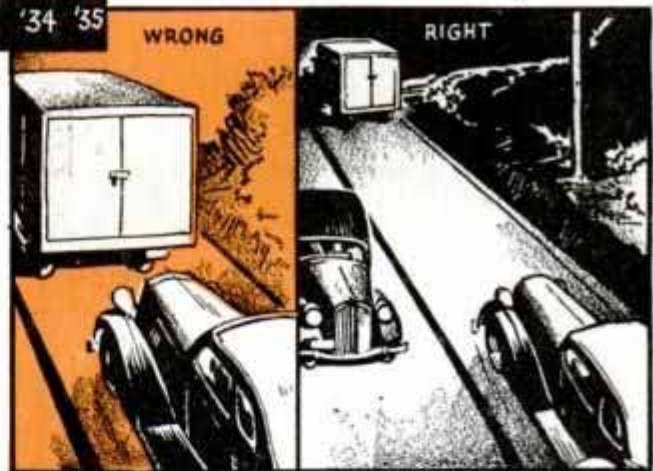

Right and wrong ways of doing it and chart showing how deaths on open road are going up while fatalities in cities are going down

that figure. It's quite easy to determine the type of accident you are most likely to have. Just study the kind most drivers had last year.

So here's a tip that will reduce your chance of killing someone nearly fifty per cent—always be on the lookout for pedestrians. Nearly half of last year's traffic fatalities were traveling afoot. The ratio of injuries to deaths is twenty to one for pedestrian accidents. Nearly 7,000 pedestrians jaywalked to their death last year but, on the other hand, mistakes by driv-

ers accounted for about two out of every three accidents of every type. If you're in the habit of letting pedestrians look out for themselves, you stand an excellent chance of killing someone. Incidentally, school children, trained to watch traffic, made a better safety record than adults last year.

Car defects cause, or help cause, at least fifteen per cent of all accidents, it is estimated, so here's another tip. You minimize your chances of killing or being killed by proper maintenance. Poor brakes and glaring lights are the mechanical defects blamed for most such accidents.

One serious mistake in driving may be your last, so don't be lulled into a sense of security just because you're on the open road. Since 1930 traffic deaths for large cities have been declining while deaths on the open road have been climbing. And don't think you are careful just because you exercise caution in turning. Nine out of ten vehicles involved in fatal accidents last year were going straight ahead. Even at intersections, most accidents involve vehicles going straight ahead. If you cross the center line occasionally, or pass on a hill or blind curve, you should be interested to learn that twenty-six per cent of all fatal accidents and fifty-eight per cent

(Continued to page 125A)

Latest Clock Has a "Voice" to Announce Time

Sleepyheads may be awakened in the near future by a clock which announces



in clear tones, "Seven o'clock," or whatever the hour may be. Such a clock has been developed by a communications laboratory. It has an odd caricature face and a "voice" circuit which will put the exact hour into words.

It is synchronized with a nationwide time service. The clock may be used as a train announcer, with a microphone connected into the speech circuit for making announcements other than telling the time.

Handy Kitchen Wrenches Have Rubber Teeth



Rubber-toothed wrench is put to varied uses around kitchen lifting hot dishes and gripping jar lids

Saving the hands from cuts and burns, two wrenches with rubber teeth or jaws serve many purposes in the kitchen. One is handy for canning, serving to lift hot jars or cans from the water, to hold the jar while the cap is tightened or loosened, to grip wide-mouth jars and to lift potatoes, corn, bottles and cans from hot water or the oven. The other wrench grips the cap of any screw-top bottle, jar or can, removes hot pans and pots from the stove, removes hot lids from cooking vessels, lifts hot clothes from washer to wringer, cracks nuts and is strong enough for a pipe wrench.

Wright Clock Co. 1935 Broadway New York

Espritale - Cabote
United Sales Corp. 37 W. 22nd St. New York, N.Y.

Wright Clock Co. 1935 Broadway

Rochester NY

F1051
**Gas Extracted from Clover
by Inexpensive Process**

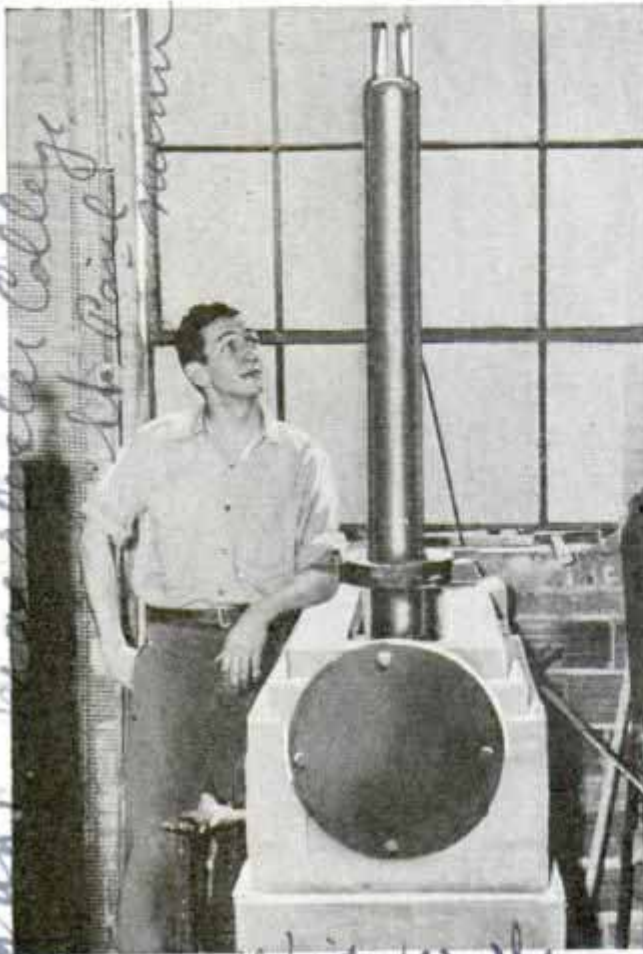

Wide World
This is part of the apparatus with which commercial gas may be extracted from clover

Dr. Wm. D. Williams, Nashville and Harold G. Williams, Chicago, Minn.
Claimed to be commercially practical, a process for extracting gas from roadside clover has been discovered by two Minnesota chemists. After manufacturing gas in their plant for several months, the chemists announced that 3,000 acres of clover would be sufficient for making a year's supply of gas for St. Paul's domestic and industrial users.

F1022
**Popular-Size Films Developed
in Adjustable Tank**



Amateur photographers can develop their own films in an adjustable tank which is made to accommodate various popular sized films. Just made available, the tank

will hold a quart of developer and is of stainless acid-resistant steel. The exposed film is wound on a reel in the darkroom, immersed in the tank of developer and covered. The rest of the process can be done in daylight, for the tank cover has a light-trapped opening through which solutions and rinsing water can be poured in or out without exposing the interior. The film remains in the tank until ready for drying. To change from one size film to another requires only a shift of the upper flange from one notch to another.

F1052
**Sunlight Cast into Dark Rooms
by Automatic Reflector**

Several hours of sunlight can be cast into dark rooms of city apartments and hotels by means of an automatic reflector. The device follows the sun whenever it is visible, sets its mirrors to catch its rays and then reflects them by a complicated series of prisms and mirrors to any 1,300-foot square area desired. The machine may be set up on the roof of an adjoining building to reflect the sunlight into rooms located on inside courts or perhaps on air shafts of large buildings.



Wide World
This odd arrangement of mirrors reflects sunlight into rooms on dark courts and airshafts

Dr. Wm. D. Williams, Nashville and Harold G. Williams, Chicago, Minn.

Wide World
Dr. Wm. D. Williams, Nashville and Harold G. Williams, Chicago, Minn.

Wide World
Dr. Wm. D. Williams, Nashville and Harold G. Williams, Chicago, Minn.

Famous Trains in Miniature on Model Line

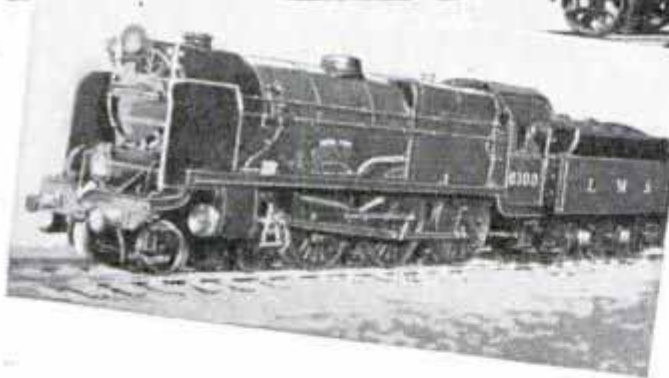
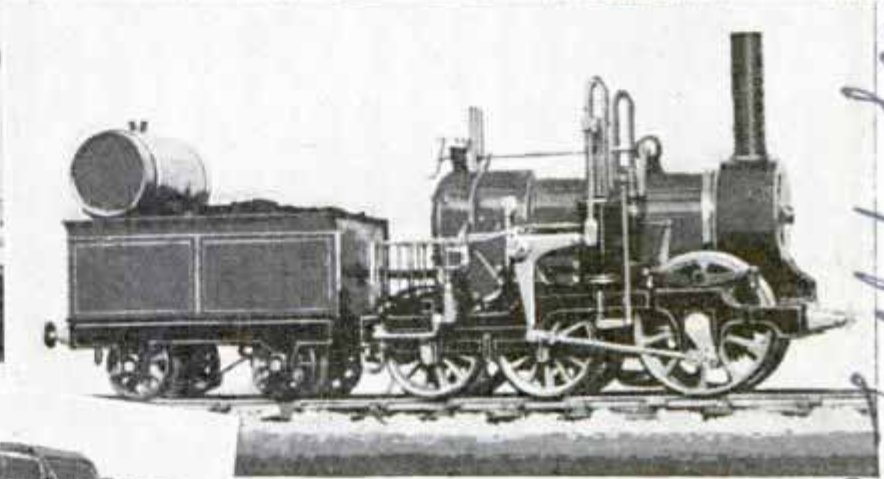
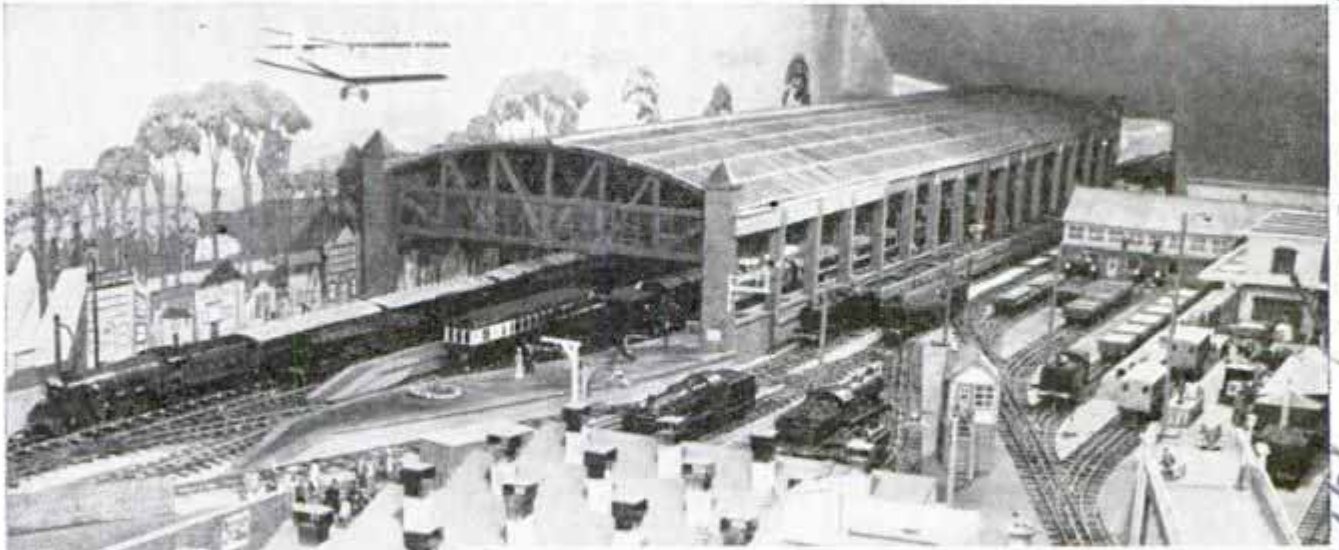

Several views of model railroad. Note the two miniature engines which are exactly like locomotives famous in English railroading circles

Operating on a model railroad constructed in Scotland are the miniatures of such famous trains as the Rocket, Royal Scot, Princess Royal, Cock O' the North, Flying Scotsman, King George V and others. The line is 800 feet long and its rolling stock consists of more than thirty locomotives, 100 freight cars and fifty passenger cars. The track has seventy switches, both electrically and manually operated. All locomotives, and the automatic couplings fitted to all cars, are controlled from one control board. The entire system is electrically interlocked. The track runs through six tunnels and is illuminated by more than 300 miniature electric lamps. The builder, C. W. Meredith, has spent thirty years on the model railroad. Sitting at the switchboard he can break up trains, shuttling cars and locomotives from one track to another, and perform many other intricate movements of the trains.

F1020

Electric Unit Sterilizes Dirt and Eliminates Weeding

Inexpensive sterilization of dirt is possible with electrical equipment consisting of four heating units with mountings. The florist or specialty grower builds these units into a wooden vat or container. Dirt to be cleaned of plant enemies, such as weed seeds, insect life and fungi, is placed in the container and the electricity turned on. A thermostat maintains automatically temperatures of 160 to 180 degrees Fahrenheit, raising the temperature of the soil sufficiently to destroy the plant enemies.

Em. G. Sabod - Smith American Council
Sturbridge - Scotland

built by C.W. Meredith

General Electric

F845

10555 Hulman Ave
Los Angeles Calif

The AMATEUR

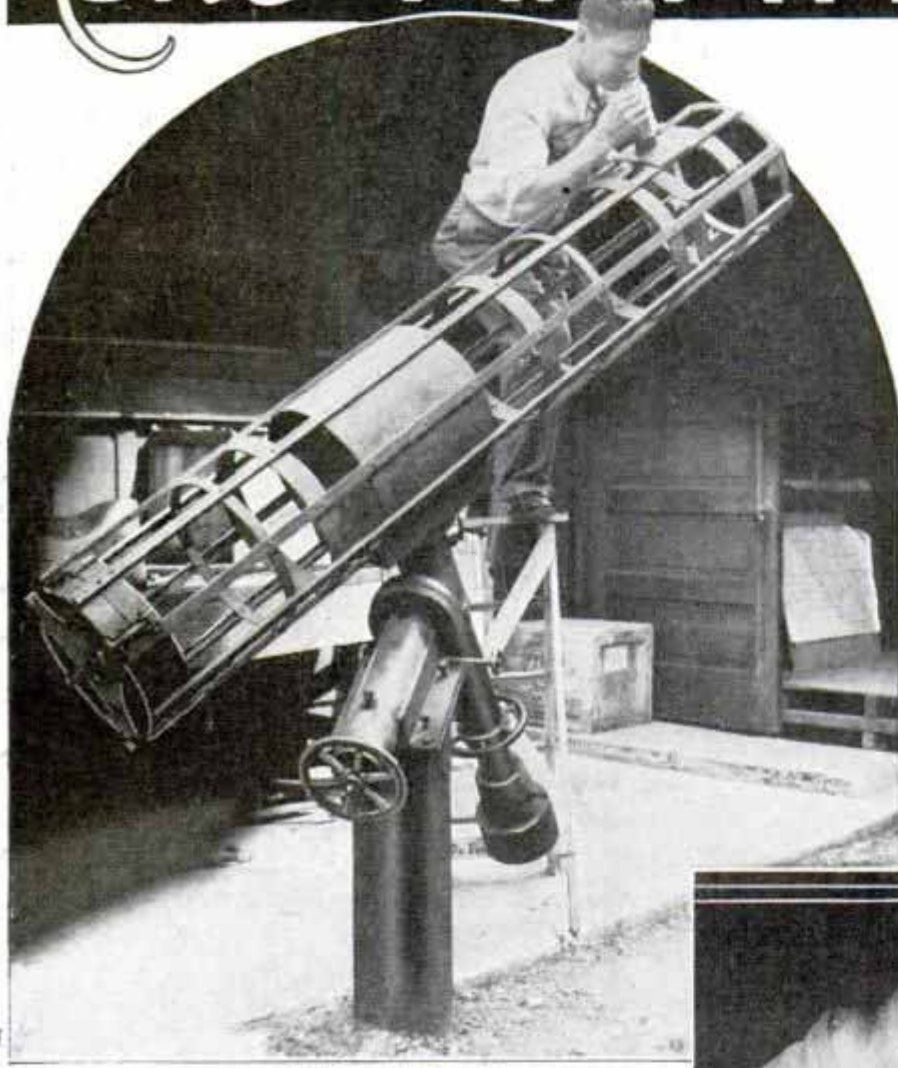

"This leaves several spectacular fields of research open for amateurs," says Porter, who is acting as consultant for the new 200-inch giant telescope in California. "One of these is hunting for new comets and another is looking for some of the minor planets. Lunar occultation is another field in which amateur astronomers can do important work. The moon is not as steady as you might think and is often ahead of or behind schedule. We know the stars are steady, so by taking the exact time at

FOR a few dollars you can create an observatory in your back yard and with a homemade telescope explore the sky for new comets and planets.

Amateur star gazers are on the job in all parts of the world and frequently a member of this star patrol finds a new dot of light in the sky. It may be a new comet, an unknown planet, or a faint star that suddenly has exploded. Amateurs are actually beating professional astronomers in discovering new heavenly bodies.

The reason for this, explains Russell W. Porter, "patron saint of amateur astronomy," is that professional astronomers are usually busy on special problems and hardly have time to sweep the skies on the chance of spotting something new. Also, the large instruments of the observatories have small fields of vision which permit only tiny patches of the sky to be observed at a time.



Polishing surface of twelve-inch mirror, and large amateur telescope with skeleton tube

Left. Making - \$3.00. + 895.

SKY PATROL

which certain stars go into eclipse, behind the moon, amateurs may collect facts from which the reasons for the moon's behavior may be found.

"Small comets that go parading back and forth through the solar system are often observed by am-

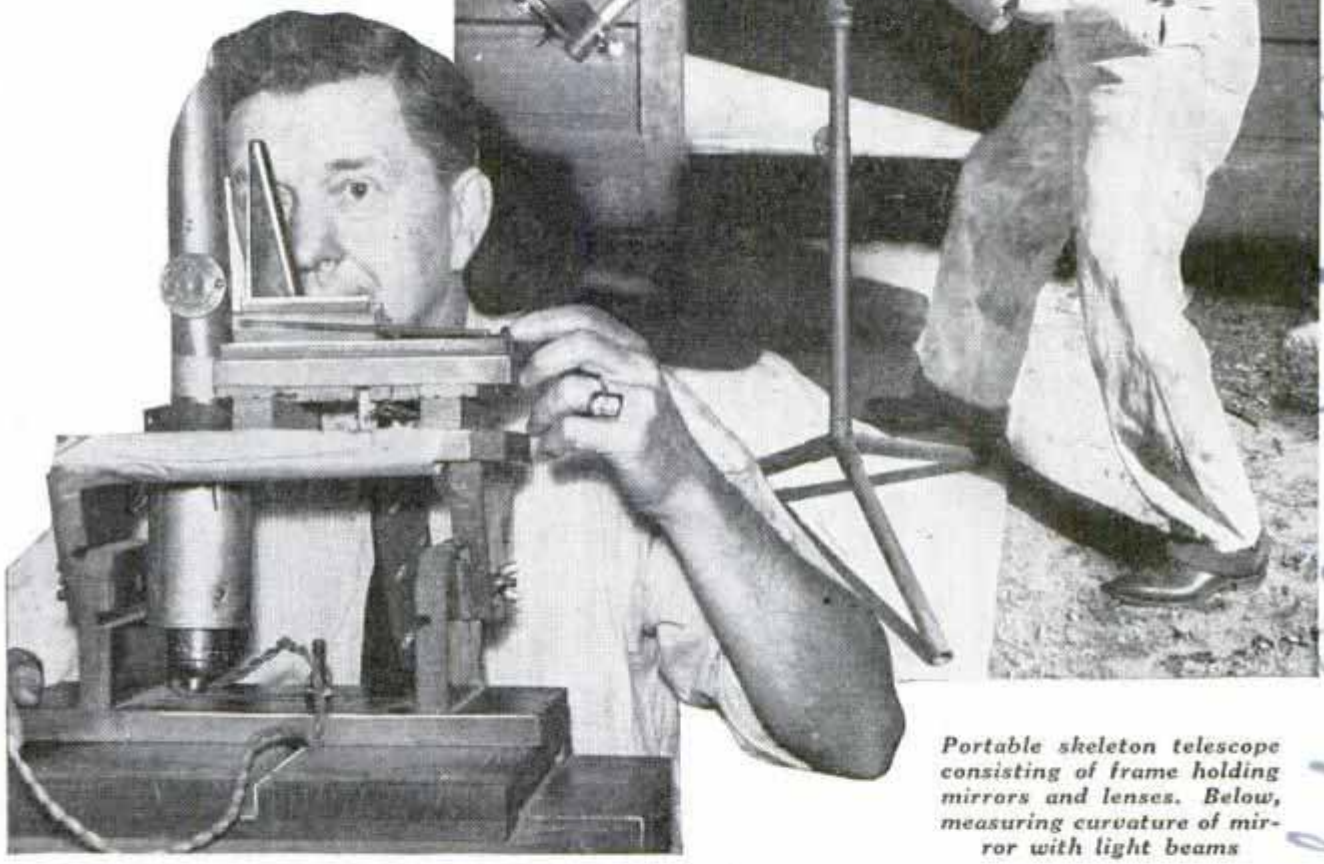

Portable skeleton telescope consisting of frame holding mirrors and lenses. Below, measuring curvature of mirror with light beams

ateurs and when a new one is found the comet is usually named after its discoverer. There are thousands of small planets in our solar system about which little is known. Most of these are too small ever to be seen, but it is probable amateurs will discover a few more of the larger masses among the minor planets.

"Professional astronomers are also aided by amateurs in the study of variable stars. These wax and wane in brightness. The amateurs keep track of the varying brilliance of these stars and draw up charts of their behavior for the observatories.

The sensational 'blowing up' of 'Nova Herculis,' a star normally 20,000 times brighter than our own sun, was first observed by an English amateur. In less than a month's time after it started to expand, 'Nova Herculis' increased its brilliance 160,000 times. Most of the variable stars observed since the beginning of the century were first found by amateurs."

Strange as it sounds, you can usually see the stars much better with a home-made telescope than with the mightiest instruments of the observatories. Small telescopes reveal the stars as steady, bright

Telescope built at the Newtonian Engineering Astronomical Society, 2608 W 8th Los Angeles.

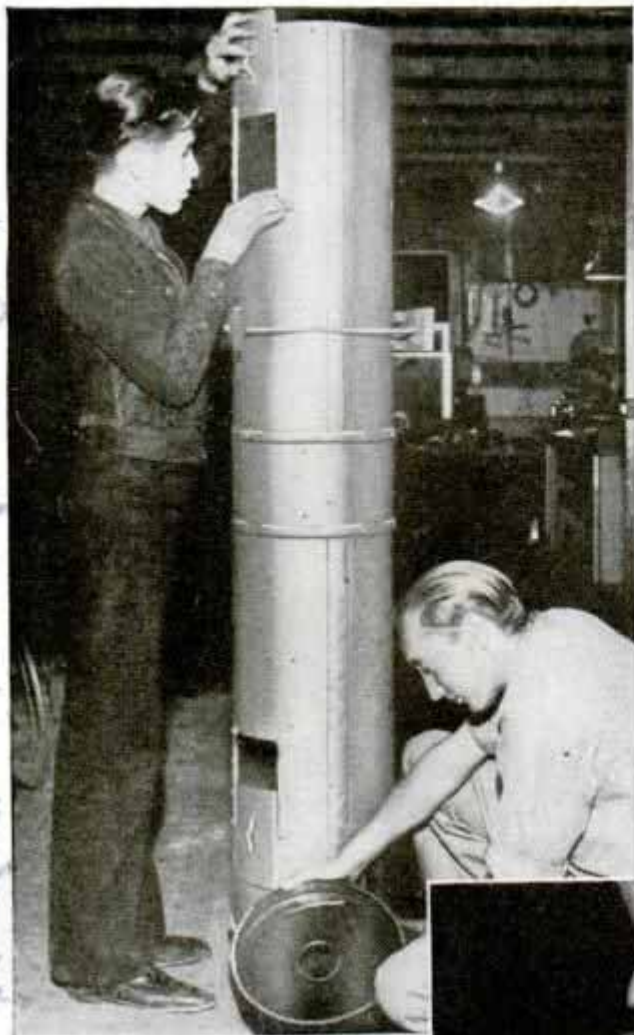

time with the vibrations. "Seeing" is usually much better after midnight when the atmosphere has cooled off.

Early this year an Ohio draftsman, Leslie C. Peltier, discovered a new comet with a six-inch telescope he made himself. A few months later the comet was only a couple of light-minutes away from the earth and was the first that could be seen with the naked eye since 1927. Peltier made his first telescope eighteen years ago and is the discoverer of two other comets, as well as co-discoverer of three more.

Amateur telescopes are simple affairs, consisting of a curved glass reflecting mirror, a small mirror mounted diagonally above the main mirror to reflect its gathered light outside the tube, and an eyepiece that magnifies the image. These parts are assembled on an equatorial mounting that allows the telescope to be pointed at any part of the sky.

You can build such an instrument for

pin points of light, while in the larger telescopes the stars seem to dance and jiggle. Even the moon trembles and blurs. Planets are just as hard to see, although through amateur telescopes the planets appear to be bright, steady disks. This is because with the largest telescopes the "hot stove effect" of atmospheric disturbances is very pronounced. The twinkling of a star becomes a steady dance and astronomers must wait for exceptionally quiet nights to make visual observations. Routine stellar photography, however, may be made at nearly any time because the astronomers guide their cameras to keep

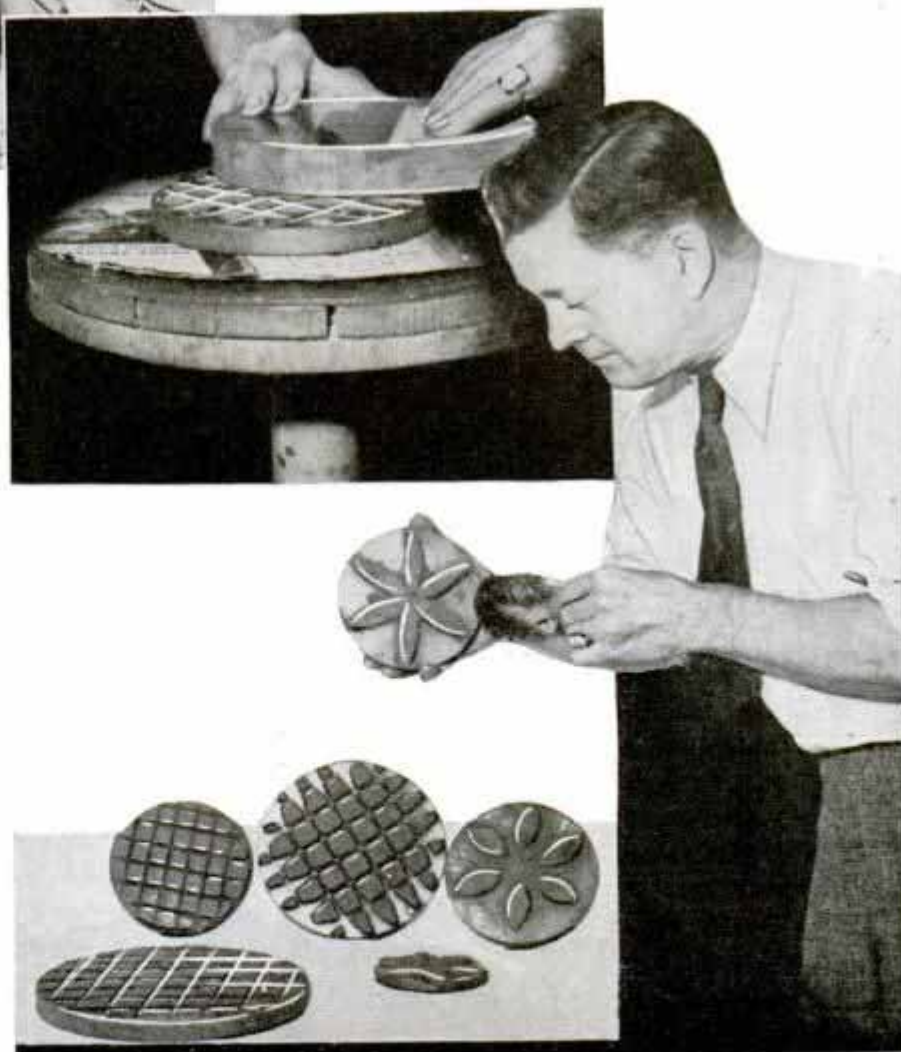

Top, tube and "doughnut" mirror of twelve-inch telescope. Center, polishing mirror for small telescope. Bottom, polishing tools used to create final curve on mirror glass

about \$12 and up, although one amateur completed his for a cash outlay of \$1.50. He found a thick piece of glass suitable for grinding out a curved mirror surface and used the lenses from an old pair of binoculars for the eyepiece, mounting them in a wooden spool. He picked up enough pipe and tubing in a junk yard to make a rigid mounting.

Glass for a mirror six inches in diameter costs about \$3, or you can use the heavy pane from a ship's porthole. Sections of large stovepipe or heating pipe make a satisfactory telescope tube although a solid tube is not necessary. A skeleton tube or merely a framework to hold the optical parts in position is enough. A good mounting on which to place the telescope can be assembled from the gears and rear end of a junked automobile. Many amateur telescope clubs assemble all the necessary parts into inexpensive kits which the members buy.

(Continued to page 116A)

T1010
**Midget Radio for Policemen
 Is Carried in Pocket**

Latest equipment for the English bobby is a miniature radio receiving set with which he picks up instructions from police headquarters while on duty. The set is so small that the policeman carries the complete outfit in his pocket.



Will World
 Listening in on a London bobby's pocket radio set to orders broadcast from police headquarters

T820
**Twenty Miles to the Pint
 Is Motorcycle's Record**



Economical motorcycle has its "outboard" engine mounted over the front wheel.

One hundred twenty miles on less than three quarts of gasoline is the record of an "underslung" type motorcycle built by a Los Angeles man and exhibited at the San Diego exposition. Its wheels are less than knee-high and equipped with balloon tires. The one-cylinder motor drives the front wheel with a belt.

T1040
**Fruit Trees Fed from Bottles
 to Speed Up Growth**

Fruit trees in a Kent, England, research station are being grown on nourishment fed them from bottles, much in the manner of rearing babies. Small holes are made in the tree trunk for insertion of the ends of flexible tubing connected to inverted bottles of special chemical solutions hung in the top limbs. The trees absorb the chemical plant foods direct. Water may be supplied the trees in the same manner during droughts. The bottle-feeding method speeds up growth and makes possible direct feeding of any part of the tree which may be undernourished.

The Director, East
 Malvern Research

Click! Handley too! Call
 station, Mr. Wardstone.

Spray Gun Applies Solder and Heats the Metal

9 42.50

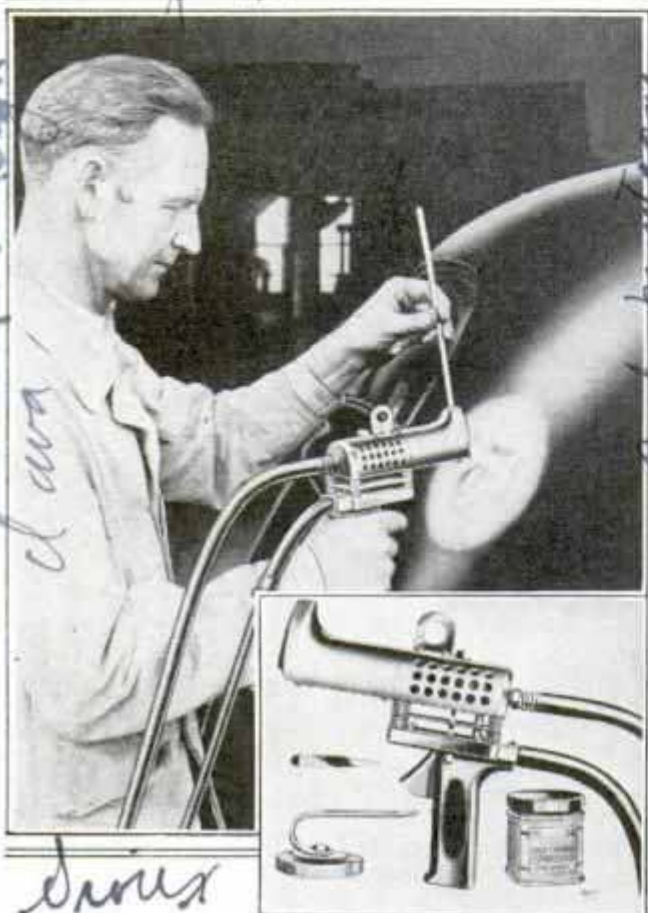

Spray gun for applying molten solder which is melted by electric element inside gun

any voltage, inc. 220
 Similar in principle to the paint guns used for applying lacquer, a spray gun has been developed for applying molten solder under pressure of compressed air. The tool eliminates the need for torches, soldering irons and liquid fluxes, the special body solder in bar form which is used being melted by an electrically heated element inside the barrel of the gun and converted into metallic spray by compressed air at a pressure of seventy pounds. The flux is part of a special compound in paste form which is applied to the surface being treated with a felt pad furnished with the gun. Little of the heat of the tool and the molten solder is transmitted to the metal panel, so the danger of igniting inflammable materials in contact with the panel is eliminated. A trigger switch controls both heat and air pressure. The gun is particularly adapted to filling dents in automobile fenders and bodies without removing the parts from the car. The secret of the tool's success lies in the ab-

presence of grease and dirt on the metal panel. A power sanding machine is used to remove paint, primer and rust before soldering and for smoothing the finished job.

Salt Makes Gravel Roads Dustless

Highways are being "salted down" in the Canadian provinces of Ontario and Quebec and rural sections of the United States. Experiments in Nova Scotia indicated that salt not only lengthened the life of clay and gravel roads but virtually eliminated dust. Salt mixed in the clay retards the evaporation of moisture when the road is first laid, and the growth of salt crystals as the road dries out tends to diminish shrinking and cracking.

Folding One-Wheel Trailer Has Beds for Four

Traveling on one knee-action swivel wheel, a folding trailer, which opens up to seven times its original size, has beds for four, a table which folds into the floor, refrigerator, food compartment, storage space



One-wheel trailer which folds into compact unit on road and expands into a home when parked

Albertson Co. Chicago Ill.
Clara
Emb. machine
Stewart Trallette Park
W.S. Co. Chicago Ill.
W.S. Co. Chicago Ill.

Special one
McLell Univ. Montreal

F 104 6

F 1013

Stewart
Yorkers
A.K. Stewart & Son

for stove and cooking utensils, six compartments for linen and toilet articles and two clothes drawers on the sides. The folding beds have mirrors and clothes hangers on the back. The trailer, which can be opened and set up for sleeping in a few minutes, may be parked independently of the car on folding legs with adjustable jacks. Canvas for spreading over the trailer can be set with four legs, making a canopy eighteen feet long and eight feet wide. Ten persons can be seated in the trailer when the beds are not in use. The chassis is connected to the bumper with double hitch brackets. Folded, the trailer is forty-seven inches wide, seventy-two inches long and twenty-four inches high.

Television Sender on Truck Transmits Olympic Pictures



Making movies of Olympic games atop a truck, preparatory to developing the film in the truck and transmitting television images

7963

Portable Hammock and Stand Handy for Outing

Easy to pack and carry, a new portable hammock with its own stand is handy for outings, the lawn, the porch or the penthouse. The stand comes apart for carrying. Upon assembly, the stand has hooks at each end for swinging the hammock.



Portable hammock with its own stand which comes apart for carrying and thus can be taken along on outings

During the recent Olympic games in Germany, experiments were conducted with a portable television transmitter mounted on a truck which could be moved about to record the various contests as they occurred. On the roof of the truck was a moving picture camera which made movies of the games. The film was developed in the truck and then run through the transmitting apparatus.

If you open your fountain pen in an airplane at high altitude, the ink will spurt because of the reduced air pressure.

New York 385 Madison Ave

Vagabond \$18.00

Marshall Field

Post Office

Wayne Univ. Eng.

Fisher Radio Co 11

Short-Measure Gas Costs Autoist Millions

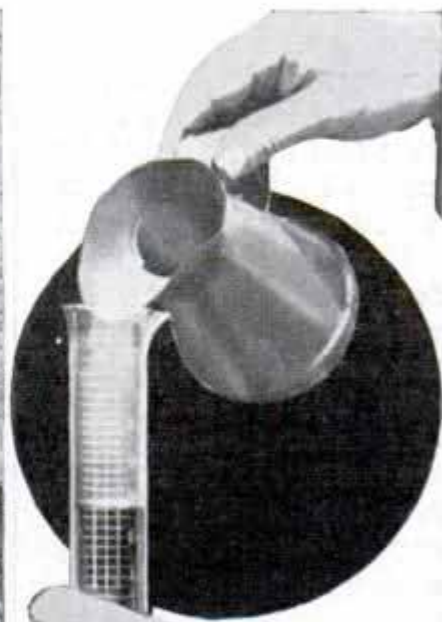

Due to ignorance or outright dishonesty of some filling station operators, automobile owners are paying millions of dollars each year for gasoline they never receive. Among the reasons for short measure on gasoline orders are: failure to prime the pump, failure to properly drain the "dry" type of hose; deliberate shutting off of the gas flow before the ordered quantity has been placed in the customer's tank; shorting the customer when he orders gas and then leaves for the rest room, and defective pumps. Top, left, inspectors pouring test order into measuring can. Right, measuring gasoline left in improperly drained hose. Below, "wet" nozzle with valve at end requires no draining because it is supposed to remain full at all times

add instructions to the inspectors

dist.

... ..

How to Get All the Gasoline You Order

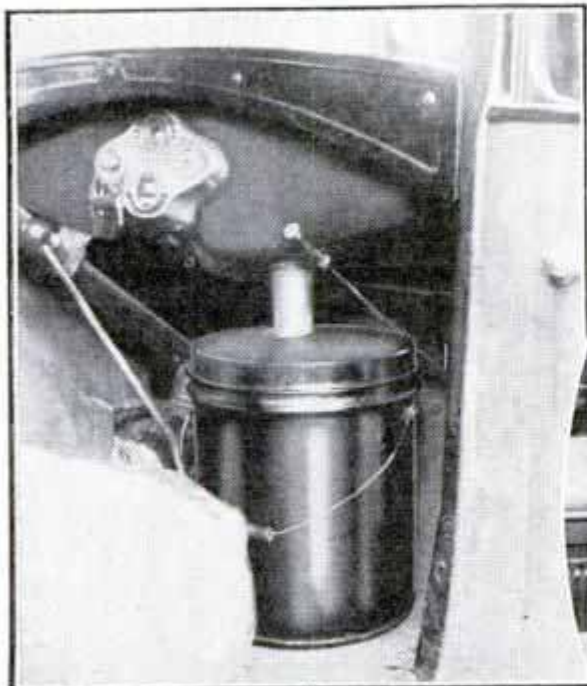

Above, concealed can in inspector's car received test order of gas which then was poured into measuring can as evidence of shortage



Above, improper way to drain "dry" type of hose. This type has no valve-controlled nozzle and motorist should receive all the gas in the hose. Bottom, left, proper way to drain hose so motorist gets what he pays for. By holding hose in this manner, all the gas runs out of line into customer's tank. Shortages up to one and one-half quarts result from improper drainage



Right, arrow points to the visi-gauge on gasoline pump. Note that the gauge is only partly full, indicating that the pump has not been primed. When the gauge is in this condition, the motorist does not get full measure. Inspectors warn customers to watch the gauge on this type of pump. Where portable pumps and old-style pumps without gauges are used, the customer is forced to rely on operator's honesty

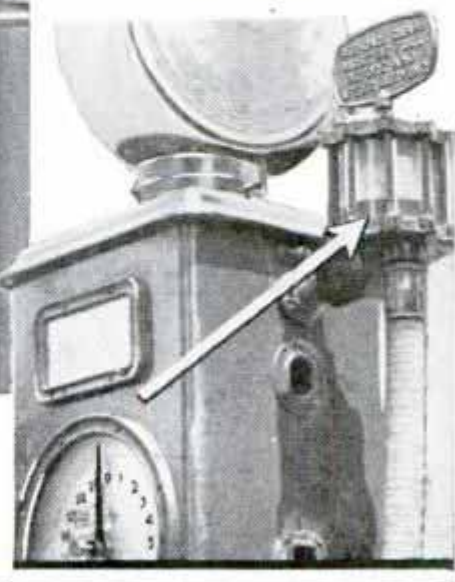

Sinker Mold for Fisherman Turns Out Six Sizes

F1000.

Specialty mfg Co. East Liverpool
Hall's A East Ohio
Bor 7/3
B. B. Exchange Exchange



Sinker mold for the angler which turns out smooth, balanced pellets in six sizes

Fishermen now can pour their own sinkers with the aid of an inexpensive mold which turns out smooth, balanced lead pellets in six sizes. The angler can pour six sinkers at a time, or any single size in the series desired, the weights ranging from one-fourth ounce to two and one-eighth ounces. Two sets of eye rods are supplied so a second pouring can be made while the first is cooling. The mold is assembled and heated, after which it is ready to receive the hot lead.

Sound Film Traps Criminals by Recording Conversation



While the dictaphone has trapped many criminals by their own recorded words, its records can cover only a small space of time unless they are changed frequently. To over-

come this difficulty, Ivan Eremeeff, sound engineer, has developed an apparatus which automatically records every sound in a room for a week and the time it occurred. The apparatus has been made possible by the high development of micro-recording on a sound-film track. A sound film thirty-five millimeters wide can carry as many as ninety-six sound tracks. With 3,000 feet of film and ninety-six sound tracks available, a week's conversation can be recorded. A small concealed microphone picks up the sound. The recording apparatus is driven by an electric motor and can be located at a distance from the microphone. A repeater winds the film which passes over the recording apparatus again and again. Knowing the rate at which the film runs, it is simple to find the time any sound occurred.

Camera "Sees" Black Lightning as Bolt Hits Monument

When lightning struck the Washington monument recently, a cameraman snapped the picture and captured the image of both



Harro & Conroy © The Washington Post
Picture taken as lightning struck Washington monument. Note "black" lightning at tip

Cheshin and 6/6
Phela

2094 January

the black and white light in the bolt. The black lightning, which appears on the photograph as streaks at the tip of the monument, is a photographic mystery. Dalvert M. Little, chief of the U. S. weather bureau's aerological division, says that scientists have never been able to explain black lightning. One theory is that the peculiar wave length of the light causes a chemical reaction on the photographic plate, making a black streak instead of a white one.

Pumps Save Fish from Death by Aerating Water in Stream

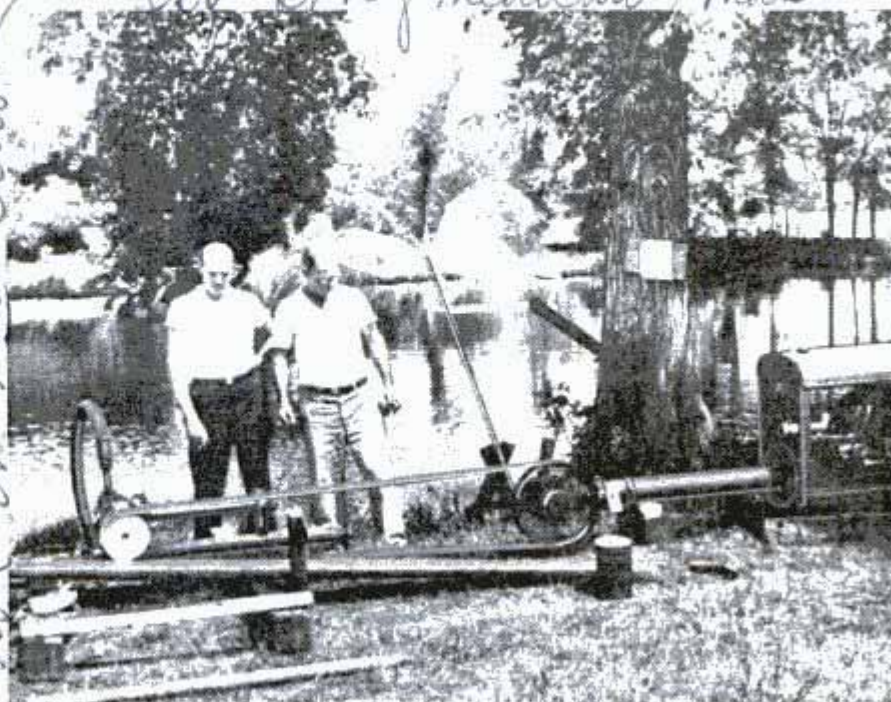

Saving fish from heat and lack of oxygen in water with aid of pump which throws fine spray into air where it picks up oxygen

Mask Guards Pilot of High-Flying Army Plane

For altitude tests in which the plane ascends to levels where the air is very thin, the British army pilot dons an oxygen mask which gives him an odd appearance. The mask supplies oxygen to the pilot when high altitudes are reached, protecting him against dizziness and difficult breathing.



Oxygen mask which protects British army pilots when they reach very high altitudes

Trout in one Massachusetts pool were saved from death from heat and lack of oxygen during the hot weather by aerating the water with the aid of three pumps which threw fine spray into the air. The water thus treated picked up sufficient oxygen from the air to supply the fish.

Census of Bacteria Population Shows Billion in Gram of Soil

When the census taker calls on a bacteria colony he needs a high-powered microscope and a high-powered adding machine. Scientists at an English agricultural station took the census of living organisms in a sample of ordinary soil. In a gram of soil—one twenty-eighth of an ounce—there were from one to four billion living bacteria, a million particles of spores of mold fungi and more than a million protozoa, tiny animals slightly larger than bacteria. In rich, well manured soil the bacteria population was even greater.

Inquiries as to makers of articles described in Popular Mechanics, will be answered by our Bureau of Information upon receipt of return postage.

Long meadow Mass

How and when built

710 31

Acme

The Director Rothamsted Agricultural Station, Harpenden, Eng.

Wid. world



The LATEST

By Bob Becker

ALTHOUGH the right kind of gun, shells and hunting ground are of primary importance to the hunter, the experienced shooter knows many a trip can be spoiled by lack of the right kind of accessories. A \$500 shotgun of the correct gauge won't keep a hunter comfortable in a duck blind if he has the wrong kind of boots. And the hunter who hasn't the right kind of raincoat, can't enjoy a rainy day in the marsh even though he has the latest long-range ammunition.

Here are a few tips on clothing, boots, mittens, and other things which often mean the difference between pleasure and discomfort on a trip. Nothing is quite as important in the hunting field as correct shoes or boots. Cold feet, wet feet or footgear too tight or too big can spoil a trip. The sportsman in a mild climate can choose lightweight leather walking or field boots for winter hunts while the sportsman of the north has a choice of fourteen-inch or sixteen-inch waterproofed leather boots, or a combination made of both rubber and leather for slushy, snowy weather.

For ordinary field shooting in



Top, left, a well-equipped hunter. Note duck call on string, metal shell box in boat and heavy mittens. Top, right, upland game shooting calls for the lightweight leather boot. Center, handy game carrier and a dry-weather hunting scene in contrast to the one at bottom which really tests the hunter's equipment and clothing

2988



for the HUNTER

of Chicago reference Chicago

fairly dry weather many use a lightweight leather boot treated with a liquid dressing to increase its water-resisting qualities. With all-wool socks it offers real foot comfort. When the walking is very wet, the hunter can keep as dry as the Sahara by putting on a "pac" that has a foot of rubber and top of leather. You can use a lightweight all-rubber shoe or boot with a fourteen-inch top. Here's a trick to fix up the rubber and leather pac. First, have your cobbler put in removable arch supports. The boots naturally are roomy and fairly flat. By adding the arch supports your feet will not tire as quickly. If you like more heel on the boot, glue small rubber heels inside. Rubber is cold, but by adding a felt inner sole your feet will stay warm in cold, snowy weather.

In buying hip boots for waterfowl shooting, consider whether the major use of the boots will be in moderate weather or on very cold days. Also, do you have a lot of wading in water and mud? Many use two different types of boots for the two purposes. One model, fairly new on the market, is ideal for plowing the mud. It is a snug, "form-fitting" boot with ample foot and leg room, yet con-



Top, left, duck shooting on ice, a situation calling for sheep-lined moccasins in boots and trap-door mittens. Top, right, this hunter is uncomfortable in the blind because he has no seat. A combination shell box and seat is available. Below, hunting on ice for ducks, a handy boot drier and a winter hunting trip which requires proper clothing



main parts are made of horsehide, reinforced by a knit top of pure wool. This fits the wrist snugly. The palm of the mitten for the right hand has a slit in it with a tiny "trap door" over it. To shoot, you just stick your trigger fingers through the trap door. Back they go into the mitten when the shooting is over. Another practical garment for the duck hunter is the rubber glove for picking up decoys. Taking in block decoys on a cold, windy day is hard on the

structured around the ankle so the mud can't pull it off. This is a lightweight model ideal for marsh hunting.

For cold weather, there is a boot available that is entirely different. This one has almost no ankle or instep because it is made to take a wool-lined moccasin. If you suffer from cold feet, try these boots with the moccasins. When you put them on, tighten up the straps over the insteps and you need not worry about losing them in the mud.

Rubber boots always get damp during a day's use. Hanging them up by the feet to dry out is not easy and the same problem comes when it is time to store them for the season. It is unwise to hang them by the tops because they get out of shape. A folding metal device weighing just six ounces makes the job easier. It attaches to the foot of the boot and holds it securely so the boot will drain and ventilate.

Next to the feet, the most important comfort problem of the hunter concerns the hands. For cold-weather hunting, many prefer the trap-door mitten. The

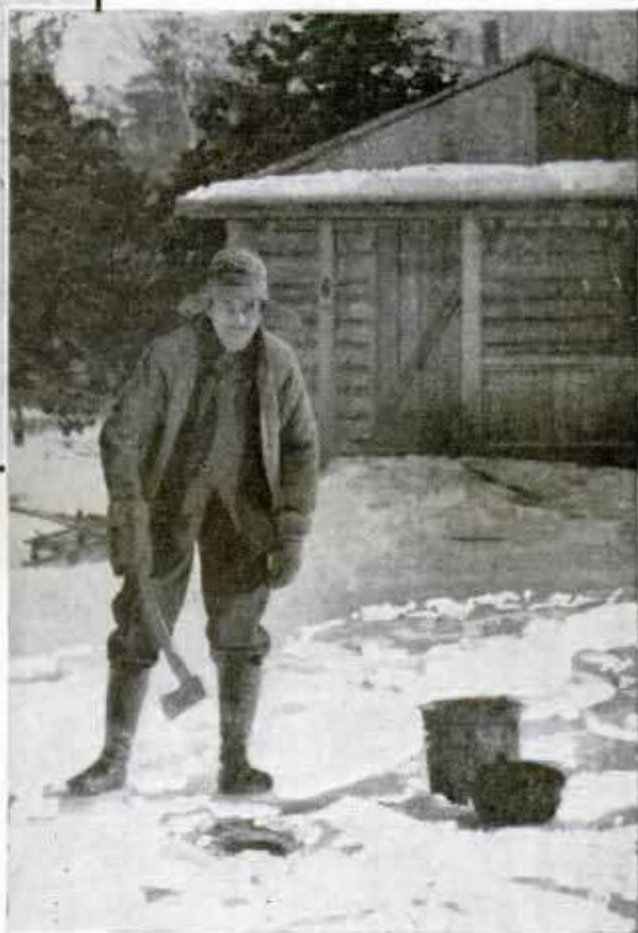

Two hunters equipped for ice, cold and snow and a serviceable, lightweight hunting boot

hands but these rubber gloves give complete protection as they are waterproofed and lined with wool fleece.

But if there is any one accessory the hunter finds a tremendous help on cold days, it's the little heat pack that can be "started" by simply adding water. For the man who waits on a deer run when the temperature is low and the ground is covered with snow, for the duck hunter in a

(Continued to page 146A)

1976

Long + Co
steel mfgs

Liner's Anchor Chain Tested to Destruction

Middlesbrough
England

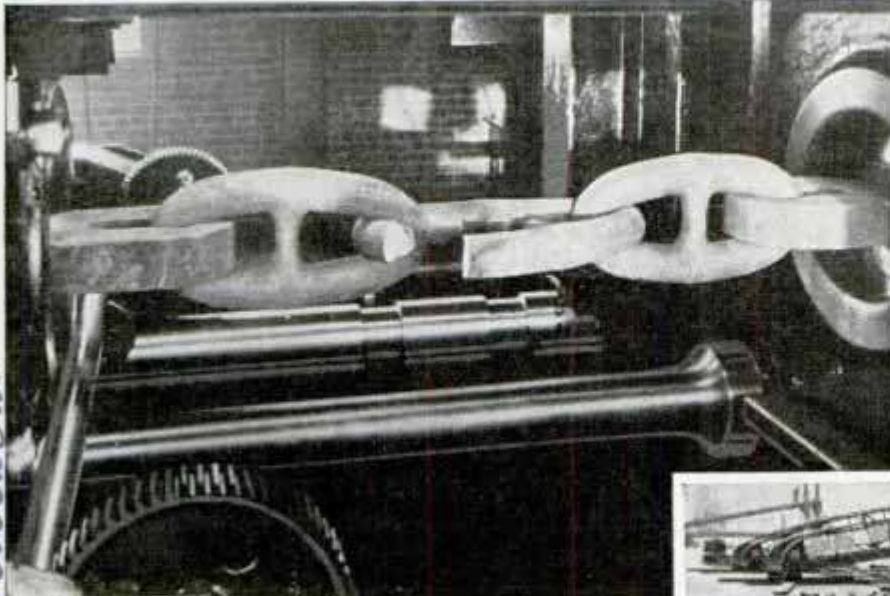

Left, here is what happened to a three-link section of the "Queen Mary's" anchor chain when a force of more than 600 tons was applied. Below, lengths of the liner's massive anchor chains ready to be placed aboard the ship

Walton

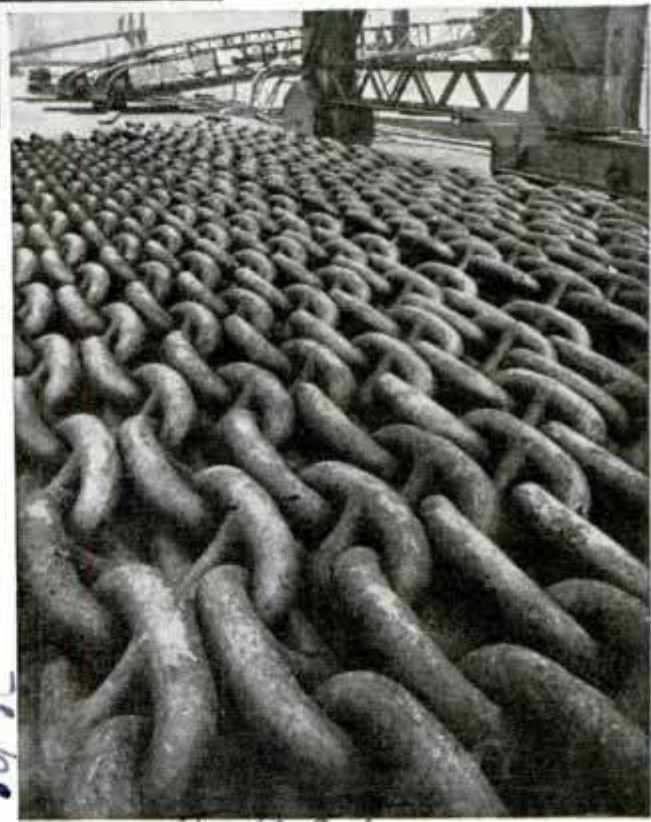

Before the liner "Queen Mary" went into service, her giant anchor chain was tested to destruction. In the first test the whole chain withstood a pull equivalent to 289 tons. Then three-link sections of the chain resisted a pull of more than 405 tons without signs of breaking. In a final test, the pulling machine exerted a force of 693 tons before a link fractured. Two similar three-link sections parted under pulls of 657 and 690 tons, respectively.

7996

Knitter with Numbered Keys Makes Hard Stitches Easy

Knitting is made easy for the novice with the aid of a knitting board fitted with two rows of sixty-five numbered keys each, making it a simple matter to follow instructions, even for complicated designs and stitches. A two-foot rule is stamped

\$ 5.50 - doll clothes
\$ 1.50

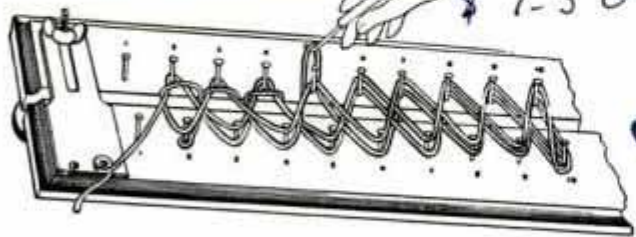

The numbered keys on this knitting board make it easy to form intricate patterns

on one side of the loom for measuring the work and a small counting device makes it easy to keep track of the number of rows knitted in making a garment.

The Peltone Co,

Poison Found for Locusts

Sodium arsenate has been found effective in poisoning locusts in Argentina where the pests destroy about thirty per cent of the country's crops. The country is obtaining more and larger machines to spray and sprinkle this poison during the autumn and winter when the locusts have to cross the desert regions, and again in the spring when they move south. Many methods have been tried in Argentina to combat the locust plague but none has been entirely successful. One of the most common methods has been to erect sheet-metal barriers to divert the insects into trenches where they can be destroyed.

71025

Dept. of Commerce

Ministry of Agriculture

Reported by Trade Commissioner
G. D. Walbridge
Bureau of Census

Electrical Robot Tells the Time Every Three Seconds



Listening to sound-track voice which recites the correct hour and minute every three seconds

Utilizing sound track movie film, an electrical robot operated by a synchronous motor tells the time in a loud, clear voice at three second intervals. It was designed particularly for use by radio stations and metropolitan telephone exchanges. There are two small endless belts of sound track film, less than twenty feet long; hours are recorded on one and minutes on the other. A scanning optic and photoelectric cell travel the length of the film and return every three seconds, and at the end of each trip the exact time in hours and minutes is announced. After twenty trips a cam moves the minute belt one notch, changing the time and the oral announcement; after sixty moves of the minute reel the hour film is moved up one notch. For advertising purposes, sound track carrying the name of an advertiser could be inserted for announcement with the time.

Fruit Is Kept Free from Decay by Iodized Paper Wrapper

Thin wrapping paper slightly impregnated with iodine is used in England to keep oranges, tomatoes, apples, peaches, plums, grapes and other fresh fruit from decaying. It was found that iodine pre-

vented the formation of mold on the fruit during shipment and storage, thus saving considerable loss. The small amount of iodine does not affect the flavor, nor does it hasten nor delay the ripening of the fruit.

Shielded Loop Antenna Helps Pilot Keep on Course

Enabling pilots to ascertain their location by a turn of a loop antenna and a simple calculation of a dial reading, an improved radio direction finder is being installed on Transcontinental and Western Air planes. The loop antenna, of the shielded type, has the property of reducing static to a minimum. In operation the direction finder consists of an auxiliary receiver and the antenna which can be turned on an axis to a position providing the best reception qualities in tuning in on any selected radio station. At the position



Arrow points to the shielded loop antenna which reduces static to minimum on direction finder

giving the best reception, a reading is taken on the loop dial. A pilot flying the radio beam needs to tune in only one station off the beam to determine his exact location. The angle denoted on the dial in relation to the direction of flight gives the accurate position of the plane.

not on market. To 5000 copies. Program John W. Wells. Club.

F105

F104

F103

British Food

R A

D I O . . .



73589

FOUR-TUBE *Transceiver* *for* FIVE METERS

UNLIKE the usual 5-meter transceiver, this portable combination receiver and phone transmitter has separate tubes and tuning controls for the r.f. functions of the receiving and transmitting sections. The audio system, however, is common to both, acting as a signal amplifier for receiving and as a speech-amplifier and modulator for transmitting. Two independent 5-meter anten-



nas are used; therefore it is possible to adjust the transmitter

for maximum efficiency at the frequency desired, after which the entire band may be covered with the separate receiver control without making compromising antenna ad-

justments. The complete unit shown in the photos is called a "transceptor" by the designer in order to identify it from the ordinary transceiver. It employs two type-30 and two type-19 tubes, and is housed in a 7½ by 15 by 15-in. metal cabinet provided with a hinged cover to protect the controls as shown in photo No. 1. A back view of the unit with the rear cover removed, appears in photo No. 2. It will be noted that there is a shield between the receiving and transmitting r.f. circuits. A door in the side of the cabinet provides easy access to the handset compartment. Separate headphones and microphone may be used instead of the handset if preferred.

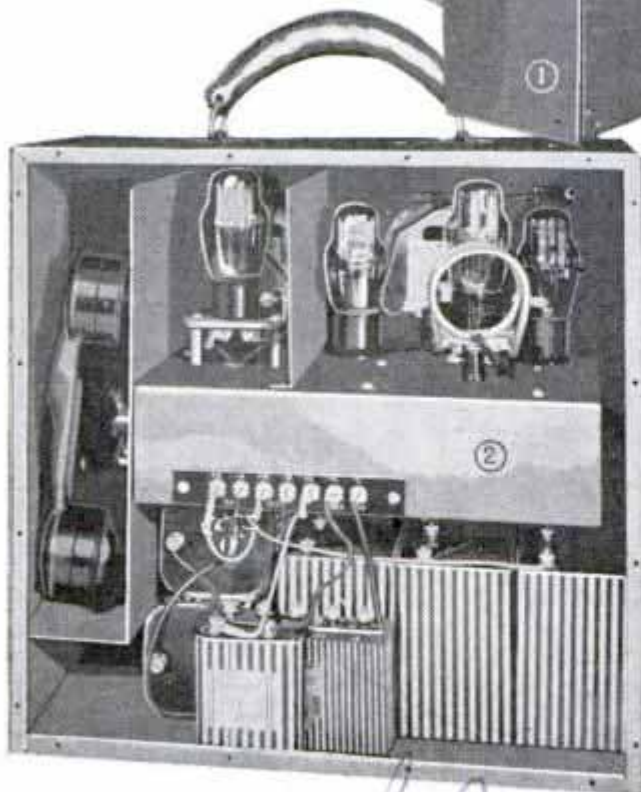

Wholesale Radio Service Co. 737
101 6th Ave New York

AMPLIFIER



are inexpensive, and, when properly amplified and reproduced, add realism to amateur dramatic productions.

The two-channel-input amplifier to be described, is built from standard parts and delivers 18 watts of audio power, sufficient for auditoriums seating up to 500 persons. A single potentiometer controls the volume and permits the operator to select either the phonograph or crystal-microphone channel

ALTHOUGH the amateur actress in the above sketch is holding a doll in her arms, the audience hears a real baby crying lustily. This is only one of many recorded sound effects available for amateur theatrical use. Others include laughter, mixed cheers, applause, dog barking, angry mob, street and carnival noises as well as trains, airplanes and many additional background sound effects. These records, recorded from the actual sound sources,

at will. Adaptable for public address, dance orchestras and school use, the output is capable of operating from one to four loud-speakers.

Modern metal tubes are employed in an amplifier circuit which has a flat frequency response and practically no distortion.

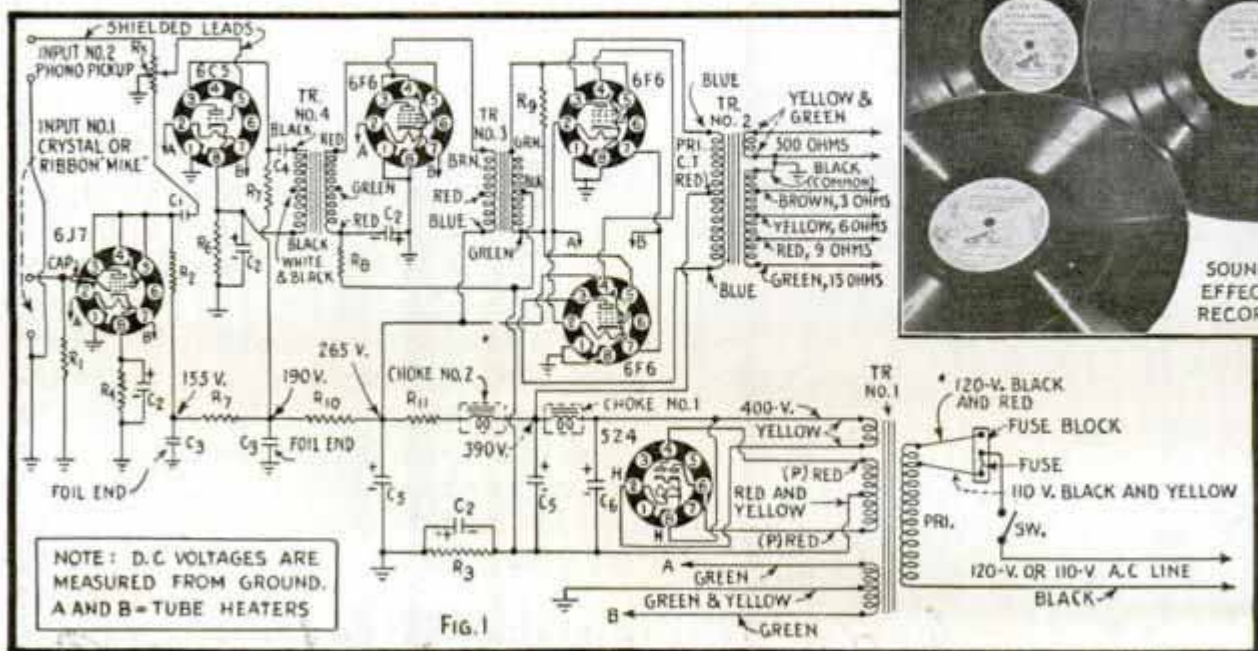

150-Watt all-band TRANSMITTER



By

R. E. Davy—W9GKU
F. L. Brittin—W9DCX

OBTAINING maximum results with a minimum of parts, this all-band transmitter of advanced design might be compared to an improved model automobile motor for which the manufacturer claims some 500 less parts are required.

All-band transmitters usually consist of a crystal oscillator, operating at the lowest frequency "longest wavelength" used, and a number of frequency-multiplier stages and amplifiers, depending upon the power output desired at the highest frequency. As the frequency increases, so do the losses, making efficient operation more difficult; thus a transmitter which is perfectly stable on 160 or 80 meters may become erratic and operate at low efficiency on 40 or 20 meters. If the experimenter has to check through a number of doubler and amplifier stages it may be weeks before the trouble is located.

This 150-watt all-band transmitter has but two stages to adjust. A type RK-20 pentode tube is used in a "tri-tet" oscillator circuit which employs the tube both as an oscillator and frequency multiplier. The second stage consists of two RK-20's in push-pull as amplifiers; the high-power oscillator fully excites this amplifier either on the crystal frequency or harmonics. A 160-meter crystal also permits operation

on 80 or 40 meters, an 80-meter crystal further serves for 40 and 20-meters, while for 10-meters a 40-meter crystal is used.

The complete 2-stage R.F. section is mounted on a metal base 18 by 12 by 3½ in. deep. As the tuning condenser frames are grounded, they are mounted directly on the underside of the base together with the various fixed condensers, resistors, R.F. chokes and filament coils L and L. "Thru-panel" insulators with plug-in coil jacks are used to keep all wiring below the base. This

(Continued to page 126A)

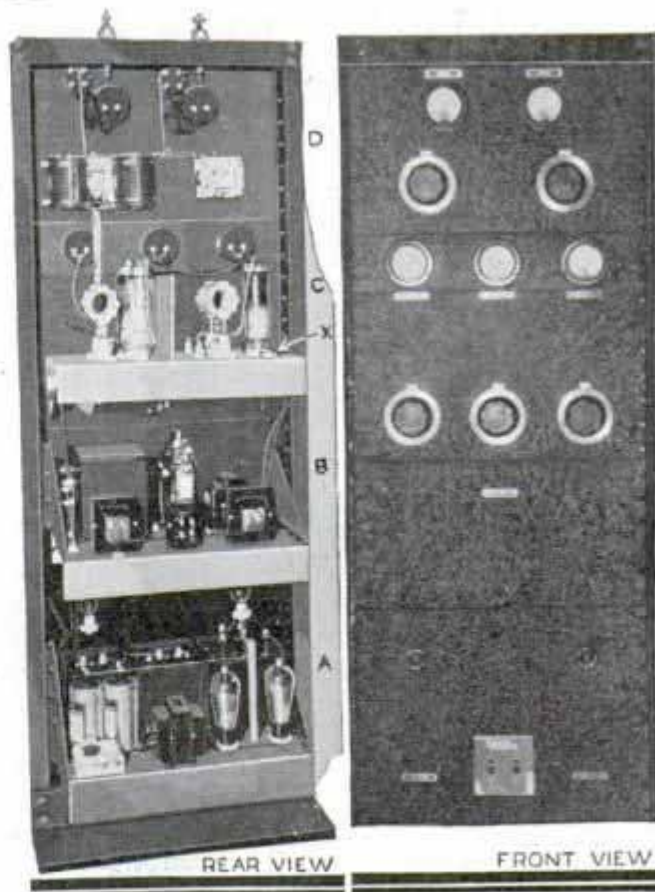

Easy Solutions for Everyday Radio Problems

Several advantages are offered by the under-seat auto-set installation shown in photos 1 and 2. Out of the way but easily accessible for repairs, the receiver and antenna lead-in are kept as far as possible from interfering motor noises. The control unit is mounted on a metal bracket bolted to the seat frame, or floor, in a handy position for tuning without extending your arm to the dash. As the speaker leads do not pick up noise, it may be mounted behind the dash. Fig. 3 shows a universal-mounting roof header speaker easily installed with any car set; the kit includes a dome-shaped metal grille, cloth cover, mounting ring and hardware.



aca wya & ...

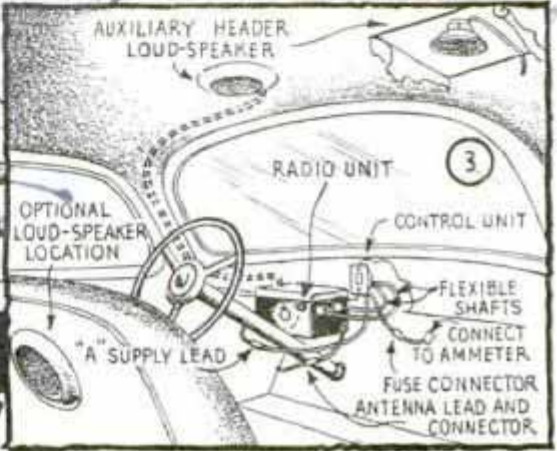
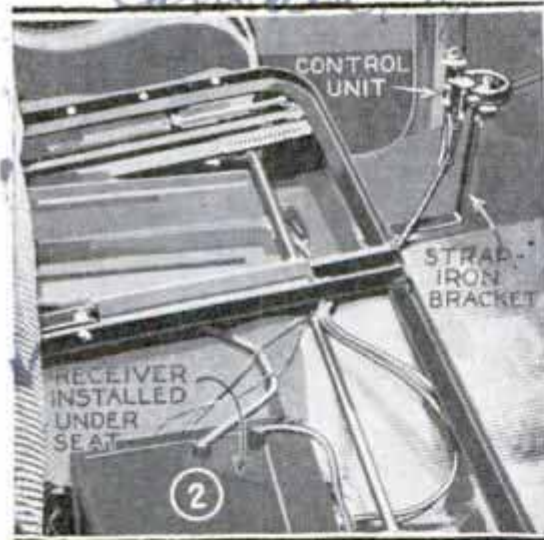

Right, thin wrench, used instead of pliers, for mounting panel-type toggle switch provided with round outer nut having a milled edge that is easily damaged. Milled nut is screwed on by hand before tightening hex nut at rear

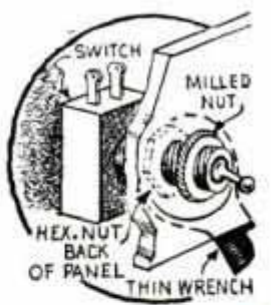

Left, time-saving mounting template for sub-panel-terminal transformer quickly made by pressing terminal lugs on paper to locate drilling centers for chassis clearance holes



Above, protective mounting for cartridge-type paper, or electrolytic condensers, removes mechanical strain

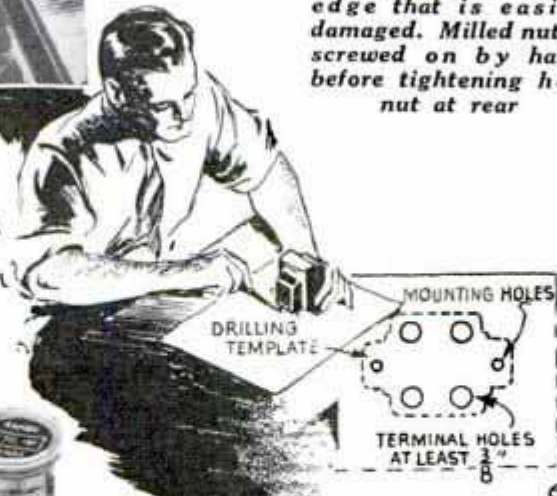

Drain stoppers make chassis shock proof. Left, wave trap eliminates amateur code interference; standard or homemade plug-in coils used; winding given is for 80-meter band

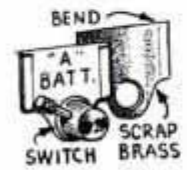

Label holder for panel switches, and jacks, made from thin sheet brass held in place by mounting nut

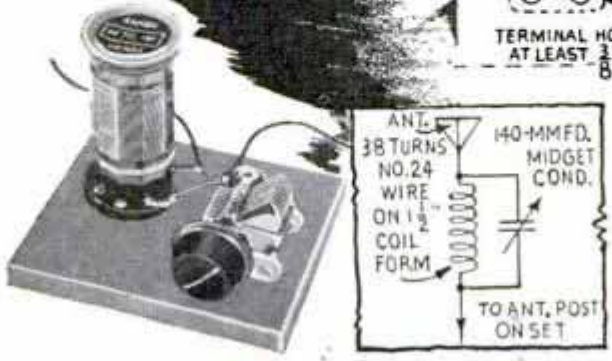

Ultramodern Lounging Chair Has Built-in Receiver

I 3592



Complete with built-in antenna and a line cord for plugging into any convenient wall socket, this up-to-date receiver installation in a lounging chair provides both comfort and entertainment.

I 360 3 ——— Windcharger for Trailers

An auxiliary battery-charging unit for use on camp trailers and trucks employs a wind-driven generator. Installed as



shown in the photo, the unit begins charging at a road speed of about 22 miles per hour. An automatic cutout provides against damage when driving into strong winds. Generator connections can be made directly to the car battery or to radio and lighting batteries in the camp trailer.

I 3684 ——— Desk "Mike" for Call Systems

Handy for desk and counter use with call and public-address systems, this compact unit contains a single-button carbon microphone mounted in cushion rubber and housed in a cast aluminum case. It is completely wired with push-type switch and protective condenser, and operates on 1½ volts at 4 to 6 ma. supplied from either a battery or the amplifier. A jewel is arranged so a pilot lamp and bracket may be installed when operating several of these microphones through one amplifier.

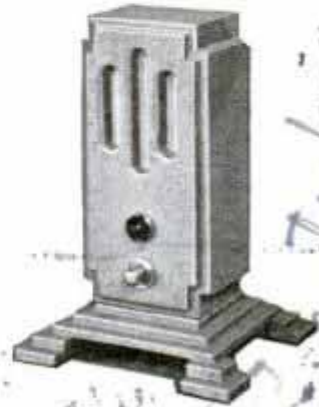

D 4507 ——— Noise Filter for Car Heater

Owners of older type auto sets can eliminate troublesome interference from the motor of their car heater by means of a simple noise filter mounted on the frame and connected as shown in the sketch.

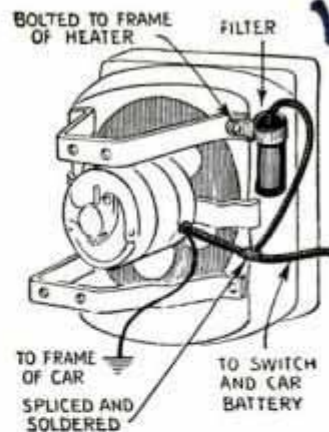

Blueprints covering radio construction articles in past issues can be obtained for 25 cents each; material lists are available without charge on receipt of postage.

NEXT MONTH—Beginner's Short-Wave Two-Tube with Universal Coil Selector. A simple and inexpensive battery set that anyone can build. Uses auto-type tubes and a 4-band coil-switching unit which holds four ordinary plug-in coils. Other features include construction details for a **Low-Cost "A-B" Power Unit.**

2702 Hawkeye Ave.

Southwestern Engineering Co.
Winchenger Corp.

Double
- \$ 10.00
C 4913 of Western
Spangley
Kleitachman
Canton
Mar 10

John



*the latest in
streamlined
model trains!*

By
Alexander Maxwell

THIS striking model gives the attic rail-roader a real-life glimpse into the future of high-speed rail transportation. Along with ultramodern streamlining, it combines simplicity of construction. There's no need to spend long hours over a lathe when making the railplane for there is no machine work to be done.

You start out in the same way as you would in building a ship model. In examining Figs. 1, 2, and 4, you will notice that the body consists of five lifts, the $\frac{7}{8}$ -in. lower lift being in three sections to make room for the trucks. The second is solid, with a slot cut down the center. This lift and those above it are $\frac{5}{8}$ in. thick. The first three and the last two lifts are glued together as separate units and form the two parts you see in Fig. 1. The latter unit

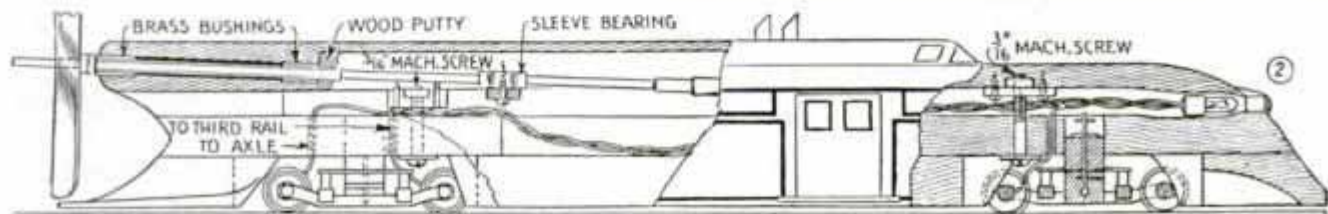



forms the removable roof. Use selected white pine and cut all the lifts slightly oversize. Before you begin carving, enlarge the right-hand detail in Fig. 4 to full-size and make $\frac{1}{8}$ -in. plywood templates of all the curved lines. This detail is shown on $\frac{1}{4}$ -in. squares. Notice from this that lines F to J inclusive will continue $\frac{1}{4}$ in. higher than indicated on the squared diagrams, as the top of the body is curved. Now fasten the two units together with two long screws driven up from the bottom and carve to the finish contour with a plane and gouge, using the templates on the station lines just as you

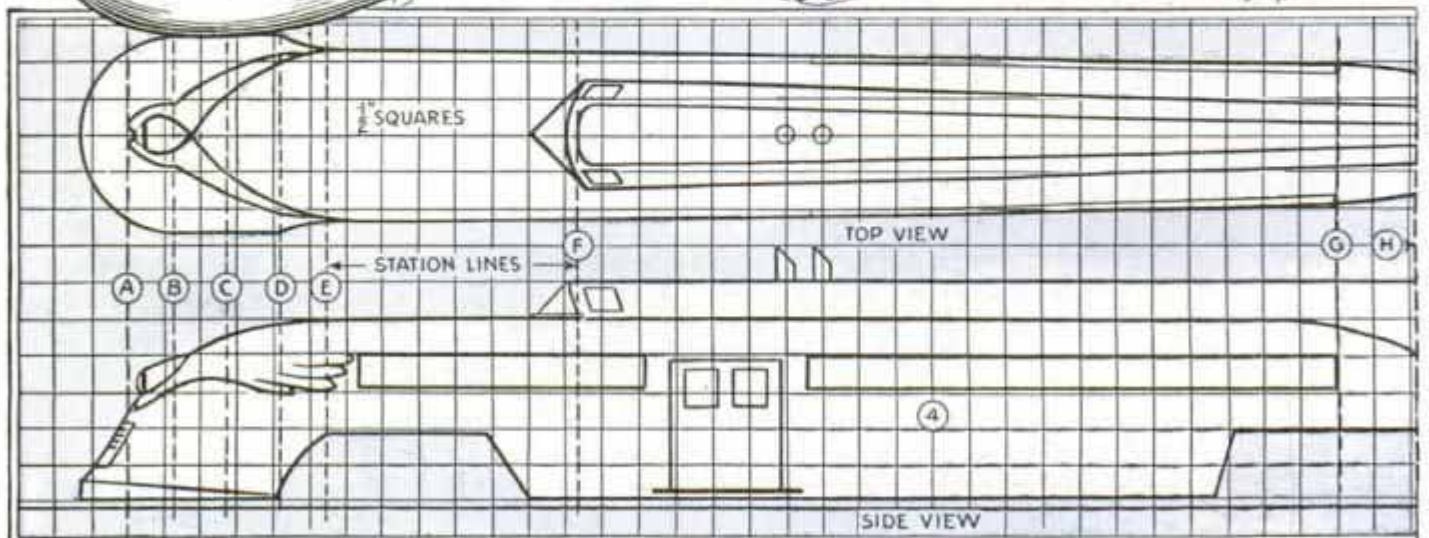
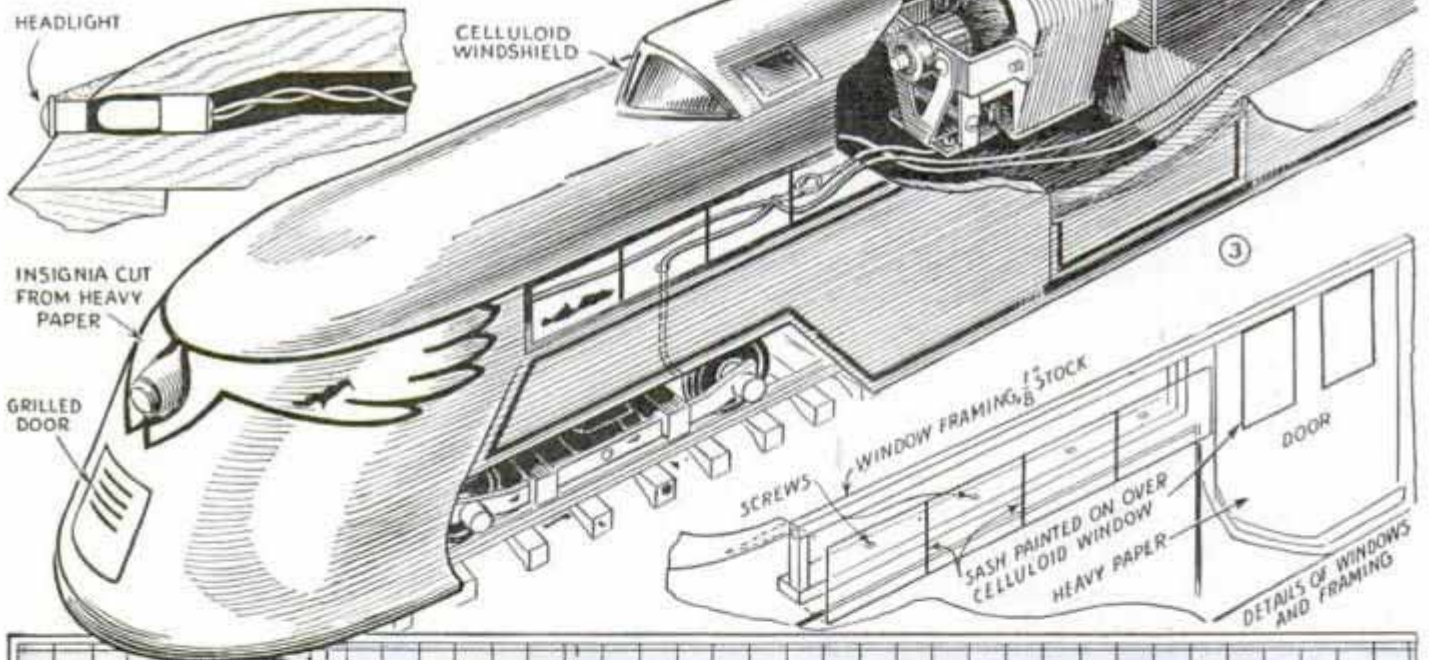

would in shaping the hull of a ship model. When you get to the final contour, give it a thorough sanding. Light scratches or dents will show up under the paint job so don't stop sanding until the surface is satin-smooth.

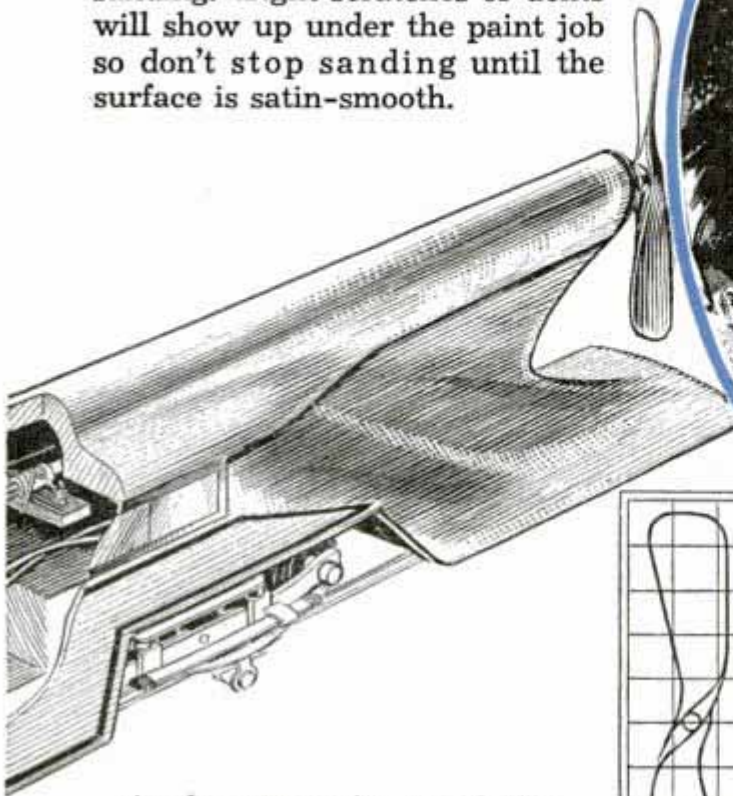

At this stage it's a good idea to give the wood a thin coat of shellac. Figs. 2 and 3 give you a clear idea of how the motor is mounted to drive the propeller. Dimensions of the motor and propeller-shaft compartments are not given as these will depend on the motor you use. The motor used to propel the original railplane is of the type designed for driving the conventional $\frac{1}{4}$ -in. scale model locomotive. Its free-running speed is about 6000 r.p.m. Motors of this type will usually run on 12-volts d.c. or 16-volts a.c. Though the motor runs cool-

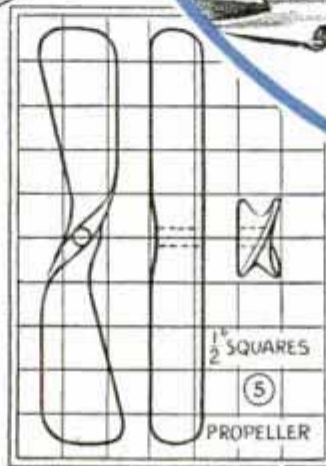
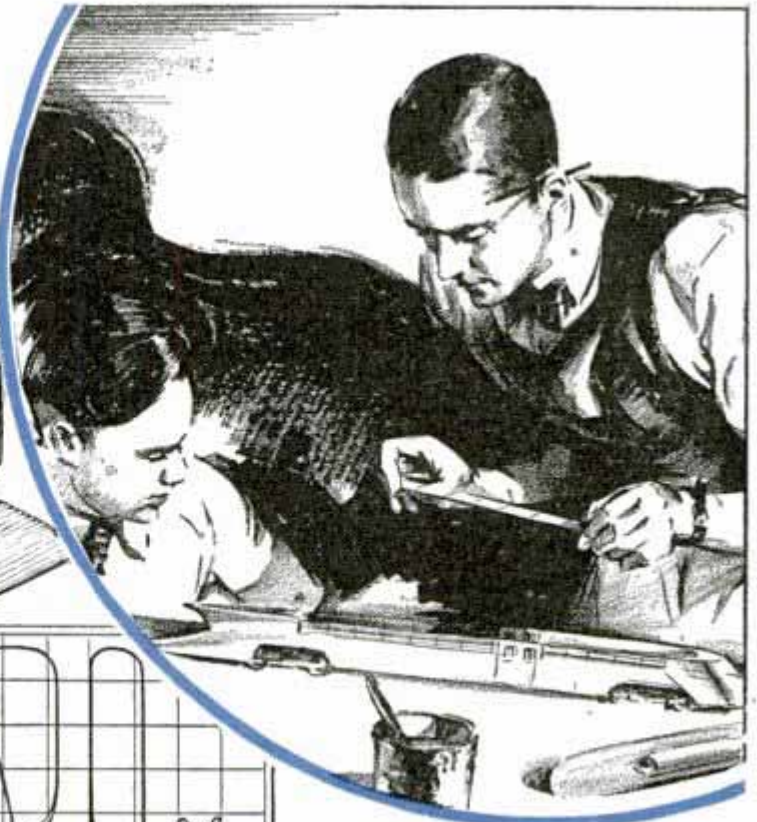

er on d.c. furnished by two storage batteries, a transformer delivering 16-volts a.c. will operate it.

Note from Fig. 1 that the entire power plant is fastened to the top section of the car body, the motor

dropping into the well which is already formed in the lower section as in Fig. 3. The motor, as you see, is bolted to a $\frac{1}{2}$ -in. brass angle plate, which is screwed to the roof of the "conning tower." It will be necessary, of course, to pare away some wood to get the motor in position to line up with the propeller shaft. The latter is a length of $\frac{3}{16}$ -in. drill rod connected to the motor through a flexible coupling made of rubber tubing as in Fig. 3. The ends of the rubber tubing are bushed with short lengths of brass tubing, and holes are drilled transversely through the meeting ends of the motor and propeller shafts for cotters made from ordinary pins. When you assemble the coupling, coat the sleeves and the inside of the rubber tubing with rubber cement. To allow for error, you use a $\frac{5}{16}$ -in. bit to drill the hole for the propeller shaft, Fig. 2. The shaft can be made to run in a long bushing, or "log," or it can be mounted in two separate bushings, as in Fig. 2. It must be carefully lined up so that there is a minimum of

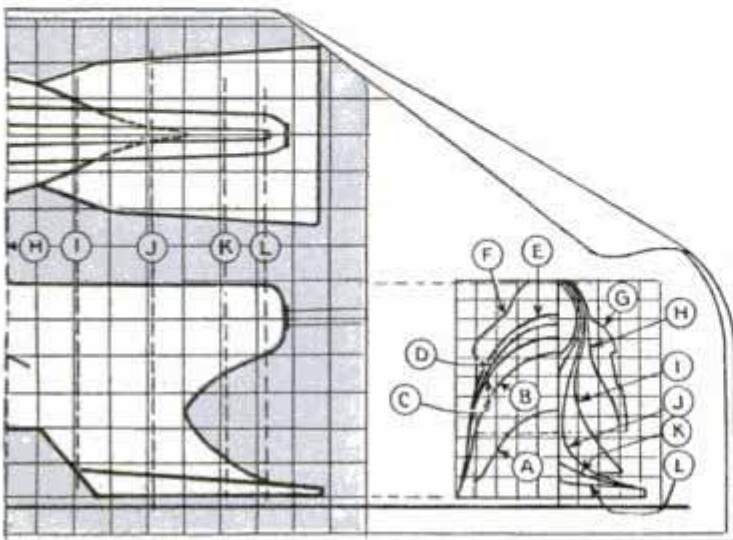

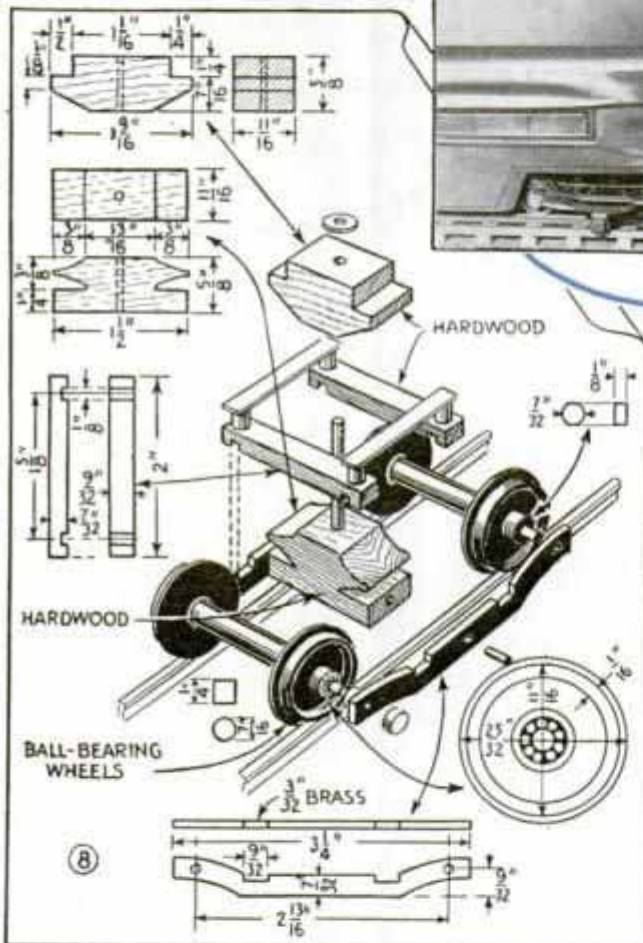
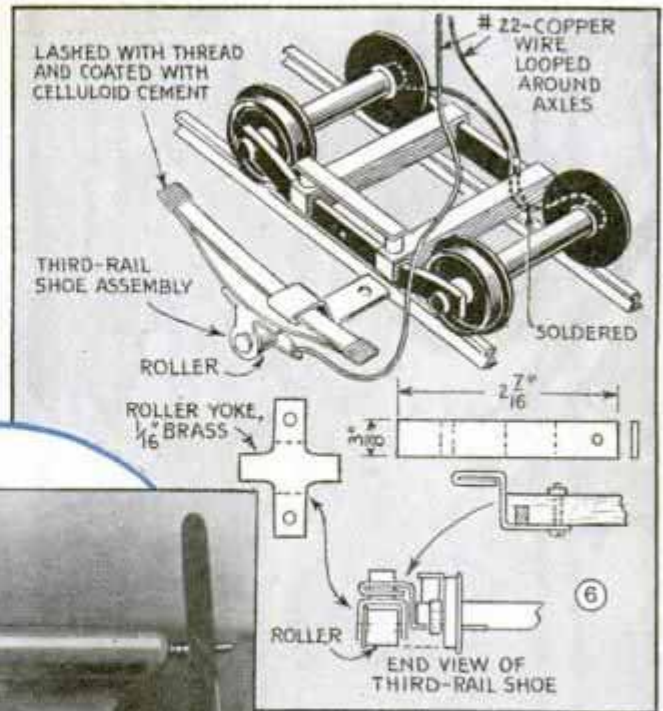

and 6. Use rubber-covered wire for all connections and solder all joints. Because the truck frames are wood, electrical connections are made directly to the axles as in Fig. 6. Use No. 22-ga. wire, spring the side member away from the wheel, and wind three turns of the wire around the axle. When the frame springs back it will hold the wire in place. Repeat the operation on the second wheel. Then make "pigtail" connections to this wire, solder them and connect to the car circuit.

Use aluminum paint with an asphalt base for finishing the body. Paint trucks yellow and black. Notice in Fig. 2 that the two members of the body are fastened together with $\frac{3}{16}$ -in. machine screws. The screws pass through a metal plate and turn into nuts mortised into the roof. The screws are located off center in the truck wells so that they may be reached with a screwdriver without removing the truck. When you test the railplane see that the track curves are banked and that the trucks take the curves without binding. It may be necessary to cut away more stock to allow the trucks to swivel freely.

This Depth Gauge Can't Slip

Made from a short piece of $\frac{3}{4}$ -in. brass tubing, this depth gauge will fit auger bits or drills from $\frac{1}{4}$ up to $\frac{3}{4}$ in. Adjustable

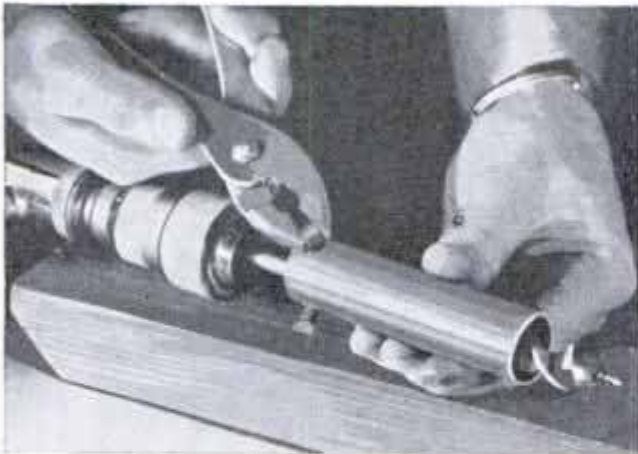

Locked in place with set screws, this gauge fits bits from $\frac{1}{4}$ to $\frac{3}{4}$ in. in diameter

for various depths, the gauge is held in place by three equally spaced set screws located close to the upper end. This gauge has an advantage over many others improvised for this purpose in that it cannot slip out of adjustment.

—E. E. Stanton, Huntington, Mass.

Anchor Wires in Concrete Forms Tightened Quickly

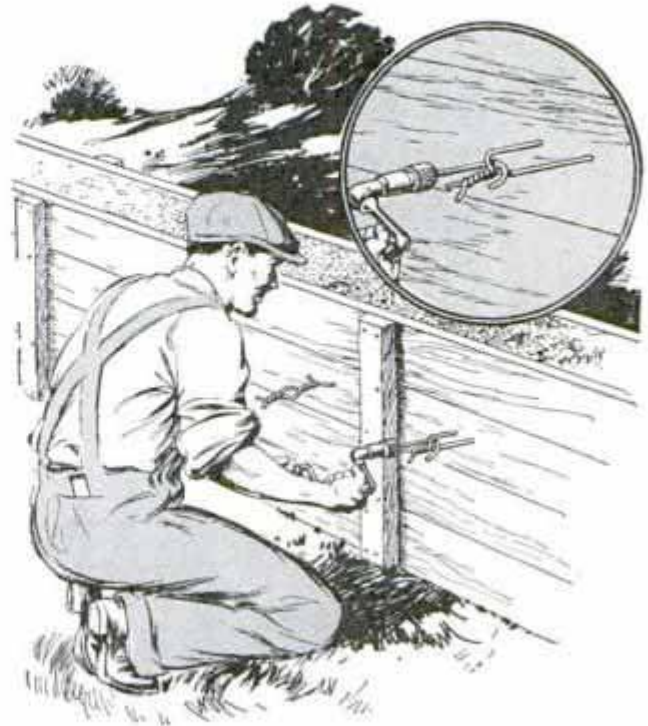

It takes only a few minutes to tighten a number of anchor wires in a form with this tool

Anchor wires placed through concrete forms to hold them from spreading may be tightened easily with a carpenter's brace in which a hook is inserted. The hook is easily made from a short length of iron rod, which can be held securely in the chucks of most braces.

Handles of Pliers Are Notched to Cut Wire

A pair of ordinary pliers can often be made into practical wire cutters by slotting the handles as shown.

Open the pliers about one-third of the way, grip them in a vise with the handles pointing upward. Then take a hacksaw and run the blade right between the handles so that a slot is made in both of them. This will form slots for cutting wire of small size. Larger slots can be cut by mounting two blades, side by side, in the hacksaw frame.

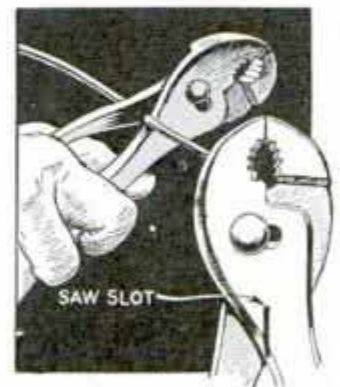

Larger slots can be cut by mounting two blades, side by side, in the hacksaw frame.

SPOOL BED

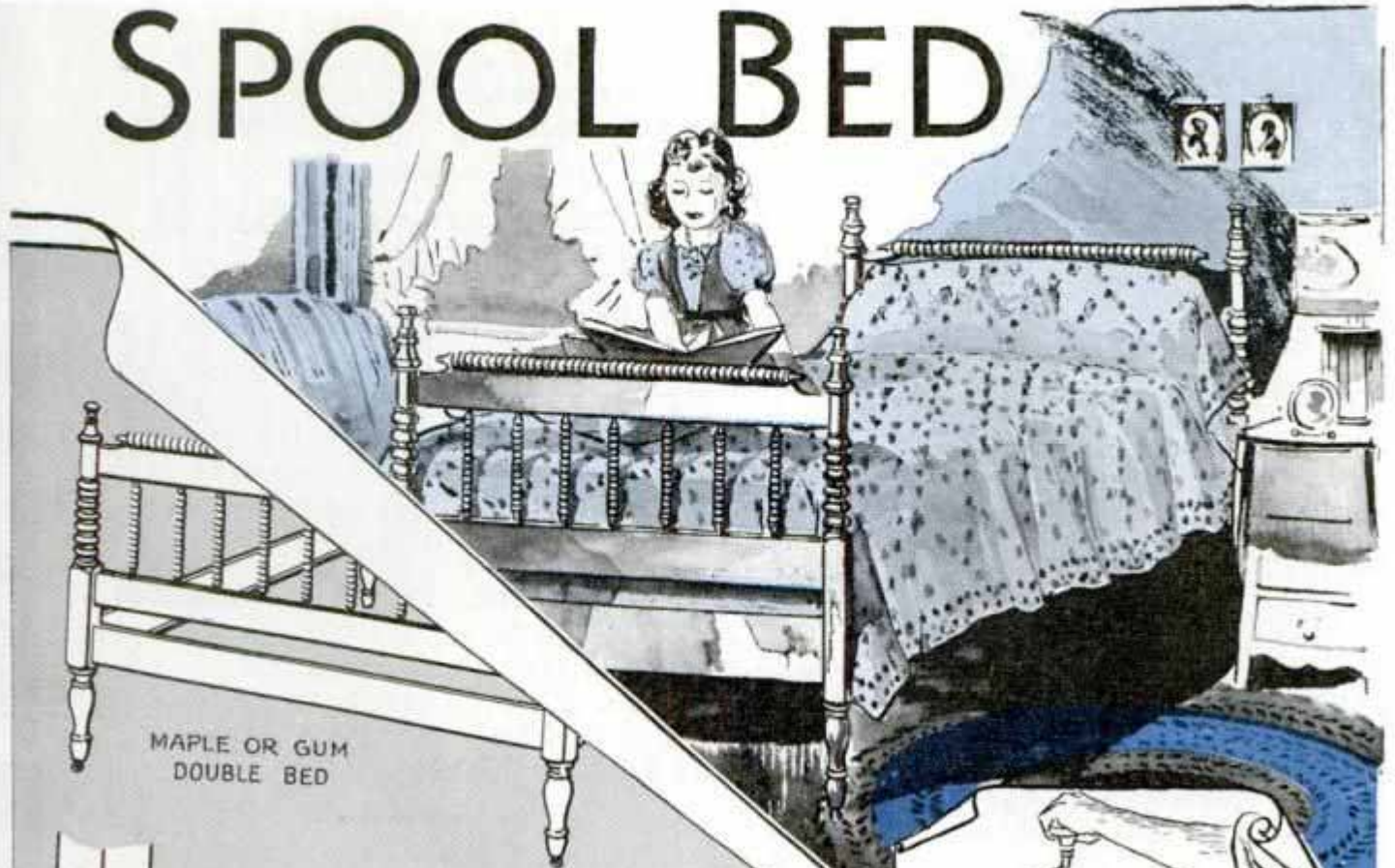

MAPLE OR GUM
DOUBLE BED

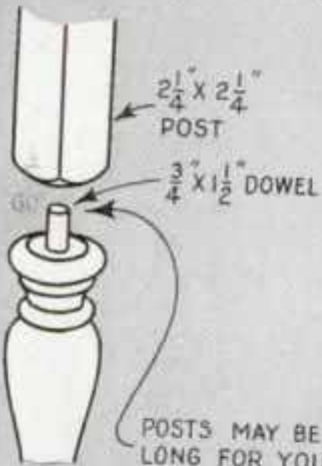

POSTS MAY BE JOINTED IF TOO LONG FOR YOUR LATHE

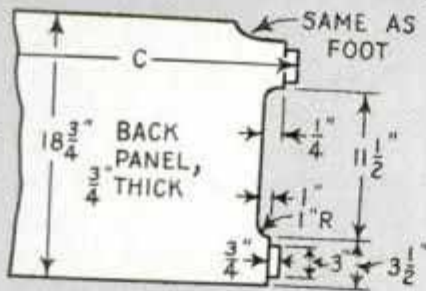

DETAIL OF BACK PANEL

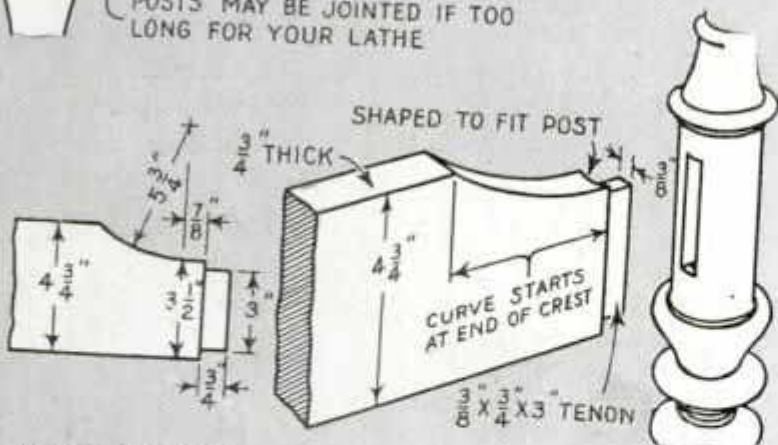

DETAIL OF RAIL JOINT

NOTE - MORTISE CUT & PLUGGED WITH SOFT WOOD BEFORE TURNING

SHEET NO. 1

ISSUE

POPULAR MECHANICS MAGAZINE
200 E. ONTARIO ST. CHICAGO

BLUES

000954

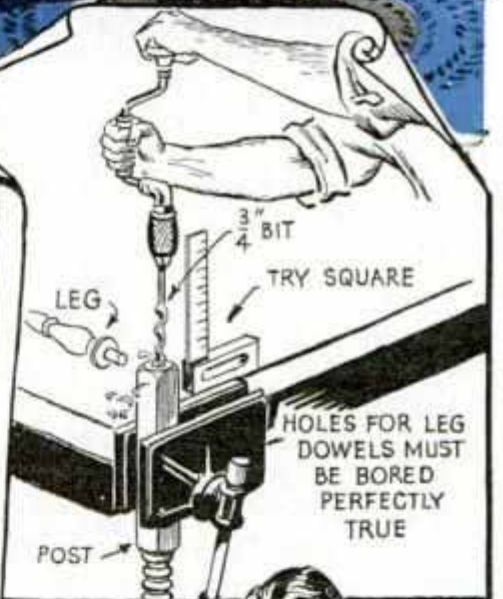

Wheeled Ash Can Easy to Move on Floor or Walk



It's much easier to wheel a filled ash can to the alley than it is to carry it

Instead of carrying a heavy ash can, why not fit it with a couple of casters and wheel it to the alley? Bolt a couple of blocks to the bottom, near opposite sides as shown, one being considerably thicker than the other to keep the can level when casters are attached. It's a good idea to rivet a sheet-metal shield to the top of the can on the same side as the casters to keep the ashes from falling out when the can is tipped to wheel it.

New Feet for Your Sink Strainer



Does the portable strainer you keep around your sink cause black marks on the porcelain? If so, put three rubber feet on it. Get three small rubber bumpers and three faucet washers from the dime store. File off the points of the screws on the bumpers and drill a hole

at each corner of the strainer. Then screw the bumpers through the strainer holes into the washers.

—Walter A. Humphrey, Columbus, Ohio.

Rounded Surfaces Smoothed with Hose Sanding Block

The next time you have a rounded surface to sand, such as a table edge, chair leg, etc., try using a short piece of large rubber hose as a sanding block.

Split it up one side and then cut a piece of sandpaper to fit inside. A small quantity of shellac applied to the back of the sandpaper will help hold it in place.



Mono-Scooter Is Speedy

With a little practice, you can get more speed out of this mono-scooter than out of a pair of roller skates. It is made from two roller-skate wheels and a hardwood block as wide as the shoe and about 5 in. longer. Round the ends of the block and slot them to take the wheels. Steel rods serve as axles, and washers are placed on either side of each wheel to keep it true. These should be lubricated. Triangular blocks serve as heel and toe plates, and a single toe strap keeps the scooter on the shoe. Tilting the foot to one side brings the block into contact with the sidewalk to get efficient braking.

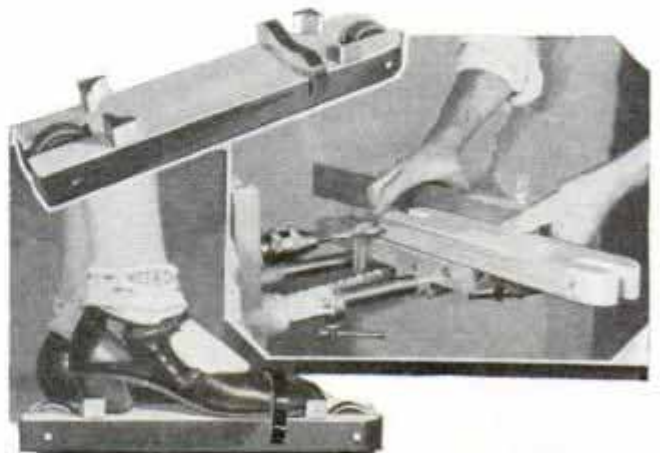

Strapped to one shoe, this mono-scooter will take you along at a fast pace

Angle Sawing for Economy

HERE'S a novel scroll or band-saw technique, which can be used to good advantage in making lamp bases, book ends, model boat hulls, and many other projects. The two lamp bases shown in the top photo are typical examples. Each of these bases is cut from one piece of wood, the size of the original board being the size of the largest piece of the base.

The "beehive" lamp base illustrates the procedure: The lines on which the stock is to be cut are laid out, starting with a radius of $\frac{5}{8}$ in., and increasing $\frac{3}{8}$ in. until a radius of $3\frac{1}{4}$ in. is reached. Small holes are drilled to permit the insertion of a fine scroll-saw blade, and the various rings are sawed out. The saw table is not level, but is on an angle of about 2 degrees.

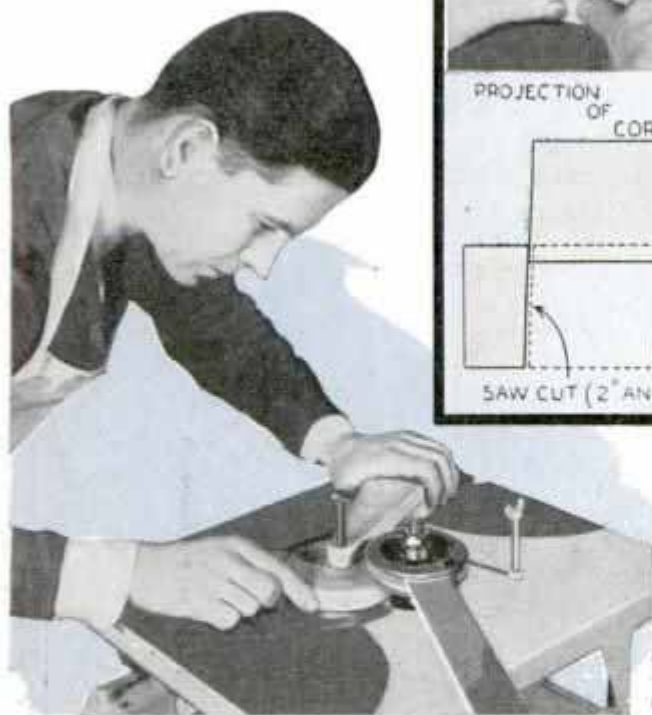

Forms glued up in this fashion can be turned or otherwise machined to form wooden bowls, boat hulls, etc. The principle used is thoroughly practical, and will effect a considerable saving in material on production work where the nature of the project permits its use

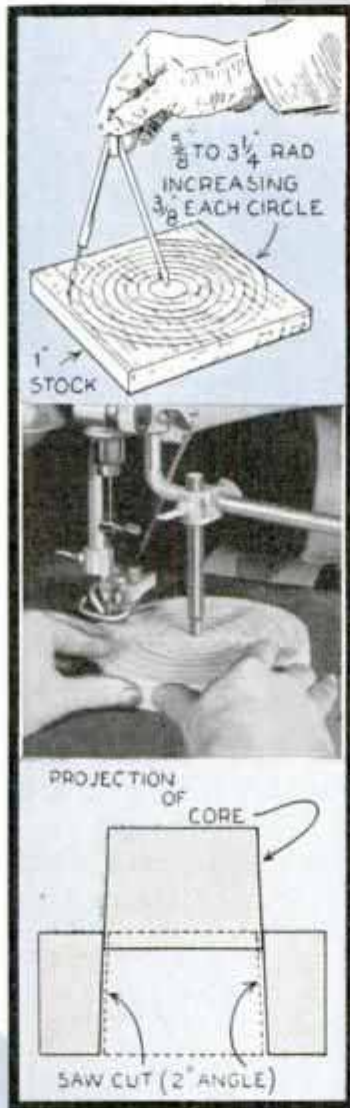

COMPLETE LAMP BASES ARE CUT FROM ONE PIECE OF WOOD BY ANGLE SAWING

A center jig can be used, or the cut can be guided by hand. Each of the rings, being cut on an angle, will project a certain distance from the next larger ring. One of the illustrations shows how the rings are projected to form the lamp base. Glue is used to maintain the pieces in this position. In production work, a master form would be used to set each ring quickly at the required distance.

The small holes necessary for scroll sawing can be plugged or filled with plastic wood readily. The edge of each circle of the original lamp was rounded on the shaper, but a master form could be used for the same operation done on the lathe after gluing.

☐ Clothespins soaked in a soap solution and dried without rinsing, will not freeze to the line or clothes in cold weather.

Hat Rack Pivoted to Closet Door Utilizes Waste Space



WOOD DISK
This rack raises and lowers, the parallel links holding it horizontally in any position

Screwed to the door or wall of a small closet where space is limited, this hat rack is raised out of the way, utilizing waste space above the garment rails, and is lowered to a convenient height for selecting the hats. A wood disk carrying seven "mushroom" supports is pivoted to the door by means of two pairs of parallel links or arms, the link brackets on the disk being cut from heavy sheet metal, while those on the door are short pieces of angle iron. The pivot bolts or rivets should be drawn up snugly so that friction will hold the rack in any position.

—Jas. H. Rodgers, Toronto, Ont., Can.

Runners on Refrigerator Trays Make Removal Easy



You won't have any trouble removing ice-coated trays from your refrigerator, if they are fitted with wire runners, which permit only a small amount of metal surface to

come in contact with the freezing compartment. Suitable runners are made by bending pieces of heavy wire to a U-shape, as indicated. They can be slipped in under the trays loosely, or soldered on.

Holding Magazine Pages Open to Read Plans

When building an article from plans given in a book or magazine, I find a trouser hanger of the type shown, handy for holding the pages open. Besides this, you can hang up the plans so that they are easy to



see, and where they will not become soiled.
—Vernon Tracey, Centerville, N. B., Can.

Profile of Lathe Turning Tools Checked with Special Gauge

Amateur lathe operators who have difficulty in remembering the exact shape to which various turning tools should be ground, will find this gauge a help. Take a piece of sheet metal of any convenient size and file the profiles of the various tools in the edges as shown. Attach it to your grinder where it will always be at hand. Different profiles may be ground on each end of a tool to save material.

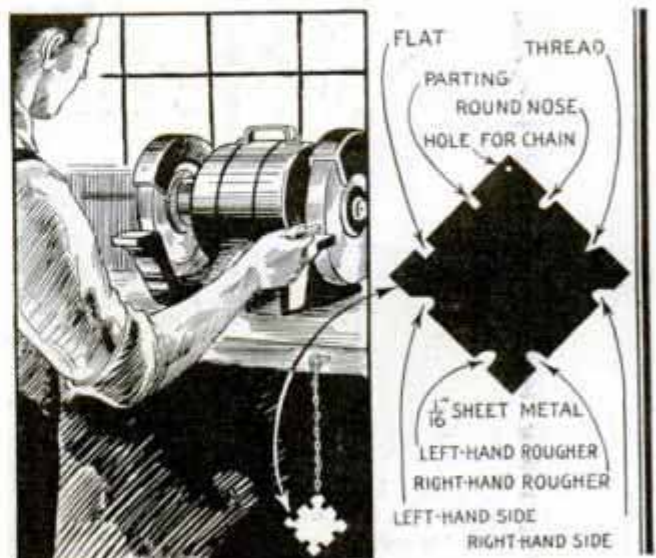

You can grind your lathe turning tools correctly if they are checked with this profile gauge

Roll-Film Guide Simplifies Tray Development

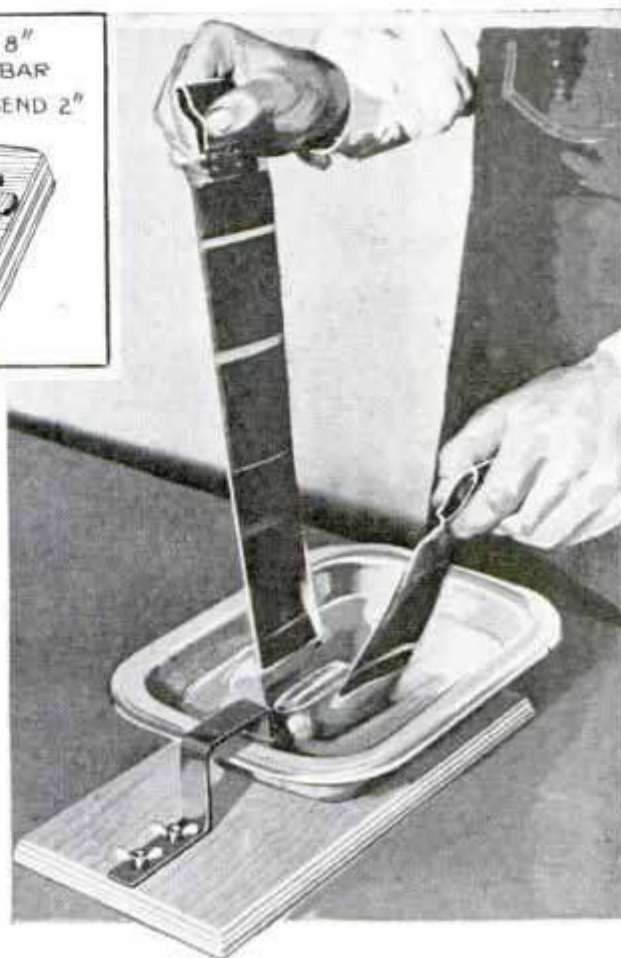
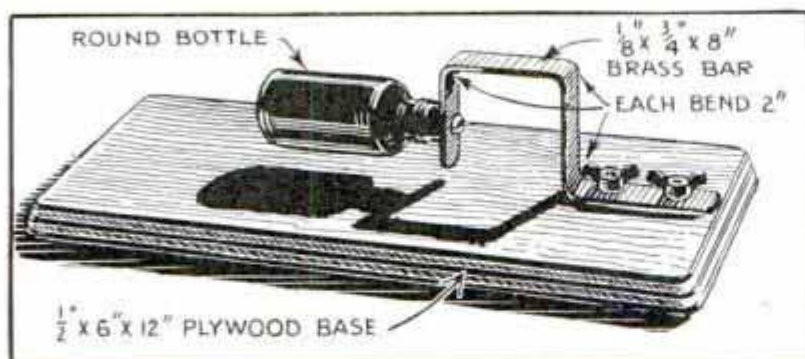

Eliminating the possibility of scratching the emulsion side of roll film, when developing it in a tray, this simple guide also effects a saving in developing fluid and prevents the film from curling and getting out of the tray. The guide consists of a small, round bottle, a brass arm and a plywood base. The parts are assembled as shown in the detail with the tray resting on the base as indicated in the photo. The bottle cap, which is cemented to the glass to keep it from loosening, is fastened to the end of the arm with a machine screw, and the arm is attached to the base with small bolts and wing nuts to permit easy removal, as it must be taken off to empty and clean the trays. It is best to use separate guides for developing and washing, and all metal parts should be given several coats of lacquer to keep them from affecting the fluids. In use, the tray is filled with enough fluid to come well over

the bottle, after which the film is slipped under the bottle, emulsion side out, and pulled back and forth through the fluid, this operation being continued for the length of time necessary to develop the film.—Robert J. Williams, Chicago.

Rooms Facing Narrow Court Brightened by Reflected Light

If buildings are so close to your home that they darken the rooms, you'll be surprised how much the rooms can be brightened by setting white-cloth frames outside of the windows at an angle. The cloth is tacked to wood frames, which are hinged to the window sills, small chains being used to hold them in place. White oilcloth, or pieces of sheet metal, painted white, may be used instead of cloth, and they are easier to keep clean.

☞ Unsightly deposits that often form at the water line of fish bowls and aquariums may be removed by rubbing them with a cloth saturated in vinegar; rinse the bowl thoroughly before filling with fresh water.

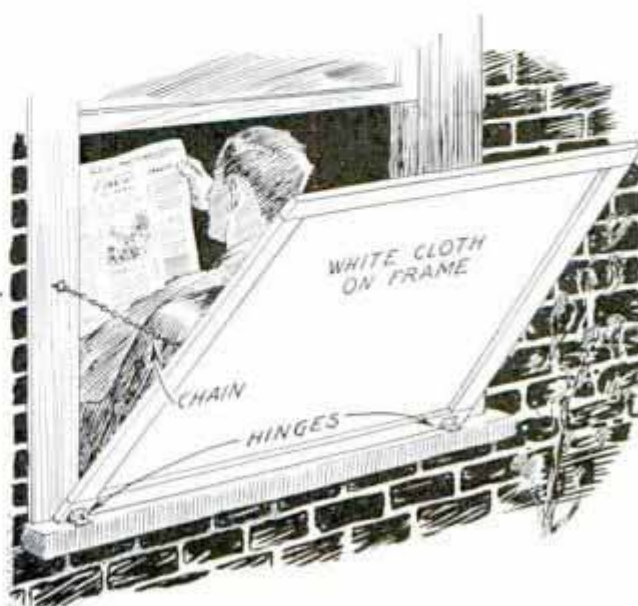

Cool Handle on Furnace Poker Prevents Burned Hands

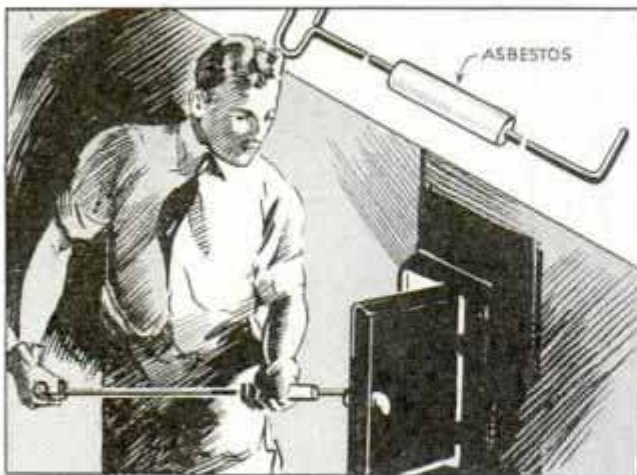

No matter how hot the lower part of the poker gets you can always grip it with this sliding handle

Made by wrapping several turns of sheet asbestos on your poker, clinker hook or similar tools used around the home-heating plant, this sliding grip is always cool, regardless of how long the tool is kept inside the firebox. The turns of asbestos are cemented with water glass.

Dangers in Diving Helmets to Be Avoided

There is extreme danger in using home-made diving helmets. No person should attempt to submerge in such a device unless he is a good swimmer and is physically fit. For amateurs, a diving helmet must be designed so that it can be dropped off the wearer's shoulders any instant, and for this reason a harness must be avoided. The diver should be able to rise to the surface at will, without being dependent on anyone above. A diving helmet, therefore, should fit over the head with enough excessive space to permit "dumping" it by a forward movement of the body. A constant flow of fresh air pumped into the helmet through a single length, unspliced, non-kinking hose by means of a pump having a capacity greater than needed, must be provided to assure the diver enough fresh air. Never use hose that is joined and taped together. Breathing in a helmet should be easy, and the air inside should be as "fresh" as outside air; if this is not the case enough air is not being delivered and the hose or pump may be at fault. If the air inside seems stale, "dump"

the helmet at once—don't continue to wear it because, should the supply of fresh air be inadequate, gradual suffocation from lack of oxygen may result, and you may not be able to hold your breath until you reach the surface. For the novice, it may be best to leave the practice of diving to professionals, but if you are determined to use a diving helmet, no better advice can be given than to practice in water not over six feet deep until you are thoroughly aware of any emergencies that may arise. At no time should a person use such an apparatus at a greater depth than he can make a surface dive. Further, no novice should use the equipment until it has been tested by persons who are in a position to know whether it is safe.

Cutter on Spool of Heavy Thread



Attached to a spool of thread with a thumbtack, this handy cutter eliminates the trouble of locating a pair of scissors every time you wish to cut off a piece of thread. The cutter is made from sheet metal and filed to a sharp edge. In use, the

thread is brought down over the end of the spool and across the cutting edge.

Teeth on One Side of File Filled to Protect Adjoining Work

When smoothing the bottom of a narrow slot where it is necessary to prevent marring the adjoining work, coat the teeth on one side of the file with water glass. Apply it liberally and wait for it to dry. When the job is finished remove the water glass with a file card.



Upholstered DEN COUCH

has storage space

By C. H. Deerwester

TWO frames of the same size hinged together, the top frame upholstered, the lower mounted on four turned legs and provided with a plywood bottom—and there's your combination couch and storage chest. The upholstery is so simplified that if you can drive tacks you can do the job. The first thing is to find an old set of bedsprings and dismantle it. What you're after, of course, are the coil springs and holders. Now, the top half of the couch frame is made up as in the details on this page. Then the spring-holder bars are cut to fit between the side pieces, to which they are anchored with screws. It is a simple matter to snap the springs into the holes provided in the holders. Next, both lateral and longitudinal strips of cotton tape or webbing are tacked to sides and ends of the frame. Each spring is sewed to the tape at the four points with a waxed string. The springs are first covered with a heavy material, preferably canvas, which is tacked at about 2-in. intervals completely around the frame. It is to be expected that the two outer rows of springs will be compressed to a greater degree than the inner rows.

Four rolls of cotton batting are spread over the canvas, layer upon layer. Be sure that the thickness of the padding is uniform then cover it

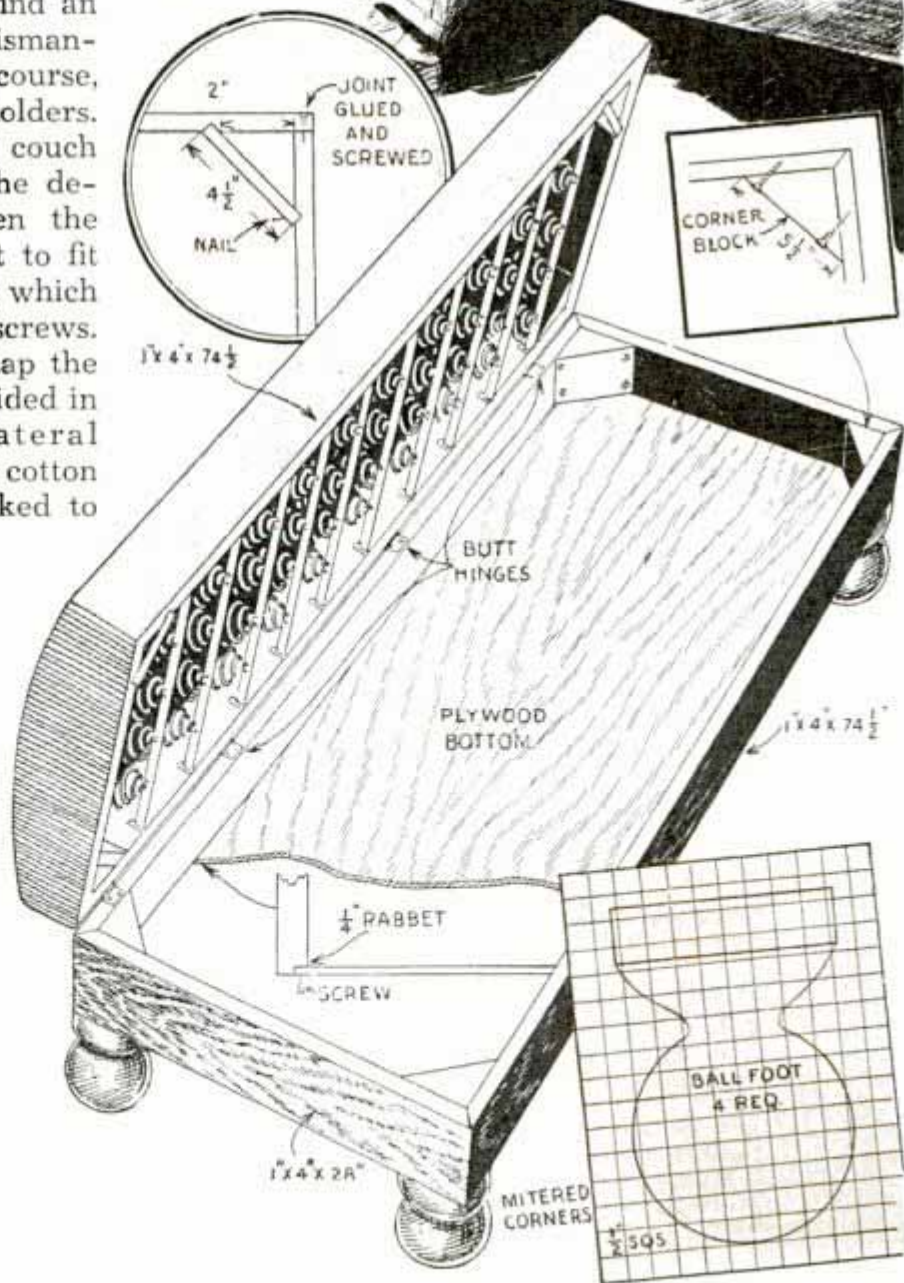

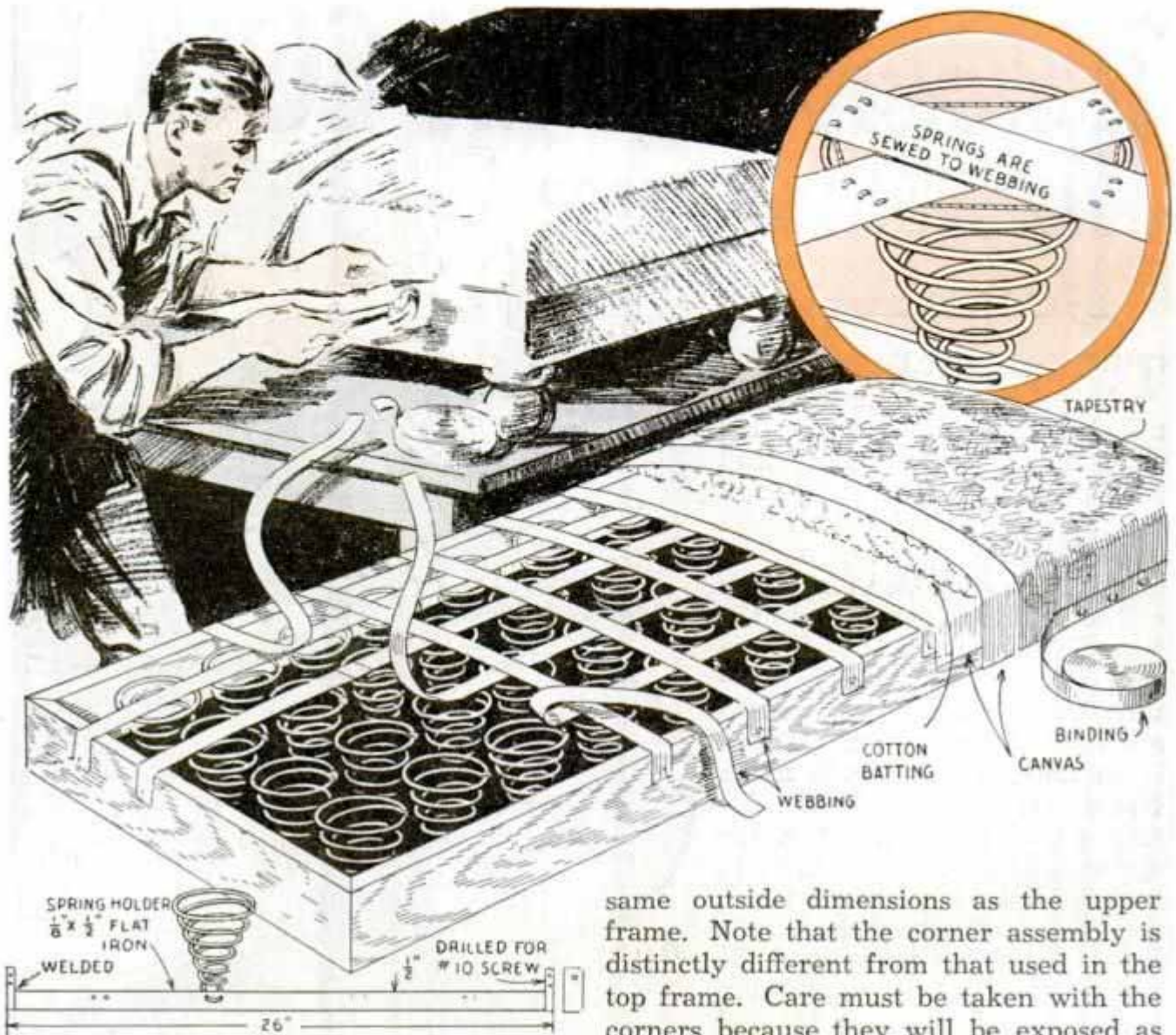

with an old linen sheet or other similar material, tacked to the frame in the same manner as the canvas. This cover will prevent the padding from shifting with use. When tacking the tapestry, be sure to draw it evenly to prevent wrinkles. Space the tacks about 1 in. apart and keep them in a line $\frac{1}{4}$ in. above the bottom edge of the frame. This precaution must be taken in order that the tacks will not show after the binding has been applied. The binding comes in various widths and can be purchased in any department store handling upholstery materials. It should be of a contrasting shade of the same color as the cover. For the back, pillows can be made of material left over from upholstering, filled with kapok, and fitted with slip covers of a matching color. This finishes the upholstering job.

The lower frame is now assembled as indicated in the details. It must have the

same outside dimensions as the upper frame. Note that the corner assembly is distinctly different from that used in the top frame. Care must be taken with the corners because they will be exposed as finished wood in the completed assembly. The plywood bottom should be placed immediately after the lower frame has been assembled. It can be nailed directly onto the underside of the frame and the corners beveled with a hand plane to prevent showing, or set in a rabbet and fastened with screws as shown. The legs can then be turned and screwed into place. The proper method of mounting is with screws driven through the four corners of the leg. This done, the hinges are mortised into the frames and fastened with screws. Use brass butt hinges with removable pins. You can now finish the lower frame and legs in any color you desire. First, give the wood a thorough sanding with progressively finer grades of paper. If you use an open-grain wood it will require filling with a paste filler, then stain, shellac and wax. Or, in place of the latter, you can use a high-grade varnish, laid on over a coat of white shellac.

Nicked Nails Easily Broken Off

Where nails often must be used that are a little too long for the job, I find that instead of clinching the projecting ends it is better to file or cut a series of notches in each one as shown, before driving them. Then they can be broken off with a couple of twists. This method is especially handy on work where it may be necessary to use a plane after nailing.

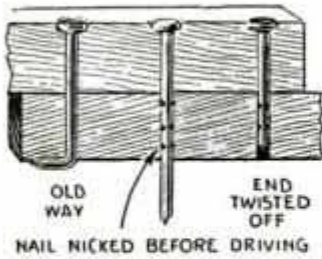

—W. S. Houseburg, Pittsburgh, Pa.

Garments Dried Out of Sight on Back of Radiator

By simply attaching a small wood or iron bar to the rear side of a radiator cover in your home, a dandy place for quickly drying stockings, handkerchiefs, etc., is provided. Your particular cover and the type of bar or rod you have will determine the method of attachment.

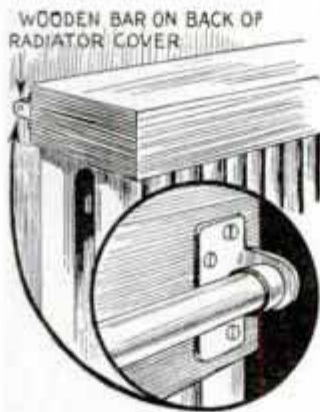

Storm Windows Sealed Tightly with Adhesive Tape

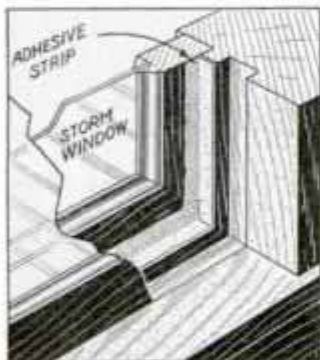

To increase the efficiency of a storm window that doesn't fit snugly in the casing, strips of tape, such as Scotch drafting tape, placed around the inside surface as shown, have been found effective in sealing the joints against passage of cold air. Before applying the tape, the surfaces that it contacts must be cleaned thoroughly so that it will stick. The tape is easily stripped off.

Minnesota Mining
April 10, 1971

Why Risk Injuring Your Fingers in a Food Chopper?



Rather than push meat and other materials into a food chopper with the fingers, which may result in an injury, use a spoon as shown. A tablespoon is just the right size for the average chopper.

Buttonholes Punched in Cloth

Instead of cutting buttonholes with a pair of scissors, one seamstress prefers punching them with a spear-pointed tool made by grinding the blade of an ordinary table knife to a point as shown and then

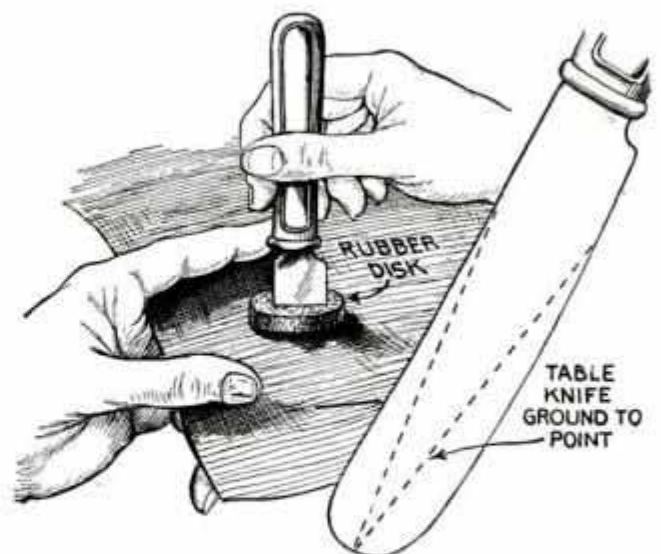

Buttonholes quickly and accurately punched with blade of table knife ground to a spear point

sharpening both edges. A rubber disk with a slit in the center slides on the blade and serves as a stop so that a number of holes can be cut to the same width.

SAFE FUN *for*



① When the party starts guests are fingerprinted "electrically"

UPON arriving, every member of this Halloween party must be fingerprinted and "mugged" as regular routine for identification records in the archives. The newcomer presses the thumb of his right hand down on the "ink pad," for which purpose ordinary carbon paper will do. This is pasted to a piece of sheet metal on a small box which contains two dry cells and a Ford vibrating coil, connected together as shown in Fig. 1. The "guard" presses a push-button switch the moment the guest touches the carbon paper and has his left hand on the table directly over another sheet-metal plate also wired up as indicated. The result is a sudden shock which is surprising but not harmful. To offset suspicion, it is a good idea to place the left-hand electrode under a tablecloth. Direct contact with the metal is not necessary. A long strip of metal along the edge of the table is better than a small plate as any one seated at the table naturally rests the left hand somewhere along the edge.

"Mugging" with an exploding camera



Another shocking episode, which may take place right on the "welcome" mat, is shaking hands with the "ghost host" who is a head taller than anyone in the party. See Fig. 11. He stands near the entrance and

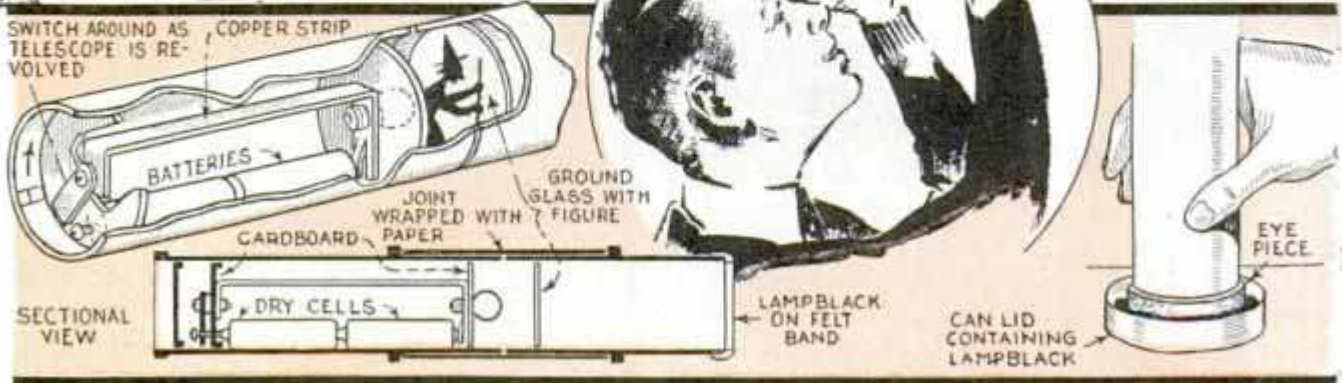

③ You will see a real picture in the telescope, but...

HALLOWEEN

extends his hand to the guest who takes hold of a cloth glove having four wiggly coil-spring fingers. These and a metal door mat are the electrodes, and are connected to a vibrating coil or a toy shocking machine operated by someone behind the ghost. The ghost has pearly eyes, which look as if they were suspended in void space of an empty hood.

The next job to get the records straight is mugging. This is done in a semidarkened room with a cardboard camera as in Fig. 2. The startling effect comes when the light is suddenly flashed and a cap pistol is fired at the same instant. After this, everything tried on the newcomer will be looked upon with great suspicion but he may be convinced to observe Mars without a shock or a scare. He will actually see something through the enchanted telescope, pictured in Fig. 3. When the star gazer first puts it to his eye he sees nothing, and is told to revolve it until he does. The eyepiece has a felt rim dipped in lampblack, which leaves an interesting ring around the eye. However, the victim has his reward for with one complete revolution of the telescope, a swinging switch lever makes contact and a small light inside reveals a witch or comic figure. To make the telescope, use a mailing tube about 14 in. long and 2½ in. in diameter. Cardboard partitions hold the lamp

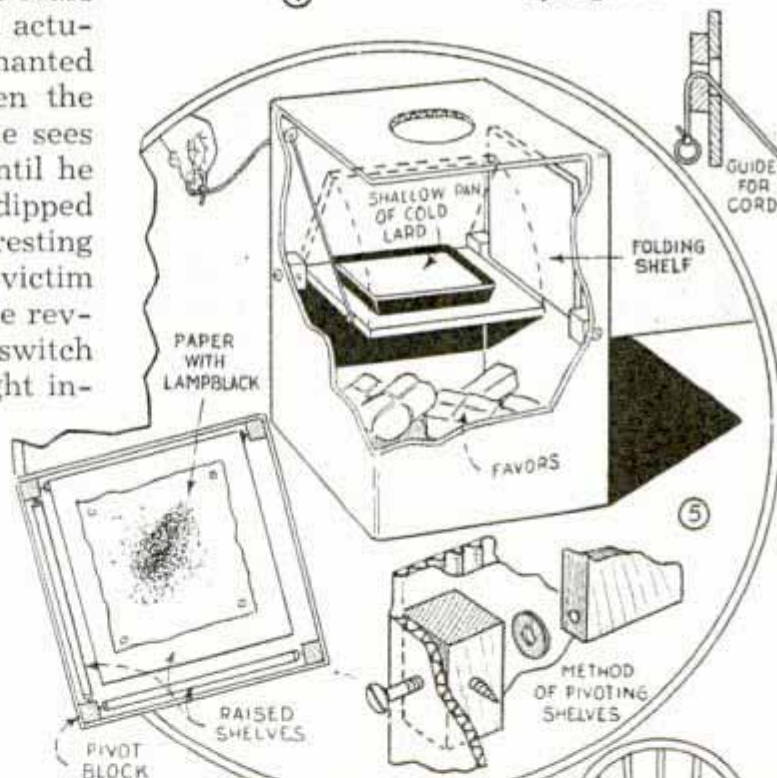

This chair has two levels

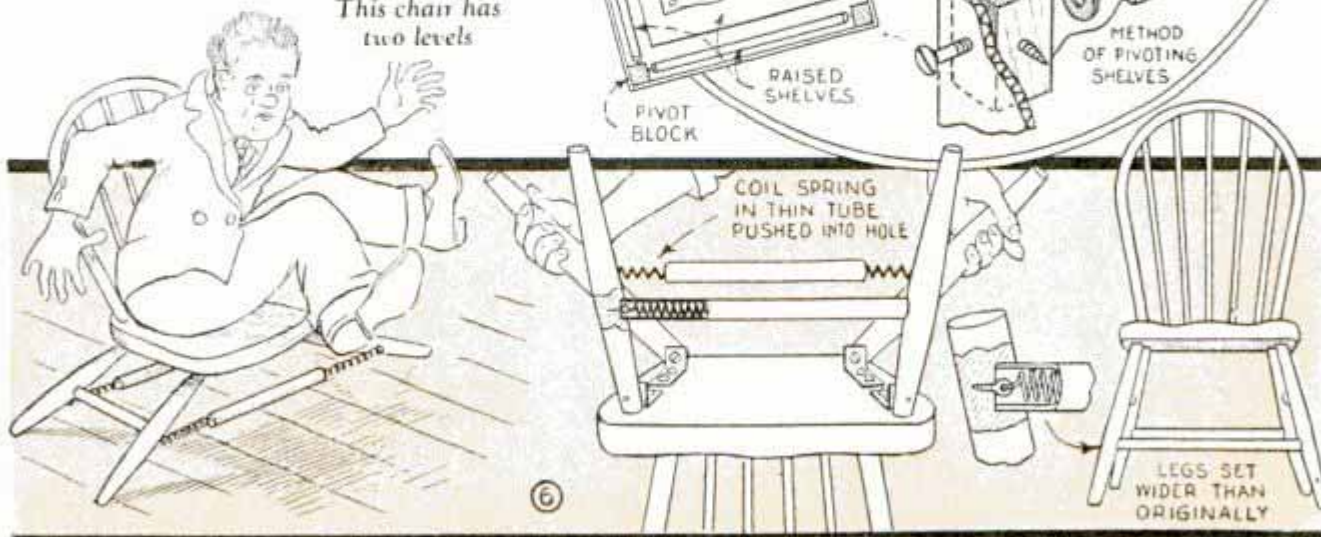



Everything ahead recedes as you walk toward it

7

bulb and the revolving switch, which are joined by a copper strip. The switch must work freely. By making the tube in two parts, the assembly is easy. Paper wrapped around it completes the joint. Four bands of black paper are wrapped around the telescope to make the sooty eyepiece less conspicuous.

Fig. 4 shows an elaboration of the popular "grab-bag" idea. In this case a large carton is equipped with three shelves, which fold up against the sides of the box, giving free access to the favors for guests in the bottom. Lights are arranged so that the inside of the box is dark. After two or three merry-makers have drawn prizes from the box, an attendant "in the know" lets down one of the shelves by means of a concealed string. This shelf may have on it a shallow pan of lard, or a sheet of paper coated with lampblack or graphite and oil, or red grease—anything that will not flow when the shelf is in the vertical position. In the laughter which follows the victim's predicament, the attendant draws up the shelf and another guest is invited to draw from the box, this one of course brings out a favor. Eventually the other two shelves are let down to provoke more laughter.

A collapsible chair can easily be made from a common kitchen chair, and, if others of the same design are placed in the room, the tricky one will not be noticeable. Remove the legs and round off both ends as in Fig. 6. They are then joined in two pairs consisting of one front and one back leg connected with a rung. Coil springs, concealed inside of thin tubes are substituted for the front and rear rungs.



A surprise confetti shower

8

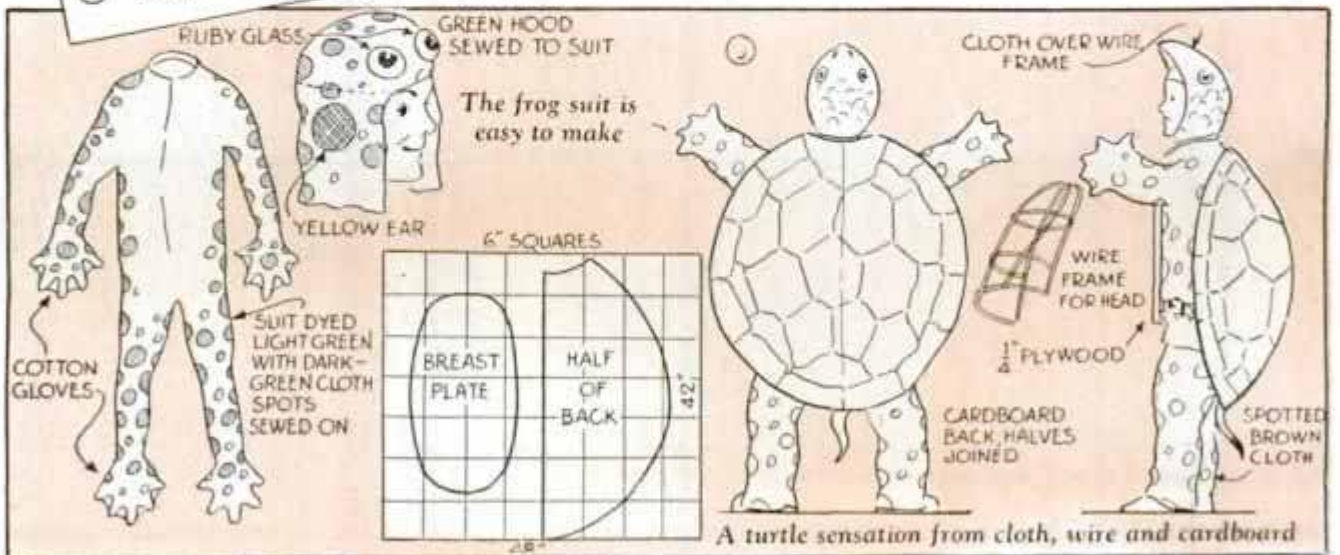

The frog suit is easy to make

A turtle sensation from cloth, wire and cardboard

The tubes should fit into the holes formerly occupied by the rungs, and are painted to resemble them. As soon as a guest sits on the chair the tubes pull out and the chair sprawls. Strong tension springs should be used.

A most surprising effect is afforded by the "X-ray" helmet shown in Fig. 7. This, briefly, is a cardboard box with two mirrors arranged to throw the vision directly behind. The user of the helmet will have the strange sensation of seeing what appears to be the foreground receding from him as he progresses, and although there may appear to be an open door ahead, more likely he will fetch up against a wall.

For a confetti blizzard, an electric fan is rigged as shown in Fig. 8. This also can be operated by an extension switch. Make a large cardboard cylinder to fit over the fan frame, paste a disk of tissue over the front end, just enough to hold it until the blast strikes it, and then fill the space half full of confetti. When the unwary guest steps in front of the fan, he is deluged with a shower of confetti.

Ideas for Halloween costumes are pictured in Figs. 9 and 10. The frog suit is an ordinary union suit dyed a light green, with dark green cloth spots sewed or cemented on. Cardboard, plywood, wire and cloth are all that is necessary to make the turtle costume. By cutting the back halves as indicated and joining along the ridge with adhesive tape, a very convincing shell can be made. The anchor is simply made of plywood and cardboard, and the wearer should be clad in trunks and have tattoo figures on arms and legs painted with harmless coloring, such as fruit juice.

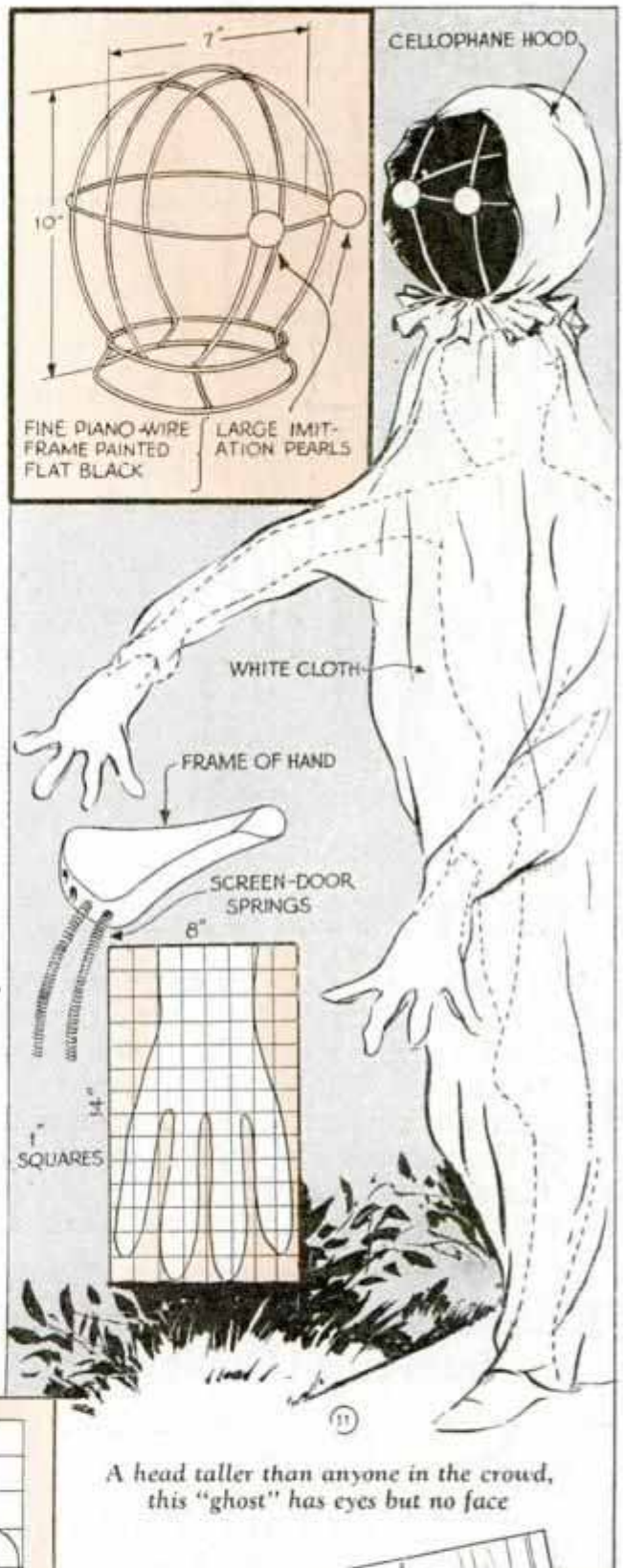

A head taller than anyone in the crowd, this "ghost" has eyes but no face

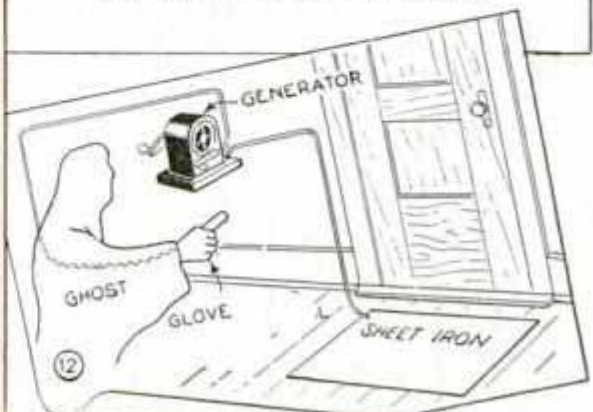
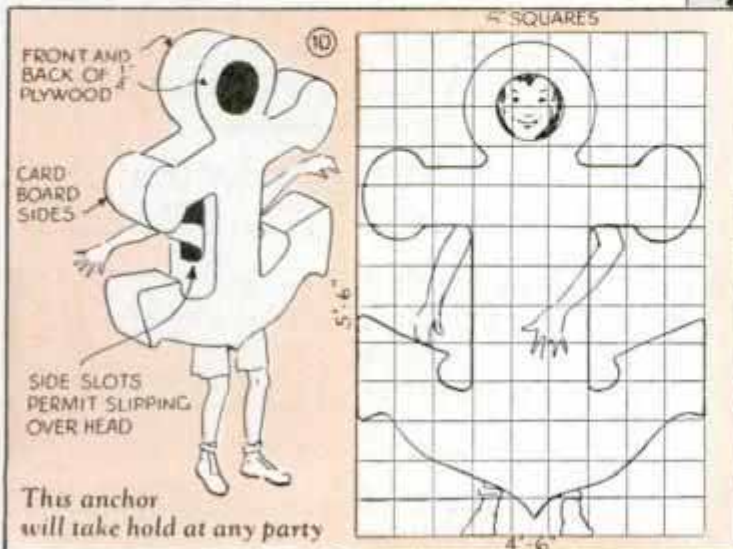

Twist Tamper Does Not Stick in Clay or Concrete



Twisting the tamper slightly tends to break the vacuum between it and the wet material

The tendency of wet clay or concrete to adhere to the bottom of a tamper can be avoided by giving it a slight twist as it is lifted each time. The twisting action tends to clean the surface of the tamper and break the vacuum that exists between it and the wet material. To facilitate twisting the tamper, a hand grip is provided.

Flexible "Finger" Picks Articles from Small Gratings

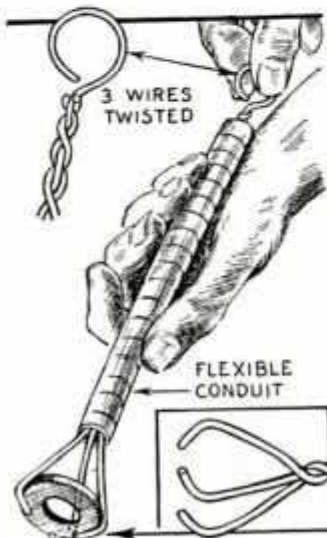

For retrieving small articles in places where you can't reach them with the hands, such as heating registers and gratings, you can use this simple "finger." It consists of three lengths of spring brass wire twisted together, leaving three prongs at one end,

which are bent to form jaws. Insert the assembly into a length of flexible conduit and form an eye on the other end of the wires. Moving them back and forth in the conduit opens and closes the jaws.

Upholsterers' Gimp Is Spread with Steel Ball

Instead of trying to hold upholsterers' gimp open with the fingers to keep it in place while driving the tacks, use a steel ball as shown. Besides keeping the gimp spread apart, the use of the ball lessens the danger of hitting the fingers with the tack hammer.—A. H. Waychoff, Tempe, Ariz.

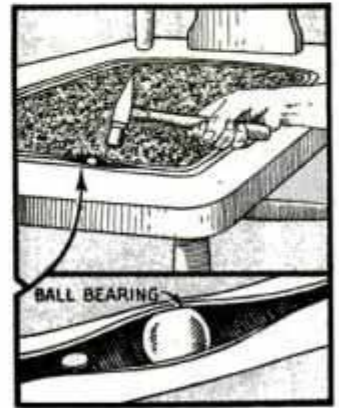

Depth of Small Holes Measured with Automatic Pencil



Here is a simple method of measuring the depth of small holes. The point of an automatic pencil is inserted in the hole and the lead is forced out until it touches the bottom. When the pointed end of the pencil is even with the surface of the work the projecting lead is equal to the depth of the hole.

the surface of the work the projecting lead is equal to the depth of the hole.

Broom to Sweep Snow and Slush Stiffened with Wood Backing

Stiffened with a piece of plywood, an ordinary broom can be used effectively for cleaning sidewalks of fairly deep snow. Cut the plywood to the



shape of the broom and drill a few small holes through it to take fine wire, which attaches it to the broom. It is best to cut the plywood about an inch shorter than the broom straws so that they will project from the bottom edge. Thus, the plywood pushes the heavy snow, while the projecting straws sweep the walk clean.

Oven Rack Has Guard on Edge to Prevent Accidents



There won't be any danger of accidentally pushing a roaster off the rear edge of a wire rack in an oven if the rack is fitted with a metal guard as shown. To make such a guard, you simply bend a

piece of galvanized iron of suitable length at right angles, drill holes through the metal, and wire it onto the rack.

—L. H. Georger, Buffalo, N. Y.

Pipe Insulation in Metal Sleeves Is Well Protected

When heavily insulated steam pipes pass through a room where the insulation is likely to be damaged by objects striking

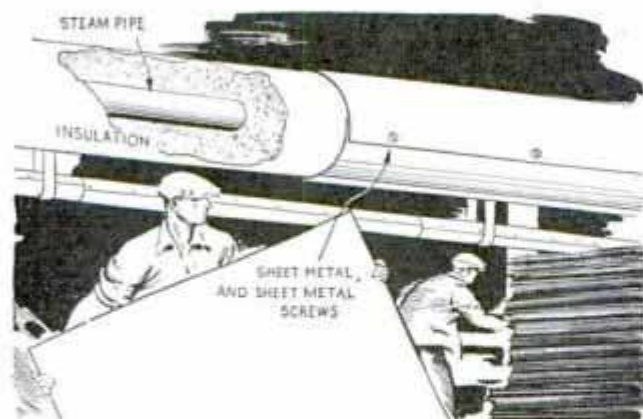

If some insulation has been knocked off your steam pipes, replace it and sheath it with sheet metal

or rubbing against it, you can avoid such trouble by encasing the pipes in sheet metal as shown. Use a metal light enough to be formed around the insulation by hand and fasten it at the seams with sheet-metal screws.

Putting Up Cloth or Paper Sign in Windy Weather



Wind cannot tear a paper sign when putting it up if it is rolled on a broomstick

It's a simple matter to put up a cloth or paper sign single-handed on a windy day, if it is first rolled on a stick. Fasten the free end of the sign and then gradually unroll it as you tack down the edges. With this method, the untacked portion of the paper is kept tightly rolled so that there is no chance for the wind to tear it.

—G. E. Hendrickson, Argyle, Wis.

Reflector for Photo-Flash Bulbs from Small Hand Mirror

An ordinary hand mirror makes a good reflector for use with photo-flash bulbs. Just mount a porcelain wall socket on a small wood block and screw the latter to the handle of the mirror as shown so that the bulb, when inserted into the socket, will be directly in front of the mirror. To control the bulb, a small toggle switch should be fastened to the block within easy reach.—Paul Hadley, Piggott, Ark.



SELECTING



By
W. CLYDE LAMMEY

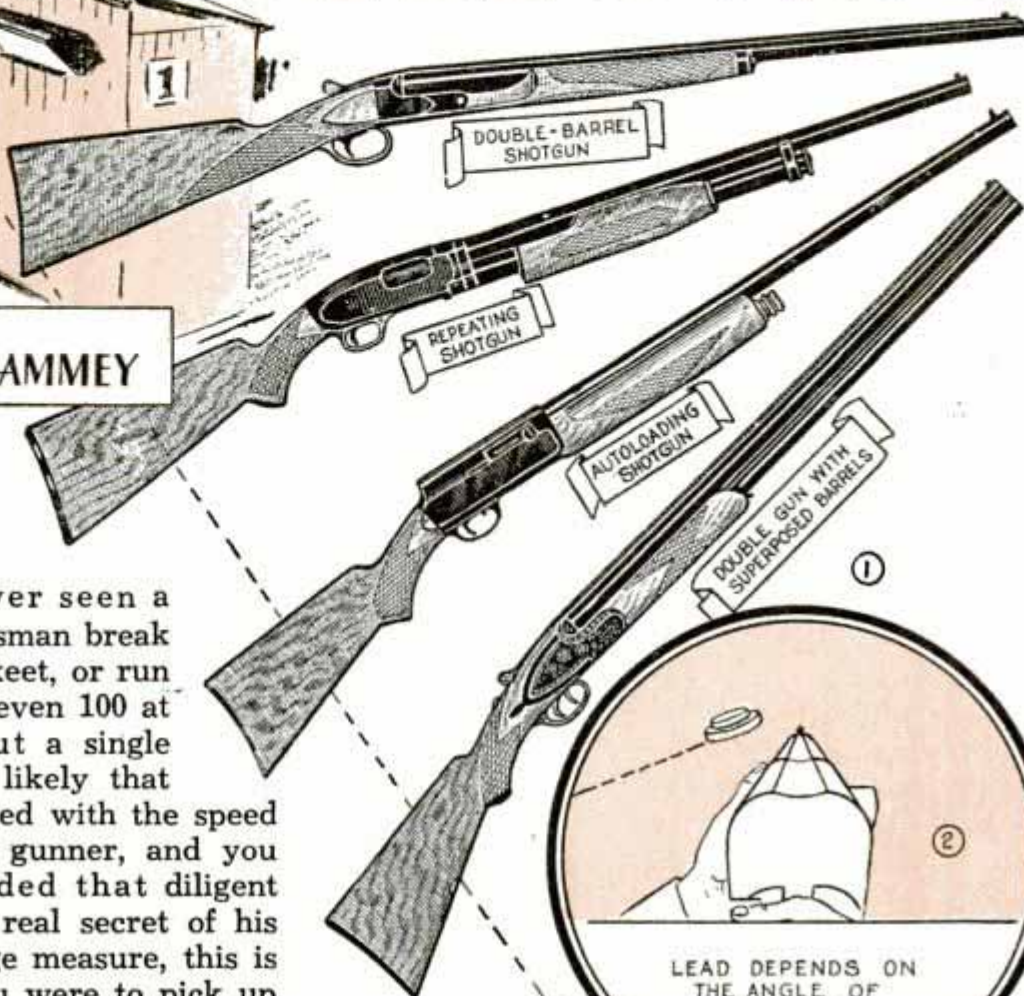

HAVE you ever seen a skilled marksman break "25 straight" at skeet, or run a string of 50 or even 100 at the traps without a single miss? If so, it's likely that you were impressed with the speed and form of the gunner, and you probably concluded that diligent practice was the real secret of his success. In a large measure, this is correct, but if you were to pick up his gun and throw it to your shoulder you might discover that it didn't suit you at all. Possibly you would have to make a conscious muscular effort to bring the barrel into alignment. This would slow up your speed in pointing the gun. Again, the design of the stock might cause your right hand to be cramped. In other words, the gun would not fit your needs individually, because the owner has selected it to suit his own taste and requirements, just like selecting and fitting a suit of clothes.

Skillful handling of a shotgun is a matter of speed. This does not mean a series of sudden, violent movements but rather a smooth, unbroken sequence of motion that gets the gun to your shoulder, your cheek on the comb, and your eyes on the object to be hit—all in a split second. Roughly, the effective range of the average shotgun is 35 to 40 yards. Because of this, the experienced gunner knows that when he steps up to a station on the skeet field and calls for his bird, or when swift-winged game flushes in the field, he must get into action instantly. In doing this his whole attention centers on the object to be hit; he is not conscious of the movements



your SHOTGUN

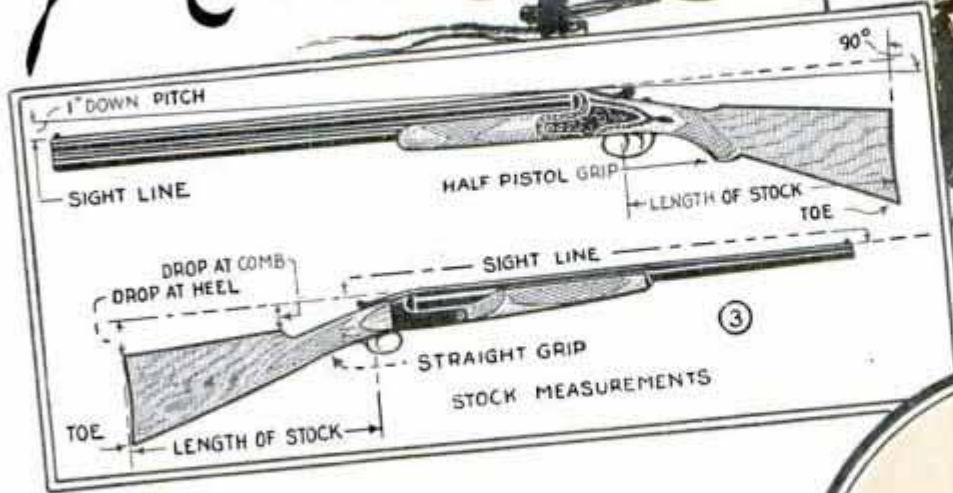

required to bring the gun into position and fire it. You do not aim a shotgun like you do a rifle. Rather you point it, in much the same fashion that you point your finger.

Generally speaking, gun fit hinges on just three dimensions of the stock, which you will find in Fig. 3. These are the length measured from the trigger to the center of the curved butt plate, and the comb and heel drop measured in inches from the sight line. Manufacturers, considering the design of their own product, have worked out average stock dimensions that are intended to be suitable for

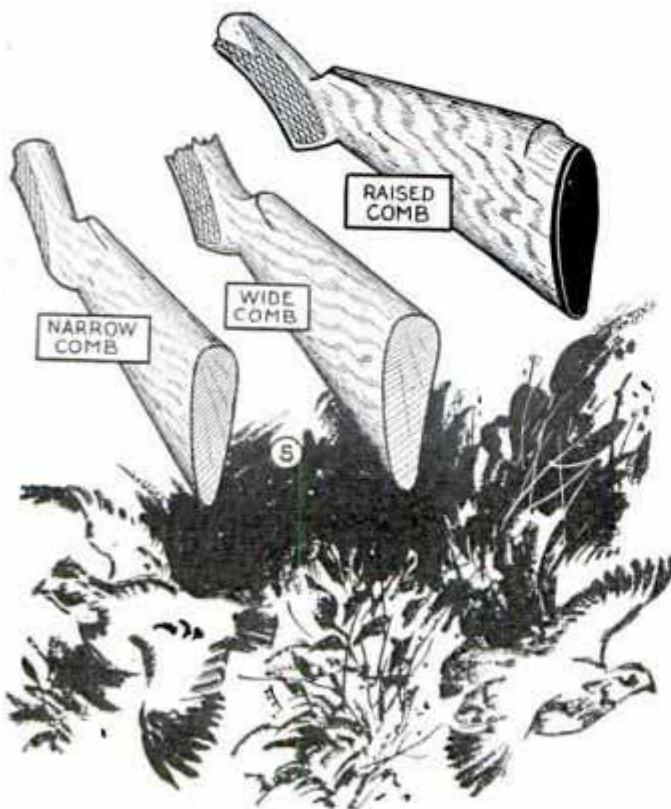

most shooters of average stature. Then there is the structure of the gun itself. For example, you might find a double gun, similar to that in Fig. 1, unsuited to you individually, while the repeating or auto-loading gun, with essentially the same stock dimensions, might fit exactly. This would likely be due to the variation in the type of gun rather than in the stock alone.

Now, to find out whether the gun in hand fits you individually: Sometimes this is rather difficult to determine fully at the outset. With any one of the four shotguns shown in Fig. 1, at your shoulder, go through the five positions shown in Fig. 7. In each case, the arrow indicates the direction in which the gun is pointing at the start of the swing. The foot positions are only approximations, of course, but if you practice them until you acquire the habit, they will help greatly in balancing for a quick shot. Remember that your arms must "lock" the gun to your shoulder; your feet do not move. Your body does the swinging. Now take the first two, in Fig. 7, as an example. At the start of the swing, in each case, hold the gun as in

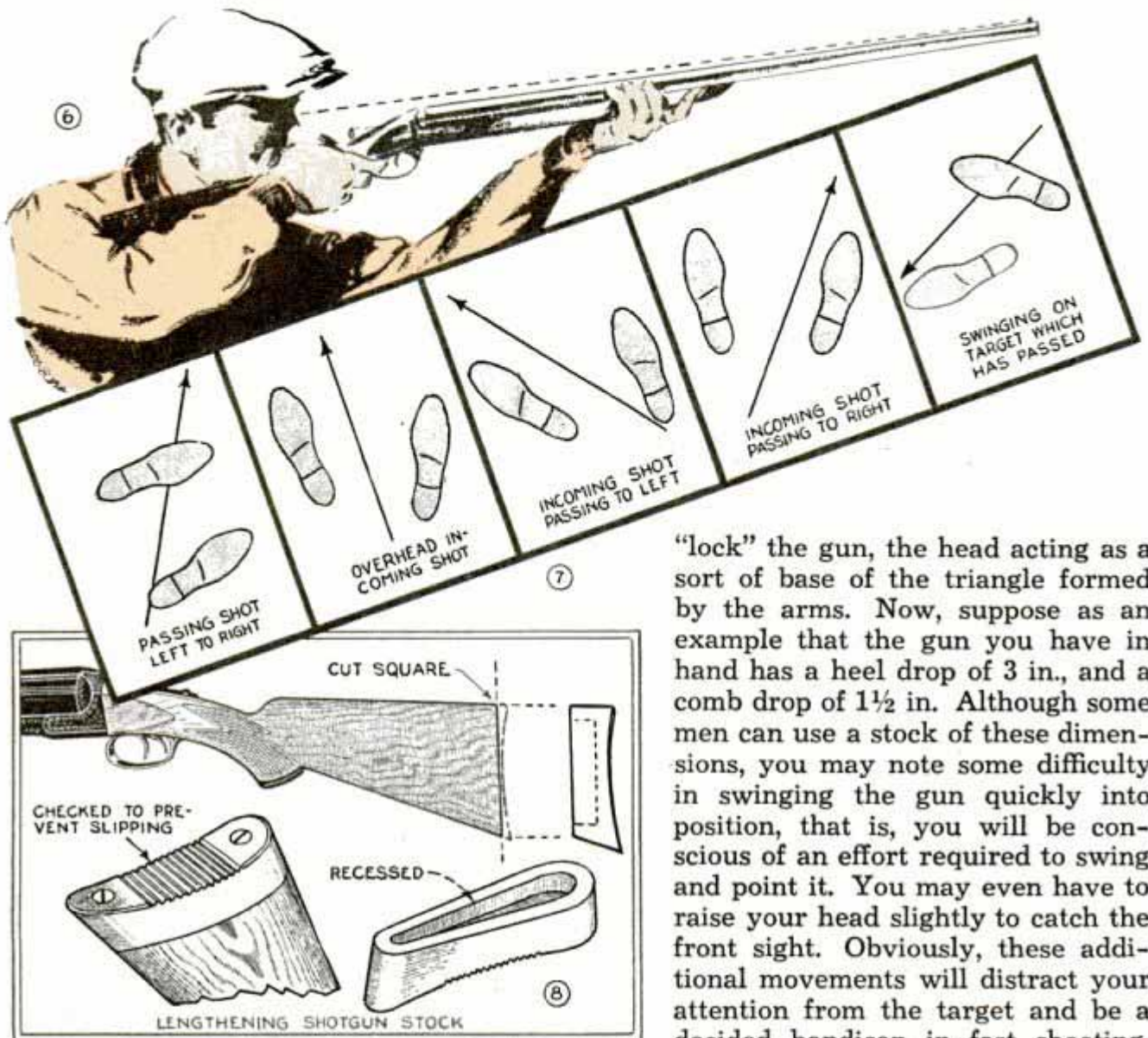

Fig. 6. In the first swing, left to right, you'll notice a gradual tightening of the muscular tension as you come around, also a more or less involuntary tendency of the cheek to slide backward on the comb. The latter will be more pronounced if the stock is too short for you, although it is not as evident as it will be when you try the second swing on an imaginary overhead incoming target. This time the cheek will tend strongly to slide forward. Some shooters take this shot with a backward body bend; others by arm swing.

Now go back to Figs. 2, 3 and 4. Most crack wing shots use a "straight" stock, which means, first of all, but little variation between the comb and heel drop, Fig. 3. Most of these shooters habitually "cheek" the gun hard, that is, the cheek is pressed firmly onto the comb in all shooting positions. This has a tendency to

"lock" the gun, the head acting as a sort of base of the triangle formed by the arms. Now, suppose as an example that the gun you have in hand has a heel drop of 3 in., and a comb drop of 1½ in. Although some men can use a stock of these dimensions, you may note some difficulty in swinging the gun quickly into position, that is, you will be conscious of an effort required to swing and point it. You may even have to raise your head slightly to catch the front sight. Obviously, these additional movements will distract your attention from the target and be a decided handicap in fast shooting. Trying the same type gun with a

heel drop of only 2 in., the comb drop being 1½ in. as before, you will probably note a difference at once. The straighter stock will bring your eye above the breech as in Fig. 6, and the barrel, or barrels, will be in full view, as in Figs. 2 and 4. Such a position enables you to judge distance and lead quickly and accurately. Keep in mind that in all tests of this kind as well as in actual shooting, you should acquire the habit of keeping both eyes open. This utilizes a principle of stereoscopies, the value of which you can easily check by closing one eye and then attempting to gauge the distance quickly to either a moving or stationary object.

Length of the stock and degree of pitch also have something to do with the "feel" of a shotgun. Most shooters find that a stock length of 14 in. is right for them. This, combined with a heel drop of 2 or

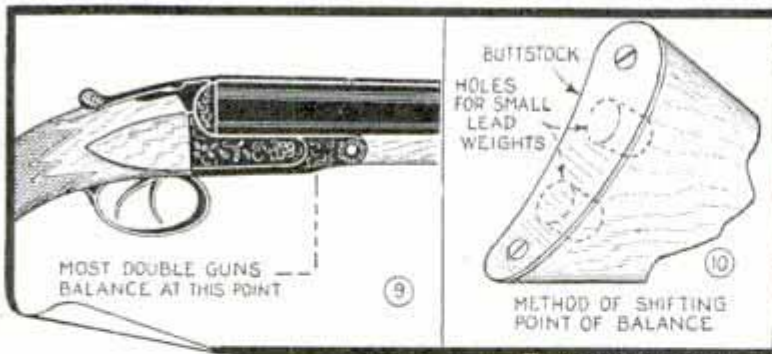

2¼ in. and a comb drop of 1½ in., will prove suitable for a majority of those of average stature. Manufacturers can usually furnish such stocks as standard on the better grades of guns. Stocks are usually furnished with a 1-in. pitch, Fig. 3, but this also varies from zero to as much as 3 in. Certain physical characteristics may make it necessary to specify a special type of comb when selecting a new gun. For instance, if you are full-faced you will probably find a narrow comb, Fig. 5, more suitable. A man with a thin face will likely find a wide or raised comb an advantage. In all this the shooter must determine for himself, by experiment, just what stock characteristics suit him best. Fig. 8 shows one way of lengthening the standard stock that is too short. A new butt plate is made of a pressed-fiber material. The butt is squared and the longer butt plate is screwed in place and worked down flush with the wood. A rubber recoil pad will also accomplish the same thing. Any reputable gunsmith can fit the latter for a nominal charge. As a rule nearly all types of shotguns balance at a point from 4 to 6 in. above the trigger as in Fig. 9. Under certain conditions it may be advisable to shift this slightly to make a gun handle better. By taking off the butt plate as in Fig. 10, and boring two or more shallow holes in the stock you can move this point forward, or, by filling one or more holes with lead the point will be moved nearer the trigger. Another stock alteration is shown in Fig. 11. Here you can do either of two things, change both drop and position of the butt plate, or change the drop alone. Either is a comparatively simple job but it must be done with care. By raising the comb and butt plate as in the first two details, you can correct a tendency to undershooting. If you have an expensive gun, it's best to

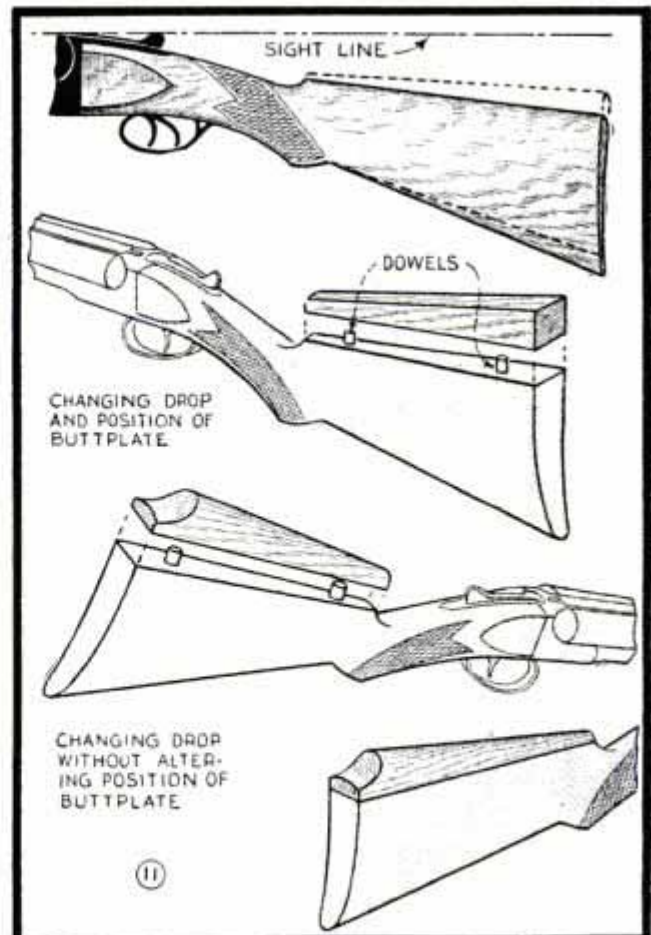

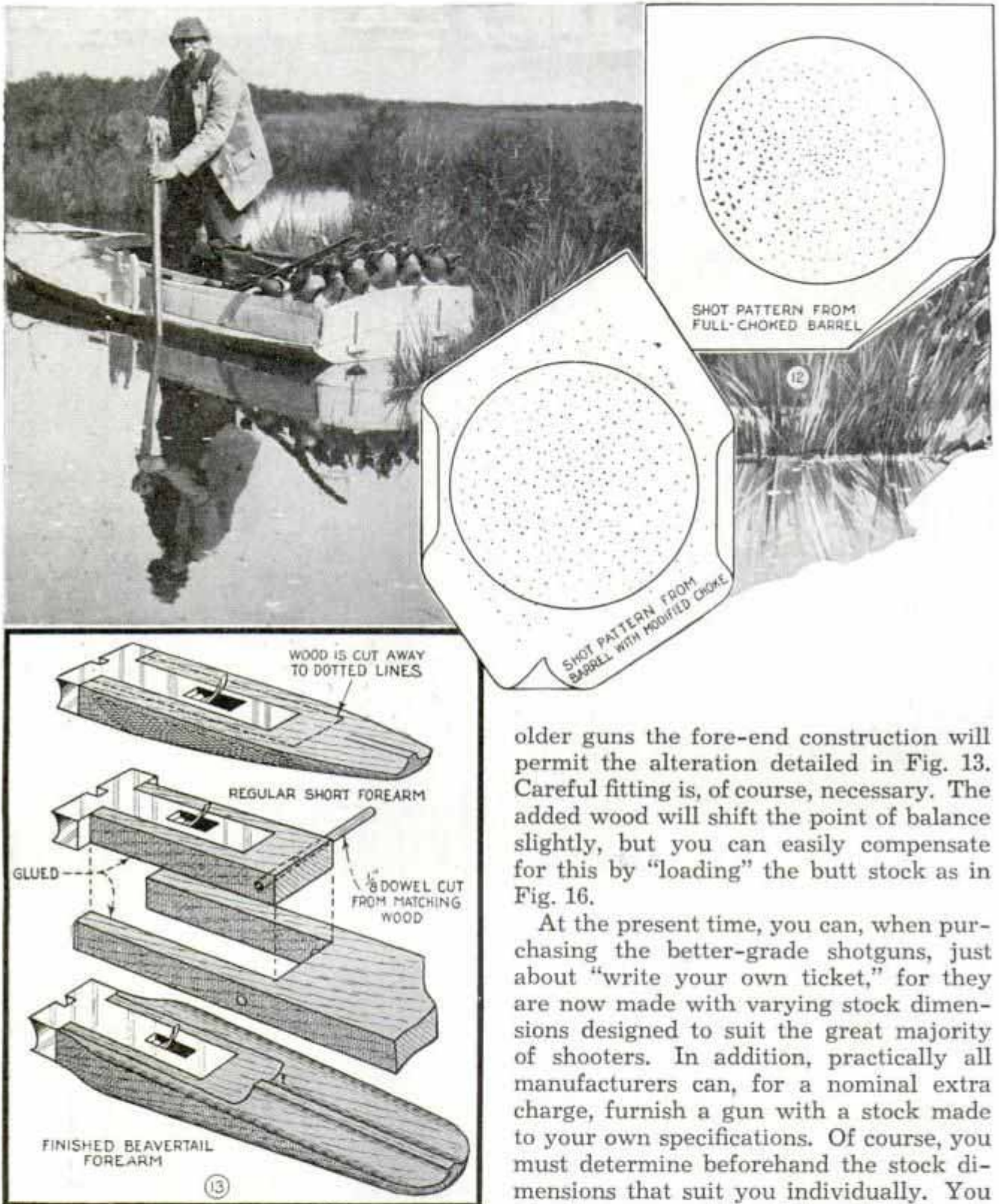

take it to a gunsmith to have this work done, as he can probably fit a new stock made to your own specifications for little more than the alteration would cost. But if the stock is plain, straight-grained wood, you can do the job yourself. It is only in later years that the "beavertail" forearm, or fore end, as it is also termed, has come into widespread use. Its real advantage is its greater length and width. On most

older guns the fore-end construction will permit the alteration detailed in Fig. 13. Careful fitting is, of course, necessary. The added wood will shift the point of balance slightly, but you can easily compensate for this by "loading" the butt stock as in Fig. 16.

At the present time, you can, when purchasing the better-grade shotguns, just about "write your own ticket," for they are now made with varying stock dimensions designed to suit the great majority of shooters. In addition, practically all manufacturers can, for a nominal extra charge, furnish a gun with a stock made to your own specifications. Of course, you must determine beforehand the stock dimensions that suit you individually. You also have a variety of barrel boring to choose from. These are the cylinder, or open bore, the improved cylinder, the skeet chokes, No. 1 and No. 2, the modified, the improved modified and the full choke. These terms signify the degree of choke boring. Fig. 12 shows two representative shot patterns. The modified barrel is the best all-around choice, but for quick work at close range the improved cylinder or skeet chokes are preferable.

Chest of Drawers Hides Single-Room Lavatory

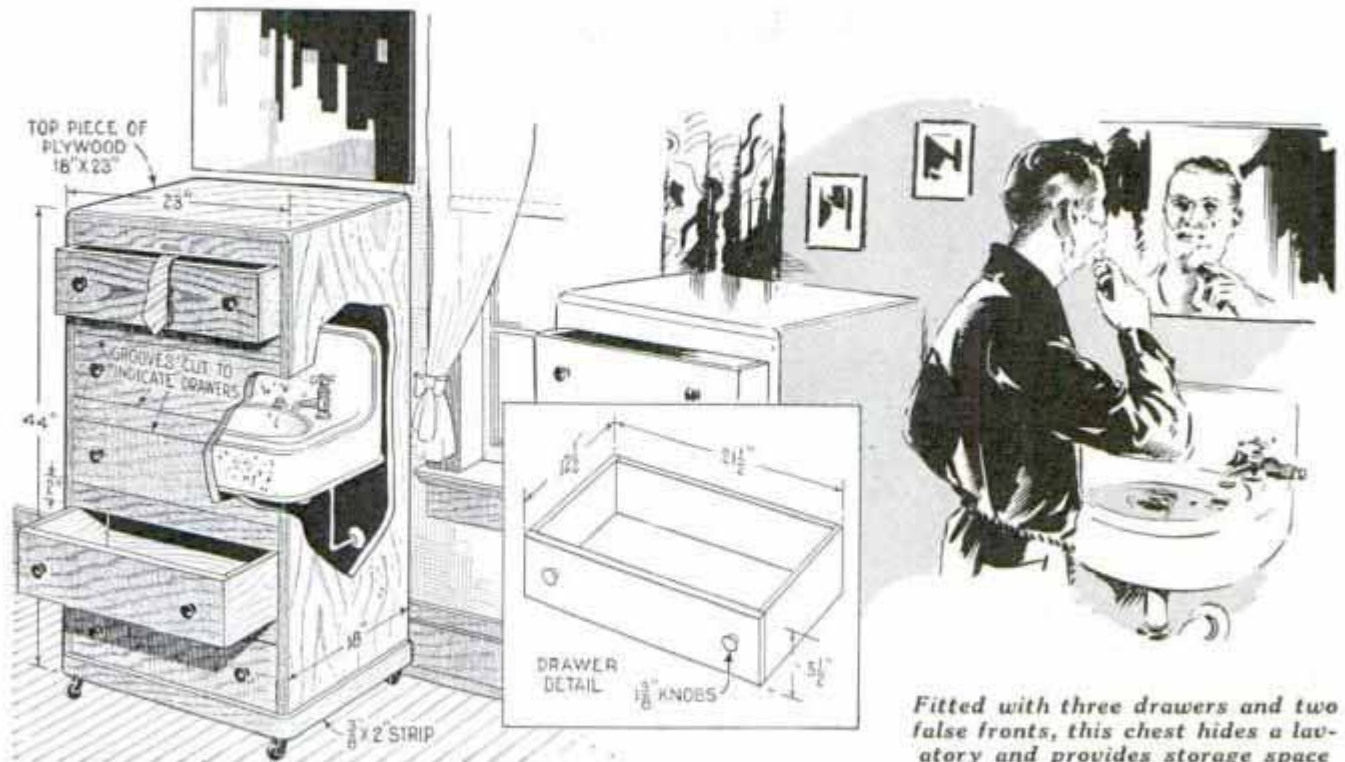

Fitted with three drawers and two false fronts, this chest hides a lavatory and provides storage space

Built with two false drawers and three regular ones, this plywood chest is open at the back so that it can be pushed against a wall over a lavatory to conceal it, as is often desired in rooming houses, hotels and dormitories. The drawers are about two-thirds the depth of the chest, the top one sliding freely over the basin, while

the two lower ones slide under it and in front of the plumbing. The false drawer fronts are made by cutting shallow grooves in a solid panel, the use of four wood-knob drawer pulls adding to the deception. Four easy-rolling casters make it a simple matter to move the chest.

—Frank Beatty, Chicago.

Kerosene Cooking Stove Supplies Warm Water in Home

Those who live in homes where running hot water is supplied by a tank connected to a water back in a coal range, or to the heating plant, can have a supply of warm water when these are not in use by installing a coil in their kerosene cooking stoves. The coil, of course, is connected to the hot-water tank and passes over the top of the stove burners. If these are of the type that must be lifted to light the stove, be sure to make an allowance when making the installation. As the coil is below the cooking grates it is hardly noticeable and does not interfere with the regular use of the stove.

—R. V. Lovejoy, Lowell, Mass.

☐ Before handling fruits which tend to stain the hands, apply olive oil to the fingers and the juice will wash off easily.

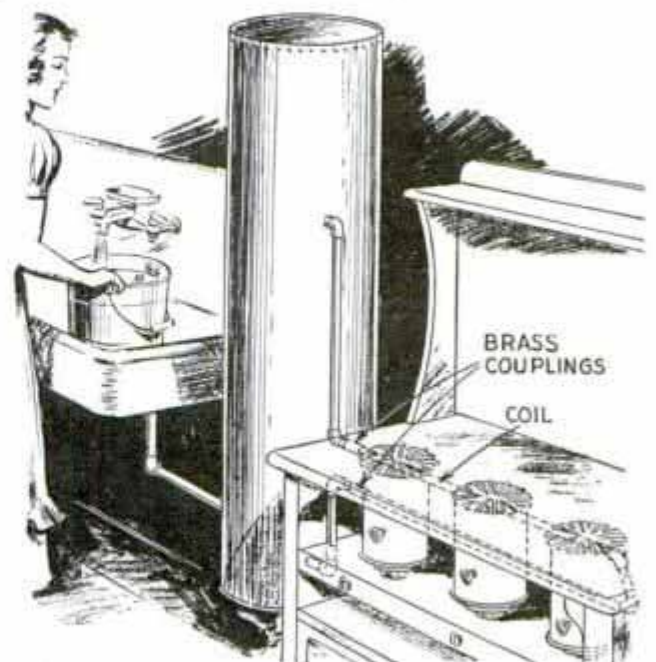

Your kerosene stove will furnish warm water if you run a coil over the burners

Metal Spinings Lubricated by Ordinary Candle



A candle rubbed on the surface of metal-spinning work lubricates it nicely

I have found that a candle stub is satisfactory for lubricating the surface of metal while spinning it, and in many cases, where sheet lead and other soft metals are to be stretched to shape inside of a hollow form, it is superior to other lubricants I have used. Just hold the end of the candle against the rotating work, and friction will melt the wax, which will spread evenly over the surface. If maple dowels are used for tools, the wood ends pick up some of the wax, but even then an occasional application of the candle is advisable. This prevents cutting of the surface and, except for a final touching up with steel wool, the work is ready for the finish after having been spun to shape.

—Dale R. Van Horn, Lincoln, Nebr.

Thread Kit from Poker-Chip Rack



An old poker-chip rack makes a dandy kit to hold spools of thread. The openings in most of these racks will hold three spools of thread when set in a ver-

tical position, or four when they are laid horizontally. A disk of heavy cardboard glued over the bottom of each opening will keep the spools from falling out.

Shaving-Brush Holder on Shelf Suspends Bristles Downward

Bent from a piece of wire and clipped to a shelf of your bathroom cabinet, this shaving-brush holder utilizes space that is usually wasted. Besides, the bristles are suspended downward so that they dry much quicker than when the brush is set on a shelf in the cabinet.

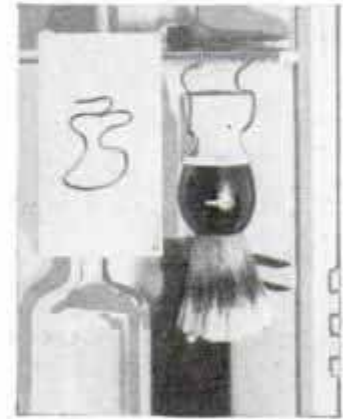

—Robert Brightman, Brooklyn, N. Y.

Gutter Nailed over Storm Door Carries Away Rain

Have you ever opened a storm door during a rain and had water run down your neck from the casing above? If so, a copper strip with one edge bent upward at right angles and nailed to the underside of the top edge of the door casing will prevent such trouble. A liberal coat of nonhardening cement applied to the casing before nailing the copper in place will keep water from running between the wood and the strip.

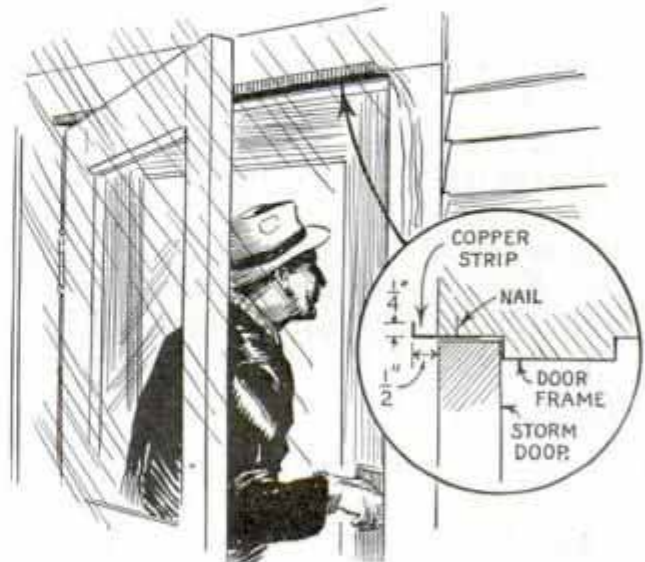

Water will not run down your back when you open a storm door if this small gutter is installed

Modern LAMP TABLE

has matched-veneer top

HARMONIZING with a base of unusual distinction, the veneered "clover-leaf" top of this table forms a clever combination of period design with modern styling. Under the veneer a glued-up core of $1\frac{1}{8}$ -in. strips checks any tendency to warp. Simple butt glue joints and dowels are used in assembling the core, and applying the clamps alternately on opposite sides of the work produces a flat surface free of twist. After the glue has hardened thoroughly, one side of the panel is planed perfectly smooth. Center-lines dividing it each way are then made and the outline of the top is laid out with a compass following the radii given in the detail below Fig. 6.

Four pieces of $\frac{1}{2}$ -in. straight-grained veneer are required to form the "herringbone" pattern as in Figs. 3 and 4. By ordering veneer with the grain running the short way of two of the pieces, waste can be reduced to a mini-

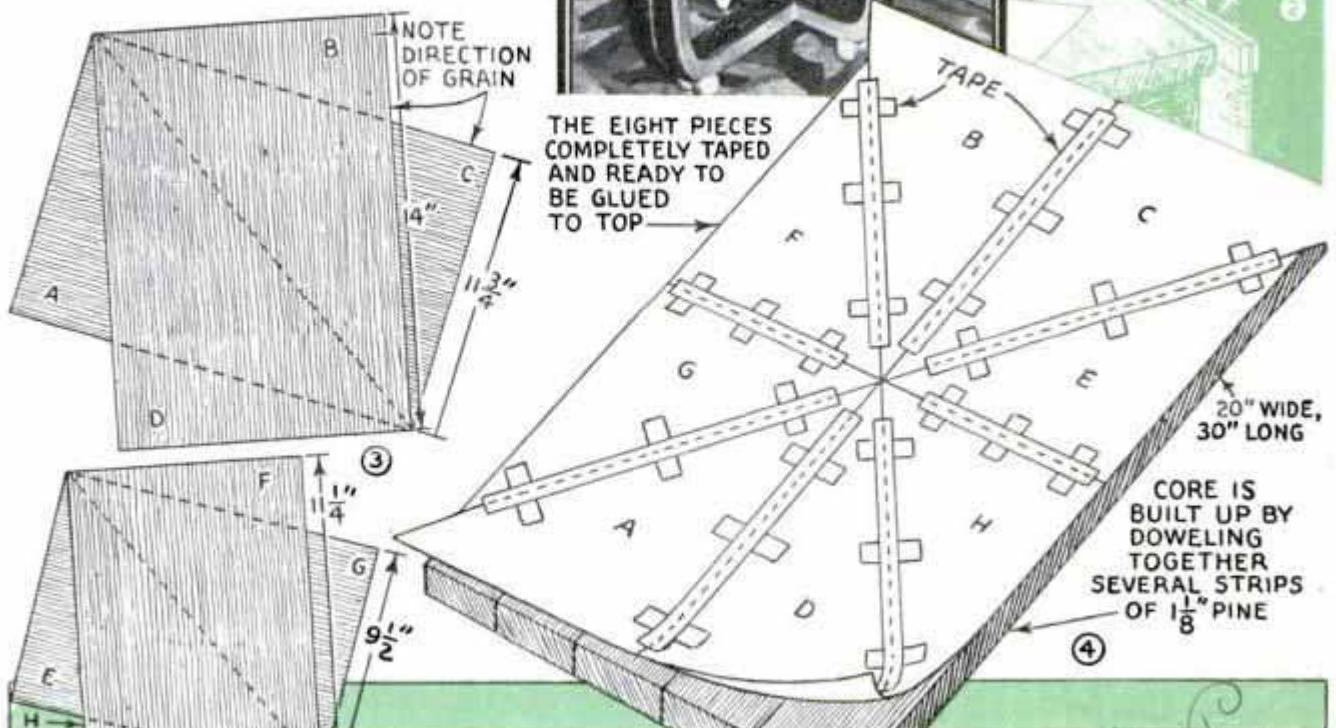
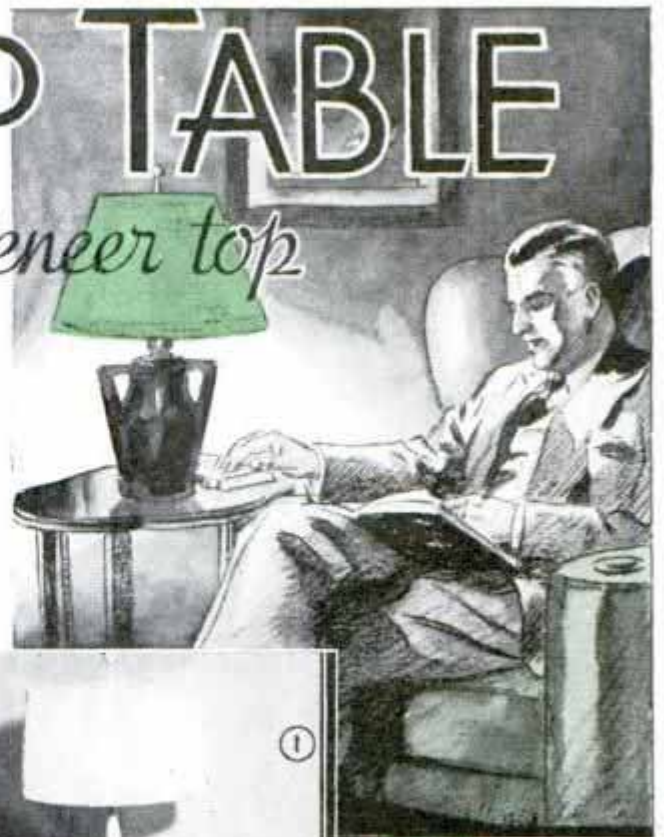

no 10-0-

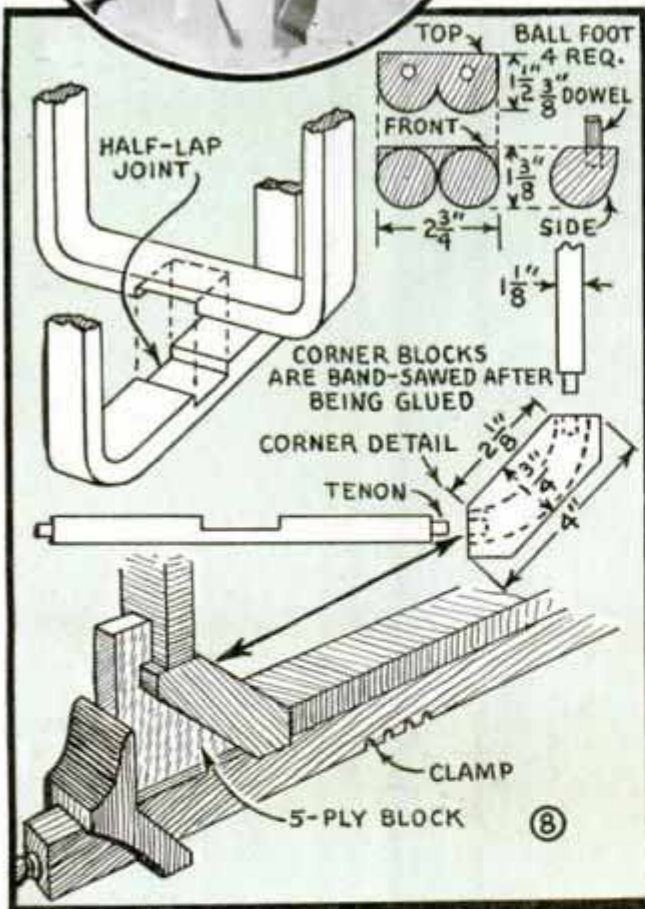
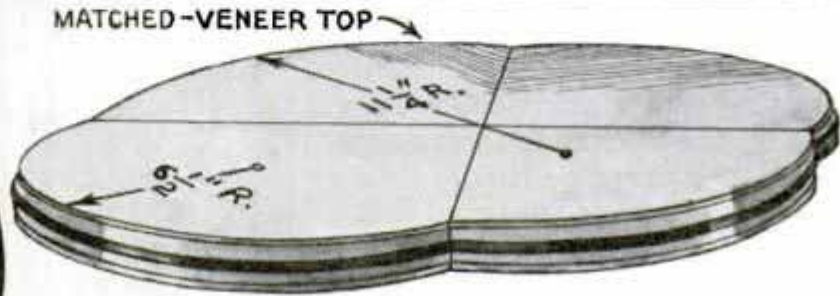
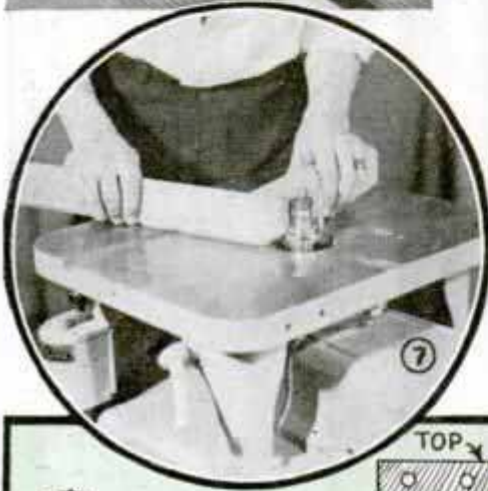
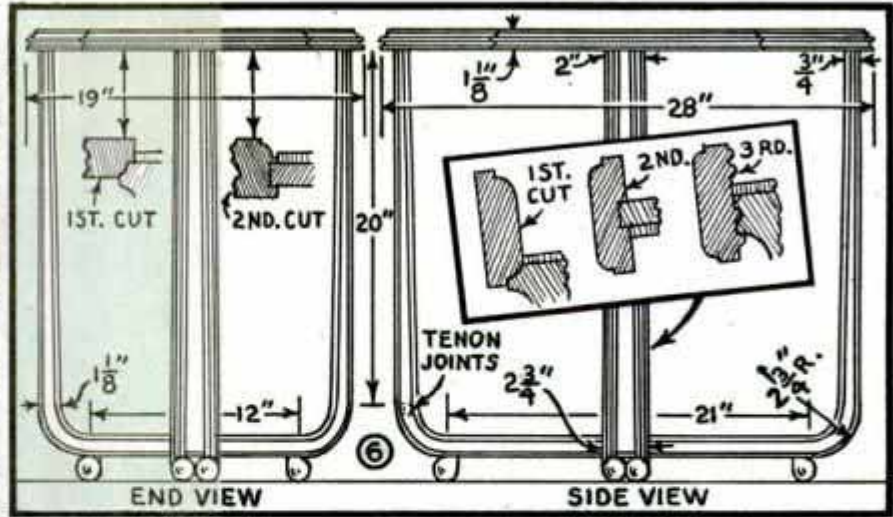

The four uprights of the leg assembly are joined to the horizontal members with four angle blocks. After sawing to the proper curve the molding is run on the edges, the molding being stopped at the halved joint

mum. Trim squarely both corresponding pairs of pieces to measure $11\frac{3}{4}$ by 14 in. and $9\frac{1}{2}$ by $11\frac{1}{4}$ in. respectively. To do this accurately, place the veneer between two pieces of scrap stock and plane it straight as in Fig. 2. Corresponding pairs are now placed diagonally one on top of the other and fastened down temporarily with tabs of gummed tape. The pieces are cut diagonally from corner to corner, using a straightedge for guiding the knife. When cut in this manner, two sets of four equal segments are produced. Pieces of corresponding size and grain are then selected and are cross-banded together with short lengths of gummed tape to form four triangular shaped assemblies as in Fig. 4. The joining of the four segments into one piece completes the taping, and the veneer is ready to be glued to the core. Sufficient clamping pressure can be applied with a number of handscrews and a few crowned edge blocks. Run the edge of a backsaw over the surface to roughen it slightly and then spread a uniform film of glue over the entire surface. When the glue becomes tacky, center the veneer sheet on the core, taped side up, and work out the wrinkles with a large dowel stick or a rolling pin. Any air bubbles appearing in the veneered surface can be split open with the edge of a razor blade. Lay a sheet

of heavy paper over the veneer, place a panel of $\frac{3}{4}$ -in. wood over this and begin applying the clamps. Remove the clamps after 24 hrs., trim the veneer $\frac{1}{4}$ in. back from the edge of the core and sand smooth. Fig. 6 details the molded edge.

The U-shaped legs are worked up from $1\frac{1}{8}$ -in. stock. Four pieces 21 by $2\frac{3}{4}$ in. for the uprights, and two pieces of the same stock, 23 and 14 in. long, for the half-lap sections, will be required. The four set-in corners are cut from a block measuring 18 by $1\frac{3}{4}$ by $2\frac{3}{4}$ in. Before the straight members of the legs are tapered, tenons are cut for the corner blocks. From the side and front elevations, Fig. 6, find the correct length for these pieces, allowing for tenons. The half-lap joint, Fig. 8, is carefully cut for a snug fit. Blocks for the curved corners are 4 in. long and are angle cut 45° to a length of $2\frac{1}{8}$ in. These are mortised to receive the tenons on the adjoining pieces. Dowel joints can be used, if desired. Tapering operation can be done on the jointer. However, the tapering of the width of the leg should not be done until after the corners have been glued and clamped as in Fig. 8. The corners are then scribed with a $2\frac{3}{4}$ -in. radius and are bandsawed outside the line as in Fig. 5 so that when sanded, the edges of the adjoining pieces will come flush. After cutting, the legs are tapered in width. The shaping must be done, of course, before the half-lap is assembled. In all shaping operations, the work is held on edge with the spindle collar bearing against the face of the work as in Fig. 7. Details of the leg molding are shown in Fig. 6. Molding cuts on the inside face of the legs are stopped at the half-lap. Attaching the ball feet, Fig. 8, completes the table as you see it in Fig. 1. These are bandsawed in much the same procedure as is used in cutting a cabriole chair leg; the scraps removed in the first cutting are saved and tacked back on to form a flat surface for making the final cut. The ball effect of the feet is then formed with knife, file and sandpaper. They are attached with $\frac{3}{8}$ -in. dowels and glue.

☞ "Wieners" may be roasted over an open fire by placing them in an ordinary corn popper, the long handle of which serves to prevent burns on the hands.

Getting Good Draft in Chimney Accommodating Two Stoves

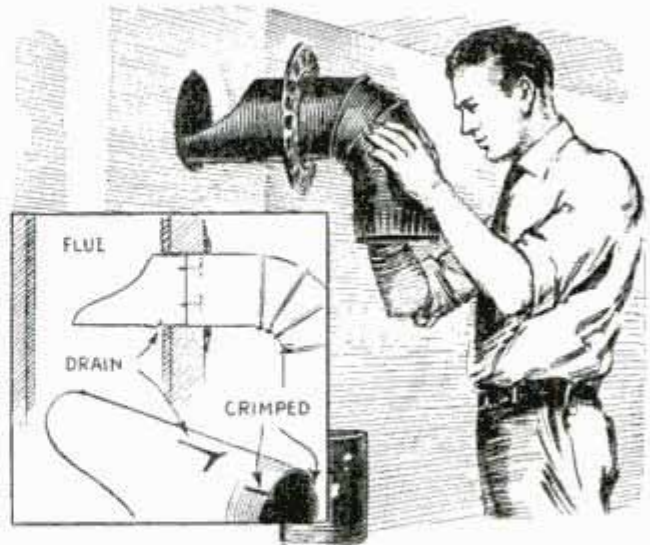

Chimney draft passing extended end of stovepipe creates strong suction in second-floor stove

After installing a stove on the second floor of a building where the same chimney also served a stove on the first floor, I found that the draft was very poor, due to the fact that there was a strong draft up the chimney from the lower stove. To eliminate this trouble, the end of the stovepipe was cut to the shape shown and pushed into the chimney for about two-thirds its width. With this arrangement, it was found that air flowing up the chimney created a strong suction inside the stovepipe on the second floor. A drain should be cut in the bottom of the pipe that extends into the chimney so that rain water will not collect in it.

—A. K. Ackroyd, Vancouver, B. C., Can.

Window Ventilator Screened to Keep Out Insects

It's a good idea to put screen wire over the ventilator openings in your storm windows. Then, if a few warm days come, while the windows are up and you have to open the ventilators, insects cannot get in the house. Small,

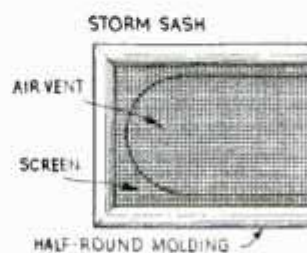

half-round molding tacked over the edges of the wire will improve the appearance of the job.

Paper Slipped into Typewriter with Aid of Envelope

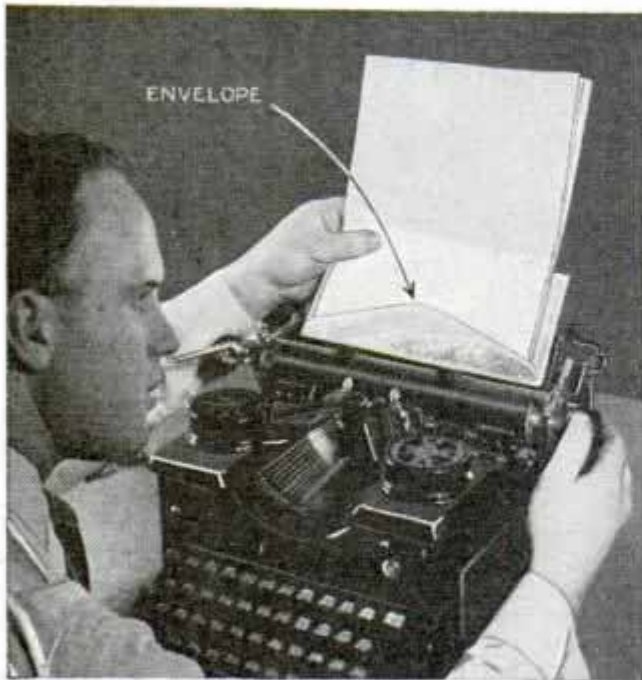

It's no trick to get a number of sheets into a typewriter evenly when an envelope is used

The usually difficult job of putting several sheets of paper into a typewriter at one time is solved by using an unsealed envelope. Just assemble the sheets, slip the envelope over one edge as shown, and feed it into the typewriter. After the envelope passes under the platen it is removed.—George A. Smith, Quarryville, Pa.

Wider Top on Sewing Machine to Handle Large Garments

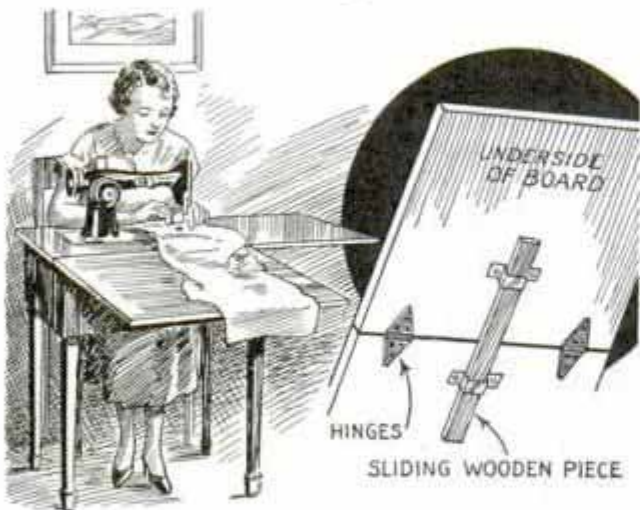

This hinged shelf will keep large garments from reaching the floor and getting soiled

Have you ever wished for a wider sewing-machine top when making large garments? If so, perhaps it's possible to hinge

an extension shelf to the rear side of your machine as shown. If you cannot use a sliding wood piece to hold the shelf in the raised position as indicated, maybe an arm or bracket can be pivoted to the machine so that it can be swung back against the rear side to let the shelf fold down when not needed.

Small Window in Storm Door Saves Heat

When answering calls, frequently it is not necessary to open a storm door during extreme cold weather if you substitute a tiny door for one of the panes. Besides conserving heat, this method is a welcome one to many housewives who do not wish to open the door to agents and peddlers. Also, small parcels can be taken in through the opening.—Abel F. McAllister, Chicago.

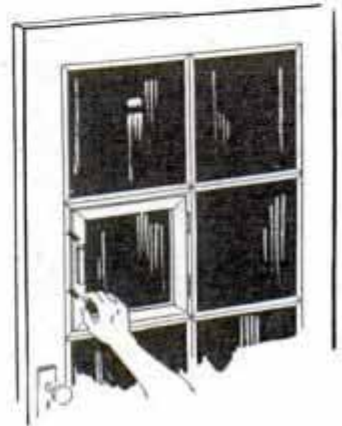

Wood Slotted Without Splitting the Work

When making wide slots and insets in wood, I cut the part to be removed into several segments with a saw and clamp the work in a vise between two hardwood blocks, the top edges of which come flush with the bottom of the slot to be made. It is then a simple matter to cut out the wood segments with a chisel without any risk of splitting the work, as the blocks reinforce it on both sides.

—Ellis O. Hinsey, Philadelphia, Pa.

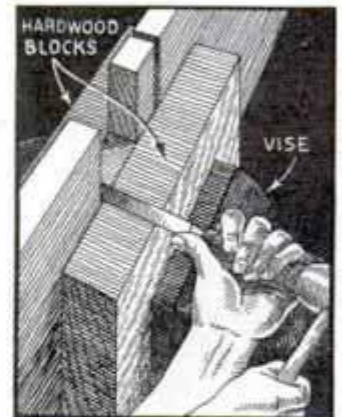

☐ An application of clear household ammonia and soap will usually remove spots of machine grease from washable fabrics.

Hot-Dish Mat of Wood to Match Your Table

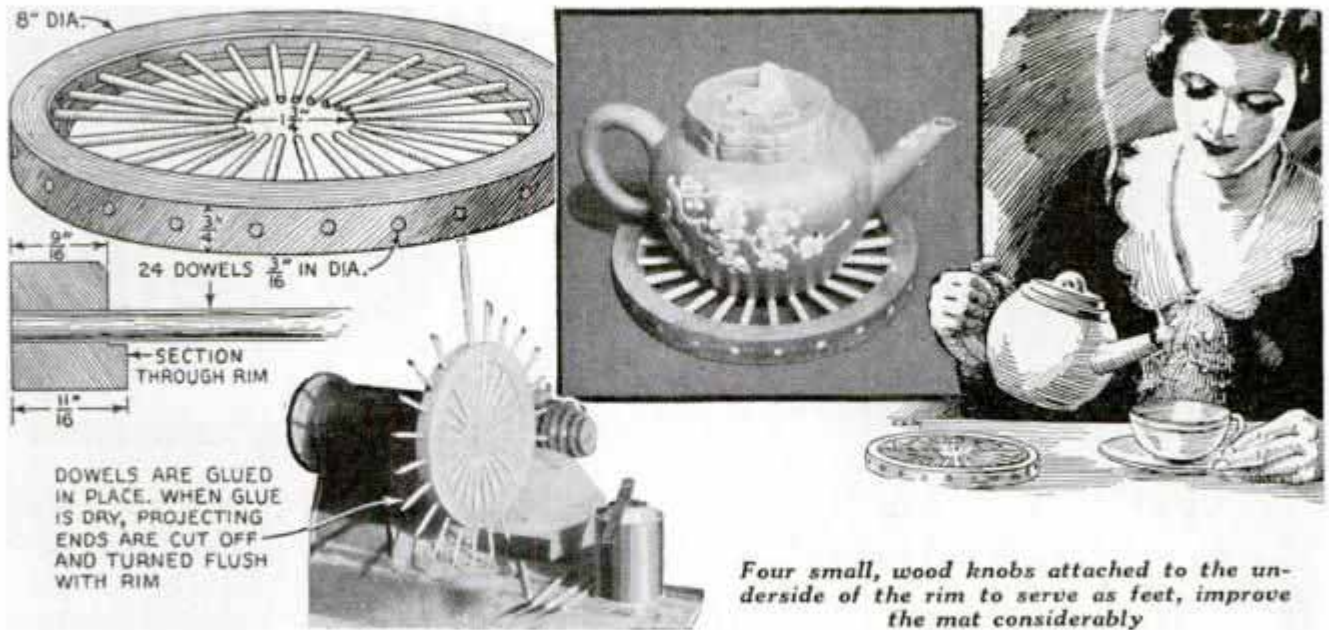

Resembling a hubless wheel, this hot-dish mat is decorative and can be made from a wood disk and some dowels. Mount the disk, which should be $\frac{3}{4}$ in. in thickness, on the screw chuck of your lathe and turn it to 8 in. in diameter. Then, $\frac{1}{16}$ in. from the edge, recess it to a little more than half of its thickness, leaving an untouched circle $1\frac{3}{4}$ in. in diameter in the center. Drill 24 equally spaced holes through the rim for $\frac{3}{16}$ -in. dowels. Be sure that each hole points true to the center of the disk. Insert the dowels, butting the

ends against the unturned portion in the center of the disk. This assures that they will project an equal distance inside the rim. Then pull them out about $\frac{1}{2}$ in., and coat the portion that goes inside the rim with glue, after which they are pushed back in place. When the glue has dried cut off the ends projecting outside the rim and turn them down flush. Now sand the rim, move the tool rest to the back of the work and cut out the center of the disk. Finishing the mat to match the table and chairs makes a nice job.

Photo Enlargements Vignetted with a Piece of Cardboard

Amateur photographers who want to vignette their photos when making enlargements, can do a good job with a homemade vignetter cut from cardboard. Get a piece larger than the printing paper to be used and cut an opening in it the shape you want. The opening should be smaller than the actual size of the image as it appears on the easel of the enlarger. When ready to make the exposure, hold the vignetter between the lens and the easel so that the light will pass through the opening onto the portion of the printing paper to be exposed. The card should be moved slowly backward and forward so that the edges of the photo will be softly blended into the border. The only requirement of this method is that the photo have a white or light background.

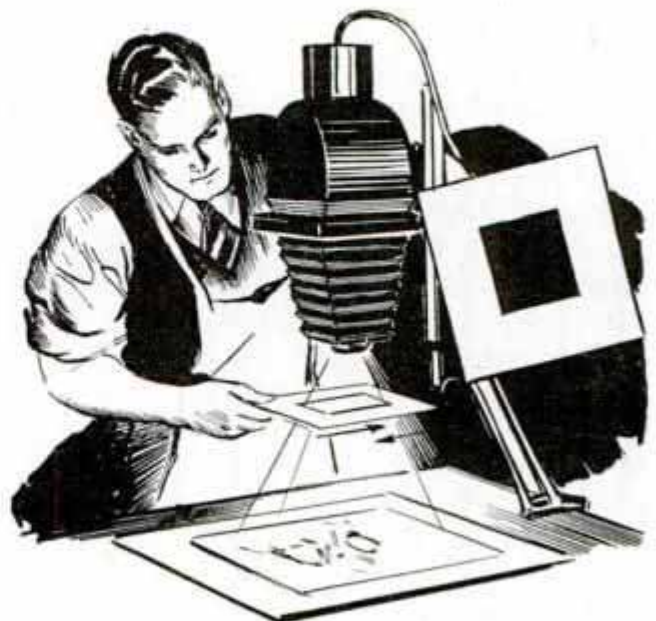

Anyone can do a fairly good job on photo enlargements with this cardboard vignetter

Favorite PHOTOS

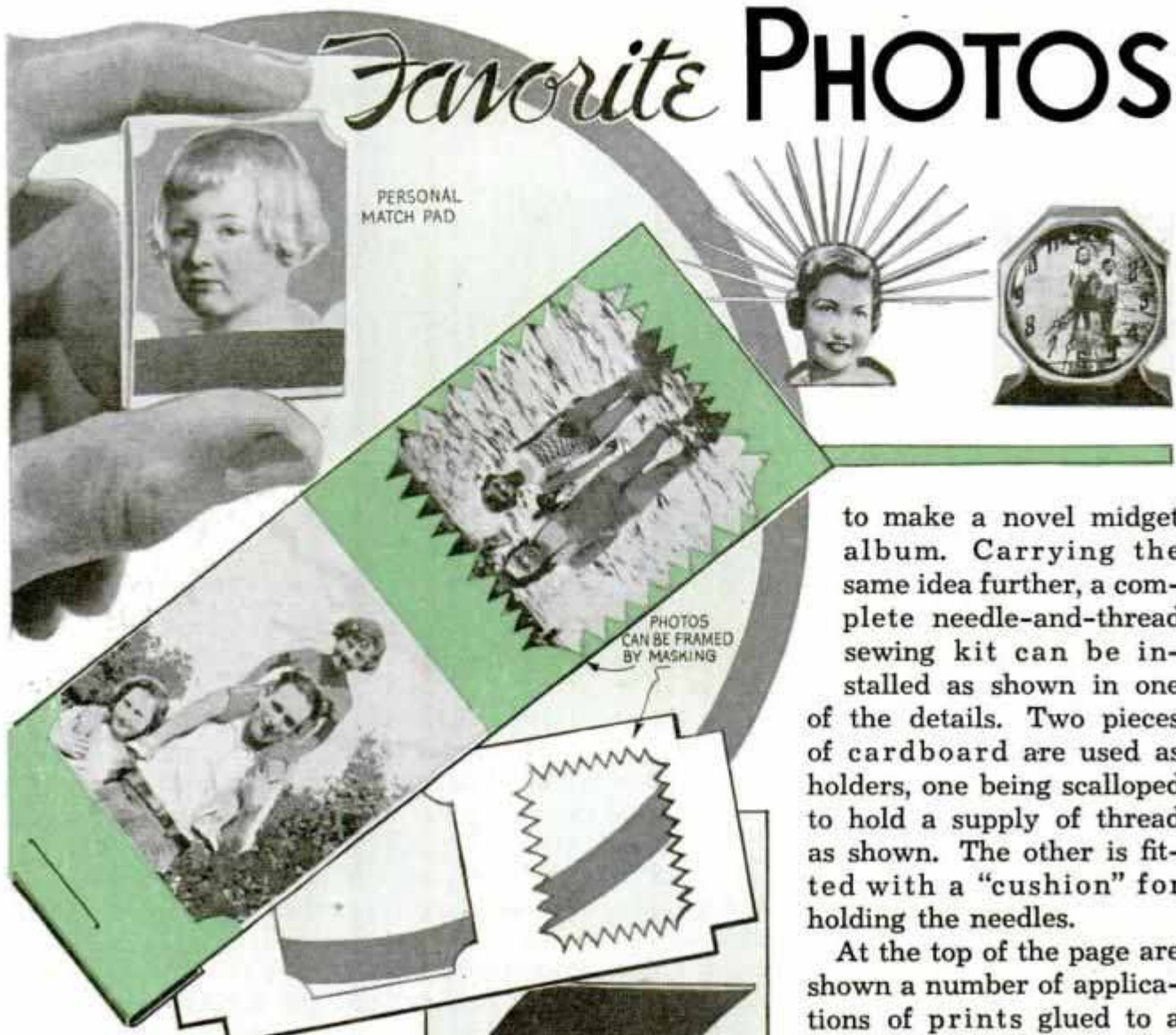

to make a novel midget album. Carrying the same idea further, a complete needle-and-thread sewing kit can be installed as shown in one of the details. Two pieces of cardboard are used as holders, one being scalloped to hold a supply of thread as shown. The other is fitted with a "cushion" for holding the needles.

At the top of the page are shown a number of applications of prints glued to a plywood backing and then outlined by sawing to the border lines of the figure. The first one, left to right, is designed as a toothpick holder. A piece of $\frac{3}{8}$ -in. plywood is used as a backing. An enlargement of the head and shoulders is glued to the backing and sawed to the outline. Then a number of holes are drilled in the edge of the plywood to hold the toothpicks. The alarm-clock mounting is a more detailed project. Here you remove the original face, replace it with a photo print and then letter on the numerals with India ink. The print is glued to the plate which forms a backing for the original clock face. The latter is usually heavy paper

VACATION snapshots in a match pad, a favorite print on your coat hanger, in an "hourglass" mounting or on the face of the alarm clock—these are some of the novel mountings you can use to "individualize" your photo collection. Take the first one, a really personal match pad. Here the photos are printed on double-weight printing paper and an attractive border is formed by masking. The strip on which the photos are printed is then folded, the scratching surface is glued to one edge, and two rows of matches are inserted and stapled. Or you can omit the matches and insert instead, a number of prints

in NOVEL MOUNTINGS



and is easily stripped off. Care should be taken to center the main feature of the photo so that the job appears neat and attractive. Now, another method of printing the numerals is to place a thin sheet of celluloid—a piece of old film with the emulsion removed will do—over the original dial and trace the markings right on the film in India ink. In making the print, place the celluloid in contact with the negative used and print both at once. The numerals will then appear in white on the photo. They can be left white, or colored to obtain contrast. The third item, a coat hanger, is made in essentially the same way as the first except the entire hanger and backing for the photo is sawed from $\frac{3}{8}$ -in. plywood. You can use any ordinary wooden hanger for a pattern in laying out the shape and size. The hook is bent from heavy wire. The fourth novelty is designed to hang on the wall and consists of a base screwed to a piece of $\frac{1}{4}$ -in. plywood on which the photo is mounted. The plywood is then sawed away to the outlines of the face. The match box slips over a small block of wood glued to the base. Miniature boxes of matches, obtainable at any cigar store, are best suited to the purpose as they are small and neat. The last item is a photo ash tray and it's made in the same way as the match holder except that the base is larger and supports an ash tray or cup. This can be a radio coil form or a short length of brass tubing with a brass disk soldered to the bottom. In all cases the edges of the plywood backing the photo print

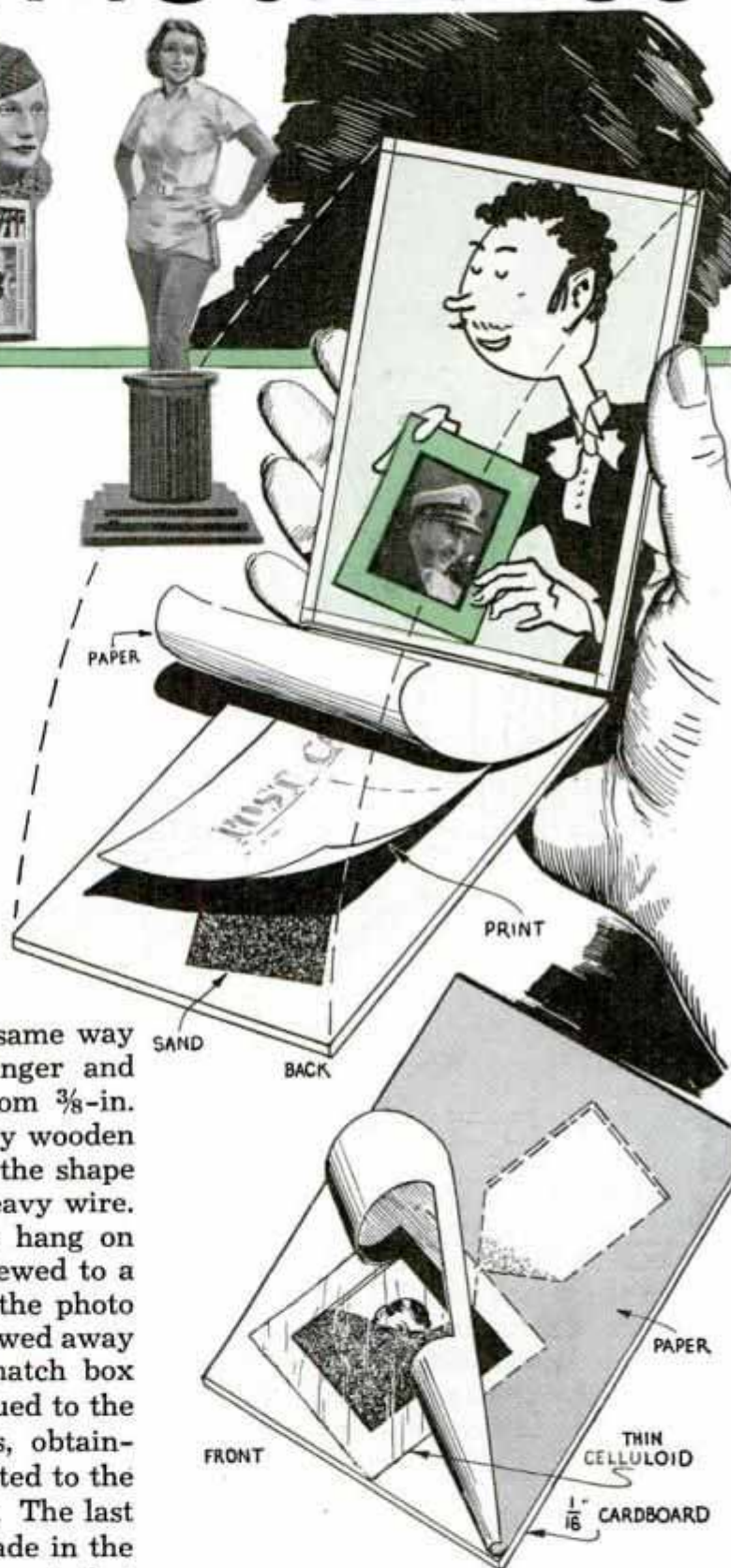

When you show this photo "postcard" to a friend just tilt it slightly and the picture showing through the "window" will be slowly blocked out. The secret is a two-compartment container, connected by a narrow channel through which fine sand runs from the hidden compartment after the fashion of an hourglass. Many variations of this same idea are possible



sand and paste on a backing of heavy, white paper. When you tilt the card, the sand runs slowly from one compartment to the other and either reveals the photo or blocks it out, depending on which way the card is tilted.

The photo book ends serve as an attractive mounting for either a full figure or a head and shoulders as shown. Making the cut-out is the same process as described before only two prints are used, the single print being reversed. Use wood or hard-pressed board for the base.

are carefully sanded and varnished. The "hourglass" mounting is a novel and mystifying attraction, but simple to make. The details show just how it's done. The cartoon can be anything appropriate that suits your fancy. It's drawn or traced on a sheet of white paper, the full size of the latter being the same as an ordinary post-card. A sheet of $\frac{1}{16}$ -in. cardboard is then cut to the same size as the cartoon. Two openings, connected by a narrow channel, are cut through the cardboard as shown. A thin sheet of celluloid is pasted over one of the openings and a "window" is cut in the paper on which the cartoon is drawn. This is glued to the cardboard. Then you put the photo in place under the window, fill one of the pockets with fine, sifted

Towel Hung on Shower Curtain Within Easy Reach

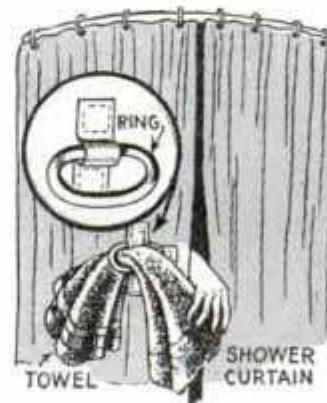

The problem of keeping a towel handy without getting it wet when taking a shower bath is solved by inserting it through a ring sewed onto the outside surface of the shower curtain. A large

wooden curtain ring will do the trick, and it can be attached with a short strip of cloth to match the curtain.

Removing Glass Stoppers



To lessen the chances of breaking a bottle when removing a tight-fitting glass stopper, run a few drops of mineral oil around the joint and apply heat from a candle or matches to slightly expand the bottle neck.

Rotate the bottle in the flame so that the glass will expand evenly.

—L. H. Georger, Buffalo, N. Y.

Work Filed to Given Line with Aid of Guides

When filing work down to a given mark, I find that the job can be done accurately by using a couple of metal guides as shown. These may be old hack-saw blades or a couple pieces of flat, hard iron placed on each side of the work so that their upper edges come exactly at the level to be reached with the file, after which the assembly is clamped in a vise.—Warren Hockert, Chicago.

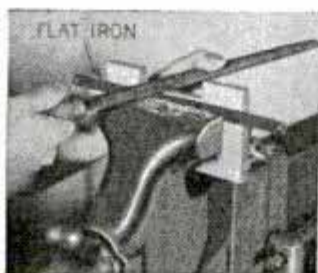

Sweeper Has Pivoted Handle to Get Under Furniture



You can clean under low furniture with this sweeper without stooping sharply

Pivoted to the handle of a carpet sweeper, a short length of broomstick will enable you to clean under beds and other low furniture without stooping sharply or getting down on your knees. A piece of sheet metal or heavy tin bent as shown in the circular detail attaches the broomstick, which folds down against the sweeper handle when not in use.

Non-Skid Shoes Have Tape on Soles



In an emergency, you can make your shoes practically slipproof for walking on icy walks by applying strips of adhesive tape to the soles as shown. Before applying the tape, be sure the soles

are clean and dry so that it will stick tightly. The tape will last a surprisingly long time, and can be quickly removed when it is not needed.

Swirl Machine Finish on Metal Can Be Done by Hand

Closely resembling a swirl finish made by machine, a metal graining can be produced with an ordinary push drill. Get a small flat-head bolt that will fit the drill chuck and shellac an emery disk to the head. Then put it in the drill and go over the metal surface as indicated in the illustration.

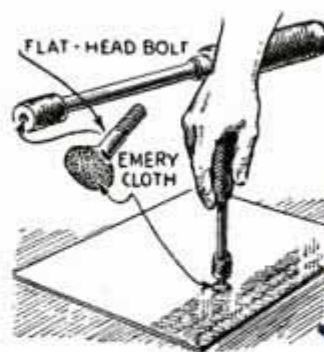

Transparent photos for decorating lamp shades can be made by treating Cellophane with one of the single-solution paper sensitizers now on the market.

22 W. Delaware, Compton, Calif.
 International Photo Laboratory
 1612 Lafayette, N.Y.

Composition Board Cut Smoothly by Sharp Tracing Wheel



With this sharpened tracing wheel, composition board can be cut more rapidly than with a saw

A carpenter who had difficulty in cutting composition boards smoothly with a saw, solved the problem by using a dress-makers' tracing wheel for the purpose. The teeth of the wheel were ground to needle points, after which it was drawn across the board, using a straightedge as a guide. One or two cuts will perforate the board to such a depth that it can be broken off easily. Also, it is possible to make curved cuts if the line is first marked on the board and carefully followed.

Cleaning Piano Keys

If the keys on your piano have become yellow, rub them carefully with one half of a lemon and cover them with powdered chalk. When this has dried, brush it off and polish the keys with a soft cloth.

1937 "WHAT TO MAKE" Book

96 Pages of Valuable Reference Data for Craftsmen, 15c Postpaid

Special features on Upholstering, Rewinding Electric Motors, Sharpening Lathe Tools, Making Sundials, Resilvering Mirrors, Electroplating Leather and Other Non-Conductors, Reading Schematic Radio Diagrams, Tools for the Modelmaker, Tricks of Driving Wood Screws, etc.



Also Includes

A complete listing of **Popular Mechanics** 410 blueprints—70 new ones—and shows pictures of most articles as they will appear when finished. Whether you are interested in a workshop for pleasure or profit you will find just what you want to make in this elaborate selection of plans.

Where to purchase "**Hard-to-Get**" materials and supplies such as clock movements, trailer axles, model fittings, small balloon tires, tape for Venetian blinds, gears, radio parts, etc., besides the latest in home workshop machines and hand tools.

Send 15c in stamps today for your copy of this interesting book

POPULAR MECHANICS MAGAZINE, Dept. BN, 200 E. Ontario Street, Chicago

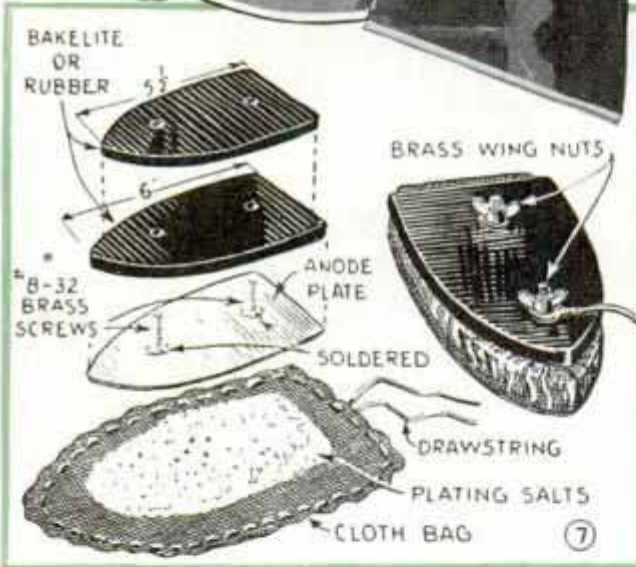

three times, washing out the brush thoroughly in between. Where solvents are used for cleaning, it is advisable to rinse the work thoroughly with soapsuds to assure the removal of any remaining traces of oil film. Soapy water will emulsify this film and thus make certain its complete removal.

Removal of Corrosion: If the metal surface to be plated is corroded or badly tarnished, it will be necessary to apply an acid rinse as in Figs. 8 and 9. A good wash for removing oxide can be made as in Fig. 8. In mixing acid solutions of this

type, it is important that the sulphuric acid be added slowly to the water, not the water to the acid. The solution should be made up and stirred in a 1-gal. glass or stone container. When applying the acid solution, it's best to wear rubber gloves to protect your hands. A medium-sized brush is used for applying the acid solution. Only a small amount of the surface should be cleaned at one time and, following the application of the acid, the surface should be rinsed off thoroughly with clean water to remove the acid as rapidly as it has accomplished its purpose of dissolving oxides and corrosion. After cleaning and thoroughly rinsing with warm water, the cleaned object should not be touched by the hands. It's important that all preparation for plating, such as arranging the equipment and mixing of the plating salts, be carried out before the cleaning operation is started.

Plating with Copper and Nickel: By this process, powdered electroplating salts are held in a bag attached to a holder and metal anode as shown in Fig. 7. The top plate and clamping plate are materials which do not conduct electricity, and the anode, shown in Fig. 2, consists of a sheet of the metal which is to be plated onto the work. For nickel plating, this must be a piece of sheet nickel; a copper sheet is used when plating copper. Brass machine screws register with the holes in the plates and one of these screws is sufficiently long to receive a nut and the terminal lug from the battery.

The bag for holding the plating salts is usually medium heavy duck, canton flannel, or other strong material and is equipped with a drawstring, as in Figs. 7 and 12, so that it can be pulled tight around the clamping plate. With the bag charged with plating salts and securely tied, the

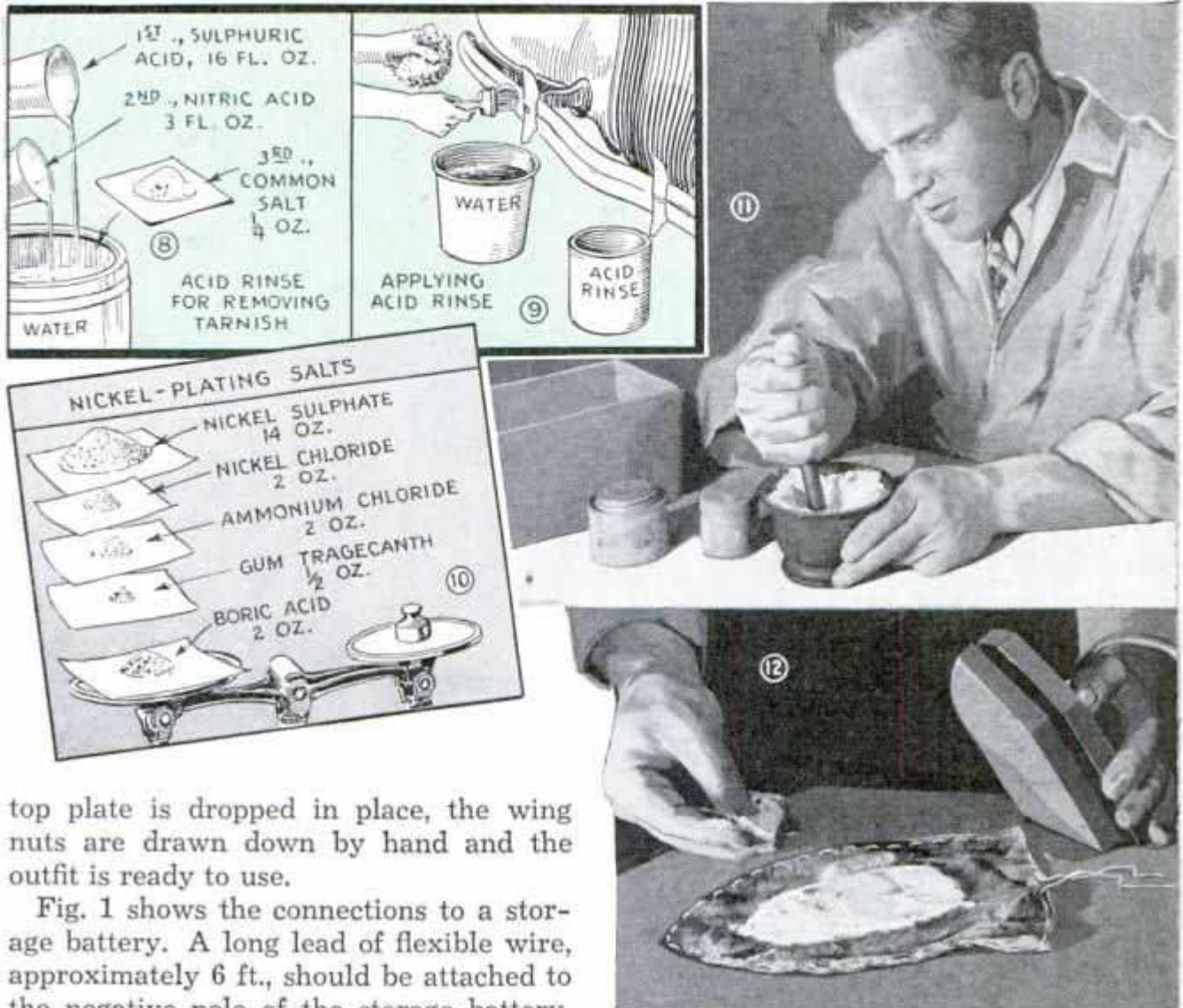

top plate is dropped in place, the wing nuts are drawn down by hand and the outfit is ready to use.

Fig. 1 shows the connections to a storage battery. A long lead of flexible wire, approximately 6 ft., should be attached to the negative pole of the storage battery. The other end of this lead is fitted with a heavy-duty battery clip which has enough spring action to take a secure "bite" on the part to be plated. The positive pole of the battery should be connected to a 6-ohm, heavy-duty radio rheostat which may be mounted on a small panel or clamped to the battery itself. The other terminal of the rheostat is connected by a 6-ft. length of flexible wire to the plater. To assure good contact, the end of the cable from the rheostat should be equipped with a terminal lug.

The only other equipment required to complete the assembly is a 1/2-gal. stone crock to hold the water into which the plating applicator is dipped from time to time as plating progresses. As the wet applicator is rubbed over the surface to be plated, the water, which has dissolved a part of the plating salts, makes electrical contact between the work and the anode exactly as if the unit were installed in a plating tank, thus completing the cir-

cuit so that the metal may be deposited. In electroplating by this method, it is important that the rheostat be adjusted with high resistance in the circuit at the start, and adjustments made as trials progress until the proper adjustment is found to produce the most satisfactory results.

Nickel Plating: Prepare the electroplating salts by mixing together the dry materials required and grinding them relatively fine, preferably in a mortar as shown in Fig. 11. An excellent formula for nickel-plating salts is shown in Fig. 10. The salts are carefully weighed and thoroughly mixed. Now, with all preparations made as described, the plater is rubbed over the surface to be plated with uniform strokes. A little experience will indicate the proper movement for the production of the best appearing plate. If the applicator is rubbed over the surface too slowly, the plate will become too thick in spots. To

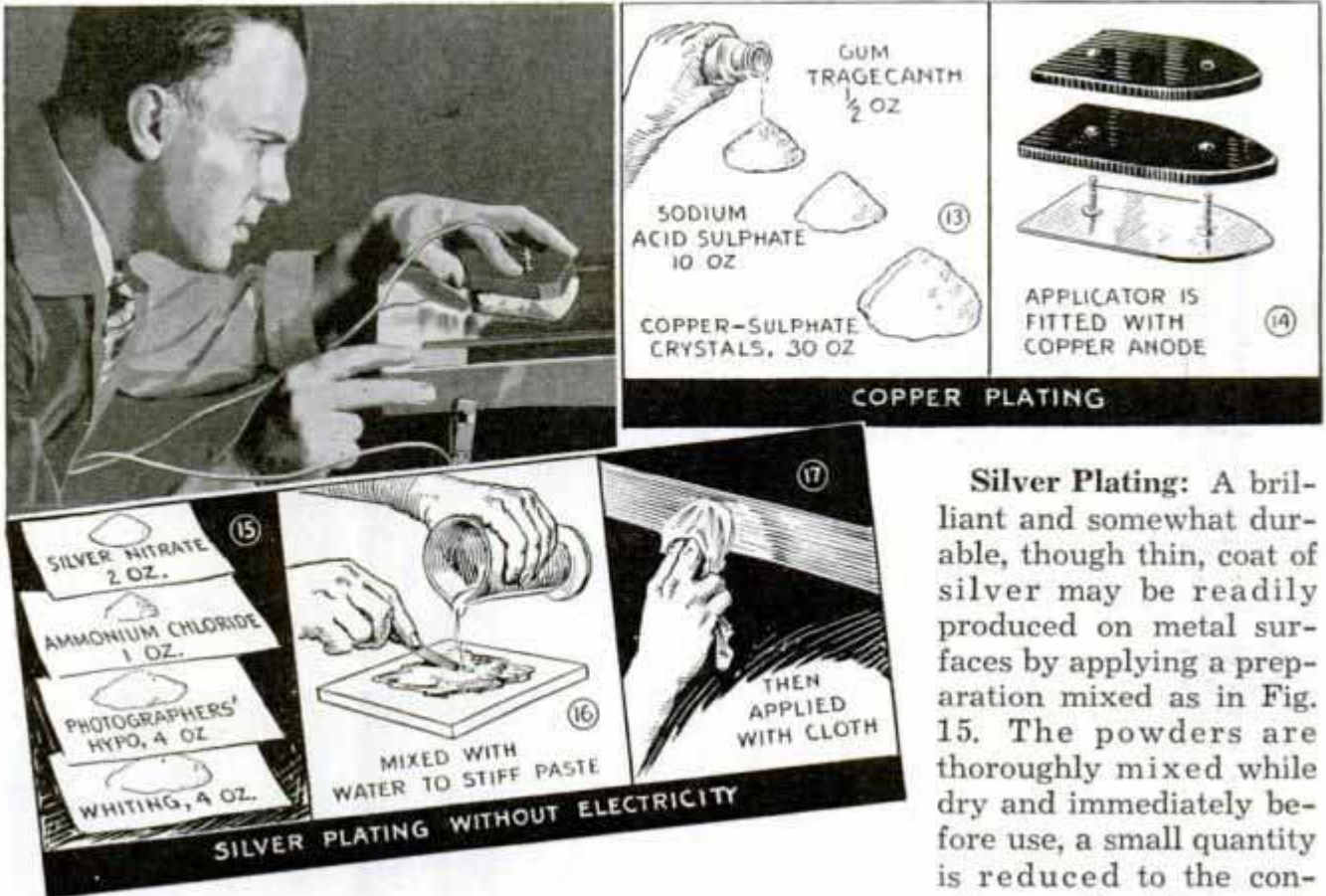

Silver Plating: A brilliant and somewhat durable, though thin, coat of silver may be readily produced on metal surfaces by applying a preparation mixed as in Fig. 15. The powders are thoroughly mixed while dry and immediately before use, a small quantity is reduced to the consistency of a thick paste

avoid this, medium strokes are used with regularity and after the entire surface has been covered once, the operation is repeated until the plate has been built up to the desired thickness.

Certain metals, such as zinc, are rather difficult to plate by this method unless a special salt mixture is used. If the plating salts are made by mixing nickel sulphate, 9 oz., ammonium chloride, 2 oz., sodium sulphate, 14 oz., gum tragacanth (powdered), $\frac{1}{4}$ oz., and boric acid, 2 oz., it will be found that better results will be produced on certain metals which are otherwise tedious to coat with nickel.

The above formulas will produce electroplates of nickel which have the characteristic appearance of this metal. If a more silvery white finish is desired, the formula for mixing the salts should be compounded by mixing together nickel sulphate, 9 oz., cadmium sulphate, 2 oz., ammonium chloride, $2\frac{1}{2}$ oz., sodium sulphate, 10 oz., boric acid, 2 oz., and gum tragacanth (powdered), $\frac{1}{4}$ oz. The amount of cadmium sulphate added will determine the whiteness of the plate. If effects different from those produced by this particular formula are desired, the quantity of cadmium sulphate may be varied.

with water as in Fig. 16. The paste is applied to the well-cleaned surface to be silvered with a piece of cloth as in Fig. 17 in the same manner as would be used for applying metal polishes. To avoid stains on the hands wear rubber gloves. As the rubbing proceeds, a lustrous film of silver will be coated over the entire surface.

Copper Plating: If the well-cleaned surface to be plated with copper is wiped over rapidly with a solution made by adding copper sulphate, 3 oz., and sulphuric acid, $\frac{1}{4}$ fl. oz., to water, 2 qts., a thin, tenacious film of copper will be formed. In applying the above solution, rubber gloves should be worn and a piece of stiff fabric used for making the application. The surface should be gone over but once, inasmuch as repeated wiping with this solution will tend to remove the initial fine coating. After the surface has been covered with a thin film of copper by this means, it is washed with clean water. Any spots which have not been covered may be wiped over again to assure complete coverage. Although the above coating of copper is not sufficiently thick nor durable to be of any value, it will serve as a base over which a satisfactory copper plate may be applied with the plater. The salts,

Fig. 13, are ground to small particles and placed in a clean bag which is mounted on the plater equipped with a copper anode as in Fig. 14. The plating process is the same as that previously explained for nickel. The first application should be made briskly and with a minimum of overlapping to insure the formation of a smooth coating. After the first application, additional quantities of copper may be deposited on the surface to give the desired thickness of plate.

Final Polishing: In all cases, the finished electroplate should be polished to bring out the full luster of the metal. For this purpose, precipitated chalk or Vienna lime should be applied with a moistened polishing cloth. A motor-driven polisher such as that shown in Fig. 6, is useful if handled carefully.

Bolts Coated with Plastic Are Removed Easily

When bolts are used where it may be necessary to remove them frequently, just coat them liberally with a plastic or non-hardening cement, applying enough to fill the space between the threads and the sides of the hole. This will prevent rusting and, in many cases, permits using cheap, black bolts instead of coated or plated ones.

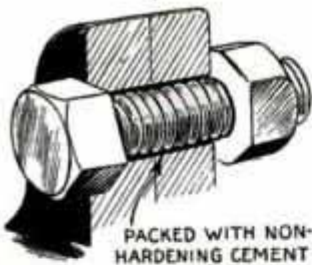

coat them liberally with a plastic or non-hardening cement, applying enough to fill the space between the threads and the sides of the hole. This will prevent rusting and, in

Harness Lines Have Rings to Ease Hand Strain

To ease strain on the hands caused by gripping the lines for long periods when driving a spirited team of horses, punch a couple of holes in each line and insert a key ring as shown. When holding the lines, let the rings rest behind the palm of the hand and you won't have to grip so tightly.



Steel Paper Cutter on Job Press Is Aid to Operator



No need to search for a knife or pair of scissors when this cutter is attached to the job press

This paper knife will be found handy for cutting strips for use when a new job is made ready. It is merely a flat steel strip screwed to the delivery board, with a thin washer under each end to hold it slightly above the board. When the pressman needs a piece of paper, he can slip a sheet under the strip and tear it off neatly and evenly to the size required. The cutter does not interfere with the normal use of the delivery board.

Roll-Up Tool Kit Is Handy on the Stepladder

An electrician who had to do considerable work on a stepladder used this kit, which could be unrolled instantly and supported conveniently on the top of the ladder. The kit is merely a piece of heavy canvas with several pockets sewed in one side and the ends hemmed to slip over iron-rod standards which are put into holes bored in the stepladder.



Sliding Board on Book Shelves Serves as Reading Table



Sliding board saves steps by holding books while looking up reference data

In libraries, law offices and similar places, a sliding board attached to the underside of one of the book shelves will be found a handy support for an open book. Heavy plywood is just the thing for this purpose and slides to hold it can be shaped from sheet metal. A drawer pull may be screwed to the underside near the edge.

Faceplate Jobs at Higher Speeds Possible without Vibration

We made up a number of lead disks of different sizes and kept them at hand for

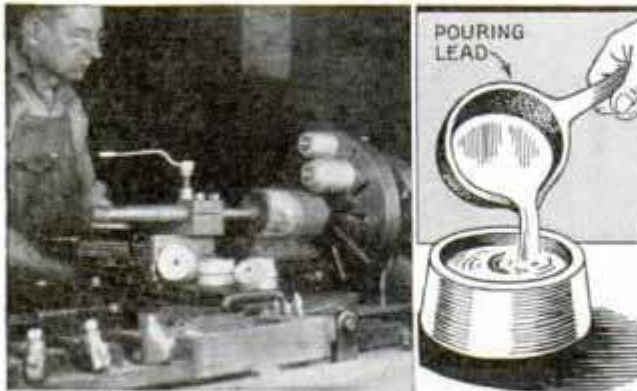

Lead weights of various sizes enable you to counterbalance a faceplate job in the lathe

counterbalancing faceplate work so that the lathe could be run at high speeds without excessive vibration. For forms in which to cast the weights, we used the

outer rings from discarded roller bearings ranging in diameter from 3 to 6 in. The weights were drilled in the center for attaching them to the faceplate, and the weight of each one was stamped on its surface.—J. H. Jobson, Mentone, Ala.

Auger Bits Are Rubber Capped to Protect Points

Slipped over the screw point of an auger bit, a rubber stopper protects it when carried in a box with other tools. These stoppers can be obtained for a few cents in a drug store, and it takes only a second to slip one of them over the bit.



Drawing Longitudinal Lines on Round Stock



When a regular tool is not available for drawing lines parallel to the axis of a shaft or other cylindrical stock, a substitute tool for this work is a piece of angle iron or brass.

Such a tool will be found accurate enough for most ordinary purposes.

Locking Pliers on Work

When using a pair of pliers to hold work tightly, they can be made handy for this purpose by pivoting a U-shaped piece of metal to one handle to engage notches filed in the upper edge of the other one. Then the pliers can be locked on the work without having to keep a constant grip on the handles.—B. Stalsberg, Breton, Alta., Can.

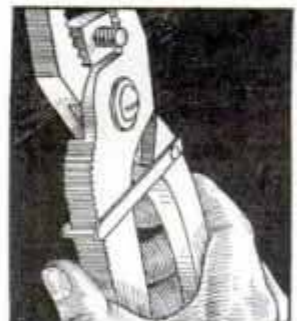

Midget GAS ENGINE

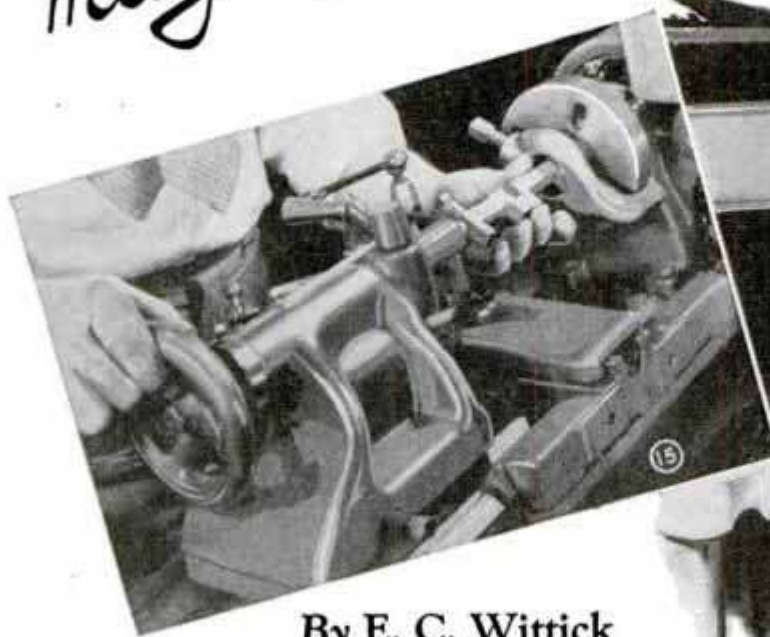

By E. C. Wittick

Part II—Machining the Castings

BEFORE you do any machining on the set of castings, it's a good idea to check the lathe centers for accurate setting, clean the chuck of all excess grease and chips, and see that the lathe tools are ground and shaped properly for the work. Be especially particular to see that your drills are properly ground. This means that the cutting edges of each bit must measure the correct angle, otherwise you are apt to have trouble doing the precision drilling necessary on this job.

Although you can begin with most any part, it's best to start with the cylinder casting, finish dimensions of which are shown in Fig. 17. Chuck this with the flanged end out for the boring and lower-end facing operations. Keep in mind that the first roughing cut must, in all cases, be deep enough to get under the scale on the surface of the casting, but make certain to allow sufficient stock under the roughing cut for finishing. The cylinder bore is brought to final dimensions with an expanding reamer. The best way of machining the outside of the cylinder barrel and the cool-

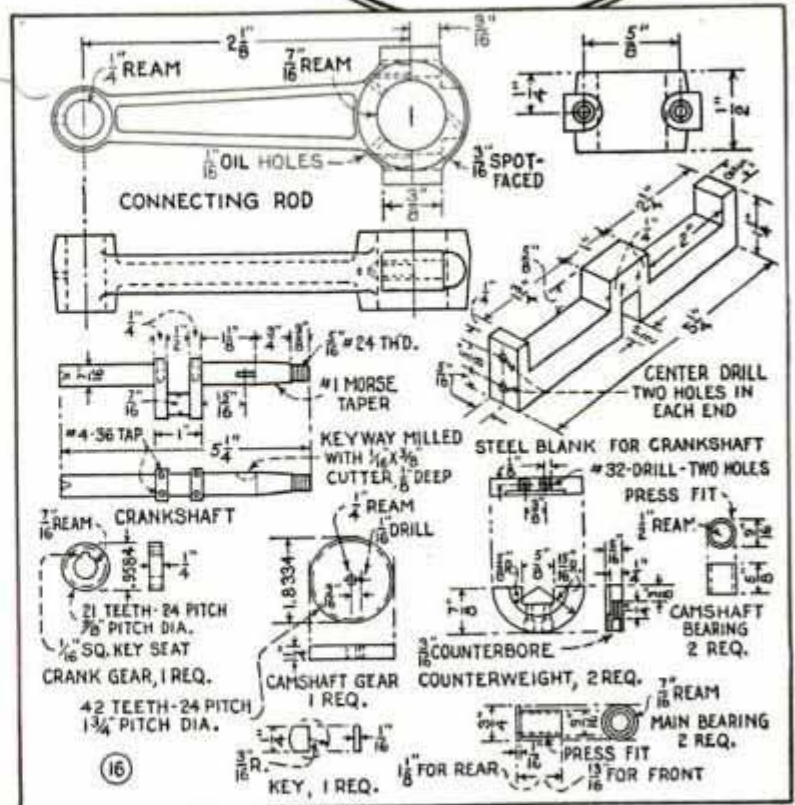
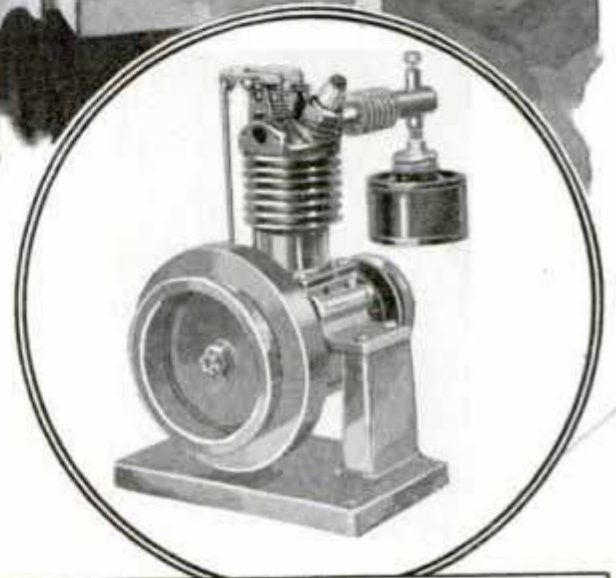

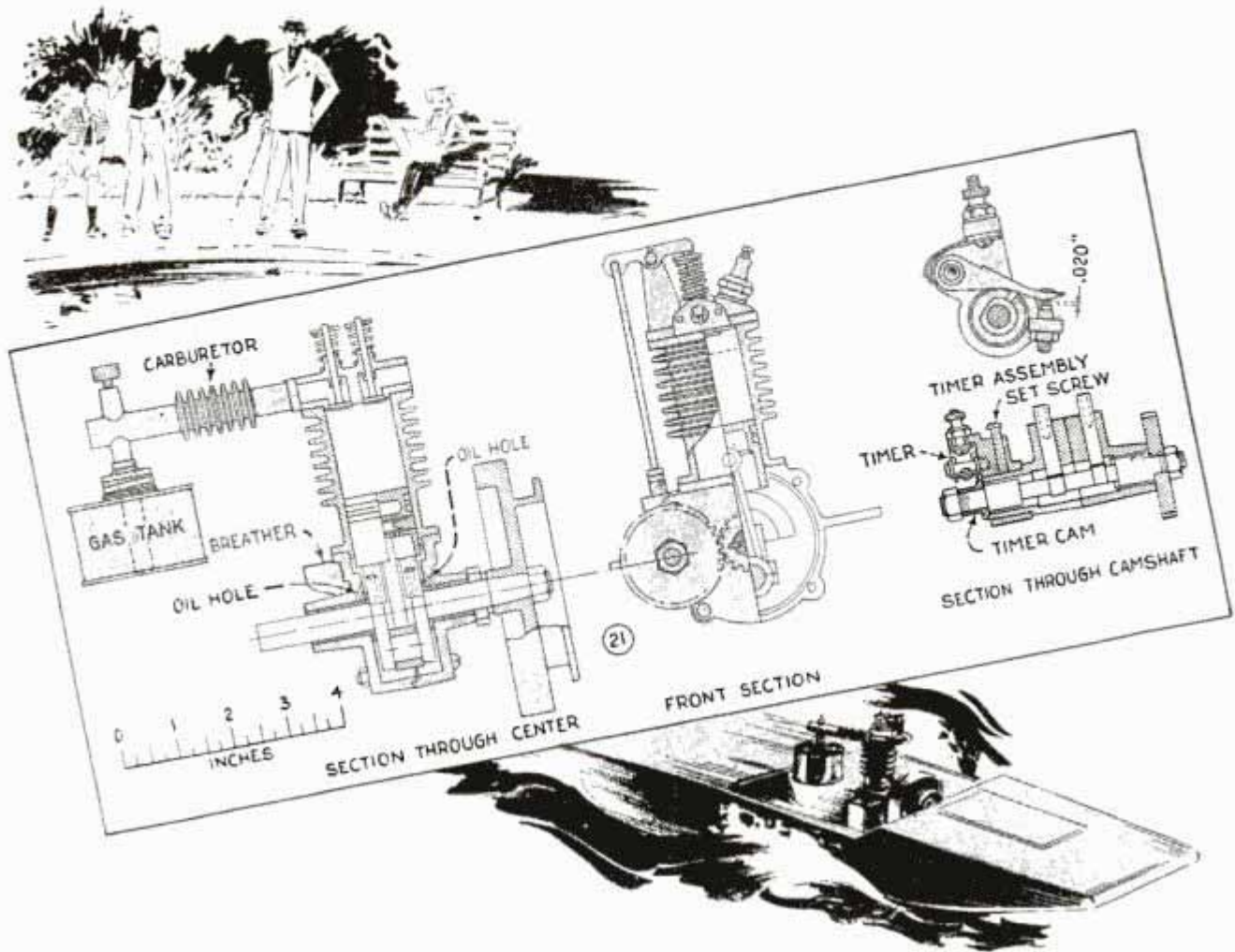

Now go back to Fig. 16 for details on the connecting rod and crankshaft. Because of its small size, the former is comparatively easy to finish up. At the big end, you first drill and tap for cap screws, then saw off the cap, which is fitted to the rod by filing or milling the meeting faces flat. The cap is then screwed to the rod. This done, you're ready to drill and ream the holes for the crank and wrist pin. Mount the rod on a mandrel to finish the sides of the bearings.

The crankshaft is made from a piece of flat, mild steel. The stock is $5\frac{1}{4}$ in. long and should be cut away by milling to the shape shown in Fig. 16. Then when the main and offset centers are located, mount in the lathe as in Fig. 15. Rough-turn the main journals, and finish-turn the crank pin. Cut off the projections with the offset centers and finish the main journals, then turn the taper and thread the front end. The keyway may be cut at this time. Counterweights are made from a steel disk which is finished true on a $\frac{5}{8}$ -in. mandrel, then split, paired and filed or milled to fit the crankshaft. The screw

holes should be laid out in the bottom of the square notch, drilled from that side and counterbored from the opposite side. When this is done the crankshaft should be marked through these holes and drilled and tapped. Bearings are made from a piece of bearing bronze mounted in the lathe chuck. Cut off each bearing as finished and press into place in the crankcase. After the bearings are in place drill $\frac{1}{16}$ -in. oil holes from the inside of the crankcase into the main bearings as shown in the assembly drawing, Fig. 21.

Next, the flywheel, Fig. 25. Rough-turn the casting on the outer side, then finish the inside, including the tapered hole. Mount on a tapered mandrel and finish the outer side. This procedure will give a true running wheel. The mandrel should be made just before the tapered end of the crankshaft is turned so that the same set-up can be used. To make duplicate setups the mandrel must be made the same length as the crankshaft.

The camshaft involves some hand work. After turning out the blank as in Fig. 23, you have to lay out and file the cams to

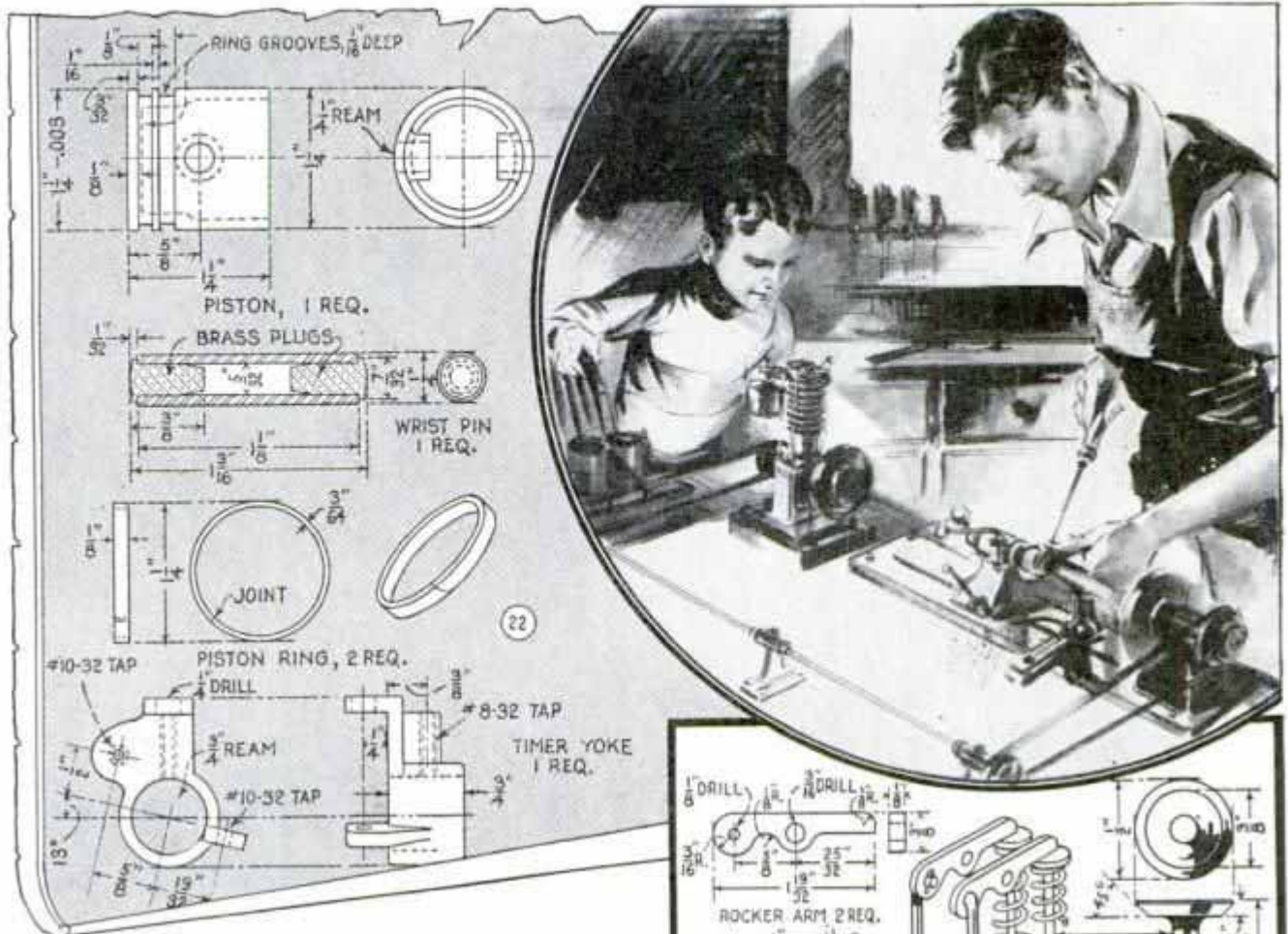

shape. Or you can make them by the cut-and-try method, the engine being assembled. With limited equipment, this may be the more accurate. However, the filing of the cams must be left until the valves, tappets, rocker arms, springs and push rods are made and fitted. Details on these parts you'll find in Fig. 23, with the timing gears detailed further in Fig. 16. This leaves only the timer yoke, Fig. 22, and the carburetor, Fig. 24, to complete the parts. Purchase of the valves and timing gears ready-made will save time.

To make and fit the camshaft you proceed as follows: File the exhaust cam to the shape shown in the drawing. The camshaft may be held between the lathe centers to do this, using the lathe merely as a vise. With the engine assembled, time this cam so that the exhaust valve begins to open about 30° before bottom dead center and closes on top dead center. Set the piston at the center of the intake stroke, which begins at 5° past top dead center and ends at 10° past bottom dead center, and mark through the tappet hole to locate the peak of the intake cam. Then file the cam to the shape shown. Both cams may have to be dressed a little one way

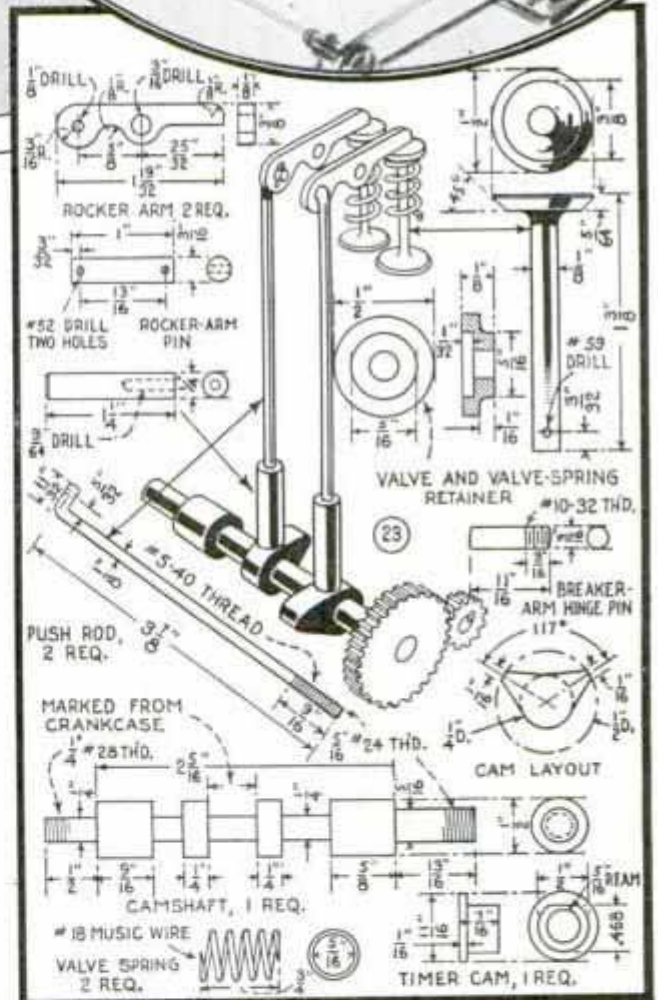

or the other to obtain the correct opening and closing points of the valves.

Assemble the engine in this order: Mount the piston on the connecting rod, put the rings on the piston, mount the connecting rod on the crankshaft, and assemble the crankshaft and crankcase parts.

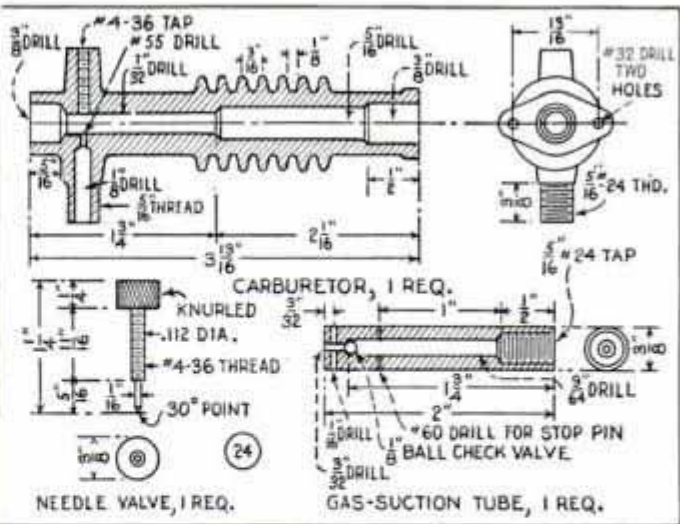
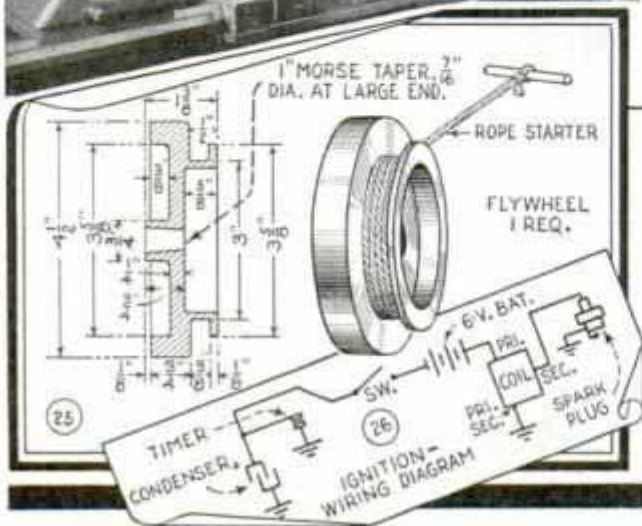

Put on the cylinder and cylinder head, on which the valves, rocker arms and push rods have been assembled. Key the crank and camshaft gears, then insert the camshaft. Adjust the tappets to .002-in. clearance and time the valves. Put on the timer cam and place so that the flat is on top when the intake valve is at its closing point. Assemble the timer and set so that the points break at about 10° before the piston reaches the top dead center. The gap at the points should be from .018 to .020 in. The exact firing point is important and can be best found by experiment. Then put on the flywheel. If there is a slight gap between the crankshaft gear and the flywheel hub it should be filled in with a washer. Lastly, mount the carburetor, to which the gas tank and fuel suction pipe have been attached. Put in the spark plug.

Now the engine is ready for a running test. Mount it on a block of wood and clamp this in a vise. Wire up the ignition system as in Fig. 26. Put about a tablespoonful of oil in the crankcase, and fill the gas tank with high-test gasoline. Close the needle valve tightly and then open it about one-sixteenth of a turn, choke by placing a finger over the end of the car-

buretor and turn the flywheel a few times to draw gas up the fuel pipe into the cylinder. Wrap a stout cord around the cranking groove of the flywheel, switch on the ignition and pull the cord. If the engine fails to start, the spark timing and needle valve may need some adjustment. Normally, the engine should run at a speed of about 3,600 revolutions per minute.

Add oil to the supply in the crankcase from time to time when the engine is running. Oil in the proportion of one teaspoonful per two ounces of gasoline may be added to the gasoline in the tank for the breaking-in period. A half-hour run with a load, such as pressing a stick against the inside rim of the flywheel, will serve to break the engine in. The breeze of an electric fan will help keep the engine cool during the running-in period.

Rubber Hose on Carpenter's Bar Avoids Marring Surfaces

When using a carpenter's bar to pull large nails and spikes in places where it is necessary to protect the surrounding surfaces, a short piece of hose split along one side and slipped over the end of the bar as shown will do the trick. The hose can be moved up on the bar out of the way or removed when it is not needed.



Mirror Used as Protractor Handles Many Jobs

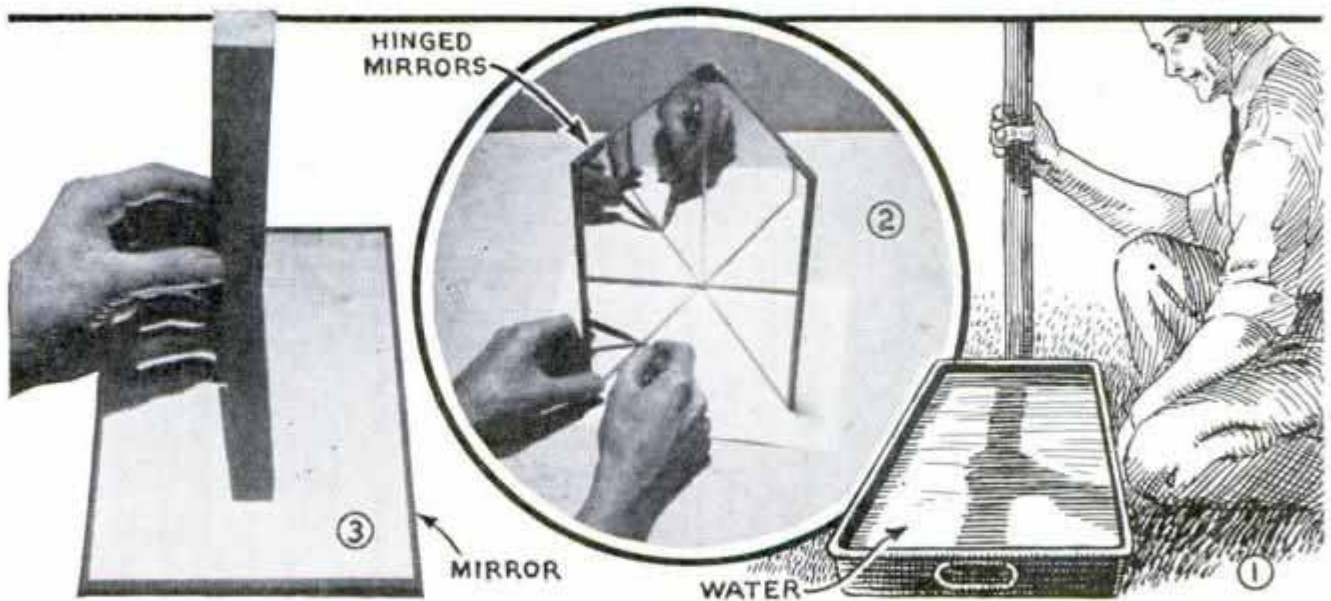

When a protractor is not at hand, you can often substitute a mirror or even a pan of water and make a check by means of reflection. Fig. 1 shows how a pan of water is helpful in determining whether a post is perpendicular. When the reflection appears in line with the post, the latter stands straight one way. Then the pan is shifted around 90° and the check repeated. Two mirrors hinged together as in Fig. 2, which may be done with a strip

of adhesive tape, will help to divide a circle into a number of equal segments. The photo shows how to measure 60° or $\frac{1}{6}$ of a circle. Other angles are measured in a similar manner. The mirrors are adjusted so that the lower edges are in line with their images. In Fig. 3, a wood block is being checked to see if the end is square, which will be the case if the reflected edges are in line with the edges of the block, as observed from two adjacent sides.

Tar Roofs Smoothed with Heated Roller to Imbed Gravel

To get a gravel covering imbedded thoroughly in a new or repaired tar roof so that it will not be dislodged easily by wind or rain, one contractor goes over it lightly with a self-heating roller. The heat from the roller softens the surface of the tar so that it seals tightly around the gravel. The roller can be made from a lightweight, 10-gal. drum, the sides of which must be smooth and straight. A flat-iron yoke to take a handle is pivoted to the drum ends, one of which has holes for inserting hot coals to heat the drum. A little coke or charcoal added occasionally will keep the fire going. The roller should be just hot enough to soften the surface of the tar, and do not apply too much pressure as this will force the gravel through the felt base.



☐ To protect valuable photographs against fading, usually caused by sulphur in the air, dip them in thin clear lacquer.

Tool-Kit Handles Made of Wire Are Interlocking

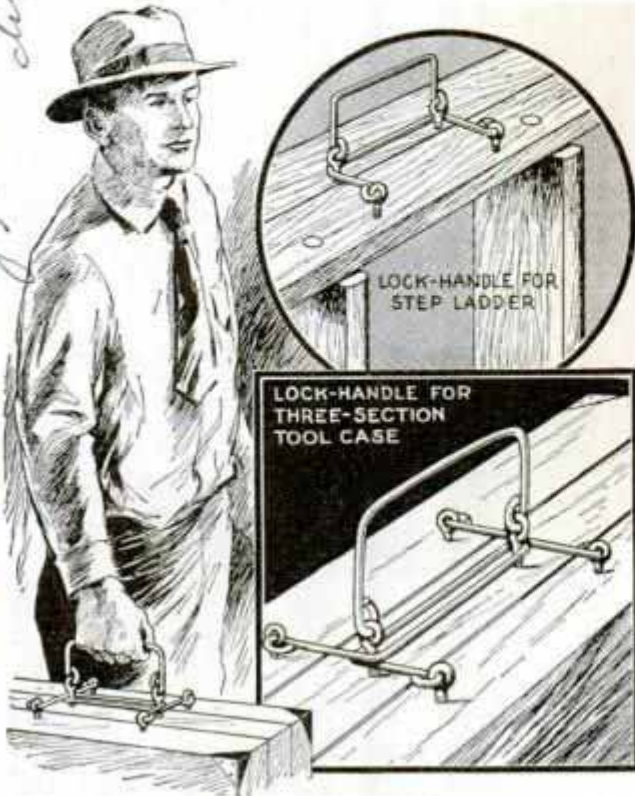

There is no possibility of a tool kit opening while carrying it, if these handles are used

After having his tool kit fall open while carrying it along the street, one carpenter removed the hook latches and substituted interlocking handles. They consisted of hinged wire loops, one on each side section of the kit in such a position that they dropped down over a similar handle in the center. These proved so handy that he used the same idea to prevent his stepladder from opening while carrying it.

Lathe Tool with "Stellite" Tip



On a job of turning a large number of narrow grooves in cast-iron rolls, we found a piece of Stellite welded to the lathe tool enabled us to increase the speed of both the lathe and feed screw

without burning the tip, thereby reducing the time of doing the job considerably. Also, we found that by carefully grinding the tip to size, both sides of the groove

could be finished in one operation, resulting in still greater saving of time. We have used Stellite on the tips of boring tools with good results, especially when working with cast iron.

—M. L. Lowrey, Livermore, Calif.

Wrist Strap on Paint-Spray Gun Helps Relieve Strain

When using a spray gun continuously on a large job, much of the hand strain can be eliminated by a wrist strap as shown. The strap, which is looped around the gun handle and sewed, is fitted with a buckle so it can be adjusted to fit the wrist.



Pockets in Carpenter's Apron Kept Open by Wire Frame

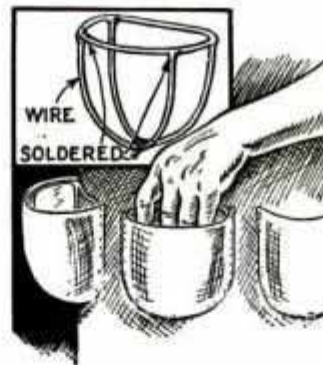

Inserted inside the pockets of a carpenter's apron, wire frames of the type shown will keep them open so that it is easy to pick out nails. The frames are made from fairly stiff wire and all joints

are soldered and then smoothed with sandpaper to protect the hands.

Rubber-Tipped Putty Knife to Set Glass Pane to Set Glass Pane

Glaziers who often tap a tight-fitting glass pane in place with the putty knife, will find that a rubber-tip handle will reduce the possibility of breaking the glass. Just drive a rubber-head tack into the handle.

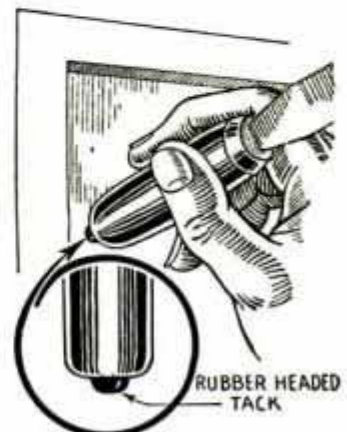

Haynes Stellite Co. / Haynes and Sunday / Kokomo, Ind.

Disk and Drum SANDERS

fit your drill press

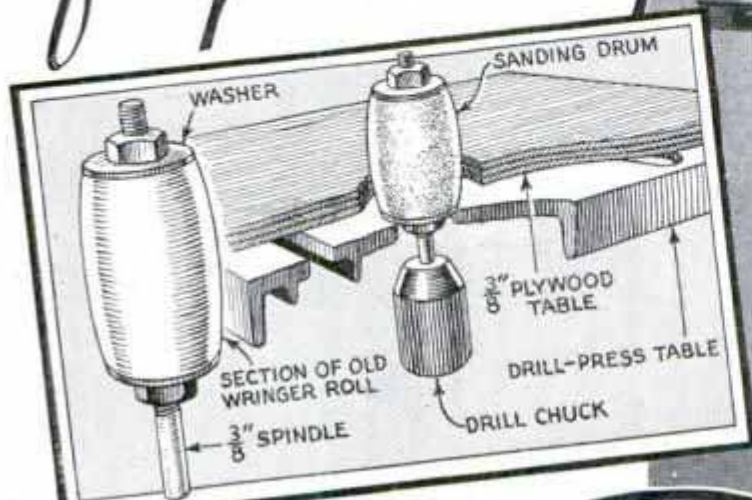

By making a few sanding drums and disks of different sizes, you can handle most light sanding jobs that come up in your home workshop. The spindle sanding attachment above is especially handy for edge work, and you can oscillate it by moving the drill-press spindle up and down with the handle

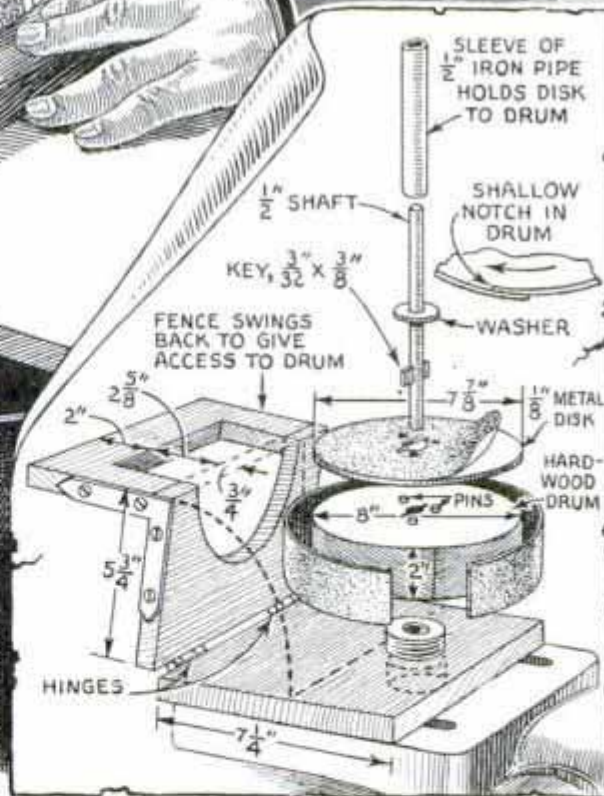
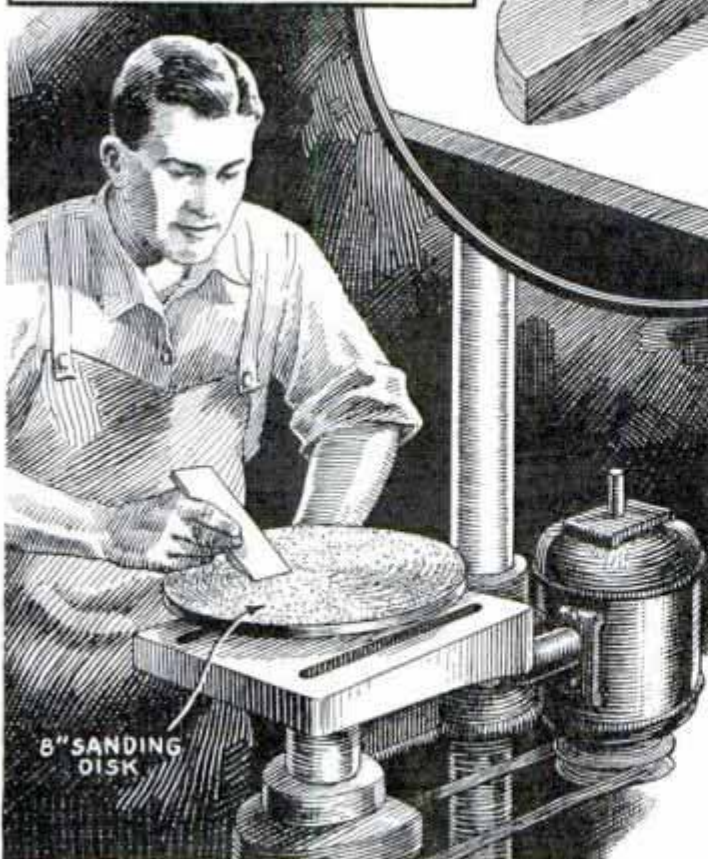

In the drum sander above, the disks are interchangeable, making a wide range of different sanding surfaces available. Nested washers in the base serve as a thrust bearing. At the left, the drill-press head is inverted to drive an 8-in. sanding disk

Tinner's Shears Operated by Foot Handle Large Wire-Cutting Job



Small shop owner quickly turns out large order for short wires with foot-operated shears

Having an order which required cutting several thousand short pieces of wire, the owner of a small shop that was not equipped for this work turned out the job quickly with a pair of heavy tinner's shears as shown. One handle of the shears was clamped in a bench vise, after which a strong strip of rubber fastened to the ceiling, and a wire fastened to a pedal on the floor were attached to the other handle. This permitted him to operate the shears rapidly with his foot as he fed the wire between the blades, a stop block, nailed to the bench, serving as a guide.

"Kick-Off" Spring Saves Time on Some Lathe Jobs

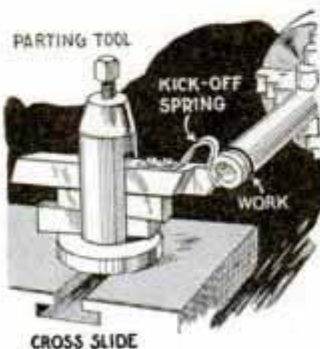

Many production jobs on a lathe can be speeded up by using this kick-off spring, which directs the parts into a box at the rear of the lathe as they are cut off with a parting

tool. The spring is bent to hug the work and is fastened to the top of the parting tool. It should touch the work before the parting tool so that when the latter advances the spring is compressed sufficiently to give the work a kick the moment it is severed.

Dividing a Ream of Paper into Equal Parts

In printing shops and other places where it is often necessary to divide reams of paper into equal parts, the job can be done quickly with a ruler. If, for example, the ream is to be divided into three parts, place the ruler against the end of the paper and force the top back to slant the sheets until the measurement from top to bottom of the ream is exactly 3 in. as shown. A card or piece of paper inserted between the sheets at each inch mark on the ruler will mark the division lines.

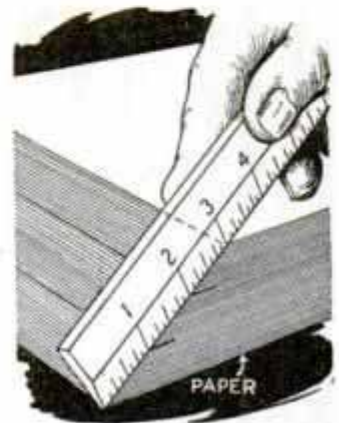

Heavy Drill-Press Vise on Skids Is Moved Easily

In a shop where heavy drill-press vises often had to be shifted from one machine to another to complete a drilling job, the

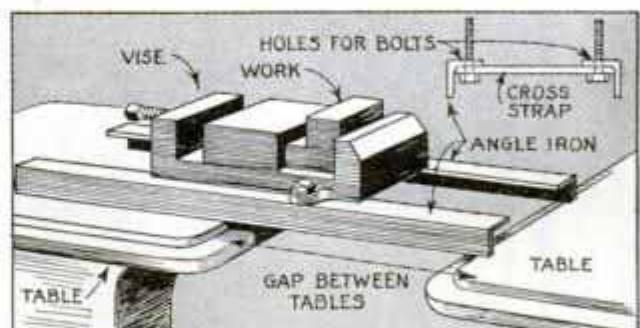

Heavy drill-press vises pushed from one machine to another to avoid lifting them

vises were fitted with angle-iron skids. This permitted them to be pushed from the table of one drill press to the table of the one nearby without lifting.

—H. Moore, Hamilton, Ont., Can.

Time Savers in Garage Increase the Profits

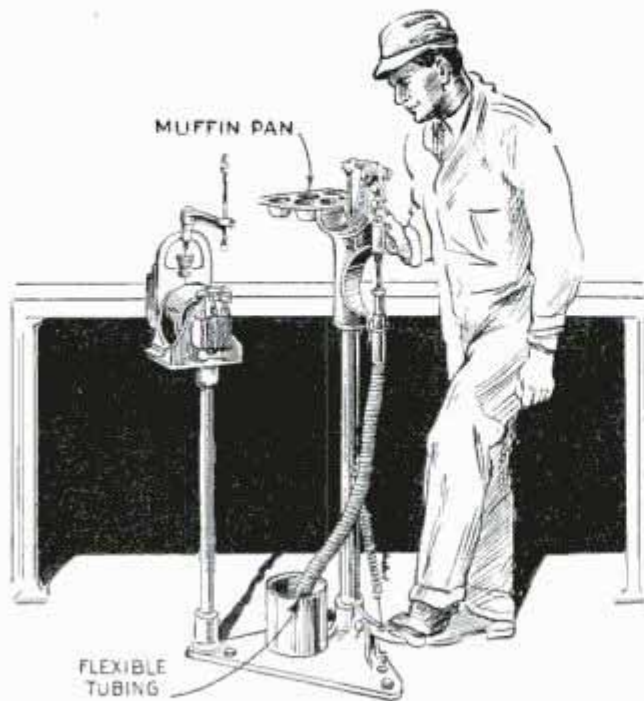

Here are three simple ideas that will save time on many jobs in your garage. The left detail shows a piece of flexible tubing attached to the anvil of a riveting machine so that the rivets fall into a can as they are punched from brake shoes, thus making it unnecessary to sweep up after each brake-lining job. A muffin pan fastened to the head of the same machine keeps several different sizes of rivets separated and always at hand. The right-hand de-

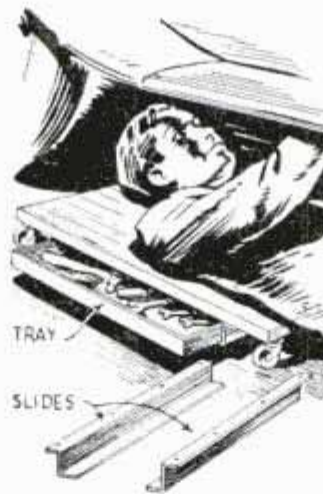

tail shows how two short, headless studs can be used as guides to install a cylinder head and gasket single-handed without damaging the latter. The upper ends of the studs are slotted to take a screwdriver so that they can be removed after a few of the cylinder-head bolts have been started. In the center detail, a creeper is fitted with a drawer in which several small tools are kept handy, thus making it unnecessary to crawl from under a car to get them.



Armrests Ease Shoulder Fatigue of Rumble-Seat Riders

Those who have ridden in rumble seats for any distance will readily understand the comfort afforded by these detachable armrests, which clip over the edges of the seat opening. Each rest consists of a wood block padded with sponge rubber to which are bolted two clips of flat, spring steel. Body construction around the seat opening will determine the shape to which the clips should be bent. After the armrests are completed, the steel clips should be covered with rubber tubing to prevent marring the car finish.

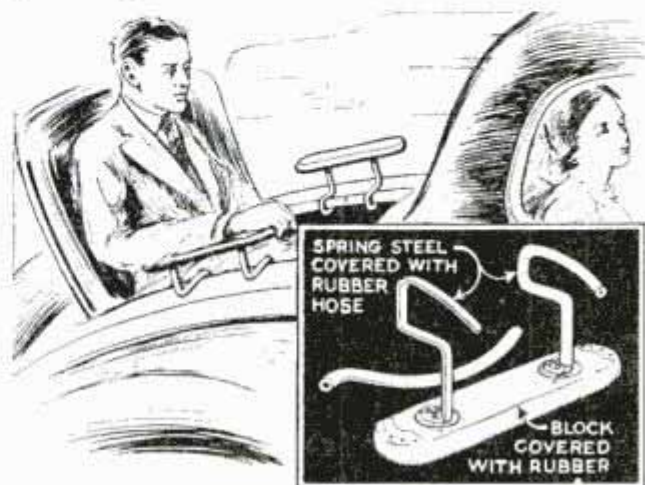

Roller on Luggage Compartment Aids in Removing Suitcases



Lifting and straining is unnecessary to remove heavy luggage when you use this roller

Salesmen and others who carry heavy suitcases and similar objects in their luggage compartments, will find that a roller mounted at the lower edge of the compartment opening is a great help in removing the luggage. Instead of climbing on the car and lifting the objects out of the compartment, you can stand on the ground and pull them out, letting them rest against the roller as they are removed. The roller may be made of wood, or from a piece of pipe filled with cement in which a rod is centered. The rod turns in metal brackets welded to the car body.

Cushioned Boot in Truck Tire Gives Long Wear

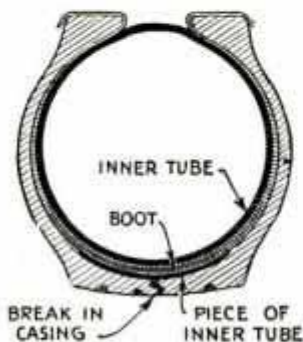

When installing the boot, the inner tube was cemented inside the tire directly over the break, after

Cushioned with a piece of inner tube, a large boot placed over a break in a truck tire was found to give longer wear than when it was used without the cushioning rubber.

which the boot was cemented to it in the regular way. In such an installation, the inner tube comes in contact with any foreign matter that works in through the break in the tire, and, being more resilient than the boot, withstands the wear better. Thus, the only function of the boot is to serve as a stiffening reinforcement over the break in the tire.

—J. A. Harper, Pinckneyville, Ill.

Small Parts in Gasoline Pan Retrieved with Brush

When using gasoline to clean small parts in a garage or shop, much of the dirt, as well as any overlocked nuts and keys, can be removed by straining the gasoline through the



bristles of a paintbrush. Just hold the brush in the mouth of the funnel as the gasoline is poured back into the can.

Lighted Glove Compartment Is Handy

Owners of cars that do not have lighted glove compartments can install a lamp in a short time. All that you need is a few feet of insulated wire, a 6-volt dash lamp

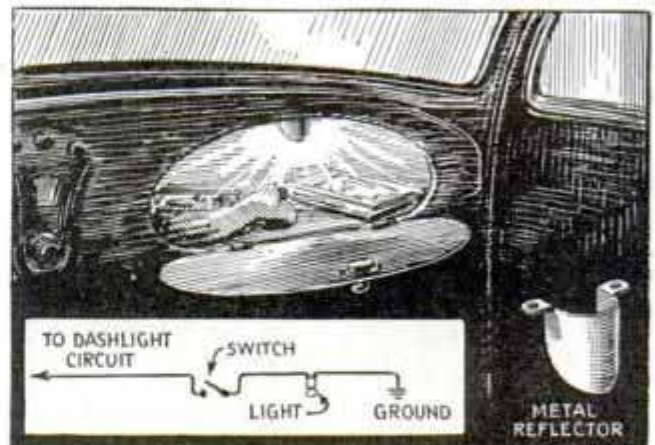

You won't have to fumble around to find an article in your glove compartment if this light is installed

and socket, and a toggle switch. Mount the socket in the top of the compartment, and wire it through the switch to the dashlight circuit or to the "hot" side of

the ammeter. Run another wire from the socket to the frame and ground it. The switch can be mounted on the instrument panel, or inside the compartment if you do not wish to mar the panel.

Adjustable Rear-View Mirror to See Behind Wide Loads

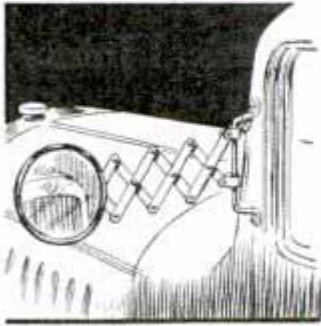

Truck drivers who haul loads of varying widths will find that a rear-view mirror attached to the cab with a "lazy tong," enables them to adjust it to see to the rear

of any load. The method of attaching the mirror to the lazy tong will depend on its particular type. The tong is fastened to the cab with a bracket.

Battery Cushioned in Holder Against Shocks

Storage batteries in cars are often cracked or their bottoms are worn through because the hold clamps loosen, allowing them to bounce and slide around in the holder. This trouble can be prevented by wrapping a long, narrow strip of inner tube spirally around the crosspiece at the bottom of the holder to serve as a shock absorber for the battery.

Trailer-Hitch Pin Locks Itself

There is no possibility of the pin in your trailer hitch working out if you use one of the type shown. It is merely a strong bolt slotted at the lower end to take a triangular-shaped key, which is pivoted in the slot. The shape of the key causes it to hang in a horizontal position with the ends projecting from the sides of the pin.

—Victor Busch, Flint, Mich.

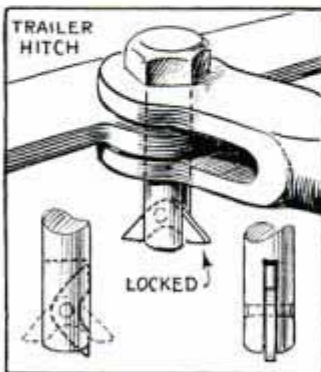

Rattan Seat Cover Weighted to Keep It in Place

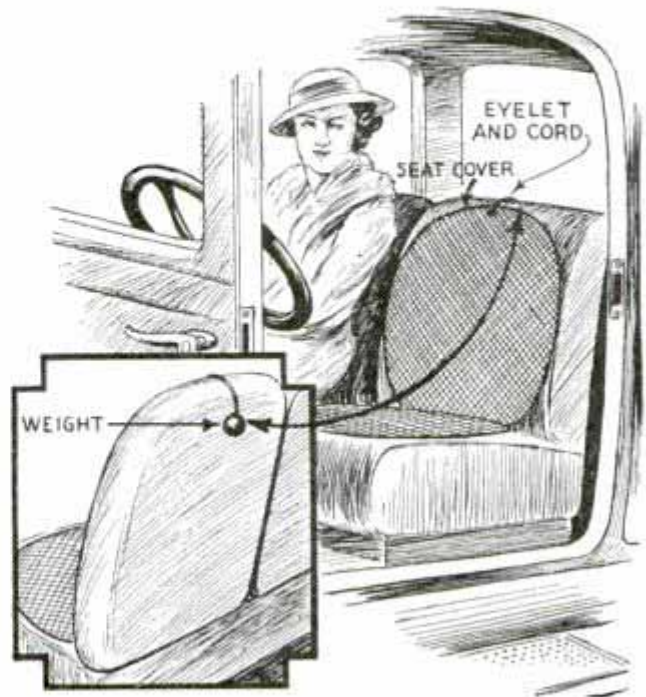

The problem of keeping the back of a rattan seat cover in place when you get out of a car is solved by a weight tied to the cover and placed over the back of the seat. As a light weight will do the trick, a fairly small steel ball, a medium-sized solid rubber ball, or a hollow ornamental knob of metal will serve the purpose.

Squeaky Car Springs Silenced by Screen Wire

It has been found that squeaks in unshielded springs can often be stopped by slipping short pieces of grease-coated screen wire under the ends of the leaves. As the greatest points of friction are at the ends of the spring leaves, the screen wire retains the grease and lubricates these points much longer than is possible by merely spraying the springs with a penetrating oil.

—Jos. C. Coyle, Tucson, Ariz.

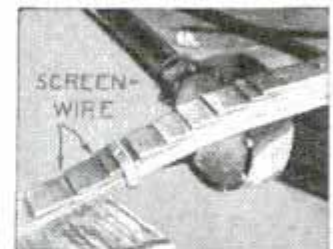

☐ When a glass stopper is not at hand for a bottle containing strong acids, an ordinary cork may be used provided it is first dipped in hot paraffin.

Jig Holds Band Saw in Alinement While Brazing Broken Ends

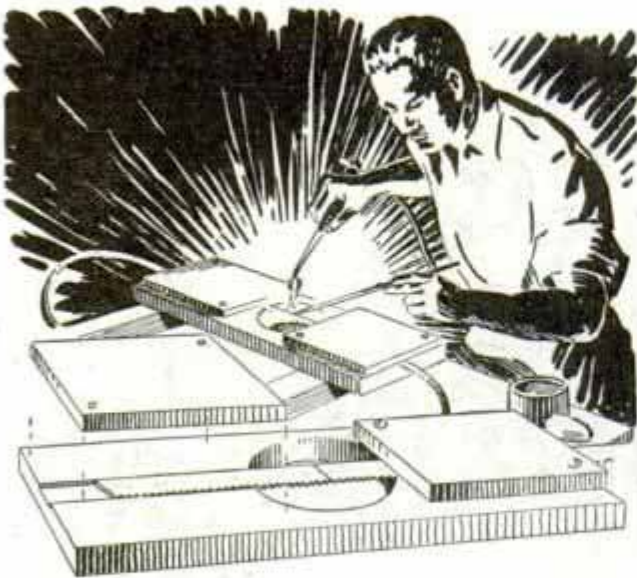

This simple jig eliminates guesswork when alining broken band saw to braze the ends together

To assure that the ends of a broken band-saw blade will be brazed together in perfect alinement, I clamp them in the jig shown while making the repair. It consists of a hardwood block grooved lengthwise

to take the blade flush, and two smaller blocks, which clamp it securely in place. A large hole bored in the center of the block allows the torch flame to pass around the saw blade without burning the wood. If desired, several grooves of different widths may be made in the jig to accommodate various saw blades.

—W. C. Leckey, Aurora, Ill.

Making Good Electrical Joints in Terminal Lugs

Difficulty of completely filling terminal lugs with solder, when making electrical

connections can be eliminated if a small hole is first drilled in the base of each lug. This permits air and gases to escape without bubbling through the incoming solder. The holes are so small that

little solder is lost through them.

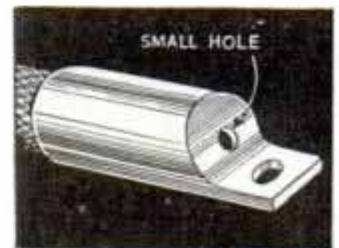

The Next Issue

MODERN LAMPS OF PLASTICS AND METALS

Beautiful lamps of subdued modern design that go well in any surroundings. Combining colorful plastics with satin-finished metals, which are easily shaped, the lamps offer the home-workshop owner handsome profits for his spare time.

FROZEN WATER PIPES THAWED UNDERGROUND

How to make a transformer to thaw out frozen water pipes underground. Operates from the 110-volt electric line in your home.

RAISED DESIGNS TAPPED IN BRASS

Artistic designs on brass in bold relief by tapping down the metal. Beautiful plaques and other decorations made with a hammer and punch.

OUTWITTING THE FUR BEARERS

Do you know the tricks of catching the fur bearers? This article tells how and where to make clever land and water sets that fool the wiliest animals.

OSCILLATING SANDER

Rugged spindle sander from inexpensive parts on which the spindle moves up and down as it rotates, giving the work a smooth finish free of sand scores.

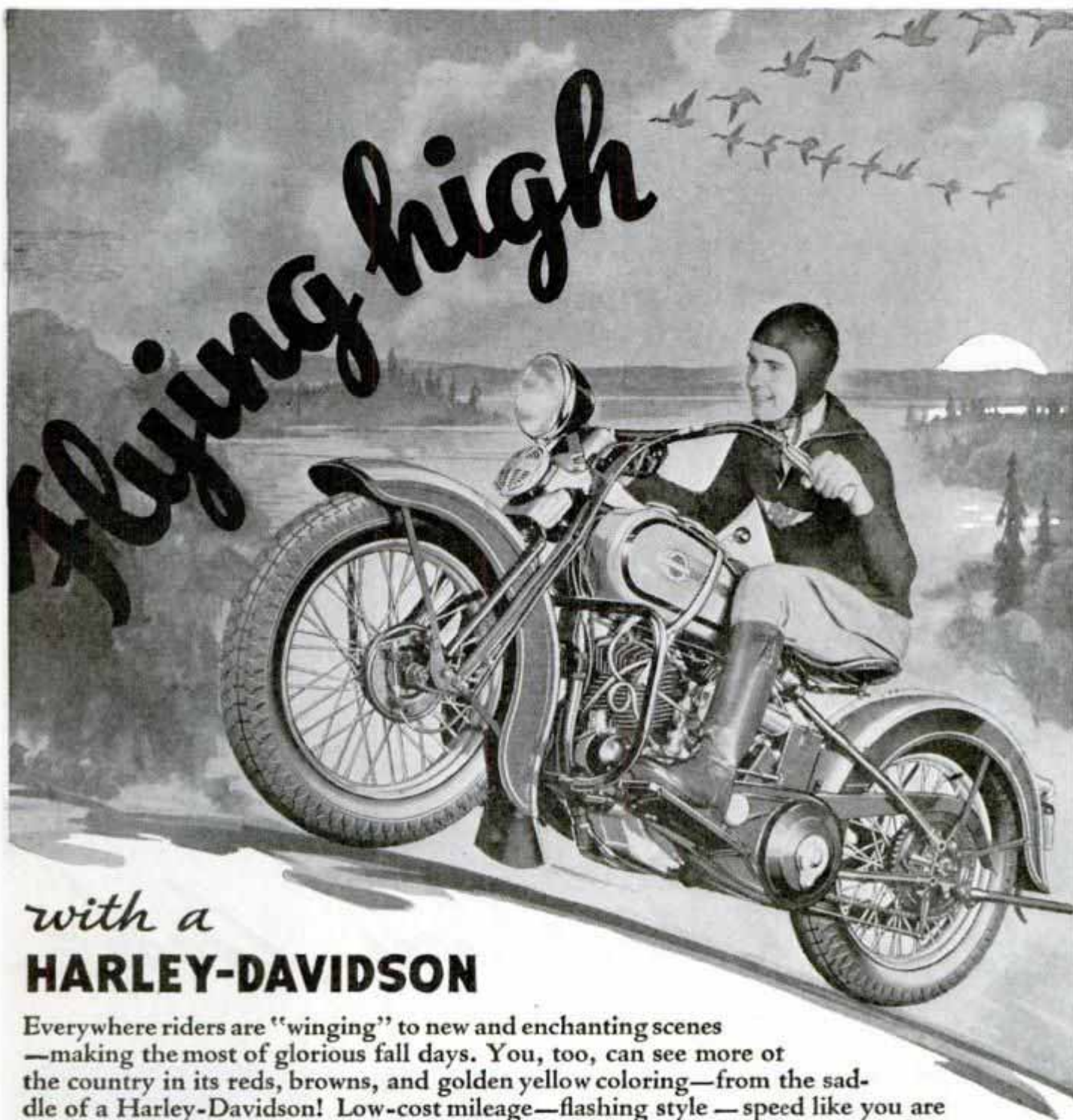

with a
HARLEY-DAVIDSON

Everywhere riders are "winging" to new and enchanting scenes —making the most of glorious fall days. You, too, can see more of the country in its reds, browns, and golden yellow coloring—from the saddle of a Harley-Davidson! Low-cost mileage—flashing style — speed like you are on wing — those are the thrills that are yours with Harley-Davidson streamline design and latest motor improvements. Get your Harley-Davidson now—and go "flying high" with those other happy Harley-Davidson riders in your town! See your Harley-Davidson dealer **RIGHT AWAY** — for a *free ride* — and details of his Easy-Pay Plans. And send in the coupon — Now!

Harley-Davidson Motor Co., Dept. P, Milwaukee, Wis.

Ride a

**HARLEY-
 DAVIDSON**

HARLEY-DAVIDSON MOTOR CO.,
 Dept. P, Milwaukee, Wis.
 Interested in motorcycling. Send illustrated literature. Stamp is enclosed to cover mailing cost.

Name.....

Address.....

My age is 16-19 years, 20-30 years, 31 years and up, under 16 years. Check your age group.

AFTER THE GREATEST FINISH under fire in golfing history, Tony Manero gets set for hearty eating by smoking Camels. He won the 1936 National Open Golf Tournament with a spectacular 282—4 strokes lower than the former Open record. His digestion stands the strain of the long grind because, as Tony himself says: "I'll go on record any time as one who thanks Camels for stimulating digestion. 'For digestion's sake—smoke Camels!' hits the ball right on the nose. I feel cheered up while I'm eating—enjoy my food more—and have a feeling of ease afterward when I enjoy Camels along with my meals. Camels set me right."

**WHETHER YOU ARE
CATCHING A QUICK BITE
OR DINING IN STATE—**



for Digestion's Sake

Copyright, 1936, R. J. Reynolds Tobacco Company, Winston-Salem, N. C.

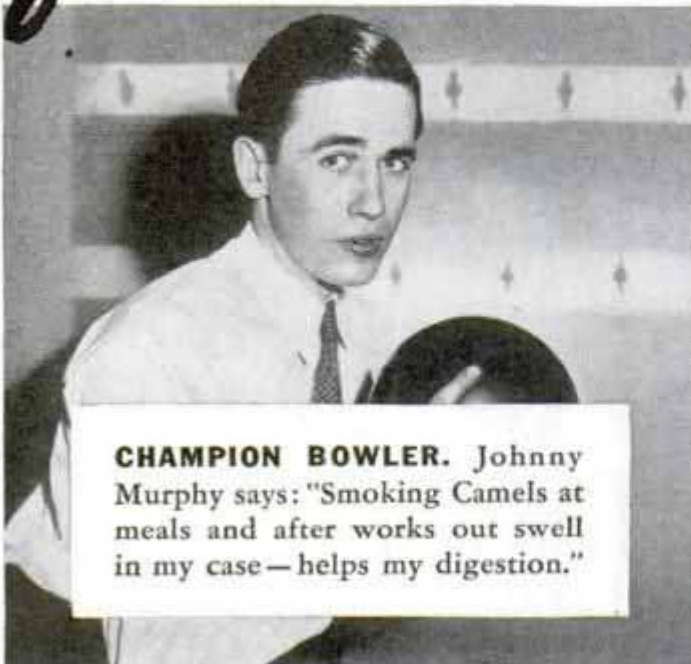

CHAMPION BOWLER. Johnny Murphy says: "Smoking Camels at meals and after works out swell in my case—helps my digestion."



"WHAT A PLEASANT aid to digestion Camels are!" says this busy homemaker, Mrs. Charles Sickles. "They add special zest to any meal."



Smoke Camels!"

Smoking Camels increases digestive activity
—encourages ease and a sense of well-being!

WITH healthy nerves and good digestion,
you're bound to feel on top of the world.

Smoke Camels at mealtime. Camels help in two special ways: Tension is lessened and Camels promote digestive well-being. Strain eases off. The flow of digestive fluids, so vital to proper nutrition, speeds up. Alkalinity is increased.

For invigorating "lift"—for matchless taste—and "for digestion's sake," the answer is the same: Camels. Camels set you right!

Camels are made from finer, MORE EXPENSIVE TOBACCOS
...Turkish and Domestic...than any other popular brand.



COSTLIER TOBACCOS!

When writing to advertisers please mention Popular Mechanics

The Amateur Sky Patrol

(Continued from page 725)

The big job is grinding and polishing the mirror glass. It may take twenty or twenty-five hours to get the right concave surface so all the parallel light the mirror picks up is reflected back to one point. The rough grinding is done with different grades of carborundum by pushing a grinding tool back and forth across the surface of the glass, with the mirror glass mounted on a small table so the builder can walk around it slowly. The tool used is a glass disk similar to the mirror disk. The final operation is to polish the concave surface, and for this the grinding tool is covered with pitch facets and a compound of jewelers' rouge suspended in water is used. Then the disk is ready for its reflecting coat of silver.

With an inexpensive six-inch telescope you can see all of the major planets, the rings of Saturn, pick out craters on the moon only a mile in diameter, and make out the nebula in Andromeda that is 900,000 light-years away. A good telescope of this size will reveal stars of the thirteenth magnitude, as compared to the naked eye which sees stars of the sixth magnitude, and the 100-inch telescope on Mount Wilson with which stars of the nineteenth magnitude may be seen. Equipped with an electric "slow-motion" motor that turns the telescope across the sky at the same speed as the stars, long-exposure photographs may be made. Some amateur pictures of the sun, moon, and planets compare in quality with those made at the large observatories. Some of the amateur comet hunters do all their exploring by photography. With a camera hitched up with their telescope, they take pictures in which it is easy to pick out the long comet trails among the round dots that represent the stars.

During the day you can use an astronomical telescope for looking at interesting things on the earth. A six-inch instrument will allow you to read a newspaper a block away or tell the time from an alarm clock a mile away. With such a telescope you can see cars on a distant road as plainly as if they were across the street, or watch passengers on the decks of ships far at sea. With a red filter to cut through the blue haze, the individual

branches of trees on mountain tops 100 miles away have been seen. Many amateurs use heavy permanent mountings in their back yards to hold their telescopes steady and also have light portable tripods that enable them to set up their telescopes almost anywhere on automobile trips.

It is estimated that 10,000 amateur telescope enthusiasts in the United States, including the memberships of fifty clubs, have built their own telescopes. One association with 350 members in all parts of the country is doing work of professional importance in keeping track of the variable stars. Some of the instruments built by amateurs are as fine as any in the world for their size and are valued at thousands of dollars. One builder made his own patterns and castings for his electrically driven instrument and values the telescope at \$3,500. Other amateurs have developed new ideas in telescope gear that have been adopted by the large observatories. A simple solar camera that takes good pictures of sunspots was built by one amateur for a few cents. It consists merely of a light-proof film holder behind a shutter. The shutter is a very thin slit between two pieces of metal and is drawn rapidly across the photographic film by a piece of rubber inner tube when it is released by cutting a string. Exposures lasting one-six-thousandths of a second may be made.

Three amateurs, a bridge builder, a dentist, and a manufacturer, built an entire observatory which they presented to a university. Among their instruments they invented a "spectroheliokinematograph" which takes motion pictures of sun phenomena. Motion pictures are also taken of solar eclipses and the movements of Jupiter's moons.

"Amateur telescope builders should plan to use their instruments after they finish building them," Porter urges. "Often an amateur works many hours to finish his telescope, calls in the neighbors a few times to look at the moon, and then lays it away. Really, the most interesting part of his hobby has just started. With a few star charts and tables to guide him, there is always a chance he may make an important discovery."

7845

NOW Kodaks work NIGHTS

It's easy to take pictures **AFTER DARK**

RUN through any collection of pictures, and you'll find that some of the finest are indoor shots—taken at night. For today films are faster; lighting has been improved. Try your skill in this new and exciting sport; start tonight.

Night pictures can be made with your present camera if it can be set for "time"; and if it boasts an *f.6.3* or faster lens, night *snapshots* are easily possible. Just load with Kodak "SS" or Kodak Verichrome Film and use Mazda Photoflood or Photoflash lamps.



FREE BOOKLET

First get the **FREE** booklet on Night Pictures at your dealer's... then you're ready to shoot. It explains everything about pictures at night... which film to use... how to set your camera... suggests a variety of picture opportunities... Eastman Kodak Company, Rochester, N. Y.

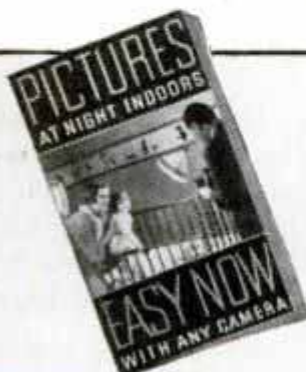

Accept nothing but the film in the familiar yellow box.

1896 "Courts" Offer Luxury for Motorists

(Continued from page 677)

vide room for Junior. And last of all there's a tile bath with hot and cold running water and a tub and shower.

There's nothing to do but drive your car into the adjoining garage, get your bags out of the trunk and "set up house-keeping." Near by there's a service station to condition your car for tomorrow's trip, and within walking distance you'll find a good restaurant and a grocery store to obtain provisions if you're doing your own cooking. After dinner you'll find outside your overnight home a comfortable bench where you can sit and admire your own individual flower garden and your own individual palm tree.

There's maid service if you need it and next morning you're ready to leave as soon as you step outside your home and stow your bags in the car. There's no tipping, no one to disturb you during the night and you disturb no one because your neighbors are far enough distant so your radio or conversation is inaudible.

And the price? Three rooms, bath and garage for your car in any good hotel offering similar conveniences would probably cost you at least eight or ten dollars, perhaps more. In the motor court your overnight home costs you from two to five dollars, depending on the size of cottage you require and the number in your party. Through the west, you can make a three weeks trip, live in a motor court cottage each night, and pay less than \$75 for this form of luxurious living.

The moderate rates are due to the location of the courts. Rarely are they found in downtown areas of high-priced real estate. You'll find them on the edge of the city or on the fringe of a quiet residential neighborhood. And while the construction is substantial, it is inexpensive as compared with the cost of a large hotel.

There's a business opportunity today in motor courts for the man with a few thousand dollars capital. A court of twenty to thirty units in an average locality can be constructed and furnished for from \$40,000 to \$50,000 including the ground, and credit usually can be obtained for part of this sum. Most courts provide a public lounge or lobby and some have their own dining rooms. One elaborate

southern establishment has separate quarters for chauffeurs and maids.

This indicates that a different class of motorists is attracted to the courts, also called "motels," "autels" and "autotels," than patronizes auto camps and tourist parks. You'll find your neighbors are people of means, driving good cars—people



Motor lodge at San Diego, Calif., typical of accommodations for motorists now available

you ordinarily would expect to find at the best hotels. They are attracted to the courts because of the conveniences offered.

Hotels which years ago did not accord a very hearty welcome to travel-stained motorists have seen the day when most of their guests arrive in their own cars, at least in many cities, and they are taking a lively interest in the motor court idea. So it will not be surprising to find motor courts conducted under hotel management. Some of the best today are run by oil companies or individual service stations.

One of the most pretentious organizations is United Motor Courts, an association of more than 100 individually owned and operated courts in the west and middle west. Members can only enter this association if their courts come up to certain high standards. There are also other associations of court owners in the west and southwest.

A few years ago touring motorists lived mostly in wayside shacks, clapboard cabins, private homes catering to tourists or hotels. Today they have available 1,500 de luxe motor courts, another 2,500 of exceptionally high standards and catering to people of substantial means, and 6,000

(Continued to page 120A)

Again
ENGINEERED QUALITY
*Gives You More For
 Your Money In These*
NEW DRIVER TOOLS for 1937

DRIVER 3-IN-1 UNIVERSAL SURFACER

(Series 700) Combines features never before offered! This tool will handle all three types of surfacing, yet it's a model of simplicity. Belt sanding on the upper belt surface, "stroke" surfacing under the lower belt surface, and butt-end or mitre sanding with the big 10" disc. Surfaces panels up to 13" wide—a feature never before available to you in a low priced machine. 4" wide belt, 18" between pulley centers. Tilting table at disc, with mitre gauge. For full details, send the coupon.

DRIVER SURFACER (Series 900)

A full production tool. Like the 700 Series, it surfaces wood, metal, plastics, fibre, etc. Has efficient dust collecting system. Rolling table under belt for "stroke" surfacing. Many other quality features.

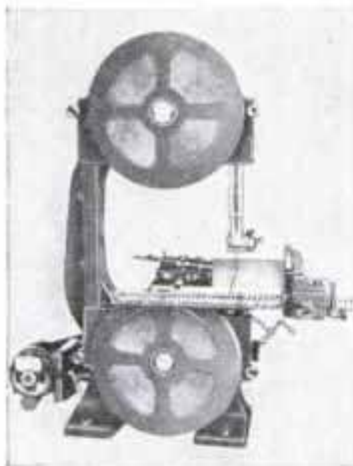

16" BAND SAW

This new Driver tool has fine appearance and graceful lines, but doesn't stop at that! Cuts true; operates without vibration; protects operator; stands up without repairs. Cutting capacity 12", throat 16". One-piece frame. 18"x17" table tilts to 45°, with calibrated quadrant. SKF ball bearings. Completely guarded—no section of blade exposed while sawing. Get the whole story in the colorful 1937 folder!



10" TILTING ARBOR SAW

Massive, rigid frame, table 35"x26", full horsepower motor, heavy duty SKF bearings, 10" blade. Heavy tilting unit swings accurately, almost without effort. With motor recommended, zips through hardwood 3 1/4" thick—greatest capacity ever offered in this price class. Get full details in the new 1937 folder.



10" BENCH SAW

Has unusually large table, plenty of room in front of blade. Cuts full 3" stock! New "kick back pawls" prevent stock being thrown toward operator. New safety guard. Precision worm gear table tilting device. Positive mechanism for raising arbor and blade. Strong ripping fence. Splitter. Get details in the 1937 folder and you'll agree it's the biggest saw value ever offered.



• You can get Driver Engineered Quality in three full lines of Bench Saws, Band Saws, Jig Saws, Jointers, Drill Presses, Lathes, Flexible Shafts, and Motor Grinders. Walker-Turner Co., Inc., 1116 South Ave., Plainfield, N. J.

DRIVER *Engineered* POWER TOOLS

WALKER-TURNER CO., Inc.,
 1116 South Ave.,
 Plainfield, N. J.

Send me your colorful folder, giving full details on the Driver Line for 1937.

Name.....

Address.....

Due to the unprecedented demand for Driver Tools, delivery of new models will be somewhat delayed. Your local Driver dealer will be kept closely informed on delivery dates from the factory.

Building a River in the Desert

(Continued from page 685)

1981
X

nent location. The webs of reinforcing steel are bent to shape, forms are erected, and the concrete is poured in. When the forms are removed the conduit is ready for use.

One problem was to eliminate the hazards of the dangerous dry rivers of the desert. These rivers, nothing more than deep, dry arroyos, remain arid for months at a time. Then a wall of water ten or twenty feet high comes rushing down one of them. A tremendous cloudburst in an adjacent range of desert mountains is the cause. To prevent their aqueduct from being destroyed in such floods, the engineers are using huge inverted siphons to cross under the channels. That way, the artificial river will be carried safely under the sudden floods.

The project has disclosed that, if properly trained and cared for, men can work face to face with the pitiless desert sun all summer long without hardship. Heat exhaustion, the district's medical corps has learned, results from loss by evaporation of part of the normal saline content of the body. A prescription of a small amount of ordinary table salt per day, in a glass or two of drinking water, restores the saline balance and keeps the men in good shape.

Temperatures underground are almost as high as above the surface and the moisture from subterranean streams creates a humid atmosphere much more uncomfortable than the dry air above. In addition, the chemical action that occurs while concrete is hardening creates its

own heat, and the tunnels are lined with concrete. Thermometers in the tunnels have registered as high as 130 degrees.

The aqueduct cuts through one of the most highly mineralized sections of California, in a district where gold and other minerals are often found, so desert prospectors are following the construction crews and carefully sampling the rock taken from canal ditches and blasted out of tunnels. So far no ores of commercial value have been reported although numerous ledges containing very small amounts of gold, silver, copper, and other metals have been discovered. The digging has, however, led to the uncovering of tons of prehistoric bones. Teeth of sabertooth tigers, miscellaneous skeletons of dinosaurs and early elephants, and even fish fossils, have been unearthed in the tunnels. Petrified trees of types no longer existing also have been discovered.

Selecting the best route for the aqueduct was a tremendous task in itself. Much of the country west of the Colorado had never been surveyed and in some sections even general exploring was incomplete. Driving their light, specially built cars through the dry hills and guiding themselves by compass, the district's surveying parties accurately mapped 25,000 square miles. Seven possible routes were compared before the best one was selected.

More than a dozen temporary towns have been built in the desert to provide quarters for the men. Most of the dormi-

(Continued to page 122A)

Courts Offer Luxury for Motorists

(Continued from page 118A)

1996
X

camp and cottage courts where those of modest means and lesser requirements can obtain clean and wholesome accommodations and surroundings. These 10,000 courts and camps have a total of 225,000 cottages and units, 300,000 beds to accommodate 550,000 travelers nightly and represent an investment of more than \$200,000,000.

The rates in these "camps" range from a dollar to \$1.50 for two persons, and in

motor courts from \$2.00 to \$3.00 per couple and about \$4.00 or \$5.00 for four persons. The simpler your tastes, the less the cost. In the inexpensive ones, you may not find the luxuries of the de luxe lodge, but you'll find all of them clean and comfortable if you exercise just a little care in making your selection. So make a trip and try living in a motor lodge—you'll be as comfortable and find it almost as cheap as staying at home!

**IT ISN'T YOUR STARTER,
MISTER, YOU NEED
QUICK-STARTING GAS**

**HERE'S WHY ETHYL
GIVES QUICK STARTING**

(Reading time 37 seconds)

WINTER ETHYL has ALL three qualities that your motor—your starter—and battery are asking for. It is volatile, *to get in the cylinders* at the first turn. It is quick-starting, *to catch the first flash of the spark plug*. It is highest anti-knock, *to give extra power—to stop waste*.

And that's important, because knock cuts down power as it wastes both gasoline and oil; and in winter, driving and road conditions are at their worst. Your very safety depends on instant, full-powered engine response.

It will pay you to change to Ethyl as you change to winter oil and put anti-freeze in your radiator. Your driving this winter will be more comfortable, safer and more economical. And your motor will be in better condition when spring at last arrives.

NEXT TIME GET ETHYL



When writing to advertisers please mention Popular Mechanics

(Continued from page 120A)

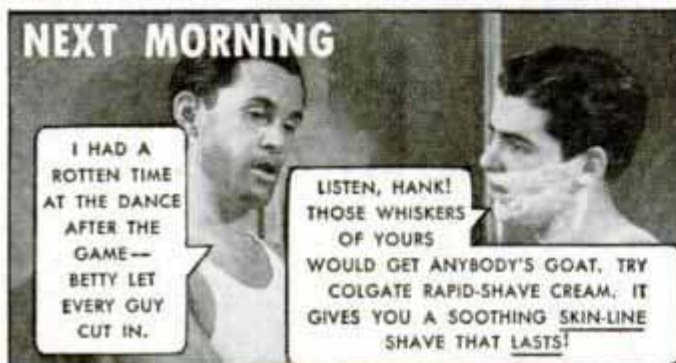

BIG BUBBLES
LEAVE STUBBLE

SMALL BUBBLES
SHAVE CLEAN

BUBBLE PICTURES SHOW WHY

MOST LATHERS are made of bubbles too big to get to the *base* of the beard! Air pockets keep the soap film from reaching the whiskers. So the beard is only *half-wilted*.

COLGATE RAPID-SHAVE CREAM makes tiny bubbles that get clear down to the skin-line. Its rich soap film soaks your beard soft at the base. Makes your shaves last longer.



COLGATE "SKIN-LINE" SHAVES
LAST HOURS LONGER



25¢ LARGE TUBE
100 SHAVES

40¢ GIANT TUBE
200 SHAVES

tories are air cooled and each little city has its own ice plant. Half a dozen hospitals are maintained and all the camps have crews of trained rescue and first aid men. In spite of the new speed records that are being made, and the use of 7,000,000 pounds of dynamite, accidents have been considerably under average.

Water is the staff of life in southern California. Already served by a 233-mile aqueduct that delivers water fresh from the Sierras to Los Angeles, that city and twelve adjacent towns will actually tap the snow banks of the Rockies by means of the new aqueduct. Flowing down the Colorado and through the power houses at Boulder dam, the water will be diverted into the aqueduct 155 miles below the big dam. In all, the water will travel some 1,500 miles from Wyoming, Utah, and Colorado, on its way to kitchen faucets on the coast. The \$200,000,000 aqueduct will practically double the water supply of southern California and provide for a population of 7,000,000 people. It is estimated that from forty to eighty years will elapse before additional water supplies must be sought.

Here are some other facts about the aqueduct. Pumping plants along the line will use enough electricity to serve a city of 2,000,000 population. Before starting work on the aqueduct it was necessary to construct a paved trunk highway 150 miles long, a "baby" aqueduct of steel pipe 200 miles long to carry water from desert wells to the construction camps, a \$2,000,000 high-voltage power line along the right-of-way, and a private telephone system that includes five exchanges.

The steamer "Queen Mary," new Titan of the seas, could not during all her normal life, carry the excavated material from the aqueduct to England if this enormous mass of dirt and rock, equal to the bulk of thirteen pyramids the size of Cheops, could be delivered in New York for shipment abroad. The concrete for tunnel linings, and canals, siphons and conduits, would make a continuous six-foot-wide street walk extending from Los Angeles south to Buenos Aires. The 22,000,000 bags of cement wrought into the aqueduct would, if placed end to end, equal the height of 2,000 Mt. Everests.

(Continued to page 124A)

THOUSANDS AMAZED HOW NEW 3-WAY TREATMENT INCREASES WEIGHT



1

Rich red blood necessary to carry proper nourishment to build up every part of the body, is especially promoted by the easily absorbed iron in this new discovery.

2

A healthy digestion which gets ALL the good out of the food you eat, requires an adequate supply of Vitamin B. This new discovery supplies this precious element.

3

Normal, regular elimination to remove poisonous waste and thereby promote health and growth, requires adequate Vitamin B. This is the third important purpose.

SCIENCE PROVES IT'S
UNNECESSARY FOR THOUSANDS
TO BE **SKINNY**



Posed by professional models

Gains of 10 to 25 pounds in a few weeks, reported

DON'T think you're "born" to be skinny and friendless. Thousands of men and women with this new easy treatment have gained pounds of solid, normally attractive flesh—in just a few weeks!

Not only has this new 3-way discovery quickly brought normal, good-looking pounds, but also naturally clear skin, freedom from indigestion and constipation, new pep and popularity.

Scientists recently discovered that thousands of people are thin and rundown for the single reason that they do not get enough digestion-strengthening Vitamin B and blood-enriching iron in their daily food. Now the richest known source of body-building Vitamin B is cultured ale yeast. By a new process the finest imported cultured ale yeast is now concentrated 7 times, making it 7 times more powerful. Then it is combined with 3 kinds of iron, pasteurized whole yeast and other valuable ingredients in pleasant little tablets known as Ironized Yeast tablets.

If you, too, need these vital elements to build you up, get these new triple-acting Ironized Yeast tablets from your druggist today. Then day after day watch flat chest develop and

skinny arms and legs round out to natural attractiveness. Constipation and indigestion from the same cause vanish, skin clears to normal beauty—you're a new person.

Money-back guarantee

No matter how skinny and rundown you may be, try these new Ironized Yeast tablets just a short time, and note the marvelous change. See if they don't build you up in just a few weeks, as they have thousands of others. If not delighted with the results of the very first package, money back instantly.

Special FREE offer!

To start you building up your health right away, we make this absolutely FREE offer. Purchase a package of Ironized Yeast tablets at once, cut out the seal on the box and mail it to us with a clipping of this paragraph. We will send you a fascinating new book on health, "New Facts About Your Body." Remember, results with the very first package—or money refunded. At all druggists. Ironized Yeast Co., Inc., Dept. 5311, Atlanta, Ga.



**GET YOUR
HIGH SCHOOL, "PREP"
OR COLLEGE RING**
bearing official seal or school letters

Certified \$2.00 Value

ONLY **25c**

with the purchase
of a bottle of

Parker
Quink



at 15c—Total 40c... **YOU SAVE \$1.75**

Listen, fellows! This amazing offer is made by the Parker Pen Co., solely to introduce Parker Quink—the miracle ink that cleans your pen as it writes—a Parker or any other pen. For Quink dissolves sediment left by pen-clogging inks. Quink dries ON PAPER 31% faster, yet does NOT dry in your pen.

Get a bottle of Parker Quink today for 15c from any store selling ink. Tear off the box-top and on the back write the FULL name of your High School, Preparatory, Military, or Normal School, or College, and its location; also ring SIZE and style wanted (man's or woman's), and your name and address. Then mail box-top with 25 cents in coin to The Parker Pen Co., Dept. 782, Janesville, Wis. Your ring will be sent promptly. Offer limited to U. S. A. and may be withdrawn any time.



RINGS FOR GRADE SCHOOLS NOT INCLUDED

FREE TREASURE BOOK **RINGS \$1.50**

PINS 30c Write For Big FREE Catalog Of Pins, Rings, Emblems, Medals, Trophies, Etc.

Class Pins, any letters, numerals, colors. Silver Plate, 25 or more, 30c ea.; 7 to 24, 35c ea.; 1 to 6, 40c ea. Gold Plate, add 10c ea. to above. Ster. 811, add 30c ea. Ster 811. Ring shown, 26 or more, \$1.20 ea.; 12 to 25, \$1.60 ea.; 1 to 11, \$1.75 ea.

METAL ARTS CO., INC., FACTORY 44, ROCHESTER, N. Y.

Send FOR THIS BIG BOOK

TRAILER BUILDERS MANUAL

25c

TRAILER ★ BUILDERS ★ BUYERS ★ OWNERS

SEND 25c TODAY

for this big 64 page book that tells how to build Tops, Beds, Cabinets, etc. All about Electric Light and Water Systems, Floor Plans, etc. Pages full of valuable information, ideas, suggestions that save time and money for trailer builders, buyers and users. Catalog of parts and equipment includes everything you want—Axles, Hitches, Pumps, Stoves, Lights, Windows, Sinks, Toilets, Mattresses—over 200 items exclusively for building and equipping a trailer. Rush 25c (coin) today—satisfaction positively guaranteed.

TRAILER SUPPLY CO., Box 438-A, Wausau, Wis.

(Continued from page 122A)

No ordinary cement is good enough for this immense water-transport structure. Aqueduct engineers know that the gnawing teeth of terrific winds, of temperatures that soar above 130 degrees, and alkalis of fierce corrosiveness are striving constantly to rip asunder their efforts. The finer the cement the stronger its bonding qualities. So the 7,000,000 barrels of aqueduct cement was re-ground to face-powder fineness to add an important tenacity of life and strength to combat the merciless forces of nature. Men and machines may be seen nearly any day drilling out concrete cores which are taken to the desert-edge laboratories of the aqueduct administration where, with the aid of elaborate scientific instruments, they are tested for strength and endurance.

Under the crushing jaws of hydraulic compression gauges the cores are tried for their failure points. Others are locked in automatic refrigerators that dampen and freeze them, in ovens they are dried and heated, so that in a few weeks, they yield the same evidence as the same number of human generations in normal aqueduct life.

In general, the fewer the air holes, the stronger the concrete. So the aqueduct engineers invented a mechanical "patter" whose two steel hands, actuated by compressed air, jar rapidly against the freshly poured mixtures, compacting the concrete into what the system's builders believe is the closest knit construction of its kind ever developed.

To the layman such detail may seem trivial, fantastic. But the engineer knows that every irregularity means compounding friction, cutting velocity and capacity. And he's leaving no loophole whereby posterity, living in one of America's most productive agricultural and industrial communities, can point to an era whose inhabitants failed to secure its permanency by insuring for themselves a continuing supply of water.

Popular Mechanics Magazine does not publish the name of the maker of, or dealer in, any device described in its pages, but this information is kept on file and will be furnished by our Bureau of Information upon request, accompanied by stamped, self-addressed envelope.

Why Gamble with Death?

(Continued from page 719)

of the non-fatal ones last year occurred in collisions between automobiles. Passing on a hill or driving on the wrong side is an excellent preliminary to a collision.

If you're in the habit of looking after you get on the railroad track instead of before, you're headed for the same fate that overtook six per cent of those killed last year and five per cent of the injured. They were killed and hurt as the result of automobiles hitting or being hit by vehicles other than automobiles.

Ever take a curve too fast and find yourself struggling for control? If your 4,000 pound car hits a curve of 100 feet radius at thirty miles per hour there's a force of 2,400 pounds trying to pull you into the ditch. That's centrifugal force. Twelve per cent of last year's fatalities and six per cent of the injuries were caused by accidents involving no collisions with anything. Which might prove that anyone can round a corner on two wheels—once. And this brings up skidding. You can't blame a skid on the "other fellow." Twelve per cent of all rural accidents in Ohio last year were caused by skids. But when roads were wet, snowy or icy, one-fourth the accidents involved skidding. The lesson seems obvious—but remember also that four out of five traffic accidents occur on dry roads and in clear weather, so don't get careless just because the road is dry.

Night accidents are more serious than daytime ones and, on a mileage basis, the accident rate at night is higher. Traffic, accidents and fatalities reach their peak about five in the evening, and their low about three in the morning. Also there are fewer accidents on Tuesday than any other day in the week, and more on Saturdays and Sundays. So in theory, the safest time to drive is about three o'clock of a Tuesday morning.

But don't take a chance, even on Tuesdays, because the law of averages will beat you if you keep it up. Why gamble with death when you know death is going to win eventually?

☐ Inquiries as to makers of articles described in Popular Mechanics, will be answered by our Bureau of Information upon receipt of return postage.

**NOW
GRADUATE
TO
KAYWOODIE**

*The World's
Finest Pipe*

\$3.50
and up

No. 51B

**-AND YOU'LL NEVER
BE SATISFIED WITH
ORDINARY PIPES AGAIN**

This ad is here to tell you that tobacco in a Kaywoodie is an entirely different proposition from tobacco in ordinary pipes. It tastes better because (1) the Drinkless Attachment keeps it sweeter, cooler, drier (2) the briar wood in this pipe costs 3 times as much as ordinary briar (3) each Kaywoodie is shaped and cut to smoke sweet. More comfortable than ordinary pipes too—*feels* right in your mouth. Kaywoodie also draws freer than ordinary pipes, and is easier to clean (Synchro-Stem prevents sticking and yanking). Go to your dealer now and ask for Kaywoodie. Four finishes: Suntan, Walnut, Thorn and Dark. Send for Catalog. Enclose 10c for mailing. Kaufmann Bros. & Bondy, Inc., New York and London.

Drinkless, \$3.50 — Carburetor, \$4
Super-Grain, \$5 — Straight Grain, \$10



LEPAGE'S
Stronger
than the
Wood
It Joins!

See the surface of this block at right. Shows wood gave way, and not LePage's.

10,955 lbs. Pressure

● Illustration above shows side view of block of rock maple, one of the hardest woods, used in testing the strength of LePage's Glue. The dark vertical line is the glue-joint. The irregular white line shows where the wood itself gave way under 10,955 lbs. pressure.

That's proof of LePage's tremendous and lasting strength. Best thing in the world to make snug joints, reinforce nails and screws, fill small cracks and nail holes.

Your hardware dealer has LePage's

RUSSIA CEMENT COMPANY

Laboratories and Factory • Gloucester, Mass.



**HALF & HALF MAKES
ONE SWELL SMOKE!**

**2 DOG WORM
CAPSULES**

*Now Combined
in*

ONE TREATMENT

NO LONGER need you guess which kind of worms afflict your dog—or guess which type capsule to use. Pulvex Worm Capsules expel "all three": Tape and Round, and Hook worms. Now you can be sure of worming your dog correctly. Easily given. No gassing, gagging or harmful effects. Guaranteed. At pet, drug, department stores, 75c.

*Expels
HOOK, TAPE
and ROUND
WORMS*



PULVEX WORM CAPSULES

150-Watt All-Band Transmitter

(Continued from page 740)

unit is shown at C in the rear-view photo of the 5-ft. homemade rack-and-panel assembly. The antenna-matching network is on panel D. For phone work, two RK-31's in class-B easily modulate the full input; this assembly is on base B and includes the Thordarson input, output and filament transformers. Combined plate and screen modulation is used, the T-7826 modulation transformer having secondary windings to

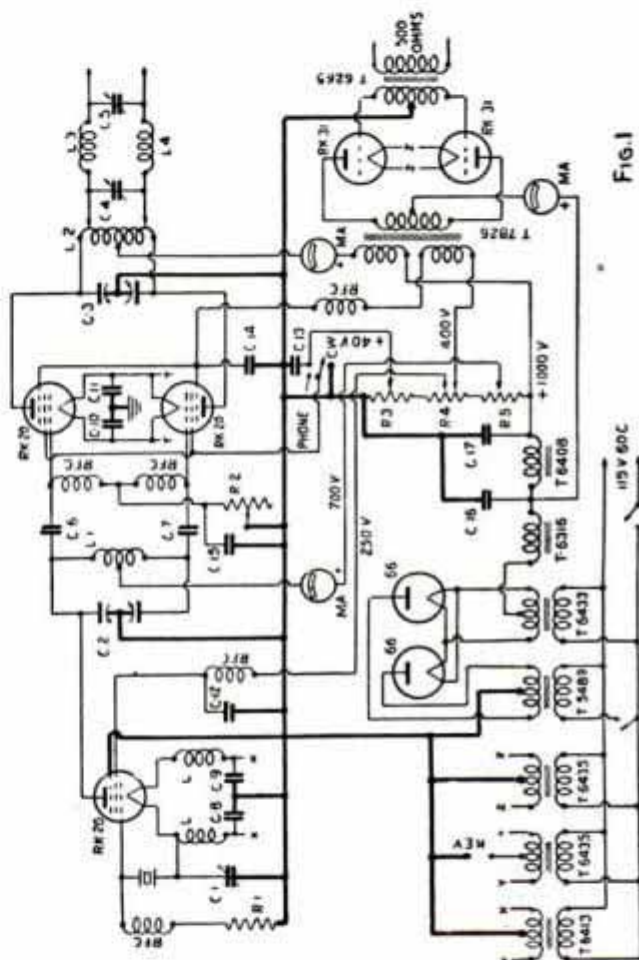

FIG. 1

carry both the plate and screen current. An original material list of all parts used, including coil data, rack-and-panel construction details and tuning instructions is available from Popular Mechanics radio department without charge. The blueprint number is R-231.

Although this transmitter is not intended for beginners, the assembly is quite simple and adjustments are easy. A single power supply mounted on base A, furnishes plate and screen voltage to all tubes as indicated in Fig. 1. Any good 18-watt speech amplifier may be used for phone operation; a compact unit of suitable design will be described in an early issue.

WITTE DIESEL ENGINES

The unbelievable economy of the small Diesel has revolutionized power costs. With a Diesel, power bills are only a fraction of their former size. Where power is used 800 hours or more a year install a WITTE Diesel Engine and it will soon pay for itself.

EFFICIENCY UP --- POWER COSTS DOWN

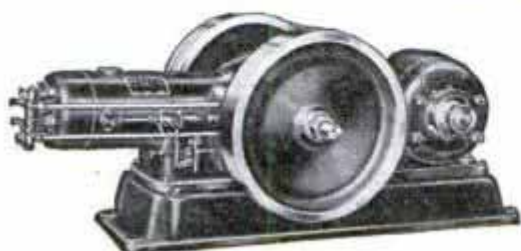

DIESEL LIGHT PLANTS

Light and power users save 50% and up with a WITTE Diesel Light Plant. No peak load or stand-by charges. Current produced for less than 1c per kilowatt. Money saved every hour of operation. Alternating or Direct Current.

2 to
10 H-P

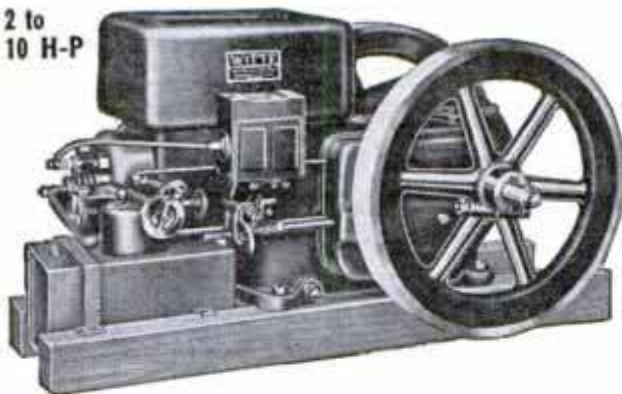

WITTE LOG AND TREE SAWS

"Saws 'em down and cuts 'em up." There is money for you to make with a WITTE, timber to be cleared, logs to be cut, wood supplied for fuel. WITTE outfits have safety lever clutch control, saw guide, automatic force feed, human arm swing and other exclusive features. Portable as a wheelbarrow. Engine may be belted to other power for year around use. Buy from a reputable firm.

FREE CATALOG—CASH or TERMS—QUICK DELIVERY

**NO-EXPLOSIVE FUEL
FIRE HAZARD**

**CASH or
TERMS**

5 and 10
H-P



The WITTE Diesel has the same important features and operating characteristics of the most modern large Diesels, and brings to the small power user the same startling economy and dependability. Fuel consumption is less than one-half pint of non-explosive fuel per hour per horse-power.

Thoroughly modern in every respect, the WITTE incorporates every worth-while advance in Diesel Engine design. Built of the finest materials ever embodied in Diesel Engine construction. Switch to WITTE Diesel power and **save your money**. Easy terms to responsible parties—immediate delivery.

WITTE GASOLINE ENGINES

TYPE "J" ON WOOD SKIDS

Where the amount of power used does not warrant a Diesel Engine our Type "J" on wood skids or Type "K" on iron base is recommended. They are Enclosed, Self Oiling and have Timken Roller Bearings. Operate on gas, gasoline, kerosene or distillate. Lubrication is automatic. Run smooth as an electric motor. Consume less oil and fuel and deliver more power. Pronounced by experts years ahead in design and construction. Buy your power equipment from a power specialist. Try a WITTE and profit.



**USED BY THE
U. S. GOVERNMENT**

The WITTE cuts logs into fire wood, cord wood, fence posts, cross ties and shingle butt lengths. It is the best sawing outfit ever built. There is no other saw like it.

215-K So. 2nd St.
HARRISBURG, PA.

WITTE ENGINE WORKS

1748Oakland Avenue
KANSAS CITY, MO.

Uncle Sam's Forest Fire Fighters

(Continued from page 699)

lons of water on their backs and a dinky hose to fight a raging forest fire sounded ridiculous, but it was learned that fifty men carrying five gallons each can put out a lot of small fires that could quickly develop into big ones. And when one of the high-pressure pumps comes into action, efficiency in quenching the flames is decidedly stepped up. The pack units of water are used in 'mopping up' after the fire has been brought under control."

On duty the year round are 801 rangers and 149 superintendents. In the fire-hazard months of the spring, summer and fall, 2,599 trained fire guards are on duty. In addition, 81,770 boys from 481 CCC camps in national forests are on constant call. Furthermore, forest rangers in any state have a right to call on the common citizen in time of emergency. However, this is seldom done. This major defense line protects 160 national forests comprising 203,082,847 acres. Almost every forest has a superintendent with a trained crew of rangers under him. Every square foot of his park is covered by strategically placed observation towers. If roads and terrain are suitable, headquarters is supplied with water trucks and pumps and the superintendent is in radio communication with the nearest of the fifty-five airports. Each observation tower is equipped with telephone and radio as well as an "Osborne fire finder," an amazingly ingenious device for locating fires. It has on its surface a small replica of the map that always hangs in the superintendent's office. A small blaze located through one of these finders presents a fairly accurate determination of its location, and when two or more different stations report the same fire, which is almost invariably the case, the determination is accurate down to almost the square inch. Furthermore, rangers carry portable radio sets.

The highly efficient radio communication system of over 1,500 stations was almost wholly developed by research engineers of the service who maintain over twenty-five laboratories and workshops. These laboratories have developed and invented the brush-cutter as well as the motor pump dropped by means of a parachute from an airplane. The latter can

pump water 2,000 feet and deliver it at 200 pounds nozzle pressure, but weighs only forty-six pounds.

Another remarkable device, the "fire predictor," has just been put into use. After painstaking data on fires had been compiled during five years of experimentation a mathematical wizard evolved the "predictor." Taking into consideration such factors as location, type of timber, weather forecasts, visibility, time of year and other elements, the highly dangerous zones can be accurately indicated.

When a fire gets out of hand, the weather bureau is called to help. A truck, complete with meteorological and weather-forecasting devices, as well as sending and receiving radio station, goes to the scene. In fighting a widespread conflagration, knowledge of forthcoming thundershowers or changes in wind is important. Such news is radioed to the fire bosses who shift their lines of attack accordingly.

Despite laborious research work, only one chemical has been found that can be used to good effect in fire fighting. It is a form of carbon dioxide, known as a "fire foam." The main difficulty has been to get any chemical to stick on trees—the wind soon dissipates it. However, the introduction of licorice, of all things, has proved successful in making the carbon dioxide adhere. The combined mixture comes out of the nozzle like a white plume and sticks to whatever it hits. The service hopes to further improve its chemical equipment, and experiments involving hand and motor pumps, extinguishers and chemicals, are being conducted.

Mr. Godwin urges precaution on the part of citizens in preventing disastrous fires. Over half of last year's blazes were caused by careless smokers, campers and incendiaries, natives with fancied grudges against the service, or just plain "fire-bugs." The total destroyed area was about one-third of the total area of all the state parks in the United States.

Where is the danger of forest fires the greatest? Mr. Godwin says it is unquestionably the Montana-Idaho area. The region is very wild, in many parts inaccessible, and the dense covering of thickets makes blazes hard to control.



★ ★ ★ ★
IT'S HERE!

THE BIG
BLUE RIBBON
RADIO
CATALOG

YOURS FOR
THE ASKING
FREE!

NEVER before has Wholesale Radio Service Co., Inc., gathered between the covers of one catalog such a tremendous collection of values in radio products. Hot off the press . . . this new catalog will open your eyes. With its 5 warehouses, its overwhelming purchasing power, "RADIO HEADQUARTERS" makes **TREMENDOUS SAVINGS POSSIBLE!**

**THE WHOLE WORKS IN
 RADIO! MORE THAN
 150 PAGES...50,000 ITEMS
 OVER 2500 ILLUSTRATIONS**

Chockful of data, handy, interesting, this catalog is a valuable reference work in addition to the **CASH SAVINGS** it offers. To the experimenter, building his own set, it brings individual parts or complete kits . . . to the amateur, "Ham" accessories at unbelievable savings . . . to the serviceman, a prompt and reliable source of **QUALITY PARTS**. To the radio "fan," a complete selection of receivers . . . from the four tube A.C.-D.C. compact



to the powerful 24 all-metal tube console, fit to grace an emperor's palace . . . from the 32 volt farm receiver to the special LAFAYETTE auto radio. Prices range from \$7.95 up.

BUILDING YOUR OWN?

When building your home receiver or Popular Mechanics radio circuit, be sure to use approved "BLUE RIBBON" Wholesale Radio Service Co., Inc., parts. They are the best obtainable! **Nothing is accepted by our research engineers which does not meet our exacting requirements.** This is your assurance of complete satisfaction when you "Buy Wholesale."

CLIP THIS COUPON—TODAY!

WHOLESALE RADIO SERVICE CO., INC.
 Dept. L7, 901 West Jackson Blvd.
 Chicago, Ill.

Please RUSH me your BIG, FREE Blue Ribbon Radio Catalog.

NAME

STREET

CITY STATE

WHOLESALE RADIO SERVICE CO. INC.

CHICAGO, ILL. • NEW YORK, N.Y. • ATLANTA, GA.
 901 W. JACKSON BLVD. • 100 SIXTH AVENUE • 430 W. PEACHTREE ST. N.W.

BRONX, N.Y.
 542 E. FORDHAM RD.

NEWARK, N.J.
 319 CENTRAL AVE.

When writing to advertisers please mention Popular Mechanics

Weather Made-to-Order for the Movies

(Continued from page 709)

combines the fumes of an acid and ammonia. The fog is conveyed to various parts of the setting by secreted tubes. The volume and density are controlled by the amount of air pressure.

In some outdoor settings where fog effects are needed and the settings are too large to inclose with walls, Redmond has developed a system of "laying" down a smoke wall which prevents the artificial fog from drifting away. The dense smoke wall is made with chemicals and hangs suspended long enough for the scene to be filmed. After the smoke walls are built up the fog is filled inside.

Snowstorms are made by sprinkling unbleached potato chips, corn flakes, or ground chicken feathers, according to the kind of storm needed. The "snow" is placed in drums two feet in diameter and four to sixteen feet in length situated above the setting. The drums which are revolved are made of wire screen, the mesh of which governs the kind of storm produced.

To simulate the early morning vapor which rises out of a meadow, "Dry Ice" is dropped in pans of water secreted about the setting. The vapor photographs very realistically. For snow on the ground, marble dust is used over which is sprayed silicate of soda to get the proper glistening effect. Corn meal ejected from special blowers makes a good sleet storm.

The sun's rays are fabricated by throwing a beam of incandescent light into the setting. Into the beam, ground mica is puffed to make a floating dust effect so the beam will photograph better. The sun's rays from reflected water which dance on the walls in ship scenes or water-front settings are made by throwing a beam of light into a polished pan containing a small amount of water. The jiggle and dance are gained by thumping the pan to agitate the water.

Fires which will burn in a prearranged manner are produced with special tools and chemicals. Fire is projected in shooting flames by what is known as a "fire head" for scenes where the entire setting is not to be destroyed or "spot" fires are required. A mixture of gasoline and oils is placed in a drumlike device into the head

of which is inserted a large hand pump and controls. Leading from the drum is a manifold with a series of jets to which is connected copper tubing to carry the oil mixture to the desired places. The outlets are so placed that the confusion of shooting flames gives the illusion of a roaring fire. The size of the flames is controlled by valves behind the outlet jets. While one operator works the pumps to force the liquid into the pipes, a second controls the size of the fire at various points by manipulating the valves. To prevent a fire from destroying the entire setting, the woodwork is first soaked with water which permits the burning oil to cling to the wood and other parts of the setting although it does not ignite the materials of which the set is constructed. Some studios also fireproof the sets, or paper them with asbestos. By varying the oil mixture the flames can be timed to burn a certain number of minutes.

Explosive fire effects are produced by "shooting" pyro aluminum dust into a gas flame with a bellows or by air pressure. When an actor throws something and a little puff of dust is seen, the effect is gained by a compressed-air line and fuller's earth. When he dives through a flaming window, the flames are so controlled and timed that when he is actually going through the window there are no flames, although the action is so rapid the audience does not notice their absence. A trigger valve controls the duration of the flame so that when the actor jumps the flames can be shut off. However, some of the stunt men wear asbestos suits and actually dive through flames.

In every film the special effects department is called on to produce or fabricate some illusion. Things as simple as the burning of a flashlight require special mechanical and electrical equipment. Ordinary flashlights do not give enough light so a shell of a flashlight is converted into a movie flashlight. A fifty-candlepower automobile headlight globe is used which gets its juice from twenty-four flashlight batteries carried in a vest under the actor's clothing. The batteries are connected to the light by a wire which runs up the actor's coat sleeve.

New Belt Sander!

A New "DELTA" Universal Sanding Machine

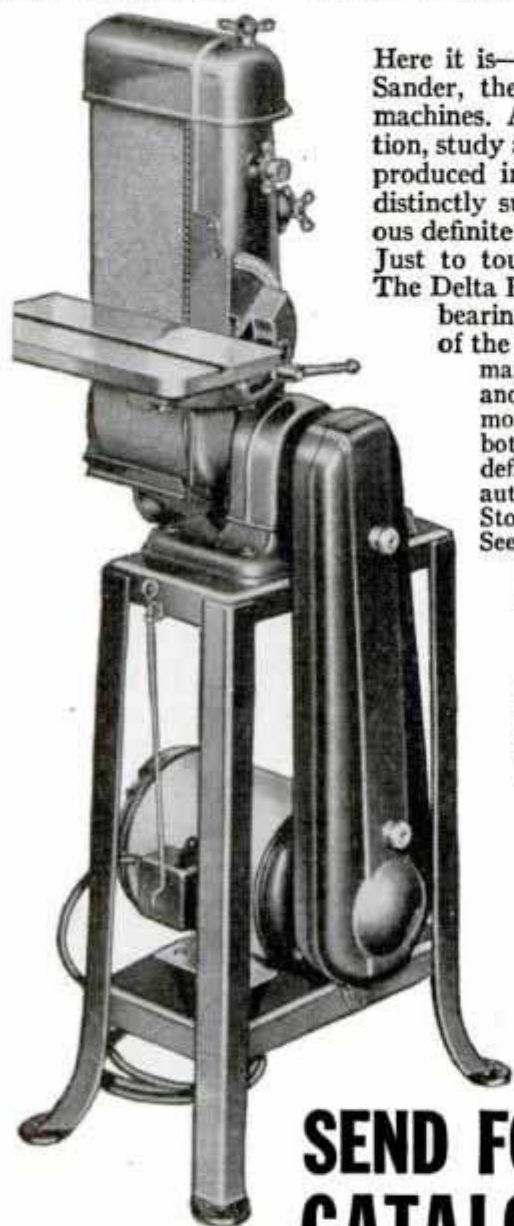

Here it is—the long awaited Delta Belt Sander, the very last word in sanding machines. As usual, careful experimentation, study and developmental work have produced in this Delta Quality Tool, a distinctly superior machine with numerous definite advantages and new features. Just to touch a few of the highlights: The Delta Belt Sander is completely ball-

bearing equipped, with all bearings lubricated and double sealed for the life of the bearing. It has a very large diameter driving drum which makes possible maximum power transmission, the sanding of long large pieces without interference, and eliminates need for rubber coverings. It has a 6 inch sanding surface. Is the most properly guarded and safest sander on the market today. Operates in both horizontal and vertical positions. Provided with efficient dust and shaving deflector with arrangement for suction fan. Tilting Table, Automatic Stop that automatically squares tilting table. Auto-Set Miter Gage, Adjustable Back Stop, Adjustable Fence, Lapless Sanding Belts, all available for this machine. See latest Delta Catalog for full details.

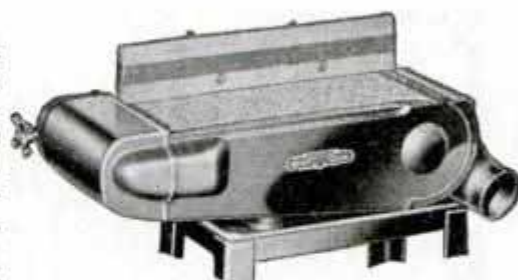

Many NEW FEATURES — NEW TOOLS in 1937 DELTA "Quality" Line!

Every man interested in motor driven tools for home or factory should see the new 1937 Delta Catalog. No pains have been spared to make the latest Delta tools the most complete and efficient line of low-cost motor-driven units ever presented.

New "DELTA" 17 in. Drill Press

It is difficult to describe even briefly the chief features of this revolutionary new drill press. Five Speeds, Double Sealed "lubricated for life" Ball Bearings, Special Inverted Spline Spindle, Special Quill, Large Tilting Table, New Type Foot Power Feed—these are but a few of the scores of features that make this new Delta Drill Press a triumph in tool engineering. Yes—the price is low, unbelievably low for a tool of this size, weight, and quality. Get the complete story in the 1937 Delta Catalog.



**SEND FOR
CATALOG**

And also the new 32-page book No. 3 of "Practical Delta Projects" crowded with new and "out of the ordinary" things to make—with many photographs, working drawings, and easy-to-understand illustrations. Simple, complete instructions make every project easy to follow. Every woodworker should have this book. Send 10c with coupon. 1937 Delta catalog mailed postpaid.

Important Note:

In order to eliminate conflict of trademarks in some countries, the Delta Mfg. Company of Milwaukee, Wis., U.S.A., announces that its complete line of "Delta Quality" tools will be known henceforth as "Tauco Quality Tools" in all countries of the world except the United States and its possessions. At the same time, we wish to state that "Tauco" tools and "Delta" tools will be identical in every respect in quality of materials, accuracy of workmanship design, conveniences, size, weight, and method of construction.

DELTA MANUFACTURING CO.

600-634 E. Vienna Ave., Milwaukee, Wis.

Dept. A 1136

I enclose 10c (stamps or coin) for which please send me one copy of the new 1937 Book No. 3 of "Practical Delta Projects." Also place me on your mailing list to receive 1937 Delta catalog of quality motor-driven tools.

I am interested in Delta Tools for:

Home Shop

Industrial Use

School Shop

Name..... Age.....

Address

City..... State.....

() Check here if you are a Delta user now.

**STOP! DON'T PUT ANTI-FREEZE
IN A DIRTY RADIATOR!**



WHEN you put anti-freeze in your car, you want it to *stay* in. Don't let a clogged radiator rob you! One cleaning with Sani-Flush (it costs a dime!) will last all winter. Sani-Flush removes rust, sediment and lime deposits that clog the delicate veins of a radiator. It's easy to use. It's safe.

Just pour Sani-Flush in the radiator. Run the motor. (Directions are on the can.) Drain. Flush and refill. Sani-Flush is harmless. Cannot hurt aluminum cylinder head, water-jacket, radiator or connections. You'll find Sani-Flush in most bathrooms for cleaning toilet bowls. Sold by grocery, drug, hardware, and five-and-ten-cent stores—25c and 10c sizes. The Hygienic Products Company, Canton, Ohio.

Sani-Flush **Safe**
KEEPS RADIATORS CLEAN **NOT CAUSTIC**

U. S. Patent No. 2915459.

**BUILD IT WITH
DOENUTS**

The most amazing tire invention developed and patented by the inventor of the air wheel for airplanes. The **Musselman Doenut Cord**. Requires only 12 to 15 lbs. air. Hauls loads up to 200 lbs. per wheel. Floats over road bumps and surface obstructions. Wins coasting contests. Tire mounted on Cadmium plated steel disc wheel with adjustable ball bearings. Build any vehicle mentioned or shown with our blue print drawings at 25c each. Wheel and parts booklet free.

THE MUSSELMAN PRODUCTS CO.
6247-K St. Clair Ave., Cleveland, Ohio

SIZE 10" x 2 3/4" LOAD CAP. 200 LBS. PER WHEEL

The New Era of Railroading

(Continued from Coloroto Section)

be controlled by shutters at the front of the locomotive, regulated from the cab.

At the end of the 2,260-mile run they park the big streamliner over a greasing pit and give it about the same care you give your automobile after a week-end trip. They vacuum and scrub the cars inside and out, man the grease guns and fill the oil and water tanks. The Diesel itself they leave pretty much alone. It's good for a few hundred thousand miles with scarcely a look. And that is why the Diesel-electric is stealing the show from the steam locomotive, which can travel just as fast. It takes no less than four steam engines—a change every 500 miles—to pull a passenger train from Chicago to the coast, with many another stop for coal, or fuel oil, or water. Half-hour stops for servicing are common. The Diesel spurns relief, stops no longer than ten minutes to refuel, keeps ordinary stops within a minute's span. The "City of Denver" pauses just forty-five seconds at Boone, Ia., for change of crew. It is this saving in operating delays, and its endurance at high speed, that enables the Diesel to clip twenty-two hours from the transcontinental time of the steam trains.

Too, the Diesel economizes in fuel and water, as well as in maintenance cost. It burns a relatively inexpensive fuel oil. It needs no boiler water, thus eliminating a cost item for such railroads as the Santa Fe, which must haul water in tank cars as far as 100 miles in dry regions of the southwest.

But the Diesel-electric locomotive still costs approximately two and one-half times as much as a steam engine, and its life span is unknown. No steam locomotive has been put to the test these Diesels are meeting. A decade may prove the old iron horse supreme, after all. Meanwhile the glittering streamliner of the new era has brought speed and glamour—and passengers—back to the railroads.

Popular Mechanics Magazine does not publish the name of the maker of, or dealer in, any device described in its pages, but this information will be furnished by our Bureau of Information upon request, accompanied by stamped envelope.

New Invention WITH SUPERCHARGE PRINCIPLE SAVES GAS



AT LAST! Automotive engineers have smashed down the barriers to perfected combustion! The new VACU-MATIC solves the secret of greater power! With almost magical action, this amazing invention instantly puts new life and pep in any motor. It adds mileage to every gallon of gasoline . . . produces split-second pick-up, sensitive accelerator response, quicker starting, greater speed and smoother running.

Automatic -- Nothing Like It!

The self-starter — four wheel brakes — knee action — streamlining . . . and now VACU-MATIC! The sensational money saving invention! With it, engineers have achieved a practical means of balancing air and gasoline automatically for all speeds.

VACU-MATIC is *entirely different!* It operates on the supercharge principle by automatically adding a charge of extra oxygen, drawn free from the outer air, into the heart of the gas mixture. It is entirely AUTOMATIC and allows the motor to "breathe" at the correct time, opening and closing automatically as required. No idling troubles—no carburetor adjustments necessary. It is so simple it will amaze you —so practical it will save you many dollars on gas costs.

USERS REPORT
3 to 7 MILES MORE PER GALLON
MOTORIST SAVES \$180.00 a YEAR
 "On my V-8 Ford it works miracles. Its added power, acceleration and top speed has sold me. The results are unbelievable."—Ralph Fields, Mass.
 "Very glad to say, the Buick showed an increase of 5 miles more per gallon."—A. V. Gross, W. Virginia.
 "On my Plymouth, I obtained an average of 22 miles per gallon, an increase of 7 miles. This means a saving of \$15 a month or \$180 a year."—F. S. Peck, California.
 "It saves me one gallon a day—now only 4 gal. buy 3 gallons each day."—L. V. Sweet, Pa.
 "I have twelve VACUMATICS on cars now, and they all show an increase in mileage. The car owners are very well pleased."—Fred Taylor, Okla.
 "I have been using VACU-MATICS on export mechanics' cars. All are well pleased."—J. W. Donahoe, W. Va.

Guaranteed Gas Savings

VACU-MATIC proves itself on every car. It is guaranteed to give worthwhile gas savings, quicker pick-up, and more power or it costs you nothing. You can instantly tell the difference in added power and motor performance — you quickly notice the cash savings on gasoline.

Fits All Cars

VACU-MATIC is constructed of six parts, assembled and fused into one unit, correctly adjusted and *sealed at the factory.* Nothing to regulate. Any motorist can attach VACU-MATIC in ten minutes. Once in, its only reminder is the surge of instant power and speed it gives to the motor and the savings it affords your pocketbook.

AGENTS & SALESMEN

VACU-MATIC offers a splendid opportunity for unusual sales and profits. Valuable territories now being assigned. Check and mail coupon.

Free Details

You owe it to yourself to know all about this remarkable discovery. Mail the coupon below. Start saving gas with VACU-MATIC and enjoy a new driving thrill! There's no obligation—so get the facts now! Write today!

FREE OFFER COUPON

THE VACU-MATIC COMPANY

7617-251 W. State St., Wauwatosa, Wis.

Gentlemen: Please send me full particulars concerning the VACU-MATIC and details of your Free Offer. This of course does not obligate me in any way.

Name

Address

City

State

Check here if interested in selling proposition.

The VACU-MATIC Co. Wauwatosa, Wis.



Trappers!

FREE \$4,500.00 IN AWARDS

INCLUDING \$1,000 FIRST AWARD; ALSO PLYMOUTH CAR for correct pelt preparation in Sears 8th National Fur Show. Every fur shipped to Sears is considered, and you don't even have to sell your furs through Sears. **You** may easily win because only the handling counts, not kind or value of skin. All awards are *in addition* to full value of your furs.

FREE Book Tells How you may share in awards. Tips to Trappers pictures and names last season's winners. Your friends are probably included. Tells how Sears act as your agent without charge to you, getting you TOP prices for your pelts through the world's largest centers. Describes strong demand for furs—HIGHER OPENING PRICES this season! Get your FREE copy.

MAIL COUPON NOW

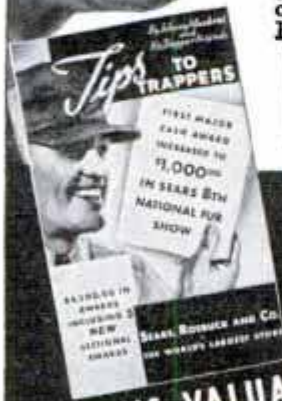

GET THIS VALUABLE BOOK—IT'S FREE!

Mail to point below nearest to you:
SEARS, ROEBUCK and CO.
 Chicago—Philadelphia—Memphis
 Dallas—Kansas City—Seattle

Please mail me, without cost or obligation, fur shipping tags and latest edition of "Tips to Trappers."

Name

Post Office

Rural Route

Street Address

State

Box No.

35P241

"GROW LEGS"
with genuine
WOOD in cans



Apply Plastic Wood to the uneven leg, set the piece of furniture on the floor, press down on it until it feels even, take off excess Plastic Wood around edges, let dry, then sandpaper smooth.

MAKES 1001 HOUSEHOLD REPAIRS

Genuine Plastic Wood makes household repairs so easy and simple—use it to fix broken furniture, cracks in shelving, cracks in baseboards; holes around pipes, reset loose bathroom fixtures, loose handles, leaky window frames, boat repairs, cover counter-sunk screws; under paint, modeling decoys, fish lures, resetting loose tiles, etc.

EASY TO USE

Genuine Plastic Wood is real wood in soft putty form—when dry it is hard wood that can be carved, sawed, turned on lathe; will hold nails and screws without cracking, splitting or crumbling. Genuine Plastic Wood is waterproof and weatherproof—adheres to any clean, dry surface—comes in nine colors including white—takes paint varnish and lacquer perfectly.

Get your can or tube of Plastic Wood at leading paint or hardware stores—insist on



PLASTIC WOOD

DO YOU

WANT a new business profession of your own, with all the trade you can attend to? Then become a foot correctionist, and in a few weeks earn big income in service fees,—not medical nor chiropody—easy terms for home training, no further capital needed, no goods to buy, no agency. Established 1894. Address Stephenson Laboratory, 1 Back Bay, Boston, Mass.

Run Your Own Railroad!

The Model Railroader, a monthly magazine, will help you plan, build, and run a miniature railroad in your own basement, attic, or backyard. Enjoy this fascinating hobby and get acquainted with other model rails throughout the country. Get started now! Send \$1.00 for a package of 7 recent back issues containing car and locomotive plans, construction details, photos, and articles. Or \$1.50 (\$1.60 Canada, \$1.90 foreign) for a year's subscription; sample 15 cents.

THE MODEL RAILROADER

Box 196-M

Wauwatosa, Wis.



Amplifier for Sound Effects

(Continued from page 739)

contact Amphenol tube sockets are used without metal adapter plates, being held in position by means of their retainer springs under the base instead of screws.

All four of the Jefferson transformers are fully shielded and provided with color-coded leads which are brought out

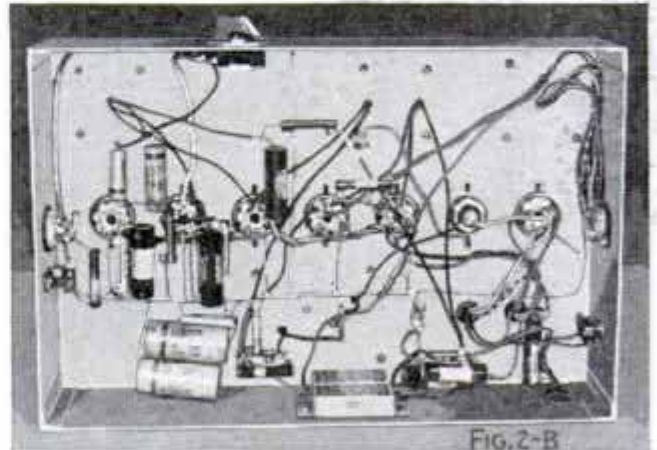

Fig. 2-B

through holes drilled in the metal base for sub-panel wiring. A drilling template for this chassis base is shown in Fig. 3, indicating the correct location and size of all mounting and lead holes, with the exception of a $\frac{3}{8}$ in. hole for mounting the potentiometer R_5 . It should be located at front, midway between the input and driver transformers. This metal base is available in a black crackle finish with all socket mounting holes cut, for those who do not wish to make their own; also an optional perforated metal cover for protecting the parts. The base lists for \$2.00 and the cover \$3.00 subject to the usual 35 to 40% discount offered to experimenters. An original list of all parts used can be obtained upon application to Popular Mechanics radio department, without charge. The blueprint number is R-230.

Photos 2-A and 2-B show the simple arrangement of all parts. Looking at the top-view photo 2-A, the transformers and chokes are located as follows: front, left to right, input, driver and output transformers; rear, left to right, choke No. 2, choke No. 1 and power transformer. Twist all heater leads and solder each tube socket connection carefully. Note that the electrolytic condenser C_6 is insulated from the base, the negative side being grounded through resistor R_3 . Fiber terminal strips

(Continued to page 136A)

BIG MONEY ASSEMBLING AT HOME

KI-YAKS ICE BOATS MOTOR SLEDS



— from Mead's, complete "cut-to-fit" kits at amazing low cost. **Ki-yaks:** 3 sizes for paddling or sailing. Also outboard model. Fast, seaworthy. Lift with one hand or take anywhere on auto. (Complete sail rig a few dollars extra.)

PRICED LOW PAY AS YOU BUILD!
IDEAL FOR CHRISTMAS

WINTER SPORTS. Start now on your Ice Boat or Motor Sled and be ready for first freeze or snow. New models, easy to assemble. Rush 10c for circulars and \$6.00 gift paddle offer on Ki-yaks. Hurry!

MEAD GLIDERS
15 S. MARKET ST. DEPT. B-11 CHICAGO, U.S.A.

FREE ELECTRICITY From Wind Power



For Lights, Power, Radio, from Auto Generators. New Copyright Book with over 100 Facts about Wind Chargers. Wind-Propellers—Generators—Plants—Batteries. Answers all questions you should know. Including plans for 6 or 32 V. Plant. Send 25c for plans, facts and catalog. **Agents Wanted. CURRIER MFG. CO. 405 Terminal Minneapolis, Minn.**

MATCHES ALWAYS DRY!



—If you carry a Marble's water-proof match box in your pocket. Absolutely water-proof —holds supply for several days. Made of seamless brass, 3/4-inch in diameter. Only 60c at your dealer's, or sent postpaid. Get one today. Write for complete FREE Catalog.

Marble Arms & Mfg. Company
578 Delta Av. Gladstone, Mich. U.S.A.

SAVE MONEY ON YOUR TRAILERS

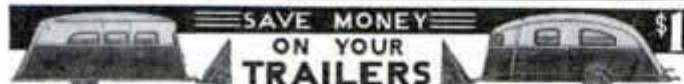

Book of 10 models, with complete plans and instructions on one model. Mail a dollar to D. VAN OOSTVELDT, 111 MARSTON, DEPT. 55, DETROIT, MICH.

DEAFNESS IS MISERY



Many people with defective hearing and Head Noises enjoy Conversation, Movies, Church and Radio, because they use Leonard Invisible Ear Drums which resemble Tiny Megaphones fitting in the Ear entirely out of sight. No wires, batteries or head piece. They are inexpensive. Write for booklet and sworn statement of the inventor who washed himself deaf.



A. O. LEONARD, Inc., Suite 699, 70 5th Ave., New York

JIG SAW \$1.50

COD or outside U.S.A. \$1.75



Including 12 assorted blades, Adapters, Puzzle Instructions, and roller Saw Guide formerly found on expensive machines only. All metal, 15" long, 8" high, 6 1/2" table. A swift and easy cutter—best ever made for the money.

"The Jigmaker" cuts wood up to 2" thick

FREE Catalog illustrating complete power tool line: Shaper, Circular Saw with oilless bearings, \$3 each; Drill Press, \$2.50; completely equipped Lathes, \$2 & \$3; Sander, \$1, etc. All practical tools for real work. Order today or send card for catalog.

J & H Metal Products Co. 5 Commercial St. Rochester, N. Y.

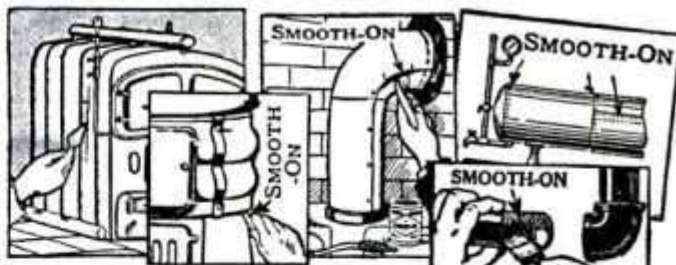

BE THRIFTY! Do your own repairing with SMOOTH-ON No. 1

THIS cement hardens into metallic iron, costs little, is easy to apply and makes dependable permanent and emergency repairs that save the householder big sums.

By following directions in the Smooth-On instruction booklet you can stop steam and water leaks from joints or cracks in the boiler, heater, piping and radiators, stop leaks from gas lines, stop leaks of fumes from air furnaces, ovens and smoke pipes, in every instance avoiding a big labor bill and often the cost of a renewal part.

Smooth-On No. 1 is also excellent for resetting loose screws, nuts, rivets, hooks, hinges, locks, handles, drawer pulls, casters, etc., anchoring bolts and pipe posts in concrete, plugging holes or seam openings in tanks, troughs and pails, tightening loose bases, etc.

Be prepared for emergencies by sending for the free book and keeping a can of Smooth-On No. 1 in your workshop. Get Smooth-On No. 1 in 7-oz., 1-lb. or 5-lb. can from any hardware store, or if necessary from us direct.



Write for **FREE BOOK**

SMOOTH-ON MFG. CO., Dept. 37, 574 Communipaw Ave., Jersey City, N. J.

Please send the free Smooth-On Repair Book.

Name.....
Address.....
11-36.....



Do it with SMOOTH-ON

When writing please mention Popular Mechanics

1937 RADIO CATALOG



**YOU'LL FIND EVERYTHING
IN RADIO IN THIS BIG
ALLIED CATALOG
AT LOWEST PRICES!**



**FREE
SEND
COUPON**

**833 W. JACKSON BL.
CHICAGO - ILLINOIS**

Everything in Radio

1937

KITS
PARTS
AMATEUR
P. A.
TEST
EQUIPT
SETS
TOOLS
BOOKS

SAVE MONEY with This 1937 Radio Catalog

Write for the big new 1937 ALLIED Radio Catalog. 152 pages packed with Everything in Radio—new Metal Tube radios—5 to 19 tubes—AC, battery, 32-volt, 6-volt and auto sets; dozens of new Set-Builders' Kits; everything in Short-Wave Receiving and Transmitting Equipment; new Public Address systems; also thousands of exact duplicate and replacement parts, radio books, tools and latest test equipment.

**Why your Dollar buys
More at ALLIED**

Because we buy in vast quantities, we get lower prices, and can sell for less. Every item is tested and approved by ALLIED'S expert engineers. Fresh, clean stocks, all under one great roof—your order shipped promptly. We save you time and money.

Free PARTS LISTS

Write to us for Free parts lists covering 1 Tube AC-DC (R209); 2 Tube Battery Portable (R211); 4 Tube Battery Portable (R223); 6 Tube Battery (R224); 3 Tube All Wave (R226); One Tube Suppl. Flashlight Cell Set (R227); 1 Tube Aid Amplifier (R229); etc. We can supply matched kits for building any Popular Mechanics circuit.

ALLIED RADIO

833 W. Jackson Blvd., Dept. 5-L
Chicago, Ill.

Send me FREE 1937 ALLIED RADIO CATALOG.

Send me FREE Parts List for.....

NAME

ADDRESS

CITY..... STATE.....

(Continued from page 134A)

are used for convenience in wiring and help to support some of the fixed resistors and condensers.

Common ground connections are made to the heavy lead shown in Fig. 2; this consists of No. 12 bare tinned-copper bus-bar wire, the actual ground point being at the soldering lug on the mounting screw of choke No. 1. Ordinary wafer-type sockets are used for the speaker-cable plug and input sockets. The open-circuit input jack has a grounded mounting and was added for convenience when plugging in a crystal microphone. Your phonograph pick-up leads should be connected to a standard plug at the prongs indicated for input channel No. 2. Shield-

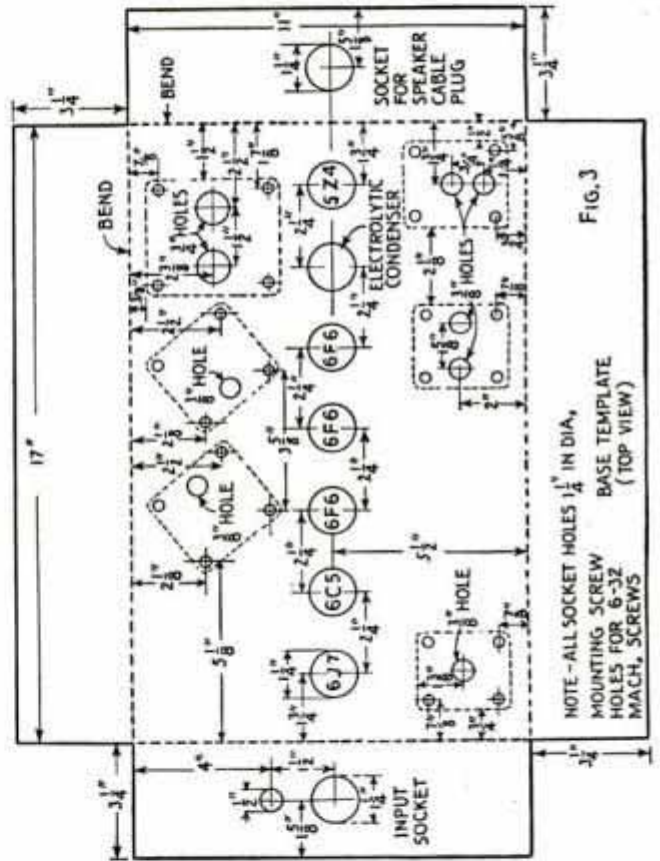

ed leads must be used where indicated, to prevent hum pick-up. The speaker, or speakers, may be any good self-powered dynamic type; a Wright-DeCoster unit was used in our laboratory tests. Note that the speaker socket provides a wide choice of voice-coil connections, one connection being made at common black and the other to the resistance value specified for your speaker. A separate 500-ohm outlet is provided for those who wish to use the unit as a speech amplifier for an amateur radiophone.

ALL PURPOSE
MOTO-TOOL



10 DAY MONEY BACK TRIAL

Grinds, drills, engraves, routs

carves and speedily does many other slow hand jobs for home, school or shop. Strong, powerful, yet handles as lightly as a pencil. Weighs 6 oz. Plugs in any light socket A. C. or D. C. 110 V. universal motor. About 18,000 R.P.M. Efficiently cooled. Universal collet chuck. Oilless self-aligning ball thrust bearings. Order on 10 day money back trial or send for free complete Moto-Tool booklet.

Utility Tool Set of 20 general accessories for all types of Moto-Tool work, \$5.75.

DREMEL MFG. CO.
2811-CT., Racine, Wis.

ONLY \$9.85
SENT POST PAID

GET YOUR TRACTOR AT FACTORY PRICE



3 Speeds Forward and Reverse. Runs 4 to 8 hours per gal.

Amazing money maker for farms, truck gardens, orchards, nurseries, poultry ranches, country homes, etc. Plows, discs, harrows, cultivates, mows lawns, cuts weeds. Runs belt machinery. 2 to 5 H.P. riding or walking types. Write for **FREE CATALOG, Low Factory Prices and 10 day Trial Plan.** Address *Nearest Office.*

SHAW MFG. CO., 4511 Front St., Galesburg, Kans.
130 G West 42nd St., New York, N. Y., 5812 G Magnolia Ave., Chicago, Ill., 688 G North 4th St., Columbus, O.

SHAW DU-ALL TRACTOR



\$9.95

2 Cub. Ft. **PRESSURE TYPE SPRAY GUN** with two fluid tips and two outer caps—fan and round spray—quilt clamp-on cup of spun aluminum \$7.45. **Metal cutting LATHE** 5x18 in.—bronze bearings—compound slide rest—No. 0 **MORSE TAPERS** \$7.95 (Screw feed Lathe 6x12" \$9.95 6x18" \$10.95). **AIR FILTER** for use with spray units \$1.25. Send for catalog. **V-Belt Free with Lathe.**

BALKO ELEC. MOTOR & SUPPLY CO., Dept. A-9, 10 S. Clinton St., Chicago, Ill.

ONE-MAN SAWMILL

Makes lumber, shingles, lath, ties, crates, boxes, cases, all forms lumber

TURN TREES INTO MONEY WITH BELSAW

Three capacities: 10, 14 and 20 ft. Accurate set works positive dogs. Full or one way type power feed runs on low power—Many owners use old auto engine. Pays for itself quickly—thousands in commercial service, everywhere. Write for free lumber handbook and catalog of mills, supplies, tools, saw tables, and woodworking equipment.

Belsaw Machinery Co., 811-X Davidson Bldg., Kansas City, Mo.

FARM MODEL \$49.00

PARTS for the POPULAR MECHANICS FAMILY TRAILER

Everything you need! Axle, Tongue, Hitch, Wheel Housings, Wood Parts, Tank, Sink, etc. Send for price list. Includes 25¢ (coin) for our big Catalog and Trailer Builders' Manual. Satisfaction guaranteed!

TRAILER SUPPLY CO., Box A, Wausau, Wis.



1/30 H.P. UNIVERSAL WESTINGHOUSE MOTOR

Use for Grinding, Polishing, Drilling, Sewing Machines: a general purpose sturdy Motor. Operates on 110 volt, AC or DC, 2000 R.P.M. Height—3 1/4 in., Length—5 1/4 in., Width—3 1/4 in. Shaft 1/4 in., one inch long. Furnished complete with detachable Arbor and 1/4" Chuck, or Motor only.

Motor complete with Arbor and 1/4 in. Chuck.....\$3.95
Motor Only.....2.95
Arbor and 1/4 in. Chuck.....\$1.00
1/4 in. Pulley......25

Plus 25¢ Postage delivered anywhere in the U.S.A. Net Weight 2 lbs. Shipping Weight 3 lbs.

NATIONAL ELECTRIC TOOL CO., 560 Washington Blvd., Dept. 311, CHICAGO, ILL.



Men Wanted at Once

Make Money Calling on Stores

New occupation. Pays big money at once without investment. Introduce sensational new line 5c and 10c necessities to stores. Self sellers. Permanent repeat business easy. Experience unnecessary. Start free. Write

PRO-CO-PAX

Dept. 25-E
1956 S. Troy
CHICAGO



Sensational BARGAINS

Brand New Portables

VERY LATEST FEATHERWEIGHT MODEL

Now Only 10c a day ON EASY TERMS

SEND NO MONEY—FREE TRIAL



Here at last—is the perfect family portable—the most revolutionary achievement in typewriters. Think of it—a fully complete, FEATHERWEIGHT, streamline model with standard 4-row keyboard, standard paper roller and every essential feature, weighing less than six (6) lbs. Priced at a great saving. Positively a mechanical jewel. Not a toy or incomplete model. The only Real Portable—mechanically perfect and complete in every respect, yet so light a child can carry it with ease. Fits into small brief case or table drawer—only 23 1/2 in. high. Guaranteed to last years.

Only by actually seeing and trying this amazing portable can you appreciate its superiority. Use Special Coupon below without risk.

FREE Typing Course

SPECIAL OFFER—ACT AT ONCE!

Send for 10-day trial—without obligation to buy—while special introductory low price holds good. See and try for yourself. If you decide to keep it pay only \$37.50 cash or 10c a day on easy term plan of \$3.00 a month until \$39.75 [term price] is paid.

INTERNATIONAL TYPEWRITER CO. Dept. PH01
Franklin and Monroe Sts., Chicago

Please send the DeLuxe FEATHERWEIGHT Portable F. O. B. Chicago on 10 days Free Trial. If I decide to keep it I will pay \$37.50 cash or \$3.00 a month until \$39.75 [term price] is paid. Or, if I am not perfectly satisfied I can return it within the 10-day trial period.

Name..... Age.....
Address.....
Town..... State.....

For quick shipment give references and occupation

Step Into Your Own Business

SELL USED & NEW CLOTHING

at Money Saving Prices

From Auto, Store or Home

Thousands of men and women right in your locality are anxious to save money on the purchase of wearing apparel for themselves and their families. Under our powerful buying plan we put you in business for yourself selling used and new clothing—suits, coats, hats, ties, hosiery, shoes—hundreds of wearing apparel items for men, women and children—at money saving prices—made possible through our cash purchases of bankrupt stocks and close-outs. You operate from your auto, or your home, or open your own **BARGAIN MERCHANDISE STORE**—and quickly build a big profit, year 'round, steady-repeating business of your own.

Our Prices are Lowest! FREE CATALOGUE!

Write quick—for our FREE CATALOGUE that lists our wide assortment of quality merchandise items at prices that net you up to 300% profit. Think of it! We positively smash competition. We back you with close cooperation. End job hunting! Be your own boss in your own business. Get the full facts—then judge!

PORTNOY & SONS,
566 Roosevelt Road, Dept. 106, Chicago, Ill.

Make Up To 300% Profit

Stoves AT FACTORY PRICES!

SALE CATALOG—FREE

Over 200 Styles and Sizes of Stoves, Ranges, Furnaces at Factory Prices and Easy Terms—as little as 18c a day. More Bargains than in 20 Big Stores. New styles, new features, new colors. Year to Pay—30 days' free trial—360 days' approval test—24-hour shipments.

THE KALAMAZOO STOVE CO., Mfrs., 391 Rochester Ave., KALAMAZOO, MICH.

36 Years in Business Over 1,000,000 Satisfied Users

"A Kalamazoo Direct to You"

Write for FREE Catalog



HANDEE TOOL OF 1001 USES!

FASTER, BETTER JOBS!

Does away with slow hand work. Plugs in any light socket. A. C. or D. C., 110 volt, 13,000 r.p.m. For use at home in shop or take to job. Uses 200 different accessories—grinds, polishes, routs, drills, cuts, carves, sands, saws, sharpens, engraves. \$10.75 and up postpaid. 3 Accessories FREE.



See at Your Dealer's

★ THE De Luxe MODEL Revolutionary Performance

For constant service . . . nothing else like this easy-to-handle production tool for saving time and labor. Fastest, smoothest, most powerful tool for its type and weight . . . 25,000 r.p.m. \$18.50 postpaid. 6 Accessories FREE.

Order Either Model on 10-Day Money-Back Trial or Send for FREE Booklet.



SEND FOR Free BOOKLET

New CRAFTSMAN Project Book

"Pleasure and Profit with a Handee." Easy working plans for making many interesting and unusual projects 25c, stamps or coin.

Chicago Wheel & Mfg. Co.
1101 W. Monroe St. Dept. Q
Chicago, Ill.

MAKE MONEY NOW

PLASTEX Industries offers industrious men an opportunity to start a business of their own, manufacturing art goods, novelties, souvenirs, etc., in Plastex and marble imitation. 5c material makes \$1 articles. Rubber moulds furnished for speed production. Small investment brings big returns. You are just in time for big Christmas business now starting. Write for interesting booklet mailed free. PLASTEX INDUSTRIES, Dept. 3, 1085 Washington Ave., New York.

NEW BENJAMIN AIR PISTOLS

Powerful—Accurate—Economical—Practical—Adjustable Shooting Force—Amazing Maximum Velocity—cal. 177 or 22 and BB—For Target and Small Game—the only Genuine Compressed Air Pistol on the market—Single Shot with Bolt Action—Hammer Fire—Hair Trigger—Safety. Price \$7.50. Also 177 and 22 Single Shot Air Rifles \$7.50—Single Shot BB Air Rifle \$6.00—25 Shot BB Repeater Air Rifle \$7.50—at Dealer or Direct—No license required—Safe for indoor use. FULL DETAILS—TARGETS—FREE—WRITE TODAY. Benjamin Air Rifle Co., 691 N. Broadway, St. Louis, Mo.



\$7.50

RADIOS

ALL NEW 1937 MODELS!

SAVE UP TO 50%



\$6.98

DEAL DIRECT—FACTORY PRICES! Iron-Clad Written Guarantee!

A penny post card brings you our new, full-color 16-page BARGAIN CATALOG free. Many models to choose from: 4 to 19 tubes; AC-DC, All-Wave and new Farm sets that operate like city radios!

30-DAY NO-RISK HOME TRIAL. Send post card or coupon below for full details of our 30-day no-risk trial and Agent-User proposition!

AGENTS! A real money-making offer. Write at once for territory.

GOLDENTONE RADIO CO., DEPT. E, Dearborn, Mich.
Without obligation, send me new 1937 Catalog and 30-day trial plan.
Name
ADDRESS

NOW - MAIL COUPON



LEARN in 10 EVENINGS

You'll learn more quickly and easily to play a P-A Sax, Trumpet, Clarinet, or Trombone, because P-As are easier to blow and have such beautiful tone. Thousands in use. Strongest guarantee backed by old, reliable manufacturer. Moderate prices. Home trial. Easy terms. See your music dealer or write for beautiful free book. Mention instrument. 1248



PAN-AMERICAN
1103 P-A Bldg., Elkhart, Ind.

WILD HAIR

Quickly tamed with our highly processed vegetable oil

LUCKY TIGER HAIR DRESSING

... and Dandruff Remover Beautifies without matting and enables you to dress hair in any style. Scientifically compounded to combat ravages to the hair of modern outdoor life. At Druggists, Barbers.



POPULAR MECHANICS FAMILY TRAILER PARTS

Available from Hammerblow Tool Company—the original.

Don't build until you get Hammerblow facts. Save money, time, wasted labor. Hammerblow guarantees a rugged, non-way, perfect trailer! BLUEPRINTS FREE WITH PARTS. Hammerblow parts are world's best. Used by nationally known auto and engineers who know. Send only 50c for 64-page Trailer Builder's Guide and Free 40 page supplement. Immense value. Or write for Free Literature. HAMMERBLOW TOOL COMPANY, Dept. 111, Wausau, Wis.



GENUINE MARBLE

MONUMENT

\$9 UP, WORLD'S BEST MARBLE or GRANITE. Direct from factory. U. S. MARBLE & GRANITE CO. Dept. A-18, ONECO, FLA.

BIG FREE CATALOG

Freight Paid or Erected

Lettered, Gypsum, etc. 30% savings. Thousands a day sold. Write for Big Free catalog.

MAN IN EACH TOWN To Plate Auto Parts,

Reflectors, Mirrors, etc., by late method. Experience unnecessary. Free particulars and proofs. Write today.

GUN METAL CO., Ave. M, Decatur, Ill.

Print Your Own

Cards, stationery, circulars, tags, labels, advertising, etc. Save money. Print for Others; Big Profits; easy rules sent. Will do popular Raised Printing like Engraving. Junior press \$2.90, job presser, \$11 up, power \$149. Send for free catalog and all details. THE KELSEY COMPANY, R-37, MERIDEN, CONN.

GO INTO BUSINESS MAKE 100% TO 300% PROFIT!

Sell new and used clothing direct from your home, auto or store. Undersell all competition. EASY SALES—FAST REPEAT ORDERS! We furnish everything and show you how. Handsome profits every day in the year. No selling experience necessary. Write at once for our Big Money Catalog—It's FREE! Liquidation Merchandise Co., 550 E. 43rd St., Dept. D-16, Chicago, Ill.

COMPLETE ELECTRIC PLANTS

ONAN ALTERNATING CURRENT PLANTS furnish same as city current anywhere. Operate on gasoline. Run Radio, Water System, Refrigerator, all Appliances.

SIZES 350 WATTS UP Easy to install. Available from stock. Ideal for Farms, Camps, Lake Homes, Commercial use. Sizes for any purpose. Write

D. W. ONAN & SONS
997 Royalston Ave. Minneapolis, Minn.

When writing please mention Popular Mechanics

Learning to Fly the Clippers

(Continued from page 663)

per. The preliminary air-mail clipper service across the Pacific has been utilized primarily for the training of personnel. Six clipper ship crews already have been prepared for their difficult duties, and four of these crews will be assigned permanently to service in the Pacific division. To date, they have safely covered more than 200,000 miles without a mishap.

The flying personnel are not the only men trained especially for duties connected with the running of an ocean air line. There are scores of men in the ground crews—meteorologists, radio operators, operations men and inspectors. More and more, the air-transport business is becoming a complex organization whose activities call for the best men and the highest possible skill. Stations in such remote spots as Midway, Wake, and Guam are wholly or partly dependent upon supplies from the outside. But soon the land surrounding these newly established bases will be yielding fruits and vegetables the year round. Hundreds of tons of rich soil have been carried to the islands.

The success of this first ocean air line is largely due to the intensive training and rehearsal of the men in their assigned duties. After Captain Edwin Musick had made two round trips across the Pacific, he turned his command over to Captain Sullivan who had served under him as first officer. The other officers were also rotated from trip to trip, until six full crews had been trained for manning the twenty-five-ton Martin clippers. These men have amazed the world by the precision and near-perfection of their performance across the globe's widest ocean. When new lines shoot across the Atlantic, you will find these graduates of the ocean-flying school manning the new clippers.

Long before the twenty-five-ton Martins had begun to fly across the Pacific, the officers had been rehearsed and drilled for their respective duties. This is illustrated by a remark which First Officer Sullivan made to Captain Musick on their first actual crossing.

"Old stuff, this," said Sullivan. "We've flown this route so many times in training that I've recognized every cloud we've passed since leaving 'Frisco."

Want More Game In Your Favorite Cover?

Western-WINCHESTER
GAME RESTORATION AREA
Help Increase Wildlife!



If you have noted a decrease in the supply of game in your favorite cover, you will be interested in the Western plan to restore wild life and improve your shooting.

The Western Game Restoration Plan is based upon our own field demonstrations. Simple. Practical. Requires less time and effort than you imagine.

Start now, this Fall. Take a census of the game in your hunting area while you hunt. Then follow the instructions in the Textbook of Game Management, sent FREE! Mail the Coupon.

WESTERN CARTRIDGE COMPANY,
Dept. K-46, East Alton, Ill.
Send your TEXTBOOK OF GAME MANAGEMENT—without charge. Also full particulars of the Western Game Restoration Plan.
Name.....
Address.....
Post Office..... State.....

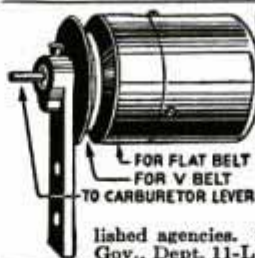

AUTO ENGINE SPEED CONTROL GOVERNORS

To control speed of any make of auto or truck engine, regardless of load changes, when used as a stationary or portable power plant. Fully guaranteed. No cash down. Governor speed range from 400 to 3000 R.P.M. Fine opportunity for established agencies. Send for free circulars. Mfrs. Candee-Smith Gov., Dept. 11-L, 215 No. L. A. St., Los Angeles, California.

FENCING World's Finest Sport Exciting Fun—Harmless



Boys! Become the best swordsmen in your neighborhood. Develops both body and mind. Harmless, because the spring-steel 3 ft. long foils are equipped with rubber buttons. Cup shaped aluminum hand guards. Complete set of two foils (sword) and free instruction booklet, only \$1.98 postpaid. Order Now.

INDUSTRIAL PROD. CO., Dept. 11M, 1182 Broadway, NEW YORK, N. Y.

Make Big Profits Filing Saws by Machine

Start in Spare Time—Earn Up to \$2 or \$3 an Hour—No Experience Needed

"Am still operating my Foley Filer after 5 years. Business better than ever this year." reports J. W. Veith, Pa. A FOLEY Automatic Saw Filer files hand, band and circular saws perfectly, quickly. No eyestrain. All cash business, no canvassing. Send postcard for FREE PLAN, no obligation.

FOLEY MFG. CO., 1116-6 Foley Bldg.
11 Main St. N. E., Minneapolis, Minn.



THREE MUSKETEERS

ATHOS - PORTHOS - ARAMIS



LOOK FOR THE LEADERS IN GROUPS OF THREE

To-day three brands of files are leading all others in ability to help hobbyists make articles of usefulness and beauty in their home shops.

NICHOLSON, BLACK DIAMOND and McCAFFREY — these three brands represent files that cut faster, leave a smoother finish and last longer.

Whether you're working in metal or wood, you'll do better work and have to buy files less frequently, if you use Nicholson, Black Diamond or McCaffrey Files. Sold by hardware stores everywhere. Nicholson File Company, Providence, R. I., U. S. A.

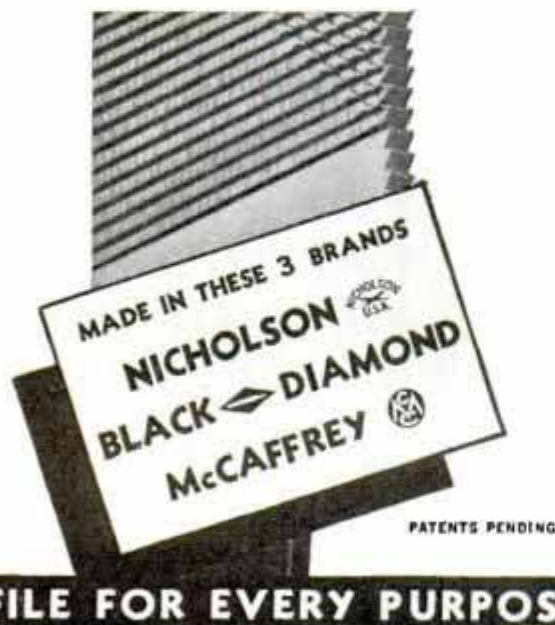

A FILE FOR EVERY PURPOSE

1961 With the Sea-Going Engineers

(Continued from page 692)

The engine room telegraph is a two-way instrument. After an engineer has carried out a command, he pulls the handle of the telegraph around to match the position of the needle that points to the order. In turn, this swings the needle of the instrument on the bridge as a report that the command has been obeyed. In addition, a private telephone system connects the bridge and engine room.

Aside from constant inspections to make sure that the engines are functioning perfectly, the engineers have an emergency system of red lights on their main instrument panels. If anything goes wrong with the water, steam, lubrication, or vacuum, the proper red light flashes. Lubricating oil flowing through each bearing spins a little metal flag projecting from the cap and as long as the flags spin attendants know the bearings are receiving oil.

When you enter one of the fire rooms of the "Monterey," you pass through an "air lock" that cuts you off from the rest of the world. The air in the fire rooms is kept under compression like the air in a deep-sea diver's suit to increase the draft in the furnaces. To enter the hermetically sealed compartment, you unlock a door leading to a small air chamber, lock it behind you, then open another door that leads into the fire room. That way, no air escapes. With both doors of an air lock open, you would hardly be able to stand against the gale of air escaping from the fire room. Each of the two huge fire rooms of the ship contains six boilers, with an air lock also separating the two rooms so the engineer in charge of one can raise or lower his atmospheric pressure without affecting the draft in the other compartment.

If the air pressure should fall off combustion would be incomplete and the ship would start to lay a dense smoke screen across the sea. The engineer in charge of each fire room can tell the efficiency of each boiler without leaving his post. Each boiler has a periscope that projects light through the gas passes of the boiler and to the instrument panel. A clear patch of light in a periscope shows the boiler fire is burning properly, while if a fire is smoking the smoke is visible in the peri-

(Continued to page 142A)

LOW COST POWER

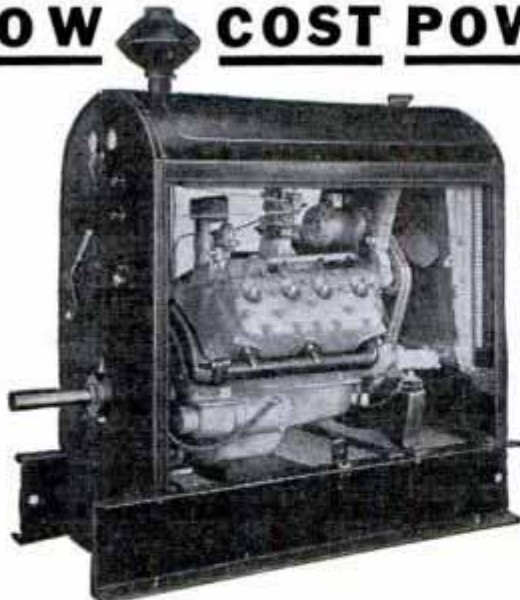

with
this
**KRW-
FORD
V-8
UNIT**

Here's dependable, low-cost power up to 60 H.P.—complete, compact, portable. Ideal for welders, compressors, hoists, pumps, amusement devices, well drillers, agricultural and contractors' equipment, etc. For complete information, prices and data showing how a K R W Unit will pay for itself out of savings in a few weeks, write us or see your local Ford Dealer.

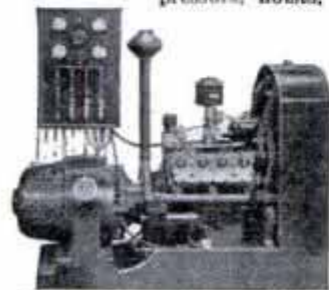

**ALSO KRW
ELECTRIC PLANTS**
110 or 220 volts—20 KW. Available also in same frame to produce single phase, three phase or direct current and also as an arc welder, plating dynamo or with pulley for power take-off. Speed 1800 R.P.M.

K. R. WILSON 17 Lock St. BUFFALO, N. Y.
EXCLUSIVE BUILDER OF APPROVED FORD SHOP EQUIPMENT SINCE 1916

**BIG NEW WOOD LATHE AT A
SENSATIONAL LOW PRICE
SPECIAL OFFER**



Turns 8 in. Diameter 36 in. between Centers. Imagine. This extra heavy wood lathe, steel bed, 48 inches long, at lowest prices. Heavy duty headstock, 3 step cone pulley for V-belt. Extra long reservoir oil bearings. Spur center and 4 inch face plate screw only spindle. Tailstock spindle has screw movement of 1 1/2 in. Tool rest 8 in. long. Priced amazingly low. Accessories include 3 step cone motor pulley, V-belt, and set of 4 turning chisels. Shipping weight 30 lbs. Send now for new FREE catalog, low prices. Not sold through agents.
BLUE STAR PRODUCTS 321 Penn Street Fairfield, Iowa.

**BURN YOUR NAME ON TOOLS
WITH THE
ARKOGRAF**

PROTECT YOUR TOOLS FROM THEFT
Write with electricity any name or design on the hardest and finest tools and instruments, or any metal, like writing on paper with pen or pencil.
Complete Outfit \$3.50—Prepaid Anywhere
Interesting illustrated circular free. Write today.
Agents wanted.
ARKOGRAF PEN CO., 3927 S.E. Stark St., Portland, Ore.

GERSTNER TOOL CHESTS
The Choice of Machinists, Tool, Die and Pattern Makers for 30 Years. Choose from Free Catalog.
GERSTNER TOOL CHESTS
459 Columbia St., Dayton, Ohio

OTTAWA LOG SAW
only \$39
**GREATEST OFFER
EVER MADE**
PUTS THIS
OTTAWA
TO WORK FOR YOU

Make Money! Wood is valuable. Saw 15 to 20 cords a day. Does more than 10 men. Ottawa easily operated by man or boy. Falls trees—saws limbs. Use 4-hp. engine for other work. Write today for FREE book.

OTTAWA MFG. CO., 1113 Wood St., Ottawa, Kansas

DISSTON

**MAKES THE SAW
to buy for your machine**



In Disston De Luxe Home Workshop Saws, you get Disston steel and Disston workmanship, of the same well-known standards, same guarantee, as the famous Disston Circular Saws used by the great lumber mills. You will take lasting satisfaction and pride in ownership of a Disston De Luxe—the finest blade made.

De Luxe Cross-Cut—Rip—Combination			
6" (1/8" hole) . . .	\$2.40	8" (1/2", 5/8", 3/4" hole) . . .	\$3.20
7" (1/2" hole) . . .	\$2.80	10" (5/8", 3/4" hole)	\$4.05
De Luxe Hollow Ground Combination			
6" (1/8" hole) . . .	\$3.90	8" (1/2", 5/8", 3/4" hole) . . .	\$4.90
7" (1/2" hole) . . .	\$4.40	10" (5/8", 3/4" hole)	\$6.20



ALSO,— your dealer has amazing values, at \$1.20 to \$2.00, in Keystone Disston-made Circular Saws! Ask to see these Keystone Saws, made by the world's foremost sawmakers. They will give you good service in your home workshop.

Keystone Cross-Cut—Rip—Combination			
6" (1/2" hole) . . .	\$1.20	8" (1/2", 5/8", 3/4" hole) . . .	\$1.60
7" (1/2" hole) . . .	\$1.40	10" (5/8", 3/4" hole)	\$2.00
Keystone Hollow Ground Combination			
6" (1/8" hole) . . .	\$3.00	8" (1/2", 5/8", 3/4" hole) . . .	\$4.00
7" (1/2" hole) . . .	\$3.50	10" (5/8", 3/4" hole)	\$5.00

In Canada, prices slightly higher

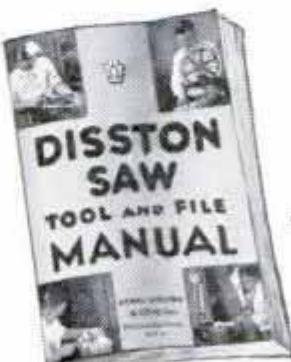

**To Give Work Speed
and Accuracy**

use Disston Saws, Tools, Files, in your home workshop. How to choose, use, care for, these fine tools, is shown in this **FREE** Disston Manual, sent

MAIL COUPON TO:

**HENRY DISSTON
& SONS, INC.**
1111 Tacony
Philadelphia, U. S. A.

Name.....

Address.....

When writing please mention Popular Mechanics

YOU'RE THERE
WITH A

CROSLEY

SUPER SENSITIVE
RADIO

**COMPARE THESE PRICES
TUBE FOR TUBE, FEATURE
FOR FEATURE, WITH ANY
RADIO ON THE MARKET**

* AUTO-EXPRESSIONATOR

Brings back the expression necessarily taken out in the studio in transmitting the program.

* MYSTIC HAND

(A. F. C.) Automatically tunes set sharply without use of meter tuning or other gadget.

♪ MAGNA CERAMIC DIAL

† VIBRACOUSTIC SOUNDING BOARD

◎ METAL TUBES

and 8 other CROSLEY FEATURES

- * * * † ◎ 15 TUBES, 44" Console, \$167.50
- * * * † ◎ 13 TUBES, 43½" Console, \$137.50
- * * * † ◎ 11 TUBES, 41½" Console, \$99.95
- * * * † ◎ 9 TUBES, 41½" Console, \$89.95
- * * * † ◎ 7 TUBES, 40" Console, \$59.95
- * * * † ◎ 6 TUBES, 39" Console, \$49.95

Prices slightly higher in Rocky Mountain States and west.



CROSLEY stands, always, as a warranty of the highest value in radio. It is only natural that the 1937 models are Crosley's greatest achievements. Beautiful . . . as near perfection as science can attain . . . and priced for you who demand the best at prices you're pleased to pay. See your Crosley dealer today . . . you will hear radio you've never heard before.

THE CROSLEY RADIO CORPORATION
Cincinnati, O. Powel Crosley, Jr., Pres.



(Continued from page 140A)

scope. In spite of the furnaces the fire rooms are usually comfortable because "mechanical lungs" are constantly breathing in quantities of fresh air to maintain the forced draft.

These days ships are equipped with brakes but the brakes aren't used to stop the ship. Attached to the propeller shafts, they are called friction clamps and are tightened around a shaft to keep it from turning when an engine is stopped for adjustment or repair. Otherwise the drive of water past the blades of the idle propeller might cause it to spin, in turn revolving the engine.

An engine room crew can make almost any kind of repair at sea without calling for outside aid. One of the worst things that can happen is the stripping of blades of a turbine. When this happens the engine is stopped and taken apart, the stripped blades cleared away, and the engine re-started. Not as efficient as before, the turbine is still able to perform part of its work. Burned-out bearings can be replaced with hardly any delay. About the only breakdowns that would put one engine out of the running are a broken tail shaft or the loss of a propeller.

Not only are the engineers in charge of the power plant, but they are responsible for the maintenance of nearly all the mechanical gear on the ship. The large refrigerating plant, the intricate electrically operated bridge controls, fire extinguishing equipment, and the lighting and ventilating systems, the elevators and telephone systems, are under their control. There are large electrical and machine shops where repair work is done at sea.

A comparative handful of trained men keeps the engines of the "Monterey" running. There are forty-eight men below decks, divided into three watches of sixteen each, which in turn spend four hours on duty and eight off. These include firemen, oilers, wipers, electricians, machinists, and other specialized trades.

"Men on board ship perform just about the same duties they would in the same trade ashore," Chief Engineer Keene says. "There is not much difference between operating the engines that drive a ship and running a stationary steam plant in a city powerhouse, except that at sea break-

(Continued to page 144A)

PHOTO ENLARGEMENTS

Is Photography your hobby? Do you want a profitable easy business at home? Make **PHOTO ENLARGEMENTS** for yourself and others. Your cost 5c each and less. The Ideal Photo Enlarger is **AUTOMATIC**. No experience required. Also **COPIES** any picture. \$5.94 COMPLETE. Interesting circular **FREE**.

5¢ ANY SIZE

IDEAL-O, 122 East 25th Street, New York City



NEW LIFE FOR LIGHT MOTORS, AUTOS, HINGES,
ACTION POINT OF TOOLS, LOCKS, ETC.
LUBRICATES—CLEANS—PREVENTS RUST

HEAT 1½¢ Per Hour!



AMAZING INVENTION—New Radiant Heater. Burns 96% air. Makes its own gas. No piping. No installation. Gives roomful of clean, healthful, penetrating heat, like sunshine, for 1½ cents an hour. Hotter than gas or electricity, at 1-10th the cost. Easy to light and operate. No smoke. No soot or ashes. No odor. Portable—carry it anywhere. **Low priced. Guaranteed.**

30-DAYS' TRIAL

Liberal Offer. Try it 30 days at our expense. Write at once for special, introductory, low-price offer and no-risk trial opportunity. No obligation. Send today.

THE AKRON LAMP CO.
1201 High Street, Akron, Ohio

AGENTS!
Make big money. New easy plan. Write quick for territory and Outfit Offer!

GENUINE ARTECO CUTTING TOOLS GIVE YOU SATISFACTORY SERVICE

SAVE UP TO 50% Now



Special Offer 6 different cutters as shown; finest steel for filing, carving, cutting, engraving on all woods, plastics, metals (1¼"x1½" shanks). Fit all hand grinders and stationary machines. Keen, sharp edges. When prepaid we pay the postage.

ONLY \$3.20 REG. \$5 VALUE

Over 500 shapes available. Largest stock in America. Dealers get our profitable proposition.

SEND FOR FREE BOOK
AMERICAN ROTARY TOOLS CO., INC.
44 Whitehall St., Dept. A-3, N. Y. City

HULL AUTO COMPASS



Don't lose time and money by taking the wrong road and going many miles out of your way. This new AIRPLANE TYPE COMPASS constantly tells your direction of travel. Sticks to windshield. Base 1¼" diameter. **ONLY \$1.95 POSTPAID**, including Compensator. **SATISFACTION GUARANTEED.**

If your dealer cannot supply you, order direct.

HULL MFG. CO., Box 246-D, WARREN, OHIO

BUILD YOUR OWN ELECTRIC OUTBOARD MOTOR

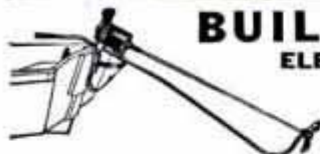

From old auto generator. We show you how. Make money building for others. Variable Speed. Light weight and Silent. Operates from 8 to 12 hours on ordinary storage battery. Dime brings complete plans and catalog.

LEJAY MFG. CO. 1547 W. LAKE MINNEAPOLIS, MINN.

Catch Fish!



Eels, Mink, Muskrats, with our new folding galvanized **STEEL WIRE TRAP**. Write for our **FREE TRAP OFFER** and Bargain Catalog. **\$1 Box** of our famous Fish Bait **FREE** to introduce our traps. **WALTON SUPPLY CO., 3509 JUNIATA AVE., ST. LOUIS, MO.**



BIG 3½ FOOT TELESCOPE Count Cattle 10 Miles away. 5 sections. 10-Power. Brass Bound. Eye-Piece for viewing Sun, **FREE**. Makes good Microscope. Postpaid \$1.90, C. O. D. 20c extra. Guar. **BENNER & COMPANY T-490 TRENTON, N. J.**

Make Money at Home!

GROW MUSHROOMS in your cellar or shed. Exclusive new process. Bigger, better, quicker crops. More money for you! Enormous new demand. We buy Mushrooms. Write for Free Book. **American Mushroom Industries Ltd., Dept. 747, Toronto, Ont.**

GIVEN AWAY



You get one—Your friends get one—without cost. Let us give you the details of this amazing Time Teller. Also it can pay you big money by showing others how to obtain without cost. Nothing to buy or sell. Write fast.

GARDEN CITY NOVELTY CO.
4318-B Ravenswood Ave., Chicago, Ill.

I WANT MEN!



Tea and Coffee Routes Paying up to \$6000 in a Week!

ROUTES Going Fast!

Hurry before someone else snaps up your locality. Look what others have reported: Whitcomb, \$146 in a week; Geisler, \$129 in a week; Ruby Hansen, a woman, \$73 in a week.

Your earnings begin at once! I'll help you start, send you a complete outfit—positively everything you need—without money risk to you. Full time pays up to \$60.00 in a week; spare time up to \$5.00 in a day.

OWN A PERMANENT ROUTE WITH BIG CASH PROFITS

Tea and Coffee Routes pay big cash earnings because people must buy foods and other necessities daily. You call on a regular list of consumers in your locality, supply their needs for over 250 food products and home necessities, take in all the cash and keep a big share for yourself. **Brand new Ford Tudor Sedans given producers as a bonus in addition to cash profits.** Complete details sent **absolutely free.**

FORDS GIVEN PRODUCERS AS A BONUS

SEND NO MONEY—Just Your Name

If you are out of a job, or need extra money to help pay bills, buy clothing, pay off the mortgage, buy yourself a home—you may be just the person I am looking for. Rush me your name—no money—so I can lay all the facts before you, then you can decide for yourself. No experience needed. Thirty-day no-money-risk trial. Send name on coupon or penny post-card for complete details—free; no obligation. Act at once.



ALBERT MILLS
8754 Monmouth Ave., Cincinnati, Ohio

ROUTE COUPON

ALBERT MILLS, ROUTE MGR., 8754 Monmouth Ave., Cincinnati, Ohio.

Without obligation to me, rush free facts about your Tea and Coffee Route Plan. Tell me how I can make up to \$60 in a week and get a Ford Sedan as a bonus.

NAME.....

ADDRESS.....

(Please print or write plainly)

When writing please mention Popular Mechanics

Free PROJECTS!



**TO ALL CASCO
HOMECRAFTERS**

Useful and Inexpensive to Build

20 prize-winning projects for you to choose from. Kayak canoe, Modern End Table, Portable Bar, Bridge Table with inlaid top, Modernistic Clock and 15 others. Some simple, can be built with hand tools—others more challenging to your skill. All are included in the Free Project Service of the famous CASCO heatproof, waterproof glue.

Here's How You Get FREE Plans

First, mail coupon below. You get, by return mail, free folder fully describing these 20 interesting and useful projects. Select the project you want to make NOW. Then buy a 25c (or larger) can of CASCO. Mark your choice project on the green ticket in can. That entitles you to FREE plans. No extras. Plans come complete, with exact working directions and list of materials needed. This FREE Project Service is designed for YOU. Take advantage of it. Fill out this coupon and get your can of CASCO today!

Hardware, Paint, Lumber Dealers sell CASCO.



FREE stick this coupon on penny postcard. It will bring you folder that describes 20 CASCO Prize Projects.

CASEIN COMPANY OF AMERICA, Inc.
350 Madison Ave., Dept. P. M. 1136, New York, N. Y.

Please send folder about FREE Project Service.

Name.....

Address.....

FREE—25¢ Gilbert Thrills Magazine

—A gold mine of scientific news. 36 big pages jam full of exciting pictures. Free if you write now.

The A. C. Gilbert Co., 659 Erector Square, New Haven, Conn.

POWERlite

HERE'S
AMERICA'S FINEST
ELECTRIC LANTERN

● 2 lights on a double acting switch. 800 ft. spot light from front reflector; broad floodlight from top.
80 to 100 Hours Light from One 6-Volt Dry Battery

The most powerful, serviceable electric lantern for all needs—fishing, camping, touring or home. Stands 6½ in. high. Unbreakable lens. At sport, hardware, electrical dealers, or write

DELTA ELECTRIC CO., Marion, Ind., Dept. 300



\$3³⁵

A GENUINE DELTA

(LESS BATTERY)

(Continued from page 142A)

downs must be guarded against more carefully.

"A sea-going electrician throws switches, runs a motion-picture projector, or repairs an electric stove in the galley just as he would on shore. There is not much novelty between a water pump or steam line just because it happens to be on a ship. The hardest work of the engineers is done in port. When we are under way we simply operate the engines and keep them in good condition. After we dock we have a chance to tear down a condenser or make light overhauls that might have interfered with the ship's schedule at sea."

Like the captain, a chief engineer stands no regular watch. That means he is always on call and often gets less sleep than his assistant officers. In foggy weather and during any maneuvering he is always on the operating platform, overseeing the work of his engineers as they "answer bells" from the bridge.

On small ships the bane of the engineers is the heavy storms that pitch the propellers clear of the water. In such storms an engineer must gauge the lift of the ship and spin the throttle down every time the stern lifts, to check the engines and prevent the propellers from racing. Otherwise the vibration is apt to damage the engines and propellers. Such storms hardly affect the large passenger liners and in case such a ship should pitch its propellers clear, automatic governors keep the engine speeds down.

Just as in getting up steam, stopping a ship's engines is a long job. This time the purpose is to cool off the power plant slowly and evenly. In the home port, when the telegraph pointers down below move across the dials to "Finished with the engines," the engineers kill the fires under all but two boilers. These are needed to furnish steam for moving cargo and to keep the auxiliary power plants running. Then the main steam lines to the engines are closed and the last wisps of steam are drawn out of the turbines.

But the engines are kept turning, this time by means of small electric jacking motors geared to the shafts. For another hour, also, pumps are kept going to circulate lubricating oil through all the bearings. Finally, the engines cool down and the pumps and motors are stopped.

Does Your Bathroom Flush Tank Waste Water?

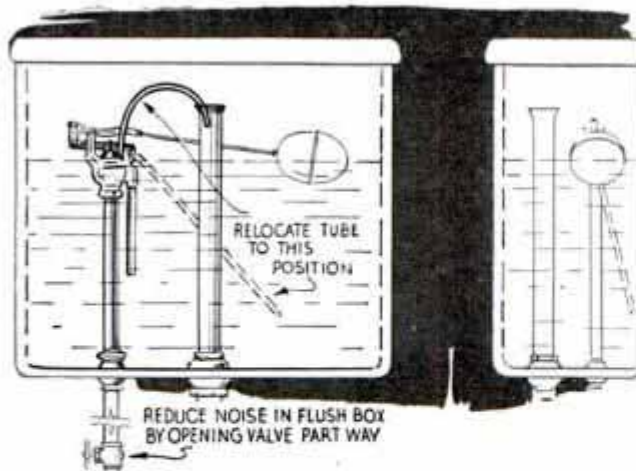

Flush tanks of this type waste a quarter to one-half gallon of water every time they are tripped

Even though every valve may seat perfectly in your bathroom flush tank, it may be wasting from $\frac{1}{4}$ to $\frac{1}{2}$ gal. of water every time it is flushed if it is of the type shown in the drawing. Note the curved copper tube running from the trip valve in the supply pipe to the overflow. This tube passes water to the overflow while the valve is open, its purpose being to ease pressure and reduce noise. To stop wasted water and still keep the noise at a minimum, remove the tube and relocate it as indicated by the dotted lines. Then partly close the valve under the tank. It will take a little longer to fill the tank when the valve is partly closed, but this is not objectionable in most homes.

—L. H. Georger, Buffalo, N. Y.

Wood Turn Button Kept Tight by Rubber Lock Washer

The tendency of a wood turn button to loosen and turn from vibration, wind, etc., can be prevented by putting a rubber washer under the screw head that holds it in place. Cut the washer from a piece of inner tube and drive the screw snugly against it. The rubber will maintain a light pressure against the button regardless of whether it swells or shrinks with weather changes.



NOW—A Genuine 7-Inch BLACK & DECKER ELECTRIC SANDER



THE NEW 7-INCH JUNIOR SANDER saves hours of slow, hard work with sandpaper, emery, files, etc. Makes quick work of such jobs as cleaning and smoothing wood or metal surfaces; removing paint and rust; grinding and smoothing welds and casting ridges; rubbing down new lacquer with felt rubbing pad; polishing metal, etc. Universal motor operates on A. C. or D. C. A great tool. A great value. Only \$39.50.

LOW PRICED B & D DRILLS, TOO

$\frac{1}{2}$ -INCH JUNIOR DRILL: (Illustrated). Drives twist drills for drilling up to $\frac{1}{2}$ " holes in steel; augers for drilling up to 1" holes in wood. Also drives Black & Decker Hole Saws for cutting clean, round holes from $\frac{3}{4}$ " to 3 $\frac{1}{2}$ " diameter in any material a hacksaw will cut. Universal motor. Only \$35.00.



$\frac{1}{4}$ -INCH JUNIOR DRILL: Drives twist drills for drilling up to $\frac{1}{4}$ " holes in metal; augers for drilling up to $\frac{1}{2}$ " holes in wood. Also drives light wheels for grinding, buffing, polishing, etc. Universal Motor. ONLY \$19.50.

MAIL THE COUPON TODAY for Black & Decker Catalog and name of nearest dealer where you can see these and other Black & Decker tools.

BLACK & DECKER

World's Largest Manufacturer of
PORTABLE ELECTRIC TOOLS

MAIL FOR FREE CATALOG

THE BLACK & DECKER MFG. CO.,
611 Pennsylvania Ave., Towson, Md.

Please send Free Catalog showing Junior Sander, Drills and other tools, and address of nearest B & D Dealer.

Name.....

Occupation.....

Address.....

City..... State.....



\$200 My First Week



... Now in
**my OWN
Business.**

L. A. Eagles took in \$200 his first week. Harry Hill says: "Paid for home with Rug-Washer. Earned \$86 first day." Fred Paulson says, "Made \$99 in 10½ hours." Many others make \$125 to \$200 per week. Thousands earning quick, easy profits. Electricity does the work. Finishes rugs like new, on customer's floor. Hundreds of customers in your vicinity and nearby towns.

EASY TERMS

Inexpensive equipment. Pay part down—balance monthly. No shop necessary. Used by the United States Government and Statler Hotel System. Manufactured since 1918—every machine guaranteed.

FREE BOOK

Send today (no obligation) for booklet illustrating Rug-Washer and telling how you can earn large profits at prices below other methods; how you can build a permanent year-around business; and how you can pay on easy terms. Enjoy a larger income. Write today—NOW.

VON SCHRADER MFG. CO.
10-N PL., Racine, Wis.



MAKE YOUR OWN VENETIAN BLINDS

Complete instruction book shows how easy you can make them in your own home shop. Postpaid only 25c. We furnish hardware, ladder-tape and cord at amazing direct-to-you low prices. Cost of book applied against hardware cost if purchased from us. Write To-day.

HESTON & ANDERSON 611 ELM STREET
FAIRFIELD, IOWA



NEW Light Weight Paint Sprayer—Only \$29.50

¼ H.P. Motor AC110 Volts. 60 Cycles—COMPLETE. Quick, easy way to paint screens, furniture, radiators, machinery—anything—in homes, Factories, Stores, Schools, Hospitals, Office Buildings, etc. Small, compact. Carry anywhere. Weight only 44 lbs. Complete with Spray Gun; 15 ft. hose. FULLY GUARANTEED. Only \$29.50 f.o.b. Chicago. \$5.00 Deposit. Balance C. O. D. or send for Free Circular. IDEAL PUMP CO., 801 Washington St., Chicago, Ill.

LEATHERCRAFT FOR PLEASURE—FOR PROFIT

Now you can get "EASCO" Complete Leather Working Outfit including everything: Tools, Materials, Tinting Dyes, Patterns, Work Block and Easy Instructions, all in one handy package. If your dealer is sold out, send Two Dollars for immediate delivery, or pay postman when package arrives. Satisfaction guaranteed.

E. A. SWEET COMPANY, Inc.
P-22 State Street, Binghamton, N. Y.



FUR—FISH—GAME

Is just the magazine you have been looking for, at a price you can afford to pay. Edited by the well known outdoorsman, A. V. Harding, F-F-G contains in each monthly issue 64 to 100 pp. of fascinating, thrilling, true stories of the outdoors dealing with HUNTING, FISHING, TRAPPING, FUR FARMING, Guns, and Ammunition, Camping, Woodcraft, Dogs, Coon and Fox Hunting, Fur Markets and Prices. New Reduced price on newsstands—15c a copy or \$1.80 a year. Save money by sending your order TODAY for our

SPECIAL OFFER
6 months only **50c**
(saves you 40c)

Clip ad, attach address and send with 50c cash, stamps or M. O. to

FUR-FISH-GAME, 168 E. Long St., Columbus, O.

The Latest for the Hunter

(Continued from page 734)

blind when a bone chilling north wind is blowing, and for other sportsmen who must face the elements, this heat pack often is a life saver. The pack is a square. It has a cover which buttons. When you want heat, you add about two tablespoonfuls of water, shake the contents of the bag until it gets warm and then slip it inside the container. It will generate heat for many hours. On very cold days, put one of these packs in the front of your hunting coat to warm your hands between shots.

The real test of the hunter's outside clothing is a snow or rainstorm on a cold day. It's fairly easy to assemble enough woolen underclothes, wool trousers, shirts, sweaters, and jackets for warmth on a dry day. But let it rain on a chilly autumn day and the hunter must turn to a different outfit. In a rain or snowstorm, the neck and back of the head are the first places to get wet and chilled.

To outwit the elements some rely on two equipment items. First, there is the parka-style rain shirt with a hood over the head. The second garment is the waterproof hunting coat that has in the collar a small compartment containing a waterproof hood. On a fair day the hood is tucked into place on the collar where a zipper arrangement keeps it out of the way. The parka rain shirt is a one-piece garment that slips over the head. It is made of heavy waterproof material, buttons around the wrists and has a hood to cover the head, thus keeping the rain from running down your neck.

Keeping shells, lunch and matches dry is a problem for the marsh or waterfowl hunter who parks in a blind for hours at a time where the wind and driving rain have full play. There is available a metal, waterproof shell box, oblong in shape, which costs about as much as three boxes of shells. Besides shells, this box will accommodate a small bottle of drinking water, extra matches, wooden duck caller, smoking necessities, an apple or orange, a bar of chocolate, and one or two film packs for the camera. Last but not least, the handle is recessed so you can use the box for a seat in a blind without "furniture."

One of the most practical things for the

waterfowl hunter is just a piece of heavy cord. Tie it to your duck, goose or crow call and drape it around your neck or you're going to be hunting for it continually and it will never be ready when you want it.

It's amazing how many pheasant and waterfowl hunters apparently have everything they need for comfort and then are in a dilemma as soon as a couple of birds are shot in the field. The reason is that they have no way to carry birds. Of course, most hunting coats contain big pockets for carrying game. These are very serviceable but many dislike the drag on the shoulders that results from putting birds in the coat pockets, so they use a game carrier. This puts the weight of the birds around the waist because it can be worn like a belt. This carrier has small loops into which you slip the heads of game birds,

For ducks there is an inexpensive rawhide carrier with five thongs on each end and slits to loop over the heads of birds. If you have ever tried to walk any distance carrying game birds you know how heavy they get after the first 200 yards. By using one of these carriers you can balance the birds on your shoulder easily. And it practically never wears out.

Last but not least, one of the handiest things for the upland game or marsh hunter is just a large belt or pocketknife. Often on marsh hunting trips you must either repair or build a blind. Without a big knife the job is not easy because you cannot gather many bundles of tall grass, weeds or willow branches without a knife or small belt axe. And with the knife or small belt axe, take a waterproof matchbox that will float in water, and a compass. No deer hunter should be into the woods without these. That waterproof matchbox is protection against the possibility of going without a fire some day when things do not go right. With a knife or small axe and matches one can face many an emergency in the woods.

Popular Mechanics Magazine does not publish the name of the maker of, or dealer in, any device described in its pages, but this information is kept on file and will be furnished by our Bureau of Information upon request, accompanied by stamped, self-addressed envelope.

HERE IT IS!

THE PERFECTED

ELECTRIC SHAVER

Hanley

Clipshave



only

\$10

CLIPSHAVE gives you new shaving comfort at a new low price. With it you can shave the heaviest beard smoothly and closely, without the slightest irritation. CLIPSHAVE massages while it shaves—it trims sideburns, mustaches and beards neatly and cleanly—and it *can't clog*.

CLIPSHAVE economy starts with its cost. It saves you the expense of blades, soap and brush—and uses only a few cents worth of current yearly. Buy yourself permanent shaving comfort—get a CLIPSHAVE today. Operates on A.C. or D.C.

Your dealer will be glad to demonstrate this marvelous shaver. If he can't supply you, send \$10 direct to Dept. B, CLIPSHAVE, INC., Port Chester, New York. Money-back guarantee.



CLIPSHAVE, INC., DEPT. B, PORT CHESTER, N. Y.

Please send me a Clipshave in payment for which \$10 is enclosed. It is understood that should I return it in good condition within 30 days, my money will be refunded.

NAME _____

STREET _____ CITY _____ STATE _____

Boys! BUILD MODELS in half the time with BOLTLESS JOINTS



It's *keen* to build models with Meccano-Morecraft. Parts just snap together. And models look big and magnificent because parts are brilliantly finished in red, blue and nickel. By *all* means visit your nearest toy store this week and ask to see this grand new construction set!

MECCANO-MORECRAFT

Send for big, 16 page, beautifully illustrated booklet of models. It's yours—free! Note the big \$5 set with dandy motor!

The Meccano Company of America, Inc.
Dept. O-9, 200 Fifth Avenue, New York City, N. Y.
Please send—free—beautifully illustrated 16 page booklet of models.

Name

Address

YOURS... FREE!

Trial Sample of CASCO,
the amazing heatproof,
waterproof Glue...and
Home Repair Guide.

Your name and address on a penny postcard. That's all you do to get a generous sample—enough to do a good-sized repair job... and convince you that CASCO is the ideal adhesive-cement for household repairs.

CASCO is unlike anything you've ever used. Entirely new in action. Sets chemically, like cement. Unaffected by moisture, heat, shocks or jars. And you only have to do the job once—because when you fix it with CASCO, it stays fixed.

But prove it to yourself... at our expense. Send TODAY for your FREE sample. The CASCO Gluing Guide—\$2-page illustrated book—tells all about this new gluing process, and gives a wealth of practical uses, based on the experiences of many satisfied woodworkers, craftsmen and householders.

Hardware, Paint, Lumber Dealers Sell CASCO

CASEIN COMPANY OF AMERICA, Inc.
350 Madison Ave., Dept. P.M.1136, New York City



The Spin Shots of Table Tennis

(Continued from page 671)

return in that direction. After a little experimentation you will be able to handle these tricky serves with little trouble.

Sidespin serves are a valuable asset to your game because even though you don't score aces outright you have a good idea where the receiver will return them. If you know approximately where the ball is coming, you can get set to smash it for a sure winner.

Another effective serve is the chop. You do just that. The stroke starts shoulder high. Then you strike down and forward very quickly, keeping the top edge of the racket tilted backward during the entire stroke. This serve if properly executed will generate a lot of underspin on the ball and your opponent will be almost certain to stroke it low, into the net. Be sure to hit the ball crisply, using generous wrist action. Don't peck at the ball, and make sure to follow through. If the other fellow pulls this serve on you—and you should be able to mark its coming by watching him closely as he serves—simply aim the ball farther above the net than usual and keep the blade of the racket slanted backward.

Although finger-spin and knuckle-ball serves have been outlawed by the United States Table Tennis Association, they are still held legal in twenty-three other nations affiliated with the International Table Tennis Federation. While they may not be used in this country in official play, you can have fun experimenting with them and using them in informal contests. Practice will enable you to develop all sorts of weird varieties of these devilish deliveries—serves that will drive many rivals to distraction.

The easiest finger spins are the knuckle-ball types. Place the ball between the thumb and fingers of the right hand like a marble. The ball should rest on the side of the third finger and is held by the thumb and first finger. Now shoot the ball like a marble with the thumb doing the propelling onto the face of the racket, which is in the left hand. For variety change the position of the hand and the angle of the racket. For different spins the ball may be ejected by the thumb of

(Continued to page 150A)

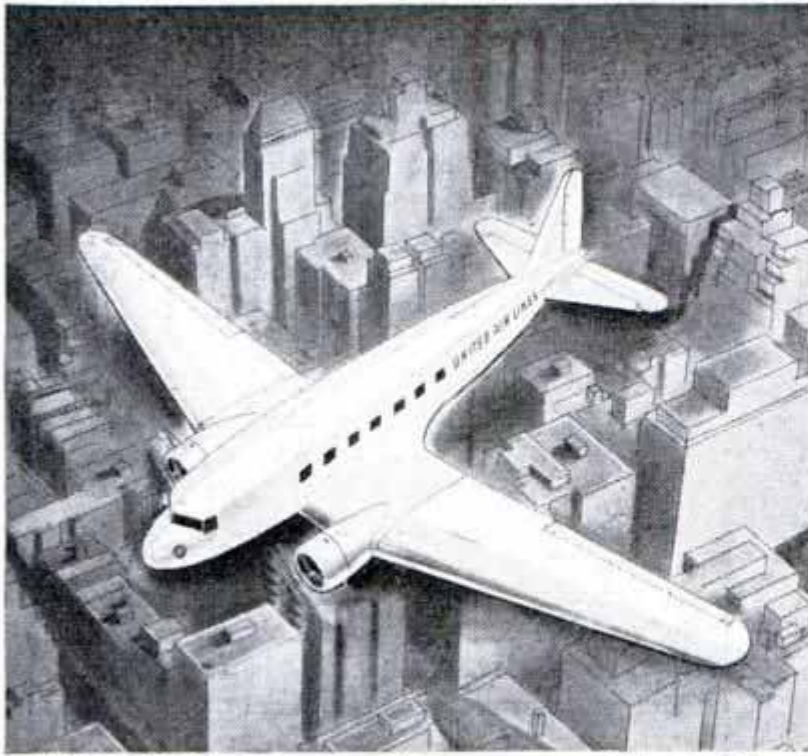

NEW WINGS ACROSS U.S.A.!

The most powerful land planes ever designed for passenger service in the United States! And these new United Air Lines' Douglas Superliners use the same oil that gives your car an extra margin of safety—Pennzoil!

Pennzoil motor oil has an exclusive tough-film that engine heat and pressure can't break down. Result: Less engine trouble—valves and piston rings stay clean and seal in compression. Your motor runs smoother, uses less gas and oil!

Member Penn. Grade Crude Oil Assn. Permit No. 2



MORE MILES OF SAFE LUBRICATION

United Air Lines' new Superliners are powered by two 14-cylinder Pratt & Whitney Engines each delivering 1150 horsepower at the take-off. Pennzoil Motor Oil is used exclusively.

United's experience in flying more than 100 million miles proves Pennzoil gives motors an extra margin of safety and reduces operating costs. You can get the same Pennzoil — and the same protection — for your car from independent bonded dealers everywhere.

STRIPE YOUR OWN CAR

Anyone can stripe a car with a ROLL-A-STRIPE. You can save the price of your striping job and earn money doing other. Specially knurled roller and dependable gauge. Paint, lacquer, enamel or varnish may be used. Stripe signs, furniture, models, etc. See any Duro Dealer today or send direct. Postpaid \$1.50.

MODCRAFT INDUSTRIES, Dept. P11, 2908 N. Nordica Ave., CHICAGO, ILL.

CLAMPS

for HOME WORK SHOPS

NOTE the new special price. (reduced \$1.00 per pair) on our most famous Pony 500 Clamp Fixtures.

ADJUSTABLE CLAMP CO.
"THE CLAMP FOLKS"
421 N. Ashland Ave., CHICAGO

Genuine Pony 500 Hand-tighten Fittings go on ordinary 3/4" pipe. Make Clamps never slip, split or of any length. Send \$2.00—postage. All sizes, new low price—plus postage (6 lbs.) for Fittings for 2 Pony 5 0 0 Clamps.

Send \$2.00 plus postage (7 lbs.) for 2 No. 1 Hand-tighten—open 6".



PONY MINIATURES STANDARD
Fine quality clamps with a thousand uses. 7 sizes 1" to 3 1/2" cap, 12c each and up.

CATALOG FREE

WHAT TO MAKE *and how* to make it ON A LATHE

WRITE for these books: (1) The Home Workshop, *free*; (2) What to Make on the Lathe, 16c; (3) How to Run a Lathe, 16c pages, 25c. Coin or stamps accepted. Any South Bend Screw Cutting Lathe on easy terms. Priced \$75 up. Ask for Catalog 15, *free*.



SOUTH BEND LATHE WORKS
359 Madison St., South Bend, Indiana, U.S.A.

TURN SNAPSHOTS INTO HUMANETTES

Sensational invention. Almost human in appearance. A life-like cut out figure. Any snapshot, photograph or picture can be "immortalized" by this strange new process. Surface covered with moisture-proof transparent PORCELITE. Will not peel, tear, crack, or soil. Looks like porcelain has-relief.

BIG MONEY FOR AGENTS
Low prices make HUMANETTES big sellers. We furnish list of prospects in your neighborhood who will pay from \$1.00 to \$2.50 for showing samples of LIFETIME HUMANETTES. If you want to make money fast, send name for free sample proposition at once.

AL SCHULER, 1037 Evans Street, Dept. 10-X, Cincinnati, Ohio

When writing please mention Popular Mechanics



BIG LEADER—SELLS ON SIGHT



Genuine Leather Ties

LOOK LIKE SILK. Won't wrinkle. Wear indefinitely. Over 50 patterns. We manufacture two lines, "Century High-Grade" and a lower-priced line.

Four-in-Hands in beautiful colors and designs. Cleaned with damp cloth. Big profits. Repeat orders. Young man sold 2 dozen ties one afternoon after school.

Century Bows known from coast to coast for quality, workmanship and satisfaction. Big outlets: letter-carriers, policemen, firemen, gasoline stations, bus, bakery, laundry drivers, etc.

Everybody a prospect. Even the ladies buy them for their sweethearts and husbands.

Send 50c for sample kit, including Bow and 4-in-Hand

Century Tie Co., Mfrs.

Dept. A, 2345 W. Grand Blvd., Detroit, Mich.

IT FLIES THROUGH THE AIR

Free Blueprints
of this Famous
Navy Plane



THE HELL DIVER

You can make it best by using Duco Cement—strong, quick-drying adhesive. Light in weight and easy to use. Send red disc from 25c tube for working plans. Du Pont, Dept. B-6, Wilmington, Del. Also choice of plans for Winnie Mae, Laird 400, Akron Fighter.

TRANSPARENT • WATERPROOF



Why Waste Gasoline!

Amazing Invention SAVES GAS

With Pre-Heated Air Simple and easy to install, Leen-

A-Mix instantly gives cars more speed—extra power and pep—new scientific principle endorsed by motor experts—automatically puts new life to motor—quicker starting, greater speed and smoother running. You quickly notice the savings on gasoline. Entirely different—controlled by Thermostat—allows the proper amount of pre-heated air balancing a perfect mixture—without disturbing carburetor.

TRY AT OUR RISK 30 DAYS TRIAL
Big Money-Maker for Agents **FREE OFFER**



**FITS
ALL
CARS**

METAL SPECIALTIES MFG. COMPANY
Dept. P-11, 3200 Carroll Avenue, Chicago, Illinois

Cord Handicraft—Fascinating—Square Knotting
Make Belts, Purses, Dog Leashes, etc. Finest materials obtainable listed in Booklet "B" catalog, sent FREE. Or enclose 10c for Instruction Booklet No. 1 and samples.

SQUARE KNOTTERS

SPECIAL OFFER: Our regular \$1.00 Instruction Book together with the 50c Beginners' Outfit all for \$1.00.

PRACTICAL EDUCATIONAL! START TODAY!
P. C. HERWIG CO., 121 Sands St., Dept. J-11, Brooklyn, N. Y.
SQUARE KNOT HEADQUARTERS

Trailers, Plans and Parts

Utility Trailers, 4' x 5', complete less tires, \$22.50. Utility trailer plans, 50c. Cabin trailer plans, \$1. Trailer parts at bargain prices. Write for free catalog of parts.



SHAMROCK TRAILERS, 11761 Grand River, Detroit, Mich.

sell DOUBLEWEAR shoes

... and make **BIG MONEY**
this **CUSHION INSOLE OXFORD**
sells for **\$3.65**

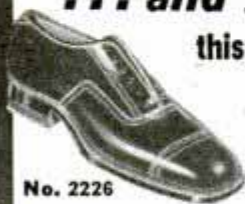

No. 2226

Our Health Shoes, styled for comfort and built for wear, properly distribute weight of body on three main contact points. Can be had in both dress and work shoes. Sell at \$5.95.

It's a Doublewear repeater, built for comfort and durability. Easy to sell. Other models featuring the patented Cushion Insole sell for \$5.45 and \$5.65. Profits are astounding. Investigate our proposition NOW.

**WRITE TODAY FOR
MONEY-MAKING PLAN**

Doublewear Shoe Co. 261 East Lake Street
Minneapolis, Minn.

(Continued from page 148A)

the left hand onto the racket, clasped in the right.

Still another variation involves holding the ball between the pad of the thumb and the nail of the middle finger, which in this case ejects the ball. Or hold the ball between the pads of the thumb and third finger. Now snap these fingers and this will shoot the ball spinning into the air. As it comes down, bat it with the racket and the rapid spin on the ball will give the receiver something to worry about.

But there are other tricky spin shots besides serves that can be used to advantage during an actual contest. Here is a real fooler, a shot that can be employed when you are on the receiving end of a serve. Some call it "Old Faithful" because the ball shoots high and abruptly into the air and reminds them of that spout of water in Yellowstone park.

It is easier to execute this shot successfully when the serve is delivered to your right or forehand side. Hold the racket pointing forward and tilted slightly backward. As the ball is served toward you, advance the arm forward and contact the ball with an upward lift on the half-volley or directly after it has touched the table. You sort of scoop the ball. The upward movement will cause the ball to soar high in the air, and the forward impetus of the stroke will impart excessive underspin. Try to so strike the ball that it will land just over the net on your opponent's half of the table. If you can do this the underspin should be strong enough to make the ball jump back to your side of the net without the receiver being able to even touch it with his racket. This will score a point for you even though your adversary finds it impossible to reach the ball. This return of service comes as a sensational surprise. It is not an easy shot to learn but if mastered it will give you no end of satisfaction. Of all the trick shots in table tennis, this shot probably is the most unusual and sensational.

Popular Mechanics Magazine does not publish the name of the maker of, or dealer in, any device described in its pages, but this information is kept on file and will be furnished by our Bureau of Information upon request, accompanied by stamped, self-addressed envelope.

HOW 10¢ A DAY Proved Joe wasn't **DUMB!**



FACTORY-TO-YOU REMINGTON NOISELESS PORTABLE

NOW **10¢** A DAY

OWN a brand-new Remington Noiseless Portable for only 10¢ a day. Its lightning-fast action is so quiet that you can type anywhere at any time without disturbing others. Standard keyboard. Variable line spacer, double shift key. Automatic ribbon reverse. Everything you need for complete writing equipment,

PLUS THE NOISELESS FEATURE!

You don't risk a penny. You can get this Remington Noiseless Portable direct from the factory for a **TEN-DAY FREE TRIAL**. If you don't think it is the finest portable you have ever used, send it back at our expense. **WE PAY ALL SHIPPING CHARGES.** Or keep it and pay for it at only 10¢ A DAY. You get a typing course and carrying case absolutely **FREE**. Get the full details without obligation! Clip out this coupon right now, and mail today!



**TEN-DAY
FREE TRIAL
OFFER**

GREATEST BARGAIN IN 10 YEARS

Remington Rand Inc., Dept. 152K
315 Fourth Avenue, New York, N. Y.

Tell me, without obligation, how to get a New Remington Noiseless Portable. Free Typing Course and Carrying Case, for 10¢ a day. Send catalogue.

Name _____
Address _____
City _____ State _____

FREE TYPING COURSE...FREE CARRYING CASE... MAIL COUPON

THROW AWAY YOUR AERIAL!



New scientific principle! Quickly connect the Warren Compact Antenna to your radio and discard your old aerial. As good or better volume and reception **ABSOLUTELY GUARANTEED**. Reduces noise. Can't get out of order. Sealed Bakelite Case. Size 3 in. by 3 1/4 in. Price \$1.95 postpaid. Money refunded if not satisfied.

Dealers Wanted

WARREN ARMATURE WORKS, Dept. A, WARREN, OHIO

EARN EXTRA MONEY

Start a Mail Order Business at Home

No experience required. No canvassing or house to house selling. Work in your spare time. Opportunity to build a well paying business. Strictly legitimate. No Wildcat scheme or stock outfit. Send \$1.00 right now for my Amazing Offer. If not satisfactory return plan in 10 days and money will be refunded.

UNION SALES CO., P.O. Box 13-B, New Rochelle, N. Y.

SHIP MODEL SUPPLIES

CATALOG - Largest assortment of model boat parts in the world. Send 5c for postage.

Selley Mfg. Co. 811 1377 Gates Ave. Brooklyn, N. Y.

Governs Speed OF ANY GAS ENGINE

Take any car motor out of the chassis, equip it with a Pierce Universal Governor, and you have a stationary power unit that runs steadily enough to operate even an electric welder. And that's some test for close speed regulation.

Pierce Universal Governors are standard controls on gasoline engines for commercial purposes—for electric lighting plants, refrigerating units, air compressors, feed grinders, hoists, saw mills, welders, etc.

Pierce Universal Governors are the time-tested flyball type and respond instantly to each change in engine load, maintaining uniform speed. Belt driven, either V or flat. Easily installed and never equaled for close regulation of speed and for dependable performance.

Write for illustrated literature and prices, whether you want to equip one used motor or a thousand new ones.

The Pierce Governor Company
1600 Ohio Avenue, Anderson, Indiana



A Pierce Governor puts "brains" into any gas motor.

FASTER - SAFER - CLEANER

7200 Strokes per Minute
Electric Operation

No Motor Required

Astounding performance! Cuts up to 1" or more, with smooth, clean edges. No sanding required. Accurate, sturdy, efficient—a revelation to skilled craftsmen in handling both intricate designs and heavy work. Ideal for cutting light metals, veneers and plastics. Operates on 60 cycle, 110 volt AC, without motor or any reciprocating parts. Requires no oiling. 10" square table; 13 1/2" throat; adjustable guide; variable stroke. Complete with underwriters approved cable and rubber plug. Built for years of continuous service.



New
**SYNCR
JIG SAWS**

FREE FOLDER

GET FREE LITERATURE TODAY
Ask your dealer to show you the models now available. Or send your name for full information and illustrated literature. **FREE.**
SYNCR DEVICES, INC.
511 Boydell Building Detroit, Mich.

VEST POCKET ADDING MACHINE

Adds, Subtracts, Multiplies, Divides. Does work of costly machine. Not a toy. Million dollar capacity. Simple and accurate. Guaranteed 5 years.

FREE TRIAL
—SEND NO MONEY— **\$2.50** Total Cost

Just name and address. We will ship Calculator immediately. On delivery pay postman \$2.50 (plus few cents postage). (If outside U. S. send each. 10¢ additional in Leatherette Case. If not satisfied after 10 days' trial you get your money back. THOUSANDS OF SATISFIED USERS. Write for Agents' Proposition. **CALCULATOR MACHINE CO. (Mfrs.)**
P. O. Box 1118, Dept. 31, CHICAGO, ILLINOIS.

**C'MON YOUSE GUYS
GET A REAL
MOVIE BARGAIN**



SPECIAL OFFER
Projector as described below with two fifty-foot films of Charlie Chaplin and Tom Mix.

All For **\$7** Post-Paid

FREE!

Latest book on **ASTRONOMY. IF YOU ACT NOW.** Learn to tell all the stars. Mytify your friends.

Projector is motor driven for 110 volts A. C. with double 2 inch lens. Shows pictures 30 inches wide at 12 feet from screen. Takes 100 feet of standard 16mm. film. (Sold separately at \$4.50).
Send NOW for our **BIG, FREE Catalogues of Movie Supplies and films including POPEYE, BETTY BOOP, MICKEY MOUSE, etc.**

PARAMOUNT MFG. CO.
Dept. G-81 BOSTON, MASS.

New Auto-Wash Glove



AJAP Auto-Wash Glove! Rubberized, water-proof mitten with rubber sponge attached, and fitted with a rubber tube which connects to garden hose. Water flows from inside of sponge and prevents dirt from accumulating under it. Makes car washing as easy as wiping off the dust. Twice as quick as any other method. Keeps hand dry—and warm in coldest weather. (See p. 338 of September Popular Mechanics.) Ask your dealer or order direct—\$1 postpaid. Money back if not satisfied. Circular on request.

Dept. 10 **AJAP PRODUCTS CO.** Holly, Mich.

WANTED: SERVICE OPERATORS

Nationally known, A-1 Corporation has openings for reliable men to inspect and service an estimated number of more than five million Underwriters' approved safety devices now in use. Service work brings handsome earnings. In addition you are trained for profitable District Dealership for new, patented safety device. No stock investment. Write details about yourself. **Ray C. Hahn, G.S.M., Dept. 90-11, Factory, Post Office Box 983, Dayton, Ohio.**

SERVICE OPERATOR

OHMITE BROWN DEVIL RESISTORS

Why take chances with low-wattage resistors? Use **BROWN DEVILS** in 10 and 20 watt sizes for constant resistance value. Specially developed vitreous enamel coating protects against failures. Ask your dealer or write **OHMITE MFG. CO., 4834 Flournoy St., Chicago, Ill.**



EXTRA \$\$ in SPARE TIME PRINT at HOME

Letterheads, circulars, billheads, cards. Printing pays BIG. Easy, interesting, educational. **PRINTING PRESS BARGAINS \$12.** Types and Supplies, lowest prices. Send stamp for catalog. **PEIFFER Co., 89-A, 6 Columbia St., Newark, N.J.**



**SALESMEN
100% PROFIT
EASILY MADE**



**BRAND NEW AUTO ACCESSORY
NO COMPETITION
EXCLUSIVE TERRITORY**

SALESMEN ARE MAKING UP TO \$15.00 DAILY SELLING THIS NEW SELF FILLING EMERGENCY GASOLINE TANK. WRITE FOR DETAILS AND FREE SAMPLE OFFER.

ACCESSORY MFG. & SALES CO.
3333 Madison St., Dept. E-11, Chicago, Ill.

The Modern Fire Walkers

(Continued from page 642)

in comfort until the metal cools off. Or they dress you in a light suit of asbestos overalls, and hold a roaring blowtorch to your chest.

But this conquest of fire was far from easy, as you learn for yourself by talking with C. E. Bridgman, one of the young men accustomed to loafing inside glowing furnaces and sitting in blazing planes.

"We began experiments in 1933 to produce asbestos helmets, gloves and suits for fire brigades," he explains. "The first experiments indicated a new asbestos yarn was required, for when subjected to fire, gloves and helmets fell off the wearer in pieces. After this problem was solved, the helmet withstood fire, but there still were two serious defects and it is fortunate a dummy was used for this test, instead of a man. The dummy was seated in a large packing case, with wood wool soaked in gasoline heaped about it. We watched the flames envelop the dummy, and then a heavy piece of wood fell on the helmet that might have proved fatal if a man had been inside. Our next helmet had a crash-proof crown and a nice visor, but when I used it, my nose was burned. So we altered the shape, and made noses quite safe by using two pieces of mica with an air space between them.

"Before taking any serious risks in the open with a burning plane, we experimented with a furnace built at one end of a brick tunnel. I tried first to enter the tunnel without an asbestos suit, but the heat was unbearable. With the suit on, I was able to enter the tunnel in comfort and approach the furnace at the other end. It was warm inside the furnace, of course, but not uncomfortably so at first. I stood in the fire for two minutes before having to clear out, and under such circumstances this is a long time.

"After coming out of the fire there is a strong temptation to tear off the asbestos suit, but this would mean such a startling change of temperature as to be a shock to the human system. One has to 'cool off' for about twenty minutes before the suit can be removed with safety."

These asbestos suits are intended to be a part of the fire-fighting equipment at all

(Continued to page 154A)

NEW! NEON Home Lamp

First Practical Home-Use of NEON Lighting!

The Ideal Gift!



Newest lighting novelty! Beautiful, rich-looking lamp—lighted with new NEON bulb. Produces a cool, soft, rose-glow. No glare. Ideal night lamp in nursery, bedroom, bathroom, sick room, etc. Or, for mantel, radio or end table—often used in pairs. Metal base, highly polished silver and black finish. Graceful tubular arch. Cord and plug. Operates on A.C. or D.C. current, 100 to 120 volt. Almost no current cost—about 1¢ per 100 hrs.! Choose from 3 designs: Poodle Dog—Mother Goose—Holy Cross.

MONEY-BACK GUARANTEE!

Your money refunded if you are not 100% pleased.

ORDER NOW

for yourself and for Xmas gifts.

New Only

SPECIAL—three, any design, only \$5.00

\$2

Postpaid (Outside of U. S., \$2.50)

NEOLITE LABORATORIES, Box 47-P, Omaha, Nebr.

Neon Truck Signs

-- NOW Possible with Amazing New TRANSFORMER and Novel Method of Tube Installation!

Old, established factory wants financially responsible business executives -- to handle distribution in exclusive territories. Signs fill long-felt Advertising need! Enable any advertiser to have brilliant, colorful, attention-getting Neon Advertising message on trucks, both day and night. Expected to quickly sweep country! Easily installed on top driver's cab. Amazing NEW TRANSFORMER enables Sign to operate on any truck's standard 6-volt auto storage battery—using only about same amount current as an extra tail light. Novel method tubing installation protects against breakage. Reasonable capital handles exclusive Distributorship Contract. Big Profits. No sign experience necessary. We furnish entire product. FREE LITERATURE gives details, explains liberal proposition. Write today! E. E. SOUTHER IRON CO. - - 1952-A-1 Kienlen Ave., St. Louis, Mo.

DISTRIBUTORS WANTED



THEY DON'T SAY NO!

Here's a fast selling line that kicks out the black cat of lost orders. Show our colorful samples of soft beautiful leather. See the amazed looks when they find that the most beautiful long-lasting stylish neckties are made with this material. Always new. Cleaned with damp cloth. No pressing. Send 50¢

now for sample tie, complete sales kit and money-back profit plan. DO IT NOW. NU-MODE TIE CO., Dept. 20, 1333 N. 12th Street, Milwaukee, Wisconsin.

BUILD CLOCKS

Hall clocks are high priced in stores -- you can make good money building them or electrifying spring clocks. Time brings "HOW" Book pricing Brass weight movements from \$10.95 and drawing of easily built Grandfather Clock--start now. KUEMPEL CHIME CLOCK CO., Building 13, Guttenberg, Iowa



BUILD IT YOURSELF

Jim Dandy CABIN CRUISER

The Trailer that has **EVERYTHING**



COMPLETE BUILDING PLANS \$100

To get the trailer you want "Build It Yourself." With my plans you can construct this beautiful coach with ease and save money. No special tools or building skill required. Plans show you every detail of building body and chassis so clearly that it is almost impossible to make a mistake. Plans tell how to build beds, cabinets, drawers, refrigerator, how to get a perfect top, how to install electric The Jim Dandy Cabin Cruiser on light and water systems and where to buy all parts. Be built in any size to accommodate 2 to 4 people. Send \$1.00 for these plans today--get started on this delightful winter project--have a roomy, comfortable, substantial house trailer to use next year. Order today! MAIL DOLLAR BILL TO JIM DANDY, Box 125-A, Wausau, Wis.

Warms the floor, too!

ENJOY MODERN OIL HEAT

Diagram shows burner, patented shutters and removable fuel tank.

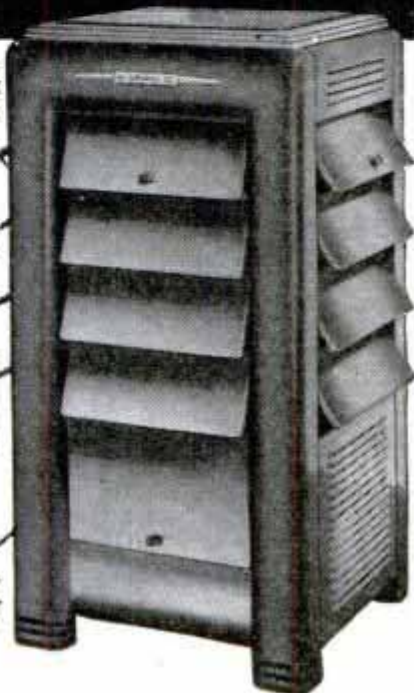
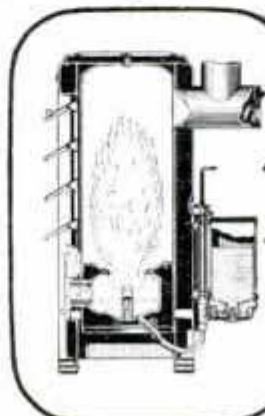

Superfex Heat-Director No. 1019 product of Perfection Stove Co.

SUPERFEX HEAT-DIRECTOR circulates and radiates heat and also offers an exclusive feature, obtainable with no other heating stove. Patented shutters on three sides of the porcelain enameled cabinet are adjustable to any position DIRECTING heat rays outward or downward to warm a wide area of floor space.

Here's plenty of heat volume for cold snaps, with instant dial control for just the heat you want throughout the season. Heat that holds over night—for as many as 42 hours on one filling of the five-gallon fuel reservoir. The fuel used is inexpensive No. 1 Light Domestic Fuel Oil, Distillate or Kerosene.

Send for free booklet showing eight new Superfex models, including several Radiating Heaters.

The mark of Quality

SUPERFEX

Oil Burning HEATERS

PERFECTION STOVE COMPANY
7758-B Platt Ave., Cleveland, Ohio

Please send me complete information about Superfex Heat-Directors and Radiating Heaters

Name _____

ST. or R.F.D. _____

Post Office _____

County _____ State _____

When writing to advertisers please mention Popular Mechanics



FROST

is in the air

Heavy-bodied summer oils must go the way of straw hats, and Palm Beach suits. Lighter oils give less sluggish, more positive lubrication in cold weather. And when you drain and refill your crankcase

DON'T FORGET TO RENEW YOUR PUROLATOR OIL FILTER

A GENUINE Purolator will conserve the new supply...and keep it effective. It removes the dirt and grit and hard carbon that settle in the crankcase...get in the oil, and grind away at cylinder walls, bearings and valves. A GENUINE Purolator keeps the oil so clean it will even retain its color after thousands of miles of driving.

Don't neglect this important economy. Service garages everywhere will attend to it while you wait. Motor Improvements, Inc., Newark, New Jersey, makers of

PUROLATOR

The Oil Filter on Your Motor Car
LICENSED UNDER SWEETLAND PATENTS

(Continued from page 152A)

British airdromes. Asbestos experts also have developed a cockpit insulated against fire. A man wearing a heavy suit of asbestos was able to sit in an insulated cockpit, with the whole machine in flames around him, for five minutes.

The experiments at Slough have been watched by architects, shipbuilders, and chemical and paint manufacturers. Houses of the future may have ceilings lined with asbestos instead of laths and plaster. A fierce fire beneath a lath and plaster ceiling broke through in seven minutes, but the same fire failed to penetrate a ceiling lined with asbestos. Also it is quite possible to insulate a ship's engine room so a fire there cannot get beyond its walls. Big buildings such as schools and hospitals could be made safer by asbestos curtains fitted at the end of each corridor. The curtain is rolled up in a metal container, and is automatically released by the heat.

71061

The Gasoline Dope Racket

(Continued from page 646)

knock properties of these materials are well known and the ones with any actual value are already patented and available in the regular gasolines of responsible oil companies. One service-station operator in California ran his fuel business up to 3,000 gallons per day with a proposition that seemed sure-fire. He explained his gasoline gave better mileage because it contained a secret compound smuggled to him from Germany. He urged every customer to check the mileage from five gallons of ordinary gasoline, then have any remaining fuel drained from his carburetor, and fill up with five gallons of his special gas. Invariably the customer found he really did get two or three more miles per gallon with the treated brand. The secret of this performance was that when the service-station operator put in five gallons of his own fuel for a test run he always threw in a half gallon or more extra gasoline. This was hardly enough to register on the average gasoline gauge and yet was enough materially to increase the distance five gallons of fuel would go.

An even greater hoax was the tablets that seemed to change water into gasoline. In this case the "slicker" would drive into

(Continued to page 162A)

NEW-TYPE BATTERY GUARANTEED AS LONG AS YOU OWN YOUR CAR



BATTERY MAN: "This new battery whips over your motor in a flash, cuts your recharging costs, gives *super-power* for electrical extras."



IMAGINE getting a battery so powerful that it will start heavy motors *double-quick* on the coldest days and so ruggedly *built* that no matter how long you own your passenger car you'll never have to buy another battery for it—or spend a penny on repairs! Yet that's exactly what you get in the new *guaranteed* Goodrich Kathanode* Electro-Pak.

And because the life of a battery depends on the life of the plates, this new Electro-Pak Battery is built with the remarkable *patented* Kathanode construction — famous for its use on airplanes, submarines and railroads—consisting of flexible, porous, spun glass retainer mats specially designed to prevent the loss of the real power-producing materials in the

plates. Thus the plates last much longer.

And another big reason why this new Goodrich Kathanode Electro-Pak will save you money and trouble is its exclusive Power-Saving Top Cover. Dirt, corrosion and acid film which collect on top

of ordinary, unprotected batteries are shut out of the new Electro-Pak. You get all the power you pay for in this battery—for quick starts, bright lights and for operating all your other power-eating equipment at top efficiency.

Save money, time and trouble this winter. Ask your Goodrich Tire dealer to show you the new Goodrich Kathanode Electro-Pak—the battery that is guaranteed as long as you own your car. Remember, there's a Goodrich Battery for every car and pocketbook.

*Made under the Kathanode Patent.

**Only Goodrich Electro-Paks
Have this Power-Saving Top Cover**



Goodrich KATHANODE *Electro-Pak*
GUARANTEED AS LONG AS YOU OWN YOUR CAR

ANOTHER B. F. GOODRICH PRODUCT

When writing to advertisers please mention Popular Mechanics

Earn \$150 to \$300 Extra Profit Monthly



...without a cent of outlay with this new *Simplified* ARC WELDING

Hundreds of paying businesses are being built with new 40 volt Simplified Arc Welding. New low prices make it available to shops that never before could afford it. Gets new paying jobs that carry a real profit. No pre-heating, no tanks to replace.

Build Your Own
Portable Welder with Hobart Generator unit and auto engine or chassis. Operates any place. Easily saves you \$300 to \$500.

Portable Electric Welder
Hobart 40 Volt Welder is the most profitable welder you can own. Welds faster, saves current.

Gas Engine Drive
For those who want a complete portable unit with electric starter.

Profits Pay For It
Extra earnings and savings make it easy for you to own without expense. You rent it on Easy-Payment-Plan out of monthly profits.

ELECTRIC DRIVE
GASOLINE DRIVE
30 Days Trial IN YOUR SHOP AT OUR RISK Easy Terms

LOOK! ALL METAL AWL



Just what you are looking for. An all aluminum sewing device that will do the work of a power machine. Sew heavy leather or light material. Complete with spool of thread, 2 needles, one straight and one curved, tracer and instruction sheet postpaid \$1.00. Agents wanted. Extra 25 yard skeins, 20c; extra needles, 10c each.

CHICAGO AWL CO., Dept. PM-11, 404 E. 79th St., Chicago, Ill.

ELECTRIC LIGHT PLANTS \$38.75



A. C. AND D. C. MODELS, 300 WATTS AND UP, FOR APPLIANCES, LIGHTS, RADIO, ETC. A dependable source of electricity for farms, camps, trailers, boats, etc. Light weight, economical operation. Air cooled motor. Fully guaranteed, 1,000 watt size as low as \$65.00. Write for full information.

J. C. ROCHE CO., 226 Acheson Bldg. Dept. M-G, Berkeley, Calif.

BRASS TAPPING



Get this big outfit for metal tapping. Make artistic Bookends, Desk Racks, What-Not Racks and Plaques. Equipment includes plywood, special non-tarnishable metals, tapping hammer, 2 tapping tools, supply of nails, and design patterns, packed in attractive carton. See your dealer or send \$1.50 for complete outfit making 4 **FREE CATALOG** Plaques.

RAPAPORT BROS., 703 W. Ohio St., Chicago

Hobart Bros., Box M-116, Troy, O.

Free!

Tell me more about—
 Building My Own Portable () Complete Gas Engine Drive Welder
 Electric Drive Welder () 30 Days' Trial—Easy Terms
 Rental Plan Privilege of Purchase.
 Send FREE Manual on Welding. Attached letter tells about the work we want to do.

Name.....
 Address.....
 Interested in () 30 DAYS TRIAL () EASY TERM

HOBART ONE OF THE WORLD'S LARGEST BUILDERS OF ARC WELDERS

Write for My New Free CAMERA & SUPPLY BOOK!



I'll be glad to send you free my latest BARGAIN BOOK of new and used cameras, Photographic Supplies. Send your name and address on a postal note. I can save you money on everything photographic! Lenses, film, movie and still cameras. Write me quick! S. J. FLESCH, Pres.

CENTRAL CAMERA CO. Dept. K-111, Chicago.
 (Est. 1899), 230 S. Wabash.

BUILD THESE PROJECTS



Easy to build. Easy to sell. Beautify your lawn or garden. Note the special low prices on BLUEPRINTS ORDERED FROM THIS AD.

ACTUAL BLUEPRINTS (Fully Detailed and Dimensioned)

Model B-25. DUTCH WINDMILL, 20 in. high. (Girl churning butter) \$0.50
 Model B-30. DUTCH WINDMILL, 24 in. high. (Farmer using buck saw) .65
 Model B-10. DUTCH WINDMILL, 24 in. high. (Hexagon style)..... .75
 Model OM60. OLD MILL, 30 in. high. (15 in. diameter water wheel)..... 1.00
 Model H-10. LIGHTHOUSE, 40 in. high. (Copper lantern)..... 1.00
 Model M-10. MARTIN HOUSE, 00 in. high. (8 family, Castle style)..... .50
SPECIAL: ANY 3 OF ABOVE PRINTS ONLY \$1.00.

LAWN-FAIRY TALE FIGURES, PATTERNS (Approx. 20" high) Dutch Schoolboy, Holland Pair, Sunbonnet Girl, Dutch Tulip Girl, Jack and Jill, Little Bo-Peep, Puss-in-Boots, Red Riding Hood, Peter, Peter, Tom The Piper's Son, each 35c.
 (Notes: Color arrangement included on all patterns. Trace direct to wood.)
SPECIAL: ANY 5 OF THE ABOVE PATTERNS, \$3.00
 Dutch Schoolboy Doorstop Pattern FREE with each order. For CATALOG illustrating many models, kits, and supplies, SEND 10c.

CRAFTSMAN'S MODEL CO., Dept. P-36, 2036-N, 41 St., Milwaukee, Wis.

60 POWER TELESCOPE \$2.29

NEW! VARIABLE EYEPIECE, 20X-40X-60X

Three telescopes in one. 3 different magnifications. 20 power for ultra-bright images with 40 and 60 power for extra long range. Guaranteed to bring distant objects, people, sports events, ships, moon, stars, etc., 60 times as clear as the unaided eye.

Most powerful made for the money. Can be collapsed to less than a foot in length. Multiple lens system. 30 mm. objective, in heavy brass mount. Directions included for using as a compound 4 lens microscope. American made. We pay the postage. Only \$2.29.

BROWNSCOPE CO., Dept. 411, 234 Fifth Ave., New York, N. Y.

GEARS

In Stock—Immediate Delivery

Gears, speed reducers, sprockets, thrust bearings, flexible couplings, pulleys, etc. A complete line is carried in our Chicago stock. Can also quote on special gears of any kind. Send us your blueprints and inquiries.

Write for Catalog No. 10
CHICAGO GEAR WORKS
 769-773 W. Jackson Blvd., CHICAGO, ILL.

HANDY Taps and Dies



Accurate . . . high grade steel . . . precision cut threads . . . carefully hardened and tempered . . . Complete range of sizes for ordinary requirements. At your local 5 and 10 cent store.



Made by **HENRY L. HANSON**
 Worcester, Massachusetts

Men & Women Earn Cash at Home!

Mrs. M. M. earned \$267 in 3 weeks (sworn statement) raising mushrooms for us in her cellar! Exceptional? Yes, but your cellar, shed, barn may be suitable to bring moderate income. Book, pictures, sample free. Est. 1908.

UNITED CO. 3848 Lincoln Ave. Dept. 68 CHICAGO

ARE YOUR KEYS THE ONLY KEYS

to your shop, home, office, store, garage, etc.? Why be in doubt? Don't take chances. Learn how to reset your own cylinders so that keys that may be in the hands of old tenants and landlords or perhaps burglars will not work. Our locksmith manual for resetting cylinders sent for \$1. After several minutes with our manual you will be able to reset cylinders very easily.

SEND NOW!

Midwest Locksmiths, 3711-D-W. Chicago Ave., Chicago, Ill.

For..BIG Money-Making..Doing ALL Work

Use **The FIFEL-GEARED**

● 2 New Pocket Machine Shops .. 7" and 8 1/2" ..
● It Takes 7 SQ. FT. OF SPACE and 101 Pictures to show the astounding Working Power, Speed and Efficiency, and the AMAZING MONEY-MAKING Power..\$35 to \$100 Weekly.. of this Greatest Hand Tool Invention of ALL Time .. so Don't expect us to tell the story Here; but..let us send you the MOST AMAZING Propositions, FREE!
** They will Please and Astound you!



PIERRENCH KIT

● ACT TODAY, and get also Free .. "the world's Most Useful small tool." It has .. 2 End, 2 Side and 3 Angle Edges ..
FREE
Turns Screws in All Positions .. \$1 worth of Uses.

● Mail this Part of Ad TODAY with your address (on a Postcard will do). Get **FREE**—101-Picture Manual of Mechanics, with .. User Offers. Or, With .. DISTRIBUTOR, Territory and **FREE KIT** Offers.
AMERICAN PIERRENCH CORP'N PMK-4809 N. Ashland Ave., CHICAGO, ILL.

Home Craftsmen, Schools, Hobbyists
METAL CASTINGS



produced in your own workshop allow you to design and build your own GASOLINE ENGINES, STEAM ENGINES, STATUARY, ART OBJECTS, SPECIAL TOOLS, NEW INVENTIONS, ETC. You can also make forgings and case hardened steel. Your shop is not complete without a **FOUNDRYETTE**. Three sizes are available capable of making bronze castings of 1 1/2, 3, and 6 pounds weight, aluminum, copper, brass, etc., in proportion to specific gravity.
Domestic gas supply and 110 volt 60 cycle energy required for operation.
Size Crucible Shipping Wt. Price
Capacity Casting Complete
351 6 cu. in. 25 lbs. 1 1/2 lbs. \$ 9.50
352 12 cu. in. 40 lbs. 3 lbs. 15.00
353 24 cu. in. 65 lbs. 6 lbs. 23.50
For 110 volt D. C. or 25 cycle Universal motor instead of 60 cycle motor add \$4.00. Prices F. O. B. K. C. Check or money order acceptable express charges C. O. D. Write for circular.

KANSAS CITY SPECIALTIES CO.
P. O. Box 6022 Kansas City, Mo.

BUILD IT YOURSELF

You can build this Trailer with ordinary tools easily from our step-by-step constructional sheets and large size blueprints.
Finest designed Trailer in existence, sleeps 4. Toilet, Shower, Electric Light, etc.
Saves 75% of the cost by building it yourself. Send 25c for plans sheet, illustrations and details.
THE PLAN SHOP, 913 Palmolive Bldg. Chicago, Ill.

100 PAGE BOOK No. 3
Make Beautiful Furniture
at a fraction of store cost. USE THE CRAFTSMAN new process of inlaying, using our new process ART INLAY GLUE, needing no clamps for the finest work. Hard to find rare grains for all wood, including foreign hard-to-find cabinet hardware. Lists and illustrates 70 blueprints of scroll patterns, inlay table tops—Kits for inlaid art boxes, plaques, trays, book ends, etc. that anyone can make—22 pages in color.
CRAFTSMAN WOOD SERVICE CO.
2721 MARY STREET CHICAGO

Win a Free Trip to Europe on the QUEEN MARY

also 28 Cash Prizes — Medals, Cups for Building this 18 in. Model

Wouldn't you like a Free Trip to Europe and return on the Queen White-Star Superliner, or \$50. Cash Money? These are two of the Prizes in the IDEAL Model Building Contest. Get the IDEAL Official Contest Kit containing a fully finished "Red-Form" Hollow Hull and all Parts, Materials and Plans to build and decorate this 18" Model. Start now; it's easy; full details and contest entry blank in every Kit.
Ask your dealer or Complete Kit \$1.00 Plus 10c postage send your order direct.

Large Size Scale Models
R. M. S. QUEEN MARY—31 1/2" long..... \$500 Each, Postpaid.
S. S. NORMANDIE—32 1/2" long..... West of Denver,
Liner REX—29" long..... add 50c extra.
Kits contain shaped wood hulls, wood decks, superstructure, metal fittings, plans, photos, instructions and everything for complete Models.
Send 5c for Model Boat and Airplane Catalogues.

The IDEAL Company, 26 West 19th Street, New York

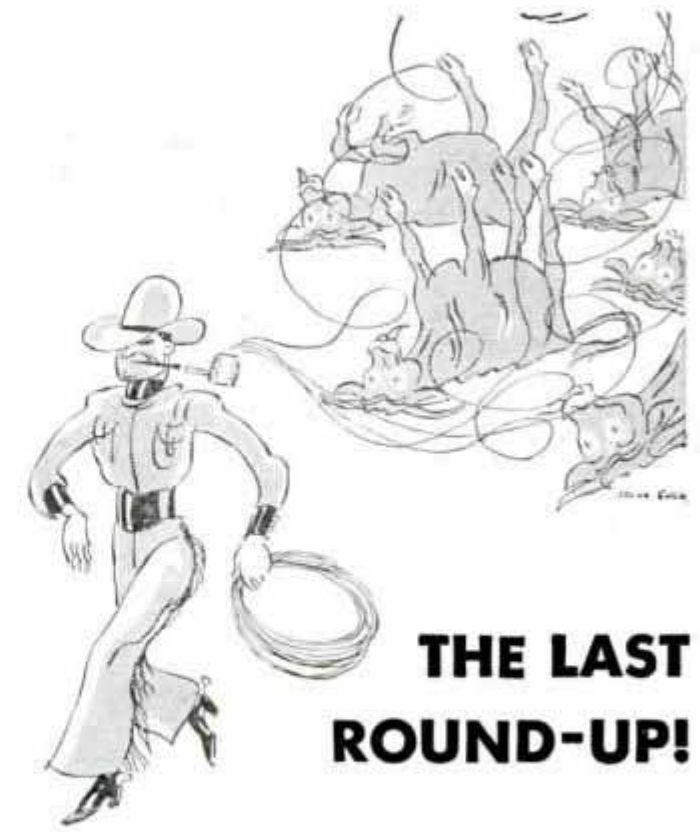

THE LAST ROUND-UP!

ONE WHIFF of maverick tobacco from that gurgling old pipe made the steers cry "Uncle!" Personally, we don't hold with strong pipes and bitter blends. We feel that a briar is improved by a daily grooming and a diet of milder, pleasanter tobacco like Sir Walter Raleigh. First, of course, because we make it; but also because this great blend of well-aged Kentucky Burleys is cooler to smoke and delightfully fragrant. Try a tin. You may not round up as many cattle, but you'll pull in a big gang of admiring friends.

SWITCH TO THE BRAND OF GRAND AROMA

SIR WALTER RALEIGH
SMOKING TOBACCO FOR PIPE AND CIGARETTES

15c UNION MADE

Sooner or Later—Your Favorite Tobacco

How to TAKE CARE of your PIPE

FREE booklet tells how to make your old pipe taste better, sweeter; how to break in a new pipe. Write for copy today. Brown & Williamson Tobacco Corporation, Louisville, Kentucky, Dept. P-611



Do You Want a WATCH or DIAMOND?

Thousands have found it easy to own America's finest diamond rings, watches, silverware or jewelry by the Santa Fe Plan. Bulova, Hamilton, or Elgin watches—brilliant blue-white diamonds—silverware from world-famous companies, and the great Santa Fe Specials—offered to you at startling cash prices on confidential liberal credit terms.

A Few Cents a Day is the Santa Fe Way

That watch or diamond you've always wanted, longed for—you needn't wait any longer for it. The Santa Fe will trust you—let you wear the watch or diamond you want while you pay only a few cents a day.



Gifts for Every Occasion

TURN PIN MONEY INTO DIAMONDS

Don't Pay Extra For Credit!

No honest person should pay extra to have someone trust him. The Santa Fe trusts you the way you want to be trusted—straight from the shoulder without any extra charges, extra fees, or taxes. You pay only the low advertised cash price in small monthly payments. Send for 1937 Catalog NOW!

FREE to Adults—Send for this beautiful book today. Sent ABSOLUTELY FREE to adults. Send your name and address, and the beautiful catalog will come to you by return mail. Do it now while you think of it.

SANTA FE WATCH COMPANY
Dept. B-6, Thomas Bldg., Topeka, Kans.

FREE! 10 SKATING LESSONS

Learn how to skate like the world champion. **Full 10-lesson course Free** with each pair of Bobby McLean Skates at \$4.95. (Lessons without skates, \$2.00.) Exact duplicates of Bobby's own skates—worn by him in all races and exhibitions—designed by him personally for **faster starts, turns and stops**. Skates riveted firmly to full-grain leather shoes—extra sharp **Vanadium tool steel-runners**—tested for hardness—**stay sharp longer**. When ordering, specify Hockeys or Racer—Boys or Girls—order one size larger than street shoe. Send \$4.95 with order and save Parcel Post and C. O. D. charges. Money back if not satisfied. Bobby McLean Ice Skate Co., 3906 Cortland St., Chicago, Ill.



By **Bobby McLean**

HANDY DRILL PRESS BENCH & MACHINE VISE

Ideal for Machine Shops, Garages, Home Workshops, etc. All working faces ACCURATELY MACHINED. Jaws 2" wide x 1 1/4" deep, open to 2". T-slot in base for machine table bolts or bench clamp. *Special Offer* includes



detachable genuine malleable iron bench clamp with 1 1/4" opening. Weight, packed, 1 lb. 7 oz.

Send Money Order or Draft to **ROBERTS TOOL CO.**
1890 E. 40th Street
Cleveland, Ohio

Only **\$1.50** Plus Postage
Dealers, Write Us Also

ELECTRIC PENCIL for Burnt Wood Etching

ONLY Loads of fun—profitable tool \$1.00 Simple—safe—durable—burns on wood, leather, velvet. Specially designed heating element keeps point at uniform temperature. Not a toy! Send for free general catalog 71M with Burnt Wood supplies, Brass Craft designs, etc.

THAYER & CHANDLER, 910 W. Van Buren St., Chicago



Electric Pencil \$1.00
Panel (Illustrated) \$2.50
ORDER TODAY

RATCHET STOP MICROMETER \$1.95

Sensational Offer to Readers of Popular Mechanics

0-1" Ratchet Stop Micrometer measures accurately to one-thousandths inch. Easy to read. Easy to adjust. A carefully finished tool of highest accuracy. Every mechanic, garage, and repair shop needs an accurate dependable micrometer. Here is an opportunity to secure one at a remarkable bargain price. Send \$1.95 plus 15 cents for postage to

PHILADELPHIA MACHINERY CO., 603 Arch St., Philadelphia, Pa.

SHIP & COACH MODELS



Queen Mary, 27 in., \$2.50. Many others from \$1.00 to \$6.00. All models comprise completely finished hulls and parts of wood. Sails, wires, rigging, and all parts included. Entirely new line for beginners now priced at \$1.00. Send 3c stamp for illustrated catalog.

MINIATURE SHIP MODELS, Dept. RT, Perkasee, Pa.

Coil of SILK TENNIS STRING GIVEN with MONEY-MAKING Re-Stringing VISE:



Genuine Split Lamb GUT 27 rolls, 19ft. Aristocrat, \$3.50; Special, \$3.00; Eclipse, \$2.50. SILK 2eels 18 & 19 ft. Superior, 65c; All Star, \$1.00.

Earn big profits with Wills' new Re-Stringing Vise, only \$2.50 plus postage. One silk tennis string coil GIVEN with Vise if you act quickly. This Special Offer good limited time only. Satisfaction guaranteed. Buy tennis equipment direct from us and save! **FREE** Catalog Badminton, Squash, Tennis strings, frames, etc. **H. E. WILLS CO., 1047 W. 467th St., Dept. 1358, CHICAGO, U.S.A.**

\$2.50

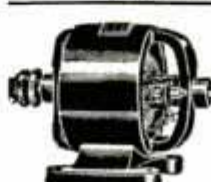

Mechanical and Electrical Catalog

Illustrating Electrical, Mechanical and Model Makers, Supplies, Small Steam & Gasoline Engines, Motors, Generators, Lathes, Drill Presses, Bench and Band Saws, etc., 16 & 32 Dymo-Motors, School Projects, Engine Castings, Motor Parts, Etc., Books, Blue Prints, Brass and Steel Tubing, Gears, Pulleys, Hangers, Experimental Material.

Big Copy. Mailed anywhere for 20 cents. 25 cents Canada, refunded first order.
LOOMIS ELECTRIC COMPANY
2822 N. California Ave. Chicago, Ill.



Draw Fat Weekly Income from NEW TWIN VENDORS

Be Independent! No selling! Get a chain of these sensational, new, low priced Siamese Twins working for you and your worries are over. Vend peanuts in one—candy in the other. Place them on every booth, table, counter, bar or wall of restaurants, beer parlors, factories, offices, filling stations, etc. Wonderful operation from cast aluminum mechanism. So low in price you can build big paying business from pocket money. Write, **NEKO MFG. CO., 1201-P S. 3rd St., Minneapolis, Minn.**

EARN EXTRA MONEY SPRAY PAINTING

Complete portable sprayer, with qt. size gun, hose, etc., \$25.00. Large tank unit for garage work, automatically controlled, only \$32.50. Supply limited—Act Now. Write for circular.

AIR COMPRESSOR SALES, Inc.
15 Harper Ave. Detroit, Mich.

425 POWER \$18.50!

Other big values—FREE book tells all



Every microscope magnifies. Then where is the distinction? One trial of a Wollensak convinces you. Its fine, clear detail reveals mysteries, wonders and even horrors you never knew. Microscopy is a lasting fascination with a Wollensak.

Write for free booklet, "Revealing Nature's Wonders." Opens the door to Nature's endless miracles. Shows microscopes—100-power (\$5) to 425 power (\$18.50), binoculars, telescopes, field glasses, spotting scopes, etc.

Write for yours now.

WOLLENSAK OPTICAL CO.
897 Hudson Ave.
Rochester, N. Y.

WOLLENSAK MICROSCOPES • TELESCOPES
RIFLESCOPES • BINOCULARS

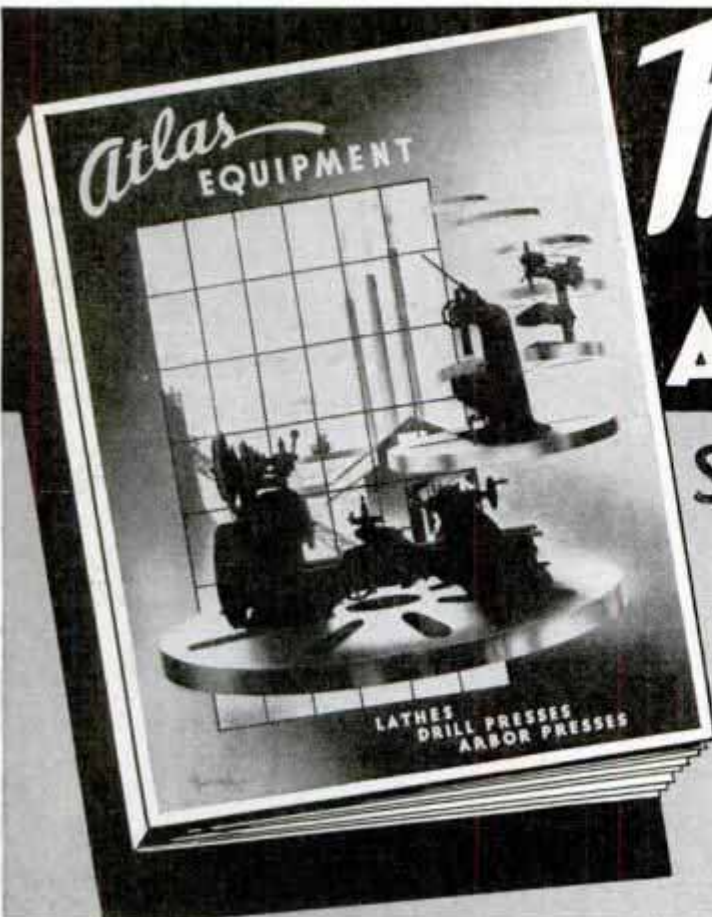

Now Ready NEW 1937 ATLAS CATALOG

Send for Your Copy Today

Ten minutes with this big new 52 page catalog will save you many dollars in equipment costs this Fall. It's our 25th Anniversary. We're offering the greatest values in our history. Mail the coupon below for your copy—it's FREE. See all the latest improvements in lathes and drill presses. See how our engineers have combined precision manufacture with modern new design. See the extra features Atlas provides at no extra cost, and get full information about our 2 weeks' trial, money back guarantee, and easy payment plan.

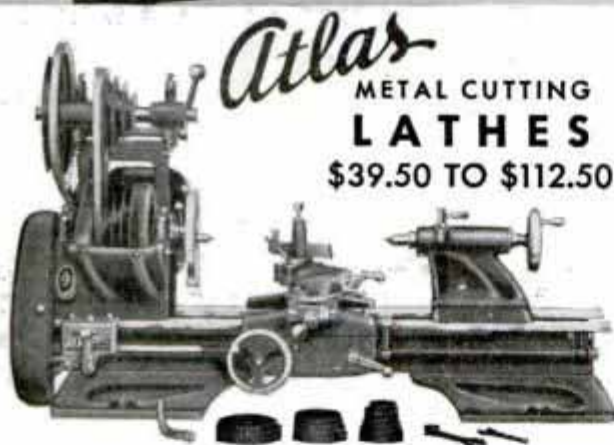

Atlas
METAL CUTTING
LATHES
\$39.50 TO \$112.50

A size for every purpose. Model illustrated is back-geared with automatically reversible power feeds priced at \$87.50. Includes many features at no extra cost.

Atlas WOOD LATHES
\$22.95 TO \$29.95



Designed for the user who wants the best possible lathe he can obtain for this type of work. Deep grooved SKF ball bearings. Ruggedly constructed throughout.

Atlas
DRILL PRESSES
\$16.45 TO \$42.45

4 sizes and prices to fit every need. Precision built of the finest materials to assure permanent accuracy and long life.



Atlas
METAL WORKING LATHES
WOOD TURNING LATHES
DRILL PRESSES • ARBOR PRESSES
TOOLS & ATTACHMENTS

MAIL THIS COUPON TODAY

ATLAS PRESS CO.
1143 N. Pitcher St., Kalamazoo, Mich.

With no obligation on my part please send your new 1937 catalog.

Name.....

Address.....

City.....

State.....

25th
ANNIVERSARY



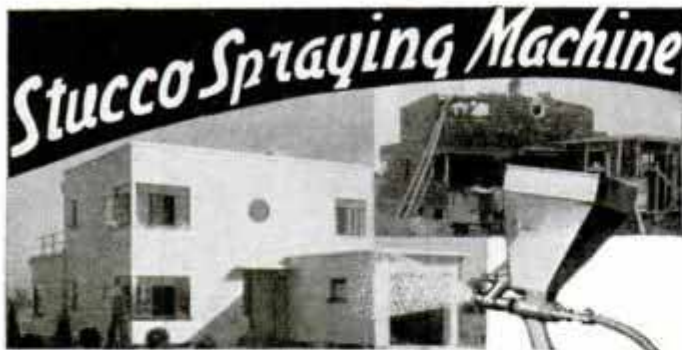

Renew old buildings. Make new construction more permanent and attractive. Plastic Colorcrete is waterproofed. It fuses with any masonry surface. It fills all cracks. It can be applied in any thickness and in 30 colors. Fully proven by over 12 years actual use under all conditions and every climate.

OFFERS BIG EARNINGS

Owners everywhere want to enhance present values. With this machine you can supply this big waiting market with permanent Colorcrete at amazingly low cost. Operators report cost of 2c and up per sq. ft. and sell up to 7c. Some have paid for their equipment from first few jobs. Machine capacity up to 1,000 sq. ft. per hour. Get the facts. Send for books, "Proven Business Opportunity." Write today. It offers you big extra income.

COLORCRETE INDUSTRIES, INC.
570 Ottawa Ave. HOLLAND, MICH.



New Invention brings SOARING PROFITS!

COIN MONEY HAND OVER FIST

A razor blade sharpener entirely new in principle—strips and hones both sides of both edges at the same time—the amazing new MAXIMAX. Gives real shaving comfort. Cuts blade bills in half. Ready to pour profit into hands of alert salesmen everywhere! **EVERY MAN NEEDS ONE!** This new kind of sharpener prevents curled over "feather" edges that scrape and scratch. MAXIMAX is the only sharpener that hones and sharpens with both back and forth and sideways movement at same time. Produces perfect shaving edge. Makes new blades better—old blades new.

CASH IN NOW! Territories now being assigned for this big money maker. 100% profit. Popular low price. Write or wire for **MONEY-BACK GUARANTEE** offer.

MAXIMAX, INC., Dept. P, 343 S. Dearborn St., Chicago

Just Published—
BIG CATALOG OF 1937 POWER TOOLS —BOICE-CRANE—

—describes this **NEW All-Purpose Belt Sander**
Don't make the mistake of wasting hard earned \$5 on small impractical sanders. Buy this new improved B-C that handles all lengths and widths of stock. **Only \$9.00**

Practical Wet Tool Grinder
Few \$5 buys it. Extra life from hand tools pays for it. Uses time-proved wet wheel.

New! TILTING-ARBOR Saw **The Finest Saw We've Built**

"Tilting-Arbor" sawing is in a class by itself. The finest tilt-table built can't ever equal its performance. Behind this new 1937 B-C Saw is six years of constant improvement.

Patented! Time Proven!

Get Your Copy of This Big FREE Catalog Now!
Describes and illustrates many other new 1937 Boice-Crane Power Tools and accessories, new features and uses. Sent **FREE** to shops, woodworkers and manual arts instructors.

BOICE-CRANE Co., Dept. 511, Toledo, Ohio
SAWS • JOINTERS • LATHES • DRILLS • SHAPERS • SANDERS • JIG-BAND SAWS

WIND CHARGER RADIO
SAVE UP to 1/2 Usual Price

Powerful WIND CHARGERS Operates RADIO AND LIGHTS From **FREE WIND POWER**

A light wind furnishes electric lights and city radio performance for the country home. No "B" or "C" batteries. Gives pleasure of care-free, full strength radio reception that will amaze you—without power lines. Foreign as well as American reception.

SENT ON 30 DAYS' TRIAL
Write for 30 day no-risk trial plan—also get offer of one **FREE** to first user-dealer in each locality. We pay liberal commissions to one person in each locality to own, operate and take orders. A little easy work brings your own radio **FREE** and a wind charger for only \$7.50 additional. **Special Temporary Offer**—be first—write quick—a 1c post card will do.

PARKER-McCRORY MFG. CO.
Pioneers in Radio—Established 1925.
N-751-2609 Walnut, Kansas City, Mo.



GAS MOTORS
Last Chance!

This is your last opportunity to obtain the G.H.Q. Motor Kit—(orders taken up to November 15th). We have decided to withdraw our temporary offer of \$8.50 for gas kits

selling finished motors only at \$12.50 after above date. The G.H.Q. Motor is actually one of the most powerful motors ever constructed! Has broken records for amazing performance—flies model planes up to 10 ft. wing spread. Easy to start, just a twist of the wrist, and simple as ABC to assemble (so easy only a screwdriver is needed). Steady running—runs 27 minutes on ounce of gas. Cylinder and piston lapped to within .0003. Kit includes plug, coil, condenser, tank, ignition wire, cylinder, piston, connecting rod, timer, crankshaft, all screws, nuts, bolts etc. Every part is fully machined and finished. No oil, gas, batteries or propeller included. Postpaid.

\$8.50

Ready-to-Run G.H.Q. Motor complete with propeller block included; entirely assembled on stand. Tested and run before shipment—Performance guaranteed—1.5 horsepower at 3000 to 7000 R.P.M.—No oil, gas or batteries included. Postpaid for only \$12.50. Send 3c for illustrated catalog including information on gas accessories.

G.H.Q. MODEL AIRPLANE CO.
854-B East 149th St. New York, N. Y.

Kits offered up to Nov. 15 only!

NEW! IMPROVED!
DUAL RAY HEALTH LAMP
TWO SEPARATE LAMPS IN ONE
ULTRA VIOLET—INFRA RED RAY

Health giving. Prevents Rickets. Gives **SUN-TAN**. Vitamin "D." Automatic safety control. 110 Volt AC-DC current. Also experimental work. Free Details.

Complete with Goggles Ready for Use. Only \$3.90

Beyer Mfg. Co. 4655 Lincoln Ave., Dept. PM-11 CHICAGO, ILL.

What You've Been Looking For!!!
CROMHEAT-ELECTRIC HOT WATER HEATER

Instant hot water for trailer, home, garage, or camp. Just plug into light socket and drop into water. Convenient for shaving and washing. Guaranteed one year.

Only \$4.95 each

Manufacturers and Dealers—write for prices. Send Dime for new complete Trailer Supply Catalog.

C. M. HOOF COMPANY 1736 S. MICHIGAN AVENUE CHICAGO, ILLINOIS DEPT. PM 11 VICTORY 8070

PLAY ELECTRIC FOOTBALL

Line smashes, trick plays, field goals, laterals, forwards, and runs, fumbles, etc. A game for football coaches as well as boys. Operates on one flashlight battery. Order C. O. D. check, or money order. \$2.00 only. We pay all postal charges.

THE ELECTRIC GAME CO. Inc. HOLYOKE, MASS.

Let us recommend the best books to study on any subject. **Popular Mechanics Press Chicago, Illinois.**

New, modern FLEXIBLE-SHAFT SCREWDRIVER

Permits access to screws in awkward places—actually curls around a corner. Ideal for radio, refrigerator, automobile, electrical appliance, motor, machinery repairs. Shaft of laminated flexible steel wires; chromium-plated, non-rust fittings; tempered steel blade; fluted wooden handle; length overall 8". **\$1.00 POSTPAID.** Commonwealth Products Company, 401-N Broadway, New York, N.Y.

Greatest Screwdriver Ever Made

Boys! Men! Get This Wonderful GIFT!

25 PIECE ELECTRICAL EXPERIMENTAL KIT

WIRE UP thief detector, extension phone, electric welder, radio code set, electro-plating, arc furnace, circuit tester, 110-volt rectifier, 110-volt motor, hundreds of fascinating experiments.

CONSTRUCT are light 5,000-ft. range, secret service phone (listen on private conversations), generate ultra violet (sun tan) health rays, make real electric stove, etc. Thrilling and educational experiments.



25 Pieces Genuine Commercial Apparatus

NOT TOYS—but real apparatus purchased from surplus and bankrupt stocks. Kit contains 110-volt A. C. power motor, sensitive microphone, transformer, polarized test receiver, arc carbons, electro-magnet, test compass, plating chemicals, condenser, secret service transmitter, powerful magnet, plating sands, test socket, 110-volt power resistor, test cord and slips—12 other valuable pieces. Complete illustrated experimental manual furnished.

Original List Price of Parts... \$18.50

Orders shipped same day received, only

FREE 3 manuals—1. Short Course in Electricity, 2. Blue Prints and Plans for Home Laboratory, 3. Fun with Electricity. Send stamp for Electrical Radio Bargain Catalog. ORDER TODAY!

ELECTRICAL SALVAGE COMPANY
Box 931-A Lincoln, Nebr.

Arc Kit 4000 Ft. Range



Works from house light current. Weld iron or brass. Melt glass, metal. Make arc light (1-mil. range), arc furnace. Generate sun-tan rays. Consists of arc holder, stand, carbons, power coils, cord, plug, etc. Exper. booklet free. (List price \$4.75.)

SPECIAL \$1.49

Technicians Tool Kit



Ideal for radio or electrical experimenter. Consists of 5 in. screwdriver, steel callipers, all-steel electrician's hammer, technicians 9-piece socket wrench set, 1 pr. thin nose pliers, 6-32 and 8-32 taps with holder. In next case.

SPECIAL List price \$4.75. \$1.99

New Pocket Radio



Operates without tubes or batteries

Amazing pocket radio fits in pocket or purse. Smaller than a cigarette package! No crystals to adjust or heater with—only one moving part—no upkeep. Beautiful clear tone and unusual selectivity and volume. Can be used by ANYONE ANYWHERE. Directions included for use in hotels, offices, autos, at home, while cycling, boating or on trains. Thousands of satisfied owners report amazing reception and distance. Takes only a second to connect and tune in. Absolutely Nothing Like It Anywhere. Choice of beautiful colors: Black, White, Brown, Green, Blue and Red. ABSOLUTELY complete with rugged phone ready to listen. Send only \$1.00 and pay postman balance or send \$2.99 (Al. O. Cash Check) and we will send postpaid. Ideal gift for any boy. Guaranteed. Order Now! State color.

SEND ONLY \$1.00

TINYTONE RADIO CO., Dept. P-11, Kearney, Neb.

BILD-UR-OWN

COASTERS • MIDGET AUTOS • SCOOTERS • BIKE TRAILERS, ETC.

4 wheel sets equipped with 10" x 2 1/2" Balloon Tires (Goodyear-Goodrich or Firestone) being offered at special price—will carry 200 lbs. per wheel. Also larger Tires and Wheels—Motors, etc.

BILD-UR-OWN DEVICES Write to-day for particulars
5237 Lake St., Dept. MN Chicago, Ill.

THOMAS TRAILER AXLES

Wider Spring Spread... Lower Center of Gravity 5 1/2" Drop Carbon Steel Hangers. 2 1/2" Carbon Steel Tubing. Nikrome Nickel Steel Spindles, to fit FORDS & CHEV. wheels. With or without flange for brakes. Send 10c for Catalog on axles & other trailer parts.

THOMAS TRAILER AXLE CO., Dept. PM 11
2408 S. CRAWFORD AVE. CHICAGO, ILL.

MAKE 200 TOYS an Hour... for 1¢ Each!

Sell toys at big profits. Get this complete outfit. You can make 3 different characters thousands of times in moulded metal. Includes paints for coloring and full casting equipment. Price \$2.50. Electrically operated, \$3.00. Send money order, stating choice of U. S. Soldiers, Wild West Cowboys, U. S. Machine Gunners. EXTRA MOULDS for 3 large figures at 95c include other soldiers, cannon, battle-ships, animals. Buck Rogers toys (\$1.00). Choice of 188 Different Characters.

FREE 3 BIG ILLUSTRATED FOLDERS ON CASTING

RAPAPORT BROS., 703 WEST OHIO STREET, CHICAGO



TURN SCRAP INTO MONEY

The new "1936" edition of "AUTOPOWER" with all the original specifications and many new ones is now off the press. The book is plainly written and illustrated—the instructions easy and simple. Change auto generators into practical A. C. and D. C. generators and motors, with voltage from 2 to 1,000 volts, for power, light, welding, radio, sound, etc. No experience nor special tools needed to make these economical changes. Generators can be driven by wind, water, fan-belt, etc. Already used and endorsed by thousands. Send for your copy today. Price only \$1 postpaid.

AUTOPOWER, INC. Dept. G 410 S. Hoyne Ave., Chicago



AMERICA'S MODEL SHIPYARD BUILD Boucher MODELS

Authentic scale model kits for Ships, Ancient and Modern. Get your kit from the pioneer model house, making real models since 1905.

Blueprints, fittings, supplies and Kits for 62 different ship models. Racing model Yachts, miniature engines, speed boats.

For 25c we will send you 2 beautifully illustrated books "Hobby" & "Scale Models of Famous Ships."

BOUCHER (Dept. P.M.11), 126 Lafayette St., N. Y.

See Boucher Models being made at the N. Y. Museum of Science and Industry—Rockefeller Centre, November 1st to January 1st.

a real MICROMETER BARGAIN!

Genuine, American made, six piece micrometer set, in velvet lined leather case. Special price, only \$11.95, a fourth off regular price and a fraction of the cost of other sets on the market.

These micrometers are precision machined for accuracy in one thousandths of an inch, up to 4 inches outside and 3/4 inches inside measurements. Guaranteed accurate, easy to read and adjust. Built to stand hard wear and give satisfaction.

Every mechanic, apprentice, garage and repair shop needs these accurate and dependable micrometers. This is your opportunity to get one at a Bargain Price if you act now. Shipped prepaid on receipt of remittance. On C.O.D. shipments, send deposit of \$2.00.

MICRO PRODUCTS 316-A Murphy Bldg. DETROIT, MICH.

Chucks for Small Lathes

Lowest Prices Ever Offered

Four-jaw independent as shown

A quality tool, accurately made. Send draft or money order. If not entirely satisfied, return chuck in 5 days and we will refund your money.

5 inch Chuck \$6.87 6 inch Chuck \$9.87

JOHN L. ALEXANDER, 424 Superior St., Detroit, Mich.

Buy Direct from the Manufacturer

MICROSCOPES CHEMICAL SETS LABORATORY APPARATUS CHEMICALS

Send 10 cents postage for Large Complete Supply Catalog.

STANDARD SCIENCE SUPPLY COMPANY
2340 Wabansia Ave. Chicago, Ill.

TYPEWRITER 1/2 Price

Now Only

10¢ a Day

AFTER 10 Day FREE Trial

No Money Down



Fully GUARANTEED

Positively the greatest bargain ever offered. A genuine full sized \$100.00 office model Underwood No. 5 for only \$44.90 (cash) or on easy terms. Has up-to-date improvements including standard 4-row keyboard, backspacer, automatic ribbon reverse, shiftlock key, 2-color ribbon, etc. The perfect all purpose typewriter. Completely rebuilt and FULLY GUARANTEED.

Learn Touch Typewriting

Complete (Home Study) Course of the Famous Van Sant Speed Typewriting System—fully illustrated, easily learned, given during this offer.

Lowest Terms—10 Cents a Day

Money-Back Guarantee

Send coupon for 10 day Trial—If you decide to keep it pay only \$3.00 a month until \$49.90 (term price) is paid. Limited offer—act at once.

INTERNATIONAL TYPEWRITER EXCHANGE, 231 West Monroe St., Chicago, Ill., Dept. 1101.

Send Underwood No. 5 (P. O. B., Chicago) at once for 10-days' trial. If I am not perfectly satisfied I can return it express collect. If I keep it I will pay \$3.00 a month until I have paid \$49.90 (term price) in full.

Name..... Age.....

Address.....

Town..... State.....

(Continued from page 154A)

a service station and calmly fill his fuel tank with water from a hose. Then, to the amazement of the attendant, he would drop a couple of pills into the tank and drive off, his engine running as well as ever. Naturally, after this happened a few times, the attendant would give almost anything for some of the pellets. The motorist would explain that ordinarily he didn't sell any pills but finally would part with several packages he had in the car, getting \$15 or \$20 for enough to "convert 500 gallons of water." That was the last the service-station man ever saw of his money or the motorist. The answer, of course, was that the motorist had a hidden fuel tank and the rear tank into which he poured the water was just a dummy.

"Motors Overhauled, Fifty Cents per Cylinder," is another bait on which many drivers bite. The advertisements usually state lost compression is restored, rings are freed, valves reseated, and other benefits are performed by capsules or paste placed in the combustion chambers. The capsules generally contain some form of mica and wax that builds up on the walls



of the cylinders. The benefits are extremely temporary, experts explain. What really impresses the motorist is the improved performance that comes from the good tune-up that is given as part of the installation service. Better business bureaus say the pellets are sometimes used as "come on" inducements to attract drivers into a garage. Then strong efforts are made to sell them new coils or other expensive ignition parts so "the compound will have a fair chance to help the motor."

7156

Human Eye's Sensitivity to Light Increases with Darkness

Human eyes are ten thousand times more sensitive to light in darkness than in daylight. Dr. Lorrin A. Riggs of Clark University found that when a frog has been kept in total darkness several hours its eye is a thousand times more sensitive, judged by the vastly increased electric currents generated in the eye nerves by a flash of light. By the same method of measuring currents, he found the human eye adapts itself much more speedily to darkness and is 10,000 times as sensitive.

GET PLANS NOW FOR THINGS YOU'LL MAKE *This Winter*

"Things To Make In Your Home Workshop", includes 16 separate and complete plans for interesting shop projects. Lists necessary tools and stock. Easy to follow.

10¢

"Stanley Tool Guide" — a big 32-page book containing scores of illustrations.

25¢

It gives clear, concise information on the proper use and care of tools and how to sharpen them correctly. Full valuable information for every homeworkshop owner.

The small cost of these books is nothing compared to the host of useful facts they give you. Send stamps or coin for one or both of them to-day.

STANLEY TOOLS

105 Elm Street, New Britain, Conn.

A BAD CASE OF PIMPLES MADE NAT HATE TO GO PLACES. READ STORY



Don't let Adolescent Pimples make YOU miss out on good times

Nearly all boys and girls are subject to pimples after the start of adolescence—from about 13 to 25, or even longer.

During these years, important glands develop and final growth takes place. Disturbances occur in the body. The skin gets oversensitive. Waste

poisons in the blood irritate this sensitive skin. Pimples appear!

Fleischmann's Yeast clears these skin irritants out of the blood. Then, pimples go! Eat 3 cakes daily—one before meals—plain, or in a little water, until skin clears.



—clears the skin
by clearing skin irritants out of the blood

Write -
FOR THESE BOOKS



South Bend Lathe Works,
910 E. Madison St., South Bend, Ind.

Please send the following:

- No. 1 10c No. 2 10c No. 3 10c
 No. 4 10c No. 5 10c No. 6 10c
 No. 7 10c No. 8 10c No. 9 10c
 No. 10 10c No. 11 10c
 No. 12 25c
 Workshop Catalog No. 15 Free
 General Catalog No. 95 Free

Name _____

Address _____

City _____ State _____

\$75⁰⁰

LESS MOTOR DRIVE

Easy Payments

IF DESIRED

9" x 3' SOUTH BEND WORKSHOP LATHE



A BACK GEARED
SCREW CUTTING LATHE

No. 415-YA 9 1/8" swing by 3' bed Workshop Bench Lathe with Horizontal Motor Drive, 1/4 H.P. Reversing Motor, Switch and belt tension countershaft as shown **\$103²⁵**

A PRECISION LATHE

The New 9-inch Workshop Lathe is a Precision Lathe with Twin Gear reverse to leadscrew, Ball Thrust Bearing on Spindle, longitudinal screw feed to carriage, precision lead screw for cutting screw threads, and scores of other important features. Recommended for the finest work in the plant, shop and tool room. Used by all important industries. Use coupon or write for complete details, free postpaid.

South Bend Lathe Works

910 E. Madison St. South Bend, Ind.

5 OTHER SIZES

9"-11"-13"-15"-16" SWING

in all bed
lengths

**\$87 to
\$1200**

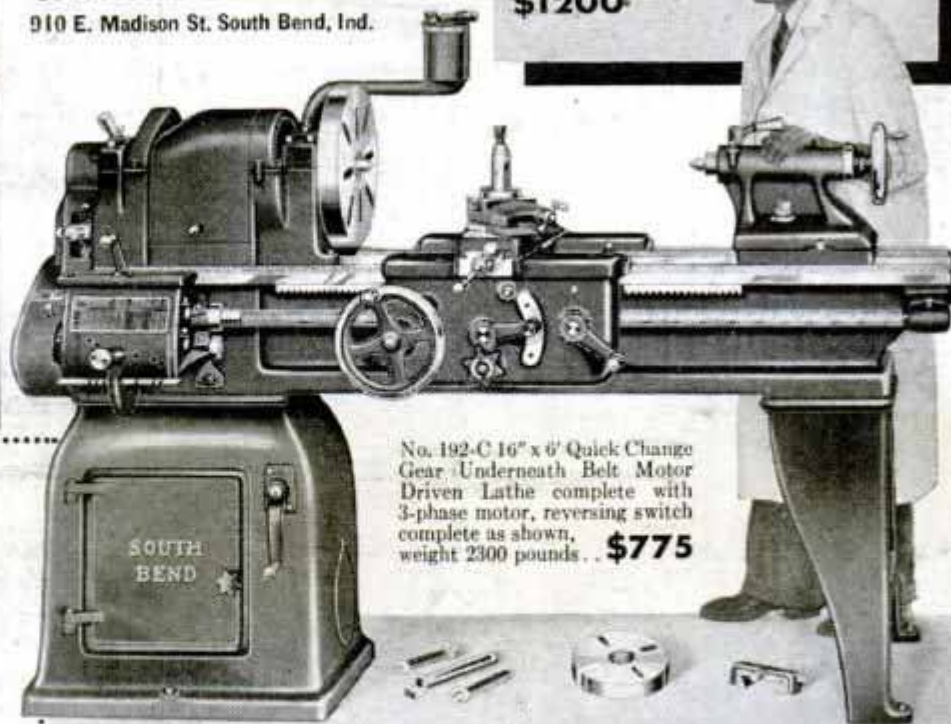

No. 192-C 16" x 6" Quick Change Gear Underneath Belt Motor Driven Lathe complete with 3-phase motor, reversing switch complete as shown, weight 2300 pounds. **\$775**

SOUTH BEND Precision LATHES

CUT COSTS. AS THOUSANDS ARE DOING WITH THIS OIL



Save on Oil and
Repair Bills with Clean, Fresh
MOBILOIL

START NOW to save with Mobiloil. It cuts oil costs—reduces repair bills.

This is because Mobiloil is clean, pure, tough—made by Socony-Vacuum's famous Clearosol Process.

Motorists everywhere are proving the economy of Mobiloil. They report savings

as high as 50% in oil alone—fewer repairs—greatly improved engine performance.

Begin saving today with Mobiloil. Drive in where you see the familiar Mobiloil sign or the famous Sign of the Flying Red Horse. Fill up with Mobiloil.

SOCONY-VACUUM OIL COMPANY, INC.



See the 1936 Mobiloil chart
for correct grade for your car

A Tribute to Football

by Grantland Rice

Blocking backs and interference -
Fifty thousand wild adherents -
Tackle thrusts and headlong clashes,
Two yard bucks and dizzy dashes,
Head and shoulder, heart and soul,
Till you fall across the goal.



And another all-star eleven -

**THEY
SATISFY**