

NEW POWER FROM THE SUN

POPULAR MECHANICS

★

MAGAZINE

WRITTEN SO YOU CAN UNDERSTAND IT

REG'D. TRADE MARK, GREAT BRITAIN, No. 410436

REG. U.S. PAT. OFF.

OCT.
25 CENTS



SEE PAGE 558

WHOSE FAULT?



GOLDEN PLY BLOW-OUT PROTECTION FOUND ONLY IN SILVERTOWNS!

Reporter: "Pretty close shave, Miss. What happened?"

Driver: "We had a blow-out that shot us right off the road. Guess it serves me right. My garage man told me my tires weren't safe, but I just laughed at him." * * *

Don't let anyone tell you that all tires are safe. They're not. And the fact that thousands are killed or injured in blow-out accidents every year proves it. To really stand up under today's high speeds a tire must be specially constructed—it must give you protection where you need it most—*inside* the tire.

The new Goodrich Silvertown

is just that kind of a tire. It's the *only* tire in the world that's built with the Life-Saver Golden Ply, a layer of special rubber and full-floating cords scientifically treated to resist internal tire heat. By resisting this heat the amazing Golden Ply keeps rubber and fabric from separating—it keeps heat blisters from forming. And when you prevent the blister, you prevent the high-speed blow-out.

When Goodrich Silvertowns cost much less than other super-quality tires, can you afford to be without the protection and months of extra mileage they give? See your Goodrich dealer now.

HEAT CAUSES BLOW-OUTS.
PREVENT THOSE
BLOW-OUTS WITH THIS
HEAT-RESISTING
GOLDEN PLY



FREE! Join the Silvertown Safety League. Sign the Safe Driving Pledge and your Goodrich dealer will get for you absolutely free a tail-light emblem with red crystal reflector. No obligation to buy.



The new **Goodrich SAFETY Silvertown**
With Life-Saver Golden Ply Blow-Out Protection

HALF & HALF MAKES ONE SWELL SMOKE!

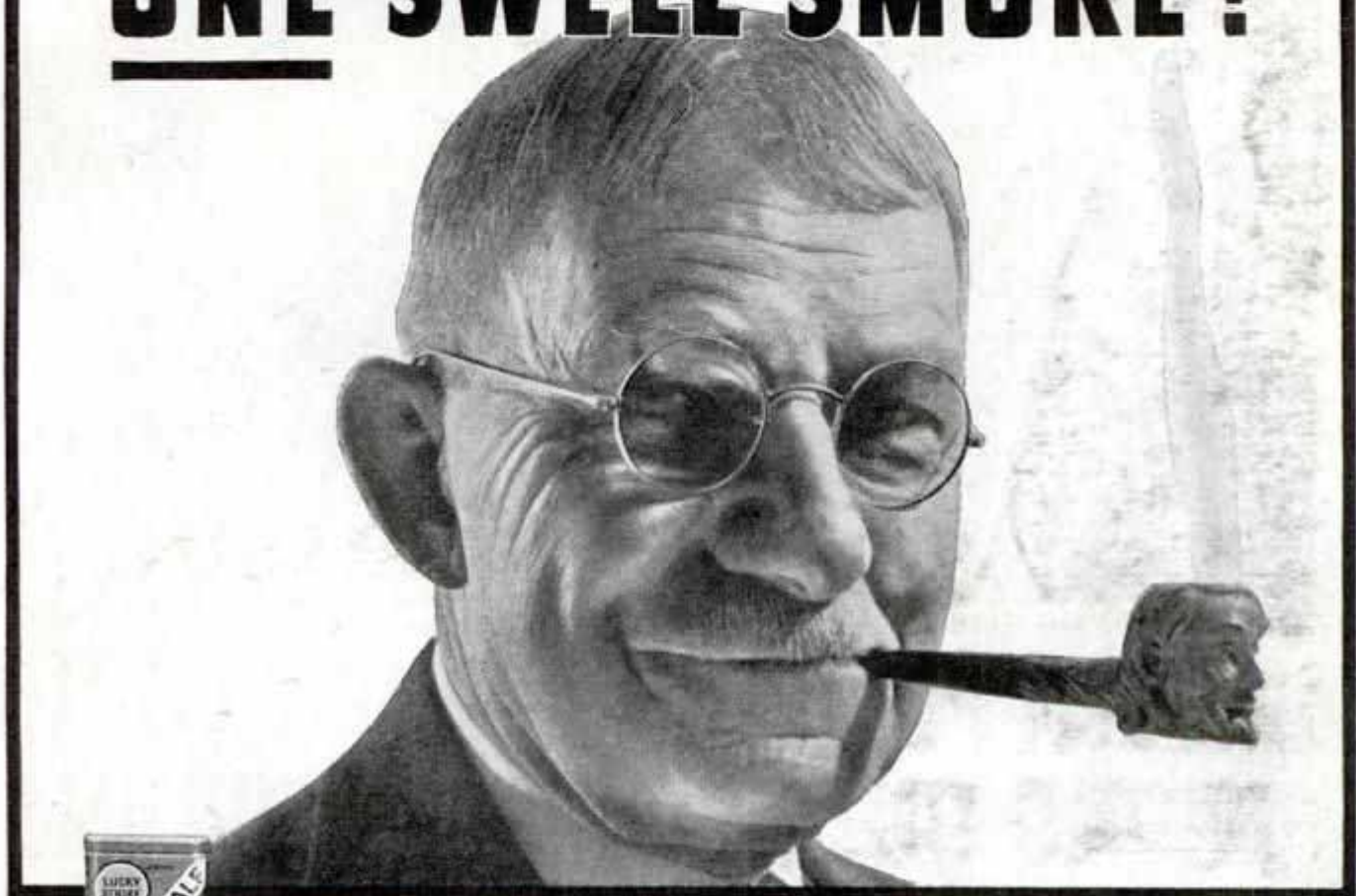

No Bite!



No Bite!



Still no Bite!

Give your pipe a new deal with Half & Half. Cool as a call to show your cards. Sweet as holding four of a kind. Fragrant, full-bodied tobacco that won't bite the tongue—in a tin that won't bite the fingers. Made by our exclusive modern process including patent No. 1,770,920. Smells good. Makes your pipe welcome anywhere. Tastes good. Your password to pleasure!

Not a bit of bite in the tobacco or the Telescope Tin, which gets smaller and smaller as you use-up the tobacco. No bitten fingers as you reach for a load, even the last one.

Copyright 1936, The American Tobacco Company

HALF AND HALF

The Safe Pipe-Tobacco

FOR PIPE OR CIGARETTE

When writing to advertisers please mention Popular Mechanics



"Fine thing, the Telephone"

"HELPS TO KEEP PEOPLE CLOSE AND FRIENDLY"

"I put through a call for my son down East. Must be three hundred miles.

"Hold the line," the operator said. And next thing you knew, there he was. Sounded just like he was right here. It wasn't like that when I was a young fellow."

THIS COUNTRY has the best telephone service in the world. And it's still getting better—quicker, clearer, more useful to more people. Each year brings improve-

ments in equipment and operating efficiency. Operating errors on local calls—always a small percentage of the millions handled daily—have decreased 40% in the past six years.

Since 1929, the average time required for long distance connections has been reduced from 2.8 to 1.4 minutes and 92% of these calls are now handled while you remain at the telephone.

Time has proved the value of Bell System operation.

BELL TELEPHONE SYSTEM



Popular Mechanics Magazine

H. H. WINDSOR, Founder

H. H. WINDSOR, Jr., Editor and Publisher

October, 1936

Vol. 66, No. 4

Special Features

<u>Beware the Spark Plug Racket</u> . . .	481
<u>The New Era of Railroading</u> . . .	Coloroto
<u>Queer Facts about Bridges</u> . . .	500
<u>Feeding Animals in the Zoo</u> . . .	508
<u>Traffic Officers of the Skyways</u> . . .	514
<u>Tricks of the Race Drivers</u> . . .	522
<u>Exploring Up and Down</u> . . .	530
<u>Growing Pearls at Home</u> . . .	535
<u>Horseshoe Pitching Comes Back</u> . . .	540
<u>New Power from the Sun</u> . . .	546
<u>They Keep Things Moving</u> . . .	552
<u>"Simple Party Magic"</u> . . .	563
<u>Fight Corrosion to Save Your Motor</u> . . .	568

(Continued on next page)

Why Gamble with Death?

SINCE 1922 automobile accidents have snuffed out the lives of more than twice as many persons as were killed in all the wars in which America ever participated. And if the present traffic accident rate continues, one out of every twenty persons in this country will be injured or killed in an automobile accident within five years. And that includes you! There's one thing you can do to help reduce this appalling slaughter, and that is to overhaul your own driving habits and eliminate the careless and "sloppy" practices which sooner or later result in accidents. Check up on your own driving by reading "Why Gamble with Death?" in the November issue.

Next Month

LIKE an arrow streamline trains shot across the country, captured public imagination and lured passengers back to the railroads. But there has been more to it than knocking off the square corners and putting pants on the engine. Power and weight were the big considerations. Read the concluding part of "The New Era of Railroading" next month and learn how the railroads found the answer. The article is illustrated with eight pages of Coloroto pictures.

Wanted—a Blizzard

NATURE cannot be relied on to produce a blizzard, a thunderstorm or a cloud bank when the movie director is ready to shoot such an effect, so Hollywood has its own corps of weather makers and its own machines for making everything from fog to sleet. Read how it's done next month.

Hunting Tips

IF YOU'RE going on a hunting trip this fall, you'll need more than a good gun and a good dog. You'll need proper clothing and such things as a knife, a waterproof matchbox and a host of other odds and ends which take up little space but add much to your comfort. Next month Bob Becker tells you what to take along and how to use it.

Published monthly by POPULAR MECHANICS CO., 200 East Ontario Street, Chicago, U. S. A. Single copy in United States, 25 cents; \$2.50 a year, \$4.00 for two years, \$5.00 for three years in United States and possessions, Canada, Newfoundland, Labrador and countries of the Americas and Spain. To all other countries add \$1.00 a year extra for overseas postage. Changes in address must be reported to us immediately to eliminate delay. Entered as Second Class Matter, Sept. 15, 1903, at the Post Office at Chicago, Illinois, under Act of March 3, 1879. Entered as Second Class Matter at the Post Office Department, Canada. Copyright 1936, by Popular Mechanics Co. in the United States, Australia and France.

This One



FHHE-YA4-KE7W

Every Car Needs SIMONIZ



**ARE YOU
NEGLECTING
THE FINISH
OF YOUR CAR?**



Weather and dirt soon play havoc with any car's beauty. They quickly dull and ruin the finish unless it is Simonized. So you are neglecting your car if you don't Simoniz the finish right away. Simoniz takes all the wear the finish ordinarily gets... makes it last longer, and keeps the colors from fading.

If your car is dull, first use the wonderful Simoniz Kleener. It's the quick, easy way to restore the lustre. So always insist on Simoniz and Simoniz Kleener for your car and it will stay beautiful.

MOTORISTS WISE

SIMONIZ

(Contents—Continued)

AUTOMOTIVE

- Auto turns into ambulance by emergency equipment . . . 526
- Hub cap pump inflates tires while car is moving . . . 527
- Claw for police car grabs fugitive auto . . . 529
- Engine head without valves for fuel saver . . . 538
- Diesel railcar for Swiss railways . . . 557
- Dog rides in pram on auto top . . . 557
- Postage-stamp shop in a bus . . . 559
- Heater swings up to clear windshield of frost . . . 560
- Taxicab has sliding door in roof . . . 561

AVIATION

- "Economy" plane flies seven miles per gallon . . . 498
- Flying library for Pacific serves island readers . . . 499
- Cathode-ray direction finder guides airplane pilot . . . 504
- Thrill-ride plane runs on ground . . . 505
- Spin-proof airplane has slots in wings . . . 513
- Air liner needs three scales to find its weight . . . 521
- Air liner big as a destroyer predicted by designer . . . 529
- Eight motors drive four propellers of air liner . . . 551
- Dummies make parachute jump in sham air war . . . 567
- Plane whips big sign into the air . . . 572

CONSTRUCTION

- Tall church spire moved to widen street . . . 528
- San Francisco water tunnel . . . 543
- Glued wall system replaces lath and plaster . . . 545

FARMS

- Spray system easy to make with water-pipe nozzle . . . 512
- Horse crated for shipment on express car . . . 519
- Basin lister dams furrows to hold water in field . . . 560

HOUSEHOLD

- Pilot light in wall switch is guide at night . . . 537
- Pinless curtain stretcher . . . 537
- Conveniences for your home . . . 574

MODELS

- Model railway is replica of junked interurban line . . . 506
- Model of first film studio in Edison exhibit . . . 533
- Cement model of Nebraska capitol . . . 556

MOVIES AND PHOTOGRAPHY

- Two-and-one-half ton camera to map the heavens . . . 505
- Unusual photo of bird family snapped by amateur . . . 507
- Diesels furnish light and power for show . . . 518
- Lights worn by swimmer trace dive on photo film . . . 537
- Flash camera for closeups aims from two inches . . . 538
- Flower "ghosts" photographed by X-ray camera . . . 549

RADIO AND ELECTRICITY

- Portable electric generator for small cottage . . . 566
- Four-tube receiver tunes from one to ten meters . . . 577
- All-purpose portable hearing-aid amplifier . . . 578
- How to read schematic circuit diagrams . . . 580
- Hints for radio experimenters . . . 581
- Radio cabinet refinishing kit for service men . . . 582
- Tiny cell supplies grid bias . . . 582

SCIENCE AND INDUSTRY

- Paint remover is washed off with water . . . 521
- "Fingerprints" of chemicals identify substances . . . 527
- Mosquitoes tinted to trace migration . . . 533
- How earth looks from moon is shown by globe . . . 556
- Laboratory like car to study air-conditioning . . . 567
- Star globe for amateur astronomer . . . 576
- Two-story "atom smasher" to aid scientists . . . 576

SPORTS

- Water skiing latest sport for German fans . . . 512
- Ice skates with double blade reduces ankle strain . . . 526
- Bobsled roller coaster ride latest in thrills . . . 544
- Streamline tennis rackets used in England . . . 572

(Continued to page 6A)



**READ HOW SKINNY
GAWKY MEN GAIN
10 TO 25 POUNDS
THIS NEW QUICK WAY**

Thousands gaining normal husky pounds—in just a few weeks!

SKINNY, friendless men who never could gain an ounce can take new hope from the experience of thousands of others with this new scientific treatment that is sweeping the country. These others have gained 10 to 25 pounds of solid, naturally attractive flesh this new, easy way—in just a few weeks!

What is more, this new discovery has given them naturally clear skin, freedom from indigestion, constipation and nervousness, new pep and popularity for social and business success.

Why it builds up so quickly

Scientists recently discovered that great numbers of people are thin and run-down for the single reason that they do not get enough digestion-strengthening Vitamin B and blood-enriching iron in their daily food. Now the richest known source of this marvelous body-building Vitamin B is cultured ale yeast. By a new process the finest imported cultured ale yeast is now concentrated 7 times—made 7 times more powerful. Then it is combined with 3 kinds of blood-building iron, pasteurized whole yeast and other valuable ingredients in pleasant little tablets known as Ironized Yeast tablets.

If you, too, need these vital elements to build you up, get these new "7-power" Ironized Yeast tablets from your druggist today. Then, day after day, watch flat chest develop and skinny limbs round out to natural, husky attractiveness. Constipation and indigestion from the same cause quickly vanish, skin clears to normal beauty—you're an entirely new person.

Money-back guarantee

No matter how skinny and run-down you may be, try these new Ironized Yeast tablets just a short time, and note the marvelous change. See if they don't build you up in just a few weeks, as they have thousands. If you are not delighted with the benefits of the very first package, your money back instantly.

Special FREE offer!

To start you building up your health right away, we make this absolutely FREE offer. Purchase a package of Ironized Yeast tablets at once, cut out the seal on the box and mail it to us with a clipping of this paragraph. We will send you a fascinating new book on health, "New Facts About Your Body." Remember, results with the very first package—or money refunded. At all druggists. Ironized Yeast Co., Inc., Dept. 5310, Atlanta, Ga.

*Posed by
professional
models*

When writing to advertisers please mention Popular Mechanics



NOW IN A NEW 12-OUNCE SIZE Tamper-Proof, Sealed Container

This new 12-ounce size of Genuine Improved Pyroil is sufficient for 5-quart, 6-quart and 7-quart crankcases. And it costs you less! A triple value; an improved product in an improved container for less money. Sealed at the factory, you can be assured of Genuine Pyroil when you ask for this new size.

Improved Pyroil is a matchless product. It definitely saves you money. Its regular use safeguards all frictionized parts of your car against excessive wear and other damages. It saves common repairs. It frees away sludges, gums and carbon. Improved Pyroil gives your car new power and "pep."

The coupon below will bring you many surprising and important facts about the money you can save when you use Improved Pyroil regularly. Sold throughout the civilized world at service stations, garages and other dealers. Manufactured and Guaranteed by Pyroil Company, W. V. Kidder, Founder, 510 Pyroil Bldg., LaCrosse, Wis., U. S. A.

PYROIL HAS BEEN TESTED BY POPULAR MECHANICS AND IS USED BY POPULAR MECHANICS' PRESSES AND EQUIPMENT.

DISTRIBUTORS: NEW PYROIL PREMIUM PLAN NOW IN EFFECT GIVES NATIONALLY ADVERTISED MERCHANDISE OF HIGH VALUE, ABSOLUTELY FREE. CHECK COUPON FOR FULL DETAILS, AND FACTS OF BUSINESS OPPORTUNITY.

Genuine Pyroil bears this signature on every can

Founder

**PYROIL COMPANY,
510 Pyroil Bldg.,
LaCrosse, Wis., U. S. A.**

Please send Free important facts on Pyroil's money saving features.

Please send details of New Premium Plan and Business Opportunity for me.

Name.....

Address.....

City.....County.....

State.....

Genuine
PYROIL
LUBRICATION PROCESS

(Contents—Continued)

MISCELLANEOUS

G-men learn trick of firing from speeding auto.....	497
Newspaper office on wheels has radio and darkroom.....	497
Design of Golden Gate fair is approved.....	498
Special gas mask for horse protects in war.....	499
Moist newspapers molded into figures.....	504
Rubber cigarette case for swimmers.....	506
War on counterfeiters uncovers plant in suitcase.....	507
Rifle bullet shaped like baby's nipple.....	513
Streamline boat with "wings" has non-sinkable hull.....	519
Flying fish glides on fins like monoplane.....	520
Piano tuned by "electric eye".....	528
Tablets of salt help workers resist heat.....	534
Trained dog rides aquaplane.....	534
Speedometer in observation car of streamline train.....	539
Tricycle rickshaw introduced in Malay.....	539
Strange insulating mineral floats like a cork.....	543
Peltier comet's path shown by model.....	544
Caterpillar swarm stops fast trains.....	550
Swim star's style caught by underwater camera.....	551
Fast boat shaped like whale is driven by air screws.....	558
Flower mosaics in streets mark ancient festival.....	559
Blind man hooks up twin bicycles for ride.....	562
Pearl oysters in cans thrill treasure hunters.....	562
Bird tamer trains big family.....	566
Indian memorial at St. Paul, Minn.....	573

Craftsman and Shop Notes

AUTOMOTIVE

Reflector on dog's collar visible to motorists.....	617
Three ideas to ease the truck driver's task.....	637
Undercutting mica on commutator with hack saw.....	637
Cylinder head lifters.....	638
Sanding block for cleaning commutators.....	638
Sloping running board foils robbers.....	639
Truck has rear bumpers on tailboard.....	639
Wanted—more auto kinks.....	639
Small-parts washing pan swings out of the way.....	640

CAMPING, FISHING, HUNTING

Fishline dried with cork.....	586
Lifelike duck decoys of metal.....	593
Drying reel winds fishline evenly.....	609
Dip net protected against wear.....	614

FARM

Dump scraper made from oil drum.....	622
Keeping rodents out of drain tile.....	624
Willow twigs planted in raw potato.....	630
Cabbage cutter from shovel.....	632
Tool and implement oiler.....	632
Toolbox from oil can.....	635
Twisting wire cables.....	636

FURNITURE

Easy chair for typewriter.....	583
Spool chest and mirror.....	588
Rickety furniture tightened by injecting glue.....	606
Space-saving drop leaf table.....	607

GARDENS

Miniature Japanese garden built on a bird bath.....	585
Hammock on wheels.....	591
"Feeding" and protecting your shade trees.....	625

HAND TOOLS

Tape reel has pencil clip to hook on belt.....	608
Ax sheathed in rubber holder.....	614
Back-facing tool is hand operated.....	631
Small punch for sheet metal.....	636

HOME IMPROVEMENTS

Enlarging drawer in cabinet sink.....	586
Finding leaks in flush-box floats.....	586

(Continued to page 8A)

Promoted—when others were fired!

The Story of LaSalle Student Shaw



"Since the War I have been book-keeper at \$35 a week. Married, with one baby girl, I found it harder every month to make ends meet. I was desperate!



"Last winter my wife brought me a LaSalle ad on Higher Accounting—showing how I could study in spare time for the job ahead. I investigated, and enrolled January 23. Just in time! For—



"Suddenly, orders came through to cut the force. I watched seven men in my department get the bad news and leave. Then the office boy tapped me, said I was 'next.' My heart sank as I followed him to the Front Office.

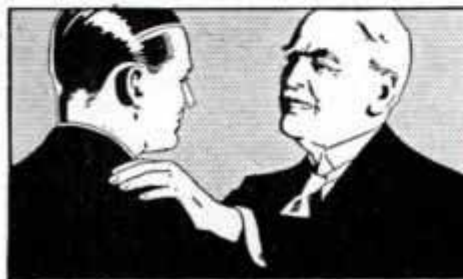

"Smiling, the boss handed me a letter. It was from LaSalle to him, announcing my enrollment and my good work on the first lesson. 'We are keeping you,' he said, 'because we like your spirit.'



"Naturally, I had more work to do, with the smaller force, but my training made it easier. I learned quickly, and when the Department Manager left, the boss moved me up.



"I have since been promoted twice, and now carry the title of Chief Accountant—at a salary several times greater. The future looks bright. If it had not been for LaSalle, I would be looking for a job right now."

BIGGER PAY FOR YOU— thru LaSalle Spare-Time Training

That's a story of what spare-time study has done for just one man. There are thousands of others like Shaw who found themselves through LaSalle. Now—how about yourself? Do you want a better position and higher pay?

You can win them, even today, if you can do the work. LaSalle experts will show you how, personally guide you step by step to success. Simply mark on the coupon the field you are interested in, and we will send you FREE, a valuable booklet about it, telling of opportunities open to you. No cost or obligation—and what you find out may put you on the road to success and financial independence.

The opportunity that is open today—right now—may not be here tomorrow. Don't put it off—but reach for your pencil, fill out, and mail today.

LASALLE EXTENSION UNIVERSITY Dept. 1064-R, Chicago

Please tell me how I can take full advantage—right now—of the opportunities in the business I am checking below. And send along your free booklet on that field.

- | | |
|---|---|
| <input type="checkbox"/> Business Management | <input type="checkbox"/> Railway Accounting |
| <input type="checkbox"/> Traffic Management | <input type="checkbox"/> Business Correspondence |
| <input type="checkbox"/> Modern Salesmanship | <input type="checkbox"/> Personnel Management |
| <input type="checkbox"/> Paper Salesmen's Training | <input type="checkbox"/> Law: LL. B. Degree |
| <input type="checkbox"/> Railway Station Management | <input type="checkbox"/> Commercial Law |
| <input type="checkbox"/> Industrial Management | <input type="checkbox"/> Office Management |
| <input type="checkbox"/> Higher Accountancy | <input type="checkbox"/> Chain Grocery Management |
| <input type="checkbox"/> Expert Bookkeeping | <input type="checkbox"/> Business English |
| <input type="checkbox"/> Effective Speaking | <input type="checkbox"/> Foremanship |

Name.....
Address.....
Position.....

LASALLE

EXTENSION UNIVERSITY



Mystifying the Man who Mystifies the Public

by Blackstone
World's Foremost Magician

MAGIC is bread and butter to me. I earn my living by mystifying the public with such famous illusions as the apparently disembodied and living head of a woman. Yes, I've amazed and baffled millions of theatre goers, but the tables were turned the other day at the Gillette factory in Boston. I was the one who was amazed during an inspection tour of this marvelous plant where Gillette Blades are made.

I stood wide-eyed with astonishment as I watched the operation of the automatically controlled furnaces in which Gillette steel is hardened. On each furnace is a magical black box. In this box is a steel strip of exactly correct hardness for perfect razor blades.

Then—as the steel in process passes through the furnace it must match this bellwether strip for hardness. If the slightest variation occurs—presto chango!—the temperature in the furnace is automatically raised or lowered to bring the steel to the exact required temper.

And I was amazed to discover that the edges of the Gillette Blade are so sharp that they are positively invisible. I was unable to see them even through the most powerful microscope.

Summing it all up—when the scientific wonders in this plant can mystify a professional magician—isn't it natural that the Gillette Blade shaves stubborn bristles with magical ease? I am convinced that every Gillette Blade shaves you in perfect comfort because every Gillette Blade is itself perfect. It's a mystery to me how any man could shave with any other blade.

With these important facts before you, why let anyone deprive you of shaving comfort by selling you a substitute! Ask for Gillette Blades and be sure to get them.

GILLETTE SAFETY RAZOR COMPANY, BOSTON, MASS.

(Contents—Continued)

Leaky water tank repaired to last	605
Sectional coal-bin door opens from any level	609
Shelves on cabinet door provide space for glassware	613
Locks and keys marked to show right key	614
Window locks	617
Guide helps locate keyhole	621

HOUSEHOLD

Smoking pipes supported by toothbrush holder	587
Pot lids stored behind cabinet door	590
Creepy washer has rope brake	594
Foods cooked by dial indicators	598
Pressing cloth kept taut in a frame	605
Ash tray from old bracelet	606
Strainer made from percolator part	608
Salt shaker covers from rubber bottle caps	615
Scrap mirror hung with garden hose	617
Clothespin used to squeeze pastry tube	618

OFFICE

Envelope sealer	605
Ink pad on mimeograph temporarily repaired	621
Large ledger has handles	622
Two-color pencil for checking	635

PAINT AND PAINTING

What you can do with aluminum paint	610
Fingerless glove aids sign writer	630
Sign copy held on window with vacuum cup	632

PHOTOGRAPHY

Novel photo wall bracket	592
Snapshots stapled in album	592
Part of film removed from camera for developing	599

POWER TOOLS

Jig-saw blower is foot-operated	590
Wood chuck to hold turned work	599
Home-workshop tools assembled on portable panel	613
Sliding cut-off saw	619
Bench lathe operated by hand clutch	623
Boring jig spaces holes accurately	631
Jigs for the shaper	633
Steady rest for fine work	640

STORE AND SHOP

Special weights for small scales	592
Mystifying window display	621
Guy wires painted white easily seen	630
Metal pattern easily removed from hook	630
Estimating cost of rope	632
Cloth bags aid clock repairman	635
Joining stovepipe easily	635
Cutting circles on stencils	636
Trough on cashier's cage catches loose coins	636

WOODWORKING

Scraper from plane parts	587
Pictures in rare woods	595
Using auger bit in tight places	598
Cutting short dowels in quantities	614
Sanding scrollwork	615

MISCELLANEOUS

Protractor triangle is quickly adjusted	586
Increasing capacity of wheelbarrow	587
Drawing-board surface repaired with cork	594
Wheeled scoop has many uses	598
Money in homemade flowers	600
Stopcock for amateur chemists	608
Ship model gratings made easily	615
Inkless pen uses indelible lead	616
Wheelbarrow has strainer in bottom	616
Motor-driven auto pump does chores around home	623
Exposed lamp sockets protected with rubber	624
Gravel removed from water-main valve	624
Midget gas engine turned from castings	626
Lumber piling jack saves labor	630

MECHANICAL ENGINEERING

— A FIELD WITH A FUTURE



This course has meant advancement to hundreds of ambitious men, mechanics, draftsmen, blacksmiths, foundrymen, patternmakers, apprentices, and mechanical engineers — men who wanted to get ahead and to earn more money. You, too, will find that enrolling for an I. C. S. Course is a real investment.



RADIO holds great rewards for trained men

Almost in a decade radio has become a giant industry. The opportunities created will be enjoyed by trained men. The I. C. S. Radio Course, prepared by leading authorities, will help make you a trained man! A fascinating book — FREE.



DIESEL POWER

A COMING AMERICAN INDUSTRY

The internal-combustion engine represents man's supreme triumph of machine power. Diesel engineers are in great demand. Many are acquiring necessary knowledge through spare-time study of this modern I. C. S. Course on Diesel engines. Send for free booklet!

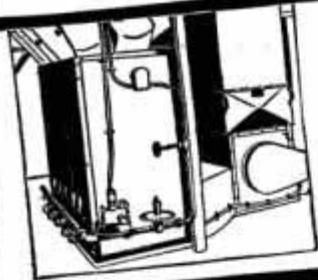

AIR CONDITIONING

THE NEXT BIG INDUSTRY

Plumbing and heating engineers must know Air Conditioning — the field in its broader aspects invites ambitious men. Write for information on the new Air Conditioning Course offered by the International Correspondence Schools.

ADVERTISING

Would you like to become an advertising man? Would you like to know if you possess the necessary qualifications? Then here's your chance! Send the coupon — today!

INTERNATIONAL CORRESPONDENCE SCHOOLS

BOX 5633-H, SCRANTON, PENNA.

★ Without cost or obligation, please send me a copy of your booklet, "Who Wins and Why," ★ and full particulars about the subject *before* which I have marked X:

- MECHANICAL ENGINEERING RADIO DIESEL POWER
 AIR CONDITIONING ADVERTISING

TECHNICAL AND INDUSTRIAL COURSES

- | | | | |
|--|---|--|--|
| <input type="checkbox"/> Structural Draftsman | <input type="checkbox"/> Mechanical Draftsman | <input type="checkbox"/> Steam Electric Engineer | <input type="checkbox"/> Surveying and Mapping |
| <input type="checkbox"/> Structural Engineer | <input type="checkbox"/> Machinist | <input type="checkbox"/> Marine Engineer | <input type="checkbox"/> Coal Mining <input type="checkbox"/> Mine Foreman |
| <input type="checkbox"/> How to Invent and Patent | <input type="checkbox"/> Toolmaker | <input type="checkbox"/> R. R. Locomotives | <input type="checkbox"/> Navigation |
| <input type="checkbox"/> Electrical Engineer | <input type="checkbox"/> Patternmaker | <input type="checkbox"/> R. R. Section Foreman | <input type="checkbox"/> Cotton Manufacturing |
| <input type="checkbox"/> Electric Lighting | <input type="checkbox"/> Gas Engines | <input type="checkbox"/> Air Brakes | <input type="checkbox"/> Woolen Manufacturing |
| <input type="checkbox"/> Welding, Electric and Gas | <input type="checkbox"/> Aviation Engines | <input type="checkbox"/> R. R. Signalmen | <input type="checkbox"/> Agriculture |
| <input type="checkbox"/> Reading Shop Blueprints | <input type="checkbox"/> Automobile Mechanic | <input type="checkbox"/> Highway Engineering | <input type="checkbox"/> Fruit Growing |
| <input type="checkbox"/> Boilermaker | <input type="checkbox"/> Refrigeration | <input type="checkbox"/> Civil Engineering | <input type="checkbox"/> Poultry Farming |

BUSINESS TRAINING COURSES

- | | | | |
|--|---|--|--|
| <input type="checkbox"/> Business Management | <input type="checkbox"/> C. P. Accountant | <input type="checkbox"/> Service Station Salesmanship | <input type="checkbox"/> Railway Mail Clerk |
| <input type="checkbox"/> Office Management | <input type="checkbox"/> Bookkeeping | <input type="checkbox"/> First Year College | <input type="checkbox"/> Grade School Subjects |
| <input type="checkbox"/> Industrial Management | <input type="checkbox"/> Secretarial Work | <input type="checkbox"/> Business Correspondence | <input type="checkbox"/> High School Subjects |
| <input type="checkbox"/> Traffic Management | <input type="checkbox"/> Spanish | <input type="checkbox"/> Lettering Show Cards <input type="checkbox"/> Signs | <input type="checkbox"/> College Preparatory |
| <input type="checkbox"/> Accountancy | <input type="checkbox"/> French | <input type="checkbox"/> Stenography and Typing | <input type="checkbox"/> Illustrating |
| <input type="checkbox"/> Cost Accountant | <input type="checkbox"/> Salesmanship | <input type="checkbox"/> Civil Service <input type="checkbox"/> Mail Carrier | <input type="checkbox"/> Cartooning |

Name.....Age.....Address.....

City.....State.....Present Position.....

If you reside in Canada, send this coupon to the International Correspondence Schools Canadian, Limited, Montreal, Canada

When writing to advertisers please mention Popular Mechanics



Ad Man and Author at 22

"Took the N.I.A. course at eighteen. Today at twenty-two am Assistant Eastern Advertising Manager of The Billboard, and editor of Ad-vents, monthly newspaper of the Association of Advertising Men of New York. Have just sold a story to Famous Detective Cases for \$185. So as an ad man and author permit me to say, 'If you want to write ad copy or fiction, try N.I.A.'"

Joseph G. Csida, Jr.
3063 Williamsbridge Rd., Bronx, N. Y.

**How do you know
you can't WRITE?**

Have you ever tried?
Have you ever attempted even the least bit of training, under competent guidance?

Or have you been sitting back, as it is so easy to do, waiting for the day to come some time when you will awaken, all of a sudden, to the discovery, "I am a writer"?

If the latter course is the one of your choosing, you probably never will write. Lawyers must be law clerks. Engineers must be draftsmen. We all know that, in our times, the egg does come before the chicken.

It is seldom that anyone becomes a writer until he (or she) has been writing for some time. That is why so many authors and writers spring up out of the newspaper business. The day-to-day necessity of writing—of gathering material about which to write—develops their talent, their background and their confidence as nothing else could.

That is why the Newspaper Institute of America bases its writing instruction on journalism—continuous writing—the training that has produced so many successful authors.

Learn to write by writing

NEWSPAPER Institute training is based on the New York Copy-Desk Method. It starts and keeps you writing in your own home, on your own time. Week by week you receive actual assignments, just as if you were right at work on a great metropolitan daily. Your writing is individually corrected and constructively criticized. Under this sympathetic guidance, you will find that (instead of vainly trying to copy someone else's writing tricks) you are rapidly developing your own distinctive, self-flavored style—undergoing an experience that has a thrill to it and which at the same time develops in you the power to make your feelings articulate.

Many people who should be writing become awe-struck by fabulous stories about millionaire authors and, therefore, give little thought to the \$25, \$50 and \$100 or more that can often be earned for material that takes little time to write—stories, articles on business, fads, travels, sports, recipes, etc.—things that can easily be turned out in leisure hours, and often on the impulse of the moment.

A chance to test yourself

We have prepared a unique Writing Aptitude Test. This tells you whether you possess the fundamental qualities necessary to successful writing—acute observation, dramatic instinct, creative imagination, etc. You'll enjoy taking this test. The coupon will bring it, without obligation. Newspaper Institute of America, One Park Avenue, New York.

Free

Newspaper Institute of America
One Park Avenue, New York

Send me, without cost or obligation, your *Writing Aptitude Test* and further information about writing for profit, as promised in POPULAR MECHANICS, October.

Mr. }
Mrs. }
Miss }

Address.....
(All correspondence confidential. No salesmen will call on you.)

**BIG PAY in AVIATION
Train Now at LINCOLN**

Because Lincoln training is complete, thorough and under Government Supervision... the kind of training aviation executives demand in the Pilots and Mechanics they hire.

Fastest growth in the history of Aviation now in progress. Airlines are adding millions of miles to their flight schedules. Factories are crowded with huge orders for airplanes. Aviation must have thousands of newly trained men! Lincoln training qualifies you for success. Training for Government Pilot's License or Government Airplane and Engine Mechanic's License. Now in 26th year, 18 years teaching aviation.

**\$700
A Month**
Airline Pilots earn up to \$700 a month. Co-Pilots \$250. Mechanics \$200.

Lincoln graduates now employed by leading airlines, factories, Foreign Governments and service companies. We are in constant contact with the industry, and recommend our graduates for positions. Act now. Write at once. Please state your age.

LINCOLN AIRPLANE & FLYING SCHOOL
201-G Aircraft Bldg., Lincoln, Nebraska



**Be an
ELECTRICAL EXPERT**

No "hard times" in Electricity—the Big Pay Field. Thousands of new Experts needed for present and future activity. Boulder Dam—"TVA"—other government electrical projects soon ready. Start Now. Earn while learning at home. Easy. Low Cost. 100,000 men successfully trained. Write for FREE BOOK. Learn to earn \$35 to \$75 a week.

L. L. Cooke School of Electricity, Dept. 17, 2150 Lawrence Ave., Chicago



LEARN MECHANICAL DENTISTRY



Special Tool Offer—Now!
Don't waste the best years of your life. Learn this money-making business in a few months. Day or Evening, and become independent. Big demand. Highly endorsed—oldest school. Practical training. Individual instruction. Easy terms. Employment Service. Write TODAY for FREE Catalog P → New York School of Mechanical Dentistry, 125 W. 31 St., New York



VOICE



100% Improvement Guaranteed
We build, strengthen the vocal organs—not with singing lessons—but by fundamentally sound and scientifically correct silent exercises... and absolutely guarantee to improve any singing or speaking voice at least 100%... Write for wonderful voice book—sent free. Learn WHY you can now have the voice you want. No literature sent to anyone under 17 years unless signed by parent.
PERFECT VOICE INSTITUTE, Studio 1357
64 E. Lake St., Chicago

LEARN WATCHMAKING AND ENGRAVING



**BY OUR PROFIT-SHARING PLAN
OUR GRADUATES SUCCEED**
One of our Iowa students started in a very small way—now doing over \$30,000 a year. Another in Wisconsin, over \$10,000 the first year. Day or night classes. Call or write for FREE BOOK.
Chicago School of Watchmaking, Dept. 4401, 155 N. Clark St., CHICAGO.

AUTOMOBILE RACING New Book

(FOURTH EDITION)
Nine Chapters—66 illustrations of dirt, midget and championship cars and drivers. How to build cars and bodies—14 plates working drawings. Converting stock cars to 135 m.p.h. racers. Answers all questions on speeding up cars, balance, speed, revs., rules, specifications, track records, etc. Postpaid \$1.00, C.O.D. \$1.12. Order NOW. Ray Kuns, Dept. B, Madisonville, Cincinnati, Ohio.



ASK FOR
LEPAGE'S
CASEIN GLUE
A real CASEIN GLUE

When writing please mention Popular Mechanics

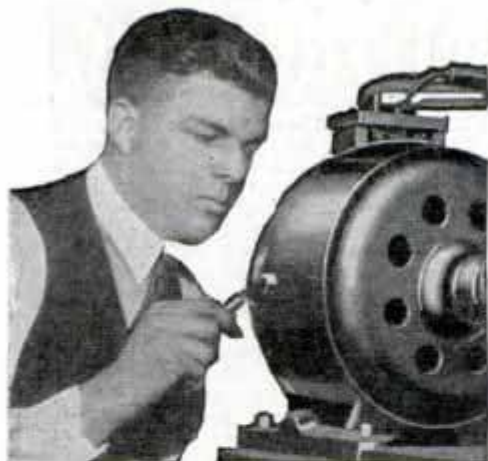

EASIER WAY TO SUCCESS *in* ELECTRICITY

LEARN THE GREATEST INDUSTRY OF THE AGE—TRAIN NOW FOR A REAL FUTURE

Finance Your Training!

Are you dissatisfied with your job? Are you out of a job because you lack specialized training for a live industry? Is your future uncertain? Then let me show you an amazing, easy way to get your start in Electricity, where thousands of TRAINED MEN earn good pay. Where hundreds of Coyne Graduates are drawing Good Pay every week. Coyne has been training ambitious fellows for the Electrical Industry since 1899. Whether you are 16 or 40 years old, Electricity thru Coyne training offers you your start for a real future—and you can start training any time.

Opportunities for a good job, or a business of your own

Here is YOUR opportunity. Every day brings news of new developments in this fascinating, big-pay field, with new jobs and a greater future for the trained man than ever before. If you are ambitious to get ahead, I want to help you. MAIL THE COUPON BELOW and I'll tell you about my finance plan, which has enabled thousands to get Coyne Training with very little money. Get training first, then take 18 months to complete small monthly tuition payments starting FIVE MONTHS after you begin your training. NOT a Home study course.



H. C. Lewis

Learn By Doing In 90 Days

The great Coyne Shops are famous the world over for their unusual Learn-by-Doing method of practical, individual instruction. There is no book study, no reciting—you learn quickly and thoroughly by doing actual jobs under the personal guidance of trained instructors, on a great outlay of machinery and equipment assembled strictly for training purposes. That is why, in 12 short weeks, we are able to take fellows without previous experience or a lot of book learning, and train them for their start to a real future.

MANY EARN WHILE LEARNING
If you need part-time work to help pay living expenses while at school, tell us your problems and we may be able to help you as we have hundreds of other students. Then, after you graduate, our Free Employment Department will give you life-time employment service. Every Coyne graduate also receives a Life Scholarship, with free technical and business service and privilege of review at any time without additional tuition charge.

**DIESEL OPERATOR
ARMATURE WINDER
AND TESTER
SUBSTATION OPERATOR
AUTO ELECTRICIAN
INVENTOR
MAINTENANCE ELECTRICIAN
SERVICE STATION OWNER**

and many other money-making opportunities in the Electrical field. Learn by actual work on real dynamos, engines, power machinery, autos, switchboards—equipment ranging from door bells to large power motors, controls and generators, in full operation every day.

**DIESEL ENGINES
REFRIGERATION
AIR CONDITIONING**

These two fast growing industries offer opportunities to the trained man. Right now I'm including instruction in Diesel Engines, Electric Refrigeration and Air Conditioning at no extra cost.

HOME OF COYNE SHOPS

This is our fireproof modern home wherein is installed thousands of dollars worth of Electrical equipment. Every comfort and convenience has been arranged to make you happy and contented during your training.

H. C. LEWIS, PRESIDENT FOUNDED 1899
ELECTRICAL SCHOOL
500 S. Paulina St., Dept. 76-72, Chicago, Ill.

PROOF That Coyne Training Gets QUICK RESULTS

"I owe my electrical success to your 12-week shop course," says R. B. Umbarger of Tennessee. "Two weeks after leaving school I took a wiring job," reports E. O. Berndt of Illinois, "and the profits from this one job alone more than paid for the entire course." A. C. Hoehnle of Ohio says "Received several raises in pay, due to the training I received at Coyne." And I could quote from hundreds of similar letters from successful Coyne-trained men. What they have done, you should be able to do!

GET THE FACTS... NOW

Coyne is your great chance to get into this big-pay field. This school is 37 years old... Coyne training is tested. And it costs you nothing to find out about this amazingly easy, practical way to learn Electricity. Simply mail the coupon below and I'll send you the big, free Coyne book, with photographs... facts... opportunities. There's no obligation... so act at once.



Send Today for this FREE Book!

H. C. LEWIS, President
Coyne Electrical School,
500 S. Paulina St., Dept. 76-72, Chicago, Ill.

Without obligating me, send full details of your "Pay-Tuition-After-Graduation" Plan and Big Free Illustrated Catalog.

Name.....
Address.....
City.....State.....
Mail in envelope or paste on a postcard.



COYNE

When writing to advertisers please mention Popular Mechanics

Arrest Him, Officer!

I'LL HAVE COMPLETE FACTS ON THE OTHER FELLOW TONIGHT!



Follow This Man!

SECRET Service Operator No. 38 is on the job... follow him through all the excitement of his chase after the counter-feit gang. See how a crafty operator works. Tell-tale finger prints in the murdered girl's room that help him solve the great mystery! BETTER than fiction because every word is TRUE. No obligation. Just mail me the coupon and get—

FREE The Confidential Reports No. 38 Made to His Chief

And the best part of it all is this—it may open your eyes to the great opportunity for YOU as a well paid Finger Print Expert. This is a young, fast-growing profession. The kind of work you would like. Excitement! Thrills! Travell A regular monthly salary. Reward money. And remember: graduates of this school HEAD 47% of all Identification Bureaus in the U. S. Quick! Mail the Coupon NOW and I'll send you these Free Confidential Reports!

INSTITUTE OF APPLIED SCIENCE
1920 Sunnyside Ave., Dept. 1357 Chicago, Illinois

Institute of Applied Science
1920 Sunnyside Ave., Dept. 1357, Chicago, Illinois

Gentlemen:—Without any obligation whatsoever, send me the Reports of Operator No. 38, also your illustrated Free Book on Finger Prints and your low prices and Easy Terms Offer. Literature will NOT be sent to boys under 17 years of age.

Name

Address

Age

When writing please mention Popular Mechanics

HOTEL TRAINING

—For Better Positions... Substantial Salaries—Classes Now Forming Increasing opportunities for trained men and women in fascinating, nationwide hotel field. Qualify thru short, specialized, intensive courses in America's only exclusive hotel training institute. Come to Washington. Learn in four months on real hotel equipment. Study under expert instructors in \$200,000 specially designed institute. Enjoy the attractions of Washington while training. Day classes start Oct., Jan., Feb. National Placement Service FREE of extra charge. Hundreds of graduates "making good" in Hotels, Resorts, Clubs, Apartment Hotels, Schools, Restaurants, Hospitals everywhere. Free Catalog gives full details—write for it now.



LEWIS HOTEL TRAINING SCHOOLS
Division RMS-340 Washington, D.C.

Be a DENTICIAN

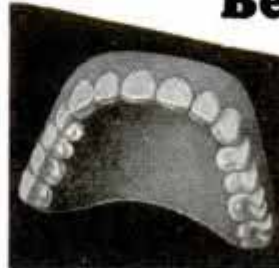

Learn at home to make Crowns, Plates, Bridgework, etc., for Dentists. Easy, practical way to learn mechanical dentistry at home in spare time. Full Equipment of Tools and Materials Included with Course. Low tuition. Easy terms. Write for FREE BOOK about this money-making profession that is not affected by "machine age."

McCARRIE SCHOOL OF MECHANICAL DENTISTRY
207 N. Broad St., Dept. 714 Philadelphia, Pa.

LEARN CARTOONING

by the method that has developed hundreds successfully. Send name, address and age for free chart to test your ability.

The Landon School, 1738 National Bldg., Cleveland, Ohio

ENGINEERING DEGREE IN TWO YEARS

B.S. Degree in Electrical, Civil, Chemical, Radio, Mechanical or Aeronautical Engineering in two years. Located in an industrial center with that Engineering atmosphere. Earn board. Low tuition. Preparatory Department. Enter Dec., Mar., June, Sept. Catalog.

INDIANA TECHNICAL COLLEGE

229 East Washington St., Fort Wayne, Indiana

"Why VOICE Students Fail"

SENT FREE No Obligation to Buy

If you act quick!—we will send postpaid—for 30 days' free reading—new Voice Book disclosing startling VOICE FACTS that may save hundreds of dollars to every man or woman seeking a strong, rich voice for either singing or speaking. 30 days' free reading—then send \$1.00. Otherwise, return it—that's all! PROF. E. FEUCHTINGER Studio 1357 64 E. Lake Street Chicago

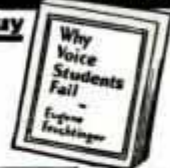

Photography



for

PLEASURE or PROFIT

Prepare for profitable business or fascinating hobby, at home under guidance of qualified instructors. No previous experience necessary, common school education sufficient. Many earn while learning. Our practical studio methods also qualify for well-paying positions upon graduation. Send coupon below at once for free booklet "Opportunities in Modern Photography", particulars and requirements.

AMERICAN SCHOOL OF PHOTOGRAPHY
3601 Michigan Avenue Dept. 1357 Chicago, Illinois

Send booklet, "Opportunities in Modern Photography", full particulars and requirements.

Name

Address

City

State



BUT JIM, I DON'T SEE HOW WE CAN AFFORD TO MARRY.

MARY'S RIGHT, I REALLY CAN'T SUPPORT A WIFE.

GUESS I HAVEN'T A RIGHT TO ASK A GIRL LIKE MARY TO MARRY AN ORDINARY MECHANIC.



LOOK HERE, N.R.I. HAS TRAINED HUNDREDS OF MEN LIKE ME TO MAKE GOOD MONEY I GUESS I'LL GET THAT FREE BOOK



THIS IS SWELL FUN, AND I AM BEGINNING TO MAKE MONEY ON THE SIDE ALREADY, RADIO SURE IS FULL OF OPPORTUNITIES FOR TRAINED MEN.



YOU CERTAINLY KNOW RADIO. MINE NEVER SOUNDED BETTER

"THANKS" YOU SEE I HAVE TAKEN N.R.I. TRAINING



OH! JIM, IT'S WONDERFUL, NOW YOU'RE ON THE WAY TO SUCCESS

YES MARY, AND THERE'S A REAL FUTURE FOR US IN THIS RADIO FIELD.

I'LL TRAIN YOU AT HOME

In Your Spare Time For A GOOD RADIO JOB

Many Radio Experts Make \$30, \$50, \$75 a Week

Do you want to make more money? Broadcasting stations employ engineers, operators, station managers and pay up to \$5,000 a year. Spare time Radio set servicing pays as much as \$200 to \$500 a year—full time servicing jobs pay as much as \$30, \$50, \$75 a week. Many Radio Experts own their own full or part time Radio businesses. Radio manufacturers and jobbers employ testers, inspectors, foremen, engineers, servicemen, paying up to \$6,000 a year. Radio operators on ships get good pay and see the world. Automobile, police, aviation, commercial Radio, and loud speaker systems offer good opportunities now and for the future. Television promises many good jobs soon. Men I trained have good jobs in these branches of Radio.



J. E. SMITH, President National Radio Institute
The man who has directed the home study training of more men for the Radio Industry than any other man in America.

Many Make \$5, \$10, \$15 a Week Extra in Spare Time While Learning

Practically every neighborhood needs a good spare time serviceman. The day you enroll I start sending you Extra Money Job Sheets. They show you how to do Radio repair jobs that you can cash in on quickly. Throughout your training I send plans and ideas that have made good spare time money for hundreds of fellows. I send special equipment which gives you practical experience—shows you how to conduct experiments and build circuits which illustrate important Radio principles.

Find Out What Radio Offers You

Mail the coupon now for "Rich Rewards in Radio." It's free to any fellow over 16 years old. It describes Radio's spare time and full time opportunities, also those coming in Television; tells about my Training in Radio and Television; shows you actual letters from men I have trained, telling what they are doing and earning; tells about my Money Back Agreement. MAIL COUPON in an envelope, or paste on a post card—NOW!

J. E. SMITH, President, Dept. 6KP
National Radio Institute, Washington, D. C.

J. E. SMITH, President, Dept. 6KP
National Radio Institute, Washington, D. C.

Dear Mr. Smith: Without obligating me, send "Rich Rewards in Radio," which points out the spare time and full time opportunities in Radio and explains your 50-50 method of training men at home in spare time to become Radio Experts. (Please Write Plainly.)

THIS FREE BOOK HAS HELPED HUNDREDS OF MEN MAKE MORE MONEY



HERE'S PROOF THAT MY TRAINING PAYS



Chief Operator Broadcasting Station

"When I completed 20 lessons, I obtained my Radio Broadcast Operator's license and immediately joined Station WMPC, where I am now Chief Operator."—**HOLLIS F. HAYES, 85 Madison St., Lapeer, Mich.**



Own Business Pays \$300 a Month

"I now have my own Radio business which shows three hundred dollars a month profit—thanks again to National Radio." **FRANK T. REESE, 39 N. Felton St., Philadelphia, Penna.**



Earned \$50 First Month in Spare Time

"I knew nothing about Radio. After four lessons I began servicing Radios, earning \$50 the first month. Last winter I made as high as \$100 a month in spare time."—**G. F. WALTON, 803 West Olney Road, Norfolk, Va.**

NAME.....AGE.....
ADDRESS.....
CITY.....STATE.....

STAMPS



and Collecting

By Richard McP. Cabeen

Ob. 900. 3337 Muehler

71026

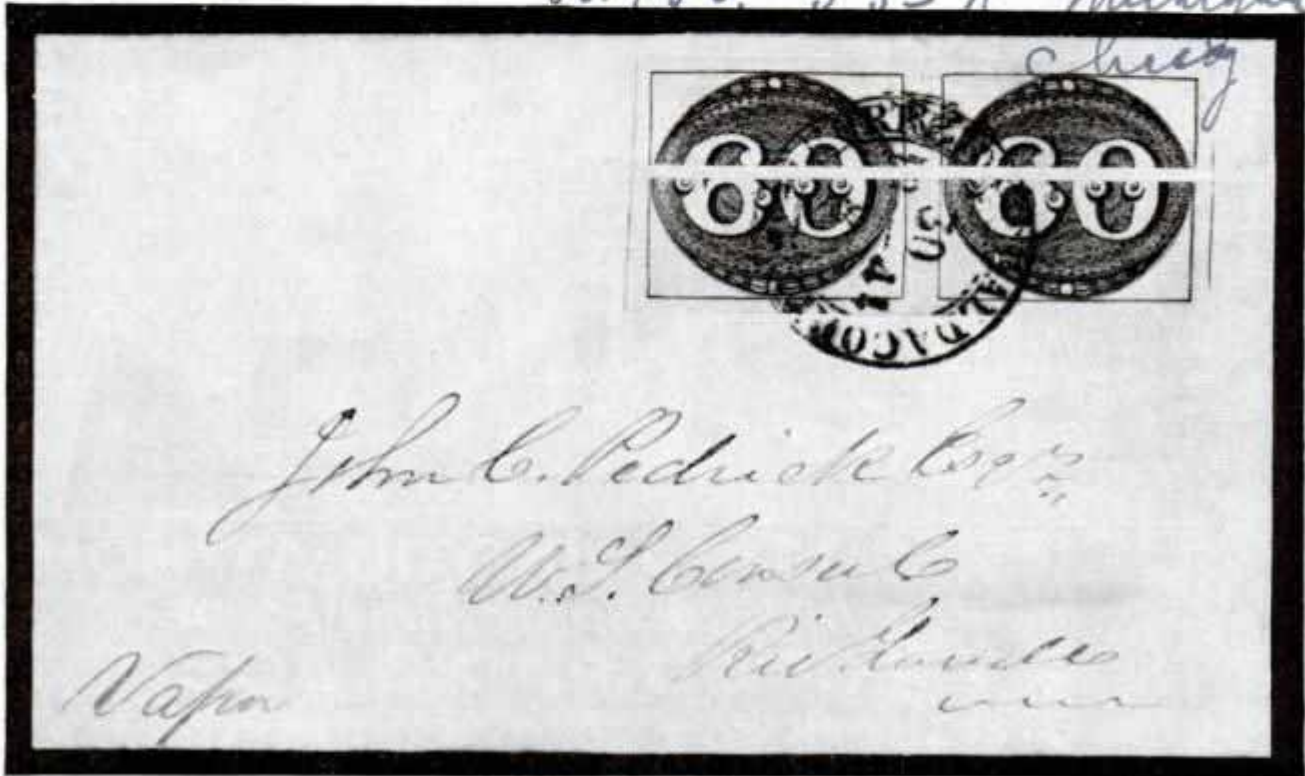

This cover, showing a pair of the rare sixty reis "bull's-eyes" issued by Brazil in 1843, is from the collection of Mr. S. Newbury, of Chicago

WHAT is there about stamp collecting that attracts countless persons? What is the strange power that makes it a pastime for all people in all conditions of life, from kings to cobblers, and from schoolboys to octogenarians?

Stamp collecting and other kindred forms of collecting are intuitive in a large percentage of mankind; perhaps an instinct, such as caused prehistoric man to save some of the implements his father used, and to pass them on to his children. From this grew the idea of saving heirlooms, and the buying of such relics, by those who had the collecting instinct. In general all mankind can be separated into two groups, those who save old things and those who save nothing which is not immediately useful.

Collecting was well established in England long before the coming of the first postage stamp in 1840, and it was only

natural that some of the people who had been saving mementoes of great people and of past civilizations, should put aside a few of the beautiful engravings of their young queen, and save the quaint labels which came on an occasional letter from Brazil or near-by Zurich or Geneva. Fundamentally stamp collecting is a hobby and its greatest benefit to mankind results from the mental relaxation which it brings to its followers. In addition, it teaches the collector an infinite variety of things without making him aware that he is studying. The beginner learns of other countries, the stamps forming the first tangible evidence of distant places mentioned in his geography, and he at once becomes more receptive to information about the places represented in his collection. From the pictures on his stamps he learns of the rulers or statesmen of the

(Continued to page 36A)

I KEPT IT A SECRET UNTIL BOB ASKED:



WHERE ARE YOU GETTING ALL THOSE GOOD LOOKING CLOTHES?

"It's no wonder Bob couldn't understand it—he hasn't gotten any bills! So, I told him about the Woman's Institute Dressmaking Course I've been taking.

"I knew Bob would approve, because he's taken several I. C. S. Courses—Woman's Institute is a part of I. C. S., you know. There's no doubt about it, those I. C. S. Courses have put Bob where he is now."

• • •

TRY a free sample lesson, and see how much fun it is! You'll love making nice things with your own hands. We'll wager that after the first lesson you'll hardly be able to wait for the next. . . .

Over 300,000 women have been taught by the Woman's Institute to design and make their own clothes. If they can learn so easily, you can too. *Many of our graduates are professional dressmakers today.*

SEND FOR FREE SAMPLE LESSON

SUCCESSFUL BUSINESS WOMEN KNOW

that the best jobs are for those with the best training. If you want a successful business or professional career, prepare yourself for it *now*. Many women are preparing themselves for better jobs and more pay by spare-time study of I. C. S. Courses.

Many well-paid illustrators today are women. Women are successful office managers, accountants, tea room managers, secretaries, bookkeepers. Some of the best advertising writers are women. *Learn* to do what you *want* to do. The first step is to mail the coupon.

WOMAN'S INSTITUTE

Box 5638-H Scranton, Penna.

Send information about course checked below and free Dressmaking Sample Lesson.

DOMESTIC SCIENCE COURSES

- | | |
|--|---|
| <input type="checkbox"/> Making Clothes for Myself | <input type="checkbox"/> Millinery |
| <input type="checkbox"/> Professional Dressmaking | <input type="checkbox"/> Tea Room Management |
| <input type="checkbox"/> Advanced Dressmaking | <input type="checkbox"/> Cafeteria Management |
| <input type="checkbox"/> Cooking | <input type="checkbox"/> Tourist Home |

BUSINESS TRAINING COURSES

- | | |
|---|---|
| <input type="checkbox"/> Secretarial Work | <input type="checkbox"/> High School Subjects |
| <input type="checkbox"/> Illustrating | <input type="checkbox"/> English |
| <input type="checkbox"/> Advertising | <input type="checkbox"/> Business Management |
| <input type="checkbox"/> C. P. Accounting | <input type="checkbox"/> Lettering Show Cards |

Miss or Mrs. Age

Address

When writing to advertisers please mention Popular Mechanics

The Diesel Engineer

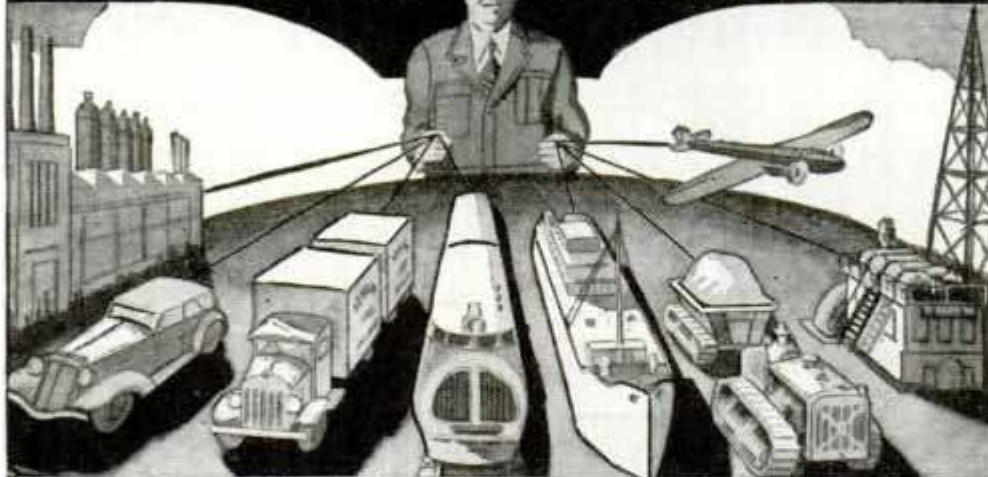

Diesel—The Newest, Fastest-Growing Power

Diesel engines—because of their high efficiency, dependability, and economy of operation—are fast replacing steam and gasoline engines in power plants, motor trucks and busses, locomotives and ships, aircraft, tractors, dredges, drills, pumps, etc.—opening up an increasing number of well-paid jobs for Diesel-trained men. The field of Diesel Engineering is on the upgrade and continually expanding. It will provide steady employment and advancement for those properly trained in this new industry—as long as they need to work.

You get complete information on all the latest Diesel developments—two- and four-stroke cycles; low- and high-speed and heavy-duty types; Diesel-electric generating systems, etc.—in our course. Includes all text material—with special diagrams for quick understanding of this new power.

American School, Dept. D-745, Drexel Avenue at 58th Street, Chicago, Illinois

Turn Your Spare Time into Dollars

DON'T BUY

guitars, mandolins, banjos, drums, or Electric Hawaiian guitars until you have tried the Slingerland May-Bell Violin Craft. Guaranteed more for your money. A wonderful snappy, powerful, and pleasing tone.



Over 100 styles at surprisingly low prices and sold on easy payments by all leading music dealers.

Send for Free Catalog. Mention instrument wanted and nearest music dealer.

Cut This Adv.
Out — Good
for \$1.00
Credit

Write today:

**Slingerland Musical Instrument Mfg. Co.,
1325 Belden Ave., Chicago, Illinois**

Is Your Job Safe

Just as the gasoline engine changed or wiped out the jobs of thousands who depended on horse-drawn vehicles for their living—just as electricity changed the entire set-up in the fields of light and power—so now the Diesel engine is fast invading both the power and transportation fields, and threatening the present jobs of thousands of workers.

If jobs in your line are steadily growing scarcer, you owe it to yourself to investigate this new, progressive, uncrowded line, that will offer good openings for many years to come.

Now is your chance to get into a big new industry and grow up with it to an important position. Today there is practically no competition in the Diesel field, but the increasing use of Diesel engines will result in keen competition for jobs in the near future. By starting your training now, you can keep ahead of such competition.

What This New Field Offers You

Get our Free Diesel Booklet and learn all about this newest, fastest-growing line—its opportunities and requirements. Find out what the Diesel field offers you—how rapidly the Diesel industry has developed during the last three years—the large number of Diesel engines and accessories being manufactured today—how quickly you can obtain a complete understanding of Diesel engine principles and operation by home study during your spare time—without interfering with your regular work.

Asking for information involves no obligation—but it may mark the turning point in your life. Write TODAY for full information.

HOME STUDY COURSES

Home-Study Courses, leading to Degrees in Arts and Sciences; Education; Writing; Psychology; Chemistry; Business and Commerce; Law; Theology; Agriculture; Engineering; also courses in Business Training; Accounting; Advertising; Sales Management; Public Speaking; Radio. Many others. Low Cost; Easy Terms.

McKinley-Roosevelt University, 4247 Clarendon Ave., Chicago

The Lost Word

THE KEY TO SECRET WISDOM

"Like a bolt from the heavens, the word was spoken and from the reverberations of its sacred syllables, came the creation of the Universe"—so relates an old, old legend. Through the ages men have searched in vain for this lost word. In its stead they found keys to a secret wisdom. They learned how to unlock the hidden possibilities slumbering within everyone—startling, unused powers that make for a greater life.

This Sealed Book—FREE

A sealed book by the Rosicrucians, reveals the plan whereby you may obtain this wealth of knowledge leading to the greater joys and rewards of living. For free copy without obligation, write Scribe M.L.Z.

The ROSICRUCIANS

SAN JOSE [AMORC] CALIFORNIA

NOT a religious organization

Learn **DIESEL** and **GAS ENGINEERING**



Partial view of Diesel-engine operating room—one of the important Departments at National Schools.



Students servicing Fairbanks-Morse Diesel power-generating unit.

YOU WORK ON FINEST and LATEST EQUIPMENT AVAILABLE IN AMERICA

National Schools' course of Diesel Training is the outgrowth of years of successful development. The instruction is **PROVEN**. Over 30,000 graduates have received National Training. Now, National offers the most comprehensive training—actually three complete courses for the price of one—Gas and Diesel Engineering, and Electric Power Generation—all of which are absolutely essential to qualify for best jobs.

Easy, Fascinating "Shop-Practice" Method

The day you begin your training at National you start right in with a practical job on the most modern Gas and Diesel equipment, including Caterpillar, Cummins, McCormick-Deering, Hercules, Venn-Severin, Fairbanks-Morse, Enterprise, and many others. The work is actually a pleasure for students—easy to understand—ever fascinating. You learn in a few months what would ordinarily take far longer.

Complete, Modern Equipment Actually Used by Students

The vast installation of modern Gas and Diesel equipment here is all used by you in learning your trade. You learn to assemble and disassemble all parts, learn trouble-shooting; operating and all essentials to qualify you for big-pay Gas and Diesel opportunities. Your instruction is personalized under direct supervision of a large staff of experts.

LEARN IN LOS ANGELES, Playground of America RAILROAD FARE ALLOWED

For a limited time, coach R. R. fare allowed to L. A. from any part of the U. S.

EARN ROOM AND BOARD

We help students obtain part-time jobs to earn room and board while learning.

NATIONAL SCHOOLS, LOS ANGELES

ESTABLISHED 1905



Electrical trouble-shooting in gas engine department.

QUALIFY FOR GOOD PAY JOBS

NATIONAL'S

Master Training
Includes
All Phases of
Diesel Engines
Fuel Injection
Gas Engines
Butane Engines
Propane
Natural Gas
Auto-Diesel Electrics
Also Diesel Power
Generation
Machine Shop
Batteries

Special Added Feature! DIESEL ELECTRIC POWER GENERATION

In keeping with National Schools' progressive policy of offering the most complete Course, we announce this added feature, made available to you by an investment on our part of thousands of dollars. Full instruction includes:

Alternating and Direct Current Power Stations

Switchboards and Instruments

Station and Motor Wiring

Motors and Controls

Distribution Lines, Transformers, etc.

This specialized training enables our graduates to expertly handle Diesel equipment in power plants, mines, public buildings and utilities, boats, trains, etc. Knowledge of Diesel Electrics is just as essential as the fundamentals of Diesels. This school is the only one in the U. S., to our knowledge, offering this extra, yet necessary, specialized training.

MAIL THIS COUPON

NATIONAL SCHOOLS, Los Angeles, Calif.
Dept. PMA-10, 4000 So. Figueroa St.
Please send Catalog

NAME.....AGE.....

ADDRESS.....

CITY.....STATE.....



WHAT KIND OF MAN ARE YOU?



This man has routine job in shop. Would like to earn more money, advance to better job, but does nothing about it. Will be doing same work 20 years from now.



This man had job in shop. Wanted more pay and better job. Learned Practical Drafting at home from Engineer Dobe. Advanced steadily, increased his earnings considerably, became full-time draftsman.

The Road to Advancement DRAFTING

In every walk of life practical training in DRAFTSMANSHIP will prove valuable. Even if you don't accept a job as a DRAFTSMAN, you will be money ahead by taking Engineer Dobe's Course. You will be amazed at the speed with which you can learn in your own home in your spare time by Engineer Dobe's PRACTICAL METHOD.

JOBS NOW OPEN

In all industries, Drafting leads the way. In Aviation, Electricity, Building, Machinery, Automobile, Draftsmen must be used, and their work comes first. Recovery in industry and building is definitely on the way. Many trained Draftsmen will be needed on better jobs at better pay and shorter hours. Prepare NOW!

Learn at Home From an Engineer

I will teach you my practical method that has been successful with thousands since 1900. I will furnish you with all tools and a drawing table. I will teach you in a very short time by mail in your spare time until you actually have a desirable Draftsman's job, or prepare you for better pay in the job you now have. No High School or previous experience needed. You must be entirely satisfied with my personal training UNTIL COMPETENT and until assisted to a position, OR YOU GET ALL YOUR MONEY BACK. Start NOW and get the training. Prepare for more pay and a better job. Send the coupon below TODAY! Time is money! Don't delay! No obligations!



Complete Outfit, size 20x25 in., furnished to you.

These TOOLS and Other EQUIPMENT Given When You Start

Free Book!

ENGINEER DOBE, Div. 3377 Libertyville, Ill.

Send me your free book, "Successful Draftsmanship" and explain how you will assist me to a good position as a draftsman.

Name..... Age.....

Address.....

Post Office..... State.....

When writing please mention Popular Mechanics

1,500 NEEDED INVENTIONS

1936 Edition of this remarkable source book for inventors by R. F. Yates tells what to invent, what inventions manufacturers are looking for, what will pay most money. Also gives new scientific discoveries important to inventors. Enables you to work on inventions that pay. Simple, practical ideas. Large cloth-bound book, 250 pages. Don't waste time. Send \$2.50 today, or send \$4.00 for this great book and INVENTORS' SELLING GUIDE which tells you where and how to sell safely your patented or unpatented inventions to its list of nearly 1000 buyers. Everything you must know about Selling Methods, Law, Royalty Contracts, Financing, Finding Buyers. 224 pages, cloth \$2.00. Send no money if you prefer C. O. D. shipment. Money back if not satisfied.

Write for FREE catalog of valuable books for inventors and sample pages of above books.

Donley Publishing Co., 509 Fifth Ave., Dept. P-10, New York, N.Y.

LEARN WATCH REPAIRING



AT HOME You can learn by our modern and original system of instruction every part of the Watch Repairing Trade at home. You can earn money while learning and prepare yourself for a well paying position or start in business after completing our course of instruction. Good watch repairers are in demand and generally earn very good salaries. For particulars apply to the Wisconsin School of Watch Repairing 524 E. Mason St., MILWAUKEE, WIS.

ELECTRICAL ENGINEERING

A BROAD, basic, intensive course complete in one school year. Includes fundamentals of Refrigeration, Air-conditioning, Electronics. Approved by educators, endorsed by industry. 44th year. Catalog.

BLISS ELECTRICAL SCHOOL
120 TAKOMA AVE., WASHINGTON, D. C.

BE A CARTOONIST



AT HOME IN YOUR SPARE TIME under personal supervision of the famous cartoonist NORMAN MARSH creator of "DAN DUNN" appearing every day in big papers. Success — Fame — Real Money may be Yours when you learn Marsh's easy simple methods and secrets. Send name and six cents—stamps or coin—for details of MARSH'S Personal course. ACT TODAY! MARSH CARTOON SCHOOL Chicago Daily News Bldg., Dept. 101, Chicago, Ill.



Learn Public Speaking

At home—in spare time. Many overcome "stage-fright," gain self-confidence, and increase their earning power, through ability to sway others by effective speech. Write for free booklet, *How to Work Wonders With Words* and requirements.

NORTH AMERICAN INSTITUTE, Dept. 1357
3601 Michigan Avenue Chicago, Illinois

GOV'T. JOBS

SALARY TO START \$90 to \$175 MONTHLY

MEN WOMEN
Age Range 18 to 50

() Village Carrier	() POSTMASTER
() P. O. Laborer	() Elevator Conductor
() R. F. D. Carrier	() Auditor
() Special Agent	() Stenographer
() Customs Inspector	() U.S. Border Patrol
() City Mail Carrier	() Telephone Opr.
() P. O. Clerk	() Watchman
() Stock Clerk	() Meat Inspector
() Special Investigator	() Secret Service Opr.
() Typist	() File Clerk

MENTAL INSTRUCTION SERVICE
Dept. 111 St. Louis, Mo.

Send me FREE particulars "How to Qualify for Government Positions" marked "X". Salaries, locations, opportunities, etc. ALL SENT FREE.

Name.....

Address.....



What's back of that Switch?

MIGHTY DIESEL ENGINES

Who keeps those Giant Power- Producers at Top Efficiency?

TRAINED DIESEL ENGINEERS

With new sales exceeding every past production record, the opportunities to trained men increase each day. If you are mechanically inclined you, too, can qualify yourself for the opportunities in this fast growing field.

America's Original Exclusive Diesel Schools can give you the same thorough and practical training that Hemphill graduate H. E. Godden received. He recently wrote:

"I have been promoted to Chief Engineer, in entire charge of Diesel engines in this big plant. Hemphill Schools are solely responsible for this fine position and in making it possible for me to hold this job." (Sgd.) H. E. Godden

HEMPHILL DIESEL SCHOOLS
located only at addresses shown below. In no way connected with any other schools.

BOSTON, 114 Brookline Avenue
NEW YORK, 31-26 Queens Blvd., L. I. City
DETROIT, 2341 West Lafayette Blvd.
CHICAGO, 2014 Larrabee Street
MEMPHIS, 417 Monroe Avenue
LOS ANGELES, 2120 San Fernando Road
SEATTLE, 501 Westlake North
VANCOUVER, B. C., 1363 Granville Street

Mail coupon today for free copy "Diesel News," containing latest facts and pictures on the opportunities in Diesel — new issue just off the press.

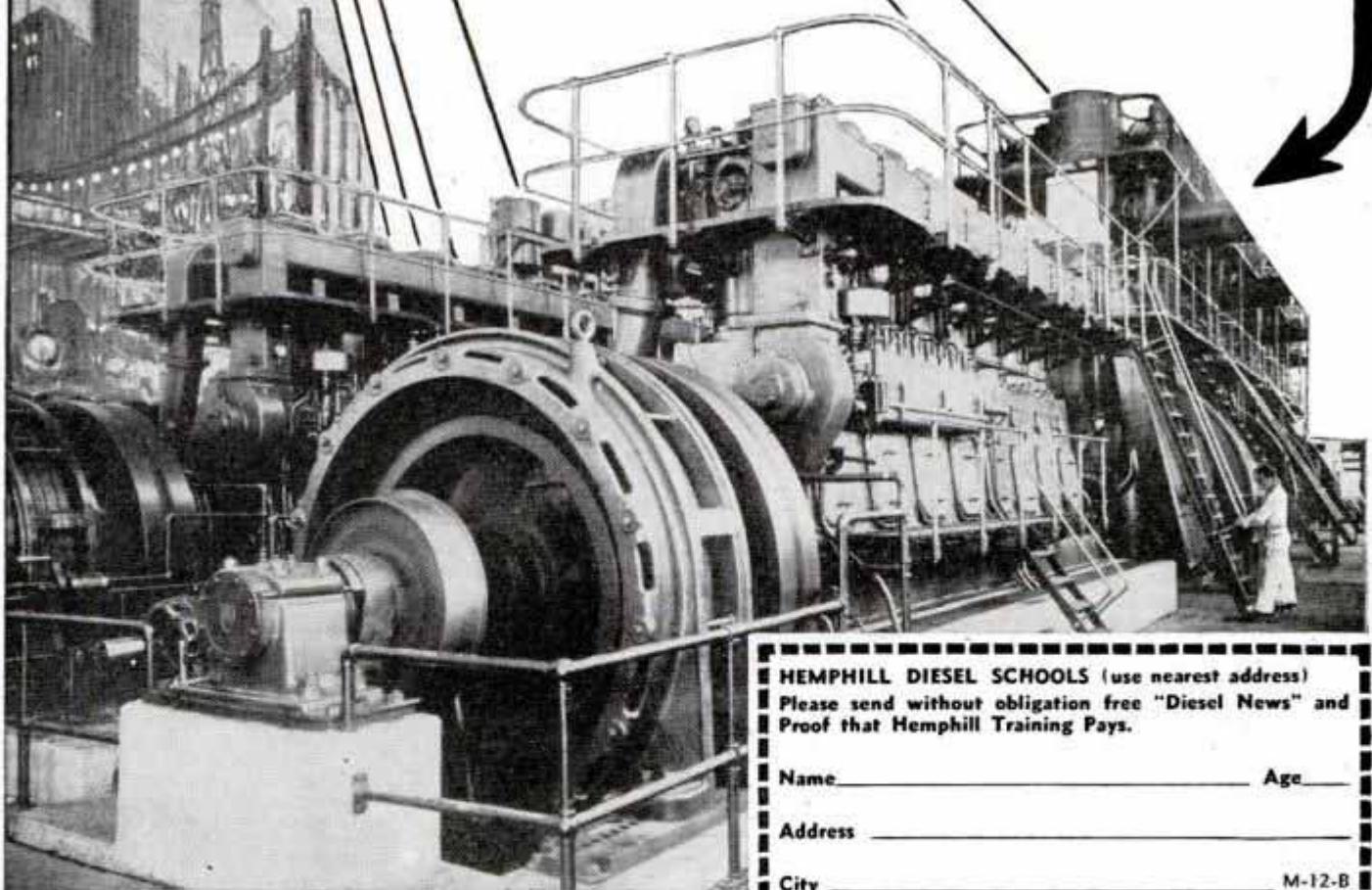

HEMPHILL DIESEL SCHOOLS (use nearest address)
Please send without obligation free "Diesel News" and
Proof that Hemphill Training Pays.

Name _____ Age _____

Address _____

City _____ M-12-B

HEMPHILL TRAINING PAYS

IF MEN WORE PRICE TAGS



HOW WOULD YOU FEEL?

WELL, your boss thinks of you in terms of so much a week! You are worth *this* or *that* to him. How much you are worth depends upon —YOU! You decide the amount chiefly by your ability—by your training. Why not increase the amount by increasing your training? Thousands of men have done it by spare-time study of I. C. S. Courses. *You are invited to earn more money.* This coupon is your invitation.

INTERNATIONAL CORRESPONDENCE SCHOOLS

Box 5635-H, Scranton, Penna.

Without cost or obligation, please send me a copy of your booklet, "Who Wins and Why," and full particulars about the subject before which I have marked X:

TECHNICAL AND INDUSTRIAL COURSES

- | | | |
|--|--|-------------------------------------|
| <input type="checkbox"/> Architect | <input type="checkbox"/> Plumbing | <input type="checkbox"/> Heating |
| <input type="checkbox"/> Architectural Draftsman | <input type="checkbox"/> Air Conditioning | |
| <input type="checkbox"/> Building Estimating | <input type="checkbox"/> Steam Engineer | |
| <input type="checkbox"/> Contractor and Builder | <input type="checkbox"/> Steam Electric Engineer | |
| <input type="checkbox"/> Structural Draftsman | <input type="checkbox"/> Marine Engineer | |
| <input type="checkbox"/> Structural Engineer | <input type="checkbox"/> Civil Engineer | |
| <input type="checkbox"/> Electrical Engineer | <input type="checkbox"/> Highway Engineer | |
| <input type="checkbox"/> Electric Lighting | <input type="checkbox"/> Bridge Engineer | |
| <input type="checkbox"/> Welding, Electric and Gas | <input type="checkbox"/> Bridge and Building Foreman | |
| <input type="checkbox"/> Reading Shop Blueprints | <input type="checkbox"/> Surveying and Mapping | |
| <input type="checkbox"/> Telegraph Engineer | <input type="checkbox"/> Refrigeration | |
| <input type="checkbox"/> Telephone Work | <input type="checkbox"/> R. R. Locomotives | <input type="checkbox"/> Air Brakes |
| <input type="checkbox"/> Mechanical Engineer | <input type="checkbox"/> R. R. Section Foreman | |
| <input type="checkbox"/> Mechanical Draftsman | <input type="checkbox"/> R. R. Signalmen | |
| <input type="checkbox"/> Machinist | <input type="checkbox"/> Chemistry | <input type="checkbox"/> Pharmacy |
| <input type="checkbox"/> Patternmaker | <input type="checkbox"/> Coal Mining | |
| <input type="checkbox"/> Sheet Metal Worker | <input type="checkbox"/> Navigation | |
| <input type="checkbox"/> Heat Treatment of Metals | <input type="checkbox"/> Cotton Manufacturing | |
| <input type="checkbox"/> Management of Inventions | <input type="checkbox"/> Woolen Manufacturing | |
| <input type="checkbox"/> Diesel Engines | <input type="checkbox"/> Agriculture | |
| <input type="checkbox"/> Aviation Engines | <input type="checkbox"/> Fruit Growing | |
| <input type="checkbox"/> Automobile Mechanic | <input type="checkbox"/> Poultry Farming | |

BUSINESS TRAINING COURSES

- | | | |
|---|---|--|
| <input type="checkbox"/> Business Management | <input type="checkbox"/> Business Correspondence | |
| <input type="checkbox"/> Office Management | <input type="checkbox"/> Lettering Show Cards | <input type="checkbox"/> Signs |
| <input type="checkbox"/> Industrial Management | <input type="checkbox"/> Stenography and Typing | |
| <input type="checkbox"/> Traffic Management | <input type="checkbox"/> Civil Service | <input type="checkbox"/> Mail Carrier |
| <input type="checkbox"/> Accountancy and C.P.A. | <input type="checkbox"/> Railway Mail Clerk | |
| <input type="checkbox"/> Coaching | <input type="checkbox"/> Grade School Subjects | |
| <input type="checkbox"/> Bookkeeping | <input type="checkbox"/> High School Subjects | |
| <input type="checkbox"/> Secretarial Work | <input type="checkbox"/> College Preparatory | |
| <input type="checkbox"/> Cost Accountant | <input type="checkbox"/> First Year College | <input type="checkbox"/> Spanish |
| <input type="checkbox"/> Salesmanship | <input type="checkbox"/> Advertising | <input type="checkbox"/> French |
| <input type="checkbox"/> Service Station Salesmanship | <input type="checkbox"/> Illustrating | |
| <input type="checkbox"/> Wallpaper Decorating | <input type="checkbox"/> Cartooning | <input type="checkbox"/> Lumber Dealer |
| <input type="checkbox"/> Salesmanship | <input type="checkbox"/> Apartment House Management | |

Name.....Age.....

Address.....

City.....State.....

Present Position.....

If you reside in Canada, send this coupon to the International Correspondence Schools Canadian, Limited, Montreal, Canada

When writing please mention Popular Mechanics

QUICK, SURE WAY TO POPULARITY

LEARN TO DANCE!—Fit in any crowd—be in demand, sought after—have fun!



There's no reason now why you can't become a good dancer—learn the popular Waltz and Fox Trot steps in a few hours at home—through Arthur Murray's amazing new method! In a short time you'll be out on the dance floor, a joy to your partner, popular everywhere! Prove it for yourself—see how easily, quickly you can become a good dancer!

SEND FOR FREE LESSON! Send your name and address with only 10c (stamps or coin) to cover printing and postage. A free lesson will be sent you at once. Study it—learn how simple it is to learn to dance the Arthur Murray way! Send for your lesson today—sure!

Arthur Murray, Studio 222, 7 E. 43d St., New York, N. Y.

BE AN ARTIST

WE CAN TEACH YOU DRAWING in your own home during your spare time. Thirty-five years of successful teaching proves our ability. Artists receive large salaries.

Write today for Art Year Book

SCHOOL OF APPLIED ART

Dept. 176, 10 E. Huron St., Chicago, Ill.



ENGINEERING



TECHNICAL AND APPLIED COURSES. Nonesentials omitted. TIME AND MONEY SAVED. Degree in 2 yrs., diploma in 1 yr. Electrical, Mechanical, Architectural, Structural, Aeronautical, Civil, Highway. Short intensive courses in Diesel-Electric, Electricity, Power Plant, Drafting. All courses include Refrigeration, Diesel, and Air-Conditioning. Low tuition. Extensive modern equipment. Part-time work for room and board. 27th year. Thousands of successful graduates in U. S. and foreign lands. Approved by industry, endorsed by educators and alumni. One and two-year courses begin in Sept. Short courses open the year round. Catalogue free.

FINLAY ENGINEERING COLLEGE
1001 Indiana Avenue Kansas City, Mo.

You Can Regain Perfect Speech, if you STAMMER

Send today for beautifully illustrated book entitled "DON'T STAMMER," which describes the Bogue Unit Method for the scientific correction of stammering and stuttering. Method successfully used at Bogue Institute for 35 years—since 1901. Endorsed by physicians. Full information concerning correction of stammering sent free. No obligation. Benjamin N. Bogue, Dept. 171, Circle Tower, Indianapolis, Indiana.

DYNAMIC POWER There is a reservoir of power within you which, if tapped, will enable you to accomplish seeming miracles—to achieve Success—to realize your greatest desires. Learn how to utilize the full power of your mind—the Dynamic Power you possess and which now lies dormant. Send for our Free brochure and learn about the New Science of Dynamic Power.
SECOR PUB. CO., 209 CHAPMAN BLDG., AURORA, ILL.

MAIL FOR FREE INFORMATION

BEDFORD

1117 Bedford Ave., Dept. PM-41
Brooklyn, New York City, N. Y.

YMCA
TRADE
SCHOOL

- Auto Mechanic
- Talking Pictures
- Aviation Mechanic
- Welding
- Aeronautical Engineering
- Refrigeration
- Machine Shop
- Oil Burner
- Diesel Engineering
- Air Conditioning
- Sign Painting
- Electrical
- Window Display
- Radio and Television Mechanic
- Architectural-Mechanical Drafting
- Armature Winding
- Diesel Engines

Name.....

Address.....

Train at Home...Under Factory Engineers for GOOD PAY Spare-Time and Full-Time Jobs in RADIO



APPOINTED BY RADIO MANUFACTURERS TO SUPERVISE R-T-I TRAINING

This is the R-T-I Advisory Board—Engineers and Executives of large Radio firms—appointed by these firms to supervise and direct R-T-I Training. Put your future in their hands. 50 great radio manufacturers now endorse this Training.

Trained Men Needed in All Branches

If you're dissatisfied with small pay—lay-offs and an uncertain future—here's an opportunity that's too good to miss. At the cost of only the time it takes you to mail the coupon, you can get my big FREE book, "RADIO'S FUTURE AND YOURS." This book tells how you can learn at home under the supervision of factory engineers, to make more money almost at once in Radio—whether you want to make Radio your life's work, or use it to pick up an extra \$5 to \$20 a week in your spare time.

More Opportunities Than Ever Before

Radio is still forging ahead. 1935 was its biggest year. Over 5 million new sets sold. Over 30 million dollars paid for service alone in 1935. Where only a few hundred men were employed a short time ago, thousands are employed today. And where a hundred jobs paid up to \$75 a week—there are thousands of such jobs today—many paying even more. And new jobs are being created all the time—full time jobs and spare time jobs. Get my book and see how easy it is to learn at home for this good-pay work.

"Shop Training" for the Home

R-T-I Training is different than any training you ever heard about. It comes to you right from the heart of the Radio Industry—right out of the factories where Radio sets and other vacuum-tube devices are made. It was planned and prepared and is supervised by big radio engineers IN these factories—by men appointed for the purpose. This means that trained the R-T-I way, you'll be trained as the Radio Industry wants you trained—just as the Radio Industry, itself, would train you if it was doing the job.

Television, Photo Electric Cells, Public Address Systems Included

Radio service work is only the starting point in R-T-I Training. From there it will take you through the whole field of Radio and Electronics. You will learn about every new development, including Television so you'll be ready when Television breaks. You'll also learn the big money subjects such as Aviation and Auto Radio; Public Address Systems; how to handle Photo Cells; Sound Picture Recording, Etc.

4 Working Outfits Furnished

Start almost at once doing part time radio work. I furnish 4 outfits of apparatus that you build into test equipment with which you can do actual jobs and earn extra money. My Training pays its own way and you get your money back if not satisfied.

Age or Lack of Experience No Handicap

You don't have to be a high school graduate, nor even have finished the grades. My Training is so simple, easy, and practical, that the average man, regardless of age, education, or previous experience can master it. It offers the chance you have wanted to get out of a small-pay, no-future job, into good pay work with a future, in Radio and all its branches.

Get My Free Book

INVESTIGATE! Learn why R-T-I Training is different. Find out why R-T-I Trained men get "Quick Results" and "Big Results." Send for your copy of "Radio's Future and Yours" today. It tells you about Radio's amazing opportunities. It describes my approved training. It tells what R.T.I. students are doing and making. It gives the names of my Advisory Board and 50 endorsing manufacturers. It's FREE. Clip, sign and mail coupon RIGHT NOW!

LEARN TO EARN
UP TO \$75 A WEEK

(MANY R-T-I TRAINED MEN EARN MORE)
MAIL COUPON BELOW



Big Money in Auto and Police Radio Work

W. H. Carr, 402 N. 16th St., Kansas City, Kansas, an R.T.I. student, has charge of 35 radio equipped cars for the Kansas City Police and Fire Departments. His salary is \$230.00 a month and he is furnished with an automobile, gas, oil, etc. He says, "If I had not taken your course I would not be able to hold this job."



Makes \$600 in One Month

Herbert B. Thomson, Gorman, Texas, formerly an oil well driller, borrowed \$170.00 to start a spare time radio business after completing 12 R-T-I lessons. He made money from the start. In two years his shop was worth \$3500. He says, "Because of my R-T-I Training I made \$450 in September and over \$600 in October 1935. It pays to be R-T-I Trained."

MAIL FOR FREE BOOK

Ray D. Smith, President,
RADIO AND TELEVISION INSTITUTE
(R-T-I),

2150 Lawrence Ave., Dept. 17, Chicago, Ill.

Without obligation, send me a copy of "Radio's Future and Yours." I am interested in your training and the opportunities in the great field of Radio for the R-T-I Trained Man.

Name.....

Address.....

City.....State.....



RAY D. SMITH,
President R-T-I,
who has directed
training of 100,000
men. Read what a
few students say.

"Made my first spare time money after finishing four lessons. Over \$500 spare time money in 10 months. R-T-I is O.K."
Dolmer Grote, Route 5, Greenville, Ohio

"I made \$14.25 in first 11 days of my training following your instructions."
C. E. Head, 431 Third St., Alexandria, La.

"Before finishing my training I was made Manager of a Department Store's radio section."
Howard N. Lentz, 123 W. Alexander St., Buchanan, Mich.

"My job paid me \$18 a week before taking your training. Shortly after starting was averaging \$60 a week. Have made as high as \$250 in single week."
Wm. T. Ridd, 3452 Evelyn St., Verdun, P.Q., Canada

RAY D. SMITH, President



RADIO AND TELEVISION INSTITUTE
PRACTICAL SHOP TRAINING FOR THE HOME

Dept. 17 • 2150 Lawrence Avenue • CHICAGO

When writing to advertisers please mention Popular Mechanics

LEARN AUTO MECHANICS in 8 weeks!

Earn \$35 to \$75 a week as an Auto Mechanic. Never in the history of the automotive business has there been such a demand for TRAINED men. 8 weeks training fits you for a job that's waiting for you or to open your own repair shop. Read what two McSweeney trained men have done. Hundreds of others can tell you facts equally interesting. Don't look for a job! TRAIN for it!

Farrell, Pa.

Dear Mac: Please forward me your catalog. I want it to add to my traveling souvenirs. I am working in a modern garage although I have been out of school only four weeks, thanks to McSweeney Training. My best regards to all. M. Klushauk

Rector, Ark.

Dear Mac: Just a few lines which might interest you. I left your school two years ago last May. Since I left I have not seen a day I could call "hard times." I have been working ever since I left and have averaged in my earnings \$173.00 a month, in spite of the hard times. Many thanks. Thos. J. Sharp

EIGHT WEEKS of Actual Shop Training

No books or lessons the McSweeney way. First you learn the "why" of everything you do; then under competent instructors, you DO the job. You work on real equipment and machines, with the real tools of the auto expert. In eight short weeks you are TRAINED to hold down a permanent BIG PAY job. Any man 16 to 50 can learn. Write today for New Low Tuition Offer.

Diesel Engines and Aviation Ground Course!

Diesel and Aviation coming fast! Prepare now for the wonderful opportunities of the future.

MONEY BACK GUARANTEE!

Eight weeks of intensive training, actual shop work with real tools on real equipment, qualifies you for a Big Pay Job. If not satisfied, your tuition will be refunded.

FREE Write today for Big Free Book on AUTOS. Get the facts about jobs; and Low Tuition Offers. Mailing the coupon does NOT obligate you. It obligates ME to tell YOU how you can train for Big Money in eight short weeks. Address Dept. 10-34,

McSWEENEY SCHOOLS
AUTOMOBILE—DIESEL—AVIATION
DETROIT, MICH.
CLEVELAND, OHIO or KANSAS CITY, MO.

Write Our School Nearest You

McSweeney Auto and Aviation School,
 Dept. 10-34, Detroit, Mich., Cleveland, Ohio, or Kansas City, Mo.

Without cost or obligation, send me your Big FREE Book on Autos; also full information about your Low Tuition Offer.

Name.....

Street.....

Town.....State.....Age.....

When writing please mention Popular Mechanics

ACCOUNTING

the profession that pays



this book free!

Accountants command big income. Thousands needed. About 14,000 Certified Public Accountants in U. S. Many earn \$3,000 to \$20,000. We train you thoroughly at home in your spare time for C. P. A. examinations or executive accounting positions. Previous bookkeeping knowledge unnecessary—we prepare you from ground up. Our training is personally given by staff of experienced C. P. A.'s. Low cost—easy terms. Write now for valuable 64-page book, "Accountancy, the Profession That Pays," free.

LASALLE EXTENSION UNIVERSITY
The school that has trained over 1,350 C.P.A.'s
 Dept. 1064-H Chicago

FREE—BOOK on MIND TRAINING

An instructive book which explains an amazing system of mind training already used by more than 750,000 people. Let us send you a free copy of "Scientific Mind-Training." It will show you how and why Pelmanism is the **only** system of teaching for developing **all** the mental powers at the same time. Endorsed by such world leaders as Frank P. Walsh, Edgar Wallace, Sir Harry Lauder, Prince Charles of Sweden and hundreds of others. Write TODAY to

THE PELMAN INSTITUTE OF AMERICA
 271 North Avenue Dept. 610 New Rochelle, N.Y.

25 Piece ELECTRICAL EXPERIMENTAL KIT



A. C. 110-volt generator—small D. C. motor—25 pieces genuine commercial apparatus—15 lbs.—50 fascinating experimental broadcast over your own radio—make arc light 4000 ft. range—secret detestophone, listen in on private conversations—generate 110-volt electricity—thief detector—generate health rays—electro-plate, etc. etc. P. R. E. E. with kit, Short Course in Electricity—Lab. Bench Plans and B. Print Order direct from ad, or send name for Free Experimental Catalog. Send NOW!

Original Cost of Parts, \$18.50
SPECIAL, only \$3.99

ELECTRICAL SALVAGE CO., Box 524-TT, LINCOLN, NEBR.



Learn to Write

Begin Today. Write for my Free Book, "How to Become a Good Penman." It contains specimens and tells how others learned to write in spare time. Your name elegantly written on a card if you enclose stamp for postage. Write today. F. W. TAMBLYN, 418 Ridge Bldg., Kansas City, Mo.

NO BOSS! SURE CASH!

SILVERING MIRRORS

Autoparts, Reflectors. Combination outfit. Write
SPRINKLE, Plater, 129, Marion, Indiana

MAKE MONEY AT HOME!

Learn to color photos and miniatures in oil. No previous experience needed. Good demand. Send for free booklet, "Make Money at Home" and requirements.
NATIONAL ART SCHOOL
 3601 Michigan Ave. Dept. 1357 Chicago

Learn Radio - 12 Weeks

SHOP TRAINING

FINANCE YOUR TUITION

GET DETAILS of MY AMAZING OFFER!

Prepare for jobs in Radio Broadcast, Talking Pictures, Television, by twelve weeks of practical shop work in the great Coyne Radio Shops, on real machinery and equipment. You don't need advanced education or experience. Free Employment Service for life. Many earn while learning. Mail coupon today for free book which tells you how hundreds have become successful Radio men after taking my training and all details of my "Pay Tuition After Graduation" Plan.

H. C. LEWIS, Pres., COYNE RADIO SCHOOL
 500 S. Paulina Street., Dept. 78-3H, Chicago, Ill.
 Send Free Radio Book and facts. Tell how I can pay for my course on easy payment plan after I graduate.

Name

Address

Town.....State.....

THESE FREE BOOKS ARE FOR INVENTORS

AND OTHER MEN WITH IDEAS

"We're only entering the great period of inventive advancement"

—says C. F. Kettering, Vice Pres., General Motors.

SOMETIMES we hear people say: "Well, there isn't much left to invent." But Charles F. Kettering, Vice-Pres. and head of Research of General Motors, who helped develop the self-starter, Duco and many other outstanding inventions, doesn't think that at all. Not long ago in a published statement, he said:

"If we took half the men employed in tool making and put them to working out new inventions, new things, we could snap out of this depression in no time. Our return to normal times depends on new manufactured products that will catch the purchaser's eye, get him to buy and thus start the ball rolling. Change and buying go together. *We are only entering the great period of inventive advancement.*"

Many Little Ideas Have Big Commercial Possibilities

Some of the world's best inventions came from men who didn't consider themselves inventors at all. The telegraph was invented by a painter, the typewriter by a farmer, the hand camera by a bank-clerk, the stock ticker by a dentist. Or look at small inventions. A husband noticed his wife bending a hair pin to make it stay put. That gave him the idea of the crinkly hair pin. One day a golfer got the idea to make a wooden tee. Now wooden tees are sold by the millions every year. There are many similar examples in inventive history. That is why we say that the books shown here are for INVENTORS and Other Men with IDEAS. Whether you consider yourself an inventor or not—if you have an idea that will make money, save time, save labor, or give pleasure—find out how you can protect your rights to it.

Our Business Is to Help You

For thirty-six years, this organization has been in the business of helping inventors. During that time inventions from every corner of the country have been turned over to us to protect. Some ideas have represented complicated mechanisms; others have been small, practical articles, like a can opener or a new toy. All this has given us a wealth of experience to use for the inventor of today. Here in Washington, we maintain a large staff of experienced Patent Specialists to give you prompt and expert service. Yet because we work efficiently—our fees are low; and if desired we help you with deferred payments. But first, find out exactly what to do to protect yourself. **Decide on that today by sending for your FREE copies of the books shown above.**

Suggestions
on
WHEN
and
HOW
to Sell an
INVENTION

THESE BOOKS TELL YOU:

How the Patent Laws protect an inventor. Simple steps to take promptly, without cost, to claim your right to your idea. Kind of sketch or model needed. How you can go about selling an invention. They are full of valuable facts, simple, easily understood suggestions and interesting bits of inventive history. We gladly send them to serious men. No charge, no obligation. Write us or use the coupon below. Get that much done today.

PATENT PROTECTION

VICTOR J.
EVANS & Co.

REGISTERED PATENT ATTORNEYS
MAIN OFFICE: 700-L, VICTOR BUILDING
WASHINGTON, D. C.

Other Offices: 1640-N Conway Bldg., Chicago; 1007-N Woolworth Bldg., New York; 514-N Empire Bldg., Pittsburgh; 1010-N Hobart Bldg., San Francisco; 736-N Security Bldg., Los Angeles.

Send me FREE copies of your books "Patent Protection" and "When and How to Sell an Invention." (Note: Same books supplied by any of branch offices listed above.)

Name.....

Street and No.....

City or Town.....

NOW FIX ANY MAKE OF AUTO



SIX BIG AUTO BOOKS ALL SHIPPED FREE

on approval; whether you want to qualify as garage owner, auto repair expert or merely wish to know how to keep your own car 100% efficient, look at these books—they are sent to you for free examination. This brand new edition has been prepared by a large group of America's greatest automotive engineers. Anybody who can read will understand them, for this great automobile encyclopedia is a veritable

gold mine of valuable facts. Take advantage of this offer now; send in the coupon for FREE examination. You don't pay us a penny, you don't obligate yourself to pay anything unless you decide to keep the books. Just tell us you want to see them and the full set of 6 great volumes, just off the press, will be sent to you! Read them, look them over and prove to your own satisfaction that one fact alone, which you will find in them, may save you an expensive repair, or help you to a better job.

**DIESEL ENGINES
AVIATION MOTORS
MOTORCYCLES
OUTBOARD MOTORS
MARINE ENGINES
TRACTORS
AUTOMOBILE RADIOS
ALL COVERED**

Very Latest Edition

Imagine books which are so new that every page is right up to date—wiring diagrams, construction details, service problems—are all right up to the minute. Nowhere else can you get as complete and timely information. Over a million dollars of resources have enabled us to give you the most authoritative books on the subject ever published. Everybody interested in automobiles in any way will welcome these books published by the world's largest publishers of Technical Cyclopedias (est. 1897) with agencies all over the world.



Can You Fix It?

Can you take out "play" in differentials? Can you kill the "shimmy" in steering? Can you reset TIMING? Can you put your finger on engine trouble without guessing or tinkering? Can you pull the starter off and fix it? Can you adjust and repair transmission, engine, rear axle, bearings?

These Books Tell How and tell you how to do any and every auto job right, the first time.

6 Big Volumes

Nearly 3,000 pages, over 2,000 illustrations, wiring diagrams, equipment charts, etc. De Luxe edition with gold-stamped flexible binding. Sent FREE for 10 days' use. If not wanted return express collect. If kept, send only \$2.00 after 10 days, then \$3.00 a month until special advertising price, \$24.80, is paid.

A Year's Consulting Membership FREE!

Privilege of consulting engineers of million-dollar American Technical Society on any automotive problem for one year without charge if you mail coupon immediately. Also an extra volume, No. 7, with all latest cars and special book "Automobile Service Shop Management."

SEND NO MONEY

AMERICAN TECHNICAL SOCIETY,
Drexel Ave. at 58th St., Dept. A719, Chicago, Illinois.

I would like to see the brand new 6-volume edition of your automobile books but without any obligation to buy. I will pay the few cents delivery charges only and will examine the books and return them at your expense in 10 days unless I like them. In which case I will send you \$2.00 then and only \$3.00 per month until the special price of only \$24.80 is paid. You are to include free, consulting membership in the American Technical Society, extra volume, No. 7, with all latest cars and special book, "Automobile Service Shop Management."

Name.....
Street.....
City..... State.....

Please give us, in addition, the name and address of your employer and that of at least one business man as reference.

When writing please mention Popular Mechanics

Cheaper HEAT Without COAL



EARN \$60 A WEEK!
Write for FREE Burner offer and protected territory

New Invention Fits Any Stove or Range

Remarkable invention burns 96% air, 4% of a cheap variety of oil obtainable everywhere. Does away with coal, wood, ashes, dirt and drudgery. Quick, clean, silent heat. 3 times hotter than coal, and cheaper. Temperature control gives any amount of heat desired—no more getting up on bitter cold, wintry mornings. Many automatic features. No gas or electricity needed. Safe as ordinary kitchen range. Easy to install—no damage to stove—simply sits in firebox of any stove range, or furnace. Costs just a few cents a day to operate.

Men and women wanted to demonstrate and take orders for this wonderful invention. This year's sales are tremendous. Make big money. Experience unnecessary.

TRY 30 DAYS AT OUR RISK

Low introductory price and 30 day trial. Write for free catalog. AGENTS and spare time workers: Oil heat saves money this year; people buy to save! Write immediately for free burner offer that starts you in business for yourself. Act NOW!

BRIGHAM OIL BURNER CO.

2927-K Clark Ave.

St. Louis, Mo.

BE A RAILWAY TRAFFIC INSPECTOR

TRAINED MEN NEEDED NOW!
A GOOD POSITION is ready for you upon completion of our simple, home-study course. We help place you as a Railway and Bus Passenger Traffic Inspector with salary up to \$135 per month, to start, plus expenses, or refund tuition. Interesting, beautiful (outdoor) work and rapid advancement for the ambitious; travel if you like. Free Booklet outlines our 17-year record of placing students. **STANDARD BUSINESS TRAINING IN-TITUTE**, Div. 210 Buffalo, N. Y.

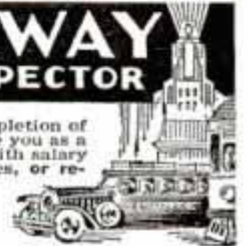

TRI-STATE COLLEGE

B. S. Degree in 2 years. World famous for technical 2-year courses in Civil, Electrical, Mechanical, Chemical, Radio, Aeronautical Engineering; Business Administration and Accounting. Equivalent in technical hours to 4-year course. Those who lack high school may make up work. Low tuition. Low living costs. Located in picturesque hill and lake region. Students from every state and many foreign countries. 53rd year. Enter Sept., Jan., March and June. Write for catalog.

4106 COLLEGE AVE.,

ANGOLA, IND.

CRIME DETECTION
SECRET SERVICE AND FINGER PRINTS

SECRET SERVICE BOOK FREE

For 30 Days Reading
No Money Down—Actual Crime Cases—
If You Are Qualified—We will send you this stirring book on Crime Detection, Secret Service and Identification Work for 30 days free reading. Send no money. If you decide to keep it, then send only \$1.00. If not, return it. **WRITE TODAY.** Not sent to boys under 17 years of age.

T. G. Cooke, Dept. 1357, 1920 Sunnyside Ave., Chicago

ARTISTS MAKE MONEY

Find out your ability. Send name, age, occupation and address for Free Vocational Art Test.
Federal Schools, Inc., 10136 Federal Schools Bldg., Minneapolis, Minn.

STUDY SYSTEMS 1819 B'WAY, N.Y.C.

Please send free booklet about how I can train for a career in one of today's big industries checked below for the total sum of \$30.

<input type="checkbox"/> Diesel Engines	<input type="checkbox"/> Air Conditioning	<input type="checkbox"/> Applied Electricity
<input type="checkbox"/> Oil Burners	<input type="checkbox"/> Refrigeration	<input type="checkbox"/> Radio
<input type="checkbox"/> Television	<input type="checkbox"/> Aviation	<input type="checkbox"/> Neon Signs

Name

Address

Be An ARTIST



It's Fun to Learn this Way

Can YOU Do THIS?

Just a few plain, quickly sketched lines—and you have the "framework" of a drawing. These first lines give you the rough proportions and lines of action.



Then YOU Can Do THIS . . .

Next we show you exactly how to apply the rules for developing the outlines and "blocking out" the areas to be shaded. Then you erase the first "framework" lines and presto!—you have this!



...and THIS!

Now you are shown how to give your drawing shape, depth and form by shading and high-lighting. In every single step you are guided by proven rules which correct your mistakes and skillfully direct your hand!



BIG ARTIST'S OUTFIT GIVEN!

This full-size professional Artist's Outfit comes with your very first lesson—at NO EXTRA COST. It contains everything you need to learn and earn. Mail coupon now for complete details of this remarkable offer.

Learn to Draw at Home This Amazingly Simple Way!

YOU have always longed for it—this fascinating ability to draw. Now it can readily be yours! Illustrating, Rapid Sketching, Decorative Designing, Commercial Art, Cartooning—you can now learn all of this right in your own home. Many of our students never had a drawing pencil in their hands before starting, yet today are successful artists with good incomes.

Our simple, proven, short-cut method makes it fun to learn, in your spare time. And now, with just a few hours' pleasant practice each week, you, too, may learn to make drawings that have a real commercial value—just as those whose reports are given below are doing! Get into this interesting, profitable field NOW! Mail coupon for FREE BOOK, "Art for Pleasure and Profit" at once!

Commercial Art, Cartooning and Designing, ALL in ONE Course!

It's like a pleasant game when you learn to draw with this simple method. You study right at home, yet every bit of your work receives the individual attention and criticism of a real art teacher. It's almost as though you had a well-known Art Instructor standing at your elbow while you work.

With this training you progress with amazing rapidity. Starting with straight lines and curves, you quickly learn action, perspective and all the more advanced secrets of drawing. You get a sound, complete, all 'round art training based on our 22 years of successful experience. See (at the left) the money others have made even before they finished the course!

Our big new FREE Book describes the latest developments and opportunities in this fascinating, good income field—and gives full details of this quick, simple method. Tells about our students—their successes—what they say about our course—shows actual reproductions of their work—and tells how many earned good money even while learning. Mail coupon or postcard today. (No salesman will call.) Please state age. Studio 1210, Washington School of Art, 1115—15th St., N. W., Washington, D. C.

Get this FREE BOOK

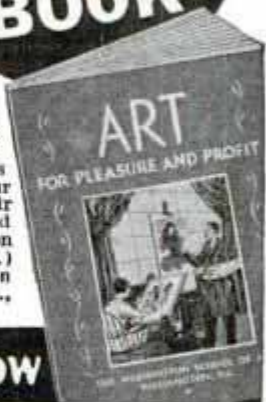

Free Book shows how

WASHINGTON SCHOOL OF ART, Studio 1210, 1115—15th Street, N. W., Washington, D. C.

Without obligation, please send me a FREE copy of your Book, "Art for Pleasure and Profit."

Name..... Age.....

Address

City..... State.....

Electricity at your finger ends



Sold Singly
Price \$1.50
A Book

Pocket Size!

AUDELS NEW ELECTRIC LIBRARY—A progressive Home Study and Reference Course in applied electricity. Easy to understand. Questions and answers plainly written for a complete working knowledge of modern electrical practice, necessary to every electrician, engineer, mechanic and student.

LEARN THE AUDEL WAY! You ask the question—Audel's New Electric Library gives the answer—9500 simplified outlines, graphic illustrations and precise explanations covering Construction, Operation and Machine Maintenance.

BOOK A MONTH PLAN—Order the volume that interests you—today! We will send that volume on 7 days' free trial. If the book helps you, send us \$1.50. If it does not help you, mail book back to us. On receipt of your first payment, we will send your second book. We allow 30 days to pay for this and for each following book until you complete the Series.

If you are not satisfied, you may cancel your subscription at any time.

FREE EXAMINATION COUPON
Theo. Audel & Co., 49 W. 23rd St., New York City
Mail Vol. I, Electric Library on 7 days' free trial. If O. K. I will remit \$1.50, otherwise I will return it. I also request you to mail one book each month on same terms. No obligation unless I am satisfied.

Name

Address

Occupation PM



DIESEL the NEW POWER

The whole world gasped at the amazing performance of the Diesel Powered Burlington R. R. Zephyr train. It opens a new era of power efficiency. Aeroplanes, automobiles, great industrial plants may soon be using these marvelously efficient engines.

It means a new profession, a new trade for thousands and thousands of men. Learn Diesel operation, construction and repair NOW. Use our magical quick reference method. Find out all you need to know through these books, "Diesel and Other Internal Combustion Engines"—"Diesel Engines, Operation and Maintenance"—"Diesel Electric Plants," which we send free for examination. This combination offer brings you the latest and most authoritative information obtainable. Over 300 illustrations.

3 BOOKS ALL SHIPPED FREE

for examination. There are no strings to this offer. If you really want to get into the most promising new field of the century—the liveliest—most up-to-date—most talked of profession, send for these books on our amazing free shipment offer. Read them, examine them, test them in any way and then if you are not sold 100% send them back at our expense and you won't owe one cent.

American Technical Society, Dept. 0719
Drexel at 58th Street, Chicago, Illinois.

Send me the 3 Volumes on Diesel Engines, listed above for 10 days FREE examination. I will pay the few cents express but don't owe you a cent unless I keep the books, in which case I agree to send \$2.00 in 10 days and \$3.00 a month until the introductory price of only \$9.80 is paid.

Note: If you prefer you may send only \$8.80, cash or money order (you save \$1.00) in full payment, and we will send the 3 books prepaid. We agree to return your money if you are not satisfied and return them in 10 days.

Name

Address

City State

Please attach a letter giving age, occupation and the name and address of your employer and that of at least one business man as reference.

Join THE BAND WITH A BUESCHER True Tone

EASY TO PLAY

● Top flight radio artists, like Hal Kemp, pictured above, choose Buescher instruments for their beautiful tone and easy playing qualities. You will learn quickly—take your place in a band or orchestra in a short time with a Buescher True Tone. **FREE TRIAL; Easy Payments.** Write now for details. Mention which interests you: saxophone, cornet, trombone, any instrument for band or orchestra.

BUESCHER BAND INSTRUMENT CO.
1010 Buescher Bldg. Elkhart, Indiana

Men Wanted

We pay your railroad fare to Nashville. Let us train you to be an expert automobile mechanic and help you get a good job. The cost to you is small. No negroes taken. For free booklet write Nashville Auto College, Dept. 75, Nashville, Tenn.

Write and Speak MASTERLY ENGLISH

Learn correct English with Sherwin Cody's new invention. No rules to memorize. Like a fascinating game. Spare-time study. 15 minutes each day, quickly, gives you command of English. Send for free book, "How You Can Master Good English in 15 Minutes a Day." Write today.

SHERWIN CODY SCHOOL OF ENGLISH
510 Searle Bldg. Rochester, N. Y.

RADIO ENGINEERING

RCA Institutes offers an intensive course of high standard embracing all phases of Radio. Practical training with modern equipment at New York and Chicago schools. Also specialized courses and Home Study Courses under "No obligation" plan. Illustrated Catalog on request

RCA INSTITUTES, Inc.
75 Varick Street, New York, N. Y.
1154 Merchandise Mart, Chicago
Recognized Standard in Radio Instruction Since 1909

Learn ADVERTISING at Home

Greater opportunities now in advertising. Learn easily and quickly in spare time. Practical work. No text books. Old established school. Low tuition—Easy terms. Send for free booklet of interesting information.

Page-Davis School of Advertising
Dept. 1357, 3601 Mich. Av., Chicago

Learn CHALK TALKING

Entertain for all occasions. Send \$1.00 for Laugh Producing Program of 23 Trick Drawings with Instructions. Catalog of Chalk Talk Supplies Free.

BALDA ART SERVICE, Dept. K, Oshkosh, Wis.

How To Secure A Government Position

Why worry about strikes, layoffs, hard times? Train now for a Government job. Increased salaries, steady work, travel, good pay. Let me help you become a Railway Postal Clerk, Post Office Clerk, City Mail Carrier, Rural Carrier—or help you get into any other Government job you want. I was a Secretary Examiner of Civil Service Commission for **Now FREE** 8 years. Have helped thousands. My 32-page book tells about Government jobs—and how my instruction helps to qualify you to get one. Send the coupon for your copy TODAY.

A. R. Patterson, Civil Service Expert
PATTERSON SCHOOL, 810 Case Bldg., Rochester, N. Y.
Send, without obligation, free book "How to Secure Government Position."

Name

Address

You CAN Learn TO Mount BIRDS AND ANIMALS

Real Fun with Profits!

Be a *Taxidermist!* Learn at Home By Mail. Know a real art—learn it in your *spare time*. Have a highly interesting *hobby* and learn a *trade* from which many earn fine *spare-time profits*.

This old reliable school, 35 years in business, with 250,000 students, offers now to reveal all mysteries of Taxidermy—to teach you how to mount and preserve, just like life, birds, animals, fish, game-heads. You learn the famous chrome tanning. You learn the new fascinating Craft and Novelty Taxidermy—using common specimens—not wild game. It's a wonderful art, full of fun and fascination, with possible real sparetime earnings. Make your workbench pay a profit.

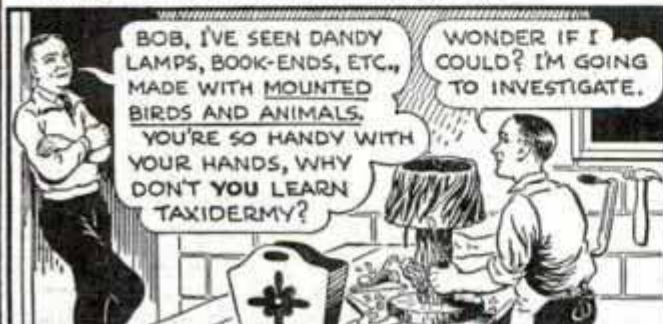

BOB, I'VE SEEN DANDY LAMPS, BOOK-ENDS, ETC., MADE WITH MOUNTED BIRDS AND ANIMALS. YOU'RE SO HANDY WITH YOUR HANDS, WHY DON'T YOU LEARN TAXIDERMY?

WONDER IF I COULD? I'M GOING TO INVESTIGATE.



LATER

TAXIDERMY STUDIO

THANKS FOR TIPPING ME OFF TO TAXIDERMY, JIM. NOW I GET TWICE AS MUCH FUN FROM HUNTING AND FISHING—AND MY WORKSHOP MAKES A DANDY STUDIO. IT'S NOT ONLY FUN—BUT I MAKE GOOD MONEY FROM MY SPARE TIME MOUNTING SPECIMENS FOR OTHERS.

Is Taxidermy Profitable?

From our wide experience we believe emphatically, "Yes!" We know of few other businesses of any kind or nature which offer such opportunities for *spare time earnings*. Some of our Taxidermy students report earnings of \$50 to \$80 a month, others a great deal more. With wild-game growing rapidly scarcer, sportsmen want their trophies mounted. The demand is increasing—the prices are liberal. Many are earning fine profits from taxidermy. Why not make your workbench pay a profit? Read these excerpts from letters:

Leslie Wick says, "Have made over \$300 since enrolling."—George Smith, "Just delivered \$120 worth of work."—Chas. R. Peak, "Made about \$700 in spare time."—Arthur Daniels, "Have my own shop; have made several thousand dollars."

We have many, many such letters—from most all civilized countries. Get our free booklet and read scores of enthusiastic students' letters and see photos of their work.

Free Book Coupon

Send Right Now for Your Copy

It's Free. Send the coupon, or a postal will do. It tells all about our school, all about Taxidermy, contains 100 photos of startling interest.

Will you investigate? Get this free book. It may open to you new fields of pleasure, new interests, and new sources of profits which may solve your financial problems. Do it now, this minute! State your age.

NORTHWESTERN SCHOOL OF TAXIDERMY
3377 Elwood Bldg., Omaha, Nebr.

Do You Hunt?

If you hunt or fish, save your trophies! Game is growing scarcer. Every specimen possesses interest and value. Save every one of them. Mount them—re-create them—just like they were in life. Decorate your home and den. Have your own attractive museum. Many specimens almost extinct may have big value later. Taxidermy will double your interest in hunting, fishing.

Wild Game Not Needed

If you hunt or fish only rarely, still Taxidermy will delight you. You can become a Taxidermist and have fun, fascination, also profits by mounting common birds and animals. Mount pigeons, crows, pets, squirrels, mice, even frogs, into interesting groups—humorous ones. You can create dozens—yes, scores, of novelty groups that everyone admires. It's a thrilling art!

Craft Taxidermy

You will learn the new and popular "Craft" Taxidermy. In this amazing art you combine real mounted specimens with other craft-work, creating innumerable useful articles, such as lamps, door stops, gun racks, ash trays, hat racks, book ends, and many other articles that will be marvelous for the home, and which sell almost at sight. Many students earn real profits the year around with "Novelty" Taxidermy.

"Krome" Tanning

At last you can learn real Tanning. We positively teach genuine Chrome Tanning, a new simplified home method, tested and tried, which gives the highest satisfaction.

At last you can make real leather—harness, sole, lace, buck, waterproof and heat proof. Will not harden or stretch. You can tan all kinds of hide with the hair on—also tan fine furs and make them into garments, trimming, gloves, caps, etc. This famous "Krome" simplified method, the best ever discovered, we believe, is fully taught in our complete course of lessons.

The readers of Popular Mechanics are especially interested in Taxidermy. Thousands of them have joined our school. Investigate! Mail the coupon TODAY. State your age.



NORTHWESTERN SCHOOL OF TAXIDERMY,
3377 Elwood Building, Omaha, Neb.

Send me your free illustrated book, "How to Mount Game". Also tell me how I may learn this fascinating art easily and quickly by mail. No obligation. State your age.

Name _____ Age _____

Address _____

INVENTEN

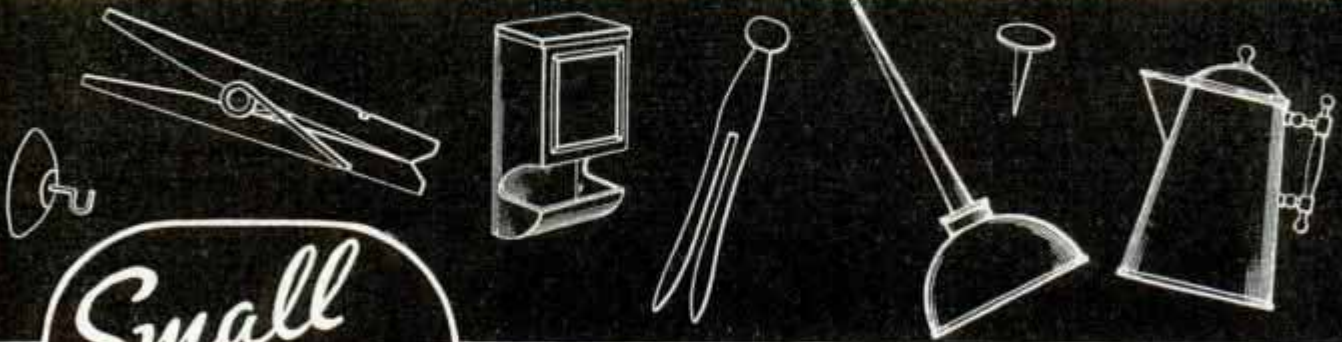

Small Ideas

**THAT HAVE
BUILT BIG
BUSINESSES**

IDEAS do not have to be complicated to be profitable when Patented. The 5c and 10c stores flourish on simple Patented products which are commercially successful. The zipper, safety pin, thumb tack, paper clip, collar button—all simple, yet familiar inventions—brought their inventors rich rewards. If you have a Patentable idea—act to protect it. Many of the most useful, widely popular, greatly profitable, and extremely successful inventions have been very simple ones. You have only to look at the devices we have pictured here to realize how a simple idea may become a utility bought by a hundred thousand or a million people soon after it is produced. Don't be afraid that the simplicity of your idea makes it valueless. The thing that you find so simple that you wonder why a thousand other people haven't already done it is often the invention worthwhile.

HOW OTHER INVENTORS GOT STARTED

The list of men who succeeded in invention with only a poor boy's start is a very long and noble one. Poverty, hardships, lack of friends, distance from the market—these could not hold back Bell, Edison, Eastman, McCormick, Whitney and others. Everyone cannot succeed. But every man can try. Courage, sacrifice, and hard work may bring you a measure of the success these men had. Lack of mechanical ability is not a serious draw-back. You can always get someone able to build a model, draw a detailed design, or otherwise materialize your idea for you. The big draw-back is discouragement.

Your idea for a practical article or an improvement upon an old one should be patented NOW. Frequently many of the thousands of applications filed in the U. S. Patent Office each year are for the same or almost the same idea. In such a case, the burden of proof rests with the last application filed. Sometimes a delay of even a few days in filing the application means the total loss of the patent. **LOSE NO TIME.**

The entire time of this large and experienced organization is devoted exclusively to patent and trade-mark cases. We know the rules and requirements of the Patent Office. We understand the technicalities of Patent Law. We can proceed in the quickest and safest ways in preparing an application for a patent covering your idea.

FREE

The Biography of George Eastman

Views of the man who used Patent Protection to amass millions and give perfection to a new art—*Photography*—itself one of the greatest inventions.



CLARENCE A. O'BRIEN & HYMAN BERMAN

REGISTERED PATENT ATTORNEYS BEFORE U. S. PATENT OFFICE

70-W ADAMS BLDG.

WASHINGTON, D. C.

When writing to advertisers please mention Popular Mechanics

T O R S

Act Now TO PROTECT YOUR
IDEAS
WITH A U.S. PATENT

Send For FREE BOOK

If you have a new idea that is patentable—and want to secure for yourself your inventor's sole right to profit from the idea—you can't afford to lose time in securing the protection of a U. S. Patent. Other inventors may be working on the same idea right now. Should they develop this idea and file patent application before you do—the burden of establishing priority will be upon you. Our Big Book—"Patent Guide for the Inventor"—will tell you the quickest possible way to secure Patent Protection for your idea. SEND FOR IT TODAY!

The FIRST IMPORTANT STEP in SECURING A PATENT

—is to obtain the services of a Registered Patent Attorney. The U. S. Patent Office advises that you secure the aid of an experienced Registered Patent Attorney to prepare your statements. Establish the date of your invention as explained in our book and disclose your idea to him in correct form. He then makes a SEARCH of the Patent Office Records and reports to you on existing U. S. Patents which might bear on your invention, giving his opinion on the advisability of proceeding and filing formal application.

REASONABLE FEES—CONVENIENT TERMS.

Don't worry about finances. Our fees are very reasonable—we can arrange convenient terms of payment. It is our custom to permit clients to pay for our services in installments as the application progresses in our office. See our Big Book for fees in obtaining Patent. It explains our arrangements clearly. Send for it NOW!

Free Record of Invention Form

Use our FREE "Record of Invention" form to assist you in recording the descriptive outline of your ideas and to establish the date of your invention. With it you can make a rough sketch of your idea and have it witnessed in a manner of value to you as evidence should occasion arise.

**TEAR OFF
AND
MAIL
NOW!**

**CLARENCE A. O'BRIEN
and HYMAN BERMAN**
Registered Patent Attorneys
**70-W Adams Bldg.
WASHINGTON, D. C.**

Please send me at once your Big Free 48-Page Book, "Patent Guide for the Inventor" and your Specially Prepared "Record of Invention" form. Also George Eastman Biography, "Inventor and Business Man." This request does not obligate me.

NAME _____

ADDRESS _____

(Please write or print plainly)

PATENTS

Booklet Free **Highest References**
Promptness Assured **Best Results**

Send drawing or model.

ALL BUSINESS GIVEN PROMPT AND PROPER ATTENTION

Listed Patent Lawyer in the latest editions of the Rand-McNally Directory of Bankers and Bank-Recommended Attorneys, published by Rand-McNally & Co., Chicago, Ill.; The Baggott & Ryall Directory of Guaranteed Attorneys, published by Legal Directory Corporation, Boston, Mass.; Flugel's Law List, published by Legal Directory Publishing Co., St. Louis, Mo.; American Lawyers Annual, Cleveland, Ohio; Bankers Service Legal Directory, Bankers Service Co., Boston, Mass.; Eyre's Law List, 9 Park Place, New York City, and the Central Guarantee Co., Bankers and Lawyers Directories, Empire State Bldg., New York City.

WATSON E. COLEMAN,
 REGISTERED PATENT LAWYER

Victor Building, 724 Ninth Street, N. W.
WASHINGTON, D.C.

INVENTORS PATENT YOUR IDEAS SEND FOR FREE BOOK



HOW TO OBTAIN A PATENT

Written by a Former Member of the Examining Corps (1922-24) of the U. S. Patent Office. If you want to profit by your idea, you should take steps to apply for a U. S. Patent at once. Your first step is to get this Free Book. This interesting illustrated book contains valuable information you should have. It tells you fully how to obtain a patent on your idea in the quickest way. With this Free Book you will also receive a "Record of Invention" form on which you can easily record your idea. Personal and Confidential Service: Your case will be personally handled only by a Registered Patent Attorney who is also a Former Member of the Examining Corps of the U. S. Patent Office. All communications confidential.

MAIL COUPON TODAY for FREE PATENT BOOK and RECORD OF INVENTION Form.

CARL MILLER

REGISTERED PATENT ATTORNEY
 FORMER MEMBER EXAMINING CORPS U. S. PATENT OFFICE

1638 Woolworth Bldg., Dept. 106A, New York City
 MILLER BUILDING, Dept. 106A, WASHINGTON, D. C.

Please send me your Free Book, "How to Obtain a Patent," and your "Record of Invention" form.

NAME.....

ADDRESS.....

STOP Scratching

RELIEVE ITCHING In One Minute

Even the most stubborn itching of eczema, blotches, pimples, athlete's foot, rashes and other skin eruptions, quickly yields to Dr. Dennis' cooling, antiseptic, liquid **D. D. D. PRESCRIPTION.** Its gentle oils soothe the irritated skin. Clear, greaseless and stainless—dries fast. Easy to use. Stops the most intense itching instantly. A 35c trial bottle, at drug stores, proves it—or money back.

ARMY AND NAVY SUPPLY CO.
 Bargains—Army, Sport Goods, Firearms, Clothes, Shoes, etc. Send 10c for new catalog, to be redeemed on first order
 Army & Navy Supply Co., 4772 Lester St., Richmond, Va.

PATENTS—TRADE MARKS

All inventions submitted held confidential and given personal attention by members of the firm.

Form, "Evidence of Conception" and instructions, "How to Establish Your Rights"—FREE!

LANCASTER, ALLWINE & ROMMEL
 Patent Law Offices

412 Bowen Bldg.

Washington, D. C.

Inventions Wanted Patented or Unpatented

We have been successfully selling inventions, patented and unpatented, since 1924. Write for proof, and tell us what you have for sale.

Chartered Institute of American Inventors
 Dept. 4, Barrister Building, Washington, D. C.

INVENTORS

who derive largest profits know and heed certain simple but vital

facts before applying for patents. Our book, Patent-Sense, gives those facts; sent free. Trade Marks—Copyrights.
 LACEY & LACEY, Est. 1869, 635 F St., N. W., Dept. 5, WASHINGTON, D. C.

ALBERT E. DIETERICH

REGISTERED PATENT ATTORNEY

512 B Colorado Building, WASHINGTON, D. C.
 Booklet on Patents sent free

No JOKE TO BE DEAF

—Every deaf person knows that—



Mr. Way made himself hear his watch tick after being deaf for twenty-five years, with his Artificial Ear Drums. He wore them day and night. They stopped his head noises. They are invisible and comfortable, no wires or batteries. Write for TRUE STORY. Also booklet on Deafness.



Artificial Ear Drum

THE WAY COMPANY

729 Hofmann Bldg.

Detroit, Michigan

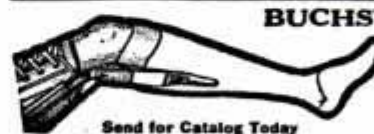

BUCHSTEIN'S FIBRE LIMB

is soothing to your stump—strong, cool, neat, light. Easy payments. Braces for all deformities. Agents wanted.
D. BUCHSTEIN CO.
 610 3rd Ave., So., MINNEAPOLIS, MINN.

Send for Catalog Today

To PROTECT YOUR INVENTION—Use this coupon, NOW

Delays are dangerous and may be very costly. My personal service assures prompt action, strict confidence, and a minimum of expense. I suggest that you send me a model or drawing, or sketch and description of your invention, and \$5.00. I will make a search and report

promptly as to its patentability and send you a copy of my 72-page booklet. Or, if you prefer to read my booklet first, mail the attached coupon at once. I will also send my "Record of Invention" form. (Over 38 years experience as a Registered Patent Attorney.)

L. F. Randolph, 302-D Victor Bldg., Washington, D.C.

Please send me at once, free of charge, your 72-page booklet and "Record of Invention" form

Name.....

Address.....

A PERSONAL CONFIDENTIAL PATENT SERVICE—



How This CHALLENGE Made Me "The World's Most Perfectly Developed Man"

I WAS then a 97 pound weakling. He was heavier, stronger, plenty tough. But I just couldn't pass up his direct challenge. A crowd gathered around to watch the slaughter. *And what a trimming I got!* He put more smashing power behind that one hand of his than I had in my whole body. It was the most embarrassing thing that ever happened to me!

But, as it turned out, that beating changed my entire life. For I made up my mind then and there to DO SOMETHING about myself—to learn something about my body and find a way to build it up—to become a HE-MAN instead of a HALF-MAN. And here's what happened:—

And Then I Made a Discovery

I began to study the structure and play of all the muscles. Then I tested out ideas I had for building muscle power and endurance—through outside road work and also through indoor exercises. Then I compared my measurements, before and after. Checked the results carefully. Made other tests. Checked again. Time after time, for months, I did this.

And finally came the great day when I felt at last I had discovered the *natural* way to build powerful, rippling muscles—without any contraptions that

Today I am devoting all of my time to passing the secret of "Dynamic Tension" along to others like yourself. And what "Dynamic Tension" has done for me—and for 92,000 other fellows—I am ready to prove it can do for YOU.

I'll Prove in the first 7 days that YOU can have a Body like Mine!

Just give me your measure—and I'll give you proof in just 7 days that I can make you a NEW MAN! Then I'll start new inches of massive power pushing out your chest—build up your shoulders to champion huskiness—put regular mountains of useful muscle on your biceps—give you a strong back—make those stomach muscles of yours hard ridges!

I'll whittle off waistline fat if you want me to. Slim down your hips and make your shoulders

may strain the heart or other vital organs! I at once put this system to work. I called it Dynamic Tension!

Well, the whole world knows what happened—and how "Dynamic Tension" changed me from a 97-pound weakling to the man who is now holder of the title of "The World's Most Perfectly Developed Man"!

This amazing method built me up—gave me the evenly developed body, the big muscles, and wonderful chest, that you see here.

look a mile wide. Put new pep into your thighs, get the calves of your legs bulging big, add weight if you need it. With a body like that you'll be so brimming-over with health *inside* that you'll feel on top of the world—free from constipation, poor digestion, bad breath, pimples, and similar weaknesses that are robbing you of the good things in life that can be yours. The ruddy glow of health will show on your face—you will be the outstanding fellow in your crowd.

CHARLES ATLAS

Twice winner and present holder of the title "The World's Most Perfectly Developed Man" won in open competition in the only national and international contest held in past 15 years.

No other Physical Instructor in the World has ever DARED to make the offer he makes in this announcement.



Sterling Silver Cup Being Given Away

Made of solid sterling silver, stands 14 in. high on mahogany base. I will award it to pupil who makes most improvement in development within next 3 months. No matter what your measurements are now, you have equal chance to win this cup... with YOUR name engraved on it!

Mail Coupon for FREE BOOK

Now make me PROVE I can do it. Let me send you the FREE BOOK that opens the door to he-man living.

This big book, "Everlasting Health and Strength"—packed with actual photographs and vital facts every fellow must know to face life—tells the whole remarkable story of Dynamic Tension. Privately printed for me, it's FREE if you act AT ONCE.

Are you ready to learn my secrets—ready to learn how I can give YOU the kind of body you've always longed to have? Then tell me where to send your copy of my book. Fill in the coupon below, and mail TODAY to me personally. Address: CHARLES ATLAS, Dept. 8K, 115 East 23rd Street, New York, N. Y.



CHARLES ATLAS, Dept. 8K,
115 East 23rd Street, New York, N. Y.

I want the proof that your system of Dynamic Tension will make a New Man of me—give me a healthy, husky body and big muscle development. Send me your free book, "Everlasting Health and Strength."

Name
(Please print or write plainly)

Address

City..... State.....

© 1936 C. A., Ltd.

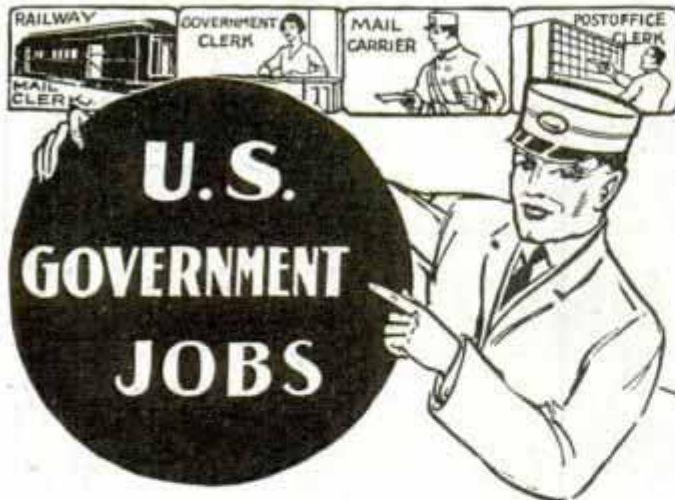

START \$1260 to \$2100 YEAR Men--Women
Common Education Usually Sufficient Influence Not Needed



City Mail Carriers, City Post Office Clerks

Clerks and carriers now get \$1,700 the first year regular and automatically increase \$100 a year to \$2,100 and \$2,300. Open to men--women 18 to 45.

Railway Postal Clerks

Railway Postal Clerks get \$1,900 the first year regular, being paid on the first and fifteenth of each month. (\$79.17 each pay day.) Their pay is automatically increased yearly to \$2,450. Advance may be had to Chief Clerk at \$2,700 a year. (\$112.50 each pay day.) Open to men, 18 to 35.

Customs Inspector

Salary \$2,100 to start. Men 23 to 45. Work connected with examining baggage and merchandise entering the country from foreign parts covering boats, trains, roads, automobiles, etc.

File Clerk--Clerk

Open to Men--Women 18 to 50. Entrance salary \$1260 -- \$1440 Year. Appointments as File Clerks and Clerks in the Departments at Washington, D. C., are made from this examination.

Get Ready At Once

Many other positions. Experience is usually unnecessary and political influence is not permitted. Let us show you how to get a government job.

Free List of Positions

Fill out the following coupon. Tear it off and mail it today --now, at once.

This investment may result in your getting a big-paid government job.

FRANKLIN INSTITUTE, Dept. P174, Rochester, N. Y.

Gentlemen: Rush to me, FREE of charge, list of U. S. Government big pay jobs obtainable. Send me FREE 32-page book describing salaries, vacations, hours, work, and full particulars on how to get one of these jobs.

Name.....

Address.....

When writing please mention Popular Mechanics



The Most Sensational Business Opportunity Since 1929

Like turning lead into gold, here is a business with gigantic possibilities. Factories, Clubs, Stores, Schools, Homes, spend millions every year for rubber mats. Think of your profit when a



HAND MACHINE and

5¢ TIRE MAKES \$2.00 MAT

Brand new. Fully patented. Few men already started report unprecedented success. Wm. Eagle writes: "Can't make mats fast enough. First week brought over 200 orders for \$1.00 to \$10.00 each." Flash from Harris says: "Orders enough to keep 15 men busy all the time." Gunter got big order from County Commissioners and now reports: "Just signed up order for all Grade Schools and High Schools." No wonder responsible men are throwing everything else aside to establish local FABRIX factories.

COSTS NOTHING to get complete facts. Just send name and address. We'll send description of simple hand machine that quickly slices old tire into strips; show you how patented method forms strips into thick, springy, long-wearing FABRIX Mats--how five cents worth of Junk Tires makes a \$2.00 Mat; how you can start on a reasonable investment and build a business so big, so fast, that it will take your breath away. Don't delay a minute. Write or wire today. All information is free. FABRIX, Inc., 325 W. Huron St., Dept. 710, Chicago, Ill.



U.S. Manufacturers desire men to learn Electric Arc Welding and get practical experience under actual production conditions in the laboratories of the School of Engineering. Moderate training fee. Accepted applicants will be fully trained until ready to pass rigid test and assisted in securing employment.

Arc Welding presents one of the outstanding opportunities for steady income and future success. Welding is growing rapidly, replacing large and intricate castings, rivets, nuts, bolts, screws. It is commonly used in assembling cranes, hoists, bridges, structural steel work, etc. No limit to the application of welding to industry, increasing durability and reducing manufacturing costs. There is a decided shortage of properly trained Welding Operators, Technicians and Welding Engineers. Why be content with ordinary work, hit and miss jobs and low pay when in a short time you can become a trained Specialist in Welding?

MILWAUKEE SCHOOL of ENGINEERING Institute of Electrotechnics

PM-10-A. Broadway & E. State St., Milwaukee, Wis.

Without obligation send me Free Illustrated Booklet "The Dawn of a Gigantic Industry," also tell me how to become a

- Welding Operator (3 mo.).....
- Welding Technician (6 mo.).....
- Welding Engineer (1 yr.).....

Send details on Self Help and Student Loan Plan

Name..... Age.....

Address.....

City..... State.....

Only MIDWEST GIVES YOU PUSH BUTTON TUNING

plus Exclusive New
ELECTRIK-SAVER
for 1937

*Doubles
World-Wide
Radio Enjoyment
and Slashes
Radio Current Bills
in Half!*



PUSH BUTTON TUNING
Finger tip tuning is made possible with the Midwest Automatic Push Button Tuning System. Doubles radio enjoyment.



ELECTRIK-SAVER

This exclusive feature cuts radio wattage consumption 50%... enables 18 and 16-tube Midwesterns to consume no more current than ordinary 7-tube radios and to operate on voltages as low as 80 volts.



NEW 1937 *Air Tested* **16-TUBE** MIDWEST FIVE-BAND RADIO

SAVE UP TO 50% DIRECT FROM FACTORY

NO middlemen's profits to pay! See for yourself that Midwest offers you greater radio values—enables you to buy the more economical factory-to-you way that scores of thousands of radio purchasers have preferred since 1920. Never before so much radio for so little money! Why pay more? The broad Midwest Foreign Reception and Money-Back Guarantee insure your satisfaction. You get 30 days FREE trial in your own home!

Once again, Midwest demonstrates its leadership by offering the world's most powerful and most beautiful ALL-WAVE 16-tube, 5-Band Radio. A startling achievement, it makes the whole world your playground. Powerful Triple-Twin tubes (two tubes in one!) give 18-tube results. This advanced radio is a master achievement, a highly perfected, precisely built, radio-musical instrument that will thrill you with its marvelous super performance...glorious crystal-clear "concert" realism...and magnificent foreign reception. The Dual Audio Program Expander gives a living, vital realistic quality to voice and musical reproduction.

74 ADVANCED 1937 FEATURES

This Super DeLuxe Midwest is so powerful, so amazingly selective, so delicately sensitive that it brings in distant foreign stations with full loud speaker volume on channels adjacent to powerful locals. Scores of marvelous Midwest features, many of them exclusive, make it easy to parade the nations of the world before you. You can switch instantly from American programs... to Canadian, police, amateur, commercial, airplane and ship broadcasts... to the finest and most fascinating foreign programs. With a Midwest, the finest entertainment the world has to offer is at your command. It is preferred by famous orchestra leaders, musicians, movie stars and discriminating radio purchasers everywhere. You can order your Midwest "Air-Tested" radio from the new 40-page catalog with as much certainty of satisfaction as if you were to come yourself to our great factory. (It pictures the beautiful 1937 radios... in their actual colors!) You pay as little as \$5.00 down! Three iron-clad guarantees protect you: (1) A Foreign Reception Guarantee — (2) Absolute Guarantee of Satisfaction — (3) One-Year Warranty.



MIDWEST USES LESS CURRENT THAN AN ORDINARY LIGHT BULB

Fill in coupon NOW, and mail TODAY!

only \$49.⁹⁵



WITH **GIANT THEATRE-SONIC SPEAKER**
(LESS TUBES)

TERMS AS LOW AS \$5.00 DOWN

Only **MIDWEST** Gives You
16 TUBES • 5 WAVE BANDS

9 TO 2200 METERS • ELECTRIK SAVER

- PUSH BUTTON TUNING •
- AUTOMATIC AERIAL ADAPTION •

DUAL AUDIO PROGRAM EXPANDER

30 DAYS FREE TRIAL!



I FIND MYSELF SINGING ALONG WITH MIDWEST'S MARVELOUSLY LIFE-LIKE PROGRAMS—
Irene Dunne



A COMPARISON CONVINCED ME I SHOULD HAVE A MIDWEST. IT IS A SPLENDID PERFORMER.
Fred Mac Murray



MAIL COUPON TODAY for
Free 30-DAY TRIAL OFFER
and **40-PAGE FOUR-COLOR Free CATALOG**

MIDWEST RADIO CORPORATION
Dept. D-15, Cincinnati, Ohio
Without obligation on my part, send me your new FREE catalog and complete details of your liberal 30-day FREE trial offer. This is NOT an order.

Special offer and prices prevail only when dealing direct with factory by mail.

Name _____
Address _____
Town _____ State _____

MIDWEST RADIO CORP.

DEPT. **D-15** CINCINNATI, OHIO, U.S.A.
Established 1920 Cable Address **MIRAGO...All Codes**



Know Electricity as Experts Know It—and Get an Expert's Pay!

Recovery has begun! The months ahead are charged with significance and expectation. What will you do to get the jump on the other fellow?

Thousands of men have used

The Croft Library of Practical Electricity

The Croft Library is a complete electrical educator. It is founded on practice—on 20 years of shirt-sleeve experience—on work as it is actually done. It is planned from cover to cover with the kind of hard-headed facts you want. Written so that the beginner can easily understand it, yet so sound, so thorough, that it is the daily guide of 50,000 highly paid electrical workers and engineers. Croft tells you the things you need to know about motors, generators, armatures, commutators, transformers, circuits, switchboards, distribution systems—electrical machinery of every type—wiring for light and power—wiring of finished buildings—underwriters' and municipal requirements—illumination in its every phase—the most improved methods of lighting—lamps and lamp effects, etc.—how to do a complete job, from estimating it, to completion.

No money down—easy payments

Fill in and mail the coupon attached and we will send you the entire set of seven volumes for ten days' Free Examination. We take all the risk—you assume no obligation. If you decide to keep the books, send \$1.50 in ten days and the balance at the rate of \$2.00 a month. Send the coupon NOW and see the books for yourself.

FREE EXAMINATION COUPON

McGraw-Hill Book Co., 330 W. 42nd St., New York

Send me for ten days' free examination the Croft Library of Practical Electricity. If satisfactory I will send you \$1.50 in 10 days and \$2.00 monthly until the price of \$19.50 is paid. If not wanted, I will return the books postpaid. (To insure prompt shipment write plainly and fill in all lines.)

Name.....
 Home Address.....
 City and State.....
 Position.....
 Name of Company..... PM-10-36

TRAIN NOW for QUICK SUCCESS in DIESEL and GAS Engineering

Raise Your Pay with "Job-Way"

Are you tired of lay-offs and low pay? Do you really want to get into a business that offers good pay, and a real future? Then you want "Job-Way" Training—the training that has started thousands on the road to success.

LEARN IN
SPARE TIME
EARN EXTRA
\$ MONEY \$

Good Jobs—Great Opportunities

Rapid growth of Auto industry has created countless opportunities for trained service and repair men. And now, Diesel—the new cheap power for trucks, buses, tractors, engines—has opened up still greater fields of power development.

Combined Auto-Diesel Training

"Job-Way" alone gives you combined Diesel and Auto Training by a practical, easy method of home study and actual job work. Thousands of our students have more than paid for their training thru our exclusive spare-time money plan

Mail Coupon for Free Book

If you want big pay and want it quick, rush the coupon TODAY for FREE AUTO-DIESEL BOOK, with full facts about "Job-Way" Training, Free Employment Service, Free Motor Testing Equipment, Liberal Pay-As-You Learn Plan, and positive Money-Back Agreement.

MOTOR INSTITUTE of AMERICA
Dept. K-11, Chicago, Illinois

D. F. GELLER, Pres., MOTOR INSTITUTE
4554 Broadway, Dept. K-11, Chicago, Illinois

Without obligating me, send Free Auto-Diesel Book with full details of "Job-Way" Training and "Pay-As-You-Learn" Offer.

Name.....
 Address.....
 City..... State.....

SEND NOW
for
FREE
Book

When writing please mention Popular Mechanics



Carry this Shirt Factory
in Your Pocket!

WE
WANT
MEN!

Big
Steady
Earnings

Yes, here's a real proposition
where you can make real money
with a real future.

Have you ever investigated the Packard Line which offers you Big Daily Commissions, Steady Employment and Regular Cash Bonuses? New complete up-to-date line is now ready and consists of a large variety of the latest Shirts, Neckwear, Men's Hosiery, Dress and Work pants. No experience necessary; work full or part time. Without question the greatest and fastest money-making line ever offered a direct selling representative. \$5.00, \$10.00 and up can be made every day and a big monthly cash bonus besides. Write for Free Complete Sample Line.

PACKARD SHIRT MANUFACTURING CORPORATION
Terre Haute Dept. P327 Indiana

FREE! LABORATORY APPARATUS BIOLOGICAL SUPPLIES MICROSCOPES TELESCOPES CHEMICALS

New complete 32 page catalog lists hundreds of items of interest to amateur and professional experimenters. Save Money—Buy Direct. Send now! It's FREE and crammed full of bargains and valuable information.



J. H. WINN MFG. CO., Dept. 410, 124 W. 23 St., New York

New JOBS for THOUSANDS in AIR CONDITIONING and REFRIGERATION

If you want steady work—all year 'round—good pay, or a business of your own, prepare NOW. Such ground-floor opportunities are rare. Learn at low cost right in your own home for at our school in Chicago. Write for FREE "Prosperity Booklet."

CHICAGO TECHNICAL COLLEGE
N 300 Tech Bldg., 118 E. 26th St., Chicago

33rd Year
Get Free
"Prosperity
Booklet!"

MONEY SAVING BARGAIN BOOK of CAMERAS & SUPPLIES

Free! Illustrates latest developments in Photography and Home Movie Making, for fun and profits. Offers hundreds of amazing, money-saving bargains in still and movie Cameras, Lenses, Films, etc. We take your old camera or equipment in trade. Write for free bargain book now!

CENTRAL CAMERA CO., Est. 1899
230 S. Wabash, Dept. K110, Chicago, U. S. A.

MAKE MONEY AT HOME

RUBBER MOLDS

Low as 6¢ EA.

Start big profit business at home. Make your own flexible rubber molds with amazing SO-LO GO-MA Molding Rubber. Turn out hundreds reproductions, BUSTS OF PRESIDENTIAL CANDIDATES, ornaments, ash trays, book-ends, etc.—in plaster, concrete, artificial marble. Costs you little as 3c each, sell for up to \$5.00 to friends, stores, by mail. Easy, quick—experience unnecessary. We supply all materials and instructions. Write today for free details and proved plans.

SO-LO WORKS, Dept. G-827, Cincinnati, Ohio

AMAZING! SILK HOSE

GUARANTEED TO OR NEW HOSE
Wear Without Holes FREE

Amazing Guarantee Replaces Fine Silk Stockings Free. From 3 to 5 months wear Guaranteed. Sold through agents only. Startling money-making proposition. Mills reports \$120 earned in one week; Poirier \$127 in five days. Enormous selection. Over 100 styles, colors for men, women, children, all Guaranteed. Samples furnished. Send 1c postal quick.

AGENTS:
UP TO \$24 IN A WEEK

Men, women, enormous earnings. Full or spare time. Write, Quick.

YOUR OWN HOSE
FREE OF EXTRA COST

WILKNIT HOSIERY CO-
37-K Midway, Greenfield, Ohio

What to Eat to Get Strength Building Iodine Into Blood and Glands!

Science Says Regular Ration of NATURAL IODINE Is Needed To Build Up Weak, Rundown, Skinny Folks — Give Them New Energy, Endurance and Pep!

If you are weak, skinny and rundown—if you go around always tired, nervous, irritable, easily upset, the chances are your blood is thin, pale and watery and lacks the nourishment needed to build up your strength, endurance and the solid pounds of new flesh you need to feel right. Science has at last got right down to the real trouble with these conditions and explains a new, quick way to correct them.

Food and medicines can't help you much. The average person usually eats enough of the right kind of food to sustain the body. The real trouble is assimilation, the body's process of converting digested food into firm flesh, pep and energy. Tiny hidden glands control this body building process—glands which require a regular ration of NATURAL IODINE (not the ordinary toxic chemical iodine, but the iodine that is found in tiny quantities in spinach, lettuce, etc.). The simplest and quickest way to get this precious needed substance is Seedol Kelpamalt,

the astonishing new mineral concentrate from the sea. Seedol Kelpamalt is 1300 times richer in iodine than oysters, hitherto considered the best source. With Seedol Kelpamalt's iodine, you quickly normalize your weight and strength building glands, promote assimilation, enrich the blood and build up a source of enduring strength. Seedol Kelpamalt, too, contains twelve other precious, vitally needed body minerals without which good digestion is impossible.

Try Seedol Kelpamalt for a single week. Notice how much better you feel, how well you sleep, how your appetite improves, color comes back into your cheeks. And if it doesn't add 5 lbs. of good solid flesh the first week, the trial is free. Your own doctor will approve this way. 100 jumbo size Seedol Kelpamalt Tablets—four to five times the size of ordinary tablets—cost but a few cents a day to use. Get Seedol Kelpamalt today. Seedol Kelpamalt is sold at all good drug stores. If your dealer has not yet received his supply, send \$1.00 for special introductory size bottle of 65 tablets to the address at the right.



**Accept
This Startling
No Risk Offer!**

**Your Money Back If
Kelpamalt Does Not**

1. Improve Appetite.
2. Add at least 5 lbs. of Good Solid Flesh.
3. Strengthen Nerves.
4. Banish Ordinary Stomach Distress.
5. Make You Sleep Sounder.
6. Give you New Strength, Energy and Endurance.
7. Clear up skin.

• **Manufacturer's Note**—Inferior products, sold as kelp and malt preparations—in imitation of the genuine Seedol Kelpamalt are being offered as substitutes. The Kelpamalt Company will reward for information covering any case where an imitation product has been represented as the original Seedol Kelpamalt. Don't be fooled. Demand genuine Seedol Kelpamalt Tablets. They are easily assimilated, do not upset stomach nor injure teeth. Results guaranteed or money back.

**SEEDOL
Kelpamalt Tablets**

SPECIAL FREE OFFER

Write today for fascinating instructive 50-page book on How to Add Weight Quickly. Build New Strength, Energy and Strong Nerves. Mineral contents of Food and their effects on the human body. New facts about NATURAL IODINE. Standard weight and measurement charts. Daily menus for weight building. Absolutely free. No obligation. Kelpamalt Co., Dept. 948, 27-33 West 20th St., New York City.

NAME

STREET

CITY



High School Course at Home

Many Finish in 2 Years

You can complete this simplified High School Course as rapidly as your time and abilities permit. Equivalent to resident school work—prepares you for entrance to college. Standard H. S. texts supplied—Diploma. Credit for H. S. subjects already completed. Single subjects if desired. High School education is very important for advancement in business and industry and socially.

College Entrance

During the past 14 years, our High School graduates have been admitted to 531 different Universities, Colleges, Junior Colleges and Normal Schools—80% of them without entrance examination. Course also prepares for teachers' certificate and pre-professional examinations.

Business—Industry

To get and hold a good position in Business today you must be able to write clear, accurate letters and reports—do figuring involving Algebra and Geometry—talk intelligently on matters requiring a knowledge of Geography, History, and Economics.

In Industry—Mechanical and Engineering lines—you must have at least an elementary knowledge of Physics and Chemistry—be able to figure quickly and accurately—know something of Mechanical Drawing and blueprints—and be able to talk and write accurately and clearly on both your work and ordinary topics of conversation.

Our High School course meets the preparatory educational requirements for Business and Industry.

An Educational Institution

The American School was chartered in 1897 as an educational institution, not for profit—and is exempt from paying Federal income tax, like the best resident colleges and universities.

Don't Be Handicapped— Complete Your Training Now

Be a High School Graduate! Prepare yourself for promotion in Business and Industry—

20 Other Courses

Over 150 noted Educators, Engineers, and Business Men helped prepare our special instruction material, which is used by many resident schools and colleges, U. S. Navy, and Province of Manitoba, Canada. We offer you quality training at home for the best-paying lines of Industry and Business, as listed in the coupon.

for the Professions, College Entrance and social success. No matter what line you may select, High School training will prove invaluable to you! Our moderate fees cover all instruction, standard textbooks and Diploma. Easy monthly terms. Get ahead in life. Start your training NOW!

Mail coupon for information about line that interests you
American School, Drexel at 58th, Chicago

American School, Dept. H-745, Drexel at 58th, Chicago
Tell me how to train for success in line checked. No obligation.

- | | |
|--|--|
| <input type="checkbox"/> High School Course | <input type="checkbox"/> Diesel Engineering |
| <input type="checkbox"/> Accounting & Auditing | <input type="checkbox"/> Drafting & Design |
| <input type="checkbox"/> Architecture & B'lding | <input type="checkbox"/> Liberal Arts |
| <input type="checkbox"/> Automotive Engin'ring | <input type="checkbox"/> Private Secretary |
| <input type="checkbox"/> Business Management | <input type="checkbox"/> Hi'er Ac't'g (C.P.A.) |
| <input type="checkbox"/> Com'ercial Aeronautics | <input type="checkbox"/> Highway Engin'r'g |
| <input type="checkbox"/> Electrical Engineering | <input type="checkbox"/> Mechanical Eng'r'g |
| <input type="checkbox"/> Electrical Refrigerat'n | <input type="checkbox"/> Radio & Television |
| <input type="checkbox"/> Air Conditioning | <input type="checkbox"/> Salesmanship |
| <input type="checkbox"/> Civil Engineering | <input type="checkbox"/> Steam Engineering |
| <input type="checkbox"/> Complete Law | |

Name

Address

STAMPS and COLLECTING

(Continued from page 14A)

various countries, or of their industries, or buildings, or animals, for each stamp subject has been selected with care, and in recent years with the obvious intention of advertising the country. From commemorative stamps the collector learns of the major events in the history of the nation. In fact, it is not possible to collect stamps without being inquisitive enough to learn something about them and the country which they represent. As collecting progresses the desire for a more intimate knowledge of the stamps themselves arises and it will be necessary to learn of paper varieties, of the three basic methods of printing, and of numerous other things which make one stamp issue differ from another. Thus the hobby takes its devotee out of his narrow line of activity and gives him an incentive for learning of other places and other things.

The Cover Collector

Collectors who go in for covers from out-of-the-way places may obtain one of the famous "Tin Can Island" covers if they will send a dime to Mr. W. G. Quensell, Niuafoo, Tonga Islands, via Suva, Fiji Islands. Mr. Quensell is practically alone on the island except for natives, and will appreciate letters from collectors.

The birth of the American navy will be the subject of a two-color cachet to be applied by Mr. S. Yates, 4504 16th avenue, Brooklyn, N. Y. Send three cents or a three-cent stamp or stamped envelope together with your name and address, or a ready-to-go cover. No forwarding fee required. Use commemoratives on outside wrapper. Closing date October 1.

Francis W. Bloch, director of the Westmont Cover Club, now located at 5439 Baywood st., Pittsburgh, Pa., announces the following presidential cachets: September 15, William H. Taft; September 24, Zachary Taylor; October 4, Rutherford B. Hayes; October 5, Chester A. Arthur; October 19, John Adams, and October 27, Theodore Roosevelt. Send stamped and addressed envelopes, unstuffed and un-

(Continued to page 62A)

HOW JIMMY BECAME THE MOST POPULAR BOY IN TOWN



Big Brother Dan: "You not going to the party, Jimmy?"
Jimmy: "Aw heck—I wasn't invited."



Dan: "When I was your age I was a dandy Harmonica player. They always wanted me at all the parties. Why don't you send for the new Hohner Instruction Book and get started?"



Dan: "Gee, Jimmy, this new Hohner Instruction Book's a lot better than the one I had. You'll be a better player than I was."

JIMMY'S brother Dan, who was in his sophomore year in college, had always been popular. Even as a youngster he was the leader of his crowd, invited to all kinds of parties. So when he came home on his vacation and found Jimmy always being passed up when party invitations were given out, he tried to find out why. Then he told Jimmy what thousands of boys and girls have found out—that a good harmonica player is always in demand for all kinds of parties and outings. And when players form Harmonica Bands, they are simply swamped with invitations to play everywhere, over the radio, at public receptions and big school events.

NEW INSTRUCTION BOOK MAKES LEARNING TO PLAY HARMONICA EASIER THAN EVER

The new Hohner Instruction Book "Harmonica Playing Made Easy" is the simplest and easiest Instruction Book ever prepared for the Harmonica. It takes you step by step right from the correct way to blow each single note, right up to where you play complete selections. A number of old time popular songs arranged for Harmonica, are included complete in the book. Also tells how to organize a Harmonica Band. Just send in the coupon below for a Free Copy.

ALL FINE PLAYERS USE HOHNER HARMONICAS

Practically all the expert players you hear over the radio or on the stage use only Hohner Harmonicas because they are true in pitch, accurate in tone and sturdy in construction. Larry Adler, the sensational stage soloist, Charles Newman, the radio star, Carl Fried, leader of the well known Harmonica Harlequins, Albert N. Hoxie, Director of the famous Philadelphia Harmonica Band, are only a few of the well known artists who use Hohner Harmonicas exclusively. So be sure to ask your dealer for a Hohner—"the world's best," and look for the Hohner name on the box and on the instrument.

M. HOHNER, Inc.
351 Fourth Ave. New York

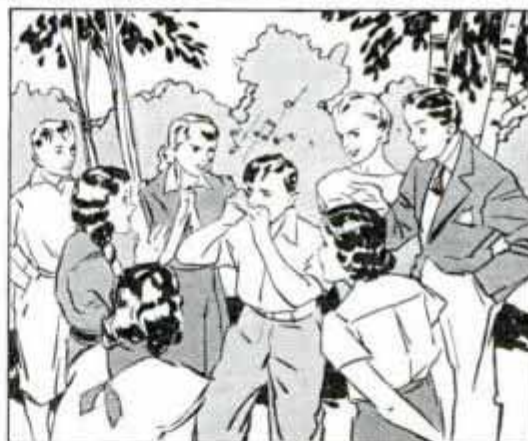

AFTER SENDING FOR HOHNER'S INSTRUCTION BOOK

Dan's girl friend: "That young brother of yours is the most popular youngster in town."
Dan: "And it's all because he took a tip from me and learned to play the Harmonica."

MAIL COUPON FOR

FREE NEW

ILLUSTRATED HARMONICA INSTRUCTION BOOK



M. HOHNER, Inc., Dept. 990K
351 Fourth Ave., New York City
Please send me your new Instruction Book

Name

Address

City State

Address Canadian Inquiries to Hough & Kohler, Ltd., 488 King St. W., Toronto

✓ How to make MONEY WITH YOUR CAMERA

**Big Demand for Photos YOU Can Take!
Learn at Home—in Spare Time**

DO you realize how many photographs are in this ONE issue of this ONE magazine? Multiply that by the thousands of publishers who buy photographs. THAT gives an idea of the pictures being bought EVERY MONTH!

WHO GETS the money paid for these pictures? YOU can get your share, no matter where you live or what you are doing NOW! Many of these pictures are supplied by amateur photographers—ordinary non-professionals who have learned how to take pictures THAT SELL!



Turn Your Hobby into a Profitable Profession

You don't have to be an expert to make money in this fascinating field! You don't have to live amidst the whirl of exciting daily news events. You don't even need a special camera, or expensive equipment. It is NOT technical ability that publishers pay for. It's the knack of knowing WHAT to photograph, HOW to photograph it, and WHERE to sell it, that brings in the money! It's SALABLE and MARKETABLE pictures—full of human interest and popular appeal—that you must learn how to produce... not technically beautiful examples of photographic genius! Send for FREE BOOK which tells all about the simple training which quickly prepares you, right at home, to make the kind of pictures that SELL.

FREE BOOK

Get your copy of "How to Make Money with Your Camera." Page 1 shows you the vast scope of the field. Page 7 tells the kind of snapshots that can bring you a good income. And on pages 12, 13, 14 and 15 are printed the pictures and letters of others who, even 4 or 5 weeks after enrollment, are already making good money.



This is The Age of Photographs. Your own eyes tell you that! Your own Camera can cash in on it! Read the reports here—from ordinary people who have always liked to do a little snapshot work—and who have NOW discovered a way to turn their hobby into money.

There's money in YOUR camera too! Mail coupon at once for this FREE BOOK telling you how easy it is to get it out! UNIVERSAL PHOTOGRAPHERS, Dept. 710, 10 West 33rd Street, New York City.

CLIP-SIGN-MAIL NOW

**UNIVERSAL PHOTOGRAPHERS,
Dept. 710, 10 West 33rd St., New York City.**

Send me without cost or obligation, booklet, "How to Make Money with Your Camera."

Name.....
Address.....
City..... State.....
(No Salesman Will Call)

PATENT

your INVENTION through this RESPONSIBLE FIRM



... and Get PROMPT EXPERIENCED ACTION

We offer you the experience and proven responsibility of 61 years. Since 1875 we have rendered expert service and counsel to tens of thousands of inventors. Every member of C. A. Snow & Co. who works on your case is a Registered Patent Attorney. This is important, for only Registered Patent Attorneys may plead your case before the Patent Office.

The home of C. A. Snow & Co. is the largest building in Washington occupied exclusively by one Patent Attorney firm. We offer you thorough, competent work.

If you have an invention, we advise immediate action to protect it, for someone else may be working on the same invention.

Write today for our FREE "Certification of Invention", which is of real value to you RIGHT NOW! Also two new guides, "How We Protect You" and "Suggestions On How To Commercialise Your Invention".

C. A. SNOW & CO.

Patent Attorneys Since 1875
SNOW BLDG. Dept. WASH., D. C.

Be a Civil Engineer!

Learn—Quick Reference Way

It's Paying Big Right NOW



Cyclopedia of Civil Engineering
7 great volumes.
2,800 pages.
1,600 illustrations.
New revised edition by twelve of America's greatest engineers.

Includes: Surveying, bridges, railroads, steel structures, municipal engineering, water supply, road building, etc.
Spanish Grain Flexible Covers Gold Stamped

Earn \$3000 with these books a Year—and Up!

"Civil engineers are wanted NOW. Enormous amounts are being spent in all kinds of public works and not a dime is spent until the Engineer has prepared plans. Then He must direct the work. It's a big job and there are not enough men to go around. Everywhere you go, you see road work going on—water and sewer systems being built—vast projects of all kinds. Here is Your Opportunity to get the necessary training right at home. These books are complete and simply written so anyone can understand them. Start now on our FREE examination plan. Mail the coupon without obligation.

American Technical Society
Dept. C719, Drexel at 58th St., Chicago

American Technical Society
Drexel at 58th St., Dept. C719, Chicago

I want to examine the CIVIL ENGINEERING Cyclopedia for 10 days FREE. I will gladly pay the few cents express, but I am to pay nothing for the 7 big volumes if I return them within 10 days. If I wish to keep them I will send you \$2 after the 10 days, then \$3 a month until special advertising price \$29.80 is paid. Send latest Edition and Slide Rule.

Shipped Free



Be prompt and we will include a brand new, circular slide rule to carry in coat pocket. Invaluable in solving all kinds of problems.

Name.....
Address.....
(Attach letter stating age, occupation, employer's name and address and that of at least one business man as reference.)

TELEVISION AND RADIO -- ARE YOUR OPPORTUNITY



"Get in
on the
ground
floor"

...if you *ACT NOW*

Bigger opportunities than ever before are open to trained men in new fields of radio. Television broadcasting is now a reality and leaders of industry predict immediate commercialization will put thousands of sets in homes; thousands of new jobs for trained men will be created as Television sweeps the nation.

Learn TELEVISION WITH RADIO

in "First National's" huge laboratories and studios, where young engineers are trained on the job—to fit the job—graduates qualify for First Class Government License—which is the "ticket" it takes to get a job—and are First National graduates getting the jobs? I'll tell the world they are.

only 6 months Training required

to qualify for your Government License. Then you are assigned to active duty in broadcasting, immediately getting valuable experience "on the job". You actually handle the control and transmitter of High-Fidelity Station W9XBY and Television Station W9XAL while training—

WRITE FOR FREE BOOK OF FACTS—Telling of big, genuine opportunities for First National Trained men—

FIRST NATIONAL TELEVISION
INCORPORATED
TRAINING DIVISION . . . KANSAS CITY, MO.

CONTROL ROOM
TRANSMITTER
TELEVISION
BROADCASTING
CAMERA-ACTION
STATION OPERATION

FREE
NEW BOOK
ON
TELEVISION

FILL OUT AND MAIL THIS COUPON TODAY

S. Q. NOEL, Pres., First National Television, Inc.
Dept. A-10, Power & Light Bldg., Kansas City, Mo.

Please send me immediately, without charge or obligation, your big, new book on Television—"Pictures On the Air"—completely illustrating Television methods, and giving full facts about big, new money-making opportunities in this career. I am ___ yrs. old.

NAME _____

STREET _____

TOWN _____

STATE _____



This Magic Box



Turns Spare Time into Money! Up to **\$40 a Week!** without Leaving the House

We show you how to make big money decorating fast-selling Giftwares and start you off with the big complete \$10 Artist's Outfit shown above. Also Free Idea Book that has started hundreds of men making big, easy money. One Fireside Member says, "I made \$100 on furniture in one week." Another writes, "My sales were \$500 for 5 weeks. This is my first year." R. M. P. of Illinois, says, "I did \$3500 worth of business last year and over \$12,000 this year." D. W., New Mexico, reports, "I would not take \$1000 for my Course." If you really want to make big money, a *guaranteed income* opportunity is now ready for you with Fireside. No tiresome study. You learn by doing. You make good money practically from the start. Our FREE Book tells you how. Send the coupon for it.

NO SOLICITING—NO CANVASSING

It's easy to dispose of everything you make. Our new "Automatic Salesman" does all the selling for you. This vendor is designed to quickly find cash buyers for all the Giftwares you can turn out! No soliciting or house to house canvassing required under this method. Nor do you need any artistic ability in order to succeed. Simple "3-Step Method" makes the work easy to learn and easy to do. Under new Plan your membership need not—**should not**—cost you a penny. Get full details. Coupon brings everything.

FREE Book on Decoration

Mail the coupon NOW for the beautiful new Book on decorating at home for big money. A new plan that gives you a quick start included free. Mail coupon now while openings for new members are still being offered.

FIRESIDE INDUSTRIES
Dept. 66-P Adrian, Michigan

Fireside Industries,
Dept. 66-P, Adrian, Michigan.
Send me FREE Book on Home Decorating for a big steady income. Also how to get the big Artist's Outfit.

Name.....
Address.....
City.....State.....



When writing please mention Popular Mechanics



Full Size Professional ARC WELDER

Details FREE!

Full size, heavy duty Aladdin Electric ARC WELDER only \$39.25 with De Luxe Accessories! Has efficiency of machines costing \$145.00 to \$800.00. Welds all metals and alloys from heavy motor block and castings to fenders and light sheet metal. Also fine for soldering and brazing. Fully guaranteed. Approved by Automotive Test Laboratories. Easily portable on casters.

WORKS FROM 110-V SOCKET. Simply plug into 110 Volt or 220 Volt light socket—costs only few pennies an hour to use. Has complete heat controls. Anyone can use easily. Full instructions included. **AMAZING DETAILS FREE!** Write today for sensational facts about Aladdin Arc Welder for \$39.25 including De Luxe Accessories!

COMMONWEALTH MFG. CORP.
3785 Beechmont Ave.
Dept. K-12 Cincinnati, Ohio



Only \$39.25
With Deluxe ACCESSORIES

CARTOON YOUR WAY TO SUCCESS!

DON'T COPY—LEARN TO ORIGINATE!

RAYE BURNS will teach you HOW to CREATE ORIGINAL CARTOONS at home that you can SELL! Course contains 26 lessons and over 600 Illustrations. All for Only... **\$2.85**

Send name and address for free details.

RAYE BURNS SCHOOL, Dept. M-X, BOX 2194, Cleveland, Ohio

ACCOUNTANCY

NEW OPPORTUNITIES NOW! Previous experience unnecessary. "Business Tech" training qualifies you for promotion and more pay. 1/2 the cost. A fraction of the time. Skilled accountants—men with thorough business training—in demand. Qualify at home under CPA supervision. FREE Book gives details. Institute of Business Technology, Dept. AS-309, Chattanooga, Tenn.



Correspondence Courses In RADIO and ELECTRICAL ENGINEERING

ELECTRICAL ENGINEERING covers complete electrical field. Most modern course. Very understandable. **RADIO ENGINEERING.** Ultra-modern course in radio, public address, photo-electric work. Trains you to be super-service man, real vacuum tube technician. Tuition ONLY \$24, either course. Deferred payment plan. WRITE TODAY for free copies of school catalog, student magazines, etc.

LINCOLN ENGINEERING SCHOOL 855-r So. 37th St., Lincoln, Neb.

SPECIAL Only \$25

RADIO ENGINEERING, broadcasting, aviation and police radio, servicing, marine and Morse telegraphy taught thoroughly. Nine months' engineering course equivalent to three years' college radio work. School established 1874. All expenses low. Catalog free.

Dodge's Institute, Ada St., Valparaiso, Ind.

GO TO HIGH SCHOOL



IN BEDROOM SLIPPERS!

If you feel the need of a high school education — regardless of your age — you can acquire it in the privacy of your own home after your day's work is done. Mail this coupon for information about our modern and widely recognized high school course. *Thousands of adults are studying it every night!*

INTERNATIONAL CORRESPONDENCE SCHOOLS

Box 5637-H, Scranton, Penna.

Explain fully about your course in the subject marked X:

<input type="checkbox"/> HIGH SCHOOL SUBJECTS	
<input type="checkbox"/> Automobile Course	<input type="checkbox"/> Architecture
<input type="checkbox"/> Concrete Construction	<input type="checkbox"/> Radio
<input type="checkbox"/> Civil Engineering	<input type="checkbox"/> Chemistry
<input type="checkbox"/> Electrical Engineering	<input type="checkbox"/> Aviation Engines

Name..... Age.....
Address.....

To those who think Learning Music is hard-

PERHAPS you think that taking music lessons is like taking a dose of medicine. It isn't any longer!

As far as you're concerned, the old days of long practice hours with their hard-work exercises, and expensive personal teacher fees are over with.

You have no alibis whatsoever for not making your start toward musical good times now!

For, through a method that removes the boredom and extravagance from music lessons, you can now learn to play your favorite instrument entirely at home—without a private teacher—at a fraction of the usual cost.

Easy As Can Be

The lessons come to you by mail from the famous U. S. School of Music. They consist of complete printed instructions, diagrams, and all the music you need. You're never in hot water. First you are told how a thing is done. Then a picture shows you how, then you do it yourself and hear it. No private teacher could make it clearer or easier.

Forget that old-fashioned idea that you need special "talent." Just read the list of instruments in the panel and decide which one you want to play. No matter which instrument you choose, the cost in each case will average just a few cents a day.

LEARN TO PLAY BY NOTE

- | | |
|-------------------------|-----------|
| Piano | Guitar |
| Violin | Saxophone |
| Organ | Mandolin |
| Tenor Banjo | |
| Hawaiian Guitar | |
| Piano Accordion | |
| Or Any Other Instrument | |

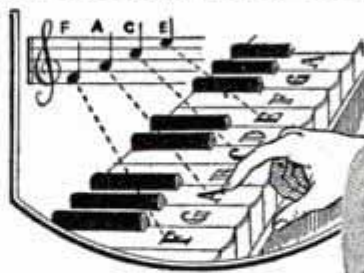

Send for Our Free Book and Demonstration Lesson

If you really do want to play your favorite instrument, fill out and mail the coupon asking for our Free Booklet and Free Demonstration Lesson. These explain our wonderful method fully and show you how easily and quickly you can learn to play at little expense. U. S. School of Music, 710 Brunswick Bldg., New York City. Instruments supplied when needed, cash or credit.

U. S. SCHOOL OF MUSIC, 710 Brunswick Bldg., New York City.

Send me your amazing free book, "How You Can Master Music in Your Own Home," with inspiring message by Dr. Frank Crane; also Free Demonstration Lesson and particulars of your easy payment plan.

Name.....
 Address.....
 Instrument..... Have you this Inst.?



Oil Burning Heater for Homes, Stores, etc. without a basement

Cut Fuel Costs 25% LACO Oil Burners

Finest Automatic Models—Marvelous Performance—Lowest Prices

● Now—clean, automatic Oil Heat without a basement! Gets utmost heat from oil. "Inner Heating Unit" with 20% extra heating surface, delivers amazing heat. Automatic temperature control. Humidifies and circulates the air. Built of very finest extra-heavy copper-bearing steel. Electrically welded into solid unit. Handsome as finest furniture. 4 sizes.

PRICED BELOW OTHERS!

Send today for illustrated folder, and very Low Prices!

● This amazingly quiet, extra compact LACO Oil Burner gives the most satisfactory, low-cost oil heating ever known! New design makes it adaptable for all installations—furnaces, boilers, air conditioners, etc. Positively the finest units. Easy to install, and service. Patented "High Pressure Carburetor" cuts fuel bills 25%!

PRICED \$100 LESS!

World's greatest value! Why pay more? 40,000 users praise it. Write for details, today!



DEALERS

Sample burnershipped for examination without obligation. Write for details!

WRITE for Free Books, Low Prices → LACO OIL BURNER CO., 1106 UNION ST. GRISWOLD, IOWA

PARKS AIR COLLEGE

Offers COLLEGE AND PROFESSIONAL TRAINING Majoring in Aeronautics

THREE two-year courses (96 weeks) lead to Bachelor of Science degrees in professional piloting; Aeronautical Engineering; Aviation Mechanics. Eight partial courses and combinations of courses requiring 36 to 152 weeks for completion are also offered.

TEN TRAINING PLANES are on the flight line. They range from the Kinner Sportster to the new bi-motor equipped with retractable landing gear, air brakes, two-way radio, radio direction finder and blind flight instruments.

52,348 hours flight instruction have been given; 650 hours now being flown each month.

THE FACULTY of 26 is composed of specialists in the various fields of aviation. AN ENROLLMENT of 243 resident students at the beginning of the Spring term, 225 being registered in two-year courses.

On its 100 acre airport, Parks has 14 buildings with a floor area of 119,352 square

feet (2 1/4 acres) all devoted to school purposes.

DORMITORIES AND DINING HALL on the Field.

1306 graduates.

137 graduates were placed in the past 18 months, 63 percent going with air transport companies in North and South America.

Requests for graduates are exceeding the number available 2.8 to 1.

Ask anyone in aviation about Parks. Then pay us a visit. You can expect more at Parks and still be agreeably surprised when you come.

The 60-page catalog gives complete information. Send for it. It is FREE. It contains 146 photographs all taken at Parks Air College. It is packed full of valuable information. A post card request will bring it to you.

PARKS AIR COLLEGE

1036-M Cahokia Rd.

East St. Louis, Illinois



Accredited by the Illinois Superintendent of Public Instruction. Government approved as a Transport Ground and Flying School and Mechanic's School.



There's Quicker, Bigger MONEY for YOU-in POULTRY

Earn \$1,000 to \$2,500 a Year or Have a Business of Your Own!

Whether you want a job at good pay or a highly profitable business of your own—the Poultry Industry offers you more than any other. There's a shortage of poultry meat and eggs — a shortage of trained poultrymen. I'll train you quickly at home—to fill a good job in Poultry—and our FREE Students' Employment Dept. will help you get one!

Spare Time or Full Time YOU CAN Cash-in BIG No matter where you live—city, town or country—or what you do now, my proved methods will assure your success right from the start. I'll help you make from \$1,000 to \$2,500 a year and UPI! And, if you choose to start your own business, I'll show you how to make your tiny investment multiply itself automatically. What I've done for thousands of others—I can do for you.

FREE Book Shows the Way to Big Pay and BIG Profits

Mail coupon below TODAY—for my Big NEW FREE Book, "How to Raise Poultry for Profit." My forty years of experience are yours. The Poultry Industry needs YOU. You need my book. Get it—and get in line for the BIG Money that's waiting for you in POULTRY.



Mail NOW for FREE Book

NATIONAL POULTRY INSTITUTE, Dept. 32-B, Adams Center, N.Y., Att'n: Harry N. Lamon, Pres.

Dear Mr. Lamon: Send me your FREE Book, "How to Raise Poultry for Profit." I want to know more about my opportunity to make \$1,000 to \$2,500 a year, spare or full time.

Name

Address

AUTO-MECHANICS & WELDERS

GOOD JOBS and Mighty GOOD PAY

Do you want to earn big money? If so let us know which of the following trades you prefer. You learn by doing. Practical work. Expert teachers. Low tuition. Personal attention. It will pay you to investigate AT ONCE. Just check the courses you'd like to take and mail today. You will receive full information, absolutely without cost or obligation. But don't delay.

Check the Trade You'd Like to Learn

- Auto Mechanics
- Welding
- Auto Collision
- Spray Painting
- Metal Finishing
- Torch Soldering

Name

Address

Mail the above to

MICHIGAN TRADE SCHOOL

Write for FREE CIRCULAR

3758 Woodward Avenue DETROIT, MICH.

When writing please mention Popular Mechanics

Earn Money at Home COLORING PHOTOS

EASY TO MAKE UP TO \$65 WEEKLY

Easy spare-time occupation for pleasure or profit. You can Hand-Paint Snapshots, Photos and Enlargements, natural as life. Earn 25c to \$3.00 each, painting photos for others. Takes only a few minutes to paint average photo. Learn by new, easy method. Earn as you learn! We show how to build wonderful spare-time or full-time business paying big weekly profits. Complete Outfit offered FREE. Write for full details and Money Making Plans.

PHOTO-ART INSTITUTE
Dept. A-10, Janesville, Wisconsin

FREE OUTFIT

AMATEUR CARTOONISTS WIN \$25.00

Wanted—Amateurs with humorous ideas. No drawing ability necessary. The amateurs of today are the professional cartoonists of tomorrow. Ideas judged and prizes awarded by Applause-O-Meter test before movie audiences. Everyone has an equal chance. 26 cash prizes in all. Rush name on post card for "Valuable Tips on How to Make Money With Simple Cartoons and Humorous Ideas," Cash Prize Entry Blank and Rules—Send No Money.

CARTOONISTS' EXCHANGE, Dept. C-910, Pleasant Hill, Ohio

WHY NOT GET A GOVERNMENT JOB?

Pleasant and dignified and important work. Short hours. High starting salaries. Immigrant Inspector, \$2100; File Clerk, \$1440; Railway Postal Clerk, \$1850; City Mail Carrier, \$1700; Post Office Clerk, \$1700; Storekeeper-Gauger, \$2000; General Clerk, \$1560; Inspector of Customs, \$2100 a year. Open to U. S. Citizens between the ages of 18 and 50. No education necessary. Write us a note asking us to mail you our FREE Bulletin of Information. This bulletin tells all about Government jobs, and how to get one. Send for this bulletin now!

CITIZENS TRAINING AND INFORMING BUREAU
Dept. A, Box 365 Mount Vernon, New York

STAMMERER S

Write for our Free List of ethical schools that correct stammering.

STAMMERERS' GUILD
280 Tremont St.—Suite 821, BOSTON, MASS.

LEARN TO PAINT SHOW CARDS SIGNS AND

BIG PROFITS We teach you quickly, by mail or at school. Enormous steady demand. Big future. Interesting. Write for full information. **DETROIT SCHOOL OF LETTERING** DETROIT, MICH. 5737-A Second Blvd.

PENNY EACH !! WINDOW SIGNS

Beautiful Window Sign Letters. Lowest Price in America. Finest Quality. 3 Year Guaranteed. New styles. Tremendous Demand. Big Profits. Easily Applied. Record Breaking Offer. FREE Samples and Working Equipment. Hurry!

Atlas Sign Works, 7943 Halsted, Chicago, Ill.

Wrestling Book FREE

Learn at Home

Be an expert wrestler. Learn at home by mail. The greatest world's champions have prepared the most wonderful course of lessons ever written on Physical Culture and Expert Wrestling. Be strong and healthy! Humble big men with ease. This great free book tells you how. Don't delay. Write now. State your age.

Farmer Burns School, 3377 Elwood Bldg., Omaha, Neb.

Start a POTATO CHIP BUSINESS

IN YOUR KITCHEN and MAKE MONEY!

Buy Potatoes for 2c A POUND
Sell Them as Vita-Seald Chips for 35c A POUND



THERE'S big money in potato chips for any man or woman who wants a business capable of paying as much as \$23.50 a day in profits. Just think of it. You can install the wonderful new machine in your kitchen—just manufacture and sack a sensational new kind of "Greaseless" Potato Chip—and let the stores sell them for you. Only \$2.50 invested in raw materials brings back \$10.00 in cash.

EVERYTHING FURNISHED You don't have to have a lot of money to start this business. A small investment in the machine puts you in a big profit business of your own. I send you everything including speed-slicer, cooker, oil-extractor (for making new "GREASELESS" chips), a big supply of printed bags and free advertising material. No experience is needed as I send complete, simple instructions showing how to make a profit the first day. Prices, pictures, and complete plans will be sent free for the asking.

DON'T BUY ANYTHING Just send your name and address on a post-card for all this Free information including the "Secret of Making Greaseless Potato Chips." No obligation, but hurry and you may become independent as so many others have done with these fast selling new "Greaseless" Chips. Address your card to

G. H. Hardt, 325 W. Huron St., Dept. B-510, Chicago, Illinois

Experience is a great teacher but you can learn MORE about ELECTRICITY



from books—quicker and cheaper

In maintenance and repair work, where the electrician is constantly faced with unusual jobs, "out-of-line" problems, the kinks and quirks of machines and systems that "won't go," he needs more than trial-and-error methods. He needs more than just what he can pick up on the job, from day to day. And right now thousands of men are meeting this very need, by bolstering their own experience with that of other men, as found in:

THE LIBRARY OF ELECTRICAL MAINTENANCE AND REPAIR

5 vols., 1810 pages, 1756 pictures and diagrams

This library gives you a sound, basic source of information and the "know how" confidence to tackle any wiring or motor problems—and get it done right. These books show you how to install all types of motor and generator units—to locate breaks in armature windings and do a workmanlike job of rewinding—to know just what is wrong with an electrical machine and take charge of installation and maintenance work—to make accurate tests of switchboards and apparatus and correctly balance the power with the load—to handle every sort of wiring job—etc., thousands of rules, methods, facts, kinks, and suggestions that you can use.

NO MONEY DOWN—FREE TRIAL EASY PAYMENTS—SEND THIS COUPON

FREE EXAMINATION COUPON

McGraw-Hill Book Co., 330 W. 42nd St., New York
Send me for 10 days' free examination the Library of Electrical Maintenance and Repair. If satisfactory I will send you \$1.00 in 10 days and \$2.00 monthly until the price of \$15.00 is paid. If not wanted, I will return the books postpaid. (To insure prompt shipment write plainly and fill in all lines.)

Name
Home Address
City and State
Position
Name of Company PM-10-36

When writing please mention Popular Mechanics



FREE TRIAL!

IMPROVES YOUR APPEARANCE 100%

Keep that Healthy TAN

That Men and Women Admire!

THERE is no need to lose that Tarzan Tan just because cool days are coming and you no longer can get out into the sunshine in a bathing suit! You can keep that tan and get even more if you wish it, right in the privacy of your own room! Just a few minutes a day under a Health Ray Sun Lamp and your friends will think you spend your week-ends in Palm Beach!

LOOK SUCCESSFUL — BE SUCCESSFUL!

■ A good, healthy coat of tan has a surprising effect on your business success. You look healthy and virile and instantly command attention. Your prosperous appearance makes people want to do business with you. Salesmen find their sales actually increase after they have acquired a real bronze tan! And you will find yourself more popular, for both men and women are attracted by that healthy outdoor look!

IMPROVES HEALTH AS WELL AS APPEARANCE!

■ The appearance of health is based on actual fact—for frequent exposure to the ultra-violet rays of the sun tones up the entire system, stimulates the body into energy and vitality, increases gland activity, builds up resistance to colds . . . and aids in clearing up many skin diseases.

4 TIMES AS POWERFUL AS THE SUMMER SUN!

■ Now Health Ray has made a really high quality, genuine carbon-arc sun lamp available at a price within the reach of all—\$7.95. In 15 minutes with your Health Ray lamp you can get the equivalent ultra-violet radiation of an hour in summer sunshine. Compact, convenient, easy to operate, approved by many of the finest testing laboratories in the country, this lamp will be the greatest investment you ever made! But don't take our word for it—test it for 7 days at our expense. You can't lose, and you can gain so much . . . mail the coupon for complete information today... NOW!

IF YOU WANT SUN-LAMP AT ONCE WITHOUT WAITING FOR LITERATURE

Send \$1 and lamp will be shipped at once—try it for 7 days—pay \$6.95 balance or get your dollar back. Or send \$7.95 with order, and we will include one box of ten carbons and bottle of Sun Tan Oil FREE, 7-day money back guarantee protects you fully!

HEALTH RAY MFG. CO., INC., 342 WEST 14TH ST. N. Y. C.



FOR EVERY MEMBER OF THE FAMILY

\$1.00 DEPOSIT BUYS IT!



TEST IT AT OUR EXPENSE — SEND FOR FREE TRIAL OFFER!

HEALTH RAY MFG. CO., INC.,
342 W. 14th Street, Dept. 1410, New York City
Send me full details of your special FREE TRIAL OFFER on the Health Ray Sun Lamp.

Name
Please write Mr., Mrs., or Miss
Address
City State

Learn in Los Angeles TALKING PICTURE PROJECTION



Talking pictures offer excellent opportunities to trained experts. Complete course at National Schools qualifies you to accept positions in theaters. Newest equipment to learn with.

SOUND RECORDING

Radio Transcription Recording is a fascinating profession. The field of opportunity for trained men is unlimited. At National Schools you receive the most complete instruction on newest equipment. Experienced instructors. Students learn on same equipment used in largest transcription studios.



TELEVISION-RADIO



All of the science of sound is based on RADIO. National Schools' course of training embodies all divisions of Radio, including Television in its latest development. Graduates are qualified for Radio engineering, home, auto and commercial radio repairing, and Broadcasting. Easy "shop-and-studio" practice methods. No dry text books. Students actually operate our own Radio and Television equipment. You don't need advanced education. National's training methods teach you the practical way.

QUALIFY FOR GOOD JOBS IN FEW MONTHS

National training is thorough. Finest equipment in America. Proven methods. When you graduate you can command jobs that assure future success.

EARN ROOM AND BOARD WHILE LEARNING

We assist students to obtain part-time jobs while learning. For limited time we will allow coach railroad fare to L.A. Send coupon for Catalog.

NATIONAL SCHOOLS

Los Angeles

MORE THAN 30,000 GRADUATES

Established 1905



REQUEST FOR BOOK

NATIONAL SCHOOLS
Dept. PMR-10, 4000 S. Figueroa St., Los Angeles, Calif.

NAME.....AGE.....

ADDRESS.....

CITY.....STATE.....

FREE BOOK Tells How to Earn Up to \$50 and MORE WEEKLY



ELECTRIC REFRIGERATION and AIR CONDITIONING

Young man—here's the easiest, quickest way to big pay and a real future. Get into Air Conditioning and Electric Refrigeration NOW. World's fastest-growing industries. New, uncrowded field.

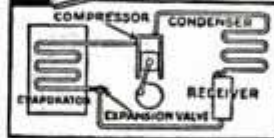

Quick Way to Big Pay!

Easy to train in spare time at home as expert in Installing and Servicing, Planning and Estimating, all kinds of Air Conditioning and Electric Refrigeration equipment. Take your choice of office and shop positions. Quick low-cost method of home study approved by leading manufacturers. Practical work in large laboratories and Employment Service free. Low easy to pay fee.

U. E. I. Training Gets Men Jobs

"Had no trouble locating job paying better than expected, thanks to U. E. I. for training, and opportunity you extended." O. I. B., Okla.

"Well satisfied with U. E. I. Training; earnings average \$54 a week." W. S., New York.

"Secured employment with C. & S., one of firms to which you referred me... taking full charge of Service Department." R. R. W., Ill.

"I am sending in my last lesson. My rise in the refrigeration industry has been rapid, having received about 100% increase in earnings and I am just getting started." E. D., Wash.

"Enjoy my lessons. Have obtained position as engineer in a new cold storage plant. I have charge of refrigeration." G. C. C., Canada.

Get Facts Now!

Get free book telling the TRUTH about big opportunities in Electric Refrigeration and Air Conditioning and how U. E. I. Training GETS MEN JOBS. Write giving age and present occupation, stating which industry interests you most.

Utilities Engineering Institute

Established 1927

400-410 N. Wells St., Dept. 1106, Chicago, Ill.

GOVERNMENT APPROVED



STATE ACCREDITED

Jobs in AVIATION

Get training now

Get into America's fastest growing, most active industry. Huge government and commercial orders mean plenty of good high paying jobs. Get your training NOW in AERONAUTICAL ENGINEERING, LICENSED MECHANIC, ADMINISTRATION. Also special short courses. Low tuition. Easy terms. Day and Evening classes. Write for booklet "Aviation As A Career."

AERONAUTICAL UNIVERSITY, Dept. A, Curtiss-Wright Bldg., 1342 S. Michigan Blvd., Chicago

DIESEL POWER

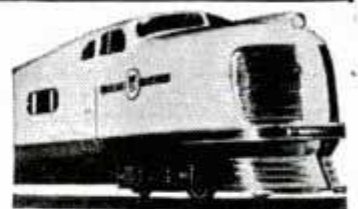

Courtesy DIESEL PROGRESS

A Coming American Industry

The internal-combustion engine represents man's supreme triumph of machine power. Diesel operators are in demand. Here is real opportunity for mechanics, draftsmen, owners of shops, motormen, farmers and all others employed where Diesel replacements will be made. Get necessary knowledge through study of the modern I. C. S. Course on Diesel engines. Free booklet!

INTERNATIONAL CORRESPONDENCE SCHOOLS

BOX 5636-H, SCRANTON, PENNA.

Please send information on course checked.

DIESEL POWER ELECTRICAL ENGINEERING

Mechanical Engineering Automobile Course
 Aviation Engines Air Conditioning

Name.....Age.....

Address.....

WELCOME TO OUR ORGANIZATION!

Drafting Opportunities Growing Daily



Drafting is fascinating work! Before any building can be built—any machine manufactured—or any bridge constructed—it must first exist on the Draftsman's board, *Birthplace of our Industrial Civilization*. The building trades, manufacturing lines and transportation systems all depend on the Draftsman before they can undertake a single step.

Home Study Quickly Fits You for a Job with a Real Future!

Any pickup in any line means *first call* for the Draftsman! Clean, interesting employment—best of working conditions. One of the steadiest of all occupations. Competent Draftsmen earn substantial salaries—and the road to promotion is *always* open to them. Learn at home without interrupting your present job. Free Bulletin tells how. *Send for it*. No obligation. Just mail coupon TODAY. *Get started in a Life Work that brings pleasure and prosperity.*

"Hello, there! Glad to see you are right on the job

"Now before you start work, I want you to realize that your future with this organization will be exactly what you make it. And that you were selected for this Drafting job out of a number of applicants because your application shows you are ambitious, earnestly interested in Drafting, have initiative, and in general have mastered the principles of the work.

"Yes, we are familiar with home-study training and we approve it. It

is the one satisfactory method by which every ambitious fellow wanting to get ahead can supplement his practical daily work with a thorough mastery of the principles governing such work. And the fact that you were farsighted enough to undertake a course of training by home study and, above all, that you were earnest enough to graduate, suggests that you have a bright future with us if you just continue as you have started."

American School, Dept. DD-746, Drexel at 58th, Chicago

 American School, Dept. DD-745
 Drexel at 58th, Chicago
 Please send up-to-the-minute facts about Drafting as a Life Work—and Home-Study training for it. No obligation.
 Name..... Age.....
 St. and No.....
 Town..... State.....

Mail This Coupon Today!

PHOTO-ENGRAVING LEARN IT AT HOME



A copper plate to print above picture size 8 by 10 inches sells for \$15.37.

We Furnish all equipment and materials including large photo-engraving camera complete with lamps, lens and screen. When you have finished the course you can establish a good paying independent business with the equipment furnished or work for others at a big salary. Photo-Engraving offers greater opportunities today than any other industry. Every picture in this issue of Popular Mechanics was engraved by the process we teach you. Earn good money while learning. Write today for our new illustrated catalog which was engraved on equipment such as we furnish. You will not be obligated in any way by writing Aurora School of Photo-Engraving, Dept. 1106, Aurora, Mo.

BE A PILOT — FLY A SHIP

If you are stumped at the high cost of training to qualify for a license and a good future in Aviation, write immediately, enclosing stamp for information on opportunities now available for Approved Training under our . . .

APPRENTICE PLAN

Mechanix Universal Aviation Service, Inc.
 Strathmoor Sta. Dept. E. Detroit, Mich.



BECOME A VENDING MACHINE OPERATOR!

Own a "chain" of 1c peanut and chewing gum vending machines. Large, steady profits, as people eat peanuts and chew gum daily. Start with \$100. Write for details today!

D. ROBBINS & CO.
 1141P DeKalb Ave. BROOKLYN, N. Y.

CIVIL SERVICE

VALUABLE INFORMATION
 COLUMBIAN CORRESPONDENCE COLLEGE
 WASHINGTON, D. C.



Earn Cash at Home!

Mrs. M. M. earned \$267 in 3 weeks (sworn statement) raising mushrooms for us in her cellar! Exceptional! Yes, but your cellar, shed, barn may be suitable to bring moderate income. Book, pictures, sample free. Est. 1908, UNITED CO. 3848 Lincoln Ave. Dept. 73 CHICAGO

STEP INTO THE Spotlight



Banish Boredom ... Earn Extra Money START TO PLAY VERY FIRST DAY

Picture the joy of playing a snappy foxtrot, dreamy waltz or mellow old favorite on the Xylorimba. No reason why you shouldn't! Xylorimba is **easiest** of instruments to play and yet the most spectacular. In constant demand by orchestras, radio stations, at lodge meetings and parties. Marvelous opportunity to increase popularity, make big spare-time money. No bothersome practice or exercises. With Free easy lessons you actually **Start to Play Very First Day**.

BIG FREE BOOK tells all about Deagan line, liberal trial offer and easy payments. Send coupon today for your free copy.

J. C. Deagan, Inc., Dept. 9457, 1770 Berceau Ave., Chicago

Send me, without obligation, full details of Free Trial offer and easy-payment plan on the Deagan Xylorimba.

Name.....

Address.....

When writing please mention Popular Mechanics

AUDELS Carpenters and Builders Guides 4 vols. \$6



Inside Trade Information for Carpenters, Builders, Joiners, Building Mechanics and all Woodworkers. These Guides give you the short-cut instructions that you want—including new methods, ideas, solutions, plans, systems and money saving suggestions. An easy progressive course for the apprentice and student. A practical daily helper and Quick Reference for the master worker. Carpenters everywhere are using these Guides as a Helping Hand to Easier Work, Better Work and Better Pay. To get this assistance for yourself, simply fill in and mail the FREE COUPON below.

Inside Trade Information On:

How to use the steel square—How to file and set saws—How to build furniture—How to use a mitre box—How to use the chalk line—How to use rules and scales—How to make joints—Carpenters arithmetic—Solving mensuration problems—Estimating strength of timbers—How to set girders and sills—How to frame houses and roofs—How to estimate costs—How to build houses, barns, garages, bungalows, etc.—How to read and draw plans—Drawing up specifications—How to excavate—How to use settings 12, 13 and 17 on the steel square—How to build hoists and scaffolds—skylights—How to build stairs—How to put on interior trim—How to hang doors—How to lath—lay floors—How to paint.



THEO. AUDEL & CO., 49 W. 23rd St., New York City

Mail Audels Carpenters and Builders Guides, 4 vols., on 7 days' free trial. If O.K. I will remit \$1 in 7 days, and \$1 monthly until \$6 is paid. Otherwise I will return them. No obligation unless I am satisfied.

Name.....
 Address.....
 Occupation.....
 Reference..... P.M.

Learn this Fascinating, Profitable Profession in 90 Days, at Home



Hundreds of men and women of all ages 18 to 50 are making \$10.00 to \$20.00 a day giving scientific Swedish Massage and Hydro-Therapy treatments. There is a big demand from Hospitals, Sanitariums, Clubs, Doctors and private patients. The field of reducing alone offers great possibilities.

Learn this interesting money-making profession in your own home by mail through our college extension course. Same instructors as in our **NATIONALLY KNOWN** resident school; same diploma awarded. Course can be completed in 3 to 4 months. No High School training necessary.

Many earn big money while learning. Enroll now and we will include anatomy charts, medical dictionary, patented reducing roller and Hydro-Therapy supplies without extra cost. The reducing course alone may be worth many times the modest tuition fee. Send coupon for special reduced price offer. Complete details and booklet containing list and photographs of successful graduates will be sent **FREE**.

National College of Massage & Physio-Therapy
 Dept. 764—20 N. Ashland Boulevard, Chicago
 You may send me **FREE** and postpaid, your illustrated catalog and details of your special offer, also booklet containing names and photographs of successful graduates.

Name.....
 Address.....
 City..... State.....

NEW YORK ELECTRICAL SCHOOL

Opportunities for Men of All Ages!

Every phase of all branches of Practical Electricity taught by Actual Practice in America's Foremost Institution of Trade Training.

Special Course in Automotive Technique

Day and Evening Sessions Open All Year.

Write for **FREE** Booklets.

Visitors Welcome.

New York Electrical School
 44 W. 17th St., New York City

PRINT-O-PRESS TYPELESS PRINTER



Professional Model Does the Work of

Equipment Costing Up to \$200, only \$7.95
 Amazing new fast Rotary Universal Printer. Prints letters, advertising, etc., for stores, offices, factories, churches, restaurants, home work. Factory-precision-built; has advanced features; does color work; portable. Simple—anyone can use it. Opens four big profit sources. Order direct. Rush \$7.95 for yours complete, post paid. Guaranteed.

Write for Free details Dept. 1010
The Professional Products Corp. Silverton, Ohio

MAN IN EACH TOWN To Plate Auto Parts,

Reflectors, Mirrors, etc., by late method. Experience unnecessary. Free particulars and proofs. Write today.
GUN METAL CO., Ave. M, Decatur, Ill.

Start Your Own NOVELTY MAKING BUSINESS At Home



We Teach You How to Make Your Own Molds with Liquid Live Rubber and Cast Beautiful Novelties from Plaster, Cement, Liquid Marble, Etc.

STEWART'S LIQUID LIVE RUBBER

There's fun, fascination and a steady income ahead for you making Garden Furniture, Book Ends, Ash Trays, Flower Holders, Plaques and hundreds of useful artistic novelties—with **LIQUID LIVE RUBBER**. It's new—different—the finest development for the flexible mold maker. Our complete instructions tell you each step-by-step procedure in the fascinating use of this marvelous discovery. You quickly build your own business with hundreds of customers for your novelty creations.

FREE STARTING OFFER! Write quick for full details of our **FREE** COURSE in Flexible Mold Making. For quick starting action, send \$1 for 1/2 pint can of **LIQUID LIVE RUBBER**, postpaid, with **FREE** MODERNISTIC HEAD MODEL (value \$1) included. Money refunded if not delighted.

STEWART'S STUDIO 2102 West 19th Street, Dept. P-106, Chicago, Ill.



Important Message TO DIESEL - MINDED MEN

*Is It True What They Say
About Diesel?*

*Can Adcox help YOU get a
big-pay DIESEL job?*

Diesel's amazing growth, the countless opportunities being created for those qualified to take them, beckon YOU.

Come to the Pacific Northwest. It is the "hot spot" of Diesel activity and a center of Diesel employment probably unequalled by any other Diesel center in the world. That is where the Adcox School is located.

For 27 years the Adcox School has been supplying the needs of employers in the Pacific Northwest and throughout the United States. It has a high reputation for competent, thoroughly-trained Diesel Experts. Leading educational authorities recommend it as one of the finest practical trade schools in the world.

Increase YOUR chances of making all the wonderful things they say about Diesel come true. Get the kind of training demanded by employers. Be backed by a school of matchless reputation among Diesel employers throughout America. Attend Adcox.

Read the big, new, 40-page Adcox Diesel Book and decide for yourself. It's FREE for the asking. Before you pick a Diesel school you owe it to yourself to read "How to Choose a Diesel School" in this book.

Send for it and learn how hundreds of Adcox graduates have reached big-pay jobs. Meet, not one or two, but more than a score of them face to face in the pages of this revealing, gripping book of opportunity.

Study in the ideal climate of the Pacific Northwest amid numerous outdoor recreations such as fishing, hunting, hiking, sight-seeing, mountain climbing, swimming and other thrilling, healthful diversions. Earn board and room while learning.

Adcox is a conservative School that invites serious, ambitious, Diesel-minded men to take advantage of the outstandingly successful Adcox way to big-pay jobs in Diesel. Send this coupon and full details will be mailed you absolutely without obligation.

BIG 40 PAGE DIESEL SCHOOL CATALOG FREE

Mr. L. L. Adcox, President
L. L. Adcox Trade School
Portland, Oregon.

Without obligation, please send FREE
Big Diesel Book No. 18E.

Name.....

Address.....

Town.....State.....



**Raise
GIANT**

FROGS



"Nuford Giants"
weigh up to 3 lbs. each!

START BACKYARD—GOOD POSSIBILITIES

Pair of breeders lays 10,000 eggs yearly! Frogs sell up to \$5.00 per dozen! Compare with other livestock!

We Buy Frogs! As originators of "canned frog legs" we are developing one of the world's largest frog markets. Canned frog legs now on sale in most large cities.

Attractive Future! We believe frog raising is one of America's most promising new industries. Get the facts today! See what others are actually doing already! Our big, free illustrated book "A Future in Frogs" explains everything in detail. Send for it TODAY!

FREE BOOK



AMERICAN FROG CANNING CO. Dept. 133 T New Orleans, La.

GOVERNMENT JOBS START \$1260 TO \$2100 A YEAR

**MEN—WOMEN
GET READY IMMEDIATELY**

**Experience Usually Unnecessary
Common Education Usually Sufficient**

Full Particulars FREE

Write your name and address on coupon and mail at once. This may result in you getting a big paid, U. S. Government job.

FRANKLIN INSTITUTE

Dept. P183, Rochester, N. Y.

Rush to me, entirely free of charge (1) a full description of U. S. Government Jobs; (2) Free copy of illustrated 32-page book, "U. S. Government Positions and How to Get Them"; (3) List of U. S. Government Jobs; (4) Tell me how to get one of these positions.

Name.....

Address..... Age.....

Use This Coupon Before You Mislay It—Write or Print Plainly



Acquire LAW nights at HOME

—the law library illustrated here—written by outstanding law professors—supplemented by lectures—cases—and personal tuition by qualified lawyer-instructors, will give you law training by home study.

THOUSANDS of men today, who never intend to practice before the bar, are studying law.

They realize that the law trained man is a leader—that law training makes keen, clear, quick, correct thinking—that there is a real reason why legally trained men head many of America's greatest corporations.

Practical Law Through HOME STUDY

The home study Law training offered by LaSalle has proven itself practical and valuable far beyond the time and money cost.

In certain permitted states every year, LaSalle trained men pass bar examinations with high honors.

But many, many more men, take their LaSalle law training to use in business and find in it a quick, sure key to progress and leadership—to the avoidance of pitfalls and the picking of the sure and certain paths of progress.

A Most Unusual Law Library

The basis of LaSalle law instruction is a fourteen volume library—we believe the most remarkable set of law books you have seen—compiled by leading professors and authorities.

This library might well be called—"Law Simplified and Condensed"—for it covers the whole basic field of law in an orderly, classified and simple manner. In many resident universities, the LaSalle Law Library is the reference work most used by students. In one of the great resident law schools, fourteen sets of LaSalle's Law Library are at the student's disposal and constantly used.

Supplementing this great library, are lectures and personal instruction of the highest grade, all under a definite, clear plan involving continual use of the Problem Method, where you train in law by dealing with actual legal problems—learn by doing the work—not by memorizing rules.

To get the whole story, you must investigate. And the coupon below is the easy way to start that.

Many of the leaders of 1936-1940 will be determined in 1936. Will you be one of them?

LA SALLE EXTENSION UNIVERSITY, Dept. 1064-LR CHICAGO

Law: Degree of LL. B. I would like to have full information about your law training, together with a copy of "Law Training for Leadership" and your booklet "Evidence," all without obligation.

Other LaSalle Opportunities: LaSalle opens the way to success in every important phase of business. If more interested in one of the fields indicated below, check and mail now.

- | | | | |
|---|--|--|---|
| <input type="checkbox"/> Commercial Law | <input type="checkbox"/> Banking and Finance | <input type="checkbox"/> Expert Bookkeeping | <input type="checkbox"/> Effective Speaking |
| <input type="checkbox"/> Business Management | <input type="checkbox"/> Industrial Management | <input type="checkbox"/> Business Correspondence | <input type="checkbox"/> Office Management |
| <input type="checkbox"/> Modern Salesmanship | <input type="checkbox"/> Modern Foremanship | <input type="checkbox"/> C. P. A. Coaching | <input type="checkbox"/> Railway Accounting |
| <input type="checkbox"/> Higher Accountancy | <input type="checkbox"/> Personnel Management | <input type="checkbox"/> Business English | <input type="checkbox"/> Paper Salesmanship |
| <input type="checkbox"/> Traffic Management | | <input type="checkbox"/> Stenotypy | <input type="checkbox"/> Credit and Collection Correspondence |
| <input type="checkbox"/> Railway Station Management | | | |

Name..... Present Position.....

Address..... City.....

LaSalle Extension University

THE WORLD'S LARGEST BUSINESS TRAINING INSTITUTION

When writing to advertisers please mention Popular Mechanics



FREE

**WORLD'S
BEST
WANT AD
MEDIUM**

CLASSIFIED Advertisements

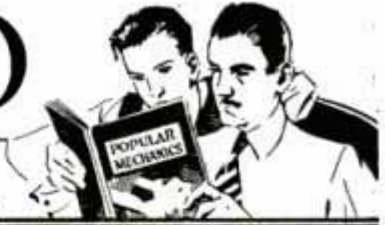

Advertisements in this section, 35 cents per word, each insertion, minimum 10 words, payable in advance. To be inserted under proper classification in November issue, copy should be in our office September 10th Popular Mechanics Magazine, 200 East Ontario Street, Chicago, Illinois

YOU'LL PROFIT

By reading and answering the classified ads in this section. Hundreds of opportunities to make and save money.

Popular Mechanics Magazine, Chicago, Ill.

Gentlemen: As you perhaps know, we have used the classified section of Popular Mechanics Magazine for a good many years, and have always kept a very accurate record of the results obtained, and in most instances these results are quite interesting. Your advertising naturally has always paid us or we would have discontinued it, and we can attribute many thousands of dollars in sales to the classified department. We also owe quite a lot of export business to the results obtained from your advertising. Through this medium we have obtained splendid distributors in West Indies, Syria, Egypt, China, Japan and many foreign countries. With best wishes for your continued success, we are

(Original letter on file in our office)

Yours very truly,
WORLD'S PRODUCTS COMPANY

AUTOMOBILES

INCREASED Mileage; lower cost. Oldest and original conversion blueprints to burn stove distillate in any car. Get parts in junk yard. Complete detailed information and blueprint 50c (coin). Thousands of successful conversions. Maydwell Mfg. Co., Box 492, Glendale, Calif.

ANY Automobile purchased if more than 15 years old. Write particulars. Condition immaterial. Vanacour, 344 New Jersey Avenue, Brooklyn.

DIESELIZE Gasoline engines—Simple installation low as \$3.00. No special parts. Use cheap fuels. Information free. Dieselizer, Box 5202, Los Angeles, Calif.

KANTFREEZE Radiator solution formulas 75c. Gilson, 1115 East 47, Chicago.

ELIMINATE Ping from cheap gasoline and semi-diesel conversions. Increased performance and mileage. Parts, 25c, obtainable anywhere. \$1.00 bill prepays sample and plans. Plans to Dieselize gasoline engines, 10c. Autosavings, 2112 Addison, Berkeley, California.

DIESELIZERS! Former guaranteed \$1.00 Dieselizing plans now 25c postpaid. Research, Napanee, Ontario.

DIESEL Pre-combustion chamber spark-plug adapters; \$1.00 to \$3.00. Burn Diesel oil. High-turbulence; two-stage combustion. No fouled-plugs, dilution, smoke, carbon, pinging or wear. Greater mileage, smoothness, power and speed. Complete data \$1.00. Perry, Diesel Engineer, Washougal, Washington.

"SEMI-DIESELIZING With Controlled Heat." Continuous peak performance, most mileage. Copyrighted plans 50c. Crippen-Deming Labs., Norwood Rd., Jackson, Mich.

R & R MFG. Co., Anderson, Indiana. Speed equipment for Fords and Chevrolets 25c for catalogue, midgets included. Camshafts reground.

SEMI-DIESEL Conversions for gasoline motors. Enclose 3c stamp for illustrated pamphlet. Desogas, 1719 Addison, Berkeley, California.

MIDGET Racing book; facts for fans, builders, drivers; track sizes, regulations; pictures, specifications, working drawings. Also stock car conversions for fastest cars. \$1.00 postpaid. \$1.12 C.O.D. Ray Kuns, Dept. 20, Cincinnati, Ohio.

MIDGET Powered car plans, full size patterns, simple tracing, best design on market. Postpaid \$1.00. Derby Midget Car Co., I. H. Stamets, Woodstock, Ill.

MIDGET Car plans, parts, engines. Circulars dime. Storms, 13 Southside, Asheville, N. C.

MIDGET Race cars, midget motorcycles, motorscooters, handbook catalog, parts, plans, motors, 79 illustrations, 20c coin. Bates Midget Motor Engineers, 4877 Armitage, Chicago.

AUTO SUPPLIES AND EQUIPMENT

PLATING Outfits for automobile parts. Connect to battery. No tanks used. Free particulars and proofs. Gunmetal Co., Ave. J, Decatur, Ill.

PAINT Spray Protectomask. New invention. Scoles, 6701 Prospect, Kansas City, Mo.

DEALERS. Service station owners, automobile water temperature gauges repaired \$1.50. Send all parts. United Speedometer Repair Co., 436 West 57th St., New York City.

DEMONSTRATORS. Compressor, test bench, 8-hour battery charger—arc welder. Guaranteed. Trial and terms. Ken's Equipment Exchange, Box M-1061, Troy, Ohio.

A. C. GENERATORS

TURN Scrap into money. Autopower shows you how easily and economically auto generators can be converted into a.c. or d.c. generators and d.c. motors, 2 to 1000 volts; for sound, radio, power, light, or welding. No previous experience necessary—complete information all in new book, with simple instructions and illustrations. Endorsed by thousands. Only \$1.00 postpaid. Autopower, Inc., 410-F S. Hoyle Ave., Chicago.

AUTO TRAILERS

PARTS For the Popular Mechanics "Family Trailer" featured in the February, March and April issues. Everything you need—Axle, hitch, wheel housings, water tank, pump, toilet, sink, stove, wood parts, windows, screens lights, cushions, etc. Send for price list. Include 25c for our big catalog and Trailer Builders' Manual. Trailer Supply Co., 410 Grand Ave., Wausau, Wis.

TRAILER-ITES! See advertisement of Trailer Travel Magazine on page 139A.

MOTORCYCLES, BICYCLES AND SUPPLIES

MOTORCYCLE Bargains, lowest prices, bargain sheets for stamp. Motorcycles accessories. Rochester Harley Davidson Corp., 129 West Main St., Rochester, N. Y.

HENDERSON, Excelsior, Harley, Indian, used parts, alloy pistons, catalogue and wings pin 10c. Ballak, 1115 Chestnut Street, St. Louis, Mo.

SEND 15c For illustrated used motorcycle catalog. Bargains. Largest stock genuine Indian parts and motorcycles. Indian Motorcycle Sales, Kansas City, Mo.

MOTORCYCLES—Direct to you at rock-bottom wholesale prices. Rebuilt, roadtested and guaranteed Indians, Harleys, etc. Send 10c today for "Bargain Bulletin 43." Crandall Hicks Co., 789 Commonwealth Avenue, Boston, Mass.

RECONDITIONED Motorcycles. New and used parts for all makes. Complete service. Whitman Motorcycle & Supply Co., 495-9 Southwest Blvd., Kansas City, Mo.

REBUILT Motorcycles, all makes, new and used. Harley Davidson parts. Send 10c for bulletin. Western, 914 E. 15th, Kansas City, Mo.

BUILD Unique, comfortable bicycle—steering wheel—cushion seat—from old parts. Plans 25c. Ray Nix, Breckenridge, Texas.

POWER Your bike with low priced Speed-bike motor. Attach in one hour. Eighty miles to gallon. Thirty miles an hour. Free folder. Guaranteed. Outboard Motor Corp., 4042 N. 28th St., Milwaukee, Wis.

MOTORCYCLE Tires \$4.00. Motor bicycle \$45. Chains, wheels \$1. Parts at low prices. Send 12c. Bicycle \$12.50. Price Cutter Deninger, Rochester, N. Y.

AVIATION

GET Into aviation. Air transport pilots get up to \$7,000 per year; mechanics, \$2,500. Learn at this government approved school. Write for complete information. State age. Lincoln Flying School, 2004 Aircraft Building, Lincoln, Nebr.

YOUNG Men interested in entering aviation under apprentice plan. Write immediately enclosing stamps. Mechanix Universal Aviation Service, Strathmore Station, Dept. D, Detroit, Michigan.

NEW Airplanes, \$98.00. Terms. Motors, propellers, air-wheels. Send 25c for information. Hibbs, Fort Worth, Texas.

BIG Assortment of model airplane samples 10c. Aero Shop, 3050 Hurlbut, Detroit, Mich.

USED Airplanes \$75.00 and up. Easy payments. Literature 10c. Continental, Box 344, Dept. 2, Indianapolis, Ind.

BUILD Our model planes. Awards, cash prizes. Send \$2.5 for kit and literature. Markham-Draper Co., P. O. Box 1147, New Britain, Conn.

HUNDREDS Airplanes \$75 up. Terms. Complete directory, 25c, postpaid. Aircraft Directory, Athens, Ohio.

NEW American Cirrus and Wright Gipsy engines and parts. R. J. Wenger, Menasco Manufacturing Company, 6714 McKinley Ave., Los Angeles, Calif.

BECOME Junior student. Start your flying course now with home studies. For particulars write Dick Freeland, Pine Brook Airport, Pine Brook, N. J.

BATTERIES, GENERATORS, ETC.

BUILD Windcharger from automobile generator. Dime brings complete plans and catalog. Motors, welders, electric fences. LeJay Mfg., 1447 Lake, Minneapolis, Minn.

ELECTRIC Lights—Wind driven—You build them. Write Wind Motor Electric, Brainerd, Minnesota.

\$5.00 PAID For acceptable photographs or drawings of experiments with propellers and generators for producing electricity from the wind. Photographs must be dated prior to 1923. Write Weston-Barnett, Inc., Waterloo, Iowa.

EDISON Storage batteries for light-power plants. Non-acid, non-sulphating. Long life. Fully guaranteed. Low priced. Also attractive bargains in power-light plants, generators, motors, etc. T. Hawley Smith Company, Croton Falls, N. Y.

GENERATOR Propellers, expertly designed at factory prices. Hibbs, Ft. Worth, Texas.

WINDCHARGERS \$9.00 Up. Circular 10c. Six-volt propeller \$1.40 postpaid. Guaranteed performance. Beacon Mfg., Benedict, N. Dak.

EDISON Storage batteries will save you money. Replace your lead with the Edison. Non-acid. Odorless. Fifteen year life. Liberal unconditional guarantee. Bargains in complete generating plants, motor, etc. Free illustrated literature. "See Jay Battery Company," 82 Sterling Avenue, Yonkers, New York.

BUILD New batteries from old. Latest achievement. Instructions available. Battery Laboratories, St. Paul, Minn.

ELECTRICAL SUPPLIES—EQUIPMENT

HUNDREDS Of new and rare items, replacement parts and supplies. Send 10c for new, 60-page wholesale catalog. Autopower, 410-F S. Hoyne Avenue, Chicago.

ELECTRIC Engraver, designs metal beautifully, \$1.00 prepaid. Hudson Bros., East Syracuse, N. Y.

TRANSFORMERS Designed, built. Frank Greben, 2012 So. Peoria, Chicago, Ill.

BUILD Your fans. 18" airplane propellers \$2.75. Hibbs, Fort Worth, Texas.

WRITE For new wholesale Electrical Supply Catalogue, Hastings, Michigan.

WELDING AND SOLDERING

REBUILT Electric arc welders, all sizes, a.c.—d.c. Service Co., 3732 Cedar Ave., Cleveland, Ohio.

TINNERS, Shop foremen, and amateurs soldering fluid that will not corrode. A proven product formula, \$1.00. Silas Gatewood, 1142 Arch St., Zanesville, Ohio.

OXY-ACETYLENE Welding outfits on easy payment plan. Box 331, Hamilton, O.

ARC-WELDING Outfit \$1.00. Repair fenders, braze, solder. Dickerson Manufacturing, Springfield, Missouri.

60 AMPERE, 110-Volt arc welding transformer \$8.00, 100 ampere, 110-220 volt, \$16.00. Welding supplies. Literature. Arcmaster, 1936 Lyndale, South Minneapolis, Minnesota.

OXY-ACETYLENE Welding equipment—New welding torches, reduced prices on discontinued models. These torches are standard, heavy duty equipment, factory boxed, tested, and Underwriter's approved. Save money on acetylene generators, gauges, regulators, lead burning and other welding equipment. Complete oxy-acetylene welding outfits at attractive prices. Write Modern Co., 3415 Pine St., St. Louis, Mo.

ARC Welders—Efficient, safe Model 27 welds 1/16" to 5/32" coated rods, has the sensitive FlexAmp control, works from 110 or 220 volt alternating current. Low price. Model A rated 200 amp. d.c. generator with maximum output 385 amps. only \$287.50. Terms. Welders, 615 No. Commerce, Stockton, Calif.

DODGE Arc-welder 25-200 amps. Free brush ring with certified plans \$1.00, COD's \$1.12. Convert old North-East automobile generators. Plans free with guaranteed bronze electrode holders, amperage sizes 100, 200, 300, 400, 500. Prices each \$2.00, \$2.50, \$3.00, \$3.50, \$4.00. Remit to Welders' Club of America, 3432 Drake, Chicago.

ARC-WELDERS. New heavy duty welders. Factory assembled, \$27.50. Kit \$18. Plans, drawings—75c. Literature. Hildman Welders, 459 Irvin Ave., Rochester, Penna.

ARC Welder only \$29.50. Professional type—110-220 volt. Delivers 110 amperes. Easy to use. Details free. Commonwealth, Dept. K-11, Cincinnati, Ohio.

DEMONSTRATORS, Electric arc welders. Money-saving prices. Used by the government. Trial and terms guaranteed. Hobart Welders, M-1062, Troy, Ohio.

MAKE Your own arc, spot welder 110-220 a.c. transformer \$7.50 Cleveland. Weighs 25 lbs. Instructions only \$1.00. Specify which one. El-Ra Mfg., 8801 Clark Ave., Cleveland, Ohio.

ARC-WELDING Outfit \$1.25. Weld fenders, braze, solder. Lavrow, 4368-W. Warren, Detroit. Stamp appreciated.

300 AMPERE Welding generator. Fine condition \$150.00. Wilmot Auto Supply, 1970 Wilmot St., Chicago.

ENGINES, MOTORS, DYNAMOS

THREE To ten KVA alternating generators. Motors, converters. Queen City Electric, 1736 Grand Avenue, Chicago.

WINDING Data, 1000 a.c. motors, eight leading manufacturers, \$1.00. Chas. Chittenden, Jr., Box 7631, Kansas City, Missouri.

SMALL Electric motors, high speed, 1/10 h.p., 110 volts, universal rebuilt, like new. \$2.00 postpaid. L. McConnell, 1619 Edgewood Ave., Racine, Wis.

GOVERNORS Control speed of any make of auto engine, regardless of load changes, when used for stationary or portable power production. Read our ad on page 138A. Man'f'rs Candee-Smith Governor.

NEW AC Light plants—\$27.50. 350w, 110v. Rocke Company, Berkeley, California.

ALTERNATING Current—Motors, generators. New and rebuilt. Exceptional bargains. Pricelist free. Mallorder Electric Co., 1718 So. Michigan, Chicago.

25 SLIGHTLY Used 1/2 horse alternating motors \$9.85. 1/4 horse new General Electric \$5.90. Wilmot Auto Supply, 1970 Wilmot St., Chicago.

SENSATIONAL Bargains. Engines. Supplies. Money savers. Stamp required. Howardco, 2417 N. Ashland Ave., Chicago, Ill.

1/4 H.P., 60c. 110v, 3600 r.p.m. motors \$5. N. P. & M. Wks., 1367 Niagara St., Buffalo, N. Y.

MACHINERY, TOOLS AND SUPPLIES

TWO Quart electric glue pots, with copper container, 110 volt, with thermostat heat control. Regular \$16.50, special \$10.50 each postpaid, to close out. Guaranteed. Field, N. W. Terminal, Minneapolis, Minnesota.

15" x 6" SOUTH Bend screw cutting engine lathe, \$175.00. 14" Steptoe crank shaper \$125.00. All sizes of machine tools. Cincinnati Machinery & Supply Company, 27 West Second St., Cincinnati, Ohio.

TREMENDOUS Surplus of factory tools selling out. Drills, taps, files, hacksaws, etc. Send for free lists, include six cents postage. Travers Tool Co., 264 Jackson Ave., Long Island City, N. Y.

KELLOGG Air compressors \$6.00. Spray guns \$1.00. Safety valves \$1.25. Refrigerator parts. Taylor, 105 East 102nd Street, New York.

DISCARDED Automobile engines connected to illuminating gas supply, make cheapest power plant. Run at low speed. Need no overhauling. Start with a slight push. Blueprint and instructions \$1.00. Panama Oil Company, Berkeley, Calif.

FREE Price list all shapes brass, copper, steel and aluminum. All orders postpaid. Hobby Supply House, Box 2014, Pittsburgh, Pa.

50-1/2 HORSE, 110 Volt, Universal motors equipped with 14 to 1 gear reduction \$3.50. Wilmot Auto Supply, 1970 Wilmot St., Chicago.

BARGAINS, Demonstrators, electric arc welders, guaranteed, 30 days trial and terms. Write Ken's Equipment, Box M-1063, Troy, Ohio.

BOATS, OUTBOARD MOTORS, ETC.

BUILD Your own boat. Save two thirds, use our ready cut semi-assembled materials. Send 25c for catalog. Brooks Boat Co., Inc., F. 20, Saginaw, Michigan.

OUTBOARD Parts—New or used—All makes—What do you need? Crandall-Hicks Company, 782 Commonwealth Avenue, Boston, Mass.

12-FOOT Flat bottom rowboat—complete plans 25c. Free boatbuilding catalog. The Rudder, 15 Murray Street, New York.

BUILD A boat. You can build a better boat by the Welch system. 32 page catalog 25c. Welch Boat & Supply Company, Station K, Milwaukee, Wisconsin.

PROPELLERS, Stuffing boxes, gear pumps, bearings, etc. Wm. Baker, Pond St., Quincy, Mass.

SPORTING GOODS, GUNS, FISHING TACKLE, ARCHERY

60c DETAILED Instructions, build bows, arrows, targets. Hobson, Salem, Oregon.

TRAPPERS—Three size 0 Kiefflock steel animal snares, 50c. Per doz., \$1.60, postpaid. For catching fox, coon, lynx, woodchuck, rabbit. Kleffman Lock Snare Co., Dept. P, Hibbing, Minn.

COLLAPSIBLE Canvas decoys. Light, durable, lasting, lifelike. \$2.95 doz., delivered. Send money order to C. A. Frakes, Port Arthur, Texas.

FISHERMEN. Free new 1936 catalog showing many new and improved items for fly and leader makers, all that is new in tackle. Paul H. Young, 8065-3 Grand River Ave., Detroit, Mich.

HUDSON Bay blankets, Indian pack baskets, camp stoves, knives, compasses, outdoor equipment. Free catalog. Howe Fur Co., Box P. Coopers Mills, Maine.

BEST Archery bows—from the heart of the Yew country. W. I. King Woodworking Shop, 1958 Onyx St., Eugene, Ore.

FISHERMAN! Sinker molds. Only \$1.25 postpaid in United States. Free folder. Box 313-C, East Liverpool, Ohio.

COMPLETE Line fly tying materials. Prices free. Work Fly Company, Pueblo, Colorado.

FIELD GLASSES, TELESCOPES AND MICROSCOPES

TELESCOPES, Opera glasses, \$5.00. Field glasses \$1.00. Microscopes \$1.50. Postpaid. Box 66, Sta. W. Brooklyn, New York.

TELESCOPES, Microscopes, binoculars. Lowest prices. Optical catalog free. Brownscope Company, 234 Fifth Avenue, New York.

BUILD Reflecting telescopes; catalog free. Instructions 10c. Optical Laboratories, Larchmont, N. Y.

USED Microscopes, binoculars, astronomical telescopes, surveying instruments—Bought, sold, repaired. Send 10c for list. Rasmussen, P. O. Box 256, Amsterdam, N. Y.

GET Our lowest prices on telescopes, microscopes, movie cameras and hundreds of other items. Catalog free. HH Winn, 124 W. 23 St., New York.

TELESCOPES, Microscopes, binoculars. Cut prices. Easy time payments. Illustrated catalog 10c. (Refunded.) Teeko Optical, 515W, Evanston, Illinois.

ANTIQUES, RELICS, INDIAN GOODS

WORLD War relics, for club house or den. Vickers aircraft machine guns, rendered unserviceable without marring, \$7.75 each. Marlin aircraft machine guns, rendered unserviceable, \$7.75 each. Send money order, check or draft. \$1.00 deposit on C.O.D. orders. Fiala Outfits, 10-C Warren St., New York.

5 ARROWHEADS 20c. 3 Birdpoints 18c. Knife, birdpoint, scraper, spearhead 45c. Catalogue. Coins, Minerals, Curios, Lemley Curio Store, Northbranch, Kansas.

ANTIQUE Guns, Indian relics. List five cents. Elmer Ellis, Webster Groves, Mo.

100 GOOD Arrowheads \$3.00. Catalog 5c. H. Daniel, Dardanelle, Ark.

15 ARROWHEADS, Spearhead, gempoint, \$9.99. Firearms. Photolist 10c. Museum, Rutland, Illinois.

DOGS, BIRDS, PETS

COON, Fox, Beagle, Rabbit and combination hounds. Pointers, Setters. Cheap. Trial. Literature free. Dixie Kennels, B68, Herrick, Ill.

BEAUTIFUL Pure white police dogs. Ansonia Kennels, Mose, N. Dak.

SPORTSMEN: 200 Pointers, Setters, Straight Cooners, combination Hunters, Rabbit and Fox Hounds. Cheap. Lists free. Ramsey Creek Kennels, Ramsey, Ill.

PEDIGREE Saint Bernard puppies. Beautifully marked. Enoss Wilson, Harcourt, Iowa.

HIGH Class pointers and setters sold on trial, also time payment. Write Frye's Kennels, Finger, Tenn.

TAXIDERMY

BIGGEST Bargain. Complete home course. (7 easily read books, 40,000 words, full illustrations.) Makes mounting animals, fish, tanning, novelty-making, simple. \$1.00 postpaid. Formerly sold for \$15.00. Written by south's noted taxidermist, 30,000 books sold last year. Satisfaction guaranteed. 7 books, life membership, diploma, all \$1.00. Schmidt School of Taxidermy, Dept. G-4-10, Memphis, Tenn.

FREE Official catalogue. Big values. Eyes. Head forms. Everything, direct from manufacturer. Taxidermic Manufacturers, Memphis, Tenn.

TAXIDERMY Supplies—Quality artificial eyes, teeth, genuine Jonas head forms. Tools, materials, etc. Everything for the progressive taxidermist. Send for big illustrated catalogue—Free. Jonas Bros., 1049 Broadway, Denver, Colorado.

GLASS Eyes. Taxidermists', furriers' supplies. Lowest prices. Forty page catalogue, free. Write today. Elwood Supply Co., 222 Smith Building, Omaha, Nebraska.

TREES, SHRUBS, ROOTS, HERBS

FREE! Send for this amazing new "Herbalist Almanac." Interesting! Instructive! Educational! Contains over 200 valuable herb medicine recipes and Indian secrets for home use. Beautifully illustrated in natural colors. Needed every home. Dime covers postage and handling. Write today! Botanics, 145 West 112th Street, Chicago.

FARMS AND FARM LANDS

40 ACRES, Near White River, unimproved, poultry land, \$100, \$5 down, \$5 monthly. Free list and literature. Hubbard, 216 Grossman Bldg., Kansas City, Kansas.

GOOD Land still at rock bottom prices. Washington, Oregon, Minnesota, Idaho, North Dakota. Ask about new northwest developments. Literature. Specify state. J. W. Haw, 119 Northern Pacific Ry., St. Paul, Minn.

STROUTS Big fall catalog just out! 104 pages of selected farm bargains in 23 states from Maine to California; all kinds, all prices, best terms. Write today for this money-saving guide. Free, postage paid. Strout Ag'y, 255-P 4th Ave., New York City.

GOVERNMENT Lands ten cents acre up. Information all states twenty-five cents. National Tax Service, 690A Majestic Building, Detroit.

FARMS That pay in the Great Northern Railway agricultural empire—Minnesota, North Dakota, Montana, Idaho, Washington, Oregon—Fertile black soil, high producing crops, grain, fruit, vegetables, feed and livestock. Many kinds of farms for selection. Write for lists and Zone of Plenty book. E. C. Leedy, Dept. 1057, Great Northern Railway, St. Paul, Minnesota.

PROFITABLE OCCUPATIONS

MONEY In mushrooms! Start now, in cellar or shed, get highest prices. Exclusive new process. Bigger, better, quicker crops. We buy. Book free. American Mushroom Industries, Dept. 722, Toronto, Ont.

"RAISE Giant frogs!" Start backyard. We buy! Breeder lays 10,000 eggs yearly. Frogs sell up to \$5 dozen. Free book. American Frog Canning Company, (153-T), New Orleans, Louisiana.

MAKE Architectural models; profitable, dignified business. Particulars free. Weidner, 4589 Lexington, Hollywood, California.

FREE: Opportunities galore! Others succeed. Why not you? Home City Specialties, Box PM1273, Springfield, Massachusetts.

RAISE Frogs, ginseng, girasol. Particulars free. Specialty Farm, Rockford, Minn.

MAKE Superfine statuettes, easy, profitable, illustrated instructions. \$1.00. P. O. Box 415, Seattle, Wash.

TURN Spare hours into cash decorating walls, furniture, giftwares with stencils. List for stamp. Eisenmeier, 3700P-Frankford, Baltimore, Md.

BOOKS, PERIODICALS, PICTURES POSTCARDS

FREE! Big catalog describing hundreds of books on various subjects. Franklin Publishing Company, 800 North Clark Street, Dept. 2108, Chicago.

TWENTY-FIVE Assorted World's Fair cards, postpaid 25c. Particulars 3c. Rettig, 3763 Barnes Ave., Bronx, N. Y.

FREE—Send for list of new technical books at sensational discounts. FF. Winn, 124 West 23 St., New York.

FREE—Send name for beautiful 8x10 art print. Herbert Crowl, Route Four, Canton, Ohio.

FREE! 10 Thrilling, blood-chilling, uncanny stories (60,000 words) that will hold you spellbound. Enclose 5c postage. Weird Tales, 840 North Michigan, Chicago.

LARGEST Variety—All subjects. List, samples 10c. Mulligan, 255 W. 92, New York City.

USED Books wanted! Bookery, 3941 Shaker Square Station, Cleveland, Ohio.

OLD BOOKS WANTED

WE Pay up to \$5,000 each for old books; also high cash prices for old magazines, letters, newspapers. A single story book, school book, old Bible, travel book, almanac, etc., that looks worthless may bring you \$50, \$100, \$500 or more cash. Thousands wanted! A small town barber discovered a valuable edition of "Pilgrim's Progress" and sold it for \$4000. Two boys playing in an old barn found a valuable edition of "Venus and Adonis" for which we pay \$5000. Send 10c now for big price list. American Book Mart, 140 S. Dearborn, Dept. 913, Chicago.

GAMES AND ENTERTAINMENT

PLAYS, Operettas, musical comedies, complete minstrel first-parts with song programs, blackface skits, vaudeville acts, monologs, dialogues, recitations, juvenile plays and songs, musical readings, entertainments, make-up goods. Catalog free. T. S. Denison & Co., 623 So. Wabash, Dept. 11, Chicago.

MAGIC TRICKS, PUZZLES, JOKER NOVELTIES

MAGIC Tricks, joke novelties, puzzles, at lower prices. South's largest line. My famous catalogue, "Book 1000 Wonders" and "50 Mysteries Magic" postpaid 10c. Write today. You will be surprised! Lyle Douglas, Station A-5, Dallas, Texas.

ASTOUNDING, Bewildering, unusual card tricks. Defy solution. Illustrated book 50c. Foster, Box 222, Swarthmore, Pa.

AMAZE Your friends. Pull cigarettes from the air and then vanish them again. Packed in box with full instructions, only \$1. Or send dime for catalog and famous Hindu Money Vanisher. With it you can mysteriously disappear cards, coins, etc. National Magicians Service, 5710-12 Woodlawn, Chicago.

SENSATIONAL Trick. 10c coin. Box 66, Sta. W, Brooklyn, New York.

LARGE Professional magic catalogue, 25c. Holden, 220 W. 42nd St., New York.

LEARN Ventriloquism, 3c stamp brings particulars. Smith, 125 North Jefferson, Peoria, Ill.

BE A magician. Large professional magic catalogue of latest tricks 25c. Cash paid for complete Tarbell magic courses. Write. Ireland, 804 Wesley, Oak Park, Ill.

SAMPLES—Catalog, novelties, photos, 25c. Box 290-P, New Haven, Conn.

MAGIC Catalogue 20c. Lynn, 105 Beach, Dept. 3, Jersey City, N. J.

RARE COINS

THREE Foreign coins and rare coin price lists 10c. Joseph Coffin, 1182 Broadway, New York.

OLD Money wanted. Will pay fifty dollars for 1913 Liberty head nickel (not buffalo). I pay cash premiums for all rare coins. Send 4c for large coin folder. May mean much profit to you. B. Max Mehl, H Mehl Bldg., Fort Worth, Texas.

COMMEMORATIVES: Monroe, San Diego, Illinois \$1.40 each; Stone Mountain 95c. 1936 coin catalog illustrated 50c. Coinshop, 2510 Chester, Alameda, California.

2 COINS, 4 Notes—different—big bargain list, all 10c. Hubert Careaba, St. Augustine, Fla.

\$5000.00 EACH For rare coins. We guarantee to pay the world's highest prices. Large cents up to \$2000.00 each, 1860 cent \$50.00, cents of 1861, 1869, 1870, 1881, 1890, \$20.00 each, 1909 cent \$10.00, 25c before 1916 \$300.00, 50c before 1916 \$750.00, commemorative 50c—1915 to 1936 \$60.00. Gold coins \$5000.00, half cents, half dimes, foreign coins, paper money and thousands of others up to \$2500.00 each. Send dime for large illustrated catalogue before sending us anything to sell. Romano's, Dept. 148, Nantasket, Mass.

GOOD Ancient Roman coin emperor named with list of all emperors to 1806, and catalog 10c. E. Roberts, Box 329, Cedar Rapids, Iowa.

UP To \$1,000 each for U. S. coins and stamps over 10 years old. New buying list, 10c. Coin-Stamp Shop, Box 37-P, Ottawa, Ill.

\$5.00 TO \$500.00 Each paid for old coins. Keep all old money. Send 10 cents for illustrated coin value book. 4x6. Guaranteed prices. Buying and selling. Coin Exchange, Box 5, Le Roy, N. Y.

COINS—Rare and common wanted. Certain 1909 cents up to \$10. Other coins to \$6000. 1864-1865 Indian cents to \$100. Dimes before 1895 to \$450. Liberty head nickels to \$300. Large pennies to \$2000. Encased postage stamps to \$13. Half cents to \$275. Half dimes to \$175. Quarters to \$300. Fractional currencies, gold dollars to \$1500. Colonial coins to \$300. Silver dollars to \$4000. Foreign coins to \$165. Send 15c today for illustrated informative book, before sending any coins. National Coin Corporation, (80), Quincy, Mass.

FREE! Foreign coin, banknote, and large illustrated coin catalogue. Send 4c postage. Coin approvals sent. Tatham Coinco, Springfield-125, Mass.

3c STAMP Brings new price list, commemorative coins, large and small cents. Schultz, 419 First National Bank Building, Cincinnati, Ohio.

UNITED States Texas centennial coins, uncirculated. Garland Adair, Austin, Texas.

MINUTE Man medal commemorating battle of Compo, April 25, 1777, 30c. The celebrated Pony Express medal 25c. Acorn Stamp & Coin Co., South Norwalk, Conn.

\$3.00 EACH For certain Lincoln pennies dated between 1911 and 1923. Keep posted. Send 15c for complete 28 page buying book. American Coin Company, Dept. 128, Muskogee, Okla.

RARE United States, foreign coins, war medals. Catalogue 10c. Mengelle, Colorado Springs, Colorado.

COMMEMORATIVE \$½s; Illinois, Monroe, Oregon, San Diego, Texas \$1.50 each. Illustrated catalogue 25c. Norman Shultz, Salt Lake, Utah.

25 DIFFERENT Coins and bills 25c. Otto Oddehon, Springfield, Mo.

UNITED States. Large cent, 2c bronze, 3c nickel and bargain list. 25c. Thirteen dates large cents, \$1.00. George P. Coffin Company, Augusta, Maine.

STAMP COLLECTING

6 DIFFERENT Silver jubilees, including magnificent jubilees of India, are in our big packet of 57 different stamps. Only 5c to approval applicants. Berg, Linwood Station, Detroit, Mich.

SCARCE Airmail and triangle. Beautiful Uruguay "flying horse" airmail and scarce Guatemala triangle (smallest in the world) are included in our big packet of 60 different stamps from Alouites, Grand Liban, Venezuela, British and French Colonies, etc. All for 5c to approval applicants. Big illustrated lists free with each order. Write today! Mystic Stamp Co., (Dept. 80), Camden, New York.

BIG Bargain! Set triangles, including largest issued, queer Shanhaikwan, Cayman Islands, Samoa, Manchukuo, Honduras, Mauritius and multitude others; all only 10c to approval applicants. Jones Stamp Company, Box 146, Norristown, Pennsylvania.

PACKET Bargains. All different. 25 Peru, 15c; 100 Greece 50c; 50 Ecuador 60c; etc. Leslie Stamp Co., Haverhill, Mass.

STAMPS: A splendid selection sent on approval. Quality at low prices. Scarce and high value stamps are included in our approval books. Fred Herzberg, Box 91-P, Elmhurst, Ill.

20 BEAUTIFUL New issues, including Newfoundland commems., Guatemala Quetzal, Ecuador bean, Denmark Andersen set, 10c to approval applicants. Premier Stamps, 1709 Second Ave., New York.

FREE! New illustrated 56-page catalog "United States, British Colonies & Foreign Stamps"—at real money-saving prices. Includes details of amazing free stamp offer. Send postcard for copy. H. E. Harris & Co., 137 Transit Building, Boston, Mass.

50 BEAUTIFUL Stamps of Saint Pierre Miquelon. \$1.00 postpaid. Pierre Lavissiere boîte 22, Saint Pierre et Miquelon, French Colony, North America.

MINT Army, airmail, commems., 25 different, 10c. Approvals. Collectors, 166 High Street, Reading, Mass.

NEW Zealand, 15 different, one dime. Paul F. Williams, New Brunswick, New Jersey.

FAMOUS Death mask with 50 different stamps—including pictorials and British Colonials—15c to cover cost. To approval applicants only. E. Hannum, Union Mills, Va.

FREE—20 Different Canada to approval applicants. Fort Dearborn, 5439 Aberdeen, Chicago.

STAMPS From 50 countries, 6c. Star Supply Company, Lima, Ohio.

ITALIAN Commemoratives, 15 varieties, 5c. Request approvals. Edgar Meitzen, Fayetteville, Texas.

200 DIFFERENT 10c. Big 50% approvals. Covert Stamp, 39 State, Rochester, N. Y.

UNITED States—Elaborate pricelist free. 45 different 10c, 75 different 30c. Seidenberg, Baroda, Mich.

LUCKY Fifty 3c postage. Approvals. Quality Stamp Shop, Englewood, Colorado.

FREE—3 Large beautiful complete sets; to approval applicants; 3c postage. Taftlaw, 302 East 56 St., New York City.

THOUSANDS of varieties one cent each. Approvals on request. G. E. Davis, 1205 Glenhurst, Rock Island, Illinois.

AIR Mail approvals, fine. Reference. Clark, 1319 Lincoln, Springfield, Illinois.

1000 MIXED Stamps 25c. E. Seifert, Rome, N. Y., R. 5.

BADEN, (Scarce German state), Mongolia, Georgia, \$5 U. S., Azerbaijan, Caymans, Transcaucasian Federated Republic, imperforate "Chicago"—everything absolutely free to approval applicants enclosing 3c. Viking Stamp Co., 1 Hanson Place, Brooklyn, N. Y.

A BIG Bargain—All for only 55c. Stamp album, providing spaces for 2200 stamps with 700 illustrations, packet of 500 different stamps, 500 hinges, and millimetre measure. Free with each order our pamphlet which tells "How To Make A Stamp Collection Properly," and our price list of albums, supplies and hundreds of bargains in sets and packets. Queen City Stamp Company, Room 36, 604 Race Street, Cincinnati, Ohio.

STAMP Dealers, your ad here will bring wonderful returns. Ask me for proof. F. W. Johnson, Manager, Classified Advertising, Popular Mechanics Magazine, 200 E. Ontario St., Chicago.

FREE—U. S. \$10.00 stamp. Number 4316. Old stamps are always best. All old stamps particularly those of the 19th century are getting scarcer every year. We offer 10 different selected 19th century stamps including a U. S. stamp over 50 years old, together with the current highest values U. S. stamps, denominations \$2.00, \$5.00, and \$10.00; catalogue numbers 4312, 4315, and 4316, all for only 10c to serious approval applicants. Globus Stamp Company, 268 4th Ave., Dept. 50, New York, N. Y.

WE Buy stamps. Send particulars first. Leslie Stamp Co., Haverhill, Mass.

GIANT-SIZED Russian Zeppelin stamp (cat. val. 20c!) and beautiful Lithuania airmail triangle; also big packet of 53 diff. stamps including Azerbaijan, Epirus, new Martinique, etc. and illustrated lists—all for 5c to approval applicants! World-Wide Stamp Co., Box 600, Camden, New York.

1000 MIXED, 50 Cents. Cranshaw, 626 S. W. Clay St., Portland, Oregon.

50 BRITISH With scarce jubilees, Canada, Newfoundland, 10c to approval applicants. Lists free. Mantle Stamp Company, London, Canada.

FREE—\$1.00 U. S. stamp, our choice, with request for 52 page price list of United States and foreign stamps. Stamps on approval. References necessary. 1000 U. S. no current \$1.50. New Hussman Stamp Co., 1122 Pine Street, St. Louis, Mo.

CASH Or exchange for precanceled. Send lot. Gaferel, Hartsboro, Ala.

\$1.00 POSTAGE Due free. Unbeatable United States. Approvals. Nelson, 658 Laurel, St. Paul, Minn.

FREE—5 Australian commemoratives to approval applicants enclosing postage. Golden Bear Stamps, Box 66, Berkeley, California.

NO German or Austrian in this beautiful packet of 500 different foreign, including pictorials, airmails, commemoratives, etc., for only \$1.00 postage paid. Second offer, 5000 different foreign for only \$10.00, postage paid. All stamps in good condition. No approvals or lists. Quaker Stamp Company, Toledo, Ohio.

FREE! Rare airmail! Jubilee! Pictorials! Extraordinary packet 65 different stamps from strange countries (no Europe), 5c postage to approval applicants. Bargain Co., Box 39P, Station H, New York.

LINDBERGH Spanish airmail. Huge package 100 different, 10c. Approvals. Burke, Marshfield, Vermont.

FREE—40 Different U. S. stamps, to approval applicants sending 3c postage. G. P. Kunz, 2034 Boulevard, Jersey City, N. J.

WORLD'S Largest map stamp, scarce triangle, pictorials—10c including double premium approvals. Tru-Value Stamps, Box P1412, Hartford, Connecticut.

TRADE Duplicate stamps through our "Trading Columns." Yearly subscriptions—25c. Spanners Monthly Stamp Magazine, 100B Forsyth, New York.

UNITED States approvals only. Write for selection. Positively no foreign. Jack Daub, Wabash Bldg., Pittsburgh, Pa.

ONLY 10c! Two sets cataloging \$1.00, \$2.00 United States, 125 page "Stamp Finder." Clifton English Co., Nashua, N. H.

SCARCE "New Issues" packet! New giant sized, diamond-shaped Russian "sports" stamp; Nyassaland "leopard"; Morocco; Tanganyika, and other scarce countries are included in our big packet of new and recent issues—stamps most collectors have never seen! Get this valuable packet today. Only 5c to approval applicants. Reimers, 115 Flatiron, Fort Worth, Texas.

40 UNITED States, commemoratives, airs, etc., 10c with approvals. Stamp Shop, Mabel Hoehn, Holland Bldg., St. Louis, Mo.

LIST 850 Foreign at 1c free. Foreign approvals. Robert Holmes, Standish, Maine.

SILVER Jubilees—15 different 25c. World specials—500 different 35c, 1000 different \$1.00, 2000 different \$3.00. These offers to approval applicants only. List free. Victoria Stamp Co., London 4, Canada.

FREE—Beautiful airmails, 5 countries, including new Mozambique, to approval applicants. Green & Co., Norwood, Ohio.

BOLIVIA Airmail set and fine packet from Andorra, Congo, Mozambique Co., Porto Rico, Turkey, etc. Only 5c to approval applicants. Maynard Sundman, Dept. P10, Bristol, Conn.

SCARCE 1935 Canada pictorial, jubilee, U. S. commemoratives, beautiful bicolored airmails, French and British colonials, 60 others—5c. Approvals included. Engel, 1318 West Farms, New York.

MAPS—25 Different 25c; 40, 50c; 65, \$1. Mack Barnett, Arlington, Wash.

CAYMAN, St. Lucia, Turks jubilees. 10 other British colonials, 15c. Approvals. Iammell, Valley Stream, N. Y.

1500 HINGES 10c. Bargain approvals included. V-J Sales, 2729 N. Summit, Milwaukee, Wis.

ZANZIBAR—Also Sudan, Somaliland, Tiger stamps, Togoland, Caribbean, Archer, Algerian, Central American, British Colonials. This magnificient collection free for 5c postage. Gray Stamp Shop, Dept. PM, Toronto, Canada.

FREE!! Scarce airmail triangle and fascinating Cayman Islands map stamp; also large Silver Jubilee commemorative (a future rarity!), fine packet hard-to-get countries, including Sudan (desert scene), Epirus (sharpshooter), etc., and, finally, a set of U. S. stamps more than 50 years old. This valuable collection absolutely free to new approval applicants sending 3c postage! Midwood Stampco, Dept. P6, Midwood Station, Brooklyn, N. Y.

300 DIFFERENT 20c; 1,000, \$1; 2,000, \$3.00. Fred Onken, 630 79th St., Brooklyn.

107 DIFFERENT; Algeria, Gabon, New Zealand, Guinea, Congo, etc., 5c to approval applicants. Extra—Airmail packet free!! Hunziker, Box 225H, Minneapolis, Minnesota.

44 DIFFERENT United States including \$5 stamp, or complete set United States bicentennials, or 30 different obsolete Canada, 13c postpaid with approvals. C. A. Len'nan Co., Box 322, City Hall Annex, New York, N. Y.

FREE! Philatelic parade. Beautiful Queen Astrid, New Brunswick, Commemoratives, jubilees, air mails. Postage 3c. Approvals. Grandstamps, 619½ South Spring, Los Angeles, California.

50 STAMPS; Manchukuo, etc., 1c. Album 3c. Bullard, 268 Northampton, Boston, Mass.

TEN Lots only 10c. Includes lot each old U. S., airmails, Zanzibar, British Colonies and six others. Everything for 10c to approval applicants. John Perry, Bramwell, W. Va.

MAKE Extra money. Sell stamps in your spare time. Write for free illustrated wholesale catalogue. Fordham Co., 152 W. 42 St., New York.

SPANISH Collection 101 different airs and commemoratives, \$2.50 postpaid. F. H. Schultze, Box 55PM, Woodhaven, New York.

AIRMAILS (15) 5c To approval applicants. Wollaston Stampco, Wollaston, Mass.

NEWFOUNDLAND, 15 Different 5c with approvals. Hudson Company, Plainfield, N. J.

100 DIFFERENT U. S. 50c, 500 U. S. and nice foreign mixed 25c. Approvals if requested. Wm. Clatworthy, Upland, Calif.

ILLUSTRATED U. S. list, price 50c, large complete U. S. price list free. Send postage. Stanley Gibbons, 38P Park Row, N. Y.

LIBERIA Snake triangle, giant Spanish ship triangle, 50 other stamps, 5c. Abell Company, 2527 Guilford, Baltimore, Md.

ONLY 7c. Catalog value over \$1.40, 28 different stamps. LC Trading Company, Box 38A, Bellerose, New York.

1000 MIXED United States, 25c; 5000, \$1.00. Postpaid. Charles Seifert, 1352 Buttenwood, Reading, Penna.

UNITED States mixtures 50c lb. Canada 75c. Japan \$2.50. Mission, 4512 North Racine, Chicago.

FREE—Complete set Denmark ship stamps to approval applicants. Sanders, 267½-P West Seventh, St. Paul, Minn.

\$5.00 U. S. Stamp No. 573 perf. initials only 10c with general approvals. Hudson Company, 116 Nassau St., New York City.

U. S.—57 Different (commemorative, airmail, etc.) with approvals 9c. Moseley, 4932 Forestpark, St. Louis, Mo.

YOU'VE Tried the rest—Now get the best!—"Challenge Collection" including Cape Goodhope, triangle, Thessaly octagonal, commemoratives—10c with approvals. Free airmail collection, additional premiums given regular customers. Bargain Stamp Service, Box 5147, Los Angeles, California.

\$5000.00 EACH For rare stamps. Many others will bring you from \$5.00 to \$500.00. I will pay cash for U. S. stamps. Send 10c today for 8 page price list. L. B. Collins, Box 750, Binghamton, N. Y.

PENNY Approvals that please. Haywood, 395 Adams St., Pomona, Calif.

\$5.00 STAMP, 35 Different United States, 15c. Buckeye, Box 102, West Toledo, Ohio.

WORLD'S Largest map stamp, Pilsudski and King Albert mourning, New Zealand Kiwi, Brazil Aero and 50 other singles, together with sets of French Braule airmails (5 values), Roumanian Aviation Fund issue (3) and Grecian Missolonghi commemorative (7). All for 10 cents to approval applicants. International Stamp Corp., Dept. 64, Newport, R. I.

\$5.00 U. S. Red and blue liberty, present postage value, Scott No. 573 cat. \$1.25 (retails as high as \$1.00 net by some dealers) only 5c to approval applicants. Giant U. S. pricelist free! Tatham Stamp Company, Springfield-5, Mass.

ANNUAL Wholesale catalogue—Illustrated and enlarged. Free upon application. Empire Stamp, Department 5, Toronto, Canada.

LIBERIA: Beautiful complete issue 10c. Approvals. Oris Stamp Company, Kerrigan Ave., Union City, N. J.

FREE—100 Different stamps to new subscribers sending 25c for six month's subscription to Pacific Philatelist, 2495 Telegraph, Berkeley, California.

25 UNITED States, including \$4 and \$5 stamps free to approval applicants. 3c postage. Brownie Stamp Shop, Flint, Michigan.

MAMMOTH Mystery packet rare stamps only 10c to serious approval applicants, also valuable free premiums with every selection afterwards. Our stamps are better, our service is different. Fair-Play Stamp Service, 1215 Browning Blvd., Los Angeles, Calif.

FREE Dollar packet to penny approval applicants. Harlan, 5307 S. Marshfield, Chicago.

3000 DIFFERENT Stamps. 25c weekly—with approval and exchange service. Marshall, 1706 Eutaw, Baltimore, Md.

80 ANTIQUA, Congo, Siam, etc., 5 cents. Luffbery, Middletown, Connecticut.

APPROVALS Sent. Quality stamps. Reasonable prices. Guilmette's, 907 Brock, D20, New Bedford, Mass.

MIDGET Airmail (½-in. tall), Szechuen, Kouang-Teheou, Mozambique, etc.—5c. Deprau, Ocean Park, Calif.

DIAMOND-SHAPED Stamp, Liberia gunboat triangle, two other triangles, silver jubilee, 27 others, 5c. Crowder Company, 127E North, Baltimore, Md.

FREE—Dominican Republic triangle stamp to approval applicants. Paul's Stamps, 2149 N. Lamont, Chicago.

CANNON! Set of stamps showing cannon, firing squad, cavalry charge and 200 other different stamps only 10c to approval applicants. Paramount Stamp Co., 4225 Broadway, Chicago, Ill.

FREE!!! King George memorial packet, 15 varieties. Postage 3c. Roberts 901F Fourth, Baycity, Michigan.

NEW Issues, mostly mint, 3 varieties each: Bermuda, Cayman Cyprus, Grenada, Kenya, Nigeria, Pahang, Perak, Selangor, Sembilan, Straits, St. Lucia. Any set 10c. The lot \$1.00. Lists free. Approvals. Westminster Stamps, 5060, London, Canada.

UNBELIEVABLE—Suriname, Panama, British Honduras, Jubilee, airmail, triangle. Complete collection every country from Straits Magellan to Arctic. 10c. Approval applicants only. Mutual Stamp Service, Box 666PD, Ventura, Calif.

QUEEREST Stamp packet. Receive world's smallest stamp; Vatican City; scarce Liberia triangle (value 15c); 1935 Greek Red Cross picturing coiled snake in Garden of Eden; Australian Bushman; New Spanish Morocco; Japan "quake stamp; Manchukuo; many others. Only 5c to approval applicants. R. M. Stamp Co., P. O. Box 230P, Port Chester, N. Y.

SCOTT'S 1937 Catalogue mailed with imperforates, \$2.00. Superior approvals. Kattau, 10315 - 108th Street, Richmond Hill, N. Y.

YOUR Choice!! Fifty French or British colonies. 3c to approval applicants. Kumler, King, Lancaster, Ohio.

SCARCE Triangular Mozambique commemorative airmail and packet of 33 U. S. including imperforate 3c Chicago; early issues; high values; commemoratives; envelopes; revenues, etc., cataloging more than 75c—only 5c to approval applicants. Illustrated pricelist free. Curhan Stamp Co., Dept. P, Gloucester, Mass.

UNITED States, Canada, Newfoundland. Where? Our "Four Star" approvals. Nothing like them! 300 mixed U. S. 10c to approval applicants. Kessels, Tucson, Arizona.

NEW Hebrides, Schleswig and 25 different—10c with approvals. Fantus, 1337 Morse, Chicago, Ill.

BRITISH Silver Jubilees from 3 different countries, imperforate 3c Tipex commemorative—all included in Clipper packet containing 25 different stamps from Azerbaijan, China, Ukraina, etc. All for only 5c to approval applicants. Clipper Stamp Co., Dept. 7, Gloucester, Mass.

WORLD'S Smallest air mail, \$2.00 U. S. stamp, animals, bird, train, Indian, airplane, commemoratives, special issues with scarce stamps from 25 different countries only 5 cents with approvals. Capital Stamps, 413b Roosevelt Road, Little Rock, Arkansas.

SACRIFICING 15,000 Sets! Airmails, commemoratives, pictorials! No common Europe! 3c each. 35 different, \$1.00. Riordan's, 1738 Longfellow, Detroit, Michigan.

DISGUSTED? Try my approvals. Value instead of premium. Also half cent approvals for beginners. Viscusi, Route 4, Scotia, N. Y.

ASK For our wonderful one cent approvals Prospect Stamp Co., 225 Broadview, Toronto, Canada.

PREMIUMS With approvals, 3c postage. Harold Bowen, Fort Dodge, Iowa.

SPECIAL! 60 Ships, scenery stamps 10c. Sachse Stampco, London, Canada.

ICELAND 30 Different for 50 cents to approval applicants. Premiums. Pioneer Stamp Shop, 224 Main, El Monte, Calif.

"GOYA Nude" stamp \$0.10 to approval applicants. Jewells, Tamaqua, Penna.

BRITISH Solomon Islands! Bicolored Columbian airmail; gigantic stock stamp; beautiful complete Costa Rican set; Siberia (first stamp); weird far eastern republic. Entire combination only 5c to approval applicants. Saxon Stamp Co., Albee Bldg., Brooklyn, N. Y.

WEEKLY Stamp magazine, thirteen weeks, 10c. Stamp Journal, Kalamazoo, Mich.

WHOLESALE Catalog for dealers, illustrated. Postage 5c. Frank Co., 4900 Chalgrave, Baltimore, Md.

\$1.00 MONTHLY, Maintains New York branch office. Co-Operative Mail Service, 126H Lexington Avenue.

PENNY Approvals—World wide. Try the best. Kokomo Stamp Exchange, Kokomo, Indiana.

PENNY Approvals, that satisfy. Nell Gronberg, Box 5441-P, Philadelphia, Pa.

GIGANTIC Collection containing Ethiopia, Algeria, Andorra, Azerbaijan, Camerons, Ceylon, Eritrea, Estonia, Indo-China, and a hundred others all for 10c with approvals. Walker, 206 West 3rd Street, Los Angeles, California.

SUPERIOR "New Issues" collection, airmails, commemoratives, jubilees, pictorials, triangle, etc., only 10c providing you desire bargain approvals. Superior Stamp Service, Box 866, Sacramento, Calif.

WORLD'S Largest triangle! Giant Spain triangle and bi-colored Persia airmail; big packet 25 different Russia (catalog value nearly \$1.00); packet British Colonies including Egypt, Travancore, Ireland, Malay, etc. Big United States list. All for only 5c to approval applicants. Richfield Stamp Company, Dept. 20, McLean, Virginia.

INCREASE Your collection without expense. 25 different Canadians, all instructions for 25c. Canstex, 6864 Irwin, Montreal, Canada.

PHOTO FINISHING

MAIL Your rolls to The Kodak City. 8 guaranteed glossy Velox deckle-edged prints, 25c coin. Two professional enlargement coupons free! Photo Finishing Shop, Est. 22 yrs., 411-A Genesee Valley Trust Bldg., Rochester, N. Y. "The Kodak City."

"HOLLYTINTS Mean better prints." Two crystalline enlargements with each film developed 25c. Dollar premium coupon free. Hollytints, P-168, Hollywood, California.

IMMEDIATE Service! No delay! Roll fully developed, carefully printed and two beautiful, full-size 5x7 double weight professional enlargements (or one tinted enlargement)—all for 25c coin. The experts' choice! Reprints 3c each. The Photo Mill, Box 629Z, Minneapolis, Minn.

FRAMED 5x7 Professional enlargements 15c. 8 reprints and two 4x6 enlargements 25c. Newton, Maywood, Ill.

ROLL Developed and 8 guaranteed prints including two enlargements, 25c coin. Super Snapshot, Winona, Minn.

TRIAL Offer. Roll developed and 8 prints 25c. Reprints 3c. Beautiful 8x10 enlargement 25c. Prompt expert finishing. Young Photo Service, 405 Bertha Street, Albany, N. Y.

TWO Professional enlargements with each roll developed and printed 25c. Eight reprints, two enlargements 25c. Hygloss, River Grove, Ill.

ROLL Developed. Two double-clear prints each negative 25c. Reprints 2½c. Enlargement coupon. Willard's, Box 3535-A, Cleveland Heights, Ohio.

ROLLS Developed. Two beautiful double-weight professional enlargements and 8 guaranteed Never Fade Perfect Tone prints. 25c coin. Rays Photo Service, LaCrosse, Wisconsin.

HAND Colored enlargement with each roll 25c. 40 reprints 50c. Colorgraph, Dunning Station, Chicago.

BEAUTIFUL Glistening prints, roll developed, 8 guaranteed glistening prints, 2 enlargements, 25c. American Photo Ser., 2946-C Nicolet, Minneapolis, Minn.

ROLL Developed, two prints each, two enlargement coupons 25c. Christmas cards 60c dozen. Summers' Studio, Unionville, Missouri.

20 REPRINTS 25c—Films developed, 16 prints 25c. Enlargements 8x10—25c; 5x7, 10c. Low Photo, M-2657, Nava, Chicago.

HAVE Your pictures properly processed. Roll developed and 6 or 8 velox prints, 25c. Reprints 3c. Double "A" Studio, Dept. 3, Huntington, Indiana.

PHOTOGRAPHIC Christmas cards, 20 for \$1.00. Send your negative. Sample 10c. Seascout Service, Box 52, Chelsea, Mass.

BEAUTIFUL Colored enlargement with each film 25c. Speedy service. Satisfaction guaranteed or money refunded. LaCrosse Film Company, LaCrosse, Wis.

FOUR Glossy, 4x6 enlargements, quarter. Send negatives. Albert's, Box 76, Easton, Penna.

FILMS Developed 2 prints of each 25c; 20 reprints 25c. Pine Photo, M-5134 Nevada, Chicago.

QUALITY Counts—Two double weight gloss enlargements and eight prints guaranteed not to fade from each roll, 25c. Prompt service. Excel Photo, Box D, Dubuque, Iowa.

ROLLS Rushed! Developed and printed with two supertone enlargements 25c. Four 4x6 enlargements 25c. Newton, Maywood, Illinois.

20 REPRINTS 25c. 100 Reprints \$1.00. Rolls developed with 16 prints 25c. Nordskog, 4, Maywood, Ill.

DEVELOP And print your own pictures. Save time, money with our complete \$1.49 outfit postpaid, or pay postman \$1.55 COD. Includes electric ruby lamp, printing frame, photo paper, chemicals and equipment. One of hundreds of amazing bargains in our free, newest, money-saving bargain book. Send for it today! Central Camera Co., 230 So. Wabash, Dept. K-410, Chicago.

ROLL Developed and 8 beautiful Velox glossy prints 25c coin or stamps. Reprints 3c each. Fotoprint Service, Box E, Roanoke, Virginia.

SPECIAL—Roll developed, two sets dated prints 25c. Hensch Studio, 1814 Chestnut, Harrisburg, Penna.

20 REPRINTS 25c. Films developed, two prints each negative, 25c. Skrudland, 6970-8 George, Chicago.

TWO Beautiful double weight professional enlargements, 8 guaranteed Never Fade prints, 25c coin. Century Photo Service, LaCrosse, Wisconsin.

5x7 ENLARGEMENTS From negatives, five for 25c. Enlarging Specialists, Box 4292X, Portland, Oregon.

ONE Dime (and this ad.) finishes your trial-film roll. Fifco, Yale, Okla. (37).

ROLL Developed and 16 prints 25c. Smart Photo, Winona, Minn.

BETTY O'Brien's Film Studio, LaCrosse, Wis. Better pictures—8 prints, 2 enlargements 25c.

FILMS Developed, 16 prints 25c; prints 2c. Crotty Photo, DI, Menlo Park, Calif.

RADIO Film Company, LaCrosse, Wisconsin. Latest in photo finishing. Eight guaranteed prints—two enlargements 25c.

ROLL Developed with 16 prints and two professional enlargements 30c. 100 reprints \$1.00. 16 reprints and 2 enlargements 30c. Dependable, RiverGrove, Illinois.

FINER Finishing. Rolls developed and printed, with one colored enlargement, or two professional enlargements. All for 25c (coin). Genuine, nationally known, Moentone superior quality. Moen Photo Service, LaCrosse, Wis.

ANY Size roll developed and 8 Trutone prints 25c. Extra reprints 3c each, 116 size or smaller, 25 reprints 50c. Jefferson Studio, 6307 Holbrook, Chicago.

FREE—Hand colored print, with roll developed and 16 prints, 25c. Guarantee quality work and prompt service. Photocraft, Box 278, Oak Park, Illinois.

THREE 5x7 Enlargements 25c, tinted 50c, coin. Send negatives. Midwest Studio, Humboldt, Iowa.

DAILY Service—Roll developed, 16 guaranteed prints, 25c. Valuable enlargement coupon; 16 reprints 25c. Modern Finishers, Box 3537-L, St. Paul, Minnesota.

PHOTO-FINISHERS (Mail dealers) get our amazing profit builder. Write today! Craftsmen, Lebanon, Tennessee.

FINEST Super gloss Velox prints, roll developed and printed 25c, reprints 2c. Films 35% discount. Paramount Studio Division, 403 E. 92nd St., New York.

DAY Service! 2 projections, 8 Velox prints, 25c. Griffin Studios, Winona, Minn.

QUALITY Finishing, roll developed and printed 25c. Pocket album free with first order, enlargement coupon. Ideal Photo Service, Box 2255, Paterson, N. J.

COMPARE The difference! Roll developed, two professional double weight enlargements, 8 guaranteed prints, 25c coin. Excellent service. Nationwide Photo Service, Box 3333, St. Paul, Minnesota.

LEICA, Contax and other 35 mm. owners. Finest—Grain developing 35c. 3½x5 enlargements 5c. We specialize in 35 mm. finishing only. Feigley, The Candid Cameraman, 16, Pittsburgh, Pa.

DEVELOPING And 8 beautiful Double Deckle Velox prints, 5x7 enlargement 25c. 3x4 Leica or Univex prints 5c. Elkhart Photo Service, Elkhart, Ind.

GET The best. Roll developed, beautiful hand colored enlargement, 8 neverfade border prints, 25c coin. Prompt service. Sun Photo Service, Drawer T, St. Paul, Minn.

ROLL Films developed eight enlargements 25c coin. Enlargements from reprints 3c each if your camera is a 116 size or smaller. California Film Service, Department 44, Box 379, Pasadena, California.

TWO Prints each with every roll developed, 25c. Very finest quality. Reprints 2c each. Brown Photo Company, 2209-34 Lowry, Minneapolis, Minnesota.

TWO Beautiful professional double weight enlargements and eight lifetime prints, 25c. Mays Photo Shop, LaCrosse, Wis.

SPECIAL 4x6 Enlargement, colored, gold-en oak frame. Send negative, 50c coin. Films finished, including attractive frame 30c coin. Fotofram, Riverhead, N. Y.

PHOTOGRAPHIC Christmas cards from your own kodak negatives. Mail negative and five cents for sample and quantity prices. Send something different this Christmas—a card nobody else can duplicate. The Photo Mill, Box 629-12, Minneapolis, Minnesota.

CAMERAS, PHOTO SUPPLIES

CAMERAS And supplies. Free illustrated catalog listing everything photographic—still and movie cameras, films, lenses—at tremendous savings. Hundreds of bargains, new and used. All guaranteed. We take your old camera or equipment in trade. Write now for your free copy of our newest money-saving bargain book—just out! Limited edition. Hurry! Central Camera Co., (Photographic Headquarters since 1899), 230 So. Wabash, Dept. K-310, Chicago.

INCOME From your camera instead of expense. Low cost home course teaches you to make photographs for magazines, newspapers, advertisers. Tremendous demand. Earn good money wherever you live. Free book, Universal Photographers, Dept. 104, 10 West 33rd St., New York.

BRAND New Argus candid camera, \$12.50; Welli 35mm. F:2.8 Zeiss Tessar, list \$62.00, special \$48.50; Baidax 1 3/4 x 2 1/4 F:2.9 lens. Worth \$60 for \$37.50. Write for list of new and used camera bargains. Bass Camera Co., Dept. "AG," 179 W. Madison St., Chicago, Ill.

MAKE Money in photography. Learn quickly at home. Spare or full time. Easy plan. Previous experience unnecessary. For full information and requirements. Common school education sufficient. Write for full information and requirements. American School of Photography, 3601 Michigan Avenue, Dept. 343-A, Chicago.

HAVE You a camera? Send ten cents for recent number of our big magazine, showing how to make better pictures and earn money. American Photography, 116 Camera House, Boston, 17, Mass.

HIGHEST Prices paid for used still-movie equipment. Send description. Foto-shov, 136A West 32, New York.

35% DISCOUNT On films. Write Paramount Photo Division, 403 E. 92nd St., New York.

BIG Profits with inexpensive camera. New book tells how. (25c "Photomarkets Guide" included free!)—35c. NG. Shinn, Bellflower, California.

CAMERA Owners! Build practical photo enlarger. Instructions, plans \$1.00. Cameratach, 1857 Anthony Avenue, New York.

FREE! Sample copy sixty page photographic magazine—interesting instructive. Pocket Photo Monthly, Canton, Ohio.

MOTION PICTURES AND SOUND EQUIPMENT

BASS Bargain counter: Write today for your free copy of the latest, greatest Bass Bargaingram No. 219 of 16mm. cine apparatus. Filled with rare bargains, for instance: Keystone 8 mm. camera and projector, latest type, regularly \$69.45, at Bass only \$54.75. 100 ft. 16mm. Mono film including reversing, \$2.95. Wilco Cine exposure meter, infallible, \$5.15. 300 watt. motor driven 400 ft. capacity standard 16mm. projector, \$29.50. Bass Camera Co., Dept. A, 179 W. Madison St., Chicago, Ill.

CENTRAL'S Free, new, money-saving bargain book explains latest movie developments, offers money-saving bargains in cameras, lenses, projectors, films. Used equipment taken in trade. Write for free copy. Central Camera Company, (Photographic Headquarters since 1899), 230 So. Wabash, Dept. K-210, Chicago.

LOOK! "The World's Greatest Passion Play." Seven reels, (new) 16 mm. Superior than the Oberammergau stage play. Rent or purchase. Write Hemenway Film Co., 37 Church St., Boston, Mass.

35-MM. SOUND, Silent prints. List 3c. Star Theatre, Fenwick, Michigan.

ASTOUNDING Bargains 35 mm. silent film. Clyde Kies, Waterman, Ill.

WANTED: Sound on film 16M projector and R.C.A. camera. Konarski, 2657 Drake, Chicago.

35MM. FILMS, Bargain lists 3c. Hoffman Film Service, 57 Broad, Albany, N. Y.

8MM. COLOR, Panchromatic. Economical titling film. Film slitter, titling lens, instructions. Reversible data. Film Specialties, 111P, El Monte, California.

BASS Now exclusive distributor for Radio Corp. of America 16mm. R.C.A. Sound on Film Cameras. Anyone can record sound pictures. New low price. News reporter model was \$750.00, now \$210. Send for complete details. Bass Camera Co., Dept. AK, 179 W. Madison St., Chicago, Ill.

8MM FILMS: Cartoons, travel. List. Lincoln Film Service, Box 293-A, Saginaw, Mich.

16MM EXCEL Motor driven projector, 100-ft. reel \$3.95. Pop-Eye, Betty Boop, Hal Roach, "Our Gang" comedies and others. 3c stamp for catalogue. Excel Home Movies, 622 Madison, Toledo, Ohio.

8MM ART Films. Original Hollywood art featurettes now available in 8mm. or 16mm. Send 50c for 10 ft. 8mm. art screen test or \$1.00 for 20 ft. 16mm. test. Eight art film samples, 25c. Stamp brings illustrated art catalogues. Hollywood Cine Film Distributors, 1431-33 No. Highland, Hollywood, Calif.

THREE Cameras in one. Takes snapshots, moviebooks, 16mm movies. Springmotor driven. \$5.95 brand new. Films \$1.00. Send no money. Pay postman. Projectors \$1.00 up. Tarzan, Buck-Rogers, Joe-Palooka films 35c up. Free lists. Home Movies, Box 32, Easton, Pennsylvania.

BUY Or rent from world's largest 16mm silent, sound film distributors. Bell & Howell projector \$37.50. Eastman 100 ft. Kodachrome \$7.15. Agfa Pienachrome \$3.50. Complete line 8-9 1/4-35mm. Bargaingram full real buys free. We accept trades or buy your equipment. Mogull's, 1944-J Boston Road, New York.

16MM. FILM Headquarters. Big sound, silent rental library. Home movie films, accessories. Bargain prices. 100' toy film, \$1.00. Eastin Pictures, Davenport, Iowa.

SILENT And sound motion picture films, 35mm., rent and sell. Lists. Hastings Motion Pictures, Hastings, Michigan.

8-MM-16 MOVIE Bargains! Catalogue free. Elder, Dept. B-28, Chelsea, Massachusetts.

LEARN Motion picture theatre business. Home-study training; management, advertising, projection. Catalog. Theatre Institute, Elmira, New York.

16MM BARGAIN Bulletin free! Acme Cine, Box 794, Lima, Ohio.

TALKIES \$15. Silents \$5. Simpson, 1275 So. Broadway, Dayton, Ohio.

TALKIES, Silents, 35 mm. cheap. Lists. UFD, 15370 Littlefield, Detroit, Michigan.

8-16MM Sound-silent films. Bell-Howell Filmosound demonstrator, almost new \$590. Address: Pictures, Westport, Conn.

SALE! 16MM, 8MM projectors, films. Cine. Box 2133, Paterson, N. J.

WE Buy, trade, sell anything. Bi-Cam-Ex, 1451-P Broadway, New York.

16MM. MOVIE Camera \$4.95. Film free. Moorfield-Shannon, Nutley, New Jersey.

35MM. FILMS \$1.00 reel. Projectors \$10.00. List 10c coin. Box No. 6, Rosedale, Kansas.

FOR Dual showing, two rebuilt 35mm. portable sound equipped projectors \$345.00 complete. Guaranteed. Uhler Cine Machine Company, 1323 Trumbull, Detroit.

16MM. BELL Movie camera \$6.95. Projectors \$6.95 up. 16mm. film including processing \$1.89. Free circular. Bytom, Dept. A, Park Ridge, Ill.

RADIOS, SUPPLIES, INSTRUCTION

RADIO Engineering, broadcasting, aviation and police radio, servicing, marine and Morse telegraphy taught thoroughly. All expenses low. Catalog free. Dodge's Institute, Ames St., Valparaiso, Ind.

BE A radio expert. Many make \$30, \$50, \$75 a week. Learn at home in spare time. Radio's big growth making many good full time and spare time jobs. Write for free copy of 64 page book. National Radio Institute, Dept. 6KPA, Washington, D. C.

SW CRYSTAL Set—4250 mile record. Instructions 18 distance models: "Radio-builder" year—25c. Laboratories, 151-C Liberty, San Francisco.

RADIO Experimenters and set builders: Parts and kits of parts for portable Superhet Battery Improved Little Giant four and five tube. Economy three, 32 volt, and Pre-Amplifier described by Popular Mechanics. Lund Manufacturing Co., 43 East Ohio, Chicago.

MUSIC AND MUSICAL INSTRUMENTS

PIANO By ear quickly self-taught. Free particulars. No obligation. Day-V-Way, 1632 Woolworth Building, Dearborn, Michigan.

ARE You fitted for a career in music? Our treatise tells basis of musical talent—type of instrument—practice secrets—"composer's technique"—music structure. \$1.25 postpaid. Or send stamp for explanatory folder. Chute Publishing Co., 163 Sutter St., San Francisco.

SONG-WRITERS. Professional phonograph record of your song. Musical arrangements. Free information. Paramount Song-Recording Studio, J-8, Box 190, Hollywood, California.

SONGPOEMS Wanted. "Square Deal Plan." Send for contract. Roy Allen, Kitchel, Ind.

FREE—"Timely Tips on Successful Songwriting." Burns, Box 1048, Longview, Wash.

SONGWRITERS—Send for free copy of booklet revealing Secrets of Successful Songwriting, free rhyming dictionary and market information. If you write poems or melodies, send for our offer today. MMM Publishers, Dept. El, Studio Bldg., Portland, Ore.

FREE Songwriters' Manual reveals important information. Write Standard Song Service, 310F South Michigan, Chicago.

WRITE A song: Mother, love, patriotic, sacred, comic or any subject. Send poem today. Richard Bros., 24 Woods Bldg., Chicago.

REBUILT Band and orchestra instruments. Honestly rebuilt—fully guaranteed. Catalog of new instruments on request. Weymann Company, Dept. M-10, 1613 Chestnut St., Philadelphia.

DUO-FLEX Reeds for clarinets, and saxophones eliminate your reed troubles. Write for circular. Duo-Flex Reeds, 1204 1st Ave., Evansville, Ind.

EARN Your own musical instrument. Get free details and free attractive savings bank at your music store, or write Fred Gretsich Mfg. Co., 521 1/2 So. Wabash, Chicago.

SONG Poems wanted, 50-50 plan, instruction book sent free. Song Bureau, Salem, Indiana.

SONGWRITERS—Get all inside facts. Free booklet by famous Broadway composer. Songwriters Institute, 1234C Broadway, New York.

MUSIC Composed to words. Wonderful proposition. Bauer Bros., Oshkosh, Wis.

MUSIC Composed to song poems. Our published songs endorsed and featured by stage, radio, screen celebrities. Adelman Bros. Music House, Dept. 601, Washington, D. C.

HARMONY: Become writer, leader, and teacher of orchestra music at home. 1944 Crosby Ave., Oakland, Calif.

POEMS Wanted. Work guaranteed. We publish. Great Eastern Song Bureau, Dept. 27, Thomaston, Me.

WRITE Songs. Big money and reputation. Write for information. J. Gordon Pub. Co., 201 N. Hoyne Ave., Chicago.

SONGS! We compose, arrange, publish, sell. Superior Song Studios, 211 Hope Ave., Passaic, N. J.

SONGWRITERS! Outstanding collaboration offer. Hibbeler, D1, 2157 No. Avers, Chicago.

SONGPOEMS Wanted. Your song published. National Songland, "PM," Thomaston, Maine.

ORCHESTRATIONS 10—\$1. Sheet music 25—\$1. Orchestra Service, 3303 Lawrence, Chicago.

SONGWRITERS! Poems—melodies. Special offer. Studio PM, Guaranty Bldg., Hollywood.

SONGWRITERS. Write for special offer. Lew Gould's Harmony Studio, Peace Dale, R. I.

ORIGINAL Music composed to your words \$5. Reginald Belcher, Chatham, New Jersey. 25 years church organist, musical director.

SONG Writers. Send for our "Publishing Agreement." McKinley Music Printers, 1501 E. 55th St., Chicago.

BUSINESS OPPORTUNITIES

ARTIFICIAL Marble sanitary flooring, instructions covering wood or cement flooring 1/2 inch thick, fireproof, all colors, low cost, ornamental casting, concrete, plaster, papier-mache, garden furniture, statuary, flexible molds, particulars free. Chris Mahler, Elmont, N. Y.

WE Start you in business, furnishing outfits and instructions, operating "Specialty Candy Factory" home. Men and women, earn \$25.00 up to \$75.00 weekly, all or spare time. Booklet free. W. Hillyer Ragsdale, Inc., Drawer 4, East Orange, N. J.

FORMULAS—Fast selling products. Guaranteed. Laboratory tested. Lowest prices. Catalog free. Kemico, 55, Park Ridge, Ill.

SELL, Install, or build modern oil burners. Oil Burner Company, 1304 Washington, Chicago.

MONEY In mushrooms! Start now, in cellar or shed, get highest prices. Exclusive new process. Bigger, better, quicker crops. We buy. Books free. American Mushroom Industries, Dept. 721, Toronto, Ont.

BUILD Profitable business. Amazing details free. Box 94, Moriches, N. Y.

FORMULAS. Chemical analysis. Mail sample. Dobin Laboratory, 1746 Roscoe, Chicago.

NO Boss! Sure cash! Silvering mirrors, autographs, reflectors. Combination outfit. Write Sprinkle, Plater, 127, Marion, Ind.

MAIL Order business is your opportunity. Many began small, now earn thousands yearly. No personal contact. Boundless opportunities. Have had over 30 years experience; will help you succeed. Send 25c for valuable booklets, none free. B. Breniser, 257 South 21st, Philadelphia.

HOW And where to obtain capital fully explained, particulars free. Star Service, Wanakona, Ohio.

BIG Mail 10c. Milton Boss, 2907M 34th St., Rock Island, Ill.

MAIL Business. Start small. Everything furnished. Free details. Metromails, P-10, Cincinnati.

SELL By mail. Books, novelties. Bargains! Big profits! Particulars free. B. Elfo, 525 S. Dearborn, Chicago.

I WANT To send you proof of the wonderful pulling power of Popular Mechanics Magazine's classified pages. What's your proposition? Write me today. F. W. Johnson, Manager Classified Advertising, 200 E. Ontario St., Chicago, Ill.

GET Lots of mail. Money making offers, etc. Your name in 10,000 directories, 35c. Roscoe, 4627 Glenshade, Cincinnati.

FREE Booklet describes 107 plans for making \$20-\$100 weekly, in home or office, business of your own. Elite Co., 214 Grand St., New York.

COMPLETE Chemical service, analysis, formulas, processes, trade secrets. Particulars free. W. L. Cummings, 228 Gordon Avenue, Syracuse, N. Y.

POPCORN, Crispette, caramelcrisp, potato chip, salted nut machines. Long Eakins, 1960 High St., Springfield, Ohio.

SUCCEED With your products. Formulas, processes, analysis. Catalogue free. B. Thaxly Co., Washington, D. C.

PLASTEX Industries offers industrious men an opportunity to start a business of their own, manufacturing art goods, novelties, souvenirs, etc., in Plastex and marble imitation. 5c material makes \$1 articles. Rubber moulds furnished for speed production. Small investment brings big returns. You are just in time for the big X-mas business. Write for interesting booklet mailed free. Plastex Industries, Dept. A, 1085 Washington Ave., New York.

MILLIONS Jobless! Get dollars in mail daily for satisfying employment information (got man 76 jobs). Keep money; we fill your orders free. Stamp brings details. Co-Operative Service, 77 Swan, Buffalo.

MECHANICS Hand soap. (Powder form) formula \$1.00. R. Barton, 2403 Brownsville Rd., Pittsburgh, Pa.

HAVE Your own profitable business-profession. Many opportunities everywhere. Write Enterprise Bureau, Syracuse, N. Y.

DOLLARS \$40,000—"Moore Made" It. Plan 10c. "MooreMade," Lapeer, Michigan.

VEGETABLE Concentrates, powders, tablets, vitamins making fortunes. Mail order, local. Samples 12c. Gardena Laboratories, Drawer 1310B, Hollywood, Calif.

50 Ways to make money 25c. Stevens, 1804 Natchez Trace, Nashville, Tennessee.

START A profitable paying business in your home. Write J. R. Thurman, 135-West 17th Street, Anderson, Indiana.

PROFITABLE Business, natural repeater. \$50 plus character required. Wemco, 622 E. 6 St., Jamestown, N. Y.

MONEY. Mail business. Free plan. Stamp Blackco, New Lexington, Ohio.

ABSOLUTELY Free—12 moneymaking formulas given to every new advertiser in "The Leader," 20 words 10c. W. E. Martin, Bassett, Va.

BIG Profits operating "route" penny peanut and gum vending machines. Start with \$100. Robbins Co., 1141P DeKalb Ave., Brooklyn, N. Y.

PROFITABLE Sparetime business at home, dependable income. Particulars for stamp. Colonial, 7867a - 79th Lane, Glendale, N. Y.

NEW Beauty, barber shop products! Sell by mail! Henkle Products, Norwich, Conn.

MRS. M. earned \$267, three weeks, raising mushrooms in cellar! Exceptional, but your cellar, shed perhaps suitable. We buy crops. Book free. United, 3848-A67 Lincoln Ave., Chicago.

OPERATE Chain world's finest money making vending machines. Sells four products—same time. Instant success! Small capital—profits immediately. No curiosity seekers. Penny King, 1233 Chouteau, St. Louis.

MAIL Order and local business. All office. No canvassing; no stock; no shipping. Part of national chain. All instructions given. Shoestring capital. Circular free. Harrigan, P.O. Box 97, Drexel Hill, Pa.

MONEY-MAKING Ideas, plans, formulas, information. Literature free. J. Kornegay, 1621 County St., Portsmouth, Va.

FREE! Complete plan of a real money maker. No obligation. Stamp appreciated. Box 1131-Univ. Sta., Des Moines, Iowa.

WE Teach you new business, then buy your product. Write Superior Specialties, Springfield, Illinois.

CORRESPOND For newspapers: Profitable, interesting, easily learned. Write Publishers' Service Bureau, 4258-F Drexel, Chicago, Ill.

COLD Winter ahead! Earn \$50 weekly income by Thanksgiving. Easily possible with limited capital in practical, sensible, mail order business. Send dime for "Key to Self-Earned Wealth." Midas, 10 West 26th, Minneapolis, Minnesota.

STORY Fortunes! Quick writing method \$1.00. Plot Service, 1138 S. Elgin, Tulsa, Oklahoma.

BARGAINS—Paint spray outfit, gasoline engine drive. Terms—trial. Holmick Paint Spray Exchange, M-1064, Troy, Ohio.

GUARANTEED O.K. mailorder business. Valuable booklet for stamp. Anthony Drungis, Jr., 267 Front St., Brooklyn, New York.

"A FORTUNE In Dimes"—Daring expose dime rackets. Tips, suggestions. 25c. Unusual literature free. Craftsmen, Lebanon, Tennessee.

OPERATE Your own business. No capital required. Good pay. No selling. Literature free. Tri-City Service, Box 151, Davenport, Iowa.

NOT Colossal, not stupendous, just ordinary sensible offers. My circulars convince you. George Walker, SPP School St., Brunswick, Maine.

OPERATE Your own sales business in used household equipment. My plan starts you without investment. Complete working plan \$1.00 postpaid. Geo. R. Mobley, Independence, Kansas.

FOREIGN Distributors for "Pinhole" fountain described in July Popular Mechanics. Locust Lawn Gardens, Crafton, Pittsburgh, Pa.

"SCHEMER Magazine." Alliance, Ohio, prints schemes, ideas, business starters, formulas—big winners; \$10,000 to \$50,000 reported. 38th year; \$1.00. Trial special: six months only 30c.

OPERATE Paying business. Little capital required. No manufacturing, canvassing. S. Morse, 1009 Oak, Elmira, N. Y.

START Little business anywhere. Everything furnished. No canvassing. Maywood, PM-923 Broadway, New York.

\$1.00 MONTHLY, maintains New York branch office. Co-Operative Mail Service, 126B Lexington Avenue.

CASH For spare time! Quarter brings folio surefire moneymaking plans. Jay, 8054-P Kenwood, Chicago.

MAKE Products yourself. Tested formulas—catalogue free. Grinstead Laboratory, Edwardsville, Illinois.

LEARN Marbleizing with our new formula. Flintlike hardness. Imitates marble over wood, concrete, anything. Free samples. See our new rubber composition samples. Stands all required tests. Cowell Institute, Grayling, Michigan.

MEDICINE Business for sale. Make offer. Leonard, Box 1852, Cleveland, Ohio.

FREE. Samples and instructions, painting political signs. Big money proposition. Clark, Ellwood City, Pa.

WANT Increasing income? Own business? Start small. Details, samples 25c. Sanis, 2277-P Third Avenue, New York.

WOULD A few honest dollars interest you? If so, consider this opportunity now. Quarter direct. Schaller, Pekin, Ill.

LIQUID Marble—Anyone can make! Colourful, glazed! Moulded, brushed, sprayed. Rubberlastic moulds. Composition flooring. Big money in these! Particulars free. Marbleizing Service, Edwardsville, Illinois.

PROFIT With new products. Make, sell, repeat. Analysis. Research. Guaranteed formulas. Biggest catalog free. Special prices, leads. Gibson, Chemist, BD-1142 Sunnyside, Chicago.

MAKE Artificial marble, glazed tiles, uncanny. Tabletops, plaques, sanitary floors, yhetstones. Cement secrets. Inexpensive, fireproof. Brightly colored tile and liquid rubber samples 3c. John A. Payn, 945 Grande Vista Avenue, Los Angeles, Calif.

GOOD Looking signs. Easily painted with letter patterns. Write for catalog. John Bahn, C2120 Neva, Chicago.

BUSINESS Of your own with small investment. Details free. Anhel, 1044 Buckingham St., Toledo, Ohio.

WANT To earn \$5000 yearly? Nationally known motor oil business. Write Franklin, 1326 Beldale Street, Pittsburgh, Pa.

BOOKS Covering hundreds of subjects. Big catalog for 3c postage. Popular Mechanics Press, Room (C36), 200 E. Ontario St., Chicago.

MONEYMAKING OPPORTUNITIES

WISE Home worker and spare time money makers will send immediately for free details of new "Silent System" business. No canvassing. Harry Julius, Amarillo, Texas.

96 GUARANTEED Money making secrets—25c. Schumacher, 1502 Monticello, Chicago.

BIG Money exterminating pests. Benton, 183 Chestnut, Liberty, N. Y.

FREE Booklet describes 107 plans for making \$20-\$100 weekly, in home or office, business of your own. Elite Co., 214 Grand St., New York.

BIG Money at home plating auto parts, reflectors, mirrors, chandeliers, by late method. Experience unnecessary. Free particulars. Gunnmetal Co., Ave. N, Decatur, Ill.

WRITE For cash! Publishers offer \$75,000.00. A-C Institute, 4443-A Fullerton, Chicago.

SEE "Millions Jobless!" ad under Business Opportunities. Nothing like it!

\$50 A WEEK With a camera. Booklet describing 100 magazine markets 25c postpaid. Walnut Specialty, Everett, Mass.

LEARN Shoe dyeing, course \$1.25. Frank Lento, 36J12, Punxsutawney, Penna.

MORE dollars for you. Send 25c for 120 moneymaking ideas and other particulars. D-Co., Box 256, E. A. Sta., Akron, Ohio.

FREE Circular tells how to start your own business at home or in office. Randolph Specialty Co., 114-2nd St. S. E., Roanoke, Va.

BETTER Than any job—Make money as your own boss; men or women; "Self Help Bulletin" sent free. Smith-Dawe Co., Atmore, Ala.

1000 MONEYMAKING Ideas, book 50c; literature free. Harvey Teeple, Decatur, Ind.

THE Constitution. Distribute this much discussed document in your community. Particulars, sample 25c. (Returnable). Act today! Table, 528 Garfield Avenue, Chicago.

"HOME Factory." Start in business for yourself. Details. Elyte Supply, Linden, N. J.

BIG Profit, make homemade candles, anybody, anywhere. Recipes and proven selling methods \$1.00. The Candy Jar, Box 107, Corsicana, Texas.

BE A perfumer—at home, retail, or mail order. Hardly any capital. Free instructive booklet gives plans of operation. Call-Blossom Perfume Syndicate, Alhambra, Calif.

WEALTH Quickly and honestly made! Dime brings "Key to Business Opportunities." Valuable gift, also complete proposition. Cutler Publisher, Ephrata, Penna.

A PRACTICAL Idea for work at home. Clenco, Box 17, Verdun, Que., Canada.

MAKE Superior bath salts 5c pound. Sell 35c pound. Formula, only \$25.00. Fancy quart jar \$1.00. No agents wanted. No inquiries. Multichrome Co., Box 3014, Kansas City, Mo.

PROSPERITY For home workers, 52 page magazine. Sample, dime. Sizemore, 4917 N. Kostner, Chicago.

EMPLOY Yourself profitably at home. Free information. Innes, 21 NE. Fifth St., Minneapolis, Minn.

10c BRINGS Copy National Mail Order News, Box 1773-PM9, Roanoke, Virginia.

START Home mailorder business. Write, Dixie Mailers, King, North Carolina.

FORMULAS, PLANS, ETC.

GUARANTEED Formulas—New fast sellers. None better. Lowest prices. Catalog free. Kemico, 49, Park Ridge, Ill.

SOMETHING New! Razorless shaving preparation. Formula 50c (coln). Walter Janke, Three Rivers, Michigan.

FAST Sellers analyzed. Duplication guaranteed. Write. Associated Chemists, Indianapolis, Ind.

500 MONEYMAKING Formulas 20c. Interesting literature free. Ideal Book Shop, Park Ridge, Ill.

SUCCEED With your products. Formulas, processes, analyses. Catalogue free. B. Thaxly Co., Washington, D. C.

FORMULAS—Waterproofing of fabrics, seven formulas, \$1.00. Balco, 1150 Leonard, St. Louis, Mo.

500 MONEYMAKING Formulas 25c. Descriptive literature free. Harvey Teeple, Decatur, Indiana.

FAMOUS Dollar-dozen modern formulas: Autofloss, C'orox, Sol-o, Drano, Sav-an-upper, Sober-up, Mothpad, Plastowood, See-clear No-New Hotpad, No-flats. All \$1.00. Others, Conrad, B-186-A, Altoona, Penna.

FORMULAS—Latest money makers. Literature free. Belfort, 4042 N. Keeler, Chicago.

EXTRAORDINARY—Wealth using formulas. Large catalogue free. Brown's Formulary, 212 East Waters, Tampa, Florida.

TESTED Formulas—Newest, best, lowest prices. Catalogue free. Grinstead Laboratory, Edwardsville, Illinois.

GUARANTEED Formulas—Big list free. A Terrone, 22 Station S, Brooklyn, N. Y.

ICELESS Ice! Colder! Cleaner! Cheaper! Instructions, 25c. Duffy, Covington, Ky.

ANALYSIS. Research. Newest guaranteed formulas. Biggest catalog free. Special prices, leads. Gibson, Chemist, BD-1142 Sunnyside, Chicago.

FREE Formulas. Inclose 3c to cover postage. Kruse Products, Green Bay, Wis.

3,000 FORMULAS, Facts, processes, trade secrets in Dr. Brown's Book of Formulas—380 pages. Price, postpaid \$1.00. Ogilvie Publishing Co., 57 Rose Street, Dept. 25, New York.

MAKE Your own goods. Booklet tells how. Ogg Laboratories, Tampa, Florida.

FREE Gift with 12 moneymaking formulas for 25c. Martex, Princeton, Minnesota.

ANY Formula \$1.50, three \$1.00. Cole Laboratories, Bryant Pond, Maine.

CHEMISTRY

USED Chemical laboratory—complete \$225 worth \$1000. Also minerals. Large library. Information. Adleman, 37-41 Bowne, Flushing, N. Y.

FREE Chemistry catalogs. Supplies at 5c! Equip complete laboratory. Send 10c for postage and handling. Kemkit Scientific Corp., 135P Johnson Street, Brooklyn, New York.

CHEMICALS, Laboratory apparatus and microscopes. Mail 10c for new large catalog. Stansl, 2340 Wabansia Ave., Chicago, U.S.A.

SUPPLIES For chemistry students. Catalogue 5c. Book catalogue free. Handbook for chemical experimenters, hundreds of instructive experiments, 50c. Reading Scientific Company, Reading, Penna.

SEND 25c For new illustrated chemical experiment book with over 300 formulas and tests. Also receive 32 page illustrated catalog of apparatus, microscopes, telescopes and chemicals free. GG. Winn, 124 West 23 St., New York.

RUBBER Latex. Dime brings literature twenty experiments. Price list. Special offer included. Eastern Latex Labs., Box 64, Norfolk Downs, Mass.

CHEMICALS, Laboratory glassware and apparatus. Catalog CP. Biological Supply Co., 1176 Mt. Hope Ave., Rochester, N. Y.

HELP WANTED

GO Into wholesale business without investment. Call on stores with biggest line self-selling counter displays: Aspirin, razor blades, handkerchiefs, breathlets, household cement, 79 different items. Up to 125% profit for you. Experience unnecessary. Write for catalog and plans. Procopax, Dent, 36-D, 1956 S. Troy, Chicago.

MANUFACTURE Polishpuffs. Amazing proposition 10c. Particulars free. Hickory-dell, Glenbeulah, Wisconsin.

MAN Wanted—Manufacturer established 46 years will finance responsible man with complete stock of guaranteed food, farm and household necessities—you pay when sold. Mighty attractive proposition. Good living right from start with steady increase for industrious man. Big value combination deals, premiums and fast-selling specials now in effect. Jacob Van Dyke of Michigan sold \$441.21; Maurice Vander Haar of Michigan sold \$376.15; and B. M. Anderson of Utah sold \$530.55 in one recent week. Pleasant outdoor work. Experience not necessary. No slack seasons or layoffs. Write today for "No-Investment" offer. McConnon and Company, Room 66KS, Winona, Minn.

ABLE Men to distribute advertising circulars and handle routes. Make up to \$42.50 first week. Brand new Ford sedans given producers as bonus. Details free. Albert Mills, 2906 Monmouth, Cincinnati, Ohio.

MRS. M. earned \$267, three weeks, raising mushrooms in cellar! Exceptional, but your cellar, shed perhaps suitable. We buy crops. Book free. United, 3848-A68 Lincoln Ave., Chicago.

BIG Profits raising canaries. Lucrative, pleasurable hobby. Feathered gold. Free particulars. Crimmins, 3741H, 60th Street, Woodside, New York.

AGENTS WANTED

MAN Wanted, by shoe manufacturer established 33 years, for sales work. Ready cash daily and extra bonuses to producers. No experience needed. Your own shoes at factory prices. Sales outfit sent free. Write Mason Shoe Manufacturing Co., Dept. A6, Chippewa Falls, Wis.

DEALERS—User agents cleaning up. Farm-city radios, power plants, accessories. Largest lowest priced line. Territory. Catalog. Free offer. Marco Company, 244 East 14th St., Kansas City, Mo.

NEW Cleaner—Amazes everybody. Cleans everything. Washes clothes snow-white quickly. Spots, stains removed like magic. Startling demonstrator. Free samples make fast sales. Quick repeater. Immense profit. Write quick for "free sample." Super-X Cleaner Co., 11, Berwyn, Illinois.

150% PROFIT In Motor-Tone. Amazing new, all weather gas lubrication process. 25% more mileage, operating economy! Free merchandise offer! Choice territories open. Box 1144, Fullers Motor-Tone Sales, Kalamazoo, Michigan.

"PROFITS Of \$34.60 single day."—Says B. J. Balmer, Tennessee. Startling discovery gives amazing results in autos, trucks, etc. Fleet owner reports savings 45% on oil—\$768 yearly on gas. Agents, distributors making 185% profit. Product sells itself. Big repeat business. Millions of prospects, exclusive territories going fast. Test product free of risk. Write today. K-W Corporation, 3252 Holmes St., Kansas City, Mo.

SELL Neon signs and window displays. Big demand. Large profits. Write McGinnis Signs, Rice Lake, Wis.

EXCELLENT Trouserpresser, stretcher, creaser, hanger \$1.00, \$7.00 doz. Perfect pants hanger stretcher 10c, 60c doz. Get circulars. Witness, 208 Van Buren St., Brooklyn, N. Y.

SEALS Punctures while driving: Instantly and permanently. Sells on its merits moment it's demonstrated. Sample 50c. Auto-Tire Puncture Sealer Laboratory, 4515 South Parkway, Chicago.

MAKE More money selling shirts, ties, underwear, dresses, hosiery, raincoats, jackets, pants, uniforms. Sales outfit free. Nimrod Company, Department 8, 4922-28 Lincoln Avenue, Chicago.

500% PROFIT Selling new "20-in-1" kitchen utensil. Retail 25c. Costs you \$1.00 a dozen. \$7.20 a gross. Sample 10c. New Method Co., PMM-46, Bradford, Pa.

CHRISTMAS Cards—50 beautiful folders, name imprinted, cost 65c, sell for \$1.00. Samples free. New England Art, North Abington, 206, Mass.

SELL North American oil burners. No experience needed. Write for free particulars. Wrenn Burner Service, Nashua, New Hampshire.

SPEEDY Glass brushes, sell on sight to bars, hotels, restaurants, fountains everywhere. Big profits. Fairchild Laboratories, 1136 Broadway, Brooklyn, New York.

WANTED—Men for good paying work with a large shoe company. Good pay every day. Free shoes as bonuses to "go-getters." No experience needed. Complete sales outfit sent free. Write Consolidated Shoe System, Dept. F1, Chippewa Falls, Wis.

UP To \$32 in a week. Sell great line of hosiery backed by definite replacement guarantee, covering holes, snags, runs. Write for samples quick. Wilknit Hosiery, Desk 37-K, Greenfield, Ohio.

SELL Changeable signs. Profitable. Write Koehler, 334 Goetz, St. Louis, Missouri.

300% PROFIT In new self-starting no-flint cigar lighter. Retail 50c. Sample 25c. Get details quick on wonder seller. New Method Co., Box PM-46, Bradford, Pa.

STRANGE Ironing cord. Saves electricity. Abolishes scorching and kinking. For telephones also. 150% profit. Sales guaranteed. Big free offer. Neverknot, Dept. 10A, 4525 Ravenswood, Chicago.

CHRISTMAS Cards! Absolutely finest assortment. Big profits. Write for samples. Robinson Cards, 201 Orange, Clinton, Mass.

BIG Money applying gold initials on automobiles. Easiest thing today. No experience needed. Free samples. "Ralco," 1084 Washington, Boston, Mass.

AGENTS: Stamping names on pocket-key protectors. Sample check with your name, address, 25c. Stamping outfits. Emblem checks, check-fobs, name plates. Hart Mfg. Co., 303 Degraw St., Brooklyn, N. Y.

BIG Money and fast sales. Every owner buys gold initials for his auto. You charge \$1.50, make \$1.45. Ten orders daily easy. Write for particulars and free sample. American Monogram Company, Dept. 40, East Orange, N. J.

NEW Cleaner! Washes clothes quickly. Cleans everything. Premium deals. Free sample. Bestco, 5007 Irving Park, Chicago.

GENUINE Gold letters for store windows. Easily applied. Free samples. Liberal offer to general agents. Metallic Letter Co., 438-B North Clark, Chicago.

AGENTS—Opportunity to make money; book containing 107 successful business plans; home or office; send for free introductory booklet. Elite Co., 214 Grand St., New York.

AGENTS Mosco corn and callous remover will build you a steady repeat business. Send today for pocket-size trial outfits. The Moss Company, 64 Searle Bldg., Rochester, N. Y.

MAKE And sell your own products. Employ agents yourself. We supply formulas and full instructions for making toilet preparations, perfume, flavoring extracts, soap, household specialties. Valuable booklet free. National Scientific Laboratories, 1950W Broad, Richmond, Va.

MAN in each town to plate auto parts, reflectors, bathroom fixtures, refinish beds, mirrors, chandeliers, by late method; experience unnecessary. Simple plan of manufacturing at home starts you in big money making business. Free particulars and proofs. Gunmetal Co., Ave. H, Decatur, Ill.

COSTS 1c—Sells 25c. Make non-explosive cleaner from benzene crystals. 1c gallon. Sample 10c. Literature free. Western Reserve Laboratories, 6615 Denison Ave., Cleveland, Ohio.

AGENTS: Smash go prices! Santos coffee 12c lb. 100 sticks chewing gum 12c. Christmas cards, 21 in box, 14c. 150 other bargains. Premiums. Carnation Co., PO, St. Louis, Mo.

SUCCEED With your products. Formulas, processes, analyses. Catalogue free. B. Thaxly Co., Washington, D. C.

SEND For free wholesale list. Royal, Box 1134, Roanoke, Virginia.

BE Your own boss! Operate quality used-new clothing business from store home or auto. 200%-300% profit. Everything furnished. Portnoy, 566-G Roosevelt, Chicago.

NO Boss! Sure cash! Silvering mirrors, autoparts, reflectors, combination outfit. Write Sprinkle, Plater, 128, Marion, Ind.

WANTED—District purchasing agents. No experience or money required. Write Purchasing Manager, 174 N. Halsted, Chicago.

AGENTS! Dresses 33c, men's suits \$1.50-\$2.00, shirts 46c, ties 6½c, chiffon hose 42c. Amazing prices. Big profits. Catalogue free. Liquidation, AB-550 East 43rd, Chicago.

DO You want agents for your proposition? Your ad in this space will place your message before hundreds of men seeking fast-selling products. My folder "How to Secure Agents" is filled with proof. I'll gladly send you a copy free. F. W. Johnson, Manager Classified Advertising, Popular Mechanics Magazine, 200 E. Ontario St., Chicago.

MAKE Big money selling typewriter ribbons, etc., direct from manufacturer to consumer. Write: Quality Ink, 720 So. Dearborn, Chicago.

AMAZING New invention. Holds shirt down—trousers up. Men buy wildly. Agents cleaning up big money. Absolutely no competition. Territory going fast. Similar product for women now ready for the market. Send \$1 for two sample sets. Shir-Tro-Grip Co., 321 W. 3rd St., Los Angeles, Calif.

100 PROFITABLE Mail order and local business plans. A. Pruitt, Elburn, Ill.

MAKE 212% Profit! Metallix—amazing new "metallic liquid" instantly, permanently repairs metal, wood, glass, leather, etc., without heat, acid or tools. Holds forever! Free sample. Write, Metallix, Dept. G-313, Cincinnati.

CLEAN UP \$5 daily during fall house-cleaning with "Glasshiner," magic window cleaning compound. Seneca Specialties, 24 Main, Geneva, New York.

GENUINE "Motorite" reconductions as it lubricates. Saves gas, oil, repairs. Approved. Guaranteed. Tremendous sales. Big profits! Hurry! Motorite, Torrington, Conn.

AGENTS! Make \$5 daily selling quality household necessities. Over 250 guaranteed positive repeat sellers. Atlas Products, 2129 S. Broadway, St. Louis, Mo.

\$2.00 HOURLY With new, scientific cream that mends all cloth easily, quickly, invisibly, without needle and thread. Stands laundering. Free sample. Sewnmore, G-744, Cincinnati, O.

SALESBOARD Men—New put and take jars. Details, samples free. Tom Thumb, Dept. PM, Nauvoo, Ill.

DISTRIBUTORS—Exclusive territory; non-competitive; low price sensation; a lifetime opportunity. Write Grezner, 5039-A St. Louis, St. Louis, Mo.

EASIEST 25c Seller. Has thousand uses. Simple demonstration gets the money. Sample 25c. Dozen \$1.50. Don't pass this up. Parmer, 645 West 66th St., Chicago.

GUARANTEED Double-edged blades 50c hundred up. If there's anything else you want, write us; we have it. Samples sent. Steven Snencer, 412 E. 51, Brooklyn, N. Y.

MAKE Money selling Diamonds, Watches and Jewelry on credit. Write for particulars. Loftis Jewelry Company, 34 No. State Street, Chicago, Illinois.

DISTRIBUTORS—Sell household dusters, protected territory. W. Miller, 1596 Parkview, Detroit, Mich.

TRANSPARENT Day and night signs. 8"x14"; 4c, retails 25c; over 1000 designs; sample free! Lowy, Department 648, 8 West Broadway, New York.

MEXICAN Feather pictures. Christmas novelty, 25c (stamps) bring \$1.00 worth sample, details. Mexican Art, Apartado 1593, Mexico City.

PROFITABLE Home business. Legitimate. No canvassing. Maywood Publishers, P-923 Broadway, New York.

BIG Profits eyeglass necessity. Cleans, polishes, prevents steaming. Sample ten cents. Shurberg Chemical, Hartford, Conn.

FREE Sample new photo novelties, 300% profit. Novel-Ad Company, 3327 North Ave., Chicago.

500% PROFIT! Gold and colored sign letters for windows, offices, trucks, signs. Monograms. Easily applied. Neonite, Akron, Ohio.

ARTISTIC Window sign letters. Lowest prices. Enormous profits. Stalbrite Co., 44 West 30th, New York. Established 1903.

\$1.00 MONTHLY Maintains New York branch office. Co-Operative Mail Service, 126G Lexington Avenue.

NEW Name plate slide in metal letters, (patented), deliver at time of sale. 100% profit. Naymon Plate Company, Lowell, Mass.

MOR-HEAT Water and steam boiler solution. Saves fuel. Quick sales. Repeat orders. Retails \$2.50. Sample \$1.25. Mor-Heat Chemical Co., 3733 Lisbon Ave., Milwaukee, Wis.

FREE—Genuine Duro, 26 piece silver sets. Amazing sensational plan gives away these fine sets and you make big money. Get details quickly. Lipault Corp., 1028 Arch St., Philadelphia, Pa.

ELECTRIC Or gasoline portable lamp kills insects automatically, indoor or outside. \$1.75 up. Literature free. Sauer Bros., East Oakland, California.

AGENTS Wanted to sell Lik-Nu paint cleaner to home owners. Good profits. Lik-Nu Co., 6730 S. Halsted, Chicago.

GOLD Reflecting letters for store windows. Large sizes penny each. Free samples. Modernistic Sign, B-3004 Lincoln Ave., Chicago.

PROFIT With new products. Make, sell, repeat. Analysis. Research. Guaranteed formulas. Biggest catalog free. Special prices, leads. Gibson, Chemist, BD-1142 Sunnyside, Chicago.

ENGRAVED Name plates, numbers, signs, etc., easily sold, profits large. Brett Bros., Winthrop, Mass.

SELL Leather neckties. Look finer than silk. Big profits. Cleaned with damp cloth. All styles. Colorful designs. Always look new. Guaranteed profit plan. Send fifty cents for sample tie and complete sales outfit. Nu-Mode Ties, 1337 North Twelfth, Milwaukee, Wis.

SHOW Housewife—She buys. New spring device keeps electric iron cord from touching board. Big profits. Dept. 441, 1800 Winona, Chicago.

\$9.00 PROFIT Each sale, piano sell taught. Send \$1.00 sample copy, details. Stanley's, 616 Webster, San Francisco.

WANT A paying business of your own? I'll show you how. Write for full details and sales plan to Trout Products, Hickory, Ky.

BIG Money. Commissions daily. Free clothing. Sell quality raincoats, jackets, overcoats. New styles. Lowest prices. Sales kit free. Goodyear, 712-A Roosevelt, Chicago.

GOLD Reflecting letters for store windows. Easily applied. Large sizes, penny each, free samples! Atlas Sign Works, 7941 Halsted, Chicago.

NEW Beauty, barber shop products! Sell by mail! Henkle Manufacturing, Norwich, Conn.

MAGAZINES. Sell new and renewal subscriptions. All publications. Full or spare time. Highest commissions. Pay daily. Outfit free. Mission Circulation Company, Box 802, Santa Barbara, California.

DISTRIBUTORS To sell razor blades direct to users and stores. Exclusive territory granted real producers. Sample sales kit including blades 25c. LaSalle Blade Co., 1915 Vermont Ave., Toledo, Ohio.

WONDERFUL Opportunity to make up to \$240 a month, \$45 first week. Be a grocery route dealer. I send everything complete on trial; no money risk. Details free. Albert Mills, 2910 Monmouth, Cincinnati, Ohio.

BIG Commissions selling personal Christmas cards and stationery. New 21 folder \$1 assortment. 100% profit. Bonuses. Free samples. Wallace Brown, Inc., 225 Fifth Ave., Dept. 310, New York.

AMAZING Light discovery. Amplifiers reduce electric bills 25% to 50%. Needed by every store, factory, office. Huge profits for distributors—salesmen. Wonderful demonstrator. Nothing like it. Write today for convincing proof and no risk initial start offer. Apex Lamp Works, PM150 West 25th, New York.

SELL Neon tubes, 65c foot. Complete signs. Complete Neon plants \$395.00. Marcella's, 742 Strong, Schenectady, N. Y.

INITIALING Automobiles biggest money maker today. New type requiring no varnish to apply. Write for samples. International Monogram & Transfer Co., Box 6365, Philadelphia, Pa.

JUST Out—Drews steam pad, simple device for steaming the beard before shaving. Agents coining money. Hurry. Drew & Co., Dent. M. Puente, Calif.

SELL Novelty fun cards, novelties, etc. Samples 10c. National, Box 500M, Cincinnati.

WHOLESALE Catalog free. 500 best sellers. Paty Co., 1167 Broadway, Somerville, Massachusetts.

MEN—Women \$3 to \$6 daily. Selling 25c household necessity that repeats. Three to ten sold in every home. Free sample. Write Puro Company, 3107 Pine St., Dept. P-2046, St. Louis, Mo.

INSURANCE Claim adjuster, easily learned. Low cost. Write Modern, 1001 Nelson Avenue, New York City.

100% STEADY Profits selling cleansers, polishes, cosmetics. Sure repeats. Borlab, 426 Broome St., New York.

HIGH-GRADE SALESMEN

BRUSH Salesman—If you ever sold brushes write for our money making proposition. Donald Brush Co., Camden, New Jersey.

ATTRACTIVE Opportunity for experienced boiler compound or soot destroyer salesman with reliable company. Best commissions paid. Box 328, Saginaw, Michigan.

FAST Seller. 100% profit. No competition. 15c pkg. plus water, sugar, makes 5 glasses jelly, 5 minutes. Establish own business. Minute Foods, 257H Werdin, Los Angeles.

BRAND New grab-bag deal. Going big everywhere—big profits—swift sales—fast repeats. No restrictions. All dealers buy. Act! K&S, 4347-B Ravenswood, Chicago.

SELL Candidates! No competition. Finest most complete line of auto signs, stickers, and novelties. Union label. Free samples. Ad-Nov-Co, Newton, Iowa.

WANTED—County dealer: Man with car to demonstrate and service for large manufacturer. First class job. 247 Fyr-Fyter Company, Dayton, Ohio.

SELL Mimeograph advertising service to merchants in sparetime. Liberal commissions. Write Box 43, Siren, Wisconsin.

MEN Wanted by world wide industry. Write today for particulars about few good old Rawleigh routes that have paid well for years. Established, profitable business. Over 200 farm and home necessities. Industry and reliability main qualifications. Man with auto preferred. Give age, experience, references. Rawleigh, Dept. J-N-PPM, Freeport, Ill.

NEW Drycleaning clothes brush. Revolutionary invention. Cleans clothes like magic. Homes, offices buy instantly. Phenomenal profits. Outfit free. Kristee, Dept. 259, Akron, Ohio.

NEW Specialty—Sells every business and professional man. Four \$15 sales daily pay \$280 weekly. Ferrell cleared over \$1,000.00 monthly. Write, F. E. Armstrong, President, Dept. PM, Mobile, Ala.

MAKE More money selling shirts, ties, underwear, dresses, hosiery, raincoats, jackets, pants, uniforms. Sales outfit free. Nimrod Company, Department 65, 4922-28 Lincoln Avenue, Chicago.

FREE Booklet describes 107 plans for making \$20-\$100 weekly, in home or office, business of your own. Elite Co., 214 Grand St., New York.

SALESMEN—New deal guarantees stores \$10 for one. Two \$15 sales net you \$20 daily. Sayers, 2801-123 Sheffield, Chicago.

START A business of your own! Become a subscription representative for "Popular Mechanics." No capital required. Liberal commissions. Monthly bonus. Write for details. V. D. Angerman, Circulation Manager, 200 East Ontario Street, Room 235, Chicago.

WANTED: Reliable, energetic salesman who knows farming, to sell Martin poultry buildings and corn cribs direct to farmers on easy terms. Big profits—permanent income. Martin Steel Products Co., Dept. 8, Mansfield, Ohio.

SELL Only (4) all wool suits to get yours without cost. No limit to number of suits you may earn. Prices \$14.95 to \$26.95. Zipper leather carrying case. Sample line free. No experience needed to make big money. All suits individually cut and tailored to measure. Satisfaction or money back guarantee. Three Star Clothes, Dept. 36D, 330 So. Franklin, Chicago.

MAN—Handle regular store route. Place nationally advertised 5c-10c counter card mdse. New aspirin deal—6 tablets 5c. 85 other fast sellers. 100% profit. No investment. Samples free. World's Products Co., Dent. 10810, Spencer, Ind.

BE Your own boss. Make the largest commissions selling our complete line of brushes. Write for sales plan. Wire Grip Sanitary Brush Corp., 220 Southern Boulevard, N. Y.

CALENDAR Salesmen—Complete calendar line, all sizes, including jumbos; beautiful subjects. Samples free. Flemming Calendar Co., 6543 Cottage Grove, Chicago.

SALESMEN. Collect big commissions selling men's, women's, children's shoes. 102 styles. Special arch support. Experience unnecessary. Outfit free. Tanners, 531 C St., Boston, Mass.

EXCLUSIVE! Amazingly complete advg. book match line. Mfr. direct. Full or part time. Big comm. Free samples. Match Corporation of America, Dept. E-10, 6041 W. Grand, Chicago.

SOMETHING New in fire extinguishers—Red Comet Automatics. Proved in west five years. Exclusive territory. Low price opens pocketbooks. Write, Red Comet, 404 Comet Building, Littleton, Colorado.

BIG Money! Sell 5c horoscopes. Counter displays. Sample and 50 horoscopes \$1.00. Quantities 75c. Earnshaw, Palmer Building, Hollywood, California.

BE Independent. Own your business; experience unnecessary, selling \$10,000 accidental death, \$50 accident; \$25 sick weekly benefits—\$10.00 yearly. Other amounts proportionate. Guaranteed steady renewal income. \$726,415.63 securities deposited. Universal Policy, 716-A Lefcourt Bldg., Newark, New Jersey.

SALESMEN And agents. Sell fast moving deal to dealers, jobbers. Write for full details. Trading Post Syndicate, 327 W. Huron St., Chicago.

SALESMEN—Auto accessory, brand new. Sell direct to car owner, also wholesale to automobile dealers, gas stations, garages. Big profits. Exclusive territory. Details free. Ace Sales Co., 3333 Madison, Chicago.

SELL Stores, carded aspirin, blades, laces. National, Box 500X, Cincinnati.

\$1.00 MONTHLY Maintains New York branch office. Co-Operative Mail Service, 126E Lexington Avenue.

SALESMEN Distributors: We pay higher commission. Exclusive territory. 125 varieties, brushes, mops, specialties. Neway Brush Factory, Hartford, Conn.

BIG Money makers: Large line work uniforms, raincoats, pants, shirts, etc. Advertising embroidered. Low prices. Every business, individual prospect. Free outfit. Dove Garment Co., 1733 Milwaukee Ave., Dept. 903, Chicago.

EXTERMINATOR. Electrical, illustrated June issue. Bedbugs, flies, mosquitoes! Profitable everywhere, \$5.95, prepaid. Edelman Company, 6249 St. Lawrence, Chicago.

HATS. Caps with secret pocket! Defies detection. Protects valuables. Exclusive feature famous Taylor line low-priced "Personalized" styles. Quick easy orders. Big profits! Complete sample outfit free. Write Taylor Hat & Cap Mfrs., Dept. E-22, Cincinnati.

EDUCATIONAL AND INSTRUCTION

MEN Wanted willing to learn landscape designing and fill big paying position as landscape architects. Free test of your natural ability and chance to win in \$750 contest. No experience needed to start. Earn while you learn. Write today for free test blank. American Landscape School, 400 Plymouth Bldg., Des Moines, Iowa.

HOME Study courses leading to degrees: arts, literature, sciences, psychology, engineering, philosophy, chemistry, theology, English, education, languages, law, business and commerce. Many others. Low cost; easy terms. Catalog on request. Thomas Jefferson University 749 Independence Boulevard, Chicago.

LEARN Machinist trade, tool, die making. Automatic and hand screw machines. Modern shop methods. Actual work. Jobs open for trained men. Employment help. Illustrated booklet free. Allied Screw Machine Company, 601 Lake Street, Chicago.

LEARN Auto mechanics, body, repairing, welding, electricity, refrigeration. Diesel. Stevinson's, 2008A Main, Kansas City, Mo.

LEARN Latest methods solving arithmetical problems quickly. Frederick A. Smith, 2410 Smalley Court, Chicago.

STAMMERING. Stuttering corrected. Write Lewis Institute, 12052 Woodward, Detroit, Michigan.

HOME Study courses leading to degrees: Arts and sciences, philosophy, education, law, letters, theology, psychology, engineering, chemistry, business and commerce. Many others. McKinley-Roosevelt University, Chicago.

BEAUTIFUL Stained glass, ten colors, 25 cents. Kable, Wabash, Pittsburgh.

WORK For "Uncle Sam." Start \$105-\$175 month. Men-women, age 18-50. We can help you qualify. Write, Ozment Instruction Service, Dept. 101, St. Louis, Mo.

U. S. GOVERNMENT Positions. \$1700-\$1900 and up a year. Let our expert (former government examiner) prepare you for a position in the railway mail service, rural carrier, post office, customs and other branches. Write today for free booklet. Dept. 8, Patterson School, Rochester, N. Y.

SECRET Service. Particulars free. Write immediately. George Wagner, M-2640 Broadway, New York.

BECOME An Investigator—Secret service agent. New "Test Problem Method." Develops your ability. Particulars free. International Secret Service Institute, (PM-106), Hoboken, N. J.

DOUBLE Entry bookkeeping mastered 60 hours with keys. Diplomas. International Bookkeeping Institute, 8, Springfield, Mo.

WORK For "Uncle Sam." \$105-\$175 month. Try next examinations. List jobs and full particulars free. Write today sure. Franklin Institute, Dept. P3, Rochester, N. Y.

BIG Bargain catalogue education matter 10c. Handling, Y-799 Broadway, New York.

COMPLETE Academic or short practical courses in mathematics. The Merrick School, Garnerville, New York.

SCHOLARSHIPS For musicians at Columbia College, Dubuque, Iowa. Write for our proposition and catalog. S. C. Dovi, Band Master.

CHIROPODY Taught by correspondence. Evans School of Chiroprody, Montgomery, Alabama.

BE A transcontinental bus operator. Travel. Earn \$175-\$250 monthly. Complete preparatory course. Prepaid on receipt of \$1.00. Superintendent, 1059 East 76th St., Chicago.

FLORIDA Hotel positions. Instruction courses. Lee Institute, 176 Mystic, Somerville, Mass.

ZEJAY. Remarkably simple secret language. Correspondence, detective work, etc. Instructions 15c. Zenda, Burbank, Calif.

JIU Jitsu now simplified for everybody's self-protection. 5 sample diagrams for dime. Wandekirk, Suite 5PJ, 2504 West Seventh, Los Angeles.

CARTOONING—COMMERCIAL ART

ANIMATED Cartoons. Learn animated cartoon drawing for motion pictures. Big demand for trained men and women. Producers paying big money. Send \$3 for our special course of 15 complete lessons. Comic Art Studios, 428 Markham Bldg., Hollywood, Calif.

SIGN Painting taught by successful sign painter. Dime brings literature. James Meagher, 71 Dunham St., Norwich, Conn.

COMBINED Cartooning, sketching, lettering course with 600 illustrations by Alexander Murray. Only 50c postpaid. Lawrence Publications, 178-A West 97th St., New York.

CARTOONISTS! Markets, rates, requirements—25c. Mueller, Phillips, Glen Ellyn, Illinois.

MAKE \$25.00 Weekly duplicating advertising cartoons. Write. Paisley-K. Kintoch Bldg., St. Louis, Mo.

ADVERTISING AGENCIES

ADVERTISE Profitably: \$15 reaches 6,000,000 Sunday newspaper readers with 24 word ad. Newspaper, magazine rate-guide, free. Chicago Union Agency, 20 West Jackson, Chicago.

ADVERTISING Placed anywhere. Helpful, free service. Rate guide book free. Baker Advertising Agency, 189 W. Madison, Chicago.

FREE—New Advertisers Rate Guide, 44 pages. Includes everything. Lowest rates. E. H. Brown Advertising Agency, 140 S. Dearborn, Chicago.

INCH Display advertisement 30 magazines, year \$24. Wood's Popular Services, Atlantic City, N. J.

FOR ADVERTISERS

ADVERTISE: 24 Words in 250 newspapers \$10. Lists free. Advertising Service Bureau, 4238-C Drexel, Chicago.

50 CO-PUBLICATIONS; 4c Word. Bryant, Box 4684-E, Kansas City, Mo.

25 WORD Advertisement in big fiction magazine reaching 40,000 buyers. \$1.00. Extra words 4c each. Three insertions price two. Weird Tales, 840 North Michigan, Chicago.

25 WORDS. 25 Magazines, three months \$1.50. Empire, Shawano, Wis.

BUSINESS SERVICE

ESTABLISH New York offices at Times Square! Ideal personal, business mailing address. Builds sales; adds prestige. Room number unnecessary. Mail forwarded daily. Only \$1.00 monthly! Paramount Office Service-F, 140 West 42nd, New York.

DELAWARE Charters: Complete incorporating and organizing service \$35. Submitted forms. Chas. G. Guyer, Inc., Wilmington, Delaware.

WANT A permanent New York address? Business, personal. Mail forwarded daily. \$2.00 monthly. Associated Service, 1463 Broadway, New York.

NEW Or old businesses financed, reorganized. Prospectuses prepared. Incorporating and organizing service free. Johanson, 512 Sherman, Chicago.

ALL International legal matters. Lic. Victorios Prieto, Mexican Attorney at Law, P. O. Box 122 M. Juarez, Mexico.

\$1.00 MONTHLY Maintains New York branch office. Co-Operative Mail Service, 126C Lexington Avenue.

RUBBER STAMPS AND OFFICE SUPPLIES

2 LINES 25c, 3 Lines 35c. Stamp Works, Centerport, N. Y.

SPECIAL: 3 Lines 25c. Knob handle. Owl, 6452 Kenwood, Chicago.

TYPE Size ¼" or less, 10c per lineal inch. Minimum price 30c. Rapid Stamp Works, Huntville, Missouri.

CUSHION Mounted, one—two lines, 25c. Three 35c. Stamp Works, 814 Bradley, Peoria, Ill.

2 LINE Stamp, and pad 35c. Dahlke, Grand Island, Nebr.

NAME, Address, 2 lines 25c; 3 lines 35c. Stamp Works, Auburn, Nebr.

TYPEWRITERS, DUPLICATORS, OFFICE DEVICES

TYPEWRITERS. Duplicators, multi-graphs. Write for free list office machine bargains. Sa.e half. Pruitt, 518 Pruitt Bldg., Chicago.

INCREASE Business. "Excellograph" rotary stencil, clay and film duplicators \$3.85 to \$37.50. Prints anything. Typewritten, penned, drawn, traced. Colors. Folder free. Pittsburgh Typewriter Supply, Suite 518, Pittsburgh, Pa.

PRINT Your circulars, bulletins, etc., in attractive colors with the Vari-Color duplicator, \$27.50 complete. Single color duplicators, \$14.50 and up. Illuminoscopes (great aid for preparing stencils), \$3.95. Vari-Color Duplicator Co., Ottumwa, Iowa.

TYPEWRITER Ribbons in all colors for all machines 50c each. Carbon paper, either typewriter or pencil, \$1.00 box. Ribbon Ink Company, Cicero, Illinois.

LOWEST Price in history. Complete duplicator—Multiprinter will print menus, postcards, form letters, reports, drawings, etc., up to 9" by 12" in size. No experience needed. Complete with supplies, ready for use. \$1.25 (in U. S. only). C.O.D. (in U. S. only) \$1.39 Order today Multiprinter Company, 5710 Woodlawn, Chicago

PRINTING, MULTIGRAPHING, MIMEOGRAPHING, GUMMED LABELS

PERSONAL Printed stationery, 100 sheets and 100 envelopes \$1.00. 100 name cards 50 cents. Frank O. Wrob, 3974 E. 66 Str., Cleveland, Ohio.

300 20-LB. 8½x11 Letterheads and 300 6½ envelopes printed \$2.00. Carten, Box 52, Orange, Calif.

QUALITY Printing, minimum prices, samples. Paul James Press, 140 Ralph Ave., Brooklyn, N. Y.

250 ENVELOPES And 250 whitebond letterheads. \$2.49. Webpress, Farmland, Ind.
5000 6x9 CIRCULARS. Postcards, letterheads, envelopes \$7.49. 1000 3½x6 folders \$4.49. 1000 envelope slips \$1.00; 5000, \$3.00. Samples. Goodprint, Harrisonburg, Va.

QUALITY First; lowest prices. 24 hour service. Samples free. Master, 4931-N Hamlin, Chicago.

1000 LETTERHEADS Or envelopes \$2.50 postpaid. Kressmann, Washington, New Jersey.

250 LETTERHEADS And envelopes \$2.75. Jackson Co., Harding St., Fall River, Mass.

SPECIAL—250 Size 6½ envelopes \$1.00 delivered. Morey, 87 Somerset St., Springfield, Mass.

1000 6½ ENVELOPES Printed \$2.50. Zone 4. Fry Printing Co., Rothville, Pa.

PRINT Your own. Bargains, presses, type. List 3c. Exchange D-14, 22 Orient, Meriden, Conn.

PRINTED Envelopes 24 lb., 6½, \$1.10 M. Any quantity. 10's, \$1.75. See samples. Maloney Sales, 724 Parsells, Rochester, N. Y.

500 ROND Letterheads, envelopes \$1.75. Print anything reasonable. Bradshaw, 3214-P Huron, Chicago.

1000 BUSINESS Cards, card case, \$1.50. Miller, Printer, Ambler, Pa.

\$1.85—1,000; ENVELOPES, Letterheads, statements, circulars. Midwest, Box 205, Northfield, Minnesota.

PRINTED, Two colors: 50 envelopes, 50 paper, 50 stickers, \$1.00. Sicocan, 2038 E. Ohear, St. Louis.

ARTISTIC Two color gummed labels, 3/4x2 1/2, glossy red border, three line address blue. 250—25c; 1250—\$1.00. Ad-Man Press, 301-N. New Jersey, Indianapolis, Ind.

250 BOND Letterheads or envelopes \$1.00. Moyer, B-241-P, Milton, Pa.

PRINTING That satisfies. Complete samples. Jobey Press, 3932 Madison, Chicago.

GUMMED Labels: 1,000 printed 1x1 1/2, 20 words or less, 50c. JBS Company, Box 93, Holyoke, Mass.

LABEL Value headquarters. Specimens free. Labelers, 6618D Quimby, Cleveland, Ohio.

BETTER Business cards, 500 postpaid \$1.00. Artisan Press, Riverdale, Maryland.

SUPERB Printing at lower prices. Send copy for estimate. Buck, 2495 Telegraph, Berkeley, Calif.

ARE You seeking prestige? Then write, Hall's Printing, Dalton, Massachusetts.

125 LETTERHEADS 8 1/2x11, 100 Envelopes, \$1.00. New book "Fun at the Party" included. English Press, 1119 English, Indianapolis, Ind.

BETTER Grade printing, reasonable priced. Free samples. Economic Press, Leonia, N. J.

CUTS 2x3, \$1.10, from drawings and photos. Joe Rek, 118 Gazette Ave., Lexington, Ky.

PRINTING Bargains—100 envelopes, 100 letterheads, business size bond, both only \$1.00 or 250 for \$1.98. Personal 150 each \$1.00 Postpaid. Evans Print, 44 North Tenth, Reading, Pa.

COMBINATION Special—500 letterheads, 500 envelopes, 500 cards—\$3.00. Cleveland Card Company, 1372 West 6th, Cleveland.

GOOD Printing, reasonable prices. Samples free. Harmon Company, 318 So. 10th Street, Philadelphia, Penna. Established 1885.

2000 CARDS And case \$1.00 cash. Half-Price Printery, Phoenix, Ariz.

BUSINESS Cards, statements, envelopes, \$2.95, 1000. Oulimette's, 907 Brock D20, New Bedford, Mass.

500 TWO-COLOR Letterheads \$1.75. Samples free. Colorpress, 333-P State, Detroit.

PRINTING OUTFITS AND SUPPLIES

PRINT Your own cards, stationery, circulars, advertising, etc. Save money. Easy rules furnished. Print for others, big profits. Job presses, \$11, power \$149. Write for details. Kelsey Co., A-11, Meriden, Conn.

PRINTERS—Excellent money maker. Particulars on request. Dept. T, Suite 1102, 210 5th Avenue, New York City.

HAND Press, type and complete printers' supplies. Advise equipment you need and we quote prices; or send stamp for catalog. P. Peiffer, 87-A; 6 Columbia St., Newark, N. J.

BARGAINS, Presses, type, List 3c. Exchange D-15, 22 Orient, Meriden, Conn.

PRINTING Presses and printers needs. Lists 3c. Landts, Richland, Pa.

PRINTING Outfits—Presses, type, supplies, type novelties. Send 20c for card case samples. Catalog free. Model Press, York, Pa.

PAPER—Wholesale prices, 3c. Samples, 10c. VanDorn Paperstocks, Ottawa, Illinois.

PRINT Your own circulars, envelopes, with home made press costing less than \$1.00. Illustrated instructions 10c. Carl Edquist, Odessa, Minn.

BARGAINS—Presses, type, supplies. Send stamp. 159 Harvard, Cambridge, Mass.

PATENT ATTORNEYS

INVENTORS—Small ideas may have large commercial possibilities. Write us for free book, "Patent Guide for the Inventor" and "Record of Invention" form. Delays are dangerous in patent matters. Free information on how to proceed. Clarence A. O'Brien & Hyman Berman, 58-L Adams Building, Washington, D. C.

INVENTORS—Send for free booklet "Patent-Sense." Information based on 64 years experience. Lacey & Lacey, Dept. 5A, 635 F St., Washington, D. C.

L. F. RANDOLPH, 302-B Victor Building, Washington, D. C. Low cost. Book and information free.

INVENTORS: Send immediately for your copies of our new free books, "Patent Protection" and "Suggestions on Selling an Invention." Sixty-eight pages of interesting facts. They tell how patent laws protect you; kind of sketch or model needed; simple steps to take without cost; how successful inventors have secured financial assistance; show interesting inventions; illustrate important mechanical movements. With books we also send free Evidence of Invention form to help establish date of disclosure. Prompt service, reasonable fees, special deferred payment plan. Strictest secrecy. Thirty-six years' experience. Highest references. Write us today. The facts in our books are worth money to the man with a good invention. Address: Victor J. Evans & Co., Registered Patent Attorneys, 800-L Victor Building, Washington, D. C.

PATENTS. Protect your idea by securing free "Proof of Invention" folder. Exceptional personal service. Established 1906. E. E. Vrooman, 871 Woodward Building, Washington, D. C.

PATENTS. Instructions "How to Establish Your Rights" and form, "Evidence of Conception"—sent free! Lancaster, Allwine & Rommel, 411 Bowen Building, Washington, D. C.

PATENTS—Trade marks—Personal service, reasonable charges. Preliminary advice, book and disclosure form free. Irving L. McCathran, 700B International Bldg., Washington, D. C. Registered Patent Attorney.

PATENTS. Booklet free. Highest references. Best results. Promptness assured. Watson E. Coleman, Patent Lawyer, 724 Ninth St., Washington, D. C.

WHAT To invent. List of wanted inventions sent free on request. Use our legal form for recording evidence of ownership. Write W. T. Greene, 946 Barrister Bldg., Washington, D. C.

"INVENTOR'S Guide," 100 mechanical movements, free; advises on patenting, selling inventions. Frank Ledermann, Tribune Bldg., New York.

THEODORE H. Rutley, Registered Patent Attorney, 512 Colorado Bldg., Washington, D. C.

FOR INVENTORS

INVENTORS: Send immediately for your copies of our new free books, "Patent Protection" and "Suggestions on Selling an Invention." Sixty-eight pages of interesting facts. They tell how patent laws protect you; kind of sketch or model needed; simple steps to take without cost; how successful inventors have secured financial assistance; show interesting inventions; illustrate important mechanical movements. With books we also send free Evidence of Invention form to help establish date of disclosure. Prompt service, reasonable fees, special deferred payment plan. Strictest secrecy. Thirty-six years' experience. Highest references. Write us today. The facts in our books are worth money to the man with a good invention. Address: Victor J. Evans & Co., Registered Patent Attorneys, 801-L Victor Building, Washington, D. C.

INVENTORS: "Making Inventions Pay," our 32-page illustrated book, mailed upon receipt of 3c postage. Crescent Tool Company, Dept. Z, Cincinnati, Ohio.

INVENTORS—Send for 72-page book on patents. Reasonable terms. Conscientious treatment to inventors. L. F. Randolph, Registered Patent Attorney, 302-E Victor Bldg., Washington, D. C.

INVENTORS—Small ideas may have large commercial possibilities. Write us for free book, "Patent Guide for the Inventor" and "Record of Invention" form. Delays are dangerous in patent matters. Free information on how to proceed. Clarence A. O'Brien & Hyman Berman, 58-L Adams Building, Washington, D. C.

UNPATENTED Ideas can be sold. We tell you how and help you make the sale. Particulars, with list of manufacturers and wanted inventions sent free on request. Write W. T. Greene, 944 Barrister Building, Washington, D. C.

I SELL Patents. Established in 1900. Charles A. Scott, 773PM Garson Ave., Rochester, N. Y.

WE Make models and manufacture inventions. Send 3 cents stamps for catalog. Pierce Model Works, Tinley Park, Ill.

SELL Your patent through a small classified ad in Popular Mechanics. Many inventors have found buyers in this way. Ask me for proof—I'll gladly send it to you. F. W. Johnson, Manager, Classified Advertising, 200 E. Ontario St., Chicago.

FREE Information about new magazines for inventors who want more profit from their ideas. Write "Successful Inventions," 800 Barrister Bldg., Washington, D. C.

HAVE You a sound, practical invention for sale, patented or unpatented? If so, write Chartered Institute of American Inventors, Dept. 4A, Washington, D. C.

INVENTORS. Do you know how to develop your invention into a salable product? The Howell Engineering Company is prepared to cooperate in working out this problem. A pencil sketch and description secures this cooperation. 8119 Eastern Avenue, Philadelphia, Pa.

INVENTORS: Co-operative service. Low rates. 5748 N. 38th, Milwaukee, Wisconsin.

\$1.00 MONTHLY Maintains New York branch office. Co-operative Mail Service, 126D Lexington Avenue.

INVENTOR'S Universal Educator; contains 900 mechanical movements; 50 perpetual motions; instruction on procuring and selling patents and selecting an attorney, etc. Suggests new ideas. Price \$1.00 postpaid in U.S.A. Address Albert E. Dietrich, 511-B Colorado Bldg., Washington, D. C.

INVENTORS—Ideas developed into practical inventions. Working models built. Low prices. Confidential service. Reo-Paul Engineering Co., 722 N. Gay St., Baltimore, Maryland.

TO Inventors! We are in the market to purchase a good patent, preferably a small item made of metal. Will purchase outright or royalty. Purchasing Agent, 241 Front St., New York, N. Y.

INVENTIONS WANTED

INVENTIONS—Small ideas may have large commercial possibilities. Write us for free book, "Patent Guide for the Inventor," and "Record of Invention" form. Delays are dangerous in patent matters. Free information on how to proceed. Clarence A. O'Brien & Hyman Berman, 58-L Adams Building, Washington, D. C.

SMALL Inventions wanted by manufacturers. I'll help you sell your invention. Stanley Hull, 7829 Euclid Ave., Cleveland, Ohio.

ITEMS Wanted for volume mail order business. Mechanical Equipment Sales Co., Chamber of Commerce Building, Cincinnati, Ohio.

INVENTIONS Wanted—Patented, unpatented. If you have an idea for sale, write Hartley's, Inc., Box 928-E, Bangor, Maine.

WE Successfully sell inventions, patented and unpatented. Write for proof, and tell us what you have for sale. Chartered Institute of American Inventors, Dept. 4-C, Washington, D. C.

WANTED To purchase new invention or idea for mail-order business. State clearly what you have and price. C. Ozment, 1203-N Arcade Bldg., St. Louis, Mo.

PATENTS FOR SALE

INEXPENSIVE Device makes auto license numbers clear at night. A modern necessity. Nicholas Matula, 63 Baumer St., Johnstown, Penna.

WE Buy and sell patents. Over 200 patents for sale, all lines. Invention Center, 3876 W. Warren, Detroit, Mich.

INVENTIONS Made, perfected, \$150 per productive day. Farris, Valley Junction, Iowa.

PRACTICAL Inventions now salable before patenting. What have you? Write Chartered Institute of American Inventors, Dept. 4B, Washington, D. C.

PRACTICAL Everyday chemistry—How to make what you use. 2342 practical workable formulas of widely used products. Save 50%. Start a paying business of your own. \$2.00 postpaid. Popular Mechanics Press, Room (C36), 200 E. Ontario St., Chicago.

PATENTED Flexible tube wrench. Never on market before. Outright or royalty, use on tooth paste or shaving cream. Send 25c for samples and particulars. The Tube Wrench Co., P.O. Box 128, Herington, Kans.

INEXPENSIVE Device makes auto jacks non skid. Invaluable icy weather. Sell patent. Martinetti, 311 Central, Orange, N. J.

LAYER Cake layer. Biscuit and doughnut cutter. Outright or royalty. Eugene La Course, 2104 - 11th Ave., Ybor City, Fla.

PATENTED Adjustable wrapper for books and merchandise. Cheaply manufactured. Sell outright. L. Langehennig, 710 Braniff Building, Oklahoma City, Oklahoma.

ELECTRIC Appliance. William Baresch, 1108 131 St., College Point, N. Y.

MANUFACTURING

MANUFACTURING, Dies, machinery, models, brasswork, white metal casting moulds. Catalog 3c. Baum's Metal Specialties, Kansas City.

INVENTIONS Manufactured in any quantity at low cost. Stampings, dies, models, etc. Estimates and free catalog. Crescent Tool Co., Dept. X, Cincinnati, Ohio.

MODELS AND MODEL SUPPLIES

BUILD Queen Mary, 27 in. long, all wooden model. Fully finished hull, cut to fit parts, and plans. \$2.50 complete, plus postage. Send 3c stamp for catalog. Miniature Ship Models, Perkasie, Pa.

RAILWAY Models. Catalog handbook 25c. Walthers, 1564 West Pierce, Milwaukee.

YACHT Model fittings, for Zip, Vanja and others. Send for illustrated list. A. J. Fisher, 1002-1 Etowah Ave., Royal Oak, Mich.

MAGAZINES, Books for modelmakers. Write for free list. 25c brings sample Modelmaker and Model Railroad. Modelmaker Corp., Wauwatosa, Wis.

MODELS—Your ideas developed into practical working models. 30 years' successful experience; thousands of satisfied customers. Confidential service guaranteed. Bank references. Send 3c postage for 32-page book—"Making Inventions Pay." Crescent Tool Company, Dept. Y, Cincinnati, Ohio.

BRASS Gears, models and model supplies. Send 3 cents stamps for catalog. Pierce Model Works, Tinley Park, Ill.

POPULAR Priced model gasoline engine, ready to run, \$14.00. Circular 5c. Anton Bohaboy, 212 Price St., Rahway, N. J.

GIANT Models, 4 motor Clipper type Junkers, 34x18", \$2; LZ129 Hindenburg 38", \$2; Liner Bremen 38", \$2.50. Imported, beautifully lithographed on cardboard to cut out and glue. Puppet theater, 19x32", 24 colorful stage settings, cut-out puppets for Cinderella, \$3. Standard Specialty Company, Box 311P, Gary, Indiana.

3 NEW Catalogs: No. 36—Engines, castings, small shop machinery. No. 37—Modelmakers, experimenters and mechanics materials and supplies. No. 38—Model power engines, locomotives, boats and airplanes, supplies, etc. Either postpaid in U.S.A. for 20c silver or stamps, or all 3 for 50c. Canada 75c. Refunded first order. Evray Mechanics Supply Co., 28 North Clinton, Chicago.

MODEL Ship, yacht, speedboat supplies and fittings. Catalogs dime. Welcher, 7th St., Fulton, N. Y.

SHIP Fittings list and "Shipmodeler Helps" booklet 25c. Craftsman, 1208 Wilshire, Santa Monica, California.

BOOKS Covering hundreds of subjects. Big catalog for 3c postage. Popular Mechanics Press, Room (C36), 200 E. Ontario St., Chicago.

PLANS, BLUEPRINTS, INSTRUCTIONS

MAKE Your own blue prints. Complete copyrighted booklet free on receipt of \$.25 in stamps to cover postage. Rapid Blue Print Service, Cedar Rapids, Iowa.

HOME CRAFTSMEN

LEATHERCRAFTSMEN—Write for free instructions and price list of leather, tools and beginners' kits. Send 5c for sample cards. Address Wilder & Company, Dept. F, 1038 Crosby St., Chicago, Ill.

JOIN Profitable Homecraft Club, free. Magazine, particulars 10c. Turner, 650 E. Eldorado, Decatur, Illinois.

CHIP Carving, interesting, inexpensive. Complete instructions 10c. Bowers, 819 Federal, Los Angeles, California.

ASSEMBLED—Timken roller bearing powerhead from junk. Idea 25c coin. Craftsman, Thornburg, Arkansas.

RARE And beautiful hardwood from many lands. To receive collection, send \$1.00 to Novelty Woods, 3449 East First Street, Los Angeles, Calif.

BUILD Your own card table. We supply fancy veneer design, three contrasting woods, glued to backboard, sanded, \$5.00. Roy Hancock, 323 Douglas, Portsmouth, Va.

NEW Jewel-like colored plastics make beautiful, valuable articles. Samples, prices, project sheets, 25c. Liberal introductory kit, \$1.95. Plastics Company, 277 Broadway, New York.

"**MODERN** Wood sculpture." Complete instruction book on carving statues \$1.00. Lee Wood Art Studio, Centerville, Ia.

20 FULL-SIZED Lawn ornament patterns 25c. 20 full-sized silhouette patterns 25c. 4 shelf bracket patterns 20c. Modern Woodcraft, 1343 Wadsworth St., Saginaw, Michigan.

HOMEMADE Band saw, saw table, jointer, grinder and 356 other practical shop subjects in Shop Notes for 1936, only 50c postpaid. Popular Mechanics Press, 200 E. Ontario St., Chicago.

OLD GOLD, WATCHES, JEWELRY, PRECIOUS STONES

AUSTRALIA. The land of beautiful opals. Opal catalogue free. Norman Seward, Melbourne, Australia.

WATCHES, Material, wholesale tools, experimental movements, instructions. Lists 5c. Stewarts, Carleton Bldg., St. Louis, Mo.

GEMSTONES: I buy, sell, exchange; wholesale, retail. Cut, uncut. McCampbell, Caleico, Calif.

5000 HUNTING Waltham, Elgin watches! New chromium, engraved, open-face cases. Make big money! 12 size, 7 jewel, \$3.25. 16 size, 7 jewel, \$2.75. Ask for free catalogue, new plan. The New York Jobbers, 74 Bowery, New York.

GUARANTEED Rebuilt watches. Send for price list. Pontiac Watch Co., Box 576P, Pontiac, Mich.

MAIL Order repair service on watches and clocks. Mainsprings 50c. Crystals 15c. Send to Paul Jewelry Company, LaCrosse, Wis.

FOR THE HOME

MAKE Automatic oil furnaces for homes. Superior to many expensive jobs. Instructions 25c. Purchasing Service, Valley Junction, Iowa.

BUILD Your own automatic coal stoker. Only \$147.50, No. 50 size, fully guaranteed. Easy terms to home owners. Staples Foundry Co., Dept. B, Mt. Vernon, Indiana.

GORGEOUS Clocks given away. Details stamp. Distributors, 1931 E. 29 St., Brooklyn, N. Y.

CLOCKS: Build your own grandfather's, banjo, shelf. Thousands built successfully. Some with beautiful chimes. Directions 10c. Particulars free. Clock Company, 1672a Ruffner Street, Philadelphia.

BOOKS Covering hundreds of subjects. Big catalog for 3c postage. Popular Mechanics Press, Room (C36), 200 E. Ontario St., Chicago.

TOBACCO

CHEWING, 4 Pounds, \$1.25. Subac smoking with burley, Turkish tobacco, 3 pounds \$1.10 postpaid. Belmont Farms, Chatham, Va.

BUY At wholesale prices by mail—Cigarettes, cigars, tobaccos. All brands. Postal stating your favorite brands brings low postpaid prices. Moberly, Box 1016, Owensboro, Kentucky.

RAZOR BLADES—SHARPENING

GUARANTEED: 10 Double edge blades, 1 blade sharpener, 1 box shaving soap, 1 styptic pencil. Price \$3.55. Bonomo, 79 Jefferson St., Brooklyn, N. Y.

TATTOOING

AMATEUR Tattooing outfits, free folder, illustrated catalog 6c. "Tatuco," 651A South State, Chicago.

TATTOOING Outfits, supplies. Illustrated list. "Waters," 965 Putnam, Detroit.

(**TATTOOING** Outfits). Learn to be artistic with them. Circulars. Sergt. Bonzey, 367 South Main, Providence, Rhode Island.

PHYSICIAN'S Chemical remover enables you to remove own tattoos at home. Complete treatment—\$2.00. Case Chemical Company, 1322 L Street, Washington, D. C.

SURVEYING INSTRUMENTS

GUARANTEED Factory rebuilt transits and levels for rent (with purchase option) or sale (cash or terms). Order now before prices advance. We will repair, trade in, or buy your old instruments. Ship prepaid for estimate and valuation. Write for List M-20 and complete information to Warren-Knight Co., 136 N. 12th St., Philadelphia, Pa.

WANTED—MISCELLANEOUS

CASH For used microscopes, binoculars, slide rules, drawing sets, cameras, surveying, scientific instruments, tools, marine equipment, typewriters, calculators. Highest prices paid day shipment received. Satisfaction guaranteed or shipment promptly returned. Elman's, 2302 Van Buren, Chicago.

AGENCIES Wanted, every description. Enormous untapped market Pacific Islands. Ellis, Nadarivatu, Fiji.

PERSONAL

STUTTERING And stammering corrected at home. Descriptive booklet free. Paul J. Wolfe, Box 52, Pittsburgh, Penna.

ATHLETE'S Foot? Instant relief? Cooper powder, 60 cents postpaid. Cooper Products, Flushing, New York.

HAY Fever and head colds instantly relieved by Buckhorn Inhaler or your money back. Tell your friends. \$1.00 postpaid. Dr. Flewell, 3137 Tiffin, Toledo, Ohio.

FREE. Important literature on the attaining and maintaining of natural health. Cell Food Clinic, 308 Bigelow Bldg., Seattle, Wash.

MISCELLANEOUS

SLIDE Rule—"Blanking pressure" mathematically correct, for engineers, tool designers, draftsmen. Price 35 cents postpaid. The Engineering Novelty Co., 635 Bailey Street, Camden, New Jersey.

POPCORN Poppers, 12 qt., aluminum, \$10. Use any heat. Free circular. Baum's Metal Specialties, Kansas City, Mo.

TYPEWRITERS, Duplicators, adders, watches, books. Bargain lists free. Dee's Exchange, 1125 So. 21st, Manitowoc, Wis.

BIG Profits operating "Specialty Candy Shop" home. Outfits and instruction furnished. C. A. Webster sold 300 pounds one week. Write, Hillier Ragsdale, Inc., Drawer, 62, East Orange, N. J.

NO Boss! Sure cash! Silvering mirrors, autoparts, reflectors, combination outfit. Write, Sprinkle, Plater, 288, Marion, Ind.

ALASKA—Information opportunities for settlers, miners, fishermen, ten cents. Alaska Information Bureau, Juneau, Alaska.

MONUMENTS \$9 Up delivered, erected, guaranteed. Thousands sold. Catalog free. Marble Granite Factory, A-17, Oneco, Fla.

WANTED—Hear from parties interested gold or silver ores, buried or hidden treasures. Bergman's instrument \$5.00. Particulars free. Henry Bergman, Box 398P, Springfield, Missouri.

YOU Can correct nearsightedness, farsightedness, astigmatism, and other eye disorders through proven scientific principles. No drugs—no glasses. Send for free valuable booklet "Eye Weaknesses" today. Better Eyesight Institute, Alexandria, Minnesota.

SWAP Or sell articles you don't need. Get those you want. Send dime for Swapper's Guide, listing articles from all over United States. Swapper's Guide, Dept. PM, Delphos, Ohio.

TREASURE Seekers—Make your own gold finders. Wyss, 104½ Frances, St. Joseph, Missouri.

GOLD Ore, direct reading detector, diagram with instructions to build, \$1.00. Sculpture Art Sales Co., 200 East 88th Street, Los Angeles, Calif.

CUTS Anybody can make. Zinc etching process. Specimens, particulars, testimonials for stamp. J. C. Day, Windfall, Ind.

BRONZE Tablets, desk plates, wall plates, memorials, grave markers. Bronze, brass and aluminum casting. Wandkey Pattern & Foundry Co., Anderson, Ind.

LARGE Signs to order. Poster paper, 3 colors to 25 feet yard wide \$1.50 post paid. "Edwards," 4th Street, Galena, Ill.

WANTED, "New Screen Talent." Lynnpeltcher, 2030 Julian, San Diego, Calif.

AMATEUR Cartoonists can earn \$35.00 weekly, spare time, duplicating cartoon advertisements. 3-M Syndicate, Argyle, Wis.

\$1.00 MONTHLY Maintains New York branch office. Co-operative Mail Service, 126F Lexington Avenue.

SWAPPER'S Friend, R4, Saline, Michigan. Interests swappers, collectors, sportsmen. 50c year, sample 10c.

SCORES Of tested money making ideas for home, shop, farm. Send for list. It's free. Popular Mechanics Press, Room (C36), 200 E. Ontario St., Chicago.

REDUCED 8 INCHES!
 ... Please send me a Weil Reducing Belt for a 38 inch waist. The first one I got was a 40—this one should be 8 inches smaller."
 W. L. McGinnis
 Livermore, Cal.

REDUCED 50 POUNDS!
 ... This is a belt of great value and I find it such relief and help ... It has reduced my weight from 230 to 180 pounds."
 W. T. Anderson,
 Richmond, Va.

"REDUCED MY WAIST 8 INCHES"



Why Don't YOU Test the Weil Belt at Our Expense?
 You will appear many inches slimmer at once and in ten short days if your waist line is not actually 3 inches smaller. . . . it will cost you nothing!

Massage-Like Action Does It!
 You will be completely comfortable as the massage-like action gently but persistently eliminates fat with every move! Gives erect, athletic carriage . . . supports abdominal walls . . . keeps digestive organs in place . . . greatly increases your endurance. Experiences of thousands of men justify us in making you this unqualified agreement: If you do not REDUCE your WAIST 3 INCHES in 10 DAYS . . . it will cost you nothing!

Simply write name and address on postcard and we will send you illustrated folder and full details of our 10 DAY FREE TRIAL OFFER.
THE WEIL COMPANY, 6810, HILLSIDE, N.W. HAVEN, CONN.

NO DRUGS, DIETS OR EXERCISES

SEND FOR 10 DAY FREE TRIAL OFFER

JUST OUT!



If you are interested in the construction, operation and maintenance of modern Diesel engines, you will want this new timely book of practical, useful information.

"AUDEL'S DIESEL ENGINE MANUAL" with Questions and Answers explains in simple, concise language the Fundamental Diesel Principles—Operating Principles—Engine Starting—Air Starting Valves—Fuel Spray Valves—Inlet and Exhaust Valves—Valve Timing—Fuel Pumps—Fuel Injection Compressors—Starting Air Compressors—Scavenging Air Compressors—Pistons and Piston Rings—Cylinders—Lubrication—Cooling Systems—Fuel Oil—The Engine Indicator—Governors—Engine Reversing—Semi-Diesel Engines—High Speed Diesel Engines—Answers on Operation—Horse Power Calculations.

The illustrations and texts are clear and easy to understand. All details are plainly brought out. This book is of extreme value to engineers, operators, students and all who desire a knowledge of the Diesel engine. A handsome book, flexible, with gilt edges. 300 pages—illustrated.

Send for free Diesel folder today.

FREE EXAMINATION COUPON

THEO. AUDEL & CO., 49 W. 23rd St., New York

Please mail a copy of AUDEL'S DIESEL ENGINE MANUAL. If satisfactory, I will remit \$2 on its safe arrival, otherwise I will return the book.

Name

Address

OccupationPM

THIS EMPTY →



THIS EMPTY

IT TAKES BRAIN to earn money—trained brain! The man without training is usually the man without cash. You can train your brain! Thousands of men have done it through spare-time study of I. C. S. Courses. Be a cash man—be a trained man—mail this coupon!

INTERNATIONAL CORRESPONDENCE SCHOOLS

Box 5634-H, Scranton, Penna.

Without cost or obligation, please send me a copy of your booklet, "Who Wins and Why," and full particulars about the subject before which I have marked X:

TECHNICAL AND INDUSTRIAL COURSES

<input type="checkbox"/> Architect	<input type="checkbox"/> Plumbing	<input type="checkbox"/> Heating
<input type="checkbox"/> Architectural Draftsman	<input type="checkbox"/> Air Conditioning	
<input type="checkbox"/> Building Estimating	<input type="checkbox"/> Steam Engineer	
<input type="checkbox"/> Contractor and Builder	<input type="checkbox"/> Steam Electric Engineer	
<input type="checkbox"/> Structural Draftsman	<input type="checkbox"/> Marine Engineer	
<input type="checkbox"/> Structural Engineer	<input type="checkbox"/> Civil Engineer	
<input type="checkbox"/> Electrical Engineer	<input type="checkbox"/> Highway Engineer	
<input type="checkbox"/> Electric Lighting	<input type="checkbox"/> Bridge Engineer	
<input type="checkbox"/> Welding, Electric and Gas	<input type="checkbox"/> Bridge and Building Foreman	
<input type="checkbox"/> Reading Shop Blueprints	<input type="checkbox"/> Surveying and Mapping	
<input type="checkbox"/> Telegraph Engineer	<input type="checkbox"/> Refrigeration	
<input type="checkbox"/> Telephone Work	<input type="checkbox"/> R. R. Locomotives	<input type="checkbox"/> Air Brakes
<input type="checkbox"/> Mechanical Engineer	<input type="checkbox"/> R. R. Section Foreman	
<input type="checkbox"/> Mechanical Draftsman	<input type="checkbox"/> R. R. Signalmen	
<input type="checkbox"/> Machinist	<input type="checkbox"/> Chemistry	<input type="checkbox"/> Pharmacy
<input type="checkbox"/> Patternmaker	<input type="checkbox"/> Toolmaker	
<input type="checkbox"/> Sheet Metal Worker	<input type="checkbox"/> Boilermaker	
<input type="checkbox"/> Heat Treatment of Metals	<input type="checkbox"/> Coal Mining	
<input type="checkbox"/> Management of Inventions	<input type="checkbox"/> Navigation	
<input type="checkbox"/> Diesel Engines	<input type="checkbox"/> Cotton Manufacturing	
<input type="checkbox"/> Aviation Engines	<input type="checkbox"/> Woolen Manufacturing	
<input type="checkbox"/> Automobile Mechanic	<input type="checkbox"/> Agriculture	
	<input type="checkbox"/> Fruit Growing	
	<input type="checkbox"/> Poultry Farming	

BUSINESS TRAINING COURSES

<input type="checkbox"/> Business Management	<input type="checkbox"/> Business Correspondence	
<input type="checkbox"/> Office Management	<input type="checkbox"/> Lettering Show Cards	<input type="checkbox"/> Signs
<input type="checkbox"/> Industrial Management	<input type="checkbox"/> Stenography and Typing	
<input type="checkbox"/> Traffic Management	<input type="checkbox"/> Civil Service	<input type="checkbox"/> Mail Carrier
<input type="checkbox"/> Accountancy and C.P.A. Coaching	<input type="checkbox"/> Bookkeeping	<input type="checkbox"/> Railway Mail Clerk
<input type="checkbox"/> Secretarial Work	<input type="checkbox"/> Cost Accountant	<input type="checkbox"/> Grade School Subjects
<input type="checkbox"/> Salesmanship	<input type="checkbox"/> Advertising	<input type="checkbox"/> High School Subjects
<input type="checkbox"/> Service Station Salesmanship	<input type="checkbox"/> Wallpaper Decorating	<input type="checkbox"/> College Preparatory
<input type="checkbox"/> Salesmanship	<input type="checkbox"/> Salesmanship	<input type="checkbox"/> First Year College
		<input type="checkbox"/> Spanish
		<input type="checkbox"/> Illustrating
		<input type="checkbox"/> Cartooning
		<input type="checkbox"/> Lumber Dealer
		<input type="checkbox"/> Apartment House Management

Name.....Age.....

Address.....

City.....State.....

Present Position.....

If you reside in Canada, send this coupon to the International Correspondence Schools Canadian, Limited, Montreal, Canada

STAMPS and COLLECTING

(Continued from page 36A)



Left, recent Mother's Day stamp issued by Austria. Center, current French semipostal issue. Right, Bermuda pictorial with frame of sky blue and scene in black

sealed, and include one cent forwarding fee for each cover. Commemoratives on outer wrappers will be appreciated.

—o—

Official cachets of the Texas Centennial commission for September and October are as follows: September 7, San Angelo, pioneer celebration; September 14, Longview, Gregg County Centennial fair; October 3, West Columbia, commemorating the first congress of the republic of Texas; October 5, New Braunfels, Centennial celebration; October 14, Beaumont, South Texas State fair; October 16, Nacogdoches, historical pageant; October 21, Refugio, commemorating revolution battlefield; October 29, Waco, Brazos Valley Free fair. Collectors should prepare their covers, "ready to go," and send them under separate wrapper to the postmaster in the city named, with note requesting the cachet.

—o—

Sergio Perez Grau, editor of the Philatelic department of "Puerto Rico Illustrated" will sponsor a handsome printed cachet on October 7. Send only name and address and four cents in coin to Sr. Grau, c/o Puerto Rico Illustrated, Fortuna, P. R.

Recent Issues and Discoveries

Bermuda's recent issue of pictorial stamps was one of the last colonial sets showing the portrait of the late king upon

some values. The second, illustrated, pictures a racing yacht in full sail, in a strong breeze. In this example, a sea horse, the emblem of Bermuda, is shown in each of the upper corners. The frame of this stamp is sky blue, and the scene is in black.

—o—

The latest French semipostal issue is inscribed "For the children of the unemployed." This stamp was placed on sale as soon as the leftist party came into control of the government, and the current aid stamp, which was inscribed, "Aid for the intellectuals," was suppressed.

—o—

"One of the beautiful stamps of the year" is the description most frequently heard in connection with the mother's day stamp issued by Austria. The design is taken from a painting by Durer.

Stamp and Coin Notes

The original announcement of the two series of stamps to commemorate heroes of the army and the navy contemplated the release of the one-cent stamps about August 1. Recent reports state the first values cannot be issued until later. Rumors are current of stamps to honor Frederick Douglass and Mother Seton, both to go on sale before November 3. Should these be issued, the army and navy sets may be postponed.

THIS COMPLETE, SIMPLE, PRACTICAL COURSE FOR SELF-INSTRUCTION WILL QUICKLY GIVE YOU
A Complete Mastery of MATHEMATICS



Prepare now to advance yourself to an important job by *Mathematics Training*. *Mathematics* is the foundation of all mechanical and scientific work, and of all business or industry based on science. Without this essential knowledge even the most capable man is left behind while others forge ahead to better jobs, bigger contracts, more money. You need mathematics to solve technical problems and to improve, speed up and check on your work and the work of others.

Now you can learn mathematics by an easy, inexpensive and time-saving method. A very simple and extremely interesting course in book form has been prepared for you by an expert who has devoted a lifetime to teaching practical men the fundamentals of this important subject.

MATHEMATICS FOR SELF-STUDY

By **J. E. Thompson, B.S., A.M.,**
 Dept. of Mathematics,
 Pratt Institute

These books start right from the beginning with a review of arithmetic that gives you all special short-cuts and trick methods that save countless hours of your time. Then they go right into higher mathematics and show you how simple it is when an expert explains it for you. In no time at all you will be tackling with ease the most difficult questions on this subject.

An Expert's Simplified Methods

Mr. Thompson, the author of these books, has had many years' experience in mathematical training. He

presents each practical method and problem in the clearest, simplest way. He gets right down to the kind of information that you need in your daily work.

Send No Money—Mail This Coupon for FREE EXAMINATION

D. Van Nostrand Co., Inc., 250 Fourth Ave., New York
 Send me **MATHEMATICS FOR SELF-STUDY** in 5 volumes. Within 10 days I will either return the books or send you \$2.95 as first payment and \$2.00 per month for 3 months—total \$8.95 (5% discount for cash).

Name.....
 Address.....
 City and State.....
 Reference.....
 Address.....

FOR FREE CATALOG of best books of practical instruction and technical information check here P.M. 10-30

Every Needed Fact, Figure, Formula, Every Shortcut and Special Method in the
WHOLE FIELD of MATHEMATICS
Now in ONE Handy Volume

For the first time you can have this wealth of practical mathematical information, covering every trade and business, condensed into one handy book for quick reference. This volume puts right at your finger tips instant facts and formulas for making every kind of mathematical calculation. From hundreds of different sources, this priceless information has been gathered together, boiled down into brief, simple language, and applied to actual problems. Every man in business, every man in the mathematical trades, every man who ever uses a tool or has to make calculations or estimates in office, shop, or home, will find here a treasury of money-making, money-saving ideas.



THE HANDBOOK OF APPLIED MATHEMATICS

No previous knowledge of mathematics is needed. No study is required. The specific information you want is easy to find, by looking it up in the index. The book takes up every trade and gives you practical methods, easily-worked formulas for solving every problem. Thousands of specific examples show you just how to make your calculations. If your work involves mathematics in any way this complete reference handbook is an indispensable part of your equipment. It is an amazing time saver for any one concerned with engineering, architecture, electricity, mechanics, construction, automobiles, machinery, printing, or any other industrial work; or with accounting, auditing, manufacturing, costs, taxes, or any other

Entirely NEW Greatly ENLARGED

Revised throughout, greatly extended in scope, with a wealth of NEW MATERIAL in all sections. The subjects of pulleys, gears, the use of the slide rule, and weights and measures have been greatly lengthened. Valuable new sections deal with the topics of strength of materials, papering, glazing, and radio. Ample new material has been furnished on machine shop practice and sheet metal work. Finally, an entirely new treatment covers exhaustively the great field of business mathematics. In its new form, more than ever before, this book will simplify your most important and puzzling problems. No increase in Price
 754 Pages. Lavishly Illustrated. Strong Cloth Binding. Page Size 5 1/2 x 8 inches.

business mathematics. No practical man, no house owner who makes an occasional repair, no one who has a home work-shop can afford to be without the valuable information quickly found in this book. A few of the subjects covered:

- | | | | |
|-----------------------------------|-----------------------------|-----------------|-----------------------------|
| Arithmetic (including Slide Rule) | Excavations and Foundations | Mechanics | Sheet Metal Work |
| Algebra | Concrete | Painting | Radio |
| Geometry | Brickwork | Plumbing | Electricity (D.C. and A.C.) |
| Trigonometry | Carpentry and Building | Glazing | Print Shop |
| Weights and Measures | Plastering | Paper Hanging | Business Mathematics |
| | | Heating | Accounting |
| | | Machine Shop | |
| | | Automotive Shop | |

EXAMINE THIS BOOK FREE
Send No Money—Mail This Coupon

D. VAN NOSTRAND CO., 250 Fourth Ave., New York
 Send me on approval *The Handbook of Applied Mathematics*. Within 5 days after I receive the book, I can return it and owe nothing. If I keep it, I will send you \$2.00 as first payment and I will pay \$2.00 monthly thereafter for 2 months—\$6.00 in all. (5% discount for cash.)

Name.....
 Address.....
 City..... State.....
 Reference.....
 Address.....

FOR FREE CATALOG of best books of practical instruction and technical information check here P.M. 10-36

OL' JUDGE ROBBINS



TOBACCO BAIT

LET'S SEPARATE THIS MORNING - FISH IN DIFFERENT PARTS OF THE LAKE AND MEET HERE IN TIME TO COOK LUNCH

AND THE ONES WHO COME BACK WITHOUT FISH WILL HAVE TO DO THE COOKING!



NEARLY LUNCH TIME AND NO FISH. I'VE HAD MIGHTY POOR LUCK THIS WHOLE WEEK-END



NICE MESS O' BASS YOU'VE GOT THERE, STRANGER - I HAVEN'T EVEN HAD A STRIKE YET

WELL, YOU CAN'T HAVE EVERYTHING. I HAVEN'T A CRUMB OF TOBACCO WITH ME



I'LL SWAP MY EXTRA TIN OF PRINCE ALBERT FOR A COUPLE OF THOSE BEAUTIES

PRINCE ALBERT - MAN, OH, MAN - THAT'S WORTH THE WHOLE STRING O' FISH



I ALWAYS KNEW YOU WERE A GOOD FISHERMAN, DADDY, BUT -

I'M AFRAID YOU WEREN'T USING THE RIGHT BAIT

NONE OF THE REST OF US CAUGHT ANYTHING!



© 1936, R. J. Reynolds Tob. Co.

YOU CAN'T GO WRONG WITH PRINCE ALBERT!



When a man gets around to smoking Prince Albert, he discovers the kind of tobacco joy that otherwise he might spend a lifetime looking for. There's good reason why Prince Albert is the world's largest-selling smoking tobacco. The pick of sunny tobaccos gives it deep-down satisfying tastiness. The special "crimp cut" insures cool smoking. And the "no-bite" process takes out all nip. Prince Albert is tops for roll-your-own cigarettes too.



THE BIG
2
OUNCE
RED TIN

CRIMP CUT
LONG BURNING PIPE AND
CIGARETTE TOBACCO

TRY PRINCE ALBERT AT OUR RISK

Smoke 20 fragrant pipefuls of Prince Albert. If you don't find it the mellowest, tastiest pipe tobacco you ever smoked, return the pocket tin with the rest of the tobacco in it to us at any time within a month from this date, and we will refund full purchase price, plus postage. (Signed)
R. J. Reynolds Tobacco Co., Winston-Salem, N. C.

PRINCE ALBERT THE NATIONAL JOY SMOKE!

50 pipefuls of fragrant tobacco in every 2-oz. tin of Prince Albert

Popular Mechanics Magazine

REGISTERED IN U. S. PATENT OFFICE AND CANADA

WRITTEN SO YOU CAN UNDERSTAND IT

Vol. 66

OCTOBER, 1936

No. 4

BEWARE *the* Spark Plug Racket

F1006

material from Champion Spark Plug Co. Toledo, O.



THE traffic light turned green and every car spurted ahead of the salesman in the tan coupe. The same thing had been happening for days, so the salesman, a stranger in town, pulled in to the first garage he saw.

"She's lost her youthful pep," he complained. "Sluggish at lights and everything passes me on the road."

"What you need," advised the garage man after an inspection, "is a set of new plugs."

"O.K. Put 'em in while I make a call," ordered the salesman, glancing at a shelf filled with cartons bearing the name of a well known spark plug company.

The next week, back in his home town, the salesman's tan coupe was spitting and sputtering worse than ever. The exasperated

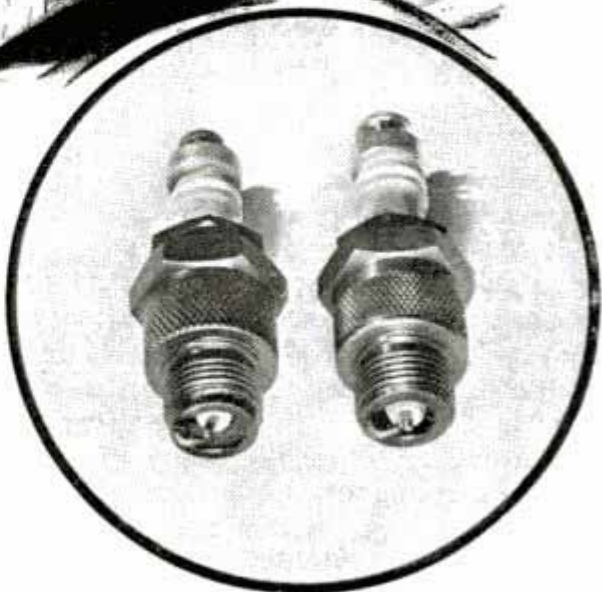

They look much alike, but plug at left is rebuilt and one on right is new

Raymond K. Robinson

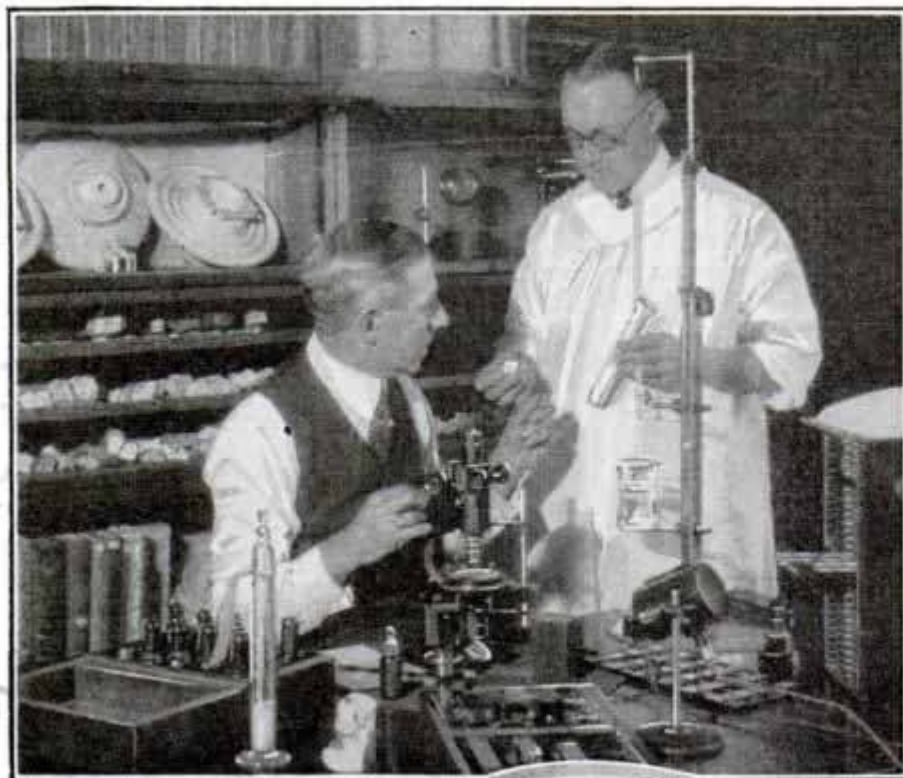

off on the public at new plug prices by unscrupulous dealers.

Unless you happen to be one of those "cranky" owners who hangs around the garage while your car is being repaired and critically inspects every part that goes into it, you also are likely some day to be taken in by a spark plug racketeer. And even if you have sharp eyes, you still may be fooled unless you know what to look for and where to look for it.

The spark plug racket is an outgrowth of the depression and the demand for low-priced merchandise. The racketeer's "factory" is

some secluded garage or loft where there will not be too many prying eyes or too many questions asked. Reputable but unsuspecting garages and repair shops

driver took it to his own service station.

"What you need," said the service man after an inspection, "is a set of new plugs."

"You're crazy," chortled the salesman. "Those plugs are new. Just put 'em in last week."

"These plugs are not new," retorted his service man. "They're old ones that have been rebuilt. Your car would have performed better if you hadn't changed at all."

The salesman was just one more innocent victim of the spark-plug racket. He paid for new plugs and assumed he was sold new plugs made by the manufacturer whose name appeared on the cartons on the shelf. But the plugs in his car came from a barrel under the counter. Perhaps if he had bothered to inspect them after they were installed, he might even have seen the name of the manufacturer on them. But they were not new plugs turned out by this factory. They were discarded and worn-out plugs which had been reconditioned so they would pass casual inspection and could thus be foisted

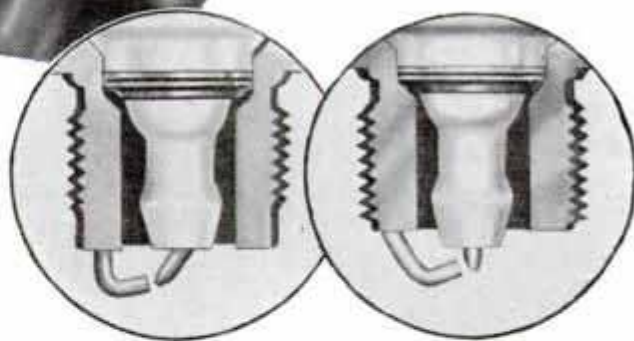

Top, examining cores with microscope in spark plug factory. Center, cores ready for firing. Bottom, note bent center electrode of rebuilt plug at left

are his source of supply and he pays men and boys two or three cents a plug to visit these places and collect worn-out and discarded plugs which the shops assume are to be sold as junk.

Instead he takes plugs apart, cleans the cores, sandblasts the bases, files off the

(Continued to page 144A)

Musical World Tries Out Odd Instruments



Aene.

Music comes in unusual packages, new instruments or combinations of old. Top, left, piano with reed back is designed for use in center of room. Center, playing the cello-horn, a combined string and brass instrument, before a recent convention

Chang.



Above, hall clock with chimes connected with a button at the front door. Pushing the button announces visitors in the mellow tones of the chimes

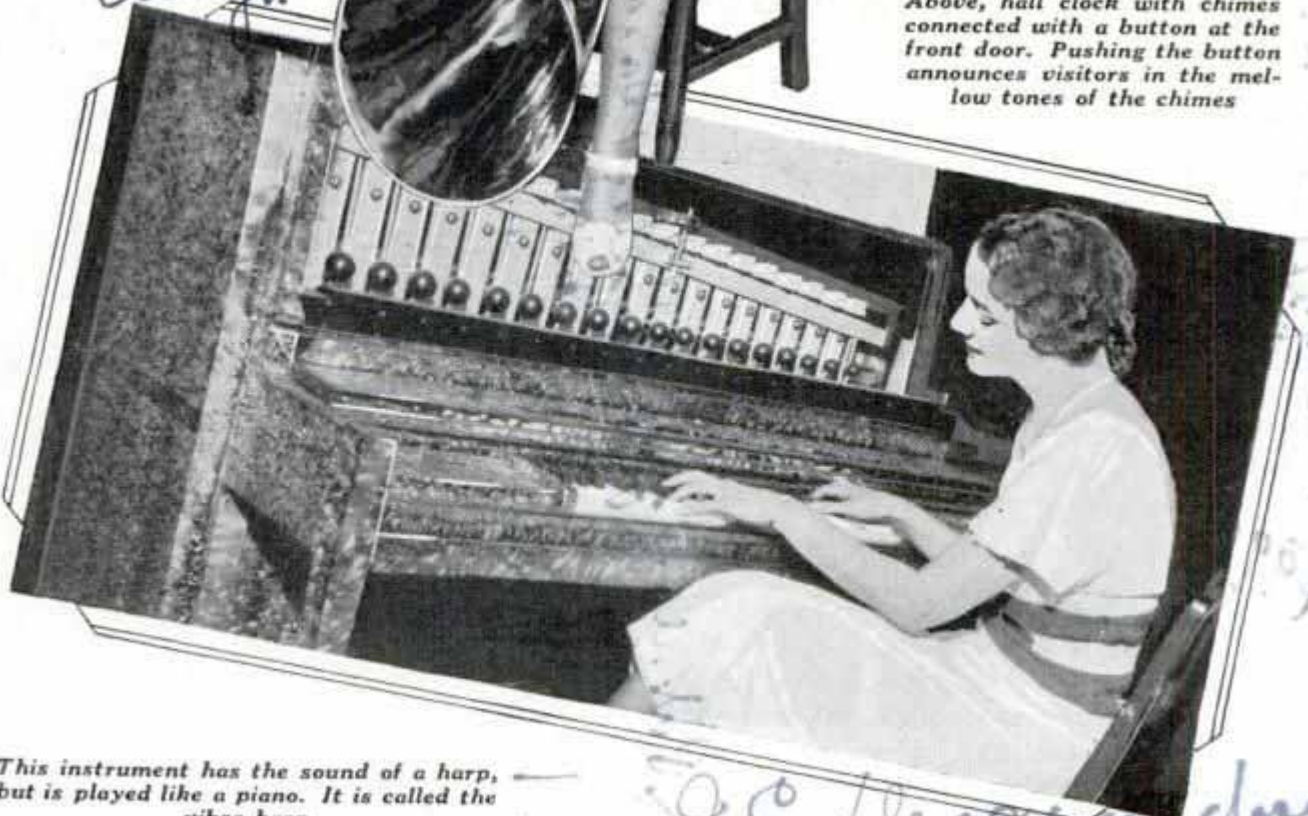

This instrument has the sound of a harp, but is played like a piano. It is called the vibra-harp

J. C. Deagon, Inc. W. B. Bertan

not in production

12/8/36

Flexible Glass Stage Settings Add Beauty to Movies



Bending a flexible glass palm leaf, part of a movie stage setting made of this glass

Glass almost as flexible as rubber is offering new stage effects in motion pictures and recently palm trees made of the glass were used as a setting for one scene of a Hollywood production. This particular kind of flexible glass was developed by Vienna scientists. It has a tensile strength of from 2,500 to 3,600 pounds and a force of 147,000 pounds is required to break it by bending. It also has been found that the glass can be permanently twisted by steaming. It possesses all the properties of ordinary glass, it is claimed, with the added advantage of flexibility. It is being tested as a material for automobile windows and windshields.

Antiblinding Photo Flash Prevents Eye Shock

Patents have been issued for an anti-blinding, nondazzling photo-flash lamp which eliminates eye shock incidental to the taking of pictures. The bulb of the lamp is coated with a lacquer colored with a blue dye which permits little glaring

yellow light to come through when the lamp flashes. Although this coating reduces the amount of light given off by the lamp, it is said that sufficient blue, violet and ultraviolet light rays pass through to produce a good negative. The inventor claims that a person may be photographed, with the new flash lamp, without knowing his picture has been taken.

F954

Bread Made with Wood Sugar Stays Fresh Longer

Bread which it is claimed remains fresh much longer than the ordinary yeast-leavened kind has been patented recently. The addition to the dough of a small amount of wood sugar, known as xylose and obtained from straw and other vegetable materials, wards off staleness, it is asserted. In other respects the dough mixture is the same as that used in making ordinary yeast-leavened bread.

F975

Auto Converted into Train Serves Mountain Line

Rapid and economical service over the Colorado Rocky mountains is provided by an auto-train. Made from a 1922 Pierce-Arrow automobile powered by a six-cylinder engine, the train runs six miles on one gallon of gas. Its maximum speed on the level is thirty miles per hour. The conversion was simple. Front and rear



Here is the auto-train ready for its 162-mile run through the Colorado Rockies

wheels of the automobile were removed and the chassis was set on a girder attached to the baggage car. The drive shaft was geared to the front group of four wheels. Power from the revolving axle is transmitted to the middle group of wheels by a sprocket chain. All three sets of wheels have brakes. The complete auto-

Cont. A. B. Herouman, 32-52 = 33rd St

Vertical handwritten notes on the left margin: "Los Angeles", "Hollywood", "Charles Carroll", "3/6 Architects", "Pat. 11 & 1040, 279", "Wire World", "Agent", "Kurlander", "J. H.", "July 27 1936".

train, which carries mail, light baggage and eight passengers, weighs 15,000 pounds. The train has a cowcatcher, a horn and a fuel capacity of twenty-seven gallons. Regular schedules are maintained between Durango and Ridgway in southwestern Colorado. The auto-train was devised when operation of a steam train on the 162-mile line became too expensive.

Latest "Tear Drop" Auto
Has Only Three Wheels

116 3 1/2 h. mariposa

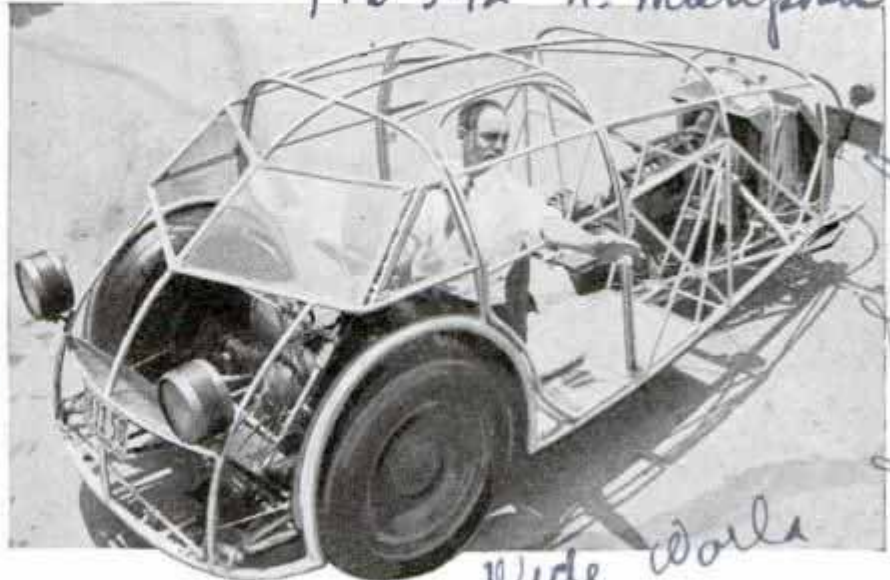

Framework of tear-drop car as the three-wheeler neared completion. Note engine located at rear, near the single wheel

Wide wheels

Adjustable Top
of Art Table
Locks Itself

Easily adjusted to the desired angle with one hand, the top of a new art table remains in that position until unlocked by raising it to its full height. This movement automatically releases the elevating rod which holds the top in position and allows the top to lower to hori-



Self-locking adjustable table top is a convenience for the artist or the draftsman

zontal position. All working parts are sealed and there are no thumbscrews, bolts or ratchet devices. The top may be adjusted to any angle.

Constructed of welded aluminum, a three-wheel streamline automobile has been built by a Los Angeles mechanic. It has four seats on rollers which will shift forward or backward. The design calls for location of the radiator under the floor at the front and for reversal of the fan to draw in air for cooling the six-cylinder engine. A back tire may be changed by jacking up the car, unbolting the wheel and permitting it to drop down. The car has a front wheel drive.

Scouring Brush Is Refillable
with Steel Wool

Designed to be refilled, the latest scouring brush feeds steel wool as it wears. Additional steel wool is pushed forward by means of an adjustable plate.



The refills are packed in light cardboard tubes for easy installation in the empty handle. The brush is handy in the kitchen, the garage and on the farm.

Archaeologists in Austria recently dug up bronze razors more than 3,000 years old.

Keweenaw Mfg. Co.

1614 Washington St.

James H. Chodas, 153 W. 1st St., Los Angeles, Calif.

Address Keweenaw Mfg. Co.
1614 MONROE STREET
EVANSTON, ILLINOIS

Copper and Brass
Research Assn. N.Y.C.

Rubber Pipe Line Is Endless "Bucket Chain"

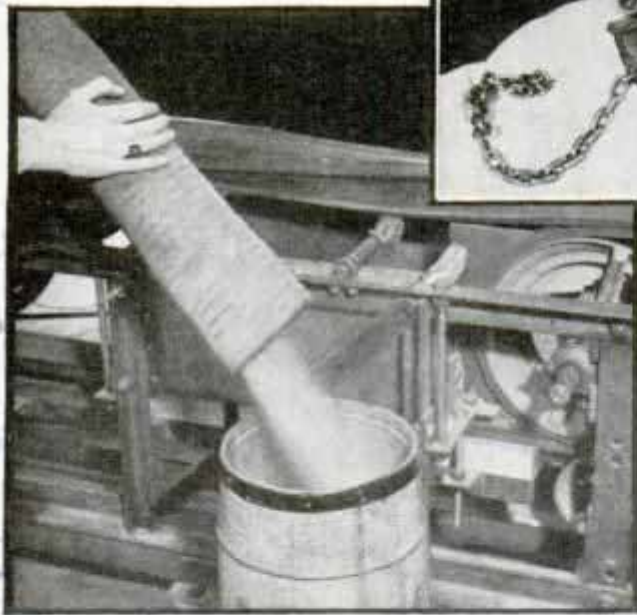

Above, rubber pipe line in industrial plant. At left, how its two halves open, discharge their load, and seal themselves together again. Chain embedded in each side of pipe reinforces it

ing sharp corners, climbing vertically and traveling beneath floors or streets. Its use in the mine would eliminate dust. Foods and chemicals which must not be polluted or subjected to atmosphere can be carried in it. The two halves are joined by a tongue-and-groove lock so tight that liquids can be conveyed for thousands of feet without losing a drop. It can be shortened or lengthened by vulcanizing ends. The sectional compartments in the rubber line distribute the load evenly, so that heavy materials do not pile up excessive pressures when traveling vertically. Rubber carries the load without stretching, for the tension is borne by two steel chains embedded in the pipe, strengthening it without affecting flexibility. A four-inch line moving 500 feet per minute could carry 120 tons of material in an hour. In the industrial plant, the mine, the freight ter-

Endless conveyors of flexible rubber, moving pipe lines sectioned off into containers like a chain of buckets, carrying liquids or solids at high speed without loss en route, have just been placed on the market. The rubber pipe line—built in two longitudinal halves which seal themselves together, but can be pulled apart at any point to receive or discharge a load—automatically picks up its cargo, locks together in airtight, watertight tubing and “flows” to its destination like a belt, turn-

The Johns. ... 605 ... Newark, N.J.

W. 103rd St. Newark

Emb. ...

... 103rd St. Newark

... 103rd St. Newark

minal, the rubber pipe conveyor can carry—wet or dry—such materials as plaster, soap, grain, sludge, wood pulp, sulphur, talc, coal, ashes, salt, chemicals, and various foods. Three products which are not readily conveyed in it are large sizes of rough-metal ores, coal and stone. It can be used to load ships or freight cars, and has certain advantages in ridding mines of water for it lifts water in its separate containers instead of pumping it out under pressure. Because rubber resists wear and the attacks of acids and weather, the flexible pipe line endures long exposure to hard work.

7994
**Photographs of Burned Bonds
 Expose Forged Signatures**

When the Brooklyn, N. Y., police attempted to bait a trap for three alleged bond forgers, they met with apparent failure when they found that the bonds and the signatures on them had been burned to ashes. However, the crime laboratory of the police department came to the rescue with microscopes and chemicals, then made 300 photographs of the charred scraps of paper. Finally a picture was obtained which, while not a photograph of a complete bond, was deemed important as evidence because the police claimed it showed the signatures which they allege were forged.



Photograph of partly burned bond made by Brooklyn police in forgery investigation

7944
**Bricks Hung on Metal Hooks
 Cut Modernizing Cost**



Thin bricks are properly aligned and supported by prongs on mesh nailed to old wall of house

Intent on developing business by cutting the costs of home modernization, a Maywood, Ill., contractor has devised a method of "hanging" thin brick veneer on metal prongs that project from a reinforcing mesh panel. Old frame and stucco houses can be given new brick walls at a small outlay, since no additional foundation is required and the three-fourths inch brick veneer, made of the same materials and in the same colors as regular face brick, is easily applied over the old wall. On the back of the brick veneer slabs is a dovetail slot, centered so that the brick is reversible. Before hanging the bricks, a stiff, copper-bearing metal mesh "curtain" is securely anchored to the old wall. Projecting hooks or prongs on this patented mesh fit into the slot of the brick slabs, the mesh thus helping support the weight of the bricks. Mortar is applied to the slotted back before the brick is "hung." The cost of modernizing a frame house by this method is repaid in a short period of years by reduced maintenance costs. One large house which had a recurring paint bill of \$400 was brick-veneered by this contractor for \$1,100. The pattern of the hooks in the mesh assures perfect alinement of the bricks.

Sound travels 11,000 feet per second in ice—more than ten times the velocity of sound through air.

Wayne Dunscomb
 Engineer June 10 36

American Rubber June 1936
 Dept. 6
 129 St. 6th Ave
 New York City

'Eye in Sky' Camera Judges Close Horse Races

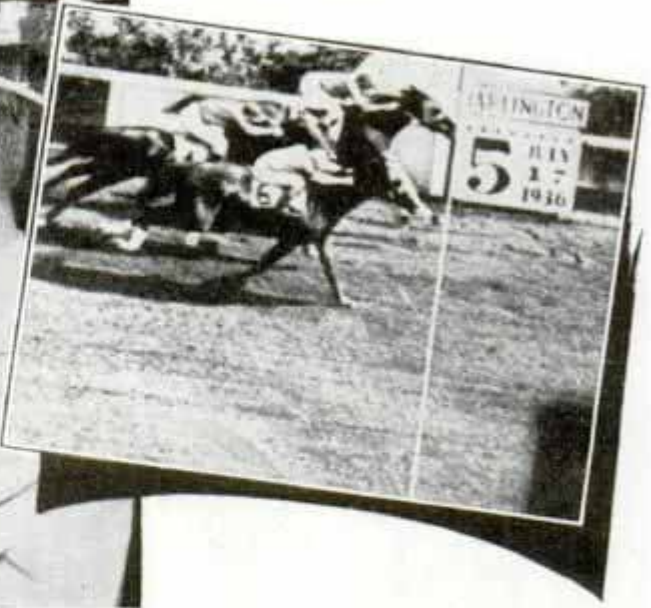
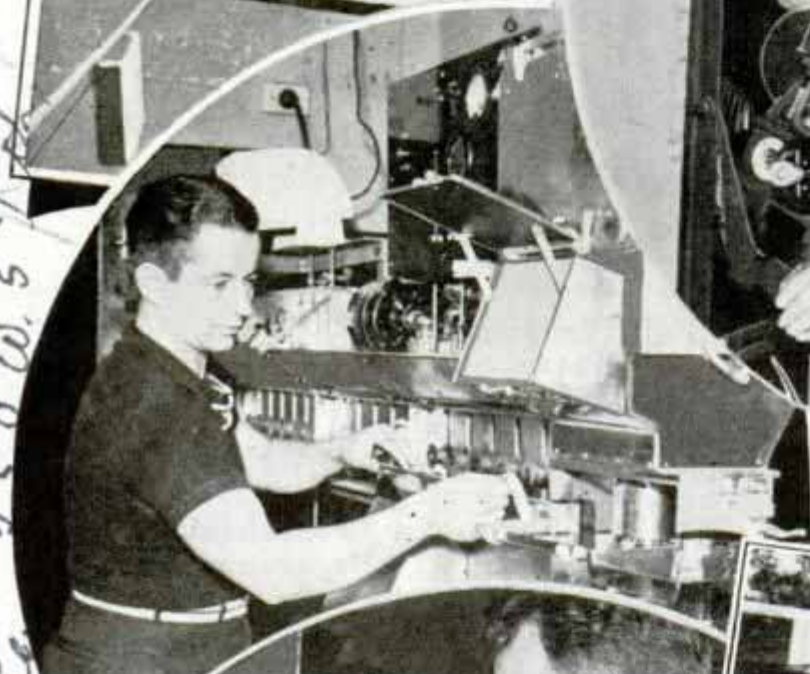
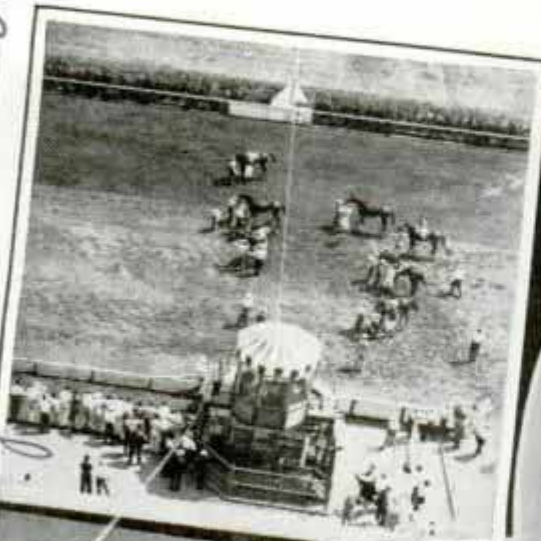

Harry I Day
 Electric Research
 250 W. 57th St.
 Chicago
 1965

cut.

When the finish is close at Arlington Park in Illinois, less than two minutes elapse before a photograph showing the winning horse is in the hands of the judges. A movie camera nearly 200 feet above the track is used to catch the horses as they race under the wire. Then the film is sent through the developer and an enlarger which magnifies the tiny motion-picture frame. From there it passes into the printing process and a second later the finished picture is sent sliding down to the judges' stand on a chutelike device. The judges frequently find it necessary to resort to the finish-line photo in determining the winner of close races

Harry I Day
 Electric Research
 250 W. 57th St.
 Chicago

#815 (Frank)

The NEW ERA of Railroading



FROM the Rockies to Chicago between twilight and dawn races the million-dollar "City of Denver," glittering ten-car streamliner hauled by this massive Diesel-electric power car.

PASSENGERS boarding the "Green Diamond," Chicago-St. Louis streamliner of the Illinois Central system, are greeted by a stewardess in green uniform who attends to every want of the traveler. The vestibule steps fold into the bullet-shaped side of the car. Below is the Diesel-electric locomotive of the "Abraham Lincoln," another Chicago-St. Louis speed train.



F813

PART I

A NEW era of railroading has captured America. Gone are the days of stuffy coaches with dingy red-plush seats, cinder-strewn window sills, aisles littered with aromatic orange peel, and exasperating waits on the siding for the limited, over an hour late, to clear.

Fast freights now rumble through at the speed of yesterday's passenger train, while America rides—and watches—the streamliner.

Across the prairies it streaks, a silver shaft, a bolt of gold or blue or canary, slicing the continent in half, bringing Chicago to the foot of the mountains, thrilling breathless "galleries" at every highway crossing. Townsfolk that had forgotten the railroads, country dwellers who had quit driving to town to meet the 8:10, park along the road to see the

streamliner flash past at eighty, ninety, a hundred miles an hour. By night the low, musical blast of an air horn, the vertical shaft of light piercing the sky warn of the speed train's approach, and suddenly it is gone, a streak of gay lighted windows alluring as the port-holes of an ocean liner.

Aboard the train a passenger, counting telegraph poles and checking his



INDIRECT lighting and wood-veneer paneled walls trimmed with aluminum lend a smart modern accent to the lounge car of the "City of Denver." One of the Burlington railroad's fleet of "Zephyrs" is shown below.





watch, asks the stewardess what speed they're making. The stewardess, dressed in a trim green uniform, picks up the telephone in the observation car and calls the head end. Telephones are located at strategic points through the streamliner. The message reaches a loudspeaker in the engine cab, and the engineer, with a look at the speedometer, lifts his speaker and calls back: "Eighty-seven miles an hour."

Minutes squeeze the miles in this new day of railroading. Two years ago the first of these modern trains rocketed across a startled continent. Today a fleet of more than twenty streamliners clicks off more than 115,000 miles each week, six million miles a year. Forty-four miles in forty-four minutes between



78/3

STEEL louvers afford privacy to occupants of berths on the Union Pacific's "City of Los Angeles," and a curtain protruding into the aisle allows more room for dressing. At the right is the ladies' "makeup room" aboard the Denver streamliner.



METAL grillwork and colored glass add decorative touches to the dining car of the "City of Denver," made more spacious by the side seating arrangement.

Boston and Providence, six round trips a day, races the "Comet" of the New York, New Haven & Hartford. Traveling salesmen who used to sleep two nights on the train now leave St. Louis after breakfast, enjoy a noonday lunch at a counter in a cool, clean car, reach Chicago in time for an afternoon's business, take the streamliner back home in time to sleep. Two hundred ninety-four miles, each way, in two hundred eighty-five minutes. Over three railway speed lanes between St. Paul-Minneapolis and Chicago, six trains run daily round trips at better than mile-a-minute paces. This was the proving ground where railroads found passengers multiply when drama

replaces drabness. Here the Burlington's twin "Zephyrs" packed in passengers so steadily that these streamliners were called on to make two trips a day. Eight hundred eighty-two miles of high-speed travel for each train every day in the week between 8 a.m. and 11 p.m., with just one hour's rest between trips in mid-afternoon. By the end of this year a \$5,000,000 fleet of eight Zephyrs will be plying the Burlington lines at a rate of probably 40,000 miles a week. The Union Pacific already has a fleet of six streamliners in service that cost \$5,000,000 or more. The Southern Pacific is building trains for a faster Los Angeles-San Francisco run. The

F813

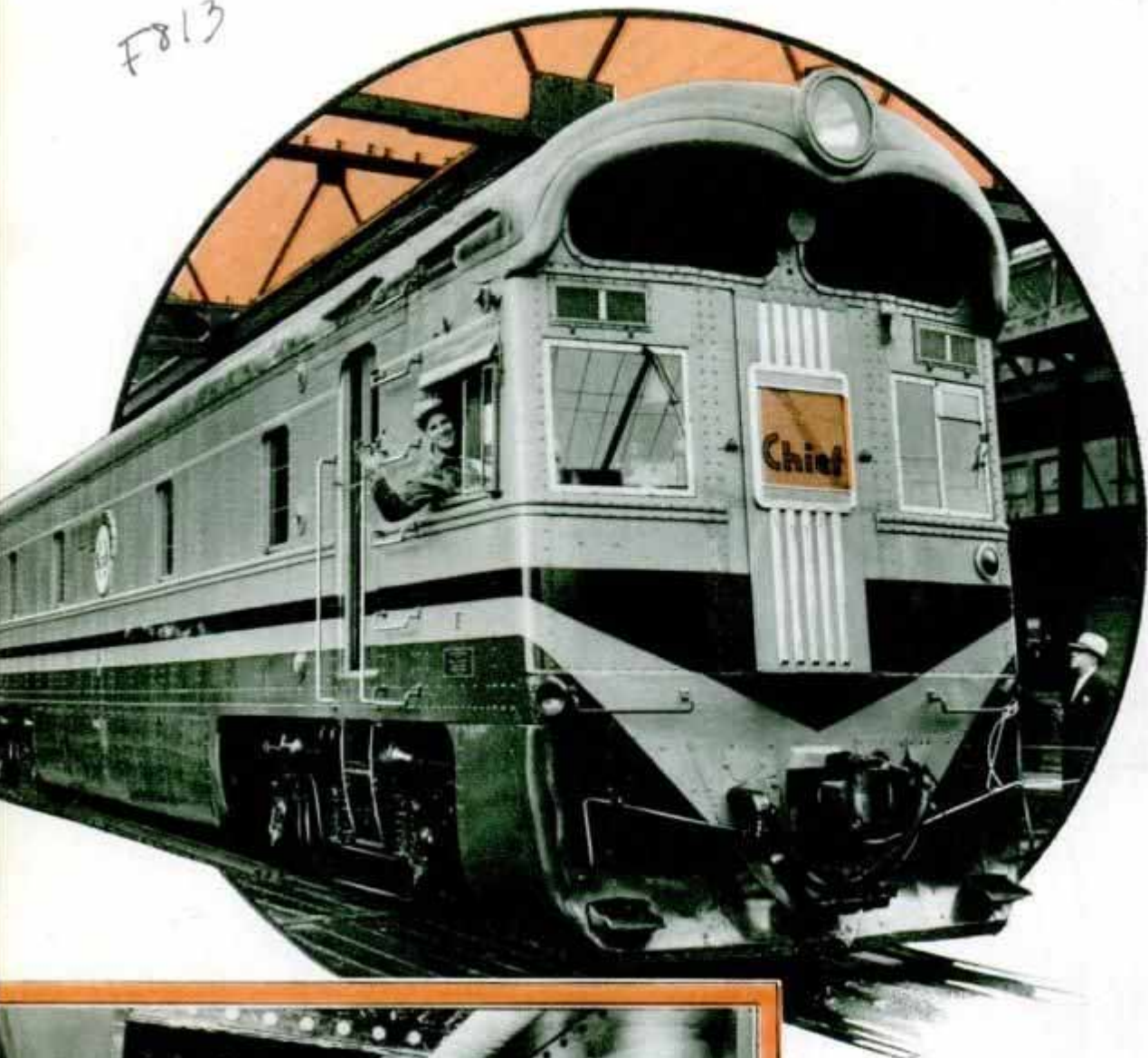

MOST powerful Diesel-electric locomotive in America is the Santa Fe "Super-Chief." Left, a streamliner's power plant.

Canadian National Railways have just built Canada's first streamline engine, a steam locomotive of gigantic proportions to haul its crack trains into Montreal from the west. And so from Boston to Bangor, from Washington to New York, from Detroit to Toledo and Cleveland, and down the Mississippi Valley, the rails are singing the new song of speed.

But it is the west that shrinks most dramatically under the flying wheels of 1936. A year ago you crossed the Nebraska plains under a blazing sun, slept two nights on the best trains from Chicago to Denver. Tonight you step aboard a million-dollar twelve-car streamliner at sunset in Chicago, glide



GATHERING speed as it leaves Chicago, the old iron horse of the North Western's "400" races streamline rival trains to St. Paul-Minneapolis.

through the night with unbelievable speed and the smoothness of articulated cars, awake to see dawn on the Rockies. Sixteen hours from Chicago to Denver—nearly ten hours faster than a year ago.

San Francisco, Los Angeles, Portland are a day closer to Chicago on the fleet of streamliners now plying across the plains and mountains. They span the western two-thirds of the continent in the time it took the best steam trains out of Chicago to reach Butte, Mont., or southwestern Colorado. The most powerful Diesel-electric locomotive in the land, the blunt-nosed "Super-Chief" of the Santa Fe route, summons its 3,600 horsepower to haul standard heavy steel sleepers from Los Angeles to Chicago in less than forty hours. Or you can ride in million-dollar luxury at two cents a mile or less on the Union Pacific's "City of Los Angeles," "City of San Francisco" and "City of Portland," spanning the west in two nights and a day.

No Indian maharajah could command more comfort than the traveler aboard one of these streamliners. They are less like the conventional railway train of two years ago than itinerant palaces, colorful, festive, comfortable. Observation cars have become solariums, curving toward the finlike tail, with lounge chairs clustered in groups as intimately as a club. Wide windows afford broad vistas of the kaleidoscopic scene. Aluminum striping and paneling, wood-veneer walls, chromium-framed furniture contrast smartly with soft-hued upholstery. And you are in a climate apart from the world. Through desert heat and mountain chill, through blinding dust storm the streamliner's weather is man-made. The railroads spent \$16,000,000 to install air-conditioning equipment last year, just as a starter. Windows are twin panes of shatterproof glass separated by a gas chamber, sealing out dust and assuring a view unclouded by moisture.



IN THE pastel-hued "solarium" of the "Green Diamond" is this buffet section. Meals are also served in the coaches.



Steel louvers along the aisle of the sleeping car let the traveler seclude himself, day or night. Upper berths have been made as attractive as lowers, with windows that admit light and a view of the outdoors. Curtains protruding into the aisle make it easy to dress in upper or lower and steps to the upper berth instead of ladders, fold automatically when not in use and are removed during the day. In the club cars, lanes of reflected light enhance the pastel coloring of the room. In the sleepers, slim pencils of light illumine the aisles, and numbered bulbs glow above each section to guide you to your berth. Wall lamps over every seat shoot bright bullets of light over your shoulder while you read, and at a flick of a switch the lamp sheds a soft, blue night light. Rheostats dim the overhead lights in the coaches to a restful blue glow at night.

(Continued to page 132A)

7982.

"G-Men" Learn to Shoot from Speeding Car



club
While the car turns at high speed, the G-man fires with a machine gun at the man-size target shown at right. Accuracy is difficult, but the student is required to pass this test in police academy

It's not easy to send a bullet crashing through a man-size target from a speeding automobile, but that is the trick which G-men, agents of the federal bureau of investigation, must perform. The weapon is a machine gun and the G-man must be able to hit the "man" while the automobile is driven swiftly past or swept in a curve. The test is one of those established by the bureau for students attending the national police academy. Representatives from law-enforcement organizations of many states gather each year to learn more about scientific crime detection.

1977

Sunlight Acts on Greenness of Seeds in Test

That sunlight acts on certain seeds through chlorophyll, the green coloring matter of vegetation, has been established by Dr. Lewis H. Flint of the U. S. department of agriculture. The discovery opens a new approach to the study of light in relation to seed sprouting and growth, plant metabolism, distribution of plants and other problems of the science of life. Yellow, orange and some types of red light which promote growth are eagerly absorbed by the chlorophyll, Dr. Flint found. At the same time, violet blue light and nearly infrared light, both of which retard growth, were absorbed by the chlorophyll. Thus the green coloring matter, Dr. Flint says, becomes almost inevitably identified with the reactions of seed to different kinds of light.

Washington
pp

7983

Newspaper Office on Wheels Has Radio and Darkroom

Completely outfitted with two-way radio, photographic equipment and a darkroom, a newspaper office on wheels has been placed in operation at Detroit. Announcers or reporters have high-frequency



Wide World
This truck has two-way radio and other equipment for quick coverage of a big news story

radio packs with which they may carry on a two-way conversation with the mobile office or with the headquarters of the newspaper. Stories may be transmitted direct in this manner. The photographic unit enables the crew to take and develop news photos on the spot. Installation of the radio transmitter also may hold the possibility of sending photos by radio to the home office.

One-eighth of an inch is added to the radius of the earth every hundred years by the fall of cosmic dust.

Wayne University
Enclosure June 1936

Science Service 7/20/36

F964.
498

2797

Design of Golden Gate Fair Wins Approval

Golden Gate International
Exposition

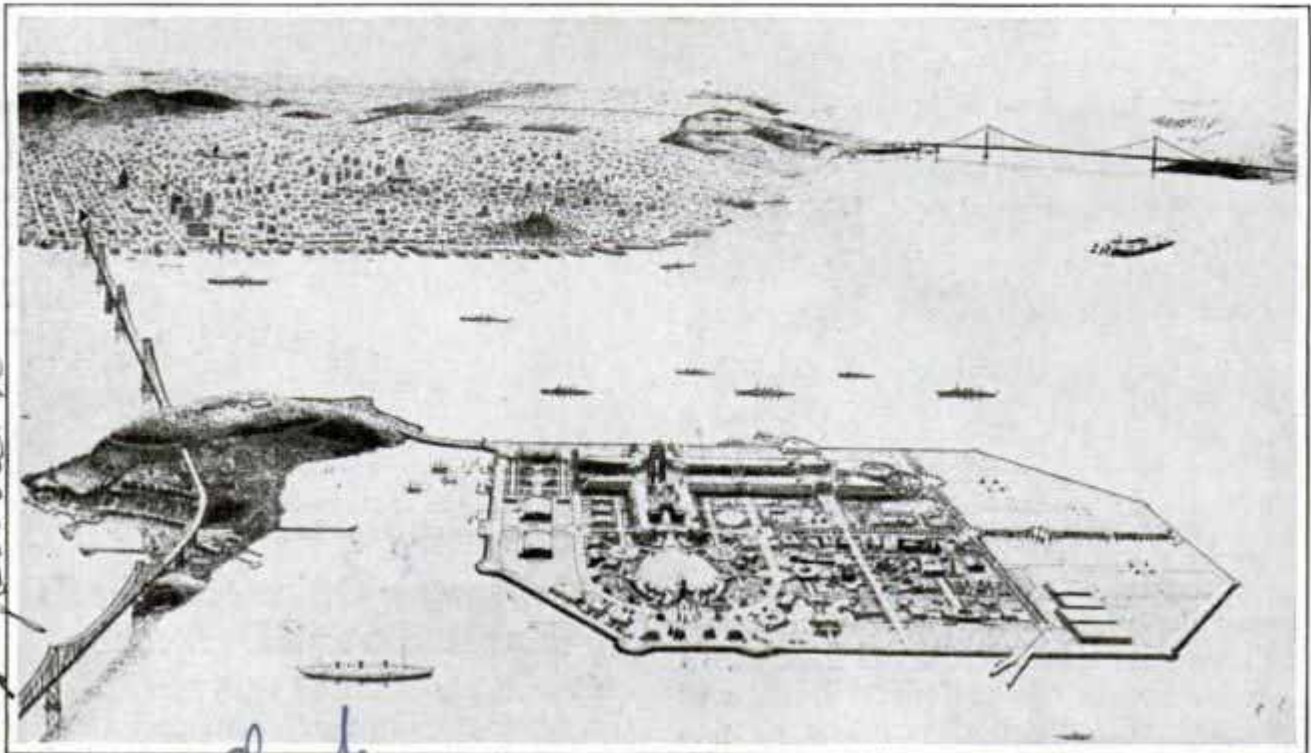

Here is the way the San Francisco exposition might appear from the air upon completion in 1939. This is the approved design. The bay bridge, ferries and planes will permit access to the ground

Approved by the management, the first architectural design of the 1939 Golden Gate fair at San Francisco, Calif., has been made public. At one side will be a six-lane highway leading from the San Francisco-Oakland bay bridge via the west side of Yerba Buena island. Near by is a semicircular three-story airport terminal building which will be used as the administration building. On the southern end of the site are two airport hangers which will

be used as exhibit palaces. The main exhibit buildings will run on two axes, at right angles, with a lagoon and a tower at the eastern end of the site. Foreign and state buildings will be grouped around the lagoon. Three ferry slips and a ferry terminal building on the western side of the site will handle boat-passenger traffic and another ferry slip on the eastern side will handle freight. Parking space will be provided on the northern end of the site.

Seventeen Miles on a Gallon Is Goal of 'Economy' Plane

Aero Engineering Corp
Los Angeles Calif



This trim craft, designed for economy, is expected to deliver high gasoline mileage without sacrificing important features of larger planes

Built to sell at a popular price and to fly at a low operating cost, a two-seater monoplane with many of the features of a big transport ship is undergoing flight tests in California. Engineers at California Institute of Technology aided in its design, and predicted the little plane would fly 150 miles an hour with its 125-horsepower motor, and would be able to

17 miles per gallon

Handwritten notes and scribbles at the bottom of the page.

cruise for 700 miles at 138 miles an hour at an average of seventeen miles to the gallon of fuel. It is "convertible," the cockpit having a removable cover. The ship is of the low-wing type, conforming to the best streamline design without a visible wire or strut. Twenty-five feet of split flaps behind the wing are used for wind-braking. Dual controls and automatic flying instruments are provided, and a two-way radio has been installed.

Pacific's 'Flying Library'

F933 Serves Readers on Islands



Loading books aboard Pan-American plane at Honolulu for readers on the isolated islands along the new Pacific air line

F951 Horse Protected by Gas Mask in Air Raid

For protection of horses during aerial gas attacks, a special gas mask resembling a feed bag has been devised and tested in Austria. The mask fits snugly on the horse's head and supplies the animal with purified air during the time the gas is floating near by.



Equipped with this gas mask, the horse is ready for the "enemy's" aerial gas attack

Supplying reading matter to the residents of Wake, Midway and other islands along the Pacific air line has been simplified by inauguration of a flying library service. When the Pan American clipper planes take off from Honolulu, packages of books are on board, each consigned to one of the islands. The Honolulu public library is in charge of the service. The books are kept in circulation by moving them from one island to another until the entire route has been covered.

F954 Automatic Stoker in Kit Form Is Assembled by Buyer

Available in kit form so that the buyer may assemble the parts at home, a low-priced automatic stoker will convert the coal-fired heating plant into a modern system. The parts may be purchased one at a time, if desired. Complete instructions for assembling and installing are furnished by the factory. The stoker also may be purchased in assembled form.

Sweden minted a thirty-one pound copper coin in 1659 worth about \$5.20.

Copier and Brass Research Assn.

Parts \$147.50 ready to install \$157.50
complete \$175.00

Tables of Agency Co. Manual

acme

11/18/38

W.C.

1812. Mr. Wm. Massman
 4 W. 103rd.
 New York

QUEER FACTS about

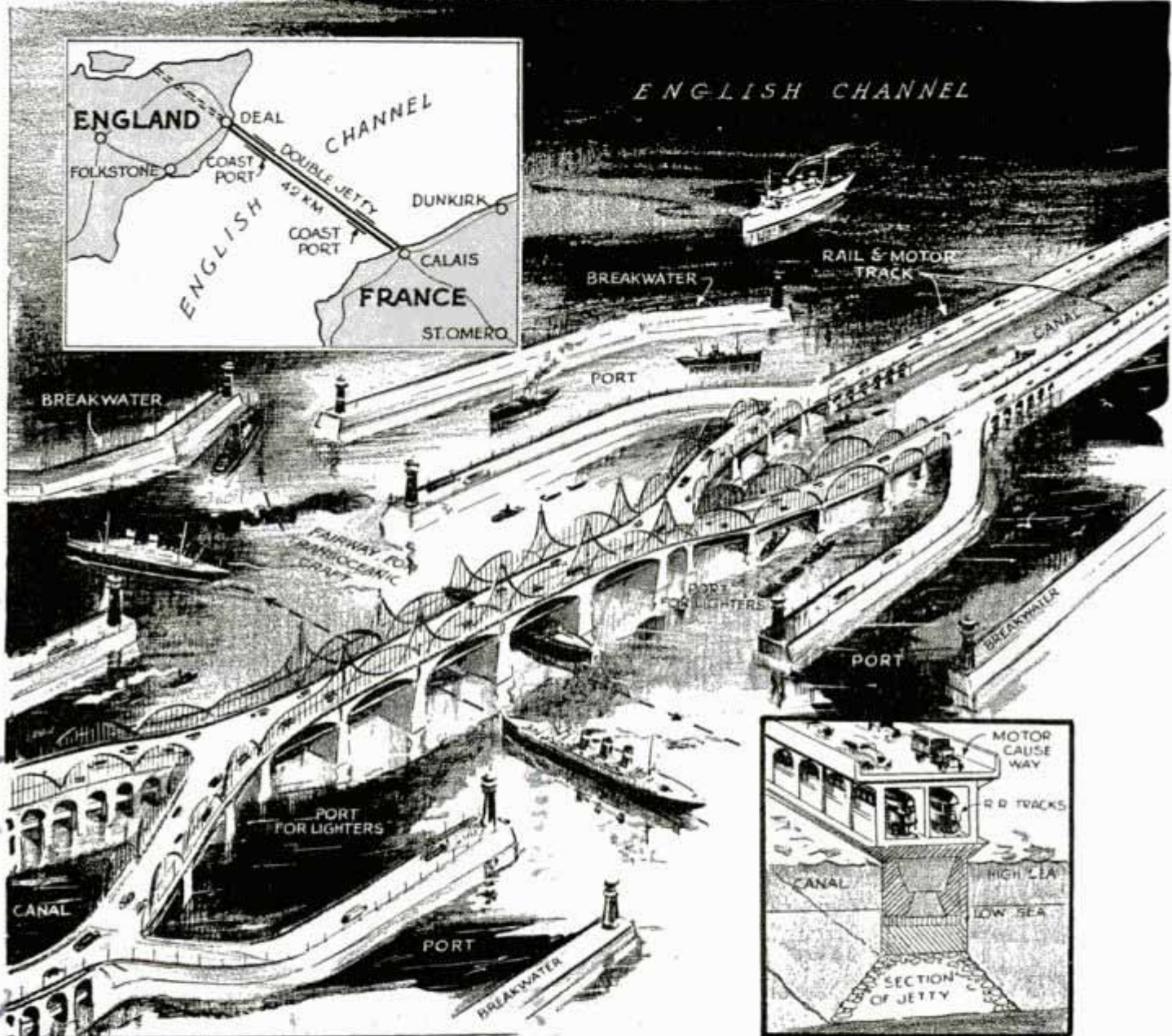

Solution of English Channel problem proposed by Swiss engineer. He would build two parallel jetties which would be linked up with shore at Deal and Calais by huge bridges

THIS is a bridge-building age. Five thousand bridges span the navigable waters of America, but America needs still more crossings to care for the ever-growing volume of traffic.

More than \$300,000,000 worth of bridges have recently or will soon be opened to traffic. Stretched end to end, the bridges and viaducts in the United States would reach across North America.

Bridges are forever growing higher, wider and roomier, and modern spans reveal the grace, beauty and strength that

goes with steel, the suspended roadways seeming to hang in space from the thinnest strands, like spider webs. American invention and enterprise have been largely responsible for the "big bridge" age. The foremost bridge designers and builders are the Yankees and at opposite gateways to the nation, San Francisco and New York, are new bridges unequalled elsewhere on earth.

In Europe the greatest bridge is the new \$8,000,000 Little Belt bridge, in Denmark, connecting the Island of Fuenen with Jut-

78/2

BRIDGES

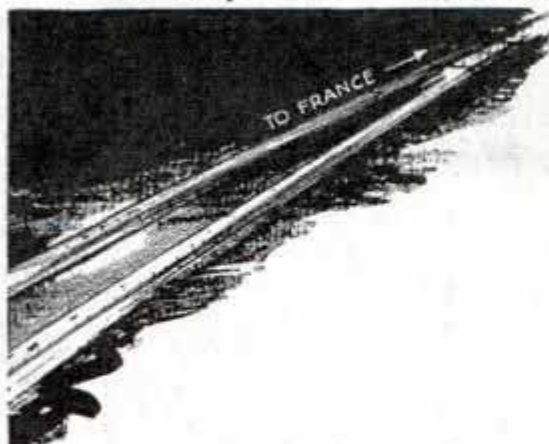

land. This bridge is three-fourths of a mile long and rests on bedrock 121 feet below the water's surface. But the great spans in America surpass the continental bridges because the United States has denser traffic and wider rivers.

Every twenty-four hours, about 3,000,000 people cross the bridges of New York City alone. When famous London bridge was built, it was as much a street for shops as a means of crossing the River Thames and its capacity was measured in terms of horse carts and pedestrians. American bridge engineers think in terms of huge capacity. It is difficult to predict the volume of traffic in the next ten years, hence new bridges are either double-decked or have provision for future double-decking. If traffic increases at the present rate, many existing bridges will prove inadequate. With six mammoth bridges lying within ten miles of each other, the bridge facilities across the East river, New York, are still considered insufficient.

The more automobiles on our highways, the more bridges are required. The opening of a new bridge causes an important change

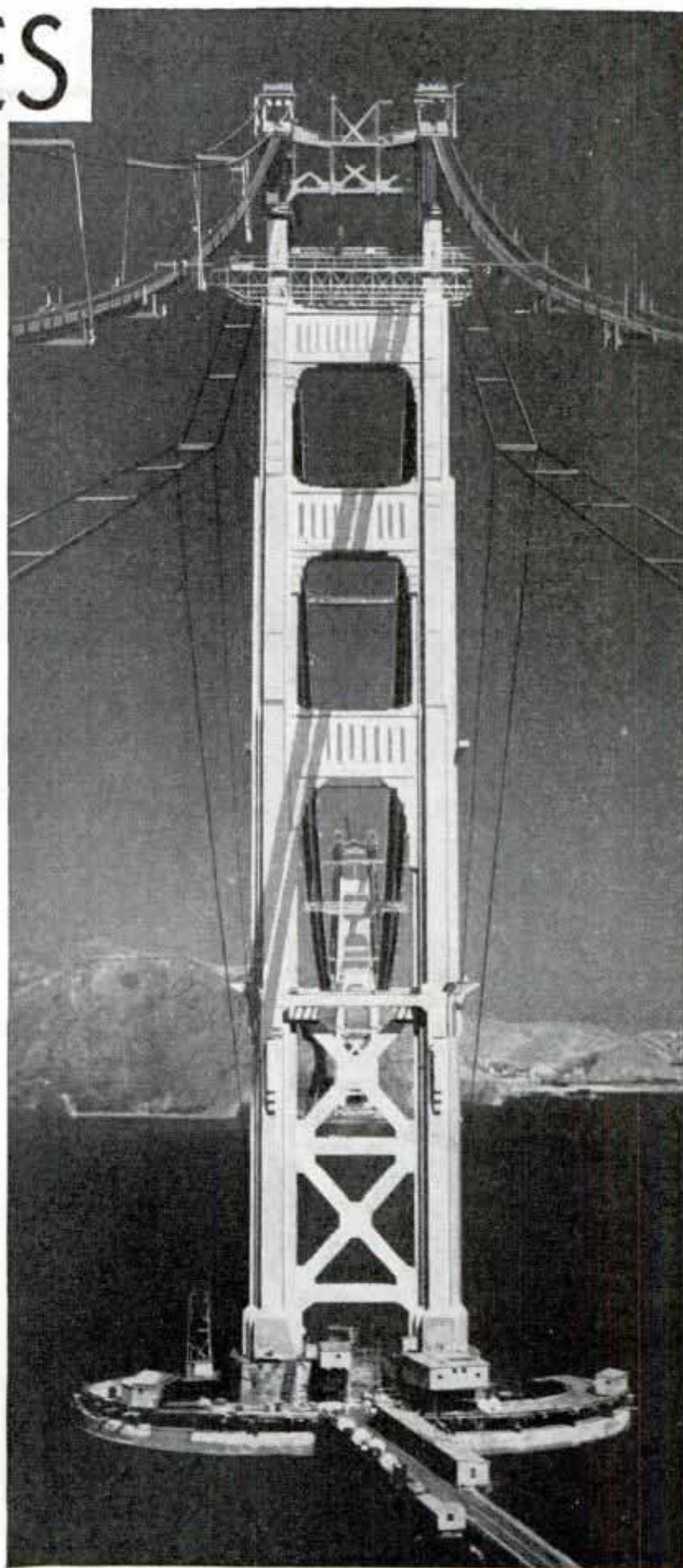

One of the huge towers of the San Francisco bridge. Through the deck level may be seen a twin tower, 4,200 feet distant



One of the few remaining covered wooden bridges. This one is more than fifty years old and is still in service near Rushville, Ind.

in the life of a city and the population spreads rapidly into the suburbs. Thus, thousands now living in the crowded areas of San Francisco proper are expected to change their residences when the new skyscraper bridges are opened.

Working with crude materials, the ancients were unable to erect spans greater than thirty or forty feet. Today we are building suspension spans up to 4,200 feet. The engineering feat of building the new San Francisco bridges may be compared with the Panama Canal. Looking at a series of skyscraper spans, costing about \$115,000,000, one wonders what the ancients would think of a double-deck, six-lane roadway hanging in free space without visible support for almost one mile. But bridges of greater length, height and capacity are still possible. Modern bridge building stops at few obstacles.

Arched structures of stone or brick go back to 4000 B. C., and their remnants are still found. For thousands of years, man found his best bridge material in stone,

but the work of keeping the ancient bridges in repair was quite costly. The same was the case with wooden bridges. Storms, winds, sunshine and flood destroyed their foundations and made them unsafe. In the middle of the nineteenth century the first metal bridges, made of cast iron, appeared. But they were impractical because cast iron lacks tensile strength. The development that revolutionized bridge building was the Bessemer process. This enabled engineers to design steel trusses, with high tensile strength.

John Roebling originated the use of wire cables for suspension bridges in America. His great undertaking, the beautiful Brooklyn bridge, was literally spun out of thin steel threads. That method also was followed in building the new Triboro, the George Washington and the San Francisco bridges. Metallurgy is expected to make possible even more spectacular developments in bridge building. This was indicated recently by the reconstruction work on the Smithfield bridge,



The George Washington bridge in New York City, erected at a cost of \$60,000,000, and a splendid example of the work of the modern bridge engineer

built in 1882 across the Monongahela river, at Pittsburgh. By redecking this bridge with aluminum girders, instead of steel, the engineers saved sixty-five per cent of the dead-load weight and added an estimated twenty-five years to the useful

service of the bridge. Formerly, vehicles were limited to thirteen tons on four wheels; today, twenty-ton trucks on four wheels can cross this bridge safely.

Dr. D. B. Steinman, one of the country's

(Continued to page 124A)

117 Liberty, New York

Figures Sculptured with Moist Newspapers



Newspaper sculpture is the latest art to attract those who like to fashion figures out of plastic materials. Wire frames are constructed and moist newspapers are molded over these frames to form human figures, houses, dolls, animals, puppets and caricatures. Flags and similar decorative objects also are created by employing hundreds of strips of colored paper and weaving the strips together to form designs.

Examples of paper sculpture made by molding moist newspapers over wire frames to form miniature figures. The flag is composed of hundreds of strips of colored paper

Cathode Ray Directs Airplane Pilot

Successful tests of a cathode-ray direction finder for airplanes have been conducted by the coast guard. When the plane approaches a broadcasting or radio range station being used for guidance, the cathode-ray pattern viewed on the "screen" on the instrument panel gradually opens out from a vertical line beam into an ellipse finally becoming an almost perfect circle as the ship arrives over the station. Should the plane miss the station the pattern may go completely off the circle, indicating the location of the transmitter. Total weight of the equipment is seventy-five pounds. Power to operate it is taken from the twelve-volt storage battery used for starting and lighting purposes. During tests, satisfactory performance over distances of 125 to 200 miles was reported with fifty-kilowatt stations.

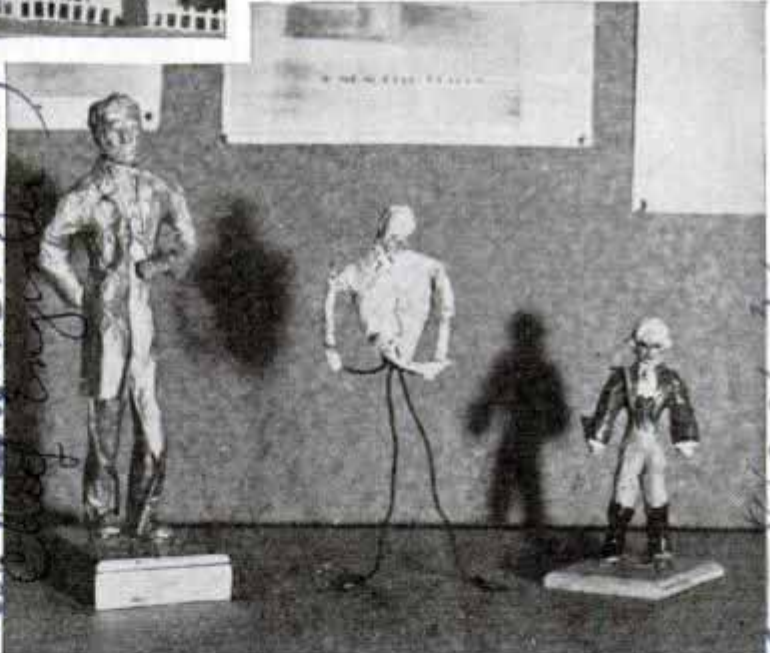

"Super-Eye" Sought to Gauge Light and Color

Scientists are searching for an eye-surpassing instrument which will measure light and color with as much reliability and ease as a voltmeter and ammeter measure electricity. Dr. Herbert E. Ives of the Bell Telephone laboratories points out that such an instrument would be a definite improvement over the eye because eyes vary from person to person and because the eye is useless as an indicating instrument and can be employed only in comparative methods. Even the "electric eye" or photoelectric cell has definite

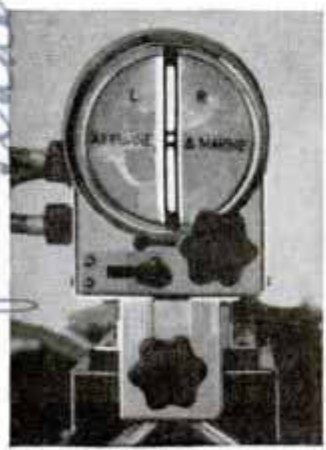

Handwritten notes on the left margin: "Airplane Direction Finder Corp", "Marine Direction Finder Corp", "Edward Teller", "1958", "1/20/56".

Handwritten address at the bottom: "463 West St. Newark".

7/20/36

T992

Two and a Half Ton Camera Will Chart the Night Sky

faults. One is that it is imperfect in ordinary light measurements, varying types being sensitive only to particular colors. By using several special cells, each sensitive to a certain part of the spectrum, Dr. Ives has obtained more accurate color measurement than any individual cell can record. This cell grouping has the advantage of eliminating errors due to scattered light of different wave lengths. But the problem is still unsolved.

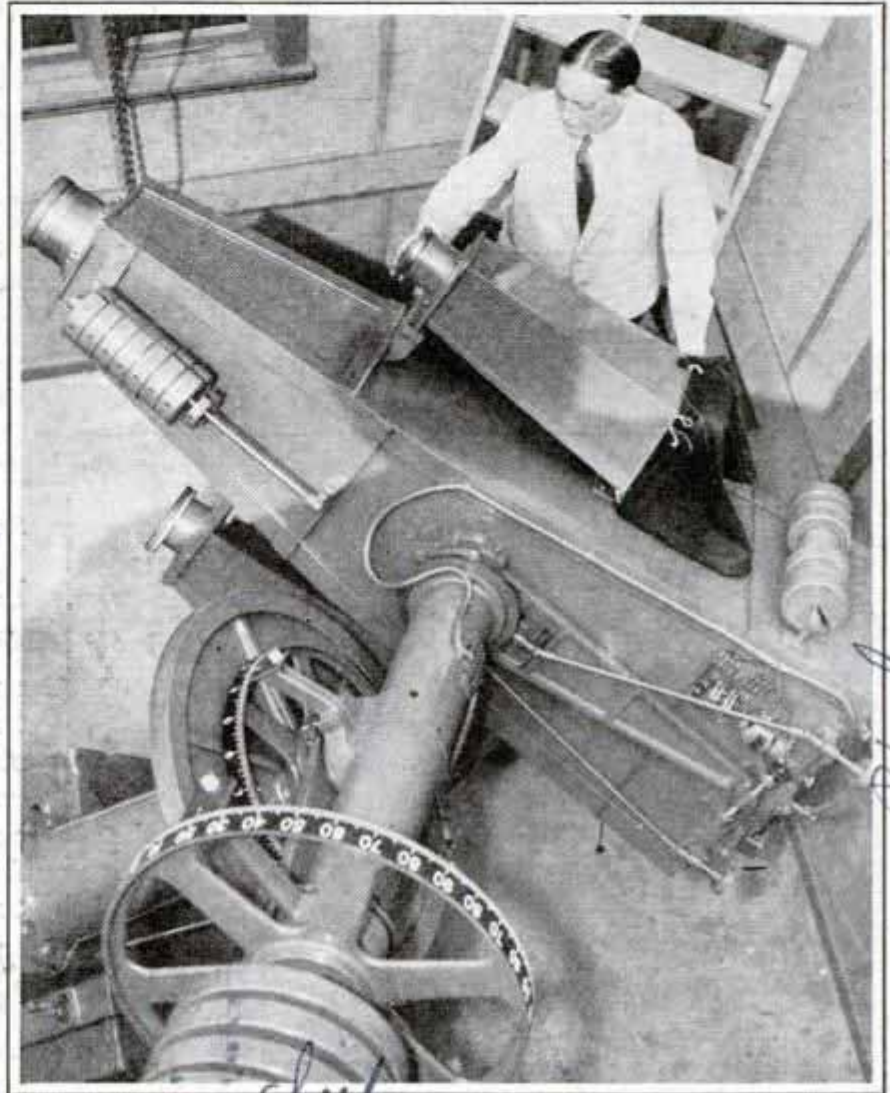

This combination of cameras in private observatory will be employed in charting the night sky by means of photographs

Mounted on an eighteen-ton base, a new two-and-one-half ton camera group has been set up in a private observatory for photographing the heavens. A photographic atlas of the universe within reach of the cameras will be compiled by Dr. Gustavus W. Cook, amateur astronomer. The big camera, which uses a plate twenty by twenty-four inches, will be trained first on the Milky Way.

High-powered rifles require steel-jacketed bullets because the terrific friction in the bore would melt lead.

Thrill-Ride Plane "Flies" Only on the Ground

Its original wings replaced with ornamental ones with no airfoil, a thrill-ride plane operates only on the ground. It has a top speed of eighteen miles an hour, produced by a small automobile engine which was substituted for the original motor. The builder plans smaller ones to be operated in amusement parks. The plane demonstrates how a ship reacts to its controls while on the ground.

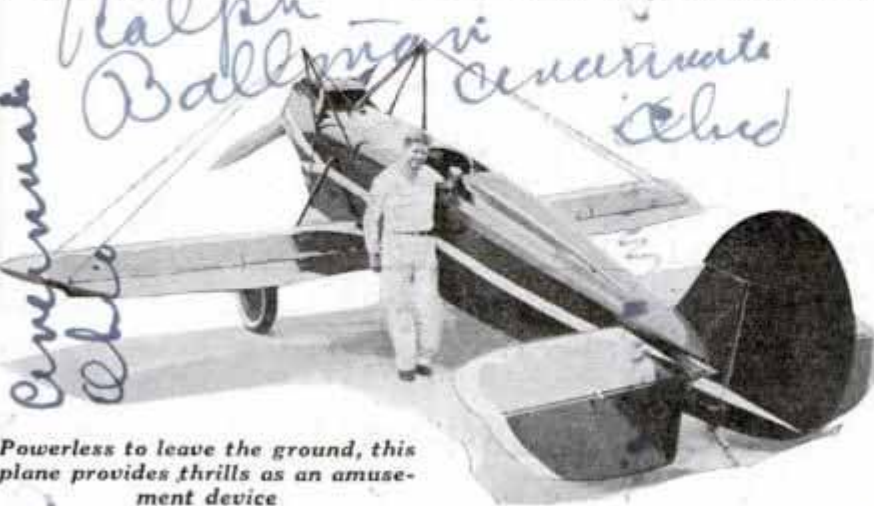

Powerless to leave the ground, this plane provides thrills as an amusement device

Conk... Alan... Henry... Lumber... Aufward...
Carpenter...
Alto

Ralph...
Ball...
Cen...
Alred

Handwritten notes on the right margin, including "Wayne... Engineer...".

Wayne...
Engineer...
P.H.

your wrist or ankle, it does not interfere with swimming. It weighs three ounces. Swim out to the raft and you can have a dry smoke, and, for the ladies, it can hold powder puff and lipstick and there is a mirror inside its Bakelite cover. It is available in six colors.

7952
**Bird Family Photo
 Wins Amateur
 Contest**

When an alert amateur photographer snapped a picture of a mother robin feeding her young, he obtained an unusual photograph which won first prize in a wild-life contest conducted recently. The photo shows the baby birds holding their mouths wide to receive the "lunch" brought back to the nest by the mother bird. One of the tiny birds is being favored by the mother, the photo showing its mouth in the act of closing on the dainty morsel.



Lunch time for the bird family—as amateur photographer's prize-winning photo shows it

U. S. War on Counterfeiters Uncovers Plant in Suitcase



This suitcase, opened to show the complete counterfeiting plant which it contained, was seized in raid by federal agents

In a recent raid by federal agents engaged in a drive to stamp out counterfeiting, a complete plant for manufacturing bogus bills was found in a suitcase. Hundreds of bills turned out by this easily portable plant had been passed in the East before the raid. Bank clerks and post-office employes have been trained to detect bogus money, but by exercising a little care any one can soon learn the difference between good and bad bills. The old method of holding up a bill to the light and looking for the silk threads woven into the paper is still a good idea, because no counterfeiter has ever successfully produced a good imitation of the paper used by the government. Perhaps the best way to detect counterfeit currency is to study the picture on the face of the bill. A close examination of a five dollar bill, for instance, will show that the features of Lincoln are expressive and lifelike. The eyes are always clear and natural. On bogus bills the eyes are always blurred. This holds true, also, of the borders, which are marvelously engraved on genuine money. Fake coins usually can be detected by the ring when dropped upon a table. Not all counterfeit bills have a new appearance. The counterfeiters have a trick of soaking bills in coffee to give them the appearance of age.

#835. Mr. William...
Ila Puy, 1001-15th St. N.W.
Washington, D.C.

FEEDING ANIMALS



AN ODD job is that of catering at the National Zoo in Washington, D. C., a job which takes the time of some thirty employes and costs the taxpayer some \$50,000 a year. So well is the task performed that the claim is sometimes made that the bears at the zoo get better bread to eat than does the President in the White House a mile away. It is two parts flour and one part bran. A loaf of this bear bread weighs sixteen pounds and the big bruins require one and a half a day and the little ones half a loaf. Only the polar bear insists on fish or meat, preferably a hunk of brisket of horse with plenty of bone for exercising the teeth.

Half a dozen loaves of bear bread are given occasionally to the elephant as a special treat. The pachyderm, however, is dietetically simple in its tastes, being satisfied with eighty pounds of hay and a bucket of oats every day.

The coat of Queeny, the lady lion of the zoo on whom the sun has never shone, has



Top, the hippo gets his spring tonic. Bottom, the rhinoceros actually likes his spinach

in the ZOO

a shimmering gloss because she gets her sunshine out of a bottle of cod-liver oil which she and hundreds of other cage dwellers get regularly. Shut it off for a few weeks and their coats become drab.

There are many fine beauty points at the zoo. The scarlet ibis, for example, must scintillate to keep people from looking at her spindling legs. When her feathers went dull attendants tried many experiments. Dried shrimp turned the trick. There was the case of the bird of paradise that would eat nothing in the bird-food pantry of the



Top, roly-poly koala bear and cub ready for the dinner bell. Bottom, left, every day's fish day for the penguins. Right, feeding a five-months old walrus a lump of whale blubber

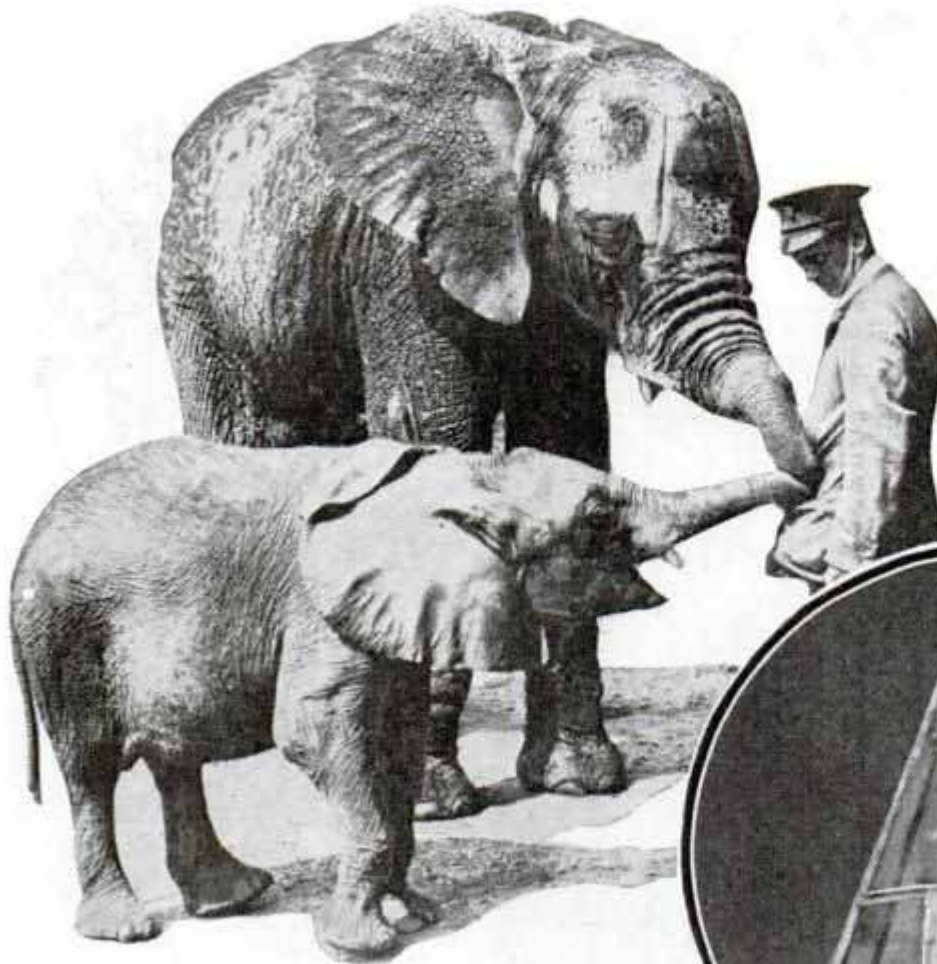

dren. They are swept up every morning to delight the palates of certain fastidious lizards, birds, fishes, and the aardvark. Other breeding cases, abundantly supplied with wax, prove gratifying to small moths which become the piece de resistance of many discriminating birds and toads. A green,

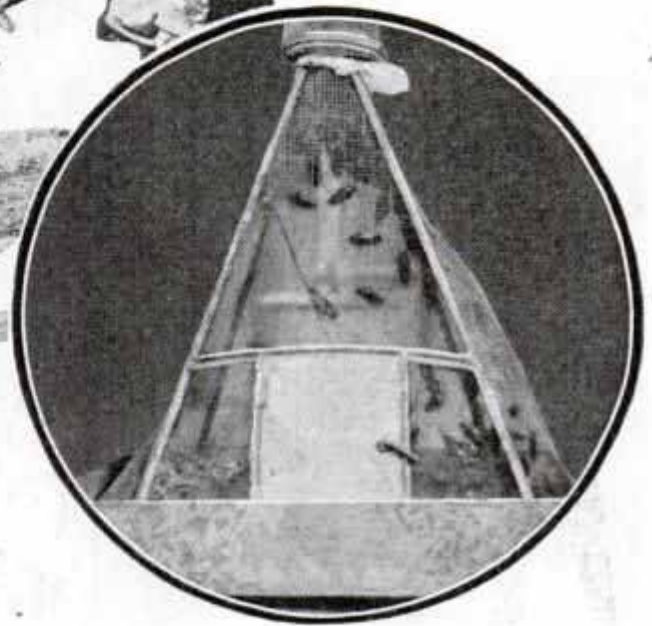

zoo. She languished and faded until Dr. William M. Mann, the scientist who superintends the zoo, thought of desiccated ant eggs, a rare product. It can be bought, however, and was bought of an importer in New York, and turned out to be the very sort of caviar for which the bird of paradise was yearning.

Do you know that mockingbird food can be bought in a can? That's true, but the kitchen at the zoo makes its own, five or six hundred pounds of it a year. It is composed of ground zwieback, crissel (a dried meat mixture) and ant eggs.

Any housewife would be shocked by the cockroaches running all over the zoo pantry, but the cockroaches are the favorite food of many toads, lizards, snakes, turtles—all denizens of the reptile house. One of the interesting devices in the zoo kitchen is a specially designed trap for catching these insects.

An old chiffonier in the zoo becomes a mealy worm-breeding establishment. Its drawers are filled with layers of gunny sacks that are covered with bran. This becomes the perfect home for beetles of which mealy worms are the larvae chil-

Left, a youngster learns a new trick from an old-timer at the zoo. The attendant's pockets are filled with tidbits—most likely, peanuts. Right, trap for catching cockroaches enables the zoo to provide many toads, lizards, snakes and turtles with their favorite food

poisonous frog from Panama and a horned toad from Arizona, with the knack of shooting blood from the corner of its eye, insist on red ants at mealtime. An over-ripe banana lures the red ants into the cages of these tiny reptiles.

There is an odd little snake from Australia that must have eggs and it swallows them whole. Sparrow eggs are the biggest it can eat. There is trouble, however, when the season for sparrow eggs is over. So plain chicken egg is stirred up, sucked into a syringe, and shot down the snake's neck. The cobra, from India, is an infrequent eater but bolts a squab every month or so. The gila monster of the southwest eats an occasional egg. Copperheads are fond of frogs.

Lions, tigers and leopards, are merely house cats grown large. What they want is good red meat, beef or horseflesh preferred, ten to twenty pounds a day for the big ones, five pounds for the leopards, two for the caracal. Pigeon day is quite an occasion. The cats eat but once a day. It has been found that they are healthier if they fast one day a week so they are not fed on Sunday. Then on Monday they get liver for a change.

The elephant seal is an expensive boarder since it consumes 100 pounds of fish a day while the sea lion requires but twenty. The prep-

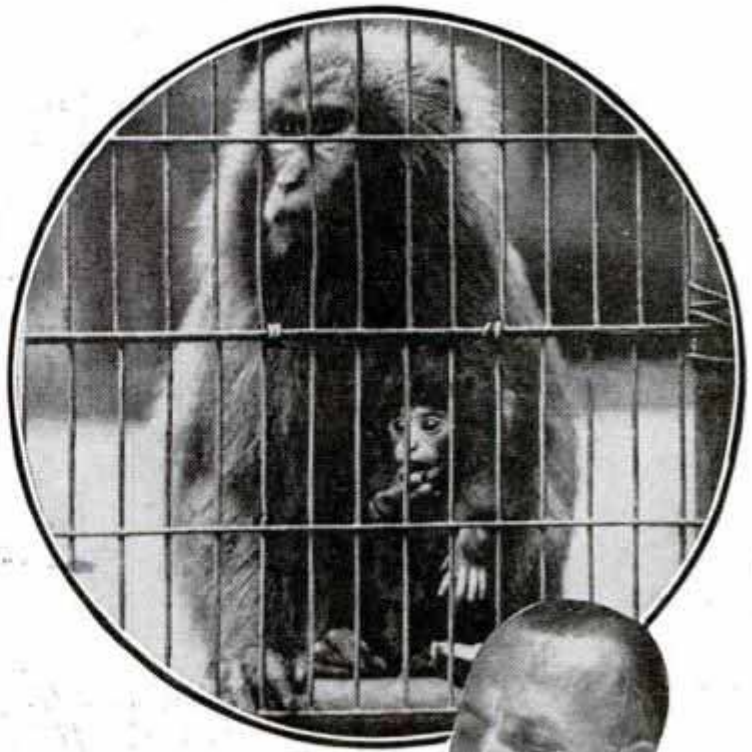

Top, this monkey and her baby like almost any food that man eats. Center, four-months old buck deer is still a "bottle baby." Bottom, here we see a large lizard refusing a banana. This one eats nothing except seed-weeds from the Galapagos islands

paration of this food makes little trouble in the kitchen since it is served raw. But it must be carefully refrigerated and kept perfectly fresh.

A staple for the carnivorous animals is the meat ball, a sort of hamburger steak, made of cooked ground meat mixed with chopped-up vegetables. It is a sight to see

(Continued to page 136A)



7/27/36

Water Skiing Is the Latest in Sports World



Water skiing offers thrills—it skier in foreground isn't careful he will get a ducking

Great popularity among water-sports devotees in Germany has been won by floating skis on which the wearer may move along the surface of the water. Using the skis appears to be an art in itself, since the water variety is about as tricky as those worn on the snow. As the wearer grows more proficient, however, he discovers that unusual speed can be developed. For various water games the skis offer many new thrills.

Grass Juice Added to Milk Promotes Growth

Recent experiments have shown that grass juice will enhance the growth-promoting properties of milk. Juice squeezed out of lawn clippings was added to the daily milk ration of young rats, causing them to gain weight much more rapidly than rats fed plain milk. Liver and brain tissue also were found to promote growth when added to winter milk.

This finding, if it proves applicable to human nutrition, may point to the desirability of fortifying winter milk with materials containing the growth factor which it lacks. Such additions will not be necessary with summer milk because cows having access to pastures give a product potent in promoting growth.

Rubber-Tired Roller Skate Has Soft-Riding Springs

Equipped with a spring for each pair of wheels, a German-designed roller skate with rubber tires is said to give a softer ride and to be easier to handle. The rollers are larger than on the conventional skate and improved ball bearings are claimed to increase the speed.



Spray System Easy to Make with Water-Pipe Nozzle

Attachable to any water pipe by drilling a small hole and tightening two nuts, a simple nozzle is available for making spraying systems, city and highway sprinklers and truck-farm irrigation systems. A deflector spreads the water into a wide spray. Several nozzles may be used on the same pipe. The unit has no shut-off valve, so the pipe valve serves all nozzles.

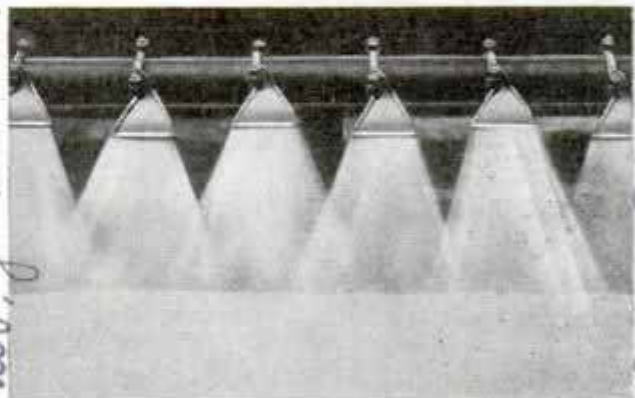

Here is how a water-pipe nozzle system appears in action. Note the separate nozzles

F992

Madison
Druid of Wisconsin

Aug. Schupmeyer, Esq. Volkmarsstein, Prussia

Am Chicago

Mrs. C. A. Elvehjem
209 1/2 Michigan

Link. Best Co
209 1/2 Michigan

Spin-Proof Plane Has Air Slots in the Wings

Successful tests were conducted recently of an airplane which the designer claims cannot go into a spin. The spin-proof feature is a slotted wing which permits some of the air to pass through. It is said this increases the lifting capacity of the wing, thus stopping any tendency of the craft to go into a spin. The plane can take off in 100 feet



Plane with air slots in wings which permit some of air to pass through. The designer claims that this feature increases the lifting capacity of the wings and stops any tendency of the craft to go into a spin

and can rise 1,000 feet per minute. The designer of the plane said he obtained his idea for the wing slots by watching pigeons in flight.

Faster Rifle Bullet Is Shaped Like Nipple of Baby's Bottle

Similar in shape to the nipple of the baby's nursing bottle, a new rifle bullet has about four times the acceleration of a normal bullet. Stabilizing fins formed on the bullet during its passage down the

rifle barrel result in greater accuracy. The base of the bullet is cup-shaped and partly hollow, giving the exploding gases greater surface area on which to act. The bullet attains an estimated speed of 3,600 miles per hour. The government has been granted full use of the new projectile without payment of royalties.

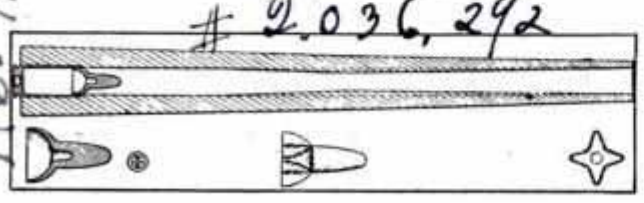

Showing how fins are formed on base as bullet passes through barrel of rifle

Four manganese bronze propellers weighing thirty-five tons each, the largest ever cast in a single unit, drive the liner "Queen Mary."

W. E. McWhorter
 600 N. Military
 Lawrenceburg
 Tenn.

H. Parker
 420 Lexington
 Av. N.Y.C.

W. E. McWhorter
 Tennessee

600 N. Military
 Lawrenceburg
 Tenn.

W. E. McWhorter
 600 N. Military
 Lawrenceburg
 Tenn.

420 Lexington
 Av. N.Y.C.

Capt. Wiley
 Research Assn
 Copper & Brass

Transcontinental and Western Air. Inc., Palmer House Lobby Chicago

TRAFFIC OFFICERS

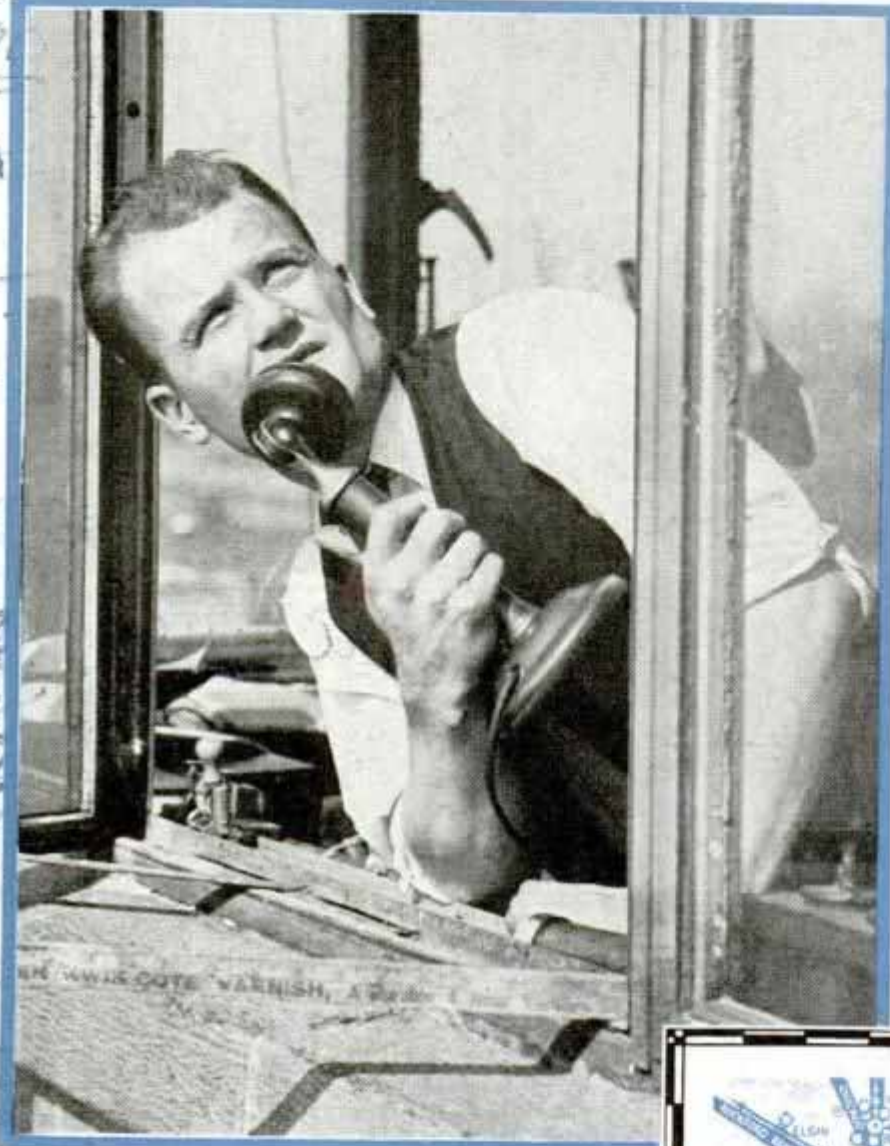

His voice blares from one of several amplifiers in a tiny glass-enclosed tower atop the passenger station at the Chicago Municipal Airport. One of the two men in the control tower picks up a radiotelephone and makes instant reply.

"WGEH to Andrews, TWA 320, ten miles west at 4,000," comes the answer in Andrews' ear-phones. "Two private planes are flying at 3,000 south of port. United's Trip 10 is taking off and will take an eastern course at 6,000 feet. Wind southwest by west five. Kollsman barometer twenty-nine. Ceiling 2,500. Visibility three miles."

"Okay, WGEH," comes the voice of Pilot An-

By H. W. Magee

HIGH above a peaceful Illinois countryside, a TWA skyliner streaks eastward, its silver wings flashing in the morning sun. In the cabin a smiling stewardess moves down the aisle, arousing her fourteen dozing passengers. "Fasten your seat belts, please," she requests. "We land at Chicago in ten minutes."

Up front Capt. Harry N. Andrews and his mate prepare to encounter the heavy traffic of the world's busiest airport. The pilot glances at his instruments, then speaks into his radiophone.

"Andrews in TWA 320," he announces. "Ten miles west of airport at 4,000. Arrive 10:58. Go ahead."

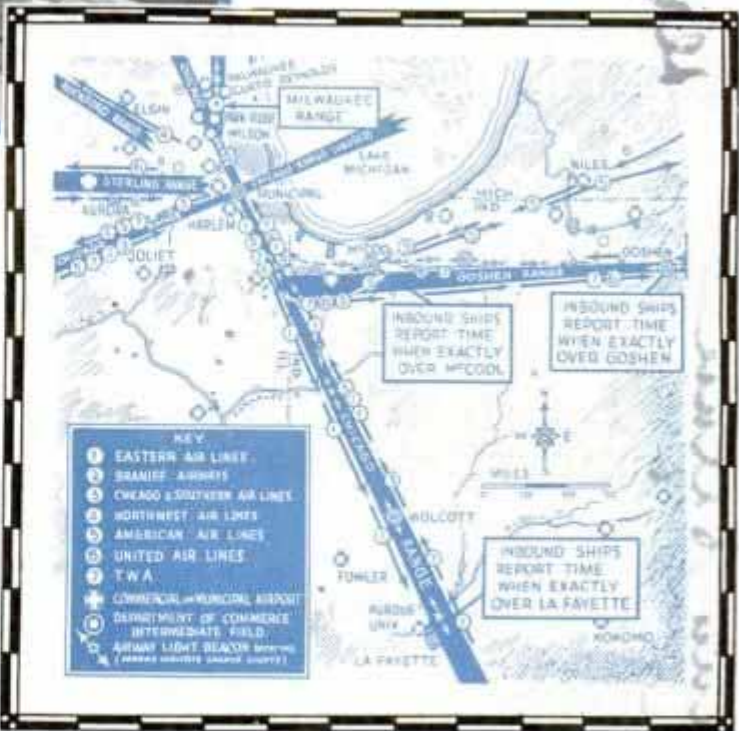

Talking by radio from tower to pilot about to land at Chicago airport, and map showing route followed by each line approaching airport

F 698

of the SKYWAYS

Pilots conversing with traffic control tower as they near Chicago. Below, air flaps on transport plane, and diagram showing application

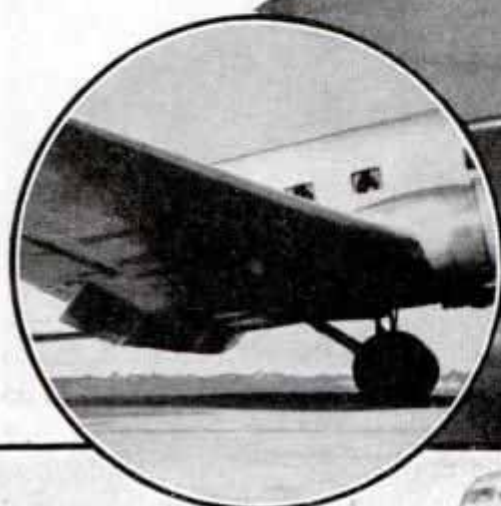
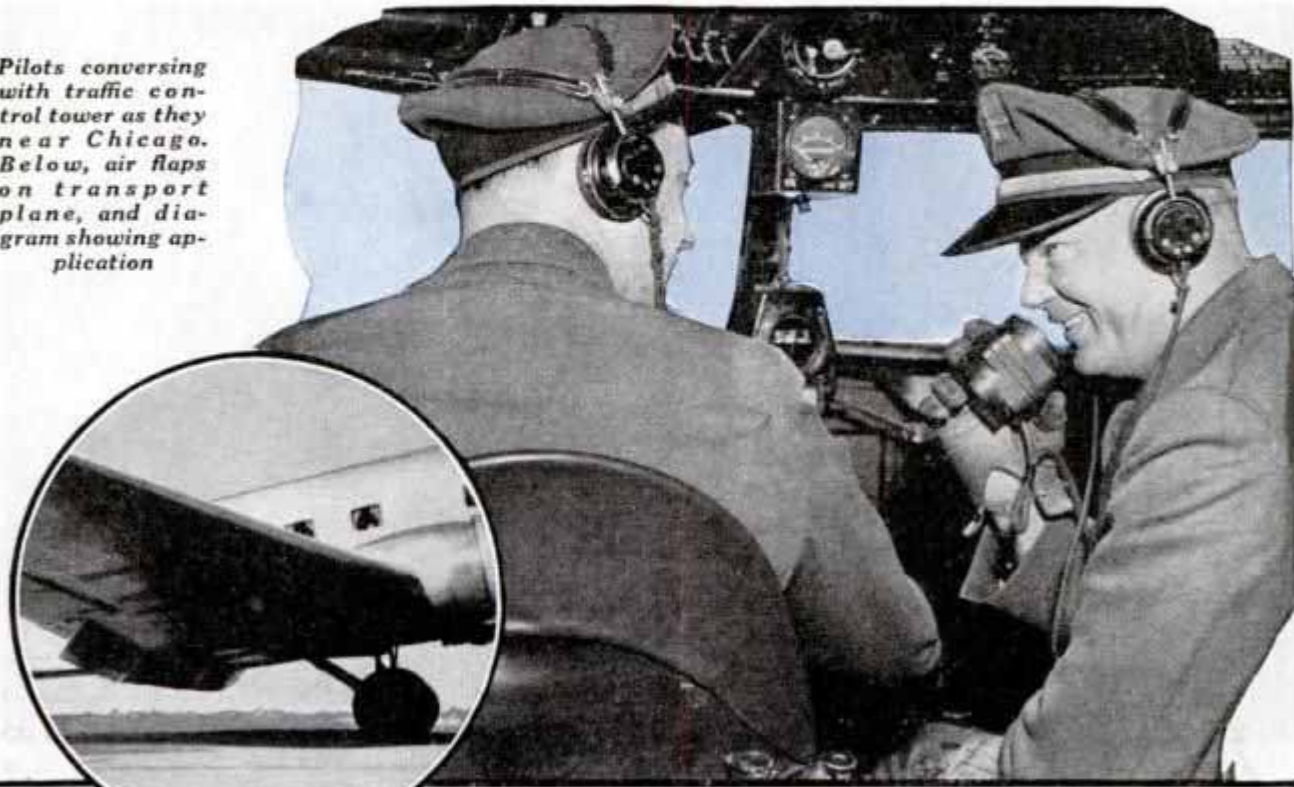

draws, "wind southwest by west five."

A few minutes later the pilot again hears the voice of the control man.

"WGEH to Andrews, TWA 320," comes the message. "I see you southwest of the field. There is nothing around that section to bother you. Those two private planes are now several miles south of here. Okay to land. Use the southwest runway, please."

The big air liner swoops low and as its wheels roll over the runway, Pilot Andrews again hears the voice of the control man.

"Okay, Andrews, to turn right," he is informed. "One of those private planes is preparing to land at your left. Taxi to Gate three."

Such is the procedure today in handling

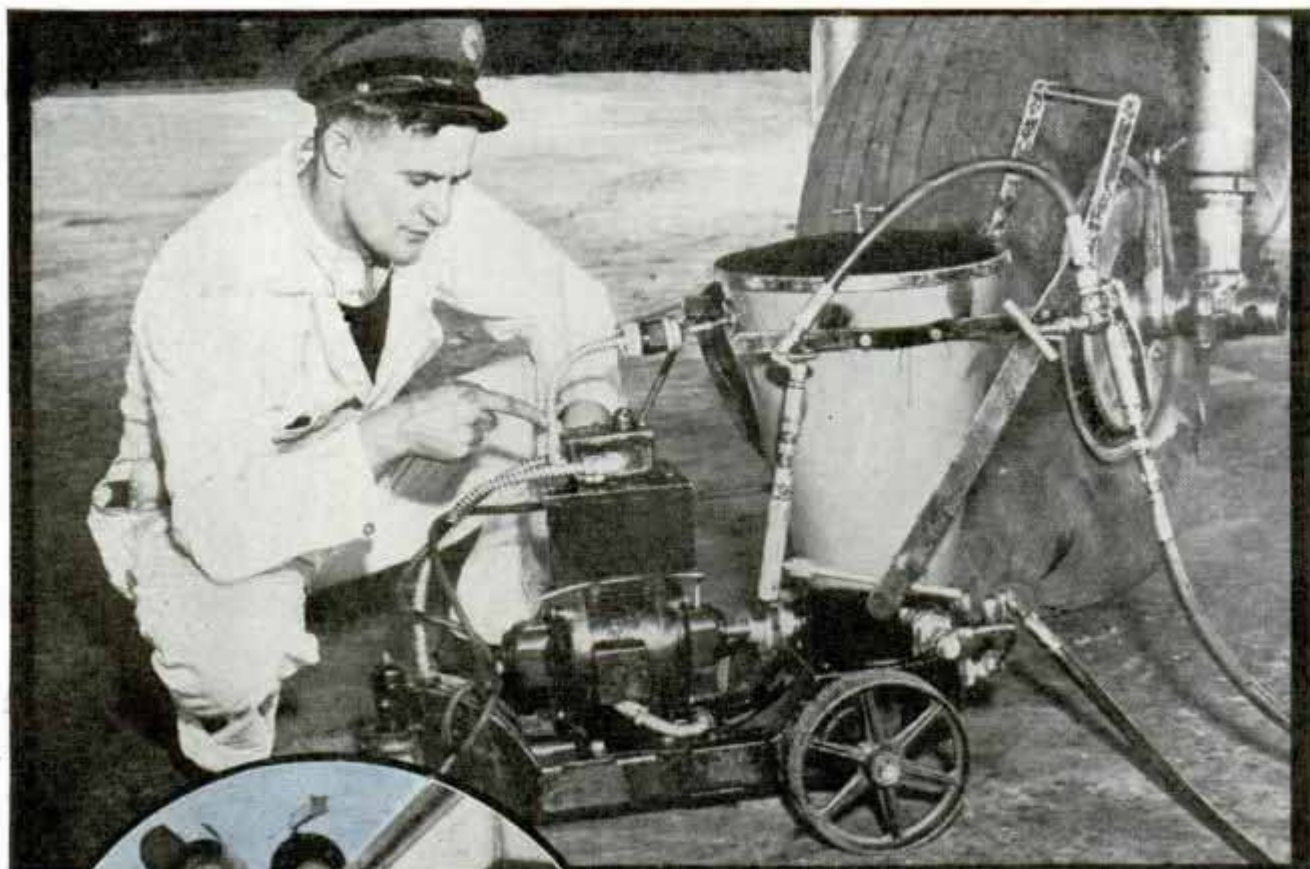

Stop-and-go light on control tower, and electric oil heater developed by TWA mechanics

traffic at the country's most congested airports. A few years ago traffic was no problem. Except for a few federal "safety rules of the road," pilots were allowed to pursue almost any course they pleased in landing and taking off.

Then, around busy airports, the air began to be full of planes. Within the last five years the number of ships making scheduled trips over the airways has about doubled. And the amount of time these same ships spend in the air has quadrupled, due to new instruments which virtually make all-weather flying possible,

and to the development of ships and engines which require less time in the hands of maintenance crews.

At the Chicago Municipal Airport, for instance, arrivals and departures average more than 150 per day or about 60,000 per year. From three to seven air lines use some of the large airports and arrivals and departures in many cases occur at approximately the same time. Pilots began to worry about the possibilities of trouble in these congested airport areas.

As a result, the federal bureau of air commerce and the commercial air line operators adopted a series of interline safety agreements, hard and fast regulations intended to prevent accidents or delays when a large number of ships are converging on the same airport simultaneously, particularly at night or under poor visibility conditions. Adoption of the agreements was followed by the appointment of a traffic coordinator for the bureau of air commerce who is directing the formulation of regulations similar to the unofficial agreements, which eventually are expected to become a part of the air commerce laws.

Because conditions were different for each airport, it was necessary to draw up

separate regulations for each of the busiest terminals. The most complicated of all was the Chicago safety agreement because seven lines center at the Chicago Municipal Airport.

The skyways traveled by commercial aircraft may be likened to broad highways traveled by automobiles, except that the skyways have a third dimension—that is, there are various levels at which ships may fly. Commercial ships follow routes marked by flashing light beacons on the ground and by radio range beacons emitting audible signals to keep pilots on course regardless of visibility of the light beacons.

Since the routes of all seven lines using the Chicago airport converge at that point, the vicinity of the airport is an area of heavy traffic for planes, just as several converging main highways would be an area of heavy traffic for automobiles. In

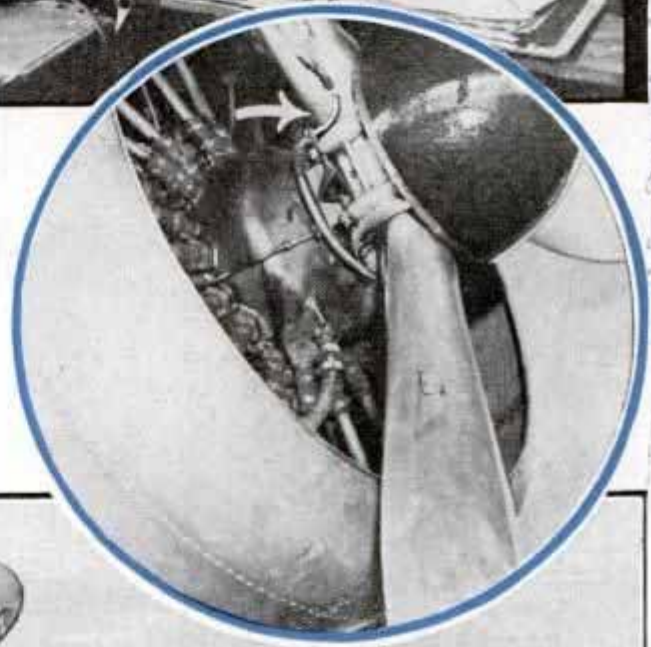

Keeping log of arrivals and departures in traffic control tower. Below, air-conditioner cooling cabin of sky liner and de-icing tubes on propeller hub

each case, regulation is necessary to prevent traffic snarls and possible accidents.

The "traffic officers" who regulate landings and take-offs from the Municipal airport in Chicago are housed in a little glass cubicle perched atop the passenger terminal. The control men issue their orders over WGEH, a fifteen-watt trans-

mitter with a maximum range of about 100 miles under ideal conditions, although most communications involve distances of only fifteen or twenty miles. A localizer radio beam enabling pilots to determine when they are over the field and guiding them down also is operated from the tower.

(Continued to page 114A)

7698
 Chicago Municipal Airport
 Chicago, Illinois

Diesels Supply Light and Power for Tent Show



Caterpillar Tractor Co
Peoria, Ill

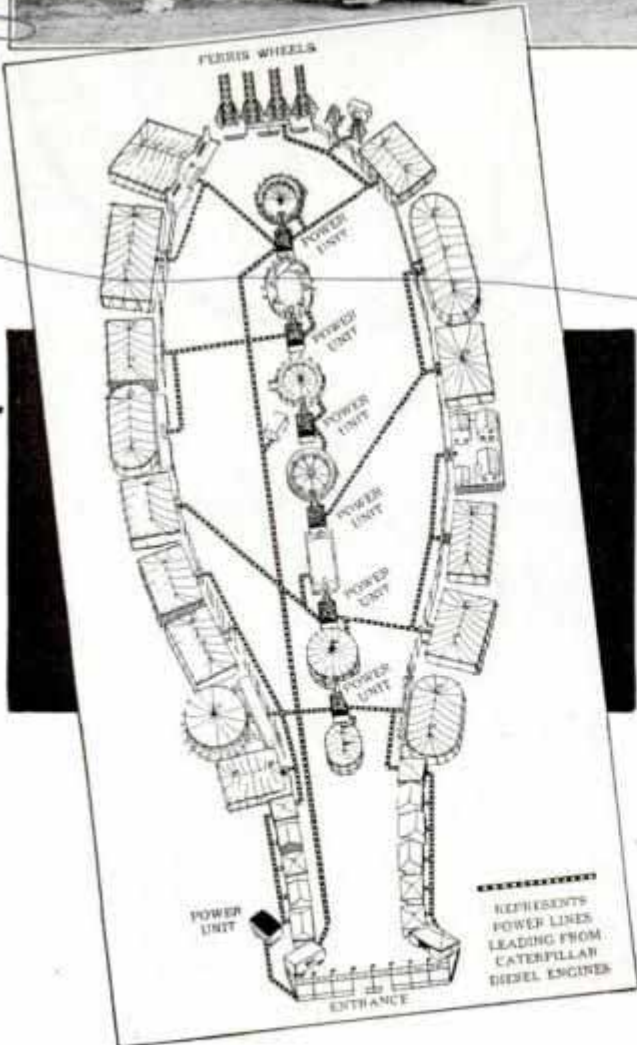

Carnival lighted at night by Diesel units, some of the power wagons and diagram of layout

Light and power for a large traveling tent show which last year cost \$40,000 in purchased electric current, is being supplied this year by seven 125-horsepower Diesel engines for only a fraction of that sum. Each power unit consists of a Diesel engine connected direct to a sixty-kilowatt, alternating-current generator. Six of the units are 120-volt, single-phase generators and the seventh is of the 120-208 volt three-phase type. The Diesel units are installed in wagons which are bases for floodlight towers sixty-seven feet high. On each tower is mounted a ton of floodlights. The towers, of steel and aluminum framework, are collapsible and occupy little space when folded and stored. The power units and other rolling equipment are moved from lot to railroad siding by tractors of the endless-track type. Six of the power wagons are set down the middle of the midway, the seventh supplying power for the thousands of bulbs and strings of neon-tube sets at the entrance. The three-phase generator set powers a battery of floodlights, furnishes current

for the major rides, lights the ticket wagon and provides heat to maintain the even temperature necessary in the snake pens. The owners of the show estimate the power and light bill this year at \$5,000, about one-eighth of the cost last year.

Horse's Shipping Crate Has Feed Rack

To avoid loss of valued livestock because of heat and other hazards of slow transportation, horses are now crated and shipped on fast express cars. The wooden crate is small enough to prevent the horse injuring itself, and ample feed for long journeys can be provided in a rack attached to the side of the crate.

'Wings' on Streamline Boat Help to Increase Its Speed

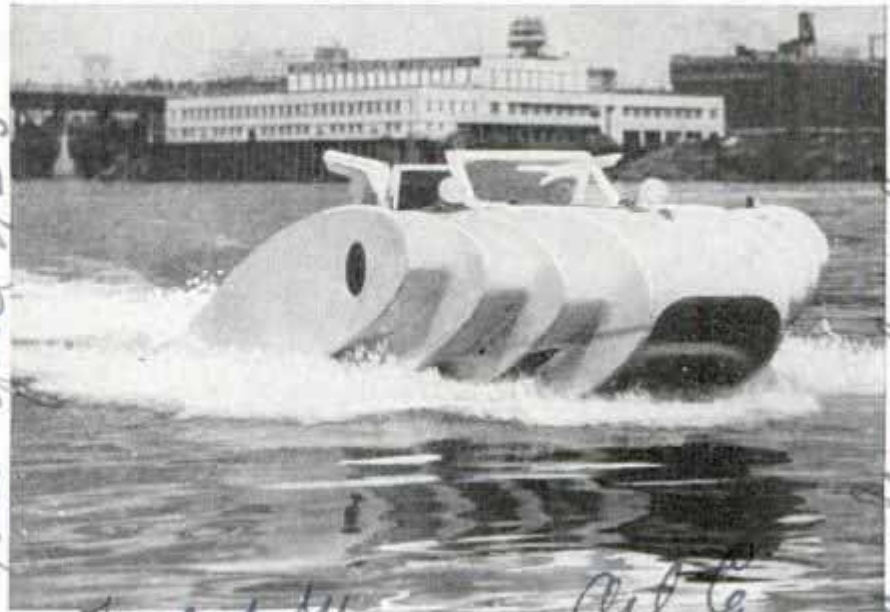

Constructed with odd wing-like outriders or planes, this boat resembles an army tank afloat. The craft rides high as speed increases

Fashioned along the lines of an airplane wing, a new streamline boat has airtight compartments shaped like wings extending from each side. These "wings" serve to lift the boat out of the water as speed is increased. This results in the boat riding almost entirely on the surface. The streamline design is said to impart high efficiency to the craft, which is used by the city of Portland, Ore., as an ambulance boat on the Willamette river.



Note the feed rack attached to this crate in which horses are shipped by express

"Tape Measure" Cartridge Varies Distance of Shot

"Tape-measure" bullets packed with powder strips by which the bullet's distance can be controlled are the invention of an army man at Aberdeen, Md. Instead of the old method of removing the top of a cartridge and scooping out part of the powder, the new method is to leave a slot in the side of the cartridge, through which the end of the tape measure of powder protrudes. The powder is rolled in strips, marked off in yards showing how far the strip remaining in the cartridge will send the bullet. To shorten the firing distance, the gunner merely pulls out the powder strip to the desired mark and tears it off.

Cent. Townsend, Esq. Jefferson City, Mo. R. D. McLeod

see April 1935

tested by Army. Vacuum Oil Co. reagent.

U. S. Stude, 867 Kelly St. Portland, Ore. dim. Gun Corps

Vertical text on the left margin, partially illegible.

Flying Fish Glides in Air with Fins for Wings

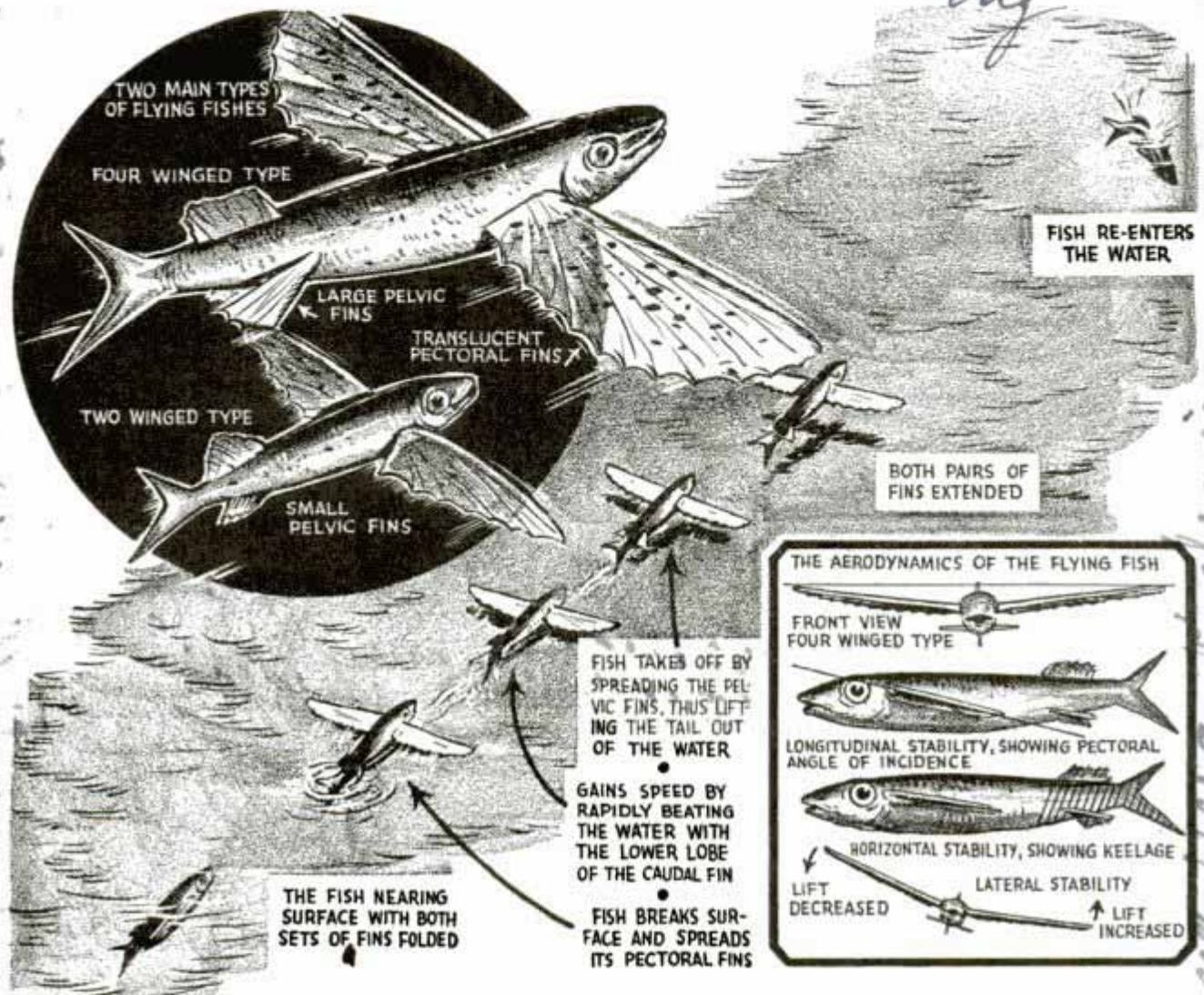

Flying fish are nature's gliders, taking off from the water at a speed of fifty to sixty feet per second and soaring, rather than flying, on pectoral fins extended like the wings of a monoplane. The fins are not "flapped" like a bird's wings in flight, but are merely supporting planes. The fish accomplishes its terrific drive by a rapid sculling motion with the lower lobe of the caudal or tail fin, which vibrates doubly from fifty to seventy times per second. Carl L. Hubbs of the University of Michigan museum of zoology, who has studied the gliding fish, says it shoots to the surface of the sea with fins folded, and as it breaks the surface spreads its pectoral fins to lift the forward part of its body clear. The caudal fin is rapidly beating the water to gain speed, and finally the fish rises clear by spreading its pelvic fins, which lift the tail from the water. A half minute is a good glide, but sometimes the fish can

prolong its flight by dipping its tail in the water and spurting up again. While the fish can make quick turns in the air, it is a clumsy glider and sometimes collides with another fish or a ship. They have been seen to make involuntary half-loops when struck by up-currents of air.

I 955
2041 127

Vinegar Bath for Oysters Causes Them to Open

Oysters now can be made to open automatically by a method of anesthetizing them which was patented recently. First, the oysters are given a "shock" by shaking them, spinning them in a centrifuge or even shocking them electrically. Stupefied or "dizzy," the oysters are next placed in a solution which may be nothing more than water containing a small amount of acetic acid which is present in ordinary

Ann Arbor. Mich.

Palau Bernie

W. S. Bureau of Fisheries, Washington, D.C.

vinegar. Ether, chloroform, alcohol or salts of many kinds also can be used. The treatment causes the shells to open automatically for removal of the meat or for planting seed pearls. The treatment does not injure the meat, it is claimed. The oysters in which seed pearls are placed recover if returned to the water within a reasonable time.

Paint Softened by Chemical Washes Off

Paint removal has been simplified by a chemical which softens the paint so that it can be washed off with a high-pressure jet of water. The preparation is applied to the painted surface with a spray, or a brush may be used on small areas. The softening process takes from one to twenty-four hours, one application usually being sufficient.

Plane Needs Three Scales to Determine Its Weight

Here is the way a giant air liner steps on the scales. The two front wheels are resting on individual scales while the framework supporting the tail is on a third. This ship weighed six tons



*Styck Chicago
J. W.A. News Service*

cont.

When a giant TWA air liner is weighed, three scales are necessary, each one supporting and weighing part of the plane. Annual reweighing is required by the bureau of air commerce. One of the large ships tipped the scales at six tons. A remarkable thing is that this same ship is capable of lifting its own weight and an additional weight of six thousand pounds and flying at 200 miles per hour. The weighing process consists of placing the wheels on special scales and hoisting the tail off the floor approximately twenty-three feet in flying position, with the hoist standing on a third scale. The weight of the blocks and hoists is subtracted from the total readings to arrive at the actual weight of the plane.

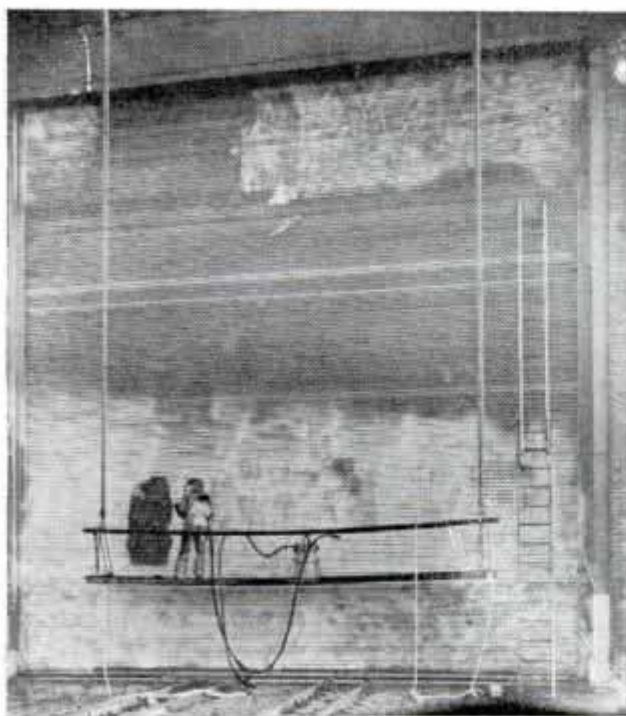

Applying new type of paint remover

It is estimated that the nation's annual bill for rust is one billion dollars, equal to the yearly interest on the public debt.

*American Chemical
Prod. - C. Doubler Pa
Copper
Research Assn.*

F995 C.W. Thomas E. Stinson, Jr
10555 Holman Ave
Los Angeles, Calif

TRICKS of the RACE



Top, roaring into a turn. Bottom, giving drivers the checkered flag at end of race as two cars finish neck-and-neck

A HANDFUL of salt once won an automobile race. Smart drivers of midget cars fill their radiators with ocean water. In an economy race some drivers have their fuel measured out the night before and others pack Dry Ice around their gasoline cans. Some drivers tune their engines with barometers and humidity indicators. "Bird trouble" is one of the hazards of driving a race car.

These are some of the odd things about

racing. Drivers will try almost anything once in their efforts to get more speed and sometimes they hit upon queer ways of winning a race.

The handful of salt played its important part during a fast race on a hot day on an eastern track. All the cars were overheating and the drivers had to stop every few laps for radiator water. Finally one racer called for a pound of salt and dumped it into his radiator. That ended his cooling problem and he finished the race without stopping. Drivers of midget cars use ocean water for the same reason. The salt makes it a better coolant than plain water. But don't try it in your own

car. Salt corrodes water passages in the engine block and the racing drivers drain and flush their radiators every time they use it.

You get more for your money when you buy gasoline on a cold day. Fuel expands with heat, hence on a hot day a gallon of gasoline is really less than a full gallon. When some tracks limited fuel the drivers who knew this demanded their gasoline on the night before, when it was cool

F 795.

DRIVERS



The "speed groove" is a shallow groove cut into the track surface, usually made of concrete or asphalt, to provide extra grip for the tires. It is often used in wet conditions to prevent aquaplaning.

enough to get full measure. At Indianapolis fuel is metered out shortly before the race, and some drivers in the past packed Dry Ice around the cans so the gasoline would condense into the smallest possible space. That way they were apt to get a few more pints, possibly enough to win the race instead of stalling with a dry tank.

High-compression engines are even sensitive to atmospheric changes and smart drivers often tune their engines according to meteorological conditions. Wilbur

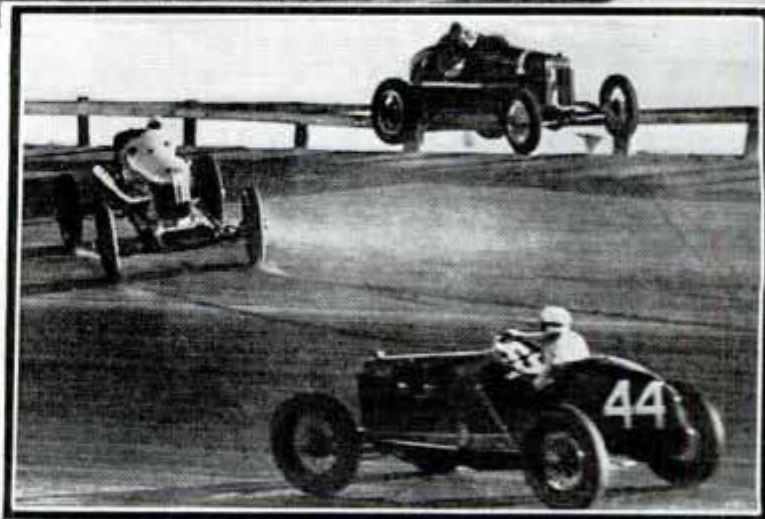

Top, explaining location of "speed groove" on track. Bottom, beginning of wreck. Note car with all four wheels off track



Throwing dirt on oil from wrecked car to prevent it from running down on the track and endangering the lives of other drivers left in the race. A wreck holds peril for every driver in the race

Shaw consults a barometer and humidity indicator when he wants to tune his motor for maximum power. Other drivers use the color of the exhaust smoke in checking the engine. If the smoke is white the fuel mixture is too rich, and if the exhaust smoke is black the oil pressure needs to be reduced. Bluish smoke shows the engine is running properly.

Nearly every veteran driver has collided with birds flying across the track. Ralph Hepburn once received a fractured skull that way but he managed to stay conscious long enough to stop his car. Crash helmets have removed some of the dangers of "bird trouble."

Every track has a "speed groove" which is the fastest although not the shortest path around the track. Drivers who hug the rail must drive slower than those who ride the groove higher on the track. It's called a groove because on dirt tracks it is usually well marked after a few laps.

Intake manifolds of racing engines are apt to freeze on hot days and the drivers pipe hot exhaust gases around the intakes to keep them warm. An unheated manifold may become covered with hoar frost, a condition that results from the cooling action of the vaporized gasoline that

rushes up the interior of the manifold pipe.

Lubricating their engines with gasoline is another of the "crazy" things that drivers do. In spite of upper cylinder oilers there are apt to be small rings at the tops of the cylinders that receive too little oil for frictionless performance. Drivers provide for this by using fuel mixtures slightly richer than would be necessary if they drove slower. The theory is that some of the unburned gasoline filters down past the tops of the pistons and lubricates the metal walls. The drivers know that the easiest way to burn up a motor is to run on too lean a fuel mixture.

You don't need to "break in" a racing engine, because it is put together with wide clearances that would never be tolerated in ordinary use. The result is a noisier engine, but it permits driving 120 or 130 miles per hour the day the engine is installed.

Stock engines would literally fly to pieces if they were turned up to the speeds that some of the racing engines achieve. A few midget racing motors have been "wound up" to 9,500 revolutions per minute without harm. This is possible because each moving part is balanced to a thousandths of an ounce and because all

Bob Blair Muncie
 Newport Los Angeles Calif

5077
 5795

F795

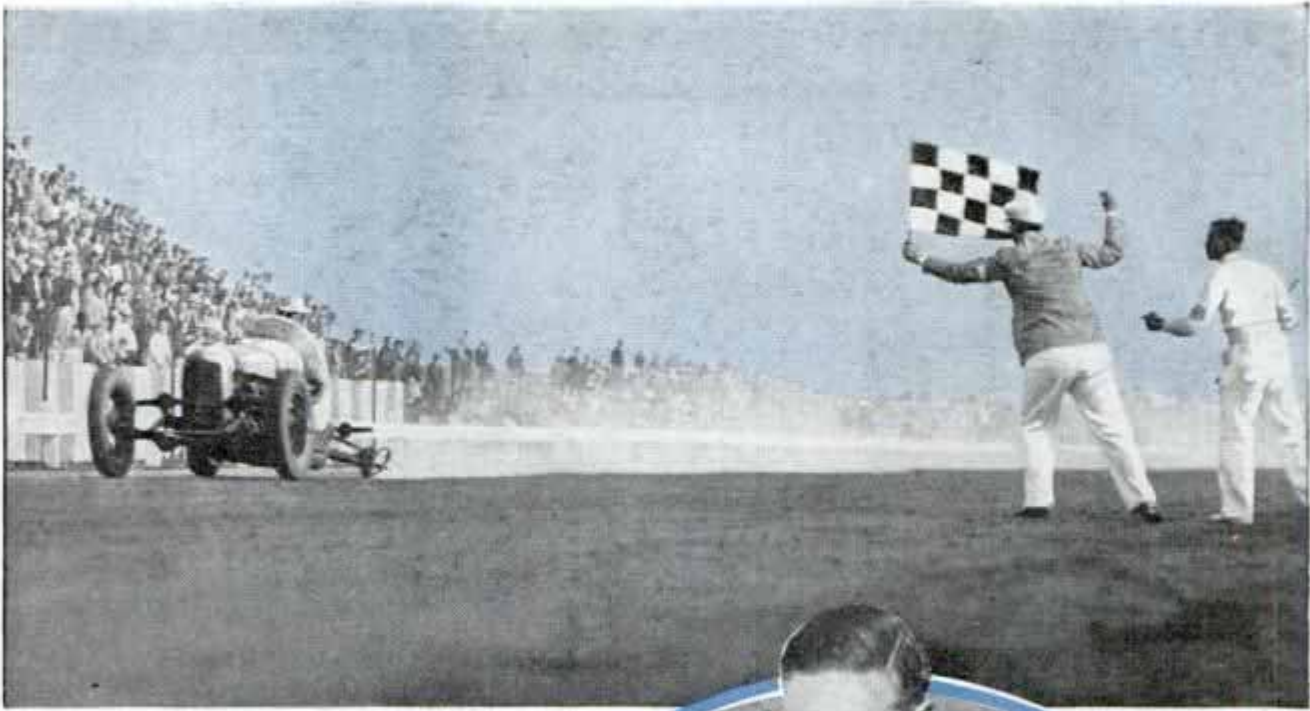

parts of the engine are heat treated.

In your own car you are lucky to get twenty miles to the gallon if you drive around forty-five miles per hour. Speed up and you pay for it by using more fuel. At 100 miles per hour your car might go only ten or eleven miles per gallon of fuel. Yet racing cars go faster than that on much less gasoline. In the 500-mile Indianapolis race this year, Louis Meyer averaged 109 miles per hour and drove about sixteen miles per gallon of gasoline. Semi-streamlining

(Continued to page 126A)



Top, car finishing race on the axle, having lost wheel two laps back. Circle, heating oil so car will be at peak efficiency. Bottom, start of wreck in which driver and mechanic were killed

(Continued to page 126A)

Auto Is Made Convertible into Ambulance

*Arntgen Chevrolet Co. Chicago
810 N. Clark*



Top, cutaway showing patient on stretcher in police car. Bottom, left and center, views of stretcher in car. Right, stretcher folded in trunk

For converting the passenger automobile into an ambulance in emergencies, special equipment is available. The change does not affect the outward appearance of the car or the interior when in normal use. Thus, the car becomes a combination vehicle, serving either purpose. The equipment is installed in the trunk. In an emergency the stretcher is unfolded and rolled on steel tubing rails into a position across the front and back seats and locked. Or, the stretcher may be removed from the car for picking up the patient and then returned to the truck to be rolled into position. Auxiliary stretchers, splints and other equipment may be obtained. In this manner any police car may be turned into a first-aid ambulance and any country doctor may have the means of moving his patient to a hospital with a minimum of discomfort. The change from passenger car to ambulance requires less than two minutes.

Ice Skate with a Double Blade Reduces Ankle Strain

Designed for safety, the latest ice skate has a double blade which reduces ankle strain and which eliminates many of the hazards for the beginner. A concealed equalizing spring returns the skate to the proper position at the conclusion of each stroke. The skater's shoe can incline freely to either side, but



*Dr. Arthur Kautz
Safety Case*

*Double Blade Ice Skate
#1, 496.925
5205*

cannot rub on the ice. Skidding is practically eliminated by the double blade, yet the skater may execute intricate figures with all the ease of any one using conventional single-blade skates. Ankle braces and straps are unnecessary and the shoe may be laced loosely, giving more comfort.

Hub Pump Keeps Tire Inflated as Car Runs

Automatic inflation of tires when the air drops below a fixed pressure is accomplished by a two-cylinder hub cap pump now on the market. If normal tire pressure is twenty-five pounds, the pump can be set to start inflating the tire whenever it drops to twenty-three pounds. Power is derived from irregularities in the road surface. When air pressure drops to the fixed minimum, resistance of a spring in the inflator is over-

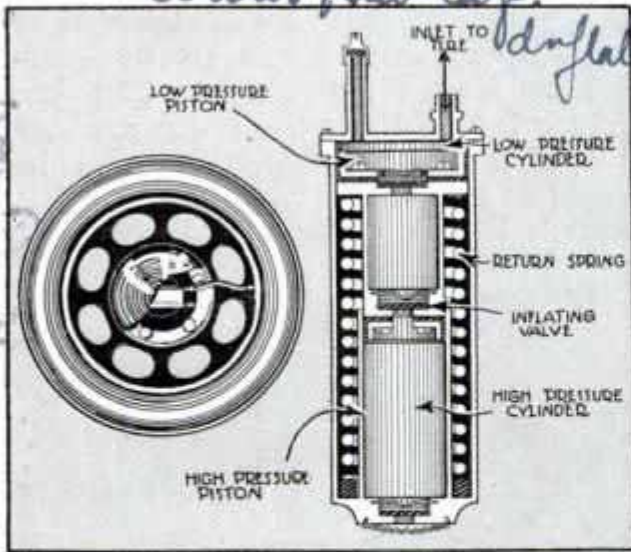

Drawings show two views of two-cylinder pump which keeps tire inflated while running.

come and the high-pressure inflator piston starts working, pumping air through a tube to the tire valve. Original inflation is through a separate valve.

*Altherm Products
One Broadway Hill*

Chemicals "Fingerprinted" to Help Identify Substances



Apparatus used in taking "fingerprints" of unknown chemical substances for comparison with "prints" of compounds already identified

Identification of unknown substances through a method of "fingerprinting" chemicals is made possible by the use of X-ray diffraction patterns. The method permits accurate analysis of particles no larger than the point of a pin, but it is not applicable to liquids or to other non-crystalline substances. The molecules of any given compound are known to be arranged in a definite geometrical structure, which is characteristic of this compound only. Equally characteristic of the compound is the photographic pattern which results from the interaction of X-rays with this definite geometrical structure. Thus, the photographic pattern can be viewed as the "fingerprint" of the chemical compound. The method permits identification, even though the unknown is a mixture of substances of similar chemical nature.

QST!—Correction—QST!

The following W1 calls were listed as W7's by error in the article "Minute Men of the Air" which appeared in our September issue: W1MY; W1JPE; W1XT and W1NF.

*Used by slow chemical compound
midland, Mich*

Haydy Brown Corp
3925 W. 7th St
Detroit, Mich

Tall Church Spire Is Moved to Permit Widening of Street

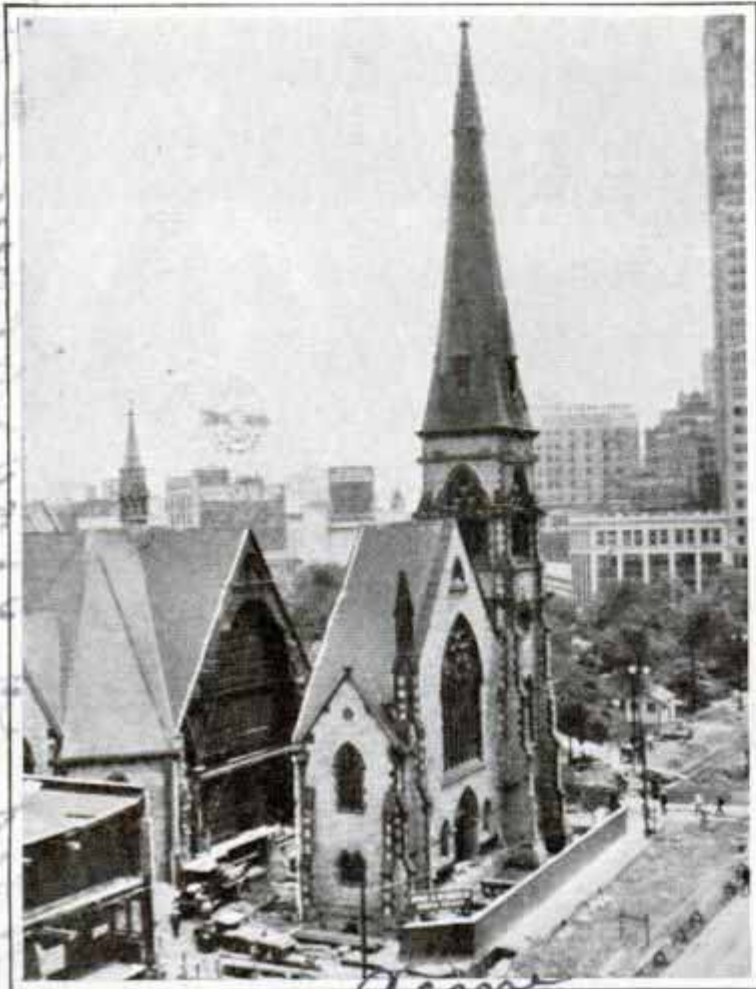

Showing spire and twenty-six-foot segment of church separated from main auditorium in unusual building operation

Widening a street in downtown Detroit meant a major surgical operation for the Central Methodist church. A twenty-six foot segment was cut from the church, and the entire front of the edifice, including its 183-foot steeple, had to be moved back from the street and rejoined to the main body of the church now shrunken in size. The spire weighs 3,500,000 pounds.

Auto Governor Is Adjustable to Speed Desired

F904

Making it unnecessary for fleet operators to use several governors for different speeds, the latest type of automotive engine governor can be adjusted and locked at the speed desired. The universal type is designed to reduce the cost of installations on fleets of trucks, buses or automob-

biles. It is available in three models, with sealed adjustment, lock adjustment type and key control adjustment located on the dash. Setting the speed from the dash makes possible the application of the governor to the passenger car since the owner is thus permitted to impose on younger members of his family a top speed at which the vehicle may be operated.

'Electric Eye' Tunes Piano to Accurate Pitch

Housed in two portable cases, an "electric eye" machine for tuning pianos has been found to give more precision in setting strings than when the work was done by ear. A more accurate pitch can be obtained and the piano stays tuned longer, makers of the instrument claim. The dial of the machine is set to the tonal pitch and quality desired. Sound of the piano strings is translated into light by the photocell. This light shows the vibration of the strings and corrections are made in accordance with the finding. The strings are adjusted by hand, as usual. By focusing the electric eye on single strings, the operator or tuner can detect sympathetic vibrations inaudible to the ear. Another feature is that operation of the machine and adjustment of the strings can be taught in a few weeks, whereas it takes years to become expert at tuning by ear.



Tuning piano with the "electric eye." Adjustments are made as machine indicates pitch

Wade
Baermen

Ocean Air Liner Big as Destroyer Predicted

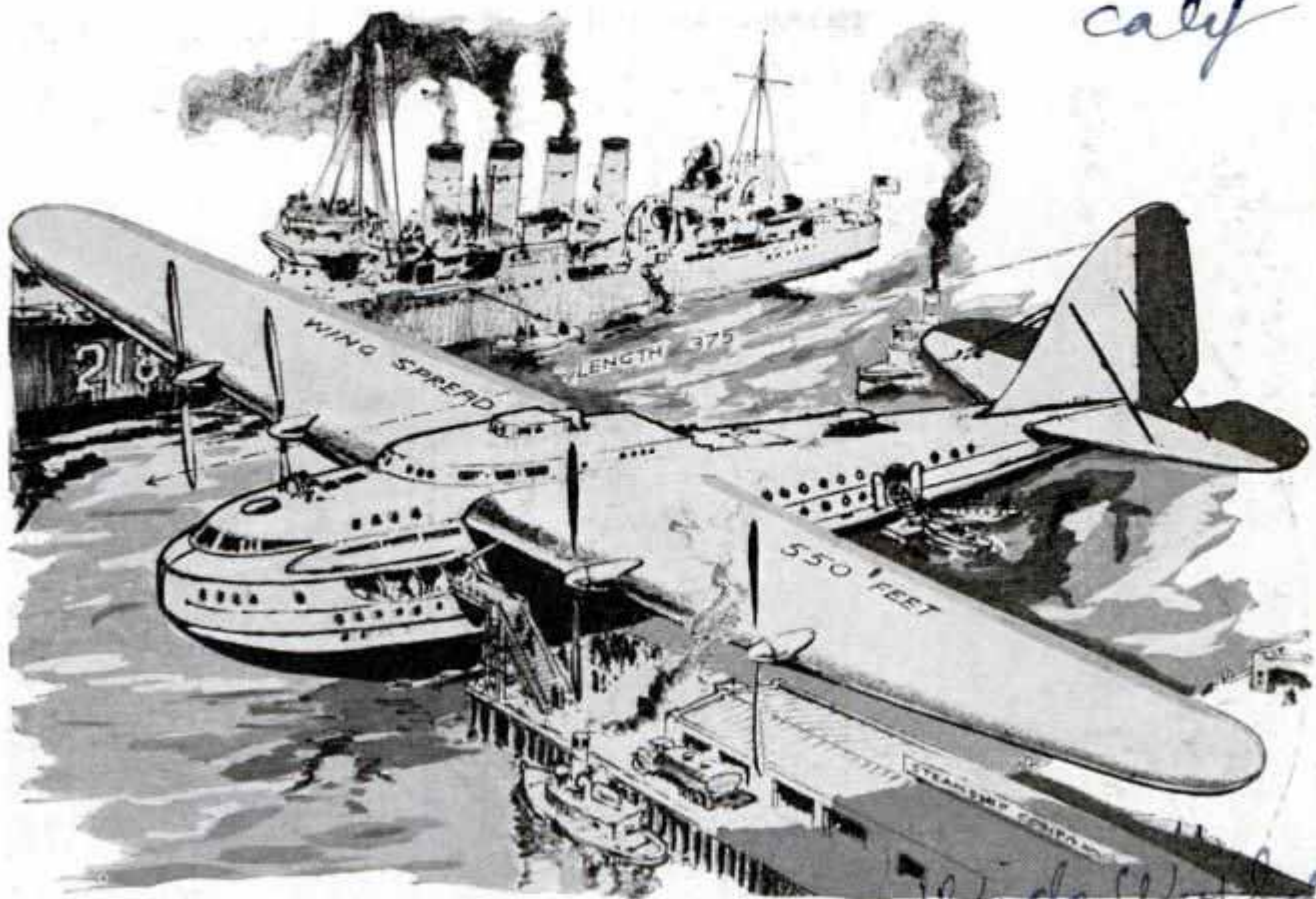

Here is the designer's idea of how the giant transatlantic air liner of the future will appear. Note the great wing spreading over the dock. Destroyer in the background helps to illustrate the plane's size

Capable of carrying 500 passengers, the flying boat of the future will be as large as a destroyer, according to *Schuler* Kleinhans, designer for one of the leading aircraft companies. More than 375 feet long, with a wing spread of 550 feet, the 1,500-ton air liner would be powered by a 200,000-horsepower engine system which would propel the craft at 300 miles per hour at an altitude of 12,000 feet. Such a plane could cross from New York to Liv-

erpool in eleven hours. It would be multi-decked, deep hulled. A crew of 100 would be required, according to the designer, who has prepared a sketch of the flying boat. This sketch pictures the liner hawsered to a steamship dock, with a destroyer of about the same length in the background to give some idea of the size of the flying boat. Powered by four engines, possibly of the Diesel type, the craft would cost about \$20,000,000.

Police Car's 'Claw' Grabs Bumper of Fugitive Automobile

Equipped with an odd claw arm which can be operated from the driving compartment, police cars may reach out and grab the spare wheel or bumper of a fugitive automobile in a chase. The claw may be moved in any direction desired. Attached to the front of the police car, it extends almost six feet. The claw is the invention of Sir Malcolm Campbell, driver of the famous "Bluebird" racing cars which hold the world's land speed record.

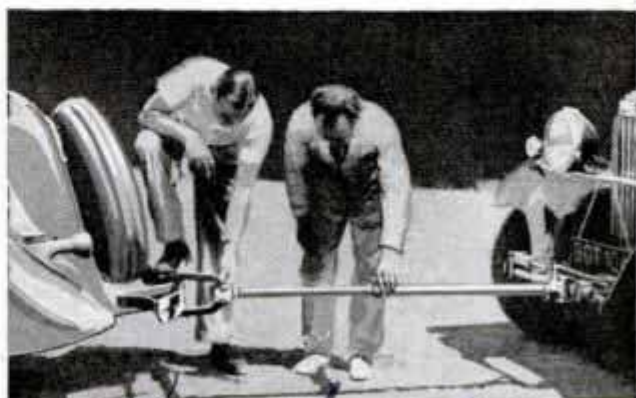

Key Stone

3. Aircraft Co. Santa Monica Calif

Wider World

1915

UP *and* DOWN



All photos © Wide World

Above, type of mail rocket which underwent tests in Belgium. Right, explosion of test rocket at night. Below, bathysphere used by Dr. William Beebe for under water exploration.

underground explorer. Thus, a new motor, as long as a bean pole, stands on its head at the bottom of a deep hole and "kicks" oil to the surface. With such devices, it is possible to extend commercial operations into the earth at greater depths than heretofore. This single invention, the "bean-pole motor," promises to increase the nation's oil reserves by millions of barrels. In the opposite direction, high altitude, a meteorological balloon loaded with instruments recently reached the highest





level ever recorded for a man-made instrument. It soared to an altitude of 138,451 feet, approximately twenty-six miles, almost twice as high as the maximum altitude yet reached by man.

Without oxygen a man can climb to an altitude of about 18,000 feet. It is a comparatively short time since men began to explore beyond three miles up. In fact, it is less than ten years since Capt. Hawthorne C. Gray of the army air corps, blazed a trail into the stratosphere. And only in the last five years has the altitude record for human

flight jumped from 42,000 to 72,395 feet, a gain of about 30,000 feet. The limit of high-altitude exploration recently has risen an average of about one mile per year. If this rate of gain continues for another century, man will have reached an altitude of about 115 miles.

The stratosphere ends at an altitude of thirty miles, and thereafter one enters the ionosphere, as unknown today as the stratosphere was twenty years ago. There is a possibility that free balloons will soon reach the upper limit of the stratosphere, and thus will commence a new epoch in the story of aerial exploration.

The present airplane altitude record, 47,806 feet, was established recently by a Russian aviator. The previous record, 47,352 feet, had been made by Renato Donati, the Italian ace. The new record, however, is still short of the stratosphere balloon record by almost five miles.

The stratosphere balloon may have an effective range up to 100,000 feet. Beyond that, we must depend upon free hydrogen balloons and rockets. Rockets hold forth the greatest possibilities for exploring the ionosphere for they are the only known self-propelling devices that can travel in very rare air without loss of efficiency.

No man-made device has ever crossed into the vast region of the ionosphere. But the promise of rockets is very bright. An American rocket has already attained a

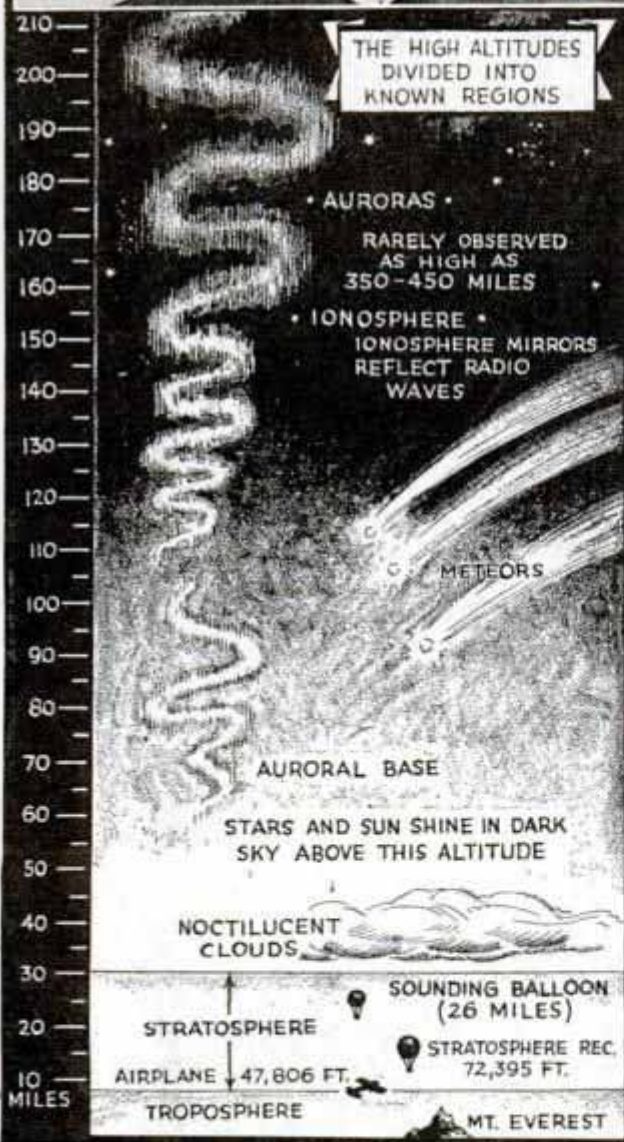

Attaching aluminum soles to suit intended for flyer penetrating the stratosphere, and diagram showing the location of the several known high-altitude regions

velocity of 700 miles an hour and rocket motors have shown remarkable efficiency. Metallurgists, aircraft designers, chemists, and physicists are working together on the problems of super-altitude rocket flight, and such attempts probably will be made in the next few years.

The ionosphere was first discovered by that long-range tool, the spectroscope. Its boundaries are not exact, but its presence is shown by the presence of ozone and by its ability to reflect sounds of heavy explosions, as well as by the behavior of meteors. At a height of about fifty miles, there are said to be "clouds" which some believe are collections of minute dust particles. But not many can explain how dust managed to collect at this altitude. At forty-five miles there are signs of twilight, indicating the presence of some air, for twilight cannot occur in a vacuum of space.

(Continued to page 121A)

Model of First Film Studio in Edison Exhibit

Among articles in an exhibit arranged to show history-making points in the career of Thomas A. Edison is a model of the first motion-picture studio in the world. The original was built at the Edison plant in Orange, N. J., at a cost of \$637.37. The model is a part of the Edison exhibit at the New York Museum of Science and Industry in Rockefeller Center.

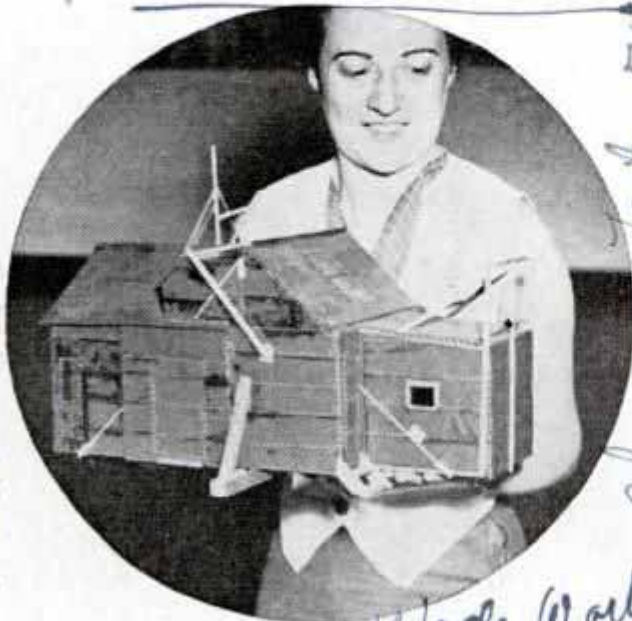

Here is the first motion-picture studio, in miniature. It appears in Edison exhibit

Tint Mosquitoes with Spray to Trace Their Migration



Spraying marshes with dye to trace the migration of mosquitoes from their breeding grounds

Swamplands west of Chicago, favorite breeding grounds of the mosquito, were sprayed with red, green, purple and yellow dyes this year to "tag" 50,000,000 mosquitoes and learn how far they fly. Would a mosquito travel more than a mile to bite a man? Officials think not, but to prove it they sprayed four marshes four different colors and then, as the tinted mosquitoes started out on their man hunt, set about to trace their migrations.

Whirling Color Filter for Lens Helps Film Blue Eyes

Blue eyes have ceased to be a dilemma for the movie cameraman. Until recently, light-colored eyes have not filmed well and many actors have been kept from screen success by this failure to register. Blue eyes would appear a pale, dishwater grey in the picture. But now the movie technicians have developed a tiny motor that whirls colored ray-filters past the lens when it is focused on a blue-eyed player, and the eyes gain depth and color.

1994

7806

7885

Chicago Trib. 7/10/36

Wide World

Perfect by Karl... m 25 m

Vertical handwritten notes on the right margin: "mosquito abatement", "Les Plaines", "Wide World", "Chicago Trib. 7/10/36", "Perfect by Karl", "m 25 m".

1975

GROWING PEARLS *at* HOME

EVER since the first aborigine cracked open the first shellfish with a stone and found embedded in its flesh a bright, lustrous ball which he prized as an ornament, man has been trying to speed up or improve on nature's method of producing pearls.

And as is usually the case when man keeps everlastingly at a problem, he has finally found the solution and today possesses the knowledge necessary to harness the mollusk to the business of producing the queen of gems "by hand." Working at the Scripps Institution of Oceanography at La Jolla, Calif., La Place Bostwick who has spent years in patient research and experiment, has succeeded in growing perfect pearls in colors in California's beautiful abalones. Some of the gems are delicate shades of green, others are in blue tints, some are blue-black and in a few flamelike flashes of red appear.

Previously Mr. Bostwick has produced ball and egg-shaped fresh water pearls in white and in colors, some of them ten grains in weight, ball and egg-shaped conch pearls and "attached" pearls up to forty grains in weight, but his experiments with abalones may point the way to a brand new industry, particularly along the Pacific coast where "pearl farming" in the future may develop into a commercial enterprise comparable to that in Japan where small white sphere pearls have been grown for years in margarita shells, or "pearl oysters."

It is well for pearl lovers that man has solved the problem of producing the gems



Sorting man-produced pearls. Below, Nordica collection of colored pearls. Drop pearl is an abalone weighing 175 grains



because no new pearl fisheries of consequence have been found in the last fifty years and the known sources have been so depleted that large, fine pearls today are about as scarce as Stradivarius violins.

Nature, it seemed, even in prehistoric times never produced enough pearls to satisfy the demand for them. More than a peck of large gems were found in one of the earthworks of the early Mound Builders and yet there is evidence that even these prehistoric people tried to grow pearls despite the fact that lakes and rivers at that time must have been paved with shells offering a seemingly inexhaustible supply. Fine pearls have been taken from many of the ancient Egyptian tombs and the earliest literature speaks of them.

When white men came to America they bartered with the Indians for pearls for a long time before they realized that the Indians were getting them out of near-by lakes and streams. While many pearl hunters searched these waters for fine specimens, it was not until the advent of the mother-of-pearl button business that it was realized that a fortune in

pearls lay hidden in our inland waters. Button factories were established and "shelling camps" dotted the shores of streams throughout the Mississippi drainage system.

Upon opening the shells, pearls were found, varying in size and shape according to the species in which they grew and the localities where they were found. There were innumerable rough barques, or pearls of ir-

regular shape, thousands of small ones and others of large size and excellent quality. Gems valued at millions of dollars often were found in one "shelling season," some worth from \$1,000 to \$3,000 each and a few large ones of exquisite

(Continued to page 128A)

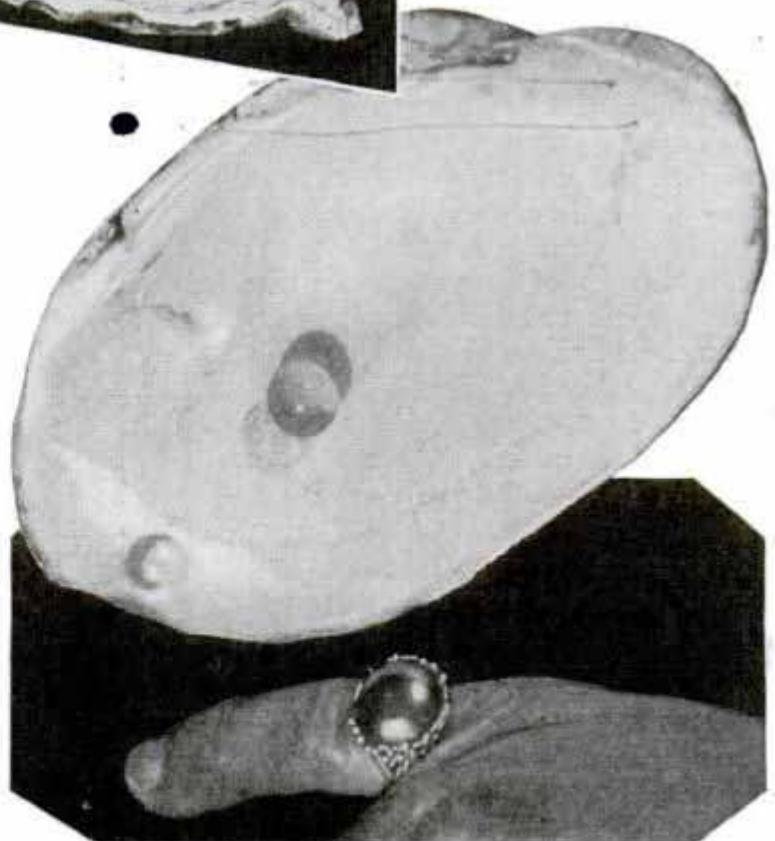

Top, operating on abalone. Center, attached conch pearls. Bottom, attached fresh water pearl on shell, pink gem conch pearl in shell and abalone pearl on finger

Flashlights Trace Dive on Photographic Plate

Charting the twists and turns of a swimmer's body in diving is now being done on photographic film by means of lights attached to the diver. Germany's Olympic diving team was trained in this manner, practicing before the camera and then studying their movements as shown by the lines in the picture. A flashlight is attached at the ankle, neck and waist, and the plate is exposed during the dive.

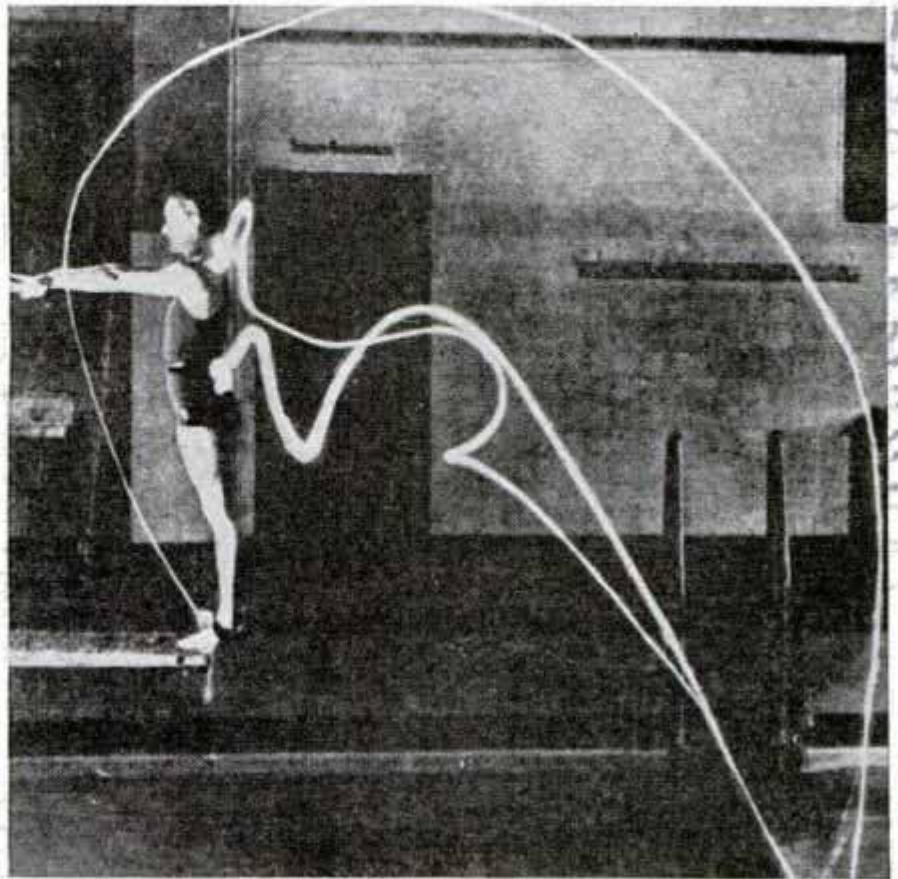

White lines mark travel of flashlights attached to feet, waist and shoulders of diver during demonstration for the camera

Curtains Are Saved by Pinless Stretcher

To save curtains from the uneven edges and occasional tearing caused by pinholes, a curtain stretcher which requires no pins has been developed. After washing the curtain, a light rod is inserted through its upper hem and a heavier rod through the lower hem. Then attachments and clips are adjusted at each side, stretching the curtain smoothly and uniformly.

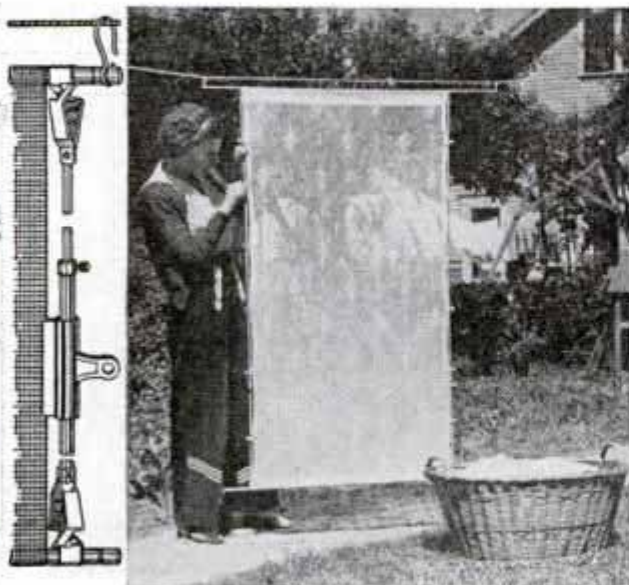

This pinless stretcher prevents damage to the finest curtain after washing

Pilot Light in Wall Switch Is Guide at Night

Equipped with a small pilot light, the latest wall switch is easy to find at night. The light emits a faint glow which is directed downward so that it does not interfere with sleep, yet is sufficient illumination to dimly outline furniture and other objects. The pilot light turns on when the bright lights are turned off and it uses hardly enough current to register on the meter.



Our Bureau of Information will answer questions regarding articles in this magazine, if accompanied by return postage.

*To lock my Co. clps.
K...*

*Stability & novelty & mayette
Cassan Antoinette...*

Flash Camera for Closeups Aims from Two Inches Away

F945



Two views of flashlight camera in action for closeup and (circle at top, left) the human eye as it appears in closeup photo. The camera is useful for taking clinical pictures and other special work

for photomicrography, clinical pictures for doctors and dentists, floral and biological views and other special closeup pictures.

F930

Valveless Head Is Offered for Auto Engine

Offered as a means of converting automobile and truck motors into valveless engines, an unusual motor head is being marketed under the claim that it effects fuel savings of thirty to fifty per cent and increases power and speed. The conversion is simple, the regular head with all valves and valve mechanism being removed, leaving the block free except for the crankshaft and the pistons. Valve openings are then closed permanently by a solid gasket. Installed in the new head is a series of pistons operated by a cam shaft which is gear-driven by a vertical shaft connected to the crankshaft. The cams operate the upper pistons at a certain given stroke. Each upper piston comes to a stop at the time of firing and acts as a head in its cylinder until the

"Firing" at an object only two inches away, a flashlight camera developed for closeup work snaps a picture remarkable for clarity of detail. It is mounted directly in front of a flashlight or floodlight bulb whose light is multiplied by mirrors set in an octagonal housing, literally bombarding the subject with light from every angle. It is adjustable for distance from two to twenty inches, with a fixed shutter speed of one-fiftieth second and a lens aperture adjustable from f-6.3 to f-45. Ordinarily the aperture is stopped down to f-45. The shutter operates like a bulb, pressure of the shutter rod exposing the film and setting off the flash, release of the rod stopping exposure. Flat plates or films three and a quarter by four and a quarter inches are used. The light bulb can be set off by batteries mounted in the back of the reflector or by plugging a cord into the house circuit. The camera, easy to operate with or without tripod, is useful

ated by a cam shaft which is gear-driven by a vertical shaft connected to the crankshaft. The cams operate the upper pistons at a certain given stroke. Each upper piston comes to a stop at the time of firing and acts as a head in its cylinder until the

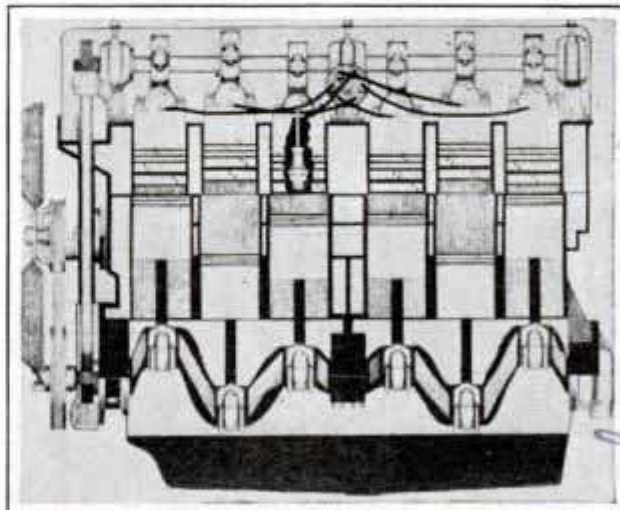

Drawing shows valveless engine head in place. Note second set of pistons in the head

Burtin mfg. Co. Chicago, Ill. 605 7
 F945
 F930
 John W. Jenkens
 Jenkens Motor Co., 2451 Ethel St. Chicago, Ill.

power stroke is spent. Then it resumes its movement. The explosive mixture and the exhaust are handled through ports on opposite sides of the head. At the time of firing both ports are closed by piston rings. The upper pistons make one stroke while the lower pistons make two. The makers claim that the valveless motor eliminates spring and valve repairs and grinding, results in reduced construction costs when used on new motors and produces greater engine efficiency.

⁷⁹³⁵
**Passengers Watch Speed Dial
 in Rear of Streamline Train**



Here's a new diversion for passengers on streamliners. The dial, located in the last car, shows the speed of the new fast train

⁷⁹³⁴
**Tricycle Rickshaw
 Takes Three
 for a Ride**

Malayan rickshaw boys still furnish the motive power for their vehicles, but now they can ride, too. A new rickshaw that resembles an old-fashioned buggy mounted on a tricycle has been introduced at Penang,



This bike-rickshaw is something new. One advantage is that the operator rides, too

Straits Settlements, by a municipal commissioner, who plans a fleet of fifty rickshaws for hire. Two passengers can ride behind the pedaling rickshaw boy.

The entire world production of radium up to today weighs less than a golf ball.

Speed has an added thrill for passengers on the "Flying Yankee," streamline train of the Boston and Maine railroad. They can sit in the solarium of the rear car and watch the speedometer, installed to tell them exactly how fast this speed train is traveling. The dial reads up to 120 miles an hour. It is illuminated at night, and there is also a clock in its face.

⁷⁸⁸⁷
**Brush Eraser Cleans Paper
 of Ink and Typing Print**

Consisting of a mineral fiber brush in a molded plastic holder, the latest eraser removes ink and typewriter print from paper, and India ink from tracing cloth. It fits the hand conveniently, being about the size of a small fountain pen. The top section of the holder turns to propel the brush through the tip. In this manner the brush can be fed through as needed until used. Refills are available.



*Clamer
 Lin Eon Thon
 Municipal Commissioner*

*Allen D. Child
 73, Kansas City, Mo
 W. J. ...
 ...*

*Wayne. D. ...
 Engineer
 June 1936*

*The Eraser Co.
 1208 Washington*

7661 Mrs. James M. ...
 20 W. Dartmouth Road,
 Knoxville City, Mo

Reference: Ted Allen, 206 4 S. Levee, 23
 Illinois, Chicago

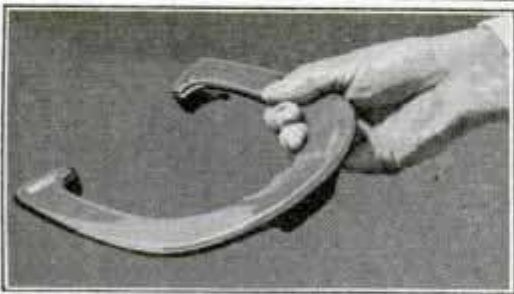
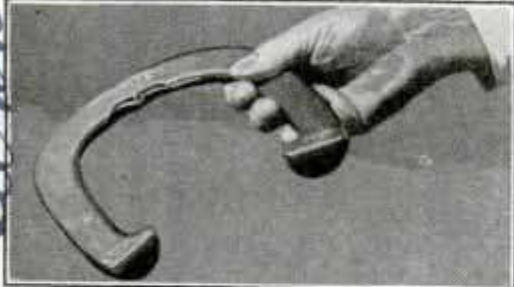

HORSESHOE

By Ted Allen

HORSESHOE pitching, like ping-pong, light-harness racing, bicycling and a few other pastimes of a by-gone era, is regaining its place after languishing in the doldrums several years.

With an enthusiastic following of approximately four million persons, horseshoe pitching may be considered a recreation of the first magnitude. And it appears to be growing in popularity in every section of the country. A number of leading universities have introduced the sport into their physical education departments. Harvard and the University of Southern California were the ringleaders in this movement and many other colleges and public schools are following suit.

Horseshoe pitching is almost the perfect game because it has many of the advantages of the more popular forms of sport without their drawbacks. To young and old, it offers amusement, competitive thrills and exercise of both mind and body, though not too strenuous in either case. It can be played indoors or out, and in such a way that the experienced player can match his skill against an inexperienced one.

But like the old gray mare, horseshoe pitching "ain't what she used to be." It has grown scientific and a little high-brow. In fact, the term

Top, left, perfect form. Strip on this and facing page, proper stance, backswing, starting throw, release and the follow-through. Note position of feet in each photo. Center, left, and bottom, learning how to hold the shoe

Reference: Ted Allen, 206 4 S. Levee, 23 Illinois, Chicago

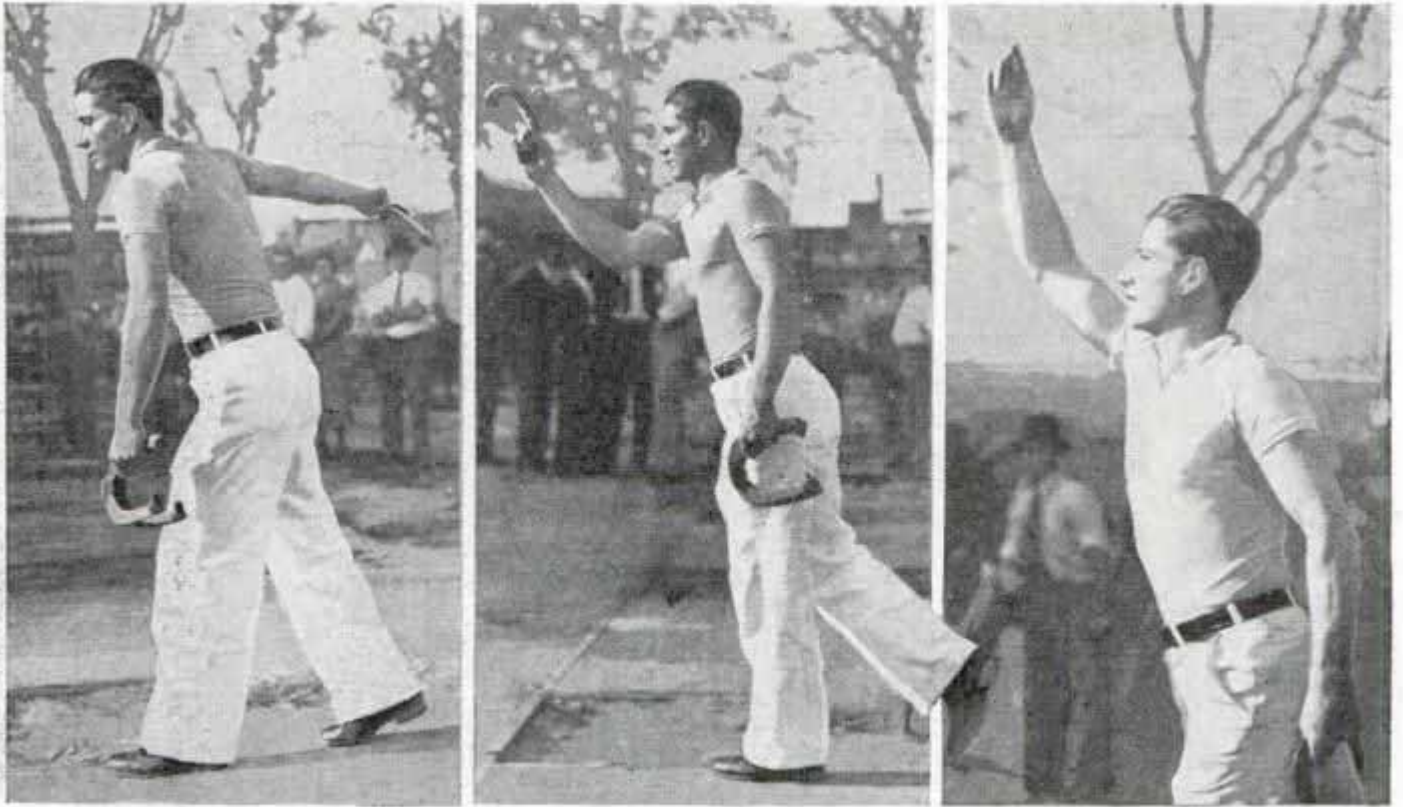

PITCHING *Comes Back*

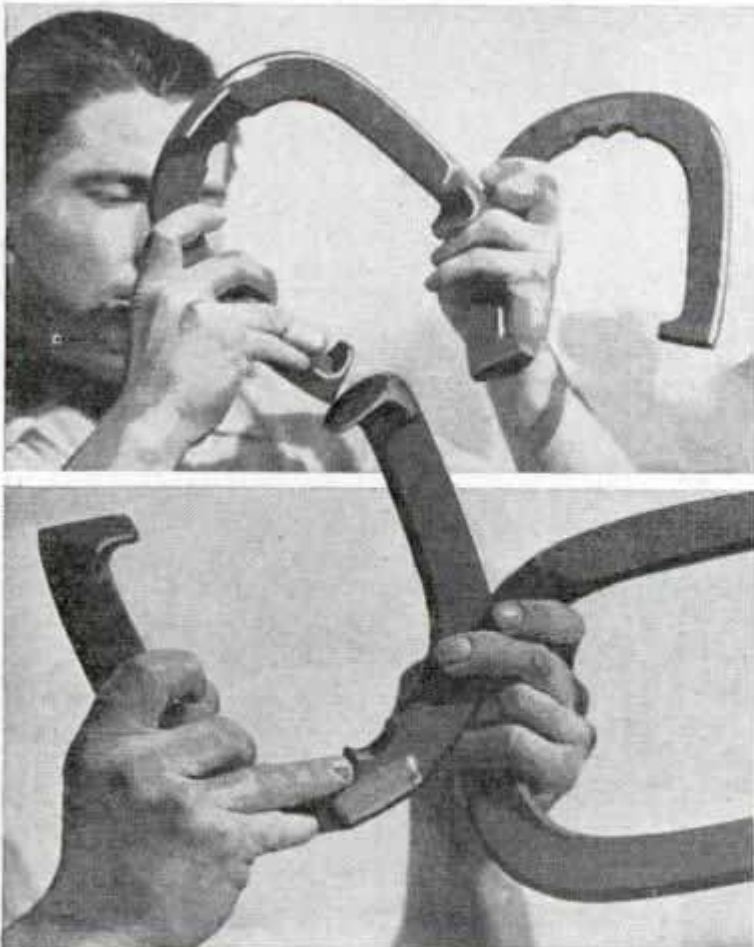

Note position of fingers as one expert player demonstrates two of the grips found effective in championship contests

horseshoe has been preserved merely for sentimental reasons. By no stretch of the imagination could anyone picture a horse shod in the game's present-day implements. They are approximately seven inches wide, seven and one-half inches long and weigh about two and one-half pounds. There are a few other requirements concerning the distance between calks and their size that would preclude them as suitable equine footwear.

Although historical minded folk will tell you that horseshoe pitching goes back to the army camps of the old Greeks and Romans, its present popularity is traceable to an Akron, O., fireman, George May, who started pitching for ringers instead of points.

Before May's time, players tossed shoes in the general direction of the peg and hoped for a ringer. It was May's theory that by adjusting the fingers on different parts of the shoe so as to reg-



ulate its revolutions in flight that the number of ringers could be increased. This is known as the open shoe. It must be admitted, however, that many other players had worked along this same line, but the Akron fireman was the first to obtain results. With this experience, May entered the national championships to walk away with the crown after winning twenty-four straight games and pitching 430 ringers.

His findings became common knowledge and the leading players grew more and more proficient at throwing ringers. In the old days, an average flipper considered himself fortunate to toss two ringers a game, while now a player must throw sixty to sixty-five per cent ringers to be classed as a first flight competitor. In championship competition seventy to seventy-five per cent of the shots are ringers.

At the national tournament last year at Moline, Ill., I was fortunate enough to make seventy-five and five-tenths per cent ringers in twenty-three consecutive games, while C. C. Davis, former titleholder, was close on my heels in this phase of competition with a score of seventy-three and six-tenths per cent.



Top, general view of horseshoe-pitching tournament on Long Island. Bottom, form of an expert player just before the shoe is released

Horseshoe pitching is the same as any other sport in that a thorough training in fundamentals supplemented by plenty of practice spells success.

After deciding on the type of shoe you can handle and control the best, the beginner should learn to pitch the open shoe. Among the most successful grips are the one and one-quarter and the one and three-quarters turn. With the one and one-quarter turn, the shoe turns one and one-quarter times from the point from where it is released until it reaches the peg. With this style, the shoe's opening should be to the player's left while with the one and three-quarters grip, it should

(Continued to page 140A)

1968.

San Francisco Water Tube Is Big as Subway

Water for thirsty San Franciscans will travel through the huge Crystal Lake tunnel on which work now is proceeding near San Mateo. This great water conveyor—minus the water—might easily be mistaken for a subway or the Holland tube in New York, so great is the diameter of the bore.

I986

Strange Mineral for Insulation Is Like Cork

Vermiculite, a strange mineral which floats on water after treatment, is the latest insulating material for electric refrigerators and hot-water heaters. In the raw state it resembles mica and is obtained principally from a mountain in Montana. Exposure to low heats causes it to expand twenty-seven times its original volume, take on a golden color and assume the lightness and toughness of cork. It also is fire resistant.



This photo gives you an idea of the size of the big water tunnel which will serve San Francisco. It is being rushed to completion

Phonograph Records of Glass Are Easy to Make at Home

Phonograph records on glass disks can be made at home by a process developed by Ivan Eremeeff, sound engineer, who first covers the glass with a coat of paint composed of automobile filler, beeswax and lacquer. The recording is made while this composition is still semidry, a steel needle marking the sound track in the paint and cutting down to the glass. Since the paint has an exceedingly fine grain, the track is sharp with no ragged edges. After the recording, the paint is permitted to harden and forms a permanent record. If a master record is desired from which other records may be pressed in wax, the glass record is taken to a photoengraver who can make a plate in which the sound track will be raised. Such a method was used in pressing music records into sheets of chocolate candy, which could be played once or twice before they were devoured.

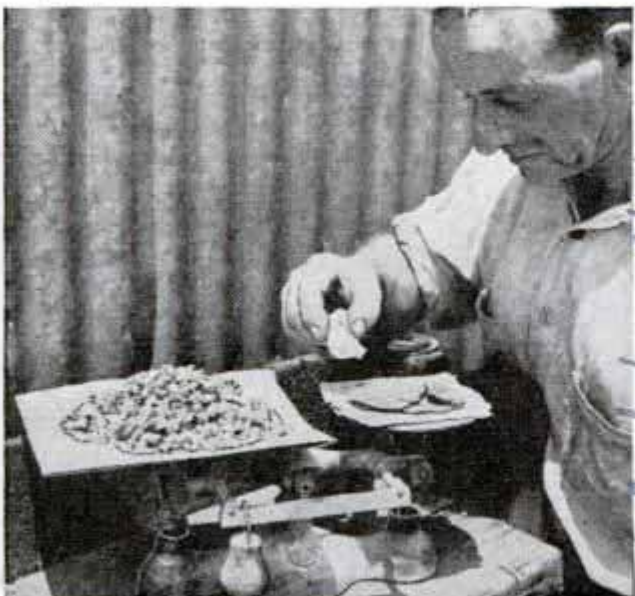

Weighing the mineral after it has been treated. It becomes light like a cork

2084 Danann M. Phila

1 1/2 lbs Bros. Chemical Co. 2159 Bay St
 Chestnut and 16th

1969.

Bobsled Roller Coaster Is Latest in Thrill Rides



Here we see the latest thing in amusement park devices—a bobsled roller coaster starting around a thrilling turn

Offering something new for the thrill seeker, a bobsled roller coaster is in operation at a Berlin amusement park. The car in which the riders are seated resembles a bobsled. The coaster speeds around a track somewhat similar to a bobsled run, containing straightaways and death-defying horseshoe turns.

Ultraviolet Rays Hold Hope of Conquering Influenza

After recovering flu virus from the air, scientists have found that it may be destroyed by bringing it in contact with ultraviolet rays. Thus there opens up a vast field of preventive medicine, whereby the air in hospitals, theaters, schools and

auditoriums may be freed from dangerous germs. Influenza spreads easily because the virus floats in the air for at least thirty minutes after a person suffering from the disease sneezes.

Peltier Comet's Path Is Shown by Model

Built to show the orbits of the Peltier comet and the earth, a novel model has strings to indicate the relative distance between the two as they approached each other recently, and then drew apart. On August 4, 1936, the comet was at its closest point to the earth, sixteen million miles away. After that date it passed rapidly from view. Each of the distance strings represented the gap between the comet and the earth on certain dates. At forty miles an hour, it would take more than forty-five years to drive sixteen million miles.

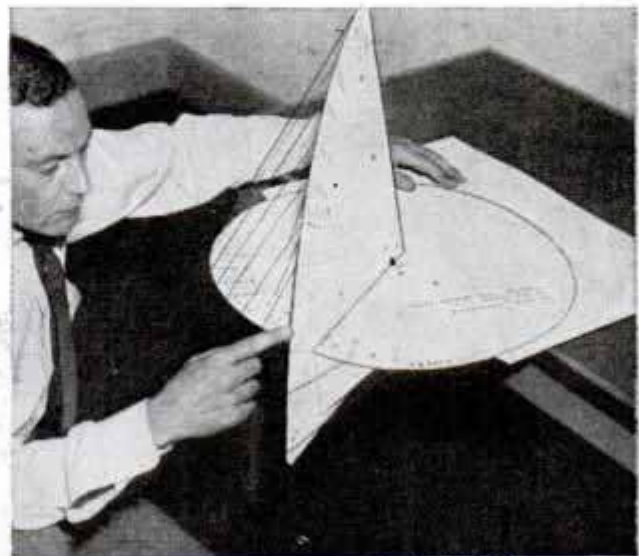

Pointing to string indicating nearest point that comet approached the earth

No further information

1979

Chicago Tribune
7/22/36

Glued Wall System Replaces Lath and Plaster

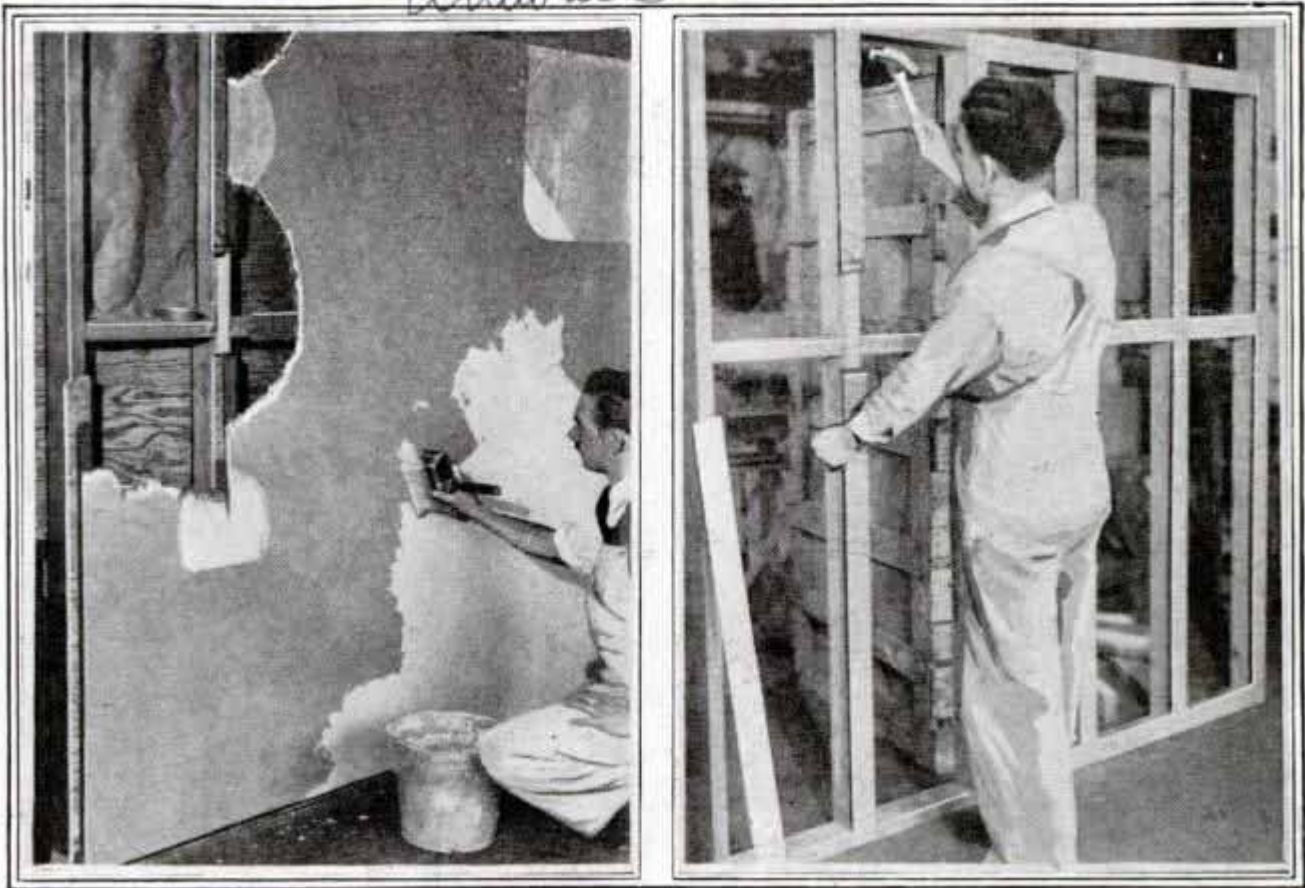

Left, cutaway section of wall shows its construction and the ease with which it may be decorated to resemble plastering. Right, nailing on the strips to which the plywood or wallboard is glued

Making lathing and plastering unnecessary, a new glued wall system employs glue instead of nails in the vital part of the joint construction. In addition the wall is strong and crackless. The system calls for the nailing of patented strips of fir plywood to studdings, rafters and headings. Then comes the gluing of panels of plywood or wallboard to these strips and edge gluing of the panels to each other to form a solid one-piece wall. Because of the self-bonding nature of the glue no excessive pressure is necessary to get a tight fit. Shrinkage and expansion of the wood are not transmitted to the surface of the wall. The wall can be decorated to look like regular plaster walls, but the glued panels will not shift and cause cracking.

Popular Mechanics Magazine does not publish the name of the maker of, or dealer in, any device described in its pages, but this information is kept on file and will be furnished by our Bureau of Information upon request, accompanied by stamped, self-addressed envelope.

Heavy-Duty Portable Drill Exerts High Pressure

When it is difficult to take the job to the stationary drill, a portable heavy-duty drill can be taken to the job. A hand drill designed for quick use anywhere, a precision tool capable of extreme accuracy with heavy pressure, is now available. It fits in and around all types of machinery, holding itself in position by its own pressure. Backbone of this drill is a sturdy steel bar on which both drill head and shoe pivot. Feed control is semi-automatic, the feed clutch engaging and disengaging from the crank by fingertip pressure. A ratchet handle makes it possible to work in close quarters.

\$16.25



Liste Corp
 Planned & made

Handwritten notes on the right margin, including the number '7' and some illegible text.



Left, melting a metal sheet with the aid of concentrated heat from a solar furnace

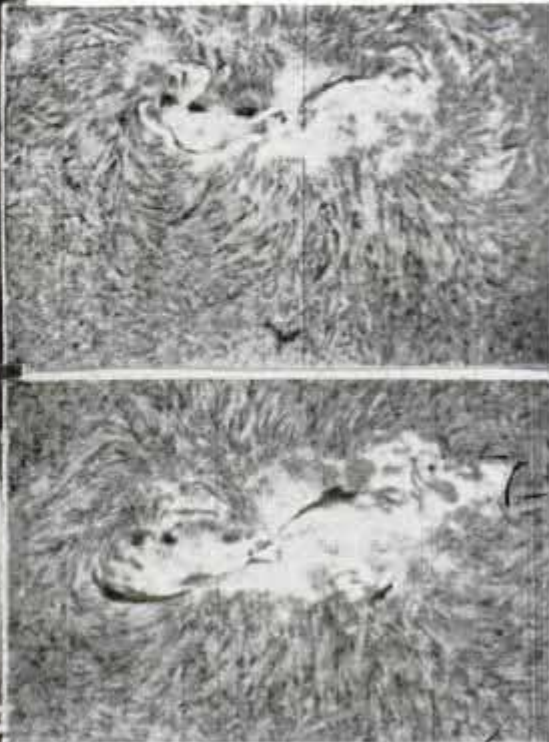

New POWER from

WILL man ever be able to transmit power by radio? Until lately science has had to reply emphatically that "on the basis of present knowledge" this was an impractical dream. Now it seems that eventually the sun may supply a different answer.

The reason is that during the last few months astronomers have learned more about an unexplained radiation that the sun broadcasts, and it may be that additional research will open up an entirely new field of knowledge. Mysterious radio interruptions are pointing the way.

The sun has been blamed for years for the peculiar "magnetic storms" that sometimes disrupt electrical communication systems. In a general way these disturbances are traced to sunspot activity. Not very much is known yet about the spots that appear on the sun, the belief being that they are regions on the surface that have a temperature 2,000 degrees less than their surroundings. Occasionally tremendous flaming clouds of hydrogen gas appear in the neighborhood of the spots. When these eruptions occur, electromagnetic disturbances are apt to happen on earth, but no theory that explains the connection has been generally accepted. Some radio experts think radio reception fades and improves in cycles lasting

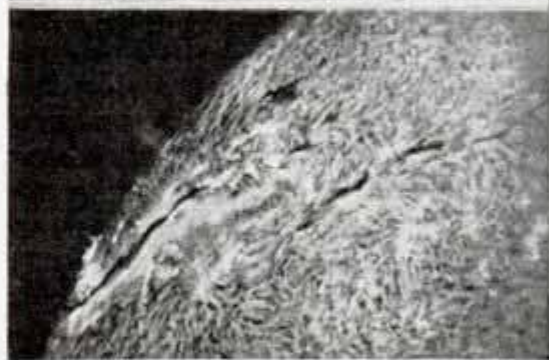
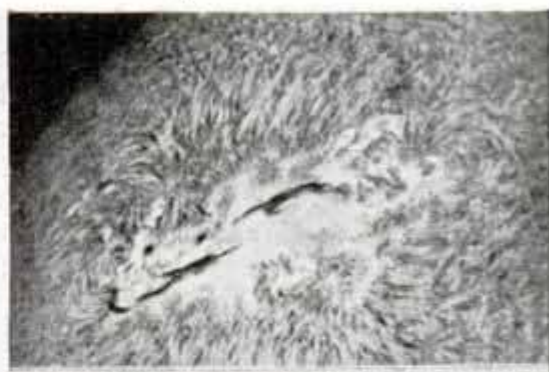

Appearance of sunspot on successive days as the rotation of the sun carries it farther and farther to one side of the turning planet until it disappears from view

F 783
 Cmd. Thomas & Lemmon of Los Angeles
 1055 Palmdale Ave. Los Angeles

7 7833 2

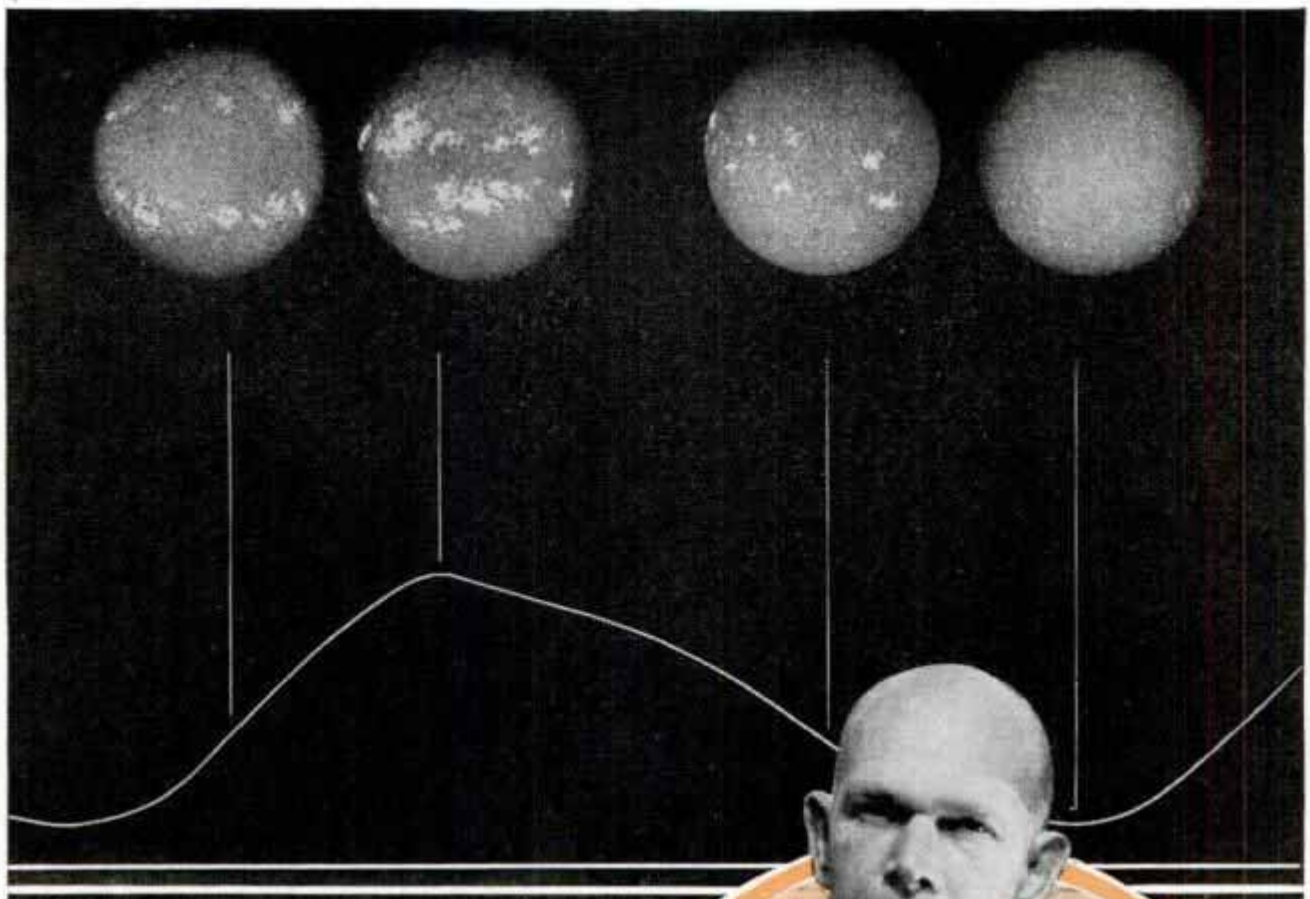

the SUN

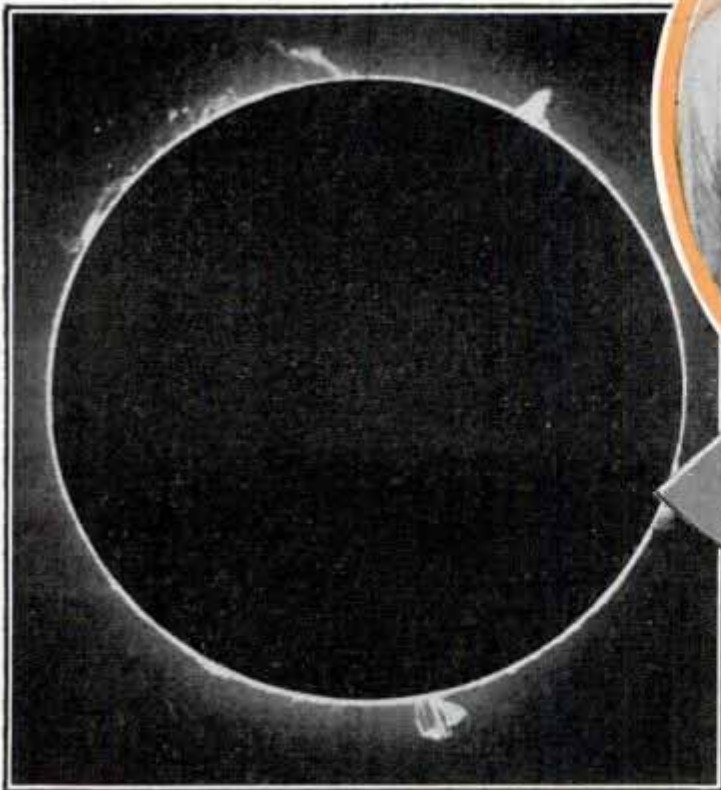
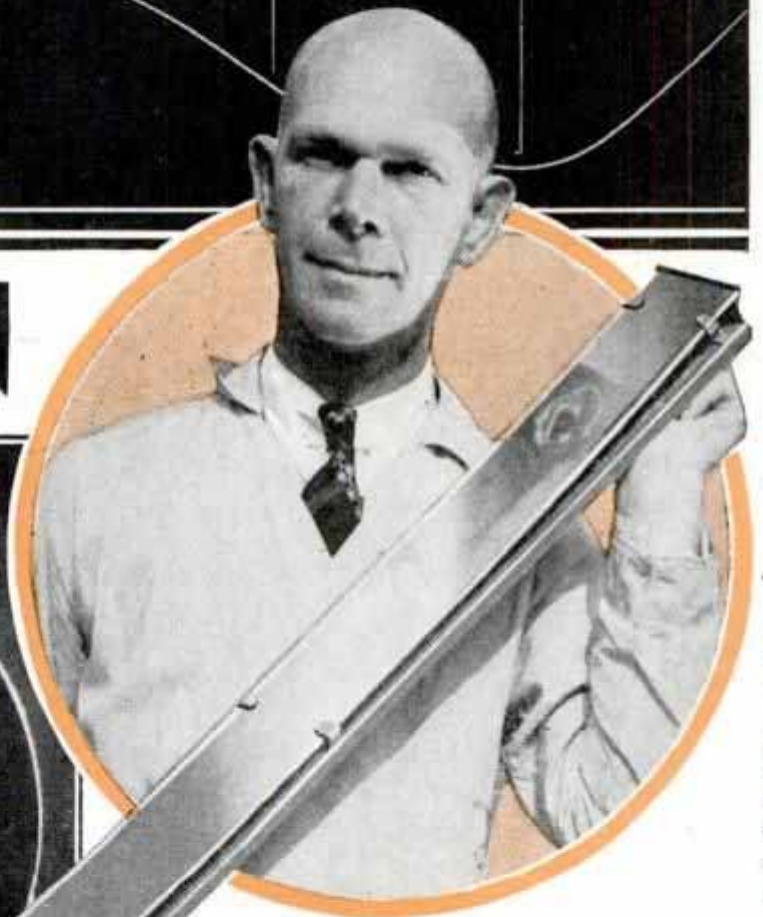

Top, curve of sunspot cycle and spectroheliograms showing appearance of sun at different phases of cycle. Below, curved glass for solar heating and gas rising from sun's surface

a number of years, paralleling periods of sunspot activity.

Today a new connection between the sun and the earth is being studied. During the last year radio men have been surprised to find that at extremely high frequencies reception sometimes dies out completely even though reception at other wave lengths, including the broadcast bands, is not interrupted. Except for faint signals from near-by stations, short-wave

Handwritten notes on the right margin: "Sun spot cycle 11 years" and "Sun spot cycle 11 years".

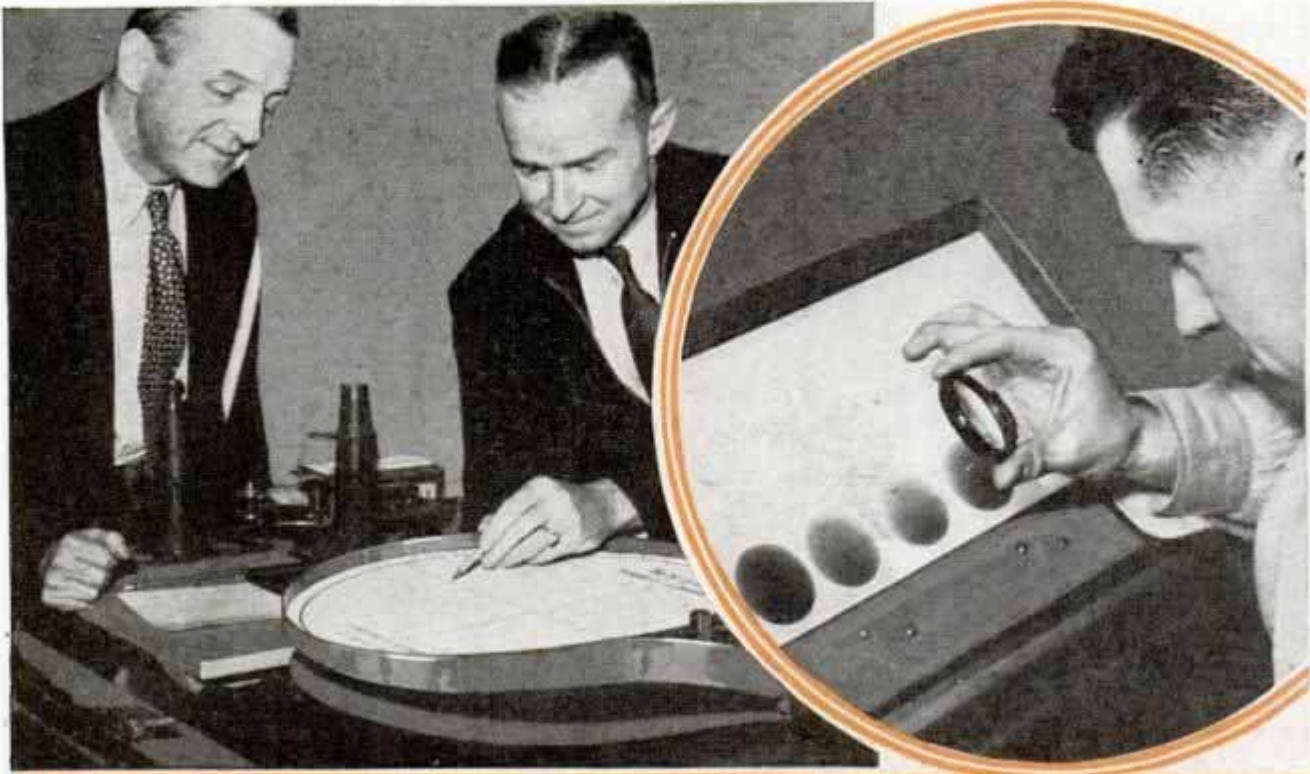

reception disappears as completely as if a fuse had blown. This happens at from seventy-five meters down past twenty meters, and depending on the wave length, lasts from fifteen minutes to four or five hours over the illuminated half of the globe.

With some exceptions the fade-out occurs about every fifty-four days. This period, being approximately twice the period of the sun's rotation, suggests that something is happening every other time the sun turns around, although no one can yet say why.

Last spring scientists estimated a fade-out was due April 8, and astronomers decided to learn all they could about the phenomenon if it should recur. In California, Dr. Robert S. Richardson, one of the "sun men" of the Mt. Wilson observatory of the Carnegie Institution of Washington, D. C., prepared a spectroheliograph to photograph solar eruptions



Top, studying sunspots on paper disk suspended in light path of solar telescope, and examining sunspots on glass negatives made with aid of telescope. Below, mirror disks of horizontal telescope used to study sun

by their hydrogen light and arranged other instruments for the test. When the work was over he had new evidence of some mysterious transfer of energy between the sun and the earth.

At 8:46 that morning the Mt. Wilson

(Continued to page 118A)

813 Sante Barbara
 Pasadena
 Calif

Caterpillar Swarm on Rails Stops Fast Trains



Always traveling in a straight line, caterpillars climb over fence post at left rather than detour around it. Right, crew attempts to clear track of caterpillar swarm that greases rails and stalls train

Caterpillars swarming six inches deep on the rails have halted transcontinental express trains in Ontario this year and denuded more than 8,000 square miles of farm lands and forests. One sixty-mile-an-hour train was stopped for forty minutes by the pests, and, unable to get traction on the heavily coated tracks, had to be broken into sections before it could be moved. Another train waited two hours while the track was cleared with live steam, and extra locomotives were sent in regularly to infested areas. Finally locomotives were all equipped with steam jets in front of the driving wheels, the live steam sweeping the caterpillars from the rails. The unusually heavy infestation this year was blamed upon lack of early frosts which ordinarily kill the insects, and an abundance of their favorite food, poplar and birch trees, which have grown up on burnt forest areas. Airplanes were sent up to spray forest and city areas with insect poison, shade trees in towns were protected with cotton wrappings and

sprays, and farmers trapped the caterpillars in trenches and burned them with gasoline and coal oil. Still, clover and hay fields were swept bare, cattle could not find grazing and forests were stripped of foliage along a 175-mile front. Chickens had their fill of caterpillar diet and quit eating them. School was dismissed near Sudbury because the caterpillars swarmed on walls and floors. Even fishermen complained, because caterpillars swept out on the lakes gave the fish plenty to eat and they would not rise for a fly.

F918.

Number of Airports Increases to Twenty-Four Hundred

Airports and landing fields in the United States totaled 2,402 on July 1, 1936, compared with 2,343 counted by the bureau of air commerce a year previous. Of the total, 701 were lighted for night use. The army maintained sixty-two airdromes, the navy twenty-six; there were 746 mu-

Cont. James Montague, 517 Harbour
 Comm. 10/10/36

June 2, 1936

Caterpillar Swarm on Rails Stops Fast Trains

nicipal, 498 commercial airports, 291 department of commerce intermediate landing fields and several hundred auxiliary, private and government airports. Seven states which had 100 or more aviation fields were California, 192; Texas 135; Pennsylvania 118; Michigan 114; Florida 112; Ohio 103 and New York 100.

Eight Motors of Air Liner Drive Its Four Propellers

7880

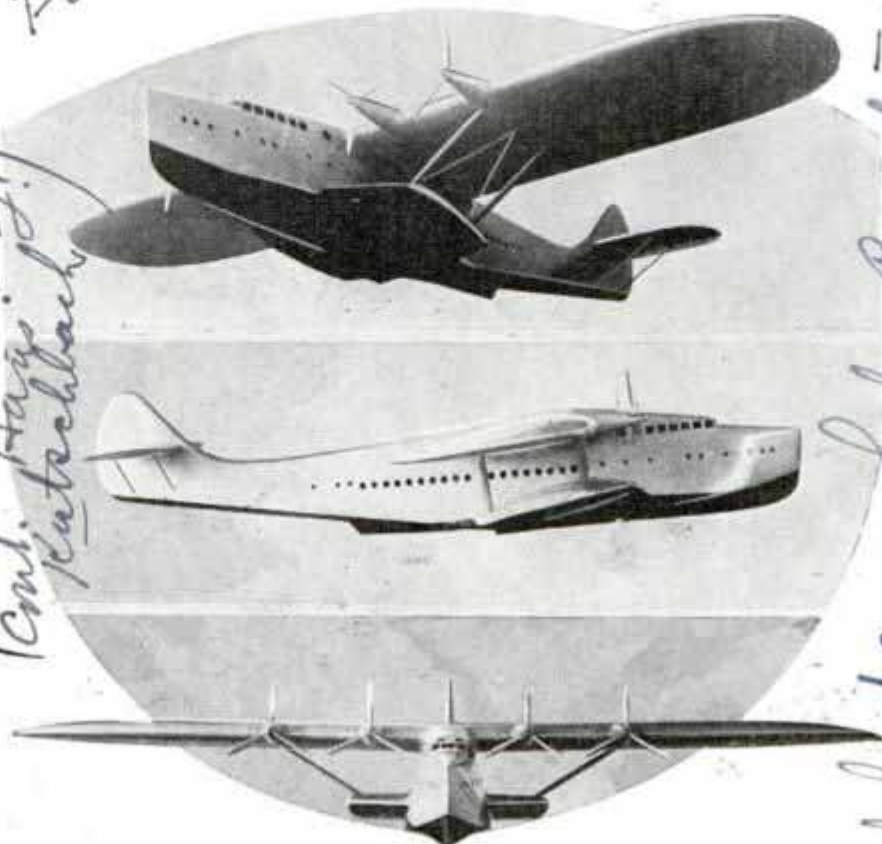

Three views of huge Diesel-powered flying boat being built in Germany for transoceanic passenger service. Engines are recessed in wings

Underwater Photo Shows Secret of Swimmer

How a star swimmer performs under water has been photographed by a camera inclosed in a special device beneath the surface. The swimmer, Shozo Makino, long-race, free-style champion of Japan, was caught by the camera as he drove through the water after diving.

7888

(Comb. by J. F. Kutschbach)

Waseda University Japan.



Unusual photograph of a swimmer in motion under water. Note twisting arm action

Destined for transoceanic service, a giant flying boat with eight motors geared to its four propellers is being built in Germany. With 8,000 horsepower available, and a wide cruising range, the plane will be capable of non-stop flight between Frankfurt-on-Main and New York City. The ship is being built at the Dornier Works and will be even larger than the famous "Do-X," which had twelve engines. Dornier engineers found it was more efficient to install four three-bladed propellers and gear two 1,000-horsepower motors to each. The engines are recessed into the wings, which have a span of 160 feet. Diesel engines are used in the new "Do-20" instead of gasoline motors which drove the "Do-X." The ship will have a cruising speed of about 160 miles an hour and top speed of about 180.

[America's 1,864,643 miles of copper telegraph lines would provide eight wires from the earth to the moon if they could be strung across space.

Copper + Brass Research Assn.

7880
Lake Constance Germany
I'm a Dornier flying boat

7-15-2. Mrs. C. Schumacher
727 Park Ave
Newport City

They KEEP THINGS



IN EVERY catastrophe, whether national or local, an "army of generals" goes into action to aid the victims, to help restore order and to keep things moving. They are the maintenance men of the telephone, electric power and gas companies and are called the army of generals because when they rush to battle an emergency, they are generally on their own, each skilled man commanding himself and such volunteers as enlist their services.

When a tornado sweeps through a town leaving death and destruction in its wake, when a flood inundates a wide area, when a devastating fire breaks out in a city or when a blizzard drops a smothering white blanket down upon the countryside, the maintenance men go into action. No mat-

Top, this freak accident made work for maintenance men. Below, repairman splicing a damaged telephone cable after flood

Copied from...

MOVING

ter what damage the elements have done, no matter what physical obstacles must be overcome, telephone lines must be repaired immediately. Electric power must be restored and gas leaks must be stopped and broken pipes shut off.

In a national emergency the maintenance man is one of the first to aid the Red Cross, the National Guard and other forces summoned to fight the disaster. In a local disaster, such as a



fire, an explosion or a cave-in, the maintenance man appears on the scene as quickly as does the fire or the police department. In most cities the fire alarm registers in the office of the gas company simultaneously with the alarm in the fire houses.

"Twenty-four hours a day, every day in the year, the emergency crews function regardless of weather" states E. E. Hill, supervisor of the New York Edison and United emergency crews. When service fails, it is the men of the emergency crews who restore it. The many situations they meet call for exceptional skill, courage and initiative, and these men are carefully chosen for the work.

"Personal hazard is often entailed in the clearing of burn-outs



Clearing flood debris from telephone poles so switchboard, center, can function. Bottom, repairing railway trestle which was undermined by flood waters



Guest arriving at Hartford, Conn., hotel in boat, and soldier operating short-wave radio during flood

the injured and applying artificial respiration are part of the regular duties of the emergency crew.

"A few years ago, the shoring of a subway under construction caved in, precipitating several people into the excavation. The emergency crew rescued the victims, one member risking his life to crawl under shaky timbers to release a pinioned woman. When an explosion and fire occurred in one of New York's largest apartment hotels, emergency men assisted in removing the dead and injured and went into the sub-basement, when fire and possible explosions endangered every one, to install temporary lighting to help in the work of rescue and fire fighting."

One of the greatest tests ever faced by the army of generals occurred during the floods this year. From Maine to the valley of the Ohio, the maintenance men were called upon to repair the damages wrought by the flood so "things might be kept moving." Some idea of the immensity of operations may be gained from the emergency supplies sent to the flooded area by the Bell Telephone System alone.

More than 50,000,000 conductor feet of rubber-covered wire; 24,000 telephones; 750,000 pounds of copper line wire; 200,000 pounds of pole line hardware; twenty-three sections of central office

and our men have been highly praised for bravery. Yet their work is not confined to routine clearing of electrical trouble. Indeed some of their most notable jobs have been at fires, floods and cave-ins where men trained and equipped for emergencies were needed. Nor is the individual citizen in distress overlooked. Stopping water leaks, giving first-aid to

switchboard and scores of private branch exchange boards in addition to telephone poles, cable conduit and rubber boots were shipped to put the telephone lines back in working order. The maintenance men repairing the long-distance lines which kept the rescue officials in the flood area in touch with the rest of the country worked night and day at the risk of their lives. The

7752

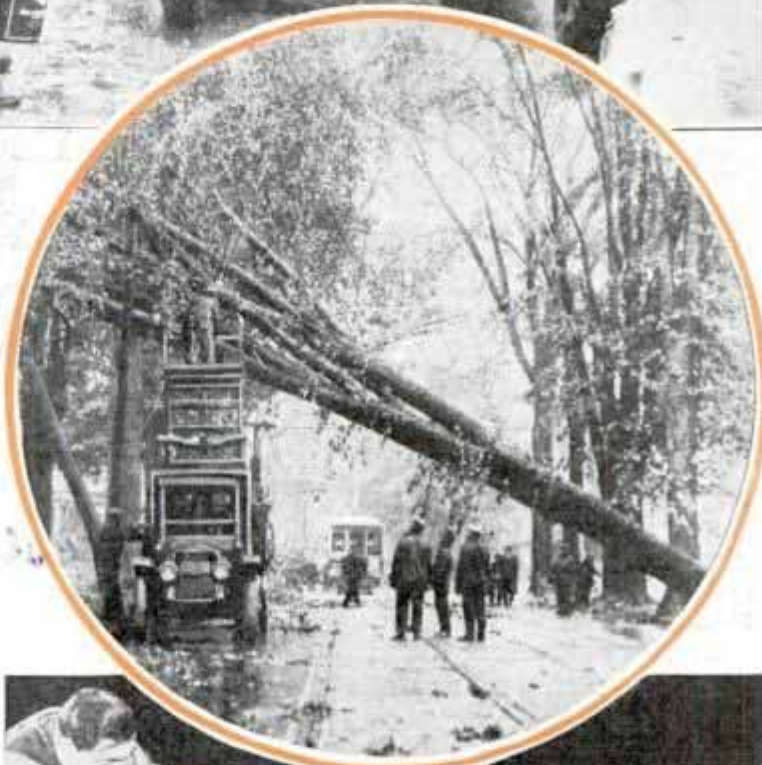

average number of "patch orders" calling for replacement of long-distance lines by providing substitutes, in normal times averages ten a day in the long-distance traffic control bureau in New York. In the six days during which the flood conditions were at their height, more than 1,000 such orders were put through.

Working in boats and wading through water, chopping lines free of trees and debris lodged against them by the crest of the flood, climbing icy poles and erecting new ones where necessary, the linemen in this period succeeded in restoring ninety-six per cent of the long-distance circuits which would normally have been in service.

"Doubtless no one will ever be able to estimate the number of lives and the extent of property saved, due to speedy warnings of the impending flood" states J. F. Kilpatrick, president of the New York Telephone company. "Numerous press reports have told how linemen risked their lives to restore the circuits broken by the mad waters, how telephone operators stayed at their switchboards day and night in many instances



Fire truck pumping drinking water after flood. Center, street in Syracuse, N. Y., after a windstorm. Below, maintenance men repairing generator

(Continued to page 116A)

Syracuse, N. Y., after a windstorm
 2/1/1935

repaired by the
 116A

Cement Model of State Capitol Has over 900 Windows



Cement model of ten-million-dollar state house at Lincoln, built in a Nebraskan's landscaped garden

There are more than 900 windows made of mirror glass in a cement model of Nebraska's \$10,000,000 state capitol building, built as a hobby by a Nebraskan. It stands in his beautifully landscaped garden. The figure of the sower on top of the skyscraper model is gilded, and the decorations over the entrance doors are hand-painted reproductions of figures and symbols of pioneer days.

*E. P. Faustman
Built by Aurada, Neb.*

The auxiliary unit, which was developed recently, also may be used independently. The unit consists of a cylinder, which has a compression spring and a trigger and which is housed beneath the regular unit by slightly altering the shape of the tail cone. An electrical switching mechanism when loaded with the antenna cartridge and released by a special control, shoots out the cartridge and closes the electric switch to put the auxiliary antenna into immediate use. When the control is released, the compression spring forces out into space a paper cylinder upon which is wrapped thirty-five feet of antenna wire. The wire unravels and discards the paper cylinder, then trails from the plane. A special loading tool is used to reload the cylinder with a new antenna cartridge.

7892

How Earth Looks from Moon Is Shown by Globe

Prepared under the guidance of an astronomer, a globe at the Franklin Institute in Philadelphia shows how the earth would look to some one on the moon. The continents are accurately outlined in the misty colors which the moon-man would see. Basis for the research which resulted in the painting of the globe was the earth's



This globe shows how the earth would appear if the observer were on the moon

F900 Pilot Shoots Second Antenna to Boost Radio Signals

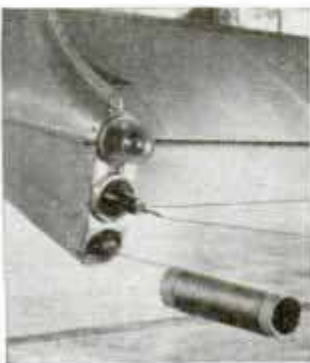

When radio reception or transmission is poor, the pilot of a TWA air liner may shoot into space an auxiliary antenna for simultaneous use with the regular antenna.

Painted by Howard Russell Butler

*Stewart D. Stewart
Astronomical Dept.
under direction of Prof. [unclear]*

light, or "earth shine," on the new moon. The small crescent shows the color of the moon, in its light from the sun, but there is also the earth shine, the light which has been reflected from earth to the moon and back. This light gives the scientist a clue as to how the earth appears from the moon. Thus, with this globe, man may go into the universe and look at the earth.

1829

Dog Rides in Pram on Top of Car

Dogs enjoy motoring as much as the family does, and it's hard to leave the pup at home when starting on a tour. All packed for a trip, one family found the car too crowded to take the dog along, but there was plenty of room on the roof. So they roped the baby's perambulator on top, put a blanket around the dog and let him ride in this special seat. The pup seemed to enjoy his perch.



Scribner Syndicate
509-6th Ave NYC
Maybe there isn't room inside, but this pup will not be left behind. He has a special observation seat in a pram on top

Streamline Diesel Railcar 1905 Hauls Swiss Passengers

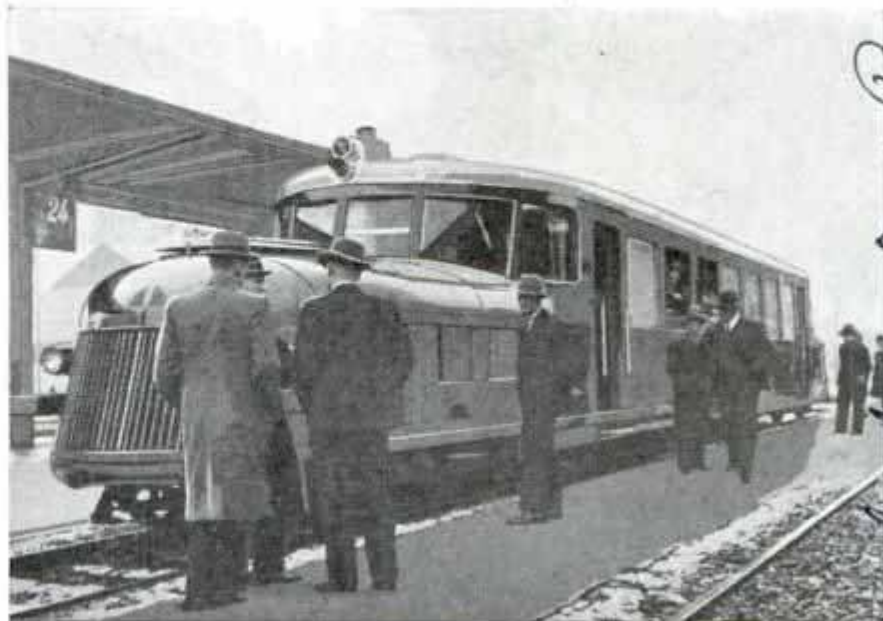

© Max Kettel

Travelers in the Swiss Alps ride on this Diesel-motored railcar which resembles a huge streamline bus

Built for passenger service on the Swiss Federal Railways, a new railcar of striking lines somewhat resembles a giant bus. Its Diesel-electric power unit is mounted low in front of the cab. The broad windows afford the car's occupants an excellent view of the Alpine country.

927 Sensitive Scale Can Weigh Atom to Four Octillionths of a Gram

So precise that it can detect a difference in weight of 4,000,000,000,000,000,000,000,000ths (four octillionths) of a gram, a scale capable of weighing atoms has been developed at the University of Chicago by Prof. Arthur J. Dempster of the physics department. It is a "mass spectrograph" of a new type, used in analyzing solid substances. With the material to be analyzed as an electrode, Dr. Dempster produces a hot spark. Atoms from this spark are drawn through an electrical field and a magnetic field and on to a photographic plate. The instrument already has helped Dr. Dempster discover hitherto unknown isotopes, variant forms of elements.

Official information Bureau of Switzerland
7/10/36
Chicago Tribune

of sheet iron. Over the one-room structure they install a shed with a wood roof. In the space between the wood roof and the sheet-iron roof is a water pipe with holes cut at intervals. When the water is turned on, it streams from the holes and cascades over the roof and down the sheet-iron sides. Inside an electric fan circulates the air. Temperatures are twenty to thirty-five degrees cooler than those outside.

7929
**Flower Mosaics
 Mark Ancient
 Festival**

Composed of millions of flowers and buds, beautiful mosaics cover the streets during the feast of Corpus Christi in Genzano, Italy. One of the unusual exhibits during the recent celebration of this ancient festival was a bust of King Victor Emmanuel made up of thousands of flowers of all colors. The mosaics are arranged on streets along which the religious procession passes.

**Postage Stamp Shop in Bus
 Sells to Collectors on Tour**

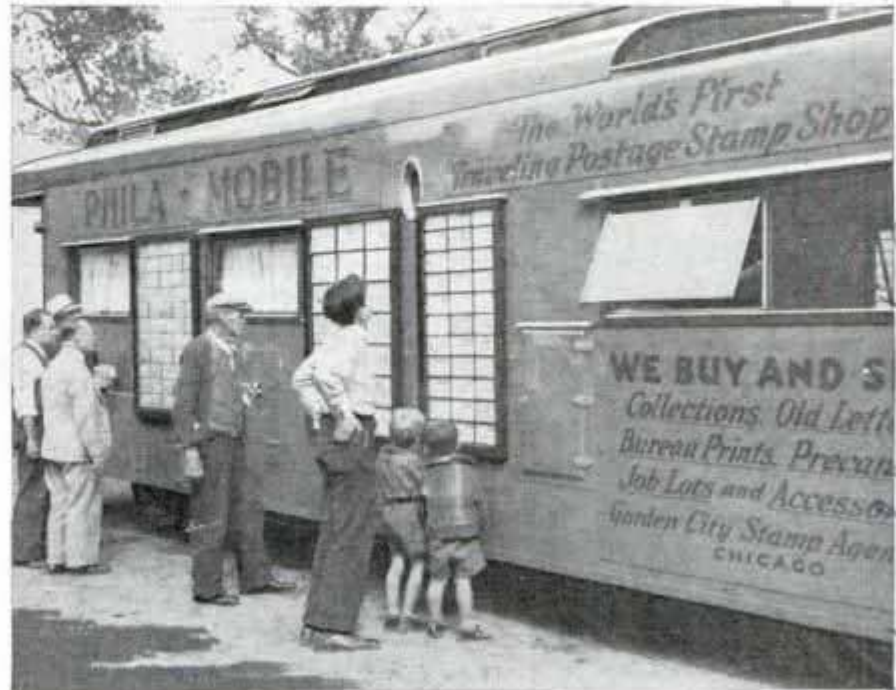

This traveling stamp trading post gets wide attention from philatelists. Thousands of stamps are exhibited in its showcases.

Stamp collectors stop and look when the "Phila-Mobile" comes to town. It is at once a traveling showcase and salesroom for a postage-stamp agency, its name being a contraction of "philatelist's automobile." Touring the country, this stamp shop enlists interest among collectors and buys

or sells stamps, taking orders to be filled from the home office. The car is divided into two rooms, with an observation platform at the rear, and is completely outfitted for all-year touring. There are twin beds, a clothes closet, gas stove for heating and kitchen with a gas range, ice box, running water and storage space for a month's provisions. There is room enough to entertain twelve persons.



Outlined in thousands of flowers, this mosaic represents bust of King Victor Emmanuel. It was one feature of ancient festival

☐The copper roof of Hildesheim cathedral in Germany, put on in 1320, is still serviceable.

*Chicago Tribune
 7/1 3/32
 City Stamp Agency
 1018 N. Dearborn St. Chicago*

*Copper and Brass
 Research Assoc.*

Lister Leaves Small Dams in Furrows to Hold Water



Top, special lister throwing up dams in furrows. Bottom, after a rain the dams hold water and prevent washing of the topsoil

To prevent valuable soil from washing away and to help hold water on the field, a new farm machine has been tested successfully in Kansas. It is a basin lister which serves the double purpose of preparing the ground for crops and of leaving dams in the furrows. A U-shaped piece of metal that fits into the furrow is dragged along collecting dirt for about ten feet, then a nub on the lister wheel catches the bar to which the shovel is attached and causes it to lift, depositing the pile of dirt at intervals in the furrow. Those dirt piles act as dams when it rains, holding the water in the furrow and resulting in unusual penetration of moisture into the ground. Tests at the Fort Hays experiment station showed that the water soaked twenty inches into the ground when the basin lister was used. Where the ordinary lister was used the soil was moist only twelve

inches. Land not worked was soaked ten inches. The dams thrown up by the lister also keep the topsoil from washing off the field during heavy rains.

Adjustable Heater Rids Windshield of Frost

Designed to keep the windshield clear of frost in cold weather, a special mounting for an automobile heater has been tested successfully. The mounting permits pulling the heater from under the instrument panel and swinging it into various positions so that the warm air may be directed against the windshield. Thus the heater may serve its usual purpose and also that of defrosting fan or blower. When not in use, the heater may be pushed back under the instrument panel. The mounting does not interfere in any way with normal

flow of hot water from the automobile cooling system through the heater.



Heater swung up to windshield, ready to eliminate frost. It adjusts to several positions

Developed at Fort Hays experiment station, Kansas

Journalism Dept. Kansas State College Manhattan Kan.

A. W. Brandt 8704 Jackson Park

Dr. W. A. ...

F891

Chrysler Corp 341
Massachusetts Ave
Detroit, Mich

Sliding Roof Converts Taxicab into Open Car

Taxicabs with a sliding door in the roof are being introduced in this country. Patrons can enjoy sunshine and fresh air, and a view of the skyscrapers as if in a sight-seeing car, by sliding open the roof above the rear seat. This feature, in addition to rear and side windows which open wide, converts the sedan into an open car. A special safety feature is a signal on the dashboard which warns the driver if a door is open.



Two views of latest model taxicab with sliding roof that makes it an open car

Three Chances in a Million Lightning Will Kill You.

Your chances of being struck dead by lightning in the next year are just three in a million, unless you live in one of the southern or western states where bolts do their deadliest work. Insurance statisticians found only three persons in every million in the United States were killed by lightning in the last ten years. In the band of states from Montana to Arizona and across the "old south" death rates are as high as six per million, while Pacific coast and eastern states ranked as least hazardous. Death by lightning is a rarity in large cities where the steel skeletons of skyscrapers act as lightning conductors and dissipate the electricity from the sky. Tall buildings are often struck without being damaged.

Cows are sometimes so annoyed by the humming of near-by high-tension wires that they cease to give milk.

Substitute for Black Walnut Sought by Gunsmiths

Scarcity of black walnut, regarded as superior to all hardwoods for making gunstocks, has started a search for a substitute. The Forest Products Laboratory, operated by the government in Wisconsin, is experimenting with low-grade lumber. Before being used in gunstocks, the wood must be given a twenty-year period of air-drying. The world war caused a shortage in black walnut, which accounted for the price obtained for two partially decayed trees in the Arkansas national forest, \$20 per 1,000 feet on the stump.

cont Kenneth P. 49 Pl. Wayne
Elvis. Engineer

Operated by Sunbeam Radio 1975

Operated by Sunbeam Radio 1975

7/6/36

O'Brien & Evans
7/21/30

Pearl Oysters Packed in Cans Thrill "Treasure Hunters"

\$2.00 can



Here's a new thrill—hunting for pearls in oysters which are shipped in cans from Japan to this country

Many of the thrills of the diver searching for pearl oysters on the sea bottom are offered purchasers of cans packed with pearl oysters and shipped to the United States from Japan. Upon opening the can, the "treasure hunter" pours off the sea water, lifts the oyster from the native sea weed and searches for the pearl embedded in the oyster's flesh. The pearls are of varying size, so the result may be a large gem of great beauty. Prior to canning, the oysters have been taken from the ocean, a small mother-of-pearl bead placed in the shells and the oysters returned to the sea to permit formation of the pearl around the bead. A few years later the oysters are again brought to the surface and canned.

Light Colors Cause Plants to Seek or Shun Others

Different colors of light cause seedling tips of plants to seek or shun each other, Dr. Enoch Karrer of the Smithsonian Institution has found. Dr. Karrer grew oat

seedlings and exposed them to the rainbow band of light obtained by splitting the white light of an electric arc. Blue light caused seedlings to bend toward the light and toward each other. Red illuminated seedling tips bent away from each other. Plants receiving orange light became greener than their neighbors and roots grew longest in the extreme blue rays.

Blind Doctor and Guide Ride Twin Bicycles

Blindness does not keep Dr. A. O. Wilson of Lincoln, Neb., from enjoying his bicycle ride every day. When he wants a bit of exercise or is called to visit a patient he teams up with some friend who has a bicycle. Dr. Wilson used to pedal a bicycle with a sidecar in which a companion rode to direct him through traffic. Now his companion has to do his own pedaling. The doctor's bicycle has a frame-brace permanently attached, with an arrangement at the other end so that any friend can "hook on" for a joint ride. Steel bars form a cross from the rear sprocket of one bicycle to the seat base of the other, a bar connects the front of each frame and a steel "bumper" links the front sprockets.



When this blind doctor goes bicycling he hooks his "bike" to that of a friend who acts as guide

Clifford...
580 x 5...
Washing ton, Ill.
2/10/30

Vertical handwritten notes on the right margin.

Handwritten notes at the bottom of the page.

1944

311 Conroy St.
Bradford, Pa.

"Simple PARTY MAGIC"

By Jack Gwynne
Famous Professional
Magician

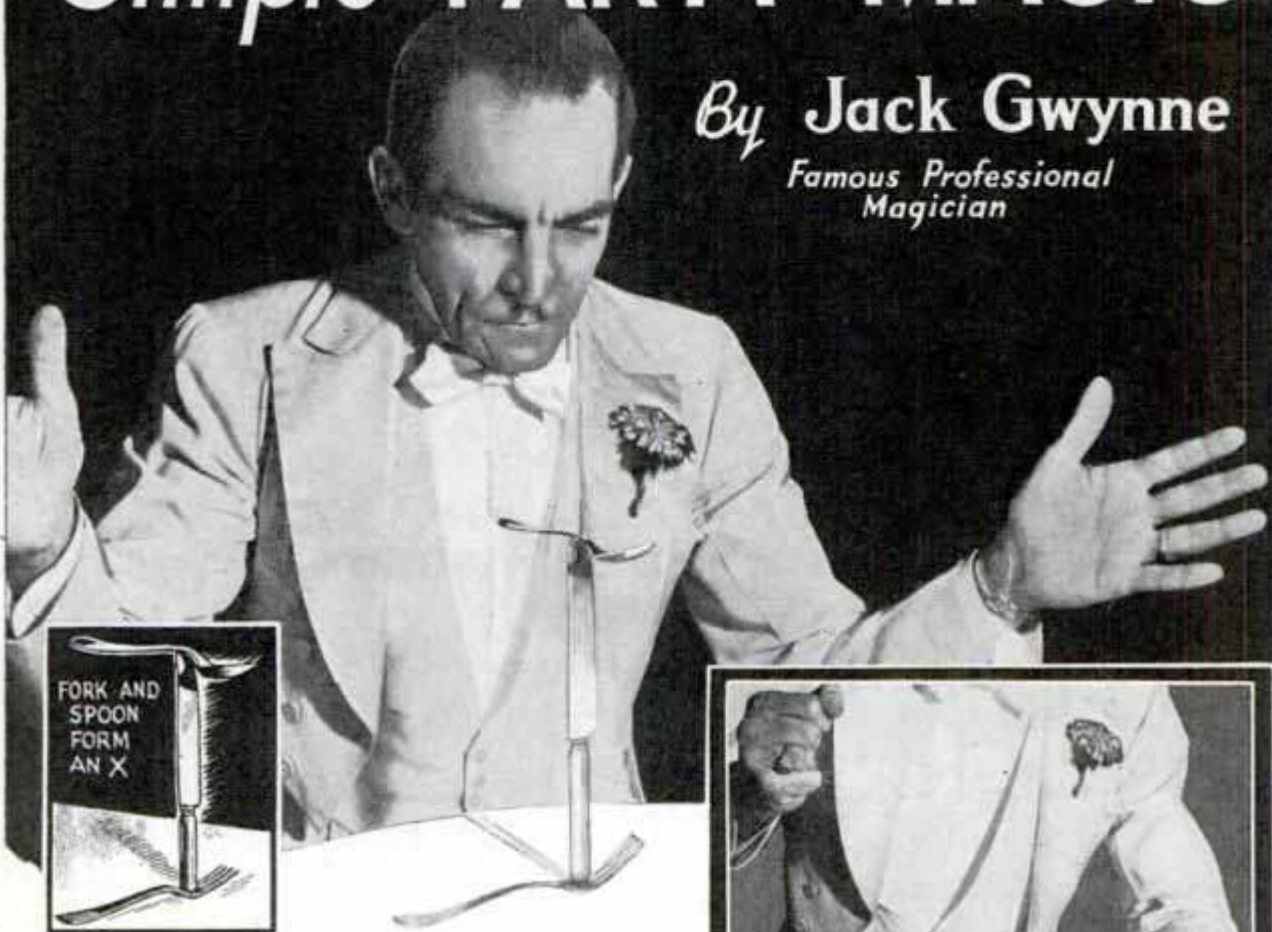

SIMPLE magic performed with everyday objects commands a ready audience everywhere and the person who is willing to spend an hour or two in serious practice can soon learn a whole repertoire of tricks that will enable him to contribute to the gaiety of social gatherings.

Before attempting any magic in public, however, the amateur entertainer should rehearse his routines with great care. A half-mastered stunt is productive only of ridicule. It is axiomatic that people like to be fooled, so the amateur who explains his methods after he has shown a trick destroys whatever pleasure his performance has brought to the crowd. The average person loses interest in a trick as soon as he learns its secret.

Playing with the silver and glassware may be a breach of table etiquette, but if you are willing to try it, an amusing balance feat can be performed with an ordinary knife, fork and spoon as shown in the illustration. Any person with fairly steady nerves and an equal amount of



Flipping spoon into glass with fork and balancing a knife, fork and spoon, two table tricks which are easy to master

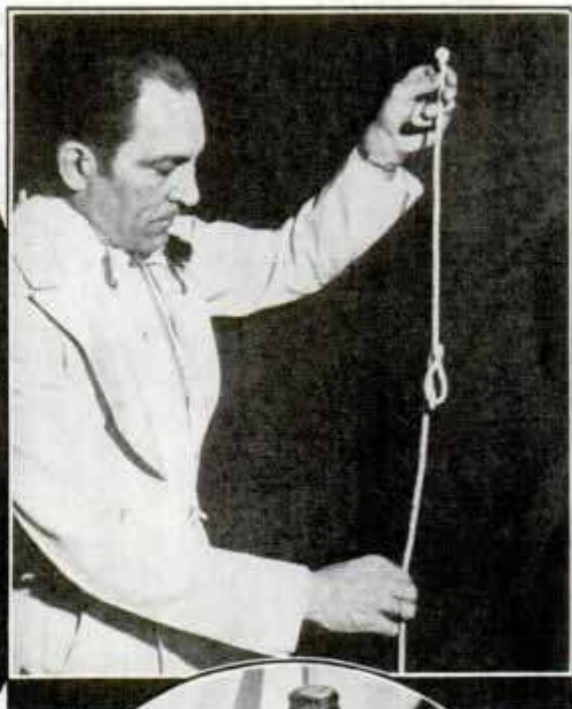
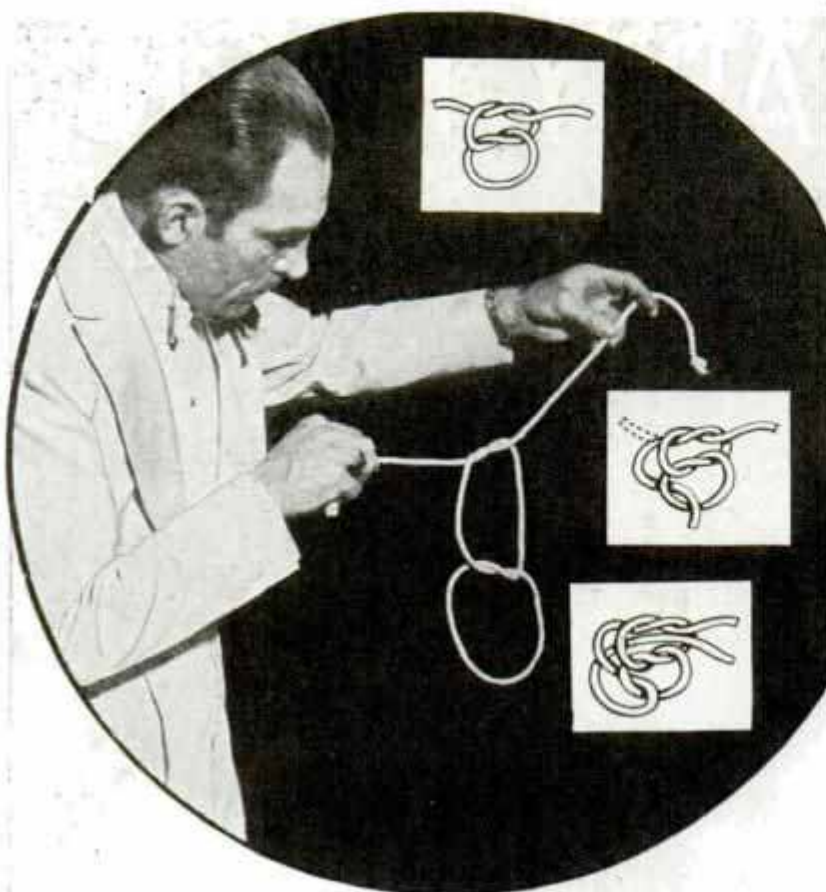

Details of rope trick, above, and right, making dime dance on bottle. Below, card trick worked by noting difference in width of margins



patience can master this stunt in ten minutes. To balance the knife handle between the fork prongs, hold the knife near the top of the blade. The spoon is then placed on top of the blade at an angle with the fork.

Another table stunt good for a laugh is to make a spoon jump into a glass. As shown in the illustration, the handle of the spoon is placed against the glass, the upper part of the fork touching the bowl of the spoon. By striking the end of the fork with the fist, the spoon can be flipped into the glass. After a few trials, the amount of force with which the fork should be struck can be determined accurately.

The dancing dime is another sure-fire stunt. A freshly emptied beverage bottle and a dime are the only "props" required. By grasping the bottle with both hands as illustrated, the dime can be made to bob up and down on the mouth of the bottle. To begin this trick, the magician places the coin on the bottle and then tips the latter a little to moisten the dime. When the entertainer presses his two hands against the glass, the dime will start moving up and down. A clever bit of patter enhances the value of this trick.

With a little preparation, a partly filled water glass also can be balanced as shown in another illustration. The secret of this one is in "planting" a large kitchen match under the tablecloth. The match is



2744

laid flat on the table and by placing a few other wrinkles in the cloth, it will not be discovered. When the glass is tilted against this match, the balance is obtained.

A simple but mystifying trick also can be done with a cube of sugar, a lead pencil and a glass of water. The magician asks someone to write his initial on the cube, which is then dropped into the water glass by the magician. As the cube dissolves, the person holds his hands over the glass with palms up, repeating certain mysterious words, after the magician, and upon turning his hands over, he discovers the initial has reappeared on his own hand. While the volunteer is writing his initial on the cube, the performer idly wets the ball of his thumb. When he takes the cube in his fingers to drop into the glass, he presses the ball of his thumb against the initial and the lead is transferred. Casually he takes the assistant's hand to hold it over the glass, and in so

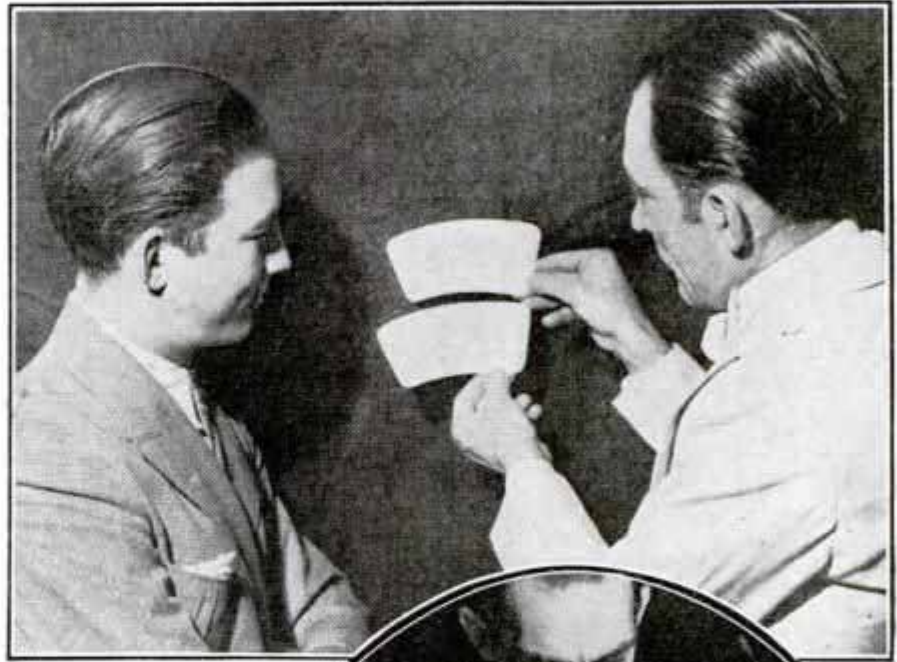

Top, the two pieces of cardboard are the same size. Center, match under tablecloth helps balance tumbler. Bottom, details of the trick in which an initial is transferred

doing stamps the initial on the back of the hand with his thumb. The moment this trick is concluded, the performer should swing into another one.

Simple rope and card tricks can be employed to supplement the above when the party moves into the parlor. One of the

best of the rope tricks is shown in accompanying illustrations and diagrams. It is called the rope with the dissolving knots and at the outset a regular square knot is tied. Then the left end of the rope is brought through the loop toward the per-

(Continued to page 33A)

25/10/20
Cassidy
33A

25/10/20
Cassidy
33A

566
T 856

Bird Tamer Trains Family to Take Food from His Lips



Wild World
Charles Edward Jones of Vancouver, B. C., with a few of the hundreds of wild birds he has tamed and trained

At the command "Ring the bell!" a wax wing robin will perch on the shoulder of Charles Edward Jones, tug playfully at his ear and then sidle around to take a tidbit from his mouth. The robin is a favorite among his pets, which number about 400 different species of birds. So tame is the family of this bird trainer at Vancouver, B. C., that even strangers are welcome and the birds fearlessly perch on dog or man.

Leather Made from Fish Skin by Inexpensive Process

Manufacture of leather from ordinary fish skins by a simple process which is commercially practical is reported in Germany. Use of fish skins for production of bookbinding leather is not new, but large scale conversion has been impossible heretofore, due to the cost. The price of the leather is near that of good quality split

leather, but it is claimed that this might be reduced if the leather were produced on a large scale. Fish skins require tanning by special materials because they are very sensitive to acids. Tests show that the fish-skin leather has a stretching capacity superior to that of sheep and calf parchment. It has withstood 50,000 foldings without breaking.

1879

Small Electric Generator Supplies Light for Cabin

Weighing only forty pounds, a portable electric generating plant supplies enough current to light six 25-watt lamps, sufficient for a small house, summer cottage or camp. Its four-cycle gasoline engine is air-cooled and runs sixteen hours on a gallon of fuel. There is a rope and pulley type starter for emergencies, but a manually operated switch allows the generator to crank itself, using current from an automobile type battery of six or twelve volts, the same voltage as the plant. The generator keeps the battery properly charged.



Air-cooled gasoline motor generates electricity to light a small house. It weighs forty pounds

Dept. of Commerce
Press memo 6/24/36

T 876

av. Rochester, N.Y.

Reported by Consul
W. W. Heligantner

Heligantner
Comp. 39 Fuel

Dummies Drop from Plane 'Hit' in War Play

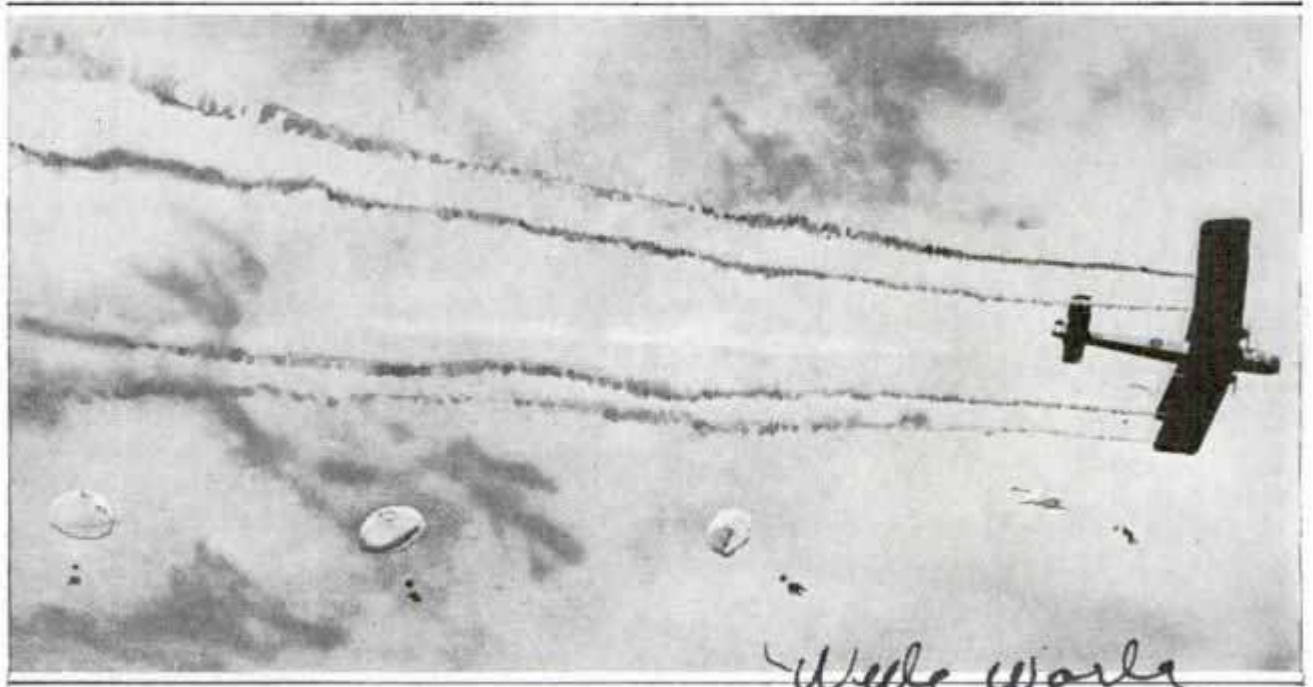

Dangerous winds were blowing during the Royal Air Force war show at Hendon, England, so dummies substituted for flyers in parachute jumps from bomber supposed to have been hit by anti-aircraft guns

To add a striking bit of realism to the sham war in the air, dummies were cast off with parachutes after a bombing plane had been "hit" in a British Royal Air Force

demonstration at Hendon, England. Smoke streams trailing from the exhausts as the big biplane roared across the sky were the signal that the guns had scored a hit.

Laboratory Like a Car Plans Railway Air-Conditioning

In order to reproduce as exactly as possible the conditions of a railway car, a full sized replica of the car interior was built as a laboratory to study railroad air-conditioning. Constructed in sections, it can be altered in dimensions or shape to represent any type of car, for conditions of draft and temperature differ in diners, sleeping cars and coaches. On one side are instruments to show temperature and humidity, on the other are temperature controls. Parallel rows of electric-light bulbs represent "body heat," giving off heat equivalent to that radiated by passengers.

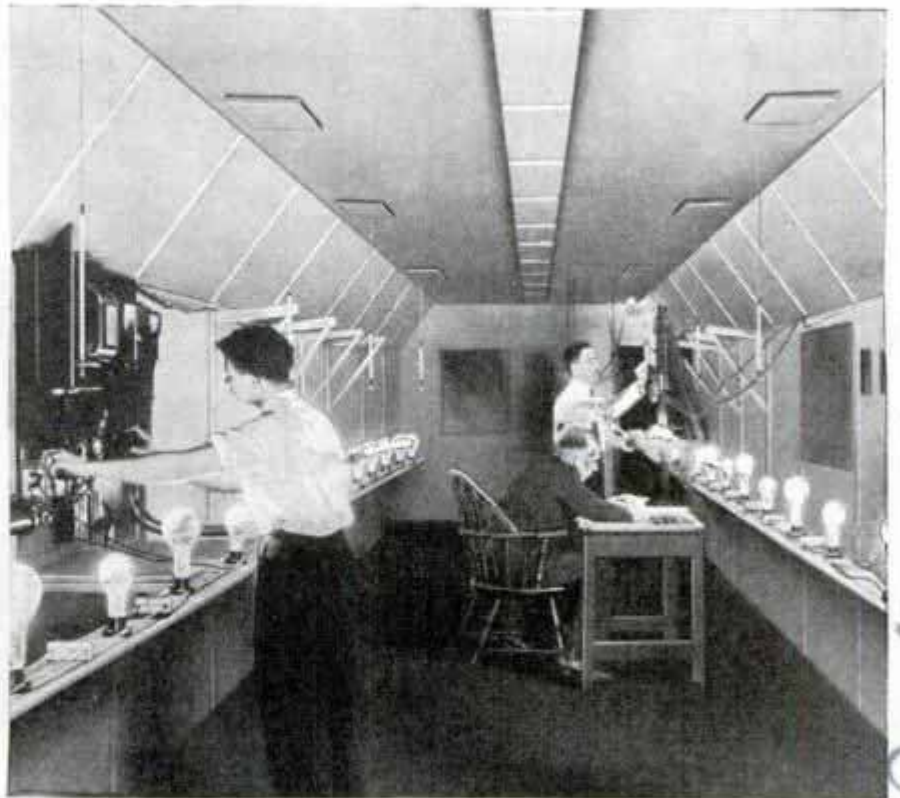

Laboratory built like railway car to study air-conditioning. Each light bulb represents body heat given off by a passenger

7862
Barlow, main
W. J. Hurler Co. 16
Windsor Park

T 7 4 3

Mr. Frederick W. ...
115 Walbridge Road
Hartford, Conn

Fight Deadly CORROSION



Anti-rust, which means anti-corrosion, solutions are on the market, inexpensive and easy to use. Called rust "inhibitors" by the automotive engineer, these anti-corrosion solutions usually are of the type which lubricates the cooling system. A little hard to believe, because the motorist knows oil and water will not

AS YOU drive along that last stretch of your vacation trip, you wonder why the car seems so sluggish, why the engine is so much hotter than when you took a similar trip two years ago. Of course, the car was new then, but there is no apparent reason for the motor to overheat now. Serviced regularly and driven carefully, the car should be in perfect condition.

But you have forgotten something—corrosion. While the car performed well and looked all right, one of the automobile engine's worst enemies was at work, eating away at all parts of the cooling system and gradually destroying the power plant. So now, with passages too clogged to permit free circulation of water, the cooling system cannot do an efficient job and the motor overheats.

This has happened to thousands of motorists, particularly in those days when too little attention was paid to the cooling system. And even today, many drivers fail to give that part of the power plant the proper care, in spite of the fact that all facilities for preventing corrosion are available at any good service station.

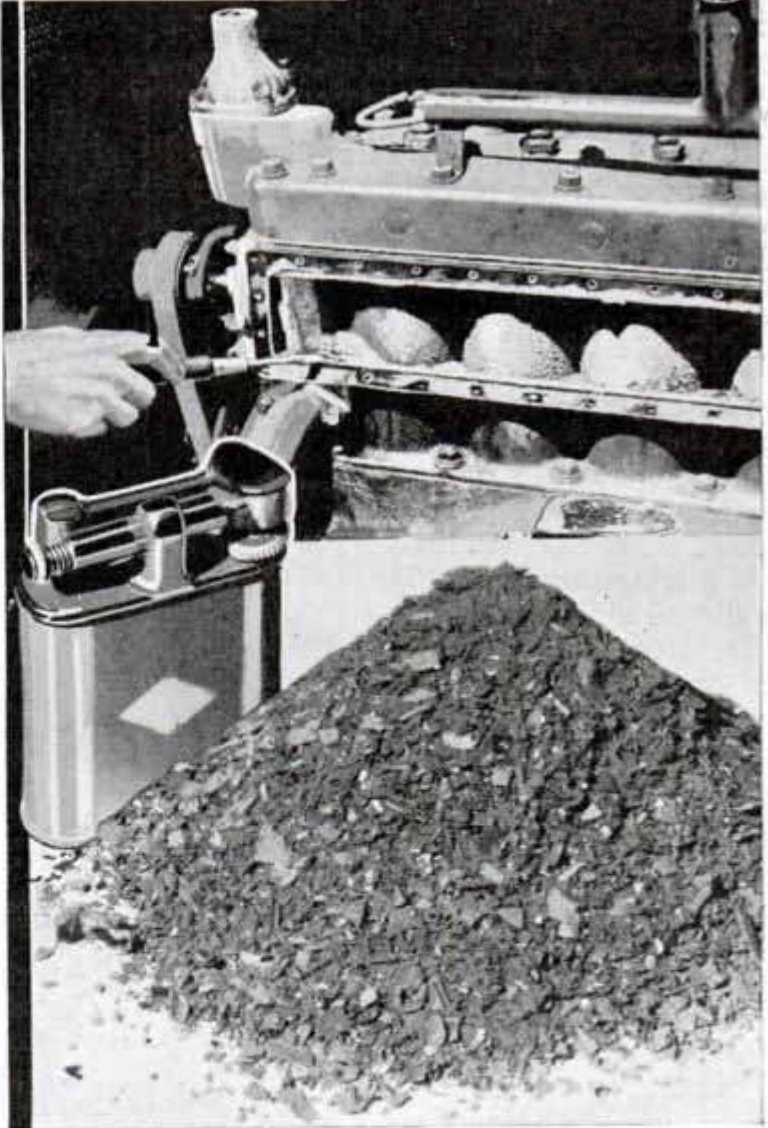

Top, steaming is evidence of clogged cooling system. Center, cleaning corrosion from around cylinders. Bottom, pile of rusted metal particles scraped from water passages

National Carbon Co.
19 E 41 st New York

Everyday Prestone

2743

to Save YOUR MOTOR

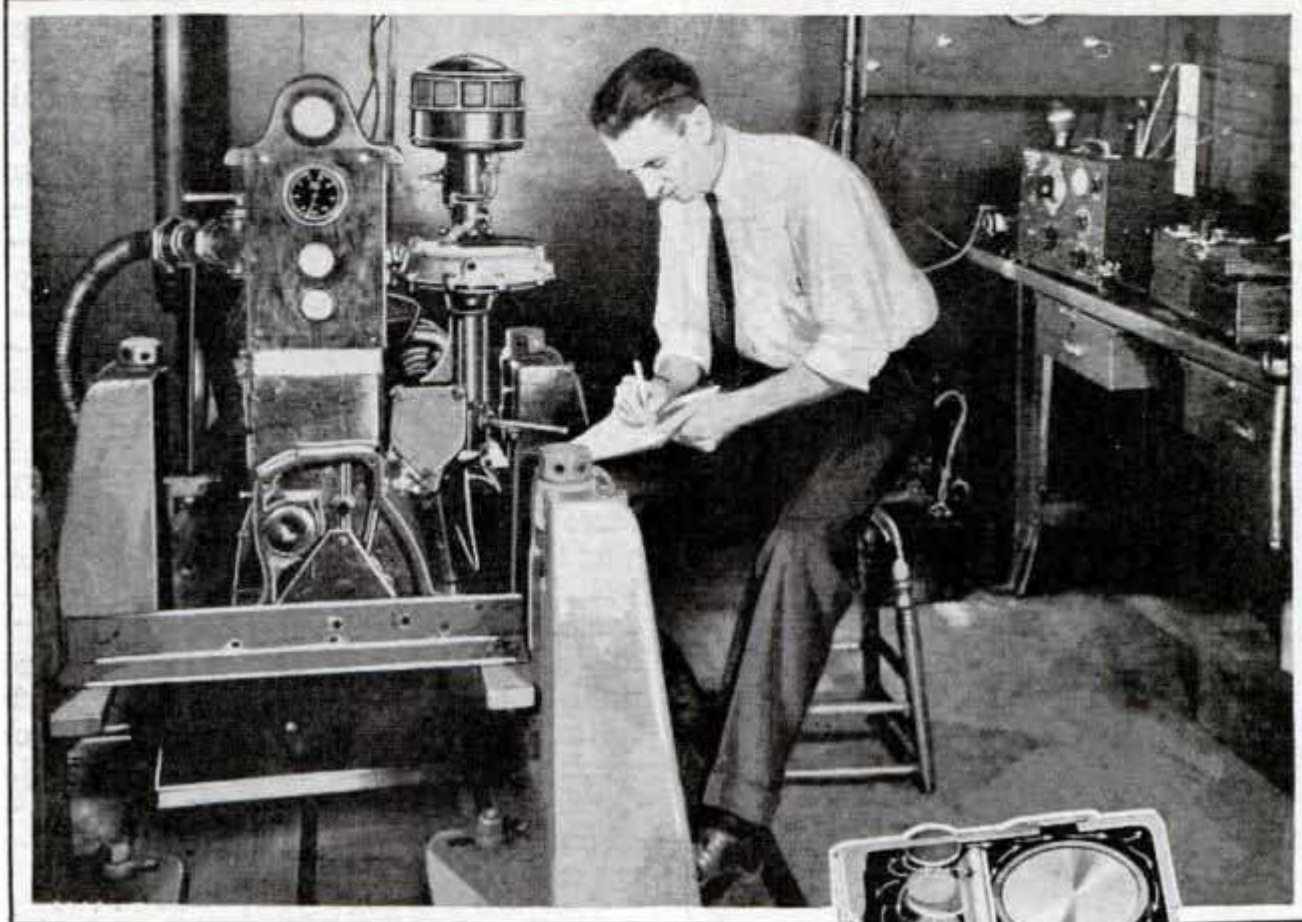

mix, but this lubricant is an oil which will dissolve in water instead of floating around at the top of the radiator or collecting on the inside of the block, engine head, hose connections, thermostat and radiator core. As the solution spreads through the engine, it coats with a thin oil film all metallic parts, thus hindering the process of oxidation.

Rust is the result of oxidation, which is the deadly effect of oxygen on iron and steel. The more oxygen in the water, the more rapid is the process of rusting or corrosion. Air entering the motor through the overflow pipe or a leaking water pump carries more oxygen into the water in the cooling system and the corrosive action continues. Rust forms faster while the car is being driven than while standing idle, first because more air is taken into the cooling system when the engine is running, and second, because rusting, like all chemical action, increases with heat. And as a general rule the faster a car is driven, the more rust is produced.

Use of the inhibitor or anti-rust solution checks corrosion, however, particularly if it is used when the car is new. So effective is the process that sometimes a very rusty system in an old car can be cleared up merely by adding more than the usual amount of



Top, testing engine. Bottom, engine with valve seats sprayed by water must have clean cooling system

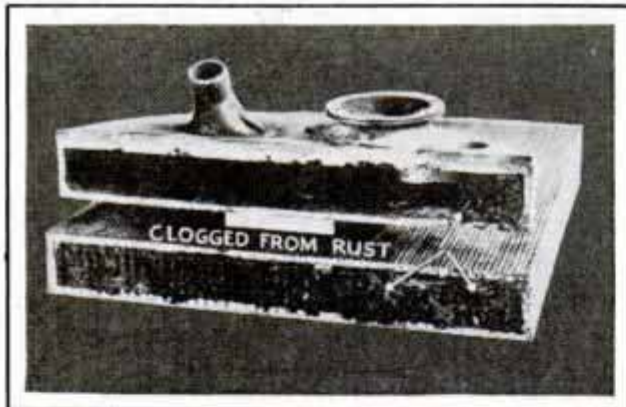
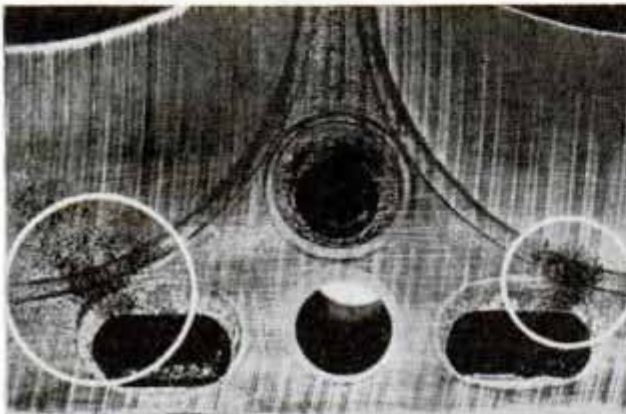
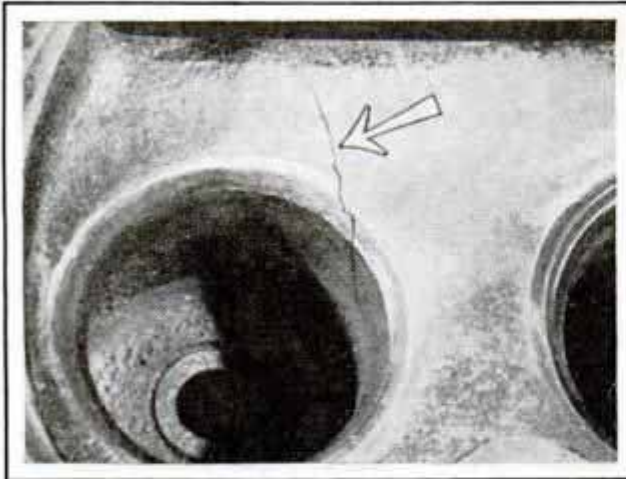

Top to bottom: Cracked block caused by overheating due to corrosion; corrosion spots; clogged radiator core, and sediment from cooling system

inhibitor. This, however, is not recommended. The cooling system of a car already in service should be flushed out before inhibitor and fresh water are added. Engines with cast-iron heads can be flushed with sal-soda solutions, but those with aluminum heads need a special cleanser. Whether the system should be reverse flushed will depend upon how badly corroded it is. In many cases accumulations of rust and sediment in the water jackets must be removed manually by first taking off the side plates of the engine block.

The wise motorist will appreciate that by using rust inhibitors from the time he takes delivery of his car he will be spared the long list of cooling troubles that befall those less provident. Corrosion, by clogging the radiator core and lining the water jackets so that heat is less efficiently conducted away from the cylinders, gradually raises the engine's operating temperature until trouble develops. This may extend to the metal of the engine itself so as to crack the block or at least warp the head. Overheating troubles can be so complicated and far-reaching that irreparable damage may follow an overdose of corrosion.

Twenty years ago many chauffeurs added a little sewing-machine oil to the contents of the cooling system and firmly believed this kept the water clear. They realized that the oil did not mix well with the water, but by using it sparingly and flushing out the system frequently they managed fairly well. They were also careful not to use so much oil as to put too heavy an insulation against heat on the inside of the cooling system.

Today the job is simplified, not only because the special solvent oil mixes so freely with the water but also because enough of it can be used at one filling to keep the water clear throughout the entire season. A pint of this oil is enough to protect the cooling system of the largest car. So effective is solvent oil that the small cans of rust inhibitor or rust preventive sold on the market contain a percentage of water. Just as in the case of adding anti-freeze, it is better to add rust inhibitor when the cooling system is half filled rather than to start pouring it into a system that is already nearly filled. This will prevent the possibility of thinning out

the mixture by losing some of it out the overflow pipe immediately. Because of expansion when the engine heats up, this overflowing is certain to take place where the owner fills up the radiator while the engine is cold.

Failure to keep the spark timing properly adjusted, allowing the fan belt to get loose, neglect of the simple matters that combine to keep an engine functioning at par will help to bring on overheating trouble, but in majority of cases overheating can be forestalled by checking corrosion in the cooling system. Allow rust to form, and the core of the radiator soon clogs with flakes of

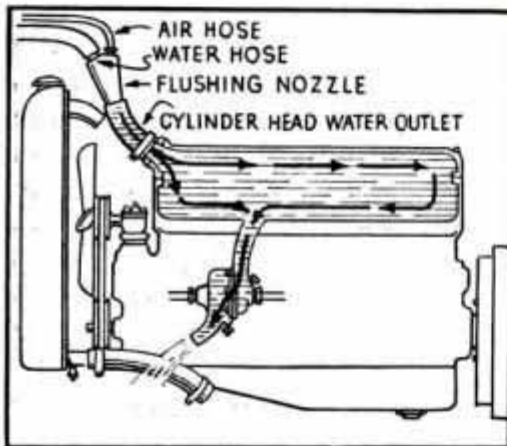

Several views of method and equipment used in pressure cleaning of auto cooling system. Air pressure is necessary to remove heavier sediment. The radiator core may be tested by removing the cap and watching water level as engine is raced. If water rises and spills over, the core is clogged

metal. This collection of sediment slows down the flow of water through the core, thus starting a vicious circle of trouble.

It is a good plan to test the cooling system frequently by looking into the radiator through the filler pipe while the car is standing still with the engine running fast. If water surges forward and spills over the top of the radiator there is every reason to suspect that the core is partly clogged. Before reaching this conclusion, however, be sure to look at the lower water hose connection. If it collapses as the engine is accelerated there would be good reason for the radiator to overflow. However, if the old hosing does not seem too flexible, and if a new piece of hose also collapses, then the radiator core itself is not clear enough.

Over a period of a few years any engine can create a surprising quantity of rust. Most of this remains in the block where

it tends to insulate heat and prevent its normal escape to the air through the metal. If only a small portion of this passes through to the radiator core it will be sufficient to clog the fine passages through which the water must pass at a rapid rate. If the car is an old one, and the owner plans to make a fresh start, he should not consider the work complete if he merely has the radiator reverse flushed or the core replaced. Cleaning out the system must include cleaning out the block and the head.

A cleansing job requires pressure, chemicals, heat, quantities of water and—in some cases—manual scraping out of those places which can be reached with suitable tools.

A car that has not enjoyed the benefits of rust prevention becomes as troublesome as one which has never had the right grade of oil or not enough oil.

Plane Whips Sign into Air at End of a 300-Foot Rope

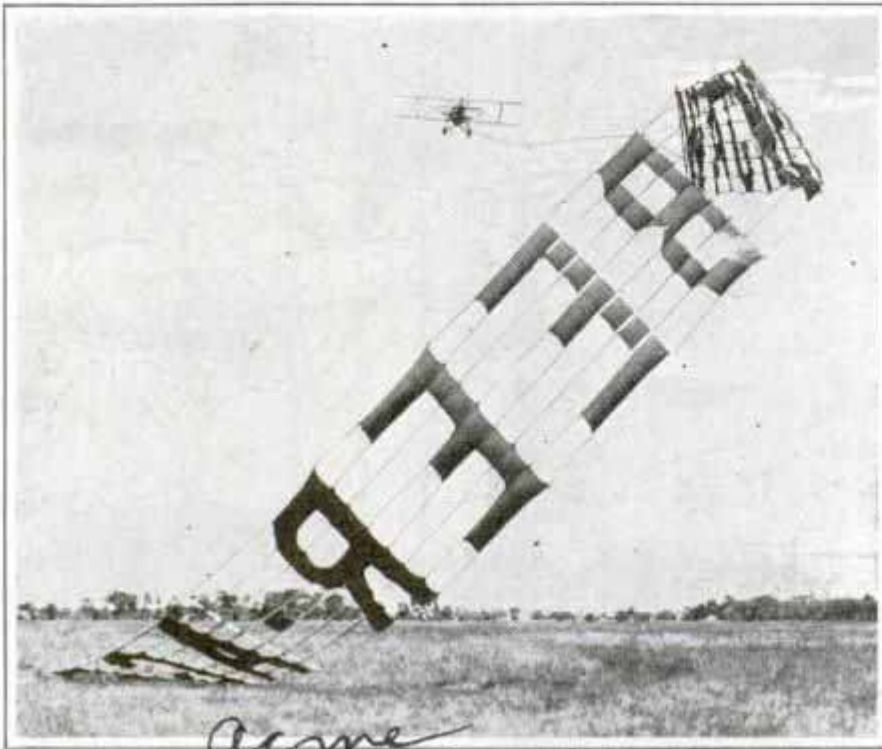

With 450 feet of towrope and advertising sign dragging behind him, the pilot must get off the ground in a hurry

Now you know how the pilot got off the ground with that huge sign trailing behind him. The advertising slogan itself is 150 feet long, its letters seven feet high, and to take off safely there must be at least 300 feet of rope between the plane and the first letter. The sign is laid on the ground in front of the plane, and as the ship sweeps across the field for a quick takeoff the sign is whipped into the air. At the end of the day's work the pilot merely cuts the sign loose over the airport.

Safety Goggles Shut off Grinder Until Operator Dons Them



To enforce a safety rule requiring machinists to wear goggles while at work, a Freeport, Ill., manufacturer devised a novel switch. When the goggles are not in use, they rest on

a tray balanced above the plunger of a sensitive electric switch connected to the motor of the grinding machine. As long as the goggles are on the tray, their weight is sufficient to depress the plunger and cut off the grinder motor. The operator can not go to work until he picks up his goggles, allowing the circuit to be completed and starting the motor.

Streamline Racket Used on Courts at Wimbledon

In a recent tennis tournament at Wimbledon, England, streamline rackets were subjected to a severe test in championship play. Instead of a solid handle and throat attached to the head, the

racket has a three-pronged throat, the upper end of each prong being attached to the head. All parts are streamlined to permit easy handling.

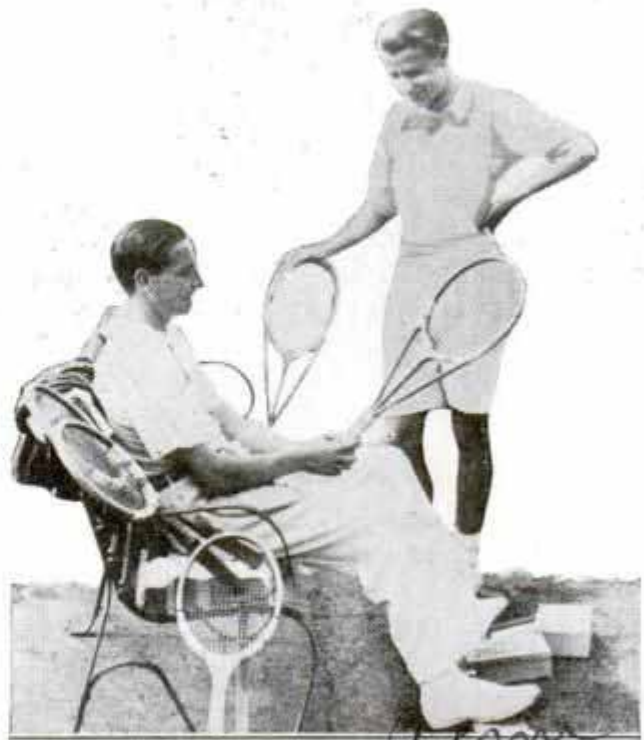

On the sidelines at Wimbledon two players examine the latest type of racket

C. F. Burgess Laboratories

F 8 7 4. *Journal of the American Institute of Architects* 6/20/36 P. 1127

Indian Memorial a Masterpiece in White Onyx



Towering above the floor of the new city hall at St. Paul, Minnesota, this thirty-six-foot statue is a masterpiece in white onyx. It consists of a base portraying a group of Indians gathered around a campfire and smoking their peace pipes. Rising high above them and as if taking shape in the smoke from their pipes is the giant figure of an Indian god, holding a peace pipe in one hand and extending the other in friendly gesture. The memorial is the work of Carl Milles, Swedish sculptor



New

*Chromium-plated skillet
which requires no scouring
since it is unaffected by
heat, grease or food acids*

Conveniences

for you

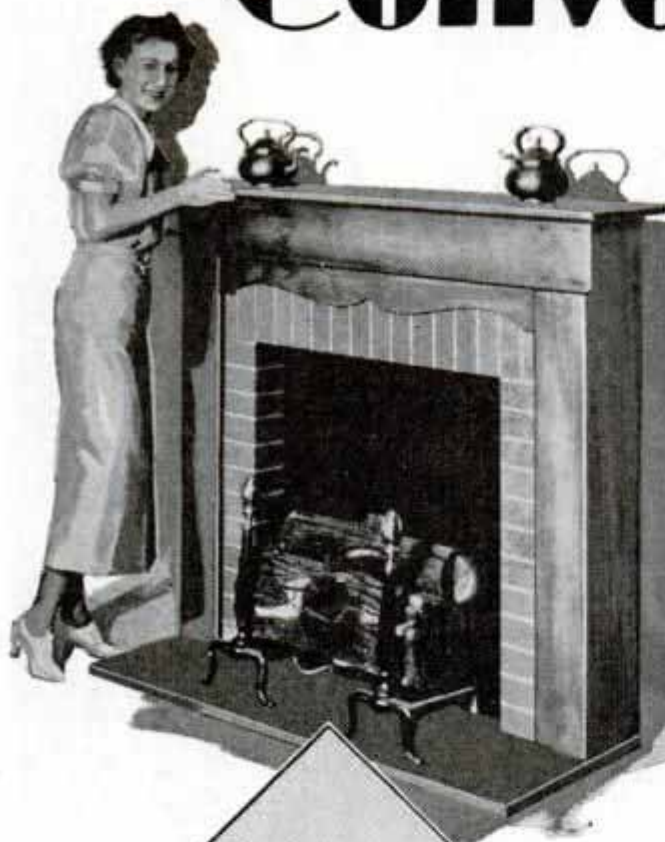

Portable fireplace for decorative purposes. It can be shifted about the room when the furniture is rearranged, or even moved from one room to another whenever a complete change in the decorative scheme of the home is desired

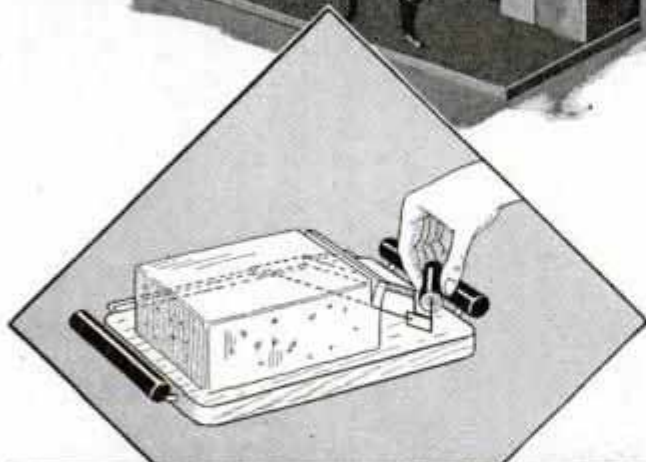

Handy cheese cutter and server, above. The cutting wire slides along rod at rear. Right, automatic gas-burning water heater which also serves as a utility table



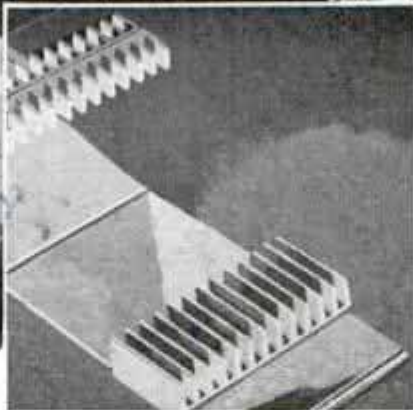
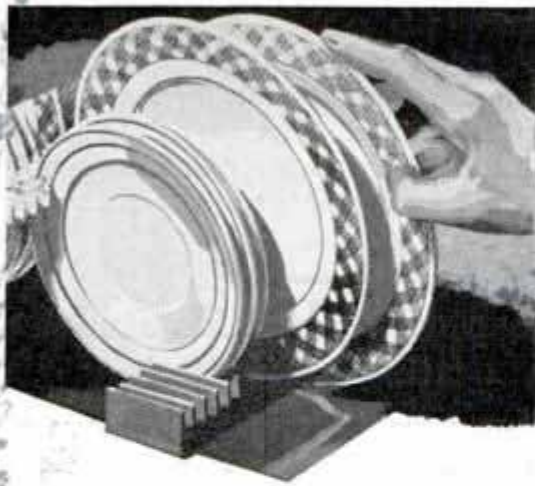

Rubber racks for your china prevent nicks. Instead of stacking plates together, you can stow them away separately in adjustable racks that save space

HOME

Lift the top of this end table, at right, swing it around and it becomes a reading desk to support your book. Likewise it is convertible into a music stand, sewing table and catchall. The pivoting desk top can be adjusted to any position



In circle at left, cake holder places one layer upon another in perfect alignment without breaking the layers. This is an especially handy kitchen tool when the cake is warm and light

Whirling yarn holder for knitting or crocheting, above at left, feeds direct to needle, preventing snarls

Two-Story "Atom Smasher" to Aid Scientists



Giant "lightning" generator under construction. Its "bolts" will be fired at atoms

Capable of developing 800,000 volts of electricity, a huge "atom smashing" machine is being constructed at the University of Chicago to help scientists study atomic structures. The apparatus stands two stories high. It is designed to shoot giant man-made bolts of electricity at the nucleus or heart of an atom in attempts to disintegrate the atom. This breaking down of the atom would enable scientists to obtain knowledge which might make possible transmutation of metals, perhaps the changing of lead into gold through a rearrangement of atoms. This, however, is regarded only as a possibility and is not the immediate purpose of the machine.

Exhaust Gas Compresses Air for High-Flying Planes

Designed for use in high altitudes, such as the stratosphere level, an exhaust-driven supercharger compresses air for the carburetor of the airplane, resulting in more efficient operation. The supercharger is a small ferris wheel propelled by jets

of exhaust gas from the plane's motor. It attains a speed of 40,000 revolutions per minute under the impact of the gases striking tiny vanes. At this velocity the wheel is a centrifugal pump which compresses the thin air of the stratosphere to sea-level density.

Star Map on Globe Aids Student in Locating Constellations

Amateur astronomers can now have a "planetarium" of their own. An English railroad man who is an enthusiastic astronomer has invented a globe on which the constellations and principal stars are mapped. It can be adjusted for any latitude in the northern hemisphere, tilting the globe by sliding a screw clamp which holds a glass rod to a quadrant arm. This arm is graduated in degrees. The rod represents the axis of the celestial sphere and points to the Pole star. The globe, six and one-half inches in diameter, is partly filled with a colored liquid to represent the horizon, and the earth is imagined to be at the center. To find the constellations, the globe is placed with the brass quadrant pointing south along the meridian of the place of observation, its axis pointing north. A magnetic compass is set in the base to aid accurate observations. A tiny red hemisphere representing the sun, its flat side a vacuum suction cup, is fixed on the surface of the globe along its ecliptic, marked by a dotted line, the location depending upon the date; then the globe is rotated to put the sun exactly on the meridian, its position at noon. The clock pointer is then set at noon, the quadrant adjusted to the right latitude, and by rotating the globe and turning the clock to the desired time of day the positions of stars and constellations can be readily seen. An unbroken line around the globe, graduated to show degrees or time, marks the celestial equator. A silvered vacuum cup represents the moon.

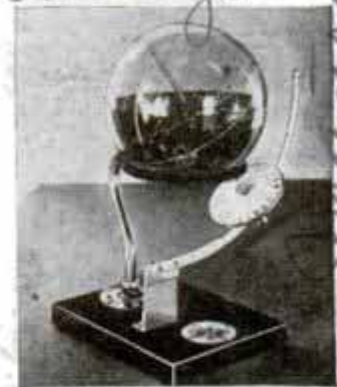

Change return 6/30/36
Prof. Samuel Allison

at Wright field
F861
Astriglobe
made by W. W. Weston N.Y.



Radio

7 35 96

ONE to TEN-METER Receiver

NAMED for its unusual tuning range of from one to ten meters, this receiver provides excellent performance in a difficult field. The enormous frequency range covered by the wave lengths between one and ten meters was, until a year or so ago, practically unused. The value of this territory is rapidly increasing, however, as shown by the activity of amateurs, two-way police radio, facsimile transmission and experimental television.

Experimenters have been seriously handicapped by lack of a suitable ultra-high-frequency receiver that must be extremely sensitive and at the same time simple and easy to operate. The set illustrated has been designed by short-wave engineers to meet this need with due regard



for the special characteristics of present-day transmitters.

It employs two miniature acorn-type tubes and two metal tubes, of the varieties shown in Fig. 1, in an improved super-regenerative circuit. A separate power unit supplies six volts for the tube heaters and 180 volts to the plate and screen circuits. If desired, the heaters may be supplied from a 6-volt storage battery and the B-circuits from B-batteries, thus making the receiver adaptable for mobile use. The coils, which are used in pairs, are shown with the covers removed in Fig. 2. These plug into the r.f. and detector coil sockets as required to cover the desired portion of the 1 to 10-meter range. An interior view of the receiver, given in the lower photo, shows the tuning unit and acorn tubes mounted in sockets built into shields between the condenser sections. This is the real heart of the set, which is tuned with a micrometer dial that makes ten revolutions to cover any one coil range. All controls are shown in the upper photo; the switch at the lower right-hand corner breaks the positive B lead for temporarily rendering the receiver inoperative during periods of transmission or when changing coils.

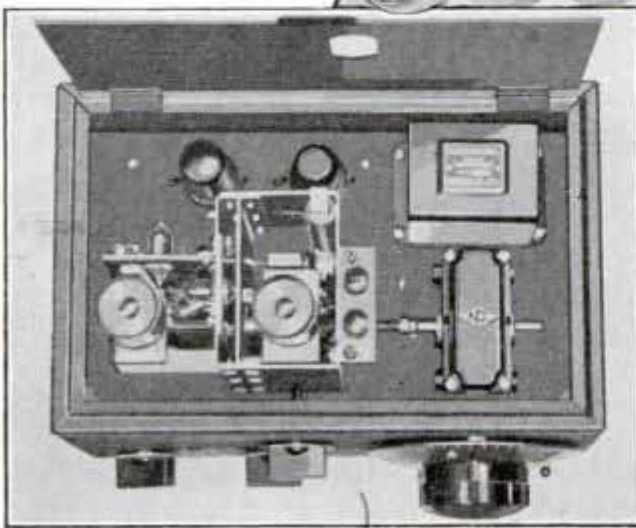

*National Company
61 Sherman St. Malden*

ALL-PURPOSE

By M. N. Beitman

YOU can assemble this portable hearing-aid amplifier with simple tools in a few interesting hours of work. It will reproduce voice and music clearly and with surprising power even when the lapel-type microphone is used some distance away from the source of sound.

The hard-of-hearing will find it a valuable means for reproducing

and amplifying radio programs to suit their needs without advancing the volume of the radio receiver to a point where it would be objectionably loud for those with normal hearing. In addition to its hearing-aid applications, it may be effectively used as a detectaphone in the manner illustrated in the sketch on the opposite page. When employed for this purpose, the microphone cord can be any length up to 25 feet. The "mike" is a small flat disk variety that may be concealed easily in an adjoining room. As a noise analyzer, it is useful to the auto mechanic and has many other applications that will suggest themselves to the builder and experimenter.

Easily portable, the amplifying unit is self-contained together with the batteries in a neat metal case. Standard high-resistance headphones or a single unit headphone may be used. The phone and "mike" cords are arranged to plug into insulated jacks conveniently located on the front panel. More than one pair of head-



For the Deaf



FIG. 3-c

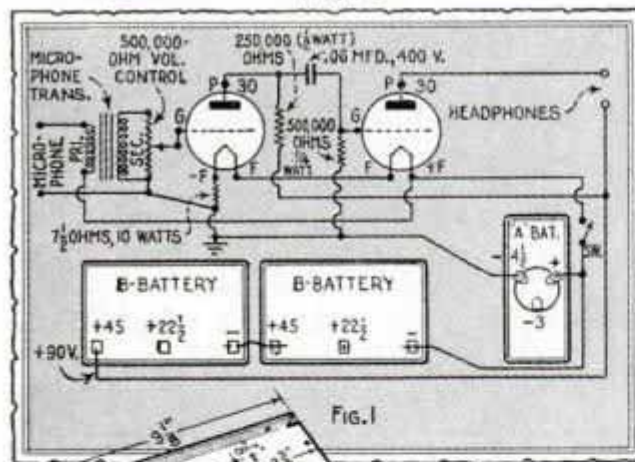

Fig. 1

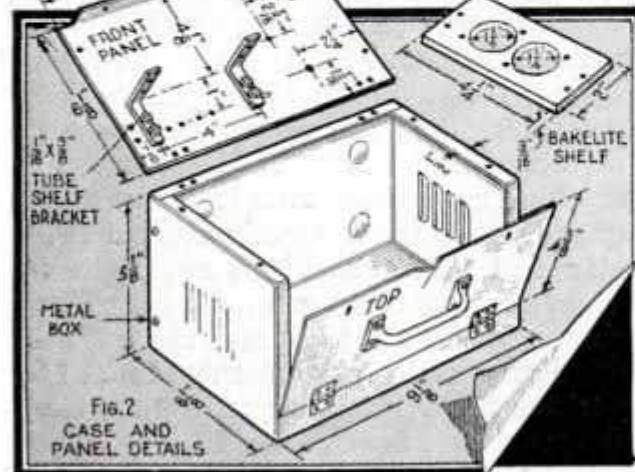

Fig. 2
CASE AND
PANEL DETAILS

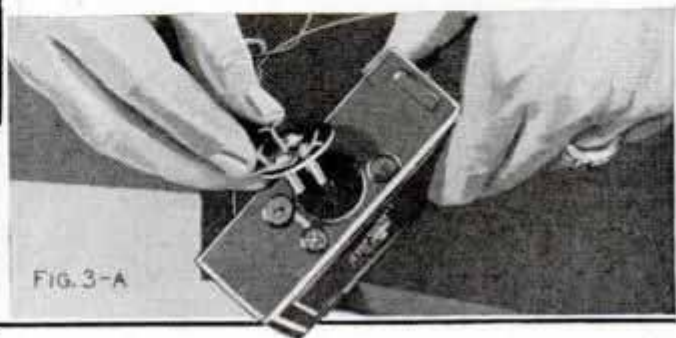

FIG. 3-A

Hearing-Aid AMPLIFIER



As a Detectaphone

phones may be operated from the amplifier, or if desirable in certain cases, a bone conduction unit may be employed.

The circuit is a simple two-stage resistance-coupled variety using type-30 tubes that operate on two volts, as shown in the schematic diagram Fig. 1. It will be noted that the filament voltage is reduced to the required value by means of a $7\frac{1}{2}$ -ohm resistor in series with the $4\frac{1}{2}$ -volt negative side of the A-battery, which is at common ground on the metal case. Proper grid bias for the tubes is obtained automatically because of the method by which the filaments are interconnected.

All case and panel details are given in Fig. 2 including the di-



FIG. 3-D

mensions of the Bakelite shelf on which the tube sockets are supported by means of angle brackets. This case, complete in every detail, is available for those who do not wish to make their own. The metal front

(Continued to page 122A)

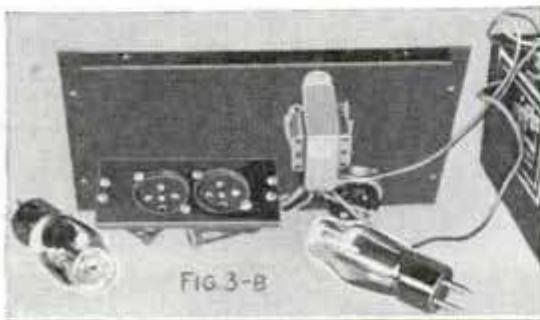
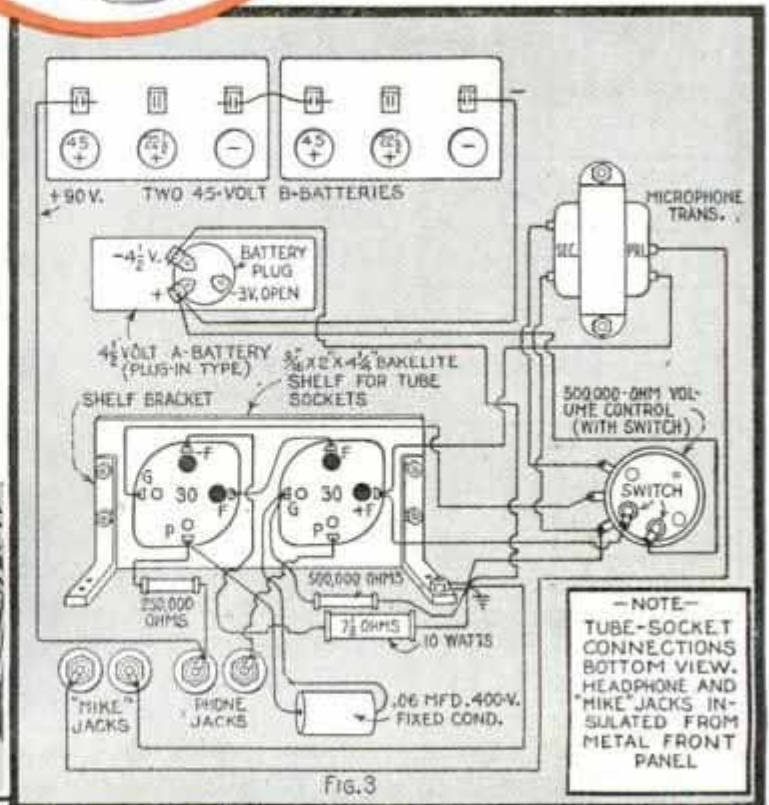
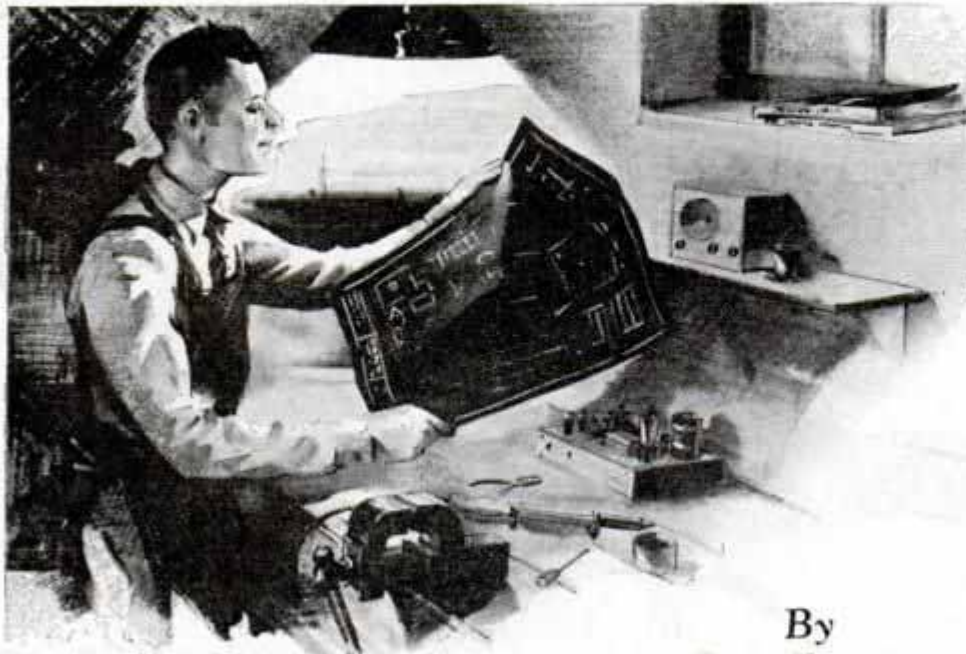

FIG. 3-B



How to Read Schematic Circuit Diagrams



By
F. L. Brittin

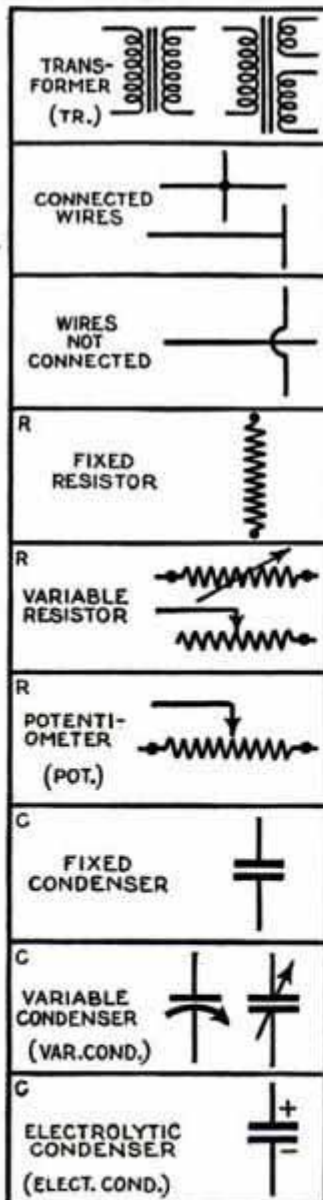

BEGINNERS should be familiar with the symbols used to represent the various radio parts as they appear in what are known as "schematic" circuit diagrams. These conventional graphic symbols, although not fully standardized, have become quite well known through popular use. They are employed as a common universal language to indicate radio parts in their proper relation in circuit diagrams. In fact, the average radio experimenter, glancing casually through a foreign radio magazine, merely needs to look at the schematic diagrams to get a pretty clear idea of the instrument described, although he may not be able to read a word of the text.

Some of the most commonly used symbols and abbreviations appear on this page. When more than one symbol is ordinarily used to indicate the same part, both are given. Most of the radio construction articles that appear in Popular Mechanics Magazine show both the schematic and a carefully prepared simplified or "picture" diagram of the parts and wiring. The simplified diagram enables the builder to see just how the mechanical arrangement of the various parts, and the actual wiring, appear on the top and underside of the

(Continued to page 134A)



Camden, N.J.

Hints for RADIO Experimenters

Arthur W. Lynch, Co. 27, 28, 29, 30, 31, 32, 33, 34, 35, 36, 37, 38, 39, 40, 41, 42, 43, 44, 45, 46, 47, 48, 49, 50, 51, 52, 53, 54, 55, 56, 57, 58, 59, 60, 61, 62, 63, 64, 65, 66, 67, 68, 69, 70, 71, 72, 73, 74, 75, 76, 77, 78, 79, 80, 81, 82, 83, 84, 85, 86, 87, 88, 89, 90, 91, 92, 93, 94, 95, 96, 97, 98, 99, 100

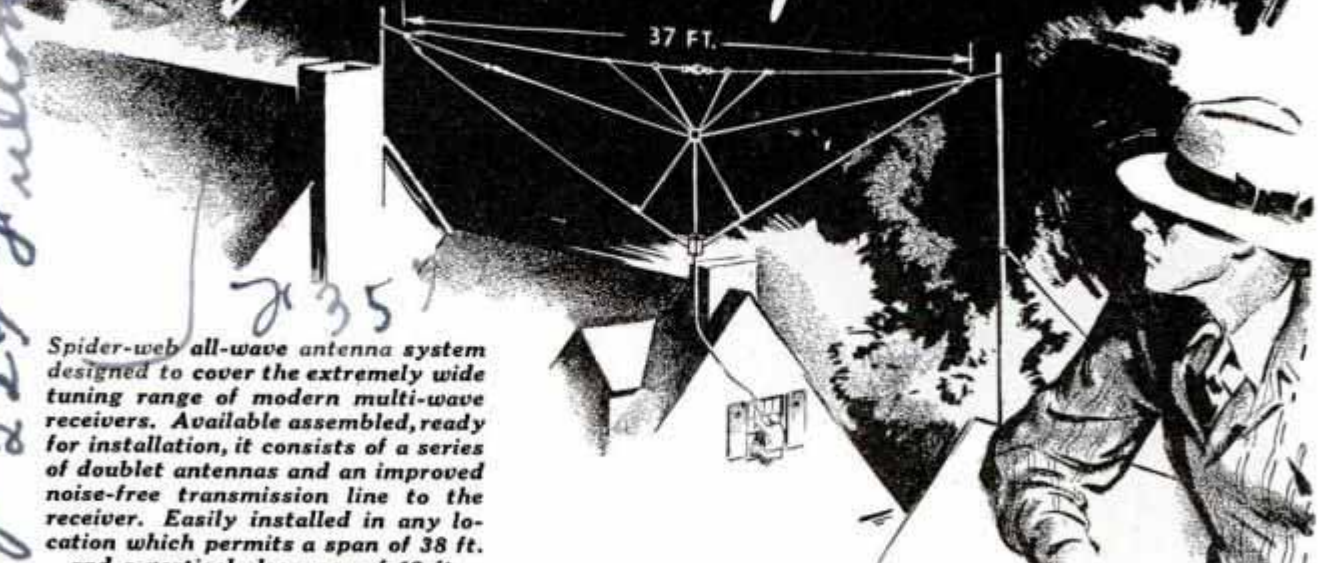

Spider-web all-wave antenna system designed to cover the extremely wide tuning range of modern multi-wave receivers. Available assembled, ready for installation, it consists of a series of doublet antennas and an improved noise-free transmission line to the receiver. Easily installed in any location which permits a span of 38 ft. and a vertical clearance of 12 ft.

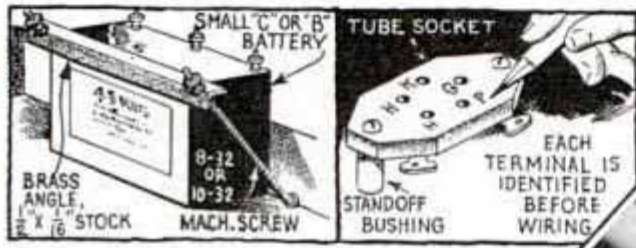

Above, brass angle and machine screws used to hold small battery in portable set; Right, errors in wiring porcelain sockets may be avoided if terminals are plainly indicated with "china" marking crayon; Below, easily installed coil-spring under-car antenna, encased in dust and grease-proof covering



Above, chassis die for punching socket holes in metal bases; Right, tube socket mounted on small hinge provides variable coupling with plug-in coils

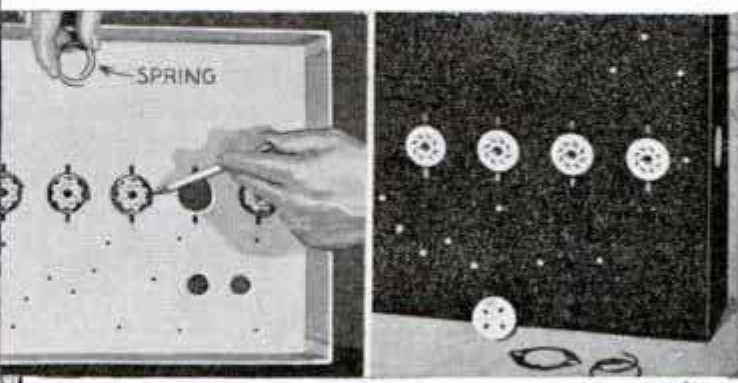
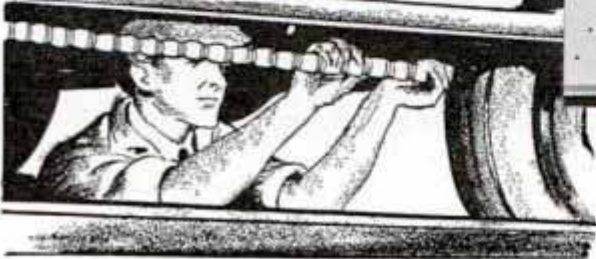
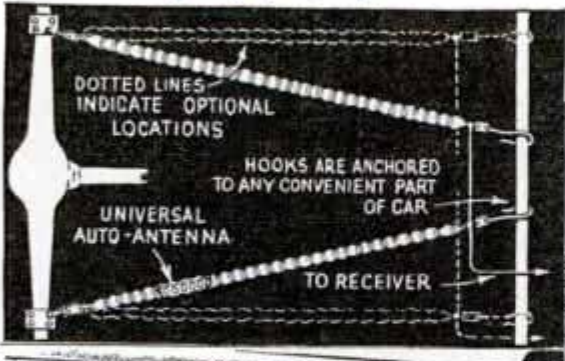

Flush-mounting ceramic tube sockets designed to mount directly into metal chassis, are held firmly by means of heavy spring-wire retainer rings; photos show top and underside views of base with sockets in position

American Chicago City Chicago



TYPE with COMFORT.. *in your easy chair*

FOR the typist who likes to work comfortably at home, this portable typewriter cabinet has a top which can be swung across the arms of an easy chair. The typewriter is bolted to the underside of the top, bringing it to correct typing position when the stand is opened for use. When not in use, the typewriter is lowered into a dust-free compartment, entirely out of sight, and the cabinet becomes a chair-side lamp table. Swinging doors in the sides of the lower compartment provide easy ac-



The top of this lamp table is swung over across the arms of a comfortable chair, bringing the typewriter into a convenient position



cess to paper and other writing material, which may be kept on shelves, while the center portion may serve as a wastebasket. There is also shelf space on the outside of the cabinet, at either end, for books, magazines or knickknacks.

As you will notice from the drawings, the top swings on a rod projecting into both sides of the cabinet at one corner. This makes it possible to swing the top across the arms of chairs varying in height. However, as a perfectly horizontal position

between the upper and lower compartments. In assembling the parts, 1 by 1-in. cleats are used at the corners and 1½-in. round-head wood screws are driven through the cleats into the sides and ends, leaving all visible surfaces on the outside smooth and free from screw heads. Note that the bottom, which fits up into a recess formed by the sides and ends, is screwed on from the outside to the cleats inside that support it. However, it is not screwed in place until all the assembly work in the lower compartment has been completed. The method of pivoting the top is completely shown in one of the drawings, the end of the top being beveled so that when fitted to the crosspiece, there is just enough space for the pivot rod. Holes bored half-way through the sides will retain the pivot rod in position, in which case the rod must be installed when the sides are assembled. Or, if you desire the rod to be removable, bore the holes entirely through the sides and use a setscrew to hold the rod

Weighted Clothesline Stays Taut

If you occasionally put up a clothesline on your porch, in the basement, or even



in the kitchen, here is a good way to keep it taut. Attach one end to a screw eye, pass the other end through a screw hook and tie an iron or similar weight to it. You can pull down the line to hang clothes and, when released, the iron will pull it up tightly.

Miniature Japanese Garden Is Built on Top of Bird Bath



This garden ornament offers unlimited variations in design, and will give you much pleasure in experimenting with different kinds of plants

With a top resembling a miniature Japanese garden from which real flowers and vines grow, this attractive garden bird bath is easily made in a short time by anyone. Lay a plywood panel across a couple of sawhorses and start the job. First trowel out the base with a mixture of equal parts of sand and cement to a depth of 1½ in. A piece of ½-in. mesh wire should be pressed into the mixture for reinforcing. Then work in your rocks, bridges, etc. Be sure that the rocks around the edge of the base are cemented tightly as they serve as the rim of the water basin. Crevices and pockets formed by the rocks are filled with rich soil for plants. A standard of rocks laid up with cement is ideal to support the bath. Painting the bridges and other architectural features in vivid colors enhances the effect. What to plant in the garden, of course, is governed by your particular taste.

—Frank E. Brown, Pasadena, Calif.

Protractor Triangle Aids Artist When Lettering Work

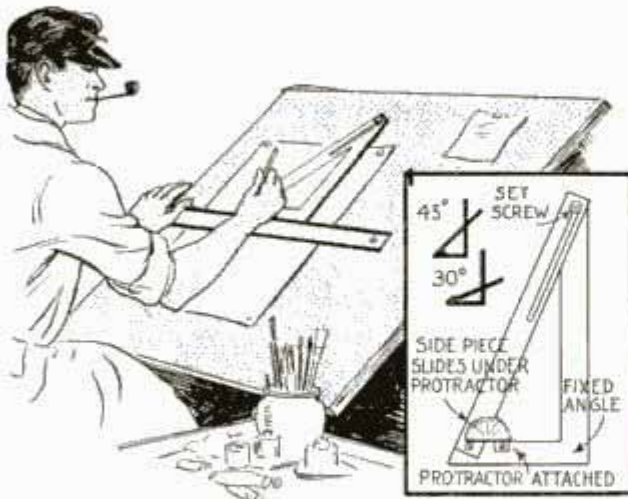

This protractor triangle is quickly adjusted to letter work at any angle

Made from a regular triangle or from pieces of wood, this protractor triangle is especially handy for artists as it is quickly adjusted to any angle for lettering. The top angle is joined over a long slot with a set screw, while a semi-circular piece of tin with the angles marked is attached to the lower left-hand angle. The apex of this protractor must be the apex of the inside angle. The left side is movable and pivots on a rivet or bolt attached to the horizontal bottom piece. Thus the left side of the triangle may be moved, while the protractor designates the angle. The set screw locks the parts at the desired angle.

Finding Leaks in Flush-Box Float



When ball floats in bathroom flush boxes develop small leaks that are almost impossible to find, yet quickly let in enough water to make the float ineffective, you can find and cure the trouble as follows:

Drill a small hole in the float close to the stem, as the metal is thicker at this point due to reinforcing the ball. Then insert a tiny tube, or even a soda straw and blow into the float. This will drive out moisture inside and show up the small holes. If air

escapes past the tube, you can seal it with a little chewing gum. After soldering the leaks and the hole drilled for the tube, the float is ready for use.

Split Cork Serves as Wringer for Drying Fishline

By slicing a large cork half-way through one side with a sharp knife or razor blade, one angler provided himself with a practical little wringer to aid in drying his fishlines. In use, the line is drawn through the slot which squeezes out the water.

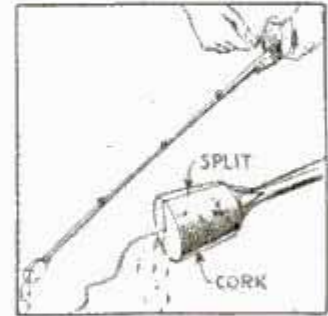

Enlarging Drawer in Sink

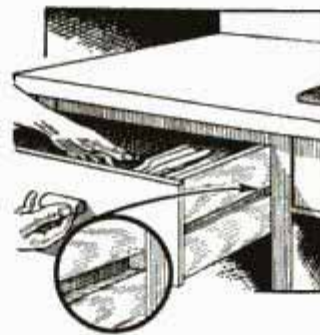

Finding the cutlery drawer in our cabinet sink much too small for the purpose, I replaced it with a deeper one, which was done by removing the strip between the drawer and the door below. This, of course, made it necessary to change the slides to the type that fitted in grooves cut in the sides of the drawer as shown.

—W. A. MacArthur, Long Beach, Calif.

Corroded Pipe Couplings Loosened by Heat



If you are making alterations on some of the plumbing lines and find that the pipe couplings are corroded so tightly that they cannot be loosened with a wrench, try expanding them with the flame of a large candle as

shown. A blowtorch is faster, of course, but if you haven't one at hand, a candle will often do the trick provided the pipe isn't too large.

Pipes on Smoking-Cabinet Door Are Always at Hand

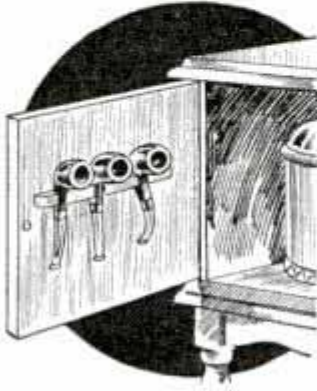

If you haven't a place on your smoking cabinet to keep your pipes, get a toothbrush holder and screw it inside the door of the cabinet. Be sure to get a large-size holder that will take the stems of all your pipes.

Wood Scraper from Plane Parts

Here is a handy cabinet or floor scraper that is easily made and one on which you can put plenty of pressure for heavy scraping jobs. It consists of a plane iron and cap attached to a maple handle shaped as shown in the squared details. As plane irons are too soft for floor scrapers, they must be heated to a cherry red and chilled in water to harden them. The cutting edge is then turned as shown in the small circular detail in the lower left-hand corner.

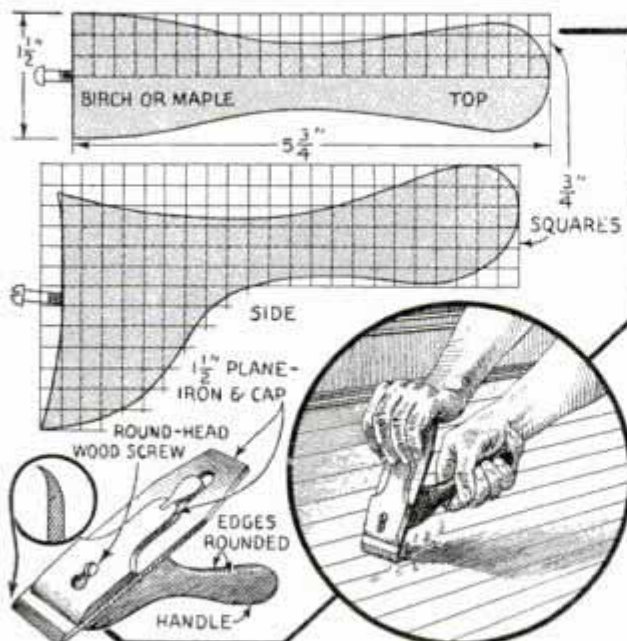

The handle is the only thing you have to make on this scraper; other parts are already assembled

Wheelbarrow Has Extra Space for Hauling Large Loads

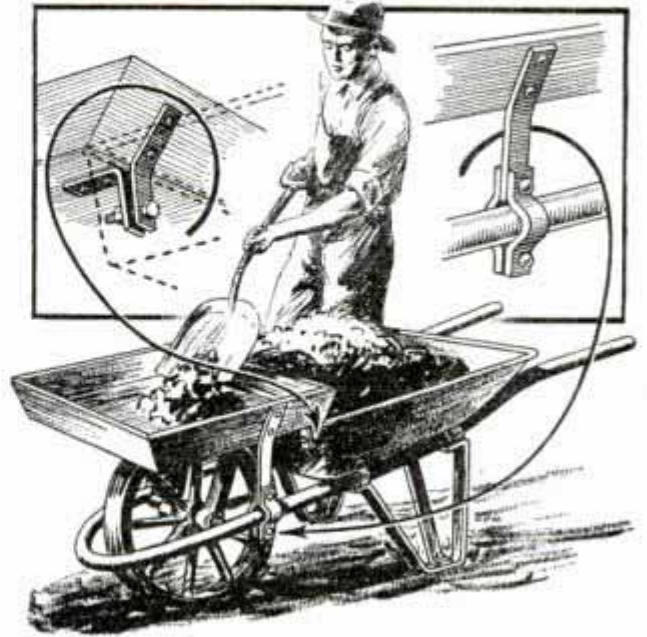

Wood tray mounted on wheelbarrow provides extra space for hauling large loads

Unusually large loads can be hauled with very little additional weight on the handles, if your wheelbarrow has an extra box mounted above the wheel as shown. The box is attached to the front end of the regular hopper with flat-iron brackets, while two long arms of the same metal support it rigidly above the wheel.

Specimen Displays on Wall Are Quickly Detached

Having a number of butterfly and beetle specimen cases hanging on the walls of my den which were frequently taken down for inspection, I was troubled with the hangers until I tried friction catches of the type shown. These were purchased at a ten-cent store. They will sustain a fairly heavy weight, thus making them handy for hanging pictures, framed charts, etc., that are taken down often.

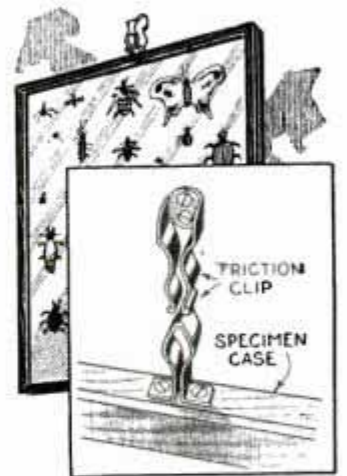

—K. F. Keith, St. Petersburg, Fla.

Jig-Saw Blower Operated by Foot Gives Strong Air Stream



An occasional tap on the bellows with your toe will keep the work free of sawdust

This bellows was used on a homemade jig saw which was not equipped with a regular blower. As the operator stands or sits at the saw, an occasional light tap with the toe will produce plenty of air. Consisting of a 7-in. length of inner tube, two wood disks $5\frac{1}{4}$ in. in diameter, a few rubber bands and a length of $\frac{1}{4}$ -in. rubber tubing, the blower can be made in an hour. One disk is slipped into the upper end of the inner tube and rubber bands are stretched around it. The other disk is provided with a flat rubber valve, and a hole for one end of the rubber tubing. An old coil spring from a bed is placed between the two disks as shown.

—Dale R. Van Horn, Lincoln, Nebr.

Ladder Platform Eases Strain on Your Feet

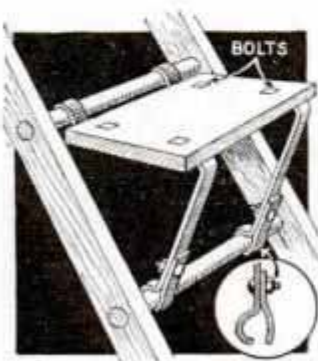

If your work requires standing on a ladder for long periods, use a small platform like the one shown which is less tiresome on the feet than a ladder rung. It is adjusted in

height easily and consists of a hardwood tread and two heavy pieces of flat iron bent to the shape shown to hook over the ladder rungs.

Removing Upholstery Tacks

You can easily remove tacks with cup-shaped heads, commonly used in upholstery work, without marring the surrounding surface, as follows: First drive the tack further by tapping it with a hammer to indent the head.

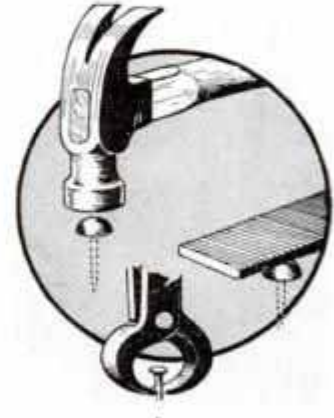

Then file across the head, which will loosen and remove it, leaving the tack with just sufficient head to be withdrawn.

Lids Held on Cabinet Door

A good way to utilize the waste space behind your cabinet doors is to tack screen-door springs across the inside as shown to hold pot lids. If a grooved wood cleat is glued to the door a few inches below each spring, you can also store pie tins and similar utensils in this way.

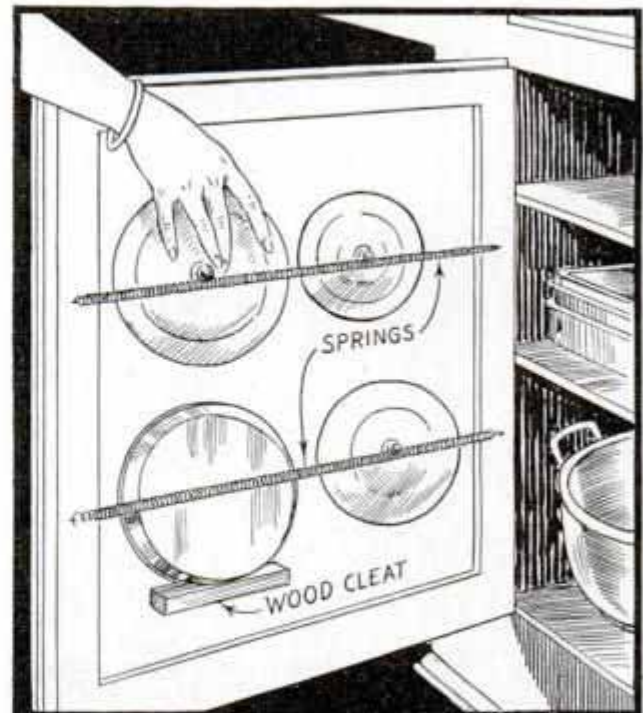

Pot lids stored behind a cabinet door utilize waste space and are always easy to reach

A HAMMOCK on Wheels



As it is fitted with two wooden wheels at one end, you can push the hammock anywhere in wheelbarrow fashion. Cutouts at the foot end of the frame serve the purpose of handles for wheeling besides providing a means of adjusting the tension on the canvas. Uniformly molded edges, done by means of a shaper, give the job a neat, finished appearance. The two main side rails are each made up of three separate pieces, the upper and center ones being half-lapped, while the center and lower ones are merely butt-joined on a cleat, which carries a plywood panel. All joints are glued and screwed.

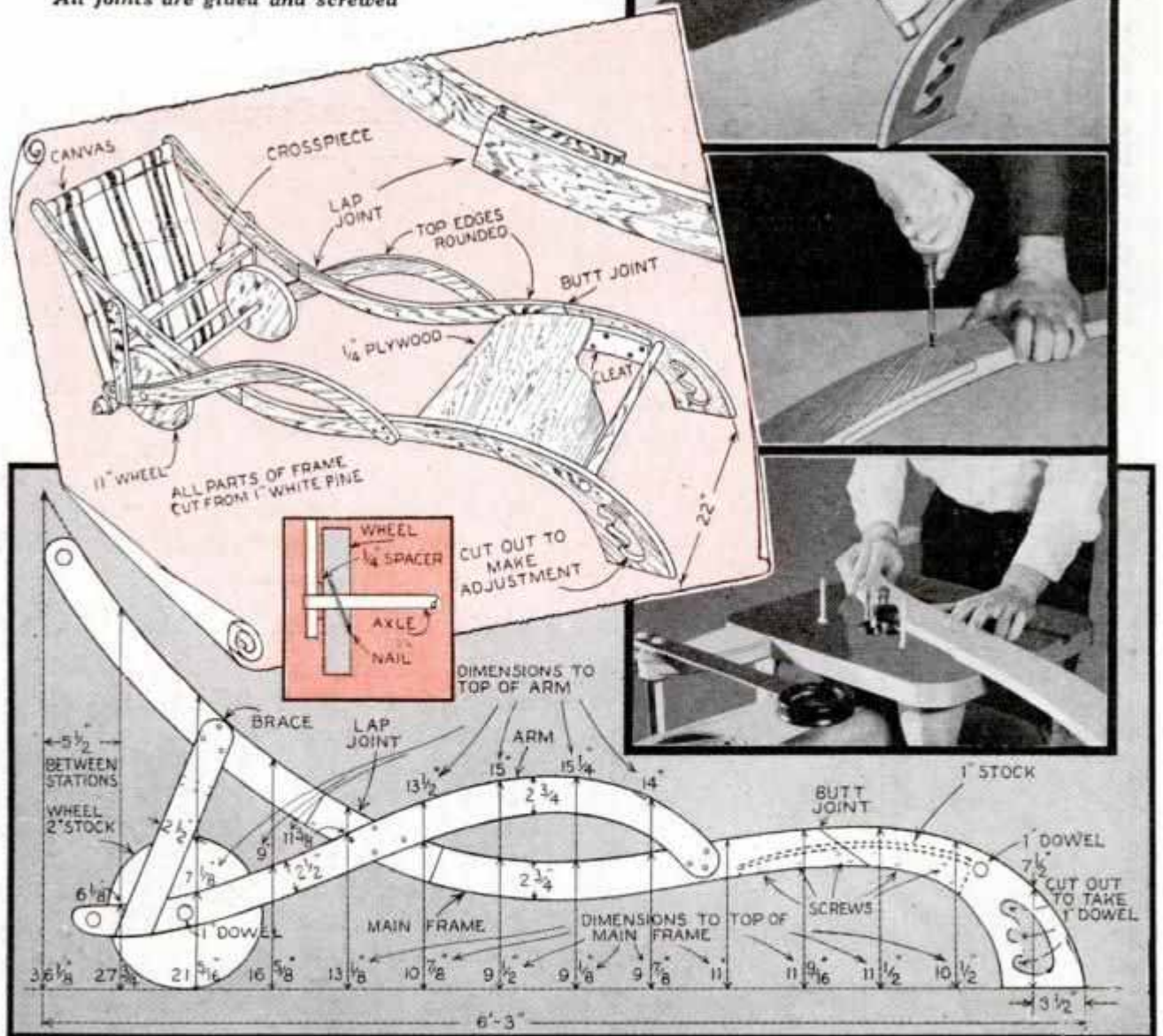
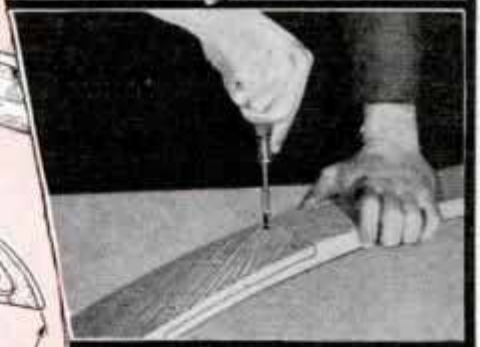
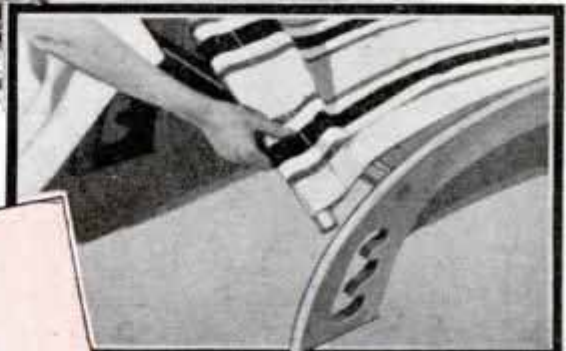

Special Weights for Small Scales Made from Wire Solder

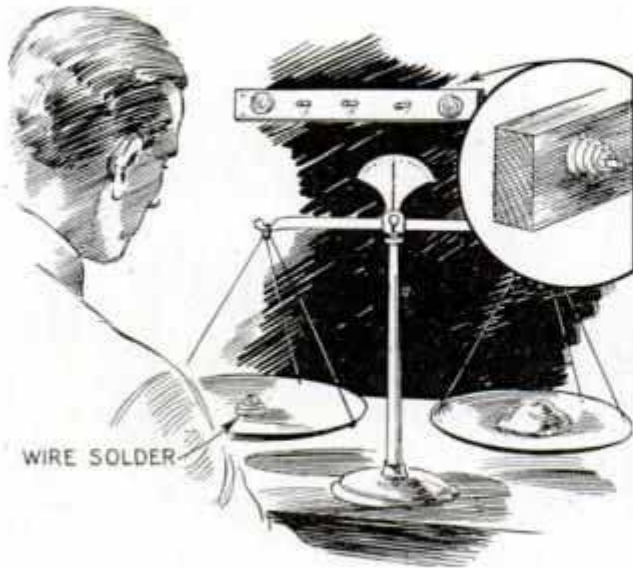

Exact weights in wire solder for various chemicals save time in duplicating formulas

When the same quantities of chemicals or other commodities are to be weighed out repeatedly, it is often convenient to have a suitable single balance weight for each. These may be provided by cutting lengths of solid wire solder and carefully trimming them down to the exact weight required. The lengths may be coiled so that they will be convenient for handling and then marked to designate the formula in which they are used.

Novel Photo Wall Bracket

Here is an unusual method of displaying a large photograph on a wall bracket which will serve to support a clock, pot of flowers or some ornament in the home. Dimensions given can be varied to suit the photo, which is glued to the surface

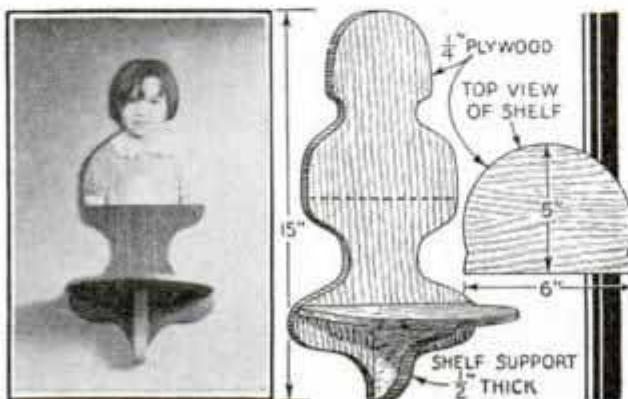
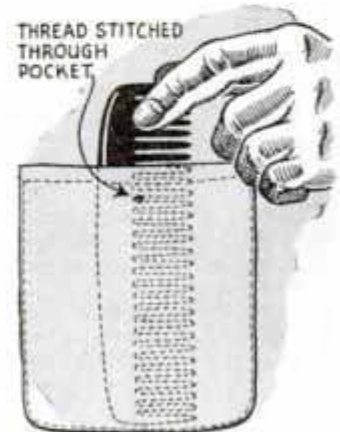

Photo mounted on a wall bracket to support ornaments gives it a personal touch

of a piece of plywood and, when dry, is cut as shown with a fine scroll saw. The exposed parts of the wood are sanded smooth. A shelf and support are required. The ones shown will take care of the average ornament, but can be modified to suit individual requirements.

Comb Slipped over Thread Stays in Pocket

To hold a comb securely in your pocket, stitch a thread through the pocket at the point indicated. Thrust the comb into the pocket and then pull it to one side so that the thread will slip between the teeth.



Snapshots Stapled in Album

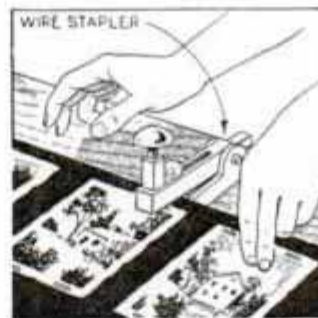

I find an office stapler handy for mounting snapshots in an album. A number of them can be mounted neatly in a short time, and there is no possibility of them loosening

and falling out, which sometimes happens when paste or art corners are used.

—J. Howard Cooper, Brooklyn, N. Y.

Hot-Pad Mitten to Reach in Oven

When reaching into a hot oven to remove or adjust pans, there is little danger of burning your hand if you use this mitten. It is made by sewing a couple of ordinary hot pads together along three sides, as illustrated.

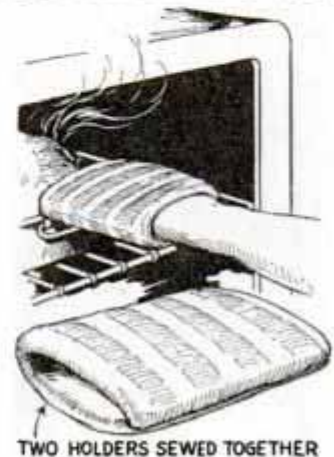

Lifelike Duck Decoys of Metal Are Lasting

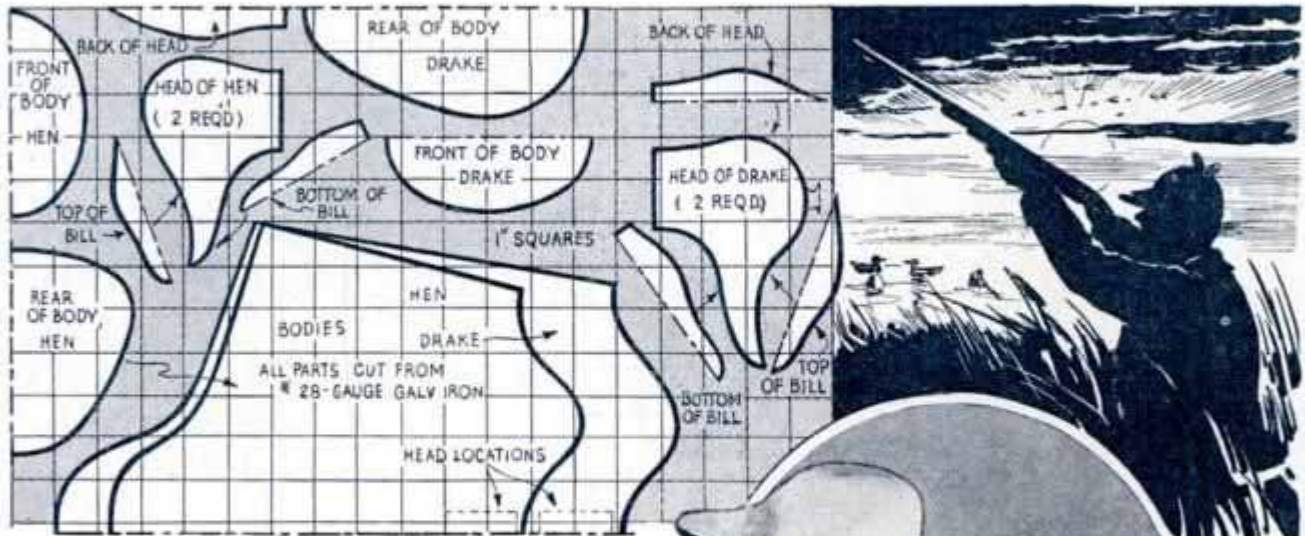

Realistic in appearance, these duck decoys are made of sheet metal and will not split or get waterlogged. They are easily constructed and will last indefinitely if given proper care. The patterns given in the squared detail are for one half of each member represented. Therefore, when the full-sized patterns are outlined on the sheet metal, they must be made double as indicated in the lower right-hand detail. When cutting out the parts, allow $\frac{1}{4}$ in. of metal along the edges to be soldered for a lap joint. The body parts that are to be rounded are easily formed over a piece of large pipe. After the decoy has been soldered carefully together to make it water tight, solder a wire ring to the bottom to attach a weight, which keeps the decoy from tipping. If galvanized sheet metal is used, paint the finished decoys with vinegar before applying the white-lead priming coat. The vinegar will roughen the surface of the metal so that the paint will adhere firmly. Finish the job by painting the decoys to resemble the wild ducks as nearly as possible. Use only flat paint to avoid reflection of light.

—Ralph T. Moore, Elyria, Ohio.

Covering for Model Airplanes

Made right in your own home, this model-airplane covering is nothing more than a thin sheet of cellulose nitrate, which is obtained by dissolving celluloid in amylacetate. Preparation of the material in sheet form is simple. Just take a pan

of water as large as the sheet desired and pour a few drops of the cellulose-nitrate solution on the water. The film spreads like oil and the evaporation of the solvent leaves a thin film of celluloid on the surface of the water. The problem of lifting the film without breaking it is solved by pinching the edges around a wire frame and sliding it off the surface of the water to avoid tearing. As soon as the sheets are dry, they are cut from the frames and applied to the model. If the water is cold and the liquid hot, very thin films can be prepared. Exposure to sunlight will deteriorate the films slowly.

—Chas. King, Chicago.

☐ Waterproof casein glue kneaded to the consistency of dough with wood flour can be shaped easily into small parts for making models.

Drawing-Board Surface Repaired with Cork Inlay



Drawing boards that are marred near the edges from thumbtacks are renewed with cork inlay

When a drawing board becomes badly marred around the edges by thumbtack marks, it can be repaired with strips of sheet cork. A wide rabbet is routed around the edges of the board to take the cork, which is glued in place. When the glue has dried, the edges of the board and cork inlay are sanded smooth.

—L. H. Georger, Buffalo, N. Y.

Pocket Check Protector at Hand When Needed

If you carry a check book, why not make this simple check protector and carry it in your pencil pocket? The protector is simply a short piece of small wire cable or rope, preferably the latter as it is made up of wires much finer than those in the cable. Insert this in the cap of a large rifle shell, the cap of an old fountain pen or the barrel of an old automatic pencil. The latter two usually have a pencil clip attached. Let the end of the wire extend a fraction of an inch from the container, and



be sure it is cut off squarely so that the tiny wires will make a good impression over the writing on the check.

Wet Sponge Drains in Funnel When Washing Walls

When washing walls, woodwork, etc., and the sponge is laid down while wiping off the work, a large funnel clamped on the water bucket as shown will hold the sponge and allow dirty water to drain into the pail. A wire clamp is easily made to hold the funnel on the inside of the bucket.

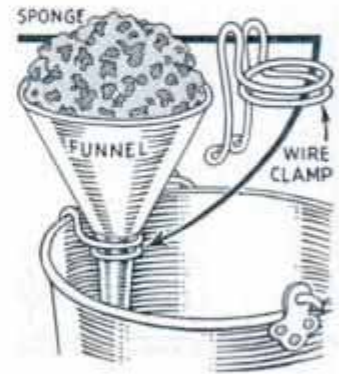

Drawer Knobs Are Kept Tight by Lead Washers

If the drawer knobs on your furniture loosen, remove the screws and slip a small lead washer under the head. Lead grommets used to seal a hole water-tight in sheet metal are ideal for the purpose and can be purchased for a few cents. Drive the screw heads tightly against them. The lead conforms to irregularities of the drawer front and will hold the screw firmly in place.



Creepy Washer Has Rope Brake

The tendency of an electric washing machine to creep when it is in operation can be stopped by tying a length of $\frac{1}{2}$ -in. rope around the four casters as shown. Or, still better, insert a small coil extension spring in the rope and you can raise it up on the legs where the spring will hold it when you want to move the machine.

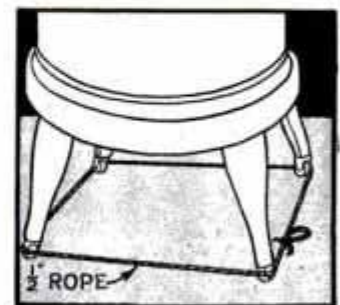

PICTURES
in
RARE WOODS



A workshop hobby that makes your scroll saw pay!

By Floyd Mix

EMBRACING all of the natural beauty found in colorful rare woods, inlay pictures offer some unusual possibilities for bringing out the touch of individuality so much desired in the modern home. The principle involved in making these pictures is a simple one—different kinds of veneer are stacked up like the layers of a cake, and with the design on top, are sawed simultaneously, as in Fig. 3. The selected pieces are then assembled in jigsaw puzzle style. Material generally used is 1/8-in. stock, which may be purchased by the square foot or in kit form.

To get right into the construction of these wood pictures, let's take the one shown in Figs. 1 and 6. The others, illustrated in Figs. 2 and 9, are made in a sim-

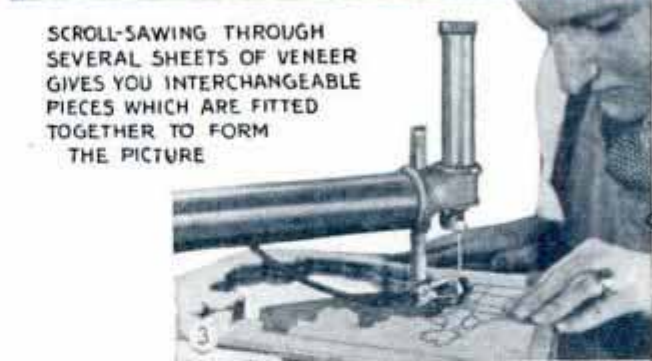
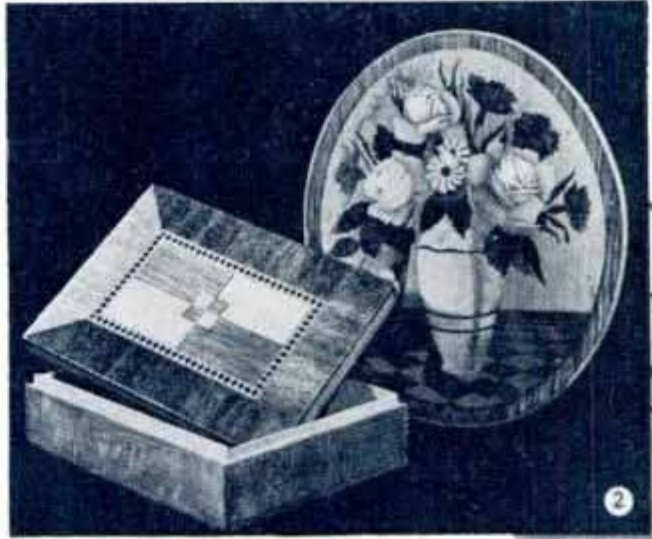

SCROLL-SAWING THROUGH SEVERAL SHEETS OF VENEER GIVES YOU INTERCHANGEABLE PIECES WHICH ARE FITTED TOGETHER TO FORM THE PICTURE

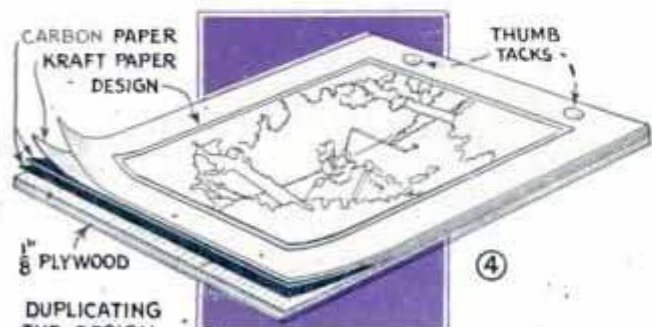

DUPLICATING THE DESIGN ON THE TOP BACKING PIECE AND ALSO IN REVERSE ON PAPER TO FACILITATE ASSEMBLY AS IN FIG. 5

ilar manner. First, trace the design on a sheet of tough paper which has been marked off in 1/2-in. squares. Then, transfer it to a piece of 1/8-in. plywood 11 by 14 in. in size, which serves as the top backing sheet when assembling the veneer pad for sawing, and a sheet of kraft paper, as shown in Fig. 4. Use two sheets of carbon back to back, arranged so that the

*Jewell's Blade for Scroll Saw
Acherbach - Steffani & Co*



KEY TO VENEERS USED

- | | | | |
|---|---------------------|---|------------------|
| A | Prima vera | I | Plain walnut |
| B | Green-dyed ash | J | Maple |
| C | Brazil rosewood | K | Brazil satinwood |
| D | East India rosewood | L | Pearwood |
| E | Walnut burl | M | White holly |
| F | Thuja burl | N | Blue dyed wood |
| G | Lacewood | O | Vernilion |
| H | Oak burl | | |

All pieces should be 11 by 14 in. unless patch method is used

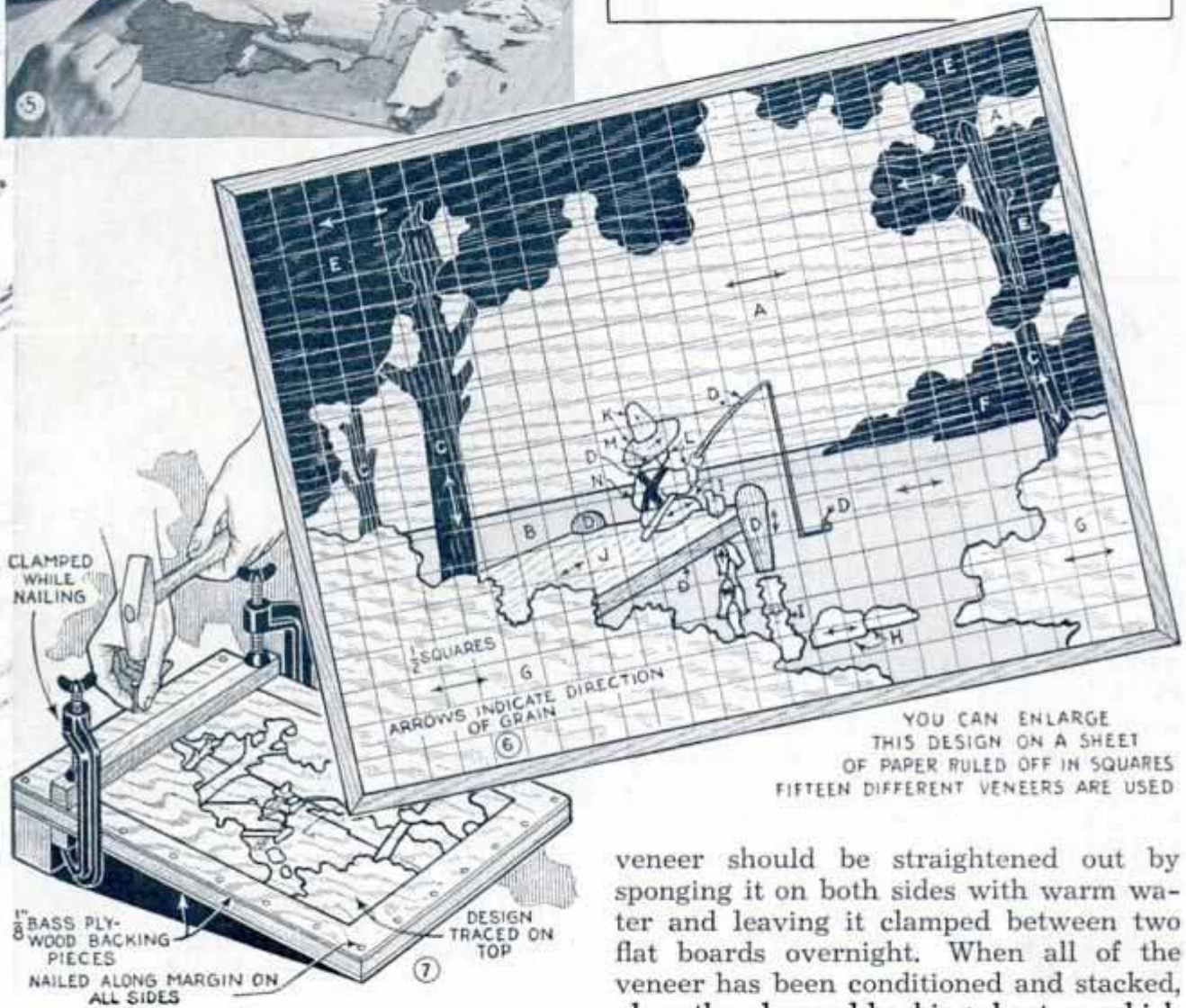

YOU CAN ENLARGE THIS DESIGN ON A SHEET OF PAPER RULED OFF IN SQUARES FIFTEEN DIFFERENT VENEERS ARE USED

design on the paper will be reversed for use in assembling the pieces. The sheets of veneer corresponding in size to the plywood backing are next assembled, placing veneer from which the small pieces are to be removed for the face, suspenders, etc., on top of the pad. Additional protection against breakage of the small pieces can be obtained by gluing thin, tough paper on one side of the veneer. An alternate method of building up the layers is to patch pieces of expensive veneer such as rosewood, satinwood, etc., into sheets of inferior quality, as in Fig. 10. Warped

veneer should be straightened out by sponging it on both sides with warm water and leaving it clamped between two flat boards overnight. When all of the veneer has been conditioned and stacked, place the plywood backing sheet on which you traced the design on top of the stack, and a similar sheet of plywood on the bottom, clamp the edges and nail along the margin of the pad, as indicated in Fig. 7.

The next step is to drill holes through the pad just large enough to take the saw blades. These should be drilled where two lines come together at a sharp angle, to prevent irregularities in the saw cuts. Before sawing, it will be necessary to slow down your scroll saw to approximately 550 or 600 strokes per minute. Tilting the table is unnecessary, as the space left by the blade, which should not be over .008

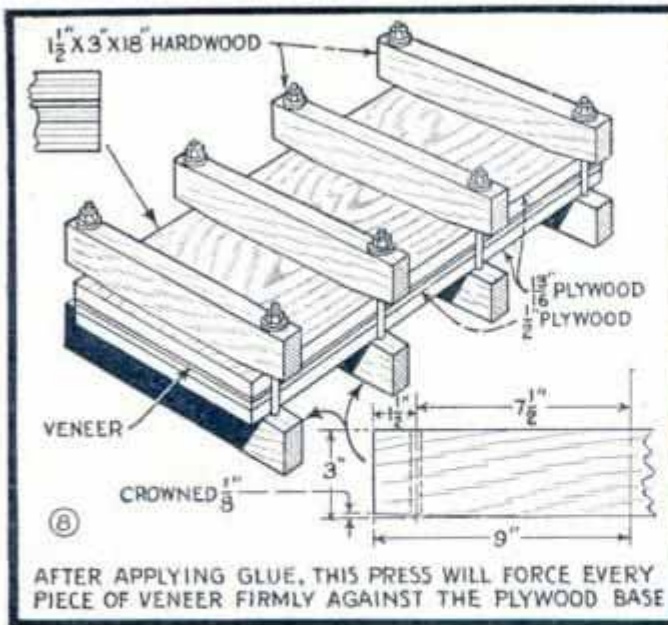

in. in thickness and .028 in. in width, will be filled when gluing. Saw the small "isolated" pieces first, pick out the ones that are to be used in the picture and assemble them temporarily with rubber cement on the reversed design on the kraft paper, as in Fig. 5. To simplify cutting, use a heavy blade for the "fishline" and fill the space with plastic after the final glue job.

When all of the pieces have been cut and assembled, you are ready to glue the veneer onto a piece of $\frac{3}{8}$ -in. plywood which serves as a backing for the completed picture. For this purpose either stainless white glue or art inlay glue is satisfactory. The latter enables you to make pictures without the use of clamps. In using stainless white glue, mix the powder with cold water to the consistency of a thick paste, let it set a few minutes, then apply liberally to the surface of the plywood and the exposed side of the inlay. Sponge the opposite side of the plywood and also the paper side of the inlay to prevent excessive warping. Place three or four thicknesses of newspaper and a layer of cardboard on top of the veneer to prevent glue from sticking to the cauls, and to equalize slight irregularities in pressure. For the clamping job, you can use a press as shown in Fig. 8. Leave the inlay in the press for at least 24 hrs., then remove it, and strip off the kraft paper.

One of the simplest, yet most effective ways to frame an inlay picture is by using inlay banding and veneer. The picture is squared up, corners of the veneer and banding mitered to fit and temporarily

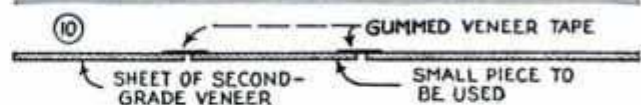
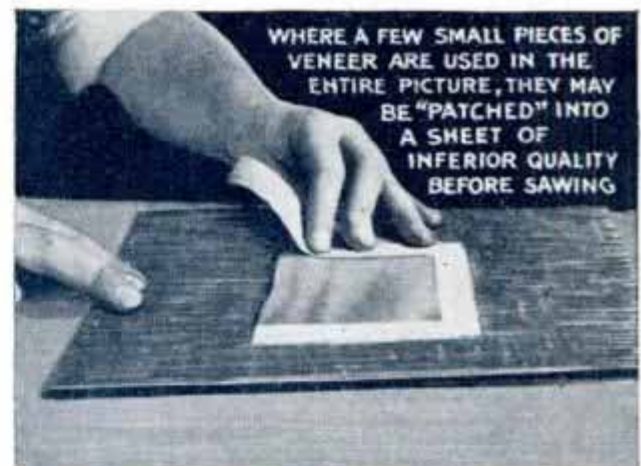

fastened with veneer tape, after which glue is applied and the assembly again clamped. When dry, the tape is removed, the entire surface sanded lightly, and shellacked. Irregularities in the saw cuts can be closed with plastic or a mixture of sawdust and glue. Applying the shellac first helps to prevent the plastic from getting into the pores of the wood and discoloring it. Next, the edges of the plywood are beveled and stained. A couple more coats of shellac, rubbed down carefully between coats, and a final coat of wax will make a satisfactory finish.

Wheeled Scoop Has Many Uses Around the Home



This scoop is handy for moving dirt, ashes, or objects that are too heavy to carry

Attached to a hand truck, this scoop will come in handy many times for wheeling coal, removing ashes, clearing away trash or for distributing soil in making lawns and flower beds. Any metal worker can form the scoop from heavy sheet metal, or you can cut it out of an old oil drum and bolt it to a hand truck as shown.

Cooking "Clocks" on the Stove

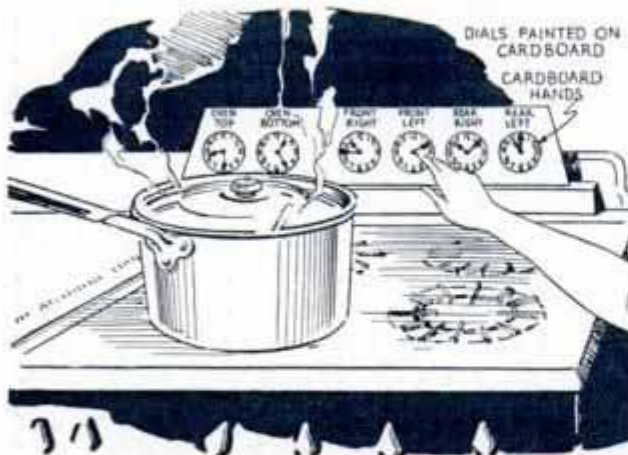

When you put the food on the stove just set the dial to indicate time for removal

Have you ever forgotten how long certain foods had been cooking when several of them were on the stove at the same

time? If so, a set of clock dials, one for each burner, painted on a strip of cardboard or metal and attached to the back of the stove will help avoid this trouble. Each dial is provided with two pivoted hands just like a clock. When the food is put on the stove, the hands are set to indicate the time it is to be removed.

Auger Bit Used in Tight Places with Doorknob "Brace"

When it is necessary to bore a hole in a tight place where a bit brace cannot be handled, try using a doorknob to drive the auger into the wood. The doorknob will slip over the squared end of most auger-bit shanks, providing a firm hand grip to apply torque. If your hand has a tendency to slip on the smooth surface of the knob, stick two or three strips of tape to it.

—P. A. Starck, Sioux City, Ia.



Does Your Dog Chase Cars?

The habit of a dog to chase cars not only endangers the animal, but may result in a serious accident if a motorist swerves the car or becomes confused in trying to avoid hitting the dog. Such a habit can often be stopped by a small rubber ball attached to one of the dog's front legs as shown. The ball is not likely to hurt the dog, will not keep it from getting plenty of exercise, yet will hinder it from running fast.



☞ Corks to be used for stopping bottles of glue or cement should be dipped first in hot paraffin to prevent sticking.

Wood Chuck Grips Work Without Marring It

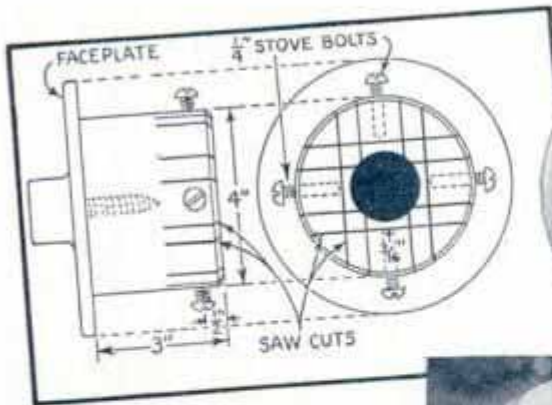

Made from a cylindrical hardwood block, this chuck holds small turned work without marring it while finishing the ends. The block is bored halfway through the center, and saw cuts are made to form a set of inner and outer jaws. Stove bolts fit tapped holes in the outer jaws and bear against the inner ones, squeezing the latter against the work.



Part of Roll Film Removed from Camera for Developing

Have you ever taken a few pictures on a roll film and wished that they could be developed without waiting until the rest of the film was exposed? To do this, turn the film ready for the next exposure. Then open the camera in a darkroom un-

der a ruby light. Pull out the film a trifle and cut it in two, close to the exposed section, but do not cut the paper. Remove the exposed strip, tape the end of the unexposed film to the paper and reassemble the camera.



Just cut off exposed film and cement end of unexposed film to paper backing

High Pressure in Blowtorch Is Dangerous

In our August, 1936 issue, page 292, a short article was published on making a repair on a blowtorch by soldering a tire valve to the pump so that an auto pump can be used. As long as a pressure not exceeding 30 to 35 lbs. is maintained in the tank the idea does not involve serious hazard. But the danger lies in the fact that by using an auto pump—or perhaps even compressed air from a service station—a much greater pressure may be applied inadvertently. Such excessive pressure, especially in an old torch, makes it definitely hazardous to use and serious accidents may result. Therefore, although the repair was used by a reader, we suggest that the old pump on the torch be repaired, and if this is impossible, to purchase a new torch.—Editor.



There's Money in HAND-

SEEING and feeling these lifelike flowers will give you little clue that they are artificial. Appropriately perfumed, the deception is almost perfect. The material is inexpensive so that anyone can establish a profitable "at home" business, making corsages, bouquets and plants.

Orchids: An artificial orchid corsage is just as attractive as a real one and durable enough to be worn many times. To make one, cut out patterns for the two types of petals and the throat, following the pat-

terns in Fig. 7. Light cardboard is used for the patterns, these being placed diagonally across a pile of three of the fiber orchid sheets, after which you cut the latter as in Fig. 1. The petals are cut from plain orchid fiber, but the throat requires a blended material. Three sets should be cut from pattern A, two from pattern B, and one from pattern C. See Fig. 7. When cutting the throat pieces, be sure that the "top" of the pattern covers the darkest part of the material. Each petal is made



MADE FLOWERS ..

up of three layers of the material supported by a short length of wire. Pile three layers together, hold with the left hand, as in Fig. 2, and apply a $\frac{1}{8}$ -in. line of cement (water glass) all around the edge of the two top layers and press firmly together. Then turn the pile over and glue one edge of the loose piece on in a similar manner. Before gluing the other edge, dip a 4-in. length of No. 32 white cotton-covered wire in the cement and insert between the middle and top layer at about the center, as in Fig. 3. This wire should extend about two thirds the length of the leaf. The remaining edge is then cemented into place to complete the petal. Each petal should be shaped before the cement is thoroughly dry to avoid breaking along the cemented edge. A special perfumed cement is on the market, but equally good results may be had by using ordinary sodium silicate (water glass) which can be obtained at any drug store for only a few cents, and adding



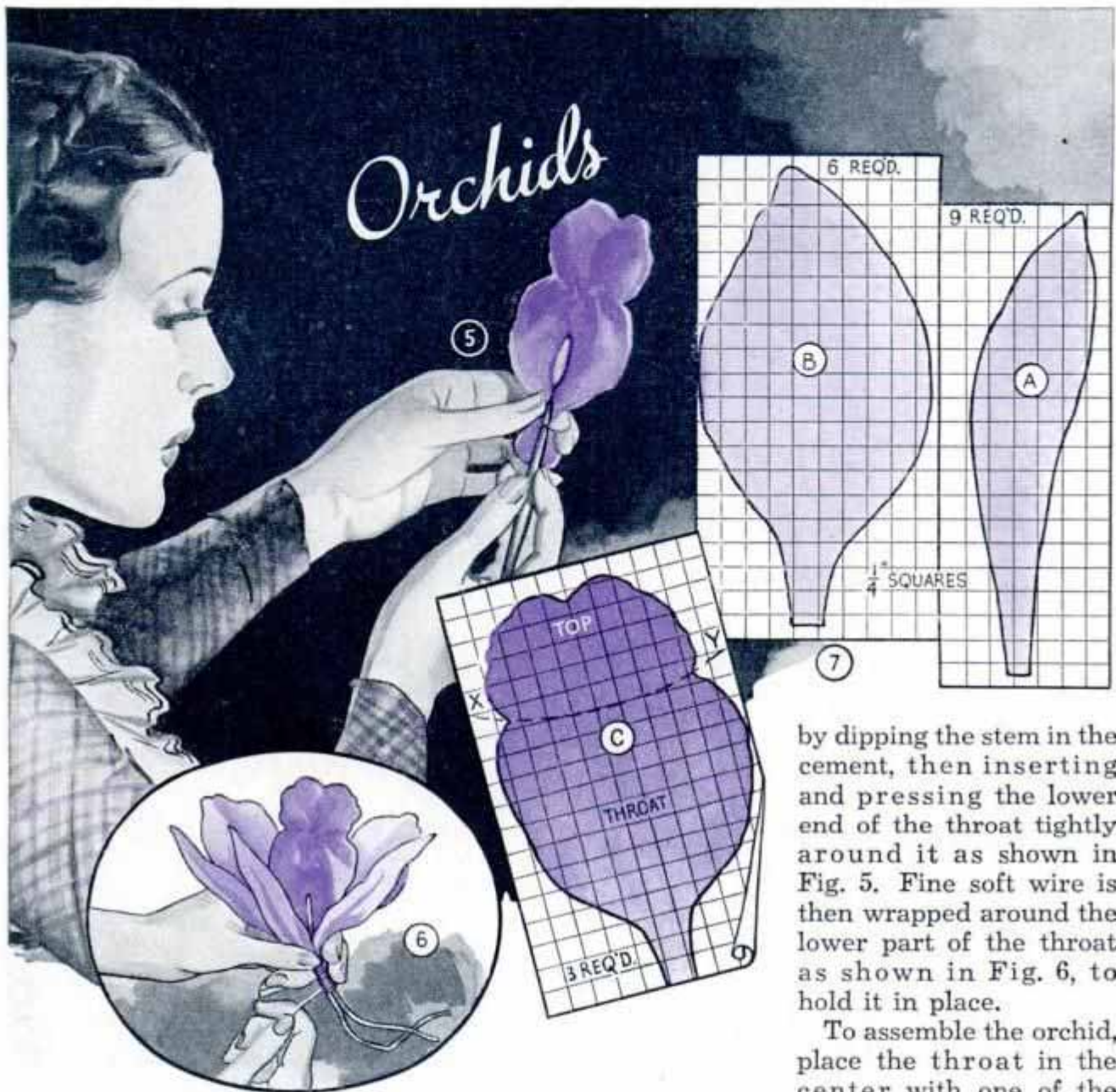

to it a small amount of suitable perfume.

The throat of the orchid is formed by cementing the edges of the lower half of the three layers together, then reversing and cementing the bottom and middle layers together at the top. Between the top and middle layer a piece of wire is inserted in the position shown by X-Y in Fig. 7. Brush cement lightly over the wire and press the top layer gently in place. While the cement is still damp, push the fiber along the wire as shown in Fig. 4, to give it a gathered appearance. Allow a few minutes for the cement to set, then carefully pull the wire out. Do not continue work on this piece until thoroughly dry, then cement the remaining top edge. The pep at the bottom of the throat is secured

by dipping the stem in the cement, then inserting and pressing the lower end of the throat tightly around it as shown in Fig. 5. Fine soft wire is then wrapped around the lower part of the throat as shown in Fig. 6, to hold it in place.

To assemble the orchid, place the throat in the center with one of the larger petals (Fig. 7, B) on each side of it. The petals should be placed so that the double thickness of the material covering the wire is at the top. The three smaller petals are spaced across the back. The petals and throat and a 6-in. length of No. 22 green cotton-covered wire are all bound together with fine tie wire and thrust into green tubing to form the stem. Combine nine sprays of lilies of the valley with one spray of fern and fasten on a 5-in. piece of No. 22 wire as before. A green rubberized tape, which adheres by pressing together with the fingers, is used to finish the stems at the top above the green tubing. To arrange the corsage, place the fern and lilies to the back of the orchid, tie all together lightly with fine tie wire and tape. A bow of silver metal-

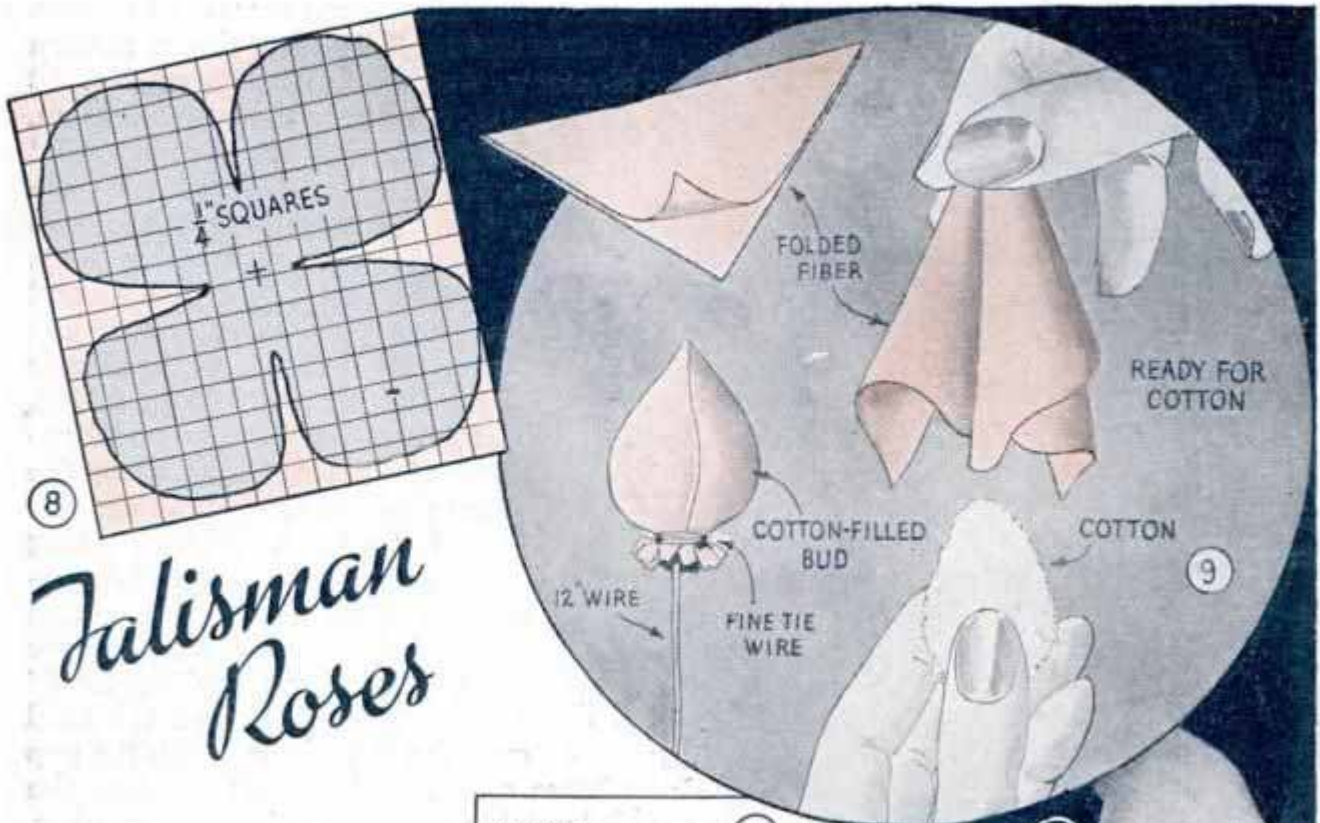

Talisman Roses

lic ribbon finishes the piece.

Talisman Roses: Talisman roses, with their delicate shading of pink and yellow, are made individually. Get the proper colored fiber, leaves and stemming. First cut out a pattern as in Fig. 8, for the petals. Cut four pieces of the fiber at one time, as two double petals are required for each rose. Cement the pieces together by brushing the adhesive along the edges as previously described. The cone-shaped center portion is made next. Fold a square of the fiber into a triangle and wrap over a piece of cotton, making a cone about $\frac{3}{4}$ in. in diameter and 1 in. long as shown in Fig. 9. A 12-in. length of No. 22 green cotton-covered wire is twisted tightly around the bottom of the cone, forming the stem. To make the bud more secure, wrap tightly with tie wire and clip away the ends of the fiber. Before assembling the petals, the edges are curled by rolling over a steel knitting needle or piece of wire as in Fig. 10. After curling, cement is applied around the base of the cone and along the inner edges of the petals as shown in Fig. 11. The wire is thrust through the slit in the center of the petals and pressed up firmly again to the bottom

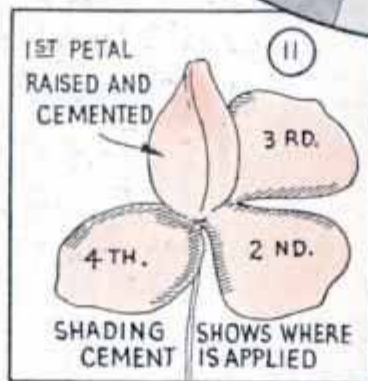

10
CURLING EDGES OF PETALS

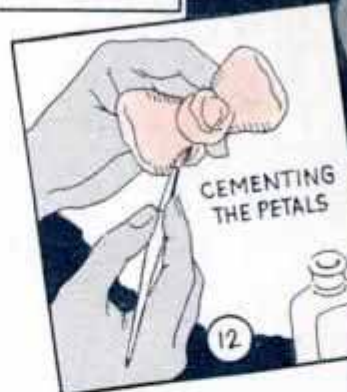

of the cone. The edges of the first petal are wrapped snugly around the cone and cemented in place, then the opposite petal is cemented likewise, following with the other two as shown in Fig. 12. Add the second set of petals in a like manner. The flower is finished by cementing a rose spider to the bottom of the petals, Fig. 13. The stems are covered with 12-in. lengths

Geraniums

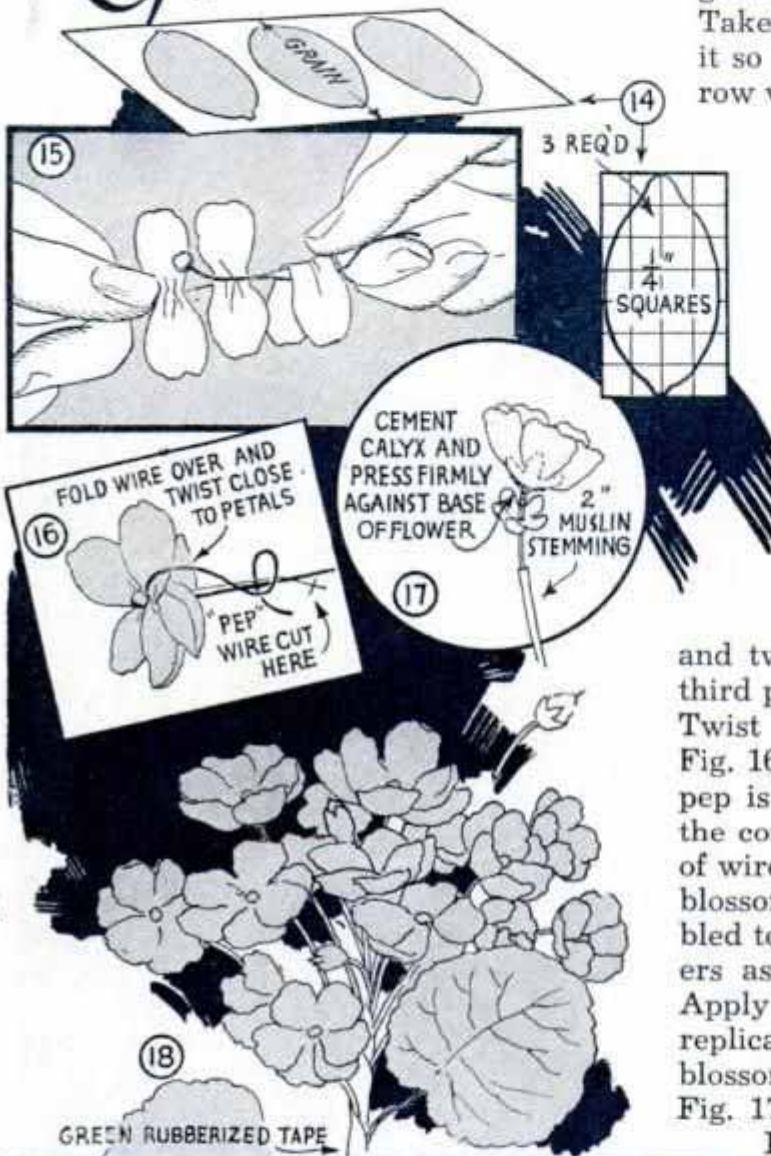

holes are punched and leaves are inserted.

Geraniums: To make the geranium blossoms, cut 4-in. lengths of No. 28 green cotton-covered wire for stems. Take a single piece of the fiber and fold it so that the grain runs across the narrow width. Six pieces, or enough for two

flowers, are cut like the pattern above, Fig. 14. Fold in half and place one piece over a wire between the thumb and forefinger of the left hand as shown in Fig. 15. Push with the thumb and forefinger of the right hand along the wire to gather the piece near one end of the wire. While holding the petals thus formed, in this position, put on a second piece and do the same. Now lay a pep over the top with the "yellow head" under the thumb and the cord over the forefinger. With the pep

and two petals held in this position, the third petal is applied in a similar manner. Twist the wire close to the petals, as in Fig. 16, being careful that the cord of the pep is twisted in, then cut off the end of the cord with scissors. About 2½ to 3 in. of wire will be left to form the stem of the blossom. The blossoms should be assembled to appear as much like the real flowers as possible by spreading the petals. Apply cement to a calyx, which is a paper replica of the green formation under the blossom, and slip over the wire stem, as in Fig. 17, pressing it close to the blossom.

Four or five buds should be prepared with a calyx also. The stems of all the blossoms and buds should be thrust into 2-in. lengths of light muslin stemming, then tied to the end of a 9-in. length of No. 16 wire. About thirty blossoms and four buds are used to make a cluster. Cover the large stem by wrapping it with green rubberized tape as in Fig. 18. The buds, which should be arranged around the base of the blossom, will look more real if they are bent downward slightly. About 2 in. below the cluster, place a small leaf against the stem, wrapping with tape. Add five

of thorn rubber stemming. A little cement should be put in the top of the stemming to hold it in place close to the spider. At random distances along the stemming,

or six more leaves at intervals of 1 in. around the stem with the small ones nearest the top. Two complete clusters are required for the plant, one of which should

be somewhat shorter than the other to give a natural appearance. To secure the cluster in a flowerpot, mix a small quantity of plaster of paris and fill pot two-thirds full, then insert the stem into the plaster and arrange as desired, before the plaster sets. The top of the plaster may be covered with artificial moss, or soil may be used.

Besides the wood-fiber flowers of the kind described in this article, conventionally decorative flowers that have a lustrous, glassy appearance, although not realistic, are very attractive and can be formed by a simple dipping process shown in Fig. 19. Thin wire is first bent to the shape of the petals and leaves, twisting both ends together to form the stem. The wire "forms" are then dipped under the surface of a tacky lacquer of the right color and slowly brought out of the liquid edgewise, after which the stem is thrust into a bar of soap to hold the petal or leaf vertically, allowing drainage of surplus lacquer toward the stem.

Label Moistener Saves Time

Fastened to the rim of a pie pan with a small C-clamp, an old paintbrush can be used as a label moistener on many odd jobs. The pan should be about half full of



Try this the next time you have a bunch of envelopes to seal or labels to stick on packages

water and slight pressure in pulling the stickers across the brush causes the bristles to dip in just enough to provide sufficient moisture.

—A. H. Waychoff, Tempe, Ariz.

Pressing Cloth Held in Frame Can't Wrinkle



Home pressing jobs are done in a jiffy when the cloth is held in this frame

You not only save time on home-pressing jobs with this frame, but you can do a neat job as the pressing cloth is kept taut so that it can't wrinkle. Make two identical frames of light, thin wood, place them together and drill three small holes along each side for bolts. Fit these with wing nuts and clamp the edges of the cloth between the frames. The cloth is dampened by sprinkling water over it, and can be removed easily for washing.

Quick Repair for Small Leak in Hot-Water Tank

If you find a small hole in your hot-water tank, it can be repaired with a brass wood screw in half an hour. Get a screw slightly larger than the hole, cut off the head and slot the end for a screwdriver. Then clean the metal



around the hole, drive in the screw, file flush and flow solder over it. Such a repair will withstand the pressure inside the tank because the screw bites into the metal and helps relieve strain on the solder.

Engraved Ash Tray at Small Cost by Utilizing Old Bracelet

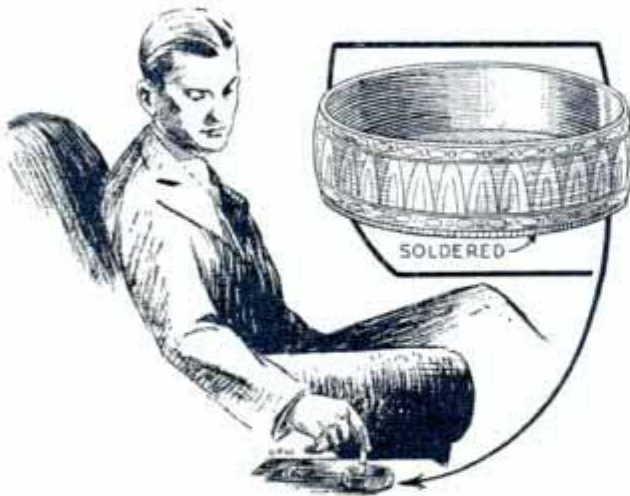

Solder a polished metal disk to an old bracelet and you will have an unusual ash tray

If some member of the family has a wide metal bracelet that has been discarded, it can be converted readily into a novel ash tray by soldering a sheet-metal disk to one edge. A piece of felt glued to the bottom of the tray will protect polished surfaces of tables and other furniture.

Siphon Keeps Liquid in Tank at Constant Level

Needing some means of keeping a liquid in a tank at a constant level, the tank being so constructed that holes could not be made in the bottom or sides, I made the device shown,

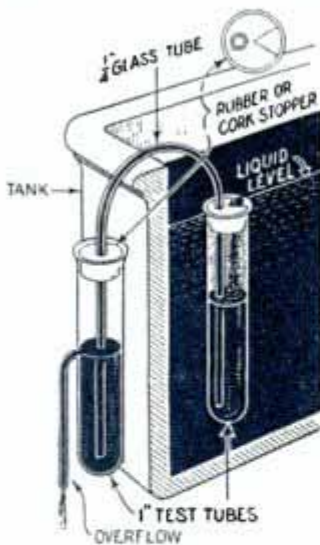

tubing, the outside tube being provided with an overflow as shown. The inside tube is fitted with a notched stopper to allow liquid to flow into it, while the outside one is tightly corked. The principle is a siphon, which works as follows: The

liquid flows into the test tube through the notched stopper and raises the level, the difference in pressure causing the liquid to flow through the glass tube into the outside test tube where it drains out through the overflow. As some liquid always remains in the test tubes, the siphon never gets air, thus it starts functioning whenever the level of the liquid in the inside tube rises.

—E. F. Nussdorfer, Mt. Vernon, Ohio.

You Won't Injure Your Fingers on This String Cutter

Utilizing an old safety-razor blade, this string cutter is very sharp, yet as the cutting edge is only

$\frac{1}{4}$ in. from the wall, there is little possibility of anyone accidentally cutting their fingers on it. The blade is held in a tube-shaped piece of spring brass, which is soldered

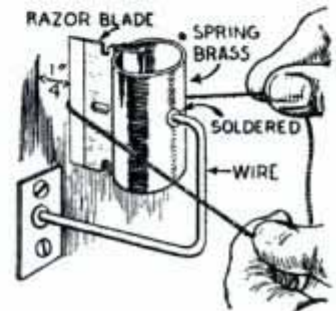

to a wire bracket. If spring brass is not at hand, you can use a piece of thin-wall tubing and slot one side with a fine metal-cutting scroll-saw blade. When the razor blade becomes dulled with use, just replace it with another one.

Furniture Given Glue Injections to Tighten Loose Joints

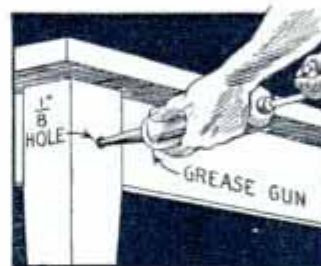

If you have some old furniture that has become rickety and would like to use it on a porch or in the basement, here is a method of regluing it without taking

the loose members apart. Just get a grease gun and fit it with a tapered nozzle. Then drill a small hole through the loose member to the joint and force in some glue with the gun. After putting in the glue, fill the hole with a small wood plug, and set the furniture aside until the glue has dried thoroughly.

Space-Saving DROP LEAF made from Old Dining Table

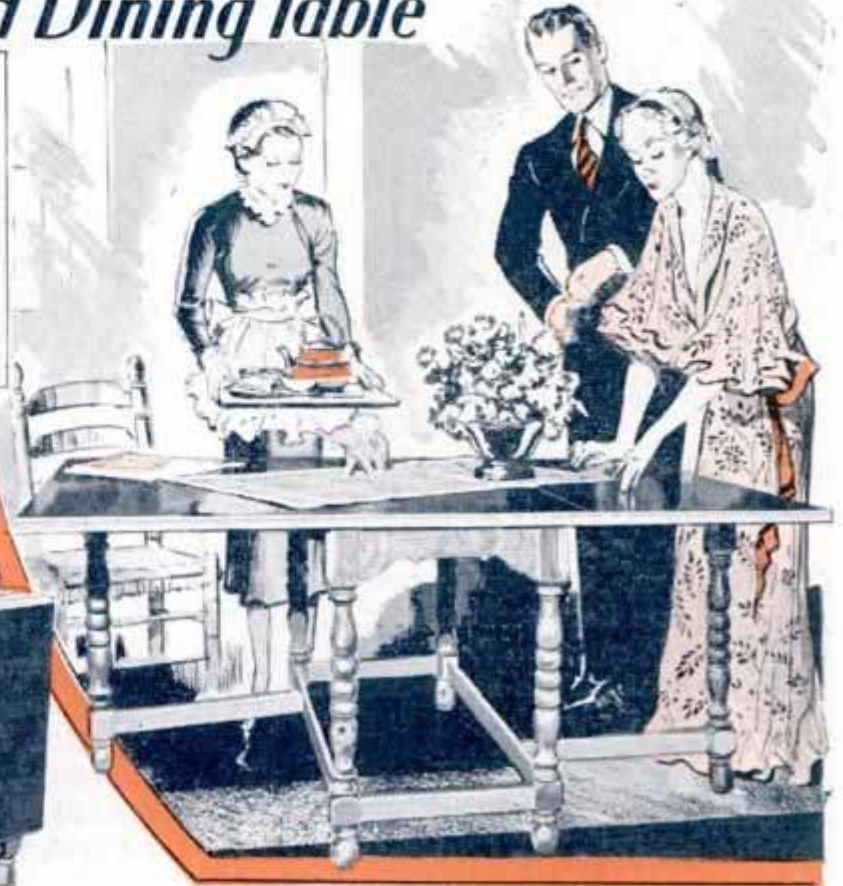

REBUILT TABLE,
LEAVES DOWN

LEGS, RAILS AND
APRONS ARE DETACHED
FROM ORIGINAL TABLE TOP

Here's the way to build that gate-leg table you've always wanted—and at the same time save yourself a lot of tedious work. An old dining table with six turned legs will furnish practically all the material ready made. Because of large flat surfaces the rebuilt table is easy to finish

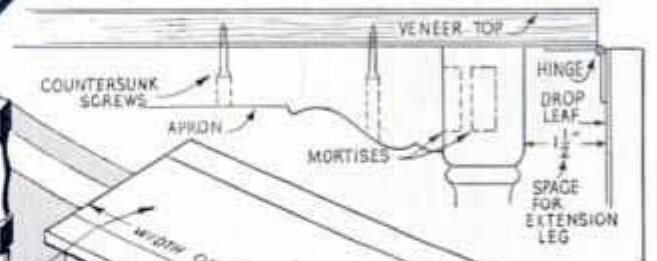
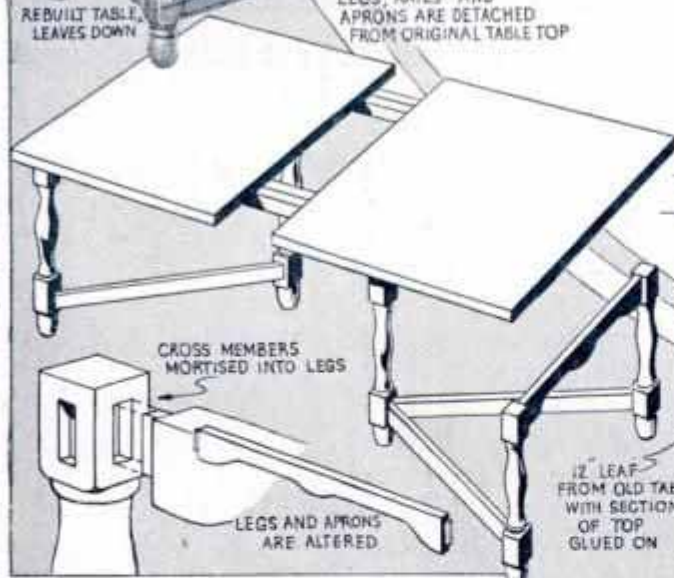

12" LEAF FROM OLD TABLE WITH SECTIONS OF TOP GLUED ON

The first step is to get the old table apart without damage. Then you build the new top from the old, the parts being doweled and glued. Rails are mortised to the center legs to form supports for the drop leaves. From here on the details above show you what's to be done in building up the center section



MORTISE ON HINGED LEGS. LEG IS CUT AWAY ON ONE SIDE

Tapeline Case Has Pencil Clip to Hook on Worker's Belt

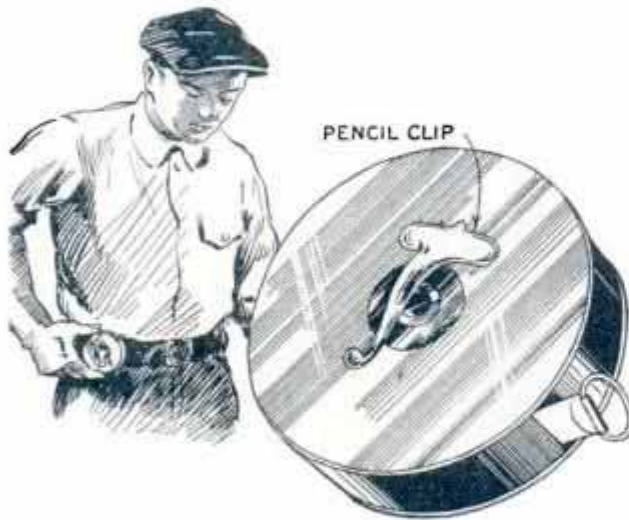

Carried on your belt, this tape reel is always at hand for instant use

Workmen who carry a tapeline ready for instant use, will find it convenient if a pencil clip is flattened and soldered onto the back of the case. This allows the reel to be snapped on the belt where it will be handy for use.

Simple Glass-Bead Stopcock for Home Chemists

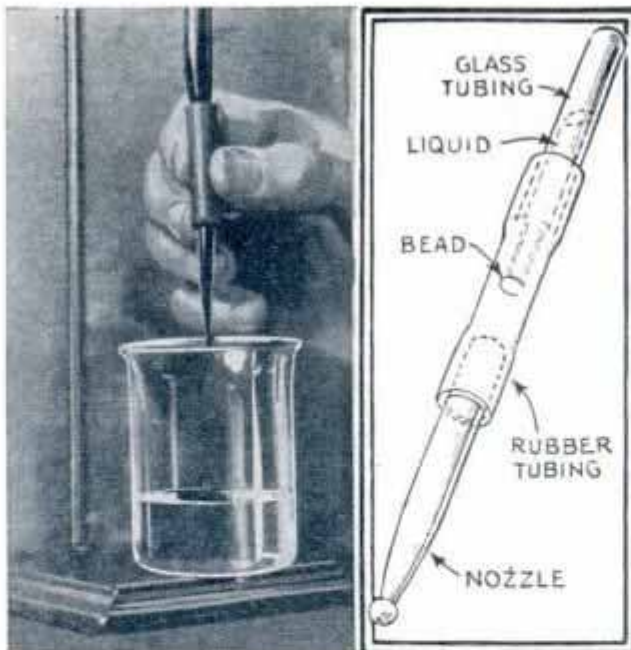

Pinching the rubber tubing allows the liquid to flow past the bead into the nozzle

The home chemist will find this simple stopcock useful in titration, where one solution is added to another drop by drop. A short piece of rubber tubing to join a

glass nozzle to a larger glass tube, and a solid glass bead, made by fusing a 1/4-in. length of glass rod in a burner flame, make up the device. To add a solution, squeeze the rubber around the bead with the fingers so that the liquid can flow. To stop the flow, remove the fingers.

—P. Ralph Dowden, Bronx, N. Y.

Sanitary Sleeves on Toothbrushes

When toothbrushes are kept in a holder outside of a cabinet, it's a good idea to keep them in transparent Cellophane sleeves. These are easily made by folding strips of the material and sewing or gluing them along one edge as shown. It's easy

to identify the brushes, and it takes only a second to remove or slip them inside the sleeves, which fit right into the holder.



This Strainer Stands Hard Use

For a strainer that not only strains out very fine particles, but one that is also substantial, take the perforated coffee container from an old percolator and attach a handle to it as shown. A piece of metal tubing or rod soldered to the tube in the center of the container and to the rim with a wire eye is a good handle. If a wood grip is desired, a piece of round stock can be bored at one end and slipped over the tubing.

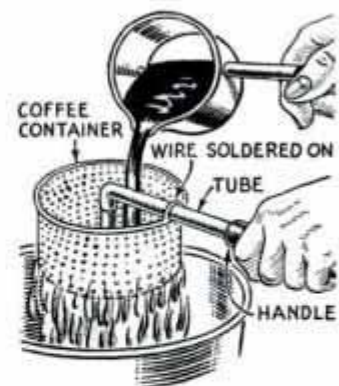

☞ To keep colored clothes from getting a gray appearance when washed, add vinegar, 1 tablespoonful, to the next-to-last rinse water.

Speedy Drying Reel Winds Fishline Evenly

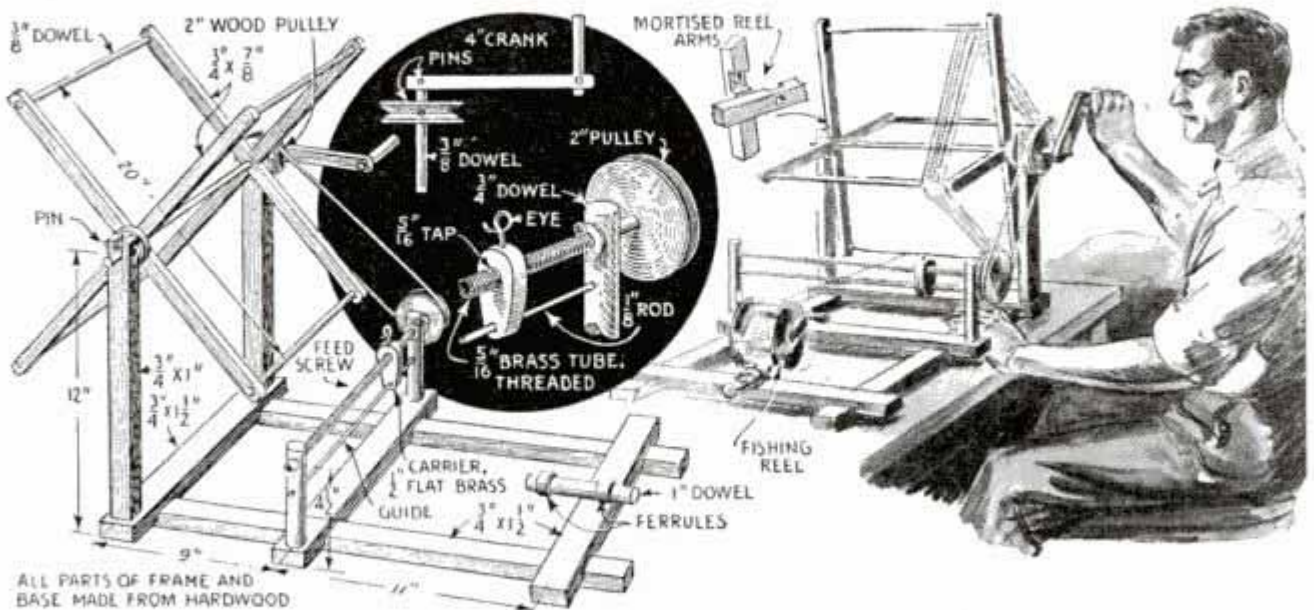

This drying reel not only winds the fishline evenly but does it quickly, approximately 4 ft. being wound at each revolution of the crank. It is constructed entirely of hardwood with the exception of a feed screw, which draws the guide along as it winds. Note that the cross members of the base are mortised into the sills, which prevents the frame from twist-

ing. Also, the arms of the reel are mortised into each other. Pulleys are turned from white pine, the crank and handle being fastened with a pin. For the feed screw, use a $\frac{5}{16}$ -in. brass rod and thread it. Each thread should be approximately the thickness of the fishline. However, by the use of different size pulleys, any thread can be made to feed the line as desired.

Coal-Bin Door Hinged in Sections Opens from the Bottom

Here is an unusual door that permits fuel to be removed from the bottom or top of a filled coal bin. As shown in the drawing, a number of boards are cut to fit the door opening. These are hinged individu-

ally to the casing and the free ends held with a hasp and staple. If you desire to open the hinged sections as one unit, after the bin has been partly emptied, screw eyes may be driven into the sections in a vertical line and a rod run through them.



This coal-bin door opens in sections to remove fuel from any level desired

Black Finish for Plaster Casts

Amateur sculptors who wish to produce a variation in the finish of plaster-of-paris objects, may give them the matte-like appearance of black basalt and similar stones by brushing on two or three coats of a solution of colloidal graphite in water. The casts to be treated should be finished off without undue sanding and they should be thoroughly dry. With a little experimenting, one can regulate the black tone produced by altering the dilution of colloidal graphite, and by polishing the highlight areas with a soft cloth.

—E. A. Bodine, Port Huron, Mich.

What you can do with

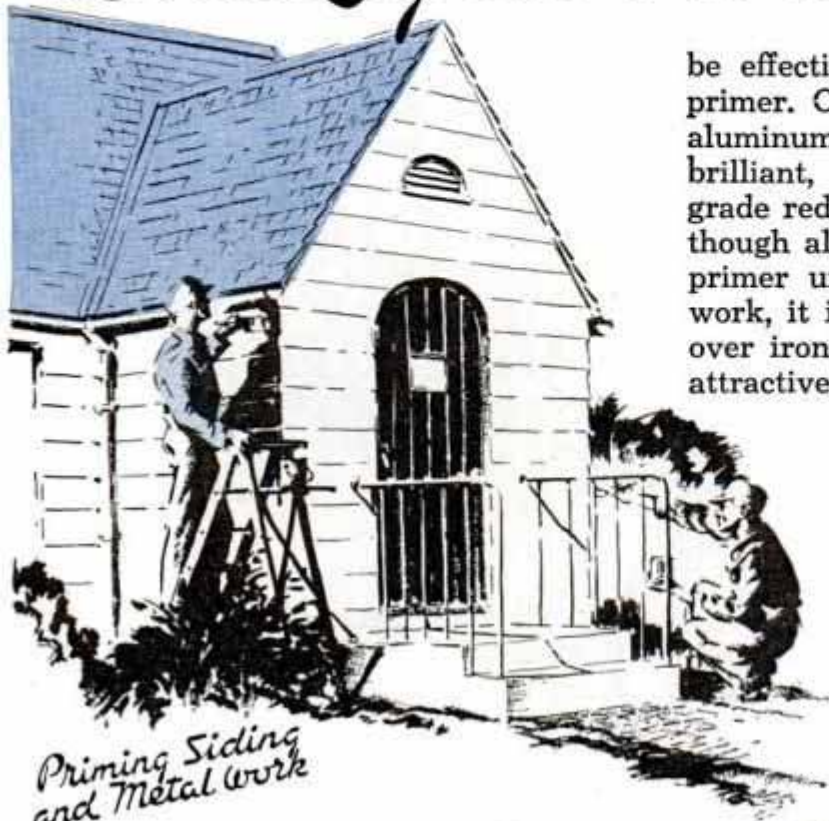

*Priming Siding
and Metal work*

be effectively sealed with an aluminum primer. On metal exposed to the elements, aluminum paint is generally used as a brilliant, silvery finish coat over a high-grade red-lead or iron-oxide primer. Although aluminum paint can be used as a primer under enamel on exterior metal work, it is generally used as a final coat over iron primers simply because of the attractive finish it produces. Indoors, on plumbing, water tanks, gas plates and furnaces it is used as a one-coat finish, for which it is most effective. It's also just the thing for priming newly plastered walls. Here the paint can be stippled on the bare wall with a sponge to produce an attractive temporary job and at the same time serve as a primer for any finish applied later on.

SEVERAL unusual properties of aluminum paint make it especially adapted to household use, indoors and out. Practical tests show that aluminum paint prolongs the life of paints applied over it. It forms a seal against moisture and has remarkable durability and covering power, due to the "leafing" action of the individual metal flakes which comprise the pigment. These flakes are flat, and are treated with an acid that causes them to float to the surface of the vehicle, where they overlap like leaves or shingles on a roof. Due to this leafing action, one coat of aluminum paint, properly applied, will hide any color, even black.

It is especially effective over woods that do not hold paint well, such as yellow pine. The formation of a "toothed" surface bonds the succeeding coats of regular oil paint or enamel and prevents scaling and peeling. Woods containing natural dyes that "bleed" through ordinary oil-paint films can



*Interior walls
and woodwork*

Aluminum paint is what might be called "self-leveling," which means that it spreads without brush marks, due to the leafing action. Because of this, proper proportions of powder to fluid and mixing are very important. The pigment is obtainable



ALUMINUM PAINT



By
R. H. Wampler



Getting the Mix Right!

Tiny, metallic flakes of aluminum paint are coated with an acid which causes them to float in the liquid vehicle. As the paint is spread these particles rise to the top of the film and overlap one another, thus forming a sheath of pure metal over the painted surface. This action of the flakes is one of the peculiar properties of aluminum paint and is known as "leafing"

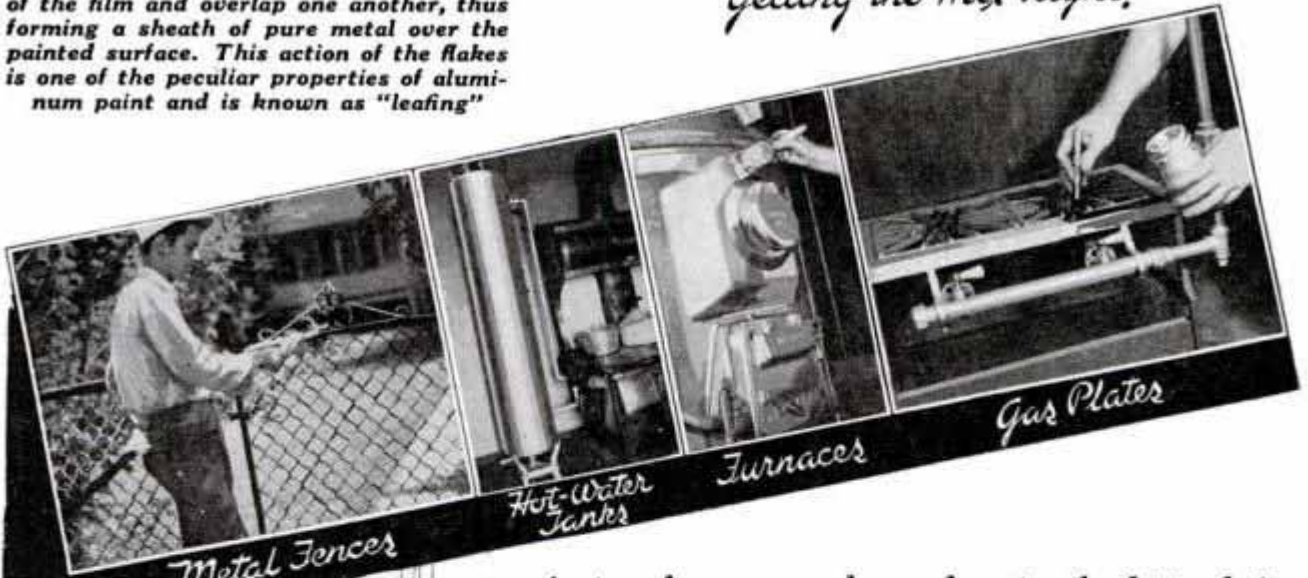

Metal Fences

Hot-Water Tanks

Furnaces

Gas Plates



Basement walls and plumbing

in two forms—powder and paste, the latter being easier to handle. The powder or paste should be weighed and mixed in the proportion of from 1½ to 2 lbs. of powder or paste to 1 gal. of liquid. The pigment in either form is placed in a suitable container and the liquid vehicle gradually added to it, with continuous stirring. Many manufacturers pack aluminum paint in two-compartment cans—one containing the powder and the other the liquid. In this case the manufacturer's directions should be followed carefully in both mixing and applying the paint.



Jobs Dressing for Cabin Cruisers

For priming coats on exterior work the powder or paste is mixed with what is known as a "very long oil" varnish and for finishing coats a "long oil" varnish vehicle. These terms are used to denote the proportions of oil to gum in the varnish. Spar varnishes and bronzing liquids are also satisfactory vehicles, the former for certain kinds of outside work and the latter only for interior work where decoration is the main purpose. Boiled linseed oil thinned with turpentine to the proper consistency, may also be used as the vehicle when painting exterior work.

Only sufficient paint for the work in hand should be mixed at a time for if it stands it loses its ability to leaf due to absorption of the acid film with which each aluminum flake is coated. The vehicle also reacts with the metal, causing it to darken to a dull gray color. However, if you have a small amount of paint left over from one job, you can seal the container and then later add this to a fresh batch of paint without

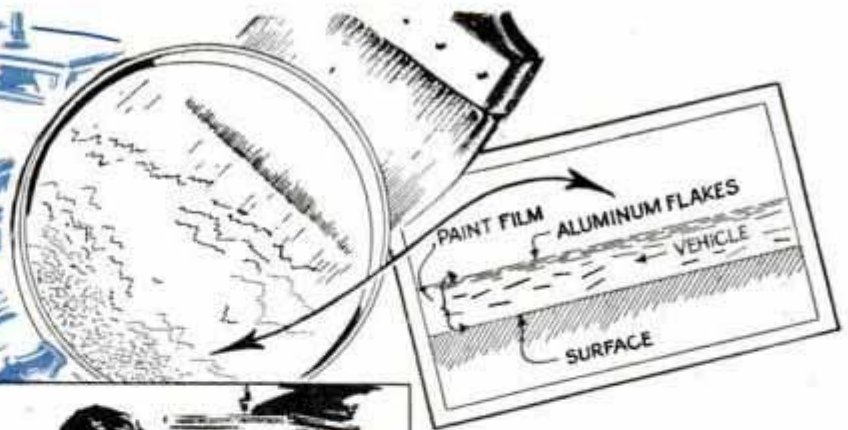

On Machines



Covering Varnish Stains



Dark Cupboards Lightened

darkening the latter appreciably. When using aluminum paint, it must be stirred constantly in order that the proper proportion of vehicle to pigment will be applied to the work.

Aluminum paint is brushed on just like any other paint. It can also be handled in a spray gun, if properly thinned so that it will atomize readily. When brushing by hand it is necessary to avoid brushing back to paint that has partially set, as the fresh film will ride up over the first coat, resulting in a lap that is likely to show when the paint dries. It's best to cover only a small area at a time.



To Reflect Light and Heat from Trailers

Portable Home Workshop Is Carried in Car

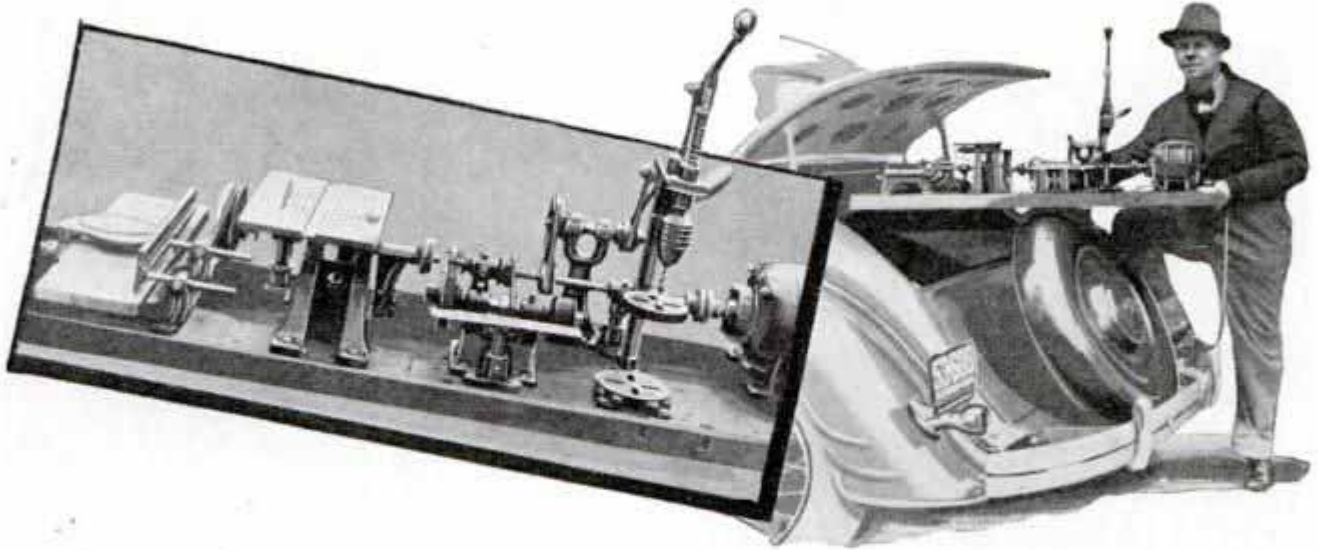

One home-workshop enthusiast who spends many week ends at his lakeside cottage has a number of small power tools mounted compactly on a panel so that he can take them back and forth in the car. This idea is also handy if you live in a small apartment where space is not available for a permanent shop. The tools can be used on a porch, in the basement or garage and stored when not in use. The exact arrangement will depend on your tools. In this case, a grinder and drill

press are run from a small shaft, one end of which is connected directly to a motor with a universal joint. The other end of the shaft is provided with a coupling that can be quickly attached to the mandrel of a circular saw, and can be disconnected when using the grinder or drill press. A pulley on the saw mandrel drives a jointer, the face of the pulley being fitted with a sanding disk. When using the latter, the fence is removed from the jointer, which then serves as a work rest for the sander.

Shelves on Cabinet Door Provide More Space for Glassware

If you need a little extra room in the kitchen cabinet, shelves that are fitted onto the doors will hold many glass tumblers. As the shelf sizes will vary with each job, a little ingenuity on the part of the craftsman will be required to work out something suitable. In some cases it is advisable to use metal brackets to support the shelves, while in others the method indicated will be satisfactory.

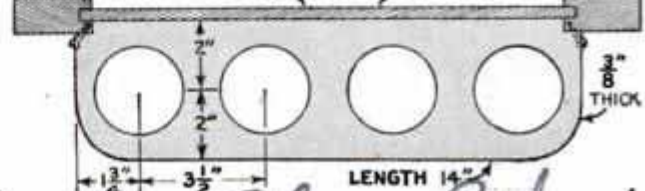

Anti-Dimming Paste for Windshields

Applied to the glass with a rag and rubbed until a polish is produced, the following mixture is useful for preventing sweat and frost on the inside of windshields: diethylene glycol, 1 1/2 oz., and precipitated chalk, 1 oz. Mix the ingredients thoroughly. More or less chalk may be added to give any desired consistency. The product may be packed in jars or collapsible tubes.

*Carbide • Carbon Chemy Co's
30 E 42nd. New York*

*Suggested by Deuggers & Co 159
W. Kemble, Chicago*

Short Dowels Cut on Circular Saw with Aid of Jig



With this jig, you can cut any number of dowels quickly without feathering the edges.

On a job requiring a large number of short dowels, a jig of the kind shown was clamped to the miter gauge of the circular saw. A block 2 in. square, was bored lengthwise through the center to take the dowel stock. After raising the table so that the saw just cuts through the hole in the block, the dowel stock is fed in at the left-hand end of the block, passed over the saw and the dowel pushed out at the right-hand end. A finger of the right hand over the hole in the block serves as a stop to keep the dowel stock from being pushed through too far. With this method there is no feathering of the severed edges of the dowel.

Dip Net Is Rubber Shielded Against Wear

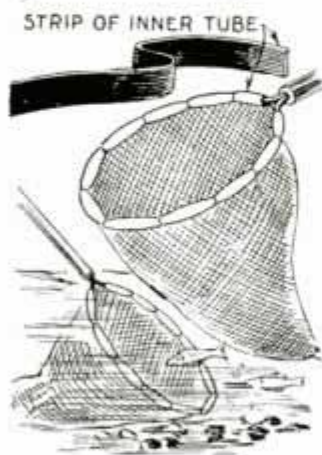

band of rubber from an oversize inner tube and stretch it around the hoop as

Dip nets used for catching minnows in shallow streams must often be forced against rough stones or gravel, with the result that the net fabric is soon worn out along the outer margin of the steel hoop. To prevent this, cut a wide

shown. If tied with stout fishline at intervals around the hoop, the rubber will protect the net and increase its period of usefulness many times.

Keys and Locks Marked to Save Time

When a bunch of keys are kept on one ring around the house, put duplicate marks on both the keys and the locks they fit. Then, when you want to unlock an unused drawer,

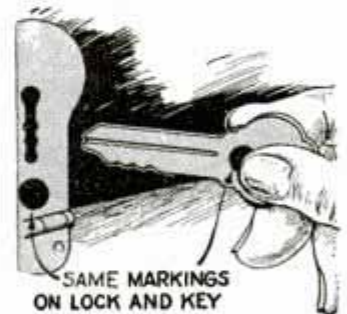

cabinet or trunk, a glance at the marking will enable you to pick out the right key quickly. The markings can be painted, scratched or filed on the locks and keys.

Ax Hung in Rubber Holder Sheaths Blade

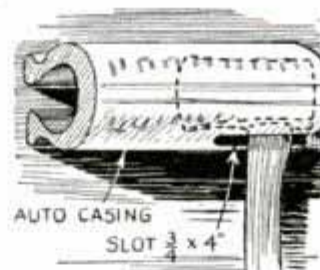

A good holder for your ax that will protect the blade can be made in a jiffy from a piece of old auto tire 8 or 10 in. long. Cut a slot

near one bead of the tire to take the handle as shown, and nail it to a wall, driving the nails through the beads. This holder is also handy for hatchets and similar tools.

Moth Balls Kept in Mesh Tubes Are Easy to Handle

Instead of putting moth balls in a drawer or trunk loosely with clothing, make up a few sleeves or tubes from mesh cloth, such as cheesecloth, slip the balls inside and tie the cloth between each one.

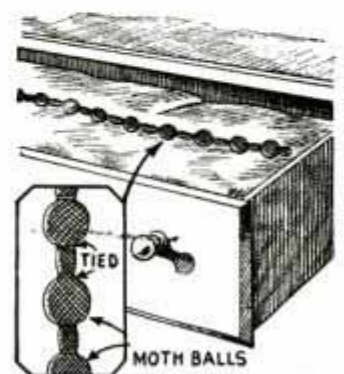

Tiny Gratings on Ship Models Simple to Build

Here's a real short cut for model builders—a simplified method of making the tiny gratings required for many ship models. You start with a hardwood block, drilling a series of equally spaced holes horizontally through the center of the block, the distance between the holes being equal to the diameter of the latter. Then the block

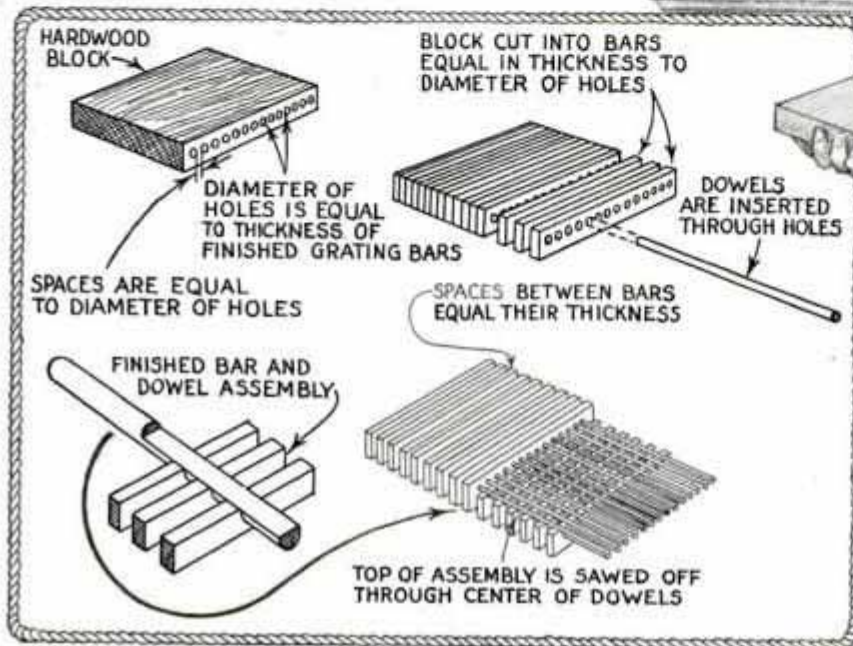
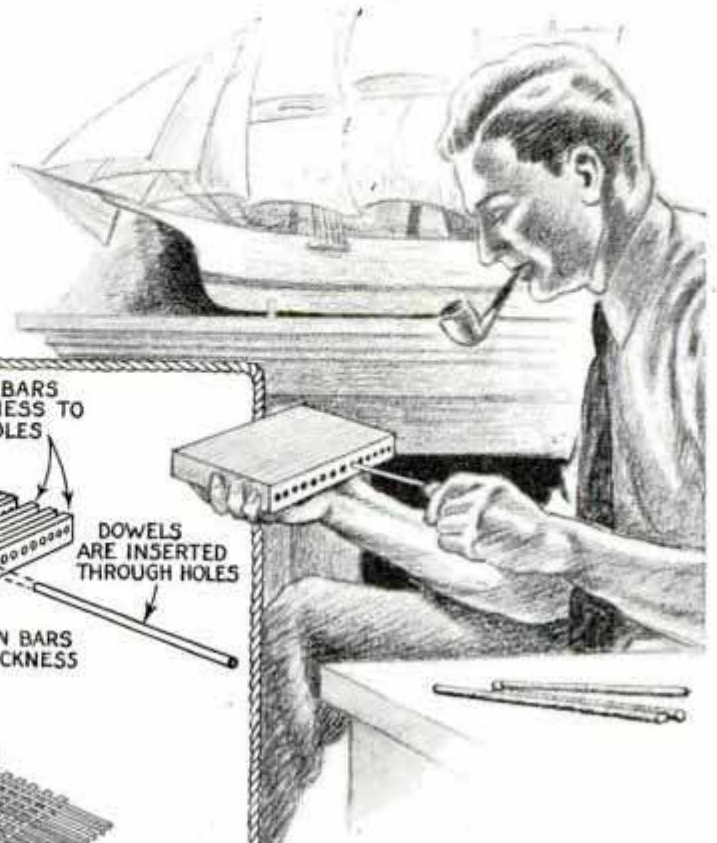

When you want a ship-model grating try this method of making it from a block of hardwood and a few small dowels

is ripped into strips of a thickness equal to the diameter of the holes. Next, the strips are stacked and hardwood dowels are inserted into the holes as shown, the spaces between the bars being equal to their thickness. Then the whole assembly is immersed in thin glue and after drying, it is sawed and sanded so that the top surface exposes bars and openings of uniform size.—Harold T. Bodkin, Chicago.

Dough to Clean Wallpaper

Here is a good wallpaper cleaner that you can make in your home. Mix whiting, 1½ lbs., wheat flour, 5 lbs., common salt, 3 oz., soda ash, 5 oz., powdered pumice stone, 4 oz., oxalic acid, ½ oz., and ammonium chloride, 4 oz. The powders are mixed dry and, before use, enough water is added to make a stiff dough. When the mixing with water is partly completed, kerosene, ½ oz., is added and worked in. A ball of the cleaner is rubbed over the wallpaper in long even strokes.

Sandpaper Fastened on Wire Smooths Scrollwork

To sand odd-shaped cutouts, wrap a sheet of sandpaper around a piece of heavy wire, and tie the ends with stout string or light wire. The wire may be bent to any angle, thus permitting access to small openings and hard-to-reach corners.



Strainer in Wheelbarrow Bottom for Washing Vegetables



When you wheel in fruits and vegetables for storage, open the strainer and wash them with a hose

If a sink strainer is installed in the bottom of a wheelbarrow that is used to bring in your fruits and vegetables for winter storage, you can wash them right in it with a hose, the strainer allowing the water to run through the bottom. The strainer should be of the double type so that it can be closed when using the wheelbarrow to move other materials.

Salt and Pepper Shaker Covers from Rubber Bottle Caps



come in a number of different sizes and can be obtained in almost any drug store.

To prevent the contents of salt and pepper shakers from being scattered over your lunch while on a hiking or camping trip, you can slip small, rubber bottle caps over them as shown. These caps

Removing Soot from Chimney

A mixture consisting of sal ammoniac, 10 lbs., and sulphur, 3½ lbs., thrown onto

a fire in a furnace or stove will burn out soot in the chimney. Too large a quantity of this compound should not be used at one time, and all drafts should be closed. It is a good idea to watch the roof closely to see that burning particles of carbon do not start a fire.

Beads Kept in "Multiple Dish" for Stringing

When decorating purses, necklaces and other work with designs worked up in different colored beads, an ordinary egg-crate separator of the type shown is handy for keeping them assorted as to color and size. The rough texture of the cardboard, from which the separators are made, helps to keep the beads from sliding around when picking them up.



Inkless Pen Uses Indelible Lead

Absence of a bottle of ink in the home need not cause you worry if this pen is kept at hand. It produces its own ink from a piece of indelible lead which projects from a small hole drilled in the end of an ordinary penholder. The lead should be in close contact with the underside of the pen point. In use, dip the pen in water, which will dissolve some of the lead.

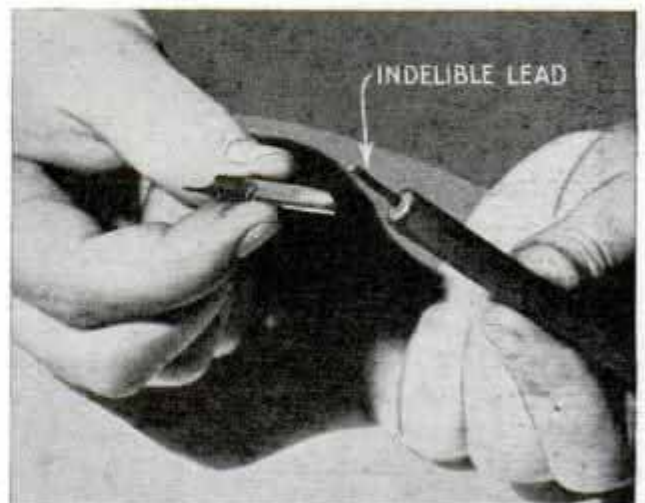

This ordinary pen produces its own ink by dipping the point in clear water

Folding Coat Hanger and Brush

Taking little space when folded, this combination coat hanger and brush fits into any traveling bag. It is made by cutting a long-handle brush in half lengthwise, sawing right through the bristles. If the brush is more than 1½ or 2 in. in

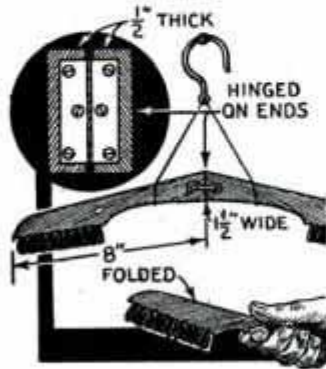

width, it is best to saw off a couple of strips ½ or 1 in. in width, instead of ripping the brush in the center, to avoid having the hanger too large. The strips are hinged in the center and are equipped with

a small hook and screw eye to hold them open. Stout cord forms a connection from the hanger to a wire hook on which it is suspended.—H. R. Wallin, Brooklyn, N. Y.

Reflectors on Dog's Collar Visible to Motorists



Reflector buttons attached to your pet's collar may keep it from being struck by a car

To lessen the chances of your dog getting hit by auto when crossing the streets after dark, attach several button reflectors to its collar or harness. A beam from the headlights makes a reflection which causes most drivers to slow up, giving a dog plenty of time to get out of the way. Reflectors such as used on road signs, bicycles, etc., are suitable for the purpose.

Small pieces of transparent Scotch adhesive tape will join the ends of torn amateur movie film until there is time to make a regular cement patch.

Scrap Pieces of Mirror Hung with Garden Hose

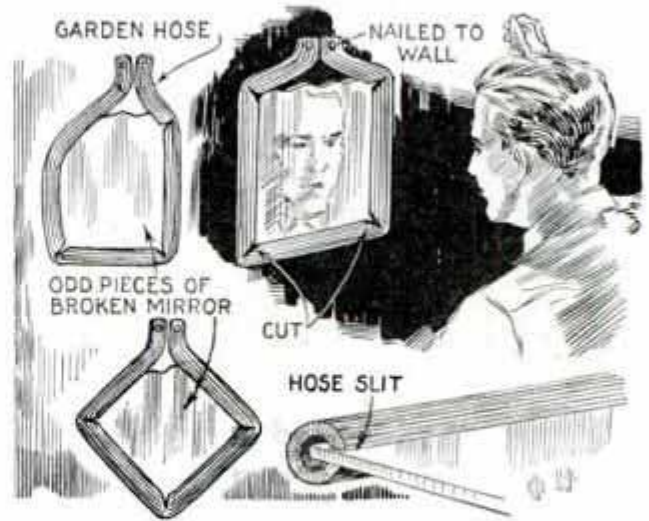

Scrap pieces of mirror are hung easily when framed with lengths of garden hose

A scrap piece of mirror often comes in handy in the basement, garage, shop or porch, but it is usually a difficult job to hang. This is done easily by using a piece of hose or tubing for the frame. The hose is slit along one side to take the glass, triangular pieces being cut out of the hose wherever a bend is made to avoid bulging at this point.

Burglarproofing Windows

Here are two ways of locking windows that will try the patience of prowlers. One consists of drilling a small hole through the sash lock and slipping in a nail to prevent it from turning. The other consists in raising the lower sash to the desired height and drilling a hole through it into the upper sash from the inside to take a heavy nail or steel pin. Two or three holes can be drilled at different heights, for the purpose of adjustment, if desired.

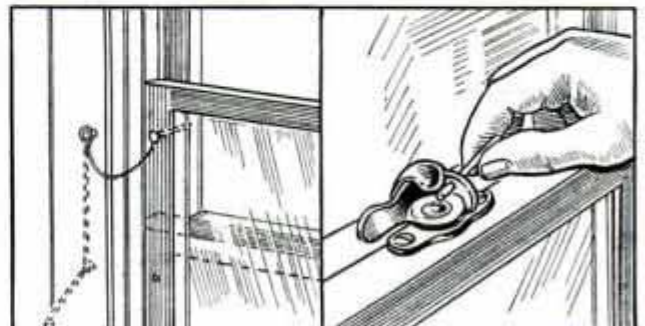

Simple precautions like these will discourage prowlers from entering the windows of your home

Clothespin Grips Pastry Tube to Aid in Squeezing

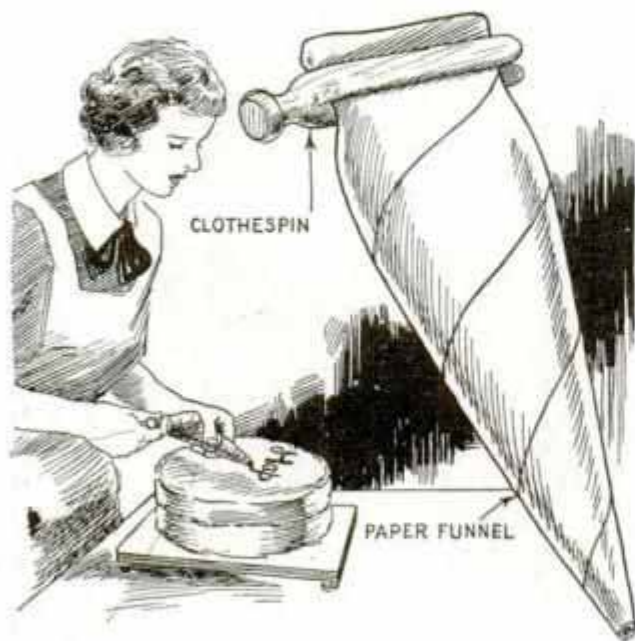

Instead of squeezing a pastry tube by hand when decorating a cake, slip a clothespin over the large end and roll it as shown. This will give perfect control of the mixture, and at the same time avoid escape of any contents past the fingers. Every drop of the mixture will be squeezed out of the tube.

An Effective Rug Cleaner

Here is a good rug-cleaning preparation that you can make yourself. Mix together diglycol oleate, 3 pts., butyl cellosolve, 5 fl. oz., ethylene dichloride, 12 fl. oz., denatured alcohol, 1 pt., and oleic acid, 12 fl. oz. In a separate container, add ammonia (strong 28%), 12 fl. oz., to water, 3¼ pts., and pour it into the first solution. The preparation should be stirred thoroughly for several minutes.

Why Not Start a Home Workshop?



Cabinet Workbench—898

DRILL PRESS—895: Pipe fittings. ½-in. chuck and ball-bearing spindle. 28 in. high—25c.

BELT SANDER—579: Heavy-duty type. Angle-iron framework and a 5 by 46-in. belt—25c.

VERTICAL SPINDLE SANDER—560: Fine for curved surfaces. Table 10 by 17 in.—25c.

All six blueprints listed above will be sent to you prepaid upon receipt of \$1.00, or separately for 25c each. Also send 12 cents for our booklet "What to Make" which lists hundreds of other blueprints for practical craftsmen. These include plans for home improvement, furniture, novelties, toys, boats, models, outdoor sports, and many other miscellaneous subjects.

A few homemade machines will enable you to get into this interesting field. Whether you want a shop for pleasure or profit, our plans will give you all of the information you need.

CABINET BENCH—898: Nearly 8 ft. long, 27 in. wide, 35 in. high. 20 drawers—25c.

22-IN. SCROLL SAW—771: Pipe fittings and hardwood. Has sewing-machine drive—25c.

12-IN. BAND SAW—836: Smooth running and sturdy. Cuts 2-in. stock easily—25c.

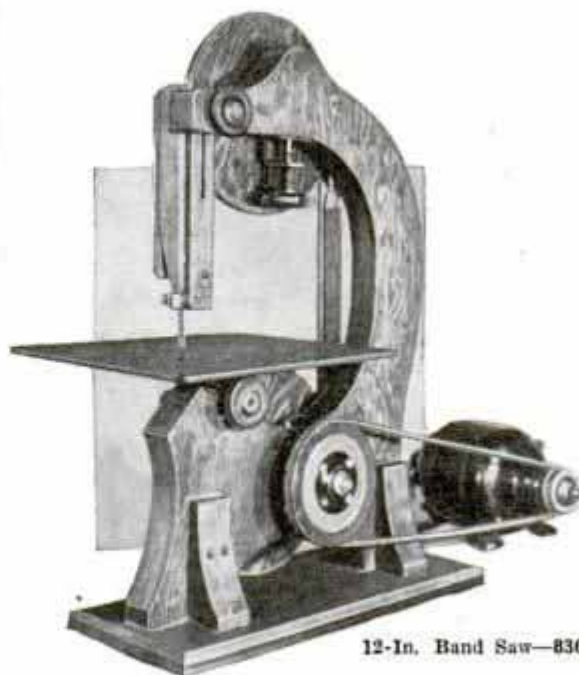

12-In. Band Saw—836

Blueprint Department, Popular Mechanics Magazine, 200 E. Ontario St., Chicago



SHOP NOTES

A SLIDING cut-off SAW

SIMPLE and compact, this sliding cut-off saw operates without the overhead rigging common to power saws of this type. It will crosscut boards 14 in. wide by 2 in. thick as in Fig. 1. The whole thing consists of a base of channel iron and a sliding T-iron carriage, the latter forming a support for the saw arbor and the motor. As shown in Figs. 2 and 3, the channel-iron base pieces are held together at the bottom by means of a wood spacing block and two through bolts. Metal crosspieces at both ends on the top side of the channel maintain exact width. Wood spacers and strips of iron are bolted to the top flange of each channel to form a hold-down for the sliding carriage.

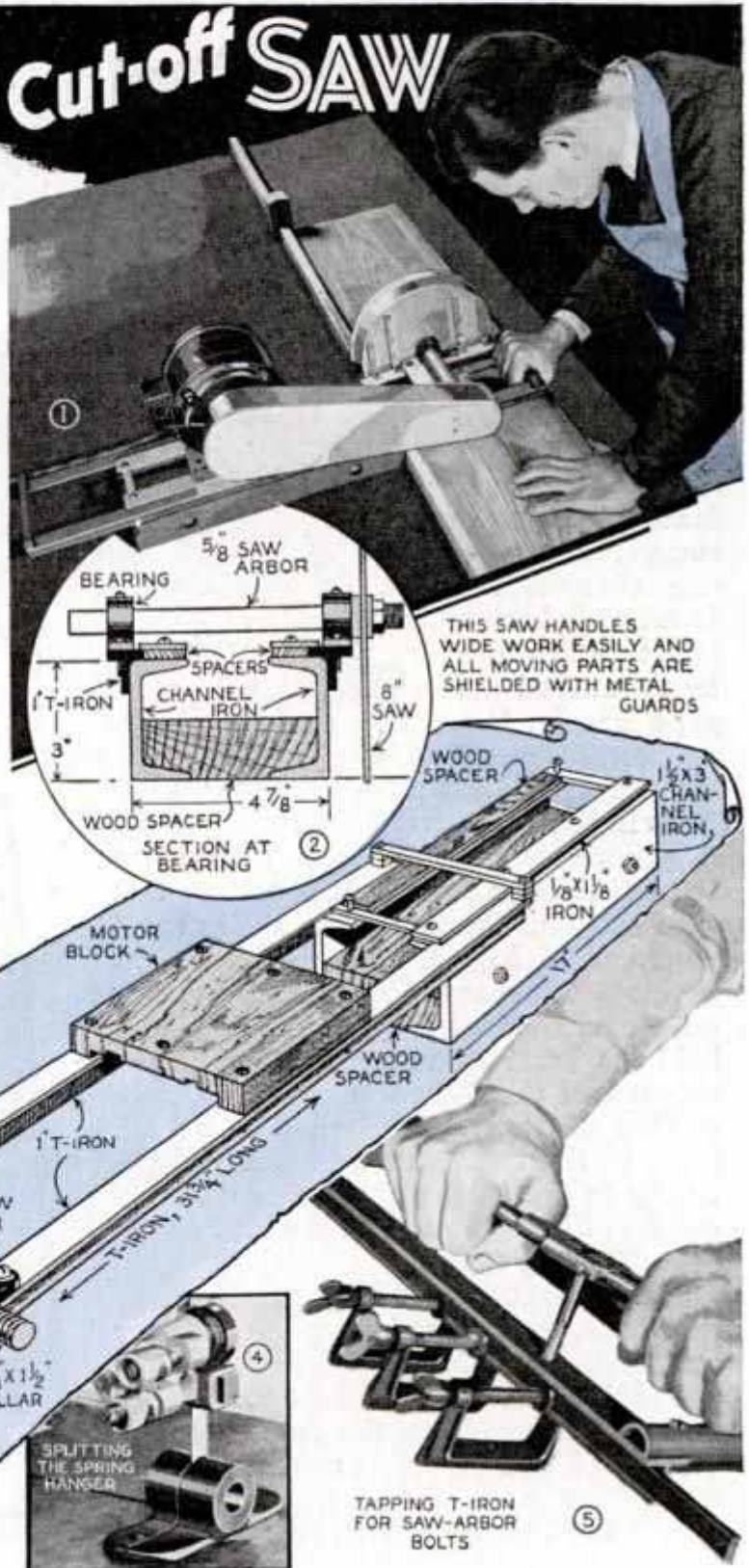



The carriage consists of two lengths of T-iron, spaced to form a snug, sliding fit on the channel-iron base and held rigidly to this width by means of the pipe handle, the rear cross tie, and the motor block. Bearings for the

saw arbor are made by cutting the flange off a Chevrolet front spring hanger and then splitting the hanger into two equal parts, as in Fig. 4. The original brass bushings are reamed out to take the saw arbor. As shown in Fig. 2, the studs that hold the bearings extend partly into the sidewall of the T-iron. Consequently, in drilling and tapping the stud holes, a scrap piece of flat iron should be clamped securely to the side of the T-iron as indicated in Fig. 5, to prevent the drill or tap from "leading off."

The saw-arbor collar is reamed a trifle undersize, then heated over a gas burner until red, after which it is forced over the end of the shaft and immediately quenched in water. Threads on the saw arbor are right hand. An important mechanical feature of the saw concerns the fit between the sliding T-iron carriage and the channel-iron base. The sharp outer corners of

the channel irons should be ground off, as shown in Fig. 6, so that the T-irons can ride in positive contact. Riding surfaces should be polished to minimize friction. Fig. 7 shows the saw in a closed position, a bolt through one of the T-irons striking against the channel base to form a positive stop. Blade and shaft guards are made from $\frac{1}{32}$ -in. sheet iron or brass. The blade and belt guards are hammered to shape over a wood form, as shown in Fig. 8. Both the blade and belt guard should be well braced with suitable metal strips. Fig. 9 offers a good view of the blade guard and shows the insertion of one of the oilers, which should be fitted in both bearings.

An 8-in. cut-off saw is used for this unit. The motor can be either $\frac{1}{4}$ or $\frac{1}{3}$ hp., depending upon the

nature of your work. The pulleys are 2 and 4 in. in diameter to give a blade speed of approximately 3,400 revolutions per minute.

A narrow slot is cut in the table top below the blade so that sawdust can pass through.



Rotating Bulb in Window Baffles Shoppers

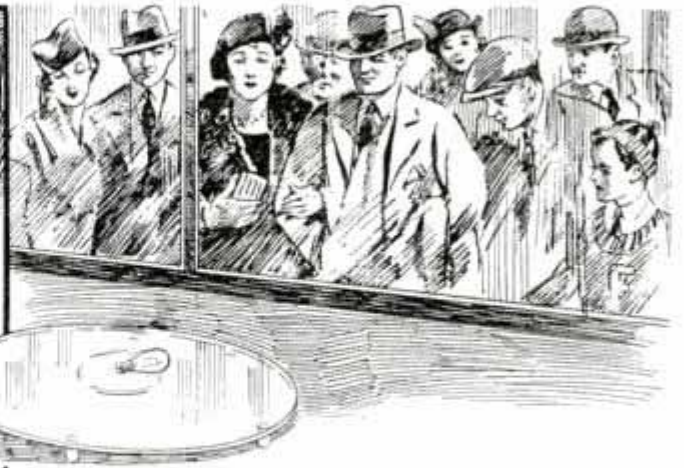
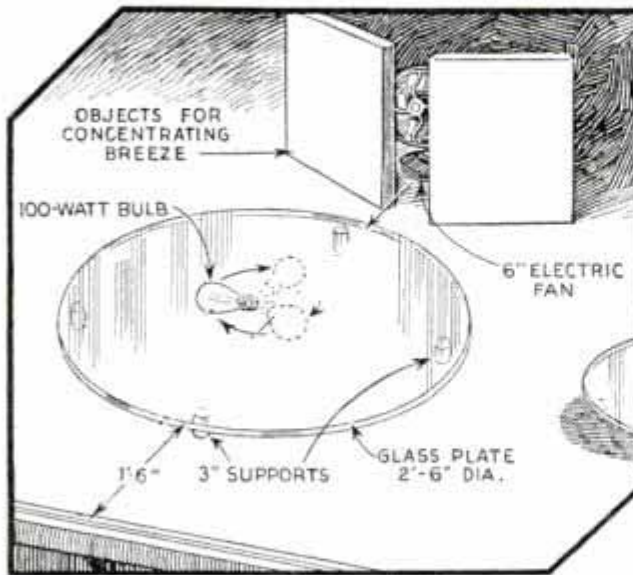

If you conceal the fan thoroughly and leave no loose scenery to move in the breeze, this display will be a real "sticker"

An electric bulb, rotating on a piece of clear glass without any apparent means of motive power, is very mystifying and makes an unusual window display. The secret is a current of air from a small electric fan hidden behind objects of background scenery. By careful arrangement of some props, the air can be directed in

a narrow stream, which passes across the glass at an angle to just catch the end of the bulb. It may take a little experimenting to get the air stream adjusted, but once this is accomplished, the bulb will rotate continually and remain exactly in the center of the glass. Be sure that the glass is supported in a perfectly level position.

Clogged Ink Pad on Mimeograph Temporarily Repaired

When the cloth ink pad on the cylinder of a mimeograph machine becomes clogged to such extent that the ink will not pass through it evenly, the trouble may be re-

lieved temporarily by removing the stencil and lifting one end of the pad away from the cylinder. This shifts the cotton fiber of the pad, makes it more porous and allows the ink to penetrate freely. This is only an emergency measure and a new pad should be obtained as soon as possible.



Lifting one end of the ink pad shifts the cloth fibers to make the pad porous

Guide Helps Locate Keyhole

Soldered to a door lock plate just above the keyhole as shown, a small, curved piece of metal will serve as a guide when unlocking the door at night. Before doing the soldering job,

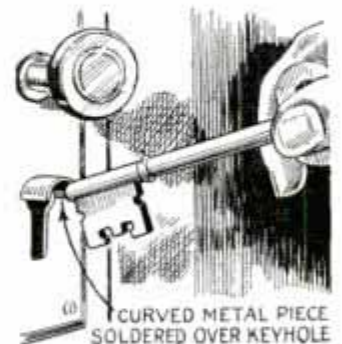

however, be sure to remove all paint from the spot on the lock plate where the metal is to be attached and clean it with emery cloth so that the solder will adhere.

Large Ledger Fitted with Handles Is Easily Carried



With a couple of handles attached to a large, bulky ledger, you can carry it easily

In offices where heavy ledgers must be carried about, a couple of handles attached as shown will provide grips so that they can be moved easily. The handles, either leather or metal, can be fastened to a wide strip of canvas, which is cemented to one side of the ledger.

Handy Scraper for Use on Farm Made from Oil Drum

Work on drainage ditches and other occasional excavating jobs on the farm may be handled readily with a dump scraper improvised from an oil drum as shown. The drum is cut in half as indicated by

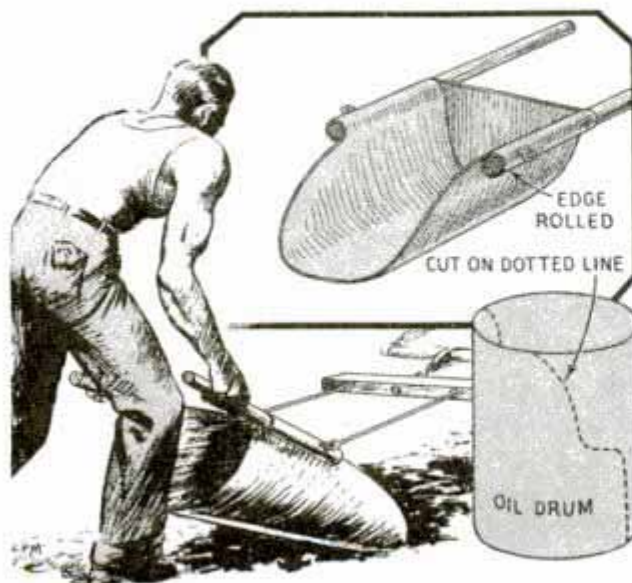

This handy dump scraper will handle most light excavating jobs on your farm

the dotted lines, after which part of the top edge on each side is rolled to form sleeves for the handles, the latter being held in place with bolts. Large eyebolts near the front ends take iron rods, which are attached to a doubletree.

Inner-Tube "Skirt" on Jack Keeps Threads Clean

A western house mover found that inner-tube coverings to keep sand, dirt, etc., from getting into the threads of jack screws, greatly reduced wear. The rubber is wired to the jack so that it hangs down over the body, and turns with the screw. Keeping the threads clean also improves lubrication.

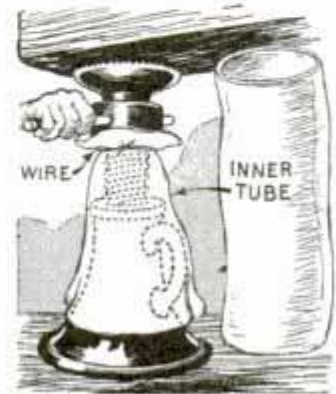

Bearings for "Turn Board"

In assembling a turn board for passing messages, mail, etc., through a wall, bearings on which the board pivots can be made from window-shade brackets, and steel balls. Brackets intended for inside window casings are preferable, although outside brackets can be used by straightening the metal at the corner bend.

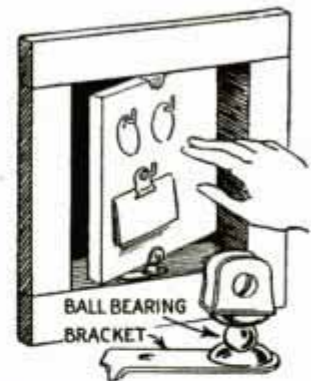

Solution to Clean Paintbrushes

Dirty paintbrushes that have been left in the following solution overnight and then washed in warm water will be perfectly clean. To make the solution, mix kerosene, 1 gal., and oleic acid, $\frac{1}{2}$ gal. In a separate container, mix ammonia (28%), 1 pt., and denatured alcohol, 1 pt. Stir this mixture into the kerosene-oleic acid solution, continuing the stirring until the product is smooth.

Bench Lathe Is Controlled by Hand Clutch

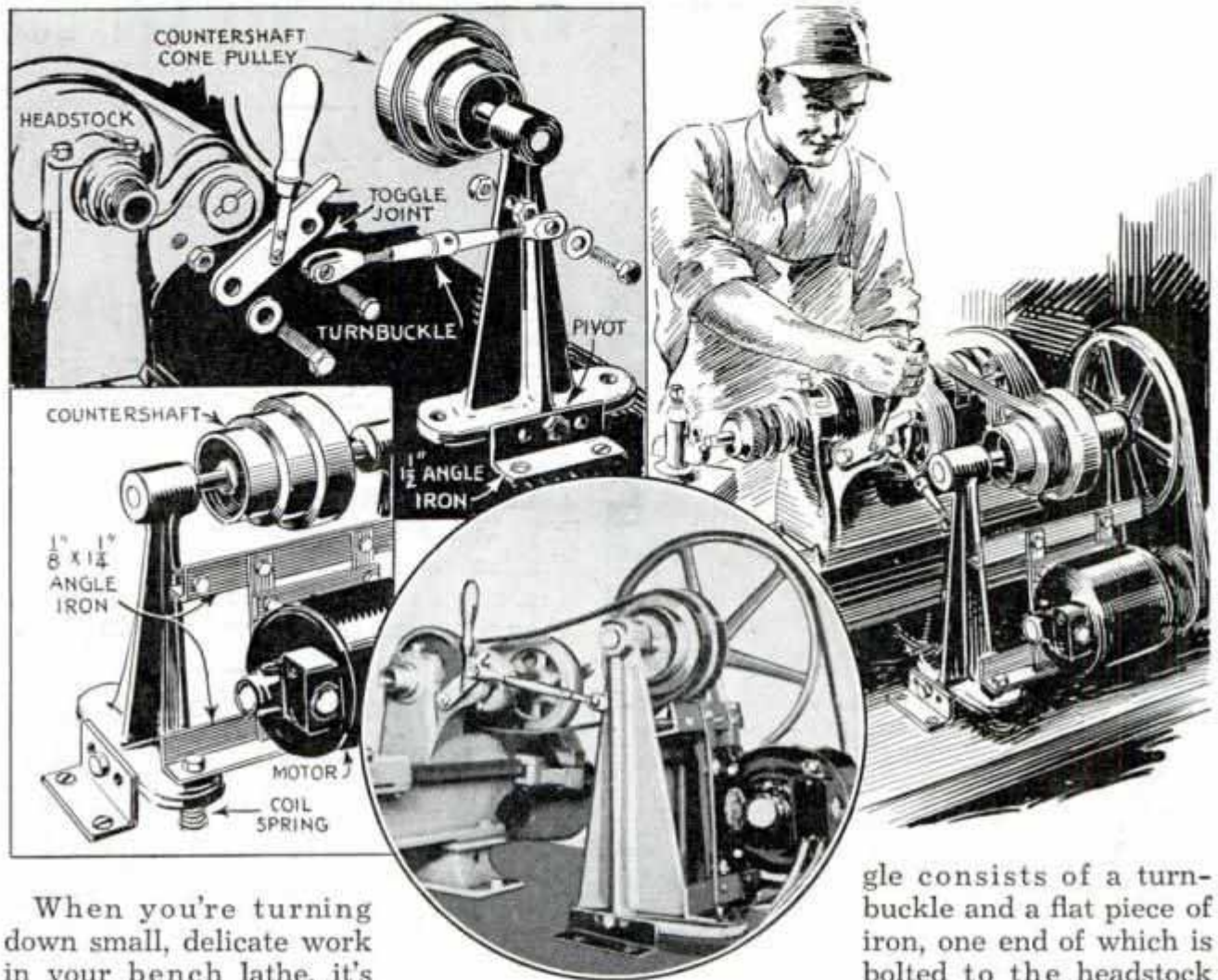

When you're turning down small, delicate work in your bench lathe, it's handy to be able to stop and start the spindle without stopping the motor. This can be done by mounting the motor on the countershaft and then pivoting the whole thing so that it will swing in toward the lathe. To shift the countershaft, you rig a toggle arrangement, one end being bolted to the countershaft and the other to the lathe headstock. The tog-

gle consists of a turnbuckle and a flat piece of iron, one end of which is bolted to the headstock and the other to the turnbuckle yoke as shown. When you pull back on the hand lever, the drive belt slackens and the lathe spindle stops. Pushing the lever forward until the toggle joint locks, tightens the belt and gradually starts the spindle to rotating. Shortening or lengthening the turnbuckle provides adjustment for belt tension.

Motor-Driven Auto Pump Does Chores Around the Home

If you need a pump for light work where the lift is not great, such as for draining your basement, emptying pools, tanks, etc., a centrifugal water pump from an old car, connected to a 1/4-hp. motor, will do the trick. It is mounted on a heavy wooden base with flat-iron brackets as shown and is connected to the motor with a short piece of garden hose. Although the unit can be mounted anywhere above the water level, a pump of this type works most efficiently on a short intake.

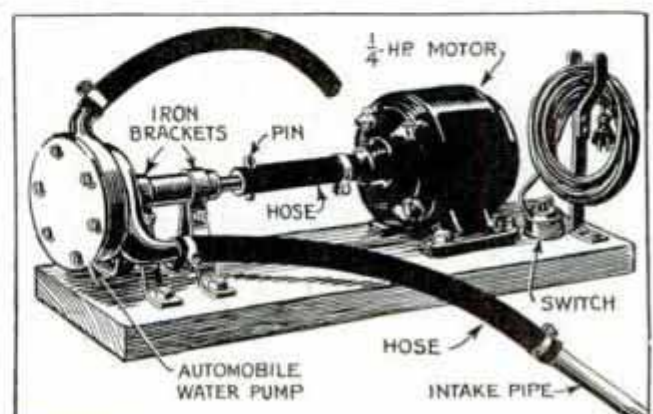

Shoe-Shining Parlor Improved by Pipe Railings

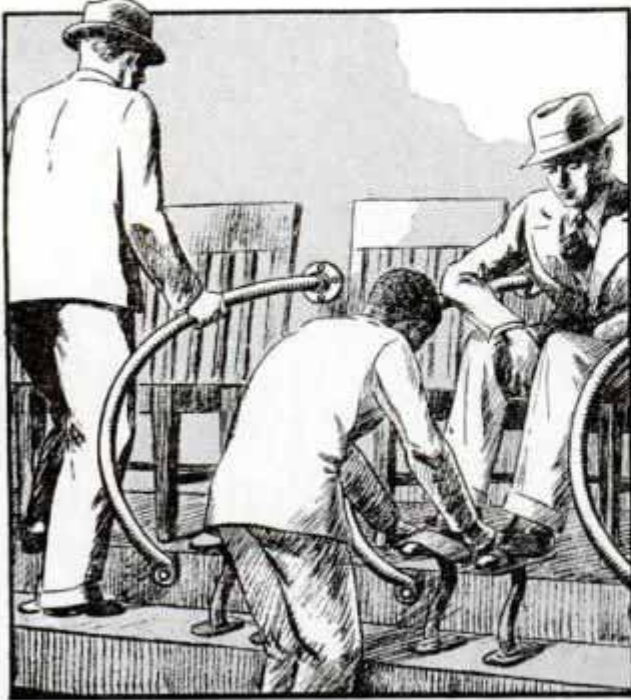

Railings between chairs in shoe-shining parlor aid customers in getting into seats

To assist his customers in reaching the seats, one bootblack mounted curved pieces of pipe between the chairs. The pipes, which also serve to divide the chairs into individual stalls, were attached to the wall with floor flanges, the lower ends being flattened and drilled to take lag screws or bolts for attachment to the platform under the chairs.

Gravel over Water-Main Valve Removed with Tared Cloth

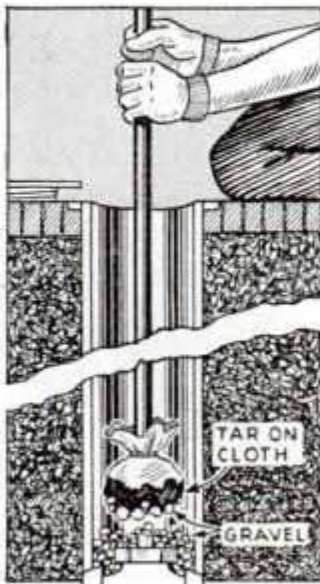

Workmen called out to repair a broken water main last winter, found that children had removed the cap from the shut-off pipe and dropped in gravel, which prevented the valve from being closed. As it was impractical to dig out the valve on account of the frozen ground, one workman wired a

small pad of cloth to a pole and painted the cloth with a thick coat of tar. When this was inserted into the shut-off pipe the pieces of gravel adhered to it and were lifted out quite readily.

Rodents Kept Out of Drain Tile

Where tile is used to drain certain low sections of farm land, a coil from a seat cushion or bedspring inserted in the outlet end will keep small animals from entering. If the spring fits loosely in the

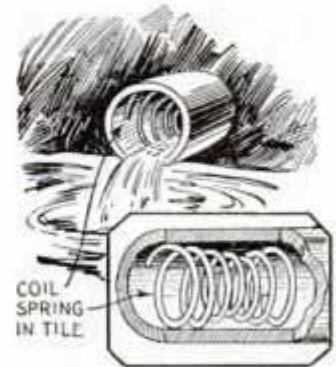

tile, stretch one or more of the coils until they provide a snug fit and stay in place.

Exposed Lamp Sockets Protected with Inner-Tube Rubber

Banjo-shaped pieces cut from an old inner tube to the approximate size indicated are just the thing to keep snow, dirt, etc., from getting into receptacles when electric lamps have been removed for the season. Cover the opening with the widest portion of the rubber, then lap the other end back and stretch the hole over the shoulder of the porcelain.

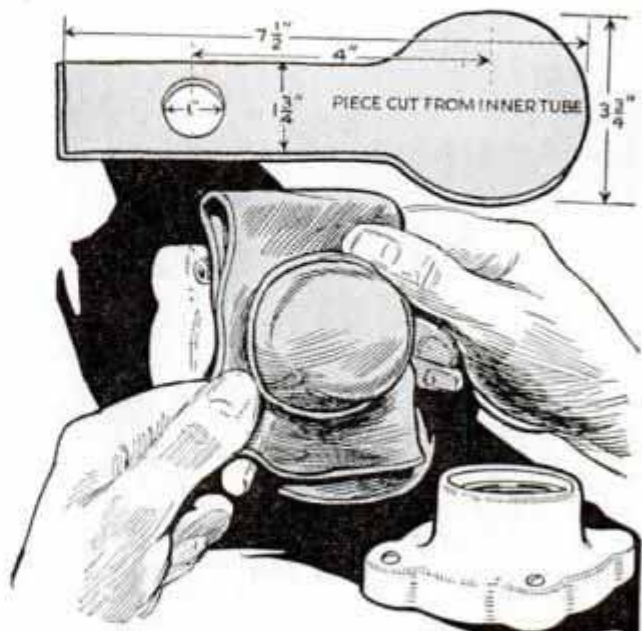

Exposed outlet receptacles should be covered to prevent corrosion of the metal parts

"Feeding" and Protecting Your Shade Trees

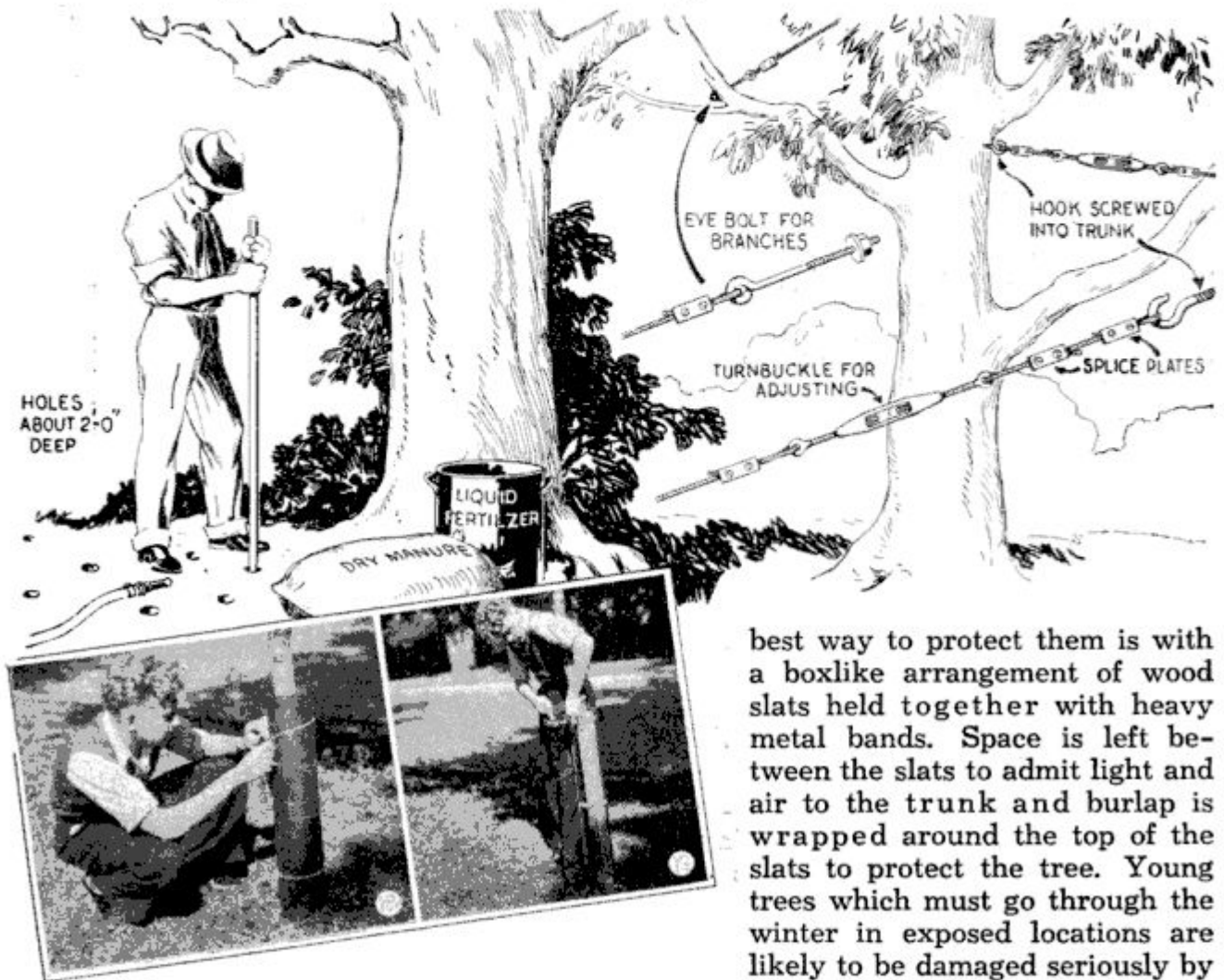

best way to protect them is with a boxlike arrangement of wood slats held together with heavy metal bands. Space is left between the slats to admit light and air to the trunk and burlap is wrapped around the top of the slats to protect the tree. Young trees which must go through the winter in exposed locations are likely to be damaged seriously by frost. To prevent this the trunks

are wrapped with several layers of burlap and the wrapping is encased in heavy tar paper. This should be fastened with wire. It's a good idea to paint a coat of tar over the top end of the wrapping to prevent water running down the trunk into the burlap where it might freeze and damage the bark. Small trees in orchards must always be protected in this way against rabbits and other small animals which gnaw away the protective bark and cause serious injury. Spreading limbs of shade trees and heavily laden branches of large fruit trees can be braced to the trunk, using cables attached to screweyes and eye bolts and fitted with turnbuckles for adjustment. The cables should not be wrapped around the trunk; this will choke the growth and eventually kill the tree.

Large trees along parkways are more or less starved by walks and pavement, which shut off air and moisture from the roots. Trees in this location are likely to have a sparse and withered-appearing foliage. Such trees will be benefited greatly by loosening the soil about the trunks so that more moisture and air can penetrate to the roots. Then you can "feed" the roots by punching a series of holes with a crowbar over a circular space 8 or 10 ft. about the trunk. The holes are filled several times with water, then packed with dry or decayed manure. This is followed in a few days with liquid fertilizer, after which the holes are sealed with a good top soil. Where a large tree is located close to the street pavement it may be necessary to feed it in this fashion once or twice each season in order to keep it in a healthy condition. Young trees on a parkway are always in danger of injury from children, lawnmowers and passersby. The

are wrapped with several layers of burlap and the wrapping is encased in heavy tar paper. This should be fastened with wire. It's a good idea to paint a coat of tar over the top end of the wrapping to prevent water running down the trunk into the burlap where it might freeze and damage the bark. Small trees in orchards must always be protected in this way against rabbits and other small animals which gnaw away the protective bark and cause serious injury. Spreading limbs of shade trees and heavily laden branches of large fruit trees can be braced to the trunk, using cables attached to screweyes and eye bolts and fitted with turnbuckles for adjustment. The cables should not be wrapped around the trunk; this will choke the growth and eventually kill the tree.

☐ A few drops of household ammonia added to the water in which fountain pens are cleaned will help remove corroded ink.

MIDGET

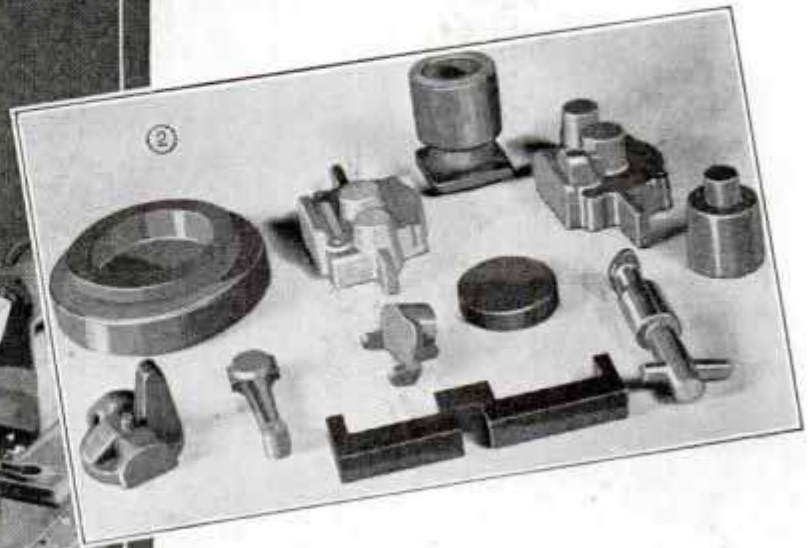

By E. C. Wittick

Part I—Making the Patterns

SPECIALY designed for construction in the home workshop, this tiny engine, which will develop about $\frac{1}{8}$ hp. at maximum speed, is really built "from the ground up." Being of the four-cycle type the engine is very easy to start, as in Fig. 4, and runs smoothly at high speeds. As a project in machine work, its construction would not be considered difficult, and it offers you not only excellent practice on your lathe but a try at pattern making as well. Now the patterns for the engine parts are not of the type that would be made by a manufacturer aiming to conserve metal, but they are designed for ease of construction and a liberal allowance of metal on the castings for finishing. The main thing to remember about pattern making is that certain projecting parts of the pattern must have "draft," that is, they must be tapered slightly so that the molder can draw the pattern from the sand mold easily. Also, certain patterns, the cylinder for example, must be made in two parts, or "parted," as it is termed. This is also done to facilitate the work of the foundry. Dimensions given for all the patterns allow for the normal shrinkage of the metal, so you don't have to lay out the work with a shrinkage rule.

Work begins with the cylinder pattern—a very simple wood-lathe job as you will see from Figs. 1 and 5. Notice especially the upper-right and the lower-left details in Fig. 5, showing beveled edges on the two parts of the pattern stock. These bevels can be run on the jointer and each of the two pieces faced on one side to form a perfect flat joint. Registering holes for short dowel pins are bored in the halves and the dowels are fitted and glued into only one of the two parts. Then the two pieces are screwed together and turned down to the dimensions indicated, after which the ends are sawed off and the whole thing smoothed up. The projection at each end is a core print and should be finished with black shellac, which is made by adding lamp black to orange shellac. The molder will insert the proper core when he makes up the mold.

Now the connecting rod, Fig. 6. The pattern is made of mahogany. One good way to make this pattern is to use a base piece of $\frac{1}{8}$ -in. stock and then fit turned disks to form bosses for the wrist-pin and big-end bearings. Notice especially the location of the parting line and how the webbed center section is formed. The right-angle corners in the webbed section

Refering. to 8, 26
air cooled.

GAS ENGINE

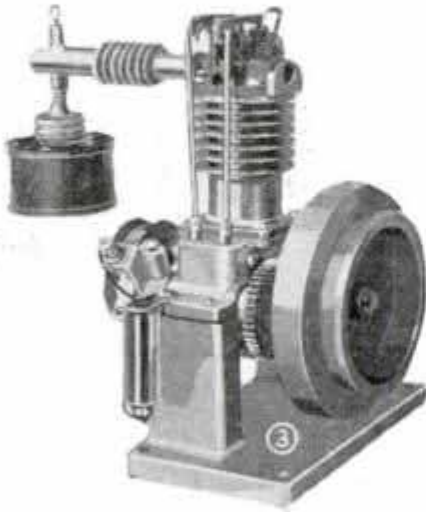

turned from castings

must be rounded with wax fillets. This can be done by softening a piece of beeswax and then pressing this into the corners, rounding it neatly with your finger. Bolt lugs are glued on and carved to shape with a knife.

The piston pattern, Fig. 13, is merely another wood-lathe job, but the piston core box shown in Fig. 8 is a trifle more intricate. Here the blocks are doweled as shown and fastened together with heavy wire staples, then the whole is mounted on the faceplate and counterbored as in the sectional view. Bosses for the wrist-pin bearings are turned separately and glued in place.

There are two ways of making the crankcase patterns, one method being shown in Fig. 9. First, the cup-shaped pieces for the main body and bearings are turned out and then the other projecting parts are turned separately and fastened on with glue or metallic cement, the latter being very good for this purpose. The pieces that form supports can be cut from a strip about 1 ft. long, planed to exact size. The flat pieces that form the cylinder seat when the castings are bolted together can be made the same way. Lugs for bolts,

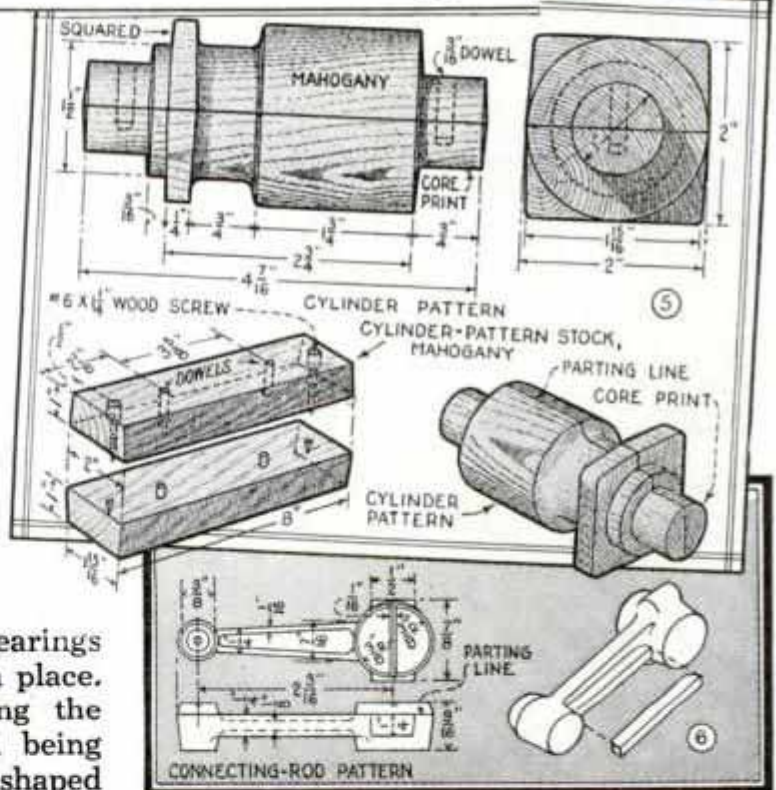

which hold the two halves together, may be made as a split turning by gluing two strips together with a piece of paper between. Then turn down to cylindrical form, split the turning apart, and after cutting to length, glue the pieces to the pattern. Now another way of making the same thing, shown in Fig. 10. This is done by sawing the main body of the pattern



7

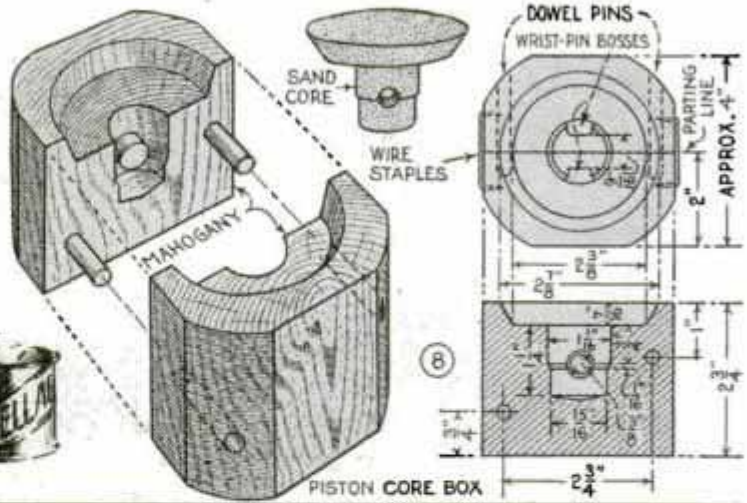

8

PISTON CORE BOX

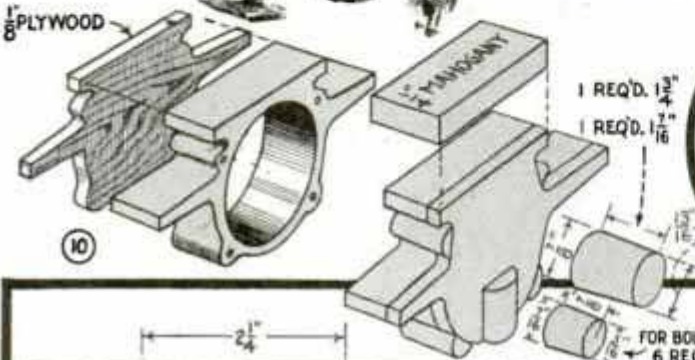

10

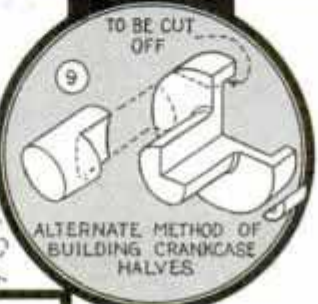

9
ALTERNATE METHOD OF BUILDING CRANKCASE HALVES

from 3/4-in. stock, the outer contour including the supports and bolt lugs. You can use a scroll saw, setting the blade at a slight angle to cut the draft inside

and out. Then a piece of 1/8-in. plywood is cemented to one side and cut to the same contour. Some smoothing up will be necessary. Figs. 11 and 12 give the details and dimensions of both halves.

In Fig. 14, the flywheel pattern is another comparatively simple lathe job, the carburetor pattern is very similar to that made for the cylinder, but the cylinder head and timer yoke involve some gluing and handwork. Taking the cylinder head first, you turn a disk to form the main body, then glue on small parts forming flanges, valve-stem guides, rocker-arm support and spark-plug seat. The timer-yoke pattern is made in the same way. The body is turned to size in the wood lathe and the projecting parts glued on. However, notice particularly that the draft on this pattern runs each way from the main flat surface.

Now a few important details applying to all the patterns for this job. It is essential that each pattern be finished smooth all over, otherwise the molder will have trouble getting it out of the sand. This means careful sanding,

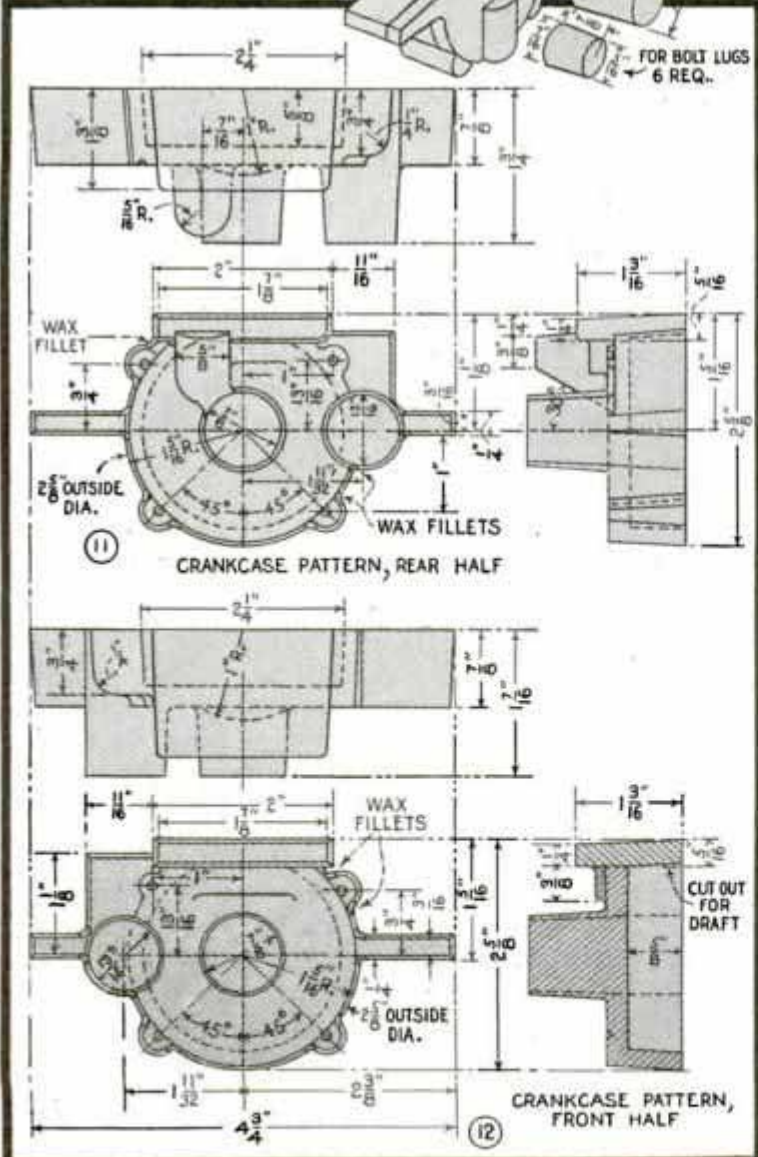

11

CRANKCASE PATTERN, REAR HALF

12

CRANKCASE PATTERN, FRONT HALF

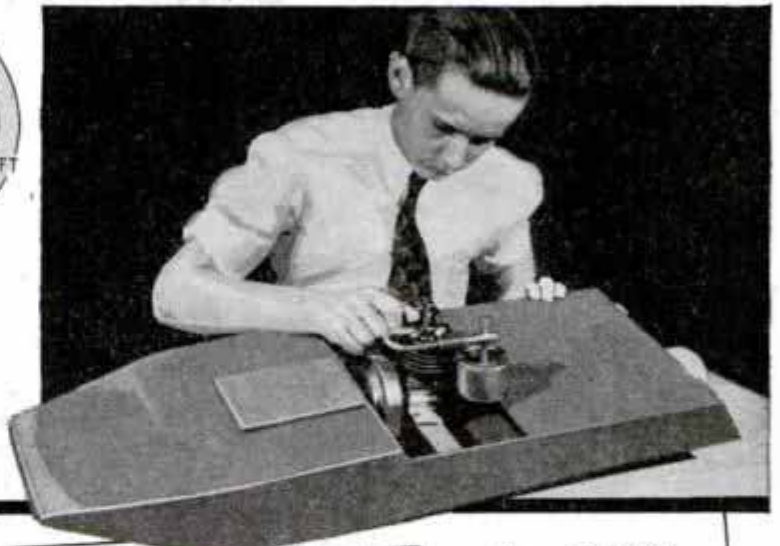
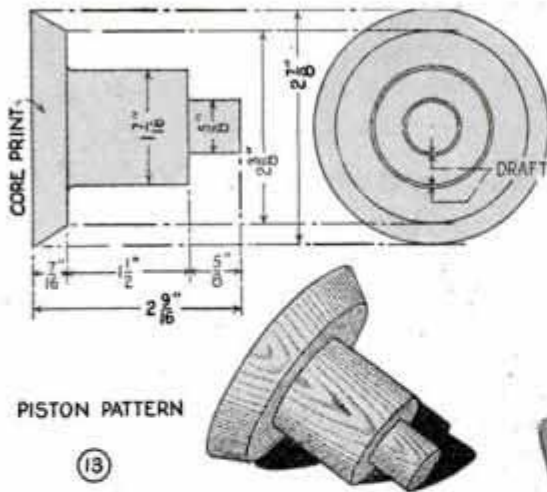

wax fillets in all corners where two parts join, and two coats of orange shellac applied as in Fig. 7. Don't forget that the core prints on the cylinder and piston patterns must be coated with black shellac. Where gluing is specified you can use either waterproof casein glue or metallic cement. Where dowels are used in the parted patterns remember that they serve only as locating or guide pins. They are glued into only one of the halves and the projecting ends are tapered slightly so that the halves will come apart easily. You will see from the drawings that wherever possible, holes to be drilled are spotted on the pattern. This is done with a short-beveled prick punch. The castings will then come back to you with the holes spotted all ready for drilling. The complete set of castings, and the steel crankshaft blank, are shown in Fig. 2. The finished engine is shown in Fig. 3. When you take the patterns to the foundry, specify soft, grey iron for the cylinder, cylinder head and flywheel; bronze for the connecting rod, timer yoke, and carburetor. The crankcase is cast in aluminum. Mahogany or selected white pine is the best wood to use for small pat-

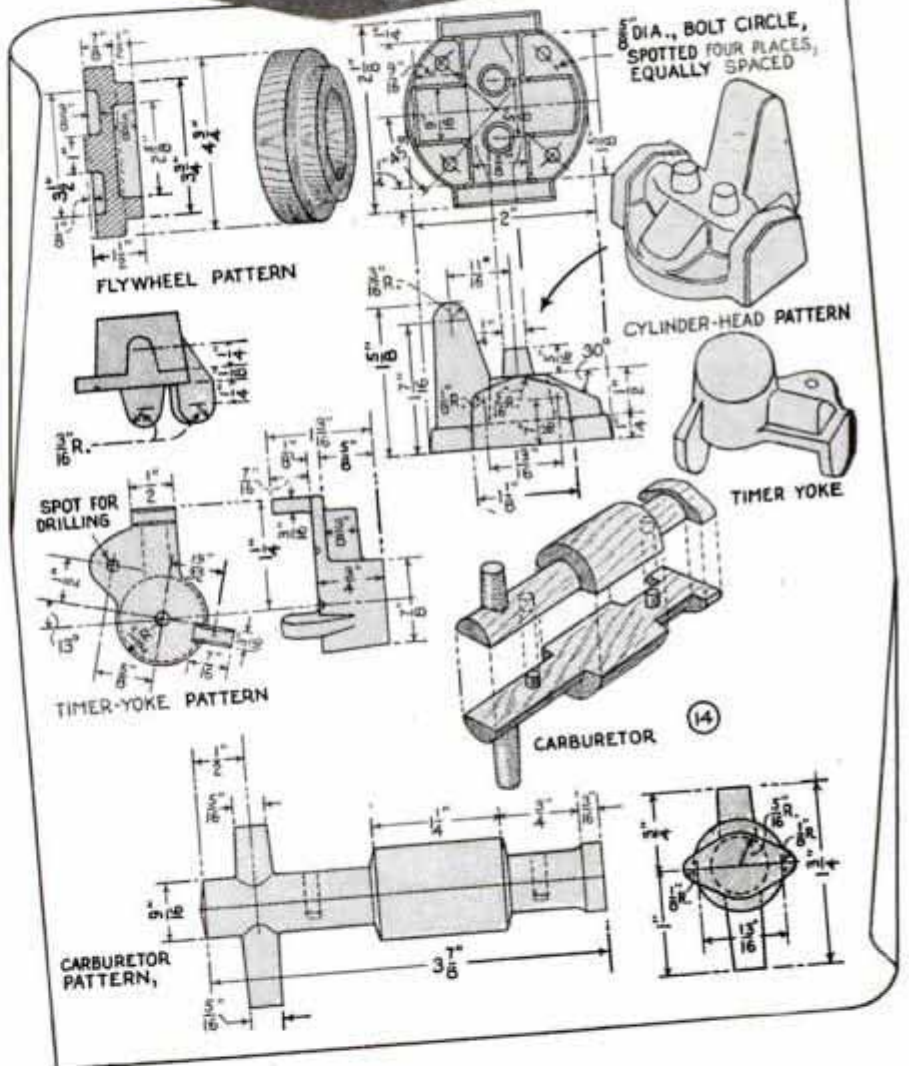

terns of this type. To make good patterns you must have good wood, of a grade suitable for pattern making. This is especially true of pine. Though the latter wood can be used, selected mahogany is always to be recommended for small patterns because of its durability, resistance to both shrinkage and expansion after working, and the ease with which it may be finished.

(To be continued)

Lumber Lifted Single-Handed to Top of High Stack

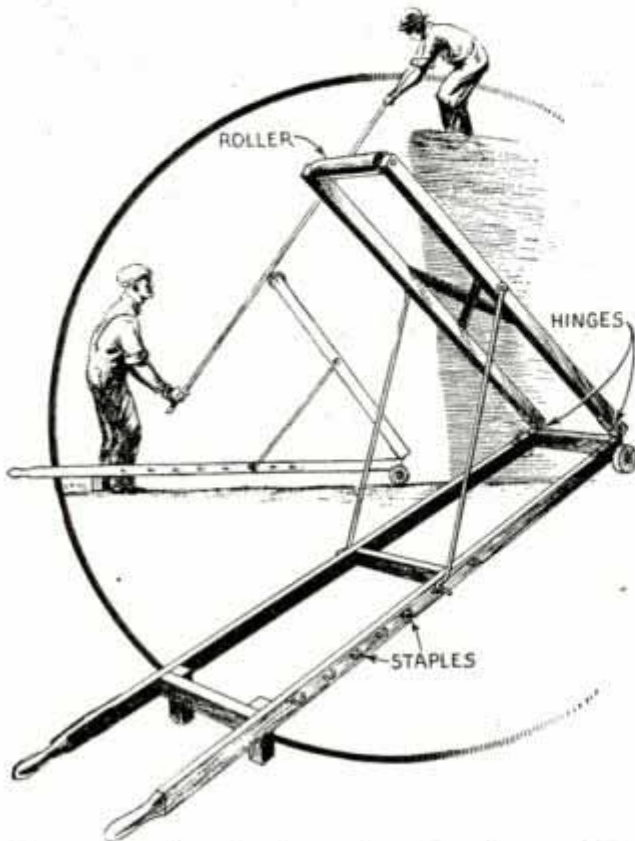

One man easily raises long, heavy boards to a helper on top of a lumber pile with this adjustable jack

When lumber is stacked in high piles in a lumber yard, this portable jack saves labor in lifting heavy boards. It is nothing more than a two-wheel truck with a frame supporting a roller. In use, the boards to be piled are placed, one at a time, on the roller, pushed down at one end and shoved forward and upward to within reach of the man on the pile.

Willow Twigs Planted in Potato Grow Rapidly

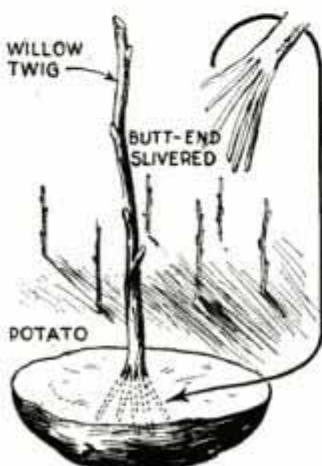

If you are planning to set out a number of willow twigs some place on your farm to stop erosion, sliver the butt end of each one and insert it into a half of a raw potato before setting it in the ground, and practically every

one of the twigs will grow. The potatoes furnish the necessary plant food and moisture until the twig gets a healthy start.

Metal Pattern with Keyhole Slot Quickly Removed from Hook

To avoid the usual necessity of removing a number of metal patterns from the hook to get the one desired, a tin-smith cuts keyhole slots in them so that any one may be removed without disturbing the others. The hook on which the patterns are hung is made from flat iron so that by merely lifting the desired pattern to a horizontal position, it may be withdrawn easily.

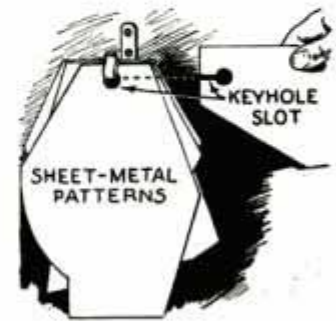

Guy Wires in White Hose Are Easy to See

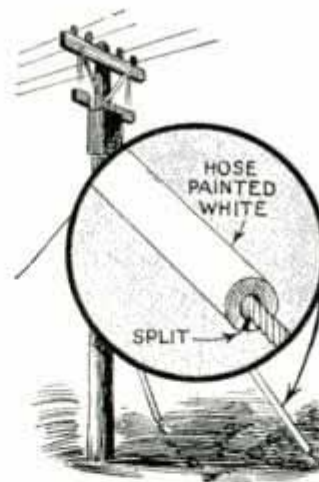

At a packing plant where guy wires on poles were often driven into at night by trucks and delivery wagons because the wires were not plainly visible, they were sheathed in lengths of rubber hose, which were painted white.

Fingerless Glove Aids Sign Writer

To avoid soiling the surface of cards and signs, and to allow your hand to glide more freely in manipulating the brush, cut the fingers from a soft, cotton glove and wear this, as shown. It will be found especially useful in warm weather.



Drill-Press Boring Jig Spaces Holes Accurately

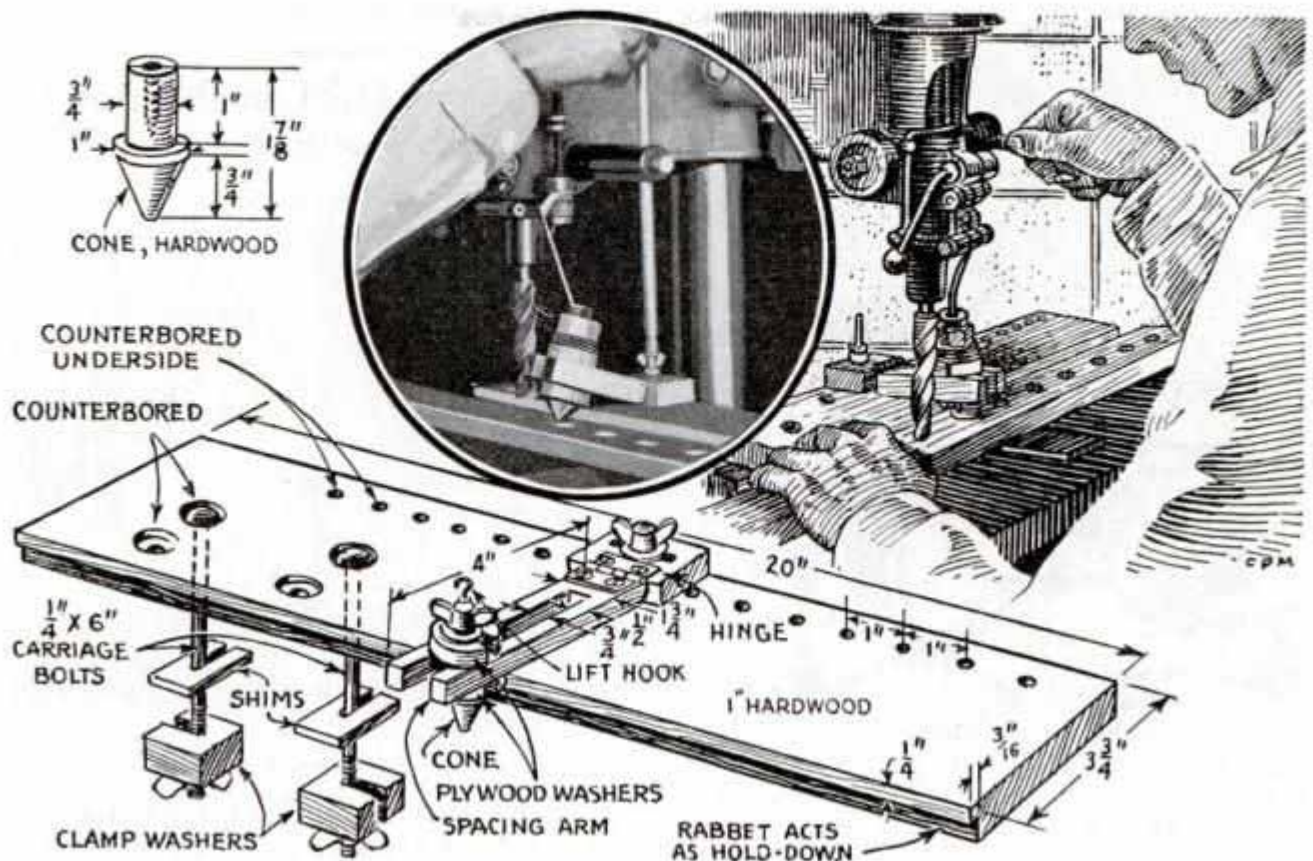

This simple jig will take care of the problem of spacing any number of holes equally. Dimensions given in the details are arbitrary as you can make considerable change in size of parts without affecting the operation. As you will see, the whole thing bolts to the drill-press table, removable hardwood shims and wing nuts permitting quick adjustment of the jig with relation to the table. In operation,

you drill the first hole in the position desired then move the work the required distance to the right. The cone is adjusted to drop into this hole when the bit is the proper distance from the center. Thereafter this spacing is duplicated for any number of holes. A cord tied to the drill-press spindle lifts the conical guide clear of the work each time the bit is raised.

—Edwin M. Love, San Gabriel, Calif.

Hand-Operated Facing Tool Will Get into Difficult Places

Made of materials picked up around the shop, this back-facing cutter will get into places inaccessible to any common tool used for this purpose. It consists of a threaded arbor, to one end of which the cutter is attached with a threaded taper pin. A steel disk, or feeder nut, tapped to fit the arbor and fitted with two 1/8-in. steel pins, bears against a bronze friction washer as in the sectional view. This gives a delicate feed. A threaded collar is turned onto the end of the arbor and pinned as shown, the pins acting as handles. Turning this collar rotates the arbor and light pressure on the feeder nut draws the cutter into the work.

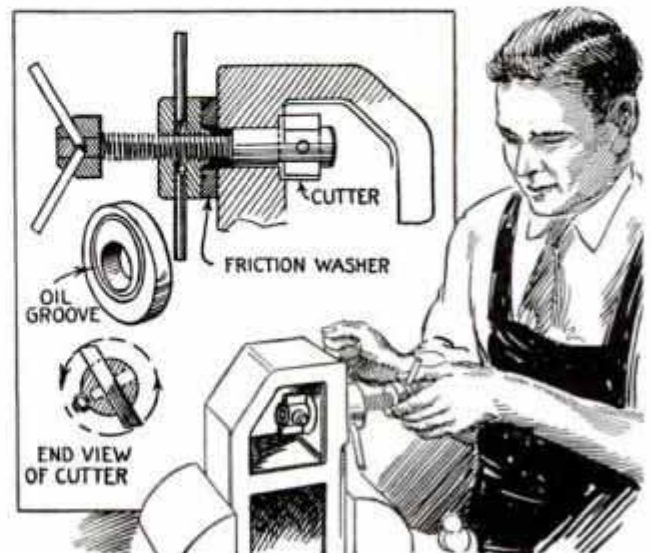

Cabbage Head Cut and Loaded in One Operation



You can cut a load of cabbages quickly with this converted long-handle shovel

Here is a tool that saves labor when harvesting cabbages as you can cut off a head and scoop it into a wheelbarrow or wagon with one sweep of the arms. The tool is merely a long-handle shovel with a wide V-notch cut in the center of the front edge of the blade, the edges of the notch being sharpened with a file.

—James Vick, Mannboro, Va.

This Improvised Plowshare Oiler Is Always at Hand

To prevent possible neglect in the oiling of plowshares, cultivator shovels and other implements,

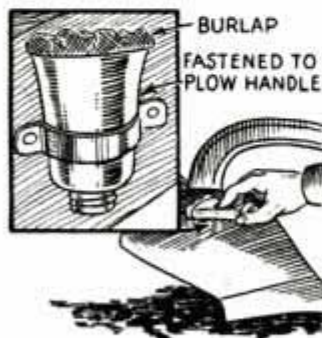

one farmer keeps a simple oiling device on the plow handle. The bottom was removed from a screw-top can, of pint size, and several folds of burlap were placed in the opening before the sides of the can were driven together.

When the can was filled with oil through

the screw top, and the cap replaced, the burlap provided a wick by which the fluid could be applied quickly.

Sign Copy Held on Window with Vacuum Cup

To hold copy securely in position for reference while lettering special sales bulletins on store windows, one artist avoids possible errors by using a music clamp as a copy holder. This is bolted to a vacuum cup, which permits it to be attached to the window in the most convenient position.

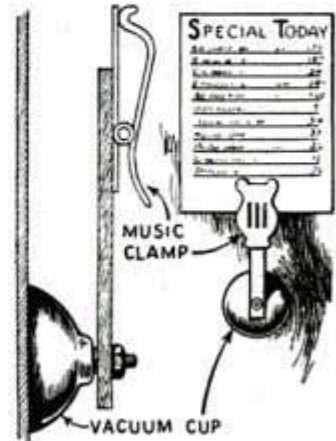
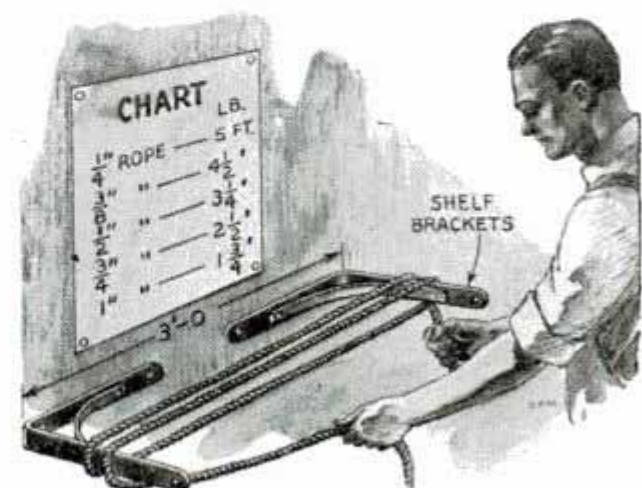

Chart Permits Cost Estimate of Rope Needed

As a means of quickly estimating the cost of a given length of rope, which is usually sold by weight, one dealer made a chart showing the number of feet in each pound of rope of different sizes. This was done by simply dividing the total length in feet of a new coil of rope by its weight in pounds. As a further convenience, a pair of shelf brackets were attached to the wall 3 ft. apart so that the rope could be wound back and forth around them to quickly measure the length of rope.



With this chart, you can give a customer the cost of any length of rope before cutting

JIGS

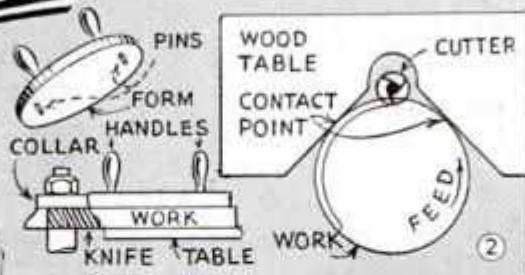

for the SHAPER

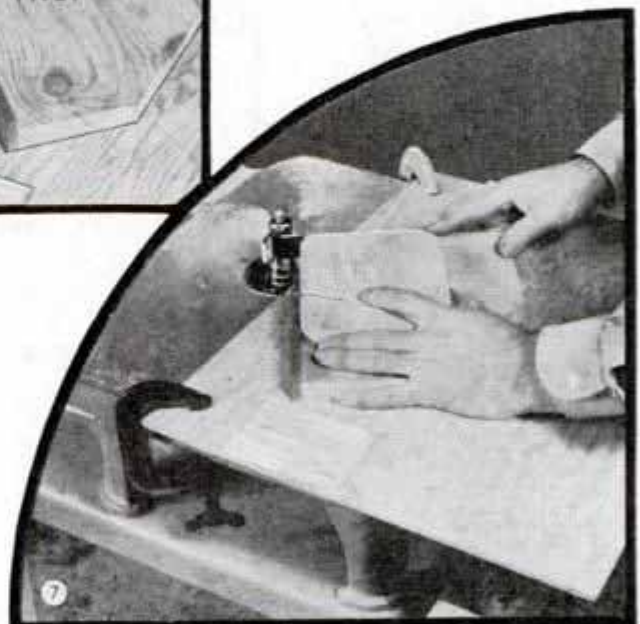
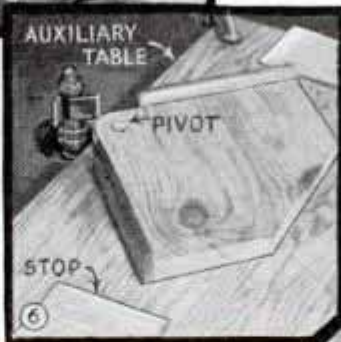

SPEED and uniformity in producing work on the shaper depend largely on the jigs and fixtures you use. For the most part, these are quite simple to make. A typical set-up for handling round work is shown in Figs. 1 and 2. The jig consists of an auxiliary wood table which is clamped to the shaper table. The wood table has a V-shaped opening, which forms an exact right angle about the shaper spindle. Circular work of almost any size can be worked in this jig, the edge of the work contacting the sides of the V-shaped opening. Continuing the same idea, Fig. 3 shows a jig for shaping round work against collars. The advantage of the form is that the original blank need not be cut to a smooth surface. The form

should be perfectly round and smooth. It is fitted with two handles on the top side, and two or three short, sharp pins projecting on the underside to engage the rough-sawed blanks. The work is shaped in the usual manner with the form riding a collar of suitable size.

In Figs. 4 and 5 is shown a useful jig for tenoning the ends of square stock. It consists of a fairly

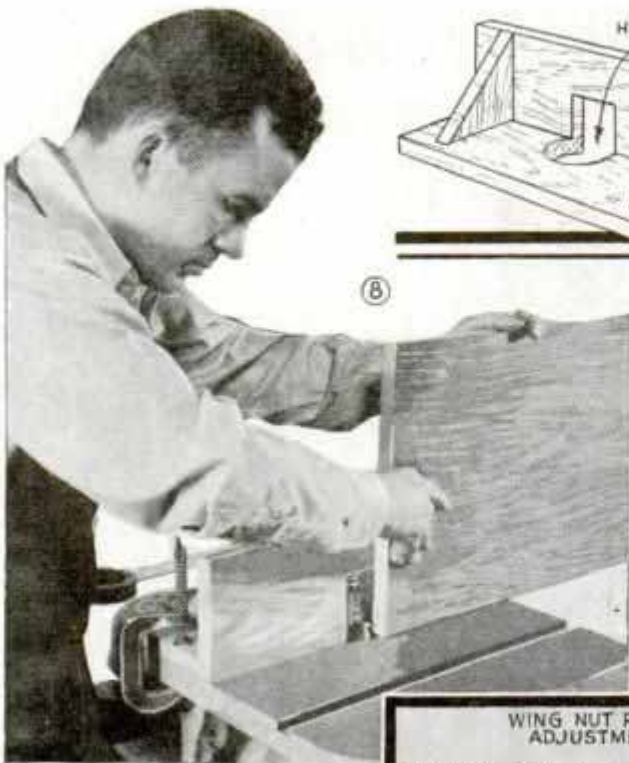

Simple, practical jigs and fixtures like these give speed, uniformity and an element of safety to shaper work. Most of them can be made in a few minutes from scraps of hardwood and attached to the shaper table with C-clamps or small bolts. One features a holder for small round disks, another, Figs. 4 and 5, provides a means of cutting round tenons on square stock

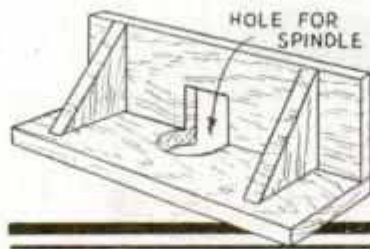

⑧

heavy square of wood, which is nailed to another piece to clear the shaper spindle. The working portion of the jig is fitted with a round plug, and a square hole is cut through the plug to take the work. A piece of plywood on the underside of the block prevents the plug from falling through, but has a round opening of a size to permit the passage of the square stock. The rest of the jig consists of a wooden collar which fits over the shaper spindle and limits the depth of cut, as can be seen in Fig. 6. The stock to be tenoned is simply pushed down through the square hole in the plug until it contacts the disk, after which the stock is revolved in the same direction as the knives, to complete the tenon.

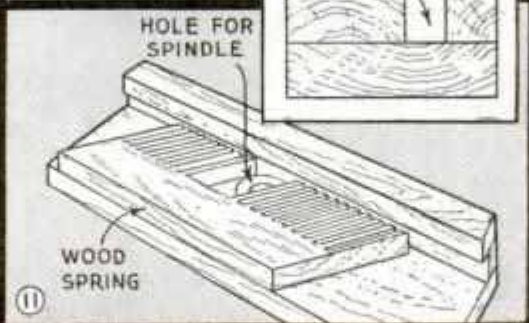
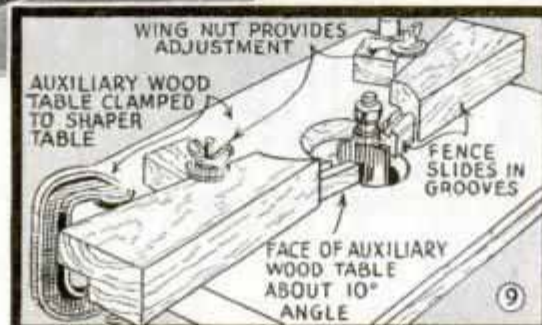

⑫

Fig. 7 pictures a useful jig for rounding corners. It consists of a wood block pivoted to a square of plywood, which is clamped to the shaper table. Work to be rounded is placed on the revolving block and fed into the cutter head. Small wood blocks are nailed to the plywood table to limit the start and stop of the cut.

Auxiliary fences on the shaper are useful for a wide variety of jobs. One of the simplest is the high fence shown in Fig. 8. Some shapers are not fitted with adjustable fences, and in this case you will find the unit shown in Fig. 9 quite practical for any type of work demanding fence adjustments. As can be seen in the

sketch, the main table is grooved to fit corresponding lugs on the two fence pieces, adjustments being made by sliding either the front or rear fence to the position required, and clamping by means of the simple washer-and-wingnut arrangement. The face of the main table should

be cut at an angle of about 10° each way from the center, and the fence pieces cut on a corresponding angle to bring the face of the fence back to a straight line. Fig. 10 shows a jig for making strip moldings, the construction being shown in Fig. 11. The height of the opening should be the same as the width of the stock, and the wood spring should be set a little closer than the thickness of the stock so that it will grip the work properly to prevent backlash. The circular fence shown in Fig. 12 is useful for a wide variety of curved work, the fence portion being cut to the same radius as the work.

Toolbox from Oil Can

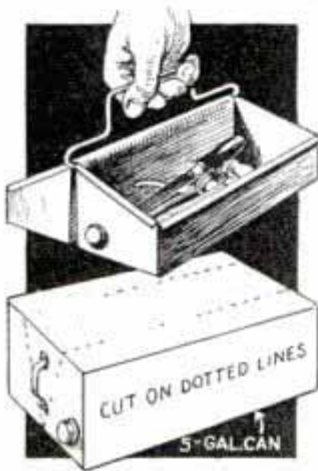

For carrying tools from place to place about the shop or farm, a 5-gal. oil can may be used quite satisfactorily. Cut the can along the dotted lines indicated in the lower detail and bend the two halves over, after which a length of wire is hooked under the

ends of the bent portion to serve as a handle.—G. E. Hendrickson, Argyle, Wis.

Joining Stovepipe Easily

One tinsmith gets around the difficulty of joining lengths of stovepipe by using this chain-twist tool with which he squeezes the crimped end of one pipe so that it will slip into the end of the next length. The tool is simply a hardwood stick to which one end of a length of small chain is fastened. This can be slipped around the pipe and fastened to a screw hook near the other end of the stick.

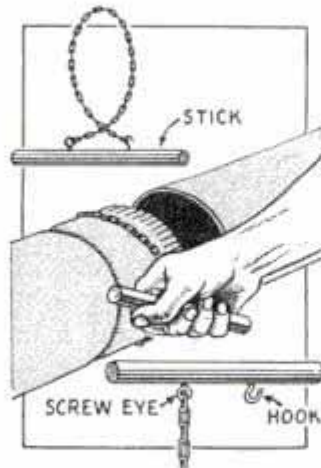

Small-Parts Trays Made of Cloth Hung Up Like Bags



When small parts of each repair job are kept on a cloth square the bench is quickly cleared

Electricians, clock repairmen and others who work on small mechanisms, often have one job on the bench when another one of more importance comes in, necessitating much tedious work in gathering up the parts and storing them where they will not be lost. To simplify matters in such cases, one mechanic places the small parts on square pieces of cloth having small brass rings stitched onto the corners. By gathering the four corners and hooking the rings over a convenient hook on the wall, the work space is cleared, and all parts kept safely at hand. A ticket on each hook indicates the contents of the bag.

Two-Color Pencil for Checking

When checking work where both a colored and a regular lead pencil are needed, just remove the eraser from the pencil and insert a short crayon in the ferrule. Then you can make the check marks in color without laying down one pencil to pick up another one, thus saving time and assuring an accurate check, as your attention is not distracted from the work.



Cashier's Counter Has Trough to Catch Rolling Coins



This trough will save stooping and hunting for coins on the floor

To prevent coins from dropping on the floor, one cashier put a sheet-metal trough on the edge of the counter as shown. A trough an inch wide will catch the average coin and, if it is finished to match the surroundings, it will not be noticeable.

Wire Cables Twisted Uniformly by Wagon Wheel

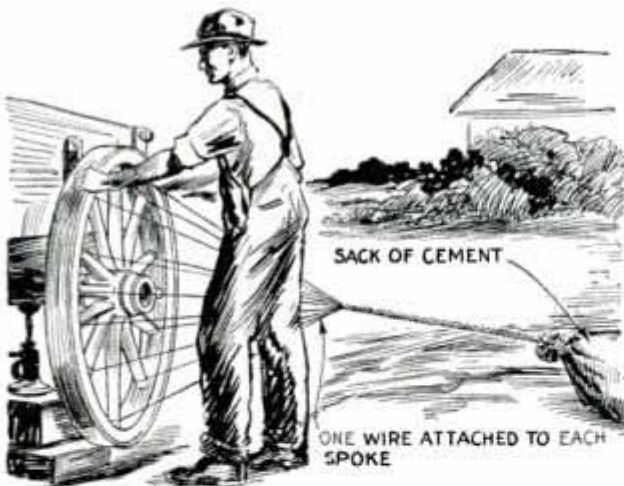

It's no trick to twist a length of wire cable needed around the farm

Wire cables for anchoring fence posts, high silos and other structures on the farm may be made by the following method: Cut as many lengths of wire as you wish strands in the cable, and attach one end of each wire to one of the spokes of a wagon wheel. Attach the other ends of the wires to any heavy, but movable ob-

ject, such as a bag of cement or sand. Then jack up the wheel and turn it slowly. This will twist the wires into a firm cable, due to the tension produced by the weight at the opposite end, which is pulled toward the wheel.

Hand Punch for Sheet Metal

For the mechanic or other worker who has only an occasional need for a punch

to perforate sheet metal, here's a simple one. Just take a short piece of bar iron or steel, drill it through the center lengthwise, and then slot it about two thirds the way through from one side as shown. As the size of the tool

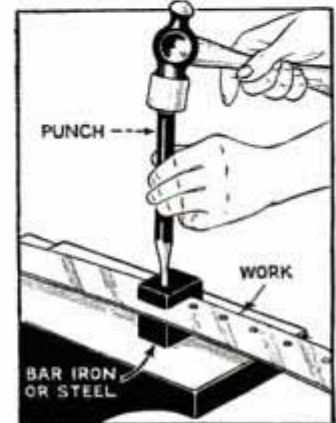

depends on the particular work at hand, it is a good idea to make up several of them to meet various requirements—or one block having several holes. The tool is set on a solid surface or it may be clamped in a vise, after which the work is inserted into the slot and a punch driven through the hole.

Perfect Circles Cut on Stencils with Can Lids

In making stencils for duplicating commercial work, circles of various sizes are frequently used

for the prominent display of special items and prices. As it is impractical to make the circles with a compass, one operator collected a number of tin-can lids of various sizes and used them for the purpose.



The lid is placed on the stencil in the desired position, pressed down firmly and given a quarter turn, which cuts the circle perfectly.

Three Ideas to Ease the Truck Driver's Task

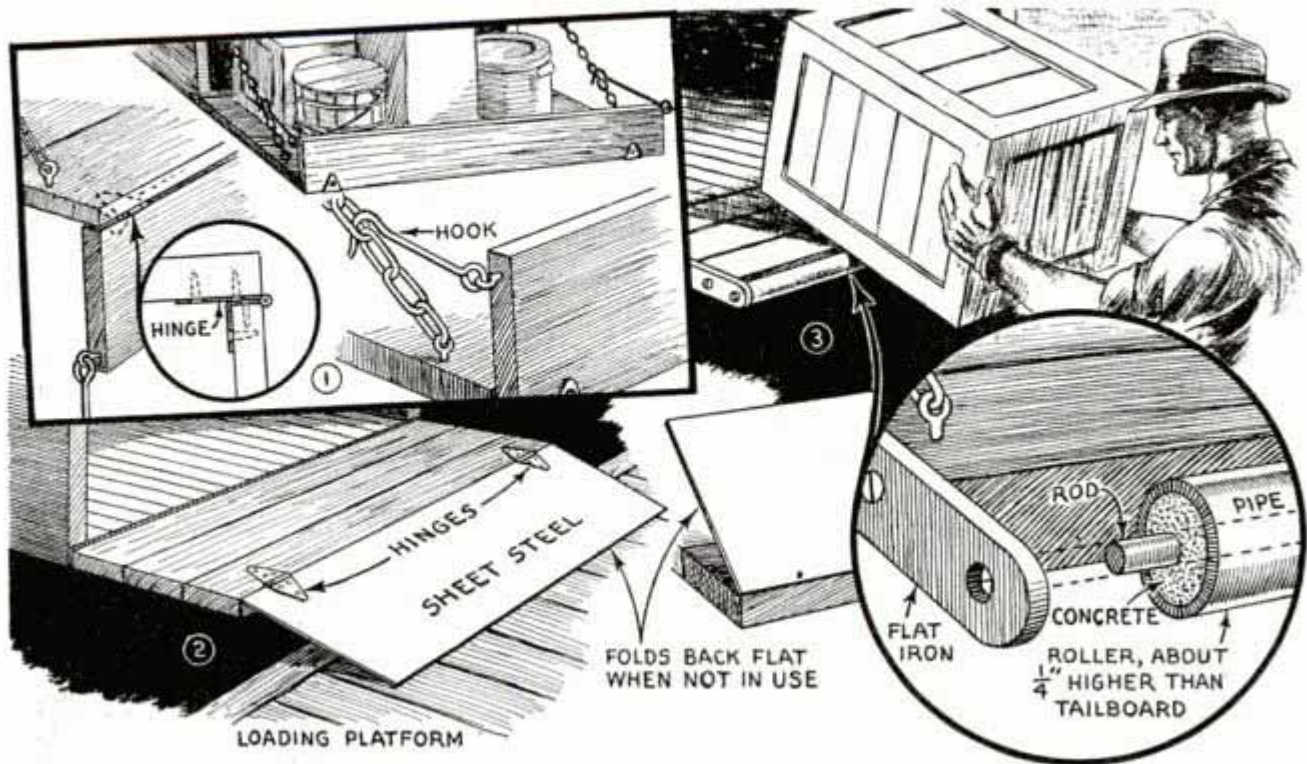

Applied to a truck tailboard, any one of the ideas above, depending on your particular type of work, will save labor. In Fig. 1, a light plank hinged to the tailboard serves as a ledge to keep boxes, cans, etc., from slipping off when the board is lowered to a horizontal position to make more room. As shown in Fig. 2, a piece of heavy sheet steel hinged to the tailboard serves as a bridge between the latter and the

loading platform, and is especially convenient when rolling barrels and other round containers into the truck. Also, it is useful when using a hand truck for loading heavy objects. For expressmen and other drivers who often have to lift heavy boxes and trunks from the curb or street into a truck single-handed, a roller on the outer edge of the tailboard, as in Fig. 3, will make it easy to shove them inside.

Undercutting Mica on Commutator with Hack-Saw Blade

When a tool for undercutting mica between the segments of a motor or generator is not at hand, the job can be done easily with a hack-saw blade and a slotted sheet-metal sleeve. The sleeve should fit snugly over the commutator as it serves to guide the blade and avoid scratching the copper segments. In use, the slot in the sleeve is adjusted so that it is directly above each mica strip as the latter is cut.

—Rev. J. A. Harper, Pinckneyville, Ill.

☞ One half of a magnet from a model-T Ford magneto makes a dandy tool for handling valve-spring keys and similar small parts that are often accidentally dropped into hard-to-reach places when working on a car motor.



Sleeve with slot in side shields commutator segments when undercutting the mica strips

Cylinder Heads Lifted Easily with These Hand Grips



These hand grips screw into the spark-plug holes so both ends of the cylinder head are lifted evenly

Lifting a cylinder head single-handed is simplified with a couple of hand grips, which are screwed into the spark-plug holes. Take a couple of old spark plugs, remove the porcelain insulators and fit the plug shells with hand grips bent from small iron rods. The grips can be fastened into the shells by forming eyes on the rods and drilling holes through the shells for pins, or they can be brazed or welded in place.

—John H. Dodge, Sr., Shamrock, R. I.

Commutators Sanded with Block Attached to Handle

Here is a sander for smoothing motor and generator commutators that permits doing the job without endangering the

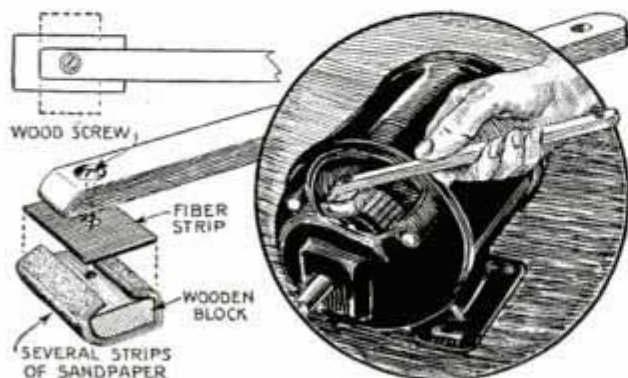

With this block, commutators can be cleaned without any danger of injuring the fingers

fingers in the moving parts. It is simply a small sanding block shaped as shown and screwed to a wood handle with several strips of sandpaper attached, a fiber strip being used between the block and handle to hold the ends of the sandpaper. As a single screw attaches the handle, it can be turned to any angle to reach the commutator so that the beveled edge of the block faces opposite the direction of rotation.

Rubber Bottoms on Oil Bottles Protect Car Fenders

It's a good idea to cushion the bottoms and sides of your filling-station oil bottles with rubber as shown. Then, if you accidentally strike the bottle against the car when in a hurry, the finish will not be marred, which is very annoying to many motorists. Rubber bases for the bottles can be purchased, or you can make them from old inner tubes.

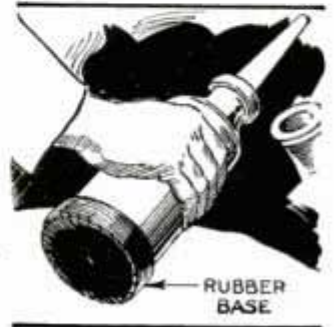

Automatic Battery Filler

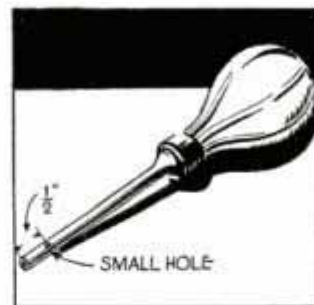

Uniform filling of storage-battery cells with distilled water is possible with any bulb type of filler if a bleed-hole is drilled through one side of the nozzle tip as shown. The hole

does not interfere with the filling, but when the surplus water is being removed, the sucking action automatically stops when the level of the water in the cells reaches the hole and allows air to enter.

Dirty Air Cleaner Chokes Motor

As all air that mixes with the fuel in your motor must pass through the air cleaner, the importance of keeping this unit clean cannot be overemphasized. A dirty cleaner not only results in low gas

mileage, but it is often the cause of a motor missing at high speed because it allows insufficient air to enter the carburetor. Most air cleaners have instructions for cleaning printed on them. If not, the information is given in your instruction book, which comes with the car.

Unburned Fuel in Manifold Causes Gassy Motor

Sometimes offensive fumes leaking into a car, after it has been driven many thousands of miles, are not monoxide gas, but are produced by a rich, poorly burning fuel mixture resulting from carbon in the intake manifold and poor carburetion. It is claimed that adjusting the carburetor carefully and sandblasting the inside surface of the manifold or replacing it with a new one usually ends the trouble.

Tailboard Bumper Protects Cars in Rear of Truck

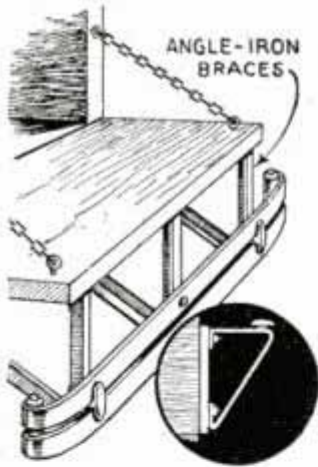

To keep motorists in the rear from accidentally bumping into the truck, when he was driving with the tailboard down and had to stop suddenly, one driver put a bumper on it like the one shown in the illustration.

Wanted—More Auto Kinks!

Simple things that will add to the convenience of driving and touring—easily made repairs for minor troubles and disorders of cars—precautions that will avoid troubles—these are some of the many things motorists would like to know about. Possibly you have devised something for your car or garage that will be helpful to thousands of others. Just describe the idea briefly but completely, illustrate it with a sketch or photo and let's have a look. Perhaps it fits in with our needs and if so, a check will be sent promptly. Avoid old practices, ideas that are of use only occasionally or those that involve too much trouble and expense. Ideas accepted must be found workable by actual practice and must be outstanding. Address Technical Editor.

Truck Driver Foils Road Bandits with Sloped Running Board

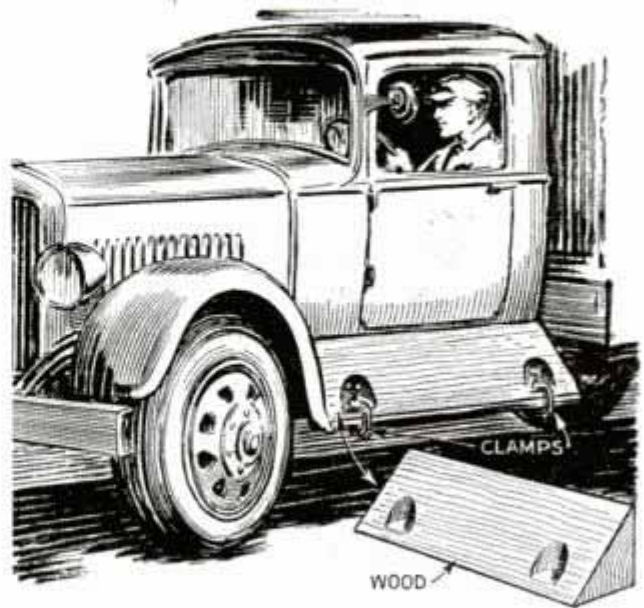

Hold-up man trying to jump on running board of truck slips off sloping block

After being held up at a lonely cross road, one truck driver clamped a large wood block with a sharply sloped top surface on the running board so that it would be difficult for anyone to jump on the truck. C-clamps in recesses in the block hold the block on the running board.

Hydraulic Brakes Refilled Single-Handed

Services of a helper or special equipment, when bleeding hydraulic brakes that have a supply tank with the master cylinder, are unnecessary if the tank is filled as shown. Take an oil bottle and stop the air hole in the spout, which should be of a size to slip well into the tank filler hole. Fill the bottle with brake fluid. When the cylinder fills up sufficiently to cover the end of the spout, the fluid will cease flowing because the air cannot get into the bottle. Thus, as the oil is pumped into the lines by the brake pedal, the bottle will automatically keep the master cylinder full.



Pan for Cleaning Small Parts Swings under Workbench



This small-parts pan swings out of the way, yet is always at hand

To keep his small-parts cleaning pan out of the way when not in use, yet have it immediately available, one mechanic swings it under the workbench on a pivoted arm. The latter is a piece of heavy

flat iron bent to the shape indicated and riveted to the pan, the bend being made to provide a spring effect to help prevent sagging. A long bolt pivots the assembly to the bench. It's best to use a pan with a handle on the front side so that it can be swung outward easily.

Steady Rest for Fine Work

Does the steady rest on your lathe mar finely polished surfaces? If so, the trouble can be prevented by cutting dovetail slots in the ends of the steady-rest jaws and inserting pieces of fiber. A little all-purpose cement on the fiber pieces will keep them in place.

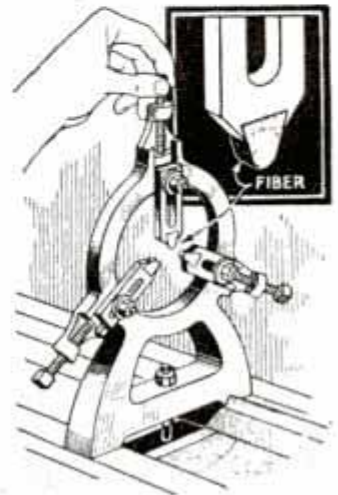

☐ When laying a new floor over an old one, be sure to allow $\frac{1}{2}$ in. space on all sides for expansion of the wood, covering the space with molding.

The Next Issue

PECK-O'-FUN FOR THE HALLOWEEN PARTY

Collapsible chairs, "X-ray" helmets, confetti blizzards, hand-shaking ghosts and finger-printing machines that shock, telescopes that give the star gazer a "black" eye, as well as a variety of costumes that resemble ghosts, frogs, turtles, etc., all assembled inexpensively right in your home workshop.

SCALE MODEL OF FUTURE RAIL SPEEDSTER

Carved from a single wood block, this model propeller-driven railplane, with its sleek, rakish lines adds a thrill to an already interesting hobby.

ELECTROPLATING BY FRICTION

Inexpensive process by which anyone can plate silver, copper or nickel on car bumpers, radiator shells and many other articles around the home or shop.

WHY CAN'T I HIT 'EM?

If this question bothers you, check up on the fit of your shotgun. This article tells how to "tailor" the gun and what to look for when buying a new one.

Blaze

AUTUMN TRAILS

with a

HARLEY-DAVIDSON

Ride the trails to good hunting spots—"where deer and antelope roam"—where ducks and geese settle between flights—or where Nature tempts you most. Wherever it is, you can get there quickest and cheapest in the saddle of a Harley-Davidson. Thrill to its fast getaway, surging power, zooming speed, flashing style—and other advantages of streamline design and latest motor improvements! . . . No use talking—you must RIDE a 1936 Harley-Davidson to know what thrills will be yours when you own one. See your nearest Harley-Davidson dealer for a *free ride*—ask about his Easy-Pay Plans—and send in the coupon.

Again Harley-Davidsons demonstrate their superiority—by winning 1st, 2nd, 4th and 7th in the 200-mile National T. T. Championship at Keene, N. H.

HARLEY-DAVIDSON MOTOR COMPANY
Department P, Milwaukee, Wis.

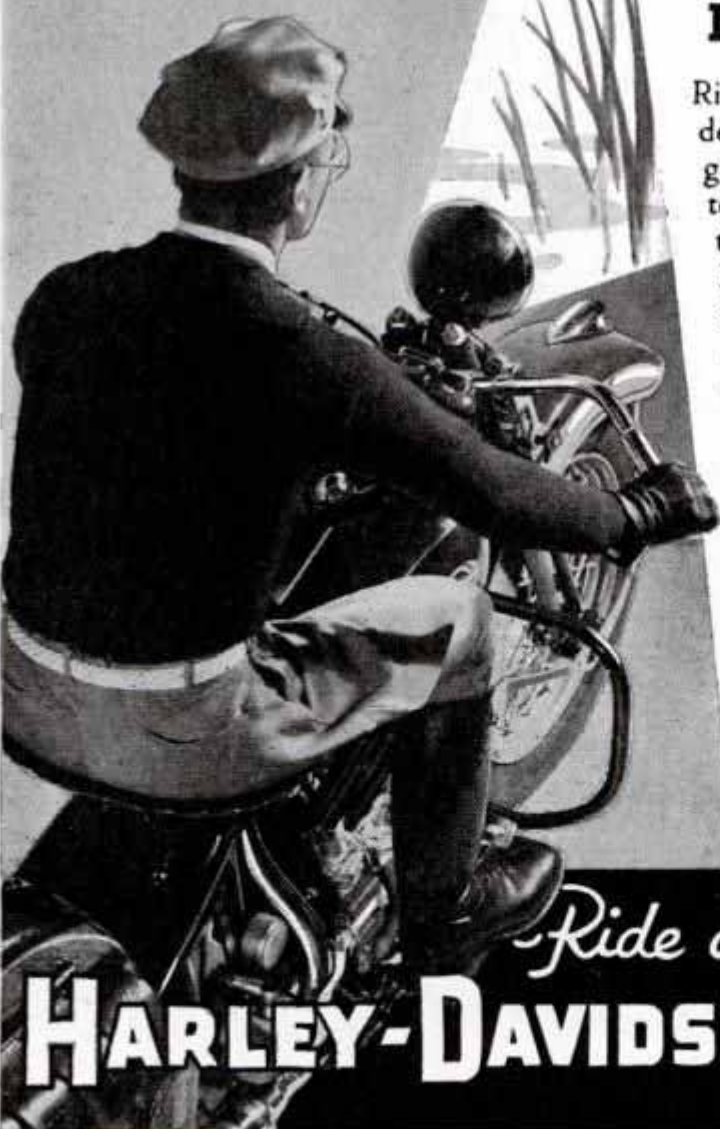

Ride a

HARLEY-DAVIDSON

HARLEY-DAVIDSON MOTOR CO.
Department P, Milwaukee, Wis.

Interested in motorcycling. Send illustrated literature.
Postage stamp is enclosed to cover mailing cost.

Name _____

Address _____

My age is 16-19 years, 20-30 years, 31 years and up, under 16 years. Check your age group.

Traffic Officers of the Skyways

(Continued from page 517)

In the tower also are more than a dozen radio receivers, each with its own loud-speaker. Over these receivers the control men hear the reports of the pilots made to their own lines while the ships are still many miles from the airport.

In the case of Pilot Andrews, for instance, the control tower was not "taken by surprise" when Andrews made his first call. The towermen knew Andrews had cleared Kansas City for Chicago, and under the safety regulations, Andrews reported to the TWA station in Chicago when 100 miles from the terminal, giving his position, altitude and estimated time of arrival. So the control towermen were anticipating the radio report from Andrews.

Red and green "stop and go" lights atop the glass tower are used by the control men as visible signals in addition to the audible instructions transmitted by radio. The lights also are used to signal ships without radio equipment. The red light "locks" the field to enable a plane to land, and no other ship can go out on the runways as long as the red light is on. Planes with radio receivers but no transmitters get their instructions by radio from the control tower and indicate they understand by dipping their wings or by some other signal requested by the towerman.

The control tower governs the take-off of planes as well as the landing. A pilot, before taking off, must inform the control tower of his destination, the altitude he expects to fly, the estimated time of arrival and any other pertinent information about the trip. This is also a rule at other control towers and the information is relayed between points. Thus WGEH is informed in advance of every departure and anticipates every arrival.

With such an arrangement it is easy, for example, to control accurately the landing of two ships from the west and one from the east even if they are due at the same time. Perhaps favorable winds indicate it is best for the ship from the east to land first. The pilot would then be so advised. At the same time the other ships would be told by their own company radio stations of their relative positions to each other, and each would be assigned a definite altitude to hold. Then each plane

would be brought in separately after the one from the east was down.

This close cooperation between the control tower and the radio stations and operations departments of the various air lines is made possible by an interphone system linking all together. If the control tower wishes to talk with TWA offices, the man in charge simply calls, "Control tower to TWA." This is audible to all stations through a loud-speaker, but when the TWA phone is picked up, the loud-speaker is disconnected, thus affording private conversation.

Included in the safety agreements is a provision that commercial planes be equipped with Kollsman altimeters adjusted to correspond to readings of the nearest ground station Kollsman barometer which is maintained at the sea-level altitude of the ground station. Eastbound planes on the radio range course are required to fly at even 1,000-foot levels—2,000 feet, 4,000 feet and so on, while westbound planes fly at odd 1,000-foot levels—such as 3,000 feet, and 5,000 feet. Pilots crossing an airway must proceed at the 500-foot levels to be out of the way of planes using that airway, and must cross at an angle of forty-five degrees or more in order to make the crossing as quickly as possible. Of course all ships are required to "keep to the right" of the radio beam along which they are proceeding.

The take-off directions are quite similar to the landing instructions from the control tower. Pilot Andrews, for example, was scheduled to take off for the east ten minutes after his landing at Chicago from the west. After calling the tower and reporting his trip, he was given his clearance by the ground dispatcher. The control tower then advised him to proceed to a certain runway, called his attention to other ships in the air or taking off, and finally gave him the "go ahead" to proceed down the runway. Once in the air, he was further advised by the control tower of other ships flying near by and of any he might encounter on his course. A final "Okay, WGEH" from pilot Andrews indicated that he had cleared the airport district and was switching to the radio station of his own line.

Snapshots this size



with this miniature camera



Kodak Duo

a true miniature camera
yet it takes a larger picture

KODAK DUO is ideal for the miniature camera enthusiast. It has all the advantages of a small, pocket camera... economy, convenience, short focal length—yet it yields a larger picture: Makes sixteen $1\frac{5}{8} \times 2\frac{1}{4}$ -inch pictures on a roll of 620 Kodak Film... actual size above.

There's no need for posing with Kodak Duo. The Compur-Rapid shutter, with speeds up to 1/500 second, stops action—covers any exposure requirement. The keen *f.3.5* anastigmat lens makes snapshots in almost any light—even at night, with Kodak

"SS" Film and Mazda Photoflood bulbs. Complete with depth-of-focus scale, optical finder. Price \$57.50. At your dealer's.

KODAK MINIATURE ENLARGER, MODEL B—Ideal supplement for the Duo. Makes enlargements from Duo negatives up to 16×21 inches. Paper cabinet base optional. Enlarger, Kodak Anastigmat *f.4.5* lens, masking paper holder, iris diaphragm, magnification scale, exposure calculator, \$82.50. Without diaphragm, \$67.50. Paper cabinet base, \$10.



CHOOSE THE RIGHT FILM
Kodak Verichrome Film is an excellent all-around picture maker. Has great latitude... guards against exposure errors. *Kodak Panatomic*... extremely fine-grained, designed

especially for miniature cameras. Makes striking enlargements... *Kodak "SS" Panchromatic*... extra speed for difficult pictures. Ideal for snapshots at night with Mazda Photoflood bulbs.



FREE a booklet you'll want in your photo library

Gives complete information about miniature Kodaks and enlargers. Write today... Eastman Kodak Company, Rochester, N. Y.



Name _____

Address _____

City _____ State _____

P.M. 10-36

When writing to advertisers please mention *Popular Mechanics*

They Keep Things Moving

(Continued from page 555)

while the waters swirled perilously near.

"A less spectacular but equally important aspect of the service provided by modern communication facilities was in preventing the disaster from being as great as it might have been had there been no facilities of this kind. No such efficient means for warning was possible during the Johnstown flood of 1889 when more than 2,000 lives were lost in one city—more than ten times the toll suffered during this year's flood which covered a much wider territory.

"At Binghamton the waters swept away cable under the Washington street bridge, cutting off the south side section of the city. But almost before the cables went, telephone plant men braving the dangerous waters strung up temporary circuits.

"An outstanding instance of heroic endeavor to keep the voiceways in order was in repairing the important Binghamton-Endicott cable which broke at a point across the Susquehanna river about midnight. Risking his life, a repairman mounted a cable cart attached to the line which was barely above the raging waters, gradually pulled himself out 2,000 feet to the point where the break had occurred in midstream and repaired the line."

Not all telephone linemen climb poles or descend through manholes to underground vaults to keep communication in order, however. There are many important telephone cables laid beneath rivers and hence "seagoing" linemen are necessary. They face extra hazards because they generally work at night when there is least interruption from water traffic. One of the veterans who keep things moving beneath the rivers is Capt. Edward H. Zimmerman who commands the "Lidiv," a cable boat used in laying, maintaining and repairing telephone cable in the waters about New York City. The "telephone navy" has had its share of exciting experiences, one of the most trying of which took place one cold winter's night.

"We got word the telephone cable beneath the Hudson river between Tarrytown and Nyack, an important toll link between New York and upstate points, had failed," says Capt. Zimmerman. "A tugboat, pushed out of the channel by floe

ice, had run aground and fouled the cable. Our orders were to proceed to Tarrytown and restore service. Ordinarily the trip takes the boat about three and one-half hours. That night it took twelve. The upper part of New York bay was full of drifting ice, but we had no real trouble until we got past the Washington bridge. Then shore ice eight or ten inches thick reached out from both sides while the ebb tide was packing half-mile wide floes into the channel, jamming them tight now and then until they tore off another floe from the shore ice.

"We plowed in, following an open lead close to the Yonkers shore, but soon the pack closed in on us, grinding against the iron sheathed sides of the 'Lidiv' and we lost our headway. Keeping our eyes open for gaps in the floes, we made our way gradually to where the broken cable lay. Before we got our grapnel down to bring up the cable, we had to break ice, but finally we had her aboard, lashed tight bow and stern with heavy chains. We began our tests and then started splicing. Thirty-six hours later we finished the job, and we were never sure while we had that cable on board whether we were going to stay upright or not."

Science, personified by electrical and research engineers is ever on the alert to lessen the work of the maintenance man and in some cases has succeeded in replacing the human element. A few months ago when "the thing that couldn't happen" did, and New York was plunged into darkness, there was scarcely a flicker of the lights at the switchboards or in the current which propels the automatic switching apparatus and the telephone bells in homes and offices. Automatic relay switches in the central offices immediately solved the problem without the aid of a human hand, turning on the reserve power sources at every telephone office, so there was no interruption in service.

Preparations for emergencies even include such minor details as having the feed wires enter the telephone buildings from different streets, so if one source is cut off, another will function. It is the maintenance man, however, who keeps things moving when disaster strikes.

WISH I KNEW WHY THEY ALL TURN ME DOWN



A PIMPLY SKIN CAN SPOIL ANY BOY'S CHANCES FOR A JOB

GEE, I HATE TO TELL UNCLE JACK I DIDN'T GET THIS JOB! DON'T SEE WHERE I SAID ANYTHING WRONG, EITHER. WISH I WASN'T SUCH A WASHOUT!



WANT A LIFT, GEORGE? SAY- WHAT'S WRONG? YOU LOOK AS IF YOU'D LOST YOUR LAST FRIEND ON EARTH!

WELL - I'VE LOST ANOTHER CHANCE FOR A JOB - GUESS THAT'S ENOUGH TO MAKE A FELLOW FEEL LOW



FEELING LOW WON'T GET YOU A JOB- AND LISTEN, GEORGE, I'VE A HUNCH THOSE PIMPLES DON'T HELP, EITHER. WHY NOT TRY FLEISCHMANN'S YEAST? IT FIXED UP BOB- AND HE LOOKED EVEN WORSE THAN YOU DO!

THANKS FOR THE COMPLIMENT!

WONDER IF SHE'S RIGHT?



LATER

WELL THEN, ADAMS- WE'LL EXPECT YOU TO START IN TOMORROW

THANK YOU SIR - I'LL BE HERE ALL RIGHT

PEG WAS RIGHT ABOUT THE OLD PIMPLES - SURE GLAD I ATE THAT FLEISCHMANN'S YEAST!



SAY, PEG - HERE'S REAL NEWS! I GOT THE JOB. SURE THING! WHAT? OH, QUIT THE KIDDING - NO, I'M NOT VICE-PRESIDENT YET, BUT I'VE GOT SWELL PROSPECTS!

PUBLIC PHONE



Don't let Adolescent Pimples keep YOU from getting a start

PIMPLES are apt to occur after the start of adolescence—from about 13 to 25, or longer. At this time important glands develop. The entire system is disturbed. The skin gets over-sensitive. Waste poisons in the blood irritate this sen-

sitive skin, pimples appear. Fleischmann's Yeast helps correct pimples. It clears the skin irritants out of the blood. Then—pimples go! Eat 3 cakes a day, a cake about ½ hour before meals—plain, or in a little water, until your skin clears.



—clears the skin
by clearing skin irritants out of the blood

New Power from the Sun

(Continued from page 548)

magnetometer registered an abrupt change in the direction and intensity of the earth's magnetic field. A magnetometer records magnetic fluctuations something like a seismograph charts the vibrations of an earthquake. Unlike the effect of an ordinary magnetic storm, however, there were no violent fluctuations of magnetic energy. At exactly the same minute, Dr. Richardson's photographs showed a large spot near the center of the sun suddenly erupted. A cloud of flaming hydrogen gas large enough to engulf the earth shot above the surface. Observatories in South America reported a similar phenomenon.

Checking up later, Dr. J. H. Dellinger, chief of the radio section of the bureau of standards, found that also at the same minute, short-wave radio receivers no longer picked up signals that had been coming in strongly a moment before. The effect was as if every short-wave transmitter in use had suddenly shut down.

"The indications are that this type of radio interruption is due to radiant energy emitted at the time of the sunspot eruption," says Dr. Richardson. "It seems to be a definite case in which a solar eruption is identified with an electromagnetic disturbance on earth, and shows that the energy that produced the radio fade-out traveled with the velocity of light.

"Instead of solving any problems, this example of energy transference only supplies new questions for which answers must be found. It does seem quite possible, however, that by additional study of the sun we will learn a great deal more than we now know about energy transmission and how to put it to practical use. It is impossible to be more specific because no one can say where the research will lead us, or whether results are five years or 500 years away."

Man has been trying to harness the sun for scores of years and some investigators think solar heat as a source of power may eventually enter the market in competition with coal and petroleum. It is estimated that solar energy falling on a square yard of surface at sea level on a clear day is equal to about one horsepower, although high losses in converting the heat are always encountered. One solar boiler that

raised 210 pounds of steam per square inch and operated a pump of 1,400-gallons-per-minute capacity was built early in the century. Sunshine has been used to run stoves, water heaters, smelting furnaces and small motors. Several attempts have been made to set up huge power plants in desert regions to collect the sun's heat and convert it into steam, although no such scheme has been commercially successful.

Dr. C. G. Abbot, Smithsonian Institution head, who has experimented with solar power for twenty years, used a solar heater in California that stored boiling water overnight and that operated a fireless stove in which all ordinary cooking could be done. His heat-gathering device consisted of a glass-covered trough, the curved glass top of which focused sun's rays on a pipe through which a heavy oil circulated to the stove and water heating coils. Electrically operated gears turned the trough so it always remained pointed at the sun while that body was above the horizon.

Dr. Abbot's latest heat collector, far more efficient, consists of a large stainless steel curved mirror that reflects eighty per cent of the sun's rays to a small focus. At the focus the concentrated rays pass through the walls of several concentric glass tubes and heat a special black heat-absorbing fluid pumped through the innermost tube. Air spaces between the outer tubes are exhausted of air like a vacuum bottle so none of the heat will radiate away. The conducting fluid is raised to a temperature of several hundred degrees by the sunlight. The hot liquid, in turn, may be used to convert water into steam. A one-half horsepower steam-raising model is now under construction.

Many types of solar water heaters are used in sunny climates. In its simplest form a water heater consists of water pipes laid along the roof of a house to absorb heat from the sun. They may be connected to an insulated storage tank where the water may be held at a high temperature for as long as twelve hours. The roof pipes are usually painted black and laid against a black tar-paper background to increase efficiency.

(Continued to page 120A)

Now
YOU CAN GET

RADIO'S GREAT NEW CATALOG



SPECIAL VALUES FOR AMATEURS, SHORT WAVE FANS, SERVICE MEN, DEALERS, ETC.

Every radio fan, amateur, experimenter, service man and dealer will find this FREE catalog an invaluable guide and reference book. Here you will find everything NEW in radio at money-saving prices—prices made possible by the tremendous purchasing power of the largest radio supply house in the world. The huge stocks, the expert technical advice, the friendly cooperation and speedy service of a great radio organization are brought to you in the pages of this BLUE RIBBON CATALOG. Send for this FREE catalog today—make it a habit to “shop at home” with this big new book—use it as your guide to *quality, value and low prices!* Mail the handy coupon . . . now!

You can get approved parts for kits described in all issues of this magazine at lowest “Wholesale” prices. Write us first!

FEATURING
EVERYTHING
THAT'S
NEW
IN
RADIO
!

FIRST BLUE-RIBBON EDITION!

IT'S here—a great N-E-W BLUE RIBBON RADIO CATALOG issued by Wholesale Radio Service Co., Inc., the largest radio supply house in the world. Every radio item listed in this big catalog has been checked and approved in our huge Testing Laboratories and has been awarded the Blue-Ribbon Seal—your guarantee of positive “purchase-insurance”!

BOOK OF A THOUSAND BARGAINS!

Here you will find “Everything in Radio” at lowest “Wholesale” prices. A brilliant array of new sets, from 4 to 24 tubes, with surprise features for 1937. A huge selection of radio parts, tubes and accessories. Special farm sets—battery sets—32 volt sets—auto sets. Complete kits for set-builders—parts for every kit described in this magazine. Newest, latest short wave and amateur equipment. Tremendous selection of public address amplifiers, systems, and accessories. Surprises galore in the way of new merchandise—new features—new equipment. Anything and everything you need is listed in this great Blue Ribbon Catalog—the most complete selective, quality radio catalog ever issued!

RUSH THIS COUPON!

Wholesale Radio Service Co., Inc.
901 W. Jackson Blvd.
Chicago, Ill. Dept. K7

Please rush FREE BLUE RIBBON Catalog No. 65.

WHOLESALE RADIO SERVICE CO. INC.

CHICAGO, ILL. • NEW YORK, N.Y. • ATLANTA, GA.
901 W. JACKSON BLVD. • 100 SIXTH AVENUE • 430 W. PEACHTREE ST., N.W.

BRONX, N.Y.
542 E. FORDHAM RD.

NEWARK, N.J.
219 CENTRAL AVE.

Name _____

Address _____

Town _____ State _____

When writing to advertisers please mention Popular Mechanics

JMS
(Continued from page 118A)

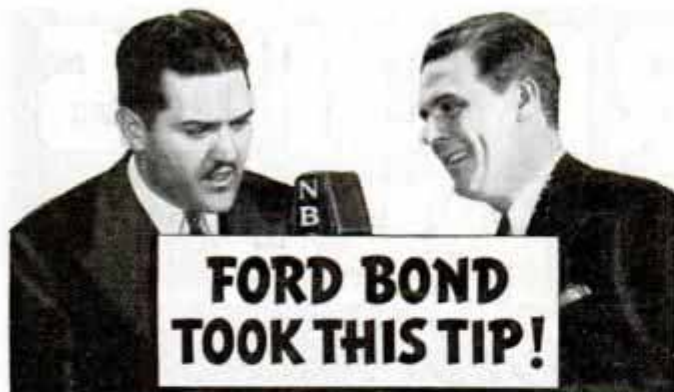

FORD BOND TOOK THIS TIP!



BOY! REHEARSAL ALL DAY.
BROADCAST TONIGHT. THEN
THAT MIDNIGHT RECEPTION!

YEAH! WITH
HARDLY
TIME TO
SHAVE!

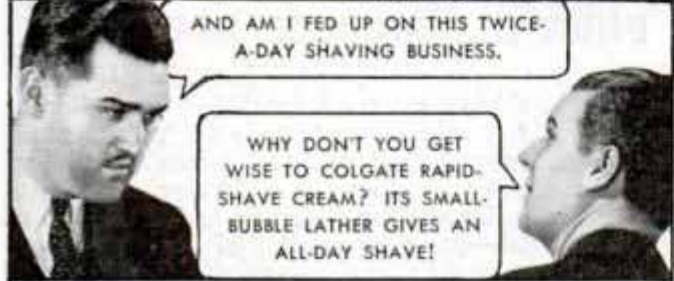

AND AM I FED UP ON THIS TWICE-
A-DAY SHAVING BUSINESS.

WHY DON'T YOU GET
WISE TO COLGATE RAPID-
SHAVE CREAM? ITS SMALL-
BUBBLE LATHER GIVES AN
ALL-DAY SHAVE!

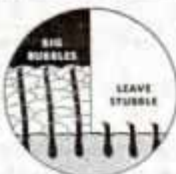

BUBBLE PICTURES SHOW WHY

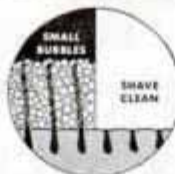

MOST LATHERS are made of bubbles too big to get to the *base* of the beard! Air pockets keep the soap film from reaching the whiskers. So the beard is only *half-wilted*.

COLGATE RAPID-SHAVE CREAM makes tiny bubbles that get clear down to the skin-line. Its rich soap film soaks your beard soft at the base. Makes your shaves last longer.

NEXT NIGHT

FOLKS, I'M HERE TO TELL YOU THERE'S NOTHING LIKE COLGATE RAPID-SHAVE CREAM FOR A SMOOTH, SOOTHING "SKIN-LINE" SHAVE THAT STAYS WITH YOU!



COLGATE "SKIN-LINE" SHAVES
LAST HOURS LONGER



25¢ LARGE TUBE
100 SHAVES
40¢ GIANT TUBE
200 SHAVES

One development of the solar heater is a "sun-cooled" refrigerator for which a patent has been issued. The action of the heat is to boil off liquid ammonia, the ammonia in turn removing heat from hydrogen gas that circulates in a freezing coil. Even on partly cloudy days there is enough heat to operate the refrigerator.

Meanwhile, astronomers are learning more about the sun itself. That body is "burning up," or losing weight at the rate of 4,000,000 tons a minute, but the bulk of the sun is so huge that its loss since the earth was born is only a minute fraction. The sun is gaseous and rotates fastest at its equator. Spectra of sunshine show many materials not found on earth but these cannot be duplicated here because the high temperatures and pressures of the sun cannot be reproduced. Recent developments in photography have more than doubled the number of lines in the spectrum available for observation, and astronomers are studying "invisible sunshine" in the infrared band.

Most important of all, possibly, is the investigation of magnetism on the sun. Even the sunspots are magnetic and seem to have north and south poles like magnetized steel bars. Whenever spots occur in pairs they have opposite magnetic polarities. The north pole of one spot is reversed in its neighbor. Spots above the solar equator have opposite magnetic polarities as compared to spots below the equator, and the whole system of polarities reverses with each sunspot cycle. That means that the magnetic cycle of the sun is about twice its sunspot period, or about twenty-three years. New spots at the beginning of each sunspot cycle appear in fairly high latitudes and as the cycle progresses the spots occur nearer the sun's equator.

At present, facts like these have little practical value. Astronomers gathering the facts have not been able to arrange them into a sensible pattern that explains some of the peculiar things about sunspots. When they do accomplish this, they hope, they will have a new law of nature that can be put to work.

Our Bureau of Information will answer questions regarding articles in this magazine, if accompanied by return postage.

Exploring Up and Down

(Continued from page 533)

Far above the so-called "dust clouds," lie the regions of auroras. These may possibly extend to an altitude of 350 or 400 miles. The aurora borealis commonly observed in polar regions has its base at about sixty miles altitude. The brilliant colorings, extending for hundreds of miles above the earth's surface, imply that the atmosphere clings to the earth with great tenacity.

Radio experiments indicate that the ionosphere is the region of reflecting "mirrors." Radio waves—a form of invisible light—are reflected from the high-altitude mirrors. There is reason to suspect the presence of mirrors at various levels.

Diving into the sea has not extended the third dimension of discovery very far. The present record, 3,028 feet, made by William Beebe, is still less than a mile but this is extraordinary when we recall that less than ten years ago man had not descended beyond 400 feet. Submarines can probably reach 500 feet below sea level, but the ideal submersible for deep-sea work is the bathysphere, built to withstand the tremendous water pressures. It is not unlikely that men will at some future date descend to the greatest ocean depth, more than five miles.

A new method of reaching hidden secrets on the ocean floor, and of describing dramatic events which took place in the distant past, was recently announced by Dr. Charles Piggott, of Carnegie Institution. Dr. Piggott has invented what may be described as a "hollow punch," which is thrust into the ocean by an explosion of powder and which, when it is hauled back, brings up a rock core of the ocean bed. He has brought up cores eight feet in length from a depth of 7,200 feet.

On land, there are also new methods of exploring and mapping conditions below the surface. Employing electrical currents, prospectors can map the underlying rock structures accurately to a depth of almost one mile. The electric currents reveal the nature and composition of the underlying rock with such faithfulness that it is possible for a geologist to prepare a detailed map, showing the position of the beds, their thickness, and their relation to each other.

Safety FOR THEIR EYES TOO!



with Lamps that
STAY BRIGHTER LONGER



GENERAL ELECTRIC
MAZDA LAMPS

GE . . . This is the mark that identifies General Electric dime lamps . . . the best 10 cent value you can buy. 7½, 15, 30 and 60 watt sizes. Try half a dozen today.



THIS MIRACLE INK

Ends 69% of the Pen Troubles

**It Cleans A Pen As It Writes—Hence
Ends Clogging—Dries 31% Faster ON PAPER
—Yet Does NOT Dry In Your Pen**

Repairmen's records indicate that 69% of the troubles caused in all kinds of fountain pens are due to inks that clog the feeds and "gum the works." This is now ended by this scientific development in writing ink—called **QUINK**. Created at a cost of \$68,000, to guard the famous Parker Pens from pen-clogging inks—*Quink* contains a secret, harmless ingredient that dissolves the sediment left by ordinary inks. Hence *Quink* actually cleanses a pen as it writes—a Parker or any other pen. You don't have to shake or fuss with your pen to make the ink flow. It starts instantly—every time.

Use **PERMANENT Quink** for accounting and general office purposes—it's permanent as the paper. For school and home, use **WASHABLE QUINK**. If spilled on hands, clothes or rugs, it washes out without trace.

QUINK dries by *penetration*—dries 31% faster **ON PAPER** than average—yet it *resists evaporation*, so does **NOT** dry in a pen.

Get a bottle of **QUINK** today from any store selling ink. It's rich and full-bodied—never watery. Has a brilliancy of color that will give your writing distinction. We promise you this: Once you use **QUINK**, you'll pour your old ink down the drain. The Parker Pen Company, Janesville, Wisconsin.

Parker Quink

Made by The Makers of The Celebrated Parker Pens

EARN MONEY

STRINGING TENNIS RACKETS

Stringing Tennis Rackets pays \$1.80 profit on \$3.00 restringing. No experience needed—we teach you how. Tennis players need new strings in their rackets two or three times yearly... every stringing means profit for you. See how simple it is to get in this business. Costs practically nothing to start. Easy work! Get started without delay.

FREE Write Today... tell us who has been restringing your racket and we will send you free our 1936 edition of "PLAY AND PROFIT STRINGING TENNIS RACKETS", including new low prices of TOMGUT "Court-Tested" Tennis Strings & Restringing Equipment. **Write Today!**

THOMPSON MFG. CO., 4535 Packers Ave., Chicago, U.S.A.
Makers of TOMGUT "Court-Tested" Tennis Strings & Restringing Equipment.



Portable Hearing-Aid Amplifier

(Continued from page 579)

panel is fastened to the box by means of self-threading screws, and the hinged top is provided with a handle for carrying.

A simplified wiring diagram is given in Fig. 3; this shows the various parts spread out so that the wiring may be traced easily. All connections are made with standard hook-up wire, covered with push-back insulation, with the exception of the various resistors and fixed condenser which are supported directly by their own wire leads. An original material list of all parts used in this hearing-aid amplifier is available from Popular Mechanics radio de-

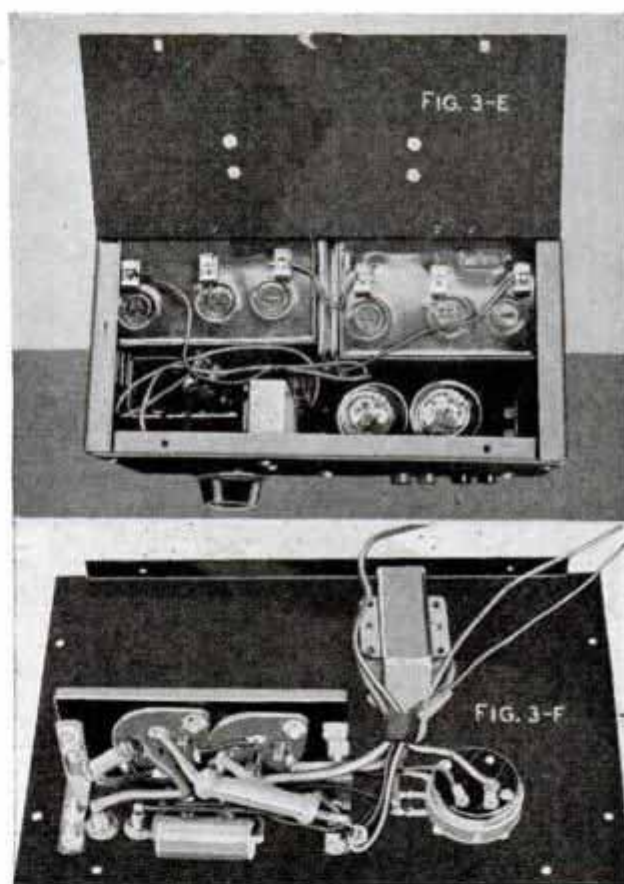

partment, without charge. The blueprint number is R-229.

As all parts are assembled on the front panel, there is plenty of room for the two portable-type B-batteries and the 4½-volt A-battery, which is provided with a handy connecting plug as shown in Fig. 3-A. Figs. 3-B, C, D, E and F are photos showing various stages of the assembly. Care should be taken to prevent the headphone case terminals from coming in contact with the metal box. The "on" and "off" switch and volume control are combined.

WITTE DIESEL ENGINES

The unbelievable economy of the small Diesel has revolutionized power cost. With a Diesel, power bills are only a fraction of their former size. Where power is used 800 hours or more a year install a WITTE Diesel Engine for lower power cost.



5 and 10
H-P

EFFICIENCY UP --- POWER COSTS DOWN

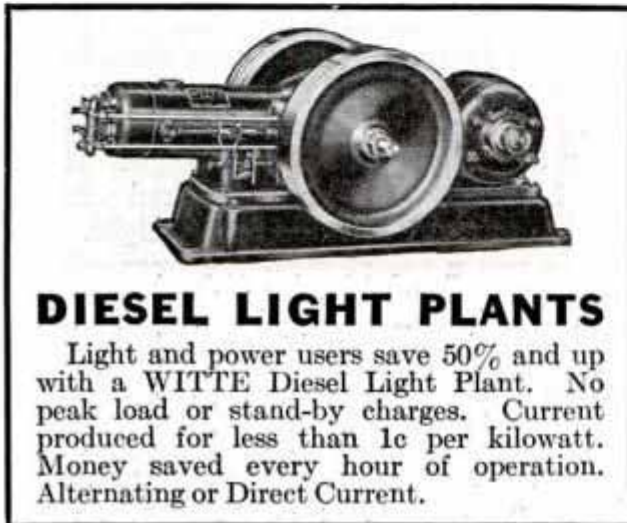

DIESEL LIGHT PLANTS

Light and power users save 50% and up with a WITTE Diesel Light Plant. No peak load or stand-by charges. Current produced for less than 1c per kilowatt. Money saved every hour of operation. Alternating or Direct Current.

The WITTE Diesel has the same important features and operating characteristics of the most modern large Diesels, and brings to the small power user the same startling economy and dependability. Fuel consumption is less than one-half pint of non-explosive fuel per hour per horse-power.

Thoroughly modern in every respect, the WITTE incorporates every worth-while advance in Diesel Engine design. Built of the finest materials ever embodied in Diesel Engine construction. Switch to WITTE Diesel power and save the difference—it soon pays for itself, easy terms, immediate delivery.

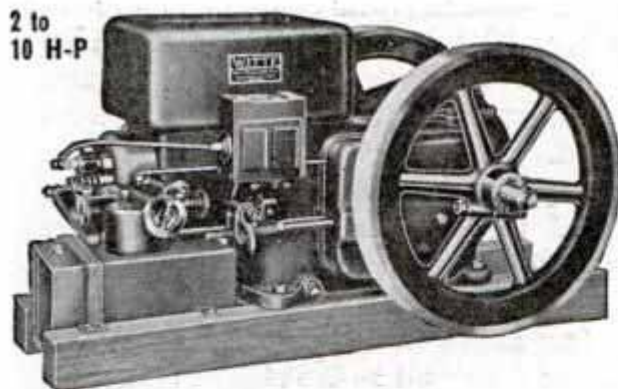

2 to
10 H-P

WITTE GASOLINE ENGINES TYPE "J" ON WOOD SKIDS

Where the amount of power used does not warrant a Diesel Engine our Type "J" on wood skids or Type "K" on iron base is recommended. They are Enclosed, Self Oiling and have Timken Roller Bearings. Operate on gas, gasoline, kerosene or distillate. Lubrication is automatic. Run smooth as an electric motor. Consume less oil and fuel and deliver more power. Pronounced by experts years ahead in design and construction. Buy your power equipment from a power specialist. Try a WITTE and profit.

WITTE LOG AND TREE SAWS

"Saws 'em down and cuts 'em up." There is money for you to make with a WITTE, timber to be cleared, logs to be cut, wood supplied for fuel. WITTE outfits have safety lever clutch control, saw guide, automatic force feed, human arm swing and other exclusive features. Portable as a wheelbarrow. Engine may be belted to other power for year around use.

FREE CATALOG—CASH or TERMS—QUICK DELIVERY



USED BY THE
U. S. GOVERNMENT

The WITTE cuts logs into fire wood, cord wood, fence posts, cross ties and shingle butt lengths. It is the best sawing outfit ever built. There is no other saw like it.

215-J So. 2nd St.
HARRISBURG, PA.

WITTE ENGINE WORKS

1747 Oakland Avenue
KANSAS CITY, MO.

**I CAN PATCH
THIS TOP with
PLASTIC WOOD**



Damaged or leaky tops or rotted posts are repaired by applying Plastic Wood firmly into cracks or holes—allow to harden—sandpaper smooth. Fabric patch can be cemented over Plastic Wood.

Make 1001 Household Repairs

Genuine Plastic Wood is actual wood in putty form—when dry it is hard wood that can be worked with any wood-working tools—sawed, planed, turned on lathe, carved—will hold nails and screws perfectly without chipping, cracking or crumbling. Adheres to any clean, dry surface—wood, metal, glass or porcelain—is waterproof and weatherproof—can be painted, varnished or lacquered perfectly.

Genuine Plastic Wood is also used to repair broken furniture, reset loose bathroom fixtures, loose casters; fill old screw holes, baseboard cracks, shelving cracks, replacing wood rot; fill holes around pipes, wiring, boat and canoe repairs, etc.

Get your can or tube at any leading paint, hardware or variety store.



PLASTIC WOOD

NEW BENJAMIN AIR PISTOLS

Powerful—Accurate—Economical—Practical—Adjustable Shooting Force—Amazing Maximum Velocity—cal. 177 or 22 and BB—For Target and Small Game—the only Genuine Compressed Air Pistol on the market—Single Shot with Bolt Action—Hammer Fire—Hair Trigger—Safety. Price \$7.50. Also 177 and 22 Single Shot Air Rifles \$7.50—Single Shot BB Air Rifle \$6.00—25 Shot BB Repeater Air Rifle \$7.00—at Dealer or Direct—No license required—Safe for indoor use.

FULL DETAILS—TARGETS—FREE—WRITE TODAY.
Benjamin Air Rifle Co., 691 N. Broadway, St. Louis, Mo.



BUILD YOURSELF OR HAVE Carpenter or Garageman BUILD
A RITZY CABIN TRAILER. COST \$100 UP
USE AUTO AXLE OR REGULAR TRAILER AXLE
ALL THREE PLANS \$1.00
Ritzy Standard
Ritzy Coupe Trailer
Ritzy Air Cutter
SIMPLE PLANS AND SPEC. BY REG. ENGINEER. SIZES 11' WIDE x HIGH 14' AND 11' LONG
EASY TO CHANGE LENGTH AND WIDTH. MAIL \$1.00 BILL TODAY FOR ALL THREE PLANS TO
RITZY CABIN TRAILER, BOX 2513, WAPAKONETA, OHIO

Queer Facts about Bridges

(Continued from page 503)

foremost bridge authorities, recently extended the mathematical theory for the design of suspension bridges.

"The old method," he said, "satisfied safety alone, but not economy. There was a substantial waste of metal in the stiffening trusses. The new method of calculating saves from twenty to sixty-five per cent of the metal in these same trusses."

Bridge building, like shipbuilding, awaits a super metal. With present materials, says Othmar Ammann, engineer consultant on the San Francisco bridges, it would be possible to build a suspension span 10,000 feet long, or a little less than two miles. As the length of the span increases, so does the amount of metal that has to be used in the support of its own weight. The limit of a bridge's length is reached when it is able to carry only its own weight. If you can use a metal with the properties of steel, but with only half its weight, it would make possible the spanning of wider waterways.

Building a bridge is one of the most delicate undertakings of engineers. One factor which must always be considered before construction is the change in a bridge's dimensions with changes in weather. The exact length of a bridge bears a direct relation to the temperature. It is longer in summer heat than in winter cold.

In high heat and under full load, the span of the George Washington bridge sags eight feet below normal. In cold weather and under no load, the span rises four feet above normal.

The cost as well as the size of bridges is mounting steadily. The Brooklyn bridge, considered the wonder of the nineteenth century, cost \$25,000,000. The George Washington bridge, completed in 1931, cost \$60,000,000. The new San Francisco bridges will total \$115,000,000. The eight and one-half mile bridge and tunnel link between Oakland and San Francisco, to be completed in 1937, will cost \$80,000,000, probably a world record.

Inquiries as to makers of articles described in Popular Mechanics, will be answered by our Bureau of Information upon receipt of return postage.



● When you stay at Hotel Cleveland your red-cap takes you from train to hotel lobby in a moment, without going out-of-doors. No time wasted, no discomfort, no taxi fare.

And at Hotel Cleveland, all the city is at your doorstep. All five buildings of the Terminal development under the same roof; stores and office buildings to the east; government buildings north; wholesale district west; industrial plants south. And comfort, friendliness, welcome, *at home*—in your room and all about you in

HOTEL CLEVELAND
Cleveland

Rooms from \$2.50 for one, \$4 for two.

PHOTO ENLARGEMENTS

Is Photography your hobby? Do you want a profitable easy business at home? Make **PHOTO ENLARGEMENTS** for yourself and others. Your cost 5c each and less. The Ideal Photo Enlarger is **AUTOMATIC**. No experience required. Also **COPIES** any picture. **\$5.94 COMPLETE**. Interesting circular **FREE**.

IDEAL PHOTO ENLARGER CO.
124 East 25th Street, New York City

5¢ ANY SIZE

PARTS for the **POPULAR MECHANICS FAMILY TRAILER**

Everything you need! Axle, Tongue, Hitch, Wheel Housings, Wood Parts, Tank, Sink, etc. Send for price list. Include 25c (min) for our big Catalog and Trailer Builders' Manual. Satisfaction guaranteed!

TRAILER SUPPLY CO., Box A, Wausau, Wis.

IN SAINT LOUIS

THE HOTEL CORONADO

LINDELL BLVD. AT SPRING AVE.

FAMOUS FOR ITS FOOD

ROOMS FROM **\$2.50**

GARAGE ADJOINING

UNDER THE DIRECTION OF PRESTON J. BRADSHAW

MASONITE
TEMPERED PRESWOOD makes this sewing-cabinet easy to build!



HERE'S a grand gift for a lady . . . a compact cabinet to hold all of her sewing paraphernalia. It folds together and can be carried in one hand. Contains spindles for spools, a tray for pincushions, etc., a shelf to work on, a pocket for materials.

The sides, the tray and the pocket are made of **MASONITE TEMPERED PRESWOOD**. This grainless material makes the entire cabinet stronger, lighter in weight, more beautiful, more economical.

MASONITE TEMPERED PRESWOOD is available in $\frac{1}{8}$ ", $\frac{3}{16}$ ", $\frac{1}{4}$ " and $\frac{5}{16}$ " thicknesses from lumber dealers everywhere. It is moisture-resisting and, properly used, will not warp, chip, split or crack. It is easy to cut or saw with regular tools. Contains no glue or artificial binder to dull the finest edges. Its natural warm-brown surface needs no decoration, but it can be varnished, painted or enameled if desired.

We'll gladly send you a free copy of the plans for this new sewing-cabinet, together with samples and further details about **MASONITE TEMPERED PRESWOOD**. Just mark and mail the coupon below.



Trade-Mark
Reg. U. S. Pat. Off.

MASONITE CORPORATION, Dept. PM-10
111 W. Washington Street, Chicago, Ill.

Please send me working drawings for the Masonite Sewing-Cabinet, with free sample and literature about **MASONITE TEMPERED PRESWOOD**.

Name _____

Address _____

City _____ State _____

When writing please mention *Popular Mechanics*

THAT SHE BLOWS!
AND SANI-FLUSH WOULD
FIX IT FOR A DIME!



AN OVERHEATED motor is dangerous. It ruins efficiency. Often it leads to expensive trouble and repairs. A clogged radiator is unnecessary. You can keep the delicate veins of the cooling system clean and open with Sani-Flush. It takes only a few pennies and a few minutes.

Pour Sani-Flush in the radiator. (Directions are on the can.) Run the motor. Drain. Flush. Refill. That's how easy it is. Sani-Flush is safe, non-caustic. Cannot harm aluminum cylinder head, block or fittings. It removes rust, sludge and sediment quickly and thoroughly. You'll find a can of Sani-Flush in most bathrooms for cleaning toilet bowls. Sold by grocery, drug, hardware, and five-and-ten-cent stores—25c and 10c sizes. The Hygienic Products Co., Canton, Ohio.

Sani-Flush **Safe**
KEEPS RADIATORS CLEAN NOT CAUSTIC

POWERlite
HERE'S
AMERICA'S FINEST
ELECTRIC LANTERN

● 2 lights on a double acting switch. 80 ft. spot light from front reflector; broad floodlight from top.
80 to 100 Hours Light from One 6-Volt Dry Battery

The most powerful, serviceable electric lantern for all needs—fishing, camping, touring or home. Stands 6½ in. high. Unbreakable lens. At sport, hardware, electrical dealers, or write

DELTA ELECTRIC CO., Marion, Ind. Dept. 308

A GENUINE DELTA



\$3³⁵
(LESS BATTERY)

T 195
Tricks of the Race Drivers

(Continued from page 525)

and special fuels are two of the reasons why race cars go so fast on so little.

The most thoroughly streamlined car at Indianapolis this year was driven by Wilbur Shaw, who had "tailored" the car to fit his body. Shaw cut a scale model of himself out of celluloid and then built a miniature padded cockpit with the driver's seat fitted to the dimensions of the model. He did the same with the mechanic's side. The result was a small streamlined body that fitted around the driver and mechanic like a glove, offering minimum wind resistance.

Many drivers prefer the braking action of a semi-streamlined design. They complain that if the streamlining is too complete the car tends to float along and that they must ease up on the accelerator long before entering a turn.

Instead of a conventional opening in front for the radiator grill, Shaw closed the front of his car and used a small wind scoop to pick up air to cool the engine. The air exhausted out of the car behind the engine through an overlapping slot designed to function like an N. A. C. A. airplane engine cowling. The efficiency of his design was demonstrated when he used not much more than a gallon and a half of fuel to drive twenty-five miles at better than 116 miles per hour.

Most drivers have pet superstitions about the track. One of them thinks that he will have bad luck if someone in his pit eats peanuts during a race, while another eats a dish of chow mein before warming up his car. He does it every time because one of the first races he ever won was driven right after eating some. Another driver withdraws from the field if he happens to drive close to an ambulance on the way to the track, and many race drivers think that some cars are luckier than others. Green is an unpopular color for race cars and many drivers dislike to have an even number as a racing symbol. Odd numbers are more popular, although "11" is not often used because it might be confused with "7" in broadcast announcements. Most of the drivers would never think of painting "13" on their cars, and yet one racer who has never had a bad accident insists on using that number!

**ALL PURPOSE
MOTO-TOOL**



**10 DAY
MONEY
BACK TRIAL**

**Grinds, drills,
engraves, routs**

carves and speedily does many other slow hand jobs for home, school or shop. Strong, powerful, yet handles as lightly as a pencil. Weighs 6 oz. Plugs in any light socket A. C. or D. C. 110 V. universal motor. About 18,000 R.P.M. Efficiently cooled. Universal collet chuck. Oilless self-aligning ball thrust bearings. Order on 10 day money back trial.

Utility Tool Set of 20 general accessories for all types of Moto-Tool work. \$5.75. Send for free complete Moto-Tool booklet.

**ONLY
\$985**

SENT POST PAID

**DREMEL MFG. CO.
Dept. 2810-Ct., Racine, Wis.**



These STUART PATENT CLAMP and Jack parts, when attached to a board connecting them, will give you great clamping strength for all widths from 1/4 inch to 20 feet or MORE. Reverse the parts and it becomes a powerful jack for forcing work apart. Simple, strong, reasonable in price. Write for illustrated price list C-2, described on page 326, September Popular Mechanics.

STUART CLAMP WORKS, GORHAM, N. H.

BURN YOUR NAME ON TOOLS

**WITH THE
ARKOGRAF**

PROTECT YOUR TOOLS FROM THEFT

Write with electricity any name or design on the hardest and finest tools and instruments, or any metal, like writing on paper with pen or pencil. Complete Outfit \$3.50—Practical Anywhere. Interesting illustrated circular free. Write today. Agents wanted.

ARKOGRAF PEN CO., 3927 S.E. Stark St., Portland, Ore.



**FREE ELECTRICITY
From Wind Power**



For Lights, Power, Radio, from Auto Generators. New Copyright Book with over 100 Facts about Wind Chargers. Wind-Propellers—Generators—Plants—Batteries. Answers all questions you should know. Including plans for 6 or 32 V. Plant. Send 25c for plans, facts and catalog.

**Agents Wanted. CURRIER MFG. CO.
405 Terminal Minneapolis, Minn.**

SYSTEMATIC CARE of TOOLS
makes your work easier. TOOLMAKERS and Machinists, let us send Free Catalog.
GERSTNER TOOL CHESTS
458 Columbia St., Dayton, Ohio

ONE-MAN PLANING MILL



LOWEST PRICED FULL-SIZE PLANER
Lumber Yards, Sawmills, Contractors, Cabinet and Pattern Shops, Blacksmith, Industrial Plants: Here is the machine you've been waiting for. Production type THICKNESS PLANER and JOINTER, combines with SAW TABLE, RABBETER, MATCHER & MOULDER, BORE AND ROUTER, SANDER AND LATHE. Round Safety Tyro Cutter-head—with this, HIGH SPEED STEEL knives. Write for FREE catalog with full specifications, illustrations and low prices. **BELSAW MACHINERY CO., 911A Davidson Building, Kansas City, Missouri.**

GET YOUR TRACTOR AT FACTORY PRICE



Amazing money maker for farms, truck gardens, orchards, nurseries, poultry ranches, country homes, etc. Plows, discs, harrows, cultivates, mows, lawns, cuts weeds. Runs left machinery. 2 to 5 H.P. riding or walking types. Write for **FREE CATALOG, Low Factory Prices and 10 day Trial Plan.** Address Nearest Office.
SHAW MFG. CO., 4510 Front St., Gatesburg, Kans., 130 G West 42nd St., New York, N. Y., 5812 G Magnolia Ave., Chicago, Ill., 658 G North 4th St., Columbus, O.

Air Tires or Steel Wheels

SHAW DU-ALL TRACTOR



**DISSTON
DE LUXE**

The World's Finest Home Workshop Saw—made for the man who won't be satisfied with anything but the best.

The kind of craftsmanship you wish to turn out has a good deal to do with the grade of saw you buy. Fine tools help fine work. In these new De Luxe Saws, you get Disston steel and Disston workmanship of the same high standards, same guarantee, as the famous Disston Circular Saws used by the world's leading lumber mills!

Cross-cut—Rip—Combination

6" (1/2" hole) \$2.40	8" (1/2", 5/8", 3/4" hole) \$3.20
7" (1/2" hole) \$2.80	10" (5/8", 3/4" hole) . . \$4.05

Hollow Ground Combination

6" (1/2" hole) \$3.90	8" (1/2", 5/8", 3/4" hole) \$4.90
7" (1/2" hole) \$4.40	10" (5/8", 3/4" hole) . . \$6.20

Ask at your dealer's, to see these saws. Made of finest Disston steel! See the high, smooth finish of the blade. Note the accurate fitting. Feel the keen teeth. They hold their cutting edge. You will realize that these fine blades mean easier and more accurate cutting. You will want these better saws to help you do better work.



This Disston Manual, Free—tells how to choose, use and care for fine tools. 200 illustrations.

MAIL COUPON
TO: HENRY DISSTON & SONS, INC.
1011 Tacony, Philadelphia
Send me free copy of "Disston Saw, Tool and File Manual."

Name _____
Address _____

Growing Pearls at Home

(Continued from page 536)

beauty bringing from \$20,000 to \$50,000. A fortune always glimmered like a mirage just ahead of the "sheller" and whole communities wild with "pearl fever" deserted business and flocked to rivers with rakes and drags. Thus was this country's great natural pearl crop harvested.

Man has tried to aid and abet nature in producing pearls for hundreds, and perhaps thousands of years. The Mound Builders tried to grow pearls and failed. The Chinese also tried it many years ago but it was not until 1913 that the Japanese scientist, K. Mikimoto, succeeded in producing small attached pearls and later little white sphere pearls. He used diminutive balls of mother-of-pearl as a nucleus and grew pearls of excellent quality and shape in margarita shells or pearl oysters. Backed by the Japanese government, the industry of growing these pearls assumed large proportions and ran into millions of dollars per year.

One great difference between "wild" or accidental pearls and purposely grown ones is that the former may have as a nucleus, or starter, some foreign material, but the latter can be of pearl substance throughout. The more common ones of the pearl oyster are usually silver white but fresh water gems run the gamut of every color and shade, even the metal hues. Since the various species of life in which pearls grow vary in anatomical structure, it is natural for pearls to vary in form. Also the composition of both shell and pearl is to some extent controlled by environment. Usually the color of the shell dominates the coloring of the pearl, but this is not always true.

Some kinds of mollusks, especially pearl oysters, are attacked by parasites, resulting in thousands of "seed pearls." The majority are so located that abortion is certain and few attain the desired size. When a mollusk is unable to abort a foreign substance which has drifted into its shell, irritation is set up and a protective secretion quickly covers it. This thickens and hardens, eventually becoming a semi-transparent layer of pearl material. If it is touching the shell, a connection is formed, resulting in an "attached" pearl, but if in the flesh, without contact with the shell,

it may develop into a round or ball pearl. However, this is unlikely for a wild pearl seldom happens to be in the right place for proper growth, and muscular or organic pressure upon the soft secretion of a growing pearl will shape it like turning it in a lathe, the resulting form often being of less value than a sphere pearl which must, while growing, remain stationary in its pearl sac and not be interfered with by movements. That is one reason why there are not more well-formed accidentals, because as a pearl becomes larger there is an ever increasing danger that the pearl sac will burst, allowing it to escape.

When growth starts, the covering is very thin, but it increases in thickness as the pearl grows, each succeeding layer adding to the size. Chemically, pearl structure is like that of the inner lining of the shell, each being composed of organic matter and carbonate of lime. Beauty and luster are determined by the shape, structural arrangement and quality of the material. The pearly nacre usually is deposited in irregular, fingerlike layers of delicate thinness which cross and overlap each other like frost on a windowpane. The laminae form angles with the surface and waves of light are reflected from different depths, minute prisms splitting the rays into their colored constituents, resulting in chromatic or iridescent effects.

In addition to using real pearl material as a nucleus, thus insuring a solid pearl, the pearl grower places this material in the anatomy of the mollusk in such a position that danger of abortion is virtually eliminated. It sounds simple, but finding out how to do it required years of time, unlimited patience and thousands of carefully checked experiments.

Mr. Bostwick began his experiments in pearl growing in Iowa and built a laboratory on the shores of the Iowa river. A cement floor was divided into runs eight inches deep, a centrifugal pump supplying a constant two-inch flow of fresh river water. On the bottom of each run he placed sand, mud or rocks mixed with soil, whatever the different kinds of mussels required. Since the mollusks must have the proper amount of oxygen or they

(Continued to page 130A)

**YOU'RE NOT GETTING
ALL THE POWER
OF YOUR MOTOR**



HOW TO GET ALL THE POWER

YOU LOSE power when the factory spark setting of your engine is *retarded*—whatever kind of gasoline you use. You lose power even when the spark is set for maximum power—if the gasoline knocks.

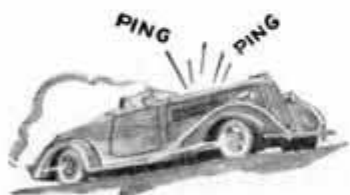

And knock is *expensive*. It means that you are tossing away good money in gasoline and oil—and that you are getting *less* power than your car was built to deliver.

For knock wastes all three—gasoline, oil and power.

TO FIGHT THE KNOCK EVIL, with its waste and expense, most oil companies now use anti-knock fluids (containing tetraethyl lead) made by the Ethyl Gasoline Corporation.



And for cars built in recent years, with their high compression engines, these oil companies offer a special high compression fuel at pumps marked "Ethyl."

HIGHEST ANTI-KNOCK! At the Ethyl pump you get a special motor fuel of highest quality on every count in which enough anti-knock fluid has been *blended* to stand the highest compression and the full-

power spark setting of your car.



And both the anti-knock quality and all-round value are *double-checked*—by the oil companies and the Ethyl Gasoline Corporation—at the refinery and at the pump.

START A REAL SAVING in your car's operating costs. Have your spark set at factory specifications *for maximum power*. Then fill up with Ethyl. See how much gas and oil you save. See how much better your car will run!



NEXT TIME GET ETHYL!

YOU'RE THERE
WITH A

CROSLEY

SUPER SENSITIVE
RADIO

COMPARE THESE PRICES TUBE FOR TUBE,
FEATURE FOR FEATURE, WITH ANY
RADIO ON THE MARKET.

* AUTO-EXPRESSIONATOR

Brings back the expression necessarily taken out in the studio in transmitting the program.

* MYSTIC HAND

(A. F. C.) Automatically tunes set sharply without use of meter tuning or other gadget.

♪ MAGNA CERAMIC DIAL

† VIBRACOUSTIC SOUNDING BOARD

◎ METAL TUBES

and 8 other CROSLEY FEATURES

* * * † ◎	15 TUBES, 44" Console,	\$167.50
* * * † ◎	13 TUBES, 43½" Console,	\$137.50
* * * † ◎	11 TUBES, 41½" Console,	\$99.95
* * * † ◎	9 TUBES, 41½" Console,	\$89.95
* * * † ◎	7 TUBES, 40" Console,	\$59.95
* * * † ◎	6 TUBES, 39" Console,	\$49.95

Prices slightly higher in Rocky Mountain States and west.



CROSLEY stands, always, as a warranty of the highest value in radio. It is only natural that the 1937 models are Crosley's greatest achievements. Beautiful . . . as near perfection as science can attain . . . and priced for you who demand the best at prices you're pleased to pay. See your Crosley dealer today . . . you will hear radio you've never heard before.

THE CROSLEY RADIO CORPORATION
Cincinnati, O. Powel Crosley, Jr., Pres.



FREE ELECTRICITY WIND DRIVEN ELECTRIC PLANTS

Light and Power for farms, country homes, and ranches.

Self-controlled, direct drive, air-cooled Generator. Built for a lifetime. 1200 and 2400 watt 32 volt plants \$488.00 to \$710.00 complete with tower and batteries, F.O.B. factory. Also 110-volt 2400 to 4800 watt plants. Free circulars. Dealers wanted.

WIND IMPELLER ELECTRIC WKS.
Dept. PM-10 Ellsworth, Ia.

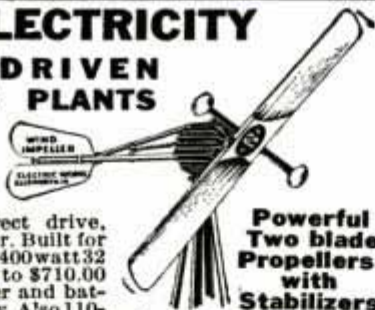

Powerful
Two blade
Propellers
with
Stabilizers

AMAZING NEW WAY TO FIX THINGS!

CASCO

IT SETS LIKE CEMENT

CASCO is the famous industrial adhesive-cement used in making airplanes, fine pianos and valuable furniture. Today it is available in handy packages for home use.

Unlike ordinary glues that set by evaporation, CASCO sets by chemical action. This makes it heat-proof and water-proof.

Easy to use, it enables you to do a "fix-it" job once and for all on broken furniture, loose tile, linoleum, piano keys and other household items.

But first try CASCO at our expense. Send today for generous free sample.

FREE

Send a penny postcard for your sample of CASCO. You'll also receive fascinating "How-to-fix-it" booklet.

Hardware, Paint, Lumber Dealers sell CASCO
CASEIN COMPANY OF AMERICA, Inc.
350 Madison Ave., Dept. PM-1035, New York, N. Y.



Mr. B

(Continued from page 128A)

will die, he aerated the water by using small fountains and dump tanks. A cement operating table over which flowed three inches of water completed the laboratory.

Here were grown the first fresh water sphere pearls ever produced by man—aided, of course, by the mollusks. They were white and in colors and some weighed ten grains. The nucleus was a little round pearl or a mother-of-pearl ball, so the result was 100 per cent pearl with no grain of sand, flake of shell or piece of mud in the middle. Here he also grew attached pearls—those touching the shells—weighing forty grains and in white and colors. The latter, of course are worth less money, but in colors they are suited particularly to the making of art jewelry. Growing pearls is not difficult, says Mr. Bostwick, and can be engaged in by anyone who masters the operating technique.

"As each species of mollusk has a different anatomical structure," he explains, "each presents a new operating problem. To a person scientifically inclined, the pleasure lies in solving these problems. When growing attached pearls, the nucleus must be placed in just the right spot, in contact with the shell, behind the mantle. When correctly located, under proper conditions the result will be a perfect attached pearl. When sphere pearls are grown, it is necessary to perform an exceedingly delicate surgical operation, using fine tools made especially for the purpose. When the anatomical location for insertion of the nucleus is chosen correctly, and the operation is performed at just the right time, the pearl will mature nicely and the result will be a perfect sphere."

After his success in growing pearls in fresh water shells and the great pink conch, Mr. Bostwick was invited to California to conduct experiments with abalones, and his discovery that large and fine specimens in color can be grown in them may make it possible in the future for man to grow pearls to order, filling a commission for a gem of any size or color.

But that's something for someone else to worry about. As for Mr. Bostwick, he's fascinated just now by a species of large silvery snail. It may or may not be able to grow a pearl. But Mr. Bostwick intends to find out.

A REAL HE-MAN'S LANTERN

FOR EVERY OUTDOOR USE



Sensational New Diamond Instant-Light, Wickless Burns 96% Air!

A brand-new light for every outdoor use. Instant light at turn of a valve. Large font holds 3 pints and gives 22 hours bright, white, non-flickering light (300 candlepower!) 20 times light of old wick lantern at fraction of cost!

Burns Kerosene or Gasoline
Makes its own gas from 96% free air, only 4% fuel—flood-lights whole camp or cottage, porch, farmyard, barn or road-stand. Ideal for tourists. Packs easily, safely. Can't leak in any position. Wind, storm and bug-proof.

30-Day Home Trial
Enjoy this amazing new invention for 30 days at our risk before deciding. Get our special short-time low-price introductory offer. Send today!

AGENTS! A year-round money-maker. Write at once for money-making details and how to get yours FREE, by helping to introduce it.

AKRON LAMP & MFG. CO.
530 Lantern Bldg.
Akron, Ohio

BIG LEADER BEATS THEM ALL

GENUINE LEATHER TIES 4-in-Hands & Bows For Men and Boys

Look like silk. Durable, neat, won't wrinkle. Cleaned with a damp cloth. 40 beautiful patterns. Started as a novelty, but now a permanent, popular, big-selling article. Big profits, repeat orders. Young man sold 23 one night after school. Men, Ladies: Send 50c or stamps for sample and kit. Information free.

CENTURY TIE CO. (Mfrs.)
Dept. A, 2345 W. Grand Blvd. Detroit, Mich.

HULL AUTO COMPASS



Don't lose time and money by taking the wrong road and going many miles out of your way. This new AIRPLANE TYPE COMPASS constantly tells your direction of travel. Sticks to windshield. Base 1 1/4" diameter. ONLY \$1.95 POSTPAID, including Compensator. SATISFACTION GUARANTEED.

If your dealer cannot supply you, order direct.
HULL MFG. CO., Box 246-D, WARREN, OHIO

BUILD IT YOURSELF

JIM DANDY CABIN TRAILER
Classy! Roomy! Easy to build at low cost! Plans and instructions only \$1.00—include all Diagrams, Sketches, Photos, Material List, etc. Big Value! Mail Dollar Bill to Jim Dandy, Box 125-A, Wausau, Wis.



STARTLING DISCOVERY Gives Amazing RESULTS



SAVES GAS & OIL in AUTOS TRUCKS CUTS REPAIR BILLS

New Scientific Discovery Takes Country by Storm. More than 80 Million Prospects for Product that Saves Millions of Dollars for Auto and Truck Owners. One Truck Fleet Saves \$768 a Year.

AGENTS—"I Made Profits Up to \$34 Per Day Sold 21 Truck Lines in 3 Weeks"—says B. J. Balmer, Tenn. Make Big Money Fast. Build Steady Business with Big Monthly Repeat Sales. Product Sells Itself. Have Exclusive Territory with Agents, Dealers working for YOU. Make up to 186% Profit. Territories Going Fast. You Can Test This New Discovery FREE of Risk. Write Today.

K-W CORPORATION, 3202 Holmes St., Kansas City, Mo.

To STOP LEAKS of water, steam, gas or oil from PIPES, BOILERS, TANKS

Smooth-On No. 1 judiciously applied at cracks, leaky seams, pipe threads and flanges, seals steam, water, gas, oil, or smoke leaks quickly and permanently.

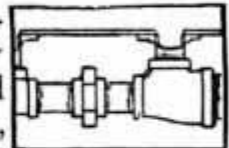

Pipe Leaks

Householders find hundreds of uses, such as making stripped screw bolt and nut threads hold, tightening loose hooks, locks, hinges, bath room fixtures, handles, casters, mending leaky pots, pans, stove ovens, etc. Excellent for stopping leaks in auto radiators, cracked water jackets, leaky seams in gas tanks, tightening loose hub caps, exhaust pipe and heater connections, lamp and tire braces, etc. A Smooth-On repair holds on any metal and is proof against pressure, heat and vibration.



Boiler Leaks

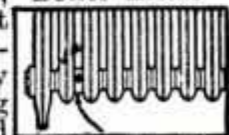

Radiator Leaks

Keep Smooth-On handy and follow the directions in our free book. Expansion of the Smooth-On in hardening will do the rest. The



Fire Pot Leaks



Write for FREE BOOK



Smooth-On Booklet shows repairs that any home owner can make with big savings, and with perfect results.



Smoke Leaks

Return the coupon for this booklet, and get Smooth-On No. 1 in 7-oz., 1-lb. or 5-lb. can from any hardware store.

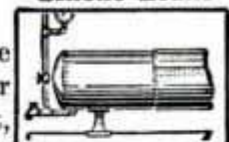

Tank Leaks



Furnace Gas Leaks

Do it with SMOOTH-ON

SMOOTH-ON MFG. CO., Dept. 37,
574 Communipaw Ave., Jersey City, N. J.
Please send the free Smooth-On Repair Book.

Name.....
Address.....
10-36.....

When writing please mention Popular Mechanics

don't
RUB YOUR EYES!

Why risk injury to delicate eye membranes? Safely remove dust and irritating particles with Murine. Gently cleanses and refreshes. Relieves tired, reddened eyes. Use it daily. Recommended for nearly 40 years.

MURINE
FOR YOUR EYES



Catch Fish! 

Eels, Mink, Muskrats, with our new folding galvanized STEEL WIRE TRAP. Write for our FREE TRAP OFFER and Bargain Catalog. 51 Box of our famous Fish Bait FREE to introduce our traps. WALTON SUPPLY CO., 3509 JUNIATA AVE., ST. LOUIS, MO.

END MONEY WORRIES
This Quick Easy Way!

Just Show New Christmas Cards

Your friends, neighbors, relatives, organizations will be eager to order these new, modern, distinctive Christmas Cards. 175 designs such as they never saw before. Beauty that will take your breath away. Values so great they seem impossible. Box assortments. Religious cards. Gift wrappings. Everyday cards. Imprinting of names when wanted. The most complete greeting-card line in America. Biggest profits. Fastest sellers. No previous experience necessary. No cash deposit required. Saleable boxes sent on approval, postpaid. Rush name today.

EXTRA BONUS
Checks mailed at Christmas, on top of regular cash profits. Just like getting a big Christmas savings check.

THISTLE GREETINGS
Dept. 29-K Cincinnati, Ohio



FUN to make—

Wiley Post's Winnie Mae is fun to make with strong, quick-drying, easy-to-use Du Pont Duco Cement. Light in weight. Used by model builders everywhere.



FOR FREE BLUEPRINTS of this flying model of the Winnie Mae, send red disc from 25c tube of Duco Cement. DU PONT, Dept. B-5, Wilmington, Delaware. Also choice of plans for Navy Hell Diver, Akron Fighter, Laird 400.

TRANSPARENT • WATERPROOF



The New Era of Railroading

(Continued from Coloroto section)

The genius of modern architects, designers, interior decorators has made the women's room a "makeup room" worthy of a fashionable home, and the bedrooms—no longer red plush, nor flecked with soot and cinders—are alternately green, rust-brown or blue, with sliding doors that open to make a spacious double room for the family. You may telephone from the club car to the dining-car steward for a dinner reservation, and listen as you wait to a sweet-toned radio set behind decorative metal grilles in the wall.

You may have a midday snack at a lunch counter where prices compare favorably with the corner drug store back home, or have the stewardess set your supper on the tray that unfolds conveniently from the seat ahead. The most unique car on the "City of Denver," streamliner of the Chicago and North Western and Union Pacific lines, is its "frontier" tavern room, a replica of an old-time western inn with unfinished log beams across its ceiling and bare pine board walls decorated with prize-fight pictures of frontier days, old newspapers and bills of traveling theatrical troupes.

Speed has not taken the place of safety in this new era. While the transcontinental streamliner weighs only half as much as its conventional predecessor, its cars are built of a sturdy aluminum alloy and the locomotive is of Cor-Ten steel. From his post high above the engine room and well back from the grilled steel nose of the "City of San Francisco," the engineer's view is unobstructed and he can see the track less than fifty feet ahead. Air brakes clap double brake shoes simultaneously on wheels throughout the train, and, if one brake line fails, the engineer can whip out the brake grip and slip it instantly into an emergency line. In a test, this streamliner was brought to a halt from eighty-seven miles an hour in 2,800 feet. Like modern steam locomotives, the Diesel-electric has a "dead-man control" which will stop the train if the engineer is disabled.

As you ride these streamliners you experience the thrill of the pioneer, for you are watching the birth of a new era. But is the streamliner just a "trial horse" of the railroads, to be forgotten in a decade?

(To be concluded next month)

"Simple Party Magic"

(Continued from page 565)

former and on around to the front, and back through the upper loop toward the performer. By gently pulling the two ends of the rope the knots will all disappear.

Most card tricks presuppose dexterity on the part of the performer, but here are two that can be mastered instantly. The first one is a pseudo mind-reading act. A number of face cards are placed on a table. The magician leaves the room and someone inverts one or two of the cards. Upon his return, the performer can tell which of the cards have been moved. The secret lies in the fact that the white border on most face cards is larger on one side than the other. Thus by lining up the cards with the large borders all on one side, it is an easy matter to tell the cards that have been turned upside down.

The other one is more of an oddity than a trick. The deck first should be sorted so the kings are on the bottom, then the queens, and so on through the deck until the four aces are on top. The performer then spells out each card, removing one card for each letter, and on the final one, turning the card face upward. In starting, for example, the performer takes one card off the deck for "A," then another one for "C," and turns up the third one, which is "E." Naturally, this one is an ace, but this is true in spelling out every card in the deck, concluding with the king.

For an optical illusion, fashion two pieces of cardboard as shown in the remaining illustration. They are identical in size, but when one is held above the other, the top one appears to be much smaller than the lower one. In presenting this trick, go through the motions of "stretching" the bottom one before comparing the two.

**Borers Driven from Trees
by Electric Shocks**

When a Kansas City man grew weary of digging out elm tree borers with his pocketknife, he rigged up a small magneto, connected it to two nails driven into a tree and turned on the electric current. Investigation revealed that the shocks had routed all the borers from the first tree and the treatment was applied to all others on the property, with the same result.

Victor H. Schmidt

817 W. 45th St.



NEW and different, Togo promises to set a new record of efficiency in clearing up Athlete's Foot trouble.

In one case Togo did the work where 14 other products had failed. Togo has an antiseptic and germ-killing action.

Easy and simple to use. Does not stain the feet. No offensive odor.

Manufactured under United States Patents and *guaranteed to do its job or you get your money back.*

Your druggist can get Togo for you—or use the coupon below, and let Togo end your trouble without waste of time or money.

TOGO, 333 N. Michigan Ave., Chicago, Ill.
I enclose \$1.00 for full size package of Togo, to be sent prepaid, which I am buying on your "results-or-money-back" offer. P.M.10-36

Name.....
Address.....
City..... State.....

Print Your Own
Cards, stationery, circulars, tags, labels, advertising, etc. Save money. Print for Others. Big Profits; easy rules sent. Will do popular Raised Printing like Engraving. Presses \$11 up, power \$149. Send for free catalog and all details. THE KELSEY COMPANY, C-37, Meriden, Conn.

FIREX
AUTOMATIC FIRE EXTINGUISHER AND ALARM

1—Anti-Fire Devices in one: 1—AUTOMATIC Fire Extinguisher. 2—AUTOMATIC Fire Alarm. 3—Hand operated fire extinguisher. On duty 24 hours a day—No refilling! No recharging—Hermetically sealed—unless released by fire, will last indefinitely. Nothing to get out of order. Priced lower than the average extinguisher. Pays GENEROUS COMMISSIONS. Every home, business place, institution, automobile, truck, etc., is your prospect. Tested and Approved by Automotive Test Lab. of America. Recommended by Insurance Men, Fire Chiefs, etc., as protection for property and human life against fire. Merit already proven. A year round seller. Write for territory and testimonials from actual fires.

FIREX CORPORATION, Dept. K-200, 516 S. Broadway, St. Louis, Mo.

does not answer

1937 RADIO CATALOG

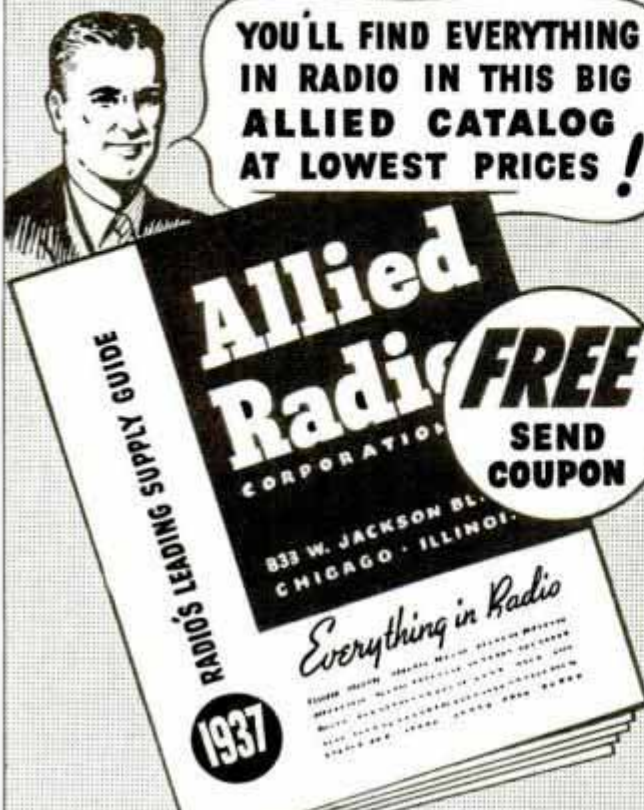

YOU'LL FIND EVERYTHING IN RADIO IN THIS BIG ALLIED CATALOG AT LOWEST PRICES!

FREE SEND COUPON

Allied Radio CORPORATION
833 W. JACKSON BL.
CHICAGO - ILLINOIS

Everything in Radio

1937

RADIO'S LEADING SUPPLY GUIDE

KITS PARTS AMATEUR P.A. TEST EQUIP'T SETS TOOLS BOOKS

SAVE MONEY with This 1937 Radio Catalog

Write for the big new 1937 ALLIED Radio Catalog. 152 pages packed with Everything in radio—new Metal Tube radios—4 to 17 tubes—AC, battery, 32-volt, 6-volt and auto sets; dozens of new Set-Builders' Kits; everything in Short-Wave Receiving and Transmitting Equipment; new Public Address systems; also thousands of exact duplicate and replacement parts, radio books, tools and latest test equipment.

Why your Dollar buys More at ALLIED

Because we buy in vast quantities, we get lower prices, and can sell for less. If you ever find identical brand and quality offered elsewhere for less, we'll refund the difference. Fresh, clean stocks, all under one great roof—your order shipped promptly. We save you time and money.

Free PARTS LISTS

Write to us for Free parts lists covering:

- 1 Tube Portable (R209); 2 Tube AC-DC (R211); 4 Tube Battery Portable (R223); 3 Tube All Wave (R224); 6 Tube All Supply (R226); One Tube Flashlight Cell Set (R227); Pre-Amplifier (R228); etc.

We can supply matched kits for building any Popular Mechanics circuit.

ALLIED RADIO

833 W. Jackson Blvd.,
Chicago, Ill.

Dept. 5-K

Send me FREE 1937 ALLIED RADIO CATALOG.

Send me FREE Parts List for.....

NAME

ADDRESS

CITY..... STATE.....

Reading Schematic Diagrams

(Continued from page 580)

completed chassis. When wiring the circuit, following the simplified wiring diagram, the builder should always check his work with the schematic diagram. In this way errors are not only avoided but at the same time the beginner will quickly learn to identify the symbol used to indicate the part that has been sketched in on the simplified or picture diagram.

Many beginners ask the meaning of the letters R, C and L that appear with a sequence of numbers near the various resistor, condenser and coil symbols in radio diagrams. The letters and numbers merely refer to the values of these parts as given in the material list. For example, R₁ may indicate a 1,000-ohm resistor, which may be either of the fixed or variable variety. If several resistors of this same value, and type, are used in the circuit, they all will be indicated as R₁. Then, resistors of other values and types will be indicated as R₂, R₃, R₄, etc., in sequence as they appear in the schematic diagram and the original material list. This also applies to C and L.

It will be noted that the symbol which is used for an electrolytic condenser is marked for polarity. This is highly important as it must be connected in the circuit with the positive and negative terminals just as shown in the diagram. The polarity is plainly marked on the condenser, by the manufacturer. Some electrolytic condenser units are of the double or triple-section variety having several flexible colored leads that not only indicate polarity but also the value of each section. The black lead is usually negative and common to the other sections. Electrolytic condensers are available in both metal cans and cardboard containers. In schematic diagrams the various condenser-unit sections may be indicated at widely separated points in the circuit; however, the polarity and value of each are shown.

Tube symbols commonly show bottom views of socket connections as well as the internal elements of the tubes. Tube characteristic charts, including standard symbols for all tubes, can be obtained from the various tube manufacturers upon application. Another article in this series of helpful hints for beginners, will appear in an early issue.

Stoves AT FACTORY PRICES!

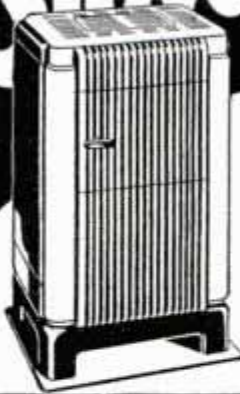

SALE CATALOG—FREE

Over 200 Styles and Sizes of Stoves, Ranges, Furnaces at Factory Prices and Easy Terms—as little as 18c a day. More Bargains than in 20 Big Stores. New styles, new features, new colors. Year to Pay—30 days' free trial—360 days' approval test—24-hour shipments, THE KALAMAZOO STOVE CO., Mfrs., 391 Rochester Avenue, KALAMAZOO, MICH.

Over 1,000,000 Satisfied Users
"A Kalamazoo Direct to You"
 Write for FREE Catalog
 Trade Mark Registered

DO YOU

WANT a new business profession of your own, with all the trade you can attend to? Then become a foot correctionist, and in a few weeks earn big income in service fees,—not medical nor chiropody—easy terms for home training, no further capital needed, no goods to buy, no agency. Established 1894. Address Stephenson Laboratory, 1 Back Bay, Boston, Mass.

GENUINE ARTCO CUTTING TOOLS GIVE YOU SATISFACTORY SERVICE

SAVE UP TO 50% Now

Special Offer 6 different cutters as shown; finest steel for filing, carving, cutting, engraving on all woods, plastics, metals (1/4"x1 1/2" shanks). Fit all hand grinders and stationary machines. Keen, sharp edges. When prepaid we pay the postage.

Over 500 shapes available. Largest stock in America. Dealers get our profitable proposition.

ONLY \$3.20 REG. \$5 VALUE

SEND FOR FREE BOOK

AMERICAN ROTARY TOOLS CO., INC.
 44 Whitehall St., Dept. A-2, N. Y. City

DEAFNESS IS MISERY

Many people with defective hearing and Head Noises enjoy Conversation, Movies, Church and Radio, because they use Leonard Invisible Ear Drums which resemble Tiny Megaphones fitting in the Ear entirely out of sight. No wires, batteries or head piece. They are inexpensive. Write for booklet and sworn statement of the inventor who washed himself deaf.

A. O. LEONARD, Inc., Suite 699, 70 5th Ave., New York

POPULAR MECHANICS FAMILY TRAILER PARTS

Available from Hammerblow Tool Company—the original.

Don't build until you get Hammerblow facts. Save money, time, wasted labor. Hammerblow guarantees a rugged, non-swaying, perfect trailer! **BLUEPRINTS FREE WITH PARTS.** Hammerblow parts are world's best. Used by nationally known mfrs. and engineers who know. Send only 50c for 64-page Trailer Builder's Guide and Free 40-page supplement. Immense value. Or write for Free Literature. **HAMMERBLOW TOOL COMPANY, Dept. 110, Wausau, Wis.**

EXTRA \$5 in SPARE TIME PRINT at HOME

Letterheads, circulars, billheads, cards. Printing pays BIG. Easy, interesting, educational. **Printing Press Bargains \$12.** Types and Supplies, lowest prices. Send stamp for catalog. **PEIFFER Co., 86-A, 6 Columbia St., Newark, N. J.**

ASK FOR **LEPAGE'S** CASEIN GLUE
 A real CASEIN GLUE

Sensational BARGAINS

Brand New Portables

VERY LATEST FEATHERWEIGHT MODEL Now Only 10c a day ON EASY TERMS



SEND NO MONEY—FREE TRIAL

Here at last—is the perfect family portable—the most revolutionary achievement in typewriters. Think of it—a fully complete, FEATHERWEIGHT, streaming model with standard 4-row keyboard, standard paper roller and every essential feature, weighing less than six (6) lbs. Priced at a great saving. Positively a mechanical jewel. Not a toy or incomplete model. The only Real Portable—mechanically perfect and complete in every respect, yet so light a child can carry it with ease. Fits into small brief case or table drawer—only 2 3/4 in. high. Guaranteed to last years.

Only by actually seeing and trying this amazing portable can you appreciate its superiority. Use Special Coupon below without risk.

FREE Typing Course

Send for 10-day trial—without obligation to buy—while special introductory low price holds good. See and try for yourself. If you decide to keep it pay only \$37.50 cash or 10c a day on easy term plan of \$3.00 a month until \$39.75 (term price) is paid.

SPECIAL OFFER—ACT AT ONCE!

INTERNATIONAL TYPEWRITER CO. Dept. P1001
 Franklin and Monroe Sts., Chicago

Please send the DeLuxe FEATHERWEIGHT Portable F. O. B. Chicago on 10 days Free Trial. If I decide to keep it I will pay \$37.50 cash or \$3.00 a month until \$39.75 (term price) is paid. Or, if I am not perfectly satisfied I can return it within the 10-day trial period.

Name..... Age.....
 Address.....
 Town..... State.....

For quick shipment give references and occupation

—A. C.— \$27.50 LIGHT PLANTS

SUPPLY 850 WATTS ALTERNATING CURRENT FOR LIGHTING, APPLIANCES, RADIO. A thoroughly dependable source of electricity for farms, camps, boats, etc. Light weight. Economical operation. Powered by dependable air-cooled engine. Fully guaranteed. 1,000 watt size also available at \$49. Write for full information, **J. C. ROCKE COMPANY, 226 Acheson Building, Berkeley, Calif.**

Men Wanted at Once

Make Money Calling on Stores

New occupation. Pays big money at once without investment. Introduce sensational new line 5c and 10c necessities to stores. Self sellers. Permanent repeat business easy. Experience unnecessary. Start free. Write **PRO-CO-PAX** Dept. 25-D 1956 S. Troy CHICAGO

JUST OUT

100 Million Customers

NEW BIG MONEY MAKER

Amazing new invention. No competition. Everybody wants it. 2 to 8 every home. **Sells on sight.** Bond-Ore: orders 2188, less than 60 days. May-Wise: 720, less than 30 days. Phillips-Ky: Ship 12 doz. Quote price 1000 lots. Butcha-Wise: rush 144. Everybody wants it. Ridgely-Calif: Rush 864 Dental Steros. Draft enclosed.

ACT NOW—CASH IN QUICK

Handiest method ever known for care of tooth-brushes. Sell 50c brush & 25c glass sanitary container & sterilizer with wall-bracket—all for only 50c. Big surprise awaits you. Chance for real clean-up. **Spare or full-time workers.** Make dollar or more every hour. Save time: get quick start. **Send 55c in stamps for two complete outfits or write for full details.** **DENTAL-STERO CO., 29-17th St., Dept 53, Toledo, Ohio.**



NEW LIFE FOR LIGHT MOTORS, AUTOS, HINGES,
ACTION POINT OF TOOLS, LOCKS, ETC.

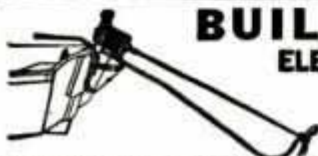

BUILD YOUR OWN ELECTRIC OUTBOARD MOTOR

from old auto generator. We show you how. Variable Speed. Light weight and Silent. Operates from 8 to 12 hours on ordinary storage battery. Dime brings complete

plans and catalog. Wind Driven Cottage Light Plants, Motors, etc.
LEJAY MFG. 1547 W. LAKE MINNEAPOLIS, MINN.

SCROLL PATTERNS EASY TO DRAW



With this inexpensive rule anyone can draw curved designs with ease. The rule is easily bent to any desired curve with the fingers. It gives a graceful curve free from irregularities, bumps or wavering. Once bent, the rule stays curved without being held.

PRICE, POSTPAID, \$1.25

ARTHUR BROWN & BRO. 127 Lexington Ave. New York City

2 Dog Worm Capsules



Worms cause 75% of a dog's ills. Worming protects and frequently restores dog health. Worming is now made easy and sure. The new "can't-go-wrong" Pulvex Worm Capsules expel Tape, and Round and Hook Worms . . . all in the same dosing. No gassing, gagging, or harmful effects. No chance to guess wrong and use wrong type of capsule. Guaranteed. At leading pet, drug and department stores, 75c, or William Cooper & Nephews, Inc., 1950 Clifton Avenue, Chicago, Illinois.

*Expels
all 3 kinds
of Worms*
**IN ONE
DOSING**

**NOW
combined
In One**

PULVEX *Combination*
WORM CAPSULES

Feeding Animals in the Zoo

(Continued from page 511)

the great East Indian hornbill snap one of these meat balls which the keeper has thrown into the air.

On the other hand, the hay and grain eaters are not greatly different from Dobbin and Bossy. An elephant will put away his sixty to 100 pounds of hay together with a half bushel of bran, although eating the latter is an acquired knack. When the elephant was first brought to the zoo



It's "teatime" for this two-year old lion, but don't let the teacup fool you. This youngster is old enough to want good, red meat—ten to twenty pounds of it a day

the bran looked like dust to him and he used it for throwing on his back to keep the flies away.

Many odd problems of feeding develop at the zoo. The cheetah, for example, is a rare and beautiful cat and, while other members of the family get along on one meal a day, it is favored with milk and eggs for breakfast and pigeon or chicken for supper. Hyenas are predisposed to goiter and their diet must be watched very carefully. The king cobra wolfs a pigeon now and then but goes long periods with nothing at all.

In the wild state the giraffe has a practical monopoly in browsing among the treetops, the leaves of the mimosa being its favorite food. In captivity, however, it takes to hay on the ground.

When Norwegian reindeer first came to the zoo shipments of moss were brought regularly from Maine and mixed with their hay and grain, but they were tapered

(Continued to page 138A)

ATLAS LATHES

\$35⁵⁰
AND UP



METAL CUTTING

Model illustrated \$82.50 complete less motor. Back-gear. Screw cutting. Automatically reversible power feeds. Has features found on no other lathes. Many models to choose from at prices and terms to fit your budget.

SEND FOR 42 PAGE BOOK

IT'S FREE! Describes and illustrates the complete line of Atlas metal lathes, wood lathes, drill presses, tools and attachments. Also describes the Atlas 6% time payment plan.

ATLAS PRESS COMPANY
1043 No. Pitcher Street, Kalamazoo, Michigan

OTTAWA LOG SAW



**GREATEST OFFER
EVER MADE**

only **\$39**

**PUTS THIS
OTTAWA
TO WORK FOR YOU**

Make Money! Wood is valuable. Saw 15 to 20 cords a day. Does more than 10 men. Ottawa easily operated by man or boy. Falls trees—saws limbs. Use 4-hp. engine for other work. Write today for **FREE** book.

OTTAWA MFG. CO., 1013 Wood St., Ottawa, Kansas



BIG 3½ FOOT TELESCOPE Count Cattle 10 Miles away. 5 sections, 10-Power. Brass Bound. Eye-Piece for viewing Sun, FREE. Makes good Microscope. Postpaid \$1.90, C. O. D. 20c extra. Guar.
BENNER & COMPANY T-490 **TRENTON, N. J.**

HANDEE TOOL OF 1001 USES!

**FASTER,
BETTER JOBS!**

Does away with slow hand work. Plugs in any light socket. A. C. or D. C., 110 volt, 13,000 r.p.m. For use at home in shop or take to job. Uses 200 different accessories—grinds, polishes, routs, drills, cuts, carves, sands, saws, sharpens, engraves. **\$10.75** and up postpaid. 3 Accessories **FREE**.

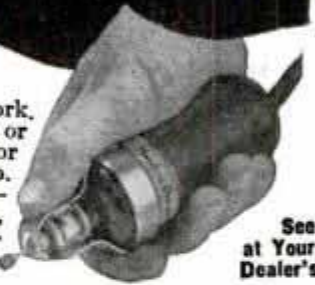

See
at Your
Dealer's

★ THE De Luxe MODEL Revolutionary Performance

For constant service . . . nothing else like this easy-to-handle production tool for saving time and labor. Fastest, smoothest, most powerful tool for its type and weight . . . 25,000 r.p.m. **\$18.50** postpaid. 6 Accessories **FREE**.

Order Either Model on 10-Day Money-Back Trial or Send for FREE Booklet.



SEND FOR
Free **BOOKLET**

New CRAFTSMAN Project Book

"Pleasure and Profit with a Handee." Easy working plans for making many interesting and unusual projects 25c, stamps or coin.

Chicago Wheel & Mfg. Co.
1101 W. Monroe St. Dept. Q
Chicago, Ill.

World's Lowest Priced Quality Home!



\$493

Buy direct from Mill. Save \$200 to \$800. Price includes all lumber readi-cut, millwork, windows, doors, interior woodwork, hardware, roofing, glass, nails, paints, varnish and stains. **We pay freight.**

BUILD IT YOURSELF

Aladdin's famous Read-cut System saves labor costs and lumber waste. Complete plans for quick, easy erection. **FREE Catalog** shows many designs in newest type Homes, Summer Cottages, Garages, and Automobile Traller Coaches. Write for it **today**. Address nearest office. Ask for Catalog No. 690.

THE ALADDIN CO. BAY CITY, MICHIGAN
PORTLAND, OREGON

AMAZING NEW KIND OF



**BURNS
96%
AIR!
ONLY 4% FUEL**

Amazing new discovery gives you instant heat from liquid fuel—glowing, sunlike, healthy radiant heat. A few pints of cheap liquid transform ordinary air into many hours of snug heat for only 1½¢ an hour. This invention built into a new-type modern portable radiant heater will heat a big room even in zero weather.

NO SOOT, NO ASHES . . . PORTABLE!

It is absolutely safe, needs no installation, has finger-tip control. Hotter than city gas or electricity at tenth the cost. It means no more wood or coal, no more ashes or dust. Use it anywhere. Ideal for home, cottage, camp, farm, roadstand.

30-DAY TRIAL IN YOUR HOME!

Prove to yourself why thousands are delighted with this amazing new heater. Get it on 30-day trial, use it for a month at our risk before deciding! **WRITE TODAY FOR DETAILS!**

AKRON LAMP & MFG. CO.
1200 HIGH ST. AKRON, OHIO

HEAT

FOR ONLY
**1½¢ Per
Hour!**

AGENTS! This marvelous heater selling quickly everywhere. You can make big full- or spare-time profits. Write at once!

Build this ESKIMO CANOE

... It's one of the 20
FREE CASCO PROJECTS

The Eskimo word for this light, one-man boat is "Kayak." The woodworker of average ability can build it easily and economically. And it's lots of fun!

HOW YOU GET FREE PLANS

The green ticket in every 25c (or larger) can of CASCO entitles you to any one plan of these 20 projects, absolutely free. The plan comes to you complete in every detail. No extras to buy... you get exact working directions, plans, and list of materials necessary to build, in your own workshop, the projects you select. This free project service is designed for you... start to use it. Buy your can of CASCO today, at any Hardware, Paint or Lumber Dealer.

● **ILLUSTRATED FOLDER**

HELPS YOU SELECT YOUR FREE PLAN



Free!

Stick the coupon below on a penny postcard. The mailman will bring you the folder that describes and pictures the 20 CASCO prize projects.

CASEIN COMPANY OF AMERICA, Inc.
850 Madison Ave., New York, N. Y., Dept. P.M. 1036
Please send folder about Free Project Service.

Name.....
Address.....

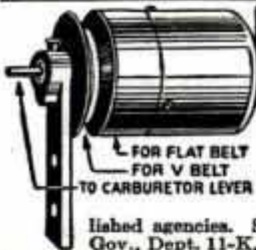

AUTO ENGINE SPEED CONTROL GOVERNORS

FOR FLAT BELT
FOR V BELT
TO CARBURETOR LEVER

To control speed of any make of auto or truck engine, regardless of load changes, when used as a stationary or portable power plant. Fully guaranteed. No cash down. Governor speed range from 400 to 3000 R.P.M. Fine opportunity for established agencies. Send for free circulars. Mfrs. Candee-Smith Gov., Dept. 11-K, 215 No. L. A. St., Los Angeles.

MOON TELESCOPE showing lunar craters.....\$1
SPECTROSCOPE for sun and ore spectra, \$2.50
CARBON ARC for generating spectra.....\$1
ELECTRIC FUN book, 200 stunts, 110 volts..\$1
KUTTING SONS, 106 M St., CAMPBELL, CALIF.

ELECTRICITY ANYWHERE

from your own complete, fully automatic Kohler Light-and-Power Plant

Just the thing for country home, cabin, camp, boat, store, filling station, etc. Rugged, portable, compact, easily installed, trouble-free. Self starting and regulating. Low operating cost. Generates standard current for lights, radio, electrical appliances, small power tools. Many models—600 watts up, A.C. or D.C. \$265 up, f.o.b. Kohler. Coupon brings details.



KOHLER OF KOHLER
Planned Plumbing and Heating Equipment

KOHLER CO., Kohler, Wisconsin
Send "Kohler Electric Plant" leaflet PM-10

Name.....
Address.....

(Continued from page 136A)

off and now get along without it. The gnu is a spunky fellow and young ones, when first captured in Africa, refused to eat. Finally they were tempted with oatmeal, were delighted with it and ate it all the way to Washington.

The apteryx is a rare, flightless bird from Australia. It is very shy, hiding by day and coming out only at night. It has a long beak at the end of which are sensitive scent glands. It used to grovel for worms with this in the wild state. At the zoo it could be induced to eat only by burying strips of meat about its cage which it would smell out by night and devour. Owls also like their meat arranged for them in advance, hung out where they can get it when they come out in the dusk. Most birds, however, are grain eaters and relish rice and sunflower seed. The lorries, of Malay, are quite fastidious and it becomes necessary to soak bread in milk, fruit juice and honey, for their gratification.

The animals have their equivalents of ptomaine poisoning, acute indigestion and what not. The cassowaries, for example, have certain trouble in dietary matters. Salted peanuts do not seem to set very well on their stomachs. One died after receiving too liberal portions of peanuts at the hands of visitors. An otter also died from eating peanuts, and eight noisy magpies, ordinarily hardy birds, went the same way.

A giant condor from the crags of the Andes died suddenly and an autopsy showed that it had a ball of lead foil in its stomach, evidently tossed idly into its cage by a visitor.

Even deadlier than peanuts at the zoo in Washington are laurel leaves. A handful thrown into the angora goat enclosure one day resulted in the death of six of those animals reputed to thrive on tin cans. Many of the monkeys are leaf eaters and so, one day, when some laurel leaves were passed into the Diana monkey, the only one of its kind in America, it ate them and died in convulsions.

Names and addresses of manufacturers and dealers in articles described in this magazine will be furnished by our Bureau of Information upon request accompanied by stamped, self-addressed envelope.

BIG MONEY ASSEMBLING AT HOME



KI-YAKS ICE BOATS MOTOR SLEDS

from complete "cut-to-fit" kits at amazing low cost. Ki-yaks: 3 sizes for paddling or sailing. Also outboard model. Fast, seaworthy. Lift with one hand or take anywhere on auto. (Complete sail rig a few dollars extra.) WINTER SPORTS. Start now on your Ice Boat or motor sled and be ready for first freeze or snow. New models, easy to assemble. Rush 10c for circulars and \$6.00 gift paddle offer on Ki-yaks. Hurry!



2400 Degrees F!!

BRONZE FOUNDRY

for Schools and Home Workshops



Complete Foundry Outfits are available in three sizes and make it possible for you to produce beautiful bronze, silver or aluminum castings in your home workshop. Presents such as book ends, ash trays, dishes, paper weights, letter openers, bottle openers, statuary, etc., can be quickly made by the sand casting process. Existing objects can be used as patterns, and sand moulds made in a few minutes' time. Previous experience unnecessary. Domestic gas supply and 110 volt 60 cycle energy required for operation.

Capacity	Wt.	Casting Complete	Price
351 6 cu. in.	23 lbs.	1 1/2 hrs.	\$ 9.50
352 12 cu. in.	40 lbs.	3 hrs.	15.00
353 24 cu. in.	65 lbs.	6 hrs.	23.50

For 110 volt D. C. or 25 cycle energy add \$4.00. Prices f. o. b. K. C. plus 1% Missouri sales tax. Check or money order acceptable, express charges C. O. D. Write for circular.

KANSAS CITY SPECIALTIES CO.

P. O. Box 6022

Kansas City, Mo.

THROW AWAY YOUR AERIAL!



New scientific principle! Quickly connect the Warren Compact Antenna to your radio and discard your old aerial. As good or better volume and reception ABSOLUTELY GUARANTEED. Reduces noise. Can't get out of order. Sealed Bakelite Case. Size 3 in. by 3 1/4 in. Price \$1.95 postpaid. Money refunded if not satisfied.

Dealers Wanted

WARREN ARMATURE WORKS, Dept. A, WARREN, OHIO

60 POWER TELESCOPE \$2.29

VARIABLE EYEPIECE. 20X-40X-60X

NEW! Three telescopes in one. 3 different magnifications. 20 power for ultra-bright images with 40 and 60 power for extra long range. Guaranteed to bring distant objects, people, sports events, ships, moon, stars, etc., 60 times as close. Most powerful made for anywhere near the money. Can be collapsed to less than a foot in length. Multiple lens system. 30 mm. objective, in heavy brass mount. Directions included for using as a compound 4 lens microscope. American made. We pay the postage. Only \$2.29.

BRUNSCOPE CO., Dept. 410, 234 Fifth Ave., New York, N. Y.

Trailer Travel Magazine



Keep abreast of trailer travel and trailer life!

If interested in trailer lore as owner, builder, buyer or prospect, you want the only magazine devoted exclusively to—

- News, articles and stories on all phases of trailer life.
- Current events in the trailer world.
- Official announcements of all trailer conclaves.
- Trailer tours and trailer camp information.
- Lists of national, state and local trailer parks.
- Developments in the trailer industry.

- New features in trailer construction and equipment.
- Helps for the trailer home-builder.
- Federal, state and local laws and regulations.
- Hunting, fishing and other sports via trailer.
- Housekeeping on wheels by the trailer wife.
- Advertisements—a directory in themselves of the field.

For 1 year monthly mail, \$1, or for sample copy 10c
TRAILER TRAVEL Magazine, PM10, 180 N. Michigan Ave., Chicago

LOW COST POWER

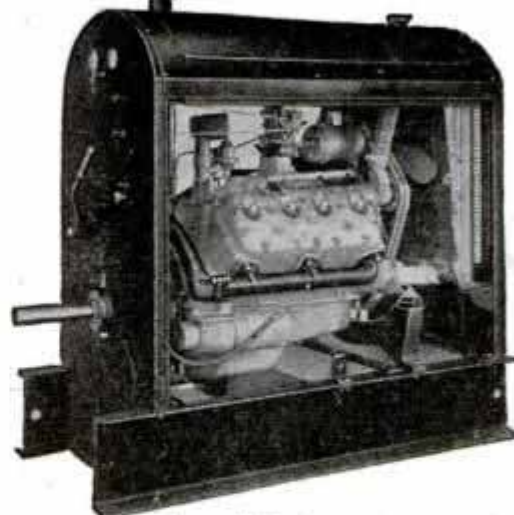

with this
KRW-
FORD
V-8
UNIT

Here's dependable, low-cost power up to 60 H.P.—complete, compact, portable. Ideal for welders, compressors, hoists, pumps, amusement devices, well drillers, agricultural and contractors' equipment, etc. For complete information, prices and data showing how a K R W Unit will pay for itself out of savings in a few weeks, write us or see your local Ford Dealer.

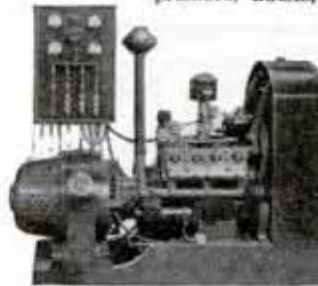

ALSO K R W ELECTRIC PLANTS
110 or 220 volts—20 KW. Available also in same frame to produce single phase, three phase or direct current and also as an arc welder, plating dynamo or with pulley for power take-off. Speed 1800 R.P.M.

K. R. WILSON 17 Lock St. BUFFALO, N. Y.
EXCLUSIVE BUILDER OF APPROVED FORD SHOP EQUIPMENT SINCE 1916

"a miracle of type-writer smoothness" —the new CORONA!

We've made nearly two million good portables—but these new Coronas hit a new high. Floating Shift, also Touch Selector, etc. Case and Touch-typing lessons included. Easily the best value we've ever offered. Now on display everywhere. Easy terms —\$1.00 a week.



with the famous "FLOATING SHIFT" —exclusive Corona feature

On most portables, the carriage lifts when you shift for capitals. Not on CORONA! Only the light type-segment moves—and it goes down, not up! That's the famous "Floating Shift"—makes typing quieter, faster, easier. Be sure to try it at your dealer's—or send coupon for leaflet.

-----MAIL COUPON TODAY-----
L C Smith & Corona Typewriters, Desk 10
723 E. Washington St., Syracuse, N. Y.
I'm thinking of buying a Corona. Please send free booklet showing models and prices.

Name.....
Street.....
City..... State.....

When writing please mention Popular Mechanics

CROSMAN SILENT .22 RIFLE



Rifled barrel

NO CLEANING ADJUSTABLE POWER LOW COST AMMUNITION

Grooves inside barrel make the Crosman a real rifle with all the hair-splitting accuracy this term implies. Shoots bullet (pell) same diameter as .22 powder rifle, but silently, powerfully, with no recoil, using the terrific force of compressed air—same force U. S. Navy uses to drive 2000 lb. torpedoes. Marvelous for target, small game. Single and 20 shot repeater models. No license required.

SuperPells



Best for all .22 cal. air rifles. Heavier, longer, more perfectly formed (secret process), thus harder hitting and more accurate. Made to American standards by American workmen. Write for folder.

FREE BOOK

Containing important target and game shooting facts; also Crosman Catalog. Write. Ask Your Dealer to Show You a Crosman.

CROSMAN ARMS CO., Inc., 387 St. Paul St., Rochester, N.Y.

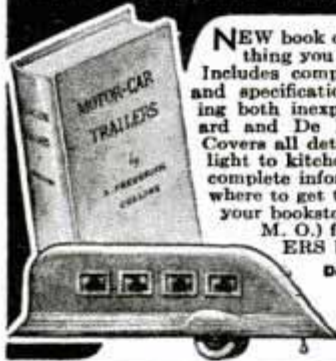
Build Your Own Trailer At Home



NEW book contains everything you need to know. Includes complete diagrams and specifications for building both inexpensive Standard and De Luxe Models. Covers all details from tail-light to kitchen stove, with complete information as to where to get them, and what to pay. At your bookstore, or send \$2.00 (check or M. O.) for MOTOR CAR TRAILERS by A. Frederick Collins to Dept. 710, J. B. Lippincott Co. 227 South 6th St. Philadelphia, Pa. Money back if not delighted.

ONLY \$2.00 Complete!



FREE FALL CATALOG JUST OFF THE PRESS

Most complete sporting goods publication in the East. Detailed description of hundreds of hunting and camping necessities, most of which we manufacture.

L. L. BEAN, Inc.
268 Main St., Freeport, Maine

Make Big Profits Filing Saws by Machine

Start in Spare Time—Earn Up to \$2 or \$3
an Hour—No Experience Needed

"Am still operating my Foley Filer after 5 years. Business better than ever this year," reports J. W. Veith, Pa. A FOLEY Automatic Saw Filer files hand, band and circular saws perfectly, quickly. No eyestrain. All cash business, no canvassing. Send postcard for FREE PLAN, no obligation.

FOLEY MFG. CO., 1016-6 Foley Bldg.
11 Main St. N. E., Minneapolis, Minn.



Horseshoe Pitching Comes Back

(Continued from page 542)

be to his right. Then, too, for the latter, it is advisable to hold close to the toe so that the shoe can be balanced better and result in a good swing. The grip should be at all times firm, comfortable and natural.

The one and three-quarters turn calls for more wrist action than the other grip to make the shoe open. Some players swing the shoe edgewise along the side of the leg to enhance the wrist action at the point of release. It is not necessary to do this on the one and one-quarter turn. It does have a tendency, however, of helping the shoe make a dead landing. The easier you can make a shoe land, the less chance of a ringer bouncing off.

Proper stance and delivery also are important. If you are a right-handed tosser, stand about eighteen inches on the left side of the peg. The right foot should be even with the peg and the left five or six inches back. It is imperative the right-handed player learn to step forward with the left foot as this is what supplies rhythm to the action.

The shoe should be held out in front of the face to get the proper alinement of the opposite peg with the arm swinging in a direct line to the stake. Another reason for this is that the backward swing is more easily accomplished because the weight of the shoe gives impetus to the swing.

When delivering the shoe, step a trifle longer than you normally do unless, of course, you are accustomed to taking long strides. The idea is to take a natural, easy step that will furnish enough propelling power for the flip.

With the body balanced and the swing directly toward the opposite stake, the player should endeavor to make each pitch alike. A naturally easy swing is best, whether it be long or short, the former being more beneficial if it can be mastered. The backward swing should extend back as high as the head, or higher, if possible. Both the backward and forward swings should be nearly alike without any push to the delivery.

As in golf, a horseshoe pitcher must follow-through on his swing if he ever hopes to rise above mediocrity. The follow-through in this case supplies the

(Continued to page 142A)

NOW I KNOW WHAT FRED MEANT WHEN HE SAID HE GOT HIS PAY BOOST OUT OF A TWO DOLLAR BOOK.



**PAY RAISING
EXTRA MONEY
BOOKS
THAT WILL HELP YOU
WIN SUCCESS**

You, too, will find the selected list of practical books below just what you need to help you improve your job, prepare for a better one, or add to your income through spare time earnings. Thousands give these books credit for their success.

SEND NO MONEY! Use this advertisement as an order blank. Check books wanted. Add name and address and mail. Just pay postman price plus few cents postage. (In U. S. and possessions.) Or remit with order and add 10 cents per book for postage.

POPULAR MECHANICS PRESS

Room 1036B 200 East Ontario Street Chicago

- AIR CONDITIONING**
Live Field; Great Future... \$3.50
- AUTO ENCYCLOPEDIA**
The Famous Dyke's Latest Edition... \$6.00
- 110-V. GENERATORS**
Made From Old Auto Units... \$1.00
- BIRD HOUSES**
Build to Sell; Easy Designs... \$1.00
- BOAT BOOK**
Power, Sail, Rowing, Paddle Plans... \$3.00
- BOY MECHANIC**
Hundreds Things Boys Can Make... \$2.00
- BUILT-IN FURNITURE**
Take Orders, Make Money... \$2.50
- CARPENTRY, PRACTICAL**
Complete 436 pages, 1936 Edition... \$2.00
- CHEMISTRY, PRACTICAL**
Make Hundreds Things Daily Use... \$2.00
- CONCRETE WORK**
173 Uses Described, Pictured... \$1.00
- DIESEL HANDBOOK**
New! Latest Information... \$5.00
- ELECTROPLATING**
Modern Practice Including Nickel, Zinc, Cadmium and Chromium... \$2.25
- FURNACE HEATING, WARM-AIR**
Every essential covered, 568 pages... \$3.00
- V-8 FORDS**
Also "A" and "B" Models, All New... \$2.50
- FORMULAS**
10,000 Money Making... \$4.00
- FROG INDUSTRY**
New! Raise and Sell Profits!... \$2.00
- FURNITURE MAKING**
Tools, Materials, Designs... \$2.50
- HYPNOTISM**
How to Become an Expert... \$2.00
- LATHE WORK (Metal)**
Drilling, Threading... \$1.00
- LOCOMOTIVE**
Folding Chart Shows all Parts... \$1.00
- LOG CABINS**
Easy Plans; Build for Profit. Value!... \$2.50

- MATHEMATICS**
Easy Guide for the Practical Man... \$1.50
- MECHANICAL DRAWING**
Learn Drafting; Good Salaries... \$1.00
- METAL PRODUCTS**
Finishing Just Out... \$3.50
- MONEY MAKING IDEAS**
1000 Ways to Make \$1000... \$2.50
- OIL HEATING**
Handbook Just Out... \$3.50
- PLUMBING**
500 Facts Every Homeowner Should Know... \$1.50
- POULTRY**
Breeding, Management, Protect Your Profits!... \$2.00
- TEST GOLD—PLATINUM**
Identify—Buy—Sell, By C. M. Hoke... \$1.00
- PROSPECTORS' HANDBOOK**
How to Mine, Appraise, Equip... \$3.00
- RADIO SERVICING**
Profit by Knowing Costs, Kinks, Etc... \$4.00
- REFRIGERATION**
Electric, Gas, Be a Service Expert... \$4.00
- REWINDING ELECTRIC MOTORS**
Fractional Sizes, Value!... \$2.50
- SHIP MODEL**
Entire Text, Famous "Sovereign" of 1637... \$1.00
- SHOP NOTES LIBRARY**
5 Vol, 2000 Wonderful Shop Ideas... \$2.50
- STAMP ALBUM**
Modern, 400 Pages... \$1.00
- STEEL SQUARE**
How to Figure Angles of Rafters, Roofs, Etc... \$1.00
- TELEVISION**
New! Book of the Hour... \$2.50
- TOYS**
For Amusement or Profit, Saleable Designs... \$1.50
- UPHOLSTERY**
Always a Big Market, Start Own Business... \$2.00
- WELDING ENCYCLOPEDIA**
Covers all kinds welding thoroughly... \$5.00

Modern **OIL HEATING**
STOVE HAS 5 big advantages

**BEAUTIFUL
NEW SUPERFEX
HEAT-DIRECTOR
OFFERS:**

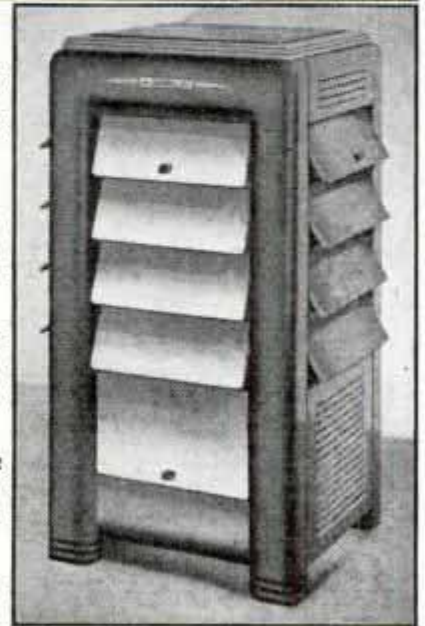

Superfex Heat-Director No. 1019, one of eight oil burning Superfex models

- 1** Circulating, radiating and directed heat, an exclusive feature
- 2** The comfort of adequate heat volume with instant control by dial
- 3** The convenience of steady heat that holds over night
- 4** The cleanliness of oil, the fuel that does away with ashes
- 5** The beauty of modern styling and quality porcelain enamel finish

Here's stove-heating that's clean and convenient. Superfex Heat-Director circulates and radiates heat, also directs heat rays by means of patented adjustable shutters on three sides. One filling of the removable oil reservoir gives as many as forty-two hours of comfort. See your dealer.

Send for our free booklets.

For one-room chilly spots, get a portable Perfection Room Heater in smart modern design. For central heating with air conditioning, choose a Superfex Oil Burning Air Conditioning Heating Plant.

The mark of Quality



SUPERFEX
Oil Burning **HEATERS**

PERFECTION STOVE COMPANY
7758-A Platt Ave. • Cleveland, Ohio

Please send me the booklets I have checked:

SUPERFEX Heat-Directors and Radiating Heaters. Oil burning portable PERFECTION Room Heaters. SUPERFEX Air Conditioning Heating Plants.

NAME _____
ST. or R. F. D. _____
POST OFFICE _____
COUNTY _____ STATE _____

When writing please mention Popular Mechanics



Make Your Fall Hunting Pay Future Dividends



While hunting this fall in your favorite game cover take a census of the birds it holds. If there's a serious shortage, or no shooting surplus over the necessary breeding stock, we can tell you exactly what to do to insure future dividends in greatly improved shooting.

The Western game restoration plan has been tested and proved at our own game farms. Mail Coupon NOW for FREE "Manual of Game Management" Complete information you've long wanted!



WESTERN CARTRIDGE COMPANY
 Dept. J-46, East Alton, Ill.
 Mail, FREE, a copy of your MANUAL OF GAME MANAGEMENT.
 Name.....
 Address.....
 Post Office..... State.....

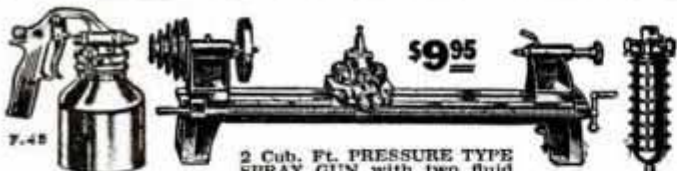

tips and two outer caps—fan and round spray—quart clamp-on cup of spun aluminum \$7.45. Metal cutting LATHE 5x18 in.—bronze bearings—compound slide rest—No. 0 MORSE TAPERS \$7.95 (Screw feed Lathe 6x12" \$9.95, 6x18" \$10.95) AIR FILTER for use with spray units \$1.25. Send for catalog.
BALKO ELEC. MOTOR & SUPPLY CO., Dept. A-8, 10 S. Clinton St., Chicago, Ill.

GAS ENGINES FOR MODEL AIRPLANES—BOATS

An Engineering Triumph!

The G.H.Q. Motor is actually one of the most powerful motors ever constructed! Has broken records for amazing performance—flies model planes up to 10 ft. wing spread. Easy to start, just a twist of the wrist, and simple as ABC to assemble (so easy only a screwdriver is needed). Steady running—runs 27 minutes on ounce of gas. Cylinder and piston lapped to within .0003. Kit includes plug, coil, condenser, tank, ignition wire, cylinder, piston, connecting rod, timer, crankshaft, all screws, nuts, bolts, etc. Every part is fully machined and finished. No oil, gas, batteries or propeller included. P.O. at paid for only **\$8.50**



At Lowest Price Ever Offered!

Ready-to-Run G.H.Q. Motor complete with propeller block included; entirely assembled on stand. Tested and run before shipment—Performance guaranteed—1.5 horsepower at 3000 to 7000 R.P.M.—No oil, gas or batteries included. Postpaid for only \$12.50. Send 3c for illustrated catalog including information on gas accessories.

G.H.Q. MODEL AIRPLANE CO.
 564-B Southern Boulevard New York, N. Y.

(Continued from page 140A)

proper elevation to the pitch. And when this part of the swing is neglected, the sport becomes work instead of play.

From the beginning, the beginner should try to keep the shoe at a height of eight to ten feet at the peak of its flight. When kept at this elevation, the shoes will be easier thrown and it will be evident to the player what he should do to cushion their landings to keep them from bounding off the peg. Some championship players stretch a wire across the center of the practice court at the desired height to school themselves in this fundamental.

Lost ringers often decide a match so the correct method of landing a shoe is of great significance. As was pointed out in the previous paragraph, elevation has some bearing on the landing of the shoe, as has the "wobble" in flight. The wobble prevents the shoe from zipping toward the peg and then bouncing off.

The horseshoe game has as many hazards as golf. If an opponent's shoe stands up in front of the peg, ready to be knocked on for a ringer, the expert must throw a high drop shoe that will come down between the peg and the shoe. If the shoe is his own, he must try and knock it on, while pitching for a straight ringer with the second shoe. Another hazard is a shoe resting near the peg with the calks up and the toe near the peg. There is the danger or the good fortune of the next shoe hitting the toe calk of the other shoe and flopping it on. Throwing skillfully to drag another shoe on or off is also quite common. When a shoe is leaning in front of and against the peg, the next shoe is apt to find difficulty in staying on the peg unless it can be rung higher or beneath the leaning shoe.

Thoughtful practice transforms the dub into a polished performer. Merely tossing shoes back and forth harms rather than helps a player's game once he has mastered fundamentals. A player must strive to pitch his best at all times whether he is alone or in competition. It's a good idea to match flips with players who are better than you because this is bound to raise your ringer percentage in time. Practice on a good court and do not throw over a few hundred shoes a day or every other day. More practice than this will result in staleness or loss of shoe control.

DOUBLE PROFITS

Distributor's Profit + **Salesman's Profit**
NO HOUSE TO HOUSE CANVASSING

This direct factory connection gives you all the profits. You sell the dealer and make liberal sales commission.

REPEAT BUSINESS
 Counter display cards are replaced or refilled frequently, making steady, permanent income with least sales effort.

MYSTERY EDGE BLADES
 are quality blades. All firsts (no seconds.) Surgical Keen Edge shaves toughest beards. Made in Fremont, the cutlery center of U.S.

Assortments for all popular razors mounted on attractive counter cards. Retail prices, 4 for 10c, 3 for 10c. We want high grade men only—no duds. A substantial business for business men. We furnish full sales instructions.

FREE—Write today, stating make of razor you use, and we will send Free blade with complete details.

Mystery Edge Razor Blade Company
 490 Ohio Street Fremont, Ohio

Selling this **NEW** Blade with the **Mystery Edge**

MYSTERY EDGE RAZOR BLADES



Forms to cast Lead Soldiers, Indians, Trappers, Hunters, Wild and Farm Animals. 239 different forms to select from. Every form guaranteed to cast perfect figures. Send 5c stamp for illustrated catalogue.

HENRY C. SCHIERCKE Spencer Rd. GHENT, N.Y.

DEVELOP & PRINT YOUR OWN SNAPSHOTS



Save One Half!

Save money developing, printing your own pictures! No experience needed. Send only \$1.49 for professional outfit including electric ruby lamp, developing and fixing trays, chemical, photograph paper, complete directions. Or pay postman \$1.53 (outside U. S. A., only \$1.49 plus postage). A \$2.63 value. Satisfaction or money refunded. Write for **FREE BARGAIN BOOK** of cameras and supplies.

Central Camera Co., Est. 1899, 230 S. Wabash, Dept K 10, Chicago



COMPLETE ELECTRIC PLANTS

ONAN ALTERNATING CURRENT PLANTS furnish same as city current anywhere. Operate on gasoline, Run Radio, Water System, Refrigerator, all Appliances.

SIZES 350 WATTS UP

Easy to install. Available from stock. Ideal for Farms, Camps, Lake Homes, Commercial use. Sizes for any purpose. Write

D. W. ONAN & SONS

996 Royalston Ave. Minneapolis, Minn.



\$1 STARTS YOU IN BUSINESS

Make easy money every day with fastest selling line of **MEN'S TIES AND NOVELTIES** in America! Every man is a prospect! These marvelous values **SELL ON SIGHT!** "No Risk" Guarantee assures satisfaction or money back. Unbeatable quality! Amazing low prices! **WE PAY POSTAGE.** Complete line of **NEW FALL NECKWEAR** priced \$1 to \$9.99 dozen. Also Muffler, Tie and Handkerchief sets. **OVER 100% PROFIT!** Big extra earnings with Patented **Slide-On** ready tied ties. Send **TODAY** for Free Illustrated Descriptive Catalog and **FREE SAMPLE SWATCHES.** See why our men are **BIGGEST MONEY-MAKERS.** Write **NOW!**

FREE SAMPLES

BOULEVARD CRAVATS, 22 WEST 21st ST., DEPT. M-2, NEW YORK

GIVEN AWAY



You get one—Your friends get one—without cost. Let us give you the details of this amazing Time Teller. Also it can pay you big money by showing others how to obtain without cost. Nothing to buy or sell. Write fast.

GARDEN CITY NOVELTY CO.
 4318-A Ravenswood Ave., Chicago, Ill.

When writing please mention Popular Mechanics

TYPEWRITER 1/2 Price

Now Only

10¢ a Day

AFTER 10 Day

FREE Trial

No Money Down



Fully GUARANTEED

Positively the greatest bargain ever offered. A genuine full sized \$100.00 office model Underwood No. 5 for only \$44.90 (cash) or on easy terms. Has up-to-date improvements including standard 4-row keyboard, backspacer, automatic ribbon reverse, shiftlock key, 2-color ribbon, etc. The perfect all purpose typewriter. Completely rebuilt and **FULLY GUARANTEED.**

Learn Touch Typewriting

Complete (Home Study) Course of the Famous Van Sant Speed Typewriting System—fully illustrated, easily learned, given during this offer.

Lowest Terms—10 Cents a Day

Money-Back Guarantee

Send coupon for 10 day Trial—if you decide to keep it pay only \$3.00 a month until \$49.90 (term price) is paid. Limited offer—act at once.

INTERNATIONAL TYPEWRITER EXCHANGE,

231 West Monroe St., Chicago, Ill., Dept. 1001.

Send Underwood No. 5 (F. O. B., Chicago) at once for 10-days' trial. If I am not perfectly satisfied I can return it express collect. If I keep it I will pay \$3.00 a month until I have paid \$49.90 (term price) in full.

Name Age.....
 Address
 Town State.....

FASTER - SAFER - CLEANER

7200 Strokes per Minute
 Electric Operation

No Motor Required

Astounding performance! Cuts up to 1" or more, with smooth, clean edges. No sanding required. Accurate, sturdy, efficient—a revelation to skilled craftsmen in handling both intricate designs and heavy work. Ideal for cutting light metals, veneers and plastics. Operates on 60 cycle, 110 volt AC, without motor or any reciprocating parts. Requires no oiling. 10" square table; 13 1/2" throat; adjustable guide; variable stroke. Complete with underwriters approved cable and rubber plug. Built for years of continuous service.



New **SYNCRIO JIG SAWS**

FREE FOLDER

Ask your dealer to show you the models now available. Or send your name for full information and illustrated literature, **FREE.**

SYNCRO DEVICES, INC.

511 Boydell Building Detroit, Mich.

Make up to **\$150 Weekly** GIVING AWAY

FREE RADIO RCA LICENSED



RCA Licensed Automobile and Home Radio Sets for American, European and South American Reception. Beautiful World Master floor model radios. **Guaranteed foreign reception.** Custom made with exclusive all matched walnut cabinet, aeroplane dial, twin illumination, dynamic speaker and automatic volume control. Given away absolutely **FREE** with our new sensational unique **PUNCH SALES CARD PLAN.** This is the opportunity of the year—make up to \$100 cash each week for yourself. Every home, car owner, store, office, factory, lodge, club or individual wants these marvelous new **FREE RCA LICENSED RADIOS.**

Can also furnish Radios for Battery Use.

WRITE TODAY FOR OUR NEW STARTING OFFERS

Start at once making money with our unique sales plan. Write for full information how you can secure any or all of these plans.

DELUXE MFG. CO., Dept. 270, 173 W. Madison St., Chicago, Ill.



**FREE
BOOK**

Easy to play

● If you want to be *really* popular, have *all* the fun, be the center of attraction *everywhere*, just learn to play this thrilling instrument from Italy. A complete band or orchestra in itself, and so easy to learn to play.

Take It Everywhere—No other instrument can give you half so much musical enjoyment. It's fun from the start. But only with the new exclusive ampliphonic Soprani is rapid progress assured. New ampliphonic models are *lighter, smaller, yet with increased volume, more beautiful tone, easier to play.* Your music dealer will demonstrate and explain convenient terms. Or send postal for beautifully illustrated book and complete details. This is the instrument you want for *your own* personal satisfaction. Write today sure. 108

SOPRANI, INC. Dept. 1029, 630 S. Wabash Ave. Chicago, Illinois

MARVELOUS INVENTION SAVES GAS

Adds Mileage to Every Gallon With Pre-Heated Air

Simple and easy to install, Leen-A-Mix instantly gives cars more speed—extra power and pep—new scientific principle endorsed by motor experts—automatically puts new life to motor—quicker starting, greater speed and smoother running. You quickly notice the savings on gasoline. Entirely different—controlled by Thermostat—allows the proper amount of pre-heated air balancing a perfect mixture—without disturbing carburetor.

TRY at OUR RISK 30 DAYS TRIAL FREE OFFER

Big Money-Maker for Agents
METAL SPECIALTIES MFG. COMPANY
Dept. P-10, 3200 Carroll Avenue, Chicago, Illinois

SAVES
GAS



**FITS
ALL
CARS**

VENETIAN BLIND MATERIALS

You can make fine blinds for your own home at low cost, also go into the business. All parts supplied. Send 10c for circular and samples of ladder tape, cord, slats and rails.

R. A. Peterson, 6300 North Ashland Blvd., Chicago, Ill.



HANDY Taps and Dies

Accurate . . . high grade steel . . . precision cut threads . . . carefully hardened and tempered . . . Complete range of sizes for ordinary requirements. At your local chain store.



Made by HENRY L. HANSON
Worcester, Massachusetts

Beware the Spark Plug Racket

(Continued from page 482)

tips of the electrodes and bends the wires in an effort to restore the proper spark gap, then reassembles the plugs, paints the shells with black paint, packs them in cartons which often resemble the packages of reputable manufacturers and marks the product "rebuilt" in very inconspicuous letters. He offers these rebuilt plugs to dealers at about half the regular price and unscrupulous dealers sell them as new plugs.

These reclaimed plugs are not new any more than a secondhand tire is new. The wear and tear on a tire, however, are quite evident, even to the most inexperienced driver, while the reconditioned spark plug looks very much like a new one to inexperienced eyes. Yet a set of these reconditioned plugs may do irreparable damage to a motor and, as a general rule, the car owner would be much better off if he had left his old plugs in his engine if they would operate at all.

There are several reasons why worn-out spark plugs cannot be rebuilt successfully to perform satisfactorily. In the first place, the sandblasting operation necessary in cleaning a plug so it will look new destroys the shape of the insulator and this, in turn, impairs the efficiency of the plug because there is a very definite relationship between insulator shape and performance. Also, each type or shape of insulating core is especially designed to operate in a certain type of engine and the metallic shell for this plug is designed to function properly with that particular type of core, and with no other. The rebuilder picks parts at random in reassembling, giving no thought to the fitness of cores and shells to function together. The result is a nondescript plug with astonishing gas leakage.

"Out of all the reclaimed plugs we have tested," says Otto C. Rohde, chief engineer of the Champion Spark Plug company, "almost every one has shown a leakage of fifty cubic centimeters per minute or more. When you consider that a gas leak of five cubic centimeters per minute will increase the tip temperature of the spark plug core from thirty to fifty degrees, you can imagine the tremendous overheating with a fifty-cubic-centimeter

leak. Is it any wonder such plugs break up because of excessive heat? Add to that the fact that this excessive heat in the plug causes preignition which increases the temperature of the entire combustion chamber tremendously, and you can readily picture how much damage to pistons and valves may result."

Another major weakness of the rebuilt plug is that it is impossible to set the gap properly. In a new plug, the gap is sawed by precision machinery and set to a thousandth of an inch. Its shape and width are carefully engineered to deliver a spark as hot as possible at this point. When the plug is rebuilt, the only recourse of the racketeer is to clip the electrode tips to make a fresh metallic surface, then force the wires together, usually by bending the center electrode. Since the wires have been clipped short, this results in improperly gapped plugs.

Let's consider for a moment the terrific punishment that a properly built plug must take. If a 100-horsepower engine develops its peak power at 3,500 revolutions per minute, a plug in this engine must not only create the spark for 1,750 explosions each minute, but it must also resist the force of these explosions. It gets pretty hot in the combustion chamber too, and the plug must withstand the heat. The average chamber temperature may be between 1,450 and 1,500 degrees Fahrenheit. And then there's the matter of pressure. In an engine with a compression of five to one, the gas is exploded when it is in a space one-fifth as large as when it entered the cylinder. The plug must withstand that too.

The loss of power through spark plugs is negligible, but hot gases escaping along the electrode may decrease the plug's efficiency and cause it to operate at a temperature for which it was not designed. Thus a "cool" plug may become a "hot" plug and operate at a temperature that neither the engine nor the plug designer intended.

Modern spark plugs of improved design are necessary for today's high-compression motors and it is hopeless to expect a worn-out plug designed five or six years ago to do the work of a modern plug, even if it could be rebuilt to function efficiently. If such plugs operate at all, the tremen-

(Continued to page 146A)

HE'LL USE LEPAGE'S



"I MADE IT MYSELF"

● As he points with pride to his doghouse, his first effort in craftsmanship, he probably didn't use glue.

But he'll try other projects where he'll want snug joints, reinforce nails and screws, fill small cracks and nail holes. Then he'll discover that glue actually helps to make a workmanlike job.

Will he bother with a glue pot, when LePage's is so easy to use right from the can? Would you, when the difference in cost is hardly worth mentioning? You can get it from your hardware dealer.

RUSSIA CEMENT COMPANY

Laboratories and Factory • Gloucester, Mass.



\$6 MOTOR \$1.50
 1/10 H. P. Utility motor—Double End—1/2" Shaft
 Variable Speeds to 6000 R. P. M.
 Base 4 1/4" x 5 1/4". Rebuilt, guaranteed perfect for sewing machine, polishing, buffing, coal-blower, etc.
 Order at once all you can use at this amazingly low price. Send \$1.00 with order. Balance C.O.D. Send 10c stamps for illustrated catalog of motors, tools, etc.
MARTIN ELECTRIC T. & S. CO.
 604 Arch St. Philadelphia, Pa.

Governs Speed OF ANY GAS ENGINE

Take any car motor out of the chassis, equip it with a Pierce Universal Governor, and you have a stationary power unit that runs steadily enough to operate even an electric welder. And that's some test for close speed regulation.

Pierce Universal Governors are standard controls on gasoline engines for commercial purposes—for electric lighting plants, refrigerating units, air compressors, feed grinders, hoists, saw mills, welders, etc.

Pierce Universal Governors are the time-tested flyball type and respond instantly to each change in engine load, maintaining uniform speed. Belt driven, either V or flat. Easily installed and never equalled for close regulation of speed and for dependable performance.

Write for illustrated literature and prices, whether you want to equip one used motor or a thousand new ones.

The Pierce Governor Company
 1600 Ohio Avenue, Anderson, Indiana



A Pierce Governor puts "brains" into any gas motor.

THE NEW "CUB" IS SAFE • ECONOMIC • STURDY • STABLE

Get into AVIATION With a Sturdy New "CUB"



✧
PAY ONLY
\$490
CASH
✧
Balance
in
Easy
Monthly
Payments

✧ **IT'S** easy to make money with one of these I CUB "flivver planes." Hundreds of young men and women are learning to fly in a New CUB. Many of them open Flying Schools of their own. One man earned \$300 the first month; another earned \$1,115 the first three months... and what a pleasant, thrilling way to make money!
The New CUB is the fastest-selling airplane the world has ever known. And why not! The old CUB was known the world over as the SAFE airplane. Now this smart, fleet, New CUB has no less than 20 improvements; greater comfort, more room, more speed, greater economy and it's safer.
Today EVERYBODY wants to fly... and everybody can afford to fly a CUB. Get into Aviation NOW... with the New CUB—America's SAFE Airplane. (\$1470, cabin model; at the factory.)
✧ **Buy a CUB and Learn to Fly FREE**

TAYLOR AIRCRAFT COMPANY
No. 10 M Street, BRADFORD, Pennsylvania

Beware the Spark Plug Racket

(Continued from page 145A)

dous temperatures developed in modern engines cannot fail to result in preignition and lead to a host of other motor and ignition troubles which are likely to cost the user more than if he bought brand new plugs every week in the year.

Protecting yourself from the spark plug racket is comparatively simple, once you understand what to look for. In the first place, the person who rebuilds plugs and sells them as such violates no law although his product may be even more worthless than the old plugs you are about to discard. The motorist who buys used plugs and knows he is buying used plugs has no one but himself to blame for results.

Wise motorists, however, do not knowingly put reclaimed plugs in their cars. But unscrupulous dealers have no hesitancy in buying reconditioned plugs as such, then palming them off on car owners as brand new plugs and doubling their profit. So the first thing to do in insuring yourself and your car against reclaimed plugs is to buy only from a reputable dealer. If there is no dealer in whom you have implicit confidence, buy plugs bearing the name of a reputable manufacturer and be sure they are packed in the manufacturer's original wrapper and package. You'll need sharp eyes here, and you'll need to know the manufacturer's label, because the racketeer often tries to imitate the package, but he cannot legally duplicate it and he usually protects himself by printing "rebuilt" or some similar term in small type somewhere on the carton.

Then, after buying new plugs, be sure that the plugs you have purchased are the ones that go in your car. The salesman saw some cartons of plugs and assumed they were to be used in his car. The cartons may have contained new plugs but the ones he got did not come out of them.

If you're in doubt whether the plugs you are purchasing are new or rebuilt, examine the bases carefully—the ends which screw into the motor. You should be suspicious if the end of the center electrode bears evidence of filing, or if it is bent to bring it close enough to the side electrode. This is often necessary due to

(Continued to page 148A)

METAL LATHE PLANS \$1



4' Back geared screw cutting lathe using no castings or flat cone pulleys, plans with specifications \$1. postpaid. TOELLEN MFG. CO. Box 25, College Park Sta., Detroit, Mich.

SAVE UP to 1/2 on Amazing WIND-CHARGER RADIO

OPERATES From FREE WIND POWER

A light wind furnishes electric lights and city radio performance for the country home. No "B" or "C" batteries. Gives pleasure of care-free, full strength radio reception that will amaze you—without power lines. Write for 30 day no-risk trial plan—also get offer of one FREE to first user-dealer in each locality.

User-Dealer AGENTS WANTED

Under our new plan a little easy work brings your own radio FREE and a wind charger for only \$7.50 additional. Special temporary offer—be first—write quick—a 1c post card will do.

PARKER-McCRORY MFG. CO.

M-751-2609 Walnut, Kansas City, Mo.



Step Into Your Own Business

SELL USED & NEW CLOTHING

at Money Saving Prices

BARGAIN SALE

From Auto, Store or Home
Thousands of men and women right in your locality are anxious to save money on the purchase of wearing apparel for themselves and their families.

Under our powerful buying plan we put you in business for yourself selling used and new clothing—suits, coats, hats, ties, hosiery, shoes—hundreds of wearing apparel items for men, women and children—at money saving prices—made possible through our cash purchases of bankrupt stocks and close-outs. You operate from your auto, or your home, or open your own BARGAIN MERCHANDISE STORE—and quickly build a big profit, year 'round, steady-repeating business of your own.

Our Prices are Lowest! FREE CATALOGUE!
Write quick—for our FREE CATALOGUE that lists our wide assortment of quality merchandise. Items at prices that net you up to 300% profit. Think of it! We positively smash competition. We back you with close cooperation. End job hunting! Be your own boss in your own business. Get the full facts—then judge!

PORTNOY & SONS,
566 Roosevelt Road, Dept. 106, Chicago, Ill.

Make Up To 300% Profit

BUILD IT YOURSELF

Jim Dandy
CABIN CRUISER
The Trailer that has EVERYTHING



COMPLETE BUILDING PLANS \$1.00

To get the trailer you want, "Build It Yourself." With my plans you can construct this beautiful coach with ease and save money. No special tools or building skill required. Plans show you every detail of building body and chassis so clearly that it is almost impossible to make a mistake. Plans tell how to build beds, cabinets, drawers, refrigerator, how to get a perfect top, how to install electric light and water systems and where to buy all parts. The Jim Dandy Cabin Cruiser can be built in any size to accommodate 2 to 4 people. Floor plans are given for various sizes. Send \$1.00 for these plans today—get started on this delightful winter project—have a roomy, comfortable, substantial house trailer to use next year. Order from this ad—we have no catalog.

MAIL DOLLAR BILL TO JIM DANDY
Box 125-A, Wausau, Wis.

RADIOS
ALL NEW 1937 MODELS!
SAVE UP TO 50%



DEAL DIRECT—FACTORY PRICES! Iron-Clad Written Guarantee!
A penny post card brings you our new, full-color 24-page **BARGAIN CATALOG** free. Many models to choose from: 4 to 17 tubes; AC-DC, All-Wave, Car and new Farm sets that operate like city radios!
30-DAY NO-RISK HOME TRIAL! Send post card or coupon below for full details of our 30-day no-risk trial and Agent-User proposition!

\$6.98

AGENTS!

NOW - MAIL COUPON



A real money-making offer. Write at once for territory.

GOLDENTONE RADIO CO., DEPT. E.
Dearborn, Mich.
Without obligation, send me new 1937 Catalog and 30-day trial plan.
Name
ADDRESS

AMAZING CAN JAR & BOTTLE OPENER



WORKS BY NEW MAGIC METHOD

Millions of women waiting for it. Three devices all in one. Opens Cans, Jars, Bottles of any size, shape or style in a jiffy. Takes off entire top of can. Leaves velvet smooth edges. No cut, bruised fingers. Removes tightest jar tops instantly. Fits on walls; always ready, handy. Money-back guarantee.

Leaves Smooth Edges

AGENTS! BIG PAY EVERY WEEK
Startling demonstration makes instant sales. Amazingly low priced. Two Magic Selling Plans pour money into your pocket. Trial sample offer.
MAGIC PRODUCTS COMPANY
1418 Pendleton Ave., Dept. CP-371, St. Louis, Mo.

Chucks for Small Lathes
Lowest Prices Ever Offered



Four-jaw independent as shown
A quality tool, accurately made. Send draft or money order. If not entirely satisfied, return chuck in 5 days and we will refund your money.
5 inch Chuck \$6.87 6 inch Chuck \$8.87
Postpaid
JOHN L. ALEXANDER, 424 Superior St., Detroit, Mich.

STOP THAT SLAM!



AMAZING INVENTION STOPS SLAMMING DOORS
KANT-SLAM closes heaviest doors silently, positively, automatically. Prevents slamming or leaving doors open. Works in oil. Lasts lifetime. Easily installed. LOW PRICED.
PAYS BIG PROFITS DAILY!
Real Demonstrator Furnished. We supply actual KANT-SLAM on easily-carried miniature door. You make big money on quick sales to stores, offices, factories—every building can use 1 to 20! Free Demonstrator to workers. Write! Get free details.
KANT-SLAM CO., Dept. J-53, Bloomfield, Ind.

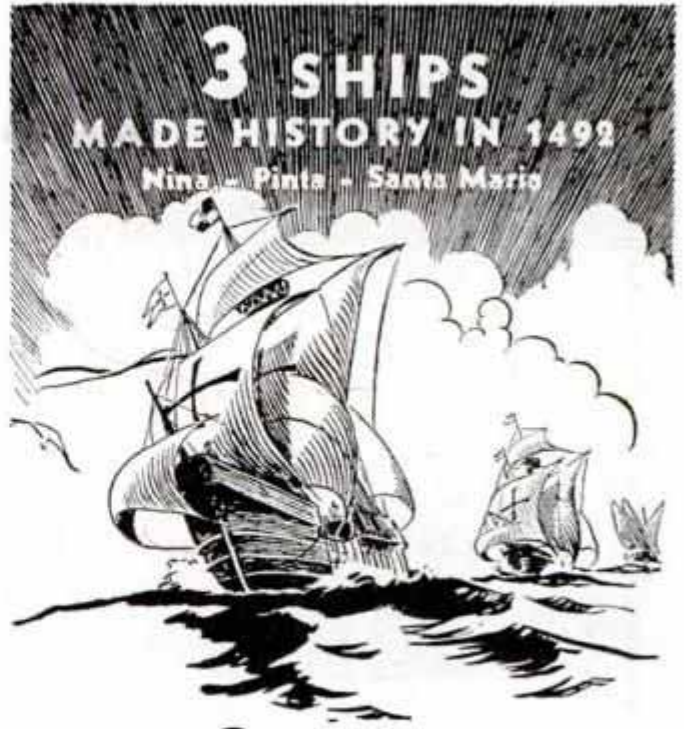

3 SHIPS
MADE HISTORY IN 1492
Nina - Pinta - Santa Maria

3 FILES
ARE MAKING HISTORY IN 1936

All through history, before and since Columbus discovered a new world with 3 ships in his fleet, the number 3 has stood for success.

Today 3 file brands — Nicholson — Black Diamond — McCaffrey — are making history at the work benches of thousands of hobbyists helping these home experts remove stock faster and do more intricate work.

Are you interested in making models or would you like to produce decorative and useful articles from metal? Let these three outstanding files help you. Your hardware store carries them in all shapes and sizes for every home filing need. Nicholson File Company, Providence, R. I., U. S. A.

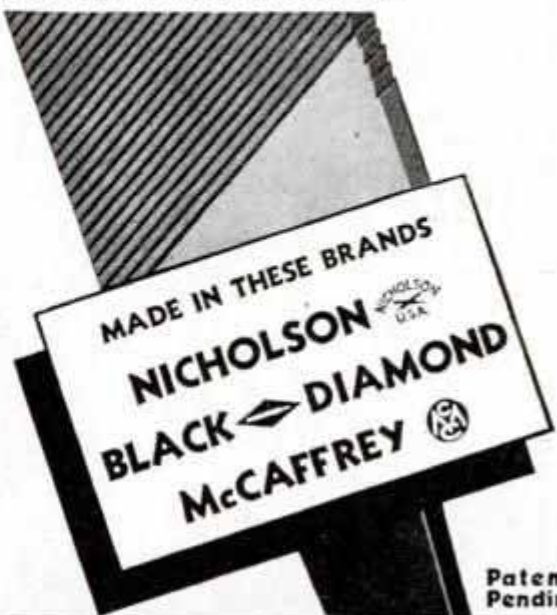

A FILE FOR EVERY PURPOSE

When writing please mention Popular Mechanics



**For Year 'Round Pleasure
Travel by COVERED WAGON**

Summer . . . Winter . . . spring . . . or fall a Covered Wagon gives you plenty of glorious travel pleasure and deluxe trailer comforts on the open road. It's yours to enjoy any time! Follow the sun. Slip off for weekends. Take the family or a group of boon companions for some fine upland shooting. Live like a king—and enjoy every minute—whether you sojourn in Florida or cross the continent. Built by the world's largest producers of trailer coaches, Covered Wagon naturally offers you greater dollar for dollar value—the finest product money can buy—proved design—tested performance—real roadability—above all, perfect home comforts. New Low Time Payment Plan.

3 MODELS—\$395—\$785—\$1185
f. o. b. Detroit

Models on display at your nearest dealer—or write the factory for full information

FREE—Illustrated literature—or send 10c for valuable 4 color Trailer Book with Plans.



COVERED WAGON COMPANY
456 Cass Avenue . . . Mt. Clemens, Michigan
TRAVEL BY COVERED WAGON . . . AND SAVE

PERFECT!-DRY LUBRICATION WITH DIXON'S GRAPH-AIR GUN



You'll never go back to oil or grease for lubricating thousands of places around a car, home, shop or office after you learn the great lubricating and lasting qualities of Dixon's Microfyne Powdered Graphite applied with the Graph-Air Gun. It is the one lubricant that cannot burn, gum or drip and is proof against acids, alkalis and brine. Circular describing many uses and name of dealer near you sent on request.

75¢ FILLED

JOS. DIXON CRUCIBLE CO.
Dept. 26-CG, Jersey City, N. J.



OHMITE
noiseless
**WIREWATT
RESISTORS**

Use **WIREWATT** in place of 1 watt composition units. They are wire-wound — no noise or fluctuation in value with temperature changes.

Ask your dealer or write
OHMITE MFG. CO.
4834 Flournoy St. Chicago, Illinois



BUILD YOUR Derby Racers • Midget Autos
Coaster Wagons • Bicycle Trailers
Wheelbarrows • Scooters • etc.

The most marvelous tire invention of the age. Perfected and patented by the inventor of the air wheel for airplanes. That is the **MUSSELMAN Doenut Cord**. Size 10" x 2 3/4". Tire mounted on Cadmium plated steel disc wheels with adjustable ball bearings. Tire requires only 12 to 15 lbs. air pressure. Hauls loads up to 200 lbs. per wheel. U. S. Patent No. 2015459. These Doenut tires take less power to propel any vehicle. They float over road bumps and surface obstructions as well as winning coasting contests. You can build any vehicle mentioned or shown with our blue print drawings at 25c each. Wheel and parts booklet free on request.

THE MUSSELMAN PRODUCTS CO.
6247-J St. Clair Ave., Cleveland, Ohio

Beware the Spark Plug Racket

(Continued from page 146A)

clipping the ends of the wires. Also, sand-blasting usually leaves telltale marks at the base of the insulator which are easy to detect.

Finally, a new plug has a natural, dull rust-resistant finish which it is impossible to duplicate with black paint. A coating of paint over a plug is virtually a sure sign that it is a rebuilt plug. If you do get stung, you'll find the paint gone after one day's driving and a set of brown second-hand plugs nestling where you thought the black, shiny new ones were.

It's also a good idea, even if you trust your dealer, to have him specify on the bill of sale that the plugs you are buying are new and unused. No reputable dealer will object and it may scare even the unscrupulous one into installing a set of plugs off the shelf instead of picking them out of the barrel under the counter. And that, in turn, is likely to save you an expensive engine repair bill.



Easy free book

● You'll learn more quickly and easily to play a P-A Sax, Trumpet, Clarinet, or Trombone, because P-As are easier to blow and have such beautiful tone. Thousands in use. Strongest guarantee backed by old, reliable manufacturer. Moderate prices. Home trial. Easy terms. See your music dealer or write for beautiful free book. Mention instrument.

PAN-AMERICAN
1247
1003 P-A Building Elkhart, Indiana



SHARPENS TOOLS? Factory Way

CHARTIER TOOL HOLDER fits ANY GRINDER. You can put factory precision edge on twist drill bits, plane irons, lathe cutters. Grind inside and outside ground gauges, auto valves. Do any sharpening job at any angle, arch or combination. Saves re-sharpening costs or ruining expensive tools.

TRIAL OFFER! Send only \$14.50. Shipped postpaid. Or send \$3.75, balance C.O.D. Use for 10 days on most difficult jobs. Money Back if not satisfied. Or send for FREE literature.

E. S. DEKKER CO., 814 Clinon Ave., Dept. 15, Oak Park, Ill.



AGENTS UP TO \$50 IN A WEEK

Big cash profits for you; full or spare time. Over 250 household necessities—things people must buy. Proven fast sellers; steady repeaters, earnings very first day. **FORD TUDOR SEDAN GIVEN YOU AS BONUS.** I'll show you how to start at once; send you everything—Big Display Outfit and quick cash plans. Details FREE—No obligation. Just send name on postcard.

ALBERT MILLS, 8643 Monmouth Ave., Cincinnati, O.

When writing please mention Popular Mechanics



**NEW models
EASIER TO PLAY**

Find out about these sensational new Conn Band Instruments. Many wonderful, exclusive features! Today, *more than ever*, Conns are the "choice of the artists." You'll advance faster and take more pride in a genuine Conn—made by the world's largest manufacturer. See your dealer or write us for Home Trial, Easy Payment offer. Mention instrument.

C. G. CONN, LTD.
1031 Conn Bldg., Elkhart, Ind.

WRITE FOR FREE BOOK

CONN
BAND INSTRUMENTS

**TURN SNAPSHOTS INTO
'HUMANETTES'**



Sensational invention. Almost human in appearance. A life-like cut out figure. Any snapshot, photograph or picture can be "immortalized" by this strange new process. Surface covered with moisture-proof transparent PORCELITE. Will not peel, tear, crack, or soil. Looks like porcelain bas-relief.

BIG MONEY FOR AGENTS
Low prices make HUMANETTES big sellers. We furnish list of prospects in your neighborhood who will pay from \$1.00 to \$2.50 for showing samples of LIFETIME HUMANETTES. If you want to make money fast, send name for free sample proposition at once.

AL SCHULER, 1037 Evans Street, Dept. 10-S, Cincinnati, Ohio

MAKE 200 TOYS an Hour... for 1¢ Each!

Sell toys at big profits. Get this complete outfit. You can make 3 different characters thousands of times in moulded metal. Includes paints for coloring and full casting equipment. Price \$2.50. Electrically operated, \$3.25. Send money order, stating choice of U. S. Soldiers, Wild West Cowboys, U. S. Machine Gunners, **EXTRA MOULDS** for 3 large figures at 9¢ include other soldiers, cannon, battle-ships, animals. **Buck Rogers toys (\$1.00).** Choice of 188 Different Characters.

FREE 2 BIG ILLUSTRATED BOOKS ON CASTING

RAPAPORT BROS., 703 WEST OHIO STREET, CHICAGO

EARN EXTRA MONEY

Start a Mail Order Business at Home

No experience required. No canvassing or house to house selling. Work in your spare time. Opportunity to build a well paying business. Strictly legitimate. No Wildcat scheme or stock outfit. Send stamp right now for my Amazing Offer.

UNION SALES CO., P.O. Box 13-M, New Rochelle, N. Y.

MONUMENT \$9 UP Freight Paid or Erected.

World's Best Marble and Granite. Direct from factory. Lettered. Guaranteed. 30% Savings. Thousands sold. Write for Free catalog. **U. S. Marble & Granite Co., Dept. A-18, Oneco, Florida.**

JIG SAW \$1.50

COD or outside U.S.A. \$1.75



Including 12 assorted blades. Adapters, Puzzle Instructions, and roller Saw Guide formerly found on expensive machines only. All metal. 15" long; 8" high. 6 1/2" table. A swift and easy cutter—best ever made for the money.

FREE catalog illustrating complete power tool line: Shaper, Circular Saw with oilless bearings, \$3 each; Drill Press, \$2.50; completely equipped Lathes, \$2 & \$3; Sander, \$1, etc. All practical tools for real work. Order today or send card for catalog.

J & H Metal Products Co. 5 Commercial St. Rochester, N. Y.

Now you can get
QUAKER STATE
SUPERFINE
GREASES

● NOW thousands of car dealers, garages and service stations all over the country are equipped to lubricate your car with genuine Quaker State Greases. Greases made to the same high-quality standards as Quaker State Motor Oil. Greases that wear. Greases that are especially made for each part of your car.

Get Ready for Winter. Cold weather will soon be here. Don't let it catch you with Summer lubricants in your car. That means hard starting . . . stiff, clashing gears . . . slow pick-up . . . loss of power . . . wear and tear on the whole car. Change to Winter grades of Quaker State Motor Oil and Greases as indicated by the Quaker State Chek-Chart lubrication guide, and your car will perform as sweetly in Winter as it did in Summer.

Grease your car at the intervals recommended by its maker. Always use Quaker State Superfine Greases and

GO FARTHER
BEFORE THE FIRST SQUEAK

Look for the dealer displaying this sign . . .

COMPLETE
QUAKER STATE
LUBRICATION SERVICE

Quaker State Oil Refining Company, Oil City, Pennsylvania

Many Features Found Only In Expensive Bench Saws!

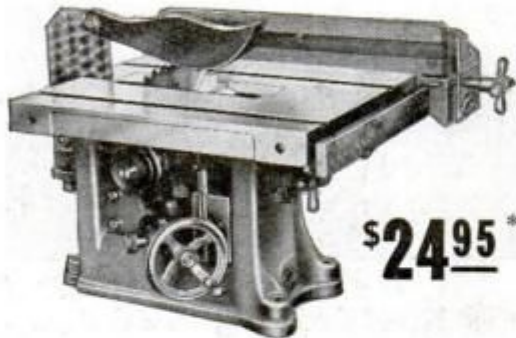

\$24.95*

DRIVER 8" BENCH SAW

*Priced as shown, complete less motor and belt, with geared self-indexing mitre gauge. And you'll say it's the biggest \$24.95 worth of quality equipment you ever saw. 16"x13" machine ground gray iron table, tilts to 45°. SKF ball bearings. 8" blade raised by worm gear, max. depth cut 2 1/4". Examine its quality features yourself at your Driver Dealer's and write for colorful new folder on 1937 Driver Tools. Walker-Turner Co., Inc., 1106 South Ave., Plainfield, N. J.

Ask Dealer About Easy Payment Plan

DRIVER Engineered POWER TOOLS

COPY-STAMP THE STAMP OF A THOUSAND USES

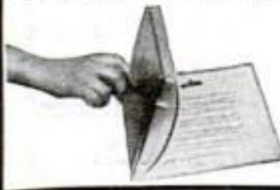

Prints postcards, letters, menus, school-work, notices, drawings, tags, etc. Used by thousands of business concerns, schools, clubs, churches, and others. Quick, clean, automatic, instantly changeable. Ask your stationer or write us direct.
THE STENCIL-STAMP CO., INC.
 53 Park Row New York, N. Y.



Renew old buildings. Make new construction more permanent and attractive. Plastic Colorete is waterproofed. It fuses with any masonry surface. It fills all cracks. It can be applied in any thickness and in 30 colors. Fully proven by over 12 years actual use under all conditions and every climate.

OFFERS BIG EARNINGS

Owners everywhere want to enhance present values. With this machine you can supply this big waiting market with permanent Colorete at amazingly low cost. Operators report cost of 2c and up per sq. ft. and sell up to 7c. Some have paid for their equipment from first few jobs. Machine capacity up to 1,000 sq. ft. per hour. Get the facts. Send for books, "Proven Business Opportunity" Write today. It may mean extra income for you.

COLORCRETE INDUSTRIES, INC.
 570 Ottawa Ave. HOLLAND, MICH.



When writing to advertisers please mention Popular Mechanics



Win a Free Trip to Europe on the QUEEN MARY

also 28 Cash Prizes — Medals, Cups for Building this 18" Model

Wouldn't you like a Free Trip to Europe and return on the Cunard White-Star Superliner, or \$50. Cash Money? These are two of the Prizes in the IDEAL Model Building Contest. Get the IDEAL Official Contest Kit containing a fully finished "Redi-Form" Hollow Hull and all Parts, Materials and Plans to build and decorate this 18" Model. Start now; it's easy; full details and contest entry blank in every Kit. Ask your dealer or Complete Kit \$1.00 Plus 10c send your order direct. only Postage

Large Size Scale Models

R. M. S. QUEEN MARY—31 1/2" long, \$500 Each, Postpaid.
 S. S. NORMANDIE—32 1/2" long, West of Denver,
 Liner REX—29" long, add 50c extra.
 Kits contain shaped wood hulls, wood decks, superstructure, metal fittings, plans, photos, instructions and everything for complete Models. Send 5c for Model Boat and Airplane Catalogues.

The IDEAL Company, 26 West 19th Street, New York



Balance as above with 1-50; 1-20; 2-10; 1-5 and 2-2 gram weights based 3/4"x3 3/4"—\$4.75. Catalog with 3000 illustrations of laboratory apparatus sent for 50c. Catalog listing 10,000 chemicals, drugs, flavors, etc. and 1700 scientific books sent for 25c; Wholesale Price List 1000 ill. 10c.

Laboratory Materials Company, 639 E. 71st St., Chicago, Ill.

Make Money at Home!



GROW MUSHROOMS in your cellar or shed. Exclusive new process. Bigger, better, quicker crops. More money for you! Enormous new demand. We buy Mushrooms. Write for Free Book.

American Mushroom Industries Ltd., Dept. 707, Toronto, Ont.



SAVE MONEY ON YOUR TRAILERS

Book of 10 models, with complete plans and instructions on one model. Mail a dollar to D. VAN OOSTVELDT, 111 MARSTON, DEPT. 55, DETROIT, MICH.

HANDICRAFT

Caning and weaving materials, chair frames, basketry materials—reed, rattan, raffia, grass, rush, fibre. Leathercraft. Cotton, Yarn, Wool, Warp. Send 10c for Catalog. Instructions free.
AMERICAN REEDCRAFT CORPORATION
 Dept. P 130 Beekman Street New York City

AGENTS 500% Profit GOLD LETTERS

For Store Fronts and Office Windows. Anyone can put them on. Free samples. Liberal Offer to general agents.
METALLIC LETTER CO., 438 N. Clark St., Chicago

OWN AN AGENTS SUPPLY FACTORY

MAKE PRODUCTS AT HOME—Toilet preparations, extracts and household necessities. Chemicals, bottles, and labels furnished. Just add water. No experience needed. Up to 900% profit. Sell yourself or hire agents. Send name for free sample and all facts.

STANDARD CHEMICAL CO.
 121 E. Second St., Dept. C-106, Dayton, Ohio



DRILL-INDEX

Keep your drills in a DRILL-INDEX. Works like a card index. A flip of the wrist opens the case. Four sizes. Ask your dealer or write to

Huet Mfg. Co., Foot Schulze Bldg., St. Paul, Minn.

GO INTO BUSINESS MAKE 100% TO 300% PROFIT!

Sell new and used clothing direct from your home, auto or store. Undersell all competition. EASY SALES—FAST REPEAT ORDERS! We furnish everything and show you how. Handsome profits every day in the year. No selling experience necessary. Write at once for our Big Money Catalog—It's FREE!
Liquidation Merchandise Co., 550 E. 43rd St., Dept. D-16, Chicago, Ill.

PAINT SPRAY OUTFITS

ELECTRIC PAINT SPRAY UNITS, COMPLETE. Westinghouse Universal Motor \$14.50 and up
 1/30 H.P. 5000 R.P.M. \$2.95 Plus 25c P.P. Send for FREE catalog.
NATIONAL ELECTRIC TOOL CO., 560 Washington Blvd., Dept. 350, CHICAGO, ILL. 19015

BUILD CLOCKS

Hall clocks are high priced in stores — you can make good money building them or electrifying spring clocks. Dime brings "HOW" Book pricing Brass weight movements from \$10.95 and drawing of easily built Grandfather Case—start now. **KUEMPEL CHIME CLOCK CO., Building 12, Guttenberg, Iowa**

BIG MONEY SELL SENSATIONAL XMAS CARDS

Amazing Value —only 99c for NAME IMPRINTED Xmas folders! Take hundreds of orders. Make big money. Newest papers, parchments, designs. Also 21 "All-Folder" Gift box Assam't only 29c! Never retailed less than \$1. Samples FREE on approval. WRITE PROCESS, Dept. KH-25, 1956 So. Troy, CHICAGO



DO YOU GET CREDIT for your GOOD IDEAS?

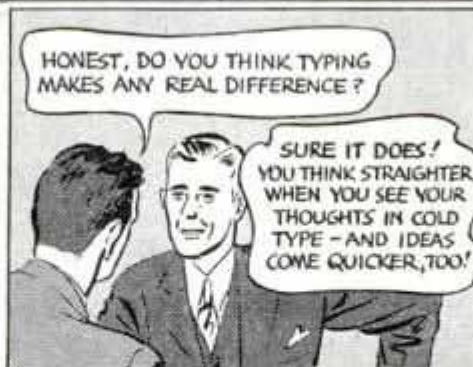

Greatest Bargain in 10 Years!

ANY REMINGTON PORTABLE NOW 10¢ A DAY

RIGHT NOW, you can get a brand new Remington Noiseless Portable for only 10¢ a day. Its lightning-fast action is so quiet that you can type anywhere at any time without disturbing others. Standard keyboard. Variable line spacer, double shift key. Automatic ribbon reverse. Everything you need for complete writing equipment, **PLUS THE NOISELESS FEATURE!**

You don't risk a penny. You can get this Remington Noiseless Portable direct from the factory for a **TEN-DAY FREE TRIAL**

Use it. Prove to yourself, with the **FREE TYPING COURSE** we send you, that you can learn to type in a few days. Then if you don't think it is the finest portable you have ever used, send it back at our expense. **WE PAY ALL SHIPPING CHARGES.** Or keep it and pay for it at only 10¢ A DAY. You get a typing course and carrying case absolutely **FREE.** Get the full details without obligation! Clip out this coupon right now, and mail it today!



10-Day Free Trial Offer

FREE
Typing Course
Carrying Case

Remington Rand Inc., Dept. D152-J
315 Fourth Avenue, New York, N. Y.

Tell me, without obligation, how to get a New Remington Noiseless Portable, Free Typing Course and Carrying Case, for 10¢ a day. Send catalogue.

Name _____
Address _____
City _____ State _____

SPECIAL FACTORY-TO-YOU OFFER MAIL TODAY!

FREE TRAILER PARTS CATALOG

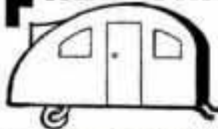

We'll save you money on—axles, springs, wheels, couplers, windows, sinks, water pumps, brakes, refrigerator, beds, lamps, inside and out, 6V lamps, furniture, jacks—everything. Special discount to manufacturers, builders' trailers for sale.

KAR-A-VAN INDUSTRIES
Dept. A. F., 308 West Randolph Street, CHICAGO



NEW Light Weight Paint Sprayer—Only \$29.50

1/4 H.P. Motor AC110 Volts. 60 Cycles—COMPLETE
Quick, easy way to paint screens, furniture, radiators, machinery—anything—in homes, factories, stores, schools, Hospitals, Office Buildings, etc. Small, compact. Carry anywhere. Weight only 44 lbs. Complete with Spray Gun; 15 ft. Hose. **FULLY GUARANTEED.** Only \$29.50 f.o.b. Chicago. \$5.00 Deposit, Balance C. O. D., or send for Free Circular. **IDEAL PUMP CO., 801 Washington St., Chicago, Ill.**

NEW SENSATIONAL TRADE BUILDER

Original "Treasure Chest Card" fastest money maker for agents. No blanks. Retail merchants buy on sight. Guaranteed to increase sales 10% to 30%. Our men making \$12.50 to \$20.00 daily. **WRITE QUICK** for Free Outline and Extra Bonus Plan.

ACE BUSINESS BUILDERS 417 S. Dearborn St., Dept. P-108, Chicago, Ill.

\$4 Cash
Commission
On Every
\$7.95
Order
Plus Bonus

ALUMAWELD

High Strength - All Metal Solder

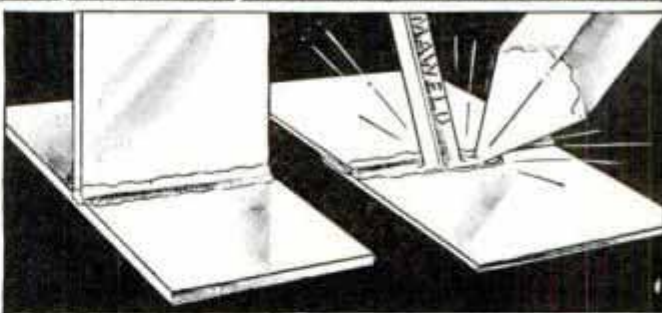

SOLDERS ALUMINUM

This is the product described on pages 461-462, Sept. issue, Popular Mechanics.

SOLDERING ALUMINUM once was considered impossible! Now, with Alumaweld Solder and FLUX the job is accomplished quickly and permanently! In fact, any metal can be soldered to aluminum forming a perfect bond. •ALUMAWELD is 10 times stronger than ordinary solder. It can be machined—will take a brilliant finish and can be plated. •Regardless of the metal you want to solder, Aluminum, Stainless Steel, Die Cast Metal, Cast Iron, Brass, Copper, Etc., ALUMAWELD does a permanent job. Sold on our **MONEY BACK GUARANTEE—SPECIAL INTRODUCTORY OFFER to POPULAR MECHANICS READERS.** Regular \$1.25 Kit containing 5 bars of ALUMAWELD, 1 bottle Flux, 1 Oil Tempered Wire Brush and Instruction Sheet, all for \$1.00 postpaid. **Mail Coupon Today!**

ALUMAWELD COMPANY of AMERICA
2440 42 South Parkway Chicago, Illinois

Enclosed find \$1.00 for \$1.25 Kit of ALUMAWELD.

Name

Address

MIDGET Electric RADIO



World's Smallest Loudspeaker Radios

Just a handful. Weight only 1 1/2 lbs. Size 3 1/2 x 5 x 2 1/2, either model. Uses two Multi-purpose ligain tubes—built-in aerial. Needs no ground. Midget **BUILT-IN** speaker reproduces all programs with unusual tone and clarity. **Tunes broadcast band and SHORT WAVE.** Ideal personal radio. Operates on 110 volt A.C. D.C. current any cycle. Kit of parts with set of tubes and diagram for only \$6.49. **COMPLETELY WIRED** ready to listen for only 50¢ extra or \$6.99. Send only \$2.00—pay post-man balance. **GUARAN-TEED.** Comes in beautiful colors: **WHITE, Black, Brown, Blue** and **State color** and if up-right or oblong model is wanted. **ORDER NOW!**

TINYTONE RADIO CO.

Dept. P-10
Kearney, Nebraska

SEND ONLY \$2.00

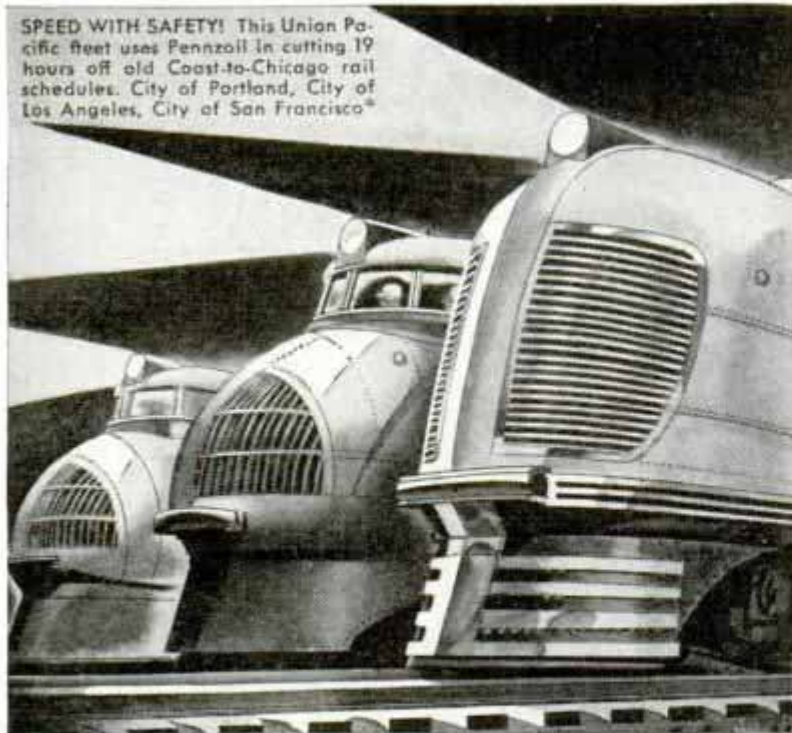

SPEED WITH SAFETY! This Union Pacific fleet uses Pennzoil in cutting 19 hours off old Coast-to-Chicago rail schedules. City of Portland, City of Los Angeles, City of San Francisco*

*This train operated jointly with Southern Pacific.

Pennzoil's margin of safety enables you to drive farther between crankcase drains. See your independent dealer for correct grade of Pennzoil for your car.

PENNZOIL GIVES YOUR CAR AN EXTRA MARGIN OF SAFETY

Copyright, The Pennzoil Co., 1936

WORLD'S SAFEST OIL GUARDS FIRST TRANSCONTINENTAL FLEET STREAMLINER

The huge Diesel engines of these streamliners are three times as hard on oil as your car. Yet regular Pennzoil stands up safely on their 2,000-mile, high-speed runs.

So think what an amazing margin of safety you get when you use in your car the same Pennzoil that experts insist on for *all three* of Union Pacific's Coast-to-Chicago streamliners!

Member Penn. Grade Crude Oil Assn. Permit No. 2



MORE MILES OF SAFE LUBRICATION

ARE YOUR KEYS THE ONLY KEYS to your shop, home, office, store, garage, etc.? Why be in doubt? Don't take chances. Learn how to reset your own cylinders so that keys that may be in the hands of old tenants and landlords or perhaps burglars will not work. Our locksmith manual for resetting cylinders sent for \$1. After several minutes with our manual you will be able to reset cylinders very easily. **SEND NOW!**



Midwest Locksmiths, 3711-C-W. Chicago Ave., Chicago, Ill.

Hand Out FREE CIGARETTES

EARN UP TO \$95 WEEKLY

Introducing NEW WAY TO SMOKE. We furnish you Free Cigarettes. Ask any man to have a Free Smoke. Hand him LIGHTED Cigarette from beautiful pocket-size "Magic Case." Just touch button. Presto! Out comes Lighted Cigarette automatically. No batteries or electricity. Get Magic Case for 15 days' trial at our risk. State favorite brand cigarettes.

MAGIC CASE MFRS., Dept. P-371
4234 Cozens Ave. St. Louis Mo.



MARVELOUS INVENTION!
"All-in-one" Combination Blow Torch & Soldering Iron



Now garage men, plumbers, mechanics, engineers can cut cost and time—with this new Justrite Combination Blow Torch and Soldering Iron! Supplies its own pressure—without pumps of any kind. Generates its own heat—without charcoal or stove. Light, convenient, portable, foolproof gives 100% customer satisfaction. **SELLS ON DEMONSTRATION.**

AGENTS' SAMPLES: A special proposition for new, fast-working agents who can start now—and produce! **Exclusive Territories** are open for agents who know how to sell this **PROVED MONEY MAKER.** Thousands of Justrite Torches are in use now. This success is ready for YOU! Write today!

JUSTRITE MFG. CO.
2061 Southport, Dept. JM-10, Chicago

100 PAGE BOOK No. 8
Make Beautiful Furniture
at a fraction of store cost. USE THE CRAFTSMAN new process of inlaying, using our new process ART INLAY GLUE, needing no clamps for the finest work. Hard to find rare grains for all wood, including foreign hard-to-find cabinet hardware. Lists and illustrates 75 blueprints of scroll patterns, inlay table tops—Kits for inlay art boxes, plaques, trays, book ends, etc., that anyone can make—22 pages in color. **CRAFTSMAN WOOD SERVICE CO.**
2723 MARY STREET CHICAGO

only 10¢

SENSATIONAL MOUSE TRAP
A Child Can Safely Set It

All Steel—Nickel Plated—Sets with touch finger or foot—No More Nipped Fingers. Remove Mouse from trap without touching—Lightning trigger action. Sold by most hardware, grocery and variety stores everywhere, also all Montgomery-Ward stores. If unable to obtain, send 20c for 2 mouse traps or 25c for 1 rat trap.
Elgin Products Company, 3954 Drexel Blvd., Dept. 10, Chicago

BUILD a BOAT
AT HOME

FOR PLEASURE OR PROFIT

Now you can have just the boat you've always wanted—power, sail, or rowboat—and at rock bottom cost, plus the fun of building. Make a nice profit if you want to sell. Get the

BOAT BOOK—New Edition

This famous book with 6 new boats added, shows exactly how to build 15 different popular boats. Step-by-step instructions with hundreds of pictures. Gives all plans, methods and materials. Includes racing hydroplane, inboards, outboards, sailing and sectional boat to carry on car. Also old Ford motor for marine use and all boating terms, pilot rules, boat knots, navigation rules, etc. You can't go wrong. Specially prepared for those with limited tools and skill. Price only \$3. Write for descriptive folder or order now and pay postman on delivery.

Popular Mechanics Press
Room 1036B
200 East Ontario Street,
CHICAGO

When writing please mention Popular Mechanics

Learn to Re-Seat Your Chairs



Have you a chair, stool or bench that you would like to re-seat? We will teach you how to do it. Use either Cane, Rush, Reed, Splints, Fibre Rush, Cane Webbing or Grass. **Instruction Book Only 10c** Send 10c today for our illustrated Instruction Book and price list explaining how to do Seat Weaving.

The H. H. PERKINS CO., 252 Shelton Ave., New Haven, Conn.



BUILD DUTCH WINDMILLS

and other popular projects. Easy and fascinating with our blueprints. B-10, 30-in. hexagon windmill, Blueprint 75c; A-2, 6-room doll mansion; blueprint 50c, knockdown kit \$3.75. Illustrated catalog over 25 projects sent for 10c. Order today.

CRAFTSMAN'S MODEL CO., Dept. P35, 2030 N. 41st St., MILWAUKEE, WIS.

900 WORKSHOP IDEAS!

How to Make Articles of Beauty and Utility that Sell

Get the most out of your hobby. Turn your Work Shop hours into profit. The "Make It Yourself" book shows you what to make and how to make it, with that "professional touch"—models—toys—useful decorative articles of all kinds. Newest edition—480 pages, 823 pictures, 7 x 10 inches. Sent postpaid for \$3.00 or in U. S. and possessions C.O.D.—you pay postman. Order Now.

POPULAR MECHANICS PRESS, Room 1036B

200 East Ontario Street, CHICAGO

"MAKE IT YOURSELF" INCLUDES:

Toys—Models—Furniture—Garden Equipment—Home Repairs—Sports Equipment—Auto Kinks—Radio Equipment—Workshop Tools and Machinery. Articles on Working: Wood, Metal, Leather, Glass, Etc., Etc., Etc.



MAKE MONEY

with "SHOP NOTES" Ideas, Kinks, Helps

1936 SHOP NOTES and LATHE HANDBOOK

Extra Big Book Value—ONLY 98¢ For Both

Be the man who knows the easiest and best ways of doing things—the fellow who is up-to-date—cash in on handy kinks and short cuts. Get Shop Notes for 1936 and make money. For many years the helpful, handy guide for men doing mechanical, carpentry, auto repairing, concrete, plumbing, electrical, building, masonry, farming, home repair work, etc. Now ready—1936 edition and famous Lathe Handbook—both for only 98 cents.

2000 Money Making Ideas for Shop and Handy Men

Get the Shop Notes Library. Complete set 5 books—Over 800 pages—2000 pictures—2000 money making facts, methods, processes and time saving kinks. They'll pay for themselves over and over. Whole set only \$2.50. Order now. Supply soon exhausted.

Popular Mechanics Press, Room 1306A, 200 East Ontario St., Chicago



A FEW OF 360 ARTICLES IN 1936 SHOP NOTES

Shop Notes for 1936 has 224 pages—360 articles—793 illustrations. Some of the subjects are:

Air Conditioning
Auto Owner Helps
Auto Service Kinks
Brake Tester
Drill Press Work
Electrical Kinks
Furniture Making
Lathe Operating Kinks
Model Makers Helps
Sander for Lathe
Sheet Metal, Things to Do With
Tool Kinks
Welding and Cutting
Wood Turning Helps
Workshop Kinks

SEND NO MONEY!

Combination offer above 98 cents. Shop Notes Library—5 books—\$2.50. Pay postman plus few cents delivery in U. S. and possessions. Elsewhere remit with order. Order now.

Man, what Bargains!

Now every workshop can afford these **NEW LOW-PRICED Black & Decker Electric Tools**



NEW 6 INCH BENCH GRINDER ONLY \$24

NEW 1/4 INCH JUNIOR DRILL ONLY \$19.50

NEW 6-INCH BENCH GRINDER

Even the smallest shop can afford this power grinder. Just the thing for tool sharpening, light grinding, buffing, polishing, wire-brushing, etc. Equipped with tool rests, wheel guards, carrying handle and rubber feet which anchor it firmly without bolts. Fitted with "Compo" oil-less bearings. All moving parts carefully balanced. A great tool for only \$24.

NEW 1/4-INCH JUNIOR DRILL—a sturdy, practical tool which will handle a thousand and one jobs around the shop, home or garage. Drives twist drills up to 1/4-inch in metal; wood augers up to 1/2-inch. Also drives wheels for light grinding, buffing, wire-brushing, polishing, etc. Has big easy-grip handle; sliding thumb switch; powerful universal motor; 3-jaw keyed chuck. A sensation—for only \$19.50.

NEW 1/2-INCH JUNIOR DRILL (not shown) drills holes up to 1/2" in metal; 1/4" in wood; drives hole saws up to 3 1/2" in any material a hack saw will cut. A wonderful bargain—only \$35.

MAIL THE COUPON today for the name of the nearest dealer where you can see these new B. & D. Tools and for free circular giving complete descriptions.



MAIL THIS COUPON NOW

The Black & Decker Mfg. Co., 610 Pennsylvania Ave., Towson, Md.

Please send me Free Literature describing new low-priced Black & Decker Tools and the address of my nearest B. & D. dealer.

Name

Occupation

Address

City State

Get into this PROFIT MAKING BUSINESS
"Simplified" ARC WELDING



EARN \$150 to \$300 EXTRA Profit Monthly

New low prices on modern 40 Volt Simplified Arc Welding makes this money making service available to shops that up until now could not afford it. It opens the doors to hundreds of big paying jobs that carry a real profit for you. Hobart is far easier to operate, faster on each job—and guaranteed to bring quality welding to your shop. Don't miss today's opportunity to get into this most profitable business—extra profits will easily pay for your welder without expense to you.

30 DAYS' TRIAL

You don't take our word for Hobart being five years ahead in performance and design—we give you 30 Days' Trial at our risk, to prove it.



VALUABLE BOOK FREE!

HOBART BROS., Box M106 Troy, Ohio
 Tell me more about

[] Building My Own [] Complete Gas Engine
 [] Portable Welder [] Drive
 [] Electric Drive Welder [] 30 Days' Trial—Easy Terms

[] Rental Plan Privilege of Purchase
 [] Send FREE Booklet on Welding. Attached letter tells about the work we want to do.

Name

Address

"BUILD YOUR OWN"—Portable Welder with Hobart Generator unit and auto engine or chassis. Lets you operate any place, especially on the profitable outside jobs. Easily saves you \$300 to \$500.

"ELECTRIC DRIVE"—In new small sizes as well as large, the new Hobart 40 Volt Welder is the most profitable shop welder you can own. Welds faster, saves current.

EASIEST TO OPERATE
 Hobart Welders are Simplified in operation. Weld faster. Your own men can use successfully. Uncertainty of obtaining correct welding current eliminated.

60% EXTRA CAPACITY
 40 Volt Ratings mean easier welding with new coated rods. Automatic reactance handles light welding work without losing arc.

REMOTE CONTROL
 No extra cost. Controls welder from any working point. Saves time and need for helper on overhead or concealed work.

HOBART IS FASTEST SELLING WELDER TODAY—Used by U. S. Government, U. S. Navy, Ford Motor and going into hundreds of welding and repair shops each month.

GET 30 DAYS TRIAL— AT OUR RISK NO INVESTMENT TERMS— PROFITS PAY FOR IT

Extra earnings and savings possible with Hobart Welders make it easy for you to own one without expense. You can even rent a new Hobart—and later purchase it without loss. Check Rental Purchase Plan.

HOBART ONE OF THE WORLD'S LARGEST BUILDERS OF ARC WELDERS

PLAY IN THE BAND



Free Chart HELPS YOU CHOOSE YOUR INSTRUMENT

You can join a band or orchestra quickly, playing an easy-to-learn Elkhart instrument. Free Chart pictures and tells uses of all band and orchestra instruments—cornet, saxophone, trombone, etc., helps you choose the one for your talent. **FREE TRIAL; EASY PAYMENTS.** Write now for details and Free Chart, without obligation.

ELKHART BAND INSTRUMENT CO., 1010A JACKSON ST., ELKHART, IND.

ELKHART

OWN A Potato Chip Factory

COMPLETE



New Home Factory Makes New Kind of Potato Chips—Donuts—Salted Nuts

Stop looking for something difficult. Turn potatoes into cash. I show you just how with my newly perfected outfit. Start anywhere. Very little cash needed. Exclusive location. Profits pour in. No experience needed. I furnish the plans. Begin anywhere—village, small town, city or suburb. A big opportunity is waiting. Business permanent.

MAKE UP TO 300% PROFIT ON RAW MATERIALS

Raw materials are plentiful and cheap. Highly perfected outfit and confidential plans make operation simple, with startling profits certain.

WE HELP FINANCE YOU and locate you. Send no money, just name, for book of facts and free opportunity.

LONG-EAKINS COMPANY
 1028-S High St., Springfield, Ohio



Complete 16-unit Outfit includes new type vitreous white enamel ROUND Cooking Vat. Direct-to-fat high speed slicer, centrifugal Grease Extractor, Thermometer—Positively everything necessary to start—all at new low price.

New Pocket Radio

Operates without tubes or batteries



Amazing pocket radio fits in pocket or purse. Smaller than a cigarette package! No crystals to adjust or bother with—only one moving part—no upkeep. Beautiful clear tone and unusual selectivity and volume. Can be used by ANYONE ANYWHERE. Directions included for use in hotels, offices, autos, at home, while cycling, boating or on trains. Thousands of satisfied owners report amazing reception and distance. Takes only a second to connect and tune in. Absorbs Choice of beautiful colors: Black, White, Brown, Green, Blue and Red. ABSOLUTELY complete with midget phone ready to listen. Send only \$1.00 and pay postman balance or send \$2.99 (M. O., Cash, Check) and we will send postpaid. Ideal gift for any boy. Guaranteed. Order Now! State color.

TINYTONE RADIO CO., Dept. P-10, Kearney, Neb.

SEND ONLY \$1.00

Prices Are ADVANCING Buy at BOTTOM Prices



All over the world, thrifty, far-sighted people are going to take advantage of this last chance to buy quality watches at these low prices. We bought these watches for you at bottom prices. When these are gone, even our great buying power will not enable us to continue selling these fine watches and diamonds at such low prices.

Diamond Rings Wrist Watches

Write for our New Diamond Ring of Romance and Bulova Wrist Watch Catalog showing marvelous new designs at prices which cannot be continued. Catalog sent FREE. All Watches and Diamonds Sold on Easy Payments.

Don't Delay—Send for Catalog at Once
SANTA FE WATCH CO.
 Dept. A6, Thomas Bldg., Topeka, Kans.

FOR FACTORY OR HOME SHOP NEW *Delta* TOOLS

PROVIDE EFFICIENCY AND
ACCURACY AT LOW COST!



The New Delta 10-inch Circular Saw, shown in the illustration above in combination with the new Delta 6-inch Jointer, is the largest, heaviest and most completely equipped circular saw yet offered for the home work shop, tool shop, pattern shop, contractor and builder.

Delta Motor-driven Tools have spread rapidly into many thousands of industrial plants as well as home workshops. And no wonder! Compact, rugged, accurate with many features not found on heavy expensive machines—Delta Tools offer dependable quality and skillful design at surprisingly low cost. Before selecting new tools—be sure to see the new 1937 Delta line.

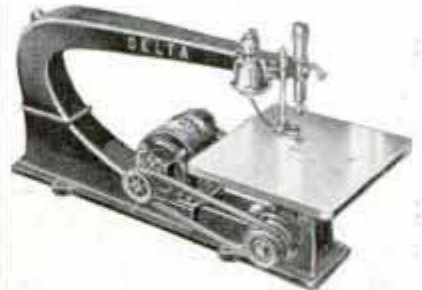

New 1937 Line to Be Announced Shortly SEND COUPON—Get on mailing list

The new 1937 Delta Catalog will be off the press soon. It will contain full description, illustrations and photographs of the complete Delta Line, including the many new Delta Tools with improvements incorporated in the 1937 line.

Every man interested in low-cost, quality tools should see the new Delta Catalog. In order to make sure that your name will be placed on the mailing list to receive a copy, send the coupon below today. At the same time enclose only 10c for the new 1937 book of "Practical Delta Projects," Book No. 3, containing 32 pages of new and novel things to make, with many blue prints, working drawings, photographs, illustrations—and complete directions. Be sure to mail the coupon at once.

New 1937 Project Book

Now out, the new 32-page book No. 3 of "Practical Delta Projects"—crowded with new and "out of ordinary" things to make—with many photographs, working drawings, and easy-to-understand illustrations. Simple, complete instructions make every project easy to follow. Every woodworker should have this book. Send 10c with coupon. 1937 Delta catalog mailed postpaid.



DELTA MANUFACTURING CO., Dept. A1036
600-634 E. Vienna Ave., Milwaukee, Wis.

I enclose 10c (stamps or coin) for which please send me one copy of the new 1937 Book No. 3 of "Practical Delta Projects." Also place me on your mailing list to receive 1937 Delta catalog of quality motor-driven woodworking tools.

Name.....Age.....

Address.....

City.....State.....

Check here if you are a Delta user now.

When writing to advertisers please mention Popular Mechanics

DOUBLE A Power TOOLS

The **Champion**—America's outstanding power tool value. Cuts up to 1 1/2 inches. Has 8-inch table, 10-inch throat, sturdy frame, adjustable guide, enclosed top spring, V-belt pulley drive. Takes 5 inch plain-end saw blade. Runs quietly. Shipping wt. 6 lb. Price, \$1.79, prepaid east of Rockies. 6 all-purpose blades, 25c extra. 5 assorted blades, 25c extra.

10 IN.
JIG SAW
\$1.79



WOODWORKER'S VISE \$1.39
Strong, rugged, practical. Carefully and accurately finished. Jaws, 6 by 2 5/8 inches. Open to 6 inches. Shipping wt. 6 lb. Price, only \$1.39, prepaid east of Rockies.

MOTOR-DRIVEN HACK SAW \$8.95



The new, portable **Pioneer** is sturdy, built for hard use. Needed in every shop and garage. Cuts 2-inch stock. Has 8-inch saw blade, strong vise, cut steel gears, firm cast iron frame. Accurately machined for true cutting. Recommended speed, 125-150 strokes per minute. Motor recommended, 1/2 H. P. Shipping wt. 20 lb. Price, \$8.95, prepaid east of Rockies. Stock carrier, to steady stock from rear, 50c extra.



METAL LATHE \$10.95
1936 model, longitudinal feed, heavy-duty, 6 by 18 inches for precision turning. Hollow spindles. Oilite bronze-bearing headstock. Sturdy tallstock. No. 0 Morse taper 60° centers. 26-inch bed, 4-step pulley. Accurately fitted and machined. Easily converted to wood turning lathe. Shipping wt. 27 lb. Price, \$10.95, prepaid east of Rockies. Extra, 4-Step Pulley, for motor or lineshaft, 75c extra. 3-in. 4-Jaw Independent Chuck, \$4.50 extra.

WRITE FOR FREE LITERATURE

Describes full line of wood and metal lathes, grinders, sanders, spindle shapers, drills, motors, pulleys, belts, line shaft equipment and accessories. Orders filled promptly. Price for continental U. S. only. West of Rockies, prices are F. O. B. Ann Arbor, Mich., East of Rockies, prepaid.

DOUBLE-A PRODUCTS CO., INC.

407 No. Fifth Avenue -2- Ann Arbor, Mich.

BRASS TAPPING

Get this big outfit for metal tapping. Make artistic Bookends, Desk Racks, What-Not Racks and Plaques. Equipment includes plywood, special non-tarnishable metals, tapping hammer, 2 tapping tools, supply of nails, and design patterns, packed in attractive carton. See your dealer or send \$1.50 for complete outfit making 4 Plaques. **FREE CATALOG**

RAPAPORT BROS., 703 W. Ohio St., Chicago

For..BIG Money-Making..Doing ALL Work

Use **the EIFEL-GEARED PUIERENCH KIT**
● 2 New Pocket Machine Shops . . 7" and 8 1/2" . .
● It Takes 7 SQ. FT. OF SPACE and 101 Pictures to show the astounding Working Power, Speed and Efficiency, and the AMAZING MONEY-MAKING Power..\$35 to \$100 Weekly.. of this Greatest Hand Tool Invention of ALL Time . . so Don't expect us to tell the story Here; but..let us send you the MOST AMAZING Propositions, FREE!
** They will Please and Astound you!



● ACT TODAY, and get also Free . . "the world's Most Useful small tool." It has . . 2 End, 2 Side and 3 Angle Edges . . turns Screws in All Positions . . \$1 worth of Uses.

● Mail this Part of Ad TODAY with your address (on a Postcard will do). Get FREE—101-Picture Manual of Mechanics, with . . User Offers. Or, With . . DISTRIBUTOR, Territory and FREE KIT Offers.
AMERICAN PUIERENCH CORP'N PMJ-4809 N. Ashland Ave., CHICAGO, ILL.

VEST POCKET ADDING MACHINE

Adds, Subtracts, Multiplies, Divides. Does work of costly machine. Not a toy. Million dollar capacity. Simple and accurate. Guaranteed 5 years.

FREE TRIAL \$2.50
—SEND NO MONEY—
Total Cost

Just name and address. We will ship Calculator immediately. On delivery pay postman \$2.50 (plus few cents postage). (If outside U. S. send cash.) 10c additional in Leatherette Case. If not satisfied after 10 days' trial you get your money back. THOUSANDS OF SATISFIED USERS. Write for Agents' Proposition. **CALCULATOR MACHINE CO.** (Mrs.) P. O. Box 1118, Dept. 31, CHICAGO, ILLINOIS.

TRAILER

★ BUILDERS
★ BUYERS
★ OWNERS

Send FOR THIS BIG BOOK



Guaranteed to contain more valuable information for trailer builders than any book ever offered! Tells how to build tops, beds, cabinets, drawers, etc. How to install electric light and water systems—page after page of valuable information, suggestions, ideas about building and using trailers that will save you time and money! The catalog of parts and equipment includes everything a trailer builder and user can possibly want—over 200 items—axles, hitches, windows, lights, pumps, sinks, toilets, mattresses, etc., etc.—all in a variety from which to choose. Send 25c today for a copy of this book—the first complete manual and catalog issued. Satisfaction positively guaranteed!

TRAILER SUPPLY CO.
Box 438-A Wausau, Wis.

GUARANTEED FOR LIFE

MONEY BACK GUARANTEE WITH EACH PEN SET SAMPLE 30¢ DOZ. \$3.00



Suggested selling price 69c. No. R61. Vacuum pen set without box. Consists of: fountain pen fitted with the latest type, size 4, stainless durium point, vacuum filler and transparent barrel. Mechanical pencil to match. Comes in attractive mottled colors. (Send for FREE Wholesale Catalog of 3000 fast sellers.)

SPORS CO. 8-36 MAIN ST., Le Center, Minn.

New Adding Machine Fits Vest Pocket!

Adds, subtracts, divides, multiplies like \$300 machines. Weighs only 4 ounces. Not a toy—strong guarantee. Absolutely accurate, lightning fast. Sells on sight to offices, stores, homes—all who use figures. Write quick for **FREE AGENTS** sample offer and Money-Making Plan. **C. M. Cleary, Dept. 26, 303 W. Monroe St., Chicago** Costs only \$2.95

CASH for you every week raising **ROYAL** squab baby birds. Orders waiting for hundreds of thousands. Easy to raise. You get your money for them when only 25 days old. Send 3-ct. U. S. stamp for particulars and picture book. Write **PR COMPANY, 635 Howard St., Melrose, Massachusetts.** Refer any bank.

RAISE RABBITS FOR US

WE PAY YOU UP TO \$5.00 EACH. ALSO PUT YOU IN TOUCH WITH MARKETS EVERYWHERE. Large illustrated book and catalog, also copy of the **AMERICAN RABBIT FARMER** and monthly market bulletins showing names of buyers in various parts of America who continuously buy all rabbits offered them. All for 10 cents. Address **OUTDOOR ENTERPRISE CO., 101 Main St., Holmes Park, Mo.**

Men & Women Earn Cash at Home!

Mrs. M. M. earned \$267 in 3 weeks (sworn statement) raising mushrooms for us in her cellar! Exceptional? Yes, but your cellar, shed, barn may be suitable to bring moderate income. Book, pictures, sample free. Est. 1908. **UNITED CO. 3848 Lincoln Ave. Dept. 74 CHICAGO**

NEW SCIENTIFIC WONDER "X-RAY" CURIO

10c 3 for 25c

Ref. U.S. Pat. Off.

Boys Big Fun. You apparently see thru clothes, Wood, Stone, any object. See Bones in Flesh. **FREE PACKAGE** radio picture films, take pictures without camera. "You'll like 'em." 1 package with each 25c order. **MARVEL MFG.CO. Dept. 80 — NEW HAVEN, CONN.**

When writing please mention Popular Mechanics

Sweeping the Country!

NEW-TYPE CHEAP OIL BURNER INVENTED!



COOK and HEAT
without **COAL or WOOD** In Your Present
 Stove or Furnace

TWICE THE HEAT AT LESS COST—NO DIRT OR ASHES
QUICK HEAT AT TURN OF VALVE
COOKS A MEAL for LESS

An Amazing New-Type Oil Burner Which Experts and 25,000 Users Say BEATS ANY EVER GOTTEN OUT FOR LOW COST, PERFECT PERFORMANCE, Burns Cheap Oil a NEW WAY Without Pre-generating or Clogging Up, Cuts Fuel Bills in Half and Pays for Itself Quickly by What It Saves. READ BELOW HOW YOU CAN TEST THIS REMARKABLE SUPER FLAME OIL BURNER in Your Own Home or Business FREE OF RISK. Then Mail Coupon.

Why burn coal or wood with its dirt and drudgery of building and feeding fires? Why carry ashes and get uneven, slow-starting heat, when you can burn cheap oil a NEW WAY and get TWICE THE HEAT at LESS COST—and have QUICK HEAT regulated to any degree desired by a simple turn of a valve?

Your present coal or wood stove, heating stove or furnace can be fitted easily and quickly with our Super Flame "HEAT KING." Thousands have acclaimed it the most perfect oil burner. Nothing like it ever on the market—the lowest priced efficient oil burner—Positively guaranteed NOT TO CLOG, NOT TO CARBON OR STOP UP. The only oil burner that has a record of over 11 years constant use without ever needing any cleaning. Simple—safe—economical—no electrical connections—no moving parts to wear out—all unnecessary parts eliminated—does better work at less cost. Burns 95% air and 5% cheap oil and the result is TWICE THE HEAT OF COAL by simply turning valve. What an Engineer of National Reputation Says:

Combustion principles of the Heat King are simple, efficient, excellent—assures economical

oil consumption and maximum amount of heat. Tests made on burner with one year's hard service prove there was no evidence of dirt or residue within the burner or any carbon deposit on any interior parts. There are no nozzles or tips to "choke up" or stop up with sediment, scale, etc.—C. W. Lovelace—K. C., Mo.

WHAT USERS SAY:

There are fifteen oil burners of different kinds here but Heat King is cheapest and best—J. R. Goldthorp—Washington.

I get more heat from your burner than I ever had from coal, wood or anything else I ever burned in my furnace—W. C. Nicholson—Ind.

My wife and her mother say they have reduced their coal bill fifty percent since they put your oil burner in—W. S. Collins, Pa.

Your oil burner is the poor man's friend—L. Gradner—N. C.

TRY AT OUR RISK—30 DAYS TRIAL

If you want to SAVE MONEY in cooking and heating you may try the "HEAT KING" AT OUR RISK—Prove that it ends drudgery and dirt of coal or wood, cuts fuel bills in half, pays for itself quickly by what it SAVES. You must be satisfied under our liberal guarantee or YOU PAY FOR THE BURNER ABSOLUTELY NOTHING.



Slips Into Any STOVE RANGE or FURNACE

ON OR OFF AT Turn of VALVE

FREE SAMPLE to Agents

and salesmen offered to one energetic man or woman in each locality who will demonstrate and take orders. Send no money—just sign and mail coupon (or 1c postcard will do). You can't lose for here's a revolutionary cheap new type oil burner that is safe, economical and efficient. So mail coupon quick, be first in your locality to learn how satisfactory oil heat can really be and how you can MAKE REAL MONEY spare or full time. Mail Coupon or 1c postcard today—NOW.

AGENTS SALESMEN DISTRIBUTORS—BIG MONEY

Startling low price puts this amazing new-type oil burner within the reach of everyone. No wonder so many homes, small business firms, oil filling stations, etc., are buying it—no wonder salesmen and distributors are breaking records in sales. All YOU have to do is to bring it to the attention of prospects and show how it gives QUICK HEAT, HOTTER, CHEAPER, WITHOUT DIRT AND ASHES, and how it quickly pays for itself by what IT SAVES—then, reap BIG CASH PROFITS. It sells fast because low-priced, cheap to operate, efficient.

WHAT SALESMEN SAY:

Greatly pleased with installation. Installed one when weather was 10 degrees below zero. Kept

house well heated and owner is still raving about the wonderful burner. I can dispose of 250 "HEAT KING" before this year ends.—F. Silver—Canada.

Demand for oil burners is great. Have fifteen salesmen starting. Would like to turn out 200 burners a week—C. A. Pierce—N. Y.

Heat King satisfactory in demonstration to one of the largest oil companies—W. DeJesters—Ohio.

I am a plumber, have installed all kinds of oil burners, but, I never knew before there was such a thing to get that much heat out of oil. There is money in selling them—W. C. Nicholson—Ind.

If you want to DOUBLE and TREBLE your earnings and own your own business, you can't beat the "HEAT KING" as a money maker. Get YOUR OWN OIL BURNER SAMPLE AT NO COST and CASH IN BIG PROFITS. Act quick—be FIRST in your locality—MAIL COUPON at right or 1c postcard today—NOW.

MAIL COUPON

UNITED FACTORIES, M-751 Factory Bldg., Kansas City, Mo.

Without cost or obligation, rush generous TRIAL OFFER on the wonderful "HEAT KING" Oil Burner **WITHOUT RISK TO ME.**

Name.....

Address.....

City.....

State.....

Check here if you also want to know how to make money in sales agency of your own and get NO COST SAMPLE. This does NOT obligate in any way.

UNITED FACTORIES M-751 Factory Building Kansas City, Mo.

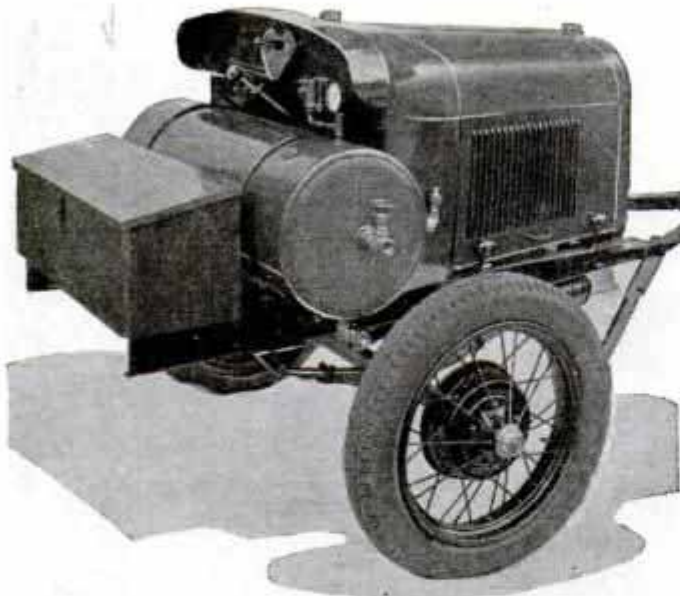

AIR COMPRESSOR FROM FORD PARTS

60 cubic feet capacity. Will operate rock drill, paving breaker, spades, tampers, riveting hammer, rivet busters, sanders, carving tools, sand blast, hoist, saw, etc.

Available as a complete machine with automatic control or may be assembled by the customer. Write for literature.

GORDON SMITH & COMPANY, INC.
BOX 285 BOWLING GREEN, KY.

Dandruff!

THIS MENACE MUST GO!

Lucky Tiger Hair Tonic rids your scalp of every speck of dandruff... used by millions... safe for children and adults...

use Lucky Tiger now and enjoy the tingle of new life and cleanliness... costs little at druggists and barbers.



LUCKY TIGER

I BUY-SELL-TRADE

All Makes of Home Workshop Machinery

New and used. Trade in your old equipment for the newest Delta, Boice-Crane, and Driver machines. Let me save you money on your machinery purchases.

Sampson Machinery Co., Dept. M, Central City, Nebr.



POCKET SLIDE RULE \$1

With A-B-C-D Scales. Multiplies, divides, squares, takes square root, finds circumference and area of circles. 6 inches long—thin construction. No Wood or Celluloid. Fits in vest pocket. Send \$1 in cash, money order, or check and receive slide rule with genuine leather case and instructions. Box M. M. MANHEIM CO., 15 E. 26th St., NEW YORK CITY

SAFETY OIL-IGNITION CONTROL

This low cost device prevents burning out expensive motor bearings and saves many other costly repair bills due to lack of oil. It shuts off your motor before your oil gets down to the danger point. This Safety Oil-Ignition Control also prevents running down your battery too. When your motor stops with your switch on, it automatically turns it off. Only \$5.00 and easily installed. Get one now before you have a big repair bill.

SAFETY OIL-IGNITION CONTROL

503 13th Avenue New Brighton, Pa.

Bicycle Horn Clears the Road

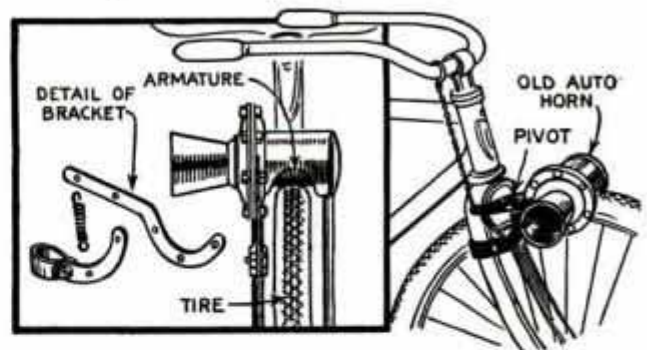

The horn-motor armature on contacting the front tire, is driven at high speed

Here is a bicycle horn that can be heard many hundred feet ahead, and it costs practically nothing. Just get an old auto horn of the motor-driven type from the junk yard and cut out a half-moon shaped section from one side of the motor housing as shown, so that the armature will be exposed. Then bolt it to a bracket of the type indicated and clamp it to the bicycle fork with the exposed part of the armature directly above the tire. When you pull up on the free end of the bracket arm, the armature will contact the tire and be driven at high speed in a manner similar to that of a regular bicycle siren.

Opening a Sealed Envelope



It's easy to open a sealed letter by alternately pulling on the flap and envelope

Instead of steaming a sealed envelope to open it, I find that less damage is done to the paper by opening it as follows: Lay it, flap side down, on a smooth surface and work it gently away from the flap as shown. Then turn it over and pull on the flap, repeating this operation alternately until the flap is loosened. You will have to use a little mucilage to reseal the letter.

—Andrew Vena, New York, N. Y.

VACU-MATIC SCORES AGAIN!

BOB McKENZIE

TRANSCONTINENTAL AUTOMOBILE CHAMPION
COAST TO COAST

WESTERN UNION
TIMED

NEW YORK

LOS ANGELES

LOS ANGELES

NEW YORK

CANADA

LOS ANGELES

NEW YORK

WASHINGTON, D.C.

MEXICO CITY

LOS ANGELES

PHOENIX

MURKIN LAKE

LOS ANGELES

ALPHA, WIS.

TO

TO

TO

TO

TO

TO

TO

TO

TO

TO

TO

TO

TO

TO

TO

TO

TO

TO

TO

TO

TO

TO

TO

TO

TO

TO

TO

TO

TO

TO

TO

TO

TO

TO

TO

TO

TO

TO

TO

TO

TO

TO

TO

TO

TO

TO

TO

TO

TO

TO

TO

TO

TO

TO

Vacu-matic Carburetor Co.
7617 W. State St.
Wauwatosa, Wisconsin

Dear Sirs:

Having just completed a new speed record between Los Angeles and Chicago, driving a 1936 Chevrolet equipped with a Vacu-matic carburetor control, I thought you might be interested in knowing some of the facts and the important part Vacu-matic played in the success of the run.

The distance covered was 2322 miles in thirty nine hours and forty-two minutes, officially timed by Western Union, which gave me an average speed of 59.7 M.P.H. based on elapsed time and with the Vacu-matic averaged 18 1/2 miles per gallon on gas-line.

Before leaving Los Angeles, we made several test runs both with and without the Vacu-matic, and the tests proved that Vacu-matic increased my gas mileage 3 1/2 miles per gallon at the driving speed of 80 M.P.H. and also very noticeable increase in both acceleration and power.

After this experience with Vacu-matic, you can depend that on my future speed runs across country that I will be depending on Vacu-matic to give me the same added performance it has proven on this last record breaking drive.

Yours very truly,

Bob McKenzie



Sets New
Coast-to-Chicago
Record

New Supercharge
Principle
SAVES GAS

MORE POWER - MORE SPEED
FASTER PICK-UP - - NEW LIFE

ESTABLISHING new mileage records on cars in all sections of the country, the Vacu-matic again scores in a new speed record established by Bob McKenzie transcontinental automobile champion. Los Angeles to Chicago—2,322 miles in 39 hours and 42 minutes—driving 75 and 80 to maintain a speed average of 59.7 miles per hour!

Here is speed—a gruelling grind—where quick acceleration, greater top speed — and less stops for gasoline mean those precious moments saved that make new speed records possible. The same Vacu-matic that helped Bob McKenzie establish this speed record and gave him such fine gas savings is now available for all car owners. It is positively automatic—simple to install—inexpensive—and pays for itself many times over in gas savings

Automatic - - Nothing Like It!

Vacu-matic is *entirely different!* It operates on the supercharge principle by automatically adding a charge of extra oxygen, drawn free from the outer air, into the heart of the gas mixture. It is entirely AUTOMATIC and allows the motor to "breathe" at the correct time, opening and closing automatically as required. No idling troubles—no carburetor adjustments necessary. It is so simple it will amaze you—so practical it will save you many dollars on gas costs.

Fits All Cars

VACU-MATIC is constructed of six parts, assembled and fused into one unit, correctly adjusted and sealed at the factory. Nothing to regulate. Easily attached in ten minutes.

Agents and Salesmen

VACU-MATIC offers a splendid opportunity for unusual sales and profits. Valuable territories now being assigned. Check and mail coupon.

The VACU-MATIC Co. Wauwatosa, Wis.

Guaranteed Gas Savings

VACU-MATIC must prove itself on every car. It is guaranteed to give worthwhile gas savings, quicker pick-up and more power, or it costs you nothing. "On my V-8 Ford it works miracles", says Ralph Fields. James Seeley—"On an International Truck on a round trip to Cleveland, 385 miles, it saved 19 gallons of gas." A. V. Grove—"On the Buick it showed 5 miles more per gallon." F. S. Peck—"I average 22 miles per gal. on my Plymouth, an increase of 7 miles, for a saving of \$15.00 a month, or \$180.00 a year." Wm. Lyons—"Averaged 25 miles on a gal. with a Model A Ford at 40 miles per hour."

Free Details

You owe it to yourself to know all about this remarkable discovery. Mail the coupon below. Start saving gas with VACU-MATIC and enjoy a new driving thrill! There's no obligation—so get the facts now! Write today!

FREE OFFER COUPON

THE VACU-MATIC COMPANY

7617-241 W. State St., Wauwatosa, Wis.

Gentlemen: Please send me full particulars concerning the Vacu-matic and details of your Free Offer. This of course does not obligate me in any way.

Name

Address

City State.....

Check here if interested in selling proposition.

Write-
FOR THESE BOOKS



\$75⁰⁰

LESS MOTOR DRIVE

Easy Payments

IF DESIRED

9" x 3' SOUTH BEND WORKSHOP LATHE



A BACK GEARED SCREW CUTTING LATHE

Weight
320
lbs.

No. 415-YA 9 1/2" swing by 3' bed Workshop Bench Lathe with Horizontal Motor Drive, 3/4 H.P. Reversing Motor, Switch and belt tension countershaft as shown **\$103²⁵**

A PRECISION LATHE

The New 9-inch Workshop Lathe is a Precision Lathe with Twin Gear reverse to leadcrew, Ball Thrust Bearing on Spindle, longitudinal screw feed to carriage, precision lead screw for cutting screw threads, and scores of other important features. Recommended for the finest work in the plant, shop and tool room. Used by all important industries. Use coupon or write for complete details, free postpaid.

South Bend Lathe Works

909 E. Madison St. South Bend, Ind.

5 OTHER SIZES
9"-11"-13"-15"-16" SWING

in all bed lengths

\$87 to \$1200



No. 192-C 16" x 6' Quick Change Gear Underneath Belt Motor Driven Lathe complete with 3-phase motor, reversing switch complete as shown, weight 2300 pounds... **\$775**

South Bend Lathe Works,
909 E. Madison St., South Bend, Ind.

Please send the following:

- No. 1 10c No. 2 10c No. 3 10c
- No. 4 10c No. 5 10c No. 6 10c
- No. 7 10c No. 8 10c No. 9 10c
- No. 10 10c No. 11 10c
- No. 12 25c
- Workshop Catalog No. 15 Free
- General Catalog No. 95 Free

Name _____

Address _____

City _____ State _____

SOUTH BEND *Precision* **LATHES**

Safe at the Plate....



.... a casualty
ten feet beyond



His Head Cut Open
Harold Genesen Rushed
to Camp Hospital Where
Lights Fail



WE HAVE A "twilight league" at our summer camp. One time, when I was on second base and a teammate made a hit, I dashed for home, thinking of nothing but how badly we needed another run.

I crossed the plate breathless and ran smack into a bat a fellow was swinging carelessly. It laid open a deep wound along my eyebrow, so they took me to the doctor's cabin. It was getting dusk and the camp electric plant was out of order, so the doctor told the boys to bring flashlights. We all had them, of course, but only one boy had one bright enough for the doctor to use. It was an Eveready Boy Scout. And the fellow who owned it said it was brighter because he had real, fresh Eveready Batteries in it and not just any old

kind. That accident showed me that just having a flashlight isn't enough . . . you've got to have good fresh Eveready Batteries in it . . . if you are going to live up to the Scout motto: "Be Prepared."



**EVEREADY
BATTERIES**

←
**ARE FRESH
BATTERIES**

NATIONAL CARBON CO.,
INC., 30 East 42nd Street,
New York, New York



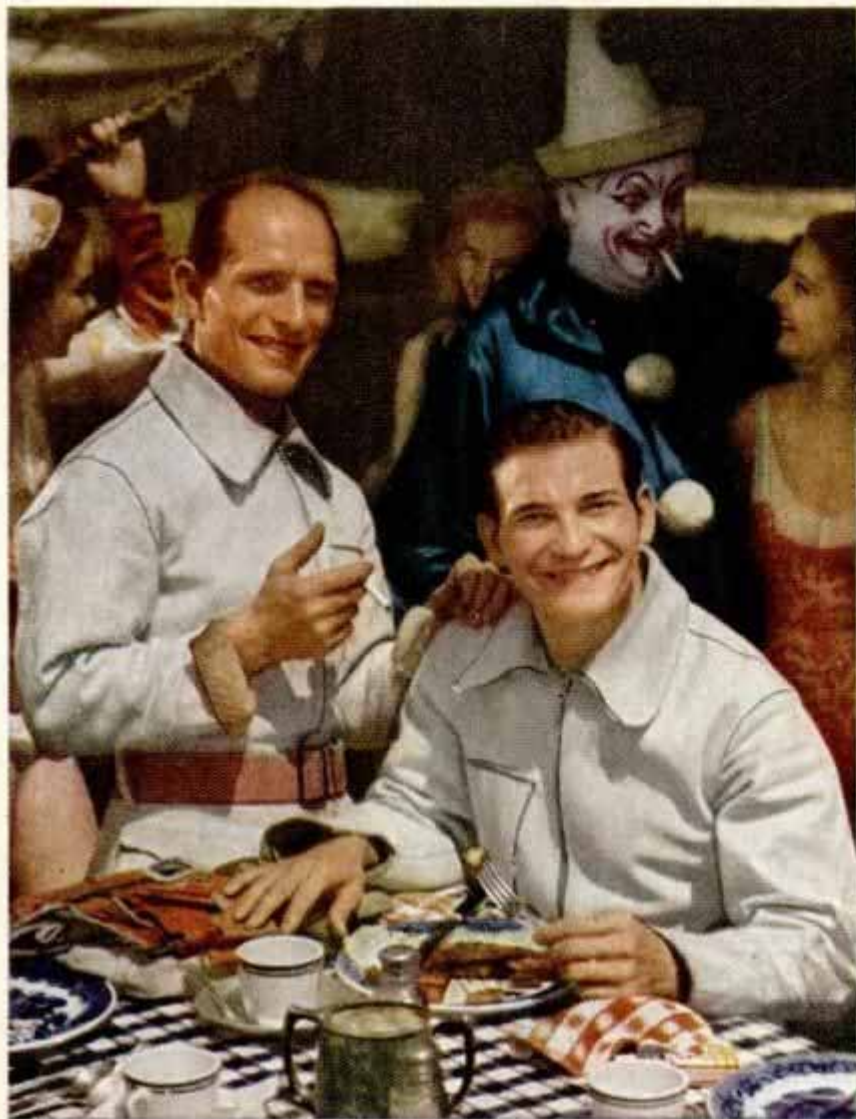

HUMAN COMETS: Hugo and Mario Zacchini disappear deep into the maw of a monster cannon. *A flah!—a crash!*—and these human bullets hurtle across the arena. As a test of digestion, this stands by itself. "We smoke Camels," says Hugo. "Camels keep digestion working smoothly."



"NEWS COMES FIRST," says Miss Helen Nolan, reporter, "eating, second. So I turn to Camels. Food tastes better and digests easier when I smoke Camels."



FIRST in the Albany-New York Outboard Marathon! Clayton Bishop says: "Camels are a swell aid to digestion—make my food taste better and digest easier."

**PEOPLE CAN MEET TERRIFIC STRAIN—YET ENJOY GOOD DIGESTION.
SMOKERS SPEAK FROM EXPERIENCE WHEN THEY SAY—**

"For Digestion's Sake — Smoke Camels!"

*Costlier
Tobacco!*

Camels are made from finer, **MORE EXPENSIVE TOBACCOS**—Turkish and Domestic—than any other popular brand.



© 1936
R. J.
Reynolds
Tob. Co.

MODERN life bombards us all with a thousand and one shocks and nervous irritations. The strain tells on digestion... slows down the flow of digestive fluids.

And it is to the comforting cheer and refreshment of Camels that one naturally turns to put more enjoyment into eating. As you enjoy your Camels at mealtime, the flow of digestive fluids speeds up... alkalinity is increased. You feel at rights with the world!

Camels set you right! And they don't get on your nerves or tire your taste.