

APRIL

25 CENTS

# POPULAR MECHANICS

## MAGAZINE

WRITTEN SO YOU CAN UNDERSTAND IT

REGD. TRADE MARK (U.K.) AT BRITAIN, No. 40428

REG. U.S. PAT. OFF.



SEE PAGE 544



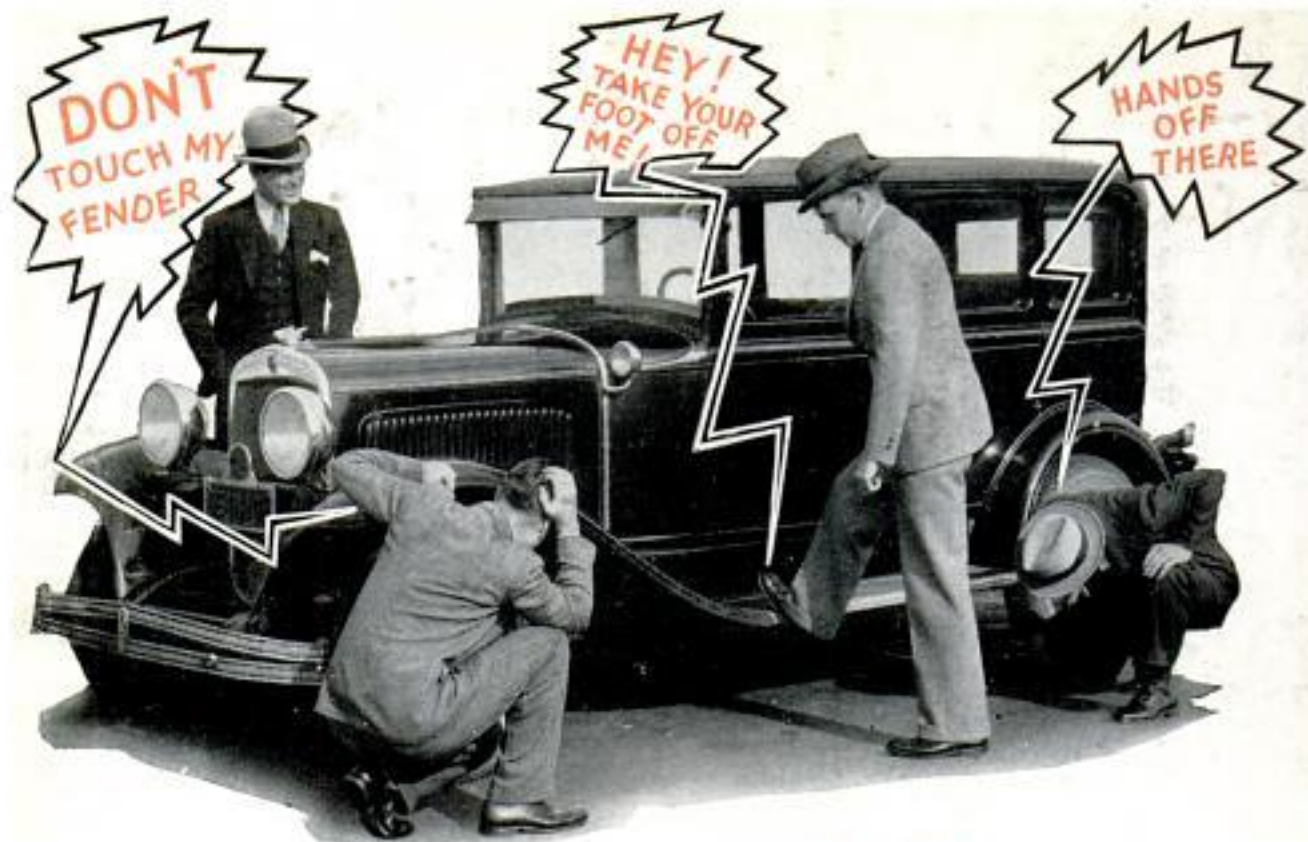

## Uncanny Invention Startles Motorists Protects Your Car From Thieves, Puzzles Your Friends!

Here is something incredibly new and revolutionary. More mysterious than anything since the first discoveries of radio! As uncanny as electricity itself! Actually more

useful and valuable than the self-starter on your car! As easily controlled as your headlights! Inexpensive! No wonder it has turned the motor world topsy-turvy overnight!

### Pays Agent Record Earnings Of \$138 In A Day!

**I**MAGINE having a car that no sneak thief can tamper with! No joy-rider can steal! No friend can touch without being warned to keep away! Then think of offering this uncanny electrical device to other motorists at a price scarcely greater than the cost of a new radio tube!

In the above few words you have the reason why G. Oliver of Illinois set a profit record of \$138 in a single day. James Harper of London, England, cables, "Devil-Dogs received, ship immediately three hundred, cable best terms for sales concession, Great Britain." A. Karratti of Hawaii writes, "Have equipped my car with Devil-Dog and am creating a sensation." Ernest Flom, No. Dakota, states, "The Police force praise it highly." Richard Jacques, Canada, writes, "Have sold one for Police armored car and am getting letters from Chief of Police and Detective Departments. What these men say is just an indication of what motorists everywhere are saying. No wonder our agents are making money hand over fist, both spare time and full time.

can be installed by anyone in ten minutes or less. There is no cost for operation. No extra batteries to buy. An introductory offer now lets you examine the most spectacular invention since the radio first came in, on 5-day test. Profit possibilities as our agent are almost unlimited. Mail the coupon for 5-day offer and complete territory details. No obligation whatever, but do it now!



AUTOMATIC  
**DEVIL DOG**

**NORTHWEST ELECTRIC CORP.**  
Dept. D-10, Pukwana, S. Dakota

#### Send Quick For 5 Day Test

This astounding invention fits any car from a Ford to a Rolls-Royce without adjustment or fussing. It

Northwest Electric Corp., Dept. D-10, Pukwana, S. Dak.  
Rush me your 5-day test offer and distributor's territory details.

Name.....

Address.....

Town.....State.....





Three Chicago food experts invent a delightful new food that is revolutionizing the doughnut business.

# Here's an Amazing New Business That Pays **\$1,000** a Month Up to....

Here is a surprising new opportunity. Now you can immediately become the owner of a big business that is paying others from \$75 up to \$250 a week. There is no "Red Tape"—no delay. Wherever you live there are quick, easy profits waiting for you to grab them. Just mail the coupon for full details.

## Individual Plans to Fit Every Need

### FULL TIME

You can start a Brown Bobby shop with floor space as little as 6 by 6 feet. Sell retail and wholesale.

Thos. Minch, Fla., made \$3,000 his first 3 months.

### PART TIME

Invest a few dollars in this new business and get someone else to run it for you. A few hours of your time each week can easily bring you \$50 up to \$150 a week extra cash.

### SPARE TIME

Start at home. Make money like Mrs. Nelson, Ill., who sold 90 dozen Brown Bobbys at retail in one week, then went out to triple her profits through wholesale business.

**MEN**, this is absolutely new! A real red-hot money-making opportunity! Something every red-blooded man has always longed for. It's a chance to jump into business for yourself and make more money every week than the average man makes in a month!

Surprising, yes, almost incredible as it may sound, we actually start you in a **proven business!** The first day's profits often run from \$18 to \$55—and a business of \$350 to \$600 the first month is not exceptional for ambitious men or women.

### A Sensational Big-Money Plan

There is just one thing you need to make a "go" of this business, and that is the ambition to make real money. We give you all the plans, advice and help needed to make a big success right from the jump. We supply you with the equipment to make an amazing new food—a **greaseless** doughnut baked by electricity! You sell to homes, bakeries, delicatessens, groceries, restaurants, etc., at a profit of 150% to 600%! No wonder the dollars simply pour in!

### A New Food Secret

The **greaseless** doughnut is altogether novel and unique. It's a crispy, flaky, delicious new kind of doughnut cooked without one drop of oil or grease. Easily digested by everyone. More appetizing than old-style doughnuts ever were. Yet costs you less to make. This new business is copyrighted under the trade name "BROWN BOBBY," so there is no competition.

Everyone likes doughnuts. Millions of old-style doughnuts are sold every day. Now you can bake and sell the perfect doughnut—the toothsome **BROWN BOBBY greaseless** doughnut that sells four times as fast as any other.

### Start At Once—Anywhere

In this limited space I am able to suggest only the bare possibilities. The details are even more sensational than the facts given here can indicate. I am looking for sincere, ambitious, wide-awake men. I offer such men a plan that is a real eye-opener. The first week's profits usually amount to more than your entire investment. After that it is up to you entirely whether you will make \$3.00 or \$1,000 a month clear profit.

Men and women start in this business daily. You do not obligate yourself in any way by mailing the attached coupon. So get the details of this amazing new idea at once. Decide for independence! Fill out and mail the coupon today—**now—THIS MINUTE!**

This One



EJN6-2E8-PZJC

Address.....

City.....State.....

**FOOD DISPLAY MACHINE CORP.**  
Dept. 3-D, 500-510 N. Dearborn St., Chicago, Ill.



---

# FOR VALUE RECEIVED

---



A GREAT MANY PEOPLE will tell you that the biggest single service that five cents can buy today is a local telephone call. Without question, it is big value . . . and value that steadily grows as new telephones come into your neighborhood.

There are times when telephone service is priceless . . . when the ability to call instantly a doctor, a policeman, or the fire department could not be measured in terms of money.

But it is not alone the emergencies that give the telephone its value. There are the commonplaces of every-day conversation . . . in the home, the shop, the office . . . whenever you wish two-way communication with any one, almost anywhere.

The telephone has become such an every-

day, matter-of-fact convenience—like running water and electricity—that it is natural to take it for granted. It is well to pause occasionally and consider the nation-wide organization of men, money, and materials that makes this vital service possible, and at such low cost.

Here is a system of the public, for the public . . . run on the barest margin of profit consistent with service, security, and expansion. A service that grows as the community grows . . . placing within the reach of an increasing number the means to talk back and forth with people in the next block, the next county, a distant state, a foreign country, or on a ship at sea! No other money that you spend can bring you more actual value.

---

★ AMERICAN TELEPHONE AND TELEGRAPH COMPANY ★





# Popular Mechanics Magazine

200 E. Ontario Street, Chicago, U. S. A.

H. H. WINDSOR, Founder

H. H. WINDSOR, Jr., Editor and Publisher

London: Hachette & Cie.,  
3 La Belle Sauvage, Ludgate Hill, W. C. 2

Paris: Hachette & Cie.,  
111 Rue Reaumur

Melbourne: Gordon & Gotch  
509-513 Little Collins St.

ISSUED MONTHLY

SUBSCRIPTION:

SINGLE COPY, 25 CENTS

In United States and its possessions, Canada, Cuba, Mexico, and all }  
countries in the Pan-American Postal Union, per year, postpaid } \$2.50

To all other countries in the Postal Union . . . . . 3.00

All subscriptions are discontinued at expiration. Please examine the date printed on your wrapper.

Entered as Second Class Matter Sept. 15, 1903, at the Post Office at Chicago, Illinois, under Act of March 3rd, 1879.  
Entered as Second Class Matter at the Post Office Department, Canada.

Published monthly by POPULAR MECHANICS CO.

Copyright, 1931, by Popular Mechanics Co.

Copyright in Australia. Copyright in France

Vol. 55

Contents for April, 1931

No. 4

## Special Features

Wings for Everybody	546
The Luck of the Roaring Road	562
A Museum Comes to Life	570
Jumping into the Mayan Jungles	578
How Uncle Sam Guards Your Food	594
A Riddle of the Sea—Still Unsolved	602
With the Movie Circus	610
With the Black Ivory Patrol	618
Italian Liner to Defy the Waves	626
The Hazards of Winter Navigation	643
Advertising—stilt walker on bicycle boosts sales	625
Airplanes	
break-proof fuel tube aids plane safety	554
business office with wings	560
electrically operated external starter	614
midget-size pusher plane	609
plane that "flies" on ground helps train pilots	554
Airships—metal-covered dirigible carries twenty tons	552
Alphabet—known in Canaan, pottery indicates	552
Animals—teaspoon holds tiny monkey	535
Army, German—generals of future, study horse anatomy	553
Army, U. S.—air safety increases 1,000 per cent	559
Art Museum—phonograph records help explain pictures	560
Astronomy—astronomers ride platform	531
Auger—new machine avoids tearing up pavements	641
Automobile, Accessories	
drain valve simplifies oil change	634
electric sand box prevents skidding	645
flame arrester ends blazes from backfire	633
hammocks for seats give rest for head	616
power booster for carburetor	625
stronger wheel rims have "drop centers"	624
trunk attached to car door	566
vacuum cups on tire chains prevent skidding	646
Automobile, Design—wind-tunnel test helps improve	647
Automobile, Tires	
automatic tire pump	640
salvage old tires for use in Europe	633
Automobiles, Truck—like war tank hauls German papers	634
Aviation	
Italy's flying fleet conquers Atlantic	598
river tenders for air liners	617
robot pilots to increase safety	593
Ball Bearings—in swivel eliminate squeak	554
Baseball—new ball to aid pitchers	545
Battleship	
giant anchor given spring cleaning	613
steered by radio is target for guns	608
Bearings—self-oiling bearing material	634
Boats and Boating	
driven by hand, sail or motor	637
outboard motor run inboard	559
Brick—women press brick with bare feet	545
Carriage—one-wheel run by man-power	632
Cattle—bloomers aid study of new disease	641
Church—gilded ball on spire seats eight	623
Cotton—drier blows hot air to remove moisture	567
Deafness—deaf man "talks" and "hears" by television	614
Diorama—magic of, to reveal wonders of fair	622
Disease—oxygen tent aids lung treatment	631
Drum—with lock head simplifies shipping	576
Duck Decoys—flying, lure ducks to surface	624
Electric Heater—with fan circulates warm air	636
Electric Lights	
better lights for home use less power	621
efficiency of, tested by photo cell	550
Electricity—increasing capacity of arc rectifiers	616
Firemen—training school for, in seven-story tower	614
Flag—designed in corn kernels by boy	569
Foods—light treatment for	640
Fourth Dimension—model of	634
Fruit—orange-peeling machine	576
Furniture—from old papers	607
Goggles—fitted with lights	616
Golf—pocket course has nine holes	559
Handwriting—chart test for	640
Heating and Ventilating—weight tests aid	601
Household Devices	638

*Barnacle*

*Carburetor Flame Arrester*

*Flame mixed with water 633*

*Flame arrester*

*Flame submerged in water boiler 576*

*Boiler, longer life 605*

Army World Power 590 [Continued on Page 4]

*Butcher Shop 559*

*Chicago World's Fair 622*



*lights*  
*seller, for home 621*  
*World*  
*591*

*Electrician 645*  
*Radio 645*  
*Water 556*

House Plan—plan No. G-F-6	704
Ice—"sub-zero," shipped from tropics	632
Insects—strange fly species live in oil pools	576
Lamp Shades—Christmas cards make decoration for	569
Life Saving—suit has hood to protect the face	636
Lighthouse	
life lines relieve crew of	615
radio, that talks warns ships	567
Loading and Unloading—freight car emptied by electrical loader	609
Machinery—"still" picture of, moving at high speed	560
Mail—\$10 paid for letter in Pony express days	642
Metals—more uses found for zinc	625
Milk—coin-in-slot machine dispenses	623
Mines and Mining—electric mine-gas detector	553
Models—Tinytown attracts thousands	558
Moistener— <del>that won't break</del> made of rubber	631
Motor—rays of daylight harnessed to run	554
Motor Bus—for rails or road	617
Motorcycle	
belt on wheel adds to riding comfort	632
safety switch stops engine	633
Moving Pictures	
movie thrillers cost many lives	551
talkie theater on wheels to tour highways	607
Mushrooms—growing is a money-making hobby	606
Niagara Falls—contour of, changed by break in	646
Oilcan—with pistol trigger has force-feed pump	561
Oil Wells—tricks in fighting oil fires	568
Paints and Painting—shield tape holds stencils	561
Photo-Electric Cell—latest ways of putting to work	635
Photography	
headrest for flash lamp operates with camera	565
jackal takes own picture	603
Plants—turning stand helps grow	576
Projector—pictures projected in space without screen	593
Radio—simplified answers to your problems	655
Radio, Aerials	
making an antenna regulator	651
removing film from insulators	654
wired wireless to serve 2,000 rooms	575
Radio, Apparatus	
plug and jack combinations	653
radio owl turns off set	660
Radio, Construction—make your own coil shields	660
Radio, Power Units—testing	648
Radio, Receivers	
building a midget a. c.	657
building a "pocket-size" short-wave	652
four-tube DX uses two-volt tubes	656
phonograph combined with	654
receiver in a pillow replaces earphones	625
skyscraper-type contains electric clock	599
two-volt tubes used in auto set	649
Radio, Television	
projector for amateurs	654
"singing" arc light to aid reception	568
stock quotations transmitted by	601
Radio, Tubes—tube controls line voltage	653
Railroads	
device registers strain on rails	62
heater for railway switch melts ice and snow	633
Scythe—power, run by motor	606
Ships and Shipping—Italian liner to defy waves	626
Skyscrapers—dream of artist exceeded by reality	621
Sled—plane fuselage on runners becomes an air sled	624
Sledge—on greased runners slides down mountain	616
Soldering—iron has switch in handle	593
Sports, Water—fun and thrills combined in latest	556
Steam Boiler—longer life for, by water treatment	605
Sugar Cane—giant harvester does work of many men	647
Swimming—paddle float for swimmer	617
Telephone	
phone dial shows number called	631
users are served by super-robot	637
Theater—unique lighting effects in miniature	600
Toys—hand-power rail car thrills children	605
Tractor Crane—lays pipe to speed gas line	601
Water Tower—floodlighted, guides night flyers	599
Windmill—tower converted into church	640
Wind Wheel—wind electric-power plant for farm	545
X-Ray—gun-shaped apparatus promotes safety	642
Zoo—dwarf hippo born in	567

Automobiles, Accessories	
hookless fastener closes hole in curtain	675
rubber band keeps windshield wiper out of way	682
secret lock in ignition circuit	677
warm air keeps windshield clear	686
Automobiles, Cleaning—keeping auto floor clean	681
Automobiles, Painting—masking windows with newspapers	663
Automobiles, Repairing—shortcuts worth remembering	684
Bags—kit made from paper carton	663
Bottles—rack for draining	672
Centerpiece—bouquet of Christmas lights as	663
Chimney—hole in, improves draft	681
Clothes Basket—folding cart to carry	671
Coaster—for roller skates	674
Door—wooden guard keeps snow from	685
Doorways—new for old	678
Electricity—self-locking spring connectors	682
Flag Sling—for boy scouts	681
Flower Box—starting early	677
Flowers—how to tell color of unlabeled bulbs	663
Glue—battery filler used for gluing	664
Ice Skates—inner tubes protect runners	681
Ironing Board—slides under table	670
Kerosene Can—tire pump supplies pressure for	673
Lamps—wax fastens socket	673
Lock—door hook serves as	683
Magazine—cardboard binding for	670
Metals—producing gun-metal finish on	676
Neckties—a cabinet for your	683
Oilstone—truing up an	672
Paints and Painting—keeping dust out of varnish can	673
Photo Cut-Outs—football line-up in	669
Photography	
a battery-case "darkroom"	681
how to print on photos	669
Plaster of Paris—speeding up the setting of	683
Poultry	
hook for catching fowl	685
Rubber Stamps—homemade	677
Shelves—sliding, save space	680
Smokers' Accessories—an alligator pipe holder	664
Tank—water used to lower into pit	675
Time Switch—alarm clock operates electric	686
Waffle Iron—curing a sticky	682
Woodbox—kitchen, filled outdoors	675

SHOP NOTES

Animals—how to preserve specimens for mounting	688
Automobiles, Repairing	
replacing lower piston rings	690
silencing brake-lever rattles	699
tin can holds piston ring for filing	689
Babbitt Ladle—improving the	700
Belts	
lacing with rawhide	700
this jig trims quickly	694
Boards—nailing ends of hardwood	695
Carpet—removing stains from	689
Castings—moving heavy circular	688
Centering Plug—improved	696
Disks—sheet-metal, cut in vise	700
Drills	
cardboard drill holder	703
portable electric, has many uses	689
Dynamite—shelter tank for workers	696
Heater—smokeless, for tool kit	696
Kindling—kerosene-soaked magazines used for	701
Metal—finding cracks in	701
Nails—split wedge helps pulling	699
Paints and Painting—cleaning shellac brushes	701
Paperhanging—improved paste table	700
Printing—improved pouring ladle for printers	695
Saws and Sawing	
adding square, bevel and rule to handsaw	688
how slipping pulleys can be cured	702
Shovel—lock washers for foot pad	695
Soldering—homemade gas-heated iron	690
Thermometer—electric fan settles liquid in	703
Tools—hardening and tempering small	687
Tractor—portable canvas garage for	703
Triangle—improving the draftsman's	701
Vise—angle-iron jaws strengthen	699
Wallboard—a saw guide for cutting	701
Wall Outlets—are easy to install	697
Water Pump—rubber hose stops thumbing of	699
Water Wall—old auto bodies make a strong	696
Welding—holding irregular-shaped pieces for	694
Wood—bending at home	691
Workbench—old magnet as small anvil for	689

AMATEUR MECHANICS

Airplanes, Model	
electric iron bends bamboo for parts	669
flies as biplane or monoplane	665
Aquarium—auto glass used to make a large	676
Archery—indoor target practice with crossbows	661

*Water sports 556*



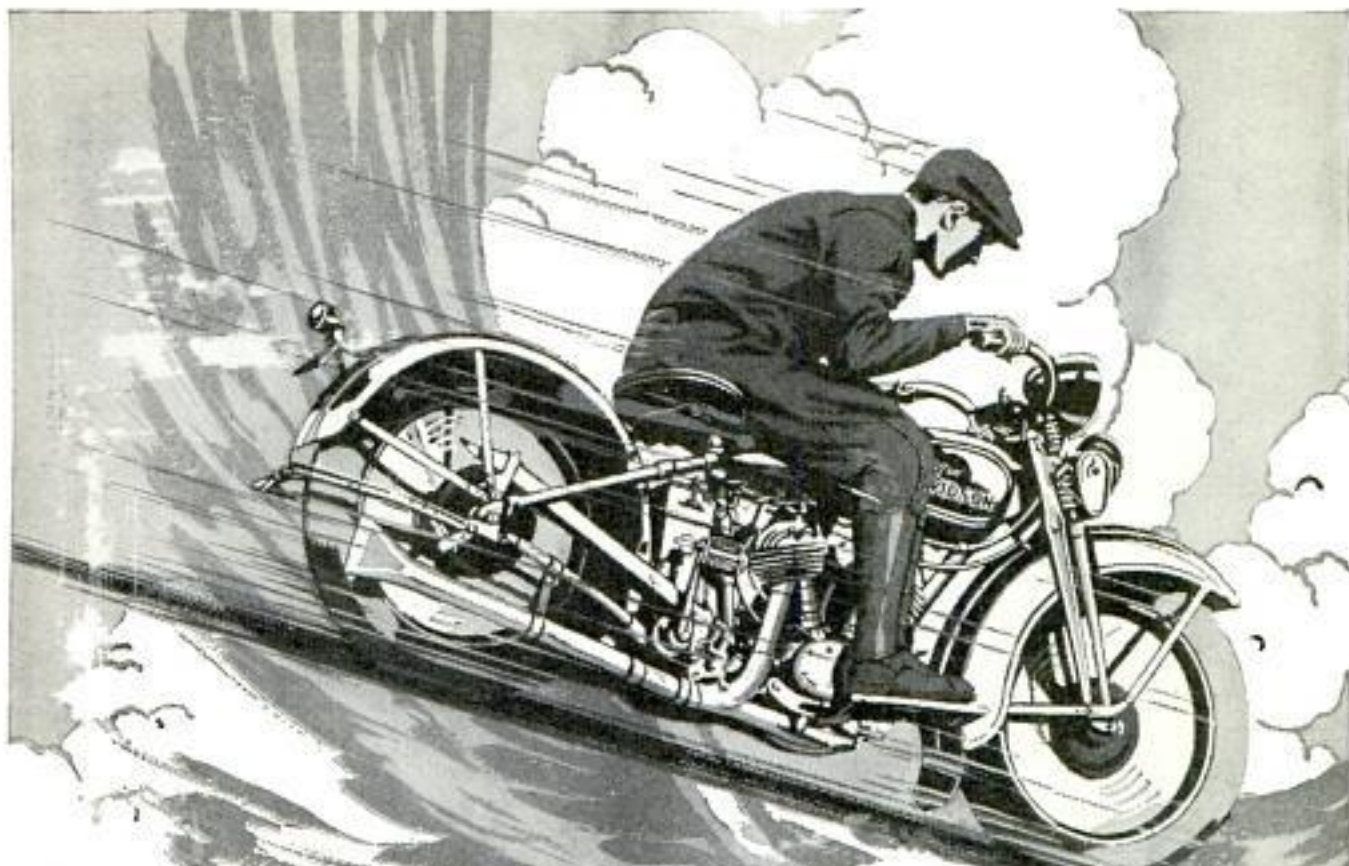

## SWOOP LIKE AN EAGLE!

Mus  
Np

Split the wind, with the keen air fanning your face, and the red blood zipping through your veins!

In all the sports, there's no thrill like motorcycling—astride a 1931 Harley-Davidson. Here is speed that just melts the miles—power that laughs at hills—getaway that nearly takes your breath away.

Let your nearest Harley-Davidson Dealer show you the amazing new Twins, and the thrifty Single. Ride one or all of them—see how easy they are to handle—get the thrill of their performance. See him soon.

Mail the Coupon for Illustrated Literature showing the new 1931 Motorcycles and Sidecars.

Ride a  
**HARLEY-DAVIDSON**

HARLEY-DAVIDSON MOTOR COMPANY  
Dept. P., Milwaukee, Wis.

Interested in your motorcycles. Send literature.

Name.....

Address.....

My age is  16-19 years,  20-30 years,  
 31 years and up,  under 16 years.  
Check your age group.





# WILL YOU TRADE

one year's leisure time  
for  
Success ten years earlier?



**F**ASTER, faster, the years speed by—yet your work drags and your goal seems still so distant that despair grips your heart.

You ask yourself—"Will I ever get there? Or will I get there *too late*?" And you see yourself finally winning success, an old man trying to enjoy the rewards which only the younger man can fully appreciate.

You know what the next ten years are likely to be—barren years—drudgery years, wrongly called *experience years!*

Business demands—and pays—trained men. But business leaves it to you whether you prepare yourself through long routine, or short cut with specialized training.

You can actually "trade" a year's spare-time study for ten years' routine experience—get at home in leisure time the experience-knowledge that most men spend years of labor to get—the trained ability that business pays for handsomely. This is no idle statement, but a fact—established by over 50,000 records in our files. Let us consider a few of these—

**In 1924 a Bookkeeper—  
In 1927, Vice-President**

Mr. A—of Indiana was marking time in a bookkeeper's job back in 1924—after a fine war service and various attempts to find himself in farming, in managing a truck line,

and in other jobs. With his enrollment in LaSalle came the change upward.

First he became office manager of a cannery firm, then entered the automobile field, and in 1927 became vice-president of one of the large automobile sales agencies of the Middle West. He says, "*Spare time invested in study with LaSalle pays compound interest.*"

**In 1918 a Rate Clerk—In 1923,  
Head of Own Traffic Bureau**

After a few years in a little Indiana school, Mr. P—learned telegraphy and went on from that through a number of railroad jobs. In 1918, and already over 40, he had progressed only as far as a rate clerk's job in an automobile plant. Then he learned about LaSalle training in Traffic Management and his real success began. In five years he established his own Traffic Bureau and has made an outstanding success of it. Today he is a registered Practitioner before the Interstate Commerce Commission and a charter member of the Association of I. C. C. Practitioners. And he writes, "*LaSalle training pays.*"

**Experience Got Him Nowhere—  
Training Solved His Problem**

If day by day experience were enough for success, Mr. B—of Texas should have been a world beater. For

after high-school and part of a university course, he had been in the Navy, in a bank, in a department store, and in a wholesale grocery—and in each had made a good record. But when he substituted specialized training in Accountancy and Law, he moved up fast. Today, he is a member of the Bar and is serving as counsel for a number of Texas corporations. In telling of it, he adds, "*I know that without the help of LaSalle, I would not have made it to my present point.*"

**Where Will 1936 Find YOU?**

Five, ten years from now—will you be holding a responsible position or will you still be gathering "experience"?

The choice is yours. The decision rests in your hands—*this very instant*. What are you going to do about it?

Take the old-traveled road of experience, if you wish. It has led you a merry goose chase so far, but it may turn out all right. We hope it will—

—but we know—through the records of some 730,000 men—that long before you reach the end of the long road of experience, some other man will take the "short cut" of specialized training and beat you to your goal!

Fill out, mail the coupon now, and future years will not mock your progress.

## LaSalle Extension University

THE WORLD'S LARGEST BUSINESS TRAINING INSTITUTION

LA SALLE EXTENSION UNIVERSITY

Dept. 464-R CHICAGO

Michigan Ave. at 41st Street

Please tell me how I can utilize my leisure time to speed up my success in the business field I have checked—and send along your free booklet "Ten Years' Promotion in One."

- Business Management
- Higher Accountancy
- Expert Bookkeeping
- C. P. A. Coaching
- Modern Salesmanship
- Paper Salesman's Training
- Modern Business Corres.
- Law: LL.B. Degree

- Commercial Law
- Industrial Management
- Modern Foremanship
- Personnel Management
- Railway Accounting
- Railway Station Mgmt.
- Traffic Management

- Credit and Collection Correspondence
- Business English
- Effective Speaking
- Banking and Finance
- Commercial Spanish
- Telegraphy—Railway and Commercial



Name

Present Position

Address



**\$75 a Week for Dobbins!**

My graduate R. N. Dobbins, got a job immediately after finishing my course. *or his earnings are big too!*



# Get on AVIATION'S PAYROLL!

## Let Me Show You How to EARN \$60 to \$100 a Week and UP in AVIATION!

My up-to-date home study Course gives you the ground work you need to *get and keep a real job* in this fascinating, fast growing industry. Scores of my graduates, who didn't know a thing about Aviation a few months ago, are holding down fine jobs right now—in the air and on the ground. *Over forty different types of jobs to choose from*, once you have this necessary training. Get the facts about my practical training, free Employment Service and Money-Back Agreement NOW!

### I Teach You QUICKLY— at Home—in Your Spare Time

You don't need to give up your present job—don't need to leave home, to get your training in Aviation. I've made it easy for you. I've put my own fifteen years of experience—backed by over 400,000 miles of flying—five years of instructing in the Navy—all into my thorough, quickly mastered home study Course.

#### No Previous Experience Needed

You don't even need a high school education—don't have to know anything about planes or engines to learn the ground work of Aviation with my Course. Everything is clearly explained—illustrated by hundreds of pictures, drawings and charts—made as simple and easy as possible. You get all the information you need to pass the Gov't's, written examinations for Mechanic's or Pilot's Licenses, in a few short months. If you want to learn to fly, I can save you many times the cost of my course on your flying time at good airports all over the country.

#### FREE Airplane Ride!

Right now I'm making an offer of a free airplane ride to all of my students. Write me at once and I'll send you complete information. Act now—to get in on this fine offer—while it is still open!

### There's No Time to Lose— Get My FREE Book NOW!

Aviation is growing by leaps and bounds—while many other industries are slumping. Don't wait and let the other fellows get ahead of you. Think about your own future. Let me prepare you for a job paying \$60 to \$100 a week or more—in Aviation. Get the FACTS. Mail the handy coupon on the right, today—right now—while you're thinking about it. I'll send you my big new FREE Book—packed with interesting facts about your opportunities in Aviation by return mail! Do it NOW.

**WALTER HINTON, President**  
**Aviation Institute of U. S. A., Inc.**  
1115 Connecticut Ave. Washington, D. C.



**Walter Hinton**

First to fly the Atlantic; first to fly to South America; first to explore the upper regions of the Amazon by plane. Flying Instructor in Navy for five years. Now giving ambitious men practical groundwork training in Aviation at home. If you are 16 or over, mail the coupon below for your copy of his big new FREE Book today.

#### I'll Help You Get a JOB, Too!

My nation-wide Employment Department is at your service—the minute you are qualified to accept a job in Aviation. We are constantly in touch with scores of airports, plane factories, etc., that want trained men for good jobs paying from \$40 to \$100 a week. No extra charge to graduates for this extra service. Free Book tells all about how I help my graduates get the kind of jobs they want! Mail the coupon now.



## Mail for my big FREE BOOK on AVIATION Now!

Walter Hinton, President, 301-Y  
Aviation Institute of U. S. A., Inc.  
1115 Connecticut Avenue, Washington, D. C.

Please send me a Free copy of your book, "Wings of Opportunity," telling all about my opportunities in Aviation, how you will train me at home and help me get a job.

Name \_\_\_\_\_  
PRINT CLEARLY

Address \_\_\_\_\_ Age \_\_\_\_\_  
(Must be 16 or over.)

City \_\_\_\_\_ State \_\_\_\_\_



# There's Quicker, Bigger MONEY for YOU in POULTRY RAISING!



Wherever You Live—  
Whatever You Do Now—  
\$2,000 to \$5,000 a Year  
Can Be Yours!



## Spare Time or Full Time YOU Can Cash-In BIG

The Poultry Industry is growing by leaps and bounds. Eggs and Poultry meat are commanding high prices—prices that mean real profits on every bird you raise—every egg your flock produces. Thousands of my students have turned to Poultry Raising for part-time extra money or full-time big pay. I'll show you how to start in a small way—in your own back yard—and make it pay—make your little investment multiply itself exponentially. Or, if you want to work for someone else at a good salary—my FREE Employment Dept. will help place you in one of the thousands of splendid positions open to trained poultrymen. Why wait? I'll PROVE that I can put you among the big money makers QUICK.

## My Proved Methods Assure Success Right from START

All the "mystery," all the "secrets," all the guesswork are taken out of Poultry Raising by my sure, tested, proved successful methods. I will teach them all to you. Nothing left out, nothing for you to have to figure yourself. I make it easy for you. It's so fascinating, healthful, pleasant, profitable. You'll be your own boss—I'll show you how to make \$1,000 to \$3,000 for every hour of your spare time. What's more, I'll show you the way to a salary of \$5,000 a year AND UP! Start as small as you want; my methods will get the maximum profits out of your flock and make it grow automatically into a sure source of steady big money for YOU.

## FREE BOOK Shows Way to BIG PROFITS

My big new FREE book, "How to Raise Poultry for Profit," will show you! It brings evidence a-plenty—absolute proof—of what I have done for thousands of others. My forty years' experience as Commercial Poultryman and former Senior Poultryman in the U. S. Dept. of Agriculture a year for real Success and Independence. The Poultry Business needs you—and you need the profits that the poultry business brings. You need my book. Get it in ten QUICKER, BIGGER MONEY. Don't let this minute—don't delay a day. Get this opportunity into the very next mail!

## YOU Can Do What They Have Done

"Your Course on Poultry Raising is the most practical and complete in the country. You have opened up a pleasant and profitable way for me to make an independent living."—S. Anderson, Barrington, R. I.  
J. L. Mosher of Buffalo, N. Y., started at \$30 a week after 10th Lesson.  
Louie Baker, Reynolds, N. C., secured position paying \$45 a week after completing 15th lesson.



48 Pages  
of Money-  
making FACTS

## Get this FREE Book NOW!

Harry M. Lamon, Pres.,  
NATIONAL POULTRY INSTITUTE,  
Dept. 411-H, Washington, D. C.

Dear Mr. Lamon: Send me your FREE Book, "How to Raise Poultry for Profit." I want to know more about MY opportunity to make \$2,000 to \$5,000 a year, spare time or full time.

Name.....

Address.....

City..... State.....

# Learn to Write

## I Teach by Mail

I CAN make a good penman of you at your home during spare time, no matter where you live or how poorly you now write. My simplified system has shown thousands of others the way to good penmanship during the past twenty years—it can and will do the same for YOU!

Beautifully Illustrated Book  
"How to Become  
a Good Penman"  
FREE!

It contains general information, with testimonials and beautiful specimens of penmanship showing what others have accomplished by the Tamblin System. (Your name elegantly written on a card if you enclose stamp for postage.) WRITE TODAY. Address

F. W. TAMBLIN  
418 Ridge Bldg., Kansas City, Mo., U. S. A.

## HOT PIANO

Ultra-modern Piano

Jazz taught by mail. Note or ear. Easy rapid lessons for adult beginners. Also Self-instruction system for advanced pianists. Learn 358 Bass Styles, 976 Jazz Breaks, hundreds of Trick Endings, Hot Rhythms, Sock, Stomp and Dirt Effects; Symphonic and Wicked Harmony in latest Radio and Record Style. Write for Free Booklet.

WATERMAN PIANO SCHOOL, 1828 W. Adams St., Los Angeles, Calif.

## AVIATION INFORMATION FREE

Send us your name and address for full information regarding the Aviation and Airplane business. Find out about the many great opportunities now open and how we prepare you at home, during spare time, to qualify. Our new book "Opportunities in the Airplane Industry" also sent free if you answer at once.

AMERICAN SCHOOL OF AVIATION  
3601 Michigan Ave. Dept. 1354 CHICAGO

## Photography

for PLEASURE or PROFIT

A fascinating hobby or a profitable business can now be yours. Prepare quickly at home under the personal guidance of leading experts in the fine art of photography. No experience necessary. Full of spare time, money earned while learning. Our thorough studio method also qualifies you to fill a well paying position upon graduation. Send coupon now for FREE booklet, Opportunities in Modern Photography.

AMERICAN SCHOOL OF PHOTOGRAPHY  
3601 Michigan Avenue Dept. 1354 Chicago, Ill.  
Send FREE booklet, Opportunities in Modern Photography, and full information.

Name.....

Address.....

City..... State.....



# "The Boss



# was Stumped"

"HE WAS trying to figure out a way to speed up the machines. I could see he was stumped and I asked him if he would let me try my hand at it.

"Go ahead," he said, "but I don't believe you can help much. Looks like an outside job to me."

"So I started right in and pretty soon I had the whole thing worked out. The boss was watching me and I could see he was surprised.

"How did you learn all that?" he asked in that quiet way of his. And then I told him I'd been studying at home nights through the International Correspondence Schools.

"He didn't say anything more and I thought he had forgotten all about it until he called me in his office a few weeks later and said he was going to make me foreman and increase my salary \$75 a month.

"Keep on studying," he told me, "and you'll get another promotion soon. You can't beat those International Correspondence Schools text-books for good, sound, practical knowledge."

That's a true story of what spare-time study has done for just one man. There are thousands of others. Why don't you take up a home-study course with the International Correspondence Schools and prepare yourself to earn more money? At least get the facts.

### Mail the Coupon for Free Booklet

#### INTERNATIONAL CORRESPONDENCE SCHOOLS

"The Universal University"

Box 5536-G, Scranton, Penna.

Without cost or obligation, please send me a copy of your booklet, "Who Wins and Why," and full particulars about the subject before which I have marked X in the list below:

#### TECHNICAL AND INDUSTRIAL COURSES

- |  |   |  |   |
|--|---|--|---|
| <input type="checkbox"/> Electrical Engineering            | <input type="checkbox"/> Wiring         | <input type="checkbox"/> Architect               | <input type="checkbox"/> Draftsman              |
| <input type="checkbox"/> Machinist                         | <input type="checkbox"/> Toolmaker      | <input type="checkbox"/> Architects' Blueprints  | <input type="checkbox"/> Contractor and Builder |
| <input type="checkbox"/> Patternmaker                      | <input type="checkbox"/> Automobiles    | <input type="checkbox"/> Architectural Draftsman | <input type="checkbox"/> Structural Draftsman   |
| <input type="checkbox"/> Reading Shop Blueprints           |   | <input type="checkbox"/> Concrete Construction   | <input type="checkbox"/> Concrete Engineering   |
| <input type="checkbox"/> R. R. Section Foreman             |   | <input type="checkbox"/> Mechanical Engineer     | <input type="checkbox"/> Steam Engineering      |
| <input type="checkbox"/> R. R. Bridge and Building Foreman |   | <input type="checkbox"/> Structural Engineer     | <input type="checkbox"/> Chemistry              |
| <input type="checkbox"/> Gas Engines                       | <input type="checkbox"/> Diesel Engines | <input type="checkbox"/> Pharmacy                | <input type="checkbox"/> Poultry                |
| <input type="checkbox"/> Aviation Engines                  |   | <input type="checkbox"/> Navigation              | <input type="checkbox"/> Radio                  |
| <input type="checkbox"/> Highway Engineering               |   |  |   |
| <input type="checkbox"/> Civil Engineer                    | <input type="checkbox"/> Coal Mining    |  |   |
| <input type="checkbox"/> Surveying and Mapping             |   |  |   |
| <input type="checkbox"/> Plumbing                          | <input type="checkbox"/> Steam Fitting  |  |   |
| <input type="checkbox"/> Heating                           | <input type="checkbox"/> Ventilation    |  |   |

#### BUSINESS TRAINING COURSES

- |  |   |   |
|--|---|---|
| <input type="checkbox"/> Business Management     | <input type="checkbox"/> Advertising            | <input type="checkbox"/> Signs                |
| <input type="checkbox"/> Industrial Management   | <input type="checkbox"/> Salesmanship           | <input type="checkbox"/> Lettering Show Cards |
| <input type="checkbox"/> Personnel Management    | <input type="checkbox"/> Stenography and Typing | <input type="checkbox"/> Civil Service        |
| <input type="checkbox"/> Traffic Management      | <input type="checkbox"/> Mail Carrier           | <input type="checkbox"/> Railway Mail Clerk   |
| <input type="checkbox"/> Accountancy             | <input type="checkbox"/> Grade School Subjects  | <input type="checkbox"/> High School Subjects |
| <input type="checkbox"/> Cost Accounting         | <input type="checkbox"/> Illustrating           | <input type="checkbox"/> Cartooning           |
| <input type="checkbox"/> C. P. Accountant        | <input type="checkbox"/> Designing              |   |
| <input type="checkbox"/> Secretarial Work        |   |   |
| <input type="checkbox"/> Business Correspondence |   |   |
| <input type="checkbox"/> Spanish                 | <input type="checkbox"/> French                 |   |

Name.....Age.....

Street Address.....

City.....State.....

Occupation.....

Persons residing in Canada should send this coupon to the International Correspondence Schools Canadian, Limited, Montreal, Canada



# LEARN ELECTRICITY

## Without Lessons In 90 Days

### BY ACTUAL WORK GREAT COYNE



*Students working in our Alternating Current Dept.*



*Instructor explaining operation of modern airplane motor*

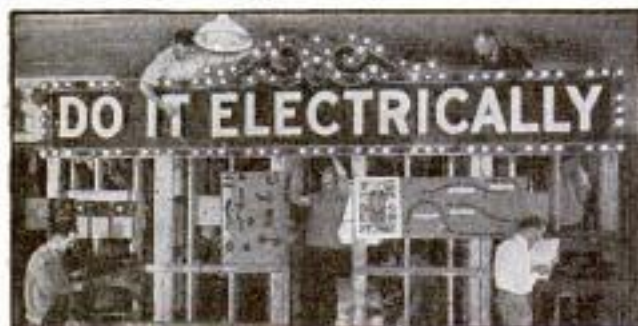

*Students getting actual experience on modern electric sign*

Don't spend your life in a dull, hopeless job! Don't be satisfied with a mere \$30.00 or \$40.00 a week! You don't have to. Electricity pays salaries of \$60, \$70 and even \$200 a week to thousands of fellows no smarter than you. And you can learn Electricity at Coyne in 90 days—NOT BY CORRESPONDENCE, but by actual electrical work.

### **Golden Opportunities**

#### **Paying \$60 a Week and Up!**

In Power Plant work, Armature Winding, Auto Ignition, House Wiring, Radio Service, Refrigeration, Welding, Aviation Electricity, Illumination, etc. Thousands of Big Pay Opportunities for the Trained Man. And you can prepare for one of them in 90 days at Coyne!

### **No Books—No Lessons**

Coyne is not a Correspondence School. We train you by actual electrical work—on huge motors and generators, switchboards, power plants, substations.

**H. C. LEWIS**  
**PRESIDENT** **COYNE**  
500 SOUTH PAULINA STREET,

## MAIL COUPON FOR





## IN THE SHOPS

tions, auto and airplane engines, armatures, etc.

You don't need advanced education or previous experience. Coyne has been placing men in Electrical Jobs since 1899. Let Coyne help you to a good electrical position!

### Free Employment Service EARN AS YOU LEARN

My Employment Department gives you a FREE lifetime service. And if you need part-time work while at school to help pay expenses, we'll gladly help you get it.

### GET MY BIG FREE BOOK

But get the PROOF! Mail the coupon below for my BIG FREE BOOK—telling all about jobs, salaries, opportunities. Find out about my Free Radio Service, Auto and Aviation Electricity offers. This costs you nothing and does not obligate you in any way. **Just Mail the Coupon!**

**ELECTRICAL SCHOOL**  
FOUNDED 1899  
Dept. 41-72, CHICAGO, ILLINOIS

**MY FREE BOOK →**



*Students working on a large synchronous Converter*



*Students learning switchboard work by actual practice*

H. C. LEWIS, PRESIDENT  
**COYNE ELECTRICAL SCHOOL, Dept. 41-72**  
500 S. Paulina St., Chicago, Ill.

Gentlemen: Please send me your big Free Electrical Book with 151 illustrations. This does not obligate me.

Name.....

Address.....

City.....State.....



## Easy home method quickly teaches HAWAIIAN GUITAR



Play all the latest hits  
just as the Hawaiians do!  
Have good times aplenty!

### Native Hawaiian expert directs you

You get expert instruction directed by a world-famous player and teacher, Prof. Walter Kolomoku. He quickly reveals to you the secrets of this fascinating instrument.

**Only 4 Motions** to learn. Then you can play any music—popular songs, classical, old-time melodies, native Hawaiian airs—or real jazz. You'll never be lonesome after you learn the Hawaiian Guitar.

**Complete Course** 52 lessons. Nothing omitted. Pictures explain every move. You are sure to learn—what we can do for others we can do for you. Over 50,000 successful students.

**Payasyouplay** We make it easy for you. Start with small first payment—then pay while learning. Costs only few cents per lesson. You only pay the cost of instruction—we furnish everything.

### Learn at home in spare time

Study in spare time at home. Even if you don't know a note our method is so simple, plain and easy, you begin a piece your first lesson. In half an hour you can play it!

## Sweet Toned HAWAIIAN GUITAR

### GIVEN when you enroll

—with genuine seal grain Fabrikoid Cover and complete playing outfit. Reliable retailers ask \$18 to \$20 for a similar instrument and outfit without the fine Fabrikoid Case, which alone is valued at \$3.50.

### TENOR BANJO and other courses

The same thorough instruction on the Tenor Banjo, Violin, Triple Tenor Guitar, Ukulele, Banjo Ukulele—well known instructors. Write for full information.

**FIRST HAWAIIAN CONSERVATORY OF MUSIC, Inc.**  
9th Floor, Woolworth Bldg., Dept. 748, New York

Approved as a Correspondence School Under the Laws of the State of New York

Member National Home Study Council

### Send This Coupon for Liberal Offer!

**FIRST HAWAIIAN CONSERVATORY OF MUSIC, Inc.**  
9th Floor, Woolworth Bldg., Dept. 748, New York, N.Y.  
Please mail full information about your 52-lesson Hawaiian Guitar Course. I am not obliged to enroll unless I want to.

Name \_\_\_\_\_

Address \_\_\_\_\_

City \_\_\_\_\_ State \_\_\_\_\_

## FREE BOOKS of BUSINESS HELPS

We publish over 200 Home Study Books, each a complete treatise of its subject. We have one or more for you. Books on

- |  |   |
|--|---|
| <input type="checkbox"/> Commercial Art      | <input type="checkbox"/> Decoration       |
| <input type="checkbox"/> Lettering           | <input type="checkbox"/> Automobiles      |
| <input type="checkbox"/> Advertising         | <input type="checkbox"/> Battery Work     |
| <input type="checkbox"/> Sign Making         | <input type="checkbox"/> Electricity      |
| <input type="checkbox"/> Radio               | <input type="checkbox"/> Carpentry        |
| <input type="checkbox"/> Aviation            | <input type="checkbox"/> Building         |
| <input type="checkbox"/> Painting            | <input type="checkbox"/> Contracting      |
| <input type="checkbox"/> Silk Screen Process | <input type="checkbox"/> Sheet Metal Work |

and many other subjects. All fully described in our FREE CATALOG. Check the subjects in which you are interested and write today.

**FREDERICK J. DRAKE & CO., Publishers**  
Room 508—179 No. Michigan Blvd., Chicago  
Drake books are for sale in all book stores.

## BEDFORD YMCA TRADE SCHOOL

Caterpillar Tractor Mechanic  
Aviation Mechanic  
Flying  
Airplane Welding  
Airplane Drafting  
Air Navigation  
Starting, Lighting, Ignition  
Auto Mechanic  
Machine Shop. Electric Welding  
Oxy-Acetylene Welding  
Radio Mechanic. Air Brush  
Mechanical, Architectural Drawing  
Sign Painting, Show Card Writing  
Talking Pictures, Western Electric  
Commercial Art. Fine Art  
DAY AND EVENING SESSIONS  
Write for Catalog 50  
Brooklyn Engineering Institute  
(Operated by Bedford Y. M. C. A.)  
1125 Bedford Avenue, Brooklyn  
New York City

## LEARN MECHANICAL DENTISTRY



### Earn Big Money—Steady Work

Don't waste the best years of your life. Prepare now for your future. Learn this money-making business in a few months in Day or Evening sessions. Big Demand. School highly endorsed. Practical training. Individual instruction. Easy terms. Write NOW for catalog P and special tool offer.  
New York School of Mechanical Dentistry  
125 West 31st Street New York

SEND FOR  
FREE BOOK



Wonderful, new device, guides your hand; corrects your writing in a few days. Big improvement in three hours. No failures. Complete outline FREE. Write C. J. Osment, Dept. 34, St. Louis, Mo.

## LEARN WATCHMAKING AND ENGRAVING



### BY OUR PROFIT-SHARING PLAN OUR GRADUATES SUCCEED

One of our Iowa students started in a very small way—now doing over \$30,000 a year. Another in Wisconsin, over \$10,000 the first year. Day or night classes. Call or write for FREE BOOK

Chicago School of Watchmaking, Dept. 7101, 549 W. Randolph St., CHICAGO



## Anyone CAN LEARN

No talent or experience necessary. Fascinating work. Pays big money. Complete instruction book tells about: Alphabets, Colors, How to Mix Paints, Show Cards, Window Board and Wall Signs, Ready made letters, Gliding, Tricks of the Trade, also gives 100 Alphabets and Designs. Book bound in flexible int. leather-gold edges, and four ball bearing Show Card Pens. Sent postpaid \$3.00. (C.O.D.) 10c extra.

Ogilvie Pub. Co., 57 Ross St., Dept. 20, N.Y. City

**EARN MONEY IMMEDIATELY—  
WE FURNISH EQUIPMENT TO START !!**





We have placed machinists, carpenters, masons, plumbers, railroad men, office clerks, farmers and even laborers in fine Drafting Jobs under this plan. Mail coupon for details of our remarkable offer.



# Men Who Work With Their Hands Make the Best DRAFTSMEN



## —and we'll back them with this EMPLOYMENT CONTRACT

We are looking for more ambitious young fellows with factory, building-trade or any other kind of mechanical experience to prepare for and help place in well-paid Drafting positions. Such men, we find, are unusually successful as Draftsmen, because they know how things are done, and that's a priceless asset to the man who makes the blueprint plans. Get in touch with me and I'll tell you how you can cash in on your entire past mechanical experience.

### Drafting Is Logically Your Next Move!

Of course you realize the biggest handicap to mechanical work is that you're limited in earning capacity to the output of your two hands, as long as you live. Even the skilled mechanic earning \$50 to \$60 a week has reached his limit. He can never earn more and when he gets old he will earn less. So I don't blame any man for wanting to get away from this futureless outlook. For wanting to get into something where he can use his head as well as his hands—where he will be paid for what he knows, instead of only for what he does . . . You know enough about blueprints to understand that PLANS govern every move in factory and construction job. The Draftsman who makes them is several jumps ahead of the workman who follows them. And so I want you to know that DRAFTING is a logical, natural PROMOTION from mechanical and building work—better-paid, more interesting—just the kind of work you'd enjoy doing.

### Get Our NO-RISK PLAN

The way to a fine Drafting job for you—is easier than you think. It takes no "artistic talent" or advanced education. Thousands of men no smarter than you, with no more education or ability, have learned it quickly and you can, too. With the co-operation of some of the biggest employers and engineers in the U. S., we have worked out a plan to prepare you for Drafting work in your spare time at home—then to help you get a fine position when you're only half way through the course. Mail the coupon and we'll be glad to tell you all about this lifetime chance.

**THE AMERICAN SCHOOL**  
Dept. D-447, Drexel Ave. and 58th St., Chicago, Illinois



### 36-Page Drafting Book—FREE

Tells how easy Drafting is to learn—how interesting the work is—what remarkable opportunities are open for Draftsmen right now. Mail coupon for a copy—without cost or obligation.

AMERICAN SCHOOL, Dept. D-447, Drexel Ave. & 58th St., Chicago, Ill.

Please tell me, without cost or obligation, about your training and employment service in line marked X below.

#### DRAFTING

- Architecture  Civil Engineering  
 Building  Auto Engineering  
 Electrical Engineering  
 Business Management  
 Accounting  
 Mechanical Engineering  
 Shop Superintendent  
 Foremanship  
 High School in 2 years  
 Structural Steel

Name \_\_\_\_\_

St. No. \_\_\_\_\_

City \_\_\_\_\_ State \_\_\_\_\_

Age \_\_\_\_\_ Occupation \_\_\_\_\_



"I have landed a job with the Pacific Tel. and Tel. Co. in Seattle, and I must say that I am greatly indebted to the American School for my success. You have done all that you promised in helping me obtain employment."

T. C. White  
Seattle, Wash.



"I have obtained a position as a junior draftsman with the Muncie Oil Engine Co., and so far I like the work real well. I appreciate your aid in obtaining this position very much."

M. N. Bareham  
Muncie, Ind.



Full Railroad Fare from Your Home to Los Angeles deducted from cost of training if you enroll soon!

**MEN WANTED —**  
*Train in California*  
for  
*Good Jobs!*



**Learn Autos**  
**IN LOS ANGELES**

**and LEARN RIGHT!**  
**Full Railroad Fare Allowed to Los Angeles!**

It's only human for you to want to come to California, Everyone does. How much better to come and get started right—quickly qualifying for the *best pay jobs*. We are allowing full railroad fare from any point in the United States for a limited time only, to encourage more men to take advantage of California Training. Never again will you get an opportunity like this. Come West NOW!

**A Few Short Weeks at National and You're Ready For A Big Pay Job!**

For 26 years National has quickly helped men get ready for big pay, steady positions in the profitable Automobile fields. Don't worry about previous experience, or whether you're too old or too young. We train you by "Actual Shop" Methods on thousands of dollars worth of right-up-to-the-minute equipment. Not a Correspondence School. Start any time.

**...and Don't Worry About Money! We'll Help You!** Even if you're short on cash you can get National Training. We help you secure good part-time jobs to earn living expenses while learning. Unlimited Employment Service assures you real, friendly co-operation in getting started on the road to real money, steady work and a prosperous future. Employers keep us busy sending them men—they know that National Auto Men are best, so they don't waste their time on half-baked, untrained mechanics. 25,000 successful graduates since 1905.

**National Doors Are Open to You!**  
**Investigate at Once!**

Write now—today—for the whole story. Our big free book with details sent FREE. Don't lose another minute. These offers are necessarily limited for a short time. Mail the coupon and soon you can be on the train for Los Angeles.

**WRITE for FREE BOOK NOW!**

**National Automotive School**

Dept. 44-e 4605 S. Figueroa Street, Los Angeles, California

Send me, absolutely free, your big illustrated catalog of Automotive Opportunities, cost of training and Special Railroad Fare Offer.

Name \_\_\_\_\_

Address \_\_\_\_\_

City \_\_\_\_\_ State \_\_\_\_\_

*Your Future assured!*

National Automotive School  
LOS ANGELES

Page by page  
my  
**Free Book**  
tells you how to  
get a steady

**GOVERNMENT JOB**

- PAGE 4**—tells What Uncle Sam Pays  
Steady salary; no lay-offs; up to \$4,700 a year.  
**PAGE 9**—How to Pick Your Job  
Openings everywhere; home or travel.  
**PAGE 12**—How I Prepare You Quickly  
Eight years official experience; my men pass HIGH; get FIRST Jobs open.  
**PAGE 18**—About Raises Every Year  
Uncle Sam keeps promises; steady increase.  
**PAGE 18**—About Vacations with Pay  
30-day vacations; sick leaves; salary goes on.  
**PAGE 10**—About Civil Service Pensions  
Faithful service rewarded; Uncle Sam retires you.

**GET IT NOW** →

My FREE BOOK, "How to Secure a Government Position" tells you the whole story: If you're an American Citizen, over 18, you can stop worrying about lay-offs, low pay and "hard times." There's a good permanent position waiting for you now: Railway Postal Clerk, Postmaster, Customs Service Man, Panama Canal Clerk, or other good jobs. Send for my FREE BOOK today! ARTHUR R. PATTERSON, Patterson School, 84 Wisner Bldg., Rochester, N. Y.



**COLLEGE COURSES**

**AT HOME**



Carry on your education. Develop power to initiate and achieve. Prepare for college. Earn credit toward a Bachelor degree or Teaching Certificates by correspondence. Select from 450 courses in 45 subjects including English, Mathematics, History, Education, Psychology, Economics, the Languages, etc. Write for catalog.

**The University of Chicago**

627 ELLIS HALL CHICAGO, ILL.

**MUSIC LESSONS IN YOUR HOME**

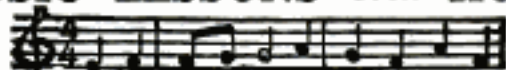

You can play music like this quickly

Write today for our FREE BOOKLET AND SAMPLE LESSON. It tells how to learn to play Piano, Organ, Violin, Mandolin, Guitar, Banjo, etc. Beginners or advanced players. You pay as you learn. Costs you only a few cents a day. Thousands of satisfied students.

**AMERICAN SCHOOL of MUSIC, 51 Manhattan Bldg., CHICAGO**

**WHY STAMMER?**

Don't be a failure. Master perfect speech. Live a healthy, normal and happy life. Send for free book which tells you how. **THE LEWIS INSTITUTE, 12972 Woodward Ave., Detroit, Mich.**

**ART COMMERCIAL ART**

Taught by Meyer Both, an internationally known art organization with 8,000 advertisers as active clients. This training—based on 30 years' resultful experience—transforms indefinite theory into definite fact. Prepare in spare time for a career in Art—a fascinating, lucrative profession open to both men and women. Write for illustrated

book telling of our successful students.  
**Meyer Both Co., Dept. 16, 20th & Michigan, Chicago, Ill.**



# Earle Liederman says:

1. "He Can Make Anyone Strong"
2. "He Can Put One Inch on Your Arm in 30 Days"
3. "He Can Put Two Inches on Your Chest in 30 Days"
4. "He Will Give You a Physique To Be Proud Of"
5. "He Will Add Many Healthy Years To Your Life"
6. "He Will Make You The Popular Idol of Your Crowd"
7. "He Will Take The Wrinkles Out of Your Spine"

## He Doesn't Promise— He Guarantees

He has done all these things and more for thousands of others. That's why he backs up his statements with an iron-clad guarantee. You want muscle—you want health and you want the pep that only supermen have. You can have them all—almost as quick as a wink!

## Put Him To The Test

An ounce of action is worth a thousand words. Make him prove that he can put one inch of muscle on your arm and two inches on your chest in less than 30 days. Make him prove that he can make anyone strong. Make him prove that he can give you a physique to be proud of. Make him prove that he will add many healthy years to your life. Make him prove that he will make you the popular idol of your gang. Make him prove that he will take the wrinkles out of your spine. He likes to be challenged because he is sure he can make good. Put him to the test. His guarantee protects you against risk.

## You Can't Lose

If Earle Liederman doesn't make good every single promise, you are out nothing. He takes all the risk. He has been guaranteeing to make physical marvels out of all sorts of muscleless men, for many years—that's why they call him The Muscle Builder. You'll call him that, too, before 30 days roll by. Write him today.

## He Never Fails

There must be a reason for his success—there is. He discovered the secret of muscle and health. And he knows how to give help to others. He doesn't give you a lot of "don'ts." He tells you what to do. He gives you the "know-how" of strength getting. That's why he never fails. That's why you should write to him today.

Send for his  
new 64-page  
book

# "Muscular Development"

It Is  
FREE

It contains forty-eight full-page photographs of himself and some of the many prize-winning pupils he has trained. Many of these are leaders in their business professions today. He has not only given them a body to be proud of, but made them better doctors, lawyers, merchants, etc. Some of these came to him as pitiful weaklings, imploring him to help them. Look them over now and you will marvel at their physiques. This book will prove an impetus and a real inspiration to you. Send today—right now before you turn this page.

**EARLE LIEDERMAN**

Dept. 2004 305 Broadway, New York City

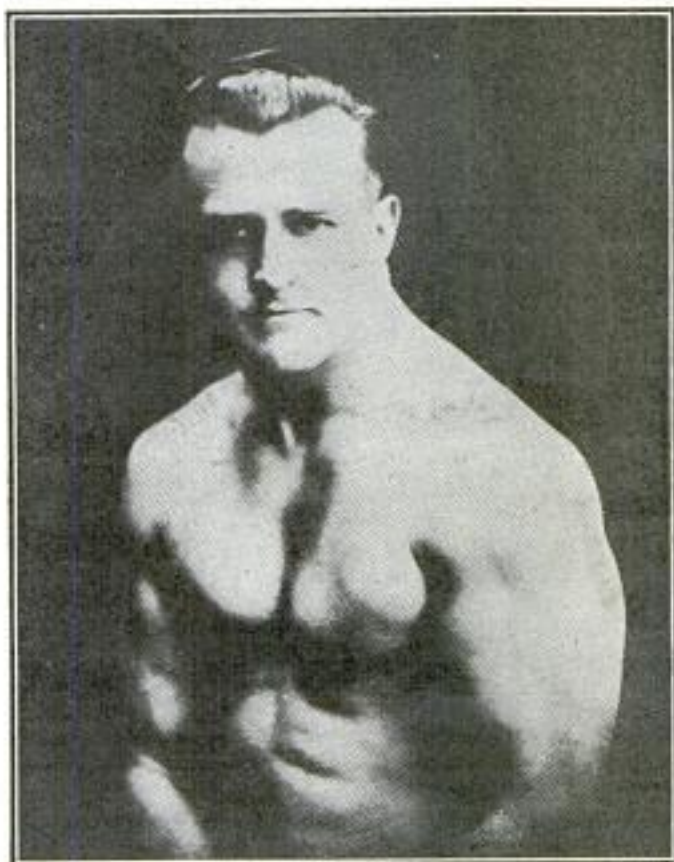

**EARLE LIEDERMAN, The Muscle Builder**

Author of "Science of Wrestling," "Muscle Building,"  
"Secrets of Strength," "Here's Health," "Endurance," Etc.

**EARLE LIEDERMAN**  
Dept. 2004, 305 Broadway, New York City

Dear Sir:—Please send me without any obligation on my part whatever, a copy of your latest book "Muscular Development." (Please write or print plainly.)

Name.....Age.....

Street.....

City.....State.....



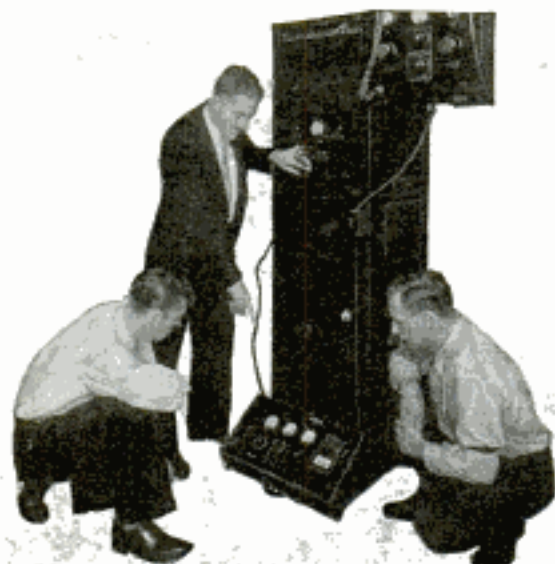

## Get the **RADIO TRAINING** you need at home in your spare time

In order to help you learn radio in the shortest possible time, RCA Institutes, Inc., was established. You may study radio at home in your spare time... or at any one of the Institute's resident schools throughout the country.

It is not hard to study radio the way it's taught by RCA Institutes. You learn radio by actual experience on the latest type of radio equipment. And you need not give up the position you now hold. You can study an hour a day or any number of hours a day, at home in your spare time.

The RCA Institutes Home Laboratory Training Course teaches you in a most thorough manner. You learn about servicing and selling, operating, radio telephony and telegraphy... also instruction in sound motion picture installation, maintenance and repairs. And you receive at no additional cost the complete RCA Institutes home laboratory equipment, a modern outlay of apparatus furnished to every student enabling you to easily solve radio problems.

### Home Training Course by America's Finest and Foremost Radio Training Organization

This home training course and free laboratory equipment are backed by more than twenty years' experience.

#### Send for our FREE BOOK Today!

Everything you want to know about radio... describes in detail the home training that has placed thousands of men in good paying positions.



## RCA INSTITUTES, Inc.

RCA INSTITUTES, Inc.,  
Dept. M. P. 4  
75 Varick St., New York, N. Y.

Gentlemen: Please send me your FREE 40-page book which tells about the many opportunities in Radio and about your famous laboratory method of radio instruction at home.

Name.....

Address.....

Occupation.....

## BE A RAILWAY TRAFFIC INSPECTOR



**EARN UP TO \$250** per month plus expenses

**Active men—19 to 55—**graduates of the Standard Business Training Institute—earn up to \$250 monthly and expenses riding on railways or bus lines as Traffic Inspectors. Fascinating outdoor work. Report to high officials.

We train you at home—spare time, give you Certificate on completion of a few weeks' course—help place you immediately to earn \$120 per month up or ahead your money. Advancement is rapid. Unusual opportunities for promotion to even higher positions.

This is the day of testing for special work. Begin your advancement now in this uncrowded profession. Write for Free Booklet and testimonial letters.

**Standard Business Training Institute**  
Div. 204 Buffalo, N. Y.

## TRI-STATE COLLEGE

DEGREE IN 2 YEARS



**B. S. DEGREE** in Civil, Electrical, Mechanical, Chemical, Aeronautical Engineering in 2 years. Those who lack high school may make up work. Living costs, tuition low.

441 College Ave., Angola, Ind.

Catalog

## ENGINEERING ELECTRICAL MECHANICAL STRUCTURAL and ARCHITECTURE

**INTENSIVE PRACTICAL TECHNICAL COURSES.** Degree in 2 years, diploma in 1 year. Special short courses 6 Weeks to 4 Months in Electricity, Radio, Power Plant, Electric Refrigeration, Air-Conditioning, Welding, Wiring, Testing, Drafting, Welding. **LOW TUITION.** Expert instructors. Extensively equipped laboratories. Free life-line employment service for graduates. Part-time work while attending. Write for new free illustrated catalog giving all facts. 30th year.

**FINLAY ENGINEERING COLLEGE**

1001 A Indiana Avenue

Kansas City, Missouri



## "STAMMERING

### Its Cause and Cure"

You can be quickly cured if you stammer. Send 10 cents, coin or stamps, for 188-page cloth-bound book on Stammering and Stuttering. It tells how I cured myself after Stammering and Stuttering for 20 years. **BENJAMIN N. BOGUE**  
1140 Bogue Building, 1147 N. Illinois Street, Indianapolis

## Learn Watchwork, Jewelrywork and Engraving

A fine trade commanding a good salary, and your services always in demand. Address **Horological**, Dept. P, Bradley Institute, PEORIA, ILLINOIS, for our latest catalog.

## NERVES?

Are You Always Excited? Fatigued? Worried? Gloomy? Pessimistic? Constipation, indigestion, cold sweats, dizzy spells and heartfulness are caused by **NERVE EXHAUSTION.** Drugs, tonics and medicines cannot help you! Learn how to regain **Vigor, Calmness and Self-Confidence.** Send 25c for this amazing book.  
**RICHARD BLACKSTONE, N-474 PLATIRON BUILDING, N. Y.**



Now science has added low cost to the convenience of automatic oil heat. Amazing discovery of the Laco Mineral Wick does it—ends fuel waste, smoke, soot, grease. Eliminates the high cost of heating forever.  
**Dealers Wanted Quick! Think what an opportunity for dealers.** Sells fastest because lowest priced, cheapest to operate. Liberal discounts! Exclusive territories. Openings for BIG Jobs. Get full information and sensational low price offer at once! Listed as standard by Underwriters. Price as low as \$70.  
**LACO OIL BURNER CO., 142 Union St., Griswold, Iowa, U. S. A.**





National Salesmen's Training Assn.  
Dept. D-103, N. S. T. A. Bldg.  
Chicago, Ill.

Without cost or obligation you may send me your free book, "The Key to Master Salesmanship."

Name.....

Address.....

City.....State.....

Age.....Occupation.....

# They Laughed When I Mailed This Coupon

*..But It Brought Me The Book That Showed Me How to Make \$10,000 a Year!*

AS I walked up to the mail box, Joe nudged Ed and winked broadly for my benefit.

"Sh!" he hissed in a loud stage-whisper. "This is going to be the big turning point in Frank Parker's life! He's writing for a book that tells how to get into salesmanship. Pretty soon he'll be earning so much that he'll make the rest of us look like pikers!"

Ed snickered. "Won't it be grand!" he grinned. "Now he can quit punching time-clocks and eating 40-cent lunches." He raised his voice. "Drop me a postal sometime when you get out into big business and start making \$10,000 a year, will you, Frank?"

They both laughed uproariously. And probably it *did* seem like a joke to them that a \$30 a week clerk would have the nerve to think he could ever get anywhere or make real money without some special "gift" or "pull."

But they laughed too soon. Just yesterday I sat down and wrote to Ed who is still at the shop, dragging along at the same old job.

"Dear Ed"—I wrote. "You asked me to send you a card when I 'got into big business and started making \$10,000 a year.' Well, here's your card. Yesterday I was promoted to the job of assistant Sales Manager of the Western Metal Works, at a salary that goes with it. I'll loan you my copy of that book on salesmanship you used to think was such a joke."

Only a book! Just seven ounces of paper and printers' ink—but it contains one of the most vivid and inspiring messages that any ambitious man can read. It reveals the real truth about the art of selling, explains the science of selling in simple terms, and tells exactly how the great sales records of nationally-known star salesmen are achieved. And not only that—it outlines a simple plan that will enable almost any man to master scientific salesmanship without spending a moment on the road—without losing a day or a dollar from his present position.

## A Few Weeks—Then Bigger Pay

Reason it out for yourself. Salesmanship offers bigger returns and delivers them quicker than any other line of work under the sun. But many people have subscribed to the foolish notion that a man has to be "born" with some sort of "gift" for salesmanship. Nothing could be farther from the truth. Just like any other pro-

fession, salesmanship is governed by certain fundamental rules and laws—laws which you can master as easily as you learned the alphabet.

Right now an unusual demand for salesmen is being reported. City and traveling sales positions are open in nearly every line all over the country. Last year requests for over 50,000 trained men were received. This employment service is free to both employers and employees, and thousands have secured excellent positions this way.

## Free to Every Man

See for yourself why "The Key to Master Salesmanship" has been the deciding factor in the careers of so many men who are now making \$10,000 a year. See how Mark Barichievich of San Francisco, Calif., for example, jumped from \$8 a week as dish-washer to \$150 as salesman. Find out how F. B. Englehardt of Chattanooga doubled his pay and commenced earning \$7,000. Learn for yourself the REAL truth about the art of selling! If we were asking \$2 or \$3 a copy you might hesitate. But the book is now FREE. You do not risk one penny nor incur the slightest obligation. And since it may alter your entire future, it certainly is worth your time to fill out and clip the coupon at the top of this page. Why not do it now!

National Salesmen's Training Association

Dept. D-103

N. S. T. A. Bldg. Chicago, Ill.



**Where Shall We Send Your Copy FREE?**

**Mail Coupon Above Today**



# Learn Electricity IN LOS ANGELES

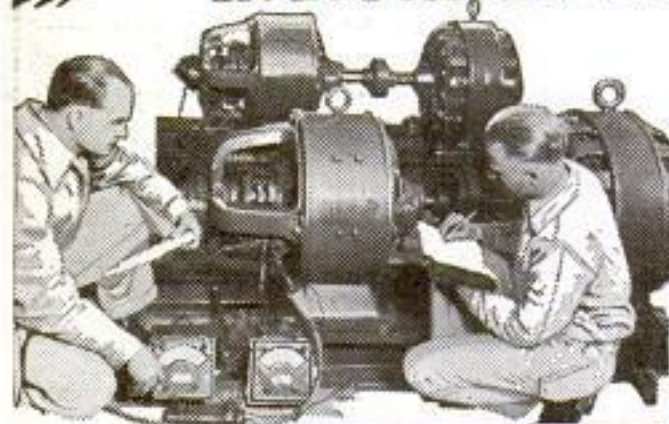

**and LEARN RIGHT!**  
YOU NEED GOOD TRAINING  
TO EARN BIG PAY!

National Electrical School—a million dollar institution—established in 1905—is recognized throughout the electrical industry as the foremost school of the West. National gives you practical intensive training in all electrical branches. No age limit. No previous experience necessary. Life Scholarship privileges. Unlimited training prepares you for bigger opportunities. Start any time of the year. Individual instruction under Experts.

### You Can Qualify Quickly For Big Pay Jobs!

We train you *right* in the *shortest possible time*. Our condensed practical training in one of the best equipped schools in the country qualifies you as a Skilled Electrician. Don't take a chance without this training. NOT a Correspondence Course.

### Don't Worry About Enough Money! We'll Help You!

If you are low on cash, we'll make it easy for you to get National Training. We help you secure part-time jobs to earn living expense while learning. Unlimited Life-Time Employment Service assures you proper co-operation in getting started in the electrical game. The Electrical Industry needs you as soon as you can get this training—that's why it's easy for us to help you.

### Your Railroad Fare Allowed To Los Angeles!

We'll allow your full railroad fare from any point in the United States. Come West, get trained, enjoy life, and make more money because you are qualified. This offer is made for a limited time only, to encourage ambitious men seeking the best training.

### New Descriptive Book Tells Everything! Write Today!

Fill out coupon now—and mail it today for full details of the greatest offer ever made ambitious men. You'll never equal this great offer—so send today for the complete story. Mail this coupon at once. Get names and addresses of many of our 25,000 Successful Graduates—some right near you.

**WRITE for FREE BOOK NOW!**

**NATIONAL  
Electrical School**

Dept. 44-F 4006 S. Figueroa Street,  
Los Angeles, California

Send me your big free illustrated catalog of Electrical Opportunities showing how I can learn quickly and get a Big-Pay Electrical Job.

Name

Address

Age  City  State

## Books on Many Practical Subjects

Popular Mechanics Press specializes in supplying the outstanding best books on many subjects. As new books of merit appear, we will revise the list accordingly.

<b>ARCHERY</b> Modern..... \$3.00	<b>INVENTION</b> Popular History of American..... \$1.00
<b>ARCHITECTURAL</b> Design and Lettering... \$2.00	<b>JOINT WIPING</b> (New Edition)..... \$1.00
<b>ARMATURE WINDING</b> Excellent new book... \$2.00	<b>KITES THAT FLY</b> How to Make..... \$1.25
<b>AUTO ENCYCLOPEDIA</b> Dyke's. (Covers New Model A Ford)..... \$6.00	<b>LANDSCAPING</b> Practical..... \$2.50
<b>AVIATION</b> Everybody's Guide.... \$2.00	<b>LATHE WORK (METAL)</b> and Drilling and Thread Cutting..... \$1.00
<b>BACKGAMMON</b> How to Play..... \$1.50	<b>LETTER WRITING</b> Social and Business Only..... \$1.00
<b>BIRD HOUSES</b> How to Make..... \$1.00	<b>LETTERING</b> Modernistic..... \$2.00
<b>BLUE PRINT READING</b> For Building Trades... \$1.25	<b>MECHANIC</b> Complete, Practical... \$3.00
<b>BOAT BUILDING</b> 35 Popular Types, Outboard Motor, Sail, Row, etc..... \$3.00	<b>MAGIC</b> 200 New Tricks for Amateurs..... \$1.00
<b>BOY MECHANIC</b> Famous 4 Vol. Library, 4000 Things to Make. \$7.00	<b>MARKETING BY MAIL</b> Science of..... \$2.00
<b>BUILT-IN FURNITURE</b> Complete Instructions. \$2.50	<b>MATHEMATICS</b> Made Easy for the Practical Man..... \$1.50
<b>CALCULATOR</b> Mathematical Ropp's... \$1.00	<b>MECHANICAL DRAWING</b> Practical Course in... \$1.00
<b>CARBURETORS</b> Excellent book on all makes..... \$2.00	<b>MODEL AIRCRAFT</b> Building and Flying... \$2.25
<b>CARPENTRY</b> Hand book of 336 Kinks. \$1.50	<b>OUTDOOR OPPORTUNITIES</b> for Making a Living... \$2.00
<b>CHALK TALK</b> How to..... \$1.00	<b>OUTDOOR SPORTS</b> for All Year 'Round New Edition..... \$2.00
<b>COLOR SIMPLIFIED</b> Practical new Book (for Color Users)..... \$3.50	<b>PAINTING</b> House (Best Methods)..... \$2.00
<b>CONCRETE</b> 173 Ways of Using New Edition (Cloth) \$1.00	<b>PLUMBING</b> 500 Plain Facts for Every Homeowner... \$1.50
<b>CONTRACT BRIDGE</b> at Sight..... \$1.00	<b>POULTRY RAISING</b> for Profit..... \$2.00
<b>DOGS</b> Care and Raising..... \$2.00	<b>PUZZLES</b> Amusing Mathematical \$1.50
<b>ELECTRICITY</b> for Beginners..... \$1.50	<b>RABBITS</b> For Food and Fur... \$2.00
<b>ELECTROPLATING</b> Practical Results Easily Obtained..... \$1.00	<b>ROOF FRAMING</b> Made Easy..... \$2.50
<b>ENGLISH</b> Self-Improvement in... \$2.50	<b>SHOP NOTES</b> 12 Vols. of 6000 Valuable Kinks..... \$3.75
<b>ETIQUETTE</b> New 560-Page Book, Only..... \$1.00	<b>SLIDE RULE</b> How to use..... \$1.75
<b>FARMER'S BOOK</b> of 861 Kinks and Book for Farmers' Wives... \$1.00	<b>STAMP ALBUM (Modern)</b> 12,000 Varieties..... \$1.50
<b>FLYING</b> Simplified..... \$1.00	<b>STEEL SQUARE</b> Pocket Book, Practical \$1.00
<b>FORMULAS</b> 10,000 Money Making \$4.00	<b>STORAGE BATTERIES</b> (New work) Best on subject..... \$3.00
<b>FURNITURE (Mission)</b> Homemade (3 vols.)... \$3.00	<b>TOY MAKING</b> Complete Instructions... \$1.50
<b>GARDENS</b> 1001 Questions Answered..... \$2.00	<b>TREASURES</b> Hunting Hidden..... \$2.00
<b>GLASS</b> Working..... \$1.75	<b>WALL DECORATION</b> (Interior) Newest Methods..... \$4.00
<b>GLIDING</b> A B C of..... \$2.00	<b>WHITTLING</b> The Art of..... \$1.35
<b>HOME REPAIRS</b> Practical Book of..... \$2.50	<b>WIRING</b> House (New Book).... \$2.50
<b>HOME WORKSHOP</b> 900 Different Things to Make..... \$3.00	<b>WOOD TURNING (LATHE)</b> Practical Course in... \$1.50
<b>IGNITION</b> (High Speed) For Garage Mechanics... \$3.50	<b>WOODWORKING SHOP</b> Modern Motor-Driven \$1.00

## Books sent C. O. D. anywhere in U.S.

Just check the books you want, write your name and address below, and mail the advertisement. It is your order blank. When postman hands you books, pay him the price and few cents postage. If outside the U. S. remit when ordering and include 10 cents per book extra for postage. We have many other books on these and 2,000 other subjects. Catalog free.

Name.....  
City..... State.....  
Address.....

Mail to Popular Mechanics Press,  
Room P4—200 East Ontario St., Chicago, Ill.



# The Britannica is a working force in the lives of those who use it



**T**HE moment the Encyclopaedia Britannica enters a home, it begins to *work* with and for every member of the family.

There is nothing static about the Britannica. You cannot put it in a corner and forget about it, any more than you could lock your automobile in a garage, and throw away the key.

For all the creative knowledge of the world down to the present time has been brought together within the pages of the Encyclopaedia Britannica.

This knowledge is, in itself, dynamic. It is *Power—Energy—Force—Assistance*—continuously demanding that you put it to work, as you immediately will.

The new Britannica does what no library, however complete, what no single intellect, however potent, can do—its twenty-four volumes hold what is essentially instructive in the contents of all the vast libraries of the world and in the ideas of all living brains, so far as they have been publicly communicated.

## Every member of the family can use it

"The people of the United States have greater and more intricate problems before them now than ever before," says Owen D. Young. "Economics, politics, and science are all inter-related, and accurate information regarding them is essential. A

good encyclopaedia is necessary, and the new Britannica meets these needs with its traditional thoroughness."

It makes children's school studies easier. Its thousands of brilliant pictures—many in full color—command their interest, and the simple text is persuasively readable and helpful.

## Advanced Students need it

Suppose that someone in your home wishes to know more about Literature—Architecture—Law—Mechanical or Electrical or Civil Engineering—Medicine—Physics and Chemistry—Art—Music—Psychology—Economics—Aviation—Astronomy—Commerce—Hydraulics—History—Manufacture—Advertising and Selling—Radio and Television, etc., etc.

In the Britannica these subjects are helpfully explained by hundreds of the world's greatest present-day authorities.

## The Incomparable Purchase

In text alone the 24 volumes of the new Britannica bring you 35,000,000 words written by 3,500 authorities—the equivalent of 500 ordinary size books. Yet you buy it—with its 15,000 brilliant illustrations and the hundreds of new maps—for a mere fraction of what the 500 books would cost you.

## NEW LOW PRICE Only \$5 Down

Only \$5 down, according to our Time Payment Plan, will bring the new Britannica and the fine bookcase table to you for immediate use. You may buy it on easy payments.

## 56-Page Free Booklet Brought by your postman

Sign and mail this coupon, and it brings you by return mail our Free Illustrated Booklet with richly printed pages, sample maps and plates in full color from the new Britannica itself, as well as a vivid description of what the Britannica is and how it works. You will be under no obligation. Simply fill out the coupon and mail it today.



P.M. 1-B2  
ENCYCLOPAEDIA BRITANNICA, Inc.  
342 Madison Avenue, New York City

Please send me, by return mail, your 56-page illustrated booklet with color plates and maps from the new Britannica, together with low price offer, etc.

Name.....

Address.....

City..... State.....

**SEND FOR FREE BOOKLET TODAY**



# GET INTO HIGHER ACCOUNTING and HIGHER PAY



Of course you want the bigger pay that goes with a bigger job—but if you're like most men you're wondering right now how you can get it. *Hundreds of thousands of men have found the answer!* Take the experience of any one of them—Vance Anderson, for instance.

For many years Anderson groped blindly for success. He tried farming—running a truck-line—then the study of mechanical engineering, then accounting at a resident school. Dissatisfied with that, he enrolled for LaSalle's course in Higher Accounting. From that time on his future assumed a definite form.

## VICE-PRESIDENT—by the time he had completed LaSalle Training

While still studying, he became Office Manager of the Central Indiana Canneries, then joined the Olin Chevrolet Company of Indianapolis, one of the large automobile agencies of the Middle West. And before he completed the course he was made Vice-President! During that time his salary increased several times over! Is it any wonder he says, "Real study with you will pay any man."

Knowledge of Higher Accounting leads the way to so many business opportunities that the well-trained man is practically proof against unemployment. A dozen doors are open to him while the untrained man is walking the street. Advancement is swift and certain—for the very foundation of business lies in accounting control. That is why LaSalle graduates in Higher Accounting occupy some of the highest executive positions.

LaSalle has made it easy for you to master this big-pay work in spare-time study at home—no matter what your previous education or experience. This is backed by a placement, consultation and advancement service that follows throughout life.

Send for "Ten Years' Promotion in One"—the little book that has led to adding hundreds of millions of dollars to the annual salaries of 700,000 men. With it we will include full information about the big-opportunity field of Higher Accounting. Sending the coupon below may be the turning point in your life. Don't delay, but send it today—NOW!

-----Find Yourself Through LaSalle-----

## LaSalle Extension University

The World's Largest Business Training Institution

Dept. 464-HR Chicago

I would welcome copy of "Accountancy, the Profession that Pays," also a copy of "Ten Years' Promotion in One," all without obligation.

### Higher Accountancy

Training for positions as Auditor, Comptroller, Certified Public Accountant, Cost Accountant, etc.

### Other LaSalle Opportunities

If more interested in one of the fields indicated below, check and mail now.

- |  |   |
|--|---|
| <input type="checkbox"/> Business Management   | <input type="checkbox"/> Banking and Finance            |
| <input type="checkbox"/> Modern Salesmanship   | <input type="checkbox"/> Modern Business Correspondence |
| <input type="checkbox"/> Traffic Management    | <input type="checkbox"/> Railway Accounting             |
| <input type="checkbox"/> Railway Station Mgmt. | <input type="checkbox"/> Expert Bookkeeping             |
| <input type="checkbox"/> Law: Degree of LL.B.  | <input type="checkbox"/> C. P. A. Coaching              |
| <input type="checkbox"/> Commercial Law        | <input type="checkbox"/> Business English               |
| <input type="checkbox"/> Industrial Management | <input type="checkbox"/> Modern Foremanship             |
| <input type="checkbox"/> Modern Foremanship    | <input type="checkbox"/> Commercial Spanish             |
| <input type="checkbox"/> Personnel Management  | <input type="checkbox"/> Effective Speaking             |
| <input type="checkbox"/> Credit and Collection | <input type="checkbox"/> Correspondence                 |

Name.....

Present Position.....

Address.....



# Free →



Write for my Job-Securing and Pay-Raising Plan today. Mailed Free.

My drafting students get these drawing tools.

## JOBS FOR DRAFTSMEN in Great Industries—Learn at Home

Automobiles—Electricity—Motor Buses—Aviation—Building Construction. Hundreds of others. Building of stores, homes, factories and office buildings is going on all the time. No structure can be erected without plans drawn by a draftsman. No machinery can be built without plans drawn by a draftsman.

I train you at home, in Drafting, spare time only. Keep the job you have now while learning drafting. Men I have trained are making from \$3,500.00 to \$9,000.00 a year.

Get started now toward a better position, paying a good straight salary, the year around. Comfortable surroundings. Inside work. Through hard times—adversity—sickness—bad luck—big bills—what can equal a Job that Lasts? You may earn as you learn. I give you employment service. Your money back if you want it and help as long as you need it.



I'll Train You at Home.

If You Earn Less Than \$70.00 a Week Write to me now for my Pay-Raising Plan.

Engineer Dobe, Div. 13-54  
1951 Lawrence Ave., Chicago

Operator No. 38



## FOLLOW THIS MAN

Secret Service Operator No. 38 is on the job! Running down dangerous Counterfeit Gang. Tell-tale finger prints in murdered girl's room.

**Free** The Confidential Report Operator No. 38 made to his chief. Write for 6c. \$3000 a year and up.

YOU can become a Finger Print Operator at home, in your spare time, at small cost. Write for confidential full report and details. Literature will NOT be sent to boys under 17 years of age.

INSTITUTE OF APPLIED SCIENCE  
1920 Sunnyside Ave. Chicago, Ill.  
Dept. 13-54

SONG REQUIREMENTS OF TALKING PICTURES



## SONG WRITERS

Advance Royalty Payments, New Talking-Picture Song requirements, etc., fully explained in our free instructive book. Writers of Words or Music for songs may submit their work for free advice. We revise, compose, arrange and copyright music. Write today.

Newcomer Associates, 1676-Y Broadway, New York

## LEARN TO Mount Birds

We teach you At Home by Mail to mount Birds, Animals, Heads, Tax Furs and Make Bags. Be a taxidermy artist. Easily, quickly learned by men, women and boys. Tremendously interesting and fascinating. Decorate home and den with beautiful art. Make Big Profits from Spare Time Selling Specimens and Mounting for Others.

**Free Book**—beautiful book telling all about how to learn taxidermy sent Free if you state your AGE. Send Today. You will be delighted.

Northwestern School of Taxidermy 3374 Elwood Bldg. OMAHA, NEB.



## LEARN WATCH REPAIRING



You can learn by our modern and original system of instruction every part of the Watch Repairing Trade at home as good or better than at a shop. You can earn money while learning and secure a well paying position or start in business after completing our course of instruction. Good watch repairers are always in demand and earn from \$50 to \$75 per week. For particulars apply to the Wisconsin School of Watch Repairing 524 E. Mason St., MILWAUKEE, WIS.



# I will train you at home



**Here's  
Proof**

to fill a  
**BIG PAY**  
**Radio Job!**

If you are earning a penny less than \$50 a week, send for my book of information on the opportunities in Radio. It is free. Clip the coupon NOW. Why be satisfied with \$25, \$30 or \$40 a week for longer than the short time it takes to get ready for Radio.

**Radio's growth opening hundreds of \$50, \$75, \$100 a week jobs every year**

In about ten years Radio has grown from a \$2,000,000 to a \$1,000,000,000 industry. Over 800,000 jobs have been created. Hundreds more are being opened every year by its continued growth. Men and young men with the right training—the kind of training I give you—are needed continually.

**You have many jobs to choose from**

Broadcasting stations use engineers, operators, station managers and pay \$1,800 to \$5,000 a year. Manufacturers continually need testers, inspectors, foremen, engineers, service men, buyers, for jobs paying up to \$15,000 a year. Shipping companies use hundreds of Radio operators, give them world wide travel at practically no expense and a salary of \$85 to \$200 a month. Dealers and jobbers employ service men, salesmen, buyers, managers, and pay \$30 to \$100 a week. There are many other opportunities too.

**So many opportunities many N. R. I. men make \$5 to \$25 a week extra while learning**

The day you enroll with me I'll show you how to do 10 jobs, common in most every neighborhood, for spare time money. Throughout your course I send you information on servicing popular makes of sets; I give you the plans and ideas that are making \$200 to \$1,000 for hundreds of N. R. I. students in their spare time while studying.

**Talking Movies, Television, Wired Radio are also included**

Radio principles as used in Talking Movies, Television and home Television experiments, Wired Radio, Radio's use in Aviation, are all given. I am so sure that I can train you satisfactorily that I will agree in writing to refund every penny of your tuition if you are not satisfied with my Lessons and Instruction Service upon completing.

**64-page book of information FREE**

Get your copy today. It tells you where Radio's good jobs are, what they pay, tells you about my course, what others who have taken it are doing and making. Find out what Radio offers you, without the slightest obligation. ACT NOW.

**J. E. SMITH, President  
National Radio Institute Dept. 1DQ  
Washington, D. C.**



I will give you my new 8 OUTFITS of RADIO PARTS for a home Experimental Laboratory

You can build over 100 circuits with these outfits. You build and experiment with the circuits used in Crosley, Atwater-Kent, Eveready, Majestic, Zenith, and other popular sets. You learn how these sets work, why they work, how to make them work. This makes learning at home easy, fascinating, practical.

Back view of 5 tube Screen Grid A. C. set—only one of many circuits you can build.



I am doubling and tripling the salaries of many in one year and less Find out about this quick way to

**BIGGER  
PAY**

**FILL OUT AND MAIL  
THIS COUPON TODAY**

J. E. SMITH, President,  
National Radio Institute, Dept. 1DQ  
Washington, D. C.

Dear Mr. Smith: Send me your book.  
This request does not obligate me.

Name .....

Address .....

City ..... State .....



**\$100 a week**

"My earnings in Radio are many times greater than I ever expected they would be when I enrolled. They seldom fall under \$100 a week."  
E. K. WINBORNE,  
1267 W. 48th St.,  
Norfolk, Va.



**Jumped from \$35 to \$100 a week**

"Before I entered Radio I was making \$35 a week. Last week I earned \$110 servicing and selling Radios. I owe my success to N. R. I."

J. A. VAUGHN  
4075 S. Grand Blvd.,  
St. Louis Mo.



**\$500 extra in 6 months**

"I find I made \$500 from January to May in my spare time. My best week brought me \$107. I should have taken it long ago."

HOYT MOORE  
R. R. 3, Box 919,  
Indianapolis, Ind.

**Lifetime Employment Service to all Graduates**





## "There's One Man We're Going to Keep"

"Ed Wilson, there, is one of the most ambitious men in the plant. I notice that he never fools away his spare time. He studies his International Correspondence Schools course every chance he gets.

"It's been the making of him too. He hasn't been here nearly so long as Tom Downey, who was laid off yesterday, but he knows ten times as much about this business.

"I'm going to give him Tom's job at a raise in salary. He's the kind of man we want around here."

How do you stand in your shop or office? Are you an Ed Wilson or a Tom Downey? Are you going up? Or down?

No matter where you live, the International Correspondence Schools will come to you. No matter what your handicaps or how small your means, we have a plan to meet your circumstances. No matter how limited your previous education, the simply-written, wonderfully-illustrated I. C. S. textbooks make it easy to learn.

This is all we ask: Without cost, without obligating yourself in any way, put it up to us to prove how we can help you. Just mark and mail this coupon.

### INTERNATIONAL CORRESPONDENCE SCHOOLS

"The Universal University"

Box 5537-G, Scranton, Penna.

Without cost or obligation, please send me a copy of your booklet, "Who Wins and Why," and full particulars about the subject before which I have marked X:

#### TECHNICAL AND INDUSTRIAL COURSES

- |  |  |
|--|--|
| <input type="checkbox"/> Architect   | <input type="checkbox"/> Automobile Mechanic                                 |
| <input type="checkbox"/> Architectural Draftsman                             | <input type="checkbox"/> Plumbing <input type="checkbox"/> Steam Fitting     |
| <input type="checkbox"/> Building Estimating                                 | <input type="checkbox"/> Heating <input type="checkbox"/> Ventilation        |
| <input type="checkbox"/> Wood Millworking                                    | <input type="checkbox"/> Sheet Metal Worker                                  |
| <input type="checkbox"/> Contractor and Builder                              | <input type="checkbox"/> Steam Engineer                                      |
| <input type="checkbox"/> Structural Draftsman                                | <input type="checkbox"/> Steam Electric Engineer                             |
| <input type="checkbox"/> Structural Engineer                                 | <input type="checkbox"/> Civil Engineer                                      |
| <input type="checkbox"/> Electric Wiring                                     | <input type="checkbox"/> Surveying and Mapping                               |
| <input type="checkbox"/> Electrical Engineer                                 | <input type="checkbox"/> Refrigeration                                       |
| <input type="checkbox"/> Electric Lighting                                   | <input type="checkbox"/> R. R. Locomotives                                   |
| <input type="checkbox"/> Welding, Electric and Gas                           | <input type="checkbox"/> R. R. Section Foreman                               |
| <input type="checkbox"/> Reading Shop Blueprints                             | <input type="checkbox"/> R. R. Bridge and Building Foreman                   |
| <input type="checkbox"/> Telegraph Engineer                                  | <input type="checkbox"/> Air Brakes <input type="checkbox"/> Train Operation |
| <input type="checkbox"/> Telephone Work                                      | <input type="checkbox"/> Highway Engineering                                 |
| <input type="checkbox"/> Mechanical Engineer                                 | <input type="checkbox"/> Chemistry <input type="checkbox"/> Pharmacy         |
| <input type="checkbox"/> Mechanical Draftsman                                | <input type="checkbox"/> Coal Mining Engineer                                |
| <input type="checkbox"/> Machinist <input type="checkbox"/> Toolmaker        | <input type="checkbox"/> Navigation <input type="checkbox"/> Boilermaker     |
| <input type="checkbox"/> Patternmaker  | <input type="checkbox"/> Textile Overseer or Supt.                           |
| <input type="checkbox"/> Pipefitter <input type="checkbox"/> Tinsmith        | <input type="checkbox"/> Cotton Manufacturing                                |
| <input type="checkbox"/> Bridge Engineer                                     | <input type="checkbox"/> Woolen Manufacturing                                |
| <input type="checkbox"/> Bridge and Building Foreman                         | <input type="checkbox"/> Agriculture <input type="checkbox"/> Fruit Growing  |
| <input type="checkbox"/> Gas Engines <input type="checkbox"/> Diesel Engines | <input type="checkbox"/> Poultry Farming <input type="checkbox"/> Radio      |
| <input type="checkbox"/> Aviation Engines                                    | <input type="checkbox"/> Marine Engineer                                     |

#### BUSINESS TRAINING COURSES

- |   |  |
|---|--|
| <input type="checkbox"/> Business Management                                  | <input type="checkbox"/> Business Correspondence                             |
| <input type="checkbox"/> Office Management                                    | <input type="checkbox"/> Lettering Show Cards <input type="checkbox"/> Signs |
| <input type="checkbox"/> Industrial Management                                | <input type="checkbox"/> Stenography and Typing                              |
| <input type="checkbox"/> Personnel Management                                 | <input type="checkbox"/> Complete Commercial                                 |
| <input type="checkbox"/> Traffic Management                                   | <input type="checkbox"/> Civil Service <input type="checkbox"/> Mail Carrier |
| <input type="checkbox"/> Accountancy <input type="checkbox"/> Cost Accountant | <input type="checkbox"/> Railway Mail Clerk                                  |
| <input type="checkbox"/> C. P. Accountant                                     | <input type="checkbox"/> Grade School Subjects                               |
| <input type="checkbox"/> Bookkeeping  | <input type="checkbox"/> High School Subjects                                |
| <input type="checkbox"/> Secretarial Work                                     | <input type="checkbox"/> College Preparatory                                 |
| <input type="checkbox"/> Spanish <input type="checkbox"/> French              | <input type="checkbox"/> Illustrating <input type="checkbox"/> Cartooning    |
| <input type="checkbox"/> Salesmanship <input type="checkbox"/> Advertising    | <input type="checkbox"/> Lumber Dealer                                       |

Name.....Age.....

Address.....

City.....State.....

Occupation.....

If you reside in Canada, send this coupon to the International Correspondence Schools Canadian, Limited, Montreal, Canada

## NEW INDUSTRY NEEDS MEN

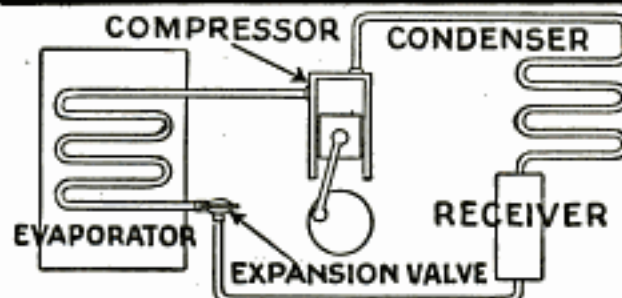

### ELECTRIC REFRIGERATION Calls You!

Newest American Industry needs men for \$200 to \$1,000 a month jobs in production service, installation and sales. Fastest growing, money-making field—backed by General Motors, General Electric, etc. New easy home training qualifies you for big pay job. This training endorsed by Servel, Kelvinator, Copeland and other large manufacturers.

#### Get Valuable New Book—FREE

Our new illustrated book—*Rich Rewards in Electric Refrigeration*—just off the press, reveals amazing plan to ambitious men. Sent absolutely free, without obligation. Be the first in your locality to get into this new magic industry. Write today!

UTILITIES ENGINEERING INSTITUTE

4403 Sheridan Road, Dept. 141, Chicago, Ill.



## LAW STUDY AT HOME

Become a lawyer. Legally trained men win high positions and big success in business and public life. Be independent. Greater opportunities now than ever before. Big corporations are loaded by men with legal training. Earn \$5,000 to \$10,000 Annually

We guide you step by step. You can train at home during spare time. Degree of LL.B. conferred. LaSalle students found among practicing attorneys of every state. We furnish all text material, including fourteen-volume Law Library. Low cost, easy terms. Get our valuable 64-page "Law Guide" and "Evidence" books FREE. Send for them NOW.

LaSalle Extension University, Dept. 464-L, Chicago. The World's Largest Business Training Institution



### "BECOME A LIGHTNING TRICK CARTOONIST"

Send \$1.00 for Laugh Producer Program of 23 Trick Drawings with instructions. Catalog of Chalk Talk Supplies Free. BALDA ART SERVICE, Dept. 1, Oshkosh, Wis.



**CAN YOU** remove the loose ring? It appears impossible, yet it is not, but requires clear head work. Try it. This is one of best wire puzzles made—is a money-back article. Postpaid with illustrated folder of others for 10c. 3 for 25c. 75c dozen. Retail at 25c. Fine pocket piece. Secret solution with each. Dealers and agents wanted.

**WESTERN PUZZLE WORKS, St. Paul, Minn.**

## BASHFUL?

"Shame on you!" Are you nervous, embarrassed in company of the other sex? Stop being shy of strangers. Conquer the terrible fear of your superiors. Be cheerful and confident of your future! Your faults easily overcome as you can enjoy life to the fullest. Send 25c for this amazing book.

**RICHARD BLACKSTONE, D-472, FLATIRON BLDG., NEW YORK**

## GOV'T. POSITIONS SPLENDID SALARIES

**WE HELP YOU GET ONE**

<input type="checkbox"/> By. Mail Clerk	<input type="checkbox"/> Steno Typist.
<input type="checkbox"/> P. O. Laborer	<input type="checkbox"/> Immigrant Insp.
<input type="checkbox"/> R. F. D. Carrier	<input type="checkbox"/> Seamstress
<input type="checkbox"/> Special Agent	<input type="checkbox"/> Auditor
<input type="checkbox"/> Customs Inspector	<input type="checkbox"/> Prohibition Agent
<input type="checkbox"/> City Mail Carrier	<input type="checkbox"/> U.S. Border Patrol
<input type="checkbox"/> Meat Inspector	<input type="checkbox"/> Chauffeur
<input type="checkbox"/> P. O. Clerk	<input type="checkbox"/> Watchman
<input type="checkbox"/> File Clerk	<input type="checkbox"/> Skilled Laborer
<input type="checkbox"/> General Clerk	<input type="checkbox"/> Postmaster
<input type="checkbox"/> Matron	<input type="checkbox"/> Typist

Omaha Instruction Bureau, Dept. 111, St. Louis, Mo. Send me FREE particulars "How to Qualify" for positions marked "X". Salaries, Locations, Opportunities, etc. ALL SENT FREE.

Name.....

Address.....

MEN - WOMEN

AGE 18 and UP



*I Offer You a Chance to get this*

Sport Model 3 Place

**AIRPLANE**

**FREE!**

When You Become  
One of my  
Students

**MAJOR R.L. ROCKWELL**



**I Will Train You at Home for  
Aviation and Prepare You to**

**Earn <sup>up</sup> to \$75<sup>00</sup> to \$100<sup>00</sup> a Week**

AVIATION—America's newest big industry—offers many opportunities to ambitious men who want to enter a fast growing industry with a bright future.

## Just a Few Months

Out of my 14 years of Aviation experience—starting back in war days—I have prepared a Home Training Course in practical Aviation. Just an hour a day for a few months devoted to my Home Training will enable you to master the principles of ground work which you must know before you can qualify for any of the better pay jobs open to men trained in Aviation.

## My Home Training Course Is What You Need

When you have finished my Home Training you can qualify for any one of the 40 kinds of well-paid ground jobs. If you wish, I will arrange for your flying instructions in Dayton or at an airport near your home at special reduced rates.

## Enroll NOW—and Qualify for This FREE Airplane

For a limited time only all students who enroll now are given a chance to get this Sport Model International 3 Place Airplane without one cent of cost. Become one of my students while this offer is on, because it is limited. And let me train you for one of the many well-paid Aviation jobs open only to the trained man. I will prepare you to take your place in the most fascinating, fastest growing industry. Rush this coupon to me for a copy of my famous FREE Book and your chance for a FREE Airplane.

**Major Rob't L. Rockwell**  
THE DAYTON SCHOOL OF AVIATION  
Desk L-1 DAYTON, OHIO

## No Special Education Needed

You don't need to have an advanced education or even know anything about airplanes, motors, or mechanics. My Home Training course is thorough and complete. It is clearly explained, with easy-to-understand text and pictures, so that in a few short months you will be able to grasp the fundamental principles of Aviation ground work and be able to qualify for important aviation work, that will later lead to a job paying up to \$75.00 to \$100.00 a week. My Home Training Course will give you the knowledge necessary to pass the government's written examinations for mechanics' or pilots' licenses.

## MONEY BACK AGREEMENT

I am so sure you can learn Aviation with my help that if you are not satisfied after you have completed my course, I'll refund every penny you have paid me.



## Mail Coupon for FREE Book and FREE Airplane Offer

Major Rob't L. Rockwell,  
The Dayton School of Aviation,  
Desk L-1, Dayton, Ohio.

Dear Major: Please send me FREE a copy of your famous book on Aviation; and your FREE Airplane Offer.

Name..... Age.....

Address.....

Town..... State.....



# New Kind of Can Opener

*"Works Like Magic"*

**Brings Agents Up To \$8 and \$10 In An Hour!**

IMAGINE having a little automatic machine to open cans! Why, to women everywhere, the very idea is revolutionary as well as amazing! No more fuss, muss or bother. And danger absolutely banished! No wonder agents who demonstrate this astonishing invention have made almost incredible sums. E. T. Barclay, N. Y., cleaned up \$117 in a day and a half. Mrs. M. Bridges, Me., made over \$300 in a couple of months spare time. O. C. Gregg, Wyo., made part time profits of \$20 in 3 hours. And why not?

## The "Million-Dollar" Can Opener

The wonder-working little machine holds the can for you so you don't need to touch it. Then spins the can quickly around. Next the lid pops up so you can take hold of it. Entire top is cut out slick, smooth and clean. Opens round, square and oval cans. Approved by Good Housekeeping Inst. Guaranteed for five full years. If your present income is less than \$60 a week write quick for details of Territory Reservation, Sales Outfit, and FREE Test Offer.

**CENTRAL STATES MANUFACTURING CO.**

Dept. D-704, 4500 Mary Ave., ST. LOUIS, MISSOURI

Central States Mfg. Co., Dept. D-704,  
4500 Mary Ave., St. Louis, Mo.

Rush your FREE TEST OFFER.

Name.....

Address.....

Town.....State.....

Check here if interested only in one for your home.



## NO MORE DANGER

Every woman knows how dangerous the old-style can opener is. Almost daily the newspapers tell of blood-poison, amputations, even death, that sometimes follow the very tiniest "can opener scratches." Now all danger is banished forever. No wonder so many buy on sight!

Write and Speak **MASTERLY ENGLISH**



Learn correct English with Sherwin Cody's new invention. No rules to memorize. Like a fascinating game. Spare-time-study, 15 minutes each day, quickly gives you command of English. Send for free booklet "How You Can Master Good English in 15 Minutes a Day." Write today. Sherwin Cody School of English, 54 Searis Bldg., Rochester, N. Y.

## LEARN WATCHMAKING

and become independent. We help you secure a position.

Easy to learn. Send for FREE CATALOG.

ST. LOUIS WATCHMAKING SCHOOL Dept. 5, ST. LOUIS, MO.



WHY NOT spend Spring, Summer and Fall gathering butterflies, insects? I buy hundreds of kinds for collections. Some worth \$1 to \$7 each. Simple outdoor work with my instructions, pictures, price-list. Send 10 cents (not stamps) for my illustrated Prospectus before sending butterflies. **MH. SINCLAIR, DEALER IN INSECTS.** Dept. 6, Box 1424, San Diego, Calif.

# LEARN CARTOONING

AT HOME DURING SPARE TIME

with the course that has trained HUNDREDS of beginners successfully. The Landon Picture Chart Method of teaching ORIGINAL drawing by mail makes cartooning easy to learn. This school is a Member of The National Home Study Council. Write today for sample picture chart to TEST YOUR ABILITY and examples of the work of successful students now earning from \$50 to \$200 and more per week.

Enclose 6c in stamps and STATE YOUR AGE.

**THE LANDON SCHOOL, 2838 National Bldg., Cleveland, Ohio**



# PATENTS

Booklet Free Highest References  
Promptness Assured Best Results

Send drawing or model.

**ALL BUSINESS GIVEN PROMPT AND PROPER ATTENTION**

Listed Patent Lawyer in the latest editions of the Rand-McNally Directory of Bankers and Bank-Recommended Attorneys, published by Rand-McNally & Co., Chicago, Ill.; The Baggott & Ryall Directory of Guaranteed Attorneys, published by Legal Directory Corporation, Boston, Mass.; Flugel's Law List, published by Legal Directory Publishing Co., St. Louis, Mo.; American Lawyers Annual, published in Cleveland, Ohio; Bankers Service Legal Directory, published by Bankers Service Co., Boston, Mass.; Eyre's Law List, 9 Park Place, New York City; Walters Legal Directory, Omaha, Nebraska, and the National Directory of Attorneys, Baltimore, Maryland.

**WATSON E. COLEMAN,**  
REGISTERED PATENT LAWYER

Victor Building, 724 Ninth Street, N. W.  
**WASHINGTON, D. C.**



# HERE IT IS ....

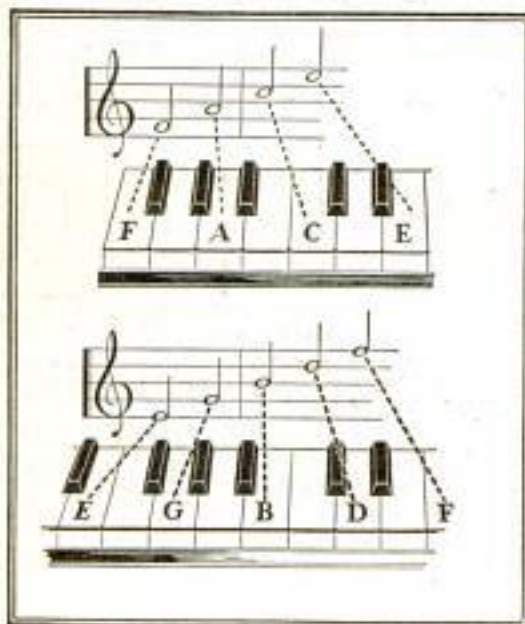

## —your first lesson in this popular, easy as A-B-C way of learning music

**YES**, learning to play your favorite instrument this thrilling new way is actually as easy as it looks.

Notice the first picture. The notes spell F-A-C-E—face. That wasn't hard . . . was it? Then look at the second E-G-B-D-F—Every Good Boy Does Fine. You can't help learning. All you do is look at the pictures and you know the entire scale!

Your next step is to play actual tunes, right from the notes. And all of the lessons of the famous U. S. School of Music course are just as easy, just as simple as that.

For by this remarkably clear course, you learn in the privacy of your own home, without the aid of a private teacher. No more tedious hours of dry theory or finger-twisting exercises.

Just imagine . . . a method by which you learn music in less than half the usual time, and at an average cost of only a few cents a day!

### Easy as can be!

These fascinating lessons are like a game. Everything is right before your eyes—printed instructions, diagrams, and

all the music you need. You can't possibly go wrong. First you are told what to do, then a picture shows you how, and then you do it yourself and hear it. The best private teacher could not make it clearer or easier.

Forget the old-fashioned idea that you have to have "talent" or "musical ability." You don't at all, now! More than 600,000 people who could not read one note from another, are now popular and accomplished players, thanks to the U. S. School of Music.

### New Popularity—Plenty of Good Times

If you are tired of always sitting on the outer rim of a party, of being a professional looker-on—if you've often been jealous because others could entertain friends and were always in demand—if you've wanted to play but never thought you had the time or money to learn, let the time tested and proven U. S. School come to your rescue.

Don't miss any more good times! Learn to play your favorite instrument and be the center of attraction wherever you go. Musicians are invited everywhere, they are always in demand. Enjoy this greater new popularity you have been missing. Have the good times that pass you by. You can have them—easily!

### PICK YOUR COURSE

Piano	Violin
Organ	Clarinet
Ukulele	Flute
Cornet	Saxophone
Trombone	Harp
Piccolo	Mandolin
Guitar	Cello
Hawaiian Steel Guitar	
Sight Singing	
Voice and Speech Culture	
Drums and Traps	
Automatic Finger Control	
Banjo (Plectrum, 5-String or Tenor)	
Piano Accordion	
Italian and German Accordion	
Harmony and Composition	
Juniors' Piano Course	

### Free Booklet and Demonstration Lesson

Our wonderful illustrated Free Book and Free Demonstration Lesson explain all about this remarkable method. No matter what instrument you choose to play, the Free Demonstration Lesson will show you at once the amazingly simple principles upon which this famous method is founded. As soon as the lesson arrives, you see for yourself just how anyone can learn to play his favorite instrument by note in almost no time and at a fraction of what the old slow methods cost. The booklet will also tell you about the astounding new Automatic Finger Control.

Read the list of instruments to the left, decide which you want to play, and the U. S. School of Music will do the rest. Act NOW. Clip and mail this coupon today, and the fascinating Free Book and Free Demonstration Lesson will be sent to you at once. No obligation, of course. Instruments supplied when needed, cash or credit, U. S. SCHOOL OF MUSIC, 74 Brunswick Building, New York City.

U. S. SCHOOL OF MUSIC,  
74 Brunswick Bldg., New York City.

Please send me your free book, "Music Lessons in Your Own Home," with introduction by Dr. Frank Cassin, Free Demonstration Lesson, and particulars of your easy payment plan. I am interested in the following course:

Name you  
Name.....  
Address.....  
City.....



# THERE'S A BIG PAY For the Trained Man in RADIO

Dissatisfied with your job? Not making enough money? Then let me show you how to get into Radio, the liveliest, biggest money-making game on earth. Thousands of opportunities for jobs leading to salaries of \$60 a week and up! Jobs as Designer,

Inspector and Tester paying \$3,000 to \$10,000 a year; as Salesman and in Service and Installation work at \$45 to \$100 a week; as Operator or Manager of Broadcasting Station at \$1800 to \$5000 a year—as Wireless Operator on Ship or Airplane, as Talking Picture or Sound Expert. Thousands of Big Pay opportunities for you to choose from!

## LEARN RADIO TALKING PICTURES By Actual Work in Great Coyne Shops -

Come to Coyne and learn all branches of Radio in ten short, pleasant weeks. NOT BY CORRESPONDENCE, but by actual work on scores of modern Radio Receivers, huge Broadcasting equipment, the very latest Television transmitting and receiving apparatus, Talking Picture equipment, etc. Broadcast yourself in our sound proof studio room!

Put on your own Television program! Learn Radio the practical way—by actual radio work on actual radio equipment! You don't need advanced education or previous experience. I don't care if you are 16 years old or 46. Come to Coyne and I'll prepare YOU for a good paying Radio job in 10 weeks' time!



## TELEVISION IS NOW HERE!

And Television is already here! Soon there'll be a demand for thousands of Television experts. The man who learns Television now can make a fortune in this great new field. Get in on the ground-floor of this amazing new development! Mail coupon on the opposite page for full information—absolutely free!

**Radio Division**  
H. C. LEWIS, President **COYNE**  
500 South Paulina Street,



# JOB



## Free Employment Service EARN AS YOU LEARN

You get free Employment Service as long as you live. And if you'll need part-time work while at school to help pay expenses, we'll gladly help you get it. Many of our students pay nearly all of their living expenses that way. Mail coupon below for full details.

# TELEVISION ♦♦ IN 10 WEEKS

## Not by Correspondence !!

Don't let anything keep you out of Radio! Start now, and after just ten short weeks of fascinating work in the great Coyne Radio Shops, you'll be all set for the best job and biggest pay you ever had in your life!

## Coyne is 32 Years Old!

Coyne Training is tested, proven beyond all doubt. You can find out everything absolutely free—how you can prepare for a good Radio Job or how you can go into business for yourself and earn \$3,000 to \$15,000 a year. It costs nothing to investigate!

## Mail Coupon for My Big Free Book

Fill in this coupon, tear it out and mail it to me at once. This will not obligate you in any way and positively no salesmen or agents will call on you. It will bring you—ABSOLUTELY FREE—a copy of my big Radio and Television Book, telling all about jobs, salaries, opportunities, etc. MAIL THE COUPON—NOW!

# Electrical School

Dept. 41-3H, Chicago, Illinois

H. C. LEWIS, President

Radio Div. Coyne Electrical School

500 S. Paulina St., Dept. 41-3H, Chicago, Ill.

Send me your Big Free Radio Book and all details of your Special Introductory Offer. This does not obligate me in any way.

Name.....

Address.....

City.....State.....





## "The Happiest Day of My Life!"

"OUR WEDDING DAY! A year ago it seemed like a dream that would never come true, for my salary then was barely enough for one to live on. I faced the facts. Unless I could make more money I had no right to keep Ruth waiting. What I had to do was find some way to make myself worth more.

"It was Ruth herself who showed me the way. She clipped a coupon out of a magazine and we sent it to the International Correspondence Schools for information about their courses. Within a week I had enrolled. The training I got from studying at home showed up almost at once in my office work. They gave me more responsibilities. Inside of six months I was promoted, with a substantial raise. Now I'm getting double what I was a year ago—and we're married!"

I. C. S. Courses have given thousands the special knowledge they need to win better jobs and bigger pay. Why not you?

One hour of spare time a day, spent in I. C. S. study, will prepare you for the position you want, in the work you like best. Find out how. It won't obligate you in the least to ask for full particulars. Do it now—for HER!

Mail the Coupon for Free Booklet

### INTERNATIONAL CORRESPONDENCE SCHOOLS

"The Universal University"

Box 5538-G, Scranton, Penna.

Without cost or obligation, please send me a copy of your booklet, "Who Wins and Why," and full particulars about the subject before which I have marked X:

#### TECHNICAL AND INDUSTRIAL COURSES

- |  |  |
|--|--|
| <input type="checkbox"/> Architect   | <input type="checkbox"/> Automobile Mechanic                                 |
| <input type="checkbox"/> Architectural Draftsman                             | <input type="checkbox"/> Plumbing <input type="checkbox"/> Steam Fitting     |
| <input type="checkbox"/> Building Estimating                                 | <input type="checkbox"/> Heating <input type="checkbox"/> Ventilation        |
| <input type="checkbox"/> Wood Millworking                                    | <input type="checkbox"/> Sheet Metal Worker                                  |
| <input type="checkbox"/> Contractor and Builder                              | <input type="checkbox"/> Steam Engineer                                      |
| <input type="checkbox"/> Structural Draftsman                                | <input type="checkbox"/> Steam Electric Engineer                             |
| <input type="checkbox"/> Structural Engineer                                 | <input type="checkbox"/> Civil Engineer                                      |
| <input type="checkbox"/> Electric Wiring                                     | <input type="checkbox"/> Surveying and Mapping                               |
| <input type="checkbox"/> Electrical Engineer                                 | <input type="checkbox"/> Refrigeration                                       |
| <input type="checkbox"/> Electric Lighting                                   | <input type="checkbox"/> R. R. Locomotives                                   |
| <input type="checkbox"/> Welding, Electric and Gas                           | <input type="checkbox"/> R. R. Section Foreman                               |
| <input type="checkbox"/> Reading Shop Blueprints                             | <input type="checkbox"/> R. R. Bridge and Building Foreman                   |
| <input type="checkbox"/> Telegraph Engineer                                  | <input type="checkbox"/> Air Brakes <input type="checkbox"/> Train Operation |
| <input type="checkbox"/> Telephone Work                                      | <input type="checkbox"/> Highway Engineering                                 |
| <input type="checkbox"/> Mechanical Engineer                                 | <input type="checkbox"/> Chemistry <input type="checkbox"/> Pharmacy         |
| <input type="checkbox"/> Mechanical Draftsman                                | <input type="checkbox"/> Coal Mining Engineer                                |
| <input type="checkbox"/> Machinist <input type="checkbox"/> Toolmaker        | <input type="checkbox"/> Navigation <input type="checkbox"/> Boilermaker     |
| <input type="checkbox"/> Patternmaker  | <input type="checkbox"/> Textile Overseer or Supt.                           |
| <input type="checkbox"/> Pipefitter <input type="checkbox"/> Tinsmith        | <input type="checkbox"/> Cotton Manufacturing                                |
| <input type="checkbox"/> Bridge Engineer                                     | <input type="checkbox"/> Woolen Manufacturing                                |
| <input type="checkbox"/> Bridge and Building Foreman                         | <input type="checkbox"/> Agriculture <input type="checkbox"/> Fruit Growing  |
| <input type="checkbox"/> Gas Engines <input type="checkbox"/> Diesel Engines | <input type="checkbox"/> Poultry Farming <input type="checkbox"/> Radio      |
| <input type="checkbox"/> Aviation Engines                                    | <input type="checkbox"/> Marine Engineer                                     |

#### BUSINESS TRAINING COURSES

- |   |  |
|---|--|
| <input type="checkbox"/> Business Management                                  | <input type="checkbox"/> Business Correspondence                             |
| <input type="checkbox"/> Office Management                                    | <input type="checkbox"/> Lettering Show Cards <input type="checkbox"/> Signs |
| <input type="checkbox"/> Industrial Management                                | <input type="checkbox"/> Stenography and Typing                              |
| <input type="checkbox"/> Personnel Management                                 | <input type="checkbox"/> Complete Commercial                                 |
| <input type="checkbox"/> Traffic Management                                   | <input type="checkbox"/> Civil Service <input type="checkbox"/> Mail Carrier |
| <input type="checkbox"/> Accountancy <input type="checkbox"/> Cost Accountant | <input type="checkbox"/> Railway Mail Clerk                                  |
| <input type="checkbox"/> C. P. Accountant                                     | <input type="checkbox"/> Grade School Subjects                               |
| <input type="checkbox"/> Bookkeeping  | <input type="checkbox"/> High School Subjects                                |
| <input type="checkbox"/> Secretarial Work                                     | <input type="checkbox"/> College Preparatory                                 |
| <input type="checkbox"/> Spanish <input type="checkbox"/> French              | <input type="checkbox"/> Illustrating <input type="checkbox"/> Cartooning    |
| <input type="checkbox"/> Salesmanship <input type="checkbox"/> Advertising    | <input type="checkbox"/> Lumber Dealer                                       |

Name.....Age.....

Address.....

City.....State.....

Occupation.....

If you reside in Canada, send this coupon to the International Correspondence Schools, Canadian, Limited, Montreal, Canada.

## ELECTRICAL ENGINEERING

A CONCISE, comprehensive course for men of limited time, complete in one year. Mathematics, engineering drawing, shop-work. Students construct motors, install wiring, test electrical machinery. Buildings fireproof. 35 years' successful experience. Catalog on request.



### BLISS ELECTRICAL SCHOOL

134 Takema Ave., Washington, D. C.

Learn  
**ADVERTISING**  
at Home

Greater opportunities now in advertising. Learn easily and quickly in spare time. Practical work. No text books. Old established school. Low tuition—Easy terms. Send for free booklet of interesting information.

Page-Davis School of Advertising  
Dept. 1354, 3601 Mich. Ave., Chicago

## Wireless (Radio)

and Morse telegraphy taught thoroughly. School, oldest and largest, endorsed by Telegraph, Radio, Railway and Government officials. Unusual opportunities. Expenses low—can earn part. Catalog free. DODGE INSTITUTE, Jones St., Valparaiso, Indiana.

Study  
**LAW**  
AT HOME

Lincoln did it! Also thousands of other great lawyers, politicians and business men. YOU, too, can become a lawyer or law-trained businessman through home study guided by the successful practicing lawyers of our faculty. Write today for free book.

AMERICAN CORR. SCHOOL OF LAW  
3601 Michigan Ave., Dept. 1354, Chicago



## Minstrels

Unique First Parts for complete show with special songs and choruses. Make-up. Costing Free.



T. S. Denison & Co., 623 S. Wabash, Dept. 19 Chicago

## BOW LEGS?

THIS GARTER (Pat'd)

Makes Trousers Hang Straight  
If Legs Bend In or Out

Free Booklet—Plain Sealed Envelope

THE T. GARTER CO., Dept. E  
South Bend, Ind.



AN EASY WAY TO

## SHAPE your NOSE

Anita Nose Adjuster shapes flesh and cartilage—quickly, safely, painlessly, while you sleep or work. Lasting results. Gold Medal Winner. Doctors praise it. 78,000 users. Write today for FREE BOOKLET.

ANITA INSTITUTE, D-12 Anita Bldg., Newark, N. J.

## Save Your Feet

When all else fails end your suffering with the flexible "no metal"

Heefner ARCH SUPPORT

WRITE FOR FREE BOOKLET



HEEFNER ARCH SUPPORT CO., 681 N. E. TAYLOR BUILDING, LOUISVILLE, KY.

## RUPTURE



Here is a proved method.

Absolutely comfortable.

Overcomes painful boring pressure. Never slips. Special combination plate and rupture pads permit accurate location and perfect adjustability; insure protection and safety. Furnishes general body benefits while holding rupture.

WRITE for illustrated literature & liberal trial offer.

The Natural Body Brace Co.

Howard C. Rank, President

4050 Rush Bldg., Salina, Kansas



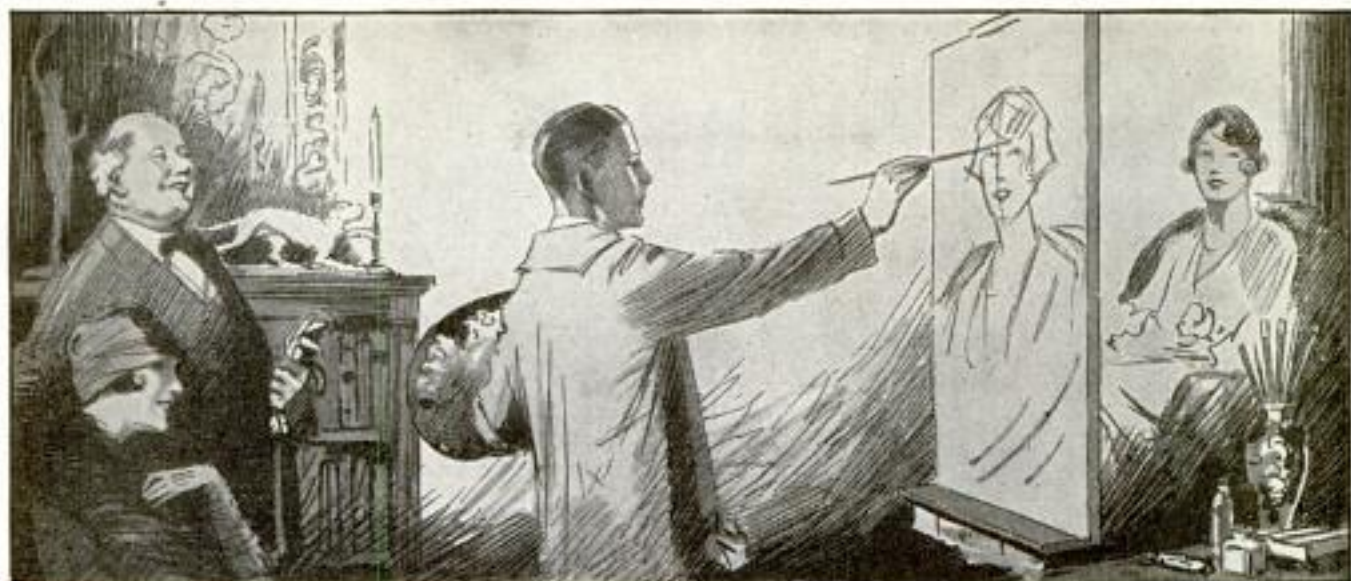

## SIMPLE LINES EARN FAME AND FORTUNE

"YOU certainly make your money easily," remarked the heavy-set publisher. "My, such speed," interrupted his lady business associate. "How do you get such a true likeness in so few lines?" They had dropped in to purchase illustrations from the young artist whose masterful drawings in magazines and newspapers had started him on the road to fame.

"I never thought it was possible myself," he replied as he added a few telling strokes with his brush. "But I liked to draw. I knew it was fascinating and that it offered opportunities. So I decided to study. Through proper training I have learned to form simple lines into finished illustrations."

It was only a short time ago that this young artist filled out a coupon like the one below and mailed it to the Federal School of Illustrating. "And now," he continued, "each time I make a simple stroke with my brush it means money in my pocket."

This story illustrates the success of hundreds of Federal School graduates. Careful, conscientious training by members of our faculty has put thousands of students on the "Road to Bigger Things."

Over fifty famous artists have contributed lessons and drawings exclusively to the Federal Course of Illustrating. They teach you their "tricks of the trade" about illustrating, cartooning, lettering, poster designing, window card illustrating, etc. Each subject in the course is thoroughly covered by a famous artist who has made a success in his particular field. You profit by their experience.

If you like to draw, why plod along at some tedious work? Opportunities for artists have never been better. Magazines and newspapers spend millions of dollars every year for illustrations. Drawing is easy to learn the "Federal Way." Study at home in your spare time. You can continue with your work while gaining your art education. Earn while you learn if you wish.

Every mail brings news of the success of students. Charles Phil Hexom of Decorah, Iowa, writes, "My cover work brings from \$50.00 to \$150.00 per painting." The Federal Course aims at dollars and cents profit for every student. It is a practical course planned to teach you how to turn simple lines into dollars. Hundreds of young people have freed themselves of financial worries and routine work through the Federal Course.

If you like to draw, opportunity lies no further away than the lower corner of this page. Write your name and address on the coupon and get our free book, "A Road to Bigger Things," which is illustrated below. With this book we will send our Free Vocational Art Test to find out your ability. This is your opportunity—grasp it. Mail the coupon now.



# Federal School of Illustrating

FEDERAL SCHOOL OF ILLUSTRATING,  
4131 Federal School Bldg., Minneapolis, Minn.

Gentlemen: Please send your free book, "A Road to Bigger Things," together with Vocational Art Test.

Name ..... Age .....

Occupation .....

Address .....





## Is Tobacco Hurting You?

Look the facts square in the face, Mr. Tobacco User. You may think tobacco is not hurting you.

That is because you haven't as yet, perhaps, felt the effects of the nicotine poison in YOUR system. For you know that nicotine, as absorbed into the system through smoking and chewing tobacco, is a slow working poison. Slow, yes—but sure.

Tobacco lowers efficiency. It slows a man down. Makes it harder to concentrate the mind on work. Tobacco users seldom have the amount of "pep" and energy of those who do not use the weed. There's many a man older than you in years who is younger in energy, simply because he lets tobacco alone.

Some day, probably, you will realize to what an alarming extent tobacco does undermine the system.

When your hands begin to tremble—  
and your appetite begins to fail—  
and your heart seems to "skip a beat" now and then—  
and slight exertion makes you short of breath—  
then you have a right to suspect that  
TOBACCO is getting the upper hand.

Any well-informed doctor will tell you that these are only a few of many symptoms of tobacco poisoning.

And YOU know that the use of tobacco in any form is an expensive, utterly useless habit. You know you ought to quit.

## Tobacco Habit Banished In Many Cases—Let Us Help You

It doesn't make a particle of difference whether tobacco has been used for a single month or fifty years, or how much, or in what form—whether cigars, cigarettes, pipe, plug, fine cut, or snuff. In most cases, Tobacco Redeemer removes all craving for tobacco in any form in a very few days. Not the slightest shock to the nervous system. The tobacco craving will usually begin to decrease after the very first dose—there is no long waiting for results.

Tobacco Redeemer contains no habit-forming drugs of any kind and is quick, safe, pleasant and thoroughly reliable.

It is in no sense a substitute for tobacco. It helps to quiet the nerves and makes one feel better in every way.

### Our Guarantee

A single trial will convince you. Our legal, binding, money-back guarantee goes with each full treatment. We will refund every cent you pay for the treatment if, after taking it according to the easy-to-follow directions, it should fail to banish the tobacco habit completely.

### SEND Coupon for Free Proof

Let us send you our free booklet on the injurious effects of tobacco, together with testimonial letters from men all over the country telling how they have been absolutely freed from the tobacco habit by this simple home treatment. You could not ask for stronger proof than the evidence we will gladly send on request. Just mail the coupon—or a postal will do.

### NEWELL PHARMACAL CO.

Dept. 300 Clayton Station St. Louis, Mo.



## Free Book Coupon

### NEWELL PHARMACAL CO.

Dept. 300 Clayton Station St. Louis, Mo.

Please send, without obligating me in any way, your free booklet regarding the tobacco habit and proof that Tobacco Redeemer has relieved the tobacco habit in thousands of cases. If it fails my money will be refunded.

Name.....

Street and No.....

Town..... State.....



# 'I' ll PROVE in Only 7 Days that I Can Make YOU a New Man!"

No other Physical  
Instructor in the  
World has ever  
DARED make  
such an Offer

By **CHARLES ATLAS**

Holder of the Title:

"The World's Most Perfectly Developed Man"

I HAVE proved to thousands that my system of building powerful, big-muscled men begins to show real results in only 7 days—and I can prove it to you.

You don't have to take my word for it. You don't have to take the word of my hundreds of pupils who have added inches to their chests, biceps, necks, thighs and calves in only a few days. No sir! You can prove for yourself—in just one week—by the change you see and feel in your own body—that you can actually become a husky, healthy NEW MAN—a real "Atlas Champion."

All I want to know is: Where do you want big, powerful muscles? How many pounds of firm flesh do you want distributed over your body to fill you out? Where do you lack vitality, pep and robust health? Where do you want to take off flabby surplus fat?

Just tell me, give me a week, and I'll show you that I can make a New Man of you, give you bodily power and drive, and put you in that magnificent physical condition which wins you the envy and respect of any man and the admiration of every woman.

My own system of Dynamic-Tension does it. That's the way I built myself from a 97-pound weakling to "The World's Most Perfectly Developed Man." And now you can

have a big, balanced muscular development like mine in the same easy way.

## No "Apparatus" Needed!

You begin to FEEL and SEE the difference in your physical condition at once, without using any tricky apparatus, any pills, "rays" or unnatural dieting. My Dynamic-Tension is a natural method of developing you inside and out. It not only makes you an "Atlas Champion," but goes after such ailments as constipation, pimples, skin blotches, and any other weaknesses that keep you from really enjoying life and its good times—and it starts getting rid of them at once.

## Let Me Tell You How

Gamble a 2c stamp today by mailing the coupon for a free copy of my new illustrated book, "Everlasting Health and Strength." It tells you all about my special Dynamic-Tension method. It shows you, from actual photos, how I have developed my pupils to the same perfectly balanced proportions of my own physique, by my own secret methods. What my system did for me, and these hundreds of others, it can do for you too. Don't keep on being only 25 or 50 per cent of the man you can be! Find out what I can do for you.



## FREE BOOK

Where shall I send your copy of "Everlasting Health and Strength?" Jot your name and address down on the coupon, and mail it today. Your own new "Atlas body" is waiting for you. This book tells you how easy it is to get, my way. Send the coupon to me personally—

**CHARLES ATLAS**  
Dept. 8D

133 E. 23rd St., New York City

**CHARLES ATLAS Dept. 8D**  
133 East 23rd Street, New York City

I want the proof that your system of Dynamic-Tension will make a New Man of me—give me a healthy, husky body and big muscle development. Send me your free book, "Everlasting Health and Strength."

NAME.....  
(Please print or write plainly)

ADDRESS.....

CITY.....STATE.....



# MEN WANTED

20 to 35 years old

# RADIO

First Lesson Free!

Broadcasting  
Television  
"Talkies"  
Manufacturing  
Service  
Sales  
Auto-Radio  
Aviation

## See how easy to learn

See how quickly you can get ready for well-paid positions in fastest growing, most prosperous industry.

Big demand *right now*

from employers for broadcast operators, testers, inspectors, service-men, designers, installers, and "trouble shooters."

### \$40 to \$75 a week—and more!

With free radio lesson we'll send you our amazing combined training and employment agreement—good for help in securing a beginner's job, *when you're only half way through*. Guarantees you help in finding a position, satisfactory in salary, after you finish, or money refunded.

### A World of Opportunities to Choose From

Rockefeller is building a \$500,000,000.00 "radio center" in New York. 20,000 movie theaters have gone "talkie." Auto-Radio is selling like wild-fire. Midget sets are selling at rate of 10,000 a day! Aviation, television, servicing, sales—all these mean highly paid jobs and plenty of them. All you need to get one is the kind of training we give you, backed by a real placement service.



### RADIO TESTER GIVEN

\$20.00 set analyzer and trouble-shooting job-tickets a part of this training without extra charge.

## Lesson FREE! Mail Coupon

for free radio lesson and book of thrilling facts about this wonder-industry and how to "break in."

**American School**  
Dept. R-447, Drexel Ave.  
& 58th St., Chicago

THE AMERICAN SCHOOL  
Dept. R-447, Drexel Ave. & 58th St., Chicago

Please send me without cost or obligation, free radio lesson and job ticket and radio bulletin.

Name.....Age.....

St. No.....

City.....State.....

## Increase Your Earning Power

Apply time and labor-saving kinks to your work. Your efficiency will soon be recognized and you will be in line for advancement.

If you do machine shop work of any kind, sheet-metal work, painting, carpentry, auto repairing, farming, concrete work, plumbing, electrical work, welding, building, glass work, general repairing, tool-making, poultry raising, masonry or home repair work, get this

## LIBRARY OF 6000 TIME AND LABOR SAVING IDEAS FOR SHOPMEN AND HANDYMEN

### JUST PUBLISHED

## SHOP NOTES for 1931

192 Pages  
464 Illustrations  
Price 50c

See partial list of contents below

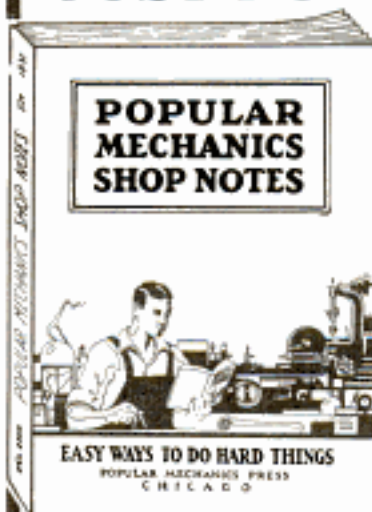

Including the new 1931 issue illustrated above, there are now 12 volumes in the Shop Notes Library of 6,000 easily understood short cuts to every-day jobs. Here are just a few of the subjects taken from the latest issue.

Auto Driving, Winter Hats	Growler for Armature Repair	Poultry Ranch for City Lot
Auto Trucks, Handy, for Paint Shop	Heater for Garage or Workshop	Reading and Filing, Ornamental
Band—Tidy Strips, Making	Horse Plans with Broad-ax Six Squares Legs	Saws, Circular, Repairing
Belt Sander Reduces Labor	Inlays, Simple, Joiner in the Home Shop	Sander, Vertical, Made from Buffing Head
Bench, Portable, for Mechanics, Saves Time	Kitchen Stool, Metal, How to Make	Silver Solder, Use of
Blower for Lowering Fuel Cost	Laboratory Stand	Shaper for Home Shop
Book Ends, Hand Wrought, Making	Makes Workshop Tool Lamp, Star, for Home	Space and Time Savers for the Shop
Calxide Leg, Cutting the	Lantern Illuminates House Numbers	Spiral Turnings, How to Make
Drawing Instruments, Homemade	Machining Chime, Varnish Cleaner	Stairway, Homemade
Fireplace, Portable, How to Build	Machining Tools, Run-ning Several with One Electric Motor	Disappearing Water Heater for Sunny Climes
Furniture, Drawer Pulls for	Milling Machine Made from Shaper	Workbench, Handy, for Model Airplane Building
Glass, How to Install	Pipe Repair, Emergency	Table, Small Drum, Making
Grinding, Surface, on Drill Press	Fixing Tricks Made Easy	Twist-Turning with Portable Router

Each volume contains approximately 500 articles and 400 illustrations and has 192 or more pages. At the regular price of 50 cents per single volume this library costs \$6.00, but for a limited period we will supply the 12 vols. when ordered at one time at the special reduced price of only \$3.75.

### SPECIAL OFFER COUPON

POPULAR MECHANICS PRESS,  
200 E. Ontario St., Room P4, Chicago, Ill.

Send me, as per your special offer, the following books. I will pay postman price and small amount of postage. My money will be refunded if I am not satisfied. (Check what you want.)

- 1931 Shop Notes and Lathe Handbook, both for 98c.  
 Complete Shop Notes Library (12 vols.) \$3.75.

Name.....

Street and No.....

City.....State.....



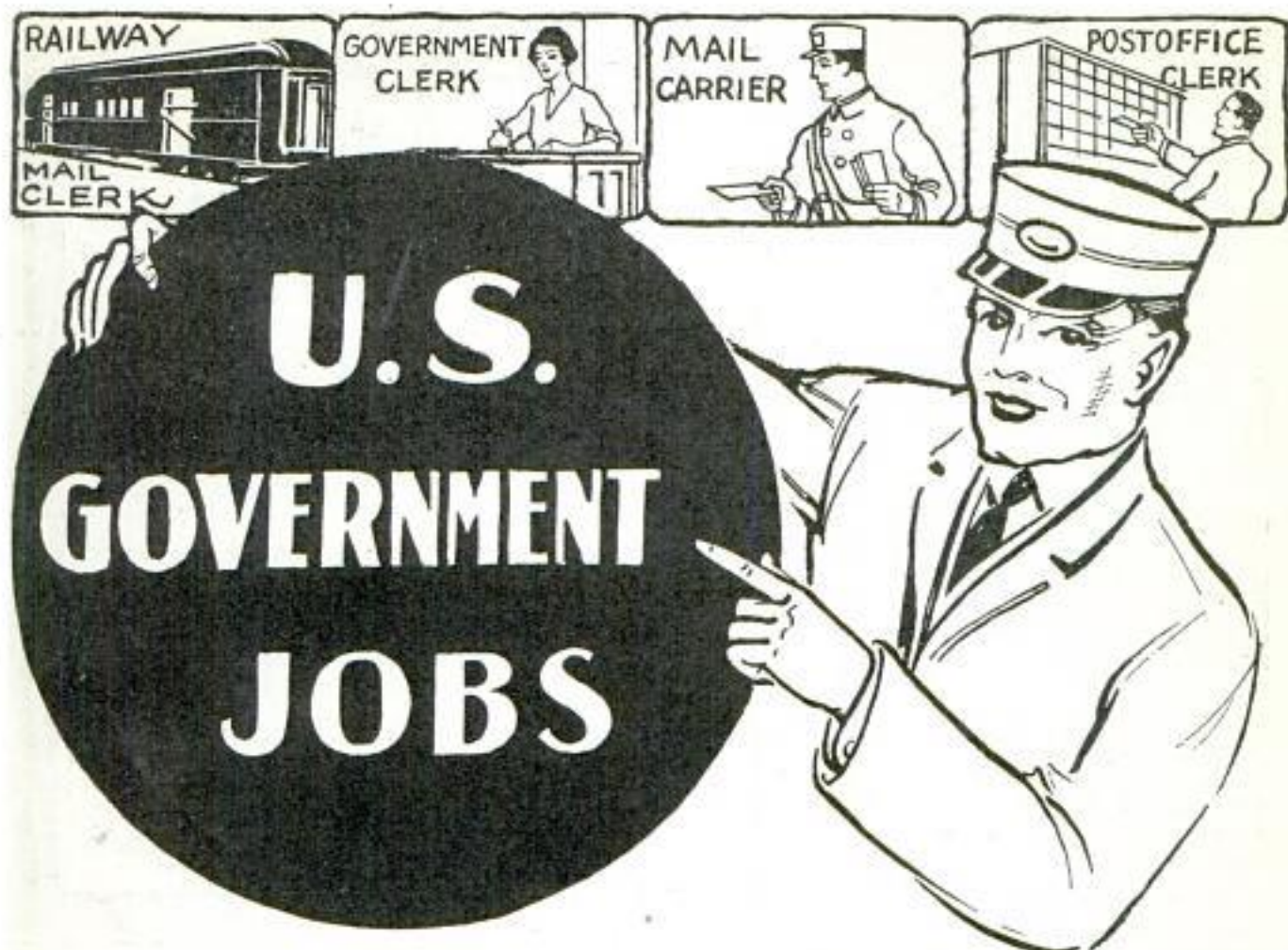

## \$1260 TO \$3400 A YEAR MEN—WOMEN 18 TO 50

U. S. Government Positions are steady. Strikes, poor business conditions, lockouts or politics do not affect them. U. S. Government employees get their pay for twelve full months every year. There is no such thing as "HARD TIMES" in the U. S. Government Service.

### TRAVEL—SEE YOUR COUNTRY

Railway Postal Clerks get \$1,900 the first year, being paid on the first and fifteenth of each month. \$79.00 each pay day. Their pay is quickly increased, the maximum being \$2,700 a year. \$112.50 each 15 days.

### PAID VACATION

Railway Postal Clerks, like all Government employees, get a yearly vacation of 15 working days (about 18 days). On runs they usually work 3 days and have 3 days off duty, or in the same proportion. During this off duty and vacation, their pay continues just as though they were working. When away from home they get extra pay for hotel expenses. When they grow old, they are retired with a pension.

### CITY MAIL CARRIERS—POST OFFICE CLERKS

Clerks and Carriers commence at \$1,700 a year and automatically increase \$100 a year to \$2,100 with special increase to \$2,300. They also have 15 days' paid vacation. City residence is unnecessary.

### Railway Mail Clerks



**GET FREE LIST OF POSITIONS.** Fill out the coupon. Tear it off and mail it today—now, at once. This investment of two cents for a postage stamp may result in your getting a Life Time Government Job.

### WHAT IS YOUR FUTURE?

Compare these conditions with your present conditions. Perhaps changing positions frequently, kicking around from post to pillar, no chance is sight for PERMANENT employment; frequently out of a position, and the year's average salary very low. DO YOU EARN \$1,400 TO \$2,700 EVERY YEAR? HAVE YOU ANY ASSURANCE THAT A FEW YEARS FROM NOW YOU WILL GET \$2,700 OR MORE A YEAR?

### YOU CAN GET A POSITION

Country residents and City residents stand equal chance. Experience is unnecessary and political influence not used.

- MAIL COUPON TODAY.**
- Railway Postal Clerk.....(\$1,900-\$2,700)
  - Post Office Clerk.....(\$1,700-\$2,300)
  - City Mail Carrier.....(\$1,700-\$2,100)
  - Rural Mail Carrier.....(\$2,100-\$3,300)
  - General Clerk—File Clerk.....(\$1,260-\$2,500)
  - Customs Inspector.....(\$2,100 up)

Name.....

Address.....  
Use This Coupon Before You Mislay It—Write or Print Plainly.

**FRANKLIN INSTITUTE**  
Dept. B174  
ROCHESTER, N. Y.

Rush to me free of charge (1) a full description of the position checked below; (2) Free copy of 32-page illustrated book "How to Get a United States Government Job"; (3) A list of the United States Government Jobs now obtainable.





## "Here's your check- your drawing's OK"

SOME men make more money playing than others do working. They started out with nothing but the ability to draw a little. You may have just as much ability. It costs nothing to find out—and it may be the most valuable discovery of your life.

The Federal Schools have taught hundreds of successful students. Many are now earning from \$2,500 to \$6,000 a year—others even more. Many famous artists contributed to this simple, thorough home course. In spare time you can learn the things they know about commercial art, color harmony, fashion drawing, lettering, poster designing, etc. Send the coupon below—get the free book, "Your Future," which tells what other Federal students have done. With it, you receive our Free Vocational Art Test which our artists will use to judge your ability. You may have real talent. Don't let it rust—it can bring you bigger money and an easier, happier life. Write today.

## FEDERAL SCHOOL OF COMMERCIAL DESIGNING

441 Federal Schools Bldg. Minneapolis, Minn.  
Please send me Art Test and book, "Your Future."

Name

Age  Occupation

Address



**YES**

## NEW YORK ELECTRICAL SCHOOL

Teaches all branches of Practical Electricity through the "Learn by Doing" Method. Enroll with N. Y. E. S. and gain a thorough understanding of the problems, a broad experience in applied engineering practice, and qualify quickly to follow an electrical career.

No books used. Day and evening classes open all year.

*Write for FREE School Booklet*

**New York Electrical School**  
44 W. 17th St.      **New York**

## RUPTURES

### Need firm but comfortable support

The patented Brooks Appliance retains securely without annoying springs or hard pads. Allows full body freedom. Worn and praised by active men and women in every walk of life. Over 3 million sold. Sent on 10 days' trial. Not obtainable through any store or agent in U. S., but made to individual measurements and sent direct from Marshall. Full information and free 28-page Rupture booklet sent in plain sealed envelope. Send for trial offer.



C. E. Brooks, inventor

**BROOKS APPLIANCE CO., 107F State St., Marshall, Mich.**

## Don't PEEL POTATOES

### Agents!

This is brand new! Going like wild-fire! Offers a real chance for \$100 a week. Spare-time and full-time sales plans offered. Jump in on the ground floor! Write quick for big-money plans and Free Outfit offer.



An amazing new automatic invention now makes potatoes peel themselves! No more paring knives! No cut fingers! No mess, muss or waste! Here's something every woman understands and wants the instant she even hears about it! A mechanical marvel,

almost incredibly small and simple, yet does more than ten pairs of hands! Peels the biggest potato in only a few seconds at the mere turn of a crank! Costs little more than a couple of good paring knives. Pays for itself many times over in saving on potatoes. Test it yourself at once. Write now. Ask quick for Introductory Offer.

**GUARANTY PRODUCTS CO.**

Dept. D-80, Francis Bldg.  
Washington at 16th St., St. Louis, Mo.



# quick SUCCESS

Today for men who

# learn Drafting

What's ahead in your present job?—no future?—no opportunities? Then consider drafting—easily and quickly learned at home. High positions, fame, fortunes, have been won by skilled draftsmen. Business and industry could not exist today without them. Modern mechanics, architecture, engineering, construction, railroading, shipping, aviation, building, manufacturing, all offer thousands of openings. Everything built or invented must first be planned or "built" on paper. Our great builders, mechanical and inventive geniuses began as draftsmen. And any man of common school education can now learn practical drafting at home in spare time under our simplified system. Drafting is your big chance—\$35 to \$50 a week to start—then swift development and promotion; \$5,000 a year and up paid experts.

**\$25 Drafting Outfit**  
**FREE**  
 of  
 extra cost



Enrollment includes this high-grade outfit complete. No extras to buy. A small first payment brings at once everything needed to start course and make rapid progress.

## An Amazingly Easy Way to Learn

Nothing difficult about it . . . the simplest, shortest, step-by-step method you can imagine—the result of years of successful experience in teaching by mail and in our resident classes. Learn in spare time and evenings at home. Send for the Chicago TECH catalog of successes—engineers, architects, designers, builders, contractors, chief draftsmen, superintendents. Chicago TECH training was the ladder on which they climbed to big incomes. **Low cost, easy terms.** Send coupon now for **Big Free Book on Drafting.** Tells everything you want to know to succeed quickly in practical drafting work. This is your big chance. Grasp it today.

### CHICAGO TECHNICAL COLLEGE

Dept. D-204, 118 E. 26th St., Chicago, Ill.

Architecture—Engineering—Drafting—Electricity—Building

We also offer resident day and evening courses in above subjects. Founded 1904, our College-Training-At-Home Plan is the result of 26 years' experience in training men both in our Chicago School and at home by mail.

CHICAGO TECHNICAL COLLEGE,  
 Dept. D-204, 118 E. 26th St., Chicago, Ill.

Please send me postpaid, your big Free Book on Drafting telling about opportunities and your College-Training-At-Home Plan.

Name.....Age.....

Occupation.....

Address.....

City.....State.....

Check here if you prefer coming to Chicago to take our short resident day or evening course in Drafting.

**AS A ROWING MACHINE**

**10 CABLE EXERCISES**

**HEAD STRAP**

## Get Strong!

### Eight Improved Muscle Builders

All for \$3.75

Easily master feats which now seem difficult. If you want physical culture for health this equipment is what you need. **SAVE AT LEAST HALF!** We furnish ten cable chest exerciser adjustable to 200 lbs. resistance. Made of new live extra strength rubber to give resistance needed for sure muscle development. Pair of patented lead arms develop powerful grip and arm. Will exercising parts develop back, arms and legs. Head strap permits exercise of neck muscles. Develop leg muscles with foot strap—gives speed, endurance. **Illustrated course shows how to develop any part of body.**

**SEND NO MONEY**  
 Send name and address. We send all by return mail. Pay postman \$3.75 plus postage. (If you live outside U. S. A. price \$4.50 cash with order.)

**MUSCLE POWER CO., Dept. PM-4**  
 150 Nassau St.  
 NEW YORK, N. Y.

**GUARANTEE**  
 Entire satisfaction guaranteed or money back.

How to get the **VOCABULARY** you want **WITHOUT** using a **DICTIONARY**

**Special Offer—\$5 Course Only \$1**

A complete, amazingly simplified and practical \$5.00 Course (exactly as given in our Resident School) to increase and broaden your vocabulary. Results immediate. You'll astonish your friends. Mailed postpaid, for \$1. **NAGARA SCHOOL, Inc., 210 B. L. E. Bldg., Cleveland, O.**

**HEALTH—POWER—BEAUTY**

**GREAT NEW INVENTION — ELCO HEALTH GENERATOR**  
 Generates High Frequency Violet Ray, Mechanical Vibration, Medical Electricity, and Gamma. For Home treatments at less than 50 cents a year.

**FREE BOOK "Health, Power, Beauty."** Revitalize yourself. Bring back energy. Be widely alive. **WRITE TODAY.**

**LINDSTROM & CO., 2322 Indiana Ave., Dept. 13-54, Chicago**

**Wrestling Book FREE**

Learn wrestling at home from former world's champions **Farmer Burns and Frank Gotch.** Free book tells how. Secret holds, blocks, tricks revealed. Be strong, healthy, handle big men easily. Write for free book. State age. **Farmer Burns School 3374 Railway Bldg., Omaha, Neb.**

# SAVE COAL!

## New "Invisible Hand" Invention

### CLOSES DOORS

# S-I-L-E-N-T-L-Y!

A tremendous long standing need is now filled by a clever little invention called Close-A-Door. Adjustable to fit any door—works on pneumatic principle. Shuts door swiftly and securely as if moved by invisible hands—checks it in time to prevent SLAM! Saves doors, saves nerves, saves glass and saves fuel. **AGENTS!** Never before an invention with from 4 to 8 possible sales in every home—sell dozens in apartments, factories, offices and business establishments. Agents make occasional easy profits everywhere they go just showing clever visitors door demonstrator. Write at once for description of Close-A-Door and generous introductory offer.

**THE CLOSE-A-DOOR CO.**  
 1521 Washington Ave. Dept. D-10 St. Louis, Mo.



# We Will Train You in a Few Months



Day and Night  
Schools in  
Chicago, Detroit  
Cleveland,  
Boston, Phila.

No Books—  
No Classes—  
Wonderful  
Future in this  
Uncrowded  
Field

## Experts Earn Up To \$125 a Week as Mechanical Dentists

We teach you to make rubber plates, crowns, bridge work, metal base dentures, etc., for dentists. After graduating you are ready for a job or can open your own laboratory. We assist you.



### Big Demand for Men

Thousands of dentists everywhere send work to mechanical dentists. We train you quickly in day or night school for this uncrowded field. No classes—no books—no mechanical experience necessary.

Work your way thru school. We help you find a job to meet your expenses while taking our training.

### FREE BOOK

Send at once for interesting free book telling all about this thriving profession. Also details of our liberal offers. Write today!

McGARRIE SCHOOL OF MECHANICAL DENTISTRY,  
1338 S. Michigan Ave., Dept. 454, Chicago.

Without cost or obligation, send me your illustrated book on Mechanical Dentistry, and complete information as to my opportunities in dental laboratory work.

Name.....

Address.....

Books on all subjects are sold by Popular Mechanics Press, 200 East Ontario Street, Chicago, Illinois.

## NEW ELECTRIC ROBOT CELL (NO LARGER THAN A GOLF BALL)

# Puts AUTO Thieves



This new all metal Electric Robot Cell, called the DETEC-TO-CELL, stands constant and faithful guard over parked cars Day and Night. No thief can touch your car or anything IN or ON it without starting a Clamorous Riot of Noise that will not stop until he runs away. Protects every part from spare tire and gas tank to bumper and headlights. Do not confuse with anything else you have ever seen or heard of. The DETEC-TO-CELL is entirely new, different and scientifically correct. An airtight and ingenious invention as the Photo-Electric Cell. Startling and necessary in effect. Positive and accurate in operation. Contains no springs, weights or sliding contacts. —cannot get out of order. Installed in ten minutes.

### AGENTS

Will Outlast Any Car

GET Our FIVE DAY Test Offer

STOP this man is a thief

Nothing beats the DETEC-TO-CELL as a full or spare time money maker. Amazing sales records are made daily by men who never sold anything before in their lives. Creates instant attention the moment it is shown. You can't keep the crowds away when you demonstrate. Every auto owner is a prospect. The Low Selling Price and Positive Protection feature automatically close your sales. Write today for Five Day Test Offer and liberal territory proposals.



ELECTRIC R. & S. CO., 64 E. Lake St., Dept. 922-PA, CHICAGO

## 1931 Radio BARGAINS

### WHOLESALE DISCOUNTS LOWEST PRICES

**RADIO CATALOG 1931**  
WHOLESALE

Greatest bargains shown at  
**REGULAR WHOLESALE TRADE DISCOUNTS!**  
Nationally-advertised, guaranteed radio merchandise including the sensational bonded LAFAYETTE ALL ELECTRIC RADIO RECEIVERS, with tone control. Write at once for FREE 1931 Radio Bargain Catalog, showing complete selection. Don't buy until you see this wonder catalog!

**WHOLESALE RADIO SERVICE CO.**  
Dept. D-11  
38 Vesey St. New York

# FREE!

## A NEW CAR in 30 minutes



Get BEAUTY and LUSTRE of NEW PAINT JOB at small fraction of cost. Do it Yourself with NUKAR. NOT a Wax. NOT a Paint. NOT a Polish. NUKAR instantly restores Original Color to dull faded cars. Actually makes old Shabby Cars look NEW. Lustre lasts for months. Does not hold Dirt or Dust. No rubbing—No hard work. Flows on like water from a sponge. No waiting—Drive a New Car the same day. Results Guaranteed.

### MEN! Amazing Cash Profits

Are being made by Agents, Distributors and Service Station operators. Makes used cars sell. Get in on biggest thing in automobile business today. Earn up to \$50 a day. Full or part time. Millions of prospects. Makes sensational sales compelling demonstration. We back you to the limit with powerful Sales Co-operation and give you FREE—A BUSINESS START that money can not buy. Let us send without charge our Large Book showing big money-making Agents and Distributors Plans. Write TODAY.

ATLAS SOLVENT CO., Dept. 56 Morgan Park Sta. CHICAGO, ILL.

## Learn Public Speaking

At home—in spare time—20 minutes a day. Overcome "stage-fright," gain self-confidence, increase your salary, through ability to sway others by effective speech. Write now for free booklet, *How to Work Wonders With Words*.

**NORTH AMERICAN INSTITUTE, Dept. 1254**  
3601 Michigan Avenue, Chicago, Illinois

## WINDOW DECORATING

### EASY TO LEARN

Write Now

Learn to design window displays. Artistic taste only requirement. Average pay from \$40 to \$100 per week. Many earn \$5,000 to \$10,000 per year.

One million neglected windows. Your opportunity studied. Every retail store needs decorations. Learn in your spare time at home. Write for descriptive catalogue.

**MVREY SCHOOL OF DECORATIVE ADVERTISING**  
107 ARLINGTON ST. - BOSTON, MASS.

**Learn Watchwork, Jewelry work and Engraving** A fine trade commanding a good salary, and your services always in demand. Address **Horological, Dept. P, Bradley Institute, PEORIA, ILLINOIS**, for our latest catalog.

## Play the Hawaiian Guitar

**\$25 Extra Each Week**  
You can make Big Money, spare-time or full-time, playing for Dinners, Parties, Orchestras, Radio! REAL CASH paid for melodious music of Hawaiian Guitar. YOU can make \$25 a week extra, or \$65 to \$100 a week full time. You can play for P.A.T. in 1 to 2 months!

**It's Easy Now to be Popular**  
Be the life of every party! Bid goodbye forever to lonely evenings! Course—Photograph Records—full outfit—everything to insure quick social and professional success—costs only a few cents a day. Write NOW for FREE Book—**HAWAIIAN STUDIO 520-41, New York Academy of Music, 100 Fifth Ave., New York City**



## 34 Lesson Drawing Course \$2.98

The biggest value you ever saw  
advertised anywhere . . . . .



Haven't you often wished that you could draw cartoons, illustrate some idea, sketch some pretty face, etc.? You can do all of these things. One of America's most famous Cartoonists and Illustrators has developed a great, simple system for success in all branches of Commercial Art. This system has revolutionized the entire theory of drawing. It means that drawing can be as easy for you as writing—much simpler than learning shorthand, bookkeeping or typewriting. We are now placing this original system for learning Drawing, Art and Cartooning, consisting of 34 lessons with over 500 illustrations, within reach of every one. If you will devote a few hours each week to the Course **WE ABSOLUTELY GUARANTEE** that you will learn to draw and draw well before you have half finished the Course. If we fail to make this claim good, we will refund every cent paid us. By eliminating a large office force for answering correspondence, expensive catalogs, etc., we are enabled to make a price of \$2.98, the cheapest price ever known for a high-grade, home study course. Learn to draw. It is a big asset, no matter what field you are in.

### Send No Money

Just order the course and on arrival pay postman **\$2.98**

plus a few cents postage, payment in full for the entire Course and Drawing Outfit. If not entirely satisfied, return within five days and we will Refund Money. Address: **LEDERER SCHOOL OF DRAWING, Dept. 624-G, Chattanooga, Tenn.** Orders from outside the U. S. A. are payable \$3.28 cash with order.

If you order the course at once, we will include a drawing outfit, consisting of artist's pencils, pens, paper, erasers, ink, wash, etc., enabling you to go to work without any additional cost.

## No Joke To Be Deaf

—EVERY DEAF PERSON KNOWS THAT George P. Way made himself hear, after being deaf for 25 years, with Artificial Ear Drums—his own invention. He wore them day and night. They stopped head noises and ringing ears. They are invisible and perfectly comfortable. No one sees them. Write for his true story, "How I Got Deaf and Made Myself Hear." Also booklet on Deafness. Address: **George P. Way, Inc., 604 Hofmann Building, Detroit, Michigan**



Artificial Ear Drum

## RADIO BLUEPRINTS

The blueprints below include the best of Popular Mechanics tested circuits. When ordering, simply quote the numbers of blueprints desired and inclose proper amount addressed to Popular Mechanics Magazine, Radio Dept., 200 E. Ontario St., Chicago, Ill. Magazines containing full descriptions of the circuits can be obtained. Send 25 cents for each magazine desired, giving date of publication.

- No. 139, Simple Television Receiver. . . . . Dec. 1928. . . 25c
  - No. 140, Power Amplifier and B-Supply for Television. . . . . Jan. 1929. . . 25c
  - No. 142, Two-Tube Screen-Grid Short-Wave Adapter. . . . . Mar. 1929. . . 25c
  - No. 143, Four-Tube Screen-Grid Receiver. . . . . May 1929. . . 25c
  - No. 144, Three-Tube Self-Contained A.C. Receiver. . . . . Oct. 1929. . . 25c
  - No. 145, One-tube S-G Set for Beginners. . . . . Nov. 1929. . . 25c
  - No. 146, Adjustable B-Eliminator. . . . . Nov. 1929. . . 25c
  - No. 148, Adding Audio Stages to S. G. Receiver. . . . . Dec. 1929. . . 25c
  - No. 150, Short-Wave Receiver Without Plug-In Coils. . . . . Sept. 1930. . . 25c
  - No. 151, Beginners Low Power S-W Transmitter. . . . . June 1930. . . 25c
  - No. 152, Portable Radio Amplifier for the Deaf. . . . . July 1930. . . 25c
  - No. 153, Low Cost Code and Phone Transmitter. . . . . Sept. 1930. . . 25c
  - No. 154, A. C. Screen-Grid DX Tuner. . . . . Oct. 1930. . . 25c
  - No. 155, Four-Tube D-X Receiver. . . . . Nov. 1930. . . 25c
  - No. 156, Switchless Test Panel. . . . . Nov. 1930. . . 25c
  - No. 157, Building a Light-Sensitive Relay. . . . . Dec. 1930. . . 25c
  - No. 158, High-Power Supply for Amateur Transmitters. . . . . Jan. 1931. . . 25c
  - No. 159, Portable S-W Transmitter. . . . . Feb. and March 1931. . . 25c
  - No. 160, Building A.C. Midget Receiver. . . . . Mar. and Apr. 1931. . . 25c
  - No. 161, Building Auto Receiver for 2-volt Tubes. . . . . Apr. and May 1931. . . 25c
- Material Lists for any of the above instruments will be mailed free upon application.

## NOW FIX ANY MAKE OF

# AUTO



## SIX BIG AUTO BOOKS ALL SHIPPED FREE

on approval; whether you want to qualify as garage owner, auto repair expert or merely wish to know how to keep your own car 100% efficient, look at these books—they are sent to you for free examination. This brand

new 1931 edition has been prepared by a large group of America's greatest automotive engineers. Anybody who can read will understand them, for this great automobile encyclopedia is a veritable gold mine of valuable facts. Take advantage of this great opportunity now; send in the coupon for FREE examination. You don't pay us a penny, you don't obligate yourself to pay anything unless you decide to keep the books. Just tell us you want to see them and the full set of 6 great volumes, just off the press, will be sent to you. Read them, look them over and prove to your own satisfaction that one fact alone, which you will find in them, may save you an expensive repair, or help you to a better job.

### Aviation Motors

In addition to being a complete encyclopedia of automobile engineering, these books contain over 100 pages on Aviation Motors, and as they are just off the press they bring to you the newest and latest information obtainable. This alone makes these books invaluable to anyone.

## New 1931 Edition

Imagine books which are so new that every page is right up to date—wiring diagrams, construction details, service problems—are all right up to the minute. Nowhere else that we know of can you get as complete and up to date information. Over a million dollars of resources have enabled us to give you the most up to date books on the subject ever published. You will find nearly 20 pages on front wheel drives alone. Everybody interested in automobiles in any way will welcome these books, especially on our no money offer.



## CAN YOU FIX IT?

Can you take out "play" in differential? Can you kill the "shimmy" in steering? Can you reset TIMING? Can you put your finger on engine trouble without guessing or tinkering? Can you pull the starter off and fix it? Can you adjust and repair transmission, engine, rear axle, bearing?

### These Books Tell How

and they tell you how to do any and every auto job right, the first time.

### 6 Big Volumes

Nearly 3,000 pages, over 2,000 illustrations, wiring diagrams, equipment charts, etc. De Luxe edition with gold-stamped flexible binding. Sent FREE for 10 days' use. If not wanted return stamps collect. If kept, send only \$2.00 after 10 days, then \$5 a month until special advertising price, \$24.80, is paid.

### A Year's Consulting Membership FREE!

Privilege of consulting engineers of million-dollar American Technical Society on any automotive problem for one year without charge, if you mail coupon immediately.

## SEND NO MONEY

American Technical Society, Dept. A-419,  
Drexel Ave. at 58th St.,  
Chicago, Illinois

I would like to see the new 6-volume 1931 edition of your automobile books but without any obligation to buy. I will pay the few cents delivery charge only and will examine the books and return them at your expense in 10 days unless I like them, in which case I will send you \$2.00 (then and only \$3.00 per month until the special price of only \$24.80 is paid). You are to include free consulting membership certificate in the American Technical Society. Send brand new 1931 edition.

Name .....

Street .....

City .....

Employer's Name .....

Employer's Address .....



# FREE For 30 Days

*Ends Buying  
Razor Blades*

**SEND NO  
MONEY**

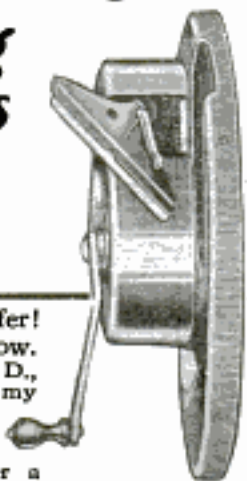

**A MAZINGLY liberal offer!**  
A just mail coupon below. Without a penny deposit or C. O. D., I'll give you the chance to try my amazing new-type blade sharpening invention that means no more razor blades to buy and keen cool shaves forever. Over a million users. One blade often gives 365 keen shaves. 10-Year guarantee. Absolutely unique. Fits any razor blade. Use for 30 days; if not delighted, return it—trial costs you nothing. When convinced of its wonderful efficiency, demonstrate it to friends and collect profits. No selling—just let them try it Free and sell themselves.

### New-Type Razor Blade FREE!

If you write at once, I'll immediately send you free a new kind of razor blade, to fit your present razor. Guaranteed to last longer and stay sharper. Act before offer expires. Rush coupon to I. L. Rhodes, Dept. D-4525, 1418 Pendleton Ave., St. Louis, Mo.

## AGENTS WANTED

New guaranteed sales plan assures big profits without selling. No risk. King made \$66 in one day. Check bottom line in coupon for selling outfit offer.

I. L. RHODES, Dept. D-4525,  
1418 Pendleton Ave., St. Louis, Mo.

Without obligation or cost to me, send me your 30 days' trial offer on your new blade sharpening invention. If not satisfied I can return it within 30 days. Send me also a free sample

razor blade for.....razor.

Name.....

Address.....

City.....State.....

Check here for full details of money-making selling outfit offer.

## There's Opportunity in ELECTRIC REFRIGERATION

### Trained Men in Great Demand!

Good Pay—steady work—ground floor opportunities await every man who gets into this growing industry.

Jobs Pay \$50 to \$200 a Week—Or You Can Go Into Business for Yourself

Manufacturers and distributors, ice cream and soft drink companies, steamship and railroad companies and other firms need thousands of refrigeration experts. Shop mechanics, installers, service men, estimators—many different positions are open. All you need to qualify for these big pay jobs is training and experience—and National Tech will give you that.

### Learn in 8 Weeks on Actual Machines

Eight pleasant weeks in the finest and best equipped school in the country qualifies you thoroughly. You'll work on leading machines—on household units, commercial jobs and air cooling equipment. You'll install them—service them and repair them. When you complete this training you'll know refrigeration—you'll be experienced and capable of holding a real job.

### And We'll Help You Find Employment

Employers everywhere call on us for graduates. Write today for the whole story. Let us prove that this new field offers you a wonderful opportunity. Read all over for free details. **THE NATIONAL TECH,** 201 Ulmer Bldg., Cleveland.

## Learn SIGN and SHOW-CARD WRITING

*In spare time few hours weekly*



**FREE  
"Book  
of  
Facts"  
—  
Write  
For It**

Fascinating profession. Big opportunity in this fast-growing trade. Earn while you learn the sign arts. No talent or experience required. Be your own boss or obtain a good position. Learn show cards, posters, bulletins, signs, advertising layouts and allied subjects. We teach by mail or at our school. Quick results—easy to learn.

### EARN \$50 TO \$200 WEEKLY

Otto C. Wiegand, Md., home-study graduate, made \$12,000 from his business in one year. Many successful graduates. Oldest and foremost school. Don't delay. Write for complete information.

### DETROIT SCHOOL OF LETTERING

193 Stimson Ave.

Est. 1899

DETROIT, MICH.

## Learn AVIATION WHERE LINDBERGH STARTED!

### Pilots Earn Big Money!

Air mail and Transport Pilots received an average salary of \$137.50 per week during the past year. Be a pilot! Learn at this Lincoln School. The best known school in America. \$250,000 worth of buildings and equipment. \$100,000 airport. **Government Approved School.** Big fleet government licensed training planes.

**Complete Mechanics', Welders' and Radio Courses.** Also Home Study Course. Mechanics' School tied in with large production aircraft factory. Reasonable tuition. We assist you to Part Time Employment to help pay cost of board and room while in training. Write for details, stating age!

**Lincoln Airplane & Flying School**  
208 Aircraft Bldg. Lincoln, Nebr.

## BE AN ARTIST

WE CAN TEACH  
YOU DRAWING in

your own home during your spare time. Twenty-five years of successful teaching proves our ability. Artists receive large salaries.

Write Today for Art Year Book

**SCHOOL OF APPLIED ART**  
ROOM NO. 2 BATTLE CREEK MICH.

## MOLES and WARTS

REMOVED PERMANENTLY

Rid your face, neck, arms and body of all unsightly moles and warts with "ANTI-MOLE." One application does it. Safe—easy to use—painless—leaves no scar. Used successfully by physicians, skin specialists and beauty experts for 28 years. Write for FREE booklet on treating all kinds of moles and warts. Miller Co., 2445 South St., Lincoln, Nebr.



## CODE RADIO and MORSE



teach you easily and quickly for jobs on Land, Sea and Air. Catalog. The Omnigraph Mfg. Co., 819 E. 39th Street, P11, Brooklyn, N. Y.

Information on any book free. Write Popular Mechanics Press, Chicago, Ill.

## Why STAMMER?



I overcame my own stammering. Let me help you. My new, free booklet tells how. You, too, can overcome your speech defects and lead a normal, happy and successful life. Write today! ROBT. E. CARD, 12590 Woodward Ave., Detroit, Mich.

Free Book





# Get the Job YOU Want

**In the Big-Pay HOTEL Field**

**Earn \$1,500 to \$7,500 a Year**

Take advantage NOW of the opportunities open for trained men in hotels, restaurants, clubs, apartment hotels, camps, hospitals, institutions and schools. Over 70,000 positions as Manager, Assistant Manager, Steward, Auditor, Engineer, Room Clerk, Sports Director, Purchasing Agent and scores of other executive positions paying \$1,500 to \$7,500 a year open annually in hotels alone. Almost \$1,000,000,000 worth of new hotels, apartment hotels, clubs and institutions being built this year mean even greater opportunities.

**Previous Experience Unnecessary**

We have trained thousands and put them in touch with good positions. All of your training under the personal supervision of Clifford Lewis, appointed Managing Consultant by over 300 hotels. Low cost, easy terms, money-back agreement. Age no obstacle—those of young or mature age can win success. A good grade-school education is all you need. Free Book, "Your Big Opportunity," shows how to train for a splendid position. Mail coupon today—NOW!

**Qualify NOW for Big Opportunities**



**FRONT OF THE HOUSE**

Chief Clerk	Front Office Cashier
Superintendent of Service	Room Clerk
Chief Porter	Accountant
Bell Captain	Houseman

**BACK OF THE HOUSE**

Steward	Assistant Steward
Maitre d'Hotel	Head Waiter
Chief Engineer	Purchasing Agent
Electrician	Food Checker

**MANAGERIAL**

Manager	Banquet Mgr.
Assistant Mgr.	Publicity Director
Auditor	Chief Accountant
Social Director	Chief Engineer

**LEWIS HOTEL TRAINING SCHOOLS**

Clifford Lewis, President

Room DE-364 Washington, D. C.

*The Original and Only School of Its Kind in the World*

Lewis Hotel Training Schools, Room DE-364, Washington, D. C.

Send us the Free Book, "Your Big Opportunity," without obligation, and details of your Personal Coaching Plan.

Name.....

Address.....

City.....State.....

**OPPORTUNITY COUPON**



## High School Course in 2 Years

This simplified, complete High School Course, specially prepared for home study by leading professors, meets all requirements for entrance to college, business, and leading professions.

**20 Other Courses**

Over 200 noted Engineers, Business Men, and Educators helped prepare the special instruction which you need for success. No matter what your inclinations may be, you can't hope to succeed without specialized training. Let us give you the practical training you need.

**American School**  
Drexel Ave. and 58th St.  
Dept. H-447, Chicago

**Money Back When You Finish If Not Satisfied**

American School, Dept. H-447, Drexel Ave. and 58th St., Chicago  
Send me full information on the subject checked and how you will help me win success in that line.

- |                          |                           |
|--------------------------|---------------------------|
| .... Architect           | .... Electrical Engineer  |
| .... Building Contractor | .... General Education    |
| .... Automobile Engineer | .... Lawyer               |
| .... Civil Engineer      | .... Mach. Shop Practice  |
| .... Structural Engineer | .... Mechanical Engineer  |
| .... Business Manager    | .... Steam Engineer       |
| .... C. P. A. & Auditor  | .... Draftsman & Designer |
| .... Bookkeeper          | .... High School Graduate |

Name.....Age.....

St. and No.....

Town.....State.....

## ARE YOU READY FOR A BETTER JOB?

Success comes to those who know HOW and WHY.



## ELECTRICITY

offers a field that will never be over-crowded. Interesting. Well-paid. Start at once to get practical working knowledge. Read a book a month.

### BOOK-A-MONTH STUDY PLAN

The newest, easiest way to study. Everything simple and clear. Test questions easy to answer. Even poor students learn quickly.

### AUDELS New Electric Library

makes electricity as easy as A B C for beginners; interesting as fiction; engineers can carry in pocket for spare-time reading and reference. Questions, answers, thousands of diagrams, calculations.

**ONLY \$1.50 PER VOL.**

**THESE SUBJECTS — others** — Dynamos, Armature Winding, Batteries, Transformers, Condensers, A-C Motors, Maintenance, Tests, Power Stations, Wiring Diagrams, Electric Railways, Elevators, Auto and Aero Ignition, Radio, Telephone, Telegraph, Motion Pictures, Talkies, Refrigeration, X-Ray, Welding, Domestic and Farm Appliances.

**FOR 6c A DAY** we help you overcome handicaps of education. What you start the Audel way you can finish.

**—SEND COUPON—NO MONEY—**

**THEO. AUDEL & CO., 65 W. 23rd St., New York City**

Mail Vol. 1, Electric Library on 7 days' free trial. If O.K. I will remit \$1.50, otherwise I will return it. I also request you to mail one book each month on same terms. No obligation unless I am satisfied.

NAME.....

ADDRESS.....

OCCUPATION.....

EMPLOYED BY.....P.M.



**Get This Strong Man's Library!**

**Molding Mighty Men**

**6 for \$1**  
**25¢ Each**

POST PAID

## Each Book a Complete Course

Think of it! A muscle building course showing how to develop a definite part of your body for only 25c or six courses which show you how to develop the entire body for only \$1.00. That's my special offer. I will show you how to mold a mighty arm for a quarter or how to mold a mighty chest, mighty legs, a mighty back or a grip of steel, or I will teach you strong man stunts. Get all of the lessons in this Strong Man's Library for only \$1.00.

I show you how to add inches on your arm, how to put steel cables on your chest, how to get a back of might. I show you how to develop legs of a giant and a grip of steel. The strong man tricks which I reveal will amaze you and your friends. Molding mighty men is the business of George F. Jowett, The Champion of Champions.

### RUSH COUPON—SPECIAL OFFER

All 6 books are profusely illustrated and will be sent to you by return mail, postpaid. Just slip a dollar bill in an envelope with the coupon below. For any single book, just send a quarter. I will include a free copy of my book titled, "The Thrill of Being Strong." Rush coupon now.

## JOWETT INSTITUTE OF PHYSICAL CULTURE

422 Poplar Street, Dept. 4Ra, Scranton, Penna.

Dear Mr. Jowett: Your proposition looks good to me. Send, by return prepaid mail, the lessons I am checking below and for which I am enclosing my remittance of \$.....

- All 6 Courses \$1.00  
 Molding a Mighty Arm 25c  
 Molding a Mighty Back 25c  
 Molding a Mighty Grip 25c  
 Molding a Mighty Chest 25c  
 Molding Mighty Legs 25c  
 Strong Man Stunts Made Easy 25c

Name.....

Address.....

## Train Now for New RADIO Opportunities

New inventions and improvements open up new fields for the Radio-trained! By following the Association money-making plans, our members earn \$3 an hour upwards, full time or spare time. Tremendous demand now for Association-trained service men. Investigate how we train you, start you in business without capital, prepare you for big-pay positions.

**NO-COST MEMBERSHIPS NOW OPEN**  
 To a number of ambitious men, we will give No-Cost Memberships that may not need not cost you a cent. Write for details and Free Radio Handbook explaining how easily you can now cash in on Radio quick.

**RADIO TRAINING ASSOCIATION OF AMERICA**  
 4513 Ravenswood Ave. Dept. PM-4 Chicago, Ill.



**SET ANALYZER**  
 —sent to all members. Locates troubles in all types of sets. Tests circuits, measures resistance and condenser capacities, detects defective tubes.

**BUCHSTEIN'S FIBRE LIMB**

is soothing to your stump—strong, cool, neat, light. Easy garments. Braces for all deformities.

Send for Catalog Today

D. BUCHSTEIN CO.  
 810 3rd Ave., So. MINNEAPOLIS, MINN.

## WE BUY POETRY!

**POPULAR POETRY**, the poet's national magazine, buys poetry and pays for it promptly on acceptance. We need 4, 8, 12 and 16 line verse; any subject. Send contributions immediately. Sample copy **Popular Poetry** on request. **POPULAR POETRY**, 6 East 12th St., Cincinnati, Ohio

## Thousands of Brooders FREE



Most During Sensational Offer. Get FREE Catalog for Details. Learn also how We Sell Baby Chicks On Time Payments—Give Big Discounts on Incubators and Brooders. Hundreds of Items Listed for Farms, Home and Family at 1-3 to 1-2 Off. Half Price on Bobbitt Incubators.

### OUR WONDER BOOK OF BARGAINS

contains 64 pages—And Big Surprise Offers on most every page. Priced in colors. Write for Free Book today, and get Free BROODER Facts. Address

J. W. MILLER CO., DEPT. 12, ROCKFORD, ILL.



## RAISE CHINCHILLA

AND NEW ZEALAND WHITE FUR RABBITS

Make Big Money We Supply Stock AND CONTRACT FOR ALL YOU RAISE

paying up to \$6.50 each. Large illustrated book, catalog and contract, also copy of Fur Farming Magazine, all for 30c. STAHL'S

OUTDOOR ENTERPRISE CO., Box 141A, Holmes Park, Missouri



## SQUAB BOOK FREE

Send PR squabs for rich trade. Sold by millions at higher prices than chickens. Send two-cent stamp for postage on latest free 48-p. book how to breed and profit by new fast sales method. No free books sent to children. The price to them is ten cents.

Plymouth Rock Squab Co., 634 H St., Melrose, Massachusetts



## 70 BREEDS Chickens, geese, turkeys,

and ducks. Pure-bred, hardy, high quality and most profitable. Fowls, Eggs, Baby Chicks and Incubators at reduced prices. America's great plant—since 1893. Valuable 100 page Poultry book and catalog FREE.

R. F. NEUBERT Co., Box 878, Mankato, Minn.

## A PRACTICAL COURSE IN MECHANICAL DRAWING

By WM. F. WILLARD

An ideal book for home study. Each exercise is clinched in the mind of the student by practical application to every day practice. 160 Pages, 157 Drawings. Cloth. Price \$1.00 Postpaid.

POPULAR MECHANICS PRESS 200 E. Ontario St. CHICAGO



# Should The "Dread Secret" Of Men Past 40 Be Guarded Any Longer?



the type of treatment used and endorsed by many hospitals, specialists, physicians and sanitariums. Not a medicine, drug, diet, exercise, or violet ray. Time has proven its results frequently not only swift, but lasting. Over 100,000 men have used it and learned the way to new health and joy. The inventor now sends it on a guarantee that if it doesn't make you feel 10 years younger in 7 days you pay nothing. He will also send free copy of a daring book that reveals facts every man past 40 should know. Send no money, just coupon for facts about trial offer and free book.

## Sent FREE!

W. J. KIRK,  
President  
2140 Morris Ave.,  
Steubenville, Ohio.

**T**HOUSANDS of men past 40 have lost their strength and pep but don't know why. Many suffer pains in back, legs and feet, frequent night rising, chronic constipation, sciatica, mental depression. They often mistake these ailments for approaching old age. But science says they are often due to prostate gland failure. This tiny gland becomes swollen and fails to function properly. If not corrected it often leads to a life of misery or perhaps grave surgery.

### Amazing New Gland Discovery

Now an American scientist has perfected a drugless home treatment that has brought joy and health to thousands. Many men report it quickly cleared up the distressing symptoms and made them feel 10 years younger in 7 days. This is

### \$10.00 PER MONTH BUYS Fibre-Lite Limbs

NEXT TO NATURE. BRACES MADE TO ORDER. AGENTS WANTED. FREE FIBRE SAMPLE. **WORMAN CO.** 252-D HENNEPIN AVE. MINNEAPOLIS, MINN.



### NEW MEDICATED SILK ADHESIVE ENDS

#### CALLOUSES

This, glove-like **Comfitape** stops pain instantly, gently absorbs corns, callouses, reduces bunions. Safe; cannot harm flesh. Binding **money-back guarantee**. Send \$1 for large spool to try at our risk. **Comfitape Lab., Dept. 20, Burlington, Vermont.**



### How to Obtain A Better Looking Nose

Improve your personal appearance. My free book tells you how I guarantee to improve the shape of your nose by remodeling the cartilage and fleshy parts, quickly, safely, and painlessly, or refund your money. The very fine, precise adjustments which only my new patented Model 25 Nose Shaper processes, make results satisfactory and lasting. Worn night or day. Over 100,000 users. Send for free book to **M. TRILETY, Pioneer Nose Shaping Specialist, Dept. 197, BINGHAMTON, N. Y.**

If you live West of the Rockies, address The Electro Thermal Co., 303 Van Nuys Building, Dept. 21-T, Los Angeles, Calif. In Canada, address The Electro Thermal Co., Desk 21-1, 53 Yonge St., Toronto, Canada.

W. J. KIRK, President,  
2140 Morris Ave., Steubenville, Ohio.

Send free copy of "The Destroyer of Male Health" and facts about your trial offer. No obligation to me.

Name.....

Address.....

City.....State.....

### SONG WRITER'S GUIDE

Contains suggestions beneficial to writers of words or music for songs. Song Writers may submit for free criticism. Arranging and revision available. Before venturing further, send stamp for free pamphlet Guide.

Write, **BEAVER, D1-1257 ELM, GREEN BAY, WISCONSIN**



### "BOW LEGS and KNOCK-KNEES" UNSIGHTLY

Send for booklet showing photos of men with and without **THE PERFECT LEG FORMS.**

**PERFECT SALES CO.**  
140 N. Mayfield Ave., Dept. S, Chicago, Ill.



## LUCKY TIGER

### FOR HAIR AND SCALP!



A single application stops that miserable itching. A single bottle corrects scalp irritations. A Proven Germicide, delicately perfumed, safe for adults and children. World's largest seller at Druggists, Barber, Beauty Parlors.

**GUARANTEED**



# New Shoe Soles

## We Pay Agents Just for Testing It

Uncanny new discovery makes it possible for any man, woman or even a child to put on brand new soles and heels in three minutes—for the amazingly small sum of 10c. It is a queer leather paste, called Re Sole. Spreads on smooth and even with a knife like butter. Sets overnight and never again softens. Makes the sole flexible, comfortable and waterproof. Wears and looks like leather. Re Sole fills up holes, covers worn out places, levels heels in a jiffy. No experience or skill required. Now shoe soles need never wear out.

# 10¢

*Spreads  
on  
like  
butter*

## Full-Size Can GIVEN

Every man, woman and child is a prospect for Re Sole. That's why we are swamped with orders. County agents needed everywhere to fill the high demand. You don't have to make sales to make money. We include a free supply of Re Sole and guarantee you a profit whether you sell or not. Men and women who want to be \$10 a day agents, are urged to send coupon for amazing free sample can offer. (Enough for 20 soles.) Also details of guaranteed profits. Whether you want to be an agent or not, rush coupon now for free offer.

### Rush This for Guaranteed Profit Offer

**Universal Laboratories, Inc.,  
Dept. 6294, Garver Bldg., Des Moines, Iowa**

Send me your free can offer to agents and tell me how I can make up to \$40 a day with your new sales plan. Also explain how you will pay me for just testing and showing people.

Name.....

Address.....

City.....

State.....

### Send for Special Offer

You don't need to make sales to make money. We can afford to make this daring profit guarantee because of the widespread and urgent need for Re Sole. Mail coupon for complete facts on this sensational offer. **Do it now.**

**HOW'D YOU LIKE to Play This Instrument?**

**FREE LESSONS!**



**YOU CAN PLAY THE KYLORIMBA**

**No reason why you shouldn't. Easy Lessons show you how. 5 days' free trial in your own home. A year to pay.**

THE whole world seems different when you learn to play and now you can play the most spectacular of all instruments—the Deagan Xylorimba. No long waiting. No finger or lip exercises. No tiresome practice. Start to play the very first day even if you can't read a note of music right now. Soon you'll be the "hit" of every party. Maybe, like the Musical Hallmans (Reading, Pa.) you'll make \$65 a week spare time.

**Our Big FREE Book** tells all about the free trial offer, the easy lessons, the wonderful payment plan. No cost or obligation—send in coupon today.

**J. C. Deagan, Inc., Dept. 4454, 1770 Bertsau Ave., Chicago**  
Send me, without obligation, full details of Free Trial offer and easy payment plan of the Deagan Xylorimba.

Name.....

Address.....

## Learn to Dance

You can learn all the modern dances—the latest Tango steps, the new Fox Trots, dreamy Waltzes, smart Collegiate Steps, and popular Society Steps at home, easily and quickly. New chart method makes dancing as simple as A-B-C. No music or partner required. Don't be a wallflower. Learn to dance. Complete course—265 pages, 54 illustrations, sent on 5 Days' Free Trial. Equals \$20.00 course. Send no money. Pay postman only \$1.98, plus postage upon arrival. Money back if not delighted. Catalog Free.



**Franklin Pub. Co., 800 No. Clark St., Dept. 9428, Chicago**

## THE AGE of CARTOON Courses for only \$2.98

48 lessons by Carl Anderson, the ACE cartoonist. Sent postpaid in U. S. A. Foreign countries \$3.25. Satisfaction guaranteed or money back. Particulars Free.

**CARL ANDERSON SCHOOL, Dept. A, Madison, Wis.**

**FREE!** Catalog of Technical and Business Books—1500 Titles—All Fields from Aviation to Welding Practice.  
**McGRAW-HILL BOOK CO. Inc., 370 Seventh Ave., New York**

## Savages Don't Wear Trusses

**5,000 Surprise Packets Free; Exciting Invention**

Savages don't wear trusses. A scientist will tell you why and send you an exciting book, and sample that will open your eyes about rupture. No dope. No ox-harness. 5,000 Sample packets free if you write today. Delay means never. Write or wire New Science Institute, 2183 Clay St., Steubenville, Ohio.



# Be The Man Behind The Camera

**BIG PAY  
FASCINATING  
WORK**

**S**PLENDID salaries are paid motion picture cameramen and "still" photographers. Qualify now for this fascinating profession. Play a major part in the production of the great movies that thrill the country or in making photographs for advertisers, magazines and newspapers.

## LEARN THIS NEW WAY

Now, you can master every phase of motion picture or "still" photography—short newsreels, great feature pictures, advertising photographs or portraiture. Our Simplified Plan trains you for a high-salaried position—makes you competent to take every kind of "still" or motion picture.



## SEND FOR BIG FREE BOOK

Write today for your copy of our FREE book, which gives full particulars about the ever-growing field of photography—tells how you can qualify through our Simplified Plan as motion picture photographer or projectionist, "still" photographer or photo-finisher, or to open a business of your own.



N. Y. Institute of Photography,  
Dept. AD-1412, 10 West 33rd St.,  
New York, N. Y.

Without cost or obligation send me a copy of your FREE Book and details about:

( ) Motion Picture Photography ( ) Projection  
( ) "Still" Photography ( ) Photo-finisher

Name.....

Address.....

City.....State.....

**YOUR SUCCESS COUPON**

## Mysterious Power of Pelmanism

Let us send you a free copy of "Scientific Mind Training." An instructive book which explains an amazing system of mind training already used by more than 750,000 people. It will show you how and why Pelmanism is the only system of teaching for developing all the mental powers at the same time. Endorsed by such distinguished men as Judge Ben B. Lindsey, Sir Harry Lauder, Jerome K. Jerome, Prince Charles of Sweden and hundreds of others. Write TODAY to

THE PELMAN INSTITUTE OF AMERICA

71 WEST 45th STREET DEPT. 64 NEW YORK CITY



## A Career in Aviation

AVIATION is the great career of the future! Get into it now by practical, proved routes—study International Correspondence Schools Courses in Aviation Engines and Ocean Navigation!

Captain Lewis A. Yancey, hero of the recent New York-Bermuda flight, says: "The I. C. S. books on Navigation are about as fine as have ever been prepared on the subject, and are to be highly recommended to the aviator who is desirous of learning the navigational side of his calling."

The Aviation Engines Course includes necessary study of Mathematics, Mechanical Principles, Combustion and Fuels, Principles of Gas Engines, Construction, Carburetion, Ignition, Lubrication and Cooling, Pumps, Propellers, etc. You can start at once. Study at home in spare time. Mark and mail the coupon today!

INTERNATIONAL CORRESPONDENCE SCHOOLS

"The Universal University"  
Box 5540-G, Scranton, Penna.

Without cost or obligation on my part, tell me how I can qualify for the position or in the subject before which I have marked X:

AVIATION ENGINES  OCEAN NAVIGATION  
 DEAD RECKONING

Name.....

Street Address.....

City.....State.....

## ACCOUNTING

New Revised Home-Study  
Course Now Ready

The uncrowded, highly paid profession of Accountancy offers marvelous opportunities. Send for "The Accountant—Who he is, What he does, How to become one," and first lesson. Both sent free. State age and position.

INTERNATIONAL ACCOUNTANTS SOCIETY, Inc.  
A Division of the  
Alexander Hamilton Institute  
Dept. 198, 3411 South Michigan Ave., Chicago, Ill.



## Let Me Give You Joyous Health —Dynamic Strength

YOU know how the aviator looks over his machine before taking off. You have seen the automobile racers tuning up before the get-away. At railroad stations you have observed the engineer and fireman oiling up the locomotive and examining the bearings. In the power house and in the shops constant inspection and supervision are given dynamos and everything that runs and wears or is likely to get out of order.

### Now how about the human machine—how about YOU?

What attention have you paid to your body? Have you seen to it that every part, every organ, every muscle was kept fit and strong, ready to function, either in performance or in warding off illness and the inroads of disease? Or have you, through ignorance or laziness or sheer neglect, permitted it to become rusty, faulty, weak, rheumatic, catarrhal, tubercular, debilitated, despised—a wreck ready for the junk heap—a reject such as no one respects nor admires?

### Thousands Are Guilty

of this crime against creation—this offense to humanity. They know deep down in their hearts that they have knowingly, willfully contributed to the wrecking of their bodies—and you may be numbered among them, perhaps a pitiful apology for a man.

### STRONGFORTISM WILL WORK WONDERS FOR YOU

Let's get together—you and I—and see what we can save—see if we can't put you on your feet, make a 100 percent man out of you—give you bigger muscles and make you vital and dynamic. Let's look facts right in the face. You tell me your story—then I'll tell you how my Course can and will help you.



**STRONGFORT**  
Builder of Men

### First Get My Free Book

It's a startling revelation of indisputable facts about the human body that will open your eyes to new visions of life and happiness and success. It will show you how to eliminate from your system, in a very short time, the distressing disorders which have made you feel yourself a misfit in the scheme of humanity; how to build up your body, strengthen ALL your vital organs and feel the thrill of New Life coursing through your veins. It will teach you how to become FIT physically and mentally; fit for business, for society, a power among men, a pleasing personality to women.

What I have done for others I can do for YOU. I GUARANTEE IT.

**SEND FOR THE BOOK NOW. IT'S FREE.** Fill out the coupon. Don't delay. **SEND IT TODAY.**

### STRONGFORT INSTITUTE

LIONEL STRONGFORT, Director

Physical and Health  
Specialist for Over  
30 Years

Dept. 115  
NEWARK, N. J.



### FREE CONSULTATION

Mr. Lionel Strongfort, Dept. 115, Newark, N. J.  
Please send me absolutely free my copy of *Promotion and Conservation of Health, Strength and Mental Energy*. I have marked (X) before the subjects in which I am most interested.

.... Colds	.... Flat Chest	.... Short Wind
.... Catarrh	.... Constipation	.... Weak Heart
.... Asthma	.... Indigestion	.... Poor Circulation
.... Hay Fever	.... Nervousness	.... Round Shoulders
.... Headache	.... Rheumatism	.... Lung Troubles
.... Thinness	.... Despondency	.... Muscular Development
.... Rupture	.... Pimples	.... Great Strength
.... Lumbago	.... Insomnia	

Other Ailments.....

Name.....

Age..... Occupation.....

Street.....

City..... State.....

## The Newest RAND McNALLY WORLD ATLAS

(Readers Edition)  
**1930 Census  
Figures**

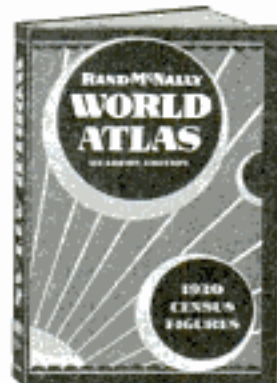

Here's a new, complete, up-to-date reference atlas of the whole world. Just the kind of atlas you need a dozen times every day at home, in the office, or at school to help you understand and appreciate current events, history, business and political developments.

### This Beautiful New Atlas Contains:

160 pages of handsome 4-color maps covering the entire face of the earth, including a map of every state and every foreign country. 72 pages of indexes to U. S. cities and towns, including over 40,000 names alphabetically arranged by states, with 1930 CENSUS POPULATION FIGURES FOR EACH. 19 pages of indexes to foreign cities and towns, with latest official population of each. Includes over 10,000 names. 5-page gazetteer-index of the world containing valuable statistics on all countries of the world. 30 pages of text matter describing inhabitants, physical features, government, climate, history, etc., of every country.

### NEW, CONVENIENT SIZE

This splendid 288-page atlas is a new convenient size—7 1/2" x 10 3/4"—that is easy to use, fits in your bookcase or on your desk. Bound in blue cloth and stamped in gold.

This book sent C. O. D. anywhere in the U. S. A. Simply pay the postman price, \$2.50, and the few cents postage when he delivers same. If outside U. S., send remittance with order.

**POPULAR MECHANICS PRESS**  
Room P 4, 200 E. Ontario St., Chicago



## ENJOY Outdoor Sports

The Year Round  
With the Aid of This  
Great Book

THE new, revised and enlarged edition of *Outdoor Sports the Year Round*, just published by Popular Mechanics Press, contains hundreds of ideas for new and popular sports and pastimes as well as the old favorites. Attractive to Young and Old Alike is the interesting variety for all seasons.

The intensive follower of a few sports will appreciate the wealth of suggestions that render the pursuit of any hobby more enjoyable. For example, for the hunter there are important details on the care and handling of guns; for the swimmer, complete instructions in fancy diving; for the camper, ideas that tend to make camping one hundred per cent comfortable and convenient; for the fisherman, many practical kinks, etc.

### SUMMER SPORT ENTHUSIASTS

will be amazed at the large number of devices that furnish thrills and excitement. Probably the most unique feature of the book is the fact that it contains complete instructions that enable any handy man or boy to make sport devices or equipment at very little cost.

352 Pages (large size, 7 x 10 in.) Price \$2.00  
650 Illustrations, Cloth Binding

Mailed Postpaid upon receipt of price anywhere in the world. Will be sent C. O. D. anywhere in U. S. Simply pay postman price plus postage when he delivers the package.

**POPULAR MECHANICS PRESS**  
(Room P-4) 200 East Ontario St. Chicago, Ill.



## Chicago TECH College

FOUNDED 1904

Degree Courses in Engineering, Electricity and Architecture. Enter any time. Day and Evening Classes. Many students earn expenses while learning. Free employment service for students and graduates. 27th year. Send for 80 page "Blue Book," Mailed Free. Address the President, Charles W. Morey, B. S., M. E.

**CHICAGO TECHNICAL COLLEGE**  
Dept. D-79, Chicago Tech. Building, 118 E. 26th Street, Chicago, Ill.

Prepare now for increasing opportunities in these fields. Save time here. Special short course (4 months) in Drafting, 1, 2 and 3 year diploma and B. S.

**DRAFTING  
Engineering  
Electricity  
Architecture**



### PAINT SHOW CARDS

and SIGNS. LEARN AT HOME IN SPARE TIME. WE TEACH YOU QUICKLY—FASCINATING WORK. \$75 WEEKLY. SEND 6c IN STAMPS FOR CIRCULAR.

Universal School of Lettering NEW HAVEN, CONN.

## NEW AUTOMATIC GAS LIGHTER

"RADIO-BELL" Lights Gas Instantly Like Magic

Make  
Up To  
\$38<sup>40</sup>—A DAY!

This sensational seller is indispensable wherever gas is used. Your prospects are everywhere. Homes, offices, restaurants, etc. Absolutely SAFE, CLEAN AND ECONOMICAL. Attractively designed with beautiful enameled COLORED HANDLES to harmonize with kitchen. Retail for 25c. A gross easily sold in a day nets you \$38.40 clear profit.

Each \$1.50 per sample down with counter display card and full details of our sure-fire selling plans and quantity prices for selling direct or wholesale to subscribers and dealers. You take no risk. Money refunded, if you want it. Sample 25c. Send today and reserve your territory.

**MASTERLITE MFG. CO.** (Dept. GD-14) 110 E. 23rd St., New York, N. Y.

**NO FLINT  
FRICTION  
SPARKS**

"RADIO-BELL" Gas Lighter—a marvel of modern science—creates a sensation with every demonstration. Held over gas lights instantly gas stoves, jets, heaters and griddles. Flame appears as if by magic—no sparks, no friction, no matches.

What Makes?  
the Gas Light?



## 861 PRACTICAL IDEAS for REDUCING FARM LABOR and INCREASING INCOME



One farmer writes: "I would not take \$100 for my copy if I could not secure another."

The Handbook for Farmers contains: 138 ideas for the farm shop, 35 on fencing, 98 on auto, truck and tractor, 61 on farm buildings, 36 on field machines, 48 on concrete work, 22 on orchard work, 23 on painting, 15 on live stock, 34 on poultry, 54 on garden work, 25 on electrical work, 22 on farm tools, 16 on hunting, fishing and trapping, 140 household helps. Pay postman 98 cents plus postage when delivered anywhere in U. S. Elsewhere remit with order and include 15 cents extra for postage.

**POPULAR MECHANICS PRESS**  
Room 104, 200 E. Ontario St., CHICAGO

## Learn to PAINT SIGNS and SHOW CARDS

We quickly teach you by mail, or at school, in spare time. Enormous demand. Big future. Interesting work. Oldest and foremost school. **EARN \$50 TO \$200 WEEKLY**

Otto Wiewand, M.D., home-study graduate, made \$12,000 from his business in one year. John Young, N. Y., gets \$25 for a show card. Crawford, B. C., writes: "Earned \$200 while taking course." Write for complete information.

**DETROIT SCHOOL OF LETTERING**  
144 Stinson Ave. Est. 1890 Detroit, Mich.



## Choose as Your Profession Electrical Engineering

Electricity offers a brilliant future to the young man who is about to choose his career. Never before has there been such wonderful opportunity in this great field. Big paying positions in electrical work the world over are open to trained men—men who possess specialized, practical knowledge. Come to the School of Engineering of Milwaukee—one of the largest and best equipped electrical schools in America. Here you are trained in both theory and practice by a faculty of experts. You learn in large, finely equipped laboratories. If you have 14 high school credits or equivalent, you can become an Electrical Engineer with a Bachelor of Science degree in 3 years. Lacking high school credits can be made up here in a short time.

**B.S. Degree  
In 3 Years**

### A Complete, Practical, Electrical Education

Learn by the thorough, approved, scientific methods which our 27 years of specializing enable us to give you. In addition to Electrical Engineering, the following complete courses are given: **A. C. and D. C. Armature Winding—Wiring and Testing—Practical Electricity—Drafting—Radio Technician—Commercial Radio Engineering and Commercial Electrical Engineering.**

## Earn While You Learn

By our special system you may earn part of your way while learning. Our Employment Department will help you to secure a position to which you may devote a part of each day, spending the remainder at the school. This plan both solves the student's financial problems and provides experience at the same time. Low tuition fee. Board and room reasonable. Daily Broadcasting WISN. School Orchestra. Fraternities.

**New Term  
Begins Now**

### Write for FREE Catalog

Write today for free, illustrated catalog. Read about this wonderful institution and the great opportunities that lie before you. Find out about our specialized method of training and the details of our "Earn While You Learn" plan.



**SCHOOL OF ENGINEERING OF MILWAUKEE,**  
Dept. PM431, 533 E. Wells Street, Milwaukee, Wis.  
Without obligating me in any way, please mail free illustrated book, "Choose as Your Life's Work, Electricity," and particulars regarding the course I have marked with an X.

- ..... Electrical Engineering
- ..... Commercial Electrical Engineering
- ..... Commercial Radio Engineering
- ..... Radio-Technician
- ..... Practical Electricity
- ..... Armature Winding
- ..... Light, Motor Wiring and Testing
- ..... Electrical Refrigeration
- ..... Home Laboratory Service

Name..... Age.....  
Address.....  
City..... State.....



**"When I Told Them  
I Graduated from VON  
HOFFMANN They Gave  
Me the Job"**

So writes Richard McDougal, who is now an instructor in another Aviation School.

Mr. T. H. Worthington, another graduate, writes that he got a job as soon as he graduated. In a letter addressed to us shortly afterward, he said "Just as soon as I stated that I graduated from Von Hoffmann Air College, I noticed they took more interest in me.

Any number of letters come to us worded similarly. They all go to prove that Von Hoffmann graduates are readily accepted.

Located on the famous \$2,000,000 Lambert-St. Louis Municipal Airport

VON HOFFMANN AIR COLLEGE  
140 Lambert-St. Louis Municipal Airport  
St. Louis, Missouri, MAIL TODAY

Name.....  
Address.....  
City..... State.....  
Age..... I am interested in  
{ } FLYING COURSE { } MECHANICS COURSE  
{ } WELDING COURSE { } HOME STUDY



**VON HOFFMANN  
TRAINED MEN  
ARE LEADERS**

## IN AVIATION

They are recognized throughout the industry. So thorough and complete is the training they get—so successful have been the men who preceded you, that air lines, commercial houses, other schools, aircraft and motor plants in all parts of the country give preference to men graduated by Von Hoffmann.

At the Von Hoffmann College, training for every branch of Aviation is thorough and complete. It is one of the few schools in the country with the highest Government rating. That rating is a U. S. Dept. of Commerce approval for Transport, Limited Commercial and Private—Ground & Flying. It was awarded only after the Government made a careful study of our equipment, instructors, and system of training. It is your guarantee of the best training. The training you get here exceeds the requirement of the Government. The perfect flying climate permits instruction every day in the year. So, prepare yourself for a place in aviation by getting the best. Send in the coupon below and get full particulars. No obligation.

United States Department of Commerce approved school for transport, limited commercial, and private—ground and flying.

**VON HOFFMANN AIR COLLEGE**  
140 Lambert-St. Louis Municipal Airport, St. Louis, Mo.

**Make Big Money  
Learn Autos**

**AT HOME!**

IF YOU'RE earning a cent less than \$60 a week, send for my Free Auto Book. See how you can get complete instruction at home, covering every branch of Auto work. Learn how you can prepare for the big opportunities—jobs paying up to \$5,000 a year. Clip coupon for full particulars.

**Earn up to \$100 a Week**

Whether you're an experienced Auto man or not—if you've had just common schooling, find out about this new, easy, practical "Job-Way" Training. Learn how my Employment Department helps you get the good jobs—Get all the details of my offer of a complete course in Aviation Free of Extra charge, and my 3 Outfits offer. Send coupon now!

Complete  
**AVIATION  
COURSE**  
FREE of Extra  
Charge  
Also 3 Testing and  
Repair Outfits

**Auto Book  
Free!**

**MAIL THIS FOR FREE BOOK**

B. W. COOKE,  
Directing Engineer  
MOTOR INSTITUTE of America  
Motor Institute Bldg., Dept. 4164  
Evanston, Ill.

Send at once your FREE Book, "Auto Facts." Also full particulars of "Job-Way" Training, and of your Aviation Course and Working Outfits Offer. No obligation on my part.

Name.....  
Address.....  
Age..... Occupation.....



**DO YOU LIKE TO DRAW?**

It's Easy To Learn When Shown In The Right Way

Some of the cleverest cartoonists and comic artists in America today learned how to draw quickly—by following CARTOONIST EVANS' SIMPLE AND EASY METHOD.

This school has over twenty years of successful teaching to its credit. If you like to draw, send a sample of your work with 6c in stamps for full details. The course is NOT EXPENSIVE.

The W. L. Evans School of Cartooning  
1021 Leader Building CLEVELAND, OHIO

**LAW HIGH-GRADE INSTRUCTION  
BY CORRESPONDENCE**

College, Post Grad, and Bar Ex. Rev. Courses. Law has attracted more keen, brainy men than any other calling. Send today for catalog. Low cost, easy terms. Standard texts. Degrees.

Chicago School of Law Dept. 801, Reader Block  
CHICAGO, ILL.

**RUBY GIVEN**

To introduce our Imported Mexican Blue-Flash Gem, the only low-priced gem exactly matching genuine diamonds with same blue-white brilliancy and rainbow fire, guaranteed for life, we'll send this beautiful, flashing, fiery, red Mexican Ruby. Just clip out this ad, mail with your name, address, and 10c to partly cover handling cost and we'll mail with catalog of gems and special half price offer. Write today.

MEXICAN GEM IMPORTING CO., Dept. 30-P, MONTEREY, CALIF.

**MAGIC  
BOOK  
SENT FREE!**

**AMAZE AND MYSTIFY YOUR FRIENDS!**

**BE POPULAR—LEARN TO ENTERTAIN!**  
My famous "Book of 1000 Wonders" now sent Free. Hundreds of Tricks require no skill. You can do them. This book describes effects for Pocket-Parlor-or Stage, all easily learned. Also Puzzles, Jokes and Imported Novelties. Large assortment; lowest prices. You will amaze and mystify your friends. Write today! LYLE DOUGLAS, Station A-11, Dallas, Texas.



# Boys a Bicycle for You

You can earn it easily in YOUR spare time

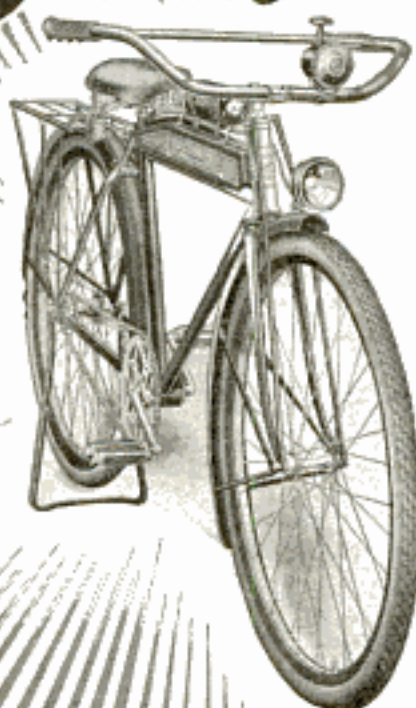

OUR deluxe model—the finest bike you ever saw. Made by Mead Cycle Company, fully equipped. Has tool tank, headlight, platform carrier, coaster brake, rear wheel stand, and horn. Enameled in beautiful colors. Built for speed, easy running, and long wear! And just think! This bike can be YOURS—without a cent of cost!

Join the Crowell Club and deliver three of America's best known magazines to regular customers in your neighborhood. No experience is necessary; we show you how to start. Win dozens of dandy prizes and earn your own spending money. Don't delay another minute. Send your name on the coupon NOW!

Mail this

Mr. Jim Thayer, Dept. 195,  
The Crowell Publishing Company,  
Springfield, Ohio.

Dear Mr. Jim:  
I want one of your bicycles. Start me off as a salesman and send me full instructions.

My Name.....

Address.....

Town.....State.....

## LAW Free Book

Write today for FREE 64-page book, "THE LAW-TRAINED MAN", which shows how to learn law in spare time through the Blackstone home-study course prepared by 20 prominent legal authorities, including law school deans, and U. S. Supreme Court justices. Combination text and case method of instruction used. All material necessary furnished with the course, including elaborate 25-volume law library, delivered immediately upon enrollment. Many successful attorneys among our graduates. LL. B. degree conferred. Moderate tuition, low monthly terms. Money-Back Agreement.

Write for free book today.

**BLACKSTONE INSTITUTE,** 207 N. Michigan Ave., Dept. 14 Chicago



## Government Positions

Clerk Carriers, Rural Carriers, Railway Mail Clerks, Postmasters, Department Clerks, and many others. Splendid salaries, easy work, vacation with pay. Only common school education required. Examinations often. 44,817 appointed last year. Send for our Civil Service Catalog No. 6. **COLUMBIAN CORRESPONDENCE COLLEGE,** Washington, D. C.

## FREE THE Gibson BOOK



Shows you the way to popularity, pleasure, bigger income with an easy playing Gibson banjo, guitar, mandolin or ukulele. If no teacher in your town ask about Reser's Correspondence Course.

**FREE TRIAL; EASY PAYMENTS** on any Gibson. Send for your book now.

Harry Reser, Chief of the Cigar Club Eskimo, banjo soloist and teacher.

*Gibson Inc.*

203 PARSONS STREET, KALAMAZOO, MICH.

## MONEY In Your Neighborhood

Here's a Wonderful Way to Get It

Our beautifully illustrated book tells how. It tells all about our new methods of art decoration, art treatment and how anybody can learn without previous training or experience. It contains page after page of handsome color illustrations of what you can make and sell. You can make good money and this book is

Our system is amazingly easy to learn and the profits are larger than in almost any other business. You can produce beautiful, finished art objects almost from the beginning. You don't have to know how to draw or have any experience. Begin making money now. All supplies are sent by us with the **FREE** instructions and many have made \$25 the first week. Some men have taken up this work as a hobby. Either way, pleasure or profit, it's the most delightful home work you can imagine. Write Now for your copy of this valuable book; it's FREE.

Dept. 66-D,

**Fireside Industries** Adrian, Mich.





# A WONDERFUL OPPORTUNITY

The great Radio industry, because of its amazingly rapid growth, is today badly in need of hundreds of "trained" men to fill its more responsible jobs in Radio, Talking Pictures, and Television work.

To qualify for these jobs men must know Radio as they know their A B Cs. They must know the theory as well as the practice, and be able to teach other men some of the things they know.

To such men the great Radio industry offers a wonderful opportunity for steady work at exceptionally good pay, now, and early advancement to still better jobs as a future. It is, in fact, the chance of a life-time for ambitious men.

But first these men must be trained, for no ordinary knowledge of Radio will do.

The Radio Industry, itself, has no time to train these men. It is growing so fast, and changing so fast, that its manufacturers and jobbers have all they can do to keep up with the trend of the times, by improving their methods of manufacture and distribution.

So the training of men for these jobs has become the task of the Radio and Television Institute, of Chicago.

As few men can afford to quit their work and get this Training at some University or Technical School, the Radio and Television Institute has been organized to train such men at home—no matter where they live—

IN THE  
**WORLD'S  
FASTEST  
GROWING  
BUSINESS**



in their spare time, and at a very nominal cost, for these better paying jobs in Radio, Talking Pictures and Television.

The Institute's Course of home-training was planned, written, and is actually supervised by an Advisory Board made up of prominent and highly paid engineers and executives, each of whom is actively connected with some big Radio concern.

This means that your training will be right, because these men, working with big Radio concerns, know exactly what the industry needs in the way of "trained" men, and exactly how you should be trained to meet that need. And this Advisory Board will have complete supervision over your training from the day that you become a student of this Institution.

For this reason, prominent Radio men, everywhere—and our country's largest and most important Radio Trades Associations—are unqualifiedly endorsing this home training, and recommending it to men whom they want to see make good in Radio work.

So if you are ambitious—if you are making a cent less than \$75 a week—investigate.

Find out for yourself all about this amazingly easy Course of home-training, and also all about the wonderful opportunities for "trained" men in this, the world's fastest growing industry. Everything is fully explained in the Radio and Television Institute's "Opportunity" book. Send today for your copy. It's free.

RADIO AND TELEVISION INSTITUTE, Dept. 14

2130 Lawrence Ave., Chicago

Without obligation of any kind please send me a copy of the Radio Opportunity Book. I am interested in your home-training and the opportunities, you say exist in the great field of Radio, for "trained" men.

NAME \_\_\_\_\_

ADDRESS \_\_\_\_\_



# Classified Advertisements

## WORLD'S BEST WANT AD MEDIUM

Advertisements in this section, 35 cents per word, each insertion, minimum 10 words, payable in advance  
To be inserted under proper classification in May issue, copy should be in our office March 18th

### ADVERTISING AGENCIES

**ADVERTISE**—24 Leading Sunday newspapers, 24 words \$15.00. Excellent for obtaining help, salesmen, or business opportunities. Information 1,000 best paying dailies, mail-order weeklies, monthlies, mailing lists, everything, 10c. Wade Agency, Great Northern Bldg., Chicago.

**GET** into advertising. Learn quickly at home. Experience unnecessary. New easy plan. No text books used. Practical work. Old established school. Send name and address for interesting free booklet. Page-Davis School of Advertising, Dept. 3131, 2601 Michigan, Chicago.

**FREE** Service—Classified advertisements placed. Publishers pay us. You pay space rate only. Save stamps, stationery, salaries. We know best mediums. Campbell-Mahaffey, 4 W. Erie, Corning, N. Y.

**FREE**—New 1931 Advertisers Rate Guide, 44 pages. Includes everything. Lowest rates. E. H. Brown Advertising Agency, 140 S. Dearborn, Chicago.

**TIME** Counts in applying for patents. See pages 138 and 139. Clarence A. O'Brien, Registered Patent Attorney, Washington, D. C.

**ADVERTISE**—Newspapers, magazines. Lists free. Martin, 276B West 43rd, New York.

**ADVERTISE**. Inch display 50 magazines, three issues \$6.00. Lists free. Pennell Standard, Corington, Kentucky.

**BEFORE** Advertising get our catalog. No charge. 25 years in business. The largest classified agency in the world. Ankrum Advertising Agency, 100 No. LaSalle St., Chicago, Ill.

**INCH** Display advertisement 50 magazines year \$24. Wood's Popular Service, Atlantic City, N. J.

**ADVERTISE** In rural weeklies. Lists free. Meyer Agency, 4112 Hartford, St. Louis, Mo.

### FOR ADVERTISERS

**ADVERTISING**: 20 Words, 50 magazines 60c; three insertions, \$1.20. Inch display, 3 months \$6.00; year \$21.00. Mailing Bureau, Laundale, Calif.

**TRIAL** Thirty words 13 "Mail-salesman" three times, 25c. Arcus, Culver City, Calif.

**ADVERTISE** 53 Magazines, old and reliable Syndicate; 3c word; \$3.00 inch. List free. Evans King Co., Box 672P, Wilmington, Delaware.

**ADVERTISE** in 250 country town newspapers 28 words, \$10. Lists free. All states. Keator, Hartford Bldg., Chicago.

**LAYOUTS** For advertising is a useful handbook of 700 layout suggestions used in magazines, newspapers, booklets, folders, brochures, letterheads and posters. Will save immense amount of time of any advertising man. Delivered to your door U. S. D. Simply pay postman \$3 and postage. Popular Mechanics Press, Room 802, 200 E. Ontario St., Chicago.

### SALES PROMOTION

**ADVERTISING** Will sell anything! Write, Manning, Times Building, Watertown, N. Y.

### INFORMATION SERVICE COUNSEL

**CONFIDENTIAL** Information any subject. Mail \$1 bill. Satisfaction guaranteed. E. K. Linton, Saginaw, Michigan.

**BECOME** A commercial counselor. Qualification experience. Box 276, Jamestown, N. Y.

**USE** Shortcuts in Figures. Save valuable time. The simplest ways of working all problems. Instructions for drilling yourself to be come rapid with figures. Complete, yet simplicity itself. Just write a postal for "Shortcuts in Figures." Pay postman \$1.25 and postage. Popular Mechanics Press, Room 802, 200 E. Ontario St., Chicago, Ill.

### AUTOMOBILES

**TIME** Counts in applying for patents. See pages 138 and 139. Clarence A. O'Brien, Registered Patent Attorney, Washington, D. C.

### AUTO SUPPLIES

**ELECTRIC** Arc soldering. New, starting. Principle electric welding. Representatives. \$12.00 day case. Sample \$2.00. Herbert Mfg. Co., Glendale, Calif.

**BARGAINS**—Excellent reprocessed compressors, battery chargers, test benches, car washers. Terms. Trial. Write Ken's Automobile Service, Box 3411, Troy, O.

**AGENTS**, Starter and choke controls for model A Ford. \$2.50 seller. Send \$1.25 for sample. H. & H. Mfg. Co., Fairfield, Iowa.

**RECHARGE** Neighborhood batteries; very profitable; outfit \$7.50. Adams-Barr, Columbus, Ohio.

**CARBURETOR** Information every auto service man needs will be found in special carburetor supplement to the famous Drake Auto Encyclopedia. Deals with every make of carburetor. 103 pages. 240 illustrations. Price \$2. Sent C. O. D. if you prefer. Popular Mechanics Press, Room 802, 200 E. Ontario St., Chicago, Ill.

**CHROMIUM** Plating powder plates iron, steel, brass, copper and nickel, without electricity or machinery. Guaranteed not to tarnish; ½ pint can \$1.50 prepaid. Gunmetal Co., Ave. J, Decatur, Ill.

**RADIATORS**: All standard makes at wholesale. Guaranteed. Send for prices. State make, model. Independent Radiator Co., 1119 So. Wabash, Chicago.

**NEW** Auto parts 25-50%. Motors, rearends, radiators, wheels, generators, carburetors, brakelining 50%. Used parts 40-80% off. Brightman, 2065 Main St., Hartford, Conn.

### AUTO SERVICE EQUIPMENT

**SUBSTANTIAL** Savings—reprocessed compressors, battery chargers, test benches, car washers. Terms. Trial. Write Ken's Automobile Service, Box 3411, Troy, Ohio.

**WOOD** Turning on the lathe. Both interesting and fascinating. Send for a copy of Milton & Wolters Course in wood turning. It gives you quickly a complete mastery of this manual art. 340 pages, cloth, 141 plates. Sent C. O. D. Pay postman price \$1.50 and small amount postage upon delivery. Popular Mechanics Press, Room 802, 200 E. Ontario St., Chicago, Ill.

**FIFTEEN** Capacity battery charger. Direct from factory; guaranteed; 110 volt; money maker for owner \$27.34. Adams Barr Corporation, Columbus, Ohio.

### MOTORCYCLES, BICYCLES AND SUPPLIES

**REBUILT** Motorcycles \$25 to \$100 easy. Tires, used tires \$2.50. New Firestone \$7. Engines for motorcycle, ice sleds, airplanes, boats \$15 to \$75. New automobile tires \$2. Forks \$3, frames \$3, cylinder \$3, valves \$3, chains \$1.50, handle bars \$3, belts \$3, wheels \$3, side cars \$25. Bicycles \$9.50, airplane wheel \$1.00 was formerly \$2.00. Save you dollar prices. Oldest house in U. S. Send 25c for catalogue. Price Cutter Denlinger, Rochester, N. Y.

**1927-8 HENDERSONS**—Fully equipped and in good running condition, \$100 each—money back if not satisfied—hundreds of other bargains in Henderson motorcycles, parts and accessories—largest stock, lowest prices. Send for list. Wiedeman, 3517 North Avenue, Chicago.

**JUST** Out! Get that new 1931 catalog. Guaranteed rebuilt Harley-Davidsons. Send 4c in stamps. \$88.00 and up. 14 models. Service and satisfaction guaranteed. The Knuth Co., 2525 Fond du Lac Avenue, Milwaukee, Wis.

**WE** Specialize in tuning motorcycles for speed and power. Genuine Harley-Davidson parts, accessories and repairs. Send 25c in stamps for our parts, accessories and flat rate repair catalog. 24 hour service on all orders. The Knuth Co., 2525 Fond du Lac Ave., Milwaukee, Wisconsin.

**REBUILT** Motorcycles for sale cheap. Used parts and motorcycles greatly reduced. Send stamps for catalog. Western Motorcycle Company, 914 E. 15th Street, Kansas City, Mo.

**REPAIR** With good used parts, save 15 or more. State parts needed, no lists. J. B. Dahl, 2601 Archer Ave., Chicago, Ill.

**HENDERSON**, Excelsior, Harley, Indian used parts, engines, accessories. Cheap. Catalogue and stamps emblem pin 10c. Bialak, 100 N. 12th, St. Louis, Mo.

**TINY** Motors also Evans light motorcycles and parts. See "October Pop." page 500. Sold by Whipple, The Motorcycle Man, 1227 West Jackson Blvd., Chicago.

**MOTORCYCLE** Bargains, lowest prices, bargain sheets for stamps, special valiant supplies, motorcycle accessories largest line in America, lowest prices. Largest motorcycle mail order house in the United States, Rochester Harley Davidson Corporation, 129 West Main St., Rochester, N. Y.

**SEND** 15c For illustrated used motorcycle catalog. Large stock. Bargains. Indian parts, accessories. Indian Motorcycle Sales, Kansas City, Mo.

### AVIATION

**HEATH** Sea Plane Parashut—lands on every small river and lake. Leaves water in 8 seconds. Climbs 400 feet per minute. Sturdy pontoons withstand roughest landings. Pilot can stand on either float without depressing ship more than few inches. Start building now for only \$12. Material complete only \$228. Or build pontoons alone for your land parashut. Material \$69. Complete ready built \$265. Can be interchanged with wheels in jiffy. 10 cents in stamps or coin brings large illustrated booklet. Heath Aircraft Corporation, Dept. 30P, 1721-9 Seligwick Street, Chicago.

**AIRPLANE** Photographs—Write for new complete catalog listing authorized airplane photographs. Get 5x7 photos of your favorite planes at only \$7.00 for ten. Photo of Captain Frank Hawks in his Mystery Ship sent free with catalog. Enclose 10c for postage and mailing. Universal Airphoto Service, P. O. Box 1131, Dept. M-4, Chicago, Ill.

**BUILD** New Aeroford—only Glider easily converted into sporty two-place power plane by our patent conversion. \$79.00 buys Makit Kit containing all glider materials. \$10.00 starts you building. Send \$2.50 today for set biggest blueprints. Aeroford Aircraft Corp., 36 South State St., Chicago.

**BUILD** This air monster! Giant 7 foot wing spread. Only model with Automatic Pilot—rights itself in full flight. Parachute drop! "Rises 500 feet—flies for miles." Details, specifications and print for only 10c. Elton-McCarville, 606 Seventh Ave., New York, Dept. PM-4.

**METAL** Tipped propellers for Henderson and V motors \$9.05 each. Ford and Chevrolet propellers \$12.50 each. Hibbs, Ft. Worth, Texas.

**BUYERS** Directory 50c. Listing where to buy thousands bargains used airplanes, motors, jumping balloons, power gliders, equipment. Midwest Company, 603-5 Security Mutual, Lincoln, Neb.

**STRIKING** Photographs. Modern aircrafts in flight. Original prints 5x7. Six for \$1.00. Start collection of all action photographs. 10c postage will bring catalog. Court Photo Hemstead, N. Y.

**CIRCULARS** And two actual photographs showing how to convert Ford motor into world's cheapest airplane motor. Price 25c. Helne Motor Works, Orwelsburg, Pa.



**NEW Heath B 4 Motor**—the perfected aircraft engine for your light plane. Free from all bearing and vibration difficulties. Delivers 30 H.P. Vastly superior to ordinary light plane engines, yet costs only \$300 fully equipped, including propeller hub. Also re-manufactured Heath Henderson motors like new as low as \$190. Fully guaranteed. 10 cents in stamps for illustrated catalog. Heath Aircraft Corporation, Dept. 32P, 1721-9 Sedgwick Street, Chicago.

**TURNBUCKLES 10c**. Bargain price list, sportplane, glider supplies two stamps. Russell Aircraft, Box 475, Toledo, Ohio.

**165 H.P. 9 Cylinder Gnome Rotary Airplane motor** \$65 each f.o.b. New York. Not used. Apply to D. B. Berrigan, 40 Bester Street, New York.

**FLYING** Information for beginners only 25c. T. Weysham, 2470 No. Rampart St., New Orleans, La.

**THE American School of Aviation** announces a new correspondence course in Mechanics of Aviation. A thorough training in Practical Aeronautics. American School of Aviation, Dept. 1873, 3601 Michigan Ave., Chicago, Ill.

**TWO Seater sport biplane**, 80-100 horsepower, less motor, \$250. Also Hirth biplane, with OX5, \$400. Hirth monoplane wing for OX5 job, \$250. Allison Airplane Co., Lawrence, Kansas.

**HEATH Parasol**—\$12 starts you building America's most popular sport plane. Designed for beginners to fly. Easy to build, easy to fly, economical to own. Material complete only \$199. May be shipped in 11 convenient progressive groups. Aeronautically clear detailed plans and instruction sheets. 10 cents in stamps or coin brings large illustrated booklet. Heath Aircraft Corporation, Dept. 31 P, 1721-9 Sedgwick Street, Chicago.

**BUILD Your flying flyer**. Blue prints \$5. Circulars 10c. Storms Aviation, Spar-tanburg, S. C.

**TIME** Counts in applying for patents. See pages 138 and 139. Clarence A. O'Brien, Registered Patent Attorney, Washington, D. C.

**HELION Motors**: 35 hp. and 60 hp. radials, air cooled. Real, modern aviation motors, not made-over motorcycle or auto engines. Catalog, data etc. 10c. Aviation Service, 923 Broadway, New York.

**ANZANI 120 H. P. Radial motors**, new, unused. Scintilla magnetos, gear oil pumps, fully guaranteed, complete with ring exhaust, ready to run \$400.00 each. Special prices in quantities. Spare parts lowest prices. Hunt Aircraft Mfg. Co., Inc., Fisherville, R. I.

**BIGGEST**. Best catalog model airplanes, parts, supplies; 5c postpaid. Ideal Company, 19 West 18th Street, New York.

**SEND Dime** for latest aviation catalog. Karl Ott, York, Penna.

**AIRCOOLED Engines**—80 and 120 horse—40 to 60 dollars. Propellers—Bargains. Smith, Box 1243, Houston, Texas.

**"AERODRIVE"** Sleds—blueprints, 4 types and 1 boat—set, \$1.00. Single prints, 25c; propellers, 3', \$5.75; 4', \$8.75; 5', \$13.25. Engines: OX5a, \$165. Hall-Scotts, \$135. Hispas, \$195. LeRhones, \$85. Ostergaard Aircraft, Dunning, Chicago.

**SEND 5c** For bundle of baiza, reeds and price list on supplies. Aero Shop, 2050 Hurlock Ave., Detroit, Mich.

#### MODEL AIRPLANES

**SPECIAL 10% Discount**, catalogue nickel. Pioneer Aircraft, Hasbrouck Heights, New Jersey.

**MODEL Airplane supplies**. Cheapest, best, for rubber and compressed air models. Catalog dime. Peru Model Aero Shop, Peru, Ind.

**SPEEDO Glider** 5c model plane \$1.25. New 1500 turn motor \$3.00. Victor Aeroplanes, 2325 Franklin, St. Louis.

#### BOATS, OUTBOARD MOTORS, ETC.

**HUBBELL Marine Coolers** convert Ford engine into marine motors. Booklet free. Ford speedboat easily built. Large blueprint and directions one dollar. C. C. Hubbell, Perry Ave., Norwalk, Conn.

**TWENTY Mile** outboard racer. Complete plans 25c. Free boatbuilding catalog. The Rubber 15 Murray Street, New York.

**PROPELLERS**. Pumps, stuffing boxes, bearings, etc. Wm. H. Baker, Pond St., Quincy, Mass.

**BUILD Your own** outboard runabout, stepper, rowboat. Write, Dept. E. Bradley & Southworth, 9710 Wyoming Ave., Detroit, Mich.

#### CARTOONING

**YOUR** Cartoon drawn. Send clear photo and 2c to cartoonist. 119 Warner Bldg., Bridgeport, Conn.

**REAL** Cartooning Tips—Ideal cartoon instruction course, 50 cents. Cartoon Publishing Co., West Springfield, Mass.

#### BOOKS AND PERIODICALS

**HYPNOTISM** Lessons Illustrated, 267 pages. \$1.00 postpaid. Book Service, Box 1385, St. Louis.

**ALCOHOL** Book—complete information on distillation, denaturing, \$3.50 postpaid. Farmers Supply, 603-P Chestnut, Phila., Pa.

**MONEY** In old books. Valuable information free. Thorsen, 1415 Melrose, Chicago.

**READ** Tobaccoism and banish tobacco, \$1. Swan, 4742 Kewawee, Chicago.

**BOOK Bargains**—New books for old—Dime brings literature. Goldenrod Company, Dept. 402, Harrisburg, Illinois.

**ASTROLOGY** Books—25c to \$8.60; free descriptive list. Bullock, Box 1285, Providence, R. I.

#### PICTURES AND POSTCARDS

**RARE** War pictures originals captured from German Signal Corps. Startling and real as taken from German side. Set of 16. \$3.00. Lt. Colonel Wm. A. Schwab, 31 Sterling Ave., Weehawken, N. J.

**1000 POSTAL** Cards from picture or negative \$12.00. Samples 5c. Tucoulats (Importers), Hillsdale, N. J.

#### NOVELTIES, CURIOS, ETC.

**THIRTEEN** Curious love letters, reading two ways, double meaning, 10c. Helmenmann, 7213 Pingree, Chicago, Illinois.

#### GAMES, ENTERTAINMENTS AND PLAYS

**PLAYS**, Operettas, musical comedies and minstrels, comedy and talking songs, black-face skills, vaudeville acts, monologs, dialogues, recitations, juvenile plays and songs, musical readings, entertainments, make-up goods. Catalog free. T. S. Denison & Co., 423 So. Wabash, Dept. 11, Chicago.

**CAN** You solve it! The great Yeaker puzzle, 15c. L. Wilkinson, 118 Gallup Ave., Mt. Clemens, Mich.

**CHECKER** Game for three, 50c plus two pounds postage. No stamps. Newman Weller, Anchorage, Kentucky.

#### CHALK TALKS

**LAUGH** Producing program, \$1.00. Catalog free. Balda, The Cartoonist, Oshkosh, Wis.

#### MAGIC TRICKS, BOOKS AND JOKER NOVELTIES

**TRICK** Catalogue, 10c; Firestar, 30c. Oaks Magical Co., 548, Oshkosh, Wis.

**FREE!** "The Book of 1000 Wonders". Over 100 pages, profusely illustrated. Tricks for pocket, parlor or stage. Also, puzzles, jokes, imported novelties. South's largest line. Be popular. Amaze and mystify your friends. Write today. Lytle Douglas, Station A-5, Dallas, Texas.

**MAGIC**—Tricks, Books and Supplies. For amateurs as well as the great professionals. Anyone can learn through our instructions. Feature Acts in Mind-Reading, Spiritualism, Rope Ties, etc. Large illustrated professional catalog, 20c. Chicago Magic Co., 140 So. Dearborn St., Dept. B, Chicago, Ill.

**ELECTRIC** Fun! 200 stunts, 110 volts, \$1. Kutting Sons, Campbell, Calif.

**ONLY 10 cents** for Master System of 6 mystifying card tricks, name any card drawn from deck, etc. Includes Magic catalog listing hundreds of tricks. Sent free. Wizard Magic Co., Dept. 15-X, Box 1075, Station C, Los Angeles, Calif.

**MAGIC** Tricks, card tricks, coin tricks, Hindu magic, hypnotism, ventriloquism. Instructive books, 10c each, all six 50c. Geo. Fenner, 2101 Jefferson, Louisville, Ky.

**\$60.00 RUBBER** Bank check joke and catalog 10c. Smiths, M374 Lowe Ave., Chicago.

**SEND Dime** for sixteen page illustrated catalog, Magic, puzzles, jokes. McCalm, Box 125, Allenhurst, New Jersey.

**FREE** Catalogue scientific novelties, magic. Walston Co., West Frankfort, Ill.

**SEVEN** Optimagical delusions. Four Magic catalogs 15c. Gilmagico, Morgan Park, Chicago.

**MAGIC** Catalog 20c. Lynn, 163 Beach, Dept. 3, Jersey City, N. J.

#### RADIO SETS AND SUPPLIES

**NEW** 300-Mile "pocket" radio, \$3.85. Complete with special loud receiver. No tubes or batteries required. Order direct. Spencer Laboratories, 116 Atlas, Aaron, Ohio.

**TIME** Counts in applying for patents. See pages 138 and 139. Clarence A. O'Brien, Registered Patent Attorney, Washington, D. C.

#### STAMP COLLECTING

**FREE!** For many years collectors have looked for an intelligent guide book on stamps. "The Lure of Stamp Collecting," our new illustrated booklet is just that and more. It tells exactly how to derive the greatest benefits from your collection, what stamps are most profitable to collect, how to judge values of stamps and a wealth of interesting facts, information and stamp stories etc. No book, even those selling as high as \$5.00 is more to the point, or offers as many benefits to the collector. We will send it free to approval applicants who send 5c to cover mailing expenses. Globus Stamp Co., 214 Third Ave., New York City.

**MYSTIC "Queer Country" Packet!** Contains scarce stamps from the following strange lands: San Marino, Antioquia, Congo, Cyprus, Fiji Islands, Gwalior Hyderabad, Ireland, Jhind, Kenya, Uganda, Lebanon, Monaco, North Borneo, Nyassa, St. Thomas Prince, Eastern Roumelia, Siam, Sierra Leone, Tanganyika, Trinidad Tobago, Ubangi, Upper Volta, Wallis Futuna, Azores. Get this wonderful packet of "freak countries" and make your friends envious! Price only 10c to approval applicants! Write today. Mystic Stamp Company, (Dept. 8), Camden, N. Y.

**A BIG Bargain**—All for only 50c. Stamp album, providing spaces for 2200 stamps with 700 illustrations, packet of 500 different stamps, 500 hinges, and millimetre measure. Free with each order our pamphlet which tells "How To Make a Stamp Collection Properly," and our 30 page price list of albums, supplies and hundreds of bargains in sets and packets. Queen City Stamp & Coin Company, Room 38, 604 Race Street, Cincinnati, Ohio.

**CANADA** Airmail stamp free if you ask for approvals and send 15c for 25 different airmails or 30 different Canada and Newfoundland; both packets only 25c. We list 329 countries in our dime packets. Lists free. Special bargains, 500 different, 25c; 1,000 different, 75c; 2,000 different \$2.50. Victoria Stamp Co., London, 4, Canada.

**GIANT** Triangle stamp! The largest triangle stamp in the world (Spain 1930 Columbus issue) is included in our packet of 34 scarce varieties from queer, far-off lands—Rodi, Nyassa, New Guinea, North Borneo, etc. No Austria, Germany or other common stamps. Wonderful packet! Only 10c to approval applicants. Vogue Stamp Co., Dept. P, Port Chester, New York.

**PACKET** Each triangle, Fiume, Sierra Leone, Congo, etc. Everything 10c to approval applicants. Dolin, Box 85, Station 8, Brooklyn, N. Y.

**ANGOLA** No. 1 Scarce; catalog value 60c, only 10c to approval applicants. Marvel Stamp Company, 509 5th Ave., New York.

**1000 ASSORTED** United States, 25c. Auburn Stamp Co., Syracuse, N. Y.

**JUMBO** Packet of pictorials, wonderful array of colored scenes, etc. Many scarce issues included. Price \$1.00. Satisfaction guaranteed. Approval service for collectors who have passed the beginner's stage. Circulars free. O. K. Richardson, Pinellas Park, Florida.

**INEXPENSIVE** Sets, cheap approvals, M. B. Anderson, 322 Edgewood Avenue, New Haven, Conn.

**100 DIFFERENT** 10c With approvals, Falls Stamp Co., Beaver Falls, Pa.

**200 DIFFERENT** 10c, 25 Japan 10c. 60% discount approvals, Covert Stamp, 39 State, Rochester, N. Y.

**BRITISH** Colonies, 100, 25c; 50, 10c. Approvals reference please. Clark Hollister, 3523 N. Seeler, Chicago.

**1000 MIXED** 25c. 100 Canada or U. S. 12c. Burton, Madison, N. Y.



**PAPUA** (Lakeland boat), Lebanon (air-mail), Zanzibar, Mesopotamia, Georgia, Congo, Morocco, Sudan, etc., in wooden packet 60 different, 5c with approvals and list. Monumental Stamps, Arlington, Baltimore, Md.

**UNITED STATES Dollar Stamp 3c to approvals.** Carl Winter, Middletown, Conn.

**JUMBO Packet** free with year's subscription Kings Hobby Stamp Magazine, 25c. Kings Hobby, Auburndale, Mass.

**AIR Mails**—50 different unused 20c. F. Buffham, Lake Ave., Barine, Wis.

**29 BRAZIL**—Shooting trains, airplanes, blacksmith, winced mercury, harve-ding, only 10c to approval applicants. Mantle Stamp Company, London, Canada.

**PRICE List U. S. and Possessions**, 28 pages, free. J. M. Bartels Co., 116P Nassau St., New York.

**50 DIFFERENT African 20c.** Michael, 542a So. 23rd, Bellwood, Ill.

**SPECIAL**—850 different stamps 25c. Miller, Box 11, Woodward, Okla.

**U. S. WHOLESALE**, free list, and approvals. Hort, Box 397, Lowell, Mass.

**1000 UNUSED Stamps**, cataloging \$22.75 only 50c, 1000 mixed stamps, 24c. Huxley, Johnson St., Lynn, Mass.

**NICE Quality stamps on approvals** 4c up. Free premium, Kelgwin Stamps, Fernandino, Florida.

**APPROVALS** Which fill those empty spaces. Arthur Ludwig, Hinsdale, Illinois.

**UNITED States \$2 present issue** (catalogs 50c) for ten cents to approval buyers. State size of collection. United States price list free. Ledur, Redden, Penna.

**51 DIFFERENT Latin Americans 15 cents.** Reuter, Santa Ana, Calif.

**75 DIFFERENT Stamps** from 75 countries and 25 different United States only 10c to applicants, with reference for bargain foreign approvals. R. D. Davis, 2068 Creston Ave., New York City.

**FREE Packet** to approval applicants. Postage 2c. Meyer, Box 94, Neuman, Georgia.

**THREE Cents** to approval applicants. Deval Stamp Co., Glensville, N. Y.

**500 DIFFERENT Stamps**, 20c; 100, 10c; 1,000, \$1; 2,000, \$3. Fred Oaken, 630 79th St., Brooklyn, N. Y.

**FREE!** Curious set Azerbaijan, big illustrated lists, air mail, commemorative, pictorial. Premiums galore, 2c postage. Penna Stamp Co., Greensburg, Pa.

**FREE 6 Different Luxembourg** to approval applicants. E. D. Stamp Co., 3295 Forest Park Ave., Baltimore, Md.

**200 DIFFERENT Stamps 8c**, sold only to approval applicants. Kenwood Stamp Company, Dept. A., 526 No. Kenwood, Glendale, California.

**SHANGHAI, Grenada, Armenia**, others, 6c to approval applicants. 1000 stamps cataloging \$70.00, \$2.75. Pluck, 7424 Bingham St., Phila., Pa.

**GET Good stamps!** "Artistic" packet, beautiful airmails, war, victory Red Cross, pictorial, animals, commemoratives, 60 others, 10c with choice approvals. Rosedale Stamp Company, Box 1733, Winnipeg, Canada.

**NEW Issues:** Japan, just out 10c; Italy; commemoratives 10c to approval applicants. Electric Co., Macbeury, W. Va.

**LARGEST Stamp** in the world! Rare China Wild Goose special delivery stamp (value 75c) for only 5c to approval applicants. Supply limited. Positively only one to a customer. Western Philatelists, 6021 Harner, M14, Chicago.

**45 SCARCE Airmails**, South America, and Canada stamps 5c to approval applicants. Glendale Stamp Co., 1312P Linden, Glendale, Calif.

**1,000 FOREIGN Stamps 17c**, to approval applicants. Fulson, Columbia, Missouri.

**FREE!** 5 Rare Stamps to approval applicants. Winthrop Smith, 3611 Cedardale Rd., Baltimore, Md.

**BEAUTIFUL** Picture stamps sent free. Paul Cornish Schenertady, N. Y.

**55 LIBERIA** Etc., 2c with approvals. Central Exchange, Cedarburg, Wis.

**WHOLESALE Catalog** for dealers. Illustrated. Postage 5c. Frank Co., 5631 Queensberry, Baltimore, Md.

**STAMPS**, sent on approval at 50% discount. Fred Herzberg, 428 Maple Ave., Elmhurst, Ill.

**COLLECTORS!** For exchanging stamps, illustrated postcards with 2000 collectors. Ask American booklet 102, Registre Echangeables, 51 Passage Bureau, Paris, France.

**PICKED** Lot 600 different including Afghanistan, North Borneo, \$2.00 postage, Triangles, Zanzibar, Hexagon Stamp, Sudan, Liberia, Congo, Creva, Albania, prettiest stamps, etc. Everything for only \$1.00. Longacre Shop, 108 West 42nd, New York.

**FREE**—Set of Ceylon stamps to serious applicants for our penny approvals. Manning, 2270 Wallon Ave., N. Y. City.

**CAYMAN Islands**—Astounding packet from Cayman Islands, thirty other unique, interesting, beautiful distant land stamps (richly colored unusual designs). Hurry! Rush! Get yours now! Free for 5c postage. Empire Stamp, Toronto, Can.

**FREE Stamp collection**—contains Salvador, Turkey, Africa, etc., 2c postage, 10 different triangles 25c, 1000 hinges 5c. Approvals sent. Tatham Stamps, West Springfield, Mass.

**FREE Premium** with approvals. A. Metzger, 1022 Liberty, Cincinnati, Ohio.

**BUILD** Your collection with our 5c and 10c packets. Free list of over 500 packets to select from. Webers Stamp Shoppe, 157 Park Avenue, Plainfield, N. J.

**TOGO:** 8 Varieties 10c to approval applicants. Allison, Anceh, Ind.

**FIFTY U. S. and foreign**, twenty-five cents. Fine approvals, send reference with request. Ray L. Picree, Lineburgh, Valparaiso, Indiana.

**100 DIFFERENT U. S. 3c.** Rowe Stampery, Mammington, West Va.

**SUPER Bargain!** British Smallland, Fiji Islands, Salvador Diamond, naughty Goya Spanish issue are just a few of the many dandies in our Marvel Packet. All for 10c. Stamp Service, Box 1385, St. Louis, Mo.

**UNUSED Stamps** from 20 countries, 5c to approval applicants. Fogg, 317 Alceffe Brook Parkway, West Ferrisville, Mass.

**ITALY Virgil** commemoratives 5c approvals. Co-Operative Stamp Co., 756 Euclid, St. Paul, Minn.

**WORLD'S Finest** triangle (rare Guatemala Quetzal Birds, also scarce dead country triangle and big packet) Eritrea, Vatican, Borneo, Natal, etc., 5c with lists and approvals. Seminole Company, Druid, Baltimore, Md.

**COLLECTION** 1150 Different postage stamps from 70 countries for \$1.00. Lists, etc. free. Beautiful new 1935 international (cloth) stamp album \$1.00 postpaid. New England Stamp Co. (Established 1893) 53-A Braintree, Boston, Mass.

**FREE 100 Different**, postage 2c, with approvals. Noemus Stamp Co., 512 East 23rd St., New York.

**UNITED States, \$2 Wines**, Catalog, 40c only 12c; 50 different U. S. 10c; 100 U. S. 3c; 50 Canada obsolete 12c. Robert Haynes, Point Place, Toledo, Ohio.

**UNITED States Dealer** stock best demand starter outfit, one dollar. Information free. Champion Products, Sandusky, Ohio.

**FREE—Ten Turkey** (beautiful) big interesting stamp mail, unbeatable penny approvals, 2c postage. Midwood Stamps, Box 6 P, Midwood Station, Brooklyn, N. Y.

**FREE—100 Different** to approval applicants, postage 2c. Norman Floyd, Norman, Oklahoma.

**ILLUSTRATED United States list**, price 50 cents; large, complete United States price list, 1931 free. Stanley Gibbs, 38P Park Row, New York City.

**100 DIFFERENT Stamps** from 100 different countries, 25 different airmails perforation gauge, all for 25c to approval applicants. Ancher Stamp Co., Rutherford, New Jersey.

**FREE—Packet 52 different** from Alaouites, Lebanon, Quillman, etc.; also watermark detector and rare old Hawaiian stamp—all free to approval applicants enclosing 4c postage. Highland Stamp Co., Newton Highlands, Mass.

**PENNY Approvals**, 5,000 Sudan, Congo, Nyassa, Liberia, etc. Also 14,000 averaging 1 1/2c. Philatelic Exchange, Huntington, W. Va.

**TRIANGLES**—Eight different triangle stamps including Guatemala (world's smallest), Latvia (air mail), Liberia, Nyassa, only 10c to approval applicants. Paul Revere Stamp Co., Box 49, Aster Station, Boston.

**GENUINE** Baden, Cilecia, Kenya Uganda, French Guinea, cataloging 25c. Orange River Colony, Algeria, Shilling Revenue, Syria, Nyassaland, etc. In our extraordinary packet 60 different stamps. Only 5c, with excellent approvals. Viking Stamp Co., Sheepshead Bay Station, Brooklyn, N. Y.

**FREE!** Loose leaf postage stamp album at rate of 8 pages each month given with subscription to monthly journal. Send 2c stamp for prospectus. United Stamp Co., Marquette Bldg., Chicago, Ill.

**NEWFOUNDLAND** Set of 5 Caribou 10c. Better grade approvals to applicants. DeLisle, 762 Harding, San Jose, Calif.

**STAMPS**—100 Varieties, Africa, Brazil, Peru, Cuba, Mexico, etc., 10c; 25 different U. S. 25c; 1,000 mixed, 50c; 1,000 hinges, 6c. C. Stegmann, 3911 Cote Brillante, St. Louis, Mo.

**FREE—French Colonial** packet (including Cameroun, Monaco, Morocco, Togoland) given approval applicants. Lincoln Stamp, Shelbyville, Illinois.

**1,000 MIXED U. S. 6c and new**, 25c. Weatherly, Lakewood, Ohio.

**301 DIFFERENT 10c** to approval applicants only. Free list of bargain packets. Kansas City Stamp Co., Lee Bldg., Kansas City, Mo.

**APPROVALS** At 1c, land what approvals! Sets at all prices. Interested? You should be! Julius Goldin, 926 Southern Boulevard, New York.

**WHOLESALE Catalog** for dealers; 4c postage. Grossman, 102 W. 42nd, New York.

**21 VARIETIES** Cuban stamps, 10 cents. List of stamps free. Chambers Stamp Co., 111P, Nassau, New York City, N. Y.

**150 GOOD Mixed** foreign stamps, 3c. Stanton, East Lyme, Conn.

**FREE 100 Different** with 50% approvals. Send 2c postage. Eganston Stamp Shop, 2412 Noyes, Evanston, Ill.

**UNITED States stamps** only on approval. Stamp House, 5 Franklin Gardens, Roxbury, Mass.

**40 DIFFERENT United States 12c**, 60% approvals. Seidenberg, Baroda, Mich.

**FREE—\$1.00 U. S. postage** Lincoln memorial free, if you write for our 50 page price-list of U. S. and foreign stamps. 2,000 illustrations and fine stamps on approval. Henson Stamp Co., 620-3 Olive St., St. Louis, Mo.

**BEST One cent** approvals in America. F. Hand, 1117 So. 60th St., Phila., Pa.

**ONLY 5c**, 33 Different stamps including scarce Latvian triangular airmail stamps, 19 airmail, 32 United States yearly issues, commemoratives, etc.) and 10 Canada. Approvals and illustrated price-list sent with each order. Curhan Stamp Company, Gloucester, Mass.

**FREE!** Triangles, airmail, Iceland and 50 others to approval applicants, including 5c postage. Hawkeye Stamp Co., Cedar Rapids, Ia.

**PENNY Approvals** that satisfy. Nell Greenberg, Box 3441, Philadelphia, Pa.

**BIG Parade**—A packet of more than twenty all different better grade stamps showing exciting scenes and records of nations at war. Includes fire-net hurler; the storming of a city; hand-to-hand bayonet struggle; bloody battle scenes; troop transport; red cross stamp; dying soldier; victory stamps; etc. Send for this thrilling "Big Parade" packet at once—limited supply. Only 10c to approval applicants. W. A. Rowell, 58 Cornhill, Boston, Mass.

**96-PAGE Illustrated Stamp Album** and 100 different stamps—25c to approval applicants. Ohio Stamp Co., Box 249, Cleveland, Ohio.

**STAMPS** sent on approval at 70% discount. Reference required. Emory Renoll, Hanover, Pa.

#### RARE COINS

**FREE** United States half cent with every order of \$3.00 or more. Large cent 8c, White cent 3c; Eagle cent 8c; 2c Bronze 7c; 3c Nickel 8c; Half dime 15c; 5c Silver 15c; trade dollars \$1.15; commemorative half dollars unreticulated, Lincoln \$1.15; Maine \$1.20; Pilgrim 93c; Grant \$1.10; Monroe \$1.60; Harriet \$1.40; Lexington \$1.15; Stone Mountain 89c; California \$1.50; Oregon \$1.25; Sequoia \$1.25; Bennington \$1.12; Bargain price list and old coin 10c. Arey, Box 483, Muskogee, Okla.

**CALIFORNIA Gold**—Quarter size, 27c; 3/4 size 53c; 2c piece and catalog, 10c. Norman Shultz, Box 730, Salt Lake, Utah.



**OLD Money wanted**—Will pay \$100.00 for 1894 dime, 8. Mint., \$50.00 for 1913 Liberty head nickel (not Buffalo). Big premiums paid for all rare coins. Send 4c for large coin folder. May mean much profit to you. Numismatic Co., Dept. H., Ft. Worth, Tex.

**ONE Ancient Roman coin** 3 large crisp notes and catalog 10c. Geo. Best, Box 283, Cedar Rapids, Iowa.

**AMERICAN Nickel cent, Confederate state note, Foreign 5 dollar note** and catalog 10c. M. Figg, L. Box 283, Cedar Rapids, Iowa.

**OLD Coins, large fall selling catalog** of coins for sale, free to collectors only. Catalog quoting prices paid for coins, ten cents. William Hesslein, 101A Tremont St., Boston, Mass.

**COLOMBIA 2½c Nickel, France 10c nickel, 5 different foreign notes** and catalogs 20c. Lester White, Box 41, West Newton, Mass.

**BARGAINS; 20 Large cents \$1.00; 20, 2c pieces \$1.00; 95 foreign coins \$1.00;** postage extra; Barzandalers, 929 Main, Springfield, Massachusetts.

**WORLD'S Best buys, United States large cents 1798 to 1814, 25c each; 1816 to 1829, 15c; 1830 to 1839, 10c; 1810 to 1850, 6c;** postage extra under \$3.00 order. Romano-Rushon, Springfield, Massachusetts.

**40 OLD Coins all different \$1.00, 100 different coins \$3.00, 100 mixed foreign coins \$1.00, 200 different Germany War-Bills \$1.00, 500 different Austria War-Bills \$1.00, Claud Denney, Box 1825, Dallas, Texas.**

**20 COINS 25c, 44 Coins 50c, 100 coins \$1.00, Oddehon, Box 681, Kansas City, Mo.**

**COIN Money selling Cohen old coins, Highest cash prices paid, Buying catalogue, 10c, Bob Cohen, Box 483, Muskogee, Okla.**

**CALIFORNIA Gold quarter 27c, Half 52c, confederate \$1.00, or \$3 1856 10c, silver 3c 40c, Wylie, 205, Wheaton, Ill.**

**BY Return mail, Six fine, old, scarce, classified coins, (some silver), no trash, and monthly bulletins, for one dollar, Southampton Coin Exchange, 5427 Nottingham, St. Louis.**

**18 DIFFERENT Coins 25c, 28 different 50c, 40 different \$1.00, Blshoff, Box 7441, North Kansas City, Mo.**

**5 TO \$500 Each paid for old coins, Many very valuable, Keep all old money, Get posted, Send 10 cents for illustrated coin value book, 40c, Guaranteed prices, We buy and sell, Coin Exchange, Box 5, Le Roy, N. Y.**

**BARGAINS in coins, 25 different 60c, 100 different \$3.00, Price list free, Troyer Stamp and Coin Co., La Fontaine, Ind.**

**GET Profit and pleasure in collecting old coins, Send 10c for large illustrated coin catalog, You'll be delighted with it, Send for it right now, B. Max Mehl, Numismatist, Mehl Bldg., Dept. P, Fort Worth, Tex., Largest Rare Coin Firm in the U. S.**

**COMMEMORATIVE Half dollars for sale at low prices, Old coin and price list 10c, Towns Davis, Box 1791, Huntington, West Virginia.**

**RARE United States and foreign coins, war medals and decorations, Indian Cent and catalogue 10c, Alexis Mengella, Colorado Springs, Colorado.**

**UNITED States, Large cent, two-cent bronze, three-cent nickel and bargain list, 25c, Thirteen dates large cents, \$1.00, George Coffin, Greenwood Mountain, Me.**

**CIVIL War cents 25c, American coin value booklet 25c, Frank Saco, 735-P 45th Street, Brooklyn, N. Y.**

### CAMERAS AND PHOTO SUPPLIES

**FILMS Developed, Special trial offer, Any size kodak film developed 5c, prints 3c each, Trial 6x10 enlargement in handsome folder 40c, Overnight service, Roanoke Photo Finishing Co., 209 Bell Ave., Roanoke, Va.**

**PHOTO-FINISHING At home, easy and interesting, Complete outfit, Instructions, \$1.50 c.o.d. plug postage, Photocraft Co., 1607½ Warburn, Detroit, Mich.**

**EXPO Watch Camera, Every tick a picture, Complete \$5 outfit postpaid \$7.98, "Fits the Christmas stocking," G. Genert, Inc., 24 E. 13th St., New York, N. Y.**

**TIME Counts in applying for patents, See pages 138 and 139, Clarence A. O'Brien, Registered Patent Attorney, Washington, D. C.**

**FREE—Our 288 page complete catalog listing new Cameras, Kodaks, Lenses and accessories, foreign and domestic, at considerable savings, Everything guaranteed and sold on 10 days trial, Money refunded if you are not satisfied, Central Camera Co., Dept. PM1E, 230 South Wabash Ave., Chicago, Ill.**

**YOUR Favorite kodak picture enlarged, size 5x7, 10c, Three for quarter, coin, Send best negative (film) today, Address Darmer Photo Lab., 221 Securities Bldg., Des Moines, Iowa.**

**HAVE You a camera? Write for free sample of our big magazine, showing how to make better pictures and earn money, American Photography, 116 Camera House, Boston, 17, Mass.**

**MAKE Money in photography, Learn quickly at home, Spare or full time, New plan, Nothing like it, Experience unnecessary, American School of Photography, Dept. 3132, 3601 Michigan Ave., Chicago.**

### MOTION PICTURES AND SOUND EQUIPMENT

**JUST Out! Bass will mail postpaid Cine Amateur, Complete Handbook of motion picture photography for the amateur, \$1.00, Voice of the Films, a complete description of the process used in making sound motion pictures just out, Price postpaid, \$1.00, Motion Pictures With Sound by James Cameron, 400 pages crammed with information on all systems, \$3.00 postpaid, Bass Bargaingram No. 202 listing red hot bargains in standard and 16mm, motion picture cameras, projectors and accessories, 4c stamps, Bass Camera Company, Motion Picture Headquarters, 179 West Madison St., Chicago, Illinois.**

**\$1.250 FOR Original photoplay story, Our sales department sold unknown author's first story for above amount, We revise, copyright and submit to studios stories for both silent and talking pictures, Being located in the heart of motion picture industry we know production requirements, Established 1917, Free booklet, Universal Scenario Company, 206 Meyer Bldg., Western and Sierra Vista, Hollywood, Calif.**

**TALKIE And movie producers are clamoring for new short story ideas, plots, etc, Perhaps you can write one that we can shape and sell for you, One writer (V.M.) received \$3,000, New York best market, Write now for free booklet, without obligation—How To Write For The Talkies! Daniel O'Malley Company, Suite P, 1776 Broadway, New York.**

**FREE—Our 288 page complete catalog listing new motion picture cameras, lenses and accessories foreign and domestic at considerable savings, Everything guaranteed and sold on ten days trial, Money refunded if not satisfied, Central Camera Co., Dept. PM1E, 230 South Wabash Ave., Chicago, Ill.**

**FREE Literature on remarkable new Kenno Amateur Movie Outfit, Uses Eastman film, Cuts the cost of making films one-fourth, Send for your copy and full information, Bass Camera Company, 179 West Madison St., Chicago, Illinois.**

**1000 FOOT Reels 35mm film \$2.00, All brands, cartoons \$5, Complete stories, 1000 foot reels wild animal jungle \$3, 100 feet 16mm comedy \$2, 35mm home projectors \$10, 16mm home projectors \$16.50, No lists, Theatre Equipment Co., Box 624, Cincinnati, Ohio.**

**200 FEET Comedies—Western 80c, Reels \$2, Lowell Films, Allentown, Pa.**

**SCHOLEFIELD Junior's own catalog, 10c stamps, Amazing! Chiraen Film Dealer, 1251 N. W. Eight Ave., Miami, Fla.**

**DRAMAS \$1.25, Westerns \$1.75, cartoons \$3.50, Jersey Film, Box 62, E. Rutherford, N. J.**

**35mm COMPLETE Reel \$2.00, Not junk, Also 16mm, 1st and sound strips from "Sunnyside Up" \$0.10, R. Jones, 209 Sunbury St., Shamokin, Penna.**

**TIME Counts in applying for patents, See pages 138 and 139, Clarence A. O'Brien, Registered Patent Attorney, Washington, D. C.**

**ONE Hundred feet sixteen millimeter film, Pathograms and others at three dollars, No list, Milton Mendelwager, 192 Ave. B, Bayonne, N. J.**

**FILMS—200 feet 50c, Reels \$1.00 postpaid, Order direct, Photo-art, Southampton, Mass.**

**SAVE Money, Movie cameras, \$25; projectors, \$35; Pathex camera, \$20; stereopticon, \$25; printing machine, \$75; 35m negative stock, 2 cents foot; 100 foot Eastman 16m negative, \$1.50; kodak, \$5, Typewriter, \$16, Cameras and films bought and exchanged, Ray, 266 W. 46th, New York.**

**ODD Reels \$1.25 plus postage, Hoffman Film Service, 57 Broad, Albany, N. Y.**

**BIG List film bargains—standard and 16m/m size (specify which) and souvenir strips sound cartoons all for dime, Eastin Feature Films—Galesburg, Illinois.**

**CAMERAS; Projectors; films; equipment, Bought, exchanged, sold, Lists free, Zehrbarh, Box 2089-P, Atlanta.**

**WORLD'S Greatest "Passion Play" 16 MM. (new) 5 reels, Rent or purchase, Write Hemenway Film Co., 37 Church Street, Boston, Mass.**

**EARN Big money, Operate your own movie theatre, Small capital needed, Complete equipment at low prices, Catalog free, Monarch Theatre Supply Co., Box 2042 Memphis, Tenn.**

### TRADE AND TECHNICAL SCHOOLS

**BE A blue print reader, Men in your trade have succeeded, Write for facts, What's your trade? Carroll Rumsay, Drexel Bldg., Philadelphia.**

### TELEGRAPHY

**LEARN Wireless (Radio) and Morse telegraphy, School, oldest and largest; endorsed by telegraph, radio, railway and government officials, Expenses low—can earn part, catalog free, Dodge's Institute, H Street, Valparaiso, Ind.**

### BUSINESS OPPORTUNITIES

**NEW "Endless Chain" selling plan guarantees you amazing profits and many repeat sales with America's greatest printing line, 40%-55% profit on every order, 120-page catalog shows 1001 printing necessities for every business—Also line of personal stationery, pictorial parcel post and shipping stickers, collection sticker system, advertising tags, druggist labels, etc. All statements, letterheads, billheads, envelopes, etc., now furnished in white and 5 beautiful colors—a tremendous selling advantage, Thousands of cuts furnished, Lowest prices, Highest quality work, Main or sideline, Experience unnecessary, This is biggest profit-maker of the year, Write quick for big new 1931 outfit, Kaiser-Blair, Inc., Dept. 291, Cincinnati, Ohio.**

**LEARN Marbleizing, with cement composition, You are taught how to enamel any concrete products, wood, lumber etc, Wall-board so finished can be cut nailed perfectly, For stoves, garden furniture, novelties, All have glossy face finish, flintlike hardness, All colors (see samples), Sanitary floors, nothing better, You are taught practical mold making, A real opportunity, nothing like it before, We are sole owners, Send dime for samples, Cowell Institute, Grayling, Mich.**

**SALESMEN—Get out of the rut—Stop working for small commissions—Let us appoint you a manufacturer's representative and make all the profit yourself, Have other salesmen working for you, Our product sells to auto dealers, garages, service stations, necessary and hardware stores, etc, Extensive territory, Curiosity seekers and once-over men are your stamps, We want only serious-minded reliable men who realize an opportunity when they see it and who will stick and grow with it, To such our proposition will appeal, Tell us something about yourself, Address Dept. P, General Manufacturing Corp., 1371 Boylston St., Boston, Mass.**

**AN Unusual opportunity—Splendid opportunity to get into exceedingly profitable business on easy terms with direct factory cooperation, We want an ambitious man with \$1000 or more to own and run legitimate money making equipment in high grade business places, You handle your own money; all cash trade; no bad accounts; income starts immediately, You become associated with a big successful, progressive manufacturing concern with 41 years of established success and highest financial rating, Call or write immediately for full information, President Room 510, 4100 Fullerton Ave., Chicago.**

**SMALL Capital, large profits, Exceptional opportunity, Bryant, Box 583, Augusta, Ga.**



**ARTIFICIAL Marble**, make it yourself, low priced. Beautiful glazed tiles all colorings. Flooring, base, wainscoting, mantelpieces, inkstands, tabletops, novelties. Extremely hard, or slabs to saw and plane. Shingles painted retards combustion. Multitudinous possibilities. Blue brings astounding assorted samples, and full particulars. John Pagn, 915 Grande Vista Drive, Los Angeles, Calif.

**DON'T** Slave all your life. We will start you in business. Thousands are making their living abroad by doing knitting at home. Others not large flat machines adapted to make all kinds of knitted goods, such as stockings, from an infant's size to the largest lady's or man's, children's knitted suits, sweaters, scarfs, vests, caps, gloves, etc. Write for catalog. **Ainslie Knitting Machine Co., Inc.**, 738-750 Grand Street, Brooklyn, N. Y.

**BUILD A** profitable business of your own. Insure a permanent income. You can succeed in collection profession. We show you exactly how by proven methods. Business referred to you. Capital is useful, but unnecessary. No competition for those scientifically trained. Many net over \$100.00 weekly. May start in spare time. Ask for catalog and details. **American Collection Service**, (established 1907) 464 Howard St., Detroit, Mich.

**UNEMPLOYED** Or employed men and women, conduct a business at home. I will show you how. Be independent. Send me a fifty cent money order to cover cost of particulars and mailing and start right away, for less than a dollar, in this legitimate, good paying business. 600 to 700% profit. **Charles E. Goodness**, 3 Wachusett Street, Worcester, Mass.

**MAKE** Money manufacturing building material. Marble, Granite, Fireproof Paint, Flooring, Roofing. No machinery, cheap; big profits; formulas, latest methods. **Win. Lang**, 477 Washington, Portland, Ore.

**EVERYBODY'S** Astounding offer: 12 guaranteed, tested, business formulas, with marketing instructions, 10 practical opportunity ideas. All 10c coin. **Teyser**, Box 1275P, Chicago.

**START A** profitable business of your own during spare time. Write for free booklet describing 25 money making opportunities. Plans suitable for any size community. **Homecraft Industries**, 213 Ninth Street, Louisville, Kentucky.

**MEN** And women interested in their future should investigate opportunities in California, Nevada, Arizona and other western states—work, investments, homestead lands, hunting, fishing, mores. For flood-hand, dependable information write. **Adelanto**, Box 884, Los Angeles, California.

**START A** sign, cleaning and pressing shop or candy kitchen. Small capital. Instructions \$2.00 each. Details for stamp. **Kauk**, Box 1706, Winston-Salem, N. C.

**TIME** Counts in applying for patents. See pages 128 and 139. **Clarence A. O'Brien**, Registered Patent Attorney, Washington, D. C.

**SEND** Me 3 names of people who want to sell their property and I'll send you, without cost or obligation, my new, 40-page, illustrated book "How to Become a Real Estate Specialist," which shows how you can make big money in your spare time with my amazingly successful system for listing, selling and exchanging real estate no matter where it is. **President**, Suite 516-BB, 205 East 42nd St., New York.

**BIG** Profits by mail with books and printing. **Prusett**, Brookfield, Ill.

**WEAVE** New cane seats in chairs. We show you. **Koch & Henne**, Ann Arbor, Mich.

**SMALL** Capital, large profits. Exceptional opportunity. **Bryant**, Box 583, Augusta, Ga.

**BUY** Quick, fine auto accessories; stock and equipment. **L. B. Welch**, K. C. A. C. Kansas City, Mo.

**CONDUCT** Your own mail order business anywhere. Small capital. Good profits. Free descriptive folder tells how. **Box 629**, Birmingham, Ala.

**\$50.00 STARTS** You in the lawn mower sharpening business. Big profits. **Chas. G. Kruckemeyer** Mach & Pts Co., 1365-77 Oakhill St., St. Louis, Mo.

**START A** profitable business during spare time. Small capital. Unlimited field. Complete plans 25c. **Homecraft Industries**, Louisville, Kentucky.

**MIRRORS** Resilvered at home costs near 5 cents per square foot; you charge 75 cents. Profitable business plating like new brass, worn-off autoparts reflectors, tableware, stoves, etc. Outfits furnished. Details free. **Sprinkle**, Plater, 125, Marlon, Indiana.

**WE** Start you in business, furnishing everything. Men and women, earn \$40 to \$100 weekly operating our original "New System Specialty Candy Factories." Begin home spare time. Unlimited opportunity. Valuable booklet free. **W. Hillier Ragsdale**, Drawer 4, East Orange, N. J.

**ELECTRIC** Lawn mower sharpener blue print and instructions, \$2.00. **Central Tool Works**, 6911 Ave C, Houston, Texas.

**BOOKLET** "How To Make Bird Homes" 25c. Postpaid, **Perley D. Porter**, Medfield, Mass.

**AMATEUR** Cartoonists—Earn \$25.00 week, spare time, copying cartoons for Advertisers. **3-Km Syndicate**, Argyle, Wis.

**INDEPENDENT** Business, easily carried in automobile. Your services in demand. Earnings are large. Buy our latest patented portable electric block re-leveling machine. Call on meat markets, restaurants. Anyone can operate. Complete instructions and outfit \$215.00. Universal and cuts any size or shape road block. **Heath Company**, 230 Lafayette St., New York.

**FURNITURE** Refinishing, painting. Start your shop on nearly nothing; mostly all profit. **John Braveland**, 1439 So. Ninth, Philadelphia, Pa.

**OPPORTUNITIES** Galore! Trial three month subscription to "Mallsalesman" 10c. **Argus**, Culver City, California.

**TELOFLASH** Spark plug. New invention. Reflects firing inside of engine. Saves gas. Increases speed. Agents wanted. **Yale Mfg. Co.**, P-777 Phila., Pa.

**250,000 ARTICLES** Wholesale. Directory 10c. **W-Publishers**, 4111 University, Des Moines, Iowa.

**NEW** Invention—Liquid marble, hard as Pyrexalin, high gloss, waterproof, no baking, no oil—costs 50c gallon. Officially tested. 25c brings samples. **The Brown Laboratories**, Box 376, Curahoga Falls, Ohio.

**\$250 BUYS** a small mail order business. **A. Barkman**, Bath, Maine.

**PAINT** Users attention! Buy finest quality paints, varnishes, caulking and roof cements, etc. direct from our large factory at a 35% saving. Sold under a money back guarantee. Exclusive distributors wanted in all sections. Complete paint catalog mailed free. **Lacting Products Corp.**, 1406 Moreland Ave., Baltimore, Md.

**EARN** \$25 Weekly and upwards growing mushrooms in your cellar or shed. Immense demand. We furnish market facilities. Commence now. Illustrated booklet free. **American Mushroom Co.**, Dept. A, Toronto, Ont.

**THE** \$1,600 Senat never fails. Tells what sells by mail—how, when and where to advertise. Price 27c. **Clayton Dawson**, Box 292, Cochocton, Ohio.

**WANTED**—Representatives in every city to make and sell illuminated signs—artistic ability unnecessary. Patented process. One order cleared 500 dollars. Read testimonials. Sample 50c. Particulars free. **Merrilltype Signs**, So. Berkeley, California.

**START** Your own business. Buying discarded old gold, silver and platinum jewelry. Most secret and profitable in the world. Write **F. Polzer**, Box 81-A, Cicero, Illinois.

**BIG** Bunch mail business opportunities. **Year 15c**. **Pennell Standard**, Corvinton, Kentucky.

**BOOK** Of money-making ideas only one dollar. Details free. **H. T. Williams**, P. O. Box 439, Greensboro, N. C.

**OPPORTUNITY** For persons able to direct. Write **Wonder Co.**, 200 W. Main, Richmond, Va.

**I HELP** You start a mail order book business. Pleasant, easy, profitable. Full or part time. Hardly any money needed. We furnish everything. Free circular. **Buchanan**, Box 2792, Boston, Mass.

**OPPORTUNITIES** Galore! Trial three month subscription to "Mallsalesman" 10c. **Argus**, Culver City, California.

**DO** You want to know where to purchase any particular kind of merchandise? **Mail \$1 bill**. **E. K. Linton**, Saginaw, Michigan.

**THANLY** Formulas produce perfect products. All lines. Catalog free. **B. Thaxly Co.**, Washington, D. C.

**"ODD-THINGS"**—Money making ideas! Plans. Opportunities. Three months 25c. Year \$1.00 with 329 page popular novel free. "Odd Things Magazine," 724 Advance Bldg., Cleveland, Ohio.

**PUBLISH** Your own magazine. We issue a syndicate magazine. Sample and particulars 10c. **Tasam Publishing Company**, P. O. Box 3594, Washington, D. C.

**BIG** Steady profits operating "chain" of peanut, chewing gum, candy vending machines. Start small capital. **Robbins Corp.**, Dodworth Street, Brooklyn, N. Y.

**ROTARY** Golf—patent pending, want state distributors. Write **Frank P. Read**, 116 North 12th St., Mt. Vernon, Illinois.

**LEARN** Sign painting. Tattooing. Illustrated list. "Watters" 965 Putnam, Detroit.

**AMATEUR** Cartoonists: Sell your work. Write **Sault's Service**, PX1191, Wenatchee, Wash.

**SUCCESS** With your own products. Make them yourself. Formulas, processes. Catalog free. **B. Thaxly Co.**, Washington, D. C.

**CHEMICAL** Expert furnishes manufacturing formulas and processes with complete working directions. Reliable individual service only. No lists. Charges reasonable. Correspondence invited. **Dr. Arthur Van-Heerden**, 7631 Bennett, Chicago.

**FIFTY** Successful mail-order propositions. Address, **K. Home**, 2949 Metropolitan, Chicago.

**PAPER** Machines, cigarette outfits. **Northsides Co.**, 1304 Fifth, Des Moines, Iowa.

**A** Business of your own. New book of plans, formulas, etc., \$1.00 postpaid. Circular free. **Joseph H. Belfort**, 4642 N. Keeler Ave., Chicago, Ill.

**SELL** By mail successfully! I show you how. Handsome folder free; stamp appreciated. **Busler**, Box 205-A, Sta. A., Canton, Ohio.

**FREE** Descriptives. Sell by mail. Small article in big demand. **Cassett Supply Co.**, 112 East 23rd St., New York, N. Y.

**CHEMICAL** Expert will furnish formulas and trade secrets. All lines. Lists free. **W. L. Cummings**, Ph. D., 228 Gordon Ave., Syracuse, N. Y.

**ONLY** 10c Brings copy system Way to Mail Order Success. Leads to system and concentration of action. Save time, money and disappointment. **A. B. Werthof**, 1520 Vine St., Philadelphia, Pa.

**CHARTERS**: Delaware; best, cheapest; free forms. **Colonial Charter Co.**, Wilmington, Del.

**LEARN** The collection business. Good income, quick results. Interesting booklet. "Skillful Collecting" free. **National Collectors Assn.**, Long St., Newark, Ohio.

**MAKE** Your own products. Employ agents yourself. Toilet articles, soap, extracts. We furnish everything. Valuable book free. **National Scientific Laboratories**, 1950 W. Broad, Richmond, Va.

**I MADE** \$30 A week home. French breadmaking. 15 years' experience; free booklet tells. **Ashbrook 67**, Marengo, Ohio.

**ARTIFICIAL** Marble sanitary flooring. Instructions covering wood or cement flooring 1/2 inch thick, fireproof, all colors, low cost. Ornamental casting, concrete plaster paper-mache decorations, garden furniture, statuary, flexible molds, particulars and illustrations free. **Chas. Mahler**, Elmont, N. Y.

**BIG** Money at home plating auto parts, reflectors, mirrors, chandeliers; by new method; experience unnecessary. Outfits furnished. **Gunmetal Co.**, Ave. N, Decatur, Ill.

**OPERATE** Chain of vending and amusement machines. Be independent for life. Start small, grow big. **P. Goodbody**, 72 VanBergh, Rochester, N. Y.

**FREE** Booklet describes 67 plans for making \$20-\$100 weekly in home or office business of your own. **Elite Co.**, 84 Elizabeth St., New York.

**FREE** Book. Start your own little business anywhere, selling novelties by mail. My beginner's outfit contains everything required, novelties, circulars, instructions, etc. Descriptive book free. **Hadwell**, 33A-74 Cortlandt St., New York.

**A BUSINESS** Of your own making—Searching Glass Name and Number plates, Checkerboards, signs. Big book and sample free. **E. Palmer**, 540, Wooster, Ohio.



**UNUSUAL**—Uncommon specialties always sell best. Make these yourself from Miller's guaranteed formulas. Why work for others when others can be working for you? Latest eye-opening literature brings you many specialty propositions for you an independent business. Miller Chemist, 706-K Chemical Bldg., Tampa, Fla.

**I MADE \$30 weekly**, renewing upholstery, rugs, etc. Free booklet. Dr. W. Abell, Alhambra, Calif.

**SELL** by mail. Books, novelties, etc. gains! Large profits. Particulars free. B. Lifo, 525 S. Dearborn, Chicago.

### CHEMISTRY

**BECOME** Trained chemist. Thousands of opportunities—fascinating career. Learn at home. Complete experimental laboratory outfit given. Write for big free book. Chemical Institute, 19 Park Place, Dept. P-411, New York.

**"HANDBOOK** For Chemical Experimenters." Hundreds of interesting experiments; illustrated, 50c. Booklet of experiments, 15c. Pricelist, 5c. General Chemical Company, P-237, Reading, Pa.

**YOUR** Chemical problem solved and formula or process furnished for Five dollars. Write me. W. Stebbins Richards, Industrial Chemist, Box 2492, Boston, Mass.

**CATALOG** listing 2,500 Illustrations, chemists' supplies, 5,000 chemical, 1,000 scientific books sent for 50c. Laboratory Materials Company, 613 E. 71st St., Chicago, Ill.

### FORMULAS AND TRADE SECRETS

**FREE** Formulas—Free materials making \$32.00 worth of guaranteed highest class specialty necessities. Thirty-third unequalled anniversary offers explains all. Miller Chemist, 707-61 Jetton, Tampa, Fla.

**ANY** Formula for home or workshop. Mail \$1 bill. E. K. Linton, Saginaw, Michigan.

**FREE** Formula catalog. Latest money makers. Western Chemical, Salem, Oregon.

**MERCURIOCHROME** Stain remover. Formula—directions \$1. W. Zahniser, Freeport, Pa.

**FORMULAS** by experienced chemist make better and more profitable products. Baskett, Joplin, Mo.

**GUARANTEED** formulas, recipes, processes, 50c up. Analysis \$5 up. Catalogue free. Industrial Institute, Dept. 204, 61 West Randolph, Chicago.

**FORMULAS** From experienced chemist make better and more profitable products. Information free. Baskett, Joplin, Mo.

**FORMULAS** All kinds. Catalog free. Clover Laboratories (P), Park Ridge, Ill.

**MAKE** Your own products. Employ agents yourself. Toilet articles, soap, extracts. We furnish everything. Valuable book free. National Scientific Laboratories, 1950W Broad, Richmond, Va.

**NEWEST** Formulas. Tested, guaranteed. Catalog free. Imperial Laboratories, Edwardsville, Ill.

**FORMULAS**, Chemical analysis, catalogue free. Herstein, Chemist, 45 Grand Ave., Grand Rapids, Mich.

**TATTOO** Remover, painless, safe method. \$2. Vestrod, Box 511, Haverford, Pa.

**SUCCEED** With your own products. Make them yourself. Formulas, processes, Catalog free. B. Thaxly Co., Washington, D. C.

**506 FORMULAS** And big illustrated catalogue 25c. Ideal Book Shop, Park Ridge, Ill.

### AGENTS WANTED

**I START** Men in a grocery business a new easy way. You use my money. Don't need to put on a penny of your own cash for stock. Expansion program now opens up many desirable opportunities also established trade. Hustlers make good money from the start increasing rapidly as they learn the business. Not a "chain" proposition but your own business. Buy on credit. Give credit if you wish. If honest and need more money write at once for application and details to McCannan & Company, Room L-6004 Winona, Minn.

**EARN** More pay the Quaker way. Take easy orders, men's fine shirts, ties, underwear, hosiery. Remarkable values. Big commissions. Shirts to producers, ties, cash bonuses. We furnish everything, deliver and collect. Complete outfit free. Write, today. Dept. J-1, Quaker, 1107 Broadway, New York.

**NEW "Endless Chain"** selling plan guarantees you amazing profits and many repeat sales with America's greatest printing line. 40%-55% profit on every order. 126-page catalog shows 1001 printing necessities for every business—Also line of personal stationery, pictorial parcel post and shipping stickers, collection sticker system, advertising tags, druggist labels, etc. All statements, letterheads, billheads, envelopes, etc., now furnished in white and 5 beautiful colors—a tremendous selling advantage. Thousands of cuts furnished. Lowest prices. Highest quality work. Main or sideline. Experience unnecessary. This is biggest profit-maker of the year. Write quick for big new 1931 outfit. Kaiser-Blair, Inc., Dept. 290, Cincinnati, Ohio.

**BRAND** New product. Just out. Mechanical wall cleaner for homes. Banishes housecleaning drudgery. Big season now on. Simple, easy to use. Cleans wallpaper, painted walls, window shades, etc. Like magic. No standing on chairs or dangerous stepladders necessary. Breathtaking demonstration. Whirlwind seller. Low prices. 170% profit. Also 47 other fast selling household specialties. Outfit free. Write quick. Kristee Manufacturing Co., 1434 Bar St., Akron, Ohio.

**MAKE \$1.00** Cash, every \$18.75 order, besides big monthly bonus. Sell Leroy's fine tailored suits and topcoats, including all wool fabrics. Satisfaction guaranteed. Many re-orders and recommendations. Expensive outfit free. Write today telling experience, etc. Dept. M-100, Leroy, 892 Broadway, New York.

**HERE'S** the biggest money-maker in years. Just show samples, collect big cash commissions. Everyone buys Longwear's sensational values, work pants, dress pants, breeches, coveralls. Big selection. Free sales outfit. Write today. Dept. P-1, Longwear Trouser Co., 489 Broome St., New York.

**AMAZING** Electric water heater. Pays big profits. Heats water instantly. Pocket size. Sells fast at \$2.95. Write quick. Bestever Co., 4317P, Irving Park, Chicago.

**AGENTS**—Up to \$12 daily demonstrating men's, women's, children's finest hosiery. Definite wear warranted or replaced. Amazingly low prices, 100 styles, colors. Auto and Hosiery given producers. Write quick! Wilkitt Hosiery Co., C-374 Midway, Greenfield, Ohio.

**AUTOMOBILE** Specialties. Guaranteed formulas latest money makers. Lowest prices. Free lists. Murphy, Chemist, 1024 Douglas St., Los Angeles, Calif.

**AGENTS**—Clever! Intention! Inkspoon makes every pen a fountain pen. Past office seller; big profit, demand increasing everywhere. Exclusive territory offered. Sample free. H. Marul Company, Tribune Bldg., New York, N. Y.

**MAKE** Your own products. Employ agents yourself. Toilet articles, soap, extracts. We furnish everything. Valuable book free. National Scientific Laboratories, 1950W Broad, Richmond, Va.

**EARN** More pay the Quaker way. Take easy orders, men's fine shirts, ties, underwear, hosiery. Remarkable values. Big commissions. Shirts to producers, ties, cash bonuses. We furnish everything, deliver and collect. Complete outfit free. Write, today. Dept. H-3, Quaker, 1107 Broadway, New York.

**BUILD** A permanent repeat order business with Rosecliff's high grade shirts, ties, underwear, hosiery. Guaranteed one full year. Cash commissions, extra cash bonuses, shirts to producers. We pay postage. Prompt service. Free sales outfit. Write Dept. K-4, Rosecliff, 1237 Broadway, N. Y.

**CASH** Paid for butterfiles, insects. See Sinclair Display Advertisement on page 24.

**MAKE \$1.00** Cash, every \$18.75 order, besides big monthly bonus. Sell Leroy's fine tailored suits and topcoats, including all wool fabrics. Satisfaction guaranteed. Many re-orders and recommendations. Expensive outfit free. Write, today telling experience, etc. Dept. M-80, Leroy, 892 Broadway, New York.

**TIME** Counts in applying for patents. See pages 178 and 159. Clarence A. O'Brien, Registered Patent Attorney, Washington, D. C.

**OUR** Offer is different! Biggest line and amazing values. Get my proposition for a real surprise. F. stad, kono, d.

**ASTOUNDING** New shaving invention: Needed by 20 million shavers. Make up to \$100 weekly without selling—place on free trial. Guaranteed profits offer—no risk. L. Rhodes, 1118 Pendleton, Dept. D-4265, St. Louis, Mo.

**THE** Human pencil. Adds mechanically. Nothing its equal for quick sales and profit. Get sample immediately. Add-O-Graph Co., Dept. 25, Safford, Miss.

**SELL** Coin-in-the-slot devices. Transforms any electric radio into nickel-in-the-slot radio in two minutes. Easily demonstrated. Liberal commission. Big field. Radiomatic Corporation, 355 Badger Ave., Newark, N. J.

**ADDRESS** of hundreds of wholesale firms, foreign supply sources, etc. Particulars free. Joseph H. Belfort, 4012 N. Keeler Ave., Chicago, Ill.

**CLEAN** Your auto for about 10c. Dri-Cleanit removes mud, grease, all one operation. No soap or water used. Write for free sample. Agents wanted. American Accessories Co., Desk A-31, Cincinnati, Ohio.

**WANTED** Men. Something different, irresistible, 100% commission. Sells \$17.50. Illustration, details amaze you. Write Eureka Exchange, 3800 East 18th, Oakland, Calif.

**MEN** And Women. Two of the biggest money making propositions ever put on the market. \$150 to \$250 week. Manager, 6137 S. Park Ave., Chicago.

**PLEASANT**, Permanent, profitable business \$1 starts. Particulars free. Ydrak Company, Waukesha, Wisconsin.

**CLEAN** Up the year round, selling miniature Roulette Wheels. A most fascinating game. Everybody wants one. Sells on sight, 100% profit. Send \$1.00 for sample and instructions. Apex Distributing Company, 4865 Milwaukee Ave., Chicago, Ill.

**FREE** Circulars describing how you can make big money in Mail Order business at home. Agraph Publishers, 1217P, Avenue V., Brooklyn, N. Y.

**MAKE** Your own products. Employ agents yourself. Toilet articles, soap, extracts. We furnish everything. Valuable book free. National Scientific Laboratories, 1950W Broad, Richmond, Va.

**100% PROFIT** in new mystery cigar lighter. No flint or friction. What makes it light? No wind can blow it out. Retail \$50c. Sample and sales plan 25c. New Method Manufacturing Co., Box PM-4, Bradford, Pa.

**ELECTRIC** Water heater—New. Heats water instantly. Pocket size—retails \$3.75. Two minute demonstration makes you \$1.95 profit. Lux-Visel, Dept. 47, Elkhart, Ind.

**QUICK** Tylex automobile dry cleaning and polishing cloth, washes and polishes finest automobile and furniture finishes in one simple operation. Exceptional sales and profit. Sample free. Other attractive items. Walter S. Doe & Co., Kent, Ohio.

**AGENTS**, New household necessity so strikingly appealing that sales and profits are positively without limits. Every housewife wants it. All can afford it. Nine out of ten buy it after they once see it. For particulars write Alto Mfg. Co., 1647 Wolfram St., Dept. 12, Chicago, Illinois.

**\$51 WEEK** Clear profit with only nine easy sales daily. Sell this amazing new discovery that re-soles worn shoes for 9c pair. Details and samples free. Write Perfect Mfg. Co., Dept. MC-505, 220 E. Third, Cincinnati, Ohio.

**AGENTS**—Improved lightweight shampoo soap. Retail \$25c, 3 dozen trial order \$1.00. Gross \$3.25 prepaid. Hair-Craft Laboratories, 438-A Center, Chicago.

**THAXLY** Formulas produce perfect products. All lines. Catalog free. B. Thaxly Co., Washington, D. C.

**DISTRIBUTORS**, Salesmen, attention, absolutely new invention, 50c article, organization now forming, exclusive territory. Badger Company, Green Bay, Wisconsin.

**AGENTS**, House to house canvassers can earn big money selling our household necessities. Big demand, free details and circulars. Wax Sales Co., 3312 Brown St., Milwaukee, Wis.

**NEW** Scientific polish shines silver without rubbing. Unlimited demand. Big profit. Investigate. Naphite, 1616 Lauderdale Ave., Cleveland.



**AGENTS**—Mechanics, amazing electrical invention starts car, truck, tractor motors without choke. Saves gas, oil. More speed. Hot shot sparks blue. Ignition O.K.—red if faulty. Sells on sight. Fits all cars. One minute installation without tools. 100% profit at \$1.50. Gold mine for hustlers. **Headlin Mfg., Dept. FC4, Peoria, Ill.**

**AGENTS**—Simple demonstration sells amazing cloth. Cleans, polishes furniture without additions. Retails 25¢; large profit; free sample. **Williams Corp., Dept. 414, Montclair, N. J.**

**MAKE** Big money selling food products, prize motor and tractor oils, paints. Sure repeat orders. Write for free sample case. **Leverin & Brown, 1402-L So. State, Chicago.**

**LOWER** Prices! Bigger profits! Fast selling soaps, toilet articles, food products, household specialties. Premiums, free deals make sales easy. Write for big surprise offer. **M. G. Beth, President, 2730 Dodder, St. Louis, Missouri.**

**MEN** Wanted. Tenth successful season now starting. Thousands enjoying big incomes, full time or spare hours, selling fine shirts, ties, underwear, guaranteed full year. Shirts, ties, cash bonuses to producers. Beautiful self-selling outfit free. Write Dept. L-4, Rosecliff, 1217 Broadway, New York.

**STRANGE** New ironing cord! Prevents scorching. Saves electricity. Cannot kink or snarl. For telephones also. Up to \$25 daily. Samples furnished. **Neverhot, Dept. 4-A, 4503 Ravenswood, Chicago.**

**TAILORING** Firm, leading field has perfected new appeal: clinches 8 of 10 calls—defeats hard times. Stores liked. Suits, topcoats, union made, all \$19.95. Your commission \$7.00. Outfit free. **Mastercraft, Dept. G-400, 873 Broadway, New York.**

**PORTRAIT** Men—Big profit catalog. Guaranteed portraits, frames, medals, etc., photo pillows, household specialties, toilet preparations, food products, remedies, pictures, crucifixes. **James Bailey Co., Station C-4 Chicago.**

**500% PROFIT** Selling Mystery Gas Lighter. Retails 25¢. Costs you \$1.00 doz. Sample free. **Square Deal Mfg., Desk PM-18, Bradford, Pa.**

**KITCHEN** Necessity: The new "28-in-1" used as a mixer, heater, whipper, egg separator, ladle, strainer, etc. 3 color circulars furnished. Retails 25¢, costs you \$1 a dozen. Sample and sales plan free. **Numethal Co., Desk P3M-4, Numethal Bldg., Bradford, Pa.**

**BIG** Money easy, simply showing new Pelly Wrench. 10 wrenches in one. Guaranteed fast seller. Sample furnished. **Ge'han Mfg. Co., Dept. G-D, Back Island, Ill.**

**PROFITABLE** Home business. Legitimate. No canvassing. **Maywood Publishers, P-923 Broadway, New York.**

**AGENTS** Can't afford to overlook opportunities in California, Nevada, Arizona and other western states. **Baynton, Box 881, Los Angeles, California.**

**AUTO** Invention just out! Ezyin revolving step-plate; continuing demonstrator, interests autoists immediately; quick \$1.00 seller. Big profits! Write quick. **Ezyin Company, Box B1, Monterey, Calif.**

**AGENTS**—New lawn mower sharpener, easily demonstrated, retails for \$1. Guaranteed. **Mac-Ben, 1230 W. 8th St., Los Angeles, Calif.**

**NEW** Invention makes car washing a pleasure! Gyro Auto Brush works by water pressure. Tremendous possibilities for aggressive workers. 100% profit. Write today for new money-making plans. **Gyro Brush, Dept. DC-11, Bloomfield, N. J.**

**MAKE** Up to \$30 weekly. Sell finest quality Ohio Neckwear direct from factory. Amazingly low prices. Nearest, smart patterns—rich materials—splendid workmanship. Samples free—earn your own ties. Write Cincinnati Neckwear Co., Dept. DC-8, Cincinnati, Ohio.

**SELL** New type double edge razor blades. **Speer's Mfg., 127B South Broadway, Los Angeles, Calif.**

**GUARANTEED** Hosiery at lowest mill prices. Men's fancy hose, dozen, \$1.40-\$1.75. Ladies' silk hose, dozen, \$3.25-\$6.00. Genuine full-fashioned hosiery, dozen, \$7.50. Catalog free. **Superior Knitting Company, Dept. 34, New Haven, Conn.**

**MAKE** Money—Your own business. Valuable formulas. Free information sent. **Arthur Terry, 1858 W. 7. Brooklyn, N. Y.**

**MAKE** Big pay and liberal merchandise and cash bonuses selling guaranteed shirts, ties, hosiery, underwear. We finance you. Scientific Sales Kit Free. Write today. **Public Service Mills, Dept. D5, West New York, N. J.**

**SNAPPY** New seller, repeats quick and often. Sell to women. Ansureth. Necessity. Your profit enormous. Get free details quick.—**American Skiko Co., 413 Dessemor Bldg., Pittsburgh, Pa.**

**ARE** You old at forty? See our advertisement on page 41 of this issue. **The Kierston Thermal Company, 2140 Morris Ave., Steubenville, Ohio.**

**NEW.** Profitable—Sell auto step mats. Quality rubber with owner's name moulded white. Details free. **Ebonite Products, Dept. K-10, 805 Main, Akron, Ohio.**

**BE** Prosperous. Join a prosperous organization. The Stanford Razor Blade Sharpener retails for One Dollar. Send for 15 blades and one sharpener, all for one dollar. Ask for agents' discount. Half million already sold. **Stanford Company, Board Tower, Baltimore.**

**NEW** 25¢ Specialty, costs agents only 2¢. Wonderful seller. Write for details. **Al Schaeffer, Importer, Myerstown, Pa.**

**AGENTS**—Jiffy glass cleaner and other new specialties offer you wonderful chance to make \$15 profit a day. Going big. **Burry, Albert Mills, 9127 Monmouth, Cincinnati, Ohio.**

**AGENTS**—Coupon workers! New Vanilla combination deal, fastest 1931 seller. Sample deal 50¢. Particulars free. **Eaton, Box 488-P, Birmingham, Ala.**

**CASH** in \$7.50 to \$12.00 a day selling 25¢ household specialty. No experience or talking necessary. Sell selling envelope does selling for you. Write for free sample and particulars. **A. Masterlite, 110 East 23rd Street, New York, N. Y.**

**MASTER** Hones, best sharpeners for razor blades. Agents make over 100%. Sample 50¢, three for dollar, dozen with free demonstrator three dollars, postpaid. **Wiseman Abrasive Co., 153 Pittsburgh, Milwaukee, Wis.**

**GIVE** Away 3¢ pound quality coffee with dollar sale **Midwest Products.** Pays 100% profit. 30 days credit given reliable buyers. **Midwest Drug Co., Dept. 116, Columbus, Ohio.**

**MIRRORS** Re-livered at home. Costs near 3 cents per square foot; you charge 75 cents. Profitable business plating auto-parts, reflectors, tableware, stove, refinishing metalware etc. Outfits furnished. Details free. Write. **Spinkole Plater, 128, Marlon, Indiana.**

**NEW** Plan brings independent cash incomes to women. Show marvelous values women's fine shirts. Give one free with every three. Removes all sales difficulty. Experience unnecessary. Complete selection beautiful pre-shrunk fabrics free. Write Dept. P-40, Albert Shirts, 860 Sixth Ave., New York.

**GUARANTEED** Hosiery at lowest mill prices. Men's latest fancy hose—dozen \$1.40-\$1.75. Ladies' silk hose, dozen \$3.25-\$6.00. Genuine full-fashioned hosiery, dozen \$7.50. Catalog free. **Superior Knitting Company, Dept. 34, New Haven, Conn.**

**AGENTS**—100% Profit on \$1.00 sale. Cleaner for autos, furniture, metal and glass. Your name on labels. Exclude territories. Free sample. Write **Minute-Kleen Laboratories, Dept. E, Evansville, Ind.**

**ABSOLUTELY** Brand new. Hand-colored popular priced panel portraits going big. Everyone wants them. Make \$16-\$25 daily. Samples furnished. **Cruver, 2402-D8 Jackson, Chicago.**

**AGENTS**—Sell tube flavors and food colors. **Thos. J. Ferguson, 7426 Richmond, Manassas, Md.**

**MAKE** 200% Profit bottling and distributing Star Food Flavors under your own name. We furnish concentrated flavors, labels, advertising matter. **Star Specialty Co., 1626 Villars, Dallas, Texas.**

**AGENTS**—Dealers: Buy direct at wholesale. Save money. Write Dept. P, United Specialty Co., Smithboro, New York.

**250,000 ARTICLES** Wholesale—Directory 166, W. Patterson, 4111 University, Des Moines, Iowa.

**EXCELLENT** Trower-Presser \$1.25. Agents 70¢. **L. J. Widness, 501 Sumner Ave., Brooklyn, N. Y.**

**NEW** Plan brings independent cash incomes to women. Show marvelous values women's fine shirts. Give one free with every three. Removes all sales difficulty. Experience unnecessary. Complete selection beautiful pre-shrunk fabrics free. Write Dept. M-10, Albert Shirts, 860 Sixth Ave., New York.

**PROTECTION** Against mosquitoes. Formula, 25¢ each. **Barker, Box 93, Valleyfield, Quebec, Canada.**

**NO-TANGLE** Ironing rod; cannot kink. Saves electricity. Tremendous profits. Sample free to workers. **Restover Co., 740 Irving Park Station, Chicago.**

**AGENTS**—Men, women, 100% profit selling needle threaders. Also have self-threading and other needles. Write today for wholesale prices. **Miller Needle Co., 500 East 175th St., New York City.**

**BIG** Profits—Easy sales. World's best selling cloth. Everybody buys. Sample free. **MagiCloth, 3317 Summit, Kansas City, Mo.**

**GENUINE** Gold Leaf Letters anyone can put on store windows. Guaranteed to never tarnish. Large profits. Enormous demand. Free samples. Write today. **Metallic Letter Co., 438-D North Clark, Chicago.**

**REPLATE** Brass worn-off automobile parts, reflectors, bath room fixtures, worn spoons, forks, etc., with pure silver. Looks like new. Use U-Kan-Plate Polish. Positively no mercury; \$1.00 half pints. Postpaid. Satisfaction guaranteed. Agents wanted. **Dept. A, U-Kan-Plate Co., Philadelphia.**

**SUCCESS** With your own products. Make them yourself. Preserving, processing. Catalog free. **B. Thaxtle Co., Washington, D. C.**

**BIG** Money daily selling shirts, ties, underwear, socks, pajamas, belts, professional uniforms, raincoats, overalls, pants, children's play suits. Outfit free. Experience unnecessary. **Numed Co., Dept. 65, 3022-28 Lincoln Ave., Chicago.**

**OH** Hello! Why didn't I see this before, Christy's Iron Rust and Stain Remover sells like blazes. Write for free sample. **Christy, Inc., 707 Union, Newark, New York.**

**AGENTS** Everywhere making money with our line of kitchen specialties, demanded in all homes. Big earnings possible. Write today for details. **P. Seed Filter Co., 352 Broadway, New York.**

**MAKE** Money. Show mystery metal polishing cloth. Approved by good housekeeping. Send for free sample. **Melzer, Onamia, Minn.**

**ARTICLES** Of merit. Repeat sellers. Big profits. For information write **Lichtenau Products Co., 676 W. Kinzie St., Chicago.**

**NEW** Can opener making agents rich. Will surprise you. Quick orders from agents sample 25¢. **Alfreds Mfg. Co., Box 125, Oak Park, Ill.**

**LARGE** Importer of neckties offers exclusive agency and entirely new proposition. Enormous demand. No competition. Unlimited possibilities. **La Romance, 505 Broadway, New York.**

**WANT** Distributing agent for handi-ek. Powdered Handi-ek; removes anything from the hands without injury to skin; everybody a customer; great opportunity for hustler to get in business; sample free. **Solar Products Co., 3-2111 So. Troy, Chicago.**

**FREE**—Picture man **Friedman's** new rule price 50 page catalog, portraits and frames. Lowest in years. **Friedman, 109 West Austin Ave., Chicago.**

**SELL.** Changeable signs to stores, size 11x22, cost 70¢, sells for \$1.50. Particulars free. **National Sign System, St. Louis, Mo.**

**AGENTS**—Move coin and roll-out remover will build you a steady repeat business. Send today for pocket-size trial outfit. **The Most Company, 101 Searle Bldg., Rochester, N. Y.**

**500-200 A WFK.** Genuine gold letters for store windows. Easily applied. Free samples. Liberal offer to general agents. **Metallic Letter Co., 438-B North Clark, Chicago.**

**BIG** Money and fast sales. Every owner gets gold initials for his auto. You charge \$1.50; make \$1.45. Ten orders daily easy. Write for particulars and free samples. **American Monogram Co., Dept. 40, East Orange, N. J.**

**MAKE** \$28 Daily demonstrating automatic cashlights, sample 25¢. Gross \$8; doz. \$1. **Rapid Mfg. 2772 Pitkin Ave., Brooklyn, N. Y.**



THIS Advertisement may make you thousands of dollars. If you write immediately for my "Eye-Opening" literature describing guaranteed formulas; valuable trade processes, money-making information how to easily make the world's best-selling specialties. All lines. Investment small. Profits immense! Start in your home, room or office. Make the good money you're entitled to. Dr. Liscombe Miller, Chemist, Tampa, Fla.

**GREATEST Opportunity;** newest proposition. Build continually paying business in your own name. Household, industrial, brushes, brooms, mops, dusters, fully guaranteed. New catalog, all net prices, no discount to bother with. Make as high as 300 per cent and over. Write today. Wire Grip Sanitary Brush Corp., 41 East 11th St., New York.

**POLMET Polishing cloth**—Removes tarnish from metal without the use of liquid, paste or powder. Agents say it sells like "hot cakes." Retail 25c. Sample free. Gale Co., Inc., 15 Edinboro St., Boston, Mass.

**MAKE Your own products.** Employ agents yourself. Toilet articles, soap, extracts. We furnish everything. Valuable book free. National Scientific Laboratories, 1950W Broad, Richmond, Va.

**MAN In cars** to plate auto parts, reflectors, bathroom fixtures, refinish beds, mirrors, chandeliers; by new method. No capital or experience required. Simple plan of manufacturing at home starts you in big money-making business. Outfit furnished. Free particulars and proofs. Gun Metal Co., Ave. H, Deratur, Ill.

**SELL Men's neckwear**—wonderful proposition. Astor-M, 29 East 28th, N. Y.

**AGENTS:** Stamping names on pocket-key protectors. Sample check with your name and address, 25c. Stamping outfits, Emblem checks, check-fobs, name plates. Hart Mfg. Co., Desk 2, 303 Degraw St., Brooklyn, N. Y.

**GET Our free sample case.** Toilet articles, floorings and specialties. Wonderfully profitable. LaDerma Co., Dept. 89, St. Louis, Mo.

**FLAVORING Extracts**—bottle yourself. Concentrated. Labels furnished. 600% profits. Whirlwind money-makers. Steady repeaters. Free offer. Thomas Manufacturing Company, Indianapolis, Indiana.

**AGENTS**—Can openers, new improved hand, wall, table models. Safety Products Co., 313 American Bank, Kansas City, Mo.

**NEW Automatic clothes washer.** Washes quickly and thoroughly. No rubbing. No electricity. Retail \$9.75. Guaranteed. Write Storm Royalty Co., 3601 Enright, St. Louis, Mo.

**SELL Housewives** something they want. They are bound to be interested. A sized guarantee to reduce gas bills 25%. No competition. 400% profit. Station C, Box 25E, San Diego, Calif.

**BIG Profit** putting our gold sign letters on store windows, without experience. Samples. Consolidated, 69-T West VanBuren, Chicago.

**MANUFACTURER** wants distributor for new "Pocket Radio," only \$3.85. "Sells itself with music." Pays 100% profit. Spencer Radio, Akron, Ohio.

**AGENTS**—Engraved name plates, signs, number plates etc., easily sold with large profits. Brett Bros., Winthrop, Mass.

**BIG Money** spinning gold initials on automobiles. Easiest thing today. No experience needed. \$1.45 profit every \$1.50 job. Free samples. "Raleo," X-1043 Washington, Boston, Mass.

**OUR Luminous crucifix** and new luminous St. Therese statue shine brilliantly in the dark. Sell on first demonstration. Write for prices, W. G. Hannan Co., 2543 So. State, Chicago.

**NO Dull times** selling food! People must eat. Federal distributors make big money; up to \$3,000 yearly or more. No capital or experience needed; unsold goods may be returned. We furnish free sample case, license and free samples for customers—sure repeat orders. Exclusive territory. Ask now. Federal Pure Food Co., A2307 Archer, Chicago.

**NEW Line Counter Displays.** Aspirin, Flints, Chewing Laxative, Breath Gum, No-tar, Silkstone, etc. Steady Repeats. Over 100% Profit. Superba Co., W5, Baltimore, Md.

**CALIFORNIA Perfumed beads** selling like hot cakes. Agents coinng money. Big profits. Catalog free. Mission Factory P, 2728 W. Pico, Los Angeles, Calif.

**CHICAGO Expert** valued \$3 stone at \$900. The diamond's only guaranteed rival. Greatest spare time, side-line article ever known! Amazing profits. \$5 pocket sample case free. Write quick. Mexican Gem Company, Dept. PM, Monterey, Calif.

**FREE "Booklet of money making opportunities,"** new ideas, original plans, money making secrets and other valuable information. None require peddling or outfits. Elite Co., 84 Elizabeth St., New York.

**SELL stores** for tarred overalls, etc. Lorraine Products, Albany, N. Y.

**A BUSINESS Of your own**—Making sparkling glass name and number plates, checkerboard signs. Big book and sample free. E. Palmer, 512, Wooster, Ohio.

**WANTED:** District manager to appoint agents. Unlimited opportunity. No canvassing. Mother Hubbard Products, 354U Congress, Chicago.

**PHOTO Medallion** men and women. The largest line of photo novelties in the world. Lowest prices, quickest service. Send for catalog showing over 200 money makers. Gibson Photo Jewelry Co., Inc., 833-837 Gravesend Ave., Brooklyn, N. Y.

**We Start you** without a dollar. Soaps, extracts, perfumes, toilet goods. Experience unnecessary. Carnation Co., 641, St. Louis, Mo.

**AGENTS**—Make a dollar an hour. Sell Mendets, a patented patch for instantly mending leaks in all utensils. Sample package free. Collette Mfg. Co., Dept. 404, Amsterdam, N. Y.

#### HIGH-GRADE SALESMEN WANTED

**NEW "Endless Chain"** selling plan guarantees you amazing profits and many repeat sales with America's greatest printing line. 40%-55% profit on every order. 128-page catalog shows 1001 printing necessities for every business—Also line of personal stationery, pictorial parcel post and shipping stickers, collection sticker system, advertising tags, druggist labels, etc. All statements, letterheads, billheads, envelopes, etc., now furnished in white and 5 beautiful colors—a tremendous selling advantage. Thousands of cuts furnished. Lowest prices. Highest quality work. Main or sideline. Experience unnecessary. This is biggest profit-maker of the year. Write quick for big new 1931 outfit. Kaiser-Blair, Inc., Dept. 289, Cincinnati, Ohio.

**WANTED**—Salesmen-Dealers. Selling experience unnecessary, but only reliable people need apply. We supply everything—products, sales outfits, sales and service methods that get the most business everywhere. Superior Raleigh quality, old established demand, lowest prices, guarantee of satisfaction or no sale, makes quick sales. 200 home and farm necessities, all guaranteed best values. If you are willing to work steady every day for good pay, write for information how to start your own business with our capital. W. T. Raleigh Co., Dept. D-R-PPM, Freeport, Ill.

**GENUINE Neon**—Priced to sell 40% commission. Buyers want it. Willis Austin, Miami, Ohio, made four calls, sold four. Collected \$80.00, three hours work. Doubt it? Write him. Every hustler hits with Nesette—the genuine Neon border display with changeable letters and posters. Sizes for all show windows. Also mounted Neon letters. Plug in any A.C. socket. Big money for early birds. Special 30-day demonstrator trial offer. Display Products Co., 409 East 31st, Kansas City, Missouri.

**SALESBOOKS.** Our wonderfully attractive line of salesbooks, manifold books, safe checks, etc., fits the need of sideline or spare time men. All stores, factories, garages are prospects. Compact pocket samples free. Our factory the last word in equipment and efficiency for mass production, low prices, and quality. Commissions paid weekly. New monthly bonus plan. Kansas City Salesbook Co., 1016 Baltimore, Kansas City, Mo.

**SELL Mechanics**—garage help—working groups their heavy-duty work shoes. \$2.95 to \$4.95. Established line—Fast sellers. Specially for this trade. Big commissions. George Merritt Shoe Co., 65 Court, Brookton, Mass.

**NEW, Startling, amazing!** \$10 to \$25 a day easily earned; home protection \$250 to \$1,000 at death; ages 10 to 80; not an insurance company but a society furnishing protection at cost. Write American Be-off Corp., Managers, Myers Bldg., Springfield, Ill.

**SAFETY Razor.** Size five blade box. Absolutely new and different. Wonderful advertising no-obj. Ideal sideline. Every business man a prospect. \$100 per day easy. Send 50c coin for sample and information. Manufacturers Distributing Corporation, 1210 West 28th Street, Kansas City, Missouri.

**250,000 ARTICLES Wholesale Directory** 10c. W. Patterson Co., 4111 University, Des Moines, Iowa.

**ELABORATE Printing outfit.** Largest assortment specialty items and novelties at half price. Union label, 72-hours delivery. Big commissions advanced. Experience unnecessary. Northwestern, 625D Jackson, Chicago.

**SALESMEN**—At last! New feature sells punchboards everywhere. Dealers wild with joy—prosperity back again. Profits enormous. Samples free. Puritan Co., 1307 Jackson Blvd., Chicago.

**CALIFORNIA Grape Concentrate**—All flavors; Post, Sherry, Champagne, etc., solid brick form; one brick makes one gallon juice; legality twice established in courts; Government financing industry; every house, hospital, church, grocery, drug store prospect. 100% profit for distributors—salesmen. Vino Sano Co., Dept. 8-170, 395 9th St., San Francisco, Calif.

**ONE \$4.75 Order** daily means \$100 weekly from original and repeat commissions. A lifetime job. Free kit. Sales Stimulators, Dept. 9H, 341 Madison, Chicago.

**MANUFACTURER** of shoes and leather goods wants salesmen. No experience. Big profits. Free sales outfit. Mason Shoe Mfg. Co., Dept. 74, Chippewa Falls, Wis.

**SALESMEN**—New fast selling line of counter display cards, 5c and 10c staples and novelties in tremendous demand everywhere. Quick repeats. 100% for you and retailers. Main or sideline. No capital necessary. Drexel Company, Elgin, Ill.

**GIVE Away Ladies'** pure silk stockings with wonderful value \$1.00 sets of toilettries. 100% profit. Paris Laboratories, 2624 Olive, Dept. 541, St. Louis, Mo.

**\$18 To \$25 Daily;** biggest selling line of men's suits. Meets present day conditions. Amazing values at \$11.95, \$11.50, \$16.95, \$18.95. Also raincoats, slippers, topcoats and boys' suits. Biggest commission paid in advance. Liberal bonus. Free outfit. State age and selling experience. "Jim" Foster, Inc., Dept. 24, 2250 South Spaulding Ave., Chicago.

**WANTED County** salesmen with car, to demonstrate for large Ohio Manufacturer. First class job. Fyr-Fyter Co., 2158 Fyr-Fyter Building, Dayton, Ohio.

**WONDERFUL Invention.** Seals fifty envelopes minute. Sells on sight at \$2.25. Attractive trial offer. Square deal. Bank references. Kendall Sealer Co., Dept. C-29, East Jaffrey, N. H.

**NEW And plenty different**—Fast selling 5c-10c merchandise on attractive counter cards. 100% commission for you and dealers. Advertised by radio. No capital required. Catalog free. World's Products (Estab. 1921), 125 Central, Spencer, Ind.

**Red Hot novelty.** Men calling on restaurants, cigar stores, etc. Make up to \$40.00 daily. Write now. Joan Products, 442 Broadway, Lorain, Ohio.

**ALL Merchants** buy 6c carded nuts, aspirin, etc. Steady repeats. Also low priced vending machines. Robbin Products, 21 Doherty Street, Brooklyn, New York.

**CHRISTMAS Cards,** business and personal, box assortments, business stationery, ready in April. Real proposition for five wide district and crew managers. Buckeye Thermographers, 1108 Adams, Toledo, Ohio.

**SALESBOARD Men;** Whirlwind seller. \$15.00 profit every call. Repeat commissions. Best season. Harry Puritan Mfg. Co., 2037-F Charleston, Chicago.

**BUSINESS Stationery**—Largest line—Highest quality. Quickest delivery. Biggest commission. Liberal bonuses. Free copyright cuts every business. Experience unnecessary. Instructions and outfit free. Wilens Co., Dept. 356, 2150 Gladys Ave., Chicago.

**POOL, Shooters,** new fascinating vending machine. Merchants everywhere buy! Splendid sideline. Big profit maker. Free pocket outfit. Specialty Mfg. Co., W-617 W. Division, Chicago.

**SALESMEN**—Wonderful sideline. 40% commission paid daily. Sell all merchants, pocket outfit free. David Lionel Press, 312 So. Hamilton, Dept. 203, Chicago.



**BIG Money** daily selling shirts, ties, underwear, Sox, pajamas, belts, professional uniforms, raincoats, coveralls, pants, children's play suits. Outfit free. Experience unnecessary. Nimrod Co., Dept. 65, 4922-28 Lincoln Ave., Chicago.

**ADVERTISING** Pencils sell fast to every business. New, quick cash commission plan. Main or sideline. Free pocket outfit to real salesmen. Chicago Graphite Co., 130 So. Clinton, Chicago.

**NEW**, Largest color catalogue, punch-boards, vending machines, produces quicker orders, big commissions. Free outfit. Lincoln Sales, 116 So. Wells, Chicago, Dept. 14. Established 20 years.

**NEW Speciality**—sells every business and professional man. Four \$15 sales daily pay \$280 weekly. Foyer cleared \$1920 in three months. Write, F. E. Armstrong, President, Dept. PM, Mobile, Alabama.

**SELLING** Like blazes. Beautiful toilet goods assortment at \$1.75 with 24 inch pearl necklace free to your customers. 100% profit. Davis Products Co., 238 North Ave., Dept. 930, Chicago.

**SALESMEN**—Become independent. Own your business; experience unnecessary, selling our \$10,000 accidental death; \$50 accident; \$25 sick weekly benefit—\$10.00 yearly. Other amounts proportionate. Guaranteed steady income from renewals. \$250,000 deposited insurance department. Universal Policy, Dept. A, 716 Lefcourt Bldg., Newark, N. J.

**SELL** Nothing! \$170 weekly empty handed. \$700,000 punchboard firm announces new plan. No investment for anyone. Season starting. Hurry! K&S Sales, 4326 Ravenswood, Chicago.

**SALESMEN**: Our men earning \$15-\$40 daily selling to stores. Savers Systems, Est. 1895, 2813 Sheffield, Chicago.

**STARTLING** New punchboard plan! We furnish everything! No investment for you or your customer! Nothing to sell or carry! 50% profit! Unsaleable merchandise returnable! Full commissions on repeats. Write quick. AJ Novelty Co., 161 W. Washington, Chicago.

**\$60-\$200 A WEEK**. Genuine gold letters for store windows. Easily applied. Free samples. Liberal offer to general agents. Metallic Letter Co., 438-A North Clark, Chicago.

**SALESMEN**—Easy selling Die-U-Rat thru jobbers. 20% commission. Kills nothing but rats and mice. Rick Drug Co., Gallon, Ohio.

**SELL** Goodyear raincoats, \$2.95 up. Good-year Rainwear, 682 Sixth Avenue, New York.

**BIG Profit** putting our gold sign letters on store windows, without experience. Samples. Consolidated, 69-V West Van Buren, Chicago.

**SALESMEN** Sell tires and auto accessories to garages, tire stores, filling stations, etc. Established line repeats everywhere. Liberal commission. Write for particulars. Economy Rubber Prod. Co., 605 Burkhardt, Dayton, Ohio.

#### SIDELINE SALESMEN WANTED

**SIDE-LINE** Or one line house to house salesmen who can stand prosperity and work hard. All territory. International Sales, Inc., 185 N. Wabash, Chicago.

#### HELP WANTED

**MAKE** Big profits selling patents. Easily learned patented process. Plans free. Wear Mirror Works, PM3, Excelsior Springs, Mo.

**STOP** Worrying about money! Here's a wonderful opportunity to make \$15 profit a day as my local representative. No capital or experience necessary. Write today for details. Albert Mills, 9128 Monmouth, Cincinnati, O.

**CASH** Paid for butterflies, insects. See Singleir Di-vision advertisement on page 21.

#### EDUCATIONAL AND INSTRUCTION

**\$105.00 TO \$250.00** Month, Men—Women, 18 up. Want a government job? Steady work. Short hours. Paid summer vacation. Common education usually sufficient. Experience usually unnecessary. We coach you without leaving home. 32 page book with full particulars and sample roofing free. Write immediately. Franklin Institute, Dept. B3, Rochester, N. Y.

**ELECTRICAL** Measurements. Study at home the real electrical necessity. Fesco System, 69 Boardman St., Boston Mass.

**FIREMEN**, Brakemen, Baggage-men; colored train or sleeping car porters, \$150-\$250 monthly. Experience not necessary. 810 Railway Instruction Bureau, East St. Louis, Ill.

**MERCHANT** Marine jobs, requirements, procedure. Seafaring for the inexperienced. \$1.00 postpaid. D. Wolf, 2122 E. 2nd St., Long Beach, Calif.

**BEGINNERS** Trained for hotel positions, beaches, mountains, Florida. Leo Institute, 151 Perkins, Somerville, Mass.

**BOOKKEEPING** And accounting easily learned. Complete course \$1.00. Accounting Institute, Duluth, Minn.

**THE** Ace of Cartoon Courses for only \$2.98. Particulars free. Carl Anderson School, Madison, Wis.

**LEARN** Gregg shorthand—complete; guaranteed; 25c week; trial lesson 10c. Nation School, Hicksville, N. Y.

**LEARN** Rapid figuring from Higher Arithmetic. Write for particulars, Frederick A. Smith, 608 South Dearborn St., Chicago.

**LEARN** Photo-Engraving at home. Signature etching and particulars free. Aurora Photo-Engraving School, Aurora, Missouri.

**LEARN** Pipelining welding. Earn \$77 weekly. 2000 welders short last year. 1931 already bigger. National Welding School, 711 Fairfax, Kansas City, Kansas.

**WANTED**—Men, Women, 18-50, qualify for permanent Government positions. \$105-\$250 month; no Government experience required; Paid vacations; common education; Thousands appointed yearly. Write, Ozment Inst., 101, St. Louis, Mo.

**LEARN** At home to make crowns, plates, bridgework, etc., for dentists. Uncrowded field. Big pay. Tools and materials included with course. Write McCarrie School, 1342 S. Michigan Ave., Chicago, Ill.

**DON'T** Prepare for any civil service examination without seeing our catalog. Free. Columbia Correspondence College, Washington, D. C.

**BECOME** A landscape architect. Uncrowded profession; wonderful opportunity for money-making. Easily mastered by mail. Earn while you learn. Est. 1916. Write for details, American Landscape School, 29A Plymouth Bldg., Des Moines, Iowa.

**PHOTOPLAY** Talking picture and magazine stories wanted for revision, development and copyright. Sell on commission. Established 1917. Booklet free. Universal Scenario Company, 406 Meyer Bldg., Western and Sierra Vista, Hollywood, Calif.

**U. S. GOVERNMENT** Wants men. \$1,700-\$1,900 and up at start. Railway mail clerk examination coming. Let our expert (former government examiner) prepare you for this and also rural carrier, post office, customs, internal revenue, and other branches. Write today for free booklet. Dept. 8, Patterson School, Rochester, N. Y.

**DOUBLE** Entry bookkeeping 60 hours with 8 keys guaranteed. (Diplomas.) International Bookkeeping Inst., 8 Springfield, Mo.

#### SHORT STORIES

**SHORT** Stories revised, typewritten and marketed. Details free. Hursh Service, Box P-1013, Harrisburg, Penna.

#### TYPEWRITERS AND SUPPLIES

**TYPEWRITERS**—All makes, guaranteed, \$6 to \$34. Free catalog. Typewriter Exchange, Ada, Okla.

**TYPEWRITERS**—All standard makes \$10 up. Catalog free. Northwestern Typewriter Exchange, 121 N. Francisco Ave., Chicago.

#### ADDING MACHINES

**NEW** \$4.75 Automatic Adding Machine. Fully guaranteed. Bassett 1458-A, Hollywood Avenue, Chicago.

#### PRINTING, MULTIGRAPHING AND MIMEOGRAPHING

250 **BUSINESS** Cards \$1.00; 1,000, \$2.75, postpaid. Samples. D. N. Fox, Perryville, Md.

200 **LETTERHEADS** And 150 envelopes, \$1.75 Webster's Press, Farmland, Indiana.

5,000 **ENVELOPES**, (Printed) \$9.75, postpaid. Lawrence Envelope Co., 355 South Crawford, Chicago.

**PERSONAL** Stationery—200 sheets bond 6x7, 100 envelopes \$1.50, 500 Bristol business cards, \$2.00. George Barnaskey, 350 Malvern Drive, Scraper, N. Y.

1000 **BUSINESS** Cards \$2.75 postpaid. Samples. Miller, Printer, Narberth, Pa.

5000 **TWO** Color gum labels 2½x1, \$1.25 per thousand. 5000 20 pound Hammermill Bond letterheads in neat cartons, \$3.25 per thousand. Write for other prices. Old Dominion Label Co., Bridgewater, Virginia.

200 **LETTERHEADS**, 100 Envelopes, printed, \$1.00, Postpaid. Abbott Printery, Oswego, Kans.

**USE** Good printing; costs less; gets results. Circulars 5x7 \$2.50, letterheads \$3.25, Envelopes \$2.95. Battifield Press, Gettysburg, Penna.

**ARTISTIC** Printing, Bargains, Samples free. Printcraft, Box 483, Chelsea, Mich.

**NEW** Printing device—Anyone can make. Particulars free. Imperial Laboratories, Edwardsville, Illinois.

**PINK** Grade stationery and cards. Box 305, Scarsdale, New York.

**PATHFINDER** Magazine, 200 letterheads, 200 envelopes \$1.75. Charles Rittenhouse, Belvidere, New Jersey.

**LETTERHEADS** In color! Trial 100 and 100 envelopes, \$1.25. Samples free. Printing, 934 Bayless, St. Paul.

**RAISED** Letter printing. Samples and prices on request. LaClyde Service, Westfield, Mass.

250 **BOND** Letterheads, envelopes, billheads, cards, \$1.35 each. Economic Press, Leonia, N. J.

**NOVELTY** Midget cards, name telephone and address, 50c-50c cards case included, 100-50c, agents wanted. Olsen & Collins Co., 5-7 Kelly Parkway, Baronne, N. J.

5000 **LOTS**—Attractive colored envelope slips, \$5.00; 3½x6. Tinted folders, \$13.75; 6x9 circulars, \$7.50. Samples. Goodprint, Harrisonburg, Va.

**LETTERHEADS**, Envelopes, 500, \$1.10 1,000, \$2.00; 5,000, \$8.00, plus postage. Samples. Coyle & Kimball, Newport, N. Y.

**QUALITY** Printing! Reasonable prices! Send for free standardized samples and prices. Folders, Circulars, Catalogs our specialty. Earnest Fantus, 525 South Dearborn, Chicago.

200 **LETTERHEADS** And 100 envelopes, \$1.60; 200 letterheads, 3½x11, 150 envelopes, \$2.00; 250 cards, \$1.00. Hoosier Print Shop, Portland, Ind.

**WE** Print stationery, booklets, catalogs, circulars. Samples. Commercial Press, Batavia, Ohio.

#### PRINTING OUTFITS AND SUPPLIES

**BUILD** An 8x10 printing press for \$1.00. Complete instructions only 50 cents. K. Wise, 100 E. Broadway, Red Lion, Pa.

**COMPLETE** Printing outfits, presses, type, ink, paper, supplies. Write for free catalog. Kelsey Co., B-11, Meriden, Conn.

**PREFERRED** Printing presses and supplies, Lists 2c stamp. Popular Bargains, Richmond, Pa.

**PRINTING** Outfits—Presses, type supplies, type novelties. Send stamp for catalog. Model Press, York, Penna.

#### GUMMED LABELS

**TRIAL** Thousand 2 color stickers, 75c, 15 words. Harvey Wolf, 6618P Quinsy, Cleveland, Ohio.

#### DUPLICATORS AND DEVICES

**"EXCELLOGRAPH"** Rotary stencil duplicator \$39.00. "Two-Faced" film duplicator \$6.00. Booklet free. Pittsburgh Typewriter Supply, Dept. 601, Pittsburgh, Pa.

**STENCIL** Duplicator—Anyone can make. Particulars, samples free. Imperial Laboratories, Edwardsville, Ill.

#### RUBBER STAMPS

5 **INCHES** Long, ½ inch type, 50 cents line. Additional lines 20 cents. Blomquist, New Albany, Ind.

**RUBBER** STAMPS—All kinds. Catalogue free. Rapid Service, Box 170, Edwardsville, Illinois.

**MAKE** Good rubber stamps at home. Complete instructions 50c, postpaid. Melvin M. Biehl, N. Ohio St., Prairie du Chien, Wisconsin.

**RUBBER** Stamps—Name, address 35c, Newman & Son, 2208 O. Lincoln, Nebraska.

**RUBBER** Stamps, name, address 35c. Stamp Works, B22M, Auburn, Nebr.

#### FOR MEN

**SIDELINE**—Cartoon books, Samples 10c, 20c. Meyer G P O, Box 471, New York.



## FOR THE HOME

**CEDAR Chests only \$11.65**—"Red-I-Kut" complete with rich copper trim—souvenir and save half—send for pictures. Kaempel Furniture Company, Guttentberg Iowa.

## DIAMONDS, CLOCKS, WATCHES AND JEWELRY

**CLOCKS** Electrified; outfits as low as \$1.95. Splendid opportunity for handy men. Breitinger the Clock Maker, 1675 Sumner St., Phila.

## FOR SMOKERS

**SAVE** Money buy best natural leaf smoking and cherishing from grower, 101b., \$2.45. Joan J. Morris, Fulton, Ky.

**CIGARETTE** Machine makes 50 for 10 cents. Home use. Ask illustrated folder. Introductory offer \$2.75. Automatic Cigarette Machine Wks., 1055 Sheridan Rd., Chicago.

## RAZORS AND BLADES

**TWO** Gillette blades sharpened free to demonstrate new patent process. Periodical, 4630 No. Ashland Ave., Chicago.

**GILLETTE** blades honed, sharpened, so each. Petter Wetterquist, Rockford, Ill.

## FIELD GLASSES, TELESCOPES AND MICROSCOPES

**\$5.00 BRIGHT** New lot government field glasses with case. Send free list. Bimocular field glasses, telescopes, aeroplane cameras, lenses, optical instruments and government radio sets and parts. We'll's Curiosity Shop, 29 South Second St., Philadelphia, Pa.

**AIR** Navigation and meteorology—A practical book for every flyer. Capt. R. Duman, the author, has presented the subject in a simple, non-technical way. 212 pages. Illustrated. Delivered to your door C. O. D. Simply pay postman \$3 and postage. Popular Mechanics Press, Room 802, 200 E. Ontario St., Chicago.

## ARCHERY

**MAKE** Your own bows and arrows. We furnish material with complete instructions. Write for catalogue. Sidney Archery Co., Sidney, Ohio.

## ANTIQUES, WAR RELICS AND INDIAN GOODS

**WAR** Medals for collections. Illustrated catalog 10c. Durr, 670 E. 42, Brooklyn, N. Y.

**200 ANTIQUE** Clocks. Rare specimens. Grandfathers, Bracket, Wettered, Watchmaker, Bath, England.

**10,000 INDIAN** Stone relics, 25 arrows \$5.00. Battle axe \$2.50. 2 gem points, \$1.00. Heaulite axe, \$15.00. Pestles \$3.00. Circular 2c. Heike, Pontiac, Ill.

**SEND** for fine new list Indian relics, antique firearms. F. E. Ellis, Webster Groves, Missouri.

**INDIAN** Relics, Coins, Curios, Beadwork. Catalogue free. Vernon Lesley, Osborne, Kansas.

## MUSIC AND MUSICAL INSTRUMENTS

**SONG** Writers. Send for our "Publishing Agreement." McKinley Music Printers, 1561 E. 53th St., Chicago.

**SONG** Poets. Write Squola Songwriters Service, Sherman Branch, Los Angeles, Calif.

**SONGWRITERS**—Arranging, composing, copyrights. Information? Gladly. Turker, 320 Wadsworth, New York.

**SONGPOEM** Writers—For better proposition, write Studio, 115M, Orville, Ohio.

**CORNETISTS**—Trumpeters—Saxophonists—Clarinetists. Get "Free Printers." Name instrument. Virtuosi School, Buffalo, N. Y.

**WRITE** Songs. Big money and reputation. Write for information. J. Gordon Pub. Co., 201 N. Hoyne Ave., Chicago.

**FREE!** Song writers guide. Beaver, 1257 Elm, Green Bay, Wis.

**SONG** Poems wanted—A different proposition. Richard Broughton, Sioux Falls, S. D.

**COMPOSERS**—Verse or music. Brilliant opportunity. Write VanBuren, 2529 McClurg Bldg., Chicago.

**SONGWRITERS**: Free examination of song-poems or complete songs. If unsuitable, returned immediately. Chester A. Escher, Music Publisher, 125 W. 43th St., New York City.

**\$7,500 PAID** For one song! More wanted! Particulars free. Greenstreet, Park Avenue, Kenosha, Ill.

**SONGWRITERS!** Advance royalty payments, new talking picture song requirements, etc., fully explained in our free instructive booklet. Newcomer Associates, 1671-DD Broadway, New York.

**SUBMIT** Modern song poems. Valuable marketing assistance. Clifford Studios, 4562 Hollywood Blvd., Hollywood, Calif.

**SONGWRITERS** Free criticism. Edward Madden, 113 Michaels, Syracuse, N. Y.

**Duo-Flex** needs for clarinets and saxophones eliminate your reed troubles. Write for circular, Duo-Flex Reeds, 1294 1st Ave., Evansville, Ind.

**POEMS** Wanted. Work guaranteed. We publish. Great Eastern Song Bureau, Dept. 27, Thomaston, Me.

**"MUSIC" composed** to words. Bauer Bros. (formerly of Sousa's Band), Oshkosh, Wis.

**SEND** Song poems, 50-50 plan. Indiana Song Bureau. (Brookside), Salem, Ind.

## PATENT ATTORNEYS

**LANCASTER**, Allwine & Rummel, 221 Ouray Bldg., Washington, D. C. "Origination of the Form Evidence of Conception." More disclosing your invention to anyone and for blank form to be signed and witnessed. Form and patent information bulletin free.

**PATENTS** Procured. Prompt, careful efficient service. Highest references. Moderate fees. Send sketch or model for actual search and advice. George P. Kimmel, Master of Patent Law, 54-D, Legal Bldg., Washington, D. C.

**PATENTS** Obtained at low cost. Free booklet. See page 142. Write today. Harry W. Johnson, McGill Bldg., Washington, D. C.

**PATENTS**—Write for our free book, "How to Obtain a Patent" and Record of Invention Blank. Send model or sketch of invention for inspection and instructions free. Terms reasonable. See advertisement on pages 140 and 141. Victor J. Evans & Co., 934 Ninth, Washington, D. C.

**LACEY'S** Patent Sense. Valuable book free. See ad page 143.

**TIME** Counts in applying for patents. See pages 138 and 139. Clarence A. O'Brien, Registered Patent Attorney, Washington, D. C.

**PATENTS**—Write for free information. How To Obtain a Patent and Record of Invention—or send drawing or model for examination. Miller & Miller, Patent Attorneys (former Patent Office Examiners), 1064-A Woolworth Building, New York; 250 McGill Building, Washington, D. C.

**INVENTORS:** Send for booklet telling how to patent and sell your inventions at lowest cost. Ralph Burch, Patent Lawyer, 900 F St., Washington, D. C.

**PATENTS.** Send sketch or model for advice. Free book, "How to Obtain a Patent." Established thirty years. Highest references. Prompt service. Reasonable charges. Chandler & Chandler, 908 F Street, Washington, D. C.

**INVENTIONS** Patented and Exploited. Former patent office examiner; Master patent law. Benj. Webster, Esq., No. 15 East 26 Street, New York.

**INVENTORS**—Write for our Guide Book, "How to Get Your Patent," and Evidence of Invention Blank. Send model or sketch of your invention for our prompt examination and instructions free. Randolph & Co., Dent, 430, Washington, D. C.

**"INVENTOR'S** Guide," valuable information, free. Frank Ledermann, Registered Attorney-Engineer, 1512 Woolworth Bldg., New York.

**PATENTS** Procured: trade marks registered—preliminary advice furnished without charge. Booklet and form for disclosing idea free. Irving L. McCathran, 704 International Bldg., Washington, D. C.

**PATENTS.** Booklet free. Highest references. Best results. Promptness assured. Watson E. Coleman, Patent Lawyer, 124 Ninth St., Washington, D. C.

**ESTABLISHED** 1894. Mills B. Stevens Company. Free booklet. Patents. Trade marks. Copyrights. Offices, Monadnock Block, Chicago; Barrister Bldg., Washington, D. C.

## FOR INVENTORS

**INVENTOR'S** Universal Educator: contains 900 mechanical movements; 50 perpetual motions; instruction on procuring and selling patents and selecting an attorney, etc. Suggests new ideas. Price \$1.00 postpaid in U. S. A. Address Dietrich Co., 602B Ouray Bldg., Washington, D. C.

**LEARN** Patent drafting \$1.00. Blanks, Supplies. Wade Service, 2274-G Brooklyn Station, Cleveland, Ohio.

**MANUFACTURERS** now want sound, practical inventions, patented or unpatented, to meet keen competition. Information free. Chartered Institute American Inventors, Barrister Building, Washington, D. C.

**INVENTORS** Sell your own patent. List of responsible manufacturers for one dollar bill. State Title of Invention. Mr. Thrane, 1088 Fifty-fourth Street, Oakland, Calif.

**INVENTIONS**—Write for our free book "How to Obtain a Patent" and Record of Invention Blank. Send model or sketch of invention for inspection and instructions free. Terms reasonable. See advertisement on pages 140 and 141. Victor J. Evans & Co., 157 Ninth, Washington, D. C.

**LACEY'S** Patent Sense. Valuable book free. See ad page 143.

**TIME** Counts in applying for patents. See pages 138 and 139. Clarence A. O'Brien, Registered Patent Attorney, Washington, D. C.

**INVENTORS:** Would you sell your patent? Send description and \$1.00 for professional engineer's advice and selected list of manufacturers who may be interested. L. G. Heller, Box 248, Marshalltown, Iowa.

**MANUFACTURERS** Everywhere seek new inventions to improve their product. Names of manufacturers and wanted inventions sent free on request. Write W. T. Greene, 914 Barrister Building, Washington, D. C.

**OFFICIAL** Patent office drawings made. Patents obtained. A. M. Jacobson, 53 West Jackson, Chicago.

**WANTED**—Invention—Will manufacture on royalty. Urbano Manufacturing Co., 501 Howard St., San Francisco, Calif.

**NATION** Wide search for best inventions now on. Write American Society of Inventors, Crosby Bldg., Buffalo.

**INVENTIONS** Patented and Exploited. Former patent office examiner; Master patent law. Benj. Webster, Esq., No. 15 East 26 Street, New York.

**LOW** Cost manufacturing. Large plant completely equipped for blanking, drawing, stamping and wire forming in any finish. Can save you money on your product. Our figures will convince. Eastern States Products, Box 721, New Haven, Conn.

**MANUFACTURERS** Everywhere seek new inventions to improve their product. Names of manufacturers and wanted inventions sent free on request. Write W. T. Greene, 914 Barrister Building, Washington, D. C.

**WELDING** Encyclopedia. The latest, completely revised edition of this famous book contains every known fact regarding every kind of welding. Covers such up-to-date subjects as aircraft welding. 542 pages. Illustrated. Flexibly bound. Sent C. O. D. Pay postman price, \$5 and small amount of postage upon delivery. Popular Mechanics Press, Room 802, 200 E. Ontario St., Chicago, Ill.

## PATENTS FOR SALE

**ELECTRIC** Three switch—Can be wired to turn on and off automatically, any amount of circuits. Carl Schlauch, 1517 Cleveland Ave., Chicago, Ill.

**STRAFAC** Spark plug outsell all others. Georges, 192 Fourth Street, South Boston.

**OUTRIGHT** Or royalty. Mechanical auto cooling system cleaner. Radiators and water jackets cleaned without removing John Ludvig, Carpenter, So. Dak.

**ROYALTY**—Large tin traps, exclusively for 10c stores. Models to manufacturers. S. Tallman, San Bernardino, California.

**OUTRIGHT** Or royalty. Electric primer. Starts autos instantly. Model furnished. Just out. Louis Colvin, Denver, Missouri.

**ROYALTY** Or manufacturing. Complete automatic automobile safety signal—one unit, stop, go, reverse and turn—adapted all cars and trucks. Fully proven and protected serial 467590. AA Safety Signal, 10306 Carnegie Ave., Cleveland.

**OUTRIGHT** Or royalty. New improved automobile washer, soft, pliable without equal. A. B. Carlson, Fairmont Hotel, Spokane, Wash.



**PATENT 1,788,865** For sale a safety ear lock to prevent the hands from getting hurt can be manufactured cheap. Ignatius Goode, 124 Peterboro Street, Boston, Mass.

**GRASSHOPPER**—Jumps 3 feet. Boys' toy. See article. Principles only. Outright or royalty. R. Blake, 234 Hoyt St., Brooklyn, N. Y.

**OUTRIGHT** Or royalty, new flexible ring-less piston. J. Casey, 1936 St. Antoine St., Montreal, Quebec.

**PATENTRIGHT** And trademark "Cedarator," cedar moth repellent. Cedarator, 2910 Willard, Milwaukee, Wis.

**TIME** Counts in applying for patents. See pages 138 and 139. Clarence A. O'Brien, Registered Patent Attorney, Washington.

**OUTRIGHT**, Automobile inner-tube tester, spherifire. Geo. Mancos, Westhampton Station, Richmond, Va.

**MANUFACTURERS** Looking for new inventions should write W. T. Greene, 939 Barrister Building, Washington, D. C.

**MANUFACTURERS**—Get our complete list of inventions for sale. American Society of Inventors, Crosby Bldg., Buffalo.

**INVENTORS**—Cash in on your invention now! Don't delay the sale any longer! Send for a free copy of our specially prepared booklet, "Turn Your Patent into Money," today! It contains helpful information for all inventors. M. L. Rund, Mgr. Classified Advertising, Popular Mechanics Magazine, 290 E. Ontario St., Chicago, Ill.

#### MODELS AND MODEL SUPPLIES

**INVENTORS**: Send us sketch or crude model of your idea. Crescent craftsmen will develop it into a practical working model. 30 years of successful experience and thousands of satisfied clients. Confidential service guaranteed. Bank references furnished. Free illustrated book: "Making Inventions Pay." Crescent Tool Co., Dept. 8-1, Cincinnati, Ohio.

**TIME** Counts in applying for patents. See pages 138 and 139. Clarence A. O'Brien, Registered Patent Attorney, Washington, D. C.

**DO-X** Blue Prints. 7 full size drawings \$1.50. Famous enterprise (boat) blue prints. 6 full size drawings \$1.50. Free catalog. Hawk Model Co., 4944 Irving Park Blvd., Chicago.

**THREE** Ship model plans for \$1. Catalog 6 cents. Richter's, 3227-A West Walnut St., Milwaukee, Wis.

**SCALE** Model railroad supplies—not toys. For hobbies or railroad exhibition work. The first and only complete model railroad catalog in the country—35c with credit slip. Well illustrated, parts for five gauges. American Model Railway Company, New Rochelle, N. Y.

**BUILD** The famous patented Multicraft Woodworker, 8 practical machines in one, most advanced invention, nothing like it. Blue prints and full details, \$1.00 cash with order. The Multicraft Co., 1445 Rivard St., Detroit, Mich.

**SHIPMODELER**. Magazine of the ship model makers' club. Sample copy 20 cents. 55-A, Midland St., Brooklyn, N. Y.

**EXPERT** Craftsmanship for developing of ideas, working or demonstration models. Confidential service guaranteed. J. W. Olsson, 112 Swan St., Seattle, N. Y.

**SHIP** And yacht model fittings. Send fifteen cents for illustrated catalog No. 7. A. J. Fisher, 1092 Etowah Ave., Royal Oak, Michigan.

**WE** Make working models for inventors and do experimental work and carry a complete stock of brass gears and model supplies. Send for catalog. The Pierre Model Works, Tinley Park, Ill.

**MODEL** Steam engines and boilers for model power boats. Boat and boiler fittings. New catalog 15c. Model Machine Shop, 212 Price St., Rahway, New Jersey.

**POWER** Models. Steam and gasoline engines, accessories, supplies, metals for model-makers. Catalog 35c. Chas. Cole, 1355 Church St., Ventura, Calif.

#### MANUFACTURING

**WE** Develop small and medium size working models and mechanical devices to specifications. Experimental work. Tools, dies for light manufacturing. Dependable Tool and Mfg. Company, 3115 No. Racine, Chicago.

**MAJESTIC'S** Engineering department is devoted to improving your product without charge. Experienced craftsmen manufacture your dies, stampings, deep drawing, casting, screw machine and wire specialties very economically. Plating, enameling, assembling, boring, warehousing. We recently doubled our space to better serve our customers. Estimates promptly submitted. Majestic Products Mfg. Company, Box 877, Chicago.

**MANUFACTURING** Novelties, inventions, metal moulds. Automobile cap fitting Venus. Baum's Metal Specialties, Kansas City, Mo.

**EXPERIMENTAL** Work. tools, dies, stampings, contract work, models. Edw. Persberg, Northfield, Ohio.

**SPECIALIZED** Complete manufacture, dies, tools, special machinery and patterns. Models made. Atlas Indicator Works, 821 W. Washington, Chicago, Ill.

**SPECIAL** Machinery or parts, dies, tools, metal specialties, models, special gears, stock gears and model supplies. Send for catalog. The Pierce Model Works, Tinley Park, Ill.

**LOW** Cost manufacturing. Large plant completely equipped for blanking, drawing, stamping and wire forming in any finish. Can save you money on your product. Our figures will convince. Eastern States Products, Box 721, New Haven, Conn.

**WHITE** Goods made to order. Cooley Mfg. Co., 310 N. Western Ave., Chicago.

**ECONOMICAL** Manufacturing from sheet, bar, wire or tubing. Models, dies, special machinery. Swanberg, 5124 N. Kildare Ave., Chicago.

**METAL** Articles developed and manufactured. Model making. Reasonable price and first class workmanship. W. F. Meyers Company, Bedford, Indiana.

**FAMOUS** Bailey Handbook—Prepares you to pass the examination for any grade of license for stationary, marine and Diesel engineers, firemen and boiler inspector in any state of the Union or any province of Canada. Flexible cover. Handy pocket size. Pay postman \$2.00 plus postage when he hands you the package. Popular Mechanics Press, Room 802, 200 E. Ontario St., Chicago, Ill.

#### FOR MANUFACTURERS

**THE** International Sales Co., with more than 2,000 salesmen and the largest exclusive mail-order coverage wants to hear about your profitable specialties. You may write us freely, for we have a reputation of 38 years fair dealing and successful selling. Address: 185 N. Wabash Ave., Chicago.

#### BENDING MACHINES

**THE** Famous Hossfeld "Wrenchless" Universal Iron Bender is the last word in bending machines. Bends metal, coil or bar, into most any conceivable shape. Including Eye Bolts and Automobile Spring Eyes. Bends up to 1" bars or 1½" pipe cold. Also bends "Angle Iron." Thousands in use by all classes of trade, from the smallest shops to the largest railway systems. Write for circular and prices. Hossfeld Mfg. Co., Winona, Minn.

#### SURVEYING INSTRUMENTS

**GUARANTEED**—Rebuilt transits and levels—all makes any type. Cash or easy payment. Satisfaction guaranteed. Don't put it off—write today for list M-54. Warren-Knight Co., (Makers of "Sterling" Transits and Levels) 136 N. 12th St., Philadelphia, Pa.

#### WELDING AND SOLDERING

**BARGAINS**—Excellent repossessed arc welders, buffers and grinders. Entirely rebuilt—guaranteed. Trial. Terms. Write Ken's Service, Box M412, Troy, Ohio.

**SHOP** Notes for 1931. Get your copy now. Only a limited edition. Contains all the articles published in the Shop Notes department of Popular Mechanics Magazine during 1930. Send 50 cents. If you want the entire set of Shop Note books consisting of 12 volumes including the 1931 number and 11 others issued previously we will send them C. O. D. at a special reduced price of \$3.75. Popular Mechanics Press, Room 802, 200 E. Ontario St., Chicago.

#### MACHINERY, TOOLS & SUPPLIES

**KELOG** Air Compressors, excellent condition \$6.00. Taylor, 105 East 102nd St., New York City.

15"x6" **SEBASTIAN** Lathe, \$150.00. No. 3½ Fox Hand and Power Plain Milling Machine \$175.00. No. 60 Heald Cylinder Grinder \$500.00. 15" Steptoe Shaper \$200.00. 36"x18" Field Lathe \$750.00. Baldwin Saw Table \$100.00. Parks Combination Woodworker \$225.00. 10" New Drill Press \$21.00. Air compressor, complete with tank, motor, fittings \$100.00. Write for catalog. Cincinnati Machinery & Supply Co., 27 W. 2nd St., Cincinnati, Ohio.

**SUBSTANTIAL** Savings—used arc welders, buffers, grinders, paters, compressors, paint sprays. Entirely rebuilt, guaranteed. Trial and terms. Write Ken's Equipment, Box M413, Troy, Ohio.

**MANUFACTURE** RE Concrete building tile. Big profits. Experience unnecessary. Concrete outfits as low as \$25.00. New! Patented! Send for catalogue. Economy Manufacturing Company, Atlanta, Georgia.

**FOR** Sale—Several engine lathes, from 14"x6" to 26"x10". Bargains. Also motors all sizes. R. H. Roby, Truro, Iowa.

**NEW** 12" Band-saw driven from manufacturer \$17.50. Free circular. Kayro Machine Co., 3974 Parker Place, Cincinnati, Ohio.

**ALL** Sizes gears, pulleys, belting, electric motors, castings. Lowest prices—List 5c. Service Electric Company, Indianapolis.

**ELECTRIC** Bench grinder. Miller Falls hack saw. Mill cutters. Gages, drills, reamers. Stamp For Reply Tool Crib, 130 Bennett St., Bridgeport, Conn.

**LATHES** 8"x1" Bed \$14.00. Bronze bearings. No. 1 M. T. centers, 3 cone pulley, heavy construction. Tunk Mfg. Co., 4065 Waukegan Ave., Chicago, Ill.

**CONCRETE** Building block machines and molds. Easy payments. Catalog free. Concrete Machine Co., 5 North Main St., St. Louis, Mo.

**CASTINGS**, Lathes, 4 sizes, drilling machines, bench grinders, lathe grinders various castings. Kenipp & Son, Mt. Carmel, Ill.

**START** Business of your own, small investment required, doing chromium, nickel, copper, silver plating. This work in big demand. Information free. Electro Platers Supply Co., 28 West Second St., Cincinnati, Ohio.

#### ENGINES, MOTORS AND DYNAMOS

**NEW** ¼ Horse, 110 volt alternating motors, \$0.50; some used, \$1.50. New 1-12 horse, 110 volt universal, \$2.75. New ¼ horse, 110 volt 3,450 speed alternating, \$16.50. Other bargains. Electrical Surplus Company, Dept. 12, 1911 Chicago Ave., Chicago.

**BRAND** New rotary converters, 32r. or 110v. dc to 110v. ac for radio \$37.00. ¼ hp. ac motors \$6.50; ½ hp. repulsion \$14.50. ¼ hp. 110v. dc motors \$16.00. Many other bargains. Queen City Electric, 1736 Grand Avenue, Chicago.

**200** UNIVERSAL Phonograph motors, double-shaft, \$4.00. Ludeke Bros., 61 Beekman Street, New York City.

**TIME** Counts in applying for patents. See pages 138 and 139. Clarence A. O'Brien, Registered Patent Attorney, Washington, D. C.

**WANTED** Used steam engines 1 to 4 horse-power. Engine catalogue postpaid 10c. Howard Engine and Manufacturing Co., 2417 North Ashland Ave., Chicago.

**FAMOUS** Dunlap Fordpower governor and shaft for pulley makes practical gasoline engines from old Ford motors. Price \$10. Dunlap Fordpower Co., Wichita, Kansas.

**AUTO** Engines for stationary or portable power. We make necessary attachments. Canlee-Smith Governor Co., 215 North Los Angeles St., Los Angeles.

**FOR** Sale—Slightly used electric motors, Sixty cycle, 110 volt A.C. One-sixth hp., \$4.50. One-fourth hp., \$5.00. Cash with order. Maytag Chicago Co., 160 E. Illinois St., Chicago.

#### FARMS AND FARM LANDS

**400** ACRES Only \$7 acre, attractive home 8 rooms, bath, furnace, views for miles; orchard, timberlot, brooks, good 60 ft. barn; \$2800 complete, part cash. This, 1600 others in big free catalog. Strout Agency, 257-P Fourth Ave., N. Y. City.

**HOMESTEAD** Free western land. Any state list 25c in coin. Reanos Newton, Murray, Ky.



**FREE** Books on opportunities in Minnesota, North Dakota, Montana, Idaho, Washington, or Oregon. Complete information on climate, crops, location for farm or suburban tract for grain, live-stock, dairying, fruit, poultry—a home, independence, plenty of food, clothing, continuous employment. No occupation offers more to industrious capable men. Write E. C. Leedy, Dept. 257, Great Northern Railway, St. Paul, Minn.

**V.C.N.** Dollars monthly requires five acres pecans, tungs, figs, oranges. Guaranteed care. Big returns. Suburban Orchards, Dept. M. Biloxi, Miss.

**MINNESOTA** Lake Shore. 135 acres excellent unimproved farm land, Wabana Lake Itasca County. Live Farm Bureau community. Fine opportunity for man with limited means. K. W. Thomson, Maple Plain, Minn.

**OWN A Farm** in Minnesota, Dakota, Montana, Idaho, Washington or Oregon. Crop payment or easy terms. Free literature; mention state. H. W. Byerly, 119 Northern Pacific Railway, St. Paul, Minn.

**CALIFORNIA**, Oregon, Arizona and other Western States. Fruit, alfalfa; stock ranches; hunting preserves. \$2.00 acre and up. Crescenta, Box 881, Los Angeles, Calif.

**MUSKRAT**, Beaver, or fur farm lands, \$10.00 down, \$10.00 monthly. Harry B. Bradley, 127 Evans, Oshkosh, Wisconsin.

**MONEY** Made in Michigan potatoes. \$10 down now and easy terms buys land near markets, lakes, streams. Write today. Swartz & Co., P-601, 32 N. State St. Bldg., Chicago, Ill.

**OZARKS**—20 Acres, timbered, \$100, \$5 monthly. Poultry, bugs, fruit; fishing, hunting, trapping. Hubbard, 216 Grossman Bldg., Kansas City, Kansas.

**SELL** Your property quickly for cash, no matter where located. Don't pay big commission. Particulars free. Real Estate Salesmen Co., Desk B, Lincoln, Neb.

**801 PRACTICAL** Ways to Reduce Farm Labor and Expense and Increase Income. One farmer writes he could not part with this information for \$100, if he could not duplicate it. Nothing experimental. These ideas have all been put to test and proven practical. Send today for a copy of our Handbook for Farmers and get ready to put these ideas to operation for your own benefit. Pay postman only 98 cents and the postage when he hands you the package Popular Mechanics Press, Room 802, 200 E. Ontario St., Chicago, Ill.

#### RABBITS

**RAISE** Chinchilla and New Zealand White Fur Rabbits. Make big money—We supply stock and contract for all you raise paying up to \$0.50 each. Large illustrated book, catalog and contract, also copy of Fur Farming Magazine, all for 10 cents. Stahl's Outdoor Enterprise Co., Box 169A, Holmes Park, Mo.

**STABLES** Chinchilla and New Zealand Whites. Guaranteed to satisfy or money refunded. Juniors \$7.00, breeders \$70.50. Large book and catalogue 10c. Hilltop Rabbitry, Willburton, Penna.

**RAISE** Rabbits. We sell on terms and furnish market. Shields Rabbitry, Sweetwater, Texas.

**MAKE** Money with chinchilla, white New Zealand, Silver Marten, fur rabbits. Wholesale prices. Ernest Conrad, 852, Englewood, Colorado.

**RABBITS** And supplies. Complete literature. Dr. Albert Farer, Inc., 115-N, Valley Stream, New York.

#### MINK

**BRED** Yukon, Quebec females. Buy now and raise young. Alaskan Mink Ranch, Earl, Wisconsin.

**MINK**, Labrador, Yukon, Eastern Quebec and Alaskan bred females. March and April delivery. \$60 each. Send 25c. balance C. O. D. Free instruction with shipment. American Minkery, Box M134, Valhalla, N. Y.

**RAISE** Mink—The money makers. Booklet—Why You Should Raise Mink, 25c. Adarkmink Ranch, Onehota, N. Y.

**BIG** Money made raising mink. Free information. Pennell Fur Farm, Dalkena, Wash.

#### MUSKRATS

**RAISE** Muskrats. Extra profit from your back yard illustrated book and wealth of information one dollar. Box 275, Plano, Illinois.

**WHOLESALE** Prices on dark muskrats, \$1.00 for bulletins, on pen raising or swamp raising. Ernest Conrad, 652, Englewood, Colorado.

**MUSKRAT** Farming—The greatest book on one of the greatest opportunities today. Tells of the opportunity in this business and how to do everything in connection with the raising and marketing of muskrats. Pay postman only \$2.25 and postage when delivered or, if outside U. S., remit when ordering. Popular Mechanics Press, Room 802, 200 E. Ontario St., Chicago.

#### DOGS AND PETS

**ABERDEEN** Terriers (Scotties) all ages. Best of bloodlines. Also Boston and Wire Fox terriers. Write, Campbellcroft Kennels, Registered, Plantagenet, Ontario, Can.

\$30.00 buys a coonhound that must please you. Kentucky Coonhound Kennel B113, Keokuk, Ky.

**AQUARIUMS**. Fancy fishes for pleasure and pastime. Water plants, etc. Catalog free. Gemma Aquarium, 3823 N. Richmond, Chicago.

#### WANTED—MISCELLANEOUS

**MAIL** Us your discarded jewelry, gold crowns and bridges, watches, diamonds, silver, platinum. Money promptly mailed. Goods returned if offer refused. United States Smelting Works (The Old Reliable), Dept. 71, Chicago.

**CASH** For old gold jewelry. Highest prices paid for dental gold bridges, filled scrap old watches, diamonds. Check for full value promptly mailed. Your shipment returned if not satisfied. Mail to Standard Gold Smelting Corporation, 23 N. Penn St., Indianapolis, Indiana.

**MAIL** Us your gold jewelry, bullcens, crowns. Prompt payment if offer accepted. Whitehall Mfg. Co., 2902 Leupp, St. Louis, Mo.

**CASH** For gold teeth. Highest prices. Information free. Southwest Gold & Silver Co., Box 68, Fort Worth, Tex.

#### FOR SALE—MISCELLANEOUS

**ADDRESSOGRAPHS**. Letter folders, multi-graphs, envelope sealers, duplicators, less than half price. Guaranteed. Pruitt Co., Suite 108, 190 N. LaSalle St., Chicago.

**FINE** Home workshop outfit—Utilized combination work-shop—lathe, shaper, saws, water, accessories. Cheap for quick sale. Send for details. Aron Tool Company, Toledo, Ohio.

**2 DIFFERENT** Daily used products (value 75c) sent for only 25c. Agents wanted. Selay Products Co., 2459 Station St., Chicago.

**ADDRESSOGRAPHS**. Letter folders, multi-graphs, envelope sealers, duplicators, less than half price. Guaranteed. Pruitt Co., Suite 108, 190 N. LaSalle St., Chicago.

**WATCHMAKERS** Lathe for sale at a bargain. R. Jaegermann, 5815 Easton Ave., St. Louis, Mo.

#### ROOTS AND HERBS

**JUST** Out! 61-page illustrated medicine man almanac. Contains over 500 old-fashioned herb medicine recipes and Indian secrets for home use. 10c postpaid. Worth dollars! Botanic, 145 West 112th Street, Chicago.

#### PERSONAL

**DANDRUFF** Cured completely in five days. Itching scalp, falling or unruly hair or eyebrows immediately corrected with New Way Hair Tonic, a clean, harmless liquid for men or women discovered by a licensed druggist. Try a large bottle. Sent in special for \$1.00. Money instantly refunded if not satisfactory. Superior Manufacturing Company, 2400 Belmont Avenue, Baltimore, Md.

**CHARACTER** Read from handwriting, \$1.00. Send liberal sample with remittance. Verax Graphology Service, Box 424 River Edge, N. J.

**FLYING** Simplified—Just out. Here is a remarkable non-technical book for beginners, prospective or advanced students that teaches in an easily understood manner all you can need to know to master the art of flying. Will save you many dollars when you learn to fly. Pay postman only \$1 and postage when book is delivered at your door C. O. D. Popular Mechanics Press, Room 802, 200 E. Ontario St., Chicago.

**STOP** Constipation without drugs. 48-page booklet, full details, 25c silver. Dr. Cushman, 425 First St. North, St. Petersburg, Fla.

**LOOKING** For employment? Let me show you how and where to obtain it. Mail \$1 bill. I can help you. E. K. Linton, Saginaw, Michigan.

**ASTROLOGY** Reveals your future. Trial astounding. Send birthday with 20c, "Eureka." 3680 East 14th St., Oakland, Calif.

**MIND** Reading, taught, free information. Dr. Mumford, 429 Cottage, Chicago.

**KNOW** Your future. Your complete personal astrological forecast—25 large pages. Employment, love, marriage, etc. Give birth-date. Pay 75c and postage when delivered. Complete satisfaction or money back. Thurston, W-20 W. Jackson, Chicago.

**TOBACCO** Habit overcome or no pay. 500,000 used Superba to help stop cigarettes, cigars, chewing, pipe, snuff. Treatment sent on trial. Costs \$2.00 if successful, Superba Co., 184, Baltimore, Md.

**CASH'S** Women names. For marking men's, women's, children's clothing. Sample free. Outlets's Mail-Order House, 81 Holly, Dent, 20, New Bedford, Mass.

**ASTROLOGER** Can read your life. Test predictions for one year 20c, dimes or stamps. Send year and birthdate. G. Niemeyer, Box 228, Mays Landing, N. J.

#### MISCELLANEOUS

**AMATEUR** Cartoonists: Sell your work. Write Smith's Service, PW1194, Wenatchee, Wash.

**WHOLESALE** Novelties. Sample and circulars Ten cents. Kant Novelty, 246P Third Ave., Pittsburgh, Pa.

**LEARN** Tattooing. Instruction catalogue, dime. Miller, V-431 Main, Norfolk, Va.

**MIRRORS** Resilvered at home. Costs near 5 cents per square foot; you charge 75 cents. Profitable business plating auto-parts, reflectors, tableware, stoves, refinishing metalware etc. Outfits furnished. Details free. Write, Sprinkle, Plater, 288, Marion, Indiana.

**CASH** Paid for butterflies, insects. See Sinclair display advertisement on page 21.

**TIME** Counts in applying for patents. See pages 138 and 139. Clarence A. O'Brien, Registered Patent Attorney, Washington, D. C.

**ARE** You old at forty? See our advertisement on page 41 of this issue. The Electro Thermal Company, 2140 Morris Ave., Scotchville, Ohio.

**FIR** And Pine pillows, plain, \$1.00, Rayon, \$2.00, (wonderful for sick). White birch bark, Postcards, placecards, etc., \$1.00 dozen. Box 30, Presque Isle, Maine.

**200 TRICKS** You can do—Mystify your friends; have loads of fun. This collection of tricks has been selected by Thurston for the average person. Neither unusual skill nor elaborate apparatus are required. Send for this 200-page illustrated book. Pay postman \$1 plus postage when delivered. If outside U. S. remit when ordering. Popular Mechanics Press, Room 802, 200 E. Ontario St., Chicago.

**QUIT** Tobacco easy. Harmless home treatment. No-Ko System, Oriskany, California.

**HOMIOPATHIC** And biochemic preparations sent postpaid to all parts of the world. Booklets free. Halsey Bros. Co., 5547 Ravenswood Ave., Chicago. Established 1855.

**PRINT** Signs, pictures without press, type or machinery. Samples 10c. Straley, 12 1/2 W. Main, Springfield, Ohio.

**TATTOOING** Outfits. Illustrated catalogue, dime. Miller, V-431 Main, Norfolk, Va.

**AMATEUR** Cartoonists—Earn \$25.00 week, spare time, copying cartoons for advertisers. 3-M Syndicate, Argyle, Wis.

**TATTOOING** Outfits, supplies. Illustrated list free. "Waters," 905 Putnam, Detroit.

**YOU** Need a better grip on mathematics? Ask us to send you a copy of "Mathematics for the Practical Man," only \$1.50. By common sense methods it removes the mystery and difficulties so algebra and calculus are made simple. Assuming your knowledge is limited to arithmetic you quickly and easily gain a working knowledge of algebra, geometry, Trigonometry and calculus. Simply pay postman when he hands you the package. Address Popular Mechanics Press, Room 802, 200 E. Ontario St., Chicago, Ill.





# NEW KIND OF AUTO EYES

## Makes Night Driving Safer Than Day!

No more driving "blind" on a crowded highway at night! An astonishing new invention banishes night wrecks and smashups. Ends fear of running over children or animals. Mail coupon quick for the manufacturer's introductory Free Test Offer.

### FITS ANY HEADLIGHT—ENDS DANGEROUS DIMMING—DOUBLES ROAD LIGHT!

**A**T LAST! An amazingly queer yet simple invention lifts the bane and curse of night driving from the motoring world. Actually like magic this altogether new discovery replaces the "bulbs" in automobile headlights with truly amazing results. Road illumination is instantly doubled, yet glare is absolutely banished. Ordinary objects in the road, ruts, animals, obstructions, etc., are made clearly visible at least **three** times as far. Even cuts right through fog, mist, rain and snow. Gives you a solid wall of light 3 feet high, 25 to 30 feet wide. Instead of ordinary "direct" light, this beam is composed entirely of double-reflected or "infused" light. This new kind of beam pours down the highway ahead of you so far that you can actually see to go 70 miles an hour in safety. At a 40 to 50 mile an hour clip, it is positively safer than daylight because all the light is on the road and you see nothing of your surroundings to distract you.

#### INEXPENSIVE

Patent rights in this new lighting invention are fully protected. It is not in any sense a new "attachment." There is no wiring or installation. No extra up-keep. In the past, millions of motorists have paid from \$10 to \$25

for so-called spot-lights and driving-lights that at best are only make-shifts. This new method costs only a fraction as much and actually **doubles** road illumination with your present headlights! Cuts through the other fellow's light so you can see the road, yet absolutely cannot glare in his eyes. No wonder fleet owners, manufacturers, taxi and bus lines, etc., concerns like H. J. Heinz Company (57 varieties), Pittsburgh; Houston Post-Dispatch, Tex.; Wallace & Tiernan, N. J.; Columbus, Ohio, Fire Trucks, etc., are fast turning to this discovery as standard equipment. It's positively needed on every car in America, new or old **right this minute.**

#### Offered On Introductory Test

Every driver who ever rolled half-blind down the highway at night knows exactly what such an invention means in added speed, nervous energy saved, perhaps fatal accidents banished. To prove as quickly as possible to motorists in every section what this invention will do, the manufacturer now makes a liberal **FREE TEST OFFER.** Simply mail the coupon for details. No obligation. **Send it today.**

**HACHMEISTER-LIND CO.**  
Dept. D-30, PITTSBURGH, PA.

### Agent Makes \$525 In One Week

Full-time and spare-time workers. New **FREE DEMONSTRATION Plan with SALES GUARANTEED. EXCLUSIVE TERRITORY.** Sell in bunches to fleet owners. A real chance for \$8 to \$14 very first hour; \$6,000 to \$10,000 a year. Wehner, Pa., made \$1,125 in 90 days' spare time; Owens, W. Va., made \$500 a month; Ebenabade actually made \$525 in one week! No limit for distributors. Use coupon for full details of money-making proposition. It's red-hot! **ACT NOW!**

**HACHMEISTER-LIND CO.,**  
Dept. D-30,  
Pittsburgh, Pa.

Rush details of your Free Test Offer; also facts about agent's money-making opportunities without obligation.

Name.....

Address.....

Town..... State.....

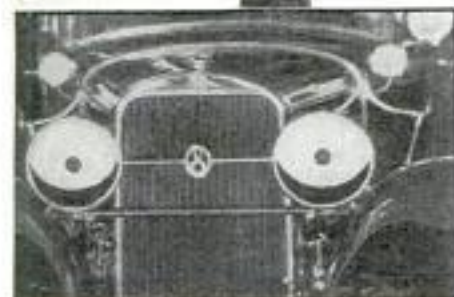

These new kind of Lights even **LOOK** entirely different. No wonder every installation brings a dozen more sales.



Lights up entire roadway, including ditches at side. Gives perfect illumination without shadows or flickering.



Banishes Glare Shields, Spot Lights, etc. Floods the road with light, yet absolutely cannot glare.



# DRAFTING

BOOKS SENT FREE!

ON APPROVAL

NEW 1931 EDITION

**For Beginners**

Written, so you can understand every word, by 22 famous engineers and architects. DeLuxe flexible binding, nearly 2,000 pages, 1546 blue-prints, charts and diagrams; prepares you for a good drafting job in mechanical or architectural lines. Sent for 10 days' free use if you mail coupon immediately.

Only 15 minutes a day with these WONDER BOOKS will prepare you for a good drafting job in less than a year. Mechanical and architectural drafting from simple straight lines to important complex plans. *A step at a time!* Built especially for beginners, for men with only grammar schooling. Drafting room practice. PLUS ENGINEERING, made easy and clear. Includes complete course in blue-print reading.

**Big Field Big Demand Big Pay**

Competent draftsmen are urgently needed right now in all building and manufacturing lines at \$50.00 to \$100.00 a week. That's just the beginning—FOR DRAFTSMEN HAVE THE BEST CHANCES FOR ADVANCEMENT. Pleasant, fascinating work, easy to learn and do. Learn quickly with these books—send coupon for a set FREE and see for yourself. A year's consulting membership in the American Technical Society now given free to all readers of this famous encyclopedia of drafting. Many say that it is worth more than the cost of the books.

## SEND NO MONEY

Don't send a cent on this great offer. Your name and address, with that of your employer or other reference, will bring these books to you absolutely free for examination. Test them, read them, find out anything you want to know and then if you are not more than pleased send them back and you will not owe us one cent. If you decide to keep them, then pay only \$3.00 a month until the special introductory price of only \$19.80 is paid.

AMERICAN TECHNICAL SOCIETY  
Dept. D-419, Drexel at 58th St., Chicago, Ill.

American Technical Society, Dept. D-419,  
Drexel at 58th St., Chicago, Ill.

Send for 10 days' free use New 5 volume set of drafting. I will pay the few cents delivery charges. If I wish, I may return books in 10 days and owe you nothing but if I decide to keep them I will send \$2.00 after 10 days, then only \$3.00 a month until \$19.80, the special introductory price, is paid. Send 1931 edition.

Name.....

Address.....

Employer or Reference.....

Address.....

# Free TO MECHANICS

## Amazing Offer on Brand New

Books just off the press, which cover every phase of Modern Shop Practice. These seven big books contain over 2600 pages, nearly 3000 illustrations and are bound in special gold stamped flexible covers. Everything that any mechanic could possibly be interested in is explained in detail and in simple language that anyone can understand. Machine shop work, machine set-ups, machine repairs, mechanical drawing, metallurgy, forging, shop arithmetic, tool making, pattern making and hundreds and hundreds of other items, any one of which is worth the special price of these books.

## Shipped FREE

Anyone doing mechanical work of any kind can have these books shipped for examination without any penny down. If you want to \$4 yourself for a raise in pay, if you want to make yourself worth more money, if you want to be a tool maker, pattern maker, shop foreman or better superintendent don't fail to look these books over. We mean just what we say. They will be sent to you absolutely free. Don't send us a penny, just your name and address. After you receive the books, then decide whether or not you want to keep them. This is the best way to prove that these UP TO THE MINUTE books should be in every mechanic's hands and that they are worth at least ten times their price to you. This is a Brand New edition.

### JIFFY INDEX

Don't waste time. Don't study long hours to get a result; the Jiffy Index puts facts at your finger tips instantly

American Technical Society,  
Dept. S-419,  
Drexel Ave. at 58th St., Chicago, Ill.

Send the seven volumes, Modern Shop Practice, FREE. If I decide to keep them I will send \$2.00 in 10 days and then only \$3.00 a month until the special low price of \$19.80 is paid. Otherwise I will return the books and owe you nothing. By sending now I will get a free membership in the American Technical Society entitling me to free consultation privileges for one year by letter or wire with 18 experts.

Name.....

Address.....

Employer or Reference.....

Address.....

# Car Washing

now a PLEASURE!

GYRO WHIRLO BRUSH  
washes CARS  
CLEAN!

WITHOUT  
Chamois, Soap or Spray!  
"WATER PRESSURE  
MAKES IT WORK"

Any Garden Hose Will Do



Useful Around the Home

Washes walls, mops, a painting job. Also cleans screens, windows, etc.



Nothing like Gyro Whirlo anywhere. No fuss—no bother. Self cleaning. Guaranteed for 1000 washings.

The days are gone when an autoist must "take a swim" to wash his car! No longer is car washing a process of "drip on drip" with a spongy hose, soap and a slippery chamois. Since the invention of the Gyro-Whirlo Wash, car washing has become a few moments of the easiest work imaginable. Chamois, soap and spray have been discarded as obsolete and unnecessary.

## AUTO OWNERS WILD ABOUT THE GYRO!

Car owners everywhere recognized GYRO as the first real device to simplify auto cleaning. It cleans cars CLEAN in a jiffy. It works on the simple law of water pressure. Water from ordinary garden hose passes thru center-rotating brushes whirl. These whirling brushes cut right thru dirt and mud. They do all the work. You simply brush down the car. Every autoist will buy one.

## 100% PROFIT FOR AGENTS!

Live agents are needed everywhere to demonstrate this amazing invention, needed by auto owners, garages, service stations everywhere. 100% profit for spare or full time workers.

### WRITE AT ONCE!

Send name and address for all particulars. Don't delay or you may lose territory. Even showing to friends will net you handsome profits. WRITE NOW!

### GYRO BRUSH COMPANY

Dept. D-14 BLOOMFIELD, N. J.

## PNEUMATIC

Haenel Air Pistol, most powerful made. Ideal for target, rats, vermin and small game; no license required. Rifled accurate, hard shooting. 10 1/2" over all; wt. 2 1/2 lbs. Ammunition costs a trifle. Any one would be proud to own a Haenel. Guaranteed. .177 or .22 Cal. [500 lead pellets FREE]—\$11.75 Extra Pellets, per 1000—\$17.50; \$22—\$25.00 Write for catalog "W"—Guns, Rifles, etc.

HUDSON SPORTING GOODS CO. W-52 Warren St., N. Y. C.

## New Orange Juicer

Clever new machine ends squeezing, straining, seeding, necessary with old-type juicers. Simply turn handle, gives up 25% more juice. Priced amazingly low. Housewives, hotels, restaurants, etc., buy on sight. Big commission—up to 25% on large full time, spare time. Write quick for BIG MONEY offer!

### KWIKWAY PRODUCTS, Inc.

1415 Pine St., Dept. D-121, St. Louis, Mo.

## PREVENT FATAL NIGHT CRASHES

And Get In On This BIG PROFIT Opportunity!

An amazing "two-beam" light invented by a famous light engineer now gives drivers complete safety at night. Road is bright as day for 1000 feet—yet secret principle absolutely prevents glare! Kinney of Chicago made \$96 in one day! Big territories—a fat share of 23 million prospects. Write today for full facts about this amazing safety Speedlight and find out about wonderful money-making sales proposition.

### SPEEDLIGHT COMPANY

1731 Belmont Ave., Dept. 10-D Chicago, Ill.

67,000 BEAM CANDLE POWER  
ONE FIFTH OF MILE OF LIGHT  
NO GLARE

SPEEDLIGHT BEAM

LOWE'S SIGN





Join with 1,000 other men and women . . .

# Accept free trial membership in Putnam's new 15-Minutes-of-English Club

. . . for quick mastery of  
*Correct English and Fluent Speech*

New method gives mastery of every phase of written and spoken English in only 15 minutes of leisure time daily. Ends embarrassing, costly mistakes. 5-VOL. CLUB SET makes a five-step short-cut to your greatest business and social advancement. NOT a "correspondence course"—CLUB SET is complete in itself—Sent FREE for five days' trial of plan.

**H**ERE is your opportunity to acquire the poise and the self-confident bearing that are yours when you KNOW you are using correct English. A new nation-wide Club is being formed and you are invited to be one of the first 1,000 Charter Members. The new 15-Minutes-of-English Club shows you how to overcome every weakness in your spoken and written English—quickly, easily—in only 15 minutes a day of your leisure time.

Here is the true secret of getting ahead! Every successful man or woman has used this great aid to business and social advancement. More than anything else, your language reveals your true culture and refinement. As the photographic scene at the right shows, even what you may now consider "little" mistakes may be causing others to form a poor opinion of you—may be holding you back from your greatest advancement.

The 15-Minutes-of-English Club offers you this mastery of correct English and fluent speech through the remarkable five-volume CLUB SET. This Club Set covers all your needs. Whether your

"weakness" is in English, in Pronunciation, in Vocabulary, in the ability to write the many forms of Social Letters, or to influence others through effective Speech-Making—the 15-Minute Club Plan is ready to help you.

The five-volume Club Set allows you to concentrate upon your special weaknesses and to correct quickly all your errors. This is not a long-drawn-out "correspondence course" that you must arbitrarily follow through from start to finish, with "home work" and "examination papers." You receive the five volumes all at one time. You use them first to check and correct your present mistakes and then for handy reference—showing you always, to meet all situations, the correct thing to say and how to say it!

You have always wanted the certainty that you were speaking correctly, the



An important social function that could mean so much to their advancement—but their very first words showed glaring errors in English. All who heard them couldn't help feeling that they were not accustomed to associating with people of culture and refinement.

freedom from embarrassment caused by mistakes in English, the ability to express yourself clearly and most effectively. Find out how the 15-Minutes-of-English Club plan can help you—accept free trial membership. Take advantage of the liberal offer below—get the five-volume Club Set free for five days' examination. Then see how quickly and easily you can master this way every phase of written and spoken English.

## 5-VOL. CLUB SET SENT FREE for 5 days' examination!

Charter Membership in the 15-Minutes-of-English Club gives the privilege of five days' free examination of the Club Set. Just mail the coupon and the complete five volumes in the specially designed book-box will be shipped to you, all charges paid. Then during the five days go through each volume, test yourself, correct errors you may now unconsciously make, and "sample" all of the many amazing features.

After thorough examination and actual use of the Club Set, if you are not entirely satisfied that this

new plan can help you to your greatest business and social advancement, return the five volumes at our expense! No risk—you need send no money now. If after five days' actual test you decide to become a Charter Member, keep the five volumes and the free book-box and make the five easy, monthly payments as stated in the coupon. Otherwise return the books at our expense and pay nothing! Don't "put off"—mail the coupon NOW—before it is too late. Send to: G. P. PUTNAM'S SONS (Dept. 244), 2 West 45th St., New York, N. Y.

G. P. PUTNAM'S SONS (Dept. 244), 2 West 45th St., New York, N. Y.

Gentlemen: I accept free trial membership in your new 15-Minutes-of-English Club. Send the 5-VOL. CLUB SET at once, all charges paid, for five days' free examination. If I wish to keep the books and the free book-box, at the end of five days I will send \$2.00 and then \$2.00 each month until \$9.85 has been paid, or I will send \$9.00 at once in full payment. Otherwise I will return the books at your expense and owe nothing. There are no dues nor other payments except for the Club Set. Ship to

My Name.....

Street & No.....

City & State.....





a 390

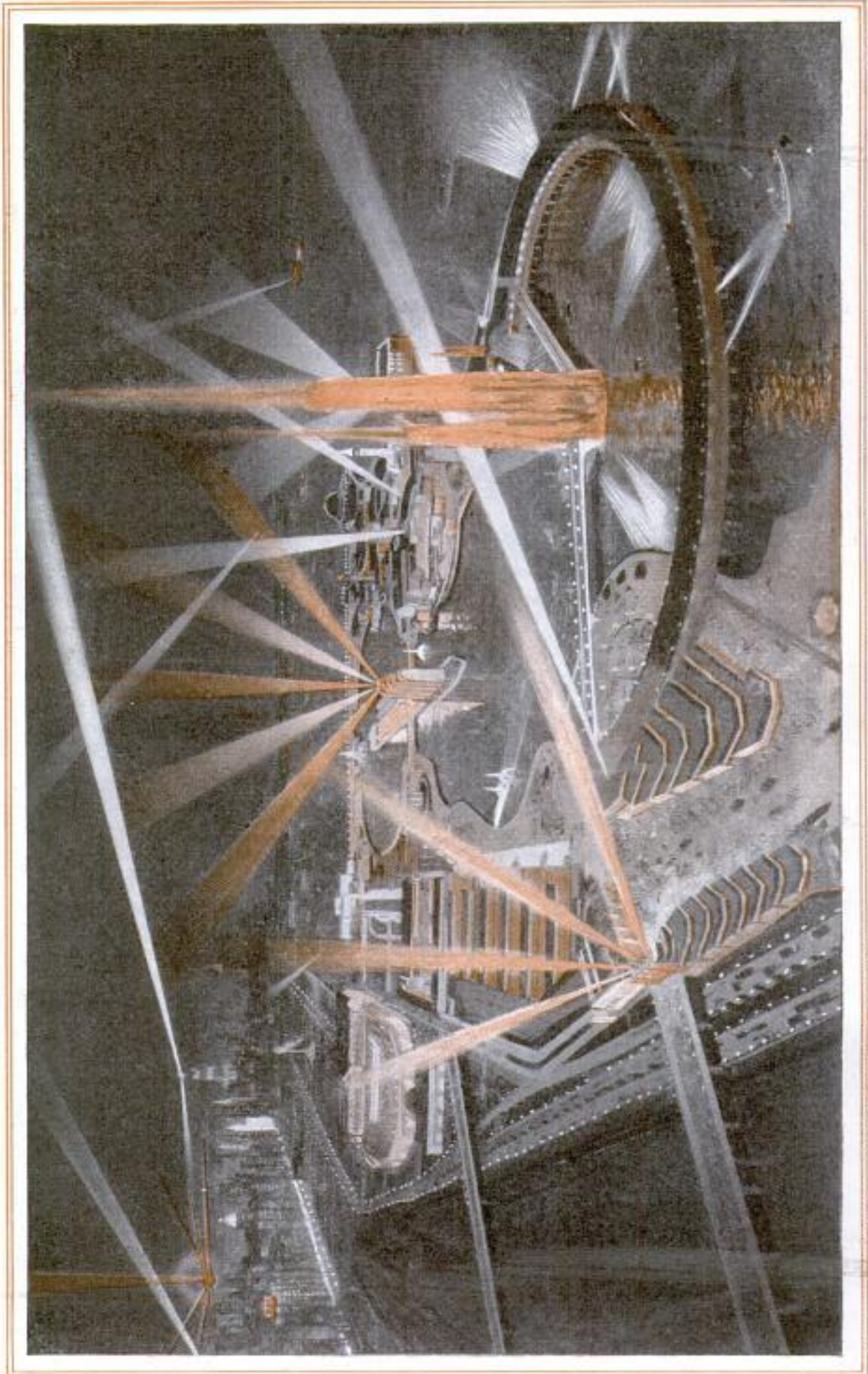

Visitors to the Chicago World's Fair in 1933 Will Enjoy a Night Scene Somewhat Like That Above; It Shows Some of the Buildings to Be Constructed on the Lake Front, Together with the Contemplated Lighting Effects; Models of the Structures Were Used in Composing the Picture

Drawn by Wm. Macy, Copyright Chicago Aerial Survey Co.

332 S. Michigan Ave.

Copyrighted material



# Popular Mechanics Magazine

REGISTERED IN U. S. PATENT OFFICE

WRITTEN SO YOU CAN UNDERSTAND IT

Vol. 55

APRIL, 1931

No. 4

## To Europe (via) the North Pole!

A. 295

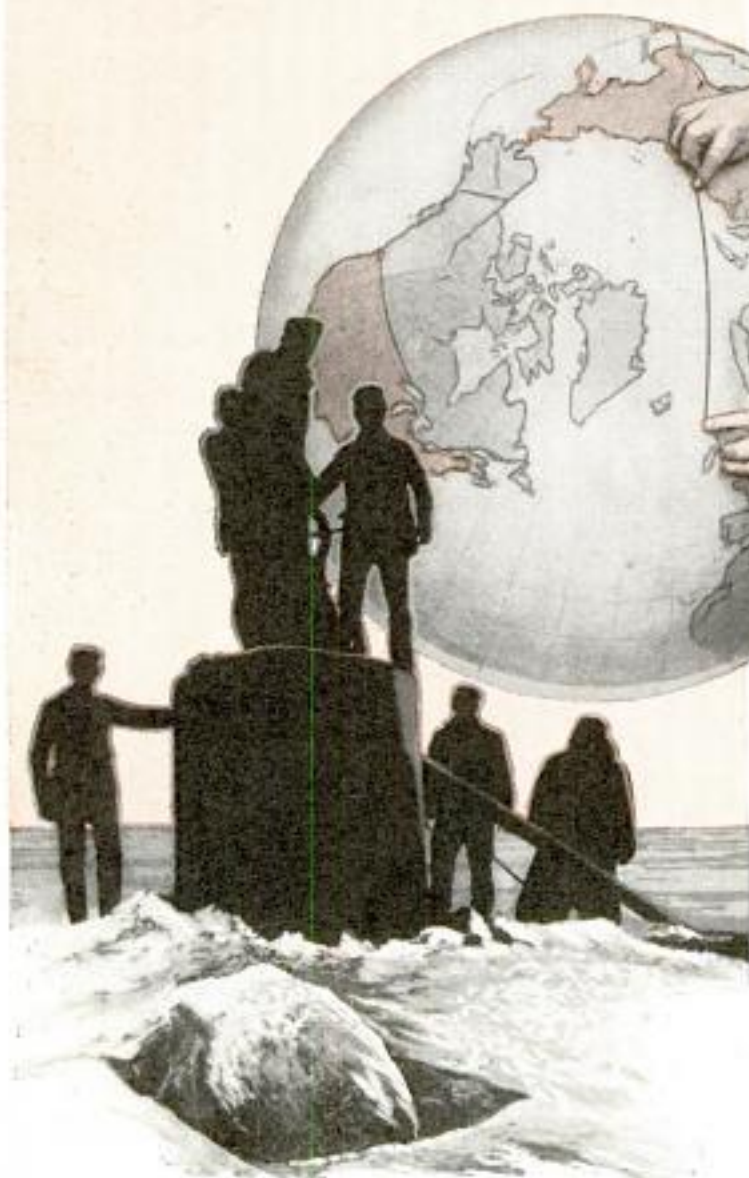

polar ice cap, on a course extending from Spitsbergen, across the top of the world, through Bering strait and on to some Pacific coast harbor, will open a new era in undersea navigation, according to Simon Lake, noted inventor, designer and builder of submarines.

The voyage will be attempted during the coming summer. For many months, Mr. Lake has been at a Camden, N. J., shipyard, preparing a submarine for the trip. It is no new job to him. Already he has been successful in navigating an undersea craft beneath fields of thick ice. In his little submarine, the "Defender," fitted with ice-breaking devices, he has demonstrated

Conning Tower of Sub Emerging through Ice, and Simon Lake, Showing One Trade Route He Expects to Open

THE SUCCESSFUL completion of the first submarine cruise beneath the

Cont. John L. Coggswell, 16,

Edgewater Road, Belmont, Mass

Budgetpost, Conn



a-295  
530



A Small Submarine Returning to Harbor after Demonstrating Its Ability to Break through Fields of Ice by Rising from Beneath Them

unqualified opinion that the arctic trip will be a success from start to finish. Furthermore, he declares, it will be of the greatest importance to shipping interests the world over. In fact, he deems it so important that he has already prepared complete working plans for a big cargo-carrying submarine, and is ready to start its construction.

This new submarine is a real colossus as compared with any heretofore built. Fighting submarines average well under 200 feet in length. The giant undersea cargo carrier, the "Deutschland," that in the early days of the world war made successful voyages between Germany and the United States, was

the ability of the craft to submerge, take position under a heavy field of ice and by its buoyancy smash through to the surface.

True, these excursions under the ice were of very brief duration compared with the Spitsbergen to Bering sea voyage, but the veteran submarine builder is of the

315 feet in length and had a beam of thirty feet, with cargo capacity of about a thousand tons. The new Lake submarine will have a length of 395 feet, a beam of fifty-six feet and will be capable of carrying a load of 7,500 tons.

"There is a real place for such a craft in the shipping of the world," declared

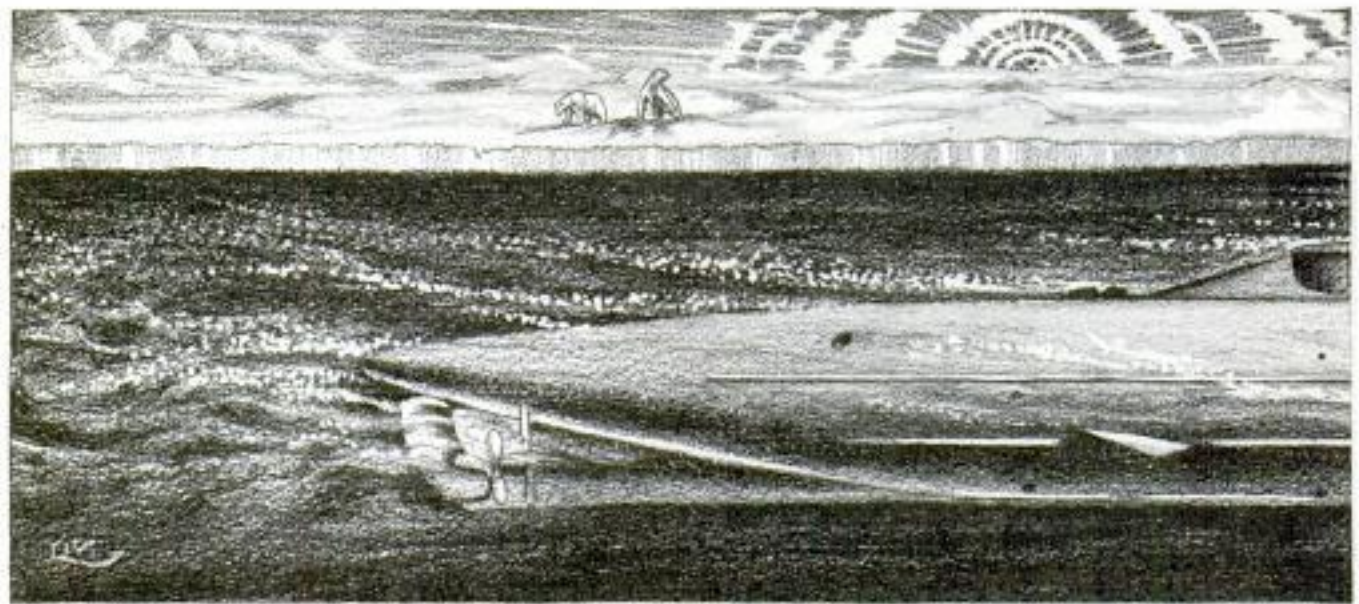

A Giant Cargo Submarine Which Is Intended to Carry Freight to Europe by Taking the Short Route through the Arctic Ocean, Making the Trip under the Ice



Mr. Lake in an exclusive interview for Popular Mechanics Magazine. "The cargo-carrying submarine will afford a vehicle for shortening many world shipping routes and lessening of elapsed time between the port of loading and the port of unloading.

The supreme directness of these submarine routes proposed by Mr. Lake cannot be appreciated by study of an ordinary flat map, which distorts distances and even directions. Tracing them out on a globe, however, makes the matter clear.

"Let's take a look at these routes," suggested Mr. Lake, stepping to the globe. "The distance from Liverpool to Yokohama by way of the Panama canal is a little over 13,000 miles. That's the shortest route available to a surface vessel. A submarine, capable of cruising beneath the ice, finds this round-about path replaced by an absolutely straight course—the one up through the Arctic ocean. The distance from Liverpool to Yokohama, via the north pole, is 5,800 miles, a saving of more than half the mileage. Going from Liverpool to Seattle by the latter route would mean a

saving of about 4,000 miles over the Panama canal route.

"A submarine can cruise as rapidly as the ordinary cargo surface craft. Furthermore, lying low in the water, its progress will be little retarded by head winds. In the event of encountering heavy gales, the undersea craft can submerge and proceed in the calmness of the lower waters.

"The submarine capable of cruising the arctic seas will open up vast storehouses of natural wealth, at present unreachable. North of the arctic circle, close by the mouth of the Mackenzie river are great de-

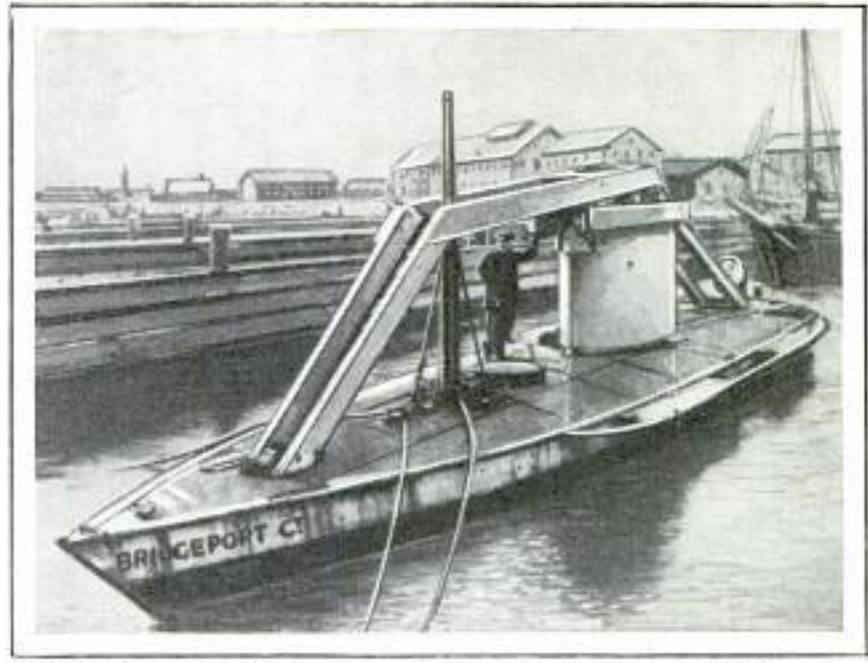

A Small Submarine Fitted with an Ice-Breaking Attachment, Enabling It to Rise under the Ice and Force Its Way Up

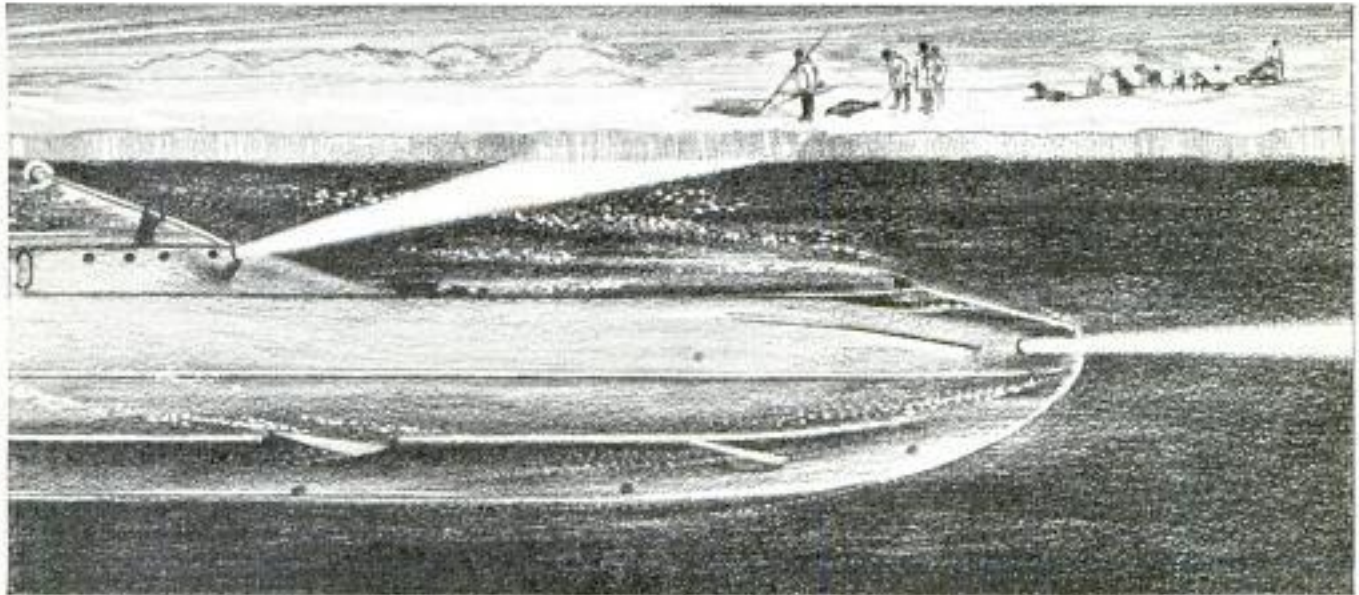

The Diagonal Attachment, Like a Street-Car Trolley Pole, Is Intended to Protect the Submarine from the Ice; the Boat Also Would Carry Ice-Breaking Attachments





Above, Sealing Vessel Caught in Ice, a Fate the Submarine Would Avoid by Traveling under the Floe; Right, German Submarine That Brought Load of Dyestuffs to America during World War

posits of copper ore so rich that one may pick the virgin metal out of the seams. Besides copper, the same district has huge deposits of high-quality coal and petroleum. The submarine will make them available.

"Then, consider Siberia. There's a wondrous store of wealth locked up in her inaccessible expanse. Under present conditions, the expense of getting out her gold, silver and base metals and the great crops of grain that could be raised on her fields with their twenty feet of rich, black loam, would take all the profit out of the operation. However, five great rivers, open to navigation for several months of the year, lead from the interior to points on the Arctic ocean coast. River boats could bring this vast store of wealth down to ports established at the river mouths. These harbors are ice-bound the year round, but a cargo submarine could reach them at any season.

"The testimony of polar explorers proves the practicability of navigation beneath the arctic ice. Their evidence is that there are no bergs in the great ice cap, to form an impediment beneath the surface; glaciers are necessary for the formation of ice bergs and glaciers form on land. No land has as yet been discovered in the polar district.

"Both those who have traversed the ice cap with dog teams and those who have

flown above it, declare that there are many open leads of water at intervals throughout the flow. This is another factor in favor of submarine navigation of the route. A submarine cannot cruise indefinitely beneath the surface; the craft must have access to the open air at intervals so that the engines may be run to recharge the batteries that give power when cruising below.

"However, even if no

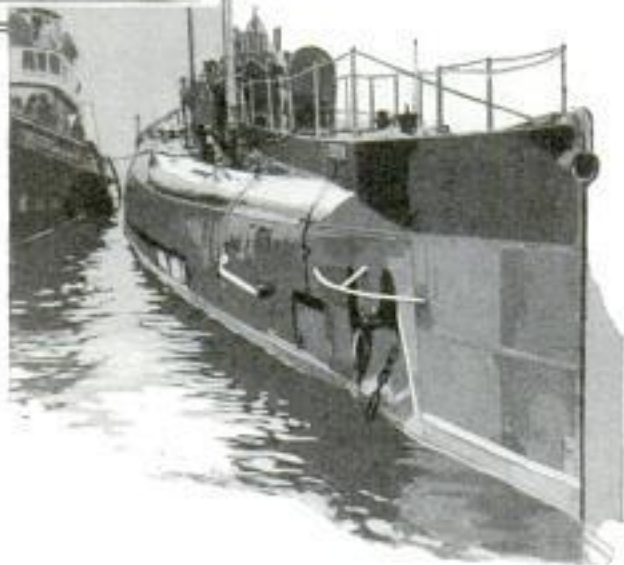

open leads are encountered, a properly equipped submarine will have no difficulty in recharging her batteries. In the Gulf of Finland, I demonstrated the use of an ice-boring machine attached to the deck of the submarine and operated from the interior. There was no difficulty in boring upward through some twelve feet of solid ice, running up an air-intake pipe and operating the engines, with the craft several feet below the surface.

"The cargo submarine designed for under-ice navigation will, of course, be equipped with an ice borer. The upper part of the hull will carry a device of proved practicability for smashing through fields of light ice.

"It is my prediction that a direct outcome of next summer's cruise from Spitsbergen to Bering sea, will be opening of the northwest passage to regular traffic."



ALL THRILLS OF GOLF IN TWENTY-FIVE-FOOT RING

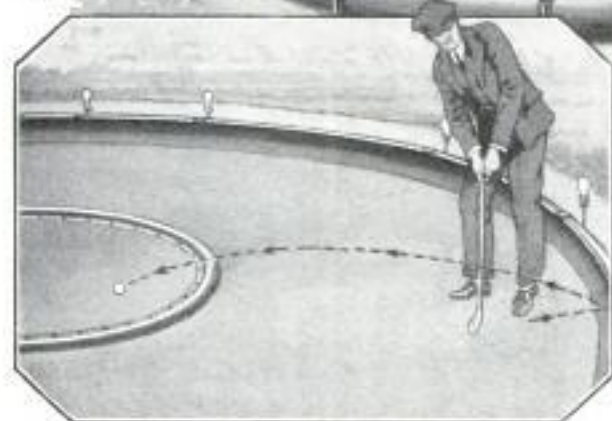
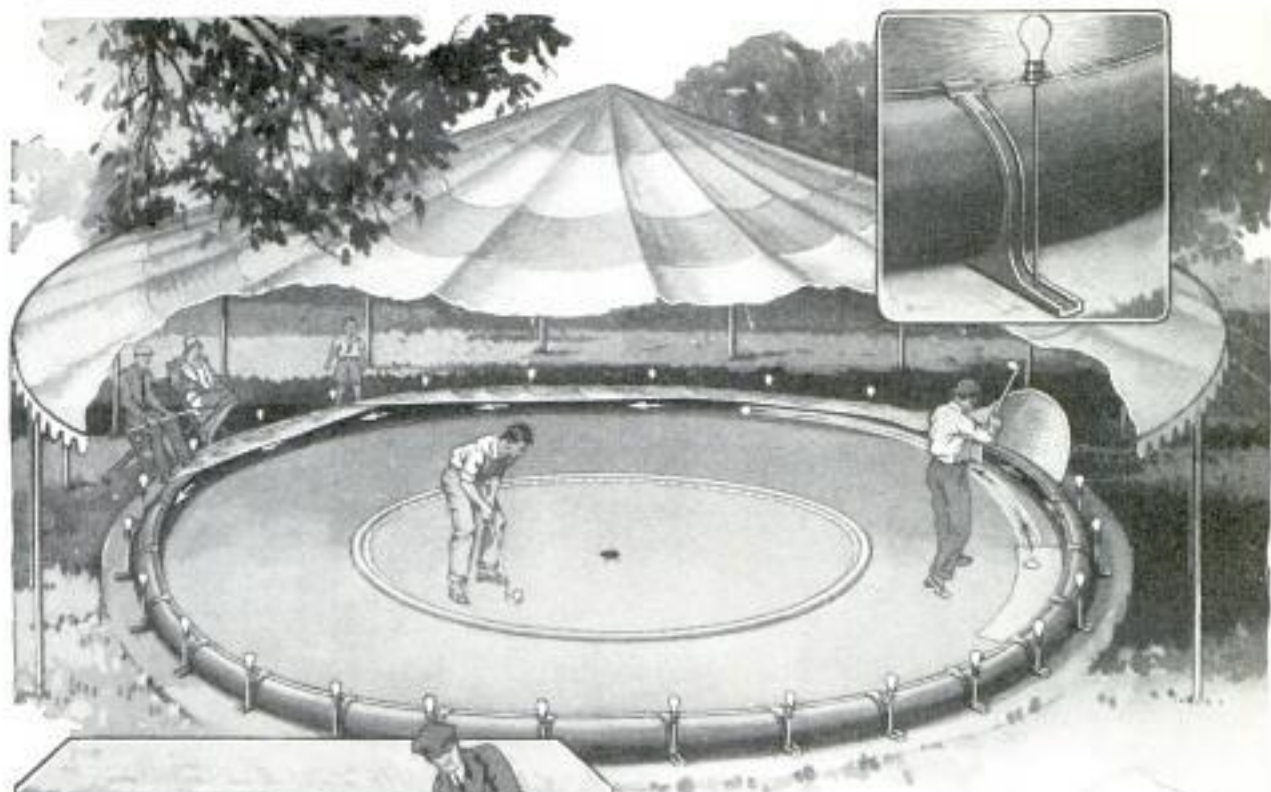

How a 300-Foot Drive and Many Other Shots Are Possible on a Twenty-Five-Foot Circular Golf Course Surrounded by a Concave Ring in Which Ball Travels

All the thrills, hazards, difficulties and shots that are possible on a real golf course are contained within the space of a twenty-five-foot circle in the latest variation of the miniature course. The course, however, is miniature only in the sense that it occupies a small extent of space and can be set up on the lawn or in a large room, for it offers virtually every kind of stroke that can be made on any fairway, from 300-yard drives to exasperating bank and chip shots. The secret of making a 300-yard drive within the restrictions of a twenty-five-foot circle lies in the construction of the frame. The cast-iron ring, about a foot high, is molded in a deep concave shape. It is in this grooved circle that the ball travels when

the player takes a healthy swing from a tee beside the one-yard line. If the swing is executed in proper form, the ball is sent into the groove, the centrifugal force keeping the pellet traveling many times around this groove which offers little friction. If the blow is improperly executed, the ball flies upward against a net which extends over the rim of the ring halfway round the circle, and its force is wasted. The ring is marked in yards, one trip around its circumference representing twenty-five yards, so the yardage for each stroke is quickly estimated when the ball stops. The cup is in the center of the circle, but at a distance of six feet from it is a ring of cotton hose, folded so its outer edge presents an effective trap for the ball at every point. The only way of reaching the green is by employing bank or chip shots. Execution of a successful bank shot is difficult, even for the expert golfer, because the bank must be made against the concave surface of the outer ring, and unless the angle is calculated with exactness, the ball is almost certain to fall short or overshoot the green. Once on the green, there still remains the possibility that a six-foot putt will be necessary to hole out.



BOAT SPEEDS MORE THAN HUNDRED MILES AN HOUR



Photos by Planet News, Ltd.

Two Views of the Speedboat "Miss England II," in Which Kaye Don Recently Broke the World's Speed Record

Driven by Kaye Don, British racer, the speedboat "Miss England II" attained a speed of more than 107 miles an hour to set up a new world's record during recent tests on Loch Neagh, near Belfast, Ireland. A pace of 110 miles an hour was not officially recognized during the trials. This is the craft in which the late Sir Henry Segrave, British automobile racer, was killed when it capsized in Lake Windermere. Since that accident it was overhauled and repaired for a race at Buenos Aires, in which Don also will act as the pilot.

**INCREASE IN AIR PASSENGERS  
30% CARRIED BY U. S. PLANES**

American air-transport lines in 1930 carried 385,910 passengers, an increase of 133 per cent over 1929. Thirty-four major lines, according to a survey of the aeronautical chamber of commerce, were op-

erated regularly over more than 50,000 miles of airways in the United States, southern Canada and a score of Latin-American countries. These lines flew 28,833,967 miles, a forty-two-per cent increase over 1929. There was a marked increase in safety, only one fatality being recorded for every 3,900,000 passenger-miles. Less than seven per cent of the 53,000 scheduled trips were canceled or not completed, bad flying weather accounting for nearly all incom- pleted trips. A few trips were canceled because of insufficient traffic, but mechanical difficulties accounted for only a minute fraction of the trouble. More than 8,000,000 pounds of air mail were carried, an increase of about 1,000,000 pounds.

a-316  
**GIGANTIC BRIDGE SPAN LIFTED  
BY PULLEY-BLOCK METHOD**

Lifting a heavy load in a warehouse is accomplished simply by hanging a pulley block from the ceiling, attaching another to the load, and hauling on a rope passing through the pulleys. The same principle was recently employed by engineers faced with the job of lifting two spans of a steel-truss bridge, each 139 feet long and weighing forty-five tons. The problem arose when it was found that, because of a new dam, a bridge near Stanwood,

*N.Y. Herald Tribune  
2/8/31*

*Slavis Bridge  
near Stanwood  
Mich.*

Copyrighted material



*Amb. O. A. Swadlow,  
5542 Marmora Ave*

*A. 288*

*Chicago*

Mich., would have to stand twenty-nine feet above the mean water level which required lifting the spans twenty-one feet to concrete abutments, one at each side of the stream and one in the center. Steel columns and crossbars were mounted on the foundations and pulley blocks were suspended. Each span was raised separately by rigging pulley blocks at each corner, the upper block attached to the temporary frame and the lower lashed to the lowest part of the bridge structure. Cables, passing through each set of blocks in a six-part line, were pulled by two two-drum hoists, one on each side of the river, and the use of six-part lines on each of four corners, thus making the load actually lifted by each drum of each hoist a little less than two tons. Each corner was raised four inches at a time, and the first span was lifted in less than three hours, the second one requiring even less time.

### BETTER INSULATION IS FOUND FOR ELECTRIC WIRES



Preparing to Apply Solventless Varnish Insulation to Electric Equipment in Container

### AIRPLANE FOLDS INTO TUBE TO FIT SUBMARINE

*A. 29*

Successful test flights have been made by the navy with a collapsible seaplane that can be taken apart and folded into a tube in three minutes for carrying on a submarine. It has a wing span of thirty-one feet, a length of forty-nine feet and develops a speed of approximately 100 miles an hour. The wings do not fold but are easily and quickly detached. The engine drives a pusher propeller and folds down upon the fuselage. Wings and propeller are constructed to fit into a tank turret on the submarine, while the folding fuselage fits into a larger tank.

Successful tests recently have been concluded by the Westinghouse Electric and Manufacturing company with a solventless varnish insulation for electric wires that is expected to save the electrical industry over \$1,000,000 a year. The insulation provides a new method of forcing electricity to follow a prescribed path, and is applicable to virtually every field of the industry from tiny clock motors to electrical giants. The varnish completely fills the pores of the fibrous material between the wires, becoming an integral part of the electrical apparatus. The varnish is placed in a container, heated to make it flow freely, and the object to be insulated is placed in a second container and the lid is clamped down. The air inside is removed to form a high vacuum and pressure is applied, after which the varnish is drawn from the first container into the second, until the object is submerged. Apparatus so treated have no hot spots such as develop in ordinary impregnating materials where air holes are likely to form, making the insulation poor.

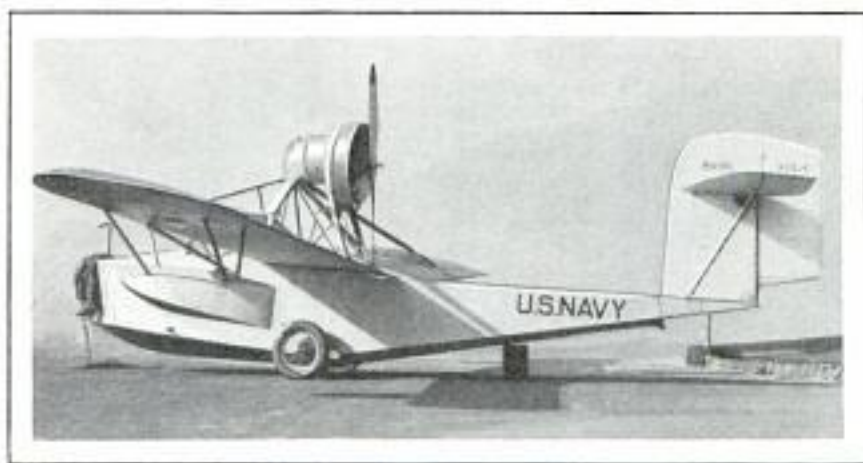

Collapsible Airplane That Can Be Taken Apart and Folded into a Tube in Three Minutes for Carrying in a Submarine

*Being tested by Loening Laboratories*



a. 277.

SUBMERGED FLAME MIXED WITH WATER IN BOILER

C. Featherstone Hainey and Submerged Combustion Ltd. 28 Victoria St. Westminster, London, S.W. 1, Eng.

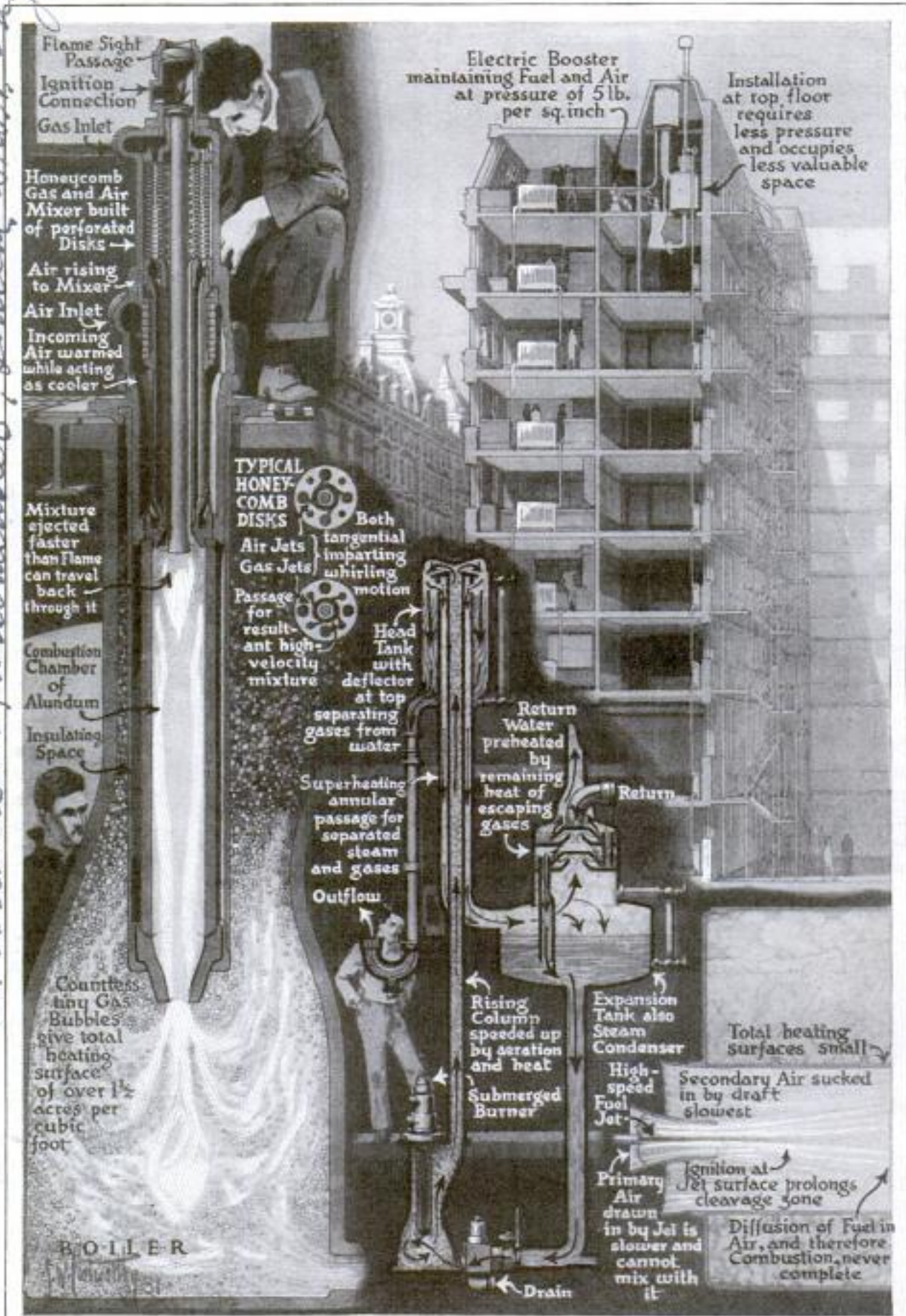

Drawing by J. W. Clatworthy

Copyrighted material



A-27  
 W. C. Featherstone  
 Hainmond.

California Sheet  
 Metal Works  
 52nd Street

POPULAR MECHANICS

FLAME BURNING UNDER WATER  
 FOUND MORE EFFICIENT

For heating boilers, a remarkable system of submerged combustion, in which the flame, burning under water, is applied directly to the liquid, has been tried successfully in England in actual heating installations. This system differs radically from an earlier process wherein the flame of an oxyacetylene torch burned in a space blown clear of water by compressed air. The latest flame is intimately mixed with the water itself, a honeycomb device, through which gas and air pass, insuring a perfect mixture of the two in order to achieve virtually complete combustion in the boiler. The method is based on the fact that the flame is generated faster than it can be dispersed and is therefore unquenchable. The speed of the flame in the combustion chamber reaches 300 feet a second. It is in the enormously increased efficiency that submerged combustion scores over the ordinary plant, shown on the opposite page at the lower right, due to the great total heating surface provided by countless bubbles, as compared with the usual furnace sides. These gas bubbles give a heating surface of over one and one-half acres per cubic foot. At the upper right in the drawing is shown an actual installation with automatic push-button control.

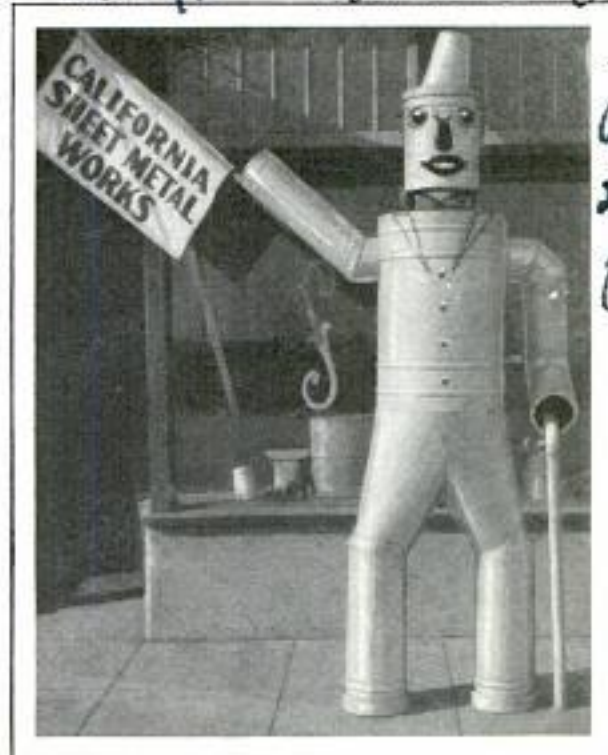

He Looks Like a Mechanical Man, but the Robot Figure Only Calls Attention to a Sheet-Metal Shop

ROBOT OF SHEET-METAL PIPE  
 ADVERTISES SHOP

Taking advantage of the vogue in robots, or mechanical men, for advertising purposes, a California sheet-metal dealer constructed a realistic replica to attract attention to his wares. The figure, which cost but a few dollars, was placed in a conspicuous position outside the store and was made more effective by using bright paint for the face markings.

FOLDING FACE MIRROR SHOWS  
 SIDES AS WELL AS FRONT



Two facing mirrors are joined together by a hinged handle so that when they are opened, they show the front and sides of the face, and may be adjusted to obtain a view of the back of the head as well. The outer covering of the mirror is a durable substance re-

sembling mother of pearl, and since the glasses fold together, they are protected from dust and from being scratched.

ELECTRIC EYE WATCHES STAR  
 TO GIVE ACCURATE TIME

To give an absolute check for setting the clock, a photo-electric cell, or electric eye, is used to record with utmost accuracy the passage of a star over a given meridian. For this purpose, the cell is placed behind the collimator slit of an astronomical telescope, a hair line being focused at the middle of the slit. When the image of the star comes upon one edge of the opening, the light passing the edge is used to produce a musical note in an auxiliary device connected to the cell. When the star coincides exactly with the hair line, the light and also the musical note are interrupted. Simultaneously a photographic record of the transit is made.

All-View Mirror Co. Inc.  
 11 W. 42nd St. New York

Details from  
 contributor  
 Charles A. White

Long Beach Long Beach Cal

3/3  
 Details for tests at



A-285

Carl Lees, H. Eckhardt  
4528 Walnut  
Phila

Originated by J. A. De Bruine and  
H. A. Johnson, U. S. Public Health  
Service



Outboard-Motor Boat Equipped with Power Blower Used to Dust Mosquito-Infested Waters

### POWER FAN KILLS MOSQUITOES BY BLOWING POISON DUST

Portable power fans, installed on outboard-motor boats, are being used with much success in mosquito extermination in some areas. The boat is propelled in mosquito-infested waters, and the fan dusts the area with Paris green and powdered lime. Only one man is needed to operate both boat and fan, the latter being gasoline-driven. The nozzle capacity of the blower is 1,500 cubic feet a minute, and the dust emitted is effective for more than 500 feet. In other sections, natural enemies of mosquitoes, birds, fish, lizards, bats and frogs are being enlisted against them. The greatest known destroyer of mosquito larvæ is the dragonfly, but bladderwort, a plant that lives in the marshes, also traps large numbers of them, and some kinds of minnows have been known to eat fifty-six times their weight of larvæ in an hour. Bats will often consume 1,000 mosquitoes in a night. The cannibal, or French, mosquito has a great antipathy for humans, but feeds on the mosquito that does annoy humans.

### POWER-PLANT CAPACITY TOLD BY WEATHER OBSERVERS

A-315

Weather observers foretell other things besides tomorrow's rain or shine. Several of them are regularly engaged in forecasting the daily capacity of the Conowingo hydroelectric plant on the Susquehanna river. This power project differs from most installations because at certain periods of the year, during low water, it serves as an auxiliary to the steam plants of a Philadelphia electric company, while during high water, the steam plants are auxiliary to it, neither being large enough to carry the entire load alone. It therefore is necessary to approximate the amount of electricity the hydroelectric plant can supply at all times. For this purpose weather observers are stationed along the river at fixed points. They keep accurate check on rainfall and the condition of the river, wiring the information to a central base.

### LOUVER-TYPE WINDOW AWNING PROMOTES ROOM COMFORT

A-457

Better circulation of air, reduction of fire hazard and greater beauty are among the advantages claimed for louver-type window awnings recently introduced. Since they can easily be adjusted to various angles, they admit light and air while excluding the sun, and the openings prevent the gathering of dirt and the lodging of cigar or cigaret stubs, a frequent cause of fires on usual awnings.

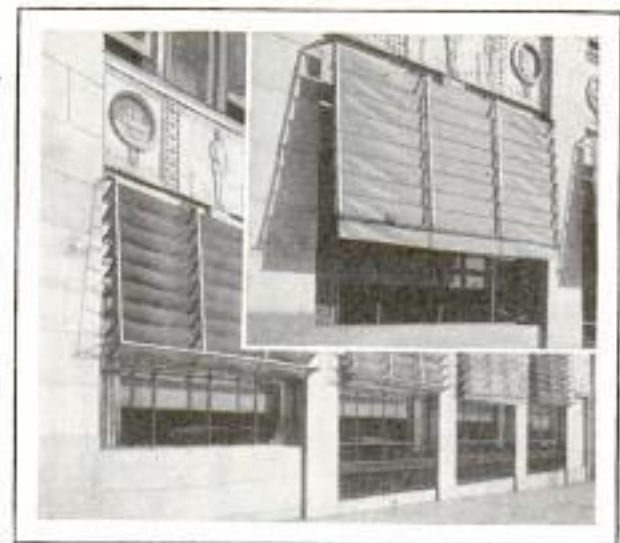

Louver-Type Awnings in Various Positions, for Admitting Air and Preventing Accumulation of Dirt

William F. Holgee Co.  
1348 S. Main St.  
Los Angeles, Calif.



A. 93 Cont. Elton Slassman  
55 W 86th  
New York

# The New Magic Movies

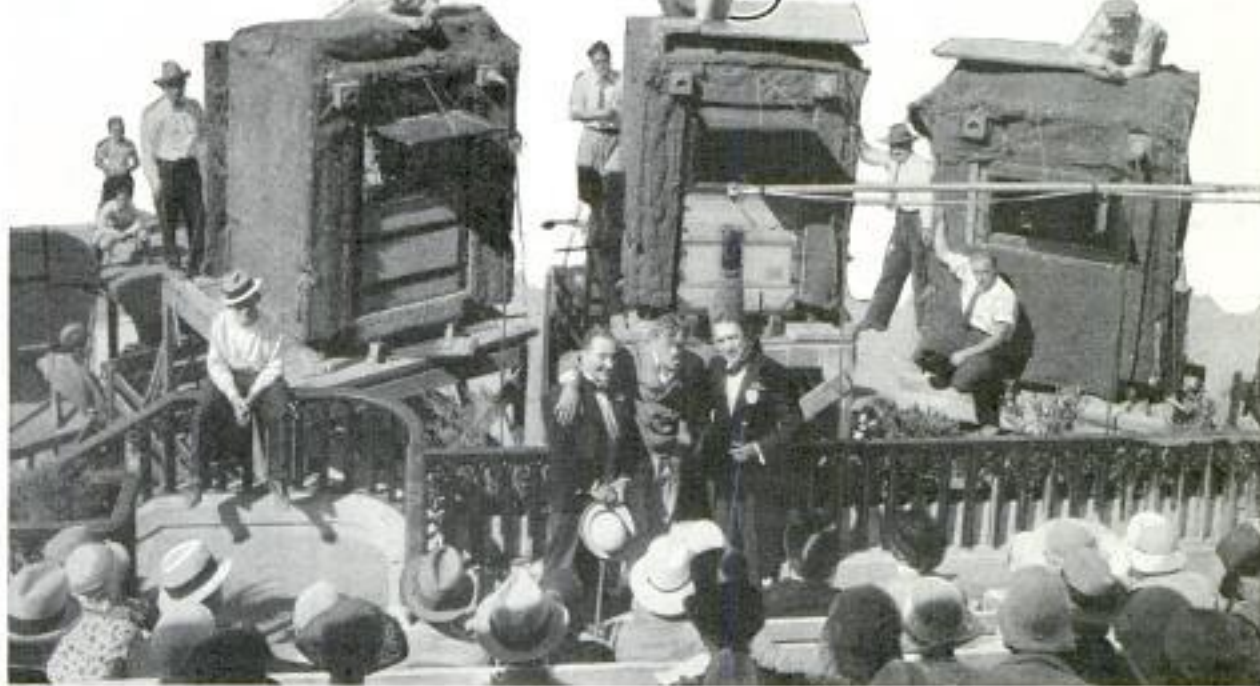

© Western Electric Co.

Director Lloyd Bacon Telling a Mob of Extras How to Register Action for a Color Comedy; Note Soundproof Shields around Cameras and Apparatus at Rear

**I**N THE LAST twelvemonth, movie realism has grown in every dimension. All the world moves across a screen, and the players thereon are electrons. In the movies, science has for the first time vitalized and strengthened an art.

Shadows now talk with the fidelity of men and women in the flesh. The latest method of recording and reproducing brings the greatest single advance to this technique in the past four years. A product of the west-coast laboratories of the Electrical Research Products, Inc., the new process of noiseless recording will soon be used by 7,500 theaters. It is the answer of sound engineers to the public's criticism of ground noises, static, scratching and "noisy" silence.

Before these problems were attacked, recorded sounds extended only from about 200 cycles per second, in the lower ranges, up to 4,000 at the higher ranges. This kind of reproduction gave reasonable clarity to the spoken word, but faithful musical reproduction was impossible because one could hear none of the bass or shrill frequencies. The once-familiar lisp in the movie voice was caused by the

absence of higher frequencies. Pictures in production at the present time, therefore, have their sound sequences recorded in a greatly extended range of frequencies: from sixty cycles at the low end, to 6,000 cycles at the high end. What now is sought is a low-range goal of thirty cycles and high-range goal of 10,000 cycles. The human ear's reception extends between twenty and 14,000 cycles per second; that is, the maximum range possible with highly sensitive eardrums. If you lose the high, shrill voice of the violin, the cello bass, and the full range of the piano, the human ear senses at once the lack of "musical personality" or timbre.

As a receiving apparatus, the ear is extraordinarily efficient. It cannot be deceived so readily as the eye. It hears the equivalent of nine and one-half octaves, that is, from the lowest rumbles of pipe organs to the high jingle of keys. And as regards loudness, the ear is sensitive to the rustle of leaves and the thunder of artillery. The ratio of volume between these noises is as 1 to 100,000,000. The ear detects a change of only three-thousandths in an octave.





Better to understand the problem, the Bell Telephone Laboratories devised a "sound filter" or sound analyzer.

This instrument has the ability to distinguish and separate the different frequencies making up a given sound. The human voice is made up of sounds ranging from fairly low to a high pitch.

The electric filter can quench any frequency in the voice, so that, when it is reproduced, we have a sound that is free from either high or low tones. If the filter is made to cut out high pitches, the voice sounds low and guttural, and hardly understandable. All sibilants, such as the letter "s," are dropped and the speaker sounds as if he were lisping. Quenching the low notes makes the male voice sound effeminate and screechy.

Theater acoustics are another factor which determines timbre and sound-frequency range. The problem, therefore, is to quench a sound before it echoes, but not to stifle resonance. The average speaker utters three words per second, and if a theater's acoustics are such that each word persists five seconds, you have fifteen words flying about simultaneously, and the ear is in agony. The amount of absorption in the walls determines how long a sound will persist. Rugs, clothes, curtains, upholstery and, recently, acoustic cells, may be used to quench a vibration or echo.

Each theater provides the sound engineer with its own peculiarities. Recently one was asked to investigate why talking-

picture reproduction is better in winter than in summer. His answer was that winter clothing absorbed more sound than summer clothing.

A Broadway showman asked the engineer to determine why reproduction was better in the afternoon than in the evening. And the answer was that starched shirt fronts on the men deflected the sound waves and caused a slight echo.

A crew of four sound engineers were

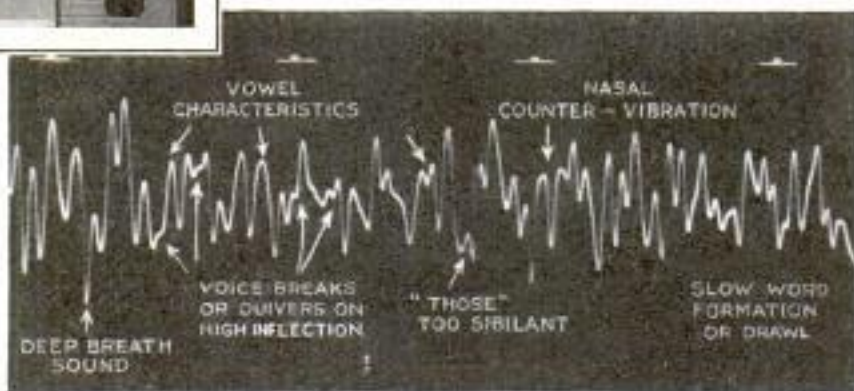

Strip of Talking Film Showing Sound Track, and Vibration Study of the Voice of Anita Page

assigned to diagnose and eliminate the hum in the sound equipment of a New York theater. They began work after the theater closed, near midnight. A 1,000-foot reel of tested film was run through the projector. The hum persisted. An analysis revealed at once that the outside current was impure. All night they tried to eliminate noise by hitching on condensers. Dawn came, and still no results. At length, one decided to walk around the block for a breath of air. Thus he discovered that the block housed a power station that had been tampering with the voltage of the theater current. A special condenser eliminated that interference.

The new-process noiseless recording has solved some of the sound engineer's most pressing problems. He has cut mechanical and artificial noises to a point where nothing save refinement is necessary to bring the system to absolute perfection.

In the early days of sound pictures, the monitor man, or mixer, sat in a separate soundproof room and judged the quality of the sound. Soon the portable monitor room was developed. But now the moni-



tor may walk about with his head insulated against all noises except those that come to him through a set of earmuffs.

To measure the development of film, a new "sensiometer" and "densiometer" have been introduced. A new system of reproducing sound on a disk has been perfected. It engraves an up-and-down groove, the "hill-and-dale," instead of the old "lateral cut." Hill and dale permit a closer spacing of the groove, so that a twelve-inch disk will run as long as a sixteen-inch disk of the old type.

In order to take "fading"—the matter of controlling volume—out of the hands of the projection operator, ERPI has invented a "dubbing" machine. The average 8,000-foot picture is made up from about 200,000 feet of negative, expertly cut and assembled. Naturally, the tone and quality of sounds in different scenes do not run into each other with pleasant transition. The dubbing machine makes possible the re-recording of the film under controlled conditions, so that the producer or director, and not the projectionist, can lay the exact emphasis on both voices and music. The sound quality is not marred by distortion. In dubbing, sound effects can also be added, such as instrumental music and artificial noises. This is a highly specialized art.

**THREE-WHEELED POLICE AUTOS  
DODGE HEAVY TRAFFIC**

Small three-wheeled automobiles are being used by squads of London police to speed through dense traffic. The cars are sturdily constructed, and their distinctive appearance helps identify them and keep other drivers out of the way.



Three-Wheeled Auto Employed by London Police to Make Better Time in Heavy Traffic

**FOOT-OPERATED BANK ALARM  
WORKS AUTOMATICALLY**



Foot-Operated Bank Alarm Which Rings Continuously When the Pedal Bar Is Moved Upward

To provide a continuous alarm in case of a bank holdup, a foot-operated system has been devised that, once started, keeps on ringing until it is switched off. Many foot-alarm systems depend for operation on the pressing of a contact button. When this is released, the alarm no longer functions. Bank bandits have learned this, and often warn tellers and cashiers away from counters or cages so they have no opportunity to operate the alarm. The latest warning is operated by a bar under the teller's desk. This bar is lifted up with the toe. This action makes a contact with switches which start the alarm ringing and at the same time cause swinging legs on the crossbar to assume a vertical position, thus keeping the alarm switches in contact. The device then operates automatically until the bar is released and pushed down. The upward movement for contact makes it less likely that the alarm will be set off accidentally.

*Developed in Laboratories of Voltger-Cabot Electric Co. 185 Amory St. Boston*



*a. 273*

### PATHS OF SHIPS ARE SHOWN IN MINIATURE OCEAN



Map of Miniature Ocean with Lanes Indicated by Lines and the Position of Ships by Numbers; the Map Is an Aid to Passengers in Getting Their Bearings on a Voyage

Passengers on ocean liners often have difficulty in getting their bearings unless they are familiar with latitude and longitude readings and meanings. To assist them in determining their position at sea easily, some German vessels are provided with maps in the form of miniature oceans with the steamship lanes all plainly marked. Numbered markers show the position of various ships on the lanes, these markers being shifted daily as the vessels proceed.

### ELEVATED POWER LINES RUN OVER RAILWAY TRACKS

*a. 314*  
With many central power plants in operation, the problem of finding a right of way for transmission lines is important since the cost of underground cables is often prohibitive and the line frequently must pass over valuable ground. One company is using a railroad right of way

for the purpose. The railroad owned no excess ground in congested areas, so it was impossible to run the lines beside the track. The company therefore built framework over the tracks to carry the lines. In the future the elevated structure may be employed as supports for the wires for electrification of the railroad.

### TWO-SPEED AUTO AXLE GIVES GREATER FLEXIBILITY

*a. 302*



Giving Ford passenger cars and trucks the advantages of a four-speed transmission, a two-speed axle actually offers a choice of six forward speeds and two reverse. The twin

*Com. Leo H. Eckhardt.*  
*4528 W. 2nd St.*  
*Phila.*

*Pricey Hallister Co.*  
*Rockford, Ill.*  
Copyrighted material



A. 271

see also Aug 1930 210 543

axle gives two high speeds, one a high-way speed geared direct 2.84 to one, compared with the standard Ford gear of 3.77 to one, and the other a traffic speed geared semi-direct, 3.93 to one, both noiseless and easily shifted. This provides for a high rate of road speed with reduced engine revolutions. The six forward speeds are achieved by using either axle gearing desired for the two low speeds. The highway-speed gear cuts down motor revolutions one-fourth. The top speed is increased about ten per cent because, at an engine speed of forty-five miles, the road speed is sixty miles an hour. The extra gears also provide a direct saving in fuel

W.H. Sargent, New York



Elongated Stethoscope with Folding "Ears" That Is Used to Locate Leaks in Water Pipes

FOLDING "EARS" FIND LEAKS IN WATER PIPES

Operating on the principle of the stethoscope, an instrument invented in London enables a tester to detect leaks in water pipes and also to determine in which direction the water is flowing. It is an adaptation of the principles used during the war to locate hostile aircraft. The outfit is compact and portable, and is said to be so effective that it will register sounds in pipes at a considerable depth.

PLASTER MACHINE COATS PIPE TO PREVENT CORROSION

To coat pipe lines with cement mortar and thus prevent corrosion, a compact outfit, introduced by a western firm, saves time and work and is said to apply the material so effectively that a longer-lasting coating is formed. The apparatus consists of a gasoline engine, to operate the blower, and a generator, to furnish power for the hopper and brush-head motor. Damp sand is mixed with cement and moistened as the materials pass through the machine so that a spray of fine particles of sand, each coated with the proper amount of cement, is forcibly applied to the pipe, driving away the air

A. 259



Portable Outfit Used for Coating Pipe Lines with Cement Mortar to Prevent Corrosion

as it strikes the surface and clinging tightly until a suitable coating is formed. Pipes treated in this way have successfully withstood corrosion for long periods. The machine is also adapted to applying acoustical and other plasters.

no longer made.

PORTABLE PHOTO-PRINT PRESS IS LIGHT AND COMPACT

Taking the place of the heavy and cumbersome letter press, a portable photographic-print press now is being offered as a light and compact unit for photographers who do work while traveling. It is made of heavy oak pieces mitered together to prevent warping, and is equipped with heavy preshrunk webbing. The malleable-iron metal parts are intended to withstand many times the strain likely to be placed on them. The boards are drawn together with great pressure by the leverage principle. The lever is fastened into anchor plates, and then brought forward to exert an evenly distributed pressure throughout the press.

A. 311

Conley Plastering Machine Co. 3200 N. Alameda

Belaham Ltd. Queen Victoria St. London E.C. 2. Price 1/6

Wardman & Pldy 3816 Chrysler Bldg. Price \$ 1.00

Conley Plastering Machine Co. 3200 N. Alameda St. Berkeley, Calif. Price \$ 1.00



a. 129  
544

Je Sais Tout

Photos by Dr. Jesse W. Muir and Harry Kirkpatrick

Jun 1931 P. 561

number not known



California Institute of Technology. It has long been assumed that electrons in solids, like those in gases, are in rapid motion, but this remained merely a theory until X-ray pictures offered proof. The apparatus used in obtaining the pictures consisted largely of an X-ray tube, a strip of metal to serve as a scattering body, or target, a device for gathering some of the scattered X-rays after they struck the target, and photographic instruments for reproducing the impressions made by the scattered rays. When struck by X-rays, electrons recoil just as does a billiard ball when the cue ball hits it. But recoils differ, depending on whether the billiard ball is in motion or not when the cue ball strikes it. In the experiments, the X-rays corresponded to the cue

Courtesy Je Sais Tout  
Camera on a Swinging Crane for Taking Crowd Movies: the Crane Is Mounted on a Truck, Thus Affording Great Maneuverability

### CAMERA ON A SWINGING BOOM MAKES CROWD PICTURES

To give the illusion of large masses of troops participating in battle scenes in one of the war films, cameras which made the pictures were mounted on a swinging crane which in turn rested on a heavy central column placed upright on a truck. This mobile movie equipment is capable of great maneuverability since the platform on which the cameras and cameramen stand can be moved horizontally along the length of the boom, and the boom itself can be swung in a circle or moved up or down on its base.

### ELECTRONS OF SOLIDS SHOWN TO BE IN MOTION

Direct photographic evidence that myriads of electrons are rotating in orbits in solid matter at high velocities has been obtained by two scientists of the Cali-

ball. Had the rays, all of uniform length at the beginning, struck a stationary object, they would have been scattered, but would still have been more or less uniform in appearance. Instead, the photograph showed a blurred band of many lines, each of which represented scattered rays of one wavelength. This indicated that the electrons were in motion.

### METAL SEAL FOR AUTO BRAKES A. 257 KEEPS OUT DIRT



Fitting tightly over the brake drums and housing of the model-A Ford car, metal seals keep out dirt, grease and water. They are easily adjusted, require no drilling of holes or new parts.

Modern Mfg Co  
5421 Esplanade  
Detroit, Mich



Answers 2/4/31

a-229

**ELECTRICAL HEATING OF SOIL  
USED TO SPEED CROPS**

A-246

Truck growers in Europe are experimenting with a system of electric heating for the soil to obtain better and earlier crops. One farm near Berlin has an acre of ground warmed by electric cables on which early vegetables are grown. On the same farm the poultry houses are kept at constant temperature day and night, and when an egg is laid, it drops to a traveling band and is immediately carried away to be stamped with the date.

**WIND ELECTRIC-POWER PLANT  
MOUNTED ON A DERRICK**

A-199

Breezes blowing over an Indiana farm furnish all the energy required to provide electric power and lights through the medium of a wind electric-power plant somewhat resembling an ordinary windmill. The outfit consists of a wind wheel mounted on a seventy-five-foot derrick. The main body of the wheel is constructed of two pieces of sixteen-and-one-half-foot steel tubing, and at each end of the propeller inside the tubing is a weight, held in place by a spring and connected to a governor in the center of the propeller. As the speed increases, the weights cause the governor bar to turn, and this, through a system of gears, causes the dampers to turn crosswise in the path of the wind, opening up more than half the wind surface on the blade. The tail is rigid, and the wheel is stopped by a mechanical device that allows an operator on the ground to turn the damper, or sections of the blade, crosswise. The generator is mounted on a platform below.



Wide World

Women Brickmakers in England Engaged in Pressing the Clay into Molds with the Bare Feet

**WOMEN STILL PRESS BRICK  
WITH BARE FEET**

In these days, when machinery turns out nearly every article used by mankind, the primitive art of treading bricks with the bare feet still is practiced near Stourbridge, England. Here sturdy women, survivors of the original women brickmakers of Worcestershire, knead the clay into the molds with their feet while supporting themselves with sticks.

**RAISED STITCHES ON BASEBALL  
TO AID PITCHERS**

A-239

Fewer homeruns and three-base hits may be chalked up in baseball this year as the result of changes in the cover of the sphere. It is to be heavier, and the stitching is to be raised instead of counter-sunk as before. It is predicted that this change will give the pitcher a much better grip on the ball. The total weight and size of the ball remain the same in spite of the cover alterations. The National-league ball cover will be thicker than it was before, while American-league officials have adopted one of the same thickness but with heavier threads, which are expected to slow up the sphere.

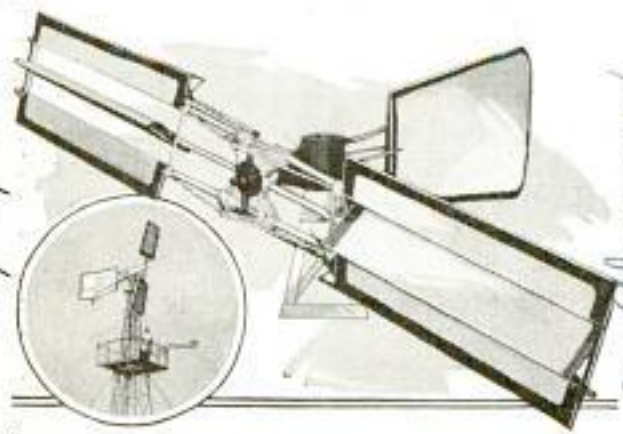

Wind Wheel Which Generates Electric Power for a Farm; Note Blades Which Turn to Act as Dampers

Discontinued 2/17/42

no change

Chas. E. Miller Corp.  
Meridian 14th Main  
Anderson, Ind.

Chicago Tribune  
2/4/31  
Copyrighted material



a. 61

Langley Field, Hampton, Va

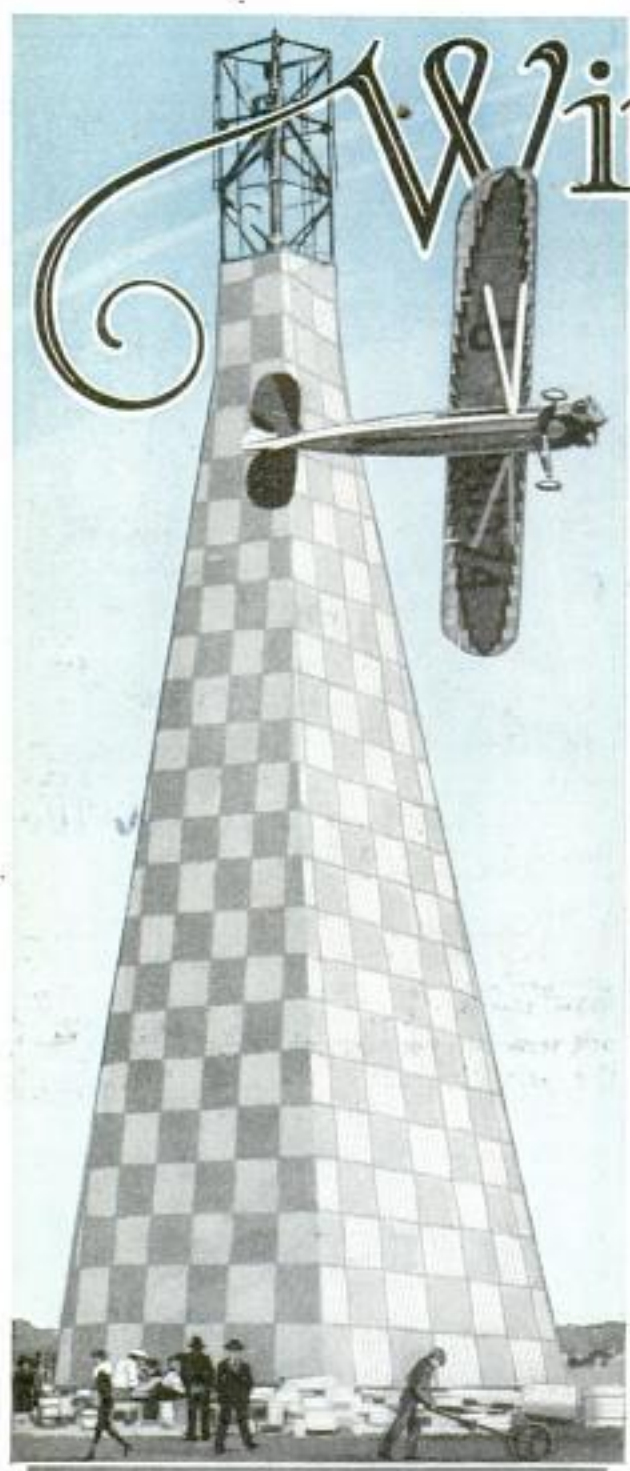

Heath Parasol Winning Light-Plane Race at 1930 National Air Races in Chicago

Des. By CORLEY McDARMENT

**F**ROM the thundering giants of the air with their great lifting power, ultra streamlining and high speed there has been born a newer type of airplane—a small, light low-powered machine of great efficiency and wonderfully suited for the man of average means. The possibilities for this plane, capable of carrying one to three persons, are almost unlimited. It

# Wings for

embodies the efficiency of strictly commercial machines and even greater safety due to its lighter weight.

Small airplanes have always been built. In fact, the very first machines were little more than big gliders with a motor nailed in them. But the light planes of the past have not had those deft touches of genius, combined with the soundest principles of aerodynamics, which characterize the newly born craft.

At the present time you may buy for less than \$1,000 an airplane embracing all the safety features and most of the efficiency of the bigger machines. You may buy the parts and assemble an airplane for much less.

This means that people now able to have automobiles may own an airplane. These small machines almost fly themselves. With low center of gravity, low landing speed and sturdy construction, many more people are able to learn the flying art than heretofore.

With the steady progress in building strong and efficient airplane wings and light powerful motors, it has been possible to build little machines of wonderful performance, and the many late safety devices, like wing slots and flaps, make an airplane almost fool-proof.

Everybody in the commercial-flying business has long known that airplanes would never be the success of automobiles unless a plane were developed which could be flown by sister Sue and brother Bill. And now that such a plane has appeared upon the horizon, people are wondering how far and how quickly the flying craze will go.

It has been said that every big economic advancement has been found in some new article of general use or method of work. It may be that the advent of cheap and safe airplanes for everybody will be an article which thousands or millions of

unusual



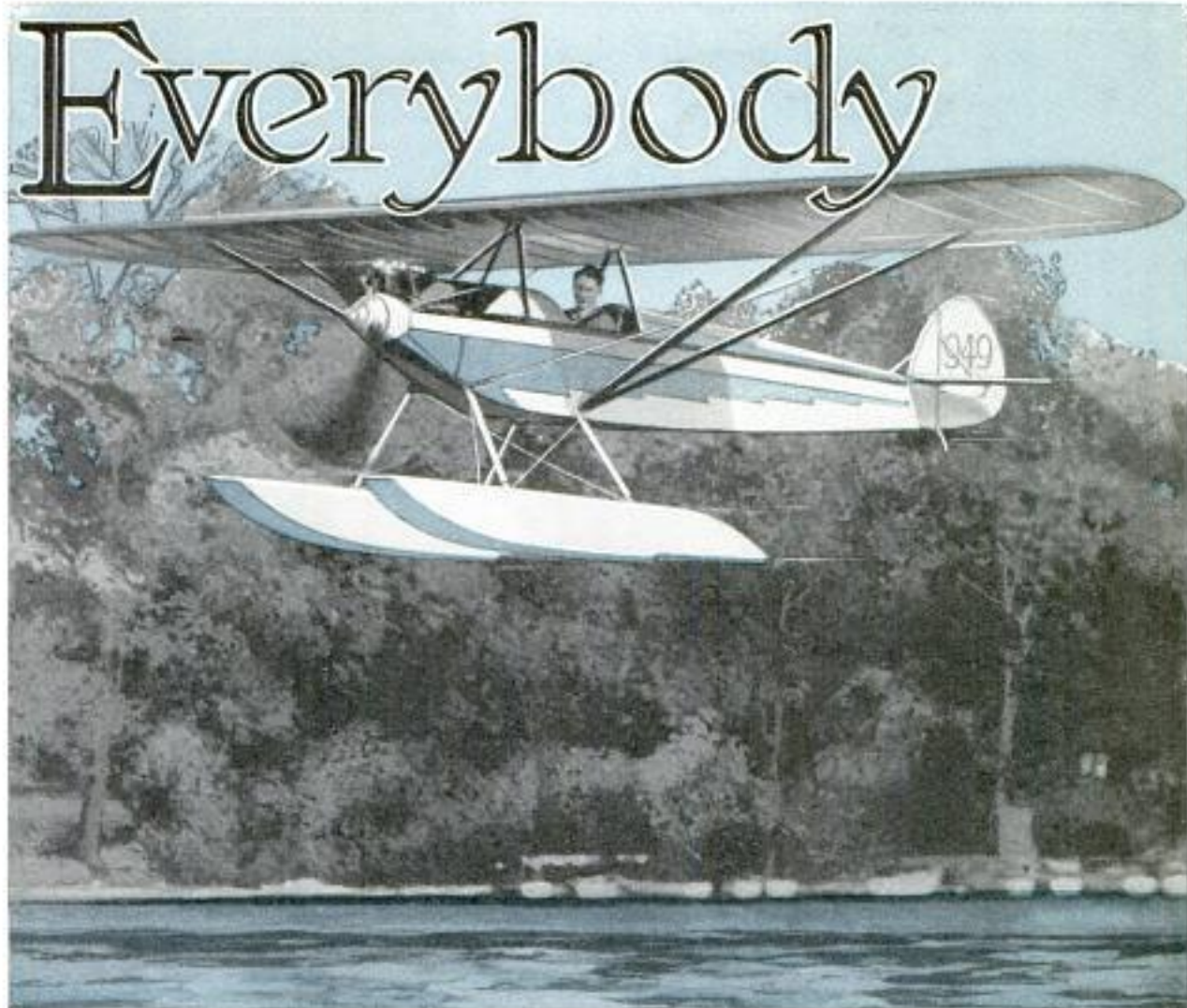

Heath Plane Equipped with Pontoons for Water Landings and Take-Offs; as a Seaplane, This Small Ship Has Given Many Creditable Performances

people will buy, and the manufacture of them will afford work for thousands.

Automobiles became personal necessities only after low-priced cars were put on the market. The safety and ease of operating automobiles was another factor in making them popular. Time was when very few people were capable of running an automobile—or at least this was the general opinion. Wealthy people used to import French chauffeurs, who were supposed to be mechanical geniuses, to run their cars. It once took a mechanical wizard to work on an automobile and the pay of mechanics and chauffeurs was high. The horseless carriage remained a mystery to the average citizen for many years. The aviation industry faces the same problems that confronted motor-car manufacturers twenty years ago.

As soon as the worth of the small airplanes is realized, the demand for them

probably will be greater than it was for automobiles at the start. There are a multitude of uses for a small, light machine. Many of these uses are not thought of at all now, but the various duties would multiply after the plane is operating.

With a light airplane people may commute from farther distances; they can take long trips within a short time and without all the traffic bother of the highways; and for hunting, fishing or other forms of recreation it would be much better than a car. People usually go at least a hundred miles on fishing and hunting trips. The time it takes to make these trips by automobile, boat or train, is considerable. An average speed of thirty-five miles an hour on most country roads in the vicinity of the best hunting and fishing grounds is about the limit. But a little airplane, sailing at seventy-

Heath Aircraft Corp. 1727  
N. W. Michigan St. Chicago, Ill. 547  
Copyrighted material





adjacent valleys by means of these small planes. It takes a long time to climb up and down mountain ridges and get to points which, by a straight line, are quite near. The small plane may be loaded with only a part of its gasoline capacity and fly over mountain ridges into the other valleys with great ease and carry a good pay load.

People who live on islands, or other places where boat communication is slow, will find the new planes a joy and a necessity. For quick communication across rivers and lakes, nothing could be better than these little machines set on either pontoons or wheels.

five to a hundred miles an hour, pays no attention to bad roads.

Boys going and coming from camping trips should be able to use these small machines.

There is no reason why a boy in the early teens cannot learn to fly just as well as an older person. In tests, it has been shown that boys should learn to fly easier and quicker than grown people.

Farmers may be able to use these small planes to make quick trips to towns for supplies during bad-road seasons as well as at other times. Three to five hundred pounds and more may be carried in some of these new machines. Some of them have a cruising radius of 400 to 500 miles. They fly forty miles on one gallon of gasoline. Light airplane engines have been built which will run as low as sixty miles to a gallon. This is economy. With crude oil coming in as engine fuel, greater economy and safety will result.

It is not always necessary that whole loads of fuel be carried in these light planes. They will carry enough fuel to fly 400 or 500 miles, but if a person is not going to fly so far, the extra fuel may be replaced by its weight in baggage. People living in mountainous country may have rapid communication with folks living in



Storing Heath Parasol in Shed, and Taking the Air While the Pilot Keeps Hands Off, a Demonstration of Stability

They are small enough to be pulled up into boat houses if they are equipped with pontoons, and a wide garage will accommodate them if set upon wheels. A few years hence, people will no doubt wonder how they ever managed to travel over rough, dusty roads in cars, or creep along the surface of water at twelve to twenty miles an hour.

Regions on the earth which are now inaccessible or have no methods of transportation, may be visited with ease by means of these light airplanes. There are beautiful spots in the Rocky mountains and the Appalachians which are seldom visited because it takes too long to get there by ordinary means. Such roads as exist wind around the mountains several times before getting to the destination. But with an airplane, a person can take off, do a little circling for altitude and quietly settle at the destination within a few minutes. If a lake exists in the mountains, a good natural landing place is thereby afforded.



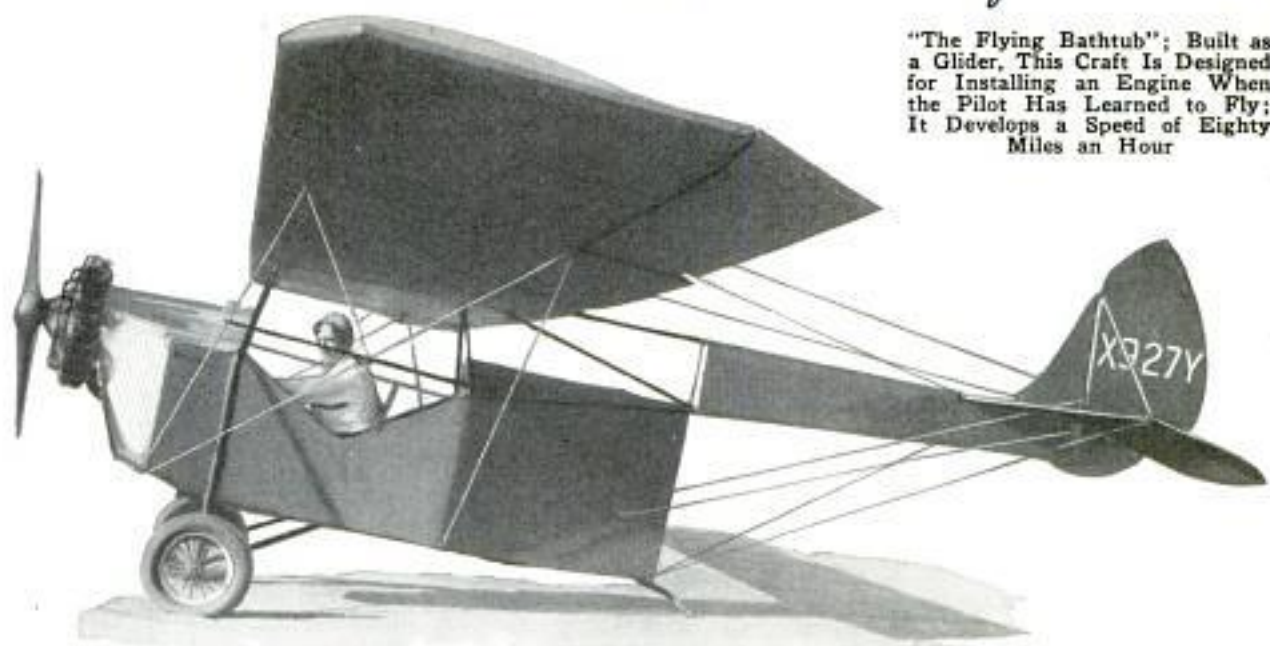

"The Flying Bathtub"; Built as a Glider, This Craft Is Designed for Installing an Engine When the Pilot Has Learned to Fly; It Develops a Speed of Eighty Miles an Hour

With the new planes and their safety factors, parents should be no more afraid of letting their children go on trips by air than taking similar trips in automobiles. There are more hazards with driving automobiles today than exist with the small safety planes. Much more work is involved in driving a car on the congested roads than in flying an airplane. Aviators now who are accustomed to flying military or commercial planes, feel a sense of delight in one of the small machines.

There is no reason why light individual airplanes should cost very much money, provided they can be made in large quantities. Quantity production will cut the cost of airplanes as it has done with automobiles.

Airplane-engine cost could be cut one-half by large production. Wings, struts, landing gear, fittings, fuselage members, and all other parts, could be reduced in price at least half, if large

numbers were made. It has been said that metal wings could be stamped out nearly as cheaply as automobile fenders, if enough of them were needed. In time, we may see regular airplane-assembling plants in all large towns. This will indeed be a big and new business. The radio development helped out the business depression a few years ago, and as already stated, this new airplane development may step out and create the biggest business boom the industrial world has ever known.

The wear and tear on the small light planes should be negligible. Airplanes are not subject to the same jolts and rough handling as automobiles. Friction of the air does not wear down an airplane wing, neither does it injure any other part of a plane. The mechanical side of these new airplanes is far simpler than in an automobile. There is no transmission or rear-end worries. All is straight drive and everything is in sight.

#### SLANG OF THE AIRWAYS

SOME of the latest additions to the growing language of aviation are explained as follows:

"Stick pusher"—a pilot.

"Horsing down"—a nosing toward earth.

"Counting the insulators"—being low enough to see telegraph poles.

"The old ladies' home"—the home airport.

"A milk route"—short feeder airline, disdained by flying aces.

"The iron compass"—railroad tracks followed as a guide in storms.

"Windmill"—propeller.

"Big Bertha"—30-passenger Fokker plane. A 12-passenger is a "Geppy."

"A Duck"—An amphibian plane.



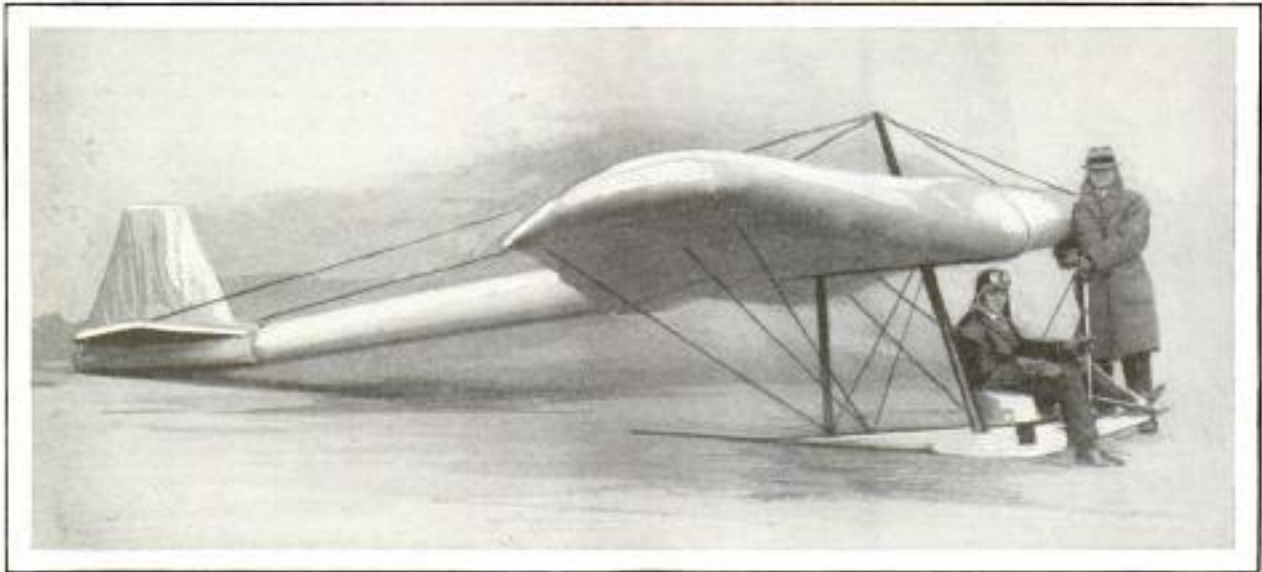

Rubber Glider That Made Successful Flights at Hoover Field, Washington, D. C.; It Is Designed to Withstand Various Strains and Stresses Better than the Usual Glider

With stock airplane engines running for weeks in non-stop flights, the danger of motor stoppage in the air is reduced to a minimum. One set of tires will last an airplane a lifetime. Only by deterioration of rubber would new tires ever be needed. The big reason automobiles do not last longer than they do is the constant road vibrations. An airplane vibrates, but the strain is not so destructive as that of automobiles. And as soon as the general public finds out that small safe machines may be bought and flown with all the ease of automobile driving, there will be a bigger demand for airplanes than ever existed for any other vehicle of travel.

downward, the oxygen content increased again, reaching its highest point at the bottom. The highest deep-water oxygen ratio found was 3.45 parts per thousand.

**EFFICIENCY OF LIGHTS TESTED BY PHOTO-ELECTRIC CELLS**

How bright is an electric light? Photo-electric cells give the answer in an apparatus demonstrated recently in London. The lamp to be tested is placed in a cylindrical chamber where its light is converted into electrical current by means of the cell. The measure of current gives an index as to the power of the light.

**PACIFIC CONTAINS LESS OXYGEN THAN ATLANTIC OCEAN**

There is less free oxygen in the water of the Pacific ocean than in that of the Atlantic, and there is more in the water of great deeps of both oceans than in that from moderate depths. These discoveries were made by Dr. Erik G. Moberg, oceanographer, after a chemical study of thousands of samples. Since all plant and animal life in the ocean is dependent on oxygen, the results announced are of fundamental as well as theoretical importance. The greatest oxygen content in Pacific ocean water was found at the surface, where it was nearly saturated. The content fell off with depth, until at 2,000 feet there was less than one part of oxygen per thousand of water. From this depth



© Planet News, Ltd.  
Testing Brilliance of Electric-Light Bulbs in Cylinder with Aid of Photo-Electric Cell

Scripts & illustrations of Oceanography

Science Service  
News Bulletin 514  
1/27/31

Scientific Illustrations  
Imperial Science Museum



A-135 Suggested by Mr. Harlow Shapley, Director of Harvard University Observatory

ASTRONOMERS RIDE PLATFORM WHILE STAR GAZING

Because large telescopes in observatories must be moved constantly in studying celestial bodies, astronomers have been common sufferers from backache and stiff necks due to the many awkward positions they must assume in order to see through the eyepiece. To make the astronomer's work easier, electrical engineers have produced a mobile telescope observer's platform on which the astronomer can ride around the dome of the observatory in comfort with his eye almost constantly glued to the telescope. This apparatus, intended for the Boyden station of Harvard observatory, at Bloemfontein, South Africa, consists of a carriage on wheels which runs around the base supporting the telescope on a circular track. Mounted on the carriage is a skeleton tower, fourteen feet high, which in turn supports a gallery or platform upon which the observer and his assistants sit or stand. The gallery can be raised or lowered, or turned horizontally about the tower, the observer's stage moving automatically with the telescope

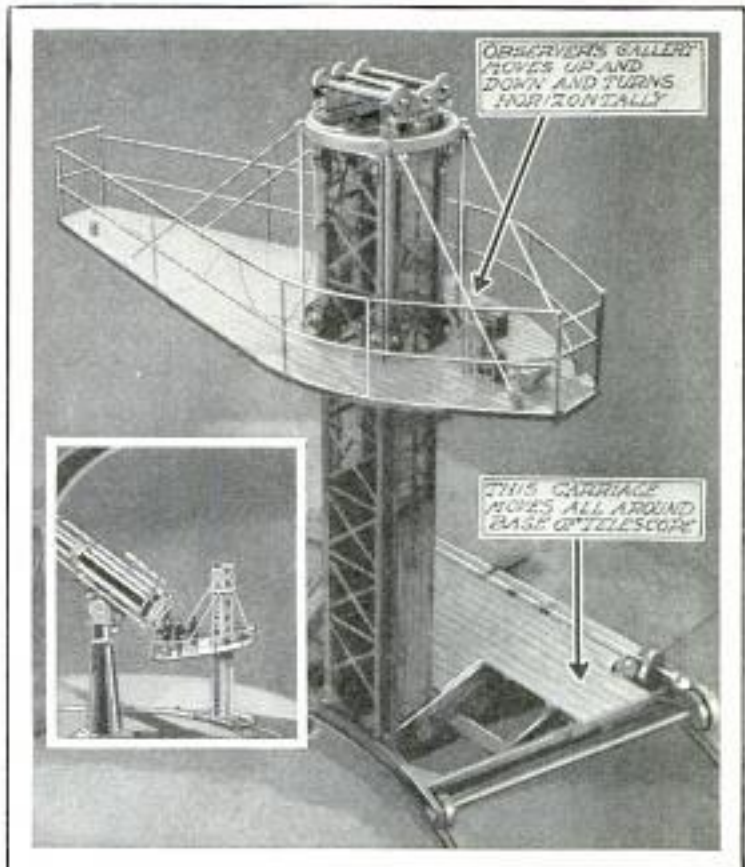

Observer's Platform from Which Astronomers Gaze through Big Telescope; Tower and Telescope Move Together

itself. The apparatus is controlled electrically by a system of relays operated by a push-button switch.

MOVIE THRILLERS COST LIVES OF FIFTY-FIVE PERSONS

Packing thrills and realism into the movies is fraught with deaths and accidents often as tragic and thrilling as the scenes depicted. During the last five years, fifty-five actors, extras and studio workmen have lost their lives in making pictures, and scores of others received permanent or temporary injuries in the effort to provide "hair-raisers" for movie fans. In addition, the California state industrial-accident commission paid out \$421,850 to members of the motion-picture industry for deaths and accidents arising in the course of employment. During 1929, when war films were in vogue, sixteen lives were lost, and last year ten lives were sacrificed at one time when an airplane plunged into the ocean after colliding with another ship during the making

of a film. Almost every picture of greater than average scope has its tale of bravery and daring on the part of those who helped create it, although the producers do what they can to guard against accidents. Accidents as unusual as the scenes that are portrayed, are an inevitable result of picture making. In setting off a two-ton charge of dynamite in one picture, someone underestimated the force of one of five charges, and the top of a hill was blown off, two men were killed and forty hurt. A freak blizzard, while one company was on location in the mountains, cost the lives of two men who mistook a yielding bank of snow for a road, and caused the illness of many others, while nine men were hurt, three fatally, during the making of the same picture when 500 men on horseback charged down a rocky hillside. Among minor injuries for which compensation was paid are many freaks.

Silver Screen Jan 1931



## METAL-COVERED AIRSHIP TO CARRY TWENTY TONS

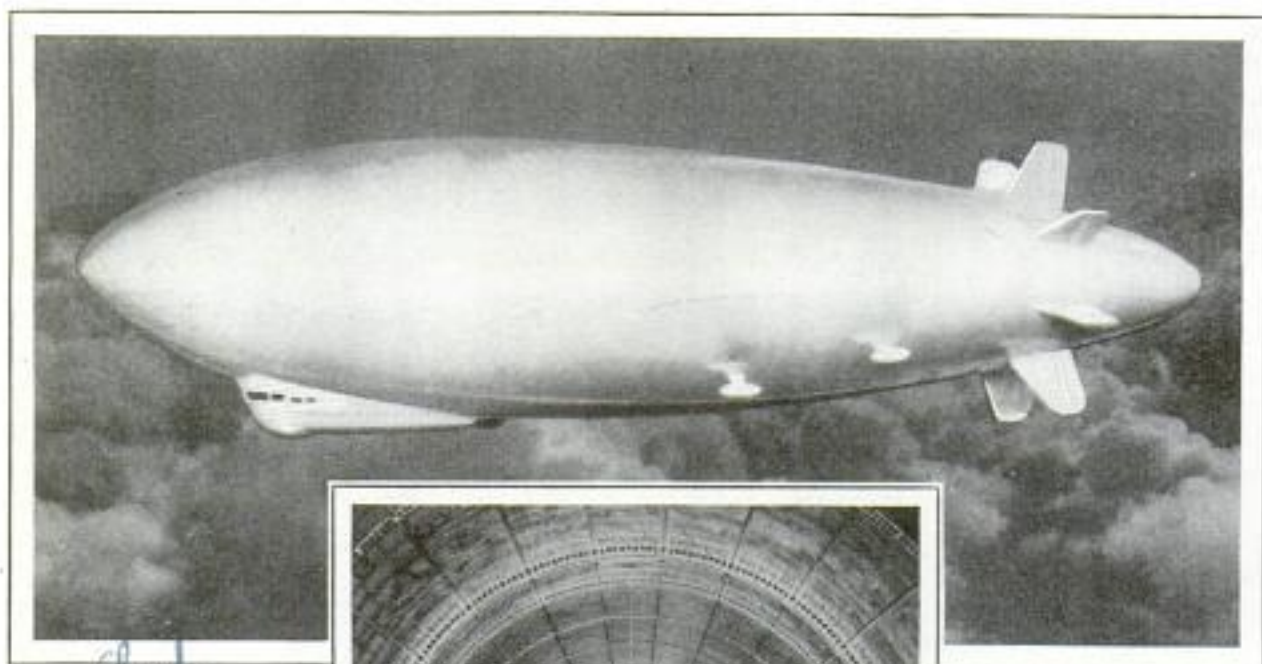

Club.

Capable of carrying a useful load of 40,000 pounds, a huge metal-covered dirigible, larger and faster than the "Graf Zeppelin," is to be built for the army at a cost of \$4,500,000. It is intended as an air tender for a fleet of airplanes. The metal "skin" of the airship will act as the container for the helium gas, being rein-

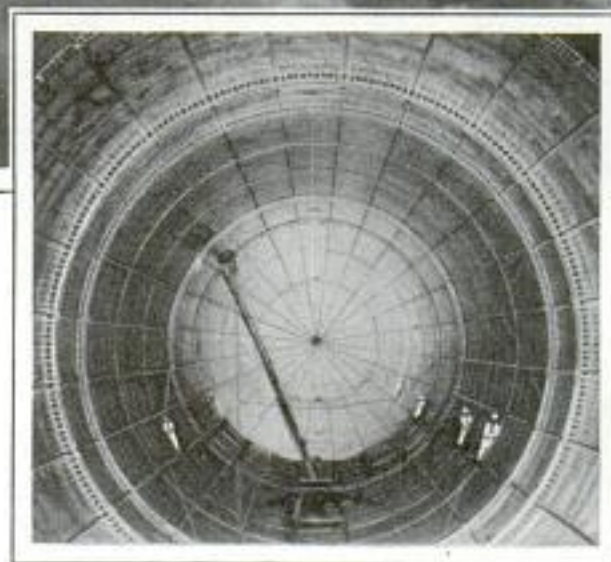

Model of Huge Metal-Covered Dirigible to Be Built for Army; Below, Looking into Nose of a Small Metal-Clad Airship

forced by circular rings and longitudinal members. Eight motors of 600 to 800 horsepower will drive the ship at a maximum speed of 100 miles an hour when fully loaded. This big airship will be forty times the size of the "ZMC-2," the metal-clad dirigible built in 1929 as an experiment and since thoroughly tested.

### ALPHABET KNOWN IN CANAAN POTTERY INDICATES

a-200

Three signs like "hen tracks," cut into a broken scrap of pottery jar, are considered as fresh evidence of the antiquity of the alphabet by Prof. Romain Butin, of the Catholic University of America. The fragment was found at the ruins of the Canaanite royal city of Gezer and is believed to show that alphabet writing existed as early as the nineteenth century B. C. This scrap is regarded as evidence that the Canaanites, who held the Promised Land before the Children of Israel came to claim it, not only knew a system of writing, but had an alphabet. When

first discovered, the fragment was classed with objects a thousand years younger than itself, until the figures were found to be similar to inscriptions found in the wilderness of Sinai, south of Palestine. The Sinai writings show evidence of having been evolved from Egyptian picture writing, and the fragment of pottery found at Gezer makes it clear that the Sinai alphabet is older than 1,600 B. C., and probably as old as 1,900 B. C. These three letters are believed to be the oldest writing ever found in Palestine. The characters, experts say, mean "Children of," the rest of the inscription being broken off, and was probably an ownership mark similar in character to the title "Children

Science Service  
News Bulletin 1/27/31  
514-D



Illustrated by  
"Utah State"  
Industrial Chemistry

938

of Israel" used centuries later. Two other evidences of alphabetizing processes have recently come to light, one found in Syria based on cuneiform signs, and the other a semi-alphabetic writing found in another section of the same country.

Attn. Mr. McShane

**ELECTRIC MINE-GAS DETECTOR TO PREVENT EXPLOSIONS**

To detect the presence of dangerous gas in coal and other mines, an electrical tester has been devised for use instead of canary birds or lamps with a flame. A small wire in the "nose" of the tester is kept heated to a temperature of approximately 1,000 degrees Fahrenheit. In case methane gas is encountered, the vapor automatically causes the tester to become hotter. This is recorded on a gauge carried on the chest of the miner, giving him instant warning of the dangerous gas. A special feature of the tester is that it can be used with an extension, so that the ceilings and other remote parts of the mine shafts can easily be tested. The outfit is no more cumbersome than the ordinary electric-lighting equipment worn by the miner, and presents no additional hazard in making a test.



Electrical Tester Which Quickly Detects the Presence of Dangerous Gases in Coal Mines

Europe has fifteen reigning monarchs and fourteen presidents.



German Cadets Listening to a Lecture on Horses with a Living Animal before Them

**GENERALS OF FUTURE STUDY HORSE ANATOMY**

Cadets attending a German military school are given thorough lectures on the horse as well as instruction in the use of gas masks, the firing and maintenance of machine guns and many other subjects. The cavalry lectures are given by an expert veterinarian and are illustrated with living animals and skeletons.

**SEA PENETRATES EARTH'S CORE IS LATEST THEORY**

To explain the fourteen great ocean currents, such as the Gulf stream, one scientist recently advanced a theory that the sea water circulates through the center of the earth by means of innumerable fissures reaching down from the ocean floor. This revolutionary idea, suggested by Dr. Richard Ammo Meentz, geologist of Southern Methodist University, is that water is sucked from the bottom of the ocean in the equatorial regions to the earth's center and then expelled in the vicinity of either the north or south poles. He conceives the interior of the earth to be composed of gaseous vapors, plastic material and solids. To support his theory, he points to the fact that fifty-seven fissures in equatorial regions with a known depth of more than 18,000 feet have been located.

Harold Tribune 1/29/31

Interborough Artillery  
Training School



A-176  
554

Cyclopsplane Co Ltd  
3781 Angeles Mesa Drive  
Los Angeles, Calif

Democratized by A-Z Woodman  
and Al Clark. Inghres. of L.A.  
see Oct. 19 20-608

Club of Mechanics  
2/28/34



From the Ground to the Air in a Few Easy Lessons; the Plane That Cannot Fly, Shown Below, Gives First Training

### PLANE THAT "FLIES" ON GROUND HELPS TRAIN PILOTS

Student pilots are taught the first essentials of flying by practice in a special training plane, identically the same as a real ship except that it has insufficient wing area to allow it to leave the ground. The student soon becomes familiar with the different controls, how they affect the plane, and what to do in various maneuvers as he taxis around the landing field. When he is ready for the air, the transition to a plane that flies is said to be accomplished with little difficulty.

### BALL-BEARINGS IN SWIVEL ELIMINATE SQUEAK



Ball-bearing swivels for suspending porch swings, bird cages, block-and-tackle chain hoists, and many other units, reduce friction to a minimum and eliminate unpleasant squeaks and

Leas & Tafelberg

Patd 2/11/34

Chas. Warren  
A. Leas, 302 Monument Ave  
Wilmington, Pa

rasping noises. A feature of equal importance is that the swivel prevents the cables, ropes or chains from becoming twisted.

### BREAK-PROOF FUEL TUBE AIDS PLANE SAFETY

A-210

Broken fuel or oil lines have been a frequent source of trouble to aviators, but this difficulty may be entirely eliminated through the introduction of a kind of tubing that will not break under the strain of engine vibrations and other stresses. The secret of its strength lies in the fact that an oil-proof fabricated-rubber covering has been vulcanized to the copper or alumi-

Hard core  
3657  
Sprenter's Corp.  
Detroit, Mich.

num tubing. If the metal tubing should break, there will be no leak, for the outer covering will still retain the oil or gasoline. If a crack in the line does occur while flying, the fact will be apparent in a small hump at the point of fracture. This can be remedied by inspection and repair crews at the hangar.

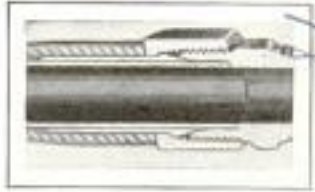

### RAYS OF DAYLIGHT HARNESSSED TO RUN SMALL MOTOR

A-247

Operation of a half-volt motor on energy supplied by the rays of daylight alone is the claim made recently by Dr. Bruno Lange, Berlin scientist. The energy was created by the action of light on a special metal-alloy plate. The motor gets its power from light reacting on a photoelectric cell which transmits the energy directly to the motor, the cell being actuated strongly by the invisible red and ultra-red rays. Doctor Lange said he expected the process of thus utilizing the sun's energy will greatly affect the future of both television and talking pictures.

Inco Germany 2/4/31  
Kaiser Wilhelm Institute  
Copyrighted material



### NURSERY FOR BREEDING BUGS TO WAR ON INSECT PESTS

Imported bugs will be coddled in the lap of luxury in an "insectary" in California erected for the breeding and care of beneficial insects that are raised to war on crop pests, particularly those attacking citrus fruit. The structure is an H-shaped building of reinforced concrete with tile roof and over-all dimensions of about 100 by fifty feet. There are twenty insect-rearing rooms in the four wings. The plant has been made insect-proof to keep the nursery bugs in and others out. Corridors are painted black and lights are extinguished when doors are opened to avoid attracting the bugs. All electric fixtures are insect-proof and gas-tight. Twelve changes of air are provided hourly, the air-conditioning system removing dirt and supplying proper humidity and temperature. Each nursery room is equipped with an electric heating unit and a thermostat providing a temperature range from seventy to ninety degrees. Air ducts are covered with silk screens and supply and exhaust ducts are fitted with air-tight dampers so rooms may be closed and fumigated at any time.

### TEASPOON HOLDS TINY MONKEY FOUND IN SOUTH AMERICA

So small that it can be placed comfortably in an ordinary teaspoon, a tiny monkey found in South America recently was placed on exhibition in the London zoo. It is a pigmy marmoset, has a tail three times its length, and weighs less than a pound.

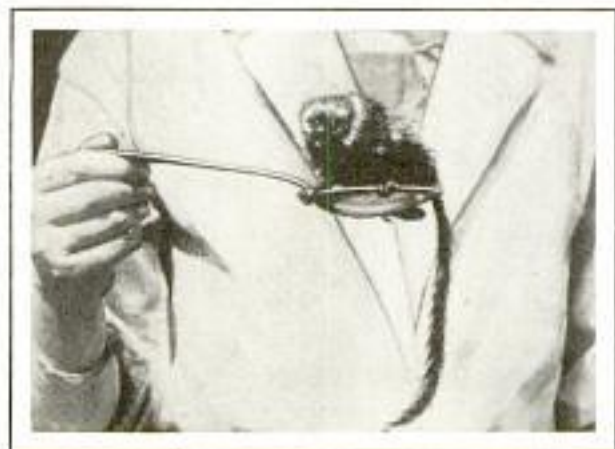

Pigmy Marmoset Monkey Which Is So Small That It Rests Comfortably in a Teaspoon



Headrest for Photo Flash Bulb and Battery; the Camera Shutter Sets Off the Flashlight

### FLASH LAMP RESTING ON HEAD OPERATES WITH CAMERA

Electric photo-flashlamps for making snapshots now are being placed by some photographers in a receptacle which fits on top of the operator's head, the lamp-rest being held by a broad band which passes about the face and under the chin. This places the bulb higher and farther away from the camera than when held in the hand, and eliminates the need of a tripod, both hands being free to hold and operate the camera. A porcelain lamp socket is fastened to a small wooden base, a flat-type pocket flashlight battery being inserted beneath the base and clamped by means of a similar board. The underside of the board is padded to fit the head, and a removable aluminum reflector is attached with thumbscrews to the back of the lamp base. From the bulb a lamp cord extends to the camera, terminating in contacts mounted on a bakelite block that can be plugged into the frame supporting the shutter. This provides a unit readily detachable from the camera, and, in operation, the contacts are pressed together when the shutter is released, thus closing the circuit to set off the flash.

Arizona contains the most extensive pine forests in this country.

General Electric Co.  
Chemist, N.Y.



Seltner Mfg Co, Fairbault, Minn

556

water wheel

POPULAR MECHANICS

FUN AND THRILLS ARE COMBINED IN THE LATEST

2207

Pat pending  
65.00

no charge



Borrowing an Idea from the Fiji Islands, the Boat Makers Have Introduced a Safe though Speedy Sailing Canoe with Outriggers to Prevent Capsizing; in the Foreground Is a Motorized Surfboard for Speedy Sport without the Need of a Towing Craft



Water Slides Give Healthful Sport; as Shown, the Sleds Have Cleats That Run in Grooves, in Order to Prevent Spills

\$ 130.00, \$ 109.00, \$ 150.00, \$ 180.00



*2. Ar. vault, man*

WATER SPORTS SEEN AT THE WINTER BEACHES



*Hunter water*  
*Pat's*  
*man*  
*\$165.00*  
*Junior*  
*125.00*



In the Background Is a Spinning Platform That Spills Its Riders into the Water, and, in the Foreground, Jumping with Water Skis, One of the Most Thrilling of Modern Water Sports



*Sellner*  
*125.00*

Being Towed on Water Skis, Twin Surfboards, and, Above, Riding the Water Wheel, for a Slow, Easy Dive

*Akwa shoes - sport model 15.00*  
*safety spec 25.00*  
*Copyrighted material*  
*\$ 35.00*



a. 175

TINYTOWN ATTRACTS THOUSANDS OF SIGHT-SEERS



Above, a Bird's-Eye View of "Tinytown"; Center, a Business Block in Winter; Below, a Residential Street in This Lilliputian City

On the banks of a mountain stream near Denver is a Lilliputian city of doll houses, complete in every detail of the modern town, and built exactly to scale throughout. Known as "Tinytown," the little city covers half an acre and has residences three feet tall, cement sidewalks, graveled streets, electric lights on ornamental posts, and other modern improvements. It was started by a Denver man whose little daughter wanted a doll house. From the one home, the Lilliputian settlement grew to a village and then to a town as addi-

tions were made, until today it is a Mecca for children and attracts thousands of sight-seers. When the village was started, each home was landscaped. It grew like any other town, a railroad finally passing through it, and the coming of the iron horse was followed by a boom and the building of the corner drug store, a filling station, hotel, pool hall and barber shop. Then a cultural wave hit Tinytown, and a theater, library, movie show, parks, playground, and finally a pool in which a small steamer floats, were added. The town had one flurry of excitement when its builder, reverting to frontier memories, developed a gold-mining camp on a hill back of the village. This camp also is built to scale and complete in detail, including shaft houses and reduction mills. Every building in the town is wired for

Constructed by George Turner. Located in Turkey Creek Canyon, at out of miles from Denver.



General Market House  
815 1/2 Main  
Evanston, Ill

The Calpro Sales Co  
1539 429 Santa Monica Blvd Beverly Hills Calif

POPULAR MECHANICS 559

electricity, and at night the hamlet is a blaze of lights. Lawns are carefully sprinkled and clipped by an attendant, the gravel streets kept smooth and clean, and buildings are painted frequently.

a-235

### BUTCHERSHOP HAS NO BUTCHER

Butcherless meat shops are appearing throughout the country as one of the latest developments of the chain-store and package-merchandising idea. Meats are already weighed and are displayed, wrapped in transparent material, in refrigerated, mirror-backed show cases where the shopper can observe their quality and the price too. This kind of butcher shop is merely a distributing center for the central cooling rooms and packing houses where the meats are cut, trimmed, sorted, inspected and wrapped. The improved refrigeration methods under which they are kept are said to insure better cooking, better flavor and increased nutriment.



Pouring Poison Sirup into Special Stone Jars, Which Are Placed in the Garden to Kill Ants

### POISON SIRUP IN STONE JARS KILLS INSECT PESTS

Containing a poison sirup, vitrified stone jars that will not upset nor allow the entrance of water, are set about the garden or other places to kill ants and other insect pests. The liquid is not instantly fatal, but is certain, and since, in the case of ants, for instance, it is taken to the nests by the workers, it will soon exterminate the entire colony.

### OUTBOARD MOTOR RUN INBOARD ON BOAT OR CANOE

Adapted to practically all kinds of small boats or canoes, a motor case installed in the hull, puts the outboard motor inboard with several desirable features, according to the manufacturers. The boat will

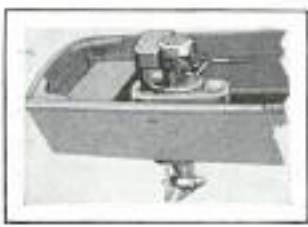

develop higher speed, it is held, since the propeller is always in water; there is a special attachment which is said to increase steering efficiency, and certain power losses are eliminated. The case does not prevent the tilting of the drive and motor so that full propeller protection is afforded, and boats equipped with the device can be dragged upon the wharf without damage to the motor just as in the case of outboards. Boats so rigged are said to run quietly and smoothly.

731 Butterfield Bldg  
A. G. Smith

### GOLF COURSE FITTING POCKET CONTAINS NINE HOLES

Golf courses now have shrunk to coat-pocket size, and one amusement device includes a full nine-hole course contained in a cardboard box measuring only four by seven inches. "Strokes" are made by tipping the box so that a steel ball rolls toward the proper hole. If it strikes a trap it drops in and emerges at another opening, counting as one stroke. If it travels safely to the hole aimed at, it emerges at still another opening and the play proceeds to the next tee. The game should be interesting to both young and old.



The world investment in radio broadcasting and receiving was calculated as of November, 1929, at \$1,502,019,720, of which ninety-eight per cent was listeners' outlay.

Kennebec Canoe Co  
Waterville Maine

Miniature Game Co  
Hancock Copy Right  
Phila.

Hills  
Calif

a-195

250





Adjusting Record in Phonograph Which Gives Lectures on Art to Visitors in a German Museum

**RECORDS AS MUSEUM GUIDE HELP EXPLAIN PICTURES**

Visitors at a German art museum may listen to a description of the paintings and other objects from a phonograph which serves as a substitute for a human guide. The tone may be amplified to serve a large or small crowd, and the records are changed by an attendant.

**BUSINESS OFFICE WITH WINGS HAS COMFORTS OF HOME**

Most of the comforts of a modern home are present in a big tri-motored airplane used as a business office by executives of a large corporation in making cross-country trips. Features of the luxurious ship include a buffet, gas stove, refrigerator, overstuffed furniture, Pullman beds, radio for amusement broadcasts, telephone service between passengers and pilots, and hot and cold running water. The plane, driven by three 525-horsepower motors, has a high speed of 145 miles an hour and a cruising speed of 120 miles an hour. It can fly from New York to San Francisco with only three stops for fueling. The pilots' compartment has ninety controls and instruments or aids to navigation. There is a special night-flying equipment

and radio-telephone enabling the pilots to talk with ground stations or other planes. The ship has a wing span of eighty feet.

**"STILL" PICTURE OF HIGH SPEED ENGINE TAKEN BY AID OF NEW TUBE**

To study the behavior of machines while they are operating at high speed by "stopping" or slowing down the rapid motion so the eye can perceive it, an improved type of instrument, known as a stroboscope, has recently been developed. With this apparatus it is possible to take still or moving pictures showing the moving parts of speeding machinery in clear detail. Such pictures are made possible by using a thyratron mercury-arc tube, the intense actinic light which allows

making photographs at exposures of ten-millionths of a second. In the accompanying picture of a 160-horsepower motor, for instance, the north and south poles of the rotor marked by the letters moved past the lens at ninety-five miles an hour.



"Still" Picture of Machinery Moving at High Speed, Taken to Study the Parts in Motion

*Return by Standard Oil Company of California*

*Developed at Cambridge Mass*

*Boeing Airplane Co., Georgetown Station Seattle, Wash*

*developed at Massachusetts Institute of Technology*



*Committee on Surface*

*Features of Moon*

*Carnegie & Co. 2-160*

**MYSTERY OF MOON'S SURFACE STUDIED WITH NEW AIDS**

*Washington*

What is the moon made of? Scientists are not certain, but they are studying the mystery with sensitive instruments that measure the heat from the distant stars, special eyepieces for the big telescopes, and other apparatus that have been devised to explore the mysteries of the heavens and the earth. By comparing the behavior of light as it strikes the surface of the moon with its action when it comes in contact with certain known substances on earth, a clue is obtained as to the character of the moon's surface. A special polarizing eyepiece is fitted into the big telescope to help study how the light is reflected from the moon. Astronomers now feel reasonably certain that the moon's surface contains no appreciable amount of basalt, as the light is not reflected from the moon in the way that it is reflected from that volcanic rock. The moon is being carefully studied with a thermocouple, an electrical heat-registering device so sensitive that it records the heat from the stars millions of miles farther away from the earth than the moon, and from this investigation the searchers are assured that the satellite must be covered with an unusually good heat-insulating material, something which reflects most of the heat rays from the sun. Dr. Paul Epstein, of the California Institute of Technology, says that the only known substance which insulates so well is pumicestone or volcanic ash.

**OILCAN WITH PISTOL TRIGGER HAS FORCE-FEED PUMP**

Small oilcans with forced-feed attachments now are being offered, one of the handy models operating the pressure pump by means of a trigger. The can has an angle spout and the trigger projects at the side of the oiler so that the container can be held and operated by one hand. The pump is made entirely of metal parts and has no leather plungers or valves that would be likely to get out of order.



Holding Stencil with Special Tape While Painting, and Close View of a Roll of the Tape

**SHIELD TAPE HOLDS STENCILS TO SPEED PAINT JOBS**

Time and labor are saved in using stencils on various painting jobs by employing lengths of a recently developed form of adhesive shielding tape. It sticks the stencils to the wall, leaving both hands free for work, aids in producing panel effects, in striping and in many other operations. A strip or two of it applied to the woodwork, window trim, sills or other parts, protect them from smears when the other surfaces are being painted. The tape is furnished in several widths, and requires no wetting or heating to make it stick.

**ROCK THAT RESEMBLES CORK FLOATS ON WATER**

Found mostly in the Swiss Tyrol, a rare specimen of rock known as mountain cork, floats on water and has about the consistency of a sponge. It is actually a form of asbestos, and appears in chunks like other rocks, or in layers that are called mountain leather. In the latter form the rock resembles tough gray leather. Several rocks or other minerals will float on water. Pumicestone will stay up until it is waterlogged, and meerschauam indefinitely.

*A-152*

*Kodak Co. Rochester, N.Y.*

*Castron Kodak Co. Curator of Minerals*

*Sold by Hardware & Supply Co. 975*

*Phew's Oiler Co. Boston 210g*

*one newspaper*



208 D Cmt. Elmer Blasseman,  
55 W. 86 St., New York

# The Luck of the



five miles per hour. Inside the furnace, he fights for air, and for brakes. The brakes jam. He jumps in burning clothes. No skipper ever held a ship as Norman did that car. Had he allowed it to run amuck, it might have plowed into the wooden grandstands and endangered the lives of

By JOHN L. DRAPER

**M**EMORIAL Day at the Indianapolis motor speedway. One hundred thousand fans shout for a winner. Jules Ellingboe tears down the straightaway with a pack of screaming motors on his trail. Around the north turn, he skims across the thirty-six degree bank, and as his car levels off, it hops the track and leaps for a wall.

One instant later, Norman Batten skids around that fatal curve. Road clear ahead. Norman's big right toe spurs his motor. Zip! Half a spring leaf from Ellingboe's wreck flies after Norman like a javelin, and drills through the gas tank. Norman clips 140 miles per hour down the straightaway, drowned in a geyser of fire. A pillar of flame forty feet high, and to stunned spectators it looks like Norman had sacrificed his life for a sport.

But the race goes on. The cranky motors whine around the oval. Norman's car slows down to a snail's pace, thirty-



Above, Billy Arnold, Winner of the 1930 Indianapolis Speedway Classic, and His Mechanic; Below, Start of a 500-Mile Race

100,000 people. It is the only time on record that the timing crew failed to score a car. In five months, Norman came out of a hospital.

Racers, and men who know racing, are disposed to call that the most valorous performance they have seen on a speedway. And the race track, as every one knows, demands nerve and valor above all.

In the early days of racing, when entries were run by hired chauffeurs driving



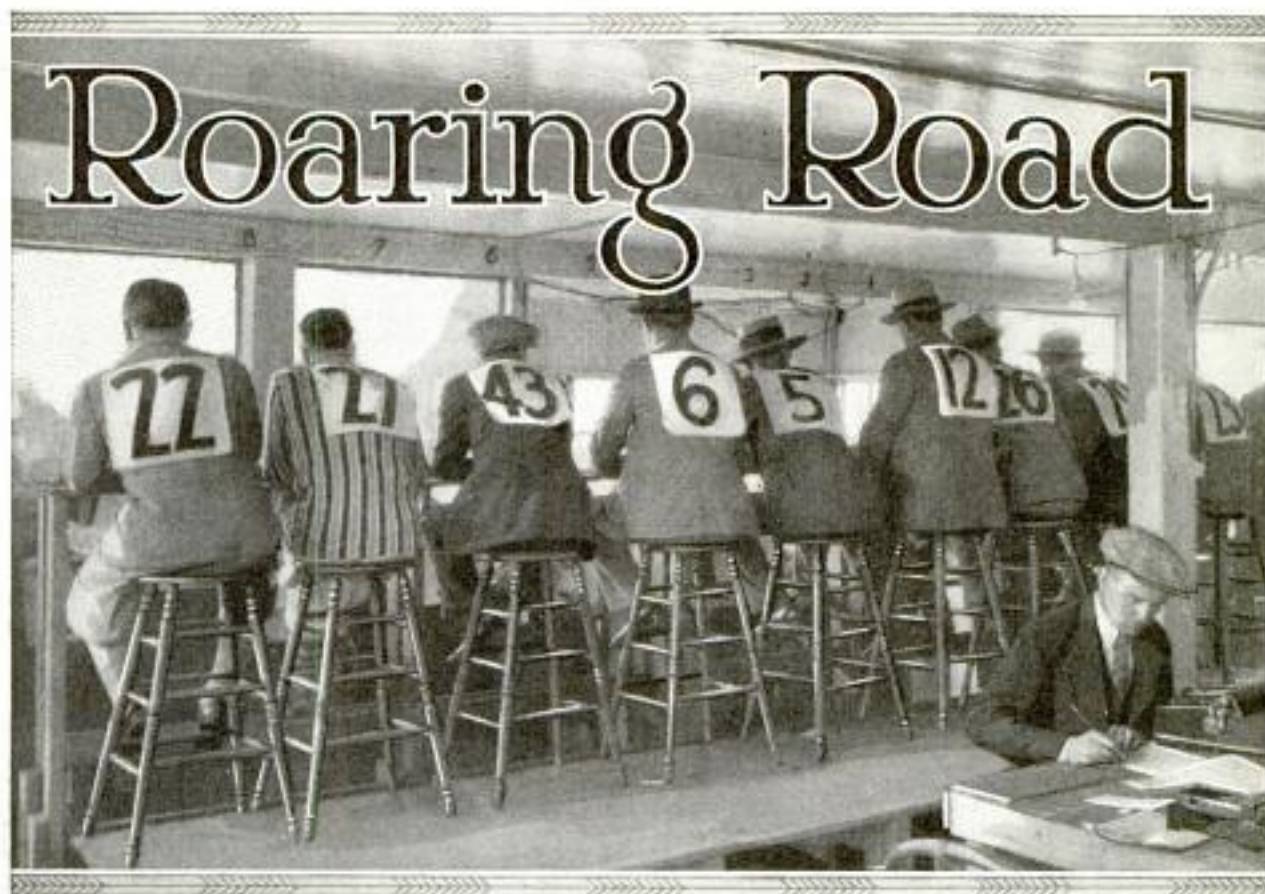

A View of the Individual Scorers of Racing Cars at the Indianapolis Speedway; Each Man Carries on His Back the Number of the Car Whose Position He Is Checking

for wealthy men, sport was the principal motive. Auto racing was like horse racing. Blue-blooded mares will not be much better tomorrow than today, but automobiles are improved by grueling tests on the race track. No less than seventy-five per cent of the refinement in modern machines came from the speedway. Four-wheel brakes and eight-cylinder-in-line motors grew up at Indianapolis. Also the front-wheel drive. And the maximum cylinder displacement has been reduced, from 300 cubic inches in 1915, to 183 cubic inches in 1920, to 122 cubic inches in 1925, down to ninety cubic inches recently.

But if the speedway is a proving ground for steel, rubber and hydrocarbons, it is nothing less for men. Chester S. Ricker, American Automobile Association director of timing and scoring, who has officiated at racing events since 1907, told me that the new vintage of auto racers are technically trained in engineering schools at universities

Frank Lockhart, a kingpin in racing, was the first of a line of university-trained men to bring his skill to the speedway. Lockhart suffered an untimely

death when his Stutz "Bearcat" turned turtle at Daytona Beach. However, most of the engineer-drivers still attend a training school that has bred many racers, the dirt track. Dare-devils still make good on dirt, but they have little chance in a classic on hard surface. Your ideal driver attends school, masters the theory of internal-combustion engines, and while still in his early twenties, starts training on small dirt tracks. Here he acquires finesse and courage, so that when he finally drives in a classic, his mental and physical equipment are well-nigh perfect.

In the old guard, Earl Cooper was the only driver-engineer, and perhaps that accounts for the fact that he was America's champion racer in 1909 and 1910. Since the war, the old drivers who started racing as barnstormers have been displaced by daring young men who pit a technical education and skill against mere daredeviltry. We now have a breed of drivers so sensitive to the qualities of metals, rubber and fuel that they can drive cars to the utmost without damaging them; whereas, one who possesses courage without knowledge is sure to overstep the



limits of possible speed, or he feels so uncertain of his power plant that he lags in the race.

The Anglo-Saxons brought speed to the race, particularly the Americans, although Major Seagrave's record still stands. But all the world respects the French for bringing style to the speedway. In the balmy days when Paul Sartori drove a Fiat for Alfred Vanderbilt, when Bernin drove Clifford Brokaw's Renault, and Harry Grant ran his Alco neck-and-neck with Mercedes, Chalmers and Duracqs, when the classics were held at Fairmount Park and Briarcliff; in those precious bygone days, no man was a driver unless his garments were greasy, grimy and, often, filthy. It got to be an axiom that a racer was not worth his weight in petrol unless his face and clothes were soiled.

Jules Goux, a gentleman from Gaul, came to Indianapolis on a memorable Memorial Day, in 1913. His little Peugeot had multiple valves—four per cylinder. And Jules walked off with the race. That called attention to his personality. The American drivers ended up as usual, bathed in dirt and grease. But Jules was a Rue de la Paix magnifico. Swanky and stylish, gracious and courte-

ous, he stepped out of his seat, dressed in bright checkered puttees, a tight-fitting blue shirt to match his Peugeot, and, behold!—a racing helmet, spotless and immaculate. Secretly, they made a demigod out of Jules, and to this day, American racing drivers have followed his example, although he himself was well-nigh imitable.

Dave Lewis, now dead, also contributed to style in racing. He drove the first front-wheel drive in a 500-mile classic, the car owned by Cliff Durant, millionaire sportsman. In fast driving, Lewis found that the front wheels threw castor oil back into his face. His simple remedy was a powder puff affixed to the steering wheel. Attached to a rubber band, the puff would fly back into place after the driver had wiped a drop of oil off his face.

While drivers began taking powder puffs seriously, they also began to wear corsets, another French innovation, first introduced at Atlanta. Can a man expect his body to sustain what will break any but the strongest steel? All 500-mile racers now wear corsets of gauze, a bandage extending from the hips to the armpits, and from wrists to elbow.

Jimmy Murphy is still god of the American speedway, the greatest driver in his-



Another View of the Individual Car Scorers; Each Man Keeps Track of One Car Only, and the Man on the Right Was Scoring the Car in Leading Position When Picture Was Taken



tory. He started barnstorming in 1909, and drove his chariots over dirt, clay, gravel, sand, brick and concrete. In the period when racing entries were made by leading manufacturers, Jimmy piloted a Dusen-berg, and won the 500-mile contest in 1922. When he first entered speedways, drivers had to win or there was

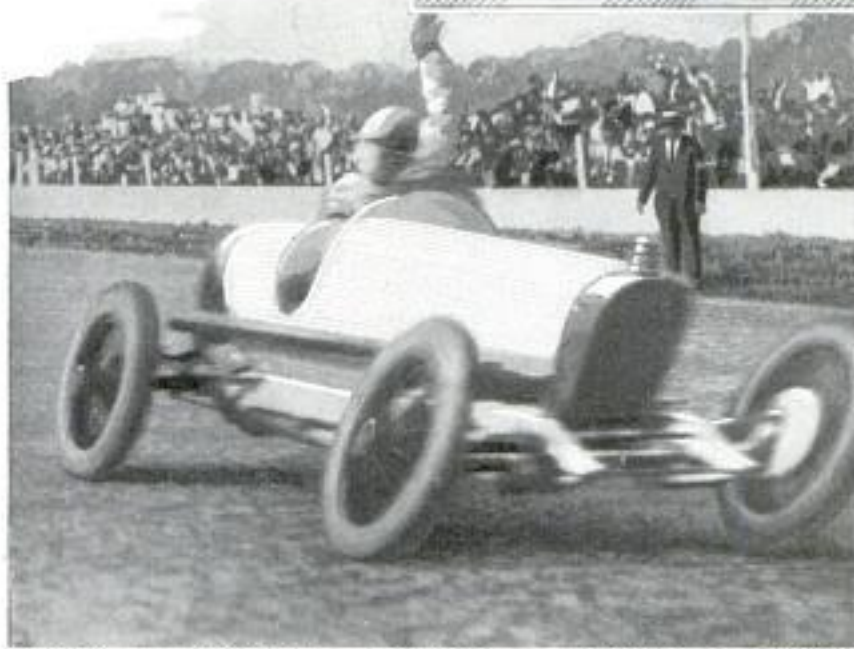

Above, a Wreck at the Indianapolis Motor Speedway during the 1930 Race;  
Below, Tommy Milton at End of a Winning Race

nothing to eat. He won a great many races, and in one year earned \$110,000. He was a great mechanic as well as a driver; thus he mastered the art of "tooling" a car around the oval. Jimmy Murphy was the last of the "by-guess and by-God boys." Frank Lockhart ranks after him.

"We had a most exciting time," Ricker said, "when Louis Chevrolet drove a Frontenac around the track and threw off a front wheel while driving seventy-five miles per hour. With superhuman strength he held the car to her groove and drove more than a mile on three wheels. Aiming for the pits, he cut the timing wire stretched across the track,

causing it to coil around the neck of Elmer Shannon as he raced down the home stretch. Shannon's injuries were slight.

"In 1914, Ray Gilhooley took the southwest turn at high speed and spun around three times, blocking traffic so well that Joe Dawson, his successor, smacked Gilhooley's car, and both of them rolled down the inside of the track. Ever since, a spin or bad turn is called a 'Gilhooley'."

Since the successful driver wins handsome rewards, a contestant takes the best possible care of himself. Two or three days before races, he submits to a medical examination. To train his eye for speed, and to co-ordinate his senses, he boxes or he plays handball. He gets a full quota of sleep. A rule of the speedway is that he cannot work on his car the night before the race. One thing he does not do, however, is diet.

For 500-mile races, the average speed is around 100 miles per hour. Roughly it requires five hours to see the race over, during which the car speed at various times goes up to 130 and 140 miles per hour. All cars carry tachometers to tell revolutions per minute of the crankshaft. During a 500-mile race, the crankshaft



2088 566

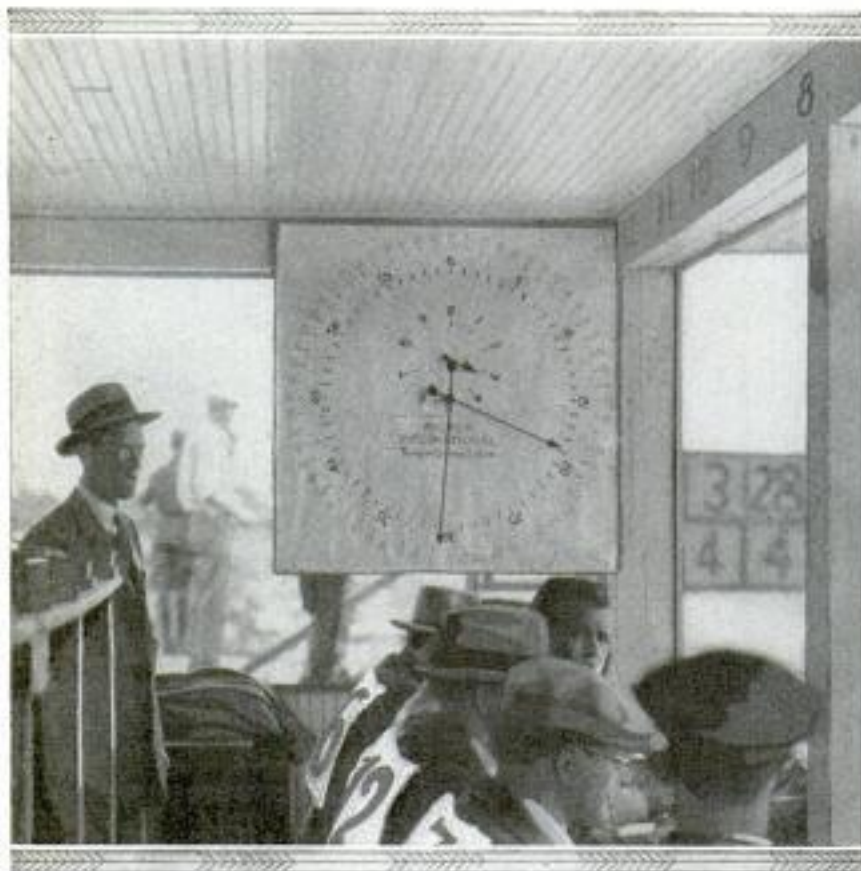

Clock Synchronized with Electric Timer; It Ticks Off the Seconds so Each Car Scorer Is Able to Time His Own Racer

"If we only had to worry about the bookkeeping end of the race," said Ricker, "it would be easy, but the modern public-address system, the radio hookup, combined with lap prize scoring and press reports, completely upset the system we used before the war. Announcing is now considered as important a function of scoring as bookkeeping."

**COTTONSEED FED TO FISH**

Cottonseed meal has been found to be one of the most satisfactory plant products for rearing brook trout. It cannot be fed alone, but is mixed with equal parts of dry skim milk and a good quality of fish meal. This dry feed is made in-

makes about 2,500,000 revolutions, while the spark plugs flash 10,000,000 times.

Now compare the speed of these racers with other forms of locomotion. Running at about fourteen and a half miles per hour, the fastest sprinter would cover seventy-two and a half miles in five hours, and it would take him thirty-four and a half hours to finish the race (if he could run that long). An ice skater, at thirty-one miles per hour would require sixteen hours to finish. An ocean steamship would require fifteen hours. The running horse, at forty miles per hour would arrive at his goal in twelve and a half hours, and a swift American destroyer, at forty-five miles per hour, would require about eleven hours, while a fast railway train, at ninety miles per hour, would finish in five and a half hours. Only an airplane can outstrip the automobile.

One hundred men are necessary to take care of the timing and scoring. And they are kept so busy that Ricker, the chief, confesses that he hasn't seen a race since 1905. The judges depend upon the calculations of Ricker and his staff, and so do the drivers.

to a paste with water and combined with a small quantity of raw meat. On the other hand, linseed meal will poison brook trout, killing them in a few weeks.

*Cornell University*

**TRUNK ATTACHED TO CAR DOOR CARRIES EXTRA LUGGAGE**

Extra luggage on the motor trip now can be carried in spare trunks that are attached quickly to the car doors. The trunks allow doors to swing open and do not interfere with the opening and closing of the windows, nor do they mar the finish of the auto. They also may take the place of luggage racks at the rear of the car.



Our Bureau of Information will answer all questions regarding articles appearing in this magazine.

*George A. Prichard  
Atlantic Beach, Fla*

2190

*Salerno Service 508-22  
12/18/21*







Richard K. Henry, General Supt.

568

POPULAR MECHANICS

*a-130 of Prod. Deep Rock Oil Corp.*  
**TRICKS IN FIGHTING OIL FIRES CONQUER WELLS**

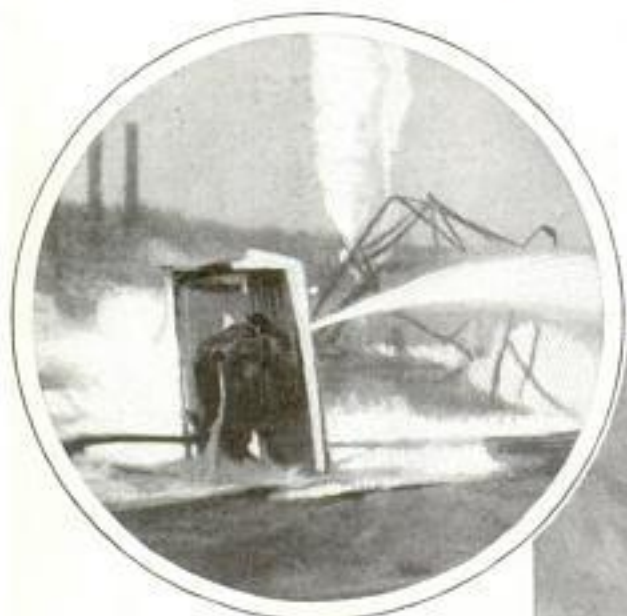

Courtesy Deep Oil Corp.

There are tricks to every trade, oil-well fire fighting included. Take the oil and gas fire at the "Wild Abe" well near Tulsa, Okla., recently. The rotary drills were down slightly more than 3,000 feet, when suddenly a blow-out shot 1,550 feet of heavy drill pipe clear out of the hole, wrecking rig and derrick. Sparks ignited the gas, and in a few seconds, a geyser of flame, visible seventy miles away, was roaring skyward. How the fire was put out and the well capped is one of the stirring stories in which the oil fields abound. Tricks played an important part in the conquest. The first trick was to drag away all the metal debris, for metal is a greater hazard than wood after the oil-well fire has started. It gets so hot that it will re-ignite the gas and start the trouble all over even after the fire has been extinguished. About eighty-five tons of metal were dragged out of the flames of "Wild Abe" before direct attack was made on the fire. Then the workers used another trick. Instead of wearing heavy suits of fireproof material that get tiringly heavy when soaked with water, they wore lighter but just as effective clothing of heavy wool, woolen gloves and woolen caps that came down over the ears and back of the neck. The men were drenched with water

before they went into the fire and lines of hose were played upon them, while they labored in the fire, by assistants who operated from behind metal shields. The steel derrick and part of the drill pipe had to be cut with torches before it could be hauled away. Oxygen hose leading to the torches was kept wet to prevent it from



Pouring Water on Debris around "Wild Abe" from Behind Steel Screen, and Getting Ready to Shoot Out the Flame

melting. It took three shots of nitroglycerine to snuff out the flaming geyser, then cap it. The final victory was won with a steel nipple and valve anchored into place.

**"SINGING" ARC LIGHT TO AID TELEVISION RECEPTION**

*a-158*  
Finding a sufficiently brilliant light to use at the receiving end of the television circuit has been one of the problems that has perplexed inventors, but a solution of the difficulty is suggested by J. L. Baird, British television pioneer, in his experiments with the "singing" arc light. Its great brilliancy, and the fact that it varies



1/22/31

instantly with the current supplied to it, adapt it to the special requirements of television, Mr. Baird demonstrated. He and other engineers have shown how it can be made to sing or talk. When a high-frequency current is superimposed upon the current supplying the carbons in the light, the arc varies in step with the frequencies, causing air waves to radiate from the light. If the high-frequency is modulated by a microphone, the arc acts as a loud speaker, reproducing the voice or music. The light varies also, and it is this property which makes the arc fit for television. Neon tubes have been widely used for receivers, but they do not furnish sufficient light to enable projection of the image through a lens and upon a screen.

**FLAG DESIGN IN CORN KERNELS SHOWS BOY'S SKILL**

Thousands of colored corn kernels have been formed into an accurate mosaic representing the United States flag, by a Los Angeles boy. Much time and considerable skill were required to select kernels of the right color and size to form a smooth pattern.

Boy Artist with Replica of Flag Done in Carefully Matched Kernels of Corn

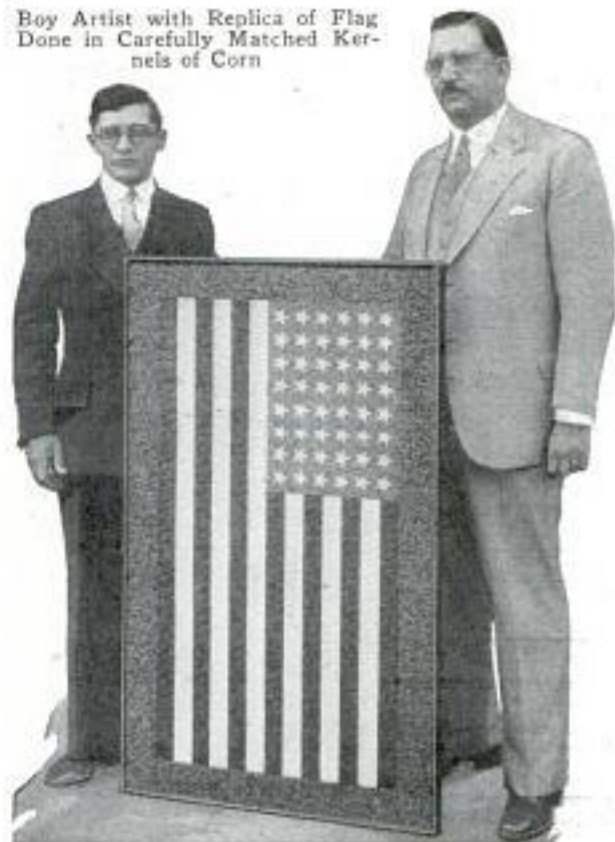

Charles A. Bayer,  
Los Angeles, Calif

**XMAS CARDS MAKE DECORATION FOR LAMP SHADES**

a-83

Key Stone



Christmas-Greeting Cards Pasted on Lamp Shade to Make a Permanent Record of Good Wishes

At last a practical use has been found for old Christmas-greeting cards usually laid aside or destroyed after they have been read. A California woman makes a permanent record of the well-wishes of her friends by incorporating them in the decoration of lamp shades, hat boxes, waste-paper baskets, card tables, and similar objects. Several coats of shellac, applied after the cards have been pasted to the article, give a durable finish.

**ARMY AIR SAFETY INCREASES THOUSAND PER CENT**

a-117

In the last ten years, safety in aerial operations of the air corps has increased 1,000 per cent, the war department has announced. During the last six months of 1930, for each fatal accident, 16,903 hours were flown. In 1921, only 1,718 miles were flown to each fatality. Between July 1 and December 31 of last year, there were eleven fatal accidents and nearly half of these were due to collisions in the air, indicating that military flying is naturally more hazardous than commercial flying because many maneuvers must be executed in formation.

U.S. Daily 1/19/31



Carl. Elm Island man.

35 W 56 St. New York

u-91

# A MUSEUM

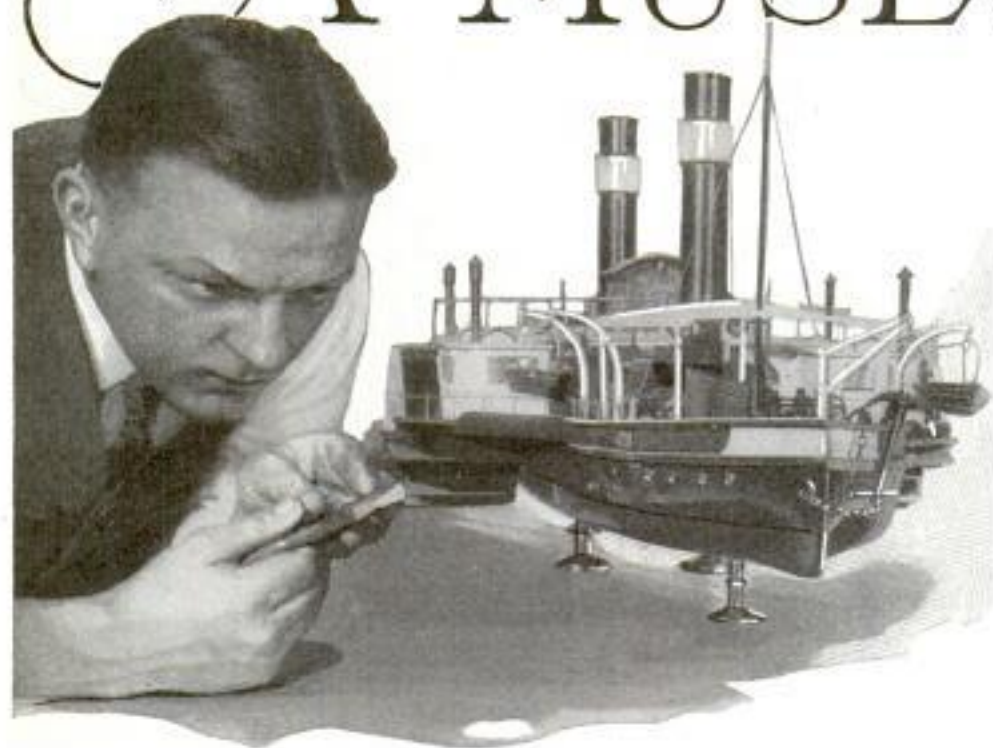

A THINKING creature reaching this earth from another planet would surely ask, "How did you get this way?"

What way? Up in skyscrapers, for example. And swimming in the air 300 miles an hour. Traveling over continents in swift caravans. Listening to music 10,000 miles away. Looking at moving images plucked out of space. Eating fresh food out of cans. Lighting cities at the touch of buttons.

The modern young man scarcely wonders at these performances. He grew up with them. Nothing on the street suggests that skyscrapers evolved from log cabins. Such an insignificant tool as a needle might be studied in a series of 5,000 models. Because they were not collected earlier, the complete history of the needle is still unknown.

After the needle came the sewing machine, and it liberated countless hands needed for other labor. Whole industries were built around the sewing machine. Likewise, the elevator inspired the skyscraper, much as sound broadcasting gave birth to television.

The skyscraper dream was not fulfilled until men learned to fabricate steel and build elevators. In turn, the skyscraper

affects our living and thinking. It sustains that cyclops of invention, the modern city—a colossal social hunting ground. What are machines but extensions of the human arm, the eye, the ear, the nerve and the brain? Machines take roles in politics, economies and international law. Whitney's cotton gin, demanding quantities of cheap labor, is said to have been the real cause of the Civil War.

The absorbing story of man's rise to technical supremacy remains to be told. In Chicago, a group of earnest men labors at this project with the thought of resurrecting a buried romance and giving it substance in the form of a museum. The building for this institution nears completion in Jackson park, on the site of the old Fine Arts building, left from the Columbian exposition of 1893. To make this structure suitable, the city of Chicago is spending \$5,000,000 as against an initial endowment of \$3,000,000 from Julius Rosenwald, philanthropist.

Among the exhibits which Waldemar Kaempffert, the director, is intending to build, is a series showing the gradual transition from such simple tools as the club and ax to the modern steamship and locomotive. Essentially, they will show a

Museum of Science  
and Industry



# COMES TO LIFE

history of the application of power, too. From the use of simple hand tools, man began to impress the service of domestic animals. Then he evolved the hand-power machine, followed by such simple contrivances as could be operated by animals. Then came machines run by water power, wind, gravity, and others operated by steam and electricity.

Stressing human, rather than scientific values, the Rosenwald museum will superimpose upon this strictly technical exhibit a social and economic interpretation. Various exhibits will compare the civilizations of modern cities with those of ancient Greece. The average free-born American citizen commands the equivalent of fifty slaves. In the times of Pericles, a Greek free-man commanded the services of only five slaves, the equivalent of only half a horsepower. In contrast to this, put the case of a modern flourmill producing 20,000 barrels of flour a day. And a steel mill or automobile factory employe may command the energy of about 10,000 horses.

What does all this mean? Suppose we deprive man of his powered tools and compel him to produce by brawn and muscle what he produces today with machinery. Harness him to shovels that gouge at cliffs, make him pull trains, lift the loads of derricks, push freight up inclines or swing hammers weighing tons.



Completing Accurate Model of Sailing Vessel, and a Tiny Steam Winch

England would have to support a population thirty times as great as it does today, and the United States would have to support one sixty times as numerous, in order to maintain the prevailing standards of comfort. We would have no time for recreation, and our working day would surely double in length. It is doubtful whether civilization could sup-

port its present population were it deprived of machinery. Within the first month, one fourth of the world's population would suffer great hardship. And at the end of the first year, more than half of us would be dead.

"Consider the typewriter," Kaempffert said. "We will have about twenty such machines to show their evolution. But



what is the social significance of a typewriter? It placed women in offices, gave millions of them jobs. Similarly, with Watt's steam engine. We will explain and have this engine working. We will stress the point that this engine created the factory and mass production.

"Electrical-power stations are now interconnective. We are in the age of 'super-power.' The Pacific coast is one power pool; the middle west another pool, and so on. Energy is free. It can be carried to the most remote places. We concern ourselves now with coal, land values,

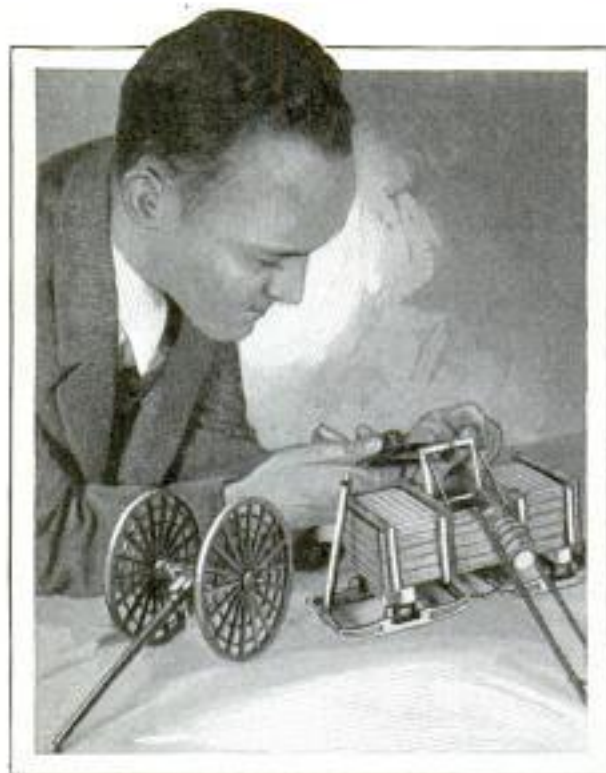

labor supplies and transportation.

"A tremendous social disturbance is now going on as a result of the invention of the dynamo. Power pools have made it possible for industries to invade the small town. Big cities have reached their peak, and in the near future are destined to lose much of their industrial importance.

"Industry has made possible the stabilization of prices and the warding off of starvation. We have never had famines in America. They occur only in the Far East, where there are few inventions in use. To me a locomotive

means more than an engine on wheels; it is a thing which places breakfast on a table."

The director pointed out what he considers a great advantage of the industrial museum over any other type of museum. In an art museum, for example, an original is sought after most. But the technical museum does not suffer much because it lacks Stephenson's "Rocket," for example. "It follows," he said, "that a technical museum can always be more coherent and systematic than any art museum. An exact replica of the 'Rocket' engine will teach all the original can."

From the experience of similar European museums, one million people are expected to visit the Chicago institution annually. It will be a new adventure for Americans. Visitors will be encouraged to work the various machines by pushing buttons and levers. One hundred moving-picture projectors will give one-man shows of such events and machines as cannot be brought under a roof.

If interested in the development of sleeping cars, the visitor will be asked to lie in the earliest type of rolling bed known, and he will be given a shaking that will correspond to the shakings his

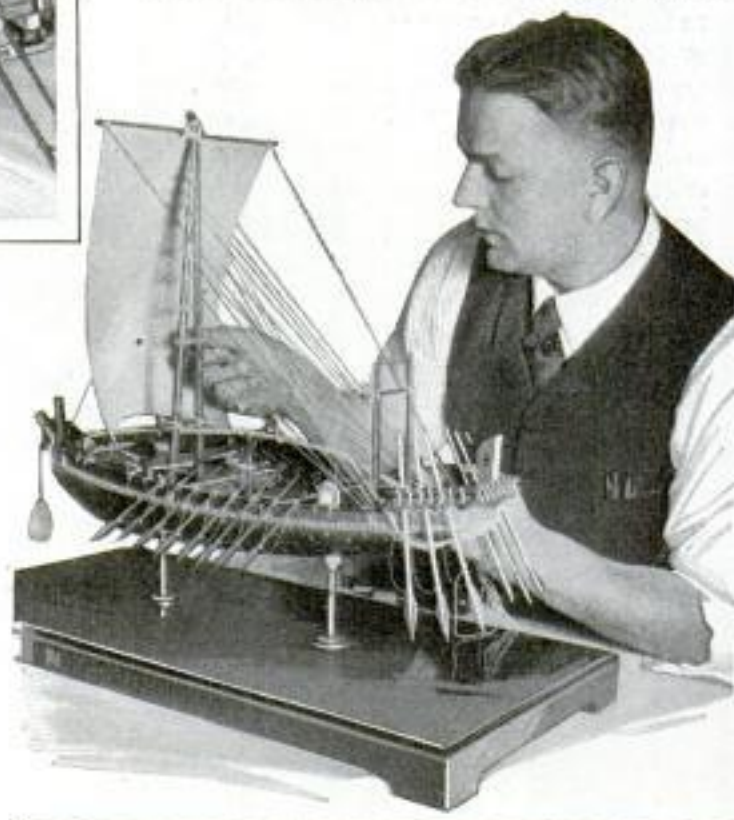

Miniature Road Icer Used in Logging Districts, and Graceful Model of an Egyptian Galley



grandfather received while riding in the same contraption. Then he will be asked to try a more modern type, the first sleeping car with lights and bed clothing. Thereafter he will go into the latest type of Pullman and be asked to relax on the yielding cushions. All the while, he will hear the grinding noise of wheels beneath his feet, the click of rails, and from the window he will see bits of scenery flying by.

There will be models of ships built to scale in faithful detail. Many of these are now under construction in the mu-

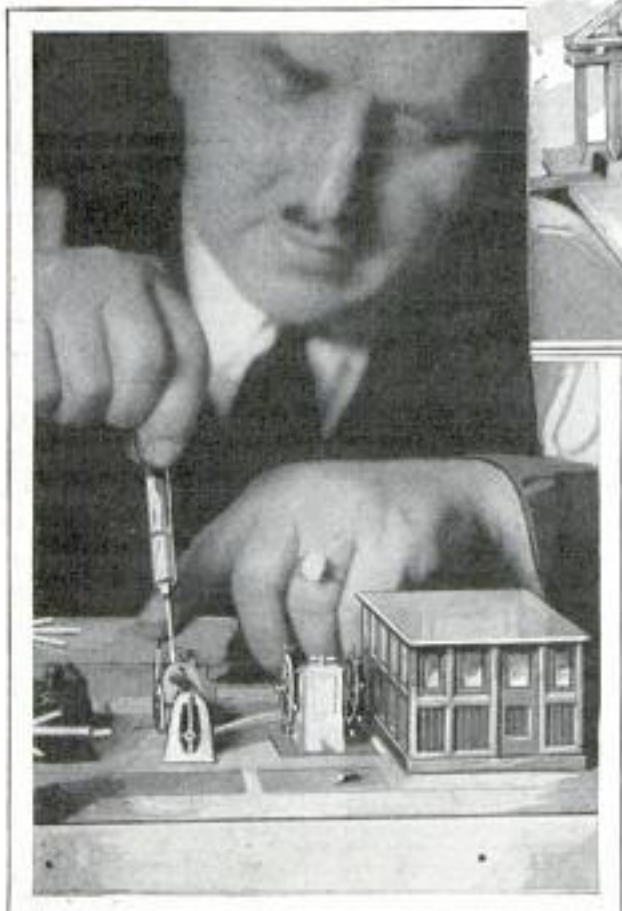

Ancient Type of Bridge, and Close View of Accurately Made Fittings for Model Sailing Vessel

seum's own shops. Others are being made abroad and by American manufacturers. A craftsman may work months and months on a miniature bridge or ship, and the cost of one model may reach \$10,000. Parts of the ship models' superstructures are goldplated, to ward off rust and corrosion. When the museum is complete, it is estimated that its collection will number 60,000 objects, ranging from a full-size locomotive and section of a coal mine down to things invisible to the eye.

Because of the sentimental value, an

earnest attempt is being made to collect the original masterpieces of invention. Concerning Stephenson's "Rocket," Kaempffert said the Chicago museum has ordered the construction of a full-size replica which will be more accurate in detail than the original "Rocket" itself, owned by the Science Museum at Kensington. Since the "Rocket" of 1829 became standard practice in locomotive design, it was very necessary that the Chicago museum should have one. How can a copy be more original than the original itself? Kaempffert explained that the early locomotive builders never worked from drawings. The old "Rocket" came to Kensington in a dilapidated condition; it was partially restored, but the restorers blundered.

"We have insisted," he went on, "that the locomotive be built with the methods of 1829, and not with automatic machinery and riveters. In complying with our request, Stephenson and Company, descendants of the original firm, have discovered how the missing parts should have been built."

At least one locomotive in the exhibit will have steam up practically all the time and will pant like an engine ready to be off and away.



a-91  
574

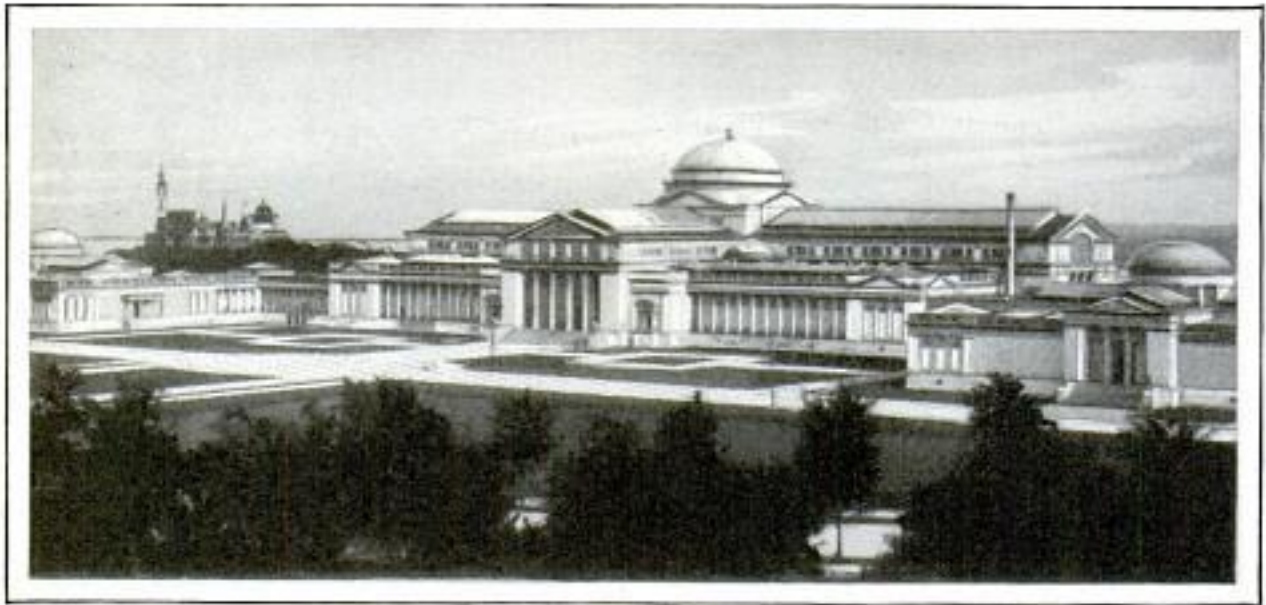

View of Old Fine Arts Building, a Relic of the World's Fair of 1893, before Its Restoration to House the Museum of Science and Industry

So far as possible, the Rosenwald museum will bar the glass cage. Visitors will be encouraged to feel and touch, push and pull. By pushing a button they will launch a fifteen-foot model of an ocean greyhound. The Panama canal will be represented with its locks and adjacent topography. In a miniature of the Welland canal, the visitor will be able to supervise the passage of ships through the locks. The ship exhibit, probably the most complete miniature collection in the world, will include 200 models, all on a scale of 1 to 48, so that it will be easy to judge the size of an ocean greyhound in comparison with a felucca from the Mediterranean.

The development of the paved street will be shown in a reproduction of a real street. The visitor will be led along a jungle path; then along a paved Roman road, then along a rock road of the Middle Ages, and finally over a series of modern pavements. Miniature cross sections will show how cables, sewers and tunnels are constructed beneath highways.

The coal mine will extend seventeen feet below the surface. A real mule will pull the string of coal cars. Miners and picks will show how coal is gotten out of the earth by old methods. And adjacent to this exhibit will be a modern mine, in which the visitor may operate the electrical and pneumatic machinery.

**MYSTERIOUS COINS OF BRASS  
CLUE TO TREASURE?**

Two heart-shaped coins of brass, recently found by excavators on Catalina island, have aroused the curiosity of coin

specialists because the metal is unusual for such pieces. Old coins have been found on the island before, evidently dropped by Spanish or Chinese pirates. It is held possible that the peculiar marking on the coins may designate the location of hidden treasure.



Heart-Shaped Brass Coins Found on Catalina Island; It Is Believed They May Be Part of Pirate Hoard

**BRITISH INVENTIONS DECREASE**

British inventions decreased slightly in 1930 as compared with 1929, when 39,898 applications for patents were made. The decline amounts to about 600, and was attributed to the world-wide depression. America and Germany were the most active foreign countries.

Owner: Paul J. Burks  
231 W. 4th St.  
Los Angeles Calif

a-161  
Capt. A. C. Blackhall  
7, Vincent Square  
mansions, London, W. 1  
Copyrighted material



A-136 Cont. Dwight Lloyd  
Capitol Hill Sta. Box 96  
Denver, Colo

# WIRED WIRELESS TO SERVE TWO THOUSAND ROOMS

Three triangular strands of wire, one-sixteenth of an inch in diameter, almost invisible from the street 660 feet below, will serve as the antenna system for a complicated radio hookup in New York's new Waldorf-Astoria hotel, connecting each of the 2,000 private rooms with a loud speaker. By means of a program selector, each guest will have a choice of six radio broadcasts at any time, and the same apparatus will pick up public events in the hotel itself. The outside radio programs all will be picked up on a single-strand antenna from which six large receivers will operate. In addition, there are two extra strands which will serve private receivers in 140 tower suites, where it will only be neces-

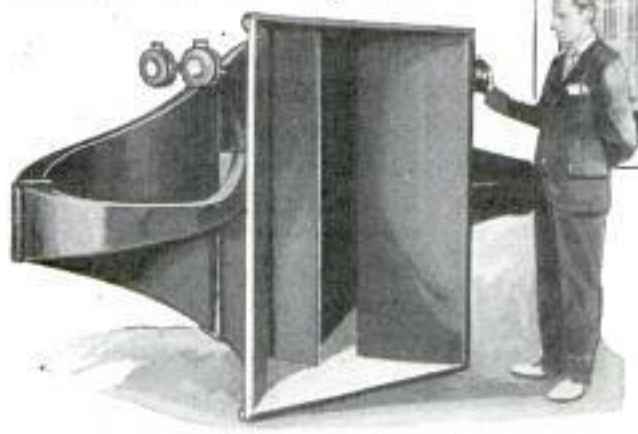
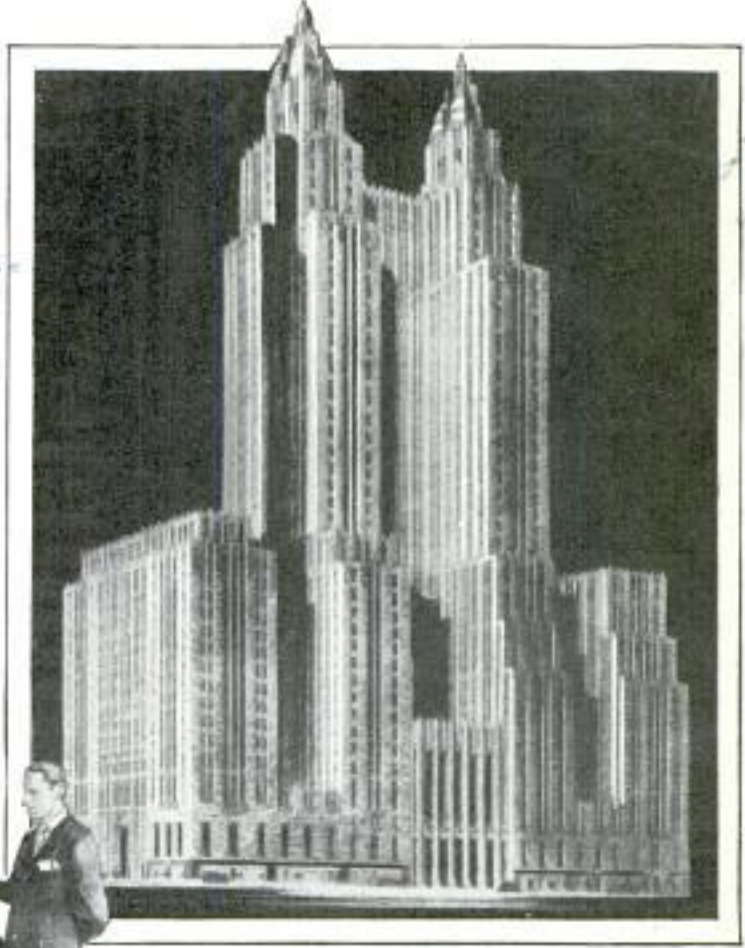

New Waldorf-Astoria Hotel as It Will Look When Completed; Below, One of Loud Speakers in Its Radio Communication System

and orders throughout the various departments. There also will be one permanent sound-picture installation in the ballroom and several portable ones.

## PLANT SUBSTITUTE FOR FLAX PRODUCES VALUABLE OIL

sary to plug in an ordinary receiver, automatically providing all facilities for picking up radio broadcasts. A unilateral arrangement introduced into the antenna circuit makes it possible for a large number of receivers to operate simultaneously from the same antenna, picking up a variety of programs without causing interference. Speakers in the guestrooms will be located on tables or desks and so tuned that the volume cannot be made so loud as to annoy other guests. In addition to a telephone switchboard, large enough to serve a city of 20,000 persons, two telephone-typewriter systems will be used to report arrivals and departures of guests and for paging and transmitting messages

Safflower, which looks like a thistle without prickles and has been cultivated in India and Egypt as an oil-seed crop, is being tested in this country as a partial substitute for flax. The seeds contain a drying oil valuable in the production of paints and varnishes, and the oil cake is useful as stock feed. The United States now imports much flax seed for the linseed oil it contains, and safflower is suggested by the department of agriculture as a possible supplementary crop to flax in the northwest. The same farm machinery for sowing and harvesting other small-grain crops can be used in cultivating it. It appears more resistant to frost than flax and is well adapted to the northern great plains region.

under supervision of  
Frank Rabak Bureau of  
Plant Industry

of volume & source  
573-71 1/24/31



described by Dr. W. H. Charles, Imperial Institute of Entomology



Orange-Peeling Machine That Removes the Skin without Injuring or Crushing the Pulp

ORANGE PEELER REMOVES SKIN WITHOUT INJURING FRUIT

Squeezers and other devices for removing the juice from oranges have long been in use, but recently a machine was invented which peels the oranges without injuring the pulp or extracting any of the juice.

TURNING FLOWERPOT STAND HELPS PLANTS GROW



So that pots can easily be turned and all sides of the plant may be exposed to the sun and thus promote growth, a revolving holder has been introduced.

saucer, mounted on a ball-bearing base. Even large pots can easily be turned and without damage to shelves or tables.

POOLS OF OIL ARE NURSERIES FOR STRANGE FLY SPECIES

Despite the fact that oil is usually fatal to most insects, one strange species of fly spends its infancy at the bottom of oil pools. It answers to the imposing name of "Psilopa petrolii," and is found in parts of the California oil field.

STEEL DRUM WITH LOCK HEAD SIMPLIFIES SHIPPING

Locked without the aid of tools, screws or bolts, the head of a steel shipping drum now on the market can be tightly closed or opened in a few seconds simply by moving a lever on the head.



Cook's Fruit Machinery Co. 285 Rochester, N.Y.

9-159 9-131 9-131

2.60683.50

H. Abbe Abbe 21 Rochester, Mass.

Have no metal products mas. abbe



A-113 Com. Newton H. Hartman,  
1049 Edgemore Road  
POPULAR MECHANICS *Shelton* 577

## SUBMARINE FOR POLAR TRIP TO BORE THROUGH ICE



Dog sleds, ships and airplanes all have carried their parties of explorers to the Arctic, and, now a north-pole voyage by submarine is being arranged, the sub-sea craft intending to chart its course through the ocean beneath many feet of ice. This underwater trip to the pole is planned by Sir George Hubert Wilkins and his associates, who have fitted a former navy submarine for the journey. The "Nautilus," as the altered craft has been named, bears little resemblance to the ordinary submersible. Across its top, from end to end, extends a curved steel framework giving it the appearance of an inverted sled, and where the conning tower used to be, a huge steel tube now protrudes. This telescoping tube contains a "cat-head" drill in its top which is expected to be able to bore through thirteen feet of ice, thus providing an exit for the crew in case the boat is trapped or disabled in the polar regions. The ice-breaking drill is mounted in a tube which in turn is contained in another tube to keep the structure water-tight. When traveling under ice, the tube will be retracted, its lower end resting on the bottom of the hull, and its top flush with the curved sled-deck. The inverted runners allow the craft to rise to the ice layer and travel in this position without damage, the runners protecting the hull from the ice. Shafts extend through the ice-boring tube, and these rotate the entire head or cap, and also revolve the disk-shaped cut-

Upper Left, Submarine Fitted for Trip to Pole under the Ice; Note Framework Like Inverted Sled Runners for Ice Protection; Above, Ladder That Will Be Used by Diver; in Circle, the Ice-Cutting Disk

ter which extends beyond the edge of the tube, so a hole, slightly larger than the conning tower, can be made. It is estimated the drill will penetrate eighteen inches of ice a minute. Once the ice is punctured, the cap can be removed and the crew can climb out. Two smaller drills, capable of boring through ice 100 feet thick, are mounted aft. These are for the purpose of drilling through nearly any thickness of ice that may be encountered, to obtain air. Thus the crew, even under 100 feet of ice, still will be able to breathe pure air.

### A. 302 OVER THOUSAND U. S. AIRPORTS WORTH HUNDRED MILLION

Some idea of the expansion of aviation is gained from department of commerce figures showing the United States now has 1,113 airports valued at \$115,068,500. Improvements in progress call for additional expenditures of \$20,225,000. There are 564 commercial airports and 549 municipally owned fields, New York leading the states with an investment of 19,890,000 dollars.

*Christian Science Monitor*

*new picture Dec. 1930-973*



G. 112 Lt. Carley Mc Harmer

Langley Field,

Hampton Va

# Jumping into the

Leaping by parachute into the heart of dense, tropical jungle is an experience that few people would choose. But early this year an American aviator and soldier of fortune did that very thing. He jumped from a speeding airplane over Central America and descended in a parachute.

This was not done as an aerial stunt. It was a case of using the latest mechanical means to reach a hitherto unexplored Mayan city which lies beneath the tangled vines and interlocked boughs that form the impregnable jungle in the locality where the leap was made. It was a unique attempt to reach the scene of former Mayan glory and, perhaps, discover some of the secrets of this ancient civilization. And also it is believed that in some of these interior temples vast stores of gold lie hidden.

But making a great discovery beneath the shadows of the heavy growth of trees would do the finder no good unless he could escape the tentacles of the tropical vines and tell the world. This problem of escape is the point about such a jump which impresses most people. No medieval knight would have need of more implements for cutting than a man descending into a jungle. One or two machetes are needed for close-in work, an ax is indispensable for cutting larger branches of trees, and a gun, preferably a pistol, is a most useful weapon.



Aviation Has Opened Up a New Way of Exploration Whereby Secrets of Ancient Civilizations Are Being Revealed to Science

Against jaguars the pistol is the best defense, and against hostile natives armed with spears and bows, it is also a lifesaver. But against huge snakes which lie in wait on overhanging boughs, the pistol is of little use. At such close quarters the machete with a sharp blade is a man's best defense.

The ex-army aviator and soldier of fortune who leaped into the jungle went



# MAYAN JungLES



Parachute Jump Made by an American Aviator into a Yucatan Jungle to Explore an Otherwise Inaccessible Mayan City

prepared for all ordinary emergencies. It was in the fastness of Yucatan he made his descent. This is where the undergrowth is the thickest and where some of the most important of the old Mayan cities lie hidden. If these places could have been approached without prodigious labor on the ground, they would long ago have been thoroughly explored. The aviator who took the short cut by the

parachute route had numerous weapons and supplies strapped to his person. In addition to weapons, he carried flasks of water and concentrated foods.

Flying over jungles is not a new experience to many aviators. Army, navy and marine flyers have often made long trips over such lands. The marines have plenty of "bush" in Nicaragua. The army and navy have plenty of jungles in the Philippines. Over all of this sort of country the airmen go prepared for forced landings. They carry, in the cockpit of their planes, concentrated foods which are specially prepared and put up in tins; bolos; automatics; a blanket, and canteens of water. The heavy growth of trees permits a forced landing without serious effect. If a plane is "pancaked" down, the undergrowth takes up so much of the shock and forward speed that disastrous consequences purely from the landings themselves are seldom feared. But a plane afire is a terrible thing

to bring down in the jungle.

There has been considerable air traffic over the Central American jungles during the last few years. Commercial air lines make regular trips over portions of bad forced-landing country. Due to the fact that a man can cut only a few hundred yards of undergrowth a day while trying to make his way to open country, forced landings there are hazardous and feared



a-112  
580



Courtesy Century of Progress

high walls surround him and, at various places on the lake, little spots of smoke or steam shooting up. At once, the terrible fact struck him that he had landed in the crater of a volcano. And a volcano not yet dead at that. The hull of the plane sank deeply into the warm water and with a missing motor and high sheer walls all around, there was not a chance of getting out immediately. Needless to say, a most uncomfortable night set in for that aviator and his mechanic. They could find no place where they could pull to a shore and anchor. The steep walls prevented that. They stuck it out until morning and then

by airmen. Very few will jump to avoid such landings over jungles. Most of them declare they would go down with the ship and take a chance of hitting a soft spot.

One American army aviator had a harrowing experience a few years ago while flying over Central American wilds. He was flying at about 10,000 feet in an amphibian, and dusk was coming on when his engine began to miss. Looking below, he saw a beautiful little round lake. He looked at it carefully and decided to take a chance on it. Accordingly, he began to spiral. Down he came and as he approached the water he noticed the air getting hotter. By skillful maneuvering, he managed to set the plane down in the little lake. But the spray from the hull came up into his face—and it was hot!

He was thoroughly frightened and at once began to take stock of his surroundings. In the gathering darkness, he saw

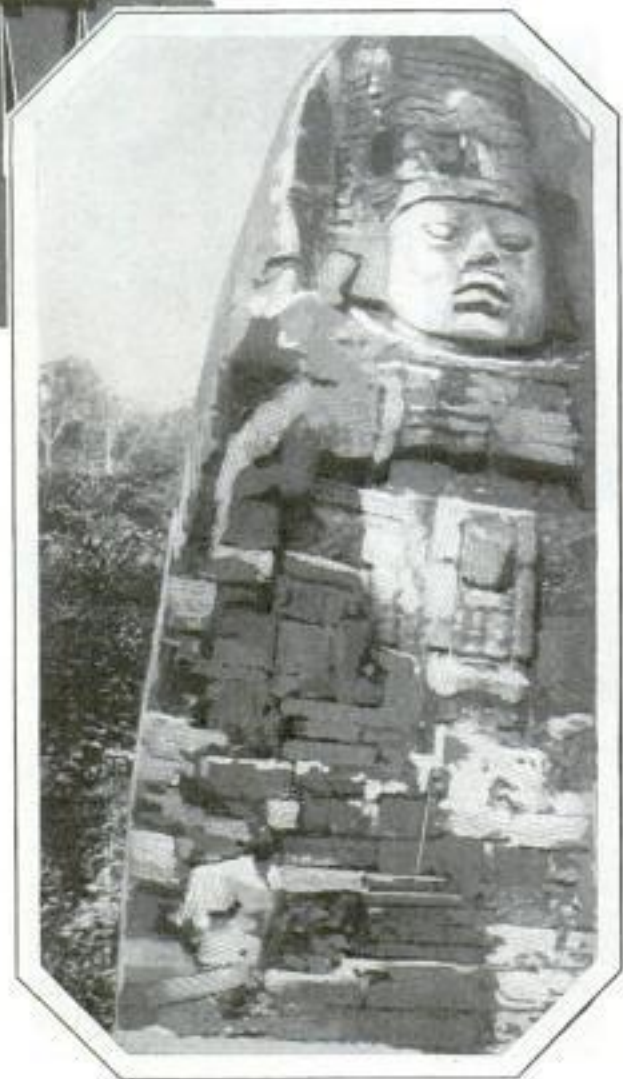

Members of Chicago World's Fair Expedition at Work on Drawings of Ruins at Uxmal, and Mysterious Sphinx



repaired their motor. Before taking off, they saw human figures wave to them from across the lake. They taxied over and found that a narrow trail led from the rim to the water, and some natives had come down to see the plane. After trying in vain to talk to the natives, the airmen let the motor full out in a circular take-off. The plane was lightly loaded with gasoline by this time, and it managed to stagger into the air. After two sickening spirals the southern rim of the crater was cleared and the airmen headed for the nearest seacoast. Later they learned that this volcano, which had been dormant for many years, was beginning to show signs of activity.

A peculiar, but quite natural thing in connection with seeking lost Mayan cities by airplane, is the fact that high-flying airplanes do not disclose the ancient sites to the observer. So thoroughly has the jungle conquered



Courtesy Century of Progress

the old cities and temples that, from high in the air, the jungle looks uninterrupted. But down closer, a spot of vegetation greener than the rest, with a faint sign of straight lines prevailing in the vicinity, usually indicates a hidden city.

The place where the soldier of fortune descended in a parachute was apparently deserted.

But beneath the dense bushes almost anything may exist. The old city was carefully studied from the air. It was considered one of the most important places of all the undiscovered sites. One of the best ways of detecting the Mayan cities is to fly very low and watch the horizon for high points. The temples and other buildings are often some 200 feet high. This is higher than most of the jungle growth, and the ruins, vine-covered though they be, stand up from the surrounding landscape.

One of the secrets that scientists hope to uncover in the country of the Mayas is some clue as to where the ancient civilization got its start. Many believe



Ancient Ruins at Uxmal, and Former President J. M. Orellana of Guatemala and Party About to Take Off



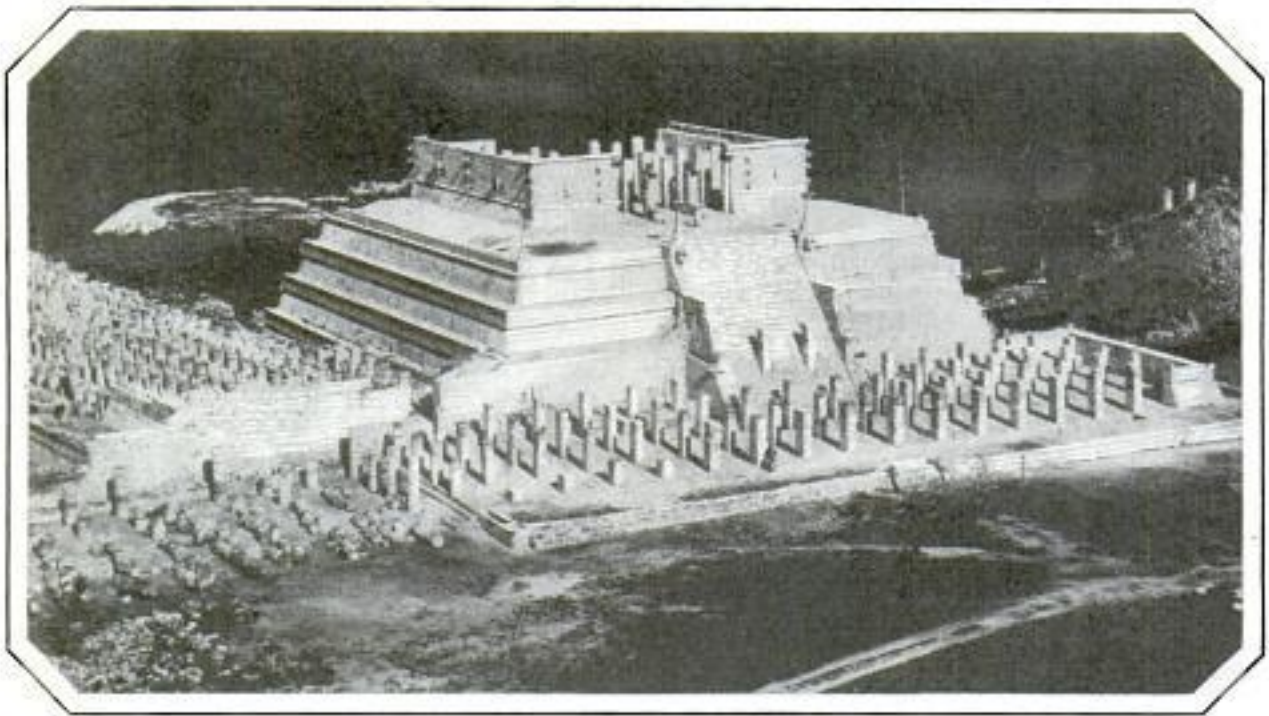

Where Early Inhabitants of Western World Bowed in Worship; Temple of the Warriors at Chichen-Itza, Yucatan; the Temple Proper Rested on a Base 136 Feet Square

that there was a continent "Atlantis" which had a high culture and that the Mayas were a part of that civilization. If any light can be thrown upon this, it will explain the origin of ancient Egyptian and Greek legends.

One of the greatest of Mayan centers was Chichen-Itza. It covered some twelve square miles and had 250,000 inhabitants.

It was a city of palaces and temples, just one of which, if built today, would cost \$32,000,000, it is estimated. It was built without beasts of burden or wheeled vehicles.

**MICROMETER GAUGE FOR PEN MAKES RULING EASY**

Pens with micrometer adjustments now can be obtained for fine ruling work. The adjustment screw has twenty divisions used to set the pen at any predetermined distance, each division of the micrometer equaling approximately



three-thousandths of an inch. This makes possible the exact determination of the size of the line used, without careful comparisons or guesswork. The scissorlike motion of the pen leaves allows the instrument to be cleaned easily. Another pen with a similar attachment is used for making fine lines only.

**SMALL CHANGES IN SUN'S HEAT AFFECT EARTH'S WEATHER**

When it radiates heat and light to the earth, the sun also broadcasts information that can be employed to foretell the weather, and eventually the weather may be forecast weeks, months or even years in advance. This is the view of Dr. C. G. Abbot, secretary of the Smithsonian Institution, who declares that the weather appears to be governed by variations in sun radiation. Doctor Abbot compared temperatures, as officially recorded at Washington, with changes of intensity in sun radiation as obtained from daily measurements, and found solar variations produce certain changes in weather conditions. Average fluctuations in mean temperature of five degrees Fahrenheit were found to correspond to solar changes averaging only eight-tenths of one per cent. After testing his theory that major changes in

Sold by A. S. Svenson  
426 N. Adams St.  
Blandale, Calif.

Science Service  
S.T.C. 2/4/31



weather are due to short-period changes in the sun in widely separated localities, he decided that the sun's rays do not act directly on the earth's atmosphere, some of the large effects occurring two weeks or more after the solar cause ceases to operate. Doctor Abbot suggests that the circulation of the atmosphere is changed by the sun's variations, the radiation absorbed by the atmosphere tending to displace the centers of great cyclonic whirls, and hence to alter wind direction at various places. He suggests that solar variations may be particularly effective at certain parts of the earth where weather is "born." Long swings of variation in the sun's heat, extending over many months, also were discovered, and these give promise of very long-range forecasting.

**PRESSED-WOOD CHURCH MODEL SHOWS BOY'S SKILL** A. 256

Architects, artists and others have been admiring a model of St. Cecilia's Church, Cincinnati, executed by Robert J. Schultz, fifteen years old, of Oak Park, Ill. The model is carefully designed from architect's drawings and is a faithful replica of the original both as to exterior and interior. It is made of a pressed-wood material in several layers. The windows

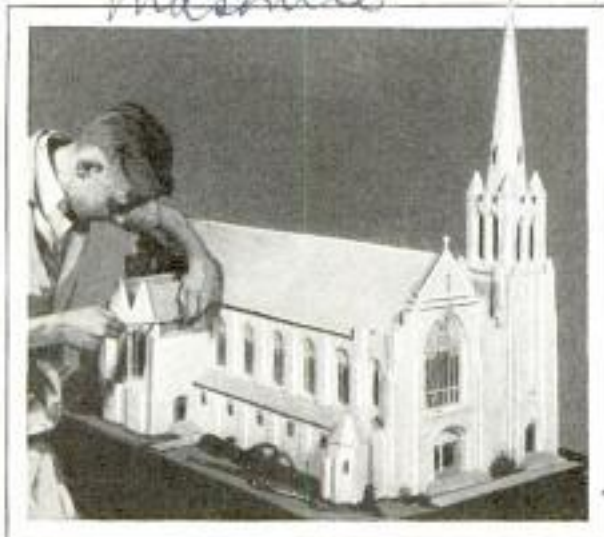

© The Masonite Corporation  
Pressed Wood Model of a Church Made by Fifteen-Year-Old Boy; The Interior Is as Carefully Made

are of mica which has been painted to represent stained glass. The window frames are of balsa wood, hand-carved with safety-razor blades.

*sophomore at Fenwick High School*



Coal-Truck Body Elevated and Tilted to Allow Loading of Bags through Chutes in the Sides

**AUTO LIFT BODY WITH CHUTES SPEEDS COAL UNLOADING**

Adapted especially to handling coal, a truck body for the Chevrolet chassis can be elevated and tilted and has chutes under which bags of coal may be loaded for carrying into the cellar. Extension sides are provided for hauling larger loads, as of coke, for instance. The side delivery permits dumping the coal without running the truck out into the street.

**FEVER IN DISEASED PLANTS TRACED TO MICROBE** A. 269

Plants, like animals and human beings, develop a fever when afflicted with certain ailments, and the tiny bacterium that causes rot of the roots has been found responsible for much of the trouble. Experts in Texas recently reported that the temperature of leaves on some afflicted plants was about three degrees higher than normal. Tests have shown that the germ which causes root rot does not thrive in acid soils, hence efforts are being made to raise crops that will grow successfully in ground of relatively high acidity. In the case of cotton, a way has been found to defeat the pest by speeding the plants to produce their bolls before the root-rot germ can do its damage.

*Dr. Walter H. Egebury and Dr. J. L. ...*

*Science Service 515 B 2/2/31*

*Desas plant pathologist*



a-63

## FOUR MILES A MINUTE—AND HIGHER SPEED IS SEEN

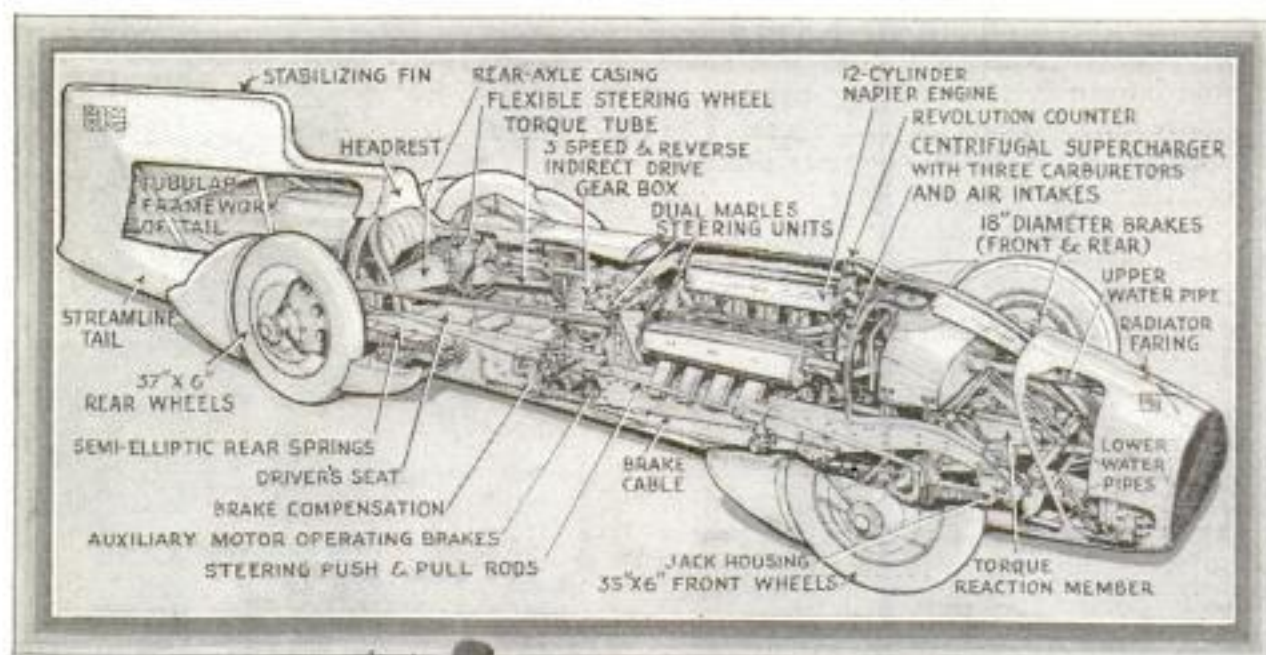

Wide World

Although he is the first man who ever has traveled more than four miles a minute in an automobile, Capt. Malcolm Campbell, British racer who recently broke the world's speed record at Daytona Beach, Fla., is not satisfied with his mark and predicts even higher speeds for the future.

Even his own powerful "Bluebird II," in which he traveled 245.733 miles an hour for the official record, is capable of doing 260 miles or better under favorable conditions, Captain Campbell believes. In fact, on his first run over the two-way course, his 1,450-horsepower machine did better than 246 miles an hour, despite the fact that the beach was not in the best condition, and visibility was poor. On the return trip, the speed was about two miles less, the two being averaged for his record which beat that of the late Sir Henry Segrave, set in 1929, by over fourteen miles an hour. After spending more than a year in careful preparation, the British driver required less than five minutes to

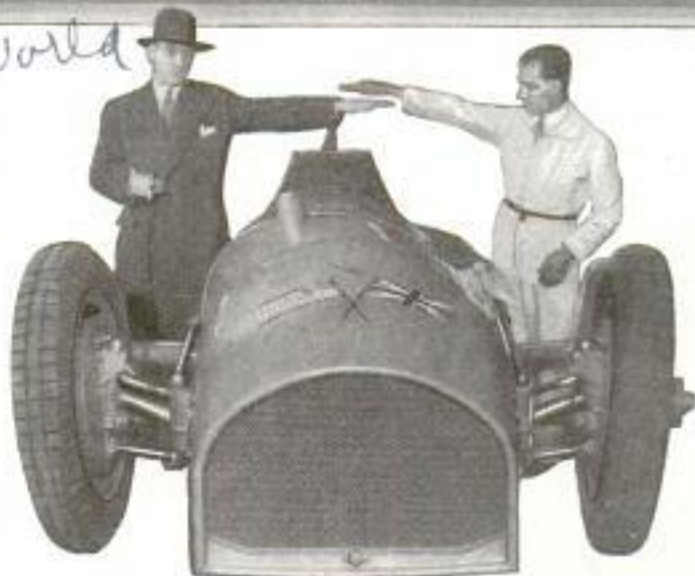

Above, Unusual Construction Features of the "Bluebird II"; Below, Head-On View; Note How Low the Body Is

establish his record, roaring twice over the ten-mile course and through the measured mile without a stop. The engine which set the new mark is probably the most powerful ever constructed, although it weighs only 1,140 pounds. In spite of its tremendous power output, the twelve-

cylinder engine is only a little over five feet long, about three feet wide and three feet high. Some idea of the driving of such a racer may be gained from the fact that Captain Campbell shifted from low to second gear at seventy or eighty miles an hour, and from second into high at 125 or 130 miles an hour. The stream-lined car had a stabilizing fin at the rear to help control it, and other features included use of the Handley-Page slotted-wing principle to reduce air resistance, separate cowling of the radiator, offsetting of the gearbox, propeller shaft and final drive, and tubular body construction to afford the driver protection in case of an accident.



Neue Iseldzahl  
 Maschinen Gesellschaft  
 Luiseustrasse 27, Berlin. NW 6

**COINS WRAPPED AND COUNTED BY MACHINE** *A-274*

Coins now can be wrapped and counted in a single operation by simply dumping them into a machine that is being used for this purpose by banks and other business concerns in Europe. The money is shaken out on a table and pushed into the counter, which shows the total of coins handled on a control dial so that, at any moment, the operator knows the number counted. As soon as fifty coins have been tabulated, the wrapping device begins its work automatically, the counter continuing operations. The coins are wrapped in such manner that the first and last remain visible, although the roll cannot be opened accidentally. To set the machine for handling coins of different size, it is only necessary to move a small lever. The apparatus is operated by a small motor and handles from 600 to 800 coins a minute.

*no U.S. agent known*

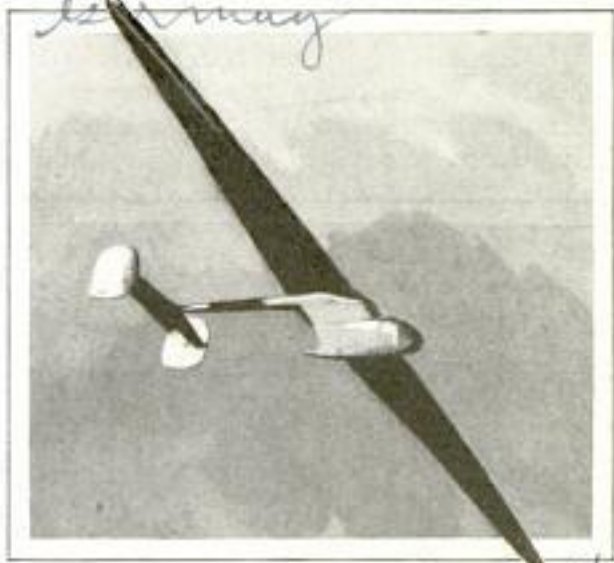

Sailplane with Wing Span of Over Ninety Feet; the Wings Can Be Folded Back for Transporting

*Wide Woller*

**BIG SAILPLANE HAS WING SPAN OF OVER NINETY FEET**

Gliders, like airplanes, are growing larger and larger, and a sailplane with a wing span of more than ninety feet was constructed in Germany recently for the Austrian glider, Robert Kronfeld. This ship, with a wing area greater than that of most motor-driven planes, can be transported easily, as the wings can be folded back onto the body in sections.

*Rasset*

**WORM REMOVES THE ASHES FROM FAMILY FURNACE** *A-22*

Furnaces now can be tended automatically with a stoking apparatus that also removes the ashes. A Cleveland man has made a soft-coal stoker for use in the home, a part of the device being an "ash worm" which gathers up the ashes and conveys them from the ashpit to a near-by container, thus making operation of the heating plant almost entirely mechanical.



Furnace Stoker That Also Contains an "Ash Worm" Which Removes Contents of Pit Automatically

*no further information*

Triple-fast films have been developed for the movies.

*Developed by Reuben  
 Hitchcock  
 Cleveland, O.*

**DOG AND CAT OF SAME FAMILY**  
**FOSSIL RECORDS SHOW** *A-270*

Dogs and cats are descendants of the same ancestral race, findings of the late Prof. W. D. Matthew, of the University of California, seem to indicate. They separated many thousands of years ago, long before the ice age, and since that time, the dog has had an especially interesting history. Its remote ancestors were small, not much larger than a fox, and had short noses. Later, one line developed size, a surviving family being represented by the bears. One of the species now extinct was even larger than the bears of today, but was quite like the dog in its other characteristics. The smaller branch of the original family developed into the dogs, wolves, foxes, and other like animals, of the present. The domestic dog of today is probably a descendant of the wolf or of the wolflike wild dog of the ice age.

*same Service 515.03  
 2/20/31*



### FOOTLIGHTS IN THE HEN HOUSE INCREASE EGG LAYING

Artificial sunlight in simplified form is being introduced into the poultry house



Hens Standing before Electric Lamps Emitting Ultra-violet Rays, to Increase Egg Production

and brooder to increase egg production and insure healthier chickens. This extra light, in the form of ultraviolet radiation, not only provides the essential vitamin D when hens cannot obtain it from ordinary sunlight, but also causes the hens to work overtime, results in firmer shells and prevents rickets in chicks. To produce these results the General Electric company has made two lights, one a sunlight lamp similar to those used in many homes, and the other an incandescent light resembling an ordinary frosted bulb in many respects. The sunlight lamp produces, inside a bulb of ultraviolet-transmitting glass, a tungsten-mercury arc rich in healthful rays. The incandescent bulb has a filament heated to high temperature and a glass that allows the short-wave light to pass through. These lamps are being used to replace the carbon-arc and high-power quartz-mercury arc lamps previously employed, the older equipment being expensive, more or less complicated and requiring the operator to wear goggles. The sunlight lamp, suspended a few feet above the floor, serves 100 chickens. The incandescent types, of 60 or 500-watt rating, are weaker sources of ultraviolet illumination and are operated for longer periods the weaker often being used in a brooder to give heat, light and radiation. The lamps usually are placed about feed-

ing troughs, and because the feathers do not admit the beneficial rays, the weaker bulbs are placed in trays below the feed containers, thus serving as true footlights. The equipment can be controlled to provide regular hours of darkness and light.

*Science Service 5/5. 9 2p/20*

### COYOTE BREAKS SPEED MARK IN RACE WITH AUTO

*a-251*

Coyotes are noted for their speed, but until recently it was thought that their best performance was around twenty-four miles an hour. It took Joseph Joffe, assistant to the superintendent of Yellowstone national park, and his car to prove that a coyote, when pressed, can run between twenty-five and thirty-five miles an hour and keep it up for a distance of nearly two miles. Joffe was on his way to the buffalo ranch a few weeks ago when a coyote, deserting its companion, loped along the road in front of the automobile. The animal seemed intent on giving the car a brisk race. When Joffe speeded up, the coyote speeded up. Once when the car was almost up to the fleeing animal, the horn was blown. The coyote turned, made a dash at the car, but quickly wheeled around and continued running. Close watch was kept on the speedometer, and after the coyote finally jumped out of the road, Joffe turned back and carefully measured the distance of the race. It was one and six-tenths miles, and at no time, Joffe declared, did the speedometer drop below twenty-five miles an hour. At one point, it reached a maximum of thirty-five miles.

### GOLF SCORE REGISTER FITTED TO END OF CLUB

*a-181* TO END OF CLUB

Fitting over the end of any standard putting shaft, a golf scorer is handy to check the number of strokes when the player sinks the ball. The scorer is made of metal, the numbers appearing in a slot.



*Smith, J. & Sons, Valley Home*

*60 and 500. volt for 110, 115, 120*

*Leaf Specialty Co. Valley Home, Calif. Copyrighted material*

*Experiment made by L.L. Porter and C.E. Egeler, Nela Park Engineering Dept. Cleveland, Ohio*

*EX*



A. 233 Cont. Stanley W. Todd,

230 Park Ave  
New York

# HOW RAILWAYS MAKE MILLIONS OF TIME-TABLES

"Stringing the board" is one of the interesting operations many railroads practice in preparing the millions of time-tables that must be issued each year. On a chart, lined and lettered to indicate the hours of the day and shorter intervals, the names of the stations and other data, strings are stretched between pins

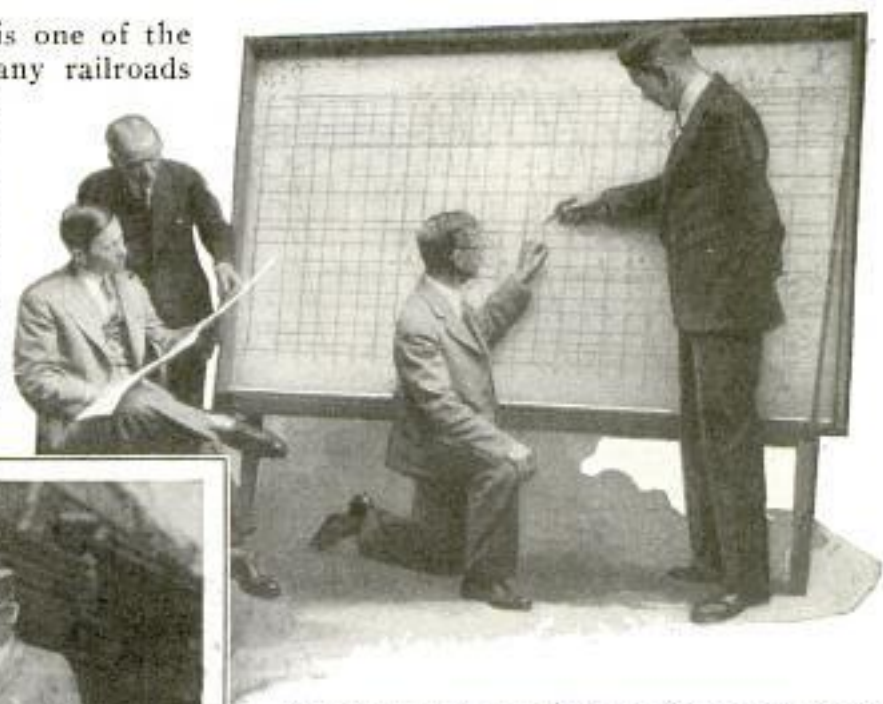

Chart Being Fitted with Strings Representing Trains Preliminary to Making Up a Railroad Time-Table; Below, Engineer and Conductor Checking Watches



as red for passenger trains, black for freight and yellow for "Sunday only" or special trains. When the chart data have been obtained, dispatchers, printers, division officials, and others, collaborate to check and recheck the information until it is ready for final compilation in the time-table.

## GRANITE IS FLOATED IN LIQUID HEAVIER THAN WATER

A. 255

to represent the trains. Those that run in one direction are indicated by strings going down the board from left to right, and those in the opposite direction by strings running upward from right to left. Points of intersection represent places where two trains would meet, and the time data show when. The schedule thus has to be arranged so that these meetings occur at places equipped to handle two trains. To allow for unavoidable losses of time, the strings are arranged on diagonals by officials of the divisions familiar with their parts of the road. In a mountainous territory, the chart strings will therefore usually be strung in zigzag fashion, while level areas are represented by strings that run straight. Some lines use colors to indicate the different trains,

At ordinary temperatures the metal mercury is a liquid over seven times as heavy as water, but few think of it as a true liquid. Now, however, a scientist has made a clear and transparent fluid that is four times as heavy as water. It is produced from the rare metal thallium which, although a solid, is much heavier than mercury. The heavy liquid is a mixture of thallium formate and thallium mullinate, two organic acids. Granite and all of the gems, including diamonds, float in this liquid. There are several liquids heavier than water, and the floating test sometimes is used by jewelers to determine the value of precious stones. Methylene iodide is about three times as heavy as water when the chemical is pure, and it can be lightened by adding benzol.

(Cleric)

Authority: Samuel S. Gordon  
Curator of Minerals  
Academy of Natural Sciences  
Philadelphia



A. 209  
588

From Emma 12/30/30

Motos Majestic, 75, Avenue Antony, Chateaux, France

THE LATEST IN MOTOR CYCLES SEEN IN EUROPE

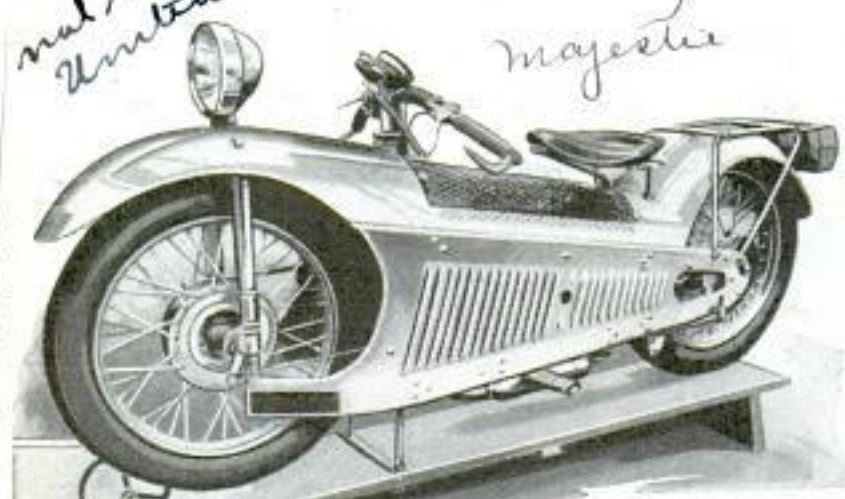

and folding top, headlights and other details were of auto type. The distinctive features of the new motorcycle were its inclosed engine and transmission, and better streamline design.

a-252

OCEAN AIR-MAIL PLANES PUT UP TO CONGRESS

Airships, carrying tons of mail and passengers, may be speeding across the oceans within the near future as a result of a bill before congress that would legalize the ships as common carriers and authorize the postmaster-general to make air-mail carrying contracts with their operators. One line, according to present plans, would deliver letters from the United States to Europe in two and one-half or three days from the eastern coast, and to China in five or six days from the west coast. Terminals for the airship lines would be built in this country, Europe, Hawaii and the Orient, and would be used interchangeably by dirigibles of different nations. The proposed ships would carry about ten tons of mail each, but it will probably be a



Villard des Bouches Automobiles Villard des Bouches



B.S.A. Birmingham England

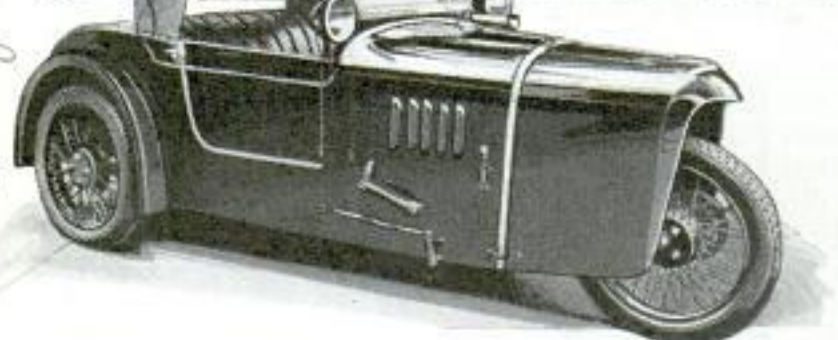

A Motorcycle and Some Three-Wheeled Auto Cars, Shown Recently in Europe; Note the Streamlined Vehicle at the Top

"Tricycle" automobiles and motorcycles attracted much attention at a recent motor show in Paris where emphasis was placed on the small car and its possibilities in easy operation and economy. The three-wheeled automobiles were of two main types, with a single or double driving and steering wheel in front. The engine was of three-horsepower capacity, windshield

long time before dirigibles will be able to carry any large portion of overseas passengers. Even four dirigibles of mighty size, as many as can be constructed in the near future, could carry only about eight per cent of the first-class passengers now traveling abroad, it is estimated. Congress is also discussing plans for a huge metal-clad airship for the army, to cost

Scene Service 515-A

Copyrighted material

Austral - Ste. Ame. des Cycles Austral. n. de la Republique 7, Porteaux, France



**Detroit Seamless Steel Tubes Co.**

*Exclusive rights*  
**W. Warren & Wyoming**  
**POPULAR MECHANICS**  
**Detroit, Mich.**

589  
 a. 243

\$4,500,000. It would be able to carry a 40,000-pound load from Washington to Panama in twenty-eight hours. In line with transatlantic aviation, the post office department is expected again to advertise for bids for air-mail carrying across the Atlantic by planes.

*a. 253*  
**STEEL TUBING IS BEING LINED WITH MANY METALS**

Steel tubing is now being lined with a variety of metals or alloys by a new process which combines the tube and its lining inseparably by fusion. It is expected that such tubes will be of great importance in the production of steel-backed bearings. The thickness of the bearing metal can be accurately controlled, and the tubes can be furnished in lengths as great as sixteen feet or longer, so that bearings of varying lengths, but with the same outside and inside diameters, may be produced from one piece of tubing. The tubes will also be useful, when lined with non-corrosive metals, for conveying chemicals that would injure the steel, for water-tube boilers, and for water pipes where strength is a desirable factor.

**INCLOSED HATCH ON OUTBOARD PROTECTS THE MOTOR**

Outboard motorboats this year are being provided with many accessories to give more comfort and efficiency. One of these features is a hatch to inclose and protect the motor, thus getting rid of spray and eliminating much of the noise. The hatch gives the boat a runabout appearance with outboard inexpensiveness.



Inclosed Hatch over Outboard Motor Which Protects Engine and Gives Runabout Appearance



Automatic Grocery Where the Purchaser Inserts Coin in Slots to Obtain Any Article Desired

**COIN-IN-THE-SLOT GROCERY SAVES SHOPPER TIME**

Groceries are dispensed from coin-in-the-slot compartments in an electrically operated show case recently introduced. The customer has a clear view of the merchandise before making a selection, the articles are properly wrapped and tied for carrying, and there is no delay in waiting for a clerk. The compartments hold a generous supply of each article, so that stock taking is possible almost at a glance and renewal simplified.

**DEEP-SEA DIVERS HELP BUILD STORE IN HEART OF CITY**

Deep-sea divers recently were working 100 feet under the city streets of Philadelphia. During excavations for the foundation of a department store, it was found necessary to go down more than 100 feet to reach bedrock. At one point, a subterranean stream was encountered, and the divers were called on to do the excavating in this river. They donned regular diving equipment, descended to the bed of the stream and loosened the gravel with compressed-air hose.

*Comp. 2057 4th. nyc*  
*2057 4th. nyc*

*589*  
*a. 243*  
*delamar*  
*Chicago 337 S Michigan*  
*Mr. Robert Harney*  
*1407 E 47th St*  
*Brooklyn 11*  
*Letter held 10/16/19*

*name*

*Strawbridge & Clothiers*  
*Market, Phila.*  
*Copyrighted material*  
*Com. Secy H. Eckhardt.*  
*4528 Walnut St. Phila.*



a-142  
590

The Illustrated London News P-10067  
reprinted from Berliner Illustriert  
POPULAR MECHANICS Zeitung

# The Strength



**RUSSIA**  
ACTIVE 624,000  
RESERVE 4,528,000



**FRANCE**  
ACTIVE 584,767  
RESERVE 3,675,561



**ITALY**  
ACTIVE 390,334  
RESERVE 5,551,450

## MAN-POWER OF AIR FORCES

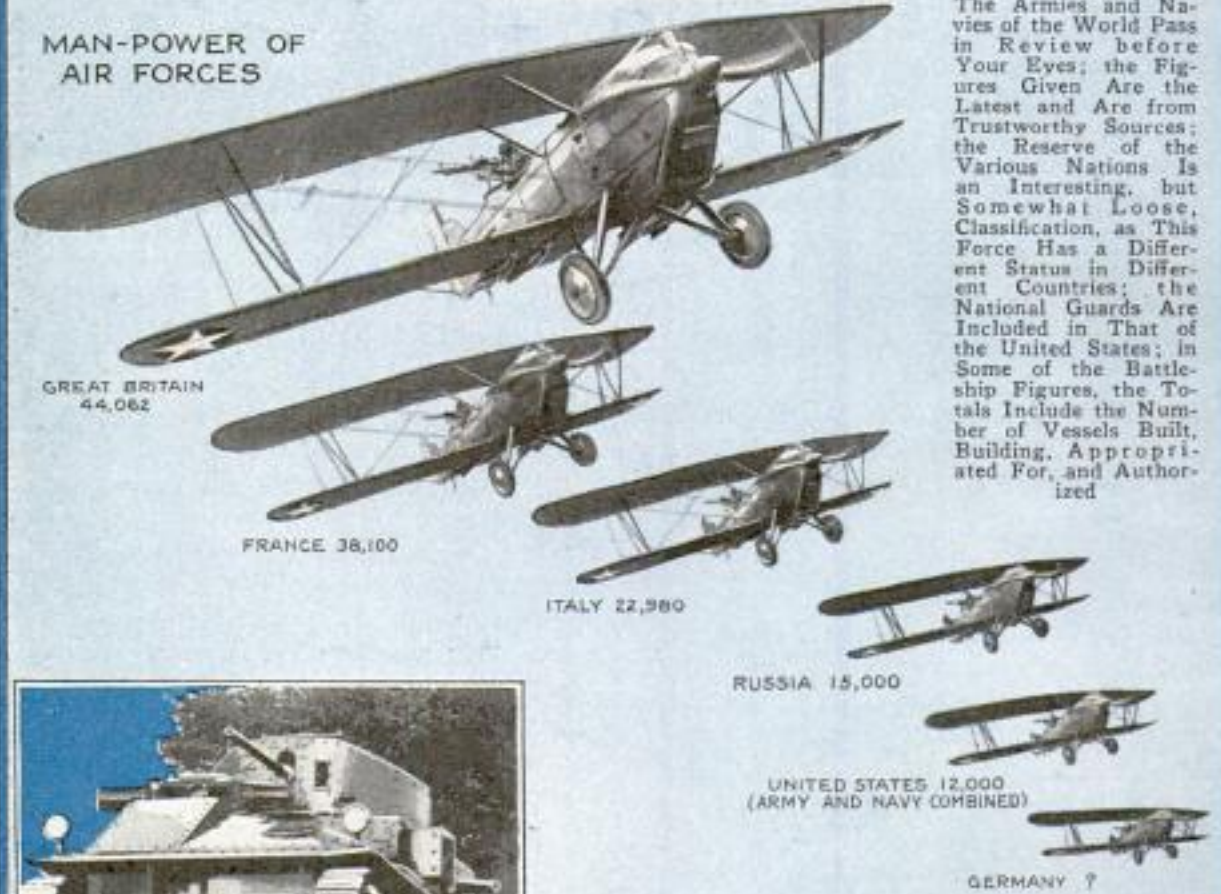

The Armies and Navies of the World Pass in Review before Your Eyes; the Figures Given Are the Latest and Are from Trustworthy Sources; the Reserve of the Various Nations is an Interesting, but Somewhat Loose, Classification, as This Force Has a Different Status in Different Countries; the National Guards Are Included in That of the United States; in Some of the Battleship Figures, the Totals Include the Number of Vessels Built, Building, Appropriated For, and Authorized



**FRANCE - STRENGTH IN TANKS 2,500**  
A FORM OF WAR MATERIAL OF WHICH GERMANY HAS NONE



**RUSSIA STRENGTH IN TANKS-250**



**ITALY STRENGTH IN TANKS - 250**



**GREAT BRITAIN TANKS 200 AND 150 IN COLONIES**



**POLAND STRENGTH IN TANKS-100**



# of the World Powers



**POLAND**  
 ACTIVE 299,000



**JAPAN**  
 ACTIVE 210,000  
 RESERVE 1,735,000



**GREAT BRITAIN**  
 ACTIVE 202,012  
 RESERVE 318,959



**U.S.**  
 ACTIVE 137,472  
 RESERVE 289,925



**GERMANY**  
 ACTIVE 100,500

## BATTLESHIPS



**GREAT BRITAIN - 20 SHIPS - 606,450 TONS**



**U.S. - 18 SHIPS - 523,400 TONS**



**JAPAN - 10 SHIPS - 292,400 TONS**



**FRANCE - 9 SHIPS - 135,925 TONS**



**ITALY - 4 SHIPS - 86,532 TONS**

## FIRST-LINE CRUISERS UNDER 20 YEARS OLD



**GREAT BRITAIN - 59 SHIPS - 370,411 TONS**



**U.S. - 33 SHIPS - 300,500 TONS**



**JAPAN - 33 SHIPS - 206,815 TONS**



**ITALY - 21 SHIPS - 130,573 TONS**



**FRANCE - 16 SHIPS - 128,296 TONS**

## FIRST-LINE DESTROYERS UNDER 20 YEARS OLD



**U.S. - 213 SHIPS - 217,503 TONS**



**GREAT BRITAIN - 175 SHIPS - 191,261 TONS**



**FRANCE - 88 SHIPS - 131,003 TONS**



**JAPAN - 115 SHIPS - 129,375 TONS**



**ITALY - 89 SHIPS - 88,386 TONS**

## FIRST-LINE SUBMARINES UNDER 13 YEARS OLD



**FRANCE - 102 SHIPS - 92,996 TONS**



**JAPAN - 71 SHIPS - 77,842 TONS**



**U.S. - 69 SHIPS - 63,370 TONS**



**GREAT BRITAIN - 66 SHIPS - 63,324 TONS**



**ITALY - 57 SHIPS - 37,076 TONS**

## AIRCRAFT CARRIERS



**GREAT BRITAIN - 6 SHIPS - 115,350 TONS**



**U.S. - 4 SHIPS - 90,086 TONS**



**JAPAN - 4 SHIPS - 68,870 TONS**



**FRANCE - 1 SHIP - 22,050 TONS**

**ITALY - HAS NO AIRCRAFT CARRIERS BUILT OR BUILDING**



## FLAG FACTORY KEPT BUSY BY UNCLE SAM'S ARMY



Top, Inspecting an Army Flag; Left, Attaching Staples to Head of the Flag; Above, a Modern Betsy Ross Trimming a Star

Even in peace times, the United States army requires thirty flags a day to replace those worn out in service, and more than 100 women and girls are constantly employed making them at the quartermaster's depot in Philadelphia. Since 1912, there have been twelve standard flag sizes varying in width from twenty to 1.31 feet. Originally one woman made the entire flag, but today each banner passes through thirteen different hands. The stripes are cut by an electric machine handling 100 thicknesses of cloth at once, and these are sewed on another machine. The stars, of white percale, are cut with dies on an electrically driven press. After that the blue field is marked off with a stencil and an operator sews on the stars, a star being placed on one side and sewed to one slightly larger on the opposite side, the larger star being trimmed off later by

hand. The field is then joined to the stripes, and finally the heavy piece of canvas joining the flag to the halyards is attached. Aside from the national colors, this army factory also turns out regimental colors and standards, garrison, post and storm flags, ensigns, harbor and boat jacks, and even pennants and guidons. The most interesting flag is that of the president, which accompanies him on all ceremonial occasions. It is the privilege of each executive to order his own design, and while the background usually is blue, President Roosevelt chose red. These banners are of hand-embroidered silk, and each is made entirely by hand. No flag is ever cast aside. When it has outlived its usefulness, it is burned by order of the commander of the post to which it had been allotted, thus preserving the sacredness of the emblem.

☐ Waving a black flag at a bull is as effective as a red one because the animal is color-blind and sees both as black.



Designed especially for lecture and classroom use, a mirror-projector apparatus magnifies objects and shows them in three dimensions without the aid of a screen and without darkening the room. The object to be shown is adjusted on a moving holder in front of the mirror, which is concave and about two feet in diameter. Ordinary incandescent lights are played on the glass. Their illumination, reflected back up on the article, helps to reveal it more clearly. To persons sitting in front of the mirror, the object being examined appears to be floating in space in a greatly enlarged and more distinct form than would be possible on a screen. The holder for the objects can be turned so that they can be studied from all sides.

Mirror Projector Below; Sketch above It Illustrates How It Might Have Been Used in Ancient Rites

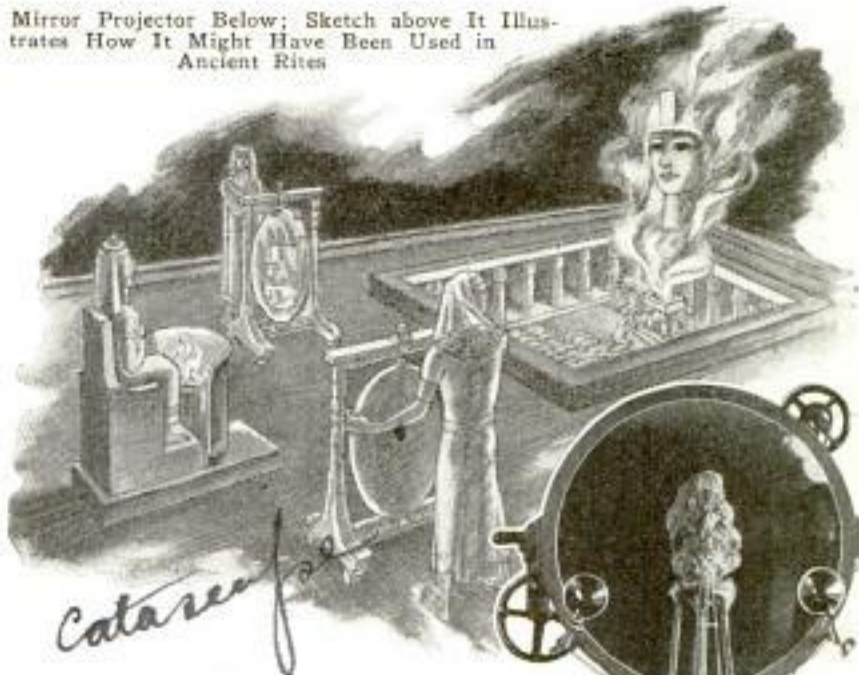

*Catarepe*



development of helpful instruments to aid the pilot. In the plane of the immediate future, the human pilot may have nothing more to do than to take the ship off, set his course and, from then on, save for keeping the engine in mind, he may let the ship operate itself until it comes time to land. Directional and "attitude" controls being developed by the General Electric company and the Sperry Gyroscope company are two of the important units that will possibly supplement the pilot. A sonic altimeter for use in taking off and in landing will also help. The interesting service of the attitude control is that it keeps the plane right side up and in balance, something often difficult for the pilot to do when the visibility is poor, the horizon obscure or the air currents are rough. The directional equipment is expected to operate on the principle of the compass and of radio equipment; that is, it will be governed by the earth's magnetic field and from radio beacons. The sonic altimeter tells, by means of an echo, the distance of the plane from the ground at all times, a great help in landing. It will be some time before the instruments will be given extensive tests.

**SOLDERING IRON HAS SWITCH IN HANDLE TO SAVE TIME**

Equipped with two tips, an electric soldering iron has a switch in the handle so that current can be turned on or off with



Soldering Iron with Switch in Handle

the fingers, saving the trouble of pulling out a plug. This arrangement saves time and insures better work through more accurate heat regulation.

**ROBOT PILOTS TO FLY PLANES TO INCREASE SAFETY**

Automatic airplane flying is predicted within the near future as a result of the

*Chicago-222 N. Bank Drive*

*Sarnison United Corp.  
P. Jones St. Rochester  
N.Y.*

*Not sold in U.S. What was done of*



a. 74 Cmh C. Moran 3825-13th  
N. W. Washington D.C.

# How Uncle Sam



Expert Food Tasters of the United States Department of Agriculture Making Taste Tests on Samples of Cooked Meats to Determine Flavor, Tenderness, and Other Qualities

THREE men in a laboratory were crushing pods of peas in a queer contraption of wheels, pulleys and scales. One man sliced the peas in half, another placed the pods on a small platform beneath a can of mercury, and the third manipulated a lever that caused the can to descend upon the pea pod while scales automatically registered the pressure needed to smash the pea into paste.

This apparatus is being used in fixing food standards, and application has been made for a public patent on it. The chemists say that the weight needed to crush peas, beans, and similar products, is an indication of food quality. Another curious device is a set of false teeth which are made to chew beef, pork and veal mechanically so as to determine the tenderness of these meats.

Officials of the United States department of agriculture, describing these and other unusual devices that are applied to the solution of problems which have arisen recently in the production, transportation and storage of foods—a camera for photographing the inside of eggs, an apparatus that stamps numerals in the rind of cheese, a "glass stomach" that digests food as does the human organs, an instrument that determines what odors of foods attract insects—say that these ma-

chines, strange as they may seem, are necessary adjuncts in food research.

The investigators are trying to discover whether the new methods of handling foods, such as the sand-blasting of eggs, the gassing of fruits and vegetables, artificial coloring of meats, and the congealing of fruit juices into blocks of ice, have any harmful effect on the food value of the products. They are studying a score of processes that have been developed to hasten the production of foods and to preserve them indefinitely.

The canning industry revolutionized agriculture by making possible the utilization of products too ripe to be shipped to market fresh. Now the chemist with his solid carbon dioxide, his ethylene gas, and other chemicals, is making it possible for consumers to eat tree-ripened and field-ripened products in their fresh state, months after they have been harvested.

In Georgia, last summer, a plant that freezes tree-ripened peaches in cans turned out 700,000 pounds of that product. Approximately 100,000 barrels of cherries were frozen-packed in Wisconsin. Factories have been opened in Florida and California where the juice from cull citrus fruits is frozen. Quick-frozen meats in package form are available now in all large cities.



# Guards *your* Food

In New York City, recently, 200 representatives of industries interested in the production, transportation and distribution of foods sat down to a luncheon of fresh fruits, vegetables and meats that had been produced six months before, but whose qualities of "freshness" had been remarkably preserved by various processes of gassing and freezing. These food specialists declared

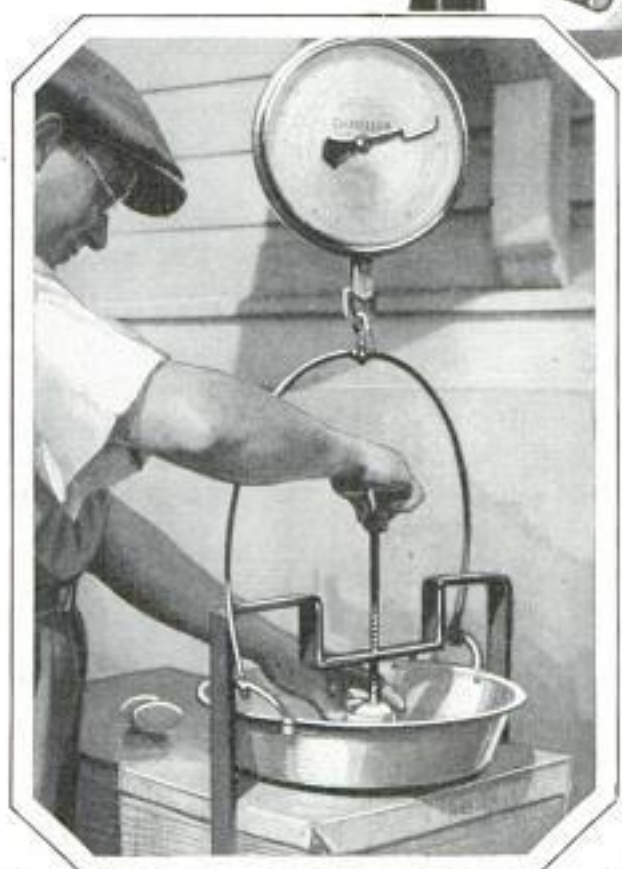
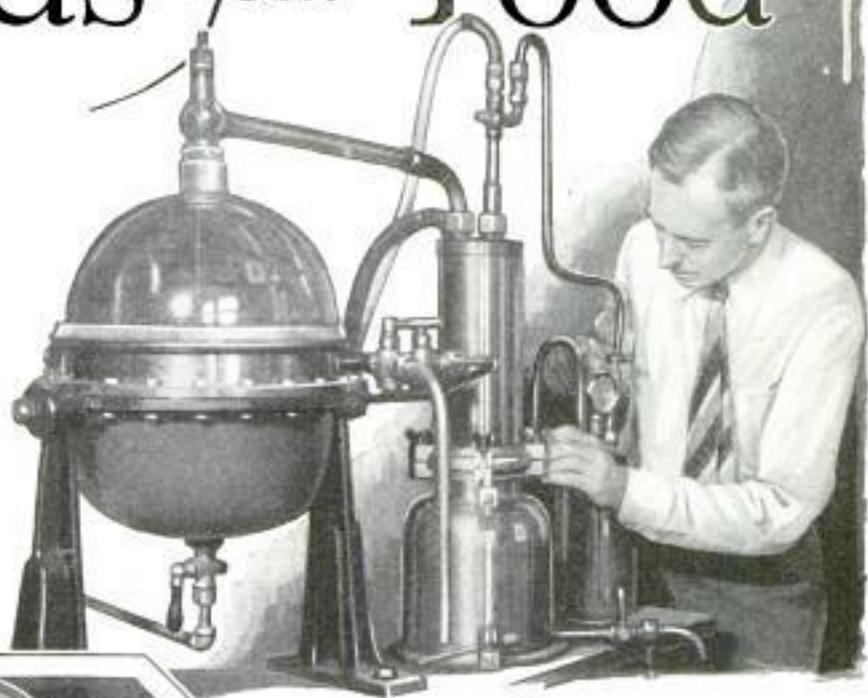

Vacuum Still Used to Study Flavor-Giving Content of Fruits, and Testing Strength of Eggs in Shell

These new methods of food handling are of such importance and are being developed so rapidly that the United States bureau of chemistry has temporarily laid aside many research projects of long standing in order to ascertain the effects of the new processes upon the nutritional value of the foods. Experiments are being made with small animals, including guinea pigs, cats, rabbits, and white rats, under automatic temperature control. Microphotographic studies are being made of bones and tissues, and ultraviolet light is being used to stimulate growth. An apparatus has been devised for preparing large quantities of vitamin-free casein for feeding experiments.

Dr. Henry G. Knight, of the bureau of chemistry, discussing the new methods of food handling, says that, "with increased facilities for the storage and distribution of food products at greatly reduced temperatures, the question has arisen whether many of the fruit juices which undergo hurtful changes on sterilization cannot be satisfactorily prepared by freezing. The greatly reduced cost of solid carbon dioxide (known commercially as 'Dry Ice' or 'Nu Ice') prompts the investigation of the possibility of preparing, shipping, and distributing fruits and fruit juices to the

that the new quick-freezing processes, whereby fresh foods are congealed under temperatures as low as fifty degrees below zero, will reduce food costs through the use of products that otherwise would be wasted on the farm.





Government Chemist Inspecting Meats Produced in Various Parts of the Country, in Order to Develop Better Methods of Feeding Stock

Soon there will be no such thing as "bad" eggs, as methods are being developed for preserving them indefinitely. The eggs revolve on a belt under a spray of fine sand, and are then dipped in oil to seal the pores. Government chemists have devised a method for coating eggs with oil under vacuum to make a better seal of the shell. Oil coating of the shell markedly inhibits shrinkage under ordinary cold-storage conditions, and application of the oil by the vacuum method results in even less shrinkage.

Waterless canning of non-acid vegetables is another innovation in food handling, and recently the food chemists have learned how to ferment turnips into "sauerkraut."

The product is said to be pleasing in flavor, and, aside from general appearance, is not unlike the cabbage variety. Experiments in the bakery field have shown that as good, and often better, cake can be made by mixing all the ingredients together and at once than by following heretofore approved directions which call

housewife in a frozen condition. There are now being kept in experimental storage several hundred packages of citrus and other products which have been frozen at temperatures ranging from thirty degrees to fifty degrees below zero. The possibilities of the different types of packages are being investigated, and methods devised for packing the products in inert gas and under high vacuum. It is believed that the next few years will show a marked change in food distribution, with frozen foods playing a very important part in household economy."

It has been learned that in seasons when pears do not soften readily, they can be softened economically with ethylene gas and thus made ready for canning. Varieties of apricots which tend to mature unevenly, one side softening while the other remains hard, are being harvested and softened by means of ethylene treatment. Ethylene-treated tomatoes take on color at a somewhat faster rate than untreated fruit kept at the same temperature and not in direct sunlight, and there is less acidity in their juice.

krout." The product is said to be pleasing in flavor, and, aside from general appearance, is not unlike the cabbage variety. Experiments in the bakery field have shown that as good, and often better, cake can be made by mixing all the ingredients together and at once than by following heretofore approved directions which call



Nutritional Value of Products Is Tested by Feeding Them to Small Animals in Cages



Commis. U.S. Dept. of Agriculture

for creaming the fat and sugar first and then adding the other ingredients.

Food standards are being revised by the federal authorities in view of the development of new food-processing methods, and standards are being developed for canned products to enable consumers to ascertain on the label the quality of the goods. Canned tomatoes, peas, corn, and other products, are purchased in stores, subjected to chemical analysis, palatability and nutritional tests, and classified according to quality.

Palatability tests consist in cooking the foods under identical conditions and then having government officials eat the products and write their impressions on score cards. The chief objective of this is to discover new production methods that will shorten the producing period and yet contribute most satisfactorily to consumer taste. The products are also fed to small animals in connection with nutrition studies, and analyzed for vitamin content. While the federal officials are desirous of developing new production methods that will yield larger profits to farmers, they are mindful also of the



food value of products in the interest of public health.

BILLIONS FOR GOOD ROADS *Q-145*

At least \$3,000,000,000 will be spent in 1931 on roads by 110 nations, according to an estimate of the bureau of foreign and domestic commerce. The United States leads the parade with road expenditures estimated at \$2,000,000,000. In this country, and in many others as well, the road-construction program for 1931 is being undertaken partly as a measure to aid unemployment conditions. Mexico is pushing a national trunk system, Canada has increased its road budget by \$20,000,000 and Japan by a similar amount, while Argentina intends to spend \$200,000,000 in building 800 miles of paved highways. In Europe, conditions are similar, Italy alone employing 60,000 men for road building.

Bureau of Agricultural

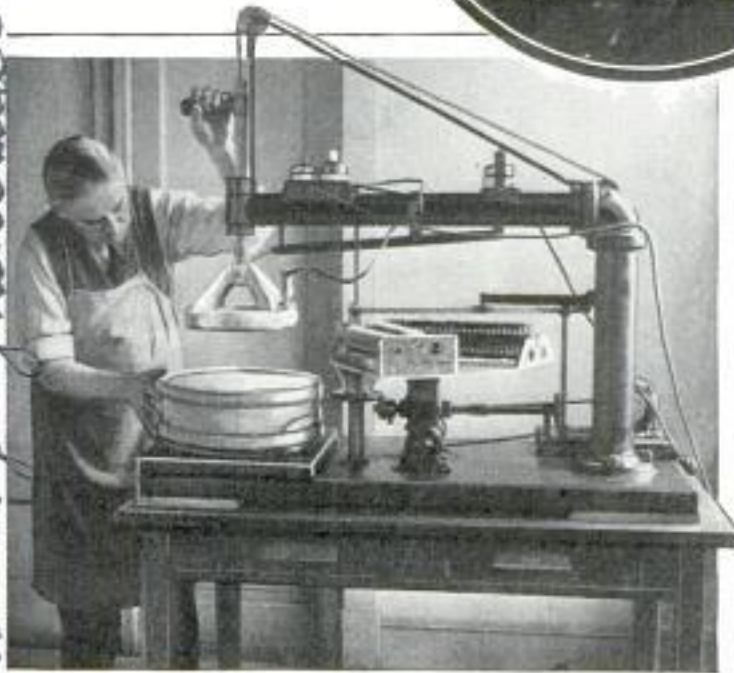

Injecting Chemical into Tree; Rat Used in Cottonseed-Meal Tests, and Stamping Cheese with Government Label

*pat pend. Refer eng to J. F. Beza housey, Senior Technologist.*



ITALY'S FLYING FLEET CONQUERS SOUTH ATLANTIC



call the roll and issue orders to his comrades by radio was another important reason for the success of the squadron's expedition. The flight is considered an important step in the development of long-distance and transoceanic flying, and shows the feasibility of formation flights on journeys of this length. General Balbo laid much of the success of the flight to his instruments. The journey began in

Ten flying boats of the Italian royal air force, roared into Port Natal, Brazil, skimmed smoothly down upon the water and came to rest after an 1,800-mile hop from Bolama, Portuguese Guinea. The moment was a pleasing one to Gen. Italo Balbo, leader of the fleet, and to his tired companions, for it marked the completion of the most difficult stage of the squadron's flight from Rome to Rio de Janeiro. Fourteen flying boats had started nearly a month before, two were forced down almost immediately after taking off from Bolama, with the death of four men, and two more were forced to descend upon the Atlantic after several hours of flying. They were picked up by steamers and towed to port, one being able to join the main squadron later. The flight across the Atlantic was accomplished in seventeen hours, in unfavorable weather, with poor visibility and the added hazards of heavy loads. The steamer patrol that guarded the way and helped keep in contact with the flying fleet proved to be of great aid, and the fact that General Balbo could



Top, Small Pneumatic Boat, One of the Twin-Hull Flying Boats, and Close View of an Engine

darkness with altimeters and air-speed indicators as chief guides for the pilots.

SOUND RECORD ON PAPER DISK BY PHOTOGRAPHIC PROCESS

Sound can now be recorded on cardboard paper disks through a photographic process by the use of an apparatus known as an "optophone" which has been developed in Germany. Perfect sound reproduction is claimed over the whole audible range. The records are cheap because, after the photographically produced mas-

*no further information*



*Carl G. W. Herbert.  
Pragerstr. 15. Berlin  
W. 50, Germany*

599  
A-146

ter disk is made, the commercial ones can be copied on cardboard very cheaply. The paper disks are durable because no needle is used in reproduction. They present a spiral of white on a dark background, the white spiral under a magnifying lens representing the characteristic variations on a film record for talking pictures. A photoelectric cell is used in producing the master photographic plate and, in playing the paper disks, converting the fluctuating waves from the microphone into electrical impulses and vice versa. Amplification and loud speaker are used.

**FLOODLIGHTED WATER TOWER GUIDES NIGHT FLYERS** *A-134*

Aviators flying at night near Ypsilanti, Mich., are guided by a brilliantly illuminated landmark, a 135-foot water tower, the dome of which is floodlighted to serve as an aerial beacon. The tower, forty feet in diameter at its base, is covered with silver-gray shingles which gleam with a sparkling brilliance under the rays of a battery of concealed searchlights. The structure, standing on the highest point in the city, is visible for ten miles when viewed from the ground, and for a much greater distance in the air.



© C. E. Lamb. *Ypsilanti Mich*  
Floodlighted Water Tower Which Serves Also as a Landmark for Aviators Flying at Night

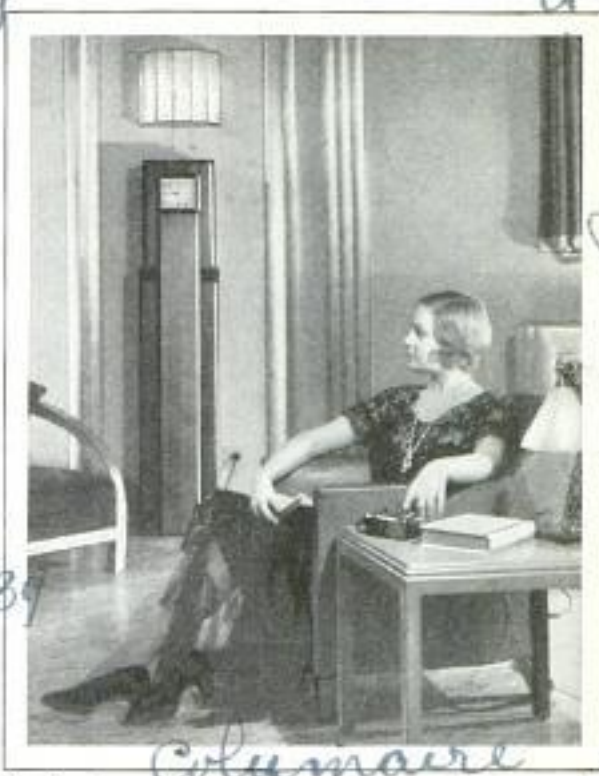

*Columbia*  
Tuning In on Program by Remote-Control Buttons; the Radio Set Is the Tall Cabinet in Left Background

**SKYSCRAPER-TYPE RADIO SET CONTAINS ELECTRIC CLOCK**

Economy of space, improved tone quality and convenience are features claimed for a tall radio cabinet that also contains an electric clock and may be operated by remote control buttons. The cabinet is nearly six feet tall, but occupies a floor area of only ten by twelve inches. Aside from its handsome appearance and adaptability to the modern skyscraper note in interior decoration, its height and design have given the acoustic engineers an opportunity to improve the tone quality. The ordinary speaker grill has been eliminated from the face of the set and is placed vertically so that it is directed upward through the top of the cabinet. This arrangement provides a five-foot column of air under the speaker, an important aid to tone improvement. Controls and dials are mounted flush on the sides of the cabinet. The set is a nine-tube screen-grid superheterodyne.

☐ An "ever-lasting match," invented by a Vienna chemist and recently tested with satisfactory results, can be ignited 200 times, it is claimed, although it is no larger than an ordinary safety match.

*Carl Cyril & Lamb, Ypsilanti Mich*

*Westinghouse Electric & Mfg. Corp. 901 P. H. H.*

*Dr. Ferdinand  
see illus 903/1  
Copyrighted material  
C. W. C. W. C. W.*



## UNIQUE LIGHTING EFFECTS IN MINIATURE THEATER

*Sterling Leach, 2102 La Salle Ave  
Los Angeles Calif  
A. 27*



Complete in every detail, even to unusual lighting effects, a miniature theater stage has been built by a Los Angeles high-school boy, mostly from odds and ends found about the home. The proscenium arch is twenty-seven and one-half by twenty-one inches, and the entire stage rests on a table. An organ with painted toothpick keys rises from the orchestra pit with a doll organist at the keyboard. A color wheel is lighted by an old bicycle lamp, a phonograph provides the organ music, tiny footlights were made from radio-panel bulbs, and gelatin used to obtain colors came from small scraps thrown away by others. The grillwork around the stage is of plastic wood, and other equipment includes projection apparatus, floodlights and a switchboard with twenty-four switches, all made of inexpensive odds and

ends. The lighting system, stepped down by a transformer, uses no more current than one common light bulb. Desert and oasis scenes are interchangeable by substituting different bits of cardboard scenery, while a fishing scene is only a piece of ordinary tapestry, magically turned into a thing of beauty by the ingenious use of lights. One set, copied from a stage production, consists of a few cents' worth of tinsel which against a flimsy silver cloth catches brilliant lighting effects.

QUAKES GOOD FOR THE WORLD  
A. 191 MAKE IT SAFER

More than 8,000 earthquakes are recorded every year and many more probably occur but are not registered, yet the world would probably be better off if there were

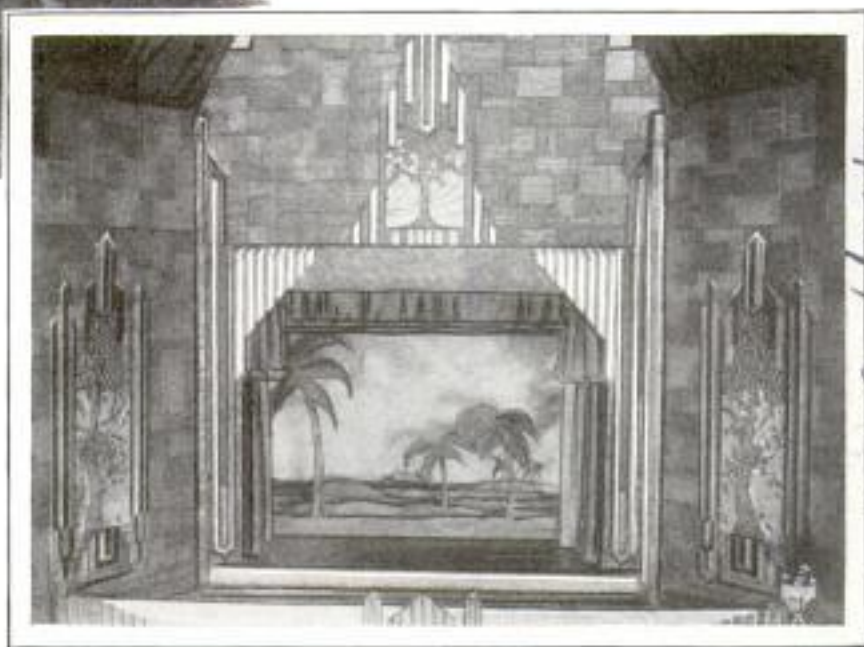

One of the Settings for the Miniature Stage Built by a Los Angeles High-School Boy, Shown, Upper Left, at His Studio Entrance

still larger numbers of quakes, according to Dr. William Bowie, of the United States coast and geodetic survey. He points out that the more quakes there are, the less will be the intensity of any one of them, and hence likelihood of less damage. The tremors are caused, it is believed, by the breaking of rock areas from thirty to sixty miles below the earth's surface. Doctor Bowie believes that we shall have quakes as long as the sun shines and we have evaporation of rainfall.

*radio talk over  
© B.S. 1/30/37*

*price: 514-00: 6/25/37*



Station Wg x a 9  
 Conducted by  
 Chicago Daily News

Emb. Leo W. Harris,  
 202 Arnot St. Carver  
 P. O. 601  
 Allentown Pa.

POPULAR MECHANICS

a-149

TELEVISION GIVES  
 QUOTATIONS TO  
 BROKERS

a-199

Herald Tribune 1/27/31

Stock quotations recently were transmitted by television to brokers in the Chicago district, pictures of the ticker tape being sent as the quotations were received. In its reception, the tape resembled that which runs across the top of brokers' bulletin boards. The symbols were black against a reddish-brown background and could be seen from a distance of twenty-five feet. Radio technicians expressed the opinion that such a broadcast could be received by television within a radius of 150 miles, enabling those within such a radius to keep in touch with the stock market in their own homes.

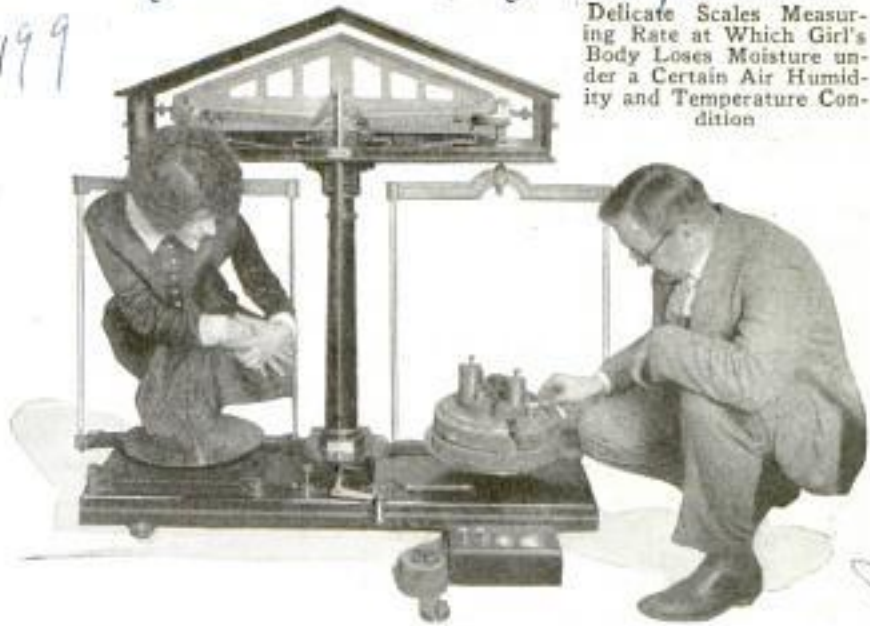

**Delicate Scales Measuring Rate at Which Girl's Body Loses Moisture under a Certain Air Humidity and Temperature Condition**

DELICATE WEIGHT TESTS AID  
 IN AIR CONDITIONING

To establish human reactions to various atmospheric conditions, delicate scales are employed in the research laboratory of the American Society of Heating and Ventilating Engineers, to determine the rate at which persons lose heat and moisture in atmospheres of various temperatures, humidities and motions. These weight tests show the relation of air conditions to health and comfort and help the engineer design air-treating systems for theaters, and other places of assemblage, where the heat and moisture given off by large numbers of persons plays an important role. In one test, for instance, a girl, normally weighing 110 pounds, was found to lose almost a gram of weight a minute under a particular atmospheric condition, this loss being due to evaporation of moisture from the body and respiratory tract.

Research Laboratory  
 also U.S. Bureau of Mines

TRACTOR CRANE LAYS PIPE  
 TO SPEED GAS LINE

a-156

Time and labor have been saved in the laying of a gas line near Los Angeles, by using an endless-tread tractor crane to swing the heavy lengths of pipe into position. Sections, twenty-four feet long and twenty-two inches in diameter, are easily lowered into the trench so that comparatively little hand labor is necessary.



Photo Ewing Galloway  
 Swinging Heavy Length of Gas Main into Ditch with the Tractor Crane Which Saves Hand Labor

Pure cane sugar now can supply most of the ingredients for a glass of lemonade; plants now are being built for making citric acid, the active principle of lemons, directly from sugar, by fermenting the sugar solution with a special mold.

a-220

Crager Machine and Industrial Works

Southern Calif. Gas Co

Cloustrick & Co.  
 7 Eastcheap St. London E.C. 3



A-103 Cont. Es. H. Stacy  
46 39 Montgomery Ave  
Bethesda Md

# A Riddle of the Sea

Price \$2.00  
\$2.50  
Diving helmet similar to one made by  
Miller. Glenn Co. Ches 2517 N.W. 23rd Terrace  
Miami Florida

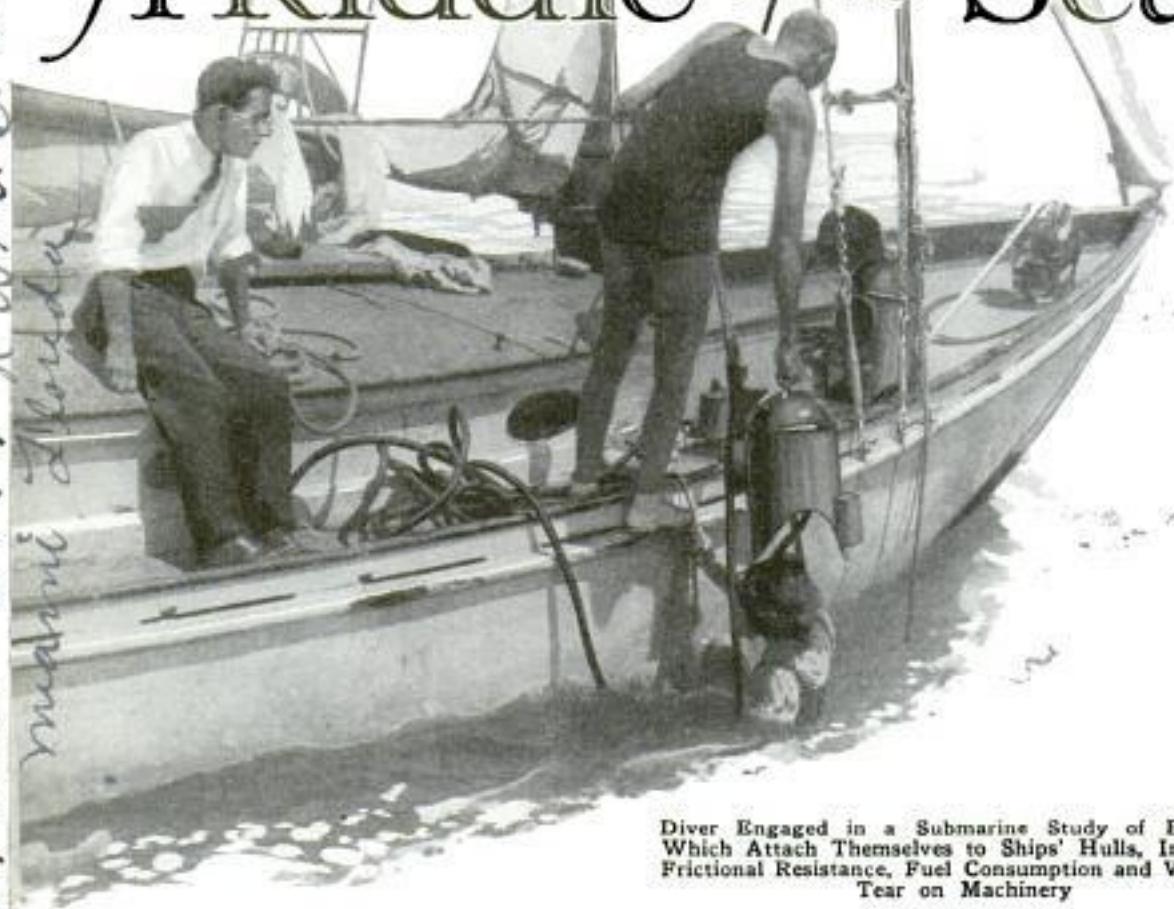

Diver Engaged in a Submarine Study of Barnacles Which Attach Themselves to Ships' Hulls, Increasing Frictional Resistance, Fuel Consumption and Wear and Tear on Machinery

**A** RIDDLE which puzzled the Chinese, Egyptians, Phœnicians and Romans is just as much of a conundrum now as it was during the dawn days of shipping—that of preventing the fouling of ship bottoms by barnacles.

Merchant marine and naval shipping pay \$100,000,000 annually in tribute to the barnacles which inhabit salt water and collect on the submerged parts of ships. Ever since the Romans devised the expedient of sheathing warships with lead attached by copper nails, maritime science has sought control measures. More than 150 devices and materials have been patented in the United States for the eradication of barnacles. None has been effective. Science, although it has learned much about the barnacle since the first Chinese junk was built some 4,000 years ago, has thus far failed in its battle to subdue this pillager. The barnacle stands unrivaled as the most persistent "Captain Kidd" of the undersea kingdom.

Barnacles are pirates in that they collect

in stupendous numbers on the bottoms of ships, thus increasing frictional resistance so that from one-fifth to one-third more fuel is required to operate the vessels. The speed of the ship is reduced from one-fourth to one-third of normal velocity after drydock service. All ships that sail the seven seas have to be dry-docked once every six or eight months to have the barnacles scraped by hand from their hulls—a slow, laborious and expensive process. When the barnacles are detached, the paint comes with them. This involves painting the ship bottom again, and additional losses are caused by the ship's enforced idleness.

Take the "Leviathan," for example. That part of her bottom which is exposed to barnacle attack has a surface of more than one acre. At least ten days in drydock are required to scrape off the accumulation of barnacles and to repaint the hull. The drydocking cost alone is \$50,000. During that interval, the famous liner, if in service, could make one round trip



no address

# - Still Unsolved

across the Atlantic, carrying her passenger capacity.

Dr. J. Paul Visscher, of the Western Reserve University, at the request of the government, has devoted three years to the study of barnacles. Much of his research has been carried on at Loggerhead key, the most southerly of the Tortugas group. Wearing a bathing suit and a diver's helmet with a special airline, Doctor Visscher has worked at depths of twenty-five feet. Altogether he has surveyed and experi-

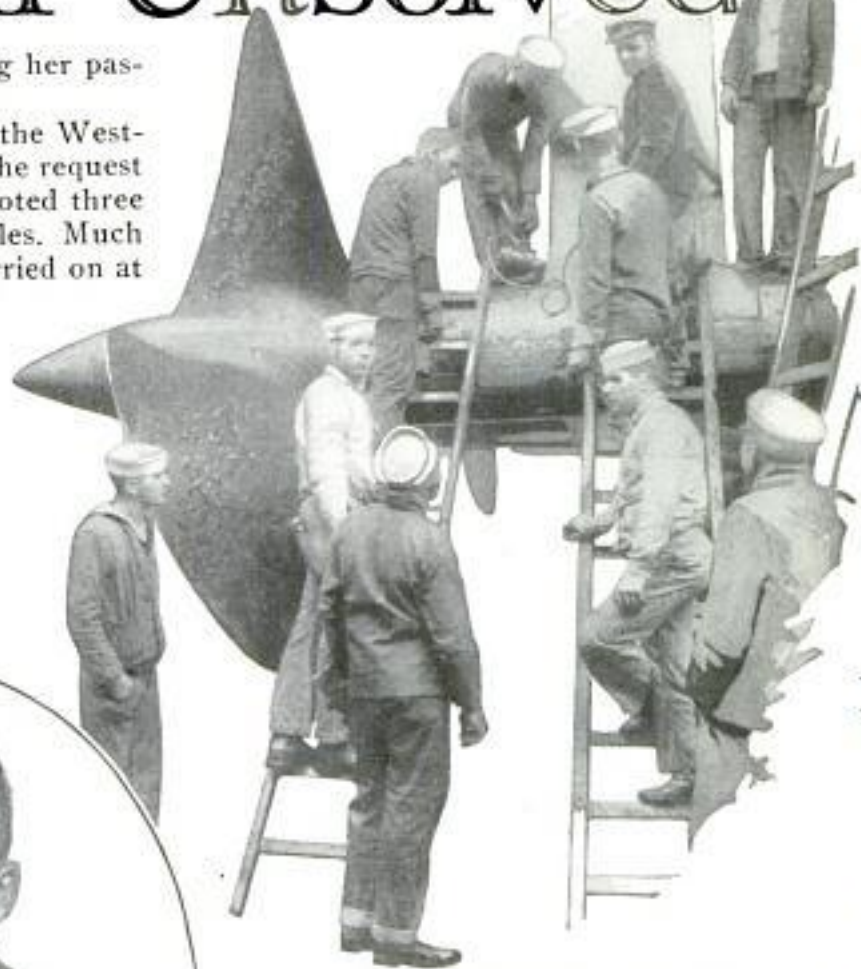

Propeller Incrusted with Barnacles, and Dr. J. Paul Visscher, Barnacle Researcher for the Navy

mented with the various kinds of barnacles found on 250 ships of the U. S. navy and private owners from the far corners of the earth while they were in drydock. His collection of barnacles recovered from these vessels includes some specimens which are over 2,000,000 years old. The barnacles range in size from microscopic mites to giants, three inches long and two

inches wide. From fifty to 100 tons of barnacles are removed during a single scraping from some vessels, while cases are on record of from 200 to 300 tons of barnacles being removed from the hulls of very large vessels.

Barnacles are among the oldest animals which science knows anything about. They are like starfish and sea urchins in that they thrive only in salt water. Some of them die after four to six hours' exposure to fresh water, while others survive for fifty hours. Ship captains for centuries have taken advantage of this fact by anchoring their boats at regular intervals in fresh water. They believed that the practice aided measurably in the destruction of the attached adult barnacles. Doctor Visscher, however, has found barnacle shells on the bottoms of salt-water ships after they have been anchored continuously for thirty-five months in fresh water. In three months, barnacles grow to be as large as pigeon eggs, and a con-

Documment #1091. South Printing Office Washington, D.C

Report: Nature and Extent of Foulings of Ships' Bottoms - Bureau of Fisheries 603





Doctor Visscher has demonstrated that barnacles in their youth are sensitive to light in the blue-green but not in the ultraviolet portion of the spectrum. Blue-green light stimulates them so that they are attracted by such somber colors as red, brown, dark yellow and black. These colors, particularly dark red iron-oxide paints, are used chiefly in painting the subsurface of ships' hulls. In his study of ship hulls, Doctor Visscher also found that barnacles were most numerous in the shaded areas where bright light did not penetrate. This suggested employing light-colored paints for use on the

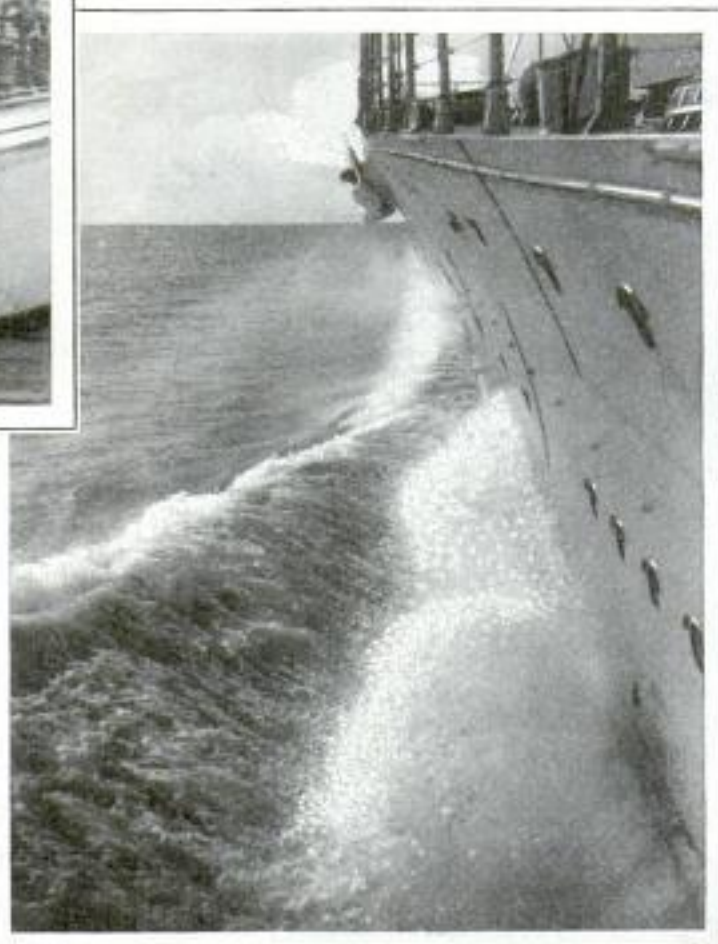

trol measure much more drastic than exposure to fresh water is necessary to loosen the binder which causes their adherence and to remove these shells.

Poisoning the paint used on the ship hull has been recommended as a preventive of fouling. According to Doctor Visscher, it is unsatisfactory, because, in order to make the poison effective, it would be necessary to apply ten times as much paint as possibly can be used. The official records of the patent office are rich in anti-fouling materials, such as mixtures containing quicksilver, gutta-percha, asphalt, plumbago, shellac, clay, fat, sawdust, hair glue, oil, soot, emery, castor oil, grease from boiled bones, unsalted butter and paris green, which have never worked for any length of time in practice. Even the government has developed a special anti-fouling paint which contains mineral spirits, pine oil, coal tar, rosin, zinc oxide, mercuric oxide, iron oxide, copper oxide and silicates.

Above, Type of Helmet and Special Airline Used in Barnacle Surveys; Below, a Ship Freshly Cleaned of Barnacles

hulls of ships. Unfortunately light-colored paints are especially soluble in salt water. Furthermore, the dirty water in many harbors darkens light paint even after short exposures. Here is a problem for the paint industry to solve—the development of a light paint which will not dissolve readily in salt water and will not change color easily in dirty water.

Future research may evolve practical



264

methods of electrocuting the barnacles by methods now undreamed of. This is a field of experimentation which has thus far been neglected as a possible source of a practical and relatively inexpensive system of divorcing barnacles from their favorite anchorage.

**HAND-POWER RAIL CAR GIVES THRILL TO CHILDREN**

Features of a real railroad enter into the design and operation of a hand-propelled car for children. It runs on a track of steel rails and oak ties, the drivewheels have siderods like a large locomotive, and the two four-wheeled trucks are designed like those that appear on regulation railroad equipment. The propelling mechanism consists simply of a chain-and-sprocket drive leading from the front axle to a head fitted with two crank handles, on top of the car. The child drives from a sitting position and can crank the three-foot car along the track with considerable speed and with perfect safety. The wheels are flanged, rails and ties are substantial and, if properly laid, will convert a backyard, a lane or any vacant lot into a playground for the child. The car can be driven in either direction and may be used to haul other units, so the youngsters can play "real" railroad.

Cranking the Car along Its Track of Real Rails and Ties; the Trucks Are Like Those of a Locomotive; the Car Runs Backward or Forward



W. H. Blue  
Montezuma  
Montezuma  
clad

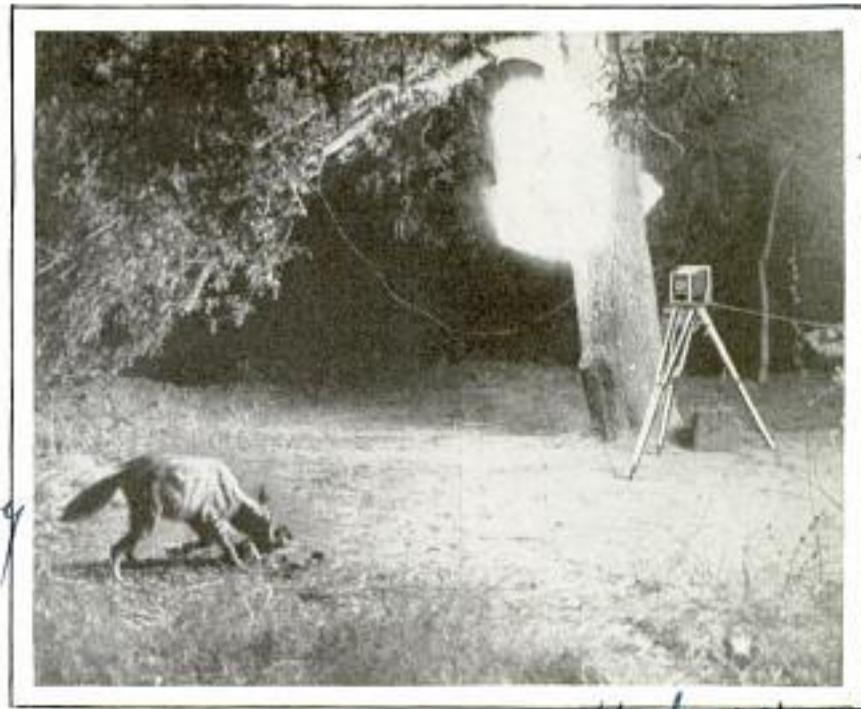

© C. Court Treatt  
This Jackal Took Its Own Flashlight Picture When It Tugged at a Lure Which Was Attached by a Cord to a Camera Near By

Medo Warka

**JACKAL TAKES OWN PICTURE BY SNAPPING FLASHLIGHT**

Those who hunt wild animals with a camera in order to obtain pictures that are true to life, are often highly successful in inducing specimens to snap their own pictures by connecting a string from the camera to bait placed nearby. Maj. C. Court Treatt, veteran explorer of Egypt and the Sudan, obtained a picture of a jackal in this manner. Cameras were placed about the lure and connected to it, and the animal set off a flashlight when it tugged at the bait.

**BOILER IS GIVEN LONGER LIFE BY WATER TREATMENT**

Through a water-treatment process which has been tested for six years at the University of Illinois, the life of high-pressure steam boilers will be greatly prolonged, thereby saving millions of dollars to industries. The process has been found to prevent explosions from boiler embrittlement and has already resulted in a saving of \$10,000,000 in the Chicago area alone. Because of alkaline waters high-pressure boilers have had to be replaced frequently, while a boiler normally should last from twenty to thirty years with this danger removed.

9-198  
carried on under direction  
Prof. Fred L. S. Strain  
Department of Chemistry



Cent. John L. County, 7 14 Jefferson  
in U.S. Washington, D.C.  
POPULAR MECHANICS, U.S.

### GROWING MUSHROOMS IS A MONEY-MAKING HOBBY

*Vanoyan Seed Co. 10 W. Chandler St. Chicago*

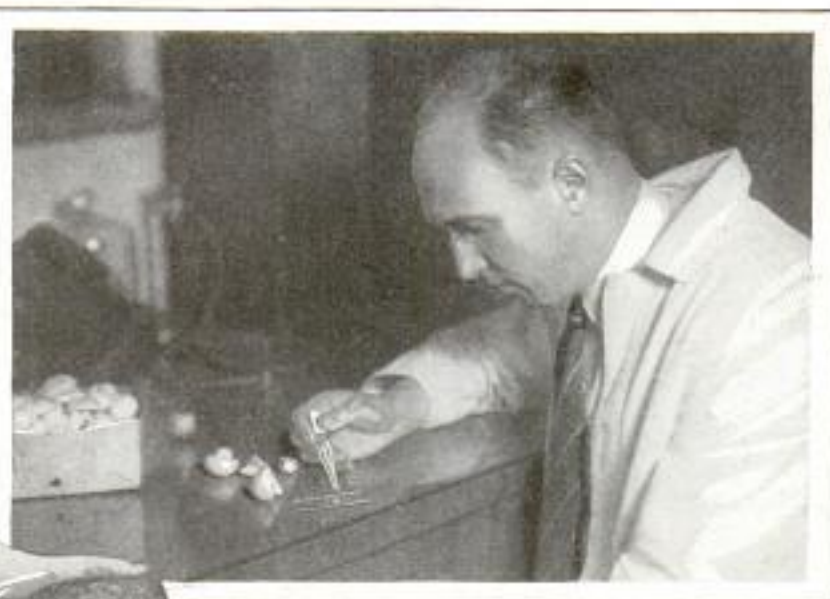

Bottled Mushroom "Spawn," and Studying Young Mushrooms; the Growing of This Product Has Become a Scientific and Frequently Successful Business

Mushrooms are now easily and safely grown, thanks to the scientific development of the industry. Today, fifteen to twenty millions of pounds of mushrooms are grown annually in the United States. In New York City alone it is not uncommon that twenty to thirty tons of mushrooms come on the market daily. And there are other great city markets for this delicious tidbit, notably Chicago, Philadelphia and Baltimore. What are the new developments which have advanced this lowly fungus to an exceedingly profitable commercial product? Chiefly the control of the method of making spawn—the threadlike growth of mushrooms underground—which insures them against diseases and pests. Now, cultivators of mushroom spawn distribute and sell it directly to growers. In old days they used to gather it wild and sell inoculated growing material compressed into small bricks. But this was crude and dangerous. The new method gives the mushroom grower a pure product called "bottle spawn." Houses are now built especially for mushroom culture. The beds are in tiers one above the other at intervals of about two feet. After the beds have cooled to ordinary temperature, the spawn is placed in them, a piece every eight or ten inches, and allowed to grow for a

month. Then it is ready for a dirt mulch about an inch and a quarter thick. In two or three weeks mushrooms begin to appear and keep coming for five or six months. At the end of this period, the growing is over, and it becomes necessary to throw out the beds, disinfect the house and start all over again.

### POWER SCYTHE RUN BY MOTOR OPERATED BY ONE MAN

Operated by a one-half horsepower motor, a power scythe for mowing roadside grass and weeds, and for airports, golf courses and large grounds generally, can be operated easily by one man. The



scythe is attached to a one-wheeled frame with handles like a plow, the operator pushing the implement while the motor operates the cutter blade. A starter operates the motor with the pull of a handle, and vibration has been reduced by a frame of cantilever construction and by having the handlebars trunnioned at the axle of the wheel.

*Johnson Motor Co  
Waukegan Ill*



*A-148* Constructed by American  
 Broadcasting System, Inc. 607  
 Popular Mechanics  
 Angeles, Calif.

**TALKIE THEATER ON WHEELS TO TOUR HIGHWAYS**

Roadside audiences on the Pacific coast are being entertained by a talking-picture theater on wheels which brings the movies to the patrons. This traveling theater, costing \$50,000, is contained in a giant truck, weighing 20,000 pounds and provided not only with projection room and sound system, but also equipped with running hot and cold water, tiled shower bath, kitchen and living-room facilities and sleeping accommodations for six persons. It is being used by a theater organization to advertise its films. This huge land cruiser is thirty-four feet long, eight feet wide, twelve and one-half feet high, and is driven by a 160-horsepower motor. A pilot house is located above the engine room at the front of the vehicle and is reached by a stairway. The projection room is lined with metal and equipped with an automatic sprinkler system for use in case of fire. The generating system includes one 2,500-watt direct-current automatic gas-engine-driven plant, and a one-kilowatt alternating-current electri-

cally driven plant. The kitchen is equipped with an electric range, and there is an auto-



Giant Truck Containing a Complete Talking-Picture Projection Apparatus; the Vehicle Has Living Accommodations for Six Persons

*Designed by W. H. Adams*  
 automatic electric water heater, an air-compressor system to provide pressure for the water plant, and electric refrigeration is a feature, while built-in furniture saves space in the living room. When two large doors at the rear are opened, the screen is exposed, and pictures are projected to and through it from the projection room at the front, being viewed by an audience standing outside the vehicle at the rear. Sound reproducers are located just under the screen. The projection room is fitted with the most modern equipment and resembles that found in the up-to-date moving-picture theater.

*Used by Fox West Coast  
 Exhibitors*

*Cont. Sales Lewis 336 Broadway Bldg  
 Angeles Calif.*

**FURNITURE FROM OLD PAPERS USED IN SUMMER HOME**

Novel furniture for a summer cottage in Massachusetts has been fashioned from old newspapers, tightly rolled into small "sticks" and fastened together. The

outer surface was treated to make it waterproof. Chairs, tables, floor lamps and other articles have been made from the paper rolls.



Floor Lamp, Table and Chairs Fashioned of Rolled and Pressed Newspapers

**OYSTER LARVAE NEED COPPER BEFORE SETTLING DOWN**

Young oysters will not forsake a roving life and settle down as substantial citizens until they have had a dose of copper. This has been discovered by government investigators who are trying to make oysters more abundant. When an oyster first hatches from the egg, it lives for two weeks as a free-swimming larva. If it lacks copper, it is victimized by microscopic organisms. If it gets its copper, it sinks to the bottom, protrudes its one foot on which it crawls about for a time, then exudes a glue-like substance, plants its shell squarely in this, and is fixed for life.

*at Pigeon Cove  
 Rockport, Mass*

*H. F. Pythearch,  
 U.S. Bureau of Fisheries*

*A-190*

*A-125*

*Nov*

Copyrighted material



a-137 608 Cmb. H. J. Wilkins. Esq  
 POPULAR MECHANICS, *Box by 2*  
 Colombe, 29 Bean Road, Heath, in *Nov 1918*



stroyer steers the deserted warship by radio, the radio pilot and steersman being located on a control platform on the "Shikari," from which they operate the steering gear and steam valves of the abandoned boat, regulating the speed and maneuvers, and even dodging torpedoes fired

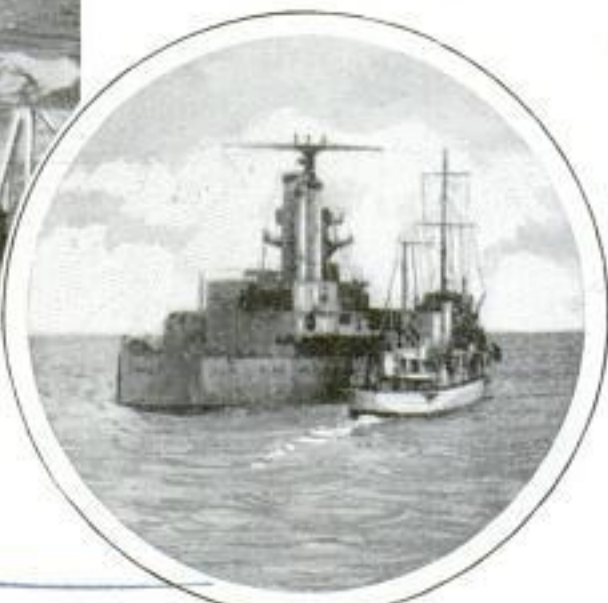

© Pathetone Weekly

**BATTLESHIP STEERED BY RADIO IS TARGET FOR GUNS**

Steered and controlled entirely by radio, a 20,000-ton derelict battleship is a fascinating target for Great Britain's Atlantic fleet. This boat, which returns to the dockyard for repairs after every "engagement," is the "Centurion," and it is shelled and bombed regularly by battleships, cruisers, destroyers and airplanes. It carries a crew of 250 who desert the ship just before it goes into battle. The crew takes the vessel to the war area, strips the wheelhouse of its fittings, removes the contents of the deck cabins, and, leaving the engines throbbing, quits the big boat for the little destroyer "Shikari." From a distance of about a mile astern, the de-

Left, View of Destroyer Which Steers the Abandoned Target Battleship by Radio; in Circle, Target Ship and Her Destroyer Companion

by attacking vessels. The old boat is pommelled and battered by high explosives until the attackers decide she has had enough, then the crew again boards it and takes it to port for repairs. It carries no guns and no turrets and the engines are about the only vital parts that have not suffered damage at some time or another.

**CELLULOSE SPRAYED ON EARTH TO ERADICATE WEEDS**

Eradicating weeds from a field under cultivation by smothering them is the method proposed by a German engineer who has made a cellulose sprayer for this purpose. By spraying a field with one part of cellulose diluted in ten parts of water, a continuous tough skin, adhering to the ground, is produced. This will not dissolve or wash away but can be peeled off easily after harvest. The method is inexpensive, and tests have shown that it chokes weeds with weak germinating

power, and so saves weeding and ridging. At the same time, it insures a richer and better crop, because the nutriment in the ground is available solely for useful plants, and also because moisture and heat absorbed by the earth are prevented from evaporating or escaping. The idea of covering weeds with paper to destroy them first was tried in Honolulu, where tough wood paper was laid by machines operated by tractors or horses. This process, however, is both expensive and often impractical while the spraying method is applicable to all useful plants except cereals.

Chicago Evening Post  
 1/26/31

Arthur Storch  
 Berlin, Germany.

Ernest Amund  
 3rd Ave. 18th  
 New York  
 Aulake. 3.00 \$.



Prof of Theoretical  
Physics

A. 212 Barber. Isre in  
Co. Aurora Ill!

Chicago Tribune 2/4/21

### SPEED OF LIGHT IS UNCHANGING ACCORDING TO TESTS

Light travels always at the same speed, according to the finding of a scientist who thus adds fresh proof of the correctness of Professor Einstein's relativity theory in which it is assumed that the velocity of light is absolute. Prof. Georg Joos, of Jena University, Germany, claims to have proved the uniformity in the speed of light by the use of a device which he says measures accurately one-thousandth of the length of a light ray. A wavelength of light varies from about one twenty-five-thousandth of an inch for red to about half as much for violet, and Professor Joos claims to detect fractions of wavelengths ranging from one twenty-five-millionth to about one fifty-millionth of an inch. He obtained the added accuracy partly by the use of quartz in his instrument, the light rays coming from a mercury quartz lamp, and being measured with the aid of a camera. The instrument is so sensitive that a sound such as a hand clap registers as a visible dent in the curve the camera produces.

Chicago Tribune



Electric Loader Which Handles Bulk Material; It Is Used to Empty Freight Cars Quickly

### FREIGHT CAR EMPTIED QUICKLY BY ELECTRIC LOADER

Bulk materials, such as grain, cement, sand, slack coal and gravel, are speedily removed from box cars by an electric loader which handles lumps not exceeding four inches at the rate of one-half cubic yard a minute, dumping the material directly into wheelbarrows or hopper conveyors. The machine is mounted on two roller-bearing wheels with a smaller wheel for steering, and is run by a five-horsepower motor. A pawl-and-ratchet mechanism crowds the machine into the material, and the feeding drive can be backed out by reversing the pawl. Five speeds are available in either direction. One man can easily move the equipment by disengaging the drive and tilting the boom back on the chassis, the boom support being almost at the center of gravity. The material is fed into buckets on the loader by means of a spiral ribbon-type feeder. For dusty material, a canvas chute is hung from the discharge end, and the bucket line is housed.

### MIDGET-SIZE PUSHER PLANE STEERED BY WING FLAPS

Weighing less than 400 pounds and powered by a twenty-five-horse engine, a two-place monoplane attracted attention at an aircraft show in Omaha, Nebr. It is of the pusher type, that is, the propeller is behind instead of in front of the wing, and the usual rudder is replaced by flaps in the "trailing wings," surfaces at the rear of the main wing. In addition to serving as a rudder, these flaps, which work independently, can be used to decrease the speed of the plane, it is said.

Price \$8000



One of the Midget Planes That Promise Wide Favor This Year; the Engine behind the Wing Affords Added Visibility

Lincoln Aircraft Co  
Lincoln, Nebr.



# With the Movie



By ANDREW R. BOONE

TEN years ago a wandering circus owner "played the sticks" across the continent and eventually landed in Hollywood. As his train of automobiles passed the studios, he decided a permanent location with performances for the screen offered more comfort than one-day stands and uncertain seasons.

Since then Al Copeland has made forty-one circus pictures; has put on fifty carnivals for motion pictures, and has supplied equipment, actors, acrobats, freaks, fleas, ants and elephants for innumerable bazars, county fairs, medicine shows, picnics, traveling museums and European fairs—all for the screen.

In less than a day and night, he will gather his canvas and props, bring in the animals from his ranch, assemble the performers and have his five-ring circus ready for the cameras to shoot the scene. When Copeland puts on his circus for a picture, unless the story requires a different arrangement, he runs through the entire show. Veteran troupers—clowns

Staging a Circus Parade for the Movies; the Buildings Have False Fronts but Everything Else Is Real

and trapeze artists—put on their acts just as though they were appearing before a paying audience. As a result, whenever a circus picture is being shot, crowds storm studio gates. Recently 10,000 people crowded into the tent one morning to see the performance, and another throng came in the afternoon for the second performance. They saw the show and the movie stars free, and the studio saved \$50,000 by not paying the regular wage for extras.

Every time you see circuses, or hot-air balloons and parachutes, or exciting circus-fire scenes, or well-trained animals in that type of picture, you know Copeland



# Circus

has a good deal to do with it. He's the only one of his kind in the movies, and he has at his tongue's tip the names of 800 circus performers living in and near Hollywood. He can produce in a half day forty expert trainers who will undertake to train anything from a flea to an elephant, a minnow to a whale, to act acceptably before any audience. "I have never failed yet to fill an order," he says. "When the talkies arrived we trained the animals almost overnight to respond to pantomime instructions. Today we can provide anything that lives for any kind of a show. Recently a studio called for 1,000,000 red ants for a comedy scene. Our men went into the hills with a half barrel of sugar and several nets. By scattering trails of sugar to the nets, they soon gathered in the ants.

"Another studio wanted bats. Our men got them from underground mines. We get hurry orders for queer people, the tallest or the fattest."

Twice recently, a director suddenly called for five fish and a fire. Cope-land produced the live fish in two hours and later burned his own circus to the ground to satisfy the director!

A rehearsal preceded the fire. All the paraphernalia, except the poles and some old seats, were removed. Then several smoke candles were lighted to determine how the animals would react. Zebras, horses, elephants and camels stampeded.

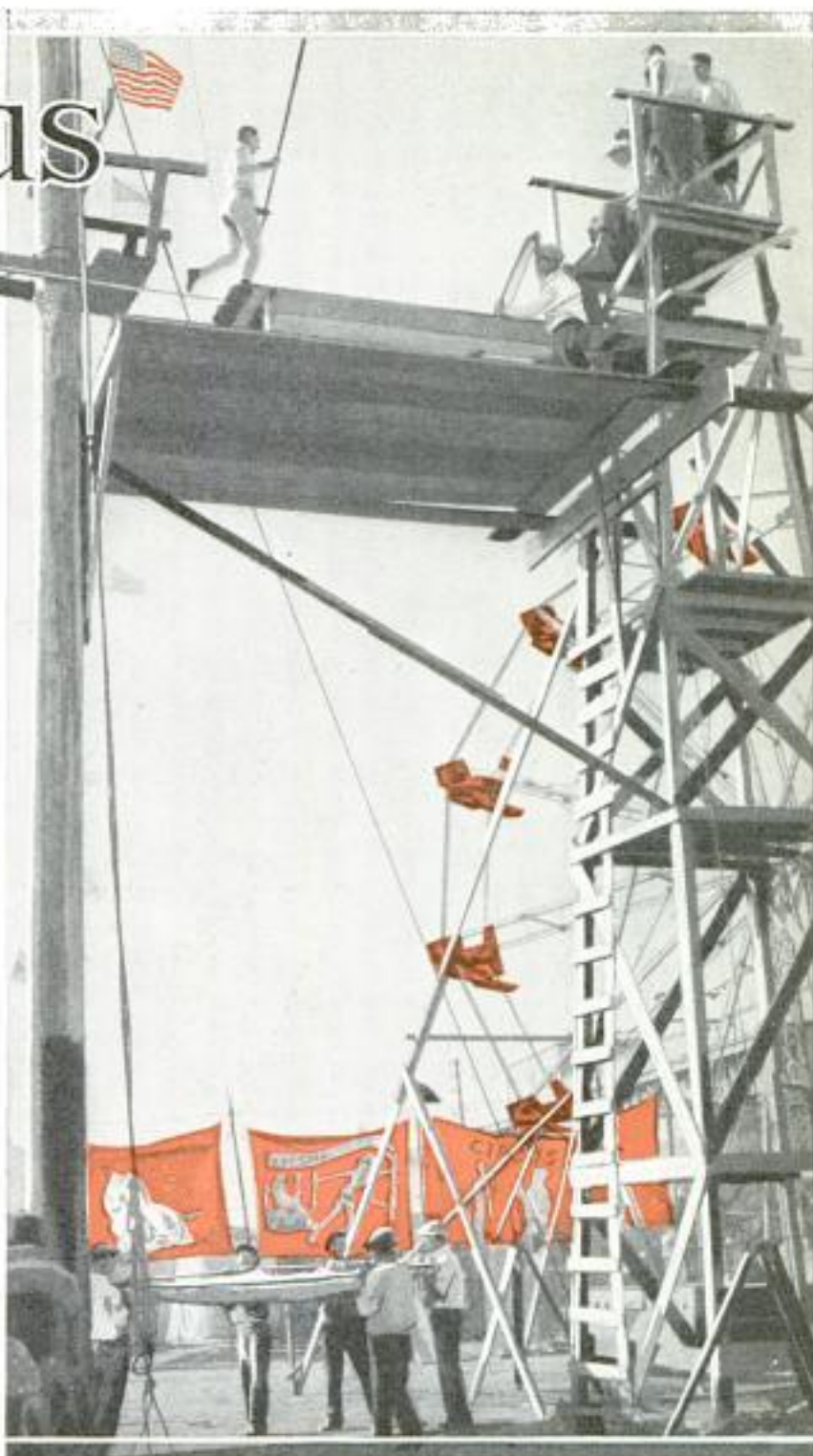

Filming a High Wire-Walking Scene; the Platform and Life Net Were Rigged to Catch the Performer in Case of a Fall

One camel dived head-long into the rear of a sound truck where the "mixer" was adjusting his apparatus to record the stampede. The horses fled to one corner of the lot, the zebras herded in another, but the camels galloped singly in all directions. Thirty-five cowboys rounded them up and brought them back for the real conflagration.



The story, a comedy, called for a riot to start among the spectators and show people. One group inadvertently knocked over a pop-corn wagon, and in a few minutes the tiny blaze had run up a side wall and spread over the entire "big top." Soon the tent had burned to the ground. Fires of this sort require careful timing. The gasoline-soaked side walls and top spread the blaze very fast. Before the action commences, the unpaid audience departs, and only a handful of paid extras remain inside to rush past the camera as the flames spread. Animals are herded near the exit with cowboys and attendants at hand to drive them out safely.

In filming such a picture many miles of cables bring the noises from ten microphones to the mixing booth where all are blended for the celluloid. Voices of actors record well, under canvas, although they are pitched higher than when recorded on a soundproof stage. Sometimes,

though, the animal sounds you hear in a circus picture do not come from the animals. Movie technicians improve on nature and make synthetic growls and squeals better than the animals themselves.

The story is told of one monitor man, new to a circus picture, who was instructed to record a giraffe's laugh. The microphone on its sliding boom would not quite reach the giraffe's head, so the monitor man hung special ropes to extend the "mike" higher into the air. Meantime he inquired of actors, circus men and assistants just how a giraffe's sounds should be recorded. They "cued" him and he practiced a half day, emitting sounds he thought should come to his ears. At last the microphone was hung properly and then—only then—did he learn a giraffe, having no vocal cords, can emit no controlled sounds.

One of Copeland's most difficult tasks comes when several "doubles" are needed for an animal star. Suppose a star horse, having appeared in several scenes, cannot do certain bits of required acting. Copeland may examine 100 horses to find three like the original in size and color. Then he may train these to do individual scenes, for he has found that too much training complicates an animal's mental processes. Thus the animal you see doing tricks in a circus picture may be three or four.

Such deception as practiced in filming a circus is done only for your enjoyment and to make a real circus even more real. Many properties you see have no necessary part in the picture other than to hide lights scattered around the big tent. Even the ropes are

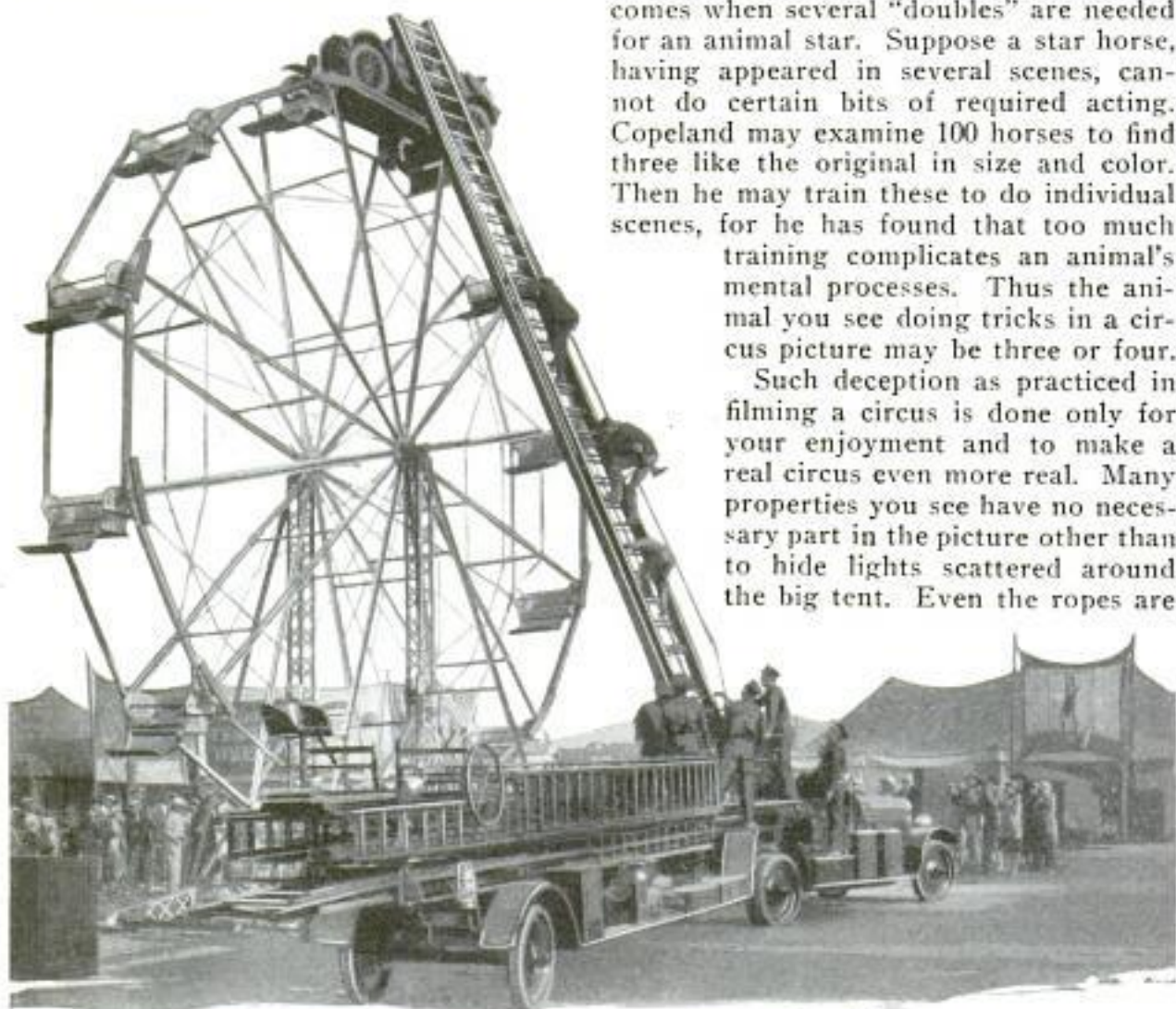

In One Circus Stunt for the Movies, an Automobile with a Substitute Wooden Engine, Was Carried to the Top of a Ferris Wheel



painted a light gray, to photograph white, and all poles and boxes are tinted and aged with burned umber to kill the glare. Seats are moved out four to six feet from the side walls to make room for batteries of lights.

Recently one studio called in the morning for a circus. Twelve hours later two of the twenty-six acres comprising the studio lot were under canvas. A score of daily painted wagons paraded onto the lot. Five tons of sawdust appeared as if by magic and was scattered about the "big top," the menagerie tents, pad tents and side-show booths. Peanuts and popcorn, elephants and a steam calliope were on hand. Most important of all, 200 trained performers had reported in costume ready for work.

**SIMPLE WOOL GAUGE TESTS  
SIZE OF FIBERS**

To determine the thickness of wool and other fibers in certain tests, a gauge introduced in Germany is said to be so simple that it requires no professional skill or knowledge to operate. The instrument either compares the fiber under investigation with standard fibers, or makes an actual measurement of the sample itself. In the former test, an enlargement of the fiber is thrown upon a screen, where it is quickly compared with several standard measurements displayed in a similar manner. When an actual measurement is to



Measuring Fabric Fibers in Special Gauge Which Compares Their Size with Known Standards

be made, the fiber is still further enlarged and quickly gauged according to an accurate scale. As many as 100 fiber tests can be made in ten minutes after short practice, it is said, and photographs of the fiber's rating can be taken from the machine. Current to operate the projector is obtained from a lighting socket.

*Reichert Optical works,  
Venna III/2, Austria*

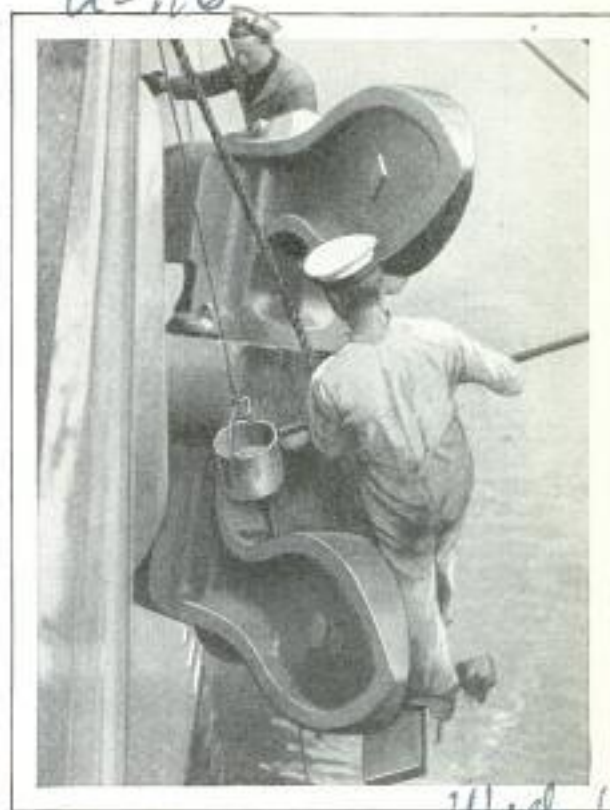

Sailors at Work Painting One of the Giant Anchors of the British Battleship "Nelson"

**GIANT ANCHOR OF BATTLESHIP  
GIVEN SPRING CLEANING**

Some idea of the huge dimensions of the H.M.S. "Nelson," one of Great Britain's finest and largest battleships, was offered when a photograph was obtained of sailors at work painting one of the giant anchors. This ship and others of the Atlantic fleet were given a thorough cleaning from anchors to gun turrets before the vessels started on the first leg of a voyage to the Panama Canal zone.

**TRAFFIC LIGHTS SUNK IN ROAD  
ARE EASILY SEEN**

Some English cities are taking their traffic lights from posts beside street intersections and sinking them in a line across the roadway, flush with the surface. When traffic is to be stopped these lights make a vivid red line across the highway. Those adopting this system claim the sunken lights are more easily seen by motorists, who naturally have their eyes on the road ahead. It also is claimed the line of red lights exerts a psychological effect on drivers who are less likely to drive across a red line than to disregard a red light beside the road.

*Dr. Herbert A. Reicher, Munich Engineering College*

*Webb Clark*

*Cont. Morris H. Whitehead  
987 Trinity Ave. Boston, Mass.*



*Mr. Thomas F. Fox  
Senior assistant and  
librarian, New York Institute*

*A-203*



Recruits at Detroit's Training School for Firemen Learning to Carry Victims down Ladders

**TRAINING SCHOOL FOR FIREMEN IN SEVEN-STORY TOWER**

One of the finest training schools for firemen in the world recently was built in Detroit at a cost of \$250,000, the structure being a seven-story tower containing every appliance known to the fire-fighting profession. Indoor and outdoor drills are provided for, the interior being built to represent a factory or building wall, complete with fire escapes and windows of every type found in such structures. It is high enough to operate a seventy-five-foot aerial ladder. Among other features are classrooms where recruits are instructed in artificial respiration, knot-tying and other drills.

**DEAF MAN "TALKS" AND "HEARS" OVER TELEVISION WIRES**

Using the finger alphabet, a deaf man in New York recently carried on a conversation with his son over a two-way television system, thus being able to

"talk" and "hear" over the telephone for the first time. The son, whose hearing is normal, conversed with his father in the sign language. The only case at all similar was that of a deaf girl who had communicated by lip movement over a like system. In the latest test, the participants had the added trouble of trying to distinguish between the face of the "talker" and the fingers superimposed on the same plane, but the eyes soon became accustomed to this. One advantage of the system, which may open up a new vista in the life of the deaf, is its elimination of the use of telephone instruments which so obstruct the view as to impede such a form of communication. This is accomplished by using a microphone sensitive to remote sounds and a loud speaker concealed near the television image at each station.

*for information of deaf and dumb*

**ENGINE STARTER FOR PLANES PLUGS IN LIGHT CIRCUIT**

*A-173*

To speed up the cranking of airplane engines not equipped with automatic starters, an electric starter, known as an external energizer, now is being employed. It is plugged into an electric outlet on the field and is slipped over the crank fitting of the hand starter. If electric lines are not available, the starter can be operated by a 110-volt direct-current generator driven by a gas engine mounted on a truck. Only one man is required to use the energizer.

*Material des. Army Lt. J. L. ...  
Air Corps, W. M. ...  
Dayton, Ohio*



Electrically Operated External Airplane Starter Which Fits over Crank of Hand Starter

*A-286*

*Bell Telephone Laboratories  
195 Broadway  
N.Y.C.*

*Tested at Primary  
Flying School  
Brooks Field, San Antonio*



a-189

LIFE LINES RELIEVE THE CREW OF OCEAN BEACON

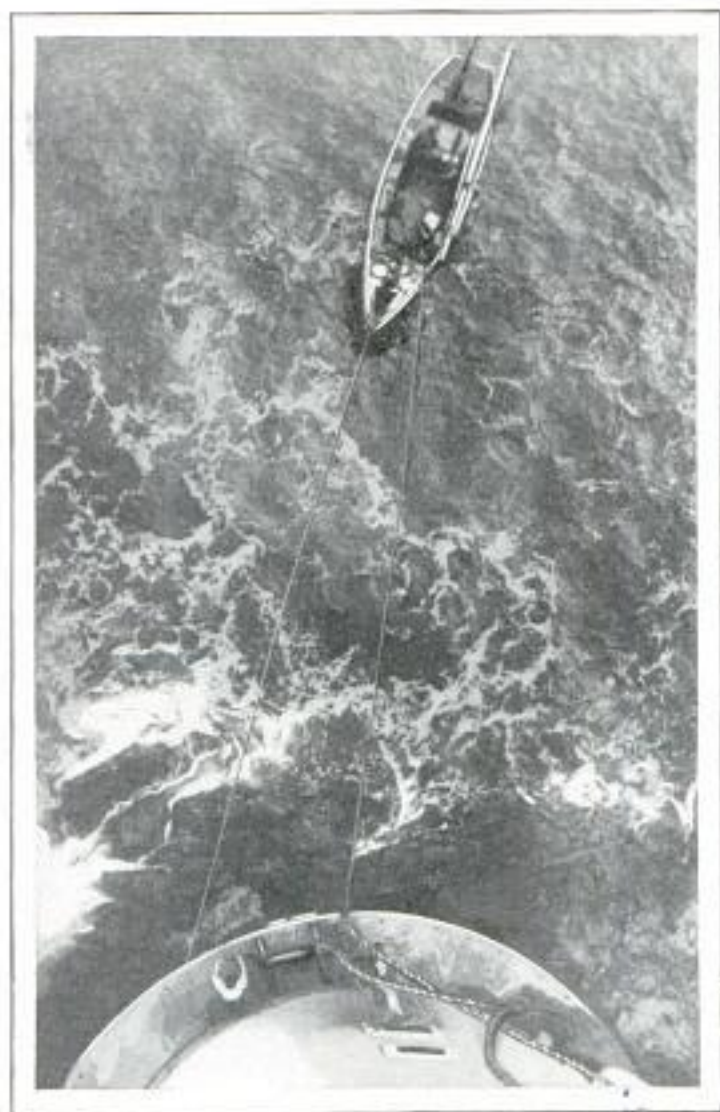

Above, Relief Boat with Lines Attached to Bishop's Rock Lighthouse, off Scilly Islands, England, Where Tides Are So Dangerous Vessels Cannot Tie Up at the Rock; at Right, Above, Relief Entering Main Doorway of Lighthouse, and, Below, One of the Keepers Sliding Down to the Relief Boat on Ropes; Note Swirling Waters at the Foot

*Acme*





Natives in Madeira Grease the Runners of This Sled as It Slides down a Mountain Side

### SLEDGE ON GREASED RUNNERS SLIDES DOWN MOUNTAIN

Visitors to Madeira always go to the top of the mountain which dominates Funchal, the principal town. Once at the top, they have no worry about descending the 3,000-foot elevation as they slide down in huge basket-work sledges. These sledges are controlled by two natives who grease the runners as the strange conveyance proceeds down the smooth path laid for it.

### GOGGLES FITTED WITH LIGHTS FOR USE IN THE DARK

Goggles provided with electric lights and reflectors instead of lenses are useful in performing tasks in the dark, since the wearer has both hands free for work, the light being concentrated in whatever direction the head and eyes are turned. Reflectors are mounted in the frames and small electric lights are set at the top of the reflectors, with protective disks



around them. In the center of the reflectors are circular sight holes with screens, which keep the direct light from

the lamps out of the eyes. The goggles are connected by a length of cord containing a switch to a small battery that can be carried in a vest pocket, or a connection can be made by plugging into a socket.

### CAPACITY OF ARC RECTIFIERS IS EASILY INCREASED

By using a large number of small anodes, or their equivalent, and narrow arc paths, engineers of the General Electric company have devised a way to increase the current-carrying capacity of mercury-arc rectifiers employed in changing alternating current to direct current. This is accomplished practically by combining the small anodes into a single large one and subdividing the area below it into a multiplicity of small, parallel arc paths. The maximum current-carrying capacity today is represented by the twenty-four-anode 10,000-ampere 625-volt General Electric rectifier for an electrolytic plant. A twelve-anode rectifier now being built at Schenectady for railroad service will handle 14,400 amperes at 625 volts.

### HAMMOCKS FOR AUTO SEATS GIVE REST FOR HEAD

To afford a comfortable rest to the head when automobile driving, and to shield the occupants of the car from drafts, an adjustable hammock arrangement for the seats has been introduced. It is attached at one end to brackets screwed to the bows of the auto top and descends over the seat, providing a pillow, adjustable to different heights, for the head, and an efficient screen that cuts off drafts around the head and the back of the neck when one of the car windows is open. Springs eliminate the transmission of vibrations from the top of the car to the head. The hammocks are made of durable seat-cover material, are easily adjusted and, when not in use, can be taken down and folded away in a small space.



*The Hartford Ledger Co.  
290 Broadway,  
Boston, Mass.*

Out of business.  
3/18/31

*Calrew. d. ne,  
609 Nevada Bank Bldg  
San Francisco, Calif.*



a-219

Berkeley Calif

**TO STOP MARINE BORERS  
BY EMBALMING TREE  
BEFORE CUTTING**

To protect wood against marine borers, termites, fungi and other pests, entire trees are being embalmed with a poisonous compound before they are cut, under a method instituted by two members of the staff of the University of California. The bark of the tree is ringed three feet from the ground, holes being bored at intervals about the ring. The tree is encircled with two crescent-shaped pipes, and a solution of arsenic and copper compound runs by gravity from a tank to the tree and there is distributed by the sap to every cell of the plant. The solvent holding the poison soon evaporates, thus leaving the compound to become a part of the wood tissue in which it is deposited. Large trees can be embalmed by the method in from twenty-four to seventy-two hours.

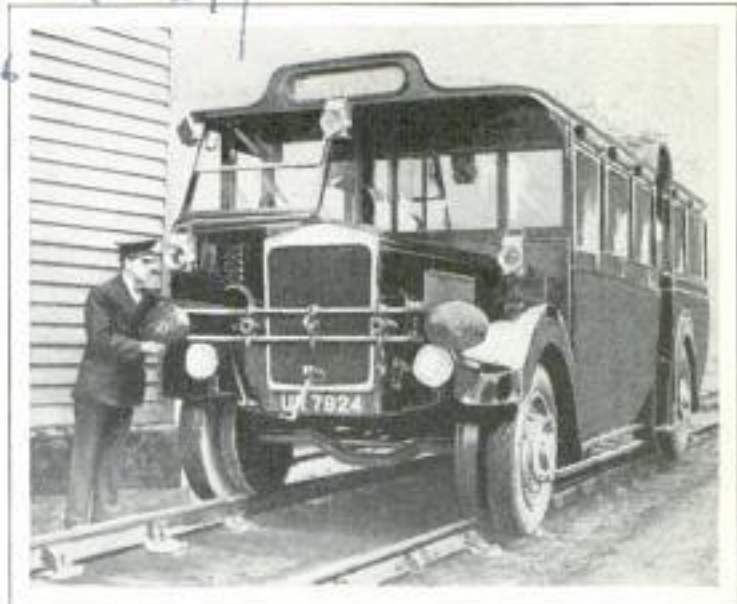

Motor Bus with Flanged Wheels, Set beside Road Wheels, That Enable It to Travel on Railroad Tracks or Highways

**MOTOR BUS FOR RAILS OR ROAD  
HAS FLANGED WHEELS**

Capable of traveling on railroad tracks or on paved highways, a motor coach with flanged wheels set beside road wheels recently was placed in use in England. The flanged wheels are fitted to the axles, and on the outside of these are placed pneumatic-tired road wheels which are mounted on eccentrics. The bus can be operated independently on rails or attached to a train. Change from one method of travel to the other requires less than three minutes.

St. Railway at  
Berkeley

L M

**PADDLE FLOAT FOR SWIMMER  
GIVES HELPFUL EXERCISE**

Devised especially to develop the swimmer's leg movements, a paddle-propelled float has proved popular at bathing beaches. The rider lies in a natural swimming position with the legs free to practice various strokes, and is kept afloat by the buoyant body of the slender raft. The hand-propelled paddles provide forward movement and since the arms are also moved as in swimming, the rider enjoys helpful practice and exercise while mastering various strokes.

a-65



Using the Paddle Float for Swimming Exercise; the Rider Takes Essentially the Same Position as in Swimming Unaided

**RIVER TENDERS FOR AIR LINERS**

To establish rapid communication with the shore for passengers and mails when the flying boats of the English-African airways alight at various points along the river Nile, the Imperial Airways has provided river tenders in the form of power boats, luxuriously equipped and capable of a speed of twenty-five miles per hour. As soon as the air liners touch the water, the power boats draw alongside, and the transfer of passengers and mail is completed in a matter of minutes.

a-297

man for

Aeroplane  
1-7-B/







# Ivory Patrol



"Man overboard, sir," shouted the lookout.

The dhow, finding the pace too hot for her, had dropped a slave over the side. It is an old trick of the slave ships, the object being to force the pursuer to stop and pick up the slave, and there are occasions when these ruthless tactics in shark-infested waters have attained their object. But, in this case, the move was foreseen and checkmated.

The slave, a strong swimmer, got astride the life buoy that was thrown to him from the gunboat and thrashed the sea vigorously with his feet to scare the sharks.

Soon the warship is abreast of the dhow which is packed with armed Arabs, dressed in white robes and turbans. Confronted by two four-inch guns and a battery of machine guns ready to fire at almost point-blank range, the slaver decides to let the British patrol come aboard, and the black cargo is diverted from the open slave markets of Mocha and the Hedjaz.

It is estimated that 500 slaves each year are secretly shipped across the Red Sea



British Anti-Slavery Patrol Sloop on Duty in Red Sea with a Machine Gun Trained on an Arab Slave Dhow

from Somaliland and Abyssinia, but owing to the vigilant patrol of the British naval sloops "Clematis," "Dahlia," "Lupin," and the new oil burner "Folkestone," slavers are finding it yearly harder to elude the sloops and land their cargo.

Max Gruhl, a former German officer, who has spent twenty-four years in the wilder regions of Abyssinia and, disguised as an Arab, has watched the Arab dhows ship their cargoes across the Gulf of Perim to Arabia, says there are hiding places in the dangerous regions of savage Somaliland, where no European consul dares go, and where Arab slavers pen kidnapped blacks behind bomas, or thick thorn-hedge stockades.





© G. P. A., Ltd.

"All naval officers know of the slave dealing," recently said Comm. Hugh Woodward, R. N., retired, late of the sloop "Clematis" on patrol in the Red Sea, "but not one man in a hundred would believe the appalling facts. In five recent years, 5,000 slaves—men, women and children—have been shipped across the Red Sea to Arabia, for sale in the open markets. Powerful Abyssinian chiefs derive much profit from the traffic. They raid for slaves with armed forces and ship them in Arabian dhows which land them across the Red Sea. Here, the slaves are split up into twenties and thirties, and put into smaller craft which keep inside the rocky shoals and reefs at night."

The commander adds that the slave trader has his spies and agents all over the hinterland of the Sudan in Africa, in Arabia, and in the wild regions back of Italian Eritrea and French Somaliland. "His armed columns swoop down at night on a village and the entire salable population, men, women and children, is carried off in chains. For days, they are marched toward the coast, through Abys-

sinia and French Somaliland, right into the streets of Tajoura and Obok, and there shipped in dhows and carried across the straits of Perim to South Arabia."

Ras Tafari, the "conquering Lion of Judah," who was recently crowned emperor of Abyssinia, has declared against the slave traffic and tried to free the two million slaves in Abyssinia, but the powerful vassal chiefs, some of whom have retinues and households of 1,500 slaves each, refuse to heed him. Slaves, it is stated, can be bought in thousands at certain inland markets in Abyssinian wilds. These markets are stocked by Arab raiders and by



Wealthy Abyssinian Chief Starting to the Hunt with His Slaves, and, Below, Typical Patrol Sloop on Duty

Abyssinian chiefs, who raid for slaves when taxes remain unpaid. Smaller sheiks hand over black ivory to the greater, in lieu of tribute.

Watching the southern borders of Abyssinia, are the King's African Rifles, in Kenya colony, where slave raids are frequent. One dark night, a few months ago, these British-African troops encountered a large force of well-armed Arabs, who had stolen across the frontier to raid the negro villages and kraals of Galla. When the troops met them, the Arabs were returning with a black cargo. A sharp fight followed. The slavers were armed with 400 rifles. Three of them were killed and ten wounded. Then the King's African Rifles got on the trail of slavers who had rounded up hundreds of men and women from native villages near the Loburin river on the Kenya frontier. They chased



Claude Neon Light, Inc. - 41 & 42nd New York

the raiders for many miles, and overtook them. Seven of the Arabs were shot, and the captive negroes and many hundreds of stolen cattle recovered.

Lord Cecil has estimated that there are at least 5,000,000 human slaves today. A tale of murder, torture and oppression was recently unfolded in the report of an international commission of inquiry into slavery in Liberia.

Among the slavelands today are listed Abyssinia, Afghanistan, Arabia, Sierra Leone and Liberia, while modified slavery is said to be found in Portuguese East Africa, Portugal's West African colonies, St. Thomas and Principe, French Equatorial Africa, and Tanganyika territory.

BETTER LIGHTS FOR HOME TO USE LESS POWER

Better light on half the power required for incandescent-filament bulbs is promised from glowing tubes filled with rare gases, a refinement of the tubing system now widely employed in advertising signs and similar displays. The new lighting, suited to home and office illumination, will operate on either 110 or 220 volts, instead of requiring such excessively high voltages as are now necessary in neon tubes. It will give much less heat than is generated from incandescent lighting and produces the most efficient light for reading without eye strain. The development is the result of four years of laboratory research in which one of the main problems was to obtain the proper mixture of helium, neon, argon, krypton and xenon, rare gases of the atmosphere, to produce the desired results.

Chicago 8700 State

SKYSCRAPER DREAM OF ARTIST EXCEEDED BY REALITIES

Fifty years ago Thomas Nast, a cartoonist, made a pen-and-ink drawing of the New York of the future as he foresaw it. Skyscrapers were then just beginning to catch the American fancy, and he let his imagination run riot, producing a group of buildings, one of them almost thirty stories high. The sketch, termed a "dizzy dream" in 1881, has been exceeded three times over by present-day realities, as proved by superimposing the drawing

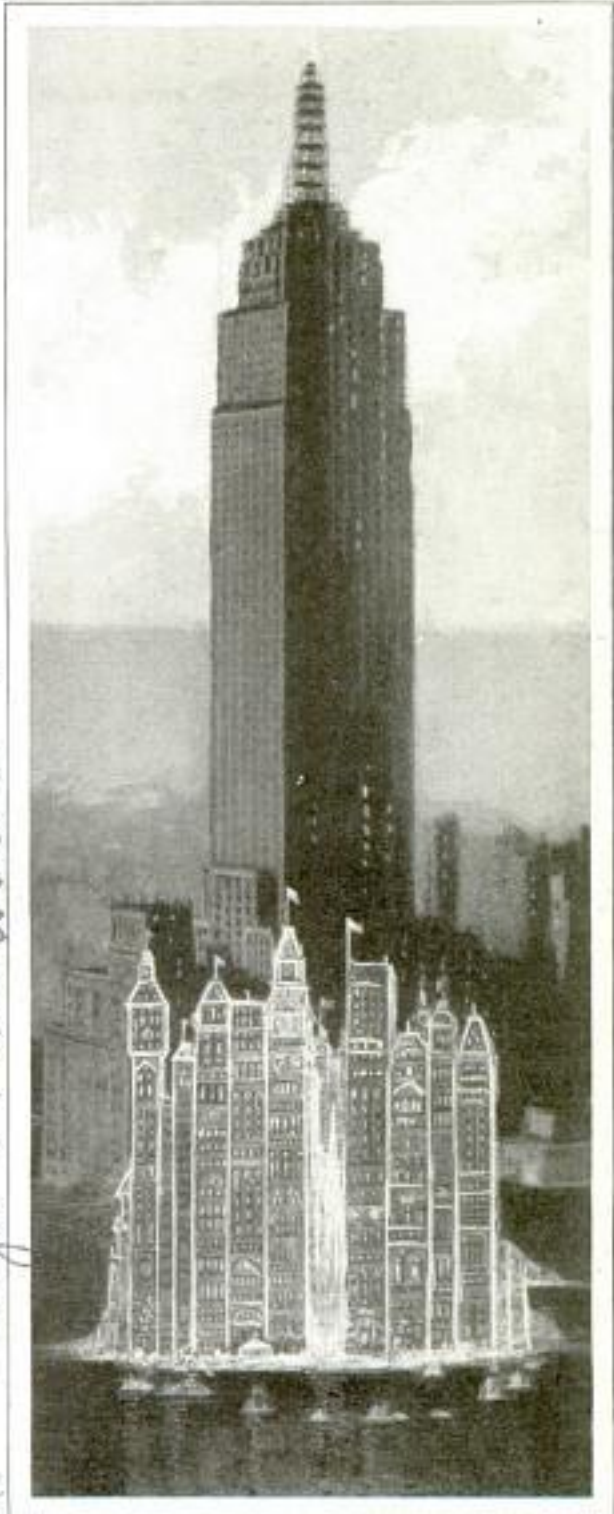

Drawing Made Fifty Years Ago of an Artist's Conception of the New York of the Future Superimposed on Photograph of Empire State Building

on an actual photograph of the Empire State building, taken from another structure half a mile distant. The modern skyscraper lifts its eighty-five layers of offices 1,050 feet above the sidewalk and the top of the dirigible mooring mast is 1,250 feet above street level. In all, the shaft reaches the equivalent of 102 stories.



*a-196*  
**MAGIC OF DIORAMA TO REVEAL WONDERS OF FAIR**



bine their skill in coloring, modeling and placing the parts of the diorama. Colors and lighting are adapted to produce a natural appearance and effective shadows. Figures are so modeled that they carry out the illusion of depth. For instance, a miniature horse, if placed at an angle with its hind quarters toward the front of the diorama, will have a small head to carry

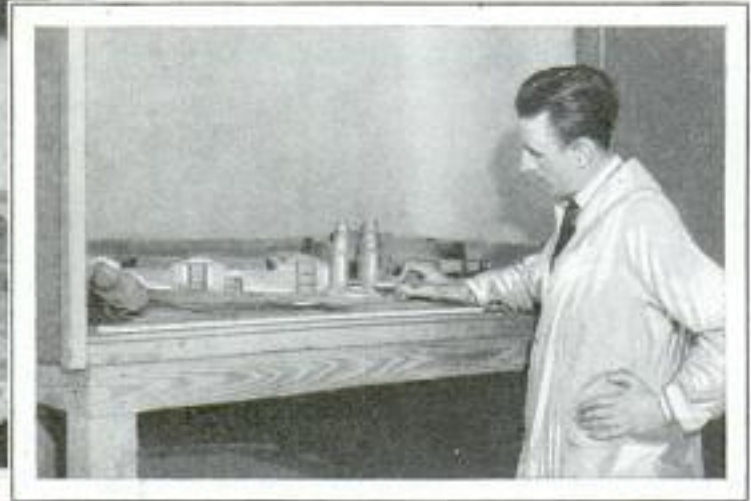

*U.S.*  
 Finishing Model Sketch from Which the Diorama Will Be Prepared, and Partly Completed Diorama in Cabinet; the Figures Represent Buildings Proposed for the Century of Progress World's Fair

Realistic displays, representing machines, industrial plants and scenes from many phases of life in true colors and proportions are being constructed for the coming Chicago Centennial world's fair. These exhibits, known as dioramas, "shrink" into the space of but a few square feet in area that occupies several square miles in real life, but the arrangement of the figures, scenery and all details is so carefully done that the illusion is accurate, and the effect on the eye is practically the same as that of the actual scene. To do this, artist, sculptor and architect com-

out the impression of distance. Every detail of the set is arranged to blend into the general plan, and the result is so accurate that a photograph of the scene within the diorama is difficult to distinguish from a photograph of the actual scene on which the display is based. Edward J. Ashenden, of London, an expert in this form of art, has been brought to Chicago to supervise the construction of the dioramas, and a large studio, the only one of its kind in the world, has been equipped for the sole purpose of devising these magical displays.

*a-21*  
**BIRD "ACROBATS" RIVAL PLANES  
 IN FLYING UPSIDE DOWN**

Flying stunts are usually associated with planes and aviators, but naturalists report that some birds are also skilled in aerial acrobatics. Sydney Evershed, a British bird lover, tells how he saw a raven fly upside down, evidently to attract admiration from its mate. The bird rolled over sideways, he reports, fell a short distance in confused fashion and then con-

tinued to fly on its back, some five or six feet below the other bird. It flapped its wings and traveled in what appeared to be level flight. After flying in this position for a considerable distance, it righted itself and flew in the normal manner. Evershed narrates. Seagulls have been seen to turn somersaults in the air, the equivalent of an outside loop, but such maneuvers are probably accidental and more often displayed by young gulls that encounter a sudden air current that tips them over.

*in British Science  
 Journal Nature*

*Science Service 514 LL  
 11/29/34*



Cooperating with  
 Locomotive Engineers  
**POPULAR MECHANICS**  
 310 Michigan Chicago

shown at National  
 Dairy Show at  
 Elgin, Ill. 623  
 A-227

**EFFICIENCY OF ENGINES AIDED  
 BY THERMIC SIPHON**

Possible savings of \$25,000,000 annually in the operation of 40,000 locomotives may be realized through use of the thermic siphon, a device applied in the fire boxes to stimulate the circulation of water within the boiler and to accelerate the transmission of heat from the coal to the steam. In tests with a locomotive at the University of Illinois, it was indicated that the thermic siphon makes possible a gain of eight and one-half per cent in efficiency. In other respects, aside from generating more steam per pound of coal, locomotive performance is substantially the same.

**GILDED BALL ON CHURCH SPIRE  
 SEATS EIGHT PERSONS**

Erected more than 150 years ago, an English church of several unusual architectural features is surmounted by a gilded ball on its spire. Inside the great golden sphere is a circular bench which comfortably seats eight persons. Access to the interior of the ball is gained by climbing

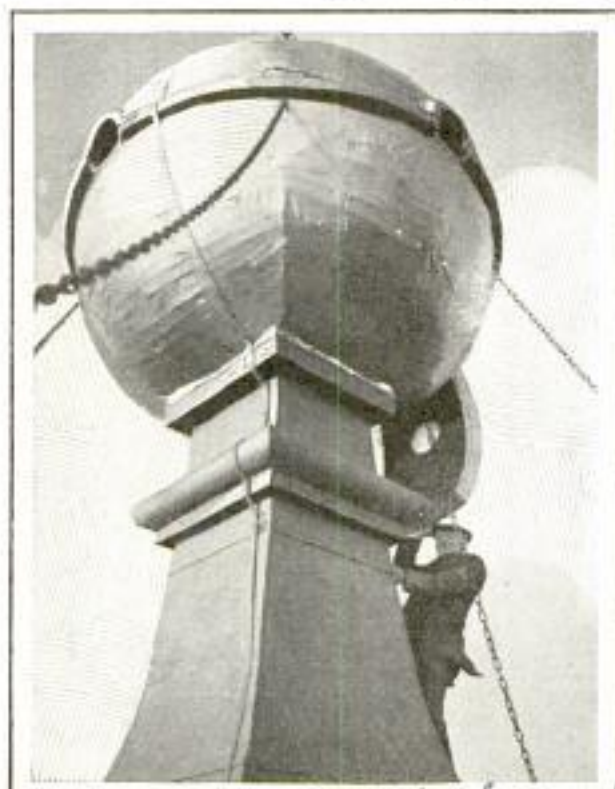

Huge Gilded Ball on an Old English Church; a Bench inside the Sphere Seats Eight Persons

a ladder from the tower up the outside of the spire.

at West Wycombe  
 Bucks, England



Automatic Dairy Which Delivers a Mug of Milk When a Coin Is Deposited and a Handle Turned

**COIN-IN-SLOT DAIRY DISPENSES  
 MILK AUTOMATICALLY**

Milk has now joined the long list of food articles dispensed by automatic machines. A coin-in-the-slot machine pours out a mug of cool milk when a penny is dropped in it and a handle is turned.

**CHEMICALS ACT AS SUBSTITUTE  
 FOR GROWTH VITAMIN**

Iron, iodine and fats in combination have been found to act as a synthetic substitute for vitamin A, the growth factor. In experiments at the University of West Virginia thus far, the substance has been tried only on rats, and the results were obtained by feeding them with meals ferrous oxide, containing iodine and iron, and linoleic acid, which has the fats. Apparently the chemicals contained about the same substance as vitamin A, for animals which otherwise would have died for lack of this vitamin were kept alive for many months by feeding them ferrous oxide alone. On the iron diet they failed to grow, but when fats were added, they showed improvement in three days and put on weight. Another experiment recently indicated that fatty acids from coconut oil serve as a substitute for vitamin B, the nerve factor.

by Dr. F. E. Chidester

Information Available

Chicago Daily News  
 2/4/31



Westinghouse Elec  
Mfg Co  
East Pittsburgh Pa



Fuselage of Wrecked Airplane Mounted on Runners and Powered by Airplane Motor; the Craft Makes Seventy-Five Miles an Hour

### PLANE FUSELAGE ON RUNNERS BECOMES AN AIR SLED

Removing the wings from a wrecked airplane and mounting the fuselage on runners, two Michigan youths have constructed an iceplane or air sled capable of a speed of seventy-five miles an hour. The craft is driven by a sixty-horsepower airplane motor, and the controls are the same as were employed in the airplane in its original form.

### FLYING DECOYS LURE DUCKS TO SURFACE OF WATER

On the principle that flying ducks always gather, decoys that appear poised in flight now are offered as an added in-

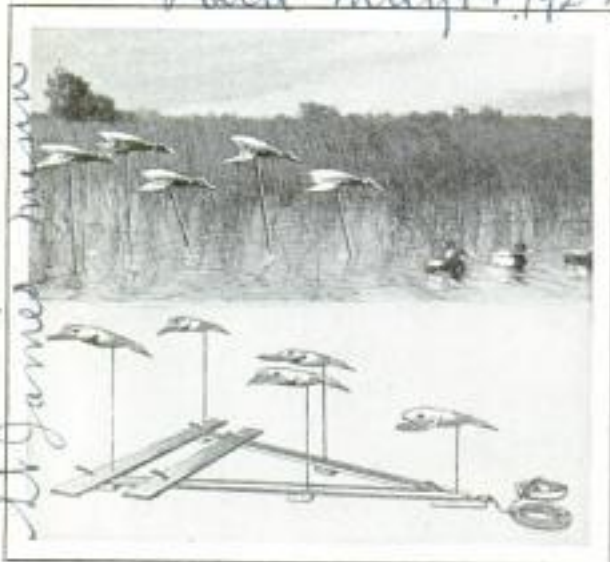

Flying Duck Decoys Set on Upright Rods on a Raft Prove Better Lure Than Floaters

ducement to coax the birds within gun range. A set of flyers consists of five birds which can be obtained in various species. The outfit includes a triangular frame to which an anchor and rope are attached. The decoys are placed on upright rods which fit in holes in the frame.

### DEVICE REGISTERS STRAIN ON RAILS

4-108 To measure the strain on railroad rails, a magnetic gauge, easily adjusted and simple to read, has been introduced. It is also useful in determining the strain on members of buildings, bridges and other units. The gauge is so connected, when used on the rails, for instance, that the strain to which the rail is subjected, is converted into terms of electrical current on a recorder where readings or photographs can be taken. Undue stresses are thus quickly determined. The instrument, developed by engineers of the Westinghouse Electric and Manufacturing company, is expected to prove of great service in detecting unsafe tracks, bridges and other structures.

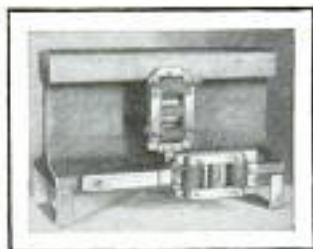

### STRONGER AUTO WHEEL RIMS HAVE "DROP CENTERS"

9-121 Automobile wheel rims that are stronger, truer and enable easy tire changing are being developed as the result of extensive experiments with various rim types. Known as the "drop-center rim," the new wheel part has its center portion between the two tire-bead seats depressed so as to be smaller in diameter than the edges. This provides a well into which the tire beads are dropped when changing tires, the change being made in much the same way as with the plain clincher rim, which had a tendency to produce rim

Charles S. Ash  
Detroit Engineer

Rayell Ellwell and  
John Caldwell,  
St. Clair Mount  
Sweet's Mfg. Co.  
721-4th Ave. North  
St. James, Minn.



Robert M. Curtis

New Jersey Zinc Co

POPULAR MECHANICS

2nd road Fletcher New York

625 a-66

cuts. Its successor, the straight-side tire, has required the use of detachable side flanges or split rims. The split or straight-side rims give difficulties in removal, a trouble not encountered with the drop-center ones.

### MORE USES FOUND FOR ZINC IN MAKING AUTOMOBILES

Zinc is playing an increasingly important part in the manufacture of automobiles. Rolled, cast and extruded alloys of the metal are replacing more costly substances because of their lower cost and superior mechanical qualities and resistance to corrosion. Hub and tank caps and running-board moldings are being made of rolled zinc, plated with chromium. Die-cast alloys of the metal with copper, aluminum and other materials, are being used successfully for gears and windshield frames. Zinc-plated iron is coming back into favor, as it has been found more resistant to corrosion than some of the more expensive materials.

### AUTO "POWER BOOSTER" GIVES BETTER ACCELERATION

To provide more perfect combustion of gasoline and eliminate fuel waste and engine wear, a power booster for the automobile carburetor is being offered. This simple device, in the form of an auxiliary air and gas feed, can be attached in a few minutes to the manifold and is operated automatically by the foot accelerator. The power booster provides quicker pick-up, more speed and a smoother, quieter motor, with a saving in oil as well as fuel.

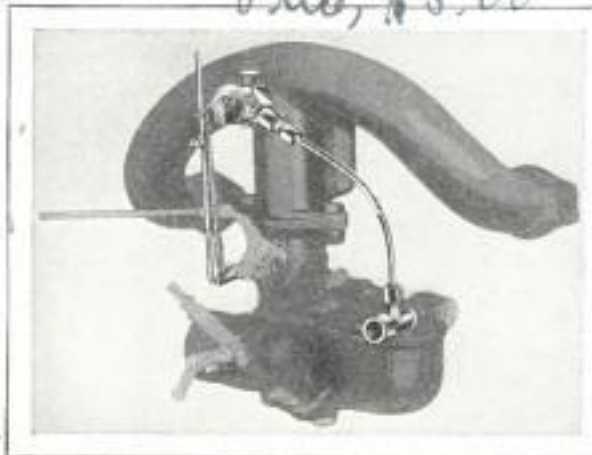

Power Booster for Automobile Carburetor Which Saves Fuel and Gives Better Acceleration

Walverton Inc.  
P.O. 627 43 E Ohio, Chicago



Fearing Depression, Berlin Tobacco Merchants Employed This Outfit to Advertise Their Wares

### STILT WALKER RIDES BICYCLE TO BOOST SALES

Berlin tobacco merchants, anticipating an increase in taxes on their goods, adopted novel means to boost the sale of their wares recently. One shop hired an expert stilt walker to ride an elongated bicycle about the streets. The idea proved doubly effective. It not only attracted attention to a brand of cigarettes, but emphasized the fact that higher taxes were imminent.

### RADIO RECEIVER IN A PILLOW REPLACES EARPHONES

Intended for use in hospitals and Pullman cars, a radio pillow containing a reproducing unit has recently been brought out. The pillow is of regulation size and is made of sponge rubber in which a sensitive receiver is concealed. It is so constructed that, although the sound permeates the pillow, it cannot be heard except by resting the head on it. It can be used instead of earphones and also replaces the loud speaker, which may disturb others.

710

Price, \$5.00

Chicago 1000

Engineering Products Dept. R. C. A. Victor Co. 411 S. La Salle St. N.Y.C.



2202

# Italian Liner to Defy

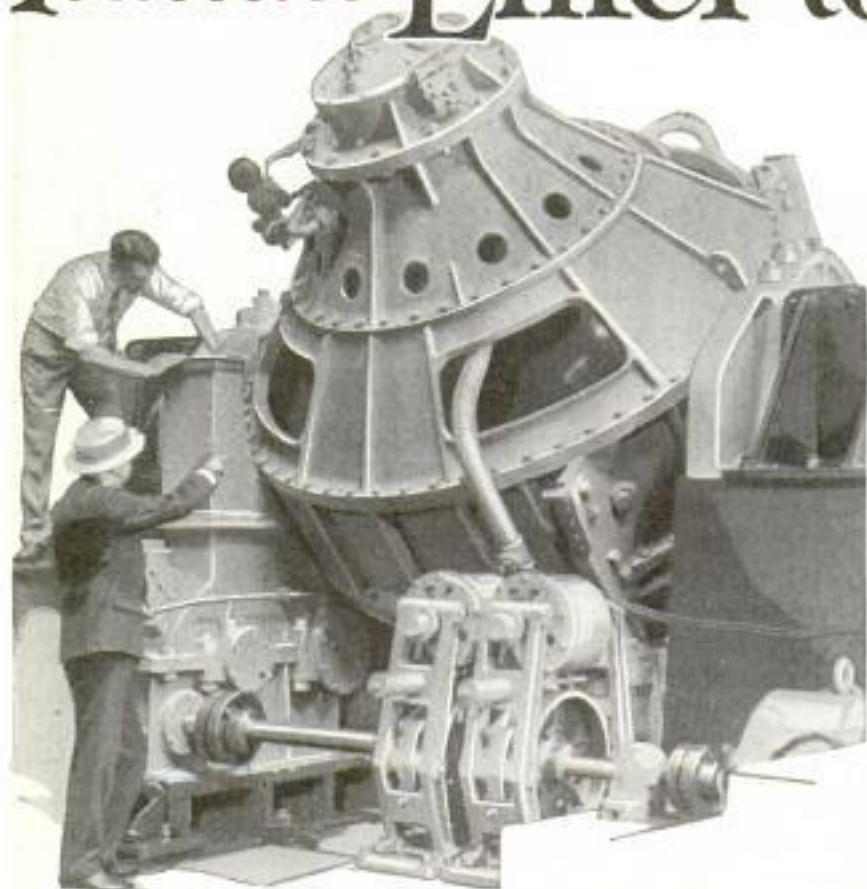

Close View of One of the Huge Gyro-Stabilizers Which Help Counteract Wave Motion to Insure a Smoother Ride on Vessel

By DON GLASSMAN

55 W. 86th Street  
New York

**W**HO believes that a thing no larger than an apple can steady a barrel?

If the barrel were floating on rough water and the apple made to spin within, it would have a steadying effect on the barrel.

Thus you have stabilized a barrel with an apple. The principle is ancient and was first demonstrated in 1851 by a French genius, Foucault, who built the first gyro-compass.

Forty gyro-stabilized ships sail the high seas, the largest a 10,000-ton man of war. While others pitch and dance, these vessels brush aside rollers as if they were fleas.

What prevents most people from taking voyages is, of course, the dread of seasickness. No matter how palatial and comfortable your floating home, this nausea damages happiness and health.

Now the Italians have come to the aid

of travelers with a sample of adventurous enterprise. They have contracted with the Sperry Gyroscope company for three stabilizers, the largest ever built, to steady the new 45,000-ton "Conte di Savoia," now under construction at Trieste. Thus the Lloyd Sabaud line plans to invest a cool \$1,000,000 to minimize illness and maximize passenger comfort.

The size of this order is prodigious. We have, first, a ship exceeded in size by only seven others in the world. The gyro units, weighing 900 tons together, will be expected to stabilize a 45,000-ton mass. Thus we strike this equation: Nine hundred tons of stabilizing machinery equals two per cent of the ship's displacement.

News of this installation threw a bomb into the shipping industry. So long as all companies steer clear of special innovations, the merchant marines remain on a basis of equality. But let one seize an improvement and proceed to place it in operation, and the others begin to sniff in half-terror. Thus it was when the "Bremen" flashed across the headlines with her blunt bow. Every greyhound now planned or under construction has a similar bulbous bow.

But the miracle of a stabilized passenger vessel surpassed that of a bulbous bow. Heretofore gyro-stabilizers have been employed only on private yachts, on aircraft carriers and destroyers. All merchant mariners await the trials of the "Conte di Savoia." To make a prediction, which is hardly bold, if this great ship



# the Waves

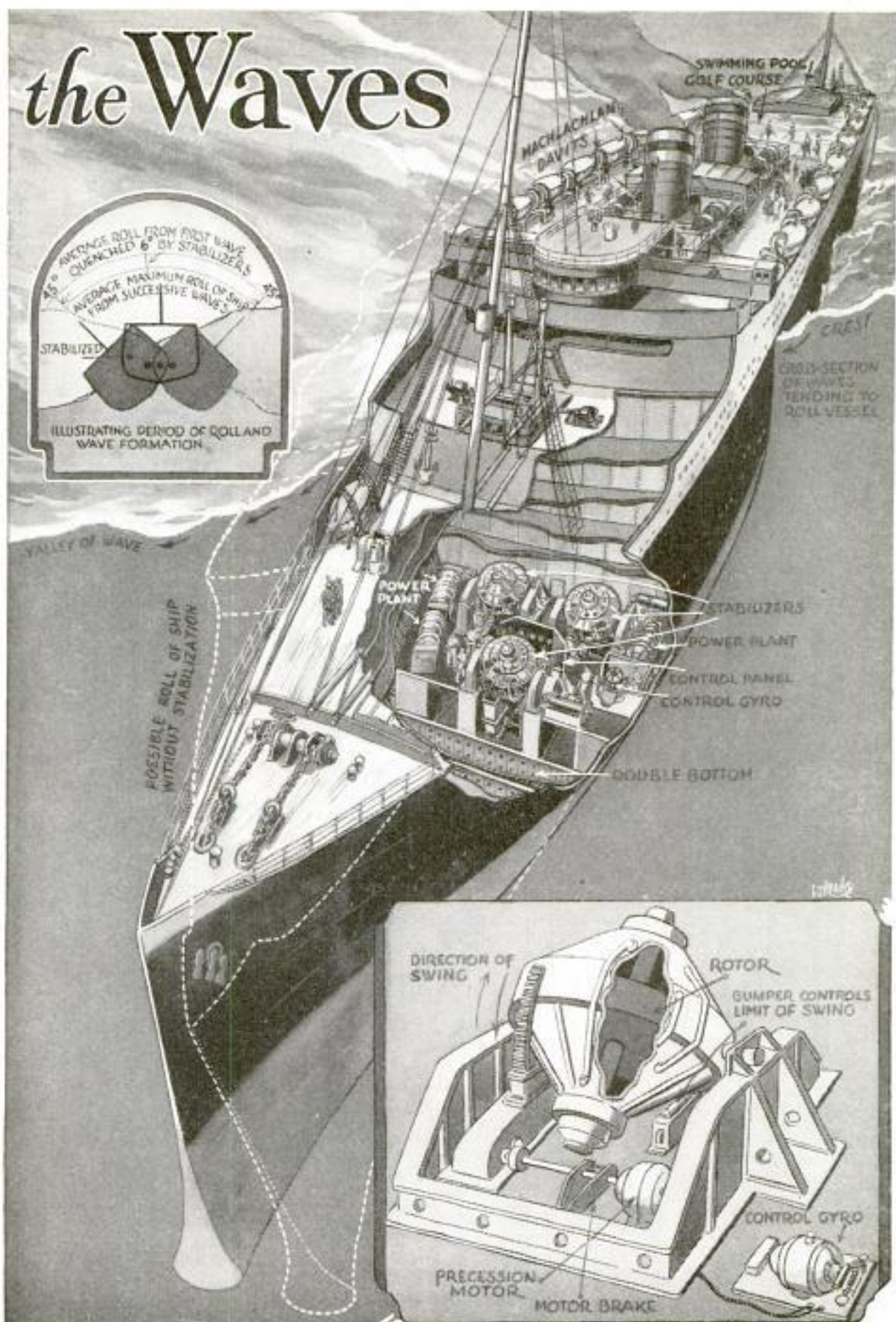
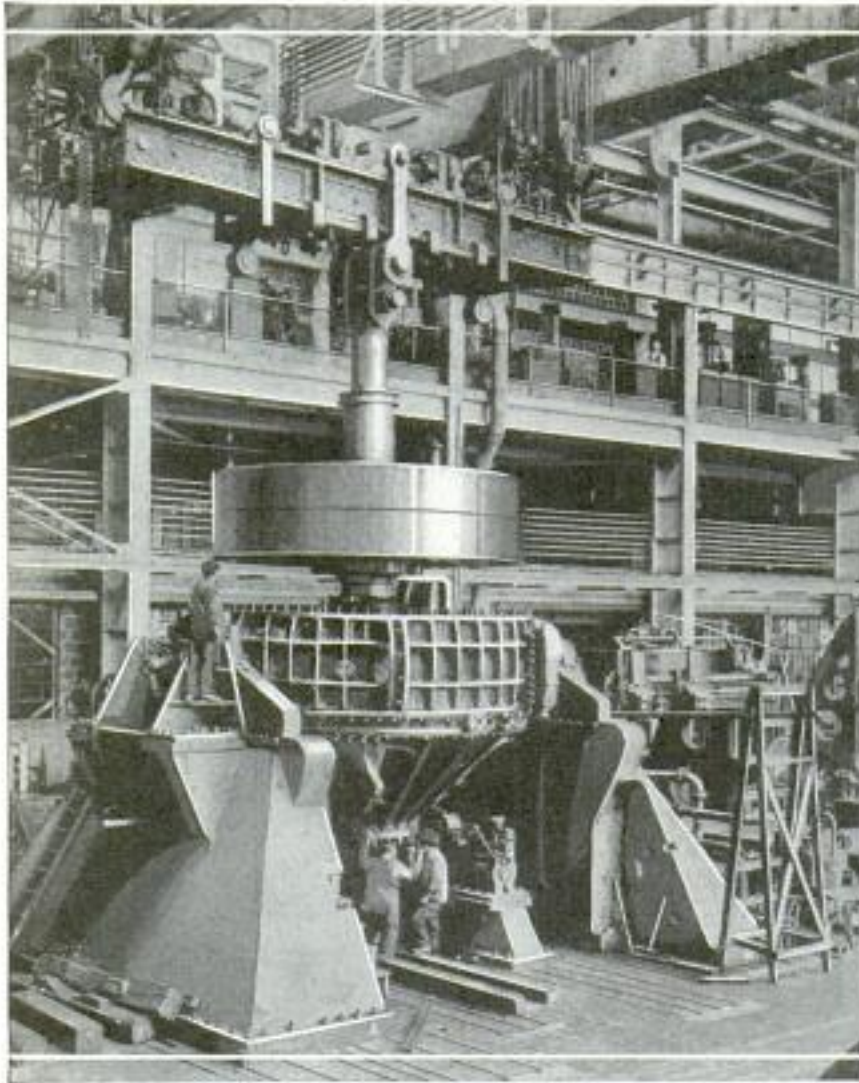

Diagram Showing Position of Stabilizers in Vessel, Effect of Waves on Boat, and Sketch of Stabilizer with Its Motor and Gyro Control



2202



Setting Up Stabilizer for 10,000-Ton Cruiser; the Gyro Wheel Is Thirteen and One-Half Feet in Diameter and Weighs 139,000 Pounds

overcomes pitching and rolling even moderately, the next five years will witness the adoption of stabilizers as standard equipment for all merchant marines. No man who anticipates the ghastly horror of seasickness will board a non-stabilized vessel if he can help it.

To build a single stabilizer for the "Savoia" would be impracticable. Single units are all right for yachts or 10,000-ton warships. But it requires three apples to stabilize a 45,000-ton ship. No ship afloat carries more than one of these apples.

The "Savoia's" three units will operate singly or together. For the moderate ocean swell, only one unit will be necessary; for fairly bad weather, two stabilizers; for stormy seas and battering waves, all three stabilizers will be turned on. Extreme flexibility is their great advantage. In ideal weather, such as may prevail on

the South Atlantic, a ship requires no stabilization; but nine-tenths of the time passengers are discomforted by tipping decks.

"Turn off the waves," will be the captain's order hereafter. And to execute the command, one of his subordinates will merely throw a switch. The ship fools Neptune, who stirs the deep.

There is the story of an American yachtsman who hired a local pilot to steer his ship into a foreign port. While still in open water, the skipper ordered the "waves turned off." The pilot suddenly found himself standing on a floor as stable as a sidewalk. He dropped the wheel, ordered the engines stopped and turned to the yachtsman, saying pathetically: "We've run aground!" When shown the apple spinning in the barrel, he shook his head. It looked fishy.

The stabilizer can be turned on and off just like an elevator. When off, it stands silent and rigid like a dumb robot. The three units for "Savoia" will stand on the ship's double bottom, in the forward end, right below the bridge, in what corresponds to hold No. 3. The units will extend above F-deck and halfway up the wall of E-deck. The floor arrangement of the gyros will correspond to an isosceles triangle, the altitude of which will be twenty-five feet. At the base, the gyros will be about seven feet apart. The switchboard will be at the heart of the triangle, which will be flanked on the port side by three control gyro units, and on the starboard side by the generating machinery.

The three small gyros will control the larger units by electrical connections. The smaller mechanisms will naturally



be more sensitive and respond quicker to rolling. The controls can be so adjusted that the slightest tipping of the ship will direct the gyros which way to apply force.

The gyro is essentially a balanced flywheel inside a casing. This flywheel, called a rotor, makes 750 revolutions per minute and measures thirteen feet in diameter. It is balanced with high



Thomas A. Morgan, President of Sperry Gyroscope Company, Demonstrating Action of Stabilizer, and Close View of Rotor

precision, so that a coin can stand up on its casing. Its weight is 100 tons. The casing is kept airtight in order that the rotor may spin with the least air friction.

Spin these 100-ton rotors at 750 revolutions, and they acquire stupendous amounts of thrust and force energy. If the wheel axle is turned in one direction, it resists, and turns instead at right angles applying the force on bearing gears at the ends of the axle.

The ship frame receives the thrust. A great ship does not take to rolling sud-

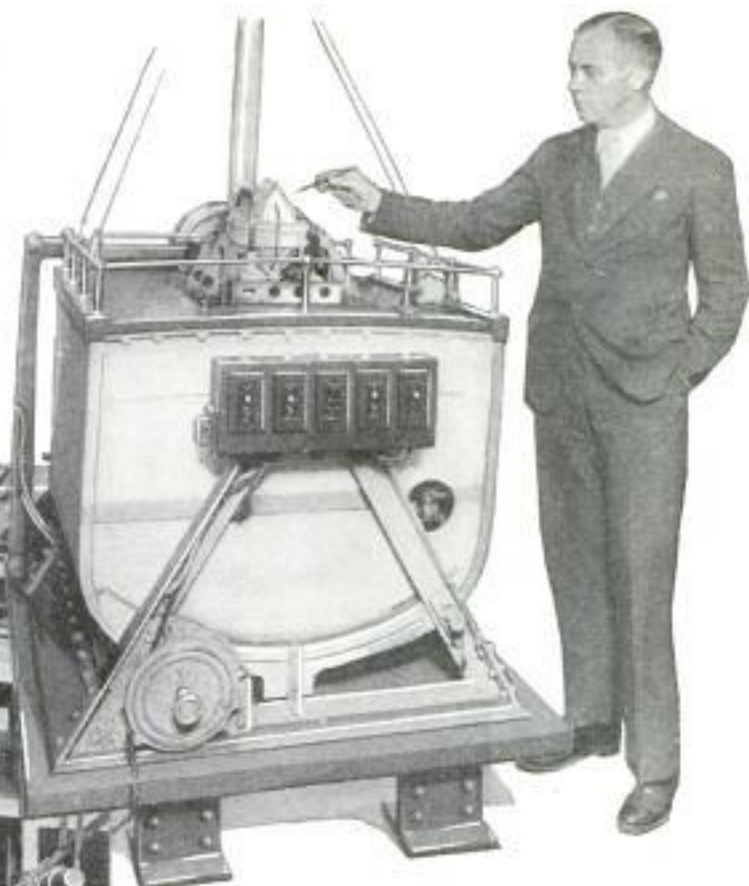

denly. It gains momentum like a swinging pendulum, the first swing having a longer amplitude than the preceding swings, until a maximum is reached. If the pounding of rollers grew stronger progressively, the vessel would be thrown over on her beam ends and capsized.

The gyro goes into action at the very word "roll." The first feel of a tipping foundation starts the rotor turning. By stifling the first roll and the second, etc., the gyro never allows the waves to throw the ship out of control.

For every thrust from the waves, the gyro delivers a counterthrust. It is a blow-for-blow battle. Round in, round out, the gyro retaliates, never missing, always cool and courageous. By quenching rolling at its beginning, a small gyro is thus able to control a mammoth ship. The wave passes under the hull, and the gyro is ready for the next one. In holding the vessel from listing, the stabilizer does the same work as gradually lifting a weight from one side of a ship and gently placing it on the other side.

In addition to giving comfort, the stabilizer decreases stress on a ship's hull. A stabilized vessel does not creak and groan. An ordinary vessel rolling in a seaway

40, Flatbush Avenue  
Brooklyn, N.Y.  
is tenam. Brooklyn NY



accumulates a great deal of strain on the ship's superstructure. There is a sympathetic bond between rolling and pitching. Although the gyro has no direct control over pitching, the reduction of rolling automatically minimizes the forward plunge and dip.

To accomplish all this on the new "Savoia," her generators will have to deliver only 1,500 horsepower to the three stabilizers. With these stabilizers, a ship in perfectly calm water can be made to roll violently—experimentally, of course. In rough water a twenty to thirty-degree roll can be reduced to one and a half degrees.

Ships left to themselves, plow and wallow through heavy seas. It is difficult to steer them on straight courses. Stabilized ships can be held to any point of the compass. Ships are said to roll because "they have nothing else to do."

The strains forced on ships by waves are stupendous. There is one instance of a large vessel having been broken in two by a terrific wave. The wrenching, twisting movements of choppy seas are estimated to exert as much as 2,400,000 foot-tons on a vessel of large displacement. When wave crests are at both ends of the ship and the middle sags, the strain is said to equal 1,050,000 foot-tons. Hence the shipping world awaits the "Conte di Savoia" with more than ordinary suspense. Aside from her ultramodern stabilizing equipment, this greyhound will embody the latest improvements, a number of which are made possible by her gyros.

Her top deck will be so steady that it will have a great swimming pool inclosed by glass admitting ultraviolet rays from

the sun. The pool will be aft of the twin funnels, and around it will be laid out a miniature golf course. This pool may be used in all kinds of weather because the stabilizers will maintain constant equilibrium. There will be another pool between lower decks for the use of second and tourist classes.

The "Savoia's" hull design will not only embody the bulbous bow but other refinements now being worked out in the test pool at Hamburg, Germany. Her outboard profile will extend 820 feet. The beam will be ninety-six feet. Her silhouette will appear rakish and jaunty. Short, stubby funnels will lean back to preserve the streamline effect.

Another notable feature of this ship will be the absence of the third, or dummy, funnel. Most passenger greyhounds have included it, merely to balance the superstructure and to give the ship an appearance of greatness. But the Lloyd Sabaudo architects believe that the day when a passenger stops to count funnels is past, and they are aware that a modern electrically propelled ship might just as well do away with all her smokestacks. What happens when you eliminate the rear funnel? First, the ship acquires the lines of a destroyer. The funnels forward of the amidship section give her a larger head, so to speak. To the rear of the funnels, the decks sweep back in long graceful lines that taper off gradually to the taffrail.

But the passengers gain when the dummy funnel is absent. They acquire an amazing area of free space on the top deck, exposed to the sun and sky without hindrance. And on the new "Savoia" they will have the largest open deck space on

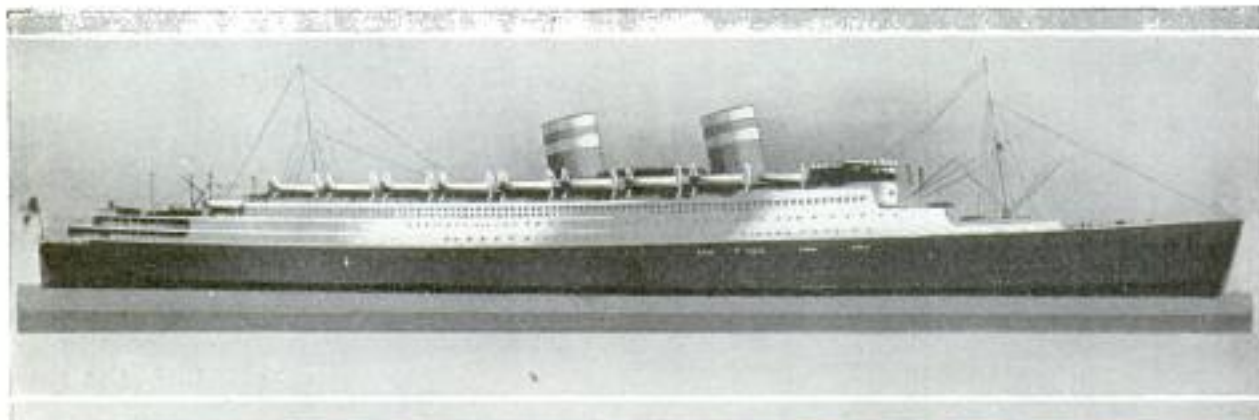

Drawing of the "Conte di Savoia" Palatial Italian Liner; the Stern Funnel Was Eliminated to Help Increase the Deck Space for the Convenience of Passengers



A-87  
W. H. Kinsburgh  
Pa

any steamer afloat. She will have the first full-size tennis court, the first all-weather swimming pool, and the first miniature golf course.

When the \$15,000,000 "Savoia" slips down the ways in the spring of 1932, Italy will have launched the first of a fleet of superships which will surely have a place in maritime history. The "Savoia" will make her maiden voyage between New York and Naples in the fall of 1932. Her guaranteed speed will be twenty-seven and a half knots, but she will probably develop several knots more. When she is launched, at any rate, she will have heels at least as fast as any passenger vessel afloat. Thus she will cover the New York-Gibraltar run in five days (equivalent to the New York-Cherbourg run of other vessels) and add two more days to her schedule for the voyage from Gibraltar to Naples. By a recent arrangement, however, passengers will be able to reach Naples or Rome only five and one-half days after leaving New York. A seaplane service from Gibraltar to Italian ports, covers the distance in half a day.

Chicago-H. L. Soggin, 1123 Washington Coal Park

**MOISTENER THAT WON'T BREAK  
MADE OF RUBBER**



Made entirely of rubber, an unbreakable moistener for the desk operates at the press of a button. It contains a hollow handle of semisoft rubber and a tip into which a piece of sponge rubber

fits. The top end is covered by a soft-rubber cap, in the center of which is a hard rubber rod that forms part of a valve arrangement. When the handle is filled with water and the cap is pressed, several drops are released on the sponge. When not in use, the moistener fits into a rubber cap that serves as a support and prevents evaporation.

The longest air route with a regular service of planes is from New York to Buenos Aires, a distance of 5,880 miles.

San Rubber Co  
Barberton, Ohio



Oxygen Tent and Tank for Treating Pneumonia and Other Lung Maladies; No Motor Is Required

**OXYGEN TENT AIDS TREATMENT  
OF LUNG DISEASES**

Devised especially for treating persons suffering from pneumonia and other lung diseases, an oxygen-breathing tent is said to be an improvement over similar units of its kind as it needs no motor. "Dry ice"—carbon-dioxide snow—is used for cooling, and the oxygen is released and mixed with air from a portable container. As air comes from the hood in which the person is placed, it is regenerated by passing through a small soda-lime container. The amount of oxygen can be regulated and the temperature can be kept nearly constant.

**PHONE DIAL WITH REGISTER  
SHOWS NUMBER CALLED**

On the dial of the automatic telephone is a register which shows the number called so that the user can tell if he has made a mistake without waiting for the connection to be completed. If an error has been made, a button is pressed which breaks the circuit and clears the instrument for another call.



80-5ndth  
D. W. Williams  
Greenberg

3rd Clark  
New York  
Copyrighted material



To be used by John H. Steele

632 with expedition organizer  
POPULAR MECHANICS

2284 by Iscoffrey Malins

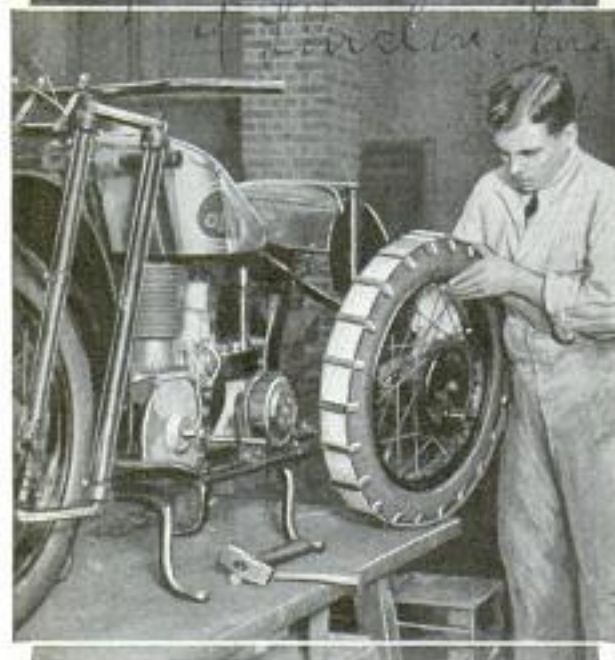

Cotton Belt on Rear Wheel of Motorcycle Adds to Rider Comfort and Increases Traction

### BELT ON MOTORCYCLE WHEEL ADDS TO RIDING COMFORT

British motor cars, and a motorcycle unit making a 12,000-mile trade-exhibit tour from England to Africa, have been fitted with many special devices to add to the comfort and safety of members of the expedition. The cycle which will lead the tour as a scout when the party crosses the desert, has a woven cotton belt attached to the rear wheel, tubular framework to add to its strength, and extra-large gasoline tanks. The wheel cover not only protects the tire, but adds materially to the comfort of the rider in traveling rough country.

serving any food. Sub-zero ice derives from reclaimed gas wells in the Tampico-Quebrache oil field, in Mexico. One of these wells, drilled in 1925, began blowing 200,000,000 cubic feet of carbon dioxide into the air daily. James W. Martin, a consulting engineer, is largely responsible for the process by which natural carbon dioxide is made into ice. He invented a method of purifying the gas by high-pressure absorption; secret chemicals remove the hydrocarbon impurities. When the gas comes out of the earth, it has a temperature of 100 degrees. It is cooled by contact with cold water, and soon liquefies. When squirted through a nozzle, using the gas pressure of the well itself, about one-third of the liquid turns to carbon-dioxide snow. Laborers shovel the snow into metal tanks and pack it closely. Each tank holds 300 pounds of snow, which after recrystallization makes about five cubic feet of carbon-dioxide ice. This product weighs seventy pounds per cubic foot, as against fifty-six pounds per cubic foot for water ice. Sub-zero ice placed in freight cars, can within an hour increase the carbon-dioxide content of the air to the extent that fruit rots and softening of ripe fruits are checked in the same degree as by a drop in temperature of thirty to forty degrees.

### CARRIAGE WITH SINGLE WHEEL RUN BY MAN-POWER

Residents of Seoul, Chosen, Korea, who take a ride must be adept balancers because the popular carriage is a one-wheeled



Adept Balancing Is Necessary to Ride on This Single-Wheeled Conveyance Run by Man-Power

### "SUB-ZERO" ICE IS SHIPPED FROM TROPICS TO U. S.

"Sub-zero" ice, manufactured and shipped from the tropics, is arriving in New York in cork-insulated holds of steamships, and offered to ice-cream and refrigerating companies for \$80 to \$90 per ton, about equal to the price of domestic "carbon" ice. The ice arrives in port at a temperature of 109.3 degrees below zero, and is immediately placed in a warehouse, whence it is delivered to consumers. It analyzes 99.9 per cent carbon dioxide, and this high degree of purity renders it perfectly odorless and satisfactory for pre-

9-94  
see ind. 1930 5 39

Cook Hill Glassman



vehicle. A seat for one passenger is placed high above the single wheel on a frame containing shafts fore and aft for pulling and pushing. Loss of balance is likely to spell disaster for the rider unless his servants are proficient.

**HEATER FOR RAILWAY SWITCH  
 MELTS ICE AND SNOW** *a-10*

Accumulation of snow and ice around railway-track switches is prevented by an electric heater, consisting of an iron casting about a yard long in which is inclosed a nickel-chromium heating element. The unit is placed beneath the switch frog or rail and current is supplied from lines that operate automatic signal devices. It is estimated that a dozen units are needed for each switch to supply the proper amount and distribution of heat, these units replacing the large forces of men often required to keep the switches working.

**SAFETY SWITCH STOPS ENGINE  
 ON MOTORCYCLE** *226 7*

Intended particularly for police motorcycles, a mercury switch shuts off the engine automatically when the machine is placed on its side. A tiny ball of mercury running in a sealed tube operates the switch. It does not cut out when the motorcycle is banked on a sharp turn or on a rough road, but the ignition is cut off the instant the machine is laid down. It is easily attached and provides an added safety factor when a motorcycle officer must dismount suddenly, or leap from his machine to the running board of a car he is overtaking.



**SALVAGE OLD AUTO TIRES  
 FOR USE IN EUROPE** *a. 38*

Large quantities of old automobile tires are salvaged every year, but it is not generally known that tons of them are exported for sale in foreign countries. The



File of Old Automobile Tires in Los Angeles, Awaiting Shipment to Germany

accompanying photograph shows a few awaiting shipment for Germany at Los Angeles.

**FLAME ARRESTER ENDS DANGER  
 OF BLAZE FROM BACKFIRE** *a-14*

Blazes from backfire sources are prevented by a flame arrester which can be attached to the intake of any carburetor in either an automobile or motorboat. It prevents carburetor backfires from reaching the outside air and igniting inflammables beneath the hood of the car or fumes from bilge of a boat. The arrester cools the hot gases as they are forced through a series of evenly spaced steel plates.



Names of manufacturers of articles described in this magazine will be furnished free by our Bureau of Information.

*Chicago - 1150 W Jackson*

*Indian Motorcycle Co. Springfield, Mass.*

*Tillotson Mfg Co Toledo, Ohio*  
 Copyrighted Material





Not an Armored Tank, but a Six-Wheeled Truck Used by a German Publishing House for High-Speed Deliveries

### MOTOR TRUCK LIKE WAR TANK HAULS GERMAN PAPERS

Resembling a huge armored tank, but devoted exclusively to peaceful pursuits, a big six-wheeled truck is used by a German publishing house as a fast transport car for papers, books and magazines. It has a streamlined body and is operated by 100-horsepower motor. Oval-shaped sections on each side add to its tanklike appearance, resembling tractor chain treads.

### MODEL OF FOURTH DIMENSION LIKE A LAMPSHADE FRAME

Resembling somewhat the wire frame of a lampshade, a model representing the fourth dimension of space has been constructed by Dr. Paul Heyl, of the bureau of standards. Most persons' mentality can deal with only line, plane and space,

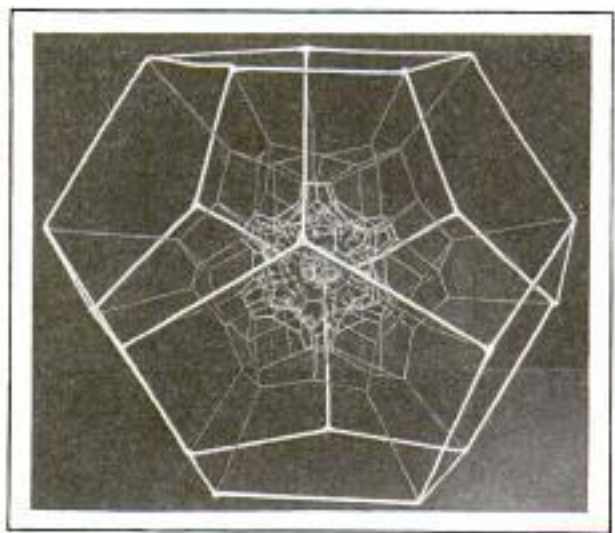

© Acme-P. & A.

This Wire Frame, Looking Like a Lampshade, Is a Model Representing the Fourth Dimension

*Maybach motor*  
*Brown Spring Co*  
*50 Peterboro St*  
*Detroit Mich*

or length, breadth and thickness, so that any fourth dimension dealing with space or time must be left mostly to the imagination. The model is in the form of a regular polygon and inside of it an intricate symmetrical figure.

### DRAIN VALVE FOR AUTO PAN SIMPLIFIES OIL CHANGE

Draining the auto oil becomes a task that any motorist can do himself without having to go to

a service station if he has provided himself with a recently introduced valve which can easily be reached from the side of the car without crawling under it. A pair of pliers or a slotted stick is the only tool required for mounting and the valve is so designed and placed that it cannot very well strike anything on the road and thus open accidentally even when driving on rough highways. A lock washer prevents its working open.



### SELF-OILING BEARING MATERIAL LIKE A METAL SPONGE

Self-lubricating bearing material that eliminates squeaks and excessive wear and minimizes friction has been produced by Chrysler motors engineers who have named the material "oilite." It is an alloy of copper, tin and other metals, and is subjected to tremendous pressure, heat-treated and then impregnated with hot oil in a vacuum. It absorbs up to forty per cent of oil by volume and has great strength. Due to the high oil content, a hydraulic cushion exists that permits loads in excess of those carried by conventional materials, making the self-oiling bearing superior to high-grade cast bronze where severe duty and high pressures are encountered. It imparts a high polish to shafts, instead of scoring or tearing them and is particularly useful in spring shackles and on steering gear cross-shafts.

*225*  
*Oilite*  
*Arifles Mfg Co*  
*7900 Joseph Campbell*  
*ax Detroit, Mich*

*The Holtzstein House*  
*Berlin, Germany*



LATEST WAYS BEAMS OF LIGHT ARE PUT TO WORK

Wembley Greyhound Racing Track

As the Door of the Trap flies open, starting the Race, a Trip Switch sets Timing Clock in Action.



The Timekeeper's Box & Gear.

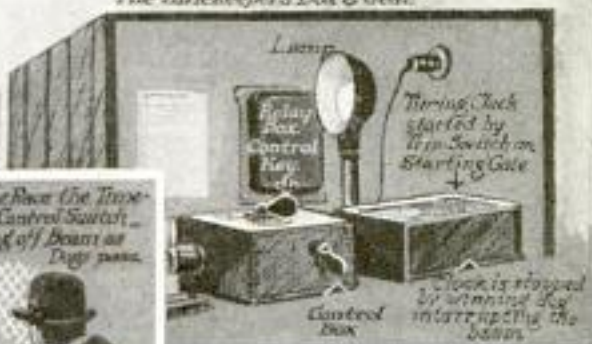

On the first lap of the Race the Time-keeper moves his Control Switch, temporarily shutting off beam as Dog passes.

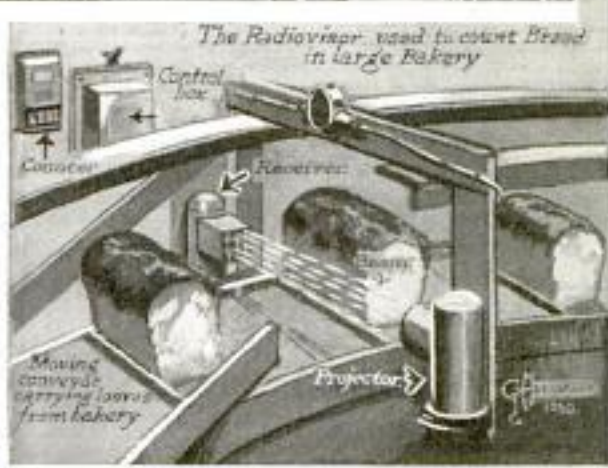
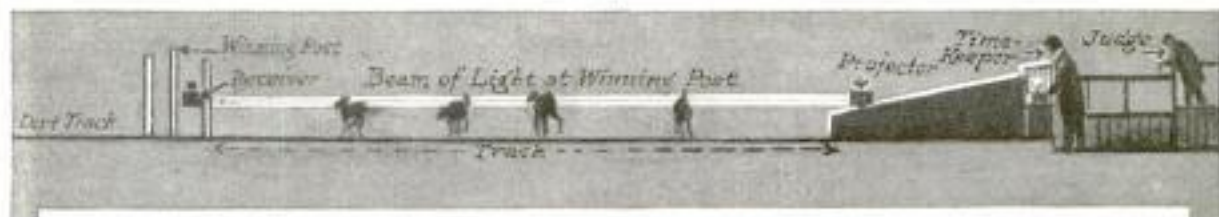
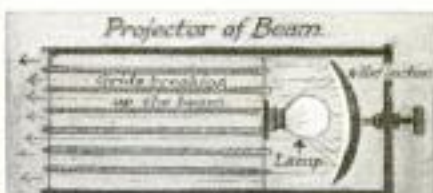



LIFE-SAVING SUIT HAS HOOD TO PROTECT THE FACE

a. 58

tested at Los Angeles Calif



Testing the New Life-Saving Suit Which Permits the Wearer to Remain in an Upright Position While Floating; Note Breathing Equipment and the Hood That Completely Covers the Face

Wearing a life-saving suit developed in Italy, victims of shipwrecks are able to float in a vertical position and also have a hood that protects the face. In case of heavy seas, this hood can be lowered to give complete covering. The person breathes through a special mouthpiece arrangement, fitted with air valves.

NUMBER OF LICENSED PLANES AND PILOTS INCREASING

a 92

Substantial growth was shown in 1930 in the number of licensed pilots, aircraft and mechanics. Department of commerce records show that at the beginning of 1931 there were 385 licensed women pilots among the 15,280 holders of pilots' licenses, while the group of 8,993 mechanics included five women with licenses. In addition to 7,354 licensed aircraft, there were 2,464 without such credentials, Illinois having the most unlicensed ships. On Jan. 1, 1930, there were 10,215 licensed pilots, 6,685 aircraft and 7,624 mechanics.

U.S. Daily 1/14/31

The number of unlicensed aircraft decreased in 1930, and California led in the number of licensed pilots with 2,852.

ELECTRIC HEATER WITH A FAN CIRCULATES WARM AIR

2129

Inclosed in a metal cabinet, an electric heater that employs a fan to circulate the air is capable of heating a large room quickly. The heater is simply plugged into a light socket, and the fan draws the cold air from the floor, blows it past the electric heating elements and out into the room. The heater is also convenient for drying the hair or clothing.



Briar pipes are made from heather roots grown in southern Europe.

Jiffy Electric Co  
Hazel Park  
Copyrighted material  
Detroit Mich



Cont. Ben Glassman.  
55 W 86 St

## POPULAR MECHANICS

TELEPHONE USERS  
ARE SERVED BY  
SUPER-ROBOT

When one of the 10,000,000 people in greater New York picks up a telephone receiver and asks to send a Western Union telegram, the operator switches the customer into one of 120 trunk lines leading to the telegraph company's headquarters. The customer is then in the hands of a robot. This magic apparatus, described as an "automatic call distributor," has been placed into operation after two years of experimentation in the Bell Telephone laboratories, which owns the patents. The robot receiving unit provides the speed of lightning and "brains" to machinery. Even before it receives a call, it knows which of the 110 girls is prepared to receive it. Not only that, it distributes these calls equally, so that during the course of a shift, every girl receives the same number of messages. The largest crew of message-taking operators in the world, 110 of them, are arranged in three groups. After the robot has selected the proper group, it sets into motion a rotary switch which hunts over the terminals and connects the customer to the first idle line. The average call receives attention in one second or less. The recording operators sit at long desks in a room insulated against all outside noises. Each girl operates a noiseless typewriter and speaks through an individual transmitter. In her idle moments, she does not have to watch any lights as with the old switchboard. The robot warns her to get ready with a double buzz in the earphone. She immediately speaks and proceeds to type the customer's words on a telegraph blank. The supervisor has learned many things about the telegraphing habits of people. Most calls originate between 10:00 and 11:00 a.m. and 2:00 and 3:30 p.m. On holidays, a great many messages are sent in the morning. And more people telegraph on rainy than on fair days.

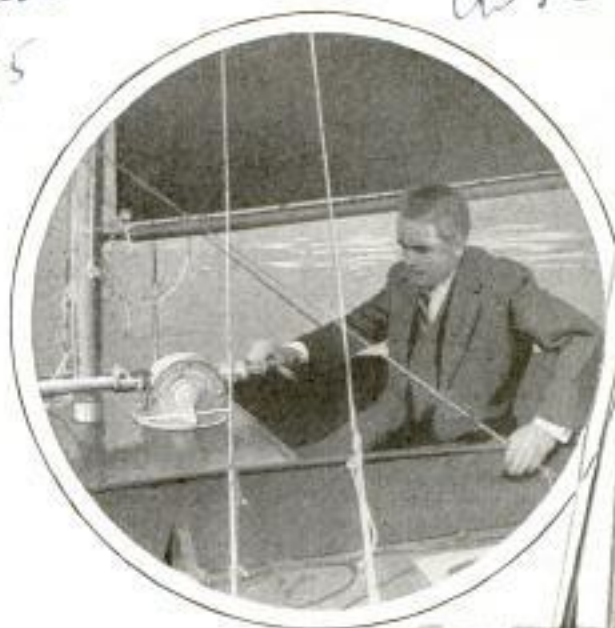

### BOAT WITH DUAL HULL DRIVEN BY HAND, SAIL OR MOTOR

Three types of power are available to propel a sixteen-foot boat whose hull consists of two buoyant pontoons of great stability. Hand propulsion, sails or an outboard motor may be used. The hand mechanism is forward in the cockpit and, just aft of the forward deck, is the operator's seat which slides back and forth like that in a racing rowboat. In front of the operator is a driving rod to which a handle is attached. When drawn back gently, as an oarsman pulls his oar, this rod spins the propeller, located beneath the operator driving the boat forward. At the end of the stroke, the rod returns forward, while a flywheel maintains the constant speed of the propeller. Steering is done by the feet, operating at once the rudder and propeller.

Dr. W. Lee Hampton,  
Lee Hampton, Inc.

637

a-73

11 W. 42nd St

Boat with Double Hull Operated by Hand, Sails or Motor

New York



2149

# New Conveniences



Blanket Bag for the Baby Has an Interlocking Fastener to Keep the Child Warm and Safe



Holder-Squeezer for Tooth-Paste Tube Saves Time and Waste



Above Is an Adjustable Wire Screen for Doors and Windows to Protect Children and Keep Out Prowlers

At Right, a Simple Device to Keep Water Pipes from Bursting if They Freeze; the Small Valve Attachment Allows for Expansion and Helps Prevent Freezing; It Is Easily Installed and Requires No Attention

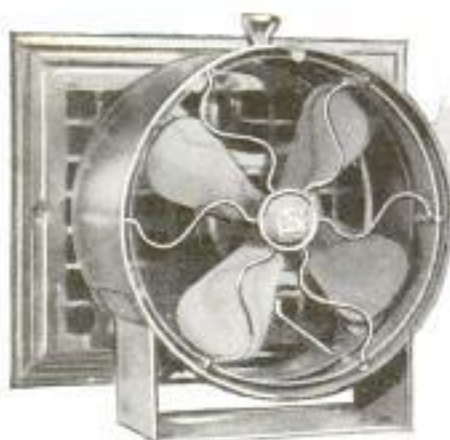

Above, an Electric Fan, Adjusted in Front of a Register, Speeds Up Circulation of Warm Air in Winter and Cool Air in Summer When Hung in a Convenient Place; at Right, Portable Electric Clothes Washer That Operates from the Lighting Socket and Has No Moving Parts to Tear or Damage the Articles; the Necessary Motion Is Obtained by Pulsating Action of Air Bubbles, Soapsuds and Warm Water





# for Your Home



This Gaily Colored Bag Keeps a Ball of String Handily within Reach; Prevents the Cord from Becoming Snarled; as the String is Pulled through Opening Below, the Ball Cannot Easily Fall Out; Metal-Rimmed Hole in Flap Fits Nail or Hook

At Right, a Sanitary Pasteurizer for Baby's Milk Bottles, and, Below, a Portable Oven for Stoves and Hot Plates Has a Top Door for Easy Access to the Interior



Brush and Dust Pan in One Save Stooping; the Pan Is Adjustable



Changing the Mop Rag Is a Matter of a Few Seconds with This Arrangement, as the Rag Slides onto the Holder Bar

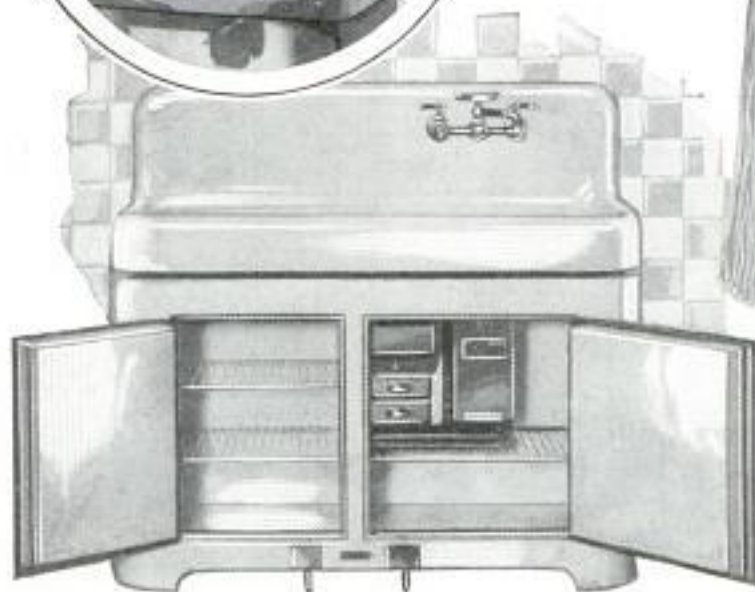

Sink and Electric Refrigerator Are Conveniently Combined in Arrangement Shown at Left, Hiding Un-sightly Pipes, Saving Space and Steps; the Doors Are Opened by Pressing Pedals at the Bottom; a Plain Exterior Simplifies Cleaning



*a-10 7*



Windmill Tower Converted into Church: the Bell Is Suspended in Niche of Old Hub Opening

### OLD WINDMILL AS CHURCH SERVES GERMAN PARISH

Out of service for some time, an old windmill in Germany was converted into a church. The tower was transformed into a small, but comfortable auditorium, and a bell was suspended in a niche below the top window, where the axle of the sails once turned.

### CHART TEST FOR SIGNATURES TELLS WHICH IS GENUINE

Examining handwriting is one of the important phases of the work in the scientific laboratory of the Detroit police department, and comparison of samples by a chart method is often effective in revealing spurious writing and establishing

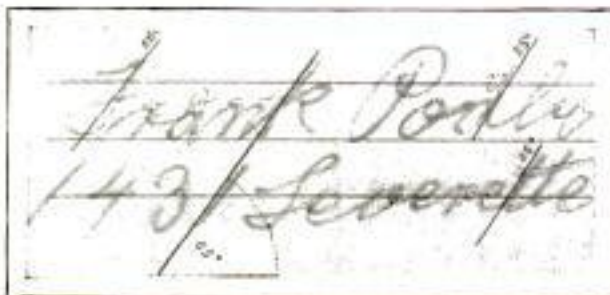

Handwriting Specimen Lined for Study: the Slant of the Letters Is an Important Feature

*Refer Aug 8 Ls H  
Meiser & Co  
32.7 E. Marquette Road  
Chicago*

*Well Mfg Co 2975 College Ave. Chicago*

### AUTOMATIC TIRE PUMP DRIVEN BY ONE CYLINDER OF CAR

Motorists now may carry their own air station in a pocket of their cars in the form of an automatic tire pump operated from one cylinder of the engine. It consists essentially of a length of hose with an attachment for the tire valve at one end, and at the other a connection to be inserted in a cylinder after a spark plug is removed. This makes an air compressor of the cylinder when the engine is idling. Air is admitted so freely through the valves that the suction in the intake manifold causes the gasoline to be held back so that only clean air can enter the tire.



### LIGHT TREATMENT FOR FOODS a-97 CREATES VITAMIN D

Ultraviolet radiation has been found to help preserve foods, enhance the bone-building vitamin content and enable food products to retain their fresh flavors and odors for longer periods. By exposing milk and other foods to narrow bands in the "rainbow" of invisible light, Prof. George Sperti, of the University of Cincinnati, produced the artificial antirachitic vitamin D without any offensive taste or smell in the foods. Foods treated with ultraviolet light act in all ways as though containing vitamin D, but by using only a part of the total band of light waves, much

*in charge of Dept.  
Earl & Stephen*

*Saena Service  
512-8 7/20/31*



General Woods Corp.

Hydranger Corp. Ltd.

Sept 2-71.

POPULAR MECHANICS

641

250 Park Ave. New York 1298 Bryant St.

larger quantities of the vitamin have been obtained. Filtered radiations promise to be effective also in preserving foods, as milk, orange juice and other products have been sterilized by exposing them to the narrow spectral limits of invisible light. Selective irradiation depends on the existence of a critical wavelength at which biological reactions begin. A given effect occurs with shorter wavelengths that contain more energy, but longer waves than the critical one are inactive. If yeast used in bread making is irradiated with a narrow frequency band of X-rays, unwanted mold cells, that would spoil the bread after being baked, are killed, while the yeast cells are unharmed.

**CATTLE BLOOMERS AID STUDY OF NEW DISEASE**

Bossy is being dressed in bloomers for the sake of her health. Scientists of the department of agriculture, engaged in studying anaplasmosis, a relatively new cattle disease, decided that common dog ticks carry the disease from one animal to another. To prove this, however, it was necessary to study the ticks for several generations. Their habits made it difficult to collect them, as the young live on the animal until time to molt, then drop to the ground. To get them when they dropped off, bloomers were made for several cows under observation. They are of white canvas, and have elastic suspenders attached to a collar about the animal's neck, allowing the cow to turn her head or body without getting them out of place. The legs are fastened with elastic garters to prevent the escape of the ticks.



Cow Being Fitted with Bloomers; the Garment Is Used to Collect Ticks for Scientific Study



Hydraulic Auger Which Bores Holes for Pipes under Streets without Disturbing Pavement

**NEW BORING MACHINE AVOIDS TEARING UP PAVEMENTS**

Tearing up streets and highways for the placing of pipes and conduits will be reduced to a minimum when a remarkable, patented hydraulic auger comes into use. It can bore under wide thoroughfares without previous trenching with all its unsightly and bothersome results. Automobiles have rolled unimpeded over the surface of the Redwood highway, for instance, while the boring was being made beneath for the placing of three-inch pipe. The tool is notable in that it has succeeded in overcoming the tendency of drilling a gradually declining hole. An operator can direct its bore with the precision of a marksman, at distances of forty feet bringing it out to within two or three inches of the point at which it is aimed. The machine is capable of boring at distances of 100 feet or more. Not only does the use of the implement obviate the necessity for cutting up streets and highways, but it also is used for laying pipe under gardens and buildings.

Those wishing further information on anything described in the editorial pages can obtain it by addressing Bureau of Information, Popular Mechanics Magazine, Chicago.

San Francisco, Calif.

Field Laboratory  
at Jeanerette, La



Pony Express Museum  
Pasadena

Prof. Wm Seifriz

642

POPULAR MECHANICS

radio call  
on CBS

a 961

Calif

### TADPOLE'S HEAD HASTENS ROOT GROWTH



Relics of Pioneer Days in Museum Established as a Result of Interest in Collecting Stamps of the Pony Express Era

By pointing a tadpole's head at growing plant roots, experimenters at the University of Pennsylvania demonstrated that the roots grew more rapidly. Turning the tadpole around and pointing the tail, had no effect. The test suggests a bit of fanciful magic, but is explained by the theory that invisible radiations, given off by some living cells, stimulate the growth of other cells. The radiations have been reported from root tips, embryonic animal tissue, cancer cells and many

### TEN DOLLARS PAID FOR LETTER IN PONY EXPRESS DAYS

It was not uncommon in the gold-rush days of California for miners far up in the hills, to pay as high as \$10 for the delivery of a single letter. Carriers took big bags of mail on their backs or by dog sled into some of the mining camps. Jerry Green, according to legend, once "packed" 60 pounds of letters as he trudged on foot from Nevada City to camps on the high divide. Interesting relics of the early days of the mail service in this country have been gathered and exhibited in a museum at Pasadena, Calif., by W. Parker Lyon, who developed his hobby from his enthusiasm in stamp collecting. Pioneer weapons, household articles, and many other objects, recall the days when the Pony express bridged the gap across the Rockies. It was officially started April 3, 1860, between San Francisco and St. Joseph, Mo. The schedule was made in less than eleven days, and the Pony riders continued to be on time and regular as long as the service was conducted. One of the most famous of its riders was Robert H. Hoslem, "Pony Bob." He made a continuous ride of 380 miles, whereas the usual galloping expressman rode seventy-five miles and wore out three horses before taking a rest.

other living things, although some investigators have obtained only negative results in the experiments, and doubt the existence of the emanations. The rays are believed to be of the same nature as the ultraviolet rays.

### X-RAY GUN PROMOTES SAFETY AND AIDS TREATMENTS

Greater safety and ease in giving X-ray treatments are features claimed for a gun-shaped apparatus introduced in Berlin. An inclosed barrel, or chamber, is said to afford ample protection against unintentional radiation and exposure to high voltages, and the tube is easily adjusted to the best position for treating a patient.

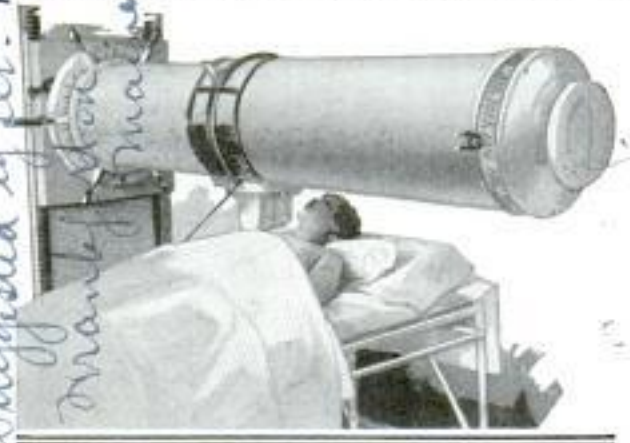

Barrel-Shaped X-Ray Apparatus Which Can Be Moved to Many Positions and Shields Attendants

Siemens-Stein  
Werke, Berlin, Germany

Science Service 512-A 1/17/31

a-79  
Suggested by Mr. Holders  
Frank Stone

copyrighted material



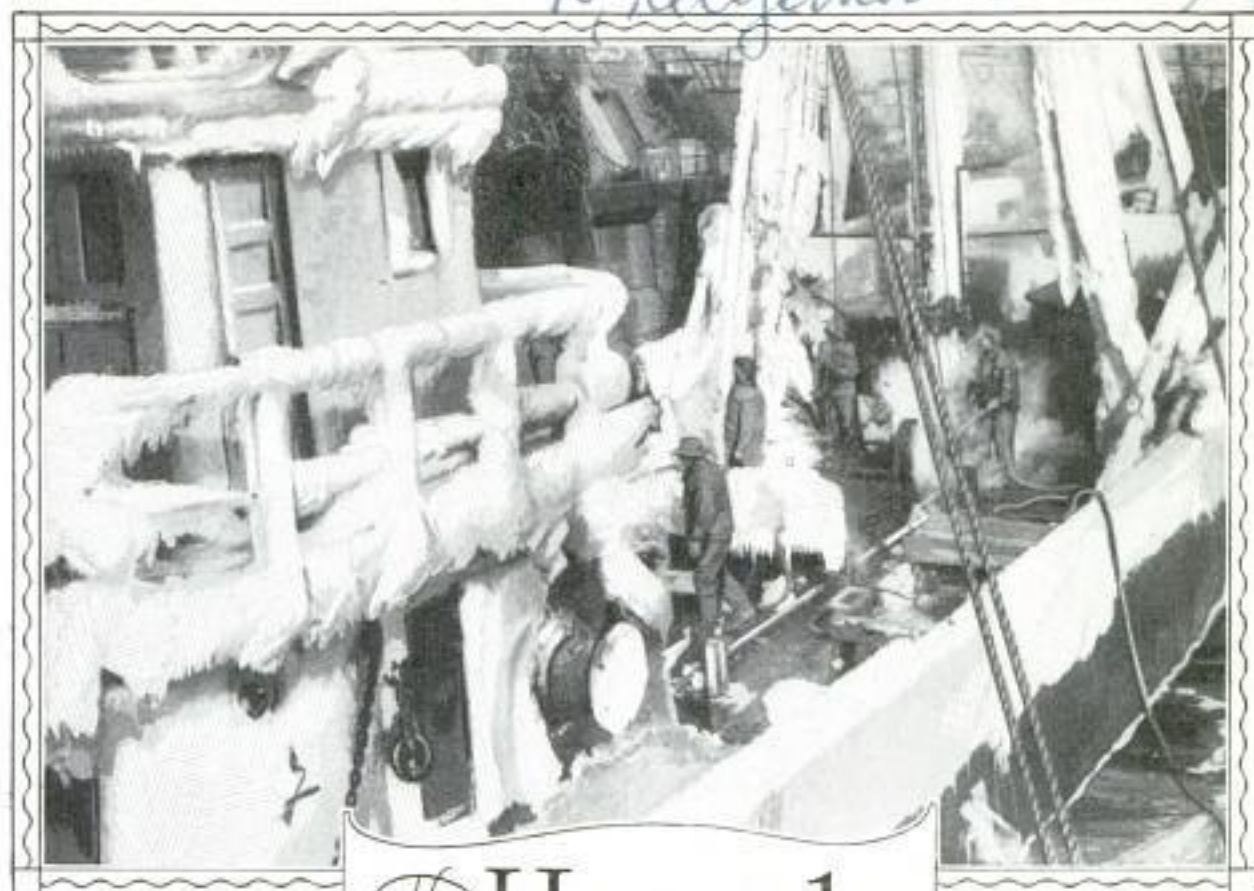

## The Hazards of Winter Navigation

**T**HE STEAM trawler "Foam" was a ghost ship that February night. White she was from stem to stern, from water line to mast top. Down from the Hudson bay country whistled a north-wester, out over Massachusetts bay, bringing with it a temperature close to the zero mark.

The big waves smothered the bow of the little craft and, receding, each added to the burden of solid ice on her deck. The spray flew mast-high and congealed instantly when it struck spar or rigging. Lashed to masts and stanchions, the crew labored feverishly with ax and bar, to keep the scuppers clear.

Out of the door of the pilothouse, stuck the head and shoulders of Capt. Richard Tobin, his outer clothing frozen solid. Hours before, the freezing spray had covered the windows inches deep, and he

had to stay outside to pilot the vessel.

When the "Foam" had sailed for Boston

market, from Georges bank, early in the morning, she was already loaded deep, for fishing had been good, and 150,000 pounds of cod and haddock were in her hold pens. Even against the fast rising wind, she had made a good run homeward until she passed the tip of Cape Cod.

There the arctic blast caught her fair as it rose to full-gale strength and the thermometer dropped lower and lower. It's only forty miles from the tip of the Cape to Boston harbor—ordinarily but a few hours' run. That night, it took the "Foam" nearly fourteen hours to make the distance across the Massachusetts bay. Only one thing saved the "Foam" that night. Hose were run out from the boiler room and streams of boiling-hot water were played upon the ice.



2262

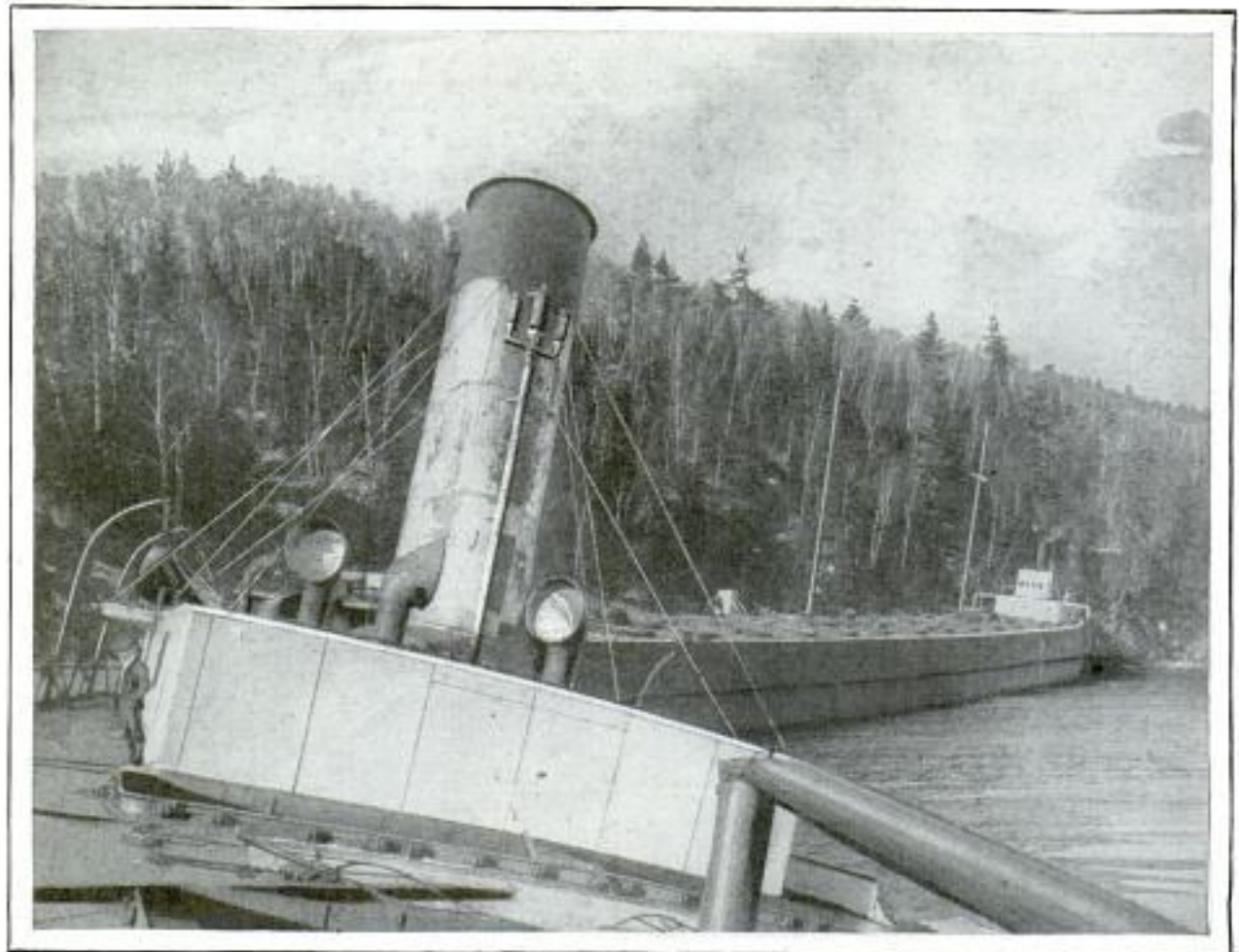

What a Severe November Storm Did to a Freighter; the Vessel Was Driven against the Shore Almost Out of the Water, Only a Steep Bank Keeping It from the Trees

Not for a day, until late in March, will fishing craft be safe from north winds, zero temperatures and the threat of unwelcome loads of ice, for Massachusetts bay is considered one of the two worst bodies of water in North America for cold-weather navigation. The other is Lake Superior, where navigation closes about the middle of December and does not reopen until March. During that short period of fall and spring shipping, the greatest of the Great Lakes holds just as much menace for inland-water navigators as the New England bay does for those who ply their craft on salt water.

The couple of weeks just preceding the close of navigation is a period of frenzied activity on the Great Lakes, especially on Superior. The eastern blast furnaces need a lot of iron ore to keep them going during the winter months. Hundreds of thousands of bushels of grain are arriving daily from the western fields, and the dock elevators are full almost to overflowing. Europe will need every bushel of wheat

that can be shipped before the freeze-up.

In that last grand rush, over a quarter-million tons of iron ore have been shipped from the Duluth-Two Harbors ports in a two-day period. More than a score of freighters took 86,747,000 bushels of grain out of the twin ports—Fort William and Port Arthur, Ontario—in one day late in November.

Again, in the early spring, the rush begins as soon as the ice goes out of the rivers that join the lakes. The iron-ore stock piles at the furnaces are getting low and the east is crying for wheat. Elevators at the head of the lakes are fairly bulging with grain and the interior is demanding storage facilities.

At the first sign of the ice rotting, the big icebreakers get busy and clear the river at Sault St. Marie, and the lake fleet that has wintered in the east surges forward into Lake Superior. Often they find hard going. Terrific storms send them to shelter behind Whitefish Point. Sudden drops in temperature cement the float ice



together, and the fleet is frozen in. An early April day in 1928 saw twenty-nine big lake freighters fast in the ice off the entrance to Duluth harbor.

Years ago, the "Western Reserve," the first of the big-tonnage ore carriers, left Duluth late in November with a full cargo. A few hours after she cleared, a northeaster howled down over the lake. No trace of the ship was ever found, except one lone life preserver washed up on the south shore. Lake sailors believe that she broke in two in the big seas and plunged to the bottom before the crew could take to the boats.

Since then there scarcely has been a single year without its fall or spring tragedy. The upper lakes are just naturally cold and stormy in the late fall and early spring. A variety of circumstances makes Mass-

achusetts bay a fearful stretch of waters for cold-weather navigation. A portion of the Atlantic seaboard gets some measure of warmth from the Gulf Stream. By the time that warm current has reached the latitude of New England, however, it is far out to sea.

From whatever northerly point the wind blows, it sweeps down from districts noted for their low winter temperatures. A northwester howls from out the Hudson bay district, across the coldest section of Canada and New England. A northeaster usually originates in the vicinity of Greenland and whistles along the frigid waters of the icy Labrador current, that flows down from Baffin Land and loses but little of its fridity until it encounters the Gulf Stream in the latitude of Long Island, too far south to moderate the intense cold of Massachusetts bay.

The ship making for Boston harbor across Massachusetts bay from the open

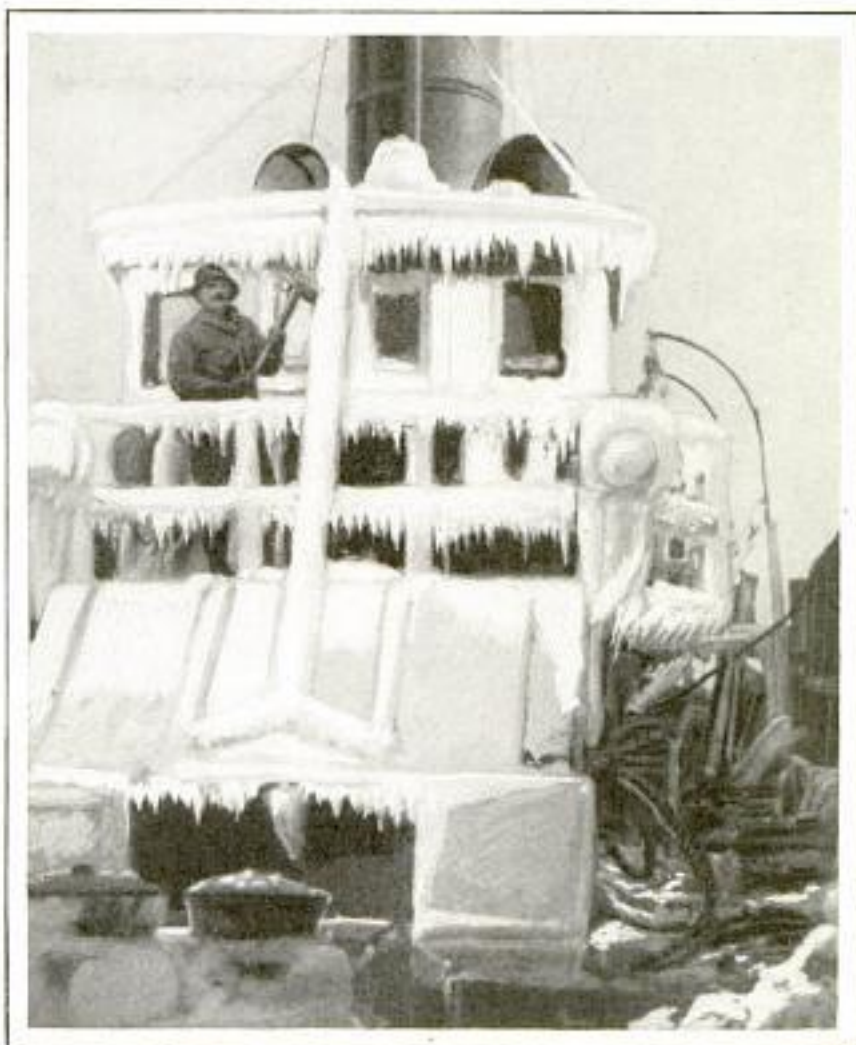

Chopping Ice from Pilothouse of Trawler; on a Trip across Massachusetts Bay, the Windows Were Covered with Ice Several Inches Thick

ocean, finds not a fragment of shelter from either of these arctic winds. The fishing fleets from Georges banks have to take the blast on the nose as they run for harbor. Those from the Grand banks get the full sweep of the gale from the starboard beam, which is just as bad—if, indeed, not worse.

#### ELECTRIC SAND BOX FOR AUTO PREVENTS SKIDDING 2264



Sand is released from a trap under the car to supply traction for the rear wheels on slippery surfaces. Pressing a button on the dashboard or steering wheel opens or shuts the trap.

*English. no data*  
Copyrighted material



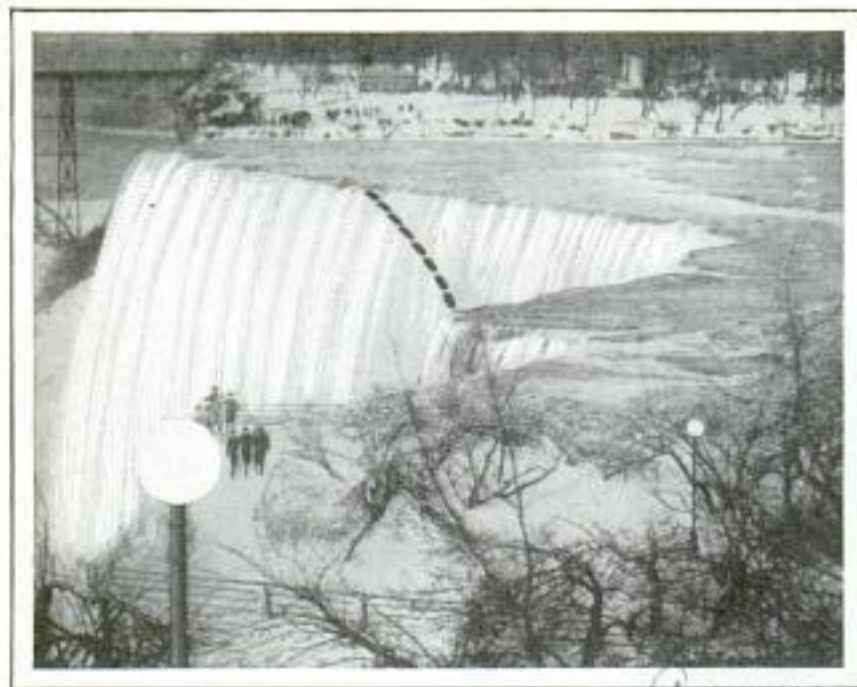

Niagara Falls with V-Shaped Slice Gouged Out When Section of the Brink Gave Way; Dotted Line Shows Former Edge

### CONTOUR OF NIAGARA CHANGED BY BREAK IN FALLS

Niagara Falls, seemingly as changeless as the Pyramids, is feeling the ravages of time and nature. The greatest single change of all history in the contour of one of the natural wonders of the world occurred in January, when a gigantic section of the brink on the American side broke away and plunged into the turbulent river bed. A V-shaped slice was gouged out of the edge when a section of rock, 200 feet long and 150 feet deep, fell and piled halfway up the 162-foot precipice of the cataract. The most recent fall of rock comparable with that of January occurred on the Canadian side in 1850, when the Table rock section gave way. There also was a break in 1818, and three sections of the Horseshoe falls gave way in 1828. For about a quarter of a century, the curving brink of Horseshoe falls has been cut back more than two feet a year by erosion.

### SECRET OF INDIAN SPIRIT TENT FOUND IN SET OF ROPES

Possible solution of the mystery of the shaking tent, a phenomenon produced by medicine men of the Chippewa tribe in calling up spirits to cure illness, has been

offered by Miss Frances Densmore, an authority on Indian lore. Not long ago, she and her sister chanced to see the ceremony, a rite few medicine men can conduct and that fewer white persons have ever witnessed. The medicine man retired within his little tepee or pointed tent, was tied tightly with ropes and after awhile began to chant and beat on a drum. The tent shook violently although there was no wind. Miss Densmore visited the medicine man the next day and arranged to see the tepee. On the inside, she noticed hoops and

ropes attached to the cloth covering in such a way that she believed the medicine man could use them to shake the tent after he had freed himself from his bonds and cause the covering to sway rhythmically.

### VACUUM CUPS ON TIRE CHAINS PREVENT SKIDDING

Tire chains constructed on the vacuum-cup principle are being offered to provide another safety factor for the motorist in winter. Three or four steel vacuum cups are used for each cross chain. It was found that cups shaped like those made of rubber were unsatisfactory because they filled with ice and snow and did not work long. The steel cups are open at both ends, the vacuum being created between the road surface and the tire to keep the car from slipping on icy pavements. The cups taper slightly, being smaller where they come in contact with the road, and when the wheel turns, the snow and ice fall out as the cups come



Page Chain Co., Inc.  
Isrotm, W.  
Copyrighted material

a-98  
Source Source  
5/2-8. 1/16/3.



Ill. Cont. Pub. Utility  
Major 790  
Munroe Chicago

Cont. Isaac F. Paul  
B-1409  
537 647  
Dearborn  
Chicago

POPULAR MECHANICS

into an inverted position. Oval links connect the cups in such a way that road wear is greatly reduced.

WHAT ELECTRICITY COULD DO BUILDING PYRAMID a-96

History records that the ancient Pharaohs used 100,000 slaves for twenty years to build the Great Pyramid of Egypt, but electric-power stations in Illinois alone supply in two weeks an amount of energy equivalent to that expended over two decades by 100,000 men. These stations have a capacity of 3,125,100 horsepower, each horsepower being equivalent to the work of five men. Operating only eight hours a day, the stations can produce in a year the equivalent of 45,626,460,000 man-power hours. If the slaves had worked eight hours a day for twenty years, they would have expended 5,840,000,000 man-power hours. If the Illinois power plants operated twenty-four hours a day, however, they could produce the equivalent of 136,879,380,000 man-power hours.

GIANT SUGAR-CANE HARVESTER DOES WORK OF MANY MEN 2278

After fifteen years of experiment, two Australian inventors have made a sugar-cane harvester which will do the work of between 200 and 300 laborers. It weighs seventeen tons and travels on its own power on crawler tracks, one man operating all the controls. As the harvester goes down the rows, it cuts the stalks below the surface of the ground, saving the entire sugar content, carries them to rotating knives to be cut into four-inch lengths and then over an air blast to remove leaves and dirt.

One-Man Sugar-Cane Harvester: It Does the Work of More Than 200 Laborers

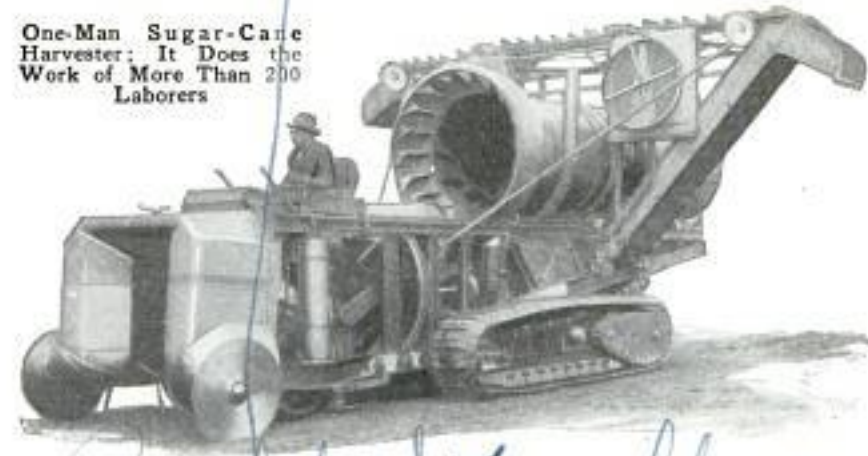

Ralph S. Faulkner  
and Walter S. Charley

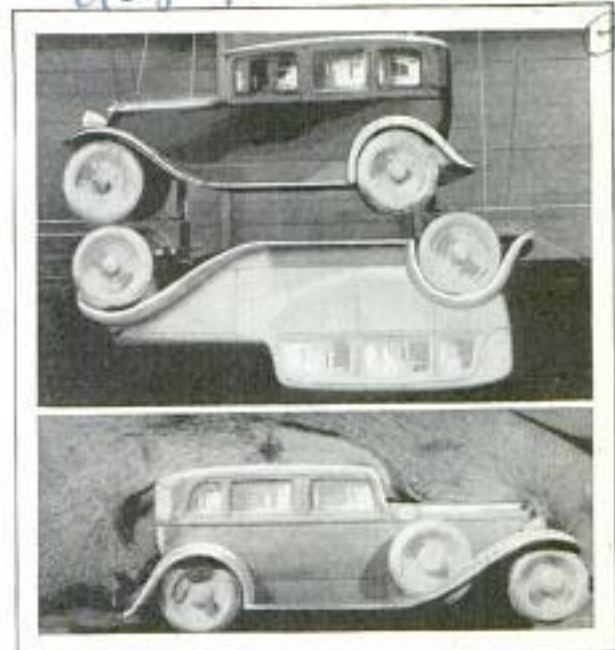

Model Autos Ready for Wind-Tunnel Test, and Plate That Shows Air Currents by Marks on Lampblack

WIND-TUNNEL TEST FOR AUTO HELPS IMPROVE DESIGN

Wind-tunnel tests, similar to those given aircraft, are being applied to automobiles in order to show the wind resistance and other factors of various designs. Small models of the cars are suspended inside the tunnel, the results being obtained by accurate gauges that register the pressure and by an interesting "map" arrangement that shows the course of the air currents. A plate of aluminum is attached to the model at the longitudinal center line. It is previously coated with a mixture of lampblack and kerosene. As the wind blows along, the kerosene scours channels in the black, indicating the direction of the air flow around the model and the presence of eddies or partial vacuums that affect the performance of the car. Important data have been obtained from these tests, as, for instance, that careful streamlining saves as much as fifteen per cent in fuel consumption at top speed. The reduced power requirement makes it possible to gear the axle higher and turn the engine a smaller number of revolutions per mile of travel.



## IT'S EASY TO MAKE YOUR OWN SHIELDS FOR COILS



Three Coffee Cans Are Cut Up and Flattened Out to Provide the Base Material for the Can-Type Coil Shields; an Equal Number of Base Pieces Are Then Cut from the Templates Below; Soup or Baking Powder Cans Form the Shields

Fig. 1 Shows Coil Mounted Directly on Movable Base Plate, and Fig. 2 a Socket for Using Plug-In Coils; Can Size Depends on Coil Diameter, Keeping Proportions Shown

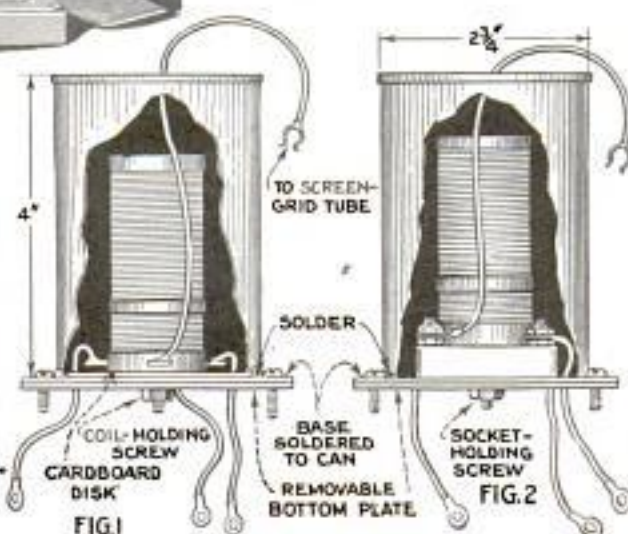
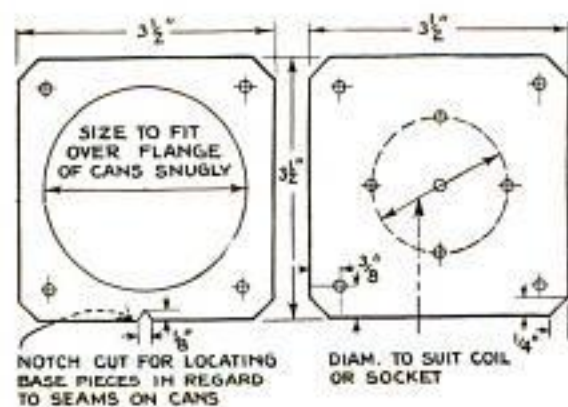

The Photos and Diagrams Show the Construction and Assembly Details Clearly; the Base Templates Provide Uniform Mounting Holes Making the Shields Interchangeable; Fig. 3 Shows a Coil Shield Made of Copper Screen Which Is Formed around a Wooden Block or Cardboard Tube of Desired Size. The Copper-Screen Shield Is Very Effective, but the Can Shields Will Meet the Experimenters Requirements

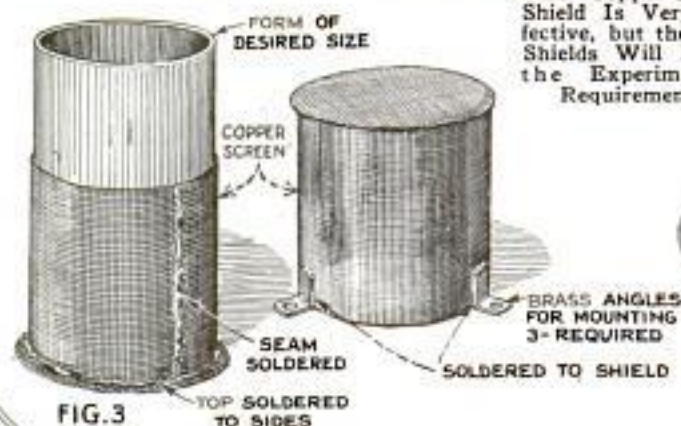

FIG. 3





# Two-Volt Tubes Used in Simple Auto Set

by J.O. Barnes

**T**HIS homemade auto receiver fits into any car and provides ample volume. It has been carefully designed and thoroughly tested in several makes of cars, and will work on practically any type of car antenna. Those interested in building an inexpensive and efficient set for this purpose will find it entirely satisfactory.

There are several outstanding features that make this set quite different from the usual auto receiver. The new two-volt low-current tubes have two distinct advantages: First, it is not necessary to use the car battery to light the tubes; this does away with excessive battery drain; second, less filtering and spark-plug suppressing is required to eliminate ignition disturbances, making installation considerably easier and less expensive.

The circuit is extremely easy to build, and it has proved to be very sensitive and selective, two very desirable features. All parts are as light and compact as possible, and have been arranged for the short and direct connections quite necessary in a receiver of this kind.

Four ordinary No. 6 dry cells, connected in series-parallel, are used to light the filaments of the tubes. From 200 to 300 hours of operation may be expected from these A-batteries which can be renewed at a very low cost. The cells supply 3 volts, which are reduced by the two  $1\frac{1}{2}$ -ohm fixed resistors,  $R_1$  and  $R_2$ , to 2 volts, and the correct current supply for the tubes. The cells may be placed under the car seat or racked at a convenient point under the dash. Three 45-volt B-batteries and a  $22\frac{1}{2}$ -volt C-battery are also required; these are placed in an ordinary battery box, either under the car, on the running board or under the seat. A multi-plug cable is used to connect the batteries to the set; this is plugged into the sta-

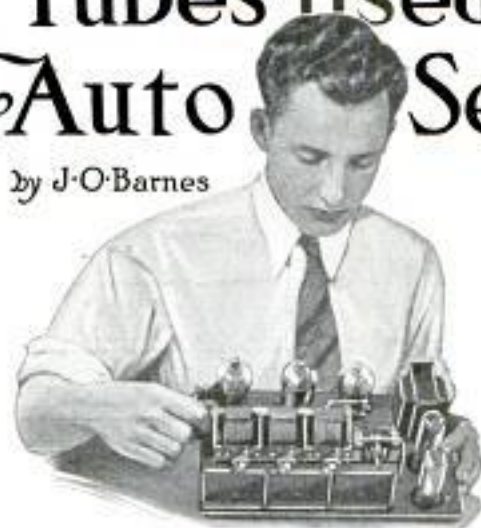

tionary terminal unit, mounted in the set, and indicated in the photo on page 651. The schematic circuit diagram shows the leads running to this unit numbered from 1 to 5. The simplified wiring diagram, battery hookup and details of the metal cabinet,

together with instructions for making the installation in the car, will be given in a concluding article in the May issue. A complete list of the materials is available, however, for those who wish to start construction immediately.

As shown in the schematic diagram, the circuit consists of two stages of screen-grid amplification, screen-grid detector, and two audio stages. The first audio stage is resistance-coupled and the second transformer-coupled. This arrangement is most satisfactory when using a screen-grid detector, and the resistance-coupled stage saves the weight of one audio transformer. The three small 55-mmfd. trimming condensers,  $C_7$ ,  $C_8$  and  $C_9$ , are used to line up the .00035-mfd. ganged tuning condensers after the set has been installed in the car. This fine tuning adjustment is made with a wooden spudger, or ordinary screwdriver, through holes in the side of the metal

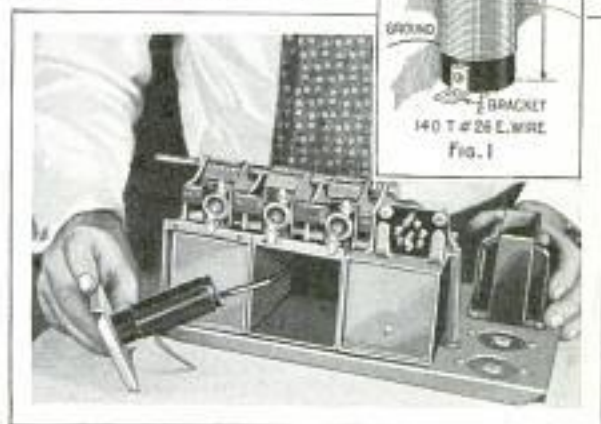
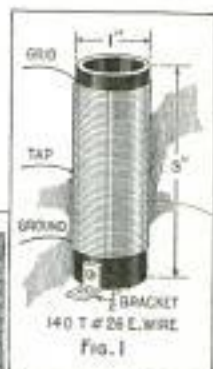



cabinet and, when once made, requires no further attention. The trimming condensers are clearly shown on the side of the ganged condenser in the photographs on the preceding page.

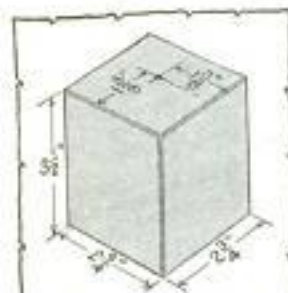

FIG. 3 COIL SHIELDS

The homemade coils are hand-wound on bakelite tubing as shown in Fig. 1 and are indicated in the circuit diagram as  $L_1$ ,  $L_2$  and  $L_3$ . All coils should have the same number of turns and be as nearly alike as possible, with no irregularities in winding or wire. The an-



tenna coil  $L_1$  is tapped at the 25th turn and coils  $L_2$  and  $L_3$  at the 20th turn. These leads are run down through the coil shields and metal base  $L_1$  to the antenna post, and  $L_2$  and  $L_3$  to the .002-mfd. fixed condensers  $C_6$  and  $C_{10}$ . The top lead of each coil is run through a hole in top of the coil-shield can and goes to the control-grid cap and the tuning-condenser stator of each r.f. stage. The bottom terminal of each coil is soldered to a lug placed under the small angle bracket, used to mount

the coil on the metal coil-shield base. This grounds each coil on the metal chassis, which is the common negative-A and ground side of the set.

The metal base detailed in Fig. 2, and the coil-shield cans, Fig. 3, are made of 16-oz. copper sheet and may be burnished and lacquered if desired. The base should be cut  $\frac{1}{2}$  in. larger all around, clipped at the corners and bent down to provide room for the small fixed condensers, resistors and chokes underneath, as shown in the photo on this page. The coil-shield bases are also cut  $\frac{1}{4}$  in. larger and turned down to fit snugly, as will be noted in the lower right-hand photo on page 649.

The metal base should be laid out carefully, as shown in Fig. 2, and the holes drilled for mounting the various parts. The five holes for the subpanel mounting sockets may be cut with an adjustable flycutter, and two extra mounting holes are required for the short 6-32 machine screws used to fasten the sockets to the base. These holes are easily located by using a socket as a template. A No. 27 drill is used for all the small holes in the base. The holes for mounting the coil-shield cans are shown within the space ruled off at the upper right. These cans are mounted with the open ends toward the edge of the base and are screwed

down to the base by means of two short machine screws through the side of each can.

The coil-shield cans provide a mounting base for the ganged tuning condenser, multi-terminal plug and the grid condenser and gridleak. This .00025-mfd. grid condenser,  $C_4$ , and the 3-meg. gridleak,  $R_3$ , which is

connected across it, are insulated from the metal can. One side of this unit is connected to the top end of the coil  $L_3$  and the stator of the tuning condenser  $C_3$ . A flexible clip-lead connected to the other side goes to the control-grid cap on the detector tube.

The base is now reversed, and the vari-

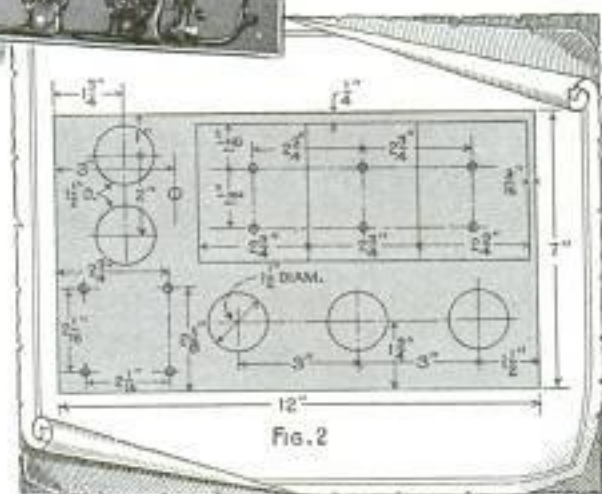
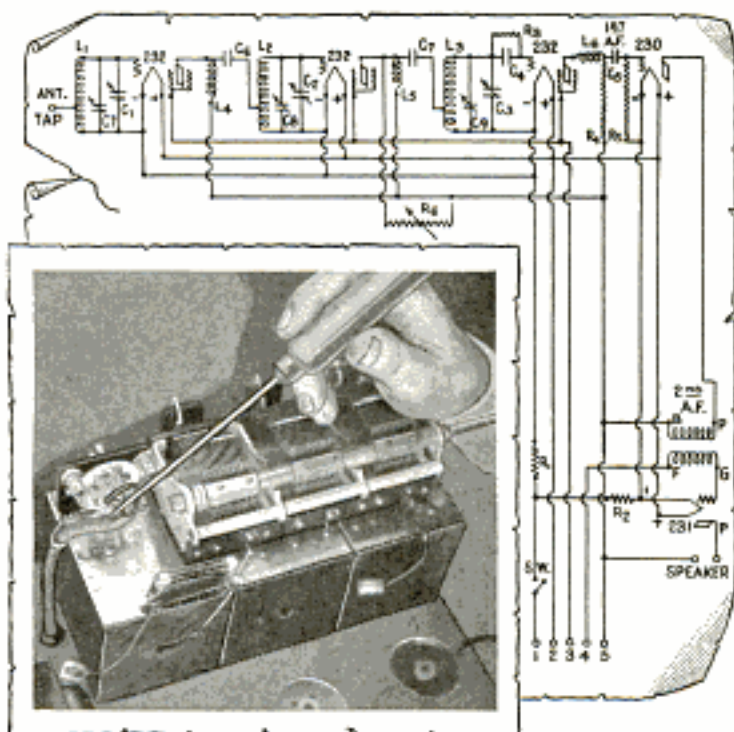

FIG. 2



ous fixed condensers and resistors, as well as the three small flat-type 60-millihenry choke coils  $L_4$ ,  $L_5$  and  $L_6$ , mounted. The resistance-coupled audio stage consists of the resistor  $R_4$  of 250,000 ohms,  $R_5$  of 500,000 ohms, and the .1-mfd. blocking condenser  $C_5$ . The A-battery switch is combined with the 10,000-ohm volume-control unit  $R_6$ , and the leads to this unit are made quite long, as shown in the photo on page 650, so that the unit may be either mounted on the front of the metal cabinet or extended up to the auto instrument board, if desired. The audio transformer in the second stage may be any small type having a ratio of about  $3\frac{1}{2}$  to 1. When wiring the set, care should be taken that all leads passing through the metal panel or shields are well insulated. Ordinary flexible rubber-covered hookup wire may be used for the circuit, but the long leads running up to switch and volume-control unit mounted on the instrument board, should be made with heavier insulated wire. For



the leads from the coils that are taken out through the cans, a good grade of spaghetti tubing should be used. A flexible rubber grommet is used in the metal base where the short cabled leads are taken up to the multi-plug terminal unit mounted on top of the coil-shield cans.

### Making an Antenna Regulator

An inductance and capacity unit that is connected in series with the outside antenna aids materially in separating stations at the lower end of the dial. The illustration shows a unit of this kind. The coil and mounting form is made of  $\frac{1}{8}$ -in. bakelite cut to the shape shown; the base is  $3\frac{1}{2}$  in. in diameter with a slight extension for the binding posts; holes are drilled, one in the center to pass a  $\frac{1}{4}$ -in.

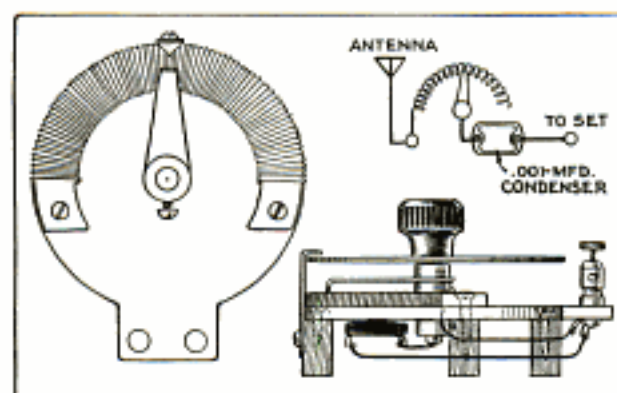

Top View of Unit; Simplified Circuit Diagram, and Sectional View of Assembly

shaft, two in the extension, and three for screws to hold the coil form in position. The coil form is  $\frac{5}{8}$  in. wide and is wound with No. 28 s.c.c. wire, the exact number of turns being immaterial. The wire is shellacked to the form, and, when dry, the insulation is scraped from the turns in the path to be followed by the contact arm. The shaft is a piece of  $\frac{1}{4}$ -in. threaded brass rod and the contact arm is obtained from an old rheostat. A celluloid or aluminum dial of the flat type and a pointer, cut from sheet brass and mounted on one of the three short wooden feet that support the unit, complete the assembly. One end of the coil is fastened to one of the binding posts and the other end of the coil left dead. The small fixed condenser is wired in series with the contact arm and the remaining binding post.—E. Laschi, Union City, N. J.

For further information on any radio construction article write to the radio department; this service is free.



## BUILDING A POCKET-SIZE SHORT-WAVE RECEIVER

Particularly suited for the hiker, the pocket-size short-wave receiver illustrated in the photos and diagram is completely housed in a cigar box, the only other piece of apparatus necessary being a pair of headphones. The parts are simple and inexpensive; in fact, most of them will be found in any radio experimenter's junk box. The circuit diagram, shown pasted in the lid of the box, is self-explanatory, but a simplified diagram and material list is available to

on a piece of cardboard tubing taken from an old flashlight battery. The tube is  $1\frac{5}{16}$  in. in diameter and  $2\frac{1}{4}$  in. long. Coil  $L_1$  consists of 5 turns of No. 28 d.c.c. wire, and coil  $L_2$  of 9 turns of the same-size wire. Both coils are wound in the same direction and are spaced about  $\frac{1}{8}$  in. apart. A disk of wood, cut to fit inside the tube at one end, is screwed to the inside of the box and the tube is tacked to it. Hand-capacity effects are minimized by wind-

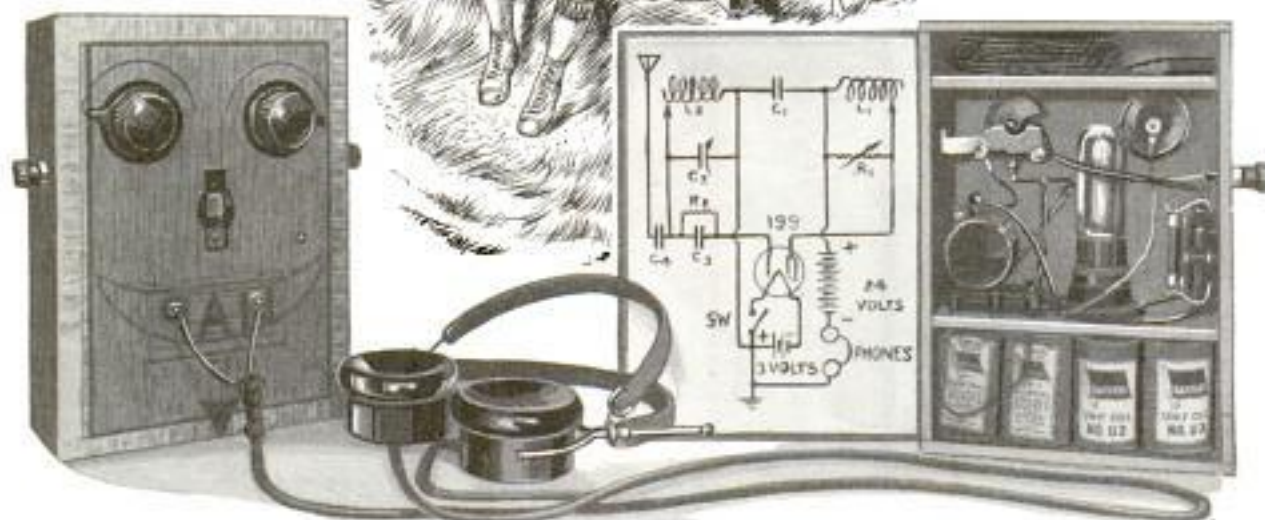

Left, Front View Showing Switch and Control Knobs; Right, Rear View with Lid Opened, Showing Arrangement of the Various Parts and Wiring Diagram

all who wish them. The two flashlight cells, shown in the rear view at the right, are small round,  $1\frac{1}{2}$ -volt unicells connected in series to supply 3 volts for the 199-tube filament. At the left, are eight small 3-volt flashlight batteries connected in series to furnish 24 volts of B-battery for the plate of the tube. The center compartment contains the tube, grid condenser  $C_3$  and gridleak  $R_2$ , and the variable resistance  $R_1$ , of 500,000 ohms for controlling regeneration. The tuning condenser  $C_2$ , consisting of a five-plate midget type, is mounted at the left, and directly below are the coils  $L_1$  and  $L_2$ , which are wound

ing the coils so that the grid end of coil  $L_2$  is near the rear of the receiver, as far away from the hands of the operator as possible. The receiver is designed to cover the amateur 20-meter band with a generous margin on each side. The blocking condenser  $C_1$  is a .002-mfd. fixed type and is mounted directly below the coils. The grid condenser  $C_3$  is .00004 mfd., and the gridleak is an 8-meg. cartridge type. Condenser  $C_4$  is in series with the antenna and consists of two pieces of aluminum,  $\frac{3}{4}$ -in. square, spaced  $\frac{1}{8}$  in. apart. The filament switch and binding posts for the phones are located in the posi-



tions noted in the photo at the left. The posts for the antenna and ground are placed on either side of the box at convenient locations. The upper compartment holds a small logbook, pad, pencil and a 100-ft. coil of No. 30 enameled wire for an antenna. To operate the receiver, connect a small glass insulator to the end of the antenna wire, uncoil the wire and fasten the insulator to a limb of a near-by tree, or, if preferred, shorter wire can be connected to a wire-fence antenna as shown in the sketch. The ground connection may be made with a metal rod driven into damp ground, to which a flexible lead is soldered and connected to the ground binding post. This receiver has not a great deal of volume, but as there is very little interference in the open country this is not of much consequence. It actually works and even has DX-possibilities.—L. F. Leuck, Lincoln, Nebr.

#### Plug and Jack Combinations Are Aids to the Experimenter

The radio experimenter's "breadboard" layout may be made into a flexible and economical arrangement if it is provided with the necessary standard-spaced jacks for plugging in various circuits. This is now made possible by several devices, some of which are shown in the illustration, and others equipped with mounting bases that may be quickly plugged in and out of breadboards designed for them. The midget condenser at A, the rheostat at C, and the gridleak and condenser at D, are a few simple applications of the

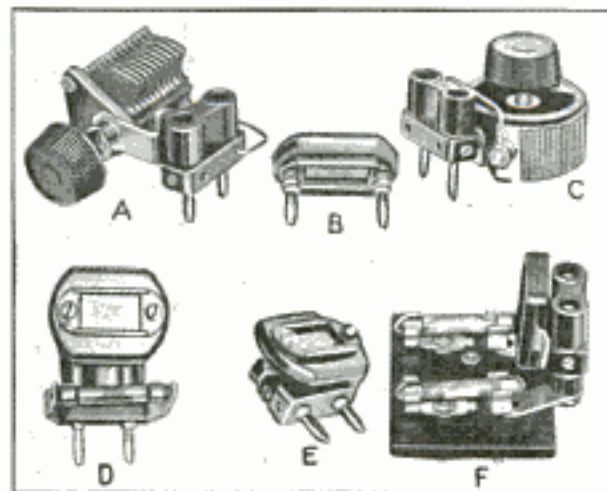

Handy Plug and Jack Combinations Which Are Highly Useful to the Experimenter

idea. Single plugs are used for the fixed condenser B, or the twin unit may be used, as shown at E. A complete resistance-coupled stage ready for plugging in is shown at F.

#### Tube Controls Line Voltage

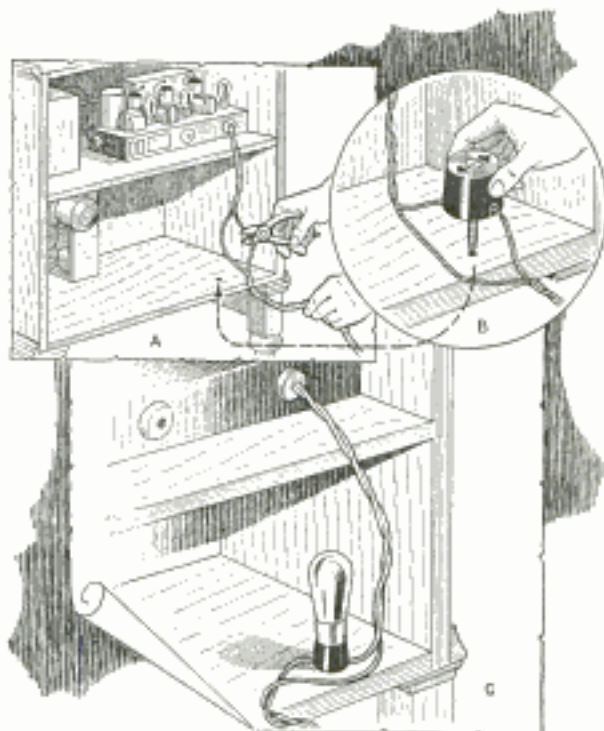

Installing Line-Voltage Regulator

Power companies cannot maintain a definite 110-volt current at the light socket. Therefore, as a means of compensating for fluctuating voltages, to protect the tubes in a.c. sets and enable the owners to get the best results, a self-adjusting line-control tube is available. It is connected in series with one side of the a.c. supply line, between the set and the wall socket, and installed in three simple steps, as illustrated at A, B and C. There is a special socket for the tube, but if this is not available, a UX-tube socket may be used in its stead.

#### Testing Power Units

An open or short circuit in the output of a power unit employing either a 280 or 281-tube will cause a zero reading at the terminal board. If the tube burns normally, look for an open circuit in one of the resistance units in the voltage divider or wiring. If the tube burns with a blue glow, it is very likely caused by a short circuit in filter condensers or wiring.



Insuline Corp

Cardinal Radio Mfg Co

654 America POPULAR MECHANICS

2812 S Main St  
Los Angeles, Calif

Chicago 549 W Washington

Television Projector for Amateurs

New York City  
23 Park Place

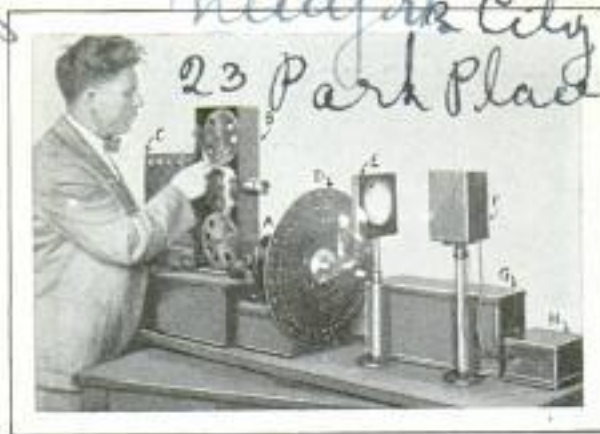

Front View of the Transmitting Unit, Showing Operator Inserting Film

A simple transmitter now enables amateurs to project television images over a wire from room to room. With this equipment, and standard-size (35 millimeter) silhouette film, any experimenter may work with wired television without the handicap of poor reception. The apparatus consists of a motion-picture projector combined with the usual motor-driven scanning disk, photo-electric cell and television-frequency amplifier. A simplified receiver, consisting of a similar synchronous motor with scanning disk and neon tube, completes the installation. The motors, operated on the same a.c. supply, keep both disks in perfect step. No license is required for this kind of operation, but licensed amateurs may use the modulated energy output of the transmitter to regulate the carrier wave of their short-wave transmitter in the usual manner. In the photo, A is the reduction gear, which is driven from rear end of motor shaft; B, the reel housing; C, the exciter lamp; D, the scanning disk; E, the lens; F, the photo-electric cell; G, the frequency amplifier, and H, the phase reverser. The purpose of the latter is to enable either positives (black on white

background) or negatives (white on black background) to be televised.

### Red Pencil Prevents Wiring Errors

When wiring a new circuit it is a good idea to have a red pencil handy and draw a line over each connection in the blueprint as you complete the corresponding lead in the set. In this way a constant check may be kept on the amount of work completed and no connections will be overlooked. By adopting this scheme needless checking is avoided as well as loss through damage to tubes and parts.

### Phonograph Is Combined with Midget Set



Phonograph entertainment as well as radio programs may now be enjoyed by midget-set fans, a compact little receiver recently placed on the market combining both features. It consists of a 6-tube a.c. screen-grid circuit, a small dynamic speaker and a phonograph motor with automatic stop and pick-up arm.

combining both features. It consists of a 6-tube a.c. screen-grid circuit, a small dynamic speaker and a phonograph motor with automatic stop and pick-up arm.

### Removing Film from Antenna Insulators

Within a few months' time antenna insulators will gather a film of soot that will lower their efficiency. This is true of any type of insulator, and the lowered insulating value is quickly noticed in amateur transmitting installations. The effect in standard broadcast receivers is noted by the increasing difficulty in tuning in distant stations. It is a good plan to lower the antenna at least once every six months and wash the insulators with warm water or carbon tetrachloride, after which they should be polished with a soft rag. At this time, the antenna should be inspected for bad connections, and the guy wires and lead-in checked.

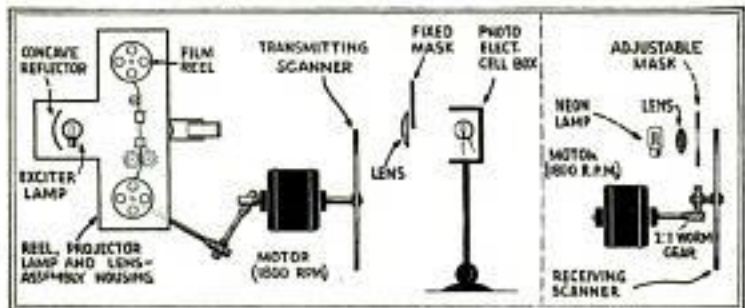

Arrangement of the Apparatus; the Transmitter Is Shown at the Left and the Receiver at the Right



SIMPLIFIED ANSWERS TO YOUR RADIO PROBLEMS



THIS WIRE REMOVED AND FASTENED TO FILTER POST

YELLOW-STRIPE WIRE



Above, Filter Installed in Base of Automatic Dial Telephone Removes One Source of Radio Interference; Right, Screwdriver with Insulated Handle Used to Discharge Condensers before Making Power-Unit Adjustments, as Such Condensers Hold a Charge for Some Time After Line Switch Is Thrown



Below, Catch for Lid of Metal Shield Box Made from Old Binding Post and Switch Lever; Left, Strips of Old Inner Tube Tacked Flat behind Speaker Baffle Improve Tone

*Chicago 2307 Michigan*

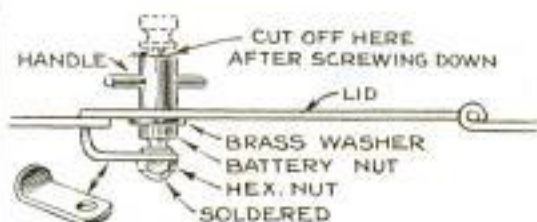

Above, Simple Metal Base for Homemade Amplifier Units Easily Constructed from 3/32-In. Aluminum Sheet; Left, These Sturdy New 2-Volt Tubes and the Long-Life Air-Cell A-Battery Designed for Them. Now Bring to Homes Not Served with Power Lines, the Same-Quality Reception and Ease of Operation as That Enjoyed by Users of Power Sets

*National Carbon Co. Inc.*  
 308 42nd St. N.Y.C.

*Plasticolite Corp.*  
 of America  
 Copyrighted material  
 2330 Washington







# Building A Midget A.C. Receiver — Part 2

THE ASSEMBLY and wiring of the midget set, described in Part 1, being completed, we will now take up the construction of a suitable cabinet and the installation of the chassis. The design, which is a modified modernistic type, is well suited to the proportions of the receiver, and will harmonize well with the furnishings of most homes.

With the exception of a few pieces, the entire cabinet is made of plywood panels. Most of the edges are painted with an opaque color that completely hides the core lines, and the remainder are at the corners, where they are neatly and completely housed by cutting back all the stock except the thin outside veneer which, when glued in place, covers the edge of the other piece.

All the general dimensions are given in Fig. 1. The following pieces are all cut from one  $\frac{3}{8}$  by 32 by 48-in. panel: Two,  $10\frac{3}{4}$  by 22 in., for the sides; one,  $10\frac{3}{4}$  by



$17\frac{1}{2}$  in., for top; two for top overlay, one  $10\frac{3}{4}$  by  $13\frac{1}{2}$  in., and the other  $9\frac{3}{8}$  by  $11\frac{1}{2}$  in., and for side overlay, two 8 by 19 in., and two  $6\frac{1}{2}$  by  $17\frac{3}{4}$  in. Another panel,  $\frac{1}{4}$  by 24 by 42 in., supplies the material for the following pieces: One,  $17\frac{9}{16}$  by  $22\frac{1}{2}$  in., for front panel, allowing for joints; two,  $2\frac{3}{4}$  by  $18\frac{3}{4}$  in., for overlay wings; one,  $2\frac{1}{2}$  by  $14\frac{1}{2}$  in., for bottom overlay triangle, and one, 1 by  $8\frac{1}{2}$  in., for top overlay triangle. Both of these panels should be walnut on one side. In addition, a piece of so-called "drawer-bottom" panel,  $\frac{1}{4}$  by 24 by 36 in., will be needed for the backing and speaker support. The back piece is  $17\frac{1}{8}$  by  $21\frac{1}{2}$  in., and the speaker-supporting piece 10 by  $15\frac{3}{4}$  in. Any  $\frac{1}{2}$ -in. soft wood may be used for the bottom and cleats, but  $\frac{1}{2}$ -in. solid walnut is required for base molding.

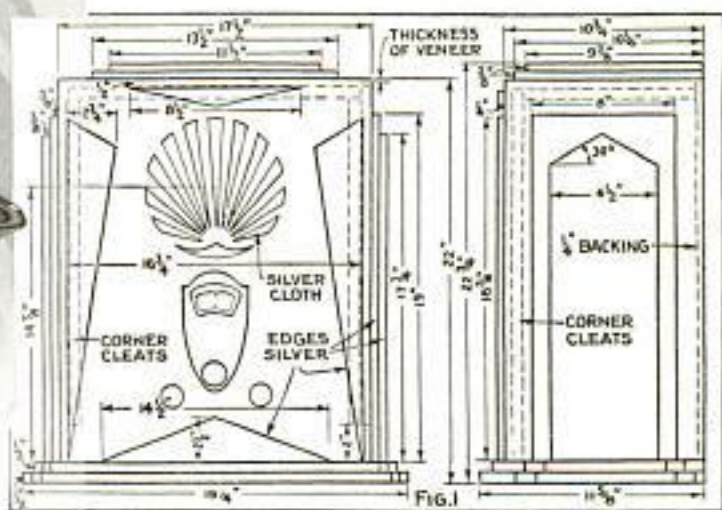



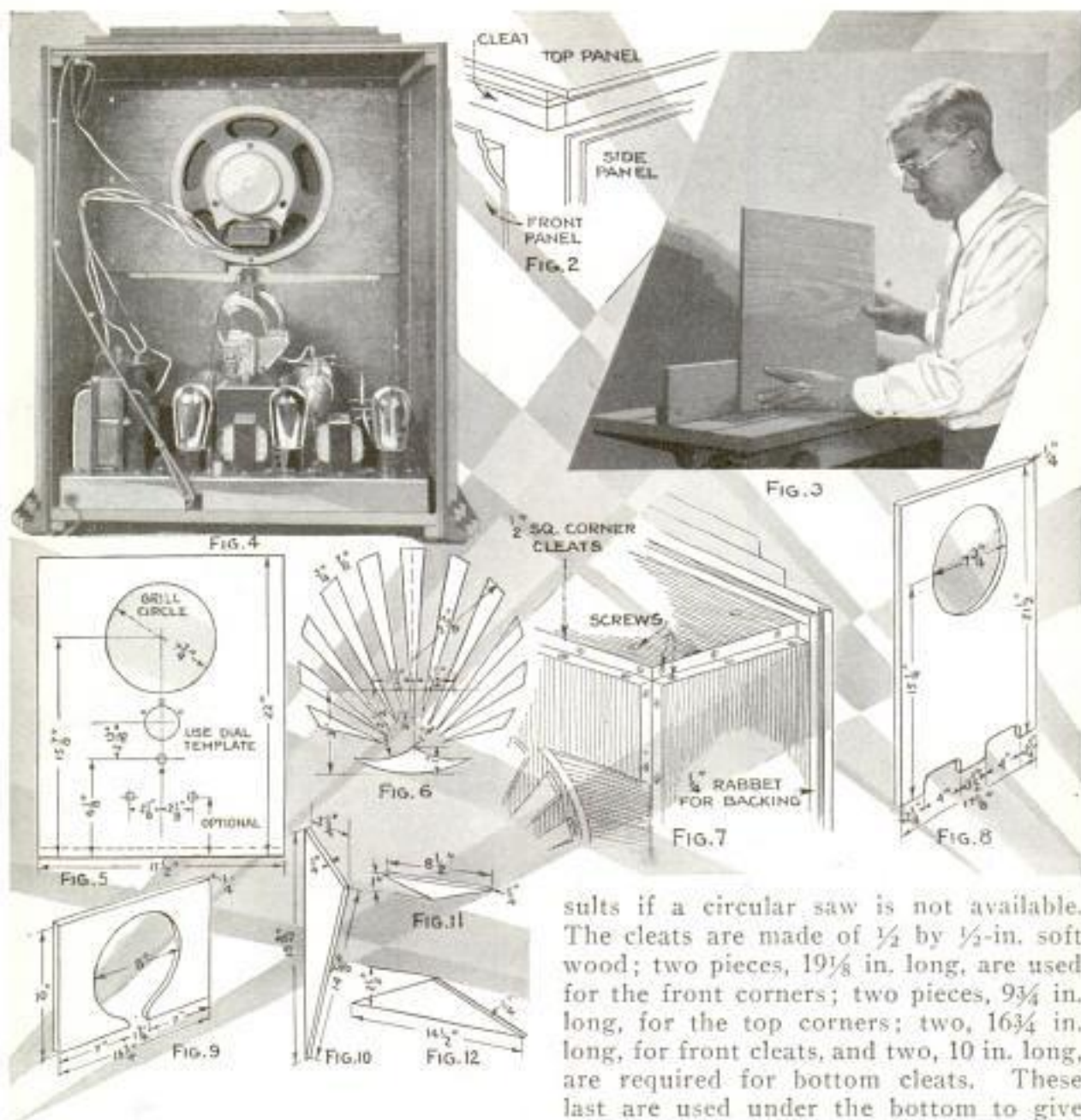

After the side and top panels have been cut to size, a joint should be run on each end of the top piece as shown in Fig. 2. This is done by cutting away all of the stock, except the outside veneer, sufficiently to house the sidepieces. Fig. 3 shows a step in making these cuts on a circular saw. A 4-in. board is screwed to the fence of the saw guide to keep the work perfectly true. When performing the first operation, the panel is held flat on the table with the edge against the fence; the second step, shown in the photo, is obvious, but both require a careful set-up and test on scraps of similar veneer before cutting the piece to be used. A chisel or hacksaw will accomplish the same re-

sults if a circular saw is not available. The cleats are made of  $\frac{1}{2}$  by  $\frac{1}{2}$ -in. soft wood; two pieces,  $19\frac{1}{8}$  in. long, are used for the front corners; two pieces,  $9\frac{3}{4}$  in. long, for the top corners; two,  $16\frac{3}{4}$  in. long, for front cleats, and two, 10 in. long, are required for bottom cleats. These last are used under the bottom to give rigidity to the cabinet. The solid stock piece for the bottom is  $\frac{1}{2}$  by  $10\frac{1}{4}$  by  $16\frac{3}{4}$  inches.

The sides, top and bottom should be assembled first. By placing the cleats a trifle back from the edge, the screws may be made to draw the joints snugly together without the use of bar clamps. Screws may also be driven from the outside of the cabinet, through the panels, to fasten the bottom into place, as the heads will be covered by the base molding. If the back panel is cut to size and tacked into the  $\frac{1}{4}$ -in. rabbet, which has previously been cut in the sides and top, it will hold the frame square while the glue is setting. This rabbet is clearly shown in the rear-view photo Fig. 4.



Fig. 5 shows the layout of the front panel. The controls may be mounted on the chassis or the leads extended for mounting directly on the front panel. The pattern of the grill is given in Fig. 6, and should be laid out carefully on a piece of heavy paper. A jig or scrollsaw is used to make the cut-outs. Three edges of the front panel are cut away as shown in Fig. 2 to form the joints. The panel should be made a trifle larger than the measurements given so that the veneer will extend beyond the edges and can be sanded down to a nice square corner after the glue is dry. Screws through the cleats are used as before to draw the joints tight. Fig. 7 is a view of the cabinet from the back, and shows the arrangement of cleats by which the panels are joined and reinforced.

A hole is cut through the back and slots are left at the bottom, as shown in Fig. 8. Since the front panel is only  $\frac{1}{4}$  in. thick, a second piece, shown in Fig. 9, which may be called the speaker support, is used. This is screwed and glued to the panel after the grill has been backed with cloth.

The overlay panels are fastened to each other and to the cabinet with screws driven from the inside. This method of fastening is used rather

than gluing because it is less difficult to finish and paint the edges of the pieces when they can be separated. Figs. 10, 11 and 12 show the sides of the ornamental overlays on the front panel. Care must be taken on the sharp corners to avoid tearing the core out from between the outer layers. Be sure that the screws are not so long that they come through the face of the stock.

The following pieces of solid-walnut base molding are required and allowance has been made for joints: Two pieces  $\frac{1}{2}$  by  $1\frac{1}{8}$  by 11 in., for upper side base; two,  $\frac{1}{2}$  by  $1\frac{7}{8}$  by 11 in., for lower side base; one,  $\frac{1}{2}$  by  $\frac{3}{8}$  by  $18\frac{1}{2}$  in., for upper front base, and one,  $\frac{1}{2}$  by  $\frac{7}{8}$  by  $18\frac{1}{2}$  in., for lower front base. These moldings are made in two parts, or layers, which are glued together, and then glued and screwed to the sides and front of the cabinet at the bottom. Figs. 13 and 14



FIG. 15

show the method of laying out the steps, which may be cut with a hacksaw and chisel, or with a bandsaw as shown in Fig. 15. The corners of the molding are mitered, which will require careful fitting. Fig. 16 shows how the finished corner should look. The job is now ready for sanding and finishing.

The finish consists of a coat of dark walnut wood-paste filler, which should be rubbed off when it loses its gloss, two coats of dark walnut oil stain, and five or more coats of boiled linseed oil. Fig. 17 shows the designer of the cabinet applying a coat of stain to the front panel. The oil should be ap-

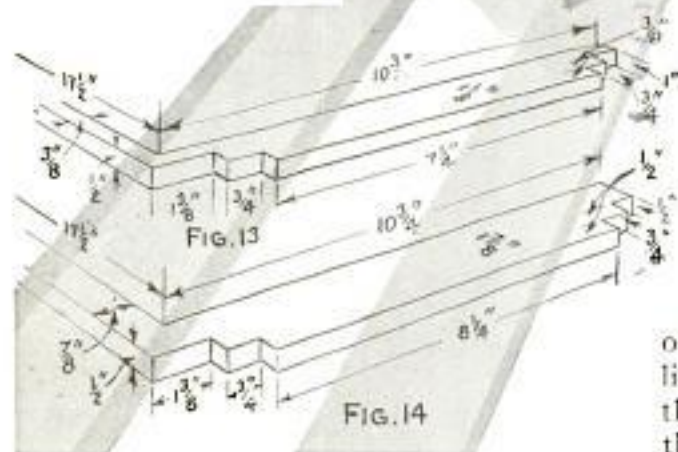





FIG. 17

plied and allowed to soak in for a few minutes, then rubbed vigorously. A second application may be given the cabinet immediately.

In order to cover the edges of the veneer and give life to the cabinet, all of the exposed veneered edges are painted with so-called "silver paint." The end grain, which is exposed on the base molding, should also be painted in this manner. A piece of silver cloth stretched behind the grill and covered with the speaker-support board completes the cabinet. Enlarged diagrams of receiver and cabinet construction details are available.

The receiver should be checked and balanced before the chassis is installed in the cabinet. The set-up for testing is shown in the lower photo on page 657. The leads to the dynamic speaker are left quite long, and the tuning dial is mounted temporarily on the condenser shaft. The chassis is placed near the cabinet, and the speaker is then mounted on the supporting board.

If the set is to be used in crowded localities near powerful broadcasting stations, it will be necessary to shield all three of the screen-grid tubes. It is also advisable to use trimming condensers across both of the ganged tuning condensers in the band-pass filter for maximum selectivity. Further tests have shown that better volume control may be obtained by substituting a 2,000-ohm variable resistor for

the 10,000-ohm unit shown in the simplified diagram in Part 1. It is connected between the antenna post and chassis.

To balance the receiver, a distant station, or faint local, is tuned in and the trimmers adjusted with a wooden spudger until the signal is received with greatest volume and no stations overlap. In most cases it is not necessary to use a ground connection, and the length of antenna will differ in various locations, six or eight feet being about right near strong locals.

After completing the tests, the dial escutcheon is mounted on the front of the cabinet together with the volume-control unit and line switch. The chassis is then installed and the leads connected to the panel controls. Small blocks of wood or strips of packing cardboard are used between the chassis and the cabinet at each side to hold the set firmly. The back panel is then screwed in position, completing the installation.

#### Radio Owl Turns Off Set

An automatic switch, built into a bronze owl, shuts off a radio receiver or other electrical appliance at any desired time. The device is equipped with double leads for plugging into the electric outlet and for connection to the apparatus to be controlled. After the connections have been made, the operator pushes the owl's head down, which switches on the current, and sets the shut-off time by means of an indicator on the front.



The Radio Owl on Duty; Below, Putting the Device in Operation

Agents  
Edward J. Buckley  
154 Nassau, N.Y.  
Copyrighted material



# AMATEUR MECHANICS



## Indoor Target Practice with Crossbows

By J. V. HAZZARD

**D**RIVING short arrows at lightning speed and with pleasing accuracy up to a range of about 30 ft., homemade crossbows make the illustrated shooting gallery an interesting indoor diversion.

The stock of the weapon is cut from a  $\frac{3}{4}$  by 4 by 24-in. piece of tongue-and-grooved pine, while the bow itself can be made of hacksaw blades, umbrella ribs or corset stays. If hacksaw blades are used,

the bow will somewhat resemble an automobile spring, except that it should be wrapped closely with fine wire from end to end. The longest blades, of which there should be 3 or 4, are 12 in. long. Upon these are laid an equal number of shorter pieces of gradually diminishing size, the shortest one forming the back of the bow. With a 12-in. bow, the catch for the string should be set about 6 in. behind it, since



Short Arrows, Driven Accurately by Means of Homemade Crossbows, Make a Basement Shooting Gallery an Interesting Diversion

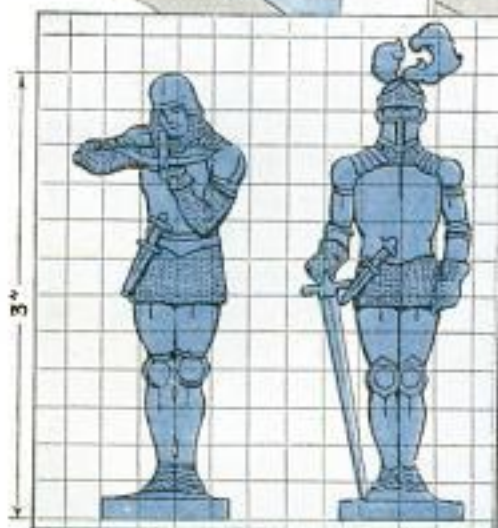

a longer draw would result in fracturing the bow. Hickory, maple or steel may be used for the trigger and catch, and the width of the mortise to receive this mechanism must be determined accordingly. A  $\frac{1}{4}$ -in. mortise is satisfactory for wood, and a  $\frac{3}{16}$ -in. mortise if a metal catch and trigger are used. It is a good plan to set up the trigger mechanism on the side of the stock, using shingle nails as pivots, and making all necessary adjustments before attempting to set it permanently in the mortise, as the mechanism must work



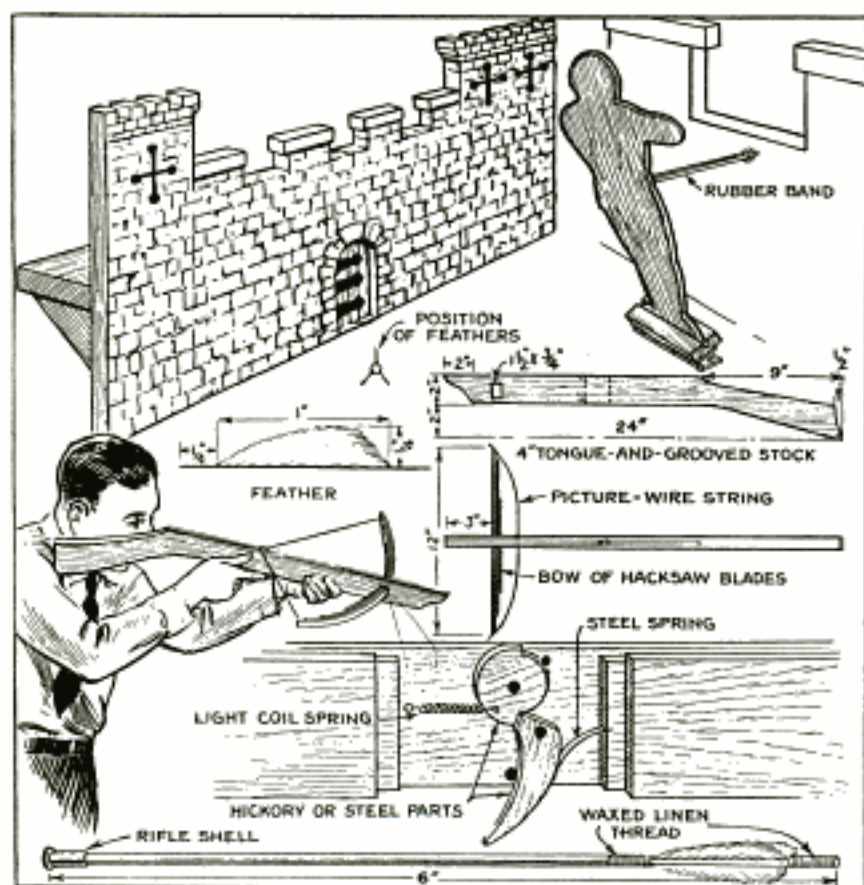

Details of the Castle, the Bow, the Gun Stock with the String-Releasing Mechanism and the Darts

smoothly for good results. When finally adjusted, holes for the pivots are drilled where nails were driven in temporarily, and unused holes are plugged with plastic wood. To keep the trigger in place, a short steel spring is used, one end being pushed into a cut made at the rear end of the mortise and the other bearing against the trigger as shown. If desired, a staple may be driven in the front end of the mortise, and the back side of the trigger notched so that a rubber band can be used to keep it in place. A small pin in front of the trigger serves as a stop. The catch has two notches as shown, and is returned to the correct position, after making a shot, by means of a small coil spring or rubber band. After the trigger is pulled, which releases the catch, it is held back with the finger until the catch returns to its original position.

Picture wire makes an ideal string for the bow. It should be long enough to reach from end to end of the bow without bending it, but should not be loose as shown in the illustration. The bow is bent only when the string is hooked over

the catch. Darts may be made from a variety of materials, although rattan and cattail stems are well suited to the purpose. They should be 6 in. long, tipped with 22-gauge rifle shells of the long type, and are feathered at the other end as indicated. One feather drops into the groove along which the dart is shot, while the other two ride over the edges.

For an indoor target it is hard to improve on a castle, which can be made of 1-in. wood in a suitable box. The box should be large enough to catch wild shots, and deep enough to permit falling men to clear the back if they are hinged to the parapet, or shelf, on which they stand. Both box and castle should be

painted to represent stone masonry. The men-at-arms and the knights are cut from plywood, as shown in the drawing, in which each square represents  $\frac{1}{4}$ -in. After painting, they are mounted on small blocks of wood. If desired, these may be hinged to the parapet and a rubber band provided to allow them to be knocked down, but pulling them back to standing position.

Another variation is to provide a string to pull the figures up, the string extending to the line from which the players shoot. One man-at-arms stands in each embrasure and scores 25 when hit, while the knights are stationed at the far edges of the parapet immediately behind one of the battlements and, being harder to hit, count 75. The castle should be placed about 4 ft. above the floor. At a 12-ft. range, the shooting will be as accurate as if the men were of full size on a wall 40 ft. high and 40 to 50 yd. away. The embrasures measure  $1\frac{1}{2}$  in. across at the bottom and are separated  $1\frac{3}{8}$  in. from each other at the top. The floor of the parapet is arranged so that the bowmen reach to the top of the embrasures.



### How to Tell Color of Unlabeled Flower Bulbs

Sometimes, after saving flower bulbs, they are mislabeled or the label is lost, causing considerable loss to the grower or dealer. In varieties such as the ordinary garden crocus, where color is the first requisite, the loss of labels can be rectified by a very simple method. Take a bulb that shows a sprout, cut it open with a sharp knife or razor blade, cutting through the shoot. Inside of the shoot you will find miniature flowers of the color that they will show when in blossom. Although the colors will be of a light shade they can nevertheless be identified.—J. Herbert Ferris, Elberta, Mich.

### Kit Made from Paper Carton

To make a serviceable carrying bag, cut off the top of a cardboard carton and part of the sides as indicated by the shaded portion of the right-hand detail. Split the edges down to the second dotted line, score the board on both lines and bend the ends inward until the container takes the shape shown at the left. Slip a length of doubled wire over the top ends and cut a handhole through them. The handle portion can be strengthened by gluing a strip of wood along each edge, on the outside. A few coats of shellac or varnish on the outside will make the box last much longer than it would if not protected.—L. T. Stroeve, Piedmont, Calif.

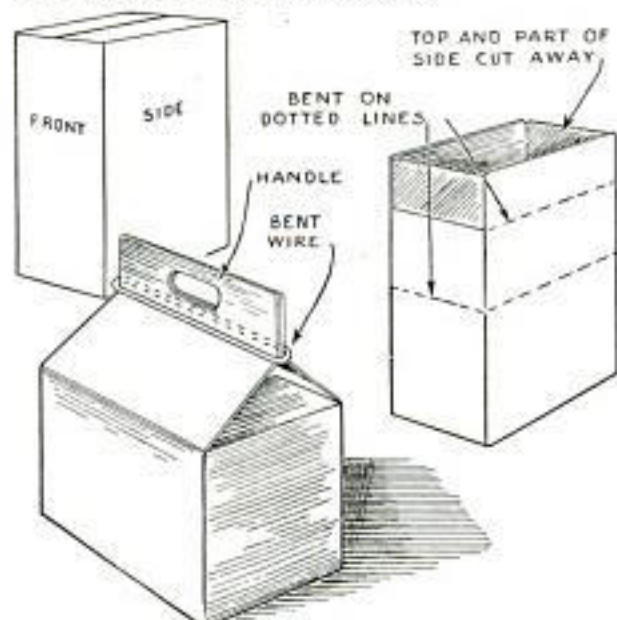

Serviceable Carrying Bag for Groceries or Tools Can Be Made from a Cardboard Carton



Newspapers Make Cheap and Effective Masking for Use when Spray-Painting Automobiles

### Masking Auto Windows with Newspapers

When spray-painting a car, no better and cheaper masking for the windows can be found than newspaper. To apply it, lower the window slightly, insert one edge and then close the window to hold the paper in place. The three other edges are held with strips of tin, inserted between the window channel and the metal frame. These strips also prevent the paint from getting on the window channel, and can be used repeatedly, the coating of paint on them being removed occasionally when it gets too thick.—F. J. McGinnis, Cleveland, Ohio.

### Bouquet of Christmas Lights As Centerpiece

Crepe-paper flowers and a Christmas-tree lighting outfit can be combined to form an attractive electric bouquet as a centerpiece for the table. The paper flowers are placed around the socket of each light, and the cord wrapped with green crepe paper to give the appearance of a stem and leaves. A piece of wire can be used to make the stems stiff. Bulbs of a color corresponding to the flower in the center of which they are placed are screwed into the sockets, and the flowers bunched together and placed in a basket or vase. The bouquet often provides all the light needed for a dinner party.—Sterling D. Fox, St. Louis, Mo.



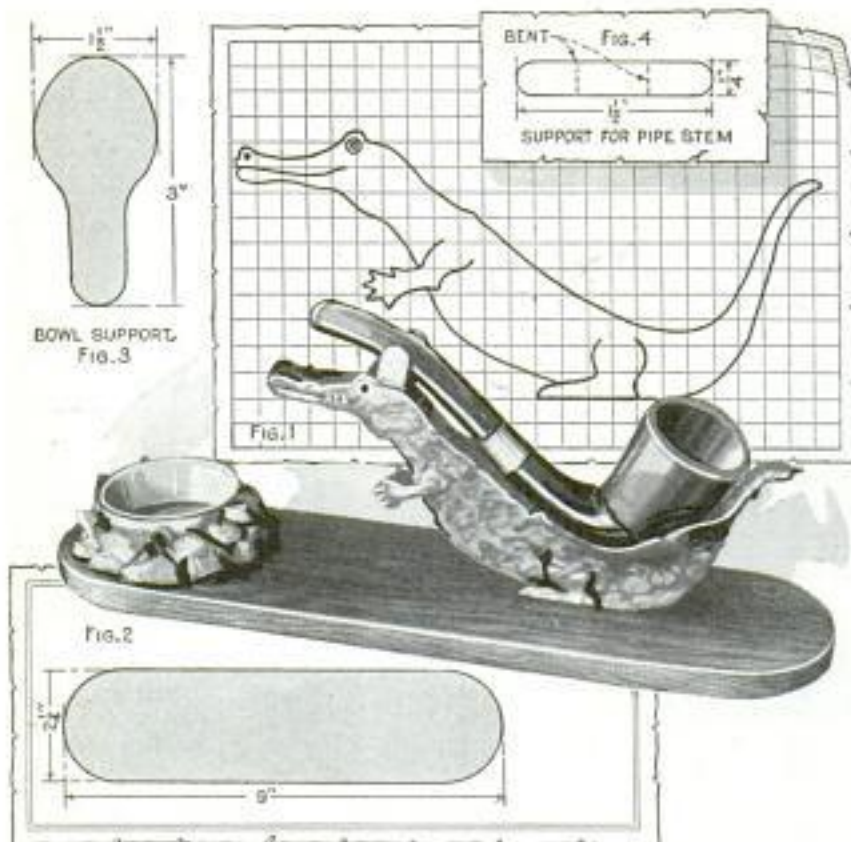

Besides Making an Attractive Ornament for Your Desk This Holder Keeps Your Pipe from Upsetting

### An Alligator Pipe Holder

For pipes with curved stems a holder made to resemble a miniature alligator will not only make an attractive ornament but will also prevent ashes and tobacco from being spilled on the table. Both the alligator body and the base are cut from three-ply veneer,  $\frac{3}{8}$  in. thick. The dimensions for the base are given in Fig. 2, while Fig. 1, laid off in  $\frac{1}{4}$ -in. squares, outlines the alligator. It may be necessary, however, to modify the curve of the back to make it fit the pipe stem. The stem and bowl supports are cut from sheet copper or brass to the shapes and sizes given in Figs. 3 and 4. Hammer the bowl support to the proper shape, using a piece of soft wood having a suitable hollow. Small brads are used to attach the copper parts to the wood, and the alligator is fastened to the base with two woodscrews driven from the underside. Plastic paint or gesso, which can be obtained at almost any paint or art store, is then applied to the alligator body. Try to make this coating as realistic as possible in its resemblance to alligator hide. While the plastic paint is drying, the ash tray or

match holder, as you prefer, is made of small pebbles cemented together with plastic paint. A very small pan is used for the tray. When finished, the base and the "mortar" may be enameled or lacquered. This should be allowed to dry before the alligator is painted. A yellow or brown is preferable, and the coat is allowed to dry until barely tacky, when statuary bronze is applied. When the paint has dried still more so that it will not come off when the bronze is rubbed with the fingers, some green bronze is applied and rubbed into the paint with a soft camel's-hair brush. The surplus is blown off and after 15 minutes, a clean, soft

cloth is used to rub down the high spots, leaving the green in the depressions only. The dull bronze will remain on the sides of the depressions while the high spots will take a sheen. Afterward black lines, indicating legs, and the black spots for eyes can be carefully painted on.

### Battery Filler Used for Gluing

For applying small quantities of glue, a battery filler, or common ear syringe with a removable tip, has been found handy. Pour some glue into the rubber bulb using a small funnel, then replace the tip. Squeezing the bulb brings out the glue in any amount. A small nail or large tack can be used as a stopper to plug the open end of the tip to prevent the glue from drying out and closing the opening. — William A. Thomas, Chicago, Illinois.







HERE is a splendid model plane that has performed well both as a biplane and as monoplane. The oval fuselage is gracefully streamlined. The construction of this fuselage has been greatly simplified in that the bulkhead frames are made up of only four pieces of  $\frac{1}{16}$ -in. soft balsa, notched to be set over the longerons. This construction saves much time and cement over the older method of building up rectangular frames and cementing curved strips over them.

First make the nose, shown in Figs. 5 and 16, using a disk of soft balsa,  $2\frac{3}{4}$  in. in diameter and  $1\frac{1}{4}$  in. thick, with the grain at right angles to the axis. Before the front is rounded, locate the positions of the cork cylinders that are to be cemented on later. As there are nine cylinders, they will be set  $40^\circ$  apart as shown in Fig. 4. Drill a  $\frac{1}{16}$ -in. hole in the edge of the disk at each location. These are for dowels that hold the cylinders on, Fig. 5, and the holes must not be effaced when finishing the nose. Drill a  $\frac{1}{8}$ -in. hole through the center to receive the shaft bearing; hollow out the inside and round off the front.

Next build the side frames of the fuselage, using  $\frac{1}{8}$ -in. square medium-balsa longerons, 21 in. long, and 6 curved bulkheads of  $\frac{1}{16}$ -in. soft balsa. These frames are spaced as shown in the perspective drawing Fig. 16, with the greatest dimensions at bulkhead No. 3, where the longerons are 2 in. apart across the top and bottom, and 3 in. apart from the top to the bottom. The exact details of this bulkhead and its dimensions, are given in Fig. 8. The other bulkheads are cut to conform

to the curve of the longerons, the upper pair being spaced 2 in. from the lower pair at the nose and  $1\frac{1}{2}$  in. where they join at the tail. All joints should be neatly cemented together. Cut notches in the nose, about  $\frac{1}{4}$  in. long and of such depth that the ends of the longerons will come flush. Cement in place, and insert a pair of diagonal braces of  $\frac{1}{8}$ -in. square medium balsa between bulkheads No. 2 and 3. Install the 16 fairing strips of  $\frac{1}{16}$  by  $\frac{1}{8}$ -in. soft balsa, evenly spaced, four between each pair of longerons. A  $\frac{1}{4}$  by  $\frac{3}{8}$ -in. piece of hard balsa, with an aluminum or brass tube running through the center, is used for the upright and the S-hook support at the tail. Fairing strips do not cover the extreme rear panels, as these are left open to get at the S-hook. A piece of soft balsa, tapered toward the front end, is cemented on top of this section.

The cockpit is located between bulkheads No. 3 and 4, and a cowling is made



Streamlined Throughout, This Graceful Monoplane Has Been Found an Exceptional Performer

A.A.C. Model Aircrafts, 188 St. New York  
 340 E. 188 St. New York

Supplies of deal Co. 19 W. 18 St. New York  
 Peru Model Aero Shop  
 Peru. Ind



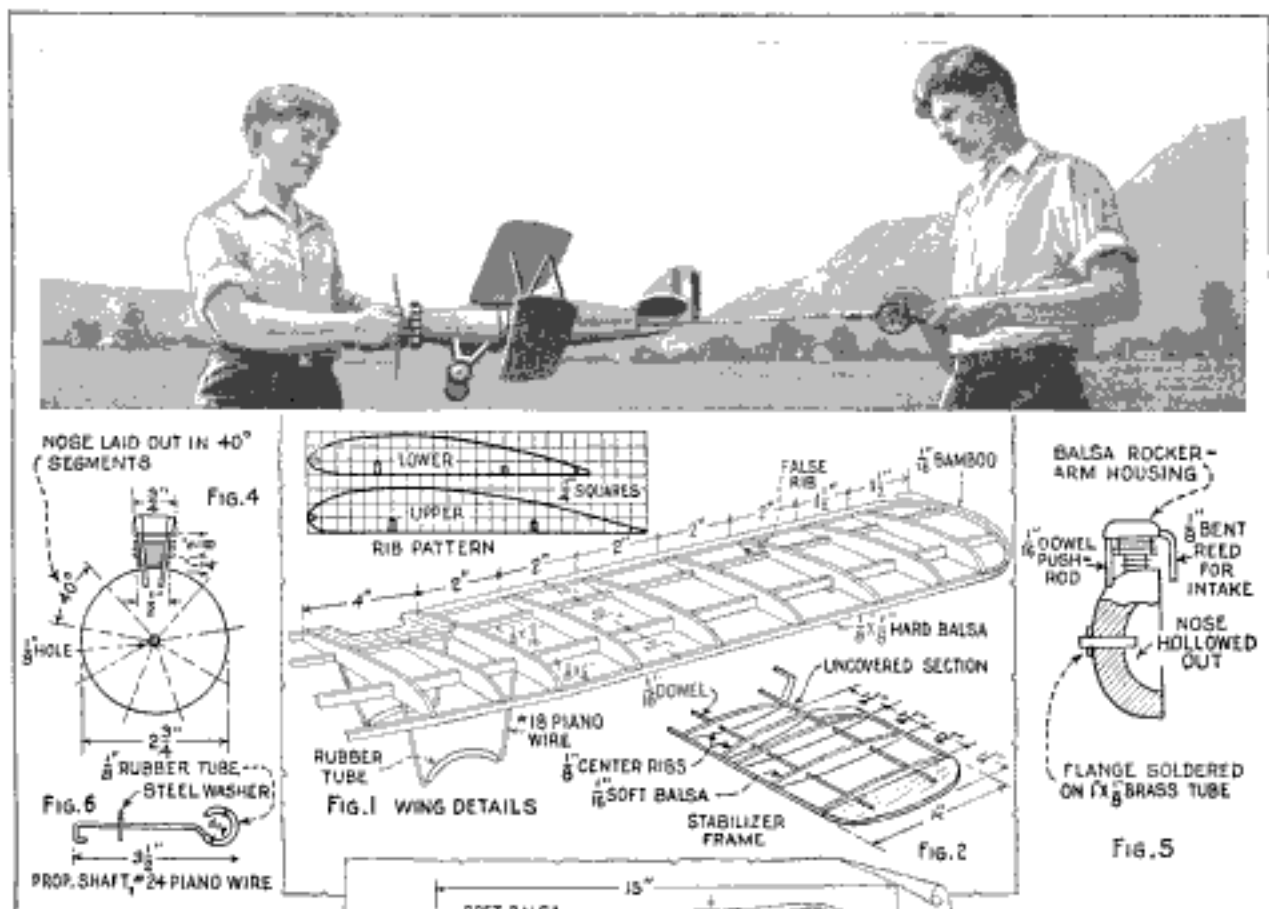

of thin sheet balsa. No. 24 piano wire is used for landing gear, attached in the manner illustrated, and carrying  $2\frac{1}{4}$ -in. wheels made of wood curtain rings for tires, button-mold disks, and hubs of  $\frac{1}{8}$ -in. brass tubing, outside diameter, as shown in Fig. 14. A soft-balsa trapdoor under the fuselage, between the nose and bulkhead No. 1, completes the fuselage.

In building the wings, you will notice that the top one has a slight dihedral, Fig. 9, and a sweepback, Fig. 3 and 7, making it very effective in appearance, besides, of course, increasing its efficiency. The lower wing, Fig. 12, is flat and straight. In both wings, however, the tension of the doped covering will draw the tips up, but will not seriously affect performance. Forward spars are made of  $\frac{1}{8}$  by  $\frac{1}{4}$ -in., the rear ones of  $\frac{1}{8}$  by  $\frac{3}{16}$ -in., the leading edge of  $\frac{1}{8}$  by  $\frac{1}{8}$ -in. hard balsa, rounded in front, and the trailing edge of  $\frac{1}{8}$  by  $\frac{1}{4}$ -in. spruce, tapered toward the back. See Figs. 1 and 12. The tapering can be

done with a small, sharp plane set for a very thin cut, finishing with fine sandpaper stretched over a flat block. The rib outlines are given in the details above Fig. 1, and show the locations of the entering and trailing edges, and spars. Use only a good grade of  $\frac{1}{16}$ -in. soft sheet balsa for the ribs, cutting them with a razor blade. The two central ribs on the lower wing, however, are made of  $\frac{1}{8}$ -in. balsa and braced to adjoining ribs with two  $\frac{1}{8}$ -in. pieces. To make the sweepback on the upper wing, bend the frame pieces to the required position, cement spars, ribs and edges together, and hold in place with pins on a flat board until the cement hardens. The dihedral on the upper wing should be about  $2^\circ$  so that the tips will be about  $\frac{3}{4}$  in. higher than the center, as shown in Fig. 9. By setting the wing frame on two boards joined to form a  $1^\circ$  angle and holding them down with small weights until the cement has set, they will retain this angle until the paper is put on, and then the dope will









With Certain Variations in Design, the Ship Has Been Modeled after a Vought "Corsair"

draw them up another degree. Curved wing tips, Fig. 1 and 12, can be made either of  $\frac{1}{16}$ -in. bamboo or dowel stock, moistened and bent to shape over a candle flame or electric lamp. Upper-wing supports, which raise the wing above the fuselage about  $1\frac{1}{4}$  in. at the leading edge and 1 in. at the trailing edge, are made of No. 18 or 20 piano wire, bent to the proper shape and covered with streamlined strips, as shown in Fig. 14. Eyelets or loops for the wing struts are made of No. 12 wire and are located as indicated in Figs. 3 and 12.

The rudder is formed of  $\frac{1}{16}$ -in. dowel stock and pieces of balsa, Fig. 11. The rudder turns on a wire axle inserted in a metal tube at the tail end of the fuselage. Adjustment to port or starboard is made by means of a short wire at the leading edge, set in one of a number of small holes in an aluminum plate cemented to the top of the fuselage. Dowels,  $\frac{1}{16}$  in. in diameter, are used for the edges and spars in the stabilizer, Fig. 15, and sheet balsa forms the curved tips. The stabilizer is held to the fuselage with rubber bands, as are the wings. No dimensions are given for the length of the wing struts, as these must be fitted. They are made in the shape of a reverse letter "N," Fig. 13, the parts being bound together with tinned wire and soldered, while the streamlined balsa strips are cemented on. Wing skids of semicircular shape are attached to the underside of the lower-wing tips, and are made of No. 12 piano wire, indicated in

Fig. 14. As this ship is powered with 12 or 14 strands of  $\frac{3}{16}$ -in. flat rubber band, an 11-in. propeller can be used. It is the toothpick type, made of hard balsa and has a moderate pitch. The detail, Fig. 10, gives the pattern for the blades.

There is considerable work on the cork-cylinder motor, but it adds greatly to the appearance of this little craft. The cylinders are made of bottle corks, with the grooves between the cooling fins cut with a thin hacksaw blade and smoothed with a piece of fine sandpaper folded over the saw blade. For doing this on a lathe, or with a handdrill used as a lathe, cut the head off a small wood screw, clamp it in a chuck and screw the cork on. The rocker-arm housings are made of soft balsa, pushrods of small dowel or reed, and the intake pipes of reed. The cylinders, however, should not be put on until after the fuselage has been covered. Care must be taken in this part of the job. Use a good grade of rice paper, applying the glue lightly with the fingertip to the longerons, but not to the fairing strips. Separate strips of paper are required for the sides, top and bottom. Put on the side strips first, then the top and bottom strips. The wings should be covered on the bottom first, with glue applied only on the central ribs, the entering and trailing edges and the wing tips. Do not glue to the intermediate ribs. The same procedure applies to the rudder and stabilizer. After the glue has dried, put on two or more coats of dope, with time between for each to dry. Aluminum paint makes an effective finish for the entire ship, with the exception of the wing struts, tires, and cylinders, which should be black. A small pilot's head, carved from soft balsa, with helmet and goggles painted on, adds a realistic touch.

As all model builders know, a biplane is not as easy to fly as a monoplane, owing to the more intricate adjustment of two wings. Properly set, however, this model has been found to be an exceptional performer in both ways. The wings should have an angle of incidence of about  $1^\circ$ , Fig. 14, but as no two models built from the same plans are exactly alike, experiment may prove a slightly different setting more efficient. Generally, the plane will fly best with the leading edge of the upper



wing located directly over bulkhead No. 1, and the leading edge of the lower wing as far forward as the landing struts will permit. Adjustment of the trailing edge of the stabilizer is also a factor in proper flight. This can be raised by slipping a small piece of wood between it and the end of the fuselage. Try gliding it before taking off under power. At first, do not wind the bands more than 75 turns, but after the rubbers have been worked in, about 125 turns are a safe limit. To fly as a monoplane, simply remove the bottom wing and adjust the upper wing to the proper location, which should be determined by test gliding.

### Glue Stiffens Limp Rugs

Small rugs that have become limp, have a tendency to be kicked up on every possible occasion, keeping the floor in an untidy state and offering a menacing obstacle to trip over. To re-size such a rug and give it the necessary stiffness, dissolve 1 lb. of granulated glue in 1 gal. of boiling water, tack the rug to the floor, face down, and apply the glue to the back with a whitewash brush. Leave in this position undisturbed until thoroughly dry.

### Football Line-Up in Photo Cut-Outs

Photo cut-outs afford the school or individual fan an inexpensive method of maintaining a miniature hall of fame for the yearly crop of football heroes. Individual pictures of the players in uniform are pasted on cardboard and then cut out and mounted on wooden bases. The cut-outs are arranged in a group in which the picture of each player is inserted in his playing position, affording a realistic set. The same idea applies also to other sports.

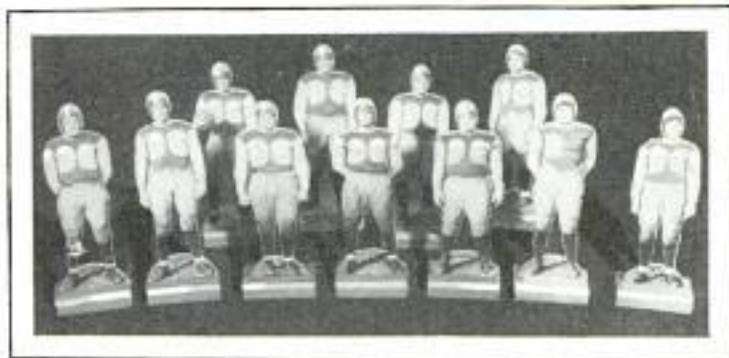

Photos of Football or Basketball Players Glued on Cardboard Cutouts and Mounted on Small Blocks

### How to Print on Photos

Printing your name on photos when developing them is easy to do. Have a show-card writer paint the name in black

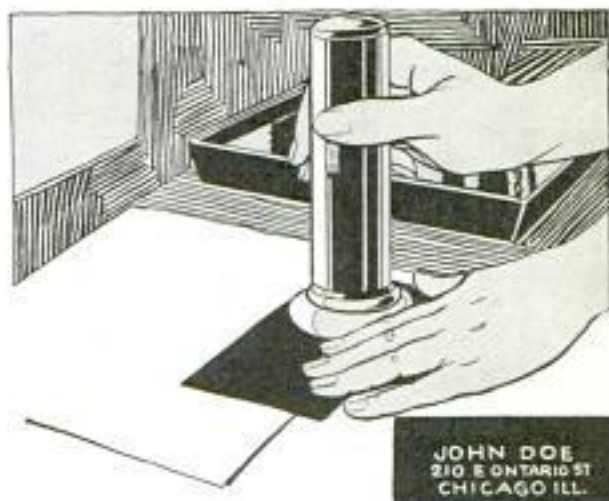

This Negative Is Used to Print Your Name and Address on Photographs

on a white card. Make a photographic reduction, which can be transferred to the photo with the aid of a flashlight having a flat lens about 2 in. in diameter. After the print has been exposed in the usual manner, place the flashlight with the nameplate negative in contact with the print. Hold the plate tightly over the lens so that no light will leak through around the edges, and expose the print to a short flash with the light. After developing in the usual manner, the name will appear in black letters on the finished print.

### Electric Iron Bends Bamboo for Model Airplane Parts

Heat an electric iron and set it up on end. Take the bamboo, after it has been cut to size, and bend it as near as possible to the desired shape. While it is being held in this position, place that part of it where the bend is sharpest, against the hot surface of the iron. The heat will soften the bamboo so that it can easily be bent. If the piece is to have more than one curve, or if the curve is very large, heat it in several places. Hold it against the iron until it gives, then remove and hold it in shape until cool. Blowing on it will hasten cooling. —John Louis Cato, St. Louis, Mo.





Ironing Board, Which Slides under Kitchen Table, Is Ideal for Use in Small Apartments

### Ironing Board Slides under Table

An ironing board that slides under the kitchen table will be appreciated by many women who live in small apartments and have only a few small articles to iron. A slot is cut in the end of the table frame for the board, and a notch for the single leg, which is hinged to the end of the board. With the leg folded up against the board and held there with a small hook at the end, both can be slid back under the table top. A cleat, screwed onto the under side of the board at its inner end, will serve as a stop to prevent the board from being pulled out too far.—Mrs. C. Harmon, South Bend, Ind.

### Waterproofing Protects Canvas against Mildew

Unless canvas is waterproofed, it will deteriorate rapidly from mildew. The best grade of untreated cotton duck will last only from one to four years, but if properly waterproofed, it will be serviceable for eight to ten years. Painting white cotton duck with linseed or cottonseed oil is objectionable as this treatment reduces its strength and makes it inflammable and subject to spontaneous combustion. Canvas dyed with mineral dyes to a khaki color is strong, serviceable and waterproof. However, this kind of canvas is expensive and hard to obtain. A cheap but effective method of waterproofing canvas is as follows: Purchase 6 lb. of medium-hard petroleum asphalt, 2½ lb. of

neutral or extracted wool grease and 1½ lb. of technical lead oleate. Place these materials in a can and melt slowly and carefully at as low a temperature as possible, stirring the mixture constantly. Also get 3 gal. of gasoline and 2 gal. of kerosene and mix them together. After the chemicals have melted entirely, remove them a safe distance from the fire and pour the liquid slowly into the gasoline-kerosene mixture, stirring constantly. If the ingredients settle to the bottom, heat the mixture in a can of hot water just before applying it to the canvas. In treating large tents or covers, a spray pump that will develop a pressure of at least 50 lb. can be used. Some loss of material results where the spray pump is used, but much time and labor are saved. Ten pounds of the chemicals and 5 gal. of gasoline and kerosene are sufficient to treat 40 sq. yd. of canvas.

### Cardboard Binding for Magazines

To keep a number of magazines together so that they will not be lost or mislaid, a cardboard binding will be found convenient. Cut two pieces of heavy cardboard just a trifle larger than the magazines. Make two slits near each side as indicated, pull a length of ½-in. tape through the slits and tie the ends of the tape together. Thus the magazines are always ready for reference.—H. Bosshard, Couvet, Switzerland.

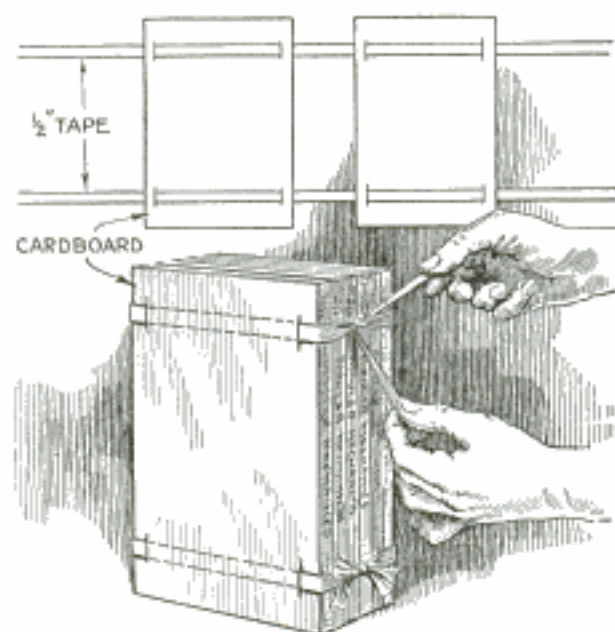

This Neat Cardboard Binding Can Be Quickly Untied When Magazines Are Needed for Reference



## A FOLDING CART TO CARRY THE CLOTHES BASKET

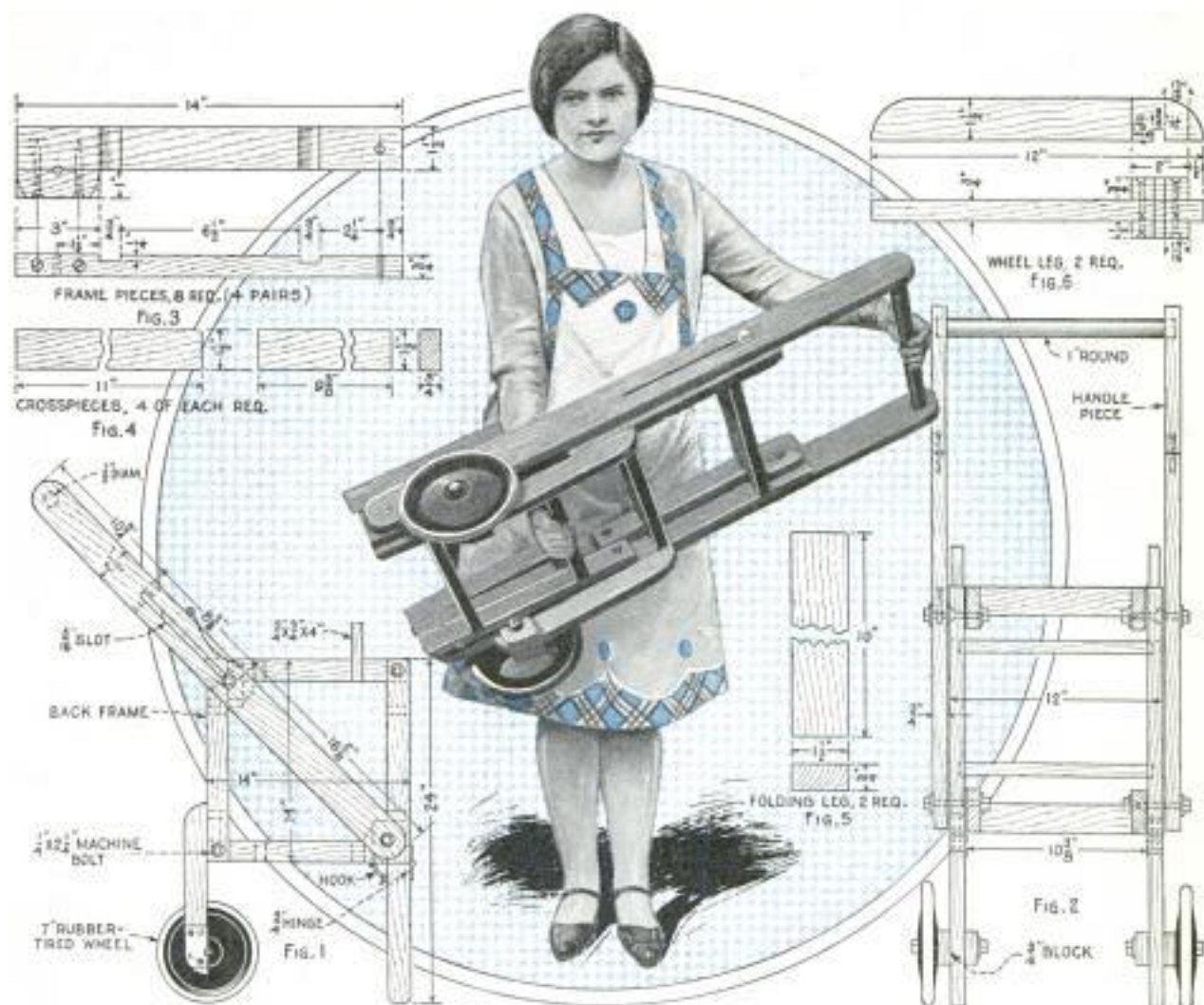

This collapsible cart places your clothes basket at the most convenient height and is pushed along while hanging or taking in the clothes. Figs. 1 and 2 show the cart assembled, and the other details show the two handle pieces and framework. Cut two lengths of 1 by 3-in. pine, 2 ft.  $11\frac{3}{4}$  in. long, and round the ends. Drill a  $\frac{1}{4}$ -in. hole through one end, for bolts, and a 1-in. hole,  $\frac{1}{2}$  in. deep, in the other, for the handle. The slide slots are  $\frac{5}{16}$  in. wide and are made at the points indicated. Smooth the pieces with No. 1 sandpaper, rounding the sharp edges slightly. Fig. 3 shows one of the eight parts of the main frame. Cut a pattern from 1 by 2-in. stock, 14 in. long, marking the length of the others from it. Also lay out the first piece for dadoes,  $\frac{3}{4}$  in. wide and  $\frac{1}{4}$  in. deep, located 3 in. from each end. Cut the sides with a saw, keeping the blade in the waste wood while splitting the lines, and chisel to depth.

When these parts are finished, cut blocks,  $\frac{3}{4}$  by 1 by 3 in. in dimensions, drilling holes through the edges 1 in. from each end, and countersinking to take 2-in. No. 10 flat-head wood screws. Glue and screw the blocks at one end of each main frame member. Be sure to arrange the blocks to make four pairs of the frame pieces. On two of these, the ends of the blocks are rounded to clear the crosspieces when folding. Eight crosspieces, as shown in Fig. 4, are required. Four of these are 11 in. long, and the other four  $9\frac{3}{8}$  in. Glue and nail the ends of these into the dadoes of the main frame pieces. The two vertical frames take the 11-in. crosspieces, while the horizontal frames take the shorter ones. Square the frames, tacking strips diagonally across to hold them rigid until the glue has dried. Two folding legs, shown in Fig. 5, are hinged to the lower ends of the front frame, and two wheel legs are made as shown in Fig. 6. Two-





Easy to Push Along While Hanging Clothes, This Folding Cart Will Prove a Great Convenience

inch blocks, one  $\frac{3}{4}$  in. and the other  $\frac{1}{2}$  in. thick, are screwed on at one end, and the dado is continued through them. Screw the wheel legs to the back frame, lapping the edges 4 in. When the frames are dry, remove the braces, and assemble the cart. Join the frames with  $\frac{1}{4}$  by  $2\frac{1}{4}$ -in. machine bolts passed through from the outside, having the heads sunk into recesses and the pieces separated with washers. To hold the folding legs straight when open, provide a hook and screweye. Mount the cart on 7-in. rubber-tired wheels, using  $\frac{3}{8}$  by 4-in. bolts as axles, and placing washers between the wheels and the wood and under the nuts. Clamp the bolts in the dados with five-penny finishing nails driven obliquely. If desired, a  $\frac{3}{8}$ -in. rod may be used as a single axle for both wheels. To hold the clothes basket in place, nail two  $\frac{3}{4}$  by  $\frac{3}{4}$  by 4-in. blocks to the sides of the upper frame. With the cart open, drill holes through the edges of the handle pieces, just above the through bolts, to receive spikes that prevent the bolts from sliding up the slots and allowing the cart to collapse. Drive screweyes into the upper edges of the handle pieces, and tie the nails to these with strings. To fold the cart, unhook the legs, push them back and then withdraw the slot nails, allowing the assembly to

collapse. If the inner washers of the wheel bolts strike, drive them into the frame parts with a hammer. Drill holes through the upper ends of the handle-piece slots, to receive nails which lock the cart in the folded position. A coat of linseed oil will protect the wood, but if a paint finish is desired, remove the bolts and paint the parts separately, allowing them to dry before reassembling.

### Truing Up an Oilstone

Oilstones are easily and quickly trued up without running the risk of spoiling them, as is often the case when they are held against an emery wheel, by grinding them on a planed cast-iron surface covered with a mixture of emery and water. Rubbing the stone back and forth across this surface will soon produce a smooth, true face.

### Rack for Draining Bottles

Those who make beverages at home often find the draining of freshly washed bottles a tedious task. By building a rack as shown in the photo, a number of bottles can be drained at the same time without making a mess in the kitchen or basement. The drain board slopes toward one end so that the water will run into a pail. As soon as the last bottle is placed on the rack the first is ready to be removed, making the work continuous.

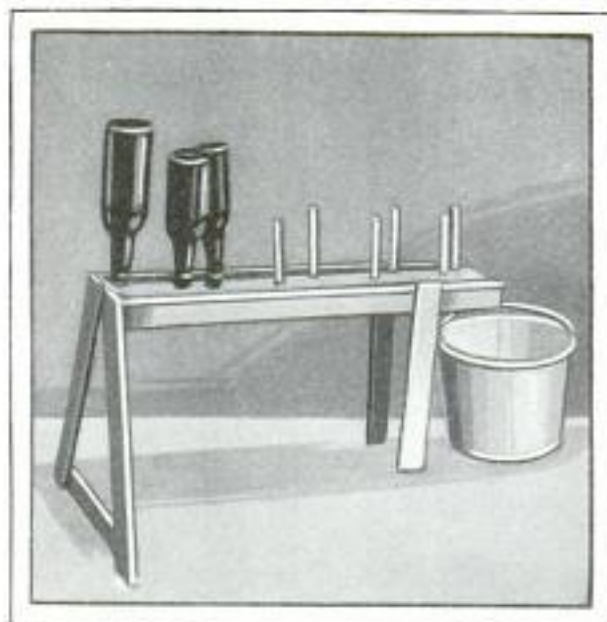

Rack Holds Washed Bottles for Draining and Water Runs Off into Pail



### Wax Fastens Lamp Socket

When converting a candlestick into an electric lamp, difficulty is often encountered in fastening the socket to the base. Drill a hole for the wires in the center of the candlestick. After the wires have been connected to the lamp socket, pour a quantity of hot sealing wax, battery tar, or a mixture of the two, into the candle hole and quickly press the socket in place, holding it there until the wax cools.

### Feathers Transferred to New Pillows

To transfer feathers from one pillow to another, sew the new pillow shut with the exception of a small opening at one corner. Rip a similar opening in one corner of the old pillow and sew the edges of the openings together so that the feathers can be shaken from one pillow into the other. After this has been done rip the pillows apart and sew up the opening.

### Tire Pump Used to Supply Pressure for Kerosene Container

After the pump on an old pressure-type kerosene can was found broken beyond repair, a valve stem was soldered in a hole punched through the top to permit the use of a tire pump, which was found entirely satisfactory for the purpose. If desired, any ordinary can having a screw cap on the cover can be quickly converted into a pressure tank by soldering in a valve stem and also a length of copper or brass tubing, bent over at the top end while the lower end is extended nearly to the bottom of the can, as shown in the drawing. The screw cap is fitted with cork or rubber gaskets to make it air-tight.

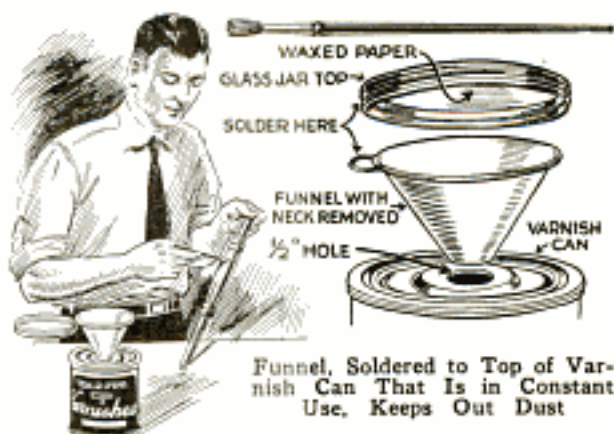

### Keeping Dust Out of Varnish Can

When a small can of varnish is open for constant use, a considerable amount of dust gets in. To avoid this, cut or drill a hole through the lid and solder part of a tin funnel over the hole as shown in the drawing. Also solder a jar top with waxed paper on the inside to the ring on the edge of the funnel, which serves as a hinge. The varnish is then always accessible without the trouble of prying off the lid and replacing it.

### Celluloid Cement Has Many Uses

Celluloid dissolved in acetone can be used as an adhesive, as a preservative varnish, or for purposes of strengthening porous materials by impregnation. Celluloid scraps are cut into fragments and put into a bottle until it is about one-fourth full, after which enough acetone is added to fill the container about three-fourths. Shaking the bottle will help dissolve the mixture until it assumes the consistency of a sirup, which may be thickened by exposure to the air to form a cement, or thinned by adding more acetone and shaking. The solution should be as free from water as possible, as the varnish tends to whiten on drying if it contains water. When dry, this cement has great strength, is air-tight and waterproof, yet flexible. It is attacked by few chemicals and can be colored by adding a dye. It is valuable in repairing glass, amber, pottery, porcelain, ivory, enamel and like substances. As a varnish, it is useful to cover metallic surfaces to prevent oxidation, and may be applied by brushing, dipping or spraying. For fine fabrics, the varnish is diluted with acetone and applied with an atomizer.

*Copyrighted material*  
 C.W. Douglas Leechman  
 National Museum

*Ottawa, Canada*



## GREAT SPORT WITH THIS ROLLER-SKATE COASTER

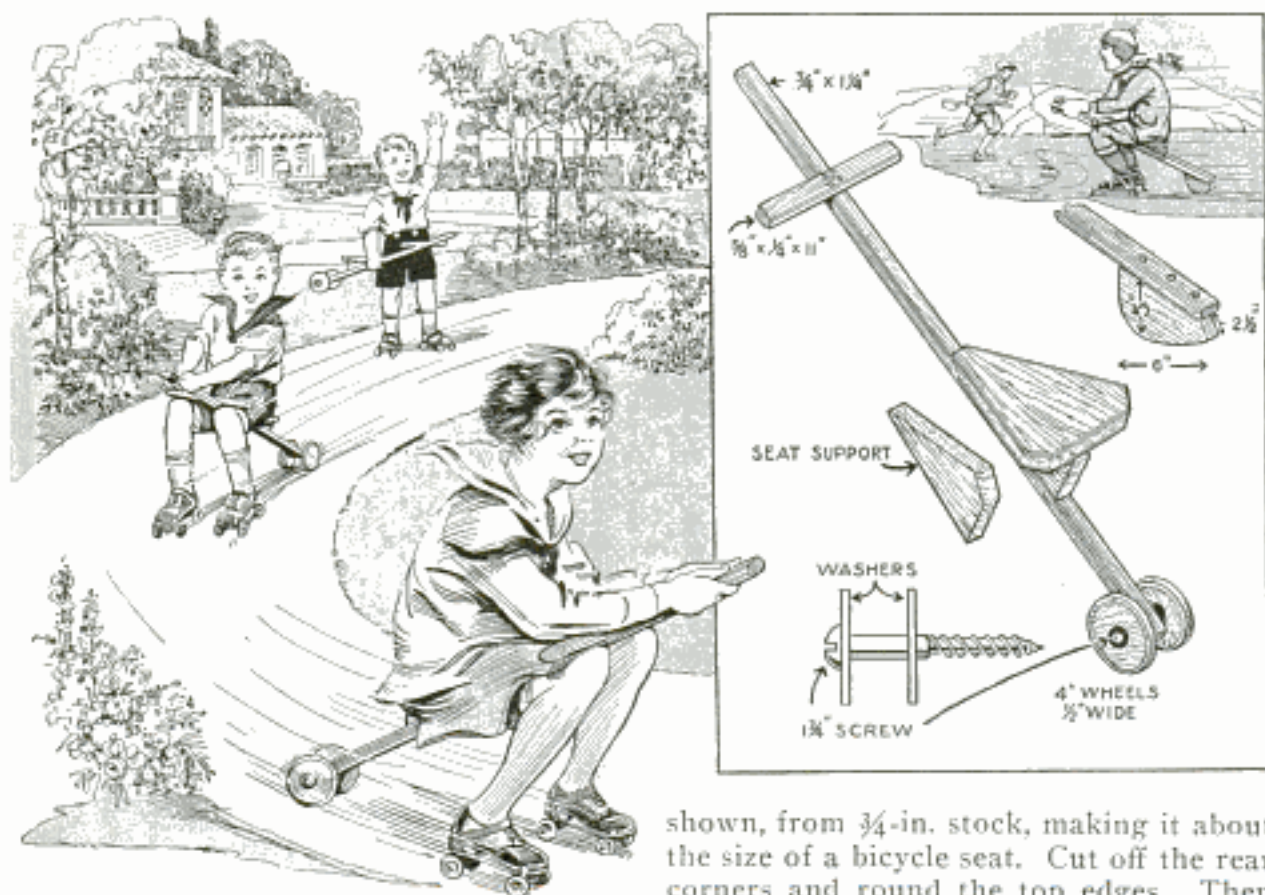

Lightweight Convertible Coaster for Skates Can Be Used Both Summer and Winter

Here is a coaster you can use with your roller skates. It is so light that you can easily carry it in one hand and either sit down to coast after getting up speed or use it on hills. When winter comes, simply take off the wheels and substitute a single runner underneath and use it on ice or for coasting. A crosspiece near the front makes riding comfortable, as it rests on the knees. In this manner a three-point support is provided, your skates forming two in front, and the pair of wheels behind, the third. To make it, get a piece of hardwood 32 to 40 in. long, depending on the size of coaster desired, and taper the board from  $\frac{3}{4}$  by  $1\frac{1}{4}$  in. at one end to  $\frac{3}{4}$  by  $2\frac{1}{2}$  in. at the other. From  $\frac{1}{2}$  or  $\frac{3}{4}$ -in. hardwood, cut two wheels 4 in. in diameter. Either turn them out on a lathe or cut them with a jig or coping saw. Fasten them to the wide end of the stick with  $2\frac{1}{2}$ -in. wood screws, using a washer on both sides to reduce friction. Also grease the screws. Taper the wheels to  $\frac{1}{4}$  in. in width at the edge, for smoother running. Cut out a triangular seat as

shown, from  $\frac{3}{4}$ -in. stock, making it about the size of a bicycle seat. Cut off the rear corners and round the top edges. Then saw off the front point at an angle, and cut a support block to fit between the seat and the stick, which will hold the seat in a horizontal position when in use. A little experimenting will give you the most convenient angles to use. After attaching the seat temporarily put your skates on and sit on the coaster, holding up the handle, and determine the best location for the seat and knee brace, after which they are permanently nailed or screwed on. The knee brace should be about  $\frac{5}{8}$  by  $1\frac{1}{4}$  by 11 in., and the edges rounded off for comfort. To obtain a strong joint, glue the contacting surfaces of the seat and knee brace before nailing. To change the coaster for winter use with ice skates, remove the screws holding the wheels and provide a single runner of the size shown in the detail. Glue and fasten with screws to the underside of the stick as shown. Go over the whole job with a double coat of red, yellow or white paint. A strip of light strap iron or heavy galvanized sheet iron will make the edge of the runner more durable. Nails or screws used on the underside of the runner should, of course, be countersunk and filed flush.



### Oil-and-Charcoal Mixture Preserves Fence Posts

Almost any kind of wood used for fence posts, can be made to last if coated with a solution consisting of boiled linseed oil in which pulverized charcoal has been stirred to the consistency of paint. This mixture is cheap, easy to prepare and is applied with an ordinary paintbrush. A number of poplar posts left in the ground for seven years were found to be as sound and free from defects as they were when new. The paint should, of course, be allowed to dry before putting the posts in the ground.—Chas. Illingworth, Vancouver, B. C., Can.

### Turning a Set of Chessmen

Turning a set of chessmen is an interesting job for any amateur woodworker. The white men are made of birch or maple and the others of mahogany or walnut. All the pieces are mounted on a screw chuck. Be sure to use sharp tools and very little sandpaper. Dimensions are given in the drawing, but these can be varied somewhat to suit your taste. The knights with carved heads may seem hard to make, but with a little care and patience the job can be done by anyone. Finish with a small file and sandpaper. After turning the pieces, sand them carefully and then give them three coats of shellac, polishing each coat with powdered pumicestone and oil.

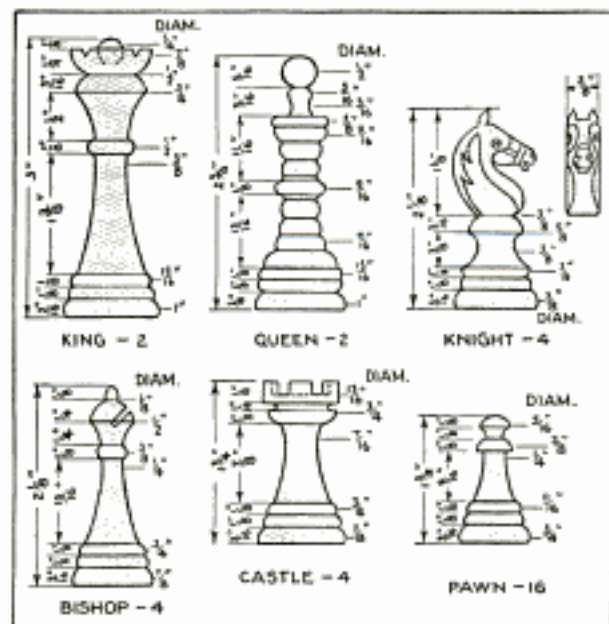

Here Are All the Necessary Dimensions for Turning an Attractive Set of Chessmen

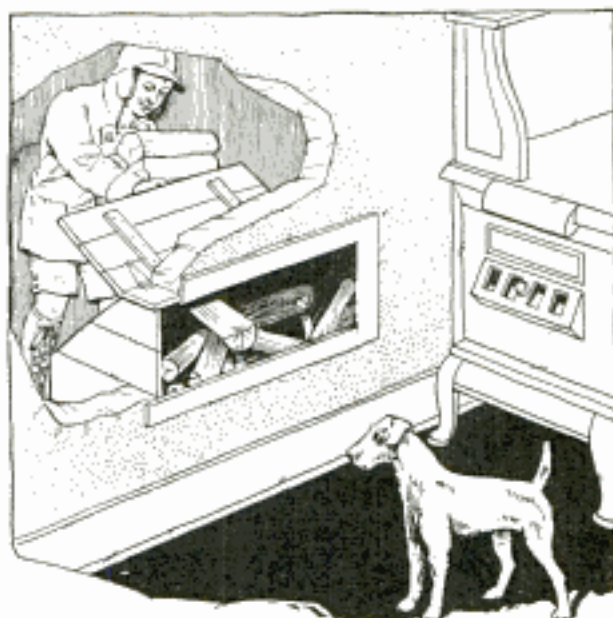

This Built-In Woodbox for the Farm Kitchen Can Be Filled from the Outside

### Kitchen Woodbox Filled Outdoors

It will be found convenient to build a wood box for the farm kitchen that can be filled from the outside, as shown in the drawing. An opening through the wall allows access to the box from the inside, and it will be found best to provide a hinged door for the opening to keep out the cold.

### Hookless Fastener Closes Hole in Auto Curtain

When driving a car with side curtains, an opening through the curtain on the driver's side is convenient for signaling a motorist behind. Instead of using a flap to cover the opening, provide a hookless fastener. When the opening is not needed constantly, it can be closed tight to keep out the cold air.

### Water Used to Lower Tank into Pit

After digging a hole for a large gasoline-storage tank, a western man found the container too large for him to lower alone. He had no help, but finally solved the problem by filling the hole with water, rolling the tank in and then pumping out the water. The tank settled safely and easily to the bottom.

☛ To tighten loose doorknobs, wrap two or three turns of  $\frac{1}{2}$ -in. adhesive tape around the shank at the setscrew.



## AUTO GLASS USED TO MAKE A LARGE AQUARIUM



A Plate-Glass Aquarium with a Frame of Angle-Iron Will Accommodate a Large Number of Goldfish

With four pieces of plate glass, a length of angle iron, a few iron rivets and some homemade cement, you can build a large goldfish aquarium holding over 20 gal. of water for less than \$5. The glass can be obtained from an automobile junk yard. Rear windows of closed cars are used, as their size is most suitable for the purpose, each piece being approximately  $29\frac{1}{2}$  by  $13\frac{3}{4}$  in. in dimensions. For the framework, a length of 1 by 1 by  $\frac{1}{8}$ -in. angle iron is needed. Dimensions for the glass and iron can be varied to suit the size of the aquarium desired. The frame should be slightly larger than the glass, so that the cement will seal the edges completely. Where the ends of the iron are joined, as shown in Fig. 3, they are cut at a  $45^\circ$  angle by using a miter box as shown in Fig. 1. Iron rivets, cut fairly short and with heads on the outside, are used to assemble the frame, as shown in Fig. 2, although welding is better. Holes for rivets are drilled while the pieces are held together in a vise in order to assure accuracy. The cement used consists of plaster of paris, 6 oz.; fine, washed sand,

6 oz.; powdered rosin, 2 oz.; enough linseed oil to form a stiff paste, and a small quantity of drier, the last two ingredients being obtainable at a paint or hardware store, and the others at a drug store. The cement is applied generously, so that it completely fills up the space between the frame and the glass. Two batches of cement made in the proportions given may be required. Allow several days for setting. For patching small holes, another cement is made of litharge moistened with glycerine to form a paste, which will dry as hard as stone. This cement is excellent for making water-tight joints, but it is too costly for use on the entire aquarium. Support the glass with braces

and clamps until the cement dries. When finished, sandpaper the frame, and paint or lacquer it in the color desired. The weight of a water-filled tank makes it necessary to provide a sturdy support. Fish authorities recommend 20 sq. in. of surface area in a tank for each linear inch of fish, which one should take into consideration when stocking the tank. Such a large aquarium should also be provided with adequate plant growth to supply oxygen to the water and a number of snails or other scavengers to keep the water clean. Place a 2 or 3-in. layer of sand on the bottom to provide rooting for the plants.

### Swiss Method of Producing Gun-Metal Finish

Gun-metal finish on metal can be produced with a solution consisting of 48 oz. water, 7 oz. chloride of iron,  $\frac{1}{4}$  oz. hydrochloric acid, and a  $\frac{1}{4}$  oz. copper sulphate. These are mixed in the order given and kept in dark bottles until ready for use. The parts to be treated are first polished



with fine emery dust and oil, and then wiped thoroughly clean of the oil. An even coating of the solution is applied with an old sponge. The metal will first turn to a light copper color. Let it dry for half an hour, or more if necessary, until a greenish color appears. Then place the article in the oven, heated to a temperature of about 212° F., and leave it there about 15 minutes until the color turns to a dark brown. This is the oxide of iron. Now give the article a thorough steaming over the spout of a water kettle, and then immerse it in boiling water, leaving it there for about half an hour until the color turns black. Dry the article, rub it with good flannel, and if a rustproof finish is desired, apply a thin coat of boiled linseed oil, and dry in an oven. This is the process used by the Swiss on watch-cases. It is safe, requires no special tools and can be done at home. Use only as much of the solution as needed and do not pour the surplus or used liquid back into the bottle.

### Homemade Rubber Stamps

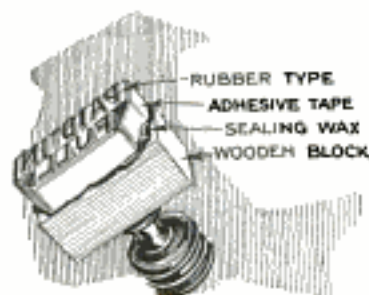

Most users of rubber-type printing sets have many surplus letters but no extra holders. Good stamps can be made

by binding each line of type with a narrow strip of adhesive tape, and then holding the lines together in the same way. After you have assembled the letters completely, taking care to get the type level, place the letters, face down, on a flat surface and press a small wooden block, with melted sealing wax on one side, against the back of the type.

### Glue Helps to Extract Splinters

Small splinters that are difficult to remove from the flesh with a needle, can sometimes be extracted by applying liquid glue, celluloid cement or collodion. Let the glue dry thoroughly, then peel it off with a single motion. Usually, the splinter will be dragged along with it.

### Secret Lock in Ignition Circuit

Anyone can readily install this secret lock in the ignition circuit of his car. Drill a hole through the floorboard to receive a flat-head machine screw. Countersink the hole so that the top of the screw comes flush. On the underside of the floorboard screw two angles made of spring brass, which will grip the nut on the end of the screw securely when the screw is pulled up. The end of the screw is peened over to prevent the nut from coming off, or two nuts can be used, being driven together to lock each other. One lead of the low-tension side of the ignition circuit is cut, and leads from the two ends connected to the brass angles, as shown. When the car is left, the screw is pushed down flush with the floor where its service as a switch will never be suspected. When the ignition current is needed, the screw is pulled up so that the nuts are wedged between the brass angles.

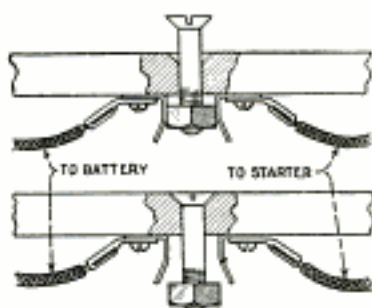

### Starting the Flower Box Early

In order to get an early start with the flower box, first put a layer of manure in the bottom and then fill up with black dirt. Nail a couple of cleats on the inside of the box to hold a pane of glass, which is cut to fit, and then plant your seeds. This arrangement provides a miniature hotbed and makes it possible to plant the seeds several weeks ahead of the usual time so that the seedlings will be quite large when warm weather arrives. If you have been in the habit of buying plants instead of seeds, to have a box blooming early, try this and note the saving.

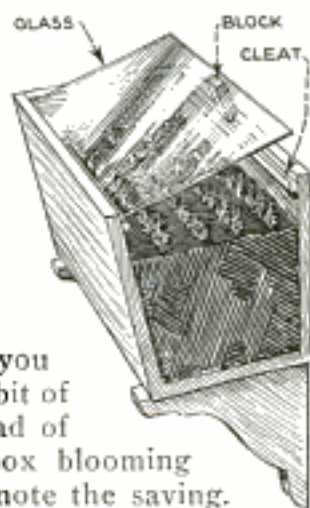



# New Doorways

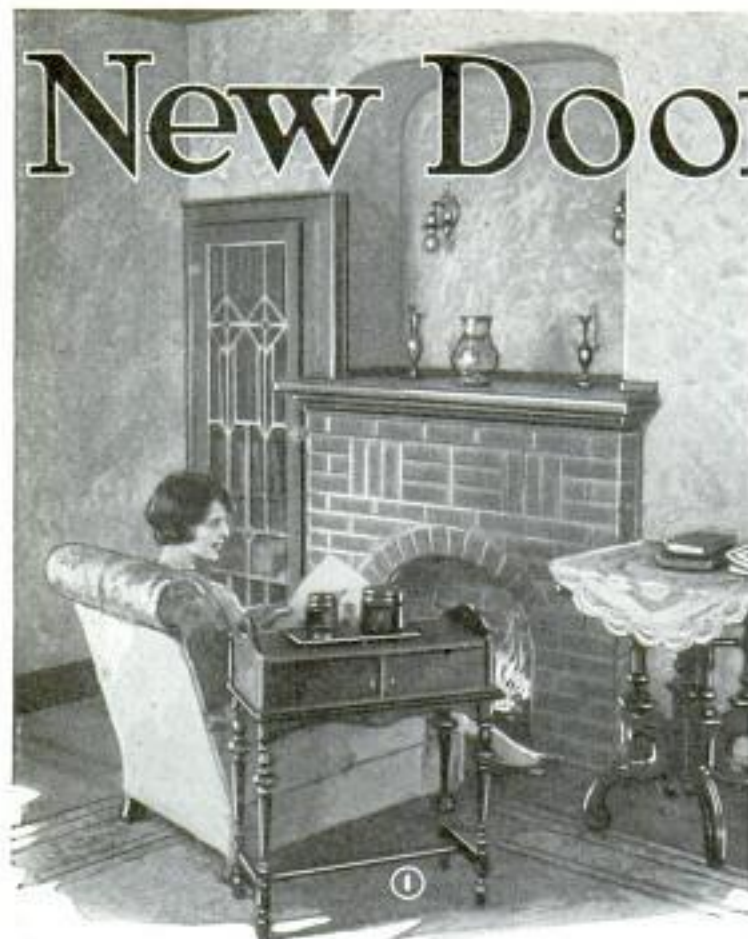

ANY home where the dining room is connected with the living room by a narrow hinged door, can be modernized, beautified and made apparently larger by simply removing the door and substituting a large arched doorway. Thus, for instance, the doorway shown in Fig. 2 originally was merely a single door.

Before tearing down the old door, the arch must be carefully planned, and it is advisable to mark it off on the wall. The top line will be at the same height as the old one but the sides of the archway may be extended as far as desired. The first step is the removal of the old door and framework. As this can sometimes be resold, try to take it down without damaging the wood. Next, the plaster and lath is cut out along the lines laid out on the wall, using a keyhole saw for the curved portions and a crosscut saw for the straight lines. This part of the work is simply a matter of "saw, man, saw," and one must keep at it until the entire cut-out is made. Do not attempt to cut through both sides of the wall at once, as this tends to loosen the plaster on the wall opposite the side you are working from, and

makes it necessary to do considerable replastering. Carefully done, the plaster and lath can be cut easily and without much plaster breaking off. Bore a hole with an auger for starting the cut with a keyhole saw. If the baseboard has not been removed entirely, one must remember, when sawing, that the corners must project sufficiently to take care of a miter joint, and the baseboard should, therefore, not be sawed off in line with the plaster cut. It is better to remove the baseboard and replace it later.

The double studs to which the old door frame was attached can be used again in the new by merely changing their position.

Reset them inside of the wall and flush with the edge of the cut-out. The top crosspiece or header will, of course, be too short for the new doorway and must be replaced with a longer one. The cut ends of the lath are then nailed to the frame. The next item on the material list consists of four arched pieces of 1-in. lumber, cut more or less to the shape shown in Fig. 3. If you wish a completely rounded arch, these pieces must be cut to carry out the required curve, but if you merely desire to round the corners, you can use the dimensions given in the detail. Doorways with little or no arch, as in Fig. 2, can be made to look quite attractive. The curved pieces are nailed to the framework and lath is then tacked on across them, allowing enough space between adjacent pieces to permit the plaster to anchor properly. The lathing is carried entirely around the doorway, and metal beading is then nailed over the corners as shown in Fig. 6. This material comes in 8-ft. lengths, and can be purchased from any dealer in building supplies. For an archway about 7 ft. high by 5 ft. wide you will need six lengths. In order to allow



same as wood fiber  
Certain Seed Product Co.

# for Old

by Robert Gregg

the metal strip to go around the curve nicely, it must be cut on either side of every nail hole as shown in Fig. 4, and all joining ends of the beading should be held together with a finishing nail, as in Fig. 5. It is obvious that no great skill is needed in putting on this beading, but the task requires care so that the curve and general form of the arch will be true and free from humps or hollows. Applying the plaster is no trick, even if you have never handled a trowel in your life. By using wood-pulp plaster almost any man can manage this bit of "mud slinging" and make a good job. (See Fig. 7.) Full instructions for mixing the plaster should be obtained from the dealer, and depends on the kind you get. Recutting and fitting the old baseboard to the new archway completes the job. The edges are mitered to fit accurately. In the case of many old houses, the flooring extends completely through the house from room to room, and needs no attention other than scraping, sandpapering and finishing with filler and varnish stain to blend with the rest of the flooring. New paper or other wall finish, which is to go on immediately after the plaster is set, should be the same in both rooms as it covers the arch also.

Stairways can often be improved by using arched

Arches of Unusual Attraction  
Will Modernize an Old Home  
and Greatly Increase Its Value

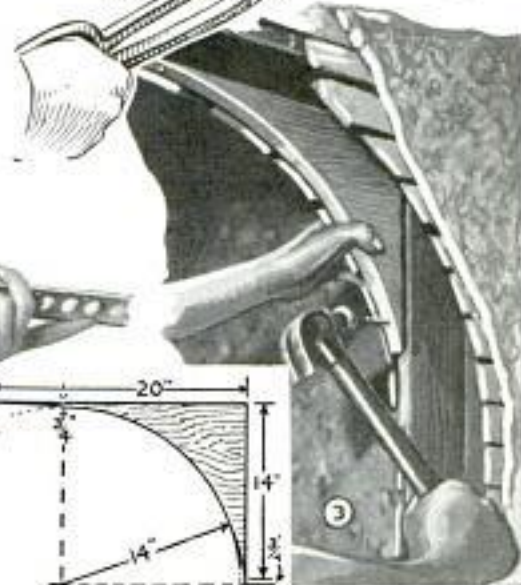
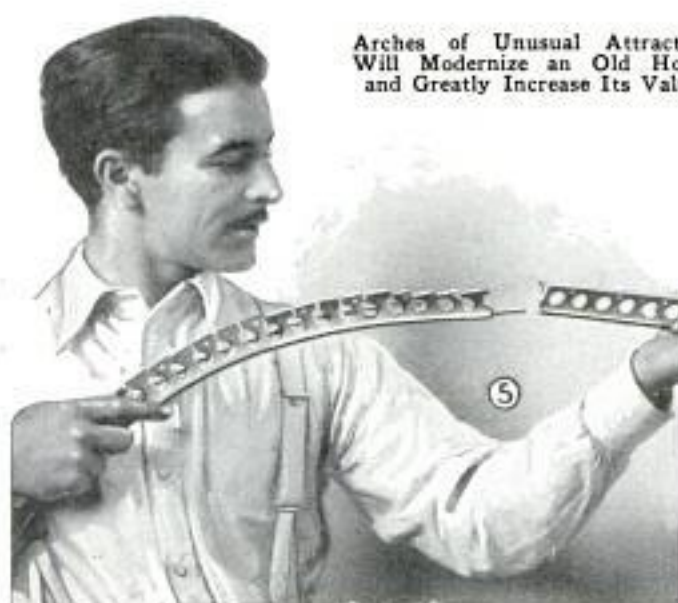





doorways. A window at the lower landing helps considerably to lighten the adjacent room. Similarly, the interior of a room can be improved by building arched recesses in the wall, as, for instance, over a fireplace, which provides an attractive mantelpiece, Fig. 1. Outside doors, especially the front door, can be modernized by working along the same general lines, although the job is more difficult, particularly in the case of brick houses. After you have graduated from the work of making interior arches, you might tackle an outside job, but not before.

In designing arches, an unlimited number of variations are possible. The basic idea can be applied all the way from a built-in bathtub to a cozy breakfast nook in the kitchen. Arched windows, while involving a trifle more work and costing more, are also practical projects when remodeling. And why stop at one arch? Between large rooms several arches in one wall have been found practical.

#### Renewing Old Clocks

Old pendulum clocks can often be given a new lease on life by drawing up the rod that holds the pendulum, and bending it over  $\frac{1}{8}$  in. This renews the spring in the upper end of the wire, which helps to make the clock go. To compensate for

the shortening of the wire, screw the pendulum down the same distance that the rod was drawn up. Pendulum clocks that have stopped after many years of service have often been put into good order by this simple method.—C. R. McClelland, Monessen, Pa.

#### Solution Keeps Photo Prints Flat

To keep photographic prints from curling or cracking while drying, soak them for a few moments in a solution consisting of 1 oz. glycerine and 20 oz. water. It will last indefinitely and can be applied to glossy or matt papers. Prints thus treated will lie flat and remain soft and pliable after they are dry. If weather conditions are such that this treatment is not sufficiently effective, use more glycerine.

#### Sliding Shelves Save Space

In small stores and shops where wall space is rather limited, a number of sliding shelves, as shown in the photo, will be found convenient for holding glass jars containing small parts. One section of the shelving is built rigidly against the wall in the usual way, and its width should be just sufficient to accommodate the jars. Two sections of shelving of the same width are built to slide in front of the stationary shelf, suitable runners being provided to permit the shelving to be moved about so that one can get at any jar without trouble.—Geo. R. Harrison, Council Bluffs, Iowa.



Sliding Shelving in a Store Holds Hundreds of Glass Jars Filled with Small Parts





### A Battery-Case "Darkroom"

The case of a three-cell storage battery makes an excellent container for developing solution for cut-film, plate or film-pack negatives. The solution is placed in one of the end compartments, water in the middle one, and the fixing bath in the other. Negatives are held by means of film clips or plate hangers. The normal battery case will take negatives of 4 by 5-in. size and smaller. The developer used should be one that remains active over a long period, so that the tank need not be emptied frequently. The level of the liquids should be kept sufficiently far below the top of the partitions to keep them from running over into adjoining compartments. If it is found that the developer or hypo baths creep up over the edges, paint the edges with melted paraffin. The

cells can be emptied individually by means of a siphon, started by a rubber bulb. One-piece containers of this kind can be obtained from most battery-service stations for a small sum. They should be thor-



oughly cleaned before they are put to use for this purpose.

### Hole in Chimney Improves Draft

One cause of insufficient draft in chimneys at the cellar opening is the formation of a vacuum in the chamber below the furnace by the hot air and gases that rush up the chimney. When air moves down to fill the vacuum, the draft is momentarily checked. The trouble can be remedied by making a small hole in the chimney wall above all accumulations of dirt and soot.

### Keeping Auto Floor Clean

Removing dust and dirt from the floor mat in the model-A Ford cars is simplified by nailing a triangular wooden strip to the floorboard just inside the sills and placing the mat on top of it. This raises the mat so that the dirt can be swept out.

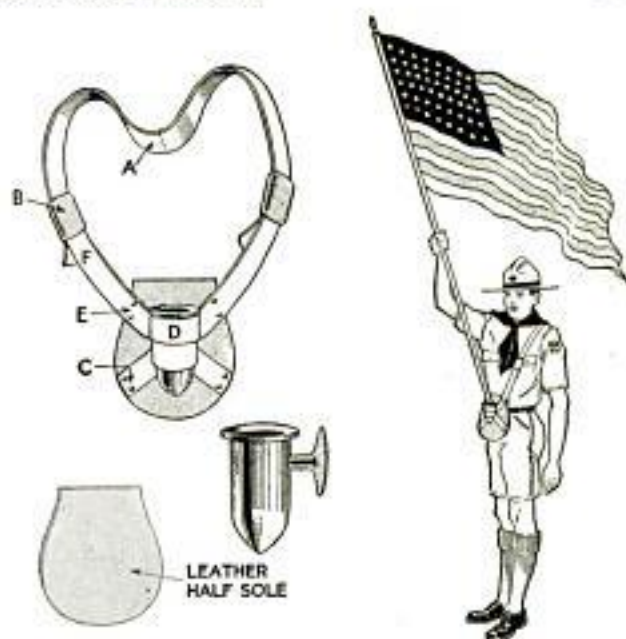

A Bakelite Ash Tray, a Halfsole and Two Belts Make This Flag Sling for the Scout Parade

### A Flag Sling for Boy Scouts

When a flag sling is needed for the parade, get a bakelite or hard-rubber ash tray of the kind fitted with a suction cup, a composition half-sole, two leather or composition belts with slide buckles, and eight  $\frac{1}{4}$ -in. brass rivets. Cut the belts in half and sew the cut ends together at A. Rivet the tongues of the belts to the halfsole at four points, C and E, wrapping them tightly around the ash tray as shown at point D, after the suction cup has been removed. The tongues are run through the slide buckles and the straps can be slipped over one's shoulder.

### Inner Tubes Protect Skates

Guards to protect skate runners can be made from inner tubes. Cut two pieces, each about  $1\frac{1}{2}$  in. wide, and pull them

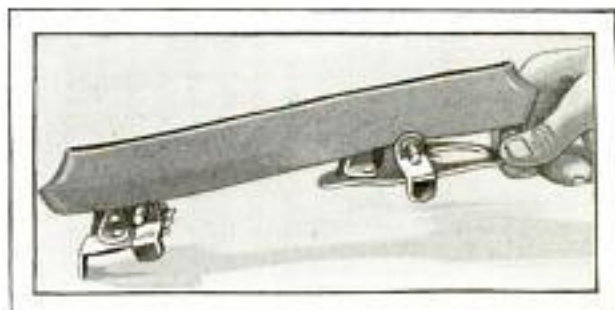

Sections of Inner Tube Stretched over Skate Runners Protect Them from Damage

over the blades. No buckles or other fastenings are needed.



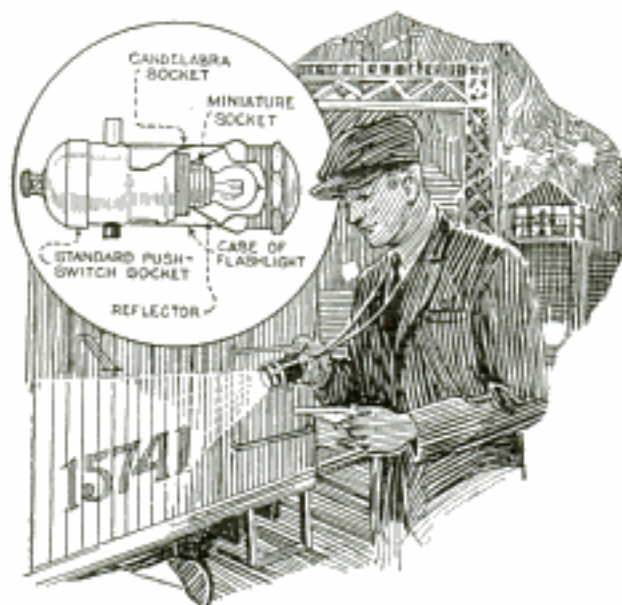

Night Workers, Who Have to Use a Flashlight Constantly, Will Appreciate This Variation

### Stubby Flashlight Gets "Juice" from Pocket Battery

Railroad inspectors, and others who have to use a flashlight regularly in their work, will find the illustrated stubby flashlight highly convenient. It is suspended from the neck on a length of lampcord which also serves to connect it to the batteries carried in the pocket. While it takes the place of any ordinary flashlight, it will be found especially handy when it is necessary to use both hands in writing in a notebook, as the latter can be held in the light while the flashlight is suspended. To make it, cut off the front end of an old metal flashlight case, get a standard push-switch socket, a candelabra socket and a miniature socket. The three sockets are screwed together as shown in the detail, after which the cut end of the flashlight case is slipped over the end of the standard socket and soldered to it. The case must, of course, be cut off sufficiently to allow the reflector to come against or over the end of the miniature socket, so that a lamp can be screwed in. The length of lampcord connected to both the standard socket and batteries is looped to enable suspension from one's neck at a convenient height.

Buttons can be arranged in assorted sizes or colors by stringing them on safety pins; this method will keep the sewing box in good order, and makes for easy matching of the buttons.

### Curing a Sticky Waffle Iron

If the batter in your waffle iron sticks, try the following method: Turn on the current to the waffle iron, and after it has become hot, rub paraffin over the plates and close the lid. Wrap a wet towel around the iron and let the paraffin boil for 10 to 15 minutes. Remove the towel, and brush the hot surfaces of the plates with a steel brush or with steel wool. Then clean off with warm water, being careful to remove all traces of the steel wool. After this treatment, the waffle iron will not give any more trouble.

### Self-Locking Spring Connectors

For those who experiment with electricity, these quickly made, self-locking spring connectors for clipping wires to terminals temporarily, will be found useful when regular clips are not at hand. Strips of spring brass, about 4 in. long, are drilled at one end and about 1 in. from the other end, after which the strip is rolled so that the holes nearly come into alignment. By squeezing the strip until the holes coincide, it can be slipped over the terminal, and its tendency to pull apart locks the clip on the terminal. The clips are soldered to one end of the wire, and if necessary, the straight part can be wrapped with tape, in order to make the connection stronger.

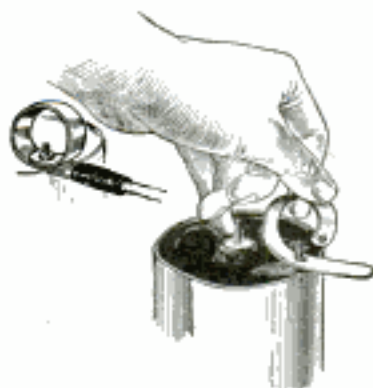

### Rubber Band Keeps Windshield Wiper Out of Way

Loop an elastic band over the blade of your windshield wiper and then pass the free end over the body of the wiper motor. This will keep the wiper out of the line of vision when not in use, and no harm will result should you forget to remove the band when the wiper is turned on, although the band will of course, hamper its operation.—F. H. Friedel, San Bernardino, Calif.



### Speeding Up the Setting of Plaster of Paris

Although plaster of paris sets in a fairly short time, it is sometimes a great convenience to have it set still more quickly. To do this, add one teaspoonful of salt to each pound of dry plaster and mix well. Then add the required amount of water, preferably hot, and mix quickly. When the mixture is free from lumps, pour it into the mold without the least delay, as the setting will take place rapidly. The process can be slowed up a trifle by using cold water instead of hot, but in either case the set will take less than two minutes. The more salt added per pound of plaster, and the hotter the water, the less will be the time required for setting. Some casts have set in less than a minute, a fact that will interest workers in plaster casts.

### Door Hook Serves as Lock

By making a few changes in a flat-iron door hook, it can be made to serve as an efficient lock, which is tamper-proof from the outside. At the pivot end a number of holes are drilled to form an L-shaped slot which is filed smooth to receive a wood screw of suitable size. A notch is filed at the end which engages with the

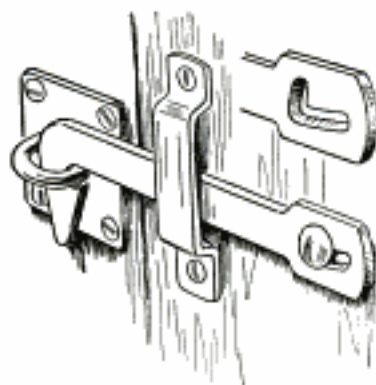

staple. The hook is installed at a slant so that it will have a tendency to slide toward the locked position. The latch is lifted by pushing the pivot end and then removing the hook from the staple in the usual way.

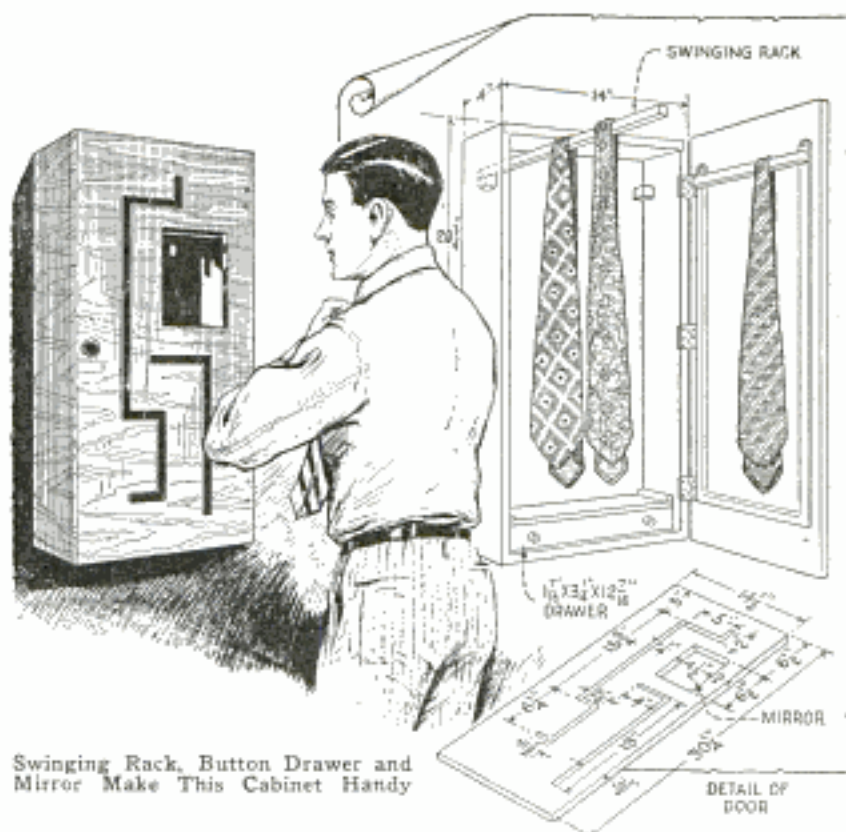

Swinging Rack, Button Drawer and Mirror Make This Cabinet Handy

### A Cabinet for Your Neckties

Replacing the familiar rack, this cabinet for your neckties will protect them from dust and also provide a place for cuff and collar buttons, tie pins, etc. A mirror, set at the right height, will also be found useful and the door may be inlaid to make it more attractive. One rack is fastened to the back of the door while the other rack is pivoted to a bracket screwed to the side near the top, so that it can be swung outward. All necessary dimensions are given in the drawing. The sides can be made of  $\frac{3}{4}$ -in. poplar, the back from a piece of composition board, and the door is cut from three-ply veneer. The cabinet is mounted on the wall on wood screws at a suitable height.

### Proper Humidity Helps Chicks Break Shells

By placing a can of water in an incubator a few days before the eggs are to hatch, chicks will be better able to break the shells. The lid should be perforated with holes to allow evaporation and to prevent the chicks from falling into the can if it is shallow.—G. R. Dymont, Hamilton, Can.



## AUTO SHORTCUTS THAT ARE WORTH REMEMBERING

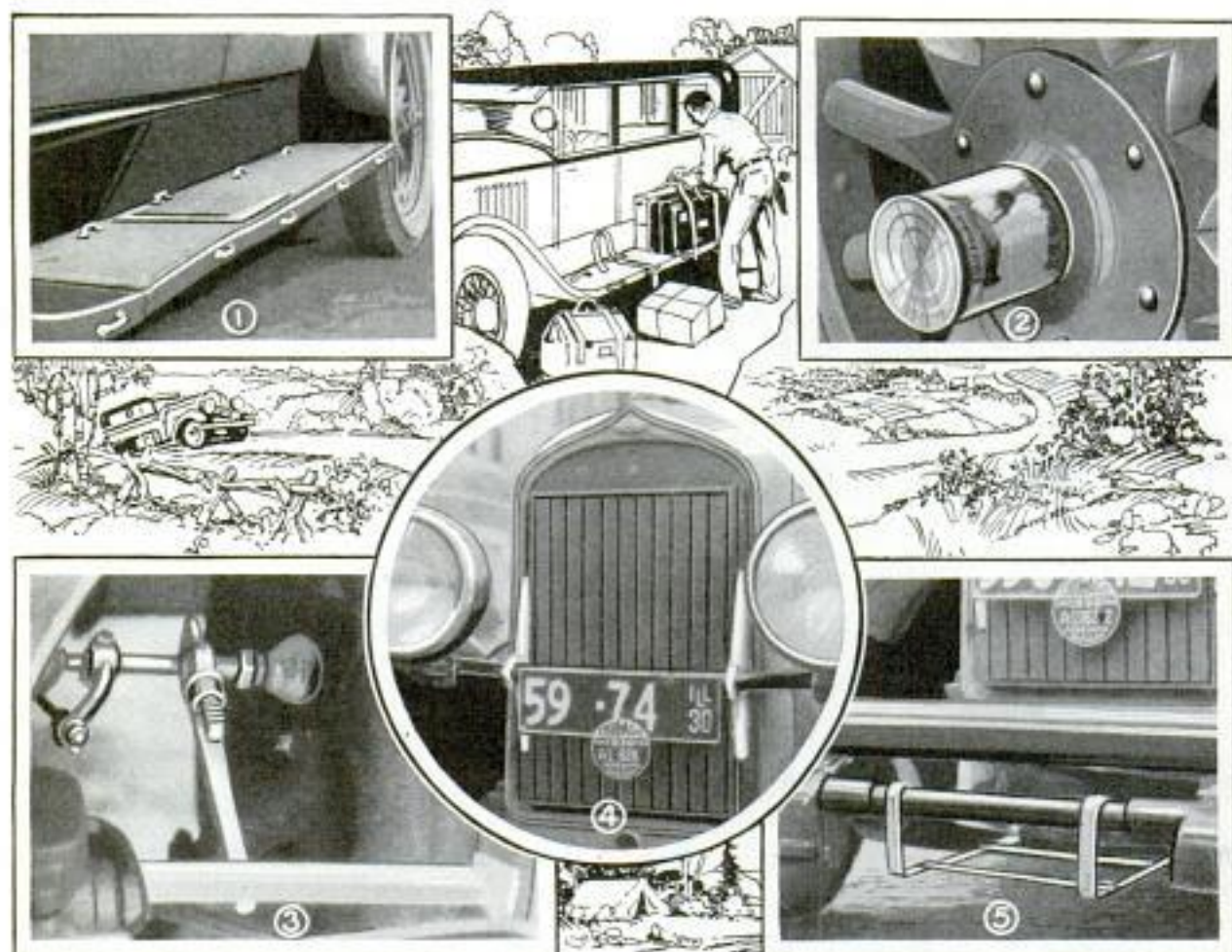

Luggage Straps and Holders, Emergency Hub Caps, and Shutters That Won't Cause Radiator Leaks, Are a Few Shortcuts Worth Remembering by Motorists

Luggage loops for the running board, as shown in Fig. 1, are out of the way when not in use but always at hand when needed for packing large, clumsy objects, such as tents, suitcases, etc. A number of stout straps for tying down the load are kept under the rear seat. Campers will find these fittings a great convenience. Another method of providing a luggage carrier is shown in Fig. 5. Made of strap iron about  $\frac{3}{4}$  or 1 in. wide to hook over the front crosspiece of the frame, this basket is fastened at the rear to the splash apron below the radiator, using  $\frac{3}{16}$ -in. bolts. The crosspieces of the basket are bent over and clinched to the sides, or, if desired, they may be welded on. Drilling holes at these points weakens the basket, and therefore it is not advisable to bolt the parts together. When the basket is finished, give it a coat of black paint or auto enamel.

When your hub cap comes off and im-

mediate replacement is impossible, substitute an empty tin can of suitable size to fit over the flange on the wheel, as shown in Fig. 2. This is an excellent emergency method of keeping sand and dust out.

In adjusting brakes, the problem of holding the brake fully applied is quickly accomplished, as shown in Fig. 3. A good way is to apply a 10-in. pipe wrench on the brake-rod arm in the direction that sets the brake, and hold it in position with a tire tool that is placed across the handle with one end butted against the frame or heavy fitting of the car and the other projected through the spokes of the wheel. Turning the wheel forward locks the brakes and holds the wheel, permitting one to reset the lever in the usual way.

Radiator shutters, that are fastened by means of long screws pushed through the openings between the fins, sometimes have the disadvantage of causing a radia-



tor leak, owing to the pressure and vibrations of the screws. To clamp the shutter securely in position from the outside, eliminating the need of screws, make a couple of hardwood wedges, as shown in Fig. 4, clamping these to the lamp bracket. Make the wedges about 8 in. long. After they are pressed down behind the lamp brackets, screw on pipe straps to keep them in this position.

*no clips - see diagram*

#### Removing Stains from Marble

Iron stains on marble can be removed by applying a solution of sodium citrate, followed by sodium hydrosulphite in dry form, and then covering with a paste of whiting and water. A poultice of whiting, soap solution and sodium carbonate will efface tobacco stains, while ordinary ink stains can often be deleted with a solution of whiting and sodium perborate, followed by a few applications of the sodium-citrate solution.

#### Hook for Catching Fowl

For catching crated fowl, a length of heavy wire with one end bent over to form a hook with about  $\frac{3}{4}$ -in. clearance will be found highly convenient. In use, the hook is slipped over the fowl's leg so that it cannot get away, and it is then an easy matter to reach in and pull the fowl out. If the hook is attached to a longer pole, it can be used for catching fowl in the lot.—J. N. Stody, Kenosha, Wis.



Catching Fowl in a Crate or Lot Is Easy with the Aid of This Wire Hook



This Wooden Guard with Hinged Flap, Keeps Snow Away from Outside Doors

#### Wooden Guard Keeps Snow from Door

When snow is drifting against doors, the wooden guard shown in the drawing will be found useful. A 12-in. board is nailed over the door tread a few inches from the door and a wooden flap is hinged to the upper edge. Ordinarily the flap is kept closed against the door, which prevents snow from accumulating between the guard and the door. When the door must be opened, the flap is pulled back. The guard keeps snow out of places where it might prevent closing the door.

#### Paper Makes Water-Tight Seams in Sheet-Metal Containers

Water-tight seams in sheet-metal containers can be made without the use of solder by employing paper in the following way: Bend the edges of the sheet metal to interlock. Before joining them, get a strip of medium-weight wrapping paper, about 2 in. wide, and fold it so it can be laid in the turned edge of the under metal sheet. The edge of the other piece is hooked in place, making sure that the paper fits well in the joint, and the seam is then hammered together in the usual way. Excess paper is trimmed off. On long seams, rivets may be used every 8 or 10 in. Paper can also be used in the seam where the sides and bottom join. In this case, a piece 2 in. larger in diameter than the bottom should be used. The seam is made in the usual way and no rivets are needed. In use, the paper inside of the seam swells and makes a tight joint.—Francis Wilkin, Pittsburgh, Pa.



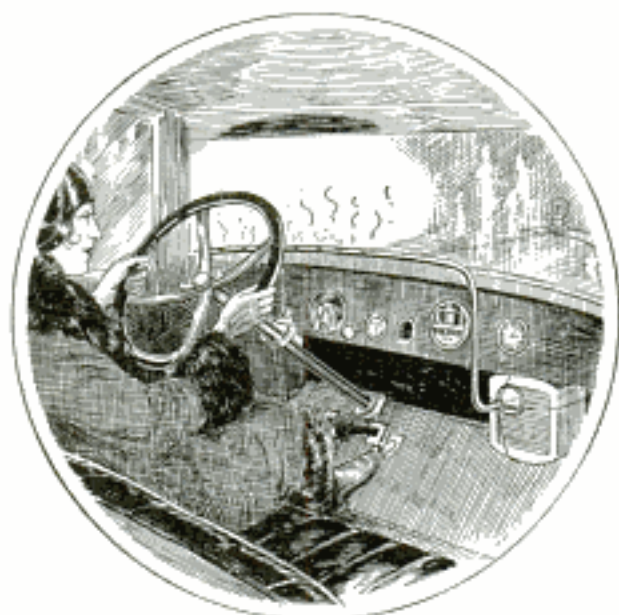

Warm Air Forced through Copper Tubing by Heater Keeps the Windshield Clear

### Warm Air Keeps Windshield Clear

Warm air from the water or manifold heater in the car can be used to keep the windshield free from frost. A length of  $\frac{1}{4}$ -in. copper tubing is soldered to the spout of a small funnel, which is attached directly in front of the heater, as shown in the drawing, so that warm air will be driven through the tubing. The tubing is run up and along the lower edge of the windshield, the end being pinched shut and a number of holes drilled in the side, about 4 in. apart, to direct warm air against the glass.—E. Strand, Orr, Minnesota.

### Alarm Clock Operates Homemade Electric Time Switch

For turning on the electric current to an auto heater, or the like, at a predetermined time, a switch can be made from

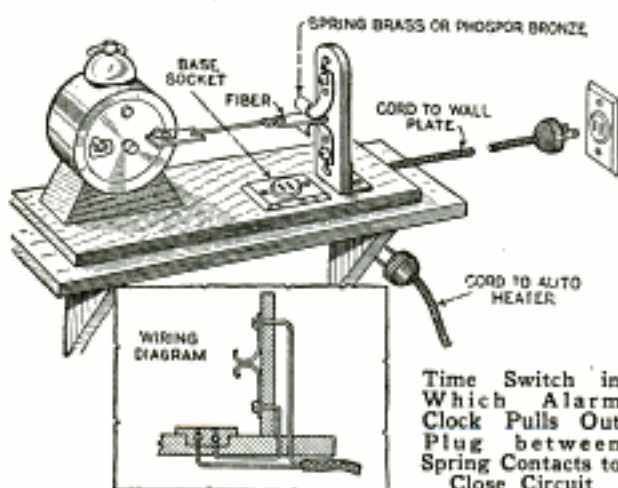

Time Switch in Which Alarm Clock Pulls Out Plug between Spring Contacts to Close Circuit

an old alarm clock, a few pieces of spring sheet brass, a wall socket, plug and extension cord. These are rigged up on a suitable wooden baseboard as shown in the drawing. The pieces of spring brass are screwed to a wooden block mounted vertically, the curved ends making contact with each other unless held apart by the piece of fiber. A length of cord is tied to the fiber and to the alarm key of the clock so that, when the key turns, the piece of fiber is pulled from its position between the spring contacts. This closes the circuit, and current is furnished at the point desired.

### Odorizing Natural Gas for Safety

As natural gas is virtually odorless, a leak in the lines is extremely dangerous and has been the cause of many accidents. This condition may be remedied by odorizing the gas, which in one case was done by using oil of garlic. The cover of the water trap, which is connected in the gas line near the meter, was removed and a rubber sponge put in the trap, after which a small can, such as a shoe-polish can, was filled with oil of garlic. A hole was punched in the lid, a wick pulled through the hole, and the can was then set on the rubber sponge in the trap, tucking the extending wick a short distance into the gas line and then replacing the trap cover. The odor from the oil impregnates the gas, so that when a gas jet is opened and the gas not ignited, the smell distinctly advertises the fact. The burning gas has no odor.

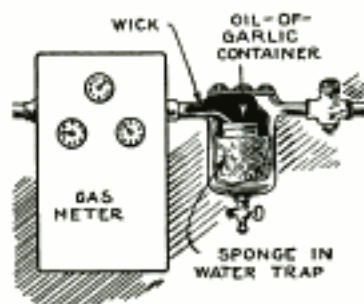

### Stiffening Shoelace Ends

Dipping shoelace ends in varnish, shellac or glue, rolling them between the thumb and forefinger and allowing them to dry thoroughly, protects them from fraying and forms a tough stub that makes an excellent substitute for the usual tinned cap. This method is especially useful when laces have to be cut to special lengths and the caps are lost or destroyed.



# SHOP NOTES



## Hardening and Tempering Small Tools\*

By RUSSELL HAYS

**A**LTHOUGH the grinding of small bench tools, such as cold chisels, is an easy task for the average man, hardening and tempering them properly is not such a well-known procedure, but like so many things, it is relatively simple after one knows how.

After the point of the chisel or other tool has been roughly ground and sharpened, a 3-in. portion of the point is slowly heated to a dull red, but no further, as overheating of finished steel coarsens the grain and weakens it. About half of the heated portion is then plunged into the water, which hardens the steel. The time required to cool the point varies with the thickness of the steel, but usually is about 10 seconds. The tool should be moved back and forth in the water so that there is no definite dividing line between the cooled and the heated portion. If this is not done, the sudden change in temperature along a sharp line is likely to weaken the tool so that it will break when in use, perhaps at the first blow. Then take some emery paper and polish the point as quickly as possible, until it is bright.

Now comes the tempering. After re-

moving the chisel from the water, the heated portion begins to diffuse its heat into the cooled point, and a series of colored bands, blending into each other, yet clearly discernible on the polished surface, seem to follow each other down toward the point. The hardened portion, that is barely touched by the oncoming heat, assumes a pale-yellow color. Just behind it lies a band of straw-yellow where the steel is slightly warmer, yet too brittle to be used as a bench tool. Following this comes a line of deeper yellow and indicates a steel quite a bit harder than a file, but not too brittle to be occasionally used on the tip of lathe tools. This band merges into a light purple band, where the steel has a hardness suitable for the cutting edge of chisels and most other bench tools. It is just the least bit softer than the teeth of a file and is tough enough not to chip. As the chisel cools, the colors move more slowly. When the blue-and-red band, which follows the light-purple one, nears the cutting edge, plunge the chisel into the pail of water just long enough to cool

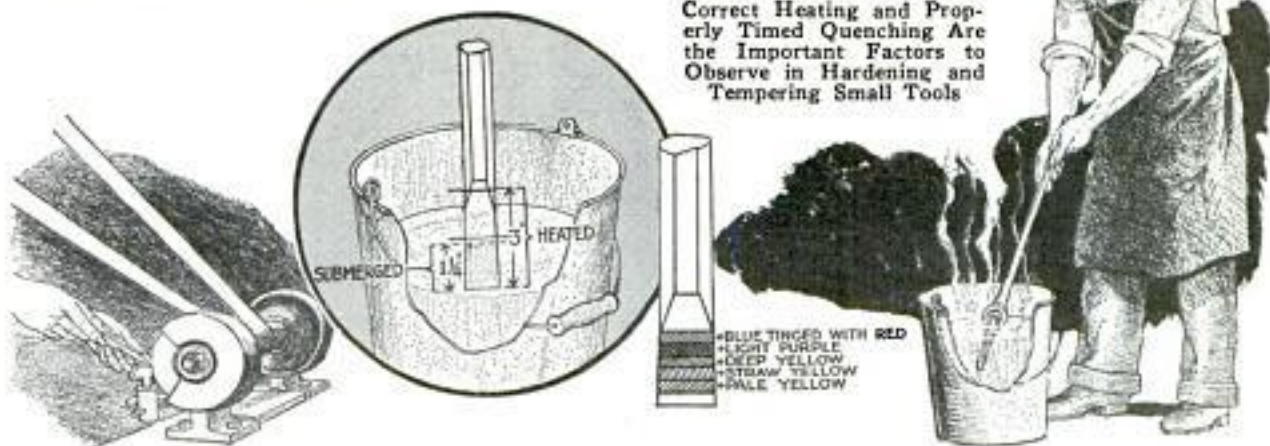



the entire tool, so that the hardness will not be run completely off the point. It takes only a second to stop the movement of the colors, and a few more dippings will gradually cool the tool. The tempered point is permanently fixed, while the rest of the tool is soft and pliable, and will not shatter under a blow.

### Adding a Square, Bevel and Rule to Your Handsaw



A Straight-Back Handsaw Can Be Improved by Equipping It with a Square, Bevel and Rule

By adding a square, bevel and rule to a handsaw that has a blade with a straight upper edge, its usefulness will be greatly increased. Cut out suitable blocks to fit against the handle snugly on each side of the blade, as shown in the drawing. A side of one block is cut to be at right angles to the upper edge of the blade, while the corresponding side of the other block should be at 45° angle to the edge. Both blocks are drilled and counterbored for woodscrews with which they are attached

To anneal or soften a piece of hard steel, heat to redness and allow it to cool gradually. Placing the piece in ashes beside the fire will cool it slowly enough. Thin knives cannot be tempered in the manner described, because water cools them too rapidly. Such work is usually done in oil and requires a great deal of care.

to the handle. Rule graduations are carefully laid off on the edge of the blade with the aid of a sharp file, or they may be etched in the metal.

### How to Preserve Animal Specimens Until Ready for Mounting

Museum workers have found that the best way to preserve a bird, squirrel or other animal specimen until it can be taken to a taxidermist, is to keep it submerged in water. The specimen is placed in a covered container filled with water and anchored in a running stream. This preserves the body better than if it were placed in a refrigerator.

### Moving Heavy Circular Castings

Large circular castings, which are often too heavy to be loaded on trucks and transported over roads in the usual manner, can be moved by the method shown in the drawing. A steel cable is passed around the casting, and the ends attached to two trucks. One truck, with brakes set and wheels blocked, remains stationary while the other moves ahead, rolling the casting forward. As the casting moves like a pulley it goes only half as fast as the truck and consequently requires only half the tractive effort that would otherwise be necessary. When the casting reaches the stationary truck, it is blocked in place and the trucks shifted to a new starting position.



Moving Large and Heavy Circular Castings with the Use of Two Trucks and a Length of Steel Cable



## PORTABLE ELECTRIC DRILL HAS MANY USES

This electric tool chest, which furnishes power for small drills, grinders, buffers, etc., will be found useful by those who engage in general repair work. It consists of a 1/4-hp. 110-volt motor which will operate on the house-lighting current. Any speed from 1,200 to 1,700 r.p.m. will be suitable for the purpose. A flexible shaft, which is attached to the motor, and a 1/4-in. chuck can be obtained at any 25-cent to \$1 store. Also get a flush-type toggle switch, a metal box to hold it, a switch plate, a length of lampcord, or other flexible double-conductor cable, and a plug. The motor is screwed to the bottom of a small wooden box, just large enough to hold it, a hole being drilled at one end for the shaft to project, and the switch installed

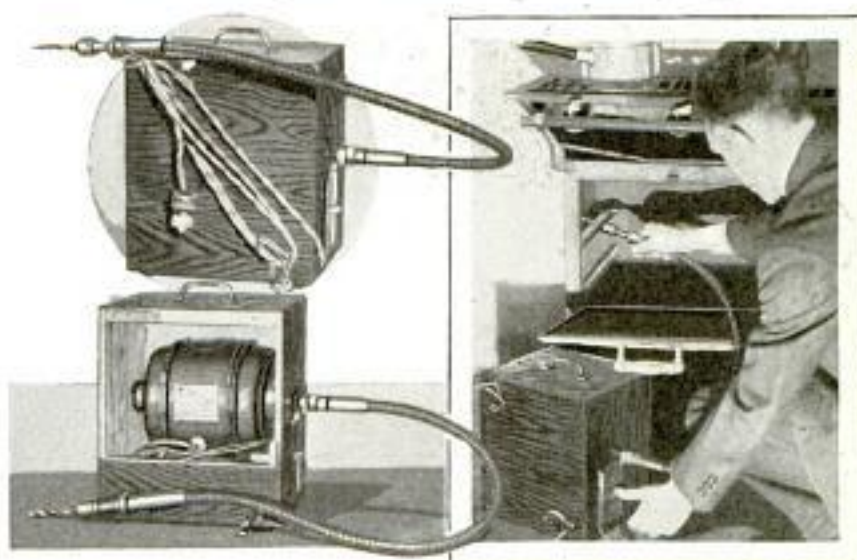

Repair Men Will Find Considerable Use for a Portable Electric Drill Equipped with a Flexible Shaft and Chuck

where it will be handy to open and close, even with one's foot. A drawer pull provides a neat, sturdy handle, while two clothes hooks on the side are used for holding the extension cord, and a hook of galvanized-iron wire is slipped over the chuck when the outfit is not in use.

### Tin Can Holds Ring for Filing



When it is necessary to file the ends of a piston ring to obtain the proper clearance, and the vise at hand is too heavy for the work, get a

small tobacco tin of the kind shown in the photo. File or nick the edge of the lid in two places so that, when the ring is inserted as shown and the cover squeezed down, the ring will be held securely.

### To Remove Carpet Stains

Grease stains can often be removed from carpets by first scraping off as much of the material as possible with a knife, then, applying a piece of heavy brown paper to the remaining spot, pass a hot iron over it repeatedly. Oil stains should

be rubbed with a rag dipped in benzine. Sour milk is often effective in eradicating black ink after a thorough blotting. Lemon juice, followed by a sponging with warm soapy water, takes out red-ink marks on many carpets. If the stain is caused by tar, cover it with lard, remove as much as possible later with warm soapy water and, when dry, apply benzine.

### Old Magnet Useful as Small Anvil for Workbench

An old magnet picked from the junk pile will be found handy as a small anvil when fastened to the workbench as shown. Drill a hole through one of its legs and through the bench top, and bolt the magnet down firmly.



*suggest 1st hand & pieces of any large hardware store  
Barrett*



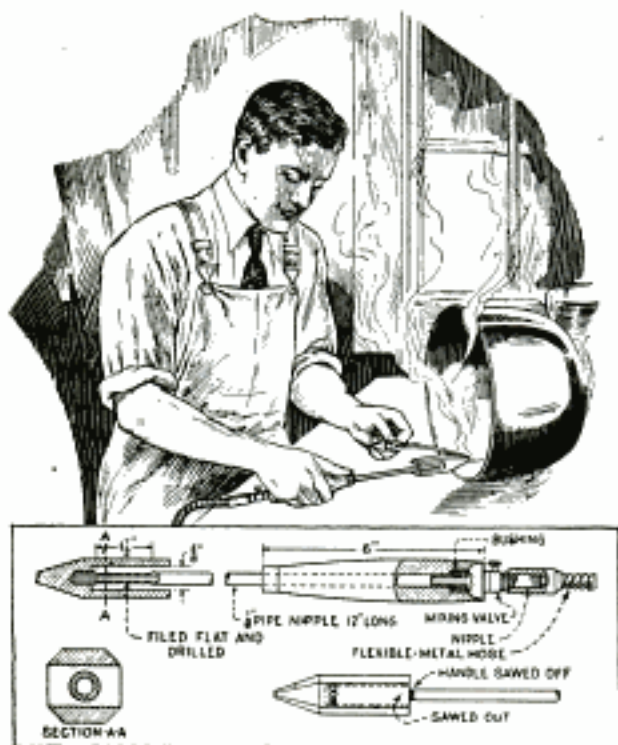

This Homemade Soldering Iron, Operating on Gas, Is Handy for the Workshop

### A Homemade Gas Soldering Iron

The gas-heated soldering iron illustrated will be found very useful about the shop or home. It is simple and inexpensive to make, all parts being readily obtainable. The copper head is cut out with a hacksaw and drilled as shown. A 1-lb. head will be found most suitable. The hole, into which the burner tube is screwed, is drilled about  $\frac{1}{2}$  in. deep with a  $\frac{21}{64}$ -in. drill. The burner tube is a  $\frac{1}{8}$ -in. pipe nipple, 12 in. long, already threaded at both ends. Flat surfaces are filed on one end of the tube, and burner holes are drilled as indicated. The other end of the tube is fitted with a mixing valve of the type used on inverted gas-mantle lamps. As the burner end of the valve is slightly larger than the tube, it will have to be bushed. The valve has a short  $\frac{1}{8}$ -in. nipple screwed into the intake end. A length of flexible metal hose with rubber end connections is used to join the soldering iron to the gas supply. A large wooden handle, drilled lengthwise and with the large end hollowed out to fit over the mixing valve, completes the job. In using the iron, the mixing valve should be adjusted so that the gas will burn with a clear blue flame. The flame should not extend beyond the sides of the head.

### Tooling Aluminum

For drilling aluminum, sharpen the drill as when cutting brass, but give it a sharper rake. This will cut fast and produce very little burr where it breaks through. Straight-fluted taps should not be used on aluminum, as they will not clear the chips as fast as a spiral-fluted tap. The speed with which the chips are cleared is important, as they spoil the threads when not removed immediately. A high speed and a light feed result in the best work. Lard oil and kerosene, mixed in equal parts, make the best lubricant for aluminum work. Many machinists find it difficult to get a smooth finish with the lathe tool, and resort to filing for a satin finish. This is unnecessary. When sharpening the cutting tool, give it plenty of back clearance so that the chips will not break off at once but will curl back and break, thus clearing the work and preventing mars. This also prevents the chips from building up on the tool and dulling it. If the same tool is used for both roughing and finishing, be sure to sharpen it before making the finishing cut.

### Replacing Lower Piston Rings

Trouble often experienced in forcing the lower piston rings together when the piston is pushed back into the cylinder from below, has been eliminated by using the illustrated tool. A length of wire is formed into a loop, one end of which is fastened to the upper end of a rod, and the other end threaded through a hole. When the loose end is pulled, the loop contracts. In use, the loop is slipped over the lower ring and pulled tight to squeeze the ends of the ring together, after which it is an easy matter to push the piston into place.

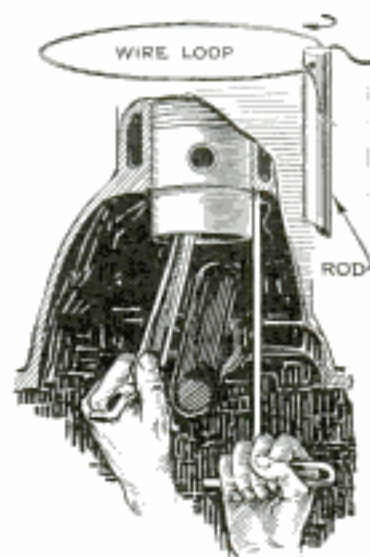



# Bending Wood at Home

By John E. Hyler

THERE are many cases where work, which is not very distinctive in itself, can be greatly improved by the addition of bent parts, some examples of which are shown here. A bent piece of wood, also, is much stronger than a curved piece that has been sawed out, as the former has no crossgrain. Wood cannot be stretched, and in this respect it is unlike most metals, which are usually ductile. Attempts to stretch wood invariably result in fracturing it. However, after bending a piece of wood, one side will naturally be longer than the other, and as stretching is impossible, it follows that the shortest side has either been compressed or part of it removed.

In cases where the wood is too thick to permit bending it in the solid, "kerfing" is usually resorted to, especially on jobs that are not very particular and must be finished quickly. Kerfing is the process of making saw cuts across the back surface of the portion to be bent, as shown in Figs. 5 and 7, and then bending it to shape. This method is used where only one side of the work is to show. In bending wood by kerfing, the curve is first laid out on paper, as shown in Fig. 2, the distance AB representing the inside radius. The first kerf is cut a short distance from the end if the bend is to start here, as shown in Fig. 2, at point A, and its depth should be equal to about two-thirds of the thickness of the wood. Using this kerf as a starting point, mark off the distance AB, in Fig. 3, which is equal to the radius AB. Clamp the end of the piece

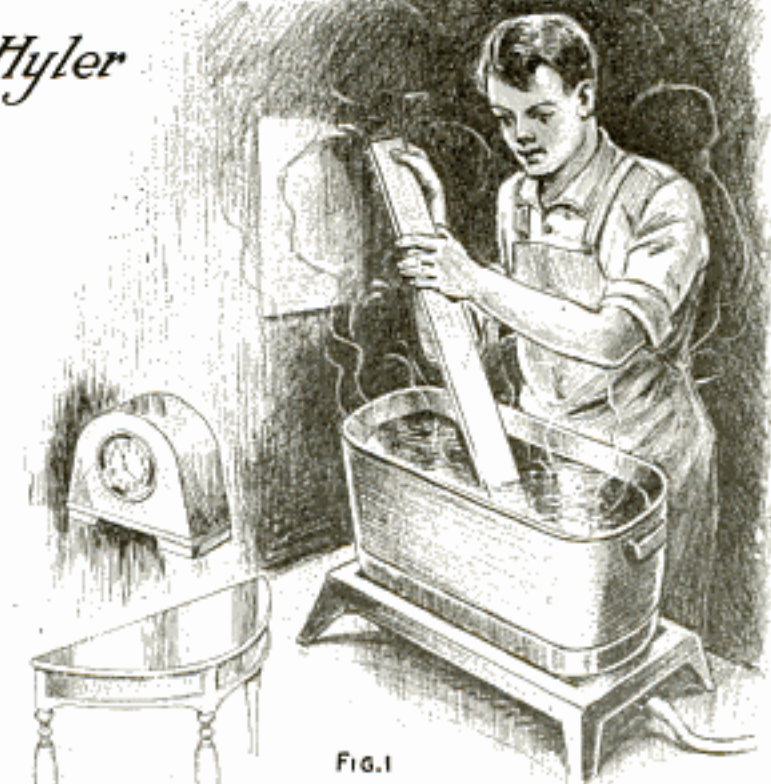

FIG. 1

Wood Can Be Made Pliable for Bending by Heating It in Boiling Water

to the bench top, as in Fig. 6, so that the kerf is on the upper side, and carefully raise the other end until the kerf closes. With a try-square or rule, measure the vertical distance between the points B and C, Fig. 4, which is the distance from the lower edge of the board to the bench top in Fig. 6. If the piece shows any inclination to splinter at the bend, the kerf must be cut a little deeper, and in this way the required depth of kerf can be found. The distance BC is the correct spacing for the

kerfs along the entire inner surface of the portion to be bent, as shown in Fig. 5. Often this method of bending is used in making a bent riser for the bottom step of a stairway, platform riser or other similar purpose, and the step or floor serves to hold it in place. When a piece has to be bent so that the kerfs come on the outside or convex side, wedges are glued





in the kerfs to keep the wood apart. The piece must be handled carefully and should be bent around a form to which it can be clamped as shown in Fig. 7, until the

than necessary, and are glued and tapped in place, after which the projecting ends are cut off flush. A piece of sheet metal, bent around the outside as in Fig. 10, provides added insurance against breaking the wood.

Figs. 11 and 12 illustrate how wood can be bent in the solid, the degree of success depending on the kind of wood used. Hard close-grained woods do not bend readily, unless they are very tough. As a rule the more open-grained a piece of wood is, the easier it is to bend. Elm and hickory are two outstanding kinds of

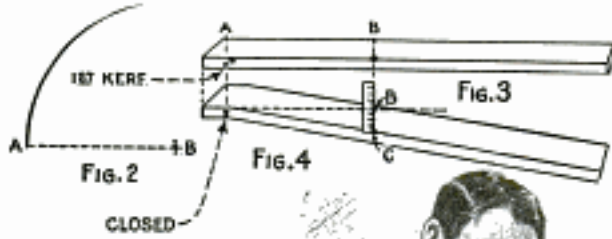

FIG. 5

Kerfing Greatly Simplifies the Task of Bending Heavy Stock



FIG. 6

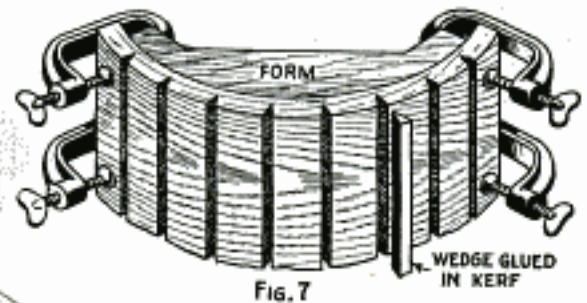

FIG. 7

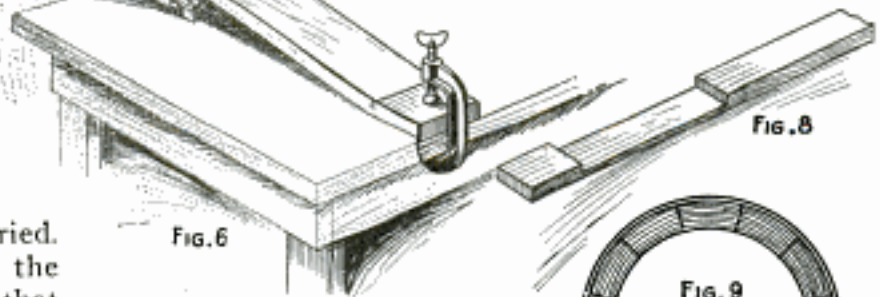

FIG. 8

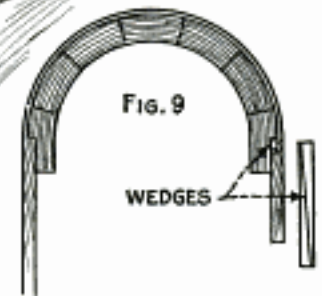

FIG. 9

glue on the wedges has dried. One objection to having the finished side concave is that faint vertical lines will show through at the location of the saw kerfs, but this can be partly overcome by scraping and sanding.

Another method of bending wood over a permanent form is shown in Figs. 8 and 9. It consists of "backing a piece out," or recessing, and then bending it around the form. The portion to be bent is carefully backed out until only a thin part remains, as shown in Fig. 8. The job of recessing can be done by kerfing at intervals and then using a chisel and smoothing plane. The form is built up of blocks of wood, as shown in Fig. 9. After gluing the blocks together, they are cut to the desired curvature on a bandsaw, so that the outside will provide a smooth bearing for the bent piece. Notches are cut in the corners for the end of the thicker part to butt against, allowance being made for a pair of wedges to keep the assembly tight. The wedges are made up longer

tough woods that can be bent well. Oak, ash, chestnut and walnut are good examples of open-grained woods with a fair degree of toughness, which makes them a good risk for bending. Mahogany will bend fairly well. Green wood will bend better than seasoned wood, but usually it is not suitable, as it cannot be finished well or expected to keep the same shape and size. Air-seasoned wood will bend much better than kiln-dried wood. To increase the bending properties of wood, it can either be steamed or soaked in boiling water. Where it is to be bent throughout its entire length, the first method is best, but if the bend is to be on one end only, the balance of the piece will hold its shape much better if only that end is immersed in boiling water, as shown in Fig. 1. It is



the heat rather than the moisture that makes the wood more pliable, but wet heat penetrates better and faster than dry heat. When bending wood in the solid, the outside surface tends to stretch, and to avoid this, pressure must be applied to the ends of the piece while making the bend. This can be done by using a strip of sheet metal, a little longer than the work so that metal lugs can be securely screwed onto the ends, as shown in Figs. 11 and 12. The work should fit snugly between the lugs. It is bent slowly and gently until it reaches the desired arc, after which it is clamped to a form and left there until it has dried out thoroughly. The sheet metal confines the wood, preventing it from stretching, while the lugs at the ends compress the inner surface. Never bend a piece suddenly, but always with a slow, gentle and positive motion.

Where both sides of a bent piece must be finished, there is only one other method known to the writer, which

To hold the wood in position, a number of blocks or brackets, of the kind shown in Fig. 10, are nailed down to the floor or bench top along a line equal to the desired curve. The thickness of the material used will determine the spacing of the blocks. For very thin veneers they must be set as closely as possible. After the pieces have been coated with glue, they are set up against the brackets, paper being placed between the brackets and the work to prevent them from adhering in

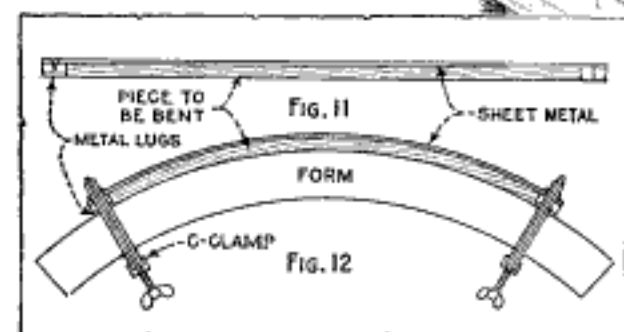

Bent Pieces of Considerable Thickness Are Often Built Up by Gluing Together Several Layers of Thin Stock

is practical without the use of very expensive bending equipment, and that is by laminating or building up the bent piece from a number of thin parts, either stock or veneer, as shown in Fig. 10. The sharper the bend, the thinner the individual pieces must be. Each one is coated with glue on both sides. In bending, the pieces will slip over each other while the glue is wet. After the glue has dried they will straighten out a little, and therefore one should make some allowance for this, say,  $\frac{1}{2}$  in. to each foot of radius. To get a radius of 2 ft., make the actual bend 23 in.

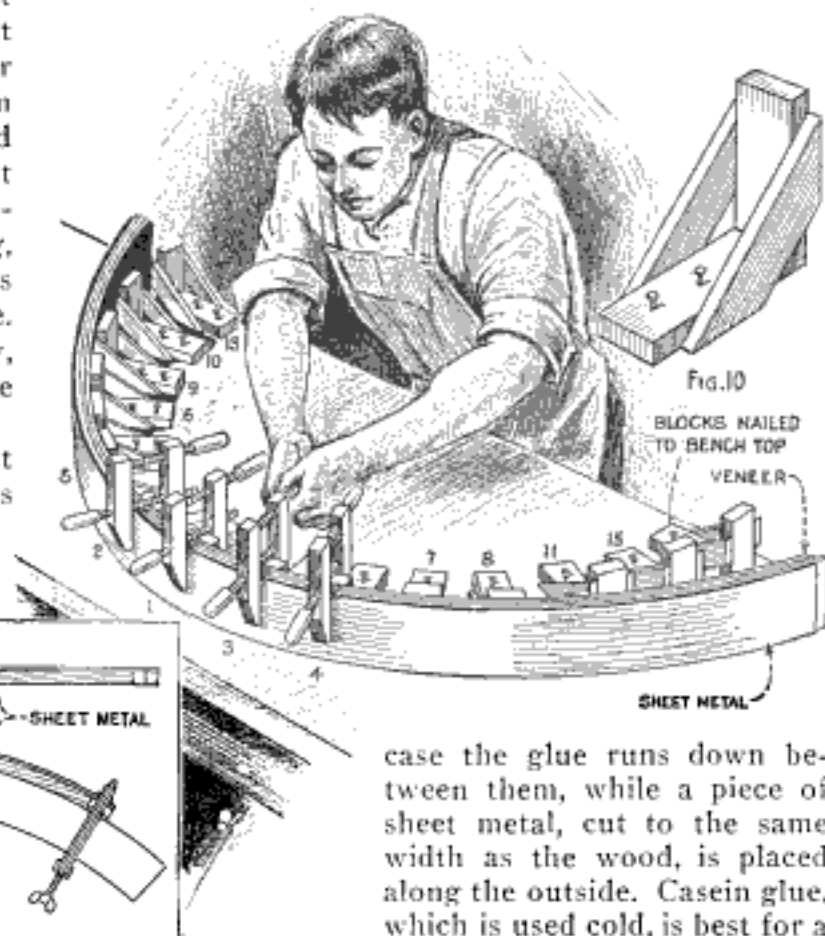

case the glue runs down between them, while a piece of sheet metal, cut to the same width as the wood, is placed along the outside. Casein glue, which is used cold, is best for a job like this, as one is not rushed in using it, for it does not chill. Start clamping in the middle of the assembly, and work both ways, putting on the end clamps last, the correct sequence being indicated by the numbers. In this way any irregularities are "ironed out" of the material as one goes along, and trouble from buckling is overcome. Be sure that the pieces are tightly squeezed up at each step before proceeding to the next, in order to prevent buckling. The glue must be allowed to dry thoroughly before removing the clamps. Do not apply too much glue as it will only squeeze out at the edges and cause trouble.



### Holding Irregular-Shaped Pieces for Welding



In the average small welding shop, where two jobs are seldom alike, the use of specially made jigs for holding the work is impractical. The usual method of supporting the work by means of fire bricks and wedges or lumps of carbon putty is not reliable,

as the work often slips just as it is being finished, with the result that it must be done all over again. Besides, it requires more time to set up a job in this way than it does to make the weld. The use of sand as a supporting medium has been tried but not found satisfactory, as it flies about badly and also breaks down when subjected to the flame. A better material for the purpose is wood ashes. By first tamping the ashes firmly, the broken pieces to be welded can be pressed down in any desired position. That part of the ash which is struck by the flame blows away and the remainder becomes incandescent, aiding materially to bring the work to the proper temperature. Some of the ash may fuse onto the work but can easily be scraped or brushed off. Although the use of ashes was found quite satisfactory, a still better bed for supporting the work can be made from carbon rods of old dry cells. Crush the rods to the size of peas. Carbon does not break down even when subjected to direct flame, does not pop and crack or fly about. It becomes very hot next to the weld and holds the heat, thus preventing chilling. Tests have shown that, contrary to what might be supposed, no undue hardening takes place in the metal due to the absorption of carbon. Although any handy con-

tainer can be used for holding the carbon, a revolving stand held by a discarded auto shaft and housing, the universal joint of which was poured full of babbitt to make it solid, was found highly convenient in one welding shop. The container consists of a metal disk and an old auto-wheel rim, the latter being held to the disk by means of three or four hooks. —C. R. Van Druff, McLouth, Kans.

### Uses for Old Crankcase Oil

Old crankcase oil has many uses on the farm. It will kill weeds and grass, prevent rust on tools, protect paint on stored machinery, guard chicken houses against lice, lay dust and keep ants and other insects out of ice boxes.

### This Jig Trims Belts Quickly

By tacking four pieces of wood of suitable size to a board clamped to the workbench, and driving the point of a sharp knife into the board as shown in the drawing, it is a simple matter to trim belts quickly and accurately. The two bottom pieces of the jig should be a trifle thicker than the belt and they are laid against the sides of the belt, while the third piece is tacked across them with a couple of nails at each end. The knife edge is set against the crosspiece at the point where it is desired to cut the belt, and is driven down firmly. In use, the belt is drawn through the jig as indicated.

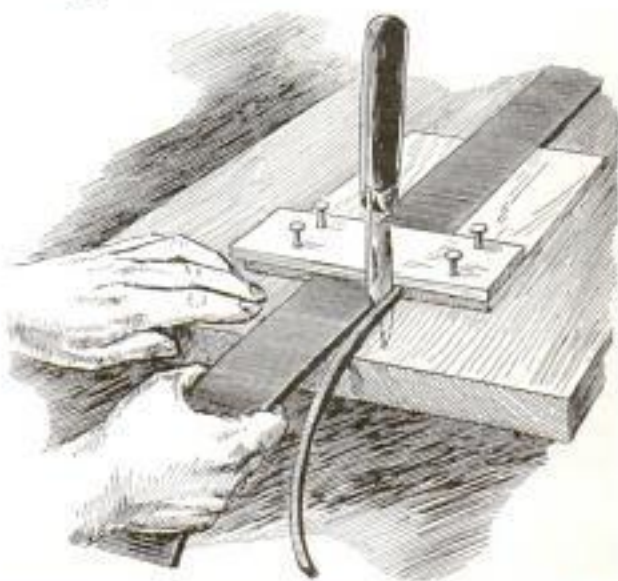

Belt Trimming Is a Simple Task With the Aid of This Improved Jig



### Nailing Ends of Hardwood Boards

When nailing close to the end of hard pine or other hardwood boards, it is almost impossible to avoid splitting the wood with the nails unless a brad awl is used to make a hole for them. In hardwood, it is difficult to push in a brad awl. It is much better to sharpen a nail as the awl is sharpened, and then drive it in and pull it out again. In order to avoid bending the nail when pulling it, as would be the case with a full-length nail, make them only a little longer than the thickness of the board, letting the head project so you can catch it in the hammer claw.

### Lock Washers for Shovel Foot Pad

Almost any kind of shovel foot pad will come off and soon wears out, unless made of metal. An excellent pad can be made from a number of lock washers, driven



over the top edge, side by side, as shown in the photo. Besides being comfortable, this pad will last the life of the shovel, and the washers, once driven on, will not come off.

### Keeping a File Clean When Working Aluminum

When filing aluminum, especially in cleaning up castings used for metal patterns, the filings soon fill up the teeth of the file and much time is spent in keeping the file clean enough to make a smooth cut. The trouble can be eliminated by coating the file with any of the various compounds used as a lubricant for tapping aluminum. The following preparation has been successfully used for this purpose: Gasoline, 70 per cent, beeswax, 15 per cent, and turpentine, 15 per cent. Apply this solution liberally to the file. Taps can also be cleaned of aluminum particles in the same way.—V. C. Darby, Cedar Rapids, Iowa.



Self-Closing Funnel on Printers' Ladle Is Handy for Filling Irregular Spaces in Forms

### Improved Pouring Ladle for Printers

Printers using ordinary ladles for pouring metal in irregular spaces in advertising forms, will find the illustrated container much better, as the metal can be carried and poured with less risk of spilling it. It consists of a funnel fastened to a piece of flat iron which serves as a handle and is fitted with a wooden grip. A stopper for closing the lower end of the funnel is made from a rod slightly larger in diameter than the hole and tapered to fit the hole snugly so that the metal will not leak out. Two brackets, riveted to the handle, are drilled so that the rod makes a sliding fit in them, and a coil spring is slipped over the rod between the brackets. A finger hold for raising the stopper rod and heavy enough to hold a setscrew, is drilled to a sliding fit on the rod, the setscrew serving to lock it against the rod. The grip is pushed down against the spring, which is hooked over it and over the lower bracket. When the grip is pulled upward, the stopper is raised with it, and the metal runs out, while the stopper closes automatically as soon as the finger grip is released.—Jas. H. Rodgers, Toronto, Can.

❏ Cheap brass tubing, made with a split down the side, is often difficult to cut; by inserting a round stick, large enough to fit inside of the tube tightly, the tube may be held in the vise easily.





Wheeled Metal Tank Provides Shelter against Flying Stones and Dirt Thrown by Dynamite Blasts

#### Shelter Tank for Dynamite Workers

In putting through an approach to a mine, a large metal tank, mounted on wheels, served as a shelter for the workers to protect them against flying stone and frozen earth thrown up by the surface blasts. A rectangular section of the side was cut out to afford an easy entrance, and a door, consisting of iron-bar framework covered with  $\frac{1}{4}$ -in. mesh, was hinged on one side of the opening. The open top was similarly covered with wire mesh.

#### Use for Old Auto Bodies

Filled with rocks to weight them, junked auto bodies were found useful in making a strong water wall in a swift mountain stream. As the rocks were retained in the bodies, it was impossible for



Old Auto Bodies Lined on River Bank and Filled with Rocks Make a Strong Water Wall

the current to carry them downstream, and erosion of the banks has been practically eliminated.

#### To Drill Spongy Iron

Drilling a straight hole in spongy cast iron is often difficult, but can be done as follows: Take a piece of flat steel and drill a hole the same size as the one to be made in the iron. Clamp the piece of steel to the iron so that the hole will be directly over the spot to be drilled. If the hole is to be tapped, leave the steel piece on to serve as a guide during the tapping.

#### Improved Centering Plug

Instead of driving a wooden plug in a bored hole when it is necessary to scribe circles concentric with it, one mechanic finds it better to use a T-shaped wedge as shown in the illustration. A piece of  $\frac{1}{2}$  by  $\frac{3}{4}$ -in. wood



is cut to fit the hole easily, after which another piece of the same stock is cut a trifle less than the radius of the hole. One nail is used to tack

the end of the shorter piece to the center of the longer one, and the outer end of the short piece is rounded so that the assembly can be pushed into the hole sideways. A quarter twist on the short piece locks the wedge.

#### Smokeless Heater for Tool Kit

From a 1-qt. tin can, a cake of paraffin and some cotton or muslin rags, a small smokeless heater that can be carried in the tool kit, is easily made for a plumber or other workman who has to work in a cold room. The rags are cut into strips as wide as the depth of the can and rolled up tightly to fit in it. The paraffin is melted and poured over the rags which are then ignited. They will burn for several hours without producing smoke, and the heat will quickly raise the temperature to the comfort point.—Fred C. Wegener, Indianapolis, Ind.



# Wall Outlets Are Easy to Install

By E. R. HAAN

**N**EARLY every home owner needs extra wall outlets for connecting lamps and electrical appliances. The materials necessary for an outlet are a switch box, a single or double flush receptacle with a plate to match as shown in Fig. 1, a length of flexible-metal two-conductor cable, which will extend from the wall outlet to the nearest ceiling outlet in the basement, and two box connectors, used to attach the cable to the boxes. All of these parts can be obtained at any hardware store and often at 5 and 10-cent stores.

In this article only the installation of outlets on the first floor of a house will be considered. Pick out the location for the outlet, usually a few inches above the baseboard, and make sure that there is no beam or other obstruction running directly under the partition at the point where you intend to install the outlet. Drive a light finishing nail into the plaster a number of times in a vertical row, not covering more than 4 in., as shown in Fig. 3, to locate the exact position of the lath under the plaster. Then take the switch box and place it with the open side

against the wall over the nail holes so that one lath will cross the center of the box. This lath is to be cut out entirely, while only portions of the two adjacent ones are to be removed. The proper location for the box is shown in Fig. 2. Draw a line along the edge of the box to outline it on the wall, and then cut along these lines with a sharp chisel or knife, proceeding with care to avoid breaking off the plaster and wallpaper outside of the portion marked off. After the plaster has been carefully removed, take a keyhole saw or a hacksaw blade to cut out the exposed portion of the center lath, and to make cuts into the adjacent laths to the edge of the plaster, after which the exposed wood is cut away. The box should now nearly fit



Fig. 5

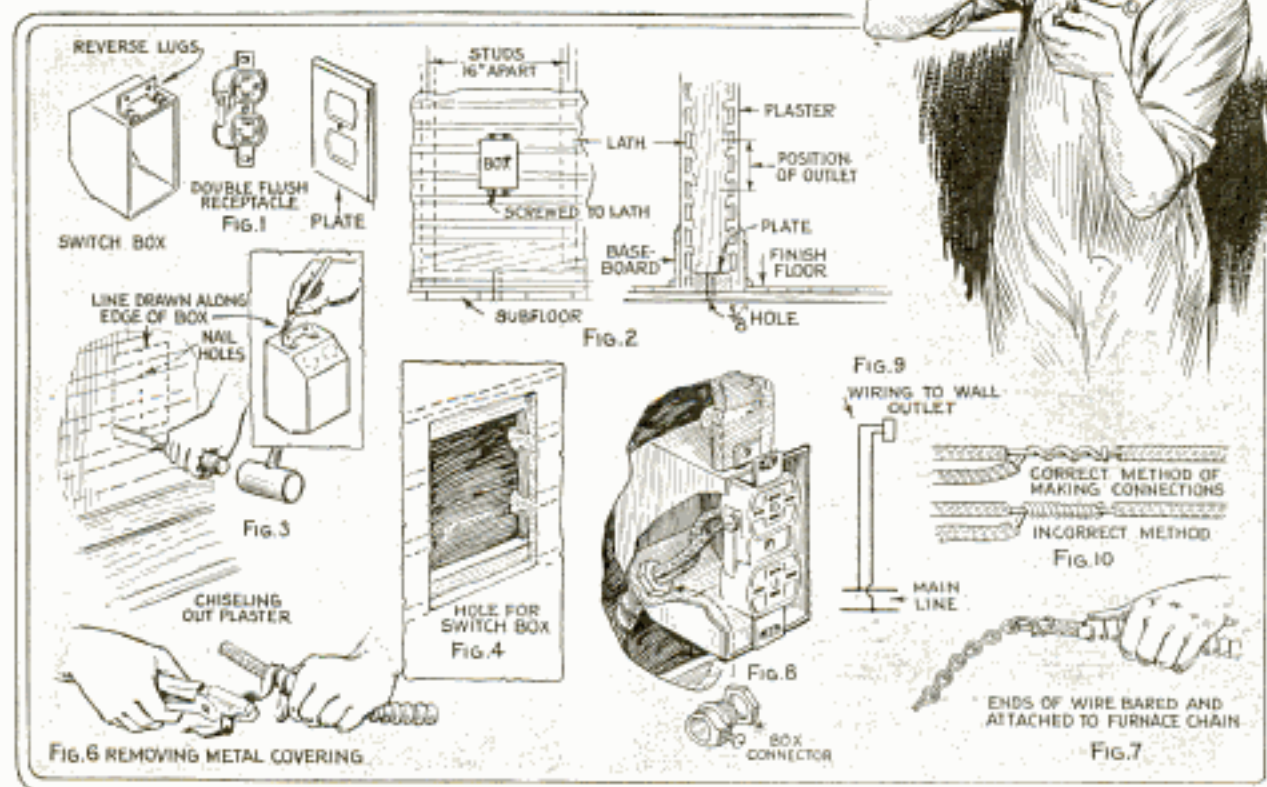



in the hole with the lugs extending, although a little trimming may be necessary. Just enough plaster is cut away at the top and bottom so that the lugs will fit against the exposed portions of lath. The lugs must be adjusted, and perhaps reversed, so that, when they are pressed tightly against the lath, the edge of the box will



Soldering the Connections Is Important and Should Not Be Omitted for Any Reason

come flush with the surface of the plaster. After this, the box is set aside temporarily, and the opening in the wall appears as shown in Fig. 4.

Bringing the cable up through the partition is next. Take your auger and bore a  $\frac{5}{8}$ -in. hole straight up through the center of the partition, right under the outlet, as shown in Fig. 5. Before boring the hole be sure to measure its location with precision as a slight error may result in a hole through the finish floor. Bore up through the subfloor, which forms the basement ceiling, and also through the plate of the partition. Now get a length of ordinary furnace chain, drop one end through the hole from above, and let it hang down into the basement, anchoring the upper end to prevent the entire chain from slipping through. In case a wall outlet is made more than a few inches above the baseboard and one cannot reach the plate to insert the chain in the hole, the chain must be lowered to the plate and anchored as before. Then a slender wire, having the top end bent over to form a hook, is pushed up through the hole and the chain is "fished" out of the partition from below. Remove the metal covering of the cable at both ends for

about 6 in., Fig. 6, and bare the ends of the conductors about 2 in., after which the bared ends are hooked to the furnace chain as indicated in Fig. 7. Go upstairs again and pull up the chain, having someone feed the cable into the hole. When the end of the cable comes through the hole in the wall, remove the chain. Attach the clamp part of the connector to the end of the cable, slip it through a hole in the box, made by punching out a perforation, and screw the nut on the collar from the inside of the box. This fastens the box and cable together securely, as shown in Fig. 8. Small woodscrews are used to fasten the box to the lath. The bared ends of the cable are clamped under the terminal screws of the flush receptacle, which in turn is fastened to the switch box with the two small screws accompanying it, and the plate can be attached. The plate will cover the ragged edges of the plaster, if you have been careful not to chip too much away.

The last part of the job consists merely in connecting the other ends of the cable to the nearest ceiling outlet in the basement, or to the most convenient point in the basement circuit if the wiring is open. The diagram, Fig. 9, shows how the wires are connected. The end of the flexible conduit is also attached to a ceiling outlet with a box connector. When making the wiring connections, be sure to have the main switch of the house circuit off, so that there will be no danger of shock. Bare each conductor of the basement circuit for about  $1\frac{1}{2}$  in. at the point where the connection is to be made, and wrap the bared ends of the cable around them as shown in Fig. 10, following the correct method of permitting the solder to flow between the turns, which insures a good connection. All traces of rubber covering should be removed, and the bared ends scraped perfectly clean to make a good soldered connection possible. Apply a paste flux, solder, which is absolutely necessary, and cover with rubber tape and friction tape. Turn on the main switch and you will be able to get "juice".

☞ Always use a new tube in a new casing; an old tube may give way and the tire run flat, so reducing its life that a new tube would have been cheaper.



### Rubber Hose Stops Thumping of Water Pump

Thumping of an automatic electric water pump, which is especially noticeable at night, can easily be eliminated by inserting a length of rubber hose in the supply line near the pressure tank. Cut out a section of the pipe about 12 in. long and substitute the hose, pushing it a couple of inches over the ends of the pipe. Use hose clamps for fastening the hose securely. The rubber expands when the pressure increases suddenly and thus eliminates the noise.—E. P. Smith, Turner Center, Me.

### Split Wedge Helps Pulling Nails

A heavy nail may be drawn a short distance with a light hammer without breaking the handle, but drawing it further may cause a break. If a block is set under the head to raise the claw, the risk is lessened, but a block of the right height isn't always at hand. A split wedge, as shown in the drawing, can be kept in the tool box for this purpose. It is made from two pieces of  $\frac{1}{2}$ -in. hardwood, preferably

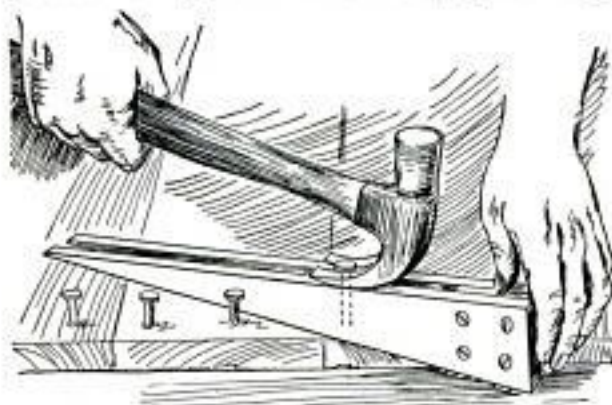

For Pulling Heavy Nails, This Split Wedge is a Handy Addition to Your Tool Kit

maple, about 14 or 15 in. long and tapering from 2 in. at one end to a point as indicated. Bolt or screw the pieces together at the wide ends, with a  $\frac{3}{16}$ -in. piece of wood between them. In use, the wedge is inserted between the work and the hammer with the nail in the slot, and as the nail is pulled out the wedge is slipped up.—W. F. Willis, Los Angeles, Calif.

Worn ball bearings can be repaired by truing up the races and substituting larger balls for the worn ones.



Woodworkers' Vise Can Be Greatly Strengthened by Fitting It with Angle-Iron Jaws

### Angle-Iron Jaws Strengthen Woodworkers' Vise

By providing an ordinary woodworkers' vise with angle-iron jaws, its life will be greatly increased, and the piece on the bench edge may be extended several feet to provide a solid edge that can be used as a light anvil for shaping sheet metal, wire, etc. You can recess the wood so that the angle-iron will come flush with the surface of the bench, or it may be left to project above the surface to serve as a bench stop for planing. Drill and countersink the iron and use flat-head screws, which will come flush with the surface. Projecting screws would, of course, be sure to mar the wood that is held between the jaws.

### Silencing Brake-Lever Rattles

If the emergency brake lever in the model-A Ford develops a rattle, the noise can often be stopped by inserting a piece of thin cardboard on each side of the catch and shel-lacking it on one side next to the handle. A rubber band or a drop or two of solder will also correct the trouble in case the button on top of the brake lever should begin to rattle.

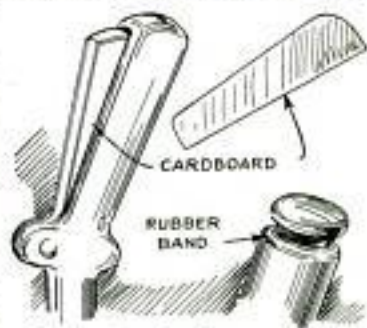





Paste Table Fitted with a Roller for Holding the Paper Makes Work Easier and Saves Time

### Improved Paste Table for Paperhangers

Paperhangers can handle wallpaper much easier by using a holder for the roll at the end of the paste table as shown. The fixture consists of a frame made of flat iron with the ends bent over at right angles and drilled to take a wooden roller of the proper length. The whole is screwed to the underside of the table top. The provision of two strips of wood along the sides, spaced apart so that a standard width of wallpaper will fit between them, was found convenient for pasting, as there is no risk of getting the paste on the face side. The small amount of paste that gets on the edge of the strips can easily be wiped off before coating the next piece.—C. L. Sample, Augusta, Ga.

### Improving the Babbitt Ladle

This babbitt ladle has a long handle and two spouts which are fed through holes in the side near the bottom as shown. This arrangement makes it possible to pour metal that is entirely free from slag. The



spouts were made of  $\frac{1}{8}$ -in. sheet steel, heated and forged to shape, after which they were welded to the cup. Another advantage of this ladle is that the risk of spilling is greatly reduced, and consequently also the danger of injury.

### Sheet-Metal Disks Cut in Vise

Sheet-metal disks, can be cut without any other tools than a vise, cold chisel and a hammer. A hole is drilled in the metal to fit a rod, which is held vertically in the vise, serving as a center on which the work swings. Similarly, a cold chisel with a sharp cutting edge is clamped between the jaws so that the cutting edge just projects. If the diameter of both rod and chisel are the same, they will be held equally tight, but if the rod is smaller, a



Vise, Hammer and Cold Chisel Are the Only Tools Required for Cutting Neat Sheet-Metal Disks

piece of wood is used to block it up. The distance from the center of the rod to the chisel edge should be equal to the radius of the desired disk. In use, the piece of sheet metal is moved over the cutting edge and tapped lightly with a mallet.

### Lacing Belts with Rawhide

Lacing belts with rawhide strings can be made much easier by holding the tips of the rawhide lace over the flame of a match. The fire hardens the leather and forms a stiff point that is easily inserted into the holes in the belt.—A. C. Wilson, Columbia Cross Roads, Pa.



### Cleaning Shellac Brushes

The proper way to clean a shellac brush is to use alcohol liberally. A tomato or soup can, suiting the size of the brush, is the best container. With enough alcohol to nearly submerge the brush press the bristles forcibly sidewise on the bottom of the container, first one side then the other, time and again. After most of the shellac has been removed repeat the process, using clean alcohol. It may even be necessary to use a third portion to get the brush perfectly clean. Then free the brush from the liquid by shaking it, and wipe with a rag. Don't throw the alcohol away, but put it away in a bottle. After it clears and the shellac settles to the bottom it can be used again. In this way there is no waste. Much trouble can be avoided if the brush is cleaned at once after a job is finished. If a shellac brush is dry and hard, set it in alcohol for several days, covering the can to prevent evaporation. The writer has a brush used for shellac only for more than 10 years, and it is still soft and as good as ever.—C. D. Cheney, Lyndhurst, N. J.

### Improving the Draftsman's Triangle

Draftsmen's triangles can be trimmed down so that the inside edges give the proper angles for laying out screw heads, threads on screws and bolts, sections of I-beams, and anything else in which the angles used are more or less standard. Another idea that has been found useful, is a slot in the lower section of the triangle with small holes drilled on each side, these being spaced equidistantly and

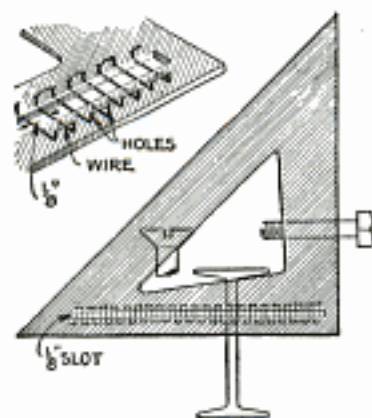

laced with thin copper wire as shown. This provides a quick method of making uniform dotted lines.—G. Burrows, No. Tonawanda, N. Y.

☐ When out of cast-iron flux or scaling compound for welding, fine table salt makes a good substitute.

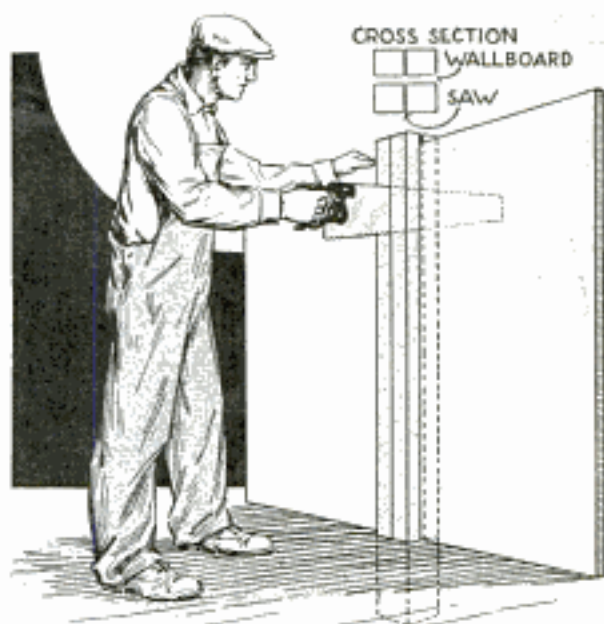

A Convenient Saw Guide That Will Save You Time in Cutting Through Wallboard

### A Saw Guide for Cutting Wallboard

For cutting wallboard quickly, the illustrated guide will be found helpful. It consists of two 5-ft. lengths of 2 by 6-in. stock, nailed together at one end with a 10-in. piece of 1/2-in. stock between to serve as a spacer so that the wallboard can be slipped between. A saw slit is made through the center, and the guide is erected as indicated.—Robert Paulson, Hutchinson, Minn.

### Finding Cracks in Metal

Surface cracks in small metal articles can be detected by cleaning the articles in a hot soda solution and immersing them, while warm, in kerosene. They are then wiped dry and coated with white-wash. After this is dry, the article is struck several blows with a hammer. If there are any cracks, the kerosene in them will ooze out and show up on the white-washed surface. If the objects are too large to be immersed, wash them with the soda and proceed as before.

### Kerosene-Soaked Magazines Used for Kindling

Discarded magazines, wrapped into tight rolls and bound with wire, make satisfactory kindling when soaked in kerosene. The roll is safer to use than loose paper and burns longer, forming a good substitute for wood in starting a fire.



## HOW SLIPPING PULLEYS CAN BE CURED BY LAGGING

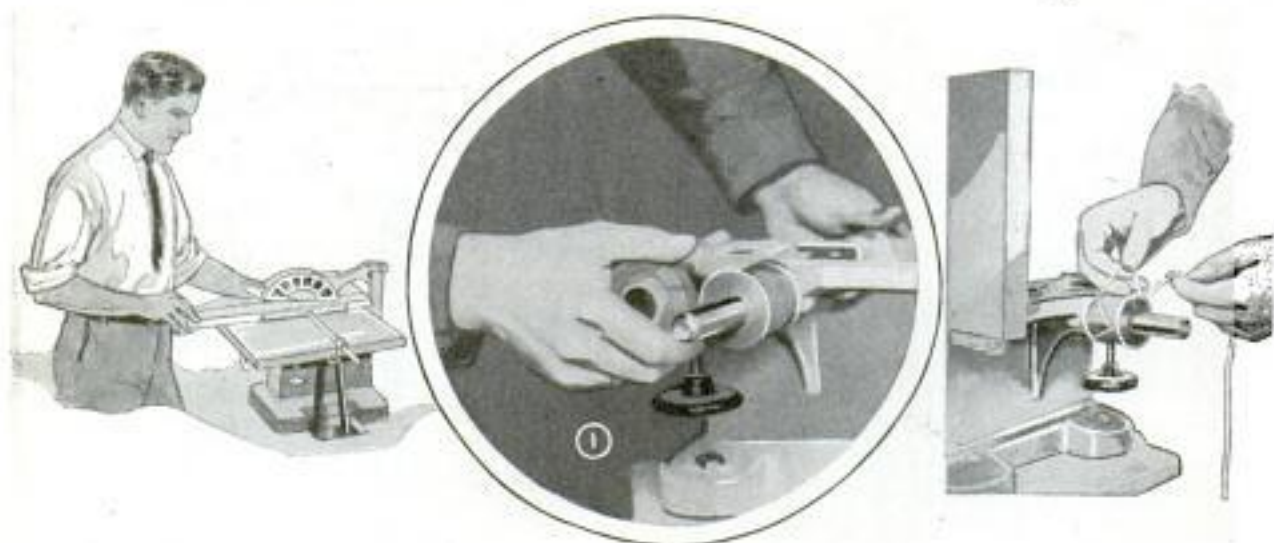

Although Not Intended as a Permanent Remedy for Slipping Pulleys, This Method of Lagging Will Last a Long Time, and the Wrapping Can Be Removed or Renewed in a Few Moments

Cast-iron pulleys keyed to the shaft of small bench saws, often give trouble owing to the surface being worn smooth by the belt. Belt dressing is of little or no avail, and a stiff tension on the belt is usually considered the only alternative cure. However, this results in excessive wear on the light bearings in both the saw and the motor, and is therefore not desirable. Belt slippage on small iron pulleys can best be remedied by lagging, or wrapping the surface with something to increase its friction. To do a satisfactory job, one cannot stop by merely winding the pulley with thread in crisscross fashion, spreading glue on the thread, although this method has been found serviceable for a short time under light load. But when taking a heavy ripping cut with a  $\frac{1}{2}$ -hp. motor, the thread will let go entirely or will break and wind up in the bearing. After experimenting with several other methods, the illustrated wrapping was found strong enough for any strain likely to be applied to the saw. The pulley is first wound with a layer of friction tape, the wrapping being started at one side with only the edges overlapping slightly. Be sure to wind it as tightly as possible without tearing. On the average flanged pulley only a single-layer wrapping is advisable, because, after the thread has been wound on, the lagging will be so bulky that the flanges will not hold the belt in place under a heavy load. Thread a strand of cobblers' thread through a fairly heavy

sewing needle, double it and tie the ends together after which the thread is thoroughly waxed. Begin at one side of the pulley and stitch through the tape, back and forth from one side to the other so that the strands cross the pulley diagonally, as shown in the right-hand detail. Pull the thread fairly tight, but not so tight that it will draw the tape loose. Continue the stitching all the way around the pulley. Pass another length of thread through the needle, doubling and tying again in the same way. Wax the thread and start winding at one side of the pulley, taking a halfhitch of the thread over every second one of the cross stitches.

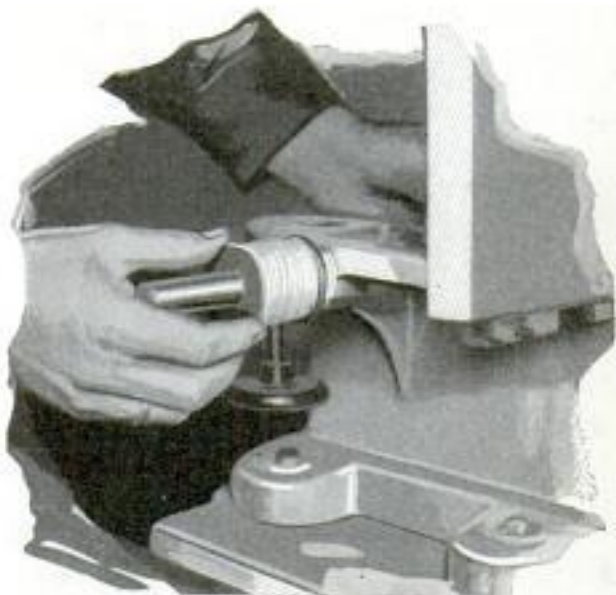

The Thread Will Not Unravel As It Is Tied to Cross Strands Stitched to Tape



Keep the strands close together but separate, so that they will not be doubled, and be sure to keep them drawn tight. Continue the winding in this way, halfhitching each winding to the cross stitches until the pulley face has been entirely covered. Then sew the end of the thread into the lagging in several places so that it will not loosen. After this has been done, the lagged surface is given at least two coats of shellac. When thoroughly dry, put on the belt and start the motor. Do not put the pulley under a load immediately, but allow it to run idle for a short time and give the belt one or two applications of dressing. This will collect on the lagging and serve to level the strands of thread, besides providing more friction. The cross stitching prevents the thread from unwinding as soon as one or two strands break. In this way, fraying thread will be held in place until the lagging is virtually worn out. While not a permanent remedy, this method will effectively prevent slipping, and it takes but a few minutes to renew or remove the lagging when necessary.

#### Electric Fan Settles Liquid in Thermometer

When the column of liquid in a thermometer is separated, and it cannot be shaken down, attach the thermometer to the blades of an electric fan as shown, using strong rubber bands to hold it in place. Be sure to get all the liquid of the thermometer on one side of the center of



the fan so that when the latter is run at low speed for a few minutes, the liquid will all be forced toward the bulb. Thermometers should always be hung in a vertical position even when not in use, so that the column of liquid will not be broken.—Dr. Ford Carpenter, Los Angeles, Calif.

☛ The ends of a revolving shaft should be inclosed to avoid accidents.

#### Portable Canvas Garage for Tractor

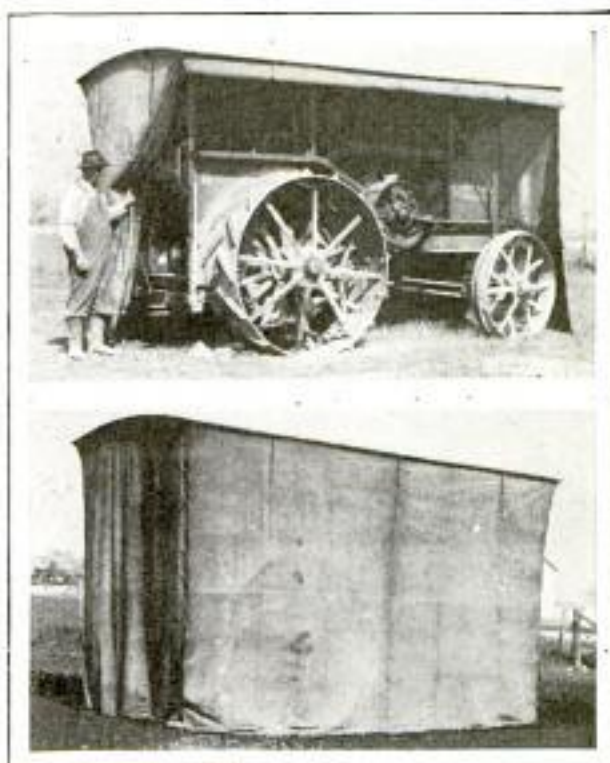

Canvas Garage for Tractor Protects It against the Weather When Left Outdoors

As he was often obliged to leave his tractor out in the field on a job that required several days, a western farmer built a portable garage of canvas to protect the tractor against the weather. A permanent roof was provided and the canvas suspended from the sides. When the tractor is to be used, the sides are rolled up and fastened to the top with straps. The upper edge of the canvas was attached to the roof by means of 1 by 2-in. strips securely bolted to the roof and sewed to the canvas. Any shoe repairman will do the job of sewing the strips to the canvas. Suitable grommets should be provided in the vertical edges of the canvas so that adjacent sides can be securely laced together to prevent them from being blown apart in a storm.

#### A Cardboard Drill Holder

A piece of corrugated cardboard, tacked to the side of a shouldered block of wood, makes a satisfactory holder for small drills. A narrow strip along the top is torn away so that the divisions for the drills may be seen more easily. Several applications of shellac make the paper durable.



# Distinctive Dutch Colonial House

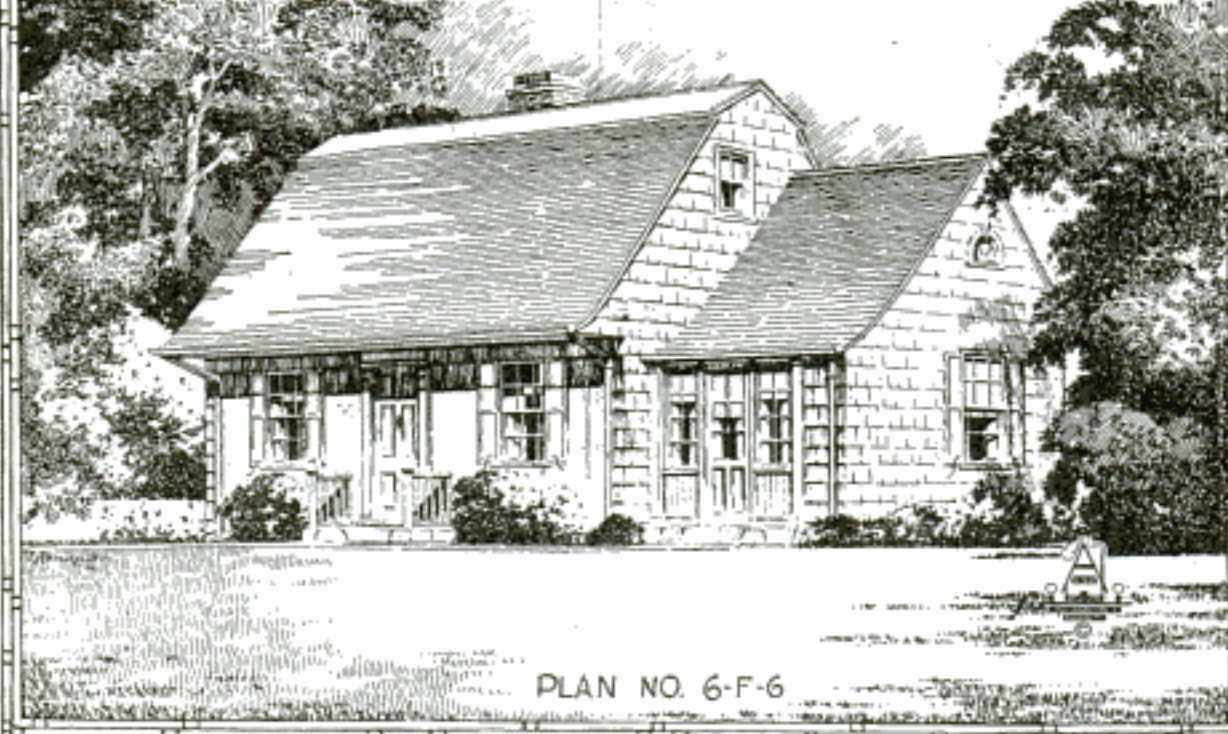

© The Architects' Small House Service Bureau, Inc.

HERE is another plan that has the wanted flexibility of everything on the first floor for the first, and more rooms on the second floor when needed. After the house is completed, that first-story bedroom will be a source of comfort and convenience that practically every one will cherish.

But you can leave that whole wing off. If your lot is only forty feet wide, that will be the thing to do. Then the house becomes a five-room type complete in itself.

Some folks wonder why we left off the usual dormers in the front roof. That was not accident; it was planned. The idea is to get the true Dutch flavor—a broad expanse of unbroken roof designed with a graceful curve at the eaves. Such roofs on old houses of the Dutch period are extremely beautiful. As a matter of fact, dormers could only add needlessly to the expense, for each of the bedrooms is cross-ventilated and the bath has adequate lighting. There is planned convenience at every turn. Plans for small homes fit or misfit. All depends on the family needs and what can be afforded. This one is not costly. Whether or not it suits your family depends on personal taste.

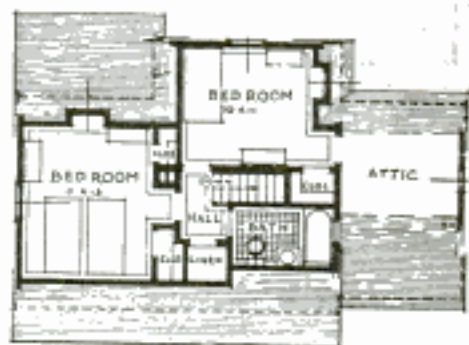
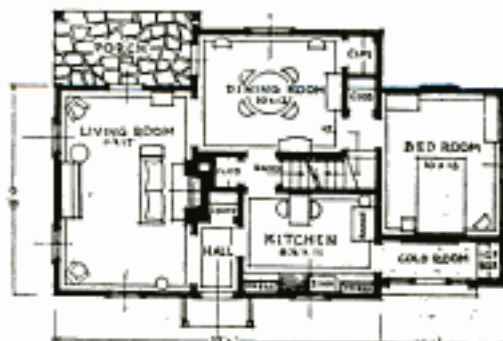

The Architects' Small House Service Bureau of the United States, Inc., was formed to furnish a complete and dependable small-house plan service at moderate cost. For information regarding the blueprints and specifications address the bureau at 1200 Second Avenue, South, in Minneapolis, Minn., from which also a booklet, containing twenty-seven selected small-house plans, may be had for the price of 10 cents. The bureau is under the control of the American Institute of Architects.



**E**VERY so often, there is an invention so important in saving time and labor as to be outstanding in its class and a world leader. In hand tools the "Yankee" Spiral Ratchet Screw-driver is thus distinguished.

"Yankee" No. 30-A.—Standard Spiral Ratchet Screw-driver. Price, with three bits.....\$3.00

"Yankee" No. 130-A.—Spring in handle makes it the Quick-Return Spiral Ratchet Screw-driver. Three bits.....\$3.45

Also Heavy and Light Patterns.

"Yankee" Attachments for drilling, counter-sinking, etc., sold separately.

# "YANKEE" TOOLS

MAKE BETTER MECHANICS

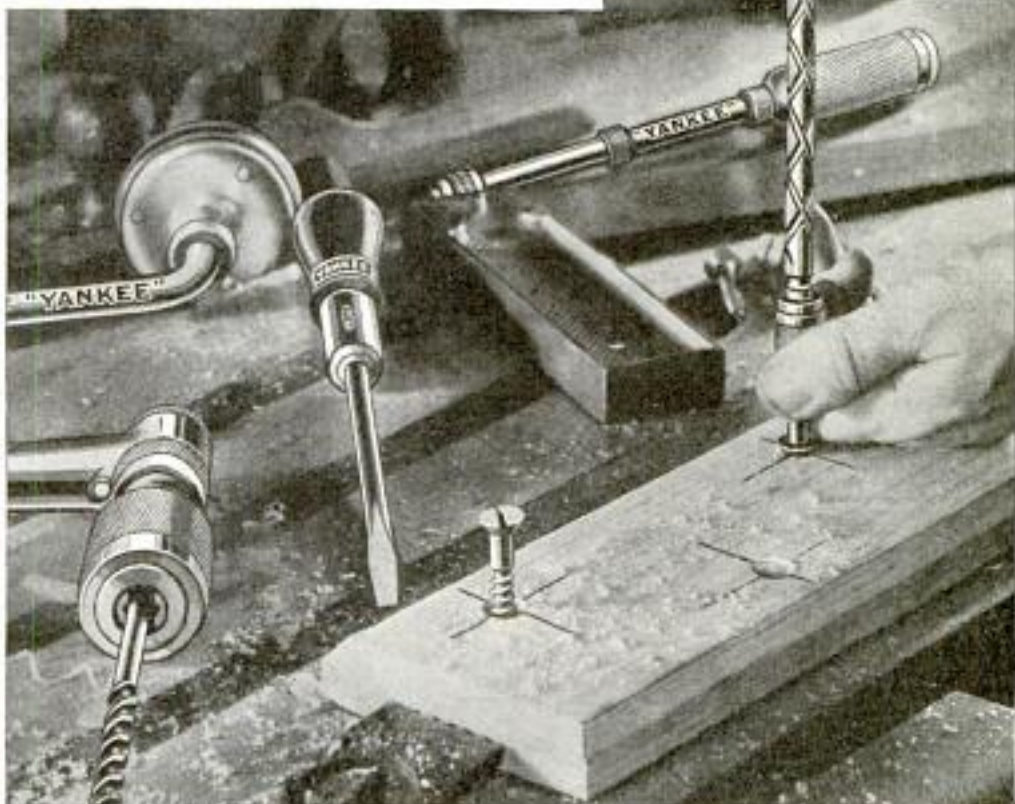

North Bros. Mfg. Co.,  
Lehigh Avenue, Philadelphia, U. S. A.

"Yankee" Tools are made for the mechanic or amateur who values his time and labor, and knows the economy of using the best tools he can buy. Good workmen everywhere have come to know that "Yankee" on the tool you buy means the utmost in quality, efficiency and durability.



USE Coupon to get "Yankee" Tool Book. Shows "Yankee" Tools saving time and labor: Ratchet Bit Braces, Automatic Push Drills, Two-speed (11-inch) Hand Drills, Ratchet Tap Wrenches, Automatic Bench and Chain Drills, Ratchet Breast and Hand Drills, Removable-base Vises, etc.

YOUR NAME.....ADDRESS.....(pm)



# Popular faces are *shaved with* Barbasol

*\*"For the man who wants to keep on friendly terms with his face—I recommend Barbasol. It's 'fast' . . . side-steps all the old shaving troubles, while making the whiskers come clean. I'm a Barbasol rooster every morning when I shave, and all day, too."*



*James J. Corbett (Gentleman Jim) who leaped to fame when, as a boy, he vanquished John L. Sullivan and has been famous ever since.*

\* Barbasol testimonials are not paid for

SOME men never have that seedy look as if they needed a shave. How do they do it? Ten to one they're Barbasol Believers because Barbasol is so easy on the face that two shaves a day won't hurt the tenderest skin, planted with the toughest whiskers.

Like magic this new, quick, modern shaving cream softens the beard while holding the hairs straight up to the blade. Crisp and easy the razor slides along; no pull; no scrape. Its wonderful ingredients protect your face. Your skin actually feels better, softer, more relaxed—after the Barbasol shave.

*Follow these directions and you'll follow the crowd*

1. Wet your face and leave it wet . . .
2. Spread on Barbasol. Don't rub it in—just be sure it's spread on evenly



between the hairs . . . 3.  
Wet a good blade and  
SHAVE.

That's all you have to do to get the finest shave in the world. It's simple, easy, quick. Try it today. Generous tubes at all druggists', 35¢ and 65¢,

will quickly make YOU a Barbasol Believer, too.

**FREE** A refillable Tefra Toothbrush, value 75¢, with your first name or initial on handle. Finest quality; cuts family toothbrush bill in half. Mail entire empty Barbasol carton (35¢ or 65¢ size, or jar) with your name and address. We will mail toothbrush absolutely free with your first name or initial engraved on handle. The Barbasol Company, Dept. 15, Indianapolis, Indiana



*Listen to Barbasol Ben and His Boys—Laughs—music—fast and furious fun—the happiest entertainment on the air. Tune IN, every Monday, Wednesday and Friday evening at 8:15, Eastern Standard Time, Columbia Network; Stations WABC, WMAQ, WCAU, WXYZ, KMOX, WHK, WJAS, WNAC, WCAO, WKBW, WISN, KMBC, WCCO, WKRC, WFBM, WMAL, WEAN, WSPD, KOIL, WADC, WFBL, WDRG, WPG.*



**DISSTON**  
SAW  
TOOL  
AND  
FILE  
**MANUAL**  
HENRY DISSTON  
& SONS Inc.  
PHILADELPHIA  
U.S.A.

**A NEW BOOK for Tool Users**  
"THE DISSTON SAW, TOOL, AND FILE MANUAL" . . . SENT FREE

Just out! The most interesting, helpful book ever offered without charge to tool users. Full of information to make your work with tools better and easier.

It tells how to choose and use circular saws, hand saws, rip saws, back saws, coping saws, compass saws, etc., and how to sharpen your saws. It shows how to adjust, operate and refit saws for electric home workshop outfits.

This new book also tells and shows how to select the proper files or hack saw blades for any job; how to hold the work; and how to use hack saws and files most efficiently.

It shows how to sharpen and use cabinet scrapers, and how to use levels, bevels, gauges, etc.

This new Disston book with 229 illustrations is worth dollars to any tool user. The coupon or postcard will bring it promptly.

## DISSTON

*The World's Foremost Saw Makers*  
Henry Disston & Sons, Inc., Philadelphia  
(Henry Disston & Sons, Ltd., Toronto, Can.)

Send me the new "Disston Saw, Tool and File Manual", just published, which tells and shows how to choose, use and care for tools.

Name.....

Address.....





## When the "Urge-to-Go" gets you . . . .

GO!—Go the man's way, on the *man's* steed—an Indian Motorcycle. Leave the glass enclosures for your wheel-chair days. Now, while your blood runs and your heart sings, put *thrill* in your goings—ride a lean, lithe motorcycle. Let the wind tear at your hair, let the sun beat down on your shoulders . . . what do you care? A million miles invite you . . . a million miles, every one a mile of joy—at the lowest cost in the world.

Valuable dealer franchises are open . . . write for details before they are snapped up.



## Indian MOTORCYCLES

INDIAN MOTORCYCLE CO.,  
Dept. A-4, SPRINGFIELD, MASS.  
Please send folder on Indian Motorcycles.

My age is . . . . . years.

NAME . . . . .

ADDRESS . . . . .



THERE is no introduction which carries the dignity, prestige, or personality of a well-arranged business card. A tab of perfect business cards will be sent in response to your request.

The JOHN B. WIGGINS  
Company

Established 1857  
1153 Fullerton Ave., Chicago, Ill.

## WIGGINS Peerless Book Form CARDS

### Sport Bodies for Fords At Factory Prices



This Model in Grey Prime \$38<sup>50</sup>

Send 10c for catalog showing all models of bodies and other equipment for Ford and Chevrolet. Hi-compression heads, underbody parts, 3:1 gears, headlights, fenders. Cut shows body on Model A Ford. Also made for Model T Ford.

Make Your Ford Into Classy Car

Sport Factories, Dept. B-2, Aurora, Illinois

	<h3>CLASS PINS 35c</h3> <p>FREE CATALOG</p> <p>Either pin, silver plate . . . 35c ea. Starting silver or gold plate . . . 50c ea. For 2 colors, enamel, any 3 or 4 letters &amp; dates</p> <p>Lower Prices on Dagen Logo</p>	
BASTIAN BROS. CO.	361 EAST 10th ST. ROCHESTER, N. Y.	

SHOES

## Get Into The Shoe Business Without Investment!

We start you, inexperienced workers and big money with our direct to wearer plan. Easy to take orders. Just show the famous Tanners line of shoes and hosiery for Men, Women and Children. We tell how and where to sell. Patented measurement system insures perfect fit. Big facilities guarantee prompt deliveries. You collect your pay daily. We furnish \$40.00 worth containing actual shoes and actual hosiery in larger variety of styles and sizes than any store. Send for free book, "Learning Ahead" and full particulars. No obligations. Write now!

TANNERS SHOE CO.  
874 E Street, Boston, Mass.

FOOTWEAR  
SPECIALTY

**Experience Unnecessary!**



# Starretts

for your plane



Combination Square No. 23 — handiest tool you can have in your kit — six-inch size: \$1.00.



Combination Depth Gage and Hook Rule No. 236 H — another handy tool — caliper — depth gage — plain rule — hook rule — handy protractor — \$2.50.



Pocket Steel Tape No. 500 — graduated in inches and 16ths — nickel plated case — strong, flexible steel ribbon — 36' size: \$1.75 — 120' size: \$1.90.



Micrometer Caliper No. 224-AA — range 0 to 1" by 1000ths — a general purpose mike — without ratchet stop: \$18.00.

car



Above: Checking propeller blade with a Starrett Micrometer No. 222.

Left: Setting breaker points with a Starrett Thickness Gage No. 172.

Below: Laying out felloes for coach-model wheels.

coach - model

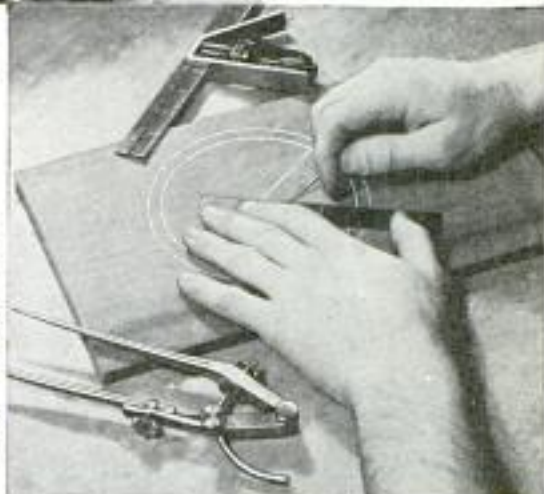

Wherever a job requires accurate measurement — whether it's the roof of a house or the balance-staff of a wrist-watch or the wheels of your coach-model — you'll find a Starrett Tool that *seems made-to-order* for it.

There are over 2500 different Starrett Tools. They handle measurements between 0.0001 inches and 100 feet with unfailing accuracy. They handle scores of different *kinds* of measurements.

Send the coupon for a copy of the big Starrett Catalog No. 25 "AP" that describes and prices all of these tools, shows how you can use them to do better work *faster*.



# Use Starrett

THE L. S. STARRETT CO., ATHOL, MASS.  
Please send me my free copy of Starrett Catalog No. 25 "AP"

Name \_\_\_\_\_  
Address \_\_\_\_\_  
City \_\_\_\_\_ State \_\_\_\_\_

# Tools





## THE CIGARETTE IS MIGHTIER THAN THE PEN.

No thanks, Mr. Webster . . . no words today. OLD GOLD, the cigarette itself, tells its own story better than all the diction in the dictionary. One pack's worth more than a thousand words. 158 victories in 165 public *taste-tests* of the four leading brands showed how even a few puffs could tell OLD GOLD'S taste-winning, throat-thrilling story. Light up . . . and write up your own opinion.

© P. Lorillard Co., Inc.

# OLD GOLD CIGARETTES

NOT A COUGH IN A CARLOAD

## Thompson BEATS the World on BOATS

### THOMPSON BOATS

# CATALOG FREE!



**OUTBOARD MOTOR BOATS**—For Every Purpose and Every Purse—The very fastest and most seaworthy Boats for family use, and a strictly up-to-date line of Step Plane Racing Models. Holders World's Outboard Endurance Record.

**Rowboats**  
\$48.00  
and up—  
Most complete line ever offered, at real money-saving prices.

**Canoes**  
\$50.00  
and up—  
Some all wood, others canvas covered. Light, swift, safe, strong and durable. Many color combinations.



**Motor Boat**  
\$745

**Mahogany Runabout.** 16 and 18 ft. Speed 25 to 35 mi. per hr. Complete with 4-cycle motor installed, including electric starter and reverse gear.

CATALOG FREE—SAVE MONEY—ORDER BY MAIL.  
Please state the kind of boat you are interested in (45)

—TWO LARGE FACTORIES—  
**THOMPSON BROS. BOAT MFG. CO.**  
213 Ann St. (Write to) 113 Elm St.  
PESHTIGO, WIS. (Either Place) CORTLAND, N.Y.

## Catch Fish!

Eels, Mink, Muskrats with our new folding galvanized **STEEL WIRE TRAP.** Write for our **FREE TRAP OFFER** and Bargain Catalog. \$1 Box of our famous Fish Bait FREE to introduce our traps. **WALTON SUPPLY CO., 3502 JUNIATA AVE., ST. LOUIS, MO.**

## Factory to Rider

Save \$10 to \$25 on the Mead Bicycle you select from 44 Styles, colors and sizes.

## 30 Days' Free Trial

We ship on approval. If not satisfied after trial return the bicycle. **EASY PAYMENTS.** \$5 down on RANGER Bicycles.

**Tires**—large, wheels, equipment at half usual prices. Write for marvelous new prices, wonderful 30 day trial offer and terms.

## Mead Cycle Company

Write us today for free catalog  
Dept. C111 Chicago

**MAKE YOUR FORD INTO THIS SPORT CAR** Picture your's, \$3.99  
**STEEL REAR PATTERNS.** \$3.99

Famous sure-fit RED-I-KUT life-size patterns and picture instructions show how you can easily convert your Ford into this Fast, Saucy Sport-Car as thousands have with easily obtained materials. \$3.99 includes pressed metal rear.

No need to buy up the car, makes wonderful riding speed car. You'll be the talk of the town. Send dime for actual photo of sport car and new manual of distinctive sport car patterns from \$2.00 up — "RED" Steel "Swing-Lo" Undercarriage

\$1.98. Sport and speed accessories. **ORDER RIGHT NOW** for a real thrill.

**KUEMPEL COMPANY, "Speed Engineers," No. 2 Kuempel Bldg., Guttentberg, Ia.**



**\$10.00 DOWN**  
Brings this Lathe to You

Lathes \$6.00 to \$75.00. Largest line of small lathes in America. Send ten cents for 32 page catalog No. DB4 of lathes, drill presses, bench saws, jig saws, bandsaws, etc.

**SYIPHER-ARCON CO.** 1524 Fernwood Toledo, Ohio



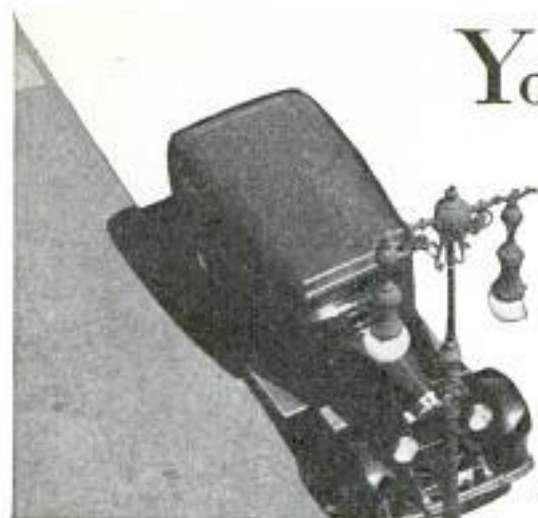

You call it an *Automobile*

**BUT-**

we call it *apparatus*  
in Ethyl laboratories

FROM the garage doors of the Ethyl Engineering Laboratory in Detroit — cars come and go. Stock cars, special cars; cars like the one you drive today and like the one you'll probably drive tomorrow. They are a part of the *apparatus* that engineers of the Ethyl Gasoline Corporation use in their everlasting search for fact.

During the past three years over 500 cars have been purchased, many of them worn out and destroyed by gruelling tests that tell the facts about motor fuel.

These tests prove that Ethyl Gasoline gives more power, that it takes better care of your car, that it does not "knock" and that it is admirably suited to the needs of *any* car sold today.

All Ethyl Gasoline is made from *good* gasoline. It all contains enough Ethyl fluid to *control combustion*. Try it yourself from the pump that bears the Ethyl emblem. You will like it. Ethyl Gasoline Corporation, Chrysler Building, New York City.

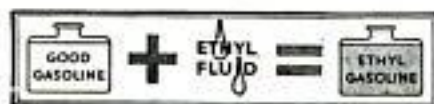
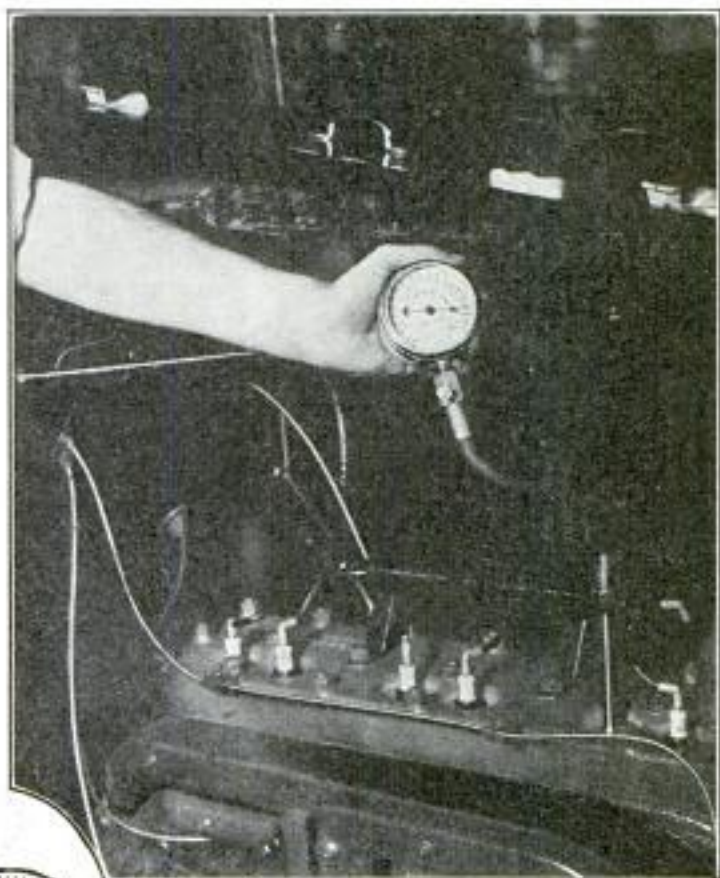

The active ingredient used in Ethyl fluid is lead.



Taking the compression pressure of a stock car with special head, 175 pounds compression is a much higher pressure than that of any car on the market, and this engine is operating satisfactorily on Ethyl Gasoline. Such high pressure develops amazing performance.

ETHYL GASOLINE © E. G. C. 1934



# Earn up to \$12<sup>00</sup> a Day

## In Your Own Business

You can do it filing saws on the Foley Automatic Saw Filer! Start in spare time and build up a fine-paying cash business of your own. V. H. Vander Espt writes, "... I filed 21 saws from 8 A. M. to 5:30 P. M. at an average of 80c apiece (\$16.80)..." Frank Bradek writes, "... Cleaned up \$56.00 in three days..." It is easy work—no eye-strain—no previous filing experience necessary. The Foley Filer automatically files saws perfectly.



## FOLEY AUTO MATIC SAW FILER

This one machine files all kinds of hand saws, band saws and cross-cut circular saws much better than the most expert hand filer. Its work is mechanically accurate, with every tooth exactly uniform in size, height and spacing. Every tooth cuts—that is why saw users like Foley-filed saws best—they cut better, faster, cleaner, truer and stay sharp longer.

## Make BIG Profits

FREE PLAN tells you how to get started. Easy to get business—one customer brings you more. 96c out of every dollar CLEAR PROFIT. J. W. Cremeans writes, "... I have a Foley Filer and it is a money-maker because it turns out perfect work..."

YOU can have your own steady business, too. Small capital needed—pay as you go along. We will help you get started. Send coupon below for FREE PLAN now.

**Foley Manufacturing Co.**  
212 Foley Bldg.

11 Main St. N. E. Minneapolis, Minn.

Please send me FREE PLAN and tell me how I can start my own business in spare time filing saws on the Foley Automatic Saw Filer.

Name.....

Address.....

City and State.....

## A New Business in Your Town

A delightful, dignified and fascinating business. Make and sell Crispettes. Delicious confection. Young and old like them. Come again and again for more. Easy to make. I supply everything. Raw material plentiful and cheap. Profits big. No town too small. Start now.

**Quick Success Possible** anywhere—cities, towns, villages; open a little retail store; or, begin at home; wholesale to stores, grocers, bakers, druggists, parks, baseball games, picnics, wayside stands.

**Exceptional (average) Profits**—\$11,265 sales in 3 months reported by California man. New Jersey \$4,000 profits in less than two months. Revel of Michigan wrote: "Made \$25 on my first day." A. Leib of Montreal wrote: "My sales averaged \$400 per week."

**We Start You in Business** for little money. Supply machines, secret formulas, and raw material. Little capital starts you. No experience needed.



Write for "Book of Facts"  
—it's free, contains success letters from others—shows their places of business, tells how to start.

SALES  
**\$606.81**

One Week Ending July 20 1929

W. H. ADAMS  
OHIO

AVERAGING  
**\$3000.00**

PROFIT FOR 3  
SUMMER MONTHS  
Report July 14 1929

E. R. NABOR  
MASSACHUSETTS

**LONG EAKINS CO.**  
428 High St., Springfield, Ohio

## Send for Free Catalog



2000 illustrations—Diamonds, Watches, Jewelry. Largest Diamond & Watch Credit House in the World.

**LOFTIS BROS. & CO**

Dept. M-334

108 No. State St., Chicago, Illinois

## Burning Feet Ended in 3 Seconds!

THOUSANDS get instant relief from sore, tired, burning, aching feet with this cooling, ivory-white vanishing cream—Coolene. Its soothing, healing oils and unguents quickly penetrate to the inflamed tissues—relieve congestion—and all pain and burning in 3 seconds. Does not stain. Get Coolene today.



This Book  
SHOWS  
YOU

HOW TO BUILD

a NEW  
Outfit  
for Your  
SHOP

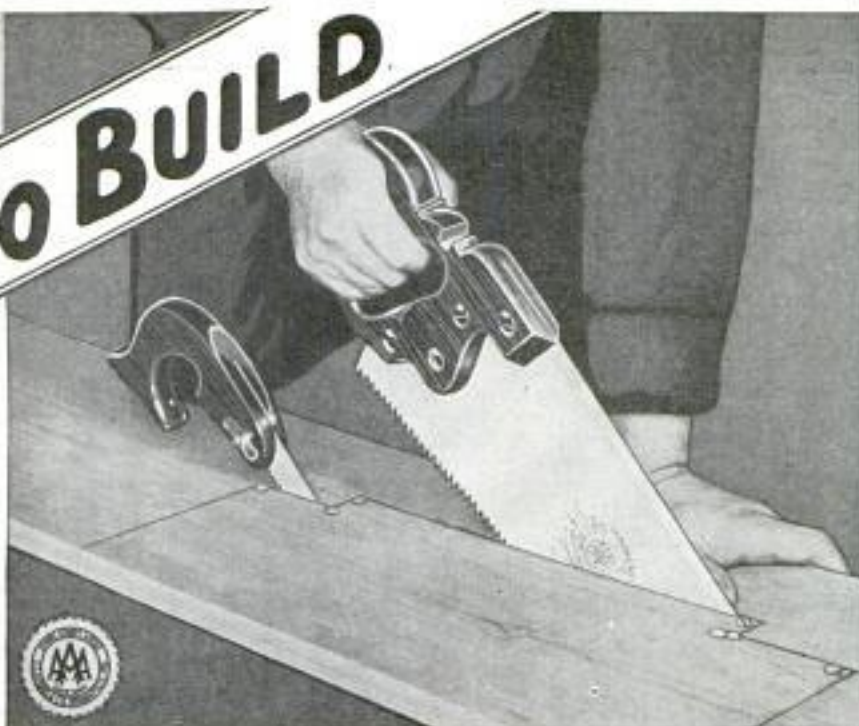

Cutting drawer opening in bench apron with ATKINS Silver Steel Hand Rip Saw No. 33, 26" blade, ..... \$3.75  
Compass Saw No. 9 used to begin cut, 12".....\$0.90

Ask your hardware dealer for any ATKINS Saws you want. If he does not have them, write us and we will see you are supplied promptly.

## Work-Table, Bench, Saw Horse, Tool Cabinet!

**M**AKING your own workshop furniture is FUN when you have the expert guidance given in this new ATKINS Saw Book. The section on "Building Your Shop Outfit" gives you clear working drawings and step-by-step instructions for making a pair of sturdy saw horses, a folding work-table, a substantial bench, a tool box-seat, and a handy wall cabinet for tools.

And to help you do accurate joinery in building these and all other projects, eight pages of the book are devoted to wood joints—showing easy ways to cut and fit 24 types widely used in shop work.

It is a complete home-shop guide! Tells just the things you want to know about home-crafting! The pleasure and profit in this popular hobby... how to plan a new shop... what tools and bench machines to get... discusses 20 types of saws and their uses... tells where to obtain plans to build 200 projects... shows best way to sharpen saws... lists books for shop workers... and so on!

Finally, you come to fifty pictures of "Silver Steel" Saws and Saw Tools selected for shop use, with reasons why they cut so much faster, run easier, hold a keen edge better, and last so much longer than ordinary saws.

The book is brimful of helpful information for amateur or expert. It has 32 pages, costs only a dime, and will save your time, improve your work and add to your fun in home-crafting. Thousands send for it every week. Mail the coupon for your copy NOW.



ATKINS Dovetail Saw No. 25 with 10" Silver Steel blade is... \$1.60



Silver Steel Circular Saw, of Rip or Cross-cut type, 8".....\$2.77



Ideal for fine cutting, is ATKINS No. 2 Back Saw, 12" blade...\$2.70



Narrow Band Saws, 1/4" width, \$0.091 per foot. Brazing, 35c each



E. C. ATKINS and Company, 426 S. Illinois St., Indianapolis, Ind.

I enclose a dime for the new ATKINS Saw Book. (PRINT name below.)

Name.....

Street.....

City..... State.....

Dealer.....



# BUY PROTECTION



## WHEN YOU BUY OIL.....

Ordinary mineral oils often fall down on workshop jobs. Some "gum" very quickly. Some penetrate too slowly. Others give way at high speeds, and leave working parts exposed to frictional wear.

Three-in-One Oil is just right. For it is not an "ordinary" oil, but a scientific blend of *animal*, *mineral* and *vegetable* oils. It penetrates to any friction point instantly. It lasts long without gumming. And every time you use it, 3-in-One Oil does three important things.

It *cleans* old, dirty oil from bearings and working parts. It *lubricates*. And it *prevents* both *rust* and *tarnish*. Used regularly in your workshop—on tools, motors and high-speed equipment—this oil prolongs service; saves many a repair bill.

Three-in-One Oil is sold by all good stores. Both handy cans and bottles. Write now for free sample and "Dictionary of Uses."

THREE-IN-ONE OIL COMPANY, DEPT. 301  
130 William Street, New York  
Factories: Rahway, N. J. • Montreal, Que.

# 3-in-One Oil

CLEANS - OILS - PROTECTS

## HERE'S A BOAT YOU WON'T HAVE TO CAULK!



Even though she's been stored for the winter, you slide your Old Town over—hop aboard—and go right away! She won't need to be soaked or caulked. The heavy, non-leak canvas-covering can't open up. Nor does an Old Town shimmy, shake, or vibrate. And the stern is braced at every angle, so a heavy-weight motor won't harm it. Yet an Old Town is light—easy to handle—and has all the speed you want.

Free catalog shows prices and models. Also canoes; rowboats; dinghies; big, fast, seaworthy, all-wood, out-board family-boats, and speedy step-planes. Write today. Old Town Canoe Co., 1244 Middle Street, Old Town, Maine.

## "Old Town Boats"



## MOTORCYCLES

**Direct to you at wholesale prices**

Send 10c today for the latest Illustrated Bulletin and Confidential Price List of Guaranteed Indians Harleys Hendersons SuperX etc.

(Sold on easy terms if desired)

**CRANDALL CYCLE CO. 826-28 State St. Shipments to all Motorcycles Since 1905 Springfield, Mass. parts of the world**

**Big 3 ft. Telescope** Five Sections, Brass bound. Powerful Lenses. 10-Mile range. Special Eye Piece for looking at the Sun, included FREE. Can be used as a Microscope. Guaranteed. Big value. Postpaid, \$1.75. C. O. D. 15c extra. **Benner & Company, 148, Trenton, N.J.**

**DO YOU** WANT a new business profession of your own, with all the trade you can attend to? Then become a foot correctionist, and in a few weeks earn big income in service fees.—not medical nor chiropody—easy terms for home training, no further capital needed, no goods to buy, no agency. Address **Stephenson Laboratory, 1 Back Bay, Boston, Mass.**

THE FLAVOR

# WRIGLEY'S

## SPEARMINT

THE PERFECT GUM LASTS

MINT LEAF FLAVOR

Good and Good for You.



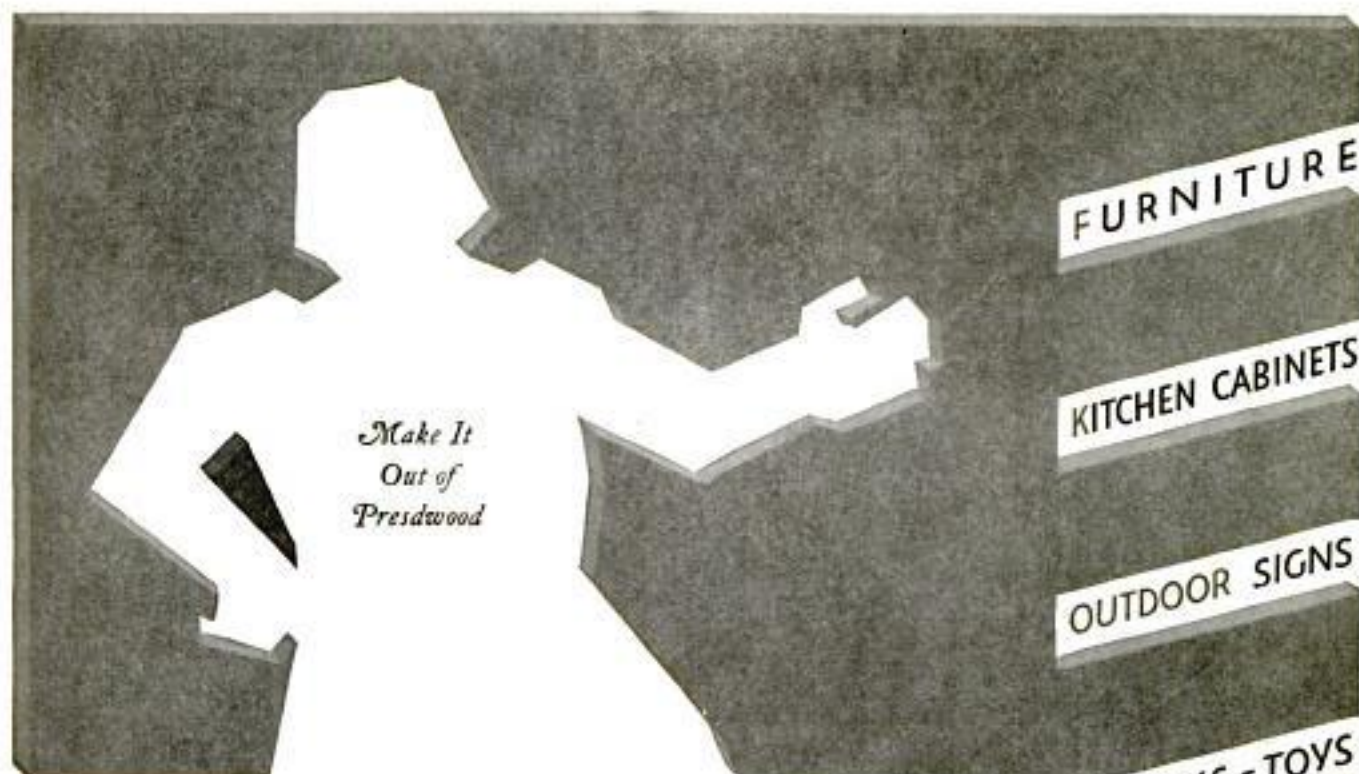

## Industry daily finds new uses for this all-purpose board

GLANCE over the articles listed on this page. Masonite Presdwood helps to build them. Their makers will testify that, with Presdwood, they are better and more durably built, at a decided economy in manufacturing cost.

Presdwood is a versatile product. Each day brings new uses, and each new use suggests another. Somewhere in your own business, Presdwood can be of service to you . . . and it will serve you well.

Smooth, grainless, and attractively finished, Presdwood comes in boards up to 12 feet long, or cut to order. It can be sawed, punched or drilled, will not chip, crack, split or splinter. Its resistance to moisture and freedom from warping are valuable assets where products serve outdoors.

In construction work, Presdwood lines concrete forms and produces concrete that needs no expensive hand-finishing. In the home, it makes beautiful wall and ceiling panels, turns waste space into delightful living quarters, helps the handy-man in any number of odd jobs.

Write for the helpful Presdwood booklet. No cost; no obligation. Lists 80 of its many uses and the best ways to apply many attractive finishes. Simply send coupon. Your lumber dealer will be glad to tell you about Presdwood.

MASONITE CORPORATION • 111 W. Washington St., Chicago, Ill.

# Masonite

STRUCTURAL INSULATION • INSULATING LATH  
PRESDWOOD • QUARTERBOARD  
"Made in Mississippi"

Masonite Corporation, Dept. L-4 © 1931, M. C.  
111 W. Washington St., Chicago, Ill.  
Please send me, free, the story of Masonite.

Name.....

Street.....

City..... State.....

If interested in Masonite Presdwood, check here.





# SAFE

For

# RHEUMATISM

Prompt relief from HEADACHE,  
COLDS, LUMBAGO, NEURALGIA,  
RHEUMATISM, SORE THROAT,  
NEURITIS, ACHES and PAINS



DOES NOT HARM THE HEART

# BAYER ASPIRIN

Accept only "Bayer" package which contains proven directions. Handy "Bayer" boxes of 12 tablets. Also bottles of 24 and 100—All druggists.



Don't get discouraged,  
Bill—thousands of other  
fellows get their hands  
just as dirty as yours.

But do they worry  
about it? Not on your  
life! They just go  
after that dirt with  
a cake of Lava Soap.

In 58 seconds its  
pumice-filled lather  
makes new hands of  
'em. Take my advice  
and buy yourself a few  
cakes to-night.



George, the  
Lava  
Soap  
Man

A Procter & Gamble  
Product

## AGENTS AND SIGN MEN

Earn up to \$100 Weekly, and over, Putting up  
OUR GENUINE GOLD LEAF SIGN LETTERS

# R

—on store and office windows, board signs, trucks  
and glass signs. We also make to order script  
signs and business emblems singly or by the  
thousands. A permanent business. No capital  
or experience required. Big demand in every  
City. Samples and Literature Free.

CONSOLIDATED SIGN LETTER CO. 71-X W. Van Buren  
CHICAGO, ILLINOIS



## BUILD "FLYING CLOUD"

Send for quality parts and clear blue-  
prints of 20" model. Readily made in  
spare hours as hull fully shaped and  
sanded. Set includes anchor, bell, capstan,  
dead eyes, wheel, rigging line, etc. Com-  
plete for \$11. Postage 5 lbs. White metal  
figurehead 50c. Send 15c (coins) for beau-  
tiful catalog of ships and coaches.

R. E. HANCOCK  
323 Douglas Ave. Portsmouth, Va.





**GATHERING for the Council**—a scene from the Paramount film, "The Silent Enemy," in which Chief Long Lance plays the part of Baluk, the mighty hunter.

*Around a thousand  
Tribal Fires..*

## Long Lance learned this secret

**BUFFALO CHILD LONG LANCE**—Chief of the Blood Band of the Blackfeet—now a famous athlete. Says the Chief, "When we were boys, our moccasins were made to give our muscles freedom to develop."

This was the secret that he learned from the elders—that in the ways of nature are freedom and strength.

The Chief designed the Long Lance Sport Shoe to answer his own exacting requirements. It is built to give protection and to develop your leg muscles. Try it at your shoe store—feel the joy and comfort of swift, free feet. It is one of many models prepared by Goodrich for every sporting and outdoor need.

The B. F. Goodrich Footwear Corp., Watertown, Mass.



**THE CHIEF LONG LANCE SHOE**, designed by the Chief himself after long experience as athlete and hunter. The cut-out shank gives perfect flexibility and the natural "moccasin tread."

**THE PONTIAC**—an ideal training shoe with plenty of style and a sturdy sole. In white, gray, khaki or buff.



# Goodrich Sport Shoes

Ask your shoe dealer about the Goodrich National Poster Contest for boys and girls — Valuable Prizes! Real Fun!

Write for Chief Long Lance's booklet, "How to Talk in the Indian Sign Language." Eighty illustrations make it easy to learn.

The B. F. Goodrich Footwear Corporation  
Watertown, Mass., Dept. 2M

Enclosed please find 10¢ in coin or stamps. Please send me "How to Talk in the Indian Sign Language," by Chief Buffalo Child Long Lance.

Name \_\_\_\_\_

Address \_\_\_\_\_

City \_\_\_\_\_ State \_\_\_\_\_





**YES**, brothers, there's too much unnecessary swearing going on. What if joints don't fit or a board is cut too short? Don't get excited! Don't curse! Just mix up a little Savogran Crack Filler, press into place, and after you paint it, I defy you to find the repair. What could be simpler? This handy material works and finishes like wood—saws, cuts, smooths, holds nails and screws firmly, and stays put. It *will not shrink!* Fixes things so easily that you'll go 'round hunting for trouble. And the whole family will find it handy for making repairs to wood, stone, metal, and plaster, mending furniture, building models and toys, and hundreds of other uses.

#### GET THIS HANDY FREE BOOKLET!

Get a can of Savogran Crack Filler today at your paint or hardware store. (Big 1-lb. can only 30c.; 5-lb. can, \$1.25; 35-lb. steel pail, \$7.70.) Ask also for Painters' Savogran—saves swearing on painting and heavy cleaning jobs. And write today for your free copy of the valuable 24-page booklet, "How to Repair and Refinish Furniture." It's great!

SAVOGRAN CO., DEPT. M-4, INDIA WHARF, BOSTON

## SAVOGRAN CRACK FILLER

Reg. U. S. Pat. Off.

Patent 1785223

**WILL NOT SHRINK!**

Cal. 30-40 Six Shot



### KRAG CARBINE

All the qualities of a high price rifle. In fine used condition, all working parts guaranteed for one year. Send today for our Free 60-page illustrated catalog of money saving values: Guns, Ammunition, Cutlery, Sports and Gov't goods.

Deposit required on all orders. Money refunded if not satisfactory.

W. Stokes Kirk, Dept. P. M.-4, 1627 N. 10th St., Phila., Pa.

Price  
**\$9.75**

# NYOIL

SPORTSMAN'S FRIEND

## KEEN SPORTSMEN PREFER IT



Nothing can equal Nyoil. Sportsmen insist on it. It cleans, lubricates, polishes, and prevents rust on all fishing tackle and firearms. It is odorless, stainless, clean, and highly refined. Per can 35c.

If your dealer cannot supply it, send to  
**WM. F. NYE, Inc.**  
Dept. T, NEW BEDFORD, MASS.

## OLD MONEY and stamps WANTED



**POST YOURSELF!** It pays! I paid J. D. Martin, Virginia, \$200 for a single copper cent. Mr. Manning, New York, \$2,500 for one silver dollar. Mrs. G. F. Adams \$740 for a few old coins. I want all kinds of old coins, medals, bills and stamps. I pay big cash premiums.

#### WILL PAY \$100 FOR DIME

1894 S. Mint; \$50 for 1913 Liberty Head Nickel (not buffalo) and hundreds of other amazing prices for coins. Get in touch with me. Send 4c for Large Illustrated Coin Folder and further particulars. It may mean much profit to you. Write today to

**NUMISMATIC COMPANY OF TEXAS**

Dept. 370

FORT WORTH, TEXAS

(Largest Rare Coin Establishment in U. S.)

**INCREASE YOUR BUSINESS** by using the NEW **\$5.85 "Two-Faced"** Film Duplicator to make 100 copies, in 1 to 5 Colors each time. Or the **\$37.05 "Excaligraph"** Rotary Stencil Duplicator to Print Copies of Anything Typed. Panned, Drawn or Traced in numbers up to 3000 each operation, as Price Lists, Hand Bills, Special Sales Announcements, Bulletins, Menus, Quotations, or "what have you?" Write—

Easy Terms

**PITTSBURGH TYPEWRITER & SUPPLY CO.**  
Suite 552, 339 Fifth Avenue, Pittsburgh, Pa.

## MOTORCYCLES

Pay As Low As \$2.00 per Week  
Hendersons, Harley-Davidsons, Indians  
Slightly used and rebuilt. Hundreds to select from. Send 10c for list today.

**MYEROW BROS. CO., 15 Berkeley St., Boston, Mass., U. S. A.**

**TRY IT  
30 DAYS FREE  
BEFORE YOU BUY**

Factory to you. Save up to 50% on latest Screen Grid Electric or Battery Radio. Get "Send No Money" Offer.

### MIRACO Radio

Amazing bargains direct from big, old reliable factory. Don't buy unless 30 days' use proves entire outfit unbeatable at up to twice our price for tone, selectivity, distance, power, 1 yr. guar.

**FREE!** Send for 1930 SPECIAL OFFER—No obligation.

**MIRACO Radio Corporation**  
1114 Successful Yr.  
902-DA Miraco Dept., Cincinnati, Ohio

**SUPER  
Screen  
Grid  
\$49.88  
Complete  
less tubes**

ALL  
styles of  
latest  
cabinets



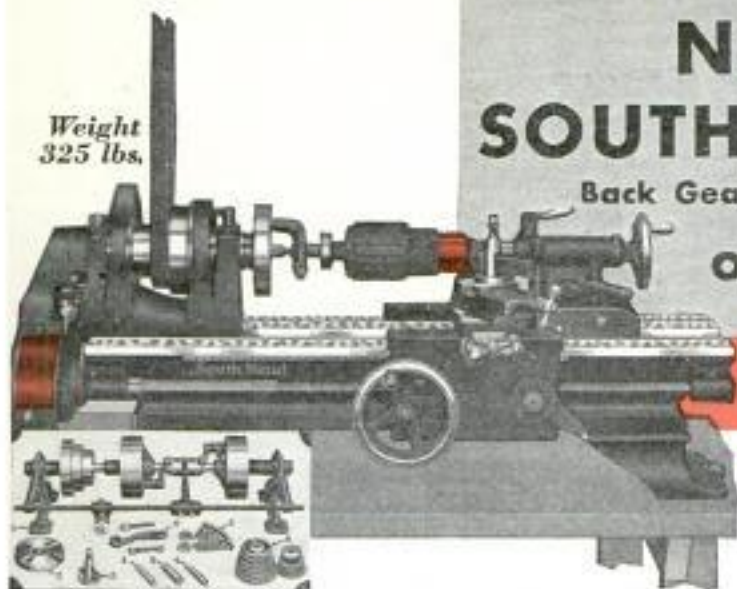

Weight  
325 lbs.

## New Model SOUTH BEND LATHES

Back Geared Screw Cutting Precision Lathes  
on Easy Payments

**Only \$30.00 Down**

\$10.50 per month for 12 months for this 9" x 2' New Model Junior South Bend Back-Geared, Screw Cutting Bench Lathe with countershaft and equipment, Wt. 325 lbs.

9" x 2' New Model Junior South Bend Bench Lathe **\$150**

Prices of Other Popular Size 9" Junior Lathes

Size of Lathe	Shipping Weight	Countershaft Drive	Down Payment	12 Monthly Payments Each
9" x 2½'	350 lbs.	\$160.00	\$32.00	\$11.20
9" x 3'	375 lbs.	\$169.00	\$33.80	\$11.83
9" x 3½'	400 lbs.	\$175.00	\$35.00	\$12.25
9" x 4'	425 lbs.	\$182.00	\$36.40	\$12.74
9" x 4½'	450 lbs.	\$190.00	\$38.00	\$13.30

Send Now for these Books

**"How to Run a Lathe"**  
25c Postpaid

Latest Edition of this famous work, contains 160 pages, with more than 300 illustrations. Simplest, most complete and practical book on lathe operation. Shows how to handle 400 different types of lathe jobs as practiced in the modern machine shop. Sent postpaid for only 25 cents; coin or stamps of any country accepted.

**Latest Shop Practice,**  
Free

This 48 page book shows a model auto service shop; gives up-to-date methods for servicing armatures, valves, bushings and pistons; describes complete equipment for these jobs, costing only \$265.00 Complete. Sent free, postpaid.

**Catalog No. 91-A, Free**

This 104 page book illustrates and describes the 96 different sizes and types of New Model South Bend Lathes. Send the coupon now for your copy, free.

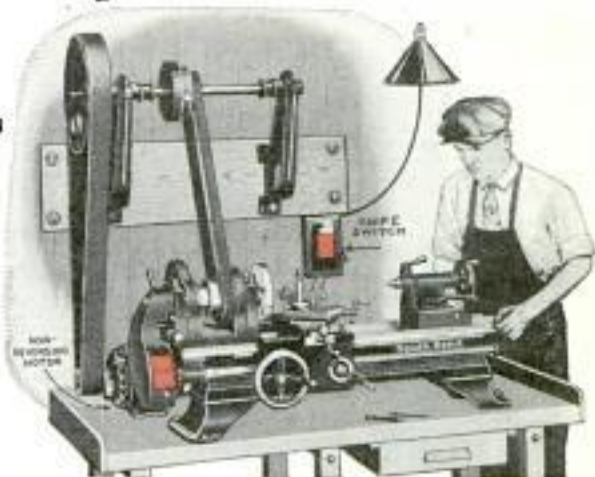

9" x 2' Junior New Model South Bend Lathe with Simplex Wall Countershaft and Lathe Equipment **\$150**

**Extra Parts for Drive**

¼ H. P. Motor, 1750 R. P. M. Non-Reversing (1-Phase 60 Cycle A. C.) . . . . . \$20.25  
Switch, Knife Type . . . . . 2.50  
Conduit and Wiring . . . . . 4.00  
Belting (Motor to Countershaft) 2" wide x 8¼' long 2.75  
Belting (Lathe to Countershaft) 1¼" wide x 6¾' long 1.25  
**Total for Complete Motor Driven Lathe \$180.75**  
as shown

May be bought on down payment of \$36.15 and \$12.65 for 12 months.

### SOUTH BEND LATHE WORKS

634 E. Madison St., South Bend, Indiana, U.S.A.

Gentlemen: Please send me books checked

- "How to Run a Lathe" (25c)  
 Latest Shop Practice (Free)  
 Catalog No. 91-A (Free)  
 Easy Payment Plan

Name \_\_\_\_\_

Address \_\_\_\_\_

City \_\_\_\_\_

State \_\_\_\_\_

# SOUTH BEND LATHE WORKS

634 E. Madison St., South Bend, Ind., U.S.A.

Lathe Builders for 24 Years — Over 50,000 South Bend Lathes in Use



## Amazing NEW TOOL VALUE

An Automatic Push Drill Carrying in the Handle Eight Sizes of Drill Points

Pick out the size drill you want from the separate numbered compartment. Insert it in the steel jaws.

Place drill point where you want hole.

Push—push—and presto, you have a smooth clean hole.

The handiest tool ever invented for household use.

Made by one of America's

leading makers of fine tools.

SHOW THIS AD TO

YOUR DEALER AND

SECURE DRILL FOR

\$1.25 or if he hasn't a

stock yet, mail coupon to

us and tool will be sent

postpaid, C.O.D. \$1.40.

USE THE COUPON TODAY!



SCREENS



\$1.25

Goodell-Pratt Company, Dept. M-4, Greenfield, Mass.

Please send me a No. 188 Automatic Drill. I will pay postman \$1.40.

Name.....

Street.....

City..... State.....

My hardware dealer is.....

Nothing under \$2.00 ever bought such a good tool!

## THIS BOOK tells you how

Do you know how to build a workbench, how to carve wood, how to sharpen all your tools?

The Stanley Book No.

157b "How to Work with

Tools and Wood" tells you how to do these and hundreds of other things with tools.

176 pages of information for anyone interested in a home workshop. Send only \$1.00 for a copy.

Costs only  
\$1.00

THE STANLEY RULE & LEVEL PLANT  
New Britain, Conn.

STANLEY TOOLS



## BIG MONEY

easily made resurfacing, waxing and polishing floors by the new American Method. Plenty of work easy to get—No experience required. Small amount starts you—Many make \$25.00 a day. This is your big opportunity—Write quick for full particulars.

THE AMERICAN FLOOR SURFACING  
MACHINE COMPANY  
523 South St. Clair Street Toledo, Ohio



## New Tractors from Old Fords Do All Farm Work!

Makes powerful tractor out of your Model "T" or "A" Ford, or Chevrolet with SHAW Tractor Equipment. Low cost! New HIGH ARCH Model with 30 inch clearance straddles 1 or 3 rows of corn and other crops. Cultivator, plow, seeds, disc, etc. Runs belt machinery. Easy to attach. SPECIAL LOW INTRODUCTORY PRICE! Write for FREE literature!

SHAW MFG. CO., 4504 Center St., GALESBURG, KANS.

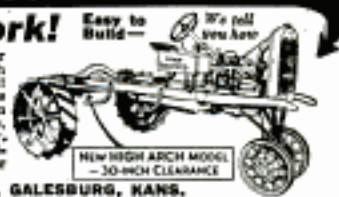

**CICO CELL**

PRACTICAL PHOTO-SENSITIVE CELL OF MERIT  
SMALL—UNBREAKABLE—POSITIVE  
A SWITCH THAT IS OPERATED  
BY A BEAM OF LIGHT.  
SUITABLE FOR COUNTING, SORTING,  
TRAFFIC CONTROL, ALARMS & ETC.  
PRICE \$5.50—POSTPAID

CLARK INSTRUMENT CO.  
119 N. 4<sup>th</sup> ST., CAMDEN, N. J.

## The PRODUCTO Electric Work Shop Combination



A sturdier home work shop—completely equipped. Send for circular.

Note:

Our complete catalog of individual and combination woodworking machines will also be sent you on request.

THE PARKS WOODWORKING MACHINE CO.  
Dept. PM-4, 1530 Knowlton St., Cincinnati, Ohio  
Canadian Factory: 338 Notre Dame East, Montreal

**PARKS**  
WOODWORKING MACHINES

\$89.90

**GERSTNER Tool Chests**

are made good, are finished attractively, and are splendid values. A free catalog for machinists and toolmakers.

*Gerstner & Sons*  
488 Columbia St. Dayton, Ohio

**Walsh Garden Tractor**  
and Power Mower  
For Gardeners, Florists, Fruitmen, Suburbanites  
Plows, Seeds, Cultivates, Mows Lawns & Hay  
Single and Twin Engine-Belt Jobs Walk and Ride  
SPECIAL FACTORY PRICE  
New Improved Models—CATALOG FREE  
WALSH TRACTOR CO. Minneapolis, Minn.  
3328 Talmage Av. SE

**Brown & Sharpe Tools** [BS]  
"World's Standard of Accuracy"

Send for Catalog No. 31 describing 2300 Precision Tools.  
Brown & Sharpe Mfg. Co., Providence, R. I., U. S. A.

**BURN YOUR NAME ON TOOLS**  
WITH THE  
**ARKOGRAF**

PROTECT YOUR TOOLS FROM THEFT  
Write with electricity any name or design on the hardest and finest tools and instruments, or any metal, like writing on paper with pen or pencil.  
Complete Outfit \$3.50—Prepaid Anywhere  
Interesting Illustrated circular free. Write today. Agents wanted.  
ARKOGRAF PEN CO., 1171 E. Stark St., Portland, Oregon



# *You can make* \$4<sup>00</sup> to \$6<sup>00</sup> an hour with the **IDEAL** LAWNMOWER SHARPENER

## THIS MAN IS DOING IT! SO CAN YOU

HERMAN BARBER, Ashland, Ky., writes: "I have sharpened to date 459 mowers, receiving \$988.30. These were sharpened evenings and in my spare time. I have seen other machines, but this is the most perfect one I have seen yet."

### Profits Year After Year

C. S. CORVUN, North Little Rock, Ark., writes that his Ideal Sharpener, in evenings alone, earned enough in 18 months to pay for itself and \$1857 worth of additional machinery.

ZENO BRANDON, Middletown, Ohio, writes: "I have made \$820.70 in 55 days with my Ideal. Have made as high as \$38.70 in one day."

W. F. KENDT, Buffalo, writes: "I have sharpened 994 lawnmowers last season and the receipts were nearly \$2100—not bad for a side line."

### A Big, Permanent Business

S. E. RAUP, Harrisburg, Pa., writes: "I started sharpening lawnmowers 5 years ago, as a side line, setting up an Ideal in my cellar. Now I am arranging to build a large shop and apartment to take care of my increasing business which employs 2 to 3 men besides myself."

### Hundreds of Dull Mowers Waiting for You

to be sharpened right in your locality—no town too small. WILLIAM G. MERCIEN, Oswego, N. Y., writes: "We have our shop on a truck and travel all over the county." W. W. DUKESER, Sanford, Florida, writes: "I live five miles out of town, so have no rent to pay. Collect and deliver mowers. Get \$2.00 or better. Buy up old mowers and repair them and make from \$4.00 to \$10.00 on same."

**No Training Required** You don't have to be a mechanic to use the Ideal. Its operation is simple and practically automatic once you start to grind.

### Here Is Your Chance

Send for the book "LET GEORGE SAY IT"—It's the proof of what we advertise. We also show you the best ways to get the mowers to sharpen.

## THE FATE-ROOT- HEATH COMPANY

Dept. K, Plymouth, Ohio, U. S. A.



**MAKE EVERY  
SPARE HOUR PAY  
YOU \$4<sup>00</sup> to \$6<sup>00</sup>**

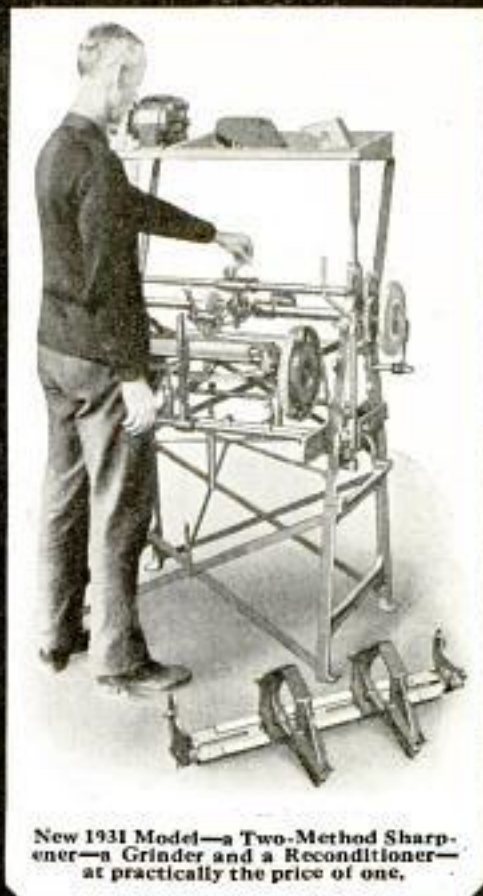

New 1931 Model—a Two-Method Sharpener—a Grinder and a Reconditioner—at practically the price of one.

### Now a Two-Methods Sharpener—A Grind- er and a Recondi- tioner—at Practically the Price of One

The 1931 Model Ideal Lawnmower Sharpener is the ONLY machine that grinds the very dull, thick bladed, hard running mowers as well as the slightly dull, easy running ones.

### Sharpens Any Mower in 15 to 20 Minutes

Just pick up the mower, set it in the Ideal, make a few simple adjustments and proceed to sharpen. In 15 to 20 minutes after you pick up the mower it is ready for the lawn, and you have made \$1.50 to \$2.00, depending on the condition of the mower.

### Set Up Ready to Grind in a Few Minutes

Shipped practically completely assembled. Uncrate it, place in position, plug into a light socket and it is ready to start earning money for you.

**Special Grinding Wheel Attachment**  
For sharpening grass shears, hedge shears, sickles, scythes, axes, etc., etc. Will add many dollars to your income.

### Skate Sharpener Attachment Included

Sharpens all makes of skates—including hockey with shoe attached. The "Ideal" earns money all the year round.

**Uses Little Power**  
Operated by 1/2 H.P. Motor attached to light socket or can be run direct from line shaft.

Send for **FREE BOOK**  
*Today*

Sign and Mail This Today

**The Fate-Root-Heath Co.,  
Dept. K, Plymouth, Ohio.**

You'll have to prove that I can make real money with the "Ideal" Sharpener. Send me your **FREE BOOK**,

Name.....

Address.....

City.....State.....





### JAPANESE ROSE BUSHES

#### The Wonder of the World

Japanese Rose Bushes bloom all the year round. Just think of it. Six weeks after planting the seed, the plants will be in full bloom. It may not seem possible, but we positively guarantee it to be so. They will bloom every ten weeks, Summer or Winter, and when three years old the bush will be a mass of roses, bearing from five hundred to a thousand roses on each bush. The flowers are in three shades—white, pink, and crimson. The plants will do well both in and out doors. We guarantee at least three bushes to grow from each packet of seed. Price, 10c packet, 3 pkts. for 25c postpaid.

### Chinese Fragrant Tree Fern

Just introduced, noted for its rapid growth. An exceptionally pretty ornamental plant. Foliage is rich dark green. Forms grand pyramidal bushes about 5 feet high. Branches very desirable for decorative purposes, wreaths, etc. Seeds 15c pkt., 3 for 40c.

### Weather Plant

NATURE'S WEATHER PROPHECY by mysterious changes that take place, this remarkable plant accurately forecasts the weather many hours in advance. Will grow anywhere all the year around. An interesting house plant. Bears large, fragrant, pink, butterfly shaped flowers. Seeds, 15c packet, 3 for 40c, postpaid

### GROUND ALMONDS

Amazingly Prolific—Easily Grown From Seed The Ground Almond has a flavor that is MOST EXCELLENT, resembling the coconut. The meat is snow white, covered with a shell or skin of brown color. It grows close to the surface and anything from 200 to 300 Almonds may be expected from a single nut. There is no trouble whatever in growing anywhere and in any kind of soil. May be planted any time, and in eight or ten weeks from time of planting you will have an ENORMOUS CROPPING of the MOST DELICIOUS ALMONDS YOU EVER TASTED. Seeds 15c Pkt.



### Perfume Plant

Blooms early at night, giving forth the most delightful scented fragrance for quite a distance. Grows in house or garden. Also valuable because of rare perfume made from it. SEEDS, 10c pkt., 3 for 25c.

### SENSITIVE PLANT

Marvel of the Philippines. Leaves curl, fronds droop when touched. Apparently senses interference. A handsome shrub for house or garden; very curious and interesting. SEEDS, 15c pkt., 3 for 40c.

### Calabash or Pipe Gourds

A luxuriant and rapid growing climber; three-seeded, where it produces the ornamental gourds for a m which the famous African calabash pipes are made. Grow this interesting vine and make your own. Seeds, with instructions, 15c pkt., 3 for 40c.

### Japanese Nest Egg Gourd

Very curious. Produces fruit same size, shape and color of nest eggs. Matured fruit does not crack. Will store for years as a nest egg, stocking darning, ornamental purposes, etc. Seeds 15c pkt., 3 pkts. for 40c, J.S. & CO.

### THE REMARKABLE FIREFLY PLANT A Vine that Blooms at Night Fills the Atmosphere with Fragrant Aroma



One of the most rapid growing vines known. Under favorable conditions this vine has been known to grow OVER 25 FEET IN A SINGLE WEEK. In a very short space of time instead of a Vine, it shrives to a great height, and is covered with IMMENSE FLOWERS, from 6 to 7 inches in diameter. It is, indeed, a great novelty, for, unlike other plants, the flowers OPEN IN THE EVENING, and remain open until about noon the following day. In dull weather they will remain open all day. It is a most INTERESTING NIGHT to watch the opening and closing of the flowers, as the clouds appear and disappear. As the flowers open they give forth the most DELIGHTFUL AROMA and the whole atmosphere around is full of scented fragrance. It is always the object of favorable comment, and much curiosity is aroused by people passing at night time as to the cause of the charming aroma, frequently stopping in an endeavor to satisfy their curiosity. PRICE, 15 CENTS packet, two packets for 35 CENTS, POSTPAID. J. S. & CO.

### The Great Wonderberry

A luscious berry that may be grown and ripened from seed in any soil or climate in 3 months. The flavor is fine and unspiced for eating raw, cooked, canned or preserved in any form. The fruit is blue-black in color, and tastes like a luscious, rich blueberry. One bush will produce an enormous amount of fruit, yielding great masses of rich fruit all Summer and Fall. Packet, 10c, 3 pkts. for 25c, postpaid.

### Shoo Fly Plant

A very remarkable Botanical curiosity you should have. Though quite odorous it is said this will not remain in a room where it is grown. Bears very pretty blossoms summer and winter. Grows rapidly from seed. SEEDS 15c pkt., 3 for 40c, postpaid. Banana Musk Melon Quite a curiosity. Looks and smells like a banana. Peculiar shape and its delicious flavor make it well worth your while cultivating. Flesh is deep and of exquisite flavor. Very high prices are obtained in choice city markets, as high as a dollar sometimes being demanded for one single specimen. Seeds 10c, 3 pkts. for 25c.

### The Great Japanese Umbrella Palm

The Japanese Umbrella Palm is a semi-aquatic plant. It is easily grown from seed either in a bowl of water or in very damp soil. Probably the most usual, as well as the most interesting method, is to cultivate the plant in a bowl or jardiniere filled with water, with two or three inches of good garden soil at the bottom. The seeds soon commence to germinate, and the plant shoots up stems two to three feet high and rapidly assumes a most pretty palm-like appearance, as shown in the engraving. The tops of the stems are surmounted by a wheel of umbrella-shaped leaves, of a waxy appearance. We will send a package of this seed, with full instructions for culture, for only 15c or three packets for 40c postpaid.

### A Graceful House or Conservatory Plant

Easily Grown From Seed Winter or Summer

### Butterfly's Own Bush

This plant is a veritable refuge or haven for butterflies, and it attracts all the most beautiful types of butterflies to the neighborhood. Bees, too, are very fond of it. It is a pretty plant bearing perfectly double flowers, ranging from white to rich crimson, deep red and pink, lilac and other delicate shades. Packet 10 cents, 3 for 25 cents postpaid.

### FAMOUS MEXICAN FIREFLY PLANT

Beautiful, hedge-like plant, grows 2 to 2 1/2 feet high and resembling a closely clipped ornamental greenery. The globe-shaped or pyramidal bushes are close and compact, and of a pleasing light green color. May be grown singly or in the form of a hedge or background. In early autumn the whole bush becomes carmine or blood red, hence the name of Mexican Fire Plant, or "Burning Bush," as it is sometimes called. Selected Seeds, 10c

### Mammoth Peanuts

Peanuts can be easily cultivated. Their culture is very simple and exceedingly interesting. Mammoth Peanuts grow to an astonishing size. It is a good producer, very prolific, and the giant nuts have a thick, heavily ribbed protecting shell. The plant is very attractive, the leaves being of odd shape and a handsome green shade, tinted through the center with white. You will derive much pleasure cultivating this interesting species. Seeds 15c pkt., 3 pkts. for 40c.



### CROWN OF THORNS

A very curious clover-like plant, can be cultivated indoors or outdoors, the seed is a red blotches on the leaves representing the three wounds of Christ. Has delicate thorny seed if loosened at tip the ball is found to consist of a long pickle-edged band wound spirally around the seed cluster, giving the plant its name. Seeds 15c packet, 3 for 40c.

### Asparagus Sprengeri

The best plant for hanging baskets. Masses of rich, gleaming foliage droop in a very graceful manner. The foliage when cut for decorative purposes will last for weeks in water. The seed pods are very pretty red berries adding to its beauty. Packet, 25c, 3 pkts. for 65c postpaid

### Musk Plant

A universally admired favorite for bouquets, flower gardens or greenhouses. A very fine house plant. Lives for years. Is of the sweet scented variety, giving forth much fragrance. Also valuable as source of the perfume that can be made from it. Seeds 15c pkt., 3 for 40c.

### Japanese Climbing Cucumber

Unusually strong and vigorous growing vine. Attains twice the size of ordinary varieties. Grows readily on fences, poles, trellises, etc. One hill will keep an entire family supplied all summer. Seeds 15c packet, 3 for 40c, postpaid

### "Wong-Bok" Chinese Cabbage

Novelty from China and should be grown in every garden. Seems to be a cross between Celery and Cos Lettuce. Flavor is more mild than any other cabbage. Can be served on the table and eaten raw or cooked like cabbage, spinach or lettuce or made into salad. Grows very rapidly, easy to cultivate. You can create quite a sensation by cultivating this remarkable novelty. Seeds, 15c packet, 3 pkts. for 40c.

### TREE OF HEAVEN

This splendid ornamental tree is a native of China, and is called the Tree of Heaven on account of its great beauty. Very hardy. Thrives in any soil, no matter how poor, and grows from 10 to 20 feet high from seed the first summer. The leaves are from 5 to 6 feet in size, giving it a grand appearance. Nothing outside the tropics can rival it for lawn decorations. Large masses of bloom, followed in season by great clusters of colored seed pods, make the tree a continual thing of beauty. Packet, 15c; 3 packets 40c



### GIGANTIC NEW GUINEA BUTTER BEANS

THE NEW EDIBLE VEGETABLE WONDER Grows to an astonishing size, the Beans measuring from 3 to 4 feet long, and weighing anything from 10 to 16 lbs. and even more. One Bean is sufficient for a family for several meals. Very palatable and rich in nutritious materials. The delicate buttery flavor is much appreciated. The Vines are easily grown, very prolific, and a most welcome and valuable adjunct to your garden. Try them; you will find them the most delicious vegetable you have ever tasted. Imported direct. Unobtainable elsewhere. Sample packets of Seeds with full directions for cultivating and cooking. 25c, postpaid.

### Kudzu Vine

Most rapid growing vine known. Will grow 20 feet in one week. Luxuriant foliage, lovely purple flowers, very fragrant. Nothing to equal it for shade purposes and quick growth. Seeds 15c packet, 3 for 40c.

### Yard Long Bean

Produces enormous crop of long, slender, round pods, of excellent quality for soup beans. Pods grow from 3 to 5 feet in length. Very tender and fine flavor. The vines are rampant growers, as interesting curiosity. Seeds, 15c pkt., 3 for 40c

### SURPRISE FLOWER GARDEN

Over Hundred Varieties of Mixed Flower Seeds MANY RARE AND CURIOUS NOVELTIES An Abundance of Flowers Assured throughout the Season A mixture of easily grown annuals that bloom very soon after sowing the seed; others vary in their time of blooming. Those who cannot give the constant care necessary for finely arranged flower beds will be delighted with the Surprise Wild Flower Garden. Will prove a continual surprise and pleasure, as new varieties and the old garden favorites flower successively throughout the season. These are over a hundred varieties of seeds. Many of the plants may be grown inside as house plants and will bloom during the winter. Fine for children, also teachers for school gardens. Packet, 15 cents, three packets for 40 cents, Postpaid. J. S. & CO.



# Real Woodworking Efficiency with Delta Motor-Driven Tools

## They Save Time and Labor—Produce Better Work

There is a new thrill in woodworking these days. Motor-driven tools have taken out all the drudgery, all the tiresome "elbow grease" from working with wood—and left only the sheer pleasure of making things quickly, easily and **beautifully**. Motor-driven band saws and circular saws have supplemented the hand saw . . . motor-driven jointers are replacing the hand plane . . . motor-driven borers and routers are eliminating hand drills and chisels. For this is a modern age . . . and the modern way is the motor-driven way!

## "DELTA" Quality—What It Is

Every "Delta" woodworking machine must perform its work **efficiently, conveniently and quickly**. In each machine there is practical design, quality in workmanship and materials (even where it cannot be seen), and numerous exclusive constructional features. That's why woodworkers everywhere say that the "Delta" gives most machine value for the dollar.

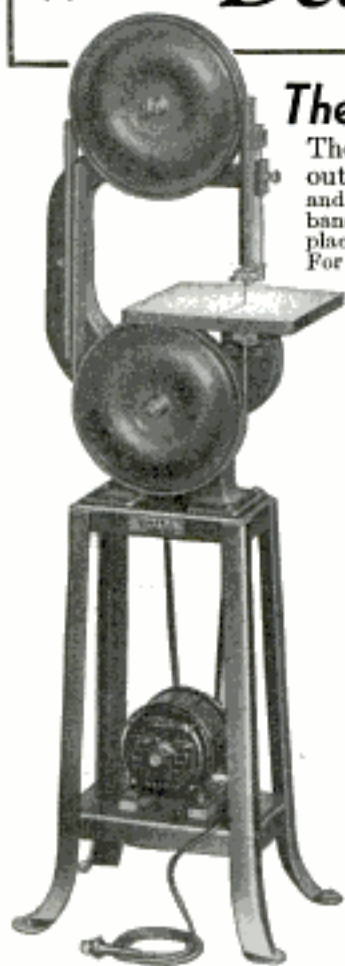

"Delta" Band Saw has many exclusive features. Provided with extra-safe guard. With or without stand.

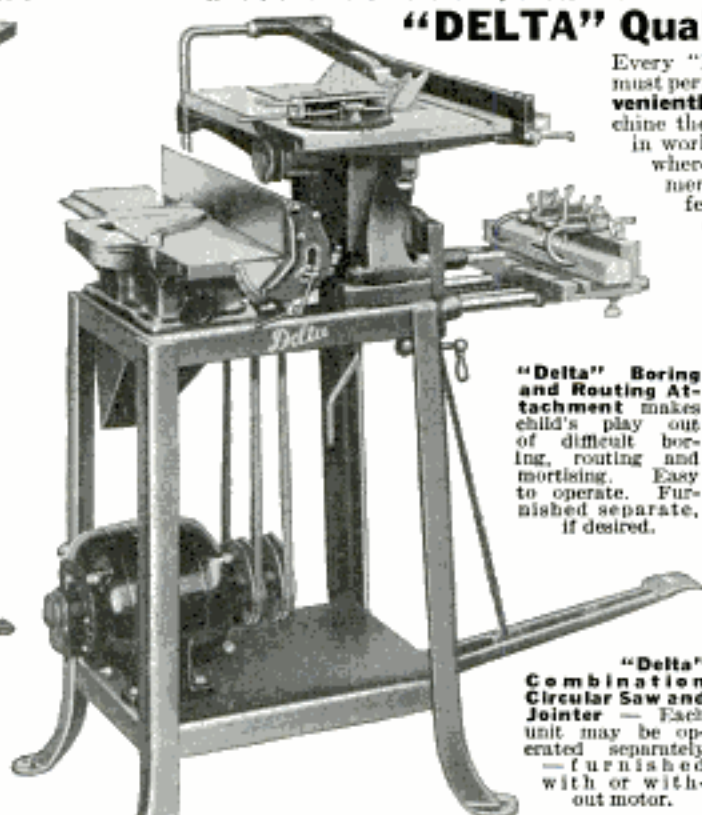

"Delta" Boring and Routing Attachment makes child's play out of difficult boring, routing and mortising. Easy to operate. Furnished separate, if desired.

"Delta" Combination Circular Saw and Jointer — Each unit may be operated separately — furnished with or without motor.

### Complete DELTA 1931 Line Includes

- Woodturning Lathes
- Complete Handi-Shop
- Jointer
- Circular Saws
- Band Saw
- Mortiser and Router
- Moulding Cutter
- Scroll Saws

Check the items in which you are interested and mail with the coupon below.

## 10 DAY TRIAL EASY TERMS

Send coupon today for complete details and FREE illustrated literature fully describing the new 1931 "Delta" line of woodworking units. You will learn also how you can try any "Delta" equipment for 10 days under actual working conditions—AT OUR RISK. Choice of three convenient Easy Payment Plans. Mail the coupon TODAY!

### Delta Specialty Company

DIVISION OF DELTA MFG. COMPANY

3775 N. Holton St. Dept. A.431 Milwaukee, Wis.

DELTA SPECIALTY CO., 3775 N. Holton Street  
Milwaukee, Wisconsin, Dept. A.431.

Gentlemen: Please send me FREE illustrated literature describing 1931 "Delta" line, including the items which I have checked; also full details of 10-day Trial Offer and Easy Payment Plan.

Name.....

Address..... Age.....

## DEAFNESS IS MISERY



Many people with defective hearing and Head Noises enjoy conversation, go to Theatre and Church because they use Leonard Invisible Ear Drums which resemble Tiny Megaphones fitting in the Ear entirely out of sight. No wires, batteries or head piece. They are inexpensive. Write for booklet and sworn statement of the inventor, himself deaf.



A.O. LEONARD, Inc., Suite 699, 70 5th Ave., New York

## MOVIES In Your Home



Our marvelous, practical Movie Machines sell as low as \$5.00 postpaid. Also finest 16 mm. cameras and projectors at factory prices. A complete line of both standard and 16 mm. film available at low prices with exchange service. Write for big, FREE catalogue.

PARAMOUNT MFG. CO. Dept. G-38  
Boston, Mass.



# Now HOT WATER INSTANTLY Anywhere-Any Time

Spectacular—amazing—actually breath-taking, the new LUX ELECTRIC WATER HEATER holds spectators spellbound as it dynamically raises clouds of steam from cold water in split seconds!

**Entirely New Principle. Extremely Low Cost**  
Every home can now afford the luxury of boiling hot water with this new and amazing electrical invention.

**MEN—WOMEN AGENTS**  
**Rich Profits—No Investment**  
Full or spare time. We'll prove you can earn up to

**\$20—\$30 AND MORE DAILY CASH IN ADVANCE EVERY SALE**

You can sell dozens daily. Everyone wants LUX even they witness its convincing miracle-like performance. No danger, no trouble—foolproof, guaranteed. Switch LUX into action anywhere, night or day and have boiling water instantly. Faster, easier, safer, saves than any other home heating unit.

**NEVER SOLD IN STORES. NO COMPETITION**  
**PROFIT BUILDING—PROFIT SHARING SALES PLAN**  
**LIBERAL CO-OPERATION—TERRITORY**

Write at once for full details



**LUX-VISEL CO.**

47 Jackson St.

Elkhart, Ind.

## SIMONDS SAWS

Best for every cutting purpose

SIMONDS SAW & STEEL CO., FITCHBURG, MASS.

## NEW VEST POCKET ADDING MACHINE

Guaranteed 5 yrs.

**BABY CALCULATOR**  
CHICAGO, U.S.A.  
PATENT APPLIED FOR

000000

ADDITION  
SUBTRACTION  
MULTIPLICATION  
DIVISION

**\$2.50**  
Total Cost

### ADDS, SUBTRACTS, MULTIPLIES, DIVIDES

Costs only \$2.50 each, yet does work of \$100 machine. Not a Ter hot a reading machine that everyone should carry. Made of steel and indestructible. Million dollar capacity. Fits in pocket. Weighs 8 ounces. Will not make mistakes. So simple child can operate. Instructions furnished. Be modern in dealing with figures—order your machine today.

### Free Trial

**SEND NO MONEY—**

Just name and address. We will ship Calculator immediately. On delivery pay postpaid. **SEND \$2.50** (Plus few cents Postage.) (If outside U. S. send cash.) (No additional in Leatherette Case. If not satisfied after 10 day trial you get your money back. **THOUSANDS OF SATISFIED USERS.**

This is the lowest priced practical calculator made. "Way more for inferior imitations!" Order from this ad.

**—Mail Coupon Today—**

**BABY CALCULATOR MACHINE CO. (Manufacturers)**

Dept. 71, P. O. Box 1118, CHICAGO, ILL., U. S. A.

- I am enclosing \$2.50—send adding machine prepaid.  
 Send Adding Machine C. O. D. \$2.50 plus 18c postage. (10c additional in Leatherette Case)

Name .....

Address .....

City .....

State .....

City .....

State .....

City .....

State .....

City .....

State .....

City .....

State .....

**AGENTS**

Write for big commission and territory proposition.

# You Need This

## husky handy Screwdriver



**W**HETHER you're a mechanic by trade or just a man who enjoys doing things with tools about the car and home, you need this new husky, handy Crescent Screwdriver. Its unusual features spell unusual strength and long life.

Drop-forged bits; sharp, clean points; shanks hardened full length to prevent bending; steel ferrule forced onto shank under great pressure; straight-grained, solid, hard maple handle that can't split or chip and is finished to prevent grease or water soaking... these are some of the reasons why the new Crescent Screwdriver will outwork and outlast ordinary tools. Remember it carries the unconditional Crescent guarantee. Try one and you'll buy one!

**CRESCENT TOOL COMPANY**  
Jamestown, N. Y.

**CRESCENT and Smith & Hemmenway TOOLS**



Build your own outboard hydroplane motor or sail boat. Use our plans or knock-down frames and machined parts. Many models to select from. Write for new catalog. Please enclose 10c for catalog. **J. B. WELCH, Inc., Dept. B, 3211 No. 41st St., Milwaukee, Wis.**

## ENGINES

Lifetime Guarantee  
All Sizes and Styles

**300,000 in World-Wide Use**

The WITTE (Magneto Equipped) provides cheapest reliable power for farm and ranch. Does more work in less time at less cost. Put one to work—will pay for itself. *Send for Big Free Catalog.*

**WITTE ENGINE WORKS**

1744 Oakland Avenue, KANSAS CITY, MO.

## Only 8 Sales a Day Nets You \$110 a Week

Profits on larger size run higher. Unusual earning opportunity for ambitious men. No experience necessary; we teach. Part or full time.

### FUGO World's Simplest Fire Extinguisher

Automatic and instantaneous action. Within reach of every home, shop, store, theatre, garage, car owner, etc. Even smallest place needs two or more. Exclusive territory to producers. You get your pay every day. Write for full details.

**The National Formetal Co.**  
6335 Metta Ave. Cleveland, O.





# NEW INVENTION

## Free \$1 "Quik-Whip" TRIAL TO AGENTS!

Send post card today for free trial sample of "Quik-Whip" (actual value \$1.00) the sensational new 3-in-1 invention that whips, beats and mixes with lightning speed and that does it easier and better than women ever dreamed possible. World's first one-handed whipper! A sensation everywhere. Inexperienced men and women in every locality making up to

**\$60 A WEEK** Brand new article. Market not yet scratched. Wonderful opportunity for spare time of full-time workers. Everything on free trial so start now. Amazing 10-second demonstration and Secret Sales Plan actually turns nickels into dollar bills! Write quick for free trial sample and three amazing new profit facts. Read post card today.

Household Helps, Inc., Dept. 54, Muncie, Ind.



## A Buescher Sax' Put RUDY VALLEE on the Map

New York's idol of today made his first bid for fame at college with his Buescher Saxophone. Then, as now, he was the idol of the student body. Like hundreds more, his Buescher has led him on to fame and fortune.

### You can do it too

Who knows, you may be a Rudy Vallee in the rough. At least it's worth a trial that costs you nothing. Go now, today, to your local Buescher dealer; take a Buescher home for six days' test. See what you can do. Or send a postal for beautiful catalog—any instrument. This is the big "opportunity" year. Get set now. Get your share. B100 BUESCHER BAND INSTRUMENT CO. 410 Buescher Block Elkhart, Ind.

## MOTORCYCLES



**WONDERFUL BARGAINS**  
Can be purchased through our co-operative plan for as low as \$1.00 per week.

Indians Harley-Davidsons Ace and Henderson

Send ten cents for Bulletin A. Motorcycles shipped to all parts of the world.

WALKER-INDIAN CO., 1309 Boylston St., BOSTON, MASS.

## PANTS MATCHED

**Don't Throw Away That Coat and Vest!**  
Save \$15 or more! Let us match your coat and vest with new trousers tailored to your measure. Save the price of a new suit. (Average price \$8.50.) Over 100,000 patterns. Mail sample of suit, or your vest which will be returned with FREE SAMPLE for your approval.

Match Pants Co. 20 W. JACKSON BLVD., Dept. A10, CHICAGO

## ITALIAN ACCORDIONS

Ask for FREE Catalog



### OF ALL TYPES

Hand-made—Best quality at lowest prices—Absolute Guarantee of Satisfaction. Special Type Accordions Made to Order.

Free Accordion Lessons to buyers by Prof. Rosanova DO NOT miss the pleasure

ACCORDION PLAYING offers you. Act now. RUATTA, SERENELLI & CO. 1014 Blue Island Ave., Dept. P-2, CHICAGO

For Modeling

You Can Plane It Carve It



For Repairing

You Can Turn It Finish It

# AMAZING

what you can do with this new kind of wood you mould with your hands

THIS new kind of wood that so expertly mends a thousand and one things and makes almost anything that can be made from natural wood or modeling clay is really an amazing adventure.

## You've never used anything like it

Though it handles just like putty... it quickly hardens into wood you can carve, plane, saw and work with any wood-working tool. It won't crack, splinter or crumble. It's actually wood—Plastic Wood—sold by paint, hardware and department stores.

## Big Book of Uses—FREE

Just fill in and mail this coupon and we'll send you a great big, profusely illustrated book of 48 pages crammed full of interesting uses for this remarkable new kind of wood that handles like putty, hardens into wood and comes in 9 different colors. Send for your copy—today.

## Big 48-Page Book FREE

THE A. S. BOYLE CO., Dept. 4-PM-19  
Cincinnati, Ohio

Send me—free—big, illustrated book of uses for PLASTIC WOOD.

Name.....

Street.....

City..... State.....





### MONEY BUYS MORE AT SEARS-ROEBUCK

Here's one thing that we have made certain in our new Catalog for Spring and Summer—today's dollar travels farther. Nowhere is this more true than with our Hercules Work Shirts. More workmen buy them than any other kind.

This new catalog offers 48,000 articles—all priced at new low levels—all guaranteed to give complete satisfaction.

# USE YOUR SEARS CATALOG

## why in the world should you buy anywhere else?

Frankly, we can't think of a single reason. For prices are *always* lower at Sears. And this season they are the lowest this generation has seen. Quality is assured by definite high standards. Satisfaction is guaranteed by the World's Largest Store. If you haven't a copy of our new Spring and Summer Book, we'll gladly send one free. Write our mail order store nearest you.

### SEARS, ROEBUCK AND CO.

Chicago  
Dallas

Philadelphia  
Atlanta

Boston  
Memphis

Kansas City  
Los Angeles

Minneapolis  
Seattle

# USE YOUR SEARS CATALOG

## A Precision Grinder and a High Speed Drill . . . . IN ONE TOOL

A TOOL post grinder for bench lathes and for off-hand grinding operations. Grinds to the finest limits. Easily changed into a high speed drill for wood or other material. Takes drills from No. 42 to No. 22 inclusive. Has many uses in shop and home. Equipment includes six grinding wheels. Write for complete information.—Dumore Company, 52—16th Street, Racine, Wis.

MAXIMUM  
SPEED  
20,000 R.P.M.

THE  
**DUMORE**  
MIDGET

\$27<sup>50</sup>  
COMPLETE



\$28 west of Rockies—Canada Price on request

## Boys Fly the IDEAL EAGLET



20 in. Size  
Construction  
Outfit  
**50c**  
Postpaid

A Perfect Model of a Commercial Plane. All balsawood (not cardboard) with many features of expensive models. Easy, quick construction; everything ready to put together; weighs 1 oz. complete. Files like a big one! Get one now and have some real fun!

Send 5c for Big 48-pg. Catalog of New Models and Reduced Prices. Ideal Aeroplane & Supply Company, Inc., 26 West 19th Street, New York City

## Build a CLOCK for Pleasure or PROFIT!

### FREE BOOK

of Clock Making,  
Money Making  
Ideas. Gives details  
prices of move-  
ments, parts.  
Write NOW for  
copy!

Shows How YOU Can Make Fine  
Clocks Right at Home

—for yourself, or to sell at Big Profits. We furnish instructions, parts. Works \$1.50 up; others with chimes, all prices. Make men or assemble parts. Cash-in on demand for Mantel, Radio, Grandfather's Clocks. Write for Special Blue Print Offer, FREE Catalog.

**AMERICAN CHIME CLOCK COMPANY**  
1670-J Ruffner St. Philadelphia, Pa.

## Get Into A Business of Your Own—EARN \$150 to \$300 Monthly

8 HOUR  
BATTERY  
CHARGING



### NEW ATTRACTIVE PRICES—TERMS AS LOW AS \$10 MONTHLY

Charge batteries in one-third the usual time and at half the cost. Hundreds doing profitable business with HB. Recommended by leading battery manufacturers, approved by U. S. Bureau of Standards. Small space required—start in your home or small corner of a shop. HB Car Washing, Test Benches, Paint Spray, Arc Welding offer same opportunity. No special experience needed to operate. HB shouldn't cost a cent—will pay for itself as EASY MONTHLY PAYMENTS, mean practically no investment and a handsome profit for you.

WRITE NOW for details to HOBART BROTHERS, Box M41, TROY, OHIO.

**30 DAYS TRIAL—Pay Out of Income Terms**



# DON'T CHOKE ME

## JUST GIVE ME A HOT SHOT

Amazing electrical invention starts car, truck or tractor motor without choke. Saves plenty gas, oil. More speed. **HOT SHOT** sparks **BLUE** if ignition O. K.—**RED** if faulty. Draws big crowds. Sells on sight. 25,000,000 prospects. 100% profit at \$1.50. Gold mine for agents. "\$25 a day easy," says Akeman. "Rush 500 **HOT SHOTS**," says Klint. "Send 200 more," say Berg-Williams. "We want exclusive." "Never saw anything to beat it." "My first winner." Selling like wildfire. Your best bet part time—full time. **FREE** Sample Offer. **Act QUICK.**

Reardon Mfg. Co., Dept. F4, Peoria, Ill.



## BUILD YOUR OWN

### AUTOMATIC ELECTRIC REFRIGERATOR

Why pay \$200.00 and upwards? You can use your present ice-box - We supply special parts - Costs only \$34.50 complete - Easily made - No special tools required - Operating cost, quality and size of machine same as well known makes - Complete blue-prints and thorough instructions - \$1.00.

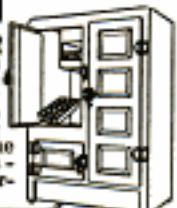

B. & L. ENGINEERING Co. 62 Greenville Av. Jersey City, N. J.

## OTTAWA LOG SAW



GREATEST OFFER  
EVER MADE

PUTS THIS  
OTTAWA  
TO WORK FOR YOU

**Make Money!** Wood is valuable. Saw 15 to 20 cords a day. Does more than 10 men. Ottawa saw easily operated by man or boy. Falls trees - saves limbs. Use 4-hp. engine for other work. **30 DAYS TRIAL.** Write today for **FREE** book. Shipped from factory or nearest of 4 branch houses.

OTTAWA MFG. CO., 1741 - W Wood Street, Ottawa, Kansas

## NEW & IMPROVED MODEL BOILER

EXTRA  
STRONG  
COPPER

### Most Practical Boiler and Cooker

Made with large 5-inch Improved Cap and Spout. Safe, practical and simple. Nothing to get out of order, most substantial and durable on the market. Will last a life time, gives real service, satisfaction.

### Easily Cleaned

Cap removed in a second; no burning of hands. An ideal low pressure boiler and pasteurizer for home and farm.

## Save 20%

By ordering direct from factory. No article of such high quality and utility ever sold at such amazingly low prices. Prices quoted are cash with order or one-fourth cash, balance C. O. D. Send check, money order prompt shipment made in plain strong box. The only boiler worth having. Large Catalog Free.

Home Manufacturing Co. 10 E. Kinzie St., Dept. 7216 CHICAGO, ILLINOIS



Catalog  
Free

# See the World FREE!



## Taste Romance and Adventure In the Far Lands of the Earth

How often you've longed to see for yourself the awe of Egypt's pyramids—the beauties of the gorgeous Mediterranean sunset—the squalor of China's ancient cities!

Spend a few years, or the rest of your life, tasting high adventure on the seven seas and in all the world's great ports—roving the earth's highways and byways! You can do it **FREE**—all your expenses paid—and earn a good salary besides!

Only one profession will carry you around the world at will, traveling like a gentleman, but that's the most interesting and pleasant work there is—Radio Operating! Easily and quickly learned, there's no other profession like it for the man who wants the experiences and pleasures of world-travel. Radio operators are needed—all sea-going ships like the one shown here must carry from one to half a dozen or more.



## Take a Look Beyond the Skyline Without a Penny's Expense

Radio operators aboard ocean liners live luxuriously—they rank as officers of the ship. Meals, a private cabin, all other living needs are furnished free, and besides the operator draws a good salary. You can learn quickly and easily at home in your spare time to be a Radio operator through our practical training methods. Take a look at the **FREE** BOOK which tells how—mail coupon below.

This U. S. Government-recognized school has been training successful operators since 1914. Our graduates are all over the world. We maintain an Employment Department to help put you on your own ship. The famous **NACOMETER**, a patented home code teacher, given our students, is recognized as the best and easiest way to learn the Radio code at home. A few short months, with the aid of the famous Nacometer and our quick home training, and you too can be a fully qualified Radio operator, sitting in your cabin like the one shown above, bound out for Liverpool or Nagasaki!

Read the Free Book that tells all about this fascinating profession and our practical Government-recognized methods of training you for it. Send coupon **TODAY**—no obligation. Special tuition offer now on includes the Nacometer, famous code teaching machine. Find out what Radio offers you. Act at once. Mail the coupon.

**NATIONAL RADIO INSTITUTE**  
Dept. 1DP WASHINGTON, D. C.

### SPECIAL OFFER COUPON

National Radio Institute,  
Dept. 1DP, Washington, D. C.

Gentlemen: Without obligating me in any way send me your free book and information about your Nacometer, the Home Code teaching machine given with your course.

Name .....

Address .....

Occupation .....



# Rupture No Longer Spoils My Fun

"Now that I am rid of my rupture and do not wear a truss, I enjoy dancing again. Many strenuous activities are pleasures, because I am not handicapped in any way. My work is no longer a task—I enjoy it. No one would ever believe I was crippled by rupture."

This is the way people write us after ridding themselves of rupture by using STUART'S ADHESIF PLAPAO-PADS.

Stacks of sworn endorsements report success—without delay from work.

Plapao-Pads cling to the body without straps, buckles or springs.



Easy to apply—economical and comfortable.

Convince yourself by actually testing Plapao at our expense. Send coupon today.

Test of Factor "PLAPAO"

**FREE!** *ACT SPEEDILY*

MAIL COUPON BELOW TO-DAY

Plapao Laboratories, Inc.  
789 Stuart Bldg., St. Louis, Mo.

Send me FREE Trial Plapao and 48-page book on Rupture. No charge for this now or later.

Name .....

Address .....

## AGENTS! SELLS LIKE WILD FIRE



\$380 monthly selling 10 new improved window washers daily. Cleans, dries, polishes. Eliminates all mess. Approved by Good Housekeeping. Restricted territory. Write today.  
CARTER PRODUCTS CORPORATION, 998 Front Ave., Cleveland, O.

**FREE \$1.25 PENCIL** **FREE \$1.50 QUART SIZE ACID PROOF INK**

WITH EACH PURCHASE OF No. 8 PEN SELLING FOR \$1

Just think of selling deal No. D8 as illustrated for \$1 and still make over 200% profit. DEAL NO. D8 contains a \$1.25 pencil; ink powder sufficient to make a quart of ink valued at \$1.50; and a No. 8 pen with adjustable ink feed, valued at \$1.25; total value \$4 selling for \$1. You give the pencil and ink powder, FREE, with each purchase of pen No. 8 selling for special price of \$1. Agents making up to \$10 to \$20 daily with this deal.

**SAMPLE DEAL** Dozen deals, 42c ea. 45c EACH Gross deals, 37c ea.

**SPORS IMPT. CO.**  
231 Main St., Lesueur Center, Minn.



## Auto Seat Covers \$2.95

Special Price Offer

AGENTS Make \$20 a Day

WRITE NOW!

Write orders fast for this excellent quality line Auto Seat Covers. Amazing value—quick sales. Quality Sales, 1834-36 North Ave., Dept. 416, Chicago

## Choo Choo—Another \$240 Profit!

Another HOLLYWOOD knock-out selling hit—the CHOO-CHOO-AUTO HORN. (Pat. Pending.) Closely resembles the sound of a roaring locomotive whistle. Not a toy, nor trick horn but a real motor car horn—preferable to most others. Hundreds being installed—from FORDS TO LINCOLNS!

Sells best at \$4.50—costs you \$2.40. NO-ROUSE-TO-HOUSE SELLING. Send \$1 and collect the crowd—and then COLLECT THE MONEY! Agents are actually "cleaning up" on this new hit. Everybody wants one. Installed in 2 minutes by anyone. Be first in your locality with this clever horn.

SEND \$2.40 for sample horn or write for details.

**PACIFIC COAST PRODUCTS CO., LTD.**  
Dept. B20 1616 Cahuenga Blvd., Hollywood, California

Also 14" Size.

## Everything in Bench Power Tools

Just a few shown. Also 7" 8" and 11" Lathes, 10" and 20" Jig Saws, Mortiser and Shaper. We have what you want in quality, low price and easy terms. Get our FREE 1931 catalog.

**12" Band Saw**  
less guards,  
**\$32.50**

Table tilts 45 degrees. Saws 4 1/2" thick. Bronze bearings. Very rigid frame. Blades for wood, metal or composition cutting. Remarkable value.



Also massive 6" ball bearing Jointer. Extra long tables.

**New 4" Jointer**  
Ball Bearing  
Less Guard **\$25**

Nothing on earth like it. Graduated fence tilts two ways. Long tables. Wide rabbet arm.

**Universal Handisaw \$30**

Wonderful value. Will rip, grind, dado, bore, mitre, rabbet, joint, sand and mortise.

Get FREE Screen Book



Buy Now Pay Later

W. B. & J. E. BOICE

DEPT. PM-4G

TOLEDO, OHIO



## Don't Be Afraid To Tackle That Concrete Job!

With the instructions found in the new, revised edition of Popular Mechanics Concrete Handbook you can make any of the following useful articles:



Garden Seats—Fountain and Basin—Flower Boxes and Vases—Pedestals and Bird Baths—Ornamental Pools—Sanitary Drinking Fountain—Gateposts—Auto Driveway—Sidewalks—Boat Landings and Docks—Entrance and Garden Walks—Sidewalk Flagging—Narrow Car Walks—Curbs and Gutters—Wall Capping—Steps—Garage Floor—Basement Floor—Fence Posts—Lawn Roller—Cistern—Chimney Cap—Refuse Burner—Culvert—Benches for Greenhouses—Tile—Retaining Walls—Foundation Supports—Engine Foundations—Septic Tank—Toy Blocks—Forge—Fireproof Safe—Ice House—Watering Troughs—Milk House—Smokehouse—Silo—Horse Stalls—Hitching Post—Rural Mail Box Post—Cyclone Cellar

### Build With Ease for Permanence and Beauty

This is a book of practical plans for using concrete about the home, farm or shop. For amateurs as well as contractors. In addition to making all the articles mentioned above the making of good concrete mixtures for various classes of construction is given; mechanical mixers and homemade tools are dealt with. All necessary form and mold making are covered as well as many other valuable pointers too numerous to mention here.

Simply write and ask us to send you this book. When postman hands you the package pay him \$1.00 plus the postage. If outside U. S. remit when ordering and include 15 cents extra for mailing.

**POPULAR MECHANICS PRESS**  
Room P4 200 E. Ontario Street CHICAGO

## NEED A BETTER GRIP ON MATHEMATICS?

SEND for a copy of "Mathematics for the Practical Man," only \$1.50. By common sense methods it removes the mystery and difficulties so that algebra and even calculus are made simple.

Assuming your knowledge is limited to arithmetic you quickly and easily gain a working knowledge of Algebra, Geometry, Trigonometry and Calculus. Simply pay postman price of book plus the postage when he hands you the package.

**Popular Mechanics Press**  
Room P4  
200 E. Ontario Street, Chicago

## BLUEPRINT READING For the Building Trades

Every man who is ambitious to learn the last detail of blueprint reading will want this new book which is thorough, complete and up-to-the-minute. Written in a clear, non-technical manner. An ideal working tool for apprentices, teachers, students, carpenters, bricklayers, etc.

Over 100 pages—50 plans and illustrations.

Cloth—Price \$1.25 postpaid  
**Popular Mechanics Press**  
Room P4  
200 E. Ontario St. Chicago

# Buy DIRECT on credit at New Low Prices

Our 1931 Cut-Price  
Offers a Remarkable  
Opportunity to Own  
A 21 Jewel ~

## Santa Fe Special

Send  
for  
Catalog  
Now!



Compare  
the Santa Fe Special  
with other Watches costing  
30% to 50% More ~

**Send No Cash** In addition to our NEW LOW PRICE, I will send for your approval one of these Standard Watches, guaranteed for a lifetime of satisfactory service, not only by the Santa Fe Watch Company, but by the Great Illinois Watch Factory. So accurate, Government officials carry them; so perfect and beautiful, jewelers say they are worth 1-3 to 1-2 more than we ask for them. I will send you one to see WITHOUT ONE PENNY DOWN—allow you to wear it 30 days FREE—then sell it to you on easy payments.

### Diamond Rings— Wrist Watches

Write for our New Diamond Ring of Romance and Bulova Wrist Watch Catalog, showing marvelous new designs. Never have we been able to offer such beautiful diamond rings and artistic dependable watches at such low prices. The catalog is sent FREE. Ask for our Special Spot Cash Offer. Good for 30 days only.

## Santa Fe Watch Co.

46 Thomas Bldg., KANSAS  
TOPEKA, KANSAS

To SANTA FE WATCH CO.,  
46 Thomas Bldg., Topeka, Kans.  
Please send me catalog I have checked,  
Railroad and dress Pocket-Watches.....   
Ladies' and Men's Wrist Watches.....   
Ladies' and Men's Diamond Rings.....

Name.....

Address.....



# PATENT

## Protect Your Ideas

### Take the First Step Today

If you have a useful, practical, novel idea for any new article or for an improvement on an old one, you should communicate with a competent Registered Patent Attorney AT ONCE. Every year thousands of applications for patents are filed in the U. S. Patent Office. Frequently two or more applications are made for the same or substantially the same idea (even though the inventors may live in different sections of the country and be entirely unknown to one another). In such a case, the burden of proof rests upon the last application filed. Delays of even a few days in filing the application sometimes mean the loss of a patent. So lose no time. Get in touch with me at once by mailing the coupon on the opposite page.

### Prompt, Careful, Efficient Service

This large, experienced organization devotes its entire time and attention to patent and trade mark cases. Our offices are directly across the street from the U. S. Patent Office. We understand the technicalities of patent law. We know the rules and requirements of the Patent Office. We can proceed in the quickest, safest and best ways in preparing an application for a patent covering your idea. Our success has been built on the strength of careful, efficient, satisfactory service to inventors and trademark owners located in every state in the Union.

### NO CHARGE for Information On How to Proceed

The booklet shown here contains valuable information relating to patent procedure that every inventor should have. And with it I will also send you my "Record of Invention" form on which you can sketch your idea and establish its date before a witness. Such evidence may later prove valuable to you. Simply mail the coupon and I will send you the booklet, and the "Record of Invention" form, together with detailed information on how to proceed and the costs involved. Do this NOW. No need to lose a minute's time. The coupon will bring you complete information entirely without charge or obligation.



My Offices  
Just Across  
Street From  
U.S. Pat. Office



Above is a view of my drafting and specification offices where a large staff of experienced experts are in my constant employ. All drawings and specifications are prepared in my offices.

# INVENTORS

## Write for these Free Books

### Strict Secrecy Preserved

All communications, sketches, drawings, etc., are held in strictest confidence in strong, steel, fireproof files, which are accessible only to authorized members of my staff. Feel free to write me fully and frankly. It is probable that I can help you. Highest references. But **FIRST**—clip the coupon and get my free book. Do **THAT** right now.

## Clarence A. O'Brien

*Registered Patent Attorney*

Member of Bar of: Supreme Court of the United States; Court of Appeals, District of Columbia; Supreme Court, District of Columbia; United States Court of Claims.

Practice confined exclusively to Patents, Trademarks and Copyrights



**Clip this Coupon and Mail it Now!**

**CLARENCE A. O'BRIEN, Registered Patent Attorney**  
70-F Security Savings and Commercial Bank Bldg.  
Washington, D. C.

(Or, Suite 1106, Dept. A-10, Woolworth Bldg., New York City)

Please send me your free book, "How to Obtain a Patent," and your "Record of Invention" form without any cost or obligation on my part.

Name.....

Address .....

(Important—Write or print name plainly and address office nearest you)



# PATENTS TRADE MARKS COPYRIGHTS



Our New York Office  
Suite 1007 Woolworth Bldg.



Our Philadelphia Office  
828 Fidelity Phila. Trust Bldg.



VICTOR BUILDING  
Our New Building Nearly Opposite U. S. Patent  
Office Specially Erected by Us for Our Own Use



## Have You An Idea?

**Our Offer:** FOR THE PROTECTION  
OF YOUR INVENTION

**YOUR FIRST STEP**—The Inventor should write for our blank form "RECORD OF INVENTION." A sketch and description should be made on this Blank, signed, witnessed, then returned to us. We also give our opinion as to whether the invention comes within the Patent Office definition of a patentable invention. This "Record of Invention" will serve as "proof of conception." *There is no charge or obligation for this service.*

**Our Five Books Mailed  
Free to Inventors**  
*Our Illustrated Guide BOOK*

### How to Obtain a Patent

Contains full instructions regarding U. S. Patents. Our Methods, Terms, and 100 Mechanical Movements illustrated and described.

### Our Trade Mark Book

Shows value and necessity of Trade Mark Protection. Information regarding *Trade Marks and unfair competition in trade.*

### Our Foreign Book

We have Direct Agencies in Foreign Countries and secure Foreign Patents in shortest time and lowest cost.

### Progress of Invention

Description of World's Most Pressing Problems by Leading Scientists and Inventors.

### Payment of Fees in Installments

It is not necessary that the total cost for the preparation and prosecution of a patent be paid in one payment. Our custom is to permit our clients to pay for their applications in three installments as the preparation of the application progresses in our office. This plan makes the payments easy for the inventor.

*We Regard a Satisfied Client* as our best advertisement, and furnish anyone, upon request, lists of clients in any state for whom we have secured patents.

**Highest References—Prompt Service  
—Reasonable Terms**

## VICTOR J. EVANS & CO.

Patent Attorneys, Established in 1898  
Main Offices: 789 9th St., N. W., Washington, D. C.  
*Nearly Opposite U. S. Patent Office*



# DELAYS ARE DANGEROUS IN PATENT MATTERS

## IMPORTANT! To Avoid Delay!

YOU SHOULD HAVE YOUR CASE MADE SPECIAL IN OUR OFFICE to save correspondence, secure protection and early filing date in the Patent Office. To secure **special preparation** of your case send \$25.00 on account with model or sketch and description of invention. If the invention is not patentable we will return fee less cost of search.

**We Assist our Clients to Sell their Inventions.**



Our Chicago Office  
Suite 1640-42 Conway Bldg.



Our Pittsburgh Office  
Suite 514 Empire Building



Our San Francisco Office  
Suite 1010 Hobart Building



MAIN OFFICE, VICTOR J. EVANS & CO.—VICTOR BUILDING, WASHINGTON, D. C.

Our Large, Comprehensive Organization has been established for 30 years and offers Prompt, Efficient and **Personal Service** by experienced Patent Lawyers and Draftsmen. Every case is in charge of a Specialist who has been selected for his knowledge and experience in certain lines of invention. Our Lawyers practice in all U. S. Courts and defend clients in suits involving Patents, Trademarks and Copyrights. All Communications, Sketches, Drawings, etc., preserved in fireproof Files, strictly **Secret and Confidential**. We shall be glad to have you consult us or to answer any questions in regard to Patents, Trademarks or Copyrights without charge or obligation.

**FREE  
COUPON**

**VICTOR J. EVANS & CO.**  
**PATENT ATTORNEYS** *Established  
in 1898*

NEW YORK OFFICES  
1007 Woolworth Bldg.

CHICAGO OFFICES  
Suite 1640-42 Conway Bldg.

PHILADELPHIA OFFICES  
828 Fidelity Phlla. Trust Bldg.

PITTSBURGH OFFICES  
514 Empire Bldg.

SAN FRANCISCO OFFICES  
1010 Hobart Bldg.

MAIN OFFICES: 789-9th Street, N. W., WASHINGTON, D. C.

Gentlemen: Please send me *Free of Charge* your books as described on preceding page.

Name .....

Address .....



"I've  
lost a  
fortune"  
he cried!



He rushed headlong into our office. "I might have made \$100,000," he cried, "but now I've lost it all!"

Between half-sobs and self-reproaches, he blurted out the miserable story. A year before he had come to us with an idea for an invention. It had merit and we made several suggestions for its development. We strongly advised a working-model to check up on its operation. We pointed out that our 25 years of experience in developing inventions would enable us to make certain very necessary improvements in his invention.

He left our office, went home to his workshop, developed a rough working-model of his own and immediately had it patented. That patent was his proudest possession. But he failed to realize that the patent guaranteed nothing but protection against infringements on the exact machine he had built!

In his haste, he overlooked the fact that a minor addition to his machine would so have broadened its use as to allow extensively larger basic patent claims, which might be of great value in the future.

He overlooked it. But others had not! His invention, only a year old, was already as outdated as Noah's Ark. In its improved form it was already beginning to earn a great fortune—for SOMEONE ELSE!

Have a working-model of your invention made by us. It enables you to understand better your invention possibilities—your attorney will be better able to establish patent claims—your financial backer and manufacturer will be more receptive.

Our guarantee protects you, before disclosing to anyone, even to us. Write TODAY for Free Booklet "No Wonder They Fail!"

**BERNARD & HELLER**  
Complete Service to  
INVENTORS and MANUFACTURERS  
31 East 17<sup>th</sup> St. New York N.Y.

Information on any book free. Write Popular Mechanics Press, Chicago, Ill.

## PATENTS TRADE-MARKS

Don't Lose Your Rights  
To Patent Protection

Before disclosing your invention to anyone send for blank form "EVIDENCE OF CONCEPTION" to be signed and witnessed.

**LANCASTER, ALLWINE & ROMMEL**  
489 Ouray Bldg. WASHINGTON, D. C.  
Originators of forms "Evidence of Conception."

## PATENTS

### PROTECT YOUR IDEAS

Write today for FREE BOOKLET, HOW TO OBTAIN A PATENT and RECORD OF INVENTION—or send Drawing or Model of your Invention for Examination.

Promptness Assured with Best Results

## MILLER & MILLER

REGISTERED PATENT ATTORNEYS  
Former Members Examining Corps U. S. Patent Office  
Dept. A-1006 Woolworth Bldg. New York  
255 McGill Building Washington, D. C.

## TRADE MARKS - PATENTS COPY-RIGHTS

BEST RESULTS. LOWEST FEES. PARTIAL PAYMENT PLAN

Write today for free information—No obligation, sending sketches and description of invention.

**HARRY W. JOHNSON**

Registered Patent and Trade Mark Attorney

FORMERLY MEMBER EXAMINING CORPS U. S. PATENT OFFICE  
Member of the (Bar) Supreme Court of the District of Columbia, the Court of Appeals of the District of Columbia, and the U. S. Court of Customs and Patent Appeals.

219 MCGILL BUILDING, WASHINGTON, D. C.

## PATENTS

### TO THE MAN WITH AN IDEA

Preliminary advice gladly furnished without charge. Booklet of information and form for disclosing idea free on request.

**IRVING L. McCATHRAN, Patent Lawyer**

Formerly with and successor to RICHARD B. OWEN  
750 International Bldg. Washington, D. C.  
41-E Park Row New York City

TRADE-MARKS

## PATENTS

Booklet Free Highest References  
Promptness Assured Best Results

Send drawing or model.

### ALL BUSINESS GIVEN PROMPT AND PROPER ATTENTION

Listed Patent Lawyer in the latest editions of the Rand-McNally Directory of Bankers and Bank-Recommended Attorneys, published by Rand-McNally & Co., Chicago, Ill.; The Baggott & Ryall Directory of Guaranteed Attorneys, published by Legal Directory Corporation, Boston, Mass.; Flugel's Law List, published by Legal Directory Publishing Co., St. Louis, Mo.; American Lawyers Annual, published in Cleveland, Ohio; Bankers Service Legal Directory, published by Bankers Service Co., Boston, Mass.; Eyre's Law List, 9 Park Place, New York City; Walters Legal Directory, Omaha, Nebraska, and the National Directory of Attorneys, Baltimore, Maryland.

**WATSON E. COLEMAN,**  
REGISTERED PATENT LAWYER

Victor Building, 724 Ninth Street, N. W.  
**WASHINGTON, D. C.**

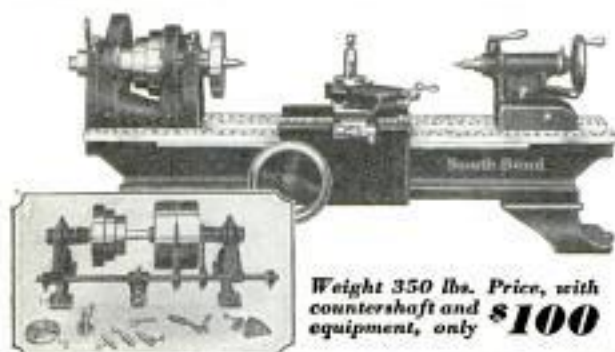

**\$7<sup>00</sup>**  
A Month**for this 9" x 2' Back-Geared Special Metal Turning  
SOUTH BEND PRECISION BENCH LATHE**

Weight 350 lbs. Price, with  
countershaft and  
equipment, only **\$100**

9 $\frac{1}{4}$ " swing ... Precision type ...  $\frac{3}{4}$ " hole thru spindle ... Phosphor bronze bearings ... Back-geared headstock ... Set over tail-stock ... Graduated compound rest ... Cone pulley steps 1" wide ... Bed lengths 2' to 4 $\frac{1}{2}$ ' with between center distances, 5" to 36".

The No. 20 9" Special is our regular Quick Change Gear Lathe stripped of all extras not needed in the small shop. Used for manufacturing, machine shop, repairing, automobile servicing, etc. Suitable for all turning jobs in cast iron, steel, brass, aluminum, bronze, wood, fibre, etc. **WRITE NOW** for descriptive circular—also catalog of other sizes up to 24" swing at \$2,000.

**SOUTH BEND LATHE WORKS**

803 East Madison Street South Bend, Indiana, U. S. A.  
LATHE BUILDERS FOR 25 YEARS—OVER 50,000 SOUTH BEND LATHES IN USE

**PATENTS**

Trade Marks, Copyrights, Patent Litigation Handbook with illustrations, 100 mechanical movements. *Send free on request.*

**ALBERT E. DIETERICH**

Successor to Fred G. Dieterich & Co.

formerly member Examining Corps, U. S. Patent Office

REGISTERED

**PATENT LAWYER and SOLICITOR**

621-A, Ouray Bldg.

30 Years' Experience Washington, D. C.

**PATENTS**

As one of the oldest patent firms in America we give inventors at lowest consistent charge, a service noted for results, evidenced by many well-known Patents of extraordinary value. Book, Patent-Sense, free.

Lacey & Lacey, 635 F St. N. W., Dept. 5, Wash., D. C. Estab. 1889

**GEARS**

In Stock—Immediate Delivery

Gears, speed reducers, sprockets, thrust bearings, flexible couplings, pulleys, etc. A complete line is carried in our Chicago stock. Can also quote on special gears of any kind. Send us your blue prints and inquiries.

Write for Catalog No. 10

**CHICAGO GEAR WORKS**

760-773 W. Jackson Blvd., CHICAGO, ILL.

**Do Your PRINTING**

Cards, stationery, circulars, tags, labels, advertising, etc. Save money. Print for others, big profits; easy rules sent. Will do popular Raised Printing like Engraving. Junior Press, \$5.00. Job Presses \$11 up, Power \$149. Write for free catalog. **THE KELSEY, CO., Y-37, Meriden, Conn.**

**BASHFUL?**

"Shame on you!" Are you nervous, embarrassed in company of the other sex? Stop being shy of strangers. Conquer the terrible fear of your superiors. Be cheerful and confident of your future! Your faults easily overcome so you can enjoy life to the fullest. Send 25c for this amazing book. **RICHARD BLACKSTONE, B-474 Flatiron Bldg., N. Y.**

**New Craft Work  
Pays Big Money****Easy Way to Make  
Money at Home**

Miniature coach, covered wagon and spinning wheel craze is sweeping the country. There is a tremendous demand for these and similar products. Here's your chance to be in business for yourself and to make some much-needed money at home. Earn up to \$50 a week in spare time this new way. Easy, pleasant, dignified work. Assemble and decorate exclusive beautiful gifts ... antique spinning wheels, coaches, covered wagons, and many other gorgeous gift wares.

**Creative Artistic Work  
No Experience Needed**

New practical method enables you to turn out quickly unique decorative gifts that sell at sight. No special experience or training needed. Splendid fun and relaxation, too. Full instructions furnished to start you making money at once!

**Write for FREE Details**

of our introductory FREE gift offer and full information about our plan for making exclusive fast-selling gifts. No obligation. Write today.

**Home Crafters Guild**  
Dept. 12 Terre Haute, Ind.

**PATENTS SECURED  
TRADE-MARKS REGISTERED**

High-class professional service for Inventors and Trade-Mark Users is necessary for PROPER PROTECTION. We Offer you our facilities on Reasonable Terms. If you have an invention send us a model or sketch and description and we will give you our OPINION whether your invention comes within the provisions of the Patent Laws. Our book, "HOW TO GET YOUR PATENT" and Record of Invention Certificate sent on request. *DELAYS are DANGEROUS* in Patent Matters.

Terms Reasonable.

Best References.

WRITE TODAY

**RANDOLPH & COMPANY, Patent Attorneys**

301 VICTOR BUILDING, WASHINGTON, D. C.

Name.....

Address.....





## TO YOU— THE HANDY MAN

**YOU'RE** the man they call upon when the fuse blows out or the radio won't work. You fixed the leg on the card table, helped Junior make his stage coach and carved the modernistic door stops. You can do most anything with a few simple tools and a generous portion of ingenuity.

And the one tool you use in every job is your knife. You'd be sunk without it. Take a look at the knife we show here. We don't have to tell you where you'd use it, you know that. And you know that if it's a Remington, it's made of the finest tool steel and that it will hold a keen edge.

Ask your dealer about it. If he hasn't got it, send us his name and \$1.50 and we'll mail it to you at once. Address: Remington Cutlery Works, 942 Barnum Ave., Bridgeport, Connecticut.

Go to your dealer and ask him to show you The Remington Standard American Dollar Pocket Knife

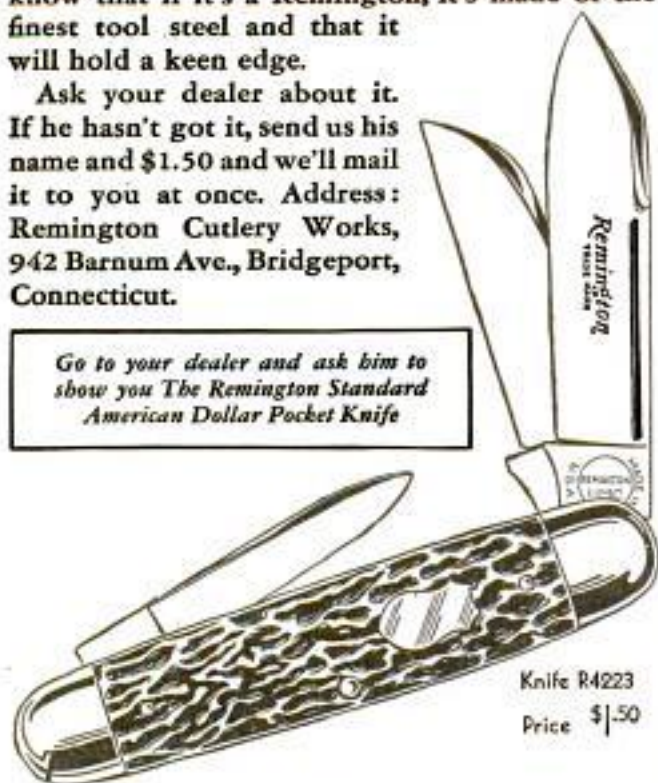

Knife R4223  
Price \$1.50

REMINGTON ARMS COMPANY, Inc.  
Originators of Kleanbore Ammunition

# Remington

## HOT WATER Instantly from any COLD WATER faucet

Simply attach a Hot Shot Electric Water Heater as shown in picture, plug cord in electrical appliance outlet, turn switch and get an unlimited supply of pure hot water instantly, at any desired temperature. A "Hot Shot" fits all faucets, can be moved from one faucet to another in a jiffy. A REAL necessity for homes, shops, garages, or anywhere hot water is desired. Sold at a price anyone can afford to pay.



Has Automatic Shut-off — comes complete with Adapter

for all faucets and water-proof, insulated cord. Fully Guaranteed. Write for low price.

### Responsible Agents

Write for Sales Plan, Terms and Territory

### The Sensation of 1930

Write for full information, descriptive literature, and low introductory price. Not an experiment — but a Proven Success over a period of 15 months—in thousands of places, everywhere, all over the U. S. Address:

Hot Shot Electric Water Heater Corporation  
Dept. 405 520 N. Michigan Ave. Chicago, Ill.



## The Musical Sensation ACCORDEON Played by Music Rolls

Play the most wonderful Musical Instrument on earth, without any knowledge of music or notes. Simply insert a small roll and start playing. Play the biggest hits in Dance Music, Operas, Songs, etc. Rolls changed in fraction of a minute. Everyone will think you are an artist.



## CORNETINO PLAYED WITH MUSIC ROLLS

The latest musical invention.

You are an artist in five minutes.

These instruments not only furnish pleasure, entertainment and recreation, they also offer a liberal income by playing at Moving Pictures, Radio Stations, Fairs, Dances and entertainments. We make arrangements for players and supply Entertainers' Cards for well paid engagements.

Write for our descriptive circular.

### TREASURE SALES COMPANY

1690 Boston Road NEW YORK, N. Y.

## A POPULAR AVIATION GUIDE at a Popular Price

Prepared to meet the demand for a simplified book on Aviation suitable for young people, beginners, and all persons desiring general information.

Everybody's Aviation Guide by V. W. Page, just published. 256 pages, 140 illustrations, tells all about flying in simple, easily understood language.

Aviation terms, operating principles, elementary rules, forms of air craft, functions of parts, types of power plants, machines, control systems and methods of flying. Learn now and prepare for the future. Price \$2

Will be sent C. O. D. in U. S. Pay postman price and postage.

POPULAR MECHANICS PRESS  
Room 210, 200 E. Ontario St., Chicago





## Announcing . . . . .



## the CHALLENGER . . . . .

a highly efficient utility glider built under the famous Rhon Ranger. Complete CHALLENGER CONSTRUCTION KIT only \$131.00. (Also sold in 8 progressive groups averaging \$17.00 each.) If you already own a Rhon Ranger, you can easily convert it to the CHALLENGER for \$44.00.

There is no guesswork about MEAD gliders; their high performance has been ably demonstrated in thousands of flights all over the world. Their sturdy structure meets government requirements. Send 10c today for our latest catalogs covering the famous MEAD line of gliders and supplies.

## MEAD GLIDERS

Dept. B-9 12 S. Market St. Chicago, Ill.

**CRESCENT**

**No. 87**

**Universal**

**Wood**

**Worker**

**Comprises**

**20" Band Saw**

**6" Jointer**

**Saw Table**

**Shaper**

**Borer**

Send

Today for

Special

Circular

**We Also Build:**

Band Saws	Borers—
Saw Tables	Tenons
Self Feed Rip	Racer Saws
Saws	Disk Grinders
Shapers—	Cut-off
Jointers	Tables
Variety	Universal
Wood	Variety
workers	Saws
Planers and	Universal
Matchers	Woods
Planers	workbenches
Hollow Chisel	
Mortisers	

Each unit driven by its own individual motor. Instantly adaptable to any of the many jobs it will perform without putting on or taking off a single attachment. Start up just *you* want, shut it off and go to next one. No time wasted, no bother. Operates from large socket—very economical. Thoroughly practical, convenient, exceptionally substantial—full bearings throughout. This machine is a time saver. It will make money for you.

**THE CRESCENT MACHINE CO. 93 Columbia St., Leontonia, Ohio**

## SHIP MODELS

Build them better! Follow reliable, authentic data. The Mariner, published quarterly, contains accurate drawings, plans of ships, photographs of models and articles on ship model building. Write for FREE sample pages.

**The Ship Model Society of Rhode Island**  
75 Upton Ave., Providence, R. I.

MAKE \$100.00 A WEEK

FOR ONLY 2 SALES DAILY

Take orders for my wonder value all-wool suits, tailored-to-measure. Union made. New low prices. Bigger commissions than ever, paid daily. Generous bonus to producers. Style creations to please critical men. A big selling, big profit line. No experience needed. Write now for **FREE** outfit of large swatch samples. You are under no obligation.

**W. Z. GIBSON, Inc., Dept. B-51E, 500 Throop St., Chicago, Ill.**

## Electric Portable Sprayer

Sprays Paint, Varnish, Duco, Enamel, Lacquer, etc., by Electricity.

Reg. Price \$68<sup>50</sup>

our Price

# \$21<sup>50</sup>

without Motor

Complete with spray gun.

Attach to light socket, turn on switch and point the Power way. Does work of 5 men.

SEND FOR CATALOG

NATIONAL JOBBING AND EXPORT CO.

192 N. Clark Street      Dept. 99      CHICAGO, ILL.

Do You Want  
a Fine Paying  
Cash Business  
Like This?



**This Man Makes BIG MONEY!**

“Six years ago I bought a Foley Electrakeen Lawn Mower Sharpener and mounted it on a small truck for a portable shop. First day I took in \$13.60 in the afternoon. From then on as I became more accustomed to the work, I earned from \$25 to \$30 a day for the balance of the season. Since then I built and operated four trucks on a profit-sharing basis, and I can make at least \$200 a month average net income from each truck as my share. The Foley turns out a perfect job and I have the same customers year after year.”

H. N. WOODMANCY, Minnesota

## FREE PLAN Starts You

A BIG OPPORTUNITY is waiting for wide-awake men who want to make BIG PROFITS and have an INDEPENDENT INCOME. Plenty of business everywhere. We tell you how to get started. No experience necessary—very little capital needed. Start at home in spare time, and build a steady, permanent business sharpening lawn mowers by the Foley Electrakeen System—same system as used by leading lawn mower manufacturers.

## BIG PROFITS for You

Get started NOW! 99c out of every dollar is CLEAR PROFIT! Mail coupon for complete information and FREE PLAN immediately.

## Foley Manufacturing Co.

1509 Foley Bldg., 11 Main St. N. E.  
Minneapolis, Minn.

Send me FREE PLAN and complete information about the Foley Electrakeen Lawn Mower Sharpener.

Name .....

Address .....



## LUMINOUS PAINT

**Make Your Watches, Clocks, Etc., Visible by Night** The very latest discovery in the scientific world, hitherto practically unknown, LUMINOUS PAINT, when applied to the surface of any article, emits rays of white light, rendering it perfectly visible in the dark. THE DARKER THE NIGHT, THE MORE BRILLIANT IT SHINES. Quite simple to use. Anyone—you can do it. A little applied to the dial of your watch or clock will enable you to tell the time by night. You can coat the push buttons or switch plates of your electric lights, match boxes, and innumerable other articles; make your own Luminous Candles, Luminous Roasting etc. Strick bottles, prices 25¢. Cigarette sticks, 50¢ and \$1 postpaid. JOHNSON SMITH & CO. Dept. 813 RACINE, WIS.



### CIGARETTE MAKER

Roll your own and save money. Better and quicker, saves more than half. Use your favorite brand of tobacco. Nuts, useful, handy. Pocket size, weighs 1/2 lb. Made entirely of metal, nickel plated. 25¢, 3 for 65¢.



### GOOD LUCK RING

Very striking, quiet and uncommon. Silver finish; skull and crossbones design. Two brilliant, flashing gems sparkle out of the ring. Said to bring good luck. Only 25¢ post.

### Exploding Cigarettes

Box contains ten exquisite cigarettes of excellent quality. They appear so real, but when each cigarette is about one-third smoked, the victim gets a very great surprise as it goes off with a loud BANG! A great mirth provoker yet entirely harmless. Price 25¢ box.

### NOVELTY BADGES SURPRISE MATCHES



Kissing Permit 10c. Garter Inspector 10c. Two very novel metal badges, nickel plated, that you can wear, giving you fun out of all proportion to their trifling cost. 10c, each badge, 3 for 25c, or 75c per doz. postpaid anywhere.

More fun than fighting with your wife. Look just like ordinary matches. As the victim tries to light one he gets quite a surprise. Price 10c per box, 3 boxes for 25c, 12 for 75 cents.

### STAR TOY MAKER

Greatest boys' book written. Tells how to make a Pinhole Camera, a Camera, model Railroad, a Telephone, Rocket, a Telescope, a Telegraph, a Kite, a Talking Machine, a Microscope, Electric Motor, Electric Door Bell, Water Wheel, Padlock, a pair of Skis, a Dog Sled, Bird House, Rabbit Yard, etc. 64 pages. 150 illustrations. PRICE 10c.

AMATEUR ELECTRICIAN, all about electricity in simple language. How to make batteries, dynamos, motors, telephones, bells, electric coils, engines, lights, etc. Price 10c postpaid.

### BOOK ON ROPE SPLICING!

Useful knots, lizards, splices, etc. How different knots are made and what they are used for. Knots that are unsafe, etc. Over 100 illustrations. All about wire rope attachments, lashing in blocks, tackles, etc. PRICE 20 CENTS.

### Wonderful X-Ray Tube

A wonderful little instrument producing optical illusions both surprising and startling. With it you can see what is apparently the bones of your fingers, the lead in a lead pencil, the leaves of a rose stem, and many other similar illusions. Price 10c, 3 for 25c.

### NOSE BLOWER

When some men blow their noses it sounds like a trombone. Now the NOSE BLOWER has come to torment us. It is a starter! It is ingeniously concealed in the handkerchief. Proceed to blow your nose and your friends will think they heard a steam engine or something. You can blow the hideous noise to your liking a very loud sound and keep up the fun as long as you like. PRICE 10c, 3 for 25c, or 75c doz. postpaid.

### Serpent's Eggs

Box contains 12 eggs. When lit with a match, each one gradually hatches itself into a snake several feet long, which curls and twists about in a most life-like manner. Price per box, 10c postpaid 3 for 25c.

## BLANK CARTRIDGE PISTOL

Protection against Burglars, Tramps, & Dogs. Special Offer 1 Blank Cartridge Pistol 100 Blank Cartridges 100-page Novelty Catalogue ONLY \$1.50 The Lot shipped by Express Cash With Order Only

Well made and effective, modelled on latest type of Revolver; appearance alone is enough to scare a burglar. When loaded it may be as effective as a real revolver without danger to life. It takes standard .25 Cal. Blank Cartridge—obtainable everywhere. Special case with order offers 1 Superior quality Blank Cartridge Pistol, 100 Blank Cartridges, and our new 100-page De Luxe Catalog of latest novelties, all for ONLY \$1.50. Shipped by Express only. Cannot go by parcel post. Extra Blank Cartridges 50c per 100. Special rates (Dewey Type) 10c per 50c. No U.O.D. shipments.

## LOOK 35¢ LOOK Wonderful instrument.

Everybody delighted with it. Odd, Curious and Interesting. Lots of pleasure as well as very useful. It is a double Microscope for examining the wonders of nature. It is also an Opera Glass, a Stereoscope, a Burning Lens, a Reading Glass, a Telescope, a Compass, a pocket Mirror, and a Laryngoscope—for examining eye, ear, nose and throat. It is worth all the cost to locate even one painful cluder in the eye. Folds flat and fits the pocket. Something great—you need one. Don't miss it. Sent by mail. Only 35c or 3 for \$1.00.

## Watch Charm \$1.00 Pistol

Exact reproduction of a real pistol. Actually fires REAL BLANK CARTRIDGES of miniature size. Illustration is actual size. It is loaded long, with ring at end for a chain to attach to watch chain. Loads like a regular pistol. Pull the trigger and it goes off with a loud bang. Pistol is break open type; illustration shows position for loading. Made entirely of high grade steel, nickel plated, octagon barrel, handsomely engraved handle, complete in box with reloading tool. PRICE \$1.00. BLANK CARTRIDGES, 50c per box of 25 (shipped by Express).

## PISTOL CIGARETTE CASE

It looks like a dandy weapon, but it is merely a novel Cigarette Case. This clever contrivance has proved itself better than the real thing in many an awkward encounter. Great fun "stealing up" your friends. They squirm and protest it might be loaded. Pull the trigger and the slide flies open disclosing the cigarettes. Well made, light and compact. Weight only 2 ounces. PRICE POSTPAID 25c

## MICROPHONE TRANSMITTER BUTTON

You can easily make a highly sensitive detector phone by using this Transmitter Button to collect the sound waves. You can build your own outfit without buying expensive equipment. It is simple and inexpensive. You can install an outfit in your home and have conversations being held all over the house. You can connect up different rooms of a hotel. This outfit was used by secret service operatives during the war. It is being used on the stage. It is ultra-sensitive and is the greatest invention in microphones. You can mount the button almost anywhere—and board houses, store pipes, still eavesdroppers, on the wall behind a picture frame, etc. Button is so light and small it cannot be detected. Eavesdroppers can be overheard without suspecting it. You can listen in on conversations in another room. A deaf person in the audience can hear the speaker. Connected to phonograph, piano or other musical instrument, music can be heard hundreds of feet away. Button may be used to renew telephone transmitters; often makes an old line "talk up" when nothing else will. The ideal microphone for radio use; carries heavy current and is extremely sensitive. Amplifies radio signals. Countless other novelties will suggest themselves. Experimenters find the button useful for hundreds of other purposes along the lines of telephony, amplifiers, loud speakers, etc. Many fascinating stunts may be devised, such as holding the button against the throat or chest to reproduce speech without sound waves. PRICE \$1.00. JOHNSON SMITH & CO., Dept. 813, RACINE, WIS.

## MIDGET BIBLE

GREAT CURIOSITY. Smallest Bible in the World. Size of a postage stamp. 200 Pages. Said to bring good luck to the owner. A genuine work of art. Must be seen to be appreciated. Makes good money selling them to friends, church organizations, etc. PRICE 15c each, 3 for 40c, 12 for \$1.35, 100 for \$7.50. Also obtainable in Leather Binding with gold edges. Price 50c each, 3 for \$1.35, \$4.50 per doz. Magnifying Glass for use with Midget Bible 15c.

## STAGE MONEY

With a bunch of these bills, it is easy for each person of limited means to appear prosperous by flashing a roll of these bills at the proper time and peeling off a genuine bill or two from the outside of the roll, the effect created will be found to be all that can be desired. Prices, postpaid: 40 Bills 20c, 120 for 50c, or \$3.50 thousand postpaid.

## NOSE FLUTE

The Magic Nose Flute, or Harmonica, is a unique and novel musical instrument that is played with nose and mouth combined. There is just a little knack in playing it which, when once acquired after a little practice, will enable you to produce very sweet music that somewhat resembles a flute. There is no fingering, and once you have mastered it you can play all kinds of music with facility and ease. When played as an accompaniment to a piano or any other musical instrument, the effect is as charming as it is surprising.



**JOHNSON SMITH & CO.**  
Dept. 813 RACINE, WIS.  
A De Luxe Edition of our new CATALOG mailed on receipt of 25c. Handsome binding. Bigger and better than ever. Only book of its kind in existence. Nearly 600 pages of all the latest tricks in magic, the newest novelties, puzzles, games, sporting goods, rubber stamps, unusual and interesting books, curiosities in seeds and plants, etc., unobtainable elsewhere. Remit by Cash, Money Order, Check or unusual U.S. Government and Foreign Stamps for all articles listed above. See next page also.



# BOYS! BOYS! BOYS! THROW YOUR VOICE



Into a trunk, under the bed, under a table, back of the door, into a desk at school, or anywhere. You get lots of fun fooling the teacher, policemen, peddlers, and surprise and fool all your friends besides.



## The Ventrilo

is a little instrument that fits in the mouth out of sight. Cannot be detected. It is used in connection with the above, and with the aid of this wonderful DOUBLE THROAT, or VENTRILLO, you can imitate many kinds of birds, animals, etc. Remember you get everything for ONLY TEN CENTS—a booklet giving you full instructions how to become a ventriloquist and throw your voice, the Double Throat, or Ventrilo, and our big catalog of novelties, tricks, puzzles, masks, books, etc.

All Sent Postpaid to Any Address for Only **10c**

### INVISIBLE INK Rubber Chewing Gum

The most confidential messages can be written with this ink, for the writing makes no mark. Cannot be seen unless you know the secret. Invaluable for many reasons. Keep your secrets and other private memoranda away from prying eyes. Great fun for playing practical jokes. Only 15c a bottle; 3 for 40c



It is just like a regular package of chewing gum and looks so real that it fools everybody. Of course no one suspects it is not genuine until they start to chew it. There's a world of fun in this rubber chewing gum—5 sticks to the package. Price, 10c Pkg.; 3 for 25c; 12 for 75c postpaid.

Rubber Tacks, . . . . . Box 10c Rubber Cigarettes, Price per Box, 20c  
Rubber Cigars, Price Ea. 10c Rubber Matches, Price per Pkg. 10c

### U. S. BABY TANK



It goes with real Yankee Pep—by its own power

Most remarkable toy ever invented. By drawing the Tank backward, either with the hand or over the floor or table and then placing it down, it will crawl along, overcoming all obstacles, in the same life-like manner as the latest Tank that proved so deadly in the great war. What makes it go is so wonderful a mystery, but there is no mechanism to wind up as is usually understood with mechanical toys, yet this tank will keep plodding along ten times longer than the ordinary run of toys. It will perform dozens of the most wonderful stunts: 2 1/2 inches long. Price only 25c prepaid. Stamps accepted. JOHNSON SMITH & CO.

### 125 TRICKS WITH CARDS



Containing all the tricks and deceptions with cards ever invented, including the latest Tricks of the most celebrated Conjurers, Magicians and Prestidigitators popularly explained, simplified and adapted for home amusement and social entertainments. The whole so explained that any one can, with a little practice, perform the most difficult feat, to his own satisfaction and to the wonder and admiration of his friends. There is also added a Complete Exposure of all the Card Tricks made use of by Professional Card Players and Gamblers. Shows how "Six in" Gamblers cheat and win money by their infernal "palm fling" and other tricks. These features make it the best work ever published on Card Tricks.

PRICE 25c POSTPAID

Heller's Book of Magic . . . . . Price 25c Postpaid

### TRICKS AND SOCIAL ENTERTAINER



Cleverly performed feats of conjuring, sleight-of-hand and illusion interest everybody, and ability of the kind always makes one a welcome guest. This is a book of 96 pages, with nearly 100 illustrations. The instructions for performing are so plainly given that even a child, with a little practice, can do them, as they only require SIMPLE APPARATUS. The book gives full and clear explanations of an unusually large number of clever tricks of all kinds, and a choice of the partial contents given below will give you a very good idea as to the comprehensive nature of this book. In addition there is a chapter on "SECOND RIGHT," a combination of five different methods which baffles the most astute investigators. The book is well worth the while even for those who merely wish to know how the tricks are done, while for the amateur magician it is a perfect treasury of golden opportunities.

PRICE 25c POSTPAID

Magic for the Amateur Magician . . . . . Price 25c Postpaid

Send remittance (Postage Stamps accepted) for all articles listed above, also in our other ad on previous page

# THE DANDY PERISCOPE

Very Interesting and Amusing Novelty  
SEE WITHOUT BEING SEEN



Look Over the Heads of the Tallest Men in a Crowd.

See Over a Fence, Around Corners, Etc.

## LOTS OF FUN AND AMUSEMENT

Strongly Made. Equipped with Mirrors, Sight-Finder and Eye-Piece.

THIS is the same kind of instrument that the soldiers use in the trenches to watch the enemy without risk of being seen themselves, and every submarine has one to project above the surface of the sea to keep a look-out for other vessels, etc. With it you can gaze over a high wall or see around a corner without being seen yourself, or, if you are in a crowd, you can look right over the heads of the tallest men and watch all the fun. Our illustrations will give you some idea as to the numerous uses to which the Periscope can be put. Every Boy Scout should have one for spying and anyone else who wants some rare amusement. The Dandy Periscope is very strongly made, will stand the roughest handling and the hardest wear, and with ordinary use should last a lifetime. It measures 17 inches long, and a little over two inches wide. The Periscope tube is handsomely decorated with colored designs to show many of its uses, and each Periscope comes complete in box.

Price Postpaid to any Address . . . . . **\$1.00**

### MAGICIAN'S BOX OF TRICKS

Apparatus and Directions for a Number of Mysterious Tricks, Enough for an Entire Evening's Entertainment . . . . . **\$1.00**

ANYONE CAN DO THEM

It is great fun mystifying your friends. Get the Conjuror's Cabinet, and you will be the cleverest fellow in your district. It contains the apparatus for ten historic tricks, including THE MAGIC BALL AND VASE TRICK (a wooden ball is placed inside, and upon replacing the lid has disappeared and is found in someone else's pocket); THE HINDOO TRICK CARDS (can be made to change completely as often as five times); DISAPPEARING COIN BOX (a coin, placed in the wooden box, vanishes entirely or changes into a coin of another denomination); THE GLASS GLOBULE TRICK (a coin is dropped into a glass of water and when the water is poured out the coin has vanished and is found somewhere else); THE RIBBON FACTORY FROM THE MOUTH TRICK (is seemingly endless supply of colored paper ribbons comes out of your mouth); THE DISAPPEARING HANDKERCHIEF (is handkerchief held in the hand mysteriously vanishes); THE HEART'S KING COIN TRICK; the ENCHANTED BOTTLE (no one but yourself is able to make it lay down); the GREAT RAT AND DICE TRICK (a large die is placed on top of a hat, disappears, and is found underneath yet no one has touched the hat), and last, but not least, the GREAT PHANTOM CARD TRICK, or two from five leaves nothing. Full instructions are sent for performing each trick. In addition to the above, a number of other tests and illusions are fully explained for which you can easily make or procure the necessary apparatus. Price complete \$1.00 postpaid. JOHNSON SMITH & CO.



### RESURRECTION PLANT

Great curiosity. Place in water, plant opens up and starts to grow in few minutes. Taken out it dries up and goes to sleep until put in water again. PRICE 10c, 3 for 25c, 75c per dozen, postpaid



### MAGIC MADE EASY 250 MAGIC TRICKS 10c

An excellent little book containing 250 Parlor Tricks, tricks with cards, coins, e.g., rings, glasses, etc. So simple that a child can perform them. Postpaid, to any address for only 10c, 3 copies for 25c.



Comical Motto Rings

Lots of harmless fun and amusement wearing these rings. Made in platinum finish (to resemble platinum), with wording on enameloid, as illustrated. Price only 25c Postpaid.

### The "Little Giant" Typewriter

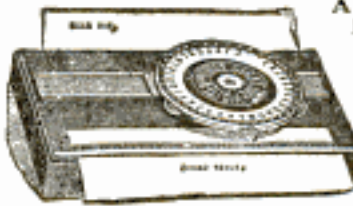

A First Class Writing Machine For \$1.50

A perfect little typewriter for \$1.50. There are thousands of persons who would like to use a typewriter but whose needs and incomes do not warrant the expense attached to the purchase and use of a fifty or seventy-five dollar machine. To such persons we cordially recommend our "Little Giant." It is strongly made, but simple in construction, so that anyone can quickly learn to operate it, and write as rapidly as they would with pen and ink. The letters of the alphabet

most frequently used are so grouped as to enable one to write rapidly, the entire set to be 15, and the construction is so being together. With this machine you can send your best girl typewritten love letters, address envelopes, make out bills, and do almost any kind of work not requiring a large, expensive machine. With each typewriter we send a tube of ink and full printed instructions for using the machine. Price complete \$1.50 by mail postpaid to any address in the world. Stamps accepted.

**JOHNSON SMITH & CO. Dept. 813 Racine, Wis.**



# Have you a Wet Cellar?

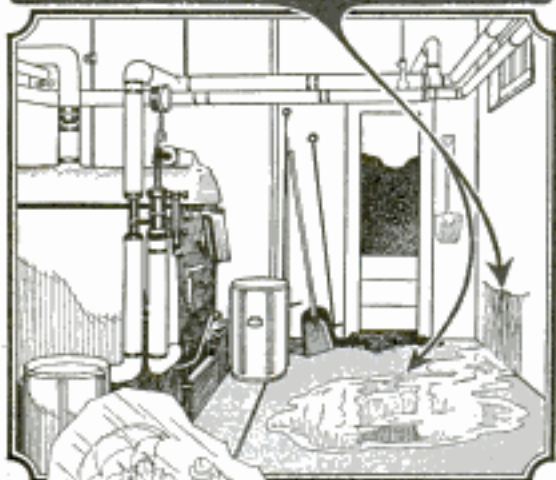

Dampness and flooding from ground water getting in is easily stopped by filling the cracks and painting over the porous spots in concrete or brick walls and floor with

## SMOOTH-ON NO. 7

—the only effective waterproofing material that can be applied from inside and to wet or dry surface.

Excellent also for waterproofing boiler pits, cisterns, tanks, ponds, wash-room, garage and stable floors, etc. About 25 lbs. required for each 100 sq. ft. of surface.

## You should also know SMOOTH-ON NO. 1

—the good old standby for stopping leaks in pressure joints, mending cracks, making loose handles, screws, etc., tight, stopping leaks in automobile radiators and hose connections, keeping lubricators, hub caps and nuts from loosening, etc.

## The Free Smooth-On Repair Book

will show you how, and by doing the work yourself you make big savings. Mail the coupon for free copy.

Get Smooth-On No. 7 in 1 or 5-lb. can, or 25 or 100-lb. keg and Smooth-On No. 1 in 7-oz. or 1 or 5-lb. can. At any hardware store, or from us direct.



Do it with **SMOOTH-ON**

SMOOTH-ON MFG. CO., Dept. 37,  
574 Communipaw Ave., Jersey City, N. J.

Please send the free Smooth-On Repair Book.

Name.....

Address.....  
4-31

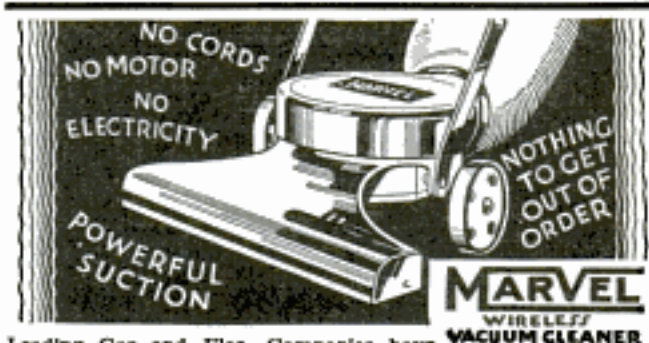

Leading Gas and Elec. Companies have stopped selling "Marvels," because the "Marvel" does not increase power consumption. So now—for the first time we are offering to the public direct—this Marvel Cleaner—**GUARANTEED FOR THE LIFETIME** of the original purchaser. **MORE TOO**—here's your chance to make money. Those Gas Companies sold "Marvels" by the hundreds, but now we're building our own sales organization. If you want a steady growing income—sell Marvels—with crew—full or spare time. Sold in city, town, and country to homes, hotels, rooming houses and railroads. Write for facts and figures about this attractive, high-eye money-making proposition. Remember a "Marvel" in your own home means—long efficient service—**THE LIFETIME GUARANTEE**. For all particulars write Desk 2.

THE MARVEL CO., 3450-54 Archer Ave., CHICAGO



A new radio thrill for you! Listen in **DIRECT** to London, Paris, Berlin, Buenos Aires and other broadcasting stations throughout the world via short waves. Enjoy unique foreign programs from strange lands. Your ordinary receiver cannot tune in these low wave stations. **WORLD-WIDE RECEIVER** gets 14 to 150 meter stations with surprising clarity. **SEND NO MONEY!** Just write your name and address on a postcard and ask us to send you this wonderful guaranteed short wave set. Pay postman \$6.45 plus a small delivery charge. All orders west of Rockies must be accompanied by \$1.00 deposit. Foreign countries \$2.00 extra, post-paid. **Write today for new catalog of radio bargains.**

CHAS. HOODWIN CO. CHICAGO  
4240 Lincoln Ave., Dept. D.2

## BE YOUR OWN BOSS MAKE BIG PROFITS

**The ELECTRIC CARPENTER**

enables you to make screens, storm sash, porch enclosures, furniture, cabinets, toys, repairs. Substantial, speedy. Ideal for expert craftsmen and amateur. Not a toy. Weight 570 lbs. Power from ordinary light socket.

**Many Start In Spare Time**

In the basement or garage. Easy to operate. Combines Saw Table, Lathe, Mortiser, Shaper, Jointer, Speed Sander (for Disc sanding, polishing, etc.) and an improved 1921 Band Saw that folds over out of the way. 25 separate operations. No job too difficult. The way to bigger earnings and better living. No obligation. Write for **FREE Illustrated Folder and Easy Payment Plan.**

**The AMERICAN FLOORSURFACING MACHINE CO.**  
524 SOUTH ST. CLAIR ST. TOLEDO, OHIO

## KINKADE GARDEN TRACTOR

and Power Lawnmower  
A Practical, Proven Power cultivator for Gardeners, Suburbanites, Truckers, Florists, Nurserymen, Fruit Growers.

**New Low Prices—Easy Terms**  
AMERICAN FARM MACHINE COMPANY  
1058, 33rd Ave. SE. Minneapolis, Minn.

## New Complete "Wonder" Workshop

**\$1830 BUY DIRECT. SAVE 35% TO 60%**

All Without Motors	12" Band Saw ..	\$24.75	\$31.35
	11" Lathe .....	21.00	29.25
	4" to 36" Scroll Saw ..	4.80	13.44
	6" BB Jointer .....	44.00	54.00
	Home Workshop—11" 3 spd. lathe, 7" saw table, 8" scroll saw .....		\$54.00

Write for Circular. **S & B MFG. CO.**  
4611 W. 20th St. CHICAGO, ILL.





## SORE MUSCLES? Stiff Neck?

Stiff muscles tingle with warm, healing blood as soon as you pat on Sloan's Liniment. Blood carries off fatigue poisons that cause muscle-lameness. Pain goes.

Don't put up with stiff neck and sore muscles. Sloan's Liniment costs only 35¢. And *it warms like sunshine*. Drives out that terrible pain. Get a *fresh* bottle today.

## SLOAN'S Liniment

### COACH BUILDING MADE EASY



You can build a beautiful coach model in a few hours. We supply all the parts, cut to fit and ready to put together, of the George Washington coach, the Falls-Ho, or the Deauville coach (famous Western stage) for \$4.95. Full instructions for building included with each kit. Build coaches for pleasure or profit. Models sent C.O.D. plus a few cents postage. Foreign orders must be accompanied by U. S. check or money order.

HISTORICAL COACH MODELS, INC.  
Dept. F. M. 11, 2208 Fairmount Ave., Philadelphia, Pa.

## A NEW HOUSE WIRING MANUAL

PRACTICAL — PLAINLY WRITTEN

BY J. G. WOLBER AND O. K. ROSE  
Cass Technical H. S., Detroit, Mich.

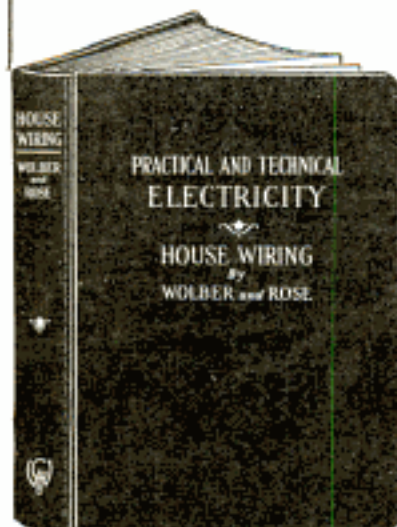

This book is the result of the author's fifteen years of industrial experience and of teaching. The material accumulated during this period of time has been worked over and over until in the author's opinion it was ready for publication.

320 Pages  
662 Illustrations  
Size 7 1/2 x 5 1/2 inches  
Flexible Binding  
Price \$2.50 Postpaid  
Will be sent C. O. D. anywhere in U. S. or possessions.

POPULAR  
MECHANICS  
PRESS  
Room P 4  
200 E. Ontario  
St., Chicago

# THRILLS ADVENTURE COMEDY

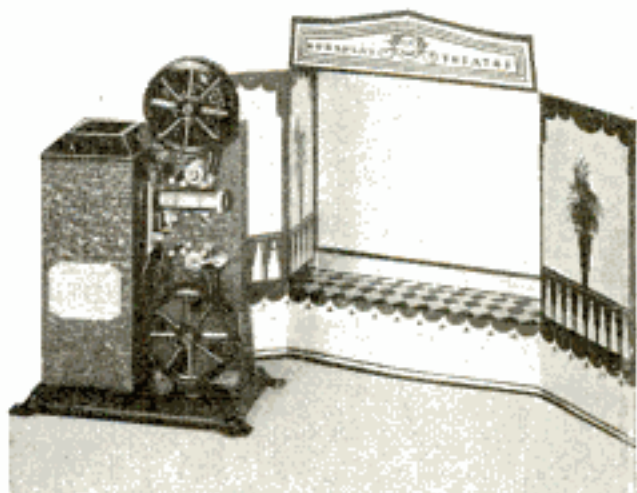

... in this New Eastman movie projector  
that children run themselves

## KODATOY

\$12 COMPLETE

**K**ODATOY, an efficient movie projector made by Eastman for children, is amazingly simple . . . entirely safe. Kodatoy uses 16 mm. safety film—100-foot reels or less . . . shows bright, clear, flickerless movies.

There's a whole catalog of Kodaplay movie films to choose from. Airplane flights; Felix the Cat; Charlie Chaplin; Sports and Westerns. All moderately priced at 30 cents, 60 cents, 90 cents per reel.

Complete outfit—Kodatoy and a miniature theatre with "silvered" screen—costs but \$12. Motor-driven model, \$18.50. Or motor sold separately, \$6.50. Any leading Kodak dealer, toy or department store will show you Kodatoy. Write for interesting folder telling you more about this practical playroom projector.



Eastman Kodak Company, Rochester, New York  
Please send me FREE without obligation the folder describing Kodatoy, the movie projector for children.

Name \_\_\_\_\_  
Street \_\_\_\_\_  
City \_\_\_\_\_

P. M. 4



## ALADDIN PORTABLE ELECTRO-PLATER



**Introductory  
AGENTS  
OFFER**  
\$0.50

### Instantly Applies Real Nickel

Also Electrically Plates Brass, Copper, Silver, Gold, Etc.

With the inexpensive Aladdin outfit you can easily nickel plate the nickel on your car and do a good job of it. The Aladdin outfit is also a home necessity.

#### MAKE BIG PROFITS WITH THE ALADDIN

Whether you are interested in the Aladdin for yourself or should you wish to go into business putting real nickel on autos or doing metal plating in your neighborhood, or if you would like to act as our agent in your territory, write us immediately for free particulars.



**P. J. F. BATENBURG CO.**

DEPT. 200

RACINE, WISCONSIN

#### Send for FREE Catalog

of Genuine Diamonds, Standard Watches, Fine Jewelry and Silverware. Adults Only.

**ROYAL DIAMOND AND WATCH CO.**  
170 Broadway, Dept. 11-R, N. Y. City



**"Been on a  
vacation  
Bill?"**

"No, Jim—I've stopped smoking. Gained six pounds in a week. You know how I used to smoke—a package of cigarettes and a cigar or two a day—it sure had some

hold on me. I tried to stop many times but could only quit for a few days. But I'm through forever now—took a scientific home tobacco treatment—fixed me up in two weeks.

"Wasn't hard on me at all—noticed improvement the first day—I feel like a new man. It didn't interfere with my work—didn't leave any druggish after-effects—the money I saved in the last two weeks has paid for the treatment alone.

"Why don't you take it? It has entirely banished the tobacco habit for many thousands of men like you and me. It has been successfully used for over fifty years and comes to you with a money-back guarantee—it is a doctor's individual prescription that sure fixes you up. Write for full information NOW. No obligation. All correspondence is strictly confidential."

**The Keeley Institute, Dept. A-944, Dwight, Ill.**

Home of the famous "Keeley Treatment for  
Liquor and Drugs." Booklet sent on request.  
Correspondence Strictly Confidential.

Name \_\_\_\_\_  
Address \_\_\_\_\_  
City \_\_\_\_\_

## HERE'S \$\$\$ FOR YOU

The wires are hot with orders of 100 to 1000! Most useful invention in years. A second to demonstrate—a minute to sell.

#### 6-IN-1 FUSE PLUG

"A turn to the right, brings back the light." Think of it! 6 Fuses in one plug. Factories, stores, theatres, homes—all need it. Safe, speedy, convenient, economical and dependable, 100% profit. Big money all or part time.

#### Distributors and Crew Managers

We have openings in exclusive territory for men who can operate in big way. Write for details.

**WRITE NOW!** Start making money right away. Get our proposition. Send 25c for sample and be convinced. But don't delay! Act today!

**6-IN-1 FUSE CO., 801 W. Madison St., Dept. 15, CHICAGO**

## WHY WATCH OTHERS FLY!

#### HEATH PARASOL

Build it for  
**\$199**  
Ready to Fly  
**\$975**



#### HEATH SEA-PLANE PARASOL

Build it for  
**\$228**  
Ready to Fly  
**\$1175**

#### QUICK FACTS

1. 85 miles per hour top speed
2. 400 mile cruising radius
3. Steps within 60 feet after landing
4. 40 miles per gallon of gas
5. Easy to build. Parts shipped in 11 convenient progressive groups
6. First place winner at National Air Races for 3 consecutive years!

Here at last is a plane you can fly—America's most popular sport plane—the famous Heath Parasol—designed for beginners to fly. Easy to build, easy to fly, it affords complete safety at a flying cost less than 1 cent a mile. Build it now from clear detailed plans. No technical training needed. Parts may be purchased in 11 convenient progressive groups. \$12 brings first shipment, 10 cents in stamps or coin brings large illustrated booklet. Write today.

**Heath Aircraft Corporation**  
Dept. P 431, 1721 Sedgwick St.  
CHICAGO, ILLINOIS

## A. C. Electric Plants



ONAN A. C. PLANTS furnish the same current as city service—110 volt, 60 cycle A. C. Operates Radio, Water Systems, Refrigerators, all Household Appliances.

Sizes 500 to 2000 Watts Available from stock. No battery used except to start the engine. Ideal for farms, camps and lake homes.

Also a complete line of D. C. Models.  
**D. W. ONAN & SONS**  
66 Royalston Ave., Minneapolis, Minn.

## AGENTS 500% PROFIT GENUINE GOLD LEAF LETTERS

**S** guaranteed to never tarnish. Anyone can put them on stores and office windows. Enormous demand, large profits. Paul Clark says: Smallest day \$28.70. H. L. Reel made \$920 in two months. Write today for free sample and liberal offer to general agents.  
**METALLIC LETTER CO. 433-B N. Clark St., CHICAGO**

## BUILD MODEL SHIPS OF THE BETTER KIND

We can supply construction sets, semi-finished hulls, flags, steering wheels, blocks, deadeyes, guns, capstans, anchors, life rafts, books, etc., for building fine scale models of the Torpedo Destroyer Preston, Flying Cloud, Constitution, Spanish Galleon, Mississippi Steamboat, Revenue Cutter, Sea, Zulu, Mayflower, Viking, Baltimore clipper and many others. Also special construction sets for racing and boats, power boats, model steam engines, propellers, etc., and fine tools for the model maker. Our large 36 page photographically illustrated ship model booklet contains valuable information and hints for building ship models, in addition to prices, and full description of the above articles. Many people only slightly interested in models, have become greatly enthused upon receiving this booklet. A copy will be mailed postpaid upon receipt of 15c coin ordered.

**MODEL SHIP  
SUPPLY  
COMPANY**  
Dept. E  
Mineola, N. Y.





**SOLDER LIKE A PROFESSIONAL**  
with the **"Junior"**  
Reg. U. S. Pat. Off.



The Highest Quality Iron Ever Offered at the Price

Every radio worker—amateur or professional—needs this iron. A high grade 85-watt tool at a moderate price. Plugs in any current; heats quickly; stays hot! Same features as the famous "Esico" Heavy Duty types used by U. S. Navy and leading radio firms. Replaceable forged copper tip; grade A nickel chrome heating element; heat-insulated handle, dark mahogany. Length 13 3/4 in.; wt. 1 lb. Complete, with 6 ft. cord, \$2.75.

Send to us direct if your dealer can't supply you, we pay parcel post.

Electric Soldering Iron Co., Inc., 137 West 17th St., New York, N. Y.

**AMAZING NEW GUN**  
Men all over the country are turning to this full size automatic high power rifle using round steel shot. Light, Speedy, Sporting arm balance and precision.

TRY THE **BENJAMIN**  
**25 SHOT AUTOMATIC**  
"THE MYSTERY RIFLE"

OUTSHOOTS ALL OTHERS



Companion to the world famous Benjamin Single Shot. Same effective compressed air action with 25 shot automatic feed. 10 to 12 rapid fire shots on one pump ping. Price \$10.00. Benjamin Single Shot Air Rifle \$5.00. Ask your dealer for demonstration or write for details and "BB MAGIC" FREE.

BENJAMIN AIR RIFLE CO., 605 North Broadway, St. Louis, Mo.

**BB MAGIC**

**MAKES A COMPLETE MACHINE SHOP**

**\$1.75** UNITOOL ELECTRIC MOTOR ATTACHMENT without chuck  
**\$2.25** with chuck



Fastens directly on motor shaft, no pulleys or belts necessary. Holds grindstones, buffs, saws, wire scratch brushes, drills, etc. Serves as pulley. Made to fit 1/2, 1-2 and 1-2 in. shafts. State size. Fender spread if resistance accessories order.

United Electric Motor Co., 178 Centre St., Dept. C-14, New York

**GIANT TELESCOPE** \$1.75



5 SECTIONS—3 FT. LONG

See Miles Away! Distant people and objects seem close. Over 3 ft. long, brass bound. Made in Europe. Bbls. of fun. Thousands pleased.

Send No Money! On arrival pay Postman special price, only \$1.75, plus postage. Two for \$3.25. (Or send price and we pay postage.) Satisfaction guaranteed or money back. Send today.

Bargain House, 549 Washington St., Dept. 13, Chicago

**FREE** With Order  
Strong leatherette Carrying Case and Solar Eye Piece to view the sun.

**No. 162 SAFETY ROLL CAN OPENER**  
**LEAVES A SMOOTH EDGE**



Opens all sizes and shapes of cans with standard rims. Impossible to cut hand. Polished and double plated. Genuine tempered tool steel cutting blade. Save the juices with a SAFETY ROLL. MONEY BACK IF NOT PLEASED. Write for our FREE WHOLESALE catalog, showing over 600 fast sellers.

Sells for 25c — Doz. 98c  
Sample 15c — Gross \$10.90

**SPORS IMPT. CO.**  
231 Elm St. Lesueur Center, Minn.



## "I had to make more money—for her"

"THREE weeks after I met Ann we were engaged. It was when we began talking about rents and furniture and such things that I woke up.

"I'd been drifting along in a routine office job for years. I knew I didn't deserve a raise. And yet I had to make more money—a lot of it—and quick. It was Ann herself who suggested the International Correspondence Schools. She believed in me so thoroughly that she made me believe in myself, and I started studying the I. C. S. course in Accounting in my spare time.

"That was a year and a half ago. We've been married six months and I just got my third promotion. I'm head of the cost accounting department now. My I. C. S. course was the finest investment I ever made."

Are you one of the thousands of young men who need a bigger salary and a better job? In an hour a day of your spare time you can secure the training that will bring you advancement. Without cost, without obligation, find out what the I. C. S. can do for you. Mark and mail this coupon now!

### INTERNATIONAL CORRESPONDENCE SCHOOLS

"The Universal University"

Box 5539-G, Scranton, Penna.

Without cost or obligation, please send me a copy of your booklet, "Who Wins and Why," and full particulars about the subject before which I have marked X:

#### TECHNICAL AND INDUSTRIAL COURSES

- |  |  |
|--|--|
| <input type="checkbox"/> Architect   | <input type="checkbox"/> Automobile Mechanic                                 |
| <input type="checkbox"/> Architectural Draftsman                             | <input type="checkbox"/> Plumbing <input type="checkbox"/> Steam Fitting     |
| <input type="checkbox"/> Building Estimating                                 | <input type="checkbox"/> Heating <input type="checkbox"/> Ventilation        |
| <input type="checkbox"/> Wood Millworking                                    | <input type="checkbox"/> Sheet Metal Worker                                  |
| <input type="checkbox"/> Contractor and Builder                              | <input type="checkbox"/> Steam Engineer                                      |
| <input type="checkbox"/> Structural Draftsman                                | <input type="checkbox"/> Steam Electric Engineer                             |
| <input type="checkbox"/> Structural Engineer                                 | <input type="checkbox"/> Civil Engineer                                      |
| <input type="checkbox"/> Electric Wiring                                     | <input type="checkbox"/> Surveying and Mapping                               |
| <input type="checkbox"/> Electrical Engineer                                 | <input type="checkbox"/> Refrigeration                                       |
| <input type="checkbox"/> Electric Lighting                                   | <input type="checkbox"/> R. R. Locomotives                                   |
| <input type="checkbox"/> Welding, Electric and Gas                           | <input type="checkbox"/> R. R. Section Foreman                               |
| <input type="checkbox"/> Reading Shop Blueprints                             | <input type="checkbox"/> R. R. Bridge and Building Foreman                   |
| <input type="checkbox"/> Telegraph Engineer                                  | <input type="checkbox"/> Air Brakes <input type="checkbox"/> Train Operation |
| <input type="checkbox"/> Telephone Work                                      | <input type="checkbox"/> Highway Engineering                                 |
| <input type="checkbox"/> Mechanical Engineer                                 | <input type="checkbox"/> Chemistry <input type="checkbox"/> Pharmacy         |
| <input type="checkbox"/> Mechanical Draftsman                                | <input type="checkbox"/> Coal Mining Engineer                                |
| <input type="checkbox"/> Machinist <input type="checkbox"/> Toolmaker        | <input type="checkbox"/> Navigation <input type="checkbox"/> Boilermaker     |
| <input type="checkbox"/> Patternmaker  | <input type="checkbox"/> Textile Overseer or Supt.                           |
| <input type="checkbox"/> Pipefitter <input type="checkbox"/> Tinsmith        | <input type="checkbox"/> Cotton Manufacturing                                |
| <input type="checkbox"/> Bridge Engineer                                     | <input type="checkbox"/> Woolen Manufacturing                                |
| <input type="checkbox"/> Bridge and Building Foreman                         | <input type="checkbox"/> Agriculture <input type="checkbox"/> Fruit Growing  |
| <input type="checkbox"/> Gas Engines <input type="checkbox"/> Diesel Engines | <input type="checkbox"/> Poultry Farming <input type="checkbox"/> Radio      |
| <input type="checkbox"/> Aviation Engines                                    | <input type="checkbox"/> Marine Engineer                                     |

#### BUSINESS TRAINING COURSES

- |   |  |
|---|--|
| <input type="checkbox"/> Business Management                                  | <input type="checkbox"/> Business Correspondence                             |
| <input type="checkbox"/> Office Management                                    | <input type="checkbox"/> Lettering Show Cards <input type="checkbox"/> Signs |
| <input type="checkbox"/> Industrial Management                                | <input type="checkbox"/> Stenography and Typing                              |
| <input type="checkbox"/> Personnel Management                                 | <input type="checkbox"/> Complete Commercial                                 |
| <input type="checkbox"/> Traffic Management                                   | <input type="checkbox"/> Civil Service <input type="checkbox"/> Mail Carrier |
| <input type="checkbox"/> Accountancy <input type="checkbox"/> Cost Accountant | <input type="checkbox"/> Railway Mail Clerk                                  |
| <input type="checkbox"/> C. P. Accountant                                     | <input type="checkbox"/> Grade School Subjects                               |
| <input type="checkbox"/> Bookkeeping  | <input type="checkbox"/> High School Subjects                                |
| <input type="checkbox"/> Secretarial Work                                     | <input type="checkbox"/> College Preparatory                                 |
| <input type="checkbox"/> Spanish <input type="checkbox"/> French              | <input type="checkbox"/> Illustrating <input type="checkbox"/> Cartooning    |
| <input type="checkbox"/> Salesmanship <input type="checkbox"/> Advertising    | <input type="checkbox"/> Lumber Dealer                                       |

Name..... Age.....

Address.....

City..... State.....

Occupation.....

If you reside in Canada, send this coupon to the International Correspondence Schools Canadian, Limited, Montreal, Canada





The eyes of Loretta Young, lovely 18 year old star of First National Pictures

## end eye strain this quick way

When reading or shop or office work has left you with tired, aching, blood-shot eyes, simply apply a few drops of harmless *Murine*. Almost immediately they'll feel fresh and rested; soon the bloodshot condition will disappear. Also use *Murine* after motoring and outdoor sports to offset eye irritation. 60 applications cost but 60c at drug and department stores everywhere. Try it soon!

# MURINE

FOR YOUR EYES

## NEW IDEAS for the Home Woodworker

Contains 16 projects by W. W. Klenke—also describes latest machines and their uses.

### THE DRIVER MANUAL

A 48-page book crammed full of useful information on how to set up an electric woodworking outfit at a fraction of the cost ordinarily required. Reliable data on use of tools; choice of woods; glueing; staining, finishing. 24 joints shown and described. How to get the most out of the lathe, jig saw, planer, belt sander, spindle shaper, drill press, flexible shaft and bench saw.

25¢  
EACH

**Jig Saw Cut-Outs** Large 4-color book devoted entirely to Jig Saw work. Full of ideas and designs for increasing utility of this creative machine. Complete details for making model yachts by unique "Driver" telescoping method. Plans for making silhouettes, book-ends, door stops, toys, weather-vanes, lawn ornaments, etc.

WALKER-TURNER CO., Inc., 70 York St., Jersey City, N. J.

Please send me the following:

- The DRIVER MANUAL, 25c.  
 JIG SAW CUTOUTS, 25c.

Name.....  
Street.....  
City..... State.....

## FOR YOUR HOME WORKSHOP

If you like to make things, you will enjoy this new book just published by Popular Mechanics entitled



### Make It Yourself

The home mechanic, whether young or old, amateur or professional, will take pride and delight in making many of the things described therein.

Both father and son will find fascination and an association of interest in making useful and ornamental articles for mother to admire upon their completion.

### 900 Articles All Different

There are attractive ship models, a great variety of toys that operate themselves by means of an ingenious application of mechanical principles, novel amusement devices for indoors and outdoors, for both water and land, unique designs in furniture for children, scores of useful appliances for the home, things of beauty and utility for lawn and garden, etc.

Special articles instruct the amateur mechanic in the care and use of tools, special tools for special purposes, how to read and use plans, how to solder, the making of a handy work bench, cuts, joints and methods in woodworking, automobile repairing, installing radio equipment, house wiring, fixture hanging, working in glass, leather, metal, celluloid, lathe work, utilizing parts of old machines to make equipment that would be expensive to buy, etc.

480 Pages—823 Illustrations.

Size 7x10x1 1/4 in. Cloth Binding

Price \$3.00

Mailed Postpaid upon receipt of price anywhere in the world. If you reside in U. S., Hawaii, Porto Rico, Alaska or Mexico, we will send the book by mail C. O. D. if you prefer.

POPULAR MECHANICS PRESS (ROOM P-4)  
200 East Ontario St. Chicago, Ill.

## What Do You Do When You Cannot Find the Book You Want ?

Don't give up in despair. Send for a copy of the unique catalog published by Popular Mechanics Press. It contains 5000 books listed alphabetically under 2000 main subjects and sub-headings—literally from A to Z—Abrasive Manufacture to Zoologist and everything in between.

### FREE UPON REQUEST

Send for your copy today

POPULAR MECHANICS PRESS  
200 E. Ontario Street, CHICAGO

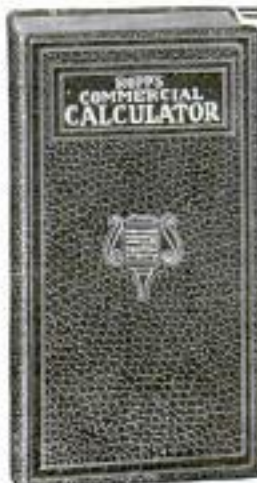

## Mathematics Made Easy by ROPP'S CALCULATOR AND SHORT-CUT ARITHMETIC

Shows the Answer as Quickly as a Watch shows the Time to all Problems likely to occur in the Office, Store, Shop, Bank, Farm, or Factory.

Over 2,000,000 Sold

Explains and simplifies every principle in Arithmetic, Mechanics, and Mensuration.

### PRICES POSTPAID

Desk Size, Flexible Keratol Binding, \$2.00  
Pocket Size, Art Leather Binding, \$1.00  
Pocket Size, Cloth Binding, \$0.50

POPULAR MECHANICS PRESS  
Room P4 200 E. Ontario St. CHICAGO



# Inventor Produces Mysterious "Gas Bug"

*That Will Save  
Gasoline*

## And do 44 Other Amazing Things

Here's a creation so utterly amazing in its action and results that it sounds almost like fiction. Yet it exists as a scientific fact—already tested by engineering authorities and on thousands of cars. It has been called "the strangest acting auto discovery under the sun," for it puzzles even shrewd minds. A mysterious discovery called "Gas Bug"—an uncanny "miracle" fluid that "crawls" and "climbs" as though filled with invisible life. Not a gasoline dope, carburetor device, electrical apparatus or other "contraption." No wonder agents are offered such big money-making possibilities thru our plan of giving car owners Free Sample Demonstrations that do a vital engine job absolutely Free for owners—a job any mechanic would charge up to \$10 to do.

### More Power—Speed—Pep

The 4 vital engine improvements that motordom has always striven for may be actually realized—increased gas mileage, reduction of the many engine evils that cost motorists millions, increased engine efficiency and many more miles of engine service. Saves money in gas, engine repairs, upkeep, wear and tear, valve grinding, carbon removing and many other ways. In 3 minutes you see amazing results—more power, more speed, more pep, smoother running engine. Loosens carbon. Valves operate snappier, faster, more accurately. Winter starting is easier. Missing, bucking, carbon knocks and spark plug troubles diminish. Makes these and many other vital engine improvements.

### NO CANVASSING For Prospects

This queer discovery has proved so sensational in results and offers agents such big, quick money possibilities that no one less than the United States Motor Industries itself has taken it over and backs it with its own warrantees. Now, at last, the dream of nearly every agent has come true! A plan to make big money quick without personal "cold turkey" canvassing for prospects—yes, without even leaving your house. Stay at home and let the mails get the prospects for you. The newest, liveliest plan we have heard of in years. We actually start you in a "Mail Order Business" of your own, at home, in full or spare time—on our warrantee given to protect you against money loss. You mail out free sample demonstration offers to motorists in your territory. Then watch your profits begin to roll in—up to \$35 a day right from the start. We furnish you with these samples, powerful Circulars, return Post Cards with your name imprinted, Envelopes, Order Blanks—all the mail order literature needed to start this sensational plan—all without extra charge to you. So wonderful are the results of "Gas Bug" that we make it possible for agents to place it



with motorists on 30 days' trial without risk to them. No wonder "Gas Bug" offers agents such a big-money opportunity.

### Cash Pay for Merely Demonstrating

Every car, truck and tractor owner in the country needs this amazing discovery so quick that we do the unheard-of to get you started at once. On another daring, startling offer we actually pay you cash for merely demonstrating and giving away the samples to motorists free that do a vital engine job worth up to \$10 or \$12 FREE. No need to make sales to get this pay. But that is not all we do—we even pay you an extra cash forfeit if you don't satisfy yourself that "Gas Bug" offers you up to \$35 a day.

Now Make up to  
**\$35 a Day**

Without Leaving  
Your House For  
Prospects. New  
Plan puts you in a  
Mail Order Business  
of Your Own  
at Home

### \$100.00 REWARD

We do as we promise! We will pay \$100.00 cash reward to any worthy charity if anyone can show that we do not fulfill every offer we make to our agents.

### SAMPLE OFFER

### \$1.00 Cash Pay for Testing It

So that you can test the astounding merits of this amazing discovery and to start you quick as our big money making agent, we will send you our generous introductory offer of a complete "Gas Bug" outfit for your own car without risk to you. Just rush coupon. Send no money. Nothing will be sent C. O. D. If "Gas Bug" doesn't do everything we claim, we will actually pay you a cash bonus for trying it. We expect this sensational announcement to bring thousands of applications for these big money openings. So rush coupon. United States Motor Industries, Inc., 311 North Desplaines St., Dept. 64, Chicago, Illinois.

United States Motor Industries, Inc.,  
Accessory Division,  
311 North Desplaines St., Dept. 64, Chicago, Illinois.

Without cost or obligation to me, rush generous introductory sample offer: offer of \$1.00 Cash Bonus for testing it; plus that lets me start in a "Mail Order Business" of my own at home; Warrantee of cash pay for merely demonstrating, and Details of Cash Bonus if your plan doesn't show me \$35 a day possibilities. This is not an order. Send nothing C. O. D.

Name.....

Address.....

City.....State.....



**AGENTS - DISTRIBUTORS**  
An Amazing New Opportunity  
EARN up to \$200 WEEKLY

# PYROIL

Heat-proof  
Liquified Graphite

A highly concentrated lubricant for every type of internal combustion motor.

## THE MOST AMAZING MOTOR PRODUCT EVER DEVELOPED

Pyroil, a new and astounding lubricating discovery has revolutionized the motor world. LIQUEFIED GRAPHITE—the greatest known enemy of heat and friction now made possible to use in any internal combustion motor!

### POSITIVELY

STOPS WEAR—STOPS NOISE—CUTS REPAIR BILLS, DOUBLES TRIPLES LIFE OF ORDINARY CRANKCASE OIL. REDUCES GAS CONSUMPTION UP TO 20% TO 40%. WITHSTANDS HEAT UP TO 2500° F. CANNOT BURN—CANNOT WASH OFF BEARINGS. PASSES ANY FILTER—EVEN CHAMOIS SKIN. GIVES INSTANT STARTING AT 40° BELOW ZERO. ENJOYS PATENTED PROTECTION—IS ADOPTED BY NATIONWIDE FLEET OPERATORS—IS GUARANTEED 100% SATISFACTORY OR MONEY BACK. SAVES 10 TIMES ITS SMALL COST.

Guaranteed not to harm the finest motor mechanism. Used and endorsed by the country's leading motor industries.

**FREE**  
Testimonials—Endorsements—Proven Facts

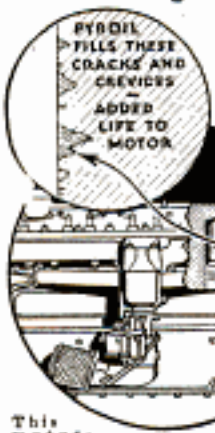

This motor, when conditioned with PYROIL, can run 20 to 25 miles at 25 mi. per hr. with all oil drained from crankcase—with no harm to motor!

Only 1 pt. of PYROIL to 8 qts. of oil.

You can assess a fortune with exclusive sales rights in your territory. Write at once for details of record-breaking performance absolutely unheard of before. DON'T DELAY. WRITE AT ONCE.

**THE PYROIL COMPANY**

541 Pyroil Bldg., La Crosse, Wisconsin

I CAN'T TALK  
BUT  
YOU CAN  
MAKE ME SAY  
ANYTHING  
YOU WANT

## MEN! MEN! MEN!

**YOUR CHANCE TO CLEAN UP!**  
Make \$35.00 to \$100.00 weekly selling Magic Changeable Signs to every class of business. Made in 3 attractive colors, sizes 11x14" and 14x22", a large number of letters and figures FREE with each sign.

### Send Now for Special Offer

3 sample signs..... \$1.00  
12 signs assorted..... 3.90  
Retail price \$1.00 and \$1.50 each, you make over 300% profit! ACT QUICK.

Modern Sign Works M-816 N. WELLS STREET, CHICAGO

SEND FOR **FREE RADIO CATALOG** **LOWEST PRICES!**

**COAST TO COAST RADIO CORPORATION**

HEADQUARTERS  
ALL RADIO REPLACEMENT PARTS

142 P. LIBERTY ST. NEW YORK

# 100 Shaves from EACH blade

The Master-Hone puts a hair-splitting edge on the dullest safety razor blade—ANY make—in 5 seconds. Many average 100 shaves per blade. Honing gives barbers thousands of smooth, clean shaves from a single straight-edge blade. This scientifically beveled hone makes each 10¢ blade give \$1 to \$3 worth of service. MONEY REFUNDED if not THOROUGHLY satisfied.



## \$30 a day

Agents set as high as \$30 in a single day.

Mr. Nor sold 40 during noon hour at a 512-waikoa factory—two weeks later 50 more men bought at noon. R. Blosser sold 1,000 one week from Detroit alone. \$40 to \$115 a week in constant profit selling blades and others. Earn \$25 to \$60 a week in spare time. The Master-Hone SELLS ITSELF. Men buy on sight—no salesmanship required. Their friends come to you. 100% PROFIT AND BETTER when sold for only 20¢.

**Yours FREE** We will send you a Master-Hone absolutely free for your sample WITH FIRST ORDER of 12 for \$3; or send 50¢ for 1 or \$1 for 3, POSTPAID. Or you may send no money and pay postman plus postal charges. But SEND TODAY and start enjoying these easy profits.

Wisconsin Abrasive Co., Dept. 6094, Station A, Milwaukee, Wis.

## A Real 6" Bench Saw....

Heavy cast metal TABLE, 8" x 12", rigid and strong. Heavy duty 3/8" bearings with means for adjustment. Reinforced steel base on skid for true running. Real "V" pulley. Table instantly removable to use STAND for grinding, buffing or polishing wheels, or for drum or disc sander. Oil well lubrication. Shipped by express. Money back if not satisfied.

Send for free catalog on this and other C-A Equipment

**C-A MANUFACTURING CO.**  
213 E. South St., Indianapolis, Ind.

Saw Table Stand & Pulley \$3

## ATTRACTIVE NEW BINDERS

For POPULAR MECHANICS MAGAZINE

Your choice of colors; blue, green, brown, red or black in beautiful and durable art binders at \$1.25 postpaid. Your name in gold on front cover for 25 cents extra. Address

POPULAR MECHANICS CO., 200 E. Ontario St., CHICAGO

## 366 SHORT CUTS FOR CARPENTRY WORK

Popular Mechanics Carpenter's Handbook is filled with illustrated short cuts and improved methods for doing all sorts of carpentry work and odd jobs. Each idea was discovered by a practical man in the course of his work. Each idea is practical, a time-saver, a money-saver. The 229 Pictures are so clear that in many cases, the picture itself explains the short cut. This new book is a book for professional carpenters, for amateurs, and for boys. It is destined to be just as popular as the many other handbooks published in recent months. This new book is beautifully bound in golden brown cloth, is a handy size, and sells for the remarkably low price of \$1.50.

**Send No Money** Simply write a postal saying that you want Popular Mechanics Carpenter's Handbook. It will be sent C. O. D. and you may pay the postman the price of the book and the few cents postage when he delivers the book to you. If you live outside the U. S. or if you are not at home when the postman delivers your mail, send \$1.50 with your order.

POPULAR MECHANICS PRESS  
Room 704, Popular Mechanics Bldg., 200 E. Ontario Street, Chicago, Ill.

# A CLIPPER SHIP MODEL for only \$4.00



## The Famous FLYING CLOUD

All parts, including sails, cut to fit and easily put together by following detailed instructions and numbered diagrams. Send for FREE illustrated catalog of many other models. Santa Maria, Mayflower or La Pinta \$4.50; Constitution \$6.00. Coach models and covered wagon \$4.50. Sent by parcel post C. O. D. to U. S. or Canada.

"YOU CAN BUILD ONE"

**MINIATURE SHIP MODELS, INC.**  
Dept. RT, Perkasie, Penna.

Canadian Branch,  
90 KING STREET WEST, TORONTO  
Canadian prices, duty paid,  
slightly higher.



# Press the Button and Make \$130<sup>00</sup> A WEEK

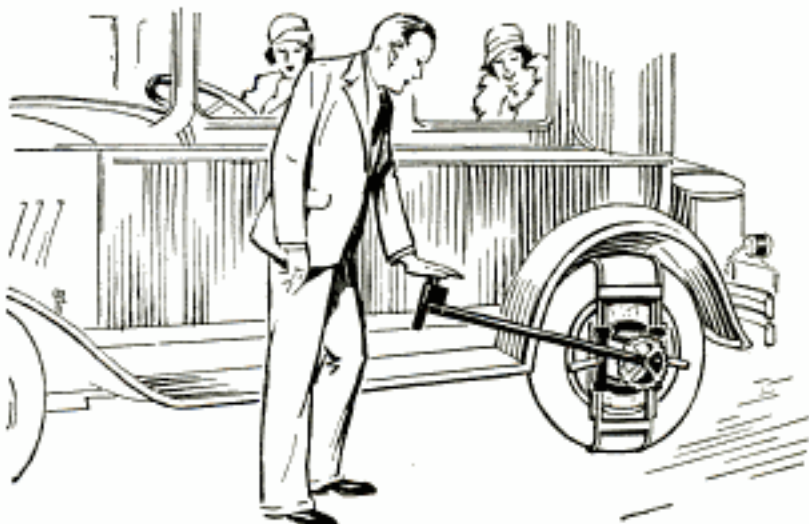

## No experience necessary— Only a few dollars start you!

Here's a new way to make money and make it fast. Be a Brake Specialist. Get away from the over-crowded, poorly paid trades and professions that offer no future. You can simply coin money—from the first day. And profits pile up still faster as the word gets around that you're the Brake Expert in your town, that your tests are made quickly and are dependable.

### Be Your Own Boss

Make the big money for yourself! Why slave for the other fellow and get nothing out of it? There's no sense in working yourself to death for \$30 a week when you can bank \$100 additional each week in this fast growing business.

#### Easy To Learn

No wonder men make \$130 a week and more when the job is so easy to learn—and the testing so easy to do. The Badger Brake Tester is simple. Anyone with or without mechanical knowledge can learn in no time. You'll scarcely believe your eyes when you see your bank balance swelling week by week. But there's a reason for your wonderful income from such light, pleasant work.

#### Millions Want Brakes Tested

Car owners all over the country today are looking for men with the equipment and experience to test their brakes and adjust them. Car owners know that serious injuries, loss of life and cash damages are the penalties for driving with brakes that are not equalized—brakes that fail in an emergency. No wonder men who buy the Badger Brake Tester pay for it and stack up a good profit the first week.

#### Brake Specialists Needed Everywhere

The day you get your Badger Brake Tester you are set up in a fast money-making profession. No matter where you live, your customers are ready and waiting for you. The demand for your services is a natural as the demand for gas and oil. And the profits are big and continuous. Because the public wants brake tests by the Badger—it's known as the tester approved by the large car manufacturers. It's sure and dependable.

#### GENEROUS TERMS

##### Your Badger Pays for Itself

The cost of the Badger Brake Tester is so small—and the easy payment plan so generous—that

your Badger quickly pays for itself and earns you an income in addition. Some men have paid for their Badgers in a week or ten days. It's so easy to get started. And you are fully protected by a

#### Money Back Guarantee

The Badger Brake Tester can be and is fully guaranteed because it is such a wonderful mechanism and a marvelous money maker. We gladly give you this additional assurance because we know what the Badger can do. Guarantee fully explained in our literature—write NOW.

#### Get Going—Coupon Brings You Special Offer

Don't delay. Just write your name and address in the coupon below—tear it off and mail to us. The special offer, full particulars regarding the construction and operation of the Badger Brake Tester will go forward to you immediately.

Let us tell you why you can easily earn \$130 a week and more, and not work hard either. This is the time to get started. Car owners are having their brakes tested—getting ready for spring and summer driving. Get going. Address

#### BADGER BRAKE TESTER MFG. CO.

301 Baker Building, RACINE, WISCONSIN

Badger Brake Tester Mfg. Co.,  
301 Baker Building, Racine, Wis.

Please send me complete information about Brake Testing—and why the Badger will earn \$130 a week. Also all facts about Easy Payments and Guarantee.

Name.....

Street and Number.....

City.....

State.....

### BADGER BRAKE TESTER

Works Faster Than  
Big \$500-\$1,200  
Machines—Yet  
Cost But a Trifle

Of course you make big money with the Badger Brake Tester—why wouldn't you when your investment is only a few dollars—yet you make your tests faster than the big, cumbersome machines costing up to \$1,200.

Garages write us they are replacing their big testing machines with Badgers—because they test brakes accurately—in less time—with less work than the costly, clumsy, complicated machines. And the Badger takes up no space on the garage floor. You can make test anywhere—inside or at curb.



## World's Lowest Priced Quality Homes

Price includes all lumber readi-cut, mill-work, windows, doors, interior woodwork, hardware, roofing, glass, nails, paints, varnish, stains. All material shipped in a sealed box car. We pay freight.



4 to 9 Room Homes

**\$366 to \$2392**  
WE PAY FREIGHT

## Summer Cottages

Buy direct from Mill at Wholesale. Aladdin's famous Read-Cut System saves 18% lumber waste and 30% labor cost.



Summer Cottages

**\$231 to \$1495**  
WE PAY FREIGHT

**Garages** Complete instructions and drawings enable you to build an Aladdin yourself if you are handy with tools.

**FREE Catalog**  
Address nearest office. No obligation. Ask for Free Catalog No.

**THE ALADDIN CO.**  
Bay City, Mich., Portland, Ore.

# ALADDIN



Garages

**\$92 to \$307**  
WE PAY FREIGHT

World's Oldest and Largest Exclusive Manufacturers of Read-Cut Homes

## A Real Flexible Shaft <sup>only</sup> \$285 COMPLETE PREPAID WITHOUT MOTOR



**A FLEXIBLE SHAFT YOU HAVE ALWAYS WANTED**  
At an unheard of price, has a thousand uses for Grinding, Polishing, and Buffing. Flexible Shaft complete with 1-4" sewed buff, 1-4" loose buff, and 1-4" wire scratch wheel. Motor shaft coupling can be furnished from 3/4" to 1 1/2". State motor shaft size. \$1 Deposit on C. O. D. orders.  
**FLEXO SALES CO.** 164 N. Desplains St. Chicago, Ill.

## Amazing Discovery Resoles Shoes-9¢



**PAYS AGENTS UP TO \$90 WEEKLY**

This amazing new shoe resoling discovery — **SAVASOLE** — makes old shoes good as new and saves many dollars in shoe repair bills. A scientific substance made of ingredients imported from those continents. Fills in all the cracks and breaks. Looks like genuine leather — wears like iron. Also rebuilds worn down heels. Takes only a minute to apply with my old hair-dress hand and smooth & convenient. Parents will love it for children's shoes. Agents earning up to \$90 weekly supplying thousands of established customers. Fastest selling and most profitable specialty in America. **SAMPLE FREE**

Many cheap imitations have recently been put on the market. But none can delight your customers and pay you handsome profits like the genuine, guaranteed **SAVASOLE**. Without experience and starting in spare time you too can enjoy profits like Lewis, of Kansas, who made \$300.00 his first morning. And Berkey, of Chicago, who makes \$125.00 every week. See up your territory. Write immediately for details and **FREE SAMPLES**. WE'LL PAY YOU 60¢ CASH TO TEST **SAVASOLE**

The Perfect Mfg. Co., Dept. M-505, Cincinnati, O.



## A NEW SHAPER BALL BEARING REVERSIBLE ROTATION CONSTANT SPEED

Ask for Complete Details and Information  
We have a complete line of Bench Type Woodworking Machinery. Catalog Free.  
**HESTON & ANDERSON**  
604 Stone St. Fairfield, Iowa

## A CLIPPER SHIP FOR \$4.50

**WITH ELECTRIC LIGHTS** 27 inches long  
We supply all the parts, cut and numbered ready to put together. Instructions show full details how each numbered part fits into the other. A few hours of pleasant pastime and you will have a beautiful and valuable model. We also have parts for the Santa Maria, La Plata, Mayflower, and Flying Cloud at \$4.50 each. Constitution (Old Ironsides), \$5.95. Spanish Galleon with electric lights, \$3.95. Flying Cloud with electric lights, \$4.50. We also have kits for coasting around; Deadwood Steer, Tally Ho, George Washington's private coach, Despatch to London. Princeton in Philadelphia, the postage. U. S. money order or check must accompany all foreign orders.  
**C. J. BIERBOWER, DEPT. P. M.**  
3216 Baring Street Philadelphia, Pa.  
Originator of Build-your-own-ship-models

**LEARN TO PAINT SIGNS and SHOW CARDS**

We quickly teach you by mail or at school, in spare time. High demand! Big future, interesting work. Oldest, foremost school. **EARN \$50 TO \$200 WEEKLY**

Otto Wiegand, Md., home-study graduate, made \$12,000 from his business in one year. John Vassos, N. Y., sets \$35 for a show card. Crawford, W. O., writes: "Earned \$290 while taking course." Write for complete information.

**DETROIT SCHOOL OF LETTERING**  
150 Simson Ave. Est. 1899 DETROIT, MICH.

**FREE "Book of Facts"**  
Write For It

Let us recommend the best books to study on any subject. Popular Mechanics Press, Chicago, Illinois.

## AUTO REPAIRMEN EARN GREATER PROFITS

Get your share of the big money being spent on automobile upkeep.

Put improved time, labor and money-saving ideas to work in your shop to-day. Take advantage of our special bargain offer and secure 3 valuable kink books at a reduced price.

1. 334 Valuable Discoveries made by auto mechanics in our **Automobile Repairman's Handbook**. 337 Illustrations.

2. 301 Ways to use drills, drill presses, taps and dies more effectively in our **Drilling and Thread Cutting Handbook**. 298 Illustrations.

3. 259 Kinks furnished by the most expert Lathe Operators in our **Lathe Handbook**. 212 Illustrations.

**Special Offer**—These 3 books (regular price 50 cents each, \$1.50 value) are offered for a limited time for only 98 cents plus postage. Pay postman C. O. D. when he delivers or if outside U.S. send 98 cents and 15 cents extra for postage.

**POPULAR MECHANICS PRESS**  
Room P4  
200 E. Ontario St. CHICAGO

Copyrighted material



## Stories of Stars who were not "Born" but "Made." No. 11

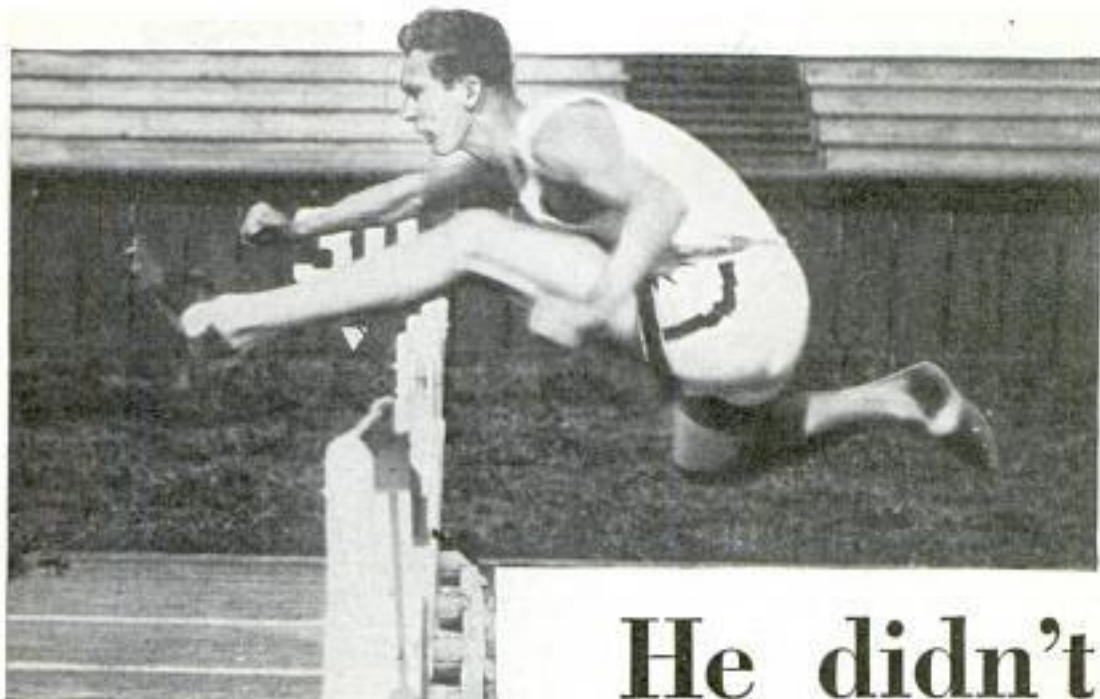

# He didn't stumble in the Olympics

"All out for the high hurdles." A tall, gangling freshman knelt nervously at the starting line. The gun cracked. He sped away.

But he ran awkwardly. As he neared the first hurdle, he stumbled. The hurdle came up to meet him. With one last clumsy effort he leaped *through*, not *over* it and fell sprawling in the cinders.

Yet, three years later, on another track in another country, this same boy scored for the

United States in the Olympic games!

He *made* himself a star because he *trained* to become a star. He taught himself what every star player must know — how to *handle himself well*. The secret of it is *footwork*. Train yourself in footwork. Star players do. And here's something they've discovered: there's just one best shoe for developing footwork—Keds —the Shoe of Champions.

Keds' safety soles of specially compounded rubber give you a grip as sure as four-wheel brakes. Keds' tough canvas tops are built for complete protection against painful twists and sprains. And Keds' insoles keep your feet comfortable and cool.

The best shoe dealers in your town carry a complete line of Keds. Ask for Keds by name and look for the name "Keds" on every pair you buy.



**Keds "Gladiator"**—A famous Keds model with many new improvements. Outsoles of red and black, uppers of suntan or white duck and snug supporting stays.

United States  Rubber Company

Keds sell for \$1.00, \$1.25, \$1.50, \$1.75 and up to \$4.00. The more you pay, the more you get — but full value whatever you spend.

Footwork Builds Stars

# Keds

REG. U. S. PAT. OFF.

The Shoe of Champions



**Keds "Holdfast"**—This popular Keds model gives excellent service for low price. Comes with white or suntan uppers, and black outsoles of new "basket-weave" design.



**MOTOR DRIVE**      **SMOOTH OPERATION**

**FEED ROD**      **EASY PAYMENT**

**GEARED HEAD**

**5 POINTS**  
about the **REGAL**

The Regal passes the LeBlond precision tests and carries the LeBlond guarantee tag.

The Regal shown here is 10" (18" between centers). It sells for \$398.00, F. O. B. factory. Down payment is \$79.60. Balance in monthly payments of \$27.86.

**\$398**  
F. O. B.  
Factory

These five points alone bring you a profit maker that may be purchased on an easy payment plan. A splendid opportunity for the hobbyist, student, experimenter, garage owner, or service shop proprietor to own a modern engine lathe with the precision, accuracy and utility of a high-priced tool.

It has an eight-speed selective geared headstock that makes shifting easy, and there are no overhead belts or pulleys to cause trouble.

Reversing type G. E. motor mounted on leg to avoid headstock vibration. Vee belt motor drive. Feed rod to take the wear off the lead screw. Normalized, heat-treated and hardened gears, with final drive through helical gears. Heavy bed reinforced for greater rigidity. Large and small

face plates, small driving plate, steady rest, graduated compound rest, tool post, collar and wedge, taper spindle sleeve, lag screws and washers, foundation plan, centers and necessary wrenches.

The Regal is built for safety, simplicity, precision and accuracy. Simply plug into the electric socket. Speed changes can be made very quickly. The Regal is made in five sizes from 10" to 18". Prices range from \$398.00 to \$1144.00. Mail the coupon.

## The R.K. LEBLOND Machine Tool Co.

### CINCINNATI, OHIO, U.S.A.



THE R. K. LEBLOND MACHINE TOOL CO.,  
102 Regal Division, Cincinnati, Ohio.  
Send me full details of the Regal Line of LeBlond Lathes.

Name.....  
Address.....  
City..... State.....



# 450 MILES in a gallon of gas

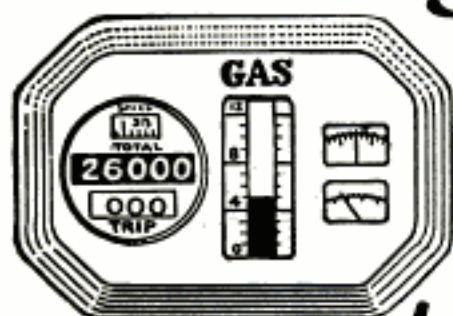

*startling  
statement  
of famous  
Automotive Engineers*

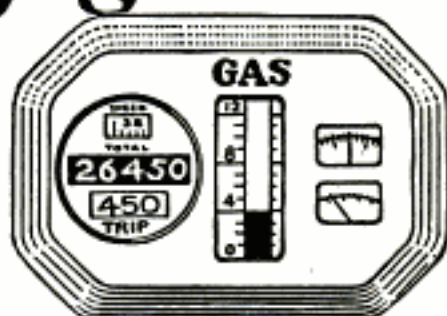

How to increase gasoline mileage has been a problem that Automotive Engineers have been trying for years to solve. Recently a world famous engineer made the statement that the energy produced by burning a gallon of gasoline would run an auto a distance of 450 miles. Other well known authorities go on record as saying that eventually it may be possible to get over four times as much out of gasoline as in the past.

## Amazing Whirlwind Device Saving Millions of Gallons of Gas for Auto Owners

The Whirlwind Carbureting device embodies scientific features which conserves part of the gasoline that formerly went to waste.

Letters coming into the office tell of record mileages resulting in amazing gas savings. Low gasoline mileage is reported on practically every make of car. Greater power and smoother running motors are also noticed by users. The cost of the Whirlwind is so little that, basing its gas saving features even on the most modest reports, it would pay for itself almost immediately and then save many, many dollars for its owner by reducing gasoline consumption.

Car owners all over the world are saving money every day with the Whirlwind, besides having better operating motors. Think what this means on your own car. Figure up your savings—enough for a radio—a bank account—added pleasures. Why let the Oil Companies profit by your waste? Find out about this amazing little device that will pay for itself every few weeks in gas saving alone.

### FITS ALL CARS

In just a few minutes the Whirlwind can be installed on any make of car, truck or tractor. It's actually less work than changing your oil or putting water in the battery. No drilling, tapping or changes of any kind necessary. It is guaranteed to work perfectly on any make of car, truck or tractor, large or small, new model or old model. The more you drive the more you will save.

### SALESMEN and DISTRIBUTORS WANTED To Make Up To \$100.00 a Week and More

Whirlwind men are making big profits supplying this fast-selling device that car owners cannot afford to be without. Good territory is still open. Free sample offer to workers. Full particulars sent on request. Just check the coupon.

**WHIRLWIND MANUFACTURING CO.**  
Dept. 510-A, Station C. Milwaukee, Wis.

### GUARANTEE

No matter what kind of a car you have—no matter how big a gas eater it is—the Whirlwind will save you money. We absolutely guarantee that the Whirlwind will more than save its cost in gasoline alone within thirty days, or the trial will cost you nothing. We invite you to test it at our risk and expense. You are to be the sole judge.

### FREE OFFER COUPON

WHIRLWIND MANUFACTURING CO.,  
Dept. 510-A, Station C. Milwaukee, Wis.

Gentlemen: You may send me full particulars of your Whirlwind Carbureting device and tell me how I can get one free. This does not obligate me in any way whatever.

Name.....

Address.....

City.....State.....

( ) Check here if you are interested in full or part time salesman position.



# Think of it! Genuine UNDERWOOD

## Yours for 10 Days TRIAL

Regular \$100 Model  
Now Only **39.90**

Yes—this world-famous Underwood is yours for full 10 days. See for yourself the *real bargain* it is. See how beautiful and new it looks—compare its neat, perfect work—without obligation.



Now Only



on Easy Terms

## Buy Direct at Below 1/2 Mfg's Original Price



My unchallenged direct sale price and easy terms on this genuine Underwood refinished No. 4 is the lowest ever offered. While they last—less than half (1/2) the manufacturer's original price—and easy terms besides. Do not confuse this genuine late model Underwood with inferior or frail machines worth only one-half as much. This is the full sized standard Underwood with 4-row keyboard and late improvements, manufactured to sell originally for \$100. **Fully Guaranteed** in writing.

## Easy Terms — Only 10c a Day

Think of it—a genuine late model Underwood reduced to \$39.90 (Cash). A saving of over \$60 by acting now. Send only \$1 deposit for a 10-day Trial. Then only 10c a day on my easy year-to-pay plan. And you use and enjoy your typewriter all the time. This Underwood all refinished like new is without question the greatest value ever offered at this rock-bottom price. (See column to right for its many outstanding features and improvements.)

## Limited Quantity—Send at Once!

This exceptional bargain offer is for a very limited time only. Remember, every typewriter is sent on 10-days' Trial and Fully Guaranteed.

International Typewriter Exchange,  
231 West Monroe St., Chicago, Ill., Dept. 401.

I am enclosing \$1.00 deposit. Please send the Underwood No. 4 F.O.B. Chicago at the special reduced price for 10-day Trial, with the understanding that if I am not perfectly satisfied I can return it Express Collect and get my deposit back. If I keep it I will pay \$3 a month until I have paid \$44.90 (term price) in full.

Name.....Age.....

Address.....

Town.....State.....



## FREE Complete 9-Piece Office Supply Set and Typewriting Course

We teach you speed typewriting free. Complete Home Study Course of the Famous Van Sant Speed Typewriting System, fully illustrated, easily learned. We also give complete office supply set free during this sensational sale.

### 12 REASONS WHY this is the Greatest Value Ever Offered

1. Genuine Underwood
2. Standard 4-row Keyboard
3. 2-color Ribbon
4. Back Spacer
5. Ribbon Reverse
6. Tabulator
7. Automatic Release
8. Shift Lock
9. Lowest Price
10. Easiest Terms
11. 10-Day Trial
12. Fully Guaranteed



# New **FLASHER** SIGN

**Pays Men Up To  
\$30 a Day**

**Newly Discovered Process Gives  
Merchants This Famous Sign at  
One-Tenth Price of Others**

Everyone has seen them, the sign of such piercing brilliance that ordinary electric signs are dull in comparison. Every merchant has wanted to have such a sign but the price has been prohibitive. Now a miraculous new process duplicates effect of the expensive signs at one-tenth the cost! Now, for very little more than the cost of an ordinary show-card, stores, restaurants, banks, theatres, barber shops, etc., can attract customers with this famous sign. It not only has unparalleled brilliance but a new added feature makes it F-L-A-S-H—on—off—on—off! No long, hard, messy job to install. The whole unit is completely enclosed in beautiful mahogany finish metal box. Simply plug into electric light socket.

**No "Selling Talk" necessary —  
2 Minute Demonstration  
Makes Sales**

No "selling talk" to memorize—no experience in selling is necessary. A two-minute demonstration gives the whole story and takes 3 orders out of five calls. Walk into a store; set the sign on a show case or in the window; plug into an electric light socket. In half a moment the sign is flashing its message with a brilliance that fairly screams for attention. Show him how the message can be changed quick as a flash—YOUR SALE IS MADE RIGHT THERE! That's why \$30 a day can be made so easily! That's how Tettens of Iowa earned at the rate of \$10 an hour his first day, and how others are making such big money.

**QUICK! GET SIGN WE LOAN YOU**

Merchants in your locality want this sign. Within the next 30 days they will be ordering these signs from some lucky man. Be the one to get from \$2.50 up on every order. You risk no money to get started—we loan you complete sign to use in demonstrating. Just take the orders. We deliver and collect. Rush the coupon; get the generous free offer; get money immediately.

**MAIL  
Coupon**

Williams Name Plate Sign Co.

30 No. La Salle St., Dept. 4-4, Chicago, Ill.

Rush me details of your free offer and loan of full size working sample WIL-O-LITE sign without risk to me.

Name.....

Address..... City..... State.....



**ON-OFF  
ON-OFF**







“I’ve ridden the Western Plains

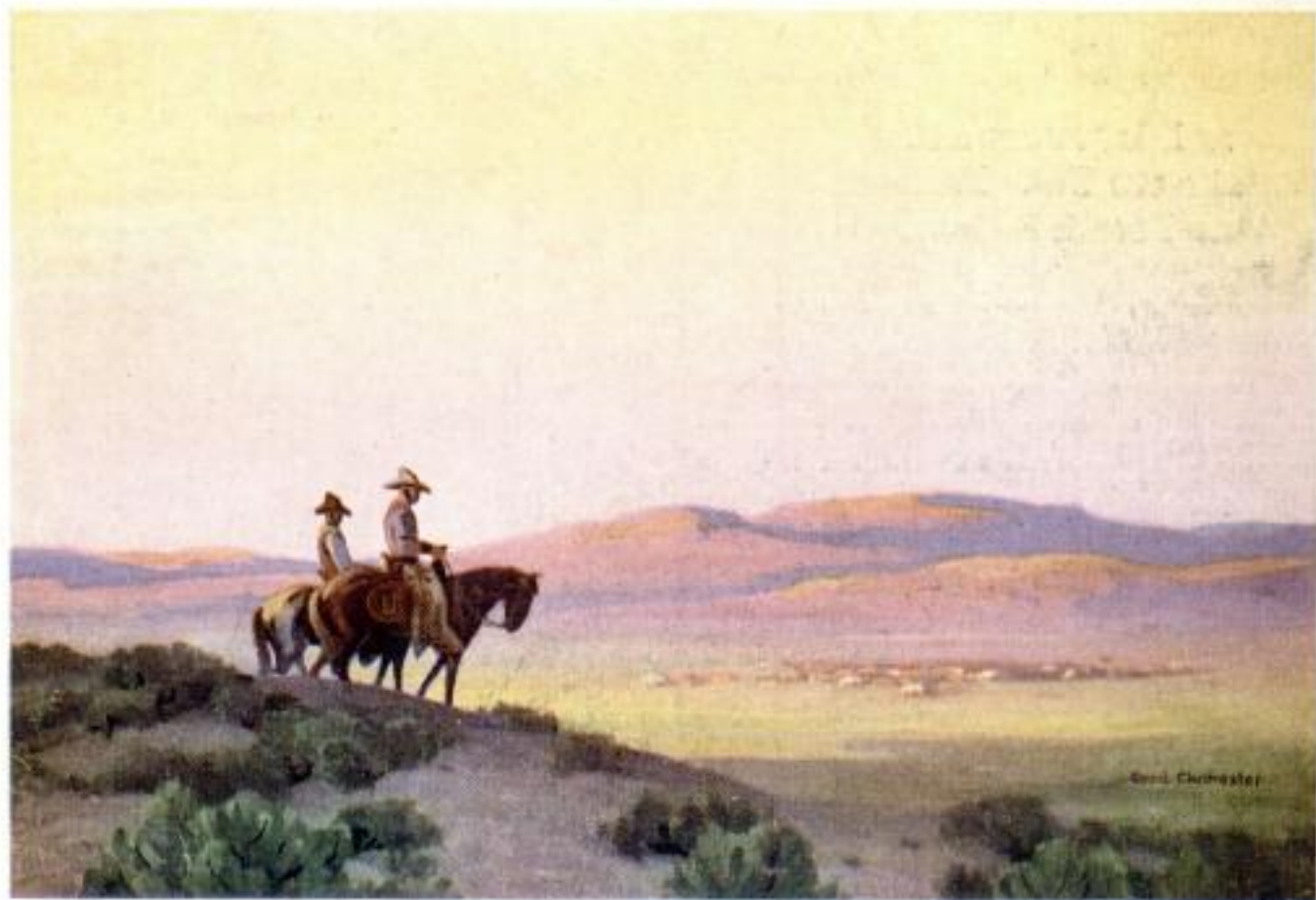

*yet* you’ll meet me in the thick of a Broadway crowd”

It’s a far cry from the cow country to Broadway. But what it takes to make the broncho buster “open up” about his cigarette is exactly what you want in your smoke. *Taste*—and lots of it! And taste is a matter of tobacco quality, nothing else. What you taste in Chesterfield is milder, better tobaccos — unchanged! Unsweetened! Unspoiled!

*Chesterfield*



*They satisfy  
— that’s why!*